

Conoflow

ITT Fluid Technology Corporation

Highway 78 P.O. Box 768
 St. George, South Carolina 29477-0768
 Telephone: (803) 563-9281
 Telex 4945706 FAX (803) 563-2131

WARNING

Conoflow's products are designed and manufactured using materials and workmanship required to meet all applicable industry standards. The use of these products should be confined to services specified and/or recommended in the Conoflow catalogs, instructions or by Conoflow application engineers (i.e. exceeding pressure-temperature rating or using device for services other than those specified).

To avoid personal injury or equipment damage due to misuse or misapplication of a product, it is necessary to select the proper materials of construction and pressure-temperature ratings which are consistent with performance requirements.

INSTRUCTION AND MAINTENANCE MANUAL GB52 / 53 Series Lever Actuator

These instructions should be read carefully before installation or maintenance.

UNPACKING ACTUATOR

Check for accessory equipment packed with the actuator. Match all parts with items listed on packing list and record nameplate serial numbers. The actuator nameplate will provide necessary data required for complete identification. Always refer to serial numbers when ordering spare parts, conversion parts, or accessory equipment.

INSTALLATION

The piston can be mounted in any position. Regulator and gauge for loading one side of piston are mounted and piped. Air supply should be regulated and filtered.

Note: A Conoflow Airpak (filter-regulator) can be integrally mounted to provide constant regulation and filtration of air supply to the actuator.

OPERATION

Normal range of the actuator positioner for full stroke is 3-15 PSI(21-103 kPa) (other ranges, including 3-9 PSI(21-62 kPa) and 9-15 PSI(62-103 kPa), are available). Connect the signal input to the connection marked 'INST' on the positioner. Then, connect a supply of clean, filtered air to the supply connection (see Piping Schematic, Positioner Instruction Manual*) to supply both the positioner and the cushion loading regulator. The supply pressure required is a function of the cylinder diameter and the force required. Air supply up to 100 PSI(690 kPa) can safely be used to insure a reserve of power and a maximum speed. However,

for economy of operation use the lowest supply pressure with which satisfactory results can be obtained. The positioner has been adjusted for operation with a supply pressure up to 100 PSI(690 kPa).

* Refer to Instruction booklets for appropriate positioner, See Page 2.

ZERO ADJUSTMENT

To check zero adjustment (preset at factory), set the instrument output signal at the mid-point of its range (9 PSI(62 kPa) on a 3-15 PSI(21-103 kPa) range), turn zero adjustment coupling and note position of actuator stem. Continue rotation of zero adjustment coupling in proper direction until actuator stem is at the mid-point of stroke. Adjust instrument output signal to low and high points in range and check the stem position at both ends of the stroke.

If stroke adjustment does not fall within specifications, refer to positioner manual for further instructions.

CUSHION LOADING REGULATOR (GH04XSK)

The cushion loading pressure has been arbitrarily set at approximately 20 PSI(138 kPa). This pressure may be adjusted by means of the cushion loading regulator when higher or lower return forces are required. The standard regulator supplied can provide settings up to 60 PSI(414 kPa) and as low as 5 PSI(35 kPa).

RANGE CHANGES

Standard range is 3-15 PSI(21-103 kPa). Other ranges are available, consult the factory.

DIMENSIONS

INSTR. CONN. 1/4" N.P.T.
 SUPPLY CONN. 1/4" N.P.T.
 4 MTL. HOLES 5/16" DIA. 120°
 DIA. CH 2.75
 1/8" DIA. HOLES
 1/8" DIA. HOLES

MODEL	A	B	C	D	E	F	G	H
GB5252C	18.38	7.28	8.18	6.78	8.18	6.78	1.84	1.84
GB5252D	(188.85)	(184.15)	(182.70)	(171.45)	(208.50)	(184.80)	(11.80)	(11.80)
GB5252E	(18.25)	8.38	7.25	6.78	8.18	6.78	2.18	2.18
GB5252F	(188.85)	(228.25)	(184.15)	(171.45)	(208.50)	(181.80)	(85.80)	(85.80)

LEVER POSITION CHART

LEVER POSITION	GH115 OCB GH145	GH115 OCB OCB50	GH115 OCB OCB50	GH115 OCB50
NORMAL LEVER POSITION	UP	DOWN	DOWN	UP
AS INSTRUMENT SIGNAL INCREASES LEVER MOVES	DOWN	UP	UP	DOWN

LEVER HOLES (3/4" Dia.)	LEVER TRAVEL In (mm)	TRAVEL AND FORCES DEVELOPED AVAILABLE FORCE (lbs.)			
		GB5252C		GB5252E	
		60 PSI (414 kPa)	70 PSI (483 kPa)	60 PSI (414 kPa)	70 PSI (483 kPa)
3	2 (11.27)	218	444	758	1,000
4	6 (11.82)	288	370	650	880
5	7 (11.82)	224	280	480	720
6	8 (12.88)	200	280	478	680
8	12 (22.88)	178	250	428	600
10	15 (25.40)	150	220	378	520
11	17 (27.92)	150	200	348	480
12	20 (30.44)	138	180	318	440

MAINTENANCE

POSITIONER

The COMMANDAIRE positioners require a minimum of maintenance. If servicing or replacements are necessary, refer to the appropriate Instructions and Parts List Booklets. Refer to listing below.

CYLINDER

Life of lipseals (5) is such that replacement will seldom be necessary under normal operating conditions. **Should disassembly become necessary the following procedure must be followed. Piston (2) should be in "up" position. Disconnect tubing and bleed air out of unit.** Remove cap from positioner (1) and spirolox ring directly under cap, so that positioner headplate can be lifted out. Loosen set screw and remove spring rod nut. Then remove six cap screws around positioner flange and lift positioner from headplate (16). Remove cover (17) spirolox retaining ring (4) and lift out

cylinder headplate (16). Disconnect actuator stem (11) from unit being serviced. Slide out piston (2) and actuator stem assembly (11). Lipseals (5) may now be inspected. Any water, dirt or sludge which may have accumulated inside the cylinder should be removed. "O"ring (19) should be replaced each time by removing truarc ring (9) and retaining plate (20).

Before reassembling, apply a thin layer of grease (Dow-Corning #DC-33 light lubricant or equivalent) to inner wall of cylinder (8), actuator stem (11), lipseals (5), and the lipseal grooves in piston (2). Care should be exercised when reinserting piston (2) into cylinder (8), because lipseal (5) flare is designed of a larger diameter than the cylinder bore. **If the piston will not enter the cylinder bore, run a shim [approximately .010" thick x 1/2" wide] between the lipseals and cylinder wall while applying slight pressure on the piston. [See Figure 1].** Stem (11) should be carefully inserted through bearing (7) to prevent damage of bearing surface by thread of stem (11).

Figure 1. Lipseal/Piston Arrangement

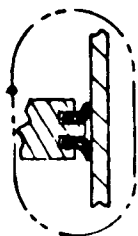

LEVER POSITION

POSITIONER TYPE	GJ1103 GC31 GJ2103	GJ1215 GJ1230 GC32 GC3230	GJ1315 GJ1330 GC33 GC3330 GJ2215 GJ2230	GJ14 GC34
NORMAL LEVER POSITION	UP	DOWN	DOWN	UP
AS INSTRUMENT SIGNAL INCREASES LEVER MOVES	DOWN	UP	UP	DOWN

Positioner Instruction Manuals

GB52/53SC - GC31	Positioner	C-8033
GB52/53SH - GC32	Positioner	C-8034
GB52/53S7 - GC3230	Positioner	C-8034
GB52/53SK - GC33	Positioner	C-8035
GB52/53S8 - GC3330	Positioner	C-8035
GB52/53SV - GC34	Positioner	C-8036
GB52/53SR - GJ1103	Positioner	C-8032/C-8032A
GB52/53SS - GJ1215	Positioner	C-8032/C-8032A
GB52/53S9 - GJ1230	Positioner	C-8032/C-8032A
GB52/53ST - GJ1315	Positioner	C-8032/C-8032A
GB52/53SI - GJ1330	Positioner	C-8032/C-8032A
GB52/53SU - GJ1403	Positioner	C-8032/C-8032A
GB52/53SN - GJ2103	Positioner	C-8037
GB52/53SP - GJ2215	Positioner	C-8037
GB52/53SQ - GJ2230	Positioner	C-8037

GH04XS Regulator. Refer to C-8025 for Instruction and Maintenance

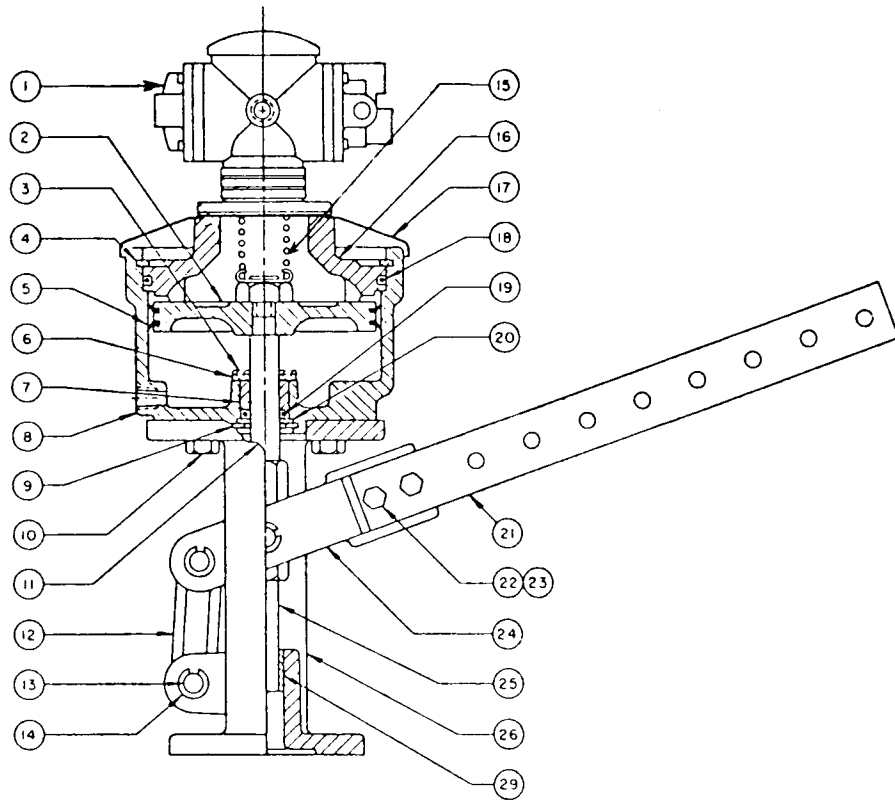

Item No.	Qty. Req'd.	Description	GB52SC	GB53SC
1	1	Positioner	Refer To Page 2	Refer To Page 2
2	1	Piston	6004386	G6004402
3	1	Collar	-----	G6009658
4	1	Retaining Ring	6004725	G6004683
5 ⁽¹⁾	2	Lipseal	6004154	G6004162
6	1	Collar	-----	G6211288
7 ⁽⁴⁾	1	Oilite Bearing	6074736	G6074652
8 ⁽⁴⁾	1	Cylinder	6001788	G6001796
9	1	Truarc Ring	6075980	G6075980
10	4	Hex Head Capscrew 1/2" - 13 x 1" Lg.	6900152	G6900152
11	1	Stem	6006175	G6006183
12	1	Pivot Arm	6006241	G6006241
13	3	Pin	6006258	G6006258
14	6	Truarc Ring	6076046	G6076046
15	1	Range Spring Assembly	GJ80041812	GJ80052412
16	1	Headplate	6001119	G6001689
17	1	Cover	6001812	G6001994
18 ⁽¹⁾	1	"O" Ring	6077192	G6077200
19 ⁽¹⁾	1	"O" Ring	6077028	G6077036
20	1	Retaining Plate	6009021	G6009039
21	1	Arm	6006266	G6006266
22	2	Hex Head Capscrew 3/8" - 16 x 1 1/2" Lg.	6900139	G6900139
23	2	Hex Nut 3/8" - 16"	6900214	G6900214
24	1	Fulcrum Arm	6006217	G6006217
25	1	Lower Stem	6006233	G6006233
26 ⁽⁴⁾	1	Yoke	6006191	G6006191
27	1	Regulator (Not Shown)	GH04XSKEXXF	GH04XSKEXXF
28	1	Gauge (0-60 PSI(0-414 kPa)) (Not Shown)	6077705	G6077705
29 ⁽⁴⁾	1	Oilite Bearing	6074652	G6074652

NOTES: 1. Recommended spare parts can be purchased individually or as a Spare Parts Kit, under number

6385345
Spare Parts Kit

6385346
Spare Parts Kit

2. For definition of Catalog No., refer to Control Engineering Data Sheet C-9000.

3. When ordering spare parts, specify complete catalog no., item no. and part no. This will permit positive identification and rapid handling of order.

4. Items 7 and 8 — 26 and 29 are to be purchased as matched sets.

WARNING - TECHNICAL DATA SUBJECT TO EAR CONTROLS

This document contains technical data whose export is restricted by the Export Administration Act of 1979, as amended (Title 50, U.S.C., App. 2401, et seq.) Violation of this export control law is subject to severe criminal penalties.



Conoflow

ITT Fluid Technology Corporation

Highway 78 P.O. Box 768
St. George, South Carolina 29477-0768
Telephone: (803) 563-9281
Telex 4945706 FAX (803) 563-2131

**WARNING: MANUFACTURED WITH (1, 1, 1-TRICHLOROETHANE),
A SUBSTANCE WHICH HARMS PUBLIC HEALTH AND
ENVIRONMENT BY DESTROYING OZONE IN THE UP-
PER ATMOSPHERE.**

WARNING – TECHNICAL DATA SUBJECT TO EAR CONTROLS

This document contains technical data whose export is restricted by the Export Administration Act of 1979,
as amended (Title 50, U.S.C., App. 2401, et seq.) Violation of this export control law is subject to severe criminal penalties.