

Wiring and Grounding Guidelines for Pulse-width Modulated (PWM) AC Drives

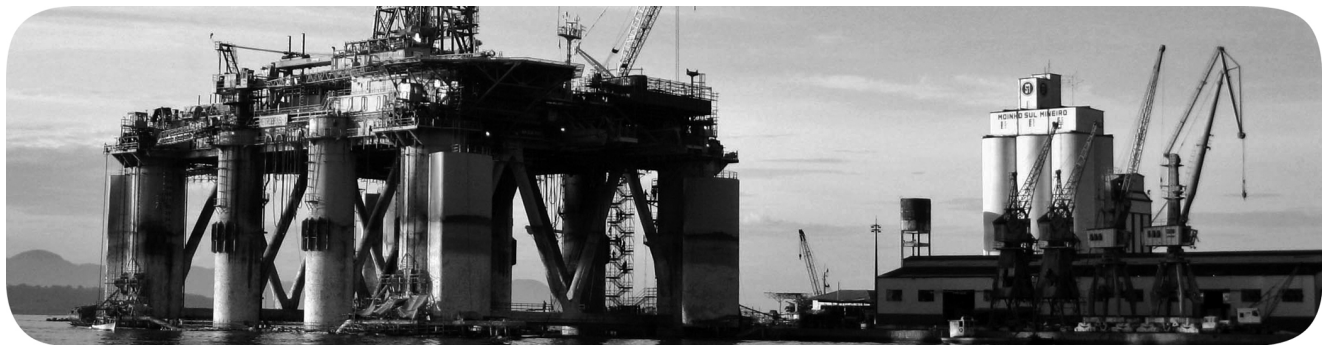

Important User Information

Read this document and the documents listed in the additional resources section about installation, configuration, and operation of this equipment before you install, configure, operate, or maintain this product. Users are required to familiarize themselves with installation and wiring instructions in addition to requirements of all applicable codes, laws, and standards.

Activities including installation, adjustments, putting into service, use, assembly, disassembly, and maintenance are required to be carried out by suitably trained personnel in accordance with applicable code of practice.

If this equipment is used in a manner not specified by the manufacturer, the protection provided by the equipment may be impaired.

In no event will Rockwell Automation, Inc. be responsible or liable for indirect or consequential damages resulting from the use or application of this equipment.

The examples and diagrams in this manual are included solely for illustrative purposes. Because of the many variables and requirements associated with any particular installation, Rockwell Automation, Inc. cannot assume responsibility or liability for actual use based on the examples and diagrams.

No patent liability is assumed by Rockwell Automation, Inc. with respect to use of information, circuits, equipment, or software described in this manual.

Reproduction of the contents of this manual, in whole or in part, without written permission of Rockwell Automation, Inc., is prohibited

Throughout this manual, when necessary, we use notes to make you aware of safety considerations.



WARNING: Identifies information about practices or circumstances that can cause an explosion in a hazardous environment, which may lead to personal injury or death, property damage, or economic loss.



ATTENTION: Identifies information about practices or circumstances that can lead to personal injury or death, property damage, or economic loss. Attentions help you identify a hazard, avoid a hazard, and recognize the consequence.

IMPORTANT

Identifies information that is critical for successful application and understanding of the product.

Labels may also be on or inside the equipment to provide specific precautions.



SHOCK HAZARD: Labels may be on or inside the equipment, for example, a drive or motor, to alert people that dangerous voltage may be present.



BURN HAZARD: Labels may be on or inside the equipment, for example, a drive or motor, to alert people that surfaces may reach dangerous temperatures.



ARC FLASH HAZARD: Labels may be on or inside the equipment, for example, a motor control center, to alert people to potential Arc Flash. Arc Flash will cause severe injury or death. Wear proper Personal Protective Equipment (PPE). Follow ALL Regulatory requirements for safe work practices and for Personal Protective Equipment (PPE).

| | | |
|---------------------------|--|----|
| | Preface | 7 |
| | Summary of Changes | 7 |
| | Line to Load Installation Guidelines | 8 |
| | Additional Resources | 11 |
| | Chapter 1 | |
| Wire/Cable Types | General | 13 |
| | Recommended Cable/Wire | 13 |
| | General Precautions | 14 |
| | Material | 14 |
| | Exterior Cover | 14 |
| | Temperature Rating | 15 |
| | Gauge | 16 |
| | Number of Conductors | 16 |
| | Insulation Thickness and Concentricity | 17 |
| | Geometry | 17 |
| | Unshielded Cable | 18 |
| | Shielded Cable | 19 |
| | Armored Cable | 20 |
| | European Style Cable | 22 |
| | Input Power Cables | 22 |
| | Motor Cables | 23 |
| | Cable for Discrete Drive I/O | 24 |
| | Analog Signal and Encoder Cable | 24 |
| | Communication | 25 |
| | DeviceNet Communication | 25 |
| | ControlNet Communication | 26 |
| | Ethernet Communication | 26 |
| | Remote I/O and Data Highway Plus™ (DH+™) Communication | 27 |
| | Serial (RS-232 and RS-485) Communication | 27 |
| | Chapter 2 | |
| Power Distribution | System Configurations | 29 |
| | Delta/Wye with Grounded Wye Neutral | 29 |
| | Delta/Delta with Grounded Leg, or Four-wire Connected Secondary Delta | 30 |
| | Three-phase Open Delta with Single-phase Center Tapped ... | 30 |
| | Ungrounded Secondary | 31 |
| | High-Resistance Ground | 31 |
| | TN-S Five-wire System | 32 |
| | AC Line Voltage | 32 |
| | AC Line Impedance | 32 |
| | Multi-drive Protection | 48 |
| | Surge Protection MOVs and Common Mode Capacitors | 50 |

Use PowerFlex Drives with Regenerative Units 51
 DC Bus Wiring Guidelines 51
 Drive Lineup 51
 DC Bus Connections 52

Chapter 3

Grounding

Grounding Safety Grounds 55
 Structural Steel of a Building 55
 Grounding PE or Ground 56
 RFI Filter Grounding 56
 Grounding Motors 56
 Grounding and TN-S Five-wire Systems 56
 Noise Related Grounds 57
 Acceptable Grounding Practices 59
 Effective Grounding Practices 60
 Optimal – Recommended Grounding Practices 60
 Cable Shields 61
 Isolated Inputs 61

Chapter 4

Best Practices

Mounting 63
 Standard Installations 63
 EMC Specific Installations 64
 Layout 64
 Hardware 65
 Conduit Entry 66
 Entry Plates 66
 Cable Connectors/Glands 66
 Shield Termination Via Pigtail (lead) 67
 Ground Connections 67
 Wire Routing 69
 General 69
 Within a Cabinet 71
 Within Conduit 72
 Loops, Antennas, and Noise 73
 Conduit 73
 Cable Trays 74
 Parallel Motor Cable Runs 75
 Shield Termination 75
 Termination Via Circular Clamp 75
 Shield Termination Via Pigtail (lead) 76
 Shield Termination Via Cable Clamp 77
 Conductor Termination 78
 Power TB 78
 Control TB 78
 Signal TB 78

| | | |
|--|--|-----|
| | Moisture | 79 |
| | Chapter 5 | |
| Reflected Wave | Description | 81 |
| | Effects On Wire Types | 81 |
| | Length Restrictions for Motor Protection | 82 |
| | Chapter 6 | |
| Electromagnetic Interference | What Causes Common Mode Noise..... | 83 |
| | Containing Common Mode Noise With Cabling..... | 84 |
| | Conduit | 84 |
| | Shielded or Armored Power Cable | 84 |
| | How Electromechanical Switches Cause Transient Interference... | 85 |
| | How to Prevent or Mitigate Transient Interference from Electromechanical Switches | 86 |
| | Enclosure Lighting | 89 |
| | Bearing Current..... | 89 |
| | Appendix A | |
| Motor Cable Length Restrictions | Overview | 91 |
| | Motor Cable Length Restrictions Tables Cross-reference | 94 |
| | Cable Charging Current Phenomenon..... | 95 |
| | How to Read the Motor Cable Length Restrictions Tables..... | 96 |
| | PowerFlex 4 Drives..... | 98 |
| | PowerFlex 4M Drives..... | 99 |
| | PowerFlex 40 Drives..... | 100 |
| | PowerFlex 400 Drives | 102 |
| | PowerFlex 520-Series Drives | 104 |
| | PowerFlex 70 and 700 Drives..... | 107 |
| | PowerFlex 700H Drives | 113 |
| | PowerFlex 700L Drives | 115 |
| | PowerFlex 700S Drives | 119 |
| | PowerFlex 753 and 755 Wall Mount Drives | 125 |
| | PowerFlex 755 Floor Mount Drives..... | 135 |
| | PowerFlex 755T Drive Products..... | 141 |
| | 1336 PLUS II and 1336 IMPACT Drives..... | 147 |
| | 1305 Drives..... | 150 |
| | 160 Drives..... | 151 |
| | Reflected Wave Reduction Guidelines (for catalog number 1321-RWR) | 152 |
| | Glossary | 157 |
| | Index | 161 |

Notes:

This manual provides basic information to install, protect, wire, and ground pulse-width modulated (PWM) AC drives.

This manual is intended for qualified personnel who plan and design installations of PWM AC drives.

Summary of Changes

This manual contains new and updated information as indicated in the following table.

| Topic | Page |
|--|-------------|
| Added reference to these new products: <ul style="list-style-type: none">• PowerFlex® 755TL low harmonic drives• PowerFlex 755TR regenerative drives• PowerFlex 755TM drive systems (Throughout this manual, the PowerFlex 755TL low harmonic drives, PowerFlex 755TR regenerative drives, and PowerFlex 755TM drive systems are also referred to as PowerFlex 755T drive products.) | 8 |
| Added the PowerFlex 755T drive products to the motor cable length restrictions tables cross-reference. | 94 |
| Added the PowerFlex 755T drive products motor cable length data. | 141...145 |

Line to Load Installation Guidelines

This section provides direction for how and where to find information from line to load on the successful installation and implementation of PWM drives.

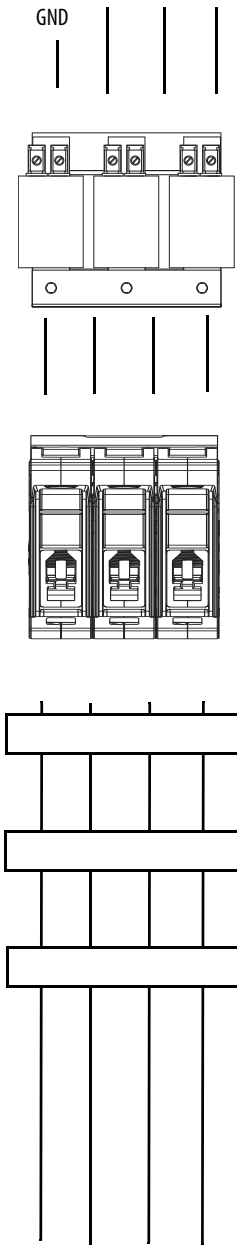

| Topic | PowerFlex 755T Drive Products | PowerFlex 750-Series Drives | PowerFlex 520-Series Drives | |
|-----------------------------------|---|---|--|---|
| AC supply source | Wiring and Grounding Guidelines for Pulse-width Modulated (PWM) AC Drives Installation Instructions, publication DRIVES-IN001 See Chapter 2 – System Configurations on page 29 . | | | |
| Input power conditioning | Wiring and Grounding Guidelines for Pulse-width Modulated (PWM) AC Drives Installation Instructions, publication DRIVES-IN001 See Chapter 2 – AC Line Impedance on page 32 . | | | |
| | 1321 Power Conditioning Products Technical Data, publication 1321-TD001 See this publication for line reactors and isolation transformers. | | | |
| Input fusing and circuit breakers | PowerFlex 750-Series Products with TotalFORCE™ Control Installation Instructions, publication 750-IN100 See the Fuses and Circuit Breakers Ratings section. | PowerFlex 750-Series AC Drives Installation Instructions, publication 750-IN001 See Chapter 4 – Fuse and Circuit Breaker Ratings. | PowerFlex 520-Series Adjustable Frequency AC Drive User Manual, publication 520-UM001 See Chapter 1 – Fuses and Circuit Breakers. | PowerFlex 527 Adjustable Frequency AC Drive User Manual, publication 520-UM002 See Chapter 1 – Fuses and Circuit Breakers. |
| Input power wire and cable | Wiring and Grounding Guidelines for Pulse-width Modulated (PWM) AC Drives Installation Instructions, publication DRIVES-IN001 See Chapter 1 – Input Power Cables on page 22 . | | | |
| EMC filters | PowerFlex 750-Series Products with TotalFORCE Control Installation Instructions, publication 750-IN100 See Chapter 3– Installation Requirements Related to EN 61800-3 and the EMC Directive. | PowerFlex 750-Series AC Drives Installation Instructions, publication 750-IN001 See Chapter 2 – Installation Requirements Related to EN 61800-3 and the EMC Directive. | PowerFlex 520-Series Adjustable Frequency AC Drive User Manual, publication 520-UM001 See Chapter 1 – General Considerations. | PowerFlex 527 Adjustable Frequency AC Drive User Manual, publication 520-UM002 See Chapter 1 – General Considerations. |
| Electrical interference | Wiring and Grounding Guidelines for Pulse-width Modulated (PWM) AC Drives Installation Instructions, publication DRIVES-IN001 See Chapter 6 – How Electromechanical Switches Cause Transient Interference on page 85 . | | | |
| Grounding | Wiring and Grounding Guidelines for Pulse-width Modulated (PWM) AC Drives Installation Instructions, publication DRIVES-IN001 See Chapter 3 – Grounding on page 55 . | | | |
| | PowerFlex 750-Series Products with TotalFORCE Control Installation Instructions, publication 750-IN100 See Chapter 5 – Grounding Requirements | PowerFlex 750-Series AC Drives Installation Instructions, publication 750-IN001 See Chapter 4 – Grounding Requirements. | PowerFlex 520-Series Adjustable Frequency AC Drive User Manual, publication 520-UM001 See Chapter 1 – General Grounding Requirements. | PowerFlex 527 Adjustable Frequency AC Drive User Manual, publication 520-UM002 See Chapter 1 – General Grounding Requirements. |

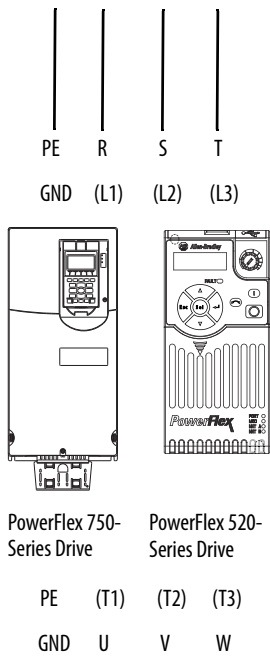

| Topic | PowerFlex 755T Drive Products | PowerFlex 750-Series Drives | PowerFlex 520-Series Drives | |
|----------------------------|--|---|---|--|
| Jumpers | PowerFlex 750-Series Products with TotalFORCE Control Installation Instructions, publication 750-IN100 See Chapter 5 – Power Jumper Configuration. | PowerFlex 750-Series AC Drives Installation Instructions, publication 750-IN001 See Chapter 4 – Drive Power Jumper Configuration. | PowerFlex 520-Series Adjustable Frequency AC Drive User Manual, publication 520-UM001 See Chapter 1 – AC Supply Source Considerations. | PowerFlex 527 Adjustable Frequency AC Drive User Manual, publication 520-UM002 See Chapter 1 – AC Supply Source Considerations. |
| Mounting considerations | PowerFlex 750-Series Products with TotalFORCE Control Installation Instructions, publication 750-IN100 See Chapter 3 – Mounting Requirements, Minimum Clearances | PowerFlex 750-Series AC Drives Installation Instructions, publication 750-IN001 See Chapter 2 – Minimum Clearances, Mounting Considerations. | PowerFlex 520-Series Adjustable Frequency AC Drive User Manual, publication 520-UM001 See Chapter 1 – Mounting Considerations. | PowerFlex 527 Adjustable Frequency AC Drive User Manual, publication 520-UM002 See Chapter 1 – Mounting Considerations. |
| Environment | Industry Installation Guidelines for Pulse-width Modulated (PWM) AC Drives Application Technique, publication DRIVES-AT003 See this publication for information for different enclosure systems and environmental/location considerations (to help protect against environmental contaminants), and power and grounding considerations. | | | |
| | PowerFlex 750-Series Products with TotalFORCE Control Installation Instructions, publication 750-IN100 See Chapter 3 – Environmental Conditions, Environmental Specifications | PowerFlex 750-Series AC Drives Installation Instructions, publication 750-IN001 See Chapter 2 – Environmental Specifications. | PowerFlex 520-Series Adjustable Frequency AC Drive User Manual, publication 520-UM001 See Appendix A – Environmental Specifications. | PowerFlex 527 Adjustable Frequency AC Drive User Manual, publication 520-UM002 See Appendix A – Environmental Specifications. |
| Control and signal cabling | Wiring and Grounding Guidelines for Pulse-width Modulated (PWM) AC Drives Installation Instructions, publication DRIVES-IN001 See Chapter 4 – Wire Routing on page 69 . | | | |
| | PowerFlex 750-Series Products with TotalFORCE Control Installation Instructions, publication 750-IN100 See Chapter 6 – Wire I/O | PowerFlex 750-Series AC Drives Installation Instructions, publication 750-IN001 See Chapter 5 – I/O Wiring. | PowerFlex 520-Series Adjustable Frequency AC Drive User Manual, publication 520-UM001 See Chapter 1 – I/O Wiring. | PowerFlex 527 Adjustable Frequency AC Drive User Manual, publication 520-UM002 See Chapter 1 – I/O Wiring. |

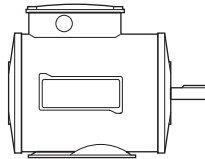
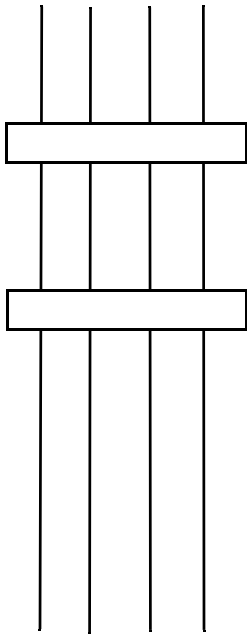

| Topic | PowerFlex 755T Drive Products | PowerFlex 750-Series Drives | PowerFlex 520-Series Drives | |
|----------------------|--|--|---|--|
| Output power cabling | Wiring and Grounding Guidelines for Pulse-width Modulated (PWM) AC Drives Installation Instructions, publication DRIVES-IN001 See Chapter 1 – Motor Cables on page 23 . | | | |
| Output devices | Wiring and Grounding Guidelines for Pulse-width Modulated (PWM) AC Drives Installation Instructions, publication DRIVES-IN001 See Chapter 6 – Shielded or Armored Power Cable on page 84 | | | |
| | 1321 Power Conditioning Products Technical Data, publication 1321-TD001 See this publication for load reactors, RWRs, and common mode chokes/cores. | | | |
| | 1204 Terminator Instructions, publication 1204-IN002 See this publication for motor terminators. | | | |
| | PowerFlex 750-Series Products with TotalFORCE Control Installation Instructions, publication 750-IN100 See Chapter 5 – Output Contactor Precautions. | PowerFlex 750-Series AC Drives Installation Instructions, publication 750-IN001 See Chapter 4 – Output Contactor Precautions. | PowerFlex 520-Series Adjustable Frequency AC Drive User Manual, publication 520-UM001 See Chapter 1 – Output Disconnect. | PowerFlex 527 Adjustable Frequency AC Drive User Manual, publication 520-UM002 See Chapter 1 – Output Disconnect. |
| Cable length | Wiring and Grounding Guidelines for Pulse-width Modulated (PWM) AC Drives Installation Instructions, publication DRIVES-IN001 See Chapter 5 – Length Restrictions for Motor Protection on page 82 . | | | |
| Encoder | Wiring and Grounding Guidelines for Pulse-width Modulated (PWM) AC Drives Installation Instructions, publication DRIVES-IN001 See Chapter 1 – Analog Signal and Encoder Cable on page 24 . | | | |
| Motor | Wiring and Grounding Guidelines for Pulse-width Modulated (PWM) AC Drives Installation Instructions, publication DRIVES-IN001 See Appendix A – Overview on page 91 . | | | |

Additional Resources

These documents contain additional information concerning related products from Rockwell Automation.

| Resource | Description |
|--|--|
| Safety Guidelines for the Application, Installation, and Maintenance of Solid-State Control, publication SGI-1.1 | Provides general guidelines for the application, installation, and maintenance of solid-state control devices or assemblies. |
| 1321 Power Conditioning Products Technical Data, Don't Ignore the Cost of Power Line Disturbance, publication 1321-TD001 | Provides technical data on Allen-Bradley® power conditioning products. |
| IEEE Guide for the Installation of Electrical Equipment to Minimize Electrical Noise Inputs to Controllers from External Sources, publication IEEE 518. Available from IEEE Xplore Digital Library . | Provides techniques for installing controllers and control systems so that proper operation can be achieved in the presence of electrical noise. |
| Recommended Practice for Powering and Grounding Electronic Equipment - IEEE Emerald Book, publication IEEE STD 1100. Available from IEEE Xplore Digital Library . | Provides the recommended practices for powering and grounding electronic equipment. |
| IEEE Recommended Practice for Grounding of Industrial and Commercial Power Systems, publication IEEE Std 142-1991. Available from IEEE Xplore Digital Library . | Provides recommended practices to ground power systems. |
| Cable Alternatives for PWM AC Drive Applications, publication IEEE Paper. No. PCIC-99-23. Available from IEEE Xplore Digital Library . | Describes an alternative solution for cables used with IGBT variable frequency drives (VFDs). |
| EMI Emissions of Modern PWM AC Drives. IEEE Industry Applications Magazine , Nov./Dec. 1999 | Provides an understanding of EMI issues and with pre-installation and post-installation guidelines. |
| Electromagnetic Interference and Compatibility, Volume 3, by Donald R. J. White. | This book provides information EMI control methods and techniques. |
| Grounding, Bonding, and Shielding for Electronic Equipment and Facilities (Military Handbook 419). | Provides information on how to ground, bond, and shield communication electronics equipment and facilities. |
| Noise Reduction Techniques in Electronic Systems by Henry W. Ott. | This book provides information on controlling emissions from electronic systems, and techniques for providing electromagnetic compatibility (EMC). |
| Grounding for the Control of EMI by Hugh W. Denny. | This book provides grounding guidelines for the control of EMI. |
| EMC for Product Designers by Tim Williams. | This book provides information to help you meet the requirements of the latest EMC Directive. |
| National Electrical Code (ANSI/NFPA 70) Articles 250, 725-5, 725-15, 725-52 and 800-52 (www.nfpa.org) | Provides information on the installation of electrical components, signaling, and communication conductors and grounding. |
| Application Guide for AC Adjustable Speed Drive Systems, NEMA (www.nema.org) | Provides a NEMA application guide for AC drive systems. |
| IEC 60364-5-52 Selection and Erection of Electrical Equipment - Wiring systems, IEC (www.iec.ch) | IEC wiring systems. |

You can view or download publications at <http://www.rockwellautomation.com/global/literature-library/overview.page>. To order paper copies of technical documentation, contact your local Allen-Bradley distributor or Rockwell Automation sales representative.

Notes:

Wire/Cable Types

AC drive installations have specific wire and cable requirements. This section includes information about the major issues for proper selection of cable, and provides recommendations to address these issues. Consider these conditions and requirements when you choose cable material and construction for your installation:

- Environment – such as moisture, temperature, and harsh or corrosive chemicals.
- Mechanical needs – such as geometry, shielding, flexibility, and crush resistance.
- Electrical characteristics – such as cable capacitance/charging current, resistance/voltage drop, current rating, and insulation. Insulation can be the most significant of these characteristics. Because drives can create voltages in excess of line voltage, the industry standard cables that were used in the past are not appropriate for variable speed drives. Drive installations benefit from cable that is different than cable used to wire contactors and push buttons.
- Safety issues – such as electrical code requirements, grounding needs, and others.

Incorrect cables can be costly and can adversely affect the performance of your installation.

General

Recommended Cable/Wire

The recommended wire and cable that is referenced in this publication can be obtained from third-party companies found in our PartnerNetwork™ Encompass™ Program.

For further information on these suppliers and their products, follow these steps to find recommended wire and cable for your drives.

1. Go to the Encompass website at <http://www.rockwellautomation.com/rockwellautomation/sales-partners/complementary-products/overview.page>.
2. Under Find an Encompass Referenced Product, click FIND NOW.
3. In the Product Category pull-down list, choose Drive - Cables.
4. Click SEARCH.

General Precautions



ATTENTION: To avoid an electric shock hazard, verify that the voltage on the bus capacitors has discharged before performing any work on the drive. Measure the DC bus voltage at the +DC and –DC terminals of the power terminal block. The voltage must be zero.

Material

Use only copper wire. The wire clamp-type terminals in Allen-Bradley® drives are made for use with copper wire. If you use aluminum wire, the connections can loosen and cause premature equipment failure.

Wire gauge requirements and recommendations are based on 75 °C (167 °F) rating. Do not reduce wire gauge when you use higher temperature wire.

Exterior Cover

Whether shielded or unshielded, the cable must meet all application requirements. Consider insulation value and resistance to moisture, contaminants, corrosive agents, and other invasive elements. Consult the cable manufacturer and [Figure 1 on page 15](#) for cable selection criteria.

Figure 1 - Wire Selection Flowchart

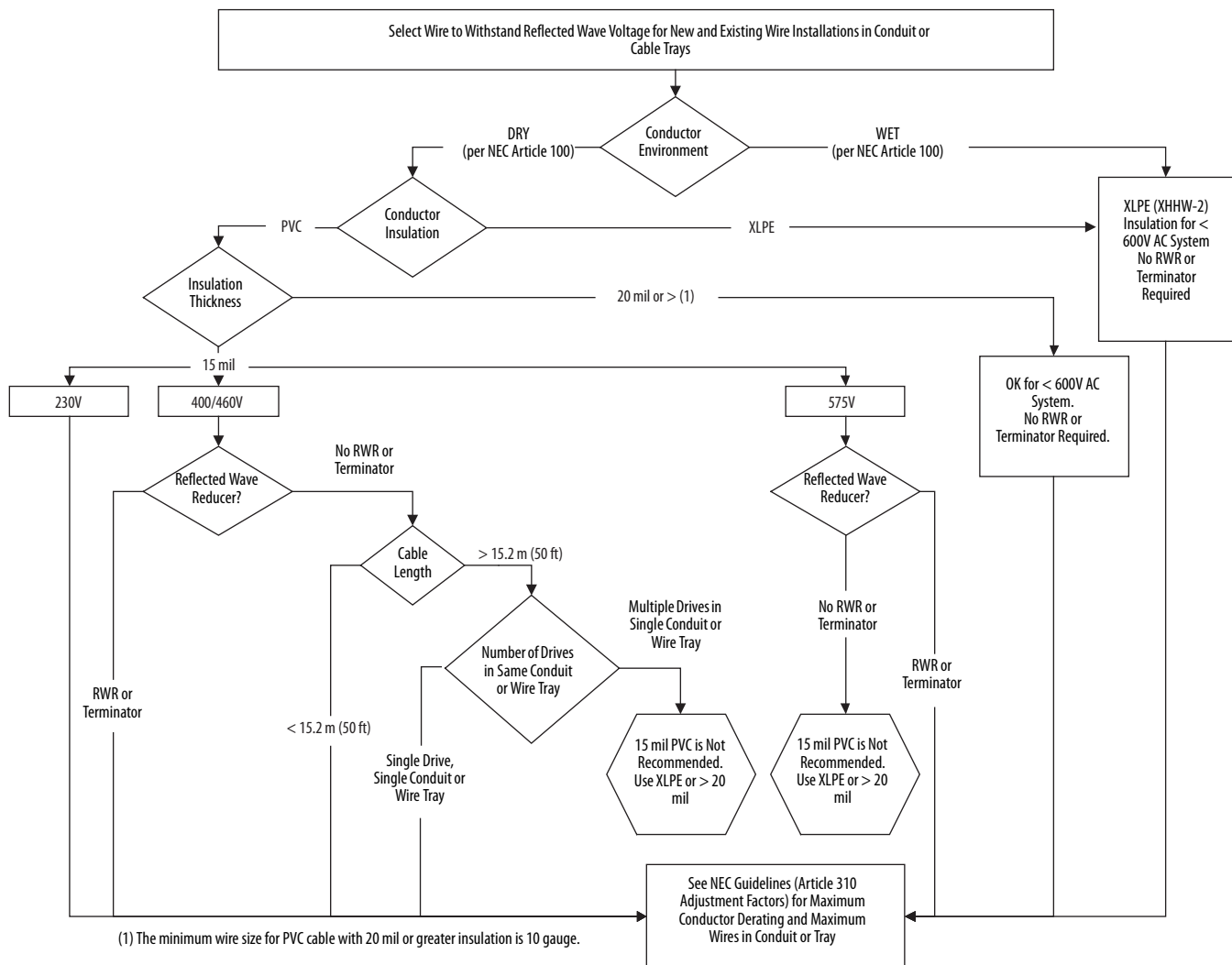

Temperature Rating

In general, follow these temperature ratings for installations:

- In surrounding air temperature of 50 °C (122 °F), use 90 °C (194 °F) wire (required for UL)
- In surrounding air temperature of 40 °C (104 °F), use 75 °C (167 °F) wire (required for UL)

See the user manual of the drive for other restrictions.

IMPORTANT The temperature rating of the wire affects the required gauge. Verify that your installation meets all applicable national, state, and local codes.

Gauge

Multiple factors determine the correct wire size. The user manual for each drive lists a minimum and maximum wire gauge based on the amperage rating of the drive and the physical limitations of the terminal blocks. Local or National Electrical Codes also set the required minimum gauge based on motor full load current (FLA). Follow both of these requirements.

Number of Conductors

Local or National Electrical Codes can determine the required number of conductors. Generally, these configurations are recommended:

- [Figure 2](#) shows cable with one ground conductor that is recommended for drives up to and including 200 Hp (150 kW).
- [Figure 3](#) shows cable with three ground conductors that is recommended for drives larger than 200 Hp (150 kW).

Space the ground conductors symmetrically around the power conductors. Verify that the ground conductors are rated for full drive ampacity.

Figure 2 - Cable with One Ground Conductor

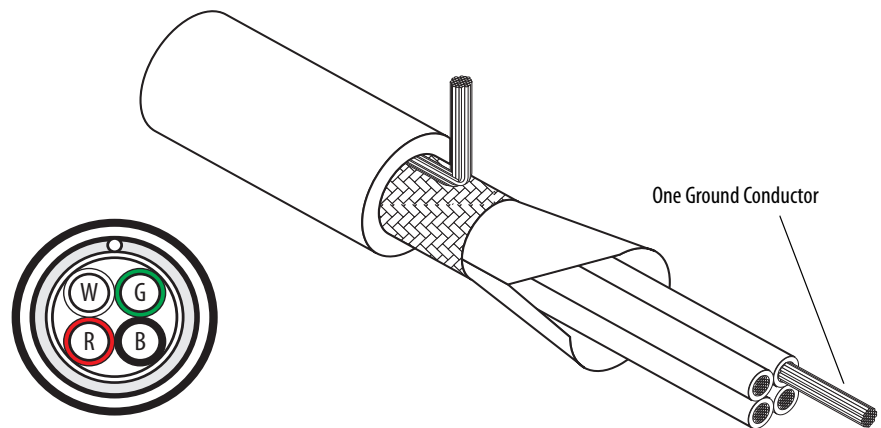
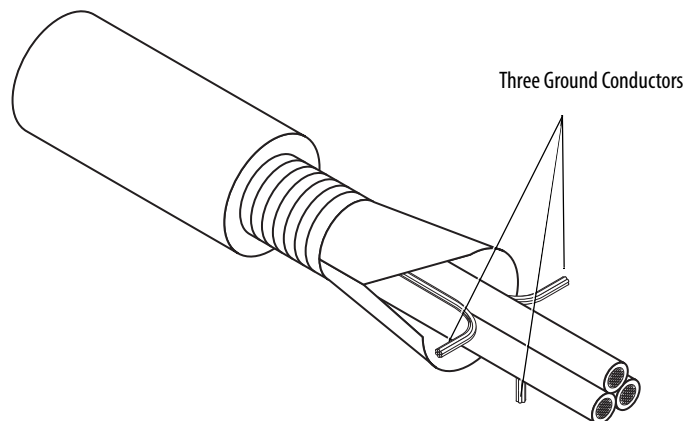

Figure 3 - Cable with Three Ground Conductors



Insulation Thickness and Concentricity

Wire must have an insulation thickness of ≥ 15 mil (0.4 mm/0.015 in.). The wire insulation must not have significant variations of concentricity around the wire.

Figure 4 - Insulation Concentricity

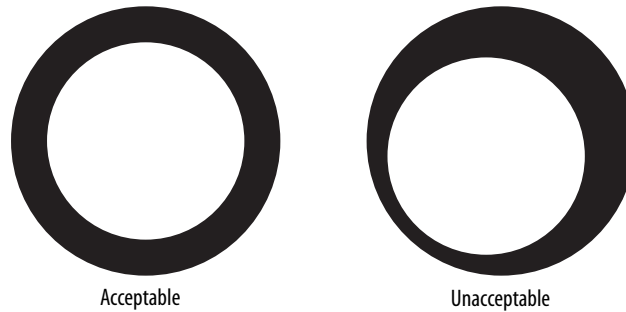

Geometry

The physical relationship between individual conductors is important in drive installations.

Individual conductors in conduit or cable trays have no fixed relationship and are subject to cross coupling of noise, induced voltages, excess insulation stress, and other possible interference.

Fixed geometry cable (cable that keeps the spacing and orientation of the individual conductors constant) offers significant advantages over individual loose conductors, including reduced cross-coupling noise and insulation stress. Three types of fixed geometry, multi-conductor cables are discussed in this section. See [Unshielded Cable on page 18](#), [Shielded Cable on page 19](#), and [Armored Cable on page 20](#).

Table 1 - Recommended Cable Design

| Type | Max Wire Size | Where Used | Rating/Type | Description |
|--------|---------------|---|--|---|
| Type 1 | 2 AWG | Standard installations 100 Hp or less | 600V, 90 °C (194 °F) XHHW2/RHW-2 | Four tinned copper conductors with cross-linked polyethylene (XLPE) insulation |
| Type 2 | 2 AWG | Standard installations 100 Hp or less with brake conductors | 600V, 90 °C (194 °F) RHH/RHW-2 | Four tinned copper conductors with XLPE insulation plus one shielded pair of brake conductors. |
| Type 3 | 500 MCM AWG | Standard installations 150 Hp or more | Tray-rated 600V, 90 °C (194 °F) RHH/RHW-2 | Three tinned copper conductors with XLPE insulation and three bare copper grounds and polyvinyl chloride (PVC) jacket. |
| Type 4 | 500 MCM AWG | Water, caustic chemical, crush resistance | Tray-rated 600V, 90 °C (194 °F) RHH/RHW-2 | Three bare copper conductors with XLPE insulation and three copper grounds on 10 AWG and smaller. Acceptable in Class I and II, Division I and II locations. |
| Type 5 | 500 MCM AWG | 690V applications | Tray-rated 2000V, 90 °C (194 °F) | Three tinned copper conductors with XLPE insulation. Three bare copper grounds and PVC jacket. IMPORTANT: If terminator network or output filter is used, connector insulation must be XLPE, not PVC. |

Unshielded Cable

Properly designed multi-conductor cable can provide excellent performance in wet applications, significantly reduce voltage stress on wire insulation, and reduce cross coupling between drives.

Cables without shielding is acceptable for installations where electrical noise that the drive creates does not interfere with the operation of other devices, such as communication cards, photoelectric switches, weigh scales, and others. Verify that the installation does not require shielded cable to meet specific electromagnetic compatibility (EMC) standards for CE, C-Tick, or FCC requirements. Cable specifications depend on the installation type.

Type 1 and Type 2 Installation

Type 1 or Type 2 installations require 3-phase conductors and a fully rated individual ground conductor with or without brake leads. See [Table 1 on page 17](#) for detailed information and specifications on these installations.

Figure 5 - Type 1 Unshielded Multi-conductor Cable without Brake Leads

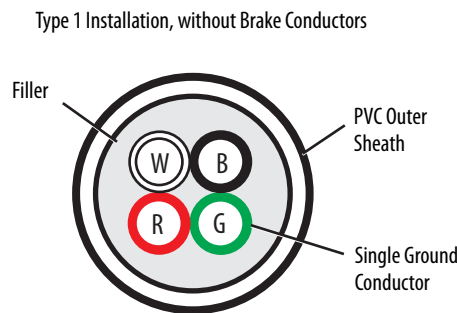

Type 3 Installation

Type 3 installation requires three symmetrical ground conductors whose ampacity equals the phase conductor. See [Table 1 on page 17](#) for detailed information and specifications on this installation.

Figure 6 - Type 3 Unshielded Multi-conductor Cable

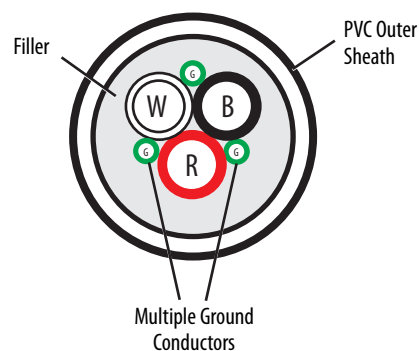

Choose the outer sheathing and other mechanical characteristics to suit the installation environment. Consider the surrounding air temperature, chemical environment, flexibility, and other factors in all installation types.

Shielded Cable

Shielded cable contains the general benefits of multi-conductor cable with the added benefit of a copper-braided shield that can contain much of the noise generated by a typical AC drive. Use shielded cable for installations with sensitive equipment, such as weigh scales, capacitive proximity switches, and other devices affected by electrical noise in the distribution system. Applications with large numbers of drives in one location, imposed EMC regulations, or a high degree of communication/networking, are also good candidates for shielded cable.

Shielded cable can also help reduce shaft voltage and induced-bearing currents for some applications. Also, the increased size of shielded cable can help extend the distance between the motor and the drive without the addition of motor protective devices, such as terminator networks. See [Chapter 5](#) for information regarding reflected wave phenomena.

Consider the general specifications dictated by the environment of the installation, including temperature, flexibility, moisture characteristics, and chemical resistance. In addition, include a braided shield specified by the cable manufacturer as having coverage of at least 75%. An additional foil shield can greatly improve noise containment.

Type 1 Installation

Shielded cable for Type 1 installations has four XLPE insulated conductors with a 100% coverage foil and an 85% coverage copper braided shield (with drain wire) surrounded by a PVC jacket. For detailed specifications and information on Type 1 installations, see [Table 1 on page 17](#).

Figure 7 - Type 1 Installation — Shielded Cable with Four Conductors

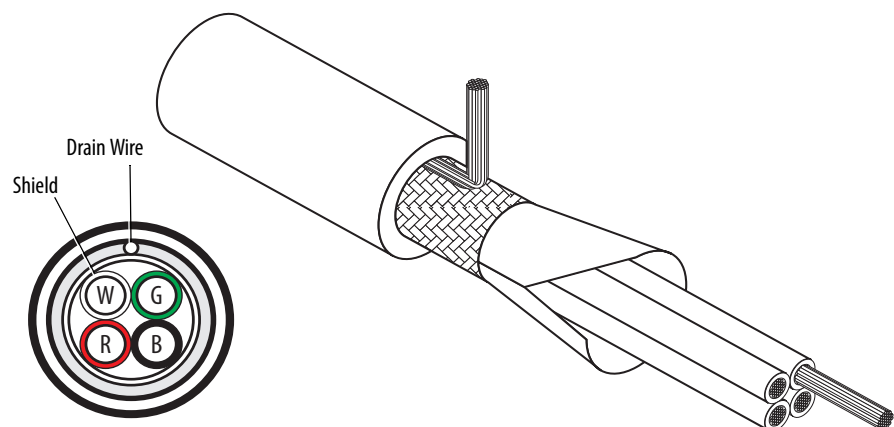

Type 2 Installation

An acceptable shielded cable for Type 2 installations is essentially the same cable as Type 1, plus one shielded pair of brake conductors. For more information on Type 2 installations, see [Table 1 on page 17](#).

Figure 8 - Type 2 Installation — Shielded Cable with Brake Conductors

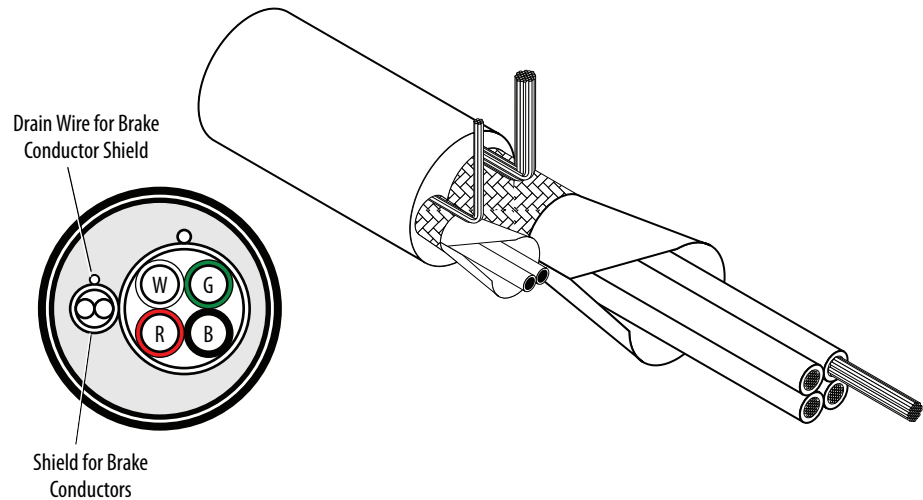

Type 3 Installation

These cables have 3 XLPE insulated copper conductors, 25% minimal overlap with helical copper tape, and three bare copper grounds in PVC jacket.

TIP Other types of shielded cable are available, but the selection of these types can limit the allowable cable length. Particularly, some of the newer cables twist four conductors of THHN wire and wrap them tightly with a foil shield. This construction can greatly increase the cable charging current required and reduce the overall drive performance. Unless specified in the individual distance tables as tested with the drive, these cables are not recommended and their performance against the lead length limits supplied is not known. For more information about motor cable lead restrictions, see [Conduit on page 73](#), [Moisture on page 79](#), [Effects On Wire Types on page 81](#), and [Appendix A](#).

Armored Cable

Cable with continuous aluminum armor is often recommended in drive system applications or specific industries. Armored cable offers most of the advantages of standard shielded cable and also combines considerable mechanical strength and resistance to moisture. It can be installed in concealed and exposed manners and removes the requirement for conduit (electrical metallic tubing [EMT]) in the installation. It can also be directly buried or embedded in concrete.

Noise containment is affected by incidental grounding of the armor to building-steel when the cable is mounted. We recommend that the armored cable has an overall PVC jacket (see [Chapter 2](#)).

Interlocked armor is acceptable for shorter cable runs, but continuous welded armor is preferred. General recommendations for ground conductors are listed here:

- Cable with one ground conductor is sufficient for drive sizes up to and including 200 Hp (150 kW).
- Cable with three ground conductors is recommended for drive sizes larger than 200 Hp (150 kW).

Space the ground conductors symmetrically around the power conductors. Verify that the ground conductors are rated for full drive ampacity.

Cable with a Single Ground Conductor

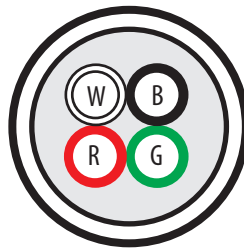

Cable with Three Ground Conductors

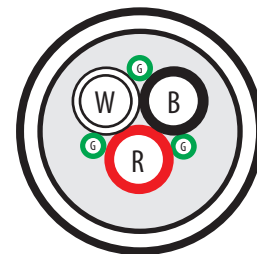
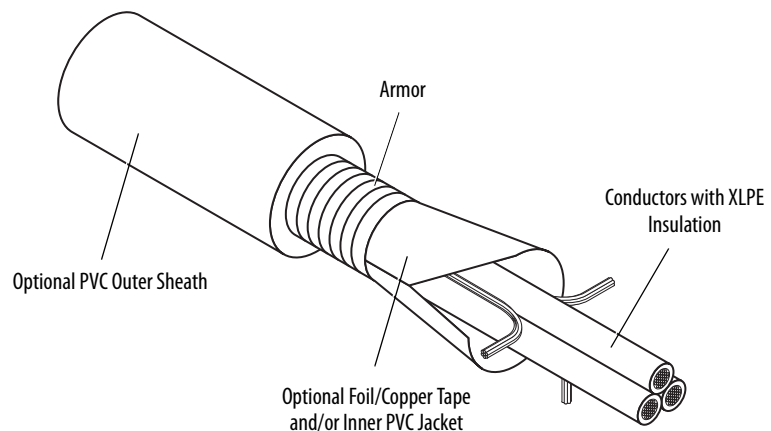
**Figure 9 - Armored Cable with Three Ground Conductors**

A good example of cable for Type 5 installation is Anixter 7V-5003-3G. This cable has three XLPE insulated copper conductors, 25% minimal overlap with the helical copper tape, and three bare copper grounds in PVC jacket.

IMPORTANT If a terminator network or output filter is used, the connector insulation must be XLPE, and not PVC.

European Style Cable

Cable that is used in many installations in Europe must conform to Low Voltage Directive (LVD) 2006/95/EC. We recommend flexible cables with a bend radius of 20 times the cable diameter for movable cable, and 6 times the cable diameter for fixed installations. Use cables with a screen (shield) of 70...85% coverage. Insulation for both conductors and the outer sheath is PVC.

The number and color of individual conductors can vary, but the recommendation is for three phase conductors (customer-preferred colors) and one ground conductor (green/yellow).

Ölflex Classic 100SY, or Ölflex Classic 110CY, are examples.

Figure 10 - European Style Multi-conductor Cable

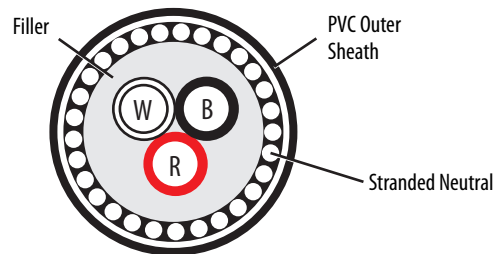

Input Power Cables

In general, the selection of cable for AC input power to a drive has no special requirements. Some installations suggest shielded cable to help prevent coupling of noise onto the cable (see [Chapter 2](#)). In some cases, shielded cable can be required to meet noise standards, such as CE for Europe, C-Tick for Australia/New Zealand, and others. Shielded cable can also be required if an input filter is required to meet a standard. The user manual for the drive has the requirements for meeting these types of standards. Additionally, individual industries can have required standards due to environment or experience.

For AC variable frequency drive applications that must satisfy EMC standards for CE, C-Tick, FCC, or others, use the same type of shielded cable that is specified for the AC motors between the drive and transformer. Check the individual user manuals or system schematics for specific additional requirements to meet EMC standards.

Motor Cables

Most recommendations regarding drive cables are for issues caused by the nature of the drive output. A PWM drive creates AC motor current by sending DC voltage pulses to the motor in a specific pattern. These pulses affect the wire insulation and can be a source of electrical noise. Consider the rise time, amplitude, and frequency of these pulses when choosing a wire/cable type. Consider these factors when choosing a cable:

- The effects of the drive output once the cable is installed.
- The need for the cable to contain noise that the drive output causes.
- The amount of cable charging current available from the drive.
- Possible voltage drop (and subsequent loss of torque) for long wire runs.

Keep the motor cable lengths within the limits set in the user manual for the drive. Various issues, including cable charging current and reflected wave voltage stress, can exist. If the cable restriction is listed because of excessive coupling current, apply the methods to calculate total cable length, as shown in [Figure 11](#). If the restriction is due to voltage reflection and motor protection, see [Appendix A](#) for exact distances allowed.

Figure 11 - Motor Cable Length for Capacitive Coupling

All examples represent motor cable length of 182.9 m (600 ft)

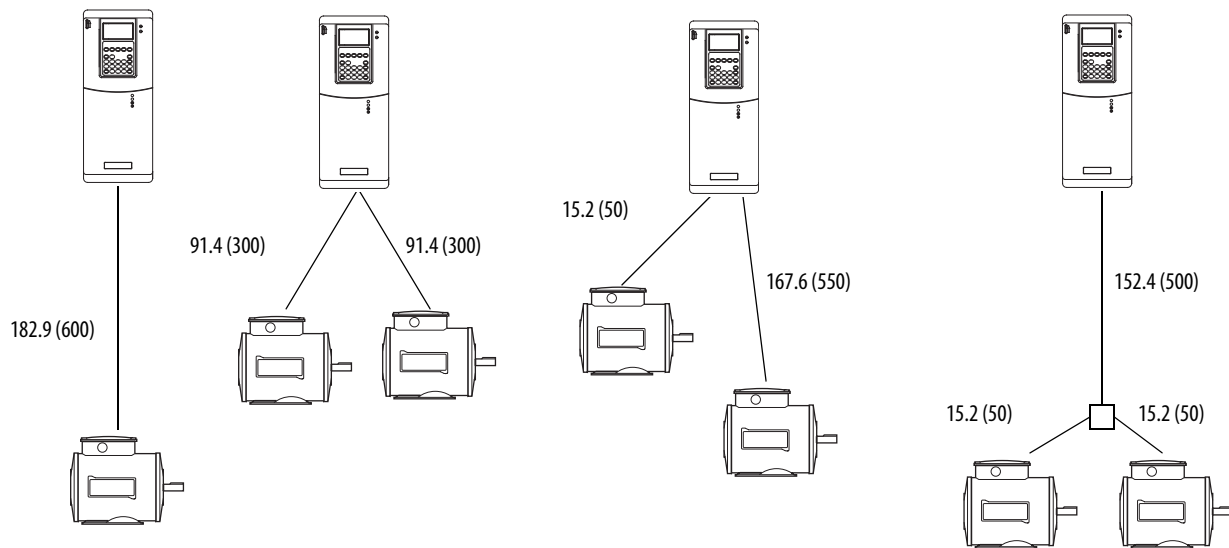

IMPORTANT For multi-motor applications, review the installation carefully. Consult your distributor drive specialist or Rockwell Automation when considering a multi-motor application with greater than two motors. In general, most installations have no issues. However, high-peak cable charging currents can cause drive overcurrents or ground faults.

Cable for Discrete Drive I/O

Digital I/O, such as start and stop commands, can be wired to the drive with various cabling. We recommend shielded cable to reduce cross-coupled noise from power cables. Standard individual conductors that meet the general requirements for type, temperature, gauge, and applicable codes are acceptable if they are routed away from higher voltage cables to minimize noise coupling. However, multi-conductor cable can be less expensive to install. Separate control wires from power wires by at least 0.3 m (1 ft)

Table 2 - Recommended Control Wire for Digital I/O

| Type ⁽¹⁾ | Wire Types | Description | Minimum Insulation Rating |
|---------------------|---|--|---------------------------|
| Unshielded | Per US NEC or applicable national or local code | – | 300V |
| Shielded | Multi-conductor shielded cable | 0.750 mm ² (18 AWG), 3-conductor, shielded. | 60 °C (140 °F) |

(1) The cable choices that are shown are for 2-channel (A and B) or 3-channel (A, B, and Z) encoders. If high resolution or other types of feedback devices are used, choose a similar cable with the correct gauge and number of conductor pairs.

Analog Signal and Encoder Cable

Always use shielded cable with copper wire. We recommend wire with an insulation rating of 300V or greater. Separate analog signal wires from power wires by at least 0.3 m (1 ft). Run encoder cables in a separate conduit. If signal cables must cross power cables, cross at right angles. Terminate the shield of the shielded cable as recommended by the manufacturer of the encoder or analog signal device.

Table 3 - Recommended Signal Wire

| Signal Type/ Where Used | Wire Types | Description | Minimum Insulation Rating |
|--|------------|---|---------------------------------------|
| Standard analog I/O | – | 0.750 mm ² (18 AWG), twisted pair, 100% shield with drain ⁽¹⁾ | 300V, 75...90 °C (167...194 °F) |
| Remote pot | – | 0.750 mm ² (18 AWG), 3-conductor, shielded | |
| Encoder/Pulse I/O < 30.5 m (100 ft) | Combined | 0.196 mm ² (24 AWG), individually shielded | 300V, 75...90 °C (167...194 °F) |
| Encoder/Pulse I/O 30.5...152.4 m (100...500 ft) | Signal | 0.196 mm ² (24 AWG), individually shielded | |
| | Power | 0.750 mm ² (18 AWG) | |
| | Combined | 0.330 mm ² or 0.500 mm ² | |
| Encoder/Pulse I/O 152.4...259.1 m (500...850 ft) | Signal | 0.196 mm ² (24 AWG), individually shielded | |
| | Power | 0.750 mm ² (18 AWG) | |
| | Combined | 0.750 mm ² (18 AWG), individually shielded pair | |

(1) If the wires are short and contained within a cabinet that has no sensitive circuits, the use of shielded wire is not always necessary, but is recommended.

Communication

This section provides cable recommendations for these communication protocols:

- [DeviceNet Communication on page 25](#)
- [ControlNet Communication on page 26](#)
- [Ethernet Communication on page 26](#)
- [Remote I/O and Data Highway Plus \(DH+\) Communication on page 27](#)
- [Serial \(RS-232 and RS-485\) Communication on page 27](#)

DeviceNet Communication

DeviceNet cable options, topology, distances that are allowed, and techniques are specific to the DeviceNet network. For more information, see DeviceNet Media Design and Installation Guide, publication [DNET-UM072](#).

In general, the four cable types for DeviceNet media meet these criteria:

- Round (thick) cable with an outside diameter of 12.2 mm (0.48 in.); normally used for trunk lines, but can also be used for drop lines.
- Round (thin) cable with an outside diameter of 6.9 mm (0.27 in.); normally used for drop lines, but can also be used for trunk lines.
- Flat cable, normally used for trunk lines.
- KwikLink™ drop cable, used only in KwikLink systems.

Round cable contains these five wires:

- One twisted pair (red and black) for 24V DC power.
- One twisted pair (blue and white) for signal.
- One drain wire (bare).

Flat cable contains these four wires:

- One pair (red and black) for 24V DC power.
- One pair (blue and white) for signal.

Drop cable for KwikLink is a 4-wire, unshielded, gray cable.

The distance between points, installation of terminating resistors, and chosen communication rate are significant to the installation. For more information, see the DeviceNet Media Design and Installation Guide, publication [DNET-UM072](#).

ControlNet Communication

ControlNet cable options, topology, distances that are allowed, and techniques are specific to the ControlNet network. For more information, see the ControlNet Coax Media Planning and Installation Guide, publication [CNET-IN002](#).

Depending on the environment at the installation site, there are several types of RG-6 quad shield cables that can be appropriate. The standard cable that is recommended is Allen-Bradley catalog number 1786-RG6, Quad Shield coax. Country, state, or local codes, such as the U.S. NEC, govern the installation.

| Installation Environment | Use This Cable Type |
|--|--|
| Light industrial | <ul style="list-style-type: none"> Standard PVC CM-CL2 |
| Heavy industrial | <ul style="list-style-type: none"> Lay-on armored Light interlocking armor |
| High/Low temperature or corrosive (harsh chemicals) | <ul style="list-style-type: none"> Plenum-FEP CMP-CL2P |
| Festooning or flexing | <ul style="list-style-type: none"> High flex |
| Moisture: direct burial, with flood compound, fungus resistant | <ul style="list-style-type: none"> Flood burial |

The allowable length of segments and installation of terminating resistors play a significant part in the installation. See the ControlNet Coax Media Planning and Installation Guide, publication [CNET-IN002](#), for details.

Ethernet Communication

Ethernet communication interface wiring is detailed for the type of cable, connectors, and routing. In general, Ethernet systems use shielded twisted pair (STP) cable, or unshielded twisted pair (UTP) cable, with RJ45 connectors that meet the IP67 standard and are appropriate for the environment. Use cables that meet Telecommunications Industry Association/Electronic Industries Alliance (TIA/EIA) standards at industrial temperatures.

Shielded cable is recommended when the installation includes items such as these:

- Welding
- Electrostatic processes
- Drives over 10 Hp
- Motor control centers (MCCs)
- High-power RF radiation
- Devices that carry current in excess of 100 A

Shield handling and single-point grounding, also discussed in this document, are also important for the proper operation of Ethernet installations.

There are also important distance and routing limitations published in detail.

Remote I/O and Data Highway Plus (DH+) Communication

IMPORTANT Only Allen-Bradley catalog number 1770-CD shielded twin-axial cabling is tested and approved for remote I/O and Data Highway Plus™ (DH+™) installations.

The maximum cable length depends on the communication rate.

| Communication Rate | Maximum Cable Length |
|--------------------|----------------------|
| 57.6 Kbps | 3048 m (10,000 ft) |
| 115.2 Kbps | 1524 m (5000 ft) |
| 230.4 Kbps | 762 m (2500 ft) |

All three connections (blue, shield, and clear) must be connected at each node.

IMPORTANT Do not connect in a star topology. Only two cables can be connected at any wiring point. Use either series or daisy chain topology at all points.

Serial (RS-232 and RS-485) Communication

Follow these recommended standard practices for serial communication wiring:

- One twisted pair and one signal common for RS-232.
- Two twisted pair, with each pair individually shielded, for RS-485.

Notes:

Power Distribution

This chapter discusses different power distribution schemes and factors that can affect drive performance.

System Configurations

The type of transformer and the connection configuration that supplies the drive have an important role in drive performance and safety. This section includes a brief description of some of the more common configurations and their qualities and shortcomings.

Delta/Wye with Grounded Wye Neutral

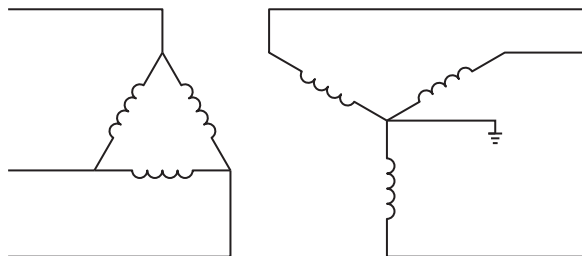

Delta/wye with grounded wye neutral is the most common type of distribution system. It provides a 30° phase shift. The grounded neutral provides a direct path for common mode current that the drive output causes (see [Chapter 3](#) and [Chapter 6](#)).

Rockwell Automation recommends the use of grounded neutral systems for these reasons:

- Controlled path for common mode noise current
- Consistent line-to-ground voltage reference that minimizes insulation stress
- Accommodation for system surge protection schemes

Delta/Delta with Grounded Leg, or Four-wire Connected Secondary Delta

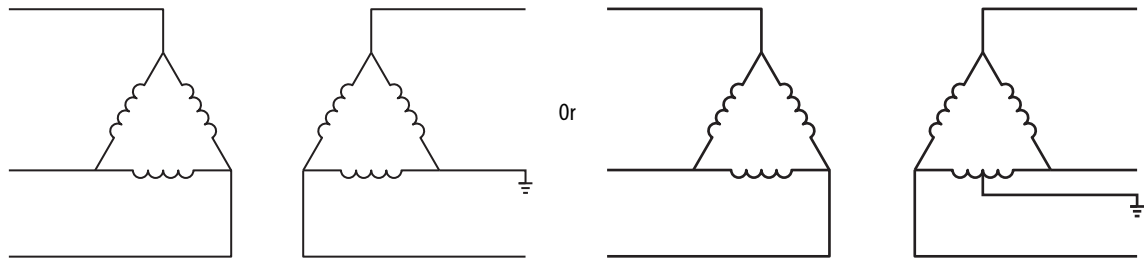

Delta/delta with grounded leg or four-wire connected secondary delta is a common configuration with no phase shift between input and output. The grounded center tap provides a direct path for common mode current caused by the drive output.

Three-phase Open Delta with Single-phase Center Tapped

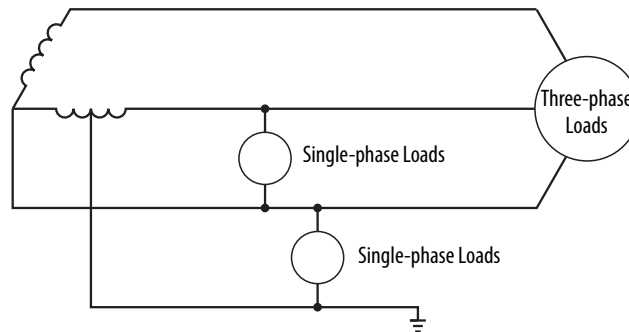

Three-phase open delta with single-phase center tapped is a configuration providing a Three-phase delta transformer with one side tapped. This tap (the neutral) is connected to earth. The configuration is called the antiphase grounded (neutral) system.

The open delta transformer connection is limited to 58% of the 240V, single-phase transformer rating. Close the delta with a third single-phase, 240V transformer to provide full rating for the two single-phase, 240V transformers.

The phase leg opposite the midpoint has an elevated voltage when compared to earth or neutral. The hottest high leg must be positively identified throughout the electrical system. Make the hottest high leg the center leg in any switch, motor control, three-phase panel board, and so on. The NEC requires orange color tape to identify this leg.

Ungrounded Secondary

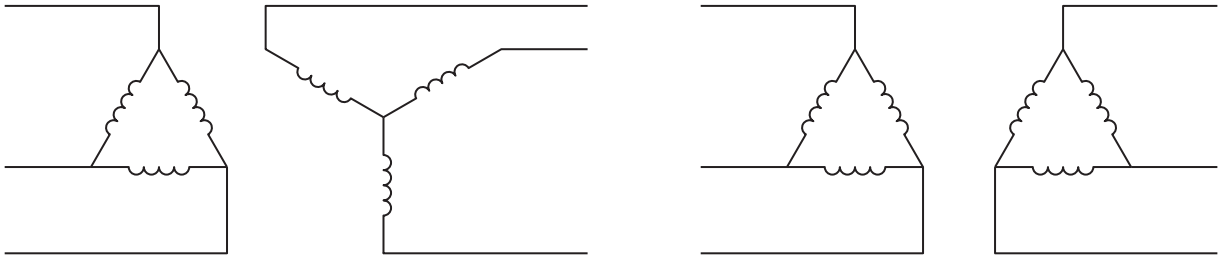

ATTENTION: Grounding the transformer secondary is essential to the safety of personnel and safe operation of the drive. Leaving the secondary floating causes dangerous high voltages between the chassis of the drive and the internal power structure components. Exceeding the voltage rating of the input metal oxide varistor (MOV) protection devices of the drive can cause a catastrophic failure. In all cases, the input power to the drive is referenced to ground.

If the system is ungrounded, other general precautions, such as a system-level ground-fault detector, or system-level line-to-ground suppressor, can be necessary. Or consider an isolation transformer with the secondary of the transformer grounded.

See local codes regarding safety requirements. Also see [Surge Protection MOVs and Common Mode Capacitors on page 50](#).

High-Resistance Ground

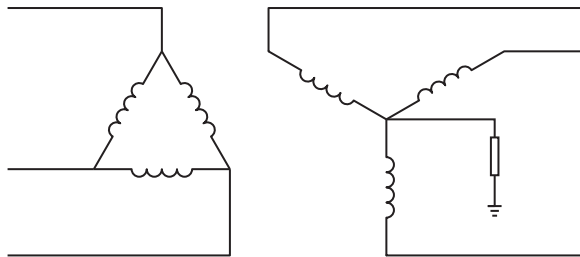

Grounding the wye secondary neutral through a resistor is an acceptable method of grounding. Under a short circuit secondary condition, any of the output phases to ground do not exceed the normal line-to-line voltage. This voltage is within the rating of the MOV input protection devices on the drive. The resistor is often used to detect ground current by monitoring the associated voltage drop. Because high frequency ground current can flow through this resistor, be sure to connect the drive motor leads by using the recommended cables and methods. In some cases, multiple drives (that can have one or more internal references to ground) on one transformer can produce a cumulative ground current that can trigger the ground fault interrupt circuit. See [Surge Protection MOVs and Common Mode Capacitors on page 50](#).

TN-S Five-wire System

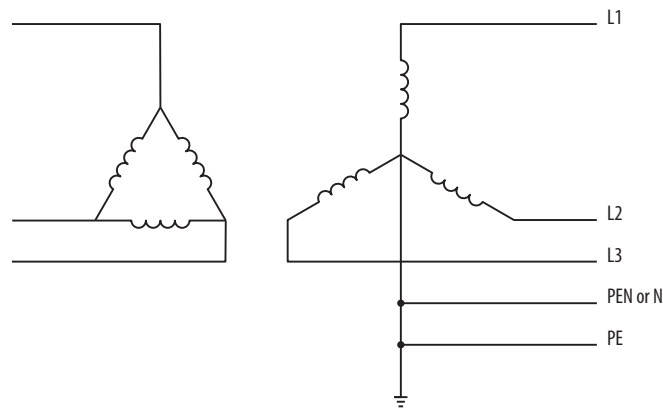

TN-S five-wire distribution systems are common throughout Europe, except for the United Kingdom and Germany. Leg-to-leg voltage (commonly at 400V) powers three-phase loads. Leg-to-neutral voltage (commonly at 230V) powers single-phase loads. Neutral is a current conducting wire, and connects through a circuit breaker. The fifth wire is a separate ground wire. There is one connection between ground and neutral, typically in the distribution system. Do not make connections between ground and neutral within the system cabinets.

AC Line Voltage

In general, all Allen-Bradley® drives are tolerant to a wide range of AC line voltage. Check the individual specifications for the drives you are installing.

Incoming voltage imbalances >2% can cause large unequal currents in a drive. Use an input line reactor when line voltage imbalances are >2%.

AC Line Impedance

To help prevent excess current that can damage drives during events such as line disturbances or certain types of ground faults, provide a minimum amount of impedance in front of the drives. In many installations, this impedance comes from the supply transformer and the supply cables. In some cases, an additional transformer or reactor is recommended. If any of these conditions exist, you can add impedance (line reactor or transformer) in front of the drive:

- Installation site has switched power factor correction capacitors.
- Installation site has lightning strikes or voltage spikes in excess of 6000V peak.
- Installation site has power interruptions or voltage dips in excess of 200V AC.
- The transformer is too large in comparison to the drive. See impedance recommendations on [Table 4 on page 34](#) through [Table 11 on page 41](#).

IMPORTANT Tables [4](#) through [11](#) define the largest transformer size for each product and rating that is based on specific differences in construction, and is the preferred method to follow.

Otherwise, use one of the following more conservative methods:

- For drives **without** built-in inductors – add line impedance whenever the transformer kVA is more than 10 times larger than the drive kVA, or the percent source impedance relative to each drive is less than 0.5%.
- For drives **with** built-in inductors – add line impedance whenever the transformer kVA is more than 20 times larger than the drive kVA, or the percent source impedance relative to each drive is less than 0.25%.

To identify drives with built-in inductors, see the product-specific information in [Table 4 on page 34](#) through [Table 11 on page 41](#). The shaded rows identify products ratings without built-in inductors.

Use these equations to calculate the impedance of the drive and transformer:

Drive Impedance (in ohms)

$$Z_{\text{drive}} = \frac{V_{\text{line-line}}}{\sqrt{3} * I_{\text{input-rating}}}$$

Transformer Impedance (in ohms)

$$Z_{\text{xfmr}} = \frac{V_{\text{line-line}}}{\sqrt{3} * I_{\text{xfmr-rated}}} * \% \text{ Impedance}$$

Or

$$Z_{\text{xfmr}} = \frac{(V_{\text{line-line}})^2}{\text{VA}} * \% \text{ Impedance}$$

% impedance is the nameplate impedance of the transformer.
Typical values range from 0.03 (3%) to 0.06 (6%).

Transformer Impedance (in ohms)

$$Z_{\text{xfmr}} = \frac{V_{\text{line-line}}}{\sqrt{3} * I_{\text{xfmr-rated}}} * \% \text{ Impedance}$$

% impedance is the nameplate impedance of the transformer.
Typical values range from 0.03 (3%) to 0.06 (6%).

EXAMPLE The drive is rated 1 Hp, 480V, 2.7 A input.
 The supply transformer is rated 50,000VA (50 kVA), 5% impedance.

$$Z_{drive} = \frac{V_{line-line}}{\sqrt{3} * I_{input-rating}} = \frac{480V}{\sqrt{3} * 2.7} = 102.6 \text{ Ohms}$$

$$Z_{xfmr} = \frac{(V_{line-line})^2}{VA} * \% \text{ Impedance} = \frac{480^2}{50,000} * 0.05 = 0.2304 \text{ Ohms}$$

The percent (%) impedance has to be in per unit (5% becomes 0.05) for the formula.

$$\frac{Z_{xfmr}}{Z_{drive}} = \frac{0.2304}{102.6} = 0.00224 = 0.22\%$$

0.22% is less than 0.5%. Therefore, this transformer is too large for the drive. Consider adding a line reactor.

IMPORTANT You can group multiple drives on one reactor. However, the reactor percent impedance must be large enough when evaluated for each drive separately, not evaluated for all loads connected at once.

These recommendations are advisory and do not address all situations. Site-specific conditions must be considered to assure a quality installation.

Table 4 - AC Line Impedance Recommendations for Bulletin 160 Drives

| Bulletin Number | Drive Catalog Number ⁽¹⁾ | Volts | kW (Hp) | Max Supply kVA ⁽²⁾ | 3% Line Reactor Open Style 1321- | Reactor Inductance (mH) | Reactor Current Rating (amps) |
|-----------------|-------------------------------------|-------|-------------|-------------------------------|----------------------------------|-------------------------|-------------------------------|
| 160 | -AA02 | 240 | 0.37(0.5) | 15 | 3R4-B | 6.5 | 4 |
| | -AA03 | 240 | 0.55 (0.75) | 20 | 3R4-A | 3 | 4 |
| | -AA04 | 240 | 0.75 (1) | 30 | 3R4-A | 3 | 4 |
| | -AA08 | 240 | 1.5 (2) | 50 | 3R8-A | 1.5 | 8 |
| | -AA12 | 240 | 2.2 (3) | 75 | 3R12-A | 1.25 | 12 |
| | -AA18 | 240 | 3.7 (5) | 100 | 3R18-A | 0.8 | 18 |
| | -BA01 | 480 | 0.37(0.5) | 15 | 3R2-B | 20 | 2 |
| | -BA02 | 480 | 0.55 (0.75) | 20 | 3R2-A | 12 | 2 |
| | -BA03 | 480 | 0.75 (1) | 30 | 3R2-A | 12 | 2 |
| | -BA04 | 480 | 1.5 (2) | 50 | 3R4-B | 6.5 | 4 |
| | -BA06 | 480 | 2.2 (3) | 75 | 3R8-B | 3 | 8 |
| | -BA10 | 480 | 3.7 (5) | 100 | 3R18-B | 1.5 | 18 |

(1) Shaded rows identify drive ratings without built-in inductors.

(2) Maximum suggested KVA supply without consideration for additional inductance.

Table 5 - AC Line Impedance Recommendations for Bulletin 1305 Drives

| Bulletin Number | Drive Catalog Number ⁽¹⁾ | Volts | kW (Hp) | Max Supply kVA ⁽²⁾ | 3% Line Reactor Open Style 1321- | Reactor Inductance (mH) | Reactor Current Rating (amps) |
|-----------------|-------------------------------------|-------|-------------|-------------------------------|----------------------------------|-------------------------|-------------------------------|
| 1305 | -AA02A | 240 | 0.37(0.5) | 15 | 3R4-A | 3 | 4 |
| | -AA03A | 240 | 0.55 (0.75) | 20 | 3R4-A | 4 | 4 |
| | -AA04A | 240 | 0.75 (1) | 30 | 3R8-A | 1.5 | 8 |
| | -AA08A | 240 | 1.5 (2) | 50 | 3R8-A | 1.5 | 8 |
| | -AA12A | 240 | 2.2 (3) | 75 | 3R18-A | 0.8 | 18 |
| | -BA01A | 480 | 0.37 (0.5) | 15 | 3R2-B | 20 | 2 |
| | -BA02A | 480 | 0.55 (0.75) | 20 | 3R2-B | 20 | 2 |
| | -BA03A | 480 | 0.75 (1) | 30 | 3R4-B | 6.5 | 4 |
| | -BA04A | 480 | 1.5 (2) | 50 | 3R4-B | 6.5 | 4 |
| | -BA06A | 480 | 2.2 (3) | 75 | 3R8-B | 3 | 8 |
| | -BA09A | 480 | 3.7 (5) | 100 | 3R18-B | 1.5 | 18 |

(1) Shaded rows identify drive ratings without built-in inductors.

(2) Maximum suggested KVA supply without consideration for additional inductance.

Table 6 - AC Line Impedance Recommendations for PowerFlex 4 Drives

| Drive | Drive Catalog Number ⁽¹⁾ | Volts | kW (Hp) | Max Supply kVA | 3% Line Reactor Open Style 1321- | Reactor Inductance (mH) | Reactor Current Rating (amps) |
|----------------|-------------------------------------|-------|------------|----------------|----------------------------------|-------------------------|-------------------------------|
| PowerFlex 4 | 22AB1P5 | 240 | 0.2 (0.25) | 15 | 3R2-A | 12 | 2 |
| | 22AB2P3 | 240 | 0.4 (0.5) | 25 | 3R4-B | 6.5 | 4 |
| | 22AB4P5 | 240 | 0.75 (1.0) | 50 | 3R8-B | 3 | 8 |
| | 22AB8P0 | 240 | 1.5 (2.0) | 100 | 3R8-A | 1.5 | 8 |
| | 22AB012 | 240 | 2.2 (3.0) | 125 | 3R12-A | 1.25 | 12 |
| | 22AB017 | 240 | 3.7 (5.0) | 150 | 3R18-A | 0.8 | 18 |
| | 22AD1P4 | 480 | 0.4 (0.5) | 15 | 3R2-B | 20 | 2 |
| | 22AD2P3 | 480 | 0.75 (1.0) | 30 | 3R4-C | 9 | 4 |
| | 22AD4P0 | 480 | 1.5 (2.0) | 50 | 3R4-B | 6.5 | 4 |
| | 22AD6P0 | 480 | 2.2 (3.0) | 75 | 3R8-C | 5 | 8 |
| | 22AD8P7 | 480 | 3.7 (5.0) | 100 | 3R8-B | 3 | 8 |

(1) Shaded rows identify drive ratings without built-in inductors.

Table 7 - AC Line Impedance Recommendations for PowerFlex 40 Drives

| Drive | Drive Catalog Number ⁽¹⁾ | Volts | kW (Hp) | Max Supply kVA ⁽²⁾ | 3% Line Reactor Open Style 1321- | Reactor Inductance (mH) | Reactor Current Rating (amps) |
|--------------|-------------------------------------|-------------|------------|-------------------------------|----------------------------------|-------------------------|-------------------------------|
| PowerFlex 40 | 22BB2P3 | 240 | 0.4 (0.5) | 25 | 3R4-B | 6.5 | 4 |
| | 22BB5P0 | 240 | 0.75 (1.0) | 50 | 3R8-B | 3 | 8 |
| | 22BB8P0 | 240 | 1.5 (2.0) | 50 | 3R8-A | 1.5 | 8 |
| | 22BB012 | 240 | 2.2 (3.0) | 50 | 3R12-A | 1.25 | 12 |
| | 22BB017 | 240 | 3.7 (5.0) | 50 | 3R18-A | 0.8 | 18 |
| | 22BB024 | 240 | 5.5 (7.5) | 100 | 3R25-A | 0.5 | 25 |
| | 22BB033 | 240 | 7.5 (10.0) | 150 | 3R35-A | 0.4 | 35 |
| | 22BD1P4 | 480 | 0.4 (0.5) | 15 | 3R2-B | 20 | 2 |
| | 22BD2P3 | 480 | 0.75 (1.0) | 30 | 3R4-C | 9 | 4 |
| | 22BD4P0 | 480 | 1.5 (2.0) | 50 | 3R4-B | 6.5 | 4 |
| | 22BD6P0 | 480 | 2.2 (3.0) | 75 | 3R8-C | 5 | 8 |
| | 22BD010 | 480 | 3.7 (5.0) | 100 | 3R8-B | 3 | 8 |
| | 22BD012 | 480 | 5.5 (7.5) | 120 | 3R12-B | 2.5 | 12 |
| | 22BD017 | 480 | 7.5 (10.0) | 150 | 3R18-B | 1.5 | 18 |
| 22BD024 | 480 | 11.0 (15.0) | 200 | 3R25-B | 1.2 | 25 | |
| 22BE1P7 | 600 | 0.75 (1.0) | 20 | 3R2-B | 20 | 2 | |
| 22BE3P0 | 600 | 1.5 (2.0) | 30 | 3R4-B | 6.5 | 4 | |
| 22BE4P2 | 600 | 2.2 (3.0) | 50 | 3R4-B | 6.5 | 4 | |
| 22BE6P6 | 600 | 3.7 (5.0) | 75 | 3R8-C | 5 | 8 | |
| 22BE9P9 | 600 | 5.5 (7.5) | 120 | 3R12-B | 2.5 | 12 | |
| 22BE012 | 600 | 7.5 (10.0) | 150 | 3R12-B | 2.5 | 12 | |
| 22BE019 | 600 | 11.0 (15.0) | 200 | 3R18-B | 1.5 | 18 | |

(1) Shaded rows identify drive ratings without built-in inductors.

(2) Maximum suggested KVA supply without consideration for additional inductance.

Table 8 - AC Line Impedance Recommendations for PowerFlex 400 Drives

| Drive | Drive Catalog Number ⁽¹⁾ | Volts | kW (Hp) | Max Supply kVA ⁽²⁾ | 3% Line Reactor Open Style 1321- | Reactor Inductance (mH) | Reactor Current Rating (amps) |
|---------------|-------------------------------------|-----------|-------------|-------------------------------|----------------------------------|-------------------------|-------------------------------|
| PowerFlex 400 | 22CB012 | 240 | 2.2 (3.0) | 50 | 3R12-A | N/A | N/A |
| | 22CB017 | 240 | 3.7 (5.0) | 50 | 3R18-A | N/A | N/A |
| | 22CB024 | 240 | 5.5 (7.5) | 200 | 3R25-A | 0.5 | 25 |
| | 22CB033 | 240 | 7.7 (10.0) | 275 | 3R35-A | 0.4 | 35 |
| | 22CB049 | 240 | 11 (15.0) | 350 | 3R45-A | 0.3 | 45 |
| | 22CB065 | 240 | 15 (20.0) | 425 | 3R55-A | 0.25 | 55 |
| | 22CB075 | 240 | 18.5 (25.0) | 550 | 3R80-A | 0.2 | 80 |
| | 22CB090 | 240 | 22 (30.0) | 600 | 3R100-A | 0.15 | 100 |
| | 22CB120 | 240 | 30 (40.0) | 750 | 3R130-A | 0.1 | 130 |
| | 22CB145 | 240 | 37 (50.0) | 800 | 3R160-A | 0.075 | 160 |
| | 22CD6P0 | 480 | 2.2 (3.0) | N/A | N/A | N/A | N/A |
| | 22CD010 | 480 | 3.7 (5.0) | N/A | N/A | N/A | N/A |
| | 22CD012 | 480 | 5.5 (7.5) | N/A | N/A | N/A | N/A |
| | 22CD017 | 480 | 7.5 (10) | N/A | N/A | N/A | N/A |
| | 22CD022 | 480 | 11 (15) | N/A | N/A | N/A | N/A |
| | 22CD030 | 480 | 15 (20) | N/A | N/A | N/A | N/A |
| | 22CD038 | 480 | 18.5 (25) | N/A | N/A | N/A | N/A |
| | 22CD045 | 480 | 22 (30) | N/A | N/A | N/A | N/A |
| | 22CD060 | 480 | 30 (40) | N/A | N/A | N/A | N/A |
| | 22CD072 | 480 | 37 (50) | N/A | N/A | N/A | N/A |
| 22CD088 | 480 | 45 (60) | N/A | N/A | N/A | N/A | |
| 22CD105 | 480 | 55 (75) | N/A | N/A | N/A | N/A | |
| 22CD142 | 480 | 75 (100) | N/A | N/A | N/A | N/A | |
| 22CD170 | 480 | 90 (125) | N/A | N/A | N/A | N/A | |
| 22CD208 | 480 | 110 (150) | N/A | N/A | N/A | N/A | |

(1) Shaded rows identify drive ratings without built-in inductors.

(2) Maximum suggested KVA supply without consideration for additional inductance.

Table 9 - AC Line Impedance Recommendations for PowerFlex 520-Series Drives

| Drive | Drive Catalog Number ⁽¹⁾ | Volts | kW (Hp) | Max Supply kVA ⁽²⁾ | 3% Line Reactor Open Style 1321- | Reactor Inductance (mH) | Reactor Current Rating (amps) |
|----------------------|-------------------------------------|-------|-------------|-------------------------------|----------------------------------|-------------------------|-------------------------------|
| PowerFlex 520-Series | 25BB2P5 | 240 | 0.4 (0.5) | 25 | 3R4-B | 6.5 | 4 |
| | 25BB5P0 | 240 | 0.75 (1.0) | 50 | 3R8-B | 3 | 8 |
| | 25BB8P0 | 240 | 1.5 (2.0) | 50 | 3R8-A | 1.5 | 8 |
| | 25BB012 | 240 | 2.2 (3.0) | 50 | 3R12-A | 1.25 | 12 |
| | 25BB017 | 240 | 3.7 (5.0) | 50 | 3R18-A | 0.8 | 18 |
| | 25BB024 | 240 | 5.5 (7.5) | 100 | 3R25-A | 0.5 | 25 |
| | 25BB032 | 240 | 7.5 (10.0) | 150 | 3R35-A | 0.4 | 35 |
| | 25BB048 | 240 | 11.0 (15.0) | 150 | 3R55-B | 0.5 | 55 |
| | 25BB062 | 240 | 7.5 (10.0) | 150 | 3R80-B | 0.4 | 80 |
| | | | | | | | |
| | 25BD1P4 | 480 | 0.4 (0.5) | 15 | 3R2-B | 20 | 2 |
| | 25BD2P3 | 480 | 0.75 (1.0) | 30 | 3R4-C | 9 | 4 |
| | 25BD4P0 | 480 | 1.5 (2.0) | 50 | 3R4-B | 6.5 | 4 |
| | 25BD6P0 | 480 | 2.2 (3.0) | 75 | 3R8-C | 5 | 8 |
| | 25BD010 | 480 | 3.7 (5.0) | 100 | 3R8-B | 3 | 8 |
| | 25BD013 | 480 | 5.5 (7.5) | 120 | 3R12-B | 2.5 | 12 |
| | 25BD017 | 480 | 7.5 (10.0) | 150 | 3R18-B | 1.5 | 18 |
| | 25BD024 | 480 | 11.0 (15.0) | 200 | 3R25-B | 1.2 | 25 |
| | 25BD030 | 480 | 15.0 (20.0) | 200 | 3R35-B | 0.8 | 35 |
| | 25BD037 | 480 | 18.5 (25.0) | 500 | 3R45-B | 0.7 | 45 |
| | 25BD043 | 480 | 22 (30.0) | 500 | 3R45-B | 0.7 | 45 |
| | | | | | | | |
| | 25BE0P9 | 600 | 0.40(0.5) | 20 | 3R2-B | 20 | 2 |
| | 25BE1P7 | 600 | 0.75 (1.0) | 20 | 3R2-B | 20 | 2 |
| | 25BE3P0 | 600 | 1.5 (2.0) | 30 | 3R4-B | 6.5 | 4 |
| | 25BE4P2 | 600 | 2.2 (3.0) | 50 | 3R4-B | 6.5 | 4 |
| | 25BE6P6 | 600 | 3.7 (5.0) | 75 | 3R8-C | 5 | 8 |
| | 25BE9P9 | 600 | 5.5 (7.5) | 120 | 3R12-B | 2.5 | 12 |
| | 25BE012 | 600 | 7.5 (10.0) | 150 | 3R12-B | 2.5 | 12 |
| | 25BE019 | 600 | 11.0 (15.0) | 200 | 3R18-B | 1.5 | 18 |
| | 25BE022 | 600 | 15.0 (20.0) | 200 | 3R25-B | 1.2 | 25 |
| | 25BE027 | 600 | 18.5 (25.0) | 500 | 3R35-B | 0.8 | 35 |
| | 25BE032 | 600 | 22 (30.0) | 500 | 3R35-B | 0.8 | 35 |

(1) Shaded rows identify drive ratings without built-in inductors.

(2) Maximum suggested KVA supply without consideration for additional inductance.

Table 10 - AC Line Impedance Recommendations for PowerFlex 70 Drives

| Drive | Drive Catalog Number ⁽¹⁾ | Volts | kW (Hp) | Max Supply kVA ⁽²⁾ | 3% Line Reactor Open Style 1321- | Reactor Inductance (mH) | Reactor Current Rating (amps) ⁽³⁾ |
|--------------|-------------------------------------|------------|------------|-------------------------------|----------------------------------|-------------------------|--|
| PowerFlex 70 | 20AB2P2 | 240 | 0.37 (0.5) | 25 | 3R2-D | 6 | 2 |
| | 20AB4P2 | 240 | 0.75 (1) | 50 | 3R4-A | 3 | 4 |
| | 20AB6P8 | 240 | 1.5 (2) | 50 | 3R8-A | 1.5 | 8 |
| | 20AB9P6 | 240 | 2.2 (3) | 50 | 3R12-A | 1.25 | 12 |
| | 20AB015 | 240 | 4.0 (5) | 200 | 3R18-A | 0.8 | 18 |
| | 20AB022 | 240 | 5.5 (7.5) | 250 | 3R25-A | 0.5 | 25 |
| | 20AB028 | 240 | 7.5 (10) | 300 | 3R35-A | 0.4 | 35 |
| | 20AB042 | 240 | 11 (15) | 1000 | 3R45-A | 0.3 | 45 |
| | 20AB054 | 240 | 15 (20) | 1000 | 3R80-A | 0.2 | 80 |
| | 20AB070 | 240 | 18.5 (25) | 1000 | 3R80-A | 0.2 | 80 |
| | 20AC1P3 | 400 | 0.37 (0.5) | 30 | 3R2-B | 20 | 2 |
| | 20AC2P1 | 400 | 0.75 (1) | 50 | 3R2-B | 20 | 2 |
| | 20AC3P4 | 400 | 1.5 (2) | 50 | 3R4-B | 6.5 | 4 |
| | 20AC5P0 | 400 | 2.2 (3) | 75 | 3R4-B | 6.5 | 4 |
| | 20AC8P0 | 400 | 4.0 (5) | 100 | 3R8-B | 3 | 8 |
| | 20AC011 | 400 | 5.5 (7.5) | 250 | 3R12-B | 2.5 | 12 |
| | 20AC015 | 400 | 7.5 (10) | 250 | 3R18-B | 1.5 | 18 |
| | 20AC022 | 400 | 11 (15) | 300 | 3R25-B | 1.2 | 25 |
| | 20AC030 | 400 | 15 (20) | 400 | 3R35-B | 0.8 | 35 |
| | 20AC037 | 400 | 18.5 (25) | 750 | 3R35-B | 0.8 | 35 |
| | 20AC043 | 400 | 22 (30) | 1000 | 3R45-B | 0.7 | 45 |
| | 20AC060 | 400 | 30 (40) | 1000 | 3R55-B | 0.5 | 55 |
| | 20AC072 | 400 | 37 (50) | 1000 | 3R80-B | 0.4 | 80 |
| | 20AD1P1 | 480 | 0.37 (0.5) | 30 | 3R2-B | 20 | 2 |
| | 20AD2P1 | 480 | 0.75 (1) | 50 | 3R2-B | 20 | 2 |
| | 20AD3P4 | 480 | 1.5 (2) | 50 | 3R4-B | 6.5 | 4 |
| | 20AD5P0 | 480 | 2.2 (3) | 75 | 3R4-B | 6.5 | 4 |
| | 20AD8P0 | 480 | 3.7 (5) | 100 | 3R8-B | 3 | 8 |
| | 20AD011 | 480 | 5.5 (7.5) | 250 | 3R12-B | 2.5 | 12 |
| | 20AD015 | 480 | 7.5 (10) | 250 | 3R18-B | 1.5 | 18 |
| | 20AD022 | 480 | 11 (15) | 300 | 3R25-B | 1.2 | 25 |
| | 20AD027 | 480 | 15 (20) | 400 | 3R35-B | 0.8 | 35 |
| | 20AD034 | 480 | 18.5 (25) | 750 | 3R35-B | N/A | N/A |
| 20AD040 | 480 | 22 (30) | 1000 | 3R45-B | N/A | N/A | |
| 20AD052 | 480 | 30 (40) | 1000 | 3R55-B | N/A | N/A | |
| 20AD065 | 480 | 37 (50) | 1000 | 3R80-B | N/A | N/A | |
| 20AE0P9 | 600 | 0.37 (0.5) | 30 | 3R2-B | 20 | 2 | |
| 20AE1P7 | 600 | 0.75 (1) | 50 | 3R2-B | 20 | 2 | |

Table 10 - AC Line Impedance Recommendations for PowerFlex 70 Drives (Continued)

| Drive | Drive Catalog Number ⁽¹⁾ | Volts | kW (Hp) | Max Supply kVA ⁽²⁾ | 3% Line Reactor Open Style 1321- | Reactor Inductance (mH) | Reactor Current Rating (amps) ⁽³⁾ |
|--------------|-------------------------------------|-------|-----------|-------------------------------|----------------------------------|-------------------------|--|
| PowerFlex 70 | 20AE2P7 | 600 | 1.5 (2) | 50 | 3R4-C | 9 | 4 |
| | 20AE3P9 | 600 | 2.2 (3) | 75 | 3R4-C | 9 | 4 |
| | 20AE6P1 | 600 | 4.0 (5) | 100 | 3R8-C | 5 | 8 |
| | 20AE9P0 | 600 | 5.5 (7.5) | 250 | 3R8-B | 3 | 8 |
| | 20AE011 | 600 | 7.5 (10) | 250 | 3R12-B | 2.5 | 12 |
| | 20AE017 | 600 | 11 (15) | 300 | 3R18-B | 1.5 | 18 |
| | 20AE022 | 600 | 15 (20) | 400 | 3R25-B | 1.2 | 25 |
| | 20AE027 | 600 | 18.5 (25) | 1000 | 3R35-B | 0.8 | 35 |
| | 20AE031 | 600 | 22 (30) | 1000 | 3R35-B | 0.8 | 35 |
| | 20AE042 | 600 | 30 (40) | 1000 | 3R45-B | 0.7 | 45 |
| | 20AE051 | 600 | 37 (50) | 1000 | 3R55-B | 0.5 | 55 |

- (1) Shaded rows identify drive ratings without built-in inductors.
- (2) Maximum suggested kVA supply without consideration for additional inductance.
- (3) N/A = not available at time of printing.

Table 11 - AC Line Impedance Recommendations for PowerFlex 700/700S Drives

| Drive | Drive Catalog Number | Volts | kW (Hp) | Max Supply KVA ⁽¹⁾ | 3% Line Reactor Open Style 1321- | Reactor Inductance (mH) | Reactor Current Rating (amps) |
|---|----------------------|-----------|------------|-------------------------------|----------------------------------|-------------------------|-------------------------------|
| PowerFlex 700/700S For PowerFlex 700S, replace 20B with 20D. | 20BB2P2 | 240 | 0.37 (0.5) | 100 | 3R2-D | 6 | 2 |
| | 20BB4P2 | 240 | 0.75 (1) | 125 | 3R4-A | 3 | 4 |
| | 20BB6P8 | 240 | 1.5 (2) | 200 | 3R8-A | 1.5 | 8 |
| | 20BB9P6 | 240 | 2.2 (3) | 300 | 3R12-A | 1.25 | 12 |
| | 20BB015 | 240 | 3.7 (5) | 400 | 3R18-A | 0.8 | 18 |
| | 20BB022 | 240 | 5.5 (7.5) | 500 | 3R25-A | 0.5 | 25 |
| | 20BB028 | 240 | 7.5 (10) | 750 | 3R35-A | 0.4 | 35 |
| | 20BB042 | 240 | 11 (15) | 1000 | 3R45-A | 0.3 | 45 |
| | 20BB052 | 240 | 15 (20) | 1000 | 3R80-A | 0.2 | 80 |
| | 20BB070 | 240 | 18.5 (25) | 1000 | 3R80-A | 0.2 | 80 |
| | 20BB080 | 240 | 22 (30) | 1000 | 3R100-A | 0.15 | 100 |
| | 20BB104 | 240 | 30 (40) | 1000 | 3R130-A | 0.1 | 130 |
| | 20BB130 | 240 | 37 (50) | 1000 | 3R130-A | 0.1 | 130 |
| | 20BB154 | 240 | 45 (60) | 1000 | 3R160-A | 0.075 | 160 |
| | 20BB192 | 240 | 55 (75) | 1000 | 3R200-A | 0.055 | 200 |
| | 20BB260 | 240 | 75 (100) | 1000 | 3R320-A | 0.04 | 320 |
| | 20BC1P3 | 400 | 0.37 (5) | 250 | 3R2-B | 20 | 2 |
| | 20BC2P1 | 400 | 0.75 (1) | 250 | 3R2-B | 20 | 2 |
| | 20BC3P5 | 400 | 1.5(2) | 500 | 3R4-B | 6.5 | 4 |
| | 20BC5P0 | 400 | 2.2 (3) | 500 | 3R4-B | 6.5 | 4 |
| 20BC8P7 | 400 | 4 (5) | 500 | 3R8-B | 3 | 8 | |
| 20BC011 | 400 | 5.5 (7.5) | 750 | 3R12-B | 2.5 | 12 | |
| 20BC015 | 400 | 7.5 (10) | 1000 | 3R18-B | 1.5 | 18 | |
| 20BC022 | 400 | 11 (15) | 1000 | 3R25-B | 1.2 | 25 | |
| 20BC030 | 400 | 15 (20) | 1000 | 3R35-B | 0.8 | 35 | |
| 20BC037 | 400 | 18.5(25) | 1000 | 3R45-B | 0.7 | 45 | |
| 20BC043 | 400 | 22 (30) | 1000 | 3R45-B | 0.7 | 45 | |
| 20BC056 | 400 | 30 (40) | 1000 | 3R55-B | 0.5 | 55 | |
| 20BC072 | 400 | 37 (50) | 1000 | 3R80-B | 0.4 | 80 | |
| 20BC085 | 400 | 45 (60) | 1000 | 3R130-B | 0.2 | 130 | |
| 20BC105 | 400 | 55 (75) | 1000 | 3R130-B | 0.2 | 130 | |
| 20BC125 | 400 | 55 (75) | 1000 | 3R130-B | 0.2 | 130 | |
| 20BC140 | 400 | 75 (100) | 1000 | 3R160-B | 0.15 | 160 | |
| 20BC170 | 400 | 90 (125) | 1500 | 3R200-B | 0.11 | 200 | |
| 20BC205 | 400 | 110 (150) | 1500 | 3R200-B | 0.11 | 200 | |
| 20BC260 | 400 | 132 (175) | 2000 | 3RB320-B | 0.075 | 320 | |

Table 11 - AC Line Impedance Recommendations for PowerFlex 700/700S Drives (Continued)

| Drive | Drive Catalog Number | Volts | kW (Hp) | Max Supply KVA ⁽¹⁾ | 3% Line Reactor Open Style 1321- | Reactor Inductance (mH) | Reactor Current Rating (amps) |
|---|----------------------|------------|------------|-------------------------------|----------------------------------|-------------------------|-------------------------------|
| PowerFlex 700/700S For PowerFlex 700S, replace 20B with 20D. | 20BD1P1 | 480 | 0.37 (0.5) | 250 | 3R2-B | 20 | 2 |
| | 20BD2P1 | 480 | 0.75 (1) | 250 | 3R2-B | 20 | 2 |
| | 20BD3P4 | 480 | 1.5 (2) | 500 | 3R4-B | 6.5 | 4 |
| | 20BD5P0 | 480 | 2.2 (3) | 500 | 3R4-B | 6.5 | 4 |
| | 20BD8P0 | 480 | 4.0 (5) | 500 | 3R8-B | 3 | 8 |
| | 20BD011 | 480 | 5.5 (7.5) | 750 | 3R12-B | 2.5 | 12 |
| | 20BD014 | 480 | 7.5 (10) | 750 | 3R18-B | 1.5 | 18 |
| | 20BD022 | 480 | 11 (15) | 750 | 3R25-B | 1.2 | 25 |
| | 20BD027 | 480 | 15 (20) | 750 | 3R35-B | 0.8 | 35 |
| | 20BD034 | 480 | 18.5 (25) | 1000 | 3R35-B | 0.8 | 35 |
| | 20BD040 | 480 | 22 (30) | 1000 | 3R45-B | 0.7 | 45 |
| | 20BD052 | 480 | 30 (40) | 1000 | 3R55-B | 0.5 | 55 |
| | 20BD065 | 480 | 37 (50) | 1000 | 3R80-B | 0.4 | 80 |
| | 20BD077 | 480 | 45 (60) | 1000 | 3R80-B | 0.4 | 80 |
| | 20BD096 | 480 | 55 (75) | 1000 | 3R100-B | 0.3 | 100 |
| | 20BD125 | 480 | 75 (100) | 1000 | 3R130-B | 0.2 | 130 |
| | 20BD140 | 480 | 75 (100) | 1000 | 3R160-B | 0.15 | 160 |
| | 20BD156 | 480 | 90 (125) | 1500 | 3R160-B | 0.15 | 160 |
| | 20BD180 | 480 | 110 (150) | 1500 | 3R200-B | 0.11 | 200 |
| | | | | | | | |
| 20BE0P9 | 600 | 0.37 (0.5) | 250 | 3R2-B | 20 | 2 | |
| 20BE1P7 | 600 | 0.75 (1) | 250 | 3R2-B | 20 | 2 | |
| 20BE2P7 | 600 | 1.5 (2) | 500 | 3R4-B | 6.5 | 4 | |
| 20BE3P9 | 600 | 2.2 (3) | 500 | 3R4-B | 6.5 | 4 | |
| 20BE6P1 | 600 | 4.0 (5) | 500 | 3R8-B | 3 | 8 | |
| 20BE9P0 | 600 | 5.5 (7.5) | 750 | 3R8-B | 3 | 8 | |
| 20BE011 | 600 | 7.5 (10) | 750 | 3R12-B | 2.5 | 12 | |
| 20BE017 | 600 | 11 (15) | 750 | 3R25-B | 1.2 | 25 | |
| 20BE022 | 600 | 15 (20) | 750 | 3R25-B | 1.2 | 25 | |
| 20BE027 | 600 | 18.5 (25) | 1000 | 3R35-B | 0.8 | 35 | |
| 20BE032 | 600 | 22 (30) | 1000 | 3R35-B | 0.8 | 35 | |
| 20BE041 | 600 | 30 (40) | 1000 | 3R45-B | 0.7 | 45 | |
| 20BE052 | 600 | 37 (50) | 1000 | 3R55-B | 0.5 | 55 | |
| 20BE062 | 600 | 45 (60) | 1000 | 3R80-B | 0.4 | 80 | |
| 20BE077 | 600 | 55 (75) | 1000 | 3R80-B | 0.4 | 80 | |
| 20BE099 | 600 | 75 (100) | 1200 | 3R100-B | 0.3 | 100 | |
| 20BE125 | 600 | 90 (125) | 1400 | 3R130-B | 0.2 | 130 | |
| 20BE144 | 600 | 110 (150) | 1500 | 3R160-B | 0.15 | 160 | |

(1) Maximum suggested KVA supply without consideration for additional inductance

Table 12 - AC Line Impedance Recommendations for PowerFlex 753/755 Drives

| Drive | Drive Catalog Number | Volts | kW (Hp) | Max Supply KVA ⁽¹⁾ | 3% Line Reactor Open Style 1321- | Reactor Inductance (mH) | Reactor Current Rating (amps) |
|--|----------------------|-------------|-----------|-------------------------------|----------------------------------|-------------------------|-------------------------------|
| PowerFlex 753/755 | 20G_RC2P1 | 400 | 0.75 (1) | 250 | 3R2-B | 20 | 2 |
| | 20G_RC3P5 | 400 | 1.5(2) | 500 | 3R4-B | 6.5 | 4 |
| For PowerFlex 753, replace 20G with 20F. | 20G_RC5P0 | 400 | 2.2 (3) | 500 | 3R4-B | 6.5 | 4 |
| | 20G_RC8P7 | 400 | 4 (5) | 500 | 3R8-B | 3 | 8 |
| | 20G_RC011 | 400 | 5.5 (7.5) | 750 | 3R12-B | 2.5 | 12 |
| | 20G_RC015 | 400 | 7.5 (10) | 1000 | 3R18-B | 1.5 | 18 |
| | 20G_C2P1 | 400 | 0.75 (1) | 250 | 3R2-B | 20 | 2 |
| | 20G_C3P5 | 400 | 1.5(2) | 500 | 3R4-B | 6.5 | 4 |
| | 20G_C5P0 | 400 | 2.2 (3) | 500 | 3R4-B | 6.5 | 4 |
| | 20G_C8P7 | 400 | 4 (5) | 500 | 3R8-B | 3 | 8 |
| | 20G_C011 | 400 | 5.5 (7.5) | 750 | 3R12-B | 2.5 | 12 |
| | 20G_C015 | 400 | 7.5 (10) | 1000 | 3R18-B | 1.5 | 18 |
| | 20G_C022 | 400 | 11 (15) | 1000 | 3R25-B | 1.2 | 25 |
| | 20G_C030 | 400 | 15 (20) | 1000 | 3R35-B | 0.8 | 35 |
| | 20G_C037 | 400 | 18.5(25) | 1000 | 3R45-B | 0.7 | 45 |
| | 20G_C043 | 400 | 22 (30) | 1000 | 3R45-B | 0.7 | 45 |
| | 20G_C060 | 400 | 30 (40) | 1000 | 3R80-B | 0.4 | 80 |
| | 20G_C072 | 400 | 37 (50) | 1000 | 3R80-B | 0.4 | 80 |
| | 20G_C085 | 400 | 45 (60) | 1000 | 3R130-B | 0.2 | 130 |
| | 20G_C105 | 400 | 55 (75) | 1000 | 3R130-B | 0.2 | 130 |
| | 20G_C125 | 400 | 55 (75) | 1000 | 3R130-B | 0.2 | 130 |
| | 20G_C140 | 400 | 75 (100) | 1000 | 3R160-B | 0.15 | 160 |
| | 20G_C170 | 400 | 90 (125) | 1500 | 3R200-B | 0.11 | 200 |
| | 20G_C205 | 400 | 110 (150) | 2000 | 3R200-B | 0.11 | 200 |
| | 20G_C260 | 400 | 132 (175) | 2500 | 3RB320-B | 0.075 | 320 |
| | 20G_C302 | 400 | 160 (214) | 2500 | 3RB320-B | 0.075 | 320 |
| | 20G_C367 | 400 | 200 (268) | 3000 | 3RB400-B | 0.06 | 400 |
| | 20G_C456 | 400 | 250 (335) | 3500 | 3R500-B | 0.05 | 500 |
| | 20G_C460 | 400 | 250 (335) | 3500 | 3R500-B | 0.05 | 500 |
| | 20G_C567 | 400 | 315(422) | 4000 | 3R600-B | 0.04 | 600 |
| 20G_C650 | 400 | 355 (476) | 4500 | 3R750-B | 0.029 | 750 | |
| 20G_C750 | 400 | 400 (536) | 4500 | 3R750-B | 0.029 | 750 | |
| 20G_C770 | 400 | 400(536) | 5000 | 3R850-B | 0.027 | 850 | |
| 20G_C1K0 | 400 | 500 (670) | 5000 | 3R1000-B | 0.022 | 1000 | |
| 20G_C1K2 | 400 | 560 (750) | 5000 | 2 x 3R750-B | 0.015 | 1500 | |
| 20G_C1K4 | 400 | 630 (175) | 5000 | 2 x 3R750-B | 0.015 | 1500 | |
| 20G_C1K5 | 400 | 850 (1070) | 5000 | 2 x 3R850-B | 0.014 | 1700 | |
| 20G_C1K6 | 400 | 900 (1200) | 5000 | 2 x 3R850-B | 0.014 | 1700 | |
| 20G_C2K1 | 400 | 1250 (1675) | 5000 | 2 x 3R1000-B | 0.011 | 2000 | |
| | | | | | | | |
| | 20G_RD2P1 | 480 | 0.75 (1) | 250 | 3R2-B | 20 | 2 |
| | 20G_RD3P4 | 480 | 1.5(2) | 500 | 3R4-B | 6.5 | 4 |
| | 20G_RD5P0 | 480 | 2.2 (3) | 500 | 3R4-B | 6.5 | 4 |
| | 20G_RD8P0 | 480 | 4 (5) | 500 | 3R8-B | 3 | 8 |
| | 20G_RD011 | 480 | 5.5 (7.5) | 750 | 3R12-B | 2.5 | 12 |
| | 20G_RD014 | 480 | 7.5 (10) | 1000 | 3R18-B | 1.5 | 18 |
| | 20G_D2P1 | 480 | 0.75 (1) | 250 | 3R2-B | 20 | 2 |
| | 20G_D3P4 | 480 | 1.5 (2) | 500 | 3R4-B | 6.5 | 4 |

Table 12 - AC Line Impedance Recommendations for PowerFlex 753/755 Drives (Continued)

| Drive | Drive Catalog Number | Volts | kW (Hp) | Max Supply KVA ⁽¹⁾ | 3% Line Reactor Open Style 1321- | Reactor Inductance (mH) | Reactor Current Rating (amps) |
|--|----------------------|-------------|-----------|-------------------------------|----------------------------------|-------------------------|-------------------------------|
| PowerFlex 753/755 | 20G_D5P0 | 480 | 2.2 (3) | 500 | 3R4-B | 6.5 | 4 |
| | 20G_D8P0 | 480 | 4.0 (5) | 500 | 3R8-B | 3 | 8 |
| For PowerFlex 753, replace 20G with 20F. | 20G_D011 | 480 | 5.5 (7.5) | 750 | 3R12-B | 2.5 | 12 |
| | 20G_D014 | 480 | 7.5 (10) | 750 | 3R18-B | 1.5 | 18 |
| | 20G_D022 | 480 | 11 (15) | 750 | 3R25-B | 1.2 | 25 |
| | 20G_D027 | 480 | 15 (20) | 750 | 3R35-B | 0.8 | 35 |
| | 20G_D034 | 480 | 18.5 (25) | 1000 | 3R35-B | 0.8 | 35 |
| | 20G_D040 | 480 | 22 (30) | 1000 | 3R45-B | 0.7 | 45 |
| | 20G_D052 | 480 | 30 (40) | 1000 | 3R55-B | 0.5 | 55 |
| | 20G_D065 | 480 | 37 (50) | 1000 | 3R80-B | 0.4 | 80 |
| | 20G_D077 | 480 | 45 (60) | 1000 | 3R80-B | 0.4 | 80 |
| | 20G_D096 | 480 | 55 (75) | 1000 | 3R100-B | 0.3 | 100 |
| | 20G_D125 | 480 | 75 (100) | 1000 | 3R130-B | 0.2 | 130 |
| | 20G_D140 | 480 | 75 (100) | 1000 | 3R160-B | 0.15 | 160 |
| | 20G_D156 | 480 | 90 (125) | 1500 | 3R160-B | 0.15 | 160 |
| | 20G_D186 | 480 | 110 (150) | 1500 | 3R200-B | 0.11 | 200 |
| | 20G_D248 | 480 | 150 (200) | 2000 | 3RB320-B | 0.075 | 320 |
| | 20G_D302 | 480 | 187(250) | 2500 | 3RB320-B | 0.075 | 320 |
| | 20G_D361 | 480 | 224 (300) | 2500 | 3RB400-B | 0.06 | 400 |
| | 20G_D415 | 480 | 260 (350) | 3000 | 3R500-B | 0.05 | 500 |
| | 20G_D430 | 480 | 260 (350) | 3500 | 3R500-B | 0.05 | 500 |
| | 20G_D485 | 480 | 298 (400) | 3500 | 3R600-B | 0.04 | 600 |
| | 20G_D545 | 480 | 336(450) | 4000 | 3R600-B | 0.04 | 600 |
| | 20G_D617 | 480 | 373 (500) | 4500 | 3R750-B | 0.029 | 750 |
| | 20G_D710 | 480 | 448 (600) | 4500 | 3R750-B | 0.029 | 750 |
| | 20G_D740 | 480 | 485 (650) | 4500 | 3R750-B | 0.029 | 750 |
| | 20G_D800 | 480 | 522 (700) | 5000 | 3R850-B | 0.027 | 850 |
| | 20G_D960 | 480 | 597 (800) | 5000 | 3R1000-B | 0.022 | 1000 |
| 20G_D1K0 | 480 | 671 (900) | 5000 | 3R1000-B | 0.022 | 1000 | |
| 20G_D1K2 | 480 | 746 (1000) | 5000 | 2 x 3R750-B | 0.015 | 1500 | |
| 20G_D1K3 | 480 | 821 (1100) | 5000 | 2 x 3R750-B | 0.015 | 1500 | |
| 20G_D1K4 | 480 | 933 (1250) | 5000 | 2 x 3R850-B | 0.014 | 1700 | |
| 20G_D1K5 | 480 | 1007(1350) | 5000 | 2 x 3R850-B | 0.014 | 1700 | |
| 20G_D2K0 | 480 | 1082 (1750) | 5000 | 2 x 3R1000-B | 0.011 | 2000 | |
| | | | | | | | |
| | 20G_E1P7 | 600 | 0.75 (1) | 250 | 3R2-B | 20 | 2 |
| | 20G_E2P7 | 600 | 1.5 (2) | 500 | 3R4-B | 6.5 | 4 |
| | 20G_E3P9 | 600 | 2.2 (3) | 500 | 3R4-B | 6.5 | 4 |
| | 20G_E6P1 | 600 | 4.0 (5) | 500 | 3R8-B | 3 | 8 |
| | 20G_E9P0 | 600 | 5.5 (7.5) | 750 | 3R8-B | 3 | 8 |
| | 20G_E011 | 600 | 7.5 (10) | 750 | 3R12-B | 2.5 | 12 |
| | 20G_E017 | 600 | 11 (15) | 750 | 3R25-B | 1.2 | 25 |
| | 20G_E018 | 600 | 15 (15) | 750 | 3R25-B | 1.2 | 25 |
| | 20G_E022 | 600 | 15 (20) | 750 | 3R25-B | 1.2 | 25 |
| | 20G_E023 | 600 | 18.5 (25) | 1000 | 3R35-B | 0.8 | 35 |
| | 20G_E024 | 600 | 18.5 (25) | 1000 | 3R35-B | 0.8 | 35 |
| | 20G_E027 | 600 | 18.5 (25) | 1000 | 3R35-B | 0.8 | 35 |
| | 20G_E028 | 600 | 18.5 (25) | 1000 | 3R35-B | 0.8 | 35 |
| | 20G_E032 | 600 | 22 (30) | 1000 | 3R35-B | 0.8 | 35 |

Table 12 - AC Line Impedance Recommendations for PowerFlex 753/755 Drives (Continued)

| Drive | Drive Catalog Number | Volts | kW (Hp) | Max Supply KVA ⁽¹⁾ | 3% Line Reactor Open Style 1321- | Reactor Inductance (mH) | Reactor Current Rating (amps) |
|--|----------------------|-------------|-----------|-------------------------------|----------------------------------|-------------------------|-------------------------------|
| PowerFlex 753/755 | 20G_E033 | 600 | 22 (30) | 1000 | 3R35-B | 0.8 | 35 |
| | 20G_E041 | 600 | 30 (40) | 1000 | 3R45-B | 0.7 | 45 |
| For PowerFlex 753, replace 20G with 20F. | 20G_E042 | 600 | 30 (40) | 1000 | 3R45-B | 0.7 | 45 |
| | 20G_E052 | 600 | 37 (50) | 1000 | 3R55-B | 0.5 | 55 |
| | 20G_E053 | 600 | 37 (50) | 1000 | 3R55-B | 0.5 | 55 |
| | 20G_E063 | 600 | 45 (60) | 1000 | 3R80-B | 0.4 | 80 |
| | 20G_E077 | 600 | 55 (75) | 1000 | 3R80-B | 0.4 | 80 |
| | 20G_E099 | 600 | 75 (100) | 1200 | 3R100-B | 0.3 | 100 |
| | 20G_E125 | 600 | 90 (125) | 1400 | 3R130-B | 0.2 | 130 |
| | 20G_E144 | 600 | 110 (150) | 1500 | 3R160-B | 0.15 | 160 |
| | 20G_E192 | 600 | 150 (200) | 1500 | 3R200-B | 0.11 | 200 |
| | 20G_E242 | 600 | 185 (250) | 2000 | 3RB320-B | 0.075 | 320 |
| | 20G_E289 | 600 | 224(300) | 2000 | 3RB320-B | 0.075 | 320 |
| | 20G_E295 | 600 | 224(300) | 2500 | 3RB320-B | 0.075 | 320 |
| | 20G_E355 | 600 | 261 (350) | 2500 | 3RB400-B | 0.06 | 400 |
| | 20G_E395 | 600 | 298 (400) | 2500 | 3RB400-B | 0.06 | 400 |
| | 20G_E435 | 600 | 336 (450) | 3000 | 3R500-B | 0.05 | 500 |
| | 20G_E460 | 600 | 373 (500) | 3000 | 3R500-B | 0.05 | 500 |
| | 20G_E510 | 600 | 373 (500) | 3500 | 3R600-B | 0.04 | 600 |
| | 20G_E595 | 600 | 448 (600) | 3500 | 3R600-B | 0.04 | 600 |
| | 20G_E630 | 600 | 312(700) | 4500 | 3R750-B | 0.029 | 750 |
| | 20G_E760 | 600 | 597 (800) | 5000 | 3R850-B | 0.027 | 850 |
| 20G_E825 | 600 | 671 (900) | 5000 | 3R850-B | 0.027 | 850 | |
| 20G_E900 | 600 | 709 (950) | 5000 | 3R1000-B | 0.022 | 1000 | |
| 20G_E980 | 600 | 746 (1000) | 5000 | 3R1000-B | 0.022 | 1000 | |
| 20G_E1K1 | 600 | 821 (1100) | 5000 | 2 x 3R600-B | 0.02 | 1200 | |
| 20G_E1K4 | 600 | 1044 (1400) | 5000 | 2 x 3R750-B | 0.015 | 1500 | |
| 20G_F012 | 690 | 7.5 (10) | 750 | 3R12-B | 2.5 | 12 | |
| 20G_F015 | 690 | 11 (15) | 750 | 3R25-B | 1.2 | 25 | |
| 20G_F020 | 690 | 15 (20) | 750 | 3R25-B | 1.2 | 25 | |
| 20G_F023 | 690 | 18.5 (25) | 1000 | 3R25-B | 1.2 | 25 | |
| 20G_F030 | 690 | 22 (30) | 1000 | 3R35-B | 0.8 | 35 | |
| 20G_F034 | 690 | 30 (40) | 1000 | 3R35-B | 0.8 | 35 | |
| 20G_F046 | 690 | 37 (50) | 1000 | 3R55-B | 0.5 | 55 | |
| 20G_F050 | 690 | 45 (60) | 1000 | 3R55-B | 0.5 | 55 | |
| 20G_F061 | 690 | 55 (75) | 1000 | 3R80-B | 0.4 | 80 | |
| 20G_F082 | 690 | 75 (100) | 1200 | 3R100-B | 0.3 | 100 | |
| 20G_F098 | 690 | 90 (125) | 1200 | 3R100-B | 0.3 | 100 | |
| 20G_F119 | 690 | 110 (150) | 1400 | 3R130-B | 0.2 | 130 | |
| 20G_F142 | 690 | 132 (177) | 1500 | 3R160-B | 0.15 | 160 | |
| 20G_F171 | 690 | 160 (215) | 1500 | 3R200-B | 0.11 | 200 | |
| 20G_F212 | 690 | 200(268) | 2000 | 3RB320-B | 0.075 | 320 | |
| 20G_F263 | 690 | 250 (335) | 2000 | 3RB320-B | 0.075 | 320 | |
| 20G_F265 | 690 | 250 (335) | 2500 | 3RB320-B | 0.075 | 320 | |
| 20G_F330 | 690 | 315 (422) | 2500 | 3RB400-B | 0.06 | 400 | |
| 20G_F370 | 690 | 355 (476) | 2500 | 3RB400-B | 0.06 | 400 | |
| 20G_F415 | 690 | 400(536) | 2500 | 3R500-B | 0.05 | 500 | |
| 20G_F460 | 690 | 450(604) | 3000 | 3R500-B | 0.05 | 500 | |

Table 12 - AC Line Impedance Recommendations for PowerFlex 753/755 Drives (Continued)

| Drive | Drive Catalog Number | Volts | kW (Hp) | Max Supply KVA ⁽¹⁾ | 3% Line Reactor Open Style 1321- | Reactor Inductance (mH) | Reactor Current Rating (amps) |
|--|----------------------|-------|-------------|-------------------------------|----------------------------------|-------------------------|-------------------------------|
| PowerFlex 753/755 | 20G_F500 | 690 | 500(670) | 3000 | 3R500-B | 0.05 | 500 |
| | 20G_F590 | 690 | 560 (750) | 3500 | 3R600-B | 0.04 | 600 |
| For PowerFlex 753, replace 20G with 20F. | 20G_F650 | 690 | 630 (845) | 4500 | 3R750-B | 0.029 | 750 |
| | 20G_F710 | 690 | 710 (952) | 4500 | 3R750-B | 0.029 | 750 |
| | 20G_F765 | 690 | 750 (1006) | 5000 | 3R850-B | 0.027 | 850 |
| | 20G_F795 | 690 | 800 (1073) | 5000 | 3R850-B | 0.027 | 850 |
| | 20G_F960 | 690 | 900 (1207) | 5000 | 3R1000-B | 0.022 | 1000 |
| | 20G_F1K0 | 690 | 1000(1341) | 5000 | 3R1000-B | 0.022 | 1000 |
| | 20G_F1K4 | 690 | 1400 (1877) | 5000 | 2 x 3R750-B | 0.015 | 1500 |

(1) Maximum suggested KVA supply without consideration for additional inductance.

Table 13 - AC Line Impedance Recommendations for Bulletin 1336 Drives

| Drive | Drive Catalog Number ⁽¹⁾ | Volts | kW (Hp) | Max Supply kVA ⁽²⁾⁽³⁾ | 3% Line Reactor Open Style, 1321- | Reactor Inductance (mH) | Reactor Current Rating (amps) ⁽⁴⁾ |
|---|-------------------------------------|-------|-------------|----------------------------------|-----------------------------------|-------------------------|--|
| 1336 PLUS™ 1336 PLUS II 1336 IMPACT™ 1336 FORCE™ | AQF05 | 240 | 0.37 (0.5) | 25 | 3R4-A | 3.0 | 4 |
| | AQF07 | 240 | 0.56 (0.75) | 25 | 3R4-A | 3.0 | 4 |
| | AQF10 | 240 | 0.75 (1) | 50 | 3R8-A | 1.5 | 8 |
| | AQF15 | 240 | 1.2 (1.5) | 75 | 3R8-A | 1.5 | 8 |
| | AQF20 | 240 | 1.5 (2) | 100 | 3R12-A | 1.25 | 12 |
| | AQF30 | 240 | 2.2 (3) | 200 | 3R12-A | 1.25 | 12 |
| | AQF50 | 240 | 3.7 (5) | 275 | 3R25-A | 0.5 | 25 |
| | AQF75 | 240 | 5.5 (7.5) | 300 | 3R25-A | 0.5 | 25 |
| | A7 | 240 | 5.5 (7.5) | 300 | 3R25-A | 0.5 | 25 |
| | A10 | 240 | 7.5 (10) | 350 | 3R35-A | 0.4 | 35 |
| | A15 | 240 | 11 (15) | 600 | 3R45-A | 0.3 | 45 |
| | A20 | 240 | 15 (20) | 800 | 3R80-A | 0.2 | 80 |
| | A25 | 240 | 18.5 (25) | 800 | 3R80-A | 0.2 | 80 |
| | A30 | 240 | 22 (30) | 950 | 3R80-A | 0.2 | 80 |
| | A40 | 240 | 30 (40) | 1000 | 3R130-A | 0.1 | 130 |
| | A50 | 240 | 37 (50) | 1000 | 3R160-A | 0.075 | 160 |
| | A60 | 240 | 45 (60) | 1000 | 3R200-A | 0.55 | 200 |
| | A75 | 240 | 56 (75) | 1000 | 3RB250-A | 0.045 | 250 |
| | A100 | 240 | 75 (100) | 1000 | 3RB320-A | 0.04 | 320 |
| | A125 | 240 | 93 (125) | 1000 | 3RB320-A | 0.04 | 320 |
| | | | | | | | |
| | BRF05 | 480 | 0.37 (0.5) | 25 | 3R2-B | 20 | 2 |
| | BRF07 | 480 | 0.56 (0.75) | 30 | 3R2-B | 20 | 2 |
| | BRF10 | 480 | 0.75 (1) | 30 | 3R4-B | 6.5 | 4 |
| | BRF15 | 480 | 1.2 (1.5) | 50 | 3R4-B | 6.5 | 4 |
| | BRF20 | 480 | 1.5 (2) | 50 | 3R8-B | 3.0 | 8 |
| | BRF30 | 480 | 2.2 (3) | 75 | 3R8-B | 3.0 | 8 |
| | BRF50 | 480 | 3.7 (5) | 100 | 3R12-B | 2.5 | 12 |
| | BRF75 | 480 | 5.5 (7.5) | 200 | 3R18-B | 1.5 | 18 |
| | BRF100 | 480 | 7.5 (10) | 275 | 3R25-B | 1.2 | 25 |
| | BRF150 | 480 | 11 (15) | 300 | 3R25-B | 1.2 | 25 |
| | BRF200 | 480 | 15 (20) | 350 | 3R25-B | 1.2 | 25 |
| | B015 | 480 | 11 (15) | 350 | 3R25-B | 1.2 | 25 |

Table 13 - AC Line Impedance Recommendations for Bulletin 1336 Drives (Continued)

| Drive | Drive Catalog Number ⁽¹⁾ | Volts | kW (Hp) | Max Supply kVA ⁽²⁾⁽³⁾ | 3% Line Reactor Open Style, 1321- | Reactor Inductance (mH) | Reactor Current Rating (amps) ⁽⁴⁾ |
|--|-------------------------------------|-----------|-----------|----------------------------------|-----------------------------------|-------------------------|--|
| 1336 PLUS 1336 PLUS II 1335 IMPACT 1336 FORCE | B020 | 480 | 15 (20) | 425 | 3R35-B | 0.8 | 35 |
| | B025 | 480 | 18.5 (25) | 550 | 3R35-B | 0.8 | 35 |
| | B030 | 480 | 22 (30) | 600 | 3R45-B | 0.7 | 45 |
| | B040 | 480 | 30 (40) | 750 | 3R55-B | 0.5 | 55 |
| | B050 | 480 | 37 (50) | 800 | 3R80-B | 0.4 | 80 |
| | B060 | 480 | 45 (60) | 900 | 3R80-B | 0.4 | 80 |
| | B075 | 480 | 56 (75) | 1000 | 3R100-B | 0.3 | 100 |
| | B100 | 480 | 75 (100) | 1000 | 3R130-B | 0.2 | 130 |
| | B125 | 480 | 93 (125) | 1400 | 3R160-B | 0.15 | 160 |
| | B150 | 480 | 112 (150) | 1500 | 3R200-B | 0.11 | N200 |
| | B200 | 480 | 149 (200) | 2000 | 3RB250-B | 0.09 | 250 |
| | B250 | 480 | 187 (250) | 2500 | 3RB320-B | 0.075 | 320 |
| | B300 | 480 | 224 (300) | 3000 | 3RB400-B | 0.06 | 400 |
| | B350 | 480 | 261 (350) | 3500 | 3R500-B | 0.05 | 500 |
| | B400 | 480 | 298 (400) | 4000 | 3R500-B | 0.05 | 500 |
| | B450 | 480 | 336 (450) | 4500 | 3R600-B | 0.04 | 600 |
| | B500 | 480 | 373 (500) | 5000 | 3R600-B | 0.04 | 600 |
| | B600 | 480 | 448 (600) | 5000 | 3R750-B | 0.029 | 750 |
| | B700 | 480 | (700) | 5000 | 3R850-B | 0.027 | 850 |
| | B800 | 480 | (800) | 5000 | 3R1000-B | 0.022 | 1000 |
| | BP/BPR250 | 480 | 187 (250) | N/A | N/A | N/A | N/A |
| | BP/BPR300 | 480 | 224 (300) | N/A | N/A | N/A | N/A |
| | BP/BPR350 | 480 | 261 (350) | N/A | N/A | N/A | N/A |
| | BP/BPR400 | 480 | 298 (400) | N/A | N/A | N/A | N/A |
| | BP/BPR450 | 480 | 336 (450) | N/A | N/A | N/A | N/A |
| | BX040 | 480 | 30 (40) | N/A | N/A | N/A | N/A |
| | BX060 | 480 | 45 (60) | N/A | N/A | N/A | N/A |
| | BX150 | 480 | 112 (150) | N/A | N/A | N/A | N/A |
| | BX250 | 480 | 187 (250) | N/A | N/A | N/A | N/A |
| | CWF10 | 600 | 0.75 (1) | 25 | 3R4-C | 9 | 4 |
| | CWF20 | 600 | 1.5 (2) | 50 | 3R4-C | 9 | 4 |
| | CWF30 | 600 | 2.2 (3) | 75 | 3R8-C | 5 | 8 |
| | CWF50 | 600 | 3.7 (5) | 100 | 3R8-B | 3 | 8 |
| CWF75 | 600 | 5.5 (7.5) | 200 | 3R8-B | 3 | 8 | |
| CWF100 | 600 | 7.5 (10) | 200 | 3R12-B | 2.5 | 12 | |
| CWF150 | 600 | 11 (15) | 300 | 3R18-B | 1.5 | 18 | |
| CWF200 | 600 | 15 (20) | 350 | 3R25-B | 1.2 | 25 | |
| C015 | 600 | 11 (15) | 300 | 3R18-B | 1.5 | 18 | |
| C020 | 600 | 15 (20) | 350 | 3R25-B | 1.2 | 25 | |
| C025 | 600 | 18.5 (25) | 500 | 3R25-B | 1.2 | 25 | |
| C030 | 600 | 22 (30) | 600 | 3R35-B | 0.8 | 35 | |
| C040 | 600 | 30 (40) | 700 | 3R45-B | 0.7 | 45 | |
| C050 | 600 | 37 (50) | 850 | 3R55-B | 0.5 | 55 | |
| C060 | 600 | 45 (60) | 900 | 3R80-B | 0.4 | 80 | |
| C075 | 600 | 56 (75) | 950 | 3R80-B | 0.4 | 80 | |
| C100 | 600 | 75 (100) | 1200 | 3R100-B | 0.3 | 100 | |
| C125 | 600 | 93 (125) | 1400 | 3R130-B | 0.2 | 130 | |
| C150 | 600 | 112 (150) | 1500 | 3R160-B | 0.15 | 160 | |

Table 13 - AC Line Impedance Recommendations for Bulletin 1336 Drives (Continued)

| Drive | Drive Catalog Number ⁽¹⁾ | Volts | kW (Hp) | Max Supply kVA ⁽²⁾⁽³⁾ | 3% Line Reactor Open Style, 1321- | Reactor Inductance (mH) | Reactor Current Rating (amps) ⁽⁴⁾ |
|--|-------------------------------------|-------|-----------|----------------------------------|-----------------------------------|-------------------------|--|
| 1336 PLUS 1336 PLUS II 1336 IMPACT 1336 FORCE | C200 | 600 | 149 (200) | 2200 | 3R200-B | 0.11 | 200 |
| | C250 | 600 | 187 (250) | 2500 | 3R250-B | 0.09 | 250 |
| | C300 | 600 | 224 (300) | 3000 | 3R320-B | 0.075 | 320 |
| | C350 | 600 | 261 (350) | 3000 | 3R400-B | 0.06 | 400 |
| | C400 | 600 | 298 (400) | 4000 | 3R400-B | 0.06 | 400 |
| | C450 | 600 | 336 (450) | 4500 | 3R500-B | 0.05 | 500 |
| | C500 | 600 | 373 (500) | 5000 | 3R500-B | 0.05 | 500 |
| | C600 | 600 | 448 (600) | 5000 | 3R600-B | 0.04 | 600 |
| | C650 | 600 | (650) | 5000 | 3R750-B | 0.029 | 750 |
| | C700 | 600 | (700) | 5000 | 3R850-B FN-1 | 0.027 | 850 |
| | C800 | 600 | (800) | 5000 | 3R850-B FN-1 | 0.027 | 850 |
| | CP/CPR350 | 600 | 261 (350) | N/A | N/A | N/A | N/A |
| | CP/CPR400 | 600 | 298 (400) | N/A | N/A | N/A | N/A |

- (1) Shaded rows identify drive ratings without built-in inductors.
- (2) Maximum suggested KVA supply without consideration for additional inductance.
- (3) 2000 KVA represents 2 MVA and greater.
- (4) N/A = not available at time of printing.

Multi-drive Protection

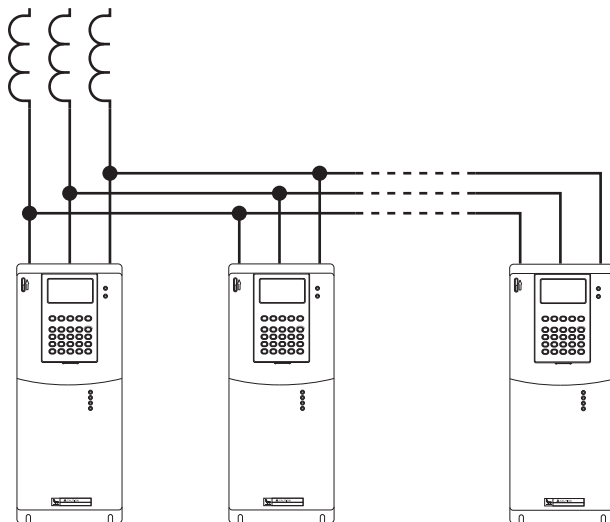

Use a separate line reactor for each drive that shares a common power line. Individual line reactors provide filtering between each drive to provide optimum surge protection for each drive. However, if it is necessary to group multiple drives on one AC line reactor, use this process to verify that the AC line reactor provides a minimum amount of impedance:

- In general, up to five drives can be grouped on one reactor.
- Add the input currents of the drives in the group.
- Multiply that sum by 125%.

- See 1321 Power Conditioning Products Technical Data, publication [1321-TD001](#), to select a reactor with a maximum continuous current rating greater than the multiplied current.
- Use this formula to verify that the impedance of the selected reactor is more than 0.5% (0.25% for drives with internal inductors) of the smallest drive in the group. If the impedance is too small, select a reactor with a larger inductance and same amperage, or regroup the drives into smaller groups and start over.

$$Z_{\text{drive}} = \frac{V_{\text{line-line}}}{\sqrt{3} * I_{\text{input-rating}}}$$

$$Z_{\text{reactor}} = L * 2 * 3.14 * f$$

L is the inductance of the reactor in henries and f is the AC line frequency.

EXAMPLE There are five drives. Each drive is rated 1 Hp, 480V, 2.7 A. These drives do not have internal inductors.

Total current is $5 \times 2.7 \text{ A} = 13.5 \text{ A}$

125% x Total current is $125\% \times 13.5 \text{ A} = 16.9 \text{ A}$

From 1321 Power Conditioning Products Technical Data, publication [1321-TD001](#), we selected the catalog number 1321-3R12-C reactor. This reactor has a maximum continuous current rating of 18 A and an inductance of 4.2 mH (0.0042 henries).

$$Z_{\text{drive}} = \frac{V_{\text{line-line}}}{\sqrt{3} * I_{\text{input-rating}}} = \frac{480\text{V}}{\sqrt{3} * 2.7} = 102.6 \text{ Ohms}$$

$$Z_{\text{reactor}} = L * (2 * 3.14) * f = 0.0042 * 6.28 * 60 = 1.58 \text{ Ohms}$$

$$\frac{Z_{\text{reactor}}}{Z_{\text{drive}}} = \frac{1.58}{102.6} = 0.0154 = 1.54\%$$

1.54% is more than the 0.5% impedance recommended. The catalog number 1321-3R12-C reactor can be used for the five 2.7 A drives in this example.

Surge Protection MOVs and Common Mode Capacitors



ATTENTION: When installing a drive on an ungrounded, high-resistance, or B-phase grounded distribution system, disconnect the phase-to-ground MOV circuit and the common mode capacitors from ground.

IMPORTANT In some drives, one jumper connects both the phase-to-ground MOV and the common mode capacitors to ground.

MOV Circuitry

Most drives are designed to operate on three-phase supply systems with symmetrical line voltages. To meet IEEE C62.41, these drives are equipped with MOVs that provide voltage surge protection and phase-to-phase and phase-to-ground protection. The MOV circuit is designed only for surge suppression (transient line protection), not for continuous operation.

Figure 12 - Typical MOV Configuration

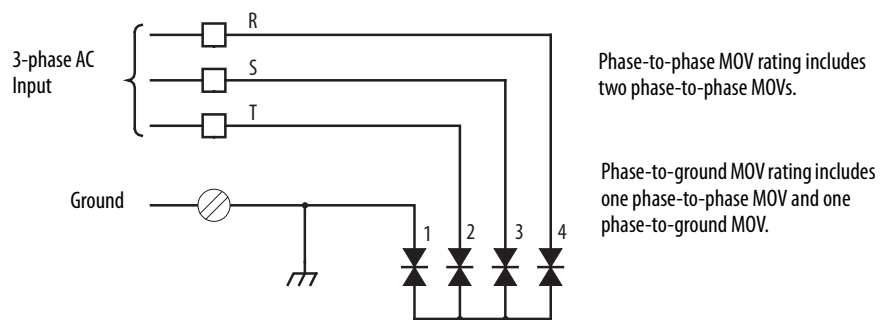

With ungrounded distribution systems, the phase-to-ground MOV connection can become a continuous current path to ground. If you exceed the published phase-to-phase voltage, phase-to-ground voltage, or energy ratings, you can damage the MOV.

Suitable isolation is required for the drive when there is potential for abnormally high phase-to-ground voltages (in excess of 125% of nominal line-to-line voltage). Suitable isolation is also required when the supply ground is tied to another system or equipment that can cause the ground potential to vary with operation. We recommend an isolation transformer when this condition exists.

Common Mode Capacitors

Many drives also contain common mode capacitors that are referenced to ground. In installations with ungrounded or high resistive ground systems, the common mode capacitors can capture high frequency common mode or ground fault currents. This capture can cause bus overvoltage conditions that can cause damage or drive faults. Systems that are ungrounded or have one phase that is grounded (commonly called B-phase grounded) apply higher than normal voltage stresses directly to the common mode capacitors and can lead to shortened drive life or damage.

Use PowerFlex Drives with Regenerative Units



ATTENTION: If a regenerative unit (for example, 1336 REGEN line regeneration package) or other active front end (AFE) is used as a bus supply or brake, disconnect the common mode capacitors. See the user manual for the drive. This disconnect guards against possible equipment damage.

DC Bus Wiring Guidelines

DC bus wiring refers to connecting the DC bus of an AC drive to the DC connections on another piece of equipment. That equipment can include any or all of these items:

- Additional AC drive
- Non-regenerative DC bus supply
- Regenerative DC bus supply
- Regenerative braking module
- Dynamic braking module
- Chopper module

For more information on the types of common DC bus configurations and applications, see PowerFlex AC Drives in Common Bus Configurations, publication [DRIVES-AT002](#).

Drive Lineup

Generally, it is desirable for the drive lineup to match the machine layout. However, if there is a mix of drive frame sizes that are used in the lineup, the general system layout places the largest drives closest to the rectifier source. The rectifier source does not need to be at the end of the system lineup. Many times, it is advantageous to put the rectifier in the middle of the lineup to minimize the distances to the farthest loads. This lineup minimizes the energy that is stored in the parasitic inductance of the bus structure and lowers peak bus voltages during transient operation.

The system must be contained in one contiguous lineup. The bus cannot be interrupted to go to another cabinet for the remainder of the system drives. A contiguous lineup maintains low inductance.

DC Bus Connections

For excellent system operation, minimize the interconnection of drives to the DC bus and the inductance levels between the drives. Use a low inductance-type DC bus (for example, 0.35 $\mu\text{H}/\text{m}$ or less).

IMPORTANT Do not daisy-chain the DC bus connections. Configure the DC bus connections in a star configuration to allow for proper fusing.

Figure 13 - Star Configuration of Common Bus Connections

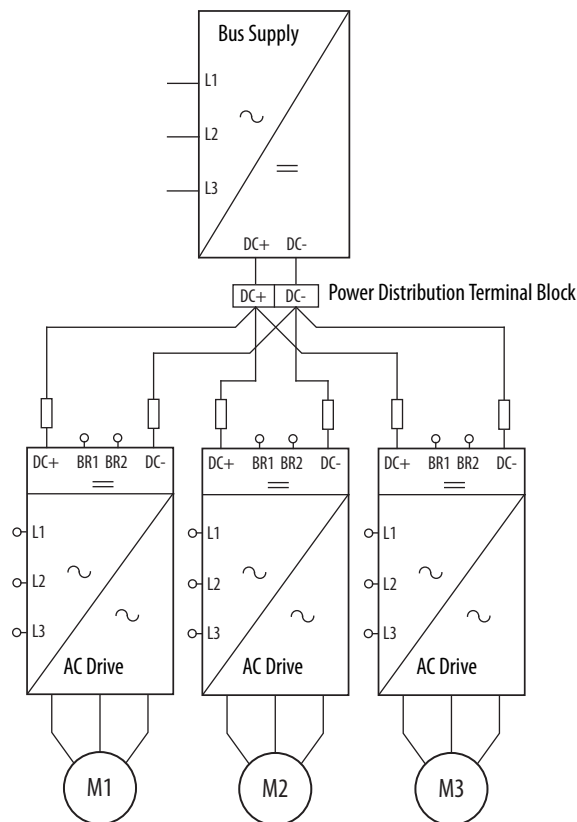

Bus Bar Versus Cable

Follow these recommendations for using a bus bar versus a cable:

- A DC bus bar is recommended versus a cable.
- When a DC bus bar cannot be used, follow these guidelines for DC bus cables:
 - Use twisted cable where possible, approximately one twist per inch.
 - Use cable rated for the equivalent AC voltage rating. The peak AC voltage is equivalent to the DC voltage. For example, the peak AC voltage on a 480V AC system no load is $480 \times 1.414 = 679\text{V}$ peak. The 679V peak corresponds to 679V DC at no load.

Braking Chopper

Connect the brake unit closest to the largest drive. If all drives are the same rating, then connect the brake unit closest to the drive that regenerates the most.

In general, mount brake units within 3 m (9.8 ft) of the drive. Resistors for use with chopper modules must be within 30 m (98.4 ft) of the chopper module. See the respective braking product documentation for details.

An RC snubber circuit is required when you use Allen-Bradley catalog number 1336-WA, 1336-WB, or 1336-WC brake choppers in the configurations listed here:

- A non-regenerative bus supply configuration that uses a PowerFlex diode bus supply.
- A shared AC/DC bus configuration that contains a PowerFlex 700/700S Frame 0...4 drive, or PowerFlex 40P drive.
- A shared DC bus (piggy back) configuration when the main drive is a PowerFlex 700/700S Frame 0...4, or PowerFlex 40P drive.

The RC snubber circuit is required to help prevent the DC bus voltage from exceeding the 1200V maximum brake chopper IGBT voltage. The 1336 brake chopper power-up delay time is 80 ms. During this time, the IGBT does not turn on. The RC snubber circuit must always be connected to the DC bus (found close to the braking chopper) to absorb the power-on voltage overshoot (see [Figure 14](#)).

The specifications for the RC snubber are described here:

- $R = 10 \Omega$, 100 W, low inductance ($< 50 \mu\text{H}$)
- $C = 20 \mu\text{F}$, 2000V

Figure 14 - Configuration Example of Diode Bus Supply with PowerFlex 700 Frame 0...4, PowerFlex 40P, 1336-W Braking Chopper, and RC Snubber Circuit.

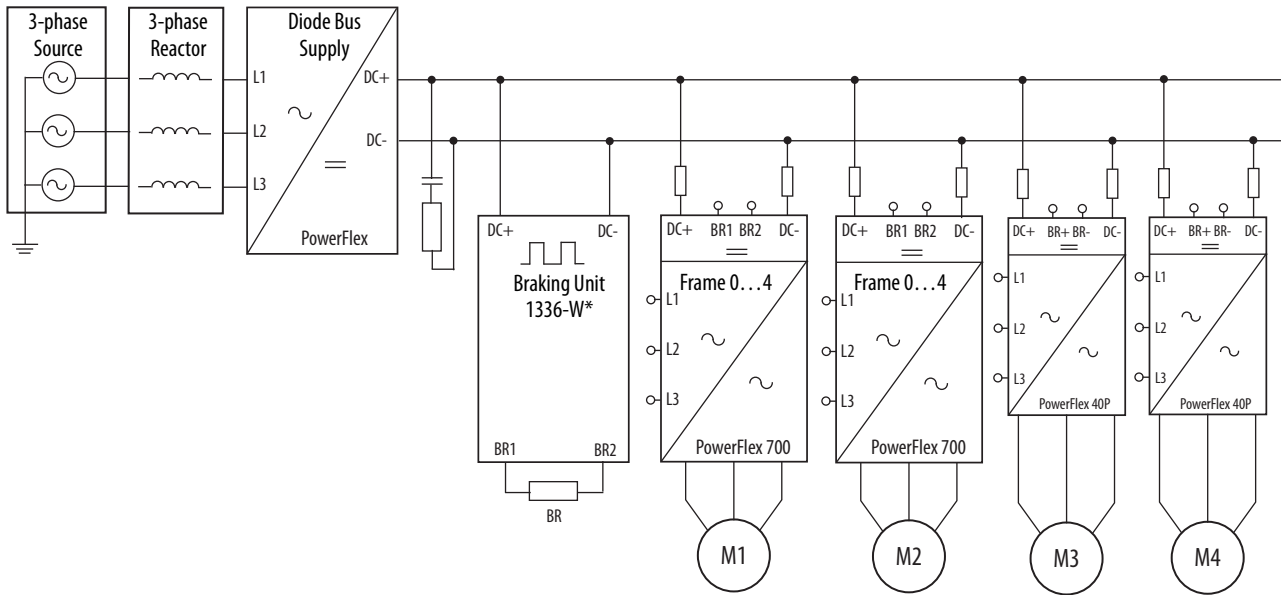

Grounding

This chapter discusses various grounding schemes for safety and noise reduction.

An effectively grounded scheme or product is intentionally connected to earth through a ground connection or connections of sufficiently low impedance. The ground also has sufficient current-carrying capacity to help prevent the buildup of voltages that can result in undue hazard to connected equipment or to persons (as defined by the US National Electric Code NFPA70, Article 100B).

Grounding of a drive or drive system is done for two basic reasons: safety and noise containment or reduction. While the safety ground scheme and the noise current return circuit can sometimes share path and components, they are considered different circuits with different requirements.

Grounding Safety Grounds

The object of safety grounding is to make sure that all metalwork is at the same ground (or earth) potential at power frequencies. Impedance between the drive and the building scheme ground must conform to the requirements of national and local industrial safety regulations or electrical codes. These regulations and codes vary based on country, type of distribution system, and other factors. Periodically check all ground connections and verify that the connections are secure and correct.

General safety requires that all metal parts are connected to earth with separate copper wire, or wires of the appropriate gauge. Always follow any specific directions for connecting a safety ground or protective earth (PE) directly to any piece of equipment.

Structural Steel of a Building

If intentionally bonded at the service entrance, the incoming supply neutral or ground is bonded to the building ground. Structural steel of a building is typically the best representation of ground or earth. The structural steel of a building is bonded together to provide a consistent ground potential. If other means of grounding are used, such as ground rods, you must understand the voltage potential between ground rods in different areas of the installation. The type of soil, ground water level, and other environmental factors can greatly affect the voltage potential between ground points if they are not bonded to each other.

Grounding PE or Ground

The drive safety ground, PE, must be connected to scheme or earth ground. PE is the safety ground for the drive required by code. This point must be connected to adjacent structural steel of a building (girder, joist), a floor ground rod, bus bar, or building ground grid. Grounding points must comply with national and local industrial safety regulations or electrical codes. Some codes require redundant ground paths and periodic examination of connection integrity. Global drive systems require the PE ground to be connected to the transformer ground that supplies the drive system.

RFI Filter Grounding

The use of an optional radio frequency interference (RFI) filter can result in relatively high ground leakage currents. Therefore, use an RFI filter only in installations with grounded AC supply systems and RFI filters that are permanently installed and solidly grounded to the building power distribution ground. Make sure the incoming supply neutral is solidly connected to the same building power distribution ground. Some codes require redundant ground connections and periodic examination of connection integrity. See the instructions supplied with the filter.

IMPORTANT Do not use flexible cables or any plug or socket that can be accidentally disconnected.

Grounding Motors

The motor frame or stator core must be connected directly to the drive PE connection with a separate ground conductor. We recommended that each motor frame is grounded to structural steel of a building at the motor. See [Cable Trays on page 74](#) for more information.

Grounding and TN-S Five-wire Systems

IMPORTANT Do not connect ground to neutral within a system cabinet if you use a TN-S Five-wire distribution system. The neutral wire is a current conducting wire. There is one connection between ground and neutral, typically in the distribution system.

TN-S Five-wire distribution systems are common throughout Europe, except for the United Kingdom and Germany. Leg-to-leg voltage (commonly at 400V) powers three-phase loads. Leg-to-neutral voltage (commonly at 230V) powers single-phase loads.

Figure 15 - Cabinet Grounding with a TN-S Five-wire System

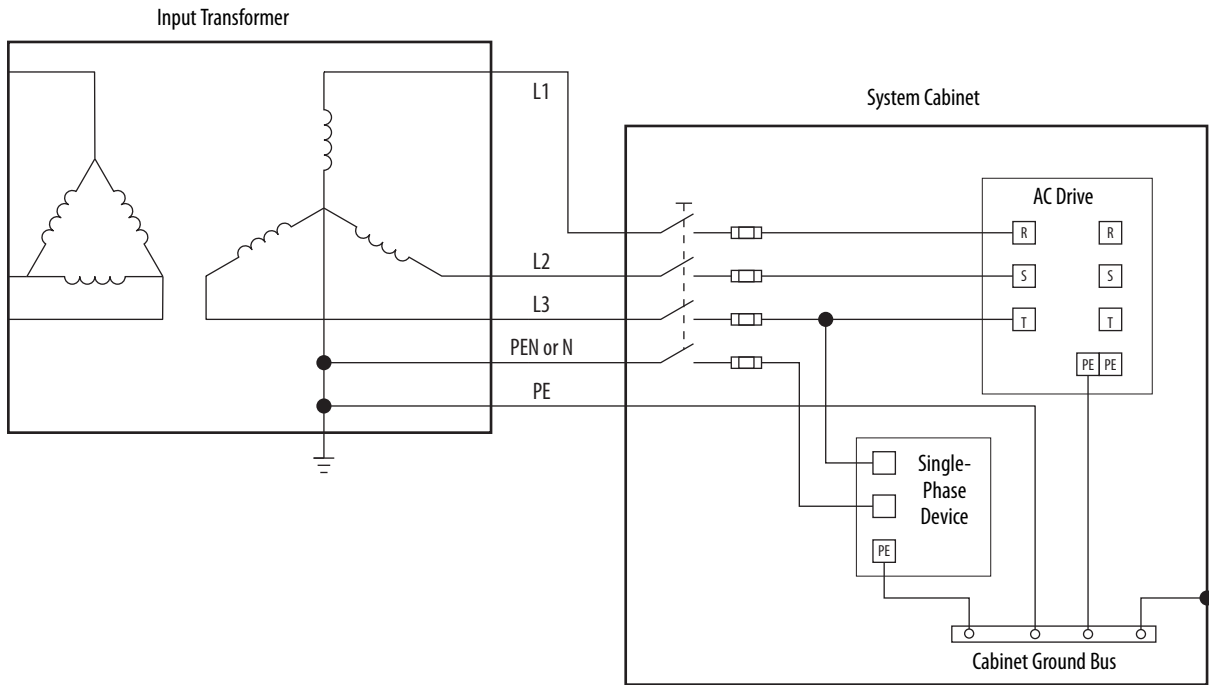

Noise Related Grounds

Use appropriate grounding schemes to reduce noise when installing PWM AC drives to reduce output that can produce high frequency common mode (coupled from output to ground) noise currents. These noise currents can cause sensitive equipment to malfunction if they are allowed to propagate.

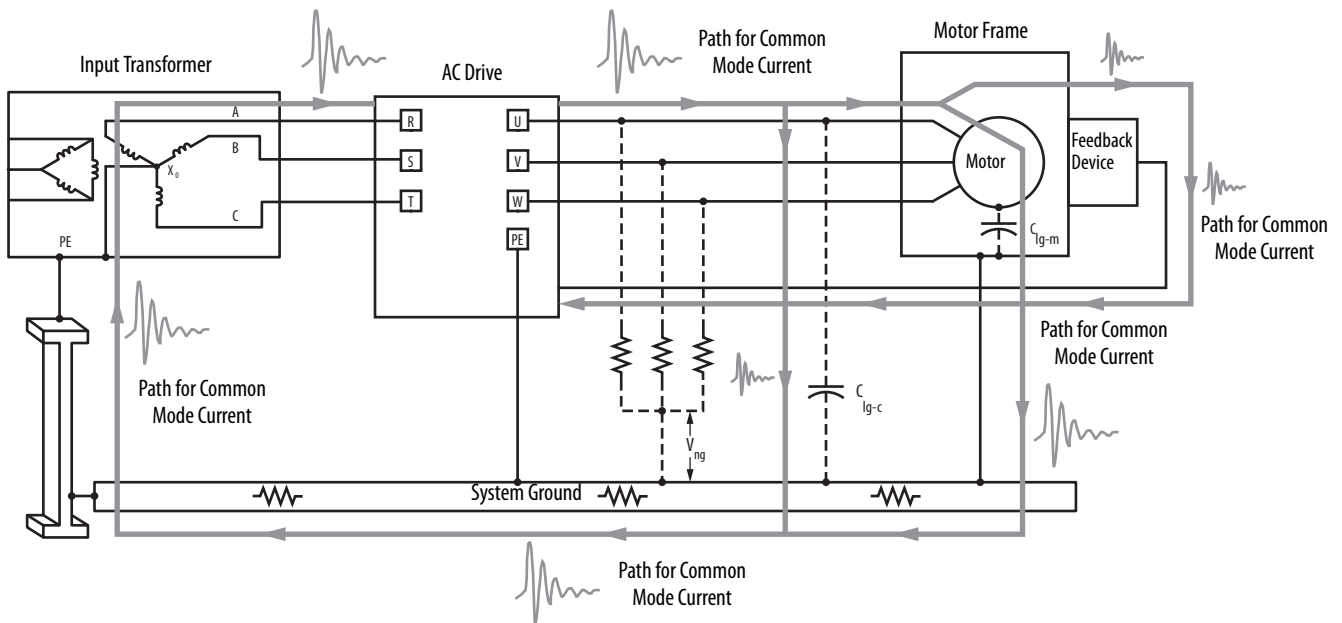

The grounding scheme can greatly affect the amount of noise and its impact on sensitive equipment. The power scheme is likely to be one of these three types:

- Ungrounded scheme
- Scheme with high-resistance ground
- Fully grounded scheme

An ungrounded scheme ([Figure 16](#)) does not provide a direct path for the common mode noise current, and causes the current to seek other uncontrolled paths. An ungrounded scheme causes related noise issues.

Figure 16 - Ungrounded Scheme

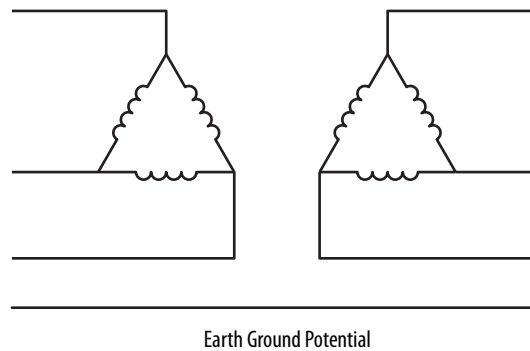

A scheme with a high-resistance ground ([Figure 17](#)) provides a direct path for common mode noise current, like a fully grounded scheme. Designers that want to minimize ground fault currents commonly choose high-resistance ground schemes.

Figure 17 - Scheme with High-Resistance Ground

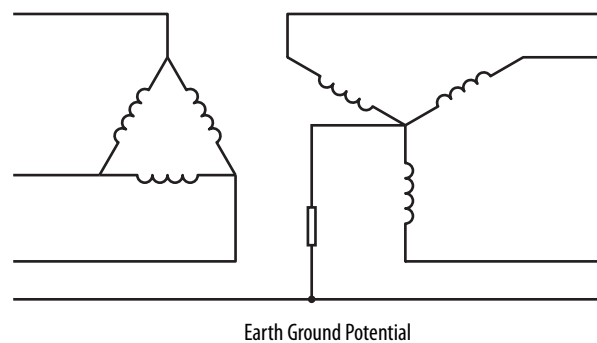

A fully grounded scheme ([Figure 18](#)) provides a direct path for common mode noise currents. The use of grounded neutral systems is recommended for these reasons:

- Controlled path for common mode noise current.
- Consistent line-to-ground voltage reference that minimizes insulation stress.
- Accommodation for system surge protection schemes.

Figure 18 - Fully Grounded Scheme

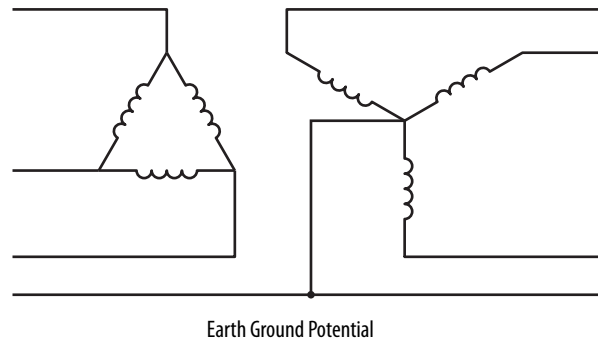

The installation and grounding practices to reduce common mode noise issues can be categorized into three ratings. The scheme that is used must consider additional costs against the operating integrity of all scheme components. If no sensitive equipment is present and noise is not an issue, the added cost of shielded cable and other components is not always justified.

Acceptable Grounding Practices

The scheme that is shown here is an acceptable ground layout for one drive installation. However, conduit does not offer the lowest impedance path for any high frequency noise. If the conduit is mounted so that it contacts the structural steel of a building, it is likely that the structural steel offers a lower impedance path and causes noise to inhabit the ground grid.

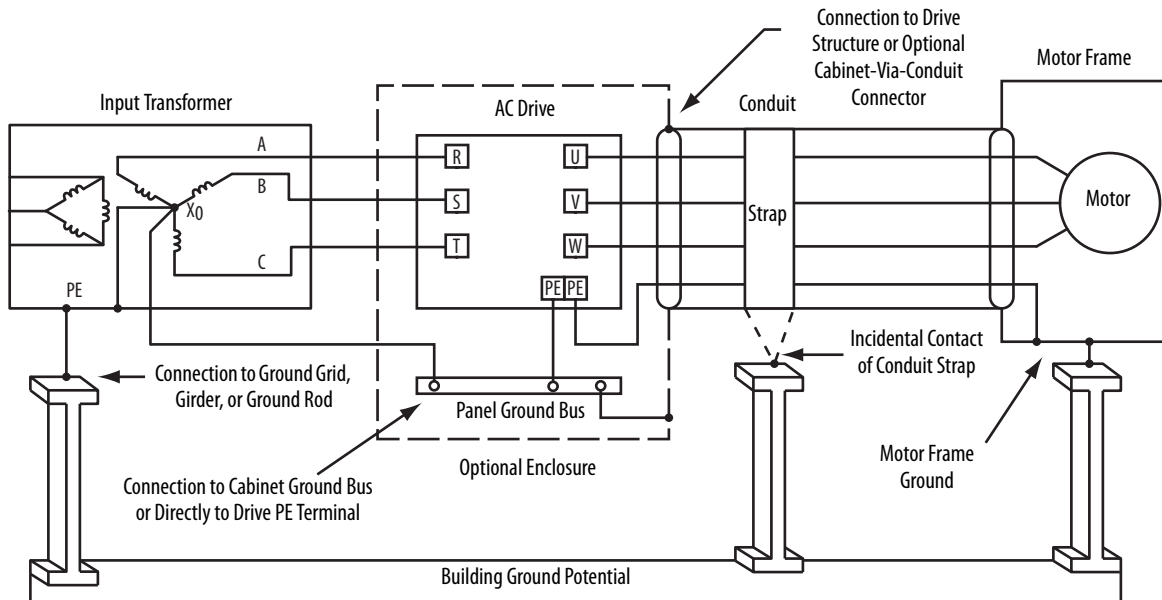

Effective Grounding Practices

This scheme replaces the conduit with shielded or armored cable that has a PVC exterior jacket. This PVC jacket helps prevent accidental contact with structural steel of a building and reduces the possibility that noise can enter the ground grid.

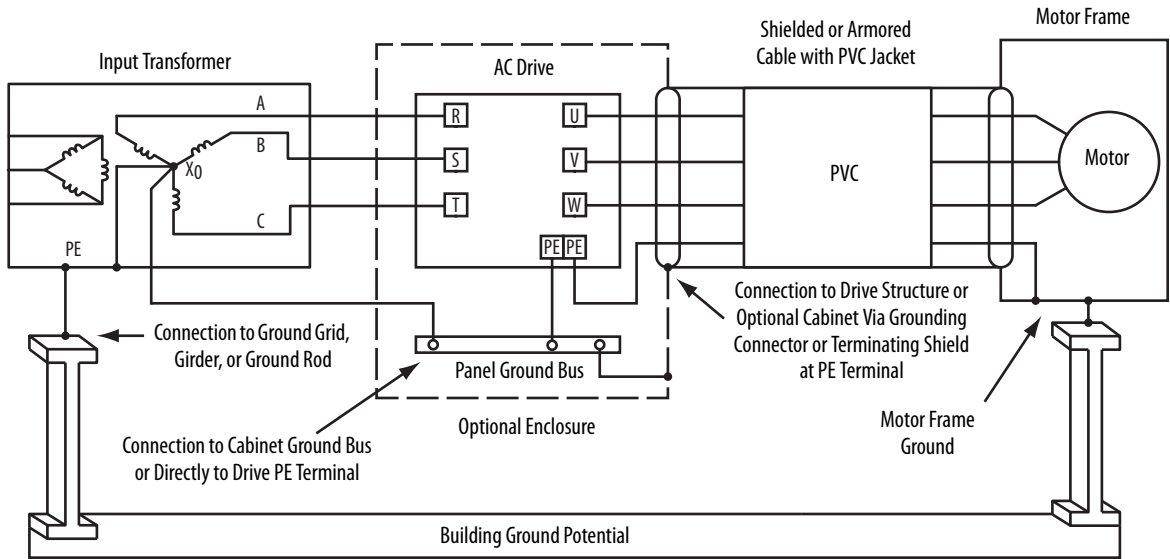

Optimal – Recommended Grounding Practices

The fully grounded scheme provides the best containment of common mode noise. It uses PVC jacketed, shielded cable on both the input and the output to the drive. This method also provides a contained noise path to the transformer to keep the ground grid as clean as possible.

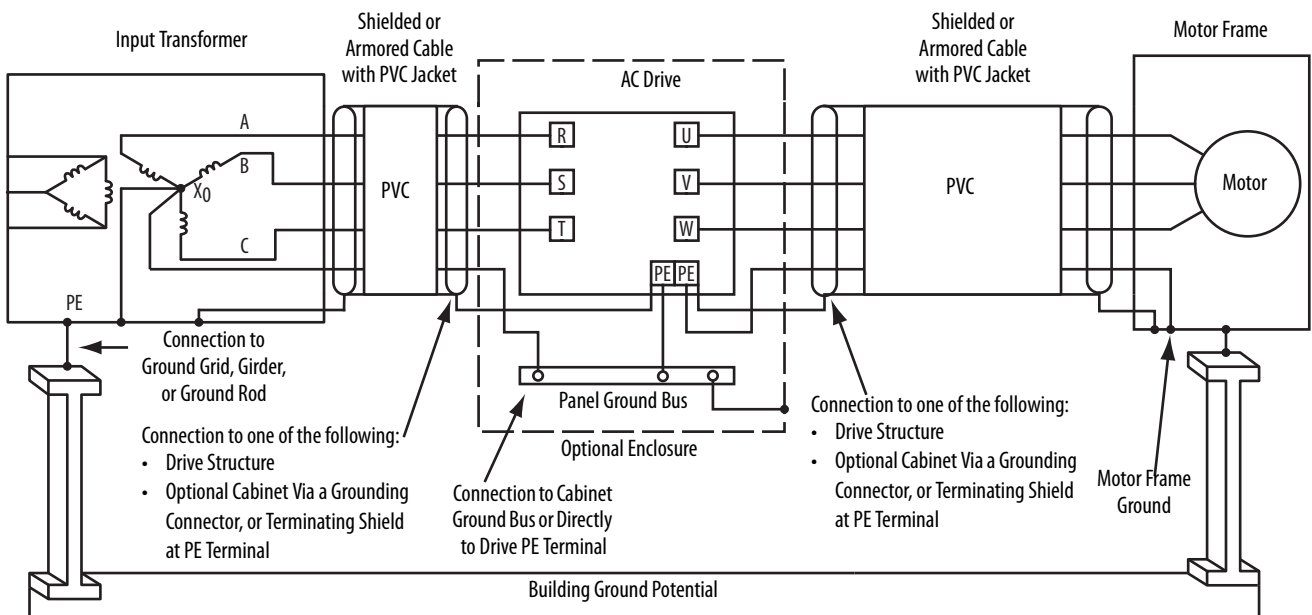

Cable Shields

Motor and Input Cables

Shields of motor and input cables must be bonded at both ends to provide a continuous path for common mode noise current.

Control and Signal Cables

Connect the shields of control cables only at one end. Cut back and insulate the other end. Follow these guidelines when you connect shields:

- The shield for a cable from one cabinet to another must be connected at the cabinet that contains the signal source.
- The shield for a cable from a cabinet to an external device must be connected at the cabinet end, unless specified by the manufacturer of the external device.

IMPORTANT Never connect a shield to the common side of a logic circuit (doing so introduces noise into the logic circuit).
Connect the shield directly to a chassis ground.

Shield Splicing

Figure 19 - Spliced Cable That Uses a Shielded Connector

If the shielded cable must be stripped, strip it back as little as possible so the continuity of the shield is not interrupted. If possible, do not splice motor power cables. Run the motor cables continuously between the drive and motor terminals. The most common reason for interrupted cable/shield is to install a disconnect switch at the motor. In these cases, the preferred method of splicing is to use fully shielded bulkhead connectors.

Single Point – Connect one safety ground point or ground bus bar directly to the structural steel of a building for cabinet installations. Ground all circuits, including the AC input ground conductor, independently and directly to this point/bar.

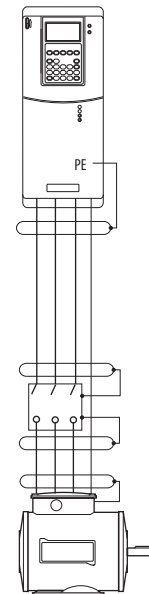

Isolated Inputs

If the analog inputs of the drive are from isolated devices and the output signal is not referenced to the ground, the inputs of the drive do not need to be isolated. An isolated input is recommended to reduce the possibility of induced noise if the signal from the transducer is referenced to ground and the ground potentials are varied (see [Noise Related Grounds on page 57](#)). An external isolator can be installed if the drive does not provide input isolation.

Notes:

Best Practices

This chapter discusses installation practices.

Mounting

Standard Installations

There are many criteria to determine the appropriate enclosure. Some criteria include these items:

- Environment
- EMC compatibility/compliance
- Available space
- Access/Wiring
- Safety guidelines

Grounding to the Component Mounting Panel

In the example below, the drive chassis ground plane is extended to the mounting panel. The panel is made of zinc-plated steel that helps to create a proper bond between chassis and panel.

Figure 20 - Drive Chassis Ground Plane Extended to the Panel

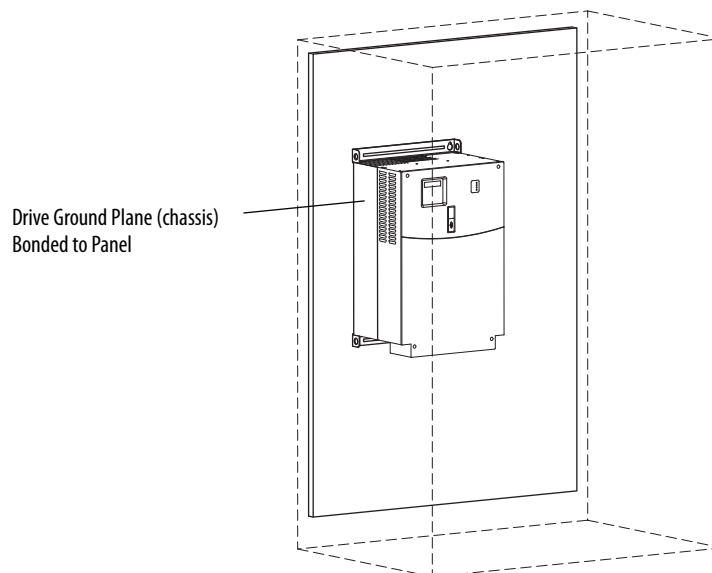

IMPORTANT Where TE and PE terminals are provided, ground each separately to the nearest point on the panel with flat braid.

In an industrial control cabinet, the equivalent to the copper ground layer of a printed circuit board (PCB) is the mounting panel. A panel made of zinc-plated, mild steel functions well as a ground plane. If painted, remove the paint at each mounting and grounding point.

Zinc-plated steel is recommended for its ability to bond with the drive chassis and resist corrosion. Painted panels are not recommended; it can be difficult to remove the paint, and verify that the paint has been properly removed. Also, future corrosion of the unprotected mild steel can compromise noise performance.

Plain stainless steel panels are also acceptable but are inferior to zinc-plated mild steel due to their higher ohms-per-square resistance.

Though not always applicable, a plated cabinet frame is also desirable because it makes a high frequency bond between panel and cabinet sections more reliable.

Doors

For doors 2 m (78 in.) in height, ground the door to the cabinet with two or three braided straps.

EMC seals are not normally required for industrial systems.

EMC Specific Installations

A steel enclosure is recommended to help guard against radiated noise to meet EMC standards. If the enclosure door has a viewing window, a laminated screen or a conductive optical substrate can block EMC.

Do not rely on the hinge for electrical contact between the door and the enclosure. Install a grounding wire. For doors 2 m (78 in.) in height, use two or three braided grounding straps between the door and the cabinet. EMC gaskets are not normally required for industrial systems.

Layout

Plan the cabinet layout so that drives are separated from sensitive equipment. Choose conduit entry points that allow any common mode noise to remain away from programmable logic controllers (PLCs) and other equipment that can be susceptible to noise. See [Moisture on page 79](#) for additional information.

Hardware

You can mount the drive and/or mounting panel with either bolts or welded studs.

Figure 21 - Stud Mounting of Ground Bus or Chassis to Back Panel

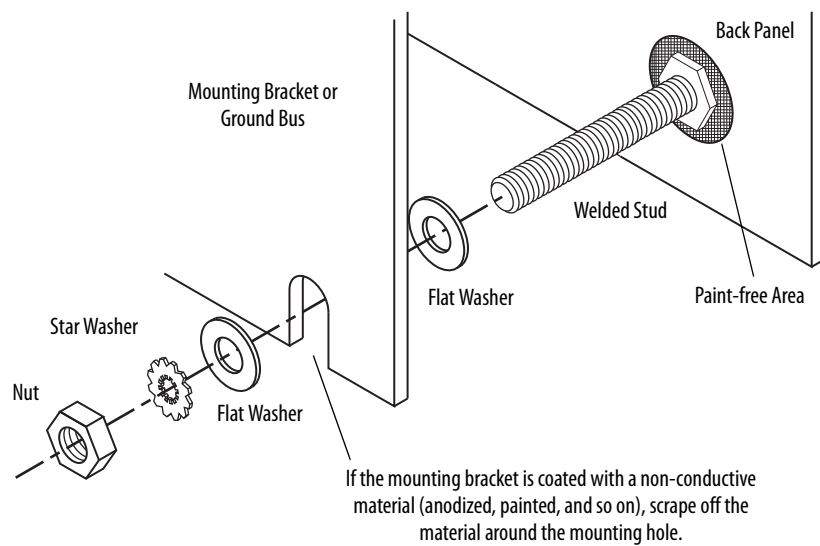
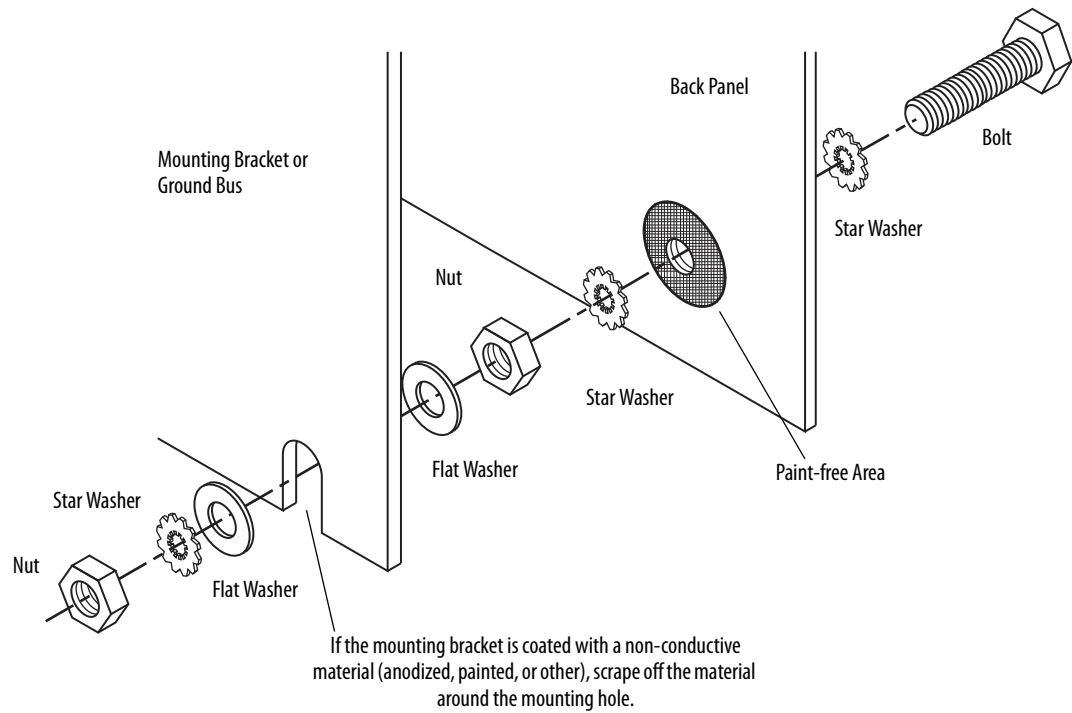

Figure 22 - Bolt Mounting of Ground Bus or Chassis to Back Panel



If the drive chassis does not lay flat before the nuts/bolts are tightened, use additional washers as shims so that the chassis does not bend when you tighten the nuts.

Conduit Entry

Entry Plates

In most cases, the conduit entry plate is a conductive material that is not painted. Make sure that the surface of the plate is clean of oil or contaminants. If the plate is painted, follow one of these steps to make a good connection:

- Use a connector that cuts through the paint and makes a high-quality connection to the plate material.
- Remove the paint around the holes down to the bare metal 1 inch in from the edge of the plate. Grind down the paint on the top and bottom surfaces. Use a high-quality joint compound when reassembling to help prevent corrosion.

Cable Connectors/Glands

Choose cable connectors or glands that offer the best cable protection, shield termination, and ground contact. See [Shield Termination on page 75](#) for more information.

Shield Terminating Connectors

The cable connector must provide 360° contact and low transfer impedance from the shield or armor of the cable to the conduit entry plate at both the motor and the drive (or drive cabinet) for electrical bonding. SKINTOP MS-SC/MS-SCL cable grounding connectors and NPT/PG adapters from LAPPUSA are good examples of this type of shield terminating glands.

Figure 23 - Terminating the Shield with a Connector

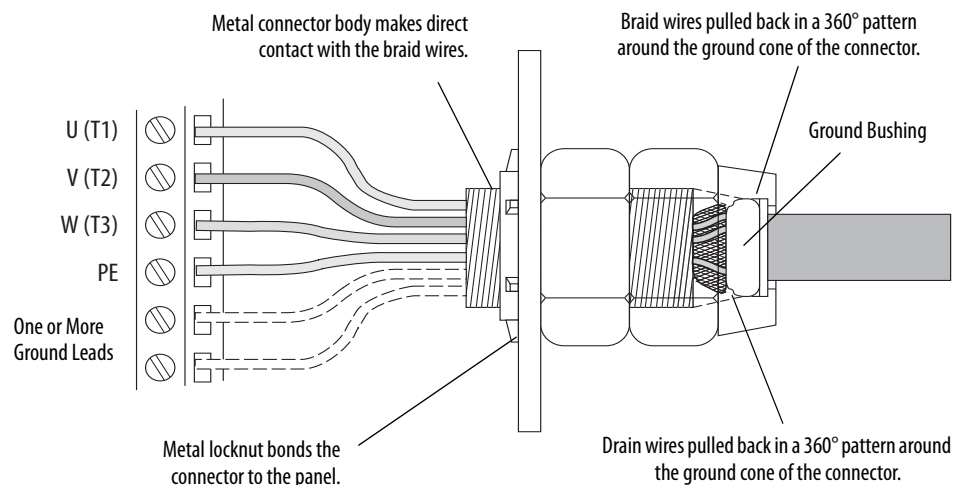

IMPORTANT Shield via connector termination is mandatory for CE-compliant installations, to meet requirements for containing radiated electromagnetic emissions.

Shield Termination Via Pigtail (lead)

If a shield terminating connector is not available, the ground conductors or shields must be terminated to the appropriate ground terminal. If necessary, use a compression fitting for ground conductors and/or shields together as they leave the cable fitting.

Figure 24 - Terminating the Shield with a Pigtail Lead

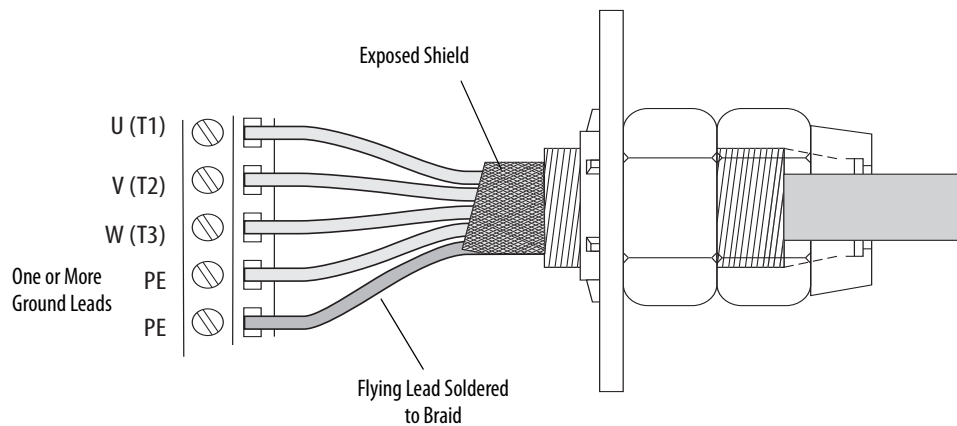

IMPORTANT Shield via pigtail termination is an acceptable industry practice for most installations to minimize stray common mode currents.

Pigtail termination is the least effective method of noise containment, and is not recommended for these conditions:

- If the cable length is greater than 1 m (3.2 ft) or extends beyond the panel
- If used in noisy areas
- If the cables are for noise-sensitive signals (for example, registration or encoder cables)
- If strain relief is required

If a pigtail is used, pull and twist the exposed shield after separation from the conductors. Solder a flying lead to the braid to extend its length.

Ground Connections

Make sure that ground conductors are properly connected to assure safe and adequate connections.

For individual ground connections, use star washers and ring lugs to make connections to mounting plates or other flat surfaces that do not provide proper compression lugs.

If a ground bus system is used in a cabinet, follow the bus bar mounting diagrams.

Figure 25 - Connections to Ground Bus

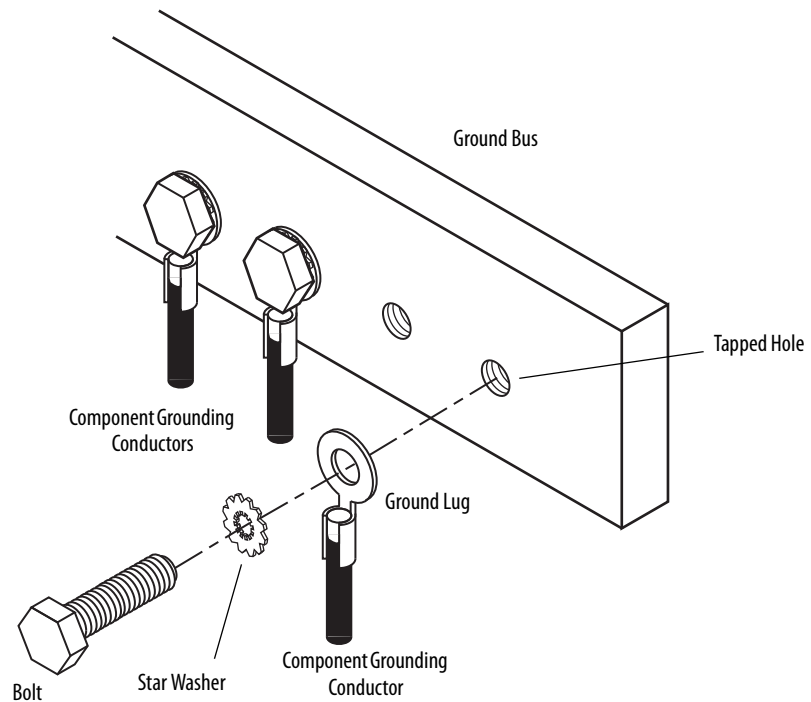
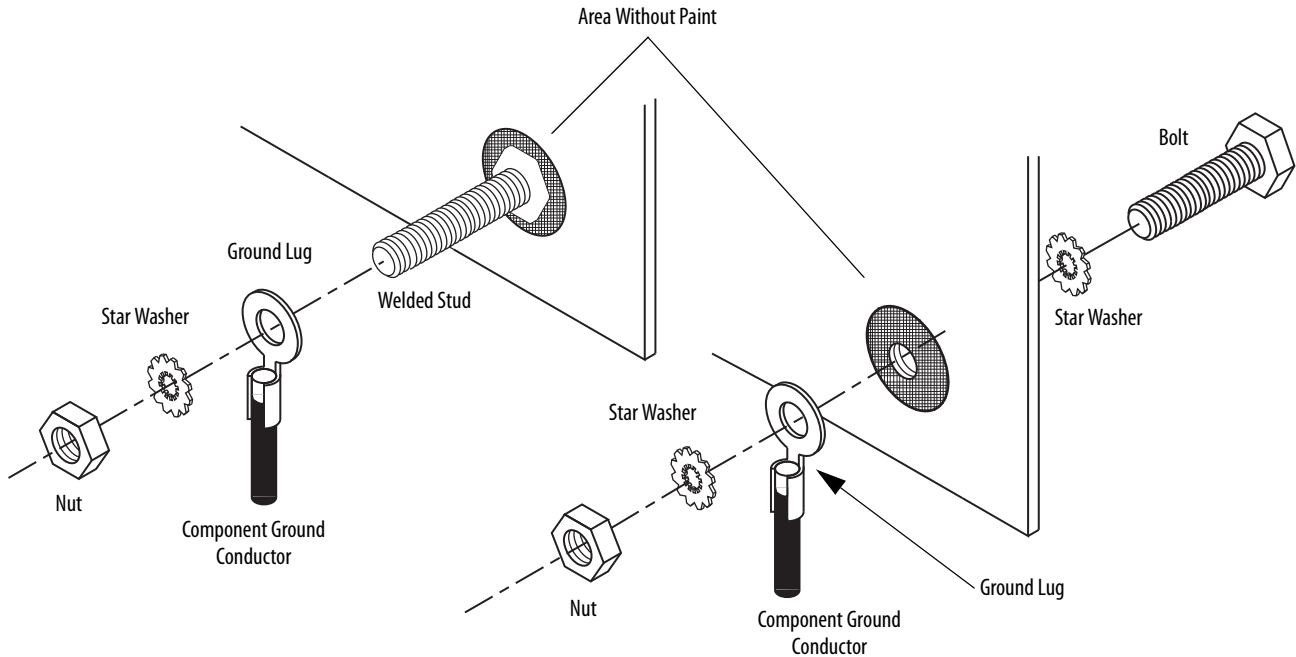
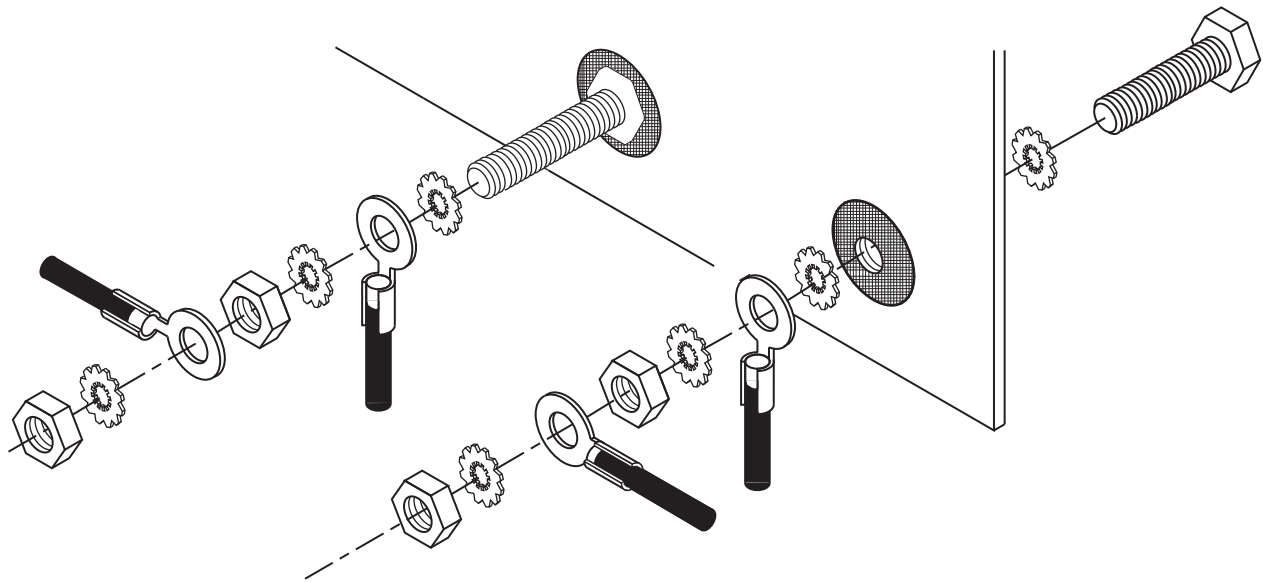

Figure 26 - Ground Connections to Enclosure Wall



Do not lay one ground lug directly on top of the other. This type of connection can become loose due to compression of the metal lugs. Sandwich the first lug between a star washer and a nut with another star washer following. After tightening the nut, sandwich the second lug between the first nut and a second nut with a captive star washer.

Figure 27 - Multiple Connections to Ground Stud or Bolts



Wire Routing

General

When routing wiring to a drive, separate high-voltage power and motor leads from I/O and signal leads. To maintain separate routes, route these wires in separate conduit or use tray dividers.

| Category | Wiring Level | Signal Definition | Signal Examples | Minimum Spacing (in inches) between Levels in Steel Conduits (cable trays) | | | | | Spacing Notes on page 70 |
|------------------|--------------|---|---|--|--------|-------|--------|------------------------------------|---|
| | | | | 1 | 2/3/4 | 5/6 | 7/8 | 9/10/11 | |
| Power | 1 | AC power (600V or greater) | 2.3 kV 3-phase AC lines | 0 | 3 (9) | 3 (9) | 3 (18) | See spacing note 6 | See spacing notes 1 , 2 , and 5 |
| | 2 | AC power (less than 600V) | 460V 3-phase AC lines | 3 (9) | 0 | 3 (6) | 3 (12) | See spacing note 6 | See spacing notes 1 , 2 , and 5 |
| | 3 | AC power | AC motor | | | | | | |
| | 4 | Dynamic brake cables | See spacing note 7 | | | | | | |
| Control | 5 | 115V AC/DC logic | Relay logic/PLC I/O motor thermostat | 3 (9) | 3 (6) | 0 | 3 (9) | See spacing note 6 | See spacing notes 1 , 2 , and 5 |
| | | 115V AC power | Power supplies, instruments | | | | | | |
| | 6 | 24V AC/DC logic | PLC I/O | | | | | | |
| Signal (process) | 7 | Analog signals, DC supplies | Reference/Feedback signal, 5...24V DC | 3 (18) | 3 (12) | 3 (9) | 0 | 1 (3) | See spacing notes 2 , 3 , 4 , and 5 |
| | | Digital (low speed) | TTK | | | | | | |
| | 8 | Digital (high speed) | I/O, encoder, counter-pulse tach | | | | | | |
| Signal (comm) | 9 | Serial communication | RS-232, 422 to terminals/printers | See spacing note 6 | | | 1 (3) | 0 | |
| | 11 | Serial communication (greater than 20k total) | ControlNet, DeviceNet, remote I/O, Data Highway | | | | | | |

EXAMPLE Spacing relationship between 480V AC incoming power leads and 24V DC logic leads:

- 480V AC leads are Level 2; 24V AC leads are Level 6.
- For separate steel conduits, the conduits must be 76 mm (3 in.) apart.
- In a cable tray, the two groups of leads must be 152 mm (6 in.) apart.

Spacing Notes

1. Both outgoing and return current-carrying conductors are pulled in the same conduit or laid adjacent in tray.
2. These cable levels can be grouped:
 - a. Level 1: Equal to or above 601V.
 - b. Levels 2, 3, and 4 can have respective circuits pulled in the same conduit or layered in the same tray.
 - c. Levels 5 and 6 can have respective circuits pulled in the same conduit or layered in the same tray.

IMPORTANT The cable bundle must not exceed conditions of NEC 310.

- d. Levels 7 and 8 can have respective circuits pulled in the same conduit or layered in the same tray.

IMPORTANT Encoder cables that are run in a bundle can experience some EMI coupling. The circuit application dictates separate spacing.

- e. Levels 9, 10, and 11 can have respective circuits pulled in the same conduit or layered in the same tray.

IMPORTANT Communication cables that are run in a bundle can experience some amount of EMI coupling and corresponding communication faults. The application dictates separate spacing.

3. Level 7 through level 11 wires must be shielded per recommendations.
4. In cable trays, steel separators are advisable between the class groupings.
5. Conduit (if used) must be continuous and composed of magnetic steel.
6. This table lists the spacing of communication cables, levels 2...6.

| Conduit Spacing | Through Air Spacing |
|---|--|
| 115V = 25.4 mm (1 in.) | 115V = 50.8 mm (2 in.) |
| 230V = 38.1 mm (1.5 in.) | 230V = 101.6 mm (4 in.) |
| 460/575V = 76.2 mm (3 in.) | 460/575V = 203.2 mm (8 in.) |
| 575V = proportional to 152.4 mm (6 in.) per 1000V | 575V proportional to 304.8 mm (12 in.) per 1000V |

7. If multiple brake modules are required, the first module must be mounted within 3.0 m (10 ft) of the drive. Each remaining brake module can be a maximum distance of 1.5 m (5 ft) from the previous module. Resistors must be within 30 m (100 ft) of the chopper module.

Within a Cabinet

When multiple equipment is mounted in a common enclosure, group the input and output conduit/armor to one side of the cabinet as shown in [Figure 28](#). Separate any PLC or other susceptible equipment cabling to the opposite side of the enclosure to minimize the effects of drive-induced noise currents.

Figure 28 - Separating Susceptible Circuits

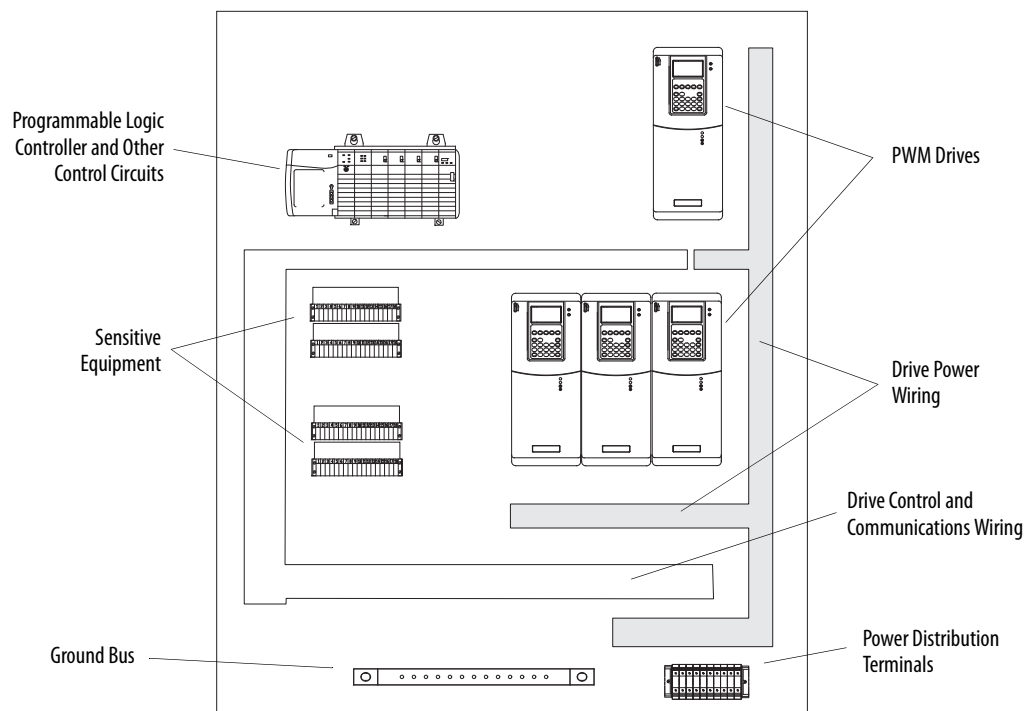

Common mode noise current returning on the output conduit, shielding, or armor can flow into the cabinet bond and most likely exit through the adjacent input conduit/armor bond near the cabinet top, well away from sensitive equipment (such as the PLC). Common mode current on the return ground wire from the motor flows to the copper PE bus and up the input PE ground wire, also away from sensitive equipment (See [Proper Cabinet Ground - Drives and Susceptible Equipment on page 72](#)).

If a cabinet PE ground wire is used, connect the wire from the same side of the cabinet as the conduit/armor connections. This connection keeps the common mode noise shunted away from the PLC backplane.

Figure 29 - Proper Cabinet Ground - Drives and Susceptible Equipment

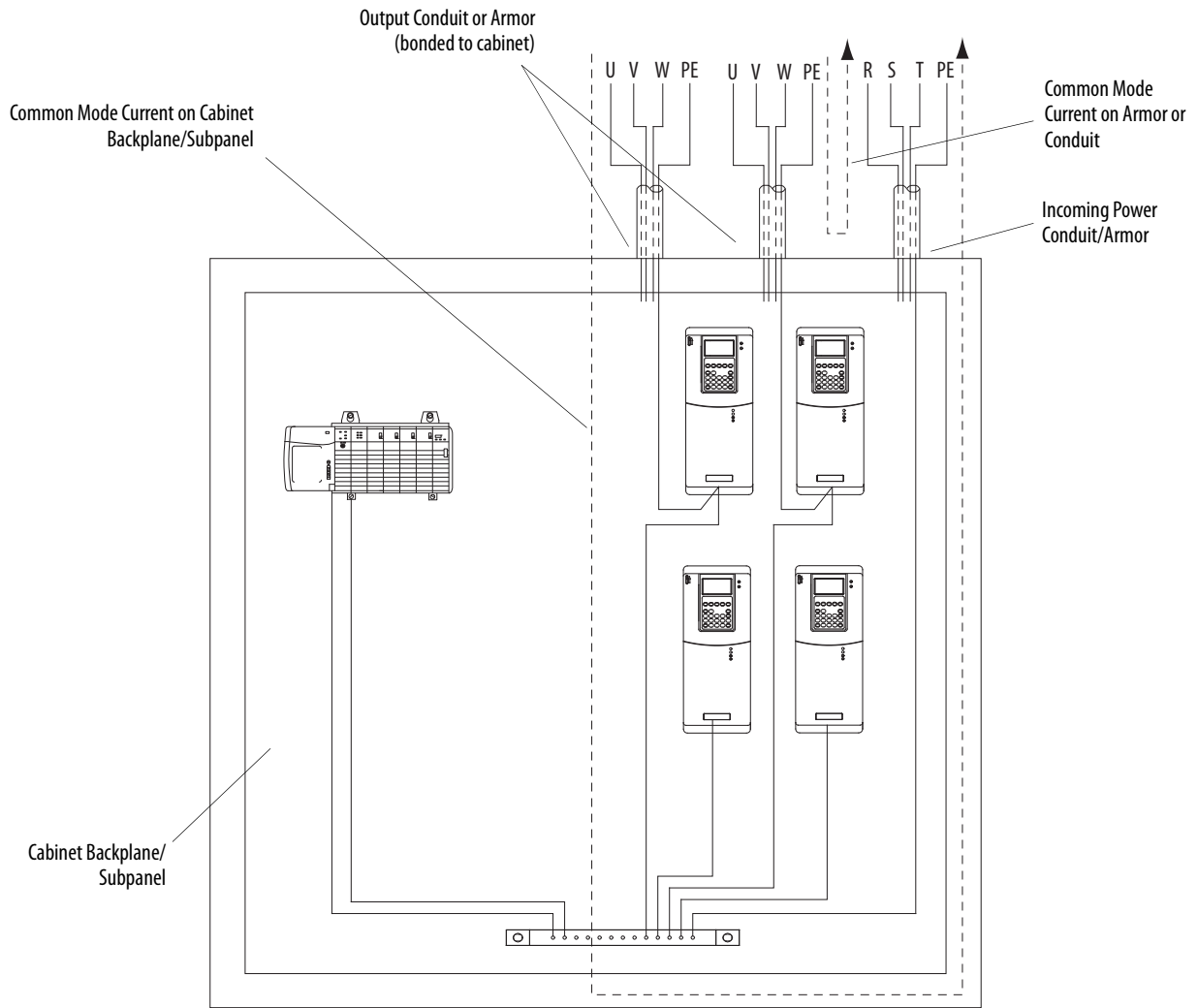

Within Conduit

Do not route more than three sets of motor leads (three drives) in the same conduit. Maintain fill rates per applicable electrical codes.

If possible, avoid running incoming power leads and motor leads in the same conduit for long runs.

IMPORTANT Do not run power or motor cables with control or communications cables in the same conduit.

Loops, Antennas, and Noise

When routing signal or communication wires, do not use routes that produce loops. Wires that form a loop can form an efficient antenna. Antennas work well in both receive and transmit modes, and these loops can be responsible for noise received into the system and noise radiated from the system. Run feed and return wires together rather than form a loop. Twist the pair together to reduce the antenna effects (see [Figure 30](#)).

Figure 30 - Avoid Loops in Wiring

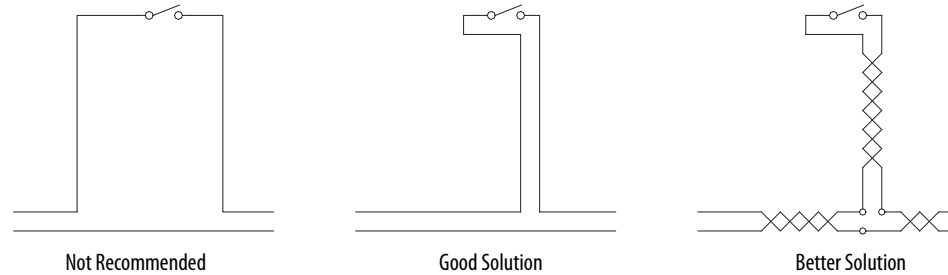

Conduit

Magnetic steel conduit is preferred. This type of conduit provides excellent magnetic shielding. However, not all applications allow the use of magnetic steel conduit. Stainless steel or PVC can be required. Conduit other than magnetic steel does not provide the same level of shielding for magnetic fields induced by the motor and input power currents.

Install the conduit so it provides a continuous electrical path through the conduit itself. This path can become important in the containment of high frequency noise.

Pull the wire gently and carefully through the conduit. Do not nick the wire insulation when pulling the wires through the conduit. Insulation damage can occur when nylon coated wiring, such as thermoplastic high heat-resistant nylon-coated (THHN) or thermoplastic heat and water-resistant nylon-coated (THWN), is pulled through conduit, particularly 90° bends. Nicking can significantly reduce or remove the insulation. Do not use water-based lubricants with nylon coated wire such as THHN.

Do not route more than three sets of motor cables in one conduit. Maintain the proper fill rates per the applicable electrical codes.

Do not rely on the conduit as the ground return for a short circuit. Route a separate ground wire inside the conduit with the motor or input power wires.

Cable Trays

When laying cable in cable trays, do not randomly distribute them. Bundle the power cables for each drive together and anchored them to the tray. Keep a minimum separation of one cable width between bundles to reduce overheating and cross-coupling. Current flowing in one set of cables can induce a hazardous voltage and/or excessive noise on the cable set of another drive, even when no power is applied to the second drive.

Figure 31 - Recommended Cable Tray Practices

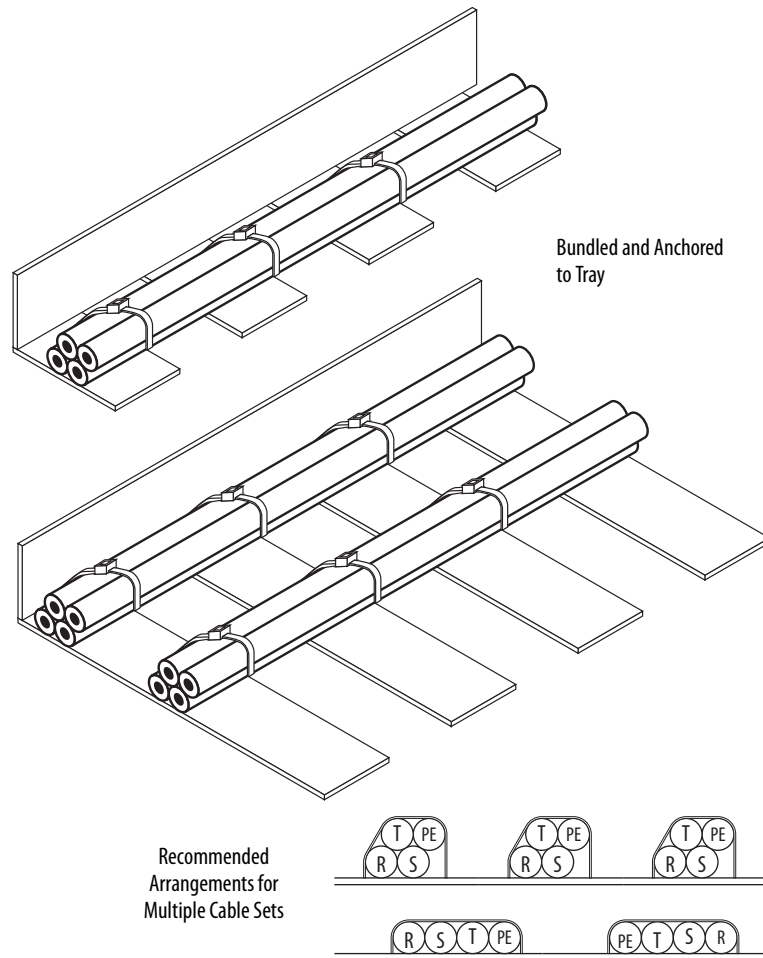

IMPORTANT Carefully arrange the geometry of multiple cable sets. Keep conductors within each group bundled. Arrange the order of the conductors to minimize the current that is induced between sets and to balance the currents. This arrangement of cable sets is critical on drives with power ratings of 200 Hp (150 kW) and higher.

Maintain separation between power and control cables. For large drives, make sure that the cable tray or conduit that contains the signal wiring is separated from the conduit or trays that contain power or motor wiring by 1 m (3.2 ft) or more.

Electromagnetic fields from power or motor currents can induce currents in the signal cables. Dividers also provide excellent separation.

Parallel Motor Cable Runs

Where there are multiple cables running between the drive and motor, be sure to allow for all three phases in each cable.

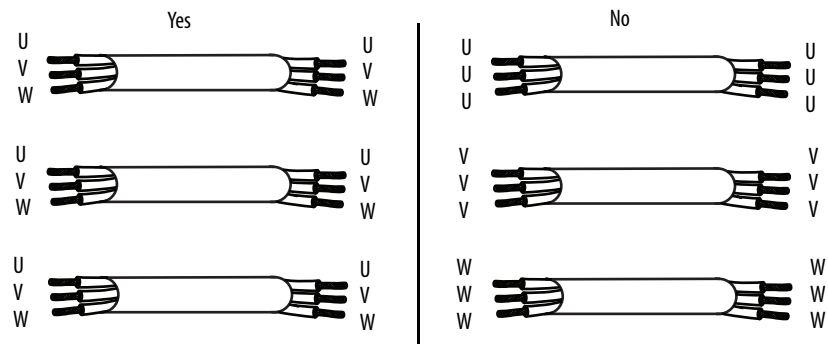

If running individual wires, combine the wires so that U, V, and W are grouped. Failure to group U, V, and W can result in hot spots in the cable.

Shield Termination

See [Shield Splicing on page 61](#) to splice shielded cables. These methods are acceptable if the gland or connector does not make the shield connection to the ground. See the table associated with each type of clamp for advantages and disadvantages.

Termination Via Circular Clamp

Use the circular section method to clamp the cable to the main panel closest to the shield terminal. The preferred method for grounding cable shields is clamping the circular section of 360° bonding (see [Figure 32](#)). This method has the advantage of covering a wide variety of cable diameters and drilling/mounting is not required. The disadvantages are cost and availability in all areas.

Figure 32 - Commercial Cable Clamp (heavy duty)

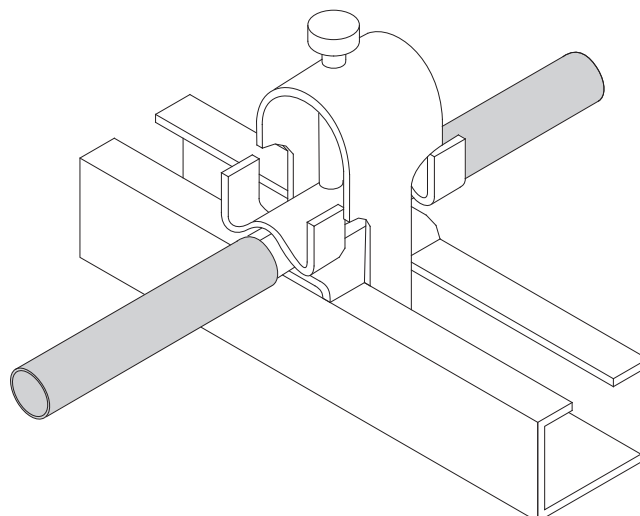

Plain copper saddle clamps (see [Figure 33](#)) are sold in many areas for plumbing purposes, and are effective and available in a range of sizes. They are low cost and offer good strain relief as well. You must drill mounting holes to use them.

Figure 33 - Plain Copper Saddle Clamp

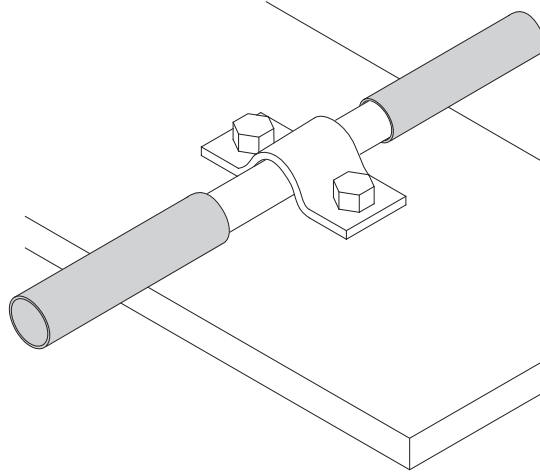

Shield Termination Via Pigtail (lead)

If a shield terminating connector is not available, the ground conductors and/or shields must be terminated to the appropriate ground terminal. If necessary, use a compression fitting on the ground conductors, or shield together as they leave the cable fitting.

IMPORTANT Pigtail termination is the least effective method of noise containment.

Pigtail termination is not recommended for these conditions:

- When the cable length is greater than 1 m (3.2 ft), or extends beyond the panel
- When used in noisy areas
- When the cables are for noise sensitive signals (for example, registration or encoder cables)
- When strain relief is required

If a pigtail is used, pull and twist the exposed shield after separation from the conductors. To extend the length, solder a flying lead to the braid.

Shield Termination Via Cable Clamp

Standard Cable

Grounding cable glands are a simple and effective method for terminating shields while offering excellent strain relief. They are applicable only when entry is through a cabinet surface or bulkhead.

The cable connector must provide 360° contact and low transfer impedance from the shield or armor of the cable to the conduit entry plate at both the motor and the drive (or drive cabinet) for electrical bonding.

SKINTOP MS-SC/MS-SCL cable grounding connectors and NPT/PG adapters from LAPPUSA are good examples of standard cable clamp-shield terminating gland.

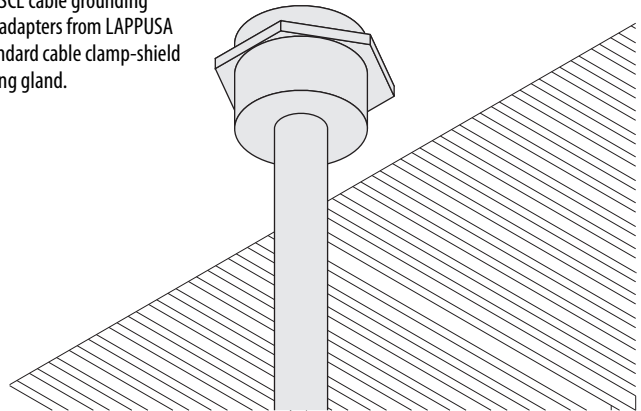

Armored Cable

Armored cable can be terminated in a similar manner to standard cable.

The Tek-Mate Fast-Fit cable clamp by O-Z/Gedney is a good example of an armored cable terminator.

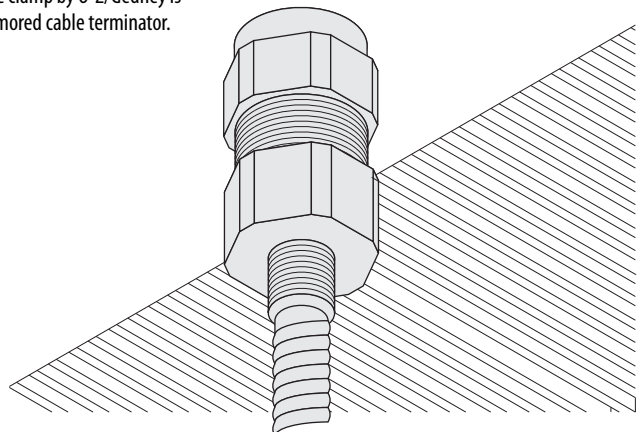

Conductor Termination

Terminate power, motor, and control connections to the drive terminal blocks. User manuals list minimum and maximum wire gauges, tightening torque for terminals, and recommended lug types if stud connections are provided. Use a connector with three ground bushings when you use a cable with three ground conductors. Follow applicable electric codes when bending radii minimums.

Power TB

Power terminals are normally fixed (non-pull apart) and can be cage clamps, barrier strips, or studs for ring-type crimp lugs depending on the drive style and rating. Cage clamp styles can require a non-standard screwdriver. Crimp lugs require a crimping tool. On smaller sizes, a stripping gauge is sometimes provided on the drive to help with the amount of insulation to remove. Normally the three-phase input is not phase sensitive. That is, the sequence of the A, B, and C phases has no effect on the operation of the drive or the direction of motor rotation.

Control TB

Control terminal blocks are either pull-apart or fixed (non-pull apart). Terminals are either spring clamp type or barrier strip. A stripping gauge is sometimes provided on the drive to help with the amount of insulation to remove. Some control connections, such as analog input and output signals, are sensitive to polarity. Consult the applicable user manual for correct connection.

Signal TB

If an encoder or tachometer feedback is used, a separate terminal block or blocks is sometimes provided.

IMPORTANT Consult the user manual for these phase-sensitive connections. Improper wiring can lead to incorrect drive operation.

Cables that are terminated here are typically shielded and the signals being carried are more sensitive to noise. Carefully check the user manual for recommendations on shield termination. Some shields can be terminated at the terminal block, and other shields are terminated at the entry point.

Moisture

See NEC Article 100 for definitions of damp, dry, and wet locations. The U.S. NEC permits the use of heat-resistant thermoplastic wire in both dry and damp applications (Table 310-13). However, PVC insulation material is more susceptible to absorbing moisture than XLPE insulation material (XHHW-2) identified for use in wet locations. Because the PVC insulating material absorbs moisture, the corona inception voltage (CIV) insulation capability of the damp or wet THHN was found to be less than half of the same wire when dry. For this reason, certain industries where water is prevalent in the environment do not use THHN wire with IGBT drives.

Based on Rockwell Automation research, tests have determined that the cable type described here is better than loose wires in dry, damp, and wet applications and can significantly reduce capacitive coupling and common mode noise:

PVC jacketed, shielded type TC with XLPE conductor insulation designed to meet NEC code designation cross-linked polyethylene high heat-resistant water-resistant (XHHW-2) (use in wet locations per the U.S. NEC, Table 310-13).

Other cable types for wet locations include continuous welded armored cables or CLX-type cables.

Notes:

Reflected Wave

This chapter discusses the reflected wave phenomenon and its impact on drive systems.

Description

The inverter section of a drive does not produce sinusoidal voltage, but rather a series of voltage pulses created from the DC bus. These pulses travel down the motor cables to the motor. The pulses are then reflected back to the drive. The reflection is dependent on the rise time of the drive output voltage, cable characteristics, cable length, and motor impedance. If the voltage reflection is combined with another subsequent pulse, peak voltages can be at a destructive level. One IGBT drive output can have reflected wave transient voltage stresses of up to twice (2 pu, or per unit) the DC bus voltage between its own output wires. Multiple drive output wires in a conduit or wire tray increase output-wire voltage-stress between multi-drive output wires that are touching. One drive can have a (+) 2 pu stress, while another drive can simultaneously have a (-) 2 pu stress.

Effects On Wire Types

Wires with dielectric constants greater than 4 cause the voltage stress to shift to the air gap between the wires that are barely touching. This electric field can be high enough to ionize the air that surrounds the wire insulation and cause a partial discharge mechanism (corona) to occur. The electric field distribution between wires increases the possibility for corona and greater ozone production. This ozone attacks the PVC insulation and produces carbon tracking that leads to the possibility of insulation breakdown.

Based on field and internal testing, Rockwell Automation has determined conductors that are manufactured with poly-vinyl chloride (PVC) wire insulation are subject to various manufacturing inconsistencies. These inconsistencies can lead to premature insulation degradation when used with IGBT drives. Flame-retardant heat-resistant thermoplastic insulation is the type of insulation listed in the NEC code for the THHN wire designation. This type of insulation is commonly referred to as PVC. Also, the physical properties of the cable can change due to environment, installation, and operation that can lead to premature insulation degradation.

This section provides a summary of our findings:

- Due to inconsistencies in manufacturing processes or wire pulling, air voids can also occur in the THHN wire between the nylon jacket and PVC insulation. Because the dielectric constant of air is much lower than the dielectric constant of the insulating material, the transient reflected wave voltage can appear across these voids. If the corona inception voltage (CIV) for the air void is reached, ozone is produced. Ozone attacks the PVC insulation that can lead to a breakdown in cable insulation.
- Asymmetrical construction of the insulation has also been observed for some manufacturers of PVC wire. A wire with a 15 mil specification was observed to have an insulation thickness of 10 mil at some points. The smaller the insulation thickness, the less voltage the wire can withstand.
- THHN jacket material has a relatively brittle nylon that lends itself to damage (for example, nicks and cuts) when pulled through conduit on long wire runs. This issue is of even greater concern when the wire is being pulled through multiple 90° bends in the conduit. These nicks can be a starting point for CIV that can lead to insulation degradation.
- During operation, the conductor heats up and a cold-flow condition can occur with PVC insulation at points where the unsupported weight of the wire can stretch the insulation. This stretch has been observed at 90° bends where wire is dropped down to equipment from an above wireway. This cold-flow condition produces thin spots in the insulation that lowers the voltage withstand capability of the cable.
- See NEC Article 100 for definitions of damp, dry, and wet locations. The U.S. NEC permits the use of heat-resistant thermoplastic wire in both dry and damp applications (Table 310-13). However, PVC insulation material is more susceptible to absorbing moisture than XLPE insulation material (XHHN-2) identified for use in wet locations. Because the PVC insulating material absorbs moisture, the Corona Inception Voltage insulation capability of the damp or wet THHN was found to be less than half of the same wire when dry. For this reason, certain industries where water is prevalent in the environment do not use THHN wire with IGBT drives. Rockwell Automation strongly suggests the use of XLPE insulation for wet areas.

Length Restrictions for Motor Protection

To help protect the motor from reflected waves, limit the length of the motor cables from the drive to the motor. The user manual for each drive lists the lead length limitations based on drive size and the quality of the insulation system in the chosen motor.

If the distance between drive and motor must exceed these limits, contact the local office or factory for analysis and advice. See [Appendix A](#) for complete tables.

Electromagnetic Interference

This chapter discusses types of electromagnetic interference and its impact on drive systems.

What Causes Common Mode Noise

Faster output dV/dt transitions of IGBT drives increase the possibility for increased common mode (CM) electrical noise. Common mode noise is a type of electrical noise induced on signals regarding ground.

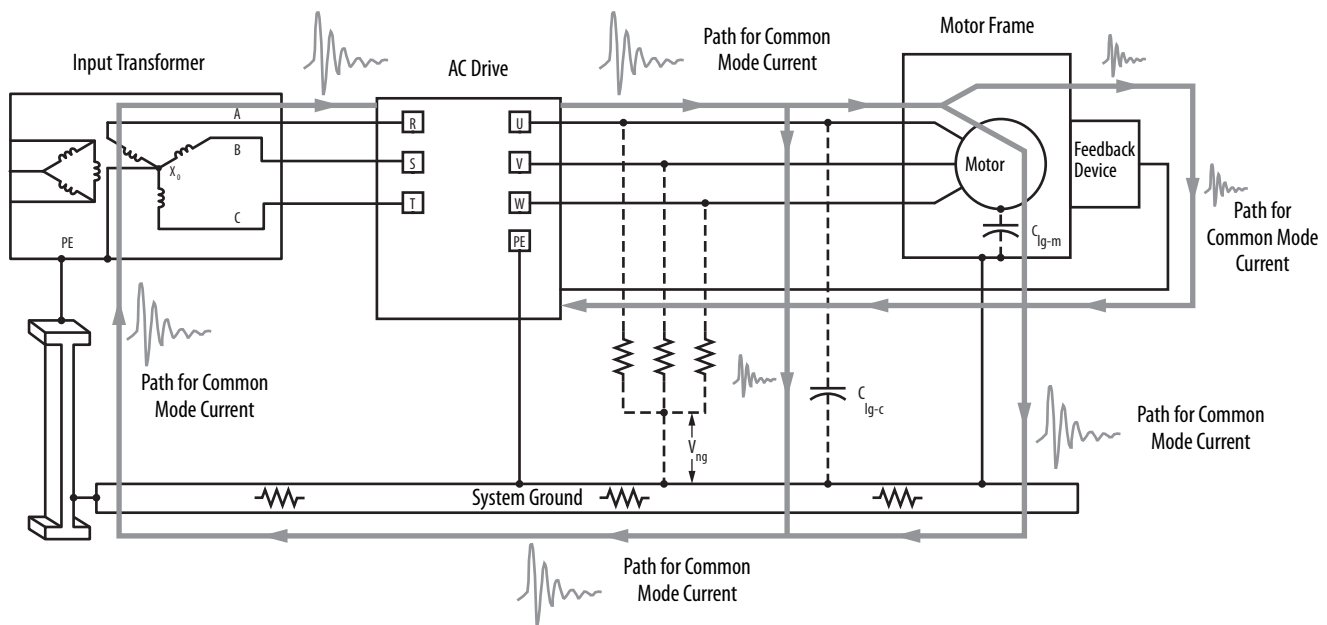

Electrical noise from drive operation can interfere with adjacent sensitive electronic equipment, especially in areas where many drives are concentrated. Generating common mode currents by varying frequency inverters is similar to the common mode currents that occur with DC drives. Although, AC drives produce a much higher frequency than DC drives (250 kHz...6 MHz).

Inverters have a greater potential for exciting circuit resonance because of fast turn on switches that cause common mode currents to look for the lowest impedance path back to the inverter. The dV/dt and di/dt from the circulating ground currents can couple into the signal and logic circuits and cause improper operation and possible circuit damage. When conventional grounding techniques do not work, you must use high frequency bonding techniques. If installers do not use these techniques, motor bearing currents increase and system circuit boards have the potential to fail prematurely.

Currents in the ground system can cause problems with computer systems and distributed control systems.

Containing Common Mode Noise With Cabling

The type of cable that is used can affect the ability to contain common mode noise in a system that incorporates a drive.

Conduit

The combination of a ground conductor and conduit contains most capacitive current and returns it to the drive without polluting the ground grid. A conduit can still have unintended contact with grid ground structure due to straps, support, and so on. The AC resistance characteristics of earth are variable and unpredictable and make it difficult to know how noise current is divided between wire, conduit, or the ground grid.

Shielded or Armored Power Cable

The predominant return path for common mode noise is the shield or armor itself when you use shielded or armored power cables. Unlike conduit, the shield or armor is isolated from accidental contact with grounds by a PVC outer coating. The coating makes most noise current flow in the controlled path and little high frequency noise flows into the ground grid.

Noise current returning on the shield or safety ground wire is routed to the drive PE terminal, down to the cabinet PE ground bus, and then directly to the grounded neutral of the drive source transformer. When bonding the armor or shield to the drive PE, use a low impedance cable or strap, as opposed to the smaller gauge ground wire supplied as part of the motor cable or supplied separately. Otherwise, the higher frequencies that are associated with the common mode noise can find this cable impedance higher and look for a lower impedance path. The radiated emissions of the cable are minimal because the armor completely covers the noisy power wires. Also, the armor helps prevent EMI coupling to other signal cables that are routed in the same cable tray.

Another effective method of reducing common mode noise is to attenuate the noise before it can reach the ground grid. Install a common mode ferrite core on the output cables to reduce the amplitude of the noise to a level that makes it relatively harmless to sensitive equipment or circuits. Common mode cores are most effective when multiple drives are in a relatively small area. For more information, see 1321-M Common Mode Chokes Instructions, publication [1321-5.0](#).

Follow these guidelines for installing common mode chokes:

- If the distance between the drive and motor, or the drive and input transformer, is greater than 22.8 m (75 ft), and
- If sensitive circuits with leads greater than 22.8 m (75 ft), such as encoders, analog or capacitive sensors, are routed in or out of the cabinet near the drive or transformer, then
- Install common mode chokes.

How Electromechanical Switches Cause Transient Interference

Electromechanical contacts cause transient interference when switching inductive loads such as relays, solenoids, motor starters, or motors. Drives, and other devices with electronic logic circuits, are susceptible to this type of interference.

Examine this circuit model for a switch controlling an inductive load. Both the load and the wiring have inductance that helps prevents the current from stopping instantly when the switch contacts open. There is also stray capacitance in the wiring.

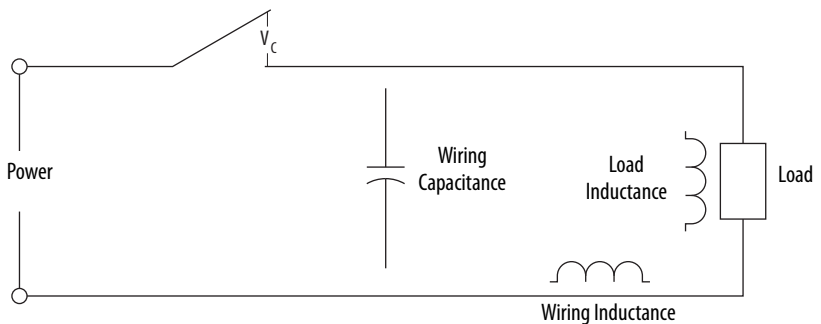

Interference occurs when the switch opens while it is carrying current. Load and cable inductance helps prevents the current from immediately stopping. The current continues to flow, and charges the capacitance in the circuit. The voltage across the switch contacts (V_c) rises, as the capacitance charges. This voltage can reach high levels. When the voltage exceeds the breakdown voltage for the space between the contacts, an arc occurs and the voltage returns to zero. Charging and arcing continues until the distance between the contacts is sufficient to provide insulation. The arcing radiates noise at energy levels and frequencies that disturb logic and communication circuits.

If the power source is periodic (like AC power), you can reduce the interference by opening the contact when the current waveform crosses zero. Opening the circuit farther from zero elevates the energy level and creates more interference.

How to Prevent or Mitigate Transient Interference from Electromechanical Switches

The most effective way to avoid this type of transient interference, is to use a device like an Allen-Bradley® Bulletin 156 contactor to switch inductive AC loads. These devices feature zero cross switching.

Figure 34 - Mitigate Transient Interference with a Contactor

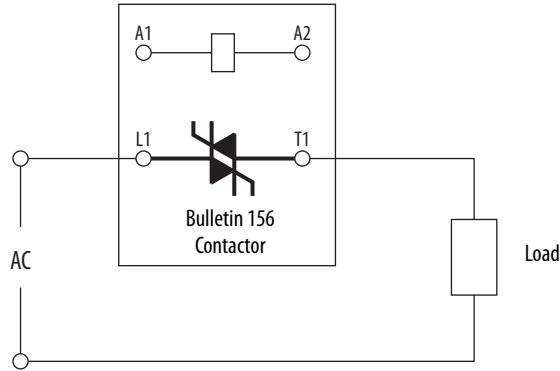

You can put resistor-capacitor (RC) networks or voltage-dependant resistors (varistors) across contacts to mitigate transient interference. Be sure to select components that are rated to withstand the voltage, power, and frequency of switching for your application.

Figure 35 - Mitigate Transient Interference with a Resistor-capacitor or Varistor

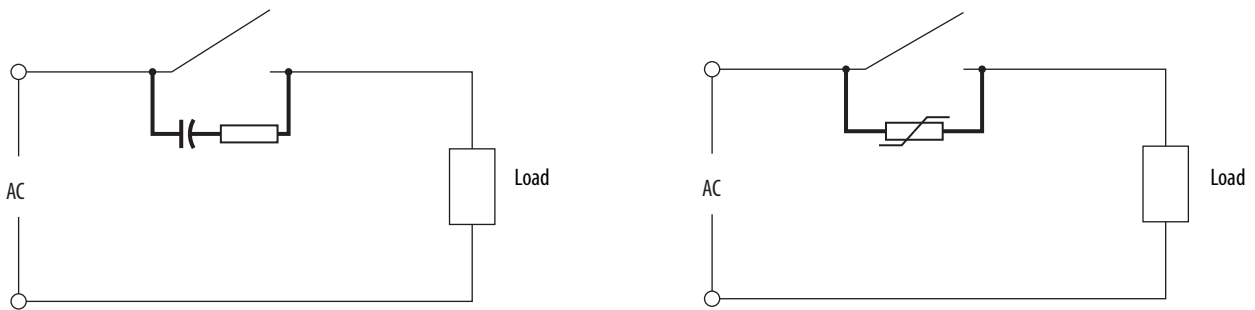

A common method for mitigating transient interference is to put a diode in parallel with an inductive DC load, or a suppressor in parallel with an inductive AC load. Be sure to select components that are rated to withstand the voltage, power, and frequency of switching for your application.

IMPORTANT These methods are not effective at stopping transient interference, because they do not entirely eliminate arcing at the contacts.

Figure 36 - Mitigate Transient Interference with a Diode or Suppressor

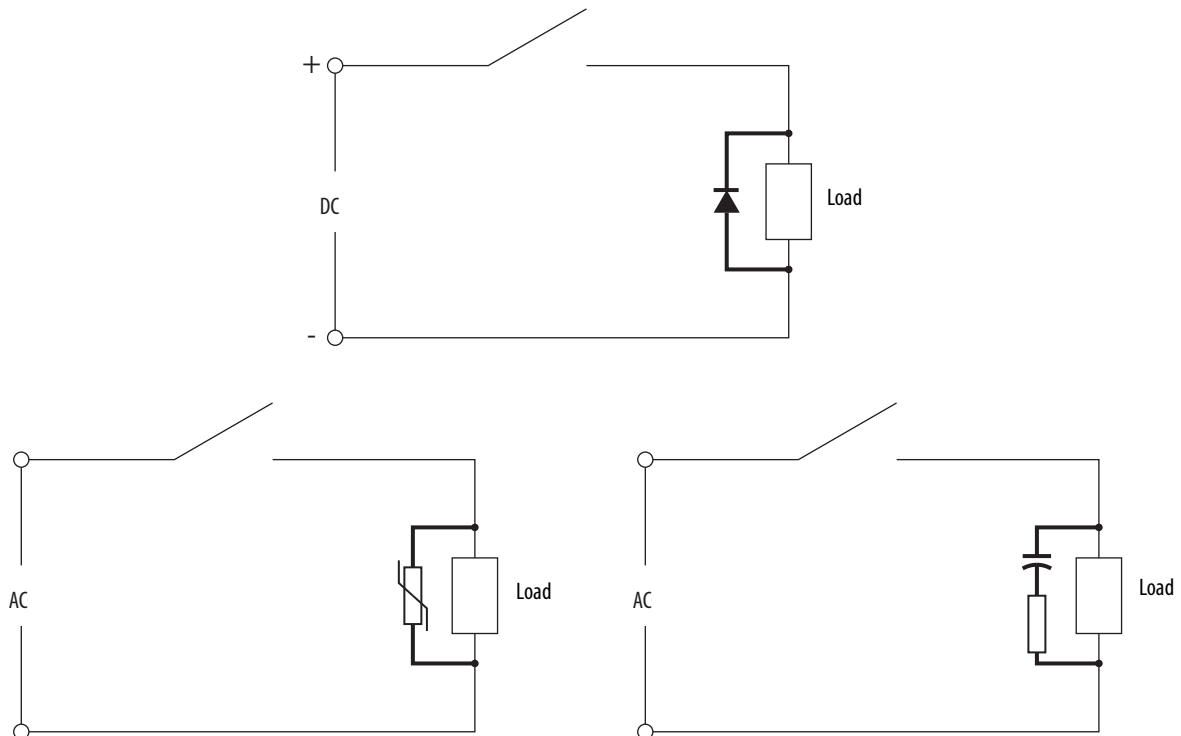

[Table 14 on page 88](#) contains examples that illustrate methods for mitigating transient interference.

Table 14 - Examples of Transient Interference Mitigation

| | |
|--|---|
| | <p>Example 1 A contact output controls a DC control relay. The relay coil requires a suppressor (blocking diode) because it is an inductive device controlled by a dry contact.</p> |
| | <p>Example 2 A DC output controls a motor starter, contacts on the starter control a motor. The contacts require RC networks or varistors. The motor requires suppressors because it is an inductive device. An inductive device that is controlled by a solid-state switching device (like the starter coil in this example) typically does not require a suppressor.</p> |
| | <p>Example 3 An AC output controls an interposing relay, but the circuit can be opened by dry contacts. Relay contacts control a solenoid coil. The contacts require RC networks or varistors. The relay coil requires a suppressor because it is an inductive device controlled by dry contacts. The solenoid coil also requires a suppressor because it is an inductive device controlled by dry contacts.</p> |
| | <p>Example 4 A contact output controls a pilot light with a built-in step-down transformer. The pilot light requires a suppressor because its transformer is an inductive device controlled by a dry contact.</p> |
| | <p>Example 5 A contact output controls a relay that controls a brake solenoid. The contacts require RC networks or varistors. Both the relay and the brake solenoid require suppressors because they are both inductive devices controlled by dry contacts.</p> |

Enclosure Lighting

Fluorescent lamps are also sources of EMI. If you must use fluorescent lamps inside an enclosure, follow these precautions to help guard against EMI problems:

- Install a shielding grid over the lamp
- Use shielded cable between the lamp and its switch
- Use a metal-encased switch
- Install a filter between the switch and the power line, or shield the power line cable

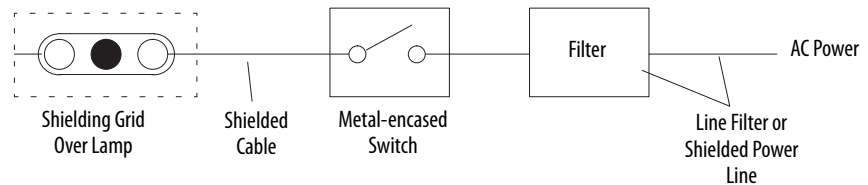

Bearing Current

The application of pulse-width modulated (PWM) inverters has led to significant advantages in terms of the performance, size, and efficiency of variable speed motor controls. However, the high switching rates that are used to obtain these advantages can also contribute to motor bearing damage due to bearing currents and electric discharge machining (EDM).

Bearing damage on motors that are supplied by PWM inverters is more likely to occur in applications where the coupling between the motor and load is not electrically conductive (such as belted loads), when the motor is lightly loaded, or when the motor is in an environment with ionized air.

Other factors, such as the type of grease and the type of bearings that are used, can also affect the longevity of motor bearings. Motor manufacturers that design and manufacture motors for use with variable frequency drives can offer solutions to help mitigate these potential problems.

Notes:

Motor Cable Length Restrictions

Overview

The distances that are listed in each table are valid only for specific cable constructions. The distances are not always accurate for lesser cable designs, particularly if the length restriction is due to cable charging current (indicated in the tables by shading). Consider these descriptions when choosing the cable.

IMPORTANT The motor cable length approximations are based on a minimum wire size of 12 AWG.

Cable charging current is not considered for motor cable length approximations.

Table 15 - Cable Type Descriptions

| Cable Type | Description |
|------------------|--|
| Unshielded cable | <ul style="list-style-type: none"> • Tray cable – fixed geometry without foil or braided shield but including an exterior cover • Individual wires that are not routed in metallic conduit |
| Shielded cable | <ul style="list-style-type: none"> • Individual conductors routed in metallic conduit • Fixed geometry cables with foil or braided shield of at least 75% coverage • Continuous weld or interlocked armored cables with no twist in the conductors (can have an optional foil shield) |

IMPORTANT Certain shielded cable constructions can cause excessive cable charging currents and can interfere with proper application performance, particularly on smaller drive ratings. Shielded cables that do not maintain a fixed geometry, but rather twist the conductors and tightly wrap the bundle with a foil shield, can cause unnecessary drive tripping. Unless stated in the table, the distances that are listed are not applicable to this type of cable. Actual distances for this cable type can be considerably less.

Table 16 - Motor Type Descriptions

| Motor Type | Description |
|----------------|--|
| Type A motor | <ul style="list-style-type: none"> No phase paper or misplaced phase paper Lower quality insulation systems Corona inception voltages between 850...1000V |
| Type B motor | <ul style="list-style-type: none"> Properly placed phase paper Medium quality insulation systems Corona inception voltages between 1000...1200V |
| 1488V motor | <ul style="list-style-type: none"> Meets NEMA MG 1-1998 section 31 standard Insulation can withstand voltage spikes of 3.1 times rated motor voltage due to inverter operation |
| 1329 R/L motor | <ul style="list-style-type: none"> AC variable speed motors are control-matched for use with Allen-Bradley® drives Motor that is designed to meet or exceed the requirements of the Federal Energy Act of 1992 Optimized for variable speed operation and include premium inverter-grade insulation systems that meet or exceed NEMA MG1 (Part 31.40.4.2) |

In the tables in this section, a ‘•’ in the available options column indicates that the drive rating can be used with an Allen-Bradley® terminator (catalog numbers 1204-TFA1/1204-TFB2), and/or reflected wave reduction device with common mode choke (catalog number 1204-RWC-17), or without choke (catalog number 1204-RWR2).

Follow these guidelines for terminators and reflected wave reduction devices:

- For the terminator, the maximum cable length is 182.9 m (600 ft) for 400/480/600V drives (not 690V). The PWM frequency must be 2 kHz. Catalog number 1204-TFA1 can be used only on low Hp (5 Hp and below), while catalog number 1204-TFB2 can be used from 2...800 Hp.
- 1204 reflected wave reduction device (all motor insulation classes):
 - Catalog number 1204-RWR2-09
 2 kHz: 182.9 m (600 ft) at 400/480V and 121.9 m (400 ft) at 600V.
 4 kHz: 91.4 m (300 ft) at 400/480V and 61.0 m (200 ft) at 600V.
 - Catalog number 1204-RWC-17
 2 kHz: 365.8 m (1200 ft) at 400/480/600V.
 4 kHz: 243.8 m (800 ft) at 400/480V and 121.9 m (400 ft) at 600V.

For both devices, power dissipation in the damping resistor limits maximum cable length.

Catalog number 1321-RWR is a complete reflected wave reduction solution available for many of the PowerFlex® drives. If available, a 1321-RWR catalog number is indicated in the Reactor/RWR column. When not available, use the reactor and resistor information that is provided in the tables in this section to build a solution.

| For This Cat. No. | See This Publication |
|--------------------------|--|
| 1321-RWR, 1321-3Rxx | 1321 Power Conditioning Products Technical Data, publication 1321-TD001 |
| 1204-RWR2 | 1204 Reflected Wave Reduction Device Instructions, publication 1204-5.1 |
| 1204-RWC | 1204 Reflected Wave Reduction Device with Common Mode Choke Instructions, publication 1204-IN001 |
| 1204-TFxx | 1204 Terminator Instructions, publication 1204-IN002 |

Motor Cable Length Restrictions Tables Cross-reference

Use this table to find the drive and voltage rating that you are looking for.

| Drive | Voltage | Table | Page |
|---|---------|-------|---------------------|
| PowerFlex 4 | 400 | 18 | 98 |
| | 480 | 19 | 98 |
| PowerFlex 4M | 400 | 20 | 99 |
| | 480 | 21 | 99 |
| PowerFlex 40 | 400 | 22 | 100 |
| | 480 | 23 | 100 |
| | 600 | 24 | 101 |
| PowerFlex 400 | 400 | 25 | 102 |
| | 480 | 26 | 103 |
| PowerFlex 520-Series | 400 | 27 | 104 |
| | 480 | 28 | 105 |
| | 600 | 29 | 106 |
| PowerFlex 70 (standard/enhanced) PowerFlex 700 (standard/vector) | 400 | 30 | 107 |
| | 480 | 31 | 109 |
| | 600 | 32 | 111 |
| PowerFlex 700 (standard/vector) | 690 | 33 | 112 |
| PowerFlex 700H | 400 | 34 | 113 |
| | 480 | 35 | 113 |
| | 600 | 36 | 114 |
| | 690 | 37 | 115 |
| PowerFlex 700L with PowerFlex 700VC Control | 400 | 38 | 115 |
| | 480 | 39 | 116 |
| | 600 | 40 | 116 |
| | 690 | 41 | 116 |
| PowerFlex 700L with PowerFlex 700S Control | 400 | 42 | 117 |
| | 480 | 43 | 117 |
| | 600 | 44 | 118 |
| | 690 | 45 | 118 |

| Drive | Voltage | Table | Page |
|--|-------------|-------|---------------------|
| PowerFlex 700S | 400 | 46 | 119 |
| | 480 | 47 | 120 |
| | 600 | 48 | 122 |
| | 690 | 49 | 123 |
| PowerFlex 753 and 755 (wall mount) | 400 | 50 | 125 |
| | 480 | 51 | 128 |
| | 600 | 52 | 131 |
| | 690 | 53 | 133 |
| PowerFlex 755 (floor mount) | 400 | 54 | 135 |
| | 480 | 55 | 136 |
| | 600 | 56 | 138 |
| | 690 | 57 | 139 |
| PowerFlex 755TL low harmonic drives PowerFlex 755TR regenerative drives PowerFlex 755TM drive systems (Also referred to as PowerFlex 755T drive products.) | 400 | 58 | 141 |
| | 480 | 59 | 142 |
| | 600 | 60 | 144 |
| | 690 | 61 | 145 |
| 1336 PLUS™ II 1336 IMPACT™ | 380...480 | 62 | 147 |
| | 600 | 63 | 149 |
| 1305 (no external devices) | 480 | 64 | 150 |
| 1305 (external devices at motor) | 480 | 65 | 150 |
| 160 | 480 | 66 | 151 |
| 160 (cable charging current) | 240 and 480 | 67 | 152 |

Cable Charging Current Phenomenon

A drive-to-motor, 3-wire plus ground cable, consists of C_{o1} line-to-line stray distributed capacitance and C_{og} distributed line to ground cable capacitance. There also exists a motor line-to-ground capacitance, which is defined by the stator winding capacitance to the motor PE frame ground, which can be added to C_{og} . During each dv/dt transition on the drive output line-to-line pulse, a capacitive coupled cable charging current is sourced from the drive, flows through C_{o1} , and returns through another phase.

The drive switching transition in a given phase output also sources another cable charging current path from line to ground through C_{og} . [Figure 37](#) shows the additional drive capacitive coupled current paths taken during a dv/dt transition. These additional currents can still exist whether the motor is connected or not. [Figure 38](#) shows that the capacitive coupled current spikes could exceed the normal drive rated current for a given motor load.

Figure 37 - Cable Charging Current Paths

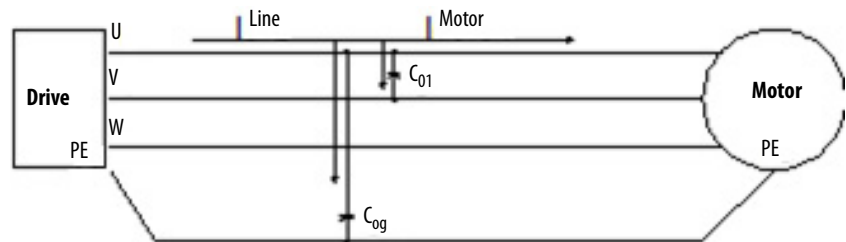

- Capacitively coupled currents can exceed the drive rating.
- C_{o1} = line-to-line capacitance path
 - C_{og} = line-to-ground capacitance path

Figure 38 - Cable Charging Current Exceeding Rated Phase Current

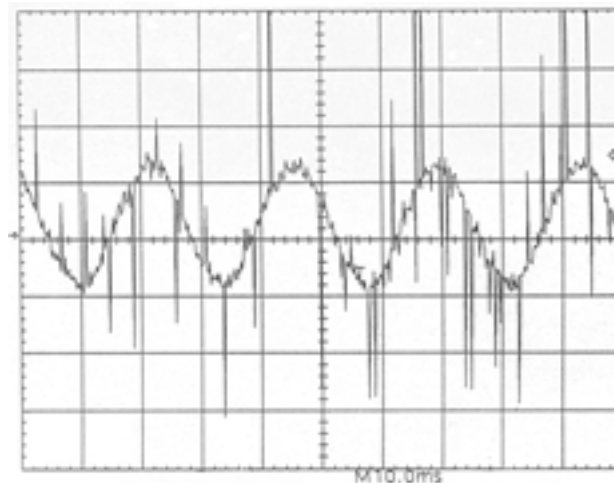

This phenomenon exists for all drives. However, drives < 2 Hp are more susceptible to overload and overcurrent trips due to the additional charging currents. This phenomenon is exhibited to a greater degree on 460V drives than on 230V drives due to the higher output transition voltage. This phenomenon is made worse by having long leads on small Hp drives, or multiple cable loads from one small drive.

The rms current value of this charging current is made higher and can approach the drive rms overload limit by increasing the carrier frequency (the number of device switchings per second). Shielded motor cable has higher capacitance line-to-line and line-to-ground than wires in a conduit and can increase the charging current magnitude. Capacitively coupled currents can also exist between the output wires of different drives that are routed in the same conduit. To help prevent additional drive-to-drive capacitive currents resulting from tightly bundled output wires in a conduit, we recommend that no more than three drive output wires be routed in the same conduit.

General methods to mitigate this effect are reducing carrier frequency to 2 kHz, reducing cable lengths to manufacturer recommended values, and using 230V drives when possible. Over-sizing the drive Hp for a smaller motor Hp load is also effective to be sure that cable charging limits are not met. Some drive manufacturers have recommended maximum allowable cable distances for various drive and motor Hp combinations in the <2 Hp applications to mitigate the cable charge effect at the installation planning stage. Another mitigation technique is to add a 3-phase inductor on the drive output to reduce the cable charge current magnitude.

How to Read the Motor Cable Length Restrictions Tables

The motor cable length restriction tables are divided into a maximum of eight columns (depending on the drive being used) going across the top. See [Table 17](#) for a description of each column.

Table 17 - Motor Cable Length Restrictions Table Definitions

| Column Heading | Description |
|----------------|---|
| Drive | This column is the frame size of the drive. Use the frame size in combination with the rating column to identify the drive. |
| Rating | This column is the rating of the drive. Use the rating in combination with the drive column to identify the drive. The Hp column refers to the Hp rating of the drive. The kW column refers to the kW of the drive. The kHz column refers to the carrier frequency of the drive. The carrier frequency can be changed via a parameter in the drive. A higher carrier frequency is typically associated with a lower motor lead length. |
| No Solution | Data in this column is for drives with only a wire between the drive and the motor. The column is divided into four subcolumns: 1000V, 1200V, 1488V, and 1600V. These voltages refer to the insulation rating on the windings in the selected motor. The insulation rating of the windings of the motor come from the motor manufacturer. Typically, an inverter-rated motor is 1488V, a newer non-inverter rated motor is 1200V, while an older non-inverter rated motor is 1000V. |
| Reactor Only | Data under this column is for drives with a reactor between the drive and the motor. In many cases, the motor lead length can be extended by adding a load reactor between the drive and the motor. The column is divided into four subcolumns: 1000V, 1200V, 1488V, and 1600V. These voltages refer to the insulation rating on the windings in the selected motor. The insulation rating of the windings of the motor come from the motor manufacturer. Typically, an inverter-rated motor is 1488V, a newer non-inverter rated motor is 1200V, while an older non-inverter rated motor is 1000V. If you have an inverter duty-rated motor, to verify that the motor has 1488V winding insulation, ask the motor manufacturer if the motor meets NEMA spec MG1par 31 1992. |

Table 17 - Motor Cable Length Restrictions Table Definitions (Continued)

| Column Heading | Description |
|--|---|
| Reactor and Damping Resistor or 1321-RWR | In cases where longer motor lead lengths are required, a load reactor in parallel with a damping resistor can be used to extend the motor lead length. The column is divided into four subcolumns: 1000V, 1200V, 1488V, and 1600V. These voltages refer to the insulation rating on the windings in the selected motor. The insulation rating of the windings of the motor come from the motor manufacturer. Typically, an inverter-rated motor is 1488V, a newer non-inverter rated motor is 1200V, while an older non-inverter rated motor is 1000V. |
| Reactor/RWR | This column gives the catalog number of the reactor based on the data from the 'Reactor and Damping Resistor or 1321-RWR' column. |
| Resistor | In many cases, this column is blank. No data is given if a 1321-RWR offering is available. In some cases, the 1321-RWR device does not exist. In these cases, a resistor size is recommended here. The ohms and watts of this resistor are given in the two subcolumns, 'Ohms' and 'Watts'. |
| Available Options | This column refers to options that can be used to extend motor lead length. The four sub columns are TFA1, TFB2, RWR2, and RWC. <ul style="list-style-type: none"> TFA1 and TFB2 refer to the motor terminators 1204-TFA1 and 1204-TFB2. See 1204 Terminator Instructions, publication 1204-5.0, for data on the motor lead length associated with these products RWR2 refers to the DVDT filter 1204-RWR2-09-B or 1204-RWR2-09-C. See 1204 Reflected Wave Reduction Device Instructions, publication 1204-5.1 for data on the motor lead length associated with this product. RWC refers to the DVDT filter 1204-RWC-17-A. See 1204 Reflected Wave Reduction Device with Common Mode Choke Installation Instructions, publication 1204-IN001A-EN-P, for data on the motor lead length associated with this product. |

Example Use Case

- PowerFlex 753 and 755 wall mount drive
- 400 volt
- Frame 3
- Rating of 15 kW
- Carrier frequency (parameter 38) in the drive at 2 kHz
- Inverter duty-rated motor at 1488V insulation rating on the windings of the motor
- The motor lead length that can be used is 365.8 meters (1200 feet)

Example PowerFlex 753 and 755 Wall Mount Drives 400V Shielded/Unshielded Cable – Meters (Feet)

| Drive | Rating | | No Solution | | | | Reactor Only | | | | Reactor and Damping Resistor or 1321-RWR | | | | Reactor/RWR (see page 152) | Resistor | | Available Options | | | | | |
|-------|--------|----|-------------|-------------|--------------|--------------|--------------|--------------|--------------|--------------|--|--------------|--------------|--------------|---|--------------|----------|-------------------|-------|------|------|------|-----|
| | Frame | kW | kHz | 1000V | 1200V | 1488V | 1600V | 1000V | 1200V | 1488V | 1600V | 1000V | 1200V | 1488V | | 1600V | Cat. No. | Ohms | Watts | TFA1 | TFB2 | RWR2 | RWC |
| 3 | 15 | 2 | 7.6 (25) | 137.2 (450) | 365.8 (1200) | 365.8 (1200) | 91.4 (300) | 365.8 (1200) | 365.8 (1200) | 365.8 (1200) | 365.8 (1200) | 365.8 (1200) | 365.8 (1200) | 365.8 (1200) | 1321-RWR35-DP | | | | • | | | | |
| | | | 4 | 7.6 (25) | 91.4 (300) | 152.4 (500) | 213.4 (700) | 18.3 (60) | 91.4 (300) | 365.8 (1200) | 365.8 (1200) | 182.9 (600) | 304.8 (1000) | 365.8 (1200) | | 365.8 (1200) | | | | | | | |
| | 18.5 | 2 | 7.6 (25) | 137.2 (450) | 365.8 (1200) | 365.8 (1200) | 91.4 (300) | 365.8 (1200) | 365.8 (1200) | 365.8 (1200) | 365.8 (1200) | 365.8 (1200) | 365.8 (1200) | 365.8 (1200) | 1321-RWR35-DP | | | | • | | | | |
| | | | 4 | 7.6 (25) | 91.4 (300) | 152.4 (500) | 213.4 (700) | 18.3 (60) | 91.4 (300) | 365.8 (1200) | 365.8 (1200) | 182.9 (600) | 304.8 (1000) | 365.8 (1200) | | 365.8 (1200) | | | | | | | |

PowerFlex 4 Drives

This section lists motor cable length restrictions, reactors, and available options for PowerFlex 4 Drives.

Table 18 - PowerFlex 4 Drives, 400V Shielded/Unshielded Cable – Meters (Feet)

| Rating | | No Solution | | | | Reactor Only | | | | Reactor and Damping Resistor or 1321-RWR | | | | Reactor/RWR (see page 152) | Resistor | | Available Options | | | |
|--------|-----|-------------|-------------|-------------|-------------|--------------|-------------|-------------|-------------|--|-------------|-------------|-------------|----------------------------|----------|-------|-------------------|------|------|-----|
| kW | kHz | 1000V | 1200V | 1488V | 1600V | 1000V | 1200V | 1488V | 1600V | 1000V | 1200V | 1488V | 1600V | Cat. No. | Ohms | Watts | TFA1 | TFB2 | RWR2 | RWC |
| 0.4 | 2/4 | 7.6 (25) | 53.3 (175) | 53.3 (175) | 53.3 (175) | 91.4 (300) | 121.9 (400) | 121.9 (400) | 121.9 (400) | 121.9 (400) | 121.9 (400) | 121.9 (400) | 121.9 (400) | | | | • | | • | • |
| 0.75 | 2/4 | 7.6 (25) | 83.8 (275) | 83.8 (275) | 83.8 (275) | 91.4 (300) | 152.4 (500) | 152.4 (500) | 152.4 (500) | 152.4 (500) | 152.4 (500) | 152.4 (500) | 152.4 (500) | | | | • | | • | • |
| 1.5 | 2/4 | 7.6 (25) | 83.8 (275) | 83.8 (275) | 83.8 (275) | 91.4 (300) | 152.4 (500) | 152.4 (500) | 152.4 (500) | 152.4 (500) | 152.4 (500) | 152.4 (500) | 152.4 (500) | | | | • | • | • | • |
| 2.2 | 2/4 | 7.6 (25) | 137.2 (450) | 182.9 (600) | 182.9 (600) | 91.4 (300) | 182.9 (600) | 182.9 (600) | 182.9 (600) | 182.9 (600) | 182.9 (600) | 182.9 (600) | 182.9 (600) | 1321-RWR8-DP | | | • | • | • | • |
| 3.7 | 2/4 | 7.6 (25) | 137.2 (450) | 243.8 (800) | 243.8 (800) | 91.4 (300) | 243.8 (800) | 243.8 (800) | 243.8 (800) | 243.8 (800) | 243.8 (800) | 243.8 (800) | 243.8 (800) | 1321-RWR12-DP | | | • | • | • | • |

Table 19 - PowerFlex 4 Drives, 480V Shielded/Unshielded Cable – Meters (Feet)

| Rating | | No Solution | | | | Reactor Only | | | | Reactor and Damping Resistor or 1321-RWR | | | | Reactor/RWR (see page 152) | Resistor | | Available Options | | | |
|--------|-----|-------------|-----------|-------------|-------------|--------------|------------|-------------|-------------|--|-------------|-------------|-------------|----------------------------|----------|-------|-------------------|------|------|-----|
| Hp | kHz | 1000V | 1200V | 1488V | 1600V | 1000V | 1200V | 1488V | 1600V | 1000V | 1200V | 1488V | 1600V | Cat. No. | Ohms | Watts | TFA1 | TFB2 | RWR2 | RWC |
| 0.5 | 2/4 | 7.6 (25) | 12.2 (40) | 53.3 (175) | 53.3 (175) | 7.6 (25) | 91.4 (300) | 121.9 (400) | 121.9 (400) | 121.9 (400) | 121.9 (400) | 121.9 (400) | 121.9 (400) | | | | • | | • | • |
| 1 | 2/4 | 7.6 (25) | 12.2 (40) | 83.8 (275) | 83.8 (275) | 7.6 (25) | 91.4 (300) | 152.4 (500) | 152.4 (500) | 152.4 (500) | 152.4 (500) | 152.4 (500) | 152.4 (500) | | | | • | | • | • |
| 2 | 2/4 | 7.6 (25) | 12.2 (40) | 83.8 (275) | 83.8 (275) | 7.6 (25) | 91.4 (300) | 182.9 (600) | 182.9 (600) | 182.9 (600) | 182.9 (600) | 182.9 (600) | 182.9 (600) | | | | • | • | • | • |
| 3 | 2/4 | 7.6 (25) | 12.2 (40) | 129.5 (425) | 129.5 (425) | 7.6 (25) | 91.4 (300) | 182.9 (600) | 182.9 (600) | 182.9 (600) | 182.9 (600) | 182.9 (600) | 182.9 (600) | 1321-RWR8-DP | | | • | • | • | • |
| 5 | 2/4 | 7.6 (25) | 12.2 (40) | 137.2 (450) | 182.9 (600) | 7.6 (25) | 91.4 (300) | 243.8 (800) | 243.8 (800) | 182.9 (600) | 243.8 (800) | 243.8 (800) | 243.8 (800) | 1321-RWR12-DP | | | • | • | • | • |

PowerFlex 4M Drives

This section lists motor cable length restrictions, reactors, and available options for PowerFlex 4M Drives.

Table 20 - PowerFlex 4M Drives, 400V Shielded/Unshielded Cable – Meters (Feet)

| Rating | | No Solution | | | | Reactor Only | | | | Reactor and Damping Resistor or 1321-RWR | | | | Reactor/RWR (see page 152) | Resistor | | Available Options | | | |
|--------|-----|-------------|-------------|--------------|--------------|--------------|--------------|--------------|--------------|--|--------------|--------------|--------------|----------------------------|----------|-------|-------------------|------|------|-----|
| kW | kHz | 1000V | 1200V | 1488V | 1600V | 1000V | 1200V | 1488V | 1600V | 1000V | 1200V | 1488V | 1600V | Cat. No. | Ohms | Watts | TFAT | TFB2 | RWR2 | RWC |
| 0.4 | 2/4 | 7.6 (25) | 53.3 (175) | 53.3 (175) | 53.3 (175) | 91.4 (300) | 121.9 (400) | 121.9 (400) | 121.9 (400) | 121.9 (400) | 121.9 (400) | 121.9 (400) | 121.9 (400) | | | | • | | • | • |
| 0.75 | 2/4 | 7.6 (25) | 83.8 (275) | 83.8 (275) | 83.8 (275) | 91.4 (300) | 152.4 (500) | 152.4 (500) | 152.4 (500) | 152.4 (500) | 152.4 (500) | 152.4 (500) | 152.4 (500) | | | | • | | • | • |
| 1.5 | 2/4 | 7.6 (25) | 83.8 (275) | 83.8 (275) | 83.8 (275) | 91.4 (300) | 152.4 (500) | 152.4 (500) | 152.4 (500) | 152.4 (500) | 152.4 (500) | 152.4 (500) | 152.4 (500) | | | | • | • | • | • |
| 2.2 | 2/4 | 7.6 (25) | 137.2 (450) | 182.9 (600) | 182.9 (600) | 91.4 (300) | 182.9 (600) | 182.9 (600) | 182.9 (600) | 182.9 (600) | 182.9 (600) | 182.9 (600) | 182.9 (600) | 1321-RWR8-DP | | | • | • | • | • |
| 3.7 | 2/4 | 7.6 (25) | 137.2 (450) | 243.8 (800) | 243.8 (800) | 91.4 (300) | 243.8 (800) | 243.8 (800) | 243.8 (800) | 243.8 (800) | 243.8 (800) | 243.8 (800) | 243.8 (800) | 1321-RWR12-DP | | | • | • | • | • |
| 5.5 | 2/4 | 7.6 (25) | 137.2 (450) | 304.8 (1000) | 304.8 (1000) | 91.4 (300) | 304.8 (1000) | 304.8 (1000) | 304.8 (1000) | 304.8 (1000) | 304.8 (1000) | 304.8 (1000) | 304.8 (1000) | 1321-RWR12-DP | | | | • | | • |
| 7.5 | 2/4 | 7.6 (25) | 137.2 (450) | 365.8 (1200) | 365.8 (1200) | 91.4 (300) | 365.8 (1200) | 365.8 (1200) | 365.8 (1200) | 365.8 (1200) | 365.8 (1200) | 365.8 (1200) | 365.8 (1200) | 1321-RWR18-DP | | | | • | | • |
| 11 | 2/4 | 7.6 (25) | 137.2 (450) | 365.8 (1200) | 365.8 (1200) | 91.4 (300) | 365.8 (1200) | 365.8 (1200) | 365.8 (1200) | 365.8 (1200) | 365.8 (1200) | 365.8 (1200) | 365.8 (1200) | 1321-RWR25-DP | | | | • | | |

Table 21 - PowerFlex 4M Drives, 480V Shielded/Unshielded Cable – Meters (Feet)

| Rating | | No Solution | | | | Reactor Only | | | | Reactor and Damping Resistor or 1321-RWR | | | | Reactor/RWR (see page 152) | Resistor | | Available Options | | | |
|--------|-----|-------------|-----------|-------------|-------------|--------------|------------|--------------|--------------|--|--------------|--------------|--------------|----------------------------|----------|-------|-------------------|------|------|-----|
| Hp | kHz | 1000V | 1200V | 1488V | 1600V | 1000V | 1200V | 1488V | 1600V | 1000V | 1200V | 1488V | 1600V | Cat. No. | Ohms | Watts | TFAT | TFB2 | RWR2 | RWC |
| 0.5 | 2/4 | 7.6 (25) | 12.2 (40) | 53.3 (175) | 53.3 (175) | 7.6 (25) | 91.4 (300) | 121.9 (400) | 121.9 (400) | 121.9 (400) | 121.9 (400) | 121.9 (400) | 121.9 (400) | | | | • | | • | • |
| 1 | 2/4 | 7.6 (25) | 12.2 (40) | 83.8 (275) | 83.8 (275) | 7.6 (25) | 91.4 (300) | 152.4 (500) | 152.4 (500) | 152.4 (500) | 152.4 (500) | 152.4 (500) | 152.4 (500) | | | | • | | • | • |
| 2 | 2/4 | 7.6 (25) | 12.2 (40) | 83.8 (275) | 83.8 (275) | 7.6 (25) | 91.4 (300) | 182.9 (600) | 182.9 (600) | 182.9 (600) | 182.9 (600) | 182.9 (600) | 182.9 (600) | | | | • | • | • | • |
| 3 | 2/4 | 7.6 (25) | 12.2 (40) | 129.5 (425) | 129.5 (425) | 7.6 (25) | 91.4 (300) | 182.9 (600) | 182.9 (600) | 182.9 (600) | 182.9 (600) | 182.9 (600) | 182.9 (600) | 1321-RWR8-DP | | | • | • | • | • |
| 5 | 2/4 | 7.6 (25) | 12.2 (40) | 137.2 (450) | 182.9 (600) | 7.6 (25) | 91.4 (300) | 243.8 (800) | 243.8 (800) | 182.9 (600) | 243.8 (800) | 243.8 (800) | 243.8 (800) | 1321-RWR12-DP | | | • | • | • | • |
| 7.5 | 2/4 | 7.6 (25) | 12.2 (40) | 137.2 (450) | 182.9 (600) | 7.6 (25) | 91.4 (300) | 304.8 (1000) | 304.8 (1000) | 182.9 (600) | 304.8 (1000) | 304.8 (1000) | 304.8 (1000) | 1321-RWR12-DP | | | | • | | • |
| 10 | 2/4 | 7.6 (25) | 12.2 (40) | 137.2 (450) | 182.9 (600) | 7.6 (25) | 91.4 (300) | 365.8 (1200) | 365.8 (1200) | 182.9 (600) | 365.8 (1200) | 365.8 (1200) | 365.8 (1200) | 1321-RWR18-DP | | | | • | | • |
| 15 | 2/4 | 7.6 (25) | 12.2 (40) | 137.2 (450) | 182.9 (600) | 7.6 (25) | 91.4 (300) | 365.8 (1200) | 365.8 (1200) | 182.9 (600) | 365.8 (1200) | 365.8 (1200) | 365.8 (1200) | 1321-RWR25-DP | | | | • | | |

PowerFlex 40 Drives

This section lists motor cable length restrictions, reactors, and available options for PowerFlex 40 Drives.

Table 22 - PowerFlex 40 Drives, 400V Shielded/Unshielded Cable – Meters (Feet)

| Rating | | No Solution | | | | Reactor Only | | | | Reactor and Damping Resistor or 1321-RWR | | | | Reactor/RWR (see page 152) | Resistor | | Available Options | | | |
|--------|-----|-------------|-------------|--------------|--------------|--------------|--------------|--------------|--------------|--|--------------|--------------|--------------|----------------------------|----------|-------|-------------------|------|------|-----|
| kW | kHz | 1000V | 1200V | 1488V | 1600V | 1000V | 1200V | 1488V | 1600V | 1000V | 1200V | 1488V | 1600V | Cat. No. | Ohms | Watts | TFA1 | TFB2 | RWR2 | RWC |
| 0.4 | 2/4 | 7.6 (25) | 53.3 (175) | 53.3 (175) | 53.3 (175) | 91.4 (300) | 121.9 (400) | 121.9 (400) | 121.9 (400) | 121.9 (400) | 121.9 (400) | 121.9 (400) | 121.9 (400) | | | | • | | • | • |
| 0.75 | 2/4 | 7.6 (25) | 83.8 (275) | 83.8 (275) | 83.8 (275) | 91.4 (300) | 152.4 (500) | 152.4 (500) | 152.4 (500) | 152.4 (500) | 152.4 (500) | 152.4 (500) | 152.4 (500) | | | | • | | • | • |
| 1.5 | 2/4 | 7.6 (25) | 83.8 (275) | 83.8 (275) | 83.8 (275) | 91.4 (300) | 152.4 (500) | 152.4 (500) | 152.4 (500) | 152.4 (500) | 152.4 (500) | 152.4 (500) | 152.4 (500) | | | | • | • | • | • |
| 2.2 | 2/4 | 7.6 (25) | 137.2 (450) | 182.9 (600) | 182.9 (600) | 91.4 (300) | 182.9 (600) | 182.9 (600) | 182.9 (600) | 182.9 (600) | 182.9 (600) | 182.9 (600) | 182.9 (600) | 1321-RWR8-DP | | | • | • | • | • |
| 4 | 2/4 | 7.6 (25) | 137.2 (450) | 243.8 (800) | 243.8 (800) | 91.4 (300) | 243.8 (800) | 243.8 (800) | 243.8 (800) | 243.8 (800) | 243.8 (800) | 243.8 (800) | 243.8 (800) | 1321-RWR12-DP | | | • | • | | • |
| 5.5 | 2/4 | 7.6 (25) | 137.2 (450) | 304.8 (1000) | 304.8 (1000) | 91.4 (300) | 304.8 (1000) | 304.8 (1000) | 304.8 (1000) | 304.8 (1000) | 304.8 (1000) | 304.8 (1000) | 304.8 (1000) | 1321-RWR12-DP | | | | • | | • |
| 7.5 | 2/4 | 7.6 (25) | 137.2 (450) | 365.8 (1200) | 365.8 (1200) | 91.4 (300) | 365.8 (1200) | 365.8 (1200) | 365.8 (1200) | 365.8 (1200) | 365.8 (1200) | 365.8 (1200) | 365.8 (1200) | 1321-RWR18-DP | | | | • | | • |
| 11 | 2/4 | 7.6 (25) | 137.2 (450) | 365.8 (1200) | 365.8 (1200) | 91.4 (300) | 365.8 (1200) | 365.8 (1200) | 365.8 (1200) | 365.8 (1200) | 365.8 (1200) | 365.8 (1200) | 365.8 (1200) | 1321-RWR25-DP | | | | • | | |

Table 23 - PowerFlex 40 Drives, 480V Shielded/Unshielded Cable – Meters (Feet)

| Rating | | No Solution | | | | Reactor Only | | | | Reactor and Damping Resistor or 1321-RWR | | | | Reactor/RWR (see page 152) | Resistor | | Available Options | | | |
|--------|-----|-------------|-----------|-------------|-------------|--------------|------------|--------------|--------------|--|--------------|--------------|--------------|----------------------------|----------|-------|-------------------|------|------|-----|
| Hp | kHz | 1000V | 1200V | 1488V | 1600V | 1000V | 1200V | 1488V | 1600V | 1000V | 1200V | 1488V | 1600V | Cat. No. | Ohms | Watts | TFA1 | TFB2 | RWR2 | RWC |
| 0.5 | 2/4 | 7.6 (25) | 12.2 (40) | 53.3 (175) | 53.3 (175) | 7.6 (25) | 91.4 (300) | 121.9 (400) | 121.9 (400) | 121.9 (400) | 121.9 (400) | 121.9 (400) | 121.9 (400) | | | | • | | • | • |
| 1 | 2/4 | 7.6 (25) | 12.2 (40) | 83.8 (275) | 83.8 (275) | 7.6 (25) | 91.4 (300) | 152.4 (500) | 152.4 (500) | 152.4 (500) | 152.4 (500) | 152.4 (500) | 152.4 (500) | | | | • | | • | • |
| 2 | 2/4 | 7.6 (25) | 12.2 (40) | 83.8 (275) | 83.8 (275) | 7.6 (25) | 91.4 (300) | 182.9 (600) | 182.9 (600) | 182.9 (600) | 182.9 (600) | 182.9 (600) | 182.9 (600) | | | | • | • | • | • |
| 3 | 2/4 | 7.6 (25) | 12.2 (40) | 129.5 (425) | 129.5 (425) | 7.6 (25) | 91.4 (300) | 182.9 (600) | 182.9 (600) | 182.9 (600) | 182.9 (600) | 182.9 (600) | 182.9 (600) | 1321-RWR8-DP | | | • | • | • | • |
| 5 | 2/4 | 7.6 (25) | 12.2 (40) | 137.2 (450) | 182.9 (600) | 7.6 (25) | 91.4 (300) | 243.8 (800) | 243.8 (800) | 243.8 (800) | 243.8 (800) | 243.8 (800) | 243.8 (800) | 1321-RWR12-DP | | | • | • | | • |
| 7.5 | 2/4 | 7.6 (25) | 12.2 (40) | 137.2 (450) | 182.9 (600) | 7.6 (25) | 91.4 (300) | 304.8 (1000) | 304.8 (1000) | 182.9 (600) | 304.8 (1000) | 304.8 (1000) | 304.8 (1000) | 1321-RWR12-DP | | | | • | | • |
| 10 | 2/4 | 7.6 (25) | 12.2 (40) | 137.2 (450) | 182.9 (600) | 7.6 (25) | 91.4 (300) | 365.8 (1200) | 365.8 (1200) | 182.9 (600) | 365.8 (1200) | 365.8 (1200) | 365.8 (1200) | 1321-RWR18-DP | | | | • | | • |
| 15 | 2/4 | 7.6 (25) | 12.2 (40) | 137.2 (450) | 182.9 (600) | 7.6 (25) | 91.4 (300) | 365.8 (1200) | 365.8 (1200) | 182.9 (600) | 365.8 (1200) | 365.8 (1200) | 365.8 (1200) | 1321-RWR25-DP | | | | • | | |

Table 24 - PowerFlex 40 Drives, 600V Shielded/Unshielded Cable – Meters (Feet)

| Rating | | No Solution | | Reactor Only | | Reactor and Damping Resistor or 1321-RWR | | Reactor/RWR (see page 152) | Resistor | | Available Options | | | |
|--------|-----|---------------|----------------|----------------|-----------------|--|-----------------|---|----------|-------|-------------------|------|------|-----|
| Hp | kHz | 1488V | 1850V | 1488V | 1600V | 1488V | 1600V | Cat. No. | Ohms | Watts | TPA1 | TFB2 | RWR2 | RWC |
| 1 | 2/4 | 42.7 (140) | 121.9 (400) | 121.9 (400) | 121.9 (400) | 121.9 (400) | 121.9 (400) | | | | • | | • | • |
| 2 | 2/4 | 42.7 (140) | 152.4 (500) | 152.4 (500) | 152.4 (500) | 152.4 (500) | 152.4 (500) | | | | • | | • | • |
| 3 | 2/4 | 42.7 (140) | 152.4 (500) | 152.4 (500) | 152.4 (500) | 182.9 (600) | 182.9 (600) | | | | • | | • | • |
| 5 | 2/4 | 42.7 (140) | 152.4 (500) | 152.4 (500) | 243.8 (800) | 243.8 (800) | 243.8 (800) | 1321-RWR8-DP | | | • | • | • | • |
| 7.5 | 2/4 | 42.7 (140) | 182.9 (600) | 152.4 (500) | 304.8 (1000) | 304.8 (1000) | 304.8 (1000) | 1321-RWR12-DP | | | | • | | • |
| 10 | 2/4 | 42.7 (140) | 182.9 (600) | 152.4 (500) | 365.8 (1200) | 365.8 (1200) | 365.8 (1200) | 1321-RWR18-DP | | | | • | | • |
| 15 | 2/4 | 42.7 (140) | 182.9 (600) | 152.4 (500) | 365.8 (1200) | 365.8 (1200) | 365.8 (1200) | 1321-RWR25-DP | | | | • | | |

PowerFlex 400 Drives

This section lists motor cable length restrictions, reactors, and available options for PowerFlex 400 Drives.

Table 25 - PowerFlex 400 Drives, 400V Shielded/Unshielded Cable – Meters (Feet)

| Rating | | No Solution | | | | Reactor Only | | | | Reactor and Damping Resistor or 1321-RWR | | | | Reactor/RWR (see page 152) | Resistor | | Available Options | | | |
|--------|------|-------------|-------------|-------------|--------------|--------------|-------------|--------------|--------------|--|--------------|--------------|--------------|----------------------------|----------|-------|-------------------|-----|------|-----|
| kW | kHz | 1000V | 1200V | 1488V | 1600V | 1000V | 1200V | 1488V | 1600V | 1000V | 1200V | 1488V | 1600V | Cat. No. | Ohms | Watts | TF1 | TF2 | RWR2 | RWC |
| 2.2 | 2, 4 | 7.6 (25) | 106.7 (350) | 182.9 (600) | 182.9 (600) | 91.4 (300) | 182.9 (600) | 182.9 (600) | 182.9 (600) | 182.9 (600) | 182.9 (600) | 182.9 (600) | 182.9 (600) | 1321-RWR8-DP | | | • | • | • | • |
| 4 | 2, 4 | 7.6 (25) | 106.7 (350) | 243.8 (800) | 243.8 (800) | 91.4 (300) | 243.8 (800) | 243.8 (800) | 243.8 (800) | 243.8 (800) | 243.8 (800) | 243.8 (800) | 243.8 (800) | 1321-RWR12-DP | | | • | • | | • |
| 5.5 | 2, 4 | 7.6 (25) | 106.7 (350) | 274.3 (900) | 304.8 (1000) | 91.4 (300) | 274.3 (900) | 304.8 (1000) | 304.8 (1000) | 304.8 (1000) | 304.8 (1000) | 304.8 (1000) | 304.8 (1000) | 1321-RWR12-DP | | | | • | | • |
| 7.5 | 2, 4 | 7.6 (25) | 106.7 (350) | 274.3 (900) | 365.8 (1200) | 91.4 (300) | 274.3 (900) | 365.8 (1200) | 365.8 (1200) | 365.8 (1200) | 365.8 (1200) | 365.8 (1200) | 365.8 (1200) | 1321-RWR18-DP | | | | • | | • |
| 11 | 2, 4 | 7.6 (25) | 106.7 (350) | 274.3 (900) | 365.8 (1200) | 76.2 (250) | 274.3 (900) | 365.8 (1200) | 365.8 (1200) | 365.8 (1200) | 365.8 (1200) | 365.8 (1200) | 365.8 (1200) | 1321-RWR25-DP | | | | • | | |
| 15 | 2, 4 | 7.6 (25) | 106.7 (350) | 274.3 (900) | 365.8 (1200) | 76.2 (250) | 274.3 (900) | 365.8 (1200) | 365.8 (1200) | 365.8 (1200) | 365.8 (1200) | 365.8 (1200) | 365.8 (1200) | 1321-RWR35-DP | | | | • | | |
| 18.5 | 2, 4 | 7.6 (25) | 106.7 (350) | 274.3 (900) | 365.8 (1200) | 76.2 (250) | 243.8 (800) | 365.8 (1200) | 365.8 (1200) | 365.8 (1200) | 365.8 (1200) | 365.8 (1200) | 365.8 (1200) | 1321-RWR45-DP | | | | • | | |
| 22 | 2, 4 | 7.6 (25) | 106.7 (350) | 274.3 (900) | 365.8 (1200) | 76.2 (250) | 213.4 (700) | 365.8 (1200) | 365.8 (1200) | 365.8 (1200) | 365.8 (1200) | 365.8 (1200) | 365.8 (1200) | 1321-RWR45-DP | | | | • | | |
| 30 | 2, 4 | 7.6 (25) | 106.7 (350) | 274.3 (900) | 365.8 (1200) | 76.2 (250) | 213.4 (700) | 365.8 (1200) | 365.8 (1200) | 365.8 (1200) | 365.8 (1200) | 365.8 (1200) | 365.8 (1200) | 1321-RWR55-DP | | | | • | | |
| 37 | 2, 4 | 12.2 (40) | 106.7 (350) | 274.3 (900) | 365.8 (1200) | 76.2 (250) | 182.9 (600) | 365.8 (1200) | 365.8 (1200) | 365.8 (1200) | 365.8 (1200) | 365.8 (1200) | 365.8 (1200) | 1321-RWR80-DP | | | | • | | |
| 45 | 2, 4 | 12.2 (40) | 106.7 (350) | 274.3 (900) | 365.8 (1200) | 61.0 (200) | 182.9 (600) | 365.8 (1200) | 365.8 (1200) | 365.8 (1200) | 365.8 (1200) | 365.8 (1200) | 365.8 (1200) | 1321-RWR100-DP | | | | • | | |
| 55 | 2, 4 | 12.2 (40) | 106.7 (350) | 213.4 (700) | 365.8 (1200) | 61.0 (200) | 152.4 (500) | 365.8 (1200) | 365.8 (1200) | 365.8 (1200) | 365.8 (1200) | 365.8 (1200) | 365.8 (1200) | 1321-RWR100-DP | | | | • | | |
| 75 | 2, 4 | 12.2 (40) | 91.4 (300) | 213.4 (700) | 365.8 (1200) | 61.0 (200) | 152.4 (500) | 365.8 (1200) | 365.8 (1200) | 304.8 (1000) | 365.8 (1200) | 365.8 (1200) | 365.8 (1200) | 1321-RWR160-DP | | | | • | | |
| 90 | 2, 4 | 18.3 (60) | 91.4 (300) | 213.4 (700) | 304.8 (1000) | 61.0 (200) | 152.4 (500) | 365.8 (1200) | 365.8 (1200) | 304.8 (1000) | 365.8 (1200) | 365.8 (1200) | 365.8 (1200) | 1321-RWR200-DP | | | | • | | |
| 110 | 2, 4 | 24.4 (80) | 91.4 (300) | 213.4 (700) | 274.3 (900) | 61.0 (200) | 152.4 (500) | 365.8 (1200) | 365.8 (1200) | 274.3 (900) | 365.8 (1200) | 365.8 (1200) | 365.8 (1200) | 1321-RWR200-DP | | | | • | | |
| 132 | 2, 4 | 24.4 (80) | 91.4 (300) | 182.9 (600) | 274.3 (900) | 61.0 (200) | 152.4 (500) | 365.8 (1200) | 365.8 (1200) | 243.8 (800) | 365.8 (1200) | 365.8 (1200) | 365.8 (1200) | 1321-RWR250-DP | | | | • | | |
| 160 | 2, 4 | 24.4 (80) | 91.4 (300) | 182.9 (600) | 274.3 (900) | 45.7 (150) | 121.9 (400) | 304.8 (1000) | 365.8 (1200) | 243.8 (800) | 365.8 (1200) | 365.8 (1200) | 365.8 (1200) | 1321-RWR320-DP | | | | • | | |
| 200 | 2, 4 | 24.4 (80) | 91.4 (300) | 167.6 (550) | 274.3 (900) | 45.7 (150) | 121.9 (400) | 304.8 (1000) | 365.8 (1200) | 243.8 (800) | 365.8 (1200) | 365.8 (1200) | 365.8 (1200) | 1321-3RB400-B | 20 | 495 | | • | | |
| 250 | 2, 4 | 24.4 (80) | 91.4 (300) | 167.6 (550) | 274.3 (900) | 45.7 (150) | 121.9 (400) | 304.8 (1000) | 365.8 (1200) | 243.8 (800) | 365.8 (1200) | 365.8 (1200) | 365.8 (1200) | 1321-3R500-B | 20 | 495 | | • | | |

Table 26 - PowerFlex 400 Drives, 480V Shielded/Unshielded Cable – Meters (Feet)

| Rating | | No Solution | | | | Reactor Only | | | | Reactor and Damping Resistor or 1321-RWR | | | | Reactor/RWR (see page 152) | Resistor | | Available Options | | | |
|--------|------|-------------|------------|-------------|-------------|--------------|------------|--------------|--------------|--|--------------|--------------|--------------|----------------------------|----------|-------|-------------------|------|------|-----|
| Hp | kHz | 1000V | 1200V | 1488V | 1600V | 1000V | 1200V | 1488V | 1600V | 1000V | 1200V | 1488V | 1600V | Cat. No. | Ohms | Watts | TFA1 | TFB2 | RWR2 | RWC |
| 3 | 2, 4 | 7.6 (25) | 12.2 (40) | 121.9 (400) | 121.9 (400) | 12.2 (40) | 91.4 (300) | 182.9 (600) | 182.9 (600) | 152.4 (500) | 182.9 (600) | 182.9 (600) | 182.9 (600) | 1321-RWR8-DP | | | • | • | • | • |
| 5 | 2, 4 | 7.6 (25) | 12.2 (40) | 137.2 (450) | 182.9 (600) | 12.2 (40) | 91.4 (300) | 243.8 (800) | 243.8 (800) | 152.4 (500) | 243.8 (800) | 243.8 (800) | 243.8 (800) | 1321-RWR12-DP | | | • | • | | • |
| 7.5 | 2, 4 | 7.6 (25) | 12.2 (40) | 137.2 (450) | 182.9 (600) | 12.2 (40) | 91.4 (300) | 304.8 (1000) | 304.8 (1000) | 152.4 (500) | 304.8 (1000) | 304.8 (1000) | 304.8 (1000) | 1321-RWR12-DP | | | | • | | • |
| 10 | 2, 4 | 7.6 (25) | 12.2 (40) | 137.2 (450) | 182.9 (600) | 12.2 (40) | 91.4 (300) | 365.8 (1200) | 365.8 (1200) | 152.4 (500) | 365.8 (1200) | 365.8 (1200) | 365.8 (1200) | 1321-RWR18-DP | | | | • | | • |
| 15 | 2, 4 | 7.6 (25) | 12.2 (40) | 137.2 (450) | 182.9 (600) | 12.2 (40) | 76.2 (250) | 365.8 (1200) | 365.8 (1200) | 152.4 (500) | 365.8 (1200) | 365.8 (1200) | 365.8 (1200) | 1321-RWR25-DP | | | | • | | |
| 20 | 2, 4 | 7.6 (25) | 12.2 (40) | 137.2 (450) | 182.9 (600) | 12.2 (40) | 76.2 (250) | 365.8 (1200) | 365.8 (1200) | 152.4 (500) | 365.8 (1200) | 365.8 (1200) | 365.8 (1200) | 1321-RWR35-DP | | | | • | | |
| 25 | 2, 4 | 7.6 (25) | 12.2 (40) | 137.2 (450) | 182.9 (600) | 12.2 (40) | 76.2 (250) | 365.8 (1200) | 365.8 (1200) | 152.4 (500) | 365.8 (1200) | 365.8 (1200) | 365.8 (1200) | 1321-RWR45-DP | | | | • | | |
| 30 | 2, 4 | 7.6 (25) | 12.2 (40) | 137.2 (450) | 182.9 (600) | 12.2 (40) | 76.2 (250) | 365.8 (1200) | 365.8 (1200) | 152.4 (500) | 365.8 (1200) | 365.8 (1200) | 365.8 (1200) | 1321-RWR45-DP | | | | • | | |
| 40 | 2, 4 | 7.6 (25) | 12.2 (40) | 137.2 (450) | 182.9 (600) | 12.2 (40) | 76.2 (250) | 365.8 (1200) | 365.8 (1200) | 121.9 (400) | 365.8 (1200) | 365.8 (1200) | 365.8 (1200) | 1321-RWR55-DP | | | | • | | |
| 50 | 2, 4 | 12.2 (40) | 18.3 (60) | 137.2 (450) | 182.9 (600) | 12.2 (40) | 61.0 (200) | 304.8 (1000) | 365.8 (1200) | 121.9 (400) | 365.8 (1200) | 365.8 (1200) | 365.8 (1200) | 1321-RWR80-DP | | | | • | | |
| 60 | 2, 4 | 12.2 (40) | 18.3 (60) | 137.2 (450) | 182.9 (600) | 12.2 (40) | 61.0 (200) | 304.8 (1000) | 365.8 (1200) | 91.4 (300) | 365.8 (1200) | 365.8 (1200) | 365.8 (1200) | 1321-RWR100-DP | | | | • | | |
| 75 | 2, 4 | 12.2 (40) | 18.3 (60) | 137.2 (450) | 182.9 (600) | 12.2 (40) | 61.0 (200) | 304.8 (1000) | 365.8 (1200) | 91.4 (300) | 365.8 (1200) | 365.8 (1200) | 365.8 (1200) | 1321-RWR100-DP | | | | • | | |
| 100 | 2, 4 | 12.2 (40) | 24.4 (80) | 137.2 (450) | 167.6 (550) | 12.2 (40) | 61.0 (200) | 243.8 (800) | 365.8 (1200) | 91.4 (300) | 365.8 (1200) | 365.8 (1200) | 365.8 (1200) | 1321-RWR160-DP | | | | • | | |
| 125 | 2, 4 | 12.2 (40) | 24.4 (80) | 137.2 (450) | 167.6 (550) | 12.2 (40) | 61.0 (200) | 243.8 (800) | 365.8 (1200) | 76.2 (250) | 304.8 (1000) | 365.8 (1200) | 365.8 (1200) | 1321-RWR200-DP | | | | • | | |
| 150 | 2, 4 | 12.2 (40) | 24.4 (80) | 137.2 (450) | 167.6 (550) | 12.2 (40) | 61.0 (200) | 213.4 (700) | 304.8 (1000) | 76.2 (250) | 304.8 (1000) | 365.8 (1200) | 365.8 (1200) | 1321-RWR200-DP | | | | • | | |
| 200 | 2, 4 | 12.2 (40) | 30.5 (100) | 121.9 (400) | 152.4 (500) | 12.2 (40) | 61.0 (200) | 152.4 (500) | 243.8 (800) | 61.0 (200) | 274.3 (900) | 365.8 (1200) | 365.8 (1200) | 1321-RWR250-DP | | | | • | | |
| 250 | 2, 4 | 12.2 (40) | 30.5 (100) | 121.9 (400) | 152.4 (500) | 12.2 (40) | 45.7 (150) | 152.4 (500) | 213.4 (700) | 61.0 (200) | 274.3 (900) | 365.8 (1200) | 365.8 (1200) | 1321-RWR320-DP | | | | • | | |
| 300 | 2, 4 | 12.2 (40) | 30.5 (100) | 106.7 (350) | 137.2 (450) | 12.2 (40) | 30.5 (100) | 121.9 (400) | 152.4 (500) | 61.0 (200) | 243.8 (800) | 304.8 (1000) | 365.8 (1200) | 1321-3RB400-B | 20 | 495 | | • | | |
| 350 | 2, 4 | 12.2 (40) | 30.5 (100) | 106.7 (350) | 137.2 (450) | 12.2 (40) | 30.5 (100) | 121.9 (400) | 152.4 (500) | 61.0 (200) | 243.8 (800) | 304.8 (1000) | 365.8 (1200) | 1321-3RS500-B | 20 | 495 | | • | | |

PowerFlex 520-Series Drives

This section lists motor cable length restrictions, reactors, and available options for PowerFlex 520-Series Drives.

Table 27 - PowerFlex 520-Series Drives, 400V Shielded/Unshielded Cable – Meters (Feet)

| Drive | | | No Solution | | | | Reactor Only | | | | Reactor and Damping Resistor or 1321-RWR | | | | Reactor/RWR (see page 152) | Resistor | | Available Options | | | | |
|-------|------|-----|-------------|------------|-------------|--------------|--------------|--------------|--------------|--------------|--|--------------|--------------|--------------|----------------------------|----------|-------|-------------------|------|------|-----|---|
| Frame | kW | kHz | 1000V | 1200V | 1488V | 1600V | 1000V | 1200V | 1488V | 1600V | 1000V | 1200V | 1488V | 1600V | Cat. No. | Ohms | Watts | TFAT | TFB2 | RWR2 | RWC | |
| A | 0.4 | 2/4 | 7.6 (25) | 35.1 (115) | 35.1 (115) | 35.1 (115) | 61.0 (200) | 121.9 (400) | 121.9 (400) | 121.9 (400) | 121.9 (400) | 121.9 (400) | 121.9 (400) | 121.9 (400) | | | | • | | • | | |
| | 0.75 | 2/4 | 7.6 (25) | 35.1 (115) | 35.1 (115) | 35.1 (115) | 61.0 (200) | 152.4 (500) | 152.4 (500) | 152.4 (500) | 152.4 (500) | 152.4 (500) | 152.4 (500) | 152.4 (500) | | | | • | | • | | |
| | 1.5 | 2/4 | 7.6 (25) | 83.8 (275) | 83.8 (275) | 83.8 (275) | 61.0 (200) | 152.4 (500) | 152.4 (500) | 152.4 (500) | 152.4 (500) | 152.4 (500) | 152.4 (500) | 152.4 (500) | | | | • | • | • | | |
| | 2.2 | 2/4 | 7.6 (25) | 83.8 (275) | 83.8 (275) | 83.8 (275) | 61.0 (200) | 182.9 (600) | 182.9 (600) | 182.9 (600) | 182.9 (600) | 182.9 (600) | 182.9 (600) | 182.9 (600) | 1321-RWR8-DP | | | | • | • | • | |
| B | 4 | 2/4 | 7.6 (25) | 83.8 (275) | 83.8 (275) | 83.8 (275) | 61.0 (200) | 182.9 (600) | 182.9 (600) | 182.9 (600) | 182.9 (600) | 182.9 (600) | 182.9 (600) | 182.9 (600) | 1321-RWR12-DP | | | | • | • | • | |
| C | 5.5 | 2 | 7.6 (25) | 91.4 (300) | 182.9 (600) | 182.9 (600) | 61.0 (200) | 304.8 (1000) | 304.8 (1000) | 304.8 (1000) | 304.8 (1000) | 304.8 (1000) | 304.8 (1000) | 304.8 (1000) | 1321-RWR18-DP | | | | | • | • | |
| | | 4 | 7.6 (25) | 91.4 (300) | 182.9 (600) | 182.9 (600) | 61.0 (200) | 182.9 (600) | 182.9 (600) | 182.9 (600) | 182.9 (600) | 182.9 (600) | 182.9 (600) | 182.9 (600) | | | | | | | | • |
| | 7.5 | 2 | 7.6 (25) | 91.4 (300) | 182.9 (600) | 182.9 (600) | 61.0 (200) | 304.8 (1000) | 304.8 (1000) | 304.8 (1000) | 304.8 (1000) | 304.8 (1000) | 304.8 (1000) | 304.8 (1000) | 1321-RWR18-DP | | | | | • | • | |
| | | 4 | 7.6 (25) | 91.4 (300) | 182.9 (600) | 182.9 (600) | 61.0 (200) | 182.9 (600) | 182.9 (600) | 182.9 (600) | 182.9 (600) | 182.9 (600) | 182.9 (600) | 182.9 (600) | | | | | | | | • |
| D | 11 | 2 | 7.6 (25) | 91.4 (300) | 243.8 (800) | 365.8 (1200) | 61.0 (200) | 365.8 (1200) | 365.8 (1200) | 365.8 (1200) | 365.8 (1200) | 365.8 (1200) | 365.8 (1200) | 365.8 (1200) | 1321-RWR25-DP | | | | | • | | |
| | | 4 | 7.6 (25) | 91.4 (300) | 182.9 (600) | 182.9 (600) | 61.0 (200) | 182.9 (600) | 182.9 (600) | 182.9 (600) | 182.9 (600) | 182.9 (600) | 182.9 (600) | 182.9 (600) | | | | | | | | |
| | 15 | 2 | 7.6 (25) | 91.4 (300) | 243.8 (800) | 365.8 (1200) | 61.0 (200) | 365.8 (1200) | 365.8 (1200) | 365.8 (1200) | 365.8 (1200) | 365.8 (1200) | 365.8 (1200) | 365.8 (1200) | 1321-RWR35-DP | | | | | • | | |
| | | 4 | 7.6 (25) | 91.4 (300) | 182.9 (600) | 182.9 (600) | 61.0 (200) | 182.9 (600) | 182.9 (600) | 182.9 (600) | 182.9 (600) | 182.9 (600) | 182.9 (600) | 182.9 (600) | | | | | | | | |
| E | 18.5 | 2 | 7.6 (25) | 91.4 (300) | 243.8 (800) | 365.8 (1200) | 61.0 (200) | 365.8 (1200) | 365.8 (1200) | 365.8 (1200) | 365.8 (1200) | 365.8 (1200) | 365.8 (1200) | 365.8 (1200) | 1321-RWR45-DP | | | | | • | | |
| | | 4 | 7.6 (25) | 91.4 (300) | 182.9 (600) | 182.9 (600) | 61.0 (200) | 182.9 (600) | 182.9 (600) | 182.9 (600) | 182.9 (600) | 182.9 (600) | 182.9 (600) | 182.9 (600) | | | | | | | | |
| | 22 | 2 | 7.6 (25) | 91.4 (300) | 243.8 (800) | 365.8 (1200) | 61.0 (200) | 365.8 (1200) | 365.8 (1200) | 365.8 (1200) | 365.8 (1200) | 365.8 (1200) | 365.8 (1200) | 365.8 (1200) | 1321-RWR45-DP | | | | | • | | |
| | | 4 | 7.6 (25) | 91.4 (300) | 182.9 (600) | 182.9 (600) | 61.0 (200) | 182.9 (600) | 182.9 (600) | 182.9 (600) | 182.9 (600) | 182.9 (600) | 182.9 (600) | 182.9 (600) | | | | | | | | |

Table 28 - PowerFlex 520-Series Drives, 480V Shielded/Unshielded Cable – Meters (Feet)

| Drive | | | No Solution | | | | Reactor Only | | | | Reactor and Damping Resistor or 1321-RWR | | | | Reactor/RWR (see page 152) | Resistor | | Available Options | | | |
|-------|-----|-----|-------------|-----------|------------|-------------|--------------|------------|--------------|--------------|--|--------------|--------------|--------------|----------------------------|----------|-------|-------------------|------|------|-----|
| Frame | Hp | kHz | 1000V | 1200V | 1488V | 1600V | 1000V | 1200V | 1488V | 1600V | 1000V | 1200V | 1488V | 1600V | Cat. No. | Ohms | Watts | TFA1 | TFB2 | RWR2 | RWC |
| A | 0.5 | 2/4 | 7.6 (25) | 12.2 (40) | 35.1 (115) | 35.1 (115) | 7.6 (25) | 61.0 (200) | 121.9 (400) | 121.9 (400) | 121.9 (400) | 121.9 (400) | 121.9 (400) | 121.9 (400) | | | | • | | • | |
| | 1 | 2/4 | 7.6 (25) | 12.2 (40) | 35.1 (115) | 35.1 (115) | 7.6 (25) | 61.0 (200) | 152.4 (500) | 152.4 (500) | 152.4 (500) | 152.4 (500) | 152.4 (500) | 152.4 (500) | | | | • | | • | |
| | 2 | 2/4 | 7.6 (25) | 12.2 (40) | 83.8 (275) | 83.8 (275) | 7.6 (25) | 61.0 (200) | 152.4 (500) | 152.4 (500) | 152.4 (500) | 152.4 (500) | 152.4 (500) | 152.4 (500) | | | | • | • | • | |
| | 3 | 2/4 | 7.6 (25) | 12.2 (40) | 83.8 (275) | 83.8 (275) | 7.6 (25) | 61.0 (200) | 182.9 (600) | 182.9 (600) | 182.9 (600) | 182.9 (600) | 182.9 (600) | 182.9 (600) | 1321-RWR8-DP | | | | • | • | • |
| B | 5 | 2/4 | 7.6 (25) | 12.2 (40) | 83.8 (275) | 83.8 (275) | 7.6 (25) | 61.0 (200) | 182.9 (600) | 182.9 (600) | 182.9 (600) | 182.9 (600) | 182.9 (600) | 182.9 (600) | 1321-RWR12-DP | | | | • | • | • |
| C | 7.5 | 2 | 7.6 (25) | 12.2 (40) | 91.4 (300) | 137.2 (450) | 7.6 (25) | 91.4 (300) | 304.8 (1000) | 304.8 (1000) | 182.9 (600) | 304.8 (1000) | 304.8 (1000) | 304.8 (1000) | 1321-RWR18-DP | | | | • | | • |
| | | 4 | 7.6 (25) | 12.2 (40) | 91.4 (300) | 137.2 (450) | 7.6 (25) | 91.4 (300) | 182.9 (600) | 182.9 (600) | 182.9 (600) | 182.9 (600) | 182.9 (600) | 182.9 (600) | | | | | | | • |
| | 10 | 2 | 7.6 (25) | 12.2 (40) | 91.4 (300) | 137.2 (450) | 7.6 (25) | 91.4 (300) | 304.8 (1000) | 304.8 (1000) | 182.9 (600) | 304.8 (1000) | 304.8 (1000) | 304.8 (1000) | 1321-RWR18-DP | | | | • | | • |
| | | 4 | 7.6 (25) | 12.2 (40) | 91.4 (300) | 137.2 (450) | 7.6 (25) | 91.4 (300) | 182.9 (600) | 182.9 (600) | 182.9 (600) | 182.9 (600) | 182.9 (600) | 182.9 (600) | | | | | | | • |
| D | 15 | 2 | 7.6 (25) | 12.2 (40) | 91.4 (300) | 137.2 (450) | 7.6 (25) | 91.4 (300) | 365.8 (1200) | 365.8 (1200) | 182.9 (600) | 365.8 (1200) | 365.8 (1200) | 365.8 (1200) | 1321-RWR25-DP | | | | • | | |
| | | 4 | 7.6 (25) | 12.2 (40) | 91.4 (300) | 137.2 (450) | 7.6 (25) | 91.4 (300) | 182.9 (600) | 182.9 (600) | 182.9 (600) | 182.9 (600) | 182.9 (600) | 182.9 (600) | | | | | | | |
| | 20 | 2 | 7.6 (25) | 12.2 (40) | 91.4 (300) | 137.2 (450) | 7.6 (25) | 91.4 (300) | 365.8 (1200) | 365.8 (1200) | 182.9 (600) | 365.8 (1200) | 365.8 (1200) | 365.8 (1200) | 1321-RWR35-DP | | | | • | | |
| | | 4 | 7.6 (25) | 12.2 (40) | 91.4 (300) | 137.2 (450) | 7.6 (25) | 91.4 (300) | 182.9 (600) | 182.9 (600) | 182.9 (600) | 182.9 (600) | 182.9 (600) | 182.9 (600) | | | | | | | |
| E | 25 | 2 | 7.6 (25) | 12.2 (40) | 91.4 (300) | 137.2 (450) | 7.6 (25) | 91.4 (300) | 365.8 (1200) | 365.8 (1200) | 182.9 (600) | 365.8 (1200) | 365.8 (1200) | 365.8 (1200) | 1321-RWR45-DP | | | | • | | |
| | | 4 | 7.6 (25) | 12.2 (40) | 91.4 (300) | 137.2 (450) | 7.6 (25) | 91.4 (300) | 182.9 (600) | 182.9 (600) | 182.9 (600) | 182.9 (600) | 182.9 (600) | 182.9 (600) | | | | | | | |
| | 30 | 2 | 7.6 (25) | 12.2 (40) | 91.4 (300) | 137.2 (450) | 7.6 (25) | 91.4 (300) | 365.8 (1200) | 365.8 (1200) | 182.9 (600) | 365.8 (1200) | 365.8 (1200) | 365.8 (1200) | 1321-RWR45-DP | | | | • | | |
| | | 4 | 7.6 (25) | 12.2 (40) | 91.4 (300) | 137.2 (450) | 7.6 (25) | 91.4 (300) | 182.9 (600) | 182.9 (600) | 182.9 (600) | 182.9 (600) | 182.9 (600) | 182.9 (600) | | | | | | | |

Table 29 - PowerFlex 520-Series Drives, 600V Shielded/Unshielded Cable – Meters (Feet)

| Drive | | | No Solution | | Reactor Only | | Reactor and Damping Resistor or 1321-RWR | | Reactor/RWR (see page 152) | Resistor | | Available Options | | | |
|-------|-----|-----|-------------|-------------|--------------|--------------|--|--------------|----------------------------|----------|-------|-------------------|------|------|-----|
| Frame | Hp | kHz | 1488V | 1850V | 1488V | 1850V | 1488V | 1850V | Cat. No. | Ohms | Watts | TFA1 | TFB2 | RWR2 | RWC |
| A | 0.5 | 2/4 | 12.2 (40) | 35.1 (115) | 76.2 (250) | 121.9 (400) | 121.9 (400) | 121.9 (400) | | | | • | | • | |
| | 1 | 2/4 | 12.2 (40) | 35.1 (115) | 76.2 (250) | 121.9 (400) | 121.9 (400) | 121.9 (400) | | | | • | | • | |
| | 2 | 2/4 | 12.2 (40) | 83.8 (275) | 76.2 (250) | 152.4 (500) | 152.4 (500) | 152.4 (500) | | | | • | • | • | |
| | 3 | 2/4 | 12.2 (40) | 83.8 (275) | 76.2 (250) | 152.4 (500) | 152.4 (500) | 152.4 (500) | 1321-RWR8-EP | | | • | • | • | |
| B | 5 | 2/4 | 12.2 (40) | 83.8 (275) | 76.2 (250) | 152.4 (500) | 152.4 (500) | 152.4 (500) | 1321-RWR8-EP | | | • | • | | • |
| C | 7.5 | 2 | 22.9 (75) | 152.4 (500) | 76.2 (250) | 304.8 (1000) | 304.8 (1000) | 304.8 (1000) | 1321-RWR12-EP | | | | • | | • |
| | | 4 | 22.9 (75) | 152.4 (500) | 76.2 (250) | 182.9 (600) | 182.9 (600) | 182.9 (600) | | | | | | | • |
| | 10 | 2 | 22.9 (75) | 152.4 (500) | 76.2 (250) | 304.8 (1000) | 304.8 (1000) | 304.8 (1000) | 1321-RWR12-EP | | | | • | | • |
| | | 4 | 22.9 (75) | 152.4 (500) | 76.2 (250) | 182.9 (600) | 182.9 (600) | 182.9 (600) | | | | | | | • |
| D | 15 | 2 | 30.5 (100) | 152.4 (500) | 76.2 (250) | 365.8 (1200) | 365.8 (1200) | 365.8 (1200) | 1321-RWR25-EP | | | | • | | |
| | | 4 | 30.5 (100) | 152.4 (500) | 76.2 (250) | 182.9 (600) | 182.9 (600) | 182.9 (600) | | | | | | | |
| | 20 | 2 | 30.5 (100) | 152.4 (500) | 76.2 (250) | 365.8 (1200) | 365.8 (1200) | 365.8 (1200) | 1321-RWR25-EP | | | | • | | |
| | | 4 | 30.5 (100) | 152.4 (500) | 76.2 (250) | 182.9 (600) | 182.9 (600) | 182.9 (600) | | | | | | | |
| E | 25 | 2 | 30.5 (100) | 152.4 (500) | 76.2 (250) | 365.8 (1200) | 365.8 (1200) | 365.8 (1200) | 1321-RWR35-EP | | | | • | | |
| | | 4 | 30.5 (100) | 152.4 (500) | 76.2 (250) | 182.9 (600) | 182.9 (600) | 182.9 (600) | | | | | | | |
| | 30 | 2 | 30.5 (100) | 152.4 (500) | 76.2 (250) | 365.8 (1200) | 365.8 (1200) | 365.8 (1200) | 1321-RWR35-EP | | | | • | | |
| | | 4 | 30.5 (100) | 152.4 (500) | 76.2 (250) | 182.9 (600) | 182.9 (600) | 182.9 (600) | | | | | | | |

PowerFlex 70 and 700 Drives

This section lists motor cable length restrictions, reactors, and available options for PowerFlex 70 and 700 Drives.

Table 30 - PowerFlex 70 (standard/enhanced) and 700 (standard/vector) Drives, 400V Shielded/Unshielded Cable – Meters (Feet)

| Drive Frame | Rating | | No Solution | | | | Reactor Only | | | | Reactor and Damping Resistor or 1321-RWR | | | | Reactor/RWR (see page 152) | Resistor | | Available Options | | | | |
|-------------|--------|-------------|----------------|-----------------|-----------------|-----------------|-----------------|-----------------|-----------------|-----------------|--|-----------------|-----------------|-----------------|----------------------------|----------|-------|-------------------|-----|------|-----|--|
| | kW | kHz | 1000V | 1200V | 1488V | 1600V | 1000V | 1200V | 1488V | 1600V | 1000V | 1200V | 1488V | 1600V | Cat. No. | Ohms | Watts | TF1 | TF2 | RWR2 | RWC | |
| A | 0 | 0.37 | 2 | 7.6 (25) | 53.3 (175) | 53.3 (175) | 53.3 (175) | 91.4 (300) | 121.9 (400) | 121.9 (400) | 121.9 (400) | 121.9 (400) | 121.9 (400) | 121.9 (400) | | | | | | | | |
| | | 4 | 7.6 (25) | 53.3 (175) | 53.3 (175) | 53.3 (175) | 18.3 (60) | 91.4 (300) | 121.9 (400) | 121.9 (400) | 121.9 (400) | 121.9 (400) | 121.9 (400) | 121.9 (400) | | | | | | | | |
| | 0.75 | 2 | 7.6 (25) | 83.8 (275) | 83.8 (275) | 83.8 (275) | 91.4 (300) | 152.4 (500) | 152.4 (500) | 152.4 (500) | 152.4 (500) | 152.4 (500) | 152.4 (500) | 152.4 (500) | | | | | | | | |
| | | 4 | 7.6 (25) | 76.2 (250) | 76.2 (250) | 76.2 (250) | 18.3 (60) | 91.4 (300) | 152.4 (500) | 152.4 (500) | 152.4 (500) | 152.4 (500) | 152.4 (500) | 152.4 (500) | | | | | | | | |
| | 1.5 | 2 | 7.6 (25) | 83.8 (275) | 83.8 (275) | 83.8 (275) | 91.4 (300) | 182.9 (600) | 182.9 (600) | 182.9 (600) | 182.9 (600) | 182.9 (600) | 182.9 (600) | 182.9 (600) | | | | | | | | |
| | | 4 | 7.6 (25) | 76.2 (250) | 76.2 (250) | 76.2 (250) | 18.3 (60) | 91.4 (300) | 182.9 (600) | 182.9 (600) | 182.9 (600) | 182.9 (600) | 182.9 (600) | 182.9 (600) | | | | | | | | |
| B | 2.2 | 2 | 7.6 (25) | 137.2 (450) | 182.9 (600) | 182.9 (600) | 91.4 (300) | 182.9 (600) | 182.9 (600) | 182.9 (600) | 182.9 (600) | 182.9 (600) | 182.9 (600) | 182.9 (600) | | | | | | | | |
| | | 4 | 7.6 (25) | 91.4 (300) | 152.4 (500) | 182.9 (600) | 18.3 (60) | 91.4 (300) | 182.9 (600) | 182.9 (600) | 182.9 (600) | 182.9 (600) | 182.9 (600) | 182.9 (600) | | | | | | | | |
| | 4 | 2 | 7.6 (25) | 137.2 (450) | 243.8 (800) | 243.8 (800) | 91.4 (300) | 243.8 (800) | 243.8 (800) | 243.8 (800) | 243.8 (800) | 243.8 (800) | 243.8 (800) | 243.8 (800) | 1321-RWR8-DP | | | | | | | |
| | | 4 | 7.6 (25) | 91.4 (300) | 152.4 (500) | 213.4 (700) | 18.3 (60) | 91.4 (300) | 243.8 (800) | 243.8 (800) | 182.9 (600) | 243.8 (800) | 243.8 (800) | 243.8 (800) | 1321-RWR8-DP | | | | | | | |
| C | 5.5 | 2 | 7.6 (25) | 137.2 (450) | 304.8 (1000) | 304.8 (1000) | 91.4 (300) | 304.8 (1000) | 304.8 (1000) | 304.8 (1000) | 304.8 (1000) | 304.8 (1000) | 304.8 (1000) | 304.8 (1000) | 1321-RWR12-DP | | | | | | | |
| | | 4 | 7.6 (25) | 91.4 (300) | 152.4 (500) | 213.4 (700) | 18.3 (60) | 91.4 (300) | 304.8 (1000) | 304.8 (1000) | 182.9 (600) | 304.8 (1000) | 304.8 (1000) | 304.8 (1000) | 1321-RWR12-DP | | | | | | | |
| 1 | 7.5 | 2 | 7.6 (25) | 137.2 (450) | 365.8 (1200) | 365.8 (1200) | 91.4 (300) | 365.8 (1200) | 365.8 (1200) | 365.8 (1200) | 365.8 (1200) | 365.8 (1200) | 365.8 (1200) | 365.8 (1200) | 1321-RWR18-DP | | | | | | | |
| | | 4 | 7.6 (25) | 91.4 (300) | 152.4 (500) | 213.4 (700) | 18.3 (60) | 91.4 (300) | 365.8 (1200) | 365.8 (1200) | 182.9 (600) | 304.8 (1000) | 365.8 (1200) | 365.8 (1200) | 1321-RWR18-DP | | | | | | | |
| D | 11 | 2 | 7.6 (25) | 137.2 (450) | 365.8 (1200) | 365.8 (1200) | 91.4 (300) | 365.8 (1200) | 365.8 (1200) | 365.8 (1200) | 365.8 (1200) | 365.8 (1200) | 365.8 (1200) | 365.8 (1200) | 1321-RWR25-DP | | | | | | | |
| | | 4 | 7.6 (25) | 91.4 (300) | 152.4 (500) | 213.4 (700) | 18.3 (60) | 91.4 (300) | 365.8 (1200) | 365.8 (1200) | 182.9 (600) | 304.8 (1000) | 365.8 (1200) | 365.8 (1200) | 1321-RWR25-DP | | | | | | | |
| | 2 | 15 | 2 | 7.6 (25) | 137.2 (450) | 365.8 (1200) | 365.8 (1200) | 91.4 (300) | 365.8 (1200) | 365.8 (1200) | 365.8 (1200) | 365.8 (1200) | 365.8 (1200) | 365.8 (1200) | 1321-RWR35-DP | | | | | | | |
| | | 4 | 7.6 (25) | 91.4 (300) | 152.4 (500) | 213.4 (700) | 18.3 (60) | 91.4 (300) | 365.8 (1200) | 365.8 (1200) | 182.9 (600) | 304.8 (1000) | 365.8 (1200) | 365.8 (1200) | 1321-RWR35-DP | | | | | | | |
| 18.5 | 2 | 7.6 (25) | 137.2 (450) | 365.8 (1200) | 365.8 (1200) | 91.4 (300) | 365.8 (1200) | 365.8 (1200) | 365.8 (1200) | 365.8 (1200) | 365.8 (1200) | 365.8 (1200) | 365.8 (1200) | 1321-RWR35-DP | | | | | | | | |
| | 4 | 7.6 (25) | 91.4 (300) | 152.4 (500) | 213.4 (700) | 18.3 (60) | 91.4 (300) | 365.8 (1200) | 365.8 (1200) | 182.9 (600) | 304.8 (1000) | 365.8 (1200) | 365.8 (1200) | 1321-RWR35-DP | | | | | | | | |
| 3 | 22 | 2 | 7.6 (25) | 137.2 (450) | 365.8 (1200) | 365.8 (1200) | 91.4 (300) | 365.8 (1200) | 365.8 (1200) | 365.8 (1200) | 365.8 (1200) | 365.8 (1200) | 365.8 (1200) | 365.8 (1200) | 1321-RWR45-DP | | | | | | | |
| | | 4 | 7.6 (25) | 91.4 (300) | 152.4 (500) | 213.4 (700) | 18.3 (60) | 91.4 (300) | 365.8 (1200) | 365.8 (1200) | 182.9 (600) | 304.8 (1000) | 365.8 (1200) | 365.8 (1200) | 1321-RWR45-DP | | | | | | | |
| E | 30 | 2 | 7.6 (25) | 137.2 (450) | 304.8 (1000) | 365.8 (1200) | 91.4 (300) | 365.8 (1200) | 365.8 (1200) | 365.8 (1200) | 365.8 (1200) | 365.8 (1200) | 365.8 (1200) | 365.8 (1200) | 1321-RWR55-DP | | | | | | | |
| | | 4 | 7.6 (25) | 91.4 (300) | 152.4 (500) | 213.4 (700) | 18.3 (60) | 91.4 (300) | 365.8 (1200) | 365.8 (1200) | 182.9 (600) | 304.8 (1000) | 365.8 (1200) | 365.8 (1200) | 1321-RWR55-DP | | | | | | | |
| | 37 | 2 | 12.2 (40) | 137.2 (450) | 304.8 (1000) | 365.8 (1200) | 91.4 (300) | 365.8 (1200) | 365.8 (1200) | 365.8 (1200) | 365.8 (1200) | 365.8 (1200) | 365.8 (1200) | 365.8 (1200) | 1321-RWR80-DP | | | | | | | |
| | | 4 | 12.2 (40) | 91.4 (300) | 152.4 (500) | 213.4 (700) | 18.3 (60) | 91.4 (300) | 365.8 (1200) | 365.8 (1200) | 182.9 (600) | 304.8 (1000) | 365.8 (1200) | 365.8 (1200) | 1321-RWR80-DP | | | | | | | |
| 4 | 45 | 2 | 12.2 (40) | 137.2 (450) | 304.8 (1000) | 365.8 (1200) | 91.4 (300) | 304.8 (1000) | 365.8 (1200) | 365.8 (1200) | 365.8 (1200) | 365.8 (1200) | 365.8 (1200) | 365.8 (1200) | 1321-RWR80-DP | | | | | | | |
| | | 4 | 12.2 (40) | 91.4 (300) | 152.4 (500) | 213.4 (700) | 24.4 (80) | 91.4 (300) | 365.8 (1200) | 365.8 (1200) | 152.4 (500) | 304.8 (1000) | 365.8 (1200) | 365.8 (1200) | 1321-RWR80-DP | | | | | | | |

Table 30 - PowerFlex 70 (standard/enhanced) and 700 (standard/vector) Drives, 400V Shielded/Unshielded Cable – Meters (Feet) (Continued)

| 70 | 700 | Rating | | No Solution | | | | Reactor Only | | | | Reactor and Damping Resistor or 1321-RWR | | | | Reactor/RWR (see page 152) | Resistor | | Available Options | | | | | |
|-----|-----|--------|-----------|-------------|--------------|--------------|--------------|--------------|--------------|--------------|--------------|--|--------------|--------------|------------------------------|-----------------------------|----------|-------|-------------------|------|------|-----|--|--|
| | | kW | kHz | 1000V | 1200V | 1488V | 1600V | 1000V | 1200V | 1488V | 1600V | 1000V | 1200V | 1488V | 1600V | Cat. No. | Ohms | Watts | TFA1 | TFB2 | RWR2 | RWC | | |
| 5 | 55 | 2 | 12.2 (40) | 137.2 (450) | 304.8 (1000) | 365.8 (1200) | 91.4 (300) | 274.3 (900) | 365.8 (1200) | 365.8 (1200) | 365.8 (1200) | 365.8 (1200) | 365.8 (1200) | 365.8 (1200) | 1321-RWR100-DP | | | | | | | | | |
| | | | 4 | 12.2 (40) | 91.4 (300) | 152.4 (500) | 213.4 (700) | 24.4 (80) | 91.4 (300) | 365.8 (1200) | 365.8 (1200) | 152.4 (500) | 304.8 (1000) | 365.8 (1200) | 365.8 (1200) | 1321-RWR100-DP | | | | | | | | |
| | | 75 | 2 | 18.3 (60) | 137.2 (450) | 304.8 (1000) | 365.8 (1200) | 91.4 (300) | 213.4 (700) | 365.8 (1200) | 365.8 (1200) | 365.8 (1200) | 365.8 (1200) | 365.8 (1200) | 365.8 (1200) | 1321-RWR130-DP | | | | | | | | |
| | | | 4 | 18.3 (60) | 91.4 (300) | 152.4 (500) | 213.4 (700) | 30.5 (100) | 91.4 (300) | 304.8 (1000) | 365.8 (1200) | 152.4 (500) | 304.8 (1000) | 365.8 (1200) | 365.8 (1200) | 1321-RWR130-DP | | | | | | | | |
| | 6 | 90 | 2 | 18.3 (60) | 137.2 (450) | 304.8 (1000) | 365.8 (1200) | 91.4 (300) | 213.4 (700) | 365.8 (1200) | 365.8 (1200) | 304.8 (1000) | 365.8 (1200) | 365.8 (1200) | 365.8 (1200) | 1321-RWR160-DP | | | | | | | | |
| | | | 4 | 18.3 (60) | 91.4 (300) | 152.4 (500) | 213.4 (700) | 30.5 (100) | 91.4 (300) | 365.8 (1200) | 365.8 (1200) | 121.9 (400) | 243.8 (800) | 365.8 (1200) | 365.8 (1200) | 1321-RWR160-DP | | | | | | | | |
| | | 110 | 2 | 24.4 (80) | 137.2 (450) | 274.3 (900) | 365.8 (1200) | 76.2 (250) | 198.1 (650) | 365.8 (1200) | 365.8 (1200) | 274.3 (900) | 365.8 (1200) | 365.8 (1200) | 365.8 (1200) | 1321-RWR200-DP | | | | | | | | |
| | | | 4 | 24.4 (80) | 91.4 (300) | 152.4 (500) | 213.4 (700) | 36.6 (120) | 91.4 (300) | 365.8 (1200) | 365.8 (1200) | 121.9 (400) | 213.4 (700) | 365.8 (1200) | 365.8 (1200) | 1321-RWR200-DP | | | | | | | | |
| 132 | | 2 | 24.4 (80) | 137.2 (450) | 274.3 (900) | 365.8 (1200) | 61.0 (200) | 182.9 (600) | 365.8 (1200) | 365.8 (1200) | 243.8 (800) | 365.8 (1200) | 365.8 (1200) | 365.8 (1200) | 1321-RWR250-DP | | | | | | | | | |
| | | 4 | 24.4 (80) | 91.4 (300) | 152.4 (500) | 213.4 (700) | 36.6 (120) | 91.4 (300) | 365.8 (1200) | 365.8 (1200) | 91.4 (300) | 182.9 (600) | 365.8 (1200) | 365.8 (1200) | 1321-RWR250-DP | | | | | | | | | |
| 7 | 160 | 2 | 24.4 (80) | 121.9 (400) | 243.8 (800) | 365.8 (1200) | 61.0 (200) | 152.4 (500) | 304.8 (1000) | 365.8 (1200) | 243.8 (800) | 365.8 (1200) | 365.8 (1200) | 365.8 (1200) | 1321-3RB320-B | 50 | 225 | | | | | | | |
| | | 4 | 24.4 (80) | 91.4 (300) | 152.4 (500) | 182.9 (600) | 36.6 (120) | 91.4 (300) | 182.9 (600) | 274.3 (900) | 91.4 (300) | 182.9 (600) | 365.8 (1200) | 365.8 (1200) | 1321-3RB320-B | 50 | 450 | | | | | | | |
| | 180 | 2 | 24.4 (80) | 121.9 (400) | 243.8 (800) | 365.8 (1200) | 61.0 (200) | 152.4 (500) | 304.8 (1000) | 365.8 (1200) | 243.8 (800) | 365.8 (1200) | 365.8 (1200) | 365.8 (1200) | 1321-3RB320-B | 50 | 225 | | | | | | | |
| | | 4 | 24.4 (80) | 91.4 (300) | 152.4 (500) | 182.9 (600) | 36.6 (120) | 91.4 (300) | 182.9 (600) | 274.3 (900) | 91.4 (300) | 182.9 (600) | 365.8 (1200) | 365.8 (1200) | 1321-3RB320-B | 50 | 450 | | | | | | | |
| 8 | 200 | 2 | 24.4 (80) | 121.9 (400) | 243.8 (800) | 365.8 (1200) | 61.0 (200) | 152.4 (500) | 304.8 (1000) | 365.8 (1200) | 243.8 (800) | 365.8 (1200) | 365.8 (1200) | 365.8 (1200) | 1321-3RB400-B ⁽¹⁾ | 20 | 495 | | | | | | | |
| | | 4 | 24.4 (80) | 91.4 (300) | 152.4 (500) | 182.9 (600) | 36.6 (120) | 91.4 (300) | 182.9 (600) | 228.6 (750) | 91.4 (300) | 182.9 (600) | 304.8 (1000) | 365.8 (1200) | 1321-3RB400-B ⁽¹⁾ | 20 | 990 | | | | | | | |
| | 240 | 2 | 24.4 (80) | 121.9 (400) | 243.8 (800) | 365.8 (1200) | 61.0 (200) | 152.4 (500) | 304.8 (1000) | 365.8 (1200) | 243.8 (800) | 365.8 (1200) | 365.8 (1200) | 365.8 (1200) | 1321-3R400-B ⁽¹⁾ | 20 | 495 | | | | | | | |
| | | 4 | 24.4 (80) | 91.4 (300) | 152.4 (500) | 182.9 (600) | 36.6 (120) | 91.4 (300) | 167.6 (550) | 213.4 (700) | 91.4 (300) | 182.9 (600) | 304.8 (1000) | 365.8 (1200) | 1321-3RB400-B ⁽¹⁾ | 20 | 990 | | | | | | | |
| | 280 | 2 | 24.4 (80) | 121.9 (400) | 213.4 (700) | 304.8 (1000) | 45.7 (150) | 121.9 (400) | 304.8 (1000) | 365.8 (1200) | 228.6 (750) | 365.8 (1200) | 365.8 (1200) | 365.8 (1200) | 1321-3R500-B ⁽¹⁾ | 20 | 495 | | | | | | | |
| | | 4 | 24.4 (80) | 91.4 (300) | 152.4 (500) | 182.9 (600) | 36.6 (120) | 91.4 (300) | 167.6 (550) | 213.4 (700) | 91.4 (300) | 182.9 (600) | 304.8 (1000) | 365.8 (1200) | 1321-3R500-B ⁽¹⁾ | 20 | 990 | | | | | | | |
| | 300 | 2 | 24.4 (80) | 121.9 (400) | 213.4 (700) | 259.1 (850) | 45.7 (150) | 121.9 (400) | 304.8 (1000) | 365.8 (1200) | 228.6 (750) | 365.8 (1200) | 365.8 (1200) | 365.8 (1200) | 1321-3R600-B ⁽¹⁾ | 20 | 495 | | | | | | | |
| | | | 4 | 24.4 (80) | 91.4 (300) | 152.4 (500) | 182.9 (600) | 36.6 (120) | 91.4 (300) | 167.6 (550) | 213.4 (700) | 91.4 (300) | 182.9 (600) | 304.8 (1000) | 365.8 (1200) | 1321-3R600-B ⁽¹⁾ | 20 | 990 | | | | | | |
| | | 350 | 2 | 24.4 (80) | 121.9 (400) | 213.4 (700) | 259.1 (850) | 45.7 (150) | 121.9 (400) | 304.8 (1000) | 365.8 (1200) | 228.6 (750) | 304.8 (1000) | 365.8 (1200) | 365.8 (1200) | 1321-3R600-B ⁽¹⁾ | 20 | 495 | | | | | | |
| | | | 4 | 24.4 (80) | 91.4 (300) | 152.4 (500) | 182.9 (600) | 36.6 (120) | 91.4 (300) | 167.6 (550) | 213.4 (700) | 91.4 (300) | 182.9 (600) | 304.8 (1000) | 365.8 (1200) | 1321-3R600-B ⁽¹⁾ | 20 | 990 | | | | | | |
| 9 | 400 | 2 | 24.4 (80) | 91.4 (300) | 152.4 (500) | 213.4 (700) | 36.6 (120) | 91.4 (300) | 304.8 (1000) | 365.8 (1200) | 198.1 (650) | 274.3 (900) | 365.8 (1200) | 365.8 (1200) | 1321-3R750-B ⁽²⁾ | 20 | 735 | | | | | | | |
| | | 4 | 24.4 (80) | 91.4 (300) | 137.2 (450) | 167.6 (550) | 36.6 (120) | 91.4 (300) | 152.4 (500) | 182.9 (600) | 76.2 (250) | 137.2 (450) | 274.3 (900) | 365.8 (1200) | 1321-3R750-B ⁽²⁾ | 20 | 1470 | | | | | | | |
| 10 | 500 | 2 | 24.4 (80) | 91.4 (300) | 152.4 (500) | 213.4 (700) | 36.6 (120) | 91.4 (300) | 304.8 (1000) | 365.8 (1200) | 198.1 (650) | 274.3 (900) | 365.8 (1200) | 365.8 (1200) | 1321-3R850-B ⁽²⁾ | 20 | 735 | | | | | | | |
| | | 4 | 24.4 (80) | 91.4 (300) | 137.2 (450) | 167.6 (550) | 36.6 (120) | 91.4 (300) | 152.4 (500) | 182.9 (600) | 76.2 (250) | 137.2 (450) | 274.3 (900) | 365.8 (1200) | 1321-3R850-B ⁽²⁾ | 20 | 1470 | | | | | | | |

(1) Requires two parallel cables.
 (2) Requires three parallel cables.

Table 31 - PowerFlex 70 (standard/enhanced) and 700 (standard/vector) Drives, 480V Shielded/Unshielded Cable – Meters (Feet)

| Drive Frame | Rating | | No Solution | | | | Reactor Only | | | | Reactor and Damping Resistor or 1321-RWR | | | | Reactor/RWR (see page 152) | Resistor | | Available Options | | | | | | |
|-------------|--------|-----|-------------|-----------|-------------|-------------|--------------|------------|--------------|--------------|--|--------------|--------------|--------------|----------------------------|--------------|---------------|-------------------|-------|------|------|------|-----|---|
| | 70 | 700 | Hp | kHz | 1000V | 1200V | 1488V | 1600V | 1000V | 1200V | 1488V | 1600V | 1000V | 1200V | 1488V | 1600V | Cat. No. | Ohms | Watts | TFAT | TFB2 | RWR2 | RWC | |
| A | 0 | 0.5 | 2 | 7.6 (25) | 12.2 (40) | 53.3 (175) | 53.3 (175) | 7.6 (25) | 91.4 (300) | 121.9 (400) | 121.9 (400) | 121.9 (400) | 121.9 (400) | 121.9 (400) | 121.9 (400) | 121.9 (400) | | | | • | | • | • | |
| | | | 4 | 7.6 (25) | 12.2 (40) | 53.3 (175) | 53.3 (175) | 7.6 (25) | 12.2 (40) | 121.9 (400) | 121.9 (400) | 121.9 (400) | 121.9 (400) | 121.9 (400) | 121.9 (400) | 121.9 (400) | 121.9 (400) | | | | | | • | • |
| | | 1 | 2 | 7.6 (25) | 12.2 (40) | 83.8 (275) | 83.8 (275) | 7.6 (25) | 91.4 (300) | 152.4 (500) | 152.4 (500) | 152.4 (500) | 152.4 (500) | 152.4 (500) | 152.4 (500) | 152.4 (500) | 152.4 (500) | | | | • | | • | • |
| | | | 4 | 7.6 (25) | 12.2 (40) | 76.2 (250) | 76.2 (250) | 7.6 (25) | 12.2 (40) | 121.9 (400) | 152.4 (500) | 152.4 (500) | 152.4 (500) | 152.4 (500) | 152.4 (500) | 152.4 (500) | 152.4 (500) | | | | | | • | • |
| | | 2 | 2 | 7.6 (25) | 12.2 (40) | 83.8 (275) | 83.8 (275) | 7.6 (25) | 91.4 (300) | 182.9 (600) | 182.9 (600) | 182.9 (600) | 182.9 (600) | 182.9 (600) | 182.9 (600) | 182.9 (600) | 182.9 (600) | | | | • | • | • | • |
| | | | 4 | 7.6 (25) | 12.2 (40) | 76.2 (250) | 76.2 (250) | 7.6 (25) | 12.2 (40) | 121.9 (400) | 182.9 (600) | 182.9 (600) | 182.9 (600) | 182.9 (600) | 182.9 (600) | 182.9 (600) | 182.9 (600) | | | | | | • | • |
| B | 3 | 2 | 7.6 (25) | 12.2 (40) | 129.5 (425) | 129.5 (425) | 7.6 (25) | 91.4 (300) | 182.9 (600) | 182.9 (600) | 182.9 (600) | 182.9 (600) | 182.9 (600) | 182.9 (600) | 182.9 (600) | 182.9 (600) | | | | • | • | • | • | |
| | | 4 | 7.6 (25) | 12.2 (40) | 121.9 (400) | 121.9 (400) | 7.6 (25) | 12.2 (40) | 121.9 (400) | 182.9 (600) | 182.9 (600) | 182.9 (600) | 182.9 (600) | 182.9 (600) | 182.9 (600) | 182.9 (600) | | | | | | • | • | |
| | 5 | 2 | 7.6 (25) | 12.2 (40) | 137.2 (450) | 182.9 (600) | 7.6 (25) | 91.4 (300) | 243.8 (800) | 243.8 (800) | 182.9 (600) | 243.8 (800) | 243.8 (800) | 243.8 (800) | 243.8 (800) | 243.8 (800) | 1321-RWR8-DP | | | | • | • | • | • |
| | | 4 | 7.6 (25) | 12.2 (40) | 121.9 (400) | 182.9 (600) | 7.6 (25) | 12.2 (40) | 121.9 (400) | 243.8 (800) | 182.9 (600) | 243.8 (800) | 243.8 (800) | 243.8 (800) | 243.8 (800) | 243.8 (800) | 1321-RWR8-DP | | | | | | • | • |
| C | 7.5 | 2 | 7.6 (25) | 12.2 (40) | 137.2 (450) | 182.9 (600) | 7.6 (25) | 91.4 (300) | 304.8 (1000) | 304.8 (1000) | 182.9 (600) | 304.8 (1000) | 304.8 (1000) | 304.8 (1000) | 304.8 (1000) | 304.8 (1000) | 1321-RWR12-DP | | | | | | • | • |
| | | 4 | 7.6 (25) | 12.2 (40) | 121.9 (400) | 182.9 (600) | 7.6 (25) | 12.2 (40) | 121.9 (400) | 304.8 (1000) | 182.9 (600) | 304.8 (1000) | 304.8 (1000) | 304.8 (1000) | 304.8 (1000) | 304.8 (1000) | 1321-RWR12-DP | | | | | | • | • |
| 1 | 10 | 2 | 7.6 (25) | 12.2 (40) | 137.2 (450) | 182.9 (600) | 7.6 (25) | 91.4 (300) | 365.8 (1200) | 365.8 (1200) | 182.9 (600) | 365.8 (1200) | 365.8 (1200) | 365.8 (1200) | 365.8 (1200) | 365.8 (1200) | 1321-RWR18-DP | | | | | | • | • |
| | | 4 | 7.6 (25) | 12.2 (40) | 121.9 (400) | 182.9 (600) | 7.6 (25) | 12.2 (40) | 121.9 (400) | 365.8 (1200) | 182.9 (600) | 365.8 (1200) | 365.8 (1200) | 365.8 (1200) | 365.8 (1200) | 365.8 (1200) | 1321-RWR18-DP | | | | | | • | • |
| D | 15 | 2 | 7.6 (25) | 12.2 (40) | 137.2 (450) | 182.9 (600) | 7.6 (25) | 91.4 (300) | 365.8 (1200) | 365.8 (1200) | 182.9 (600) | 365.8 (1200) | 365.8 (1200) | 365.8 (1200) | 365.8 (1200) | 365.8 (1200) | 1321-RWR25-DP | | | | | | • | • |
| | | 4 | 7.6 (25) | 12.2 (40) | 121.9 (400) | 182.9 (600) | 7.6 (25) | 12.2 (40) | 121.9 (400) | 365.8 (1200) | 182.9 (600) | 365.8 (1200) | 365.8 (1200) | 365.8 (1200) | 365.8 (1200) | 365.8 (1200) | 1321-RWR25-DP | | | | | | • | • |
| 2 | 20 | 2 | 7.6 (25) | 12.2 (40) | 137.2 (450) | 182.9 (600) | 7.6 (25) | 91.4 (300) | 365.8 (1200) | 365.8 (1200) | 182.9 (600) | 365.8 (1200) | 365.8 (1200) | 365.8 (1200) | 365.8 (1200) | 365.8 (1200) | 1321-RWR35-DP | | | | | | • | • |
| | | 4 | 7.6 (25) | 12.2 (40) | 121.9 (400) | 182.9 (600) | 7.6 (25) | 12.2 (40) | 121.9 (400) | 365.8 (1200) | 182.9 (600) | 365.8 (1200) | 365.8 (1200) | 365.8 (1200) | 365.8 (1200) | 365.8 (1200) | 1321-RWR35-DP | | | | | | • | • |
| | 25 | 2 | 7.6 (25) | 12.2 (40) | 137.2 (450) | 182.9 (600) | 7.6 (25) | 76.2 (250) | 365.8 (1200) | 365.8 (1200) | 182.9 (600) | 365.8 (1200) | 365.8 (1200) | 365.8 (1200) | 365.8 (1200) | 365.8 (1200) | 1321-RWR35-DP | | | | | | • | • |
| | | 4 | 7.6 (25) | 12.2 (40) | 121.9 (400) | 182.9 (600) | 7.6 (25) | 12.2 (40) | 121.9 (400) | 274.3 (900) | 152.4 (500) | 304.8 (1000) | 365.8 (1200) | 365.8 (1200) | 365.8 (1200) | 365.8 (1200) | 1321-RWR35-DP | | | | | | • | • |
| 3 | 30 | 2 | 7.6 (25) | 12.2 (40) | 137.2 (450) | 182.9 (600) | 7.6 (25) | 76.2 (250) | 365.8 (1200) | 365.8 (1200) | 182.9 (600) | 365.8 (1200) | 365.8 (1200) | 365.8 (1200) | 365.8 (1200) | 365.8 (1200) | 1321-RWR45-DP | | | | | | • | • |
| | | 4 | 7.6 (25) | 12.2 (40) | 121.9 (400) | 182.9 (600) | 7.6 (25) | 12.2 (40) | 121.9 (400) | 243.8 (800) | 152.4 (500) | 304.8 (1000) | 365.8 (1200) | 365.8 (1200) | 365.8 (1200) | 365.8 (1200) | 1321-RWR45-DP | | | | | | • | • |
| E | 40 | 2 | 7.6 (25) | 12.2 (40) | 137.2 (450) | 182.9 (600) | 7.6 (25) | 76.2 (250) | 365.8 (1200) | 365.8 (1200) | 152.4 (500) | 365.8 (1200) | 365.8 (1200) | 365.8 (1200) | 365.8 (1200) | 365.8 (1200) | 1321-RWR55-DP | | | | | | • | • |
| | | 4 | 7.6 (25) | 12.2 (40) | 106.7 (350) | 152.4 (500) | 7.6 (25) | 12.2 (40) | 106.7 (350) | 228.6 (750) | 121.9 (400) | 243.8 (800) | 365.8 (1200) | 365.8 (1200) | 365.8 (1200) | 365.8 (1200) | 1321-RWR55-DP | | | | | | • | • |
| | 50 | 2 | 12.2 (40) | 18.3 (60) | 137.2 (450) | 182.9 (600) | 12.2 (40) | 61.0 (200) | 304.8 (1000) | 365.8 (1200) | 152.4 (500) | 365.8 (1200) | 365.8 (1200) | 365.8 (1200) | 365.8 (1200) | 365.8 (1200) | 1321-RWR80-DP | | | | | | • | • |
| | | 4 | 7.6 (25) | 12.2 (40) | 91.4 (300) | 152.4 (500) | 12.2 (40) | 18.3 (60) | 106.7 (350) | 228.6 (750) | 91.4 (300) | 243.8 (800) | 365.8 (1200) | 365.8 (1200) | 365.8 (1200) | 365.8 (1200) | 1321-RWR80-DP | | | | | | • | • |
| 4 | 60 | 2 | 12.2 (40) | 18.3 (60) | 137.2 (450) | 182.9 (600) | 12.2 (40) | 61.0 (200) | 304.8 (1000) | 365.8 (1200) | 137.2 (450) | 365.8 (1200) | 365.8 (1200) | 365.8 (1200) | 365.8 (1200) | 365.8 (1200) | 1321-RWR80-DP | | | | | | • | • |
| | | 4 | 7.6 (25) | 12.2 (40) | 91.4 (300) | 152.4 (500) | 12.2 (40) | 24.4 (80) | 91.4 (300) | 228.6 (750) | 76.2 (250) | 213.4 (700) | 365.8 (1200) | 365.8 (1200) | 365.8 (1200) | 365.8 (1200) | 1321-RWR80-DP | | | | | | • | • |

Table 31 - PowerFlex 70 (standard/enhanced) and 700 (standard/vector) Drives, 480V Shielded/Unshielded Cable – Meters (Feet) (Continued)

| Drive Frame | Rating | | No Solution | | | | Reactor Only | | | | Reactor and Damping Resistor or 1321-RWR | | | | Reactor/RWR (see page 152) | Resistor | | Available Options | | | | | | | | |
|-------------|--------|------|-------------|-------|-------|-------|--------------|-------|--------|--------|--|--------|--------|-----------------------------|------------------------------|----------|----------|-------------------|-------|------|------|------|-----|--|--|--|
| | 70 | 700 | Hp | kHz | 1000V | 1200V | 1488V | 1600V | 1000V | 1200V | 1488V | 1600V | 1000V | 1200V | 1488V | 1600V | Cat. No. | Ohms | Watts | TFA1 | TFB2 | RWR2 | RWC | | | |
| 5 | 75 | 2 | 12.2 | 18.3 | 137.2 | 182.9 | 12.2 | 61.0 | 274.3 | 365.8 | 137.2 | 365.8 | 365.8 | 365.8 | 1321-RWR100-DP | | | | | | | | | | | |
| | | | (40) | (60) | (450) | (600) | (40) | (200) | (900) | (1200) | (450) | (1200) | (1200) | (1200) | 1321-RWR100-DP | | | | | | | | | | | |
| | | 4 | 7.6 | 12.2 | 91.4 | 152.4 | 12.2 | 24.4 | 91.4 | 182.9 | 76.2 | 182.9 | 365.8 | 365.8 | 1321-RWR100-DP | | | | | | | | | | | |
| | | | (25) | (40) | (300) | (500) | (40) | (80) | (300) | (600) | (200) | (600) | (1200) | (1200) | 1321-RWR100-DP | | | | | | | | | | | |
| | 100 | 2 | 12.2 | 24.4 | 137.2 | 182.9 | 12.2 | 61.0 | 243.8 | 365.8 | 137.2 | 365.8 | 365.8 | 365.8 | 1321-RWR130-DP | | | | | | | | | | | |
| | | | (40) | (80) | (450) | (600) | (40) | (200) | (800) | (1200) | (450) | (1200) | (1200) | (1200) | 1321-RWR130-DP | | | | | | | | | | | |
| | | 4 | 7.6 | 18.3 | 91.4 | 152.4 | 12.2 | 30.5 | 91.4 | 152.4 | 61.0 | 137.2 | 304.8 | 304.8 | 1321-RWR130-DP | | | | | | | | | | | |
| | | | (25) | (60) | (300) | (500) | (40) | (100) | (300) | (500) | (200) | (450) | (1000) | (1000) | 1321-RWR130-DP | | | | | | | | | | | |
| 6 | 125 | 2 | 12.2 | 24.4 | 137.2 | 182.9 | 12.2 | 61.0 | 243.8 | 365.8 | 121.9 | 304.8 | 365.8 | 365.8 | 1321-RWR160-DP | | | | | | | | | | | |
| | | | (40) | (80) | (450) | (600) | (40) | (200) | (800) | (1200) | (400) | (1000) | (1200) | (1200) | 1321-RWR160-DP | | | | | | | | | | | |
| | | 4 | 7.6 | 18.3 | 91.4 | 152.4 | 12.2 | 30.5 | 91.4 | 152.4 | 61.0 | 106.7 | 243.8 | 274.3 | 1321-RWR160-DP | | | | | | | | | | | |
| | | | (25) | (60) | (300) | (500) | (40) | (100) | (300) | (500) | (200) | (350) | (800) | (900) | 1321-RWR160-DP | | | | | | | | | | | |
| | 150 | 2 | 12.2 | 24.4 | 137.2 | 182.9 | 12.2 | 61.0 | 243.8 | 304.8 | 91.4 | 274.3 | 365.8 | 365.8 | 1321-RWR200-DP | | | | | | | | | | | |
| | | | (40) | (80) | (450) | (600) | (40) | (200) | (800) | (1000) | (300) | (900) | (1200) | (1200) | 1321-RWR200-DP | | | | | | | | | | | |
| | | 4 | 7.6 | 24.4 | 91.4 | 152.4 | 12.2 | 30.5 | 91.4 | 152.4 | 45.7 | 76.2 | 243.8 | 274.3 | 1321-RWR200-DP | | | | | | | | | | | |
| | | | (25) | (80) | (300) | (500) | (40) | (100) | (300) | (500) | (150) | (250) | (800) | (900) | 1321-RWR200-DP | | | | | | | | | | | |
| 200 | 2 | 12.2 | 30.5 | 137.2 | 182.9 | 12.2 | 61.0 | 243.8 | 304.8 | 76.2 | 274.3 | 365.8 | 365.8 | 1321-RWR250-DP | | | | | | | | | | | | |
| | | (40) | (100) | (450) | (600) | (40) | (200) | (800) | (1000) | (250) | (900) | (1200) | (1200) | 1321-RWR250-DP | | | | | | | | | | | | |
| | 4 | 7.6 | 24.4 | 91.4 | 121.9 | 12.2 | 36.6 | 91.4 | 121.9 | 45.7 | 76.2 | 213.4 | 274.3 | 1321-RWR250-DP | | | | | | | | | | | | |
| | | (25) | (80) | (300) | (400) | (40) | (120) | (300) | (400) | (150) | (250) | (700) | (900) | 1321-RWR250-DP | | | | | | | | | | | | |
| 7 | 250 | 2 | 12.2 | 30.5 | 137.2 | 167.6 | 12.2 | 61.0 | 198.1 | 259.1 | 76.2 | 243.8 | 365.8 | 365.8 | 1321-3RB320-B | 50 | 225 | | | | | | | | | |
| | | | (40) | (100) | (450) | (550) | (40) | (200) | (650) | (850) | (250) | (800) | (1200) | (1200) | 1321-3RB320-B | 50 | 225 | | | | | | | | | |
| | | 4 | 7.6 | 24.4 | 91.4 | 121.9 | 12.2 | 30.5 | 91.4 | 121.9 | 45.7 | 76.2 | 213.4 | 274.3 | 1321-3RB320-B | 50 | 450 | | | | | | | | | |
| | | | (25) | (80) | (300) | (400) | (40) | (100) | (300) | (400) | (150) | (250) | (700) | (900) | 1321-3RB320-B | 50 | 450 | | | | | | | | | |
| 8 | 300 | 2 | 12.2 | 30.5 | 106.7 | 152.4 | 12.2 | 45.7 | 137.2 | 198.1 | 61.0 | 243.8 | 365.8 | 365.8 | 1321-3RB400-B ⁽¹⁾ | 20 | 495 | | | | | | | | | |
| | | | (40) | (100) | (350) | (500) | (40) | (150) | (450) | (650) | (200) | (800) | (1200) | (1200) | 1321-3RB400-B ⁽¹⁾ | 20 | 990 | | | | | | | | | |
| | | 4 | 7.6 | 24.4 | 91.4 | 121.9 | 12.2 | 30.5 | 91.4 | 121.9 | 45.7 | 76.2 | 213.4 | 274.3 | 1321-3RB400-B ⁽¹⁾ | 20 | 990 | | | | | | | | | |
| | | | (25) | (80) | (300) | (400) | (40) | (100) | (300) | (400) | (150) | (250) | (700) | (900) | 1321-3RB400-B ⁽¹⁾ | 20 | 990 | | | | | | | | | |
| | 350 | 2 | 12.2 | 30.5 | 106.7 | 152.4 | 12.2 | 45.7 | 137.2 | 198.1 | 61.0 | 243.8 | 365.8 | 365.8 | 1321-3R400-B ⁽¹⁾ | 20 | 495 | | | | | | | | | |
| | | | (40) | (100) | (350) | (500) | (40) | (150) | (450) | (650) | (200) | (800) | (1200) | (1200) | 1321-3R400-B ⁽¹⁾ | 20 | 495 | | | | | | | | | |
| | | 4 | 7.6 | 24.4 | 91.4 | 121.9 | 12.2 | 30.5 | 91.4 | 121.9 | 45.7 | 76.2 | 167.6 | 259.1 | 1321-3RB400-B ⁽¹⁾ | 20 | 990 | | | | | | | | | |
| | | | (25) | (80) | (300) | (400) | (40) | (100) | (300) | (400) | (150) | (250) | (550) | (850) | 1321-3RB400-B ⁽¹⁾ | 20 | 990 | | | | | | | | | |
| 400 | 2 | 12.2 | 30.5 | 106.7 | 152.4 | 12.2 | 45.7 | 137.2 | 182.9 | 61.0 | 213.4 | 365.8 | 365.8 | 1321-3R500-B ⁽¹⁾ | 20 | 495 | | | | | | | | | | |
| | | (40) | (100) | (350) | (500) | (40) | (150) | (450) | (600) | (200) | (700) | (1200) | (1200) | 1321-3R500-B ⁽¹⁾ | 20 | 495 | | | | | | | | | | |
| | 4 | 7.6 | 24.4 | 91.4 | 121.9 | 12.2 | 30.5 | 91.4 | 121.9 | 45.7 | 76.2 | 167.6 | 259.1 | 1321-3R500-B ⁽¹⁾ | 20 | 990 | | | | | | | | | | |
| | | (25) | (80) | (300) | (400) | (40) | (100) | (300) | (400) | (150) | (250) | (550) | (850) | 1321-3R500-B ⁽¹⁾ | 20 | 990 | | | | | | | | | | |
| 450 | 2 | 12.2 | 30.5 | 106.7 | 152.4 | 12.2 | 45.7 | 137.2 | 182.9 | 61.0 | 213.4 | 365.8 | 365.8 | 1321-3R600-B ⁽¹⁾ | 20 | 495 | | | | | | | | | | |
| | | (40) | (100) | (350) | (500) | (40) | (150) | (450) | (600) | (200) | (700) | (1200) | (1200) | 1321-3R600-B ⁽¹⁾ | 20 | 495 | | | | | | | | | | |
| | 4 | 7.6 | 24.4 | 91.4 | 121.9 | 12.2 | 30.5 | 91.4 | 121.9 | 45.7 | 76.2 | 167.6 | 259.1 | 1321-3R600-B ⁽¹⁾ | 20 | 990 | | | | | | | | | | |
| | | (25) | (80) | (300) | (400) | (40) | (100) | (300) | (400) | (150) | (250) | (550) | (850) | 1321-3R600-B ⁽¹⁾ | 20 | 990 | | | | | | | | | | |
| 500 | 2 | 12.2 | 30.5 | 106.7 | 152.4 | 12.2 | 45.7 | 121.9 | 152.4 | 61.0 | 182.9 | 304.8 | 365.8 | 1321-3R600-B ⁽¹⁾ | 20 | 495 | | | | | | | | | | |
| | | (40) | (100) | (350) | (500) | (40) | (150) | (400) | (500) | (200) | (600) | (1000) | (1200) | 1321-3R600-B ⁽¹⁾ | 20 | 495 | | | | | | | | | | |
| | 4 | 7.6 | 24.4 | 91.4 | 121.9 | 12.2 | 30.5 | 91.4 | 121.9 | 45.7 | 76.2 | 167.6 | 243.8 | 1321-3R600-B ⁽¹⁾ | 20 | 990 | | | | | | | | | | |
| | | (25) | (80) | (300) | (400) | (40) | (100) | (300) | (400) | (150) | (250) | (550) | (800) | 1321-3R600-B ⁽¹⁾ | 20 | 990 | | | | | | | | | | |
| 9 | 600 | 2 | 12.2 | 30.5 | 91.4 | 121.9 | 12.2 | 45.7 | 106.7 | 137.2 | 61.0 | 152.4 | 274.3 | 365.8 | 1321-3R750-B ⁽²⁾ | 20 | 735 | | | | | | | | | |
| | | (40) | (100) | (300) | (400) | (40) | (150) | (350) | (450) | (200) | (500) | (900) | (1200) | 1321-3R750-B ⁽²⁾ | 20 | 735 | | | | | | | | | | |
| 10 | 700 | 2 | 12.2 | 30.5 | 91.4 | 121.9 | 12.2 | 45.7 | 106.7 | 137.2 | 61.0 | 152.4 | 274.3 | 365.8 | 1321-3R850-B ⁽²⁾ | 20 | 735 | | | | | | | | | |
| | | (40) | (100) | (300) | (400) | (40) | (150) | (350) | (450) | (200) | (500) | (900) | (1200) | 1321-3R850-B ⁽²⁾ | 20 | 735 | | | | | | | | | | |

(1) Requires two parallel cables.
 (2) Requires three parallel cables.

Table 32 - PowerFlex 70 (standard/enhanced) and 700 (standard/vector) Drives, 600V Shielded/Unshielded Cable – Meters (Feet)

| Drive Frame | | Rating | | No Solution | | Reactor Only | | 1321-RWR | | RWR (see page 152) | Available Options | | | | | |
|-------------|-----|--------|------------|-------------|-------------|--------------|--------------|--------------|---------------|-----------------------|-------------------|------|------|-----|---|---|
| 70 | 700 | Hp | kHz | 1488V | 1850V | 1488V | 1850V | 1488V | 1850V | Cat. No. | TFA1 | TFB2 | RWR2 | RWC | | |
| A | 0 | 1 | 2 | 42.7 (140) | 121.9 (400) | 121.9 (400) | 121.9 (400) | 121.9 (400) | 121.9 (400) | | • | | • | • | | |
| | | | 4 | 30.5 (100) | 121.9 (400) | 30.5 (100) | 121.9 (400) | 121.9 (400) | 121.9 (400) | | | | • | • | | |
| | | 2 | 2 | 42.7 (140) | 152.4 (500) | 152.4 (500) | 152.4 (500) | 152.4 (500) | 152.4 (500) | 152.4 (500) | | • | | • | • | |
| | | | 4 | 30.5 (100) | 137.2 (450) | 30.5 (100) | 152.4 (500) | 152.4 (500) | 152.4 (500) | | | | | • | • | |
| | B | 3 | 2 | 42.7 (140) | 152.4 (500) | 152.4 (500) | 182.9 (600) | 182.9 (600) | 182.9 (600) | 182.9 (600) | | • | | • | • | |
| | | | | 4 | 30.5 (100) | 137.2 (450) | 30.5 (100) | 152.4 (500) | 182.9 (600) | 182.9 (600) | | | | | • | • |
| | | | 5 | 2 | 42.7 (140) | 152.4 (500) | 152.4 (500) | 243.8 (800) | 243.8 (800) | 243.8 (800) | 1321-RWR8-EP | • | | | • | • |
| | | | | 4 | 30.5 (100) | 137.2 (450) | 30.5 (100) | 152.4 (500) | 243.8 (800) | 243.8 (800) | 1321-RWR8-EP | | | | • | • |
| 7.5 | | 2 | 42.7 (140) | 152.4 (500) | 152.4 (500) | 304.8 (1000) | 304.8 (1000) | 304.8 (1000) | 1321-RWR12-EP | | | | | • | | |
| | | 4 | 30.5 (100) | 137.2 (450) | 30.5 (100) | 152.4 (500) | 304.8 (1000) | 304.8 (1000) | 1321-RWR12-EP | | | | | • | | |
| C | 1 | 10 | 2 | 42.7 (140) | 182.9 (600) | 152.4 (500) | 365.8 (1200) | 365.8 (1200) | 365.8 (1200) | 1321-RWR12-EP | | | | • | | |
| | | | 4 | 30.5 (100) | 137.2 (450) | 30.5 (100) | 152.4 (500) | 304.8 (1000) | 365.8 (1200) | 1321-RWR12-EP | | | | • | | |
| | 15 | 2 | 42.7 (140) | 182.9 (600) | 152.4 (500) | 365.8 (1200) | 365.8 (1200) | 365.8 (1200) | 1321-RWR18-EP | | | | | | | |
| | | 4 | 30.5 (100) | 137.2 (450) | 30.5 (100) | 152.4 (500) | 304.8 (1000) | 365.8 (1200) | 1321-RWR18-EP | | | | | | | |
| D | 2 | 20 | 2 | 42.7 (140) | 182.9 (600) | 152.4 (500) | 365.8 (1200) | 365.8 (1200) | 365.8 (1200) | 1321-RWR25-EP | | • | | | | |
| | | | 4 | 30.5 (100) | 137.2 (450) | 30.5 (100) | 152.4 (500) | 304.8 (1000) | 365.8 (1200) | 1321-RWR25-EP | | | | | | |
| | | 25 | 2 | 42.7 (140) | 182.9 (600) | 152.4 (500) | 365.8 (1200) | 365.8 (1200) | 365.8 (1200) | 1321-RWR35-EP | | | • | | | |
| | | | 4 | 30.5 (100) | 137.2 (450) | 30.5 (100) | 152.4 (500) | 304.8 (1000) | 365.8 (1200) | 1321-RWR35-EP | | | | | | |
| | 3 | 30 | 2 | 42.7 (140) | 182.9 (600) | 152.4 (500) | 365.8 (1200) | 365.8 (1200) | 365.8 (1200) | 1321-RWR35-EP | | | • | | | |
| | | | 4 | 30.5 (100) | 137.2 (450) | 36.6 (120) | 152.4 (500) | 304.8 (1000) | 365.8 (1200) | 1321-RWR35-EP | | | | | | |
| | | 40 | 2 | 42.7 (140) | 182.9 (600) | 152.4 (500) | 365.8 (1200) | 365.8 (1200) | 365.8 (1200) | 1321-RWR45-EP | | | • | | | |
| | | | 4 | 30.5 (100) | 137.2 (450) | 36.6 (120) | 152.4 (500) | 304.8 (1000) | 365.8 (1200) | 1321-RWR45-EP | | | | | | |
| E | 50 | 2 | 42.7 (140) | 182.9 (600) | 152.4 (500) | 365.8 (1200) | 365.8 (1200) | 365.8 (1200) | 1321-RWR55-EP | | | • | | | | |
| | | 4 | 36.6 (120) | 137.2 (450) | 45.7 (150) | 152.4 (500) | 304.8 (1000) | 365.8 (1200) | 1321-RWR55-EP | | | | | | | |

Table 32 - PowerFlex 70 (standard/enhanced) and 700 (standard/vector) Drives, 600V Shielded/Unshielded Cable – Meters (Feet) (Continued)

| Drive Frame | | Rating | | No Solution | | Reactor Only | | 1321-RWR | | RWR (see page 152) | Available Options | | | | |
|-------------|-----|--------|-----|-------------|-------------|--------------|--------------|--------------|--------------|-----------------------|-------------------|---------------|------|-----|--|
| 70 | 700 | Hp | kHz | 1488V | 1850V | 1488V | 1850V | 1488V | 1850V | Cat. No. | TFA1 | TFB2 | RWR2 | RWC | |
| | | 4 | 60 | 2 | | 42.7 (140) | 182.9 (600) | 152.4 (500) | 365.8 (1200) | 365.8 (1200) | 365.8 (1200) | 1321-RWR80-EP | | • | |
| 4 | | | | 36.6 (120) | 137.2 (450) | 45.7 (150) | 152.4 (500) | 274.3 (900) | 365.8 (1200) | 1321-RWR80-EP | | | | | |
| 75 | 2 | | | 42.7 (140) | 182.9 (600) | 152.4 (500) | 365.8 (1200) | 365.8 (1200) | 365.8 (1200) | 1321-RWR80-EP | | • | | | |
| | 4 | | | 36.6 (120) | 137.2 (450) | 45.7 (150) | 152.4 (500) | 274.3 (900) | 365.8 (1200) | 1321-RWR80-EP | | | | | |
| 100 | 2 | | | 42.7 (140) | 182.9 (600) | 152.4 (500) | 304.8 (1000) | 365.8 (1200) | 365.8 (1200) | 1321-RWR100-EP | | • | | | |
| | 4 | | | 42.7 (140) | 137.2 (450) | 45.7 (150) | 152.4 (500) | 274.3 (900) | 365.8 (1200) | 1321-RWR100-EP | | | | | |
| 6 | 125 | | 2 | | 42.7 (140) | 182.9 (600) | 121.9 (400) | 304.8 (1000) | 365.8 (1200) | 365.8 (1200) | 1321-RWR130-EP | | • | | |
| | | | 4 | | 42.7 (140) | 137.2 (450) | 45.7 (150) | 152.4 (500) | 228.6 (750) | 365.8 (1200) | 1321-RWR130-EP | | | | |
| | 150 | | 2 | | 42.7 (140) | 182.9 (600) | 121.9 (400) | 304.8 (1000) | 365.8 (1200) | 365.8 (1200) | 1321-RWR160-EP | | • | | |
| | | | 4 | | 42.7 (140) | 137.2 (450) | 45.7 (150) | 152.4 (500) | 198.1 (650) | 365.8 (1200) | 1321-RWR160-EP | | | | |

Table 33 - PowerFlex 700 (standard/vector) Drives, 690V Shielded/Unshielded Cable – Meters (Feet)

| Drive | | | No Solution | | Reactor Only | | Reactor and Damping Resistor | | Reactor | Resistor | | Available Options | | | |
|-------|-----|-----|-------------|-------------|--------------|-------------|------------------------------|--------------|--------------|----------|-------|-------------------|------|------|-----|
| Frame | kW | kHz | 1850V | 2000V | 1850V | 2000V | 1850V | 2000V | Cat. No. | Ohms | Watts | TFA1 | TFB2 | RWR2 | RWC |
| 4 | 45 | 2 | 30.5 (100) | 106.7 (350) | 91.4 (300) | 152.4 (500) | 365.8 (1200) | 365.8 (1200) | 1321-3R80-C | 50 | 345 | | | | |
| | | 4 | 24.4 (80) | 76.2 (250) | 36.6 (120) | 121.9 (400) | 213.4 (700) | 274.3 (900) | 1321-3R80-C | 50 | 690 | | | | |
| | 55 | 2 | 30.5 (100) | 106.7 (350) | 91.4 (300) | 152.4 (500) | 365.8 (1200) | 365.8 (1200) | 1321-3R80-C | 50 | 345 | | | | |
| | | 4 | 24.4 (80) | 76.2 (250) | 36.6 (120) | 106.7 (350) | 213.4 (700) | 274.3 (900) | 1321-3R80-C | 50 | 690 | | | | |
| 5 | 75 | 2 | 30.5 (100) | 106.7 (350) | 91.4 (300) | 152.4 (500) | 365.8 (1200) | 365.8 (1200) | 1321-3R100-C | 50 | 345 | | | | |
| | | 4 | 30.5 (100) | 76.2 (250) | 36.6 (120) | 106.7 (350) | 213.4 (700) | 274.3 (900) | 1321-3R100-C | 50 | 690 | | | | |
| | 90 | 2 | 30.5 (100) | 106.7 (350) | 91.4 (300) | 152.4 (500) | 365.8 (1200) | 365.8 (1200) | 1321-3R130-C | 50 | 375 | | | | |
| | | 4 | 30.5 (100) | 76.2 (250) | 36.6 (120) | 106.7 (350) | 182.9 (600) | 274.3 (900) | 1321-3R130-C | 50 | 750 | | | | |
| 6 | 110 | 2 | 30.5 (100) | 106.7 (350) | 91.4 (300) | 152.4 (500) | 365.8 (1200) | 365.8 (1200) | 1321-3R160-C | 50 | 375 | | | | |
| | | 4 | 30.5 (100) | 76.2 (250) | 36.6 (120) | 99.1 (325) | 152.4 (500) | 274.3 (900) | 1321-3R160-C | 50 | 750 | | | | |
| | 132 | 2 | 30.5 (100) | 106.7 (350) | 91.4 (300) | 152.4 (500) | 365.8 (1200) | 365.8 (1200) | 1321-3R200-C | 50 | 375 | | | | |
| | | 4 | 30.5 (100) | 76.2 (250) | 36.6 (120) | 83.8 (275) | 152.4 (500) | 274.3 (900) | 1321-3R200-C | 50 | 750 | | | | |

PowerFlex 700H Drives

This section lists motor cable length restrictions, reactors, and available options for PowerFlex 700H drives.

Table 34 - PowerFlex 700H Drives, 400V Shielded/Unshielded Cable – Meters (Feet)

| Drive | | | No Solution | | | | Reactor Only | | | | Reactor and Damping Resistor or 1321-RWR | | | | Reactor/RWR (see page 152) | Resistor | | Available Options | | | |
|-------------------|--------------------|-----|-------------|------------|------------|-------------|--------------|------------|--------------|--------------|--|-------------|--------------|--------------|----------------------------|----------|--------------------|-------------------|------|------|-----|
| Frame | kW | kHz | 1000V | 1200V | 1488V | 1600V | 1000V | 1200V | 1488V | 1600V | 1000V | 1200V | 1488V | 1600V | Cat. No. | Ohms | Watts | TFA1 | TFB2 | RWR2 | RWC |
| 9 | 132 | 2 | 24.4 (80) | 48.8 (160) | 76.2 (250) | 137.2 (450) | 24.4 (80) | 48.8 (160) | 365.8 (1200) | 365.8 (1200) | 121.9 (400) | 274.3 (900) | 365.8 (1200) | 365.8 (1200) | 1321-RWR320-DP | | | | • | | |
| | 160 | 2 | 24.4 (80) | 48.8 (160) | 76.2 (250) | 137.2 (450) | 24.4 (80) | 48.8 (160) | 365.8 (1200) | 365.8 (1200) | 121.9 (400) | 274.3 (900) | 365.8 (1200) | 365.8 (1200) | 1321-RWR320-DP | | | | • | | |
| 10 | 200 | 2 | 24.4 (80) | 48.8 (160) | 76.2 (250) | 121.9 (400) | 24.4 (80) | 48.8 (160) | 365.8 (1200) | 365.8 (1200) | 121.9 (400) | 274.3 (900) | 365.8 (1200) | 365.8 (1200) | 1321-3R500-B | 20 | 495 ⁽³⁾ | | • | | |
| | 250 | 2 | 24.4 (80) | 48.8 (160) | 61.0 (200) | 121.9 (400) | 24.4 (80) | 48.8 (160) | 365.8 (1200) | 365.8 (1200) | 121.9 (400) | 274.3 (900) | 365.8 (1200) | 365.8 (1200) | 1321-3R500-B | 20 | 495 ⁽³⁾ | | • | | |
| 11 | 315 | 2 | 18.3 (60) | 42.7 (140) | 61.0 (200) | 121.9 (400) | 18.3 (60) | 42.7 (140) | 365.8 (1200) | 365.8 (1200) | 121.9 (400) | 243.8 (800) | 365.8 (1200) | 365.8 (1200) | 1321-3R600-B | 20 | 495 ⁽³⁾ | | • | | |
| | 355 | 2 | 18.3 (60) | 42.7 (140) | 61.0 (200) | 121.9 (400) | 18.3 (60) | 42.7 (140) | 304.8 (1000) | 365.8 (1200) | 121.9 (400) | 243.8 (800) | 365.8 (1200) | 365.8 (1200) | 1321-3R750-B | 20 | 495 ⁽³⁾ | | • | | |
| | 400 | 2 | 18.3 (60) | 42.7 (140) | 61.0 (200) | 121.9 (400) | 18.3 (60) | 42.7 (140) | 274.3 (900) | 365.8 (1200) | 121.9 (400) | 243.8 (800) | 365.8 (1200) | 365.8 (1200) | 1321-3R750-B | 20 | 735 ⁽⁴⁾ | | • | | |
| 12 ⁽¹⁾ | 450 | 2 | 18.3 (60) | 42.7 (140) | 61.0 (200) | 121.9 (400) | 18.3 (60) | 42.7 (140) | 243.8 (800) | 365.8 (1200) | 121.9 (400) | 243.8 (800) | 365.8 (1200) | 365.8 (1200) | 2 x 1321-3RB400-B | 40 | 375 ⁽⁴⁾ | | • | | |
| | 500 | 2 | 12.2 (40) | 42.7 (140) | 61.0 (200) | 121.9 (400) | 18.3 (60) | 42.7 (140) | 243.8 (800) | 365.8 (1200) | 121.9 (400) | 243.8 (800) | 365.8 (1200) | 365.8 (1200) | 2 x 1321-3R500-B | 40 | 375 ⁽⁴⁾ | | • | | |
| | 560 | 2 | 12.2 (40) | 42.7 (140) | 61.0 (200) | 121.9 (400) | 18.3 (60) | 42.7 (140) | 243.8 (800) | 365.8 (1200) | 121.9 (400) | 243.8 (800) | 365.8 (1200) | 365.8 (1200) | 2 x 1321-3R500-B | 20 | 525 ⁽⁵⁾ | | | | |
| 13 | 630 ⁽²⁾ | 2 | 12.2 (40) | 61.0 (200) | 99.1 (325) | 167.6 (550) | 36.6 (120) | 61.0 (200) | 304.8 (1000) | 365.8 (1200) | 198.1 (650) | 274.3 (900) | 365.8 (1200) | 365.8 (1200) | 2 x 1321-3R600-B | 20 | 525 ⁽⁵⁾ | | | | |
| | 710 ⁽²⁾ | 2 | 12.2 (40) | 61.0 (200) | 99.1 (325) | 167.6 (550) | 36.6 (120) | 61.0 (200) | 304.8 (1000) | 365.8 (1200) | 198.1 (650) | 274.3 (900) | 365.8 (1200) | 365.8 (1200) | 2 x 1321-3R750-B | 20 | 525 ⁽⁵⁾ | | | | |
| | 800 ⁽²⁾ | 2 | 12.2 (40) | 61.0 (200) | 99.1 (325) | 167.6 (550) | 36.6 (120) | 61.0 (200) | 304.8 (1000) | 365.8 (1200) | 198.1 (650) | 274.3 (900) | 365.8 (1200) | 365.8 (1200) | 2 x 1321-3R750-B | 20 | 525 ⁽⁵⁾ | | | | |

- (1) Frame 12 drives have dual inverters and require two output reactors. The resistor ratings are per phase values for each reactor.
- (2) Some Frame 13 drives require two output reactors to match drive amp rating. The resistor ratings are per phase values for each reactor.
- (3) Resistor specification is based on two cables per phase.
- (4) Resistor specification is based on three cables per phase.
- (5) Resistor specification is based on four cables per phase.

Table 35 - PowerFlex 700H Drives, 480V Shielded/Unshielded Cable – Meters (Feet)

| Drive | | | No Solution | | | | Reactor Only | | | | Reactor and Damping Resistor or 1321-RWR | | | | Reactor/RWR (see page 152) | Resistor | | Available Options | | | |
|-------|-----|-----|-------------|-----------|------------|------------|--------------|-----------|-------------|-------------|--|-------------|--------------|--------------|----------------------------|----------|--------------------|-------------------|------|------|-----|
| Frame | Hp | kHz | 1000V | 1200V | 1488V | 1600V | 1000V | 1200V | 1488V | 1600V | 1000V | 1200V | 1488V | 1600V | Cat. No. | Ohms | Watts | TFA1 | TFB2 | RWR2 | RWC |
| 9 | 200 | 2 | 12.2 (40) | 24.4 (80) | 42.7 (140) | 76.2 (250) | 12.2 (40) | 24.4 (80) | 106.7 (350) | 152.4 (500) | 61.0 (200) | 167.6 (550) | 304.8 (1000) | 365.8 (1200) | 1321-RWR320-DP | | | | • | | |
| | 250 | 2 | 12.2 (40) | 24.4 (80) | 42.7 (140) | 76.2 (250) | 12.2 (40) | 24.4 (80) | 91.4 (300) | 121.9 (400) | 61.0 (200) | 152.4 (500) | 304.8 (1000) | 365.8 (1200) | 1321-RWR320-DP | | | | • | | |
| 10 | 300 | 2 | 12.2 (40) | 24.4 (80) | 42.7 (140) | 76.2 (250) | 12.2 (40) | 24.4 (80) | 76.2 (250) | 91.4 (300) | 61.0 (200) | 121.9 (400) | 304.8 (1000) | 365.8 (1200) | 1321-3RB400-B | 20 | 495 ⁽³⁾ | | • | | |
| | 350 | 2 | 12.2 (40) | 24.4 (80) | 42.7 (140) | 76.2 (250) | 12.2 (40) | 24.4 (80) | 76.2 (250) | 91.4 (300) | 61.0 (200) | 121.9 (400) | 304.8 (1000) | 365.8 (1200) | 1321-3R500-B | 20 | 495 ⁽³⁾ | | • | | |
| | 450 | 2 | 12.2 (40) | 24.4 (80) | 36.6 (120) | 61.0 (200) | 12.2 (40) | 24.4 (80) | 61.0 (200) | 91.4 (300) | 61.0 (200) | 121.9 (400) | 274.3 (900) | 365.8 (1200) | 1321-3R500-B | 20 | 495 ⁽³⁾ | | • | | |
| 11 | 500 | 2 | 12.2 (40) | 24.4 (80) | 36.6 (120) | 61.0 (200) | 12.2 (40) | 24.4 (80) | 61.0 (200) | 91.4 (300) | 61.0 (200) | 121.9 (400) | 243.8 (800) | 365.8 (1200) | 1321-3R750-B | 20 | 495 ⁽³⁾ | | • | | |
| | 600 | 2 | 12.2 (40) | 24.4 (80) | 36.6 (120) | 61.0 (200) | 12.2 (40) | 24.4 (80) | 45.7 (150) | 91.4 (300) | 45.7 (150) | 121.9 (400) | 243.8 (800) | 365.8 (1200) | 1321-3R750-B | 20 | 735 ⁽⁴⁾ | | • | | |

Table 35 - PowerFlex 700H Drives, 480V Shielded/Unshielded Cable – Meters (Feet) (Continued)

| Drive | | | No Solution | | | | Reactor Only | | | | Reactor and Damping Resistor or 1321-RWR | | | | Reactor/RWR (see page 152) | Resistor | | Available Options | | | |
|-------------------|---------------------|-----|-------------|------------|------------|-------------|--------------|------------|------------|-------------|--|-------------|--------------|--------------|----------------------------|----------|--------------------|-------------------|-----|------|-----|
| Frame | Hp | kHz | 1000V | 1200V | 1488V | 1600V | 1000V | 1200V | 1488V | 1600V | 1000V | 1200V | 1488V | 1600V | Cat. No. | Ohms | Watts | TF1 | TF2 | RWR2 | RWC |
| 12 ⁽¹⁾ | 700 | 2 | 12.2 (40) | 24.4 (80) | 36.6 (120) | 61.0 (200) | 12.2 (40) | 24.4 (80) | 45.7 (150) | 91.4 (300) | 45.7 (150) | 106.7 (350) | 243.8 (800) | 365.8 (1200) | 2 x 1321-3RB400-B | 40 | 375 ⁽⁴⁾ | • | | | |
| | 800 | 2 | 12.2 (40) | 24.4 (80) | 36.6 (120) | 61.0 (200) | 12.2 (40) | 24.4 (80) | 45.7 (150) | 91.4 (300) | 45.7 (150) | 106.7 (350) | 243.8 (800) | 365.8 (1200) | 2 x 1321-3R500-B | 40 | 375 ⁽⁴⁾ | • | | | |
| | 900 | 2 | 12.2 (40) | 24.4 (80) | 36.6 (120) | 61.0 (200) | 12.2 (40) | 24.4 (80) | 45.7 (150) | 91.4 (300) | 45.7 (150) | 106.7 (350) | 243.8 (800) | 365.8 (1200) | 2 x 1321-3R500-B | 20 | 525 ⁽⁵⁾ | | | | |
| 13 | 1000 ⁽²⁾ | 2 | 12.2 (40) | 30.5 (100) | 61.0 (200) | 121.9 (400) | 12.2 (40) | 45.7 (150) | 61.0 (200) | 121.9 (400) | 45.7 (150) | 152.4 (500) | 304.8 (1000) | 365.8 (1200) | 2 x 1321-3R600-B | 20 | 525 ⁽⁵⁾ | | | | |
| | 1200 ⁽²⁾ | 2 | 12.2 (40) | 30.5 (100) | 61.0 (200) | 121.9 (400) | 12.2 (40) | 45.7 (150) | 61.0 (200) | 121.9 (400) | 45.7 (150) | 152.4 (500) | 304.8 (1000) | 365.8 (1200) | 2 x 1321-3R750-B | 20 | 525 ⁽⁵⁾ | | | | |
| | 1250 ⁽²⁾ | 2 | 12.2 (40) | 30.5 (100) | 61.0 (200) | 121.9 (400) | 12.2 (40) | 45.7 (150) | 61.0 (200) | 121.9 (400) | 45.7 (150) | 152.4 (500) | 304.8 (1000) | 365.8 (1200) | 2 x 1321-3R750-B | 20 | 525 ⁽⁵⁾ | | | | |

- (1) Frame 12 drives have dual inverters and require two output reactors. The resistor ratings are per phase values for each reactor.
- (2) Some Frame 13 drives require two output reactors to match drive amp rating. The resistor ratings are per phase values for each reactor.
- (3) Resistor specification is based on two cables per phase.
- (4) Resistor specification is based on three cables per phase.
- (5) Resistor specification is based on four cables per phase.

Table 36 - PowerFlex 700H Drives, 600V Shielded/Unshielded Cable – Meters (Feet)

| Drive | | | No Solution | | Reactor Only | | Reactor and Damping Resistor or 1321-RWR | | Reactor/RWR (see page 152) | Resistor | | Available Options | | | |
|-------------------|------|-----|-------------|------------|--------------|------------|--|--------------|----------------------------|----------|--------------------|-------------------|-----|------|-----|
| Frame | Hp | kHz | 1488V | 1850V | 1488V | 1850V | 1488V | 1850V | Cat. No. | Ohms | Watts | TF1 | TF2 | RWR2 | RWC |
| 9 | 150 | 2 | 24.4 (80) | 45.7 (150) | 61.0 (200) | 91.4 (300) | 198.1 (650) | 365.8 (1200) | 1321-RWR200-EP | | | | • | | |
| | 200 | 2 | 24.4 (80) | 45.7 (150) | 61.0 (200) | 91.4 (300) | 198.1 (600) | 365.8 (1200) | 1321-RWR250-EP | | | | • | | |
| 10 | 250 | 2 | 24.4 (80) | 45.7 (150) | 61.0 (200) | 91.4 (300) | 167.6 (550) | 365.8 (1200) | 1321-3RB250-B | 50 | 315 | | • | | |
| | 350 | 2 | 24.4 (80) | 45.7 (150) | 61.0 (200) | 91.4 (300) | 167.6 (550) | 365.8 (1200) | 1321-3RB350-B | 20 | 585 ⁽³⁾ | | • | | |
| | 400 | 2 | 24.4 (80) | 45.7 (150) | 61.0 (200) | 91.4 (300) | 167.6 (550) | 365.8 (1200) | 1321-3RB400-B | 20 | 585 ⁽³⁾ | | • | | |
| | 450 | 2 | 24.4 (80) | 45.7 (150) | 61.0 (200) | 91.4 (300) | 167.6 (550) | 365.8 (1200) | 1321-3R500-B | 20 | 585 ⁽³⁾ | | • | | |
| 11 | 500 | 2 | 24.4 (80) | 45.7 (150) | 61.0 (200) | 91.4 (300) | 167.6 (550) | 365.8 (1200) | 1321-3R500-B | 20 | 585 ⁽³⁾ | | • | | |
| | 600 | 2 | 24.4 (80) | 45.7 (150) | 61.0 (200) | 91.4 (300) | 152.4 (500) | 365.8 (1200) | 1321-3R600-B | 20 | 585 ⁽³⁾ | | • | | |
| 12 ⁽¹⁾ | 700 | 2 | 24.4 (80) | 45.7 (150) | 61.0 (200) | 91.4 (300) | 152.4 (500) | 365.8 (1200) | 2 x 1321-3RB320-B | 40 | 300 ⁽³⁾ | | • | | |
| | 800 | 2 | 24.4 (80) | 45.7 (150) | 61.0 (200) | 91.4 (300) | 152.4 (500) | 365.8 (1200) | 2 x 1321-3RB400-C | 40 | 480 ⁽⁴⁾ | | • | | |
| | 900 | 2 | 24.4 (80) | 45.7 (150) | 61.0 (200) | 91.4 (300) | 152.4 (500) | 365.8 (1200) | 2 x 1321-3R400-B | 40 | 480 ⁽⁴⁾ | | | | |
| 13 ⁽²⁾ | 1000 | 2 | 24.4 (80) | 45.7 (150) | 61.0 (200) | 91.4 (300) | 152.4 (500) | 365.8 (1200) | 2 x 1321-3R500-C | 20 | 480 ⁽⁴⁾ | | | | |
| | 1100 | 2 | 24.4 (80) | 45.7 (150) | 61.0 (200) | 91.4 (300) | 137.2 (450) | 365.8 (1200) | 2 x 1321-3R500-B | 20 | 720 ⁽⁵⁾ | | | | |
| | 1300 | 2 | 24.4 (80) | 45.7 (150) | 61.0 (200) | 91.4 (300) | 137.2 (450) | 365.8 (1200) | 2 x 1321-3R600-B | 20 | 720 ⁽⁵⁾ | | | | |

- (1) Frame 12 drives have dual inverters and require two output reactors. The resistor ratings are per phase values for each reactor.
- (2) Frame 13 drives require two output reactors to match drive amp rating. The resistor ratings are per phase values for each reactor.
- (3) Resistor specification is based on two parallel cables per phase.
- (4) Resistor specification is based on three parallel cables per phase.
- (5) Resistor specification is based on four parallel cables per phase.

Table 37 - PowerFlex 700H Drives, 690V Shielded/Unshielded Cable – Meters (Feet)

| Drive | | | No Solution | | Reactor Only | | Reactor and Damping Resistor | | Reactor | Resistor | | Available Options | | | |
|-------------------|---------------------|-----|-------------|------------|--------------|------------|------------------------------|-------------|-----------------|----------|--------------------|-------------------|-----|------|-----|
| Frame | kW | kHz | 1850V | 2000V | 1850V | 2000V | 1850V | 2000V | Cat. No. | Ohms | Watts | TF1 | TF2 | RWR2 | RWC |
| 9 | 160 | 2 | 7.6 (25) | 30.5 (100) | 7.6 (25) | 30.5 (100) | 121.9 (400) | 137.2 (450) | 1321-3RB250-C | 50 | 480 | | | | |
| | 200 | 2 | 7.6 (25) | 30.5 (100) | 7.6 (25) | 30.5 (100) | 121.9 (400) | 137.2 (450) | 1321-3RB250-C | 50 | 480 | | | | |
| 10 | 250 | 2 | 7.6 (25) | 30.5 (100) | 7.6 (25) | 30.5 (100) | 121.9 (400) | 137.2 (450) | 1321-3RB400-C | 50 | 480 | | | | |
| | 315 | 2 | 7.6 (25) | 30.5 (100) | 7.6 (25) | 30.5 (100) | 121.9 (400) | 152.4 (500) | 1321-3RB400-C | 20 | 960 ⁽³⁾ | | | | |
| | 355 | 2 | 7.6 (25) | 30.5 (100) | 7.6 (25) | 30.5 (100) | 121.9 (400) | 152.4 (500) | 1321-3R500-C | 20 | 960 ⁽³⁾ | | | | |
| | 400 | 2 | 7.6 (25) | 30.5 (100) | 7.6 (25) | 30.5 (100) | 121.9 (400) | 152.4 (500) | 1321-3R500-C | 20 | 960 ⁽³⁾ | | | | |
| 11 | 450 | 2 | 7.6 (25) | 30.5 (100) | 7.6 (25) | 30.5 (100) | 121.9 (400) | 152.4 (500) | 1321-3R750-C | 20 | 960 ⁽³⁾ | | | | |
| | 500 | 2 | 7.6 (25) | 30.5 (100) | 7.6 (25) | 30.5 (100) | 121.9 (400) | 152.4 (500) | 1321-3R750-C | 20 | 960 ⁽³⁾ | | | | |
| | 560 | 2 | 7.6 (25) | 30.5 (100) | 7.6 (25) | 30.5 (100) | 121.9 (400) | 152.4 (500) | 1321-3R850-C | 20 | 960 ⁽³⁾ | | | | |
| 12 ⁽¹⁾ | 630 | 2 | 7.6 (25) | 30.5 (100) | 7.6 (25) | 30.5 (100) | 121.9 (400) | 152.4 (500) | 2 x1321-3R600-C | 40 | 480 ⁽⁴⁾ | | | | |
| | 710 | 2 | 7.6 (25) | 30.5 (100) | 7.6 (25) | 30.5 (100) | 121.9 (400) | 152.4 (500) | 2 x1321-3R600-C | 40 | 645 ⁽⁴⁾ | | | | |
| | 800 | 2 | 7.6 (25) | 30.5 (100) | 7.6 (25) | 30.5 (100) | 121.9 (400) | 152.4 (500) | 2 x1321-3R750-C | 40 | 645 ⁽⁴⁾ | | | | |
| 13 | 900 | 2 | 7.6 (25) | 30.5 (100) | 7.6 (25) | 30.5 (100) | 121.9 (400) | 152.4 (500) | 2 x1321-3R600-C | 40 | 645 ⁽⁴⁾ | | | | |
| | 1000 ⁽²⁾ | 2 | 7.6 (25) | 30.5 (100) | 7.6 (25) | 30.5 (100) | 121.9 (400) | 152.4 (500) | 2 x1321-3R600-C | 20 | 840 ⁽⁵⁾ | | | | |
| | 1100 ⁽²⁾ | 2 | 7.6 (25) | 30.5 (100) | 7.6 (25) | 30.5 (100) | 121.9 (400) | 152.4 (500) | 2 x1321-3R750-C | 20 | 840 ⁽⁵⁾ | | | | |

- (1) Frame 12 drives have dual inverters and require two output reactors. The resistor ratings are per phase values for each reactor.
- (2) Some Frame 13 drives require two output reactors to match drive amp rating. The resistor ratings are per phase values for each reactor.
- (3) Resistor specification is based on two parallel cables per phase.
- (4) Resistor specification is based on three parallel cables per phase.
- (5) Resistor specification is based on four parallel cables per phase.

PowerFlex 700L Drives

This section lists motor cable length restrictions, reactors, and available options for PowerFlex 700L drives.

Table 38 - PowerFlex 700L Drives with 700VC Control, 400V Input Shielded/Unshielded Cable – Meters (Feet)

| Drive | | | No Solution | | | | Reactor Only | | | | Reactor and Damping Resistor | | | | Reactor | Resistor | | Available Options | | | | |
|-------|-----|-----|-------------|------------|-------------|-------------|--------------|------------|-------------|--------------|------------------------------|-------------|--------------|--------------|---------------------------------|----------|-------|-------------------|-----|------|-----|--|
| Frame | kW | kHz | 1000V | 1200V | 1488V | 1600V | 1000V | 1200V | 1488V | 1600V | 1000V | 1200V | 1488V | 1600V | Cat. No. | Ohms | Watts | TF1 | TF2 | RWR2 | RWC | |
| 2 | 200 | 2 | 24.4 (80) | 91.4 (300) | 152.4 (500) | 213.4 (700) | 30.5 (100) | 76.2 (250) | 228.6 (750) | 365.8 (1200) | 152.4 (500) | 274.3 (900) | 365.8 (1200) | 365.8 (1200) | 1321-3R400-B ⁽¹⁾ | 20 | 495 | | • | | | |
| | | 4 | 24.4 (80) | 91.4 (300) | 121.9 (400) | 152.4 (500) | 18.3 (60) | 76.2 (250) | 137.2 (450) | 182.9 (600) | 76.2 (250) | 137.2 (450) | 274.3 (900) | 365.8 (1200) | 1321-3R400-B ⁽¹⁾ | 20 | 990 | | | | | |
| 3A | 370 | 2 | 24.4 (80) | 91.4 (300) | 152.4 (500) | 213.4 (700) | 30.5 (100) | 76.2 (250) | 228.6 (750) | 365.8 (1200) | 152.4 (500) | 274.3 (900) | 365.8 (1200) | 365.8 (1200) | 1321-3R750-B ⁽¹⁾ | 20 | 735 | | • | | | |
| | | 4 | 24.4 (80) | 91.4 (300) | 121.9 (400) | 152.4 (500) | 18.3 (60) | 76.2 (250) | 137.2 (450) | 182.9 (600) | 76.2 (250) | 137.2 (450) | 274.3 (900) | 365.8 (1200) | 1321-3R750-B ⁽¹⁾ | 20 | 1470 | | | | | |
| 3B | 715 | 2 | 24.4 (80) | 76.2 (250) | 129.5 (425) | 160.0 (525) | 91.4 (80) | 76.2 (250) | 152.4 (500) | 228.6 (750) | 152.4 (500) | 274.3 (900) | 365.8 (1200) | 365.8 (1200) | 2 x 1321-3R600-B ⁽²⁾ | 20 | 525 | | | | | |
| | | 4 | 18.3 (60) | 76.2 (250) | 121.9 (400) | 152.4 (500) | 18.3 (60) | 76.2 (250) | 121.9 (400) | 152.4 (500) | 76.2 (250) | 137.2 (450) | 274.3 (900) | 365.8 (1200) | 2 x 1321-3R600-B ⁽²⁾ | 20 | 1050 | | | | | |

- (1) Requires two parallel cables.
- (2) Requires four parallel cables.

Table 39 - PowerFlex 700L Drives with 700VC Control, 480V Input Shielded/Unshielded Cable - Meters (Feet)

| Drive | | | No Solution | | | | Reactor Only | | | | Reactor and Damping Resistor | | | | Reactor | Resistor | | Available Options | | | |
|-------|------|-----|-------------|------------|------------|-------------|--------------|------------|------------|-------------|------------------------------|-------------|-------------|--------------|---------------------------------|----------|-------|-------------------|------|------|-----|
| Frame | Hp | kHz | 1000V | 1200V | 1488V | 1600V | 1000V | 1200V | 1488V | 1600V | 1000V | 1200V | 1488V | 1600V | Cat. No. | Ohms | Watts | TFA1 | TFB2 | RWR2 | RWC |
| 2 | 300 | 2 | 12.2 (40) | 30.5 (100) | 91.4 (300) | 121.9 (400) | 12.2 (40) | 36.6 (120) | 99.1 (325) | 137.2 (450) | 61.0 (200) | 137.2 (450) | 274.3 (900) | 365.8 (1200) | 1321-3R400-B ⁽¹⁾ | 20 | 495 | | • | | |
| | | 4 | 7.6 (25) | 24.4 (80) | 83.8 (275) | 114.3 (375) | 7.6 (25) | 24.4 (80) | 83.8 (275) | 114.3 (375) | 30.5 (100) | 61.0 (200) | 152.4 (500) | 213.4 (700) | 1321-3R400-B ⁽¹⁾ | 20 | 990 | | | | |
| 3A | 600 | 2 | 12.2 (40) | 30.5 (100) | 91.4 (300) | 121.9 (400) | 12.2 (40) | 36.6 (120) | 99.1 (325) | 137.2 (450) | 61.0 (200) | 137.2 (450) | 274.3 (900) | 365.8 (1200) | 1321-3R750-B ⁽¹⁾ | 20 | 735 | | • | | |
| | | 4 | 7.6 (25) | 24.4 (80) | 83.8 (275) | 114.3 (375) | 7.6 (25) | 24.4 (80) | 83.8 (275) | 114.3 (375) | 30.5 (100) | 61.0 (200) | 152.4 (500) | 213.4 (700) | 1321-3R750-B ⁽¹⁾ | 20 | 1470 | | | | |
| 3B | 1150 | 2 | 12.2 (40) | 24.4 (80) | 83.8 (275) | 114.3 (375) | 12.2 (40) | 30.5 (100) | 91.4 (300) | 121.9 (400) | 61.0 (200) | 137.2 (450) | 274.3 (900) | 365.8 (1200) | 2 x 1321-3R600-B ⁽²⁾ | 20 | 525 | | | | |
| | | 4 | 7.6 (25) | 24.4 (80) | 83.8 (275) | 114.3 (375) | 7.6 (25) | 24.4 (80) | 83.8 (275) | 114.3 (375) | 30.5 (100) | 61.0 (200) | 152.4 (500) | 213.4 (700) | 2 x 1321-3R600-B ⁽²⁾ | 20 | 1050 | | | | |

- (1) Requires two parallel cables.
- (2) Requires four parallel cables.

Table 40 - PowerFlex 700L Drives with 700VC Control, 600V Input Shielded/Unshielded Cable – Meters (Feet)

| Drive | | | No Solution | | Reactor Only | | Reactor and Damping Resistor | | Reactor | Resistor | | Available Options | | | |
|-------|------|-----|-------------|-------------|--------------|-------------|------------------------------|--------------|---------------------------------|----------|-------|-------------------|------|------|-----|
| Frame | Hp | kHz | 1488V | 1850V | 1488V | 1850V | 1488V | 1850V | Cat. No. | Ohms | Watts | TFA1 | TFB2 | RWR2 | RWC |
| 3A | 465 | 2 | 24.4 (80) | 106.7 (350) | 24.4 (80) | 365.8 (350) | 182.9 (600) | 365.8 (1200) | 1321-3R500-B ⁽¹⁾ | 20 | 585 | | • | | |
| | | 4 | 18.3 (60) | 61.0 (200) | 18.3 (60) | 61.0 (200) | 76.2 (250) | 190.5 (625) | 1321-3R500-B ⁽¹⁾ | 20 | 1170 | | | | |
| 3B | 870 | 2 | 18.3 (60) | 91.4 (300) | 18.3 (60) | 91.4 (300) | 152.4 (500) | 274.3 (900) | 1321-3R850-B ⁽²⁾ | 20 | 960 | | | | |
| | | 4 | 18.3 (60) | 61.0 (200) | 18.3 (60) | 61.0 (200) | 53.3 (175) | 137.2 (450) | 1321-3R850-B ⁽²⁾ | 20 | 1920 | | | | |
| 3B | 1275 | 2 | 18.3 (60) | 83.8 (275) | 18.3 (60) | 83.8 (275) | 137.2 (450) | 274.3 (900) | 2 x 1321-3R600-B ⁽³⁾ | 20 | 720 | | | | |

- (1) Requires two parallel cables.
- (2) Requires three parallel cables.
- (3) Requires four parallel cables.

Table 41 - PowerFlex 700L Drives with 700VC Control, 690V Input Shielded/Unshielded Cable – Meters (Feet)

| Drive | | | No Solution | | Reactor Only | | Reactor and Damping Resistor | | Reactor | Resistor | | Available Options | | | |
|-------|-----|-----|-------------|------------|--------------|------------|------------------------------|--------------|---------------------------------|----------|-------|-------------------|------|------|-----|
| Frame | kW | kHz | 1488V | 1850V | 1488V | 1850V | 1488V | 1850V | Cat. No. | Ohms | Watts | TFA1 | TFB2 | RWR2 | RWC |
| 3A | 355 | 2 | 24.4 (80) | 45.7 (150) | 24.4 (80) | 45.7 (150) | 228.6 (750) | 304.8 (1000) | 1321-3R500-C ⁽¹⁾ | 20 | 960 | | • | | |
| | | 4 | 24.4 (80) | 45.7 (150) | 24.4 (80) | 45.7 (150) | 76.2 (250) | 121.9 (400) | 1321-3R500-C ⁽¹⁾ | 20 | 1920 | | | | |
| 3B | 657 | 2 | 24.4 (80) | 45.7 (150) | 24.4 (80) | 45.7 (150) | 182.9 (600) | 228.6 (750) | 1321-3R850-C ⁽²⁾ | 20 | 1290 | | | | |
| | | 4 | 24.4 (80) | 45.7 (150) | 24.4 (80) | 45.7 (150) | 76.2 (250) | 121.9 (400) | 1321-3R850-C ⁽²⁾ | 20 | 2580 | | | | |
| 3B | 980 | 2 | 24.4 (80) | 45.7 (150) | 24.4 (80) | 45.7 (150) | 182.9 (600) | 228.6 (750) | 2 x 1321-3R600-C ⁽³⁾ | 20 | 840 | | | | |

- (1) Requires two parallel cables.
- (2) Requires three parallel cables.
- (3) Requires four parallel cables.

Table 42 - PowerFlex 700L Drives with 700S Control, 400V Input Shielded/Unshielded Cable – Meters (Feet)

| Drive | | | No Solution | | | | Reactor Only | | | | Reactor and Damping Resistor | | | | Reactor | Resistor | | Available Options | | | |
|-------|-----|-----|--------------|---------------|---------------|----------------|---------------|---------------|----------------|-----------------|------------------------------|----------------|-----------------|-----------------|------------------------------------|----------|-------|-------------------|------|------|-----|
| Frame | kW | kHz | 1000V | 1200V | 1488V | 1600V | 1000V | 1200V | 1488V | 1600V | 1000V | 1200V | 1488V | 1600V | Cat. No. | Ohms | Watts | TFA1 | TFB2 | RWR2 | RWC |
| | | | (60) | (225) | (325) | (550) | (120) | (225) | (900) | (1100) | (500) | (900) | (1200) | (1200) | | | | | | | |
| 2 | 200 | 2 | 18.3 (60) | 68.6 (225) | 99.1 (325) | 167.6 (550) | 36.6 (120) | 68.6 (225) | 274.3 (900) | 335.3 (1100) | 152.4 (500) | 274.3 (900) | 365.8 (1200) | 365.8 (1200) | 1321-3R400-B ⁽¹⁾ | 20 | 495 | | • | | |
| | | 4 | 18.3 (60) | 68.6 (225) | 99.1 (325) | 167.6 (550) | 36.6 (120) | 68.6 (225) | 274.3 (900) | 335.3 (1100) | 152.4 (500) | 274.3 (900) | 365.8 (1200) | 365.8 (1200) | 1321-3R400-B ⁽¹⁾ | 20 | 990 | | | | |
| 3A | 370 | 2 | 18.3 (60) | 68.6 (225) | 99.1 (325) | 167.6 (550) | 36.6 (120) | 68.6 (225) | 274.3 (900) | 335.3 (1100) | 152.4 (500) | 274.3 (900) | 365.8 (1200) | 365.8 (1200) | 1321-3R750-B ⁽¹⁾ | 20 | 735 | | • | | |
| | | 4 | 18.3 (60) | 68.6 (225) | 99.1 (325) | 167.6 (550) | 36.6 (120) | 68.6 (225) | 274.3 (900) | 335.3 (1100) | 152.4 (500) | 274.3 (900) | 365.8 (1200) | 365.8 (1200) | 1321-3R750-B ⁽¹⁾ | 20 | 1470 | | | | |
| 3B | 715 | 2 | 12.2 (40) | 68.6 (225) | 99.1 (325) | 167.6 (550) | 36.6 (120) | 68.6 (225) | 274.3 (900) | 335.3 (1100) | 152.4 (500) | 274.3 (900) | 365.8 (1200) | 365.8 (1200) | 2 x 1321-3R600-B ⁽²⁾ | 20 | 525 | | | | |
| | | 4 | 12.2 (40) | 68.6 (225) | 99.1 (325) | 167.6 (550) | 36.6 (120) | 68.6 (225) | 274.3 (900) | 335.3 (1100) | 152.4 (500) | 274.3 (900) | 365.8 (1200) | 365.8 (1200) | 2 x 1321-3R600-B ⁽²⁾ | 20 | 1050 | | | | |

- (1) Requires two parallel cables.
- (2) Requires four parallel cables.

Table 43 - PowerFlex 700L Drives with 700S Control, 480V Input Shielded/Unshielded Cable – Meters (Feet)

| Drive | | | No Solution | | | | Reactor Only | | | | Reactor and Damping Resistor | | | | Reactor | Resistor | | Available Options | | | |
|-------|------|-----|--------------|---------------|---------------|----------------|--------------|---------------|---------------|----------------|------------------------------|----------------|-----------------|-----------------|------------------------------------|----------|-------|-------------------|------|------|-----|
| Frame | Hp | kHz | 1000V | 1200V | 1488V | 1600V | 1000V | 1200V | 1488V | 1600V | 1000V | 1200V | 1488V | 1600V | Cat. No. | Ohms | Watts | TFA1 | TFB2 | RWR2 | RWC |
| | | | (100) | (100) | (200) | (400) | (40) | (150) | (200) | (400) | (200) | (700) | (1000) | (1200) | | | | | | | |
| 2 | 300 | 2 | 12.2 (40) | 30.5 (100) | 61.0 (200) | 121.9 (400) | 12.2 (40) | 45.7 (150) | 61.0 (200) | 121.9 (400) | 61.0 (200) | 213.4 (700) | 304.8 (1000) | 365.8 (1200) | 1321-3R400-B ⁽¹⁾ | 20 | 495 | | • | | |
| | | 4 | 12.2 (40) | 30.5 (100) | 61.0 (200) | 121.9 (400) | 12.2 (40) | 45.7 (150) | 61.0 (200) | 121.9 (400) | 61.0 (200) | 213.4 (700) | 304.8 (1000) | 365.8 (1200) | 1321-3R400-B ⁽¹⁾ | 20 | 990 | | | | |
| 3A | 600 | 2 | 12.2 (40) | 30.5 (100) | 61.0 (200) | 121.9 (400) | 12.2 (40) | 45.7 (150) | 61.0 (200) | 121.9 (400) | 61.0 (200) | 213.4 (700) | 304.8 (1000) | 365.8 (1200) | 1321-3R750-B ⁽¹⁾ | 20 | 735 | | • | | |
| | | 4 | 12.2 (40) | 30.5 (100) | 61.0 (200) | 121.9 (400) | 12.2 (40) | 45.7 (150) | 61.0 (200) | 121.9 (400) | 61.0 (200) | 213.4 (700) | 304.8 (1000) | 365.8 (1200) | 1321-3R750-B ⁽¹⁾ | 20 | 1470 | | | | |
| 3B | 1150 | 2 | 12.2 (40) | 30.5 (100) | 61.0 (200) | 121.9 (400) | 12.2 (40) | 45.7 (150) | 61.0 (200) | 121.9 (400) | 45.7 (150) | 152.4 (500) | 304.8 (1000) | 365.8 (1200) | 2 x 1321-3R600-B ⁽²⁾ | 20 | 525 | | | | |
| | | 4 | 12.2 (40) | 30.5 (100) | 61.0 (200) | 121.9 (400) | 12.2 (40) | 45.7 (150) | 61.0 (200) | 121.9 (400) | 45.7 (150) | 152.4 (500) | 304.8 (1000) | 365.8 (1200) | 2 x 1321-3R600-B ⁽²⁾ | 20 | 1050 | | | | |

- (1) Requires two parallel cables.
- (2) Requires four parallel cables.

Table 44 - PowerFlex 700L Drives with 700S Control, 600V Input Shielded/Unshielded Cable – Meters (Feet)

| Drive | | | No Solution | | Reactor Only | | Reactor and Damping Resistor | | Reactor | Resistor | | Available Options | | | |
|-------|------|-----|--------------|---------------|--------------|---------------|------------------------------|-----------------|------------------------------------|----------|-------|-------------------|------|------|-----|
| Frame | Hp | kHz | 1488V | 1850V | 1488V | 1850V | 1488V | 1850V | Cat. No. | Ohms | Watts | TFA1 | TFB2 | RWR2 | RWC |
| 3A | 465 | 2 | 18.3 (60) | 76.2 (250) | 18.3 (60) | 76.2 (250) | 182.9 (600) | 304.8 (1000) | 1321-3R500-B ⁽¹⁾ | 20 | 585 | | • | | |
| | | 4 | 18.3 (60) | 76.2 (250) | 18.3 (60) | 76.2 (250) | 182.9 (600) | 304.8 (1000) | 1321-3R500-B ⁽¹⁾ | 20 | 1170 | | | | |
| 3B | 870 | 2 | 18.3 (60) | 61.0 (200) | 18.3 (60) | 61.0 (200) | 152.4 (500) | 228.6 (750) | 1321-3R850-B ⁽²⁾ | 20 | 960 | | | | |
| | | 4 | 18.3 (60) | 61.0 (200) | 18.3 (60) | 61.0 (200) | 152.4 (500) | 228.6 (750) | 1321-3R850-B ⁽²⁾ | 20 | 1920 | | | | |
| 3B | 1275 | 2 | 12.2 (40) | 45.7 (150) | 12.2 (40) | 45.7 (150) | 121.9 (400) | 228.6 (750) | 2 x 1321-3R600-B ⁽³⁾ | 20 | 720 | | | | |

- (1) Requires two parallel cables.
- (2) Requires three parallel cables.
- (3) Requires four parallel cables.

Table 45 - PowerFlex 700L Drives with 700S Control, 690V Input Shielded/Unshielded Cable – Meters (Feet)

| Drive | | | No Solution | | Reactor Only | | Reactor and Damping Resistor | | Reactor | Resistor | | Available Options | | | |
|-------|-----|-----|--------------|---------------|--------------|---------------|------------------------------|-----------------|------------------------------------|----------|-------|-------------------|------|------|-----|
| Frame | kW | kHz | 1488V | 1850V | 1488V | 1850V | 1488V | 1850V | Cat. No. | Ohms | Watts | TFA1 | TFB2 | RWR2 | RWC |
| 3A | 355 | 2 | 24.4 (80) | 45.7 (150) | 24.4 (80) | 45.7 (150) | 228.6 (750) | 304.8 (1000) | 1321-3R500-C ⁽¹⁾ | 20 | 960 | | • | | |
| | | 4 | 24.4 (80) | 45.7 (150) | 24.4 (80) | 45.7 (150) | 182.9 (600) | 228.6 (750) | 1321-3R500-C ⁽¹⁾ | 20 | 1920 | | | | |
| 3B | 657 | 2 | 24.4 (80) | 45.7 (150) | 24.4 (80) | 45.7 (150) | 182.9 (600) | 228.6 (750) | 1321-3R850-C ⁽²⁾ | 20 | 1290 | | | | |
| | | 4 | 24.4 (80) | 45.7 (150) | 24.4 (80) | 45.7 (150) | 182.9 (600) | 228.6 (750) | 1321-3R850-C ⁽²⁾ | 20 | 2580 | | | | |
| 3B | 980 | 2 | 24.4 (80) | 45.7 (150) | 24.4 (80) | 45.7 (150) | 182.9 (600) | 228.6 (750) | 2 x 1321-3R600-C ⁽³⁾ | 20 | 840 | | | | |

- (1) Requires two parallel cables.
- (2) Requires three parallel cables.
- (3) Requires four parallel cables.

PowerFlex 700S Drives

This section lists motor cable length restrictions, reactors, and available options for PowerFlex 700S drives.

Table 46 - PowerFlex 700S Drives, 400V Shielded/Unshielded Cable – Meters (Feet)

| Drive | | | No Solution | | | | Reactor Only | | | | Reactor and Damping Resistor or 1321-RWR | | | | Reactor/RWR (see page 152) | Resistor | | Available Options | | | | |
|-------|------|-----|-------------|-------------|-------------|--------------|--------------|--------------|--------------|--------------|--|--------------|--------------|--------------|----------------------------|----------|--------------------|-------------------|------|------|-----|---|
| Frame | kW | kHz | 1000V | 1200V | 1488V | 1600V | 1000V | 1200V | 1488V | 1600V | 1000V | 1200V | 1488V | 1600V | Cat. No. | Ohms | Watts | IEA1 | IEB2 | RWB2 | RWC | |
| 1 | 0.75 | 2/4 | 7.6 (25) | 83.8 (275) | 83.8 (275) | 83.8 (275) | 91.4 (300) | 152.4 (500) | 152.4 (500) | 152.4 (500) | 152.4 (500) | 152.4 (500) | 152.4 (500) | 152.4 (500) | | | | • | • | • | | |
| | 1.5 | 2/4 | 7.6 (25) | 106.7 (350) | 182.9 (600) | 182.9 (600) | 91.4 (300) | 182.9 (600) | 182.9 (600) | 182.9 (600) | 182.9 (600) | 182.9 (600) | 182.9 (600) | 182.9 (600) | | | | • | • | • | • | |
| | 2.2 | 2/4 | 7.6 (25) | 106.7 (350) | 182.9 (600) | 182.9 (600) | 91.4 (300) | 182.9 (600) | 182.9 (600) | 182.9 (600) | 182.9 (600) | 182.9 (600) | 182.9 (600) | 182.9 (600) | | | | • | • | • | • | |
| | 4 | 2/4 | 7.6 (25) | 106.7 (350) | 243.8 (800) | 243.8 (800) | 91.4 (300) | 243.8 (800) | 243.8 (800) | 243.8 (800) | 243.8 (800) | 243.8 (800) | 243.8 (800) | 243.8 (800) | 1321-RWR8-DP | | | | • | • | • | • |
| | 5.5 | 2/4 | 7.6 (25) | 106.7 (350) | 274.3 (900) | 304.8 (1000) | 91.4 (300) | 274.3 (900) | 304.8 (1000) | 304.8 (1000) | 304.8 (1000) | 304.8 (1000) | 304.8 (1000) | 304.8 (1000) | 1321-RWR12-DP | | | | • | • | • | • |
| | 7.5 | 2/4 | 7.6 (25) | 106.7 (350) | 274.3 (900) | 365.8 (1200) | 91.4 (300) | 274.3 (900) | 365.8 (1200) | 365.8 (1200) | 365.8 (1200) | 365.8 (1200) | 365.8 (1200) | 365.8 (1200) | 1321-RWR18-DP | | | | • | • | • | • |
| | 11 | 2/4 | 7.6 (25) | 106.7 (350) | 274.3 (900) | 365.8 (1200) | 91.4 (300) | 274.3 (900) | 365.8 (1200) | 365.8 (1200) | 365.8 (1200) | 365.8 (1200) | 365.8 (1200) | 365.8 (1200) | 1321-RWR25-DP | | | | • | • | • | • |
| 2 | 15 | 2/4 | 7.6 (25) | 106.7 (350) | 274.3 (900) | 365.8 (1200) | 91.4 (300) | 274.3 (900) | 365.8 (1200) | 365.8 (1200) | 365.8 (1200) | 365.8 (1200) | 365.8 (1200) | 365.8 (1200) | 1321-RWR25-DP | | | | • | • | • | • |
| | 18.5 | 2/4 | 7.6 (25) | 106.7 (350) | 274.3 (900) | 365.8 (1200) | 91.4 (300) | 274.3 (900) | 365.8 (1200) | 365.8 (1200) | 365.8 (1200) | 365.8 (1200) | 365.8 (1200) | 365.8 (1200) | 1321-RWR35-DP | | | | • | • | • | • |
| 3 | 22 | 2/4 | 7.6 (25) | 106.7 (350) | 274.3 (900) | 365.8 (1200) | 91.4 (300) | 274.3 (900) | 365.8 (1200) | 365.8 (1200) | 365.8 (1200) | 365.8 (1200) | 365.8 (1200) | 365.8 (1200) | 1321-RWR45-DP | | | | • | • | • | • |
| | 30 | 2/4 | 7.6 (25) | 106.7 (350) | 274.3 (900) | 365.8 (1200) | 91.4 (300) | 274.3 (900) | 365.8 (1200) | 365.8 (1200) | 365.8 (1200) | 365.8 (1200) | 365.8 (1200) | 365.8 (1200) | 1321-RWR55-DP | | | | • | • | • | • |
| | 37 | 2/4 | 12.2 (40) | 91.4 (300) | 274.3 (900) | 365.8 (1200) | 76.2 (250) | 243.8 (800) | 365.8 (1200) | 365.8 (1200) | 365.8 (1200) | 365.8 (1200) | 365.8 (1200) | 365.8 (1200) | 1321-RWR80-DP | | | | • | • | • | • |
| 4 | 45 | 2/4 | 12.2 (40) | 106.7 (350) | 274.3 (900) | 365.8 (1200) | 76.2 (250) | 304.8 (1000) | 365.8 (1200) | 365.8 (1200) | 365.8 (1200) | 365.8 (1200) | 365.8 (1200) | 365.8 (1200) | 1321-RWR80-DP | | | | • | • | • | • |
| 5 | 55 | 2/4 | 12.2 (40) | 106.7 (350) | 274.3 (900) | 365.8 (1200) | 61.0 (200) | 274.3 (900) | 365.8 (1200) | 365.8 (1200) | 365.8 (1200) | 365.8 (1200) | 365.8 (1200) | 365.8 (1200) | 1321-RWR100-DP | | | | • | • | • | • |
| | 75 | 2/4 | 18.3 (60) | 91.4 (300) | 213.4 (700) | 304.8 (1000) | 45.7 (150) | 243.8 (800) | 365.8 (1200) | 365.8 (1200) | 304.8 (1000) | 365.8 (1200) | 365.8 (1200) | 365.8 (1200) | 1321-RWR130-DP | | | | • | • | • | • |
| 6 | 90 | 2/4 | 18.3 (60) | 91.4 (300) | 213.4 (700) | 304.8 (1000) | 45.7 (150) | 213.4 (700) | 365.8 (1200) | 365.8 (1200) | 304.8 (1000) | 365.8 (1200) | 365.8 (1200) | 365.8 (1200) | 1321-RWR160-DP | | | | • | • | • | • |
| | 110 | 2/4 | 24.4 (80) | 91.4 (300) | 213.4 (700) | 274.3 (900) | 45.7 (150) | 182.9 (600) | 365.8 (1200) | 365.8 (1200) | 274.3 (900) | 365.8 (1200) | 365.8 (1200) | 365.8 (1200) | 1321-RWR200-DP | | | | • | • | • | • |
| | 132 | 2/4 | 24.4 (80) | 91.4 (300) | 182.9 (600) | 243.8 (800) | 45.7 (150) | 152.4 (500) | 365.8 (1200) | 365.8 (1200) | 243.8 (800) | 365.8 (1200) | 365.8 (1200) | 365.8 (1200) | 1321-RWR250-DP | | | | • | • | • | • |
| 9 | 132 | 2 | 24.4 (80) | 91.4 (300) | 182.9 (600) | 243.8 (800) | 45.7 (150) | 152.4 (500) | 365.8 (1200) | 365.8 (1200) | 243.8 (800) | 365.8 (1200) | 365.8 (1200) | 365.8 (1200) | 1321-RWR320-DP | | | | • | • | • | • |
| | 160 | 2 | 24.4 (80) | 91.4 (300) | 152.4 (500) | 213.4 (700) | 45.7 (150) | 121.9 (400) | 365.8 (1200) | 365.8 (1200) | 243.8 (800) | 365.8 (1200) | 365.8 (1200) | 365.8 (1200) | 1321-RWR320-DP | | | | • | • | • | • |
| 10 | 200 | 2 | 24.4 (80) | 76.2 (250) | 121.9 (400) | 182.9 (600) | 36.6 (120) | 91.4 (300) | 304.8 (1000) | 365.8 (1200) | 243.8 (800) | 365.8 (1200) | 365.8 (1200) | 365.8 (1200) | 1321-3R500-B | 20 | 495 ⁽³⁾ | | • | • | • | • |
| | 250 | 2 | 24.4 (80) | 76.2 (250) | 99.1 (325) | 167.6 (550) | 36.6 (120) | 76.2 (250) | 304.8 (1000) | 365.8 (1200) | 228.6 (750) | 335.3 (1100) | 365.8 (1200) | 365.8 (1200) | 1321-3R500-B | 20 | 495 ⁽³⁾ | | • | • | • | • |

Table 46 - PowerFlex 700S Drives, 400V Shielded/Unshielded Cable – Meters (Feet) (Continued)

| Drive | | | No Solution | | | | Reactor Only | | | | Reactor and Damping Resistor or 1321-RWR | | | | Reactor/RWR (see page 152) | Resistor | | Available Options | | | |
|-------------------|--------------------|-----|-------------|------------|------------|-------------|--------------|------------|--------------|--------------|--|--------------|--------------|--------------|----------------------------|----------|--------------------|-------------------|------|------|-----|
| Frame | kW | kHz | 1000V | 1200V | 1488V | 1600V | 1000V | 1200V | 1488V | 1600V | 1000V | 1200V | 1488V | 1600V | Cat. No. | Ohms | Watts | TFA1 | TFB2 | RWR2 | RWC |
| 11 | 315 | 2 | 18.3 (60) | 68.6 (225) | 99.1 (325) | 167.6 (550) | 36.6 (120) | 68.6 (225) | 304.8 (1000) | 365.8 (1200) | 228.6 (750) | 335.3 (1100) | 365.8 (1200) | 365.8 (1200) | 1321-3R600-B | 20 | 495 ⁽³⁾ | | • | | |
| | 355 | 2 | 18.3 (60) | 68.6 (225) | 99.1 (325) | 167.6 (550) | 36.6 (120) | 68.6 (225) | 304.8 (1000) | 365.8 (1200) | 228.6 (750) | 274.3 (900) | 365.8 (1200) | 365.8 (1200) | 1321-3R750-B | 20 | 495 ⁽³⁾ | | • | | |
| | 400 | 2 | 18.3 (60) | 68.6 (225) | 99.1 (325) | 167.6 (550) | 36.6 (120) | 68.6 (225) | 304.8 (1000) | 365.8 (1200) | 228.6 (750) | 274.3 (900) | 365.8 (1200) | 365.8 (1200) | 1321-3R750-B | 20 | 735 ⁽⁴⁾ | | • | | |
| 12 ⁽¹⁾ | 450 | 2 | 18.3 (60) | 68.6 (225) | 99.1 (325) | 167.6 (550) | 36.6 (120) | 68.6 (225) | 304.8 (1000) | 365.8 (1200) | 228.6 (750) | 274.3 (900) | 365.8 (1200) | 365.8 (1200) | 2 x 1321-3RB400-B | 40 | 375 ⁽⁴⁾ | | • | | |
| | 500 | 2 | 12.2 (40) | 68.6 (225) | 99.1 (325) | 167.6 (550) | 36.6 (120) | 68.6 (225) | 304.8 (1000) | 365.8 (1200) | 198.1 (650) | 274.3 (900) | 365.8 (1200) | 365.8 (1200) | 2 x 1321-3R500-B | 40 | 375 ⁽⁴⁾ | | • | | |
| | 560 | 2 | 12.2 (40) | 68.6 (225) | 99.1 (325) | 167.6 (550) | 36.6 (120) | 68.6 (225) | 304.8 (1000) | 365.8 (1200) | 198.1 (650) | 274.3 (900) | 365.8 (1200) | 365.8 (1200) | 2 x 1321-3R500-B | 20 | 525 ⁽⁵⁾ | | | | |
| 13 | 630 ⁽²⁾ | 2 | 12.2 (40) | 61.0 (200) | 99.1 (325) | 167.6 (550) | 36.6 (120) | 61.0 (200) | 304.8 (1000) | 365.8 (1200) | 198.1 (650) | 274.3 (900) | 365.8 (1200) | 365.8 (1200) | 2 x 1321-3R600-B | 20 | 525 ⁽⁵⁾ | | | | |
| | 710 ⁽²⁾ | 2 | 12.2 (40) | 61.0 (200) | 99.1 (325) | 167.6 (550) | 36.6 (120) | 61.0 (200) | 304.8 (1000) | 365.8 (1200) | 198.1 (650) | 274.3 (900) | 365.8 (1200) | 365.8 (1200) | 2 x 1321-3R750-B | 20 | 525 ⁽⁵⁾ | | | | |
| | 800 ⁽²⁾ | 2 | 12.2 (40) | 61.0 (200) | 99.1 (325) | 167.6 (550) | 36.6 (120) | 61.0 (200) | 304.8 (1000) | 365.8 (1200) | 198.1 (650) | 274.3 (900) | 365.8 (1200) | 365.8 (1200) | 2 x 1321-3R750-B | 20 | 525 ⁽⁵⁾ | | | | |

- (1) Frame 12 drives have dual inverters and require two output reactors. The resistor ratings are per phase values for each reactor.
- (2) Some Frame 13 drives require two output reactors to match drive amp rating. The resistor ratings are per phase values for each reactor.
- (3) Resistor specification is based on two cables per phase.
- (4) Resistor specification is based on three cables per phase.
- (5) Resistor specification is based on four cables per phase.

Table 47 - PowerFlex 700S Drives, 480V Shielded/Unshielded Cable – Meters (Feet)

| Drive | | | No Solution | | | | Reactor Only | | | | Reactor and Damping Resistor or 1321-RWR | | | | Reactor/RWR (see page 152) | Resistor | | Available Options | | | | |
|-------|-----|-----|-------------|-----------|-------------|-------------|--------------|------------|--------------|--------------|--|--------------|--------------|--------------|----------------------------|----------|-------|-------------------|------|------|-----|---|
| Frame | Hp | kHz | 1000V | 1200V | 1488V | 1600V | 1000V | 1200V | 1488V | 1600V | 1000V | 1200V | 1488V | 1600V | Cat. No. | Ohms | Watts | TFA1 | TFB2 | RWR2 | RWC | |
| 1 | 1 | 2/4 | 7.6 (25) | 12.2 (40) | 83.8 (275) | 83.8 (275) | 7.6 (25) | 91.4 (300) | 152.4 (500) | 152.4 (500) | 152.4 (500) | 152.4 (500) | 152.4 (500) | 152.4 (500) | | | | • | • | • | • | |
| | 2 | 2/4 | 7.6 (25) | 12.2 (40) | 83.8 (275) | 83.8 (275) | 7.6 (25) | 91.4 (300) | 182.9 (600) | 182.9 (600) | 152.4 (500) | 182.9 (600) | 182.9 (600) | 182.9 (600) | | | | • | • | • | • | |
| | 3 | 2/4 | 7.6 (25) | 12.2 (40) | 106.7 (350) | 152.4 (500) | 7.6 (25) | 91.4 (300) | 182.9 (600) | 182.9 (600) | 152.4 (500) | 182.9 (600) | 182.9 (600) | 182.9 (600) | | | | • | • | • | • | |
| | 5 | 2/4 | 7.6 (25) | 12.2 (40) | 106.7 (350) | 152.4 (500) | 7.6 (25) | 91.4 (300) | 243.8 (800) | 243.8 (800) | 152.4 (500) | 243.8 (800) | 243.8 (800) | 243.8 (800) | 1321-RWR8-DP | | | | • | • | • | • |
| | 7.5 | 2/4 | 7.6 (25) | 12.2 (40) | 106.7 (350) | 152.4 (500) | 7.6 (25) | 91.4 (300) | 304.8 (1000) | 304.8 (1000) | 152.4 (500) | 304.8 (1000) | 304.8 (1000) | 304.8 (1000) | 1321-RWR12-DP | | | | | • | | • |
| | 10 | 2/4 | 7.6 (25) | 12.2 (40) | 106.7 (350) | 152.4 (500) | 7.6 (25) | 91.4 (300) | 365.8 (1200) | 365.8 (1200) | 152.4 (500) | 365.8 (1200) | 365.8 (1200) | 365.8 (1200) | 1321-RWR18-DP | | | | | • | | • |
| | 15 | 2/4 | 7.6 (25) | 12.2 (40) | 106.7 (350) | 152.4 (500) | 7.6 (25) | 91.4 (300) | 365.8 (1200) | 365.8 (1200) | 152.4 (500) | 365.8 (1200) | 365.8 (1200) | 365.8 (1200) | 1321-RWR25-DP | | | | | • | | |

Table 47 - PowerFlex 700S Drives, 480V Shielded/Unshielded Cable – Meters (Feet) (Continued)

| Drive | | | No Solution | | | | Reactor Only | | | | Reactor and Damping Resistor or 1321-RWR | | | | Reactor/RWR (see page 152) | Resistor | | Available Options | | | |
|-------------------|-----|-----|-------------|------------|-------------|-------------|--------------|------------|--------------|--------------|--|--------------|--------------|--------------|----------------------------|----------|--------------------|-------------------|-----|------|-----|
| Frame | Hp | kHz | 1000V | 1200V | 1488V | 1600V | 1000V | 1200V | 1488V | 1600V | 1000V | 1200V | 1488V | 1600V | Cat. No. | Ohms | Watts | TF1 | TF2 | RWR2 | RWC |
| 2 | 20 | 2/4 | 7.6 (25) | 12.2 (40) | 106.7 (350) | 152.4 (500) | 7.6 (25) | 91.4 (300) | 365.8 (1200) | 365.8 (1200) | 182.9 (600) | 365.8 (1200) | 365.8 (1200) | 365.8 (1200) | 1321-RWR25-DP | | | | • | | |
| | 25 | 2/4 | 7.6 (25) | 12.2 (40) | 106.7 (350) | 152.4 (500) | 7.6 (25) | 76.2 (250) | 365.8 (1200) | 365.8 (1200) | 152.4 (500) | 365.8 (1200) | 365.8 (1200) | 365.8 (1200) | 1321-RWR35-DP | | | | • | | |
| 3 | 30 | 2/4 | 7.6 (25) | 12.2 (40) | 106.7 (350) | 152.4 (500) | 7.6 (25) | 76.2 (250) | 365.8 (1200) | 365.8 (1200) | 152.4 (500) | 365.8 (1200) | 365.8 (1200) | 365.8 (1200) | 1321-RWR45-DP | | | | • | | |
| | 40 | 2/4 | 7.6 (25) | 12.2 (40) | 106.7 (350) | 152.4 (500) | 7.6 (25) | 76.2 (250) | 365.8 (1200) | 365.8 (1200) | 121.9 (400) | 365.8 (1200) | 365.8 (1200) | 365.8 (1200) | 1321-RWR55-DP | | | | • | | |
| | 50 | 2/4 | 12.2 (40) | 18.3 (60) | 106.7 (350) | 152.4 (500) | 12.2 (40) | 61.0 (200) | 304.8 (1000) | 365.8 (1200) | 121.9 (400) | 365.8 (1200) | 365.8 (1200) | 365.8 (1200) | 1321-RWR80-DP | | | | • | | |
| 4 | 60 | 2/4 | 12.2 (40) | 18.3 (60) | 91.4 (300) | 152.4 (500) | 12.2 (40) | 61.0 (200) | 304.8 (1000) | 365.8 (1200) | 91.4 (300) | 365.8 (1200) | 365.8 (1200) | 365.8 (1200) | 1321-RWR80-DP | | | | • | | |
| 5 | 75 | 2/4 | 12.2 (40) | 18.3 (60) | 91.4 (300) | 152.4 (500) | 12.2 (40) | 61.0 (200) | 274.3 (900) | 365.8 (1200) | 91.4 (300) | 365.8 (1200) | 365.8 (1200) | 365.8 (1200) | 1321-RWR100-DP | | | | • | | |
| | 100 | 2/4 | 12.2 (40) | 24.4 (80) | 91.4 (300) | 137.2 (450) | 12.2 (40) | 61.0 (200) | 243.8 (800) | 365.8 (1200) | 91.4 (300) | 365.8 (1200) | 365.8 (1200) | 365.8 (1200) | 1321-RWR130-DP | | | | • | | |
| 6 | 125 | 2/4 | 12.2 (40) | 24.4 (80) | 91.4 (300) | 137.2 (450) | 12.2 (40) | 61.0 (200) | 243.8 (800) | 365.8 (1200) | 76.2 (250) | 304.8 (1000) | 365.8 (1200) | 365.8 (1200) | 1321-RWR160-DP | | | | • | | |
| | 150 | 2/4 | 12.2 (40) | 24.4 (80) | 91.4 (300) | 137.2 (450) | 12.2 (40) | 61.0 (200) | 243.8 (800) | 304.8 (1000) | 76.2 (250) | 274.3 (900) | 365.8 (1200) | 365.8 (1200) | 1321-RWR200-DP | | | | • | | |
| | 200 | 2/4 | 12.2 (40) | 30.5 (100) | 91.4 (300) | 137.2 (450) | 12.2 (40) | 61.0 (200) | 243.8 (800) | 304.8 (1000) | 61.0 (200) | 274.3 (900) | 365.8 (1200) | 365.8 (1200) | 1321-RWR250-DP | | | | • | | |
| 9 | 200 | 2 | 12.2 (40) | 30.5 (100) | 91.4 (300) | 152.4 (500) | 12.2 (40) | 45.7 (150) | 152.4 (500) | 228.6 (750) | 61.0 (200) | 274.3 (900) | 365.8 (1200) | 365.8 (1200) | 1321-RWR320-DP | | | | • | | |
| | 250 | 2 | 12.2 (40) | 30.5 (100) | 91.4 (300) | 152.4 (500) | 12.2 (40) | 45.7 (150) | 121.9 (400) | 182.9 (600) | 61.0 (200) | 243.8 (800) | 365.8 (1200) | 365.8 (1200) | 1321-RWR320-DP | | | | • | | |
| 10 | 300 | 2 | 12.2 (40) | 30.5 (100) | 61.0 (200) | 121.9 (400) | 12.2 (40) | 45.7 (150) | 61.0 (200) | 121.9 (400) | 61.0 (200) | 243.8 (800) | 304.8 (1000) | 365.8 (1200) | 1321-3RB400-B | 20 | 495 ⁽³⁾ | | • | | |
| | 350 | 2 | 12.2 (40) | 30.5 (100) | 61.0 (200) | 121.9 (400) | 12.2 (40) | 45.7 (150) | 61.0 (200) | 121.9 (400) | 61.0 (200) | 243.8 (800) | 304.8 (1000) | 365.8 (1200) | 1321-3R500-B | 20 | 495 ⁽³⁾ | | • | | |
| | 450 | 2 | 12.2 (40) | 30.5 (100) | 61.0 (200) | 121.9 (400) | 12.2 (40) | 45.7 (150) | 61.0 (200) | 121.9 (400) | 61.0 (200) | 213.4 (700) | 304.8 (1000) | 365.8 (1200) | 1321-3R500-B | 20 | 495 ⁽³⁾ | | • | | |
| 11 | 500 | 2 | 12.2 (40) | 30.5 (100) | 61.0 (200) | 121.9 (400) | 12.2 (40) | 45.7 (150) | 61.0 (200) | 121.9 (400) | 61.0 (200) | 213.4 (700) | 304.8 (1000) | 365.8 (1200) | 1321-3R750-B | 20 | 495 ⁽³⁾ | | • | | |
| | 600 | 2 | 12.2 (40) | 30.5 (100) | 61.0 (200) | 121.9 (400) | 12.2 (40) | 45.7 (150) | 61.0 (200) | 121.9 (400) | 61.0 (200) | 213.4 (700) | 304.8 (1000) | 365.8 (1200) | 1321-3R750-B | 20 | 735 ⁽⁴⁾ | | • | | |
| 12 ⁽¹⁾ | 700 | 2 | 12.2 (40) | 30.5 (100) | 61.0 (200) | 121.9 (400) | 12.2 (40) | 45.7 (150) | 61.0 (200) | 121.9 (400) | 45.7 (150) | 182.9 (600) | 304.8 (1000) | 365.8 (1200) | 2 x 1321-3RB400-B | 40 | 375 ⁽⁴⁾ | | • | | |
| | 800 | 2 | 12.2 (40) | 30.5 (100) | 61.0 (200) | 121.9 (400) | 12.2 (40) | 45.7 (150) | 61.0 (200) | 121.9 (400) | 45.7 (150) | 182.9 (600) | 304.8 (1000) | 365.8 (1200) | 2 x 1321-3R500-B | 40 | 375 ⁽⁴⁾ | | • | | |
| | 900 | 2 | 12.2 (40) | 30.5 (100) | 61.0 (200) | 121.9 (400) | 12.2 (40) | 45.7 (150) | 61.0 (200) | 121.9 (400) | 45.7 (150) | 182.9 (600) | 304.8 (1000) | 365.8 (1200) | 2 x 1321-3R500-B | 20 | 525 ⁽⁵⁾ | | | | |

Table 47 - PowerFlex 700S Drives, 480V Shielded/Unshielded Cable – Meters (Feet) (Continued)

| Drive | | | No Solution | | | | Reactor Only | | | | Reactor and Damping Resistor or 1321-RWR | | | | Reactor/RWR (see page 152) | Resistor | | Available Options | | | |
|-------|---------------------|-----|-------------|------------|------------|-------------|--------------|------------|------------|-------------|--|-------------|--------------|--------------|----------------------------|----------|--------------------|-------------------|------|------|-----|
| Frame | Hp | kHz | 1000V | 1200V | 1488V | 1600V | 1000V | 1200V | 1488V | 1600V | 1000V | 1200V | 1488V | 1600V | Cat. No. | Ohms | Watts | TFA1 | TFB2 | RWR2 | RWC |
| 13 | 1000 ⁽²⁾ | 2 | 12.2 (40) | 30.5 (100) | 61.0 (200) | 121.9 (400) | 12.2 (40) | 45.7 (150) | 61.0 (200) | 121.9 (400) | 45.7 (150) | 152.4 (500) | 304.8 (1000) | 365.8 (1200) | 2 x 1321-3R600-B | 20 | 525 ⁽⁵⁾ | | | | |
| | 1200 ⁽²⁾ | 2 | 12.2 (40) | 30.5 (100) | 61.0 (200) | 121.9 (400) | 12.2 (40) | 45.7 (150) | 61.0 (200) | 121.9 (400) | 45.7 (150) | 152.4 (500) | 304.8 (1000) | 365.8 (1200) | 2 x 1321-3R750-B | 20 | 525 ⁽⁵⁾ | | | | |
| | 1250 ⁽²⁾ | 2 | 12.2 (40) | 30.5 (100) | 61.0 (200) | 121.9 (400) | 12.2 (40) | 45.7 (150) | 61.0 (200) | 121.9 (400) | 45.7 (150) | 152.4 (500) | 304.8 (1000) | 365.8 (1200) | 2 x 1321-3R750-B | 20 | 525 ⁽⁵⁾ | | | | |

- (1) Frame 12 drives have dual inverters and require two output reactors. The resistor ratings are per phase values for each reactor.
- (2) Some Frame 13 drives require two output reactors to match drive amp rating. The resistor ratings are per phase values for each reactor.
- (3) Resistor specification is based on two cables per phase.
- (4) Resistor specification is based on three cables per phase.
- (5) Resistor specification is based on four cables per phase.

Table 48 - PowerFlex 700S Drives, 600V Shielded/Unshielded Cable – Meters (Feet)

| Drive | | | No Solution | | Reactor Only | | Reactor and Damping Resistor or 1321-RWR | | Reactor/RWR (see page 152) | Resistor | | Available Options | | | | |
|-------|-----|-----|-------------|-------------|--------------|--------------|--|--------------|----------------------------|----------|-------|-------------------|------|------|-----|---|
| Frame | Hp | kHz | 1488V | 1850V | 1488V | 1850V | 1488V | 1850V | Cat. No. | Ohms | Watts | TFA1 | TFB2 | RWR2 | RWC | |
| 1 | 1 | 2/4 | 24.4 (80) | 121.9 (400) | 24.4 (80) | 182.9 (600) | 182.9 (600) | 182.9 (600) | | | | • | | • | • | |
| | 2 | 2/4 | 24.4 (80) | 121.9 (400) | 24.4 (80) | 182.9 (600) | 182.9 (600) | 182.9 (600) | | | | • | • | • | • | |
| | 3 | 2/4 | 24.4 (80) | 121.9 (400) | 24.4 (80) | 182.9 (600) | 182.9 (600) | 182.9 (600) | | | | • | • | • | • | |
| | 5 | 2/4 | 24.4 (80) | 121.9 (400) | 24.4 (80) | 243.8 (800) | 365.8 (1200) | 365.8 (1200) | 1321-RWR8-EP | | | | • | • | • | • |
| | 7.5 | 2/4 | 24.4 (80) | 121.9 (400) | 24.4 (80) | 304.8 (1000) | 365.8 (1200) | 365.8 (1200) | 1321-RWR8-EP | | | | • | | • | |
| | 10 | 2/4 | 24.4 (80) | 121.9 (400) | 24.4 (80) | 365.8 (1200) | 365.8 (1200) | 365.8 (1200) | 1321-RWR12-EP | | | | • | | • | |
| | 15 | 2/4 | 24.4 (80) | 121.9 (400) | 36.6 (120) | 365.8 (1200) | 365.8 (1200) | 365.8 (1200) | 1321-RWR18-EP | | | | • | | | |
| 2 | 20 | 2/4 | 24.4 (80) | 121.9 (400) | 36.6 (120) | 365.8 (1200) | 365.8 (1200) | 365.8 (1200) | 1321-RWR25-EP | | | | • | | | |
| | 25 | 2/4 | 24.4 (80) | 121.9 (400) | 45.7 (150) | 365.8 (1200) | 365.8 (1200) | 365.8 (1200) | 1321-RWR25-EP | | | | • | | | |
| 3 | 30 | 2/4 | 24.4 (80) | 121.9 (400) | 45.7 (150) | 365.8 (1200) | 365.8 (1200) | 365.8 (1200) | 1321-RWR35-EP | | | | • | | | |
| | 40 | 2/4 | 24.4 (80) | 137.2 (450) | 45.7 (150) | 365.8 (1200) | 304.8 (1000) | 365.8 (1200) | 1321-RWR45-EP | | | | • | | | |
| | 50 | 2/4 | 24.4 (80) | 137.2 (450) | 45.7 (150) | 304.8 (1000) | 304.8 (1000) | 365.8 (1200) | 1321-RWR55-EP | | | | • | | | |
| 4 | 60 | 2/4 | 24.4 (80) | 137.2 (450) | 45.7 (150) | 304.8 (1000) | 304.8 (1000) | 365.8 (1200) | 1321-RWR80-EP | | | | • | | | |
| 5 | 75 | 2/4 | 24.4 (80) | 137.2 (450) | 45.7 (150) | 274.3 (900) | 243.8 (800) | 365.8 (1200) | 1321-RWR80-EP | | | | • | | | |
| | 100 | 2/4 | 24.4 (80) | 137.2 (450) | 45.7 (150) | 243.8 (800) | 243.8 (800) | 365.8 (1200) | 1321-RWR100-EP | | | | • | | | |
| 6 | 125 | 2/4 | 24.4 (80) | 137.2 (450) | 61.0 (200) | 243.8 (800) | 198.1 (650) | 365.8 (1200) | 1321-RWR130-EP | | | | • | | | |
| | 150 | 2/4 | 24.4 (80) | 137.2 (450) | 61.0 (200) | 243.8 (800) | 198.1 (650) | 365.8 (1200) | 1321-RWR160-EP | | | | • | | | |

Table 48 - PowerFlex 700S Drives, 600V Shielded/Unshielded Cable – Meters (Feet) (Continued)

| Drive | | | No Solution | | Reactor Only | | Reactor and Damping Resistor or 1321-RWR | | Reactor/RWR (see page 152) | Resistor | | Available Options | | | |
|-------------------|------|-----|-------------|-------------|--------------|-------------|--|--------------|----------------------------|----------|--------------------|-------------------|------|------|-----|
| Frame | Hp | kHz | 1488V | 1850V | 1488V | 1850V | 1488V | 1850V | Cat. No. | Ohms | Watts | TFA1 | TFB2 | RWR2 | RWC |
| 9 | 150 | 2 | 24.4 (80) | 137.2 (450) | 61.0 (200) | 243.8 (800) | 198.1 (650) | 365.8 (1200) | 1321-RWR200-EP | | | | • | | |
| | 200 | 2 | 24.4 (80) | 137.2 (450) | 61.0 (200) | 243.8 (800) | 198.1 (650) | 365.8 (1200) | 1321-RWR250-EP | | | | • | | |
| 10 | 250 | 2 | 24.4 (80) | 137.2 (450) | 61.0 (200) | 198.1 (650) | 167.6 (550) | 365.8 (1200) | 1321-3RB250-B | 50 | 315 | | • | | |
| | 350 | 2 | 24.4 (80) | 91.4 (300) | 61.0 (200) | 152.4 (500) | 167.6 (550) | 365.8 (1200) | 1321-3RB350-B | 20 | 585 ⁽³⁾ | | • | | |
| | 400 | 2 | 24.4 (80) | 91.4 (300) | 61.0 (200) | 152.4 (500) | 167.6 (550) | 365.8 (1200) | 1321-3RB400-B | 20 | 585 ⁽³⁾ | | • | | |
| | 450 | 2 | 24.4 (80) | 91.4 (300) | 61.0 (200) | 152.4 (500) | 167.6 (550) | 365.8 (1200) | 1321-3R500-B | 20 | 585 ⁽³⁾ | | • | | |
| 11 | 500 | 2 | 24.4 (80) | 91.4 (300) | 61.0 (200) | 152.4 (500) | 167.6 (550) | 365.8 (1200) | 1321-3R500-B | 20 | 585 ⁽³⁾ | | • | | |
| | 600 | 2 | 24.4 (80) | 91.4 (300) | 61.0 (200) | 152.4 (500) | 152.4 (500) | 365.8 (1200) | 1321-3R600-B | 20 | 585 ⁽³⁾ | | • | | |
| 12 ⁽¹⁾ | 700 | 2 | 24.4 (80) | 91.4 (300) | 61.0 (200) | 152.4 (500) | 152.4 (500) | 365.8 (1200) | 2 x 1321-3RB320-B | 40 | 300 ⁽³⁾ | | • | | |
| | 800 | 2 | 24.4 (80) | 91.4 (300) | 61.0 (200) | 152.4 (500) | 152.4 (500) | 365.8 (1200) | 2 x 1321-3RB400-C | 40 | 480 ⁽⁴⁾ | | • | | |
| | 900 | 2 | 24.4 (80) | 91.4 (300) | 61.0 (200) | 152.4 (500) | 152.4 (500) | 365.8 (1200) | 2 x 1321-3R400-B | 40 | 480 ⁽⁴⁾ | | | | |
| 13 ⁽²⁾ | 1000 | 2 | 24.4 (80) | 91.4 (300) | 61.0 (200) | 152.4 (500) | 152.4 (500) | 365.8 (1200) | 2 x 1321-3R500-C | 20 | 480 ⁽⁴⁾ | | | | |
| | 1100 | 2 | 24.4 (80) | 91.4 (300) | 53.3 (175) | 137.2 (450) | 137.2 (450) | 365.8 (1200) | 2 x 1321-3R500-B | 20 | 720 ⁽⁵⁾ | | | | |
| | 1300 | 2 | 24.4 (80) | 91.4 (300) | 53.3 (175) | 137.2 (450) | 137.2 (450) | 365.8 (1200) | 2 x 1321-3R600-B | 20 | 720 ⁽⁵⁾ | | | | |

- (1) Frame 12 drives have dual inverters and require two output reactors. The resistor ratings are per phase values for each reactor.
- (2) Frame 13 drives require two output reactors to match drive amp rating. The resistor ratings are per phase values for each reactor.
- (3) Resistor specification is based on two parallel cables per phase.
- (4) Resistor specification is based on three parallel cables per phase.
- (5) Resistor specification is based on four parallel cables per phase.

Table 49 - PowerFlex 700S Drives, 690V Shielded/Unshielded Cable – Meters (Feet)

| Drive | | | No Solution | | Reactor Only | | Reactor and Damping Resistor | | Reactor | Resistor | | Available Options | | | |
|-------|-----|-----|-------------|------------|--------------|-------------|------------------------------|--------------|---------------|----------|--------------------|-------------------|------|------|-----|
| Frame | kW | kHz | 1850V | 2000V | 1850V | 2000V | 1850V | 2000V | Cat. No. | Ohms | Watts | TFA1 | TFB2 | RWR2 | RWC |
| 5 | 45 | 2/4 | 24.4 (80) | 45.7 (150) | 61.0 (200) | 106.7 (350) | 365.8 (1200) | 365.8 (1200) | 1321-3R80-C | 50 | 375/750 | | | | |
| | 55 | 2/4 | 24.4 (80) | 45.7 (150) | 61.0 (200) | 106.7 (350) | 365.8 (1200) | 365.8 (1200) | 1321-3R80-C | 50 | 375/750 | | | | |
| | 75 | 2/4 | 24.4 (80) | 45.7 (150) | 61.0 (200) | 106.7 (350) | 365.8 (1200) | 365.8 (1200) | 1321-3R100-C | 50 | 375/750 | | | | |
| | 90 | 2/4 | 24.4 (80) | 45.7 (150) | 61.0 (200) | 106.7 (350) | 243.8 (800) | 274.3 (900) | 1321-3R130-C | 50 | 375/750 | | | | |
| 6 | 110 | 2/4 | 24.4 (80) | 45.7 (150) | 76.2 (250) | 121.9 (400) | 243.8 (800) | 274.3 (900) | 1321-3R160-C | 50 | 375/750 | | | | |
| | 132 | 2/4 | 24.4 (80) | 45.7 (150) | 76.2 (250) | 121.9 (400) | 243.8 (800) | 274.3 (900) | 1321-3R200-C | 50 | 375/750 | | | | |
| 9 | 160 | 2 | 24.4 (80) | 45.7 (150) | 91.4 (300) | 121.9 (400) | 182.9 (600) | 243.8 (800) | 1321-3RB250-C | 50 | 480 | | | | |
| | 200 | 2 | 24.4 (80) | 45.7 (150) | 91.4 (300) | 121.9 (400) | 182.9 (600) | 243.8 (800) | 1321-3RB250-C | 50 | 480 | | | | |
| 10 | 250 | 2 | 24.4 (80) | 45.7 (150) | 91.4 (300) | 121.9 (400) | 182.9 (600) | 243.8 (800) | 1321-3RB400-C | 50 | 480 | | | | |
| | 315 | 2 | 24.4 (80) | 45.7 (150) | 91.4 (300) | 121.9 (400) | 182.9 (600) | 243.8 (800) | 1321-3RB400-C | 20 | 960 ⁽³⁾ | | | | |
| | 355 | 2 | 24.4 (80) | 45.7 (150) | 91.4 (300) | 121.9 (400) | 182.9 (600) | 243.8 (800) | 1321-3R500-C | 20 | 960 ⁽³⁾ | | | | |
| | 400 | 2 | 24.4 (80) | 45.7 (150) | 91.4 (300) | 121.9 (400) | 182.9 (600) | 243.8 (800) | 1321-3R500-C | 20 | 960 ⁽³⁾ | | | | |

Table 49 - PowerFlex 700S Drives, 690V Shielded/Unshielded Cable – Meters (Feet)

| Drive | | | No Solution | | Reactor Only | | Reactor and Damping Resistor | | Reactor | Resistor | | Available Options | | | |
|-------------------|---------------------|-----|-------------|------------|--------------|-------------|------------------------------|-------------|------------------|----------|--------------------|-------------------|------|------|-----|
| Frame | kW | kHz | 1850V | 2000V | 1850V | 2000V | 1850V | 2000V | Cat. No. | Ohms | Watts | TFA1 | TFB2 | RWR2 | RWC |
| 11 | 450 | 2 | 24.4 (80) | 45.7 (150) | 91.4 (300) | 121.9 (400) | 182.9 (600) | 243.8 (800) | 1321-3R750-C | 20 | 960 ⁽³⁾ | | | | |
| | 500 | 2 | 24.4 (80) | 45.7 (150) | 91.4 (300) | 121.9 (400) | 182.9 (600) | 243.8 (800) | 1321-3R750-C | 20 | 960 ⁽³⁾ | | | | |
| | 560 | 2 | 24.4 (80) | 45.7 (150) | 76.2 (250) | 121.9 (400) | 182.9 (600) | 243.8 (800) | 1321-3R850-C | 20 | 960 ⁽³⁾ | | | | |
| 12 ⁽¹⁾ | 630 | 2 | 24.4 (80) | 45.7 (150) | 76.2 (250) | 121.9 (400) | 182.9 (600) | 243.8 (800) | 2 x 1321-3R600-C | 40 | 480 ⁽⁴⁾ | | | | |
| | 710 | 2 | 24.4 (80) | 45.7 (150) | 76.2 (250) | 121.9 (400) | 182.9 (600) | 243.8 (800) | 2 x 1321-3R600-C | 40 | 645 ⁽⁴⁾ | | | | |
| | 800 | 2 | 24.4 (80) | 45.7 (150) | 76.2 (250) | 121.9 (400) | 182.9 (600) | 243.8 (800) | 2 x 1321-3R750-C | 40 | 645 ⁽⁴⁾ | | | | |
| 13 | 900 | 2 | 24.4 (80) | 45.7 (150) | 76.2 (250) | 121.9 (400) | 182.9 (600) | 243.8 (800) | 2 x 1321-3R600-C | 40 | 645 ⁽⁴⁾ | | | | |
| | 1000 ⁽²⁾ | 2 | 24.4 (80) | 45.7 (150) | 61.0 (200) | 91.4 (300) | 182.9 (600) | 243.8 (800) | 2 x 1321-3R600-C | 20 | 840 ⁽⁵⁾ | | | | |
| | 1100 ⁽²⁾ | 2 | 24.4 (80) | 45.7 (150) | 61.0 (200) | 91.4 (300) | 182.9 (600) | 243.8 (800) | 2 x 1321-3R750-C | 20 | 840 ⁽⁵⁾ | | | | |

- (1) Frame 12 drives have dual inverters and require two output reactors. The resistor ratings are per phase values for each reactor.
- (2) Some Frame 13 drives require two output reactors to match drive amp rating. The resistor ratings are per phase values for each reactor.
- (3) Resistor specification is based on two parallel cables per phase.
- (4) Resistor specification is based on three parallel cables per phase.
- (5) Resistor specification is based on four parallel cables per phase.

PowerFlex 753 and 755 Wall Mount Drives

This section lists motor cable length restrictions, reactors, and available options for PowerFlex 753 and 755 wall mount drives.

Table 50 - PowerFlex 753 and 755 Wall Mount Drives, 400V Shielded/Unshielded Cable – Meters (Feet)

| Drive | Rating | | No Solution | | | | Reactor Only | | | | Reactor and Damping Resistor or 1321-RWR | | | | Reactor/RWR (see page 152) | Resistor | | Available Options | | | | | |
|-------|--------|----|-------------|------------|-------------|--------------|--------------|-------------|--------------|--------------|--|--------------|--------------|--------------|---|----------|----------|-------------------|-------|------|------|------|-----|
| | Frame | kW | kHz | 1000V | 1200V | 1488V | 1600V | 1000V | 1200V | 1488V | 1600V | 1000V | 1200V | 1488V | | 1600V | Cat. No. | Ohms | Watts | TFA1 | TFB2 | RWR2 | RWC |
| 1 | 0.75 | 2 | 7.6 (25) | 83.8 (275) | 83.8 (275) | 83.8 (275) | 91.4 (300) | 152.4 (500) | 152.4 (500) | 152.4 (500) | 152.4 (500) | 152.4 (500) | 152.4 (500) | 152.4 (500) | | | | | • | | • | | |
| | | 4 | 7.6 (25) | 83.8 (275) | 83.8 (275) | 83.8 (275) | 91.4 (300) | 152.4 (500) | 152.4 (500) | 152.4 (500) | 152.4 (500) | 152.4 (500) | 152.4 (500) | 152.4 (500) | | | | | • | | • | | |
| | 1.5 | 2 | 7.6 (25) | 91.4 (300) | 182.9 (600) | 182.9 (600) | 91.4 (300) | 182.9 (600) | 182.9 (600) | 182.9 (600) | 182.9 (600) | 182.9 (600) | 182.9 (600) | 182.9 (600) | | | | | • | • | • | | |
| | | 4 | 7.6 (25) | 91.4 (300) | 182.9 (600) | 182.9 (600) | 91.4 (300) | 182.9 (600) | 182.9 (600) | 182.9 (600) | 182.9 (600) | 182.9 (600) | 182.9 (600) | 182.9 (600) | | | | | • | | • | | |
| | 2.2 | 2 | 7.6 (25) | 91.4 (300) | 182.9 (600) | 182.9 (600) | 91.4 (300) | 182.9 (600) | 182.9 (600) | 182.9 (600) | 182.9 (600) | 182.9 (600) | 182.9 (600) | 182.9 (600) | | | | | • | • | • | | |
| | | 4 | 7.6 (25) | 91.4 (300) | 182.9 (600) | 182.9 (600) | 91.4 (300) | 182.9 (600) | 182.9 (600) | 182.9 (600) | 182.9 (600) | 182.9 (600) | 182.9 (600) | 182.9 (600) | | | | | • | | • | | |
| | 4.0 | 2 | 7.6 (25) | 91.4 (300) | 243.8 (800) | 243.8 (800) | 91.4 (300) | 243.8 (800) | 243.8 (800) | 243.8 (800) | 243.8 (800) | 243.8 (800) | 243.8 (800) | 243.8 (800) | 1321-RWR12-DP | | | | | • | | • | |
| | | 4 | 7.6 (25) | 91.4 (300) | 182.9 (600) | 182.9 (600) | 91.4 (300) | 182.9 (600) | 182.9 (600) | 182.9 (600) | 182.9 (600) | 182.9 (600) | 182.9 (600) | 182.9 (600) | | | | | • | | • | | |
| | 5.5 | 2 | 7.6 (25) | 91.4 (300) | 274.3 (900) | 304.8 (1000) | 91.4 (300) | 274.3 (900) | 365.8 (1200) | 365.8 (1200) | 365.8 (1200) | 365.8 (1200) | 365.8 (1200) | 365.8 (1200) | 1321-RWR12-DP | | | | | • | | • | |
| | | 4 | 7.6 (25) | 91.4 (300) | 182.9 (600) | 182.9 (600) | 91.4 (300) | 182.9 (600) | 182.9 (600) | 182.9 (600) | 182.9 (600) | 182.9 (600) | 182.9 (600) | 182.9 (600) | | | | | | | • | | |
| | 7.5 | 2 | 7.6 (25) | 91.4 (300) | 274.3 (900) | 365.8 (1200) | 91.4 (300) | 274.3 (900) | 365.8 (1200) | 365.8 (1200) | 365.8 (1200) | 365.8 (1200) | 365.8 (1200) | 365.8 (1200) | 1321-RWR18-DP | | | | | • | | • | |
| | | 4 | 7.6 (25) | 91.4 (300) | 182.9 (600) | 182.9 (600) | 91.4 (300) | 182.9 (600) | 182.9 (600) | 182.9 (600) | 182.9 (600) | 182.9 (600) | 182.9 (600) | 182.9 (600) | | | | | | | • | | |

Table 50 - PowerFlex 753 and 755 Wall Mount Drives, 400V Shielded/Unshielded Cable – Meters (Feet) (Continued)

| Drive | Rating | | No Solution | | | | Reactor Only | | | | Reactor and Damping Resistor or 1321-RWR | | | | Reactor/RWR (see page 152) | Resistor | | Available Options | | | | | | | |
|-------|--------|----|-------------|-------------|--------------|--------------|--------------|--------------|--------------|--------------|--|--------------|--------------|--------------|----------------------------|----------|----------|-------------------|-------|-----|-----|------|-----|--|--|
| | Frame | kW | kHz | 1000V | 1200V | 1488V | 1600V | 1000V | 1200V | 1488V | 1600V | 1000V | 1200V | 1488V | | 1600V | Cat. No. | Ohms | Watts | TF1 | TF2 | RWR2 | RWC | | |
| 2 | 0.75 | 2 | 7.6 (25) | 91.4 (300) | 83.8 (275) | 83.8 (275) | 91.4 (300) | 152.4 (500) | 152.4 (500) | 152.4 (500) | 152.4 (500) | 152.4 (500) | 152.4 (500) | 152.4 (500) | | | | | | | | | | | |
| | | 4 | 7.6 (25) | 91.4 (300) | 83.8 (275) | 83.8 (275) | 91.4 (300) | 152.4 (500) | 152.4 (500) | 152.4 (500) | 152.4 (500) | 152.4 (500) | 152.4 (500) | 152.4 (500) | | | | | | | | | | | |
| | 1.5 | 2 | 7.6 (25) | 91.4 (300) | 182.9 (600) | 182.9 (600) | 91.4 (300) | 182.9 (600) | 182.9 (600) | 182.9 (600) | 182.9 (600) | 182.9 (600) | 182.9 (600) | 182.9 (600) | | | | | | | | | | | |
| | | 4 | 7.6 (25) | 91.4 (300) | 182.9 (600) | 182.9 (600) | 91.4 (300) | 182.9 (600) | 182.9 (600) | 182.9 (600) | 182.9 (600) | 182.9 (600) | 182.9 (600) | 182.9 (600) | | | | | | | | | | | |
| | 2.2 | 2 | 7.6 (25) | 91.4 (300) | 182.9 (600) | 182.9 (600) | 91.4 (300) | 182.9 (600) | 182.9 (600) | 182.9 (600) | 182.9 (600) | 182.9 (600) | 182.9 (600) | 182.9 (600) | | | | | | | | | | | |
| | | 4 | 7.6 (25) | 91.4 (300) | 182.9 (600) | 182.9 (600) | 91.4 (300) | 182.9 (600) | 182.9 (600) | 182.9 (600) | 182.9 (600) | 182.9 (600) | 182.9 (600) | 182.9 (600) | | | | | | | | | | | |
| | 4.0 | 2 | 7.6 (25) | 91.4 (300) | 243.8 (800) | 243.8 (800) | 91.4 (300) | 243.8 (800) | 243.8 (800) | 243.8 (800) | 243.8 (800) | 243.8 (800) | 243.8 (800) | 243.8 (800) | 321-RWR12-DP | | | | | | | | | | |
| | | 4 | 7.6 (25) | 91.4 (300) | 182.9 (600) | 182.9 (600) | 91.4 (300) | 182.9 (600) | 182.9 (600) | 182.9 (600) | 182.9 (600) | 182.9 (600) | 182.9 (600) | 182.9 (600) | | | | | | | | | | | |
| | 5.5 | 2 | 7.6 (25) | 91.4 (300) | 274.3 (900) | 304.8 (1000) | 91.4 (300) | 274.3 (900) | 365.8 (1200) | 365.8 (1200) | 365.8 (1200) | 365.8 (1200) | 365.8 (1200) | 365.8 (1200) | 321-RWR12-DP | | | | | | | | | | |
| | | 4 | 7.6 (25) | 91.4 (300) | 182.9 (600) | 182.9 (600) | 91.4 (300) | 182.9 (600) | 182.9 (600) | 182.9 (600) | 182.9 (600) | 182.9 (600) | 182.9 (600) | 182.9 (600) | | | | | | | | | | | |
| | 7.5 | 2 | 7.6 (25) | 91.4 (300) | 274.3 (900) | 365.8 (1200) | 91.4 (300) | 274.3 (900) | 365.8 (1200) | 365.8 (1200) | 365.8 (1200) | 365.8 (1200) | 365.8 (1200) | 365.8 (1200) | 1321-RWR18-DP | | | | | | | | | | |
| | | 4 | 7.6 (25) | 91.4 (300) | 182.9 (600) | 213.4 (700) | 91.4 (300) | 182.9 (600) | 182.9 (600) | 182.9 (600) | 182.9 (600) | 182.9 (600) | 182.9 (600) | 182.9 (600) | | | | | | | | | | | |
| | 11 | 2 | 7.6 (25) | 91.4 (300) | 274.3 (900) | 365.8 (1200) | 91.4 (300) | 274.3 (900) | 365.8 (1200) | 365.8 (1200) | 365.8 (1200) | 365.8 (1200) | 365.8 (1200) | 365.8 (1200) | 1321-RWR25-DP | | | | | | | | | | |
| | | 4 | 7.6 (25) | 91.4 (300) | 182.9 (600) | 213.4 (700) | 91.4 (300) | 182.9 (600) | 182.9 (600) | 182.9 (600) | 182.9 (600) | 182.9 (600) | 182.9 (600) | 182.9 (600) | | | | | | | | | | | |
| 3 | 15 | 2 | 7.6 (25) | 137.2 (450) | 365.8 (1200) | 365.8 (1200) | 91.4 (300) | 365.8 (1200) | 365.8 (1200) | 365.8 (1200) | 365.8 (1200) | 365.8 (1200) | 365.8 (1200) | 365.8 (1200) | 1321-RWR35-DP | | | | | | | | | | |
| | | 4 | 7.6 (25) | 91.4 (300) | 152.4 (500) | 213.4 (700) | 18.3 (60) | 91.4 (300) | 365.8 (1200) | 365.8 (1200) | 182.9 (600) | 304.8 (1000) | 365.8 (1200) | 365.8 (1200) | | | | | | | | | | | |
| | 18.5 | 2 | 7.6 (25) | 137.2 (450) | 365.8 (1200) | 365.8 (1200) | 91.4 (300) | 365.8 (1200) | 365.8 (1200) | 365.8 (1200) | 365.8 (1200) | 365.8 (1200) | 365.8 (1200) | 365.8 (1200) | 1321-RWR35-DP | | | | | | | | | | |
| | | 4 | 7.6 (25) | 91.4 (300) | 152.4 (500) | 213.4 (700) | 18.3 (60) | 91.4 (300) | 365.8 (1200) | 365.8 (1200) | 182.9 (600) | 304.8 (1000) | 365.8 (1200) | 365.8 (1200) | | | | | | | | | | | |
| | 22 | 2 | 7.6 (25) | 137.2 (450) | 365.8 (1200) | 365.8 (1200) | 91.4 (300) | 365.8 (1200) | 365.8 (1200) | 365.8 (1200) | 365.8 (1200) | 365.8 (1200) | 365.8 (1200) | 365.8 (1200) | 1321-RWR45-DP | | | | | | | | | | |
| | | 4 | 7.6 (25) | 91.4 (300) | 152.4 (500) | 213.4 (700) | 18.3 (60) | 91.4 (300) | 365.8 (1200) | 365.8 (1200) | 182.9 (600) | 304.8 (1000) | 365.8 (1200) | 365.8 (1200) | | | | | | | | | | | |
| 4 | 30 | 2 | 7.6 (25) | 137.2 (450) | 304.8 (1000) | 365.8 (1200) | 91.4 (300) | 365.8 (1200) | 365.8 (1200) | 365.8 (1200) | 365.8 (1200) | 365.8 (1200) | 365.8 (1200) | 365.8 (1200) | 1321-RWR55-DP | | | | | | | | | | |
| | | 4 | 7.6 (25) | 91.4 (300) | 152.4 (500) | 213.4 (700) | 18.3 (60) | 91.4 (300) | 365.8 (1200) | 365.8 (1200) | 182.9 (600) | 304.8 (1000) | 365.8 (1200) | 365.8 (1200) | | | | | | | | | | | |
| | 37 | 2 | 12.2 (40) | 137.2 (450) | 304.8 (1000) | 365.8 (1200) | 91.4 (300) | 365.8 (1200) | 365.8 (1200) | 365.8 (1200) | 365.8 (1200) | 365.8 (1200) | 365.8 (1200) | 365.8 (1200) | 1321-RWR80-DP | | | | | | | | | | |
| | | 4 | 12.2 (40) | 91.4 (300) | 152.4 (500) | 213.4 (700) | 18.3 (60) | 91.4 (300) | 365.8 (1200) | 365.8 (1200) | 182.9 (600) | 304.8 (1000) | 365.8 (1200) | 365.8 (1200) | | | | | | | | | | | |

Table 50 - PowerFlex 753 and 755 Wall Mount Drives, 400V Shielded/Unshielded Cable – Meters (Feet) (Continued)

| Drive | Rating | | No Solution | | | | Reactor Only | | | | Reactor and Damping Resistor or 1321-RWR | | | | Reactor/RWR (see page 152) | Resistor | | Available Options | | | | | |
|-------|--------|----|-------------|-------------|--------------|--------------|--------------|--------------|--------------|--------------|--|--------------|--------------|--------------|------------------------------|---------------|----------|-------------------|-------|-----|-----|------|-----|
| | Frame | kW | kHz | 1000V | 1200V | 1488V | 1600V | 1000V | 1200V | 1488V | 1600V | 1000V | 1200V | 1488V | | 1600V | Cat. No. | Ohms | Watts | TF1 | TF2 | RWR2 | RWC |
| 5 | 45 | 2 | 12.2 (40) | 137.2 (450) | 304.8 (1000) | 365.8 (1200) | 91.4 (300) | 304.8 (1000) | 365.8 (1200) | 365.8 (1200) | 365.8 (1200) | 365.8 (1200) | 365.8 (1200) | 365.8 (1200) | 365.8 (1200) | 1321-RWR80-DP | | | | • | | | |
| | | 4 | 12.2 (40) | 91.4 (300) | 152.4 (500) | 213.4 (700) | 24.4 (80) | 91.4 (300) | 365.8 (1200) | 365.8 (1200) | 152.4 (500) | 304.8 (1000) | 365.8 (1200) | 365.8 (1200) | | | | | | | | | |
| | 55 | 2 | 12.2 (40) | 137.2 (450) | 304.8 (1000) | 365.8 (1200) | 91.4 (300) | 274.3 (900) | 365.8 (1200) | 365.8 (1200) | 365.8 (1200) | 365.8 (1200) | 365.8 (1200) | 365.8 (1200) | 1321-RWR100-DP | | | | • | | | | |
| | | 4 | 12.2 (40) | 91.4 (300) | 152.4 (500) | 213.4 (700) | 24.4 (80) | 91.4 (300) | 365.8 (1200) | 365.8 (1200) | 152.4 (500) | 304.8 (1000) | 365.8 (1200) | 365.8 (1200) | | | | | | | | | |
| 6 | 75 | 2 | 18.3 (60) | 137.2 (450) | 304.8 (1000) | 365.8 (1200) | 91.4 (300) | 213.4 (700) | 365.8 (1200) | 365.8 (1200) | 365.8 (1200) | 365.8 (1200) | 365.8 (1200) | 365.8 (1200) | 1321-RWR130-DP | | | | • | | | | |
| | | 4 | 18.3 (60) | 91.4 (300) | 152.4 (500) | 213.4 (700) | 30.5 (100) | 91.4 (300) | 304.8 (1000) | 365.8 (1200) | 152.4 (500) | 304.8 (1000) | 365.8 (1200) | 365.8 (1200) | | | | | | | | | |
| | 90 | 2 | 18.3 (60) | 137.2 (450) | 304.8 (1000) | 365.8 (1200) | 91.4 (300) | 213.4 (700) | 365.8 (1200) | 365.8 (1200) | 304.8 (1000) | 365.8 (1200) | 365.8 (1200) | 365.8 (1200) | 1321-RWR160-DP | | | | • | | | | |
| | | 4 | 18.3 (60) | 91.4 (300) | 152.4 (500) | 213.4 (700) | 30.5 (100) | 91.4 (300) | 365.8 (1200) | 365.8 (1200) | 121.9 (400) | 243.8 (800) | 365.8 (1200) | 365.8 (1200) | | | | | | | | | |
| | 110 | 2 | 24.4 (80) | 137.2 (450) | 274.3 (900) | 365.8 (1200) | 76.2 (250) | 198.1 (650) | 365.8 (1200) | 365.8 (1200) | 274.3 (900) | 365.8 (1200) | 365.8 (1200) | 365.8 (1200) | 1321-RWR200-DP | | | | • | | | | |
| | | 4 | 24.4 (80) | 91.4 (300) | 152.4 (500) | 213.4 (700) | 36.6 (120) | 91.4 (300) | 365.8 (1200) | 365.8 (1200) | 121.9 (400) | 213.4 (700) | 365.8 (1200) | 365.8 (1200) | | | | | | | | | |
| 7 | 132 | 2 | 24.4 (80) | 137.2 (450) | 274.3 (900) | 365.8 (1200) | 61.0 (200) | 182.9 (600) | 365.8 (1200) | 365.8 (1200) | 243.8 (800) | 365.8 (1200) | 365.8 (1200) | 365.8 (1200) | 1321-RWR250-DP | | | | • | | | | |
| | | 4 | 24.4 (80) | 91.4 (300) | 152.4 (500) | 213.4 (700) | 36.6 (120) | 91.4 (300) | 365.8 (1200) | 365.8 (1200) | 91.4 (300) | 182.9 (600) | 365.8 (1200) | 365.8 (1200) | | | | | | | | | |
| | 160 | 2 | 24.4 (80) | 121.9 (400) | 243.8 (800) | 365.8 (1200) | 61.0 (200) | 152.4 (500) | 304.8 (1000) | 365.8 (1200) | 243.8 (800) | 365.8 (1200) | 365.8 (1200) | 365.8 (1200) | 1321-3RB320-B | 50 | 225 | | • | | | | |
| | | 4 | 24.4 (80) | 91.4 (300) | 152.4 (500) | 182.9 (600) | 36.6 (120) | 91.4 (300) | 182.9 (600) | 274.3 (900) | 91.4 (300) | 182.9 (600) | 365.8 (1200) | 365.8 (1200) | | 50 | 450 | | | | | | |
| | 200 | 2 | 24.4 (80) | 121.9 (400) | 243.8 (800) | 365.8 (1200) | 61.0 (200) | 152.4 (500) | 304.8 (1000) | 365.8 (1200) | 243.8 (800) | 365.8 (1200) | 365.8 (1200) | 365.8 (1200) | 1321-3RB400-B ⁽¹⁾ | 20 | 495 | | • | | | | |
| | | 4 | 24.4 (80) | 91.4 (300) | 152.4 (500) | 182.9 (600) | 36.6 (120) | 91.4 (300) | 182.9 (600) | 228.6 (750) | 91.4 (300) | 182.9 (600) | 304.8 (1000) | 365.8 (1200) | | 20 | 990 | | | | | | |
| | 250 | 2 | 24.4 (80) | 121.9 (400) | 213.4 (700) | 304.8 (1000) | 45.7 (150) | 121.9 (400) | 304.8 (1000) | 365.8 (1200) | 228.6 (750) | 365.8 (1200) | 365.8 (1200) | 365.8 (1200) | 1321-3R500-B ⁽¹⁾ | 20 | 495 | | • | | | | |
| | | 4 | 24.4 (80) | 91.4 (300) | 152.4 (500) | 182.9 (600) | 36.6 (120) | 91.4 (300) | 167.6 (550) | 213.4 (700) | 91.4 (300) | 182.9 (600) | 304.8 (1000) | 365.8 (1200) | | 20 | 990 | | • | | | | |
| | 315 | 2 | 24.4 (80) | 121.9 (400) | 213.4 (700) | 259.1 (850) | 45.7 (150) | 121.9 (400) | 304.8 (1000) | 365.8 (1200) | 228.6 (750) | 365.8 (1200) | 365.8 (1200) | 365.8 (1200) | 1321-3R600-B ⁽¹⁾ | 20 | 495 | | • | | | | |
| | | 4 | 24.4 (80) | 91.4 (300) | 152.4 (500) | 182.9 (600) | 36.6 (120) | 91.4 (300) | 167.6 (550) | 213.4 (700) | 91.4 (300) | 182.9 (600) | 304.8 (1000) | 365.8 (1200) | | 20 | 990 | | • | | | | |

(1) Requires two parallel cables.

Table 51 - PowerFlex 753 and 755 Wall Mount Drives, 480V Shielded/Unshielded Cable – Meters (Feet)

| Drive | Rating | | No Solution | | | | Reactor Only | | | | Reactor and Damping Resistor or 1321-RWR | | | | Reactor/RWR (see page 152) | Resistor | | Available Options | | | | | |
|-------|--------|----|-------------|-----------|-------------|-------------|--------------|------------|--------------|--------------|--|--------------|--------------|--------------|----------------------------|---------------|----------|-------------------|-------|------|------|------|-----|
| | Frame | Hp | kHz | 1000V | 1200V | 1488V | 1600V | 1000V | 1200V | 1488V | 1600V | 1000V | 1200V | 1488V | | 1600V | Cat. No. | Ohms | Watts | TFB1 | TFB2 | RWR2 | RWC |
| 1 | 1.0 | 2 | 7.6 (25) | 12.2 (40) | 83.8 (275) | 83.8 (275) | 7.6 (25) | 91.4 (300) | 152.4 (500) | 152.4 (500) | 152.4 (500) | 152.4 (500) | 152.4 (500) | 152.4 (500) | 152.4 (500) | | | | • | | • | | |
| | | 4 | 7.6 (25) | 12.2 (40) | 83.8 (275) | 83.8 (275) | 7.6 (25) | 12.2 (40) | 121.9 (400) | 152.4 (500) | 152.4 (500) | 152.4 (500) | 152.4 (500) | 152.4 (500) | 152.4 (500) | | | | • | | • | | |
| | 2.0 | 2 | 7.6 (25) | 12.2 (40) | 83.8 (275) | 83.8 (275) | 7.6 (25) | 91.4 (300) | 182.9 (600) | 182.9 (600) | 152.4 (500) | 182.9 (600) | 182.9 (600) | 182.9 (600) | 182.9 (600) | | | | • | • | • | | |
| | | 4 | 7.6 (25) | 12.2 (40) | 83.8 (275) | 83.8 (275) | 7.6 (25) | 12.2 (40) | 121.9 (400) | 182.9 (600) | 152.4 (500) | 182.9 (600) | 182.9 (600) | 182.9 (600) | 182.9 (600) | | | | • | | • | | |
| | 3.0 | 2 | 7.6 (25) | 12.2 (40) | 106.7 (350) | 152.4 (500) | 7.6 (25) | 91.4 (300) | 182.9 (600) | 182.9 (600) | 152.4 (500) | 182.9 (600) | 182.9 (600) | 182.9 (600) | 182.9 (600) | | | | • | • | • | | |
| | | 4 | 7.6 (25) | 12.2 (40) | 106.7 (350) | 152.4 (500) | 7.6 (25) | 12.2 (40) | 121.9 (400) | 182.9 (600) | 152.4 (500) | 182.9 (600) | 182.9 (600) | 182.9 (600) | 182.9 (600) | | | | • | | • | | |
| | 5.0 | 2 | 7.6 (25) | 12.2 (40) | 106.7 (350) | 152.4 (500) | 7.6 (25) | 91.4 (300) | 243.8 (800) | 243.8 (800) | 152.4 (500) | 243.8 (800) | 243.8 (800) | 243.8 (800) | 243.8 (800) | 1321-RWR8-DP | | | | | • | • | |
| | | 4 | 7.6 (25) | 12.2 (40) | 106.7 (350) | 152.4 (500) | 7.6 (25) | 12.2 (40) | 121.9 (400) | 182.9 (600) | 152.4 (500) | 182.9 (600) | 182.9 (600) | 182.9 (600) | 182.9 (600) | | | | | | • | | |
| | 7.5 | 2 | 7.6 (25) | 12.2 (40) | 106.7 (350) | 152.4 (500) | 7.6 (25) | 91.4 (300) | 304.8 (1000) | 304.8 (1000) | 152.4 (500) | 304.8 (1000) | 304.8 (1000) | 304.8 (1000) | 304.8 (1000) | 1321-RWR12-DP | | | | | • | | • |
| | | 4 | 7.6 (25) | 12.2 (40) | 106.7 (350) | 152.4 (500) | 7.6 (25) | 12.2 (40) | 121.9 (400) | 182.9 (600) | 152.4 (500) | 182.9 (600) | 182.9 (600) | 182.9 (600) | 182.9 (600) | | | | | | | • | |
| | 10 | 2 | 7.6 (25) | 12.2 (40) | 106.7 (350) | 152.4 (500) | 7.6 (25) | 91.4 (300) | 365.8 (1200) | 365.8 (1200) | 152.4 (500) | 365.8 (1200) | 365.8 (1200) | 365.8 (1200) | 365.8 (1200) | 1321-RWR18-DP | | | | | • | | • |
| | | 4 | 7.6 (25) | 12.2 (40) | 106.7 (350) | 152.4 (500) | 7.6 (25) | 12.2 (40) | 121.9 (400) | 182.9 (600) | 152.4 (500) | 182.9 (600) | 182.9 (600) | 182.9 (600) | 182.9 (600) | | | | | | | • | |

Table 51 - PowerFlex 753 and 755 Wall Mount Drives, 480V Shielded/Unshielded Cable – Meters (Feet) (Continued)

| Drive | Rating | | No Solution | | | | Reactor Only | | | | Reactor and Damping Resistor or 1321-RWR | | | | Reactor/RWR (see page 152) | Resistor | | Available Options | | | | | | | |
|-------|--------|----------|-------------|-------------|-------------|-------------|--------------|--------------|--------------|--------------|--|--------------|--------------|--------------|----------------------------|---------------|---------------|-------------------|-------|-------|------|------|-----|---|--|
| | Frame | Hp | kHz | 1000V | 1200V | 1488V | 1600V | 1000V | 1200V | 1488V | 1600V | 1000V | 1200V | 1488V | | 1600V | Cat. No. | Ohms | Watts | TF1A1 | TFB2 | RWR2 | RWC | | |
| 2 | 1.0 | 2 | 7.6 (25) | 12.2 (40) | 83.8 (275) | 83.8 (275) | 7.6 (25) | 91.4 (300) | 152.4 (500) | 152.4 (500) | 152.4 (500) | 152.4 (500) | 152.4 (500) | 152.4 (500) | 152.4 (500) | | | | • | | • | | | | |
| | | 4 | 7.6 (25) | 12.2 (40) | 83.8 (275) | 83.8 (275) | 7.6 (25) | 12.2 (40) | 121.9 (400) | 152.4 (500) | 152.4 (500) | 152.4 (500) | 152.4 (500) | 152.4 (500) | 152.4 (500) | | | | • | | • | | | | |
| | 2.0 | 2 | 7.6 (25) | 12.2 (40) | 83.8 (275) | 83.8 (275) | 7.6 (25) | 91.4 (300) | 182.9 (600) | 182.9 (600) | 152.4 (500) | 182.9 (600) | 182.9 (600) | 182.9 (600) | 182.9 (600) | | | | • | • | • | | | | |
| | | 4 | 7.6 (25) | 12.2 (40) | 83.8 (275) | 83.8 (275) | 7.6 (25) | 12.2 (40) | 121.9 (400) | 182.9 (600) | 152.4 (500) | 182.9 (600) | 182.9 (600) | 182.9 (600) | 182.9 (600) | | | | • | | • | | | | |
| | 3.0 | 2 | 7.6 (25) | 12.2 (40) | 106.7 (350) | 152.4 (500) | 7.6 (25) | 91.4 (300) | 182.9 (600) | 182.9 (600) | 152.4 (500) | 182.9 (600) | 182.9 (600) | 182.9 (600) | 182.9 (600) | | | | • | • | • | | | | |
| | | 4 | 7.6 (25) | 12.2 (40) | 106.7 (350) | 152.4 (500) | 7.6 (25) | 12.2 (40) | 121.9 (400) | 182.9 (600) | 152.4 (500) | 182.9 (600) | 182.9 (600) | 182.9 (600) | 182.9 (600) | | | | • | | • | | | | |
| | 5.0 | 2 | 7.6 (25) | 12.2 (40) | 106.7 (350) | 152.4 (500) | 7.6 (25) | 91.4 (300) | 243.8 (800) | 243.8 (800) | 152.4 (500) | 243.8 (800) | 243.8 (800) | 243.8 (800) | 243.8 (800) | 1321-RWR8-DP | | | | | | • | • | | |
| | | 4 | 7.6 (25) | 12.2 (40) | 106.7 (350) | 152.4 (500) | 7.6 (25) | 12.2 (40) | 121.9 (400) | 182.9 (600) | 152.4 (500) | 182.9 (600) | 182.9 (600) | 182.9 (600) | 182.9 (600) | | | | | | | • | | | |
| | 7.5 | 2 | 7.6 (25) | 12.2 (40) | 106.7 (350) | 152.4 (500) | 7.6 (25) | 91.4 (300) | 304.8 (1000) | 304.8 (1000) | 152.4 (500) | 304.8 (1000) | 304.8 (1000) | 304.8 (1000) | 304.8 (1000) | 1321-RWR12-DP | | | | | | • | | • | |
| | | 4 | 7.6 (25) | 12.2 (40) | 106.7 (350) | 152.4 (500) | 7.6 (25) | 12.2 (40) | 121.9 (400) | 182.9 (600) | 152.4 (500) | 182.9 (600) | 182.9 (600) | 182.9 (600) | 182.9 (600) | | | | | | | | • | | |
| | 10 | 2 | 7.6 (25) | 12.2 (40) | 106.7 (350) | 152.4 (500) | 7.6 (25) | 91.4 (300) | 365.8 (1200) | 365.8 (1200) | 152.4 (500) | 365.8 (1200) | 365.8 (1200) | 365.8 (1200) | 365.8 (1200) | 1321-RWR18-DP | | | | | | • | | • | |
| | | 4 | 7.6 (25) | 12.2 (40) | 106.7 (350) | 152.4 (500) | 7.6 (25) | 12.2 (40) | 121.9 (400) | 182.9 (600) | 152.4 (500) | 182.9 (600) | 182.9 (600) | 182.9 (600) | 182.9 (600) | | | | | | | | • | | |
| | 15 | 2 | 7.6 (25) | 12.2 (40) | 106.7 (350) | 152.4 (500) | 7.6 (25) | 91.4 (300) | 365.8 (1200) | 365.8 (1200) | 152.4 (500) | 365.8 (1200) | 365.8 (1200) | 365.8 (1200) | 365.8 (1200) | 1321-RWR25-DP | | | | | | • | | | |
| | | 4 | 7.6 (25) | 12.2 (40) | 106.7 (350) | 152.4 (500) | 7.6 (25) | 12.2 (40) | 121.9 (400) | 182.9 (600) | 152.4 (500) | 182.9 (600) | 182.9 (600) | 182.9 (600) | 182.9 (600) | | | | | | | | | | |
| | 3 | 20 | 2 | 7.6 (25) | 12.2 (40) | 137.2 (450) | 182.9 (600) | 7.6 (25) | 91.4 (300) | 365.8 (1200) | 365.8 (1200) | 182.9 (600) | 365.8 (1200) | 365.8 (1200) | 365.8 (1200) | 365.8 (1200) | 1321-RWR35-DP | | | | | | • | | |
| | | | 4 | 7.6 (25) | 12.2 (40) | 121.9 (400) | 182.9 (600) | 7.6 (25) | 12.2 (40) | 121.9 (400) | 304.8 (1000) | 182.9 (600) | 304.8 (1000) | 365.8 (1200) | 365.8 (1200) | | | | | | | | | | |
| 25 | | 2 | 7.6 (25) | 12.2 (40) | 137.2 (450) | 182.9 (600) | 7.6 (25) | 76.2 (250) | 365.8 (1200) | 365.8 (1200) | 182.9 (600) | 365.8 (1200) | 365.8 (1200) | 365.8 (1200) | 365.8 (1200) | 1321-RWR35-DP | | | | | | • | | | |
| | | 4 | 7.6 (25) | 12.2 (40) | 121.9 (400) | 182.9 (600) | 7.6 (25) | 12.2 (40) | 121.9 (400) | 274.3 (900) | 152.4 (500) | 304.8 (1000) | 365.8 (1200) | 365.8 (1200) | | | | | | | | | | | |
| 30 | 2 | 7.6 (25) | 12.2 (40) | 137.2 (450) | 182.9 (600) | 7.6 (25) | 76.2 (250) | 365.8 (1200) | 365.8 (1200) | 182.9 (600) | 365.8 (1200) | 365.8 (1200) | 365.8 (1200) | 365.8 (1200) | 1321-RWR45-DP | | | | | | • | | | | |
| | 4 | 7.6 (25) | 12.2 (40) | 121.9 (400) | 182.9 (600) | 7.6 (25) | 12.2 (40) | 121.9 (400) | 243.8 (800) | 152.4 (500) | 304.8 (1000) | 365.8 (1200) | 365.8 (1200) | | | | | | | | | | | | |
| 4 | 40 | 2 | 7.6 (25) | 12.2 (40) | 137.2 (450) | 182.9 (600) | 7.6 (25) | 76.2 (250) | 365.8 (1200) | 365.8 (1200) | 152.4 (500) | 365.8 (1200) | 365.8 (1200) | 365.8 (1200) | 365.8 (1200) | 1321-RWR55-DP | | | | | | • | | | |
| | | 4 | 7.6 (25) | 12.2 (40) | 106.7 (350) | 152.4 (500) | 7.6 (25) | 12.2 (40) | 106.7 (350) | 228.6 (750) | 121.9 (400) | 243.8 (800) | 365.8 (1200) | 365.8 (1200) | | | | | | | | | | | |
| | 50 | 2 | 12.2 (40) | 18.3 (60) | 137.2 (450) | 182.9 (600) | 12.2 (40) | 61.0 (200) | 304.8 (1000) | 365.8 (1200) | 152.4 (500) | 365.8 (1200) | 365.8 (1200) | 365.8 (1200) | 365.8 (1200) | 1321-RWR80-DP | | | | | | • | | | |
| | | 4 | 7.6 (25) | 12.2 (40) | 91.4 (300) | 152.4 (500) | 12.2 (40) | 18.3 (60) | 106.7 (350) | 228.6 (750) | 91.4 (300) | 243.8 (800) | 365.8 (1200) | 365.8 (1200) | | | | | | | | | | | |

Table 51 - PowerFlex 753 and 755 Wall Mount Drives, 480V Shielded/Unshielded Cable – Meters (Feet) (Continued)

| Drive | Rating | | No Solution | | | | Reactor Only | | | | Reactor and Damping Resistor or 1321-RWR | | | | Reactor/RWR (see page 152) | Resistor | | Available Options | | | | | |
|-------|--------|----|-------------|------------|-------------|-------------|--------------|------------|--------------|--------------|--|--------------|--------------|--------------|----------------------------|----------|--------------------|-------------------|-------|------|------|------|-----|
| | Frame | Hp | kHz | 1000V | 1200V | 1488V | 1600V | 1000V | 1200V | 1488V | 1600V | 1000V | 1200V | 1488V | | 1600V | Cat. No. | Ohms | Watts | TFA1 | TFB2 | RWR2 | RWC |
| 5 | 60 | 2 | 12.2 (40) | 18.3 (60) | 137.2 (450) | 182.9 (600) | 12.2 (40) | 61.0 (200) | 304.8 (1000) | 365.8 (1200) | 137.2 (450) | 365.8 (1200) | 365.8 (1200) | 365.8 (1200) | 1321-RWR80-DP | | | | | • | | | |
| | | 4 | 7.6 (25) | 12.2 (40) | 91.4 (300) | 152.4 (500) | 12.2 (40) | 24.4 (80) | 91.4 (300) | 228.6 (750) | 76.2 (250) | 213.4 (700) | 365.8 (1200) | 365.8 (1200) | | | | | | | | | |
| | 75 | 2 | 12.2 (40) | 18.3 (60) | 137.2 (450) | 182.9 (600) | 12.2 (40) | 61.0 (200) | 274.3 (900) | 365.8 (1200) | 137.2 (450) | 365.8 (1200) | 365.8 (1200) | 365.8 (1200) | 1321-RWR100-DP | | | | | • | | | |
| | | 4 | 7.6 (25) | 12.2 (40) | 91.4 (300) | 152.4 (500) | 12.2 (40) | 24.4 (80) | 91.4 (300) | 182.9 (600) | 76.2 (250) | 182.9 (600) | 365.8 (1200) | 365.8 (1200) | | | | | | | | | |
| 6 | 100 | 2 | 12.2 (40) | 24.4 (80) | 137.2 (450) | 182.9 (600) | 12.2 (40) | 61.0 (200) | 243.8 (800) | 365.8 (1200) | 137.2 (450) | 365.8 (1200) | 365.8 (1200) | 365.8 (1200) | 1321-3R130-DP | | | | | • | | | |
| | | 4 | 7.6 (25) | 18.3 (60) | 91.4 (300) | 152.4 (500) | 12.2 (40) | 30.5 (100) | 91.4 (300) | 152.4 (500) | 61.0 (200) | 137.2 (450) | 304.8 (1000) | 365.8 (1200) | | | | | | | | | |
| | 125 | 2 | 12.2 (40) | 24.4 (80) | 137.2 (450) | 182.9 (600) | 12.2 (40) | 61.0 (200) | 243.8 (800) | 365.8 (1200) | 121.9 (400) | 304.8 (1000) | 365.8 (1200) | 365.8 (1200) | 1321-3R160-DP | | | | | • | | | |
| | | 4 | 7.6 (25) | 18.3 (60) | 91.4 (300) | 152.4 (500) | 12.2 (40) | 30.5 (100) | 91.4 (300) | 152.4 (500) | 61.0 (200) | 137.2 (450) | 304.8 (1000) | 365.8 (1200) | | | | | | | | | |
| | 150 | 2 | 12.2 (40) | 24.4 (80) | 137.2 (450) | 182.9 (600) | 12.2 (40) | 61.0 (200) | 243.8 (800) | 304.8 (1000) | 91.4 (300) | 274.3 (900) | 365.8 (1200) | 365.8 (1200) | 1321-3R200-DP | | | | | • | | | |
| | | 4 | 7.6 (25) | 24.4 (80) | 91.4 (300) | 152.4 (500) | 12.2 (40) | 30.5 (100) | 91.4 (300) | 152.4 (500) | 61.0 (200) | 137.2 (450) | 304.8 (1000) | 365.8 (1200) | | | | | | | | | |
| 7 | 200 | 2 | 12.2 (40) | 30.5 (100) | 137.2 (450) | 167.6 (550) | 12.2 (40) | 61.0 (200) | 198.1 (650) | 259.1 (850) | 76.2 (250) | 213.4 (700) | 304.8 (1000) | 365.8 (1200) | 1321-RWR250-DP | | | | | • | | | |
| | | 4 | 7.6 (25) | 24.4 (80) | 91.4 (300) | 121.9 (400) | 12.2 (40) | 30.5 (100) | 91.4 (300) | 121.9 (400) | 45.7 (150) | 137.2 (450) | 243.8 (800) | 304.8 (1000) | | | | | | | | | |
| | 250 | 2 | 12.2 (40) | 30.5 (100) | 137.2 (450) | 167.6 (550) | 12.2 (40) | 61.0 (200) | 198.1 (650) | 259.1 (850) | 76.2 (250) | 213.4 (700) | 304.8 (1000) | 365.8 (1200) | 1321-3RB320-B | 50 | 225 | | | • | | | |
| | | 4 | 7.6 (25) | 24.4 (80) | 91.4 (300) | 121.9 (400) | 12.2 (40) | 30.5 (100) | 91.4 (300) | 121.9 (400) | 45.7 (150) | 137.2 (450) | 243.8 (800) | 304.8 (1000) | | 50 | 450 | | | | | | |
| | 300 | 2 | 12.2 (40) | 30.5 (100) | 106.7 (350) | 152.4 (500) | 12.2 (40) | 45.7 (150) | 137.2 (450) | 182.9 (600) | 61.0 (200) | 213.4 (700) | 304.8 (1000) | 365.8 (1200) | 1321-3RB400-B | 20 | 495 ⁽¹⁾ | | | • | | | |
| | | 4 | 7.6 (25) | 24.4 (80) | 91.4 (300) | 121.9 (400) | 12.2 (40) | 30.5 (100) | 91.4 (300) | 121.9 (400) | 45.7 (150) | 137.2 (450) | 243.8 (800) | 304.8 (1000) | | 20 | 990 ⁽¹⁾ | | | | | | |
| | 350 | 2 | 12.2 (40) | 30.5 (100) | 106.7 (350) | 152.4 (500) | 12.2 (40) | 45.7 (150) | 137.2 (450) | 182.9 (600) | 61.0 (200) | 213.4 (700) | 304.8 (1000) | 365.8 (1200) | 1321-3RB400-B | 20 | 495 ⁽¹⁾ | | | • | | | |
| | | 4 | 7.6 (25) | 24.4 (80) | 91.4 (300) | 121.9 (400) | 12.2 (40) | 30.5 (100) | 91.4 (300) | 121.9 (400) | 45.7 (150) | 137.2 (450) | 243.8 (800) | 304.8 (1000) | | 20 | 990 ⁽¹⁾ | | | | | | |
| | 400 | 2 | 12.2 (40) | 30.5 (100) | 106.7 (350) | 152.4 (500) | 12.2 (40) | 45.7 (150) | 137.2 (450) | 182.9 (600) | 61.0 (200) | 213.4 (700) | 304.8 (1000) | 365.8 (1200) | 1321-3R500-B | 20 | 495 ⁽¹⁾ | | | • | | | |
| | | 4 | 7.6 (25) | 24.4 (80) | 91.4 (300) | 121.9 (400) | 12.2 (40) | 30.5 (100) | 91.4 (300) | 121.9 (400) | 45.7 (150) | 137.2 (450) | 243.8 (800) | 304.8 (1000) | | 20 | 990 ⁽¹⁾ | | | | | | |

(1) Resistor specification is based on two parallel cables per phase.

Table 52 - PowerFlex 753 and 755 Wall Mount Drives, 600V Shielded/Unshielded Cable – Meters (Feet)

| Drive | Rating | | No Solution | | Reactor Only | | Reactor and Damping Resistor or 1321-RWR | | Reactor/RWR (see page 152) | Resistor | | Available Options | | | | |
|-------|--------|-----------|-------------|-------------|--------------|--------------|--|---------------|---|----------|------|-------------------|------|------|------|-----|
| | Frame | HP | kHz | 1488V | 1850V | 1488V | 1850V | 1488V | 1850V | Cat. No. | Ohms | Watts | TFA1 | TFB2 | RWR2 | RWC |
| 3 | 1.0 | 2 | 24.4 (80) | 121.9 (400) | 24.4 (80) | 182.9 (600) | 182.9 (600) | 182.9 (600) | | | | | • | | • | • |
| | | 4 | 24.4 (80) | 121.9 (400) | 24.4 (80) | 121.9 (400) | 182.9 (600) | 182.9 (600) | | | | | • | | • | • |
| | 2.0 | 2 | 24.4 (80) | 121.9 (400) | 24.4 (80) | 182.9 (600) | 182.9 (600) | 182.9 (600) | | | | | • | • | • | • |
| | | 4 | 24.4 (80) | 121.9 (400) | 24.4 (80) | 121.9 (400) | 182.9 (600) | 182.9 (600) | | | | | • | | • | • |
| | 3.0 | 2 | 24.4 (80) | 121.9 (400) | 24.4 (80) | 182.9 (600) | 182.9 (600) | 182.9 (600) | | | | | • | • | • | • |
| | | 4 | 24.4 (80) | 121.9 (400) | 24.4 (80) | 121.9 (400) | 182.9 (600) | 182.9 (600) | | | | | • | | • | • |
| | 5.0 | 2 | 24.4 (80) | 121.9 (400) | 24.4 (80) | 243.8 (800) | 365.8 (1200) | 365.8 (1200) | 1321-RWR8-EP | | | | • | • | • | • |
| | | 4 | 24.4 (80) | 121.9 (400) | 24.4 (80) | 121.9 (400) | 365.8 (1200) | 365.8 (1200) | | | | | • | | • | • |
| | 7.5 | 2 | 24.4 (80) | 121.9 (400) | 24.4 (80) | 304.8 (1000) | 365.8 (1200) | 365.8 (1200) | 1321-RWR12-EP | | | | | • | | • |
| | | 4 | 24.4 (80) | 121.9 (400) | 24.4 (80) | 121.9 (400) | 365.8 (1200) | 365.8 (1200) | | | | | | | • | • |
| | 10 | 2 | 24.4 (80) | 121.9 (400) | 24.4 (80) | 365.8 (1200) | 365.8 (1200) | 365.8 (1200) | 1321-RWR12-EP | | | | | • | | |
| | | 4 | 24.4 (80) | 121.9 (400) | 24.4 (80) | 121.9 (400) | 365.8 (1200) | 365.8 (1200) | | | | | | | | |
| | 15 | 2 | 24.4 (80) | 121.9 (400) | 36.6 (120) | 365.8 (1200) | 365.8 (1200) | 365.8 (1200) | 1321-RWR18-EP | | | | | • | | |
| | | 4 | 24.4 (80) | 121.9 (400) | 36.6 (120) | 121.9 (400) | 365.8 (1200) | 365.8 (1200) | | | | | | | | |
| 20 | 2 | 24.4 (80) | 121.9 (400) | 36.6 (120) | 365.8 (1200) | 365.8 (1200) | 365.8 (1200) | 1321-RWR25-EP | | | | | • | | | |
| | 4 | 24.4 (80) | 121.9 (400) | 36.6 (120) | 121.9 (400) | 365.8 (1200) | 365.8 (1200) | | | | | | | | | |
| 4 | 25 | 2 | 24.4 (80) | 121.9 (400) | 45.7 (150) | 365.8 (1200) | 365.8 (1200) | 365.8 (1200) | 1321-RWR35-EP | | | | | • | | |
| | | 4 | 24.4 (80) | 121.9 (400) | 45.7 (150) | 106.7 (350) | 365.8 (1200) | 365.8 (1200) | | | | | | | | |
| | 30 | 2 | 24.4 (80) | 121.9 (400) | 45.7 (150) | 365.8 (1200) | 365.8 (1200) | 365.8 (1200) | 1321-RWR35-EP | | | | | • | | |
| | | 4 | 24.4 (80) | 121.9 (400) | 45.7 (150) | 106.7 (350) | 365.8 (1200) | 365.8 (1200) | | | | | | | | |
| 5 | 40 | 2 | 24.4 (80) | 137.2 (450) | 45.7 (150) | 365.8 (1200) | 304.8 (1000) | 365.8 (1200) | 1321-RWR45-EP | | | | | • | | |
| | | 4 | 24.4 (80) | 106.7 (350) | 45.7 (150) | 106.7 (350) | 304.8 (1000) | 365.8 (1200) | | | | | | | | |
| | 50 | 2 | 24.4 (80) | 137.2 (450) | 45.7 (150) | 304.8 (1000) | 304.8 (1000) | 365.8 (1200) | 1321-RWR55-EP | | | | | • | | |
| | | 4 | 24.4 (80) | 106.7 (350) | 45.7 (150) | 91.4 (300) | 304.8 (1000) | 365.8 (1200) | | | | | | | | |

Table 52 - PowerFlex 753 and 755 Wall Mount Drives, 600V Shielded/Unshielded Cable – Meters (Feet) (Continued)

| Drive | Rating | | No Solution | | Reactor Only | | Reactor and Damping Resistor or 1321-RWR | | Reactor/RWR (see page 152) | Resistor | | Available Options | | | | |
|-------|--------|-----------|-------------|-------------|--------------|--------------|--|----------------|----------------------------|----------|----------|-------------------|-------|------|------|------|
| | Frame | HP | kHz | 1488V | 1850V | 1488V | 1850V | 1488V | | 1850V | Cat. No. | Ohms | Watts | TFA1 | TFB2 | RWR2 |
| 6 | 10 | 2 | 24.4 (80) | 121.9 (400) | 24.4 (80) | 365.8 (1200) | 365.8 (1200) | 365.8 (1200) | 1321-RWR12-EP | | | | | • | | |
| | | 4 | 24.4 (80) | 121.9 (400) | 24.4 (80) | 106.7 (350) | 365.8 (1200) | 365.8 (1200) | | | | | | | | |
| | 15 | 2 | 24.4 (80) | 121.9 (400) | 36.6 (120) | 365.8 (1200) | 365.8 (1200) | 365.8 (1200) | 1321-RWR18-EP | | | | | • | | |
| | | 4 | 24.4 (80) | 121.9 (400) | 36.6 (120) | 106.7 (350) | 365.8 (1200) | 365.8 (1200) | | | | | | | | |
| | 20 | 2 | 24.4 (80) | 121.9 (400) | 36.6 (120) | 365.8 (1200) | 365.8 (1200) | 365.8 (1200) | 1321-RWR25-EP | | | | | • | | |
| | | 4 | 24.4 (80) | 121.9 (400) | 36.6 (120) | 106.7 (350) | 365.8 (1200) | 365.8 (1200) | | | | | | | | |
| | 25 | 2 | 24.4 (80) | 121.9 (400) | 45.7 (150) | 365.8 (1200) | 365.8 (1200) | 365.8 (1200) | 1321-RWR35-EP | | | | | • | | |
| | | 4 | 24.4 (80) | 121.9 (400) | 45.7 (150) | 106.7 (350) | 365.8 (1200) | 365.8 (1200) | | | | | | | | |
| | 30 | 2 | 24.4 (80) | 121.9 (400) | 45.7 (150) | 365.8 (1200) | 365.8 (1200) | 365.8 (1200) | 1321-RWR35-EP | | | | | • | | |
| | | 4 | 24.4 (80) | 121.9 (400) | 45.7 (150) | 106.7 (350) | 365.8 (1200) | 365.8 (1200) | | | | | | | | |
| | 40 | 2 | 24.4 (80) | 137.2 (450) | 45.7 (150) | 365.8 (1200) | 304.8 (1000) | 365.8 (1200) | 1321-RWR45-EP | | | | | • | | |
| | | 4 | 24.4 (80) | 106.7 (350) | 45.7 (150) | 106.7 (350) | 304.8 (1000) | 365.8 (1200) | | | | | | | | |
| | 50 | 2 | 24.4 (80) | 137.2 (450) | 45.7 (150) | 304.8 (1000) | 304.8 (1000) | 365.8 (1200) | 1321-RWR55-EP | | | | | • | | |
| | | 4 | 24.4 (80) | 106.7 (350) | 45.7 (150) | 91.4 (300) | 304.8 (1000) | 365.8 (1200) | | | | | | | | |
| | 60 | 2 | 24.4 (80) | 137.2 (450) | 45.7 (150) | 304.8 (1000) | 304.8 (1000) | 365.8 (1200) | 1321-RWR80-EP | | | | | • | | |
| | | 4 | 24.4 (80) | 106.7 (350) | 45.7 (150) | 91.4 (300) | 304.8 (1000) | 365.8 (1200) | | | | | | | | |
| | 75 | 2 | 24.4 (80) | 137.2 (450) | 45.7 (150) | 274.3 (900) | 243.8 (800) | 365.8 (1200) | 1321-RWR80-EP | | | | | • | | |
| | | 4 | 24.4 (80) | 106.7 (350) | 45.7 (150) | 91.4 (300) | 243.8 (800) | 365.8 (1200) | | | | | | | | |
| | 100 | 2 | 24.4 (80) | 137.2 (450) | 45.7 (150) | 243.8 (800) | 243.8 (800) | 365.8 (1200) | 1321-RWR100-EP | | | | | • | | |
| | | 4 | 24.4 (80) | 106.7 (350) | 45.7 (150) | 91.4 (300) | 243.8 (800) | 365.8 (1200) | | | | | | | | |
| 125 | 2 | 24.4 (80) | 137.2 (450) | 61.0 (200) | 243.8 (800) | 198.1 (650) | 365.8 (1200) | 1321-RWR130-EP | | | | | • | | | |
| | 4 | 24.4 (80) | 106.7 (350) | 61.0 (200) | 121.9 (400) | 152.4 (500) | 274.3 (900) | | | | | | | | | |
| 150 | 2 | 24.4 (80) | 137.2 (450) | 61.0 (200) | 243.8 (800) | 198.1 (650) | 365.8 (1200) | 1321-RWR160-EP | | | | | • | | | |
| | 4 | 24.4 (80) | 106.7 (350) | 61.0 (200) | 121.9 (400) | 152.4 (500) | 274.3 (900) | | | | | | | | | |

Table 52 - PowerFlex 753 and 755 Wall Mount Drives, 600V Shielded/Unshielded Cable – Meters (Feet) (Continued)

| Drive | Rating | | No Solution | | Reactor Only | | Reactor and Damping Resistor or 1321-RWR | | Reactor/RWR (see page 152) | Resistor | | Available Options | | | |
|-------|--------|-----|-------------|-------------|--------------|-------------|--|--------------|----------------------------|----------|-------|-------------------|------|------|-----|
| Frame | HP | kHz | 1488V | 1850V | 1488V | 1850V | 1488V | 1850V | Cat. No. | Ohms | Watts | TFA1 | TFB2 | RWR2 | RWC |
| 7 | 200 | 2 | 24.4 (80) | 137.2 (450) | 61.0 (200) | 243.8 (800) | 167.6 (550) | 365.8 (1200) | 1321-RWR200-EP | | | | • | | |
| | | 4 | 24.4 (80) | 106.7 (350) | 61.0 (200) | 121.9 (400) | 121.9 (400) | 198.1 (650) | | | | | | | |
| | 250 | 2 | 24.4 (80) | 137.2 (450) | 61.0 (200) | 198.1 (650) | 167.6 (550) | 365.8 (1200) | 1321-RWR250-EP | | | | • | | |
| | | 4 | 24.4 (80) | 106.7 (350) | 61.0 (200) | 121.9 (400) | 121.9 (400) | 198.1 (650) | | | | | | | |
| | 300 | 2 | 24.4 (80) | 137.2 (450) | 61.0 (200) | 152.4 (500) | 167.6 (550) | 365.8 (1200) | 1321-3RB350-B | 50 | 315 | | • | | |
| | | 4 | 24.4 (80) | 106.7 (350) | 61.0 (200) | 121.9 (400) | 121.9 (400) | 198.1 (650) | | 50 | 630 | | | | |

Table 53 - PowerFlex 753 and 755 Wall Mount Drives, 690V Shielded/Unshielded Cable – Meters (Feet)

| Drive | Rating | | No Solution | | Reactor Only | | Reactor and Damping Resistor | | Reactor | Resistor | | Available Options | | | |
|-------|--------|-----------|-------------|------------|--------------|--------------|------------------------------|--------------|-------------|----------|-------|-------------------|------|------|-----|
| Frame | kW | kHz | 1488V | 1850V | 1488V | 1850V | 1488V | 1850V | Cat. No. | Ohms | Watts | TFA1 | TFB2 | RWR2 | RWC |
| 6 | 7.5 | 2 | 24.4 (80) | 36.6 (120) | 30.5 (100) | 45.7 (150) | 365.8 (1200) | 365.8 (1200) | 1321-3R18-C | 50 | 375 | | | | |
| | | 4 | 24.4 (80) | 36.6 (120) | 30.5 (100) | 45.7 (150) | 365.8 (1200) | 365.8 (1200) | | 50 | 750 | | | | |
| | 11 | 2 | 24.4 (80) | 36.6 (120) | 30.5 (100) | 45.7 (150) | 365.8 (1200) | 365.8 (1200) | 1321-3R25-C | 50 | 375 | | | | |
| | | 4 | 24.4 (80) | 36.6 (120) | 30.5 (100) | 45.7 (150) | 365.8 (1200) | 365.8 (1200) | | 50 | 750 | | | | |
| | 15 | 2 | 24.4 (80) | 36.6 (120) | 30.5 (100) | 45.7 (150) | 365.8 (1200) | 365.8 (1200) | 1321-3R35-C | 50 | 375 | | | | |
| | | 4 | 24.4 (80) | 36.6 (120) | 30.5 (100) | 45.7 (150) | 365.8 (1200) | 365.8 (1200) | | 50 | 750 | | | | |
| | 18.5 | 2 | 24.4 (80) | 36.6 (120) | 30.5 (100) | 45.7 (150) | 365.8 (1200) | 365.8 (1200) | 1321-3R35-C | 50 | 375 | | | | |
| | | 4 | 24.4 (80) | 36.6 (120) | 30.5 (100) | 45.7 (150) | 365.8 (1200) | 365.8 (1200) | | 50 | 750 | | | | |
| | 22 | 2 | 24.4 (80) | 36.6 (120) | 30.5 (100) | 45.7 (150) | 365.8 (1200) | 365.8 (1200) | 1321-3R45-C | 50 | 375 | | | | |
| | | 4 | 24.4 (80) | 36.6 (120) | 30.5 (100) | 45.7 (150) | 365.8 (1200) | 365.8 (1200) | | 50 | 750 | | | | |
| | 30 | 2 | 24.4 (80) | 36.6 (120) | 45.7 (150) | 76.2 (250) | 365.8 (1200) | 365.8 (1200) | 1321-3R45-C | 50 | 375 | | | | |
| | | 4 | 24.4 (80) | 36.6 (120) | 45.7 (150) | 61.0 (200) | 365.8 (1200) | 365.8 (1200) | | 50 | 750 | | | | |
| | 37 | 2 | 24.4 (80) | 45.7 (150) | 61.0 (200) | 106.7 (350) | 365.8 (1200) | 365.8 (1200) | 1321-3R55-C | 50 | 375 | | | | |
| | | 4 | 24.4 (80) | 45.7 (150) | 61.0 (200) | 76.2 (250) | 304.8 (1000) | 365.8 (1200) | | 50 | 750 | | | | |
| | 45 | 2 | 24.4 (80) | 45.7 (150) | 61.0 (200) | 106.7 (350) | 365.8 (1200) | 365.8 (1200) | 1321-3R80-C | 50 | 375 | | | | |
| | | 4 | 24.4 (80) | 45.7 (150) | 61.0 (200) | 76.2 (250) | 304.8 (1000) | 365.8 (1200) | | 50 | 750 | | | | |
| 55 | 2 | 24.4 (80) | 45.7 (150) | 61.0 (200) | 106.7 (350) | 365.8 (1200) | 365.8 (1200) | 1321-3R80-C | 50 | 375 | | | | | |
| | 4 | 24.4 (80) | 45.7 (150) | 61.0 (200) | 76.2 (250) | 304.8 (1000) | 365.8 (1200) | | 50 | 750 | | | | | |

Table 53 - PowerFlex 753 and 755 Wall Mount Drives, 690V Shielded/Unshielded Cable – Meters (Feet) (Continued)

| Drive | Rating | | No Solution | | Reactor Only | | Reactor and Damping Resistor | | Reactor | Resistor | | Available Options | | | | | | |
|-------|--------|-----|--------------|---------------|---------------|----------------|------------------------------|-----------------|----------------|---------------|----------|-------------------|-------|------|------|------|-----|--|
| | Frame | kW | kHz | 1488V | 1850V | 1488V | 1850V | 1488V | | 1850V | Cat. No. | Ohms | Watts | TFA1 | TFB2 | RWR2 | RWC | |
| 6 | 75 | 2 | 24.4 (80) | 45.7 (150) | 61.0 (200) | 106.7 (350) | 365.8 (1200) | 365.8 (1200) | 1321-3R100-C | 50 | 375 | | | | | | | |
| | | 4 | 24.4 (80) | 45.7 (150) | 61.0 (200) | 76.2 (250) | 304.8 (1000) | 365.8 (1200) | | 50 | 750 | | | | | | | |
| | 90 | 2 | 24.4 (80) | 45.7 (150) | 76.2 (250) | 121.9 (400) | 243.8 (800) | 274.3 (900) | 1321-3R130-C | 50 | 375 | | | | | | | |
| | | 4 | 24.4 (80) | 45.7 (150) | 76.2 (250) | 106.7 (350) | 182.9 (600) | 213.4 (700) | | 50 | 750 | | | | | | | |
| | 110 | 2 | 24.4 (80) | 45.7 (150) | 76.2 (250) | 121.9 (400) | 243.8 (800) | 274.3 (900) | 1321-3R160-C | 50 | 375 | | | | | | | |
| | | 4 | 24.4 (80) | 45.7 (150) | 76.2 (250) | 106.7 (350) | 182.9 (600) | 213.4 (700) | | 50 | 750 | | | | | | | |
| | 132 | 2 | 24.4 (80) | 45.7 (150) | 76.2 (250) | 121.9 (400) | 243.8 (800) | 274.3 (900) | 1321-3R200-C | 50 | 375 | | | | | | | |
| | | 4 | 24.4 (80) | 45.7 (150) | 76.2 (250) | 106.7 (350) | 182.9 (600) | 213.4 (700) | | 50 | 750 | | | | | | | |
| | 7 | 160 | 2 | 24.4 (80) | 45.7 (150) | 91.4 (300) | 121.9 (400) | 182.9 (600) | 243.8 (800) | 1321-3R200-C | 50 | 375 | | | | | | |
| | | | 4 | 24.4 (80) | 45.7 (150) | 91.4 (300) | 106.7 (350) | 152.4 (500) | 182.9 (600) | | 50 | 750 | | | | | | |
| | | 200 | 2 | 24.4 (80) | 45.7 (150) | 91.4 (300) | 121.9 (400) | 182.9 (600) | 243.8 (800) | 1321-3RB250-C | 50 | 480 | | | | | | |
| | | | 4 | 24.4 (80) | 45.7 (150) | 91.4 (300) | 106.7 (350) | 152.4 (500) | 182.9 (600) | | 50 | 960 | | | | | | |
| 250 | | 2 | 24.4 (80) | 45.7 (150) | 91.4 (300) | 121.9 (400) | 182.9 (600) | 243.8 (800) | 1321-3RB320-C | 50 | 480 | | | | | | | |
| | | 4 | 24.4 (80) | 45.7 (150) | 91.4 (300) | 106.7 (350) | 152.4 (500) | 182.9 (600) | | 50 | 960 | | | | | | | |

PowerFlex 755 Floor Mount Drives

This section lists motor cable length restrictions, reactors, and available options for PowerFlex 755 floor mount drives.

Table 54 - PowerFlex 755 Floor Mount Drives, 400V Shielded/Unshielded Cable – Meters (Feet)

| Drive | Rating | | No Solution | | | | Reactor Only | | | | Reactor and Damping Resistor | | | | Reactor | Resistor | | Available Options | | | | | |
|-------------------|------------------|-----|-------------|-------------|-------------|--------------|--------------|-------------|--------------|--------------|------------------------------|--------------|--------------|--------------|------------------|------------------|---------------------|---------------------|-------|------|------|------|-----|
| | Frame | kW | kHz | 1000V | 1200V | 1488V | 1600V | 1000V | 1200V | 1488V | 1600V | 1000V | 1200V | 1488V | | 1600V | Cat. No. | Ohms | Watts | TFA1 | TFB2 | RWR2 | RWC |
| 8 | 250 | 2 | 24.4 (80) | 121.9 (400) | 213.4 (700) | 304.8 (1000) | 45.7 (150) | 121.9 (400) | 304.8 (1000) | 365.8 (1200) | 228.6 (750) | 365.8 (1200) | 365.8 (1200) | 365.8 (1200) | 1321-3R500-B | 20 | 495 ⁽²⁾ | | • | | | | |
| | | 4 | 24.4 (80) | 91.4 (300) | 152.4 (500) | 182.9 (600) | 36.6 (120) | 91.4 (300) | 167.6 (550) | 213.4 (700) | 91.4 (300) | 182.9 (600) | 304.8 (1000) | 365.8 (1200) | | 20 | 990 ⁽²⁾ | | • | | | | |
| | 315 | 2 | 24.4 (80) | 121.9 (400) | 213.4 (700) | 259.1 (850) | 45.7 (150) | 121.9 (400) | 304.8 (1000) | 365.8 (1200) | 228.6 (750) | 365.8 (1200) | 365.8 (1200) | 365.8 (1200) | 1321-3R600-B | 20 | 495 ⁽²⁾ | | • | | | | |
| | | 4 | 24.4 (80) | 91.4 (300) | 152.4 (500) | 182.9 (600) | 36.6 (120) | 91.4 (300) | 167.6 (550) | 213.4 (700) | 91.4 (300) | 182.9 (600) | 304.8 (1000) | 365.8 (1200) | | 20 | 990 ⁽²⁾ | | • | | | | |
| | 355 | 2 | 24.4 (80) | 121.9 (400) | 213.4 (700) | 259.1 (850) | 45.7 (150) | 121.9 (400) | 304.8 (1000) | 365.8 (1200) | 228.6 (750) | 304.8 (1000) | 365.8 (1200) | 365.8 (1200) | 1321-3R750-B | 20 | 495 ⁽²⁾ | | • | | | | |
| | | 4 | 24.4 (80) | 91.4 (300) | 152.4 (500) | 182.9 (600) | 36.6 (120) | 91.4 (300) | 167.6 (550) | 213.4 (700) | 91.4 (300) | 182.9 (600) | 304.8 (1000) | 365.8 (1200) | | 20 | 990 ⁽²⁾ | | • | | | | |
| | 400 | 2 | 24.4 (80) | 91.4 (300) | 152.4 (500) | 213.4 (700) | 36.6 (120) | 91.4 (300) | 304.8 (1000) | 365.8 (1200) | 198.1 (650) | 274.3 (900) | 304.8 (1000) | 365.8 (1200) | 1321-3R850-B | 20 | 735 ⁽³⁾ | | • | | | | |
| | | 4 | 24.4 (80) | 91.4 (300) | 137.2 (450) | 167.6 (550) | 36.6 (120) | 91.4 (300) | 152.4 (500) | 182.9 (600) | 76.2 (250) | 137.2 (450) | 274.3 (900) | 365.8 (1200) | | 20 | 1470 ⁽³⁾ | | • | | | | |
| | 9 ⁽¹⁾ | 500 | 2 | 24.4 (80) | 76.2 (250) | 152.4 (500) | 213.4 (700) | 61.0 (200) | 152.4 (500) | 304.8 (1000) | 365.8 (1200) | 213.4 (700) | 304.8 (1000) | 365.8 (1200) | 365.8 (1200) | 2 x 1321-3R500-B | 40 | 375 ⁽³⁾ | | • | | | |
| | | | 4 | 24.4 (80) | 61.0 (200) | 106.7 (350) | 137.2 (450) | 36.6 (120) | 91.4 (300) | 182.9 (600) | 274.3 (900) | 91.4 (300) | 182.9 (600) | 365.8 (1200) | 365.8 (1200) | | 40 | 750 ⁽³⁾ | | | | | |
| | | 560 | 2 | 24.4 (80) | 61.0 (200) | 152.4 (500) | 182.9 (600) | 61.0 (200) | 152.4 (500) | 304.8 (1000) | 365.8 (1200) | 182.9 (600) | 274.3 (900) | 365.8 (1200) | 365.8 (1200) | 2 x 1321-3R600-B | 20 | 525 ⁽⁴⁾ | | • | | | |
| | | | 4 | 24.4 (80) | 61.0 (200) | 106.7 (350) | 137.2 (450) | 36.6 (120) | 91.4 (300) | 182.9 (600) | 274.3 (900) | 91.4 (300) | 182.9 (600) | 365.8 (1200) | 365.8 (1200) | | 20 | 1050 ⁽⁴⁾ | | | | | |
| 630 | | 2 | 24.4 (80) | 61.0 (200) | 152.4 (500) | 182.9 (600) | 61.0 (200) | 152.4 (500) | 304.8 (1000) | 365.8 (1200) | 182.9 (600) | 274.3 (900) | 365.8 (1200) | 365.8 (1200) | 2 x 1321-3R600-B | 20 | 525 ⁽⁴⁾ | | • | | | | |
| | | 4 | 24.4 (80) | 61.0 (200) | 106.7 (350) | 137.2 (450) | 36.6 (120) | 91.4 (300) | 182.9 (600) | 274.3 (900) | 91.4 (300) | 182.9 (600) | 365.8 (1200) | 365.8 (1200) | | 20 | 1050 ⁽⁴⁾ | | | | | | |
| 710 | | 2 | 24.4 (80) | 61.0 (200) | 152.4 (500) | 182.9 (600) | 61.0 (200) | 152.4 (500) | 304.8 (1000) | 365.8 (1200) | 182.9 (600) | 274.3 (900) | 365.8 (1200) | 365.8 (1200) | 2 x 1321-3R600-B | 20 | 525 ⁽⁴⁾ | | • | | | | |
| | | 4 | 24.4 (80) | 61.0 (200) | 106.7 (350) | 137.2 (450) | 36.6 (120) | 91.4 (300) | 182.9 (600) | 274.3 (900) | 91.4 (300) | 182.9 (600) | 365.8 (1200) | 365.8 (1200) | | 20 | 1050 ⁽⁴⁾ | | | | | | |
| 800 | | 2 | 24.4 (80) | 61.0 (200) | 152.4 (500) | 182.9 (600) | 61.0 (200) | 152.4 (500) | 304.8 (1000) | 365.8 (1200) | 182.9 (600) | 274.3 (900) | 365.8 (1200) | 365.8 (1200) | 2 x 1321-3R750-B | 20 | 525 ⁽⁴⁾ | | • | | | | |
| | | 4 | 24.4 (80) | 61.0 (200) | 106.7 (350) | 137.2 (450) | 36.6 (120) | 91.4 (300) | 182.9 (600) | 274.3 (900) | 91.4 (300) | 182.9 (600) | 365.8 (1200) | 365.8 (1200) | | 20 | 1050 ⁽⁴⁾ | | | | | | |
| 850 | | 2 | 24.4 (80) | 61.0 (200) | 152.4 (500) | 182.9 (600) | 61.0 (200) | 152.4 (500) | 304.8 (1000) | 365.8 (1200) | 182.9 (600) | 274.3 (900) | 365.8 (1200) | 365.8 (1200) | 2 x 1321-3R750-B | 20 | 525 ⁽⁴⁾ | | • | | | | |
| | | 4 | 24.4 (80) | 61.0 (200) | 106.7 (350) | 137.2 (450) | 36.6 (120) | 91.4 (300) | 182.9 (600) | 274.3 (900) | 91.4 (300) | 182.9 (600) | 365.8 (1200) | 365.8 (1200) | | 20 | 1050 ⁽⁴⁾ | | | | | | |
| 10 ⁽¹⁾ | 900 | 2 | 24.4 (80) | 45.7 (150) | 121.9 (400) | 182.9 (600) | 61.0 (200) | 152.4 (500) | 304.8 (1000) | 365.8 (1200) | 182.9 (600) | 274.3 (900) | 365.8 (1200) | 365.8 (1200) | 2 x 1321-3R850-B | 20 | 600 ⁽⁵⁾ | | • | | | | |
| | | 4 | 24.4 (80) | 45.7 (150) | 91.4 (300) | 137.2 (450) | 36.6 (120) | 91.4 (300) | 182.9 (600) | 274.3 (900) | 91.4 (300) | 182.9 (600) | 365.8 (1200) | 365.8 (1200) | | 20 | 1200 ⁽⁵⁾ | | | | | | |
| | 1250 | 2 | 24.4 (80) | 45.7 (150) | 106.7 (350) | 152.4 (500) | 61.0 (200) | 121.9 (400) | 304.8 (1000) | 365.8 (1200) | 152.4 (500) | 274.3 (900) | 365.8 (1200) | 365.8 (1200) | 3 x 1321-3R750-B | 30 | 500 ⁽⁶⁾ | | • | | | | |
| | | 4 | 24.4 (80) | 45.7 (150) | 76.2 (250) | 121.9 (400) | 36.6 (120) | 91.4 (300) | 152.4 (500) | 213.4 (700) | 91.4 (300) | 182.9 (600) | 365.8 (1200) | 365.8 (1200) | | 30 | 1000 ⁽⁶⁾ | | | | | | |

- (1) Frame 9 and Frame 10 drives require two or three parallel reactors to match drive amp rating. The resistor ratings are per phase values for each reactor.
- (2) Resistor specification is based on two parallel cables per phase.
- (3) Resistor specification is based on three parallel cables per phase.
- (4) Resistor specification is based on four parallel cables per phase.
- (5) Resistor specification is based on five parallel cables per phase.
- (6) Resistor specification is based on six parallel cables per phase.

Table 55 - PowerFlex 755 Floor Mount Drives, 480V Shielded/Unshielded Cable – Meters (Feet)

| Drive | Rating | | No Solution | | | | Reactor Only | | | | Reactor and Damping Resistor | | | | Reactor | Resistor | | Available Options | | | | |
|-------|--------|----|--------------|---------------|----------------|----------------|--------------|---------------|----------------|----------------|------------------------------|----------------|-----------------|-----------------|--------------|----------|---------------------|-------------------|-------|------|------|------|
| | Frame | Hp | kHz | 1000V | 1200V | 1488V | 1600V | 1000V | 1200V | 1488V | 1600V | 1000V | 1200V | 1488V | | 1600V | Cat. No. | Ohms | Watts | TFA1 | TFB2 | RWR2 |
| 8 | 350 | 2 | 12.2 (40) | 30.5 (100) | 106.7 (350) | 152.4 (500) | 12.2 (40) | 45.7 (150) | 137.2 (450) | 182.9 (600) | 61.0 (200) | 213.4 (700) | 304.8 (1000) | 365.8 (1200) | 1321-3R500-B | 20 | 495 ⁽²⁾ | | • | | | |
| | | 4 | 7.6 (25) | 24.4 (80) | 91.4 (300) | 121.9 (400) | 12.2 (40) | 30.5 (100) | 91.4 (300) | 121.9 (400) | 45.7 (150) | 137.2 (450) | 243.8 (800) | 304.8 (1000) | | 20 | 990 ⁽²⁾ | | • | | | |
| | 400 | 2 | 12.2 (40) | 30.5 (100) | 106.7 (350) | 152.4 (500) | 12.2 (40) | 45.7 (150) | 137.2 (450) | 182.9 (600) | 61.0 (200) | 213.4 (700) | 304.8 (1000) | 365.8 (1200) | 1321-3R500-B | 20 | 495 ⁽²⁾ | | • | | | |
| | | 4 | 7.6 (25) | 24.4 (80) | 91.4 (300) | 121.9 (400) | 12.2 (40) | 30.5 (100) | 91.4 (300) | 121.9 (400) | 45.7 (150) | 137.2 (450) | 243.8 (800) | 304.8 (1000) | | 20 | 990 ⁽²⁾ | | • | | | |
| | 450 | 2 | 12.2 (40) | 30.5 (100) | 106.7 (350) | 152.4 (500) | 12.2 (40) | 45.7 (150) | 137.2 (450) | 182.9 (600) | 61.0 (200) | 213.4 (700) | 304.8 (1000) | 365.8 (1200) | 1321-3R600-B | 20 | 495 ⁽²⁾ | | • | | | |
| | | 4 | 7.6 (25) | 24.4 (80) | 91.4 (300) | 121.9 (400) | 12.2 (40) | 30.5 (100) | 91.4 (300) | 121.9 (400) | 45.7 (150) | 137.2 (450) | 243.8 (800) | 304.8 (1000) | | 20 | 990 ⁽²⁾ | | • | | | |
| | 500 | 2 | 12.2 (40) | 30.5 (100) | 106.7 (350) | 152.4 (500) | 12.2 (40) | 45.7 (150) | 121.9 (400) | 182.9 (600) | 61.0 (200) | 213.4 (700) | 304.8 (1000) | 365.8 (1200) | 1321-3R750-B | 20 | 495 ⁽²⁾ | | • | | | |
| | | 4 | 7.6 (25) | 24.4 (80) | 91.4 (300) | 121.9 (400) | 12.2 (40) | 30.5 (100) | 91.4 (300) | 121.9 (400) | 45.7 (150) | 137.2 (450) | 243.8 (800) | 304.8 (1000) | | 20 | 990 ⁽²⁾ | | • | | | |
| | 600 | 2 | 12.2 (40) | 30.5 (100) | 76.2 (250) | 106.7 (350) | 12.2 (40) | 45.7 (150) | 91.4 (300) | 121.9 (400) | 61.0 (200) | 213.4 (700) | 304.8 (1000) | 365.8 (1200) | 1321-3R750-B | 20 | 735 ⁽³⁾ | | • | | | |
| | | 4 | 7.6 (25) | 24.4 (80) | 61.0 (200) | 91.4 (300) | 12.2 (40) | 30.5 (100) | 76.2 (250) | 106.7 (350) | 45.7 (150) | 137.2 (450) | 243.8 (800) | 304.8 (1000) | | 20 | 1470 ⁽³⁾ | | • | | | |
| | 650 | 2 | 12.2 (40) | 30.5 (100) | 76.2 (250) | 106.7 (350) | 12.2 (40) | 45.7 (150) | 91.4 (300) | 121.9 (400) | 61.0 (200) | 213.4 (700) | 304.8 (1000) | 365.8 (1200) | 1321-3R850-B | 20 | 735 ⁽³⁾ | | • | | | |
| | | 4 | 7.6 (25) | 24.4 (80) | 61.0 (200) | 91.4 (300) | 12.2 (40) | 30.5 (100) | 76.2 (250) | 106.7 (350) | 45.7 (150) | 137.2 (450) | 243.8 (800) | 304.8 (1000) | | 20 | 1470 ⁽³⁾ | | • | | | |

Table 55 - PowerFlex 755 Floor Mount Drives, 480V Shielded/Unshielded Cable – Meters (Feet) (Continued)

| Drive | Rating | | No Solution | | | | Reactor Only | | | | Reactor and Damping Resistor | | | | Reactor | Resistor | | Available Options | | | | |
|-------------------|--------|----|--------------|---------------|---------------|----------------|--------------|---------------|---------------|----------------|------------------------------|----------------|-----------------|-----------------|----------------------|----------|---------------------|-------------------|-------|------|------|------|
| | Frame | Hp | kHz | 1000V | 1200V | 1488V | 1600V | 1000V | 1200V | 1488V | 1600V | 1000V | 1200V | 1488V | | 1600V | Cat. No. | Ohms | Watts | TFA1 | TFB2 | RWR2 |
| 9 ⁽¹⁾ | 700 | 2 | 12.2 (40) | 30.5 (100) | 76.2 (250) | 106.7 (350) | 12.2 (40) | 45.7 (150) | 91.4 (300) | 121.9 (400) | 61.0 (200) | 213.4 (700) | 304.8 (1000) | 365.8 (1200) | 2 x 1321-3RB500-B | 40 | 375 ⁽³⁾ | | • | | | |
| | | 4 | 7.6 (25) | 24.4 (80) | 61.0 (200) | 91.4 (300) | 12.2 (40) | 30.5 (100) | 76.2 (250) | 106.7 (350) | 45.7 (150) | 137.2 (450) | 243.8 (800) | 304.8 (1000) | | 40 | 750 ⁽³⁾ | | | | | |
| | 800 | 2 | 12.2 (40) | 30.5 (100) | 76.2 (250) | 106.7 (350) | 12.2 (40) | 45.7 (150) | 91.4 (300) | 121.9 (400) | 61.0 (200) | 182.9 (600) | 304.8 (1000) | 365.8 (1200) | 2 x 1321-3R600-B | 40 | 375 ⁽⁴⁾ | | • | | | |
| | | 4 | 7.6 (25) | 24.4 (80) | 61.0 (200) | 91.4 (300) | 12.2 (40) | 30.5 (100) | 76.2 (250) | 106.7 (350) | 45.7 (150) | 121.9 (400) | 243.8 (800) | 304.8 (1000) | | 40 | 750 ⁽⁴⁾ | | | | | |
| | 900 | 2 | 12.2 (40) | 30.5 (100) | 76.2 (250) | 106.7 (350) | 12.2 (40) | 45.7 (150) | 91.4 (300) | 121.9 (400) | 61.0 (200) | 182.9 (600) | 304.8 (1000) | 365.8 (1200) | 2 x 1321-3R600-B | 20 | 525 ⁽⁴⁾ | | | | | |
| | | 4 | 7.6 (25) | 24.4 (80) | 61.0 (200) | 91.4 (300) | 12.2 (40) | 30.5 (100) | 76.2 (250) | 106.7 (350) | 45.7 (150) | 121.9 (400) | 243.8 (800) | 304.8 (1000) | | 20 | 1050 ⁽⁴⁾ | | | | | |
| | 1000 | 2 | 12.2 (40) | 30.5 (100) | 76.2 (250) | 106.7 (350) | 12.2 (40) | 45.7 (150) | 91.4 (300) | 121.9 (400) | 61.0 (200) | 182.9 (600) | 304.8 (1000) | 365.8 (1200) | 2 x 1321-3R750-B | 20 | 525 ⁽⁴⁾ | | | | | |
| | | 4 | 7.6 (25) | 24.4 (80) | 61.0 (200) | 91.4 (300) | 12.2 (40) | 30.5 (100) | 76.2 (250) | 106.7 (350) | 45.7 (150) | 121.9 (400) | 243.8 (800) | 304.8 (1000) | | 20 | 1050 ⁽⁴⁾ | | | | | |
| | 1100 | 2 | 12.2 (40) | 30.5 (100) | 76.2 (250) | 106.7 (350) | 12.2 (40) | 45.7 (150) | 91.4 (300) | 121.9 (400) | 61.0 (200) | 182.9 (600) | 304.8 (1000) | 365.8 (1200) | 2 x 1321-3R750-B | 20 | 525 ⁽⁴⁾ | | | | | |
| | | 4 | 7.6 (25) | 24.4 (80) | 61.0 (200) | 91.4 (300) | 12.2 (40) | 30.5 (100) | 76.2 (250) | 106.7 (350) | 45.7 (150) | 121.9 (400) | 243.8 (800) | 304.8 (1000) | | 20 | 1050 ⁽⁴⁾ | | | | | |
| | 1250 | 2 | 12.2 (40) | 30.5 (100) | 76.2 (250) | 106.7 (350) | 12.2 (40) | 45.7 (150) | 91.4 (300) | 121.9 (400) | 61.0 (200) | 182.9 (600) | 304.8 (1000) | 365.8 (1200) | 2 x 1321-3R850-B | 20 | 600 ⁽⁵⁾ | | | | | |
| | | 4 | 7.6 (25) | 24.4 (80) | 61.0 (200) | 91.4 (300) | 12.2 (40) | 30.5 (100) | 76.2 (250) | 106.7 (350) | 45.7 (150) | 121.9 (400) | 243.8 (800) | 304.8 (1000) | | 20 | 1200 ⁽⁵⁾ | | | | | |
| 10 ⁽¹⁾ | 1350 | 2 | 12.2 (40) | 30.5 (100) | 76.2 (250) | 106.7 (350) | 12.2 (40) | 45.7 (150) | 91.4 (300) | 121.9 (400) | 61.0 (200) | 152.4 (500) | 304.8 (1000) | 365.8 (1200) | 2 x 1321-3R850-B | 20 | 600 ⁽⁵⁾ | | | | | |
| | | 4 | 7.6 (25) | 24.4 (80) | 45.7 (150) | 76.2 (250) | 12.2 (40) | 30.5 (100) | 76.2 (250) | 106.7 (350) | 45.7 (150) | 121.9 (400) | 243.8 (800) | 304.8 (1000) | | 20 | 1200 ⁽⁵⁾ | | | | | |
| | 1750 | 2 | 12.2 (40) | 30.5 (100) | 76.2 (250) | 91.4 (300) | 12.2 (40) | 45.7 (150) | 91.4 (300) | 121.9 (400) | 45.7 (150) | 137.2 (450) | 304.8 (1000) | 365.8 (1200) | 3 x 1321-3R850-B | 30 | 500 ⁽⁶⁾ | | | | | |
| | | 4 | 7.6 (25) | 24.4 (80) | 45.7 (150) | 76.2 (250) | 12.2 (40) | 30.5 (100) | 76.2 (250) | 106.7 (350) | 30.5 (100) | 106.7 (350) | 213.4 (700) | 304.8 (1000) | | 30 | 1000 ⁽⁶⁾ | | | | | |

- (1) Frame 9 and Frame 10 drives require two or three parallel reactors to match drive amp rating. The resistor ratings are per phase values for each reactor.
- (2) Resistor specification is based on two parallel cables per phase.
- (3) Resistor specification is based on three parallel cables per phase.
- (4) Resistor specification is based on four parallel cables per phase.
- (5) Resistor specification is based on five parallel cables per phase.
- (6) Resistor specification is based on six parallel cables per phase.

Table 56 - PowerFlex 755 Floor Mount Drives, 600V Shielded/Unshielded Cable – Meters (Feet)

| Drive | Rating | | No Solution | | Reactor Only | | Reactor and Damping Resistor | | Reactor | Resistor | | Available Options | | | | | |
|---------------------|---------------------|-----|--------------|----------------|---------------|----------------|------------------------------|-----------------|---------------------|--------------|---------------------|---------------------|-------|------|------|------|-----|
| | Frame | Hp | kHz | 1488V | 1850V | 1488V | 1850V | 1488V | | 1850V | Cat. No. | Ohms | Watts | TFA1 | TFB2 | RWR2 | RWC |
| 8 | 300 | 2 | 24.4 (80) | 137.2 (450) | 61.0 (200) | 152.4 (500) | 167.6 (550) | 365.8 (1200) | 1321-3RB400-B | 50 | 315 | | • | | | | |
| | | 4 | 24.4 (80) | 106.7 (350) | 61.0 (200) | 121.9 (400) | 121.9 (400) | 198.1 (650) | | 50 | 630 | | | | | | |
| | 350 | 2 | 24.4 (80) | 91.4 (300) | 61.0 (200) | 152.4 (500) | 167.6 (550) | 365.8 (1200) | 1321-3RB400-B | 20 | 585 ⁽²⁾ | | • | | | | |
| | | 4 | 24.4 (80) | 91.4 (300) | 61.0 (200) | 121.9 (400) | 121.9 (400) | 213.4 (700) | | 20 | 1170 ⁽²⁾ | | | | | | |
| | 400 | 2 | 24.4 (80) | 91.4 (300) | 61.0 (200) | 152.4 (500) | 167.6 (550) | 365.8 (1200) | 1321-3R500-B | 20 | 585 ⁽²⁾ | | • | | | | |
| | | 4 | 24.4 (80) | 91.4 (300) | 61.0 (200) | 121.9 (400) | 121.9 (400) | 213.4 (700) | | 20 | 1170 ⁽²⁾ | | | | | | |
| | 450 | 2 | 24.4 (80) | 91.4 (300) | 61.0 (200) | 152.4 (500) | 167.6 (550) | 365.8 (1200) | 1321-3R500-B | 20 | 585 ⁽²⁾ | | • | | | | |
| | | 4 | 24.4 (80) | 91.4 (300) | 61.0 (200) | 121.9 (400) | 121.9 (400) | 213.4 (700) | | 20 | 1170 ⁽²⁾ | | | | | | |
| | 500 | 2 | 24.4 (80) | 91.4 (300) | 61.0 (200) | 152.4 (500) | 167.6 (550) | 365.8 (1200) | 1321-3R600-B | 20 | 585 ⁽²⁾ | | • | | | | |
| | | 4 | 24.4 (80) | 91.4 (300) | 61.0 (200) | 121.9 (400) | 121.9 (400) | 213.4 (700) | | 20 | 1170 ⁽²⁾ | | | | | | |
| | 9 | 600 | 2 | 24.4 (80) | 91.4 (300) | 61.0 (200) | 152.4 (500) | 152.4 (500) | 365.8 (1200) | 1321-3R750-B | 20 | 585 ⁽²⁾ | | • | | | |
| | | | 4 | 24.4 (80) | 91.4 (300) | 61.0 (200) | 121.9 (400) | 121.9 (400) | 213.4 (700) | | 20 | 1170 ⁽²⁾ | | | | | |
| 700 | | 2 | 24.4 (80) | 91.4 (300) | 61.0 (200) | 152.4 (500) | 152.4 (500) | 365.8 (1200) | 1321-3R850-B | 20 | 960 ⁽³⁾ | | • | | | | |
| | | 4 | 24.4 (80) | 91.4 (300) | 61.0 (200) | 121.9 (400) | 121.9 (400) | 213.4 (700) | | 20 | 1920 ⁽³⁾ | | | | | | |
| 800 | | 2 | 24.4 (80) | 91.4 (300) | 61.0 (200) | 152.4 (500) | 152.4 (500) | 365.8 (1200) | 1321-3R850-B | 20 | 960 ⁽³⁾ | | • | | | | |
| | | 4 | 24.4 (80) | 91.4 (300) | 61.0 (200) | 121.9 (400) | 121.9 (400) | 213.4 (700) | | 20 | 1920 ⁽³⁾ | | | | | | |
| 900 ⁽¹⁾ | | 2 | 24.4 (80) | 91.4 (300) | 61.0 (200) | 152.4 (500) | 152.4 (500) | 365.8 (1200) | 2 X 1321-3R500-B | 40 | 480 ⁽³⁾ | | | | | | |
| | | 4 | 24.4 (80) | 91.4 (300) | 61.0 (200) | 121.9 (400) | 121.9 (400) | 213.4 (700) | | 40 | 960 ⁽³⁾ | | | | | | |
| 950 ⁽¹⁾ | | 2 | 24.4 (80) | 91.4 (300) | 61.0 (200) | 152.4 (500) | 152.4 (500) | 365.8 (1200) | 2 X 1321-3R500-B | 40 | 480 ⁽³⁾ | | | | | | |
| | | 4 | 24.4 (80) | 91.4 (300) | 61.0 (200) | 121.9 (400) | 121.9 (400) | 213.4 (700) | | 40 | 960 ⁽³⁾ | | | | | | |
| 1000 ⁽¹⁾ | | 2 | 24.4 (80) | 91.4 (300) | 61.0 (200) | 152.4 (500) | 152.4 (500) | 365.8 (1200) | 2 X 1321-3R600-B | 40 | 480 ⁽³⁾ | | | | | | |
| | | 4 | 24.4 (80) | 91.4 (300) | 61.0 (200) | 121.9 (400) | 121.9 (400) | 213.4 (700) | | 40 | 960 ⁽³⁾ | | | | | | |
| 10 | 1100 ⁽¹⁾ | 2 | 24.4 (80) | 91.4 (300) | 53.3 (175) | 137.2 (450) | 137.2 (450) | 365.8 (1200) | 2 x 1321-3R750-B | 20 | 720 ⁽⁴⁾ | | | | | | |
| | | 4 | 24.4 (80) | 53.3 (175) | 53.3 (175) | 106.7 (350) | 106.7 (350) | 213.4 (700) | | 20 | 1440 ⁽⁴⁾ | | | | | | |
| | 1400 ⁽¹⁾ | 2 | 24.4 (80) | 91.4 (300) | 53.3 (175) | 137.2 (450) | 137.2 (450) | 365.8 (1200) | 2 x 1321-3R850-B | 20 | 960 ⁽⁵⁾ | | | | | | |
| | | 4 | 24.4 (80) | 53.3 (175) | 53.3 (175) | 106.7 (350) | 106.7 (350) | 213.4 (700) | | 20 | 1920 ⁽⁵⁾ | | | | | | |

- (1) Some Frame 9 and all Frame 10 drives require two reactors to match drive amp rating. The resistor ratings are per phase values for each reactor.
- (2) Resistor specification is based on two parallel cables per phase.
- (3) Resistor specification is based on three parallel cables per phase.
- (4) Resistor specification is based on four parallel cables per phase.
- (5) Resistor specification is based on five parallel cables per phase.

Table 57 - PowerFlex 755 Floor Mount Drives, 690V Shielded/Unshielded Cable – Meters (Feet)

| Drive | Rating | | No Solution | | Reactor Only | | Reactor and Damping Resistor | | Reactor | Resistor | | Available Options | | | | | |
|-------|--------|----|--------------|---------------|---------------|----------------|------------------------------|----------------|---------------|----------|---------------------|-------------------|-------|------|------|------|-----|
| | Frame | kW | kHz | 1488V | 1850V | 1488V | 1850V | 1488V | | 1850V | Cat. No. | Ohms | Watts | TFA1 | TFB2 | RWR2 | RWC |
| 8 | 250 | 2 | 24.4 (80) | 45.7 (150) | 91.4 (300) | 121.9 (400) | 182.9 (600) | 243.8 (800) | 1321-3RB400-C | 50 | 480 | | | | | | |
| | | 4 | 24.4 (80) | 45.7 (150) | 91.4 (300) | 106.7 (350) | 152.4 (500) | 182.9 (600) | | 50 | 960 | | | | | | |
| | 315 | 2 | 24.4 (80) | 45.7 (150) | 91.4 (300) | 121.9 (400) | 182.9 (600) | 243.8 (800) | 1321-3RB400-C | 50 | 480 | | | | | | |
| | | 4 | 24.4 (80) | 45.7 (150) | 91.4 (300) | 106.7 (350) | 152.4 (500) | 182.9 (600) | | 50 | 960 | | | | | | |
| | 355 | 2 | 24.4 (80) | 45.7 (150) | 91.4 (300) | 121.9 (400) | 182.9 (600) | 243.8 (800) | 1321-3R500-C | 20 | 960 ⁽²⁾ | | | | | | |
| | | 4 | 24.4 (80) | 45.7 (150) | 91.4 (300) | 106.7 (350) | 152.4 (500) | 182.9 (600) | | 20 | 1920 ⁽²⁾ | | | | | | |
| | 400 | 2 | 24.4 (80) | 45.7 (150) | 91.4 (300) | 121.9 (400) | 182.9 (600) | 243.8 (800) | 1321-3R500-C | 20 | 960 ⁽²⁾ | | | | | | |
| | | 4 | 24.4 (80) | 45.7 (150) | 91.4 (300) | 106.7 (350) | 152.4 (500) | 182.9 (600) | | 20 | 1920 ⁽²⁾ | | | | | | |
| | 450 | 2 | 24.4 (80) | 45.7 (150) | 91.4 (300) | 121.9 (400) | 182.9 (600) | 243.8 (800) | 1321-3R500-C | 20 | 960 ⁽²⁾ | | | | | | |
| | | 4 | 24.4 (80) | 45.7 (150) | 91.4 (300) | 106.7 (350) | 152.4 (500) | 182.9 (600) | | 20 | 1920 ⁽²⁾ | | | | | | |
| | 500 | 2 | 24.4 (80) | 45.7 (150) | 91.4 (300) | 121.9 (400) | 182.9 (600) | 243.8 (800) | 1321-3R600-C | 20 | 960 ⁽²⁾ | | | | | | |
| | | 4 | 24.4 (80) | 45.7 (150) | 91.4 (300) | 106.7 (350) | 152.4 (500) | 182.9 (600) | | 20 | 1920 ⁽²⁾ | | | | | | |

Table 57 - PowerFlex 755 Floor Mount Drives, 690V Shielded/Unshielded Cable – Meters (Feet) (Continued)

| Drive | Rating | | No Solution | | Reactor Only | | Reactor and Damping Resistor | | Reactor | Resistor | | Available Options | | | | |
|---------------------|--------------------|---------------------|--------------|---------------|---------------|----------------|------------------------------|----------------|---------------------|---------------------|---------------------|---------------------|------|------|-----|--|
| Frame | kW | kHz | 1488V | 1850V | 1488V | 1850V | 1488V | 1850V | Cat. No. | Ohms | Watts | TFA1 | TFB2 | RWR2 | RWC | |
| 9 | 560 | 2 | 24.4 (80) | 45.7 (150) | 76.2 (250) | 121.9 (400) | 182.9 (600) | 243.8 (800) | 1321-3R750-C | 20 | 960 ⁽²⁾ | | | | | |
| | | 4 | 24.4 (80) | 45.7 (150) | 76.2 (250) | 91.4 (300) | 152.4 (500) | 182.9 (600) | | 20 | 1920 ⁽²⁾ | | | | | |
| | 630 | 2 | 24.4 (80) | 45.7 (150) | 76.2 (250) | 121.9 (400) | 182.9 (600) | 243.8 (800) | 1321-3R750-C | 20 | 960 ⁽²⁾ | | | | | |
| | | 4 | 24.4 (80) | 45.7 (150) | 76.2 (250) | 91.4 (300) | 152.4 (500) | 182.9 (600) | | 20 | 1920 ⁽²⁾ | | | | | |
| | 710 | 2 | 24.4 (80) | 45.7 (150) | 76.2 (250) | 121.9 (400) | 182.9 (600) | 243.8 (800) | 1321-3R850-C | 20 | 1290 ⁽³⁾ | | | | | |
| | | 4 | 24.4 (80) | 45.7 (150) | 76.2 (250) | 91.4 (300) | 152.4 (500) | 182.9 (600) | | 20 | 2580 ⁽³⁾ | | | | | |
| | 750 ⁽¹⁾ | 2 | 24.4 (80) | 45.7 (150) | 76.2 (250) | 121.9 (400) | 182.9 (600) | 243.8 (800) | 2 x 1321-3R500-C | 40 | 645 ⁽³⁾ | | | | | |
| | | 4 | 24.4 (80) | 45.7 (150) | 76.2 (250) | 91.4 (300) | 152.4 (500) | 182.9 (600) | | 40 | 1290 ⁽³⁾ | | | | | |
| | 800 ⁽¹⁾ | 2 | 24.4 (80) | 45.7 (150) | 76.2 (250) | 121.9 (400) | 182.9 (600) | 243.8 (800) | 2 x 1321-3R500-C | 40 | 645 ⁽³⁾ | | | | | |
| | | 4 | 24.4 (80) | 45.7 (150) | 76.2 (250) | 91.4 (300) | 152.4 (500) | 182.9 (600) | | 40 | 1290 ⁽³⁾ | | | | | |
| | 900 ⁽¹⁾ | 2 | 24.4 (80) | 45.7 (150) | 76.2 (250) | 121.9 (400) | 182.9 (600) | 243.8 (800) | 2 x 1321-3R600-C | 40 | 645 ⁽³⁾ | | | | | |
| | | 4 | 24.4 (80) | 45.7 (150) | 76.2 (250) | 91.4 (300) | 152.4 (500) | 182.9 (600) | | 40 | 1290 ⁽³⁾ | | | | | |
| | 10 | 1000 ⁽¹⁾ | 2 | 24.4 (80) | 45.7 (150) | 61.0 (200) | 91.4 (300) | 182.9 (600) | 243.8 (800) | 2 x 1321-3R600-C | 20 | 840 ⁽⁴⁾ | | | | |
| | | | 4 | 24.4 (80) | 45.7 (150) | 61.0 (200) | 76.2 (250) | 152.4 (500) | 182.9 (600) | | 20 | 1680 ⁽⁴⁾ | | | | |
| 1400 ⁽¹⁾ | | 2 | 24.4 (80) | 45.7 (150) | 61.0 (200) | 91.4 (300) | 182.9 (600) | 243.8 (800) | 2 x 1321-3R750-C | 20 | 840 ⁽⁴⁾ | | | | | |
| | | 4 | 24.4 (80) | 45.7 (150) | 61.0 (200) | 76.2 (250) | 152.4 (500) | 182.9 (600) | | 20 | 1680 ⁽⁴⁾ | | | | | |

- (1) Some Frame 9 and all Frame 10 drives require two reactors to match drive amp rating. The resistor ratings are per phase values for each reactor.
- (2) Resistor specification is based on two parallel cables per phase.
- (3) Resistor specification is based on three parallel cables per phase.
- (4) Resistor specification is based on four parallel cables per phase.

PowerFlex 755T Drive Products

PowerFlex 755TL low harmonic drives PowerFlex 755TR regenerative drives, and PowerFlex 755TM drive systems (also referred to as 755T drive products).

This section lists motor cable length restrictions, reactors, and available options for PowerFlex 755T drive products.

Table 58 - PowerFlex 755T Drive Products, 400V Shielded/Unshielded Cable – Meters (Feet)

| Drive | | | Inverter Switching kHz | No Solution | | | | | Inverter Switching kHz | With Reactor and Damping Resistor (included in roll-in) | | | | |
|-------|-----|------|------------------------|-------------|-------------|-------------|--------------|-------------------------------|------------------------|---|--------------|--------------|--------------|-------------------------------|
| Frame | kW | Amps | | 1000V | 1200V | 1488V | 1600V | IGBT Power Structure Cat. No. | | 1000V | 1200V | 1488V | 1600V | IGBT Power Structure Cat. No. |
| 8 | 160 | 302 | 1.33, 2 | 24.4 (80) | 121.9 (400) | 213.4 (700) | 304.8 (1000) | 20-750-MI1-C302D302 | 1.33, 2 | 228.6 (750) | 365.8 (1200) | 365.8 (1200) | 365.8 (1200) | 20-750-MI3-C302D302 |
| | | | 4 | 24.4 (80) | 91.4 (300) | 152.4 (500) | 182.9 (600) | | 4 | 91.4 (300) | 182.9 (600) | 304.8 (1000) | 365.8 (1200) | |
| 8 | 200 | 367 | 1.33, 2 | 24.4 (80) | 121.9 (400) | 213.4 (700) | 304.8 (1000) | 20-750-MI1-C367D361 | 1.33, 2 | 228.6 (750) | 365.8 (1200) | 365.8 (1200) | 365.8 (1200) | 20-750-MI3-C367D361 |
| | | | 4 | 24.4 (80) | 91.4 (300) | 152.4 (500) | 182.9 (600) | | 4 | 91.4 (300) | 182.9 (600) | 304.8 (1000) | 365.8 (1200) | |
| 8 | 250 | 460 | 1.33, 2 | 24.4 (80) | 121.9 (400) | 213.4 (700) | 304.8 (1000) | 20-750-MI1-C460D430 | 1.33, 2 | 228.6 (750) | 365.8 (1200) | 365.8 (1200) | 365.8 (1200) | 20-750-MI3-C460D430 |
| | | | 4 | 24.4 (80) | 91.4 (300) | 152.4 (500) | 182.9 (600) | | 4 | 91.4 (300) | 182.9 (600) | 304.8 (1000) | 365.8 (1200) | |
| 8 | 315 | 540 | 1.33, 2 | 24.4 (80) | 121.9 (400) | 213.4 (700) | 259.1 (850) | 20-750-MI1-C540D505 | 1.33, 2 | 228.6 (750) | 365.8 (1200) | 365.8 (1200) | 365.8 (1200) | 20-750-MI3-C540D505 |
| | | | 4 | 24.4 (80) | 91.4 (300) | 152.4 (500) | 182.9 (600) | | 4 | 91.4 (300) | 182.9 (600) | 304.8 (1000) | 365.8 (1200) | |
| 8 | 315 | 585 | 1.33, 2 | 24.4 (80) | 121.9 (400) | 213.4 (700) | 259.1 (850) | 20-750-MI1-C585D545 | 1.33, 2 | 228.6 (750) | 365.8 (1200) | 365.8 (1200) | 365.8 (1200) | 20-750-MI3-C585D545 |
| | | | 4 | 24.4 (80) | 91.4 (300) | 152.4 (500) | 182.9 (600) | | 4 | 91.4 (300) | 182.9 (600) | 304.8 (1000) | 365.8 (1200) | |
| 8 | 355 | 650 | 1.33, 2 | 24.4 (80) | 121.9 (400) | 213.4 (700) | 259.1 (850) | 20-750-MI1-C650D617 | 1.33, 2 | 228.6 (750) | 304.8 (1000) | 365.8 (1200) | 365.8 (1200) | 20-750-MI3-C650D617 |
| | | | 4 | 24.4 (80) | 91.4 (300) | 152.4 (500) | 182.9 (600) | | 4 | 91.4 (300) | 182.9 (600) | 304.8 (1000) | 365.8 (1200) | |
| 8 | 400 | 750 | 1.33, 2 | 24.4 (80) | 91.4 (300) | 152.4 (500) | 213.4 (700) | 20-750-MI1-C750D710 | 1.33, 2 | 198.1 (650) | 274.3 (900) | 304.8 (1000) | 365.8 (1200) | 20-750-MI3-C750D710 |
| | | | 4 | 24.4 (80) | 91.4 (300) | 137.2 (450) | 167.6 (550) | | 4 | 76.2 (250) | 137.2 (450) | 274.8 (902) | 365.8 (1200) | |
| 8 | 400 | 770 | 1.33, 2 | 24.4 (80) | 91.4 (300) | 152.4 (500) | 213.4 (700) | 20-750-MI1-C750D710 | 1.33, 2 | 198.1 (650) | 274.3 (900) | 304.8 (1000) | 365.8 (1200) | 20-750-MI3-C770D740 |
| | | | 4 | 24.4 (80) | 91.4 (300) | 137.2 (450) | 167.6 (550) | | 4 | 76.2 (250) | 137.2 (450) | 274.8 (902) | 365.8 (1200) | |
| 9 | 500 | 920 | 1.33, 2 | 24.4 (80) | 76.2 (250) | 152.4 (500) | 213.4 (700) | 20-750-MI2-C460D430 | 1.33, 2 | 213.4 (700) | 304.8 (1000) | 365.8 (1200) | 365.8 (1200) | 20-750-MI3-C460D430 |
| | | | 4 | 24.4 (80) | 61.0 (200) | 106.7 (350) | 137.2 (450) | | 4 | 91.4 (300) | 182.9 (600) | 365.8 (1200) | 365.8 (1200) | |
| 9 | 560 | 1040 | 1.33, 2 | 24.4 (80) | 61.0 (200) | 152.4 (500) | 182.9 (600) | 20-750-MI2-C540D485 | 1.33, 2 | 182.9 (600) | 274.3 (900) | 365.8 (1200) | 365.8 (1200) | 20-750-MI3-C540D485 |
| | | | 4 | 24.4 (80) | 61.0 (200) | 106.7 (350) | 137.2 (450) | | 4 | 91.4 (300) | 182.9 (600) | 365.8 (1200) | 365.8 (1200) | |
| 9 | 630 | 1112 | 1.33, 2 | 24.4 (80) | 61.0 (200) | 152.4 (500) | 182.9 (600) | 20-750-MI2-C567D545 | 1.33, 2 | 182.9 (600) | 274.3 (900) | 365.8 (1200) | 365.8 (1200) | 20-750-MI3-C567D545 |
| | | | 4 | 24.4 (80) | 61.0 (200) | 106.7 (350) | 137.2 (450) | | 4 | 91.4 (300) | 182.9 (600) | 365.8 (1200) | 365.8 (1200) | |

Table 58 - PowerFlex 755T Drive Products, 400V Shielded/Unshielded Cable – Meters (Feet) (Continued)

| Drive | | | Inverter Switching kHz | No Solution | | | | | Inverter Switching kHz | With Reactor and Damping Resistor (included in roll-in) | | | | |
|-------|------|------|------------------------|-------------|------------|-------------|-------------|-------------------------------|------------------------|---|-------------|--------------|--------------|-------------------------------|
| Frame | kW | Amps | | 1000V | 1200V | 1488V | 1600V | IGBT Power Structure Cat. No. | | 1000V | 1200V | 1488V | 1600V | IGBT Power Structure Cat. No. |
| 9 | 710 | 1175 | 1.33, 2 | 24.4 (80) | 61.0 (200) | 152.4 (500) | 182.9 (600) | 20-750-MI2-C750D710 | 1.33, 2 | 182.9 (600) | 274.3 (900) | 365.8 (1200) | 365.8 (1200) | 20-750-MI3-C750D710 |
| | | | 4 | 24.4 (80) | 61.0 (200) | 106.7 (350) | 137.2 (450) | | 4 | 91.4 (300) | 182.9 (600) | 365.8 (1200) | 365.8 (1200) | |
| 9 | 800 | 1465 | 1.33, 2 | 24.4 (80) | 61.0 (200) | 152.4 (500) | 182.9 (600) | 20-750-MI2-C770D740 | 1.33, 2 | 182.9 (600) | 274.3 (900) | 365.8 (1200) | 365.8 (1200) | 20-750-MI3-C770D740 |
| | | | 4 | 24.4 (80) | 61.0 (200) | 106.7 (350) | 137.2 (450) | | 4 | 91.4 (300) | 182.9 (600) | 365.8 (1200) | 365.8 (1200) | |
| 10 | 850 | 1590 | 1.33, 2 | 24.4 (80) | 61.0 (200) | 152.4 (500) | 182.9 (600) | 20-750-MI2-C650D617 | 1.33, 2 | 182.9 (600) | 274.3 (900) | 365.8 (1200) | 365.8 (1200) | 20-750-MI3-C650D617 |
| | | | 4 | 24.4 (80) | 61.0 (200) | 106.7 (350) | 137.2 (450) | | 4 | 91.4 (300) | 182.9 (600) | 365.8 (1200) | 365.8 (1200) | |
| 10 | 1000 | 1715 | 1.33, 2 | 24.4 (80) | 45.7 (150) | 121.9 (400) | 182.9 (600) | 20-750-MI2-C770D740 | 1.33, 2 | 182.9 (600) | 274.3 (900) | 365.8 (1200) | 365.8 (1200) | 20-750-MI3-C770D740 |
| | | | 4 | 24.4 (80) | 45.7 (150) | 91.4 (300) | 137.2 (450) | | 4 | 91.4 (300) | 182.9 (600) | 365.8 (1200) | 365.8 (1200) | |
| 10 | 1250 | 2156 | 1.33, 2 | 24.4 (80) | 45.7 (150) | 91.4 (300) | 137.2 (450) | 20-750-MI2-C750D710 | 1.33, 2 | 152.4 (500) | 274.3 (900) | 365.8 (1200) | 365.8 (1200) | 20-750-MI3-C750D710 |
| | | | 4 | 24.4 (80) | 45.7 (150) | 106.7 (350) | 152.4 (500) | | 4 | 91.4 (300) | 182.9 (600) | 365.8 (1200) | 365.8 (1200) | |
| 11 | 1650 | 2849 | 1.33, 2 | 24.4 (80) | 45.7 (150) | 91.4 (300) | 137.2 (450) | 20-750-MI2-C770D740 | 1.33, 2 | 152.4 (500) | 274.3 (900) | 365.8 (1200) | 365.8 (1200) | 20-750-MI3-C770D740 |
| | | | 4 | 24.4 (80) | 45.7 (150) | 106.7 (350) | 152.4 (500) | | 4 | 91.4 (300) | 182.9 (600) | 365.8 (1200) | 365.8 (1200) | |
| 12 | 2000 | 3542 | 1.33, 2 | 24.4 (80) | 45.7 (150) | 91.4 (300) | 137.2 (450) | 20-750-MI2-C770D740 | 1.33, 2 | 152.4 (500) | 274.3 (900) | 365.8 (1200) | 365.8 (1200) | 20-750-MI3-C770D740 |
| | | | 4 | 24.4 (80) | 45.7 (150) | 106.7 (350) | 152.4 (500) | | 4 | 91.4 (300) | 182.9 (600) | 365.8 (1200) | 365.8 (1200) | |

Table 59 - PowerFlex 755T Drive Products, 480V Shielded/Unshielded Cable – Meters (Feet)

| Drive | | | Inverter Switching kHz | No Solution | | | | | Inverter Switching kHz | With Reactor and Damping Resistor (included in roll-in) | | | | |
|-------|-----|------|------------------------|-------------|------------|-------------|-------------|-------------------------------|------------------------|---|-------------|--------------|--------------|-------------------------------|
| Frame | Hp | Amps | | 1000V | 1200V | 1488V | 1600V | IGBT Power Structure Cat. No. | | 1000V | 1200V | 1488V | 1600V | IGBT Power Structure Cat. No. |
| 8 | 250 | 302 | 1.33, 2 | 12.2 (40) | 30.5 (100) | 106.7 (350) | 152.4 (500) | 20-750-MI1-C302D302 | 1.33, 2 | 61 (200) | 213.4 (700) | 304.8 (1000) | 365.8 (1200) | 20-750-MI3-C302D302 |
| | | | 4 | 7.6 (25) | 24.4 (80) | 91.4 (300) | 121.9 (400) | | 4 | 45.7 (150) | 137.2 (450) | 243.8 (800) | 304.8 (1000) | |
| 8 | 300 | 361 | 1.33, 2 | 12.2 (40) | 30.5 (100) | 106.7 (350) | 152.4 (500) | 20-750-MI1-C367D361 | 1.33, 2 | 61 (200) | 213.4 (700) | 304.8 (1000) | 365.8 (1200) | 20-750-MI3-C367D361 |
| | | | 4 | 7.6 (25) | 24.4 (80) | 91.4 (300) | 121.9 (400) | | 4 | 45.7 (150) | 137.2 (450) | 243.8 (800) | 304.8 (1000) | |
| 8 | 350 | 430 | 1.33, 2 | 12.2 (40) | 30.5 (100) | 106.7 (350) | 152.4 (500) | 20-750-MI1-C460D430 | 1.33, 2 | 61 (200) | 213.4 (700) | 304.8 (1000) | 365.8 (1200) | 20-750-MI3-C460D430 |
| | | | 4 | 7.6 (25) | 24.4 (80) | 91.4 (300) | 121.9 (400) | | 4 | 45.7 (150) | 137.2 (450) | 243.8 (800) | 304.8 (1000) | |
| 8 | 400 | 505 | 1.33, 2 | 12.2 (40) | 30.5 (100) | 106.7 (350) | 152.4 (500) | 20-750-MI1-C540D505 | 1.33, 2 | 61 (200) | 213.4 (700) | 304.8 (1000) | 365.8 (1200) | 20-750-MI3-C540D505 |
| | | | 4 | 7.6 (25) | 24.4 (80) | 91.4 (300) | 121.9 (400) | | 4 | 45.7 (150) | 137.2 (450) | 243.8 (800) | 304.8 (1000) | |

Table 59 - PowerFlex 755T Drive Products, 480V Shielded/Unshielded Cable – Meters (Feet) (Continued)

| Drive | | | Inverter Switching kHz | No Solution | | | | | Inverter Switching kHz | With Reactor and Damping Resistor (included in roll-in) | | | | |
|-------|------|------|------------------------|-------------|------------|-------------|-------------|-------------------------------|------------------------|---|-------------|--------------|--------------|-------------------------------|
| Frame | Hp | Amps | | 1000V | 1200V | 1488V | 1600V | IGBT Power Structure Cat. No. | | 1000V | 1200V | 1488V | 1600V | IGBT Power Structure Cat. No. |
| 8 | 450 | 545 | 1.33, 2 | 12.2 (40) | 30.5 (100) | 106.7 (350) | 152.4 (500) | 20-750-MI1-C585D545 | 1.33, 2 | 61 (200) | 213.4 (700) | 304.8 (1000) | 365.8 (1200) | 20-750-MI3-C585D545 |
| | | | 4 | 7.6 (25) | 24.4 (80) | 91.4 (300) | 121.9 (400) | | 4 | 45.7 (150) | 137.2 (450) | 243.8 (800) | 304.8 (1000) | |
| 8 | 500 | 617 | 1.33, 2 | 12.2 (40) | 30.5 (100) | 106.7 (350) | 152.4 (500) | 20-750-MI1-C650D617 | 1.33, 2 | 61 (200) | 213.4 (700) | 304.8 (1000) | 365.8 (1200) | 20-750-MI3-C650D617 |
| | | | 4 | 7.6 (25) | 24.4 (80) | 91.4 (300) | 121.9 (400) | | 4 | 45.7 (150) | 137.2 (450) | 243.8 (800) | 304.8 (1000) | |
| 8 | 600 | 710 | 1.33, 2 | 12.2 (40) | 30.5 (100) | 76.2 (250) | 106.7 (350) | 20-750-MI1-C750D710 | 1.33, 2 | 61 (200) | 213.4 (700) | 304.8 (1000) | 365.8 (1200) | 20-750-MI3-C750D710 |
| | | | 4 | 7.6 (25) | 24.4 (80) | 61.0 (200) | 91.4 (300) | | 4 | 45.7 (150) | 137.2 (450) | 243.8 (800) | 304.8 (1000) | |
| 8 | 650 | 740 | 1.33, 2 | 12.2 (40) | 30.5 (100) | 76.2 (250) | 106.7 (350) | 20-750-MI1-C750D710 | 1.33, 2 | 61 (200) | 213.4 (700) | 304.8 (1000) | 365.8 (1200) | 20-750-MI3-C770D740 |
| | | | 4 | 7.6 (25) | 24.4 (80) | 61.0 (200) | 91.4 (300) | | 4 | 45.7 (150) | 137.2 (450) | 243.8 (800) | 304.8 (1000) | |
| 9 | 700 | 800 | 1.33, 2 | 12.2 (40) | 30.5 (100) | 76.2 (250) | 106.7 (350) | 20-750-MI2-C460D430 | 1.33, 2 | 61 (200) | 213.4 (700) | 304.8 (1000) | 365.8 (1200) | 20-750-MI3-C460D430 |
| | | | 4 | 7.6 (25) | 24.4 (80) | 61.0 (200) | 91.4 (300) | | 4 | 45.7 (150) | 137.2 (450) | 243.8 (800) | 304.8 (1000) | |
| 9 | 800 | 960 | 1.33, 2 | 12.2 (40) | 30.5 (100) | 76.2 (250) | 106.7 (350) | 20-750-MI2-C540D485 | 1.33, 2 | 61 (200) | 182.9 (600) | 304.8 (1000) | 365.8 (1200) | 20-750-MI3-C540D485 |
| | | | 4 | 7.6 (25) | 24.4 (80) | 61.0 (200) | 91.4 (300) | | 4 | 45.7 (150) | 121.9 (400) | 243.8 (800) | 304.8 (1000) | |
| 9 | 900 | 1045 | 1.33, 2 | 12.2 (40) | 30.5 (100) | 76.2 (250) | 106.7 (350) | 20-750-MI2-C567D545 | 1.33, 2 | 61 (200) | 182.9 (600) | 304.8 (1000) | 365.8 (1200) | 20-750-MI3-C567D545 |
| | | | 4 | 7.6 (25) | 24.4 (80) | 61.0 (200) | 91.4 (300) | | 4 | 45.7 (150) | 121.9 (400) | 243.8 (800) | 304.8 (1000) | |
| 9 | 1000 | 1135 | 1.33, 2 | 12.2 (40) | 30.5 (100) | 76.2 (250) | 106.7 (350) | 20-750-MI2-C750D710 | 1.33, 2 | 61 (200) | 182.9 (600) | 304.8 (1000) | 365.8 (1200) | 20-750-MI3-C750D710 |
| | | | 4 | 7.6 (25) | 24.4 (80) | 61.0 (200) | 91.4 (300) | | 4 | 45.7 (150) | 121.9 (400) | 243.8 (800) | 304.8 (1000) | |
| 9 | 1100 | 1365 | 1.33, 2 | 12.2 (40) | 30.5 (100) | 76.2 (250) | 106.7 (350) | 20-750-MI2-C770D740 | 1.33, 2 | 61 (200) | 182.9 (600) | 304.8 (1000) | 365.8 (1200) | 20-750-MI3-C770D740 |
| | | | 4 | 7.6 (25) | 24.4 (80) | 61.0 (200) | 91.4 (300) | | 4 | 45.7 (150) | 121.9 (400) | 243.8 (800) | 304.8 (1000) | |
| 10 | 1250 | 1420 | 1.33, 2 | 12.2 (40) | 30.5 (100) | 76.2 (250) | 106.7 (350) | 20-750-MI2-C650D617 | 1.33, 2 | 61 (200) | 182.9 (600) | 304.8 (1000) | 365.8 (1200) | 20-750-MI3-C650D617 |
| | | | 4 | 7.6 (25) | 24.4 (80) | 61.0 (200) | 91.4 (300) | | 4 | 45.7 (150) | 121.9 (400) | 243.8 (800) | 304.8 (1000) | |
| 10 | 1500 | 1655 | 1.33, 2 | 12.2 (40) | 30.5 (100) | 76.2 (250) | 106.7 (350) | 20-750-MI2-C770D740 | 1.33, 2 | 61 (200) | 152.4 (500) | 304.8 (1000) | 365.8 (1200) | 20-750-MI3-C770D740 |
| | | | 4 | 7.6 (25) | 24.4 (80) | 45.7 (150) | 76.2 (250) | | 4 | 45.7 (150) | 121.9 (400) | 243.8 (800) | 304.8 (1000) | |
| 10 | 1800 | 2072 | 1.33, 2 | 12.2 (40) | 30.5 (100) | 76.2 (250) | 91.4 (300) | 20-750-MI2-C750D710 | 1.33, 2 | 61 (200) | 137.2 (450) | 304.8 (1000) | 365.8 (1200) | 20-750-MI3-C750D710 |
| | | | 4 | 7.6 (25) | 24.4 (80) | 45.7 (150) | 76.2 (250) | | 4 | 45.7 (150) | 106.7 (350) | 243.8 (800) | 304.8 (1000) | |

Table 59 - PowerFlex 755T Drive Products, 480V Shielded/Unshielded Cable – Meters (Feet) (Continued)

| Drive | | | Inverter Switching kHz | No Solution | | | | | Inverter Switching kHz | With Reactor and Damping Resistor (included in roll-in) | | | | |
|-------|------|------|------------------------|-------------|------------|------------|------------|-------------------------------|------------------------|---|-------------|--------------|--------------|-------------------------------|
| Frame | Hp | Amps | | 1000V | 1200V | 1488V | 1600V | IGBT Power Structure Cat. No. | | 1000V | 1200V | 1488V | 1600V | IGBT Power Structure Cat. No. |
| 11 | 2400 | 2738 | 1.33, 2 | 12.2 (40) | 30.5 (100) | 76.2 (250) | 91.4 (300) | 20-750-MI2-C770D740 | 1.33, 2 | 61 (200) | 137.2 (450) | 304.8 (1000) | 365.8 (1200) | 20-750-MI3-C770D740 |
| | | | 4 | 7.6 (25) | 24.4 (80) | 45.7 (150) | 76.2 (250) | | 4 | 45.7 (150) | 106.7 (350) | 243.8 (800) | 304.8 (1000) | |
| 12 | 3000 | 3404 | 1.33, 2 | 12.2 (40) | 30.5 (100) | 76.2 (250) | 91.4 (300) | 20-750-MI2-C770D740 | 1.33, 2 | 61 (200) | 137.2 (450) | 304.8 (1000) | 365.8 (1200) | 20-750-MI3-C770D740 |
| | | | 4 | 7.6 (25) | 24.4 (80) | 45.7 (150) | 76.2 (250) | | 4 | 45.7 (150) | 106.7 (350) | 243.8 (800) | 304.8 (1000) | |

Table 60 - PowerFlex 755T Drive Products, 600V Shielded/Unshielded Cable – Meters (Feet)

| Drive | | | Inverter Switching kHz | No Solution | | | Inverter Switching kHz | With Reactor and Damping Resistor (included in roll-in) | | |
|-------|-----|------|------------------------|-------------|-------------|-------------------------------|------------------------|---|--------------|-------------------------------|
| Frame | Hp | Amps | | 1488V | 1850V | IGBT Power Structure Cat. No. | | 1488V | 1850V | IGBT Power Structure Cat. No. |
| 8 | 250 | 242 | 1.33, 2 | 24.4 (80) | 137.2 (450) | 20-750-MI1-E242F215 | 1.33, 2 | 167.6 (550) | 365.8 (1200) | 20-750-MI3-E242F215 |
| | | | 4 | 24.4 (80) | 106.7 (350) | | 4 | 121.9 (400) | 198.1 (650) | |
| 8 | 300 | 295 | 1.33, 2 | 24.4 (80) | 137.2 (450) | 20-750-MI1-E295F265 | 1.33, 2 | 167.6 (550) | 365.8 (1200) | 20-750-MI3-E295F265 |
| | | | 4 | 24.4 (80) | 106.7 (350) | | 4 | 121.9 (400) | 198.1 (650) | |
| 8 | 350 | 355 | 1.33, 2 | 24.4 (80) | 91.4 (300) | 20-750-MI1-E355F330 | 1.33, 2 | 167.6 (550) | 365.8 (1200) | 20-750-MI3-E355F330 |
| | | | 4 | 24.4 (80) | 91.4 (300) | | 4 | 121.9 (400) | 213.4 (700) | |
| 8 | 400 | 395 | 1.33, 2 | 24.4 (80) | 91.4 (300) | 20-750-MI1-E385F385 | 1.33, 2 | 167.6 (550) | 365.8 (1200) | 20-750-MI3-E385F385 |
| | | | 4 | 24.4 (80) | 91.4 (300) | | 4 | 121.9 (400) | 213.4 (700) | |
| 8 | 450 | 435 | 1.33, 2 | 24.4 (80) | 91.4 (300) | 20-750-MI1-E435F415 | 1.33, 2 | 167.6 (550) | 365.8 (1200) | 20-750-MI3-E435F415 |
| | | | 4 | 24.4 (80) | 91.4 (300) | | 4 | 121.9 (400) | 213.4 (700) | |
| 8 | 550 | 545 | 1.33, 2 | 24.4 (80) | 91.4 (300) | 20-750-MI1-E543F500 | 1.33, 2 | 167.6 (550) | 365.8 (1200) | 20-750-MI3-E543F500 |
| | | | 4 | 24.4 (80) | 91.4 (300) | | 4 | 121.9 (400) | 213.4 (700) | |
| 9 | 600 | 580 | 1.33, 2 | 24.4 (80) | 91.4 (300) | 20-750-MI2-E385F385 | 1.33, 2 | 152.4 (500) | 365.8 (1200) | 20-750-MI3-E385F385 |
| | | | 4 | 24.4 (80) | 91.4 (300) | | 4 | 121.9 (400) | 213.4 (700) | |
| 9 | 700 | 690 | 1.33, 2 | 24.4 (80) | 91.4 (300) | 20-750-MI2-E385F385 | 1.33, 2 | 152.4 (500) | 365.8 (1200) | 20-750-MI3-E385F385 |
| | | | 4 | 24.4 (80) | 91.4 (300) | | 4 | 121.9 (400) | 213.4 (700) | |
| 9 | 800 | 760 | 1.33, 2 | 24.4 (80) | 91.4 (300) | 20-750-MI2-E385F385 | 1.33, 2 | 152.4 (500) | 365.8 (1200) | 20-750-MI3-E385F385 |
| | | | 4 | 24.4 (80) | 91.4 (300) | | 4 | 121.9 (400) | 213.4 (700) | |

Table 60 - PowerFlex 755T Drive Products, 600V Shielded/Unshielded Cable – Meters (Feet) (Continued)

| Drive | | | Inverter Switching kHz | No Solution | | | Inverter Switching kHz | With Reactor and Damping Resistor (included in roll-in) | | |
|-------|------|------|------------------------|-------------|------------|-------------------------------|------------------------|---|--------------|-------------------------------|
| Frame | Hp | Amps | | 1488V | 1850V | IGBT Power Structure Cat. No. | | 1488V | 1850V | IGBT Power Structure Cat. No. |
| 9 | 900 | 825 | 1.33, 2 | 24.4 (80) | 91.4 (300) | 20-750-MI2-E543F500 | 1.33, 2 | 152.4 (500) | 365.8 (1200) | 20-750-MI3-E543F500 |
| | | | 4 | 24.4 (80) | 91.4 (300) | | 4 | 121.9 (400) | 213.4 (700) | |
| 9 | 1000 | 980 | 1.33, 2 | 24.4 (80) | 91.4 (300) | 20-750-MI2-E543F500 | 1.33, 2 | 152.4 (500) | 365.8 (1200) | 20-750-MI3-E543F500 |
| | | | 4 | 24.4 (80) | 91.4 (300) | | 4 | 121.9 (400) | 213.4 (700) | |
| 10 | 1100 | 1045 | 1.33, 2 | 24.4 (80) | 91.4 (300) | 20-750-MI2-E543F500 | 1.33, 2 | 137.2 (450) | 365.8 (1200) | 20-750-MI3-E543F500 |
| | | | 4 | 24.4 (80) | 53.3 (175) | | 4 | 106.7 (350) | 213.4 (700) | |
| 10 | 1250 | 1220 | 1.33, 2 | 24.4 (80) | 91.4 (300) | 20-750-MI2-E543F500 | 1.33, 2 | 137.2 (450) | 365.8 (1200) | 20-750-MI3-E543F500 |
| | | | 4 | 24.4 (80) | 91.4 (300) | | 4 | 106.7 (350) | 213.4 (700) | |
| 10 | 1500 | 1430 | 1.33, 2 | 24.4 (80) | 91.4 (300) | 20-750-MI2-E543F500 | 1.33, 2 | 137.2 (450) | 365.8 (1200) | 20-750-MI3-E543F500 |
| | | | 4 | 24.4 (80) | 53.3 (175) | | 4 | 106.7 (350) | 213.4 (700) | |
| 11 | 2000 | 1946 | 1.33, 2 | 24.4 (80) | 91.4 (300) | 20-750-MI2-E543F500 | 1.33, 2 | 137.2 (450) | 365.8 (1200) | 20-750-MI3-E543F500 |
| | | | 4 | 24.4 (80) | 91.4 (300) | | 4 | 106.7 (350) | 213.4 (700) | |
| 12 | 2500 | 2420 | 1.33, 2 | 24.4 (80) | 91.4 (300) | 20-750-MI2-E543F500 | 1.33, 2 | 137.2 (450) | 365.8 (1200) | 20-750-MI3-E543F500 |
| | | | 4 | 24.4 (80) | 91.4 (300) | | 4 | 106.7 (350) | 213.4 (700) | |

Table 61 - PowerFlex 755T Drive Products, 690V Shielded/Unshielded Cable – Meters (Feet)

| Drive | | | Inverter Switching kHz | No Solution | | | Inverter Switching kHz | With Reactor and Damping Resistor (included in roll-in) | | |
|-------|-----|------|------------------------|-------------|------------|-------------------------------|------------------------|---|-------------|-------------------------------|
| Frame | kW | Amps | | 1488V | 1850V | IGBT Power Structure Cat. No. | | 1488V | 1850V | IGBT Power Structure Cat. No. |
| 8 | 200 | 215 | 1.33, 2 | 24.4 (80) | 45.7 (150) | 20-750-MI1-E242F215 | 1.33, 2 | 182.9 (600) | 243.8 (800) | 20-750-MI3-E242F215 |
| | | | 4 | 24.4 (80) | 45.7 (150) | | 4 | 152.4 (500) | 182.9 (600) | |
| 8 | 250 | 265 | 1.33, 2 | 24.4 (80) | 45.7 (150) | 20-750-MI1-E295F265 | 1.33, 2 | 182.9 (600) | 243.8 (800) | 20-750-MI3-E295F265 |
| | | | 4 | 24.4 (80) | 45.7 (150) | | 4 | 152.4 (500) | 182.9 (600) | |
| 8 | 315 | 330 | 1.33, 2 | 24.4 (80) | 45.7 (150) | 20-750-MI1-E355F330 | 1.33, 2 | 182.9 (600) | 243.8 (800) | 20-750-MI3-E355F330 |
| | | | 4 | 24.4 (80) | 45.7 (150) | | 4 | 152.4 (500) | 182.9 (600) | |
| 8 | 355 | 370 | 1.33, 2 | 24.4 (80) | 45.7 (150) | 20-750-MI1-E385F385 | 1.33, 2 | 182.9 (600) | 243.8 (800) | 20-750-MI3-E385F385 |
| | | | 4 | 24.4 (80) | 45.7 (150) | | 4 | 152.4 (500) | 182.9 (600) | |

Table 61 - PowerFlex 755T Drive Products, 690V Shielded/Unshielded Cable – Meters (Feet) (Continued)

| Drive | | | Inverter Switching kHz | No Solution | | | Inverter Switching kHz | With Reactor and Damping Resistor (included in roll-in) | | |
|-------|------|------|------------------------|-------------|------------|-------------------------------|------------------------|---|-------------|-------------------------------|
| Frame | kW | Amps | | 1488V | 1850V | IGBT Power Structure Cat. No. | | 1488V | 1850V | IGBT Power Structure Cat. No. |
| 8 | 400 | 415 | 1.33, 2 | 24.4 (80) | 45.7 (150) | 20-750-MI1-E435F415 | 1.33, 2 | 182.9 (600) | 243.8 (800) | 20-750-MI3-E435F415 |
| | | | 4 | 24.4 (80) | 45.7 (150) | | 4 | 152.4 (500) | 182.9 (600) | |
| 8 | 500 | 505 | 1.33, 2 | 24.4 (80) | 45.7 (150) | 20-750-MI1-E543F500 | 1.33, 2 | 182.9 (600) | 243.8 (800) | 20-750-MI3-E543F500 |
| | | | 4 | 24.4 (80) | 45.7 (150) | | 4 | 152.4 (500) | 182.9 (600) | |
| 9 | 560 | 565 | 1.33, 2 | 24.4 (80) | 45.7 (150) | 20-750-MI2-E385F385 | 1.33, 2 | 182.9 (600) | 243.8 (800) | 20-750-MI3-E385F385 |
| | | | 4 | 24.4 (80) | 45.7 (150) | | 4 | 152.4 (500) | 182.9 (600) | |
| 9 | 630 | 650 | 1.33, 2 | 24.4 (80) | 45.7 (150) | 20-750-MI2-E385F385 | 1.33, 2 | 182.9 (600) | 243.8 (800) | 20-750-MI3-E385F385 |
| | | | 4 | 24.4 (80) | 45.7 (150) | | 4 | 152.4 (500) | 182.9 (600) | |
| 9 | 710 | 735 | 1.33, 2 | 24.4 (80) | 45.7 (150) | 20-750-MI2-E385F385 | 1.33, 2 | 182.9 (600) | 243.8 (800) | 20-750-MI3-E385F385 |
| | | | 4 | 24.4 (80) | 45.7 (150) | | 4 | 152.4 (500) | 182.9 (600) | |
| 9 | 800 | 820 | 1.33, 2 | 24.4 (80) | 45.7 (150) | 20-750-MI2-E543F500 | 1.33, 2 | 182.9 (600) | 243.8 (800) | 20-750-MI3-E543F500 |
| | | | 4 | 24.4 (80) | 45.7 (150) | | 4 | 152.4 (500) | 182.9 (600) | |
| 9 | 900 | 920 | 1.33, 2 | 24.4 (80) | 45.7 (150) | 20-750-MI2-E543F500 | 1.33, 2 | 182.9 (600) | 243.8 (800) | 20-750-MI3-E543F500 |
| | | | 4 | 24.4 (80) | 45.7 (150) | | 4 | 152.4 (500) | 182.9 (600) | |
| 10 | 1000 | 1030 | 1.33, 2 | 24.4 (80) | 45.7 (150) | 20-750-MI2-E543F500 | 1.33, 2 | 182.9 (600) | 243.8 (800) | 20-750-MI3-E543F500 |
| | | | 4 | 24.4 (80) | 45.7 (150) | | 4 | 152.4 (500) | 182.9 (600) | |
| 10 | 1100 | 1150 | 1.33, 2 | 24.4 (80) | 45.7 (150) | 20-750-MI2-E543F500 | 1.33, 2 | 182.9 (600) | 243.8 (800) | 20-750-MI3-E543F500 |
| | | | 4 | 24.4 (80) | 45.7 (150) | | 4 | 152.4 (500) | 182.9 (600) | |
| 10 | 1400 | 1419 | 1.33, 2 | 24.4 (80) | 45.7 (150) | 20-750-MI2-E543F500 | 1.33, 2 | 182.9 (600) | 243.8 (800) | 20-750-MI3-E543F500 |
| | | | 4 | 24.4 (80) | 45.7 (150) | | 4 | 152.4 (500) | 182.9 (600) | |
| 11 | 1800 | 1865 | 1.33, 2 | 24.4 (80) | 45.7 (150) | 20-750-MI2-E543F500 | 1.33, 2 | 182.9 (600) | 243.8 (800) | 20-750-MI3-E543F500 |
| | | | 4 | 24.4 (80) | 45.7 (150) | | 4 | 152.4 (500) | 182.9 (600) | |
| 12 | 2300 | 2318 | 1.33, 2 | 24.4 (80) | 45.7 (150) | 20-750-MI2-E543F500 | 1.33, 2 | 182.9 (600) | 243.8 (800) | 20-750-MI3-E543F500 |
| | | | 4 | 24.4 (80) | 45.7 (150) | | 4 | 152.4 (500) | 182.9 (600) | |

1336 PLUS II and 1336 IMPACT Drives

To increase the distance between the 1336 PLUS II and 1336 IMPACT drives and the motor, some device (RWR or terminator) must be added to the system. Shaded distances are restricted by cable capacitance charging current.

Table 62 - 1336 PLUS II/1336 IMPACT Drives, 380...480V – Meters (Feet)

| Drive Frame | Drive kW (Hp) | Motor kW (Hp) | No External Devices ⁽¹⁾ | | | | With 1204-TFB2 Terminator ⁽¹⁾ | | | With 1204-TFA1 Terminator ⁽¹⁾ | | | | | Reactor at Drive ⁽¹⁾⁽⁴⁾ | |
|-------------|---------------|---------------|------------------------------------|------------|-------------|--------------------------|--|----------|-----------|--|------------|-----------------------|------------|-------------|------------------------------------|-------------|
| | | | Motor | | | | Motor | | | Motor | | | | | Motor | |
| | | | A | B | 1329 | 1329R/L (1600V) | A or B | | 1329 | A | | B | | 1329 | A | B or 1329 |
| | | | Any Cable | Any Cable | Any Cable | Any Cable ⁽²⁾ | Shield ⁽³⁾ | Unshield | Any Cable | Shield ⁽³⁾ | Unshield | Shield ⁽³⁾ | Unshield | Any Cable | Any Cable | Any Cable |
| A1 | 0.37 (0.5) | 0.37 (0.5) | 12.2 (40) | 33.5 (110) | 91.4 (300) | 91.4 (300) | Use 1204-TFA1 | | | 30.5 (100) | 61.0 (200) | 30.5 (100) | 61.0 (200) | 91.4 (300) | 22.9 (75) | 182.9 (600) |
| | 0.75 (1) | 0.75 (1) | 12.2 (40) | 33.5 (110) | 91.4 (300) | 91.4 (300) | | | | 30.5 (100) | 30.5 (100) | 30.5 (100) | 30.5 (100) | 91.4 (300) | 22.9 (75) | 182.9 (600) |
| | | 0.37 (0.5) | 12.2 (40) | 33.5 (110) | 91.4 (300) | 91.4 (300) | | | | 30.5 (100) | 61.0 (200) | 30.5 (100) | 61.0 (200) | 91.4 (300) | 22.9 (75) | 182.9 (600) |
| | 1.2 (1.5) | 1.2 (1.5) | 12.2 (40) | 33.5 (110) | 91.4 (300) | 91.4 (300) | | | | 30.5 (100) | 30.5 (100) | 61.0 (200) | 61.0 (200) | 91.4 (300) | 22.9 (75) | 182.9 (600) |
| | | 0.75 (1) | 12.2 (40) | 33.5 (110) | 91.4 (300) | 91.4 (300) | | | | 30.5 (100) | 30.5 (100) | 61.0 (200) | 61.0 (200) | 91.4 (300) | 22.9 (75) | 182.9 (600) |
| | | 0.37 (0.5) | 12.2 (40) | 33.5 (110) | 114.3 (375) | 121.9 (400) | | | | 30.5 (100) | 30.5 (100) | 61.0 (200) | 61.0 (200) | 121.9 (400) | 22.9 (75) | 182.9 (600) |

Table 62 - 1336 PLUS II/1336 IMPACT Drives, 380...480V – Meters (Feet) (Continued)

| Drive Frame | Drive kW (Hp) | Motor kW (Hp) | No External Devices ⁽¹⁾ | | | | With 1204-TFB2 Terminator ⁽¹⁾ | | | With 1204-TFA1 Terminator ⁽¹⁾ | | | | | Reactor at Drive ⁽¹⁾⁽⁴⁾ | | |
|-------------|------------------------|-----------------------|------------------------------------|------------|-------------|--------------------------|--|-------------|-------------|--|-------------|-----------------------|------------|------------|------------------------------------|-------------|-------------|
| | | | Motor | | | | Motor | | | Motor | | | | | Motor | | |
| | | | A | B | 1329 | 1329R/L (1600V) | A or B | | 1329 | A | | B | | 1329 | A | B or 1329 | |
| | | | Any Cable | Any Cable | Any Cable | Any Cable ⁽²⁾ | Shield ⁽³⁾ | Unshield | Any Cable | Shield ⁽³⁾ | Unshield | Shield ⁽³⁾ | Unshield | Any Cable | Any Cable | Any Cable | |
| A2 | 1.5 (2) | 1.5 (2) | 7.6 (25) | 12.2 (40) | 91.4 (300) | 91.4 (300) | 91.4 (300) | 91.4 (300) | 91.4 (300) | 30.5 (100) | 30.5 (100) | 91.4 (300) | 61.0 (200) | 91.4 (300) | 22.9 (75) | 182.9 (600) | |
| | | 1.2 (1.5) | 7.6 (25) | 12.2 (40) | 114.3 (375) | 182.9 (600) | 91.4 (300) | 182.9 (600) | 182.9 (600) | 182.9 (600) | 30.5 (100) | 30.5 (100) | 91.4 (300) | 61.0 (200) | 182.9 (600) | 22.9 (75) | 182.9 (600) |
| | | 0.75 (1) | 7.6 (25) | 12.2 (40) | 114.3 (375) | 182.9 (600) | 182.9 (600) | 182.9 (600) | 182.9 (600) | 182.9 (600) | 30.5 (100) | 30.5 (100) | 91.4 (300) | 61.0 (200) | 182.9 (600) | 22.9 (75) | 182.9 (600) |
| | | 0.37 (0.5) | 7.6 (25) | 12.2 (40) | 114.3 (375) | 182.9 (600) | 182.9 (600) | 182.9 (600) | 182.9 (600) | 182.9 (600) | 30.5 (100) | 30.5 (100) | 91.4 (300) | 61.0 (200) | 182.9 (600) | 22.9 (75) | 182.9 (600) |
| | 2.2 (3) | 2.2 (3) | 7.6 (25) | 12.2 (40) | 91.4 (300) | 91.4 (300) | 182.9 (600) | 182.9 (600) | 182.9 (600) | Use 1204-TFB2 | | | | | 22.9 (75) | 182.9 (600) | |
| | | 1.5 (2) | 7.6 (25) | 12.2 (40) | 114.3 (375) | 182.9 (600) | 182.9 (600) | 182.9 (600) | 182.9 (600) | | | | | | 22.9 (75) | 182.9 (600) | |
| | | 0.75 (1) | 7.6 (25) | 12.2 (40) | 114.3 (375) | 182.9 (600) | 182.9 (600) | 182.9 (600) | 182.9 (600) | | | | | | 22.9 (75) | 182.9 (600) | |
| | | 0.37 (0.5) | 7.6 (25) | 12.2 (40) | 114.3 (375) | 182.9 (600) | 182.9 (600) | 182.9 (600) | 182.9 (600) | | | | | | 22.9 (75) | 182.9 (600) | |
| A3 | 3.7 (5) | 3.7 (5) | 7.6 (25) | 12.2 (40) | 114.3 (375) | 182.9 (600) | 182.9 (600) | 182.9 (600) | 182.9 (600) | Use 1204-TFB2 | | | | | 22.9 (75) | 182.9 (600) | |
| | | 2.2 (3) | 7.6 (25) | 12.2 (40) | 114.3 (375) | 182.9 (600) | 182.9 (600) | 182.9 (600) | 182.9 (600) | | | | | | 22.9 (75) | 182.9 (600) | |
| | | 1.5 (2) | 7.6 (25) | 12.2 (40) | 114.3 (375) | 182.9 (600) | 182.9 (600) | 182.9 (600) | 182.9 (600) | | | | | | 22.9 (75) | 182.9 (600) | |
| | | 0.75 (1) | 7.6 (25) | 12.2 (40) | 114.3 (375) | 182.9 (600) | 182.9 (600) | 182.9 (600) | 182.9 (600) | | | | | | 22.9 (75) | 182.9 (600) | |
| | | 0.37 (0.5) | 7.6 (25) | 12.2 (40) | 114.3 (375) | 182.9 (600) | 182.9 (600) | 182.9 (600) | 182.9 (600) | | | | | | 22.9 (75) | 182.9 (600) | |
| A4 | 5.5...15 (7.5...20) | 5.5...15 (7.5...20) | 7.6 (25) | 12.2 (40) | 114.3 (375) | 182.9 (600) | 182.9 (600) | 182.9 (600) | 182.9 (600) | Use 1204-TFB2 | | | | | 24.4 (80) | 182.9 (600) | |
| B | 11...22 (15...30) | 11...22 (15...30) | 7.6 (25) | 12.2 (40) | 114.3 (375) | 182.9 (600) | 182.9 (600) | 182.9 (600) | 182.9 (600) | | | | | | 24.4 (80) | 182.9 (600) | |
| C | 30...45 (X40...X60) | 30...45 (40...60) | 7.6 (25) | 12.2 (40) | 114.3 (375) | 182.9 (600) | 182.9 (600) | 182.9 (600) | 182.9 (600) | | | | | | 76.2 (250) | 182.9 (600) | |
| D | 45...112 (60...150) | 45...112 (60...150) | 12.2 (40) | 30.5 (100) | 114.3 (375) | 182.9 (600) | 182.9 (600) | 182.9 (600) | 182.9 (600) | | | | | | 61.0 (200) | 91.4 (300) | |
| E | 112...187 (150...250) | 112...187 (150...250) | 12.2 (40) | 53.3 (175) | 114.3 (375) | 182.9 (600) | 182.9 (600) | 182.9 (600) | 182.9 (600) | | | | | | 182.9 (600) | 182.9 (600) | |
| F | 187...336 (250...450) | 187...336 (250...450) | 18.3 (60) | 53.3 (175) | 114.3 (375) | 182.9 (600) | 182.9 (600) | 182.9 (600) | 182.9 (600) | 182.9 (600) | 182.9 (600) | | | | | | |
| G | 187...448 (X250...600) | 187...448 (250...600) | 18.3 (60) | 53.3 (175) | 114.3 (375) | 182.9 (600) | 182.9 (600) | 182.9 (600) | 182.9 (600) | 182.9 (600) | 182.9 (600) | | | | | | |

(1) Values that are shown are for nominal input voltage, drive carrier frequency of 2 kHz or as shown and surrounding air temperature at the motor of 40 °C (104 °F). Consult factory regarding operation at carrier frequencies above 2 kHz. Multiply values by 0.85 for high line conditions. For input voltages of 380, 400V or 415V AC, multiply the table values by 1.25, 1.20 or 1.15, respectively.

(2) These distance restrictions are due to charging of cable capacitance and can vary from application to application.

(3) Includes wire in conduit.

(4) A 3% reactor reduces motor and cable stress but can cause a degradation of motor waveform quality. Reactors must have a turn-turn insulation rating of 2100V or higher.

Table 63 - 1336 PLUS II/IMPACT Drives, 600V – Meters (Feet)

| Drive Frame | Drive kW (Hp) | Motor kW (Hp) | No External Devices ⁽¹⁾ | | | With 1204-TFB2 Terminator ⁽¹⁾ | | | With 1204-TFA1 Terminator ⁽¹⁾ | | | Reactor at Drive ⁽¹⁾⁽³⁾ | | | | | |
|-------------|-----------------------|------------------------|------------------------------------|-----------|------------------------|--|-------------|------------------------|--|-------------|------------------------|------------------------------------|-------------|------------------------|-------------|-------------|-------------|
| | | | Motor (NR = not recommended) | | | Motor (NR = not recommended) | | | Motor (NR = not recommended) | | | Motor | | | | | |
| | | | A | B | 1329R/L ⁽²⁾ | A | B | 1329R/L ⁽²⁾ | A | B | 1329R/L ⁽²⁾ | A | B | 1329R/L ⁽²⁾ | | | |
| | | | Any Cable | Any Cable | Any Cable | Any Cable | Any Cable | Any Cable | Any Cable | Any Cable | Any Cable | Any Cable | Any Cable | Any Cable | | | |
| A4 | 0.75 (1) | 0.75 (1) | NR | NR | N/A | NR | 182.9 (600) | 335.3 (1100) | NR | 61.0 (200) | 182.9 (600) | Not Recommended | | | | | |
| | | 0.37 (0.5) | NR | NR | N/A | NR | 182.9 (600) | 335.3 (1100) | NR | 61.0 (200) | 182.9 (600) | | | | | | |
| | 1.5 (2) | 1.5 (2) | NR | NR | N/A | NR | 182.9 (600) | 335.3 (1100) | NR | 61.0 (200) | 182.9 (600) | | | | | | |
| | | 1.2 (1.5) | NR | NR | N/A | NR | 182.9 (600) | 335.3 (1100) | NR | 61.0 (200) | 182.9 (600) | | | | | | |
| | | 0.75 (1) | NR | NR | 182.9 (600) | NR | 182.9 (600) | 335.3 (1100) | NR | 61.0 (200) | 182.9 (600) | | | | | | |
| | | 0.37 (0.5) | NR | NR | 182.9 (600) | NR | 182.9 (600) | 335.3 (1100) | NR | 61.0 (200) | 182.9 (600) | | | | | | |
| | 2.2 (3) | 2.2 (3) | NR | NR | N/A | NR | 182.9 (600) | 335.3 (1100) | NR | 61.0 (200) | 182.9 (600) | | | | | | |
| | | 1.5 (2) | NR | NR | N/A | NR | 182.9 (600) | 335.3 (1100) | NR | 61.0 (200) | 182.9 (600) | | | | | | |
| | | 0.75 (1) | NR | NR | 182.9 (600) | NR | 182.9 (600) | 335.3 (1100) | NR | 61.0 (200) | 182.9 (600) | | | | | | |
| | | 0.37 (0.5) | NR | NR | 182.9 (600) | NR | 182.9 (600) | 335.3 (1100) | NR | 61.0 (200) | 182.9 (600) | | | | | | |
| | 3.7 (5) | 3.7 (5) | NR | NR | N/A | NR | 182.9 (600) | 335.3 (1100) | NR | 61.0 (200) | 182.9 (600) | | | | | | |
| | | 2.2 (3) | NR | NR | N/A | NR | 182.9 (600) | 335.3 (1100) | NR | 61.0 (200) | 182.9 (600) | | | | | | |
| | | 1.5 (2) | NR | NR | 182.9 (600) | NR | 182.9 (600) | 335.3 (1100) | NR | 61.0 (200) | 182.9 (600) | | | | | | |
| | | 0.75 (1) | NR | NR | 182.9 (600) | NR | 182.9 (600) | 335.3 (1100) | NR | 61.0 (200) | 182.9 (600) | | | | | | |
| | | 0.37 (0.5) | NR | NR | 182.9 (600) | NR | 182.9 (600) | 335.3 (1100) | NR | 61.0 (200) | 182.9 (600) | | | | | | |
| | 5.5...15 (7.5...20) | 5.5...15 (7.5...20) | NR | 9.1 (30) | 182.9 (600) | 91.4 (300) | 182.9 (600) | 182.9 (600) | NR | 61.0 (200) | 182.9 (600) | | | | 30.5 (100) | 91.4 (300) | 182.9 (600) |
| | C | 18.5...45 (25...60) | 18.5...45 (25...60) | NR | 9.1 (30) | 182.9 (600) | 91.4 (300) | 182.9 (600) | NR | 61.0 (200) | 182.9 (600) | | | | 30.5 (100) | 91.4 (300) | 182.9 (600) |
| | D | 56...93 (75...125) | 56...93 (75...125) | NR | 9.1 (30) | 182.9 (600) | 91.4 (300) | 182.9 (600) | NR | 61.0 (200) | 182.9 (600) | | | | 61.0 (200) | 91.4 (300) | 182.9 (600) |
| | E | 112...224 (150...X300) | 112...224 (150...X300) | NR | 9.1 (30) | 182.9 (600) | 91.4 (300) | 182.9 (600) | NR | 61.0 (200) | 182.9 (600) | | | | 182.9 (600) | 182.9 (600) | 182.9 (600) |
| | F | 261...298 (350...400) | 261...298 (350...400) | NR | 9.1 (30) | 182.9 (600) | 91.4 (300) | 182.9 (600) | NR | 61.0 (200) | 182.9 (600) | | | | 182.9 (600) | 182.9 (600) | 182.9 (600) |
| G | 224...448 (300...600) | 224...448 (300...600) | NR | 9.1 (30) | 182.9 (600) | 91.4 (300) | 182.9 (600) | NR | 61.0 (200) | 182.9 (600) | 182.9 (600) | 182.9 (600) | 182.9 (600) | | | | |

(1) Values that are shown are for nominal input voltage and drive carrier frequency of 2 kHz. Consult factory regarding operation at carrier frequencies above 2 kHz.
 (2) When used on 600V systems, 1329R/L motors have a corona inception voltage rating of approximately 1850V.
 (3) A 3% reactor reduces motor and cable stress but can cause a degradation of motor waveform quality. Reactors must have a turn-turn insulation rating of 2100V or higher.

1305 Drives

This section lists motor cable data for 1305 drives.

Table 64 - 1305 Drives, 480V, No External Devices at Motor – Meters (Feet)

| Drive Hp (480V) | Motor Hp (480V) | (480V) Using a Motor with Insulation V _{p,p} | | | | |
|------------------------------------|-----------------|---|--------------|--------------|--------------------------------------|-------------|
| | | Type A | | Type B | 1329R/L | |
| | | Any Cable | Shielded | Any Cable | Shielded Cable Unshielded Cable | |
| Maximum Carrier Frequency | | 4 kHz | 4 kHz | 2 kHz | 2 kHz | |
| High-line Derate Multiplier | | 0.85 | 0.85 | 0.55 | 0.55 | |
| 5 | 5 | 9.1 (30) | | 30.5 (100) | 121.9 (400) | 121.9 (400) |
| | 3 | 9.1 (30) | | 30.5 (100) | 121.9 (400) | 121.9 (400) |
| | 2 | 9.1 (30) | | 30.5 (100) | 121.9 (400) | 121.9 (400) |
| | 1 | 9.1 (30) | | 30.5 (100) | 121.9 (400) | 121.9 (400) |
| | 0.5 | 9.1 (30) | | 30.5 (100) | 121.9 (400) | 121.9 (400) |
| 3 | 3 | 9.1 (30) | | 30.5 (100) | 91.4 (300) | 121.9 (400) |
| | 2 | 9.1 (30) | | 30.5 (100) | 121.9 (400) | 121.9 (400) |
| | 1 | 9.1 (30) | | 30.5 (100) | 121.9 (400) | 121.9 (400) |
| | 0.5 | 9.1 (30) | | 30.5 (100) | 121.9 (400) | 121.9 (400) |
| 2 | 2 | 9.1 (30) | | 30.5 (100) | 76.2 (250) | 121.9 (400) |
| | 1 | 9.1 (30) | | 30.5 (100) | 121.9 (400) | 121.9 (400) |
| | 0.5 | 9.1 (30) | | 30.5 (100) | 121.9 (400) | 121.9 (400) |
| 1 | 1 | 9.1 (30) | | 30.5 (100) | 68.6 (225) | 121.9 (400) |
| | 0.5 | 9.1 (30) | | 30.5 (100) | 121.9 (400) | 121.9 (400) |
| 0.5 | 0.5 | 9.1 (30) | | 30.5 (100) | 45.7 (150) | 106.7 (350) |

Table 65 - 1305 Drive, 480V with Devices at Motor – Meters (Feet)

| Drive Hp (460V) | Motor Hp (460V) | Reactor at the Drive ⁽¹⁾ | | | With 1204-TFB2 Terminator | | With 1204-TFA1 Terminator | | | |
|--------------------------------------|-----------------|--|-------------------|--------------|---|--------------|---|--------------|--------------|--------------|
| | | Using a Motor with Insulation V _{p,p} | | | Using a Motor with Insulation V _{p,p} (NR = not recommended) | | Using a Motor with Insulation V _{p,p} (NR = not recommended) | | | |
| | | Type A | Type B or 1329R/L | | Type A or Type B | | Type A | | Type B | |
| | | Any Cable | Shielded | Unshielded | Shielded | Unshielded | Shielded | Unshielded | Shielded | Unshielded |
| Maximum Carrier Frequency | | 2 kHz | 2 kHz | 2 kHz | 2 kHz | 2 kHz | 2 kHz | 2 kHz | 2 kHz | 2 kHz |
| High-line Derating Multiplier | | 0.85 | 0.85 | 0.85 | 0.85 | 0.85 | 0.85 | 0.85 | 0.85 | 0.85 |
| 5 | 5 | 15.2 (50) | 182.9 (600) | 182.9 (600) | NR | NR | 91.4 (300) | 61.0 (200) | 91.4 (300) | 121.9 (400) |
| | 3 | 15.2 (50) | 182.9 (600) | 182.9 (600) | 91.4 (300) | 121.9 (400) | 99.1 (325) | 61.0 (200) | 152.4 (500) | 121.9 (400) |
| | 2 | 15.2 (50) | 182.9 (600) | 182.9 (600) | 121.9 (400) | 182.9 (600) | 99.1 (325) | 61.0 (200) | 182.9 (600) | 121.9 (400) |
| | 1 | 15.2 (50) | 182.9 (600) | 182.9 (600) | 121.9 (400) | 182.9 (600) | 99.1 (325) | 61.0 (200) | 182.9 (600) | 121.9 (400) |
| | 0.5 | 15.2 (50) | 182.9 (600) | 182.9 (600) | 182.9 (600) | 182.9 (600) | 99.1 (325) | 61.0 (200) | 182.9 (600) | 121.9 (400) |
| 3 | 3 | 15.2 (50) | 91.4 (300) | 182.9 (600) | NR | NR | 91.4 (300) | 61.0 (200) | 91.4 (300) | 121.9 (400) |
| | 2 | 15.2 (50) | 182.9 (600) | 182.9 (600) | 91.4 (300) | 121.9 (400) | 99.1 (325) | 61.0 (200) | 152.4 (500) | 121.9 (400) |
| | 1 | 15.2 (50) | 182.9 (600) | 182.9 (600) | 91.4 (300) | 182.9 (600) | 99.1 (325) | 61.0 (200) | 182.9 (600) | 121.9 (400) |
| | 0.5 | 15.2 (50) | 182.9 (600) | 182.9 (600) | 121.9 (400) | 182.9 (600) | 99.1 (325) | 61.0 (200) | 182.9 (600) | 121.9 (400) |
| 2 | 2 | 15.2 (50) | 76.2 (250) | 167.6 (550) | NR | NR | 91.4 (300) | 61.0 (200) | 91.4 (300) | 121.9 (400) |
| | 1 | 15.2 (50) | 182.9 (600) | 182.9 (600) | 61.0 (200) | 61.0 (200) | 99.1 (325) | 61.0 (200) | 121.9 (400) | 121.9 (400) |
| | 0.5 | 15.2 (50) | 182.9 (600) | 182.9 (600) | 91.4 (300) | 121.9 (400) | 99.1 (325) | 61.0 (200) | 152.4 (500) | 121.9 (400) |

Table 65 - 1305 Drive, 480V with Devices at Motor – Meters (Feet) (Continued)

| Drive Hp (460V) | Motor Hp (460V) | Reactor at the Drive ⁽¹⁾ | | | With 1204-TFB2 Terminator | | With 1204-TFA1 Terminator | | | |
|--------------------------------------|--------------------|--|-------------------|--------------|--|--------------|--|--------------|--------------|--------------|
| | | Using a Motor with Insulation V _{p,p} | | | Using a Motor with Insulation V _{p,p} (NR = not recommended) | | Using a Motor with Insulation V _{p,p} (NR = not recommended) | | | |
| | | Type A | Type B or 1329R/L | | Type A or Type B | | Type A | | Type B | |
| | | Any Cable | Shielded | Unshielded | Shielded | Unshielded | Shielded | Unshielded | Shielded | Unshielded |
| Maximum Carrier Frequency | | 2 kHz | 2 kHz | 2 kHz | 2 kHz | 2 kHz | 2 kHz | 2 kHz | 2 kHz | 2 kHz |
| High-line Derating Multiplier | | 0.85 | 0.85 | 0.85 | 0.85 | 0.85 | 0.85 | 0.85 | 0.85 | 0.85 |
| 1 | 1 | 15.2 (50) | 68.6 (225) | 152.4 (500) | NR | NR | 45.7 (150) | 61.0 (200) | 45.7 (150) | 76.2 (250) |
| | 0.5 | 15.2 (50) | 182.9 (600) | 182.9 (600) | NR | NR | 76.2 (250) | 61.0 (200) | 76.2 (250) | 121.9 (400) |
| 0.5 | 0.5 | 15.2 (50) | 45.7 (150) | 106.7 (350) | NR | NR | NR | NR | NR | NR |

(1) **IMPORTANT:** A 3% reactor reduces motor stress but can cause a degradation of motor waveform quality. Reactors must have a turn-to-turn insulating rating of 2100V or higher. Reactors are not recommended for lightly loaded applications because over voltage trips can result at low output frequencies.

160 Drives

This section lists motor cable data for 160 drives.

Table 66 - 160 Drives, 480V – Meters (Feet)

| 380...460V Ratings | Motor Insulation Rating - Volts _{p,p} | Motor Cable Only | | RWR at Drive | | Reactor at Motor | |
|----------------------|--|------------------|-------------|--------------|-------------|------------------|-------------|
| | | Shielded | Unshielded | Shielded | Unshielded | Shielded | Unshielded |
| 4.0 kW (5 Hp) | 1000 | 13.7 (45) | 6.1 (20) | 160.0 (525) | 182.9 (600) | 99.1 (325) | 91.4 (300) |
| | 1200 | 27.4 (90) | 12.2 (40) | 160.0 (525) | 182.9 (600) | 160.0 (525) | 129.5 (425) |
| | 1600 | 160.0 (525) | 144.8 (475) | 160.0 (525) | 182.9 (600) | 160.0 (525) | 182.9 (600) |
| 2.2 kW (3 Hp) | 1000 | 12.2 (40) | 12.2 (40) | 160.0 (525) | 182.9 (600) | 68.6 (225) | 76.2 (250) |
| | 1200 | 27.4 (90) | 18.3 (60) | 160.0 (525) | 182.9 (600) | 99.1 (325) | 129.5 (425) |
| | 1600 | 160.0 (525) | 152.4 (500) | 160.0 (525) | 182.9 (600) | 160.0 (525) | 182.9 (600) |
| 1.5 kW (2 Hp) | 1000 | 12.2 (40) | 12.2 (40) | 129.5 (425) | 182.9 (600) | 99.1 (325) | 91.4 (300) |
| | 1200 | 27.4 (90) | 18.3 (60) | 129.5 (425) | 182.9 (600) | 129.5 (425) | 137.2 (450) |
| | 1600 | 152.4 (500) | 152.4 (500) | 129.5 (425) | 182.9 (600) | 164.6 (540) | 182.9 (600) |
| 0.75 kW (1 Hp) | 1000 | 16.8 (55) | 12.2 (40) | 99.1 (325) | 182.9 (600) | 99.1 (325) | 106.7 (350) |
| | 1200 | 38.1 (125) | 18.3 (60) | 99.1 (325) | 182.9 (600) | 152.4 (500) | 137.2 (450) |
| | 1600 | 152.4 (500) | 152.4 (500) | 99.1 (325) | 182.9 (600) | 152.4 (500) | 182.9 (600) |
| 0.55 kW (0.75 Hp) | 1000 | 13.7 (45) | 12.2 (40) | 91.4 (300) | 182.9 (600) | 91.4 (300) | 91.4 (300) |
| | 1200 | 38.1 (125) | 18.3 (60) | 91.4 (300) | 182.9 (600) | 152.4 (500) | 152.4 (500) |
| | 1600 | 152.4 (500) | 152.4 (500) | 91.4 (300) | 182.9 (600) | 152.4 (500) | 182.9 (600) |
| 0.37 kW (0.5 Hp) | 1000 | 13.7 (45) | 27.4 (90) | 91.4 (300) | 129.5 (425) | 91.4 (300) | 129.5 (425) |
| | 1200 | 38.1 (125) | 54.9 (180) | 91.4 (300) | 129.5 (425) | 152.4 (500) | 152.4 (500) |
| | 1600 | 152.4 (500) | 152.4 (500) | 91.4 (300) | 129.5 (425) | 152.4 (500) | 152.4 (500) |

Table 67 - 160 Drive, 240V and 480V – Cable Charging Current – Meters (Feet)

| 480V Ratings | kHz | Motor Cable Only | | RWR at Drive (NR = not recommended) | | Reactor at Motor | |
|--|-----|--------------------------------|-------------------|-------------------------------------|-------------------|--------------------------------|-------------------|
| | | Shielded ⁽¹⁾ | Unshielded | Shielded ⁽¹⁾ | Unshielded | Shielded ⁽¹⁾ | Unshielded |
| 4.0 kW (5 Hp) | 2 | 106.7 (350) | 182.9 (600) | 91.4 (300) | 182.9 (600) | 121.9 (400) | 182.9 (600) |
| | 4 | 129.5 (425) | 182.9 (600) | 106.7 (350) | 182.9 (600) | 137.2 (450) | 182.9 (600) |
| | 8 | 144.8 (475) | 152.4 (500) | NR | NR | 137.2 (450) | 152.4 (500) |
| 2.2 kW (3 Hp) | 2 | 109.7 (360) | 182.9 (600) | 85.3 (280) | 182.9 (600) | 121.9 (400) | 182.9 (600) |
| | 4 | 114.3 (375) | 182.9 (600) | 83.8 (275) | 182.9 (600) | 121.9 (400) | 182.9 (600) |
| | 8 | 121.9 (400) | 152.4 (500) | NR | NR | 121.9 (400) | 152.4 (500) |
| 1.5 kW (2 Hp) | 2 | 91.4 (300) | 167.6 (550) | 83.8 (275) | 182.9 (600) | 91.4 (300) | 182.9 (600) |
| | 4 | 91.4 (300) | 167.6 (550) | 83.8 (275) | 182.9 (600) | 91.4 (300) | 152.4 (500) |
| | 8 | 99.1 (325) | 152.4 (500) | NR | NR | 106.7 (350) | 152.4 (500) |
| 0.75 kW (1 Hp) | 2 | 61.0 (200) | 114.3 (375) | 61.0 (200) | 129.5 (425) | 68.6 (225) | 121.9 (400) |
| | 4 | 68.6 (225) | 114.3 (375) | 61.0 (200) | 129.5 (425) | 68.6 (225) | 114.3 (375) |
| | 8 | 76.2 (250) | 114.3 (375) | NR | NR | 68.6 (225) | 121.9 (400) |
| 0.55 kW (0.75 Hp) | 2 | 54.9 (180) | 106.7 (350) | 54.9 (180) | 114.3 (375) | 54.9 (180) | 106.7 (350) |
| | 4 | 54.9 (180) | 106.7 (350) | 54.9 (180) | 114.3 (375) | 54.9 (180) | 106.7 (350) |
| | 8 | 54.9 (180) | 106.7 (350) | NR | NR | 54.9 (180) | 106.7 (350) |
| 0.37 kW (0.5 Hp) | 2 | 30.5 (100) | 99.1 (325) | 30.5 (100) | 106.7 (350) | 30.5 (100) | 91.4 (300) |
| | 4 | 30.5 (100) | 99.1 (325) | 30.5 (100) | 106.7 (350) | 30.5 (100) | 106.7 (350) |
| | 8 | 30.5 (100) | 99.1 (325) | NR | | 30.5 (100) | 106.7 (350) |
| 240V Ratings | | No Reactor | | RWR at Drive | | Reactor at Motor | |
| 0.37...4.0 kW (0.5...5 Hp) 2...8 kHz | | Shielded ⁽¹⁾ | Unshielded | Shielded ⁽¹⁾ | Unshielded | Shielded ⁽¹⁾ | Unshielded |
| | | 160.0 (525) | 182.9 (600) | NR | NR | 160.0 (525) | 182.9 (600) |

(1) When you use shielded cable at lightly loaded conditions, cable length recommendations for drives rated 0.75 kW (1 Hp) and below are 61 m (200 ft).

Reflected Wave Reduction Guidelines (for catalog number 1321-RWR)

Follow these guidelines for catalog number 1321-RWR reflected wave reduction solution:

- [Figure 39](#) shows wiring for single inverter drives (PowerFlex 70 Frames A...E; PowerFlex 700 Frames 0...6; PowerFlex 700H Frames 9...11; and PowerFlex 700S Frames 1...11 and 13).

[Figure 40](#) describes dual inverter drives (PowerFlex 700H/700S Frame 12).

[Figure 41](#) is for single inverter drives that require parallel reactors because the drive amp rating exceeds the rating of the largest available reactor (PowerFlex 700S Frame 13).

- Configurations that are shown in [Figure 39](#) and [Figure 41](#) can be used for single inverter drives with single or parallel cables, and single-motor or multi-motor applications.
- The configuration that is shown in [Figure 40](#) is used with dual inverter drives with single or parallel cables, and single-motor or multi-motor applications.

- Filter (RWR or L-R) must be connected at drive output terminals, less than 7.6 m (25 ft) from the drive.
- See the lead length tables for output reactor and resistor selection. The resistor specification is based on the number of parallel cables used.
- For PowerFlex 700H and 700S Frame 12 drives and some PowerFlex 700S Frame 13 drives, two reactors are required. In this case, the resistor ohms and watts ratings are values per phase for each reactor (see lead length tables for output reactor selection).
- Resistor must be connected to reactor with 150 °C (302 °F) wire. Select wire gauge based on rated resistor power from the lead length tables.
- Recommended cables include XLPE, EPR, and Hypalon.
- Maximum total cable distance for resistor wires is 6.1 m (20 ft) or 3 m (9.8 ft) per side.

Figure 39 - Filter Wiring for Single Inverter Drive

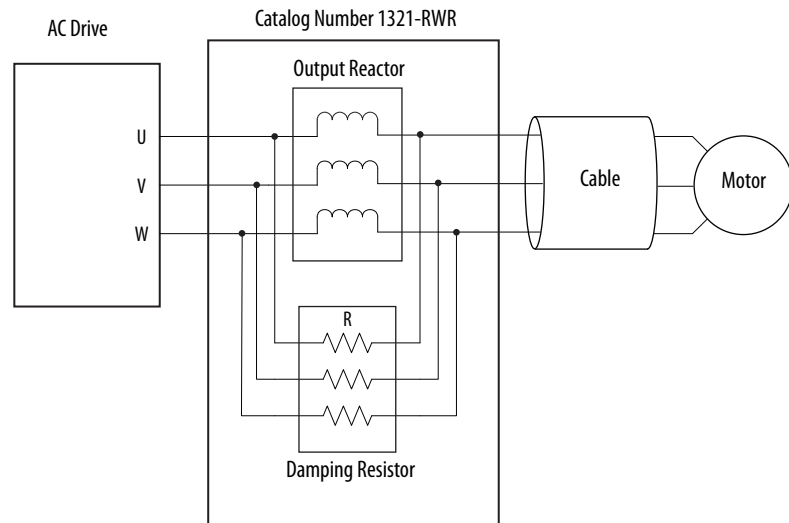

Figure 40 - Filter Wiring for Dual Inverter Frame 12 Drive

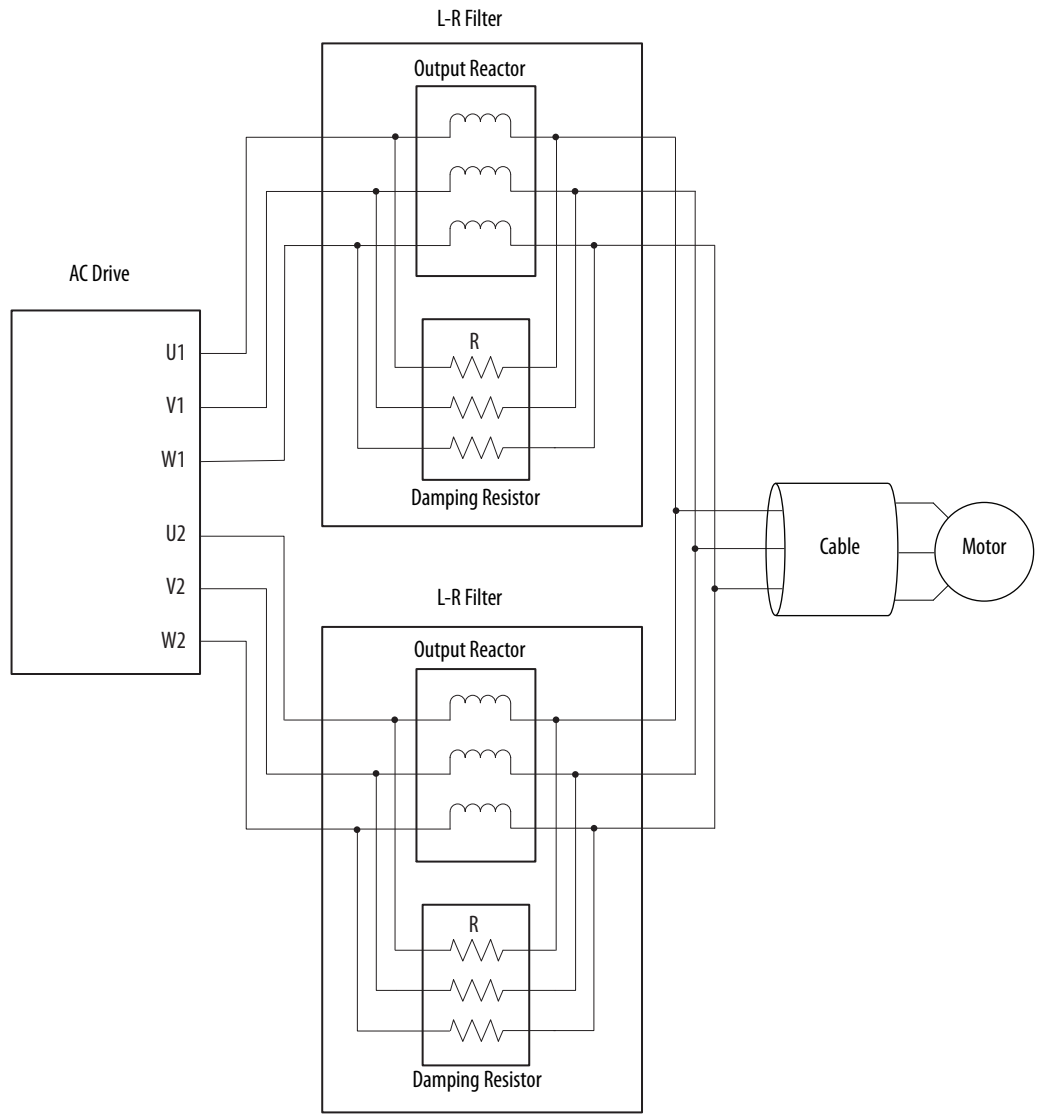
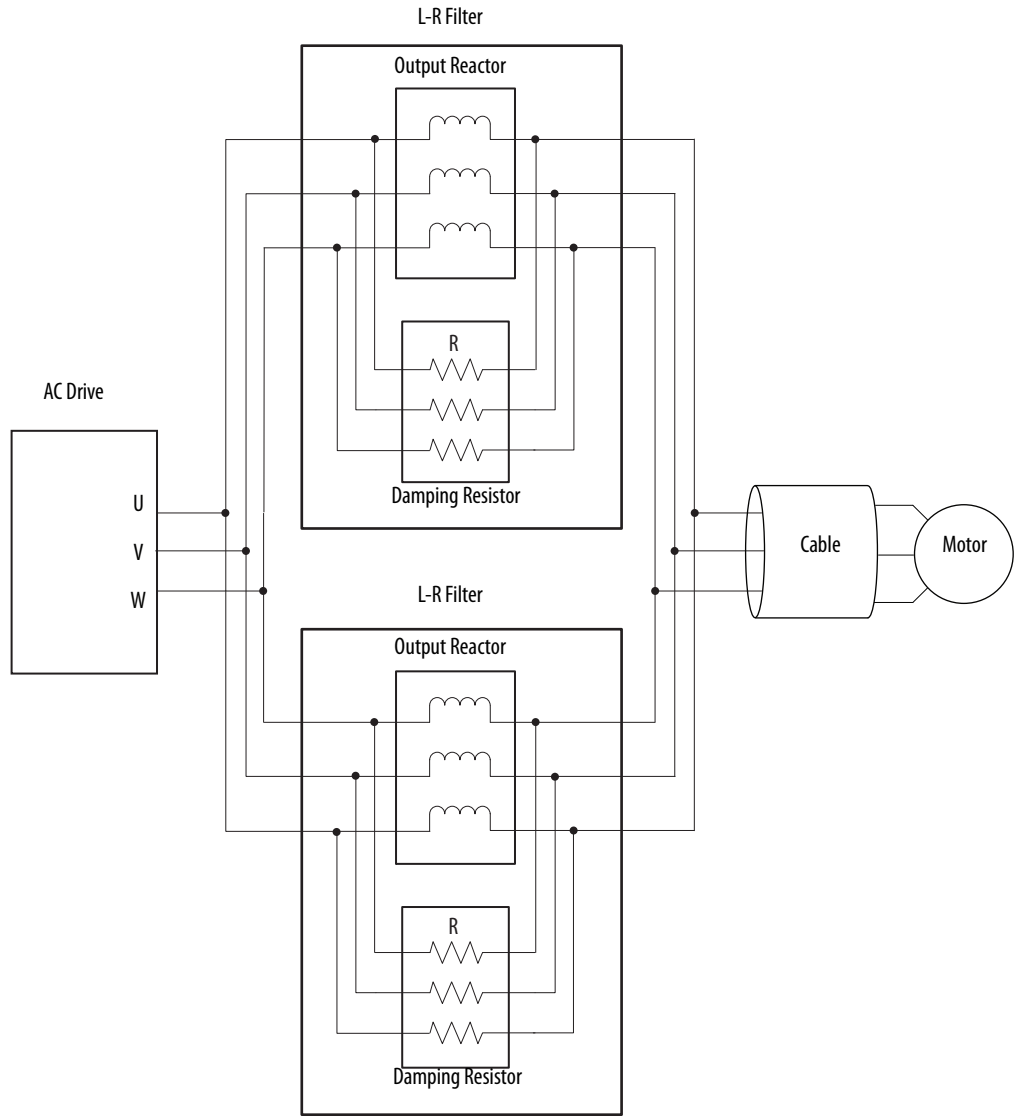

Figure 41 - Filter Wiring for Single Inverter Frame 13 Drive with Parallel Reactors



Notes:

| | |
|---------------------------------------|---|
| Ambient Air | Air around any equipment cabinet. See surrounding air for more detail. |
| Armored | A fixed geometry cable that has a protective sheath of continuous metal. |
| Capacitive Coupling | Current or voltage that is induced on one circuit by another because of their close physical proximity. For drive installations it is generally seen in two areas: <ul style="list-style-type: none">• Coupling between motor leads of two drives, such that the operating drive induces voltage onto the motor leads (and thus the motor) of a non-operating drive.• Coupling between the conductors or shields of motor leads that creates a requirement for more current than the motor itself demands. |
| CIV (Corona Inception Voltage) | The amplitude of voltage on a motor or other electrical winding that produces corona (ionization of air to ozone). CIV is increased by adding phase paper, placing windings in the proper pattern and reducing or eliminating air bubbles (voids) in the varnish applied. |
| Common Mode Core | A ferrite bead or core that can be used to pass control, communications or motor leads through to attenuate high frequency noise. Catalog number/part number 1321-Mxxx. |
| Common Mode Noise | Electrical noise, typically high frequency, that is imposed on the ground grid, carriers in an electrical system. |
| Conduit | Conductive ferrous electrical metal tubing used to contain and protect individual wires. |
| Damp | Wet locations per U.S. NEC or local code. |
| Discrete | Individual, hard-wired inputs or outputs, typically used for control of the drive (start, stop, and so on). |
| Dry | Dry locations per Per NEC Article 100 or local code. |
| dV/dt | The rate of change of voltage over time. |
| EIA | Electronic Industries Alliance |
| Fill Rates | The maximum number of conductors allowed in a conduit, as determined by local, state or national electrical code. |
| Fixed Geometry | Cable whose construction fixes the physical position of each conductor within the overall coating, usually with filler material that prevents individual conductors from moving. |
| IGBT | Insulated gate bi-polar transistor. The typical power semi conductor device used in most PWM AC drives today. |
| mil | 0.001 inches |

| | |
|------------------------------------|---|
| MOV | Metal oxide varistor |
| NEC | United States National Electric Code NFPA70 |
| Peak Cable Charging Current | The current required to charge capacitance in motor cable. This capacitance has various components: <ul style="list-style-type: none">• conductor to shield or conduit• conductor to conductor• motor stator to motor frame |
| PVC | Polyvinyl chloride (typically thermoplastic) |
| RC Network | An electric circuit composed of resistors and capacitors driven by a voltage or current source. RC circuits can be used to filter a signal by blocking certain frequencies and passing others. |
| RC Snubber Circuit | Resistor-capacitor snubber circuit (see RC Network) |
| RWR | Reflected waver reducer, an RL network mounted at or near the drive, used to reduce the amplitude and rise time of the reflected wave pulses. Catalog number 1204-RWR2-09-B or 1204-RWR2-09-C. |
| Shielded | Cable containing a foil or braided metal shield surrounding the conductors. Usually found in multi-conductor cable. Use a shield coverage of at least 75%. |
| Signal | Individual hard wired analog inputs or outputs, typically used to issue reference commands or process information to or from the drive. |
| STP Cable | Shielded twisted-pair cable. |
| Surrounding Air Temperature | The temperature of the air around the drive. If the drive is free standing or wall mounted, the surrounding air temperature is room temperature. If the drive is mounted inside another cabinet, the surrounding air temperature is the interior temperature of that cabinet. |
| TIA | Telecommunications Industry Association |
| Terminator | A resistor–capacitor (RC) network mounted at or near the motor, used to reduce the amplitude and rise time of the reflected wave pulses. Catalog number 1204-TFxx. |
| THHN | Thermoplastic high heat-resistant nylon-coated. A U.S. designation for a specific insulation material, temperature rating, and condition of use (suitable for dry and damp locations) for electrical wire and cable. |
| THWN | Thermoplastic heat and water-resistant nylon-coated. A U.S. designation for a specific insulation material, temperature rating, and condition of use (wet locations) for electrical wire and cable. |

Unshielded Cable containing no braided or foil sheath surrounding the conductors. Can be multi-conductor cable or individual conductors.

UTP Unshielded twisted-pair cable.

Wet Locations with moisture present – see [Damp](#).

XHHW-2 Cross-linked polyethylene high heat-resistant water-resistant. A U.S. designation for a specific insulation material, temperature rating, and condition of use (wet locations) for electrical wire and cable.

XLPE Cross-linked polyethylene.

UL Underwriters Laboratories

Notes:

Numerics

1305 150
1305 drive 150
1336 Impact 147
1336 PLUS II 147
1336 Plus II/Impact drive 147
1336 PLUS II/Impact drive, 600V 149
160 151
160 drive, cable charging current 152

A

AC line 32
AC line impedance recommendations
 Bulletin 1305 drives 35
 Bulletin 1336 drives 46
 Bulletin 160 drives 34
 PowerFlex 4 drives 35
 PowerFlex 40 drives 36
 PowerFlex 400 drives 37
 PowerFlex 520-Series drives 38
 PowerFlex 70 drives 39
 PowerFlex 700/700S drives 41
 PowerFlex 753/755 drives 43
analog signal cable 24
antiphase grounded (neutral) system 30
arching
 between contacts 85
armored cable 20
 containing common mode Noise 84

B

bearing current 89
best practices, grounding 63
B-phase grounded 50
brake conductors 20
brake module
 mounting distance 71
brake solenoid, noise 85, 86
braking chopper 53
built-in inductors 33

C

cable
 analog signal 24
 armored 20
 charging current 91
 connectors 66
 containing common mode noise 84
 discrete drive I/O 24
 encoder 24
 European-style 22
 exterior cover 14
 inductance 85
 input power 22, 61
 length 23
 length restrictions 91
 material 14
 recommended 17
 shielded 19
 shields 61
 trays 74
 types 13, 20
 unshielded 18
 unshielded definition 91
capacitive current cable length recommendations 152
capacitors, common mode 50
chopper modules 53
circuit resonance 83
clamp, shield termination 75
cold-flow condition 82
common DC bus configurations 51
common mode noise
 armored cable 84
 attenuate 84
 capacitors 50
 causes 83
 chokes 84
 conduit 84
 containing 84
 ferrite core 84
 motor cable length 85
 return path 84
 shielded cable 84
communication 25
 ControlNet 26
 Data Highway Plus 27
 DeviceNet 25
 Ethernet 26
 remote I/O 27
 RS-232/RS-485 27
 serial 27
concentricity, insulation 17
conductor, termination 78
conductors 16

conduit 73
 cable connectors 66
 common mode noise 84
 entry 66
 entry plates 66
 magnetic steel 73
 pulling wires 73
 PVC 73
 stainless steel 73
connections, ground 67
contact arcing 85
contacts 85, 86
contained noise path 60
control terminal 78
control wire 24
ControlNet communication 26
corona 81
corona inception voltage 82
cumulative ground current 31

D

Data Highway Plus communication 27
DC bus wiring guidelines 51
Delta/Delta with Grounded Leg 30
Delta/Wye with Grounded Wye 29
DeviceNet communication 25
DH+ communication 27
dielectric constants 81, 82
discrete drive I/O, cable 24
distribution
 Delta/Delta with Grounded Leg 30
 Delta/Wye with Grounded Wye 29
 high resistance ground 31
 TN-S five-wire system 32
 ungrounded secondary 31
documentation 11

E

electrical noise 83
electromagnetic interference (EMI)
 causes 85
 mitigating 86
 preventing 86
EMC, installation 64
EMI caused by fluorescent lamps 89
EMI coupling 84
encoder cable 24
Encompass
 website 13
Ethernet communication 26
European-style cable 22

F

filter, RFI 56
fluorescent lamps and EMI 89

G

gauge 16
geometry 17
glands 66
ground conductors 16
ground current, cumulative 31
Grounded
 Delta/Delta 30
 Delta/Wye 29
grounding 55
 acceptable practices 59
 best practices 63
 connections 67
 effective practices 60
 fully grounded system 59
 high resistance system 58
 motors 56
 optimal practices 60
 PE 56
 practices 59
 RFI filter 56
 safety 55
 structural steel of a building 55
 TN-S fiveWire 56
 ungrounded 58
grounding practices 60
grounds, noise related 57

I

I/O cable, discrete drive 24
impedance 32
 equations 33
 multiple drives 48
 reactor 32
inductive loads, noise 85, 86
inductors, built in 33
input power cables 22
inputs, isolated 61
installation
 best practices 63
 EMC-specific 64
 layout 64
insulation 13, 14, 17, 22, 23, 24, 73, 78, 81
insulation degradation 81
isolation transformer 50

L

layout, installation 64
leg-to-leg voltage 56
leg-to-neutral voltage 56
length
 common mode noise 85
 motor cable 23
 restrictions 82
length restrictions 91
lighting, noise 89

line impedance

- AC line impedance 32
- adding line reactor or transformer for
 - lightning strikes 32
 - power interruptions 32
 - transformer is too large 32
 - voltage dips 32
 - voltage spikes 32
- for drives with built-in inductors 33
- for drives without built-in inductors 33
- multiple drives 48

M**material, cable 14****mitigating transient interference**

- examples 87

mode capacitors, common 50**moisture 15, 79, 82****motor**

- 1329R/L 92
- 1488V 92
- brake solenoid noise 85, 86
- grounding 56
- type A 92
- type B 92

motor bearing damage

- due to bearing currents 89
- due to electric discharge machining 89

motor brake solenoid, noise 85, 86**motor cable length 23****motor cable length restrictions 91**

- 1305 drive, 480V with devices at motor 150
- 1305 drive, 480V, no devices at motor 150
- 1336 PLUS II/IMPACT drive, 380...480V 147
- 1336 PLUS II/IMPACT drive, 600V 149
- 160 drive, 240V and 480V 152
- 160 drive, 480V 151
- cross reference table 94
- PowerFlex 4 drive, 400V 98
- PowerFlex 4 drive, 480V 98
- PowerFlex 40 drive, 400V 100
- PowerFlex 40 drive, 480V 100
- PowerFlex 40 drive, 600V 101
- PowerFlex 400 drive, 400V 102
- PowerFlex 400 drive, 480V 103
- PowerFlex 4M drive, 400V 99
- PowerFlex 4M drive, 480V 99
- PowerFlex 520-Series drive, 400V 104
- PowerFlex 520-Series drive, 480V 105
- PowerFlex 520-Series drive, 600V 106
- PowerFlex 70 (standard/enhanced) drive, 400V 107
- PowerFlex 70 (standard/enhanced) drive, 480V 109
- PowerFlex 70 (standard/enhanced) drive, 600V 111
- PowerFlex 700 (standard/vector) drive, 400V 107
- PowerFlex 700 (standard/vector) drive, 480V 109
- PowerFlex 700 (standard/vector) drive, 600V 111
- PowerFlex 700 (standard/vector) drive, 690V 112
- PowerFlex 700H drive, 400V 113
- PowerFlex 700H drive, 480V 113
- PowerFlex 700H drive, 600V 114
- PowerFlex 700H drive, 690V 115
- PowerFlex 700L with 700S Control drive, 400V 117
- PowerFlex 700L with 700S Control drive, 480V 117
- PowerFlex 700L with 700S Control drive, 600V 118
- PowerFlex 700L with 700S Control drive, 690V 118
- PowerFlex 700L with 700VC Control drive, 400V 115
- PowerFlex 700L with 700VC Control drive, 480V 116
- PowerFlex 700L with 700VC Control drive, 600V 116
- PowerFlex 700L with 700VC Control drive, 690V 116
- PowerFlex 700S drive, 400V 119
- PowerFlex 700S drive, 480V 120
- PowerFlex 700S drive, 600V 122
- PowerFlex 700S drive, 690V 123
- PowerFlex 753 and 755 drive, wall mount
 - 400V 125
 - 480V 128
 - 600V 131
 - 690V 133
- PowerFlex 755 drive, floor mount
 - 400V 135
 - 480V 136

- 600V 138
- 690V 139
- PowerFlex 755T drive products
 - 400V 141
 - 480V 142
 - 600V 144
 - 690V 145
- motor starters, noise** 85, 86
- motors, noise** 85, 86
- Mount** 139
- mounting** 63
- MOV circuit** 50
- MOV surge protection** 50
- multiple drives**
 - line impedance 48
 - reactor 48
- multiple equipment in common enclosure** 71

N

- noise**
 - brake 85, 86
 - common mode 83
 - contacts 85, 86
 - enclosure lighting 89
 - inductive loads 86
 - lighting 89
 - mitigating 86
 - motor brake 85, 86
 - motor starters 85, 86
 - motors 85, 86
 - preventing 86
 - related grounds 57
 - relays 85, 86
 - solenoids 85, 86
 - switch contacts 85, 86
 - transient interference 85, 86

O

- overcurrent trips** 95
- ozone** 82
- ozone production** 81

P

- parasitic inductance** 51
- pigtail termination** 76
- power**
 - wire 22, 24, 61, 74, 78, 84
- power cables, input** 22
- power distribution** 29
 - Delta/Delta with Grounded Leg 30
 - Delta/Wye with Grounded Wye 29
 - high resistance ground 31
 - TN-S five-wire system 32
 - ungrounded secondary 31
- power distribution schemes** 29

- power scheme types**
 - fully grounded 58
 - high resistance ground 58
 - ungrounded 58
- power terminals** 78
 - barrier strip 78
 - barrier strips 78
 - cage clamps 78
 - crimp lugs 78
 - studs 78
- PowerFlex 755T drive products** 7
- precautions** 14
- protection**
 - MOV surge 50

R

- radiated noise** 64
- RC networks** 86
- RC snubber circuit** 53
- reactor, multiple drives** 48
- recommended cable design** 17
- recommended documentation** 11
- redundant**
 - ground paths 56
- reflected wave** 81
 - effects on wire types 81
 - length restrictions 82
 - motor protection 82
- reflected wave phenomenon** 81
- reflected wave transient voltage** 81
- regenerative unit** 51
- relays, noise** 85, 86
- remote I/O communication** 27
- resistance, ground** 31
- RFI filter grounding** 56
- routing** 69

S

- safety grounding** 55
- safety grounds**
 - grounding PE or ground 56
 - structural steel of a building 55
- safety grounds, grounding** 55
- secondary, ungrounded** 31
- serial (RS232/485) communication** 27
- shielded cables**
 - grounding 75
 - splicing 61
- shields**
 - cable 19, 61
 - termination 75
- signal**
 - analog cable 24
 - terminals 78
 - wire 24
- sinusoidal voltage** 81
- solenoids, noise** 85, 86

spacing

wiring 69, 70

spacing notes 70**splice shielded cables** 61**standard installation** 63**stray capacitance** 85**suppression, noise**

contracts 86

inductive loads 86

motor starters 86

motors 86

relays 86

solenoids 86

suppressor 50**surge protection**

MOV 50

surge suppression 50**switch contacts**

noise 85, 86

system configuration

Delta/Delta with Grounded Leg 30

Delta/Wye with Grounded Wye 29

high resistance ground 31

TN-S five-wire system 32

ungrounded secondary 31

T**TB (terminal block)**

control 78

power 78

signal 78

temperature 15**termination**

conductor 78

control terminal 78

power terminals 78

shield 75

shield via pigtail (lead) 67

signal terminals 78

via cable clamp 77

via circular clamp 75

via pigtail (lead) 76

TN-S five-wire systems 32, 56**transient interference** 85

causes 85

mitigate with diode 87

mitigate with suppressor 87

mitigating 86

suppression 86

transient line protection 50**U****ungrounded secondary** 31**ungrounded system example** 58**unshielded cable** 18**V****varistors** 50, 86**voltage reflection** 81**voltage surge protection** 50**W****wire**

control 24

insulation 13, 14, 17, 22, 23, 24, 73, 78, 81

power 22, 24, 61, 74, 78, 84

signal 24

wire routing

antennas 73

loops 73

noise 73

within conduit 72

wire/cable types 13

armored cable 20

conductors 16

European-style cable 22

exterior cover 14

gauge 16

geometry 17

insulation thickness 17

material 14

reflected wave effects 81

shielded cable 19

temperature rating 15

unshielded cable 18

wiring

category definitions 69

routing 69

spacing 69

spacing notes 70

Z**zero cross switching** 86

Notes:

Rockwell Automation Support

Use the following resources to access support information.

| | | |
|---|---|---|
| Technical Support Center | Knowledgebase Articles, How-to Videos, FAQs, Chat, User Forums, and Product Notification Updates. | https://rockwellautomation.custhelp.com/ |
| Local Technical Support Phone Numbers | Locate the phone number for your country. | http://www.rockwellautomation.com/global/support/get-support-now.page |
| Direct Dial Codes | Find the Direct Dial Code for your product. Use the code to route your call directly to a technical support engineer. | http://www.rockwellautomation.com/global/support/direct-dial.page |
| Literature Library | Installation Instructions, Manuals, Brochures, and Technical Data. | http://www.rockwellautomation.com/global/literature-library/overview.page |
| Product Compatibility and Download Center (PCDC) | Get help determining how products interact, check features and capabilities, and find associated firmware. | http://www.rockwellautomation.com/global/support/pcdc.page |

Documentation Feedback

Your comments will help us serve your documentation needs better. If you have any suggestions on how to improve this document, complete the How Are We Doing? form at http://literature.rockwellautomation.com/idc/groups/literature/documents/du/ra-du002_-en-e.pdf.

Rockwell Automation maintains current product environmental information on its website at <http://www.rockwellautomation.com/rockwellautomation/about-us/sustainability-ethics/product-environmental-compliance.page>.

Allen-Bradley, 1336 FORCE, 1336 IMPACT, 1336 PLUS, Data Highway Plus, DH+, Encompass, KwikLink, PartnerNetwork, PowerFlex, Rockwell Automation, and Rockwell Software are trademarks of Rockwell Automation, Inc. Trademarks not belonging to Rockwell Automation are property of their respective companies.

Rockwell Otomasyon Ticaret A.Ş., Kar Plaza İş Merkezi E Blok Kat:6 34752 İçerenköy, İstanbul, Tel: +90 (216) 5698400

www.rockwellautomation.com

Power, Control and Information Solutions Headquarters

Americas: Rockwell Automation, 1201 South Second Street, Milwaukee, WI 53204-2496 USA, Tel: (1) 414.382.2000, Fax: (1) 414.382.4444

Europe/Middle East/Africa: Rockwell Automation NV, Pegasus Park, De Kleetlaan 12a, 1831 Diegem, Belgium, Tel: (32) 2 663 0600, Fax: (32) 2 663 0640

Asia Pacific: Rockwell Automation, Level 14, Core F, Cyberport 3, 100 Cyberport Road, Hong Kong, Tel: (852) 2887 4788, Fax: (852) 2508 1846

Publication DRIVES-IN0010-EN-P - February 2017

Supersedes Publication DRIVES-IN001N-EN-P - July 2016

Copyright © 2017 Rockwell Automation, Inc. All rights reserved. Printed in the U.S.A.