

ENGINEERING
TOMORROW

Danfoss

Catalogue | ADAP-KOOL®

Energy efficient solutions designed to ensure **food safety**

Discover the full range of ADAP-KOOL® control and monitoring systems.



Achieve
33%
energy savings with
the total monitoring
solution from
ADAP-KOOL®

www.food-retail.danfoss.com

ADAP-KOOL® Refrigeration control systems

Contents

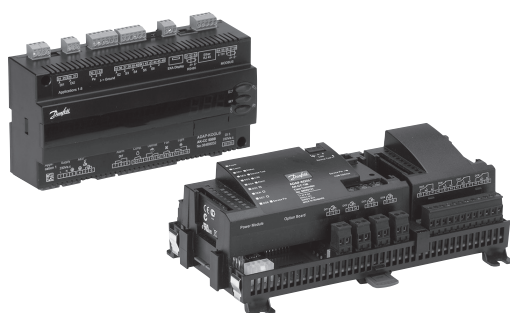
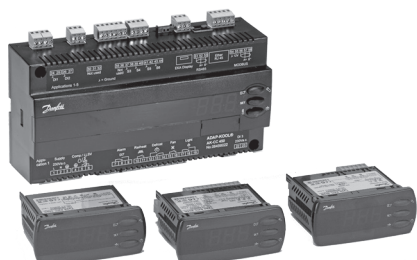

Systems	4
AK-SM 820, AK-SM 850, AK-SM 880.....	4
AK-SM 350	6
AK-SC 255	8
AK-SC 355	10
AK-SM 720	12
Monitoring.....	14
AK-LM 350	14
System Software.....	16
AK-ST 500	16
AKA 65	16
Capacity control.....	18
AK-PC 351	18
AK-PC 551	20
AK-PC 781	22
AK-PC 783	24
Gas cooler.....	26
EKC 326A.....	26
Temperature control	30
ERC 211, ERC 213, ERC 214.....	30
EKC 202A / B / C, EKC 302A / B	42
EKC 202C-MS.....	50
EKC 202D, EKC 302D	52
EKC 202D1	62
AK-CC 210.....	70
AK-CC 250A.....	79
AK-CC 350.....	82
AK-CC 450.....	84
Refrigeration appliance controls	94
AK-CC 550A.....	94
AK-CC 750.....	104
Programmable controllers.....	106
MCX	106



Accessories	108
Module overview	108
AK-XM 101A	109
AK-XM 102A/B	109
AK-XM 103A	110
AK-XM 107A	110
AK-XM 204A/B	111
AK-XM 205A/B	112
AK-XM 208C	113
AK-OB 110	113
AK-OB 101A	114
AK-PS 075 / 150 / 250	114
AK-CM 101C	115
AK-CM 102	116



Display	117
EKA 163 / 164	117
Display console	118
EKA 166	119

Temperature sensors	120
AKS 11, AKS 12, AKS 21, AK-HS 1000	120
EKS 111	122
EKS 211	123
EKS 221	124



Pressure transmitters	125
AKS 32, AKS 33, AKS 32R, AKS 2050	125

Gas detector	128
DGS	128

Expansion valves	130
AKV 10, AKV 15, AKV 20	130
AKVH 10	133
AKVA 10 AKVA 15, AKVA 20	134
Coils for expansion valves	137
ETS	138
CCM	140
CCMT	141
ICM	142
ICMTS	143

Evaporation pressure valve	144
KVS	144

Data communication	146
AKA 222/223	146
EKA 183A	147

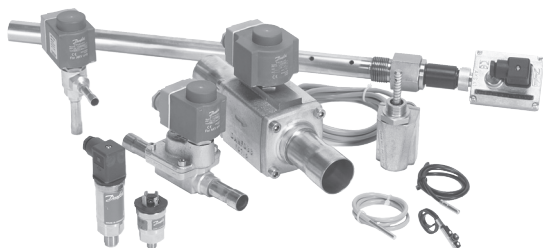

Systems

AK-SM 820, AK-SM 850, AK-SM 880

Application

This unit is a combined data acquisition and monitoring unit for small, medium and large stores covering Refrigeration, HVAC and Lighting applications

Functional description

- Control of separate cooling controllers
- Control of store lighting
- Control of HVAC
- Data collection
- Alarm management
- Data transmission to monitoring centre
- Energy optimisation functions



User interface

- Large colour display with graphic displays of refrigeration appliance in the store
- Intuitive user interface
- WEB browser-based
- Set-up and operation via RMT software (Remote Management Tool)
- Wizard configuration assistance

Data exchange

- Via TCP/IP to external monitoring centre
- XML data exchange
- Receives data from an offline programming/set-up
- Remote update of software
- Remote adjustment upon installation of new controllers
- Via USB

Example

The screenshot shows a web-based interface for a refrigeration system. The top navigation bar includes: File, Dashboard, Alarms, System View (active), Graphic View, Detail, Schedules, Info, History, and Configuration. The main content area is titled 'Refrigeration' and 'Frost Komp'. On the left, there are icons for 'Køl Komp' and 'Frost Komp'. The central panel displays the status of a compressor: 'Status: Kører', 'Alarm: OK', 'Address: 5', 'Setpoint: -31.0 °C', 'Current Value: -27.9 °C', and 'Model: AK-PC781-041x'. To the right, there is a 'Compressors' section with an icon of three compressors and the text 'Kører'. Below this, there is a grid of eight temperature sensors for different rooms, each with a blue 'S' icon and a temperature reading: Frost rum 5 17 (-19.7 °C), Frost rum 4 16 (-20.1 °C), Frost rum 4 15 (-19.4 °C), Frost rum 3 14 (-18.8 °C), Frost rum 3 13 (-19.2 °C), Frost rum 2 12 (-18.8 °C), Frost rum 2 11 (-19.0 °C), and Frost rum 1 10 (-18.7 °C). At the bottom left, there are icons for 'HVAC' and 'Lighting'.

Technical data

Power: ~ 100 - 240 V a.c. (+ / - 10%) 50/60 Hz. 12 VA

Alarm relay:

Built in. Max. 240 V a.c. 5 A ohmic (3 A inductive).

Ambient conditions:

Operating temperature (screen): -10 to +55°C

0- 95% RH. non-condensing) / no vibrations.

Screen:

Active TFT colours (thin-film transistor), SVGA 800 x 600.

Enclosure: IP 20

Dimensions:

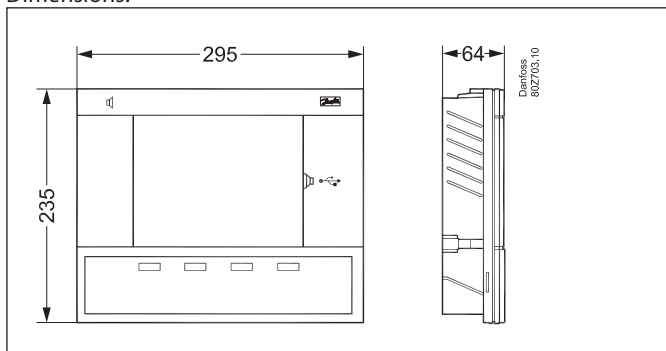

Connections:

LON RS485

Modbus

Ethernet RJ45

USB-A

Alarm relay

Approvals



E31024

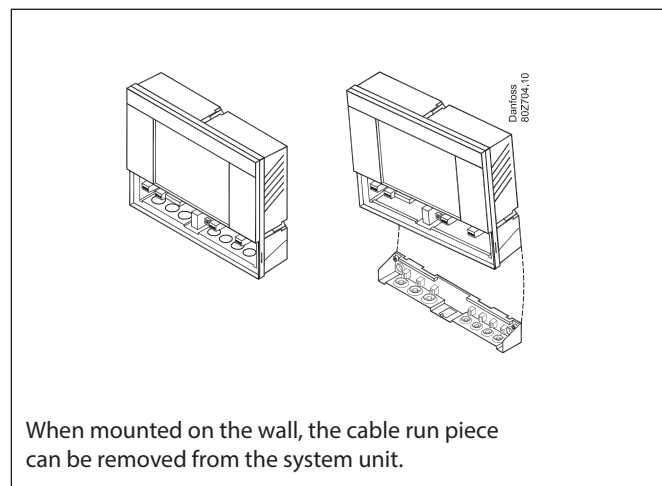

Ordering

Type	Application	Data communication	Display	Code no.
AK-SM 820	C-Store	LON RS485	Yes	080Z4004
AK-SM 850	Refrigeration			080Z4001
AK-SM 880	Full store			080Z4008

Additional information available:
USCO.PI.R1.E

AK-SM 350

Application

This unit is a combined data acquisition and monitoring unit for relatively small refrigeration installations.

- Corner shops
- Small supermarkets
- Restaurants
- Food manufacturers

Advantages

- Compact temperature recording unit
- Collects temperature data for presentation to public authorities
- Alarm function
 - Local alarm or via modem or IP
 - Alarm on deviation in temperature
 - Alarm when doors of cold storage rooms or freezer rooms are open
- A description of the measured area can be added for each measuring point.



Functional description

The monitoring unit can monitor up to 65 measuring points. They can originate from:

- up to 16 direct connections to sensors or switch contacts;
- signals from separate refrigeration controllers (type EKC or AK) via a data bus or network;
- signals from gas detectors – these readings are also transferred via the data bus or network
- Pulse counting function for energy display
- All defined points can be recorded and saved at defined time intervals.
- The values can be viewed on the display and read out by connecting a printer, PC or modem.

External connections

- Modem
 - A modem can be connected to link the unit to external alarm destinations or service companies.
 - The modem can be a standard telephone modem or a GSM modem for mobile telephony.
- Ethernet
 - If a link to a TCP/IP network is required, a server can be connected. Contact Danfoss for additional information on recommended types.
- PC
 - A PC can be connected to the unit. The PC may be stationary, portable or handheld. Configuration and/or alarm reception can be performed using an operational management program.

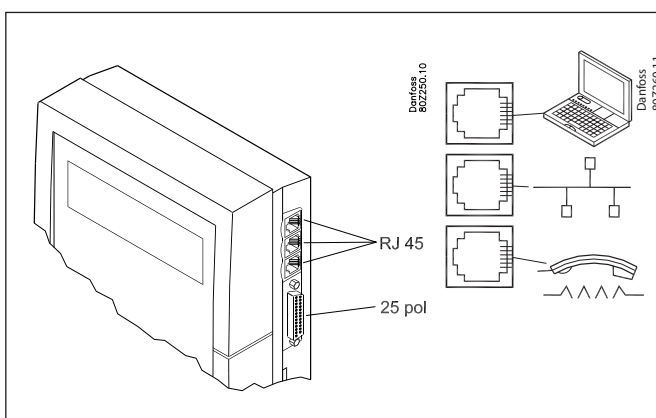
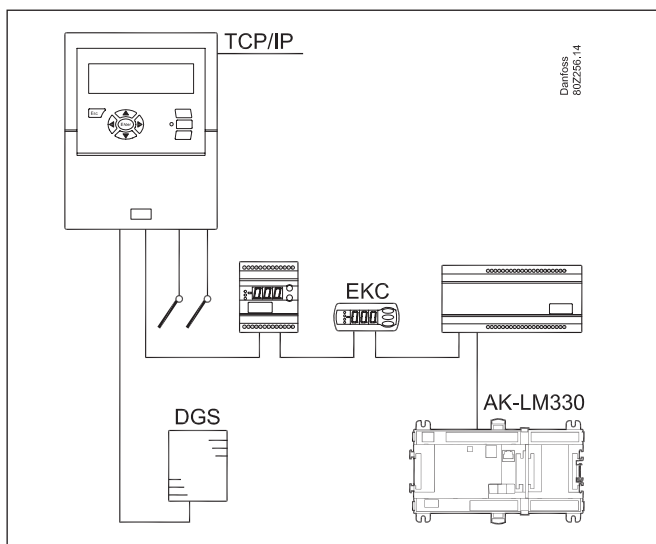

Technical data

Supply voltage	115 V / 230 V +10/-15%, 50/60 Hz, 10 VA	
Connected device	PT 1000 ohm at 0°C or PTC 1000 ohm at 25°C or NTC 5000 ohm at 25°C or thermistor (-80 to 0°C, -40 to 40°C, or 0 to 100°C) Digital on/off signal or standard 0–10 V / 4–20 mA signal	
Pulse counter inputs for output reading	Compliant with DIN 43864. (inputs 1 and 2 only)	
Display	Graphic LCD, 240 x 64	
Direct measuring points	16	
Total number of points	65	
Measuring range, general	-100 to +150°C	
Measurement accuracy with Pt1000	Resolution 0.1 K Accuracy: ±0.5 K	
Measurement interval	15, 30, 60, 120 or 240 minutes	
Data storage	12 MB flash Storage capacity for recording all data from all measuring points for one year at 30-minute intervals. Last 200 alarm warnings	
Battery backup	Button cell for clock function (2032)	
Power supply for pressure transmitter, etc.	5 V, 50 mA max. 12 V, 50 mA max.	
Printer connection	HP PCL-3, parallel	
Modem connector	RJ 45	
TCP/IP connector	RJ 45	
PC connection	RJ 45 (RS 323)	
Data communication	RS232, RS485 (LON), RS485 (Modbus), RS485 (TP) (TP = third party)	
Relays	Quantity	2
	Max. load	24 V AC or 230 V AC I _{max} (AC-1): 5 A I _{max} (AC-15): 3 A
Enclosure	IP 20	
Ambient conditions	0 to +50°C (operating) -20 to +70°C (transport) 20 to 80% RH, non-condensing No shock load or vibration	
Approvals	EN 60730-1 and EN 60730-2-9 EN 61000-6-3 and EN 61000-6-2 EN 12830 and EN 13485	
Weight	1.6 kg	

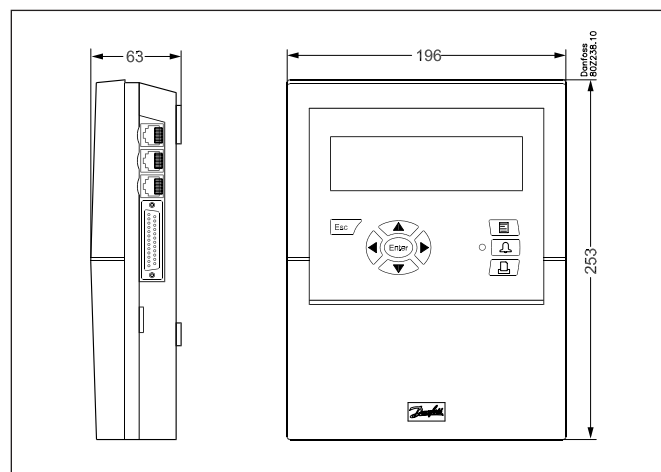

Ordering data

Type	Measuring points	Description	Language	Code
AK-SM 350	16	With inputs for PT 1000 ohm and PTC 1000 ohm	English, German, French, Dutch, Italian	080Z8500
			English (UK), Spanish, Portuguese, English (US)	080Z8502
			English, Danish, Swedish, Finnish	080Z8503
			English, Polish, Czech	080Z8504
Printer cable 3 m (parallel)				080Z8401
Cable for PC (see also AK-ST 500 documentation)		RJ 45 – Com port		080Z0262
Modem cable				080Z0261

Note:

Data bus or network cables and repeaters must be installed in accordance with the requirements specified in the following document:

Data Communication between ADAP-KOOL® Refrigeration System Controls

Document no.: RC8AC

AK-SC 255

Application

The feature-rich AK-SC 255 system controller is the heart of your control and monitoring system. It features a brilliant full colour high resolution display, context-sensitive soft keys, easy navigation to every part of your system, an on-board Ethernet port, a complete suite of maintenance management tools, extensive alarm capability, and much more.

Advantages

Front end for ADAP-KOOL®

- Supports pack and evaporator controllers and I/O modules
- Temperature monitoring and alarm generation
- Enables HACCP compliance
- Local access with keypad and VGA screen
- Full remote access (serial or Internet)
- Energy optimisation with adaptive master control
- Flexibility with Boolean logic
- Lighting control
- Off-line programming enables off-site commissioning
- Host network with up to ten connected AK-SC 255 units supports a massive range of applications
- Flexible alarm routing, including relays, e-mail, XML, and printer
- Solution scalable to hypermarket level
- Remote access and alarm management reduces service calls and expenses
- User friendly menus and shortcut keys
- Daily user web browser

Regulation

The AK-SC 255 can control and monitor up to twelve suction and condenser controllers and up to 120 controllers in total. With its compressed data storage, it provides a huge logging capacity.

There is a user-programmable logic processor for custom strategies.

Standard and custom alarms protect food products and equipment.

Software options can support up to 30 lighting zones, including motorised panels, and up to 40 HVAC systems.

Network

The AK-SC 255 can control and monitor multiple network types to suit different application levels. The network options include:

- TCP/IP EKC controllers
- MOD-bus EKC controllers
- LonWorks RS 485 AK and EKC
- LonWorks AK I/O Modules

Lighting

- 30 lighting zones
- 6 relays per zone
- Standard or relative schedules
- 8 schedules per zone
- Auto override for burglar or fire alarm
- Switch override with OVR override box

Miscellaneous features

- 96 miscellaneous Boolean logic statements per AK-SC 255
- 64 miscellaneous relay DOs per AK-SC 255
- 48 miscellaneous VOs per AK-SC 255
- 10 miscellaneous conversion factors
- 64 miscellaneous sensor inputs and on/off inputs – monitoring and alarming

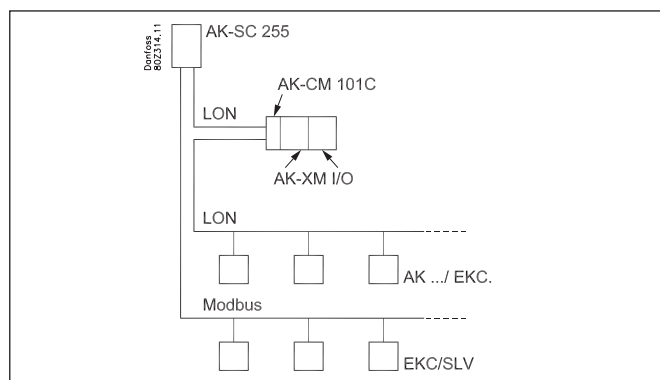

Closed system with controllers

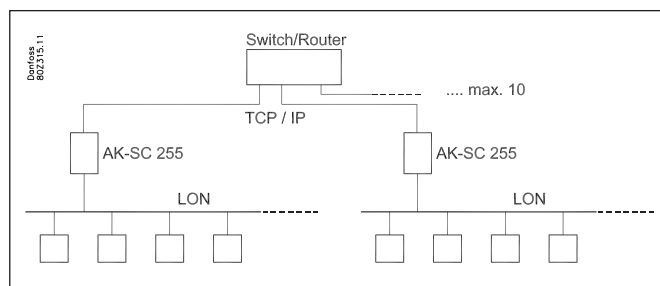

Several systems configured for setup and readout using a central AK-SC 255. Communication between systems via TCP/IP.

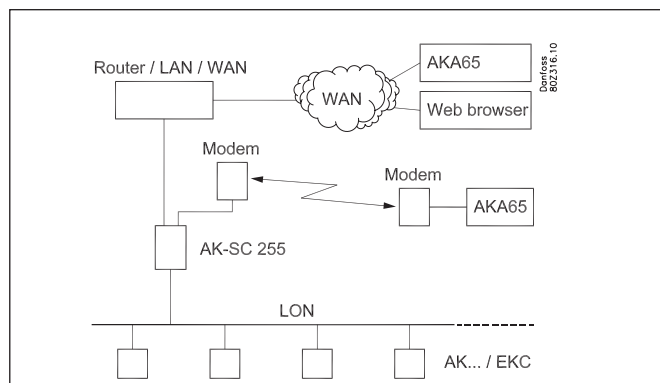

System manager with controllers and modem for remote system control via AKA 65.

Technical data

Recommended individual controller capacity per AK-SC 255	Type AK-CC 750	60	Max. configured evaporator sections: 120
	Type EKC (SNMP, LonWorks)	120	1 controller per evaporator section
Recommended remote AK I/O capacity (in addition to controllers)	AK I/O	64 points (max 8 AK-CM)	Analog (general I/O, HVAC, lighting)
	AK I/O	64 points (max 8 AK-CM)	Digital (general I/O, HVAC, lighting)
Available network protocols	Ethernet port (used for EKC SNMP controllers, 255 host network and remote AKA65 software tool) RS 485 host bus (used for multiple AK-SC 255 units) MOD-bus RS232 port (used for AKA 65 software tool) Modem port (used for serial modem)		
Energy meter (kWh) pulse input capacity	AK-XM 107A pulse module, 8 inputs maximum, Carlo Gavazzi EM24 via MOD-bus		
Additional AK-SC255 units inter connected via host network	Max. 10 AK-SC255 units (1 master and 9 slaves)		
History data entries	600		
History capacity	120 points sampled every 10 minutes = 1 year		
Remote connection software	AKA 65 v5.1: modem Daily user Web browser Ethernet Serial		
Recommended modem support	Zoom V.92 56k modem (model 3049)		
	AKA 231 modem		
Ambient conditions	Operating temperature	0 to +40°C at 95% RH (non condensing) 0 to +50°C at 0 to 90% RH (non condensing)	
	Storage temperature	-20 to +50°C	

AK input/output module family

Place strings of up to nine self-addressing I/O modules wherever you need them, in any combination. Modules are available with:

- 8 relays (with or without override)
- 8 relays (with or without override) and 8 universal inputs
- 8 universal inputs
- 8 digital inputs (high and low voltage versions)
- 4 bipolar EEPR outputs

Each module string begins with a communication and power module that is connected to the AK-SC 255 system controller via Echelon® LonWorks®. The unique intermodule bus eliminates the need for wiring to individual modules.

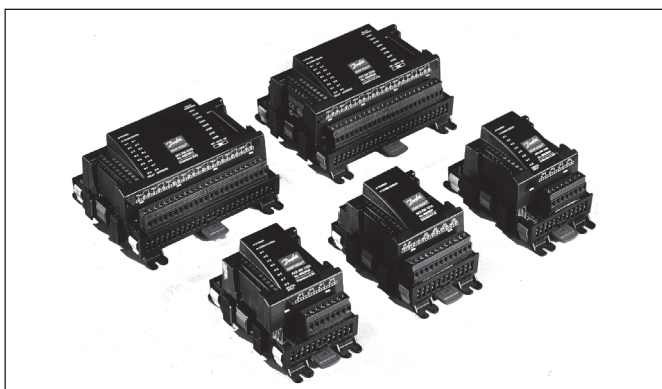

AK-SC 255 solution components:

- Communication module
- I/O modules
- Pulse counter

Ordering data

Type	Functional description	Code
AK-SC 255	Refrigeration	080Z2520
AK-SC 255	Refrigeration, lighting, HVAC	080Z2521
AK-SC 255	Refrigeration, lighting, HVAC For DIN rail mounting (without screen)	080Z2583
Modem adapter for AK-SC 255 -> Modem AKA 231		080Z2100

Note:

Data bus and network cables and repeaters must be installed in accordance with the requirements specified in the following document:

Data Communication between ADAP-KOOL® Refrigeration Controls Document number: RC8AC

Additional information:
Manual: USCO.EC.R1.A

AK-SC 355

Application

Convenience store control system, AK-SC
Designed to make your facility more profitable:

- Energy efficiency
- Risk management
- Reduced maintenance costs

Specifically designed for small retail food facilities:

- Controls and monitors refrigeration, HVAC and lighting systems
- Distributed control with Danfoss EKC refrigeration controllers and smart thermostats
- Centralised control with Danfoss AK input/output modules

Easy to use and program:

- On-board VGA display with web-like graphics
- On-board web server for remote access and programming using a web browser

Easy data management:

- Extensive logging and graphing capability
- Temperature and door open alarms
- XML compatible for third-party data access
- USB flash drive support for easy software management



Key features	Benefits
Built-in compressor, condenser and circuit control	Built-in control functions reduce complexity and cost
HVAC control using built-in functions or remote controllers and sensors	Up to ten HVAC units for tight control and energy savings
Condenser and circuit control using Danfoss controllers	Full support for market-leading Danfoss refrigeration controllers
25 schedule groups (eight schedules per group)	Central defrost, case lighting, shop & outdoor lighting, night setback, and shutdown
Flexible alarm routing and output	Support for e-mail, IP address, multiple relays, modem, and print alarms
Built-in MOD-bus and LonWorks® network support	More scope for control solutions using established protocols
Full-colour VGA local screen view and access	Access all areas of your system from the convenient local screen
Built-in buzzer and bicolour LED	Easy local alarm notification
Supports Danfoss AK I/O modules	I/O module support enables versatile, extended control and monitoring
Simple site view imagery – capability for loading custom graphics and map parameters on the local screen	Create a simple, clear graphic screen showing only the key parameters, to simplify the management of your services
600 log entries	Large history storage capacity to ensure HACCP compliance and provide service level details
Multiple users and user levels	Definable user list with clearly defined authorisation levels
Multiple language support	Local and browser language support
USB flash drive support	Reduce commissioning time and costs
Full web browser access	Standard web browser connection provides access to all areas of the system
Built-in Boolean logic commands	Define your own logic to control even the most arcane application
Remote management tool	Remotely manage your system: update software, back up the database, load images, use the VizEdit tool (built-in RMT) to create custom imagery and map parameters

Technical data

Power: 100–240 V a.c. ($\pm 10\%$) 50/60 Hz

Built in alarm relay: 30 V d.c. / 1 A, Class 2
(not available with RS 485 screen version)

Ambient conditions

Operating temperature (screen): 32 to 104 °F (0 to +40 °C)

DIN: 32 to 122 °F (0 to +50 °C)

at 90% RH (non-condensing)

Approvals



E166834

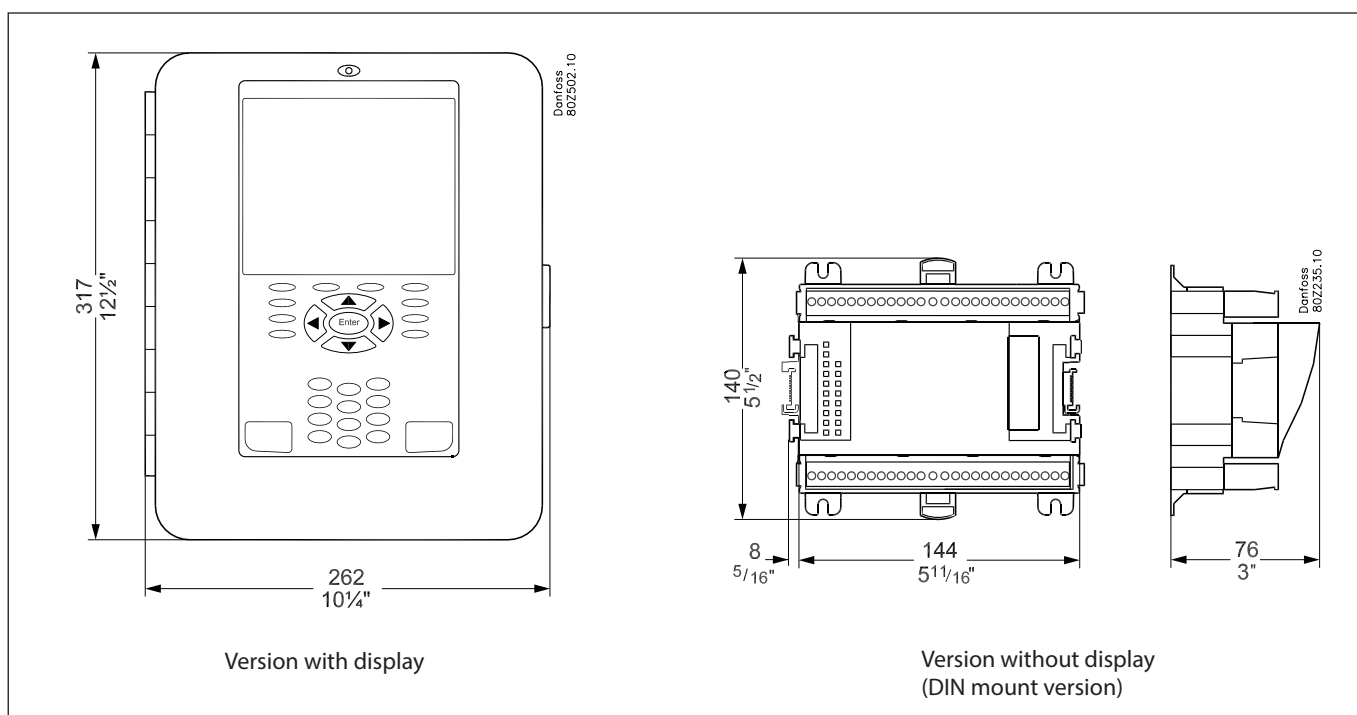

Ordering data

Type	Application	Data communication	Display	Code no.
AK-SC 355CS	C-Store	LON RS485	Yes	080Z2561
AK-SC 355CS	C-Store		No	080Z2562
AK-SC 355	Refrigeration		Yes	080Z2560
AK-SC 355	Full store		Yes	080Z2564
AK-SC 355	Full store		No	080Z2568

Note:

Data bus or network cables and repeaters must be installed in accordance with the requirements specified in the following document:

Data Communication between ADAP-KOOL® Refrigeration System Controls

Document no.: RC8AC

Additional information available:
USCO.EI.RF0.F

AK-SM 720

Application

The AK-SM 720 system manager is a system unit for use with AK series controllers.

The system manager enables the configuration of complex control systems that support alarm monitoring and data logging for decentralised refrigeration systems.

The controllers are connected to a data bus or network, with various communication options depending on the controller type:

LON RS 485
Modbus
TCP/IP
Modem

Functional description

Used for data communication with LON RS 485 or MOD-bus. Up to 200 controllers can be connected, distributed over the LON RS 485 and MOD-bus.

Several system managers can be connected via the IP link, so that measurement data from a total of up to 400 controllers can be recorded.

Remote control is possible with a modem link or a link using an IP network.

Remote control utilises the AK-ST software.

The system manager can send alarms and logs to the AKM system software, but the system manager and the connected controllers cannot be remotely controlled using the AKM software.

Ordering data

Type	Description	Language	Code No.
AK-SM 720	System manager	English, German, French, Italian, Dutch	080Z8511
		English, Spanish, Portuguese	080Z8512
		English, Danish, Swedish, Finnish	080Z8513

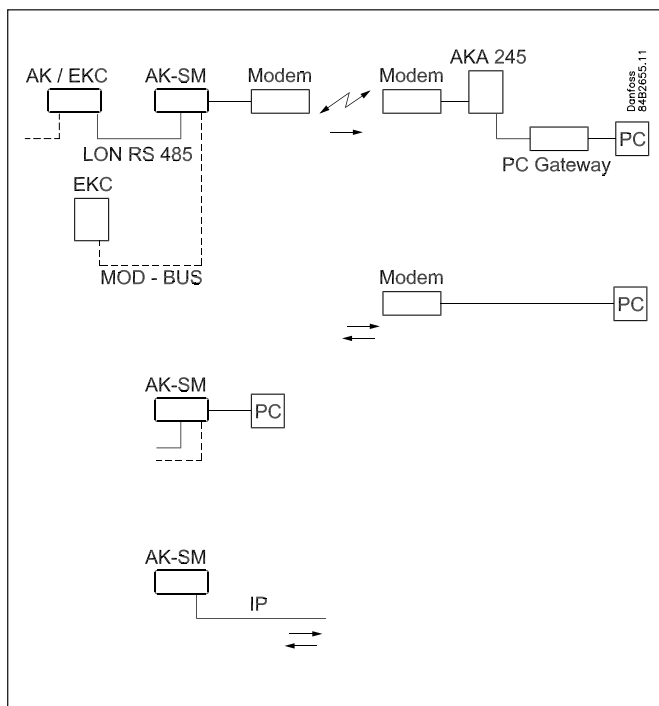
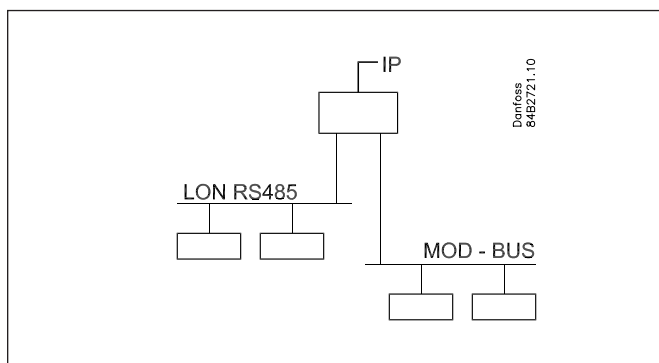
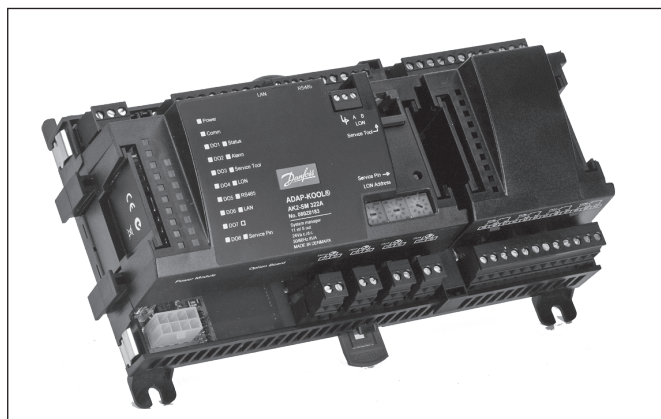

Note:

Data bus or network cables and repeaters must be installed in accordance with the requirements specified in the following document:

Data Communication between ADAP-KOOL® Refrigeration System Controls

Document no.: RC8AC

Monitoring

AK-LM 350

Application

AK-LM 350 is a complete monitoring unit with the option of regulation functions via relay switches.

The monitoring unit is used to detect temperature, pressure, functions etc. in and around appliance cases and cold rooms for commercial and industrial cooling.

COP calculation can be made on the following systems:

- CO₂ booster
- CO₂ booster with heat recovery
- CO₂ booster with heat recovery and brine
- Cascade plant
- Single stage

The monitoring unit is equipped with data communication and is operated via a PC.

Functions

Temperature

- Temperature detection
- Temperature monitoring with alarm function
- Extension of the alarm delay when a defrost signal (DI) is received
- Interruption of alarm monitoring when a switch signal (DI) is received
- Temperature control with relay function

Pressure

- Pressure detection
- Pressure monitoring with alarm function
- Pressure control with relay function

Voltages of 0-10 V

- Voltage detection
- Voltage monitoring with alarm function
- Voltage monitoring with relay function

On/Off signals

- Detection of switch signals
- Alarm function with delay + relay function, if applicable
- The switch signal can be inverted
- Hour counter for On time
- Counter for number of changes

Pulse signals

- Registration of electricity, water, gas, etc.
- Energy reading
- Energy reading in a set synchronisation period
- Energy reading in a period between synchronisation pulses
- Receiving synchronisation signal

COP calculation

- COP for MT and LT
- Etas for MT and LT
- Refrigeration capacity for MT and LT
- Heat recovery
- Heat loss
- COSP for the whole system

The COP calculation requires a 0-10 V signal that indicates how much of the compressor capacity is connected.

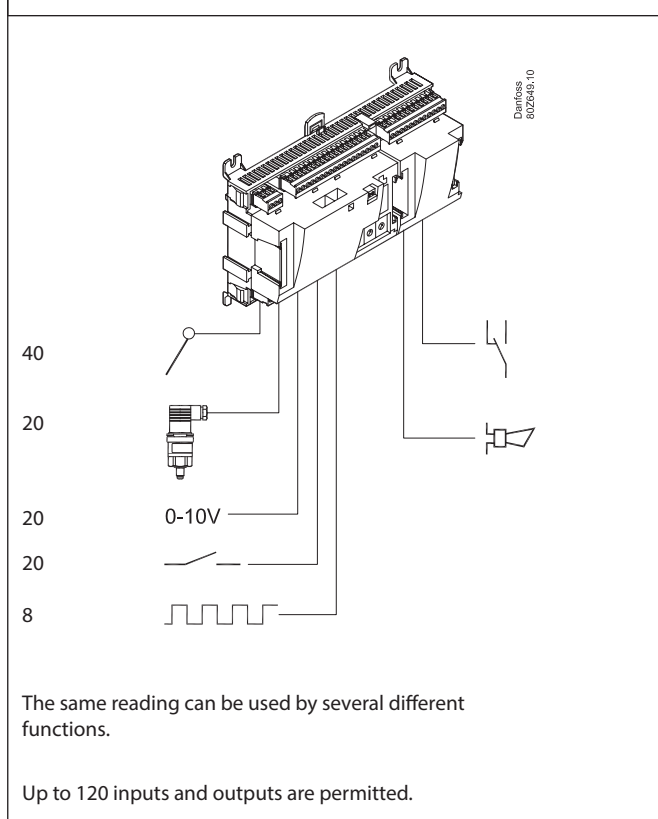
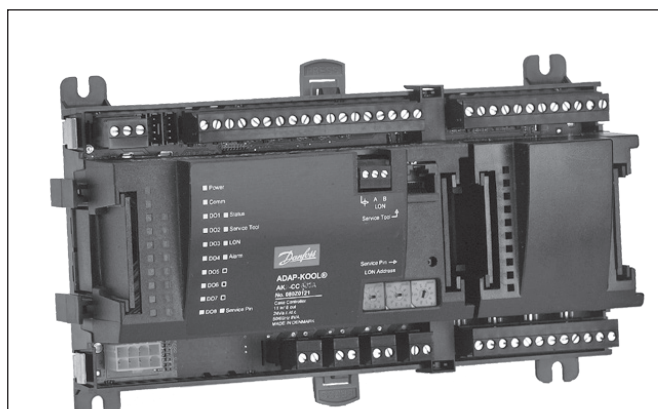

This signal can be retrieved from the compressor controller, if it is one of the following types:

- AK-PC 772
- AK-PC 781
- AK-PC 783

Alarm relay

- Two alarm relays that are enabled on different alarm priorities

Data communication

- Connection to system manager or gateway
- Monitoring and data collection
- Customised alarm texts

Technical data

Supply voltage	24 V DC / AC \pm 20%	
Power consumption	AK-LM 350	8 VA
Analog inputs	Pt 1000 ohm / 0°C	Resolution: 0.1°C Accuracy: \pm 0.5°C
	Pressure transmitter type AKS 32R / AKS 2050 / AKS 32 (1-5 V)	Resolution 1 mV Accuracy \pm 10 mV Up to five pressure transmitters can be connected to a single module.
	Other pressure transmitter: ratiometric signal Min. and max. pressure must be set Min and max. voltage must be set	
	Voltage signal 0-10 V	
Contact function (on/off)		On when R < 20 ohm Off when R > 2 kohm (gold-plated contacts not necessary)
On/off voltage input	Low voltage 0 / 80 V a.c./d.c.	Off: U < 2 V On: U > 10 V
	High voltage 0 / 260 V a.c.	Off: U < 24 V On: U > 80 V
Relay outputs SPDT	AC-1 (resistive)	4 A
	AC-15 (inductive)	3 A
	U	Min. 24 V Max. 230 V Do not connect low-voltage and high-voltage signals to the same output group.
Solid state outputs	Can be used for loads that are switched on and off frequently, such as: rail heat, fans, AKV valve	Max. 240 V AC; min. 48 V AC Max. 0.5 A, leakage < 1 mA Max. 1 AKV
Ambient temperature	During transport	-40 to 70°C
	During operation	-20 to 55°C, 0 to 95% RH (non condensing) No shock load or vibration
Enclosure	Material	PC / ABS
	Penetration resistance	IP 10, VBG 4
	Mounting	For mounting on panel, wall or DIN rail
Weight with screw terminals	Controller	approx. 600 g
Approvals	Compliant with EU Low Voltage Directive and EMC regulations	LVD tested according to EN 60730 EMC tested Immunity compliant with EN 61000-6-2 Emissions compliant with EN 61000-6-3
	UL 873,	UL file number: E166834 for XM UL file number: E31024 for LM

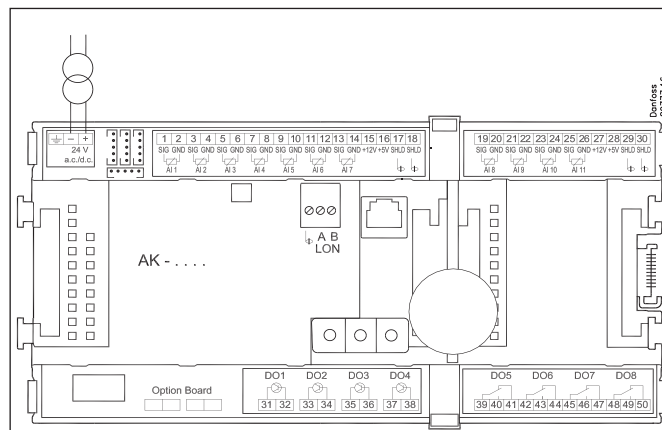

Installationen af datakommunikationen skal overholde kravene, der er beskrevet i litteratur nr. RC8AC

Ordering data

Type	Functional description	Application	Language	Code
Controller				
AK-LM 350	Monitoring unit with COP calculation	Monitoring of temperature, pressure, voltage, etc. COP calculations	English, German, French, Italian, Dutch, Spanish, Portuguese, Danish, Finnish, Russian, Polish, Czech, Chinese	080Z0176
Miscellaneous				
Expansion modules available for additional connections				See Accessories section - AK modules
Operating software for AK controllers			AK-ST 500	
Cable between PC and AK controller				
Cable between null modem cable and AK controller				
Real time clock for use in controllers that require a clock function but do not have a data communication link.			AK-OB 101A	

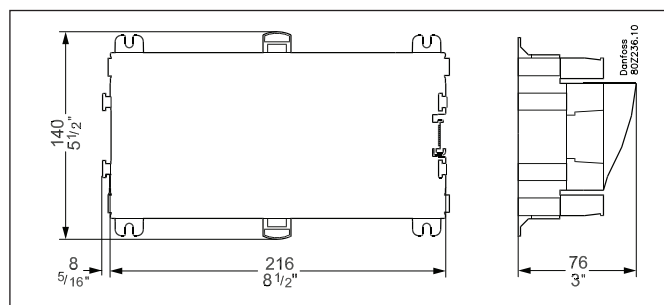

Additional information available:
Manual: RS8GX

System Software

AK-ST 500

Application

Software for operation of AK controllers from the AK series AK with expansion modules:

AK-CC 750
 AK-CH 650
 AK-PC 730
 AK-PC 772
 AK-PC 781
 AK-PC 783
 AK-LM 330
 AK-SM 720
 and others

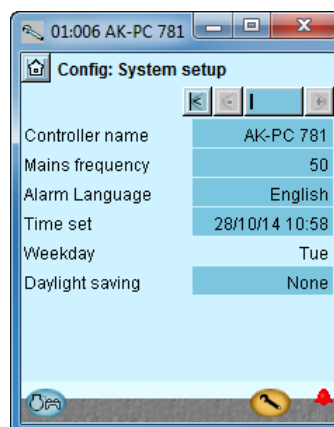

Functional description

The program is an advanced software tool for operating refrigeration controls on a network, where it acts as a sort of browser for the controllers involved since it has only one user interface.

Functions and settings are presented in a number of menus shown on the right.

Operating principle

The AK controller is connected to the PC tool installed by the program. The PC may be portable or stationary. All settings are then set using Windows menus.

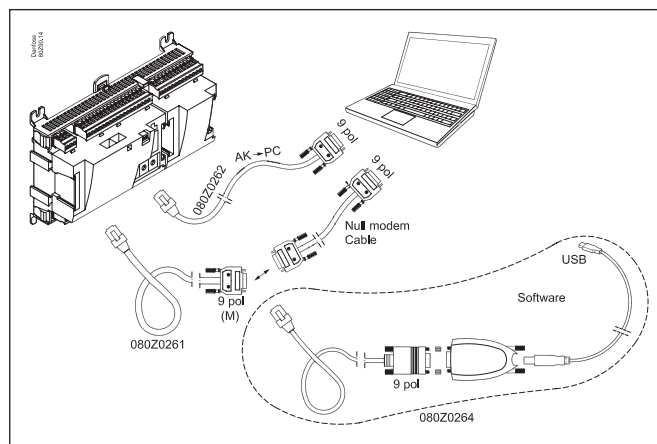

Ordering data

Type	Functional description	Application	Code
AK-ST 500	Operational software for AK controls	AK operation	080Z0161
-	Cable between PC and AK controller	AK - Com port	080Z0262
-	Cable between null modem cable and AK controller	AK - RS 232	080Z0261
-	Cable between PC and AK controller	AK-USB	080Z0264

Additional information available:
 Manual: RS8ES

AKA 65

For System controller type AK-SC 255 and controllers connected to AK-SC 255

This software is used for operating the controller from a PC.

Capacity control

AK-PC 351

Application

The controller is used for capacity regulation of compressors and condensers in small refrigeration applications. A maximum of 4 compressors and one condenser can be regulated. For example:

- One suction group + one condenser group, max. 6 steps total
- One compressor group, max. 4 steps
- One condenser group, max. 4 steps

Advantages

- Energy savings via:
 - Optimisation of suction pressure
 - Night set back
 - Floating condensing pressure

Input and output

There are a limited number of available inputs and outputs. For each signal type, though, the following can be connected:

- Analogue inputs, max. 4 pcs.
 - Signal from 2 pressure transmitters and 2 temperature sensors
- Digital inputs, max. 8 pcs.
 - Signal from automatic safety control, external start stop, night signal, general alarm.
- Relay outputs, max. 5 pcs.
 - Connection of compressors, condenser fans, alarm relay
- Solid state outputs, max. 1 pcs.
 - Control of bypass on a digital scroll or for controlling unloader on a stream compressor. If the output is not used for this function, it can be used as ordinary relay output
- Analogue outputs, max. 2 pcs.
 - Speed control of compressors and condenser fans.

Compressor types

The following types of compressor combinations can be used for regulation:

- Single-step compressors
- Speed controlled compressor together with single-step
- Digital scroll compressor together with single-step
- Stream 4 cylinder compressor together with single-step
- Compressors with an equal number of unloaders.

Fan control

The fans can be controlled incrementally using the controller's relays, or they can be speed-controlled via the controller's analogue output.

Speed control can be via a frequency VLT-type transformer. If the fans have EC motors, the 0-10 V signal can be used directly.

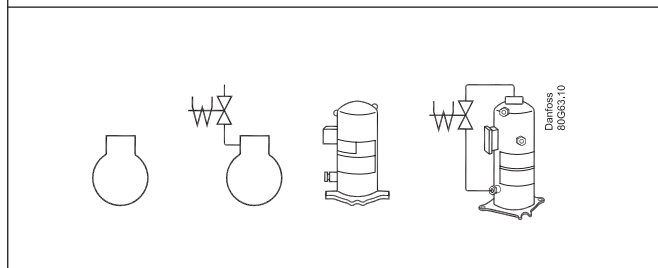
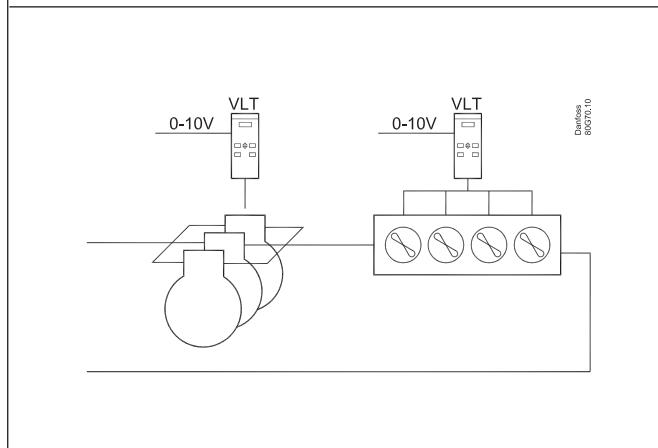
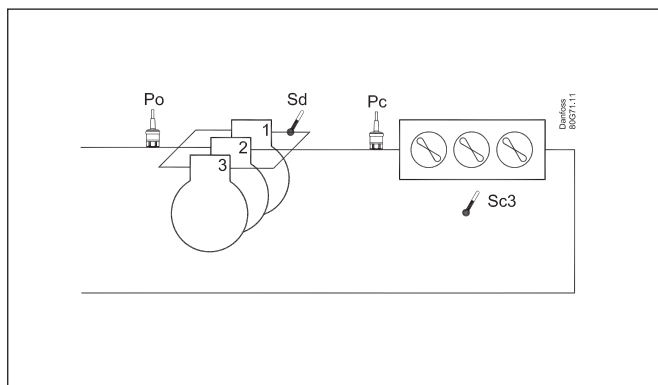

Operation

The daily operation can be set up directly on the controller. During set-up, the display images will be adjusted so that only the relevant images are opened for additional setting and end-user operation.

The operation is password protected, and three levels of access can be granted.

The controller contains several languages. Select the preferred language at start-up.

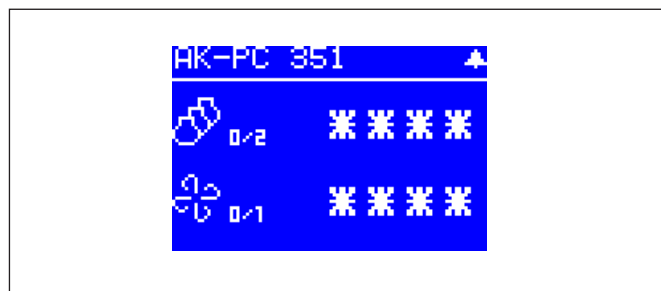

Data

Supply voltage	24 V a.c. +/-15% 50/60 Hz, 9 VA 24 V d.c. (20-60 V), 9 VA	
4 analog Input	Pressure measuring: Ratiometric pressure transmitter type AKS 32R 1-5 volt pressure transmitter type AKS 32 0-20 (4-20) mA pressure transmitter type AKS 33	
	Temperature measurement Pt 1000 ohm/0°C NTC - 86K from digital scroll / stream	
8 digital input	From contact function E.g. to: Start/stop of regulation Monitoring of safety circuits General alarm function	
Relay output to capacity control	5 pcs. SPDT (5A)	AC-1: 5 A (ohmic) AC-15: 2 A (inductive)
	1 pcs. Solid State. PWM for scroll - unload	I _{max} = 0.5A I _{min} = 50 mA. Leak < 1.5 mA
2 Voltage outputs	0-10 V d.c. Ri = 1kohm	
Data communication	Modbus for AK-SM 800	
Environments	-20 - 60°C, During operations	
	-40 - 70°C, During transport	
	20 - 80% Rh, not condensed No shock influence / vibrations	
Density	IP 20	
Weight	0,2 kg	
Mounting	DIN-rail	
Connection terminals	max. 2.5 mm ² multi core	
Approvals	EU Low Voltage Directive and EMC demands re CE-marking complied with LVD tested acc. EN 60730-1 and EN 60730-2-9 EMC-tested acc. EN61000-6-2 and 3	

Mounting /Dimensions

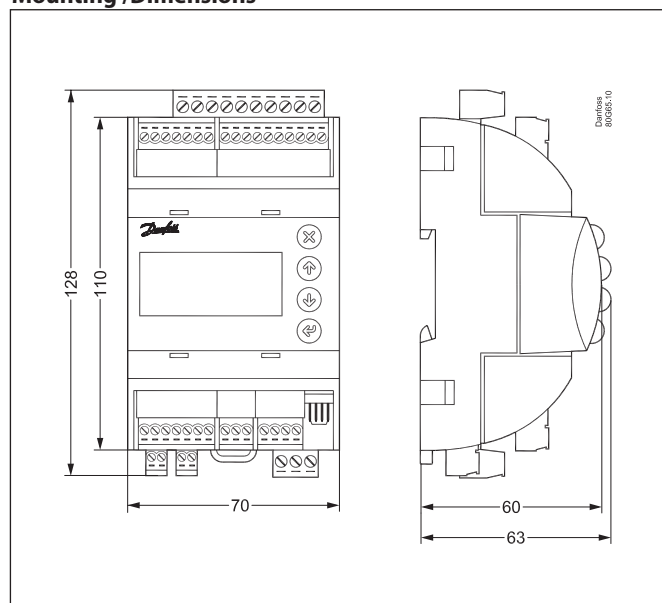

Ordering

Type	Function	Operation	Supply voltage	Code no.
AK-PC 351	Capacity controller	 With buttons and display	24 V	080G0289

Additional information available:
Manual: RS8GZ--

AK-PC 551

Application

The controller is used for capacity regulation of compressors and condensers in small refrigeration applications. A maximum of 8 compressors and one condenser can be regulated. For example:

- One suction group + one condenser group
- Two suction groups + one shared condenser (max. 4 + 4 steps)
- One compressor group, max. 8 steps
- One condenser group, max. 8 steps

Advantages

- Energy savings via:
 - Optimisation of suction pressure
 - Night time increase
 - Floating condensing pressure
 - Load limitation

Input and output

There are a limited number of available inputs and outputs. For each signal type, though, the following can be connected:

- Analogue inputs, max. 8 pcs.
Signal from pressure transmitters, temperature sensors, voltage signal, etc.
- Digital inputs, max. 8 pcs.
Signal from automatic safety control, day/night signal, etc.
- Relay outputs, max. 6 pcs.
Connection of compressors, condenser fans
- Solid state outputs, max. 2 pcs.
 - Control of capacity valve on a Copeland digital scroll
 - Control of unloader on a Copeland stream compressor.
 - Control of both unloaders on a Bitzer CRII
 If the outputs are not used for these functions, they can be used as ordinary relay outputs
- Analogue outputs, max. 2 pcs.
Speed control of compressors or condenser fans.

Compressor types

The following types of compressors can be used for regulation:

- Single-step compressors (one can be speed-regulated)
- Compressor with unloaders
- Scroll compressors (one can be a digital scroll)
- Copeland Stream compressor with one unloader (4 cylinders)
- Bitzer CRII compressor with two unloaders (4-cylinders)

Fan control

The fans can be controlled incrementally using the controller's relays, or they can be speed-controlled via the controller's analogue output. Speed control can be via a frequency VLT-type transformer. If the fans have EC motors, the 0-10 V signal can be used directly.

During night operation, the noise level of the fans can be kept down. This is done by limiting the cutin capacity. For speed control, keep the number of revolutions low. Omit step cutin for step-by-step activation.

The limitation is bypassed if safety functions Sd max. and Pc max. start to function.

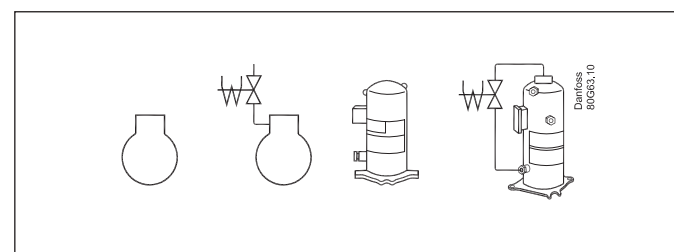
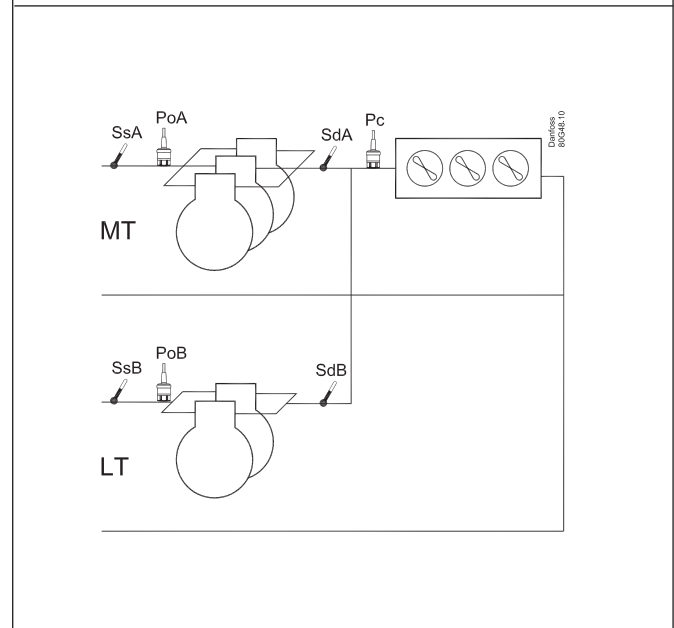
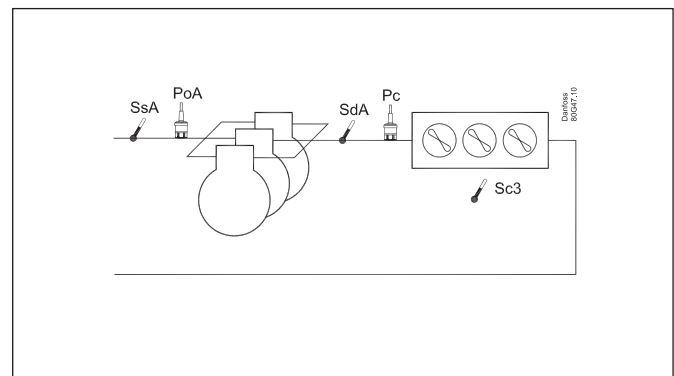

Operation

The daily operation can be set up directly on the controller or via an external display device.

During set-up, the display images will be adjusted so that only the relevant images are opened for additional setting and end-user operation.

The operation is password protected, and three levels of access can be granted.

The controller contains several languages. Select the preferred language at start-up.



Data

Supply voltage	24 V a.c. +/-15% 50/60 Hz, 17 VA 24 V d.c. (20-60 V), 17 VA 230 a.c. (85-265 V) 50/60 Hz, 20 VA	
8 analog Input	Pressure measuring: Ratiometric pressure transmitter type AKS 32R 1-5 volt pressure transmitter type AKS 32 0-20 (4-20) mA pressure transmitter type AKS 33	
	Temperature measurement Pt 1000 ohm/0°C NTC - 86K from digital scroll / stream	
8 digital input	From contact function E.g. to: Start/stop of regulation Monitoring of safety circuits General alarm function	
Relay output to capacity control	4 pcs. SPDT (8A)	AC-1: 6 A (ohmic) AC-15: 4 A (inductive)
	2 pcs. SPST (16A)	AC-1: 10 A (ohmic) AC-15: 3.5 (inductive)
	2 pcs. Solid State. PWM for scroll - unload	I _{max} = 0.5A I _{min} = 50 mA. Leak < 1.5 mA
2 Voltage output	0-10 V d.c. Ri = 1kohm Separate 24 V supply required	
Display output	For type MMIGRS2	
Data communication	Modbus for AK-SM 800	
Environments	-20 - 60°C, During operations -40 - 70°C, During transport	
	20 - 80% Rh, not condensed No shock influence / vibrations	

Density	IP 20
Weight	0,4 kg
Mounting	DIN-rail
Connection terminals	max. 2.5 mm ² multi core
Approvals	EU Low Voltage Directive and EMC demands re CE-marking complied with LVD tested acc. EN 60730-1 and EN 60730-2-9 EMC-tested acc. EN61000-6-2 and 3 UL approval

Mounting /Dimensions

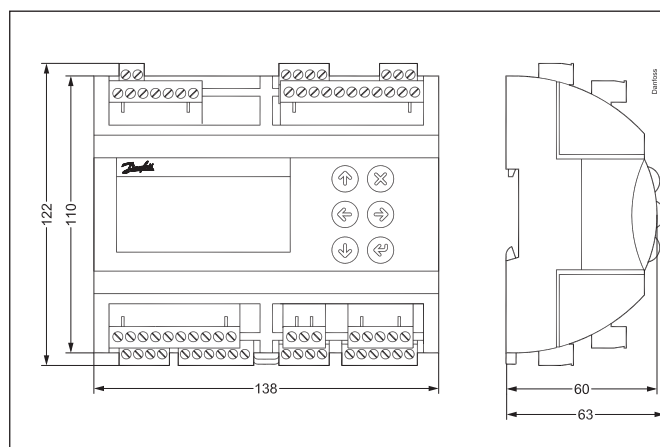

Ordering

Type	Function	Operation	Supply voltage	Code no.
AK-PC 551	Capacity controller		230 V	080G0281
			24 V	080G0283
			230 V	080G0282
			24 V	080G0288
MMIGRS2	Display unit		-	080G0294
	Wire for display unit, L = 1.5 m, 1 pcs.			080G0075
	Wire for display unit, L = 3 m, 1 pcs.			080G0076

Additional information available:
Manual: RS8GY--

AK-PC 781

Application

The AK-PC 781 is a complete regulating unit for capacity control of compressors and condensers in refrigeration systems.

The controller uses oil management, heat recovery functions and CO₂ gas pressure control.

Advantages

- Integrated oil management
- Suitable for use in CO₂ systems
- Gas pressure control
- Receiver control
- Option for parallel compression

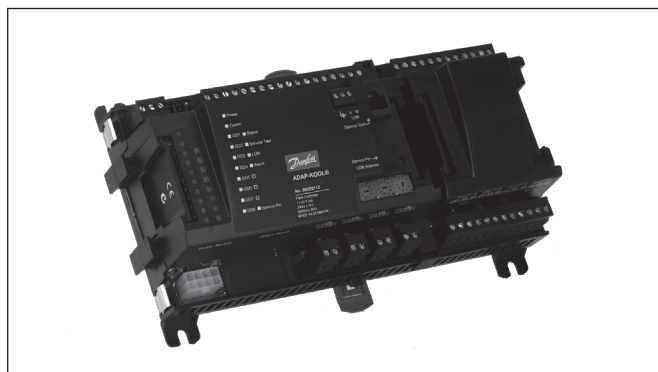

Function

- Capacity regulation of up to 8 compressors
- Capacity regulation of up to 8 fans
- shared or individual control of all oil valves
- control of oil separators
- heat recovery for tap water
- heat recovery for space heating
- control of gas cooler
- receiver pressure control

CO₂

When the refrigerant in the system is CO₂, the higher pressure and temperature make it possible to recover heat for tap water and heating. The excess heat is removed using a gas cooler.

Regulation is carried out during transcritical and subcritical states and the controller will control the gas pressure/condensing pressure so that the system achieves the optimum COP when the recovered heat is taken into account.

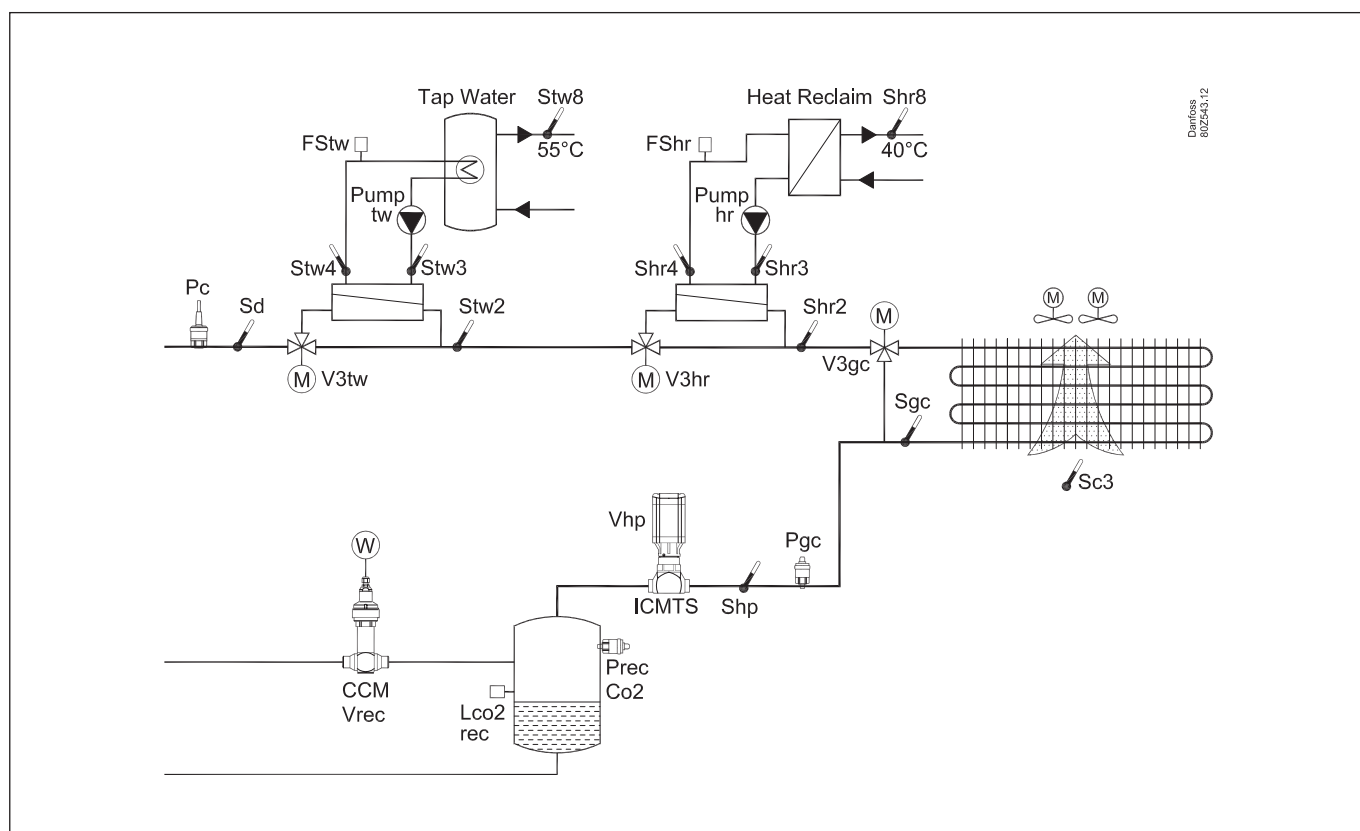

Example oil management:

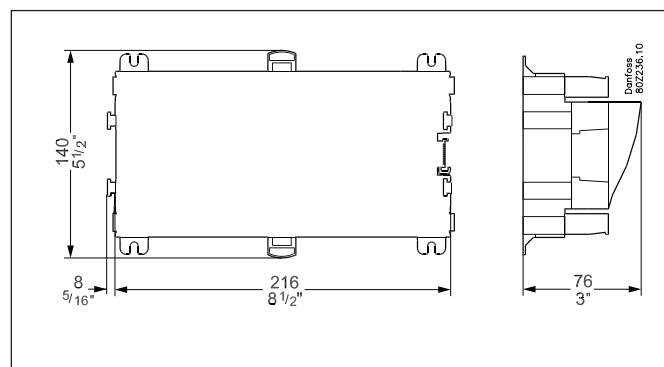
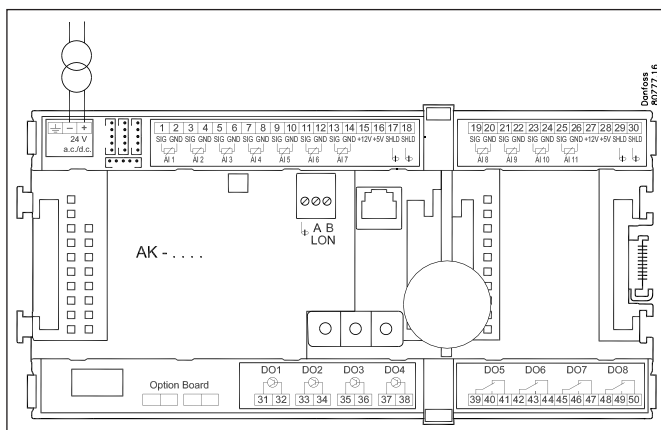
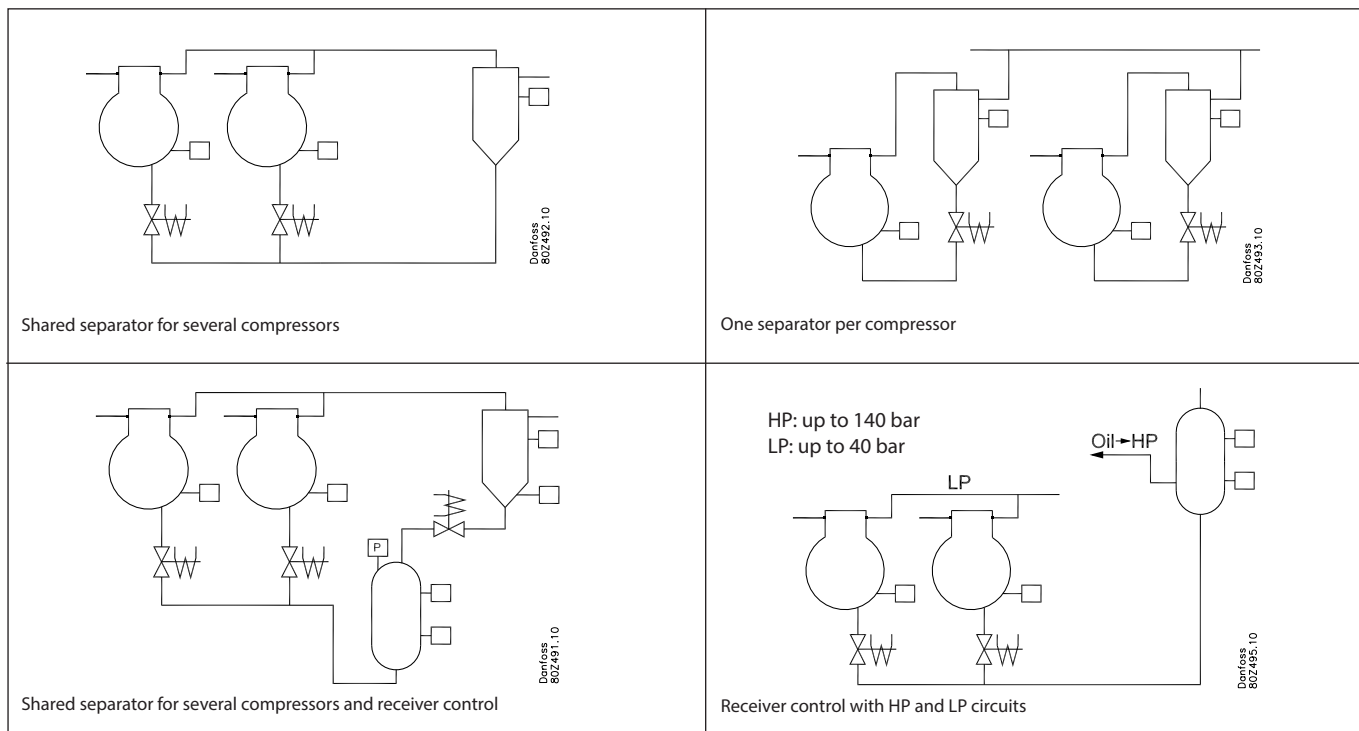

Ordering

Type	Functional description	Application	Language	Code no.
AK-PC 781	Controller for capacity control of compressors and condensers With oil management	Up to 8 compressors, 8 fans, and 120 inputs and outputs	English, German, French, Italian, Dutch, Spanish, Portuguese, Danish, Finnish, Russian, Czech, Polish, Chinese	080Z0186
Miscellaneous				
Extension modules for additional connections				See Accessories section - AK modules
Operating software for AK controllers			AK-ST 500	
Cable between PC and AK controller				
Cable between null modem cable and AK controller				
External display for connection to controller module. For displaying variables such as suction pressure			EKA 163B, EKA 164B, MMIGRS2	
Real time clock for use in controllers that require a clock function but do not have a data communication link.			AK-OB 101A	

Additional information available:
Manual: RS8GG--

AK-PC 783

Application

AK-PC 783 is complete regulating units for capacity control of compressors and condensers in refrigeration plants with cascade function.

The controller controls the high-pressure circuit, low-pressure circuit and cascade circuit.

The controller is with oil management, simple heat recovery function and coordination between the high-pressure control and low-pressure control.

In addition to capacity control the controllers can give signals to other controllers about the operating condition, e.g. forced closing of expansion valves, alarm signals and alarm messages.

The controller's main function is to control compressors and condensers so that operation all the time takes place at the energy-optimum pressure conditions. Both suction pressure and condensing pressure are controlled by signals from pressure transmitters.

Capacity control is carried out by suction pressure P_0 on the two circuits.

Cascade control is performed in accordance with the two temperature sensors, $Scasc2$ and $Scasc3$.

Advantage

- Cascade control
- Control of CO_2 pump system
- Coordination between high and low pressure controls
- Heat recovery function

Function

- Capacity control of up to 8 compressors (Max. 4 on each circuits or 5 on MT + 3 on LT)
- Up to 3 unloaders for each compressor
- Speed control of one or two compressors
- Up to 3 screw compressors
- Digital scroll compressor
- Oil equalisation function on MT circuit
- Oil management. Either shared or individual for all of the compressor's oil valves in the LT circuit. Receiver pressure control.
- Up to 6 safety inputs for each compressor
- Option for capacity limitation to minimize consumption peaks
- Capacity control of up to 8 fans on the condenser
- Control of fans with EC motors
- Safety monitoring of fans
- When the compressor does not start, signals can be transmitted to other controllers so that the electronic expansion valves will be closed
- Control of liquid injection into suction line
- Control of liquid injection into screw compressor
- Control of liquid injection in heat exchanger (cascade)
- Safety monitoring of high pressure / low pressure / discharge temperature
- Floating reference with regard to outside temperature
- Plus some completely separate functions that are totally independent of the regulation – such as alarm, thermostat, pressure and PI-regulating functions.

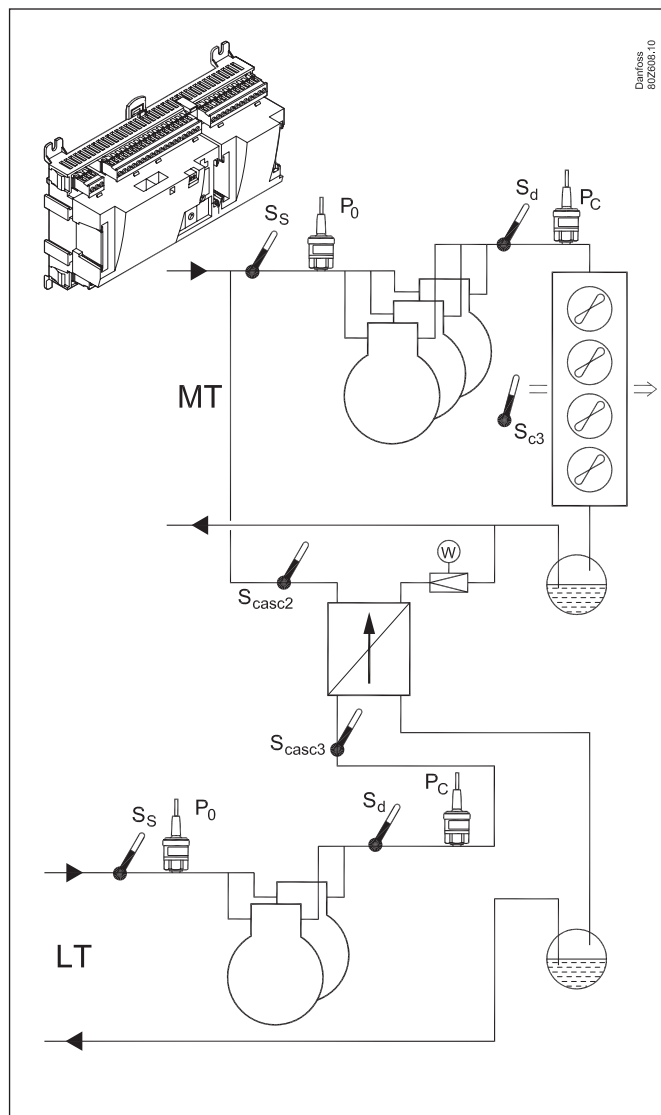
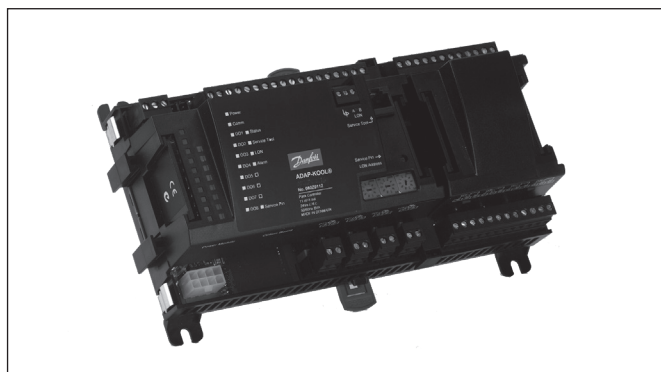

Example

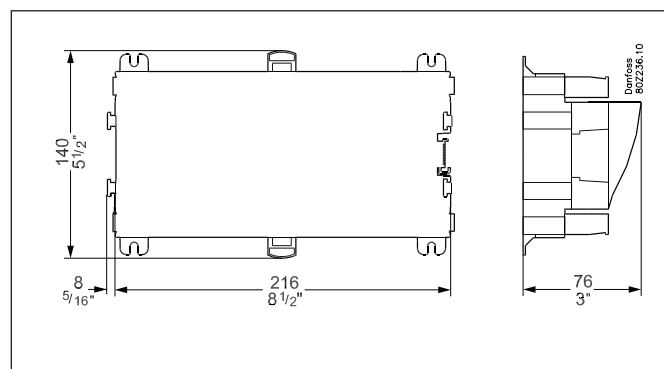
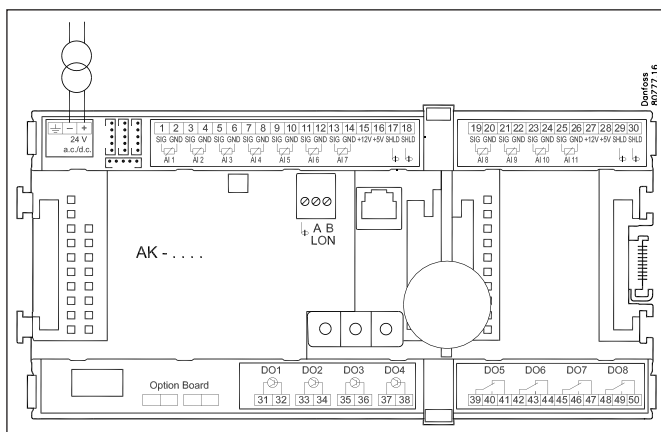
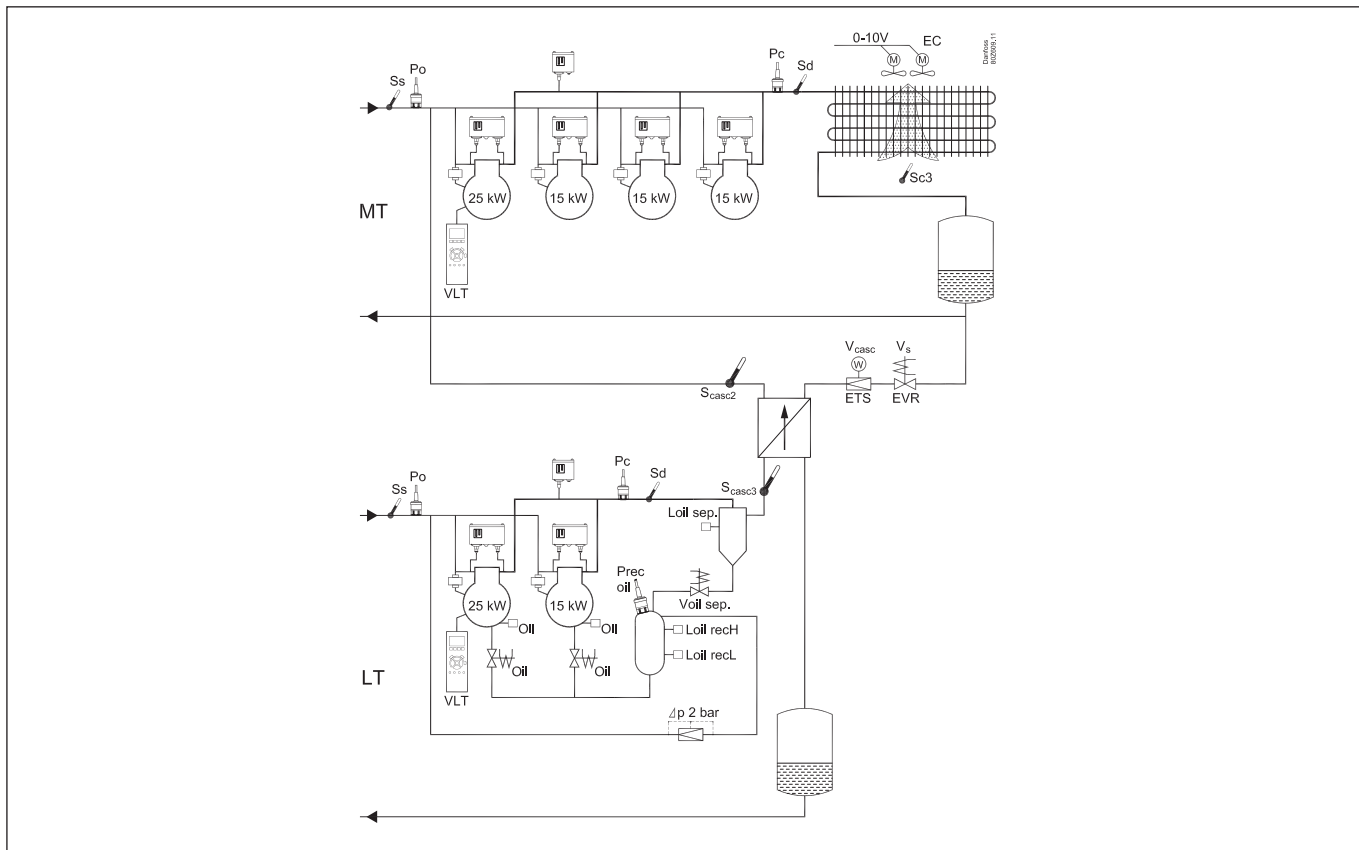

Ordering

Type	Functional description	Application	Language	Code no.
AK-PC 783	Controller for capacity control of MT compressors, condensers, LT compressors and cascade heat exchangers. With oil management	Capacity control on cascade plant	English, German, French, Italian, Dutch, Spanish, Portuguese,	080Z0196
Miscellaneous				
Extension modules for additional connections				See Accessories section - AK modules
Operating software for AK controllers			AK-ST 500	
Cable between PC and AK controller				
Cable between null modem cable and AK controller				
External display for connection to controller module. For displaying variables such as suction pressure			EKA 163B, EKA 164B, AK-MMI	
Real time clock for use in controllers that require a clock function but do not have a data communication link.			AK-OB 101A	

Additional information available:
Manual: RS8GN--

Gas cooler

EKC 326A

Application

This controller is used in systems with a gas cooler and CO₂ refrigerant. It regulates the pressure in the gas cooler (condenser) to optimise the COP of the system.

The controller supports:

- Transcritical CO₂ refrigeration systems (booster, cascade, high pressure)
- Transcritical CO₂ heat pump systems
- Transcritical CO₂ refrigeration systems with heat recovery
- Transcritical CO₂ chiller systems
- Extra capacity in warm periods. The cooling performance of the system can be improved by shifting the set point ('extra compressor')

Advantages

- Maximum COP
- The controller ensures that the system achieves maximum performance by maintaining the optimal pressure in the gas cooler when regulation occurs in the transcritical region.
- The controller always optimises operation to a subcritical state.
- Receiver pressure regulation is based on the measured receiver pressure.
- Heat recovery with adjustable reference pressure, 0–10 V
- Optimum heat pump operation

System description

The pressure in the gas cooler is controlled by the valve. The controller requires inputs from a pressure transmitter (P_{GC}) and a temperature sensor (S_{GC}). Both devices must be fitted on the outlet immediately after the gas cooler. The valve is an ICMTS valve, which is specifically designed for the prevailing pressure conditions in a transcritical CO₂ system. The motor section of the valve is an ICAD actuator, which is controlled by a 0–10 V signal from the controller.

If it is necessary to maintain a constant receiver pressure, a valve (ETS) and pressure transmitter (P_{Rec}) can be fitted. The gas from the receiver bypasses to the inlet side of the high pressure compressor.

Functional description

Maximum COP control

The controller maintains the optimal pressure in the transcritical region based on the measured pressure and temperature.

Subcooling

dP or dT subcooling can be used in the subcritical region (dT subcooling is standard).

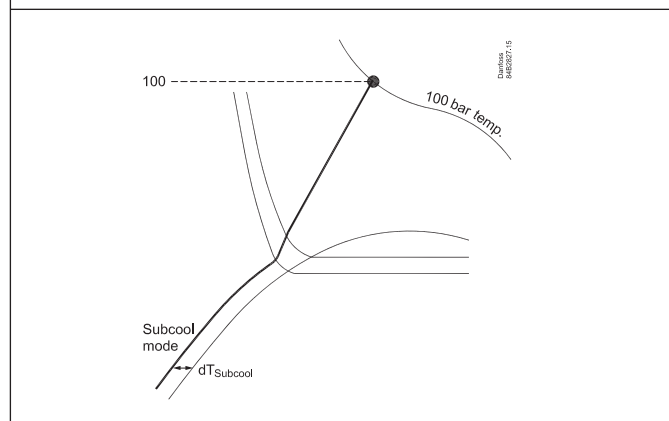
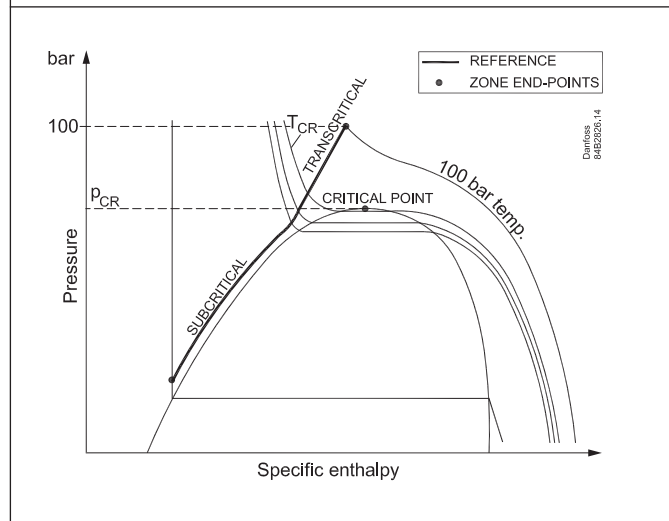
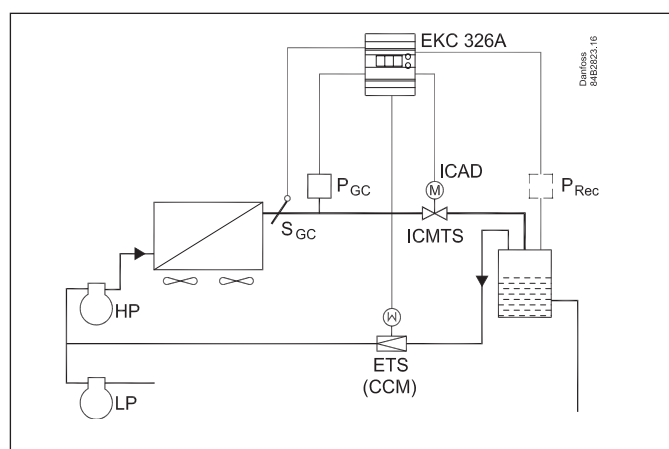

Receiver control

The receiver pressure can be regulated to a set reference point. This requires the installation of an ETS valve and a pressure transmitter. If only monitoring is required (no control function), the valve is not necessary. In this case, only the pressure transmitter should be fitted.

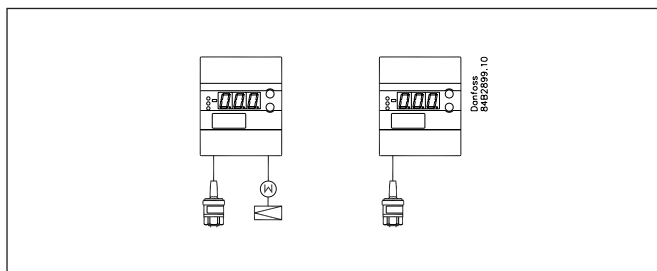

Avoiding excessively low receiver pressure

A limit value can be set, and the ICMTS valve is opened if the pressure falls below the set value. The valve is opened gradually through the associated P band. It is opened to the value set in parameter n32 (Vhp OD max).

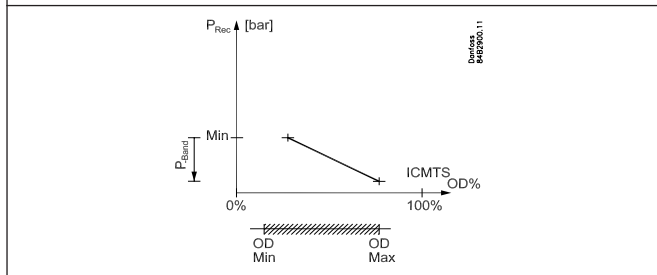

Extra refrigeration capacity ('extra compressor')

This function improves the refrigeration capacity of the system by increasing the pressure in the gas cooler. It is activated by a switch function.

The cooling performance increases to $Q_0 + dh_0$. This function also increases the load on the compressor motor as the pressure increases. The power consumption increases to $Q_m + dQ_m$.

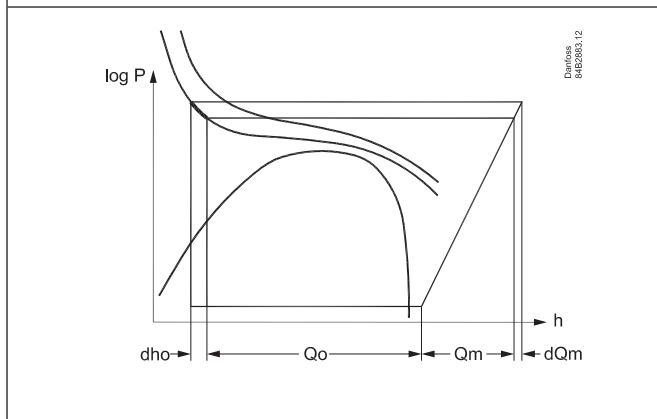

Heat recovery or heat pump

This function increases the gas pressure to a set value. This value corresponds to a certain temperature.

The value can be fixed, or it can vary according to a 0–10 V input signal as follows:

A signal level of 1.5 V or higher can activate the function and increase the reference level to the set value.

If a variable reference is required, a signal with a range of 2 to 10 V can be connected.

This function can be used in both ranges: subcritical and transcritical.

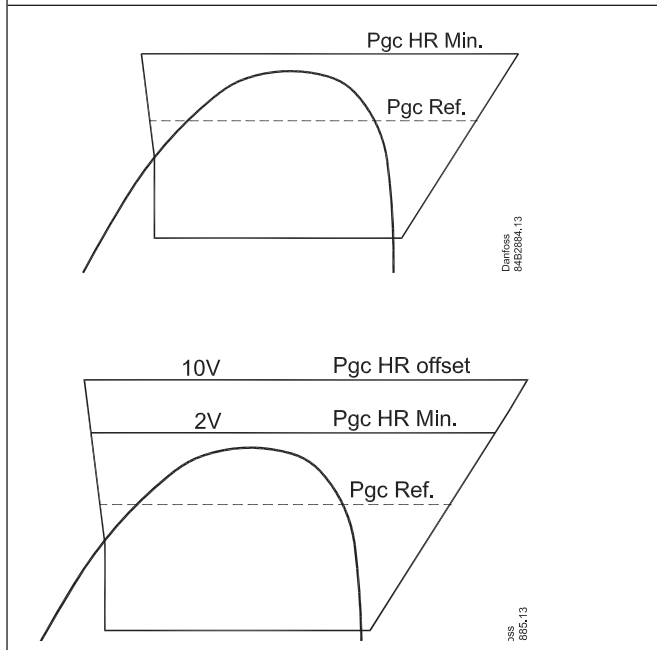

Menu survey

SW =2.0x

Function	Parameter	Min.	Max.	Factory setting
Normal display				
Shows the current pressure after the gas cooler Pushing both buttons briefly will display the reference Pushing the bottom button briefly will display Prec.	-		bar	
Start / stop				
Start / stop of regulation	r12	OFF (0)	On (1)	On (1)
Ramp for reference after heat recovery	r65	0.1	20	1
Displacement of the Pgc minimum reference (n89) during heat recovery. (Displacement value at 10 V)	r68	0 bar	100 bar	0
Alarm Settings				
Alarm limit for Pgc Min.	A65	0 bar	200 bar	40
Permitted Pgc reference variation 0 = no alarm function (recommended)	A66	0 bar	50 bar	0
Permitted Prec reference variation 0 = no alarm function (recommended)	A67	0 bar	50 bar	0
Delay time for 'A94' Pgc reference alarm	A68	5 min.	360 min	15
Delay time for 'A95' Prec reference alarm	A69	5 min.	360 min	15
Regulating parameters				
Actuator type for receiver control 0=ETS12,5/25 / CCM10/20, 1=ETS50 / CCM30, 2=ETS100 / CCM40, 3=ETS250, 4=ETS400, 5=User defined (set: n37 and n38) 6=CCMT2/4/8	n03	0	6	0
P: Amplification factor Kp	n04	0.5	20	2.0
I: Integration time Tn	n05	10 s	600 s	75
Max. opening degree. of the valve	n32	0	100	100
Number of steps from 0-100% opening degree (x10) **	n37	0	500	262
Number of steps per second	n38	0	300	250
Max. permitted receiver pressure, Prec	n58	10 bar	200 bar	60
P-belt beyond PrecMax for valve to close	n59	0 bar	60 bar	0
P: Amplification factor Kp for receiver	n60	0.5	20	5
I: Integration time Tn for receiver	n61	10	600	75
The gas cooler's max. pressure This is where you set the maximum pressure permitted in the gas cooler. If the pressure reaches this value, the valve is fully open.	n69	7	200	90
P-band under n69, so the valve is fully open if the pressure is n69.	n70	0	60	5
Min. pressure in the receiver This function is only used if the pressure transmitter Prec is mounted.	n71	7	60	30
P-band to force open the valve if the receiver pressure is too low	n72	0	60	3
Subcooling is required to be regulated according to temperature Set the desired subcooling in K.	n79	1 K	30 K	1
The gas cooler's min. pressure	n81	7	200 bar	45
Min. permissible opening degree for ICMTS	n87	0	100%	0
Extra capacity when the contact is closed. (The Pgc reference is increased with this value)	n88	0 bar	200 bar	0
Minimum permitted Pgc reference during heat recovery (AI > 2 V). The value can be increased further using the r68 function.	n89	7 bar	200 bar	7
Do you require receiver pressure control: Off=no, On=yes	n90	Off	On	On
Prec. reference for receiver pressure control	n91	7 bar	200 bar	35
Receiver pressure control. Maximum opening degree for ETS	n92	0%	100%	100
Receiver pressure control. Smallest opening degree for ETS	n93	0%	100%	0
Define the reference curve point at 100 bar.	n99	35°C	55°C	39

Miscellaneous				
Digital input signal - DI 0: The input is not used 1: External main switch 2: additional cooling capacity	o02	0	2	0
Controller's address	o03*	0	240	-
ON/OFF switch (service-pin message)	o04*	-	-	-
Set supply voltage frequency	o12	50Hz (0)	60 Hz (1)	0
Pressure transmitter range Pgc - min.	o20	-1 bar	5 bar	-1
Pressure transmitter range Pgc - max.	o21	6 bar	199 bar	159
Pressure transmitter range Prec - min.	o47	-1 bar	5 bar	-1
Pressure transmitter range Prec - max.	o48	6 bar	199 bar	59

* This setting is only possible if a data communication module is fitted in the controller.

** The controller display is limited to three digits, but the setting is a four-digit value. Only the three most significant digits are shown. For example, a value of 2500 is shown as 250.

Service		
Signal on AI the input	u07	V
Read status of input DI	u10	on/off
Read ETS/CCM valves opening degree	u24	%
Calculated reference for regulation (desired pressure in the gas cooler)	U03	bar
The output signal to the ICMTS valve converted into opening degree	U04	%
The temperature in the gas cooler. Measured using temperature sensor Sgc.	U05	°C
The pressure in the gas cooler. Measured using pressure transmitter Pgc.	U06	bar
The pressure in the receiver. Measured using pressure transmitter Prec, but only if it is mounted.	U07	bar

Technical data

Supply voltage	24 V a.c. +/-15% 50/60 Hz (the supply voltage is galvanically separated from the input and output signals)	
Power consumption	Controller	8 VA
Input signal	Pressure transmitter	Ratiometric, AKS 2050
	Pressure transmitter	Ratiometric, AKS 2050
	Digital input from external contact function	
	Voltage signal	0-10 V Ri = 100 k ohm Signal range = 2-10 V
Alarm relay	Sensor input	1 Pt 1000 ohm
	1 SPST	250 V a.c. AC-1: 4 A (resistive) AC-15: 3 A (inductive)
Actuator	ICAD mounted on ICMTS	Voltage signal 0-10 mA
	ETS or CCM	Step motor
Data communication	An EKA 174 data communication module can be connected	
Ambient conditions	-10 to +55°C, during operations -40 to +70°C, during transport	
	20 - 80% Rh, not condensed No shock influence / vibrations	
Enclosure	IP 20	
Weight	300 g	
Mounting	DIN rail	
Display	LED, 3 digits	
Terminals	max. 2.5 mm ² multicore	
Approvals	EMC acc. EN 61000-6-3 and EN 61000-4-(2-6,8,11) LVD acc. EN 60730-1 and EN 60730-2-9	

Wiring

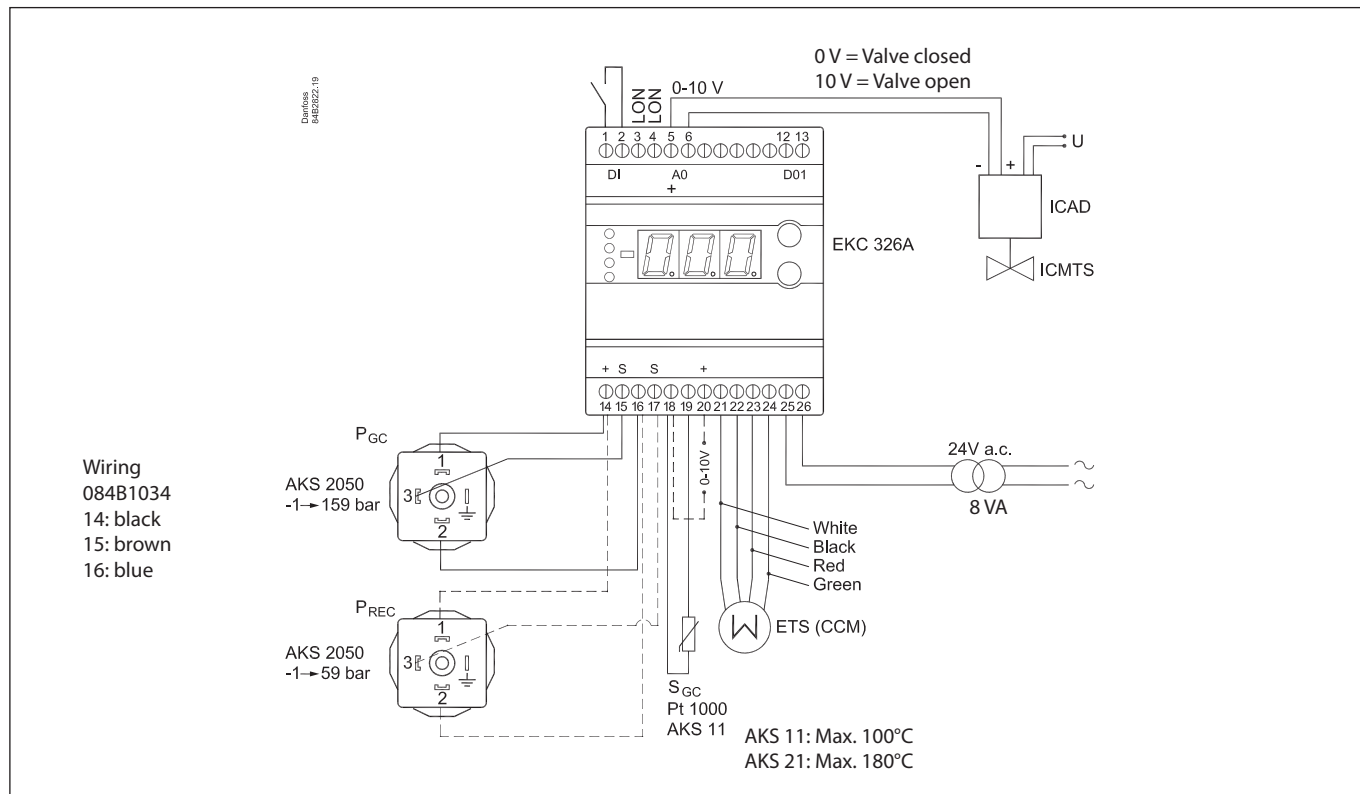

Ordering data

Type	Functional description	Code
EKC 326A	Gas pressure controller	084B7252
EKA 174	Data communication module (Lon RS 485) with galvanic isolation (accessory item)	084B7124

Data communication must be installed in accordance with the requirements specified in technical brochure RC8AC.

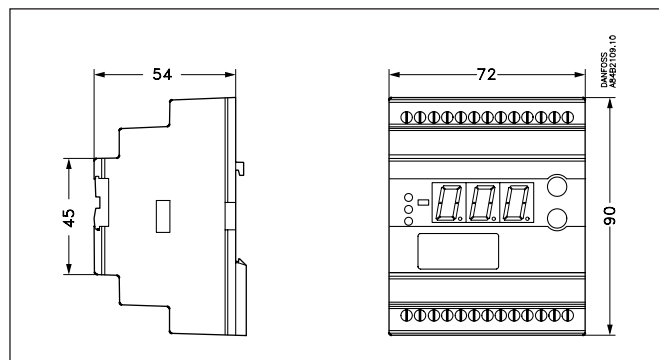

Temperature control

ERC 211, ERC 213, ERC 214

Application

- Temperature controller for refrigeration appliances and cold rooms.
- Defrost control
- Front panel mounting

Advantages

- Integrated refrigeration system functions
- Defrost on demand in 1:1 systems
- Buttons and gasket integrated in front panel
- IP 65 rating for front panel
- Digital input any one of the following:
 - Door alarm
 - Defrost start
 - Regulation start/stop
 - Night operation
 - Switching between two temperature references
 - Fast cool down
- Instant programming using programming key
- HACCP
 - Factory calibration assures measurement accuracy exceeding the requirements of the EN 441-13 standard without subsequent calibration (Pt1000 sensor).

Control

The controller contains a temperature regulator that can accept an input signal from a single temperature sensor.

The sensor can be located in the cold air flow after the evaporator or in the warm air flow just ahead the evaporator.

The controller regulates defrosting using natural defrost or electrical defrosting. Renewed cut-in after defrosting can occur based on time or temperature.

The defrost temperature can be measured directly using an S5 sensor.

One, two or three relays enable or disable the required functions as determined by the application:

- Refrigeration (compressor or solenoid valve)
- Defrost
- Alarm
- Fan
- Light

The various applications are described on the next page.

Controller versions

There are three controllers in the series:

ERC 211 model for simple regulation systems with one relay

ERC 213 model with several functions and three relays

ERC 214 model with even more functions and four relays.

None of these models supports data communication.

If data communication or additional functions is/are required, see the EKC 202 or AK-CC 210 / 250 series.

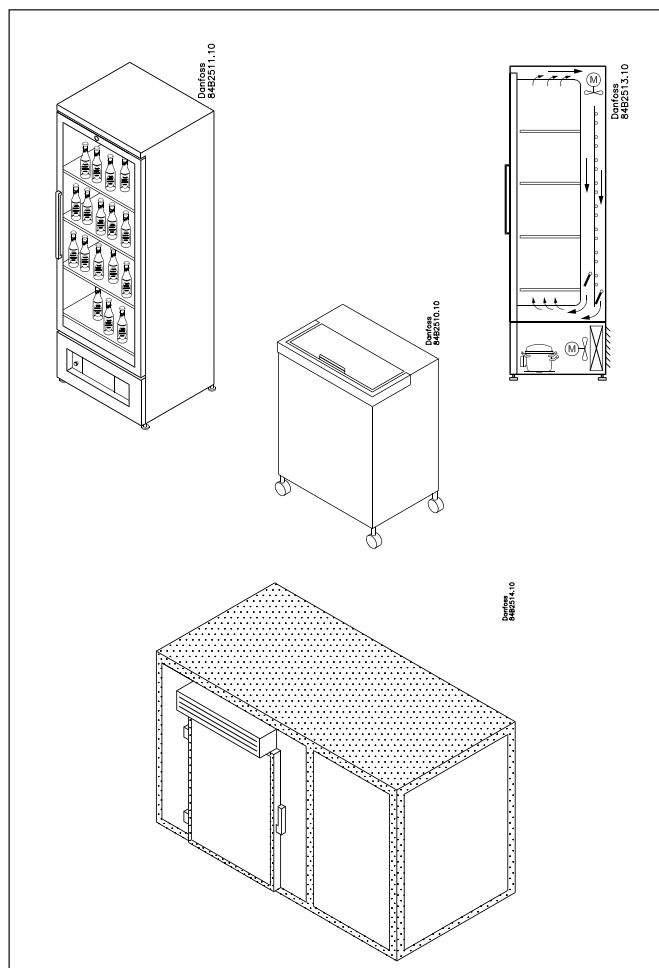
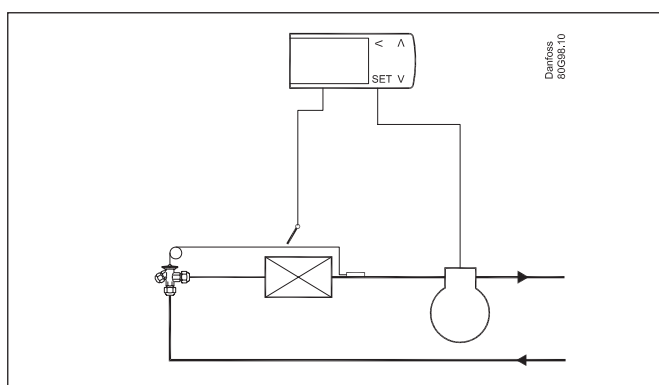

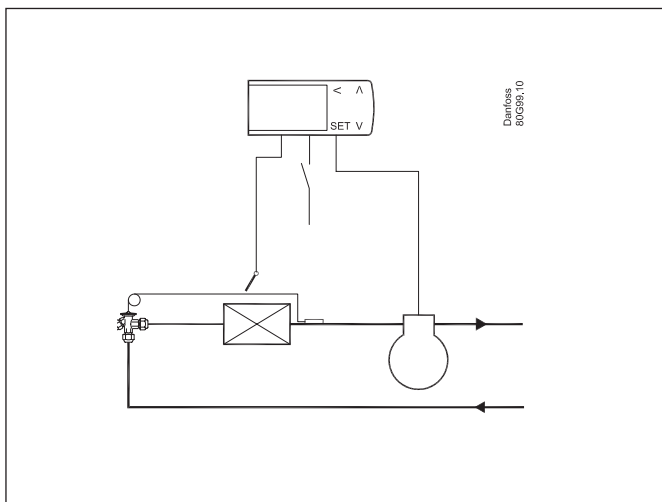

ERC 211

Controller with one relay output and one temperature sensor and one digital input.
Alternatively, the digital input is used for a signal from a temperature sensor on the condenser.

Temperature control with compressor start/stop operation.
Natural defrosting with compressor stopped
As an alternative to compressor start/stop control, a solenoid valve can be fitted in the liquid line.

Heating function
The controller can also be used as a simple on/off thermostat for heating applications.

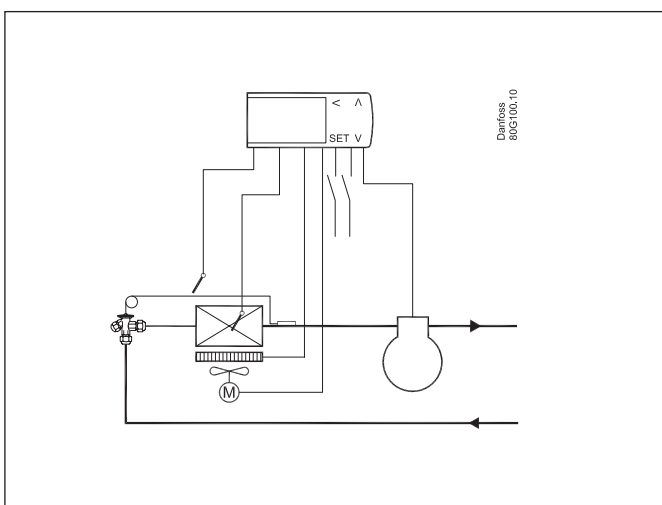

ERC 213

Controller with three relay outputs and two temperature sensor and two digital input.
Alternatively, the digital input is used for a signal from a temperature sensor on the condenser.

Temperature control with compressor start/stop or a solenoid valve
Defrost sensor
Electrical defrost / gas defrost / alarm relay
Control of fan.

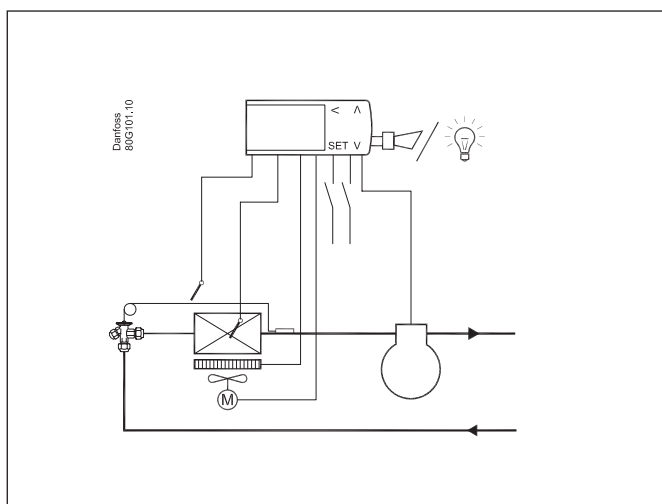

ERC 214

Controller with four relay outputs, two temperature sensors, and two digital inputs.
Alternatively, the digital input is used for a signal from a temperature sensor on the condenser.

Temperature control with compressor start/stop or a solenoid valve
Defrost sensor
Electrical defrost / gas defrost
Alarm relay / light relay
Control of fan.

Parameter Name - ERC 211	Code	Min	Max	Unit	App. 0 (Def.)	App. 1	App. 2	App. 3	App. 4	App. 5
Configuration	cFg									
Main switch <i>-1=service, 0=OFF, 1=ON</i>	r12	-1	1		1	1	1	1	1	1
Predefined applications <i>AP0, AP1, AP2, AP3, AP4</i>	o61	AP0	AP5		AP0	AP1	AP2	AP3	AP4	AP5
Sensor type selection <i>n5=NTC 5 K, n10=NTC 10 K, Ptc=PTC, Pt1=Pt1000</i>	o06	n5	Pt1		n10	n10	n10	n10	n10	n10
Reference/Thermostat	r--									
Temperature Setpoint	r00	-100.0	200.0	C/F	2.0	8.0	4.0	4.0	40.0	2.0
Differential	r01	0.1	20.0	K	2.0	2.0	2.0	2.0	2.0	2.0
Min Set Point limitation	r02	-100.0	200.0	C/F	-35.0	4.0	2.0	2.0	20.0	-35.0
Max Set Point limitation	r03	-100.0	200.0	C/F	50.0	20.0	6.0	6.0	60.0	50.0
Display offset (correction value in display temperature)	r04	-10.0	10.0	K	0.0	0.0	0.0	0.0	0.0	0.0
Display Unit (°C/°F)	r05	-C	-F		-C	-C	-C	-C	-C	-C
Calibration of Sair (offset for air temperature calibration)	r09	-20.0	20.0	K	0.0	0.0	0.0	0.0	0.0	-
Main switch <i>-1=service, 0=OFF, 1=ON</i>	r12	-1	1		1	1	1	1	1	-
Night Set back (offset temperature during night mode)	r13	-50.0	50.0	K	0.0	0.0	0.0	0.0	0.0	0.0
Thermostat reference displacement offset temperature	r40	-50.0	50.0	K	0.0	0.0	0.0	0.0	0.0	-
Pull-down duration	r96	0	960	min	0	-	0	0	-	-
Pull-down limit temperature	r97	-100.0	200.0	C/F	0.0	-	0.0	0.0	-	-
Alarm	A--									
Delay for temperature alarm during normal conditions	A03	0	240	min	30	45	45	45	30	30
Delay for temperature alarm during pull- down/start-up/defrost	A12	0	240	min	60	60	90	90	60	60
High temperature alarm limit (Cabinet/Room)	A13	-100.0	200.0	C/F	8.0	16	10	10	80	8.0
Low temperature alarm limit	A14	-100.0	200.0	C/F	-30.0	0.0	0.0	0.0	10	-30.0
DI1 delay (time delay for selected DI1 function)	A27	0	240	min	30	30	30	30	30	30
Condenser high alarm limit	A37	0	200	C/F	80	80	80	80	-	-
Condenser high block limit	A54	0	200	C/F	85	85	85	85	-	-
Voltage protection enable	A72	no	yES		no	no	no	no	no	no
Minimum cut-in voltage	A73	0	270	V	0	0	0	0	0	0
Minimum cut-out voltage	A74	0	270	V	0	0	0	0	0	0
Maximum voltage	A75	0	270	V	270	270	270	270	270	270
Defrost	d--									
Defrost Method <i>no=no defrost, nAt=natural</i>	d01	no	nAt		no	no	nAt	nAt	no	no
Defrost stop temperature	d02	0.0	50.0	C/F	6.0	-	-	8	-	6.0
Defrost interval	d03	0	240	hours	8	-	6	6	-	8
Max defrost time	d04	0	480	min	30	-	45	60	-	30
Defrost delay at power up (or DI signal)	d05	0	240.0	min	0	-	0	0	-	-
Drip delay	d06	0	60	min	0	-	0	0	-	-
Defrost stop sensor configuration <i>non=time,</i> <i>Air=Sair (air temperature)</i>	d10	non	Air		non	-	non	Air	-	non
Compressor accumulated runtime to start defrost <i>0=OFF</i>	d18	0	96	hours	0	-	0	0	-	-
Defrost delay after pull-down <i>0=OFF</i>	d30	0	960	min	0	-	0	0	-	-
Compressor	c--									
Compressor minimum ON time	C01	0	30	min	0	0	0	0	0	0.0
Compressor minimum OFF time	C02	0	30	min	2	2	2	2	2	2.0
Compressor OFF delay at door open	C04	0	15	min	0	0	0	0	0	1
Zero crossing selection	C70	no	yES		yES	yES	yES	yES	yES	YES

Parameter Name - ERC 211	Code	Min	Max	Unit	App. 0 (Def.)	App. 1	App. 2	App. 3	App. 4	App. 5
Others	o--									
Delay of outputs at startup	o01	0	600	min	5	5	5	5	5	5
DI1 configuration <i>oFF=not used, Sdc=status display output, doo=door alarm with resumption, doA=door alarm without resumption, SCH = main switch, nig=day/ night mode, rFd=reference displacement, EAL=external alarm, dEF=defrost, Pud=pull-down, Sc=condenser sensor</i>	o02	oFF	Sc		oFF	oFF	oFF	oFF	oFF	oFF
Serial address	o03	0	247		0	0	0	0	0	-
Password	o05	no	999		no	no	no	no	no	no
Sensor type selection <i>n5=NTC 5 K, n10=NTC 10 K, Ptc=PTC, Pt1=Pt1000</i>	o06	n5	Pt1		n10	n10	n10	n10	n10	-
Cooling/Heating <i>rE=refrigeration (cooling) Ht=heating</i>	o07	rE	Ht		rE	rE	rE	rE	Ht	0(rE)
Display Resolution <i>0.1=steps of 0.1 °C 0.5=steps of 0.5 °C, 1.0=steps of 1.0 °C</i>	o15	0.1	1.0		0.1	0.1	0.1	0.1	0.1	0.1
Relay 1 counter (1 count=100 cycles of operation)	o23	0	999		0	0	0	0	0	-
Predefined applications	o61	AP0	AP5		AP0	AP1	AP2	AP3	AP4	-
Save settings as factory WARNING: The earlier factory settings are overwritten	o67	no	yES		no	no	no	no	no	-
Display at defrost <i>Air=actual air temperature, FrE=freedzed temperature, -d="-d-" is displayed</i>	o91	Air	-d-		-d-	-	-d-	-d-	-	-d-
Polarity	P--									
DI1 input polarity <i>nc=normally closed, no=normally open</i>	P73	nc	no		no	no	no	no	no	no
Key board lock enable	P76	no	yES		no	no	no	no	no	-
Read outs	u--									
Controller Status <i>S0=Cooling ON/Heating ON, S2=wait for compressor ON time to elapse, S3=wait for compressor OFF time to elapse-restart time, S4=drip OFF delay after defrost, S10=cooling stop, S11=cooling stopped by thermostat/heating OFF, S14=defrosting state, S15=fan delay state after defrost, S17=door open (DI input), S20=emergency cooling, S25=manual control of outputs, S30=Continuous cycle/Pull-down, S32=delay of outputs at power up</i>	u00	S0	S32		--					
Air temperature (Sair)	u01	-100.0	200.0	C/F	---					
Read the present regulation reference	u02	-100.0	200.0	C/F	---					
DI1 input	u10	oFF	on		---					
Status of night operation	u13	oFF	on		---					
Condenser temperature (Sc)	U09	-100.0	200.0	C/F	---					
Compressor relay status	u58	oFF	on		---					
Firmware version readout	u80	000	999		---					

Note: hidden parameters are greyed

Parameter Name - ERC 213	Code	Min	Max	Unit	App. 0 (Def.)	App. 1	App. 2	App. 3	App. 4	App. 5	App. 6
Configuration	cFg										
Main switch <i>-1=service, 0=OFF, 1=ON</i>	r12	-1	1		1	1	1	1	1	1	1
Predefined applications <i>AP0, AP1, AP2, AP3, AP4, AP5</i>	o61	AP0	AP5		AP0	AP1	AP2	AP3	AP4	AP5	AP6
Sensor type selection <i>n5=NTC 5 K, n10=NTC 10 K, Ptc=PTC, Pt1=Pt1000</i>	o06	n5	Pt1		n10	n10	n10	n10	n10	n10	n10
Reference/Thermostat	r--										
Temperature Setpoint	r00	-100.0	200.0	C/F	2.0	4.0	2.0	-24.0	2.0	-24.0	2.0
Differential	r01	0.1	20.0	K	2.0	2.0	2.0	2.0	2.0	2.0	2.0
Min Set Point limitation	r02	-100.0	200.0	C/F	-35.0	2.0	0.0	-26.0	0.0	-26.0	-35.0
Max Set Point limitation	r03	-100.0	200.0	C/F	50.0	6.0	4.0	-20.0	4.0	-20.0	50.0
Display offset (correction value in display temperature)	r04	-10.0	10.0	K	0.0	0.0	0.0	0.0	0.0	0.0	0.0
Display Unit (°C/°F)	r05	-C	-F		-C	-C	-C	-C	-C	-C	-C
Calibration of Sair (offset for air temperature calibration)	r09	-20.0	20.0	K	0.0	0.0	0.0	0.0	0.0	0.0	-
Main switch <i>-1=service, 0=OFF, 1=ON</i>	r12	-1	1		1	1	1	1	1	1	-
Night Set back (offset temperature during night mode)	r13	-50.0	50.0	K	0.0	0.0	0.0	0.0	0.0	0.0	0.0
Thermostat reference displacement offset temperature	r40	-50.0	50.0	K	0.0	0.0	0.0	0.0	0.0	0.0	-
Pull-down duration	r96	0	960	min	0	0	0	0	0	0	-
Pull-down limit temperature	r97	-100.0	200.0	C/F	0.0	0.0	0.0	0.0	0.0	0.0	-
Alarm	A--										
Delay for temperature alarm during normal conditions	A03	0	240	min	30	45	30	30	30	30	30
Delay for temperature alarm during pull-down/start-up/defrost	A12	0	240	min	60	90	60	60	60	60	60
High temperature alarm limit (Cabinet/Room)	A13	-100.0	200.0	C/F	8.0	10.0	8.0	-15.0	8.0	-15.0	8.0
Low temperature alarm limit	A14	-100.0	200.0	C/F	-30.0	0.0	-2.0	-30.0	-2.0	-30.0	-30.0
DI1 delay (time delay for selected DI1 function)	A27	0	240	min	30	30	30	30	30	30	30
DI2 delay (time delay for selected DI2 function)	A28	0	240	min	30	30	30	30	30	30	30
Condenser high alarm limit	A37	0	200	C/F	80	80	80	80	80	80	-
Condenser high block limit	A54	0	200	C/F	85	85	85	85	85	85	-
Voltage protection enable	A72	no	yES		no	no	no	no	no	no	no
Minimum cut-in voltage	A73	0	270	V	0	0	0	0	0	0	0
Minimum cut-out voltage	A74	0	270	V	0	0	0	0	0	0	0
Maximum voltage	A75	0	270	V	270	270	270	270	270	270	270
Defrost	d--										
Defrost Method <i>no=no defrost, nAt=natural, EL=electrical, gAS=hot gas</i>	d01	no	gAS		EL	nAt	EL	EL	EL	EL	EL
Defrost stop temperature	d02	0.0	50.0	C/F	6.0	-	-	-	6.0	6.0	6.0
Defrost interval	d03	0	240	hours	8	6	8	12	8	12	8
Max defrost time	d04	0	480	min	30	45	15	15	30	30	30
Defrost delay at power up (or DI signal)	d05	0	240.0	min	0	0	0	0	0	0	-
Drip delay	d06	0	60	min	0	0	0	0	0	0	5
Fan delay after defrost	d07	0	60	min	0	0	0	0	0	0	5
Fan start temperature after defrost	d08	-50.0	0.0	C/F	-5.0	-	-	-	-5.0	-5.0	-
Fan during defrost	d09	oFF	on		on	on	on	on	on	on	on
Defrost stop sensor configuration <i>non=time, Air=Sair (air temperature), dEF=S5 (defrost sensor)</i>	d10	non	dEF		non	non	non	non	dEF	dEF	non
Compressor accumulated runtime to start defrost <i>0=OFF</i>	d18	0	96	hours	0	0	0	0	0	0	-
Defrost on demand <i>20.0=OFF</i>	d19	0.0	20.0	K	20.0	-	-	-	20.0	20.0	-
Defrost delay after pull-down <i>0=OFF</i>	d30	0	960	min	0	0	0	0	0	0	-

	Code	Min	Max	Unit	App. 0 (Def.)	App. 1	App. 2	App. 3	App. 4	App. 5	App. 6
Fan control											
Fan at compressor cutout <i>Ffc=fan follow compressor, FAo=fan always ON, FPL= fan pulsating</i>	F01	Ffc	FPL		FAo	FAo	FAo	FAo	FAo	FAo	FAo
Fan stop evaporator temperature <i>50,0=OFF</i>	F04	-50.0	50.0	C/F	50.0	-	-	-	50.0	50.0	-
Fan ON Cycle	F07	0	15	min	2	2	2	2	2	2	2
Fan OFF cycle	F08	0	15.0	min	2	2	2	2	2	2	2
Compressor											
Compressor minimum ON time	C01	0	30	min	0	0	0	0	0	0	0
Compressor minimum OFF time	C02	0	30	min	2	2	2	2	2	2	2
Compressor OFF delay at door open	C04	0	15	min	0	0	0	0	0	0	1
Zero crossing selection	C70	no	yES		yES	yES	yES	yES	yES	yES	yES
Others											
Delay of outputs at startup	o01	0	600	min	5	5	5	5	5	5	5
DI1 configuration <i>oFF=not used, Sdc=status display output, doo=door alarm with resumption, doA=door alarm without resumption, SCH = main switch, nig=day/ night mode, rFd=reference displacement, EAL=external alarm, dEF=defrost, Pud=pull-down, Sc=condenser sensor</i>	o02	oFF	Sc		oFF	oFF	oFF	oFF	oFF	oFF	oFF
Serial address	o03	0	247		0	0	0	0	0	0	-
Password	o05	no	999		no	no	no	no	no	no	no
Sensor type selection <i>n5=NTC 5 K, n10=NTC 10 K, Ptc=PTC, Pt1=Pt1000</i>	o06	n5	Pt1		n10	n10	n10	n10	n10	n10	-
Display Resolution <i>0.1=steps of 0.1 °C 0.5=steps of 0.5 °C, 1.0=steps of 1.0 °C</i>	o15	0.1	1.0		0.1	0.1	0.1	0.1	0.1	0.1	0.1
Relay 1 counter (1 count=100 cycles of operation)	o23	0	999		0	0	0	0	0	0	-
Relay 2 counter (1 count=100 cycles of operation)	o24	0	999		0	0	0	0	0	0	-
Relay 3 counter (1 count=100 cycles of operation)	o25	0	999		0	0	0	0	0	0	-
DI2 configuration <i>oFF=not used, Sdc=status display output, doo=door alarm with resumption, doA=door alarm without resumption, SCH=main switch, nig=day/night mode, rFd=reference displacement, EAL=external alarm, dEF=defrost, Pud=pull-down</i>	o37	oFF	Pud		oFF	oFF	oFF	oFF	oFF	oFF	oFF
Predefined applications	o61	AP0	AP5		AP0	AP1	AP2	AP3	AP4	AP5	-
Save settings as factory WARNING: The earlier factory settings are overwritten	o67	no	yES		no	no	no	no	no	no	-
DO2 config <i>(dEF=Defrost; ALA=alarm)</i>	o71	dEF	ALA		dEF	ALA	dEF	dEF	dEF	dEF	dEF
Display at defrost <i>Air=actual air temperature, FrE=freezed temperature, -d=-"d-" is displayed</i>	o91	Air	-d-		-d-	-d-	-d-	-d-	-d-	-d-	-d-
Polarity											
DI1 input polarity <i>nc=normally closed, no=normally open</i>	P73	nc	no		no	no	no	no	no	no	no
DI2 input polarity <i>nc=normally closed, no=normally open</i>	P74	nc	no		no	no	no	no	no	no	no
Invert alarm relay <i>0=normal, 1=invert relay action</i>	P75	0	1		0	0	-	-	-	-	-
Key board lock enable	P76	no	yES		no	no	no	no	no	no	-

	Code	Min	Max	Unit	App. 0 (Def.)	App. 1	App. 2	App. 3	App. 4	App. 5	App. 6
Read outs	u--										
Controller Status <i>S0=Cooling ON/Heating ON, S2=wait for compressor ON time to elapse, S3=wait for compressor OFF time to elapse-restart time, S4=drip OFF delay after defrost, S10=cooling stop, S11=cooling stopped by thermostat/heating OFF, S14=defrosting state, S15=fan delay state after defrost, S17=door open (DI input), S20=emergency cooling, S25=manual control of outputs, S30=continuous cycle/Pull-down, S32=delay of outputs at power up</i>	u00	S0	S32		--						
Air temperature (Sair)	u01	-100.0	200.0	C/F	---						
Read the present regulation reference	u02	-100.0	200.0	C/F	---						
Defrost temperature (S5)	u09	-100.0	200.0	C/F	---	-	-	-			
DI1 input	u10	oFF	on		---						
Status of night operation	u13	oFF	on		---						
DI2 input	u37	oFF	on		---						
Condenser temperature (Sc)	U09	-100.0	200.0	C/F	---						
Compressor relay status	u58	oFF	on		---						
Fan relay status	u59	oFF	on		---						
Defrost relay status	u60	oFF	on		---						
Alarm relay status	u62	oFF	on		---						
Light relay status	u63	oFF	on		---						
Firmware version readout	u80	000	999		---						

Note: hidden parameters are greyed

Parameter Name - ERC 214	Code	Min	Max	Unit	App. 0 (Def.)	App. 1	App. 2	App. 3	App. 4	App. 5	App. 6
Configuration	cFg										
Main switch <i>-1=service, 0=OFF, 1=ON</i>	r12	-1	1		1	1	1	1	1	1	1
Predefined applications <i>AP0, AP1, AP2, AP3, AP4, AP5</i>	o61	AP0	AP5		AP0	AP1	AP2	AP3	AP4	AP5	AP6
Sensor type selection <i>n5=NTC 5 K, n10=NTC 10 K, Ptc=PTC, Pt1=Pt1000</i>	o06	n5	Pt1		n10	n10	n10	n10	n10	n10	n10
DO4 configuration <i>Lig=light, ALA=alarm</i>	o36	Lig	ALA		Lig	Lig	Lig	Lig	Lig	Lig	Lig
Reference/Thermostat	r--										
Temperature Setpoint	r00	-100.0	200.0	C/F	2.0	4.0	2.0	-24.0	2.0	-24.0	2.0
Differential	r01	0.1	20.0	K	2.0	2.0	2.0	2.0	2.0	2.0	2.0
Min Set Point limitation	r02	-100.0	200.0	C/F	-35.0	2.0	0.0	-26.0	0.0	-26.0	-35.0
Max Set Point limitation	r03	-100.0	200.0	C/F	50.0	6.0	4.0	-20.0	4.0	-20.0	50.0
Display offset (correction value in display temperature)	r04	-10.0	10.0	K	0.0	0.0	0.0	0.0	0.0	0.0	0.0
Display Unit (°C/°F)	r05	-C	-F		-C	-C	-C	-C	-C	-C	-C
Calibration of Sair (offset for air temperature calibration)	r09	-20.0	20.0	K	0.0	0.0	0.0	0.0	0.0	0.0	-
Main switch <i>-1=service, 0=OFF, 1=ON</i>	r12	-1	1		1	1	1	1	1	1	-
Night Set back (offset temperature during night mode)	r13	-50.0	50.0	K	0.0	0.0	0.0	0.0	0.0	0.0	0.0
Thermostat reference displacement offset temperature	r40	-50.0	50.0	K	0.0	0.0	0.0	0.0	0.0	0.0	-
Pull-down duration	r96	0	960	min	0	0	0	0	0	0	-
Pull-down limit temperature	r97	-100.0	200.0	C/F	0.0	0.0	0.0	0.0	0.0	0.0	-
Alarm	A--										
Delay for temperature alarm during normal conditions	A03	0	240	min	30	45	30	30	30	30	30
Delay for temperature alarm during pull-down/start-up/defrost	A12	0	240	min	60	90	60	60	60	60	60
High temperature alarm limit (Cabinet/Room)	A13	-100.0	200.0	C/F	8.0	10.0	8.0	-15.0	8.0	-15.0	8.0
Low temperature alarm limit	A14	-100.0	200.0	C/F	-30.0	0.0	-2.0	-30.0	-2.0	-30.0	-30.0
DI1 delay (time delay for selected DI1 function)	A27	0	240	min	30	30	30	30	30	30	30
DI2 delay (time delay for selected DI2 function)	A28	0	240	min	30	30	30	30	30	30	30
Condenser high alarm limit	A37	0	200	C/F	80	80	80	80	80	80	-
Condenser high block limit	A54	0	200	C/F	85	85	85	85	85	85	-
Voltage protection enable	A72	no	yES		no	no	no	no	no	no	no
Minimum cut-in voltage	A73	0	270	V	0	0	0	0	0	0	0
Minimum cut-out voltage	A74	0	270	V	0	0	0	0	0	0	0
Maximum voltage	A75	0	270	V	270	270	270	270	270	270	270
Defrost	d--										
Defrost Method <i>no=no defrost, nAt=natural, EL=electrical, gAS=hot gas</i>	d01	no	gAS		EL	nAt	EL	EL	EL	EL	EL
Defrost stop temperature	d02	0.0	50.0	C/F	6.0	-	-	-	6.0	6.0	6.0
Defrost interval	d03	0	240	hours	8	6	8	12	8	12	8
Max defrost time	d04	0	480	min	30	45	15	15	30	30	30
Defrost delay at power up (or DI signal)	d05	0	240.0	min	0	0	0	0	0	0	-
Drip delay	d06	0	60	min	0	0	0	0	0	0	5
Fan delay after defrost	d07	0	60	min	0	0	0	0	0	0	5
Fan start temperature after defrost	d08	-50.0	0.0	C/F	-5.0	-	-	-	-5.0	-5.0	-
Fan during defrost	d09	oFF	on		on	on	on	on	on	on	on
Defrost stop sensor configuration <i>non=time, Air=Sair (air temperature), dEF=S5 (defrost sensor)</i>	d10	non	dEF		non	non	non	non	dEF	dEF	non
Compressor accumulated runtime to start defrost <i>0=OFF</i>	d18	0	96	hours	0	0	0	0	0	0	-
Defrost on demand <i>20.0=OFF</i>	d19	0.0	20.0	K	20.0	-	-	-	20.0	20.0	-
Defrost delay after pull-down <i>0=OFF</i>	d30	0	960	min	0	0	0	0	0	0	-

	Code	Min	Max	Unit	App. 0 (Def.)	App. 1	App. 2	App. 3	App. 4	App. 5	App. 6
Fan control	F--										
Fan at compressor cutout <i>FFc=fan follow compressor, FAo=fan always ON, FPL=fan pulsating</i>	F01	FFc	FPL		FAo	FAo	FAo	FAo	FAo	FAo	FAo
Fan stop evaporator temperature <i>50.0=OFF</i>	F04	-50.0	50.0	C/F	50.0	-	-	-	50.0	50.0	-
Fan ON Cycle	F07	0	15	min	2	2	2	2	2	2	2
Fan OFF cycle	F08	0	15.0	min	2	2	2	2	2	2	2
Compressor	c--										
Compressor minimum ON time	C01	0	30	min	0	0	0	0	0	0	0
Compressor minimum OFF time	C02	0	30	min	2	2	2	2	2	2	2
Compressor OFF delay at door open	C04	0	15	min	0	0	0	0	0	0	1
Zero crossing selection	C70	no	yES		yES	yES	yES	yES	yES	yES	yES
Others	o--										
Delay of outputs at startup	o01	0	600	min	5	5	5	5	5	5	5
D11 configuration <i>oFF=not used, Sdc=status display output, doo=door alarm with resumption, doA=door alarm without resumption, SCH = main switch, nig=day/ night mode, rFd=reference displacement, EAL=external alarm, dEF=defrost, Pud=pull-down, Sc=condenser sensor</i>	o02	oFF	Sc		oFF	oFF	oFF	oFF	oFF	oFF	oFF
Serial address	o03	0	247		0	0	0	0	0	0	-
Password	o05	no	999		no	no	no	no	no	no	0
Sensor type selection <i>n5=NTC 5 K, n10=NTC 10 K, Ptc=PTC, Pt1=Pt1000</i>	o06	n5	Pt1		n10	n10	n10	n10	n10	n10	-
Display Resolution <i>0.1=steps of 0.1 °C 0.5=steps of 0.5 °C, 1.0=steps of 1.0 °C</i>	o15	0.1	1.0		0.1	0.1	0.1	0.1	0.1	0.1	0.1
Relay 1 counter (1 count=100 cycles of operation)	o23	0	999		0	0	0	0	0	0	-
Relay 2 counter (1 count=100 cycles of operation)	o24	0	999		0	0	0	0	0	0	-
Relay 3 counter (1 count=100 cycles of operation)	o25	0	999		0	0	0	0	0	0	-
Relay 4 counter (1 count=100 cycles of operation)	o26	0	999		0	0	0	0	0	0	-
DO4 configuration <i>ALA=alarm, Lig=light</i>	o36	ALA	Lig		Lig	Lig	Lig	Lig	Lig	Lig	-
D12 configuration <i>oFF=not used, Sdc=status display output, doo=door alarm with resumption, doA=door alarm without resumption, SCH=main switch, nig=day/night mode, rFd=reference displacement, EAL=external alarm, dEF=defrost, Pud=pull-down</i>	o37	oFF	Pud		oFF	oFF	oFF	oFF	oFF	oFF	oFF
Light Control <i>on=always on, dAn=day/night, doo=based on door action</i>	o38	on	doo		on	on	on	on	on	on	on
Predefined applications	o61	AP0	AP5		AP0	AP1	AP2	AP3	AP4	AP5	-
Save settings as factory WARNING: The earlier factory settings are overwritten	o67	no	yES		no	no	no	no	no	no	-
Display at defrost <i>Air=actual air temperature, FrE=freezed temperature, -d="-d-" is displayed</i>	o91	Air	-d-		-d-	-d-	-d-	-d-	-d-	-d-	-d-
Polarity	P--										
D11 input polarity <i>nc=normally closed, no=normally open</i>	P73	nc	no		no	no	no	no	no	no	no
D12 input polarity <i>nc=normally closed, no=normally open</i>	P74	nc	no		no	no	no	no	no	no	no
Invert alarm relay <i>0=normal, 1=invert relay action</i>	P75	0	1		0	0	0	0	0	0	-
Key board lock enable	P76	no	yES		no	no	no	no	no	no	-

	Code	Min	Max	Unit	App. 0 (Def.)	App. 1	App. 2	App. 3	App. 4	App. 5	App. 6
Read outs	u--										
Controller Status <i>S0=Cooling ON/Heating ON, S2=wait for compressor ON time to elapse, S3=wait for compressor OFF time to elapse-restart time, S4=drip OFF delay after defrost, S10=cooling stop S11=cooling stopped by thermostat/heating OFF, S14=defrosting state, S15=fan delay state after defrost, S17=door open (DI input), S20=emergency cooling, S25=manual control of outputs, S30=Continuous cycle/Pull-down, S32=delay of outputs at power up</i>	u00	S0	S32		--						
Air temperature (Sair)	u01	-100.0	200.0	C/F	---						
Read the present regulation reference	u02	-100.0	200.0	C/F	---						
Defrost temperature (S5)	u09	-100.0	200.0	C/F	---	-	-	-			
DI1 input	u10	oFF	on		---						
Status of night operation	u13	oFF	on		---						
DI2 input	u37	oFF	on		---						
Condenser temperature (Sc)	U09	-100.0	200.0	C/F	---						
Compressor relay status	u58	oFF	on		---						
Fan relay status	u59	oFF	on		---						
Defrost relay status	u60	oFF	on		---						
Alarm relay status	u62	oFF	on		---						
Light relay status	u63	oFF	on		---						
Firmware version readout	u80	000	999		---						

Note: hidden parameters are greyed

Alarm status	Alarm code
Air temperature sensor (Sair) error	E29
Defrost sensor (S5) error	E27
Condenser sensor (Sc) error	E30
High temperature alarm	A01
Low temperature alarm	A02
High voltage alarm	A99
Low voltage alarm	AA1
High condenser temperature alarm	A61
Door alarm	A04
Standby alarm	A45
DI external alarm	A15

Wiring

ERC 211

Application 1, 2 and 3

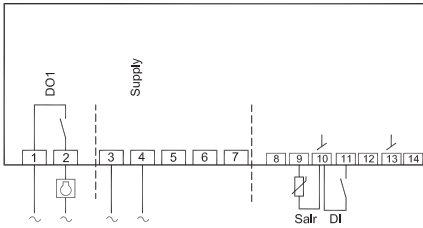

Danfoss
86C105.10

ERC 213

Application 1

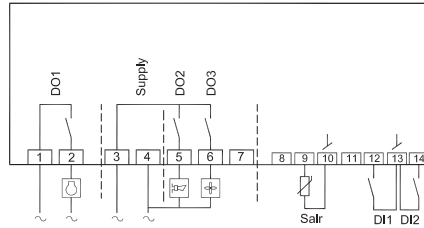

Danfoss
86C105.10

ERC 214

Application 1

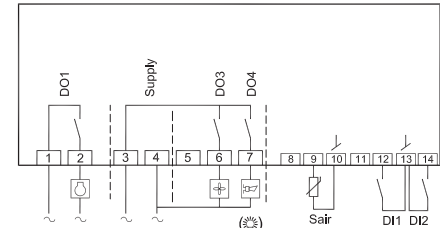

Danfoss
86C105.10

or application 4

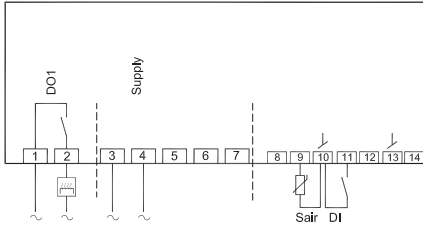

Danfoss
86C104.10

or application 2 and 3

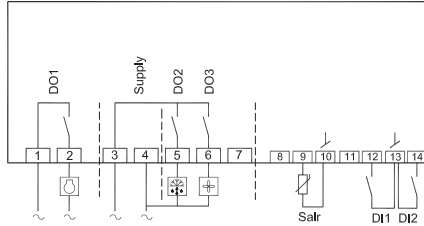

Danfoss
86C105.10

or application 2 and 3

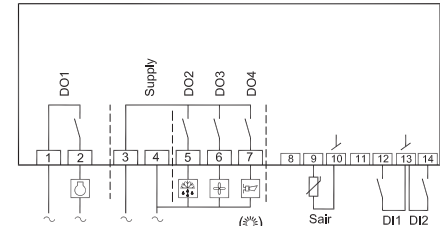

Danfoss
86C105.10

or application 4 and 5

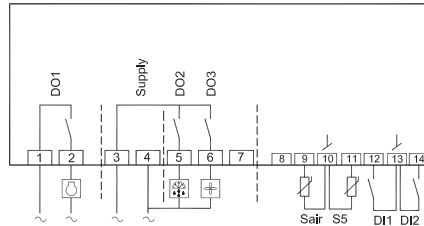

Danfoss
86C107.10

or application 4 and 5

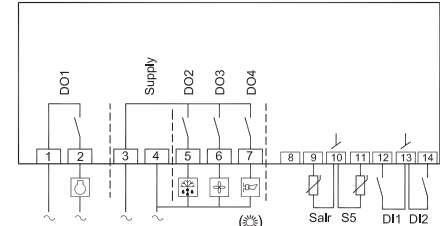

Danfoss
86C110.10

Power supply

230 V AC or 115 V AC See controller.

Sensors

SaIr is the thermostat sensor.

S5 is a defrost sensor and is used if defrost is stopped based on temperature.

Sc (not shown) is an extra sensor for measuring a temperature such as the condenser temperature.

This sensor can be connected instead of the digital input DI1.

Digital on/off signals

A cut-in input activates a function. The possible functions are described in menu o02 and menu o37.

Relays

The general configurations are:

Relay 1

Refrigeration. The contact cuts in when the controller demands refrigeration.

Relay 2

Defrost. The contact cuts in while defrosting is in progress.

Alarm. The relay is cut out when the controller is de-energised.

The setting in menu P75 will define whether it is cut in or cut out when there is an alarm situations

Relay 3

Fan.

Relay 4

Alarm. The relay is cut out when the controller is de-energised.

The setting in menu P75 will define whether it is cut in or cut out when there is an alarm situations

Light. The contact cuts in when the controller demands light.

Electrical interference

Cables for sensors and DI inputs must be kept separate from other electrical cables:

- Use separate cable trays
- Maintain a distance of at least 10 cm between cables
- Avoid connecting long cables to the DI input

Technical data

Power supply	115 V a.c. / 230 V a.c. 50-60 Hz, galvanic isolated. Low voltage regulated power supply
Rated power	Less than 0.7 VA
Inputs	4 inputs: 2 analogue, 1 analogue/digital and 1 digital
Sensors	NTC 5000 ohm at 25°C NTC 10000 ohm at 25°C PTC 1000 ohm (EKS 111) Pt 1000
Accuracy	Measuring range: -40 – 105°C (-40 – 221°F)
	Controller accuracy: ± 1 K below -35°C, ± 0.5 K between -35 – 25°C, ± 1 K above 25°C
Relays/outputs	DO1 Compressor relay: 16 A, 16(16) A, EN 60730 10 FLA/60LRA @230 V, UL60730 16 FLA/72LRA @115 V, UL60730
	DO2 Defrost relay: 8 A, 2 FLA/12 LRA, UL60730 8 A, 2 (2 A), EN60730
	DO3 Fan relay: 3 A, 2 FLA/12 LRA, UL60730 3 A, 2 (2 A), EN60730
	DO4 Alarm/Light relay: 2 A
Display	LED display, 3 digits, decimal point and multi functionality icons, °C + °F scale
Operating conditions	-10 – 55°C (14 – 131°F), 90% Rh
Storage conditions	-40 – 70°C (-40 – 158°F), 90% Rh
Enclosure	Front : IP65 (Gasket integrated) Rear: IP00
Environmental	Pollution degree II, non condensing
Resistance to heat and fire	Category D (UL94-V0)
EMC category	Category I
Approvals	UL recognition (US & Canada) (UL 60730) ENEC (EN 60730) CQC CE (LVD & EMC Directive) EAC (GHOST) NSF ROHS2.0

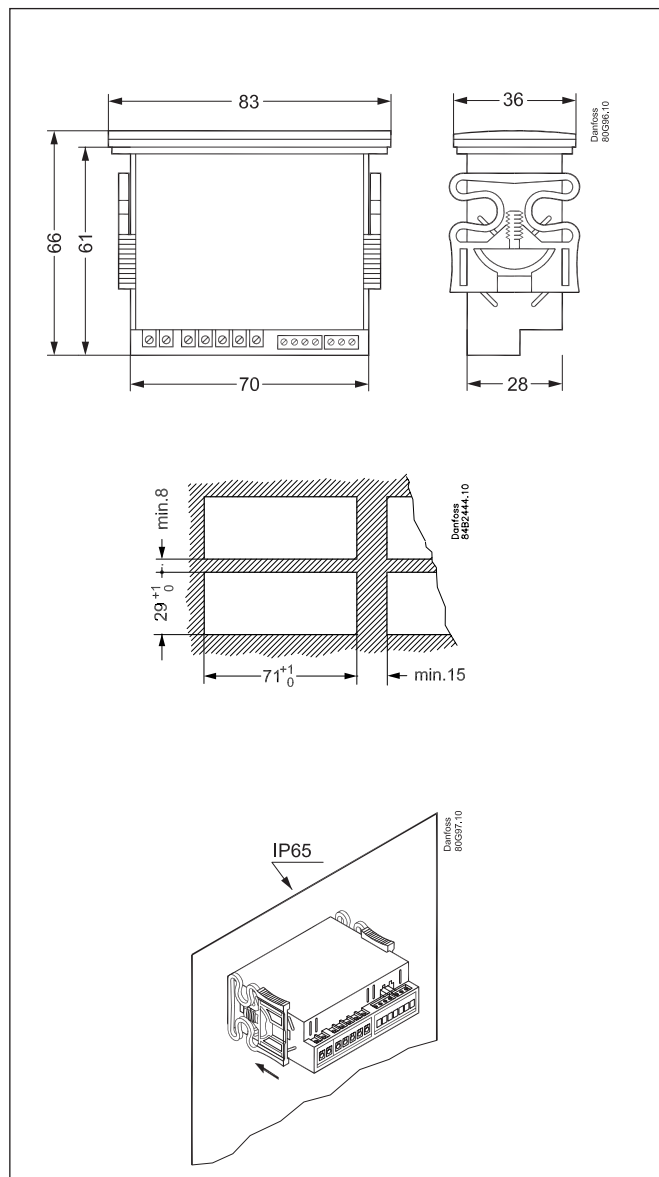

Ordering

Type		Function	Relay	Supply	Code no.
ERC 211		Temperature controller, RED LED	1	115 V a.c.	080G3290
ERC 213				230 V a.c.	080G3293
ERC 214			4	115 V a.c.	080G3291
				230 V a.c.	080G3294
EKA 183A		Programming key with adapter - ERC 21X			080G9740

Additional information available:
Manual: DKRCC.ES.RL0.H

EKC 202A / B / C, EKC 302A / B

Application

- This controller is used for temperature control of refrigeration appliances and cold rooms in supermarkets
- Control of defrost, fans, alarm and lighting
- EKC 202 is for front panel mounting
- EKC 302 is for DIN Rail mounting

Advantages

- Integrated refrigeration system functions
- Defrost on demand in 1:1 systems
- Buttons and gasket integrated in front panel
- IP 65 rating for front panel (EKC 202)
- Digital input any one of the following:
 - Door contact function with alarm
 - Defrost start
 - Regulation start/stop
 - Night operation
 - Switching between two temperature references
 - Case cleaning
- Instant programming using programming key
- HACCP
Factory calibration assures measurement accuracy exceeding the requirements of the EN 441-13 standard without subsequent calibration (Pt1000 sensor).

Extra module

- The controller can be retrofitted with a plug-in module if necessary for the application. The controller has a connector to receive the plug-in module.
 - *Battery module (EKC 202)*
This module provides back-up power to the controller if the supply voltage is interrupted for more than four hours. This ensures reliable operation of the clock function during a power failure.
 - *Data communication*
If PC-based operation is necessary, a data communication module must be fitted to the controller.
 - Coordinated defrost via data communication

Regulation

- The controller contains a temperature regulator that can accept an input signal from a single temperature sensor. The sensor can be located in the cold air flow after the evaporator or in the warm air flow just ahead the evaporator. The controller regulates defrosting using natural defrost or electrical defrosting. Renewed cut-in after defrosting can occur based on time or temperature. The defrost temperature can be measured directly by using a defrost sensor. The required functions needed for the application are cut in and out by two to four relays:
- Refrigeration (compressor or solenoid valve)
 - Defrost
 - Fan
 - Alarm
 - Lighting

The various applications are described on the next page.

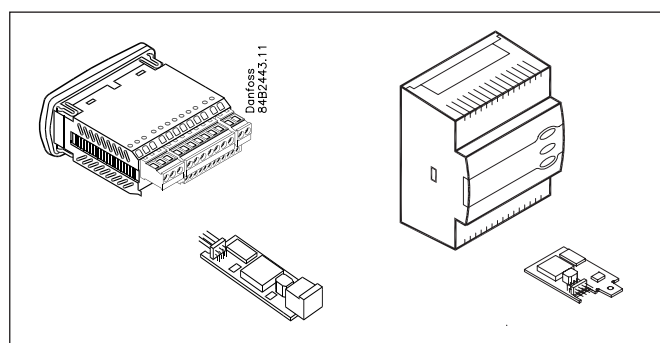
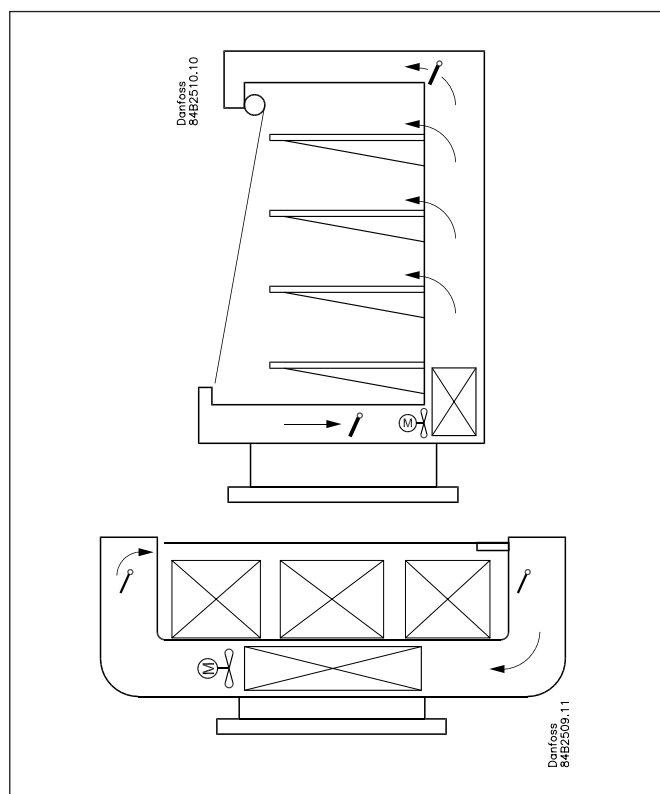
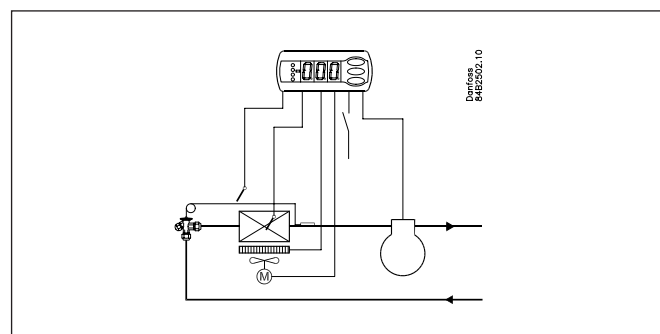

EKC 202A / EKC 302A

Controller with two relay outputs, two temperature sensors, and a digital input.

- Temperature control with compressor start/stop or a solenoid valve
- Defrost sensor
- Electrical defrost / gas defrost

Alarm function

If an alarm function is required, relay 2 can be used for this purpose.

Defrost is performed by air circulation in this case, since the fans operate continuously.

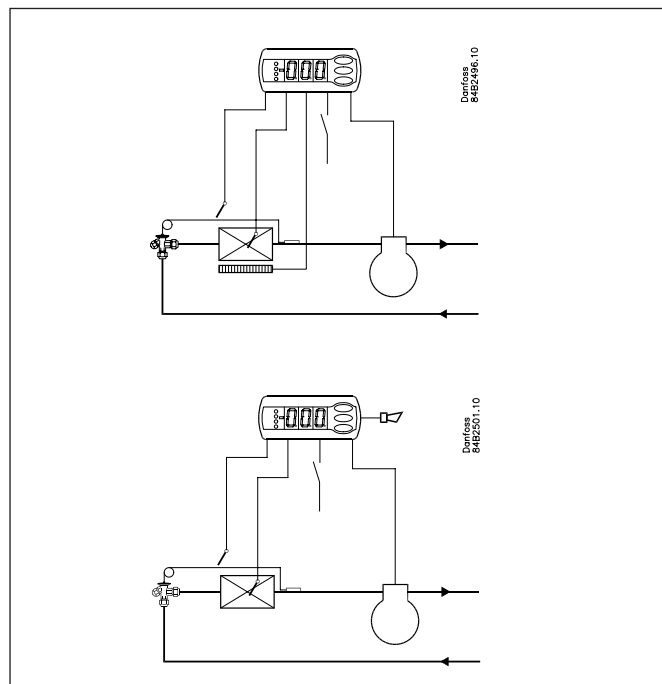

EKC 202B / EKC 302B

Controller with three relay outputs, two temperature sensors, and a digital input.

- Temperature control with compressor start/stop or a solenoid valve
- Defrost sensor
- Electrical defrost / gas defrost
- Relay output 3 is used for fan control.

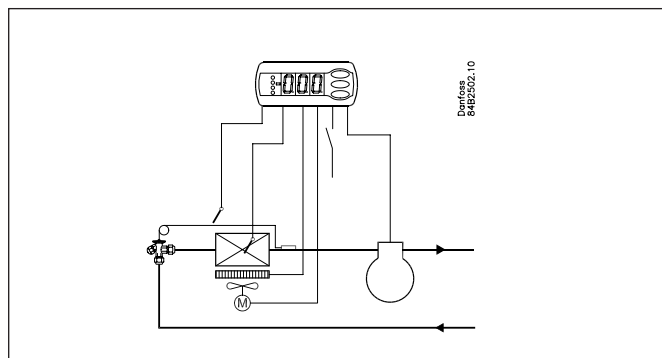

EKC 202C

Controller with four relay outputs, two temperature sensors, and a digital input.

- Temperature control with compressor start/stop or a solenoid valve
- Defrost sensor
- Electrical defrost / gas defrost
- Fan control

Relay output 4 can be used for an alarm function or a lighting function.

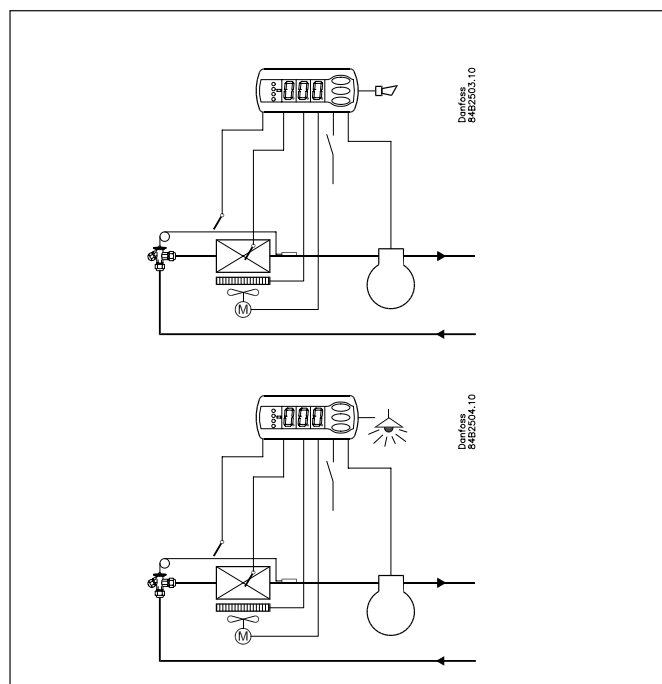

Menu overview

 EKC 202: SW = 1.3x
 EKC 302: SW = 1.0x

Function	Parameters	Controller			Min.-value	Max.-value	Factory setting	Actual setting
		Codes	EKC 202A / 302A	EKC 202B /302B				
Normal operation								
Temperature (set point)		---			-50°C	50°C	2°C	
Thermostat								
Differential	r01				0,1 K	20 K	2 K	
Max. limitation of set point setting	r02				-49°C	50°C	50°C	
Min. limitation of set point setting	r03				-50°C	49°C	-50°C	
Adjustment of temperature indication	r04				-20 K	20 K	0.0 K	
Temperature unit (°C/°F)	r05				°C	°F	°C	
Correction of the signal from Sair	r09				-10 K	10 K	0 K	
Manual service(-1), stop regulation(0), start regulation (1)	r12				-1	1	1	
Displacement of reference during night operation	r13				-10 K	10 K	0 K	
Activation of reference displacement r40	r39				OFF	on	OFF	
Value of reference displacement (activation by r39 or DI)	r40				-50 K	50 K	0 K	
Alarm								
Delay for temperature alarm	A03				0 min	240 min	30 min	
Delay for door alarm	A04				0 min	240 min	60 min	
Delay for temperature alarm after defrost	A12				0 min	240 min	90 min	
High alarm limit	A13				-50°C	50°C	8°C	
Low alarm limit	A14				-50°C	50°C	-30°C	
Alarm delay DI1	A27				0 min	240 min	30 min	
High alarm limit for condenser temperature (o70)	A37				0°C	99°C	50°C	
Compressor								
Min. ON-time	c01				0 min	30 min	0 min	
Min. OFF-time	c02				0 min	30 min	0 min	
Compressor relay must cutin and out inversely (NC-function)	c30				0 / OFF	1 / on	0 / OFF	
External relays (Zero crossing control – only EKC 302) Must be 'ON' when connecting to external relays	c70				OFF	On	On	
Defrost								
Defrost method (none/EL/gas)	d01				no	gas	EL	
Defrost stop temperature	d02				0°C	25°C	6°C	
Interval between defrost starts	d03				0 hours	48 hours	8 hours	
Max. defrost duration	d04				0 min	180 min	45 min	
Displacement of time on cutin of defrost at start-up	d05				0 min	240 min	0 min	
Drip off time	d06				0 min	60 min	0 min	
Delay for fan start after defrost	d07				0 min	60 min	0 min	
Fan start temperature	d08				-15°C	0°C	-5°C	
Fan cutin during defrost	d09				0	2	1	
0: Stopped 1: Running 2: Running during pump down and defrost								
Defrost sensor (0=time, 1=S5, 2=Sair)	d10				0	2	0	
Max. aggregate refrigeration time between two defrosts	d18				0 hours	48 hours	0 hours	
Defrost on demand - S5 temperature's permitted variation during frost build-up. On central plant choose 20 K (=off)	d19				0 K	20 K	20 K	
Fans								
Fan stop at cutout compressor	F01				no	yes	no	
Delay of fan stop	F02				0 min	30 min	0 min	
Fan stop temperature (S5)	F04				-50°C	50°C	50°C	
Real time clock								
Six start times for defrost. Setting of hours. 0=OFF	t01-t06				0 hours	23 hours	0 hours	
Six start times for defrost. Setting of minutes. 0=OFF	t11-t16				0 min	59 min	0 min	
Clock - Setting of hours	t07				0 hours	23 hours	0 hours	
Clock - Setting of minute	t08				0 min	59 min	0 min	
Clock - Setting of date	t45				1	31	1	
Clock - Setting of month	t46				1	12	1	
Clock - Setting of year	t47				0	99	0	
Miscellaneous								
Delay of output signals after start-up	o01				0 s	600 s	5 s	
Input signal on DI1. Function: 0=not used. 1=status on DI1. 2=door function with alarm when open. 3=door alarm when open. 4=defrost start (pulse-signal). 5=ext.main switch. 6=night operation 7=change reference (r40 will be activated) 8=alarm function when closed. 9=alarm function when open. 10=case cleaning (pulse signal). 11=Inject off when open.	o02				0	11	0	
Network address	o03				0	240	0	
On/Off switch (Service Pin message)	o04				OFF	ON	OFF	
Access code 1 (all settings)	o05				0	100	0	
Used sensor type (Pt /PTC/NTC)	o06				Pt	ntc	Pt	
Display step = 0.5 (normal 0.1 at Pt sensor)	o15				no	yes	no	
Max hold time after coordinated defrost	o16				0 min	60 min	20	
Configuration of light function (relay 4) 1=ON during day operation. 2=ON / OFF via data communication. 3=ON follows the DI-function, when DI is selected to door function or to door alarm	o38				1	3	1	
Activation of light relay (only if o38=2)	o39				OFF	ON	OFF	

Case cleaning. 0=no case cleaning. 1=Fans only. 2=All output Off.	o46				0	2	0	
Access code 2 (partly access)	o64				0	100	0	
EKC 202 only. Save the controllers present settings to the programming key. Select your own number.	o65				0	25	0	
EKC 202 only. Load a set of settings from the programming key (previously saved via o65 function)	o66				0	25	0	
Replace the controllers factory settings with the present settings	o67				OFF	On	OFF	
Re alternative application for the S5 sensor (maintain the setting at 0 if it is used as defrost sensor, otherwise 1 = product sensor and 2 = condenser sensor with alarm)	o70				0	2	0	
Select application for relay 4: 1=defrost/light, 2= alarm	o72	defrost / Alarm		Light / Alarm	1	2	2	
Service								
Temperature measured with S5 sensor	u09							
Status on DI1 input. on/1=closed	u10							
Status on night operation (on or off) 1=closed	u13							
Read the present regulation reference	u28							
Status on relay for cooling (Can be controlled manually, but only when r12=-1)	u58							
Status on relay for fans (Can be controlled manually, but only when r12=-1)	u59							
Status on relay for defrost. (Can be controlled manually, but only when r12=-1)	u60							
Temperature measured with Sair sensor	u69							
Status on relay 4 (alarm, defrost, light). (Can be controlled manually, but only when r12=-1)	u71							

Factory settings

If you need to restore the factory settings, proceed as follows:

- Remove power from the controller
- Hold the upper and lower button pressed while restoring power

Fault code display		Alarm code display		Status code display	
E1	Fault in controller	A 1	High temperature alarm	S0	Regulating
E6	Change battery + check clock	A 2	Low temperature alarm	S1	Waiting for end of the coordinated defrost
E 27	S5 sensor error	A 4	Door alarm	S2	ON-time Compressor
E 29	Sair sensor error	A 5	Max. Hold time	S3	OFF-time Compressor
		A 15	DI 1 alarm	S4	Drip-off time
		A 45	Standby mode	S10	Refrigeration stopped by main switch
		A 59	Case cleaning	S11	Refrigeration stopped by thermostat
		A 61	Condenser alarm	S14	Defrost sequence. Defrosting
				S15	Defrost sequence. Fan delay
				S16	Refrigeration stopped because of open DI input
				S17	Door open (open DI input)
				S20	Emergency cooling
				S25	Manual control of outputs
				S29	Case cleaning
				S32	Delay of output at start-up
				non	The defrost temperature cannot be displayed. There is stop based on time
				-d-	Defrost in progress / First cooling after defrost
				PS	Password required. Set password

Start-up:

Regulation begins when power is applied.

- 1 Review the list of factory settings. Change the parameter settings as necessary.
- 2 For network operation. Set the address in o03 and transmit it to the gateway or system unit with setting o04.

Wiring

EKC 202A

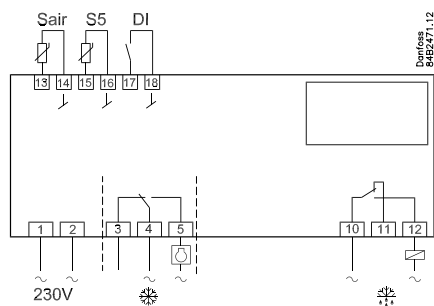

EKC 202B

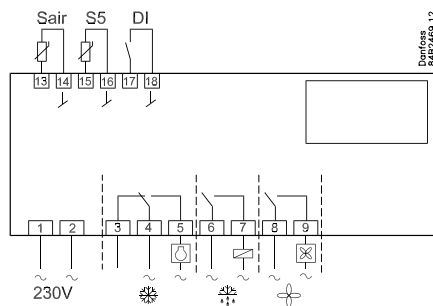

EKC 202C

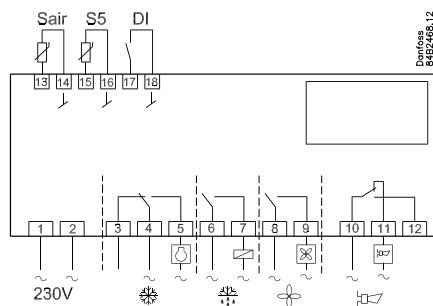

or

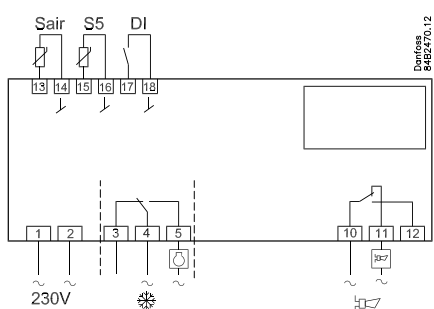

or



or

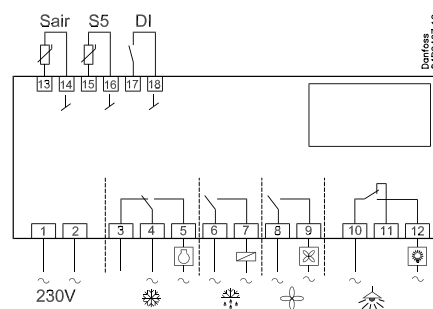

EKC 302A

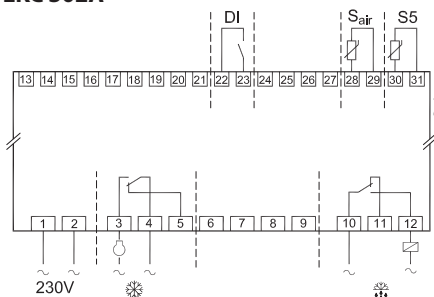

EKC 302B

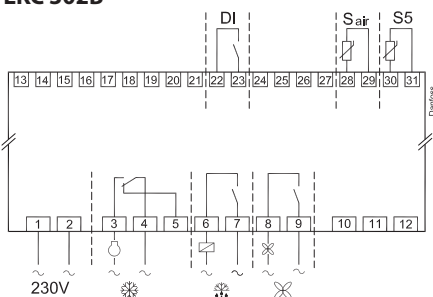

or

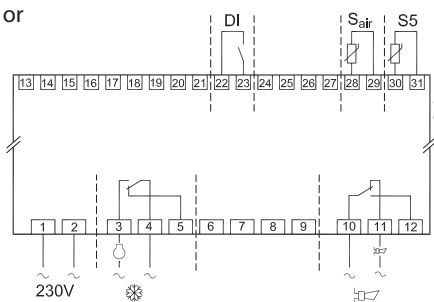

Digital On/Off signal

A cut-in input will activate a function. The possible functions are described in menu o02.

Relays

The general connections are:

Refrigeration. The contact will cut in when the controller demands refrigeration

Defrost.

Fan.

Alarm. The relay is cut out during normal operation and cuts in in alarm situations and when the controller is dead (de-energised)

Light. The contact will cut in when the controller demands light.

Power supply

230 V a.c.

Sensors

Sair is thermostat sensors.

S5 is a defrost sensor and is used if defrost has to be stopped based on temperature. It may however also be used as product sensor or condenser sensor.

Electric noise

Cables for sensors, DI inputs and data communication **must** be kept separate from other electric cables:

- Use separate cable trays
- Keep a distance between cables of at least 10 cm
- Long cables at the DI input should be avoided

Technical data

Supply voltage	230 V a.c. +10/-15 %. 2.5 VA, 50/60 Hz			
Sensors 3 pcs off either	Pt 1000 or PTC 1000 ohm or NTC-M2020 (5000 ohm / 25°C)			
Accuracy	Measuring range	-60 to +99°C		
	Controller	±1 K below -35°C ±0.5 K between -35 to +25°C ±1 K above +25°C		
	Pt 1000 sensor	±0.3 K at 0°C ±0.005 K per grad		
Display	LED, 3-digits			
External display	EKA 163A / EKA 164A			
Digital inputs	Signal from contact functions Requirements to contacts: Gold plating Cable length must be max. 15 m Use auxiliary relays when the cable is longer			
Electrical connection cable	Max. 1,5 mm ² multi-core cable Max. 1 mm ² on sensors and DI inputs			
Relays* 	EKC 202	IEC60730		
		DO1	10 (6) A & (5 FLA, 30 LRA)	
		DO2	10 (6) A & (5 FLA, 30 LRA)	
		DO3	6 (3) A & (3 FLA, 18 LRA)	
	DO4**	4 (1) A, Min. 100 mA**		
	EKC 302	DO1	10 (6) A & (5 FLA, 30 LRA)	1)
			16 (8) A & (10 FLA, 60 LRA)	2)
		DO2	6 (3) A & (3 FLA, 18 LRA)	1)
			10 (6) A & (5 FLA, 30 LRA)	2)
		DO3	6 (3) A & (3 FLA, 18 LRA)	1)
10 (6) A & (5 FLA, 30 LRA)			2)	
DO4**	4 (1)A Min. 100 mA**			
Data communication	EKC 202: Via insert card EKC 302: Fixed MODBUS. Can be expanded with LON or MODBUS via insert card			
Environments	0 to +55°C, During operations -40 to +70°C, During transport			
	20 - 80% Rh, not condensed No shock influence / vibrations			
Density	EKC 202: IP 65 from front. Buttons and packing are imbedded in the front. EKC 302: IP 20			
Escapement reserve for the clock	4 hours			
Approvals	EU Low Voltage Directive and EMC demands re CE-marking complied with EKC 202: UL approval acc. UL 60730 LVD tested acc. EN 60730-1 and EN 60730-2-9, A1, A2 EMC tested acc. EN 61000-6-3 and EN 61000-6-2 and EN 61000-4-(2-6,8,11)			

* EKC 202: DO1 and DO2 are 16 A relays. DO3 and DO4 are 8 A relays. Above max. load must be kept.

EKC 302: DO1 are 20 A relays. DO2 and DO3 are 16 A relays. DO4 are 10 A relays. The max. load listed above must be observed when connecting without zero-crossing control. When connecting with zero-crossing control, the load must be increased to the value indicated by 2)

** Gold plating ensures make function with small contact loads

1) With external relay (c70=ON) (zero-crossing control disabled)

2) Without external relay (c70=OFF) (zero-crossing control enabled)

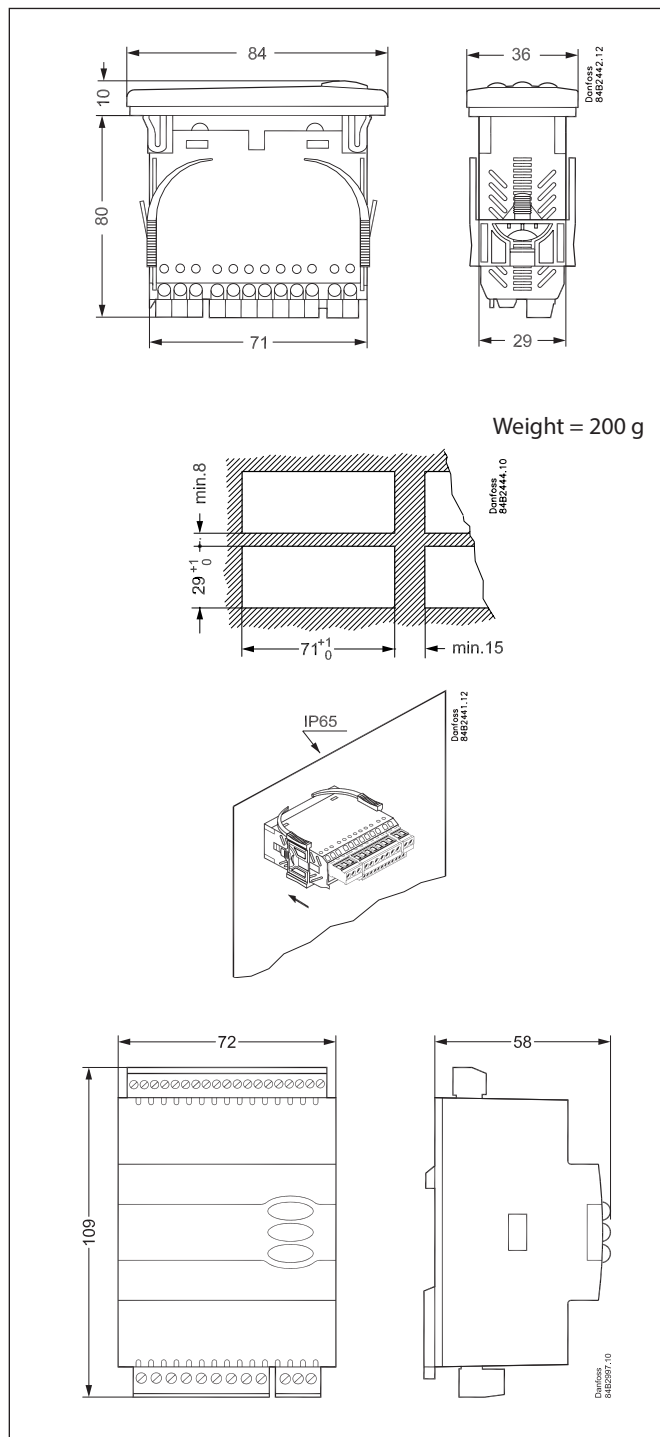

Relay contact and controller supply **must** use same phase and the load (compressor) must phase compensated to Cos φ = 1.

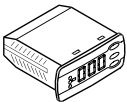
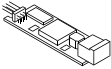
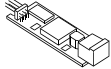
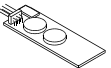
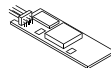

Ordering

Type		Function	Supply voltage	Code no.
EKC 202A		Refrigeration controller	230 V	084B8521
EKC 202B		Refrigeration controller with fan function		084B8522
EKC 202C		Refrigeration controller for electric defrost		084B8523
EKA 178A		Data communication module. MOD-bus		084B8564
EKA 179A		Data communication module. RS 485- LON		084B8565
EKA 181C		Battery module that will protect the clock in case of lengthy power failure		084B8577
EKA 182A		Copy key EKC - EKC		084B8567

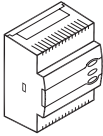
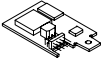
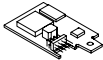
Ordering

Type		Function	Supply voltage	Code no.
EKC 302A		Refrigeration controller with MODBUS data communication	230 V	084B4162
EKC 302B		Refrigeration controller r with fan function and MODBUS data communication		084B4163
EKA 175		Data communication module LON RS485		084B8579
EKA 178B		Data communication module MODBUS		084B8571
EKA 163A		External display option		084B8562
EKA 164A		External operation option		084B8563

Additional information available:
Manual: RS8DZ

EKC 202C-MS

Application

- The controller is used for temperature control refrigeration appliances and cold room in supermarkets
- The controller has the same functionalities as the EKC 202C, but is adjusted for sensor readings from NTC sensors.
- Versatility is designed in for use in new installations as well as service replacement in existing installations.



Advantages

- Multi-application support in a single unit
- Can receive signals from known NTC sensors
- Easy data communication retrofit

EKC 202C-MS

Controller with four relay outputs, two temperature sensors and digital input.

Temperature control at start/stop of compressor / solenoid valve
 Defrost sensor
 Electrical defrost / gas defrost
 Control of fan

Relay output 4 can be used for an alarm function or for a light function.

Sensors

One or two NTC sensors of the same type must be connected.

The following can be selected:

- NTC 5000 Ω @ 25°C. M2020 (Danfoss Type = EKS 211)
- NTC 10000 Ω @ 25°C. Beta 3435 (Danfoss Type = EKS 221)
- NTC 3000 Ω @ 25°C
- NTC 2500 Ω @ 0°C
- NTC 10000 Ω @ 25°C
- NTC 2000 Ω @ 25°C

Set the type in menu o06.

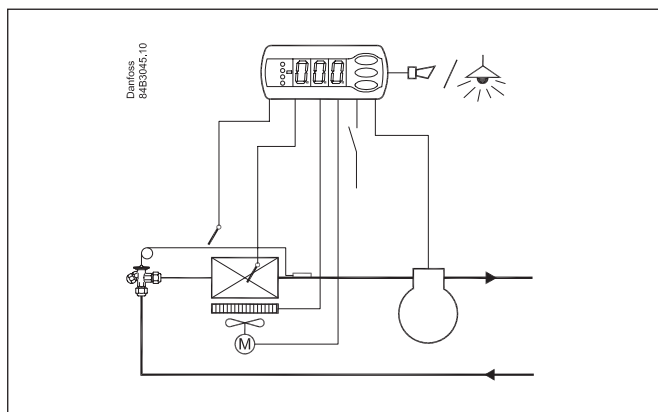

Sensor values

Type	NTC 5000 Ω @ 25°C (M2020)	NTC 10000 Ω @ 25°C (Beta 3435)	NTC 3000 Ω @ 25°C	NTC 2500 Ω @ 0°C	NTC 10000 Ω @ 25°C	NTC 2000 Ω @ 25°C
Danfoss NTC	EKS 211	EKS 221	-	-	-	-
°C	Ω	Ω	Ω	Ω	Ω	Ω
30	4029	8313	2417	-	8300	1651
25	5000	10000	3000	883	10000	2000
20	6246	12091	3747	1074	12271	2437
15	7855	14695	4712	1313	15146	2987
10	9951	17958	5970	1616	18809	3682
5	12696	22068	7617	2000	23504	4571
0	16330	27278	9798	2492	29564	5716
-5	21166	33922	12700	3124	37441	7198
-10	27681	42450	16608	3947	47754	9133
-15	36503	53468	21902	5019	61357	11644
-20	48614	67801	29168	6434	79440	14961
-25	65333	86580	39200	8306	103676	19402
-30	88766	111364	53259	10822	136428	25388
-35	121795	144324	73077	14217	181078	33505
-40	169157	188500	101490	18848	242495	44657
Alternatives		Carel: HP/WF/WP/INF Dixell: NS/NG/NX/NY/NT Eliwell: SN8 Lae: SN4K..P	Frigo: M841	Wurm: TRK 277	Wurm: T2000	Lae: SN2K..P
o06	n01	n02	n03	n04	n05	n06

Ordering

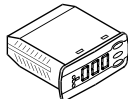
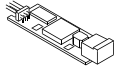
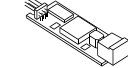
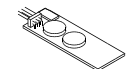
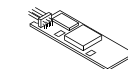
Type		Function	Code no.
EKC 202C-MS		Refrigeration controller	084B8543
EKA 178A		Data communication module MOD-bus	084B8564
EKA 179A		Data communication module RS 485 - LON	084B8565
EKA 181C		Battery module that will protect the clock in case of lengthy power failure	084B8577
EKA 182A		Copy key EKC - EKC	084B8567

Additional information available:
Manual: RS8GH

EKC 202D, EKC 302D

Application

- This controller is used for temperature control of refrigeration appliances in supermarkets.
- With support for many predefined applications, it gives you a variety of options in a single unit. Versatility is designed in for use in new installations as well as service replacement in existing installations.
- EKC 202 is for front panel mounting
- EKC 302 is for DIN Rail mounting

Advantages

- Several applications in the same unit
- The controller has integrated refrigeration-technical functions, so that it can replace a whole collection of thermostats and timers
- Buttons and seal imbedded in the front
- Easy to remount data communication
- Fixed MODBUS data communication on the DIN model, however LON RS 485 can be retrofitted
- Two temperature references
- Digital inputs for various functions
- Clock function with super cap backup

Control

The controller contains a temperature control that can receive signals from one or two temperature sensors. The thermostat sensors can be placed in the cold air flow after the evaporator, in the warm air flow just before the evaporator, or in both locations. A setting determines the effects of the two sensors on the control loop.

The defrost temperature can be measured directly from an S5 sensor or indirectly from the S4 measurement. The necessary functions are cut in and out by four relays according to the requirements of the application. The options are:

- Refrigeration (compressor or relay)
- Fan
- Defrost
- Rail heat
- Alarm
- Lighting

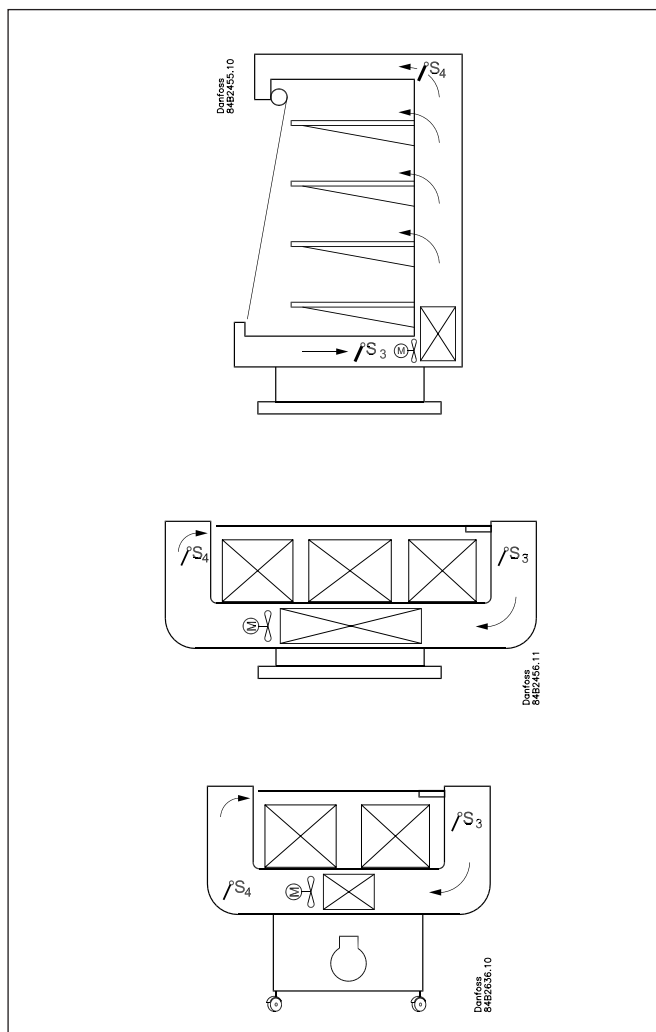
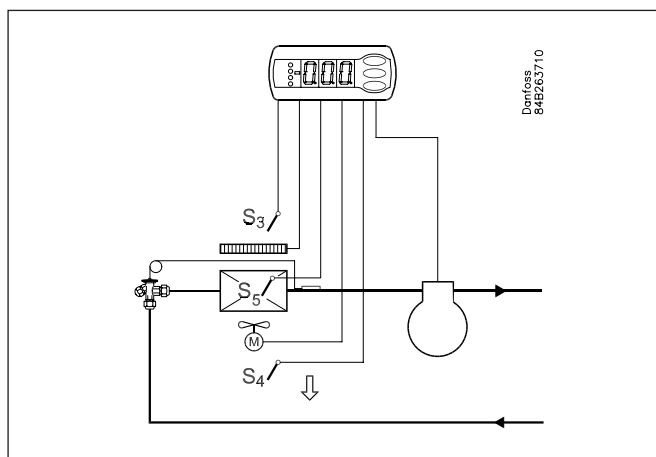
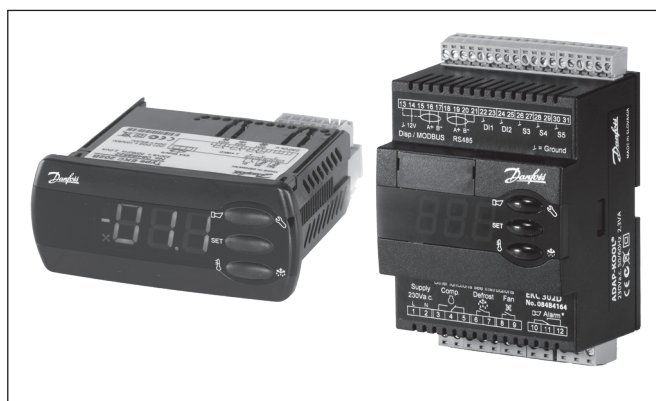

Extra module

- The controller can afterwards be fitted with an insertion module if the application requires it. The controller has been prepared with a plug, so the module simply has to be pushed in.

- Battery module (EKC 202)

The module guarantees voltage to the controller if the supply voltage should drop out for more than four hours. The clock function can thus be protected during a power failure.

- Data communication

If you require operation from a PC, a data communication module has to be placed in the EKC 202D controller. The EKC 302D has a fixed MODBUS, but can be retrofitted with an additional data communication module.

- Coordinated defrost via data communication

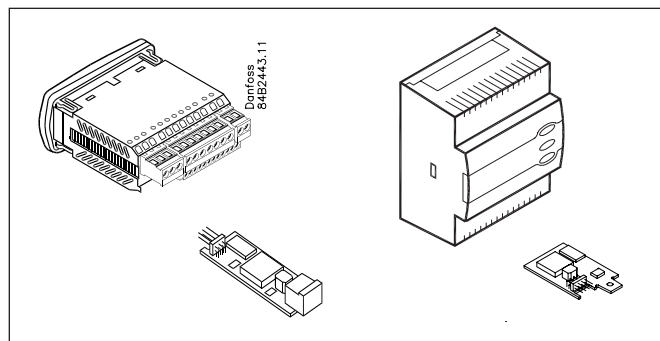

Sensors

One or two thermostat sensors can be connected to the controller, depending on the application requirements.

Sensor in the air stream ahead of the evaporator: this arrangement is used primarily with area-based control.

Sensor in the air stream after the evaporator: this arrangement is used primarily when refrigeration is controlled and there is a risk of excessively temperatures near the product.

Sensors before and after the evaporator: this arrangement lets you adapt the thermostat, the alarm thermostat and the display to the actual application. The signal to the control thermostat, alarm thermostat and display is the weighted average of the two temperatures. For example, with 50% weighting each sensor makes an equal contribution. The control thermostat, alarm thermostat and display signals can be configured independently.

Defrost sensor

The best indication of the evaporator temperature is obtained from a defrost sensor mounted directly on the evaporator. In this case the defrost function can use this signal to minimise the duration and energy consumption of the defrost cycle.

If a defrost sensor is not required, time-controlled defrosting can be used or S4 can be selected.

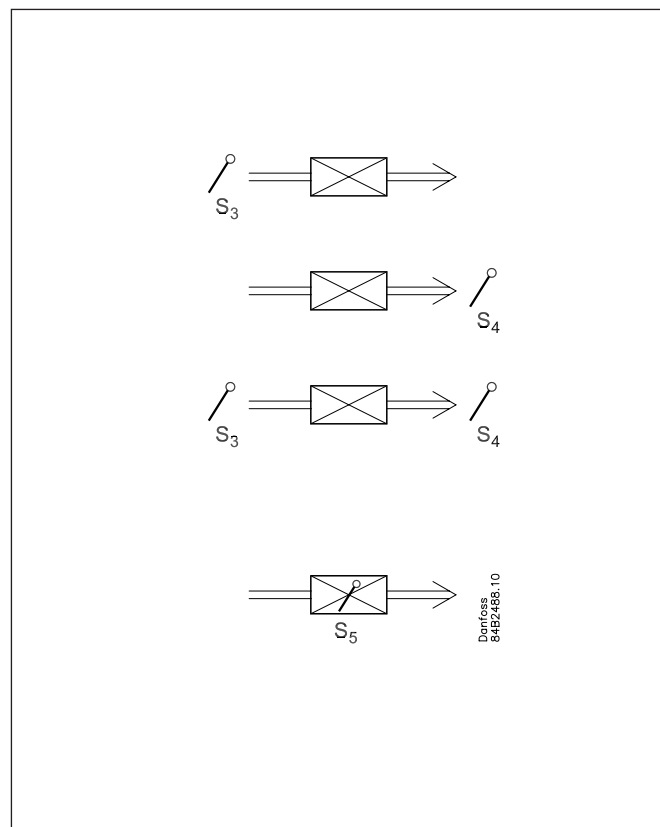

Changing the temperature reference

This may be desirable in applications such as an on/off appliance used in various product groups. The temperature reference can easily be changed by a contact signal on a digital input. This signal raises the normal thermostat setting by a predefined amount. The alarm limits are also offset accordingly.

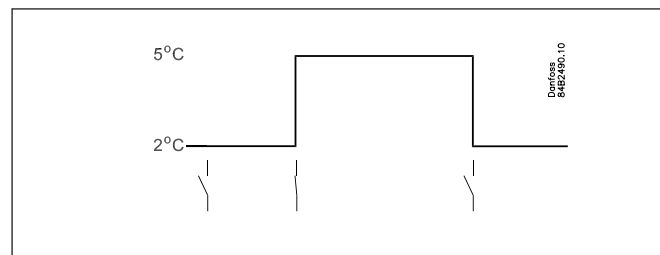

Application

The following is a brief summary of the application area of this controller.

The relay outputs are defined by a configuration setting to align the controller interface to the selected application.

S3 and S4 are temperature sensors. One or both of these sensors may be used, depending on the application. S3 is located in the air flow before the evaporator, and S4 in the air flow after the evaporator.

A percentage setting determines the relative contributions of the sensors to the control function. S5 is a defrost sensor located on the evaporator.

DI1 and DI2 are contact functions that can be used for any of the following purposes: door function, alarm function, defrost start, external main switch, night operation, change thermostat reference, appliance cleaning, forced refrigeration, or coordinated defrost. See the functions of parameters o02 and o37.

Refrigeration control with one compressor

The functions are adapted to small refrigeration systems, which may be refrigeration appliances or cold rooms. Three of the relays control refrigeration, defrost and the fans, while the fourth relay can be used for an alarm function, lighting control, or rail heat control.

- The alarm function can be linked to a contact function from a door switch. An alarm is generated if the door remains open longer than allowed.
- Lighting control can also be linked to a contact function from a door switch. The light is switched on when the door is opened and remains on for two minutes after the door is closed.
- The rail heat function can be used in refrigeration or freezer appliances or for the door heater of a freezer room.

The fans can be stopped during defrosting, and they can also track the open/closed state of a door switch.

There are several other functions for the alarm function, as well as the lighting control, rail heat control and fan control. See the corresponding parameter settings.

1

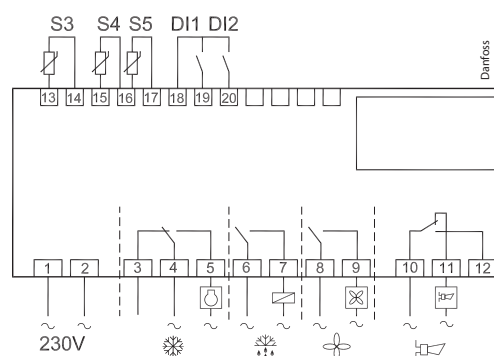

2

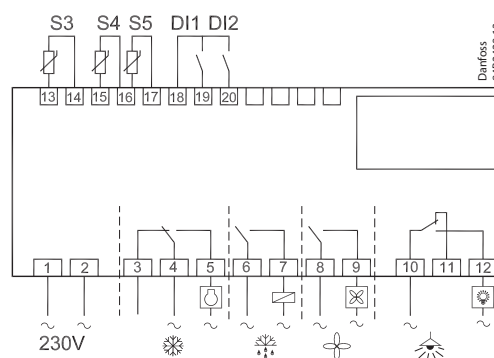

3

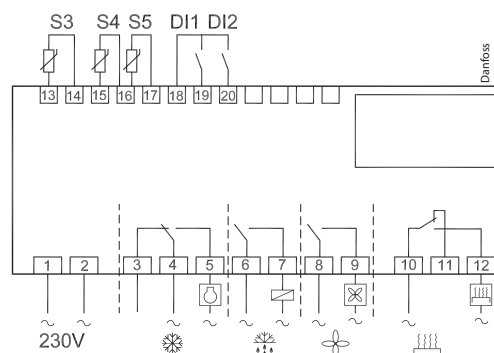

Connection options for EKC 302D (DIN rail model)

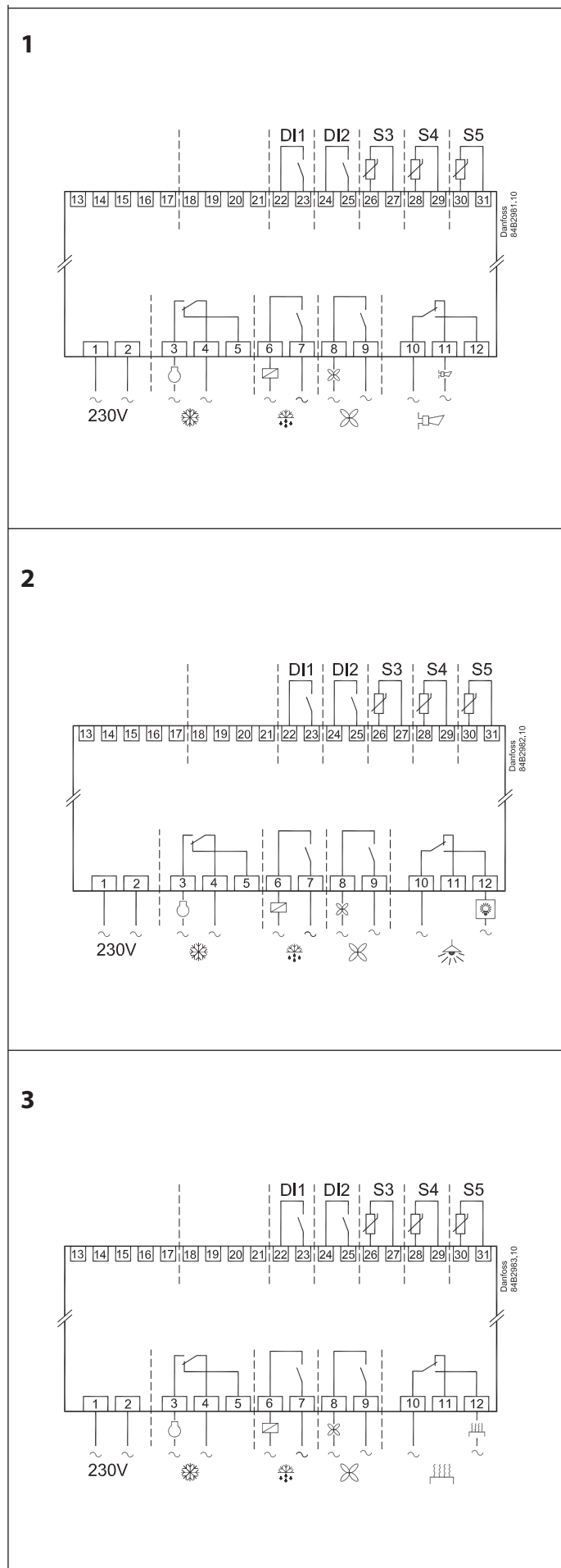

Menu overview

 EKC 202D: SW = 2.2x
 EKC 302D: SW = 1.0x

Function	Parameters		EL-diagram number			Min.-value	Max.-value	Factory setting	Actual setting
		Codes	1	2	3				
Normal operation									
Temperature (set point)		---				-50.0°C	50.0°C	2.0°C	
Thermostat									
Differential	***	r01				0.0 K	20.0K	2.0 K	
Max. limitation of setpoint setting	***	r02				-49.0°C	50°C	50.0°C	
Min. limitation of setpoint setting	***	r03				-50.0°C	49.0°C	-50.0°C	
Adjustment of temperature indication		r04				-20.0 K	20.0 K	0.0 K	
Temperature unit (°C/°F)		r05				°C	°F	°C	
Correction of the signal from S4		r09				-10.0 K	+10.0 K	0.0 K	
Correction of the signal from S3		r10				-10.0 K	+10.0 K	0.0 K	
Manual service, stop regulation, start regulation (-1, 0, 1)		r12				-1	1	0	
Displacement of reference during night operation		r13				-10.0 K	10.0 K	0.0 K	
Definition and weighting, if applicable, of thermostat sensors - S4% (100%=S4, 0%=S3)		r15				0%	100%	100%	
Activation of reference displacement r40		r39				OFF	ON	OFF	
Value of reference displacement (activate via r39 or DI)		r40				-50.0 K	50.0 K	0.0 K	
Alarm									
Delay for temperature alarm		A03				0 min	240 min	30 min	
Delay for door alarm	***	A04				0 min	240 min	60 min	
Delay for temperature alarm after defrost		A12				0 min	240 min	90 min	
High alarm limit	***	A13				-50.0°C	50.0°C	8.0°C	
Low alarm limit	***	A14				-50.0°C	50.0°C	-30.0°C	
Alarm delay DI1		A27				0 min	240 min	30 min	
Alarm delay DI2		A28				0 min	240 min	30 min	
Signal for alarm thermostat. S4% (100%=S4, 0%=S3)		A36				0%	100%	100%	
Compressor									
Min. ON-time		c01				0 min	30 min	0 min	
Min. OFF-time		c02				0 min	30 min	0 min	
Compressor relay 1 must cutin and out inversely (NC-function)		c30				0	1	0	
External relays (zero-crossing control – only EKC 302D) Must be 'ON' when connecting to external relays		c70				OFF	ON	ON	
Defrost									
Defrost method (none/EL/GAS/BRINE)		d01				no	bri	EL	
Defrost stop temperature		d02				0.0°C	25.0°C	6.0°C	
Interval between defrost starts		d03				0 hours	48 hours	8 hours	
Max. defrost duration		d04				0 min	180 min	45 min	
Displacement of time on cutin of defrost at start-up		d05				0 min	240 min	0 min	
Drip off time		d06				0 min	60 min	0 min	
Delay for fan start after defrost		d07				0 min	60 min	0 min	
Fan start temperature		d08				-15.0°C	0.0°C	-5.0°C	
Fan cutin during defrost		d09				0	2	1	
0: Stopped 1: Running 2: Running during pump down and defrost									
Defrost sensor (0=time, 1=S5, 2=S4)		d10				0	2	0	
Pump down delay		d16				0 min	60 min	0 min	
Max. aggregate refrigeration time between two defrosts		d18				0 hours	48 hours	0 hours	
Defrost on demand - S5 temperature's permitted variation during frost build-up. On central plant choose 20 K (=off)		d19				0.0 K	20.0 k	20.0 K	
Fan									
Fan stop at cutout compressor		F01				no	yes	no	
Delay of fan stop		F02				0 min	30 min	0 min	
Fan stop temperature (S5)		F04				-50.0°C	50.0°C	50.0°C	
Real time clock									
Six start times for defrost. Setting of hours. 0=OFF		t01-t06				0 hours	23 hours	0 hours	
Six start times for defrost. Setting of minutes. 0=OFF		t11-t16				0 min	59 min	0 min	
Clock - Setting of hours	***	t07				0 hours	23 hours	0 hours	
Clock - Setting of minute	***	t08				0 min	59 min	0 min	
Clock - Setting of date	***	t45				1	31	1	
Clock - Setting of month	***	t46				1	12	1	
Clock - Setting of year	***	t47				0	99	0	
Miscellaneous									
Delay of output signals after start-up		o01				0 s	600 s	5 s	
Input signal on DI1. Function: 0=not used. 1=status on DI1. 2=door function with alarm when open. 3=door alarm when open. 4=defrost start (pulse-signal). 5=ext.main switch. 6=night operation 7=change reference (activate r40). 8=alarm function when closed. 9=alarm function when open. 10=case cleaning (pulse signal). 11=forced cooling.		o02				1	11	0	
Network address (0= off)		o03				0	240	0	
On/Off switch (Service Pin message) IMPORTANT! o61 must be set prior to o04		o04				OFF	ON	OFF	
Access code 1 (all settings)		o05				0	100	0	
Used sensor type (Pt /PTC/NTC)		o06				Pt	ntc	Pt	
Display step = 0.5 (normal 0.1 at Pt sensor)		o15				no	yes	no	
Max hold time after coordinated defrost		o16				0 min	60 min	20	

Select signal for display view. S4% (100%=S4, 0%=S3)		o17				0%	100%	100%	
Input signal on DI2. Function: (0=not used. 1=status on DI2. 2=door function with alarm when open. 3=door alarm when open. 4=defrost start (pulse-signal). 5=ext. main switch 6=night operation 7=change reference (activate r40). 8=alarm function when closed. 9=alarm function when open. 10=case cleaning (pulse signal). 11=forced cooling.). 12=coordinated defrost)		o37				0	12	0	
Configuration of light function (relay 4) 1=ON during day operation. 2=ON / OFF via data communication. 3=ON follows the DI-function, when DI is selected to door function or to door alarm		o38				1	3	1	
Activation of light relay (only if o38=2)		o39				OFF	ON	OFF	
Rail heat On time during day operations		o41				0%	100%	100	
Rail heat On time during night operations		o42				0%	100%	100	
Rail heat period time (On time + Off time)		o43				6 min	60 min	10 min	
Case cleaning. 0=no case cleaning. 1=Fans only. 2=All output Off.	***	o46				0	2	0	
Selection of EL diagram.	*	o61	1	2	3	1	3	1	
Access code 2 (partly access)	***	o64				0	100	0	
EKC 202D only: Save the controllers present settings to the programming key. Select your own number.		o65				0	25	0	
EKC 202D only: Load a set of settings from the programming key (previously saved via o65 function)		o66				0	25	0	
Replace the controllers factory settings with the present settings		o67				OFF	On	OFF	
Service									
Status codes		S0-S33							
Temperature measured with S5 sensor	***	u09							
Status on DI1 input. on/1=closed		u10							
Temperature measured with S3 sensor	***	u12							
Status on night operation (on or off) 1=closed	***	u13							
Temperature measured with S4 sensor	***	u16							
Thermostat temperature		u17							
Read the present regulation reference		u28							
Status on DI2 output. on/1=closed		u37							
Temperature shown on display		u56							
Measured temperature for alarm thermostat		u57							
Status on relay for cooling	**	u58							
Status on relay for fan	**	u59							
Status on relay for defrost	**	u60							
Status on relay for railheat	**	u61							
Status on relay for alarm	**	u62							
Status on relay for light	**	u63							

* Can only be set when regulation is stopped (r12 = 0)

** Can be controlled manually, but only when r12 is -1

*** Access code 2 allows only restricted access to these menus

Factory settings

If you need to restore the factory settings, proceed as follows:

- Remove power from the controller
- Hold the upper and the lower buttons pressed while restoring power

Wiring

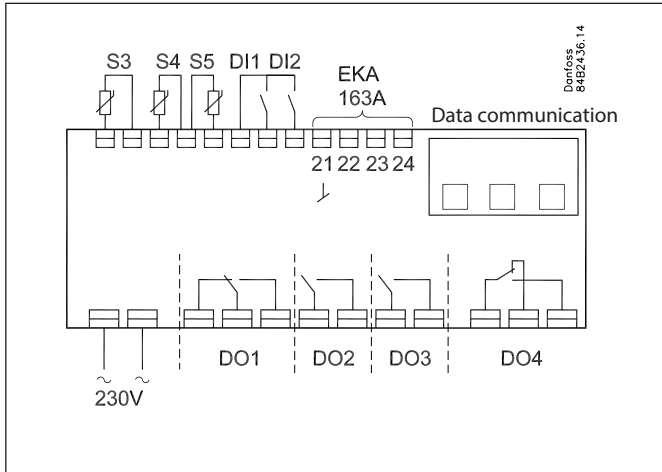

Power supply

230 V a.c.

Sensors

S3 and S4 are thermostat sensors.

A setting determines whether S3 or S4 or both of them are to be used.

S5 is a defrost sensor and is used if defrost has to be stopped based on temperature.

Digital On/Off signals

A cut-in input will activate a function. The possible functions are described in menus o02 and o37.

External display

Connection of display type EKA 163A or EKA 164A.

Relays

The general uses are mentioned here. See also el-diagram where the different applications are shown.

DO1: Refrigeration. The relay will cut in when the controller demands refrigeration

DO2: Defrost. The relay will cut in when defrost is in progress

DO3: Fans

The relay will cut in when the fans have to operate

DO4: For either alarm, rail heat or light

Alarm: Cf. diagram. The relay is cut in during normal operation and cuts out in alarm situations and when the controller is dead (de-energised)

Rail heat: The relay cuts in when rail heat is to operate

Light: The relay cuts in when the light has to be switched on

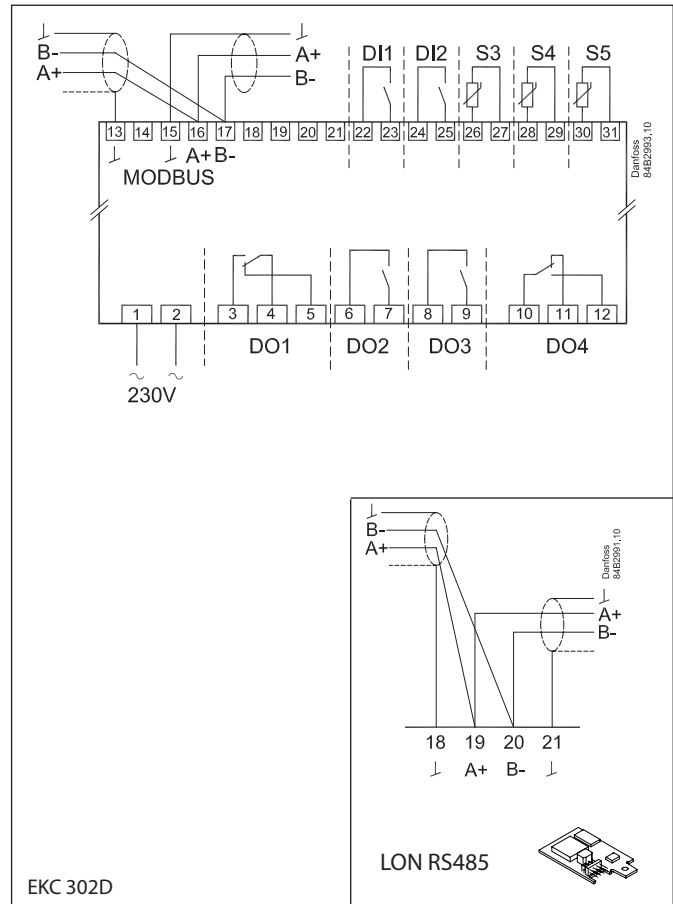

EKC 302D

Data communication

EKC 202D: MODBUS or LON-RS485 via insert cards.

EKC 302D: Fixed MODBUS or LON-RS485/MODBUS via insert card.

If data communication is used, it is important that the installation of the data communication cable is performed correctly.

See separate literature No. RC8AC...

Electric noise

Cables for sensors, DI inputs and data communication **must** be kept separate from other electric cables:

- Use separate cable trays
- Keep a distance between cables of at least 10 cm
- Long cables at the DI input should be avoided

Coordinated defrost with wiring interconnect

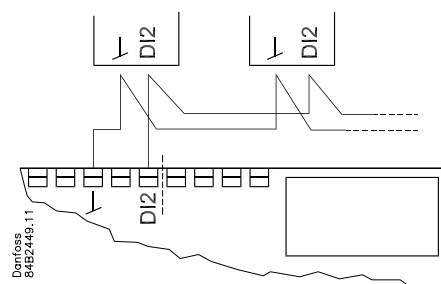

The following controllers can be connected in this manner:

EKC 202D /302D series and

AK-CC 210 and AK-CC 250

Max. 15

Refrigeration is resumed when all controllers have de-asserted the defrost signal.

Technical data

Supply voltage	230 V a.c. +10/-15 %. 2.5 VA, 50/60 Hz			
Sensors 3 pcs off either	Pt 1000 or PTC 1000 ohm or NTC-M2020 (5000 ohm / 25°C)			
Accuracy	Measuring range	-60 to +99°C		
	Controller	±1 K below -35°C ±0.5 K between -35 to +25°C ±1 K above +25°C		
	Pt 1000 sensor	±0.3 K at 0°C ±0.005 K per grad		
Display	LED, 3-digits			
External display	EKA 163A / EKA 164A			
Digital inputs	Signal from contact functions Requirements to contacts: Gold plating Cable length must be max. 15 m Use auxiliary relays when the cable is longer			
Electrical connection cable	Max. 1,5 mm ² multi-core cable Max. 1 mm ² on sensors and DI inputs			
Relays*	EKC 202D	IEC60730		
		DO1	10 (6) A & (5 FLA, 30 LRA)	
		DO2	10 (6) A & (5 FLA, 30 LRA)	
		DO3	6 (3) A & (3 FLA, 18 LRA)	
	DO4**	4 (1) A, Min. 100 mA**		
	EKC 302D	DO1	10 (6) A & (5 FLA, 30 LRA)	1)
			16 (8) A & (10 FLA, 60 LRA)	2)
		DO2	6 (3) A & (3 FLA, 18 LRA)	1)
			10 (6) A & (5 FLA, 30 LRA)	2)
		DO3	6 (3) A & (3 FLA, 18 LRA)	1)
10 (6) A & (5 FLA, 30 LRA)			2)	
DO4**	4 (1)A Min. 100 mA**			
Data communication	EKC 202D: Via insert card EKC 302D: Fixed MODBUS. Can be expanded with LON or MODBUS via insert card			
Environments	0 to +55°C, During operations -40 to +70°C, During transport			
	20 - 80% Rh, not condensed No shock influence / vibrations			
Density	EKC 202D: IP 65 from front. Buttons and packing are imbedded in the front. EKC 302D: IP 20			
Escapement reserve for the clock	4 hours			
Approvals	EU Low Voltage Directive and EMC demands re CE-marking complied with. EKC 202D: UL approval acc. UL 60730 LVD tested acc. EN 60730-1 and EN 60730-2-9, A1, A2 EMC tested acc. 61000-6-3 and EN 61000-6-2, 4-(2-6,8,11)			

* EKC 202D: DO1 and DO2 are 16 A relays. DO3 and DO4 are 8 A relays. Above max. load must be kept.

EKC 302D: DO1 is 20 A relay. DO2 and DO3 are 16 A relays. DO4 is a 10 A relay. The max. load listed above must be observed when connecting without zero-crossing control. When connecting with zero-crossing control, the load must be increased to the value indicated by 2)

** Gold plating ensures make function with small contact loads



1) With external relay (c70=ON) (zero-crossing control disabled)

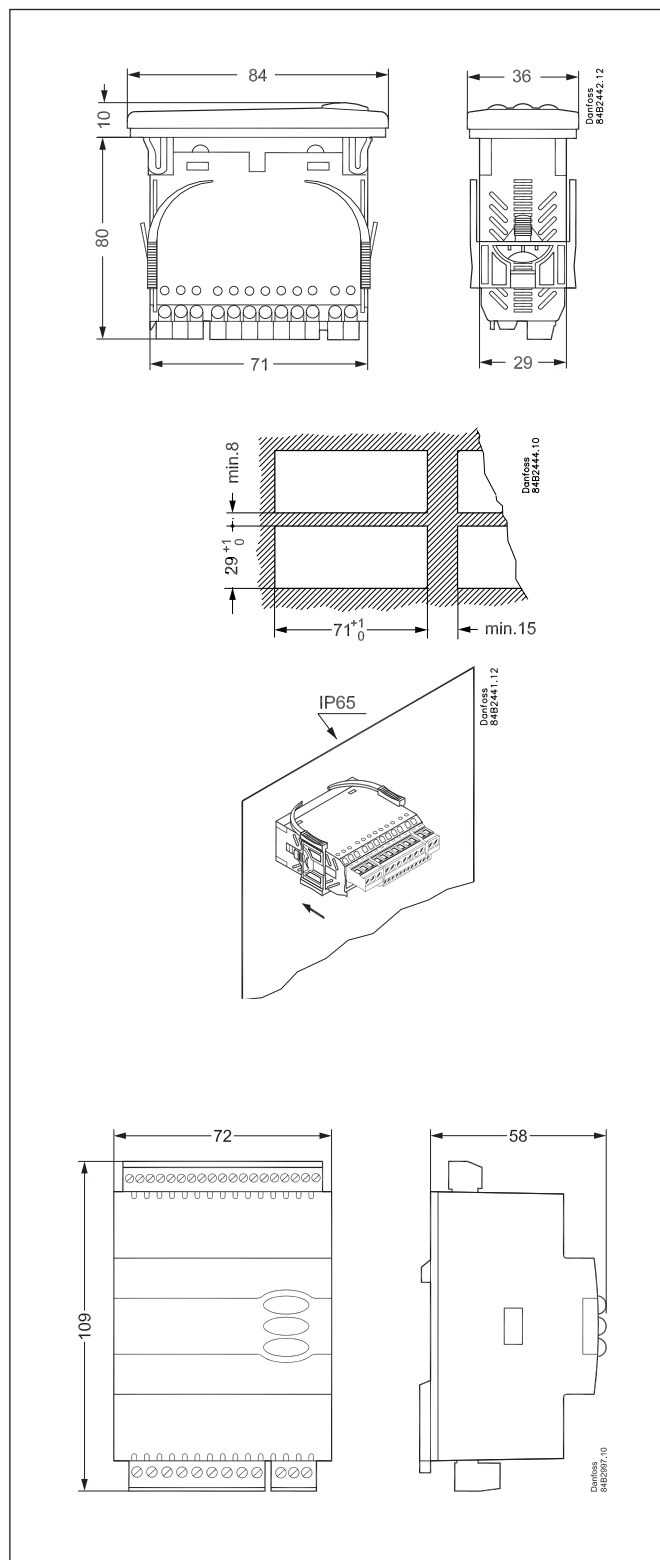

2) Without external relay (c70=OFF) (zero-crossing control enabled)

Relay contact and controller supply **must** use same phase and the load (compressor) must phase compensated to Cos φ = 1.

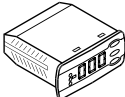
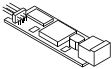
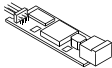
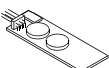
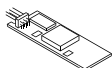

Ordering data

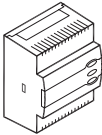
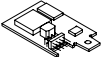
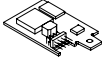
Type		Function	Voltage supply	Code no.
EKC 202D		Refrigeration controller without data communication but prepared for mounting of one module	230 V a.c.	084B8536
EKA 178A		Data communication module MOD-bus		084B8564
EKA 179A		Data communication module LON RS 485		084B8565
EKA 181C		Battery module that will protect the clock in case of lengthy power failure		084B8577
EKA 182A		Copy key EKC - EKC		084B8567
EKA 163A		External display option		084B8562
EKA 164A		External operation option		084B8563

Type		Function	Code no.
EKC 302D		Refrigeration controller with MODBUS data communication	084B4164
EKA 175		Data communication module LON RS485	084B8579
EKA 178B		Data communication module MODBUS	084B8571
EKA 163A		External display option	084B8562
EKA 164A		External operation option	084B8563

Additional information available:
Manual: RS8EE

EKC 202D1

Application

- This controller is used for temperature control of refrigeration appliances in supermarkets.
- With support for many predefined applications, it gives you a variety of options in a single unit. Versatility is designed in for use in new installations as well as service replacement in existing installations.

Advantages

- Multi-application support in a single unit
- Integrated refrigeration functions enable the controller to replace a host of thermostats and timers
- Buttons and gasket integrated in front panel
- Easy data communication retrofit
- Quick set-up
- Two temperature references
- Digital inputs for various functions
- Clock function with super cap backup

Operating principle

The controller contains a temperature regulator that can receive signals from one or two temperature sensors. The thermostat sensors can be placed in the cold air flow after the evaporator, in the warm air flow just before the evaporator, or in both locations. A setting determines the effects of the two sensors on the control loop.

The defrost temperature can be measured directly from an S5 sensor or indirectly from the S4 measurement. The necessary functions are cut in and out by four relays according to the requirements of the application. The options are:

- Refrigeration (compressor or relay)
- Fan
- Defrost
- Rail heat
- Alarm
- Lighting

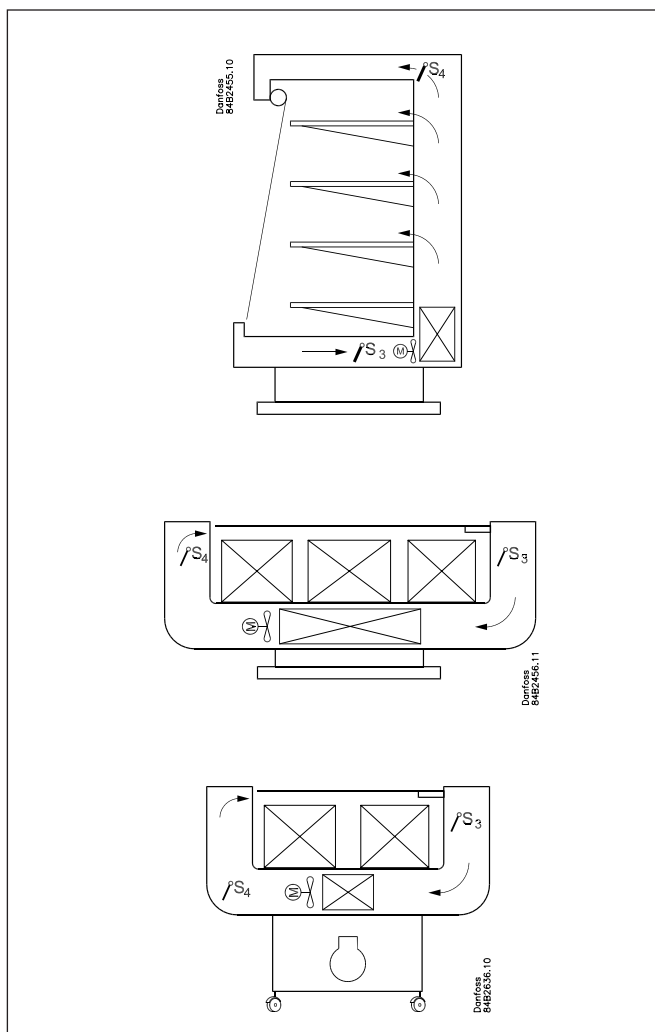
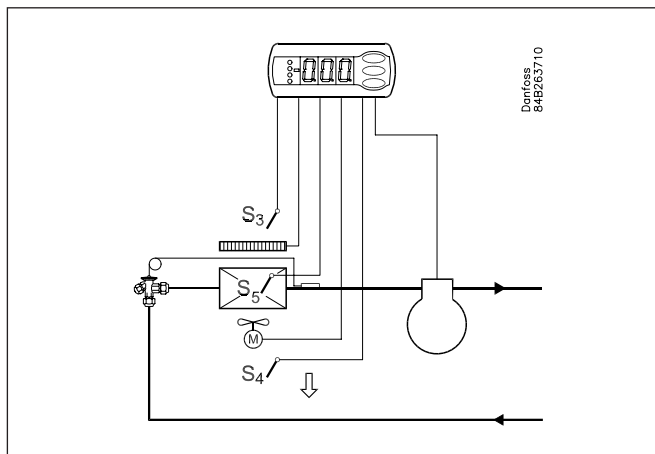

Sensors

One or two thermostat sensors can be connected to the controller, depending on the application requirements.

A sensor in the air before the evaporator: S3
this arrangement is used primarily with area-based control.

A sensor in the air after the evaporator: S4
this arrangement is used primarily when refrigeration is controlled and there is a risk of excessively temperatures near the product.

A sensor before and after the evaporator: S3 + S4
this arrangement lets you adapt the thermostat, the alarm thermostat and the display to the actual application. The signal to the control thermostat, alarm thermostat and display is the weighted average of the two temperatures. For example, with 50% weighting each sensor makes an equal contribution. The signals to the control thermostat, alarm thermostat and display can be set independently.

Defrost sensor: S5

The best indication of the evaporator temperature is obtained from a defrost sensor mounted directly on the evaporator. In this case the defrost function can use this signal to minimise the duration and energy consumption of the defrost cycle.

If a defrost sensor is not required, time-controlled defrosting can be used or S4 can be selected.

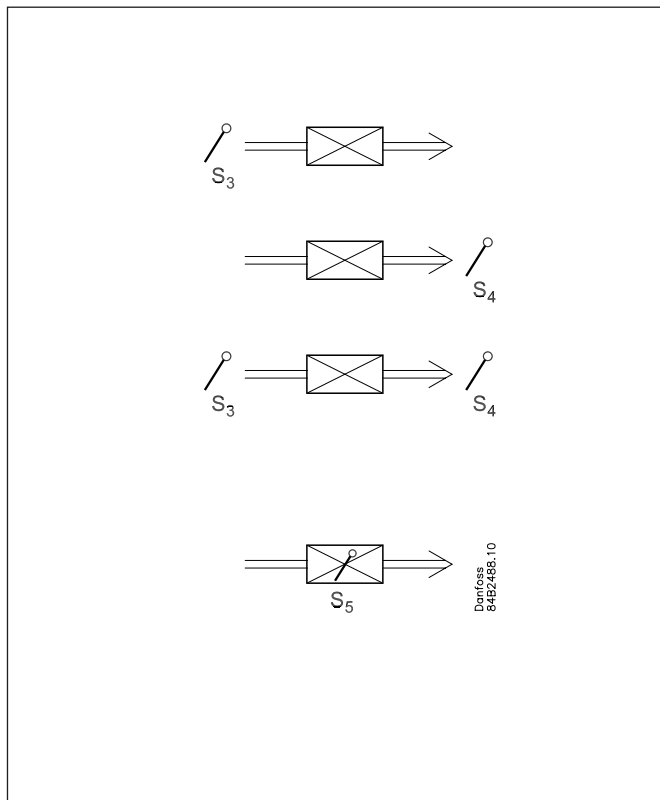

Changing the temperature reference

This may be desirable in applications such as an on/off appliance used in various product groups. The temperature reference can easily be changed by a contact signal on a digital input. This signal raises the normal thermostat setting by a predefined amount. The alarm limits are also offset accordingly.

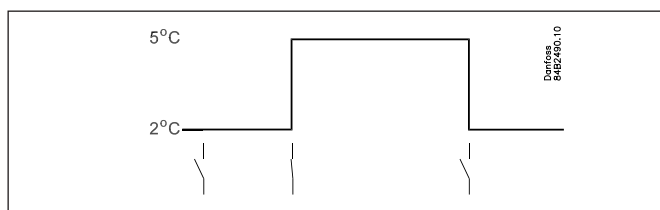

Night time cover function

The controller has a function that automatically detects when a night time cover has been placed over the refrigeration appliance. This function requires the use of both an S3 and S4 sensor. When the night time cover is placed over the appliance, heat intake and thus the need for increased cooling are reduced. The temperature difference between S3 and S4 will be reduced, and the controller will change to night operation mode once this difference becomes less than the set difference (night time cover difference).

Example:

During day operation there is a temperature difference of e.g. 8 K between S3 and S4.

During operating with a night time cover the difference drops to e.g. 3 K.

r75 Cover diff must be set to a value between the two values. In this case, 5.5 k.

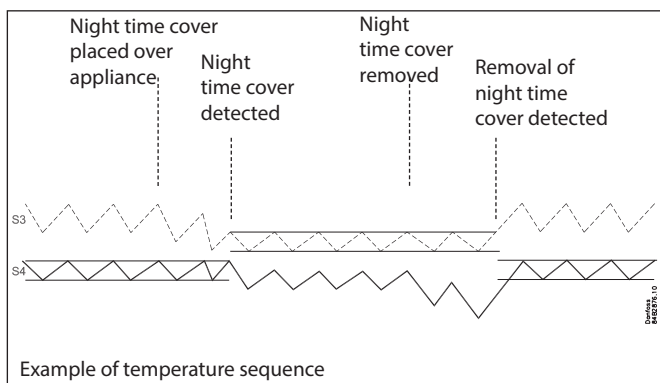

Applications

The following is a brief summary of the application area of this controller.

The relay outputs are defined by a configuration setting to align the controller interface to the selected application.

S3 and S4 are temperature sensors. One or both of these sensors may be used, depending on the application. S3 is located in the air flow before the evaporator, and S4 in the air flow after the evaporator.

A percentage setting determines the relative contributions of the sensors to the control function. S5 is a defrost sensor located on the evaporator.

DI1 and DI2 are contact functions that can be used for any of the following purposes: door function, alarm function, defrost start, external main switch, night operation, change thermostat reference, appliance cleaning, forced refrigeration, or coordinated defrost. See the functions of parameters o02 and o37.

Refrigeration control with one compressor

The functions are adapted to small refrigeration systems, which may be refrigeration appliances or cold rooms. Three of the relays control refrigeration, defrost and the fans, while the fourth relay can be used for an alarm function, lighting control, or rail heat control.

- The alarm function can be linked to a contact function from a door switch. An alarm is generated if the door remains open longer than allowed.
- Lighting control can also be linked to a contact function from a door switch. The light is switched on when the door is opened and remains on for two minutes after the door is closed.
- The rail heat function can be used in refrigeration or freezer appliances or for the door heater of a freezer room.

The fans can be stopped during defrosting, and they can also track the open/closed state of a door switch.

There are several other functions for the alarm function, as well as the lighting control, rail heat control and fan control. See the corresponding parameter settings.

The connections shown in applications 1, 2 and 3 are the recommended connections if an extra display is **not** installed.

If an extra display (type EKA 163A) is connected, terminal 21 **must** be used for the display, and **solely** for the display.

The remaining connections can be made as follows:

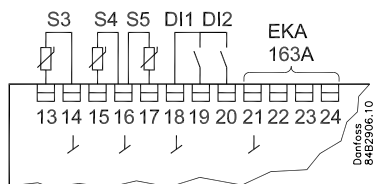

1

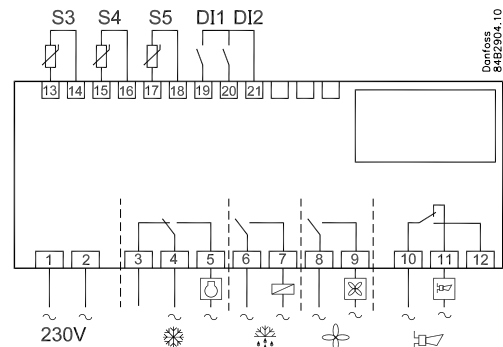

2

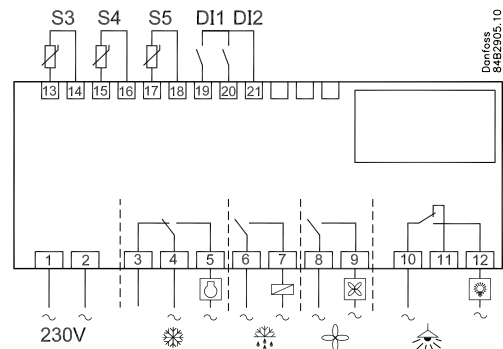

3

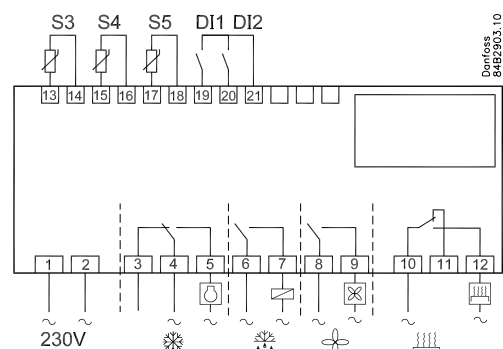

Menu overview

SW = 1.5x

Parameters	EL-diagram number			Min.-value	Max.-value	Factory setting	Actual setting
	Codes	1	2				
Function							
Normal operation							
Temperature (set point)		---			-50.0°C	50.0°C	2.0°C
Thermostat							
Differential	***	r01			0.0 K	20.0K	2.0 K
Max. limitation of setpoint setting	***	r02			-49.0°C	50°C	50.0°C
Min. limitation of setpoint setting	***	r03			-50.0°C	49.0°C	-50.0°C
Adjustment of temperature indication		r04			-20.0 K	20.0 K	0.0 K
Temperature unit (°C/°F)		r05			°C	°F	°C
Correction of the signal from S4		r09			-10.0 K	+10.0 K	0.0 K
Correction of the signal from S3		r10			-10.0 K	+10.0 K	0.0 K
Manual service, stop regulation, start regulation (-1, 0, 1)		r12			-1	1	0
Displacement of reference during night operation		r13			-10.0 K	10.0 K	0.0 K
Definition and weighting, if applicable, of thermostat sensors - S4% (100%=S4, 0%=S3)		r15			0%	100%	100%
Activation of reference displacement r40		r39			OFF	ON	OFF
Value of reference displacement (activate via r39 or DI)		r40			-50.0 K	50.0 K	0.0 K
Thermostat sensor S4% can be selected under night operation with night time cover.		r61			0%	100%	100%
Temperature difference for night time cover (0 K = not detected)		r75			0 K	20 K	0 K
Alarm							
Delay for temperature alarm		A03			0 min	240 min	30 min
Delay for door alarm	***	A04			0 min	240 min	60 min
Delay for temperature alarm after defrost		A12			0 min	240 min	90 min
High alarm limit	***	A13			-50.0°C	50.0°C	8.0°C
Low alarm limit	***	A14			-50.0°C	50.0°C	-30.0°C
Alarm delay DI1		A27			0 min	240 min	30 min
Alarm delay DI2		A28			0 min	240 min	30 min
Definition of alarm sensor 1: Combination of S3 and S4 (A36, A13 and A14 must be set) 2: Separate values for S3 and S4 (A13, A14, A56 and A57 must be set)		A33			1	2	1
Signal for alarm thermostat. S4% (100%=S4, 0%=S3)		A36			0%	100%	100%
High alarm limit for S3		A56			-50.0°C	50.0°C	8.0°C
Low alarm limit for S3		A57			-50.0°C	50.0°C	-30.0°C
Compressor							
Min. ON-time		c01			0 min	30 min	0 min
Min. OFF-time		c02			0 min	30 min	0 min
Compressor relay 1 must cutin and out inversely (NC-function)		c30			0 OFF	1 ON	0 OFF
Defrost							
Defrost method (none/EL/GAS/BRINE)		d01			no	bri	EL
Defrost stop temperature		d02			0.0°C	25.0°C	6.0°C
Interval between defrost starts		d03			0 hours	240 hours	8 hours
Max. defrost duration		d04			0 min	180 min	45 min
Displacement of time on cutin of defrost at start-up		d05			0 min	240 min	0 min
Drip off time		d06			0 min	60 min	0 min
Delay for fan start after defrost		d07			0 min	60 min	0 min
Fan start temperature		d08			-50.0°C	0.0°C	-50.0°C
Fan cutin during defrost 0: Stopped 1: Running 2: Runs during pump down and defrosting.		d09			0	2	1
Defrost sensor (0=time, 1=S5, 2=S4)		d10			0	2	0
Pump down delay		d16			0 min	60 min	0 min
Max. aggregate refrigeration time between two defrosts		d18			0 hours	48 hours	0 hours
Defrost on demand - S5 temperature's permitted variation during frost build-up. On central plant choose 20 K (=off)		d19			0.0 K	20.0 k	20.0 K
Minimum defrost time		d24			0 min	180 min	0 min
Fan							
Fan stop at cutout compressor		F01			no	yes	no
Delay of fan stop		F02			0 min	30 min	0 min
Fan stop temperature (S5)		F04			-50.0°C	50.0°C	50.0°C
Real time clock							
Six start times for defrost. Setting of hours. 0=OFF		t01- t06			0 hours	23 hours	0 hours
Six start times for defrost. Setting of minutes. 0=OFF		t11- t16			0 min	59 min	0 min
Clock - Setting of hours	***	t07			0 hours	23 hours	0 hours
Clock - Setting of minute	***	t08			0 min	59 min	0 min
Clock - Setting of date	***	t45			1	31	1
Clock - Setting of month	***	t46			1	12	1
Clock - Setting of year	***	t47			0	99	0
Miscellaneous							
Delay of output signals after start-up		o01			0 s	600 s	5 s
Input signal on DI1. Function: 0=not used. 1=status on DI1. 2=door function with alarm when open. 3=door alarm when open. 4=defrost start (pulse-signal). 5=ext.main switch. 6=night operation 7=change reference (activate r40). 8=alarm function when closed. 9=alarm function when open. 10=case cleaning (pulse signal). 11=forced cooling. 12=S5B		o02			1	12	0

Network address		o03				0	240	0	
On/Off switch (Service Pin message)		o04				OFF	ON	OFF	
IMPORTANT! o61 must be set prior to o04									
Access code 1 (all settings)		o05				0	100	0	
Used sensor type (Pt /PTC/NTC)		o06				Pt	ntc	Pt	
Display step = 0.5 (normal 0.1 at Pt sensor)		o15				no	yes	no	
Max hold time after coordinated defrost		o16				0 min	60 min	20 min	
Select signal for display view. S4% (100%=S4, 0%=S3)		o17				0%	100%	100%	
Input signal on DI2. Function: (0=not used. 1=status on DI2. 2=door function with alarm when open. 3=door alarm when open. 4=defrost start (pulse signal). 5=ext. main switch 6=night operation 7=change reference (activate r40). 8=alarm function when closed. 9=alarm function when open. 10=case cleaning (pulse signal). 11=forced cooling . 12=coordinated defrost)		o37				0	12	0	
Configuration of light function (relay 4) 1=ON during day operation. 2=ON / OFF via data communication. 3=ON follows the DI-function, when DI is selected to door function or to door alarm		o38				1	3	1	
Activation of light relay (only if o38=2)		o39				OFF	ON	OFF	
Rail heat On time during day operations		o41				0%	100%	100%	
Rail heat On time during night operations		o42				0%	100%	100%	
Rail heat period time (On time + Off time)		o43				6 min	60 min	10 min	
Case cleaning. 0=no case cleaning. 1=Fans only. 2=All output Off.	***	o46				0	2	0	
Selection of EL diagram.	*	o61	1	2	3	1	3	1	
Transfer a set of pre-settings	*	o62				0	10	0	
Access code 2 (partly access)	***	o64				0	100	0	
Save the controllers present settings to the programming key. Select your own number.		o65				0	25	0	
Load a set of settings from the programming key (previously saved via o65 function)	*	o66				0	25	0	
Replace the controllers factory settings with the present settings		o67				OFF	On	OFF	
Service									
Status codes		S0-S33							
Temperature measured with S5 sensor	***	u09							
Status on DI1 input. on/1=closed		u10							
Temperature measured with S3 sensor	***	u12							
Status on night operation (on or off) 1=closed	***	u13							
Temperature measured with S4 sensor	***	u16							
Thermostat temperature		u17							
Read the present regulation reference		u28							
Status on DI2 output. on/1=closed		u37							
Temperature shown on display		u56							
Measured temperature for alarm thermostat		u57							
Status on relay for cooling	**	u58							
Status on relay for fan	**	u59							
Status on relay for defrost	**	u60							
Status on relay for rail heat	**	u61							
Status on relay for alarm	**	u62							
Status on relay for light	**	u63							
Temperature measured with S5B sensor	***	u75							
Status of night time cover detection (On = night time cover has been detected)		U08							

*) Can only be set when regulation is stopped (r12=0)

**) Can be controlled manually, but only when r12=-1

***) With access code 2 the access to these menus will be limited

Note

With the use of the o62 for quick selection of settings, the sensor type will be set to "NTC" in 9 of the 10 pre-settings.

Factory setting

If you need to return to the factory-set values, it can be done in this way:

- Cut out the supply voltage to the controller
- Keep the top and bottom buttons depressed at the same time as you reconnect the supply voltage

Wiring

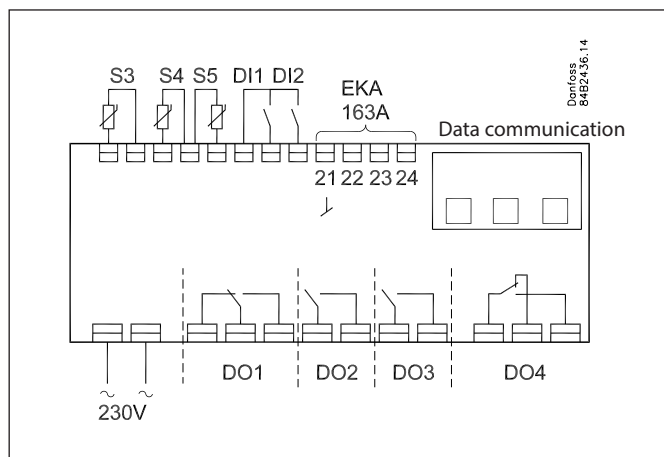

Power supply

230 V a.c.

Sensors

S3 and S4 are thermostat sensors.

A setting determines whether S3, S4, or both sensors are used.

S5 is a defrost sensor and is used if defrost is stopped based on temperature.

Digital on/off signals

A cut-in input activates a function. The available functions are shown in menus o02 and o37.

External display

An EKA 163A display can be connected.

Relays

The general uses are mentioned here. See also the page where the different applications are shown.

DO1: Refrigeration. The relay cuts in when the controller requests refrigeration.

DO2: Defrost. The relay is activated during defrosting.

DO3: Fans.

The relay cuts in when the fans must run.

DO4: Alarm, rail heat, or lighting.

Alarm: see diagram. The relay is cut in during normal operation and cuts out in alarm situations and when the controller is de-energised.

Rail heat: the relay cuts in when rail heating is needed.

Lighting: the relay cuts in when light is needed.

Data communication

The controller is available in several versions where data communication can be carried out with one of the following systems: MODBUS or LON-RS485.

If a data bus or network is used, proper installation of the bus or network cables is important.

See document RC8AC...

Electrical interference

Cables for sensors, DI inputs and data communication **must** be kept separate from other electrical cables:

- Use separate cable trays
- Keep cables separated by at least 10 cm
- Avoid long cables on DI inputs

Coordinated defrost with wiring interconnect

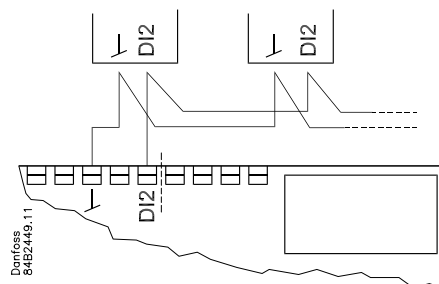

The following controllers can be connected in this manner:

EKC 202D/302D serie and
 AK-CC 210 and AK-CC 250
 (But max. 15 controllers)

Refrigeration is resumed when all controllers have de-asserted the defrost signal.

Coordinated defrost with data communication

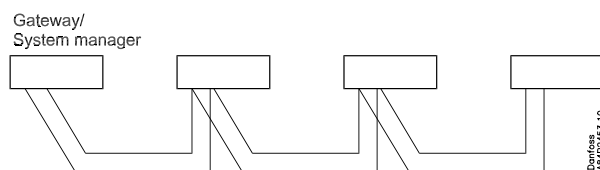



Technical data

Supply voltage	230 V a.c. +10/-15 %. 2.5 VA, 50/60 Hz	
Sensors 3 pcs off either	Pt 1000 or PTC 1000 ohm or NTC-M2020 (5000 ohm / 25°C)	
Accuracy	Measuring range	-60 to +99°C
	Controller	±1 K below -35°C ±0.5 K between -35 to +25°C ±1 K above +25°C (The level of accuracy below -25°C is more than doubled during the use of NTC sensors)
	Pt 1000 sensor	±0.3 K at 0°C ±0.005 K per grad
Display	LED, 3-digits	
External display	EKA 163A	
Digital inputs	Signal from contact functions Requirements to contacts: Gold plating Cable length must be max. 15 m Use auxiliary relays when the cable is longer	
Electrical connection cable	Max. 1.5 mm ² multi-core cable	
Relays*		CE (250 V a.c.)
	DO1. Refrigeration	10 (6) A
	DO2. Defrost	10 (6) A
	DO3. Fan	6 (3) A
	DO4. Alarm, light or rail heat	4 (1) A Min. 100 mA**
Environments	0 to +55°C, During operations -40 to +70°C, During transport	
	20 - 80% Rh, not condensed	
	No shock influence / vibrations	
Density	IP 65 from front. Buttons and packing are imbedded in the front.	
Escapement reserve for the clock	4 hours	
Approvals	EU Low Voltage Directive and EMC demands re CE-marking complied with LVD tested acc. EN 60730-1 and EN 60730-2-9, A1, A2 EMC tested acc. EN 61000-6-3 and EN 61000-6-2	

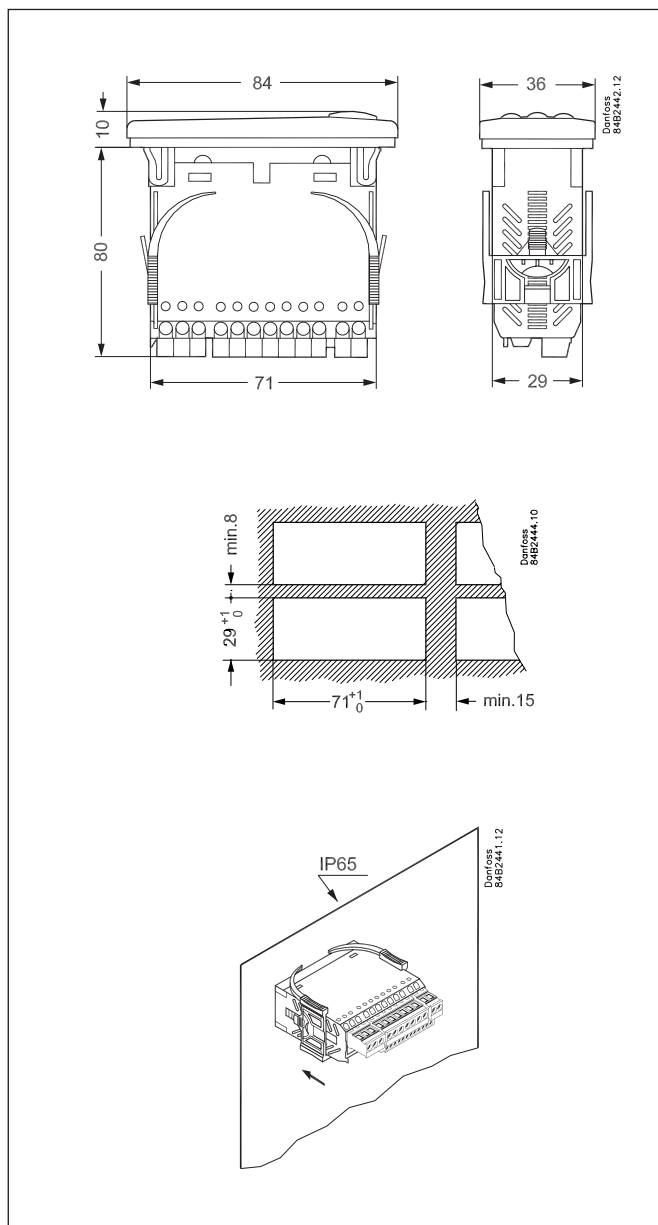
* DO1 and DO2 are 16 A relays. DO3 and DO4 are 8 A relays. Max. load must be kept.
** Gold plating ensures make function with small contact loads

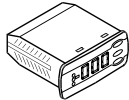
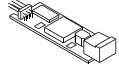
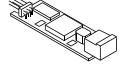
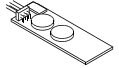

Ordering

Type		Function	Voltage supply	Number	Code no.
EKC 202D1		Refrigeration controller without data communication but prepared for mounting of one module	230 V a.c.	1	084B8554
				30	084B8654
EKA 178A		Data communication module MOD-bus			084B8564
EKA 179A		Data communication module LON RS 485			084B8565
EKA 181C		Battery module that will protect the clock in case of lengthy power failure			084B8577
EKA 163A		External display			084B8562

Additional information available:
Manual: RS8FL

AK-CC 210

Application

- This controller is used for temperature control of refrigeration appliances in supermarkets.
- It incorporates many predefined applications to provide many options in a single unit. Versatility is designed in for use in new installations as well as service replacement in existing installations.

Advantages

- Multi-application support in a single unit
- Integrated refrigeration functions enable the controller to replace a host of thermostats and timers
- Buttons and gasket integrated in front panel
- Can control two compressors
- Easy data communication retrofit
- Quick setup
- Two temperature references
- Digital inputs for various functions
- Clock function with backup
- HACCP compliance
 - Temperature monitoring and registration of periods with excessively high temperature
 - Factory calibration assures measurement accuracy exceeding the requirements of the EN 441-13 standard without subsequent calibration (Pt1000 sensor)

Control

The controller contains a temperature regulator that can receive signals from one or two temperature sensors. The thermostat sensors can be placed in the cold air flow after the evaporator, in the warm air flow just before the evaporator, or in both locations. A setting determines the effects of the two sensors on the control loop.

The defrost temperature can be measured directly from an S5 sensor or indirectly from the S4 measurement. The necessary functions are cut in and out by four relays according to the requirements of the application. The options are:

- Refrigeration (compressor or relay)
- Fan
- Defrost
- Rail heat
- Alarm
- Lighting
- Fans for hot gas defrosting
- Refrigeration 2 (compressor 2 or relay 2)

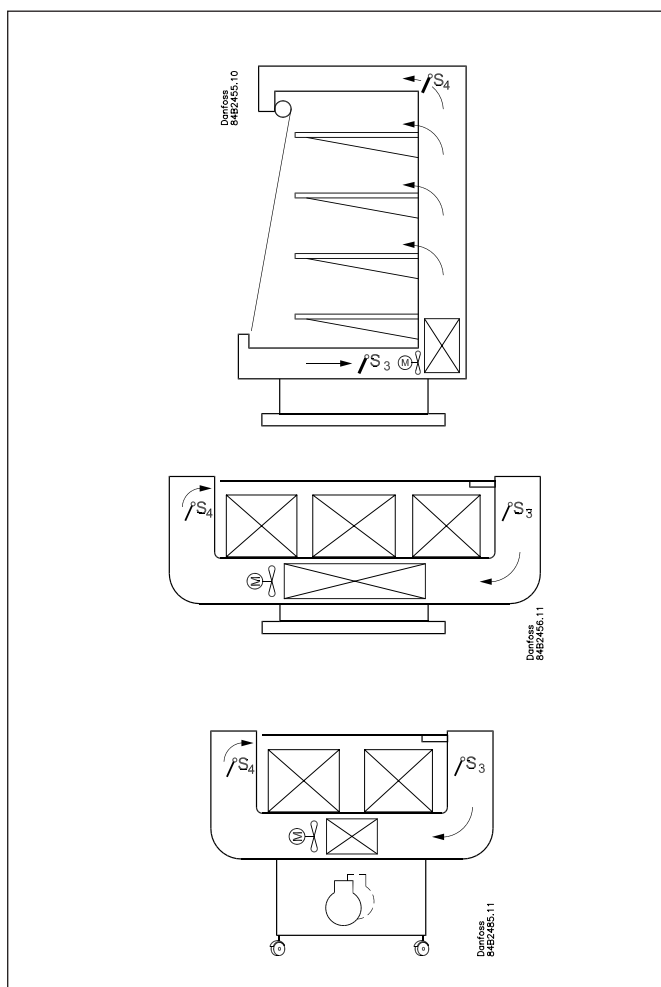
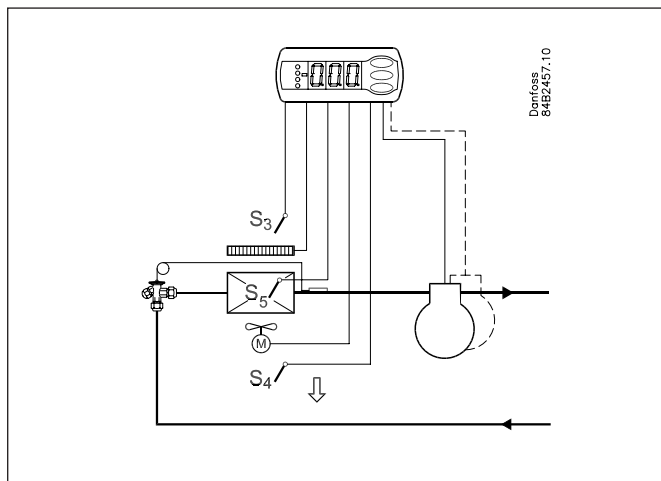

Sensors

One or two thermostat sensors can be connected to the controller, depending on the application requirements.

Sensor in the air stream ahead of the evaporator:
this arrangement is used primarily with area-based control.

Sensor in the air stream after the evaporator:
this arrangement is used primarily when refrigeration is controlled and there is a risk of excessively temperatures near the product.

Sensors before and after the evaporator:
this arrangement lets you adapt the thermostat, the alarm thermostat and the display to the actual application. The signal to the control thermostat, alarm thermostat and display is the weighted average of the two temperatures. For example, with 50% weighting each sensor makes an equal contribution. The control thermostat, alarm thermostat and display signals can be configured independently.

Defrost sensor

The best indication of the evaporator temperature is obtained from a defrost sensor mounted directly on the evaporator. In this case the defrost function can use this signal to minimise the duration and energy consumption of the defrost cycle.

If a defrost sensor is not required, time-controlled defrosting can be used or S4 can be selected.

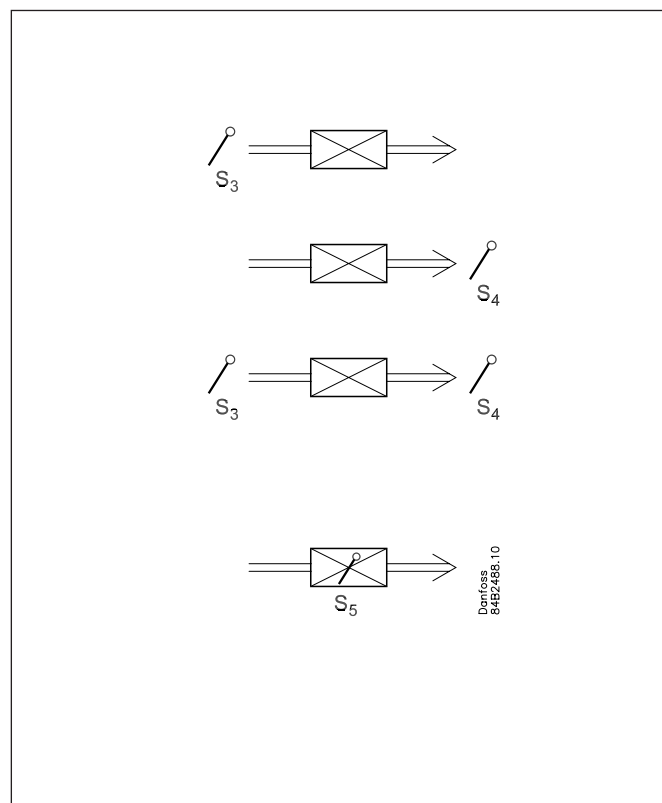

Controlling two compressors

This control is used for controlling two compressors of the same size. The principle for control is that one of the compressors connects at $\frac{1}{2}$ the differential of the thermostat, and the other at the full differential. When the thermostat cuts in the compressor with the fewest operating hours is started. The other compressor will only start after a set time delay, so that the load will be divided between them. The time delay has a higher priority than the temperature.

When the air temperature has dropped by half the differential the one compressor will stop, the other will continue working and not stop until the required temperature is achieved.

The compressors used must be of a type that is capable of starting up against a high pressure.

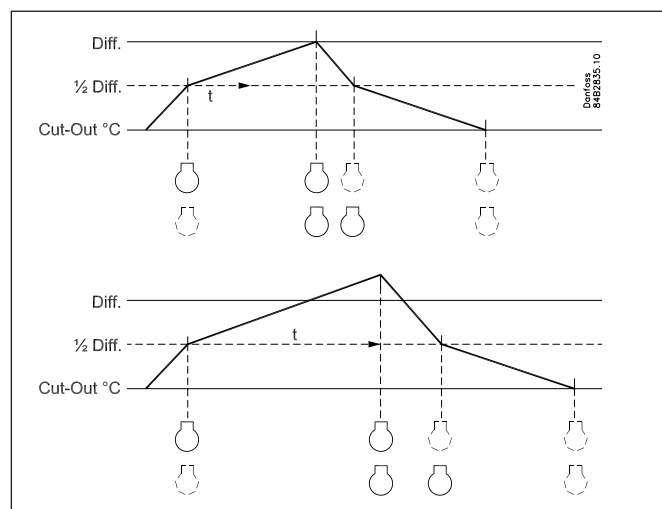

Changing the temperature reference

This may be desirable in applications such as an on/off appliance used in various product groups. The temperature reference can easily be changed by a contact signal on a digital input. This signal raises the normal thermostat setting by a predefined amount. The alarm limits are also offset accordingly.

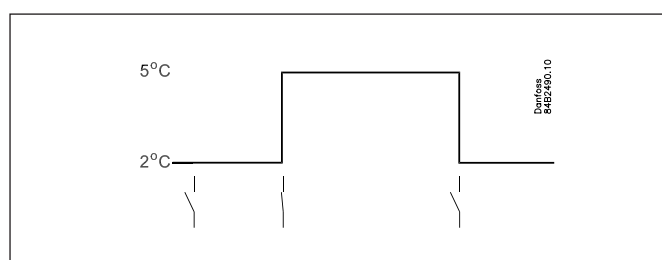

Applications

Here is a survey of the controller's field of application.

A setting will define the relay outputs so that the controller's interface will be targeted to the chosen application.

S3 and S4 are temperature sensors. The application will determine whether either one or the other or both sensors are to be used. S3 is placed in the air flow before the evaporator. S4 after the evaporator.

A percentage setting will determine according to what the control is to be based. S5 is a defrost sensor and is placed on the evaporator.

DI1 and DI2 are contact functions that can be used for one of the following functions: door function, alarm function, defrost start, external main switch, night operation, change of thermostat reference, appliance cleaning, forced refrigeration or coordinated defrost. See the functions in settings o02 and o37.

Refrigeration control with one compressor

The functions are adapted to small refrigeration systems which either may be refrigeration appliances or cold rooms. The three relays can control the refrigeration, the defrost and the fans, and the fourth relay can be used for either alarm function, light control or rail heat control

- The alarm function can be linked up with a contact function from a door switch. If the door remains open longer than allowed there will be an alarm.
- The light control can also be linked up with a contact function from a door switch. An open door will switch on the light and it will remain lit for two minutes after the door has been closed again.
- The rail heat function can be used in refrigeration or freezing appliances or on the door's heating element for frost rooms.

The fans can be stopped during defrost and they may also follow a door switch's open/close situation.

There are several other functions for the alarm function as well as the light control, rail heat control and fans. Please refer to the respective settings.

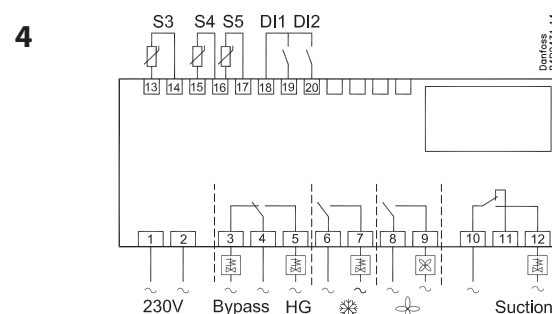
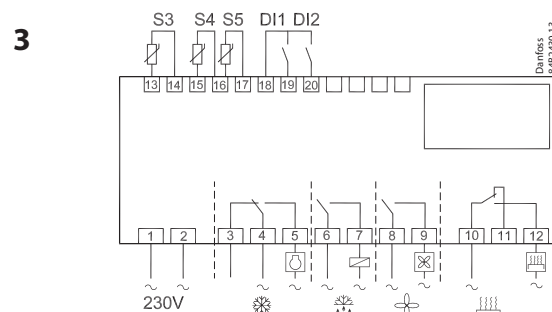
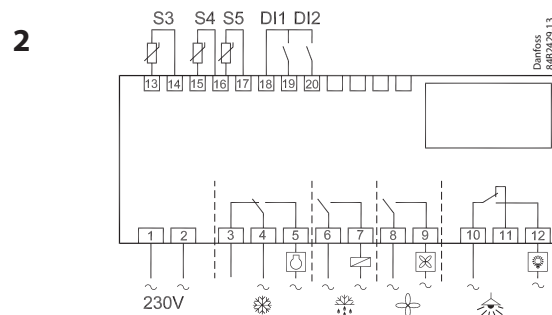
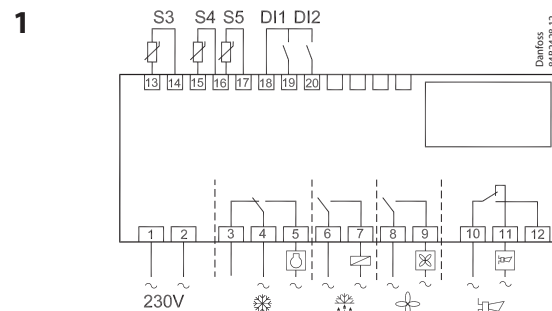

Hot gas defrost

This type of connection can be used on systems with hotgas defrost, but only in small systems in, say, supermarkets – the functional content has **not** been adapted to systems with large charges. Relay 1's change-over function can be used by the bypass valve and/or the hotgas valve.

Relay 2 is used for refrigeration.

tekst og tegninger
er hentet fra
manualen

Refrigeration control with two compressors

This group of applications can be used if the controller is to cut two compressors in and out. The functions can be compared with wiring diagrams 1 to 3, but instead of controlling fans the relay is here used for compressor 2.

The two compressors must be of the same size. When the controller demands refrigeration it will first cut in the compressor with the shortest operating time. After the time delay the second compressor will be cut in.

When the temperature has dropped to "the middle of the differential", the compressor with the longest operation time will be cut out.

If the running compressor does not manage to reduce the temperature to the cutout point, the other compressor will be cut in again. This happens when the temperature reaches the top part of the differential. If the temperature is instead "stuck" in the differential for two hours, there will be a change-over between the two compressors so that the operating time can be equalised.

The two compressors must be of a type that can start up against a high pressure.

The compressors's settings for "Min On time" and "Min Off time" will always have top priority during normal regulation. But if one of the override functions is activated, the "Min On time" will be disregarded.

If the controller is to cut 2 compressor and 1 fan in and out, relay 4 must cut the fan in and out.

This function is activated in application 10.

5

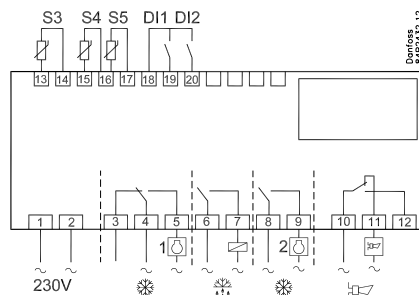

6

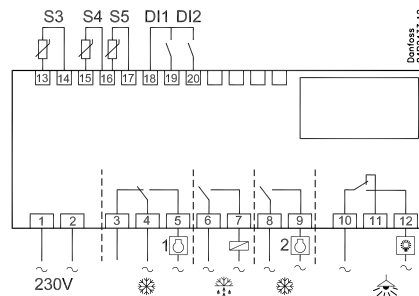

7

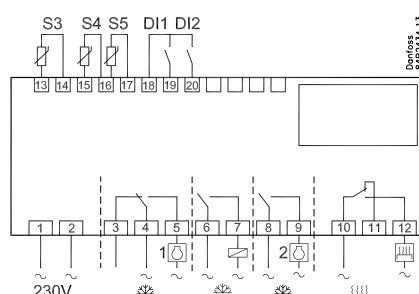

10

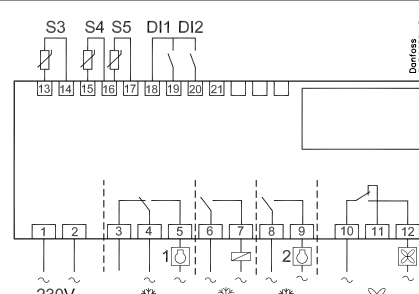

Simple refrigeration with defrost

This application can be used where there is only regulation of refrigeration and defrost.

8

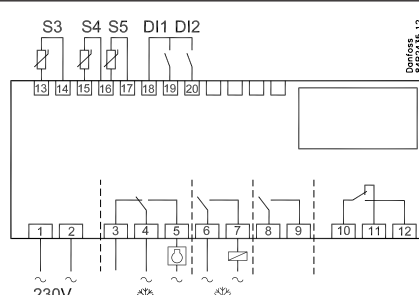

Heating function

This application is the same as under 1, but a heating function has been added which protects the unit against too low temperature. The defrost function's heating element is here used for heating.

This application is used where the temperature can go below the set cutout temperature for the refrigeration. To ensure that the temperature will not become too low the heating element is activated x degrees below the reference value.

The S3 sensor must be mounted. It supplies the signal when there is heating.

9

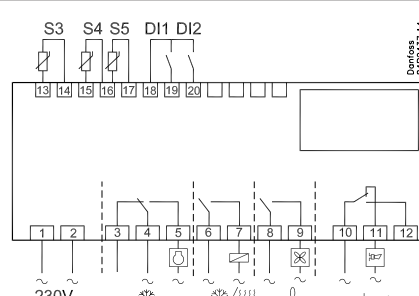

Menu survey

SW = 2.3x

Function	Parameters		EL-diagram number										Min.-value	Max.-value	Factory setting	Actual setting	
			1	2	3	4	5	6	7	8	9	10					
Normal operation																	
Temperature (set point)		---													-50.0°C	50.0°C	2.0°C
Thermostat																	
Differential	***	r01													0.1 K	20.0K	2.0 K
Max. limitation of setpoint setting	***	r02													-49.0°C	50°C	50.0°C
Min. limitation of setpoint setting	***	r03													-50.0°C	49.0°C	-50.0°C
Adjustment of temperature indication		r04													-20.0 K	20.0 K	0.0 K
Temperature unit (°C/°F)		r05													°C	°F	°C
Correction of the signal from S4		r09													-10.0 K	+10.0 K	0.0 K
Correction of the signal from S3		r10													-10.0 K	+10.0 K	0.0 K
Manual service, stop regulation, start regulation (-1, 0, 1)		r12													-1	1	0
Displacement of reference during night operation		r13													-10.0 K	10.0 K	0.0 K
Definition and weighting, if applicable, of thermostat sensors - S4% (100%=S4, 0%=S3)		r15													0%	100%	100%
The heating function is started a number of degrees below the thermostats cutout temperature		r36													-15.0 K	-3.0 K	-15.0 K
Activation of reference displacement r40		r39													OFF	ON	OFF
Value of reference displacement (activate via r39 or DI)		r40													-50.0 K	50.0 K	0.0 K
Alarm																	
Delay for temperature alarm		A03													0 min	240 min	30 min
Delay for door alarm	***	A04													0 min	240 min	60 min
Delay for temperature alarm after defrost		A12													0 min	240 min	90 min
High alarm limit	***	A13													-50.0°C	50.0°C	8.0°C
Low alarm limit	***	A14													-50.0°C	50.0°C	-30.0°C
Alarm delay DI1		A27													0 min	240 min	30 min
Alarm delay DI2		A28													0 min	240 min	30 min
Signal for alarm thermostat. S4% (100%=S4, 0%=S3)		A36													0%	100%	100%
Compressor																	
Min. ON-time		c01													0 min	30 min	0 min
Min. OFF-time		c02													0 min	30 min	0 min
Time delay for cutin of comp.2		c05													0 sec	999 sec	0 sec
Compressor relay 1 must cutin and out inversely (NC-function)		c30													0	1	0
															OFF	ON	OFF
Defrost																	
Defrost method (none/EL/GAS/BRINE)		d01													no	bri	EL
Defrost stop temperature		d02													0.0°C	25.0°C	6.0°C
Interval between defrost starts		d03													0 hours	240 hours	8 hours
Max. defrost duration		d04													0 min	180 min	45 min
Displacement of time on cutin of defrost at start-up		d05													0 min	240 min	0 min
Drip off time		d06													0 min	60 min	0 min
Delay for fan start after defrost		d07													0 min	60 min	0 min
Fan start temperature		d08													-15.0°C	0.0°C	-5.0°C
Fan cutin during defrost		d09													0	2	1
0: Stopped																	
1: Running																	
2: Running during pump down and defrost																	
Defrost sensor (0=time, 1=S5, 2=S4)		d10													0	2	0
Pump down delay		d16													0 min	60 min	0 min
Drain delay		d17													0 min	60 min	0 min
Max. aggregate refrigeration time between two defrosts		d18													0 hours	48 hours	0 hours
Defrost on demand - S5 temperature's permitted variation during frost build-up. On central plant choose 20 K (=off)		d19													0.0 K	20.0 k	20.0 K
Delay of hot gas defrost		d23													0 min	60 min	0 min
Fan																	
Fan stop at cutout compressor		F01													no	yes	no
Delay of fan stop		F02													0 min	30 min	0 min
Fan stop temperature (S5)		F04													-50.0°C	50.0°C	50.0°C
HACCP																	
Actual temperature measurement for the HACCP function		h01															
Last registered peak temperature		h10															
Selection of function and sensor for the HACCP function. 0 = no HACCP function. 1 = S4 used (maybe also S3). 2 = S5 used		h11													0	2	0
Alarm limit for the HACCP function		h12													-50.0°C	50.0°C	8.0°C
Time delay for the HACCP alarm		h13													0 min.	240 min.	30 min.
Select signal for the HACCP function. S4% (100% = S4, 0% = S3)		h14													0%	100%	100%
Real time clock																	
Six start times for defrost. Setting of hours. 0=OFF		t01-t06													0 hours	23 hours	0 hours
Six start times for defrost. Setting of minutes. 0=OFF		t11-t16													0 min	59 min	0 min
Clock - Setting of hours	***	t07													0 hours	23 hours	0 hours
Clock - Setting of minute	***	t08													0 min	59 min	0 min
Clock - Setting of date	***	t45													1	31	1
Clock - Setting of month	***	t46													1	12	1
Clock - Setting of year	***	t47													0	99	0
Miscellaneous																	
Delay of output signals after start-up		o01													0 s	600 s	5 s

		1	2	3	4	5	6	7	8	9	10			
Input signal on DI1. Function: 0=not used. 1=status on DI1. 2=door function with alarm when open. 3=door alarm when open. 4=defrost start (pulse-signal). 5=ext.main switch. 6=night operation 7=change reference (activate r40). 8=alarm function when closed. 9=alarm function when open. 10=case cleaning (pulse signal). 11=forced cooling at hot gas defrost.	o02											1	11	0
Network address	o03											0	240	0
On/Off switch (Service Pin message) IMPORTANT! o61 must be set prior to o04	o04											OFF	ON	OFF
Access code 1 (all settings)	o05											0	100	0
Used sensor type (Pt /PTC/NTC)	o06											Pt	ntc	Pt
Display step = 0.5 (normal 0.1 at Pt sensor)	o15											no	yes	no
Max hold time after coordinated defrost	o16											0 min	60 min	20
Select signal for display view. S4% (100%=S4, 0%=S3)	o17											0%	100%	100%
Input signal on DI2. Function: (0=not used. 1=status on DI2. 2=door function with alarm when open. 3=door alarm when open. 4=defrost start (pulse-signal). 5=ext. main switch 6=night operation 7=change reference (activate r40). 8=alarm function when closed. 9=alarm function when open. 10=case cleaning (pulse signal). 11=forced cooling at hot gas defrost.). 12=coordinated defrost)	o37											0	12	0
Configuration of light function (relay 4) 1=ON during day operation. 2=ON / OFF via data communication. 3=ON follows the DI-function, when DI is selected to door function or to door alarm	o38											1	3	1
Activation of light relay (only if o38=2)	o39											OFF	ON	OFF
Rail heat On time during day operations	o41											0%	100%	100
Rail heat On time during night operations	o42											0%	100%	100
Rail heat period time (On time + Off time)	o43											6 min	60 min	10 min
Case cleaning. 0=no case cleaning. 1=Fans only. 2=All output Off.	*** o46											0	2	0
Selection of EL diagram.	* o61											1	10	1
Download a set of predetermined settings.	* o62											0	6	0
Access code 2 (partly access)	*** o64											0	100	0
Save the controllers present settings to the programming key. Select your own number.	o65											0	25	0
Load a set of settings from the programming key (previously saved via o65 function)	o66											0	25	0
Replace the controllers factory settings with the present settings	o67											OFF	On	OFF
Service														
Status codes	S0-S33													
Temperature measured with S5 sensor	*** u09													
Status on DI1 input. on/1=closed	u10													
Temperature measured with S3 sensor	*** u12													
Status on night operation (on or off) 1=closed	*** u13													
Temperature measured with S4 sensor	*** u16													
Thermostat temperature	u17													
Read the present regulation reference	u28													
Status on DI2 output. on/1=closed	u37													
Temperature shown on display	u56													
Measured temperature for alarm thermostat	u57													
Status on relay for cooling	** u58													
Status on relay for fan	** u59													
Status on relay for defrost	** u60													
Status on relay for railheat	** u61													
Status on relay for alarm	** u62													
Status on relay for light	** u63													
Status on relay for valve in suction line	** u64													
Status on relay for compressor 2	** u67													

*) Can only be set when regulation is stopped (r12=0)

**) Can be controlled manually, but only when r12=-1

***) With access code 2 the access to these menus will be limited

Factory setting

If you need to return to the factory-set values, it can be done in this way:

- Cut out the supply voltage to the controller

- Keep both buttons depressed at the same time as you reconnect the supply voltage

Wiring

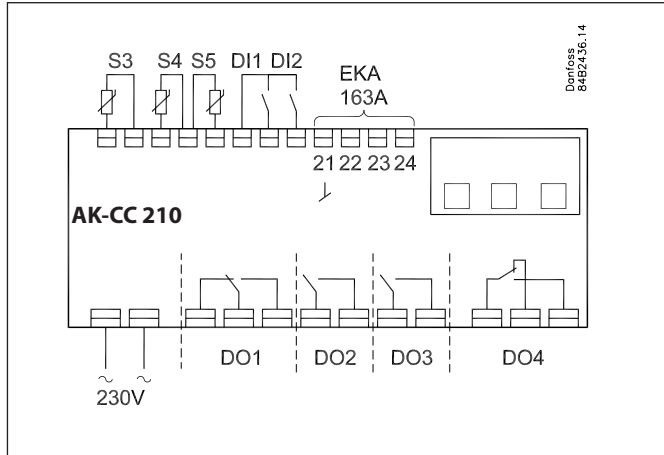

Power supply

230 V a.c.

Sensors

S3 and S4 are thermostat sensors. A setting determines whether S3, S4, or both sensors are used. S5 is a defrost sensor and is used if defrost is stopped based on temperature.

Digital on/off signals

A cut-in input activates a function. The available functions are shown in menus o02 and o37.

Relays

The general uses are described here.

DO1: Refrigeration. The relay cuts in when the controller requests refrigeration.

DO2: Defrost. The relay is activated during defrosting.

DO3: Fans or refrigeration 2

Fans: the relay cuts in when fan operation is necessary

Refrigeration 2: the relay cuts in when refrigeration level 2 is needed

DO4: Alarm, rail heat, lighting, or hot gas defrost

Alarm: see diagram. The relay is cut in during normal operation and cuts out in alarm situations and when the controller is de-energised.

Rail heat: the relay cuts in when rail heating is needed.

Lighting: the relay cuts in when light is needed.

Hot gas defrost: see diagram. The relay cuts in when defrosting is needed.

Application adaptation

The controller can be adapted to ten different applications by simple parameter selection.

Application no	Output				Input				
	DO1	DO2	DO3	DO4	DI1	DI2	S3	S4	S5
1									
2									
3									
4									
5									
6									
7									
8									
9									
10									

*1: Hot gas valve and bypass valve
*2: Liquid line solenoid valve

*3: Suction line solenoid valve

Data communication

The control function can be performed using data communication.

If data communication is used, proper installation of the data communication cables is important.

See document RC8AC...

Electrical interference

Cables for sensors, DI inputs and data communication **must** be kept separate from other electrical cables:

- Use separate cable trays
- Keep cables separated by at least 10 cm
- Avoid long cables on DI inputs

Coordinated defrost with wiring interconnect

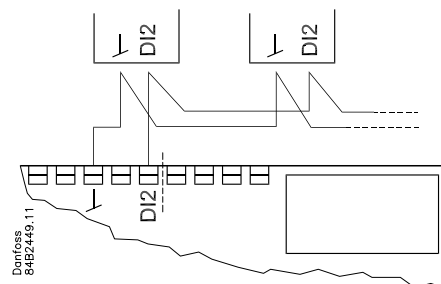

The following controllers can be connected in this manner:

EKC 202D /302D serie and
AK-CC 210 and AK-CC 250
(max. 15)

Refrigeration is resumed when all controllers have de-asserted the defrost signal.

Coordinated defrost with data communication

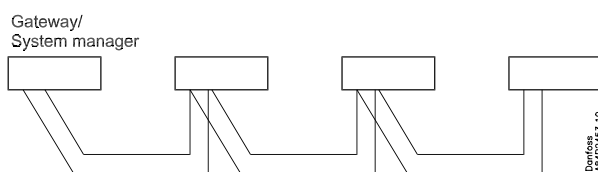

Technical data

Supply voltage	230 V a.c. +10/-15 %. 2.5 VA, 50/60 Hz		
Sensors 3 pcs off either	Pt 1000 or PTC 1000 ohm or NTC-M2020 (5000 ohm / 25°C)		
Accuracy	Measuring range	-60 to +99°C	
	Controller	±1 K below -35°C ±0.5 K between -35 to +25°C ±1 K above +25°C	
	Pt 1000 sensor	±0.3 K at 0°C ±0.005 K per grad	
Display	LED, 3-digits		
External display	EKA 163A		
Digital inputs	Signal from contact functions Requirements to contacts: Gold plating Cable length must be max. 15 m Use auxiliary relays when the cable is longer		
Electrical connection cable	Max.1,5 mm ² multi-core cable		
Relays*		CE (250 V a.c.)	UL *** (240 V a.c.)
	DO1. Refrigeration	10 (6) A	10 A Resistive 5FLA, 30LRA
	DO2. Defrost	10 (6) A	10 A Resistive 5FLA, 30LRA
	DO3. Fan	6 (3) A	6 A Resistive 3FLA, 18LRA 131 VA Pilot duty
	DO4. Alarm	4 (1) A Min. 100 mA**	4 A Resistive 131 VA Pilot duty
Environments	0 to +55°C, During operations -40 to +70°C, During transport		
	20 - 80% Rh, not condensed		
	No shock influence / vibrations		
Density	IP 65 from front. Buttons and packing are imbedded in the front.		
Escapement reserve for the clock	4 hours		
Approvals	EU Low Voltage Directive and EMC demands re CE-marking complied with LVD tested acc. EN 60730-1 and EN 60730-2-9, A1, A2 EMC tested acc. EN61000-6-3 and EN 61000-6-2		

* DO1 and DO2 are 16 A relays. DO3 and DO4 are 8 A relays. Max. load must be kept.

** Gold plating ensures make function with small contact loads

*** UL-approval based on 30000 couplings

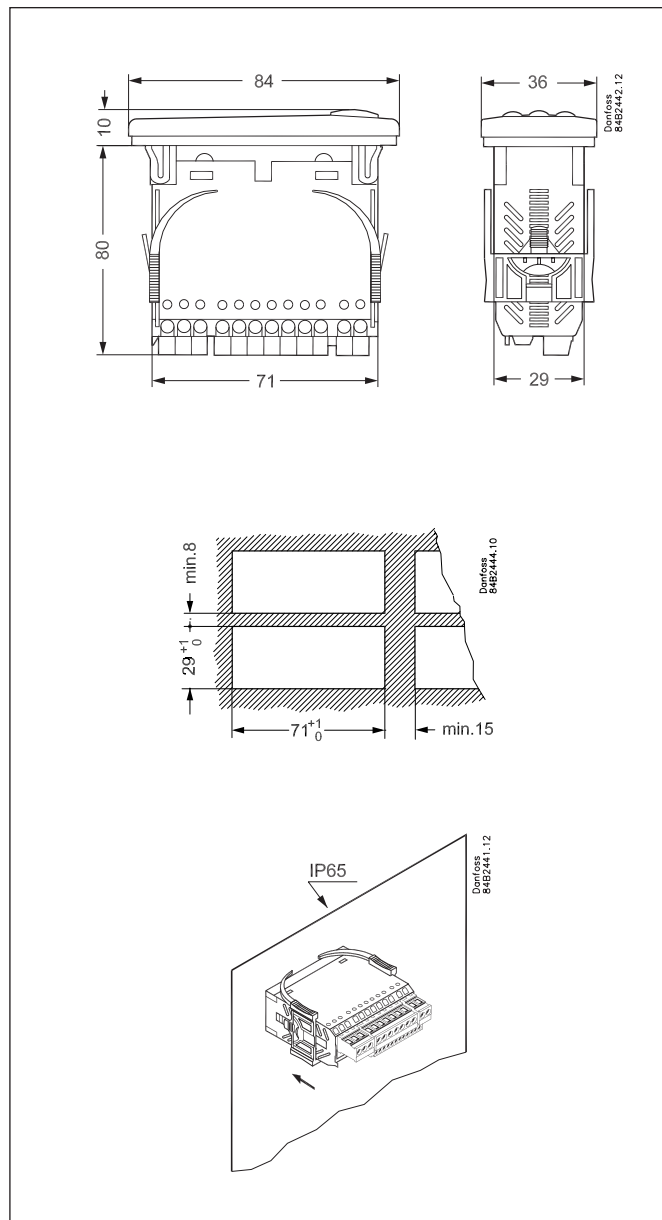

Ordering

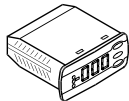
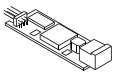
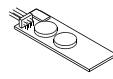
Type		Function	Power supply	Code no.
AK-CC 210		Refrigeration controller without data communication but prepared for mounting of one module	230 V a.c.	084B8520
			115 V a.c.	084B8534
EKA 178A		Data communication module MOD-BUS		084B8564
EKA 179A		Data communication module LON RS 485		084B8565
EKA 181C		Battery module that will protect the clock in case of lengthy power failure		084B8577

AK-CC 250A

Application

- The controller is used for temperature control refrigeration appliances in supermarkets
- The controller has the same functionalities as the AK-CC 210, but with the following deviations:
 - Fixed MODBUS data communication
 - The AK-CC 250A receives signals from Pt 1000 or PTC sensors
 - An external display can be connected, but only if the controller is a 'stand alone' unit and does not have data communication for system units
 - Flexibility has been planned both for new installations and for service in the refrigeration trade

In addition:

- It is not possible to mount a module with another type of data communication
- The menus are the same with the exception of o04, which has been removed.
- Menu o06 (sensor definition) has been added

Advantages

Easy to maintain because of:

- Several applications in the same device
- Can receive signals from known PTC sensors

Sensors

It is possible to connect one, two or three sensors, as long as they are all of the same type.

Select one of the following:

- Pt 1000 ohm at 0°C (Danfoss Type = AKS 11, AKS 12, AKS 21)
- PTC 1000 Ω (nominal 990 Ω) (Danfoss Type = EKS 111)
- PTC 1000 Ω @ 25°C

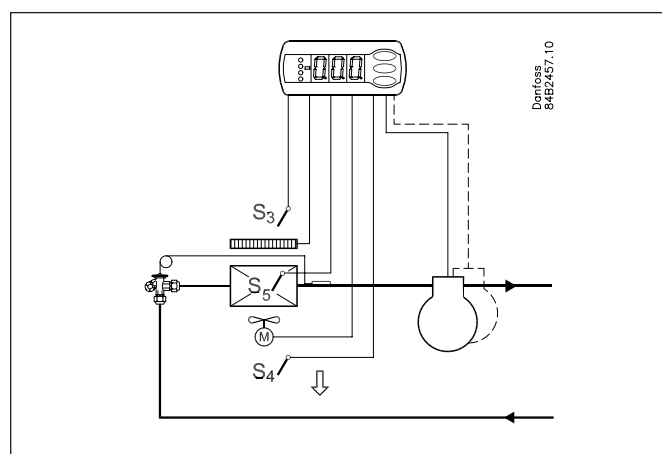

Controller with four relay outputs, three temperature sensors and two digital inputs.

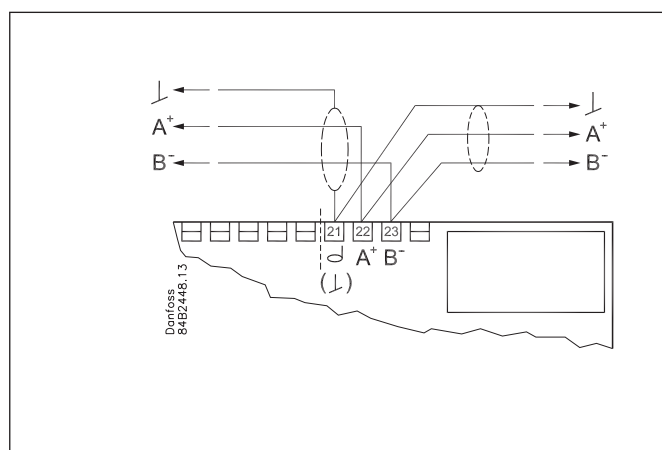

MODBUS data communication is built-in. It is not possible to retrofit another type of data communication.

Sensor overview

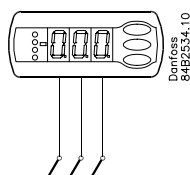
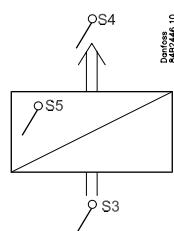

o06



Pt: Pt 1000 Ω @ 0°C (AKS 11, AKS 12, AKS 21)

P01: PTC 1000 Ω (nominal 990 Ω) = EKS 111

P02: PTC 1000 Ω @ 25°C (nominal 1000 Ω)

AK-CC 250A			
	Pt 1000 @ 0°C	PTC 1000 Ω	PTC 1000 Ω @ 25°C
	AKS 11, AKS 12, AKS 21	KTY81-121 EKS 111	KTY81-110
°C	Ω	Ω	Ω
30	1167.7	1029	1040
25	1097.3	990	1000
20	1077.9	951	961
15	1058.5	914	923
10	1039.0	877	886
5	1019.5	841	850
0	1000.0	807	815
-5	980.4	773	781
-10	960.9	740	747
-15	941.2	708	715
-20	921.6	677	684
-25	901.9	647	653
-30	882.2	617	624
-35	862.5	589	595
-40	842.7	562	567
	Carel: TSH/TST/TSM/TSQ/PT1 Dixell: PMG/PMP/PMT	Carel: 03/06/015 Dixell: S6 Eliwell: SN6/SN7 Lae: ST1K.CP	Frigo: VX6
o06	Pt	P01	P02

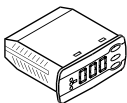
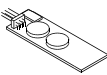
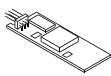
Ordering

Type		Function	Code no.
AK-CC 250A		Refrigeration controller with MODBUS data communication. For Pt 1000 or PTC sensors	084B8528
EKA 181C		Battery module that will protect the clock in case of lengthy power failure	084B8577
EKA 182A		Copy key EKC - EKC	084B8567
EKA 163A		External display option for stand alone	084B8562
EKA 164A		External operation option for stand alone	084B8563

Additional information available:
Manual: RS8GC

AK-CC 350

This controller is a variant of AK-CC 210 with the following differences:

- DIN-rail mounting
- Option for higher load to relay
- Fixed MODBUS data communication



Connection / application number

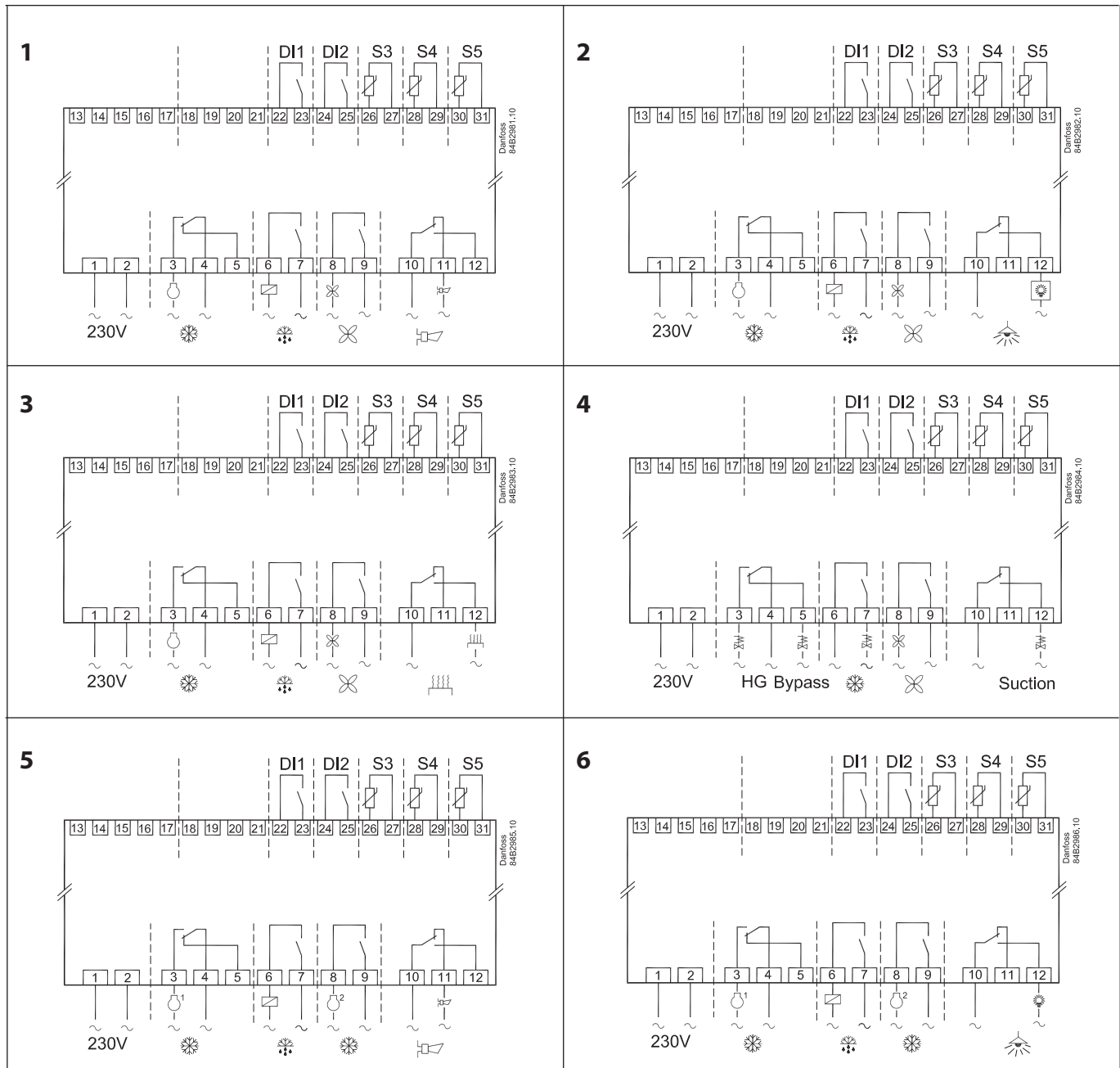

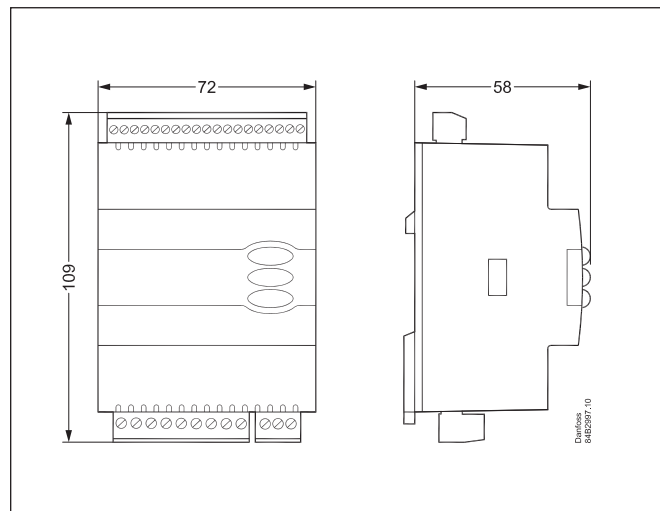
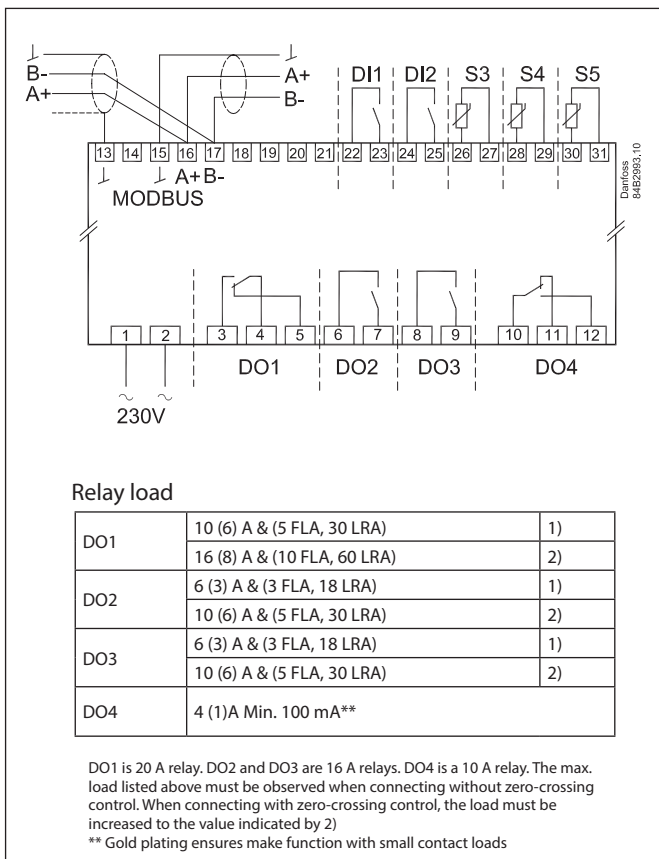
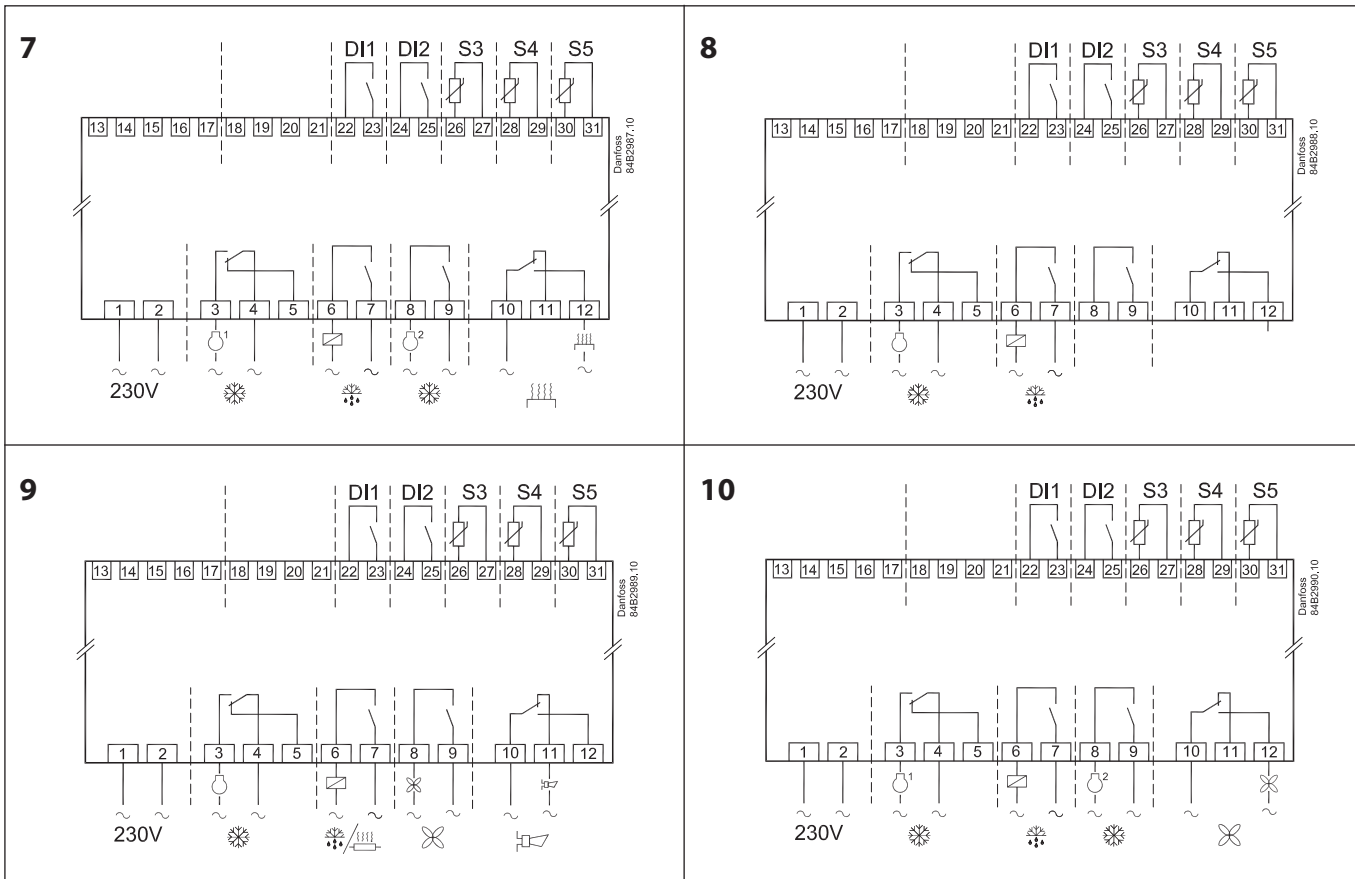

Ordering

Type	Function	Code no.
AK-CC 350	Refrigeration controller with MODBUS data communication	084B4165

Additional information available:
 Manual: RS8EQ

AK-CC 450

Application

Complete, highly versatile refrigeration appliance control for adaptation to all types of refrigeration appliances and cold storage rooms.

- For use with brine cooling
- For use with a thermostatic expansion valve

Advantages

- Energy optimisation of the entire refrigeration appliance
- A single controller for several different refrigeration appliances
- Integrated front-panel display
- Quick set-up with predefined settings
- Built-in data communication support
- Built-in clock function with power backup

Operating principle

The appliance temperature is detected by one or two temperature sensors located in the air flow before the evaporator (S3) or after the evaporator (S4). Configuration settings for the control thermostat, alarm thermostat and display reading determine how the two sensor values affect the individual functions.

In addition product sensor S6, which can optionally be fitted in the appliance, can be used to detect the temperature near the appropriate product in a certain location in the appliance.

The evaporator temperature is detected by sensor S5, which can be used as a defrost sensor.

In addition to the solenoid valve output, the controller has five relay outputs defined by selected uses.

Functional description

- Day/night thermostat with on/off or modulated operating mode
- Product sensor S6 with separate alarm limits
- Switching between thermostat settings in response to a digital input
- Defrost start controlled by a schedule, digital input or network input
- Natural, electrical or hot gas defrost
- Time-controlled and/or temperature-controlled defrost stop
- Defrost coordination with multiple controllers
- Pulsed fan operation when thermostat is cut out
- Case cleaning function for documentation of HACCP procedures
- Rail heat control by day/night signal, load or dew point
- Door function
- Controlling two compressors
- Controlling night blinds
- Lighting control
- Heater thermostat
- Factory calibration assures measurement accuracy exceeding the requirements of the EN 441-13 standard without subsequent calibration (Pt1000 sensor).
- Integrated Modbus communication with the option of fitting a LonWorks, DANBUSS or Ethernet communication card

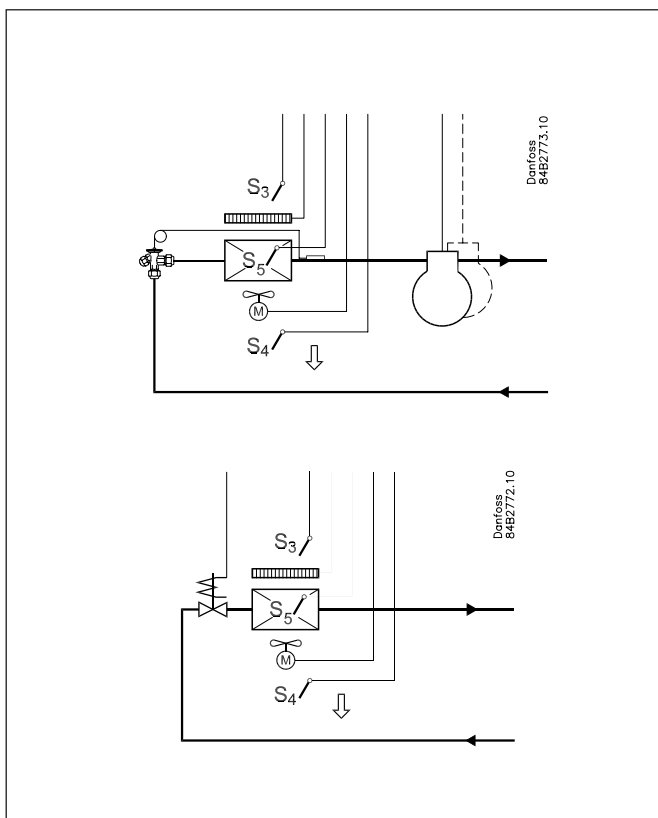
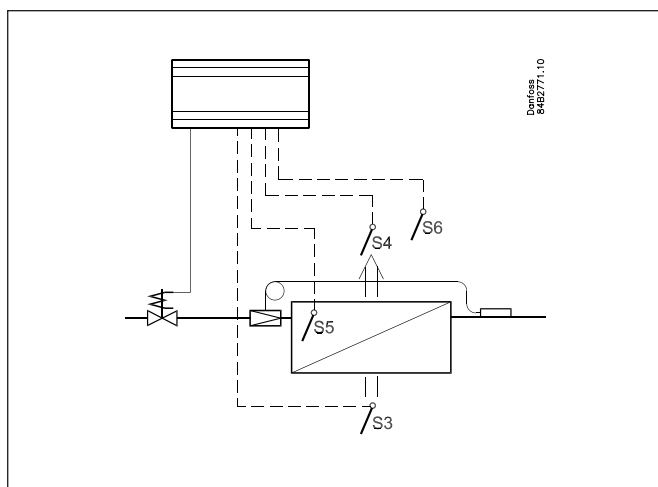
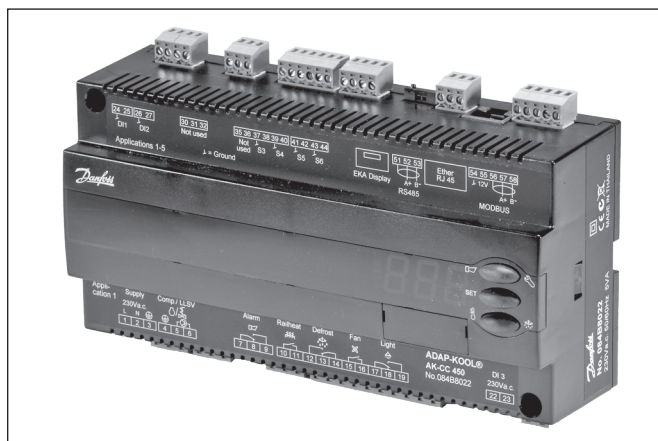

Applications

The following is a brief summary of the application options for this controller.

The inputs and outputs are configured by settings to adapt the operating interface of the controller to the selected application.

Applications 1 - 5 and 9

The configurations shown here are suitable for use with standard appliances or cold storage rooms with one valve, one evaporator and one refrigeration section.

The sensors are used in the conventional manner.

The output functions depend on the intended application.

Applications 6 and 8

These options are suitable for refrigeration appliances with one valve, two evaporators and two refrigeration sections.

There are two defrost sensors – one for each evaporator.

Application 6

Here the S4 sensor is always used for temperature control and alarm monitoring.

The two S3 values are used to display the temperatures of the individual cooling sections.

Application 6 has an alarm relay.

Application 8

Here the S4 sensor is always used for temperature control.

The two S3 sensors are used for alarm monitoring and displaying the temperatures of the individual cooling sections. There are separate alarm delays.

Application 8 has a rail heat relay.

Application 7

This configuration is suitable for refrigeration appliances with one valve, one evaporator and two cooling sections.

Here the S4 sensor is always used for temperature control.

The two S3 sensors are used for alarm monitoring and displaying the temperatures of the individual cooling sections. There are separate alarm delays. There are two product sensors S6 – one for each cooling section.

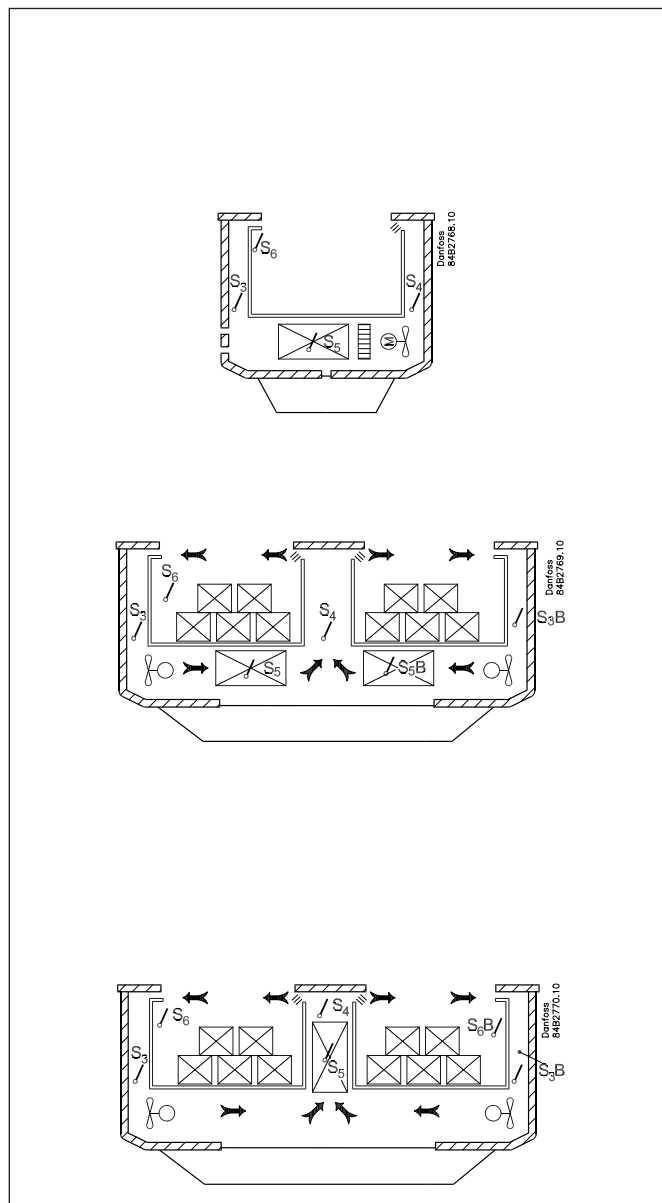

Application	DO1	DO2	DO3	DO4	DO5	DO6	DI1	DI2	DI3	AI1	AI2	AI3	AI4	AI5	AI6
1							●	●	●			S3	S4	S5	S6
2							●	●	●			S3	S4	S5	S6
3							●	●	●			S3	S4	S5	S6
4							●	●	●			S3	S4	S5	S6
5							●	●	●			S3	S4	S5	S6
6							●	●	●	S3B	S5B	S3A	S4	S5	S6
7							●	●	●	S3B	S6B	S3A	S4	S5	S6A
8							●	●	●	S3B	S5B	S3	S4	S5	S6
9							●	●	●			S3	S4	S5	S6

Digital inputs

Three digital inputs are available, with many use options for all settings. The two inputs are connection inputs and the third is a 230 V input.

Applications

The following is a brief summary of the application area of this controller.

The relay outputs are defined by a configuration setting to align the controller interface to the selected application.

S3 and S4 are temperature sensors. One or both of these sensors may be used, depending on the application. S3 is located in the air flow before the evaporator, and S4 in the air flow after the evaporator.

A percentage setting determines the control basis. S5 is a defrost sensor located on or between the fins of the evaporator.

S6 is a product sensor.

DI1, DI2 and DI3 are contact functions that can be used for any of the following purposes: door function, alarm function, defrost start, external main switch, night operation, change thermostat reference, appliance cleaning, forced refrigeration, or coordinated defrost. DI3 has a 230 V input. See the functions of settings o02, o37 and o84.

General:

All eight applications are intended for commercial refrigeration systems in the form of refrigeration appliances or cold storage rooms. They all have outputs for:

- Solenoid valve or compressor
- Fan
- Defrost
- Lighting

In addition, they have different uses and thus different inputs and outputs.

Application 1

Standard applications.

Application 2

Controlling night blinds

The night blinds track the status of the lighting function. The blinds are open when the light is switched on and closed when the light is switched off. In addition, a digital input provides the option of forced opening of the blinds so the appliance can be filled with products.

Application 3

Two-compressor operation.

The two compressors must be of the same size. On start-up (after defrosting, operational stop, etc.), the compressors are started with a preset time offset. One compressor starts at half of the differential value to provide optimum adaptation of the compressor capacity to the current load in the appliance or room. There is automatic runtime equalisation during cyclic operation.

For a more detailed description, see the manual.

Application 4

Hot gas defrosting.

Hot gas defrosting is suitable for commercial appliances or cold rooms with a limited system charge.

One relay controls the main valve in the suction line.

A changeover relay controls the hot gas valve and the drain valve.

This means there is no time delay between the end of hot gas defrosting and the start of draining.

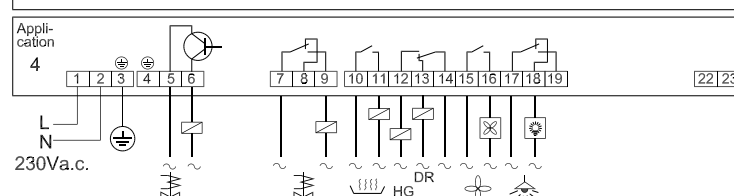
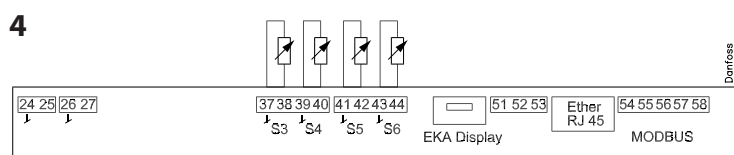
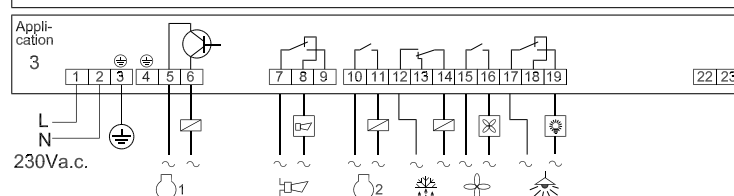
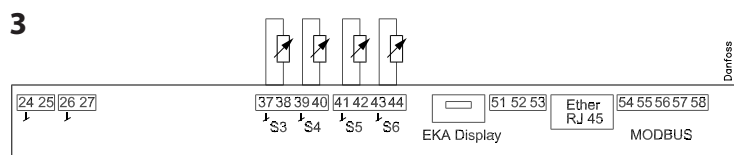
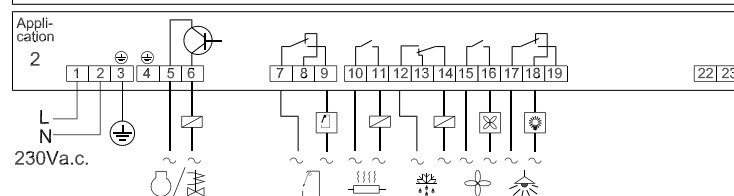
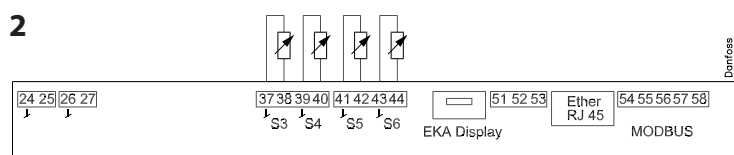
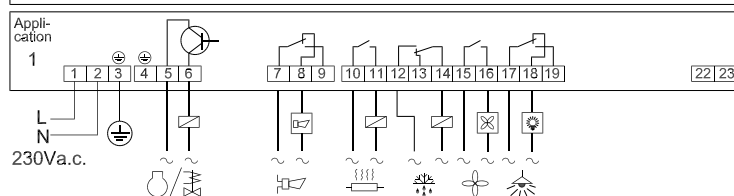
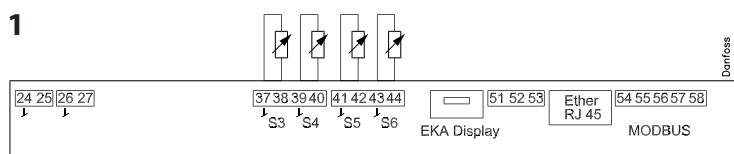

Application 5

Heater thermostat

A heater thermostat is typically used if the temperature needs to be controlled within relatively narrow limits, such as in cutting rooms. To avoid simultaneous cooling and heating, the heating thermostat can be configured as an offset relative to cut-out limit of the refrigeration thermostat.

Application 6

Two cooling sections with two defrost outputs
This application is for refrigeration appliances with one valve, two evaporators, and two refrigeration sections. The temperature is controlled and constantly alarm monitored according to the S4 temperature.

Each S3 sensor sends a signal to the display for the associated section.

Application 7

Two cooling sections with individual alarm and display via S3

This application is for refrigeration appliances with one valve, one evaporator, and two refrigeration sections. The temperature is always controlled according to the S4 temperature.

There are two S3 sensors. The S3 sensors in the cooling sections are used for individual alarm monitoring and display readings.

There is a separate alarm delay for each cooling section.

Application 8

Two cooling sections with two defrost outputs
This application is for refrigeration appliances with one valve, two evaporators, and two refrigeration sections. The temperature is always controlled according to the S4 temperature.

There are two S3 sensors. The S3 sensors in the cooling sections are used for individual alarm monitoring and display readings.

There is a separate alarm delay for each cooling section.

- Rail heat

Application 9

Thermostat band-determined compressor operation.

Runs in thermostat band 1 with sequential "two-compressor" operation; first compressor 1, and then compressor 2.

In thermostat band 2, compressor 2 can be de-selected so that only compressor 1 is used.

There are separate thermostat differences and defrost stop definitions for the two thermostat bands.

5

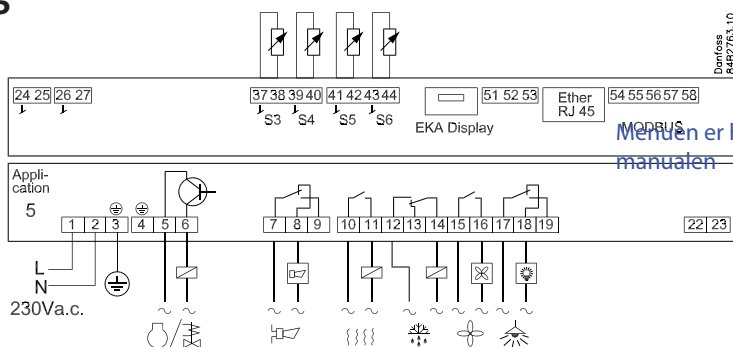

Danfoss 8482763.10

Menuen er hentet fra manualen

6

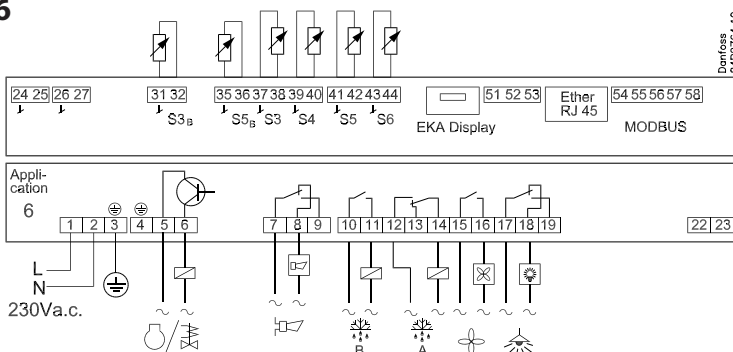

Danfoss 8482764.10

7

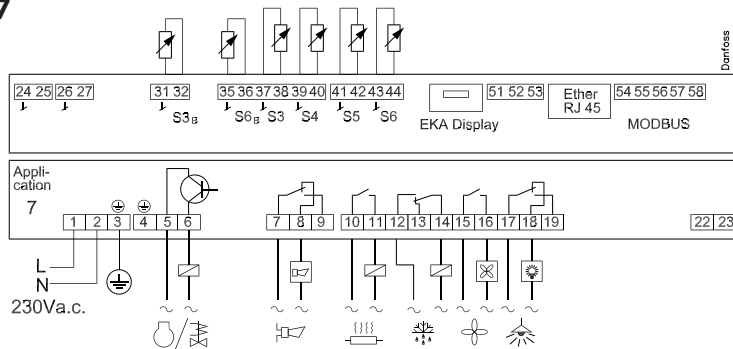

Danfoss 8482765.10

8

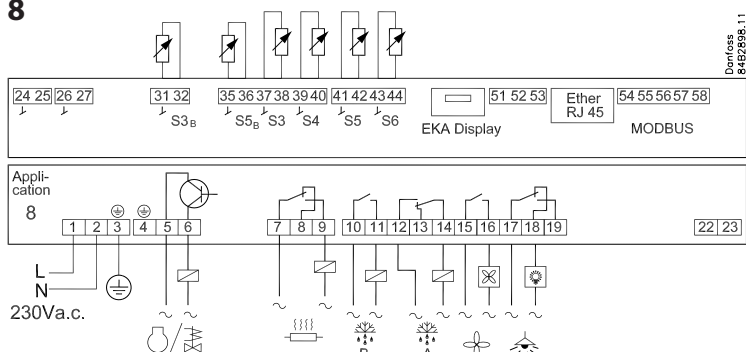

Danfoss 8482696.11

9

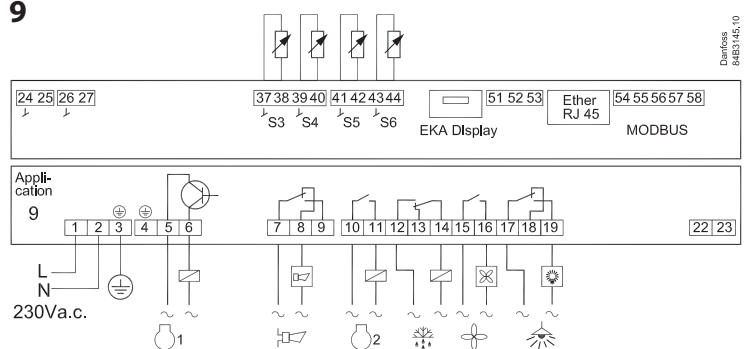

Danfoss 8483145.10

Menu survey

SW = 1.8x

Function	Parameter	Code	EL-diagram									Min.-value	Max.-value	Factory setting	Actual setting			
			1	2	3	4	5	6	7	8	9							
Normal operation																		
Temperature (setpoint)		---	1	1	1	1	1	1	1	1	1	1	1	1	-50°C	50°C	2	
Thermostat																		
Differential		r01	1	1	1	1	1	1	1	1	1	1	1	1	0.1 K	20 K	2	
Max. limitation of setpoint setting		r02	1	1	1	1	1	1	1	1	1	1	1	1	-49°C	50°C	50	
Min. limitation of setpoint setting		r03	1	1	1	1	1	1	1	1	1	1	1	1	-50°C	49°C	-50	
Adjustment of temperature indication		r04	1	1	1	1	1	1	1	1	1	1	1	1	-10	10	0	
Temperature unit (°C/°F)		r05	1	1	1	1	1	1	1	1	1	1	1	1	0/°C	1/F	0/°C	
Correction of the signal from S4		r09	1	1	1	1	1	1	1	1	1	1	1	1	-10 K	10 K	0	
Correction of the signal from S3		r10	1	1	1	1	1	1	1	1	1	1	1	1	-10 K	10 K	0	
Manual service, stop regulation, start regulation (-1, 0, 1)		r12	1	1	1	1	1	1	1	1	1	1	1	1	-1	1	0	
Displacement of reference during night operation		r13	1	1	1	1	1	1	1	1	1	1	1	1	-50 K	50 K	0	
Define thermostat function 1=ON/OFF, 2=Pulse width modulating (PWM)		r14	1	1	1	1	1	1	1	1	1	1	1	1	1	2	1	
Definition and weighting, if applicable, of thermostat sensors - S4% (100%=S4, 0%=S3)		r15	1	1	1	1	1						1		0 %	100 %	100	
Time between melt periods		r16	1	1	1	1	1	1	1	1	1	1	1	1	0 hrs	10 hrs	1	
Duration of melt periods		r17	1	1	1	1	1	1	1	1	1	1	1	1	0 min.	30 min.	5	
Temperature setting for thermostat band 2 . As differential use r01 for application 1-8. r93 for application 9		r21	1	1	1	1	1	1	1	1	1	1	1	1	-50°C	50°C	2	
Correction of the signal from S3B		r53							1	1	1				-10 K	10 K	0	
Correction of the signal from S6		r59	1	1	1	1	1	1	1	1	1	1	1	1	-10 K	10 K	0	
Correction of the signal from S6B		r60								1					-10 K	10 K	0	
Definition and weighting, if applicable, of thermostat sensors when night cover is on. (100%=S4, 0%=S3)		r61	1	1	1	1	1						1		0 %	100 %	100	
Heat function Neutral zone between refrigeration and heat function		r62					1								0 K	50 K	2	
Time delay at switch between refrigeration and heat function		r63					1						1		0 min.	240 min.	0	
Differential for thermostat band 2		r93											1		0.1	20 K	2 K	
Alarms																		
Delay for temperature alarm		A03	1	1	1	1	1	1	1	1	1	1	1	1	0 min.	240 min.	30	
Delay for door alarm		A04	1	1	1	1	1	1	1	1	1	1	1	1	0 min.	240 min.	60	
Delay for temperature alarm after defrost		A12	1	1	1	1	1	1	1	1	1	1	1	1	0 min.	240 min.	90	
High alarm limit for thermostat 1		A13	1	1	1	1	1	1	1	1	1	1	1	1	-50°C	50°C	8	
Low alarm limit for thermostat 1		A14	1	1	1	1	1	1	1	1	1	1	1	1	-50°C	50°C	-30	
High alarm limit for thermostat 2		A20	1	1	1	1	1	1	1	1	1	1	1	1	-50°C	50°C	8	
Low alarm limit for thermostat 2		A21	1	1	1	1	1	1	1	1	1	1	1	1	-50°C	50°C	-30	
High alarm limit for sensor S6 at thermostat 1		A22	1	1	1	1	1	1	1	1	1	1	1	1	-50°C	50°C	8	
Low alarm limit for sensor S6 at thermostat 1		A23	1	1	1	1	1	1	1	1	1	1	1	1	-50°C	50°C	-30	
High alarm limit for sensor S6 at thermostat 2		A24	1	1	1	1	1	1	1	1	1	1	1	1	-50°C	50°C	8	
Low alarm limit for sensor S6 at thermostat 2		A25	1	1	1	1	1	1	1	1	1	1	1	1	-50°C	50°C	-30	
S6 alarm time delay With setting = 240 the S6 alarm will be omitted		A26	1	1	1	1	1	1	1	1	1	1	1	1	0 min.	240 min.	240	
Alarm time delay or signal on the DI1 input		A27	1	1	1	1	1	1	1	1	1	1	1	1	0 min.	240 min.	30	
Alarm time delay or signal on the DI2 input		A28	1	1	1	1	1	1	1	1	1	1	1	1	0 min.	240 min.	30	
Signal for alarm thermostat. S4% (100%=S4, 0%=S3)		A36	1	1	1	1	1					1			0 %	100 %	100	
Delay for S6 (product sensor alarm) after defrost		A52	1	1	1	1	1	1	1	1	1	1	1	1	0 min.	240 min.	90	
Delay for S3B alarm during normal regulation		A53								1	1				0 min.	240 min.	90	
Compressor																		
Min. ON-time		c01	1	1	1	1	1	1	1	1	1	1	1	1	0 min.	30 min.	0	
Min. OFF-time		c02	1	1	1	1	1	1	1	1	1	1	1	1	0 min.	30 min.	0	
Time delay for cutin of comp.2		c05			1								1		0 sec	999 sec	5	
Step Mode 1= Sequential, 2=Cyclic		c08			1										1	2	2	
Comp.2 can run in thermostat band 2 0: No 1: Yes		c85											1		0	1	0	
Comp. on time when sensor fault		c86											1		0 min	240 min	15	

Continued	code	1	2	3	4	5	6	7	8	9	Min.	Max.	Fac.	Actual
Comp. off time when sensor fault	c87									1	0 min	240 min	30	
Defrost														
Defrost method: 0=none, 1=EL, 2= Gas, 3 = Brine	d01	1	1	1	1	1	1	1	1	1	0/No	3/bri	1/EL	
Defrost stop temperature	d02	1	1	1	1	1	1	1	1	1	0°C	50°C	6	
Interval between defrost starts	d03	1	1	1	1	1	1	1	1	1	0 hrs/Off	240 hrs	8	
Max. defrost duration	d04	1	1	1	1	1	1	1	1	1	0 min.	360 min.	45	
Displacement of time on cutin of defrost at start-up	d05	1	1	1	1	1	1	1	1	1	0 min.	240 min.	0	
Drip off time	d06	1	1	1	1	1	1	1	1	1	0 min.	60 min.	0	
Delay for fan start after defrost	d07	1	1	1	1	1	1	1	1	1	0 min.	60 min.	0	
Fan start temperature	d08	1	1	1	1	1	1	1	1	1	-50 °C	0 °C	-5	
Fan cutin during defrost 0: stopped 1: Running 2: Running during pump down and defrost	d09	1	1	1	1	1	1	1	1	1	0	2	1	
Defrost sensor: 0 =Stop on time, 1=S5, 2=S4, 3= (Application 1-5 and 7: Both S5A and S6A. Application 6 and 8: individual S5A and S5B)	d10	1	1	1	1	1	1	1	1	1	0	3	0	
Pump down delay	d16	1	1	1	1	1	1	1	1	1	0 min.	60 min.	0	
Drain delay (used at hot gas defrost only)	d17				1						0 min.	60 min.	0	
Max. aggregate refrigeration time between two defrosts	d18	1	1	1	1	1	1	1	1	1	0 hrs	48 hrs	0/OFF	
Heat in drip tray. Time from defrosting stops to heating in the drip tray is switched off	d20				1						0 min.	240 min.	30	
Delay time before opening hot gas valve	d23				1						0 min	60 min	0	
Rail heat during defrost 0: off 1: on 2: Pulsing	d27	1	1					1	1		0	2	2	
Defrost stop temp. thermostat band 2	d28									1	0°C	50°C	6	
Max. defrost duration thermostat band 2	d29									1	0 min	360 min	45	
Regulation parameter for refrigeration														
Period time at PWM	n63	1	1	1	1	1	1	1	1	1	30 sec.	900 sec.	300	
Max. opening degree at PWM	n64	1	1	1	1	1	1	1	1	1	0%	100%	100	
Min. opening degree at PWM	n65	1	1	1	1	1	1	1	1	1	0%	90%	0	
Expert setting. Windup at PWM	n66	1	1	1	1	1	1	1	1	1	0.2	1.0	1.0	
Expert setting. Kp at PWM	n67	1	1	1	1	1	1	1	1	1	0.5	10.0	4.0	
Expert setting. Tn at PWM	n68	1	1	1	1	1	1	1	1	1	60 sec	1800 sec	300	
Fan														
Fan stop temperature (S5)	F04	1	1	1	1	1	1	1	1	1	-50°C	50°C	50	
Pulse operation on fans: 0=No pulse operation, 1=At thermostat cuts out only, 2= Only at thermostat cut outs during night operation	F05	1	1	1	1	1	1	1	1	1	0	2	0	
Period time for fan pulsation (on-time + off-time)	F06	1	1	1	1	1	1	1	1	1	1 min.	30 min.	5	
On-time in % of period time	F07	1	1	1	1	1	1	1	1	1	0 %	100 %	100	
Real time clock														
Six start times for defrost. Setting of hours. 0=OFF	t01 - t06	1	1	1	1	1	1	1	1	1	0 hrs	23 hrs	0	
Six start times for defrost. Setting of minutes. 0=OFF	t11 - t16	1	1	1	1	1	1	1	1	1	0 min.	59 min.	0	
Clock - Setting of hours	t07	1	1	1	1	1	1	1	1	1	0 hrs	23 hrs	0	
Clock - Setting of minute	t08	1	1	1	1	1	1	1	1	1	0 min.	59 min.	0	
Clock - Setting of date	t45	1	1	1	1	1	1	1	1	1	1 day	31 day	1	
Clock - Setting of month	t46	1	1	1	1	1	1	1	1	1	1 mon.	12 mon.	1	
Clock - Setting of year	t47	1	1	1	1	1	1	1	1	1	0 year	99 year	0	
Miscellaneous														
Delay of output signals after start-up	o01	1	1	1	1	1	1	1	1	1	0 sec	600 sec	5	
Input signal on DI1. Function: 0=not used. 1=status on DI1. 2=door function with alarm when open. 3=door alarm when open. 4=defrost start (pulse-signal). 5=ext.main switch. 6=night operation 7=Thermostat band changeover (activate r21). 8=alarm function when closed. 9=alarm function when open. 10=case cleaning (pulse signal). 11=forced cooling at hot gas defrost, 12=night cover. 15=application shutdown	o02	1	1	1	1	1	1	1	1	1	0	15	0	

Continued	Code	1	2	3	4	5	6	7	8	9	Min.	Max.	Fac.	Actual
Network address (0= off)	o03	1	1	1	1	1	1	1	1	1	0	240	0	
On/Off switch (Service Pin message) IMPORTANT! o61 must be set prior to o04 (used at LON 485 only and DANBUSS)	o04	1	1	1	1	1	1	1	1	1	0/Off	1/On	0/Off	
Access code 1 (all settings)	o05	1	1	1	1	1	1	1	1	1	0	100	0	
Used sensor type : 0=Pt1000, 1=Ptc1000,	o06	1	1	1	1	1	1	1	1	1	0/Pt	1/Ptc	0/Pt	
Software Version	o08	1	1	1	1	1	1	1	1	1	100	999		
Max hold time after coordinated defrost	o16	1	1	1	1	1	1	1	1	1	0 min.	360 min.	20	
Select signal for display view. S4% (100%=S4, 0%=S3)	o17	1	1	1	1	1					0 %	100 %	100	
Input signal on DI2. Function: (0=not used. 1=status on DI2. 2=door function with alarm when open. 3=door alarm when open. 4=defrost start (pulse-signal). 5=ext. main switch 6=night operation 7=Thermostat band changeover (activate r21). 8=alarm function when closed. 9=alarm function when open. 10=case cleaning (pulse signal). 11=forced cooling at hot gas defrost.). 12=night cover, 13=coordinated defrost). 15=application shutdown	o37	1	1	1	1	1	1	1	1	1	0	15	0	
Configuration of light function: 1=Light follows day /night operation, 2=Light control via data communication via 'o39', 3=Light control with a DI-input, 4=As "2", but light switch on and night cover will open if the network cut out for more than 15 minutes.	o38	1	1	1	1	1	1	1	1	1	1	4	1	
Activation of light relay (only if o38=2) On=light	o39	1	1	1	1	1	1	1	1	1	0/Off	1/On	0/Off	
Rail heat On time during day operations	o41	1	1					1	1		0 %	100 %	100	
Rail heat On time during night operations	o42	1	1					1	1		0 %	100 %	100	
Rail heat period time (On time + Off time)	o43	1	1					1	1		6 min.	60 min.	10	
Case cleaning. 0=no case cleaning. 1=Fans only. 2=All output Off.	*** o46	1	1	1	1	1	1	1	1	1	0	2	0	
Selection of EL diagram.	* o61	1	1	1	1	1	1	1	1	1	1	8	1	
Download a set of predetermined settings.	* o62	1	1	1	1	1	1	1	1	1	0	6	0	
Access code 2 (partial access)	*** o64	1	1	1	1	1	1	1	1	1	0	100	0	
Replace the controllers factory settings with the present settings	o67	1	1	1	1	1	1	1	1	1	0/Off	1/On	0/Off	
Input signal on DI3. Function: (0=not used. 1=status on DI2. 2=door function with alarm when open. 3=door alarm when open. 4=defrost start (pulse-signal). 5=ext. main switch 6=night operation, 7=Thermostat band changeover (activate r21). 8=Not used. 9=Not used. 10=case cleaning (pulse signal). 11=forced cooling at hot gas defrost, 12=night cover. 13=Not used. 14=Refrigeration stopped (forced closing)). 15= application shutdown	o84	1	1	1	1	1	1	1	1	1	0	15	0	
Rail heat control 0=not used, 1=pulse control with timer function (o41 and o42), 2=pulse control with dew point function	o85	1	1					1	1		0	2	0	
Dew point value where the rail heat is minimum	o86	1	1					1	1		-10°C	50°C	8	
Dew point value where the rail heat is 100% on	o87	1	1					1	1		-9°C	50°C	17	
Lowest permitted rail heat effect in %	o88	1	1					1	1		0 %	100 %	30	
Time delay from "open door" refrigeration is started	o89	1	1	1	1	1	1	1	1	1	0 min.	240 min.	30	
Fan operation on stopped refrigeration (forced closing): 0 = Stopped (defrosting permitted) 1= Running (defrosting permitted) 2=Stopped (defrosting not permitted) 3= Running (defrosting not permitted)	o90	1	1	1	1	1	1	1	1	1	0	3	1	
Definition of readings on lower button: 1=defrost stop temperature, 2=S6 temperature, 3=S5_B temperature. 4= Readout of S3B temperature	o92	1	1	1	1	1	1	1	1	1	1	4	1	
Display of temperature 1= u56 Air temperature 2= u36 product temperature	o97	1	1	1	1	1	1	1	1	1	1	2	1	
Light and night blinds defined 0: Light is switch off and night blind is open when the main switch is off 1: Light and night blind is independent of main switch	o98	1	1	1	1	1	1	1	1	1	0	1	0	

Continued	Code	1	2	3	4	5	6	7	8	9	Min.	Max.	Fac.	Actual
Configuration of alarm relay The alarm relay will be activated upon an alarm signal from the following groups: 1 - High temperature alarms 2 - Low temperature alarms 4 - Sensor error 8 - Digital input is activated for alarm 16 - Defrost alarms 32 - Miscellaneous The groups that are to activate the alarm relay must be set by using a numerical value which is the sum of the groups that must be activated. (E.g. a value of 5 will activate all high temperature alarms and all sensor errors). 0 = Cancel relay function	P41	1		1		1	1	1		1	0	63	47	
Service														
Temperature measured with S5 sensor	u09	1	1	1	1	1	1	1	1	1				
Status on DI1 input. on/1=closed	u10	1	1	1	1	1	1	1	1	1				
Actual defrost time (minutes)	u11	1	1	1	1	1	1	1	1	1				
Temperature measured with S3 sensor	u12	1	1	1	1	1	1	1	1	1				
Status on night operation (on or off) 1=on	u13	1	1	1	1	1	1	1	1	1				
Temperature measured with S4 sensor	u16	1	1	1	1	1	1	1	1	1				
Thermostat temperature	u17	1	1	1	1	1	1	1	1	1				
Run time of thermostat (cooling time) in minutes	u18	1	1	1	1	1	1	1	1	1				
Temperature measured with S6 sensor (product temperature)	u36	1	1	1	1	1	1	1	1	1				
Status on DI2 output. on/1=closed	u37	1	1	1	1	1	1	1	1	1				
Air temperature. Weighted S3 + S4	u56	1	1	1	1	1				1				
Measured temperature for alarm thermostat	u57	1	1	1	1	1	1	1	1	1				
Status on relay for cooling	** u58	1	1	1	1	1	1	1	1	1				
Status on relay for fan	** u59	1	1	1	1	1	1	1	1	1				
Status on relay for defrost	** u60	1	1	1		1	1	1	1	1				
Status on relay for rail heat	** u61	1	1					1	1					
Status on relay for alarm	** u62	1		1		1	1	1		1				
Status on relay for light	** u63	1	1	1	1	1	1	1	1	1				
Status on relay for valve in suction line	** u64				1									
Status on relay for compressor 2	** u67			1										1
Temperature measured with S5B sensor	u75						1			1				
Temperature measured with S3B sensor	u76						1	1	1					
Temperature measured with S6B sensor	u79							1						
Status on relay for hot gas- / drain valve	** u80				1									
Status on relay for heating element in drip tray	** u81				1									
Status on relay for night blinds	** u82		1											
Status on relay for defrost B	** u83						1			1				
Status on relay for heat function	** u84					1								
Readout of the actual rail heat effect	u85	1	1						1	1				
1: Thermostat 1 operating, 2: Thermostat 2 operating	u86	1	1	1	1	1	1	1	1	1				
Status on high voltage input DI3	u87	1	1	1	1	1	1	1	1	1				
Readout of thermostats actual cut in value	u90	1	1	1	1	1	1	1	1	1				
Readout of thermostats actual cut out value	u91	1	1	1	1	1	1	1	1	1				
Readout the brine PWM OD%	U02	1	1	1	1	1	1	1	1	1				

*) Can only be set when regulation is stopped (r12=0)

**) Can be controlled manually, but only when r12=-1

***) With access code 2 the access to these menus will be limited

Forced control

If you need to force-control an output, you should set r12 to -1 (manual mode). You should then select the relevant relay function, e.g. u58. Go to the function by pressing the middle button. Select On.





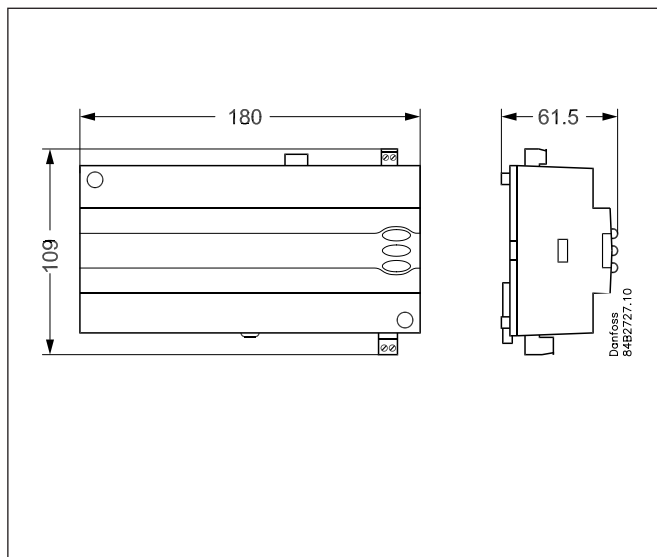



Technical data

Supply voltage	230 V a.c. +10%/-15% 50/60 Hz, 5 VA	
Sensors	Pt1000 or PTC 1000 ohm (all four (6) sensors must be of the same type)	
Accuracy	Measuring range	-60 to +120°C
	Controller	±1 K below -35°C ±0.5 K from -35 to +25°C ±1 K above +25°C
	Pt1000 sensor	±0.3 K at 0°C ±0.005 K per degree
Display	LED, 3 digits	
External display	EKA 163B or 164B (any version of EKA 163A or 164A)	
Digital inputs DI1, DI2	Signal from contact function Contacts must be gold plated Maximum allowable cable length 15 m Use an auxiliary relay with a longer cable	
Digital input DI3	230 V a.c.	
Wiring	1.5 mm ² (max.) stranded conductor	
Solid state output	DO1 (for coil)	Max. 240 V a.c.; min. 28 V AC Max. 0.5 A leakage < 1 mA 1 coil maximum
Relays*		CE (250 V a.c.)
	DO3, DO4	4 (3) A
	DO2, DO5, DO6	4 (3) A
Ambient conditions	0 to +55°C (operating)	
	-40 to +70°C (transport)	
	20 to 80% RH, non condensing No shock load or vibration	
Penetration resistance	IP 20	
Mounting	DIN rail or wall	
Weight	0.4 kg	
Data communication	Fixed / built in	MOD-bus
	Extension options	LON RS 485
		DANBUSS
		TCP/IP (OEM)
		MOD-bus
The controller cannot be connected to a type m2 monitoring unit.		
Clock power backup	4 hours	
Approvals	Compliant with the EU Low Voltage Directive and EMC requirements for CE marking LVD tested in accordance with EN 60730-1 and EN 60730-2-9, A1, A2 EMC tested in accordance with EN 61000-6-3 and EN 61000-6-2	



* DO3 and DO4 are 16 A relays. DO2, DO5 and DO6 are 8 A relays. Do not exceed the maximum rated load.

Ordering

Type		Function	Code no.
AK-CC 450		Case controller with MODBUS data communication Sensor connections are with screw terminals	084B8022
EKA 175		Data communication module LON RS 485	084B8579
EKA 178B		Data communication module MODBUS	084B8571
EKA 176		Data communication module DANBUSS + Gateway	084B8583
EKA 176A		Data communication module DANBUSS + AK-PI 200	084B8591
EKA 163B		External display with plug for direct connection	084B8574
EKA 164B		External display with operation buttons and plug for direct connections	084B8575
EKA 163A		External display with screw terminals	084B8562
EKA 164A		External display with operation buttons and screw terminals	084B8563

Additional information available:
Manual: RS8EU

Refrigeration appliance controls

AK-CC 550A

Application

Complete, highly versatile refrigeration appliance control for adaptation to all types of refrigeration appliances and cold storage rooms.

Advantages

- Complete refrigeration appliance control
- Energy optimisation of the entire refrigeration appliance
- Easy adaptation to refrigeration appliances or rooms by selection of a predefined application
- Fast set-up using predefined settings
- Can be used on CO₂ plants
- Built-in clock function with backup power

Operating principle

Sensors

The appliance temperature is detected by one or two temperature sensors located in the air flow before the evaporator (S3) or after the evaporator (S4). Configuration settings for the control thermostat, alarm thermostat and display reading determine how the two sensor values affect the individual functions.

In addition, an optional product sensor S6 in the appliance can be used to detect the temperature near the required product in a specific location in the appliance.

The evaporator temperature is detected by sensor S5, which can be used as a defrost sensor.

Injection

Liquid injection in the evaporator is controlled by a type AKV electronic injection valve. The controller regulates the opening degree of the valve to optimise evaporator operation under all conditions.

The superheat is measured with the pressure sensor Pe and temperature sensor S2.

Operation and data communication

The controller has built-in MOD-bus data communication support, which can be used for:

- network connection
- display connection

An EKA 163 display can be connected if only readout capability is needed, or an EKA 164 display can be connected if setting capability is also needed.

If data communication and a display are required, the MOD-bus port should be used for the display and a separate data communication module should be fitted in the controller. This module may be a MOD-bus module or a LON RS 485 module.

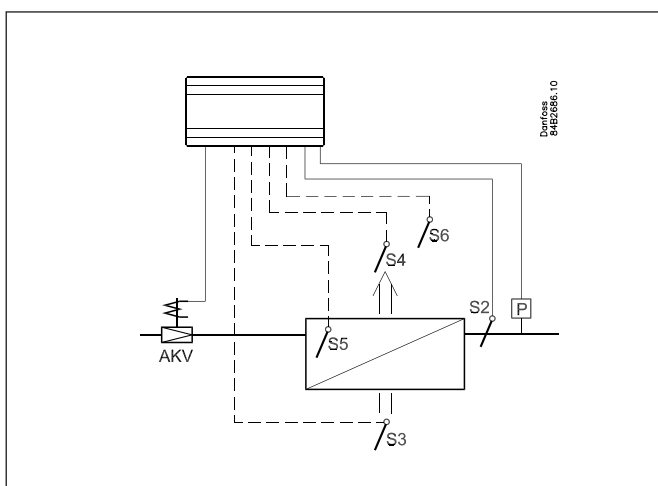
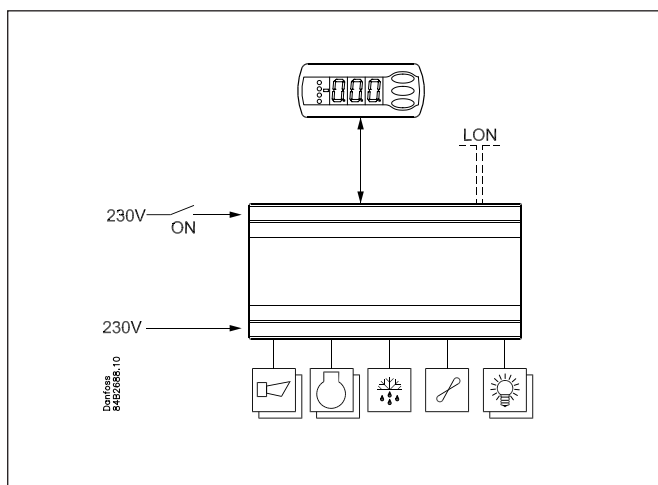
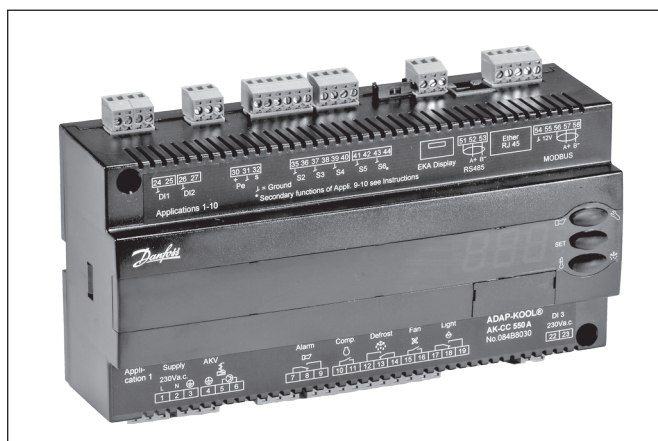

Functional description













- Adaptive control of superheat for optimal evaporator use.
- Day/night thermostat with on/of or modulated operation
- Temperature and alarm monitoring based on S3 and/or S4 temperature
- Product sensor S6 with separate alarm limits
- Thermostat setting changeover via digital input
- Defrost start controlled by an internal schedule, digital input or network signal
- Natural, electrical, or hot gas defrosting
- Defrost stop controlled by time and/or S5 temperature
- Adaptive defrosting based on intelligent detection of evaporator performance
- Defrost coordination with multiple controllers
- Pulsed fan operation when thermostat is disconnected
- Appliance cleaning function for HACCP procedure documentation
- Appliance shut-down via DI-input or data communication
- Rail heat control according to day/night operation or current dew point
- Door function
- Controlling two compressors
- Controlling night curtain
- Lighting control according to day/night operation or network signal
- Heater thermostat
- Multi-function digital inputs

Application

Any one of ten pre-programmed controller applications can be selected with a configuration setting.

Output

The outputs are configured as follows according to the selected setting:

Output use		Settings									
		1	2	3	4	5	6	7	8	9	10
Fan											
Rail heat											
Compressor											
Compressor 2											
Defrosting											
Defrosting 2											
Suction line valve											
Heating element in drip tray											
Night curtain											
Heater thermostat											
Alarm											
Lighting											
AKV valve, 230 V AC											

Sensors

Settings 1–8

Standard sensor use. See illustration.

Setting 9

Intended for special appliances with two compartments and two evaporators (the AKV valve feeds both evaporators).

The temperature is controlled by the S4 sensor.

Defrosting with the S5 sensor on evaporator A.

Sensor input S6 is used for the defrost sensor on evaporator B.

There is no product sensor.

Setting 10

Intended for special appliances with two compartments and one evaporator.

The temperature is controlled by the S4 sensor.

The temperature display and alarm monitoring use S3 and S3B.

There are common alarm limits for the two refrigeration section.

There is no product sensor.

Digital input.

Three digital inputs are available, with many use options for all settings. The two inputs are connection inputs and the third is a 230 V input.

Applications

The following is a brief summary of the application area of this controller.

The relay outputs are defined by a configuration setting to align the controller interface to the selected application.

S3 and S4 are temperature sensors. One or both of these sensors may be used, depending on the application. S3 is located in the air flow before the evaporator, and S4 in the air flow after the evaporator.

A percentage setting determines the control basis. S5 is a defrost sensor located on or between the fins of the evaporator.

S6 is a product sensor, but it is used for a different purpose in applications 9 and 10.

DI1, DI2 and DI3 are contact functions that can be used for any of the following purposes: door function, alarm function, defrost start, external main switch, night operation, change thermostat reference, appliance cleaning, forced refrigeration, or coordinated defrost. DI3 has a 230 V input. See the functions for settings o02, o37, and o84.

General

All ten applications are configured for commercial refrigeration systems in the form of refrigeration appliances or cold storage rooms.

They all have outputs for:

- AKV valve
- Fan
- Defrost

In addition, they have different uses and thus different inputs and outputs.

Applications 1–4

Standard applications.

These applications are for standard use where the only essential difference is in the configurations of the following functions and outputs:

- Alarm
- Rail heat
- Compressors
- Lighting

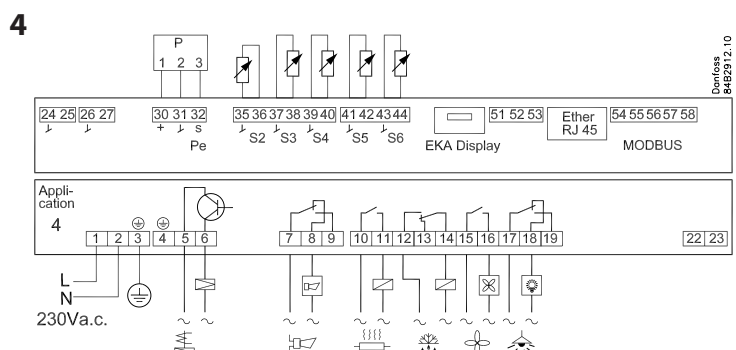
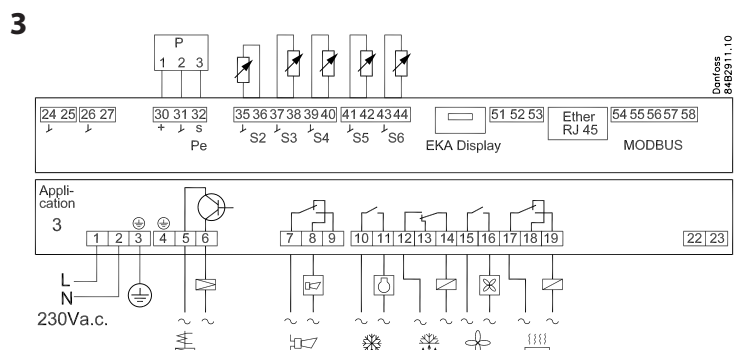
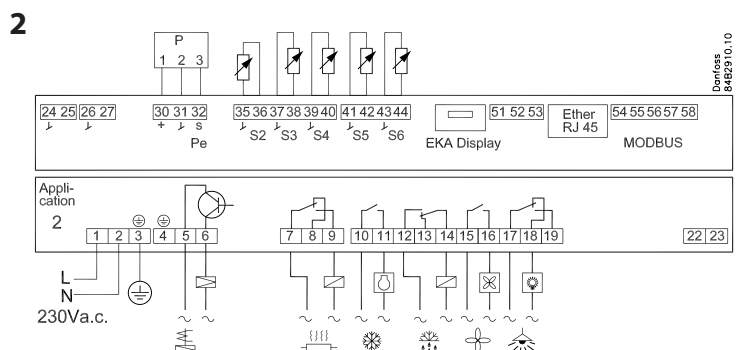
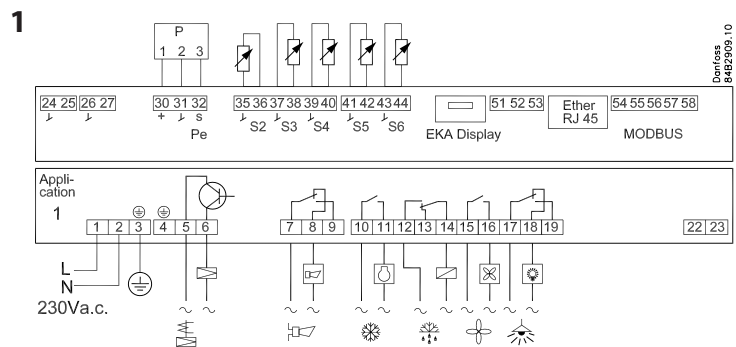

The following applications have certain special functions, which are briefly described below.

Application 5

Two-compressor operation.

The two compressors must be of the same size. On start-up (after defrosting, operational stop, etc.), the compressors are started with a preset time offset. One compressor starts at half of the differential value to provide optimum adaptation of the compressor capacity to the current load in the appliance or room. The operating hours of the compressors are equalised automatically.

Application 6

Hot gas defrosting.

Hot gas defrosting is suitable for commercial appliances or cold rooms with a limited system charge.

One relay controls the main valve in the suction line.

A changeover relay controls the hot gas valve and the drain valve.

This means there is no time delay between the end of hot gas defrosting and the start of draining.

Application 7

Controlling night blinds

The night blinds track the status of the lighting function. The blinds are open when the light is switched on and closed when the light is switched off. In addition, a digital input provides the option of forced opening of the blinds so the appliance can be filled with products.

Application 8

Heater thermostat

A heater thermostat is typically used if the temperature needs to be controlled within relatively narrow limits, such as in cutting rooms. To avoid simultaneous cooling and heating, the heating thermostat can be configured as an offset relative to cut-out limit of the refrigeration thermostat.

Application 9

Two cooling sections with two defrost outputs
This application is for refrigeration appliances with one valve, two evaporators, and two refrigeration sections. The temperature is controlled and constantly monitored for alarm conditions using sensor S4. Here the product sensor is used as a defrost stop sensor for evaporator 2.

Application 10

Two cooling sections with individual alarm and display via S3
This application is for refrigeration appliances with one valve, one evaporator, and two refrigeration sections. The temperature is always controlled according to the S4 temperature. The product sensor is used as an extra S3 sensor for section 2. The S3 sensors in the cooling sections are used for individual alarm monitoring and display readings.

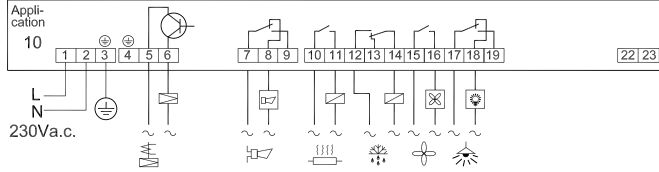
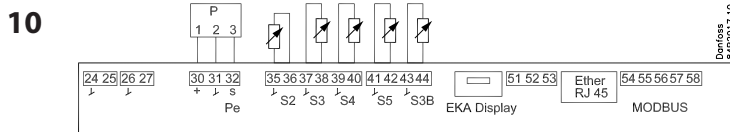
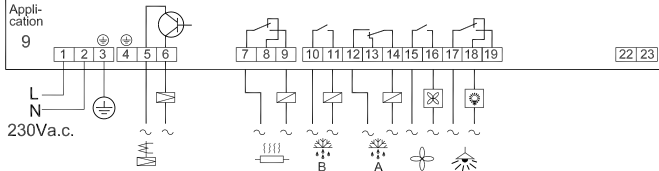
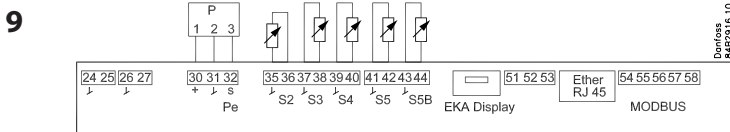
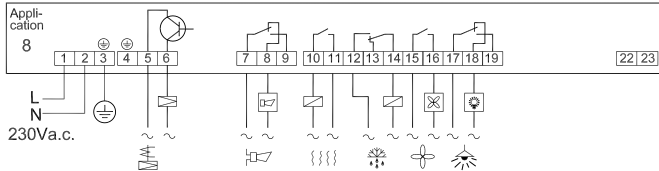
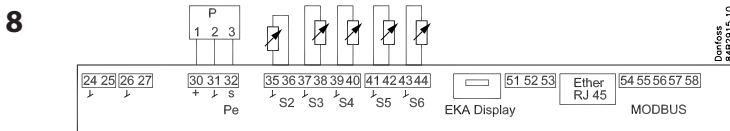
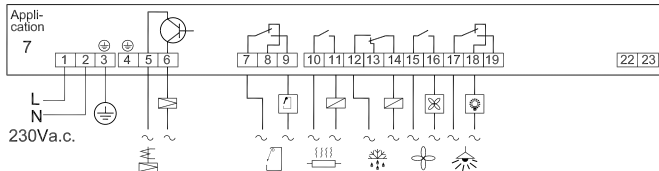
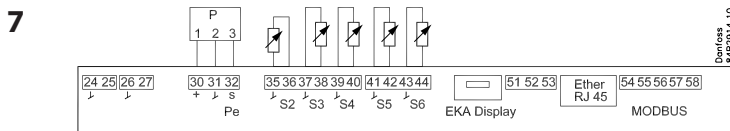
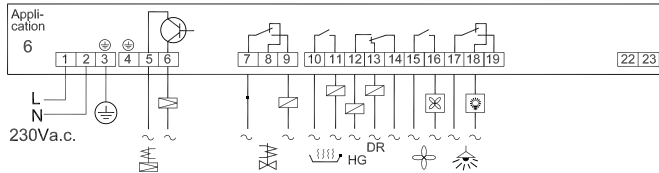
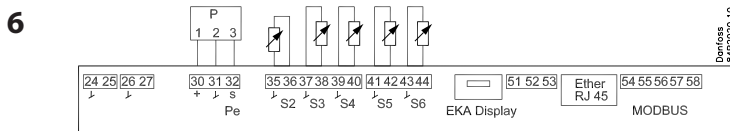
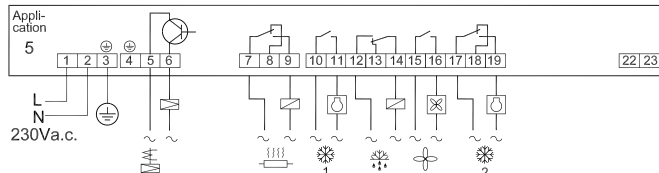

Menu survey

SW = 1.8x

Function	Parameter	Code	EL-diagram										Min.-value	Max.-value	Factory setting	Actual setting		
			1	2	3	4	5	6	7	8	9	10						
Normal operation																		
Temperature (setpoint)		---	1	1	1	1	1	1	1	1	1	1	1	1	-50°C	50°C	2	
Thermostat																		
Differential		r01	1	1	1	1	1	1	1	1	1	1	1	1	0.1 K	20 K	2	
Max. limitation of setpoint setting		r02	1	1	1	1	1	1	1	1	1	1	1	1	-49°C	50°C	50	
Min. limitation of setpoint setting		r03	1	1	1	1	1	1	1	1	1	1	1	1	-50°C	49°C	-50	
Adjustment of temperature indication		r04	1	1	1	1	1	1	1	1	1	1	1	1	-10	10	0	
Temperature unit (°C/°F)		r05	1	1	1	1	1	1	1	1	1	1	1	1	0/°C	1/F	0/°C	
Correction of the signal from S4		r09	1	1	1	1	1	1	1	1	1	1	1	1	-10 K	10 K	0	
Correction of the signal from S3		r10	1	1	1	1	1	1	1	1	1	1	1	1	-10 K	10 K	0	
Manual service, stop regulation, start regulation (-1, 0, 1)		r12	1	1	1	1	1	1	1	1	1	1	1	1	-1	1	0	
Displacement of reference during night operation		r13	1	1	1	1	1	1	1	1	1	1	1	1	-50 K	50 K	0	
Define thermostat function 1=ON/OFF, 2=Modulating		r14	1	1	1	1	1	1	1	1	1	1	1	1	1	2	1	
Definition and weighting, if applicable, of thermostat sensors - S4% (100%=S4, 0%=S3)		r15	1	1	1	1	1	1	1	1	1	1	1	1	0 %	100 %	100	
Time between melt periods		r16	1	1	1	1	1	1	1	1	1	1	1	1	0 hrs	10 hrs	1	
Duration of melt periods		r17	1	1	1	1	1	1	1	1	1	1	1	1	0 min.	30 min.	5	
Temperature setting for thermostat band 2 . As differential use r01		r21	1	1	1	1	1	1	1	1	1	1	1	1	-50°C	50°C	2	
Correction of the signal from S6		r59	1	1	1	1	1	1	1	1	1	1	1	1	-10 K	10 K	0	
Definition and weighting, if applicable, of thermostat sensors when night cover is on. (100%=S4, 0%=S3)		r61	1	1	1	1	1	1	1	1	1	1	1	1	0 %	100 %	100	
Heat function Neutral zone between refrigeration and heat function		r62												1	0 K	50 K	2	
Time delay at switch between refrigeration and heat function		r63												1	0 min.	240 min.	0	
Alarms																		
Delay for temperature alarm		A03	1	1	1	1	1	1	1	1	1	1	1	1	0 min.	240 min.	30	
Delay for door alarm		A04	1	1	1	1	1	1	1	1	1	1	1	1	0 min.	240 min.	60	
Delay for temperature alarm after defrost		A12	1	1	1	1	1	1	1	1	1	1	1	1	0 min.	240 min.	90	
High alarm limit for thermostat 1		A13	1	1	1	1	1	1	1	1	1	1	1	1	-50°C	50°C	8	
Low alarm limit for thermostat 1		A14	1	1	1	1	1	1	1	1	1	1	1	1	-50°C	50°C	-30	
High alarm limit for thermostat 2		A20	1	1	1	1	1	1	1	1	1	1	1	1	-50°C	50°C	8	
Low alarm limit for thermostat 2		A21	1	1	1	1	1	1	1	1	1	1	1	1	-50°C	50°C	-30	
High alarm limit for sensor S6 at thermostat 1		A22	1	1	1	1	1	1	1	1	1	1	1	1	-50°C	50°C	8	
Low alarm limit for sensor S6 at thermostat 1		A23	1	1	1	1	1	1	1	1	1	1	1	1	-50°C	50°C	-30	
High alarm limit for sensor S6 at thermostat 2		A24	1	1	1	1	1	1	1	1	1	1	1	1	-50°C	50°C	8	
Low alarm limit for sensor S6 at thermostat 2		A25	1	1	1	1	1	1	1	1	1	1	1	1	-50°C	50°C	-30	
S6 alarm time delay With setting = 240 the S6 alarm will be omitted		A26	1	1	1	1	1	1	1	1	1	1	1	1	0 min.	240 min.	240	
Alarm time delay or signal on the DI1 input		A27	1	1	1	1	1	1	1	1	1	1	1	1	0 min.	240 min.	30	
Alarm time delay or signal on the DI2 input		A28	1	1	1	1	1	1	1	1	1	1	1	1	0 min.	240 min.	30	
Signal for alarm thermostat. S4% (100%=S4, 0%=S3)		A36	1	1	1	1	1	1	1	1	1	1	1	1	0 %	100 %	100	
Delay for S6 (product sensor alarm) after defrost		A52	1	1	1	1	1	1	1	1	1	1	1	1	0 min.	240 min.	90	
Compressor																		
Min. ON-time		c01	1	1	1		1								0 min.	30 min.	0	
Min. OFF-time		c02	1	1	1		1								0 min.	30 min.	0	
Time delay for cutin of comp.2		c05					1								0 sec	999 sec	5	
Defrost																		
Defrost method: 0=none, 1= EL, 2= Gas		d01	1	1	1	1	1	1	1	1	1	1	1	1	0/No	2/GAs	1/EL	
Defrost stop temperature		d02	1	1	1	1	1	1	1	1	1	1	1	1	0°C	50°C	6	
Interval between defrost starts		d03	1	1	1	1	1	1	1	1	1	1	1	1	0 hrs/Off	240 hrs	8	
Max. defrost duration		d04	1	1	1	1	1	1	1	1	1	1	1	1	0 min.	360 min.	45	
Displacement of time on cutin of defrost at start-up		d05	1	1	1	1	1	1	1	1	1	1	1	1	0 min.	240 min.	0	
Drip off time		d06	1	1	1	1	1	1	1	1	1	1	1	1	0 min.	60 min.	0	
Delay for fan start after defrost		d07	1	1	1	1	1	1	1	1	1	1	1	1	0 min.	60 min.	0	
Fan start temperature		d08	1	1	1	1	1	1	1	1	1	1	1	1	-50 °C	0 °C	-5	
Fan cutin during defrost 0: Stopped 1: Running 2: Running during pump down and defrost		d09	1	1	1	1	1	1	1	1	1	1	1	1	0	2	1	

Continued	Code	1	2	3	4	5	6	7	8	9	10	Min.	Max.	Fac.	Actual
Defrost sensor: 0=Stop on time, 1=S5, 2=S4, 3=Sx (Application 1-8 and 10: both S5 and S6. Application 9: S5 and S5B)	d10	1	1	1	1	1	1	1	1	1	1	0	3	0	
Pump down delay	d16	1	1	1	1	1	1	1	1	1	1	0 min.	60 min.	0	
Drain delay (used at hot gas defrost only)	d17						1					0 min.	60 min.	0	
Max. aggregate refrigeration time between two defrosts	d18	1	1	1	1	1	1	1	1	1	1	0 hrs	48 hrs	0/OFF	
Heat in drip tray. Time from defrosting stops to heating in the drip tray is switched off	d20						1					0 min.	240 min.	30	
Adaptive defrost: 0=not active, 1=monitoring only, 2=skip allowed day, 3=skip allowed both day and night, 4=own assessment + all schedules	d21	1	1	1	1	1	1	1	1	1	1	0	4	0	
Time delay before opening of hot gas valve	d23						1					0 min	60 min	0	
Rail heat during defrost 0=off. 1=on. 2=Pulsating	d27		1	1	1	1		1		1	1	0	2	2	
Injection control function															
Max. value of superheat reference	n09	1	1	1	1	1	1	1	1	1	1	2°C	20°C	12	
Min. value of superheat reference	n10	1	1	1	1	1	1	1	1	1	1	2°C	20°C	3	
MOP temperature. Off if MOP temp. = 15.0 °C	n11	1	1	1	1	1	1	1	1	1	1	-50°C	15°C	15	
Period time of AKV pulsation Only for trained personnel	n13	1	1	1	1	1	1	1	1	1	1	3 sec	6 sec	6	
Fan															
Fan stop temperature (S5)	F04	1	1	1	1	1	1	1	1	1	1	-50°C	50°C	50	
Pulse operation on fans: 0=No pulse operation, 1=At thermostat cuts out only, 2= Only at thermostat cut outs during night operation	F05	1	1	1	1	1	1	1	1	1	1	0	2	0	
Period time for fan pulsation (on-time + off-time)	F06	1	1	1	1	1	1	1	1	1	1	1 min.	30 min.	5	
On-time in % of period time	F07	1	1	1	1	1	1	1	1	1	1	0 %	100 %	100	
Real time clock															
Six start times for defrost. Setting of hours. 0=OFF	t01 - t06	1	1	1	1	1	1	1	1	1	1	0 hrs	23 hrs	0	
Six start times for defrost. Setting of minutes. 0=OFF	t11 - t16	1	1	1	1	1	1	1	1	1	1	0 min.	59 min.	0	
Clock - Setting of hours	t07	1	1	1	1	1	1	1	1	1	1	0 hrs	23 hrs	0	
Clock - Setting of minute	t08	1	1	1	1	1	1	1	1	1	1	0 min.	59 min.	0	
Clock - Setting of date	t45	1	1	1	1	1	1	1	1	1	1	1 day	31 day	1	
Clock - Setting of month	t46	1	1	1	1	1	1	1	1	1	1	1 mon.	12 mon.	1	
Clock - Setting of year	t47	1	1	1	1	1	1	1	1	1	1	0 year	99 year	0	
Miscellaneous															
Delay of output signals after start-up	o01	1	1	1	1	1	1	1	1	1	1	0 sec	600 sec	5	
Input signal on DI1. Function: 0=not used. 1=status on DI1. 2=door function with alarm when open. 3=door alarm when open. 4=defrost start (pulse-signal). 5=ext.main switch. 6=night operation 7=thermostat band changeover (activate r21). 8=alarm function when closed. 9=alarm function when open. 10=Appliance cleaning (pulse signal). 11=forced cooling at hot gas defrost, 12=night cover. 15=case shut down	o02	1	1	1	1	1	1	1	1	1	1	0	15	0	
Network address	o03	1	1	1	1	1	1	1	1	1	1	0	240	0	
On/Off switch (Service Pin message) IMPORTANT! o61 must be set prior to o04 (used at LON 485 and DANBUSS only)	o04	1	1	1	1	1	1	1	1	1	1	0/Off	1/On	0/Off	
Access code 1 (all settings)	o05	1	1	1	1	1	1	1	1	1	1	0	100	0	
Used sensor type : 0=Pt1000, 1=Ptc1000,	o06	1	1	1	1	1	1	1	1	1	1	0/Pt	1/Ptc	0/Pt	
Readout of software version	o08	1	1	1	1	1	1	1	1	1	1				
Max hold time after coordinated defrost	o16	1	1	1	1	1	1	1	1	1	1	0 min.	360 min.	20	
Select signal for display view. S4% (100%=S4, 0%=S3)	o17	1	1	1	1	1	1	1	1	1	1	0 %	100 %	100	
Pressure transmitter working range – min. value	o20	1	1	1	1	1	1	1	1	1	1	-1 bar	5 bar	-1	
Pressure transmitter working range – max. value	o21	1	1	1	1	1	1	1	1	1	1	6 bar	200 bar	12	
Refrigerant setting: 1=R12. 2=R22. 3=R134a. 4=R502. 5=R717. 6=R13. 7=R13b1. 8=R23. 9=R500. 10=R503. 11=R114. 12=R142b. 13=User defined. 14=R32. 15=R227. 16=R401A. 17=R507. 18=R402A. 19=R404A. 20=R407C. 21=R407A. 22=R407B. 23=R410A. 24=R170. 25=R290. 26=R600. 27=R600a. 28=R744. 29=R1270. 30=R417A. 31=R422A. 32=R413A. 33=R422D. 34=R427A. 35=R438A. 36=XP10. 37=R407F. 38=R1234ze. 39=R1234yf.	o30	1	1	1	1	1	1	1	1	1	1	0	39	0	

Continued	Code	1	2	3	4	5	6	7	8	9	10	Min.	Max.	Fac.	Actual
Input signal on DI2. Function: (0=not used. 1=status on DI2. 2=door function with alarm when open. 3=door alarm when open. 4=defrost start (pulse-signal). 5=ext. main switch 6=night operation 7=thermostat band changeover (activate r21). 8=alarm function when closed. 9=alarm function when open. 10=Appliance cleaning (pulse signal). 11=forced cooling at hot gas defrost.). 12=night cover, 13=coordinated defrost). 15=case shut down	o37	1	1	1	1	1	1	1	1	1	1	0	15	0	
Configuration of light function: 1=Light follows day /night operation, 2=Light control via data communication via 'o39', 3=Light control with a DI-input, 4=As "2", but light switch on and night cover will open if the network cut out for more than 15 minutes.	o38	1	1		1		1	1	1	1	1	1	4	1	
Activation of light relay (only if o38=2) On=light	o39	1	1		1		1	1	1	1	1	0/Off	1/On	0/Off	
Rail heat On time during day operations	o41		1	1	1	1		1		1	1	0 %	100 %	100	
Rail heat On time during night operations	o42		1	1	1	1		1		1	1	0 %	100 %	100	
Rail heat period time (On time + Off time)	o43		1	1	1	1		1		1	1	6 min.	60 min.	10	
Appliance cleaning. 0=no Appliance cleaning. 1=Fans only. 2=All output Off.	*** o46	1	1	1	1	1	1	1	1	1	1	0	2	0	
Selection of EL diagram.	* o61	1	1	1	1	1	1	1	1	1	1	1	10	1	
Download a set of predetermined settings.	* o62	1	1	1	1	1	1	1	1	1	1	0	6	0	
Access code 2 (partial access)	*** o64	1	1	1	1	1	1	1	1	1	1	0	100	0	
Replace the controllers factory settings with the present settings	o67	1	1	1	1	1	1	1	1	1	1	0/Off	1/On	0/Off	
Input signal on DI3. Function: (high voltage input) (0=not used. 1=status on DI2. 2=door function with alarm when open. 3=door alarm when open. 4=defrost start (pulse-signal). 5=ext. main switch 6=night operation, 7=thermostat band changeover (activate r21). 8=Not used. 9=Not used. 10=Appliance cleaning (pulse signal). 11=forced cooling at hot gas defrost, 12=night cover. 13=Not used. 14=Refrigeration stopped (forced closing)). 15=case shut down	o84	1	1	1	1	1	1	1	1	1	1	0	15	0	
Rail heat control 0=not used, 1=pulse control with timer function (o41 and o42), 2=pulse control with dew point function	o85		1	1	1	1		1		1	1	0	2	0	
Dew point value where the rail heat is minimum	o86		1	1	1	1		1		1	1	-10°C	50°C	8	
Dew point value where the rail heat is 100% on	o87		1	1	1	1		1		1	1	-9°C	50°C	17	
Lowest permitted rail heat effect in %	o88		1	1	1	1		1		1	1	0 %	100 %	30	
Time delay from "open door" refrigeration is started	o89	1	1	1	1	1	1	1	1	1	1	0 min.	240 min.	30	
Fan operation at stopped cooling (forced closing): 0= Stopped (defrost allowed) 1= Running (defrost allowed) 2= Stopped (defrost not allowed) 3= Running (defrost not allowed)	o90	1	1	1	1	1	1	1	1	1	1	0	3	1	
1=defrost stop temperature, 2=S6 temperature, 3=S5_B temperature (application 9), 4=S3B (application 10)	o92	1	1	1	1	1	1	1	1	1	1	1	4	1	
Display of temperature 1= u56 Air temperature 2= u36 product temperature	o97	1	1	1	1	1	1	1	1	1	1	1	2	1	
Light and night blinds defined 0: Light is switch off and night blind is open when the main switch is off 1: Light and night blind is independent of main switch	o98	1	1	1	1	1	1	1	1	1	1	0	1	0	
Configuration of alarm relay The alarm relay will be activated upon an alarm signal from the following groups: 1 - High temperature alarms 2 - Low temperature alarms 4 - Sensor error 8 - Digital input enabled for alarm 16 - Defrosting alarms 32 - Miscellaneous 64 - Injection alarms The groups that are to activate the alarm relay must be set by using a numerical value which is the sum of the groups that must be activated. (E.g.: a value of 5 will activate all high temperature alarms and all sensor error and 0 will cancel the relay function).	P41	1		1	1					1	1	0	127	111	

Continued	Code	1	2	3	4	5	6	7	8	9	10	Min.	Max.	Fac.	Actual
Service															
Temperature measured with S5 sensor	u09	1	1	1	1	1	1	1	1	1	1				
Status on DI1 input. on/1=closed	u10	1	1	1	1	1	1	1	1	1	1				
Actual defrost time (minutes)	u11	1	1	1	1	1	1	1	1	1	1				
Temperature measured with S3 sensor	u12	1	1	1	1	1	1	1	1	1	1				
Status on night operation (on or off) 1=on	u13	1	1	1	1	1	1	1	1	1	1				
Temperature measured with S4 sensor	u16	1	1	1	1	1	1	1	1	1	1				
Thermostat temperature	u17	1	1	1	1	1	1	1	1	1	1				
Run time of thermostat (cooling time) in minutes	u18	1	1	1	1	1	1	1	1	1	1				
Temperature of evaporator outlet temp.	u20	1	1	1	1	1	1	1	1	1	1				
Superheat across evaporator	u21	1	1	1	1	1	1	1	1	1	1				
Reference of superheat control	u22	1	1	1	1	1	1	1	1	1	1				
Opening degree of AKV valve	** u23	1	1	1	1	1	1	1	1	1	1				
Evaporating pressure Po (relative)	u25	1	1	1	1	1	1	1	1	1	1				
Evaporator temperature To (Calculated)	u26	1	1	1	1	1	1	1	1	1	1				
Temperature measured with S6 sensor (product temperature)	u36	1	1	1	1	1	1	1	1	1	1				
Status on DI2 output. on/1=closed	u37	1	1	1	1	1	1	1	1	1	1				
Air temperature . Weighted S3 and S4	u56	1	1	1	1	1	1	1	1	1	1				
Measured temperature for alarm thermostat	u57	1	1	1	1	1	1	1	1	1	1				
Status on relay for cooling	** u58	1	1	1	1	1	1	1	1	1	1				
Status on relay for fan	** u59	1	1	1	1	1	1	1	1	1	1				
Status on relay for defrost	** u60	1	1	1	1	1	1	1	1	1	1				
Status on relay for railheat	** u61	1	1	1	1	1	1	1	1	1	1				
Status on relay for alarm	** u62	1	1	1	1	1	1	1	1	1	1				
Status on relay for light	** u63	1	1	1	1	1	1	1	1	1	1				
Status on relay for valve in suction line	** u64	1	1	1	1	1	1	1	1	1	1				
Status on relay for compressor 2	** u67	1	1	1	1	1	1	1	1	1	1				
Temperature measured with S5B sensor	u75	1	1	1	1	1	1	1	1	1	1				
Temperature measured with S3B sensor	u76	1	1	1	1	1	1	1	1	1	1				
Status on relay for hot gas- / drain valve	** u80	1	1	1	1	1	1	1	1	1	1				
Status on relay for heating element in drip tray	** u81	1	1	1	1	1	1	1	1	1	1				
Status on relay for night blinds	** u82	1	1	1	1	1	1	1	1	1	1				
Status on relay for defrost B	** u83	1	1	1	1	1	1	1	1	1	1				
Status on relay for heat function	** u84	1	1	1	1	1	1	1	1	1	1				
Readout of the actual rail heat effect	u85	1	1	1	1	1	1	1	1	1	1				
1: Thermostat 1 operating, 2: Thermostat 2 operating	u86	1	1	1	1	1	1	1	1	1	1				
Status on high voltage input DI3	u87	1	1	1	1	1	1	1	1	1	1				
Readout of thermostats actual cut in value	u90	1	1	1	1	1	1	1	1	1	1				
Readout of thermostats actual cut out value	u91	1	1	1	1	1	1	1	1	1	1				
Readout of status on the adaptive defrost 0: Off. Function is not activated and are zero set 1: Sensor error or S3/S4 are reversed. 2: Tuning is in progress 3: Normal 4: Light build-up of ice 5: Medium build-up of ice 6: Heavy build-up of ice	U01	1	1	1	1	1	1	1	1	1	1				
Number of defrosts carried out since the initial power up or since the resetting of the function	U10	1	1	1	1	1	1	1	1	1	1				
Number of defrosts skipped since the initial power up or since the resetting of the function	U11	1	1	1	1	1	1	1	1	1	1				

*) Can only be set when regulation is stopped (r12=0)

**) Can be controlled manually, but only when r12=-1

***) With access code 2 the access to these menus will be limited







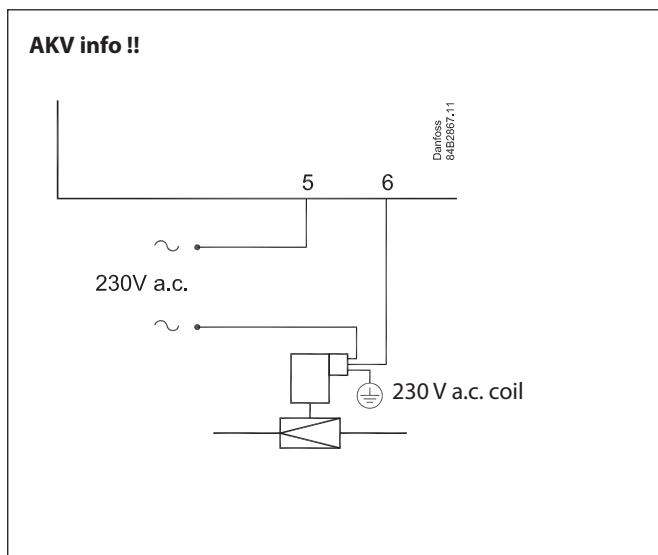
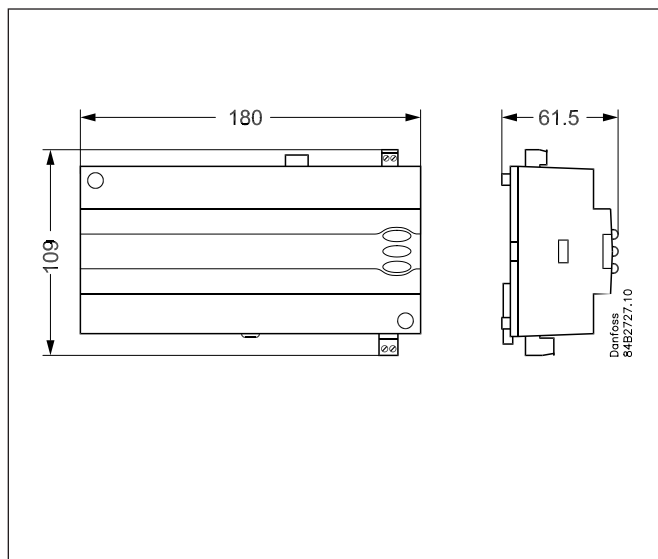

Technical data

Supply voltage	230 V a.c. +10/-15 %. 5 VA, 50/60 Hz	
Sensor S2, S6	Pt 1000	
Sensor S3, S4, S5	Pt 1000 or PTC 1000 ohm (All 3 must be of the same type)	
Accuracy	Measuring range	-60 to +120°C
	Controller	±1 K below -35°C ±0.5 K between -35 to +25°C ±1 K above +25°C
	Pt 1000 sensor	±0.3 K at 0°C ±0.005 K per grad
Measuring of Pe	Pressure transmitter	AKS 32R
Display	LED, 3-digits	
External display	EKA 163B or 164B. (any EKA 163A or 164A)	
Digital inputs DI1, DI2	Signal from contact functions Requirements to contacts: Gold plating Cable length must be max. 15 m Use auxiliary relays when the cable is longer	
Digital input DI3	230 V a.c.	
Electrical connection cable	Max. 1.5 mm ² multi-core cable	
Solid state output	DO1 (for AKV coil)	Max. 240 V a.c. , Min. 28 V a.c. Max. 0.5 A Leak < 1 mA Max. 1 pcs. AKV
Relays*		CE (250 V a.c.)
	DO3, DO4	4 (3) A
	DO2, DO5, DO6	4 (3) A
Environments	0 to +55°C, During operations	
	-40 to +70°C, During transport	
	20 - 80% Rh, not condensed	
	No shock influence / vibrations	
Density	IP 20	
Mounting	DIN-rail or wall	
Weight	0.4 Kg	
Data communication	Fixed	MODBUS
	Extension options	LON RS485
		TCP/IP
		MODBUS
		DANBUSS
	The controller cannot be hooked up with a monitoring unit type m2.	
Power reserve for the clock	4 hours	
Approvals	EU Low Voltage Directive and EMC demands re CE-marking complied with LVD tested acc. EN 60730-1 and EN 60730-2-9, A1, A2 EMC tested acc. EN 61000-6-2 and EN 61000-6-3	

* DO3 and DO4 are 16 A relays. DO2, DO5 and DO6 are 8 A relays. Max. load must be observed.



Ordering

Type		Function	Code no.
AK-CC 550A		Case controller with MODBUS data communication Sensor connections are with screw terminals	084B8030
EKA 175		Data communication module LON RS 485	084B8579
EKA 178B		Data communication module MODBUS	084B8571
EKA 176		Data communication module DANBUSS for Gateway	084B8583
EKA 176A		Data communication module DANBUSS for AK-PI 200	084B8591
EKA 163B		External display with plug for direct connection	084B8574
EKA 164B		External display with operation buttons and plug for direct connections	084B8575
EKA 163A		External display with screw terminals	084B8562
EKA 164A		External display with operation buttons and screw terminals	084B8563

Additional information available:
Manual: RS8FS

AK-CC 750

Application

AK-CC 750 controllers are complete regulating units which together with valves and sensors constitute complete evaporator controls for refrigeration appliances and freezing rooms in commercial refrigeration applications.

They generally replace all other automatic controls, including day and night thermostats, defrost, fan control, rail heat controls, alarm functions, lighting control, thermostatic valve control, solenoid valves, etc.

The controller has data network capability and is operated via a PC.

In addition to evaporator control, it can send signals to other controllers regarding operating conditions, such as forced closing of expansion valves, alarm signals, and alarm messages.

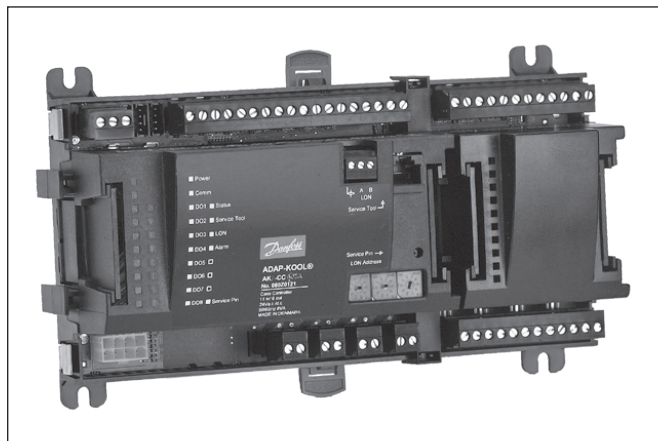

Advantages

- Controls of up to four evaporator sections
- Adaptive superheat control ensures optimum evaporator use under all operating conditions
- Electronic injection with AKV valve
- On/off or modulated temperature control
- Weighted average of control thermostat and alarm thermostat
- Defrost on demand based on evaporator capacity
- Appliance cleaning function
- Lighting control using door switch or network signal based on day/night operation
- Pulsed rail heat based on day/night operation
- Door alarm monitoring and lighting/refrigeration control based on door switch status
- Logging function for historical parameter values and alarm modes

Control

The main function of the controller is to regulate the evaporator so the refrigeration system constantly operates with the best possible energy efficiency.

A specific function detects the need for defrosting and adapts the number of defrost cycles to avoid wasting energy on unnecessary defrost cycles and subsequent cooling cycles.

Adaptive defrosting

The AK-CC 750 includes an adaptive defrosting function. By using the AKV valve as mass flow sensor for the supply of refrigerant, the controller can monitor ice formation on the evaporator. If the load is too large for the standard defrost programme, the controller initiates additional automatic defrost cycles to eliminate the need for expensive service calls due to iced-up evaporators.

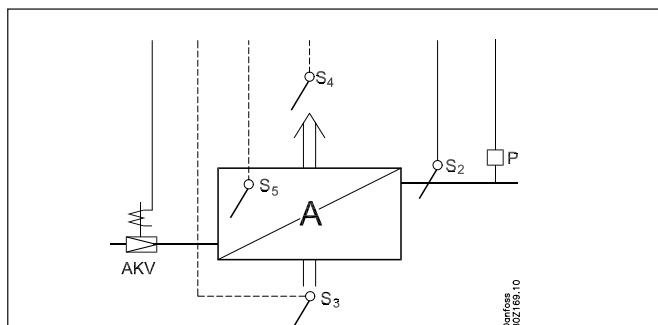
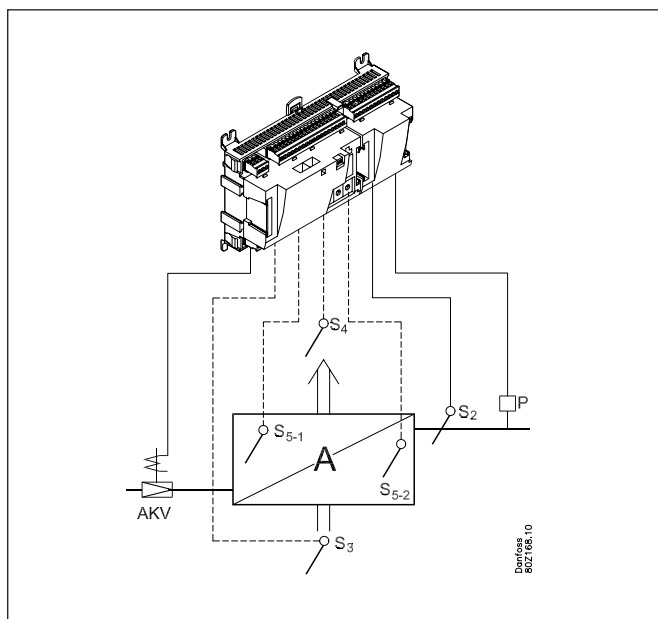

Evaporator control with one to four evaporators

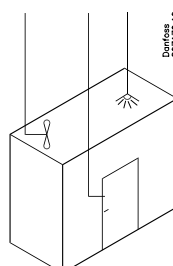

Controlling a cold room or freezer room

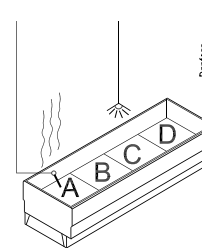

Controlling a refrigeration or freezer appliance

Technical data

Supply voltage	24 V d.c./a.c. ±20%	
Power consumption	AK-CC 750	8 VA
Analog inputs	Pt 1000 ohm / 0°C	Resolution: 0.1°C Accuracy: ±0.5°
	Pressure transmitter type AKS 32R / AKS 32 (1–5 V)	Resolution 1 mV Accuracy ±10 mV Maximum 5 pressure transmitters connected to one module
	Voltage signal 0–10 V	
	Contact function (on/off)	On when R < 20 ohm Off when R > 2K ohm (gold -plated contacts not necessary)
Relay outputs SPDT	AC-1 (resistive)	4 A
	AC-15 (inductive)	3 A
	U	Min. 24 V Max. 230 V Low and high voltage must not be connected to the same output group
Solid state outputs	Can be used for loads that are switched on and off frequently, such as: decompression, rail heating, fans and AKV valves	Max. 240 V AC; min. 48 V a.c. Max. 0.5 A, leakage < 1 mA Max. 1 AKV
Ambient temperature	During transport	-40 to 70°C
	During operation	-20 to 55°C, 0 to 95% RH (non condensing) No shock load or vibration
Enclosure	Material	PC/ABS
	Enclosure	IP 10, VBG 4
	Mounting	For mounting on wall or DIN rail
Weight with screw terminals	Modules in 100- and 200- controller-series	approx. 200 g / 500 g / 600 g
Approvals	Compliant with EU Low Voltage Directive and EMC regulations	LVD tested according to EN 60730 EMC tested Immunity compliant with EN 61000-6-2 Emissions compliant with EN 61000-6-3
	UL file number	E31024 for CC E166834 for XM

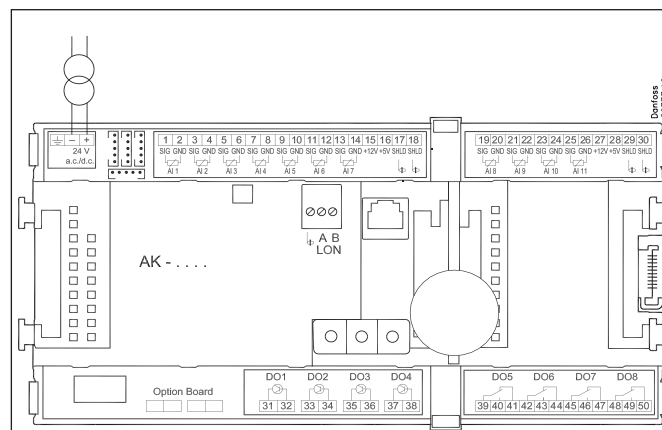

Data communication must be installed in accordance with the requirements specified in technical brochure RC8AC.

Ordering data

Type	Functional description	Application	Language	Code
Controller				
AK-CC 750	Evaporator controller	One to four sections	English, German, French, Italian, Dutch, Spanish, Finnish, Portuguese, Polish, Russian, Czech	080Z0125
Miscellaneous				
Expansion modules available for additional connections				See Accessories section - AK modules
Operating software for AK controllers			AK-ST 500	
Cable between PC and AK controller				
Cable between null modem cable and AK controller				
External display for connection to controller module. For displaying variables such as suction pressure			EKA 163B, EKA 164B	
Real time clock for use in controllers that require a clock function but do not have a data communication link.			AK-OB 101A	

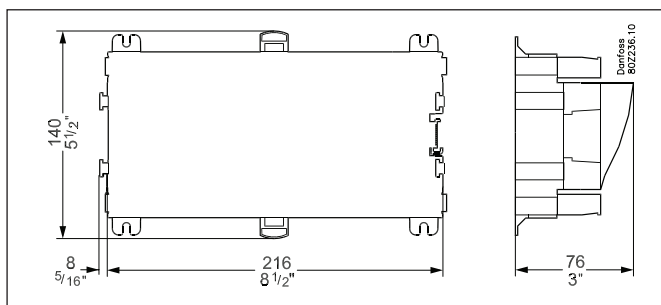

Additional information available:
Manual: RS8EM

Type	MCX06C	MCX06D	MCX061V	MCX08M	MCX15B	MCX20B
Analog inputs						
NTC 0/1V, 0/5V *	2	2		4	4	6
NTC, Pt1000, 0/1V, 0/5V, 0/10V, ON/OFF, 0/20mA, 4/20mA *	2	2	3	4	6	10
NTC, 0/1V, 0/5V, 0/10V, ON/OFF, 0/20mA, 4/20mA *			2			
Superheat S1: 0/1V, 0/5V, 0/10V, ON/OFF, 0/20mA, 4/20mA *			1			
Superheat S2: PT1000, 0/1V, 0/5V, 0/10V, ON/OFF *			1			
Digital inputs						
24 V optoisolated					18	22
++230 V a.c. optoisolated					4	4
Voltage free contact	6	8	8	8		
Max number					18	22
Analog outputs						
0/10 V d.c.			2			
0/10 V d.c. optoisolated				2	4	6
0/10 V d.c. PWM, PPM *	1	2	1			
PWM, PPM cutting phase	1	1		2	2	
Digital outputs						
SPST relay 5 A	6	5	6			
SPST relay 8 A				2	9	13
SPDT relay 8 A		1		4	4	4
SPST relay 16 A				2		2
SPDT relay 16 A					2	1
SSR 24 V a.c. / 230 V a.c. (optional)		1		2	4	4
Stepper motor			1			
Max number		6	6	8	15	20
Power supply						
20/60 V d.c. - 24 V a.c.	•	•	◦	◦	◦	◦
110-230 V a.c. - 50/60 Hz			◦	◦	◦	◦
Isolated power supply	•	•	•	•	•	•
Others						
Connection for programming key	•	•	•	•	•	•
Connection for remote display and keyboard	•	•	•	•	•	•
Buzzer		•	•	•	•	•
CANbus	•	•	•	•	•	•
RTC clock	◦	◦	•	•	•	•
Modbus RS485 serial interface (optional)	1 not isolated	1	2	1	2	2
Ethernet/ Web server			◦			
Memory card slot			•			
Dimensions	33x75mm	4DIN	8DIN	8DIN	16DIN	16DIN
Mounting	Panel	DIN rail	DIN rail	DIN rail	DIN rail	DIN rail

*) selectable via software
 • Available for all models
 ◦ Available for some models

Additional information available:
 Brochure: DKRCE.PB.RH0.A
 Chiller - Manual: DKRCC.ES.RI0.A
 Roof top - Manual: DKRCC.PS.RI0.G
 Air handler - Manual: DKRCC.PS.RI.A

Accessories

Module overview

Use the information in the controller manuals to define and select a suitable controller in this family.

The data in the following table is intended for general information and reordering.

Type	Analog inputs	On/off outputs		On/off supply voltage (DI signal)		Analog outputs	Stepper outputs	Module with switches	Code
	For sensors, pressure transmitters, etc.	Relay (SPDT)	Solid state	Low voltage (80 V max.)	High voltage (260 V max.)	0–10 V d.c.	For valves with step control	For overriding relay outputs	With screw terminals
Controller	11	4	4	-	-	-	-	-	-
The controller module supports the I/O connections listed in the previous line. If additional connections are necessary, one of the modules listed below should be used.									
Extension modules									
AK-XM 101A	8								080Z0007
AK-XM 102A				8					080Z0008
AK-XM 102B					8				080Z0013
AK-XM 103A	4					4			080Z0032
AK-XM 107A pulse module									080Z0020
AK-XM 204A		8							080Z0011
AK-XM 204B		8						x	080Z0018
AK-XM 205A	8	8							080Z0010
AK-XM 205B	8	8						x	080Z0017
AK-XM 208C	8						4		080Z0023
AK-OB 110						2			080Z0251

Miscellaneous

Type	Functional description	Application	Code
AK-ST 500	Operating software for AK controllers	AK operation	080Z0161
-	Cable between PC and AK controller	AK Com port (length 3 m)	080Z0262
-	Cable between null modem cable and AK controller	AK RS 232 (length 1 m)	080Z0261
-	Cable between PC and controller	AK-USB	084Z0264
AK-OB 101A	Real time clock with battery backup	For installation in an AK controller	080Z0252
AK-PS 075	Power supply 18 VA	Can be mounted to the left of the controller	080Z0053
AK-PS 150	Power supply 36 VA	Can be mounted to the left of the controller	080Z0054
AK-PS 250	Power supply 60 VA	Can be mounted to the left of the controller	080Z0055
AK-CM 101A	Communication module for AK-SC 355 and AK-SC 255	Lon TP 78 data communication (not available in Europe)	080Z0061
AK-CM 101C		Lon RS 485 data communication	080Z0063
AK-CM 102	Communication module for AK-PC 781 etc.	Data communication for external extension modules	080Z0064

Extension module AK-XM 101A

Functional description

This module has eight analog inputs for sensors, pressure transmitters, voltage signals and contact signals.

A pressure transmitter supply voltage can be taken from the 5 V output or the 12 V output.

Ordering data

Type	Function	Code No.
AK-XM 101A	Extension module for sensors, pressure transmitters, contact signals	080Z0007

Additional information available:
See controller manual.

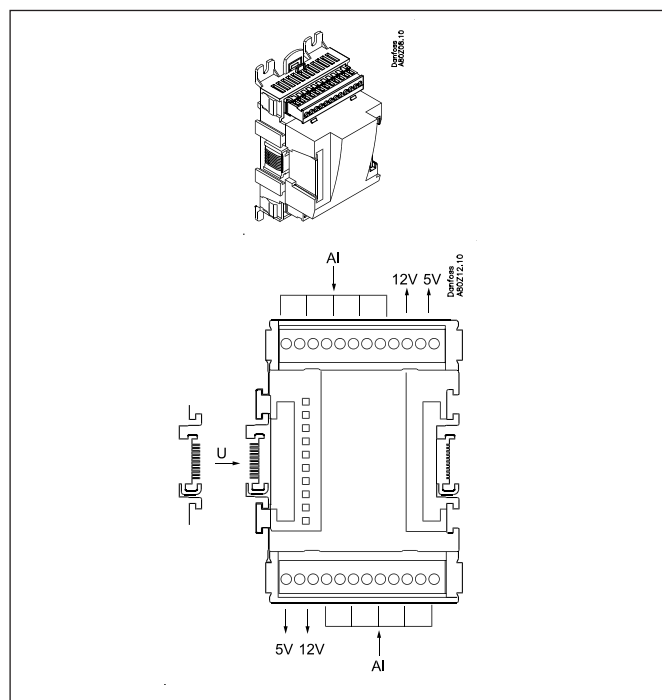

Extension module AK-XM 102A/B

Functional description

This module has eight inputs for on/off voltage signals.

LEDs

- Status of the individual inputs (voltage present when lit)

Ordering data

Type	Function	Code No.
AK-XM 102A	Extension module for on/off voltage signals Low voltage (24 V)	080Z0008
AK-XM 102B	Extension module for on/off voltage signals High voltage (230 V)	080Z0013

Additional information available:
See controller manual.

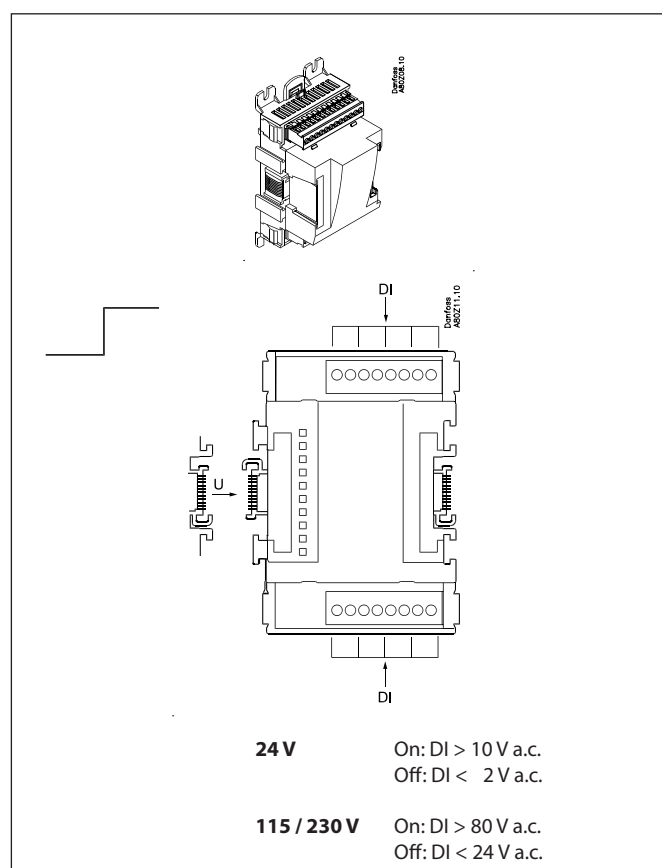

Extension module AK-XM 103A

Functional description

This module has:
four analog inputs for sensors, pressure transmitters, voltage signals and contact signals
four voltage outputs (0–10 V)

A pressure transmitter supply voltage can be taken from the 5 V output or the 12 V output.

Ordering data

Type	Function	Code No.
AK-XM 103A	Extension module for sensors, pressure transmitters, contact signal, analog outputs	080Z0032

Additional information available:
See controller manual.
Technical brochure: RD8BS

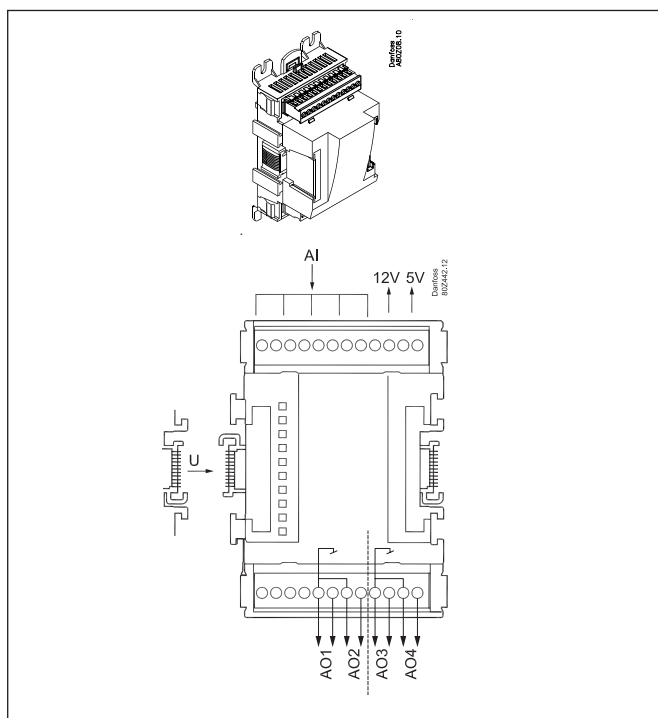

Extension module AK-XM 107A

Functional description

This module has eight digital inputs for detecting pulses or on/off signals from a switch function.
Pulses are detected in accordance with the DIN 43864/S01 interface specification.

Ordering data

Type	Function	Code No.
AK-XM 107A	Extension module for pulse measuring	080Z0020

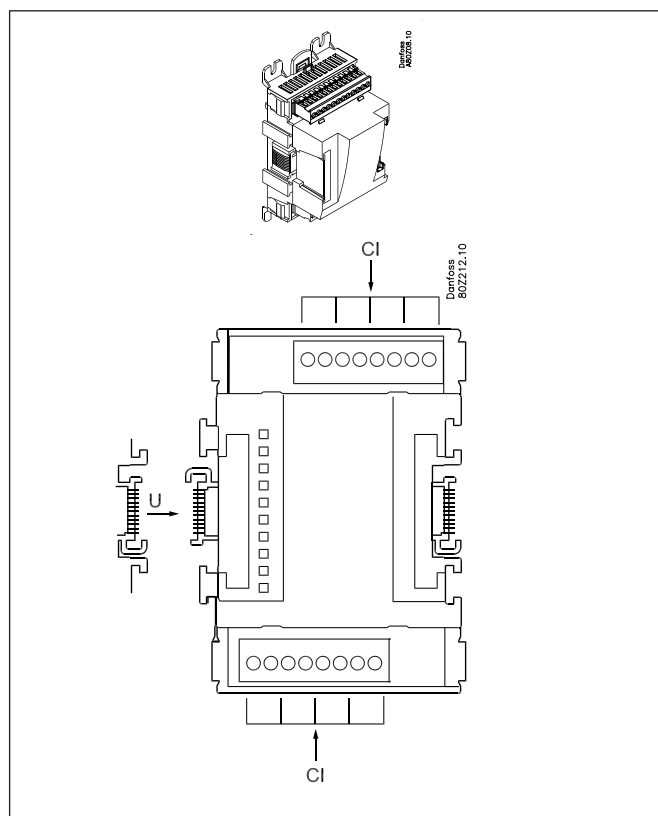

Extension module AK-XM 204A/B

Functional description

This module has eight relay outputs.

The AK-XM 204B has eight changeover switches at the front that can be used to override the relay functions and force the relay output to Off or On.

Operation is governed by the controller in the Auto position.

LEDs

Status of outputs DO1 to DO8

The AK-XM 204B also has LEDs that indicate whether the relays are being overridden.

LED on: override active

LED off: no override

Fuses

Fuses for the individual outputs are located behind the upper front panel.

Ordering data

Type	Function	Code No.
AK-XM 204A	Extension module for on/off relay outputs	080Z0011
AK-XM 204B	Extension module for on/off relay outputs with overriding function	080Z0018

Additional information available:
See controller manual.

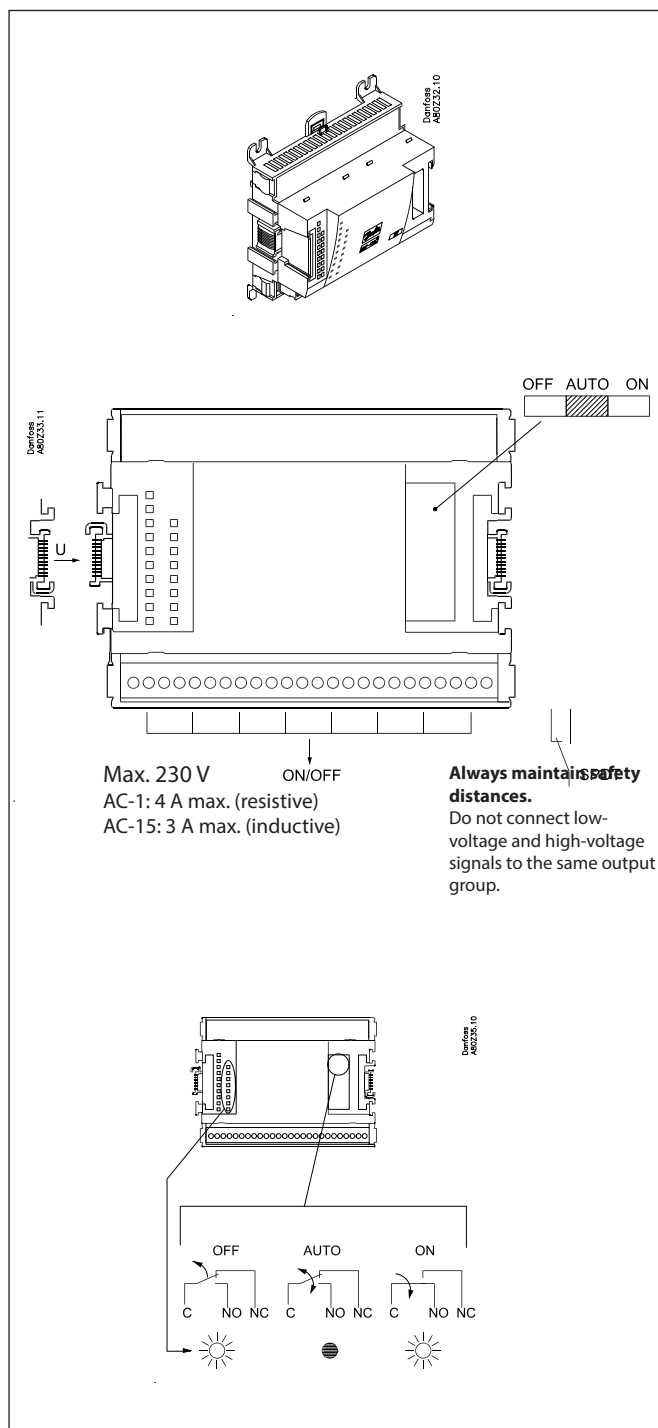

Extension module AK-XM 205A/B

Functional description

This module has:
eight analog inputs for sensors, pressure transmitters, voltage signals and contact signals
eight relay outputs

The AK-XM 205B has eight changeover switches at the front that can be used to override the relay functions and force the relay output to Off or On.
Operation is governed by the controller in the Auto position.

LEDs

Status of outputs DO1 to DO8

The AK-XM 205B also has LEDs that indicate whether the relays are being overridden.

LED on: override active

LED off: no override

Fuses

Fuses for the individual outputs are located behind the upper front panel.

Ordering data

Type	Function	Code No.
AK-XM 205A	Extension module for sensors, pressure transmitters and on/off outputs	080Z0010
AK-XM 205B	Extension module for sensors, pressure transmitters and on/off output with overriding function	080Z0017

Additional information available:
See controller manual.

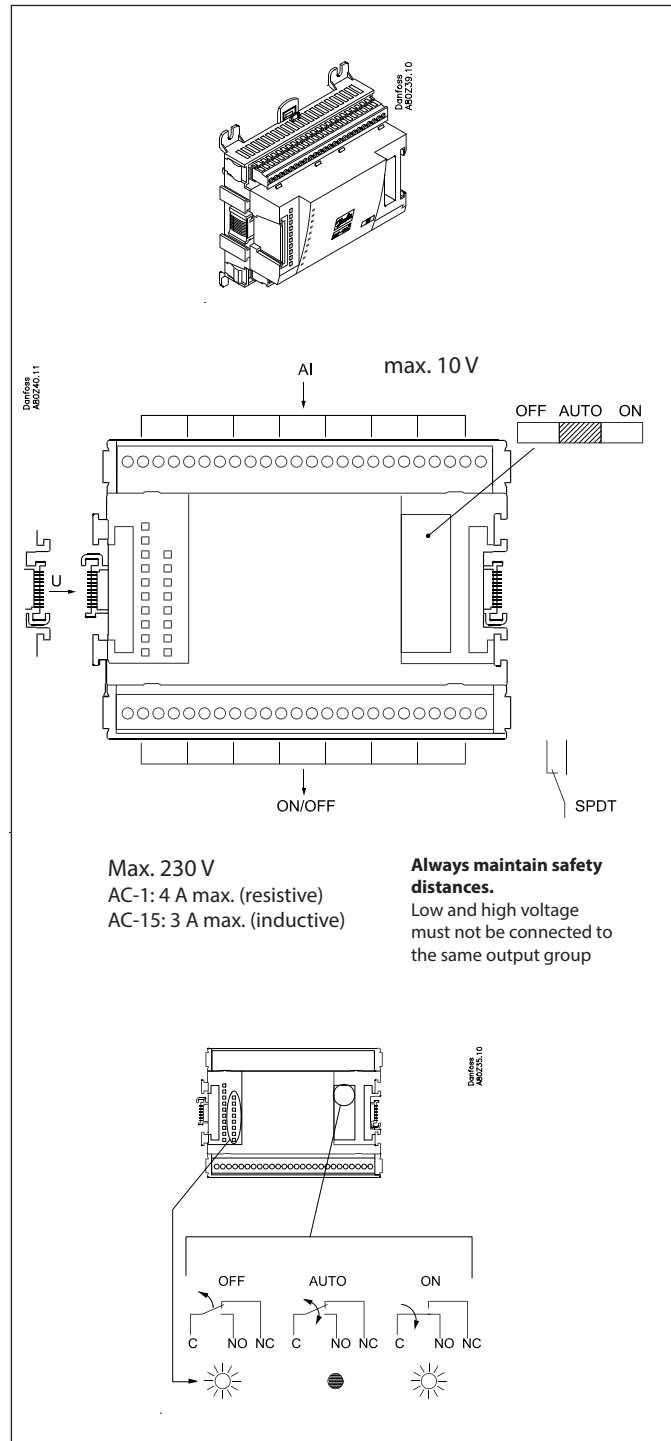

Extension module AK-XM 208C

Functional description

This module has:
eight analog inputs for sensors, pressure transmitters, voltage signals and contact signals
four outputs for stepper motor valve e.g. ETS, KVS, CCM or CCMT.

Power supply

A separate power supply for the stepper motor valve must be connected.

Ordering data

Type	Function	Code No.
AK-XM 208C	Stepper output module	080Z0023

Additional information available:
See controller manual.

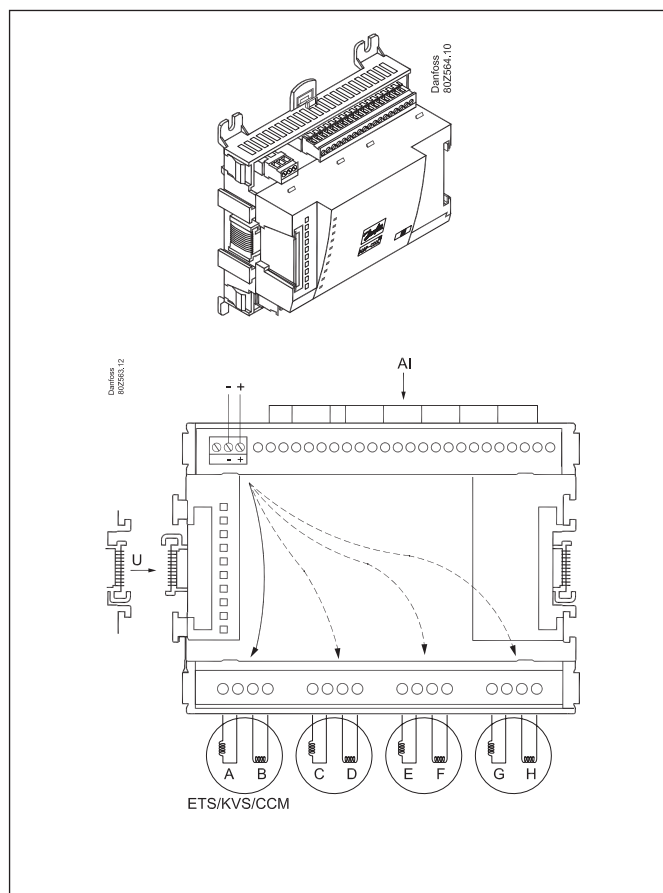

Extension module AK-OB 110

Functional description

This module has two analog voltage outputs (0–10 V).

Mounting

The module is fitted on the PCB of the controller module.

Ordering data

Type	Function	Code No.
AK-OB 110	Analog output module	080Z0251

Additional information available:
See controller manual.

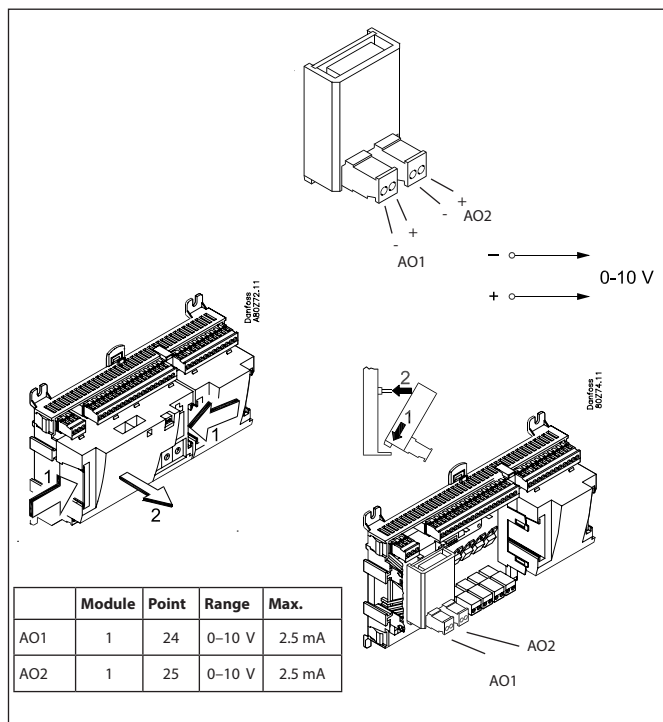

Extension module AK-OB 101A

Functional description

This module is a clock module with battery backup.

It can be used in controllers that are not linked to other controllers by a data communication module. The module is used in this situation if the controller needs a battery-backed clock for:

- clock functions;
- fixed day/night switching times;
- fixed defrost times;
- protection against loss of alarm log in the event of power failure
- protection against loss of temperature log in the event of power failure

Mounting

The module is fitted on the PCB inside the upper part of the controller.

Battery life

The battery lifetime is several years, even if power failures occur frequently.

An alarm is generated when the battery needs to be replaced.

The battery still has several months of useful life when the alarm is first generated.

Ordering data

Type	Function	Code No.
AK-OB 101A	Real-time clock with battery backup.	080Z0252

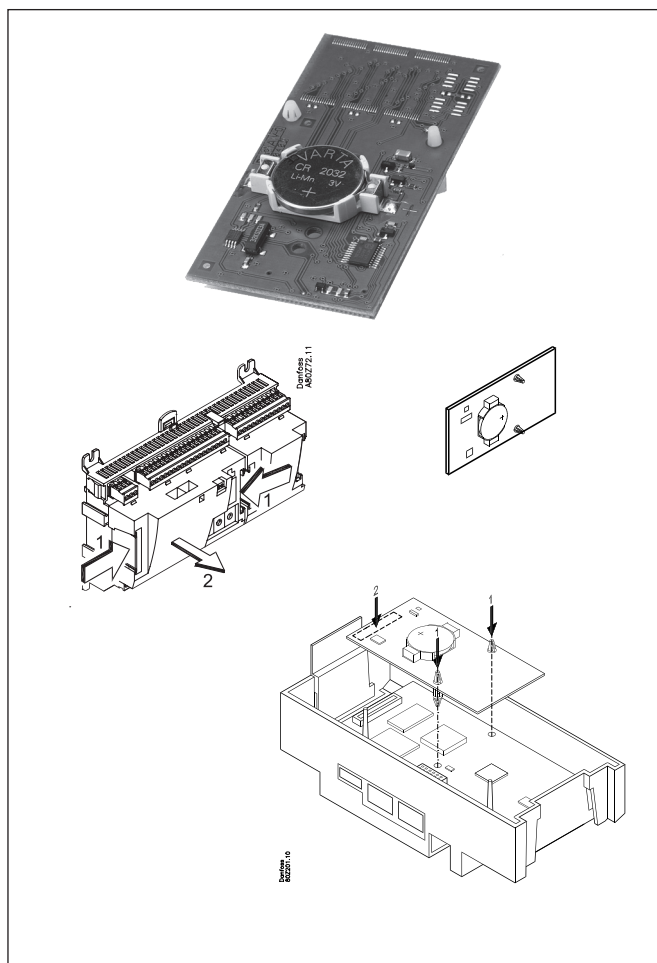

Extension module AK-PS 075 / 150 / 250

Power supply

Functional description

24 V d.c. power supply for controller

Supply voltage

115 or 230 V a.c. (operating range 100–240 V a.c.)

Mounting

DIN rail

Cannot be used with controllers that require an a.c. supply voltage

Ordering data

Type	Function	Code No.
AK-PS 075	Power supply, d.c., 18 VA	080Z0053
AK-PS 150	Power supply, d.c., 36 VA	080Z0054
AK-PS 250	Power supply, d.c., 60 VA	080Z0055

Additional information available:
See controller manual.

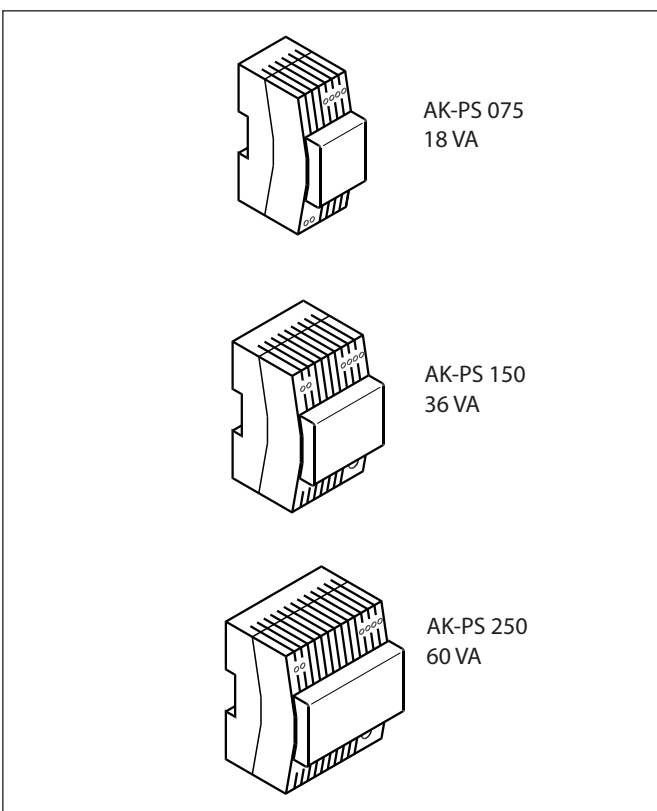

Communication module AK-CM 101C

Function

The module is a communication module, meaning the row of extension modules can be placed in distance from the system unit.

The module communicates with the system unit via data communication and forwards information to the connected extension modules.

Connection

Both the communication module and the system unit are fitted with LON RS 485 communication. Several AK-CM 101C modules can be connected to the same communication device.

Supply voltage

24 volt a.c. or d.c. should be connected to the communication module.

The terminals must **not** be earthed.

The power consumption is determined by the power consumption of the total number of modules.

Address

The Address of the communication module can be set from 1 to 99.

Ordering

Type	Function	Code no.
AK-CM 101C	Communication module	080Z0063

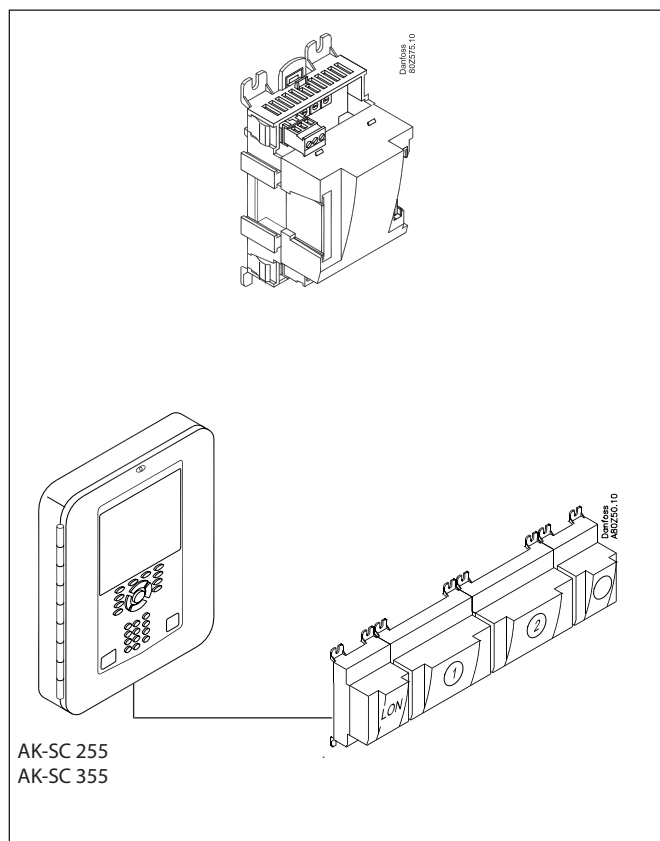

Communication module AK-CM 102

Function

The module is a new communication module, meaning the row of extension modules can be interrupted.

The module communicates with the regulator via data communication and forwards information between the controller and the connected extension modules

Connection

Communication module and controller fitted with RJ 45 plug connectors.

Nothing else should be connected to this data communication; a maximum of 5 I/O communication modules can be connected to one controller.

The communication module can be used only with controllers of the type AK-PC 781, AK-PC 783, AK-LM 340, AK-LM 350.

Positioning

Max. 30 m from the controller

(Total length of communication cables = 30 m)

Supply voltage

24 volt a.c. or d.c. should be connected to the communication module. The 24 V can be sourced from the same supply that supplies the controller. (The supply for the communication module is galvanically separated from the connected extension modules). The terminals must not be earthed.

The power consumption is determined by the power consumption of the total number of modules.

Ordering

Type	Function	Code no.
AK-CM 102	Communication module	080Z0064

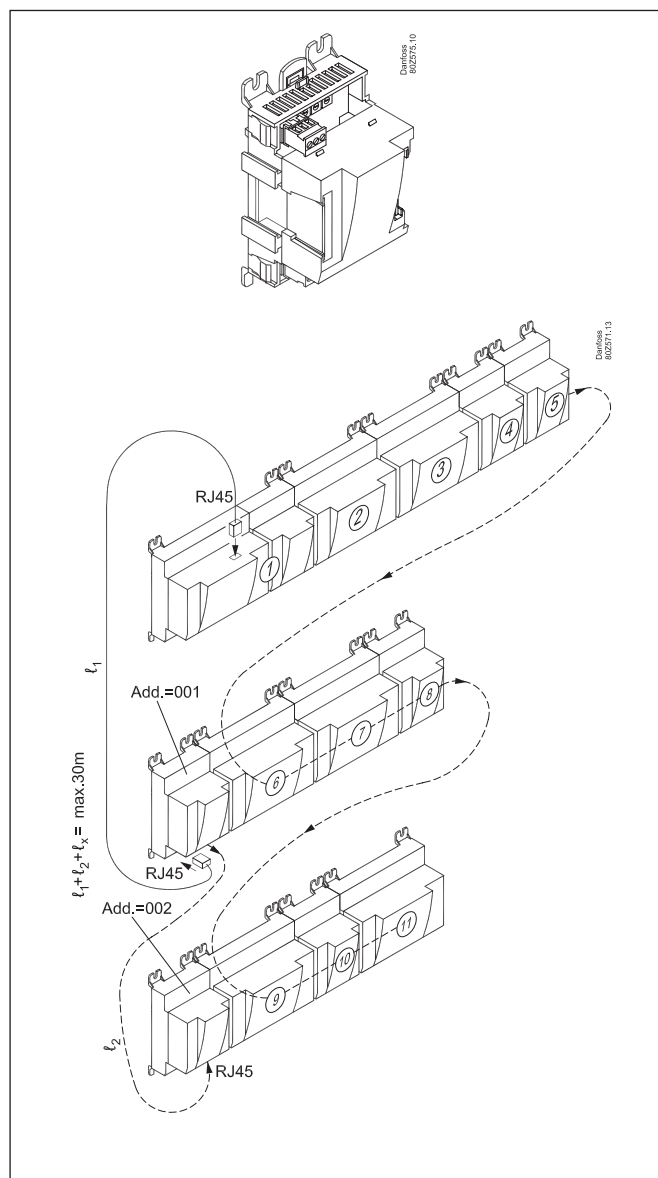

Display

EKA 163 / 164

Application

These displays can be used with certain controllers in the AK and EKC series, such as AK-CC and AK-PC.

The EKA 163 do not has control buttons. It can be mounted on a refrigeration appliance so that customers can see the temperature of the refrigerated items.

The EKA 164 has control buttons, so it can be used to set parameters in the configuration menu of the controller.

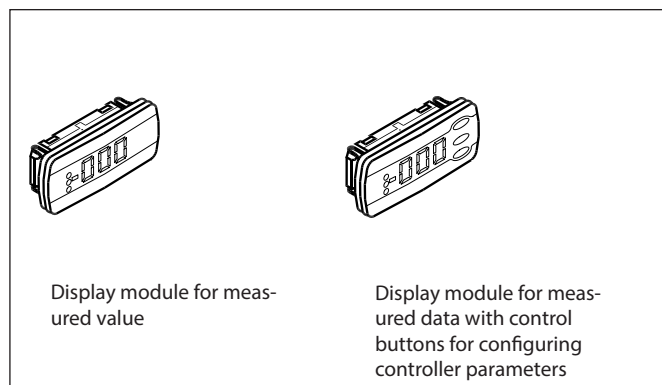
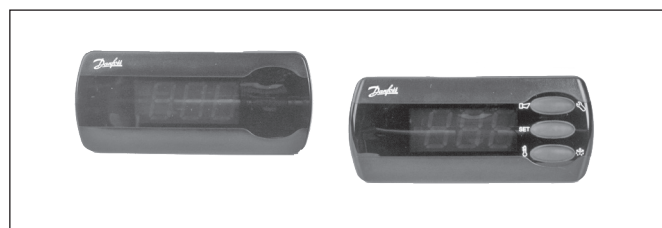
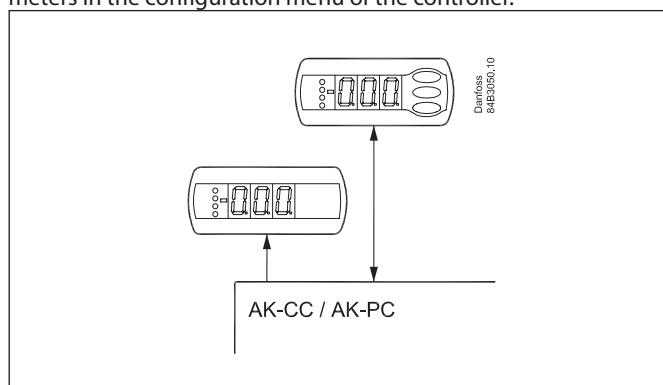

Technical data

Supply voltage	12 V \pm 15% (from controller)	
Display operation	Display accuracy in measuring range: 0.1°C EKA163, LED, 3 digits EKA 164, LED, digits, control buttons	
Electrical connection	EKA 163A EKA 164A	Screw terminals
	EKA 163B EKA 164B	Connector
Data communication	A version	RS 485* and TTL
	B version	TTL
Ambient conditions	-10 to 55°C (operating)	
	-40 to 70°C (transport)	
Enclosure	20 to 80% RH, non condensing	
	No shock load or vibration	
Enclosure	Rear:	IP 20
	From front:	IP 65

* Data communication must be installed in accordance with the requirements specified in technical brochure RC8AC.

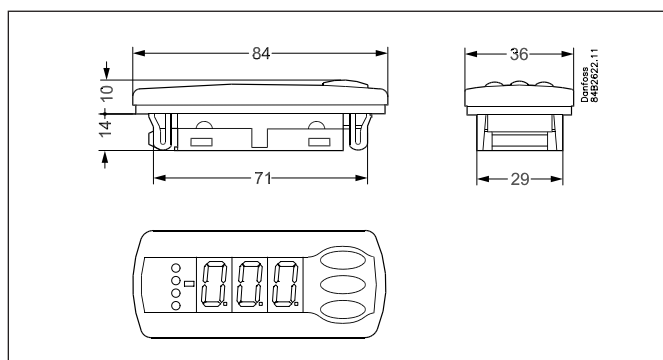

Ordering data

There are 2 types: type A and type B.

Type A has a more versatile data communication interface that supports both RS 485 and TTL.

Type A can be used in place of type B, but a type B module cannot be used when the controller requires a type A interface.

See also the ordering data of the controller that will provide the signals to the display. It includes the recommended display type.

Type	Description		Code
EKA 163A	Display unit	Screw terminals	084B8562
EKA 163B		With connector	084B8574
EKA 164A	Display unit with operation buttons	Screw terminals	084B8563
EKA 164B		With connector	084B8575
	Cable for display unit (2 m with plug)	Qty 1	084B7298
		Qty 24	084B7179
	Cable for display unit (6 m with plug)	Qty 1	084B7299
		Qty 24	084B7097
Cable for display unit (3 m with plug)	Qty 24	084B7099	
	Cable for display unit (9 m with plug)	Qty 24	084B7630

Display console

This console can be used with an EKA 163 or EKA 164 display module.

The console can be used on refrigeration appliances where the display cannot be recessed in the front panel.

The console is secured with two screws, and the display cable is routed to the rear.



Technical data

Mounting	On plate with two screws (screws included)
Enclosure	IP 65

Ordering data

Description	Application	Code
Mounting kit	With EKA 163 or EKA 164	084B8584

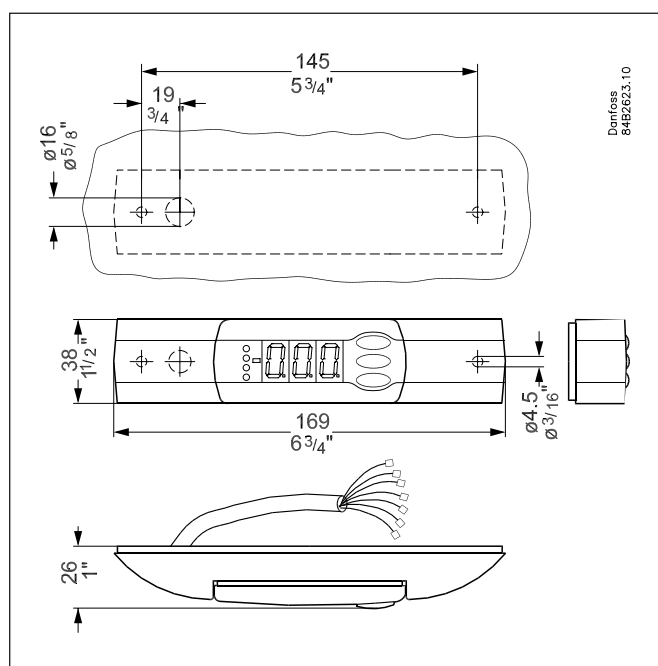

EKA 166

This display can be used with AK-PC 710 and AK-PC 781 compressor controllers.

It shows P₀ or P_c and the control loop status relative to the neutral zone.

The LEDs on the panel correspond to the connected compressors and condensers.

There are LEDs for the following functions:

- Compressors
- Fans
- Speed control
- Digital input
- Optimisation
- Alarm

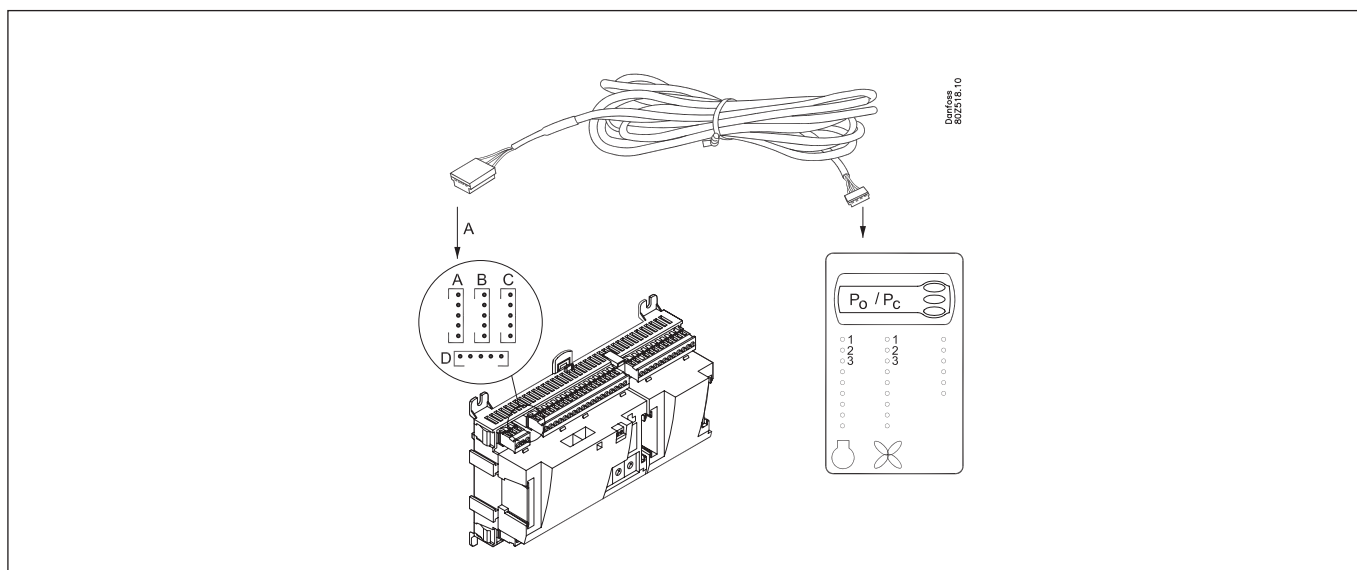
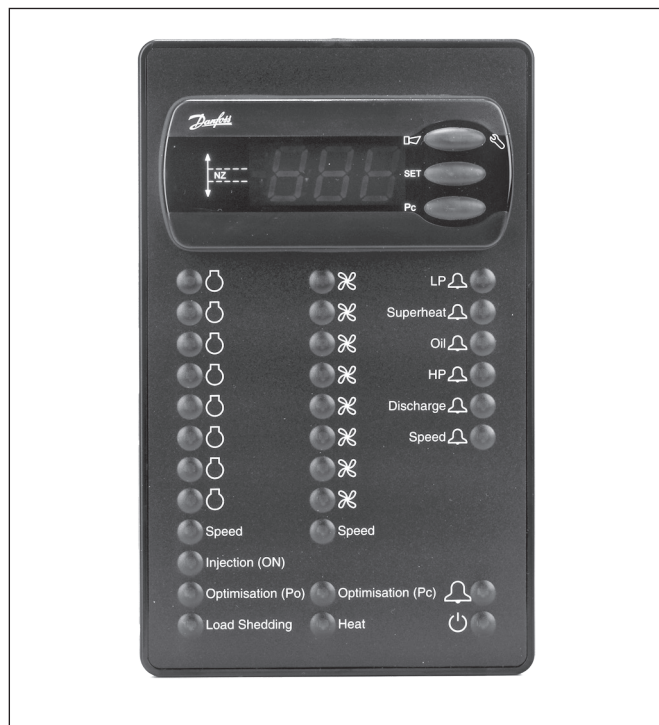

Technical data

Power supply	From controller
Display operation	Display accuracy in measuring range: 0.1°C LED, three digits, control buttons
Electrical connection	Plug
Ambient conditions	-10 to +50°C (operating)
	-40 to +70°C (transport)
	20 to 80% RH, non condensing
	No shock load or vibration
Mounting	Front panel
Enclosure	IP 65

Ordering data

Description	Type	Code no.
Display unit with control buttons and LEDs	EKA 166	084B8578
Cable to display unit (2 m with plug)	Qty 1	084B7298
	Qty 24	084B7179
Cable to display unit (6 m with plug)	Qty 1	084B7299
	Qty 24	084B7097
Cable to display unit (3 m with plug)	Qty 24	084B7099
Cable to display unit (9 m with plug)	Qty 24	084B7630

Additional information available:

AK-PC 710-Manual: RS8FT

AK-PC 781-Manual: RS8GG

Temperature sensors

Pt 1000 ohm / 0°C

AKS 11, AKS 12, AKS 21, AK-HS 1000

Application

These sensors are recommended for accurate temperature measurement in applications such as superheating, food safety logs, and other important temperature measurement applications.

Functional description

The sensor unit consists of a platinum element the resistance value of which changes proportionally with the temperature.

Pt 1000 ohm sensor (1000 ohm at 0°C).

The sensors are adjusted and meet the tolerance requirements of EN 60751 Class B.



Type	Description	Temperature range °C	Sensor/sensor body	Connection/cable	Enclosure	Time constant [s]	Cable length m	Qty	Code
AKS 11 *)	Surface and duct sensor for control and monitoring	-50 to +100	Top: PPO (Noryl) Bottom: stainless steel	PVC cable, 2 x 0.2 mm ²	IP 67	3 ¹⁾ 10 ²⁾ 35 ³⁾	3.5 m	1	084N0003
							3.5 m + AMP	110	084N0050
							5.5 m	1	084N0005
							5.5 m + AMP	70	084N0051
							8.5 m	1	084N0008
AKS 12	Air temperature sensor for monitoring	-40 to 100	18/8 stainless steel	PVC cable 2 x 0.22 mm ²	IP 67	15 ²⁾	1.5 m	1	084N0036
								30	084N0035
							3.5 m	30	084N0039
							5.5 m	30	084N0038
AKS 21A **)	Surface sensor with clip	-70 to +180	18/8 stainless steel	Fire-resistant silicone rubber cable, 2 x 0.2 mm ²	IP 67	6 ¹⁾ 14 ²⁾ 35 ³⁾	2.5 m	1	084N2007
							5.0 m	1	084N2008
AKS 21M	Multipurpose sensor	-70 to +180					2.0 m	1	084N2024
AKS 21W	Immersion sensor with cable and sensor pocket, welded version	-70 to +180	Immersion sensor, 18/8 stainless steel tube	Fire-resistant silicone rubber cable, 2 x 0.2 mm ²	IP 56	18 ¹⁾	2.5 m	1	084N2017
			Weld nipple: 18/8 stainless steel						
			Thread nipple: free cutting steel						
AK-HS 1000	Product sensor for HACCP logging	-30 to +50	ABS and PC	PVC cable 2 x 0.25 mm ²	IP 54	180-900 ³⁾	5.5 m	1	084N1007

*) Recommended for measuring superheat

**) Recommended for hot gas systems

¹⁾ Agitated liquid.

²⁾ Clamped to pipe.

³⁾ Air 4 m/s.

AKS 11, AKS 12, AKS 21, AK-HS 1000

°C	ohm	°C	ohm
0	1000.0		1000.0
1	1003.9	-1	996.1
2	1007.8	-2	992.2
3	1011.7	-3	988.3
4	1015.6	-4	984.4
5	1019.5	-5	980.4
6	1023.4	-6	976.5
7	1027.3	-7	972.6
8	1031.2	-8	968.7
9	1035.1	-9	964.8
10	1039.0	-10	960.9
11	1042.9	-11	956.9
12	1046.8	-12	953.0
13	1050.7	-13	949.1
14	1054.6	-14	945.2
15	1058.5	-15	941.2
16	1062.4	-16	937.3
17	1066.3	-17	933.4
18	1070.2	-18	929.5
19	1074.0	-19	925.5
20	1077.9	-20	921.6
21	1081.8	-21	917.7
22	1085.7	-22	913.7
23	1089.6	-23	909.8
24	1093.5	-24	905.9
25	1097.3	-25	901.9
26	1101.2	-26	898.0
27	1105.1	-27	894.0
28	1109.0	-28	890.1
29	1112.8	-29	886.2
30	1116.7	-30	882.2
31	1120.6	-31	878.3
32	1124.5	-32	874.3
33	1128.3	-33	870.4
34	1132.2	-34	866.4
35	1136.1	-35	862.5
36	1139.9	-36	858.5
37	1143.8	-37	854.6
38	1147.7	-38	850.6
39	1151.5	-39	846.7
40	1155.4	-40	842.7
41	1159.3	-41	838.8
42	1163.1	-42	835.0
43	1167.0	-43	830.8
44	1170.8	-44	826.9
45	1174.7	-45	822.9
46	1178.5	-46	818.9
47	1182.4	-47	815.0
48	1186.3	-48	811.0
49	1190.1	-49	807.0
50	1194.0	-50	803.1

approx. 3.9 ohm/K

AKS 11

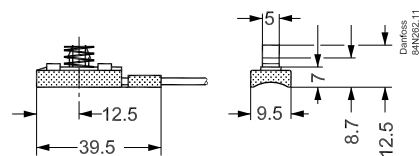

AKS 12

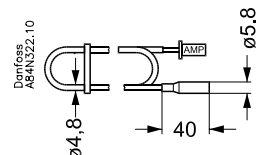

AKS 21A, AKS 21M

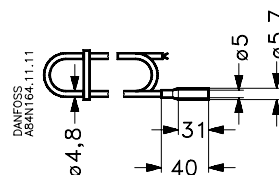

AKS 21W

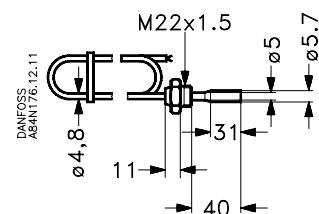

AKS 21W welded version

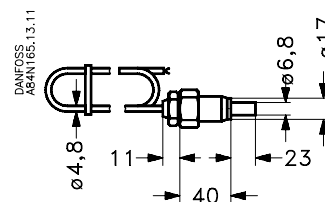

Pocket in welded version for AKS 21W

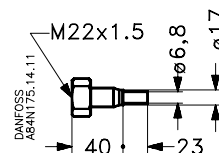

The tolerance of a Pt 1000 sensor is less than $\pm(0.3 + 0.005 T)$. This translates into a temperature error of less than 0.5 degree for refrigeration control.

Product sensor for HACCP AK-HS 1000

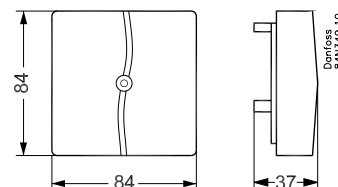

Sensors with AMP plug:
connector type AMP ital mod 2, housing 280 358,
crimp contacts type 280 708-2

PTC 1000 ohm

EKS 111

Application

This sensor is used primarily with EKC 202, AK-CC 210 and EKC 302 controllers in situations where the error due to the sensor tolerance can be tolerated or corrected.

Functional description

The sensor is based on a PTC element with a resistance of 990 ohms at 25°C.



Technical data

Nominal resistance	990 ohms at 25°C
Temperature range	-55 to 100°C
Cable material	PVC
Sensor tube	AISI 304 stainless steel
Time constant	Water
Enclosure	IP 67
AMP plug	AMP ital mod 2, housing 280 358 crimp contact 280 708-2

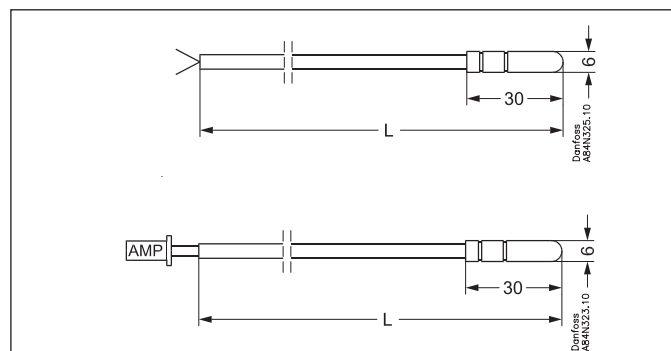

R (Typ.) Ohm	Temp. °C	Error K	Temp. °F
1679	100	+/-3.5	212
1575	90		194
1475	80		176
1378	70		158
1286	60		140
1196	50		122
1111	40		104
1029	30		86
990	25	+/-1.3	77
951	20		68
877	10		50
807	0		32
740	-10		14
677	-20		-4
617	-30		-22
562	-40		-40
510	-50		-58
485	-55	+/-3.0	-67

The sensor has a relatively large resistance tolerance. Consequently, it cannot be used to measure values used for food safety logs or superheat control.

Ordering

Type	Sensor	Cable	Number	Code no.	
EKS 111	PTC	990 ohm / 25°C	1.5 m	1	084N1178
				150	084N1161
			3.5 m	1	084N1179
				150	084N1163
			6 m	1	084N1180
				80	084N1173
			8.5 m	60	084N1168
				1	084N1181
			1.5 m with AMP plug	150	084N1174
				1	084N1182
			3.5 m with AMP plug	150	084N1170
				1	084N1177
			6 m with AMP plug	80	084N1171

Not suitable for measuring superheat or food safety log data

NTC 5000 ohm / 25°C

EKS 211

Application

This sensor is used primarily with EKC 211-214 controllers in situations where its tolerance is acceptable.

Functional description

NTC sensor for temperature measurements in the following areas:

- Refrigeration
- Air conditioning
- Heating

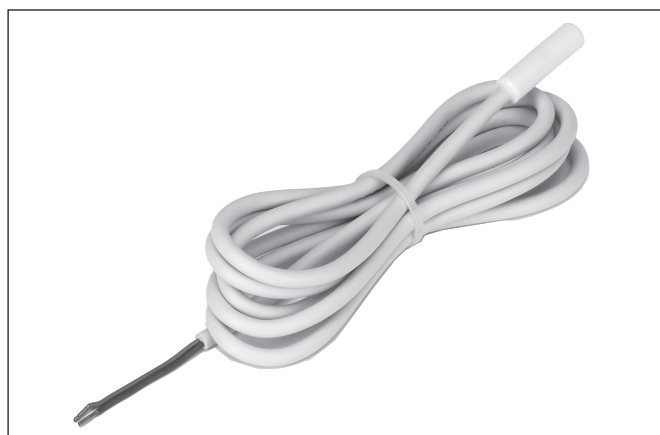

Technical data

Nominal resistance	5000 ohms at 25°C	
Temperature range	-40 to 80°C	
Cable material	PVC, 2 x 0.22 mm ²	
Sensor housing	PBT (thermoplastic polyester)	
Time constant	Water	25 seconds
	Air	80 seconds
Enclosure	IP 67	

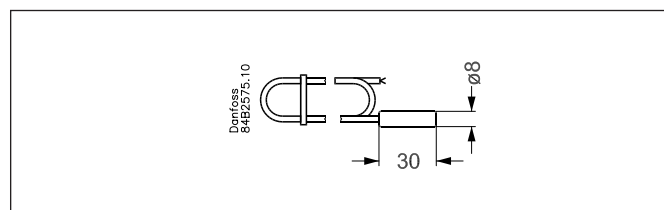

R_nom ohm	Temperature °C	Temperature °F
631.0	80	176
743.2	75	167
878.9	70	158
1044	65	149
1247	60	140
1495	55	131
1803	50	122
2186	45	113
2665	40	104
3266	35	95
4029	30	86
5000	25	77
6246	20	68
7855	15	59
9951	10	50
12696	5	41
16330	0	32
21166	-5	23
27681	-10	14
36503	-15	5
48614	-20	-4
65333	-25	-13
88766	-30	-22
121795	-35	-31
169157	-40	-40

Tolerance

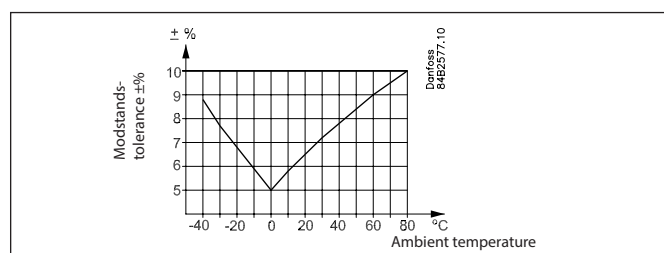

The sensor has a relatively large resistance tolerance. Consequently, it cannot be used to measure values for food safety logs.

Ordering data

Industry pack

Type	Sensor element	Connection	Cable	Quantity	Code	
EKS 211	NTC	5000 ohm / 25°C	-	1.5 m	300	084B4403
				3.5 m	150	084B4404
				6 m	50	084N3211

Single pack

Type	Sensor element	Connection	Cable	Quantity	Code	
EKS 211	NTC	5000 ohm / 25°C	-	1.5 m	1	084N1220
				3.5 m	1	084N1221

Not suitable for food safety log data

NTC 10 kohm / 25°C

EKS 221

Application

NTC sensor for temperature measurements in the following areas:

- Refrigeration
- Air conditioning
- Heating

The sensor characteristic is adapted to:

- OPTYMA room controllers
- MCX unit controllers

Functional description

The sensor is based on a NTC element with a resistance of 10000 ohms at 25°C.



Technical data

Sensor sheath	Thermoplastic rubber	Steel AISI 304
Temperature range	-50 to 120°C	-50 to 110°C
Cable material	Thermoplastic rubber, flat, 2 x 0.25 mm ²	Thermoplastic rubber, round, 2 x 0.25 mm ²
Wire ends	Tin plated	Nipples
Time constant, water 2 m/s	10 seconds	10 seconds
IP Class	IP 67	IP 68
Nominal resistance	10,000 ohms at 25°C	
Tolerance	±1%	
Beta value	3435 at 25/85 °C	
Tolerance of beta value	±1%	

R_nom Ohm	Temp. °C	Temp. °F
595	120	248
757	110	230
972	100	212
1265	90	194
1667	80	176
2228	70	158
3020	60	140
4160	50	122
5827	40	104
8313	30	86
10000	25	77
12091	20	68
17958	10	50
27278	0	32
42450	-10	14
67801	-20	-4
111364	-30	-22
188500	-40	-40

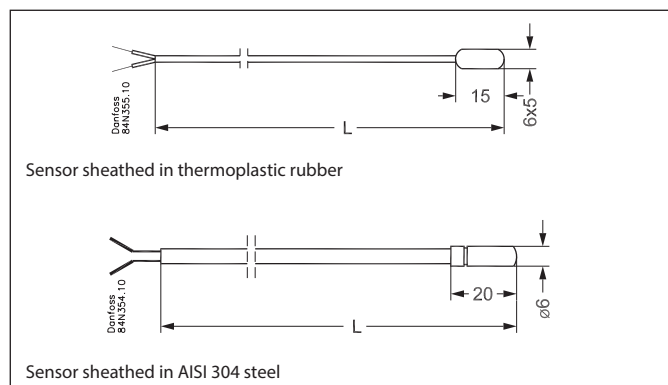

Ordering data

Type	Sensor element	Sensor sheath	Cable length	Quantity	Code no.
EKS 221	NTC 10000 ohm / 25°C	Thermoplastic rubber	3.5 m	1	084N3210
			8.5 m	50	084N3208
				1	084N3209
		Steel AISI 304	1,5 m	150	084N3200

Pressure transmitters

AKS 32, AKS 33, AKS 32R, AKS 2050

Introduction

AKS 32 and AKS 33 are pressure transmitters that measure a pressure and convert the measured value to a standard signal:

- 1 → 5 V d.c. for AKS 32
- 4 → 20 mA for AKS 33

AKS 32R and AKS 2050 are ratiometric pressure transmitters that convert the measured pressure to a linear output signal. The minimum value of the output signal is 10% of the actual supply voltage. The maximum value is 90% of the actual supply voltage.

With a supply voltage of 5 V, this yields a linear output signal with a value of:

- 0.5 V at the minimum pressure of the pressure transmitter;
- 4.5 V at the maximum pressure of the pressure transmitter.

Application

- A/C systems
- Refrigeration systems
- Process control
- Laboratories

Advantages

Advanced sensor technology enables high pressure control accuracy, which is essential for precise and energy-efficient capacity regulation in refrigeration systems.

- Temperature compensation for low-pressure and high-pressure pressure transmitters specifically designed for refrigeration systems:

Low pressure: $-30 \rightarrow +40^\circ\text{C}$ (≤ 16 bar)

High pressure: $0 \rightarrow +80^\circ\text{C}$ (> 16 bar)

- Compatible with all refrigerants, including ammonia, for reduced parts inventory and greater application flexibility.
- Effective moisture protection allows the sensors to be used in very harsh environments, such as a suction line surrounded by ice.



- Robust construction provides protection against mechanical factors as shock, vibration, and pressure surges. AKS sensors can be fitted directly on the system components.
- No adjustment is necessary. Thanks to the advanced sensor technology and sealed gauge construction, the accuracy of the factory calibration is maintained regardless of changes in ambient temperature and atmospheric pressure. This is essential for reliable control of evaporating pressure in air conditioning and refrigeration systems.
- Built-in voltage regulator
- EMC protection compliant with the EU EMC Directive (CE marking)
- UL approved

Output signal

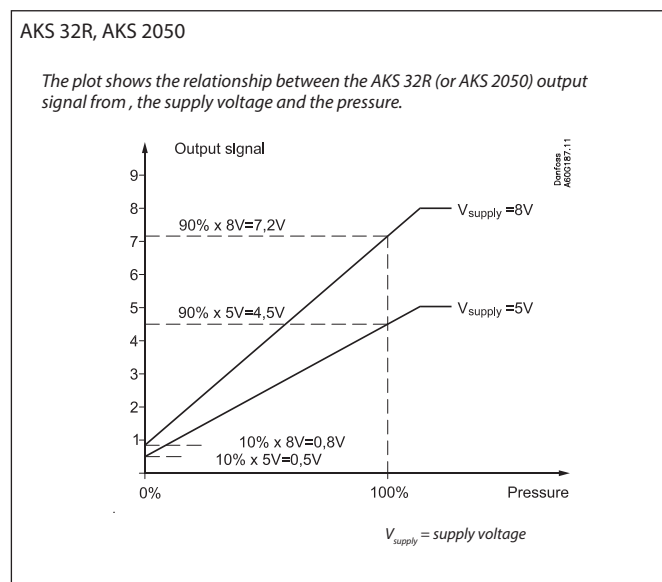
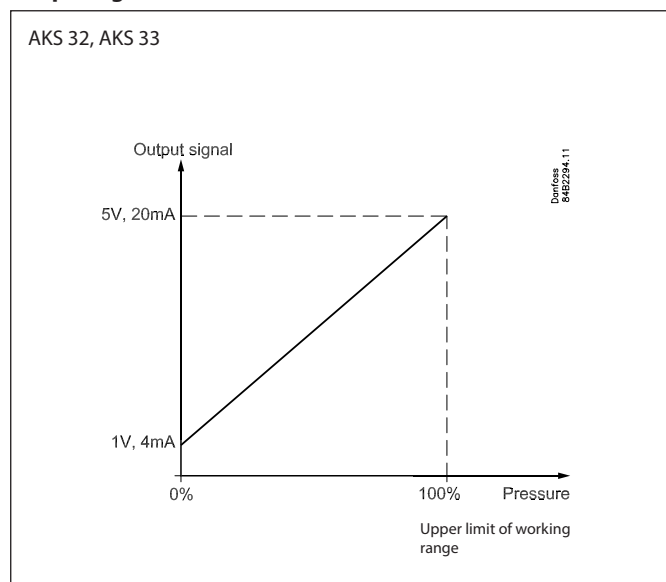

Ordering data

AKS 32, version 1 → 5 V

	Operating range [bar]	Allowable working pressure PB [bar]	Compensated temperature range [°C]	Code no.		
				EN 175301-803 plug Pg 9		
				1/4 NPT ¹	G 3/8 A ²	1/4 flare ³
	-1 to 6	33	-30 to +40	060G2000	060G2004	060G2068
	-1 to 12	33	-30 to +40	060G2001	060G2005	060G2069
	-1 to 20	40	0 to +80	060G2002	060G2006	060G2070
	-1 to 34	55	0 to +80	060G2003	060G2007	060G2071
	-1 to 50	100	0 to +80			060G2155

AKS 33, version 4 → 20 mA

	Operating range [bar]	Allowable working pressure PB [bar]	Compensated temperature range [°C]	Code no.					
				EN 175301-803 plug Pg 9			Cable		
				1/4 NPT ¹	G 3/8 A ²	1/4 flare ³	1/4 NPT ¹	G 3/8 A ²	1/4 flare ³
	-1 to 5	33	-30 to +40	060G2112	060G2108	060G2047			
	-1 to 6	33	-30 to +40	060G2100	060G2104	060G2048		060G2120	
	-1 to 9	33	-30 to +40	060G2113	060G2111	060G2044			060G2062
	-1 to 12	33	-30 to +40	060G2101	060G2105	060G2049	060G2117		
	-1 to 20	40	0 to +80	060G2102	060G2106	060G2050	060G2118		
	-1 to 34	55	0 to +80	060G2103	060G2107	060G2051	060G2119		060G2065
	0 to 16	40	0 to +80	060G2114	060G2109				
	0 to 25	40	0 to +80	060G2115	060G2110	060G2045		060G2127	060G2067

AKS 32R, AKS 2050

	Type	Operating range bar	Allowable working pressure PB [bar]	Compensated temperature range [°C]	Code no.				
					1/4 NPT ¹⁾	G 3/8 A ²⁾	1/4 flare ³⁾	3/8 solder	1/4 female flare ⁴⁾
	AKS 32R	-1 to 12	33	-30 to +40	060G1037	060G1038	060G1036	060G3551	060G6323
		-1 to 34	55	0 to +80			060G0090	060G3552	060G6341
	AKS 2050	-1 to 59	100	-30 to +40	060G6342	060G5750		060G6408	
		-1 to 99	150	-30 to +40	060G6343	060G5751			
		-1 to 159	250	0 to +80	060G6344	060G5752			
	Mating plug with 5 m cable (rated IP 67 when fitted to pressure transmitter)				060G1034				
	Plug Pg 9				060G0008				

1) 1/4-18 NPT.

2) Thread ISO 228/1 - G 3/8 A (BSP).

3) 7/16-20 UNF.

4) With depressor pin for Schraeder valve. 7/16-20 UNF.

Compact pressure transmitter for CO₂

Advantage:

- Designed for CO₂ plants
- Compact design
- High accuracy

Additional information available:
Technical brochure: IC.PD.P21.I

	Operating range bar	Allowable working pressure PB [bar]	Compensated temperature range [°C]	Signal	Code no.
					1/4 NPT ¹⁾
	-1 to 159	250	-20 to +100	Ratiometric	064G1131
				4 - 20 mA	064G1132
	Round Packard Metri-Pack. Connection plug with 10 m cable				064G0910

Dimensions and weights

AKS 32, AKS 33

Version with EN 175301-803 plug Pg 9

Cable version

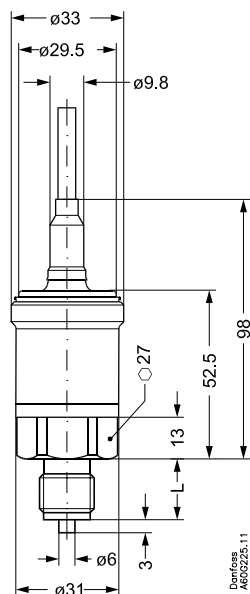
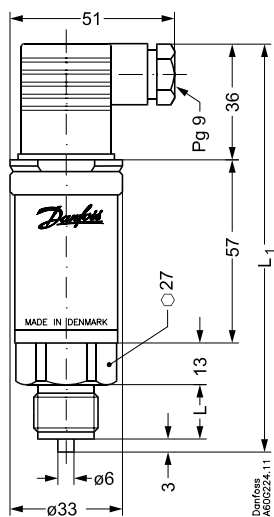

Pressure connection	1/4-18 NPT	G 3/8 A ISO 228/1	1/4 in. flare 7/16-20 UNF
L ₁ [mm]	122	127	122.5
L [mm]	16	18	16.5

Weight approx. 0.3 kg

AKS 32R, AKS 2050

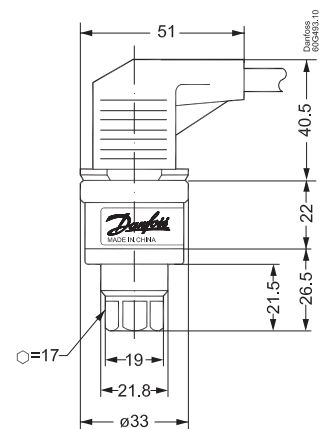
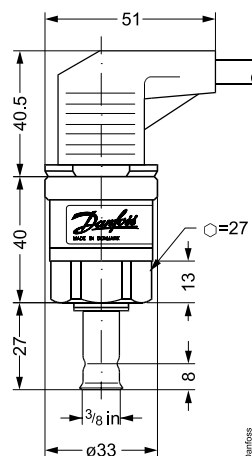
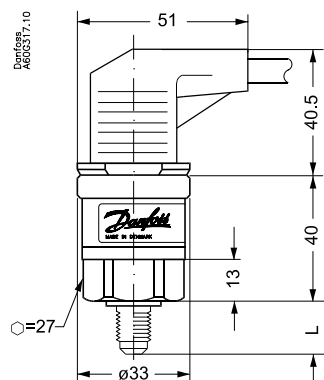

Pressure connection	1/4-18 NPT	G 3/8 A ISO 228/1	1/4 in. flare 7/16-20 UNF	3/8 Solder
L [mm]	16	21	16.5	30

Weight approx. 0.15 kg

Additional information available:

AKS 32 and AKS 33
Technical brochure: IC.PD.P21.Z

AKS 32R and AKS 2050
Technical brochure: IC.PD.P20.W

MBS 8250
Technical brochure: IC.PD.P21.I

Gas detector

DGS

Application

The DGS unit can detect a wide range of commonly used refrigerants, including carbon dioxide, halogenated hydrocarbons and hydrocarbons.

Advantages

- Alarm levels can be set locally.
- The gas sensor can be connected to a AK System unit.



Technical data

Power supply	12/24 V a.c./d.c. $\pm 20\%$
Power consumption	Semi-conductor (SC): 153 mA Infra red: (IR) 136 mA
Power monitoring	Green LED
Visual Alarm	Red LED
Audible alarm	Enabled / disabled
Fault state	0 - 0.5 V (1-5 V), 0 - 1 V(2-10 V), 0 - 2 mA (4-20 mA)
Analogue outputs	0-5 V, 1-5 V, 0-10 V, 2-10 V, 4-20 mA
Relay output	SPDT, max. 1 A / 24 V d.c.
Alarm delay. Optional	0, 1, 5 or 10 minutes

Sensor information		Semi-Conductor with filter (multigas) SC Halocarbons	Semi-Conductor (multigas) SC Hydrocarbons	Infrared IR CO ₂
Typical measurement range		0 - 1000 ppm	0 - 1000 ppm	0 - 10000 ppm 0 - 20000 ppm 0 - 50000 ppm
Factory setting (Relay activate at)		50% of the range		
Ambient	IP41	-20°C to +50°C (-4°F to 122°F)		
	IP66	-40°C to +50°C (-40°F to 122°F)		
		0 to 95 % Humidity Range (RH), non-condensing		
Life time for sensor	Typical	5 years		
Alarm Threshold	T50	76 seconds, filtered	50 seconds, filtered	50 seconds
	T90	215 seconds, filtered	90 seconds, filtered	120 seconds
Recovery time		600 seconds	200 seconds	235 seconds
Linearity		Linear over calibrated range		
Calibration		Annual test and calibration according to standards. See also guide line for calibration		
		Calibrated to a specific gas	Calibrated to a specific gas	

Ordering data

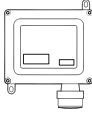
Type		Enclosure	Calibrated for	Function	Code no.
DGS		IP 41, -20°C to +50°C	R404A, R507	Gas detector	080Z2098
			R134a	Gas detector	080Z2092
			R407A	Gas detector	080Z2093
			R407F	Gas detector	080Z2076
			R410A	Gas detector	080Z2088
			R22	Gas detector	080Z2090
			R744 (CO ₂)	Gas detector	080Z2095
	Gas detector, Fail safe	080Z2294			
		IP 66, -40°C to +50°C	R404A, R507	Gas detector	080Z2099
			R134a	Gas detector	080Z2089
			R407A	Gas detector	080Z2094
			R407F	Gas detector	080Z2077
			R410A	Gas detector	080Z2087
			R22	Gas detector	080Z2091
R744 (CO ₂)			Gas detector	080Z2096	
	Gas detector, Remote 3 m	080Z2097			
	Gas detector, Fail safe	080Z2293			
	Gas detector, Fail safe, Remote	080Z2292			

DGS is also available for alternative refrigerant gases on request.

Please contact your local Danfoss sales office for details.

Dimensions

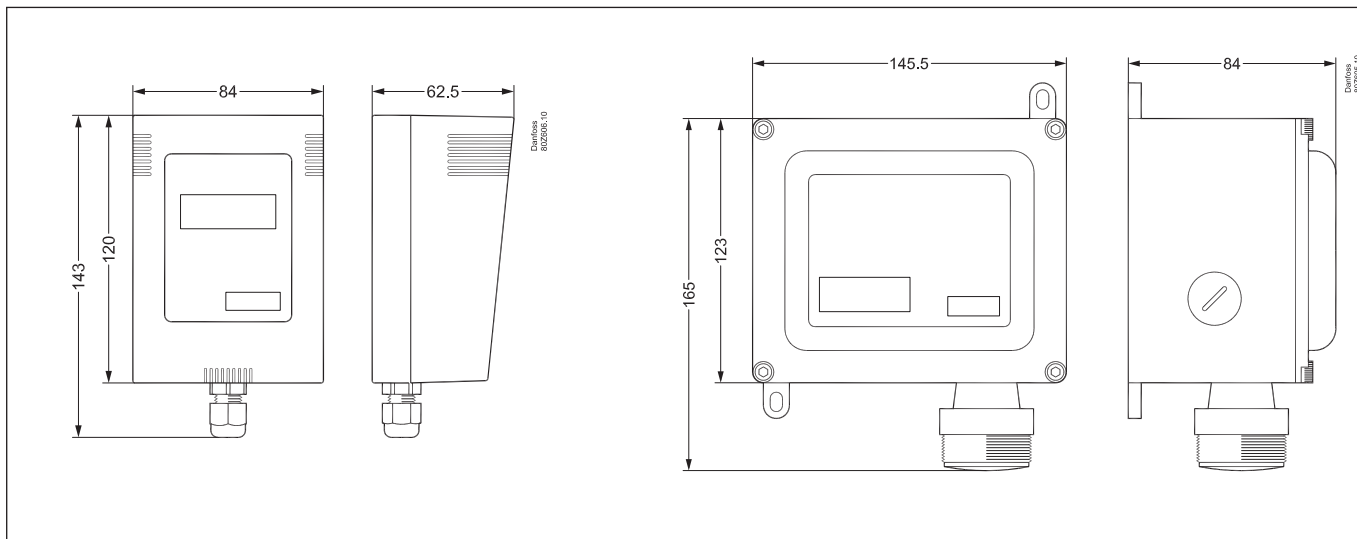

Additional information available:
Technical brochure: USCO.EN.S00.A

Expansion valves

The principal features of the most commonly used products are described briefly here.

Additional information is available in the relevant technical brochures.

In particular, additional information is necessary selection of the right valve capacity.

AKV 10, AKV 15, AKV 20

Application

The AKV valves are electrically operated expansion valves designed for refrigerating systems. They can be used with HCFC, HFC and R744 refrigerants. It cannot be used with flammable hydrocarbons. The AKV valves are usually operated by a controller from the Danfoss range of ADAP-KOOL® controllers.

Advantages

- No adjustment necessary
- Wide control range
- Replaceable orifice assembly
- Combined expansion valve and solenoid valve

Functional description

Individual components are available for AKV valves, as follows:

- Valve only
- Coil only with terminal box or cable
- Spare parts: upper part, orifice and filter

The individual capacity is indicated by a number forming part of the type designation. This number represents orifice size of the associated valve. For example, an AKV 10 valve with orifice size 3 is designated AKV 10-3.

The orifice assembly is replaceable.

Approvals

DEMKO (Denmark)

SETI (Finland)

SEV (Switzerland)

UL listed (separate code numbers)

CSA certified (separate code numbers) nr.)

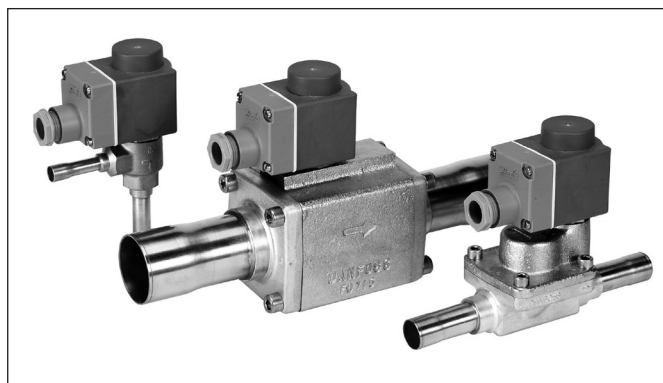

Technical data

Valve type	AKV 10	AKV 15	AKV 20
Coil voltage tolerance	+10/-15%		
Enclosure rating per IEC 529	Max. IP 67		
Operating principle	PWM (pulse width modulation)		
Recommend period	6 seconds		
Capacity (R22)	1 to 16 kW	25 to 100 kW	100 to 630 kW
Control range (capacity range)	10-100%		
Connected device	Solder	Solder	Solder or weld
Evaporating temperature	- 50 to 60°C	- 50 to 60°C	- 40 to 60°C
Ambient temperature	- 50 to 50 °C	- 40 to 50 °C	- 40 to 50 °C
Valve seat leakage	< 0.02% of Kv value		
MOPD	18 bar	22 bar	18 bar
Filter, replaceable	Internal 100 µm	External 100 µm	External 100 µm
Max. working pressure	AKV 10-1...6: Ps = 52 bar AKV 10-7: Ps = 42 bar	AKV 15-1,2,3: Ps = 42 bar AKV 15-4: Ps = 28 bar	Ps = 28 bar

Rated capacity and ordering data



Valve type	Rated capacity in kW ¹				K _v value m ³ /h	Connection			
	R22	R 134a	R 404A R 507	R 407C		Solder ODF			
						Inlet × outlet in.	Code	Inlet × outlet in.	Code
AKV 10-1	1.0	0.9	0.8	1.1	0.010	$\frac{3}{8} \times \frac{1}{2}$	068F1161	10 × 12	068F1162
AKV 10-2	1.6	1.4	1.3	1.7	0.017	$\frac{3}{8} \times \frac{1}{2}$	068F1164	10 × 12	068F1165
AKV 10-3	2.6	2.1	2.0	2.5	0.025	$\frac{3}{8} \times \frac{1}{2}$	068F1167	10 × 12	068F1168
AKV 10-4	4.1	3.4	3.1	4.0	0.046	$\frac{3}{8} \times \frac{1}{2}$	068F1170	10 × 12	068F1171
AKV 10-5	6.4	5.3	4.9	6.4	0.064	$\frac{3}{8} \times \frac{1}{2}$	068F1173	10 × 12	068F1174
AKV 10-6	10.2	8.5	7.8	10.1	0.114	$\frac{3}{8} \times \frac{1}{2}$	068F1176	10 × 12	068F1177
AKV 10-7	16.3	13.5	12.5	17.0	0.209	$\frac{1}{2} \times \frac{5}{8}$	068F1179	12 × 16	068F1180
AKV 15-1	25.5	21.2	19.6	25.2	0.25	$\frac{3}{4} \times \frac{3}{4}$	068F5000	18 × 18	068F5001
AKV 15-2	40.8	33.8	31.4	40.4	0.40	$\frac{3}{4} \times \frac{3}{4}$	068F5005	18 × 18	068F5006
AKV 15-3	64.3	53.3	49.4	63.7	0.63	$\frac{7}{8} \times \frac{7}{8}$	068F5010	22 × 22	068F5010
AKV 15-4	102	84.6	78.3	101	1.0	$1\frac{1}{8} \times 1\frac{1}{8}$	068F5015	28 × 28	068F5016

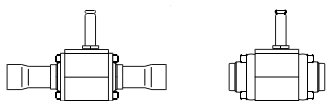

Valve type	Rated capacity in kW ¹				K _v value m ³ /h	Connections					
	R22	R 134a	R 404A R 507	R 407C		Solder ODF			Weld		
						Inlet × outlet in.	Code	Inlet × outlet mm	Code	Inlet × outlet in.	Code
AKV 20-1	102	84.6	78.3	101	1.0	$1\frac{3}{8} \times 1\frac{3}{8}$	042H2020	35 × 35	042H2020	$1\frac{1}{4} \times 1\frac{1}{4}$	042H2021
AKV 20-2	163	135	125	170	1.6	$1\frac{3}{8} \times 1\frac{3}{8}$	042H2022	35 × 35	042H2022	$1\frac{1}{4} \times 1\frac{1}{4}$	042H2023
AKV 20-3	255	212	196	252	2.5	$1\frac{5}{8} \times 1\frac{5}{8}$	042H2024	42 × 42	042H2025	$1\frac{1}{4} \times 1\frac{1}{4}$	042H2026
AKV 20-4	408	338	314	404	4.0	$2\frac{1}{8} \times 2\frac{1}{8}$	042H2027	54 × 54	042H2027	$1\frac{1}{2} \times 1\frac{1}{2}$	042H2028
AKV 20-5	643	533	494	637	6.3	$2\frac{1}{8} \times 2\frac{1}{8}$	042H2029	54 × 54	042H2029	2 × 2	042H2030

¹ The rated capacity is based on:
 Condensing temperature $t_c = 32^\circ\text{C}$
 Liquid temperature $t_l = 28^\circ\text{C}$
 Evaporating temperature $t_e = 5^\circ\text{C}$

Dimensioning

To obtain an expansion valve that will function correctly under various load conditions, the aspects listed below must be considered for valve dimensioning. They must be evaluated in the order listed.

1. Evaporator capacity
2. Pressure drop across the valve
3. Correction for subcooling
4. Correction for evaporating temperature
5. Determination of valve size
6. Correct liquid line dimensioning

Additional information available:
 Technical brochure: DKRCC.PD.VA1.A

Spare parts

AKV 10



Orifice

Orifice no.	Code no.	Contents
0	068F5283	4 pc. orifice 4 pc. gasket
1		
2		
3		
4	068F5284	3 pc. orifice 3 pc. gasket
5		
6		
7	068F5285	2 pc. orifice 2 pc. gasket
8		



Filter: **Code no. 068F0540**
 Contents: 10 filters
 10 aluminium gaskets

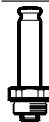

Upper part: **Code no. 068F0541**
 Contents: 1 armature assembly
 1 armature tube
 1 aluminium gasket

AKV 15



Piston

Type	Code no.	Contents
AKV 15-1	068F5265	1 piston assembly 1 gasket 1 O-ring 2 labels
AKV 15-2	068F5266	
AKV 15-3	068F5267	
AKV 15-4	068F5268	

Gasket set: **Code no. 068F5264**
 Contents: 30 O-rings
 10 copper gaskets
 10 gaskets



Filter: **Code no. 068F0540**
 Contents: 10 filters
 10 aluminium gaskets



Upper part: **Code no. 068F0545**
 Contents: 1 armature assembly
 1 armature tube
 1 aluminium gasket

AKV 20



Piston

Type	Code no.	Contents
AKV 20-0.6	042H2039	1 pc. piston assembly 3 O-rings
AKV 20-1	042H2040	
AKV 20-2	042H2041	
AKV 20-3	042H2042	
AKV 20-4	042H2043	
AKV 20-5	042H2044	

Gasket set: **Code no. 032F2327**
 Contents: Complete gasket set
 for new-model and old-model
 valves



Upper part: **Code no. 068F0545**
 Contents: 1 armature assembly
 1 armature tube
 1 aluminium gasket



Orifice set

Type	Code no.	Contents
AKV 20-0.6	068F5270	Main orifice, dia. 8 mm Pilot orifice, dia. 1.8 mm 2 aluminium gaskets O-ring
AKV 20-1		
AKV 20-2		
AKV 20-3		
AKV 20-4	068F5271	Main orifice, dia. 14 mm Pilot orifice, dia. 2.4 mm 2 aluminium gaskets O-ring
AKV 20-5		

AKVH 10

AKVH are a serie electrically operated expansion valves designed for refrigeration plants using CO₂ (R 744). The series is similar in design to the rest of the AKV range, but has been developed for the higher pressure.

Approvals

PED (97/23/EF A3.P3)



The Low Voltage Directive 73/23/EC with amendments EN 60730-2-8



Rated capacity and Ordering



Valve type	Rated capacity kW		k _v -value m ³ /t	Connections Solder ODF	
	Refrig.	Freezing		3/8 × 1/2 inch	10 × 12 mm
AKVH 10-0	0.4	0.8	0.003	068F4078	068F4088
AKVH 10-1	1.1	2.2	0.010	068F4079	068F4089
AKVH 10-2	1.7	3.5	0.017	068F4080	068F4090
AKVH 10-3	2.6	5.4	0.025	068F4081	068F4091
AKVH 10-4	4.3	8.7	0.046	068F4082	068F4092
AKVH 10-5	6.7	13.6	0.064	068F4083	068F4093
AKVH 10-6	10.7	21.7	0.114	068F4084	068F4094

Technical data

Valve type	AKVH 10
Tolerance of coil voltage	+10/-15 %
Enclosure acc. to IEC 529	Maks. IP 67
Working principle	PWM (pulse-width modulation)
Recommended period of time	6 seconds
Capacity (R 744)	Refrigeration: 0,4 kW to 11 kW Freezing: 0,8 kW to 22 kW
Regulation range (Capacity range)	10 to 100 %
Connection	Solder
Evaporating temperature	-60 to 60° C
Ambient temperature	-50 to 50° C
Leak of valve seat	<0,02 % of k _v -value
MOPD	35 bar
Filter, replaceable	Internal 100 µm
Max working pressure	PS = 90 barg ^{*)}

^{*)} 90 barg under stand still conditions, but under normal operating conditions, there must be liquid to the inlet of the valve.



Coils with coil control (EEC)

Voltage	Power	Code no.
230 V a.c.	4 W	018F6783

Spare parts

AKVH 10



Orifice

Orifice no..	Code no.	Contents
0	068F5283	4 Orifices 4 gaskets
1		
2		
3		
4	068F5284	3 Orifices 3 gaskets
5		
6		
7	068F5285	2 Orifices 2 gaskets
8		



Filter:
Contents: **Code no. 068F0540**
10 filters
10 gaskets.



Upper part:
Contents: **Code no. 068F0541**
1 armature assembly
1 armature tube
1 gasket

Additional information available:
Technical brochure: DKRCC.PD.VA1.D

AKVA 10 AKVA 15, AKVA 20

The AKVA valves are electrically operated expansion valves designed for ammonia refrigeration systems. They are usually operated by a controller from the Danfoss line of ADAP-KOOL® controllers.

AKVA valves are available as individual components as follows:

- Valve only
- Coil only with terminal box or cable
- Spare parts: upper part, orifice and filter

The individual capacity is indicated by a number forming part of the type designation. This number represents orifice size of the associated valve.

For example, an AKVA 10 valve with a size 3 orifice is designated AKVA 10-3.

The orifice assembly is replaceable.

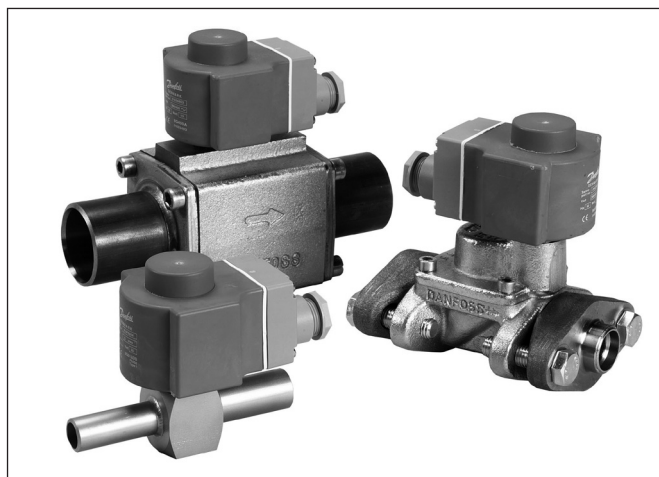

Features

- For ammonia (R 717), R744, HCFC, and HFC
- It cannot be used with flammable hydrocarbons.
- No adjustment necessary
- Wide control range
- Replaceable orifice assembly
- Can be used as a combined expansion and solenoid valve in some applications
- Wide range of coils for d.c. and a.c. operation

Approvals

DEMKO (Denmark)

SETI (Finland)

SEV (Switzerland)

 UL listed for US and Canadian standards
(separate code numbers)

AKVA 20 is CE certified in accordance with Pressure Directive 97/23

Technical data

Valve type	AKVA 10	AKVA 15	AKVA 20
Coil voltage tolerance	+10/-15%		
Enclosure rating (IEC 529)	Max. IP 67		
Operating principle	PWM (pulse width modulation)		
Recommend period	6 seconds		
Capacity (R717)	4 to 100 kW	125 to 500 kW	500 to 3150 kW
Control range (capacity range)	10-100%		
Connection	Weld		
Media temperature	- 50 to 60°C	- 40 to 60°C	- 40 to 60°C
Ambient temperature	- 50 to 50 °C	- 40 to 50 °C	- 40 to 50 °C
Valve seat leakage	< 0.02% of Kv value		
MOPD	18 bar	22 bar	18 bar
Filter, replaceable	Internal 100 µm, replaceable	External 100 mm	External 100 mm
Allowable operating pressure	Ps = 42 bar gauge	Ps = 42 bar gauge	Ps = 42 bar gauge

Rated capacity and ordering data

Symbol	Valve type	Nominal capacity ¹		Kv value m ³ /h	Connected device inlet x outlet in.	Code	Connected device inlet x outlet in.	Code
		kW	metric tons					
	AKVA 10-1	4	1.1	0.010	$\frac{3}{8} \times \frac{1}{2}$	068F3261	$\frac{1}{2} \times \frac{3}{4}$	068F3281
	AKVA 10-2	6.3	1.8	0.015	$\frac{3}{8} \times \frac{1}{2}$	068F3262	$\frac{1}{2} \times \frac{3}{4}$	068F3282
	AKVA 10-3	10	2.8	0.022	$\frac{3}{8} \times \frac{1}{2}$	068F3263	$\frac{1}{2} \times \frac{3}{4}$	068F3283
	AKVA 10-4	16	4.5	0.038	$\frac{3}{8} \times \frac{1}{2}$	068F3264	$\frac{1}{2} \times \frac{3}{4}$	068F3284
	AKVA 10-5	25	7.1	0.055	$\frac{3}{8} \times \frac{1}{2}$	068F3265	$\frac{1}{2} \times \frac{3}{4}$	068F3285
	AKVA 10-6	40	11.4	0.103	$\frac{3}{8} \times \frac{1}{2}$	068F3266	$\frac{1}{2} \times \frac{3}{4}$	068F3286
	AKVA 10-7	63	17.9	0.162			$\frac{1}{2} \times \frac{3}{4}$	068F3267
	AKVA 10-8	100	28.4	0.251			$\frac{1}{2} \times \frac{3}{4}$	068F3268
	AKVA 15-1	125	35	0.25	Flange	068F5020 ²		
	AKVA 15-2	200	60	0.40	Flange	068F5023 ²		
	AKVA 15-3	300	90	0.63	Flange	068F5026 ²		
	AKVA 15-4	500	140	1.0	Flange	068F5029 ²		
	AKVA 20-1	500	140	1.0	$1 \frac{1}{4} \times 1 \frac{1}{4}$	042H2101		
	AKVA 20-2	800	240	1.6	$1 \frac{1}{4} \times 1 \frac{1}{4}$	042H2102		
	AKVA 20-3	1250	350	2.5	$1 \frac{1}{4} \times 1 \frac{1}{4}$	042H2103		
	AKVA 20-4	2000	600	4.0	$1 \frac{1}{2} \times 1 \frac{1}{2}$	042H2104		
	AKVA 20-5	3150	900	6.3	2 x 2	042H2105		

1 The rated capacity is based on:

Condensing temperature $t_c = 32^\circ\text{C}$

Liquid temperature $t_l = 28^\circ\text{C}$

Evaporating temperature $t_e = 5^\circ\text{C}$

2 Including screws and gaskets, but not flanges

Flange set for AKVA 15

Symbol	Valve type	Connected device in.	Code
	AKVA 15-1 to 15-4	$\frac{3}{4}$	027N1220
		1	027N1225

Filter

For installations using ammonia and similar industrial systems, a filter must be fitted ahead of an AKVA 15 or AKVA 20 valve. The AKVA 10 valve has a built-in filter, so an external filter is not necessary.

Recommended filters for AKVA 15/20 = FIA.

Additional information:

Technical brochure DKRCI.PD.FN1.A

Dimensioning

To obtain an expansion valve that will function correctly under various load conditions, the aspects listed below must be considered for valve dimensioning.

They must be evaluated in the order listed.

1. Evaporator capacity
2. Pressure drop across the valve
3. Correction for subcooling
4. Correction for evaporating temperature
5. Determination of valve size
6. Correct liquid line dimensioning

Additional information is available:

Technical brochure: DKRCC.PD.VA1.B

Spare parts

AKVA 10



Orifice

Type	Code	Contents
AKVA 10-1	068F0526	1 orifice 1 aluminium gasket 1 coil cap
AKVA 10-2	068F0527	
AKVA 10-3	068F0528	
AKVA 10-4	068F0529	
AKVA 10-5	068F0530	
AKVA 10-6	068F0531	
AKVA 10-7	068F0532	
AKVA 10-8	068F0533	

Filter



Code	Contents
068F0540	10 filters 10 aluminium gaskets

Upper part



Code	Contents
068F5045	1 armature 1 armature tube Qty 1 aluminium gasket

AKVA 15



Piston

Type	Code	Contents
AKVA 15-1	068F5265	1 piston assembly 1 gasket Qty 1 O-ring 2 labels
AKVA 15-2	068F5266	
AKVA 15-3	068F5267	
AKVA 15-4	068F5268	

Gasket set	068F5264	Complete gasket set
------------	-----------------	---------------------

Orifice set



Code	Contents
068F5261	Main orifice Pilot orifice aluminium gaskets O-rings Gaskets

Upper part



Code	Contents
068F5045	1 armature 1 armature tube Qty 1 aluminium gasket

Filter



Code	Contents
068F0540	10 filters 10 aluminium gaskets

AKVA 20



Piston

Type	Code	Contents
AKVA 20-0.6	042H2039	1 piston assembly 3 ea. O-rings
AKVA 20-1	042H2040	
AKVA 20-2	042H2041	
AKVA 20-3	042H2042	
AKVA 20-4	042H2043	
AKVA 20-5	042H2044	

Upper part



Code	Contents
068F5045	1 armature 1 armature tube Qty 1 aluminium gasket

Orifice set



Type	Code	Contents
AKVA 20-0.6	068F5270	Main orifice, dia. 8 mm Pilot orifice, dia. 1.8 mm 2 aluminium gaskets O-ring
AKVA 20-1		
AKVA 20-2		
AKVA 20-3		
AKVA 20-4	068F5271	Main orifice, dia. 14 mm Pilot orifice, dia. 2.4 mm 2 aluminium gaskets O-ring
AKVA 20-5		

Gasket set	032F2327	Complete gasket set for new and old valve versions
------------	-----------------	--

Coils for expansion valves

These coils are used with type AKV, AKVH and AKVA expansion valves.

Technical data

3-conductor cable

The external thread of the threaded cable entry is suitable for flexible steel conduit or equivalent cable protection.



Terminal box

Leads are connected to terminal screws in the terminal box. The box is fitted with a PG 13.5 cable gland for 6 → 14 mm cable. Max. conductor cross section.: 2.5 mm².

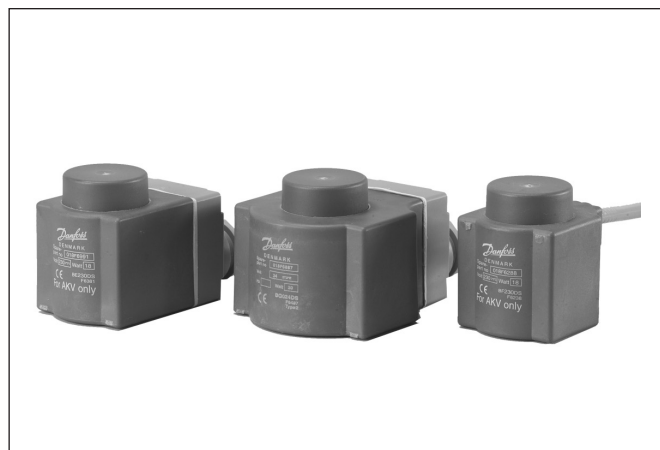
Enclosure
IP 67

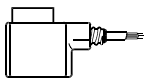
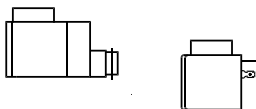
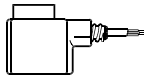

Coils for AKV and AKVA valves

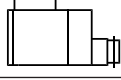
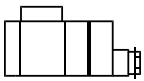
Voltage	Type	Cable/terminal box/DIN plug	Power consumption	Code no.
230 V d.c.		With 2.5 m cable	18 W *)	018F6288
		With 4 m cable		018F6278
		With 8 m cable		018F6279
		With terminal box	18 W *)	018F6781
		Without terminal box		018F6991
230 V a.c.		With 1 m cable	10 W, 50 Hz (AKV 10, 1-6) (AKV 15)	018F6251
		With terminal box		018F7351
		Coil and terminal box with coil control (EEC)	4 W (recommended for AKVH)	018F6783
24 V a.c.		With terminal box	12 W, 50 Hz. **)	018F6807
			12 W, 60 Hz **)	018F6815
			20 W, 50 Hz	018F6901
			20 W, 60 Hz	018F6902

*) Not for AKVH 10 orifice 6 or higher at high MOPD (35 bar).

**) Not for orifice 6 or higher. Not for high MOPD (35 bar).

ETS

Application

ETS is a series of electrically operated expansion valves for precise liquid injection in evaporators for air conditioning and refrigeration applications. It cannot be used with flammable hydrocarbons.

Functional description

The valve piston and linear positioning mechanism is fully balanced, providing bidirectional flow capability and tight solenoid shut-off in both flow directions.



Advantages

- Precise positioning for optimal control of liquid injection.
- The ETS 12½, 25, 50 and 100 are designed for HFC and HCFC operation, including R410A, and rated for working pressures up to 45.5 bar (660 psig).
- The ETS 50 and 100 have bimetallic connections for fluxless brazing, which makes processing easier and increases productivity.
- The ETS 50 to 400 are available with a built-in sight glass.
- The ETS 250 and 400 are designed for HFC and HCFC operating and rated for working pressures up to 34 bar (493 psig).
- Balanced design enables bidirectional flow operation and tight solenoid tight shut-off in both flow directions at a MOPD of 33 bar (478.6 psig).
- The AST-g service driver is available for manual operation and servicing. For additional information, see document RI4JY.
- Special valves for CO2 are available.

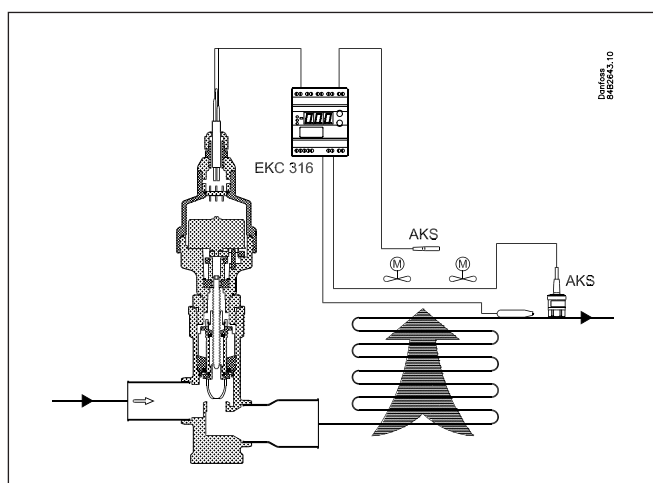

Technical data

Parameter	ETS 12½ / ETS 25	ETS 50 / ETS 100	ETS 250/ ETS 400
Compatibility	HFC, HCFC	HFC, HCFC	HFC, HCFC
P.E.D	Yes	Yes	Yes
Max. opening difference pres. MOPD	33 bar (478 psi)	33 bar (478 psi)	33 bar (478 psi)
Max. opening difference press. (MOPD) in opposite flow direction	33 bar (478 psi)	33 bar (478 psi)	10 bar (145 psi)
Max. working pressure (PS/MWP)	45.5 bar (660 psi)	45.5 bar (660 psi)	34 bar (493 psi)
Refrigerant temperature range	-40°C to 65°C (-40°F to 149°F)	-40°C to 65°C (-40°F to 149°F)	-40°C to 65°C (-40°F to 149°F)
Ambient temperature	-40°C to 60°C (-40°F to 140°F)	-40°C to 60°C (-40°F to 140°F)	-40°C to 60°C (-40°F to 140°F)
Total stroke	13 mm (0.5 in.)	13 mm / 16 mm (0.5 in. / 0.6 in.)	17.2 mm (0.68 in.)
Motor enclosure	IP 67	IP 67	IP 67

Electrical data

Parameter	ETS 12½-400
Stepper motor type	Bipolar, permanent magnet
Stepping mode	2 phase, full step
Winding resistance (1 phase)	52 Ω ±10%
Winding inductance (1 phase)	85 mH
Holding current	Depends on application. Full current allowed (100% duty cycle)
Step angle	7.5° (motor), 0.9° (lead screw), Gear ratio 8.5:1 (38/13) ² :1
Rated voltage	(Constant-voltage drive) 12 V DC -4%/+15%, 150 step/s
Phase current	(Switch-mode drive) 100 mA RMS -4/+15%
Maximum total power	Voltage drive: 5.5 W, current drive: 1.3 W (UL NEC Class 2)
Step rate	150 step/s (constant-voltage drive) 0–300 step/s; 300 recommended (switch-mode current drive)
Total steps	ETS 12½, 25, 50: 2625 (+160/-0) ETS 100: 3530 (+160/-0) ETS 250 and 400: 3810 (+160/-0)
Full travel time	ETS 12½, 25, 50: 17 s (voltage current) / 8.5 s (current drive) ETS 100: 23 s (voltage current) / 11.5 s (current drive) ETS 250 and 400: 25.4 s (voltage current) / 12.7 s (current drive)
Lifting height	ETS 12½, 25, 50: 13 mm (0.5 in.) ETS 100: 16 mm (0.6 in.) ETS 250-400: 17.2 mm (0.7 in.)
Reference position	Overdrive against full closed position
Electrical connection	M12 Connector

Ordering data

Type	Connection		Code no.	
	ODF × ODF [in]	ODF × ODF [mm]	Straight way	Angle way
ETS 12½	½ × ½	12 × 12	034G4209	034G4213
	5/8 × 5/8	16 × 16	034G4210	034G4214
	7/8 × 7/8	22 × 22	034G4211	034G4215
	1 × 1	25 × 25		
ETS 25	½ × ½	12 × 12	034G4201	034G4205
	5/8 × 5/8	16 × 16	034G4202	034G4206
	7/8 × 7/8	22 × 22	034G4203	034G4207
ETS 50	7/8 × 7/8	22 × 22	034G1708	
	1 × 1	25 × 25	034G1705	
	1 1/8 × 1 1/8	28 × 28	034G1706	
	1 1/2 × 1 1/2	38 × 38	034G1704	
ETS 100	1 1/8 × 1 1/8	28 × 28	034G0507	
	1 1/2 × 1 1/2	38 × 38	034G0501	
	1 3/4 × 1 3/4	35 × 35	034G0508	
	1 5/8 × 1 5/8	35 × 35	034G0505	
ETS 250	1 1/8 × 1 1/8	28 × 28	034G2600	
	1 3/8 × 1 3/8	35 × 35	034G2601	
	1 5/8 × 1 5/8	35 × 35	034G2602	
ETS 400	1 5/8 × 1 5/8	35 × 35	034G3500	
	2 1/8 × 2 1/8	54 × 54	034G3501	

ETS 50-400 are delivered with sight glass

Stepper motor switching sequence:

STEP	Coil I		Coil II		
	Red	Green	White	Black	
↓ OPENING ↓	1	+	-	+	-
	2	+	-	-	+
	3	-	+	-	+
↑ CLOSING ↑	4	-	+	+	-
	1	+	-	+	-

ETS for CO₂ application (MWP 45.5 bar / 660 psig).

Expansion valve / gas bypass valve.

For capacities, please contact Danfoss.

Type	Connection	Code no.
	ODF × ODF [in.]	Straight way
ETS 12.5	7/8 x 7/8	034G4220
ETS 25	7/8 x 7/8	034G4219
ETS 50	1 1/8 x 1 1/8	034G1714
ETS 100	1 1/8 x 1 1/8	034G0515

Capacity

Type	Rated capacity ¹									
	R410A		R407C		R22		R134a		R404A	
	kW	TR	kW	TR	kW	TR	kW	TR	kW	TR
ETS 12½	70	20	63	18	57	16	45	13	43	12
ETS 25	144	41	129	37	117	34	93	27	88	25
ETS 50	262.3	75.7	240.5	69.1	215	62	170	48.9	161.4	46.3
ETS 100	488.4	140.9	447.8	128.7	400.4	115.4	316.5	91.2	300.5	86.6
ETS 250	-	-	1212	349	1106	319	874	252	828	239
ETS 400	-	-	1933	556	1764	509	1394	402	1320	381

¹ The rated capacity is based on:

Evaporating temperature te: 5°C (40°F)

Liquid temperature tl: 28°C (82°F)

Condensing temperature tc: 32°C (90°F)

Full stroke opening.

Cable with M12 plug

Material	Temperature range	Cable length	Code
Plug: PVC Insulation: PVC	-50 / +80°C	2 m	034G2201
		8 m	034G2200
Plug: CPE Insulation: CPE	-40 / +80°C	2 m	034G2202
		3 m	034G2203
		5 m	034G2205

Additional information available:

Technical brochure: DKRCC.PD.VD1.C

Less capacity:

See ETS 6. (must be controlled by controller type EKD)

Technical brochure: DKRCC.PD.VD1.D

CCM

Application

The CCM is an electrically operated valve designed specifically for operation in CO₂ systems. The valve is capable of functioning both as an expansion valve, and as a gas bypass valve with back-pressure regulation in subcritical applications.

Function

The CCM can be used in a variety of applications within CO₂ refrigeration systems. Typically it is used as a gas bypass valve in a transcritical CO₂ booster system or as an expansion valve.

Advantage

- Up to 90 bar (1305 psi) working pressure to accommodate CO₂ system pressures during standstill conditions.
- Precise positioning for optimal control of intermediate pressures in transcritical CO₂ systems or liquid injection in heat exchangers.
- Possibility of bi-flow operation
- MOPD up to 50 bar (725 psi)
- Combined stainless steel butt weld/solder connections for installation in copper piped systems (K65 alloy or standard) as well as steel piped systems.
- Standard M12 connector for simple and flexible connection to the motor driver.
- For manual operation and service of the CCM an AST-g service driver is available. For further information please contact Danfoss (Commercial Refrigeration and Air Conditioning Controls).

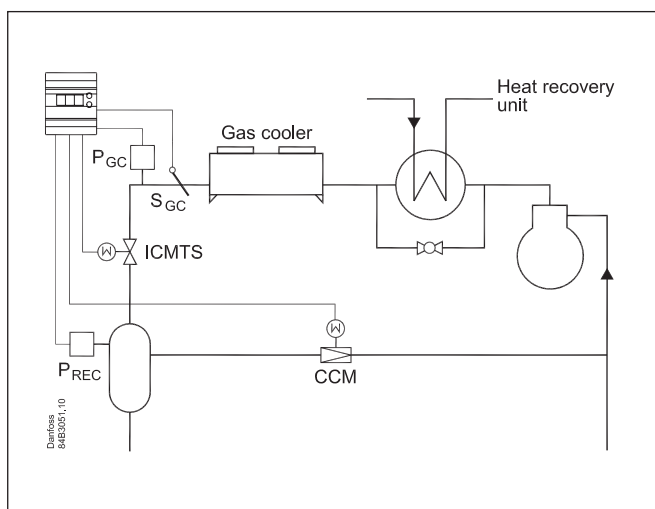

Technical data

Parameter	CCM
Compatibility	R744
MOPD	50 bar (725 psi)
Max. working pressure (PS/MWP)	90 bar (1305 psi)
Refrigerant temperature range	-40°C to 60°C (-40°F to 140°F)
Ambient temperature	-40°C to 60°C (-40°F to 140°F)
Total stroke	13 mm / 16 mm (0.5 in. / 0.6 in.)
Motor enclosure	IP 67

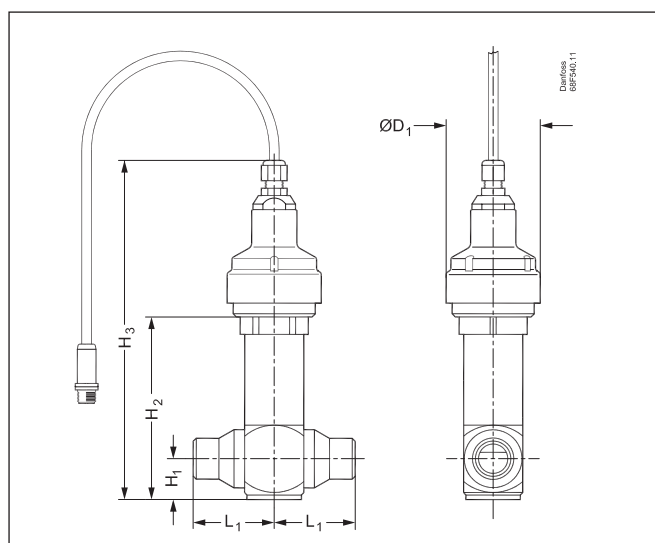

Type	H ₁		H ₂		H ₃		L ₁		ØD ₁		Weight	
	mm	in.	mm	in.	mm	in.	mm	in.	mm	in.	kg	lb.
CCM	26.2	1.0	120.0	4.7	225.0	8.9	53.0	2.1	62.0	2.4	1.8	4.0

Electrical data

Parameter	CCM
Stepper motor type	Bi-polar - permanent magnet
Step mode	2 phase full step
Phase resistance	52Ω ±10%
Phase inductance	85 mH
Holding current	Depends on application. Full current allowed (100% duty cycle)
Step angle	7.5° (motor), 0.9° (lead screw), Gearing ration 8.5:1. (38/13) ² :1
Nominal voltage	(Constant voltage drive) 12 V dc -4% +15%, 150 steps/sec.
Phase current	(Using chopper drive) 100 mA RMS -4% +15%,
Max. total power	Voltage / current drive: 5.5 / 1.3 W (UL: NEC class 2)
Step rate	150 steps/sec. (constant voltage drive) 0-300 steps/sec. 300 recommended (chopper current drive)
Total steps	CCM 10, 20, 30 2625 [+160 / -0] steps CCM 40 3530 [+160 / -0] steps
Full travel time	CCM 10, 20, 30 17 / 8.5 sec. (voltage / current) CCM 40 23 / 11.5 sec. (voltage / current)
Lifting height	CCM 10, 20, 30 13 mm (0.5 in.) CCM 40 16 mm (0.6 in.)
Reference position	Overdriving against the full close position
Electrical connection	4 wire 0.5 mm ² (0.02 in ²), 0.3 m (1 ft) long cable

Coupling sequence, step motor:

STEP	Coil I		Coil II		
	Red	Green	White	Black	
↓ OPENING ↓	1	+	-	+	-
	2	+	-	-	+
	3	-	+	-	+
↑ CLOSING ↑	4	-	+	+	-
	1	+	-	+	-

Ordering

Valve incl. actuator

Type	Connections (Combi)		Code nos
	Weld ¹⁾ [in]	Solder ODF x ODF [in]	
CCM 10	1/2 x 1/2	5/8 x 5/8	027H7188
CCM 20	3/4 x 3/4	7/8 x 7/8	027H7187
CCM 30	1 x 1	1 1/8 x 1 1/8	027H7186
CCM 40	1 x 1	1 1/8 x 1 1/8	027H7185

¹⁾OD according to EN 10220

Spare parts

Actuator CCM CO ₂ valve	027H7184
Wire with M12 plug, 8 m	034G2323
AST-G driver manual box for operating the valve	034G0013

Additional information available:
Technical brochure: DKRCI.PD.VK1.A

CCMT For high pressure

Application

The CCMT is designed to regulate the flow of transcritical gas or subcritical liquid from the gascooler in transcritical CO₂ systems. The CCMT can also be used for other control functions in CO₂ systems or other high pressure systems. It cannot be used with flammable hydrocarbons.

Advantages

- Variant of the CCM valve
- Designed for high pressure CO₂ systems with applications for a maximum working pressure of 140 bar (2030 psig).

Technical data

Temperature range:

- Media: -40 to 60°C (-40 to 140°F)

Pressure:

- Max. working pressure Ps: 140 bar g (2030 psig)
- Max. MOPD: 90 bar (1305 psi)

Additional information available:
Technical brochure:: : DKRCC.PD.VK1.B



Ordering

Valve with actuator

Type	Connection		kv-value m ³ /h	Code no.
	Weld [in]	Solder ODF x ODF [in]		
CCMT 2	1/2 x 1/2	5/8 x 5/8	0.17	027H7200
CCMT 4			0.45	027H7201
CCMT 8			0.8	027H7202

ICM Motor valve

Application

ICM valves are intended to be used to control expansion processes in liquid lines with or without phase shift, or to control the pressure or temperature in dry and wet liquid lines as well in hot gas lines.

Functional description

ICM motor valves belong to the ICV (industrial control valve) family. They consist of three main components: the valve body, the combined top cover / operating module, and the actuator.

ICM valves are directly operated motorised valves driven by an ICAD actuator (industrial control actuator with display).

ICM valves are designed to have balanced opening and closing forces, so only three sizes of ICAD actuators are necessary for the complete range of ICM valves, from DN 20 to DN 105. The ICM motorised valve and ICAD actuator assembly forms a very compact unit.

The following table shows the possible combinations of ICM motorised valve and ICAD actuator:

Actuator	ICAD 600	ICAD 900/1200	ICAD 1200
Valve size	ICM 20	ICM 40	ICM 100
	ICM 25	ICM 50	ICM 125
	ICM 32	ICM 65	ICM 150

ICAD 600 / ICAD 900 / ICAD 1200

ICAD actuators can be controlled using the following signals:

- 0–20 mA
- 4–20 mA (default)
- 0–10 V
- 2–10 V

An ICAD actuator can also operate an ICM valve in on/off mode controlled by a digital input.

The ICM valve can be operated manually using the ICAD actuator or the ICM multifunction tool.

Fail-safe supply options

Several options are available for fail-safe operation in case of power failure, assuming an ICAD UPS or similar device used.

The ICM can be configured to operate as follows during a power failure:

- close ICM;
- open ICM;
- maintain the position at the time of power failure;
- go to a specified ICM valve opening degree.



Advantages

- Designed for industrial refrigeration applications with a maximum working pressure of 52 bar/754 psig.
- ICM 20-65: Can be used with all common refrigerants, including R717, R744 (CO₂), and non-corrosive gases or liquids.
- ICM 100-150: Can be used with R 717. For other refrigerants, please contact Danfoss
- Directly coupled connections
- Connection types include butt weld, socket weld, solder, and threaded
- Low temperature steel body.
- Low weight and compact design.
- V-port regulating cone ensures optimum control accuracy, especially with partial load
- Cavitation-resistant valve seat.
- Modular concept:
 - Each valve body is available with several connection types and sizes
 - Valve overhaul is performed by replacing the operating module.
 - ICM motor valves can be converted to ICS servo valves
- Manual opening possible using ICAD or multifunction tool
- The PTFE seat provides excellent valve tightness.
- Magnetic coupling with true hermetic enclosure

Design

Connections

A very wide range of connection types are available with ICM valves:

D: butt weld, EN 10220

A: butt weld, ANSI (B 36.10)

J: butt weld, JIS (B S 602)

SOC: socket weld, ANSI (B 16.11)

SD: solder connection, EN 1254-1

SA: solder connection, ANSI (B 16.22)

FPT: female pipe thread (ANSI/ASME B 1.20.1)

Approvals

ICV valves are designed to fulfil global refrigeration requirements. Contact Danfoss for specific approval information.

ICM valves are approved in accordance with European standards specified in the Pressure Equipment Directive and are CE marked. See the installation instructions for additional information and restrictions.

Valve body and top cover material

Low temperature steel

ICM valves			
Nominal bore	DN ≤ 25 (1 in.)	DN 32-65 mm (1 1/4 - 2 1/2 in.)	DN 80-125 mm (3- 5 in.)
Classified for	Fluid group I I		
Category	Article 3, paragraph 3	II	III

Technical data

Refrigerants

Suitable for use with all common refrigerants, including R717, R744 (CO₂), and non-corrosive gases and liquids.

Not recommended for use with flammable hydrocarbons.

Temperature range

Media: -60/+120°C (-76/+248°F).

Pressure

The valve is designed for a maximum working pressure of 52 bar g (754 psig).

Surface protection

ICM 20-150:

External surfaces are zinc chromated to provide good corrosion protection.

Maximum opening pressure differential (MOPD)

- ICM 20-32: 52 bar (750 psi)

- ICM 40: 40 bar (580 psi)

- ICM 50: 30 bar (435 psi)

- ICM 65: 20 bar (290 psi)

- ICM 100: 20 bar (290 psi)

- ICM 125: 20 bar (290 psi)

- ICM 150: 20 bar (290 psi)

Additional information available:
Technical brochure: DKRCI.PD.HT0.B

ICMTS

Motor valve for high pressure

Application

The ICMTS valve is designed to control the flow of transcritical gas or subcritical liquid from the gas cooler in transcritical CO₂ systems. The ICMTS valve can also be used for other control functions in CO₂ systems or other high pressure systems. It cannot be used with flammable hydrocarbons.

Advantages

- Variant of the ICM valve
- Designed for high pressure CO₂ systems with a maximum working pressure of 140 bar (2030 psig)

Actuator

ICAD 600A-TS

Technical data

Temperature range:

- Media: -60 to 120°C (-76 to 248°F)

Pressure

- Maximum working pressure Ps: 140 bar gauge (2030 psig)
- Maximum MOPD: 90 bar (1305 psi)



Additional information available:
Technical brochure: DKRCI.PD.HY0.B

Evaporation pressure valve

KVS

Application

KVS is a series of electrically operated modulating suction control valves for air conditioning and refrigeration applications. It cannot be used with flammable hydrocarbons.

Functional description

Accurate temperature or pressure control is obtained by modulating the refrigerant flow in the evaporator, using a current or voltage driver.

With an EKC 368 controller (current driver) and an AKS sensor located in the media to be controlled, an accuracy better than ± 0.5 K can be obtained.

The balanced design enables bidirectional flow operation and solenoid shut-off in both flow directions at an MOPD of 33 bar (478 psi).

Advantages

- Balanced port design
- High resolution for precise control
- Tight solenoid shut-off
- Low power consumption
- Corrosion resistant design inside and outside

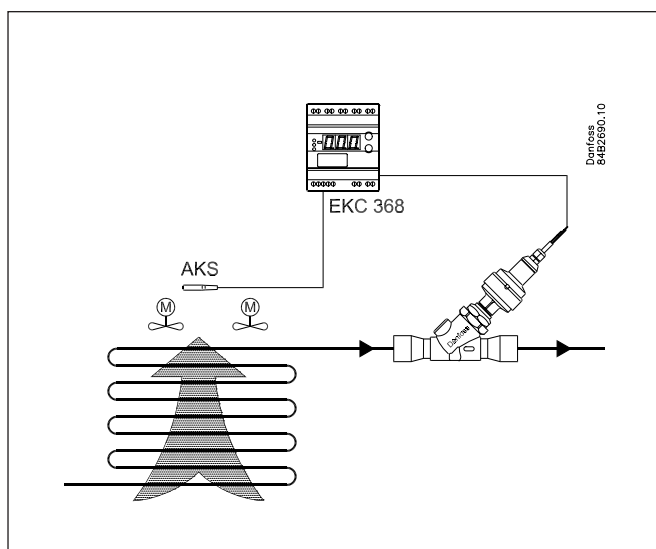

Technical data

Parameter	KVS 15	KVS 42
Compatibility	HFC, HCFC	HFC, HCFC
CE marking	-	Yes
MOPD	33 bar (478 psi)	33 bar (478 psi)
Maximum working pressure	45.5 bar (660 psig)	34 bar (493 psig)
Refrigerant temperature range	-40 to +65°C (-40 to +149°F)	-40 to +65°C (-40 to +149°F)
Ambient temperature	-40 to +60°C (-40 to +140°F)	-40 to +60°C (-40 to +140°F)
Total stroke	13 mm (0.5 in.)	17.2 mm (0.68 in.)
Motor enclosure	IP 67	IP 67

Electrical data

Parameter	KVS 15, 42
Stepper motor type	Bipolar, permanent magnet
Stepping mode	2 phase, full step
Winding resistance (1 phase)	52 Ω ±10%
Winding inductance (1 phase)	85 mH
Holding current	Depends on application. Full current allowed (100% duty cycle)
Step angle	7.5° (motor), 0.9° (lead screw), Gear ratio 8.5:1 (38/13) ² :1
Rated voltage	(Constant-voltage drive) 12 V d.c. -4%/+15%, 150 step/s
Phase current	(Switch-mode drive) 100 mA RMS -4/+15%
Maximum total power	Voltage drive: 5.5 W, current drive: 1.3 W (UL NEC Class 2)
Step rate	150 step/s (constant-voltage drive) 0–300 step/s; 300 recommended (switch-mode current drive)
Total steps	KVS 15: 2625 (+160 / -0) KVS 42 : 3810 (+160 / -0)
Full travel time	KVS 15: 17 / 8.5 s (voltage or current drive) KVS 42 : 25.4 / 12.7 s (voltage or current drive)
Lifting height	KVS 15: 13 mm (0.5 in.) KVS 42 = 17.2 mm (0.68 in.)
Reference position	Overdrive against full closed position
Electrical connection	M12 plug

Stepper motor switching sequence:

STEP		Coil I		Coil II	
		Red	Green	White	Black
↓ OPENING ↓	1	+	-	+	-
	2	+	-	-	+
↑ CLOSING ↑	3	-	+	-	+
	4	-	+	+	-
	1	+	-	+	-

Ordering data

Type	Rated capacity ¹						KVS valve + AST actuator		
	R22		R134a		R404A/R507		Connected device		Code single pack
	kW	TR	kW	TR	kW	TR	mm	in.	
KVS 15	5.15	1.31	3.78	0.94	4.58	1.07	16	5.8	034G4252
							22	7.8	034G4253
KVS 42	40.4	11.4	29.3	8.3	35.3	10.0	22	7/8	034G2858
							28	1 1/8	034G2850
							35	1 3/8	034G2851
							⊗	1 5/8	034G2852

¹ The rated capacity is the valve capacity under the following conditions:
 evaporating temperature $t_e = -10^\circ\text{C}$ (14°F)
 condensing temperature $t_c = +25^\circ\text{C}$ (77°F)
 pressure drop across valve $\Delta p = 0.2$ bar (2.9 psig)

Cable with M12 plug

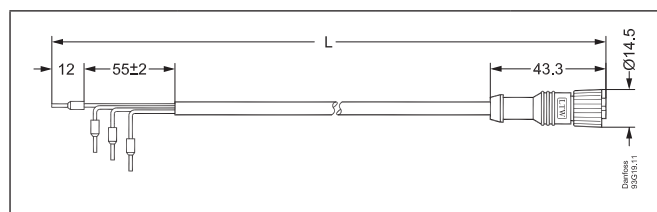

Material	Temperature range	Cable length	Code
Plug: PVC Insulation: PVC	-50 / +80°C	2 m	034G2201
		8 m	034G2200
Plug: CPE Insulation: EPR	-40 / +80°C	2 m	034G2202

Additional information available:
 Technical brochure: DKRCC.PD.VD1.C

Data communication

AKA 222/223 Repeater

Application

This module is a repeater for use with ADAP-KOOL® control systems. It can amplify and regenerate the signals on the data communication cable between a refrigeration system controller and the system unit.

This module can be used with the following communication interfaces:

- DANBUSS
- Lon RS 485
- Modbus

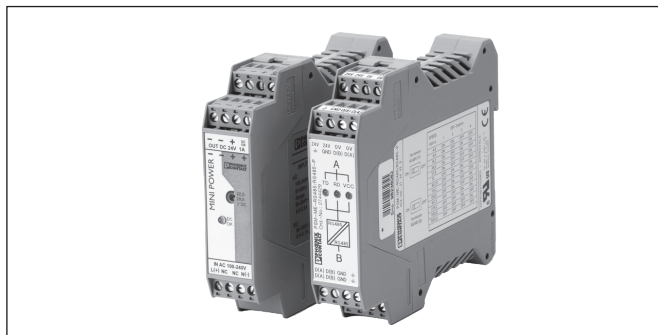

Functional description

The repeater regenerates the bus signals in situations with long connecting cables and many connected controllers.

Technical data

Power supply	Input voltage	100–240 V AC 50/60 Hz (supplies 24 V DC 90 mA to repeater)
Connections	Screw terminals	
Baud rate	Lon (RS 485)	78.1 (factory setting)
	DANBUSS	4800 (factory setting)
	MOD-bus	19.2 (must be set)
CE compliance	In accordance with EMC Directive 89/336/EEC	
Ambient temperature	0 to 55°C	
Mounting	DIN rail	
Dimensions (H x W x D)	99 x 22.5 x 114.5 mm	
Weight	Repeater	200 g
	Power supply	290 g

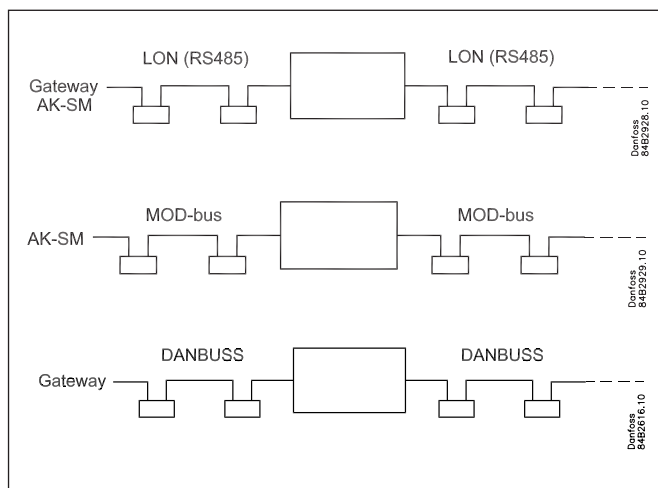

Ordering data

Type	Description	Code
AKA 222	Bus repeater DANBUSS and MOD-bus (power supply included)	084B2240
AKA 223	Bus repeater Lon (RS 485) (power supply included)	084B2241

Note:

Data bus or network cables and repeaters must be installed according to the requirements specified in the following document:

Data Communication between ADAP-KOOL® Refrigeration Controls Document number: RC8AC

EKA 183A Programming key

Application

The EKA 183A programming key is used to copy settings to an EKC and ERC controller.

It can also be used to copy settings from one controller to another controller of the same type (same order number and software version).

The programming key can hold only one file for each order number, but it has room for many order numbers.

It can be used with the following modules:

EKC 102, EKC 202, EKC 204, AK-CC 210

EKC 3xx (except EKC 301), EKC 4xx, EKC 5xx, AK-CC 450, AK-CC 550.

ERC 211, ERC 213, ERC 214.

A suitable adapter is necessary for use with the ERC 21x, EKC 3xx, EKC 4xx, EKC 5xx, AK-CC 450, and AK-CC 550 modules.

Advantages

- OEM tool for controller configuration
- Service tool for configuring controllers quickly
- Power for the programming key and the necessary components of the controller can be provided by a USB cable, eliminating the need a source of 230-V power with panel-mounted controllers.

Functional description

Basic operation

The EKA 183A is plugged in to the controller. The controller is connected to the AC mains.

Data can be copied from the programming key to the controller or vice versa by pressing the button.

Pre-programming

The EKA 183A is plugged into a USB port on the PC. The current file is transferred. The settings are configured using Microsoft Excel.

Fast data transfer

For OEM use, the programming key can be configured to start data transfer as soon as the key is plugged in to the controller.

Ordering data

Type	Description	Code no.
EKA 183A	Programming key	084B8582
EKA 183A	Programming key + adapter for ERC 21x	080G9740

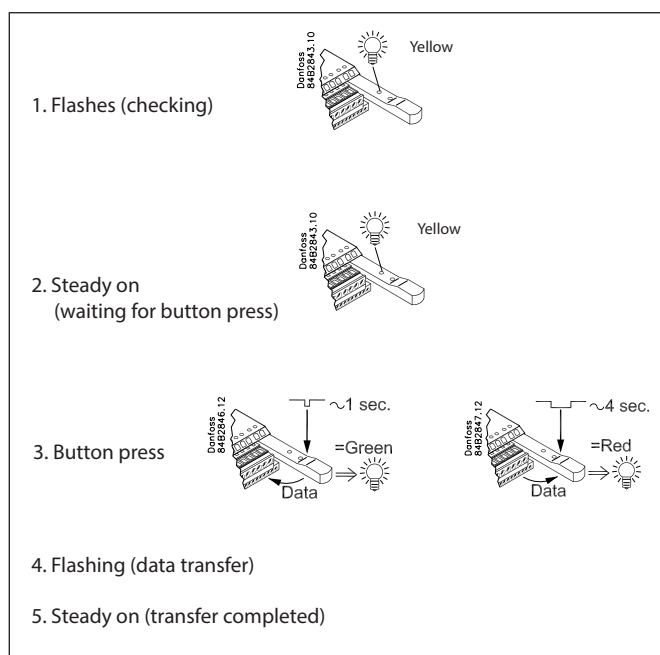
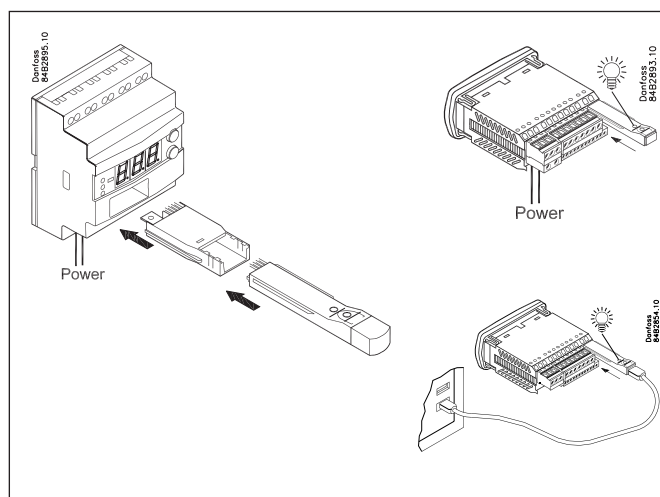
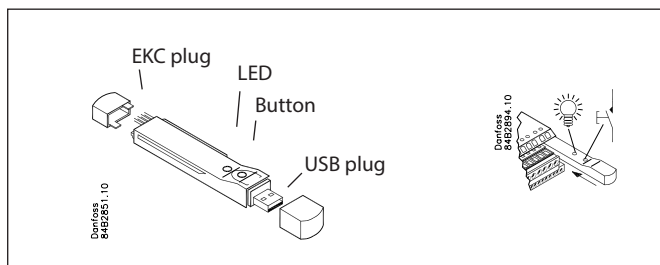
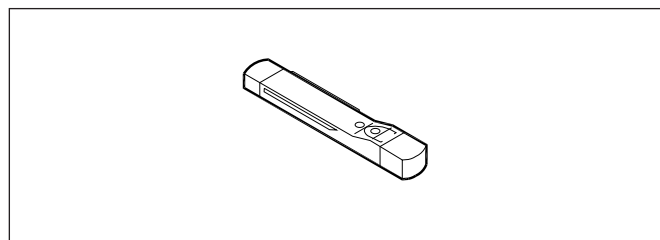

ENGINEERING
TOMORROW



Danfoss can accept no responsibility for possible errors in catalogues, brochures and other printed material. Danfoss reserves the right to alter its products without notice. This also applies to products already on order provided that such alternations can be made without subsequential changes being necessary in specifications already agreed. All trademarks in this material are property of the respective companies. Danfoss and Danfoss logotype are trademarks of Danfoss A/S. All rights reserved.