



**PACKAGED ROOFTOP
AIR CONDITIONING UNITS**

INSTALLATION, OPERATION & MAINTENANCE

Supersedes: Form 100.50-NOM1 (502)

Form 100.50-NOM1 (604)

eco²

**50 THROUGH 105 TONS
R-407C AND R-22
DESIGN LEVEL C**



00566VIP



ALLY

IMPORTANT!

READ BEFORE PROCEEDING!

GENERAL SAFETY GUIDELINES

This equipment is a relatively complicated apparatus. During installation, operation, maintenance or service, individuals may be exposed to certain components or conditions including, but not limited to: refrigerants, oils, materials under pressure, rotating components, and both high and low voltage. Each of these items has the potential, if misused or handled improperly, to cause bodily injury or death. It is the obligation and responsibility of operating/service personnel to identify and recognize these inherent hazards, protect themselves, and proceed safely in completing their tasks. Failure to comply with any of these requirements could result in serious damage to the equipment and the property in

which it is situated, as well as severe personal injury or death to themselves and people at the site.

This document is intended for use by owner-authorized operating/service personnel. It is expected that this individual possesses independent training that will enable them to perform their assigned tasks properly and safely. It is essential that, prior to performing any task on this equipment, this individual will have read and understood this document and any referenced materials. This individual will also be familiar with and comply with all applicable governmental standards and regulations pertaining to the task in question.

SAFETY SYMBOLS

The following symbols are used in this document to alert the reader to areas of potential hazard:



DANGER indicates an imminently hazardous situation which, if not avoided, will result in death or serious injury.



CAUTION identifies a hazard which could lead to damage to the machine, damage to other equipment and/or environmental pollution. Usually an instruction will be given, together with a brief explanation.



WARNING indicates a potentially hazardous situation which, if not avoided, could result in death or serious injury.



NOTE is used to highlight additional information which may be helpful to you.



External wiring, unless specified as an optional connection in the manufacturer's product line, is NOT to be connected inside the micro panel cabinet. Devices such as relays, switches, transducers and controls may NOT be installed inside the micro panel. NO external wiring is allowed to be run through the micro panel. All wiring must be in accordance with YORK's published specifications and must be performed ONLY by qualified YORK personnel. YORK will not be responsible for damages/problems resulting from improper connections to the controls or application of improper control signals. Failure to follow this will void the manufacturer's warranty and cause serious damage to property or injury to persons.

CHANGEABILITY OF THIS DOCUMENT

In complying with YORK's policy for continuous product improvement, the information contained in this document is subject to change without notice. While YORK makes no commitment to update or provide current information automatically to the manual owner, that information, if applicable, can be obtained by contacting the nearest YORK Applied Systems office.

It is the responsibility of operating/service personnel to verify the applicability of these documents to the equipment in question. If there is any question in the mind of operating/service personnel as to the applicability of these documents, then prior to working on the equipment, they should verify with the owner whether the equipment has been modified and if current literature is available.

NOMENCLATURE

BASE MODEL NUMBER

1	2	3	4	5	6	7	8	9	10	11	12	13	14	15	16
BASE PRODUCT TYPE				NOMINAL CAPACITY			APPLICATION		REFRIGERANT	VOLTAGE		DUCT LOCATIONS		DESIGN SPECIAL	
Y	P	A	: YORK : Packaged Rooftop : Air-Cooled	0	2	5	C	N	B	1	7	B	: Bottom Supply	C	: Rev. Level B
			: Scroll	0	3	0	N	G	C	2	8	L	: Left Supply	X	: Std. Product
				0	3	5	M	M	C	4	6	R	: Right Supply	S	: Special
				0	4	0	E	E	C	4	5	B	: Bottom Return		
				0	4	5	S	S	C	5	8	R	: Rear Return		
				0	5	0	H	H	C	5	8	S	: Side Return		
				0	5	5	C	C	V	6	0				
				0	6	0	V	V	F	6	3				
				0	6	5	F	F	F	6	3				
				0	7	0				7	200				
				0	7	5				8	230				
				0	7	5				4	460				
				0	8	0				4	5				
				0	8	5				5	8				
				0	9	0				4	0				
				0	9	5									
				1	0	5									

TABLE OF CONTENTS

Nomenclature	3
SECTION 1 INTRODUCTION	
Ecological & Economical Design	8
Indoor Air Quality	8
Reliable Scroll Compressor Technology	9
Serviceability	9
Install With Ease and Safety	9
SECTION 2 INSTALLATION	
Approvals	11
Limitations	11
Unit Inspection	11
Location and Clearances	11
Rigging and Handling	12
Physical Data	13
Airflow and Entering Air/Ambient Limitations	23
Filters	24
Condensate Drain	24
Air Hoods For Economizer	25
Air Hoods For Fixed Outside Air (Units Without Economizer)	25
Air Hoods For Exhaust Air	25
Field Wiring	25
Evaporator Coil Face Damper	26
Return Air Bypass Damper	26
Roof Link	27
Bacnet and Lon Network Communication	27
Dirty Filter Switch	27
CTB2	29
Power Wiring	30
Electrical Service Sizing	30
Single-Point Power Supply Wiring	31
Single-Point Power Supply Wiring with Non-Fused Disconnect Switch	32
Dual-Point Power Supply Wiring	33
Roof Curb Installation	34
Duct System	34
Sound and Vibration Transmission	35
SECTION 3 START-UP	
Crankcase Heaters	36
Checking The System Prior To Initial Start (No Power)	36
Unit Checks (Power Applied)	37
Initial Start-Up	38
Gas Heat Models	41
SECTION 4 MAINTENANCE	
General	44
Periodic Maintenance – Monthly	44
Periodic Maintenance – Three To Six Months	45
Periodic Maintenance – Yearly	45

SECTION 5 UNIT SEQUENCE OF OPERATION

Compressor Staging	51
Compressor Average Run Times	52
Supply Fan Operation	52
Timeouts and Delays	53
Constant Volume Sequence of Operation	53
Variable Air Volume Sequence of Operation	58
Economizer Operation	63
Ventilation Option Operation	64
Area and K Factor	66
Low Ambient Operation	70
Controlling Excessive Supply Air Temperature (SAT)	72
Power Exhaust Operation	72
Time Clock/Scheduling	75
Changeover Relay Operation	75
High Pressure Unloading	75
Comfort Ventilation Operation	75
Hot Water Freeze Protection Using RA Operation	76
Smoke Purge Operation	76
Return Fan Operation	77
Modulating Gas Heat	80
Compressor Operating Controls	81
Refrigerant Safety Operation	82
Flexsys VAV Operation	82

SECTION 6 MENU NAVIGATION AND DISPLAY DESCRIPTIONS

OptiLogic Control Center	85
Navigating The Menus	85
History Menu Navigation	85
“Unit Status” Navigation	85
“Operation Data” Navigation	89
“Setpoints” Navigation	92
“Unit Setup” Navigation	92
“Configuration” Navigation	94
“Service” Navigation	95
“History” Navigation	98

SECTION 7 PARAMETER DESCRIPTIONS AND OPTIONS (SETPOINTS)

Parameter Description and Options (Setpoints)	100
Status Key Parameters	100
Setpoint Key Parameters	100
Unit Setup Key Parameters	102
General Setup	102
Heat/Cool System	103
VAV System	104
Econo/Exhaust System	105
Ventilation	106
Warm-Up Purge	106
Configuration Key Parameters	107
General	107
Run Test	107
Panel Test	108
Heat/Cool System	108
Excessive SAT	108
Econo/Exhaust Vent	109
Service Key Parameters	110
Changing Setpoints	110

Passwords.....	112
----------------	-----

SECTION **8** SERVICE

Binary Input Operation	119
Analog Input Operation.....	122
Low Ambient Operation - Condenser Fan Motor VSD	124
Input/Output Table	129
Fault Descriptions	131
Wiring Diagrams	136

LIST OF TABLES

Table 1 – Voltage Limitations	11	Table 17 – VAV Modes of Operation.....	62
Table 2 – Physical Data	13	Table 18 – Area and K Factor.....	66
Table 3 – Electrical Data	21	Table 19 – History Function Text	99
Table 4 – Air Flow & Entering Amb. Limitations.....	23	Table 20 – History Points Data List.....	99
Table 5 – R-22 Temperature/Pressure Chart.....	39	Table 21 – Setpoints and Values	113
Table 6 – 407C Temperature/Pressure Chart.....	40	Table 22 – Temperature Sensor Resistance	122
Table 7 – Gas Heat Performance Data.....	42	Table 23 – Duct Pressure Transducer Output	122
Table 8 – Fan Bearing Lubrication Intervals.....	44	Table 24 – Building Pressure Transducer Output.....	123
Table 9 – Set Screw Torque	50	Table 25 – AMS Pressure Transducer Output	123
Table 10 – CV 4 or 6 Compressor Logic - Staging Up	51	Table 26 – Discharge Pressure Transducer Output.....	123
Table 11 – CV 4 or 6 Compressor Logic - Staging Down.....	51	Table 27 – Suction Pressure Transducer Output.....	124
Table 12 – VAV Four or Six Compressor Logic - Staging Up	51	Table 28 – Monitor & Control I/O for Primary Unit Controller.....	125
Table 13 – VAV Four or Six Compressor Logic - Staging Down	52	Table 29 – Humidity Sensor Output.....	126
Table 14 – Timeouts and Delays	53	Table 30 – CO2 Sensor Output.....	126
Table 15 – Staged Heating Steps	54	Table 31 – T’stat Interface Board Voltage Outputs	127
Table 16 – Modes of Operation	57	Table 32 – T’stat Interface Board Connections	128
		Table 33 – Input/Output Table.....	129
		Table 34 – Fault Description Table.....	132

LIST OF FIGURES

Fig. 1 – Packaged Rooftop Air Conditioning Unit	8	Fig. 21 – Split Bearing	50
Fig. 2 – Unit Rigging	12	Fig. 22 – CV Space Sensor Cooling Algorithm - Economizer Not Suitable.....	55
Fig. 3 – Unit Clearances.....	12	Fig. 23 – CV Space Sensor Cooling Algorithm - Economizer Suitable.....	55
Fig. 4 – Drain Trap Water Location-Draw Through	24	Fig. 24 – CV Space Sensor Stepped Heat Algorithm	56
Fig. 5 – Trap Detail-draw Through Application	24	Fig. 25 – CV Space Sensor Hydronic Heat Algorithm	56
Fig. 6 – Network Communication Board.....	27	Fig. 26 – VAV Occupied Heating To Maintain RAT Morning Warm Up	59
Fig. 7 – Field Control Wiring.....	28	Fig. 27 – VAV Unoccupied Stepped Heating Temperature Control	59
Fig. 8 – FlexSys CTB2 Wiring.....	29	Fig. 28 – VAV Unoccupied Cooling Temperature Control	60
Fig. 9 – Single-point Power Supply Wiring.....	31	Fig. 29 – Compressor Staging For VAV Cooling.....	60
Fig. 10 – Single-point Power Supply Wiring With Non-fused Disconnect	32	Fig. 30 – Occupied Heating And Cooling Setpoint Selection Algorithm	61
Fig. 11 – Dual-point Power Supply Wiring	33	Fig. 31 – OAD Minimum Position Reset.....	65
Fig. 12 – Static Pressure Probe Location	35	Fig. 32 – Minimum Flow Measurement Arrangement	67
Fig. 13 – Supply Fan Isolator Spring Bolts.....	37	Fig. 33 – Control For Minimum AMS – Economizer Not Available	67
Fig. 14 – Sheave Alignment.....	45		
Fig. 15 – Fan Data Plate - Belt Tension	46		
Fig. 16 – Belt Tensioning Gauge.....	46		
Fig. 17 – Example of FC Fan Shaft/Wheel Marking	47		
Fig. 18 – Bearing With Setscrew Type Locking	49		
Fig. 19 – Bearing With Eccentric Cam	49		
Fig. 20 – Eccentric Cam Locking Collar	50		

Fig. 34 – Minimum Flow Measurement Option, Economizer Sequence.....	68	Fig. 43 – Exhaust Fan Control, Proportional Option	74
Fig. 35 – Full Flow Measurement Arrangement	68	Fig. 44 – Modulating Gas Heat Staging.....	80
Fig. 36 – Full Flow Measurement Option, Economizer Not Available	69	Fig. 45 – By-Pass Damper Formulas	83
Fig. 37 – Full Flow Measurement Option Economizer Sequence	69	Fig. 46 – By-Pass Damper Setpoints	84
Fig. 38 – Low Ambient Hardware	71	Fig. 47 – ODA Damper Position vs. VAV Supply Fan Output	101
Fig. 39 – Condensing Pressure Control Proportional Band.....	71	Fig. 48 – Primary Unit Controller.....	116
Fig. 40 – OAD Position Control	73	Fig. 49 – Primary Unit Controller Connection Map	117
Fig. 41 – Building Pressure Control.....	73	Fig. 50 – Binary LED Designations.....	118
Fig. 42 – Exhaust Proportional Band.....	74	Fig. 51 – MOD-UNT	125
		Fig. 52 – MOD-UNT Wiring Diagram	125
		Fig. 53 – Thermostat Interface Board	128

ACRONYM CHART

ACRONYM	TEXT	ACRONYM	TEXT
APS	Air Proving Switch	oah	Outside Air Humidity
ascd	Anti-Short Cycle Delay	occ	Occupied
ams	Air Measurement Station	p	Purge
aq	Air Quality (CO ₂)	pe	Power Exhaust Output
bs	Building Static	ra	Return Air
cor	Cooling / Heating Changeover Relay	rat	Return Air Temperature
cp1 – cp3	Condensing Pressure Circuit 1 Through 3	rah	Return Air Humidity
cs1 – cs3	Compressor Circuit 1 Through 3	rdu	Remote Display Unit
cv	Constant Volume	sat	Supply Air Temperature
dfs	Dirty Filter Switch	sf	Supply Fan
ds	Duct Static Pressure	ss	Space Sensor
dvm	Demand Ventilation Multiplier	ssa	Space Setpoint Adjust
ead	Exhaust Air Damper	smk	Smoke Purge
ec	Economizer	sp1 – sp3	Suction Pressure Circuit 1 Through 3
edat	Evaporator Discharge Air Temperature	st	Space Temperature
ef	Exhaust Fan	stg1 – stg6	Cooling/Heating Stage 1 Through 6
estop	Emergency Stop	unocc	Unoccupied
fs	Freeze Stat (HW/Steam)	vav	Variable Air Volume
g	Thermostat Input for the Fan	vfd	Variable Frequency Drive
hw	Hot Water	w1	Thermostat Input For The First Stage of Heating
mit	Modular Integrated Terminal	w2	Thermostat Input For The Second Stage of Heating
mitd	MIT Bypass Damper		
oa	Outdoor Air	y1	Thermostat Input For The First Stage of Cooling
oad	Outside Air Damper	y2	Thermostat Input For The Second Stage of Cooling
oat	Outside Air Temperature	ydc	YORK Digital Controller

SECTION 1 – INTRODUCTION



FIG. 1 – PACKAGED ROOFTOP AIR CONDITIONING UNIT

ECOLOGICAL AND ECONOMICAL DESIGN

- First packaged RTU with 407C optimized design
- **Cooling and Heating** – Superior operating performance provides lower operating costs. Smaller steps of cooling capacity provide tighter control of building environment and occupant comfort while optimizing energy efficiency.
- **Indoor Air Quality (IAQ)** – Outside air economizers provide energy savings in free cooling mode, and can provide a healthier and more comfortable building environment by introducing fresh outside air into the building as needed. Indoor Air Quality (IAQ) requirements for building ventilation and comfort are controlled through the microprocessor control panel. Optional airflow measurement provides an accurate means of tracking air quality and alerting the occupants or building owner to unhealthy situations.
- **High-Efficiency Motors** – High-efficiency motors are available for optimum energy efficiency. All motors used on the eco² packaged rooftop air conditioner meet U.S. EPACK 1992 minimum requirements.

INDOOR AIR QUALITY (IAQ)

- **Double-sloped stainless steel drain pan** – This double-sloped inclined stainless steel drain pan facilitates removal of evaporator condensate. Sloped in two directions conforming to ASHRAE 62n, this drain pan swiftly minimizes any condensate within the unit. Best of all, the drain pan is accessible for periodic cleaning required by IAQ standards.
- **Smart ventilation** – YORK maintains the leadership role in IAQ products with adaptive ventilation control. The OptiLogic™ controls can provide continuous monitoring of air quality and take action by opening the outside air dampers, bringing in the right amount of fresh air before air impurities reach uncomfortable or even dangerous levels.
- **Air flow measurement** – Precise measurement of ventilation airflow is possible using an airflow measurement station which can be installed in the economizer section. Proper ventilation airflow is required to ensure sufficient fresh air is in the building. A myriad of airflow measurement options are available from minimum airflow to high-accuracy

full airflow capabilities. The complete system is designed as an integrated component of the OptiLogic™ control system to ensure optimum system performance.

- **Double-wall construction** – Rigid double-wall construction throughout provides ease of cleaning and protects against insulation fiber entrainment in the breathable air. Double-wall construction also helps improve the acoustical characteristics of the air handling unit.
- **Enhanced filtration** – The eco² unit gives designers the flexibility to meet various IAQ requirements with a full range of rigid and throwaway filters at various efficiency levels.

RELIABLE SCROLL COMPRESSOR TECHNOLOGY

Reliable, efficient, trouble-free operation is the true measure of a packaged rooftop's value. That's why YORK eco² Packaged Rooftop Air Conditioners use established scroll-compressor technology to deliver dependable, economical performance in a wide range of applications. With the eco² Packaged Rooftop, you get the latest generation of compressor enhancements added to the scroll's inherent strengths. The simplicity of a hermetic scroll compressor allows the use of fewer moving parts to minimize breakdown. The result: a maintenance-free compressor providing minimum wear and maximum runtime.

A scroll compressor operates with two scroll members—a fixed scroll and an identical orbiting scroll turned 180 degrees, like two hands curled and interlocked together. As the orbiting scroll oscillates against the fixed scroll, it traps and compresses suction gas inside involute pockets. As the orbiting scroll moves, the gas is compressed into the central area, where it is discharged as compressed gas. High efficiency is achieved through a precisely controlled orbit and the use of advanced scroll geometry. There is no wasted motion. All rotating parts are statically and dynamically balanced to ensure optimal performance over the long haul.

Balanced components and precision machining also ensure that smooth compression occurs in all involute pockets simultaneously. When compression forces are equally distributed over the entire scroll surface, equal forces in opposing directions cancel one another, min-

imizing any imbalance. Consequently, compression is smooth, continuous, and quiet. Vibration isolators on each compressor handle normal vibration. For extra quiet operation, acoustic sound blankets for each compressor are available as options.

SERVICEABILITY

- **OptiLogic™** – fully-integrated factory-packaged controls are standard on every unit and include a display unit with a 4x20 character LCD display. OptiLogic™ continually monitors all control setpoints and configurations. If a unit or control component or sensor fails, the controller notifies the user of a problem. If desired, YORK service can provide remote monitoring and automatically schedule a service technician to make the repair and maintain your comfort.
- **Access doors** – full-sized access doors provide easy access into the unit for routine maintenance and inspection.
- **Optional Suction & discharge service valves** – oversized service valves to provide isolation and quick reclamation and charging of system refrigerant are available to minimize downtime and simplify the service and repair task.
- **Optional VFD Fan Motor Control with Manual Bypass** – Optional manual VFD bypass reduces time required for troubleshooting, commissioning and system balancing.
- **Optional Convenience Outlet** – for maintenance tasks requiring power tools, an optional 110V GFCI power supply can power lights, drills or any other power hand tool needed.
- **Optional Filter Maintenance Alarm** – An optional filter maintenance alarm indicates when a filter becomes dirty and requires replacement or cleaning.

INSTALL WITH EASE AND SAFETY

- **Factory run-tested** – Each unit is subjected to a series of quality assurance checks as well as an automated quality control process before being run-tested. Fans and drives are balanced at the factory during testing. The factory run-test ensures safe, proper operation when the unit is installed, and reduces installation and commissioning time.

- **Optional Single-point power connection** – Single-point power connection reduces installation time by providing a single point for incoming power, including the optional convenience outlet. All incoming power is connected in one location, reducing the cost of field-supplied and installed power wiring.
- **Factory-mounted and wired controls** – All control points within the unit are factory-installed, wired and tested. The OptiLogic™ controls can communicate with BACNet IP, BACNet, MSTP or LON.
- **Optional Non-fused disconnect** – A factory-installed non-fused disconnect switch simplifies unit installation and serviceability by reducing installed labor costs. The disconnect switch is interlocked with the power cabinet ensuring that all power to the unit has been disconnected before servicing.
- **Hot Gas Bypass** – Optional on constant volume units, hot gas bypass reduces the cycling of compressors which helps prolong the life of the equipment. Hot Gas Bypass is standard on VAV.
- **Supply Air Openings** – Side supply connections are available on select configurations, offering more flexibility for duct layout and improving sound transmission characteristics.
- **Optional Compressor Sound Blankets** – For applications in sound-sensitive areas, compressor sound blankets are available to reduce sound emitted from the rooftop unit.
- **Fan Spring Isolators** – One-inch (deflection) spring isolation is standard. Two-inch spring isolation is available as an option. Spring isolation is used to prevent vibration transmission from the roof top unit's supply to the building.
- **Harsh Environments** – A variety of coil coating and materials, as well as hail guards, are available to protect coils from weather damage. Seismic and hurricane duty curbs and fan restraints are available.

Design Flexibility

- **Low Ambient Operation** – Head-pressure control is accomplished via a VFD motor controller rather than an inefficient and noisy condenser fan damper. By varying the speed of the condenser fan, better control and quieter operation is obtained during the colder months. Low ambient controls are available on all systems offering higher rooftop cooling capacity than competitive units.

SECTION 2 – INSTALLATION

APPROVALS

Designed certified by CSA, ETL, CETL as follows:

1. For use as a forced air furnace with cooling unit (gas heat models).
2. For outdoor installation only.
3. For installation on combustible material and may be installed directly on combustible flooring or Class A, Class B or Class C roof covering materials.
4. For use with natural gas or LP.
5. When used with LP propane gas, conversion kit part number 026-36399-000 must be installed before the gas heat section is fired.

Not suitable for use with conventional venting systems.

LIMITATIONS

The installation of this unit must conform to local building codes, or in the absence of local codes, with ANSI Z23.1 Natural Fuel Gas Code and /or CAN/CGA B149 installation codes.

In U.S.A.:

1. National Electrical Code ANSI/NFPA No. 70 - Latest Edition.
2. National Fuel Gas Code Z223.1 - Latest Edition.
3. Gas-Fired Central Furnace Standard ANSI Z21.47 - Latest Edition.
4. Local gas utility requirements.

Refer to Table 4 for airflow and entering air/ambient conditions limitations, and Table 1 for voltage limitations.

TABLE 1 – VOLTAGE LIMITATIONS

UNIT POWER SUPPLY	VOLTAGE VARIATIONS	
	MIN. VOLTS	MAX. VOLTS
575-3-60	520	632
480-3-60	415	505
230-3-60	207	253
208-3-60	187	229

UNIT INSPECTION

Immediately upon receiving the unit, it should be inspected for possible damage, which may have oc-

curred during transit. If damage is evident, it should be noted in the carrier's freight bill. A written request for inspection by the carrier's agent should be made at once. See "Instruction" manual, Form 50.15-NM for more information and details.



To ensure warranty coverage, this equipment must be commissioned and serviced by an authorized YORK service mechanic or a qualified service person experienced in packaged rooftop installation. Installation must comply with all applicable codes, particularly in regard to electrical wiring and other safety elements such as relief valves, HP cut-out settings, design working pressures, and ventilation requirements consistent with the amount and type of refrigerant charge.

Lethal voltages exist within the control panels. Before servicing, open and tag all disconnect switches.

LOCATIONS AND CLEARANCES

The following guidelines should be used to select a suitable location for unit installation.

1. Unit is designed for outdoor installation only.
2. Condenser coils must have an unlimited supply of air. Where a choice of location is possible, position the unit on either north or east side of building.
3. Suitable for roof mount on curb.
4. Roof structures must be able to support the weight of the unit and its accessories. Unit must be installed on a solid level roof curb or appropriate angle iron frame.
5. Maintain level tolerance to 1/2 inch across width and 2 inches along the length.

Unit clearances are shown in Figure 3.

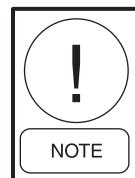

The clearances shown are to provide adequate condenser airflow and service access to inside the unit. Additional clearance should be considered for component replacement such as compressors, evaporator coils, and supply or exhaust fans.



While it is a common practice to operate the fan as soon as possible (air movement during construction) on the job site, the incomplete ductwork and missing diffuser grilles will greatly reduce air resistance and will allow the fan to operate beyond design parameters. This practice may result in water carry over and flooding of the unit. Also, the supply fan motor may overamp and become damaged.

rigger must be advised that the unit contains internal components and that it be handled in an upright position. Care must be exercised to avoid twisting the equipment structure.

Unit weights are listed under Table 2 in this manual. These weights must be referred to when selecting a crane for rigging and figuring roof weight loads. Contact your YORK Sales Office if you have any questions regarding unit weights.

RIGGING AND HANDLING

Proper rigging and handling of the equipment is mandatory during unloading and setting it into position to retain warranty status. All lifting lugs must be used to prevent twisting and damage to the unit.

Care must be taken to keep the unit in the upright position during rigging and to prevent damage to the water-tight seams in the unit casing. Avoid unnecessary jarring or rough handling.

Proper spreader bars and cables should be used when rigging - see Figure 2. It is also mandatory that an experienced and reliable rigger be selected to handle unloading and final placement of the equipment. The



FIG. 2 – UNIT RIGGING

00543VIP

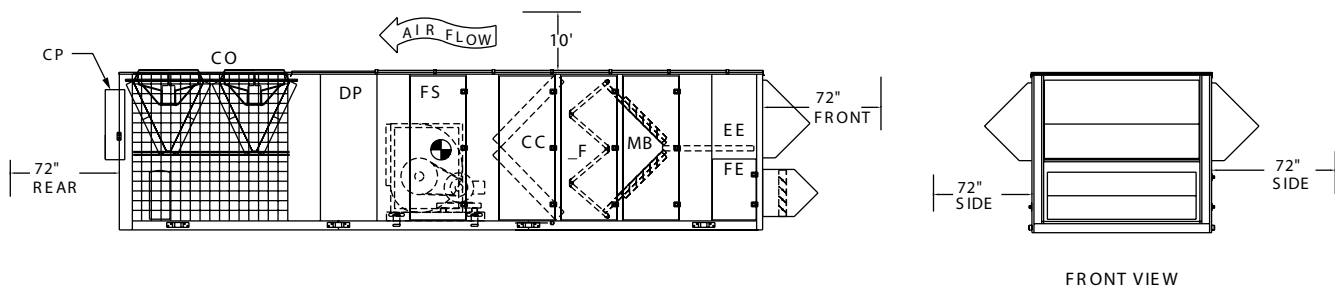

FRONT VIEW

LD06685A

NOTES:

1. 10' clearance minimal over the top of the condensing unit.
2. Only one adjacent wall can exceed unit height.
3. 12' clearance required to adjacent units.
4. 8' service access recommended on one side.
5. Economizer and exhaust hoods, where applicable, are folded inside unit for shipment.
6. Dim. is to outside of lifting lugs.

FIG. 3 – UNIT CLEARANCES

TABLE 2 – PHYSICAL DATA

50 - 70 TON MODELS

MODEL SIZE	050	055	060	065	070
General Data					
Standard cabinet length without hoods (inches)	344	344	344	344	454
Extended cabinet length without hoods (inches)	389	389	389	389	517
Width (Inches)	92	92	92	92	92
Height (Inches)	82	82	82	82	92
Weights (Lbs.) (base unit, no option)					
Base cabinet, cooling only with economizer	8282	8394	8607	8703	11,951
Extended cabinet, cooling only with economizer	9126	9238	9451	9547	13,161
Option Weights (Lbs.)					
Power Exhaust (Blower, mtr, mtr base, fan skid, mod damper & hood)	685	685	685	685	1045
Power Exhaust (Blower, mtr, mtr base, fan skid, VFD, baro damper & hood)	692	692	692	692	1044
100% AMS (Measurement Station & Mounting)	110	110	110	110	125
25/75% AMS (Measurement Station & Mounting)	130	130	130	130	146
Min. AMS (Measurement Station & Mounting)	40	40	40	40	45
Barometric only	36	36	36	36	45
375 MBH Gas Heat	162	162	162	162	162
750 MBH Gas Heat	324	324	324	324	324
1050 MBH Gas Heat	NA	NA	NA	NA	486
40 kW/415/3/60 or 40 kW/480/3/60 2 Steps Electric Heat	410	410	410	410	NA
80 kW/208/3/60 or 108 kW/240/3/60 5 Steps Electric Heat	490	490	490	490	NA
108 kW/415/3/60 4 steps Electric Heat	450	450	450	450	470
150 kW/415/3/60 5 Steps Electric Heat	470	470	470	470	490
200 kW/415/3/60 or 200 kW/480/3/60 6 Steps Electric Heat	NA	NA	NA	NA	510
250 kW/480/3/60 7 Steps Electric Heat	NA	NA	NA	NA	530
Condenser Wire Guard	32	32	32	32	40
Copper Condenser Coils (additional)	617	617	793	793	617
Copper Evaporator Coils (additional)	262	320	400	500	280
Hot water coil	281	281	281	281	318
Steam heating coil	202	202	202	202	236
Diffuser ³	44	44	44	44	53
Final filters ³	344	344	344	344	535
Final filters, racks only ³	224	224	224	224	297
Roof Curb Weights (Lbs.)					
14" Full Perimeter Roof Curb	825	825	825	825	1,020
14" Open Condenser Roof Curb	555	555	555	555	577
Compressor Data					
Quantity/Size (Nominal HP)	4x13	4x13	4x15	4x15	4x10, 2x13
Type	Scroll	Scroll	Scroll	Scroll	Scroll
Capacity Steps (Qty x %)	4x25	4x25	4x25	4x25	4x15, 2x20

2

TABLE 2 – PHYSICAL DATA (CONTINUED)

50 - 70 TON MODELS

MODEL SIZE	050	055	060	065	070
Supply Fan and Drive					
Quantity	1	1	1	1	1
Type	FC	FC	FC	FC	FC
Size	25-22	25-22	25-22	25-22	28-25
Motor Size Range (min. to max. HP)	7.5-40	7.5-40	7.5-40	7.5-40	7.5-50
Air Flow Range (min. to max. cfm)	10000-22500	10000-24000	14000-27000	14000-27000	14000-32000
Static Pressure Range (min. to max. ESP)	0-4"	0-4"	0-4"	0-4"	0-4"
Optional Airfoil Supply Fan					
Quantity	1 / 1	1 / 1	1 / 1	1 / 1	1 / 1
Type	AF	AF	AF	AF	AF
Size	25	25	25	25	32
Motor Size Range (min. to max. HP)	7.5-40	7.5-40	7.5-40	7.5-40	7.5-50
Air Flow Range (min. to max. cfm)	10000-27000	10000-27000	14000-27000	14000-27000	14000-32000
Static Pressure Range (min. to max. ESP)	0-6"	0-6"	0-6"	0-6"	0-6"
Exhaust Fan					
Quantity	2	2	2	2	2
Type	FC	FC	FC	FC	FC
Size	15-15	15-15	15-15	15-15	18-18
Motor Size Range (min. to max. HP)	5-20	5-20	5-20	5-20	5-20
Air Flow Range (min. to max. cfm)	0-20000	0-20000	0-20000	0-20000	0-27000
Static Pressure Range (min. to max. ESP)	0-1"	0-1"	0-1"	0-1"	0-1"
Optional Exhaust Fan					
Quantity Fans/Motors	2 / 1	2 / 1	2 / 1	2 / 1	2 / 1
Type	FC	FC	FC	FC	FC
Size	18-18	18-18	18-18	18-18	20-18
Motor Size Range (min. to max. HP)	5-20	5-20	5-20	5-20	5-30
Airflow Range (min. to max. cfm)	0-22500	0-24000	0-27000	0-27000	0-32000
Static pressure range (min. to max., iwg)	0-2"	0-2"	0-2"	0-2"	0-2"
Optional Return Fan					
Quantity Fans/Motors	2 / 2	2 / 2	2 / 2	2 / 2	2 / 2
Type	Plenum	Plenum	Plenum	Plenum	Plenum
Size	245	245	245	245	270
Motor Size Range (min. to max. HP)	5-30	5-30	5-30	5-30	5-30
Airflow Range (min. to max. cfm)	0-22500	0-24000	0-27000	0-27000	0-32000
Static pressure range (min. to max., iwg)	0-3"	0-3"	0-3"	0-3"	0-3"
Evaporator Coil					
Size (square feet)	48.8	48.8	48.8	48.8	56.9
Number of rows/fins per inch	3/8	4/8	4/10	5/8	4/8
Tube Diameter/Surface	1/2"/enhanced	1/2"/enhanced	1/2"/enhanced	1/2"/enhanced	1/2"/enhanced
Condenser Coil (R22, Al & Cu Fin)					
Size (square feet)	121	121	121	121	182
Number of rows/fins per inch	2/14	2/14	2/14	2/14	2/10
Tube diameter	3/8"	3/8"	3/8"	3/8"	3/8"

TABLE 2 – PHYSICAL DATA (CONTINUED)

50 - 70 TON MODELS

MODEL SIZE	050	055	060	065	070
Condenser Coil (R407C, Al & Cu Fin)					
Size (square feet)	121	121	121	121	182
Number of rows/fins per inch	3/16	3/16	3/16	3/16	2/14
Tube diameter	3/8"	3/8"	3/8"	3/8"	3/8"
Condenser Fans					
Quantity	4	4	4	4	6
Type	Prop.	Prop.	Prop.	Prop.	Prop.
Diameter (inches)	36	36	36	36	36
Power (hp each)	2	2	2	2	2
Filters - 2" throwaway (pre-filter position)					
Quantity	8 / 12	8 / 12	8 / 12	8 / 12	10 / 15
Size (length x width) (in.)	25X16 / 25x20	25X16 / 25x20	25X16 / 25x20	25X16 / 25x20	25X16 / 25x20
Total Filter Face Area (square feet)	61.6	61.6	61.6	61.6	77.1
Filters - 2" cleanable (pre-filter position)					
Quantity	8 / 12	8 / 12	8 / 12	8 / 12	10 / 15
Size (length x width) (in.)	25X16 / 25x20	25X16 / 25x20	25X16 / 25x20	25X16 / 25x20	25X16 / 25x20
Total Filter Face Area (square feet)	63.9	63.9	63.9	63.9	77.1
Filters - 2" pleated, 30% efficient (pre-filter position)					
Quantity	8 / 12	8 / 12	8 / 12	8 / 12	10 / 15
Size (length x width) (in.)	25X16 / 25x20	25X16 / 25x20	25X16 / 25x20	25X16 / 25x20	25X16 / 25x20
Total Filter Face Area (square feet)	63.9	63.9	63.9	63.9	77.1
Filters -12" rigid 65%, 2" 30% prefilter (pre-filter position)					
Quantity	1 / 4 / 9	1 / 4 / 9	1 / 4 / 9	1 / 4 / 9	2 / 8 / 9
Size (length x width) (in.)	16x20/25x16/25x20	16x20/25x16/25x20	16x20/25x16/25x20	16x20/25x16/25x20	16x20/25x16/25x20
Total Filter Face Area (square feet)	43.0	43.0	43.0	43.0	55.8
Filters -12" rigid 95%, 2" 30% prefilter (pre-filter position)					
Quantity	1 / 4 / 9	1 / 4 / 9	1 / 4 / 9	1 / 4 / 9	2 / 8 / 9
Size (length x width) (in.)	16x20/25x16/25x20	16x20/25x16/25x20	16x20/25x16/25x20	16x20/25x16/25x20	16x20/25x16/25x20
Total Filter Face Area (square feet)	44.6	44.6	44.6	44.6	55.8
Filters - 2" carbon (pre-filter position)					
Quantity	8 / 12	8 / 12	8 / 12	8 / 12	10 / 15
Size (length x width) (in.)	25X16 / 25x20	25X16 / 25x20	25X16 / 25x20	25X16 / 25x20	25X16 / 25x20
Total Filter Face Area (square feet)	63.9	63.9	63.9	63.9	77.1
Filters - 12" rigid 95% in Post-filter Position					
Quantity	1 / 3 / 9	1 / 3 / 9	1 / 3 / 9	1 / 3 / 9	2 / 7 / 9
Size (length x width) (in.)	16x20/25x16/25x20	16x20/25x16/25x20	16x20/25x16/25x20	16x20/25x16/25x20	16x20/25x16/25x20
Total Filter Face Area (square feet)	41.8	41.8	41.8	41.8	55.1

TABLE 2 – PHYSICAL DATA (CONTINUED)

50 - 70 TON MODELS

MODEL SIZE	050	055	060	065	070
Gas Furnace					
Staged Furnace Sizes (input/output/stages)	375 mbh / 300 mbh / 2 stages				
	750 mbh / 600 mbh / 4 stages				
					1125 mbh / 900 mbh / 6 stages
Gas Pressure Range (min. to max. iwg)	3-14" w.c.		3-14" w.c.		3-14" w.c.
Airflow Range (min. to max. cfm)	6,950-27,000		11,150-27,000		6,950-36,000
Modulating Furnace Sizes (input/output/turndown)	375 mbh / 300 mbh / 8:1 turndown				
	750 mbh / 600 mbh / 16:1 turndown				
					1125 mbh / 900 mbh / 24: 1 turndown
Gas Pressure Range (min. to max. iwg)	3.5-14" w.c. ²				
Airflow Range (min. to max. cfm)	8,250-27,000		11,150-27,000		8,250-36,000
Electric Heaters					
Size Range (min. to max. kW)	40-150	40-150	40-150	40-150	80-200
Heating steps ¹	2-7	2-7	2-7	2-7	2-7
Minimum OA Temp. for Mech. Cig.	45	45	45	45	45
Low Ambient Option Min. OA Temp	0	0	0	0	0

1. Electric heat steps and airflow range depends on voltage and size. Consult the air pressure drop tables for specific number of steps for a given voltage.
2. 3.5" is minimum gas pressure for full firing rate. 3.0" is acceptable at reduced firing rate.
3. Weights are for components only and need to be added to the extended cabinet weights. The diffuser is required in the extended cabinet for any unit with hot water or final filter option.

TABLE 2 – PHYSICAL DATA (CONTINUED)

75 - 105 TON MODELS

MODEL SIZE	075	080	085	090	095	105
General Data						
Standard cabinet length without hoods (inches)	454	454	454	488	488	488
Extended cabinet length without hoods (inches)	517	517	517	557	557	557
Width (Inches)	92	92	92	92	92	92
Height (Inches)	92	92	92	92	92	92
Weights (Lbs.) (base unit, no option)						
Base cabinet, cooling only with economizer	12,100	12,466	12,565	12,671	12,771	12,891
Extended cabinet, cooling only with economizer	13,310	13,676	13,775	13,967	14,067	14,187
Option Weights (Lbs.)						
Power Exhaust (Blower, mtr, mtr base, fan skid, mod damper & hood)	1045	1045	1045	1074	1074	1074
Power Exhaust (Blower, mtr, mtr base, fan skid, VFD, baro damper & hood)	1044	1044	1044	1068	1068	1068
100% AMS (Measurement Station & Mounting)	125	125	125	140	140	140
25/75% AMS (Measurement Station & Mounting)	146	146	146	162	162	162
Min. AMS (Measurement Station & Mounting)	45	45	45	50	50	50
Barometric only	45	45	45	55	55	55
375 MBH Gas Heat	162	162	162	162	162	162
750 MBH Gas Heat	324	324	324	324	324	324
1050 MBH Gas Heat	486	486	486	486	486	486
40 kW/415/3/60 or 40 kW/480/3/60 2 Steps Electric Heat	NA	NA	NA	NA	NA	NA
80 kW/208/3/60 or 108 kW/240/3/60 5 Steps Electric Heat	510	510	510	NA	NA	NA
108 kW/415/3/60 4 steps Electric Heat	470	470	470	510	510	510
150 kW/415/3/60 5 Steps Electric Heat	490	490	490	530	530	530
200 kW/415/3/60 or 200 kW/480/3/60 6 Steps Electric Heat	510	510	510	550	550	550
250 kW/480/3/60 7 Steps Electric Heat	NA	NA	NA	570	570	570
Condenser Wire Guard	40	40	40	45	45	45
Copper Condenser Coils (additional)	617	1,058	1,058	1,190	1,190	1,190
Copper Evaporator Coils (additional)	460	280	460	460	580	580
Hot water coil	318	318	318	318	318	318
Steam heating coil	236	236	236	236	236	236
Diffuser ³	53	53	53	53	53	53
Final filters ³	535	535	535	565	565	565
Final filters, racks only ³	297	297	297	327	327	327
Roof Curb Weights (Lbs.)						
14" Full Perimeter Roof Curb	1,020	1,020	1,020	1,040	1,040	1,040
14" Open Condenser Roof Curb	577	577	577	615	615	615
Compressor Data						
Quantity/Size (Nominal HP)	4x10, 2x13	6x13	6x13	2x13, 4x15	2x13, 4x15	6x15
Type	Scroll	Scroll	Scroll	Scroll	Scroll	Scroll
Capacity Steps (Qty x %)	4x15, 2x20	6x16	6x16	4x18, 2x15	4x18, 2x15	6x16

TABLE 2 – PHYSICAL DATA (CONTINUED)

75 - 105 TON MODELS

MODEL SIZE	075	080	085	090	095	105
Supply Fan and Drive						
Quantity	1	1	1	1	1	1
Type	FC	FC	FC	FC	FC	FC
Size	28-25	28-25	28-25	28-28	28-28	28-28
Motor Size Range (min. to max. HP)	7.5-50	7.5-50	7.5-50	7.5-60	7.5-60	7.5-60
Air Flow Range (min. to max. cfm)	14000-32000	14000-32000	14000-32000	18000-36000	18000-36000	18000-36000
Static Pressure Range (min. to max. ESP)	0-4"	0-4"	0-4"	0-4"	0-4"	0-4"
Optional Airfoil Supply Fan						
Quantity	1 / 1	1 / 1	1 / 1	1 / 1	1 / 1	1 / 1
Type	AF	AF	AF	AF	AF	AF
Size	32	32	32	32	32	32
Motor Size Range (min. to max. HP)	7.5-50	7.5-50	7.5-50	7.5-60	7.5-60	7.5-60
Air Flow Range (min. to max. cfm)	14000-32000	14000-32000	14000-32000	18000-36000	18000-36000	18000-36000
Static Pressure Range (min. to max. ESP)	0-6"	0-6"	0-6"	0-6"	0-6"	0-6"
Exhaust Fan						
Quantity	2	2	2	2	2	2
Type	FC	FC	FC	FC	FC	FC
Size	18-18	18-18	18-18	18-18	18-18	18-18
Motor Size Range (min. to max. HP)	5-20	5-20	5-20	5-20	5-20	5-20
Air Flow Range (min. to max. cfm)	0-20000	0-20000	0-20000	0-20000	0-20000	0-27000
Static Pressure Range (min. to max. ESP)	0-1"	0-1"	0-1"	0-1"	0-1"	0-1"
Optional Exhaust Fan						
Quantity Fans/Motors	2 / 1	2 / 1	2 / 1	2 / 1	2 / 1	2 / 1
Type	FC	FC	FC	FC	FC	FC
Size	20-18	20-18	20-18	20-18	20-18	20-18
Motor Size Range (min. to max. HP)	5-30	5-30	5-30	5-30	5-30	5-30
Airflow Range (min. to max. cfm)	0-32000	0-32000	0-32000	0-36000	0-36000	0-36000
Static pressure range (min. to max., iwg)	0-2"	0-2"	0-2"	0-2"	0-2"	0-2"
Optional Return Fan						
Quantity Fans/Motors	2 / 2	2 / 2	2 / 2	2 / 2	2 / 2	2 / 2
Type	Plenum	Plenum	Plenum	Plenum	Plenum	Plenum
Size	270	270	270	270	270	270
Motor Size Range (min. to max. HP)	5-30	5-30	5-30	5-40	5-40	5-40
Airflow Range (min. to max. cfm)	0-32000	0-32000	0-32000	0-36000	0-36000	0-36000
Static pressure range (min. to max., iwg)	0-3"	0-3"	0-3"	0-3"	0-3"	0-3"
Evaporator Coil						
Size (square feet)	56.9	56.9	56.9	56.9	56.9	56.9
Number of rows/fins per inch	5/8	4/10	5/8	4/10	5/8	5/10
Tube Diameter/Surface	1/2"/enhanced	1/2"/enhanced	1/2"/enhanced	1/2"/enhanced	1/2"/enhanced	1/2"/enhanced
Condenser Coil (R22, Al & Cu Fin)						
Size (square feet)	182	182	182	182	182	182
Number of rows/fins per inch	2/10	2/14	2/14	2/14	2/14	2/16
Tube diameter	3/8"	3/8"	3/8"	3/8"	3/8"	3/8"

TABLE 2 – PHYSICAL DATA (CONTINUED)

75 - 105 TON MODELS

MODEL SIZE	075	080	085	090	095	105
Condenser Coil (R407C, Al & Cu Fin)						
Size (square feet)	182	182	182	182	182	182
Number of rows/fins per inch	2/14	3/16	3/16	3/16	3/16	3/16
Tube diameter	3/8"	3/8"	3/8"	3/8"	3/8"	3/8"
Condenser Fans						
Quantity	6	6	6	6	6	6
Type	Prop.	Prop.	Prop.	Prop.	Prop.	Prop.
Diameter (inches)	36	36	36	36	36	36
Power (hp each)	2	2	2	2	2	2
Filters - 2" throwaway (pre-filter position)						
Quantity	10 / 15	10 / 15	10 / 15	12 / 18	12 / 18	12 / 18
Size (length x width) (in.)	25X16 / 25x20	25X16 / 25x20	25X16 / 25x20	25X16 / 25x20	25X16 / 25x20	25X16 / 25x20
Total Filter Face Area (square feet)	77.1	77.1	77.1	92.5	92.5	92.5
Filters - 2" cleanable (pre-filter position)						
Quantity	10 / 15	10 / 15	10 / 15	12 / 18	12 / 18	12 / 18
Size (length x width) (in.)	25X16 / 25x20	25X16 / 25x20	25X16 / 25x20	25X16 / 25x20	25X16 / 25x20	25X16 / 25x20
Total Filter Face Area (square feet)	77.1	77.1	77.1	92.5	92.5	92.5
Filters - 2" pleated, 30% efficient (pre-filter position)						
Quantity	10 / 15	10 / 15	10 / 15	12 / 18	12 / 18	12 / 18
Size (length x width) (in.)	25X16 / 25x20	25X16 / 25x20	25X16 / 25x20	25X16 / 25x20	25X16 / 25x20	25X16 / 25x20
Total Filter Face Area (square feet)	77.1	77.1	77.1	92.5	92.5	92.5
Filters -12" rigid 65%, 2" 30% prefilter (pre-filter position)						
Quantity	2 / 8 / 9	2 / 8 / 9	2 / 8 / 9	8 / 12	8 / 12	8 / 12
Size (length x width) (in.)	16x20/25x16/ 25x20	16x20/25x16/ 25x20	16x20/25x16/ 25x20	25x16/25x20	25x16/25x20	25x16/25x20
Total Filter Face Area (square feet)	55.8	55.8	55.8	61.6	61.6	61.6
Filters -12" rigid 95%, 2" 30% prefilter (pre-filter position)						
Quantity	2 / 8 / 9	2 / 8 / 9	2 / 8 / 9	8 / 12	8 / 12	8 / 12
Size (length x width) (in.)	16x20/25x16/ 25x20	16x20/25x16/ 25x20	16x20/25x16/ 25x20	25x16/25x20	25x16/25x20	25x16/25x20
Total Filter Face Area (square feet)	55.8	55.8	55.8	61.6	61.6	61.6
Filters - 2" carbon (pre-filter position)						
Quantity	10 / 15	10 / 15	10 / 15	12 / 18	12 / 18	12 / 18
Size (length x width) (in.)	25X16 / 25x20	25X16 / 25x20	25X16 / 25x20	25X16 / 25x20	25X16 / 25x20	25X16 / 25x20
Total Filter Face Area (square feet)	77.1	77.1	77.1	92.5	92.5	92.5
Filters - 12" rigid 95% in Post-filter Position						
Quantity	2 / 7 / 9	2 / 7 / 9	2 / 7 / 9	7 / 12	7 / 12	7 / 12
Size (length x width) (in.)	16x20/25x16/ 25x20	16x20/25x16/ 25x20	16x20/25x16/ 25x20	25x16/25x20	25x16/25x20	25x16/25x20
Total Filter Face Area (square feet)	55.1	55.1	55.1	61.1	61.1	61.1

TABLE 2 – PHYSICAL DATA (CONTINUED)

75 - 105 TON MODELS

MODEL SIZE	075	080	085	090	095	105
Gas Furnace						
Staged Furnace Sizes (input/output/stages)	375 mbh / 300 mbh / 2 stages					
	750 mbh / 600 mbh / 4 stages					
	1125 mbh / 900 mbh / 6 stages					
Gas Pressure Range (min. to max. iwg)	3-14" w.c.					
Airflow Range (min. to max. cfm)	6,950-36,000	11,150-36,000		15,150-36,000		
Modulating Furnace Sizes (input/output/turndown)	375 mbh / 300 mbh / 8:1 turndown					
	750 mbh / 600 mbh / 16:1 turndown					
	1125 mbh / 900 mbh / 24:1 turndown					
Gas Pressure Range (min. to max. iwg)	3.5-14" w.c. ²					
Airflow Range (min. to max. cfm)	8,250-36,000	11,150-36,000		15,150-36,000		
Electric Heaters						
Size Range (min. to max. kW)	80-200	80-200	80-200	108-250	108-250	108-250
Heating steps ¹	2-7	2-7	2-7	2-7	2-7	2-8
Minimum OA Temp. for Mech. Cig.	45	45	45	45	45	45
Low Ambient Option Min. OA Temp	0	0	0	0	0	0

1. Electric heat steps and airflow range depends on voltage and size. Consult the air pressure drop tables for specific number of steps for a given voltage.
2. 3.5" is minimum gas pressure for full firing rate. 3.0" is acceptable at reduced firing rate.
3. Weights are for components only and need to be added to the extended cabinet weights. The diffuser is required in the extended cabinet for any unit with hot water or final filter option.

TABLE 3 – ELECTRICAL DATA

SUPPLY, EXHAUST, RETURN FAN MOTOR DATA

OPEN MOTOR HIGH EFFICIENCY				
MOTOR HP	208/3/60 FLA	230/3/60 FLA	460/3/60 FLA	575/3/60 FLA
5	16.1	13.2	6.6	5.3
7.5	25.0	21.6	10.8	8.2
10	33.0	28.0	14.0	11.0
15	44.8	40.6	20.3	16.2
20	61.0	50.0	25.0	20.0
25	74.0	62.0	31.0	23.8
30	87.0	72.0	36.0	28.0
40	113.0	98.0	49.0	38.8
50	144.0	124.0	62.0	49.2
60	167.0	144.0	72.0	57.4

OPEN MOTOR PREMIUM EFFICIENCY				
MOTOR HP	208/3/60 FLA	230/3/60 FLA	460/3/60 FLA	575/3/60 FLA
5	14.9	12.8	6.4	5.2
7.5	21.3	20.0	10.0	7.4
10	29.0	25.8	12.9	10.3
15	40.7	35.4	17.7	14.1
20	54.3	47.0	23.5	18.9
25	69.5	60.0	30.0	24.2
30	81.0	70.0	35.0	28.0
40	111.0	92.0	46.0	37.4
50	137.0	114.0	57.0	46.0
60	160.0	136.0	68.0	56.0

TOTALLY ENCLOSED HIGH EFFICIENCY				
MOTOR HP	208/3/60 FLA	230/3/60 FLA	460/3/60 FLA	575/3/60 FLA
5	15.2	13.4	6.7	5.4
7.5	24.8	20.4	10.2	8.2
10	29.5	28.4	14.2	11.4
15	43.7	38.8	19.4	15.5
20	60.0	48.0	24.0	19.1
25	73.0	60.0	30.0	24.2
30	87.0	74.0	37.0	29.6
40	113.0	94.0	47.0	38.0
50	140.0	118.0	59.0	47.4
60	161.0	140.0	70.0	56.0

TOTALLY ENCLOSED PREMIUM EFFICIENCY				
MOTOR HP	208/3/60 FLA	230/3/60 FLA	460/3/60 FLA	575/3/60 FLA
5	14.6	13.0	6.5	5.2
7.5	22.0	20.0	10.0	8.0
10	28.5	25.0	12.5	10.0
15	42.4	37.0	18.5	14.8
20	56.0	48.0	24.0	19.0
25	68.4	60.0	30.0	23.9
30	83.0	72.0	36.0	29.0
40	107.0	94.0	47.0	37.0
50	131.0	118.0	59.0	46.0
60	159.0	138.0	69.0	55.0

CONDENSER FAN MOTORS / TOTAL				
NOMINAL TONS	208/3/60 FLA	230/3/60 FLA	460/3/60 FLA	575/3/60 FLA
50	29.2	24.8	12.4	10
55	29.2	24.8	12.4	10
60	29.2	24.8	12.4	10
65	29.2	24.8	12.4	10
70	43.8	37.2	18.6	15
75	43.8	37.2	18.6	15
80	43.8	37.2	18.6	15
85	43.8	37.2	18.6	15
90	43.8	37.2	18.6	15
95	43.8	37.2	18.6	15
105	43.8	37.2	18.6	15

CONTROL TRANSFORMER				
DESCRIPTION	NOMINAL VOLTAGE			
	208/3/60 AMPS	230/3/60 AMPS	460/3/60 AMPS	575/3/60 AMPS
YPAL050-065	3.6	3.3	1.6	1.3
YPAL070-105	4.8	4.3	2.2	1.7

TABLE 3 – ELECTRICAL DATA (CONT)

COMPRESSOR DATA R-22										
MODEL	COMPRESSOR		NOMINAL VOLTAGE							
	QUANTITY PER UNIT	MODEL	208/3/60		230/3/60		460/3/60		575/3/60	
			RLA	LRA	RLA	LRA	RLA	LRA	RLA	LRA
50	4	ZR16M3	46.9	350	40.8	350	20.4	158	16.3	125
55	4	ZR16M3	46.9	350	40.8	350	20.4	158	16.3	125
60	4	ZR19M3	55.2	425	51.5	425	25.8	187	20.6	148
65	4	ZR19M3	55.2	425	51.5	425	25.8	187	20.6	148
70	4	ZR12M3	38.3	278	33.3	278	16.7	127	13.3	100
	2	ZR16M3	46.9	350	40.8	350	20.4	158	16.3	125
75	4	ZR12M3	38.3	278	33.3	278	16.7	127	13.3	100
	2	ZR16M3	46.9	350	40.8	350	20.4	158	16.3	125
80	6	ZR16M3	46.9	350	40.8	350	20.4	158	16.3	125
85	6	ZR16M3	46.9	350	40.8	350	20.4	158	16.3	125
90	2	ZR16M3	46.9	350	40.8	350	20.4	158	16.3	125
	4	ZR19M3	55.2	425	51.5	425	25.8	187	20.6	148
95	2	ZR16M3	46.9	350	40.8	350	20.4	158	16.3	125
	4	ZR19M3	55.2	425	51.5	425	25.8	187	20.6	148
105	6	ZR19M3	46.9	350	40.8	350	20.4	158	16.3	125

COMPRESSOR DATA R-407C										
MODEL	COMPRESSOR		NOMINAL VOLTAGE							
	QUANTITY PER UNIT	MODEL	208/3/60		230/3/60		460/3/60		575/3/60	
			RLA	LRA	RLA	LRA	RLA	LRA	RLA	LRA
50	4	ZR16M3	48.8	350	42.4	350	21.2	158	17	125
55	4	ZR16M3	48.8	350	42.4	350	21.2	158	17	125
60	4	ZR19M3	57.6	425	51.7	425	25.9	187	20.7	148
65	4	ZR19M3	57.6	425	51.7	425	25.9	187	20.7	148
70	4	ZR12M3	37.5	278	34.2	278	17.1	127	13.7	100
	2	ZR16M3	48.8	350	42.4	350	21.2	158	17	125
75	4	ZR12M3	37.5	278	34.2	278	17.1	127	13.7	100
	2	ZR16M3	48.8	350	42.4	350	21.2	158	17	125
80	6	ZR16M3	48.8	350	42.4	350	21.2	158	17	125
85	6	ZR16M3	48.8	350	42.4	350	21.2	158	17	125
90	2	ZR16M3	48.8	350	42.4	350	21.2	158	17	125
	4	ZR19M3	57.6	425	51.7	425	25.9	187	20.7	148
95	2	ZR16M3	48.8	350	42.4	350	21.2	158	17	125
	4	ZR19M3	57.6	425	51.7	425	25.9	187	20.7	148
105	6	ZR19M3	57.6	425	51.7	425	25.9	187	20.7	148

TABLE 3 – ELECTRICAL DATA (CONTINUED)**ELECTRIC HEAT**

KW	NOMINAL VOLTAGE			
	208/3/60 AMPS	230/3/60 AMPS	460/3/60 AMPS	575/3/60 AMPS
40	96	96	48	40
80	193	193	96	80
108	260	260	130	109
150	—	—	181	151
200	—	—	241	201
250	—	—	301	251

2**TABLE 4 – AIRFLOW AND ENTERING AIR/AMBIENT LIMITATIONS**

Limitations	Model Size									
	50	55	60	65	70	75	80	85	90	95
Design Airflow Limits CFM* (min to max)	10000 - 22500	12000 - 24000	14000 - 27000	14000 - 27000	14000 - 32000	14000 - 32000	14000 - 32000	14000 - 32000	18000 - 36000	18000 - 36000
Entering Wet Bulb Temp F° (min/max)	57/75	57/75	57/75	57/75	57/75	57/75	57/75	57/75	57/75	57/75
Entering Dry Bulb Temp F° (min/max)	68/90	68/90	68/90	68/90	68/90	68/90	68/90	68/90	68/90	68/90
Ambient Temp F° without Low Amb option	45/120	45/120	45/120	45/120	45/120	45/120	45/120	45/120	45/120	45/120
Ambient Temp F° with Low Amb option	0/120	0/120	0/120	0/120	0/120	0/120	0/120	0/120	0/120	0/120

* Cooling Only Units

FILTERS

Two-inch “throwaway” filters are standard and factory installed in a filter rack located prior to the evaporator coil. Any optional pre-filters ordered with the unit will be shipped inside the unit, but must be filed installed. The unit can also be ordered with an extended cabinet and 95% efficient post-filters. These post-filters are installed at the factory.

Pre-filters must always be installed ahead of the evaporator coil. Post and pre-filters must be kept clean and replaced with the same size and type as shipped with the unit. Dirty filters will reduce the capacity of the unit and may result in frosted coils and safety shutdowns. Required filter sizes and qualities are shown in Table 2. The unit should never be operated for any length of time without the proper filters installed in the unit.

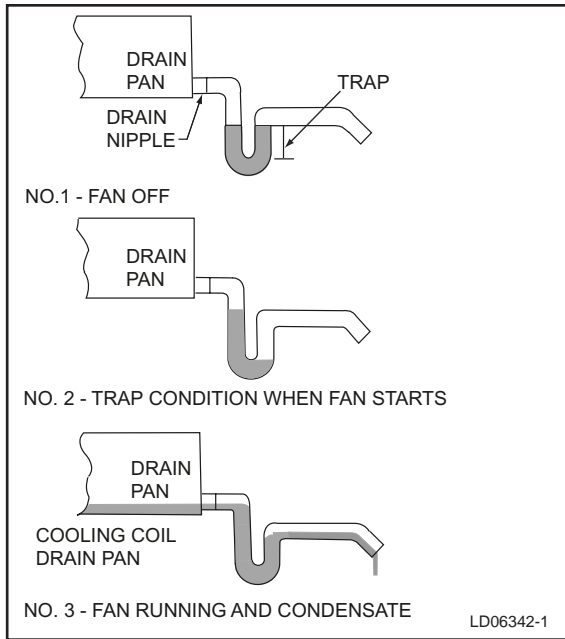

FIG. 4 – DRAIN TRAP SHOWING WATER LOCATION DURING DRAW THROUGH OPERATION STAGES

CONDENSATE DRAIN

Condensate Drain Piping

The ECO² cooling coils are located in the units so that the supply air is drawn through them. This results in the condensate being subjected to negative (-) static

pressure. Unless some means of pressure equalization is provided in the condensate drain, the air rushing back through the drainpipe will cause the condensate to build up in the drain pan. As the unit continues to operate, the accumulated water will be carried with the air stream, overflowing the drain pan causing possible water leaks into the supply duct and/or causing water damage in the building. A trap must be installed to prevent this condensate water build-up (see Figures 4 & 5).

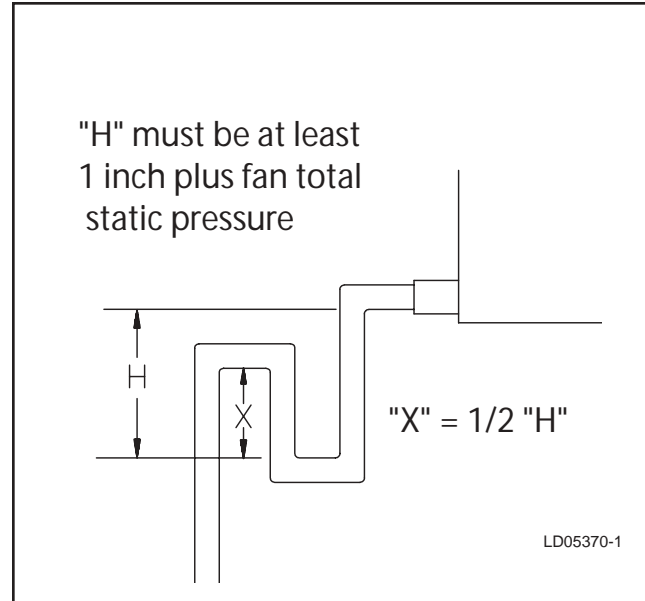
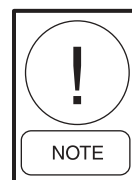

FIG. 5 - TRAP DETAIL FOR DRAW THROUGH APPLICATION

Condensate Drain Trap

For "Draw-through" applications install a trapped condensate drain line at unit drain connection (see Figure 5) according to all governing codes. "H" dimension must be at least 1 inch greater than design Total Static Pressure (TSP) of fan.

The trap and drain lines should be protected from freezing. Plumbing must conform to local codes. Use a sealing compound on male pipe threads. Install condensate drain lines from the 1-1/4 inch NPT female connections on the unit to an open drain.



The unit must be properly trapped and charged with water before the units are started.

AIR HOODS FOR ECONOMIZER

There are three (3) economizer outside air intake hoods provided with the unit. The hood on the end of the unit is factory mounted. The two (2) front and rear hoods are made operational per the following instructions:

- Remove the screws holding the economizer hood shipping covers in place. Discard covers.
- Apply a bead of RTV sealer along the edge of both hoods and each pivot joint to prevent water leakage.
- Rotate the hoods out (each hood is hinged). Secure the hoods with screws along the top and sides.
- Seal any unused screw holes with RTV or by replacing the screw.

AIR HOODS FOR FIXED OUTSIDE AIR (UNITS WITHOUT ECONOMIZER)

These hoods are factory installed. The dampers may be adjusted by loosening the thumb screw, turning the lever to the desired position, and retightening the thumb screw.

AIR HOODS FOR EXHAUST AIR

When furnished, these hoods and dampers are factory installed.

FIELD WIRING

Figure 7 shows the field control wiring to CTB1 for both a Constant Volume and Variable Air Volume units. All field control wiring is field supplied and installed. Figure 8 shows field control wiring for FlexSys options, wired to CTB2.

Figure 7 shows CTB1 field control wiring.

Thermostat

A thermostat (2 stage cool or 2 stage heat) can be used for either CV or VAV units. On CV units the thermostat is the primary means of control for the unit. The thermostat should be mounted on an inside wall approximately 56" above the floor where it will not be subject to drafts, sun exposure or heat from electrical fixtures or appliances.

Space Sensor

The space sensor (if used) can be used on either CV or VAV units. The space sensor can be used for unit control in lieu of a thermostat. Even if a thermostat is wired to the rooftop unit, the space sensor will supply space air temperature values if connected. When mounting a space sensor, it should be located on an inside wall approximately 56" above the floor where it will not be subject to drafts, sun exposure or heat from electrical fixtures or appliances. **Shielded Wire must be used that is grounded at control panel only.**

CO₂ Sensor

The optional CO₂ sensor is used for demand ventilation and must be wired to the field control wiring terminal block using two-conductor shield wire. **Shielded Wire must be used.**

Occupied/Unoccupied Input

A contact-closure input is provided for hard-wiring an external device such as a central time clock, a thermostat with scheduling or BAS system, or a manual switch.

Contact Closure = Occupied

Contacts Open = Unoccupied

Note that 24 volts (R), terminal 16, must be used as the 24 volt AC source for switching the contact to the unit controller Occupied/Unoccupied input. Use of any power source external to the controller will result in damage to the unit controller.

Shutdown Input

A contact-closure input is provided for emergency shutdown of the unit. When a contact closure to this input, the unit shuts down with supply fan, exhaust fan turned off, and outside air dampers are closed. This state is maintained until the input is deactivated (contacts open).

Contact Closed = Shutdown

Contacts Open = Normal Operation

Note that 24 volts (R), terminal 16, must be used as the 24 volt AC source for switching the contact to the unit controller shutdown input. Use of any power source external to the controller will result in damage to the unit controller.

Smoke Purge Input

A contact-closure input is provided for a smoke purge sequence. When a contact-closure occurs at this input, one of five purge sequences will be initiated, depending on unit programming. This input will cause a specific operation of supply fan, exhaust fans, return dampers, outside air dampers, and exhaust dampers. The five possible smoke purge modes (Shutdown, Pressurization, Exhaust, Purge, and Purge with Duct Pressure Control) are described in the controls section of this manual. This state is maintained until the input is deactivated (contacts open).

Contacts Closed = Smoke Purge Operation

Contacts Open = Normal Operation.

Note that 24 volts (R), terminal 16, must be used as the 24 volt AC source for switching the contact to the unit controller Shutdown input. Use of any power source external to the controller will result in damage to the unit controller.



No external power source may be used when field wiring any of the above dry contact inputs. The 24 volt AC source on terminal 16 (R) of the Terminal Block CTB1 must be used as the power source when field wiring these inputs, as shown in Fig. 7. Failure to do so will result in improper unit operation and damage to the unit controller.

VAV Heat Relay Output

This is a field wired *OUTPUT* that is used to command the VAV boxes to full open during smoke purge operation. This 24VAC signal should have a maximum current draw not to exceed 20VA. If the VA requirement of the VAV boxes approaches 20VA, isolation relays should be field supplied and installed to avoid overloading the unit power supply.

Note that this signal is used to drive the VAV boxes open in purge operations. Failure to drive the VAV boxes open during this mode of operation can cause unit shutdown and/or damage to the duct work due to overpressurization.



The VAV Heat Relay Output cannot exceed a current draw of 20VA. If the power requirements of the VAV boxes exceed this amount, isolation relays must be field supplied and installed to prevent overloading the unit controller power supply.

EVAPORATOR COIL FACE DAMPER

An evaporator coil face damper is only used on units built with the Flexsys option. The damper is designed to shut off airflow to the top section of the evaporator coil when only one compressor system is operating. This forces all the airflow through the lower coil resulting in higher low side pressures. The damper motor is normally open and is driven closed. In a power failure the damper will open.

RETURN AIR BYPASS DAMPER

Units built with the Flexsys option will have an opening in the base of the unit between the evaporator coil and the supply air blower. A Flexsys unit requires a means to bypass return air and mix it with the air off the evaporator coil. York does have a special curb with the return duct bypass and bypass damper built into the curb. The purpose of the damper is to temper the supply air to the under floor system by mixing return air with the air off the evaporator coil. After the system is initialized, the mixed air damper modulates based ratio of the difference between the mixed air temperature minus the supply air temperature compared to the return air temperature minus the supply air temperature. As the return air temperature decreases, the damper opens allowing more air to bypass the evaporator coil resulting in a higher mixed air temperature supply to the under floor system.

The mixed air damper must be wired and installed into the system in the field. The wires to connect the actuator are located in the supply fan section, in the proximity of the actuator in the supply fan section floor, opposite the supply fan motor side. The plug assembly/wires are attached with an elastic band and must be wired to the actuator, and the “plugs” mated together. Connect the wires to the motor as follows:

- Wire labeled “2(COM)” to terminal 1 in the actuator
- Wire labeled “200” to terminal 2 in the actuator
- Wire labeled “5(AO)” to terminal 5 in the actuator

ROOF-LINK

Roof-Link is intended for installations that require communication between an existing building automation system and an eco2-packaged rooftop that is not capable of communicating via the optional BACnet or LON protocols. Roof-Link offers a third method of interfacing that provides hard-wired communication between the building automation system and the eco2 unit through five analog inputs, three analog outputs, and four binary inputs/outputs.

BACNET AND LON NETWORK COMMUNICATION

The eco2 rooftop unit can communicate to any building automation system. There are three options available: BACnet Internet Protocol (Ethernet), BACnet MSTP

(RS485), and LON. These options require the application of an additional communication board to the Primary Unit Controller (*See Figure 6*)

DIRTY FILTER SWITCH

On units with a dirty filter switch option, an adjustable differential pressure switch is installed to monitor the pressure drop across the filters. When the pressure drop across the filters exceeds the setting of the switch the switch closes sending a 24-volt signal to the Primary Unit Controller. The Primary Unit Controller posts a trouble fault in the service memory buffer; but will not shut down the unit.

2

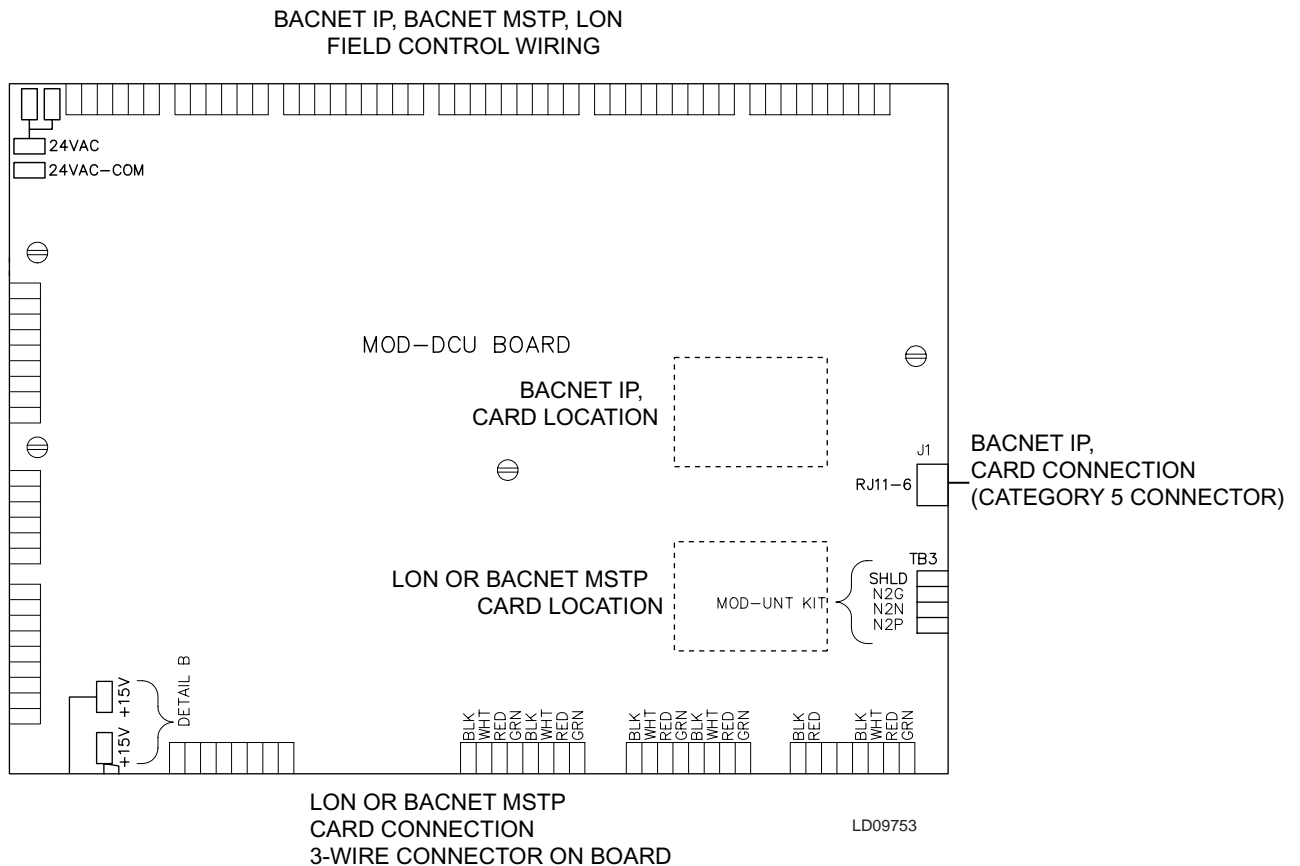
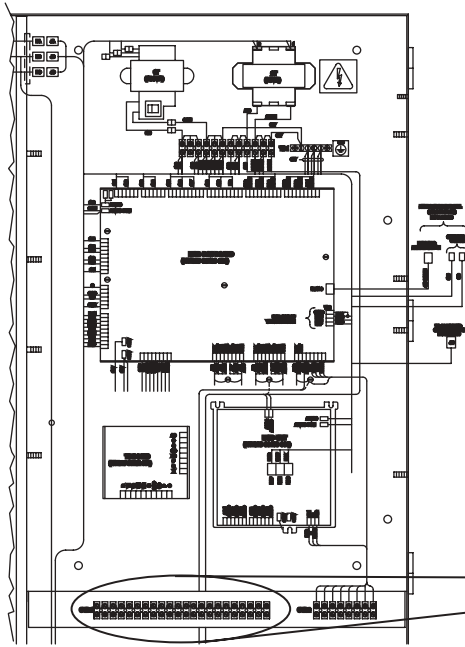

FIG. 6 – NETWORK COMMUNICATION BOARD

CTB1 FIELD CONTROL WIRING



Wiring Notes:

1. Wiring shown indicates typical wiring.
2. All wiring is Class 2, low voltage.
3. Maximum power available from the 24 VAC terminal is 40 VA.
4. Use shielded wire where shown.

LOCATION OF CTB1

7 Wire Thermostat

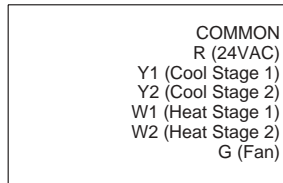

Space Sensor

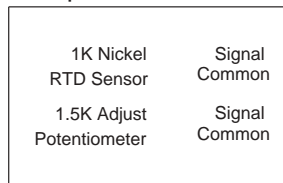

CO² Sensor

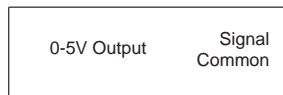

Note, 24VAC switch voltage must be sourced from the unit. Use of another power source external of the unit may cause equipment damage.

Occupied / Unoccupied Input

Shutdown Input

Smoke Purge Input

VAV Heat Relay Output 24 VAC Signal Common

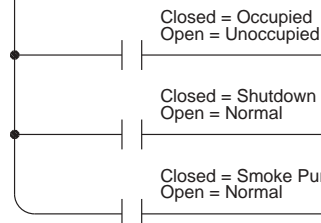

Note: VAV Heat Relay output shall be used to command the VAV boxes to open full.

CTB1

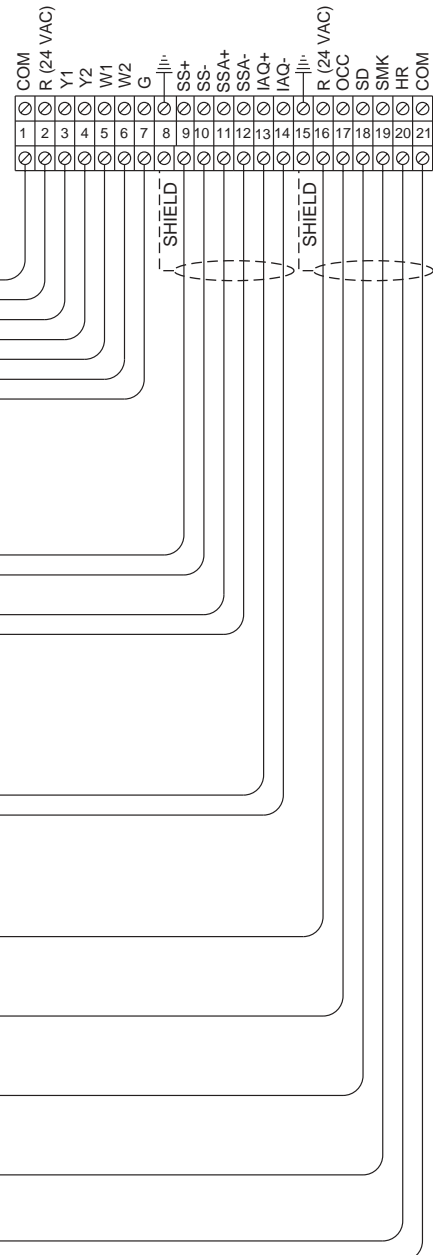

LD07414

FIG. 7 – FIELD CONTROL WIRING

CTB2 FLEXSYS WIRING

CTB2

FlexSys UnderFloor Slab Temperature Sensor:

The Flexsys Under-Floor Slab Temperature sensor is located on the concrete slab, which makes up the bottom of the Under-Floor plenum, and measures the temperature of this slab.

FlexSys UnderFloor Relative Humidity Sensor:

The Flexsys Underfloor Relative Humidity Sensor is located in the under-floor plenum and measures the relative humidity of the underfloor air.

FlexSys Evap Temperature Reset Input:

This is used to initiate reset of the SAT if enabled.

FlexSys Bypass Filter Dirty Filter Switch Input:

Is a field mounted differential pressure switch that indicates the present of a dirty bypass air filter.

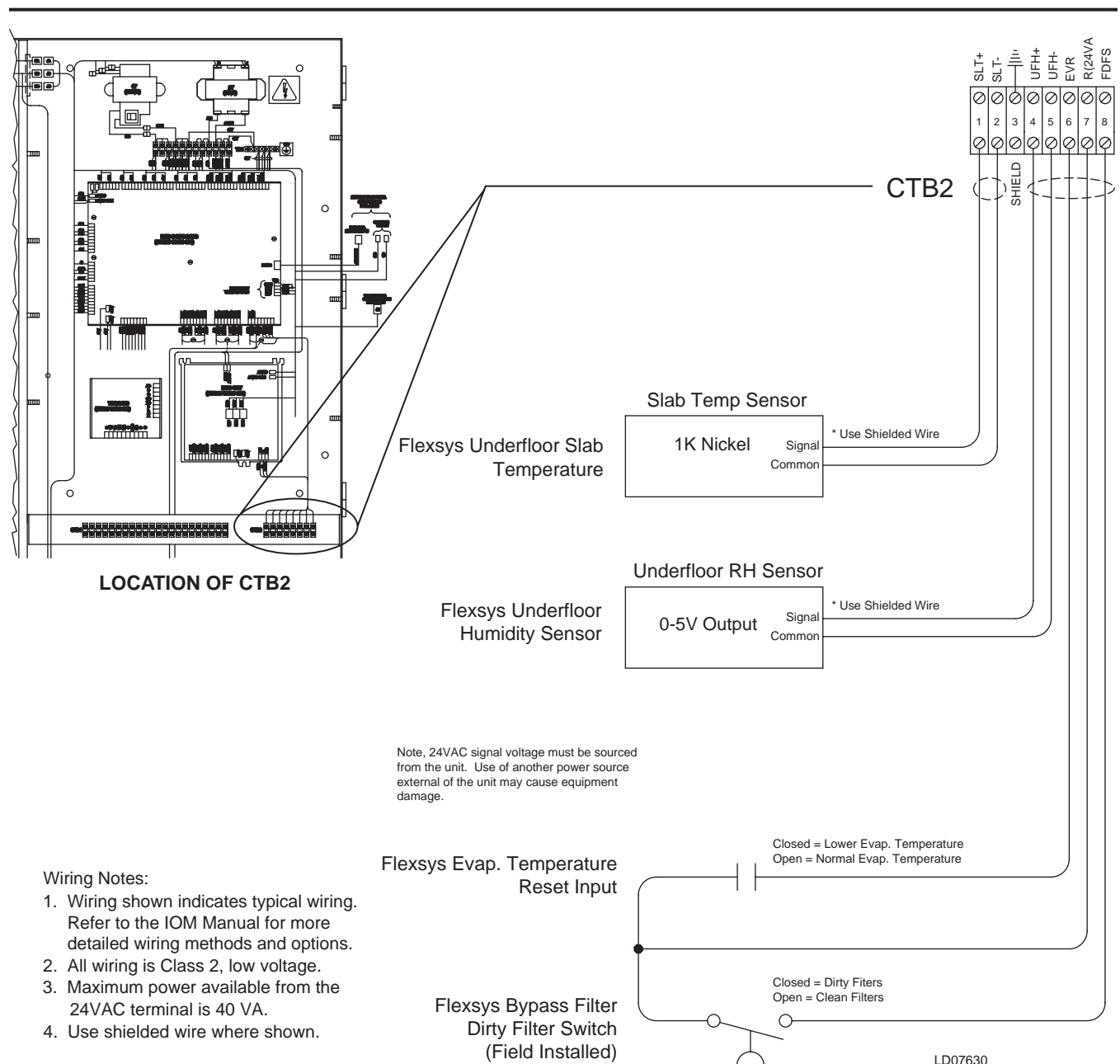

Wiring Notes:

1. Wiring shown indicates typical wiring. Refer to the IOM Manual for more detailed wiring methods and options.
2. All wiring is Class 2, low voltage.
3. Maximum power available from the 24VAC terminal is 40 VA.
4. Use shielded wire where shown.

FIG. 8 – FLEXSYS CTB2 WIRING

POWER WIRING

POWER WIRING

Field wiring to the unit must conform to provisions of National Electrical Code (NEC) ANSI / NFPA 70-Latest Edition and / or local ordinances. The unit must be electrically grounded in accordance with the NEC and / or local codes. Voltage tolerances, which must be maintained during starting and running conditions, are indicated on the unit data plate.

The internal wiring harnesses furnished with this unit are an integral part of the design certified unit. Field alteration to comply with electrical codes should not be required. If any of the wire supplied with the unit must be replaced, replacement wire must be of the type shown on the wiring diagram and the same minimum gauge as the replaced wire.

Power supply to the unit must be NEC Class 1 and must comply with all applicable codes. A disconnect switch must be provided (factory option available). The switch must be separate from all other circuits. Wire entry at knockout openings requires conduit fittings to comply with NEC and/or Local Codes.

Refer to Figures 9, 10 & 11 for typical field wiring and to the appropriate unit wiring diagram mounted inside control doors for control circuit and power wiring information.

ELECTRICAL SERVICE SIZING

Electrical service required for the cooling only eco² rooftop, use the appropriate calculations listed below from U.L. 1995. Based on the operating mode and configuration of the rooftop, the calculations will yield different MCA (minimum circuit ampacity), and MOP (maximum overcurrent protection). **MCA and Overcurrent Protection Device Data is supplied on the unit data plate. Also refer to Table 3, Electrical Data.**

The following calculations apply to electrical data for the rooftop unit. All concurrent load conditions must be considered in the calculations, and you must use the highest value for any combination of loads.

Minimum Circuit Ampacity (MCA) is based on 125% of the rated load amps for the largest motor plus 100% of the rated load amps for all other loads included in the circuit, per N.E.C. Article 440-34.

The minimum recommended disconnect switch is based on 115% of the rated load amps for all loads included in the circuit, per N.E.C.

Maximum overcurrent protection is based upon 225% of the rated load amps for the largest motor plus 100% of the rated load amps for all other loads included in the circuit, per N.E.C. Article 440-22. If the maximum overcurrent protection does not equal a standard current rating of an overcurrent protective device, then the marked maximum rating is to be the next lower standard rating. However, if the device selected for maximum overcurrent protection is less than the MCA, then select the lowest standard maximum fuse size greater than or equal to the MCA.

Figures 9 - 11 show the power wiring that must be field supplied and installed.

For dual point power connections, TB1 in the power panel supplies the all unit compressors and condenser fans. TB2 in the power panel supplies power to the unit supply, return and exhaust fans, and control circuitry.

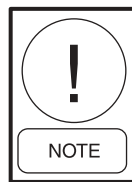

All wiring must conform to the National Electrical Code (NEC) and local codes that may be in addition to NEC.

SINGLE-POINT POWER SUPPLY WIRING

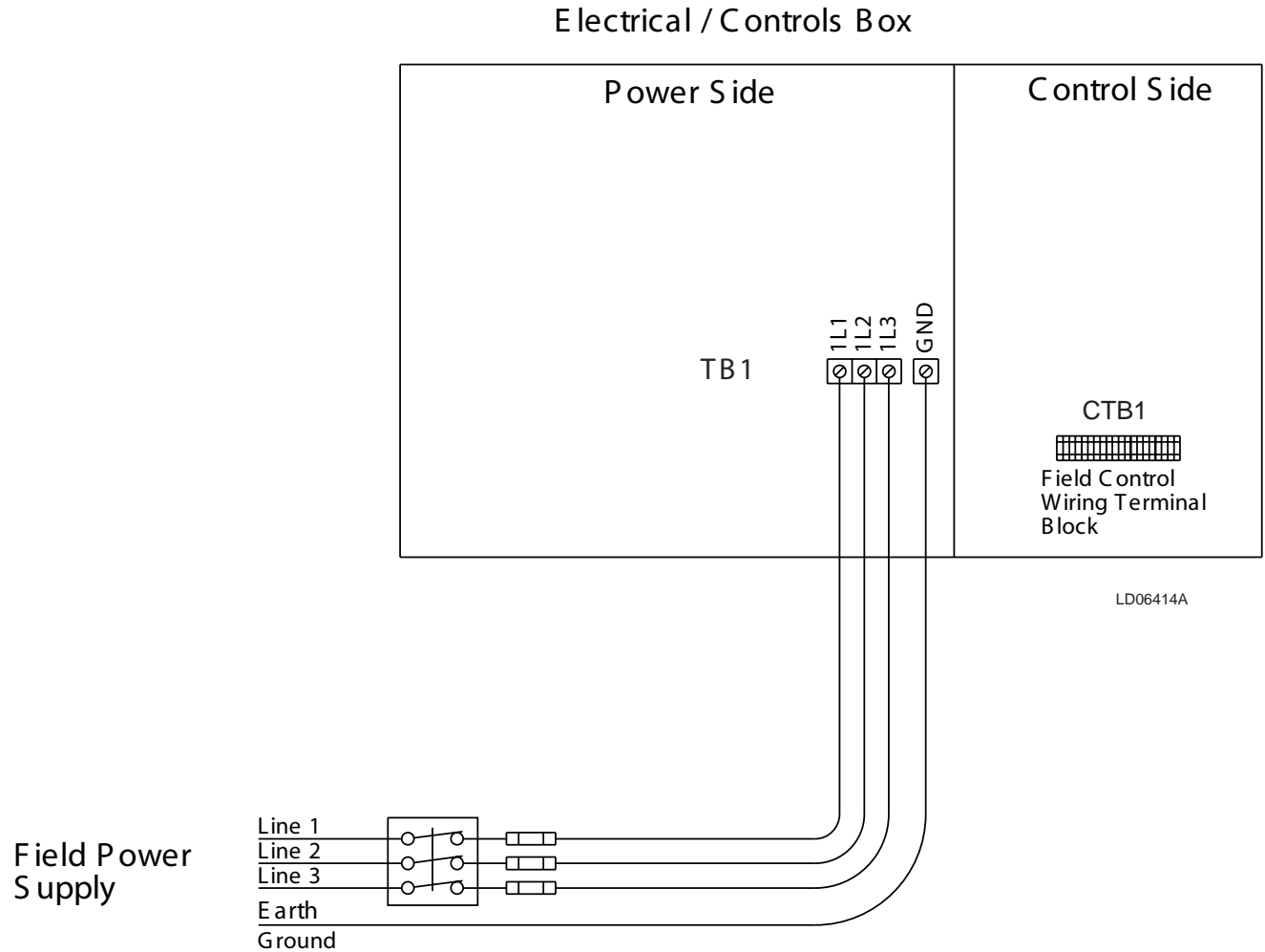

NOTES:

1. All field wiring must be provided through a field-supplied fused disconnect switch to the unit terminals (or optional molded disconnect switch).
2. All electrical wiring must be made in accordance with all N.E.C. and/or local code requirements.
3. Minimum Circuit Ampacity (MCA) is based on U.L. Standard 1995, Section 36.14 (N.E.C. Section 440-34).
4. Maximum Dual Element Fuse size is based on U.L. Standard 1995, Section 36.15 (N.E.C. Section 440-22)
5. Use copper conductors only.
6. On units with an optional disconnect switch, the supplied disconnect switch is a "Disconnecting Means" as defined in the N.E.C. Section 100, and is intended for isolating the unit from the available power supply to perform maintenance and troubleshooting. This disconnect switch is not intended to be a Load Break Device.

FIG. 9 – SINGLE-POINT POWER SUPPLY WIRING

SINGLE-POINT POWER SUPPLY WIRING WITH NON-FUSED DISCONNECT SWITCH

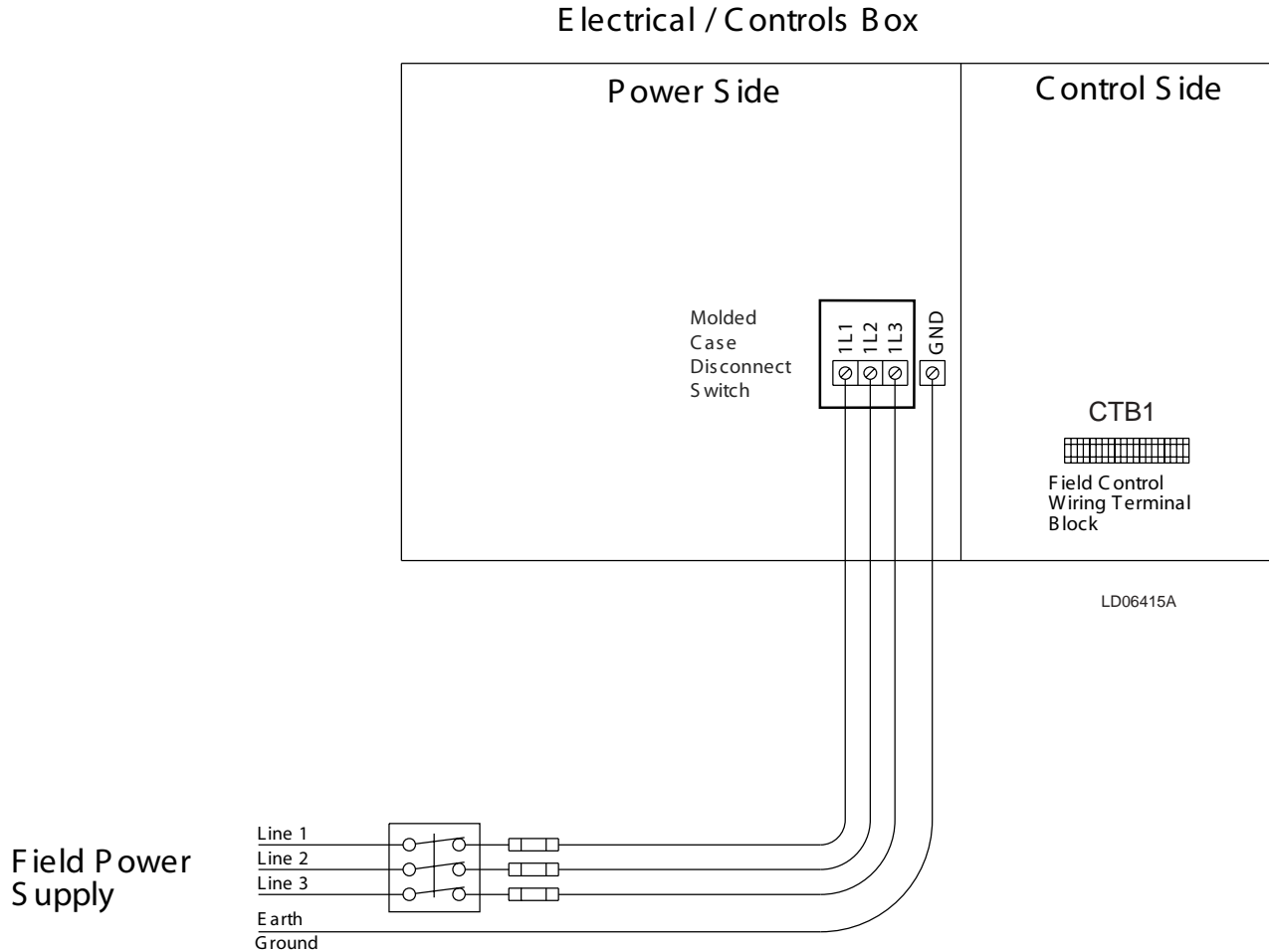

NOTES:

1. All field wiring must be provided through a field-supplied fused disconnect switch to the unit terminals (or optional molded disconnect switch).
2. All electrical wiring must be made in accordance with all N.E.C. and/or local code requirements.
3. Minimum Circuit Ampacity (MCA) is based on U.L. Standard 1995, Section 36.14 (N.E.C. Section 440-34).
4. Maximum Dual Element Fuse size is based on U.L. Standard 1995, Section 36.15 (N.E.C. Section 440-22)
5. Use copper conductors only.
6. On units with an optional disconnect switch, the supplied disconnect switch is a “Disconnecting Means” as defined in the N.E.C. Section 100, and is intended for isolating the unit from the available power supply to perform maintenance and troubleshooting. This disconnect switch is not intended to be a Load Break Device.

FIG. 10 – SINGLE-POINT POWER SUPPLY WIRING WITH NON-FUSED DISCONNECT

DUAL-POINT POWER SUPPLY WIRING

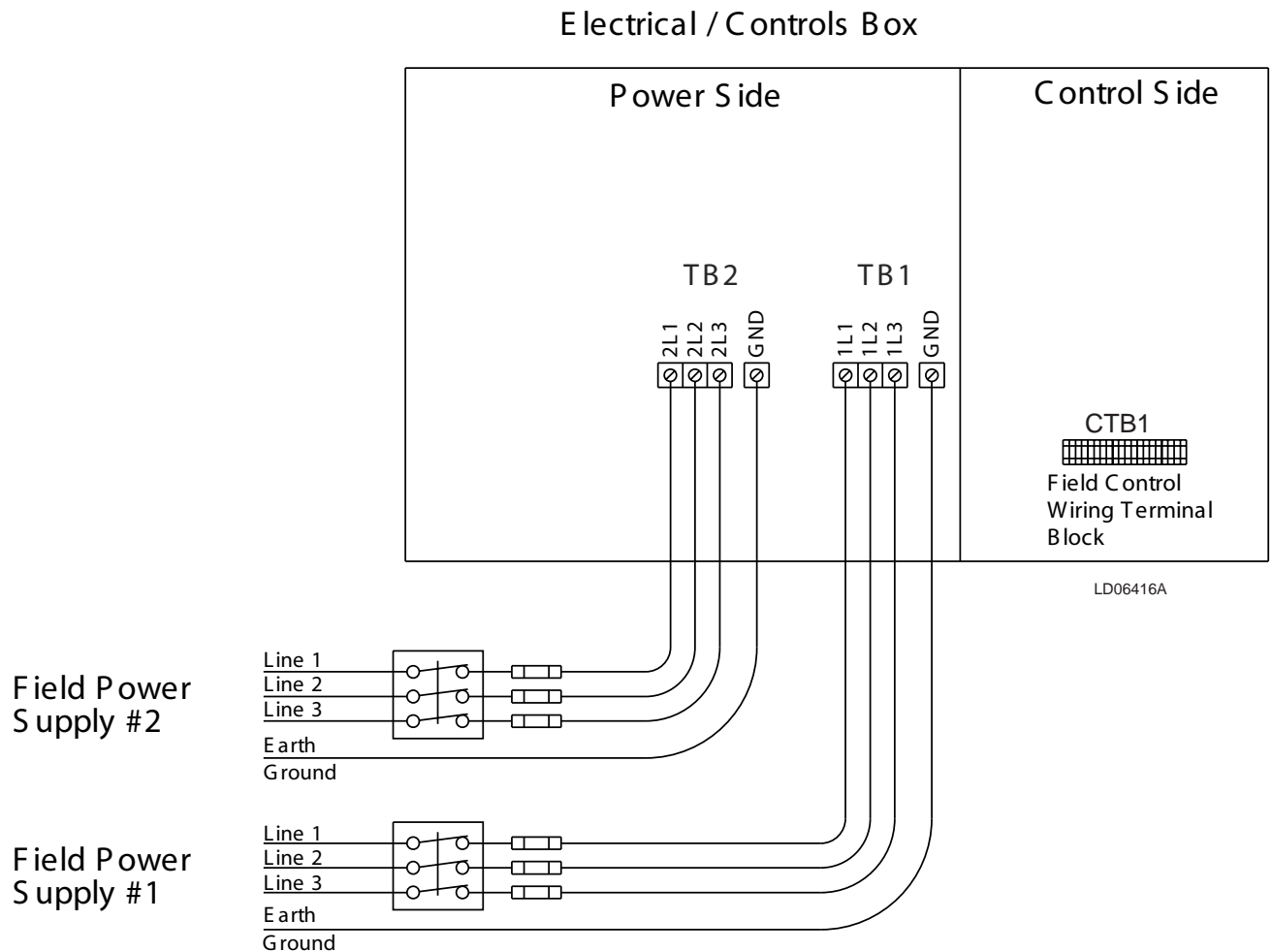

NOTES:

1. All field wiring must be provided through a field-supplied fused disconnect switch to the unit terminals (or optional molded disconnect switch).
2. All electrical wiring must be made in accordance with all N.E.C. and/or local code requirements.
3. Minimum Circuit Ampacity (MCA) is based on U.L. Standard 1995, Section 36.14 (N.E.C. Section 440.34).
4. Maximum Dual Element Fuse size is based on U.L. Standard 1995, Section 36.15 (N.E.C. Section 440.22).
5. Use copper conductors only.
6. On units with an optional disconnect switch, the supplied disconnect switch is a "Disconnecting Means" as defined in the N.E.C. Section 100, and is intended for isolating the unit from the available power supply to perform maintenance and troubleshooting. This disconnect switch is not intended to be a Load Break Device.

FIG. 11 – DUAL-POINT POWER SUPPLY WIRING

Static Pressure Control Plastic Tubing (Pneumatic Tubing)

Duct static transducers (all VAV units) and any unit with an optional building pressure control transducer, require pneumatic tubing to be field supplied and installed. **The “High” side** of the respective transducer must be routed to the location in the building or ductwork where a constant pressure is desired. Both the duct static transducer (VAV only) and optional building pressure transducer are mounted behind the left hand damper door. All wiring from the transducers is factory installed.

Duct Static Transducer

Plastic tubing (3/16" ID) must be run from the high pressure tap of the transducer to a static pressure tap (field supplied) in the supply duct, located at a point where constant pressure is desired. This is normally 2/3rds of the way down the duct.

Building Pressure Transducer

Plastic tubing (3/16" ID) must be run from the high pressure tap of the building static pressure transducer to a static pressure tap (field supplied), located in the conditioned space or return air duct at a point where constant pressure is desired.

Static Pressure Probe Installation

On units with duct static transducers (VAV units) and any unit with an optional building pressure, a factory supplied Static Pressure Probe must be field installed at the top of the rear corner post on the unit - see Fig. 10.

The factory supplied atmospheric pressure probe and associated mounting hardware are shipped inside the unit control panel. The hardware consists of a mounting bracket and a short section of pneumatic tubing. ***The pneumatic tubing must be field installed from a factory pressure tap (next to the mounting location for the static pressure probe) to the atmospheric pressure probe (see Installation Instructions, Form 100.50-N1)***

If the unit is equipped with both a building pressure transducer and a duct static transducer, a “tee” will be factory installed, and both the duct static pressure transducer and building pressure will be connected to the “tee” - both building static pressure transducer and duct static transducer will use the same factory supplied atmospheric pressure probe.

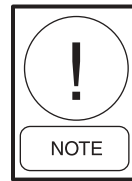

The “low” side connection of the duct static or building pressure transducers are shipped with the pneumatic tubing factory installed and routed, to the external factory pressure tap.

ROOF CURB INSTALLATION

General Information

When ordered, the roof curb is shipped knocked-down in a separate container and needs to be field assembled and installed. Refer to Installation Manual that is shipped with the roof curb for specific instructions.

On full perimeter roof curb the opening in the roof should not extend under the condenser section of the curb. The condenser section of the roof curb is not insulated and could result in condensation build up under the condenser section as well as higher than normal sound levels in the conditioned space.

The roof curb drawings contained in the York literature are not intended as construction documents for the field fabrication of a roof curb. York will not be responsible for the unit fit up, leak integrity, or sound level with field fabricated roof curbs.

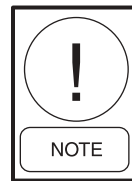

Wood or Fiber Cant Strips, Roofing Felts, Roofing Material, Caulking and Curb-To-Roof Fasteners are to be field supplied.

DUCT SYSTEM

Duct Connection Guidelines

All intake and discharge air duct connection to the unit may be made directly to the unit. These air duct connections should be on flexible material and should be installed so they are sufficiently loose. Duct runs and transitions must be made carefully to hold friction loss to a minimum. Avoid short turns, and duct elbows should contain splitters or turning vanes.

Duct work connected to the fan discharge should run in a straight line for at least **two** equivalent outlet diameters. Never deadhead the discharge into the flat surface of a plenum.



Installation of elbows, discharge damper and other abrupt flow area changes installed directly at the fan outlet will cause system losses. These losses must be taken into account during the design phase and must be added to any field measurements.

SOUND AND VIBRATION TRANSMISSION

All roof mounted air handling units generate some sound and vibration, that may or may not require some special treatment of the air conditioned space. The noise generated by the air handling unit is dependent on the speed of the fan, the amount of air the fan is moving, the fan type and the static efficiency of the fan. In applications where sound and vibration transmissions may be objectionable, good acoustical engineering practices must be incorporated in the system design.

2

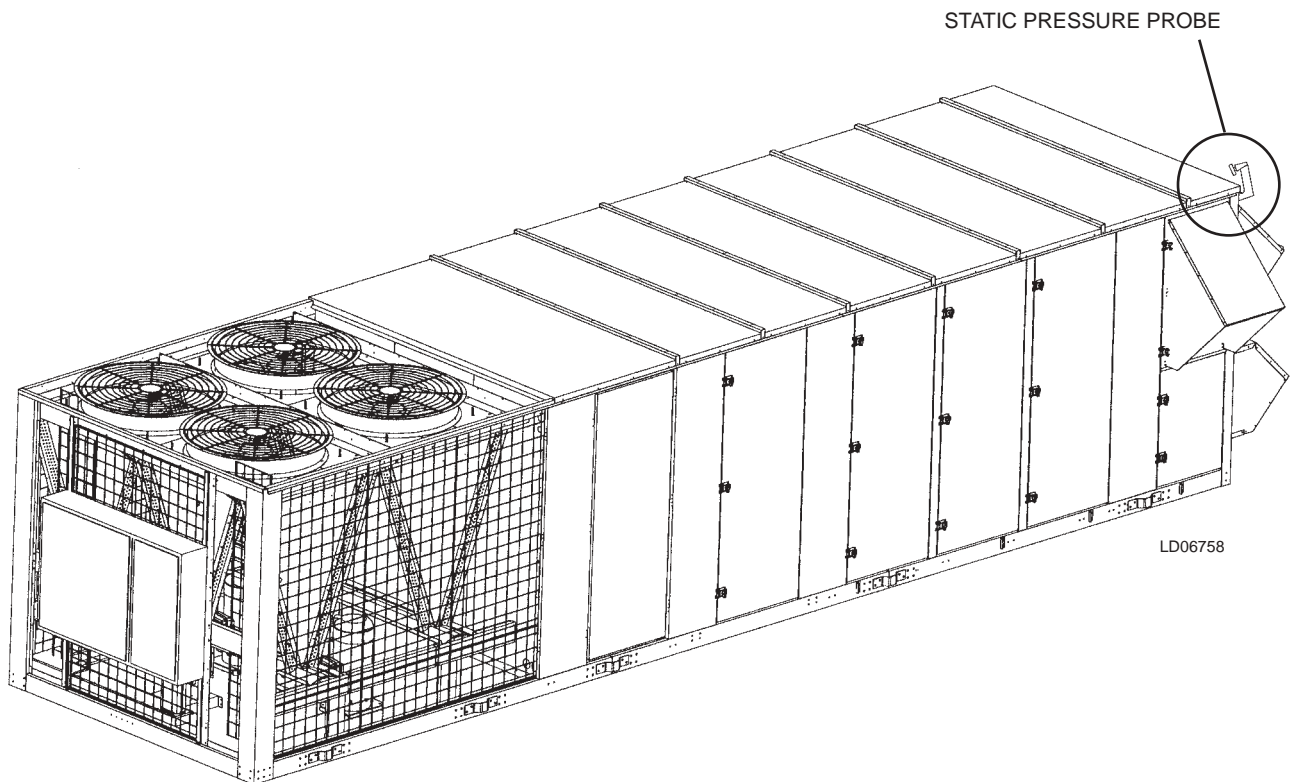

FIG. 12 – STATIC PRESSURE PROBE LOCATION

SECTION 3 – START-UP



To protect warranty, this equipment must be installed and serviced by an authorized YORK service mechanic or a qualified service person experienced in air handling and condenser unit installation. Installation must comply with all applicable codes, particularly in regard to electrical wiring and other safety elements such as relief valves, HP cut-out settings, design working pressures and ventilation requirements consistent with the amount and type of refrigerant charge.

Lethal voltages exist within the Control Panel. Before servicing, open and tag all disconnect switches.

Reference publication Form 100.50-N01 (302) "Quick Startup Guide" for additional information.

CRANKCASE HEATERS

With power applied to the rooftop unit, the crankcase heater for each compressor will be ON whenever the compressor is not running. The heater is interlocked into the compressor motor contactor and is not controlled by the microprocessor.

The purpose of the crankcase heater is to prevent the migration of refrigerant to the crankcase during shutdown, assuring proper lubrication of the compressor on start-up.

Anytime power is removed from the unit for more than an hour, the crankcase heater should be left on for 24 hours prior to start.



Power must be applied to the rooftop unit 24 hours prior to starting the unit compressors. Failure to observe this requirement can lead to compressor damage and voiding of the compressor warranty.

CHECKING THE SYSTEM PRIOR TO INITIAL START (NO POWER)

Unit Checks

1. Inspect the unit for shipping or installation damage.
2. Visually check for refrigerant piping leaks.
3. The compressor oil level should be maintained so that an oil level is visible in the sight glass. The oil level can only be tested when the compressor is running in stabilized conditions, guaranteeing that there is no liquid refrigerant in the lower shell of the compressor. In this case, the oil must be between 1/4 and 3/4 in the sight glass. At shutdown, the oil level can fall to the bottom limit of the oil sight glass.
4. Check the control panel to assure it is free of foreign material (wires, metal chips, etc.).
5. Visually inspect field wiring (power and control). Wiring MUST meet N.E.C. and local codes.
6. Check tightness of terminal lugs inside the power panel on both sides of the contactors, overloads, fuses, and power connections.
7. Verify fuse sizing in main circuits.
8. Verify field wiring for thermostat (if applicable), optional zone sensor, and optional CO₂ sensor.
9. Verify all applicable pneumatic tubing has been field installed for duct static pressure transducers (VAV units), optional building pressure transducer for power exhaust option, and outdoor static pressure probe.
10. Supply fan isolators spring bolts removed (refer to Figure 13).
11. *Verify proper bearing and locking collar torque values on supply and exhaust fans (refer to Maintenance section of manual).*
12. Verify proper drive alignment of supply and exhaust fans (refer to Maintenance section of manual).

13. Verify proper belt tension of supply fan, exhaust fan or return fan (*refer to Maintenance section of manual*). Belts must be checked after 24 hours of initial operation.
14. Manually rotate condenser fan blades, supply exhaust and return blower wheels and motors, to assure freedom of movement.
15. Verify proper condensate drain trap installation (refer to Figure 4). Fill traps with water prior to unit start-up.
16. If applicable, verify installation of air filters (refer to Installation section for size and quantity).
17. Verify Variable Frequency Drive setpoints for VAV units and optional Variable Frequency Drive Exhaust or Return Fans. Both VFD's are located in the supply blower section of the unit. *Refer to separate manual for VFD operation and programming, supplied with the rooftop unit (Form 100.40-N04).*
18. If equipped, open suction line ball valve, discharge line ball valve, and liquid line ball valve for each refrigerant system.

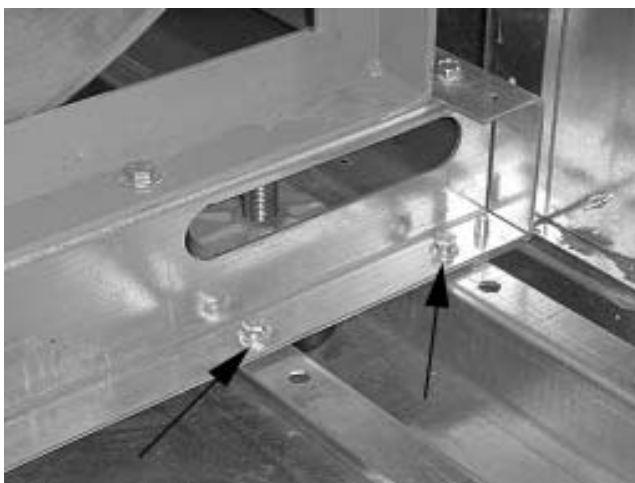

00496VIP

FIG. 13 – SUPPLY FAN ISOLATOR SPRING BOLTS (TOTAL OF 8)

UNIT CHECKS – POWER APPLIED

1. Apply 3-phase power and verify its value. Voltage imbalance should be no more than 2% of the average voltage.
2. Verify programmed units Setpoints (*refer to “Quick Start-Up Guide”, Form 100.50-N01*).
3. Verify correct fan rotation – fan should rotate in direction of arrow on fan housing.
4. Insure proper compressor rotation - see following instruction on **Verifying Compressor Rotation**.

Verifying Compressor Rotation



This unit uses scroll compressors, which will only operate in one direction. Failure to observe these steps could lead to compressor failure.

The eco² rooftop unit uses hermetic scroll compressors, which only pump in one direction. Therefore, it is necessary to verify proper rotation at unit start-up. Operation of the compressor in the reverse direction will not produce any capacity, and cause the compressor to cycle on internal overload. Operating the compressor in reverse for “extended” periods can result in failure of the compressor.

To verify proper rotation, monitor the suction and discharge pressures of the respective refrigerant circuit while the compressor cycles on. If the discharge pressure increases and suction pressure decreases as the compressor cycles on, the compressor is properly phased and operating in the correct rotation.

Suction and discharge pressure may be monitored with the OptiLogic™ display if the optional suction and discharge pressure transducers are installed (refer to the section on Menu Navigation). If the optional transducers are not installed, pressures must be monitored with a manifold gauge connected to the service valves located on the suction and discharge lines.

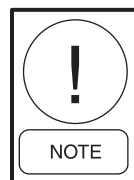

Upon initial application of power to the rooftop unit, there is a three minute period of non unit operation as the Primary Unit Controller goes through a self-test period. During this time, it will not respond to keypad selections. After three minutes, the display will revert to unit configuration and allow normal operation of the rooftop unit.

Compressor Oil Level Check

The oil level can only be tested when the compressor is running in stabilized conditions, to ensure that there is no liquid refrigerant in the lower shell of the compressor. When the compressor is running in stabilized conditions, the oil level must be between 1/2 and 3/4 in the oil sight glass. *Note: at shutdown, the oil level can fall to the bottom limit of the oil sight glass.*

INITIAL START-UP

After all of the preceding checks have been completed and the control panel has been programmed as required, the unit may be placed into operation.

1. Place the Unit Switch in the control panel to the RUN position.
2. With a demand, the supply fan will cycle on, and permit compressor operation if the air proving pressure switch for the supply fan has closed.
3. The first compressor will start. After several minutes of operation, a flow of refrigerant will be noted in the sight glass, the vapor in the sight glass will clear, and there should be a solid column of liquid visible in the sightglass when the TXV stabilizes.
4. Allow the compressor to run a short time, being ready to stop it immediately if any unusual noise or adverse conditions develop.
5. Check the system operating parameters by checking evaporator superheat and condensing subcooling. Connect a gauge manifold set to the Schrader service valve connections on the liquid and common suction line in the condensing section of the unit. After the system is running and the pressures have stabilized, measure the temperature at the liquid and common suction lines near the Schrader service valves. Calculate evaporator superheat and condensing subcooling. Both should be approximately 15 degrees. Refer to the next section for information on how to calculate evaporator superheat and condenser subcooling. Repeat the above process for each of the refrigerant systems.
6. With an ammeter, verify that each phase of the condenser fans, compressors, supply fan, and exhaust fan are within the RLA/FLA as listed on the unit data plate.

Refrigerant Charge

This rooftop unit comes fully charged from the factory with refrigerant R-407C or R-22 as standard. Because the components of R-407C evaporate (or condense) at different rates, the blend's composition constantly changes between bubble point and dew point. Because of this, only liquid refrigerant should be used when adding charge to the unit. The only exception would be if the entire contents of a refrigerant cylinder were added at one time.

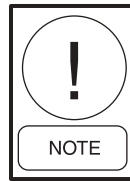

Always charge with liquid when adding 407C refrigerant. Failure to do so will compromise the properties of the refrigerant being added to the rooftop unit, and result in substandard performance of the unit.

Checking Superheat and Subcooling

R-22 temperature charts list the associated *saturation* temperature in one column, with the associated pressure in another column. As a result, only one temperature/pressure column is needed to show the relationship. However, the properties of the new zeotropic blends, such as 407C, are different than that of traditional refrigerants and must be treated as such.

Subcooling (R-407C)

When the refrigerant charge is correct, there will be no vapor in the liquid sight glass with the system operating under full load conditions.

The subcooling temperature of each system can be calculated by recording the temperature of the liquid line at the outlet of the condenser and subtracting it from the bubble point temperature listed in Table 6, for the corresponding discharge pressure. If the rooftop unit does not have an access port for liquid access, subtract 10 PSIG from the discharge pressure to determine the equivalent bubble point temperature

$$\begin{array}{rcl}
 \text{Example: Discharge pressure} & = & 225 \text{ PSIG} \\
 \text{minus 10 PSIG} & = & \text{bubble point} \quad 98^\circ\text{F} \\
 & & \text{minus liquid line temp.} \quad - \quad 87^\circ\text{F} \\
 & & \text{SUBCOOLING} = \quad 11^\circ\text{F}
 \end{array}$$

The subcooling should be 15°F at design conditions.

Superheat (R-407C)

The superheat should be checked only after steady state operation of the unit has been established, the discharge air temperature has been pulled down to within the control range, and the unit is running in a fully loaded condition.

The superheat is calculated as the difference between the actual temperature of the refrigerant gas in the suction line and the temperature corresponding to the Dew Point Temperature as shown in Table 6.

TABLE 5 – TEMPERATURE/PRESSURE CHART – REFRIGERANT R-22

This chart shows characteristics of Refrigerant R-22 (Monochlorodifluoromethane) when in the ‘saturated’ state.

Temperature (F)	Pressure (PSIG)	Temperature (F)	Pressure (PSI)
0	24.0	92	173.7
2	25.6	94	179.1
4	27.3	96	184.6
6	29.1	98	190.2
8	30.9	100	195.9
10	32.8	102	201.8
12	34.7	104	207.7
14	36.7	106	213.8
16	38.7	108	220.0
18	40.9	110	226.4
20	43.0	112	232.8
22	45.3	114	239.4
24	47.6	116	246.1
26	50.0	118	252.9
28	52.4	120	259.9
30	54.9	122	267.0
32	57.5	124	274.3
34	60.1	126	281.6
36	62.8	128	289.1
38	65.6	130	296.8
40	68.5	132	304.6
42	71.5	134	321.5
44	74.5	136	320.6
46	77.6	138	328.3
48	80.8	140	337.3
50	84.0	142	345.8
52	87.4	144	354.5
54	90.2	146	363.3
56	94.3	148	372.3
58	97.9	150	381.5
60	101.6	152	390.8
62	105.4	154	400.3
64	109.3	156	410.0
66	113.2	158	419.8
68	117.3	160	429.8
70	121.4		
72	125.7		
74	130.0		
76	134.5		
78	139.0		
80	143.6		
82	148.4		
84	153.2		
86	158.2		
88	163.2		
90	168.4		

SUCTION

DISCHARGE

Borders mark typical operating ranges that can be expected for suction and discharge pressures under moderate to full load, 44°F setpoint, with ambient air temperatures between 90-100°F. This is only a guideline and readings beyond these ranges will occur.

Vapor entering compressor should be superheated 12-15°F. Liquid from condenser should be subcooled 12-15°F.

TABLE 6 – TEMPERATURE/PRESSURE CHART – 407C SATURATION PROPERTIES

PRESSURE PSIG	TEMPERATURE °F		PRESSURE PSIG	TEMPERATURE °F	
	BUBBLE POINT	DEW POINT		BUBBLE POINT	DEW POINT
20.0*	-84	-71	120	62	72
15.0*	-71	-58	125	64	75
10.0*	-61	-48	130	66	77
5.0*	-53	-40	135	69	79
0	-46	-34	140	71	81
2	-42	-29	145	73	83
4	-37	-24	150	75	85
6	-33	-20	155	77	87
8	-29	-17	160	79	89
10	-26	-13	165	81	90
12	-22	-10	170	82	92
14	-19	-7	175	84	94
16	-16	-4	180	86	96
18	-13	-1	185	88	97
20	-11	1	190	90	99
22	-8	4	195	91	101
24	-6	6	200	93	102
26	-3	9	205	95	104
28	-1	11	210	96	105
30	1	13	215	98	107
32	3	15	220	99	108
34	5	17	225	101	110
36	7	19	230	102	111
38	9	21	235	104	113
40	11	23	240	105	114
42	13	25	245	107	116
44	15	26	250	108	117
46	16	28	255	110	118
48	18	30	260	111	120
50	20	31	265	112	121
52	21	33	270	114	122
54	23	35	275	115	123
56	24	36	280	116	125
58	26	37	285	118	126
60	27	39	290	119	127
62	29	40	295	120	128
64	30	42	300	121	129
66	32	43	310	124	132
68	33	44	320	126	134
70	34	46	330	129	136
75	38	49	340	131	138
80	41	52	350	133	141
85	44	55	360	135	143
90	46	57	370	138	145
95	49	60	380	140	147
100	52	63	390	142	149
105	55	65	400	144	151
110	57	68	425	149	155
115	59	70	450	154	160

* Inches of Hg mm

Example:

$$\begin{array}{rcl} \text{Suction Temp} & = & 56^{\circ}\text{F} \\ \text{Minus Suction Press of} & & \\ \text{65 PSIG converted to} & & \\ \text{the Dew Point Temp} & - & 43^{\circ}\text{F} \\ \text{Superheat} & = & 13^{\circ}\text{F} \end{array}$$

When adjusting the expansion valve, the adjusting screw should be turned not more than one turn at a time, allowing sufficient time (approximately 15 minutes) between adjustments for the system and the thermal expansion valve to respond and stabilize.

The superheat setting should be adjusted to 15°F at design conditions.

Subcooling (R-22)

The subcooling temperature of each system can be calculated by recording the temperature of the liquid line at the outlet of the condenser and subtracting it from the liquid line saturation temperature at the liquid stop valve (liquid line saturation temp. is converted from a temperature/pressure chart) (See Table 5).

Example:

$$\begin{array}{rcl} \text{Liquid line pressure} & = & 102^{\circ}\text{F} \\ \text{202 PSIG converted to} & & \\ \text{Minus liquid line temp.} & - & 87^{\circ}\text{F} \\ \text{Subcooling} & = & 15^{\circ}\text{F} \end{array}$$

The subcooling should be adjusted to 15°F at design conditions.

After the subcooling is verified, the suction superheat should be checked. The superheat should be checked only after steady state operation of the unit has been established, and the unit is running in a fully loaded condition.

Superheat (R-22)

The superheat is calculated as the difference between the actual temperature of the returned refrigerant gas in the suction line entering the compressor and the temperature corresponding to the suction pressure as shown in a standard pressure/temperature chart in Fig. 5.

Example:

$$\begin{array}{rcl} \text{Suction Temp} & = & 46^{\circ}\text{F} \\ \text{Minus Suction Press} & & \\ \text{60 PSIG converted to Temp} & - & 34^{\circ}\text{F} \\ \text{Superheat} & = & 12^{\circ}\text{F} \end{array}$$

When adjusting the expansion valve, the adjusting screw should be turned not more than one turn at a time, allowing sufficient time (approximately 15 minutes) between adjustments for the system and the thermal expansion valve to respond and stabilize.

Assure that superheat is set at 15°F.

Leak Checking

Leak check compressors, fittings and piping to assure no leaks. Verify the evaporator distributor tubes do not have bare copper touching each other or are against a sheet metal edge. If you are leak checking a unit charged with R-407C make sure the leak test device is capable of sensing refrigerant R-407C.

If the unit is functioning satisfactorily during the initial operating period, no safeties trip and the unit controls are functioning properly, the rooftop unit is ready to be placed into operation.

GAS HEAT MODELS

Pre-Start Checks:

- Startup of gas heat includes verification of incoming gas line pressure and leak checks in the field installed gas line, are the responsibility of the installing contractor, but should be verified prior to unit start-up. Correct values are located later in this section.
- Verify wiring inside the burner compartment to insure the wiring/terminals are tight and securely connected to the components, such as the ignition control, flame sensor, gas valve, rollout switches and igniter.
- Check that the transformer is wired for the correct voltage. The transformer has 2 taps, one for 208 volts and one for 240 volts. Check that the wire terminal is on the correct terminal on the transformer (on 208 volt units, the tap should be on the 208 term of the trans; for all other voltages, it should be on the 240 volt terminal).

- The control will look for the remote flame sensor proving flame.
- If it does prove, the burners will continue; if not, the gas valve will be closed, there will be a 30 second purge period; the igniter will again energize and gas valve will open for 7 secs; there will be 3 tries for ignition; after 3 tries, the control will lock out.
- The control will also restart the process if the rollout switch(es) (2 switches, located above the burners) opened and have been reset, indicating burning inside the burners and/or outside of the heat exchanger tubing.
- Rollout switches are manual reset, and need to physically reset if they open for any reason. This is because the problem is usually blockage of the flue passages and service personnel needs to observe the passages first hand.
- The control circuit is tested in the factory to insure that all of these steps are followed, however, natural gas is not actually introduced to the system in the plant; nitrogen is used in its place.

Gas pressures should be as follows:

- Entering pressure to the gas valve:
 - Natural Gas
4.5" WC min, 13.5" WC maximum
 - Propane
11" WC min, 13.5" WC maximum
- Manifold Pressure (leaving gas valve):
 - Natural
Low Fire, manifold pressure = 1.2" WC.
High Fire, manifold pressure = 3.5" WC.
 - Propane
Low Fire, manifold pressure = 2.4" WC.
High Fire, manifold pressure = 10.0" WC.
- All pressures have a tolerance of +/- 0.3" WC.

TABLE 7 – GAS HEAT PERFORMANCE DATA

UNIT	GAS INPUT CAPACITY (BTU/HR X 1000)	MAXIMUM OUTPUT CAPACITY (BTU/HR X 1000)	AIRFLOW		TEMP. RISE (°F)
			MIN.	MAX.	
50-65	375	300	6,950	27,750	10-40
	750	600	11,150	27,750	20-50
70-85	375	300	6,950	27,750	10-40
	750	600	11,150	27,750	20-50
	1125	900	15,150	33,325	25-55
90-95	375	300	6,950	27,750	10-40
	750	600	11,150	27,750	20-50
	1125	900	15,150	33,325	25-55

Post Start Checks:

- When a signal is received at the gas heat control module from the Primary Unit Controller, verify:
 - Combustion blower starts and runs for 30 seconds.
 - Spark igniter sparks continuously.
 - Gas valve opens.
 - Burners light from right to left, in a 2-5 second time frame, that each one lights in sequential order from right to left, establishes stable flame immediately upon ignition.
 - Flame is stable, with ignition starting at the end of the burner and that no burning is occurring inside the burner.
- There will be some noise on startup with units that have a thermostat, as the full burner operation will occur, skipping the low fire ignition startup, lasting for approximately 20 sec, with the burner noise reduction noticeable at this point. There may also be some smoke thru the flue, due to tooling oil burning off of the heat exchanger tubing.
- Ignition control operation is as follows:
 - Once the control receives a signal from the Primary Unit Controller for heat, the combustion blower starts for a 30 sec. pre-purge.
 - The spark igniter is then energized with the gas valve opening; it will try for ignition for 7 seconds.

THIS PAGE LEFT BLANK INTENTIONALLY

SECTION 4 – MAINTENANCE



Make sure power is removed from the unit before performing the maintenance items contained in this section.

GENERAL

A planned program of regularly scheduled maintenance will return dividends by averting possible costly and unexpected periods of down time. It is the responsibility of the owner to provide the necessary maintenance for the air handling units and coils. If a system failure occurs due to improper maintenance during the warranty period, YORK will not be liable for costs incurred to return the unit to satisfactory operation.

PERIODIC MAINTENANCE – MONTHLY

Filters

Check the cleanliness of the filters and replace or clean as required.

Linkages

Examine the damper and operator linkages to insure that each is free and operating smoothly.

Compressors

Oil Level Check: The oil level can only be tested when the compressor is running in stabilized conditions, to ensure that there is no liquid refrigerant in the lower shell of the compressor. When the compressor is running in stabilized conditions, the oil level must be between 1/4 and 3/4 in the oil sight glass. *Note: at shutdown, the oil level can fall to the bottom limit of the oil sight glass.*

Oil Analysis: Use York Type “T” POE oil (clear) for units charged with R-407C refrigerant. Use York Type “R” mineral oil (tinted yellow) for units charged with

R-22 refrigerant. The type of refrigerant and amount per system is listed on the unit rating plate. A change in the oil color or odor may be an indication of contaminants in the refrigeration system. If this occurs, an oil sample should be taken and analyzed. If contaminations are present, the system must be cleaned to prevent compressor failure. This can be accomplished through the installation of oversized suction and liquid line driers. The driers may have to be changed several times to clean up the system depending on the degree of contamination.



Never use the scroll compressor to pump the refrigerant system down into a vacuum. Doing so will cause internal arcing of the compressor motor, which will result in failure of compressor.

Fan Bearing Lubrication

Add grease slowly with shaft rotating until a slight bead forms at the seals. If necessary, re-lubricate while bearing is stationary. The fan data plate (attached to the fan scroll) lists the type of grease that must be used for lubricating the bearings. Refer to Table 8 for lubricating schedule.

Re-lubrication is generally accompanied by a temporary rise in operating temperature. Excess grease will be purged at seals.

Recommended Lubricant For Fan Bearings

A Lithium / Petroleum base grease conforming to an NLGI Grade II consistency is normally used. Lubricant must be free of any chemical impurities such as free acid or free alkali, dust, rust, metal particles or abrasive. This light viscosity, low torque grease is rust inhibited and water resistant, has a temperature range of -30°F to +200°F with intermittent highs of +250°F. Lubricate bearings as required by the severity of required duty.

TABLE 8 – FAN BEARING – LUBRICATION INTERVALS

RELUBRICATION SCHEDULE (MONTHS) BALL BEARING PILLOW BLOCKS									
SPEED (RPM)	500	1000	1500	2000	2500	3000	3500	4000	4500
SHAFT DIA									
1/2" thru 1-11/16"	6	6	5	3	3	2	2	2	1
1-15/16" thru 2-7/16"	6	5	4	2	2	1	1/2	1/4	1/4
2-11/16" thru 2-15/16"	5	4	3	2	1	1/2	1/2		
3-7/16" thru 3-15/16"	4	3	2	1	1/2	1/2			

Condenser Coils

Dirt should not be allowed to accumulate on the condenser coil surfaces. Cleaning should be as often as necessary to keep coil clean.

PERIODIC MAINTENANCE – THREE TO SIX MONTHS



Disconnect and lock-out power from the unit anytime service is being performed on the fan section. Failure to do so could result in serious injury or death due to the fan turning on while work is in progress.



Squealing belts during starting is caused by slipping belts that are not tensioned properly.

Motor Bearing Lubrication

Bearings must be re-lubricated periodically to assure long life. Motor bearing should be lubricated yearly, but may need lubrication more frequently, depending on severe operating conditions.

Belt Tension

Adjust the belt tension if necessary. Required belt tension data is supplied on the fan “skid” data plate, attached to the fan housing. Never use a belt dressing on the belts. If belts slip with the proper tension, use a good grade of belt cleanser to clean the belts. Refer to Figures 13 & 14.



Never use excessive belt tension, as this could result in damaging the bearing, motor pulleys or motor base. See drive label on fan housing adjacent to drive for specific details on tension.

When it is necessary to replace one belt in a given set, the entire set of belts must be replaced.

PERIODIC MAINTENANCE – YEARLY

Check the fan wheels and inspect the drain pan for sludge and foreign material. Clean if required.

Observe the operation of all dampers and make any necessary adjustments in linkage and blade orientation for proper operation.

Entire Unit Inspection

In addition to the checks listed in this section, periodic overall inspections of the unit should be accomplished to ensure proper equipment operation. Items such as loose hardware, component operation, refrigerant leaks, unusual noises, etc. should be investigated and corrected immediately.

Sheave Alignment:

To check sheave alignment, a straight edge or a piece of string can be used. If the sheaves are properly aligned, the string or straight edge will touch at all points, as indicated in Fig. 14. Rotating the sheaves will determine if the sheave is wobbly or the drive shaft is bent. Alignment error must be corrected to avoid bearing and belt failure.

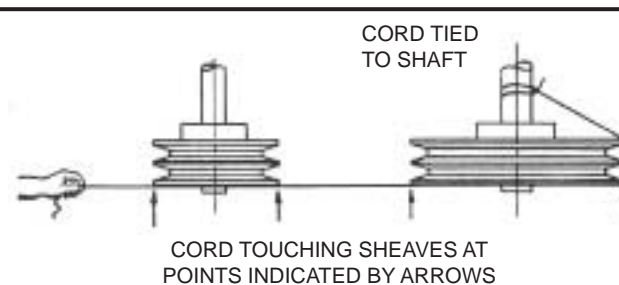

FIG. 14 – SHEAVE ALIGNMENT

LD07634

Belts

New belts should be re-checked after 24 hours of operation. On multiple belt adjustable pulleys, the pitch depth should be checked to insure identical belt travel, power transfer and wear. Adjustable motor bases are provided for belt adjustment.

Motor pulleys and blower shaft pulleys are locked in position with either set screws or split taper lock bushings. All set screws and/or taper lock bolts must be checked for tightness and alignment before putting equipment into operation.

An incorrectly aligned and tensioned belt can substantially shorten belt life or overload blower and motor bearings, shortening their life expectancy. A belt tensioned too tightly can overload the motor electrical, causing nuisance tripping of the motor overloads and/or motor failure and/or shaft failure.

Belt Replacement

Always replace belts as a set. Follow the steps below to replace belts:

1. Release the tension on the belts by loosening the adjusting nuts on the fan motor.
2. Remove old belts and recheck the sheave alignment with a straight edge.
3. Install the new belts on the sheaves.

Never place the belts on the sheaves by using a screwdriver to pry the belt over the rim of the sheave. This will damage the belts permanently.

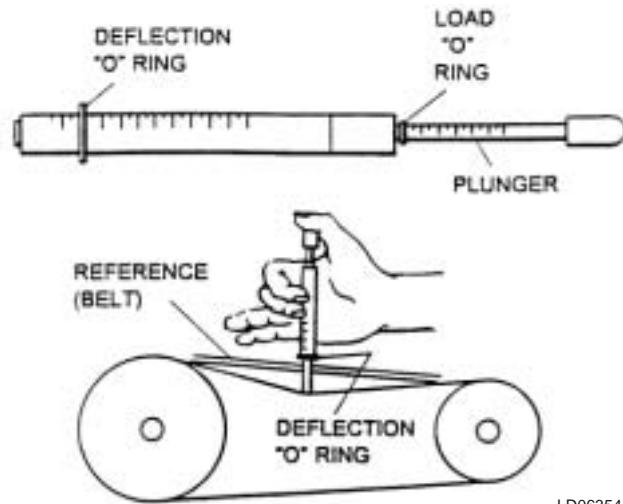

LD06354

FIG. 16 – BELT TENSIONING GAUGE

Belt Tensioning:

Belt tension information is included on the fan skid data plate as shown in Fig. 13. Sample data plate shows 4.3 lbs pressure at .30 inches deflection.

A Browning Belt tension gauge is used in Fig. 14 to properly tension belts.

	Airside Products Group	V-BELT DRIVE KIT	
YORK INTERNATIONAL			
DRIVE PART #	906-04636-100 AP		
SALES ORDER #	00-111313-00		
UNIT TAG #	AHU-7	C.O.M. #	30010
			\$35848
FAN RPM RANGE: 1244 to 1033			
TENSION INFO: 4.3 LB. .30 IN. CENTER - 19.84			
OPEN MOTOR SHEAVE 3 TURNS TO SET FAN RPM @ 1161			
MOTOR SHEAVE -	1VP60x1 3/8	MOTOR BUSHING -	
FAN SHEAVE -	BK05x1	FAN BUSHING -	
DRIVE BELTS -	BX59		

00494VIP

FIG. 15 – FAN DATA PLATE - BELT TENSION

Filter Drier Replacement

The filter/drier should be replaced any time work is performed on the refrigerant circuit. The rooftop unit comes with sealed type (non-replaceable) cores as standard. If the unit is not equipped with the optional valve package (suction, discharge, & liquid line valves), the refrigerant will need to be recovered with a recovery machine to replace the filter/drier.

If the unit is equipped with a valve package, the unit can be pumped down by closing the liquid line ball valve (prior to the filter/drier) while the unit is running, initiating a unit pump-down. The unit will shut off when the mechanical low-pressure switch closes. When the unit shuts down, close the ball valve located after the filter/drier and remove power from the unit to prevent the unit from running. Once the filter/drier core has been replaced, the filter/drier section should be evacuated via the Schrader access valve located next to the filter/drier prior to opening the ball valves and restoring the unit to normal operation.



Never shut the discharge valve while the unit is running. Doing so could cause a rupture in the discharge line or components, resulting in death or serious injury.



Never close the suction line ball valve with the compressor running. Doing so will cause the compressor to pump-down into a vacuum and damage the compressor due to internal arcing.

Forward Curved Fans

The forward curved fan wheel must be removed through the fan discharge opening. The location of other clamps, fan wheel, and shaft must be marked so each of these components can be reassembled in the same location - see Figure 15. This will preserve the balance of the rotating assembly. Proceed with the following steps:

1. Disconnect all duct work or guards attached to the blower housing to permit unobstructed access.
2. Remove the cut off plate attached at the discharge or blast area of the blower housing.
3. Thoroughly clean the shaft of all grease and rust inhibitor. Be careful not to contaminate the bearing grease. Use emery cloth to remove all rust or the wheel may become "locked" to the shaft.

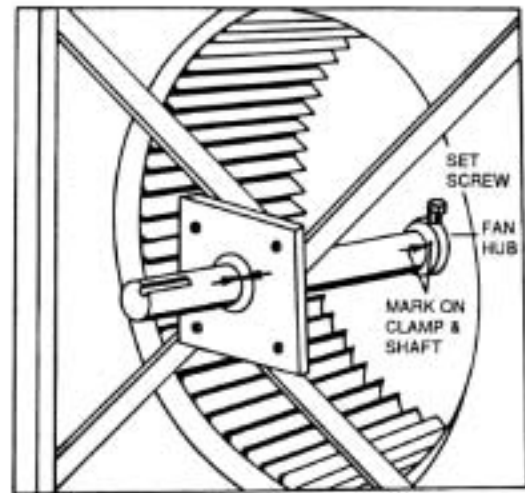

LD06355

FIG. 17 – EXAMPLE OF FC FAN SHAFT/WHEEL MARKING

4. Loosen and remove set screws on both bearing locking collars. Inspect and, if necessary, replace.
5. Loosen and remove set screws from both sides of the wheel hub. Inspect and, if necessary, replace.
6. Using a rubber mallet or brass bar, slowly drive the shaft in one direction until the set screw marks on the shaft are fully exposed. File the marks completely smooth. Drive the shaft in the opposite direction and file smooth the set screw marks. Continue to clean the shaft of all dirt and residuals.
7. To remove the key, use a rubber mallet or brass bar to drive the shaft and wheel in one direction. Drive the key in the opposite direction using a nail set or smaller size key stock until the key is completely free of the wheel. Be sure that key does not get bent by allowing it to ride up the key way edge. The slightest bend will prevent quick assembly. Should this occur, replace the key stock.
8. Remove the shaft, supporting the weight of the wheel, particularly for larger diameter wheels. Do not allow the weight of the shaft to be supported by one bearing as you disassemble.
9. Remove the wheel through the discharge or outlet area of the blower housing.
10. Reassemble in reverse order, centering the wheel between the edges of the inlet venturi. If bearings were removed or replaced, be sure to reuse any shim stock found between the mounting support/plate and bearing housings.

- Torque all hardware.



Disconnect and lock-out power from the unit anytime service is being performed on the fan section. Failure to do so could result in serious injury or death due to the fan turning on while work is in progress.

Fan Motor

- Shut off unit power and lock out.
- Disconnect and tag power wires at motor terminals.
- Loosen motor brace-to-mounting-rail attaching bolts.
- Mark belt as to position. Remove and set aside belts.
- Remove motor bracket hold down bolts.
- Remove motor pulley and set aside.
- Remove motor.
- Install new motor. Reassemble by reversing steps 1 - 6. Be sure to reinstall multiple belts in their original position. Use a complete new set if required. Do not stretch belts over sheaves. Review the sections on motor and sheave installation, sheave alignment, and belt tensioning discussed previously.
- Reconnect motor leads and restore power. Check fan for proper rotation as described in Start-Up Check List.

Fan Shaft Bearings

General – When removing and replacing the bearings, care should be taken to ensure that the area where the bearings fit on the shaft does not become scored or damaged. The shaft in this area should be thoroughly cleaned before the bearing is removed and again before the new bearing is installed.

Mounting Details –

- Check the shaft - it should be straight, free of burrs and full size. Be sure the bearing is not seated on a worn section of shafting.
- Make certain any set screws are not obstructing the bearing bore.
- Align the bearing in its housing and slide the bearing into position on shaft - never hammer the ends of the inner race. If necessary, use a brass bar or pipe against the inner race to drift bearing into place - never hit the housing, as bearing damage may result. Make sure there is lubricant between the bearing outer ring and the housing.
- Fasten the bearing housing to the unit mounting support with hex head cap screws, washers, new lock washers and hex nuts before securing the bearing to the shaft. This permits the bearing to align itself in position along the shaft and eliminates any possibility of cramping loads.
- Rotate the shaft to make certain it turns freely.
- Bearings may employ one of several different methods to lock the bearing to the shaft.

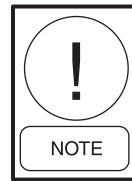

Shaft should be free from burrs. If old shaft is used, be sure a ball bearing is not seated on worn section and shaft is not bent.

There are various degrees of self-alignment in bearings of the same manufacturer. The force required for the self-alignment of the bearings used in YORK manufactured units has been specified and is closely monitored at the factory. If it is necessary to purchase a bearing locally, be sure it can be worked around in the housing with a short shaft made of wood or other soft material placed in the bearing.

Prior to installing the bearing on the shaft, it should be worked around in the housing to make sure that self-alignment will be obtained where the bearing is installed. After the shaft journal has been inspected for cleanliness, metal chips or burrs, the bearing is slipped, not forced, onto the shaft. Forcing the bearing onto the shaft by the use of flange, pillow block, or outer ring will damage the bearing internally. Force applied in this way transmits the load to the inner race through the balls in the bearing. Since the bearings are not designed for axial loading, the sides of the races in which the balls turn can be damaged. If the bearing cannot be made to slip onto the shaft by pressing on the inner ring of the bearing, check the shaft for burrs. Install the bearing so the part of the inner race, which receives the locking collar or contains setscrews, is toward the outside of the unit.

If the grease fitting must be changed on bearings that utilize a locking pin under the fitting, it is important to properly replace it. If an adapter or grease fitting of improper size and length is used, the locking pin may be either too tight or loose and can affect the alignment and re-lubrication of the bearing.

Bearing Lock Devices

Various types of locking devices are used to secure bearing(s) to the fan shaft. Refer to the instructions packed with bearings for special information. Figure 16 is a typical bearing with a setscrew-type locking device. The various locking devices can be classified under basic types: eccentric locking type, concentric locking type, and Skwezloc type.

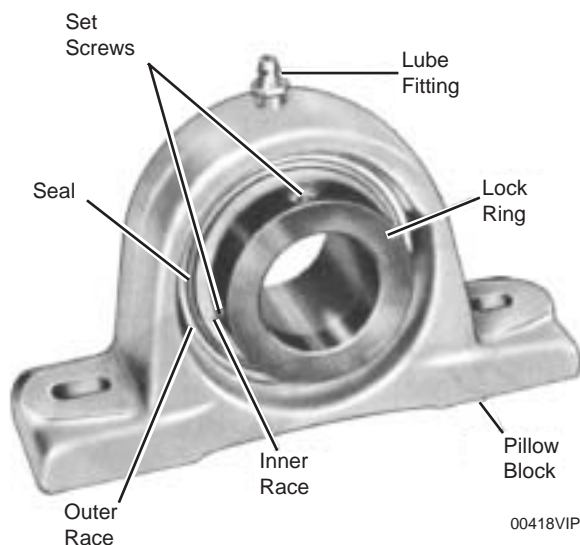

FIG. 18 – BEARING WITH SETSCREW TYPE LOCKING DEVICE

Eccentric Type

An eccentric self-locking collar is turned and driven with a punch in the direction of shaft rotation to lock the bearing inner ring to the shaft. See Figure 18.

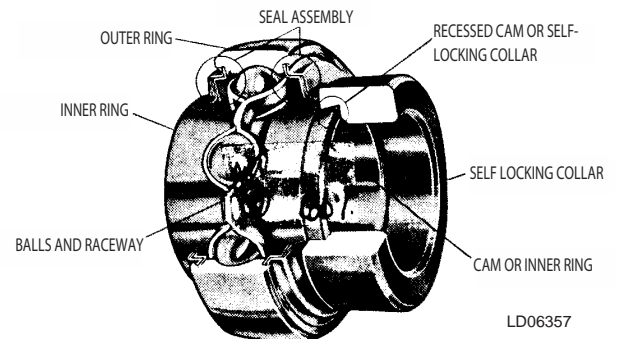

FIG. 19 – BEARING WITH ECCENTRIC CAM

When the eccentric collar is engaged to the cam on the bearing inner ring and turned in direction of rotation, it grips the shaft with a positive binding action. The collar is then locked in place with the setscrew provided in the collar.

The self-locking collar is placed on the shaft with its cam adjacent to the cam on the end of the bearing's wide inner ring. In this position, with collar and bearing cams disengaged, the collar's bore is concentric with that of the bearing's inner ring. The wide inner ring is loose on the shaft. By turning the collar in the direction of normal shaft rotation, the eccentric recessed cam will drop over and engage with the corresponding cam on the bearing inner, causing it to grip the shaft tightly with a positive binding action. See Figure 18. Make sure the two cams engage smoothly and the locking collar is down flat against the shoulder of the inner ring. The wide inner ring is now locked to the shaft. Using a punch or similar tool in the drilled hole of the collar, tap the tool lightly to lock the collar in the direction of normal shaft rotation.

As a final step, the setscrew is tightened. Torque per Table 9. It exerts a wedging action to hold the collar always in the engaged position, even under shock and reversing loads.

To disassemble, loosen the setscrew and tap the collar in the direction opposite shaft rotation.

TABLE 9 – SET SCREW TORQUE

SET SCREW DIA.	HEX. SIZE ACROSS FLATS LBS.	MIN. RECOMMENDED TORQUE	
		INCH LBS.	FOOT LBS.
1/4 1/8	66 - 85	5.5 - 7.2	
5/16	5/32	126 - 164	10.5 - 13.7
3/8 3/16	228 - 296	19.0 - 24.7	
7/16	7/32	348 - 452	29.0 - 37.7
1/2 1/4	504 - 655	42.0 - 54.6	
5/8 5/16	1104 - 1435	92.0 - 119.6	

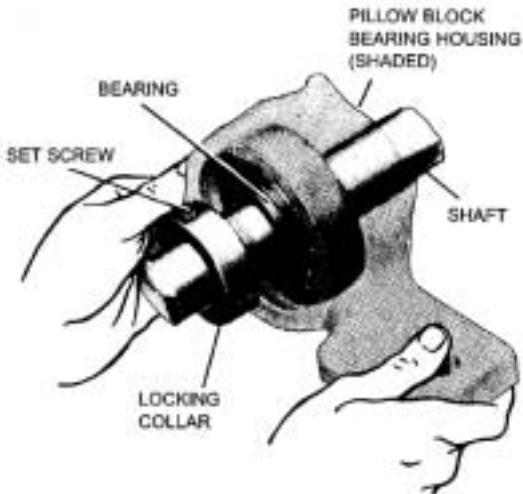

NOTE: Do Not apply excessive force to the bearing housing (pillow block or flange) when installing the bearing on the shaft.



Do not apply excessive force to the bearing housing (pillow block or flange) when installing the bearing on the shaft.



After proper installation of the bearing(s), run the unit for 10 to 15 minutes. Shut the unit down and lock it out. Check for proper engagement of locking collar and tightness of set screw(s).

When replacing split bearings, refer to manufacturer's instruction provided with the bearing. It is extremely important to ensure that proper radial clearances are observed between the roller bearings and outer face. Failure to make proper adjustments will cause premature failure of the bearing.

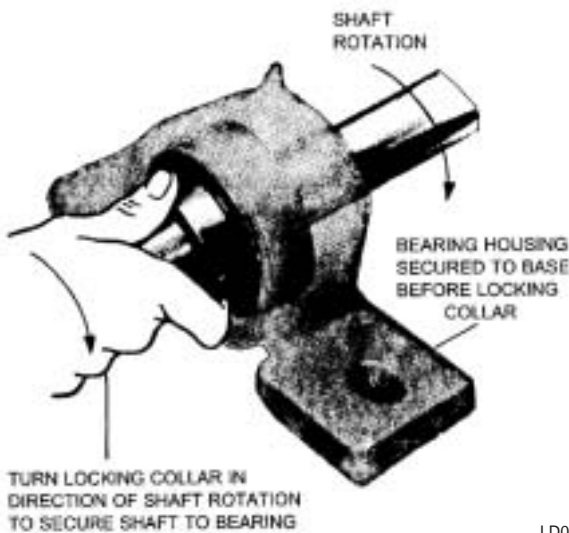

LD06358

FIG. 20 – ECCENTRIC CAM LOCKING COLLAR BEARING INSTALLATION

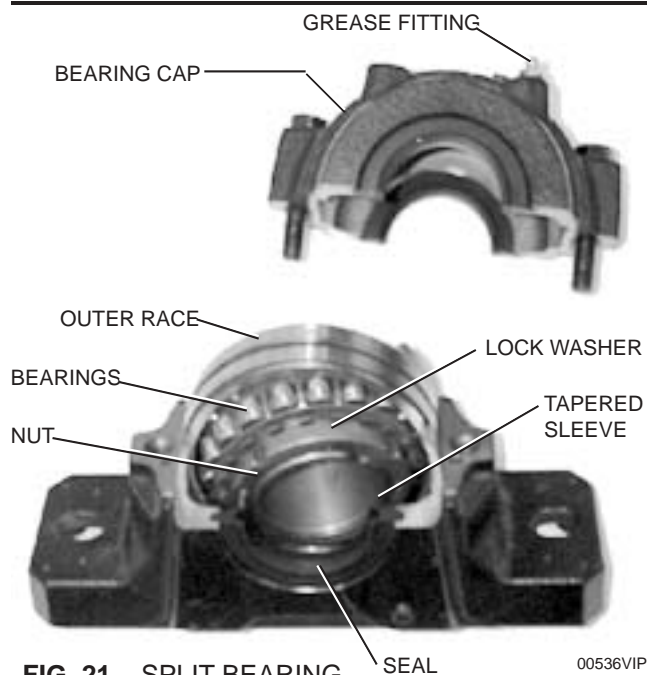

FIG. 21 – SPLIT BEARING

00536VIP

SECTION 5 – SEQUENCE OF OPERATION

COMPRESSOR STAGING

On the Design Level "C" units the Constant Volume (CV), Variable Air Volume (VAV) and FlesSys units all use the same compressor staging sequence.

TABLE 10 – FOUR OR SIX COMPRESSOR LOGIC – STAGING UP

Stage	Logic
1	Compressor 1A or 1B with shortest totalized run time and expired ASCD
2	Other compressor from System 1 (Wait for ASCD to expire if not expired)
3	Compressor 2A, 2B, 3A or 3B with shortest totalized run time and expired ASCD
4	Other compressor from System 2 or 3 with shortest run time and expired ASCD
5	Other compressor from System 2 or 3 with shortest run time and expired ASCD
6	Other compressor from System 2 or 3 with shortest run time and expired ASCD

TABLE 11 – FOUR OR SIX COMPRESSOR LOGIC – STAGING DOWN

Stage	Logic
6 to 5	Compressor from System 2 or 3 with longest run time and expired Min. Run Time.
5 to 4	Other Compressor from Sys. 2 or 3 with longest run time and expired Min. Run Time.
4 to 3	Other Compressor from Sys. 2 or 3 with longest run time and expired Min. Run Time.
3 to 2	Other Compressor from Sys. 2 or 3 with longest run time and expired Min. Run Time.
2 to 1	Compressor from System 1 with longest run time and expired Min. Run Time.
1 to Off	Last Compressor from System 1 after Min. Run Time has expired.

Note that ASCD (anti short cycle delay) and Minimum Run Time will take priority above Compressor totalized run time. For example, when turning on the first stage, the control will determine which compressor has the shortest total run time and also read the ASCD timers for each compressor. If the compressor with the shortest total run time has expired its ASCD, then that compressor will be started. If the compressor with the shortest total run time has not expired its ASCD but the other compressor has, then the compressor with the longer run time will be started.

COMPRESSOR AVERAGE RUN TIMES

To increase system reliability, all compressors will be staged up (ON) based on total run time. The compressors with the shortest total run time will always be energized first in an attempt to equalize run time.

SUPPLY FAN OPERATION

Minimum Off Time

The Supply Fan minimum OFF time is as specified in Table 14 under section on Timeouts and Delays.

The Supply Fan will be ON prior to:

- Starting any compressors.
- Turning ON any gas or electric heating stage.
- Opening any heating valve.

Overrun

The Supply Fan will continue to run for 1 minute after all compressors or heating stages turn OFF unless otherwise stated. When in Thermostat operation, the overrun requirement will override the loss of the G input from the Thermostat.

For gas or electric heat, the Supply Fan will continue to run until the SAT is less than 100°F.

CV Operation

For CV operation:

- The Supply Fan will be ON whenever the G input from the Thermostat is present.
- The Supply Fan will stay ON when the G input is no longer present to satisfy the Overrun requirement.
- If the unit is configured to use a space sensor, the Supply Fan will be ON whenever:
 - Heating or cooling is called for.
 - The "*Fan On with Sensor*" parameter is ON and occupancy is indicated.

VAV & Flexsys Operation

For VAV operation:

- The Supply Fan will be ON at the specified output level whenever occupancy is indicated.
- When occupancy is not indicated the Supply Fan will be ON at the specified output level whenever:
 - Unoccupied cooling or heating is called for.
 - The Thermostat G input is present and the *VAV with Thermostat* parameter is ON.
- In the Heating Mode, the Supply Fan will be at 100% output when ON.
- In the Cooling Mode, the Supply Fan will be operated to maintain the *Duct Static Pressure* setpoint when ON.

TIMEOUTS AND DELAYS

Table 14 lists the timeouts and delays that are to apply in all functions unless an exception for a specific function is specified.

TABLE 14 – TIMEOUTS AND DELAYS

Number	Timeout or Delay	Description
1	*ASCD for cooling	This “minimum OFF time” delay will not allow any compressor to turn on, unless it has been off for 5 minutes, except when ASCD override is ON.
2	*ASCD for “Cooling SAT Alarm”	This will not allow any compressor to turn ON after an excessive SAT trip has occurred, until it has been off for 3 minutes.
3	*ASCD for “Heating SAT Alarm”	This will not allow any heat stage to turn ON after an excessive SAT trip has occurred, until it has been off for 5 minutes.
4	*ASCD for heating	This “minimum OFF time” delay will not allow any heating stage to turn on, unless it has been off for 2 minutes. Exception: Supply Air Tempering = 1 min.
5	Energy Saver Delay	This is a 1 minute minimum time between turning on compressor stages or heating steps.
6	Minimum Run Time for Cooling	A minimum run time of 5 minutes will apply to all compressors.
7	Supply Fan *ASCD	This will not allow the Supply Fan to turn ON unless it has been OFF for 30 seconds.
8	Exhaust Fan Minimum Run Time	The exhaust fan will have a minimum ON time of 10 seconds.
9	Exhaust Fan Minimum Off Time	The exhaust fan will have a minimum OFF time of 1 minute.
10	Delay to allow SAT to stabilize	A 5 minute delay will be used any time a compressor, or a heating stage is turned ON, or OFF, before using the SAT reading for any control decisions.

*ASCD - Anti Short Cycle Delay

CONSTANT VOLUME SEQUENCE OF OPERATION

Under Constant Volume (CV) operation, the unit will be controlled from one of the following sources in order of priority:

- 7-Wire Thermostat.
- Space Sensor.

The Primary Unit Controller will monitor each source and self-configure to the source available with the highest priority.

Thermostat Control In CV Operation

Under thermostat control, the unit will monitor the G, Y1, Y2, W1, and W2 thermostat inputs and control the unit accordingly. Cooling Operation with Y1 and Y2 thermostat inputs are as follows:

Compressor Staging - ON:

- Y1 Only – Cooling Stage 1 – Both system 1 compressors and one of the System 2 or System 3 compressors on a six compressor unit.
- Y1 and Y2 – Cooling Stage 2 – All of the installed compressor on System 1, 2 and 3 if applicable.
- If Y2 is present without Y1, the unit will stage on Y1 per above and then stage on Y2.

Compressor Staging – OFF:

- Y2 Off – Shut off Cooling Stage 2 - It will shut off one-half of the installed compressor. On a four compressor system it will shut off the System 2 compressors. On a six compressor system it will shut off three of the four System 2 and System 3 compressors.

- Y1 Off – shut off Cooling Stage 1 – All compressor operation will be shut down

Heating Operation with W1 and W2 Inputs

The Primary Unit Controller can be configured for four types of heat, Gas, Electric, Steam, Hot Water. When Gas or Electric is selected, the unit must also be configured for the number of stages. The Hot Water and Steam options use a modulating valve that varies the heating capacity based on the load. A Modulating Gas Heat option is also available. When Modulating Gas Heat is installed, the unit is configured for Hot Water.

- W1 Active Only (Staged Heat) – One half of the total number of stages will be energized See Table 15.
- W1 Active Only (Modulating Heat) – The Primary Unit Controller will modulate the valve based on the temperature difference between the Supply Air Temperature (SAT) and the “Hydro Heat 1ST Stage” set point.
- W1 and W2 Active (Staged Heat) – All the stages will be energized.
- W1 and W2 Active (Modulating Heat) – The Primary Unit Controller will modulate the valve based on the temperature difference between the Supply Air Temperature (SAT) and the “Hydro Heat 2ND Stage” set point.
- W2 Active Only (Staged Heat) – Only the W2 heat stages will be energized. See Table 15
- W2 Active Only (Modulating Heat) – The Primary Unit Controller will modulate the valve based on the temperature difference between the Supply Air Temperature (SAT) and the “Hydro Heat 2ND Stage” set point.

As the Heating Stages are de-energized, or if steps of heat should be dropped due to Excessive SAT (supply air temperature), the steps of heat will be de-energized one at a time. If the unit is not equipped with heat, the control will ignore the W1 and W2 inputs.

Gas or Electric (Stepped) Heating

If the controller is configured for stepped heating, the controller will read the Heat Steps configuration setting to determine the number of heating steps available. Up to six (6) individual heating steps can be available. These steps will be divided into two Heating Stages as shown in Table 15.

TABLE 15 – STAGED HEATING STEPS

TOTAL # OF STEPS AVAILABLE	# OF STEPS ASSIGNED TO	
	HEATING STAGE 1	HEATING STAGE 2
1	1	0
2	1	1
3	2	1
4	2	2
5	3	2
6	3	3

Space Sensor Control (RTD)

Under space sensor control, the Primary Unit Controller will monitor the space temperature via the space sensor inputs and the Occupied input and control the unit accordingly. The use of a space sensor on a constant volume unit requires an unoccupied/occupied signal to the controller. This signal can be received from one of three sources: the hard-wired Unoccupied/Occupied input, internal scheduling via a Network (BAS), or from a roof link controller. The unoccupied/occupied signal determines what programmed space temperature setpoint to maintain in the controlled space.

For this option to function the configuration setting Space Sensor Enable must be set to ON and the sensor must be reliable. During this mode of operation, if the space sensor becomes unreliable, a fault will be generated. With this, the unit will shut down unless a RAT (return air temperature) sensor is enabled and reliable. If a RAT sensor is present, the unit will monitor the Return Air Temperature for unit control decisions. If the RAT sensor then becomes unreliable, the unit will be shut down.

Types of Space Sensors

No Sensor – The configuration setting, “Space Sensor Enable”, Must be selected OFF. The Control will only operate the unit from the Thermostat inputs or from a network (BAS).

Sensor Only – This Sensor only has a RTD in it for unit operation.

Sensor with Unoccupied Override Button – This Sensor has a RTD and an Override button that shorts the Sensor when pushed. After the Override button has been pushed for a minimum of one second the unit will go into the Unoccupied Override mode for the Unoccupied Override Time . The Override mode is cleared if the unit goes Occupied during this Override mode.

Sensor with Space Setpoint Adjust – This Sensor has a slider potentiometer on it that represents (as a default) $\pm 3^{\circ}\text{F}$ adjustment to the Space Setpoint. The Space Setpoint Offset Setpoint specifies the amount of \pm adjustment, in range from 0°F to 5°F .

Sensor w/ Space Setpoint Adjust and Unoccupied Override Button – This Sensor has a slider potentiometer and an Unoccupied Override button. Both functions operate as described above.

Cooling Operation with a Space Sensor

For cooling operation, the space temperature will be controlled to either the:

- Unoccupied Cooling Setpoint or the
- Occupied Cooling Setpoint based on the Occupied/Unoccupied state of the unit (i.e. Occ/Unocc Input, or Internal Scheduling).

Control Algorithm For Space Sensor Cooling – Economizer Not Suitable

The Space Sensor Cooling control algorithm is as illustrated in Figure 22.

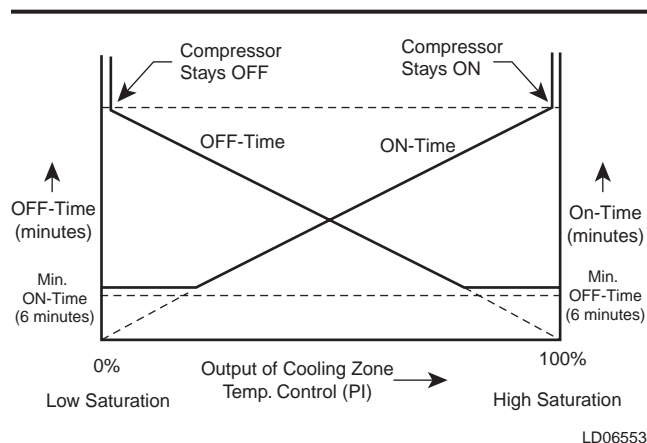

FIG. 22 – CV SPACE SENSOR COOLING ALGORITHM - ECONOMIZER NOT SUITABLE

- A direct acting, proportional – integral space temperature controller generates a 0 – 100% output signal that responds to space cooling demand.
- The output of the controller is used to calculate on and off time of the compressor most recently started based on the calculation method in Figure 22.
- PI gain values are to be determined by such that all compressors are on within 28 minutes with a 10°F space temperature error; or 42 minutes for a 6-compressor system with a 10°F space temp. error.
- When the duty cycle reaches 100% (the PI algorithm reaches a “High Saturation state” and a saturation time delay expires), the modulated compressor stops cycling and remains on.
- An additional compressor is staged every time the space control PI algorithm reaches a High Saturation state and a programmed saturation time delay expires.
- A compressor is destaged when the PI algorithm reaches a Low Saturation state and a programmed saturation time delay expires.

Control Algorithm For Space Sensor Cooling - Economizer Suitable

In CV cooling operation with a space sensor and when free cooling is available (“economizer suitable”), the SAT is controlled by the economizer control algorithm (see page 53; Economizer Operation). The control algorithm is shown in Figure 23 (see section on Economizer Operation for a more specific explanation on economizer operation).

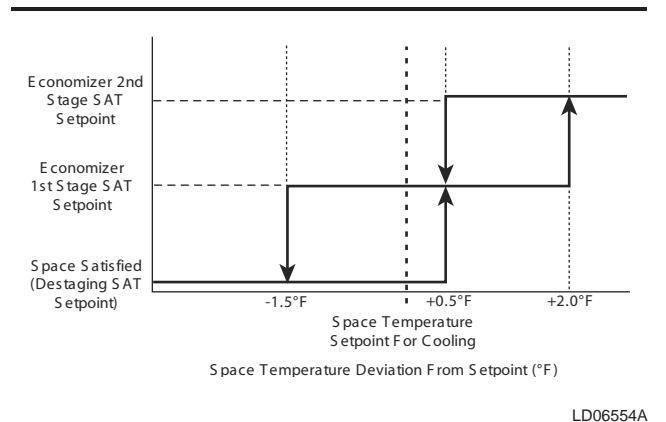

FIG. 23 – CV SPACE SENSOR COOLING ALGORITHM - ECONOMIZER SUITABLE

5

When the space temperature is 1.5°F or more less than the Economizer 1st stage or Economizer 2nd Stage set point, destaging compressors is accomplished by temporarily requesting an SAT setpoint of 90° F. This setpoint assures that there is no need for compressors even at the highest outdoor air temperature and/or enthalpies.

Note that the destaging process still occurs in cooling state, so there is no possibility of heating being activated due to the temporarily high SAT setpoint, or due to space temperature dropping below its cooling setpoint and towards space heating setpoint.

Staging of Compressors When Exiting Economizer Mode

This situation occurs when one, or more compressors are running in the economizer mode, and free cooling becomes unavailable. The sensor control mode changes – sensor algorithm is no longer selecting the active economizer SAT setpoints, but now is used to directly control the compressors. The control mode changeover process involves turning off the compressors that were running during the economizer operation, and then turning back on the compressors needed during mechanical cooling only. The compressors will continue to operate until the minimum run time criteria has been met.

Heating Operation With a Space Sensor

For Heating operation, the space temperature will be controlled to either the Unoccupied Heating Setpoint or the Occupied Heating Setpoint based on the Occupied/Unoccupied state of the unit (i.e. Occ/Unocc Input, or Internal Scheduling).

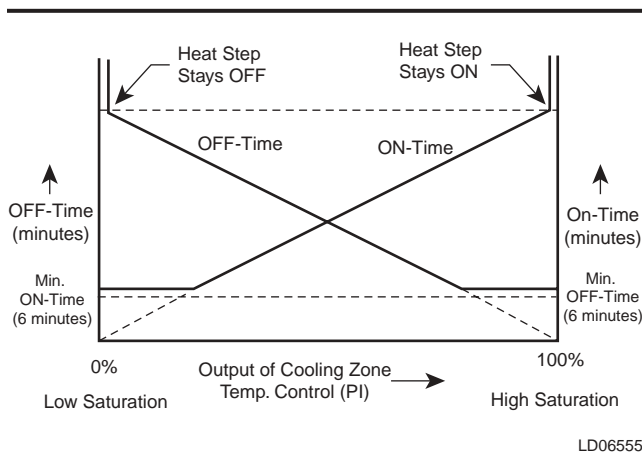

FIG. 24 – CV SPACE SENSOR STEPPED HEAT ALGORITHM

Control Algorithm For Space Sensor Stepped Heat

- The Space Sensor Stepped Heat control algorithm is as illustrated in Figure 22. The controller will read the number of Heat Steps parameter to determine the heat steps available. Heat steps will be used in number sequence.
- A direct acting, proportional – integral space temperature controller generates a 0 – 100% output signal that responds to space heating demand.
- The output of the controller is used to calculate on and off time of the heat step most recently started based on the calculation method in Figure 22.
- PI gain values are to be determined by such that all heating steps are on within 42 minutes with a 10°F space temperature error.
- When the duty cycle reaches 100% (the PI algorithm reaches a “High Saturation state” and a saturation time delay expires), the modulated heating step stops cycling and remains on.
- An additional heating step is started every time the space control PI algorithm reaches a high saturation state and a programmed saturation time delay expires.
- A heating step is stopped when the PI algorithm reaches a Low Saturation state and a programmed saturation time delay expires.

Control Algorithm For Space Sensor Hydronic Heat

In CV heating operation using hydronic heat, the SAT is controlled by algorithm as shown in Figure 23.

Table 16 details the modes of CV operation and provides an overview of the control methods in all modes.

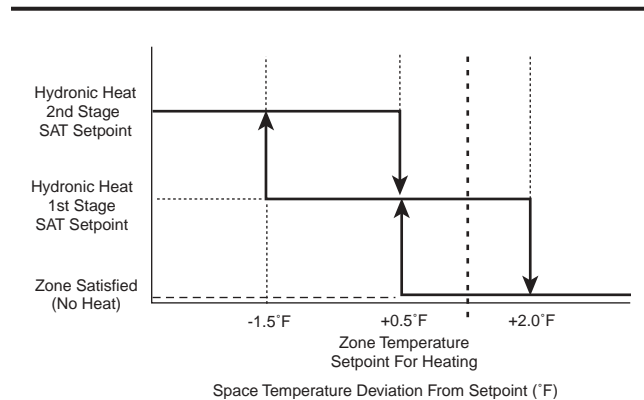

FIG. 25 – CV SPACE SENSOR HYDRONIC HEAT ALGORITHM

TABLE 16 – CV (CONSTANT VOLUME) MODES OF OPERATION

Control	Heating		Cooling	
	Occupied	Unoccupied	Occupied	Unoccupied
Thermostat	<p>Controller Occupied input is ON (energized by 'stat occ. output, or by an external command). 'stat uses its programmed occupied htg. Setpoint. Supply fan controlled by 'stat's G output. Economizer damper at programmed min. position. 'stat W1, W2 outputs control heating stages 1 and 2. If hydronic heat or modulating gas heat, 'stat W1,W2 outputs select programmed "Hydro heat 1st and 2nd stage Setpoints</p>	<p>Controller Occupied input is OFF (deenergized by 'stat occ. output, or by an external command). Economizer damper is at 0% Control is same as occupied heating, except 'stat uses its programmed unoccupied heating setpoint.</p>	<p>Controller Occupied input is ON (energized by 'stat occ. output, or by an external command). 'stat uses its programmed occupied clg. setpoint. Supply fan controlled by 'stat's G output Economizer damper at programmed min. position, may modulate open if free cooling is being used. Mechanical cooling mode: 'stat Y1, Y2 outputs control stage 1 and 2 compressors Economizer mode: 'stat Y1, Y2 outputs select High and Low programmed Economizer SAT setpoints, SAT controlled by economizer control algorithm.</p>	<p>Controller Occupied input is OFF (deenergized by 'stat occ. output, or by an external command). Economizer damper is at 0% (damper may modulate open if free cooling is being used). Control is same as occupied cooling, except 'stat uses its programmed unoccupied cooling setpoint.</p>
Space Sensor	<p>Controller Occupied input is ON (energized by an external command). Space temperature is controlled to a programmed occupied htg. setpoint. For supply fan, setting of the parameter "Fan ON mode with the Sensor Option" determines if the supply fan is ON continuously, or is in "Auto" mode (i.e. goes off when space is satisfied). Economizer damper at programmed min. position Heating is controlled by a PI algorithm that controls staging of heat stages and modulates duty cycle of the highest numbered running heating stage. If hydronic heat or modulating gas heat, space control algorithm selects programmed "Hydro Heat 1st Stage SAT Setpoint" and "Hydronic Heat 2nd Stage SAT Setpoint"</p>	<p>Controller Occupied input is OFF (deenergized by an external command). Economizer damper is at 0% Supply fan is in "Auto" mode (i.e. goes off when space is satisfied). Control is same as occupied heating, except space temperature is controlled to a programmed unoccupied heating setpoint.</p>	<p>Controller Occupied input is ON (energized by an external command). Space temperature is controlled to a programmed occupied clg. setpoint. For supply fan, setting of the parameter "Fan ON mode with the Sensor Option" determines if the supply fan is ON continuously, or is in "Auto" mode (i.e. goes off when space is satisfied). Economizer damper at programmed min. position, may modulate open if free cooling is being used. Mechanical cooling mode: Cooling is controlled by a PI algorithm that controls compressor staging and modulates duty cycle of the highest numbered running compressor. Economizer mode: Space control algorithm selects High and Low programmed Economizer SAT setpoints, SAT controlled by economizer control algorithm.</p>	<p>Controller Occupied input is OFF (deenergized by an external command). Economizer damper is at 0% (damper may modulate open if free cooling is being used). Supply fan is in "Auto" mode (i.e. goes off when space is satisfied). Control is same as occupied cooling with a space sensor, except space temperature is controlled to a programmed unoccupied clg. setpoint.</p>

VARIABLE AIR VOLUME SEQUENCE OF OPERATION

Under Variable Air Volume Operation, the unit will be controlled from one of two sources:

- 7-Wire Thermostat
- Space Sensor

In addition to the two control methods, a VAV configured unit can also operate “stand-alone” with the only direct control being the Occupied/Unoccupied signal. The method of control is as selected as described in the following sections.

VAV Operation With a Thermostat

When “VAV with Thermostat” parameter is set to ON, a Thermostat is used for SAT reset control.

If the Thermostat is not available, the Primary Unit Controller will self-configure to Standalone VAV operation

VAV Operation With a Space Sensor

A Space Sensor is used for control when:

- The VAV with Thermostat parameter is OFF, and:
 - A Space Sensor is available and the “Space Sensor Enable” parameter is ON.
- If a Space Sensor is not available, the controller will self-configure to Standalone VAV operation.

Standalone VAV Operation

Standalone VAV operation is used by the control when:

- The VAV with Thermostat parameter is OFF, and
- No Space Sensor is available.

VAV Operating Modes

VAV operating modes have the following common functions:

- For heating, the Heating Mode Enable parameter must be ON.
- For cooling, the Cooling Mode Enable parameter must be ON.
 - Cooling (compressor) stages are controlled as described in the following sections.
 - The SAT control algorithm for cooling is described in the following sections.

- The Supply Fan is:
 - Controlled as described in the Fan.
 - Controlled to maintain the Duct Static Pressure setpoint when cooling or heating is ON.
 - ON and controlled for heating or cooling when the Thermostat G output is ON.
 - Ramped up to its operation condition using its variable output control when turned ON.
 - OFF when heating or cooling is OFF and occupancy is UNOCCUPIED.
 - Optionally controlled ON and OFF by a BAS input when occupancy is UNOCCUPIED.
- For Economizer Operation, the *Economizer Installed* parameter must be ON and the *Economizer Enable* parameter must be ON. The economizer is:
 - Closed for all unoccupied heating.
 - At the minimum position for occupied heating.
 - At minimum for occupied cooling when economizer is not available.
 - Closed for unoccupied cooling when economizer is not available.
 - At the economizer algorithm determined position for cooling with economizer available.

Unoccupied Heating With A Thermostat

The heating control is as described for “Occupied Heating With A Thermostat” and the general operating conditions.

Occupied Cooling With A Thermostat

- The thermostat Y1 and Y2 outputs control SAT to:
 - Y1 = OFF, Y2 = OFF – No cooling
 - Y1 = ON, Y2 = OFF - Cooling to “VAV Cool High Temp Setpoint”.
 - Y1 = ON, Y2 = ON - Cooling to “VAV Cool Low Temp Setpoint”.
 - Y1 = OFF, Y2 = ON - Cooling to “VAV Cool Low Temp Setpoint”.

Unoccupied Cooling With A Thermostat

The cooling control is as described for Occupied Cooling With A Thermostat and the general operating conditions.

Occupied Heating With A Space Sensor

- The programmable parameter "VAV with Thermostat" is OFF, and a space sensor is available and the "Space Sensor Enable" parameter is ON.
- The programmable parameter enable setting "Occupied Heating" must be set to ON to enable the Occupied Heating With A Space Sensor function.
- The stepped heating control algorithm is:
 - Turned ON when the space temperature is less than the "VAV Sp for SAT Reset" by 20F
 - Monitors the return air temperature and controls the unit between the "Warm-Up RAT" and the "Warm-Up RAT" minus 2 F.

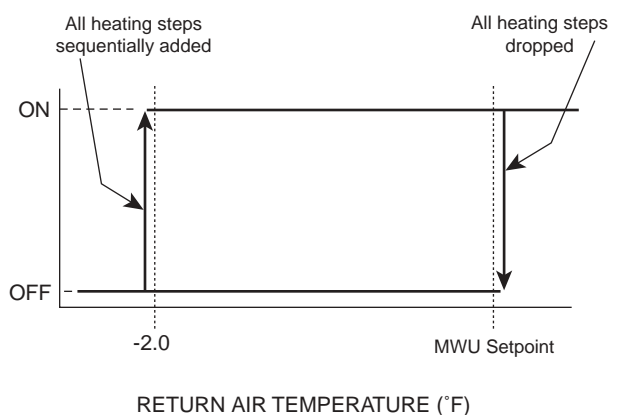

LD06557

FIG. 26 – VAV OCCUPIED HEATING TO MAINTAIN RAT AND MORNING WARM UP

- Turned OFF when the space temperature is greater than ("VAV SP for SAT Reset" - 1.5°F) or the RAT reaches setpoint.
- Figure 30 illustrates the algorithm for occupied heating required.
- For hydronic heating:
 - The SAT is controlled to the 2nd Stage Hydronic Heat Setpoint.
 - The Heat 1 output of the controller is set to control HIGH during heating.

Unoccupied Heating With A Space Sensor

- The programmable parameter "VAV Operation with Thermostat" must be set to OFF and Space Sensor signal must be reliable.
- The programmable parameter "VAV Occupied Heating" must be set to ON to enable the Occupied Heating With A Space Sensor function.

- Both the space temperature and the RAT must be 2°F below their setpoints.
- The space temperature is controlled to the Unoccupied Heating Setpoint using the algorithm illustrated in Figure 27.

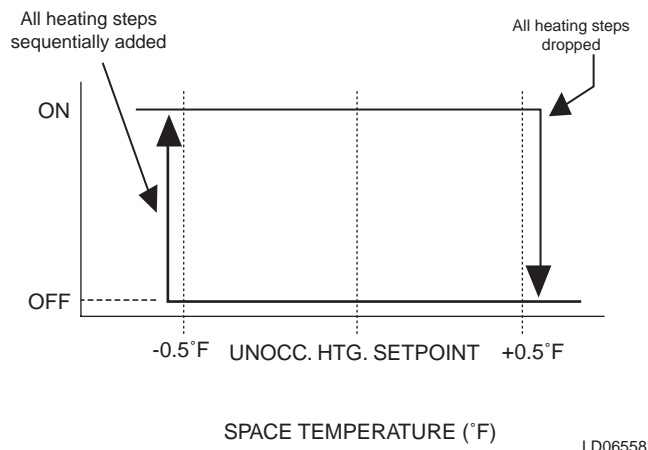

LD06558

FIG. 27 – VAV UNOCCUPIED STEPPED HEATING-TEMPERATURE CONTROL

- For hydronic heating:
 - The SAT is controlled to the 2nd Stage Hydronic Heat Setpoint.
 - The Heat 1 output of the controller is set to control HIGH during heating.

5

Occupied Cooling With A Space Sensor

- The programmable parameter VAV Operation with Thermostat must be set to OFF and Space Sensor signal must be reliable.
- The SAT setpoint for cooling is the "VAV Cool Low Temp" or "VAV Cool High Temp" through comparison of the space temperature and the "VAV SP for SAT Reset" as shown in Figure 30.

Unoccupied Cooling With A Space Sensor

- The programmable parameter VAV Operation with Thermostat must be set to OFF and Space Sensor signal must be reliable.
- Cooling is called for according to the algorithm illustrated in Figure 28.
 - The SAT setpoint for unoccupied cooling is the VAV Cool High Temperature Setpoint.

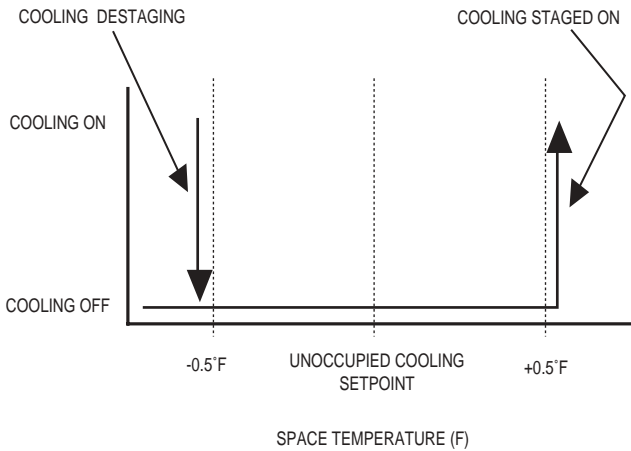

FIG. 28 – VAV UNOCCUPIED COOLING TEMPERATURE CONTROL

LD06559

Occupied Heating In Standalone Operation

The following conditions must be met to initiate heating operation:

- A RAT (Return Air Sensor) must be installed in the unit and the "RAT Sensor Enable" must be ON.
- The RAT must be 2 degrees less than the "Warm-up RAT" setting.

Unoccupied Heating In Standalone Operation

- In this mode, the unit remains shut down, unoccupied heating is never used.

Occupied Cooling In Standalone Operation

- The programmable parameter *VAV with Thermostat* must be set to OFF.
- Space Sensor signal must be unreliable or not detected.
- The SAT setpoint for occupied standalone cooling when the economizer is active is "VAV Cool High Temp" and when the economizer is not active the SAT setpoint is "VAV Cool Low Temp".

Unoccupied Cooling In Standalone Operation

- In this mode, the unit remains shut down, unoccupied cooling is never used.

SAT Control Algorithm in VAV Cooling

This section describes the control of compressors to maintain the SAT setpoint for:

- Economizer Operation when mechanical cooling is required to maintain the SAT setpoint
- or

- Non-Economizer Operation or Economizer Operation when economizer is not suitable is as described in Figure 29.

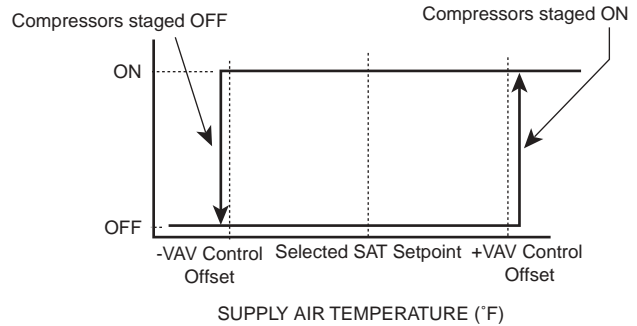

FIG. 29 – COMPRESSOR STAGING FOR VAV COOLING

LD06560

The setpoint is as determined for the space temperature condition and is either the "VAV Cool High Temp" or the "VAV Cool Low Temp" setting.

The SAT will be controlled at the above setpoints +/- "VAV Control Offset".

The compressors will stage ON after the SAT has been greater than (SAT Setpoint + VAV Control Offset) for 5 minutes.

Compressors will be staged OFF individually when the SAT drops below the (SAT Setpoint – VAV Control Offset).

Supply Duct Static Pressure Control Algorithm

The Supply Duct Static pressure will be controlled to the duct static pressure setpoint. An appropriate PI closed loop control algorithm will be used to control the supply duct static pressure by modulating the supply fan VFD.

Occupied VAV Heating / Cooling Control Algorithm With A Space Sensor

In the occupied mode, the Space Sensor will compare the space temperature to the programmed "VAV SP for SAT Reset" and request heating, or cooling, using the following control algorithm (Figure 30):

- The transition from cooling to occupied heating occurs at 2°F below the "VAV SP for SAT Reset"
- The reverse transition at 1.5°F below the "VAV SP for SAT reset". There is no "satisfied", or "idle" state of the unit between cooling and occupied heating.

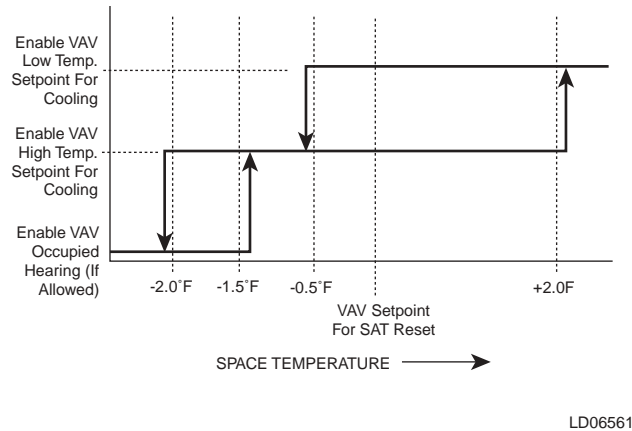

FIG. 30 – OCCUPIED HEATING AND COOLING SETPOINT SELECTION ALGORITHM

Morning Warm Up

Morning Warm Up operation is carried out when:

- The *Morning Warm Up* parameter is ON.
- The *Internal Clock/Schedule* parameter is ON.
- Occupancy is scheduled for the current day.
- Warm up command is received from BAS.

The Morning Warm Up start time will be 60 minutes prior to scheduled occupancy, or BAS initiates the morning warm-up.

When started, the Morning Warm Up operation is as follows:

- Close economizer.
- Turn the Supply Fan ON and operate for 2 minutes before beginning temperature control.
- If the RAT is 2 degrees less than the Morning Warm Up setpoint, the Primary Unit Controller will energize the heat relays and bring on all stages after one minute.
- For stepped heating - Control to maintain the RAT to the Morning Warm Up Setpoint using the algorithm illustrated in Figure 26.
- For Hydronic heating - The SAT is controlled to the 2nd Stage Hydro Heat Setpoint.

Morning Warm Up operation will end when:

- An occupancy (space is occupied) input is received from the controller input.
- The scheduled occupancy time occurs.

- The Morning Warm Up operation times out based on the "*Max Warm Up Time*" parameter if warm up signal is controlled by a BAS signal.

Supply Air Tempering

VAV Supply Air Tempering operation requires the following:

- Economizer – ON
- Unit is equipped with electric, gas, steam or hydronic heat
- Heat Enable - ON
- Economizer Enable – ON
- Conditions are suitable for Economizer operation
- Supply Air Tempering Enable – ON
- All compressors – OFF

Supply Air Tempering is a continuation of the VAV cooling operation when the Outdoor Air Temperature is below the SAT setpoint, where heating is used to maintain ventilation operation.

Supply Air Tempering With Proportional Heat

If the unit is equipped with proportional heat, Hot Water, Steam, or Modulating Gas, the control will provide Supply Air Tempering:

- When the SAT falls below the (SAT setpoint – 10°F) for 10 minutes.
- The control will control the Heating Valve analog output to maintain the current "*VAV Cool High Temp*" Setpoint.

The control will end Supply Air Tempering operation and begin Cooling operation when the SAT rises to 4°F above the "*VAV Cool High Temp*" setpoint.

Supply Air Tempering With Staged Heat

If the unit is equipped with stepped heat (electric or gas), the heat stages will be duty cycled to maintain SAT setpoint.

The duty cycle for the heat steps will be:

- A 10-minute period;
- A minimum time of 2 minutes ON;
- A minimum time of 1 minute OFF.

Table 17 details the modes of VAV operation and provides an overview of the control methods in all modes.

TABLE 17 – VAV MODES OF OPERATION

Control	Heating		Cooling	
	Occupied	Unoccupied	Occupied	Unoccupied
Thermostat	'stat uses its programmed occupied htg. Setpoint, controls SAT to "no heating" (W1=OFF), or "full heating (W1=ON). During heating, supply fan meets duct static requirements. If hydronic heat, SAT controlled to 2nd stage hydronic heat setpoint.	Same as occupied heating, except 'stat uses its programmed unoccupied heating setpoint, 'stat generates "unoccupied" output that overrides ODA damper min. position to 0%. During heating, supply fan at 100%.	'stat uses its programmed occupied clg. setpoint, 'stat Y1, Y2 outputs control SAT to "no cooling" (Y1=OFF), cooling to "VAV Cool High Temp SAT setpoint" (Y1=ON) and cooling to "VAV Cool Low Temp SAT setpoint" (Y1=ON, Y2=ON). ODA damper at min. position (damper may modulate open if free cooling is being used) Supply fan controlled during cooling by supply duct static, supply fan uses a "soft start."	Same as occupied cooling, except 'stat uses its programmed unoccupied cooling setpoint, 'stat generates "unoccupied" output that overrides ODA damper min. position to 0% (damper may modulate open if free cooling is being used). Supply fan controlled during cooling by supply duct static.
Network Communicated Sensor	Similar to thermostat operation above, 'stat W1 signal is replaced by a network command.	Similar to thermostat operation above, 'stat W1 signal is replaced by a network command. Network supplies an "unoccupied" command.	Similar to thermostat operation above, 'stat signals are replaced by network commands requesting cooling to High SAT setpoint (Stage 1), or to Low SAT setpoint (Stage 2).	Similar to thermostat operation above, 'stat signals are replaced by network commands requesting cooling to High SAT setpoint (Stage 1), or to Low SAT setpoint (Stage 2), network supplies an "unoccupied" command.
Space Sensor	Control algorithm is same as for Morning WarmUp cycle. RAT is controlled to a programmed setpoint w/ 2°F deadband when space temperature drops 2°F below "VAV setpoint for SAT reset". During heating, supply fan meets duct static requirements. If hydronic heat, SAT controlled to 2nd stage hydro heat setpoint. Both space and RAT must be below setpoints.	An external "unoccupied" signal initiates this mode. Space temperature is controlled to a programmed unoccupied htg. Setpoint by cycling unit On/Off. Full heating (all stages) is ON when space temperature drops 0.3°F below the setpoint, OFF when temperature is 0.1°F or less below the setpoint for at least 60 sec. During heating, supply fan at 100%. If hydronic heat, SAT controlled to 2nd stage hydronic heat setpoint.	Cooling SAT setpoint is reset by space temperature vs. "VAV setpoint for SAT reset". "VAV Cool Low Temp" setpoint used if space temperature 2°F above the reset setpoint, "VAV Cool High Temp" setpoint if space temperature 0.5°F below the reset setpoint. ODA damper at min. position (damper may modulate open if free cooling is being used) Supply fan controlled during cooling by supply duct static, supply fan uses a "soft start".	An external "unoccupied" signal initiates this mode, overrides ODA damper min. position to 0% (damper may modulate open if free cooling is being used). Space temperature is controlled to programmed unoccupied clg. Setpoint by cycling unit On/Off. When space temperature increases 0.3°F above the setpoint, cooling runs at programmed High SAT setpoint, when temperature is 0.1°F or less above the setpoint for at least 60 sec, unit turns OFF. During cooling, supply fan is controlled by supply duct static, supply fan uses a "soft start".
None (standalone)	RAT must be below setpoint for 10 minutes.	An external "unoccupied" signal initiates this mode, unit shuts down.	SAT is controlled to the "VAV Cool High Temp". if the economizer is active or to the "VAV Cool Low Temp" if the economizer is not active. Supply fan is always running and controlled by the duct static.	An external "unoccupied" signal initiates this mode, unit shuts down.

ECONOMIZER OPERATION

Economizer operation is described in the following sections. A final section within Economizer operation description is on Economizer Loading. Economizer Loading is a variation on the Economizer operation. Its function is to override the economizer to minimize SAT swings resulting from turning cooling/heating stages on and off.

Criteria for Economizer Operation

Economizer operation will be used for control when:

- Economizer - ON
- Economizer Enable - ON
- Required sensors are reliable
- Outside air conditions are suitable per criteria discussed in the following sections

Criteria for Economizer Suitable Decision

There are three different methods of Economizer Operation:

- **Differential Enthalpy Method:** will be self-configured and used when sensors for Outdoor Air temperature, Outdoor Air humidity, Return Air temperature, and Return Air humidity are all installed and reliable. This method is the highest priority when sensors are available.
- **Outside Enthalpy Method:** will be self-configured and used only when differential enthalpy method is not available, and sensors for Outdoor Air temperature and Outdoor Air humidity are installed and reliable.
- **Outside Temperature Method:** will be self-configured and used only when differential enthalpy or outside enthalpy methods are not available, and sensor for Outside Air temperature is installed and reliable.

Economizer Suitable Calculations

Outside Temperature Method:

Economizer will be suitable when $OAT < (SAT \text{ setpoint} + 10^\circ F)$. A $2^\circ F$ hysteresis about the $(SAT \text{ setpoint} + 10^\circ F)$ will be used. The $10^\circ F$ offset represents the highest outdoor air temperature that the DX cooling can reliably reduce to the SAT setpoint.

Outside Enthalpy Method:

Economizer will be suitable when $OA \text{ Enthalpy} < \text{Outside Enthalpy Number}$ parameter value and $OAT < (SAT \text{ setpoint} + 10^\circ F)$. A $2^\circ F$ hysteresis about the $(SAT \text{ setpoint} + 10^\circ F)$ will be used. A 1 BTU/LB hysteresis about the *Outside Enthalpy Number* will be used.

Differential Enthalpy Method:

Economizer will be suitable when $OA \text{ Enthalpy} < RA \text{ Enthalpy}$ and $OAT < (SAT \text{ setpoint} + 10^\circ F)$. A $2^\circ F$ hysteresis about the $(SAT \text{ setpoint} + 10^\circ F)$ will be used. A 1 BTU/LB hysteresis about the RA Enthalpy will be used.

SAT Setpoints Used During Cooling With Economizer Operation

Under Economizer Operation, the following SAT setpoints will be used:

CV Cooling Mode:

- With a call for first stage cooling, the *Economizer First Stage Setpoint* value will be used as the Economizer SAT setpoint.
- With a call for second stage cooling, *Economizer Second Stage Setpoint* value will be used as the Economizer SAT setpoint.

VAV Cooling Mode:

- With a call for first stage cooling, the "VAV Cool High Temp" setpoint will be used as the Economizer SAT setpoint
- With a call for second stage cooling, the "VAV Cool Low Temp" setpoint will be used as the Economizer SAT setpoint

SAT control with Economizer

The economizer control will be based on a PI, direct acting algorithm. If economizer is "suitable" (free cooling is available) and cooling is required (the unit is not in satisfied state), the algorithm will be active and modulate the economizer position (outside air and return air dampers) in order to control SAT to the SAT setpoint. If the economizer is not suitable, the Economizer Operation is no longer used and control reverts to the appropriate economizer not suitable mode of operation.

Control of Compressors with Economizer

In Economizer Operation, compressors are started only when the specified SAT setpoint cannot be achieved through outside air and return air mixing. Compressors will be turned ON / OFF individually.

Turning ON of Compressor #1:

If no compressors are ON, and the economizer controller is saturated high (i.e. the economizer is 100% open and can no longer maintain the SAT setpoint by just free cooling),

- Calculate a temporary SAT setpoint as (SAT setpoint) T = (SAT setpoint + 5°F);
- When the SAT is $0.5^{\circ}\text{F} < (\text{SAT Setpoint}) T$, turn ON compressor #1;
- Resume SAT control at SAT setpoint.

This is done in order to read and store the SAT temperature differential (drop) due to turning on compressor #1, while assuring that turning it on will not drop the SAT below compressor #1 trip point (where the Excessive SAT control would turn it off again). The same staging sequence is used for the remaining compressors.

Turning on compressors #2 through #6:

If the economizer controller is saturated High (i.e. the economizer is 100% open while one or more compressors are running and the control can no longer maintain the SAT setpoint requested by the space control),

- Calculate a temporary SAT setpoint as (SAT setpoint) T = (SAT setpoint + 5°F);
- When the SAT is $0.5^{\circ}\text{F} < (\text{SAT Setpoint}) T$, turn ON compressor #N;
- Resume SAT control at SAT setpoint.

Turning Compressors Off

Compressors are turned OFF as described in the respective sections for CV and VAV cooling operation with economizer suitable.

Compressor Control When Exiting Cooling Lockout on OAT

A situation may arise when in Economizer Mode and one or more compressors are required in addition to full available free cooling in order to maintain the SAT setpoint, but "Cool Lockout OAT" prevents the compressors' use. This situation may arise when the SAT setpoint is set very close to, or even below, the temperature set for Cooling Lockout on OAT – a relatively unusual case. If the OAT then increases above the Cooling Lockout

on OAT parameter value while the call for several compressors exists, the compressors in this case (and only in this case) will turn ON simultaneously.

Economizer Loading Operation

Economizer Loading Operation will be used when:

- Economizer - ON
- Economizer Enable - ON
- Economizer Loading to Control SAT is ON (SAT ECONO LOADING = ON)
- Conditions for Economizer Operation are not suitable
- Required sensors are reliable

This is a programmable option. The user has the ability to turn this function off. It is automatically disabled if the unit does not use an economizer. The on/off programming choice is common to both cooling and heating. The default setting is ON. This "Economizer Loading" function is used only outside the normal Economizer operation.

See also corresponding description in the section on Controlling Excessive SAT for cooling.

Economizer Loading Option In Cooling/Heating

This feature should not be used and the parameter "SAT Econo Loading" should always be set to OFF

VENTILATION OPTION OPERATION

The 50-105 ton eco² rooftop units support several different ventilation options including true Outside Airflow measurement and control. Each option will be controlled differently, depending upon what equipment is installed and how the unit is configured. For any Ventilation option operation, the unit must be configured for Economizer Operation. The ventilation options are described as follows:

Fixed Minimum OA Damper Position

This is the most common approach to ventilation control used with air handling equipment today. With this approach, the OA and RA dampers are mechanically linked together such that when the OA damper is open, the RA damper is closed, and vice versa. The sequence of operation for a fixed minimum position system simply controls the OA damper open to a fixed minimum position during the occupied mode of operation.

The fixed minimum position is set by adjusting the mechanical stops on the damper actuator.

Simply opening the OA damper to a fixed minimum position can be quite effective for bringing in a fixed volume of outside air with Constant Volume (CV) equipment. However, with Variable Air Volume (VAV) equipment, the amount of outside air brought into the air handler varies because the Supply Fan speed and total system air volume varies.

To compensate for VAV equipment, a minimum position reset scheme will be implemented as follows:

The two Unit Setup parameters "OAD Damper Position #1" and "OAD Damper Position #2" will be used to indicate two minimum positions of the OA damper. Both OAD Min Position settings will be used to linearly reset the minimum position of the OA Damper based on the output to the VFD. "OAD Damper Position #1" will indicate the Minimum Position of the OA Damper when the output to the VFD is at 100% (10 VDC). "OAD Damper Position #2" will indicate the Minimum Position of the OA Damper when the output to the VFD is at 50% (5VDC).

Figure 31 indicates how this algorithm will function:

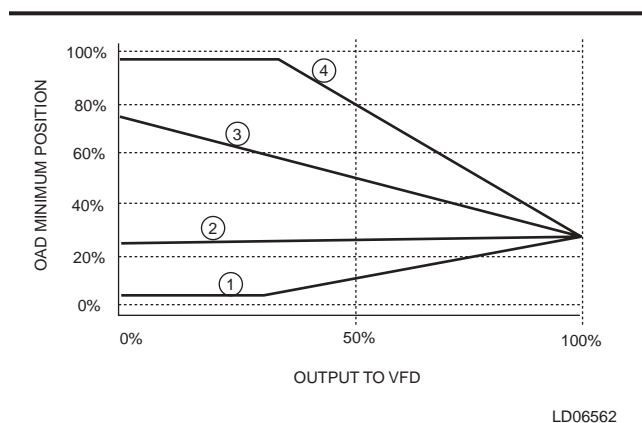

CURVE	OAD MIN. POSITION #1	OAD MIN. POSITION #2
1	25%	10%
2		25%
3		50%
4		80%

Note:

For units configured for Constant Volume Operation, the OAD Min Position #2 setting will be ignored and only OAD Min Position #1 will be used to set the Minimum Position of the outside air damper.

Outdoor Air Measurement Operation

The outdoor air measurement operation uses air measurement stations with the outdoor and return air dampers to control the amount of outdoor air entering the unit to a setpoint. Two outdoor air measurement operation configurations are used. The control will read the configuration setting Airflow Measurement Capability to determine which outside airflow measurement equipment is installed on the unit. If the setting is set to 0, then there is no airflow measurement equipment installed and the control will use fixed minimum position approach to ventilation. Because of the characteristics of the airflow measurement transducers, an auto-zeroing process will be used to ensure that the airflow sensor or sensors are calibrated at zero airflow. The "Altitude" setting of the unit's location will be used to provide additional measurement accuracy. Calibration parameters will be used for the airflow station type with the airflow station area, with the altitude correction parameter to calculate airflow.

Because the installation of the rooftop unit with its air distribution system will affect the airflow characteristics, a means to adjust the airflow station measurements using air balancer supplied data is provided.

Minimum Flow Measurement Operation

The "Airflow Measurement Configuration" parameter is set to minimum. Minimum Flow Measurement is an approach where only the minimum required OA flow rate is measured. This is accomplished by using a small Air Measurement Station (AMS) capable of only measuring 25% of the full flow capability of the unit. This is a somewhat less expensive flow measurement option and provides reasonable accuracy at low flows. However, only airflow s up to 25% are measurable by the system. This will be acceptable since maintaining only the minimum ventilation requirements is what is most important.

Full Flow Measurement Operation

The "Airflow Measurement Configuration" parameter is set to full. Full Flow Measurement is an approach where the full OA flow is measured by one large AMS. This approach is more expensive than the Minimum Flow Measurement approach; however, full OA flow is measurable. The only disadvantage to this approach is that flow measurement accuracy decreases as flow rate decreases and the inaccuracies can become quite substantial at relatively moderate flow rates.

FIG. 31 – OAD MINIMUM POSITION RESET

AREA AND K-FACTOR

When an Air Measuring Station is installed from the factory, the following parameters should be set at the factory prior to the shipment of the unit. The following parameters are found under the CONFIGURATION key of the OptiLogic control: “AMS #1 Area”, “AMS #1 K-Factor”, “AMS #2 Area”, “AMS #2 K-Factor”. Table 18 lists the values that should be entered for each of the parameters based on the capacity of the unit.

OA Flow Sensor Auto-Zero

Each OA flow sensor will under go an auto-zero process to minimize the effect of zero drift on the sensor accuracy. Auto-zero will take place when:

- Occupancy state = unoccupied
- Supply Fan = OFF
- Outdoor Air Damper = closed

The controller will take three airflow measurements with a 5 minute interval between each measurement. The measurements will be used to calculate a correction to the airflow measurement used for control.

Airflow Correction Using Balancer Data

The outdoor airflow function will allow the entry of data to correct the airflow measurement based on measurements taken by an air balancer. Computation of the compensated OA flow adjusted by air balancer input is done through the following steps and computation:

- The air balancer takes measurements and calculates an airflow (CFM) for the AMS

- The measured airflow above is entered into the Primary Unit Controller through the parameter “AMS #X Balancer Calculated Airflow at Balance”. X can be either 1 or 2. Use 1 for the Minimum and Full flow measurement option. This parameter is found under the SERVICE key of the OptiLogic Panel.
- During the same time-period of the measurements by the air balancer, record the Primary Unit Controller calculated airflow for AMS 1 or 2. This information can be found under the parameter “Outside Air Damper Flow #X” under the OPERATION DATA key of the OptiLogic Panel.
- The Primary Unit Controller calculated airflow above is entered into the Primary Unit Controller through the parameter “AMS #Xcontroller Measured Air Flow at Balance”. This parameter is found under the SERVICE key of the OptiLogic panel.

Minimum Flow Measurement

If the Configuration setting "Airflow Measurement Configuration" is set to 1 (minimum), then the unit will be equipped with minimum flow-only measurement equipment. This arrangement consists of an AMS and damper sized for 25% total unit flow and a separate economizer damper sized for the remaining 75% (does not include an AMS). The following figure details this arrangement and indicates the three independently controlled dampers required for this option. Damper #1 and #2 will be arranged Normally Closed (0V = Closed, 10V = Open) and Damper #3 will be arranged Normally Open (0V = Open, 10V = Closed). See Figure 32.

TABLE 18 – AREA AND K FACTOR

AIR MEASURING STATION OPTION	Open % Full	Unit Size (Tons)	50, 55	60,65	70,75	80,85	90,95, 105
MINIMUM	25%	A1 (Flow area sq ft)	3.61	3.61	4.17	4.17	4.72
		K1-1	0.751	0.751	0.770	0.770	0.775
FULL	100%	A1 (Flow area sq ft)	14.44	14.44	16.67	16.67	18.89
		K1-1	0.705	0.705	0.666	0.666	0.673

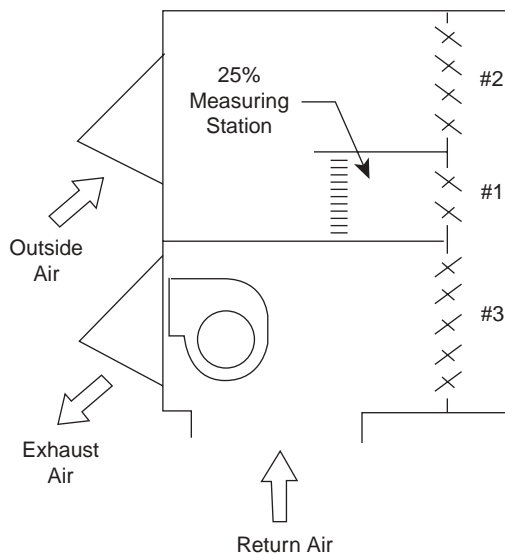

LD06563

FIG. 32 – MINIMUM FLOW MEASUREMENT ARRANGEMENT

A differential pressure transmitter will be used to measure a differential pressure across the AMS, which will correspond to an average velocity through the AMS. The measured differential pressure (read at an appropriate Analog Input) will be converted by the controller to an approximate flow. The entered data is for AMS #1.

When the unit is in the unoccupied mode of operation, dampers #1 and #2 will be 100% closed and damper #3 will be 100% open.

Airflow Control - Economizer Not Available

When the unit is in the occupied mode of operation, and:

- *Airflow Meas Config* = 1 (minimum)
- *Economizer Enable* = OFF, or
- *Economizer Enable* = ON and economizer conditions are not available:

Damper #2 will be closed and the following control of Dampers #1 and #3 will be used:

- On entering the airflow control mode of operation, Damper #3 (return air damper) is 100% open.
- An appropriate control algorithm will be used to modulate the position of Damper #1 (outdoor air) to maintain the *Minimum Flow Setpoint*.

- When the *Minimum Flow Setpoint* cannot be achieved with Damper #3 (Return Air Damper) 100% open, the RA Damper will be modulated closed so that the *Minimum Flow Setpoint* is achieved.
- The maximum closure of Damper #3 will be that position resulting in the maximum allowed airflow velocity through the AMS and Damper #1 or 1500 fpm. Divide the airflow by the area in table 18 to determine velocity.

The following figure is a representation of the damper versus airflow operation.

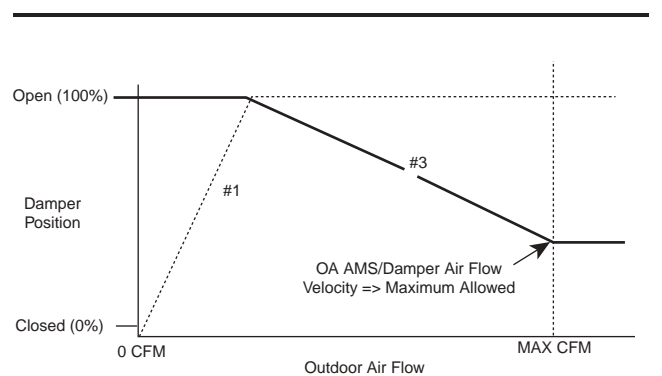

LD06564

FIG. 33 – CONTROL FOR MINIMUM AMS – ECONOMIZER NOT AVAILABLE

5

Air Flow Control - Economizer Available

When the unit is in the occupied mode of operation, and:

- *Airflow Meas Config* = 1 (minimum)
- *Economizer Enable* = ON and economizer conditions are available:

Damper #1, #2 and #3 will be controlled through an appropriate algorithm to meet the following two requirements:

- The measured outdoor airflow is => *Minimum Flow Setpoint*.
- The outdoor dampers are modulated to meet the requirements of economizer operation.

The Primary Unit Controller will use the difference between the Supply Air Temperature setpoint during economizer operation and the measured SAT and will increase the airflow above the "Min. Outside Airflow" to maintain the Supply Air temperature setpoint. The result is airflow through the damper will always be => the "Min. Outside Airflow".

- Mode 1 - Damper #1 and Damper #3 will be operated as described in *Airflow Control - Economizer Not Available* to satisfy the SAT temperature requirement using the increased airflow.

The Mode 1 to Mode 2 transition occurs when:

- The maximum AMS #1 velocity condition for Mode 1 airflow is present for 5 minutes or
- Damper #3 (Return Air) is closed for 5 minutes

Mode 2 operation is as follows:

- Damper #2 is modulated open to maintain the SAT Temperature Setpoint (as in economizer control without an AMS)
- Damper #1 and Damper #3 will be controlled to maintain the *Minimum Flow Setpoint*
- During this Damper #1 and #3 operation, the maximum closure of the Damper #3 (Return Air) will be determined by that required to limit the airflow rate through AMS #1 to =< 1500 fpm. Divide the airflow by the area in Table 18 to determine the velocity.

The Mode 2 to Mode 1 transition will occur when Damper #2 is continuously closed for 5 minutes.

The following figure illustrates the control functions.

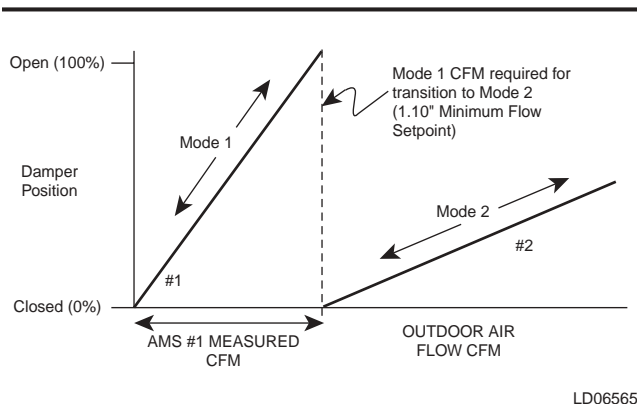

FIG. 34 – MINIMUM FLOW MEASUREMENT OPTION, ECONOMIZER SEQUENCE

Full Flow Measurement

If the Configuration setting "Airflow Measurement Config" is set to 2 (full), then the unit will be equipped with full flow measurement equipment. This arrangement consists of one AMS sized for 100% total unit flow. The following figure details this arrangement. With this arrangement, the outside and return air dampers are mechanically tied together. Only one Analog Output (AO) is required for this option.

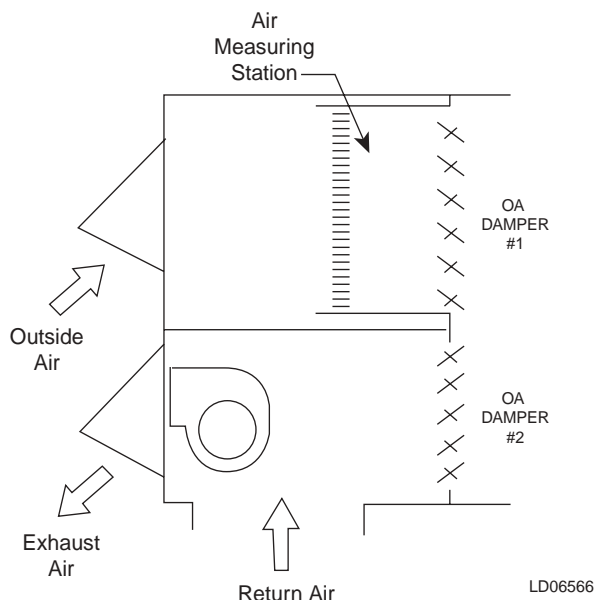

FIG. 35 – FULL FLOW MEASUREMENT ARRANGEMENT

A differential pressure transmitter is used to measure a differential pressure across the AMS, which will correspond to an average velocity through the AMS. The measured differential pressure (AI 11) will be converted by the controller to an approximate flow as given in the section on *Airflow Measurement Computation*. The entered data is for AMS #1.

In the unoccupied mode of operation the OA Damper is at 0% and the RA Damper is at 100%.

Flow Control - Economizer Not Available

When the unit is in the occupied mode of operation, and:

- *Airflow Meas Config* = 2 (full)
- *Economizer Enable* = OFF or

- *Economizer Enable* = ON and economizer conditions are not available

Damper #1 (outdoor air damper) will modulated as required to maintain the "Minimum Outside Airflow" by an appropriate PI control algorithm. The following figure illustrates the control function.

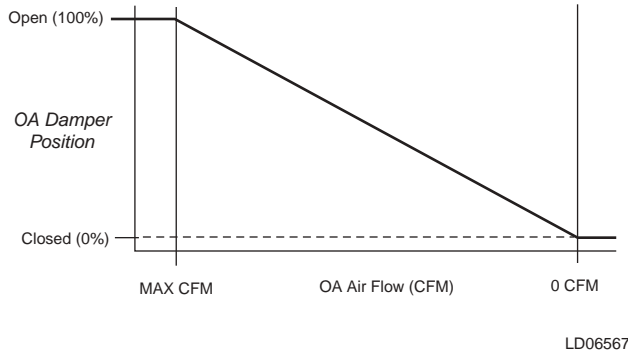

FIG. 36 – FULL FLOW MEASUREMENT OPTION, ECONOMIZER NOT AVAILABLE

Flow Control - Economizer Available

When the unit is in the occupied mode of operation, and:

- *Airflow Meas Config* = 2 (full)
- *Economizer Enable* = ON and economizer conditions are available

Damper #1 will be controlled through an appropriate algorithm to meet the following two requirements:

- The measured outdoor airflow is => *Minimum Flow Setpoint*
- The outdoor damper position is modulated to meet the requirements of economizer operation or economizer loading operation.

If the "OA Damper Min Pos 1 or 2" causes the airflow to be above the "Min Outside Airflow" setpoint, the damper will not close to allow the airflow to meet the "Min Outside Airflow" setpoint.

The following figure illustrates the control requirements.

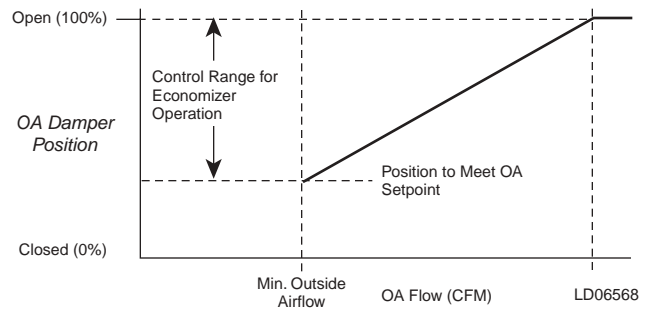

FIG. 37 – FULL FLOW MEASUREMENT OPTION ECONOMIZER SEQUENCE

Demand Ventilation

Demand Ventilation is a control sequence that can increase or decrease the amount of ventilation introduced to the building based on the level of contaminate in the conditioned space. Typically this is CO2 however based on the type of IAQ sensor used any contaminate could be used to increase the ventilation level. We will use CO2 in this example.

The demand for ventilation will be determined by comparing the level of CO2 in the building to the "Demand Ventilation" setpoint. The CO2 level in the building will be measured by an appropriate IAQ sensor connected to the unit.

The Demand Ventilation control sequence will only be allowed to function if:

- The "IAQ Sensor Enable" setting is set to ON.
- The unit is equipped with an economizer and *Economizer Enable* = ON.
- The *Airflow Meas Config* configuration is = 0 or 2
- Occupancy status is = Occupied.
- "*Economizer Installed*" is set to YES.

Demand Ventilation control will operate in both heating and cooling modes and will increase the position of the economizer (OA Damper) from the minimum position or the control positions of economizer or economizer loading as required to meet the "Demand Ventilation" programmed parameter.

Sensor

If all conditions are met, the control will look for an attached IAQ sensor at the appropriate AI 4. The reading at the AI 4 will be used along with the "*IAQ Sensor Span*" setting to determine the building CO₂ level. The sensor must be supplied in the field and the "*IAQ Sensor Span*" will vary based on the manufacturer and type of sensor.

If the CO₂ level indicated at the AI is out of range, the controller will interpret the reading as a sensor failure and generate a Trouble Fault. Demand Ventilation control sequences will not be allowed if the CO₂ sensor is determined to be unreliable.

Algorithm

An appropriate algorithm is used for Demand Ventilation control. A step and wait algorithm with the following characteristics is used:

- Step size is a function of the difference between the measured IAQ (CO₂) level and the *Demand Ventilation Setpoint*.
- Step time is fixed.

The Demand Ventilation operation will have the following constraints:

The maximum OA Damper position called for by Demand Ventilation operation will be equal to the ("*Max DV Multiplier*") * ("*OA Damper Min Pos #1*"). The "*Max DV Multiplier*" parameter can be set for a minimum of 1, which results in a damper position the same as the minimum position, to 4, which results in a damper position 4 times the minimum position.

LOW AMBIENT OPERATION

With the standard unit, mechanical refrigeration will only be allowed to operate when the ambient temperature is above the "*Cool Lockout OAT*" setting. Below this temperature, compressors will be inhibited from operating.

Optional hardware can be installed on one or more compressor systems that will allow mechanical refrigeration to occur below the *Cool Lockout OAT Setpoint*. The hardware for each Low Ambient configured system consists of a Condensing Pressure transducer on the refrigerant circuit and a Variable Speed Drive that varies the speed of one condenser fan to control the Condensing Pressure inside the condenser coil. The second condenser fan for the system is operated on/off through direct control by the compressor system. The following figure illustrates the equipment required for low ambient operation.

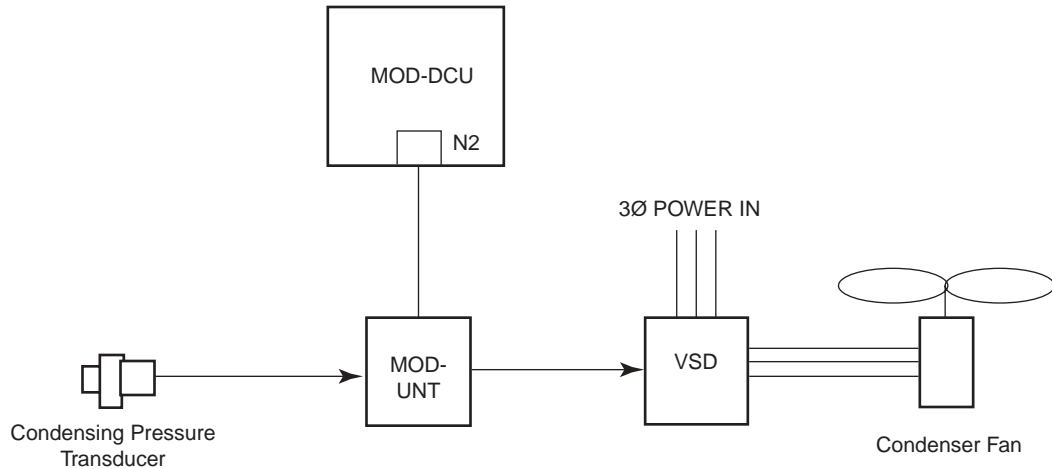

LD06574

FIG. 38 – LOW AMBIENT HARDWARE

To summarize the control, the MOD UNT monitors the condensing pressure at an appropriate input. The Primary Unit Controller will read the condensing pressure, perform the control logic, and command the

MOD-UNT to increase or decrease the output to the VFD, as required. The following figure illustrates the control logic required for this control loop.

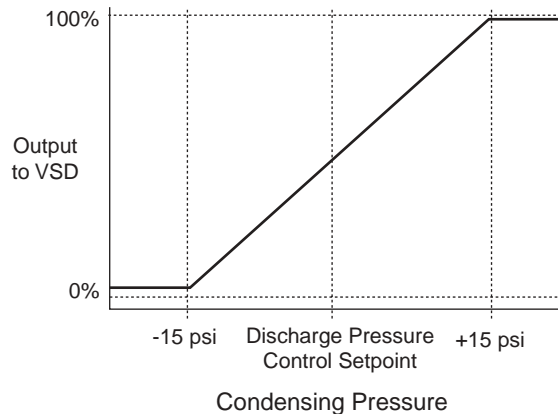

LD06575

FIG. 39 – CONDENSING PRESSURE CONTROL PROPORTIONAL BAND

Sequence of Operation

The control will read the configuration setting "*Low Ambient Config.*" to determine if low ambient hardware is installed and on what systems. Low ambient hardware can be installed on one, two, or three systems and is indicated as follows by the "*Low Ambient Config.*" Setting:

0. No low ambient hardware installed.
1. Low ambient hardware is installed on system #1 only.
2. Low ambient hardware is installed in system #1 and system #2.
3. Low ambient hardware is installed in system #1, #2, and #3.

Only systems with low ambient hardware will be allowed to operate below the *Low Ambient Lockout Temperature*.

Operation:

- If the Outside Air Temperature is above the *Low Ambient Lockout Temperature*, the controller will command all outputs for the VFD to 100%.
- If the OA Temperature falls below the *Low Ambient Lockout Temperature*, the controller will check for compressors operating. The control will then stop any compressors operating from systems not equipped with low ambient hardware. The control will monitor and control the condensing pressure on all systems equipped with the low ambient hardware. If the OA temperature falls to 0°F, all mechanical refrigeration will be stopped by the controller and not allowed to restart until the OA temperature rises above +10°F.
- A +/- 1°F hysteresis will be used about the Low Ambient Lockout Temperature.

Safeties

Communication Failure:

If the Primary Unit Controller detects a failure of the N2 communication with the MOD UNT, a fault will be generated and mechanical refrigeration below the Low Ambient Lockout Temperature will not be allowed.

The MOD UNT will continue to operate the condenser fans based on the measured discharge transducer input as last commanded by the DCU.

Unreliable Transducer:

If the discharge pressure becomes unreliable on any system, the controller will drive the VFD output for that system to 100% and prevent that system from operating below the *Cooling Lockout on OAT*. A fault will be generated.

CONTROLLING EXCESSIVE SUPPLY AIR TEMPERATURE SAT

This feature is not used. "*Excessive SAT- SAT Temper Available*" should always be configured to OFF.

POWER EXHAUST OPERATION

Power exhaust operation is used to control building pressure. For building pressure control, the unit can be equipped with the following exhaust air control configurations. These parameters are selected under "*Power Exhaust Config*".

- No power exhaust – "*None*"
- On/Off exhaust fan control based on the outside air damper position – "*2 Pos on OAD*"
- On/OFF exhaust fan control based on the building pressure– "*2 Pos on EAD*"
- On/Off exhaust fan control based on building pressure and modulating exhaust damper position – "*Modulating*"
- Proportional (VFD) exhaust damper control based on building pressure – "*Modulating*"

For power Exhaust Operation, the parameter "*Power Exhaust Enable*" must be programmed to ON and the supply fan must be running.

On/Off Control Based on OAD Position

On/Off control based on OAD position controls the powered exhaust fan ON or OFF based on the position of the Outside Air Damper. This option requires:

- "*Economizer Enable*" ON
- Supply Fan – ON
- Constant volume exhaust fan

This operation is not available when an OA Flow Station is installed.

The Exhaust Fan will be controlled by the OAD position as follows:

- Fan ON when the position = OAD Position for the Exhaust Fan to Turn ON. The damper position to turn on is programmed through the parameter “*OA DMPR Pos For ON*”
- Fan OFF when the position = OAD Position for the Exhaust Fan to Turn OFF. The damper position to turn off is programmed through the parameter “*OA DMPR Pos For OFF*”
- Exhaust fan OFF when Supply Fan is OFF

On/Off control Based on OAD Position is illustrated in Figure 40.

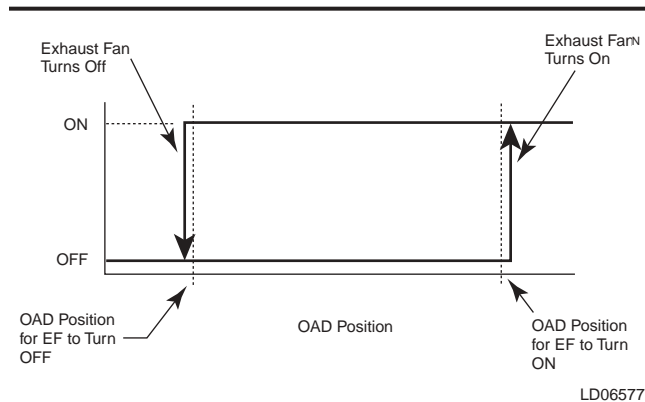

FIG. 40 – OAD POSITION CONTROL

On/Off Exhaust Fan Control Based on Building Pressure

This power exhaust option uses the building pressure to turn a constant volume exhaust fan on or off.

This option requires the following:

- “*Economizer Enable*” ON
- Supply Fan – ON
- Constant volume exhaust fan
- Building Pressure Transducer

When the Building Pressure reaches or exceeds the “*Building Pressure*” setting plus the “*Exhaust Cntrl Offset*”, the Primary Unit Controller will energize the constant volume Exhaust Fan. The Exhaust Fan will remain energized until the Building Pressure drops to or below the “*Building Pressure*” setting minus the “*Exhaust Cntrl Offset*”. Figure 41xxx illustrates this operation.

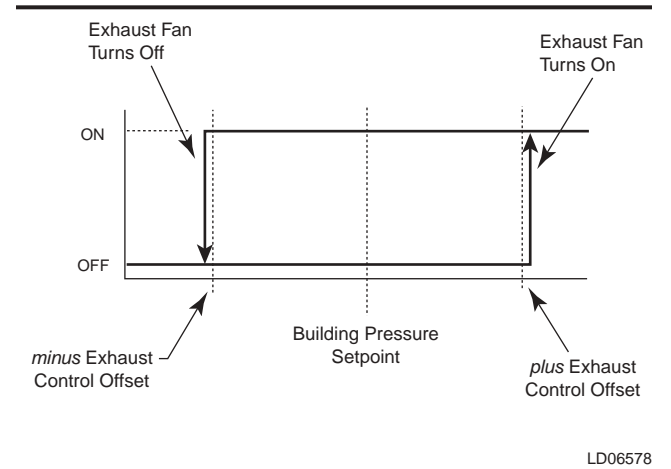

FIG. 41 – BUILDING PRESSURE CONTROL

On/Off Exhaust Fan Control Based on Building Pressure and Exhaust Damper Position

This power exhaust option uses the building pressure to modulate an exhaust damper. The position of the exhaust damper is used to turn a constant volume exhaust fan on and off.

This option requires the following:

- “*Economizer Enable*” ON
- Supply Fan – ON
- Constant volume exhaust fan
- Building Pressure Transducer
- Modulating Exhaust air damper

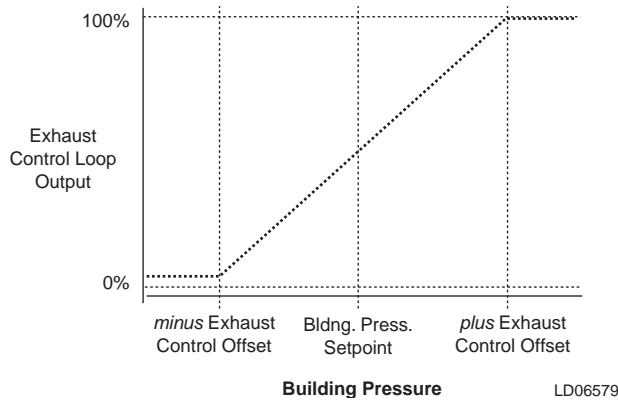

FIG. 42 – EXHAUST PROPORTIONAL BAND

The Primary Unit Controller will vary the position of the modulating exhaust damper based on the “*Building Pressure*” setting and the “*Exhasut Cntrl Offset*”. The damper will modulate from 0 to 100% with a building pressure range of the building pressure +/- the exhaust control offset. Figure 42 illustrates this operation. The constant volume exhaust fan will turn on and off based on the position of the exhaust damper as follows:

- Fan ON when the position = EAD Position for the Exhaust Fan to Turn ON. The damper position to turn on is programmed through the parameter “EXH DMPR Pos For ON”
- Fan OFF when the position = EAD Position for the Exhaust Fan to Turn OFF. The damper position to turn off is programmed through the parameter “EXH DMPR Pos For OFF”
- Exhaust fan OFF when Supply Fan is OFF

Figure 43 illustrates the On/Off operation of the exhaust fan.

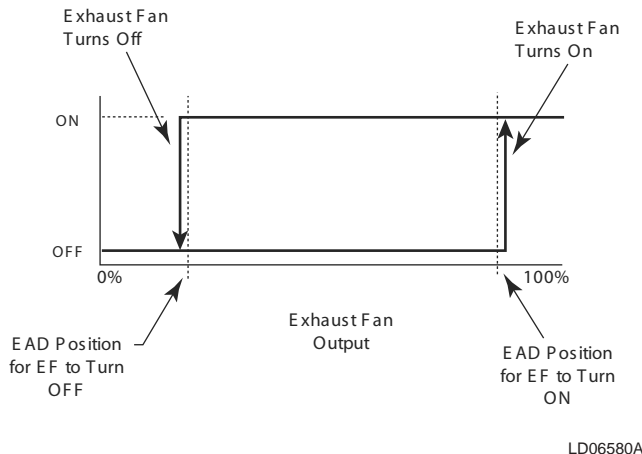

FIG. 43 – EXHAUST FAN CONTROL PROPORTIONAL OPTION

Proportional Exhaust Fan Control Based on Building Pressure

This power exhaust option uses the building pressure to vary the speed and airflow of a VFD exhaust fan. The VFD exhaust fan will still be turn On/Off based on the programmed position of the exhaust damper, even though a damper is not installed, but once the VFD exhaust fan is on it will vary its speed and airflow based on the “*Building Pressure*”.

This option requires the following:

- “*Economizer Enable*” ON
- Supply Fan – ON
- VFD exhaust fan
- Building Pressure Transducer

The VFD exhaust fan will turn on and off based on the position of the exhaust damper as follows:

- Fan ON when the position = EAD Position for the Exhaust Fan to Turn ON. The damper position to turn on is programmed through the parameter “EXH DMPR Pos For ON”
- Fan OFF when the position = EAD Position for the Exhaust Fan to Turn OFF. The damper position to turn off is programmed through the parameter “EXH DMPR Pos For OFF”
- Exhaust fan OFF when Supply Fan is OFF

After the VFD exhaust fan is turned on, the Primary Unit Controller will vary the speed of the VFD Exhaust fan based on the “*Building Pressure*” setting and the “*Exhaust Cntrl Offset*”.

Configurations employing Building Pressure requires the installation of a pressure sensor in the condition space and the connection of the sensor to the exhaust fan transducer. The location of this sensor is critical for proper operation of the exhaust fan. The sensor must be located so that the building pressure in the area it is monitoring is typical of the whole space.

TIME CLOCK / SCHEDULING

The controller will have a time of day clock and calendar with the following characteristics:

- Battery backup
- Time and date set through the RDU
- Clock and calendar compensated for Leap Year and Daylight Savings Time
- Event specification as follows:
 - Up to 16 holidays
 - A holiday schedule
 - A daily start and stop time (two times)
- Capability to set up multiple scheduling functions (i.e. time of day start-stop; time of day purge)
- Nominally +/- 4 seconds/day clock accuracy

CHANGEOVER RELAY OPERATION

The Changeover Relay (COR) is an external relay driven by the controller that allows the controller to operate 6 stages of cooling and 6 stages of heating from 6 controller outputs. The COR routes the stage signals from the controller to the compressors when mechanical cooling is required or to the staged heaters when heating is required.

The control of the Changeover Relay will be:

- For cooling operation: energize the COR output.
- For heating operation: deenergize the COR output.

Verification of the COR operation is done through the COR Status binary input (BI #15).

HIGH PRESSURE UNLOADING

The control will read the Transducer Package setting to determine if pressure transducers are installed on the unit. If the unit is equipped with pressure transducers, (*Transducer Package* setting set > 0) the control will monitor the discharge pressure from each refrigeration circuit with a pressure transducer package. If the discharge pressure of a refrigeration circuit rises to or above the "*Sys Unloading Press*" and both compressors of that circuit are ON, the control will turn OFF one of the compressors. This compressor will not be allowed to turn back on until the OAT drops 5°F.

If a refrigeration system is unloaded, a fault will be generated.

COMFORT VENTILATION OPERATION

Comfort Ventilation is applicable in CV (Constant Volume) unit configurations where:

- Space temperature is sensed through a Thermostat or Space Sensor.
- Economizer is installed.

Comfort Ventilation will operate when:

- "*Comfort Vent Mode*" is ON.
- Occupied is ON (occupancy detected).
- There is no call for heating or cooling due to the Thermostat or Space Sensor.
- If Demand Ventilation and/or Outdoor Airflow Control are enabled, these control modes are the first priority in establishing the OA Damper position.

Comfort Ventilation will operate as follows when enabled:

- Supply Fan will remain ON when mechanical refrigeration or heating are OFF.
- The Outdoor Air Damper will be modulated between the "*Comfort Vent Max Damper*" Position and the "*OA Damper Min Position #1*".

Economizer Control During Comfort Ventilation

Economizer control will use a PI controller that controls SAT within the specified SAT band by repositioning the economizer dampers. The PI controller setpoint will be calculated as a midpoint between the programmed "*Comfort Vent High SAT*" setpoint and "*Comfort Vent Low SAT*" setpoint. As the controller uses outside air to maintain the SAT at the setpoint, it must be capable of self-configuration for direct, or reverse action, depending on the relationship of the OAT to the specified SAT control band:

- If the OAT is below the specified "*Comfort Vent Low SAT*" setting, the action will be direct acting. In this case, the economizer control can lower the SAT temperature just by opening the economizer damper and using more outdoor air. However, if the economizer controller can not prevent the SAT from dropping below the bottom control band limit by closing the economizer damper to its programmed minimum position, one or more heating stages are turned ON as required. Similarly, if the economizer controller can not prevent the SAT from increasing above the top control band limit by opening the economizer damper to its programmed "*Comfort Vent High SAT*" setpoint, one or more compressors will be turned ON as required.

- If the OAT is above the specified "*Comfrt Vent High SAT*" setpoint, the action will be Reverse Acting. In this case, the economizer control can increase the SAT temperature just by opening the economizer damper and using more outdoor air. However, if the economizer controller can not prevent the SAT from increasing above the top control band limit by closing the economizer damper to its programmed minimum position, one or more compressors will be turned ON as required. Similarly, if the economizer controller can not prevent the SAT from dropping below the bottom control band limit by opening the economizer damper to its programmed "*Comfrt Vent Low SAT setpoint*" setpoint, one or more heating stages will be turned ON as required.
- If the OAT is within the SAT control band, (i.e. between the programmed "*Comfrt Vent High SAT*" setpoint and "*Comfrt Vent Low SAT setpoint*" setpoint), the economizer damper will be overridden to fully open position subject to OA flow requirements if installed and enabled. In this case, no other control action needs to be taken to maintain the SAT within the specified control band

Staging Control During Comfort Ventilation

The economizer control alone may not be able to maintain the SAT within the specified control band. A separate staging control algorithm supplements the economizer control and stages heating or mechanical cooling as necessary.

The cooling and heating operation will be as follows:

- If the SAT increases above the "*Comfort Vent High SAT*" setpoint for more than 5 minutes:
 - If heating is ON, destage a heating stage - At 5 minute intervals, repeat this test until all heating stages are OFF.
 - If heating is OFF, stage a compressor ON - At 5 minute intervals, repeat this test until SAT is below the "*Comfort Vent High SAT*" setpoint .
- If the SAT decreases below the "*Comfort Vent Low SAT*" setpoint for more than 5 minutes:
 - If cooling is ON, destage a compressor - At 5 minute intervals, repeat this test until all cooling stages are OFF.
 - If cooling is OFF, stage a heating stage ON - At 5 minute intervals, repeat this test until SAT is above the "*Comfort Vent Low SAT*" setpoint.

As the heating stages, or compressors are staged up, or destaged, the economizer controls continue using the economizer damper to "trim" the effect of the staging and to maintain the SAT as near the middle of the SAT control band as possible.

If the unit is using hydronic heat, the control will modulate the water valve to maintain SAT at the programmed "*Comfort Vent Low SAT*" setpoint. At this setpoint, the hydronic heat control does not conflict with the economizer control, and will prevent SAT from dropping outside of the specified control band when the economizer can no longer maintain the SAT at its middle-of-the-band setpoint.

HOT WATER FREEZE PROTECTION USING RETURN AIR OPERATION

When programmed for Hot Water or Steam, Return Air monitoring will be used for freeze protection. If the RA temperature is less than 40°F and the Supply Fan is OFF, the Heating Valve output will open to 100%.

When the Supply Fan is ON, or the RA temperature is greater than 50°F, the Heating Valve output returns to normal operation. No fault is generated by this operation.

SMOKE PURGE OPERATION

The Smoke Purge Operation will have five selectable options.

Setting #1, Shutdown

If the smoke purge setting is set to 1 and the Smoke Purge input is activated, the unit will do the following:

- Disable the Exhaust Fan, if activated.
- Disable the Supply Fan, if activated.
- Close the Outside Air damper(s).
- Open the Return Air damper.

Maintain this operation until the Smoke Purge input is deactivated, then return to normal operation.

Setting #2, Pressurization

If the smoke purge setting is set to 2 and the Smoke Purge input is activated, the unit will do the following:

- Disable the Exhaust Fan, if activated.
- Turn ON the Supply Fan full (VFD to 100%).
- Energize the VAV Heat Relay and drive all VAV boxes open.
- Open the Outside Air dampers full.
- Close the Return Air damper full.

Maintain this operation until the Smoke Purge input is deactivated, then return to normal operation.

Setting #3, Exhaust

If the smoke purge setting is set to 3 and the Smoke Purge input is activated, the unit will do the following:

- Disable the Supply Fan.
- Close the Outside Air damper(s).
- Turn ON the Exhaust Fan full (VFD/ED to 100%)

Maintain this operation until the Smoke Purge input is deactivated, then return to normal operation.

Setting #4, Purge

If the smoke purge setting is set to 4 and the Smoke Purge input is activated, the unit will do the following:

- Turn ON the Supply Fan full (VFD to 100%).
- Energize the VAV Heat Relay and drive all VAV boxes open.
- Turn ON the Exhaust Fan full (VFD/ED to 100%).
- Open the Outside Air Damper(s) full.
- Close the Return Air Damper full.

Maintain this operation until the Smoke Purge input is deactivated, then return to normal operation.

Setting #5, Purge w/ Duct Pressure Control

If the smoke purge setting is set to 5 and the Smoke Purge input is activated, the unit will do the following:

- Supply Fan
 - VAV units - Turn ON the Supply Fan VFD and control to the Duct Static Setpoint.
 - CV - Turn ON fan (variable output is 100%)
- Turn ON the Exhaust Fan full (VFD/ED to 100%)
- Open the Outside Air Damper(s) full.

- Close the Return Air Damper full.

Maintain this operation until the Smoke Purge input is deactivated, then return to normal operation.

RETURN FAN OPERATION

The following is an explanation of the different modes of operation for the return fan option

No Outdoor Air, 100% Return Air, VFD Supply Air Fan, No Exhaust

This configuration would be for applications where the supply fan performance cannot meet the total static requirement of the duct system. This allows the external static pressure to be split between the return air and supply air fan.

- Application uses two return air fans each with their own motor being controlled by a single VFD drive.
- The return fan VFD drive is controlled by a pressure transducer with a static pressure probe located in the return section of the unit.
- The return fan VFD is programmed to maintain -.03 to -.05 inches of WC static at the probe. These values are programmed into the VFD at the factory. The value can be verified by checking item # 204 and 205 in Menu 2 (References and Limits) in the VFD program. Refer to Installation, Operation & Maintenance Form 100.40-N04 for additional information.
- The supply air VFD is controlled by the duct static transducer.
- The supply air blower and return air fan will always be energized together.
- As the pressure in the return air section becomes more negative the return air fan will speed up. As the pressure in the return section increases above the setting the return air fan will slow down

No Outside Air, 100% Return Air, VFD Supply Fan, with Motorized Exhaust Damper

This configuration would be used for applications where the supply fan performance cannot meet the total static requirement of the duct system and there is make up air units or other outside air sources supplying air to the space. This allows the external static pressure to be split between the return air and supply air fan while removing the excess air from the building.

- Applications uses two return air fans each with their own motor being controlled by a single VFD drive.
- The return fan VFD drive is controlled by a pressure transducer with a static pressure probe located in the return section of the unit.
- The return fan VFD is programmed to maintain +0.1 to +0.15 inches of WC of static at the probe. These values are programmed into the VFD at the factory. The value can be verified by checking item # 204 and 205 in Menu 2 (References and Limits) in the VFD program. Refer to Installation, Operation & Maintenance Form 100.40-N04 for additional information.
- The unit will also require a motorized exhaust air damper that operates off a building pressure transducer.
- The supply air VFD is controlled by the duct static transducer.
- The supply air blower and return air fan will always be energized together.
- The speed of the indoor blower and the opening of the exhaust air damper will both influence the speed at which the return air fan operates.

0 – 25% Manual /2 Position Outside Air, VFD Supply Fan, with No Exhaust

This configuration would be used for applications where the supply fan performance cannot meet the total static requirement of the duct system. Ventilation air is supplied through the unit but exhaust is handled by other means. This allows the external static pressure to be split between the return air and supply air fan while bringing ventilation air into the building.

- Applications uses two return air fans each with their own motor being controlled by a single VFD drive.
- The return fan VFD drive is controlled by a pressure transducer with a static pressure probe located in the mixed air return section of the unit.
- The return fan VFD is programmed to maintain -.03 to -.05 inches of WC static at the probe. These values are programmed into the VFD at the factory. The value can be verified by checking item # 204 and 205 in Menu 2 (References and Limits) in the VFD program. Refer to Installation, Operation & Maintenance Form 100.40-N04 for additional information.

- The supply air VFD is controlled by the duct static transducer.
- The supply air blower and return air fan will always be energized together.
- As the pressure in the return air section becomes more negative the return air fan will speed up. As the pressure in the return section increases above the setting the return air fan will slow down.
- The percent of outdoor air will remain the same regardless of the airflow through the unit.

0 – 25% Manual /2 Position Outside Air, VFD Supply Fan, with Motorized Exhaust Damper

This configuration would be used for applications where the supply fan performance cannot meet the total static requirement of the duct system. Ventilation air is supplied through and exhausted by the unit. This allows the external static pressure to be split between the return air and supply air fan while bringing ventilation air into the building and exhausting return air.

- Applications uses two return air fans each with their own motor being controlled by a single VFD drive.
- The return fan VFD drive is controlled using a pressure transducer with a static pressure probe located in the mixed air return section of the unit.
- The return fan VFD is programmed to maintain -.03 to -.05 inches of WC static at the probe. These values are programmed into the VFD at the factory. The value can be verified by checking item # 204 and 205 in Menu 2 (References and Limits) in the VFD program. Refer to Installation, Operation & Maintenance Form 100.40-N04 for additional information.
- The unit will also require a motorized exhaust air damper that operates off a building pressure transducer.
- The supply air VFD is controlled by the duct static transducer.
- The supply air blower and return air fan will always be energized together.
- As the pressure in the return air section becomes more negative the return air fan will speed up. As the pressure in the return section increases above the setting the return air fan will slow down.
- The percent of outdoor air will remain the same regardless of the airflow through the unit.

- The speed of the indoor blower and the opening of the exhaust air damper will both influence the speed at which the return air fan operates.

Fully Modulating Economizer Option with VFD Supply Air Fan but No Exhaust Option

This configuration would be used for applications where the supply fan performance cannot meet the total static requirement of the duct system employing a modulating outdoor and return air damper system without exhaust. This allows the external static pressure to be split between the return air and supply air fan while having the capability of 100% outdoor air for cooling. Building pressurization would have to be handled by an external means.

- Applications uses two return air fans each with their own motor being controlled by a single VFD drive.
- The return fan VFD drive is controlled using a pressure transducer with a static pressure probe located in the mixed air section of the unit.
- The return fan VFD is programmed to maintain -.03 to -.05 inches of WC static at the probe. These values are programmed into the VFD at the factory. The value can be verified by checking item # 204 and 205 in Menu 2 (References and Limits) in the VFD program. Refer to Installation, Operation & Maintenance Form 100.40-N04 for additional information.
- The return fan static pressure setpoint is reset based on the supply air fan VFD output.
 - When the supply air fan output is at minimum, the setpoint will be -0.1 to 0.2 inches of WC.
 - When the supply air fan output is at maximum, the setpoint will be -0.5 to -0.6 inches WC.
- The change in return fan static pressure setpoint allows the unit to maintain a linear and consistent outside and return airflow at all supply airflow rates.
- The supply air VFD is controlled by the duct static transducer.

- The supply air blower and return air fan will always be energized together.

- As the pressure in the return air section becomes more negative the return air fan will speed up. As the pressure in the return section increases above the setting the return air fan will slow down.

- The return air damper will never go to a totally closed position.

Fully Modulating Economizer Option with VFD Supply Air Fan and Motorized Exhaust Damper

This configuration would be used for applications where the supply fan performance cannot meet the total static requirement of the duct system employing a modulating outdoor and return air damper system with motorized exhaust. This allows the external static pressure to be split between the return air and supply air fan while having the capability of 100% outdoor air for cooling.

- Applications uses two return air fans each with their own motor being controlled by a single VFD drive.
- The return fan VFD drive is controlled using a pressure transducer with a static pressure probe located in the mixed air section of the unit.
- The return fan VFD is programmed to maintain -.03 to -.05 inches of WC static at the probe. These values are programmed into the VFD at the factory. The value can be verified by checking item # 204 and 205 in Menu 2 (References and Limits) in the VFD program. Refer to Installation, Operation & Maintenance Form 100.40-N04 for additional information.
- The return fan static pressure setpoint is reset based on the supply air fan VFD output.
 - When the supply air fan output is at minimum, the setpoint will be -0.1 to 0.2 inches of WC.
 - When the supply air fan output is at maximum, the setpoint will be -0.5 to -0.6 inches WC.
- The change in return fan static pressure setpoint allows the unit to maintain a linear and consistent outside and return airflow at all supply airflow rates.

- The unit will also require a motorized exhaust air damper that operates off a building pressure transducer.
- The supply air VFD is controlled by the duct static transducer.
- The supply air blower and return air fan will always be energized together.
- As the pressure in the return air section becomes more negative the return air fan will speed up. As the pressure in the return section increases above the setting the return air fan will slow down.

last section on and the first section off. The number of stages between 1A and 1B operation is depended on the number of heating sections installed in the unit. The modulating heat section, 1A, must always modulate to full fire before any additional stages can be brought on. When additional stages are required, the modulating heat section will go to minimum fire and the next stage of heating will be brought on. If there continues to be a demand for additional heat, the modulating heat section re-modulates to high fire before any additional stages can come on. During a decrease in heating demand, the modulating heat section must be at a minimum fire condition before any stages are turned off.

MODULATING GAS HEAT

Modulating gas heat can be ordered with a minimum of two gas heat stages (1 heat exchanger section) and a maximum of six stages (three heat exchanger sections).

Fig 44 shows the staging sequence for the modulating heat stages. As can be seen from the chart, Heat section 1A (modulating) is always the first section on and the last section off. Heat section 1B is always the

The following Primary Unit controller parameters are required for modulating heat operation. These values will be entered into the control at the factory. Under the CONFIGURATION key of the OptiLogic control panel the “# of Heat Steps” will be set to 0. This value does not change regardless of the number of stages installed. Under the CONFIGURATION key of the OptiLogic control panel the “Heating Type” will be set to HW, even though the unit is fired on gas. Under the SETPOINTS key of the OptiLogic control panel

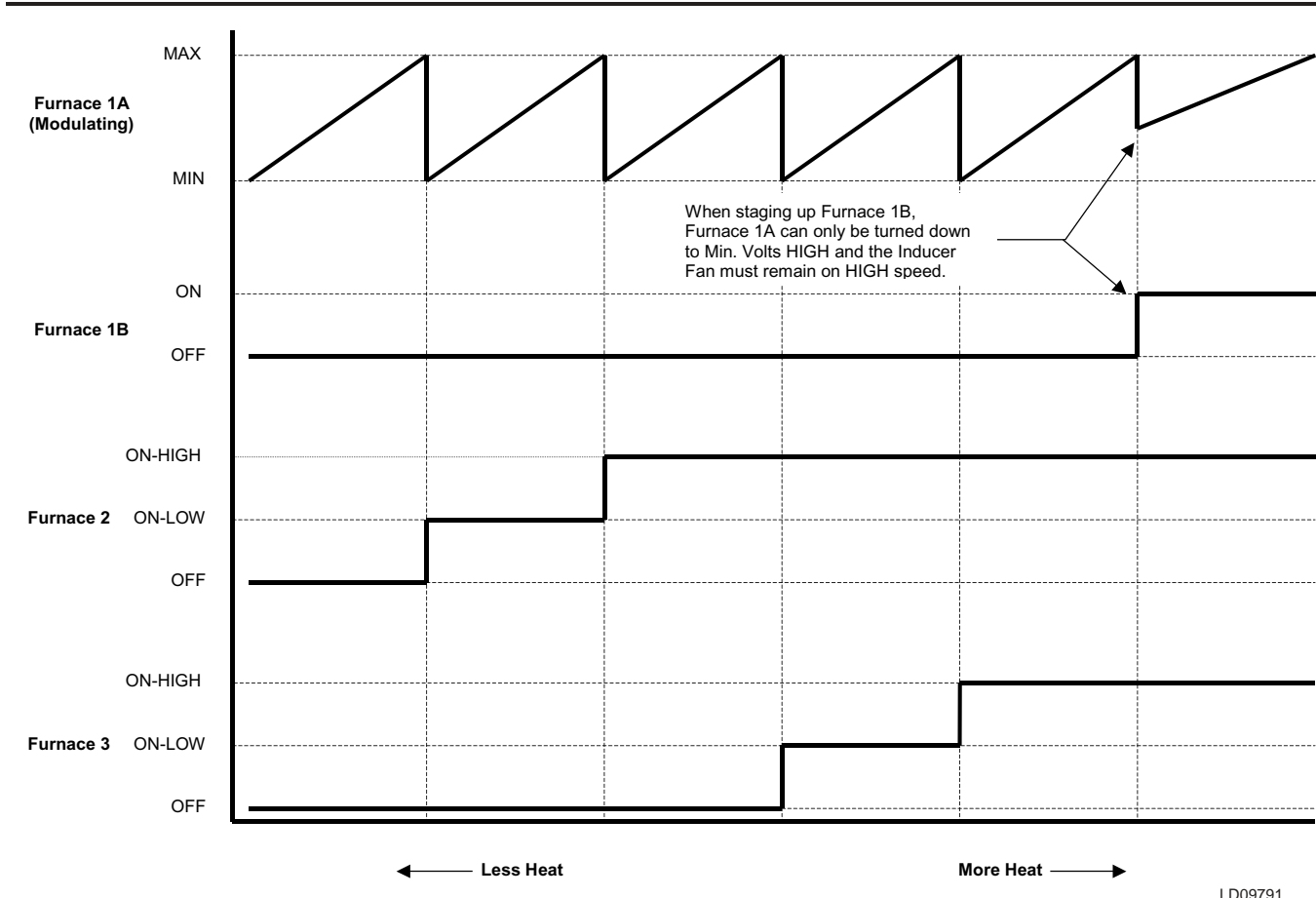

FIG. 44 – MODULATING GAS HEAT STAGING

the “*Hydro Heat 1st Stage*” is field adjustable but is factory set with a default value of 100° F. Under the SETPOINTS key of the OptiLogic control panel the “*Hydro Heat 2nd Stage*” is field adjustable but is factory set with a default value of 115° F.

The Furnace Controller, found in the gas heat section, will also be configured at the factory based on the number of gas heat sections installed. This configuration is performed at terminal 5 and 6 of terminal block TB2 of the Furnace Controller. If there is a single heat section installed there will be no connection between the two terminals. If there is two heat sections installed there will be a 1K ohm ½ watt resistor between the two terminals. If there is three heat sections installed there will be a jumper between the two terminals.

The Primary Unit Controller generates a 0 to 10 volt signal to the Furnace Controller based on the temperature difference between the supply air temperature (SAT) and the “*Hydro Heat 1st Stage*” or “*Hydro Heat 2nd Stage*”. Refer to Table 16 and 17 for an explanation on how the Primary Unit Controller determines when heating is required for the different modes of unit operation.

The 0 to 10 volt output represents a 30 degree temperature range (3 degrees = 1 volt). The midpoint of the 30 degree range is the SAT midpoint. This midpoint equals a 5 volt output to the Furnace Controller.

The Furnace Controller has a default +/- one degree offset from the midpoint. When the voltage input to the Furnace Controller is between 4 and 6 volts the controller maintains the current state of furnace operation, it will neither increase nor decrease the amount of heat.

When the voltage is between 6 and 10 volts, the Furnace Controller increases the heating output. When the voltage is between 0 and 4 volts, the Furnace Controller will decrease the heating output.

A voltage greater than 5 volts is required for the modulating furnace section to start. A voltage level less than 1 volt will turn the furnace off.

COMPRESSOR OPERATING CONTROLS

The following information describes the sequence of operation for the compressor unit control components. The information below describes System 1A and 1B

compressor operation. This same information can also be applied to System 2A and 2B and System 3A and 3B.

- When the Primary Unit Controller identifies a need for compressor operation it energizes the Cooling Change Over Relay (C/O) 12R and switches the binary outputs BO1 for compressor A1 operation and BO2 for compressor A2 operation from the Primary Unit Controller to the smart Relay SR1.
- The Smart Relay SR1 sends a 120 volt output from the Q1 output (compressor 1A) Q2 (compressor 1B) to the 1M (compressor 1A), 2M (compressor 1B) contactor which energizes compressor 1A and/or 1B.
- The Smart Relay SR1 also sends a 120 volt output from the Q3 output to the 7M contactor which energizes one condenser fan.
- The Smart Relay also receives an input signal from an ambient thermostat 9STAT at terminal I5. The thermostat opens at 75°F and closes at 85°F. If the switch is closed and there is a call for both compressor 1A and 1B the Smart Relay will send a 120 volt signal from terminal Q4 of the Smart Relay to the 8M contactor and the second condenser fan for system 1 is energized.
- Flexsys units have a solenoid valve (4LLSV) installed prior to one of the two system expansion valves in order to keep one half the system circuit inactive unless both compressor are on. Both compressor contactors 1M and 2M have auxiliary normally open contacts that close when the contactor is energized. The two auxiliary contacts are in series and control the operation of the solenoid valve. Both the auxiliary contacts must be closed before 120 volts is supplied to energize and open the solenoid valve.
- If pumpdown is installed on the unit the solenoid valve in the main system liquid line (1LLSV) will be energized with the 7M contactor at the beginning of the cycle.
- The Smart Relay uses an input to terminal I4 to monitor the condition (open or closed) of the low pressure switch. When a call for mechanical cooling for System 1 is removed, the Smart Relay deenergizes the Q3 and Q4 outputs which opens contactors 7 and 8 M and deenergizes the liquid line solenoid valve (1LLSV).

- The Smart Relay continues to keep the Q1 or Q2 contact closed until the pressure switch input to terminal I4 of the Smart Relay is removed, or for 30 seconds; whichever occurs first.
- The Smart Relay then opens the Q1 or Q2 contact shutting off the compressor.

REFRIGERANT SAFETY OPERATION

Freezestat Operation

- Freezestat protection only applies if both compressors of the system are energized.
- Both compressors must have been operating for 2 minutes before a lockout can occur.
- The Smart Relay monitors the freezestat input at terminal I3. If the input is lost, the Smart Relay turns off the Q2 output and compressor 1B is turned off.
- The Smart Relay will not close the Q2 contact until 10 minutes has elapsed since the freezestat trip, provided the freezestat contacts closed during the 10-minute time frame.

Compressor Safety Chain

- Each of the tandem compressor systems has a compressor safety chain consisting of the following components. Low Pressure Cutout, High Pressure Cutout, Compressor Motor Protector, Compressor Current Overload
- The above safeties are in series and are connected to the BI1, for system 1; BI 2, for system 2; BI3, for system 3, inputs to the Primary Unit Controller.
- The Primary Unit Controller monitors the compressor safety chain inputs only when a compressor from that system is operating.
- When a compressor is started the control shall ignore the compressor safety chain for 30 seconds.
- After the 30 seconds start delay, if the status is not present for more than one second, the control shall de-energize all compressors operating in that compressor safety chain.
- The Primary Unit Controller then waits ten minutes before making the compressors in the tripped system available for operation, provided the compressor safety chain has reset.
- Each compressor system shall be assigned two trip counters, both counters shall start at zero.

- Counter #1 shall:
 - Increment by 1 any time a trip occurs when either one or two compressors on the tripped compressor system are on.
 - Be reset to zero counts if the compressor system status input is present for one cumulative hour of compressor operation following the last compressor safety trip.
 - Be reset to zero if the power to the Primary Unit Controller is removed and reestablished.
- Counter #2 shall:
 - Increment by 1 any time a trip occurs and both compressors on the system are operating.
 - Be reset to zero counts if the compressor system status input is present for one cumulative hour of compressor operation following the last compressor safety trip.
 - Be reset to zero if the power to the Primary Unit Controller is removed and reestablished.
- If the count of either compressor status counter on a compressor system = 3
 - The compressors on the system are shut down and locked out.
 - A compressor safety lockout fault is declared.
- The power to the Primary Unit Controller must be removed and reestablished to clear a safety lockout fault.

FLEXSYS VAV OPERATION

Description of Operation

In the Flexsys mode of operation the unit operates in the VAV Stand-Alone mode and does not use a thermostat or space sensor input. See Table 17 for a summary of the VAV Stand-alone mode of operation. In a Flexsys system the eco² unit supplies condition cool air to a under floor delivery system. Compressor operation is controlled based on the supply air temperature leaving the evaporator coil. Additional sensors are added to monitor the temperature of the air off the evaporator coil. The unit has an opening below the supply air blower that allows return air to flow through a bypass duct and mix with the air off the coil. There is a damper in the by-pass duct, which modulates to temper the temperature of the mixed air being sent to the underfloor system. The unit will also accept an analog input from an underfloor temperature and humidity sensor. These sensors can be used to monitor the dew point of the air under the floor and can reset the SAT temperature if the air approaches the dew point.

The following parameters are used to set up an eco² unit for Flexsys operation.

- Under the Configuration key of the OptiLogic Control the “*Unit Type*” must be set to “Flexsys”.
- Under the Setpoints key of the OptiLogic Control the “*VAV Cool High Temp*” must be set. This is the setpoint for the temperature of the air off the evaporator coil, which the Primary Unit Controller will use to stage the economizer and mechanical cooling.
- Under the Setpoints key of the OptiLogic Control the “*VAV Cool Low Temp*” must be set. This is the setpoint of the temperature of the air off the evaporator coil that the Primary Unit Controller uses to stage the mechanical cooling if the under floor temperature and humidity approaches the dew point.
- Under the Setpoints key of the OptiLogic Control the “*Flexsys MSAT Setpoint*” must be set. This is the setpoint of the temperature of the air the eco² unit will try to deliver to the underfloor system.
- Under the Setpoints key of the OptiLogic Control the “*Flexsys Min Dewpt Diff*” must be set. When the dew point of the under floor space gets within this number of degrees of the actual dewpoint the Primary Unit Controller switches to the “*VAV Cool Low Temp*” setpoint.
- Under the Unit Setup key of the OptiLogic Control the “*Flexsys Dewpt Reset*” must be set to ON if an underfloor temperature and humidity sensor is being used to reset the supply air temperature.

A modulating damper is used to vary the amount of Return Air By-passed from the Return air Duct to the

fan section of the rooftop unit.

- The damper is direct acting (0 VDC – bypass damper 100% open, 10 VDC – bypass damper closed).
- During Unoccupied Modes of operation and during Morning Warmup, the bypass damper is commanded 100% open (10 VDC).
- During the Occupied Mode of operation, the bypass damper is controlled to maintain the “*Flexsys MSAT*” Setpoint.
- The minimum time for the by-pass damper to go from full open to closed or closed to full open will be approximately 15 minutes.
- The Primary Unit Controller will calculate a by-pass damper set point using formula 1 in Figure 45:
- The Primary Unit Controller will calculate the Active By-pass Percentage using formula 2 in Figure 45:
- The by-pass damper will be controlled as follows:
 - If the Actual By-pass Percentage is \geq to the (By-pass Percentage Setpoint + 2.5⁰ F) the By-pass damper will close until the Actual By-pass Percentage is equal to the By-pass Percentage Setpoint
 - If the Actual By-pass Percentage is \leq to the (By-pass Percentage Setpoint - 2.5⁰ F) the By-pass damper will open until the Actual By-pass Percentage is equal to the By-pass Percentage Setpoint.

Formula 1

$$\text{By-pass Percentage Setpoint} = \frac{\text{Flexsys MSAT Setpoint} - \text{Supply Air Temperature Setpoint}}{\text{Return Air Temperature} - \text{Supply Air Temperature Setpoint}}$$

Formula 2

$$\text{Actual By-pass Percentage} = \frac{\text{Current MSAT Temperature} - \text{Current Supply Air Temperature}}{\text{Current Return Air Temperature} - \text{Current Supply Air Temperature}}$$

FIG. 45 – BY-PASS DAMPER FORMULAS

- If the (By-pass Percentage Setpoint – 2.5⁰ F) < Actual By-pass Setpoint < (By-pass Percentage Setpoint + 2.5⁰ F) the bypass damper will not move.
- A change in the By-pass Damper position will only be allowed to occur 2 minutes after a compressor is started or stopped.
- Immediately after a compressor is started and stopped, the By-pass Damper will be fixed by the Primary Unit Controller
- The Primary Unit Controller will not open or close the By-pass Damper until the SAT temperature fall below the RAT.
- If the SAT temperature is above the RAT, the By-pass Damper shall remain fixed.

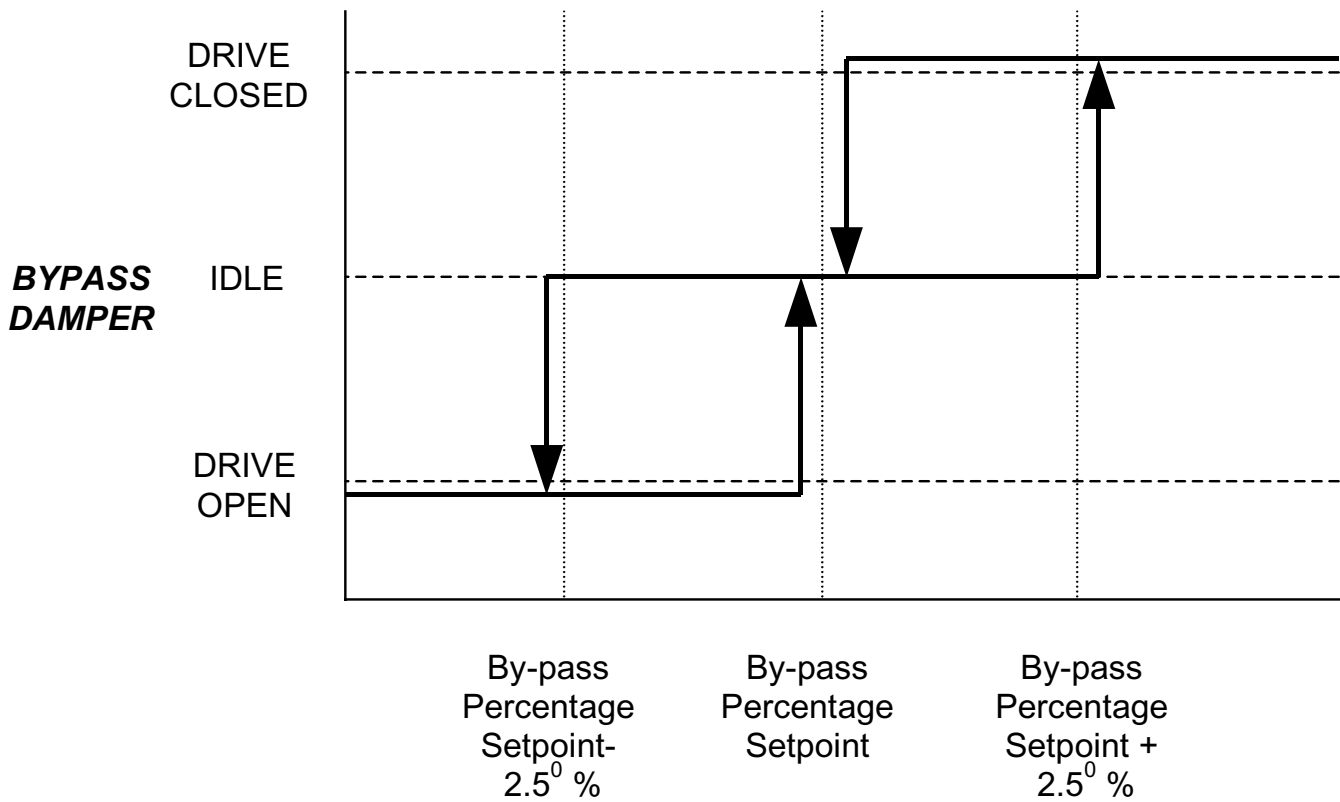

LD09792A

FIG. 46 – BYPASS DAMPER SETPOINTS

SECTION 6 – MENU NAVIGATION AND DISPLAY DESCRIPTIONS

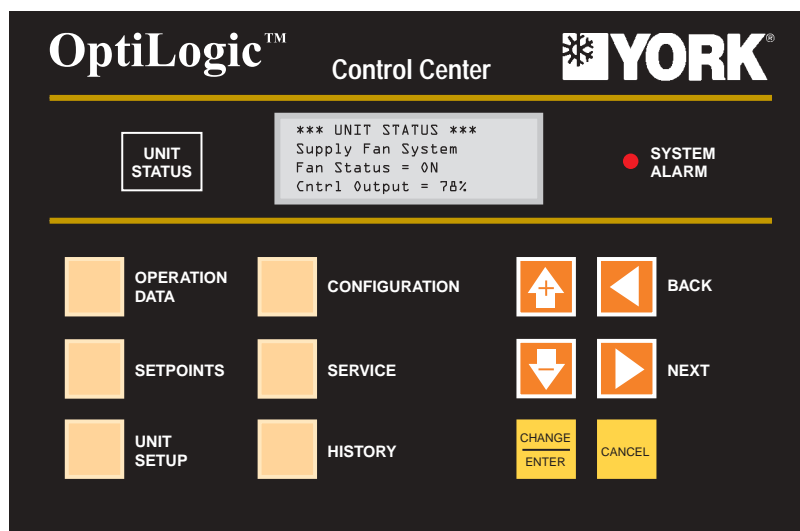

LD06581

OPTILOGIC™ CONTROL CENTER

The OptiLogic Control Center (OCC) is used to commission, monitor, and troubleshoot the rooftop unit. It provides access to operational data, setpoint programming, and access to past “history” information that record unit parameters on safety shutdowns.

The OCC is installed in the control cabinet of the rooftop unit.

The OCC keypad is a flexible membrane style keypad and has a 4 line by 20 character LCD backlit display. The backlighting will energize when any button is pressed and will be delayed to shut off 15 minutes after the last button has been pressed.

The keypad consists of thirteen keys, divided into two groups, **Function keys** and **Navigation keys**. The seven function keys are Unit Status, Operation Data, Setpoints, Unit Setup, Configuration, Service, and History. The six navigation keys will be Up Arrow (↑) {increase}, Down Arrow (↓) {decrease}, Back (<), Next (>), Change/Enter, and Cancel.

NAVIGATING THE MENUS

The primary means of navigation for the menus is performed with the Back (<) and Next (>) keys. Pressing the Back (<) and Next (>) keys will change the display to the previous or next display item, respectively. The entire menu is navigable using just the Back (<) and Next (>) keys exclusively. However, to facilitate navigation, The Function keys, mentioned in the previous paragraphs, allow the user to jump directly to the associated menu items without scrolling through every menu display.

HISTORY MENU NAVIGATION

The OptiLogic Control Panel stores a maximum of 12 history “snapshots”. These snapshots are the unit parameters and setpoints stored in memory at the time the unit shut down on a fault. In the History menu, the navigation of the menu is performed with the Up Arrow (↑) {increase} and Down Arrow (↓) {decrease} to navigate through the data points stored in that History “snapshot”. The Back (<) and Next (>) keys are still used to move through twelve History snapshots.

“UNIT STATUS” NAVIGATION

The Unit Status key (or menu item) will move the display to the first display item of the Unit Status group. The Unit Status group of display items gives the user access to information pertaining to the units’ current operating status. The Unit Status group of display items will be view only and require no password. An exception to this statement is the entry of time and date. Time and date are entered in the Unit Status group and require a Level 1 password.

The OptiLogic Control Center display has four lines of which to display data, from top to bottom. The first line will always show the Function Key group currently being accessed. The following table shows the Function Key and the respective First Line Text that will be displayed.

FUNCTION KEY	FIRST LINE TEXT
UNIT STATUS	*** UNIT STATUS ***
OPERATION DATA	** OPERATION DATA **
SETPOINTS	*** SETPOINTS ***
UNIT SETUP	*** UNIT SETUP ***
CONFIGURATION	** CONFIGURATION **
SERVICE	*** SERVICE ***
HISTORY	*** HISTORY ***

Starting with the first display item, the Unit Status display items are shown below. The values in parentheses are the possible displays.

*** UNIT STATUS ***
 General Unit Status
 Unit Type = VAV
 Status = NORMAL

Line 2 General Unit Status
 Line 3 Unit Type = VAV (CV, VAV, Flexsys)
 Line 4 Status = NORMAL (TROUBLE, ALARM)

Unit Type will be determined from the "Unit Type" configuration setting under the Configuration menu and can be programmed for either VAV (variable air volume unit), CV (constant volume unit), or Flexsys.

Status is determined by:

- NORMAL - no faults have been detected
- TROUBLE - a fault that does not cause unit shut-down has been detected
- ALARM - a fault that causes the unit to be shut down has been detected

Refer to the section on Service and Troubleshooting for fault, alarm and trouble description.

*** UNIT STATUS ***
 Date = 25-Feb-2000
 Time = 12:28:05a
 Day = WED

Line 2 Date = dd-mon-year
 Line 3 Time = hh:mm:ss a (p)
 Line 4 Day = DDD (day abbreviation)

The Date and Time are displayed and, if required, changed in this display by pressing Enter/Change and using cursor control and the Enter button to update the Date and Time parameters. A Level 1 password is required to change these parameters.

*** UNIT STATUS ***
 Current Unit Mode
 Unoccupied Standby

Line 2 Current Unit Mode
 Line 3 (Current unit operating mode)
 Line 4 (Blank)

Line 3 displays the one of the following operating modes:

- | | |
|--------------------|---------------------|
| Occupied Standby | Warm-up |
| Occupied Cooling | Sys. Start Delay |
| Occupied Heating | Preoccupancy Purge |
| Unoccupied Standby | Smoke Purge |
| Unoccupied Cooling | Emergency Shut Down |
| Unoccupied Heating | Fault Shutdown |
| Manual Override | |

*** UNIT STATUS ***
 Unit Controlled By
 Thermostat

Line 2 Unit Controlled By
 Line 3 (Determined by inputs and Setup settings)

Line 4 (Blank)

Line 3 displays one of the following four space temperature control sources or method:

- Thermostat
- Zone Sensor
- BAS Network
- Stand Alone Control

*** UNIT STATUS ***
 Supply Fan System
 Fan Status = ON
 Cntrl Output = 78%

Line 2 Supply Fan System
 Line 3 Fan Status = ON (OFF or FAULT)
 Line 4 Cntrl Output = XXX%

*** UNIT STATUS ***
 Hydronic Heat System
 Cntrl Output = 0%
 Freezestat = Normal

Line 2 Hydronic Heat System
 Line 3 Cntrl Output = XXX%
 Line 4 Freezestat = NORMAL (SAFETY TRIP)

*** UNIT STATUS ***
 Exhaust Fan System
 Fan Status = ON
 Cntrl Output = 100%

Line 2 Exhaust Fan System
 Line 3 Fan Status = ON (OFF)
 Line 4 Cntrl Output = XXX%

*** UNIT STATUS ***
 Staged Heat System
 Stages ON = 1
 Stages Avail = 3

Line 2 Staged Heat System
 Line 3 Stages ON = X
 Line 4 Stages Avail = X= 0-6

*** UNIT STATUS ***
 Comp System #1
 Status = SAFETY TRIP
 Comps ON = NONE

Line 2 Comp System #X
 Line 3 Status = NORMAL (SAFETY TRIP)
 Line 4 Comps ON = A (B, BOTH, NONE)

Display #7 repeats for compressor systems 2 and 3. If the unit is a 4-stage (2 system) unit, system 3 data will show N/A for Status and Comps ON.

*** UNIT STATUS ***
 Economizer System
 Type = Single Enth.
 Status = Inactive

Line 2 Economizer System
 Line 3 Type = (Single, Dual, Outside Air) N/A
 Line 4 Status = Active (Inactive, N/A, Fault)

Line 3 displays one of the following economizer system operation configurations:

- OA Dry Bulb
- Single Enth (Single Enthalpy)
- Dual Enthalpy
- N/A (Unit is not equipped with an economizer or economizer is not enabled)

The status displayed in Line 4 indicates one of the following:

N/A - Unit is not equipped with an economizer or economizer is not enabled

Active - Economizer operation enabled and conditions are suitable

Inactive - Economizer operation enabled and conditions are not suitable

```

*** UNIT STATUS ***
Ventilation System
Type = Min Dampr Pos
Status = Unocc/OFF
    
```

Line 2 Ventilation System

Line 3 Type = (Show Current Configuration)

Line 4 Status = Unocc/OFF (Occ/ON, N/A, Fault)

Line 3 displays one of the following configurations:

None (Line 4 Status = N/A)

Min Dampr Pos (Minimum damper position)

Min Airflow

25/75 Airflow

Full Airflow

```

*** UNIT STATUS ***
Filter Status
Status = NORMAL
RA Bypass = NORMAL
    
```

Line 2 Filter Status

Line 3 Status = NORMAL (REPLACE)

Line 4 RA Bypass = Normal (Replace)

```

*** UNIT STATUS ***
Thermostat Input
Status = Y2
    
```

Line 2 Thermostat Input

Line 3 Status = Y2 (Y1, W1, W2, None)

Line 4 (Blank)

```

*** UNIT STATUS ***
Occ Input
Status = Occ / ON
    
```

Line 2 Occ Input

Line 3 Status = Occ/ON* (UnOcc/OFF)

Line 4 (Blank)

* "Occ/ON" only if hard wired input between "R" & "G" at CTB1

```

*** UNIT STATUS ***
G Input
Status = ON
    
```

Line 2 G Input

Line 3 Status = ON* (OFF)

Line 4 (Blank)

* "ON" only if hard wired input between "R" & "G" at CTB1.

“OPERATION DATA” NAVIGATION

The Operation Data key (or Menu Item) will move the display to the first display item of the Operation Data group. The Operation Data group of display items will give the user access to the units’ current operating parameters. The Operation Data group of display items is view only and will require no password.

Starting with the first display item, the Operation Data display items are as follows:

**** OPERATION DATA ****
 Sys 1 Compressors
 Comp A = ON
 Comp B = OFF

Line 2 Sys X Compressors
 Line 3 Comp A = ON (OFF, FAULT)
 Line 4 Comp B = ON (OFF, FAULT)

**** OPERATION DATA ****
 Sys 1 Compressors
 Suc Press = 80 psig
 Dis Press = 270 psig

Line 2 Sys X Compressors
 Line 3 Suc Press = XXX PSIG (???)
 Line 4 Dis Press = XXX PSIG (???)

**** OPERATION DATA ****
 Compressor Staging
 Next ON = 2-B
 Next OFF = N/A

Line 2 Compressor Staging
 Line 3 Next ON = X-X (N/A)
 Line 4 Next OFF = X-X (N/A)

**** OPERATION DATA ****
 OA Temp = 73.4°F
 OA RH = 48%
 OA Enth = 26.8 btu/lb

Line 2 OA Temp= XXX°F (0.0, ???)
 Line 3 OA RH = XXX% (0.0, ???)
 Line 4 OA Enth= XX.X btu/lb (0.0)

**** OPERATION DATA ****
 RA Temp = 69.6°F
 RA RH = 55%
 RA Enth = 26.0 btu/lb

Line 2 RA Temp= XXX°F (0.0, ???)
 Line 3 RA RH = XXX% (0.0, ???)
 Line 4 RA Enth= XX.X btu/lb (0.0)

**** OPERATION DATA ****
 Supply Air Temp
 Temp = 57.6°F
 Setpt = 58.0°F

Line 2 Supply Air Temp
 Line 3 Temp = XXX.X°F (0.0, ???)
 Line 4 Setpt = XXX.X°F (0.0)

**** OPERATION DATA ****
 Supply Duct Pressure
 Press = 1.48 inwg
 Setpt = 1.50 inwg

Line 2 Supply Duct Pressure
 Line 3 Press = X.XX inwg (0.0, ???)
 Line 4 Setpt = X.XX inwg (0.0, ???)

**** OPERATION DATA ****
 Space Temperature
 Temp = 71.2°F
 Setpt = 71.0°F

Line 2 Space Temperature
 Line 3 Temp = XX.X°F (0.0)
 Line 4 Setpt = XX.X°F (0.0)

**** OPERATION DATA ****
 Outside Air Damper
 Flow #1= 15478 CFM

Line 2 Outside Air Damper
 Line 3 Flow #1= XXXXX cfm (0.0)
 Line 4

**** OPERATION DATA ****
 Building Pressure
 Press = +0.08 inwg
 Setpt = +0.10 inwg

Line 2 Building Pressure
 Line 3 Press = +/-X.XX inwg (0.0, ???)
 Line 4 Setpt = +/-X.XX inwg (0.0)

**** OPERATION DATA ****
 Outside Air Damper
 Flow #2= 5732 CFM

Line 2 Outside Air Damper
 Line 3 Flow #2= XXXXX cfm (0.0)
 Line 4

**** OPERATION DATA ****
 Outside Air Damper
 Position #1 = 34%
 Min Pos = 25%

Line 2 Outside Air Damper
 Line 3 Position # 1 = XXX%
 Line 4 Min Pos = XXX%

**** OPERATION DATA ****
 Outside Air Damper
 TotalFlow= 21210 CFM
 Setpt= 20000

Line 2 Outside Air Damper
 Line 3 TotalFlow= XXXXX cfm (0.0)
 Line 4 Setpt= XXXXX cfm (0.0)

**** OPERATION DATA ****
 Outside Air Damper
 Position #2= 30 %
 Position #3= 35 %

Line 2 Outside Air Damper
 Line 3 Position #2= XXX %
 Line 4 Position #3= XXX %

**** OPERATION DATA ****
 Demand Ventilation
 Sensor= XXXX ppm
 Setpt= XXXX ppm

Line 2 Demand Ventilation
 Line 3 Sensor Value= XXXX ppm (0)
 Line 4 Setpt= XXXX ppm

**** OPERATION DATA ****
 Flexsys Supply Temp
 Temp= XX.X °F
 Setpt= XX.X °F

Line 2 Flexsys Supply Temp
 Line 3 Temp= XX.X °F (0.0)
 Line 4 Setpt= XX.X °F

**** OPERATION DATA ****
 Flexsys Bypass Air
 Active Byp %= XXX %
 Byp % Setpt= XXX %

Line 2 Flexsys Bypass Air
 Line 3 Active Byp %= XXX % (0)
 Line 4 Byp % Setpt= XXX % (0)

**** OPERATION DATA ****
 FlexRH= XXX %
 Dewpoint= XX.X °F
 Slab Temp= XX.X °F

Line 2 Flex RH= XXX % (0.0)
 Line 3 Dewpoint= XX.X °F
 Line 4 Slab Temp= XX.X °F (0.0)

**** OPERATION DATA ****
 Rooflink
 Status= Active
 Smoke Purge Mode= 0

Line 2 Rooflink
 Line 3 Status= Active (Inactive)
 Line 4 Smoke Purge Mode= 0 (0-5)

**** OPERATION DATA ****
 Flexsys Bypass Dmpr
 Position= XXX %

Line 2 Flexsys Bypass Dmpr
 Line 3 Position= XXX % (0.0)
 Line 4

“SETPOINTS” NAVIGATION

The Setpoints key (or Menu Item) moves the display to the first display item of the Setpoints group. The Setpoints group of display items allows the user to view and modify general setpoint data. It should be noted that all setpoints show values, however, not all setpoints are used for operation based on how the unit is setup and configured. For example, zone sensor setpoint shows a value but is ignored if the unit is setup for use with a thermostat.

All of the display items of the Setpoints group can be changed. Changing setpoints under the “Setpoints” key is covered under “Changing Setpoints” in section “Parameter Descriptions and Options.” Editing setpoints requires the appropriate password entry, which is explained under the section “Passwords”.

Starting with the first display item, the Setpoints display items are as follows:

*** SETPOINTS ***
 Unoccupied Heating
 Setpoint = 60°F

Line 2 Unoccupied Heating
 Line 3 Setpoint = XX°F
 Line 4 (Blank)

All the remaining displays follow the same format, and are covered in sequence and explained in the section “PARAMETER DESCRIPTION AND OPTIONS.” This format will list the setpoint description on Line 2 with “Setpoint = XXXX on Line 3. Line 4 is always blank except for Flexsys.

“UNIT SETUP” NAVIGATION

The Unit Setup key moves the display to the first item of the Unit Setup group. The Unit Setup group of display items allows the user to view and modify general Unit Setup data. All Unit Setup parameters show data, however, not all Unit Setup parameters are used for operation based on how the unit is setup and configured. For example, Reverse Acting HW Valve can be selected ON or OFF even if the heating system is configured for electric or gas heat.

Unit Setup parameters are listed in Table 21 with their associated data.

Changing values in this group are covered in the section “PARAMETER DESCRIPTION AND OPTIONS”, under “CHANGING SETPOINTS.”

Changing of a Unit Setup parameter requires the entry of a password (see section on “Passwords”).

As with the other function groups, the description of the selected function, *** UNIT SETUP *** will be displayed on line 1 of the display. Line 2 will display one of the selected subgroups pertaining to the setpoint being viewed/changed. The table below illustrates the seven subgroups under Unit Setup.

Line 1 Display		Line 2 Display (Subgroup)
Unit Setup	1	General Setup
	2	Heat/Cool System
	3	VAV System
	4	Econo/Exhaust System
	5	Ventilation System
	6	Warm-up/Purge
	7	Clock/Scheduling

Line 3 will show the Setpoint Description, and line 4 will display “Setting = XXXX”, where XXXX is the data. Information shown in Table 21 details the information that is displayed with each item, which includes default value, value range, and password level. Shown below are two sample displays for the Unit Setup function.

DISPLAY - SUBGROUP 1

```
*** UNIT SETUP ***
General Setup
Language Option
Setting = English
```

Line 2 General Setup
 Line 3 Language Option
 Line 4 Setting = English

DISPLAY - SUBGROUP 4

```
*** UNIT SETUP ***
Econo/Exhaust System
Economizer Enable
Setting = OFF
```

Line 2 Econo/Exhaust System
 Line 3 Economizer Enable
 Line 4 Setting = OFF

All the displays follow the same format as shown above and are covered in sequence and explained in the section “PARAMETER DESCRIPTION AND OPTIONS (SETPOINTS)”. This format will list the Unit Setup Display Group on Line 2 with Description on Line 3. Line 4 displays “*setting = XXXX*”. Table 20 details the information that is displayed with each display item of this function group which includes the text for Line 3, units used with the associated item, default value, value range, and password level.

```
*** PURGE SCHEDULE ***↓
Mon= HH:MM - HH:MM
Tue= HH:MM - HH:MM
Wed- HH:MM - HH:MM
```

```
*** UNIT SETUP ***↓
Thu= HH:MM - HH:MM
Fri= HH:MM - HH:MM
Sat- HH:MM - HH:MM
```

Pressing the DOWN key will index the bottom three lines of text as shown.

The Preoccupancy Purge schedule is used for entering the time for start and stop of Preoccupancy Purge is entered. Line 1 is “*Purge Schedule*”. The previous displays are used to display and change the start and start times for each day of the week and for holidays. The display is illustrated as shown above.

```
*** WEEKLY SCHEDULE ***↓
Mon= HH:MM - HH:MM
Tue= HH:MM - HH:MM
Wed- HH:MM - HH:MM
```

```
*** WEEKLY SCHEDULE ***↓
Thu= HH:MM - HH:MM
Fri= HH:MM - HH:MM
Sat- HH:MM - HH:MM
```

Pressing the DOWN key will index the bottom three lines of text as shown.

Weekly Schedule and Holiday Schedule

Navigating to the Weekly Schedule display will show the above display.

Pressing the Up and Down keys at this display item will navigate the display cursor down and index the display to show the additional days of the week.

In order for the internal clock/schedule to operate, it must be turned on. The clock/scheduler is turned ON or OFF under the UNIT SETUP key of the OptiLogic Control, “*Clock/Scheduling Internal Clk/Sched Settings*” ON – OFF.

Pressing the Change/Enter key at any of these days will prompt the user for a password (refer to section on Password). Once the password is entered, the start and stop times can be changed by indexing the digits up and down with the Up and Down keys, or moving between digits with the Back or Next keys.

The Weekly Schedule sub menu will be as follows:

Weekly Schedule

- Mon = HH:MM – HH:MM
- Tue = HH:MM – HH:MM
- Wed = HH:MM – HH:MM
- Thu = HH:MM – HH:MM
- Fri = HH:MM – HH:MM
- Sat = HH:MM – HH:MM
- Sun = HH:MM – HH:MM
- Hol = HH:MM – HH:MM

Navigating to the Holiday Schedule display item will show the following:

```

** HOLIDAY SCHEDULE ** ↓
HOL 01= MMM DD
HOL 02= MMM DD
HOL 03= MMM DD
    
```

```

** HOLIDAY SCHEDULE ** ↓
HOL 14= MMM DD
HOL 15= MMM DD
HOL 16= MMM DD
    
```

Pressing the DOWN key will index the bottom three lines of text as shown.

Pressing the Up and Down keys at this display item will navigate the display cursor down and index the display to show the additional holidays. Pressing the Change/Enter key at any of these holidays will prompt the user for a password. Once the password is entered, the month (MMM) and day (DD) will be changeable by pressing the Up and Down keys, or moving between months and days with the Back or Next keys.

“CONFIGURATION” NAVIGATION

The Configuration key (or Menu Item) will move the display to the first item of the Configuration group. The

Configuration group of display items will allow the user to view and change general unit Configuration data. Not all Configuration parameters will be used for operation based on how the unit is setup and configured. For example, IAQ Sensor Span will have a setting; however, it will be ignored if the IAQ Sensor Enable Unit Setup parameter is selected OFF.

Configuration parameters are listed in Table 21 with their associated data, and explained under the section titled **“PARAMETER DESCRIPTION AND OPTIONS (SETPOINTS)”**

As with the other function groups, the description of the selected function, **** CONFIGURATION **** will be displayed on line 1 of the display. Line 2 will display one of the selected subgroups pertaining to the setpoint being viewed/changed. The table below illustrates the four subgroups under Configuration.

```

** CONFIGURATION **
Heat/Cool System
Freezestat
Setting = OFF
    
```

Line 1 Display		Line 2 Display (Subgroup)
Configuration	1	General
	2	Heat/Cool System
	3	Excess SAT
	4	Econo/Exhaust/Vent.
	5	Duct Sensor Hi Limit
	6	Evaporator Damper

Changing setpoints is explained in the section titled **“PARAMETER DESCRIPTION AND OPTIONS”** under **“Changing Setpoints.”** Changing a Configuration setpoint requires the entry of a password at the appropriate level.

Line 3 will show the display item and Line 4 will display of that item, such as **“Setting = XXX”**, where XXX is the data. Information shown in Table 21 includes the text for Line 3, units used with the associated item, default value, value range, and the password level. A sample display is shown above.

DISPLAY - SUBGROUP 2

- Line 2 Heat/Cool System
- Line 3 Freezestat
- Line 4 Setting = OFF

“SERVICE” NAVIGATION

The Service key will move the display to the first display item of the Service function group. The Service function group of display items will give access to service related information. The Service Function group of display items will be primarily view only.

The following parameter types can be changed. All others are display only.

- Four Airflow Measurement Station (AMS) parameters.
- Four/six compressor runtimes can be reset to zero but cannot be reset to a specific value.



Resetting the compressor run times to zero will result in that compressor running first on a call for cooling until the run time becomes equal to or greater than the other compressors.

- Four/six compressor starts
- Supply and exhaust fan runtimes can be set to zero but cannot be reset to a specific value.

When the service key is pressed, the following is displayed:

*** SERVICE ***
 Sys 1 Comp Runtimes
 Comp A = 347.1 hrs
 Comp B = 368.7 hrs

Display shows accumulated compressor run time.

Line 2 Sys X Comp Runtimes
 Line 3 Comp A = XXXXX.X hrs
 Line 4 Comp B = XXXXX.X hrs

Display repeats for compressor systems 1, 2, and 3. If the unit is configured as a 4-compressor unit, Display 3 (Sys 3 Comp Runtimes) will show N/A for both compressors.

*** SERVICE ***
 Sys 1 Comp Starts
 Comp A = 756
 Comp B = 685

Display shows the number of starts on each compressor.

Line 2 Sys X Comp Starts
 Line 3 Comp A = XXXXXX
 Line 4 Comp B = XXXXXX

Display repeats for compressor systems 1, 2 & 3. If the unit is configured as a 4 compressor unit, Display 3 (Sys 3 Comp starts) will show N/A for both compressors.

This display shows accumulated fan run times for the supply and exhaust fans

*** SERVICE ***
 Fan Runtimes
 Supply = 1258.3 hrs
 Exhaust = 948.2 hrs

Line 2 Fan Runtimes
 Line 3 Supply = XXXXX.X hrs
 Line 4 Exhaust= XXXXX.X hrs

This display shows the lockout status of cooling or heating as compared to the “lockout” setpoints under the Unit Setup key.

*** SERVICE ***
 OAT Lockouts
 Cooling = NO
 Heating = NO

Line 2 OAT Lockouts
 Line 3 Cooling = NO (YES)
 Line 4 Heating = NO (YES)

This display indicates whether the economizer (if applicable) is active, as compared to the setpoint programmed under the Outside Air Enthalpy setpoint under the “Setpoint” key.

```
*** SERVICE ***
Economizer Activity
Active = NO
SAT Setpt = 60°F
```

Line 2 Economizer Activity
 Line 3 Active = NO (YES)
 Line 4 SAT Setpt = XX°F

- Active = NO: Economizer installed, enabled and conditions are not suitable

or

No Economizer installed

- Active = YES: Economizer installed, enabled and conditions are suitable

SAT Setpt indicates the current SAT (supply air temperature) setpoint that the economizer will try to maintain when outside air conditions are suitable for free cooling/economizer operation.

Display shows which mode of operation the unit is in.

```
*** SERVICE ***
Modes Enable
Cooling = YES
Heating = NO
```

Line 2 Modes Enabled
 Line 3 Cooling = NO (YES)
 Line 4 Heating = NO (YES)

This display shows the status of the “compressor safety chain” which consists of a low-pressure switch, high-pressure switch, and compressor overload for each refrigerant circuit. If any of the safeties are opened, the display will show the respective system and display as follows:

```
*** SERVICE ***
Sys X Safety Chain
Status = Tripped
```

Line 2 Sys X Safety Chain (1,2,3)
 Line 3 Status = Tripped (NORMAL)
 Line 4 (Blank)

This display shows the entry made by the Air Balancer if a manual air balance is done.

```
*** SERVICE ***
AMS#1
Balancer Calculated
Airflow = 9000 cfm
```

Line 2 AMS #1
 Line 3 Balancer Calculated
 Line 4 Airflow= XXXXX cfm

The Line 4 value is entered as the result of an airflow balancer’s measurement of the unit airflow. A default value of “1” will be shown whether or not this function is used. Editing the value requires the entry of a password of the appropriate level. This function is described under Units Sequence and Operation and PARAMETER DESCRIPTION AND OPTIONS.

This display shows the entry made by the Air Balancer if a manual air balance is done.

```

*** SERVICE ***
AMS#1 Controller
Measured Airflow
at balance =9000cfm

```

Line 2 AMS #1 Controller
 Line 3 Measured Airflow
 Line 4 at balance= XXXXX cfm

The Line 4 value is entered as a part of the airflow balancer's calibration of the Airflow Measurement Station #1. A default value will be shown whether or not this function is used. Editing the value requires the entry of a password of the appropriate level. This function is described under Units Sequence and Operation and PARAMETER DESCRIPTION AND OPTIONS.

```

*** SERVICE ***
Economizer Tunins
Prop Band = 40°F
Intes Time = 45 sec

```

Line 2 Economizer Tunis
 Line 3 Prop Band = XX°F
 Line 4 Intes Time = XX sec

This display indicates the software revision

```

*** SERVICE ***
Application
Revision # = 1.63

```

Line 2 Application
 Line 3 Revision # = X.X
 Line 4 Blank

“HISTORY” NAVIGATION

The History function group will display unit error histories and will be used to troubleshoot and diagnose equipment problems and/or failures (faults). The display items for the History function group are arranged differently than the other function groups. The History function group contains twelve (12) History items. Each History item has a description of the problem as well as a list of the unit operating parameters (snap shot data) when the problem occurred.

Pressing the History key will move the display to the first History item in the History function group. The display will show ***** HISTORY XX ***** on the top line of the display. XX refers to a number 1 through 12 to list the number of the fault in the memory buffer.

History Displays

```

*** HISTORY 01 ***
Comp Safety L/O
TROUBLE - ACTIVE
06-Mar-2000 02:10:AM
    
```

- Line 2 Fault Description (Fault Name)
- Line 3 Priority – Status (Alarm, Trouble, None) – (Clear, Active)
- Line 4 Date/Time (Fault Occurred)

Pressing the Back (<) and Next (>) keys will navigate the display between the twelve History items.

Table 19 shows a list of possible system faults along with the classification of the fault (illustrated in the display line 2). Display Line 3 display shows the following (see Service section for fault response details):

- None - No fault is recorder for History XX
- Alarm - A fault has been detected that results in the unit shutting down
- Trouble - A fault has been detected that does not result in the unit shutting down
- Clear - One of the following conditions has occurred:
 - A fault has been detected on an enabled sensor failed and the sensor has since been disabled
 - A fault has been detected and the cause of the fault has ceased to be present
 - The operator has taken an action, such as cycling the controller power
- Active - The fault is still current

Each History fault display will have a point’s data list associated with it. This point’s data list contains a snapshot of the operating parameters the instant the fault occurred. Once a fault is selected, the points data list can be accessed by using the Up (↑) and Down (↓) arrow keys. This will scroll through the points data list in Table 20.

The History function group shows faults in order, starting with the most recent. History 01 will be the most recent fault. No fault History is eliminated once recorded other than being “pushed off” of the end of the list by a new fault.

When a fault is written into the fault History list, the Alarm LED is turned on next to the display. The System Alarm LED will remain on as long as an Active fault is present in the History list.

Refer to the Service Section fault response details.

TABLE 19 – HISTORY FUNCTION TEXT (LINE 2)

Error Text (Line 2)	Classification (Line 3)
COR Status Fault	Alarm
Duct Sensor Fault	Alarm
Excess Duct Pressure	Alarm
HW Freeze Fault	Alarm
MSAT Sensor Fault	Alarm
SAT Sensor Fault	Alarm
Supply Fan Fault	Alarm
Sys1 Sfty Lckout #1	Alarm
Sys1 Sfty Lckout #2	Alarm
Sys2 Sfty Lckout #1	Alarm
Sys2 Sfty Lckout #2	Alarm
Sys3 Sfty Lckout #1	Alarm
Sys3 Sfty Lckout #2	Alarm
Thermostat Conflict	Alarm
Air Switch Fault	Trouble
Bad OAF Transducer	Trouble
Bldg Pressure Fault	Trouble
Cooling SAT Fault	Trouble
DischargePress Fault	Trouble
Evap Freeze Fault	Trouble
Excess Cooling Fault	Trouble
Excess Heating Fault	Trouble
F/RH Sensor Fault	Trouble
F/Slab Sensor Fault	Trouble

Error Text (Line 2)	Classification (Line 3)
Heat SAT Fault	Trouble
High Press Unload 1	Trouble
High Press Unload 2	Trouble
High Press Unload 3	Trouble
IAQ Sensor Fault	Trouble
OA Flow Sensor Fault	Trouble
OAH Sensor Fault	Trouble
OAT Sensor Fault	Trouble
RA Byp Filter Fault	Trouble
RAH Sensor Fault	Trouble
RAT Sensor Fault	Trouble
SensConsist Fault 1	Trouble
SensConsist Fault 2	Trouble
Space Control Fault	Trouble
Space Sensor Fault	Trouble
Suction Press Fault	Trouble
Sys1 Safety Trip	Trouble
Sys2 Safety Trip	Trouble
Sys3 Safety Trip	Trouble
Tstat Cooling Fault	Trouble
Tstat Heating Fault	Trouble
Unit Filter Fault	Trouble
UNT Comm Fault	Trouble

TABLE 20 – HISTORY POINTS DATA LIST

DISPLAY TEXT
Tstat Input= Y2 (Y1,W1,W2,None)
Occ Input= OCC (UNOCC)
G Input= On (Off)
Space Temp= XX.X °F
Space Tmp SP= XX.X °F
SA Temp= XX.X °F
SATempSP= XX.X °F
RA Temp= XX.X °F
RA RH= XXX%
RA Enth= XX.X btu/lb
OA Temp= XX.X °F
OA RH= XXX %
OA Enth= XX.X btu/lb
Duct Press= X.XX inwg
Duct Pr SP= X.XX inwg
Bldg Pr= X.XX inwg
Bldg Pr SP= X.XX inwg

DISPLAY TEXT
Supply Fan= On (Off)
Sfan Output= XXX% (None)
Exhaust Fan= On (Off, None)
Efan Output= XXX%
Comp 1-A= On (Off, None, L/O)
Comp 1-B= On (Off, None, L/O)
Comp 2-A= On (Off, None, L/O)
Comp 2-B= On (Off, None, L/O)
Comp 3-A= On (Off, None, L/O)
Comp 3-B= On (Off, None, L/O)
Ht Steps ON= XX
Ht Steps Avail= X
Ht Valve Out= XXX %
OA Damper Pos= XXX %
SAT SP= XXX °F

SECTION 7 – PARAMETER DESCRIPTIONS AND OPTIONS

PARAMETER DESCRIPTION AND OPTIONS (SETPOINTS)

The parameters listed in this section are setpoints **that are programmable** through the OCC. The parameters, or setpoints, are listed by Key Pad “groups” and are arranged in order as displayed on the OCC display. These setpoints are also listed in Table 21 and show the units of measure, default values, and value ranges. The text enclosed in parentheses is the name shown on the OCC display for the setpoint when it differs from the full name as illustrated in the following explanation.

STATUS KEY PARAMETERS

Date and Time

The current date and time are entered. Twelve-hour time is used. The day of the week is calculated from the date.

SETPOINT KEY PARAMETERS

These setpoints are user setpoints that are intended to be programmed in the field.

Unoccupied Heating

This value is the Unoccupied Heating Setpoint when the unit is in the unoccupied mode.

Unoccupied Cooling

This value is the Unoccupied Cooling Setpoint when the unit is in the unoccupied mode.

Occupied Heating

This value is the Occupied Heating Setpoint for a constant volume unit when the unit is in the occupied mode.

Occupied Cooling

This value is the Occupied Cooling Setpoint for a constant volume unit when the unit is in the occupied mode.

VAV Cool High Temp

The control will maintain this SAT when operating in the VAV mode with a Thermostat or Network Commu-

nicated Sensor that is calling for first stage cooling. The control will also maintain this SAT when operating in the VAV stand alone mode with the economizer active. If “*OA SAT Reset*” is enabled and the outdoor temperature is below the “*VAV SP for SAT Reset*” the Primary Unit Controller will control to this temperature.

VAV Cool Low Temp

The control will maintain this SAT when operating in a VAV mode with a Thermostat or Network Communicated Sensor that is calling for second stage cooling. The control will also maintain this SAT when operating in the VAV stand alone mode when the economizer is not active.

VAV SP For SAT Reset

This parameter is used only in VAV mode with the **VAV Operation With Thermostat** selection set to OFF. This setpoint will be used to reset the SAT setpoint based on Space temperature or Outside Air temperature.

- If the **Outside Air SAT Reset** selection is set to ON, the control will monitor the outside air temperature and reset the SAT when the OAT is equal to or greater than this setpoint.
- If the **Outside Air SAT Reset** selection is set to OFF, the control will use the Space Sensor and reset the SAT when the space temperature is equal to or greater than this setpoint.

Duct Static Pressure

This is the supply duct static pressure setpoint that the control will maintain when operating a VFD supply fan.

Building Pressure

This is the building pressure setpoint the control will maintain when operating a Power Exhaust. This setpoint will be used for Power Exhaust Configurations 1,2 or 3 (see explanation under Configuration Key parameters).

Economizer 1st Stage

This tells the control what Supply Air Temperature to maintain for a call for first stage of cooling. This is used only during Constant Volume cooling mode with Economizer operation.

Economizer 2nd Stage

This tells the control what Supply Air Temperature to maintain for a call for second stage of cooling. This is used only during Constant Volume cooling mode with Economizer operation.

SAT Econo Load Heat

The SAT Economizer Loading for Heating Setpoint is used as the setpoint for the Supply Air Temperature when the unit is using the economizer dampers to maintain the *SAT Econo Load Heat* setpoint when one heating stage is ON.

Outside Air Enthalpy

This tells the control an outside air enthalpy limit. Below this limit, outside air is available for cooling. A one BTU/LB hysteresis on each side of the limit is to be used.

Comfort Vent High SAT

This is the SAT High Limit Setpoint for the Comfort Ventilation mode (only used with Constant Volume units).

Comfort Vent Low SAT

This is the SAT Low Limit Setpoint for the Comfort Ventilation mode (only used with Constant Volume units).

Warm-Up RAT

This is the Morning Warm Up Return Air Temperature Setpoint.

Hydro Heat 1st Stage**CV Hydronic Heating:**

When the Hydronic Heat or Modulating Gas Heat option is enabled, the control will maintain this SAT setpoint during a call for first stage Heating, by modulating the Hot Water Valve or Gas Heat Section.

VAV Heating:

This setpoint will also be the reset temperature when operating a VAV unit in the Heating mode.

Hydro Heat 2nd Stage

When the Hydronic Heat or Modulating Gas Heat option is enabled, the control will maintain this SAT setpoint during a call for second stage Heating, by modulating the Hot Water Valve or Gas Heat Section.

OA Damper Min Pos #1

This tells the control what the minimum Outdoor Air Damper (Economizer) position is during the occupied mode and when the Supply Fan is at full flow. This value will be used for CV units and VAV units.

On VAV units, this value will be used for the minimum damper position when the VFD output from the control is 100% (10VDC). *Reason: full airflow with a VAV unit will be equivalent as a CV unit which runs at its design (maximum) fan speed.*

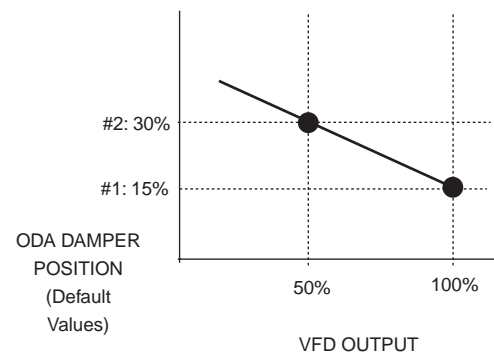

ODA DAMPER POSITION VS. VAV SUPPLY FAN OUTPUT

LD06585

FIG. 47 – ODA DAMPER POSITION VS. VAV SUPPLY FAN OUTPUT

OA Damper Min Pos #2

This tells the control what the minimum Outdoor Air Damper position is during both the occupied mode and when the Supply Fan is not at full flow. This value will be used for VAV units only and will be ignored on CV units. *Reason: when using a VAV and operating at less than full flow, the OA dampers need to open further to supply the required minimum airflow.*

This value will indicate what the minimum position of the OAD should be when the VFD output is at 50%. This value will be used with the OAD Minimum Position #1 value to linearly reset the position of the OAD with respect to the output to the VFD. See Fig. 47.

Demand Ventilation

This setpoint is the maximum IAQ (CO₂) level that the control will allow.

Min Outside Airflow

This setting is the Airflow Setpoint that the Outside air damper will be controlled to maintain. This setting is analogous to the Economizer Minimum Position setting described earlier. The only difference is that the Outside air damper will be dynamically controlled to maintain this airflow setting instead of fixed to a minimum position. This option can only be used if an air measuring station is installed.

Fxsys MSAT

The Mixed Supply Air Temperature Setpoint is the setpoint for the temperature of the supply air leaving the FlexSys configured rooftop unit.

FlexSys Min Dewpt Diff

The (FlexSys) Min Dewpt Diff setpoint will be to determine if the Evaporator Discharge Air Temperature Setpoint should be reset between the VAV Cool High Temp and VAV Cool Low Temp Setpoints.

UNIT SETUP KEY PARAMETERS

These setpoints are user setpoints that are intended to be programmed in the field.

GENERAL SETUP**Language**

English is all that is available.

Measurement Units

The units and values displayed for numeric parameters will be selectable as US Imperial units (Imperial), SI Canada units (SI Canada) or SI units (SI). SI Canada and SI are the same conversions except for airflow.

Space Sensor Enable

If this option is turned ON, it means that a Space (temperature) Sensor is installed and is used by appropriate control algorithms except when:

- Conditions are specified that override Space Sensor use, or

- The Space Sensor fails.
- If the Space Sensor fails, the control will use the RAT sensor as a backup if available.
If the sensor is not connected, or fails, a fault will be set. The fault can be turned off by turning off this option.
If the option is set to OFF and a sensor is connected, the system will use the sensor input but will not indicate a failure if the sensor becomes inoperative.

Unocc Override Time

The value programmed here will determine how long the unit will operate in the Unoccupied Override mode after the Unoccupied Override button is pressed on the Space Sensor.

Space Setpt Offset

The Space Temperature Setpoint Offset is the +/- value the control will use to offset the Space Temperature Setpoint when the sidebar on some versions of the Space Sensor products is used. For example, if the Space Temperature Setpoint Offset value is set to 3°F, shifting the sidebar all the way in minus direction will decrease the Space Temperature Setpoint by 3°F and shifting it all the way in plus direction will increase the Space Setpoint by 3°F.

Fan ON With Sensor (Constant Volume Mode)

When this option is turned ON, the Supply Fan will continue running when the Space Sensor based temperature control is satisfied and control is in the Occupied Mode.

RAT Sensor Enable

If this option is turned ON, it means that the RAT sensor will be used by appropriate control algorithms. If the sensor is not connected, or fails, a fault will be set. The fault can be turned off by turning off this option.

If the sensor is installed and this function is set to OFF, the unit will use the sensor but will not indicate a failure if the sensor becomes inoperative.

Space Temp Alarm Diff

This parameter, and the *Space Temperature Alarm Time* parameter below are used to generate a fault in case the space temperature deviates from the current space temperature setpoint by more than the *Space Temperature Alarm Differential* and continues moving away from this setpoint for longer than the time entered for the *Space Temperature Alarm Time* parameter. These two parameters are used together and should be specified (enabled) together.

This space temperature monitoring process is used only in CV units and when:

- The space temperature is monitored by a Space Sensor or a Network Communicated Sensor, and
- The value of *Space Temperature Alarm Differential* parameter is greater than zero, and
- The value of the *Space Temperature Alarm Time* is greater than zero.

When the Differential parameter value is greater than zero, the control will:

- Trend the space temperature anytime the space temperature is above the setpoint by the fault temperature differential or greater. The control must have been operating in a cooling mode for at least 10 minutes before trending begins.
- Determine if the offset is increasing.
- Declare a fault if the differential temperature continuously increases for the *Space Temperature Alarm Time*.

Space Temp Alarm Time

When this option has a value other than zero programmed, it will load a timer with this value as soon as the *Space Temperature Alarm Differential* function starts trending. Each time the trend is positive (Space temperature is moving toward the Setpoint), the timer is set to zero.

Low Ambient Operate

When this parameter is ON the control will apply Low Ambient Operation when the outside air temperature meets the specified conditions. If this setting is set to OFF, Low Ambient Operation will not be used.

If low ambient operation is not enabled, mechanical refrigeration will be inhibited at ambient temperatures below the *Cooling Lockout OAT*.

SensConsist Enable

The “*SensConsist Enable*” parameter when set to ON will permit operation of Sensor Consistency Tests 1 & 2.

HEAT/COOL SYSTEM

SAT Control For Cool

When enabled, this tells the control it is to do excessive SAT monitoring and tripping for cooling. This should be set to OFF at all times.

SAT Control For Heat

When enabled, this setting tells the control it is to do excessive SAT monitoring and tripping for heating. This function is used on Constant volume units only.

Rev Act Heat Valve

When this option is set to ON, the control outputs 10VDC when the valve is closed and 0VDC when the valve is open. The valve operation is opposite of the Direct Actuated valve and is intended for Normally Open (“fail-safe”) valves.

Cooling Mode Enable

When the Cooling Mode Enable parameter is ON, the unit is to use CV or VAV Cooling Operation to control temperature. When this parameter is OFF, no mechanical cooling will be used.

Heating Mode Enable

When the Heating Mode Enable parameter is ON, the unit is to use CV or VAV Heating Operation to control temperature. When this parameter is OFF, no heating will be used.

Heating Lockout OAT

This is the Outside Air Temperature Setpoint that the control will use to lock out Heating when the OAT is above this setpoint. A one-degree hysteresis is used on each side of the setpoint.

Cooling Lockout OAT

This is the Outside Air Temperature Setpoint that the control will use to lock out Cooling when the OAT is below this setpoint. A one-degree hysteresis is to be used on each side of the setpoint.

Cooling SAT Alarm

The SAT must be below this setpoint when all stages of compression are operating and after 60 minutes has elapsed since the last compressor was energized. If this does not happen, the control will declare a Cooling SAT Failure Alarm. Disabled if Setpoint = 0°F. This item should always be disabled by placing the set point to 0°F.

Heating SAT Alarm

The SAT must be above this setpoint when all steps of heating are operating and after 20 minutes have elapsed since the last heating step was energized. If this does not happen the control declare a Heating SAT Failure Alarm.

VAV SYSTEM**Duct Pressure Limit**

This parameter is applicable only to VAV mode of operation and controls at what static pressure to shut down the unit if this setpoint is reached. This setpoint is to insure that Supply Fan does not operate with a problem that could cause ductwork damage. When the static pressure reaches this setpoint:

- The control will drive the Supply Fan control output to zero.
- If there is no change in static pressure after 20 seconds, the control will generate a High Duct Static fault and shut down the unit.

VAV Occupied Heat

This unit setup selection tells the control to allow VAV Occupied Heating to occur if necessary. When this setting is set to ON, full heating will be energized when either:

- The thermostat W1 or W2 signal is received, or
- The space temperature falls below the VAV Setpoint for SAT Reset by more than 2°F.

OA SAT Reset

This setting will tell the control to reset the SAT setpoint on VAV units based on the Outside Air temperature instead of Space temperature. Outside Air SAT reset will only be allowed when the setting **VAV Operation With Thermostat** is set to OFF. This function can be used for Space Sensor and Stand Alone operation.

SAT Temper Enable

When SAT Tempering Enable is ON, the control will use tempering to increase the no demand stability of heating or cooling. SAT Tempering must be available for SAT Tempering to function. This configuration setting will be ignored if SAT Tempering is not available.

VAV With Thermostat

This parameter is applicable only to VAV mode of operation. If this option is selected ON, it tells the control that a Thermostat in a selected space is used to reset the SAT in cooling and to control heating. If this option is selected OFF, the control assumes that a Space Sensor in a selected space is used to reset SAT in cooling and to control heating and self-configures into this mode if the Space Sensor signal is reliable. If the Space Sensor signal is not reliable (e.g. sensor is not connected), the control will self-configure to stand-alone operation.

VAV Control Offset

The VAV Control Offset parameter is used to adjust the compressor staging offset and is used in conjunction with the VAV Cool High Temp and VAV Cool Low Temp setpoints on VAV units.

FlexSys Dewpt Reset

The FlexSys Dewpt Reset will tell the control that a FlexSys Under-Floor Humidity (FLEXRH) and Under-Floor Slab Temperature sensors are present and enabled for use. This setting will allow Evaporator Discharge Air Temperature Reset.

If this setting is enabled, both the FlexSys Under-Floor Humidity (FLEXRH) and Under-Floor Slab Temperature sensors must be installed and reliable or faults shall be generated. If this setting is disabled, alarms will not be generated for these two sensors and active faults will be cleared.

ECONO/EXHAUST SYSTEM

Exh Dmpr Pos For ON

This tells the control the Exhaust Air Damper position at which to turn ON the Exhaust Fan for building pressure control using a modulated exhaust air damper or VFD.

Exh Dmpr Pos For OFF

This tells the control the Exhaust Air Damper position at which to turn OFF the Exhaust Fan for building pressure control using a modulated exhaust air damper or VFD.

OA Dmpr Pos For ON

This tells the control the Economizer Air Damper (outdoor air damper) position at which to turn ON the Exhaust Fan.

OA Dmpr Pos For OFF

This tells the control the Economizer Damper (outdoor air damper) position at which to turn OFF the Exhaust Fan.

OAH Sensor Enable

This tells the control that an outside air humidity (OAH) sensor is present and enabled for use.

The enthalpy control function is self-configuring to make use of the available sensors to calculate the best available decision strategy for free cooling availability. For example, if it detects that OAT and OAH, and RAT and RAH sensors are all connected and reliable, it will self-configure for differential enthalpy operation. If one of the return air sensors should fail, the control will reconfigure for outside enthalpy operation, etc. When available and reliable, the RAT, RAH, and OAH sensors will be used for enthalpy control whether or not they are enabled.

Should a sensor fault be detected for the OAH sensor, the fault is displayed and recorded only if the OAH Sensor Enable is ON.

If the controller is networked, the network can be programmed to share the OAT and OAH sensed values with other controllers connected to the network or to receive these values from the network.

RAH Sensor Enable

This tells the control that a return air humidity (OAH) sensor is present and enabled for use.

The control will self-configure for enthalpy control based on the sensor availability as described above in above in *Outside Air Humidity Sensor Enable (OAH Sensor Enable)*.

Should a sensor fault be detected for the RAH sensor, the fault is displayed and recorded only if the RAH Sensor Enable is ON.

Exhaust Cntrl Offset

This setting tells the control what the control band is for the building pressure control. This setting is a plus or minus value to be added or subtracted to the **Building Pressure Setpoint**. For the proportional exhaust systems, this setting is the proportional band for the control loop. For the on/off exhaust system, this setting establishes the turn ON and turn OFF points for the exhaust fan.

Economizer Enable

This setting tells the control to allow Economizer Operation to occur. If this setting is set to ON, the control will operate the economizer normally. If this setting is set to OFF, the control will not operate the economizer, even if the unit is equipped with economizer hardware. However, all ventilation options will be operated normally, regardless of this setting.

SAT Econo Loading

This tells the control that it is to use Economizer Loading to control excessive SAT when economizer operation is calculated to be not available.

Power Exhaust Enable

This tells the control to enable or disable the power exhaust system. If the unit is configured with no Power Exhaust (See Power Exhaust Configuration), the setting will be ignored.

VENTILATION**OA Flow Cntrl Enable**

This setting tells the control that the unit is equipped with outside airflow measuring equipment and that the outside air damper should be actively controlled to a measured airflow.

Comfort Vent Mode

Comfort Ventilation operation will be carried out when the Comfort Ventilation Mode is enabled (used with Constant Volume units only).

Cmfrt Vent Max Damprr

This is the maximum Economizer damper position the control will use for Comfort Ventilation (used with Constant Volume units only).

IAQ Sensor Enable

When set to ON, this parameter tells the control that an IAQ Sensor is to be used for control of the Economizer (outside air damper). The control will use the Demand Ventilation Setpoint to control the IAQ levels in the building by modulating the Economizer. The IAQ Sensor will normally be field installed.

IAQ Sensor Span

This tells the control what the full range (span) is for the installed IAQ Sensor. The IAQ Sensor is generally expected to be a CO₂ sensor. Other types of IAQ Sensors may be used.

DV Multiplier

This tells the control what the Maximum Demand Ventilation Multiplier (DVM) is. The Maximum DVM is a multiplier limit that the control will not exceed when resetting (overriding) the outside air damper or AMS (Air Measuring Station) setpoints.

Altitude

The value entered into Altitude is the altitude of the unit above sea level. This value is used only when an Air Measurement Station is installed and Outdoor Airflow Control is enabled. The altitude value is to be entered within 1000 feet of actual.

WARM-UP PURGE**Morning Warm-Up**

When this option is turned ON, the Morning Warm Up feature is enabled and can be started. Morning Warm up is an option in Networked (BAS) applications or internally scheduled applications.

- With a Networked application, Morning Warm Up will be initialized by an appropriate network command.
 - Morning Warm Up Enable must be turned ON.
 - Internal Time Clock/Scheduling must be turned OFF.
- Morning Warm Up Enable must be turned ON.
- Internal Time Clock/Scheduling must be turned ON.

Max Warm-Up Time

This is the maximum time the control will conduct Morning Warm Up. This is used in conjunction with a BAS control system input.

Pre-Occupancy Purge

When this option is enabled, the Control will start Purge per the Pre-Occupancy Purge Schedule. On the start of the Purge, the control will, at the time Pre-Occupancy Purge is scheduled, the controller will compare the OAT to the High and Low purge limits. When enabled, Pre-Occupancy Purge will be performed per the daily Pre-Occupancy Purge schedule.

If the OAT is between the limits:

- The Supply Fan will be turned ON to 100%.
- The Economizer will be open to 100% outdoor air (0% return air).

If the OAT is outside of the limits, operation will continue in the unoccupied mode (no purge will be done).

Pre-Occupancy Purge will terminate:

- At the shut off time of the Pre-Occupancy Purge Schedule.
- When occupancy is detected.

Purge Schedule

This is the programmable time of day to start Purge for each day.

Purge OAT High Limit

This programmable temperature is the upper limit for Purge using 100% outdoor air.

Purge OAT Low Limit

This programmable temperature is the lower limit for Purge using 100% outdoor air.

Smoke Purge Mode

The smoke purge setting enables/disables the Smoke Purge function and tells the control what Smoke Purge control sequence to follow. The setting range is 0 – 5. A “0” setting tells the control to ignore the Smoke Purge input and do nothing (Smoke Purge disabled). A setting of 1 – 5 tells the control which one of five smoke purge control sequences to follow when the Smoke Purge input is active. Smoke Purge configuration options are detailed in the section on Sequence Operation.

Internal Clk/Sched

This setting tells the control to use the Internal Time Clock and Schedule built into the controller for all scheduling functions. When this function is set to ON, all Occupied/Unoccupied commands and Morning Warm Up commands received over a Network (BAS) will be ignored. Unoccupied Override commands via Space Sensors and the hard wired Occupied/Unoccupied input will take priority over the internal scheduling.

Weekly Schedule

The schedule for time-programmed operation of the unit is entered for all days of the week plus a holiday schedule. One start and stop time is allowed.

Holiday Schedule

Holiday dates are entered into the Holiday Schedule for use in time-programmed operation. Up to 16 dates are allowed. Dates are assumed to be for the current year.

CONFIGURATION KEY PARAMETERS

These setpoints are intended to be programmed at the factory and should not be changed by field personnel.

GENERAL

Unit Type

This tells the control that it is controlling one of the three selectable rooftop unit type options:

- Constant Volume
- Variable Air Volume
- Flexsys

Dirty Filter Switch

This configuration setting tells the control that a Dirty Filter Switch is installed and that the control is to monitor the *Dirty Filter Switch* input and respond as specified to the input status.

ASCD Override

This is not an option parameter but rather a one-time command issued on the OptiLogic Control Center. When this command is issued, the control will read all compressor Anti Short Cycle Delays. If any of them are loaded with more than 30 seconds, the control will load 30 seconds in them.

RUN TEST

When this command is issued the control will:

- Shut down the unit (if it is running).
- Turn ON the supply air fan.
- Start a run test sequence.

During the RUN TEST sequence, each compressor will be run for three minutes and then shut down. After a 30 second delay, the next compressor will be started.

The Primary Unit Controller will turn ON each heating step, one at a time. Each heating step will run for three minutes and then shut down. After a one-minute delay, the next heating step will be started.

Next, the Primary Unit Controller will open the Economizer to the 100% position and wait three minutes before closing it to the Minimum Position.

During the RUN TEST, the Primary Unit Controller will read all the installed sensors and verify that their readings are reliable. If an unreliable sensor is detected, an appropriate sensor fault will be identified.

PANEL TEST

The PANEL TEST is only used for factory testing when no equipment is connected to the Primary Unit Controller. THIS FEATURE IS NOT TO BE USED IN THE FIELD.

HEAT/COOL SYSTEM

Number of Compressors

This configuration setting tells the control the number of compressors available. There are two options, 4 compressors (50-65 Ton units) and 6 compressors (70-90 Ton units).

Number of Heat Steps

This configuration setting tells the control the number of heating steps available. This option will be selectable from 0 to 6. Note, zero (0) must be selected if hydronic heat is enabled.

Freezestat

This configuration setting tells the control that a hot water freeze protection Freezestat is installed on the unit and that the control should monitor the **hot water Freezestat** input. This option is used only on units with hydronic heat (*Hydronic Heat* option is turned ON).

Transducer Package

This configuration setting tells the control if a pressure transducer package is installed and on what refrigeration system. If this setting is set to:

- 0, then - no pressure transducer package is installed on any refrigeration systems.
- 1 indicates that- a pressure transducer package is installed on system #1 only.
- 2 indicates that- a pressure transducer package is installed on system #1 and system #2.
- 3 indicates that- a pressure transducer package is installed on system #1, #2, and #3.

The purpose of this setting is for establishing a fault status. This setting will tell the control what analog inputs should receive a signal from installed pressure transducers. For example, if there are pressure transducers installed on system #1 only, then the control will ignore the other four (4) inputs dedicated to optional pressure transducers. If the pressures read at the inputs for the pressure transducers are determined to be unreliable, the control will generate a fault.

Low Ambient Config

This setting tells the control that low ambient hardware is installed and the refrigeration system(s) on which it is installed. Low ambient hardware can be installed on any or all systems. This setting can be set to 0 – 3 which indicates the following:

- 0 indicates no low ambient hardware is installed.
- 1 indicates that low ambient hardware is installed only on system #1.
- 2 indicates that low ambient hardware is installed on system #1 and system #2.
- 3 indicates that low ambient hardware is installed on systems #1, #2, and #3.

Dischrg Press Cntrl

This setting tells the control what the Discharge Pressure Control Setpoint is for Low Ambient Operation.

Sys Unloading Press

This setting tells the control at what discharge pressure to unload the compressor system. This parameter applies to all compressor systems.

Reset Lead Lag

Setting Reset Lead Lag to ON tells the control to set the accumulated compressor run times to zero. This causes all compressors to be considered as if they have no runtime history. This is a one time action. The control resets the ON to OFF as soon as the run-times are zeroed.

EXCESSIVE SAT

SAT Temper Available

This tells the control that equipment necessary to do SAT Tempering is installed. SAT Tempering will be available for all heat options.

Cooling SAT Limit #1

This tells the control what the low limit is for the SAT during mechanical cooling when only one compressor is operating as used for excessive SAT cooling evaluation (used on Constant Volume units only).

Cooling SAT Limit #2

This tells the control what the low limit is for the SAT during mechanical cooling when more than one compressor is operating as used for excessive SAT cooling evaluation (used on Constant Volume units only).

Heating SAT Limit

This tells the control what the high limit is for the Supply Air Temperature during heating operation as used for excessive SAT heating evaluation.

ECONO/EXHAUST VENT**Power Exhaust Config**

This tells the control if the unit is supplied with a Power Exhaust System and what type of power exhaust system it is. There are four (4) options:

- ***No Powered Exhaust:***

This Power Exhaust Configuration setting is set to 0 when the unit is not equipped with a powered exhaust.

- ***2-Position Control Based on OAD Position:***

The Power Exhaust Configuration setting is set to 1 for this exhaust system. This is a two-position control based on OAD Position, and cycles a single speed exhaust fan based on the position of the Outside Air Damper (OAD).

- ***2-Position Control Based on Building Pressure:***

The Power Exhaust Configuration setting is set to 2 for this exhaust system. This is a two-position control based on building pressure and cycles a single speed exhaust fan based on the static pressure within the building or space.

- ***Proportional Control Based on Building Pressure:***

The Power Exhaust Configuration setting is set to 3 for this exhaust system. This setting is proportional control based on building pressure and modulates either a discharge damper on a single

speed exhaust fan, or modulates a Variable Frequency Drive (VFD) on a variable speed exhaust fan based on the static pressure within the building or space. The control output is the same for either case.

Economizer Installed

This setting tells the control that there is Economizer hardware installed on the unit.

Airflow Meas Config

This tells the control what outside airflow measurement equipment is installed on the unit. There are two options: Minimum and Full.

- The Minimum setting indicates that the airflow measuring equipment is only capable of measuring and controlling the minimum airflow requirement (typically 10-30% of unit airflow).
- The Full setting indicates that the airflow measuring equipment is capable of measuring and controlling the full airflow capability of the unit (Low Accuracy Option).

Airflow Measurement Station #1 Parameters

Airflow Measurement Station (AMS) #1 is used for the Minimum and Full options. The AMS #1 parameters are given below. If the "***Unit Setup***" parameter setting "***OA Flow Cntrl Enable***" is set to OFF, this setting will be ignored by the control.

AMS #1 Area

This tells the control what the cross sectional area is for the AMS #1. The area is used to calculate airflow through the AMS based on the average velocity of air through the AMS.

AMS #1 K-Factor

This setting will be used to correct for any AMS measurement error (test and balance correction). If the outside airflow indicated by the unit is shown to be different than actually measured by a test and balance person, this setting will be used to make a correction to the indicated measurement. This correction is a single point correction and adjusts offset only. The ratio will indicate the *Actual Airflow (Test and Balance)* divided by the *Unit Indicated Airflow*.



This adjustment ratio will be used for all AMS options, Full, 1/4 - 3/4 (1/4 station), and Minimum.

AMS #1 Balancer Calculated Airflow

This parameter is the value of airflow resulting from the Balancers measurements and calculations for the Full Face Outdoor Airflow Station or the 1/4 Airflow Station. This value is entered by the Balancer.

AMS #1 Controller Measured Air Flow At Balance

This parameter is the airflow measured by the controller at the time the Balancer Calculated Airflow is entered for AMS #1. This value is used to compare the balancer's value with the controller measured value.

Airflow Measurement Station #2 Parameters (Not Used)

AMS #2 Area (Not Used)

AMS #2 K-Factor (Not Used)

AMS #2 Balancer Calculated Airflow (Not Used)

AMS #2 Controller Measured Air Flow At Balance (Not Used)

Duct Sensor Hi Limit

The Duct Sensor High Limit is used to select the upper limit of operation for the duct static. This selection will be either 5.0 inwg for 2.50 inwg, depending on duct pressure transducer employed. If the duct static pressure exceeds this value the unit will shut down and give an alarm.

Evaporator damper installed

All Flexys units have a damper installed on the top evaporator coil. This parameter needs to be set to YES for Flexys units. The parameter is also used to determine the compressor staging sequence. On all style "C" units this parameter needs to be set to YES, even when a face damper is not installed.

SERVICE KEY PARAMETERS

These parameters are normally view-only, but can be accessed by service personnel to make changes to run-timers, such as would be the case if a compressor or fan motor was replaced.

Sys X Comp Runtimes

The compressor runtimes should never be changed, even when the compressor is changed out. The control uses the compressor runtimes to control the staging of the compressors. If this value is changed to 0, it will always become the first compressor on. This number should be updated during a Primary Unit Control board change out if the hours from the old control are available.

There are entries for each compressor. Each system (X: 1-3) is displayed with the value selected and entered for a compressor in the system (A or B).

Sys X Comp Starts

The number of compressor starts are changed only when a compressor is replaced. This entry would be 0 for a new compressor. If the compressor is previously used, this value is the no. of starts on the compressor if known.

There are entries for each compressor. Each system (X: 1-3) is displayed with the value selected and entered for a compressor in the system (Y:A or B).

Supply/Exhaust Fan Runtimes

The Supply and/or Exhaust Fan runtimes can be changed to zero when a fan is replaced but cannot be set to a specific value.

CHANGING "SETPOINTS"

For this explanation, all changeable parameters will be referred to as "setpoints". This includes those parameters that are changeable listed under function group keys of UNIT CONFIGURATION, SETPOINTS, and UNIT SETUP.

The "setpoints" are listed in Table 21 and show the units of measure, default values, value ranges, and which key the "setpoint" is located under.

The top of display will show “**edit mode**” for the particular setpoint you are changing and the “setpoint” will begin to flash. Using the Up Arrow (↑) and Down Arrow (↓) keys changes the setpoint. Pushing the Change/Enter key then enters the setpoint. After pushing the enter key the “**edit mode**” on the top line of the display will then revert to the keypad group that the setpoint pertains to.

For example if you wish to change the “Unoccupied Cooling Setpoint”, we know (from Table 21) that this setpoint is located under the SETPOINT key. Pressing the SETPOINT key results in the display shown below:

*** SETPOINTS ***
 Unoccupied Heating
 Setpoint = 60°F

Notice that the top line of the display shows what keypad group you have navigated to. In this case, the SETPOINTS key was pressed and ***SETPOINTS*** is displayed on the top line. Now, pressing the NEXT key advances from the Unoccupied Heating Setpoint, to the Unoccupied Cooling Setpoint and will result in the display shown below.

*** SETPOINTS ***
 Unoccupied Cooling
 Setpoint = 86°F

When the CHANGE/ENTER key is pressed you will enter into the **edit mode** to change the Unoccupied Cooling Setpoint, and the current value of 86°F will blink (if a password was not previously entered you will be prompted to enter the password before advancing to the edit mode – refer to explanation under section on PASSWORD entry). The top line of the display will change from ***SETPOINTS*** to **EDIT MODE** and is shown in the display shown below.

** ENTER L-2 PASSWORD

Password = 5555

*** EDIT MODE ***
 Unoccupied Cooling
 Setpoint = 86°F

With the display shown above, the 86°F will be blinking. The user can now use the Up Arrow (↑) or Down Arrow (↓) keys to change this setpoint. Once the setpoint is displaying the preferred value, the Enter/Change key is pressed again to enter the new setpoint and exit the edit mode resulting in the display shown below. Note the top line of the display has reverted back to the key group for the setpoint.

In this case it has reverted back to *** SETPOINTS*** and the new setpoint value is displayed (see below).

*** SETPOINTS ***
 Unoccupied Cooling
 Setpoint = 82°F

PASSWORDS

Five of the seven OCC functions (Setpoints, Unit Setup, Service, Unit Status and Configuration) contain values/data that can be changed by a user (see Table 21).

- Each of the parameters that can be entered will coincide with a specific password level. L1 indicates Level 1 capability such as setpoints. L2 indicates Level 2 capability such as unit configuration. Configuration is set at the factory.
- The password associated with the parameter to be changed must be entered before changes will be allowed.
- The Level 1 password is 9 6 7 5. For the Level 2 password, call your local YORK Service Office.

Entering a password will be done as follows:

- Enter password mode by pressing the “Change/Enter” key
- In the password mode, the illustrated OCC display window will show the level of password required and “5555” as place holders for the password to be entered.

- The cursor will be on the left most “5”
- The password will be entered by moving the cursor between the digits of the password with the Next (>) or Back (<) keys and changing the numbers (0-9) with the Up Arrow (↑) and Down Arrow (↓) keys.
- When all numbers are entered, the user will press the Change/Enter key. If the selected password matches the stored password, the control will initiate the “**edit mode**” and allow changes. If they do not match, < ****Invalid Password** > will be displayed on the top line of the display 3 seconds and the display will remain in the Password mode. Pressing the Cancel key will drop the user out of the password mode back to the view only display.

A password will be active until one of the following occurs:

- The user presses “cancel”, which results in the display of the Function Menu screen, and then presses “cancel” again.
- No Optilogic Control Center keypad button is pressed for more than 10 minutes.

TABLE 21 – SETPOINTS AND VALUES

	Description Text On OCC	Units	Default Value	Value Range	OCC Key
1	Unit Type		CV	CV, VAV, MIT-VAV	Configuration
2	Dirty Filter Switch		OFF	ON or OFF	Configuration
3	ASCD Override		OFF	ON or OFF	Configuration
4	Run Test		OFF	ON or OFF	Configuration
5	Panel Test		OFF	ON or OFF	Configuration
6	# of Compressors		4	4 or 6	Configuration
7	# of Heat Steps		0	0-6	Configuration
8	Heating Type1		None	None, Gas, Electric,	Configuration
9	Freezestat		OFF	ON or OFF	Configuration
10	Transducer Package		0	0 – 3	Configuration
11	Low Ambient Config		0	0 – 3	Configuration
12	Dischrg Press Cntrl	psig	200 psig	100 – 200 psig	Configuration
13	Sys Unloading Press	psig	400 psig	250-450 psig	Configuration
14	Reset Lead-Lag		OFF	ON or OFF	Configuration
15	SAT Temper Available		OFF	ON or OFF	Configuration
16	Cooling SAT Limit #1	°F	45°F	40°-50°F	Configuration
17	Cooling SAT Limit #2	°F	50°F	40°-65°F	Configuration
18	Heating SAT Limit	°F	160°F	100°-195°F	Configuration
19	Power Exhaust Config		0	0 - 3	Configuration
20	Economizer Installed		NO	YES – NO	Configuration
21	Airflow Meas Config		None	None, Full, Minimum, 1/4-3/4	Configuration
22	AMS #1 Area	sq ft	3.33	0.00 – 24.00	Configuration
23	AMS #1 K-Factor		0.75	0.500 – 1.000	Configuration
24	AMS #2 Area	sq ft	10	9.00 – 18.00	Configuration
25	AMS #2 K-Factor		0.75	0.500 – 1.000	Configuration
26	Duct Sensor Hi Limit	inwg	5	2.5 – 5.0	Configuration
27	Evaporator Damper Installed = NO		YES	YES – NO	Configuration
28	Sys X Comp Runtimes	starts	0	(> expected value)	Service
29	Sys X Comp Starts	hr	0	(> expected value)	Service
30	Exhaust (Fan Runtimes)	hr	0	(> expected value)	Service
31	AMS #1 Balancer Calculated Airflow	CFM	1	1 – 40000	Service
32	AMS #1 Controller Measured Air Flow at balance	CFM	1	1- 40000	Service
33	AMS #2 Balancer Calculated Airflow	CFM	1	1 - 40000	Service
34	AMS #1 Controller Measured Air Flow at balance	CFM	1	1- 40000	Service
35	Economizer Tunnis Prop Band Intes Time	°F sec	40 45	0-100 0-1000	Service
36	Unoccupied Heating	°F	60°	45°-99°	Setpoint
37	Unoccupied Cooling	°F	85°	45°-99°	Setpoint
38	Occupied Heating	°F	68°	45°-99°	Setpoint
39	Occupied Cooling	°F	72°	45°-99°	Setpoint
40	VAV Cool High Temp	°F	60°	50°-70°	Setpoint
41	VAV Cool Low Temp	°F	55°	50°-70°	Setpoint
42	VAV Cool Reset Temp	°F	72°	60°-95°	Setpoint

* Continued on next page

TABLE 21 – SETPOINTS AND VALUES (CONTINUED)

	Description Text On OCC	Units	Default Value	Value Range	OCC Key
43	Duct Static Pressure	inwg	1.5	0.00-5.00	Setpoint
44	Building Pressure	inwg	0.1	-0.4	Setpoint
45	Economizer 1st Stage	°F	55°	40°-65°	Setpoint
46	Economizer 2nd Stage	°F	50°	40°-65°	Setpoint
47	SAT Econo Load Heat	°F	150	100 – 195	Setpoint
48	Outside Air Enthalpy	btu/lb	28	22-40	Setpoint
49	Cmfrt Vent High SAT	°F	80°	60°-85°	Setpoint
50	Cmfrt Vent Low SAT	°F	70°	60°-85°	Setpoint
51	Warm-Up RAT	°F	70°	50°-85°	Setpoint
52	Hydro Heat 1st Stage	°F	100°	75°-150°	Setpoint
53	Hydro Heat 2nd Stage	°F	115°	75°-150°	Setpoint
54	OA Damper Min Pos #1	%	15%	0-100%	Setpoint
55	OA Damper Min Pos #2	%	30%	0-100%	Setpoint
56	Demand Ventilation	ppm	1000	750-1500	Setpoint
57	Min Outside Airflow	CFM	4000	0-15000	Setpoint
58	(FlexSys) MSAT Setpoint	°F	62	55 – 70	Setpoint
59	(FlexSys) Min Dewpt Diff	°F	3	1 – 5	Setpoint
60	Language Option		English	English, Spanish	Unit Setup
61	Measurement Units		Imperial	Imperial, SI Canada, SI	Unit Setup
62	Space Sensor Enable		OFF	ON or OFF	Unit Setup
63	Unocc Override Time	min	60 min	0-240 min	Unit Setup
64	Space Setpt Offset	°F	3°F	0°-5°F	Unit Setup
65	Fan ON With Sensor		ON	ON or OFF	Unit Setup
66	RAT Sensor Enable		OFF	ON or OFF	Unit Setup
67	Space Temp Alrm Diff	°F	5°F	0°-25°F	Unit Setup
68	Space Temp Alrm Time	min	60 min	0-120 min	Unit Setup
69	Low Ambient Operate		OFF	ON or OFF	Unit Setup
70	Sens Consist Enable		OFF	ON or OFF	Unit Setup
71	SAT Control For Cool		OFF	ON or OFF	Unit Setup
72	SAT Control For Heat	°F	OFF	ON or OFF	Unit Setup
73	Rev Act Heat Valve		OFF	ON or OFF	Unit Setup
74	Cooling Mode Enable		ON	ON or OFF	Unit Setup
75	Heating Mode Enable		ON	ON or OFF	Unit Setup
76	Heat Lockout OAT	°F	75°F	0°-100°F	Unit Setup
77	Cool Lockout OAT	°F	45°F	45°-100°F	Unit Setup
78	Cooling SAT Alarm	°F	0°F	0°/50°-80°F	Unit Setup
79	Heating SAT Alarm	°F	0°F	0°/70°-120°F	Unit Setup
80	Duct Pressure Limit	inwg	3.00 inwg	0.00-5.00 inwg	Unit Setup
81	VAV Occupied Heat		OFF	ON or OFF	Unit Setup
82	OA SAT Reset		OFF	ON or OFF	Unit Setup
83	SAT Temper Enable		OFF	ON or OFF	Unit Setup
84	VAV With Thermostat		ON	ON or OFF	Unit Setup
85	VAV Control Offset	°F	4.5	2.0 – 6.0	Unit Setup

* Continued on next page

TABLE 21 – SETPOINTS AND VALUES (CONTINUED)

	Description Text On OCC	Units	Default Value	Value Range	OCC Key
86	FlexSys Dewpt Reset		OFF	ON or OFF	Unit Setup
87	Exh Dmpr Pos For ON	%	80%	0-100%	Unit Setup
88	Exh Dmpr Pos For OFF	%	20%	0-100%	Unit Setup
89	OA Dmpr Pos For ON	%	60%	0-100%	Unit Setup
90	OA Dmpr Pos For OFF	%	20%	0-100%	Unit Setup
91	OAH Sensor Enable		OFF	ON or OFF	Unit Setup
92	RAH Sensor Enable		OFF	ON or OFF	Unit Setup
93	Exhaust Cntrl Offset	inwg	0.015 inwg	0.010 – 0.050	Unit Setup
94	Economizer Enable		ON	ON or OFF	Unit Setup
95	SAT Econo Loading		ON	ON or OFF	Unit Setup
96	Power Exhaust Enable		OFF	ON or OFF	Unit Setup
97	OA Flow Cntrl Enable		OFF	ON or OFF	Unit Setup
98	Comfort Vent Mode		OFF	ON or OFF	Unit Setup
99	Cmfrt Vent Max Dampr	%	75%	0-100%	Unit Setup
100	IAQ Sensor Enable		OFF	ON or OFF	Unit Setup
101	IAQ Sensor Span	ppm	5000	0 – 10000	Unit Setup
102	MAX DV Multiplier		1.25	2-Jan	Unit Setup
103	Altitude	Ft	1000	0-10000 Ft	Unit Setup
104	Morning Warm-Up		OFF	ON or OFF	Unit Setup
105	Max Warm-Up Time	min	120 min	0-240 min	Unit Setup
106	Pre-Occupancy Purge		OFF	ON or OFF	Unit Setup
107	Purge Schedule		4am - 5am all days	Daily-Holiday hh:mm start-end time	Unit Setup
108	Purge OAT High Limit	°F	85°	0°-110°F	Unit Setup
109	Purge OAT Low Limit	°F	55°	0°-110°F	Unit Setup
110	Smoke Purge Mode		0	0 – 5	Unit Setup
111	Internal Clk/Sched		OFF	ON or OFF	Unit Setup
112	Weekly Schedule		7am - 6pm weekdays	8 start/stop entries	Unit Setup
113	Holiday Schedule		(No Sched)	16 entries	Unit Setup
114	Date and Time		(none)	dd-mm-year hh:mm:ss am/pm	Unit Status

NOTES:

- Both gas and electric heat are referred to functionally as “stepped” heating or heating “stages”; both HW (hot water) and steam are functionally referred to as “hydronic” heat.

For Modulating Gas Heat "Heating Type" would be set to "HW".

SECTION 8 – SERVICE

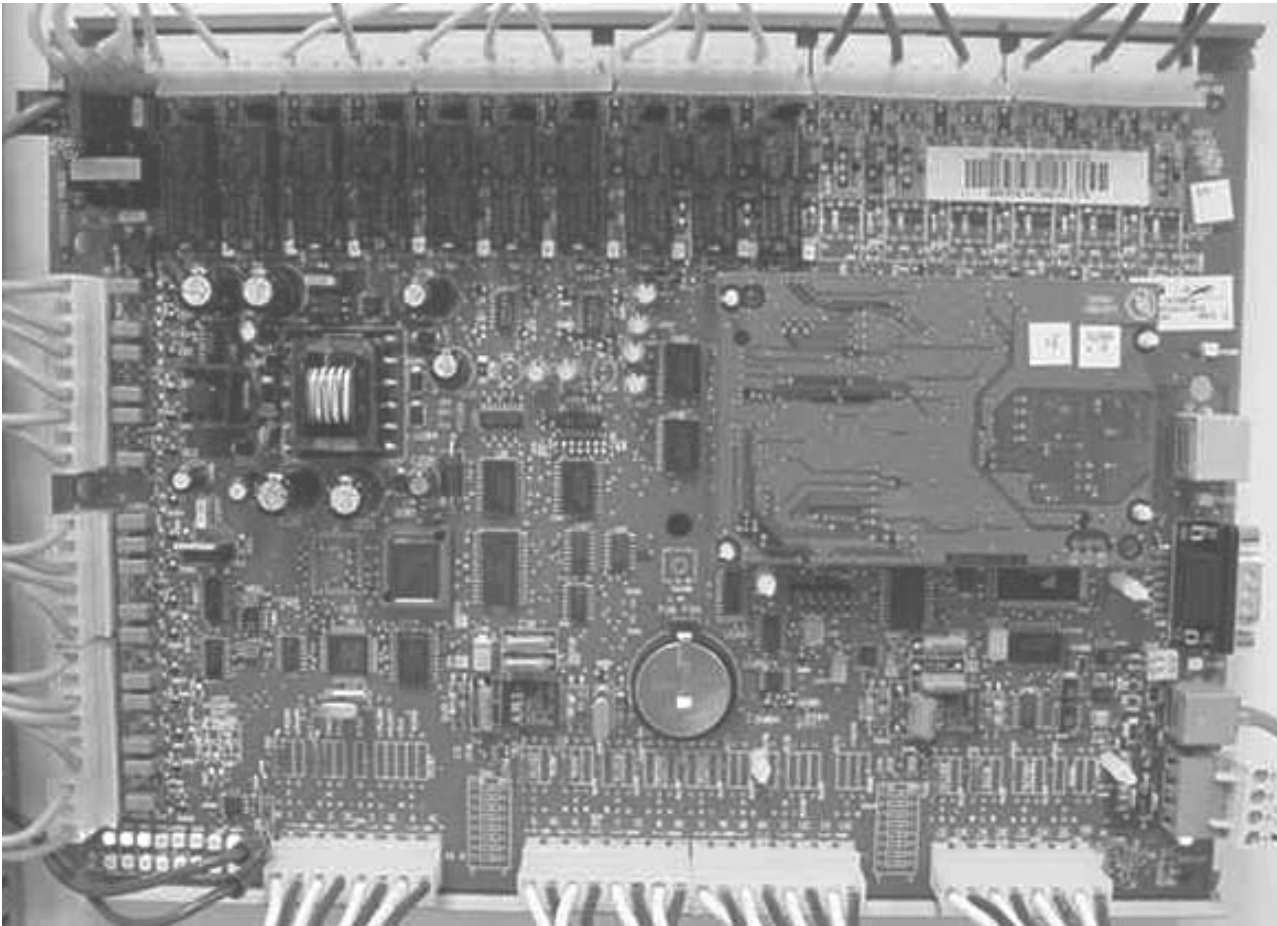

FIG. 48 – PRIMARY UNIT CONTROLLER

00636VIP

The eco² rooftop Primary Unit Controller (Primary Unit Controller) is a factory-mounted controller that uses a microprocessor-based control. The controller is housed inside the low-voltage compartment of the control/power panel. The main controller is located in the control side (right side) of the panel and is shown in Figure 48.

The main controller will be referred to as the Primary Unit Controller and is factory mounted on every unit. The Primary Unit Controller interfaces to a possible 16 binary inputs, 13 analog inputs, 10 binary outputs, and 6 analog outputs, that are used to control the rooftop unit.

The connection “layout” for the IO (inputs/outputs) is shown in the Primary Unit Controller connection map in Figure 49. Notice that the figure shows the Jack connection designated by “J”, and the pin number located on the inside of the board diagram. The input or output

designations are shown on the outside of the figure.

Table 32 lists the description of the various inputs and outputs, and the respective connections.

Figure 50 shows the Primary Unit Controller architecture as it relates to the on-board relays for the binary outputs and the associated LED’s, the location of the binary input LED’s, and LED’s for the Ethernet port, RS-232 port, the N2 port used for communication to the Secondary Controller only, and a Alarm LED for the Primary Unit Controller. A solid or flashing Alarm LED indicates a problem with the Primary Unit Controller – contact your local York service office for service.

The respective on-board binary output relay LED will be illuminated when the relay is being energized by the Primary Unit Controller. The various communication port LED’s will “flicker” when communication is present. Figure 50 illustrates the binary input LED’s and designations.

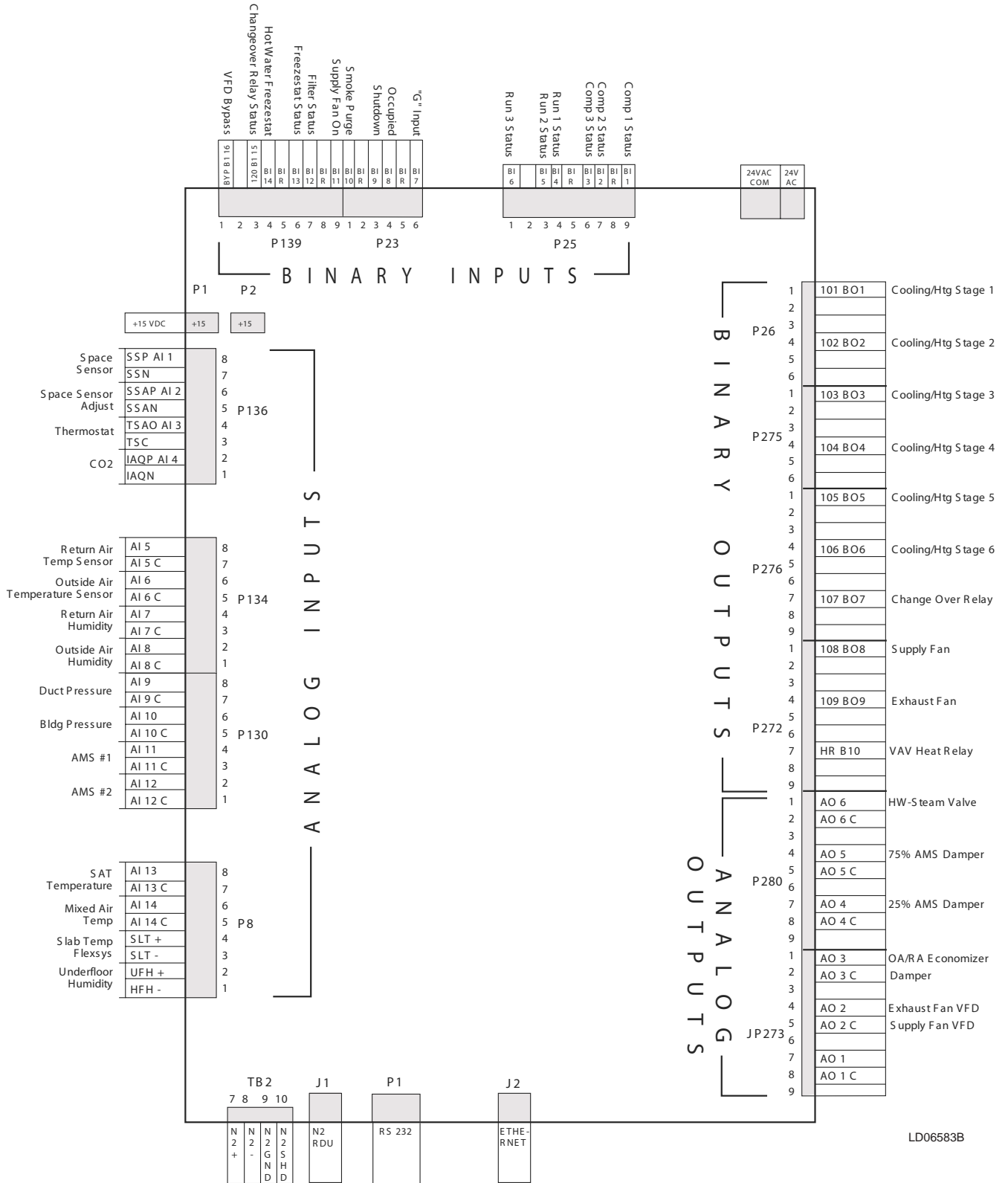
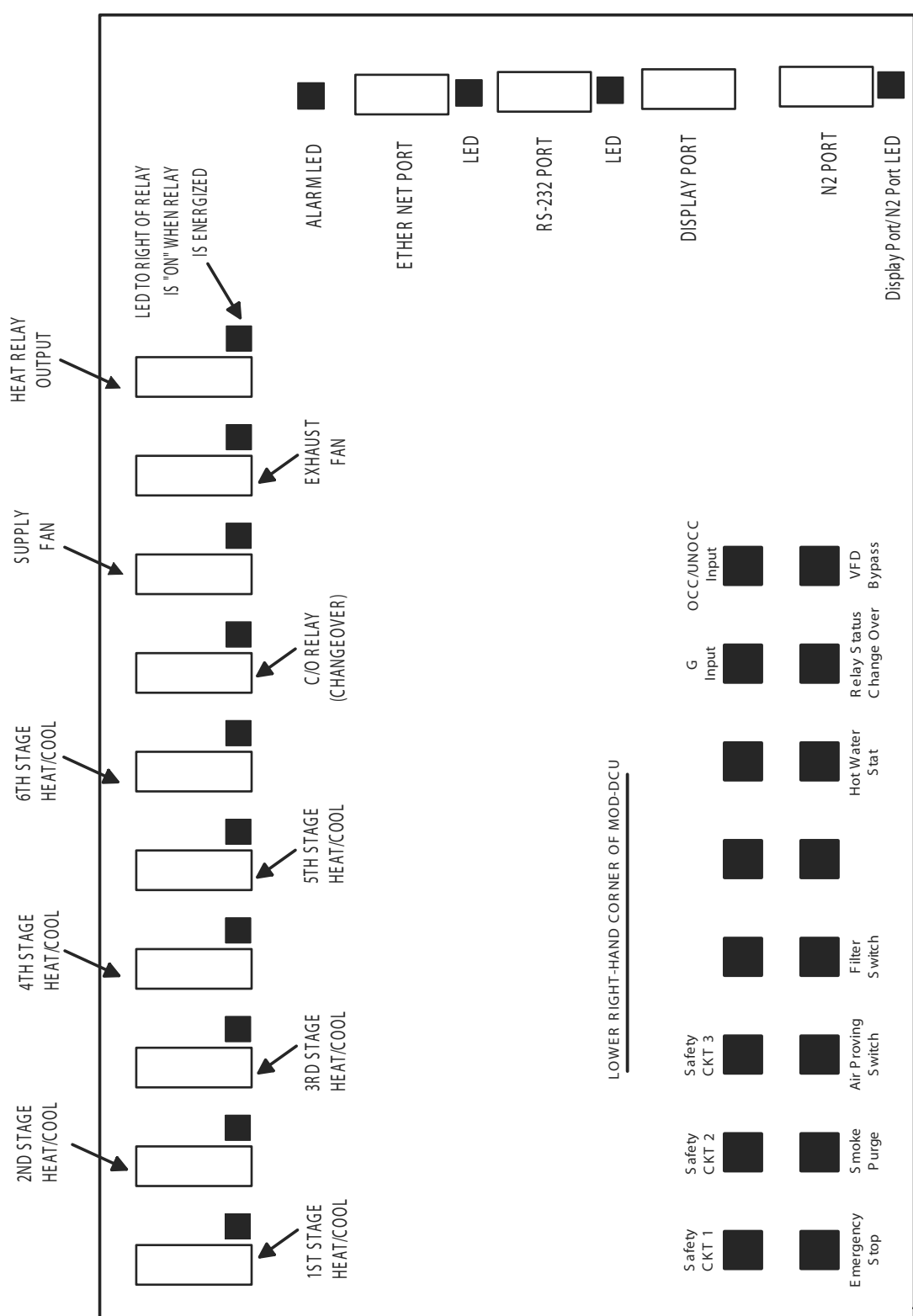

FIG. 49 – PRIMARY UNIT CONTROLLER CONNECTION MAP



LD07637A

FIG. 50 – BINARY LED DESIGNATIONS

BINARY INPUT OPERATION

This section describes the control operation of the sixteen (16) binary inputs. The Binary inputs are also described in the I/O tables in Table 33.

The unit control is equipped with sixteen (16) binary inputs. The binary inputs can be classified into two types, control and status inputs. Control inputs will be used by the control to switch control states. For example, BI #7 (J8, Pin 6), Supply Fan (G), will signal to the control to turn the supply fan ON or OFF. Status inputs will be used by the control to signal the status of, or prove, certain safety circuits. For example, BI #11 (J9, pin 9), Supply Fan Status, will signal to the control when the Supply Fan is ON and thus prove the operation of the Supply Fan.

The binary input status is defined as:

- 24VAC detected by the input - the input is “present”
- No voltage detected by the input or voltage below the 24VAC detection threshold - the input signal is “not present”

The fault conditions and responses for all binary inputs with associated faults are given in Table 33.

BI #1, 2, & 3 - Compressor Circuit #1, 2, & 3 Status Inputs

Each refrigeration circuit consists of two compressors arranged in tandem. For safety, each circuit is equipped with a “compressor safety chain”, which consists of high and low pressure safeties and overloads for each compressor motor. The electrical contacts for the safety devices in this chain will be connected in series with the entire circuit connected to a 24VAC source. In a “safe” state, the electrical contacts from all safety devices will be closed. The “compressor safety chain” for each compressor circuit will be connected to the following binary inputs:

- Compressor circuit #1 – BI #1
- Compressor circuit #2 – BI #2
- Compressor circuit #3 – BI #3

High Pressure Switch settings are:

open @ 425 +/- 10 psig
close @ 325 +/- 10 psig

Low Pressure Switch settings are:

open @ 32 +/- 5 psig
close @ 52 +/- 5 psig

For normal operation, the Compressor Circuit Status inputs must be present (24VAC to input). During low ambient conditions, when no compressor is ON, the Low Pressure safety may be tripped (open) indicating an unsafe condition. To avoid nuisance errors:

- The control will monitor the Compressor Circuit Status inputs only when a compressor from that circuit is operating.
- When any compressor is started, the control will ignore the associated Compressor Circuit Status input for 30 seconds.
- After the 30 second delay, if the status input is not present for more than 250 ms, the control will de-energize all compressors operating in that circuit and declare a Comp Safety Trip fault.
- The control will then wait ten (30) minutes before re-energizing the compressors in the tripped circuit, if still required.

Each Compressor Status Circuit input has two trip counters. Both counters will start at zero.

Counter #1 will:

- Increment by 1 any time a trip occurs.
- Be reset to zero counts if one or both compressors on the circuit are ON for 1 hour without a Comp Safety Trip.

Counter #2 will:

- Increment by 1 any time a trip occurs and both compressors are operating.
- Be reset to zero counts if both compressors on the circuit are ON for 1 hour without a Comp Safety Trip.

If the count of either Compressor Status counter on a compressor circuit = 3, the compressors on the circuit are shut down and locked out and a Compressor Safety Lockout (Comp Safety L/O) fault is declared.

Compressor Safety Lockout(s) will reset through power cycling of the controller.

BI #4, 5, & 6 , Furnace Module #1, 2, & 3 Status

For future use.

BI #7, Thermostat “G” Input

The thermostat “G” or fan output is connected to BI #7. BI #7 is monitored when the controller determines that a thermostat is to be used for temperature control. The Supply Fan is controlled as follows subject to specific conditions described in the Constant Volume or Variable Air Volume sections:

- Turn Supply Fan ON – 24VAC input present.
- Turn Supply Fan OFF - 24VAC input not present.

BI #8, Occupied / Unoccupied Input

The Occupied/Unoccupied input is used to determine when occupied or unoccupied control modes are to be used. The source of the input may be a time clock, a thermostat with a clock function or an occupancy sensor. The occupancy status is indicated as;

- Occupied – Occupied/Unoccupied 24VAC input present.
- Unoccupied – Occupied/Unoccupied input 24VAC not present.

BI #9, Shutdown Input

The Shutdown input will be monitored by the control. The control will interpret the Shutdown input as follows:

- Shut down condition – Shutdown 24VAC input present.
- Not in shut down condition – Shutdown 24VAC input not present.

When the Shutdown input is present, the control will within 1 second:

- Set all binary outputs to low (de-energize).
- Set all analog outputs to zero volts.

This input will have priority over all operation.

BI #10, Smoke Purge Input

The Smoke Purge input will monitored by the control. The control will interpret this input as follows:

- Smoke purge required – Smoke Purge 24VAC input present.
- Smoke purge not required – Smoke Purge 24VAC input not present.

When the Smoke Purge input has been continuously present for 5 seconds or more, the control will:

- Read the Smoke Purge parameter value.
- If the Smoke Purge parameter value is zero, no action is taken.
- If the Smoke Purge parameter value is not zero.
- All heating or cooling is shutdown and made unavailable.
- The configured Smoke Purge Operation will be carried out.

BI #11, Supply Fan Status

An airflow switch is used to verify the status of the Supply Fan. When airflow is detected, the binary 24VAC input is present.

Supply Fan Fault:

When the control turns the Supply Fan ON, the Supply Fan Status input will be monitored following a 60 second start up delay. If the Supply Fan Status input is not present after the delay, the unit is shut down and a "Supply Fan Fault" is declared.

If the Supply Fan is operating normally and the Supply Fan Status input is no longer present, the control will delay for 30 seconds. If after 30 seconds, the input is not present, the control will shut down the unit and declare a "Supply Fan Fault" fault.

If a "Supply Fan Fault" occurs, the controller will require a manual reset to clear the fault and allow the unit to restart.

Air Switch Fault:

When the Supply Fan is shut OFF, if the Supply Fan Status input is still present after a 5 minute shutdown delay, the control will declare an "Air Switch Fault" fault.

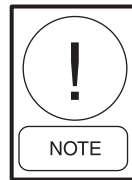

An Air Switch Fault will not cause the unit to shut down; however, the fault will remain active until the air proving switch indicates normal operation.

BI #12, Filter Status

The Filter Status input will be tied to a differential pressure switch, which will be used to indicate if the filters are dirty. The filter status will be indicated as:

- Filter dirty – Filter Status 24VAC input present
- Filter clean – Filter Status 24VAC input not present

The control will declare a dirty filter fault after the Filter Status input has been present for one minute.

The Dirty Filter Fault will remain active as long as the Filter Status input is present.

BI #13, Evaporator Freezestat Input

This input is not used on units with the smart relay installed. The smart relay monitors the freezestat circuit external to the (Primary Unit Controller).

BI #14, HW Freezestat Input

If the HW (hot water) Freezestat parameter is “ON” (indicating that a HW Freezestat sensor is installed and is to be used), the control will monitor this input. The HW Freezestat input will be interpreted as follows:

- No freeze condition – HW Freezestat 24 VAC input present
- Freeze condition – HW Freezestat 24 VAC input not present

When the HW Freezestat input opens, the control will:

- Open the Hot Water valve to 100%
- Close the OA damper(s) and open the RA damper to 100%
- HW Freezestat must close for 5 minutes before the unit will resume normal operation
- If the HW Freezestat input is open for 10 minutes, the control will declare a *HW Freeze Fault*, shut down the unit, and maintain the heating value output at 100%.

A *HW Freeze Fault* will remain active as long as the (hot water) Freezestat input is open. The fault will clear when the Freezestat input closes for 5 minutes.

HW (hot water) Thermostatic Switch Settings are:

- open @ 35° +4°/-2°
- close @ 47° +4°/-2°

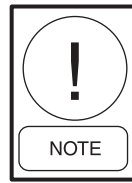

Note: This is an adjustable switch set (35° to 45°) set at the factory to 35°F.

BI #15, Cool-Heat Changeover Relay Status

The Cool-Heat Changeover Relay (COR) Status input is used to verify that the relays that route the ON/OFF commands from the controller to the heating and cooling equipment are as commanded by the controller. To verify that the changeover relays are as required for heating or cooling, the control will:

- For cooling operation – verify that the Cool-Heat COR Status 24VAC input is present
- For heating operation – verify that the Cool-Heat COR Status 24VAC input is not present

The control will delay 5 seconds from the time the Changeover Relay control output is switched before looking at the COR input for the Cool-Heat COR Status.

If the Cool-Heat COR Status input is not correct, a COR Fault is declared. The unit is shutdown. The fault is cleared through manual reset.

BI #16, VFD Bypass Input

This input will be used to signal to the control that the VFD has been bypassed and the supply fan is now running full. The control will interpret this input as follows:

- VFD not bypassed (normal condition) – VFD Bypass 24VAC input not present
- VFD bypassed – VFD Bypass 24 VAC input present (24VAC)

When VFD Bypass is present, the control will:

- Shut own all heating and cooling stages
- Shut down the Supply Fan if operating

The controller will wait 30 seconds from the time of the above control actions and then restart the Supply Fan by setting the Supply Fan output to ON (high). Normal heating or cooling operation will begin.

VFD Bypass operation will continue until the VFD Bypass input goes low (0 volts). The unit will then return to normal operation.

ANALOG INPUT OPERATION

This section describes the control operation of the (13) thirteen analog inputs. These inputs will be used by the control to monitor and respond to unit temperatures, pressures, enthalpy, etc. The connection “layout” for the IO (inputs/outputs) is shown in the Primary Unit Controller connection map in Figure 21. Notice that the figure shows the Jack connection designated by “J”, and the pin number located on the inside of the board diagram. The input or output designations are shown on the outside of the figure. For example, J11 – 8 is jack eleven - pin 8 and is AI5 (analog input 5). J13 – 6 is jack 13 - pin 6 and is AI14 (analog input 14). For example, AI5 (J11 – 8) is the input for Outside Air Relative Humidity, and is used as part of the economizer control scheme. AI13 (J13 – 8) is the input for Supply Air Temperature, and is used for control in both the CV and VAV control schemes. The analog inputs are also in the I/O tables in Table 33 with descriptions for each input.

Return, Outside, Supply Air and Slab Temperature

The temperature sensors are RTD sensors that can be checked with an ohmmeter. Table 22 provides the resistance values for a given temperature in °F.

TABLE 22 – TEMPERATURE SENSOR RESISTANCE TABLE

TEMPERATURE SENSOR OUTPUT TABLE			
TEMP. °F	OHMS RESISTANCE	TEMP. °F	OHMS RESISTANCE
-20	751	80	1030
-10	777	90	1060
0	803	100	1090
10	830	110	1121
20	858	120	1152
30	885	130	1184
40	914	140	1216
50	942	150	1248
60	971	160	1281
70	1000	170	1314

Duct Pressure Transducer

The duct pressure transducer is mounted in the return air section of the unit on the panel wall. The purpose of this transducer is to sense and convert the static pressure in the supply-side of the duct to a DC voltage. The DC voltage is then sent to the unit controller and compare against the *Duct Static Pressure setpoint*. The control wiring is factory wired, but pneumatic tubing must be field supplied and installed (refer to Installation section

in manual). The duct pressure transducer measures differential pressure between the pressure in the duct and atmospheric pressure. When verifying transducer operation, the technician must insert a tee into the pneumatic tubing to connect a manometer and verify the pressure being applied to the transducer. Once this pressure is known, a comparison can be made of the duct pressure vs. output volts DC from the transducer. Table 23 shows the relationship between the pressure applied to the duct pressure transducer and the output voltage.

TABLE 23 – *DUCT PRESSURE TRANSDUCER OUTPUT TABLE

DUCT PRESSURE TRANSDUCER OUTPUT TABLE		
DIFFERENTIAL INPUT PRESSURE - IWG		OUTPUT VOLTAGE - VDC
0.5	0.25	0.5
1.0	0.50	1.0
1.5	0.75	1.5
2.0	1.00	2.0
2.5	1.25	2.5
3.0	1.50	3.0
3.5	1.75	3.5
4.0	2.00	4.0
4.5	2.25	4.5
5.0	2.50	5.0

* 2.5 IWC Duct Transducer Available for FlexSys Option

Building Pressure Transducer

The building pressure transducer is located in the return air section of the unit. The purpose of this transducer is to sense and convert the static pressure in the building to a DC voltage. The DC voltage is then sent to the unit controller and compare against the *Building Pressure setpoint*. The control wiring from the transducer is factory wired, but pneumatic tubing must be field supplied and installed (refer to Installation section in manual). The building pressure transducer measures differential pressure between the pressure in the building and atmospheric pressure. When verifying transducer operation, the technician can insert a tee into the pneumatic tubing to connect a manometer and verify the pressure being applied to the transducer. Once this pressure is known, a comparison can be made of the duct pressure vs. output volts DC from the transducer. A practical and quick check of this transducer can also be accomplished by removing the pneumatic tubing lines from both high and low side connections on the transducer. Since both of the inputs will now be exposed to the same pressure, the differential pressure will be zero, and output 2.5 VDC according to the Table 24.

TABLE 24 – BUILDING PRESSURE TRANSDUCER OUTPUT TABLE

BUILDING PRESSURE TRANSDUCER OUTPUT	
DIFFERENTIAL INPUT PRESSURE - IWG	OUTPUT VOLTAGE - VDC
-0.50	0.00
-0.40	0.50
-0.30	1.00
-0.20	1.50
-0.10	2.00
0.00	2.50
0.10	3.00
0.20	3.50
0.30	4.00
0.40	4.50
0.50	5.00

Air Measuring Station Pressure Transducer

The rooftop unit provides for a ventilation mode that can use the optional Air Measuring Station. When using the optional Air Measuring Station, either one or two identical pressure transducers are employed. When using the Minimum AMS or the ¼ - ¾ AMS, two transducers are used. Only one transducer is used with the Full AMS. In any case, the locations of the transducers are in the return air section mounted on a panel. Both the pneumatic tubing and control wiring are factory installed. The transducer range is 0 to .25 iwg with an output range in volts DC as shown in Table 25.

TABLE 25 – AIR MEASURING STATION PRESSURE TRANSDUCER OUTPUT

AMS PRESSURE TRANSDUCER OUTPUT TABLE	
DIFFERENTIAL INPUT PRESSURE - IWG	OUTPUT VOLTAGE - VDC
0.000	0.00
0.025	0.50
0.050	1.00
0.075	1.50
0.100	2.00
0.125	2.50
0.150	3.00
0.175	3.50
0.200	4.00
0.225	4.50
0.250	5.00

Discharge Pressure Transducer

The optional discharge pressure transducer is located in common discharge line of the tandem compressors for each refrigerant circuit. The purpose of this transducer is to sense and convert the discharge pressure to a DC voltage. The DC voltage is then sent to the unit controller where it can control head pressure (with optional low ambient kit), provide compressor unloading, and display discharge pressure on the OptiLogic™ display panel. The transducer and wiring are factory installed. Whenever an optional transducer package is supplied, the transducer is wired to a factory supplied

TABLE 26 – DISCHARGE PRESSURE TRANSDUCER OUTPUT

DISCHARGE PRESSURE TRANSDUCER OUTPUT TABLE			
INPUT PRESSURE - PSIG	OUTPUT VOLTAGE - VDC	INPUT PRESSURE - PSIG	OUTPUT VOLTAGE - VDC
0	1.00	260	3.08
20	1.16	280	3.24
40	1.32	300	3.40
60	1.48	320	3.56
80	1.64	340	3.72
100	1.80	360	3.88
120	1.96	380	4.04
140	2.12	400	4.20
160	2.28	420	4.36
180	2.44	440	4.52
200	2.60	460	4.68
220	2.76	480	4.84
240	2.92	500	5.00

controller called the MOD-UNT. The MOD-UNT then communicates the pressures to the main unit controller (Primary Unit Controller) via an N2 communication buss. Figure 51 shows the MOD UNT controller, and Figure 52 illustrates the connections between the discharge pressure transducer, the MOD-UNT, and the Primary Unit Controller.

The Discharge Transducer has a range of 0 PSIG to 500 PSIG, with a linear output of 0 volts DC to 5 volts dc. Table 26 illustrates the DC volt output from the transducer for a given discharge pressure.

Suction Pressure Transducer

The optional suction pressure transducer is located in common suction line of the tandem compressors for each refrigerant circuit. The purpose of this transducer is to sense and convert the suction pressure to a DC voltage.

The DC voltage is then sent to the unit controller where it can control head pressure (with optional low ambient kit), provide compressor unloading, and display suction pressure on the OptiLogic™ display panel. The transducer and wiring are factory installed. Whenever the optional transducer package is supplied, the transducer is wired to a factory supplied controller called the MOD-UNT. The MOD-UNT then communicates the pressures to the main unit controller (Primary Unit Controller) via an N2 communication buss. Figure 52 illustrates the connections between the suction pressure transducer, the MOD-UNT, and the Primary Unit Controller.

The Suction Transducer has a range of 0 PSIG to 200 PSIG, with a linear output of 0 volts DC to 5 volts DC. Table 27 illustrates the DC volt output from the transducer for a given suction pressure.

TABLE 27 – SUCTION PRESSURE TRANSDUCER OUTPUT

SUCTION PRESSURE TRANSDUCER OUTPUT TABLE			
INPUT PRESSURE - PSIG	OUTPUT VOLTAGE - VDC	INPUT PRESSURE - PSIG	OUTPUT VOLTAGE - VDC
0	1.00	110	3.20
10	1.20	120	3.40
20	1.40	130	3.60
30	1.60	140	3.80
40	1.80	150	4.00
50	2.00	160	4.20
60	2.20	170	4.40
70	2.40	180	4.60
80	2.60	190	4.80
90	2.80	200	5.00
100	3.00		

**LOW AMBIENT OPTION –
CONDENSER FAN MOTOR VSD**

The low ambient option for the unit includes a variable speed drive (VSD) for the condenser fan motor. The VSD is located in an enclosure directly beneath the condenser fan coil. There will be one enclosure for each VSD. The VSD is a non-programmable specific application VSD circuit board that drives the condenser fan motor based on a signal from the MOD-UNT (see section on Sequence of Operation).

The condenser fan motor is driven by the VSD based on a variable 0 - 5VDC signal from the MOD – UNT. This signal is based on the pressure transducer output as compared to the preprogrammed “Discharge Pressure Control” setpoint (160 psig). The VSD outputs a 10 Hz to 60 Hz to the condenser fan motor to maintain the “Discharge Pressure Control” setpoint.

Fig. 53 illustrates the connections on the VSD board (also refer to the unit wiring diagrams at the end of this manual).

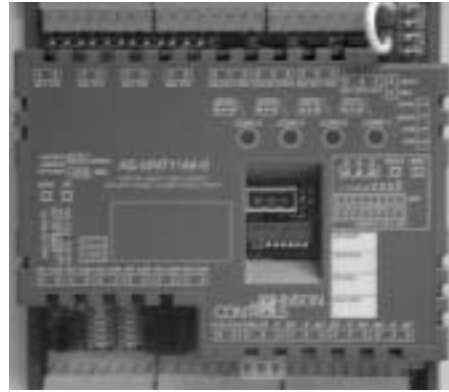

00492VIP

FIG. 51 – SECONDARY CONTROLLER

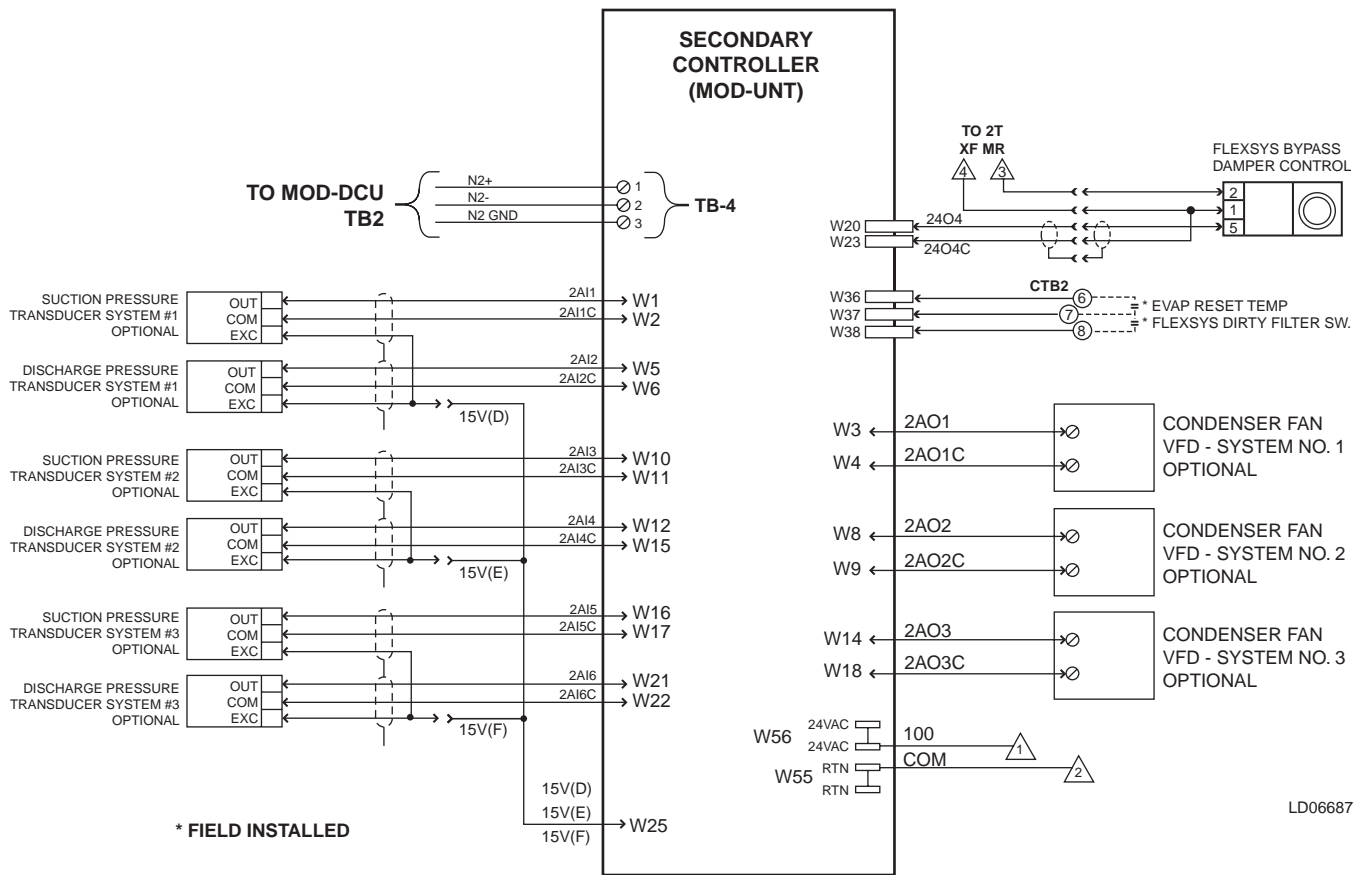

LD06687

FIG. 52 – MOD-UNT WIRING DIAGRAM

TABLE 28 – MONITOR AND CONTROL I/O FOR MOD UNT CONTROLLER

I/O NAME	ANALOG OR BINARY	SIGNAL LEVELS	APPL. VALUE RANGE	WHERE USED
System 1, Suction Pressure	AI	1.0-5.0V	0 to 200	X'Ducer Package
System 1, Discharge (Condenser) Pressure	AI	1.0-5.0V	0 to 500	X'Ducer Package
System 2, Suction Pressure	AI	1.0-5.0V	0 to 200	X'Ducer Package
System 2, Discharge (Condenser) Pressure	AI	1.0-5.0V	0 to 500	X'Ducer Package
System 3, Suction Pressure	AI	1.0-5.0V	0 to 200	X'Ducer Package
System 3, Discharge (Condenser) Pressure	AI	1.0-5.0V	0 to 500	X'Ducer Package
Cond. Fan, System 1	AO	0-10V	0 to 100%	Low Ambient
Cond. Fan, System 2	AO	0-10V	0 to 100%	Low Ambient
Cond. Fan, System 3	AO	0-10V	0 to 100%	Low Ambient

Humidity Temperature Sensor – Outside, Return and Underfloor (MIT)

The humidity/temperature sensor is a combination sensor that will output a 0 to 5 volt DC voltage in response to the relative humidity sensed. The humidity sensor is used in conjunction with the economizer function. The

combination sensor also has a temperature sensor that senses the outdoor air temperature and has the same resistance value of a “stand-alone” outdoor sensor. The resistance value for a specific outdoor temperature is shown in Table 22. Note that the combination humidity/temperature sensor has four terminals – two for the humidity sensor and two for the temperature sensor.

TABLE 29 – HUMIDITY SENSOR OUTPUT

HUMIDITY SENSOR OUTPUT TABLE			
% RELATIVE HUMIDITY	OUTPUT VOLTAGE - VDC	% RELATIVE HUMIDITY	OUTPUT VOLTAGE - VDC
5	0.25	55	2.75
10	0.50	60	3.00
15	0.75	65	3.25
20	1.00	70	3.50
25	1.25	75	3.75
30	1.50	80	4.00
35	1.75	85	4.25
40	2.00	90	4.50
45	2.25	95	4.75
50	2.50	100	5.00

CO₂ Sensor

The CO₂ sensor is used in conjunction with the *Demand Ventilation* option. The demand for ventilation is determined by comparing the level of CO₂ in the building to the *Demand Ventilation Setpoint*. The CO₂ level in the building is measured by the CO₂ sensor and outputs

0 to 5 volts DC based on the level of carbon dioxide sensed. The unit controller then modulates the outside air dampers to bring the level of CO₂. Table 30 illustrates the DC output for a given CO₂ level.

TABLE 30 – CO₂ SENSOR OUTPUT

CO ₂ OUTPUT TABLE			
PPM CO ₂	OUTPUT VOLTAGE - VDC	PPM CO ₂	OUTPUT VOLTAGE - VDC
200	0.40	2800	5.60
400	0.80	3000	6.00
600	1.20	3200	6.40
800	1.60	3400	6.80
1000	2.00	3600	7.20
1200	2.40	3800	7.60
1400	2.80	4000	8.00
1600	3.20	4200	8.40
1800	3.60	4400	8.80
2000	4.00	4600	9.20
2200	4.40	4800	9.60
2400	4.80	5000	10.00
2600	5.20		

Primary Unit Controller Analog Outputs

The Primary Unit Controller has six analog outputs that send a 0 to 10 volt DC signal to the respective actuator. Table 33 shows the analog outputs designated as AO1 through AO6, and the respective function. Note the outputs are speed reference signals to the supply fan VFD, exhaust fan VFD or exhaust damper, damper actuators for outside air/return air dampers, air measuring dampers, and heating valve. The 0 to 10 volt DC output would be linear over the respective actuator range of travel, or over the VFD frequency range of 0 to 60 Hz. As an example, if the output to the outside air damper actuator were 5 volts DC, the outside air damper actuator would be driven to one-half of its range of travel. Another example would be a 4 volt DC voltage sent to the supply fan VFD as the speed reference signal. This would “drive” the VFD to 24 hertz [(voltage reference signal X 60) / 10 volts]. The actuator connections are:

Terminal 1 = 24VAC Common

Terminal 2 = 24VAC, and

Terminal 5 = 0 - 10VDC signal.

Primary Unit Controller Binary Outputs

The Primary Unit Controller has 10 binary outputs that switch 24 volt AC to relays to cycle compressors, supply fan, exhaust fan, etc (refer to unit wiring diagram). The outputs are “dry contact” relays on-board the unit controller (Primary Unit Controller) that will output 24 volts when energized by the unit controller. The 24 volt AC output will then energize the respective relays. Table 33 lists the output designations.

Optional Thermostat Interface Board (See Fig. 53)

There are no field connections required to the thermostat interface board. Any thermostat that is field wired will be connected at CTB1 in the control panel of the rooftop unit and not to the thermostat interface board.

The thermostat interface provides the interface from an ordinary two-stage heat, two-stage cool thermostat to the Primary Unit Controller. The function of the thermostat interface board is to convert the thermostat inputs, which are basically binary inputs, to one analog output that connects to the Primary Unit Controller at analog input TSAO (J10-4). The DC voltage output for respective thermostat inputs is shown in Table 31.

**TABLE 31 – THERMOSTAT INTERFACE BOARD
VOLTAGE OUTPUTS**

ANALOG OUTPUT	W2	W1	Y1	Y2
0.0	Fault	Fault	Fault	Fault
0.5	OFF	OFF	ON	ON
1.0	OFF	OFF	ON	OFF
1.5	OFF	OFF	OFF	ON
2.0	OFF	OFF	OFF	OFF
3.0	ON	OFF	OFF	OFF
4.0	OFF	ON	OFF	OFF
5.0	ON	ON	OFF	OFF

Binary “pass-through” Connections.

Four of the T'stat interface board inputs, G, OCC, SD, Smoke Purge are connected directly from the field installed T'stat to the Primary Unit Controller binary inputs (refer to Binary Inputs). These inputs are still routed through the T'stat Interface board along with the other T'stat inputs, but they only use the T'stat Interface Board as a connecting point. Table 32 lists the connections and functions.

TABLE 32 – THERMOSTAT INTERFACE BOARD CONNECTIONS

T'STAT TERMINALS	FUNCTION	MOD DCU CONNECTION	FUNCTION
R	24 VAC from controller	R	24 VAC from controller
Y1	COOL 1	TSAO	Analog voltage
Y2	COOL 2	TSAO	Analog voltage
W1	HEAT 1	TSAO	Analog voltage
W2	HEAT 2	TSAO	Analog voltage
G			Not Used
OCC			Not Used
SD			Not Used
P			Not Used
X			Not Used
C	Common	C	Common from controller

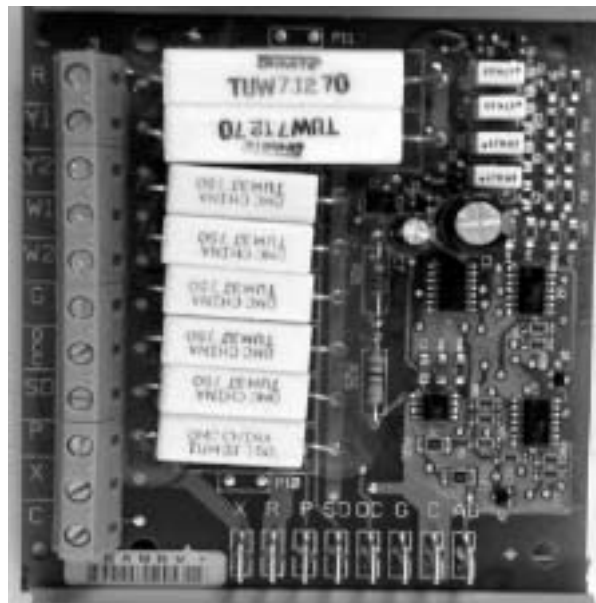

00493VIP

FIG. 53 – THERMOSTAT INTERFACE BOARD (OPTIONAL)

Table 33 lists the description of the various inputs and outputs, and the respective connections to the Primary Unit Controller.

TABLE 33 – INPUT/OUTPUT TABLE

I/O NAME	INPUT/OUTPUT TYPE	SIGNAL LEVEL	APP VALUE RANGE	APPLICATION
Space Sensor	AI 1 (SSP)	1K RTD		ALL
Space Sensor Adjust	AI 2 (SSAP)	1.5K POT	0 to 1500	ALL
T'Stat Interface	AI 3 (TSAO)	0-5V	0 to 100	ALL
CO2	AI 4 (IAQ)	0-5V	0 to set by RDU	DEMAND VENTILATION
Return Temperature	AI 8	1K RTD	-50 to 250	DIFF. ENTH. ECONO
Outside Air Temperature	AI 6	1K RTD	-50 to 250	ALL
Return Air Humidity	AI 7	0-10V	0 to 100	DIFF. ENTH. ECONO
Outside Air Humidity	AI 5	0-10V	0 to 100	SINGLE ENTH. ECONO
Duct Static Pressure	AI 9	0-5V	0 to 5	VAV
Building Static Pressure	AI 10	0-5V	-.25 to .25	POWER EXHAUST
OA Flow Meas. #1 - All AMS	AI 11	0-5V	0 to .5	OA FLOW STATION
OA Flow Meas. #2 - 25/75 AMS	AI 12	0-5V	0 to .5	OA FLOW STATION
Supply Temperature	AI 13	1K RTD	-50 to 250	ALL
Mixed Air Temperature	AI14	1K RTD	-50 to 250	FLEXYS
Slab Temperature	AI15	1K RTD	-50 to 250	FLEXYS
Underfloor Humidity	AI16	0-10V	0 TO 100	FLEXYS
Compressor Circuit #1 Status	BI 1	24VAC		ALL
Compressor Circuit #2 Status	BI 2	24VAC		ALL
Compressor Circuit #3 Status	BI 3	24VAC		70 - 90 TON UNITS
Furnace Model #1 Status	BI 4	24VAC		GAS HEAT, 1 MODULE
Furnace Model #2 Status	BI 5	24VAC		GAS HEAT, 2 MODULE
Furnace Model #3 Status	BI 6	24VAC		GAS HEAT, 3 MODULE
G (fan)	BI 7	24VAC		ALL
Occupied/Unoccupied Switch	BI 8	24VAC		ALL
Shutdown	BI 9	24VAC		ALL
Smoke Purge	BI 10	24VAC		ALL
Supply Fan Status (fan proving)	BI 11	24VAC		ALL
Filter Status (dirty filter)	BI 12	24VAC		DFS OPTION
Evaporator Freezestat	BI 13	24VAC		W/O HGBP
HW Freezestat	BI 14	24VAC		HW
Cool-Heat COR Status	BI 15	24VAC		ALL
VFD Bypass Input	BI 16	24VAC		VAV W/ VFD BYPASS
Supply Fan VFD	AO 1	0-10V	0 to 100%	VAV
Exhaust Fan VFD or Damper	AO 2	0-10V	0 to 100%	POWERED EXHAUST
OA / RA Damper & Full AMS	AO 3	0-10V	0 to 100%	ALL
OAD #1 MIN and 25/75 AMS	AO 4	0-10V	0 to 100%	AMS (ALL OPTIONS)
OAD #2 MIN and 25/75 AMS	AO 5	0-10V	0 to 100%	AMS (1/4 - 3/4 ONLY)

Continued on Next Page

NOTES: AI = Analog Input
 BI = Binary Input
 AO = Analog Output
 BO = Binary Output

TABLE 33 – INPUT/OUTPUT TABLE (CONTINUED)

I/O NAME	INPUT/OUTPUT TYPE	SIGNAL LEVEL	APP VALUE RANGE	APPLICATION
Heating Valve	AO 6	0-10V	0 to 100%	HW
Cooling/Heating Stage #1	BO 1			ALL
Cooling/Heating Stage #2	BO 2			ALL
Cooling/Heating Stage #3	BO 3			ALL
Cooling/Heating Stage #4	BO 4			ALL
Cooling/Heating Stage #5	BO 5			70 - 90 TON UNITS
Cooling/Heating Stage #6	BO 6			70 - 90 TON UNITS
Cool/Heat Changeover Relay	BO 7			ALL
Supply Fan	BO 8			ALL
Exhaust Fan	BO 9			POWERED EXHAUST
VAV Heat Relay	BO 10			VAV

NOTES: AI = Analog Input
 BI = Binary Input
 AO = Analog Output
 BO = Binary Output

FAULT DESCRIPTIONS

Failure Modes

Troubleshooting the rooftop unit is aided by the fact that the unit stores the last 12 unit “faults” in its history buffer, and can be viewed under the History key. The History navigation is explained in this manual under the section on Menu Navigation and Display Descriptions. Anytime the unit has a Fault, the System Alarm LED, just to the right of the display will be illuminated.

Fault Descriptions

The Fault Description Table, Table 34, classifies faults into two categories, *Trouble* faults and *Alarm* faults. Trouble faults will cause the event to be recorded into the history buffer, but **will not** shut the unit down. Alarm faults will cause the event to be recorded into the history buffer, and **will** cause the unit to be shut down. Both type of faults will illuminate the LED on the OptiLogic keypad.

Clearing Faults

The nature of the shutdown determines if the unit requires a “manual reset”, versus an “auto reset”. A manual reset requires removal of power from the rooftop unit control board. This can most easily be accomplished by cycling power at the unit disconnect switch. An auto reset will be reset automatically once the fault has cleared itself.

Remember, when power is recycled, the control board goes through a 5 minute self-check, with the display showing version, address, status “no Comm”, and start-up “Ok Ok Ok” being displayed.

MOD UNT Communication Fault

When the Expansion Input/Output controller is connected via the N2 bus to the controller for a Refrigerant Transducer Package, Low Ambient operation, or Flex-Sys option, the communication status will be monitored. A fault is declared if the communication is lost.

Analog Input Faults

All analog inputs will be monitored for reliability according to the type of input connected and the range

specified. The controller monitors all AI inputs to determine if the value at the input is within an acceptable range. These values are listed in Table 28. The engineering units represented are also listed as applicable.

Temperature Inputs

Temperature inputs will be monitored for reliability. If the controller determines that the input is not within the accepted range (shorted or open), a fault will be declared.

Voltage Inputs

Voltage inputs will be compared with the allowed voltage range as shown in Tables 28. Inputs with voltages outside of this range will be declared unreliable and a fault will be declared.

Negative Pressure Safety Switch

This safety device is in series with the analog output to the outside air damper when the unit is configured for an Air Measuring station. A Negative Pressure safety switch will be factory installed in the filter section of the unit whenever a Minimum Air Measuring Station is installed (none for full Air Measuring Station), and will be located upstream of the filters. This switch will open at negative 4 iwg for the purpose of preventing an excessive negative pressure in the return section, should the outside air damper fail. If the outside air damper fails (fails closed), the Primary Unit Controller will drive the return air dampers closed to increase the outside air because it sees a decrease in airflow (dampers are closed). If the pressure exceeds – 4 iwg as a result of the return dampers closing, the negative pressure switch will open and remove power from the return damper actuator. The return damper actuator is “fail open” and will open the return dampers to relieve the negative pressure. The Primary Unit Controller does not monitor the negative pressure switch. As such this safety is used only to prevent damage to the unit panels, and the failure of the outside air damper will continue to exist until noticed by service or maintenance personnel.

TABLE 34 – FAULT DESCRIPTION TABLE

FAULT TITLE RDU's HISTORY BUFFER	SET WHEN	RESET WHEN	SHUT DOWN (1)	GENERAL STATUS		ADDITIONAL ACTIONS or DISPLAYS (3) (4)
				TROUBLE	ALARM	
Excess Duct Pressure	The unit is programmed for VAV operation AND the Duct Static Pressure is greater than the Duct Pressure Limit setpoint.	Cycle power on controller.	*(5)		*	--
Sup Fan Fault	Supply Fan has to be running for 60 seconds AND Air Proving Switch has not closed for 30 seconds.	Cycle power on controller.	*		*	--
COR Status Fault	COR (Change Over Relay) is ENERGIZED (cooling requested) and COR Status input is NOT PRESENT, or COR is ENERGIZED and COR input is NOT PRESENT.	Cycle power on controller.	*		*	--
Duct Sensor Fault	Unit programmed for VAV and Duct static pressure sensor is not reliable (open or shorted).	Cycle power on controller.	*		*	--
HW Freeze Fault	HW Freezestat parameter programmed ON AND HW Freezestat Input is OPEN for 10 minutes.	HW Freezestat Tstat closes for 5 minutes.	*(6)		*	HW valve = 100% open.
Sys X Sfty Lockout #1 or Sys X Sfty Lockout #2	Three Comp Safety Trips within one hour.	Cycle power on controller OR the corresponding Compressor. Safety Trip Closes for 60 min.	*(7)		*	--
SAT Sensor Fault	SAT sensor is not reliable.	SAT sensor is not reliable.	*		*	OpData/Supply Air Temp/Temp = ???
Thermostat Conflict	{Y1 OR Y2 = ON} AND {W1 OR W2 = ON}	{(Y1 OR Y2 = ON) AND NOT (W1 OR W2 = ON)} OR {Y1 AND Y2 AND W1 AND W2 = OFF}	*		*	--
MSAT Sensor Fault	Mixed Supply Air Temp input is unreliable.	Mixed Supply Air Temp is reliable.	*		*	--
Sys X Safety Trip	>= 30 sec since a compressor in a given system was activated AND the corresponding 'Compressor System Status input' = OFF for 30 sec.	>= 10 minutes since fault was set	*(8) (9)	*		--
Evap Freeze Fault	Evap Freezestat input closes for at least 1 minute.	Evap Freezestat is open for at least 5 minutes.	*	*		--
Space Sensor Fault	Space Sensor Enable = ON AND 'Space Sensor input' is unreliable.	'Space Sensor input' is reliable OR Space Sensor Enable' = OFF.	*(12)	*		'OpData/Space Temperature/Temp' = ??? VAV Mode Only Unit Controlled in 'Stand Alone Control'.
High Press Unload x [1, 2 or 3]	Unit programmed for transducer package AND both compressors are ON in a given system AND 'Discharge Pressure is less than the Sys Unloading Setpoint.	{OAT < (OAT @ unload - 5F)} OR {Cycle power on controller}.		*		Destage the compressor in corresponding system with the most run time.

TABLE 34 – FAULT DESCRIPTION TABLE (continued)

FAULT TITLE RDU's HISTORY BUFFER	SET WHEN	RESET WHEN	SHUT DOWN (1)	GENERAL STATUS		ADDITIONAL ACTIONS or DISPLAYS (3) (4)
				TROUBLE	ALARM	
RAT Sensor Fault	Unit programmed to enable RAT Sensor AND RAT sensor is not reliable.	Unit programmed to disable RAT sensor OR RAT sensor is reliable.		*	*(14)	OpData/RA Temp = ??? OpData/RA Enth = ???
Air Switch Fault	Supply fan has been off for at least for 5 minutes AND the Air Proving Switch remains closed.	Supply fan has been off for at least 5 minutes AND Air Proving Switch opens.		*		—
Suction Press Fault	A suction pressure reading is out-of-range (range = 0 to 200 psi).	All suction pressure readings are within range.		*		—
Discharge Press Fault	A discharge pressure reading is out-of-range (range = 0 to 500 psi).	All discharge pressure readings are within range.		*		Low ambient operation for the failed circuit is locked out.
Unit Filter Fault	Unit Filter Switch input closes for at least 1 minute.	Unit Filter Switch input opens.		*		—
Space Control Fault	Unit programmed for CV AND the unit is being controlled by the Space Sensor AND Operating in cooling AND the (Space temp - setpoint) is greater than 'Space Temp Alarm Diff' and increasing in value AND 'Space Temp Alarm Time' setpoint has expired.	'Space Temp Alarm Diff' = 0 OR 'Space Temp Alarm Time' = 0 OR (Space temp - setpoint) is decreasing in value.		*		—
Cooling SAT Fault	SAT is equal to or greater than Cooling SAT Alarm setpoint AND all available compressors have been ON for 60 minutes.	SAT is less than the Cooling SAT Alarm setpoint.		*		—
Heating SAT Fault	SAT is equal to or less than the Heating SAT Alarm setpoint AND all heating stages have been ON for at least 20 minutes.	SAT is greater than the Heating SAT Alarm setpoint.		*		—
Excess Cooling Fault	Only one comp running AND SAT is less than 'Stage 1 Cooling SAT Limit' for one minute. Two or more compressors running: SAT is less than Stage 2-6 Cooling SAT Limit' for one minute.	If 'Stage 1 Cooling Limit' caused the fault: SAT is greater than 'Stage 1 Cooling Limit' + 5 degrees F) for 5 minutes. If 'Stage 2-6 Cool Limit' caused the fault: SAT is greater than 'Stage 2-6 Cool Limit' + 5 degrees F) for 5 minutes.		*		Destage compressors at one minute intervals, if necessary, to reduce the SAT and prevent a cooling stage from starting until SAT is greater than respective 'Cooling Limit' + 5 degrees F for 5 minutes.
Excess Heating Fault	SAT is greater than 'Heating SAT Limit' for one minute.	SAT is less than ('Heating SAT Limit' – 10 degrees F for 5 minutes.		*		Destage heaters at one minute intervals, if necessary, to reduce the SAT. Prevent a heating stage from starting until SAT is less than 'Heating SAT Limit' – 10 degrees F for 5 minutes.

TABLE 34 – FAULT DESCRIPTION TABLE (continued)

FAULT TITLE RDU's HISTORY BUFFER	SET WHEN	RESET WHEN	SHUT DOWN (1)	GENERAL STATUS		ADDITIONAL ACTIONS or DISPLAYS (3) (4)
				TROUBLE	ALARM	
Tstat Cooling Fault (10)	{Y1 = OFF} AND {Y2 = ON}	{Y1 AND Y2 = ON} OR {Y1 AND Y2 = OFF}		*		—
Tstat Heating Fault (10)	{W1 = OFF} AND {W2 = ON}	{W1 AND W2 = ON} OR {W1 AND W2 = OFF}		*		—
Bldg Pressure Fault	Unit is programmed for Power Exhaust AND building static pressure sensor is not reliable.	Building Pressure is within the acceptable range.		*		OpData/Building Pressure Press = ??? (11)
OAT Sensor Fault	OAT sensor is not reliable.	OAT sensor is reliable.	(13)	*		OpData/OA Temp = ??? OpData/OA Enth = ??? Unit will Ignore htg & clg lockouts, allow htg or clg, & disable the Economizer and other functions dependent on OAT.
F/SLAB Sensor Fault	FlexSys Dewpt reset programmed for ON and Slab Temp Input is unreliable.	FlexSys Dewpt Reset programmed for OFF, or Slab Temp Input is reliable.		*		Control SAT to VAV High Setpoint.
F/RH Sensor Fault	FlexSys Dewpt Reset programmed ON and Humidity Sensor Input is unreliable	FlexSys Dewpt Reset programmed for OFF, or Humidity Sensor is reliable		*		Control SAT to VAV High Temp Setpoint.
OAH Sensor Fault	Unit programmed to read OAH sensor AND OAH sensor is not reliable.	Unit reprogrammed to disable OAH sensor OR OAH sensor is reliable.		*		OpData/OA RH = ??? OpData/OA Enth = ???
RAH Sensor Fault	Unit programmed to enable RAH sensor AND RAH sensor is not reliable.	Unit programmed to disable RAH sensor or RAH sensor is reliable.		*		OpData/RA RH = ??? OpData/RA Enth = ???
IAQ Sensor Fault	Unit programmed for Economizer AND programmed to enable IAQ sensor AND CO2 sensor is not reliable.	Unit programmed to disable IAQ Sensor OR CO2 sensor is reliable.		*		Demand Ventilation is not permitted.
OA Flow Sensor Fault	Unit programmed to enable 'OA Flow Control' AND Air flow sensors are not reliable. (15)	Airflow sensors are reliable.		*		OA Flow Control not permitted.
Bad OAF Transducer	Unit programmed to enable 'OA Flow Control' AND following an OA Flow Transducer Auto-Zero Function, the transducers are not within 10% of the sensor range (i.e. > .05 in wg). (16)	Following subsequent OA Flow Transducer Auto-Zero Function, transducers are <= 10% of full range for the sensors.		*		OA Flow Control not permitted.
SensConsist Fault #1	During Sensor Consistency check the SAT-(RAT+1.5F) is greater than 3 OR RAT – Space Temperature is greater than 3.	During Sensor Consistency check the SAT-(OAT+1.5F)] is less than or equal to 3 OR Cycle power on controller.		*		—

TABLE 34 – FAULT DESCRIPTION TABLE (continued)

FAULT TITLE RDU's HISTORY BUFFER	SET WHEN	RESET WHEN	SHUT DOWN (1)	GENERAL STATUS		ADDITIONAL ACTIONS or DISPLAYS (3) (4)
				TROUBLE	ALARM	
SensConsist Fault #2	During Sensor Consistency check the SAT-(OAT+1.5F)] is greater than 3.	During Sensor Consistency check' the SAT-(RAT+1.5F)] is less than or equal to 3 AND RAT - Space Temperature is less than or equal to 3 OR Cycle power on controller.		*		—
UNT Comm Fault	Unit programmed for refrigerant refrigerant transducer package OR Low Ambient Operation AND the Primary Unit Controller loses communication with the MOD-UNT.	Communication between the Primary Unit Controller and the MOD-UNT is restored.		*		MOD-UNT controls VSDs to setpoint.
RA Byp Filter Fault	Unit is programmed for VAV FlexSys and the Bypass Filter Switch is closed for 60 sec.	Bypass filter switch opens.		*		—

TABLE 34 – FAULT DESCRIPTION TABLE – NOTES**NOTES (PAGES 132 - 135):**

- The rooftop unit is shut down when the controller for the rooftop unit is in a defined idle state, 'shutdown', where all of its outputs are OFF.
- 'General Unit Status' is the first display under 'UNIT STATUS'. When applicable, 'Trbl' (Trouble) and 'Alm' (Alarm) correlate with the RDU's History buffer.
- OpData' = Operation Data display item
- Except as noted, every fault (a) illuminates the System Alarm LED on the display and (b) creates a related entry in the History buffer.
- Supply Fan output is set to 0 after duct pressure greater than limit for 10 seconds or less
- The unit shuts down EXCEPT for the hot water valve, which is driven to 100% open.
- When commanded to turn OFF, a compressor stops operating within one second. Both compressors in the system remain OFF until the specified 'Reset When' conditions are met. If any system locks out, any other available systems may operate.
- Both compressors in the system turn OFF for at least 10 minutes. If any system turns OFF due to a trip, any other available systems may operate.
- All trip counters are reset to zero after a power cycle to the controller.
Counter #1 for each system: An individual trip counter resets if {(trip counter #1 > 0) AND (one or both compressors are operating in the associated system) AND (15 minutes has passed since the last trip added to trip counter #1)}.
- Counter #2 for each system: An individual trip counter resets if {(trip counter #2 > 0) AND (both compressors are operating in the associated system) AND (15 minutes has passed since the last trip added to trip counter #2)}.
- Neither error history nor illumination of the System Alarm LED is provided for the Tstat Cooling or Heating faults.
- 'Press= ???' is only displayed if the building static pressure sensor becomes unreliable after startup.
- In CV mode, the unit shuts down and displays the fault shutdown message if the RAT sensor is not detected OR is unreliable. In VAV mode, the unit self configures to Stand Alone mode and continues to operate, though it will shut down if the SAT sensor is not detected OR is unreliable.
- This message appears if the OAT sensor is disconnected or is unreliable and if 'Economizer Enable' = ON.
- If the RAT sensor becomes unreliable after operation defaulted to it due to the space temperature sensor becoming unreliable the unit will shut down.
- The airflow sensor on Input #2 is only present when the ¼ - ¾ configuration is installed.
- The Bad OAF Transducer test is not run if an OAF sensor is unreliable and only tested in UNOCC mode.

WIRING DIAGRAMS

ELEMENTARY DIAGRAM - YPAL MOD-B/C POWER SIDE 50-65 TON, SINGLE POINT POWER

035-13472-001
REV. A

NOTES:
1. ON UNITS EQUIPPED WITH ELECTRIC HEAT, SUPPLY CIRCUIT #1 IS FED FROM THE LOOP FEED POWER BOX MOUNTED TO THE RIGHT OF THE MICRO/POWER PANEL.

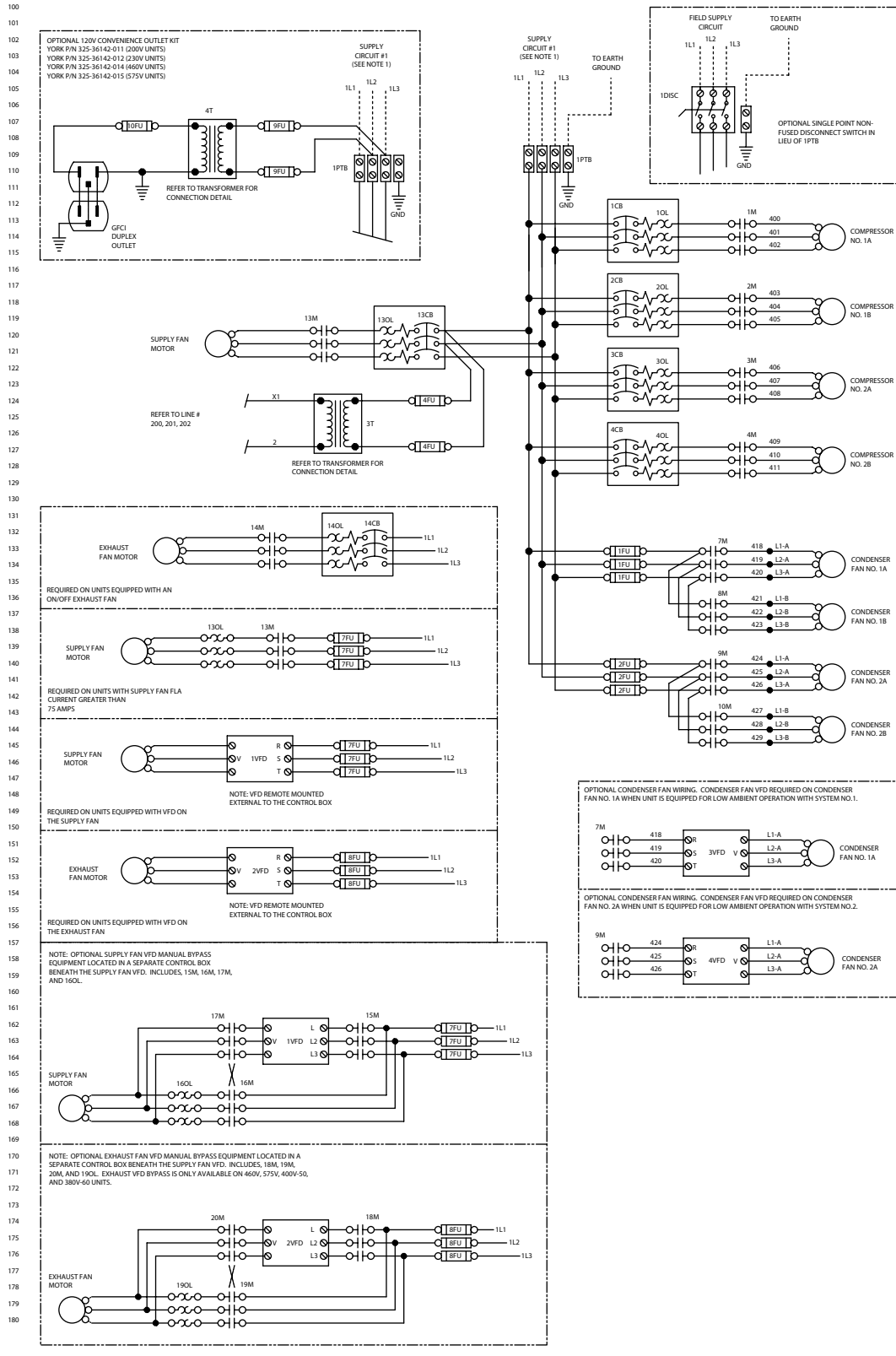

LD09829

**ELEMENTARY DIAGRAM - YPAL MOD-B/C
POWER SIDE
50-65 TON, DUAL POINT POWER**

**035-13472-002
REV. A**

NOTES:
1. ON UNITS EQUIPPED WITH ELECTRIC HEAT, SUPPLY CIRCUIT #1 IS FED FROM THE LOOP FEED POWER BOX MOUNTED TO THE RIGHT OF THE MICRO-POWER PANEL.

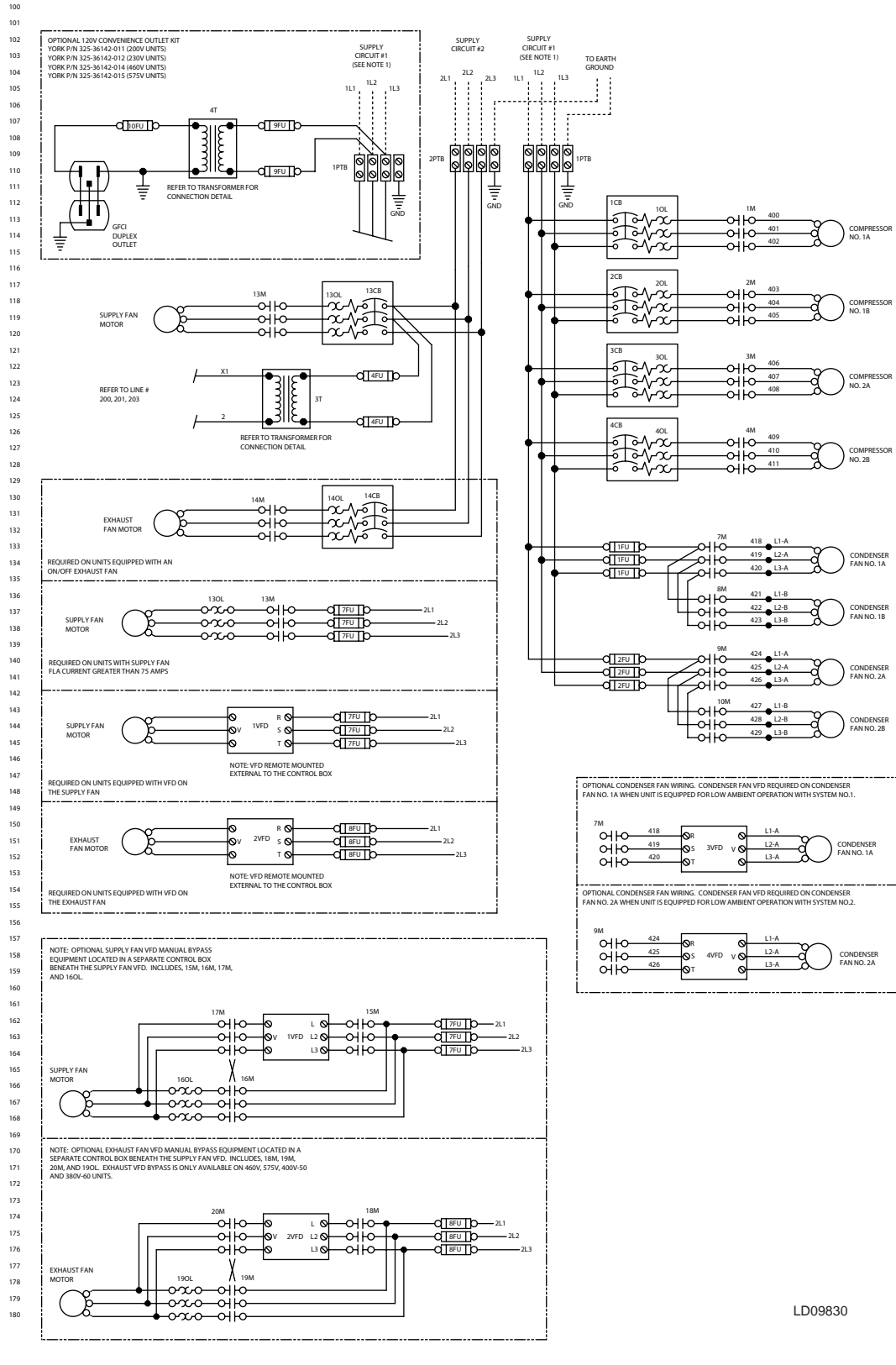

LD09830

ELEMENTARY DIAGRAM - YPAL MOD-B/C
POWER SIDE
70-105 TON, SINGLE POINT POWER

035-13472-003
REV. B

NOTES:
1. ON UNITS EQUIPPED WITH ELECTRIC HEAT, SUPPLY CIRCUIT #1 IS FED FROM THE LOOP FEED POWER BOX MOUNTED TO THE RIGHT OF THE MICRO/POWER PANEL.

100
101
102
103
104
105
106
107
108
109
110
111
112
113
114
115
116
117
118
119
120
121
122
123
124
125
126
127
128
129
130
131
132
133
134
135
136
137
138
139
140
141
142
143
144
145
146
147
148
149
150
151
152
153
154
155
156
157
158
159
160
161
162
163
164
165
166
167
168
169
170
171
172
173
174
175
176
177
178
179
180

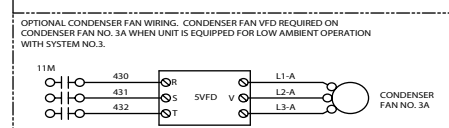
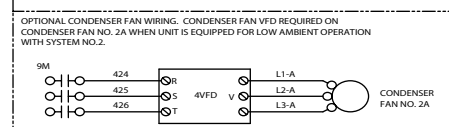
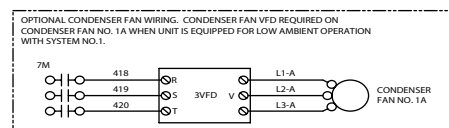
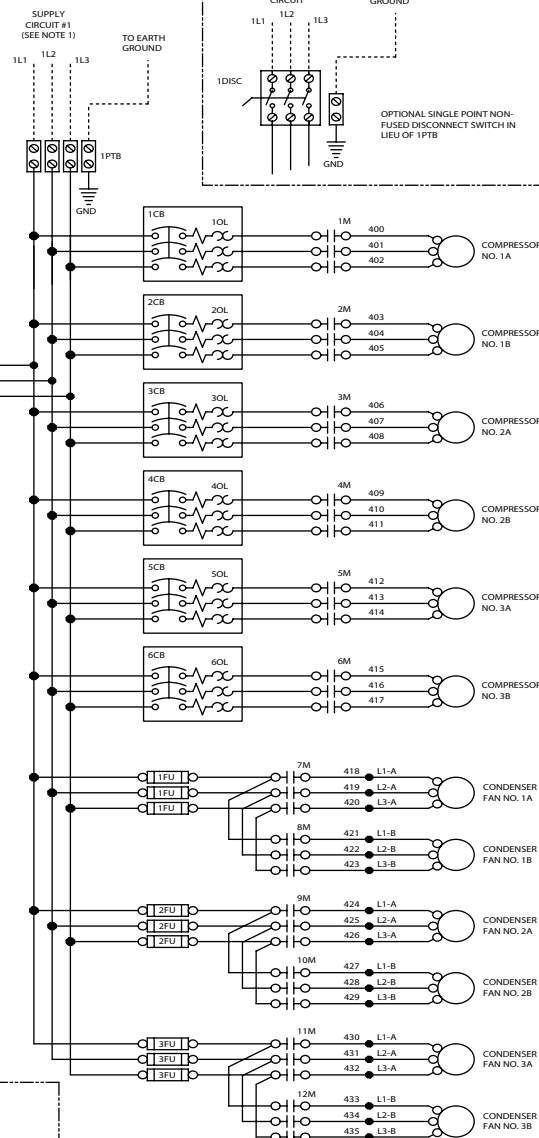
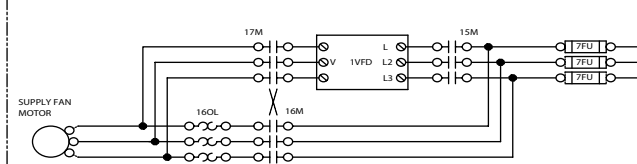
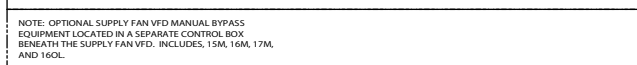
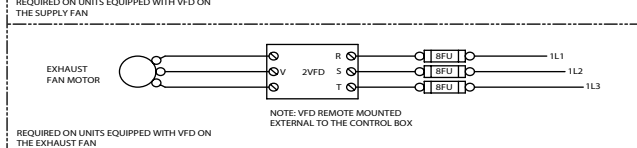
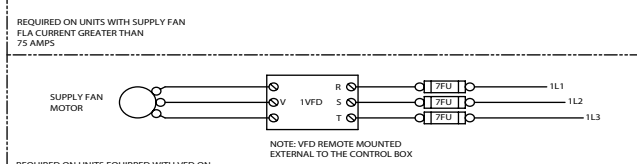
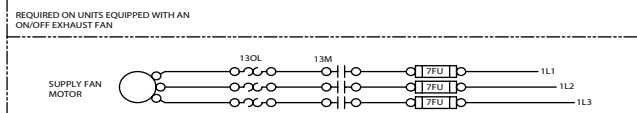
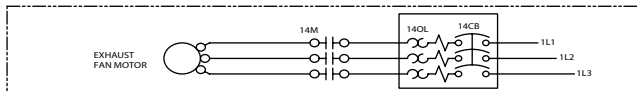
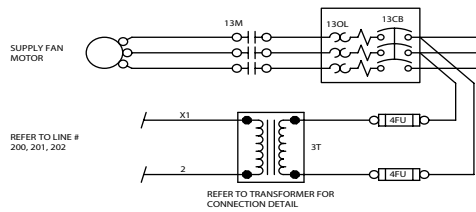
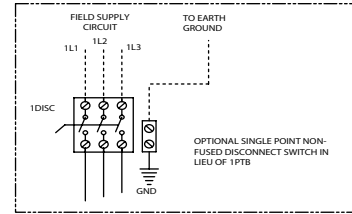
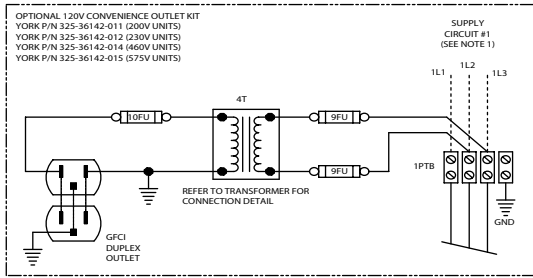

LD09831

**ELEMENTARY DIAGRAM - YPAL MOD-B/C
POWER SIDE
70-105 TON, DUAL POINT POWER**

**035-13472-004
REV. B**

NOTES:
1. ON UNITS EQUIPPED WITH ELECTRIC HEAT, SUPPLY CIRCUIT #1 IS FED FROM THE LOOP FEED POWER BOX MOUNTED TO THE RIGHT OF THE MICRO/POWER PANEL.

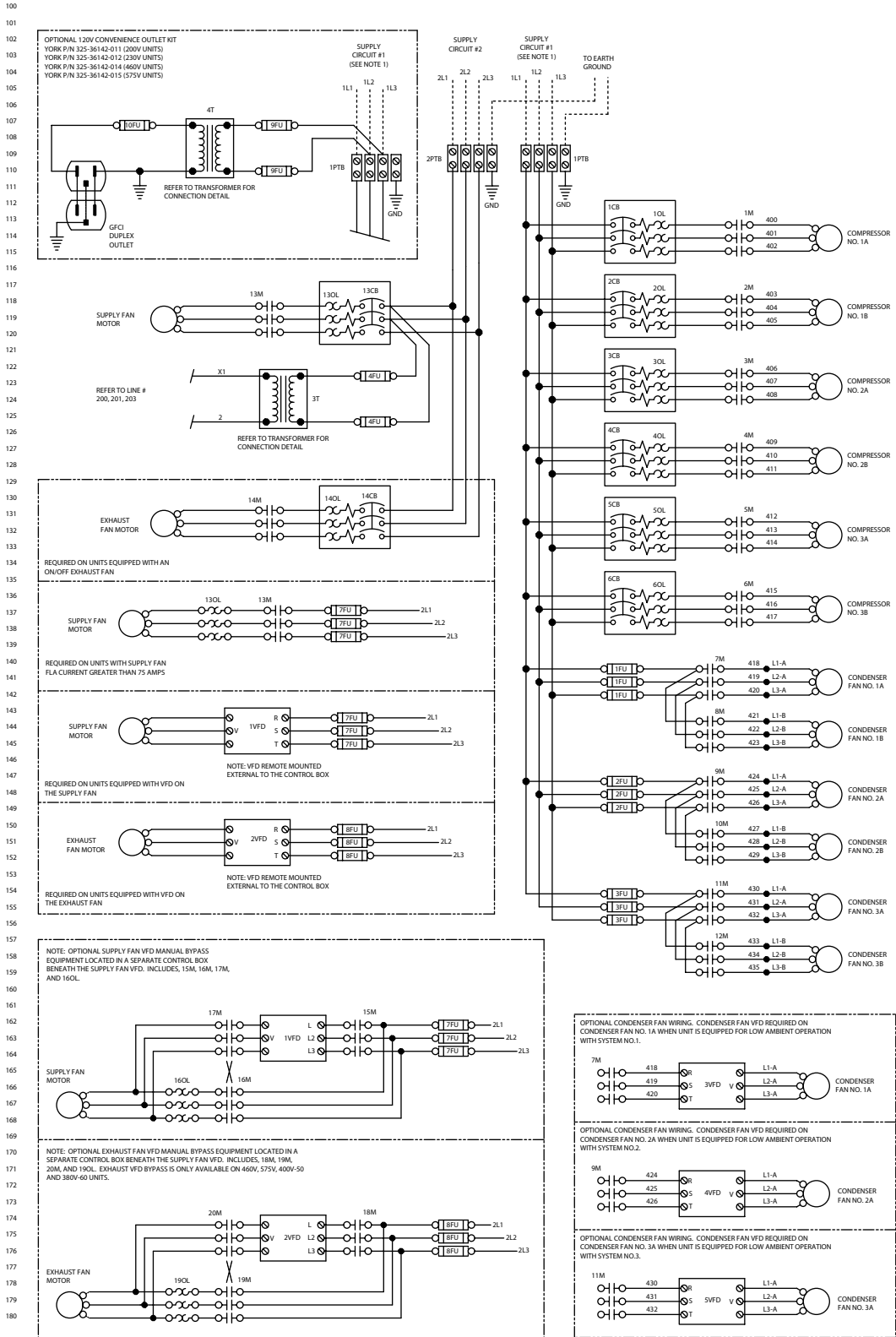

LD09832

ELEMENTARY DIAGRAM - YPAL MOD-B/C
POWER SIDE - 50-65 TON
SINGLE POINT POWER w/ RETURN FAN

035-13472-011
REV. -

NOTES:
1. ON UNITS EQUIPPED WITH ELECTRIC HEAT, SUPPLY CIRCUIT #1 IS FED FROM THE LOOP FEED POWER BOX MOUNTED TO THE RIGHT OF THE MICRO-POWER PANEL.

100
101
102
103
104
105
106
107
108
109
110
111
112
113
114
115
116
117
118
119
120
121
122
123
124
125
126
127
128
129
130
131
132
133
134
135
136
137
138
139
140
141
142
143
144
145
146
147
148
149
150
151
152
153
154
155
156
157
158
159
160
161
162
163
164
165
166
167
168
169
170
171
172
173
174
175
176
177
178
179
180

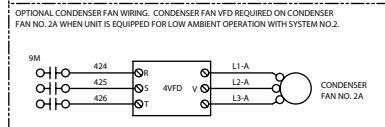
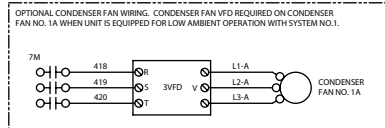
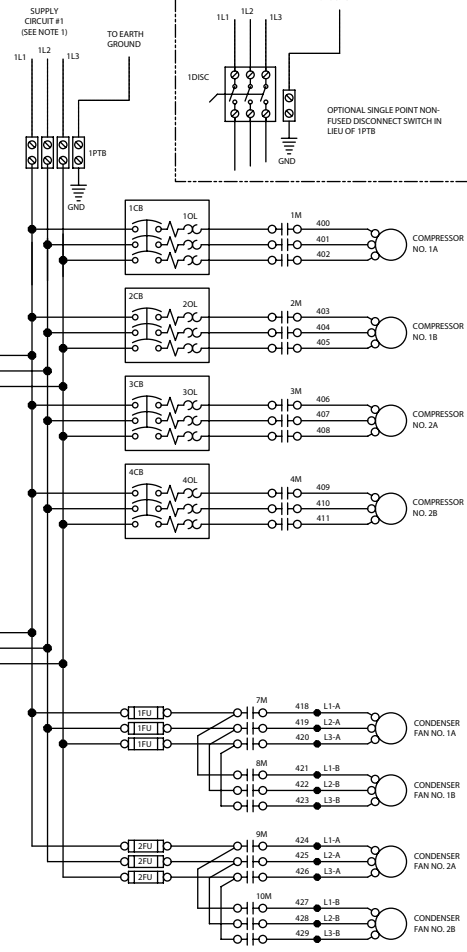
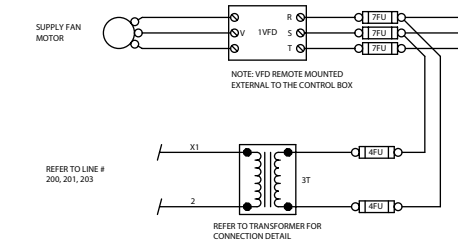
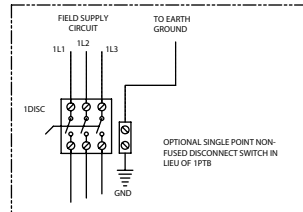
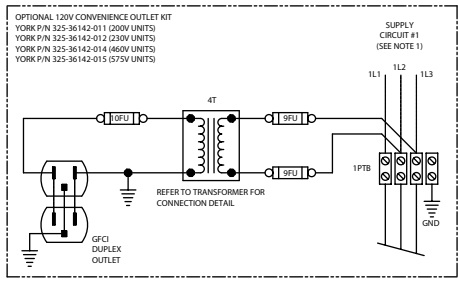

LD09833

**ELEMENTARY DIAGRAM - YPAL MOD-B/C
POWER SIDE - 50-65 TON
DUAL POINT POWER w/ RETURN FAN**

**035-13472-012
REV. -**

NOTES:
1. ON UNITS EQUIPPED WITH ELECTRIC HEAT, SUPPLY CIRCUIT #1 IS FED FROM THE LOOP FEED POWER BOX MOUNTED TO THE RIGHT OF THE MICRO/POWER PANEL.

100
101
102
103
104
105
106
107
108
109
110
111
112
113
114
115
116
117
118
119
120
121
122
123
124
125
126
127
128
129
130
131
132
133
134
135
136
137
138
139
140
141
142
143
144
145
146
147
148
149
150
151
152
153
154
155
156
157
158
159
160
161
162
163
164
165
166
167
168
169
170
171
172
173
174
175
176
177
178
179
180

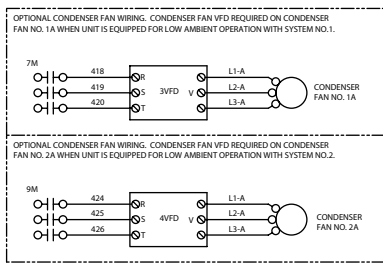
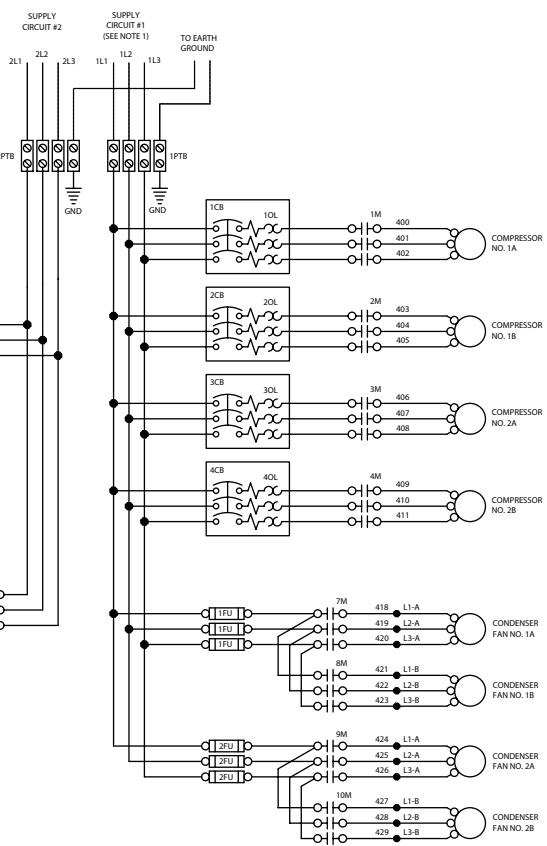
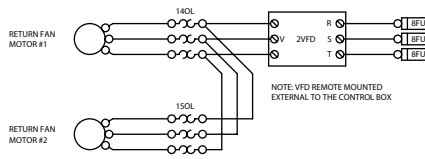
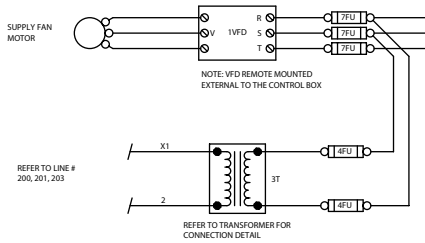
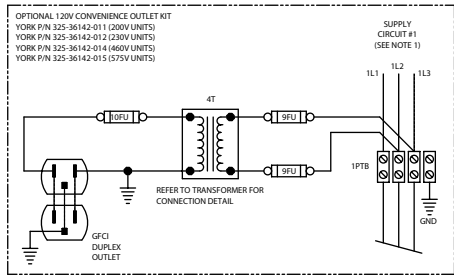

LD09834

ELEMENTARY DIAGRAM - YPAL MOD-B/C
POWER SIDE - 70-105 TON
SINGLE POINT POWER w/ RETURN FAN

035-13472-013
REV. A

NOTES:
1. ON UNITS EQUIPPED WITH ELECTRIC HEAT, SUPPLY CIRCUIT #1 IS FED FROM THE LOOP FEED POWER BOX MOUNTED TO THE RIGHT OF THE MICRO/POWER PANEL.

100
101
102
103
104
105
106
107
108
109
110
111
112
113
114
115
116
117
118
119
120
121
122
123
124
125
126
127
128
129
130
131
132
133
134
135
136
137
138
139
140
141
142
143
144
145
146
147
148
149
150
151
152
153
154
155
156
157
158
159
160
161
162
163
164
165
166
167
168
169
170
171
172
173
174
175
176
177
178
179
180

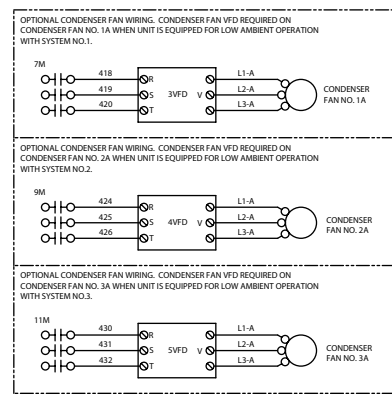
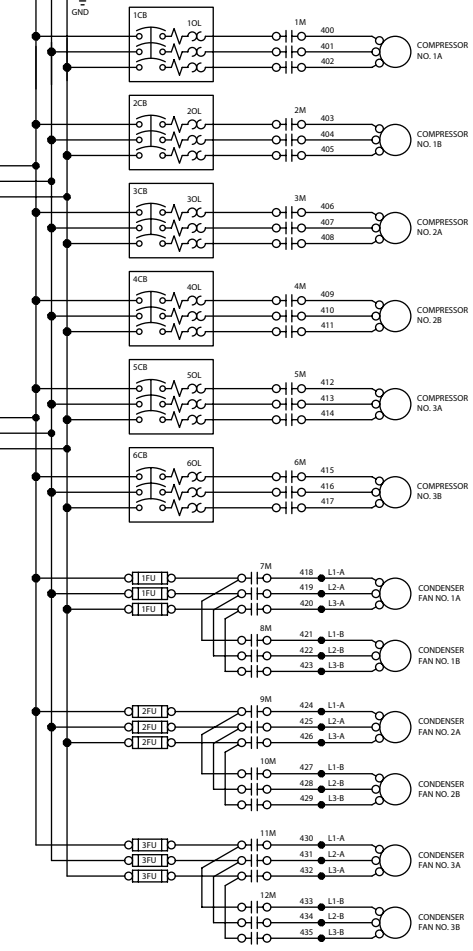
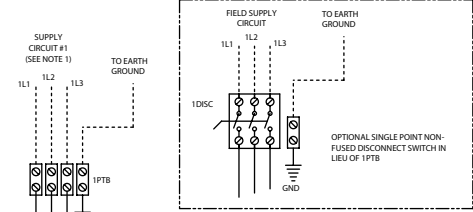
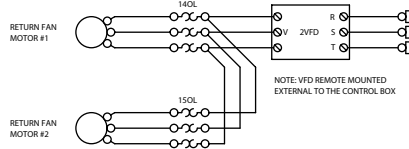
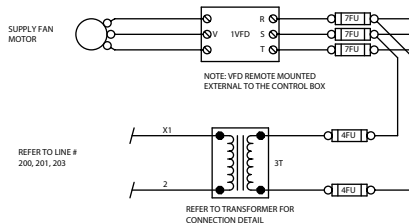
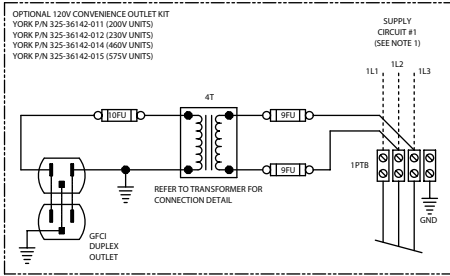

LD09835

ELEMENTARY DIAGRAM - YPAL MOD-C
CLASS 1 CONTROL
50-65 TON

035-13473-101
REV. -

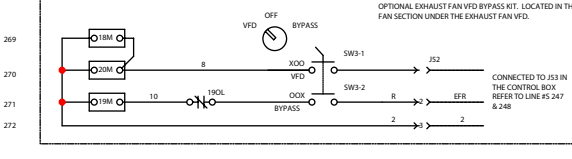
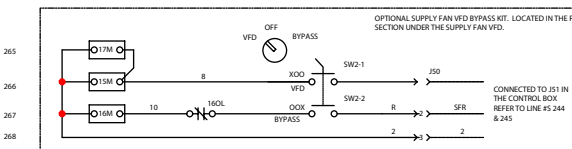
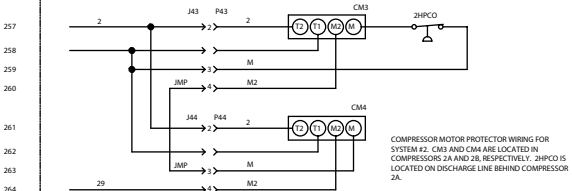
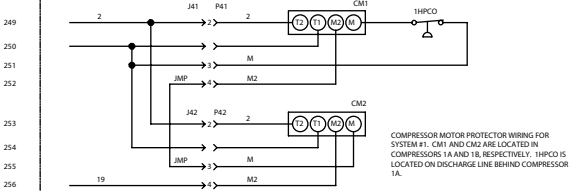
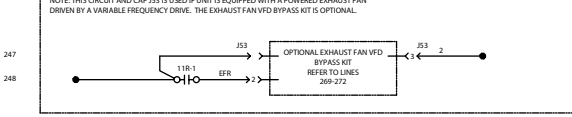
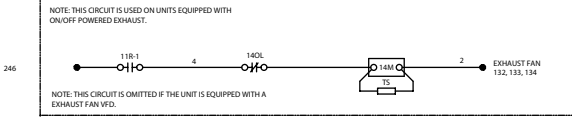
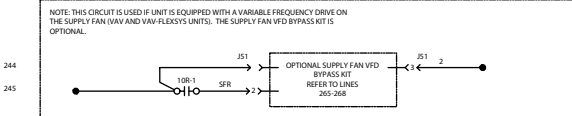
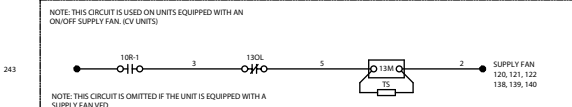
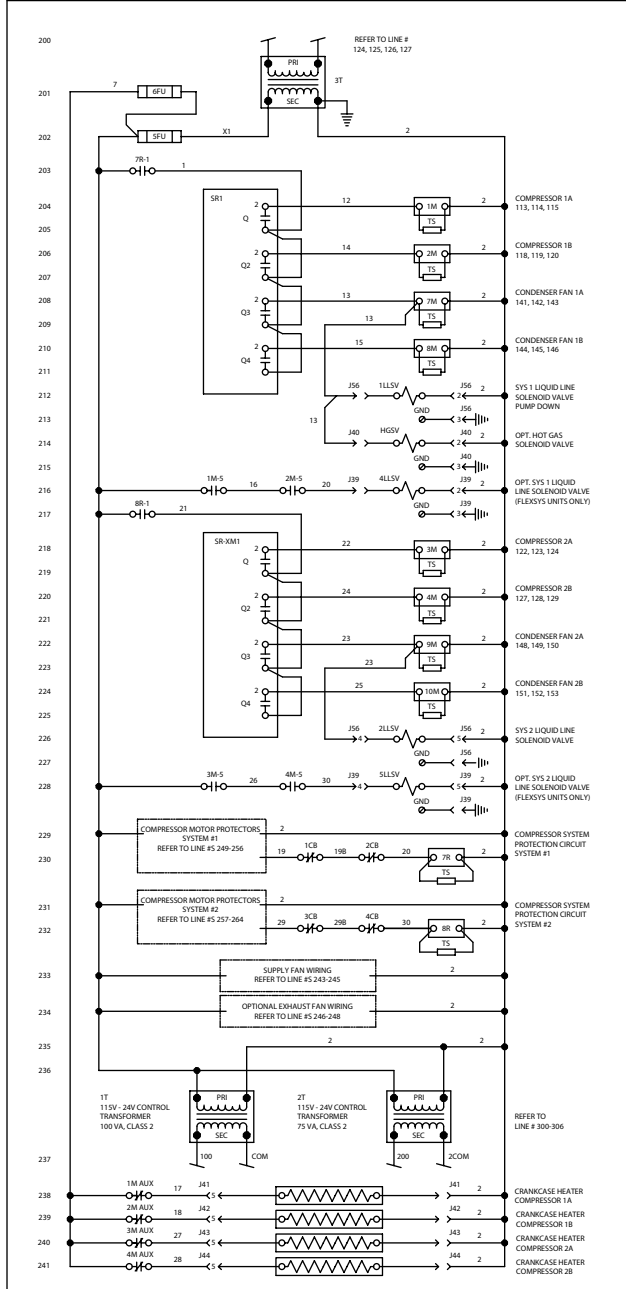

LD09837

ELEMENTARY DIAGRAM - YPAL MOD-C
CLASS 1 CONTROL
70-105 TON

035-13473-102
REV. A

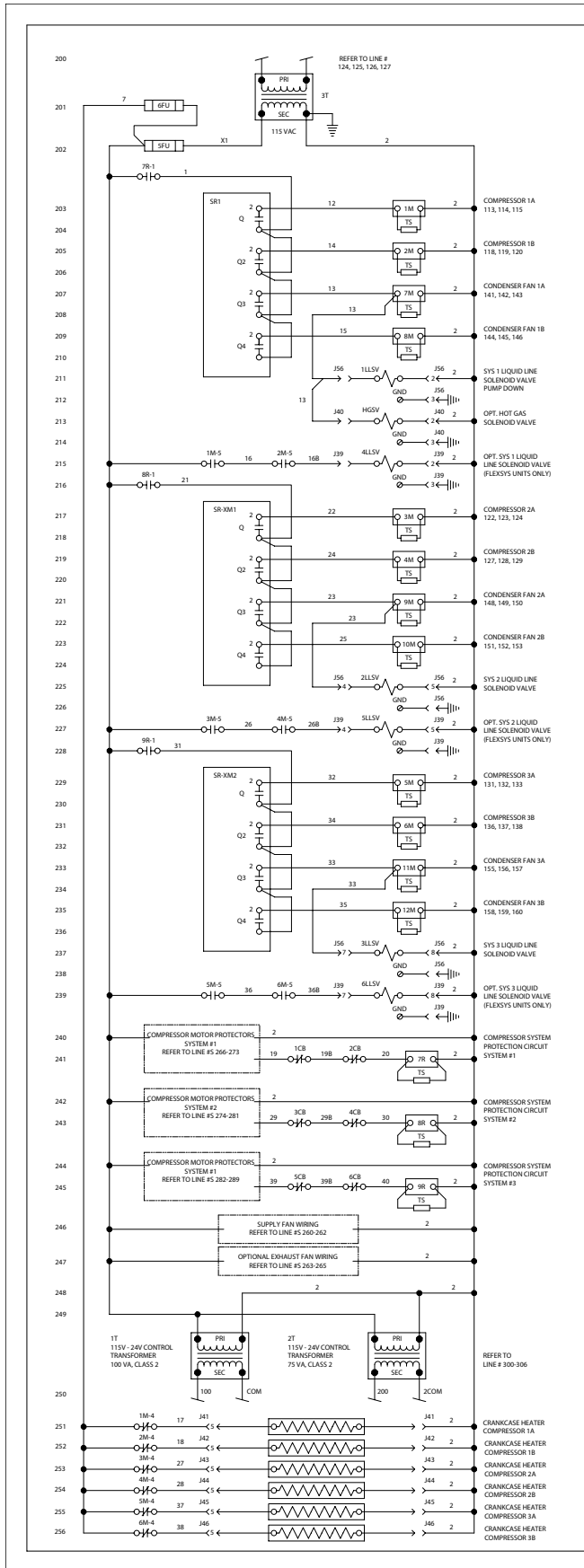

NOTE: THIS CIRCUIT IS USED ON UNITS EQUIPPED WITH AN ON/OFF SUPPLY FAN. (CV UNITS)



NOTE: THIS CIRCUIT IS OMITTED IF THE UNIT IS EQUIPPED WITH A SUPPLY FAN VFD.

NOTE: THIS CIRCUIT IS USED IF UNIT IS EQUIPPED WITH A VARIABLE FREQUENCY DRIVE ON THE SUPPLY FAN (VAV AND VAV FLEXSYS UNITS). THE SUPPLY FAN VFD BYPASS KIT IS OPTIONAL.

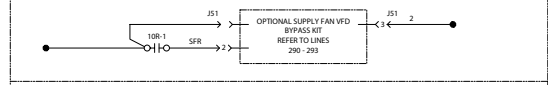

NOTE: THIS CIRCUIT IS USED ON UNITS EQUIPPED WITH ON/OFF POWERED EXHAUST.

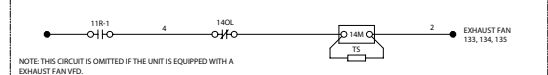

NOTE: THIS CIRCUIT IS OMITTED IF THE UNIT IS EQUIPPED WITH A EXHAUST FAN VFD.

NOTE: THIS CIRCUIT AND CAP 315 IS USED IF UNIT IS EQUIPPED WITH A POWERED EXHAUST FAN DRIVEN BY A VARIABLE FREQUENCY DRIVE. THE EXHAUST FAN VFD BYPASS KIT IS OPTIONAL.

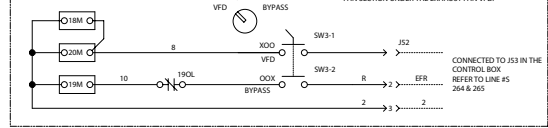
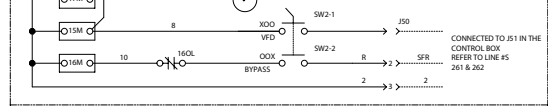
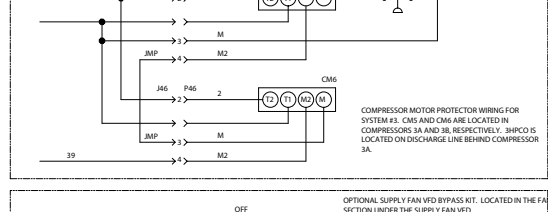
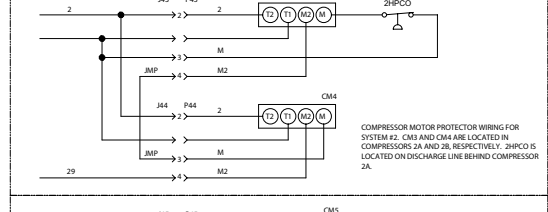
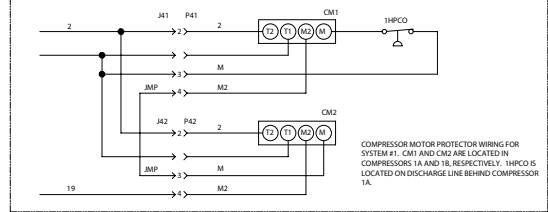

LD09839

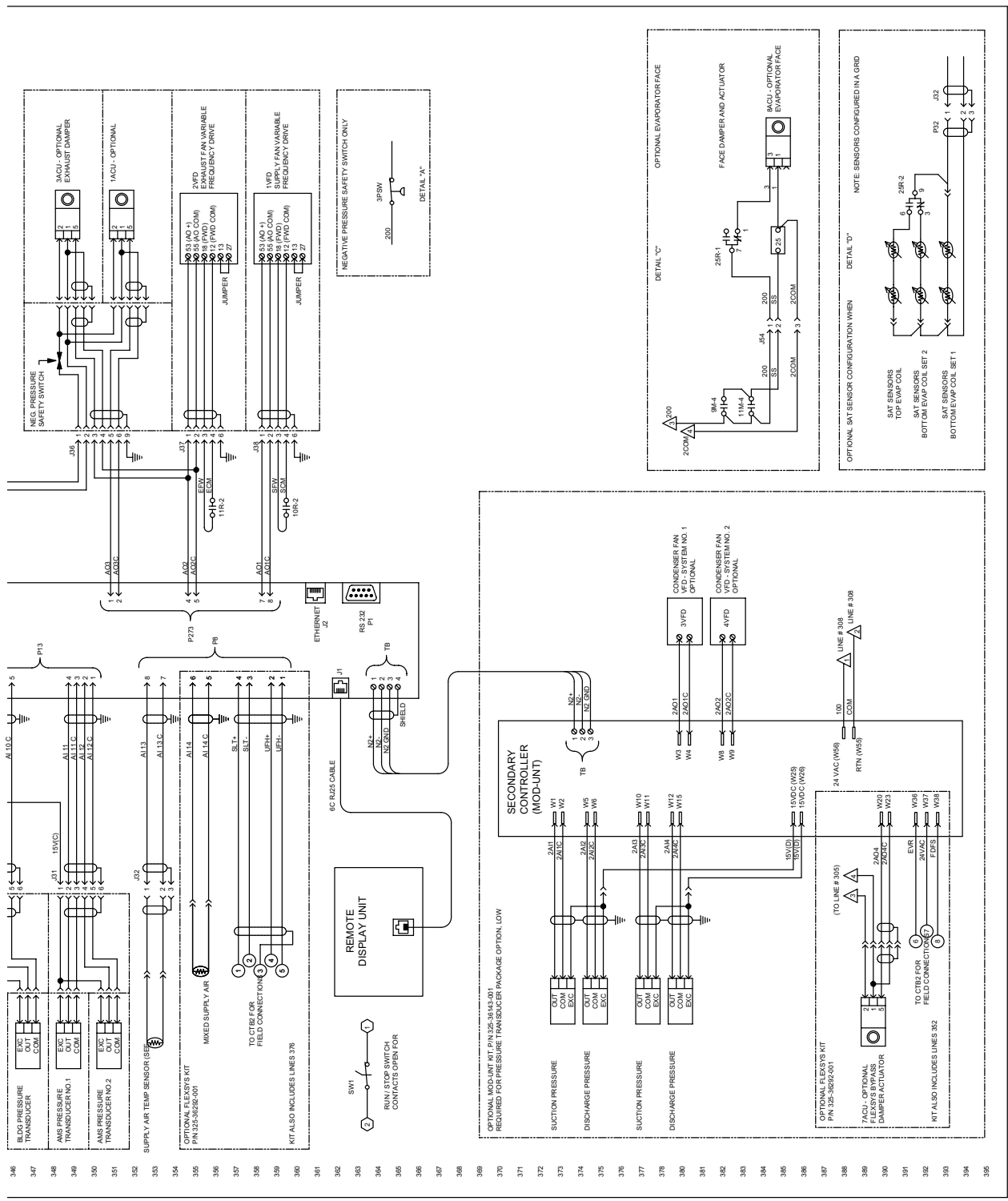

346
347
348
349
350
351
352
353
354
355
356
357
358
359
360
361
362
363
364
365
366
367
368
369
370
371
372
373
374
375
376
377
378
379
380
381
382
383
384
385
386
387
388
389
390
391
392
393
394
395

LD09840C

035-13474-111
REV. B

ELEMENTARY DIAGRAM - YPAL MOD-C
CLASS 2 CONTROL w/ RETURN FAN
50-65 TON

LEGEND

- ⊕ CTB1 CONTROL TERMINAL BLOCK FOR CUSTOMER CONNECTION
- ⊕ CTB2 OPTIONAL FLEXIBLE CONTROL CONNECTION
- ⊕ CTB3 BS46C COMMON BUS CONTROL TERMINAL BLOCK FOR FIELD CONNECTIONS (NOT FOR BS43, USE !!!)

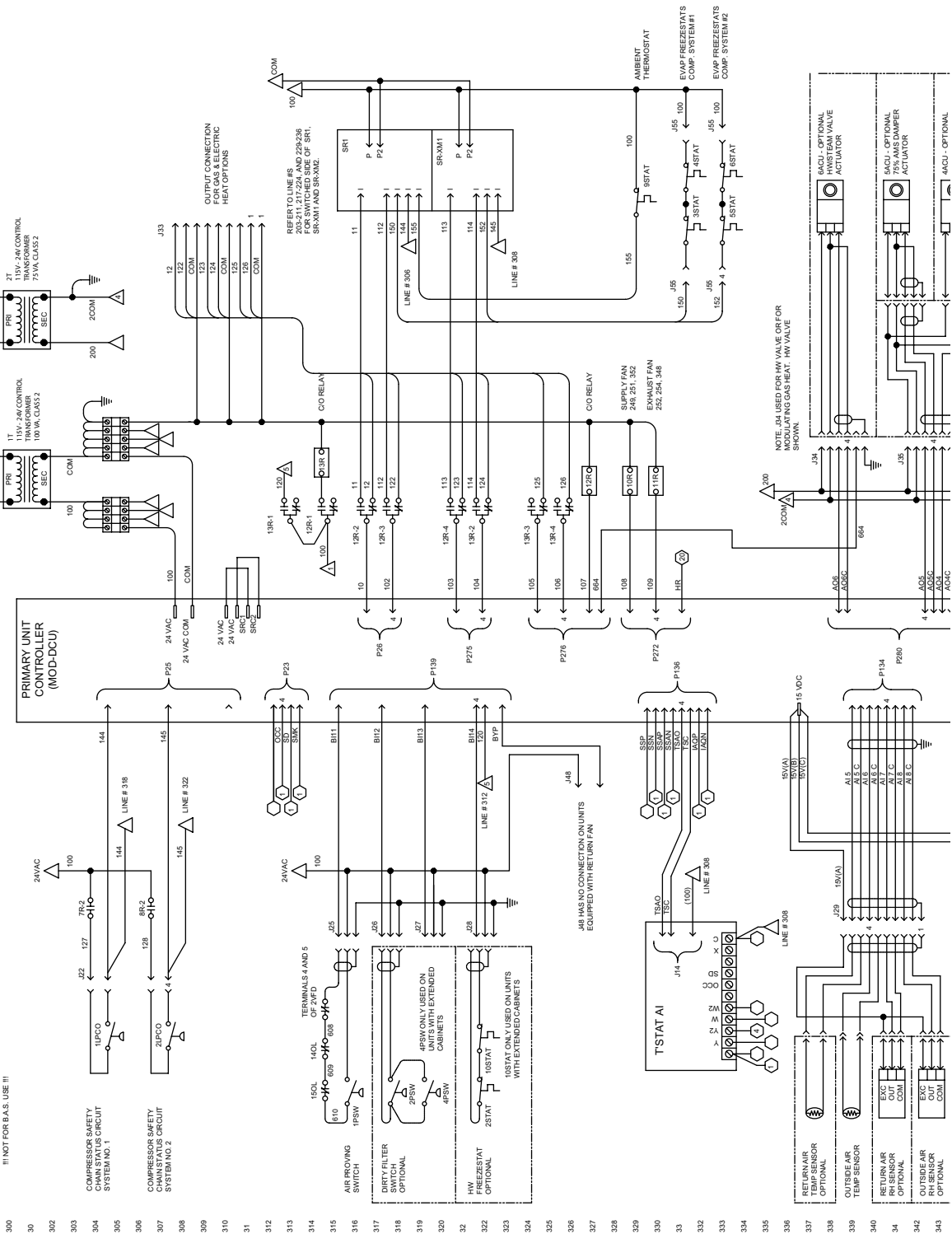

300
30
302
303
304
305
306
307
308
309
310
311
312
313
314
315
316
317
318
319
320
32
322
323
324
325
326
327
328
329
330
33
332
333
334
335
336
337
338
339
34
342
343

LD09841B

035-13474-102
REV. B

ELEMENTARY DIAGRAM - YPAL MOD-C
CLASS 2 CONTROL
70-105 TON

LEGEND

- ⊕ CTR CONTROL TERMINAL BLOCK FOR CUSTOMER CONNECTION
- ⊖ CTRB OPTIONAL FLEXTYS CONTROL TERMINAL BLOCK FOR FIELD CONNECTION
- ⊕ CTRB FLEXICOM UNIT CONTROL TERMINAL BLOCK FOR FIELD CONNECTIONS
- ⊖ NOT FOR E.A.S. USE

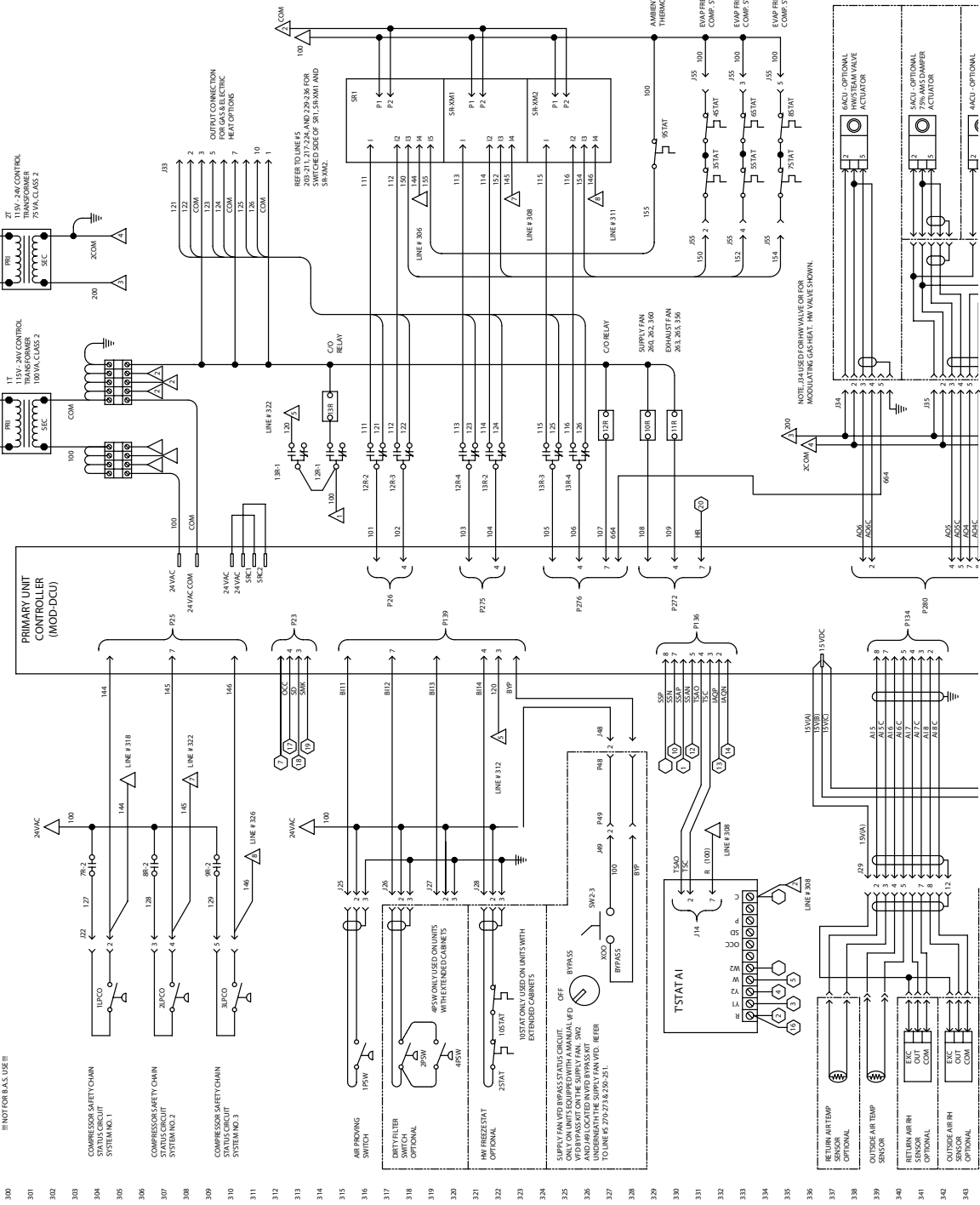

LD09842B

035-13474-112 REV. B
ELEMENTARY DIAGRAM - YPAL MOD-C
CLASS 2 CONTROL w/ RETURN FAN
70-105 TON

- LEGEND**
- ⊕ CBL CONTROL TERMINAL BLOCK FOR CUSTOMER CONNECTION
 - ⊙ CBL CONTROL TERMINAL BLOCK FOR RELAY CONNECTION
 - ⊕ CBL CONTROL TERMINAL BLOCK FOR FIELD CONNECTIONS # NOT FOR B.A.S. USE !!

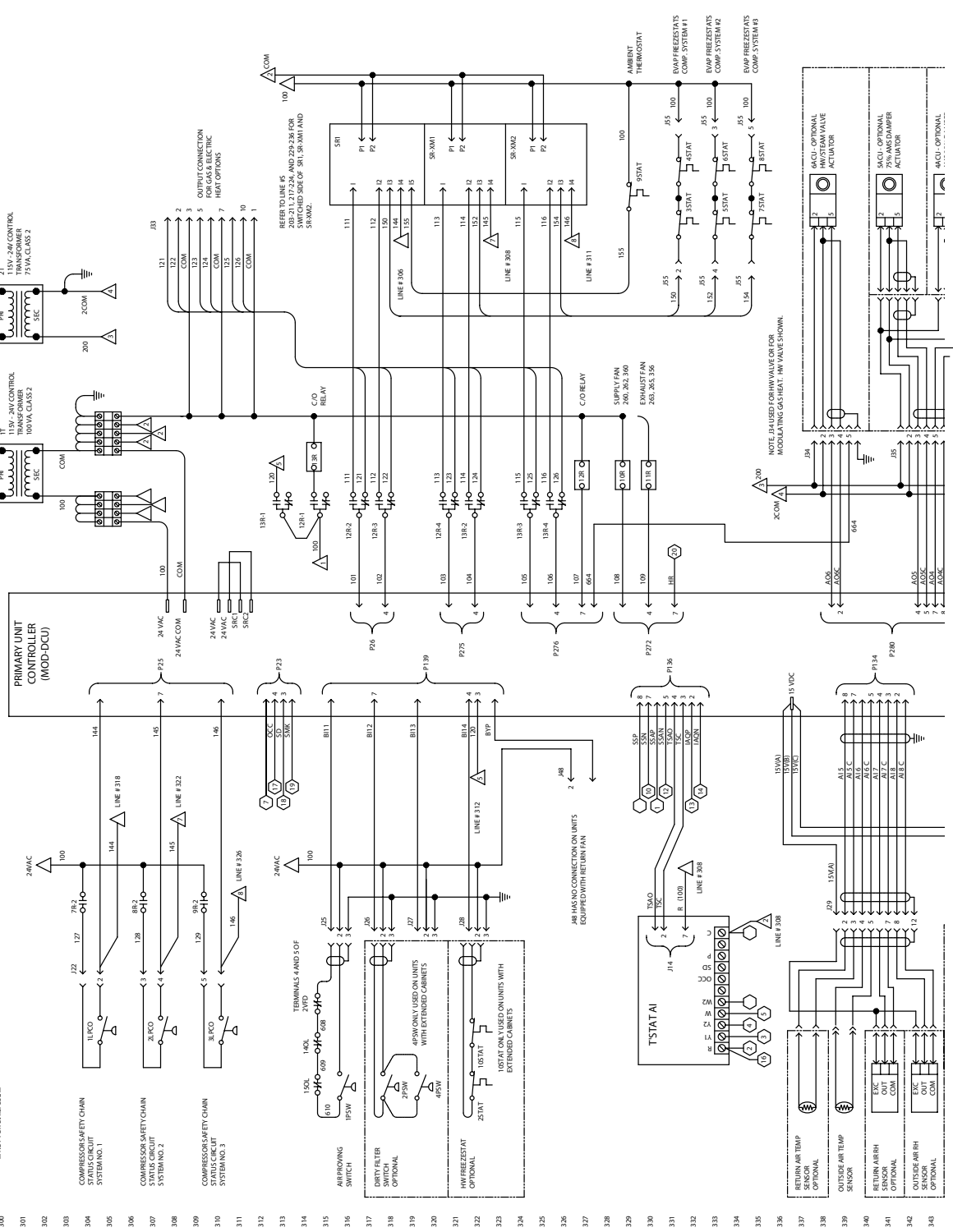

LD09843B

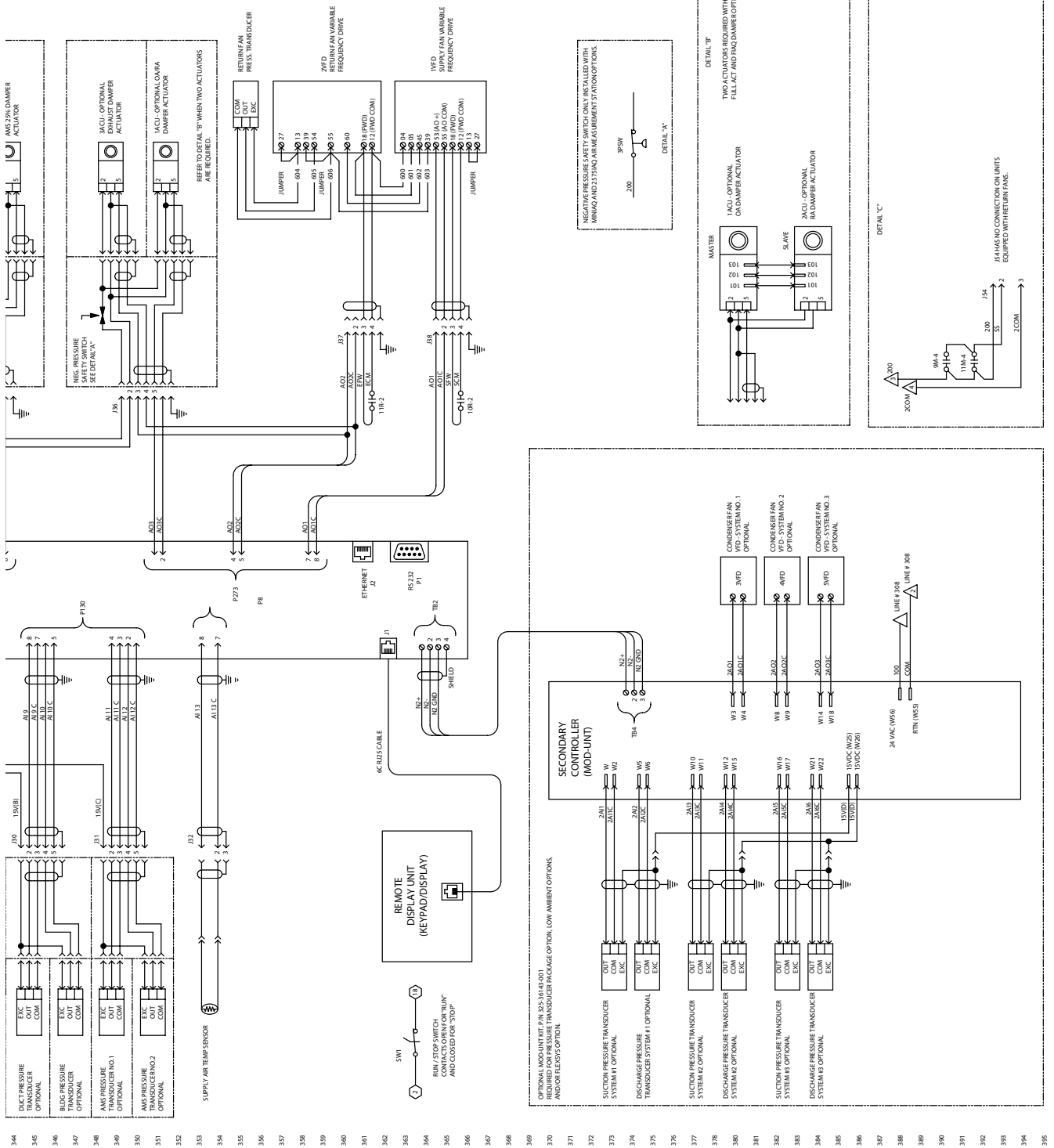

344
345
346
347
348
349
350
351
352
353
354
355
356
357
358
359
360
361
362
363
364
365
366
367
368
369
370
371
372
373
374
375
376
377
378
380
381
382
383
384
385
386
387
388
389
390
391
392
393
394
395

**YPAL COMPONENT MAP
POWER PANEL, 50-65 TON
MOD C**

035-13475-101
REV. -

LOCATION	WIRE NO.	LOCATION
1	101	1
2	102	2
3	103	3
4	104	4
5	105	5
6	106	6
7	107	7
8	108	8
9	109	9
10	110	10

LOCATION	WIRE NO.	LOCATION
1	101	1
2	102	2
3	103	3
4	104	4
5	105	5
6	106	6
7	107	7
8	108	8
9	109	9
10	110	10

LOCATION	WIRE NO.	LOCATION
1	101	1
2	102	2
3	103	3
4	104	4
5	105	5
6	106	6
7	107	7
8	108	8
9	109	9
10	110	10

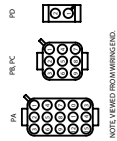

NOTE: WIRE NO. FROM WIRING END.

NOTE:
1. AT 480V, 3PH, 3W, 3WY, 480V AND 337V UNITS WITH GAS
TRANSFORMER, THE PRIMARY WIRE MUST BE CONNECTED TO THE
2. AT 240V AND 180V, ARE ONLY REQUIRED FOR OPTIONAL CONVENIENCE OUTLET.

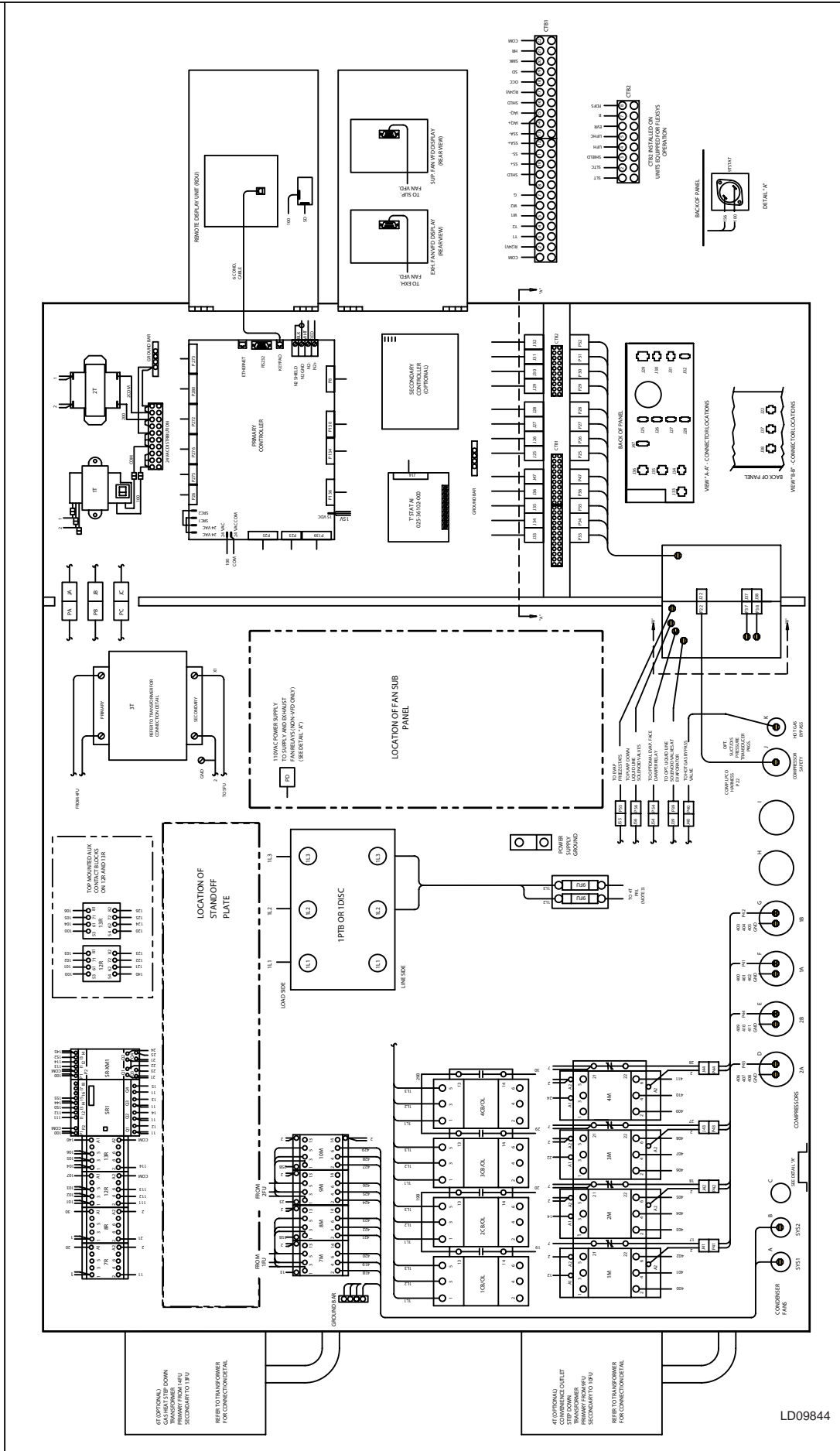

LD09844

035-13475-102
REV. -

YPAL COMPONENT MAP
POWER PANEL, 70-85 TON
MOD C

PLUGGING	WIRE NO.	POSITION
PA	1	2
PC	3	2

PLUGGING	WIRE NO.	POSITION
PA	109	2
PC	108	2
PC	104	3
PC	103	3
PC	102	3
PC	101	3

PLUGGING	WIRE NO.	POSITION
PA	108	2
PC	104	3
PC	103	3
PC	102	3
PC	101	3

PLUGGING	WIRE NO.	POSITION
PA	108	2
PC	104	3
PC	103	3
PC	102	3
PC	101	3

PLUGGING	WIRE NO.	POSITION
PA	108	2
PC	104	3
PC	103	3
PC	102	3
PC	101	3

PLUGGING	WIRE NO.	POSITION
PA	108	2
PC	104	3
PC	103	3
PC	102	3
PC	101	3

NOTE: ONLY REQUIRED ON 400V, 50, 60HZ AND 230V UNIT WITH GAS
MATH AND 100V ARE ONLY REQUIRED FOR OPTIONAL CONVENIENCE OUTLET.
PA, PC AND 100V ARE ONLY REQUIRED FOR OPTIONAL CONVENIENCE OUTLET.

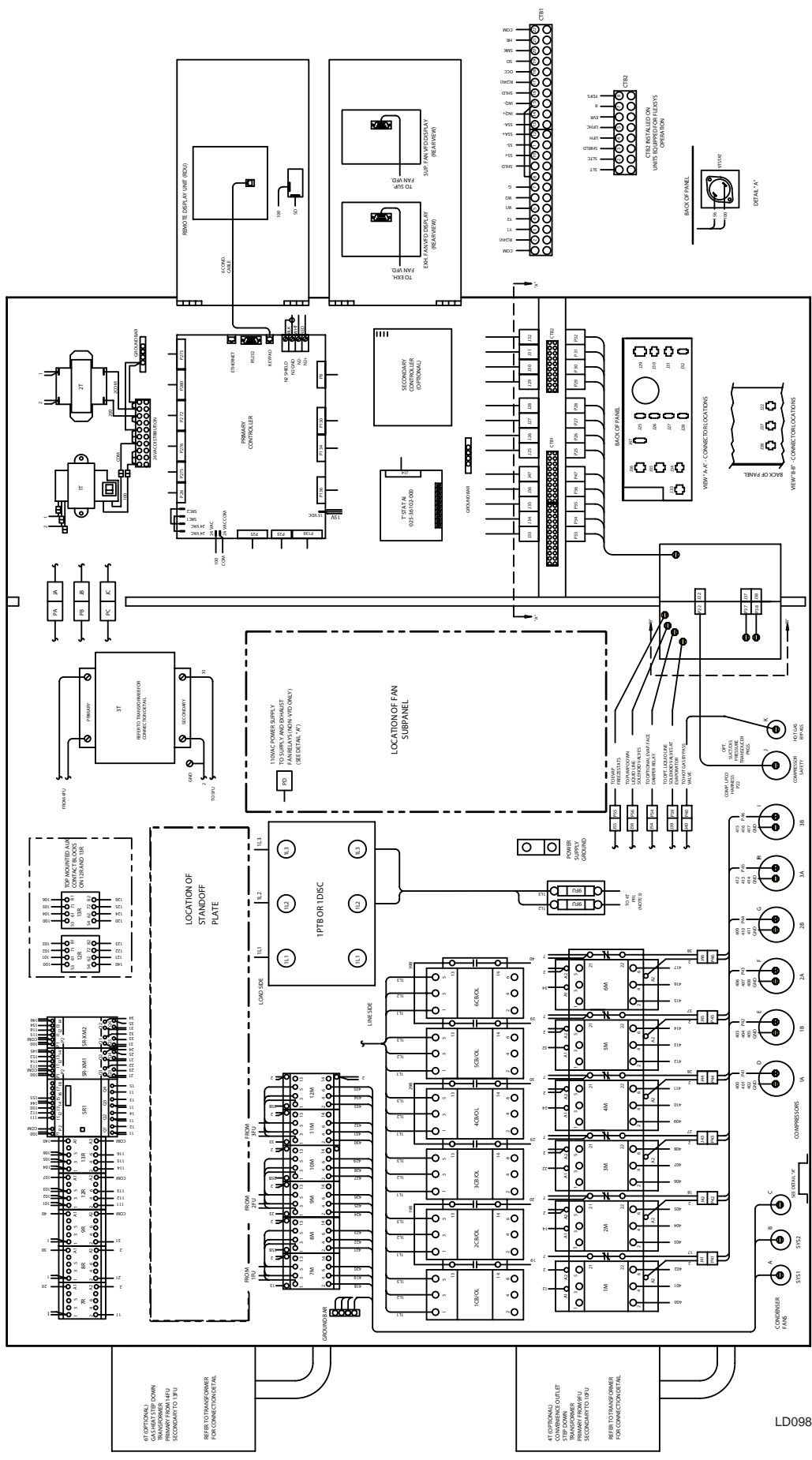

LD09846

035-13475-104
REV. A

**YPAL COMPONENT MAP
POWER PANEL, 70-105 TON
MOD C**

WIRING NO.	EXTENSION	LOCATION
1	1	1
2	1	1
3	1	1
4	1	1
5	1	1
6	1	1
7	1	1
8	1	1
9	1	1
10	1	1
11	1	1
12	1	1
13	1	1
14	1	1
15	1	1
16	1	1
17	1	1
18	1	1
19	1	1
20	1	1
21	1	1
22	1	1
23	1	1
24	1	1
25	1	1
26	1	1
27	1	1
28	1	1
29	1	1
30	1	1
31	1	1
32	1	1
33	1	1
34	1	1
35	1	1
36	1	1
37	1	1
38	1	1
39	1	1
40	1	1
41	1	1
42	1	1
43	1	1
44	1	1
45	1	1
46	1	1
47	1	1
48	1	1
49	1	1
50	1	1
51	1	1
52	1	1
53	1	1
54	1	1
55	1	1
56	1	1
57	1	1
58	1	1
59	1	1
60	1	1
61	1	1
62	1	1
63	1	1
64	1	1
65	1	1
66	1	1
67	1	1
68	1	1
69	1	1
70	1	1
71	1	1
72	1	1
73	1	1
74	1	1
75	1	1
76	1	1
77	1	1
78	1	1
79	1	1
80	1	1
81	1	1
82	1	1
83	1	1
84	1	1
85	1	1
86	1	1
87	1	1
88	1	1
89	1	1
90	1	1
91	1	1
92	1	1
93	1	1
94	1	1
95	1	1
96	1	1
97	1	1
98	1	1
99	1	1
100	1	1

WIRING NO.	EXTENSION	LOCATION
1	1	1
2	1	1
3	1	1
4	1	1
5	1	1
6	1	1
7	1	1
8	1	1
9	1	1
10	1	1
11	1	1
12	1	1
13	1	1
14	1	1
15	1	1
16	1	1
17	1	1
18	1	1
19	1	1
20	1	1
21	1	1
22	1	1
23	1	1
24	1	1
25	1	1
26	1	1
27	1	1
28	1	1
29	1	1
30	1	1
31	1	1
32	1	1
33	1	1
34	1	1
35	1	1
36	1	1
37	1	1
38	1	1
39	1	1
40	1	1
41	1	1
42	1	1
43	1	1
44	1	1
45	1	1
46	1	1
47	1	1
48	1	1
49	1	1
50	1	1
51	1	1
52	1	1
53	1	1
54	1	1
55	1	1
56	1	1
57	1	1
58	1	1
59	1	1
60	1	1
61	1	1
62	1	1
63	1	1
64	1	1
65	1	1
66	1	1
67	1	1
68	1	1
69	1	1
70	1	1
71	1	1
72	1	1
73	1	1
74	1	1
75	1	1
76	1	1
77	1	1
78	1	1
79	1	1
80	1	1
81	1	1
82	1	1
83	1	1
84	1	1
85	1	1
86	1	1
87	1	1
88	1	1
89	1	1
90	1	1
91	1	1
92	1	1
93	1	1
94	1	1
95	1	1
96	1	1
97	1	1
98	1	1
99	1	1
100	1	1

WIRING NO.	EXTENSION	LOCATION
1	1	1
2	1	1
3	1	1
4	1	1
5	1	1
6	1	1
7	1	1
8	1	1
9	1	1
10	1	1
11	1	1
12	1	1
13	1	1
14	1	1
15	1	1
16	1	1
17	1	1
18	1	1
19	1	1
20	1	1
21	1	1
22	1	1
23	1	1
24	1	1
25	1	1
26	1	1
27	1	1
28	1	1
29	1	1
30	1	1
31	1	1
32	1	1
33	1	1
34	1	1
35	1	1
36	1	1
37	1	1
38	1	1
39	1	1
40	1	1
41	1	1
42	1	1
43	1	1
44	1	1
45	1	1
46	1	1
47	1	1
48	1	1
49	1	1
50	1	1
51	1	1
52	1	1
53	1	1
54	1	1
55	1	1
56	1	1
57	1	1
58	1	1
59	1	1
60	1	1
61	1	1
62	1	1
63	1	1
64	1	1
65	1	1
66	1	1
67	1	1
68	1	1
69	1	1
70	1	1
71	1	1
72	1	1
73	1	1
74	1	1
75	1	1
76	1	1
77	1	1
78	1	1
79	1	1
80	1	1
81	1	1
82	1	1
83	1	1
84	1	1
85	1	1
86	1	1
87	1	1
88	1	1
89	1	1
90	1	1
91	1	1
92	1	1
93	1	1
94	1	1
95	1	1
96	1	1
97	1	1
98	1	1
99	1	1
100	1	1

WIRING NO.	EXTENSION	LOCATION
1	1	1
2	1	1
3	1	1
4	1	1
5	1	1
6	1	1
7	1	1
8	1	1
9	1	1
10	1	1
11	1	1
12	1	1
13	1	1
14	1	1
15	1	1
16	1	1
17	1	1
18	1	1
19	1	1
20	1	1
21	1	1
22	1	1
23	1	1
24	1	1
25	1	1
26	1	1
27	1	1
28	1	1
29	1	1
30	1	1
31	1	1
32	1	1
33	1	1
34	1	1
35	1	1
36	1	1
37	1	1
38	1	1
39	1	1
40	1	1
41	1	1
42	1	1
43	1	1
44	1	1
45	1	1
46	1	1
47	1	1
48	1	1
49	1	1
50	1	1
51	1	1
52	1	1
53	1	1
54	1	1
55	1	1
56	1	1
57	1	1
58	1	1
59	1	1
60	1	1
61	1	1
62	1	1
63	1	1
64	1	1
65	1	1
66	1	1
67	1	1
68	1	1
69	1	1
70	1	1
71	1	1
72	1	1
73	1	1
74	1	1
75	1	1
76	1	1
77	1	1
78	1	1
79	1	1
80	1	1
81	1	1
82	1	1
83	1	1
84	1	1
85	1	1
86	1	1
87	1	1
88	1	1
89	1	1
90	1	1
91	1	1
92	1	1
93	1	1
94	1	1
95	1	1
96	1	1
97	1	1
98	1	1
99	1	1
100	1	1

WIRING NO.	EXTENSION	LOCATION
1	1	1
2	1	1
3	1	1
4	1	1
5	1	1
6	1	1
7	1	1
8	1	1

NOTES:
 1. TYPICAL SHOWN, COMPONENT LOCATIONS AND SIZES MAY VARY SLIGHTLY BASED ON APPLICATION.
 2. REFER TO PANEL COMPONENT MAP FOR LOCATION OF FAN SUBPANEL.

**YPAL COMPONENT MAP
 CV FAN SUBPANEL**

**035-13465-002
 REV. -**

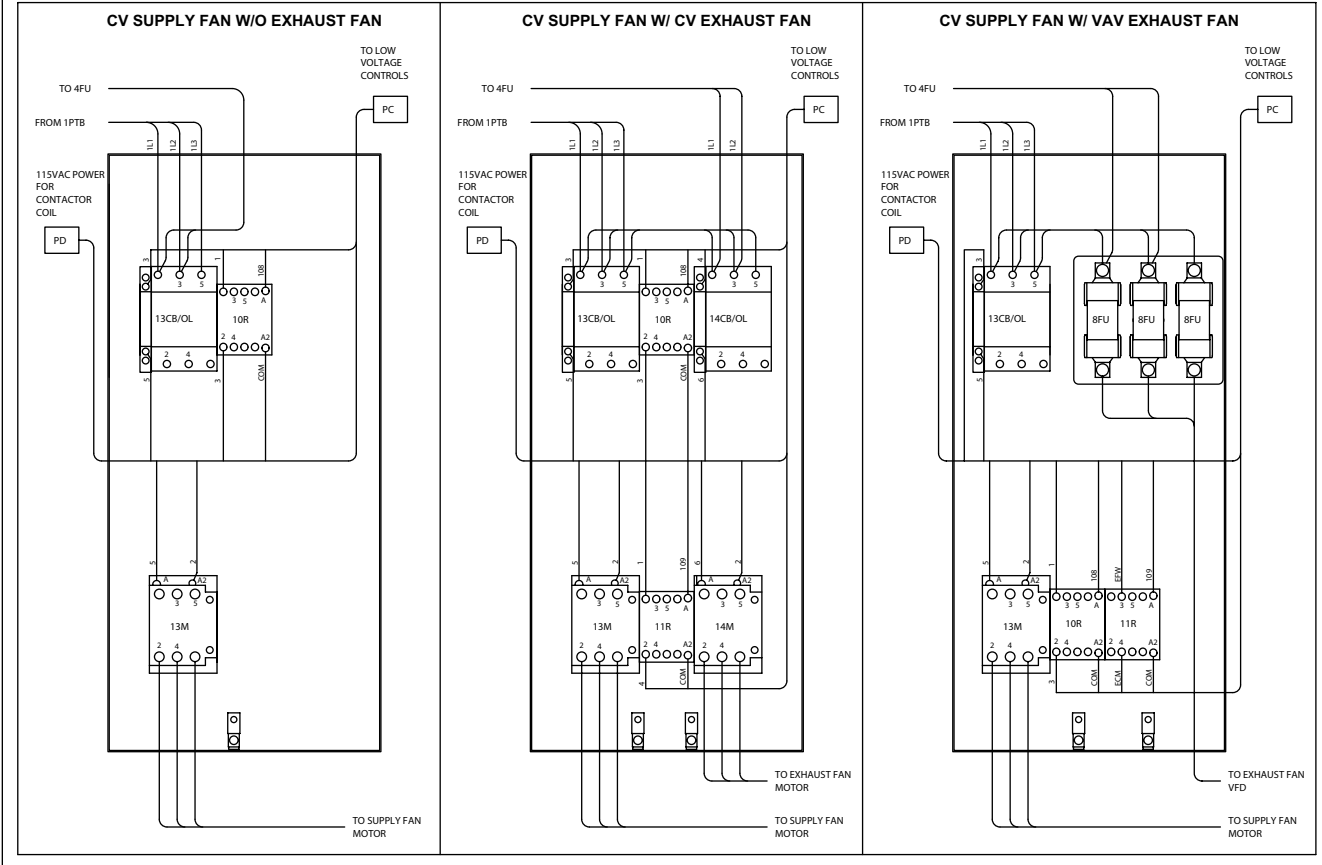

LD09848

NOTES:
 1. TYPICAL SHOWN. COMPONENT LOCATIONS AND SIZES MAY VARY SLIGHTLY BASED ON APPLICATION.
 2. REFER TO PANEL COMPONENT MAP FOR LOCATION OF FAN SUBPANEL.

**YPAL COMPONENT MAP
 CV FAN SUBPANEL**

**035-13465-003
 REV. -**

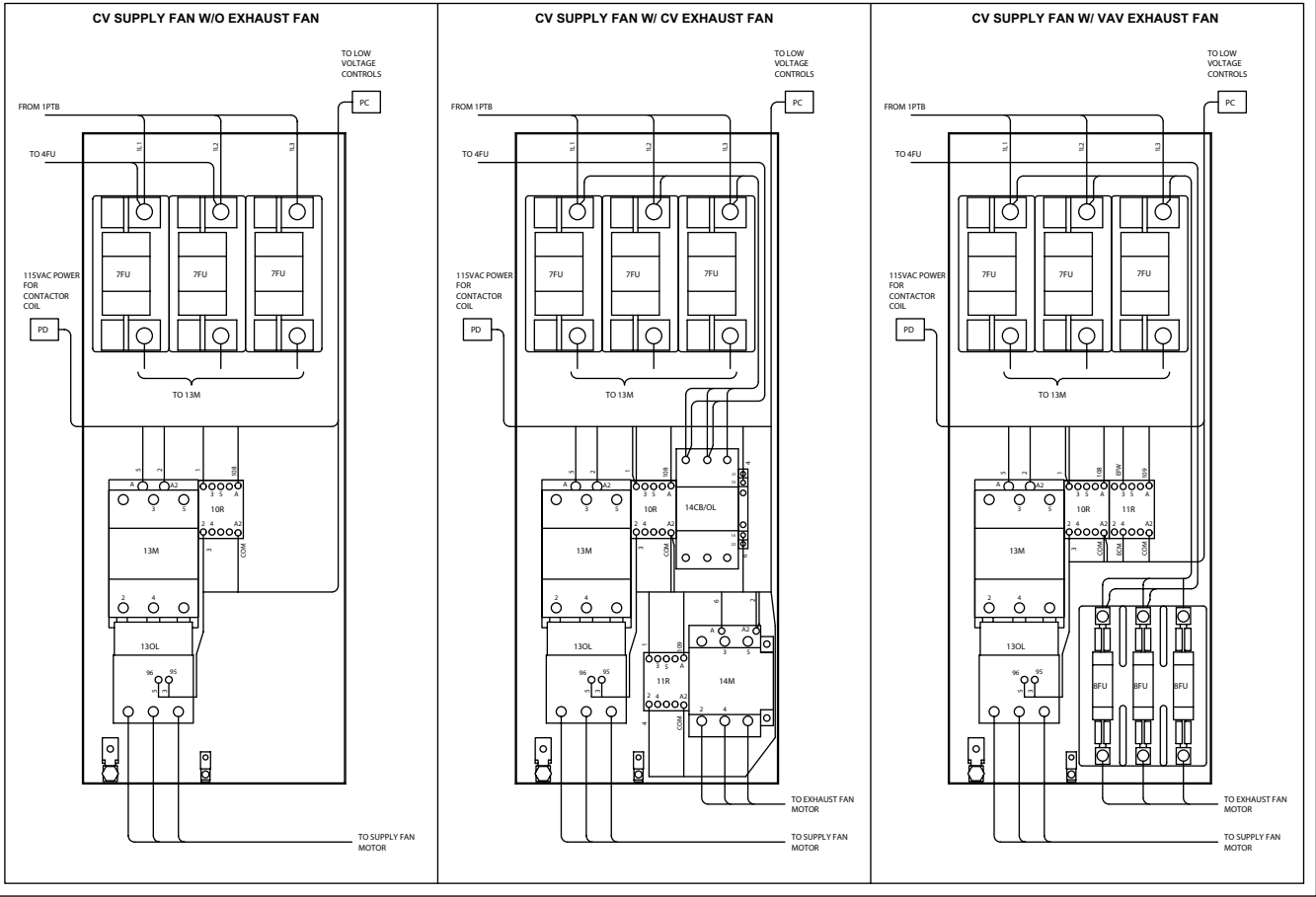

LD09849

NOTES:
 1. TYPICAL SHOWN, COMPONENT LOCATIONS AND SIZES MAY VARY SLIGHTLY BASED ON APPLICATION.
 2. REFER TO PANEL COMPONENT MAP FOR LOCATION OF FAN SUBPANEL.

**YPAL COMPONENT MAP
 CV FAN SUBPANEL**

**035-13465-005
 REV. -**

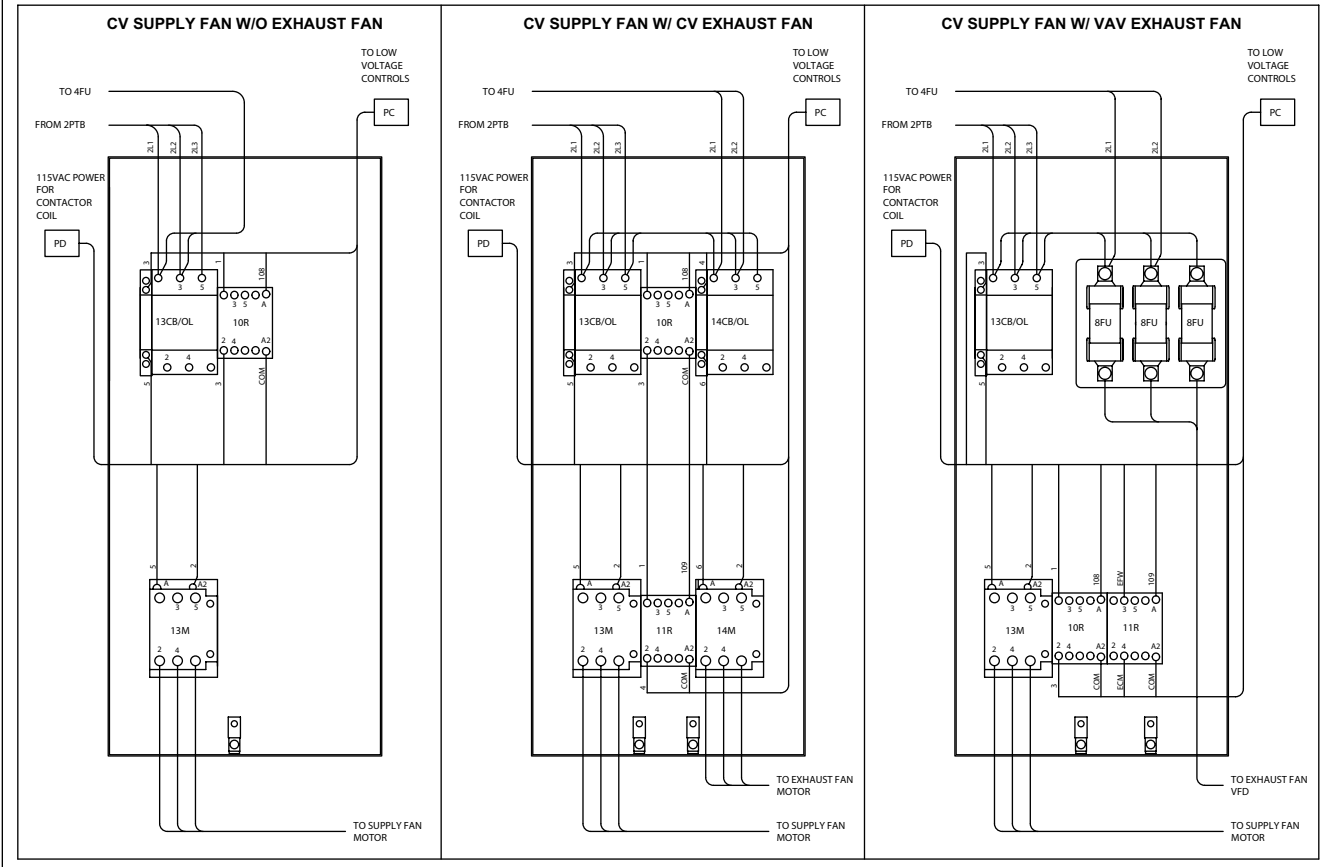

LD09850

NOTES:
 1. TYPICAL SHOWN, COMPONENT LOCATIONS AND SIZES MAY VARY SLIGHTLY BASED ON APPLICATION.
 2. REFER TO PANEL COMPONENT MAP FOR LOCATION OF FAN SUBPANEL.

**YPAL COMPONENT MAP
 CV FAN SUBPANEL**

**035-13465-006
 REV. -**

CV SUPPLY FAN W/O EXHAUST FAN

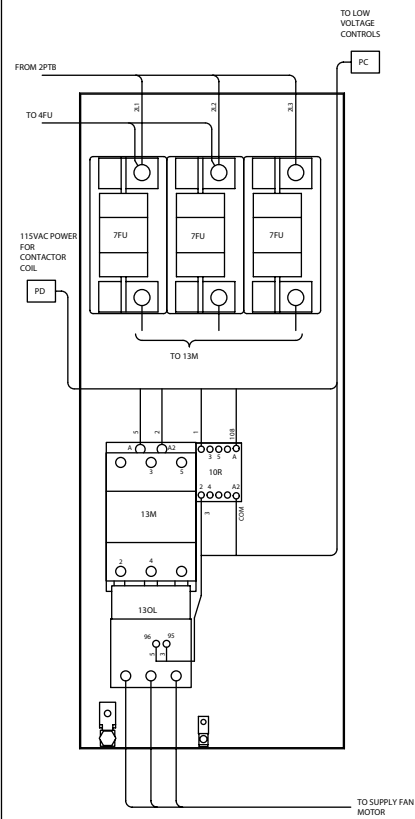

CV SUPPLY FAN W/ CV EXHAUST FAN

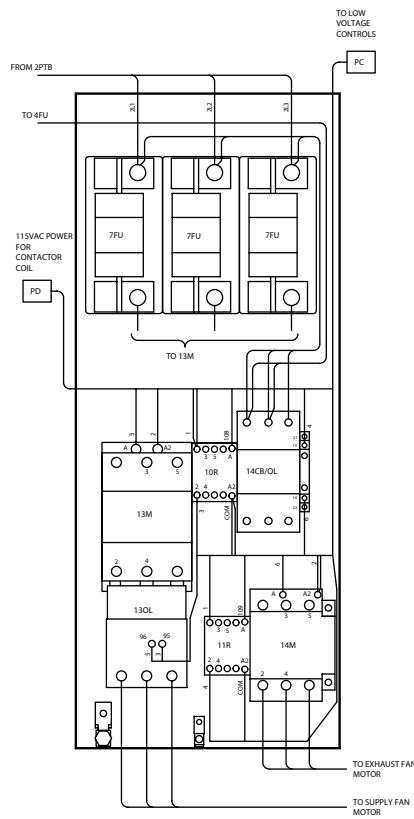

CV SUPPLY FAN W/ VAV EXHAUST FAN

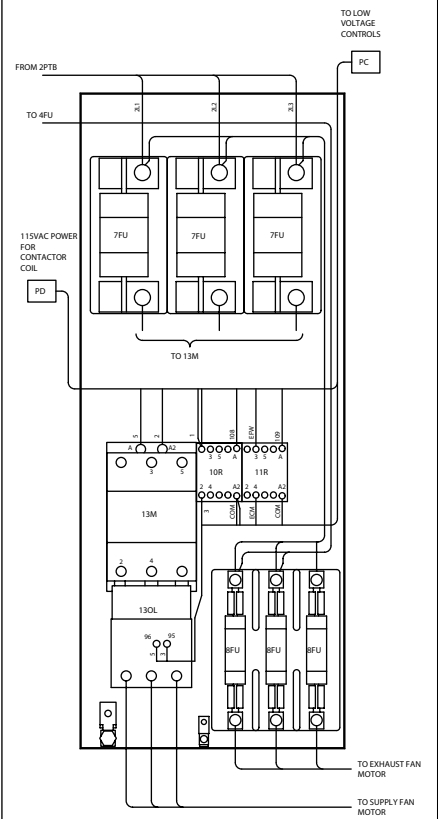

LD09851

NOTES:
 1. TYPICAL SHOWN, COMPONENT LOCATIONS AND SIZES MAY VARY SLIGHTLY BASED ON APPLICATION.
 2. REFER TO PANEL COMPONENT MAP FOR LOCATION OF FAN SUBPANEL.

**YPAL COMPONENT MAP
 VAV FAN SUBPANEL**

**035-13465-001
 REV. -**

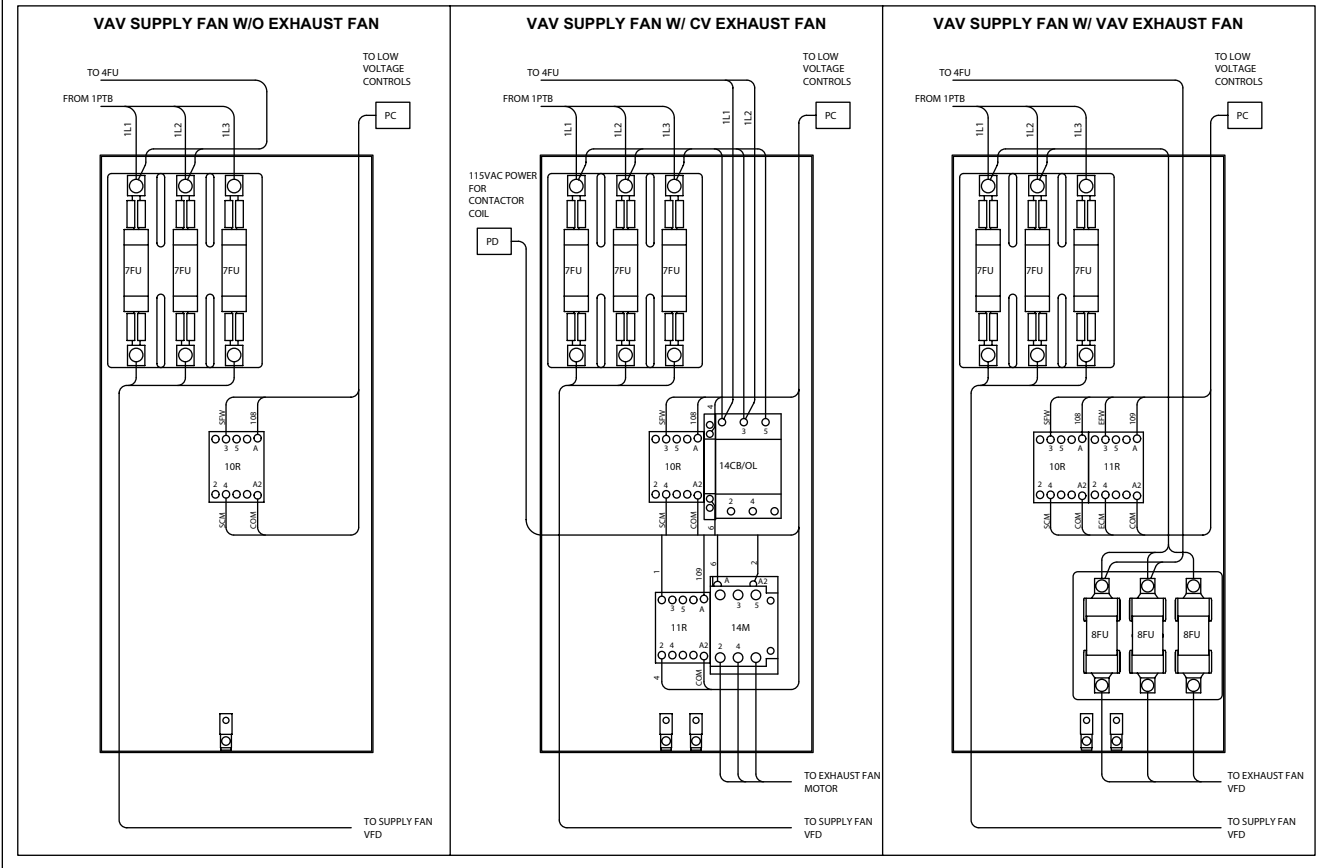

LD09852

NOTES:
 1. TYPICAL SHOWN. COMPONENT LOCATIONS AND SIZES MAY VARY SLIGHTLY BASED ON APPLICATION.
 2. REFER TO PANEL COMPONENT MAP FOR LOCATION OF FAN SUBPANEL.

**YPAL COMPONENT MAP
 VAV FAN SUBPANEL**

**035-13465-004
 REV. -**

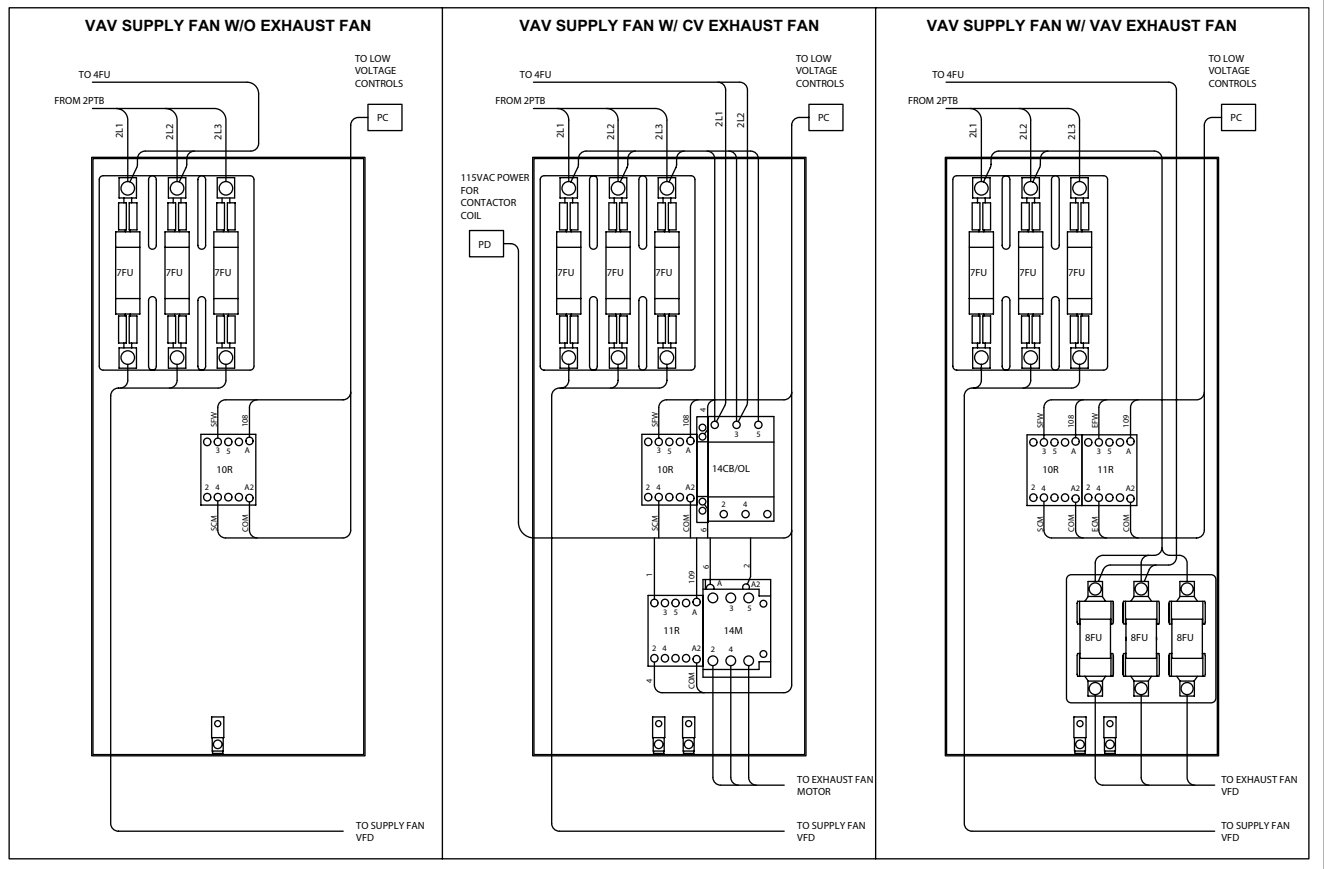

LD09853

035-13466-001
REV. A

- NOTES:
 1. TYPICAL SHOWN, COMPONENT LOCATIONS AND SIZES MAY VARY SLIGHTLY BASED ON APPLICATION.
 2. REFER TO PANEL COMPONENT MAP FOR LOCATION OF FUSE STANDOFF PLATE.
 3. 10FU ONLY REQUIRED ON UNITS WITH A CONVENIENCE OUTLET.

**YPAL COMPONENT MAP
FUSE STANDOFF PLATE**

**FUSE STANDOFF PLATE
UNITS W/O GAS HEAT**

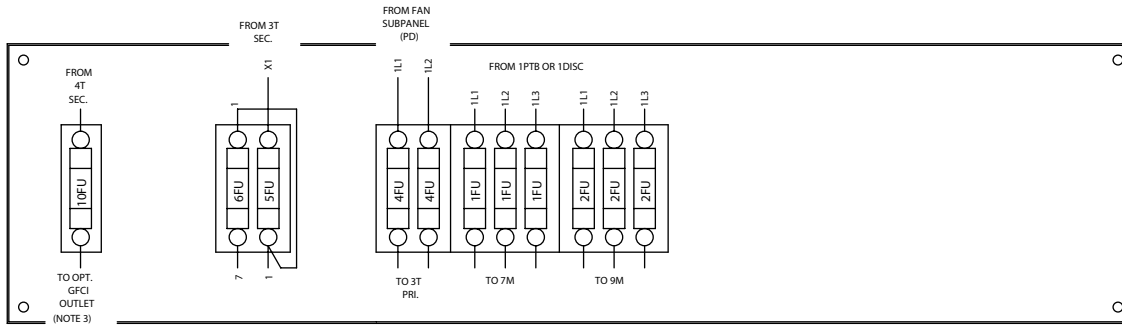

**FUSE STANDOFF PLATE
200V AND 230V UNITS W/ GAS HEAT**

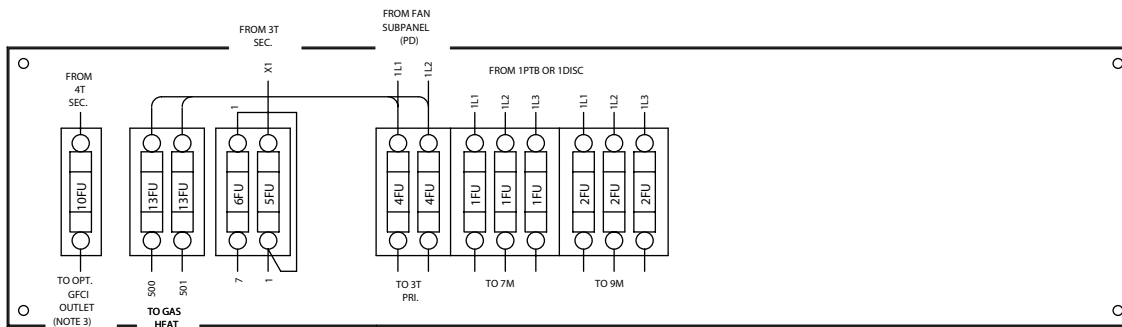

**FUSE STANDOFF PLATE
380V-60, 400V-50, 460V AND 575V UNITS W/ GAS HEAT**

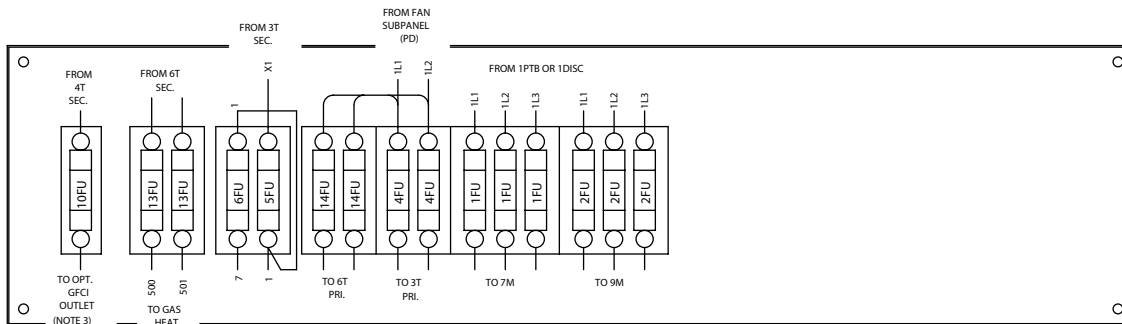

LD09854

- NOTES:
 1. TYPICAL SHOWN, COMPONENT LOCATIONS AND SIZES MAY VARY SLIGHTLY BASED ON APPLICATION.
 2. REFER TO PANEL COMPONENT MAP FOR LOCATION OF FUSE STANDOFF PLATE.
 3. 10FU ONLY REQUIRED ON UNITS WITH A CONVENIENCE OUTLET.

YPAL COMPONENT MAP FUSE STANDOFF PLATE

**035-13466-002
 REV. A**

FUSE STANDOFF PLATE UNITS W/O GAS HEAT

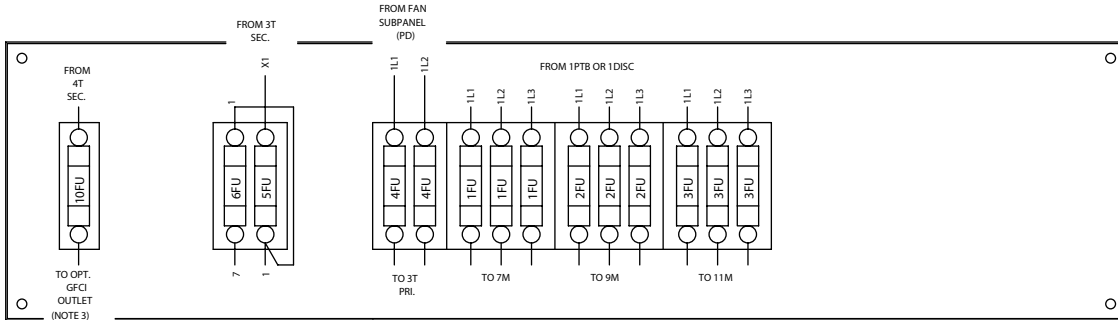

FUSE STANDOFF PLATE 200V AND 230V UNITS W/ GAS HEAT

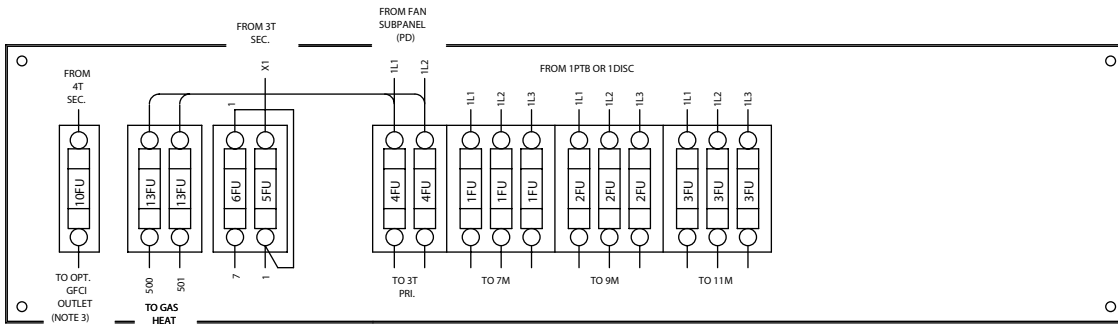

FUSE STANDOFF PLATE 380V-60, 400V-50, 460V AND 575V UNITS W/ GAS HEAT

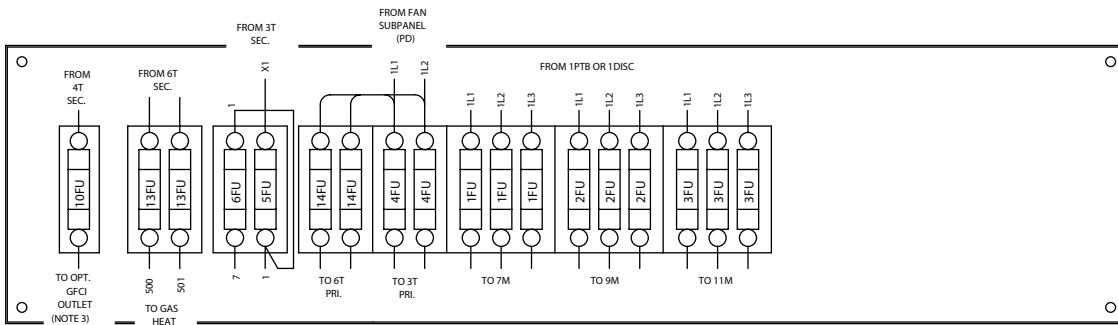

LD09855

NOTES:

1. TYPICAL SHOWN, COMPONENT LOCATIONS AND SIZES MAY VARY SLIGHTLY BASED ON APPLICATION.
2. REFER TO PANEL COMPONENT MAP FOR LOCATION OF FUSE STANDOFF PLATE.
3. 10FU ONLY REQUIRED ON UNITS WITH A CONVENIENCE OUTLET.

**YPAL COMPONENT MAP
FUSE STANDOFF PLATE**

**035-13466-003
REV. A**

**FUSE STANDOFF PLATE
UNITS W/O GAS HEAT**

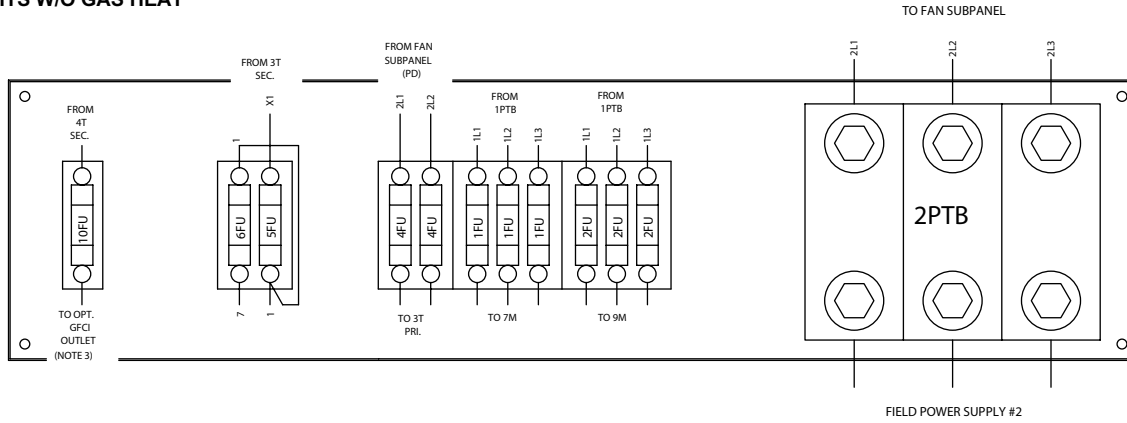

**FUSE STANDOFF PLATE
200V AND 230V UNITS W/ GAS HEAT**

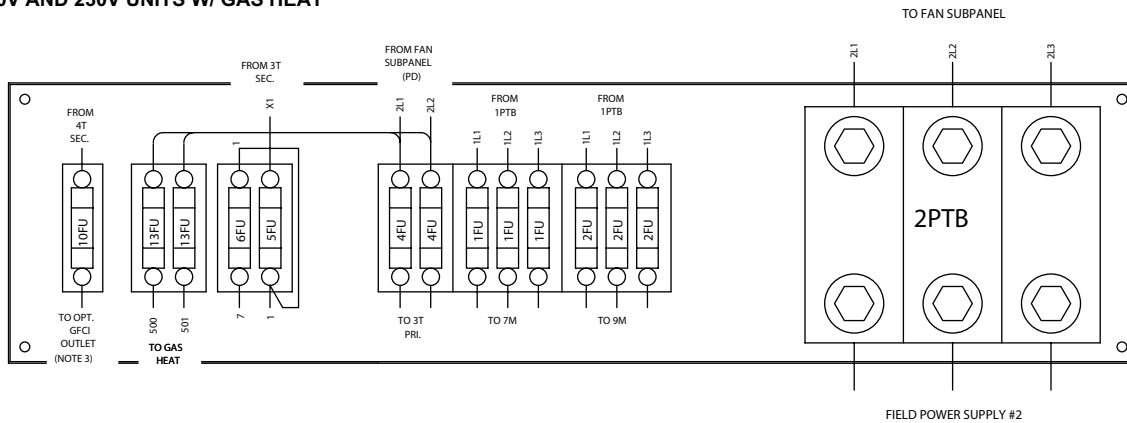

**FUSE STANDOFF PLATE
380V-60, 400V-50, 460V AND 575V UNITS W/ GAS HEAT**

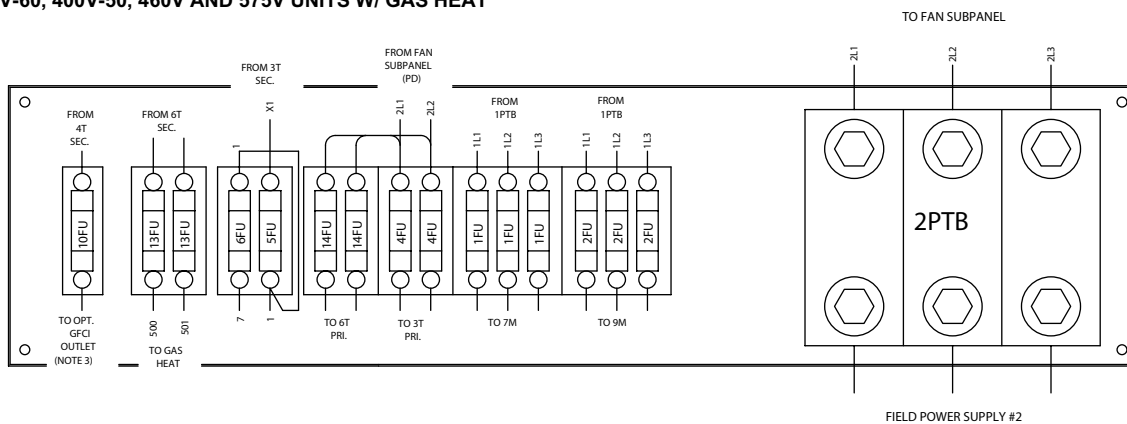

LD09856

NOTES:
 1. TYPICAL SHOWN. COMPONENT LOCATIONS AND SIZES MAY VARY SLIGHTLY BASED ON APPLICATION.
 2. REFER TO PANEL COMPONENT MAP FOR LOCATION OF FUSE STANDOFF

**YPAL COMPONENT MAP
 FUSE STANDOFF PLATE**

**035-13466-004
 REV. A**

**FUSE STANDOFF PLATE
 UNITS W/O GAS HEAT**

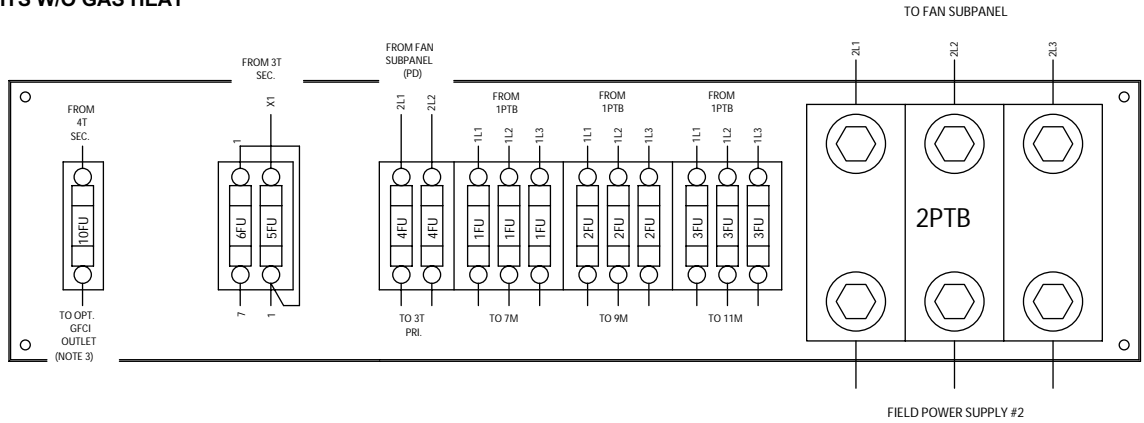

**FUSE STANDOFF PLATE
 200V AND 230V UNITS W/ GAS HEAT**

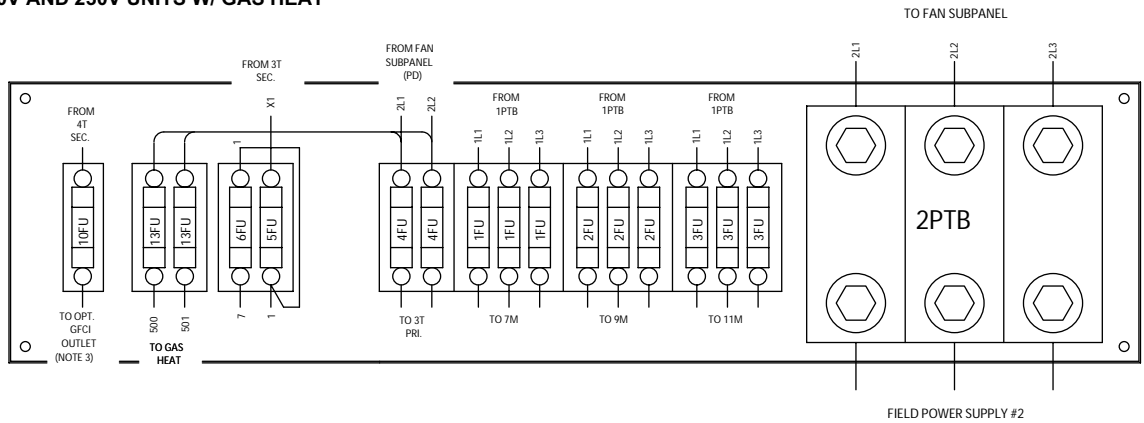

**FUSE STANDOFF PLATE
 380V-60, 400V-50, 460V AND 575V UNITS W/ GAS HEAT**

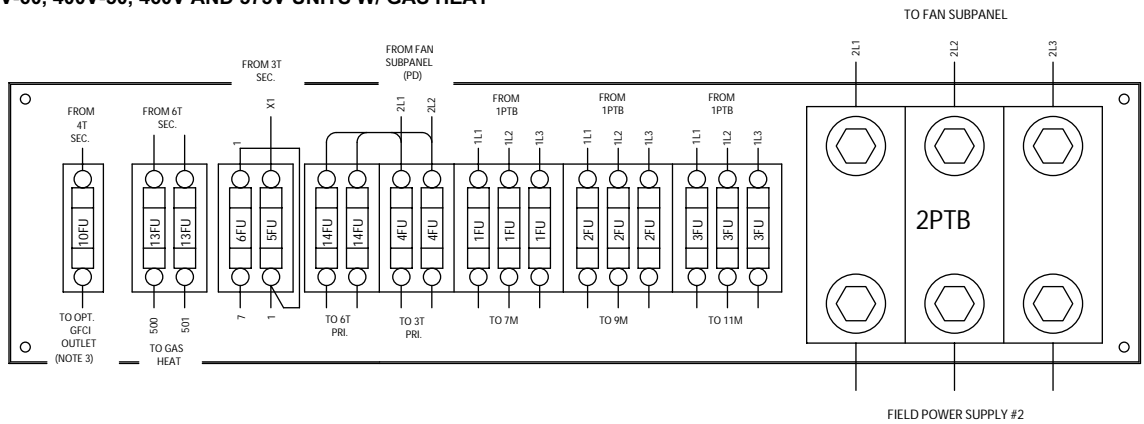

LD09857

ELEMENTARY DIAGRAM YPAL (GAS HEAT OPTION)

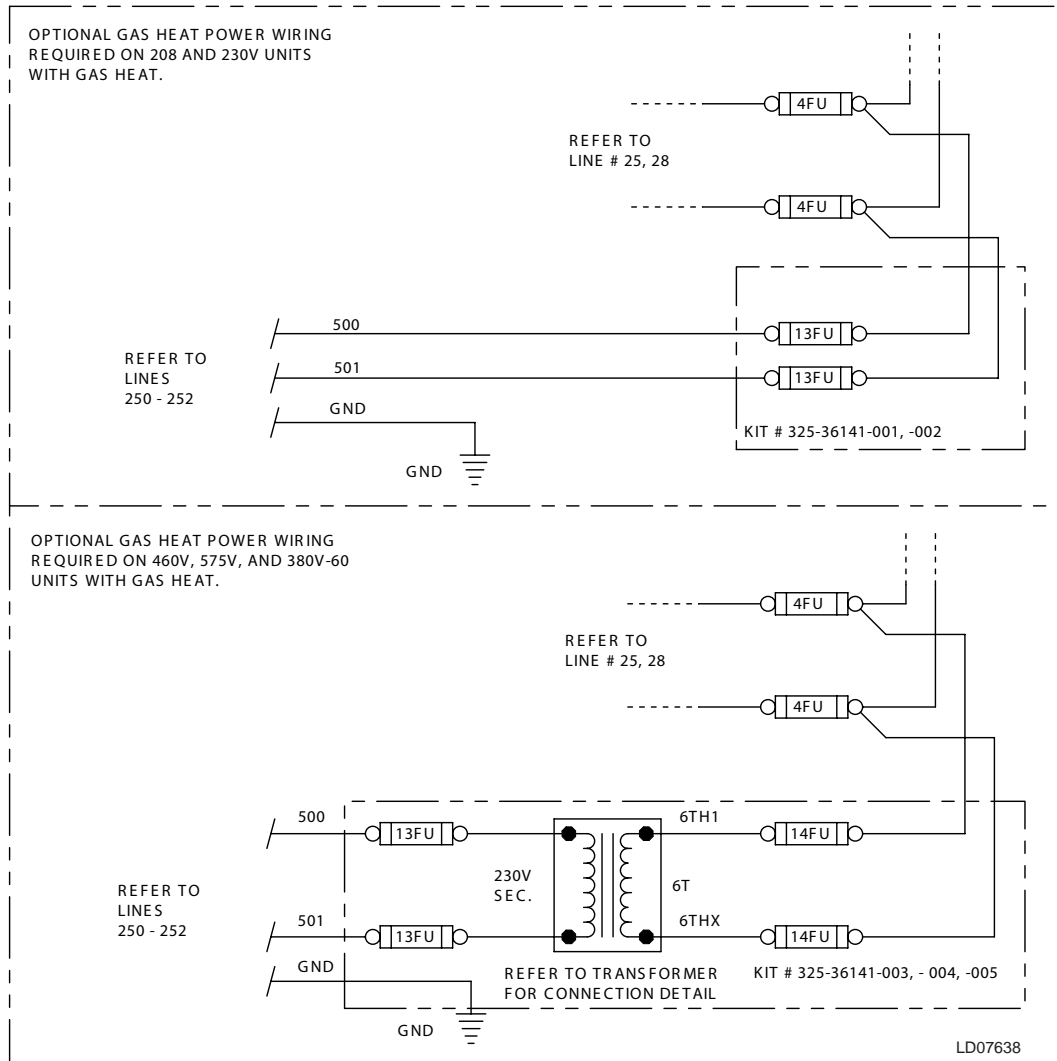

ELEMENTARY DIAGRAM YPAL GAS HEAT CONTROLS

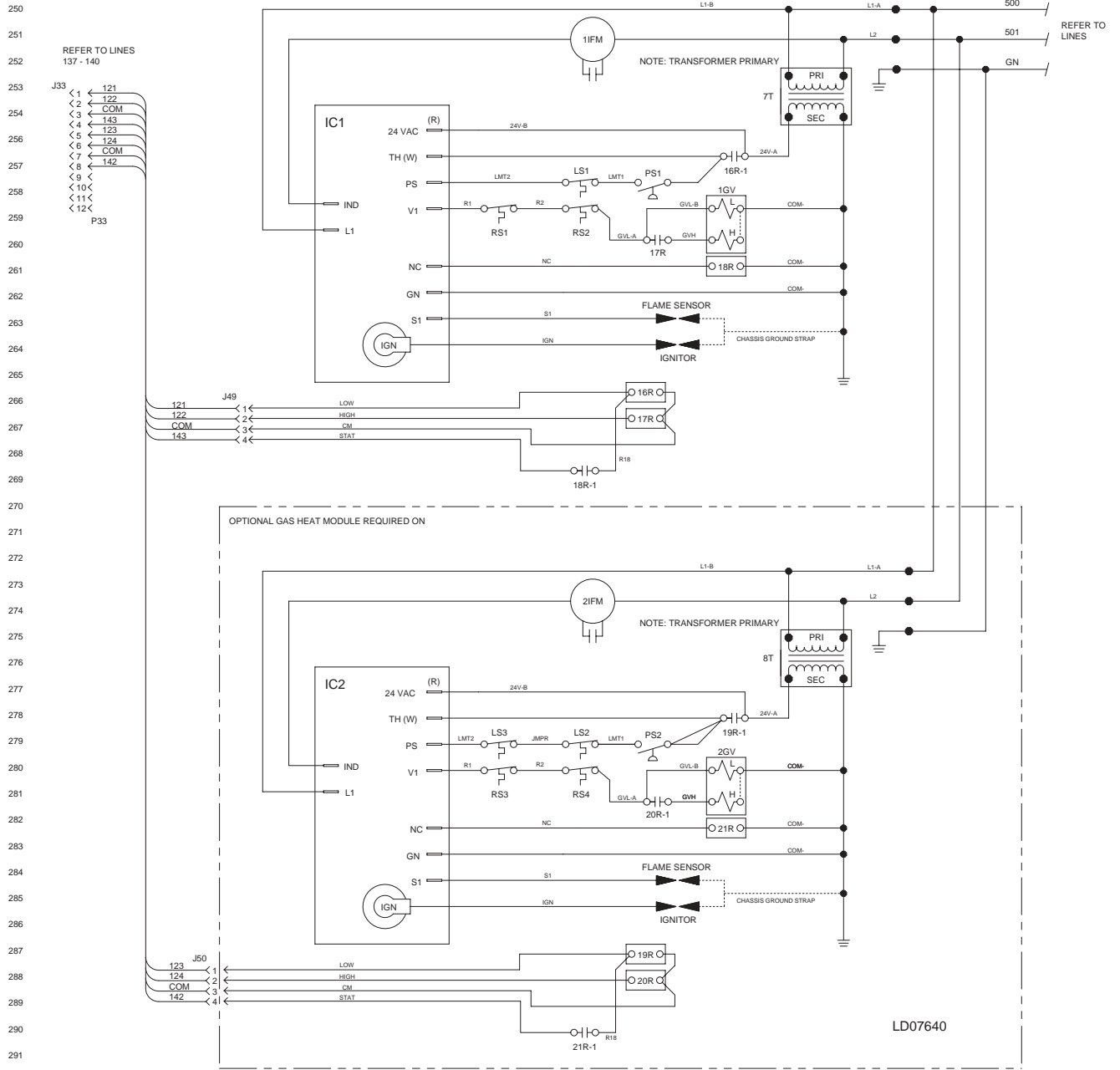

ELEMENTARY DIAGRAM YPAL GAS HEAT CONTROLS

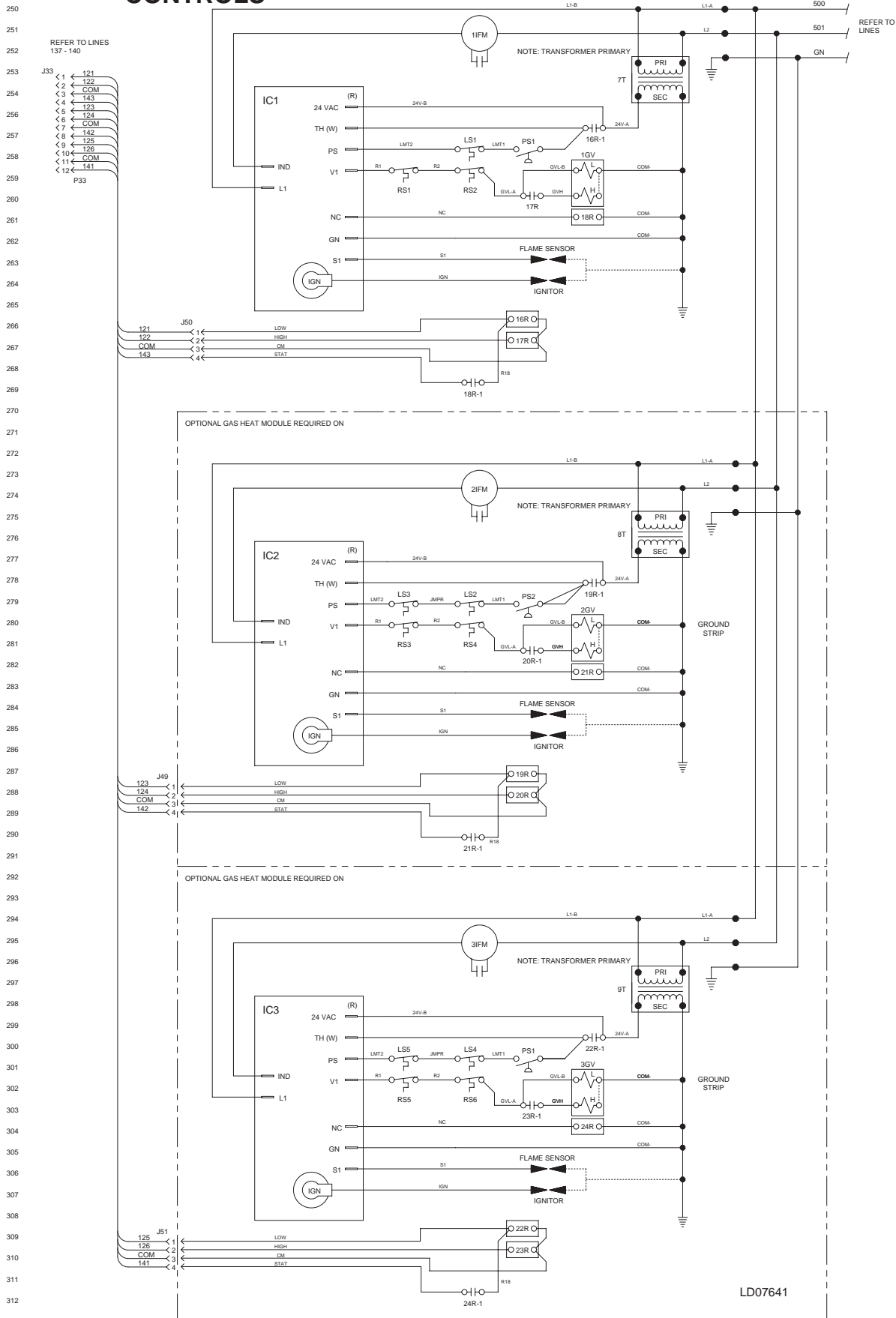

ELEMENTARY DIAGRAM YPAL W/ ELECTRIC HEAT (POWER SIDE) 50-60 TON, SINGLE POINT POWER

1
2
3
4
5
6
7
8
9
10
11
12
13
14
15
16
17
18
19
20
21
22
23
24
25
26
27
28
29
30
31
32
33
34
35
36
37
38
39
40
41
42
43
44
45
46
47
48
49
50
51
52
53
54
55
56
57
58
59
60
61
62
63
64
65
66
67
68
69
70
71

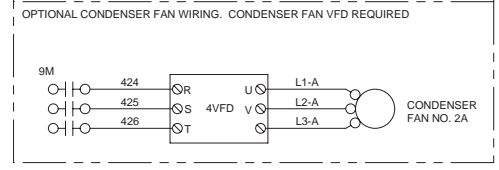
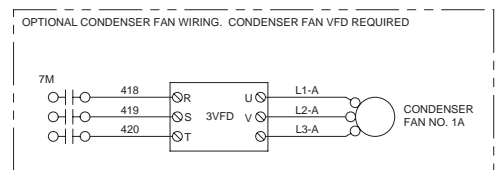
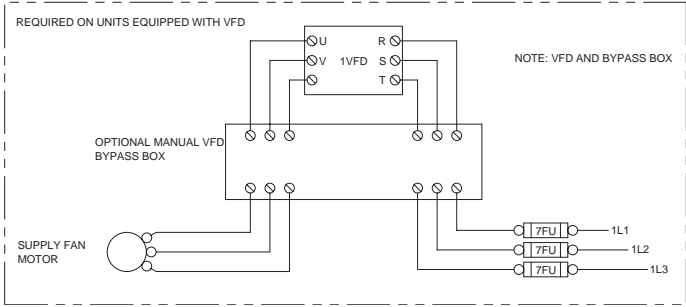
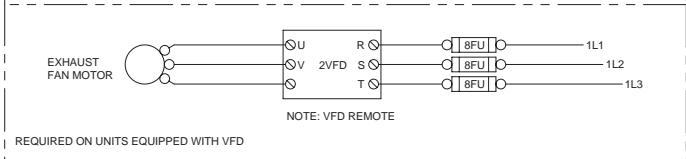
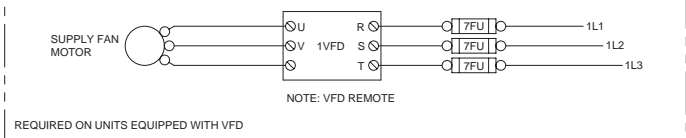
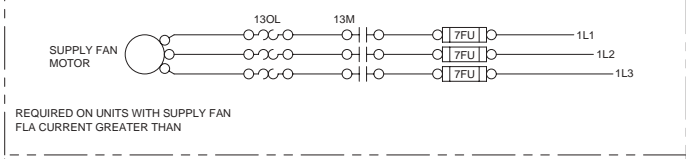
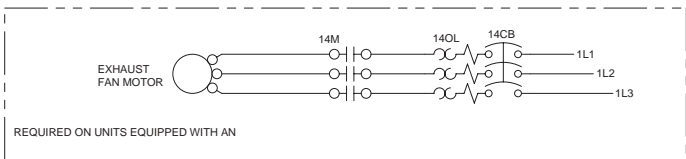
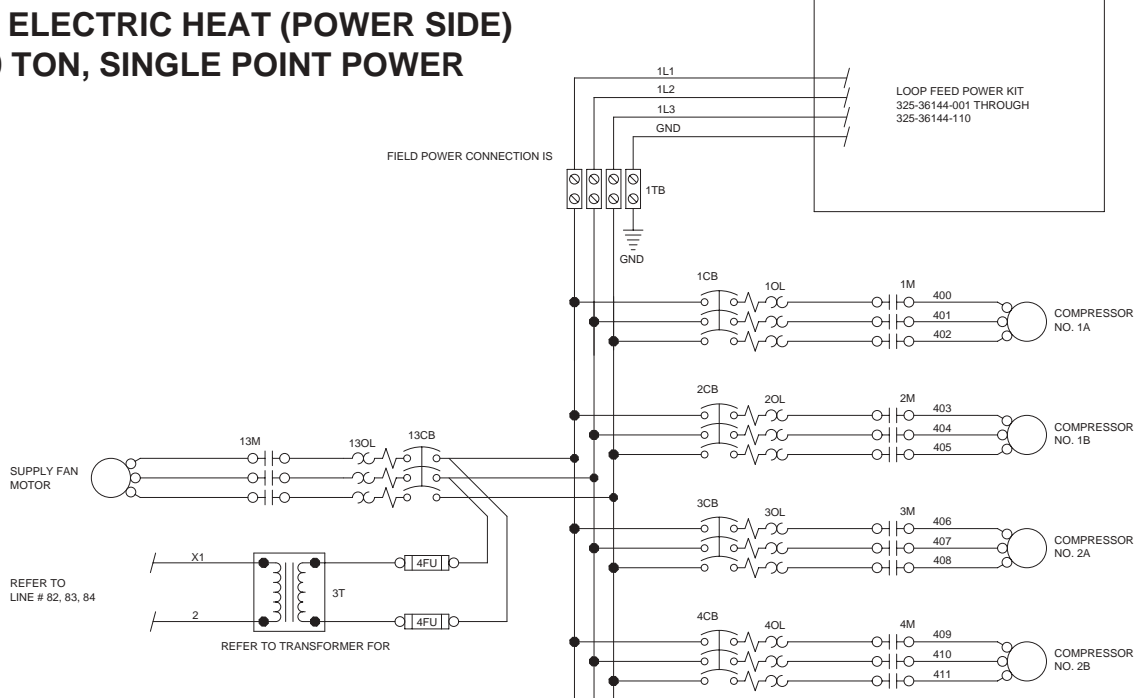

LD07643

ELEMENTARY DIAGRAM ELECTRIC HEAT CONTROLS 50-90 TON

350

351

352

REFER TO LINES
137 - 140

353

J33

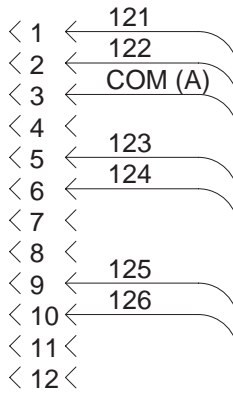

354

355

356

357

358

P33

359

360

361

362

ELECTRIC HEAT MOD.

363

364

365

366

367

368

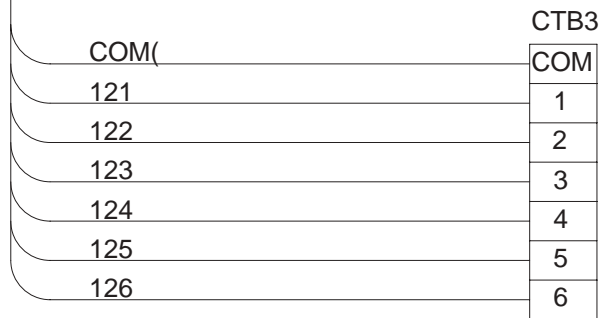

369

370

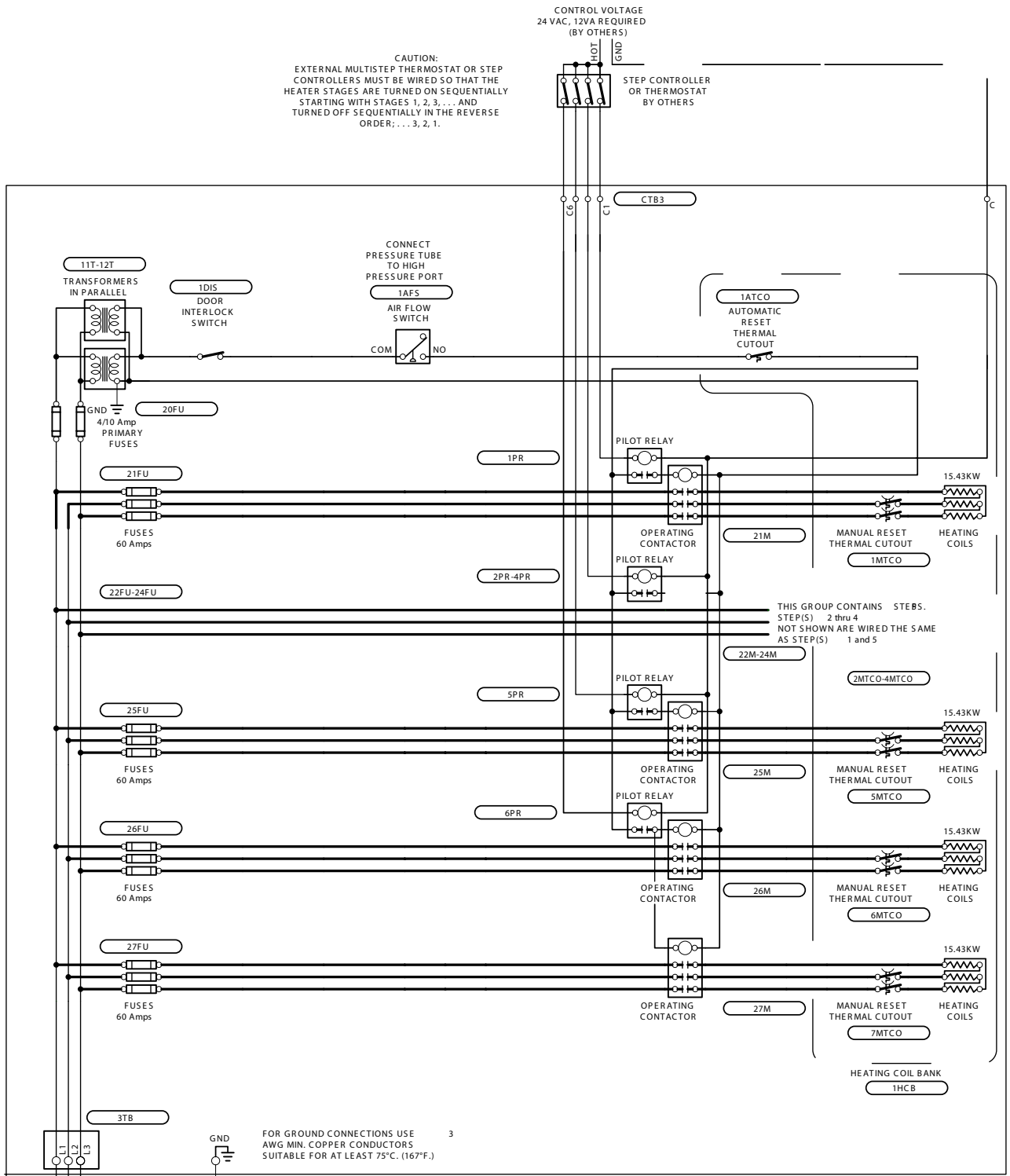

THIS GROUP CONTAINS STEPS. STEP(S) 2 thru 4 NOT SHOWN ARE WIRED THE SAME AS STEP(S) 1 and 5

1. For supply connections use min. MCM copper conductors suitable for use at 167°F (75°C).
2. Field terminals suitable for use with 1 x 500 MCM copper conductors only.
3. Wire gauges are based on not more than 3 wires in a single conduit.
4. This heater requires supply circuit(s) of .108.00 kW.
5. Supply voltage Phase 208/3
Control voltage Phase 24/1
6. Control circuit wiring to be NEC Class 1.

ELEMENTARY DIAGRAM
YPAL MODULATING GAS
HEAT CONTROLS
50-65 TON

035-13577-001
REV A

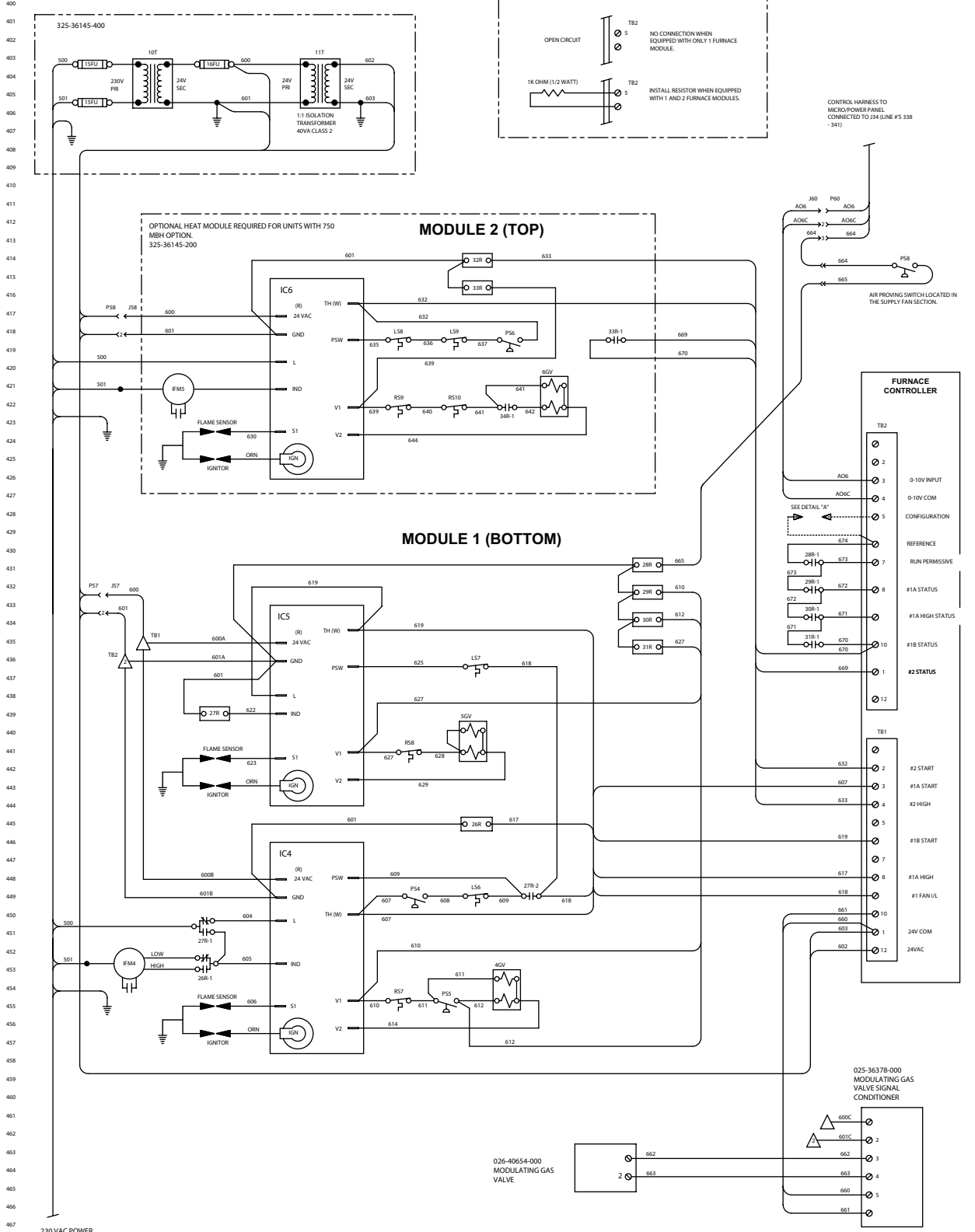

LD09859

**ELEMENTARY DIAGRAM
YPAL MODULATING GAS
HEAT CONTROLS
70-105 TON**

**035-13577-002
REV B**

