

# WIRE AND MAXIMUM OVERCURRENT PROTECTION SIZING GUIDE

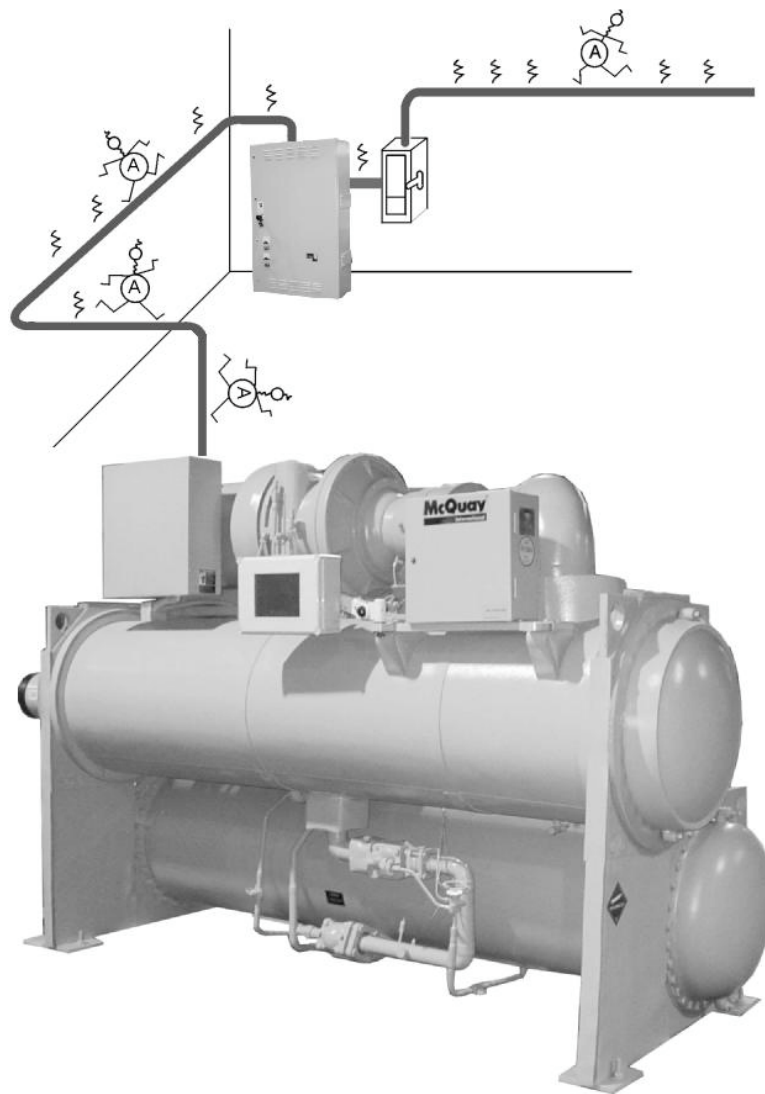

# TABLE OF CONTENTS

<b>General Information.....</b>	<b>3</b>
<b>Wire and Maximum Overcurrent Protection Selection .....</b>	<b>5</b>
<b>Ambient Temperature Correction Factors .....</b>	<b>5</b>
<b>Conductors not Covered by Wire Sizing Charts .....</b>	<b>6</b>
<b>Wire Sizing Charts Line Number References .....</b>	<b>8</b>
<b>Wire Sizing Charts .....</b>	<b>9</b>
<b>Maximum Conductor Length .....</b>	<b>13</b>
<b>Conductors in Rigid Metal Conduit .....</b>	<b>15</b>
<b>Wire Type Letters for Different Temperature Ratings .....</b>	<b>18</b>

Products manufactured in an ISO certified facility  
"McQuay" is a registered trademark of McQuay International  
Information and illustrations cover the McQuay International products at the time of publication  
and we reserve the right to make changes in design and construction at anytime without notice.

## General Information

---

1. **GENERAL** –The Information presented in this manual will help the chiller startup technician identify electrical wire and overcurrent protection sizes used on the jobsite.
2. Wire sizes are influenced by the type of motor starter used, the number of and temperature rating of the conductors, the number of conduits, and the ambient temperature surrounding the conductors and conduits. Wire sizing data presented will permit selection of 3, 6, 9, or 12 conductors in combination with 1, 2, 3, or 4 conduits (where applicable) with conductors carrying either phase or line amperes.

Wire sizing information has been presented in both chart and table form to permit selection of conductors rated from 60C to 90C for voltages from 0 to 2000 volts. In addition, conductor selection information for high voltage application (2001 to 5000 volts) is presented in chart form.

### CAUTION

**When using multiple conduits, all three phases must be carried in each conduit.**

**When using a linestarter or autotransformer starter, three different motor terminal connections are possible and will affect the amperage carried in the conductors connected to the motor. Refer to the “Line Number Reference For Wire Sizing Charts” Figure 1 on page 8.**

3. **WIRE SIZING DATA** - The information used to develop the wire sizing charts was obtained from the 2002 edition of the National Electrical Code®, Article 310 – “Conductors for General Wiring”, Article 430 – “Motors, Motor Circuits, Controllers”, Article 440 – “Air Conditioning Equipment”. The wire sizing shown is suitable for use on single motor circuits only.

Wire sizes indicated in the charts for rated load amperes through 1520 are based on the use of 75C rated wire. High voltage wire sizing (2001 to 5000 volts) has been based on the use of 90C rated wire.

When the use of 60C, 75C, or 90C rated wire in copper is required, the information contained in Table 6 on page 6 is used to make the selection. Sizes for 75C rated copper conductors through 1520 amperes are shown in chart form. THE INFORMATION IN TABLE 6 IS NOT APPLICABLE FOR CONDUCTORS APPLIED AT VOLTAGES ABOVE 2000 VOLTS.

4. **MAXIMUM OVERCURRENT PROTECTION (MOCP)** – MOCP may be provided by either dual element time delay fuses, or thermal magnetic circuit breakers. HACR type circuit breakers are not required. The fuse type may be a Class RK5, Class J (Specify time delay), or Class L (Specify time delay). If a fused disconnect is provided as an integral part of a centrifugal starter, 600 volt fuse clips will be provided, but the fuses must be provided by the installer, and the type must be as specified inside of the starter enclosure.

MOCP shown on the unit nameplate is calculated per the NEC 2002, as  $(1.75 \times RLA) + \text{any other loads}$  (typically the 3,000 VA control circuit transformer). The minimum size recommended by McQuay is based on  $(RLA \times 1.35)$ . Using a lower rating than this may cause nuisance tripping on start-ups.

Overcurrent protection sizes for the RLA ranges shown in Table 1 on page 4 are recommended for use with McQuay centrifugal chillers.

National Electrical Code® and NEC® are registered trademarks of the National Fire Protection Association, Inc. Quincy, MA

**Table 1, MOCP Sizes Recommended RLA Application Ranges**

Device Rating	RLA Range	
	Minimum	Maximum
30	17	22
40	23	30
50	29	37
60	34	44
70	40	52
80	46	59
90	51	67
100	57	74
110	63	81
125	71	93
150	86	111
175	100	130
200	114	148
250	143	185

Device Rating	RLA Range	
	Minimum	Maximum
300	171	222
350	200	259
400	229	296
450	257	333
500	286	370
600	343	444
700	400	519
800	457	593
1000	571	741
1200	686	889
1400	800	1037
1600	914	1185
2000	1143	1481
2500	1429	1852

**AMMETER READINGS** – The current value in amperes you may expect to read on an ammeter for various combinations of conductors carrying line or phase amperes can be determined from Table 2, below.

**Table 2, Conductor Ammeter Reading Factors**

TYPE OF CURRENT	NUMBER OF CONDUCTORS	AMMETER READING FACTOR
LINE AMPERES (Figure 1, Page 8)	3	1.000
	6	0.500
	9	0.333
PHASE AMPERES (Figure 1, Page 8)	12	0.250
	6	0.577
	12	0.289

**EXAMPLE** – Assume a motor with name plate rated amperes of 400 is being used with a star/delta type motor starter. What amperage would you expect to read on each conductor on the load side of the starter if 12 conductors are run between the starter and motor?

**SOLUTION** – Conductors would be carrying phase amperes. From Table 2 for 12 conductors the amperage factor = 0.289

$$\begin{aligned} \text{Amperes/Conductor} &= \text{RLA} \times 0.289 \\ &= 400 \times 0.289 = 116 \text{ AMPS} \end{aligned}$$

# Wire and Maximum Overcurrent Protection Selection

## 1. REQUIRED INFORMATION

- a. Motor nameplate rated load amperes (RLA)
- b. Motor nameplate rated voltage
- c. Type of motor starter to be used
- d. Type of current the conductors to be sized will carry. (Phase or line amperes, Figure 1 on page 8 plus Table 3 and Table 4.
- e. Ambient temperature where conductors are run.

## 2. WIRE SIZING AMPERAGE FACTORS – Wire sizing amperes for use in selecting wire size from Table 6, on page 6 can be calculated using the factors in Tables 3 and 4.

**Table 3, Line Amperes**

(LINESTARTER OR AUTO-TRANSFORMER STARTER)

NUMBER OF CONDUCTORS	NUMBER OF CONDUITS	AMPERAGE FACTOR
3	1	1.000
6	1	0.625
6	2	0.500
9	1	0.476
9	3	0.333
12	1	0.500
12	2	0.313
12	4	0.250

**EXAMPLE** – Assume a motor with 700 RLA, linestarter and 12 conductors in 2 conduits starter to motor. Calculate the wire sizing amperes.

**SOLUTION**

- **WIRE SIZING AMPERES = RLA x AMPERAGE FACTOR**
- Wire sizing amperage factor Table 3 = 0.313
- **WIRE SIZING AMPERES = 700 X 0.313 = 219.1**
- Select wire size from Table 6 using 219.1 amperes

**Table 4, Phase Amperes**

NUMBER OF CONDUCTORS	NUMBER OF CONDUITS	AMPERAGE FACTOR
6	1	0.722
6	2	0.577
12	1	0.577
12	2	0.361
12	4	0.289

## 3. AMBIENT TEMPERATURE CORRECTION – Wire sizing data shown in the charts on pages 10, 11, 12 and in Table 6, page 6 (Capacity Factors for Insulated Conductors Rated Other than 75C) is based on conductors operating in ambient temperatures not exceeding 86F (30C). When conductors will be operating in ambient temperatures exceeding 86F, the temperature correction factors contained in Table 5, page 5 should be used to adjust the rated load amperes to compensate for temperature before proceeding to select a wire size from the charts on pages 10, 11, and 12 or before attempting to use Table 6, page 6. Ambient Temperature Correction Factors.

**Table 5, Correction Factors for Ambient Temperatures Above 86F (30C) For Use with Copper Conductors Rated 0 - 2000 Volts**

AMBIENT Temp. F	CONDUCTOR TEMPERATURE RATING			AMBIENT TEMP. C
	60C	75C	90C	
87-95	1.10	1.07	1.04	31 - 35
96-104	1.22	1.14	1.10	36 - 40
105-113	1.41	1.22	1.15	41 - 45
114-122	1.72	1.33	1.22	46 - 50

**Do not use this correction table for conductors rated above 2000 volts.**

## USE OF TEMPERATURE CORRECTION FACTORS

**EXAMPLE:** Conductors rated 75C will be run in a space where the ambient temperature can be 107F. The motor to be used has nameplate rated load amperes of 360.

**SOLUTION:** From Table 5, , the correction factor will be found on the ambient temperature line 105 – 113 under the column heading 75C.

The correction factor is 1.22

$$\begin{aligned} \text{Wire sizing rated load amperes} &= \text{RLA} \times 1.22 \\ &= 360 \times 1.22 = 439.2 \end{aligned}$$

The adjusted RLA of 439.2 should be used when selecting a wire size from the wire-sizing chart on page 10 or Table 6 on page 6.

## Conductors not Covered by Wire Sizing Charts

The wire sizing charts on pages 10, 11 and 12 are based on the use of 75C copper rated wire through 1520 rated load amperes. Information following will permit selection of conductors for 60C, 75C or 90C when copper wire is to be used.



**Table 6 on page 6 applies only to conductors rated below 2000 volts. It must not be used with high voltage conductors (Rated 2001 to 5000 volts). Use the table only for single motor circuits.**

**Ensure equipment is rated for 90C wire before sizing wire per Table 6, 90C column.**

## CAPACITY FACTORS FOR INSULATED CONDUCTORS

**Table 6, Capacity in Amperes for Insulated Conductors Used on Single Motor Loads**

CONDUCTORS RATED 0 TO 2000 VOLTS – BASED ON AN AMBIENT TEMPERATURE OF 86F (30C)

WIRE SIZE AWG/ MCN	TEMPERATURE RATING OF CONDUCTOR		
	COPPER CONDUCTORS		
	60C	75C	90C
12	20	20	24
10	24	28	32
8	32	40	44
6	44	52	60
4	56	68	76
3	68	80	88
2	76	92	104
1	88	104	120
0	100	120	136
00	116	140	156
000	132	160	180
0000	156	184	208
250	172	204	232
300	192	228	256
350	208	248	280
400	224	268	304
500	256	304	344
600	284	336	380
700	308	368	416
750	320	380	428

The values contained in Table 6 were adapted from the 2002 edition of the National Electric Code®, Table 310-16 by dividing the code table values by 1.25.

### SELECTING CONDUCTORS NOT COVERED BY WIRE SIZING CHARTS

**Example 1** – Select a copper conductor rated 90C for a centrifugal where the following information applies:

- a. Nameplate rated load amperes – 300
- b. Nameplate rated voltage – 460
- c. Conductors required – Copper, rated 90C
- d. Motor starter-type – linestart
- e. Number of conductors – 6 (with copper bus bars at the motor terminals)
- f. Number of conduits – 2

**Selection** – The motor starter is a linestart type. The conductors will be carrying line amperes on both the load and line side of the starter. Bus bars will be utilized to jumper motor terminals 1-6, 2-4, 3-5. See Figure 1A on page 8.

- g. Wire sizing amperes = RLA x amperage factor
- h. From Table 3 on page 5 (line amperes) the amperage factor for 6 conductors carrying line amperes and run in two (2) conduits is 0.5.
- i. Capacity factor =  $300 \times 0.5 = 150$
- j. From Table 6 in column for 90C rated copper conductors, a size 2/0 wire has a capacity of 156 amperes.

Six (6) size 2/0 conductors will be required.

See Example 2, page 9 (Conductors operating in ambient temperatures above 86F).

**Example 2** – Use of Table 6 on page 6 with conductors running in high ambient temperature. Assume the conductors will operate in an ambient temperature of 110F. Select conductors for the conditions of Example 1 except for the 110F ambient.

**Selection:**

- a. Adjusted rated load amperes = ambient temperature correction factor x RLA
- b. Ambient temperature correction factor from Table 5 on page 5 for 90C rated wire = 1.15
- c. Adjusted rated load amperes =  $300 \times 1.15 = 345$
- d. Amperage factor for 6 conductors, 2 conduit = 0.5
- e. Capacity factor =  $0.5 \times 345 = 172.5$
- f. From Table 6 on page 6 in the column for 90C rated conductors, a size 3/0 conductor has a capacity of 180. Six (6) size 3/0 conductors will be required.

# Wire Sizing Charts Line Number References

Figure 1

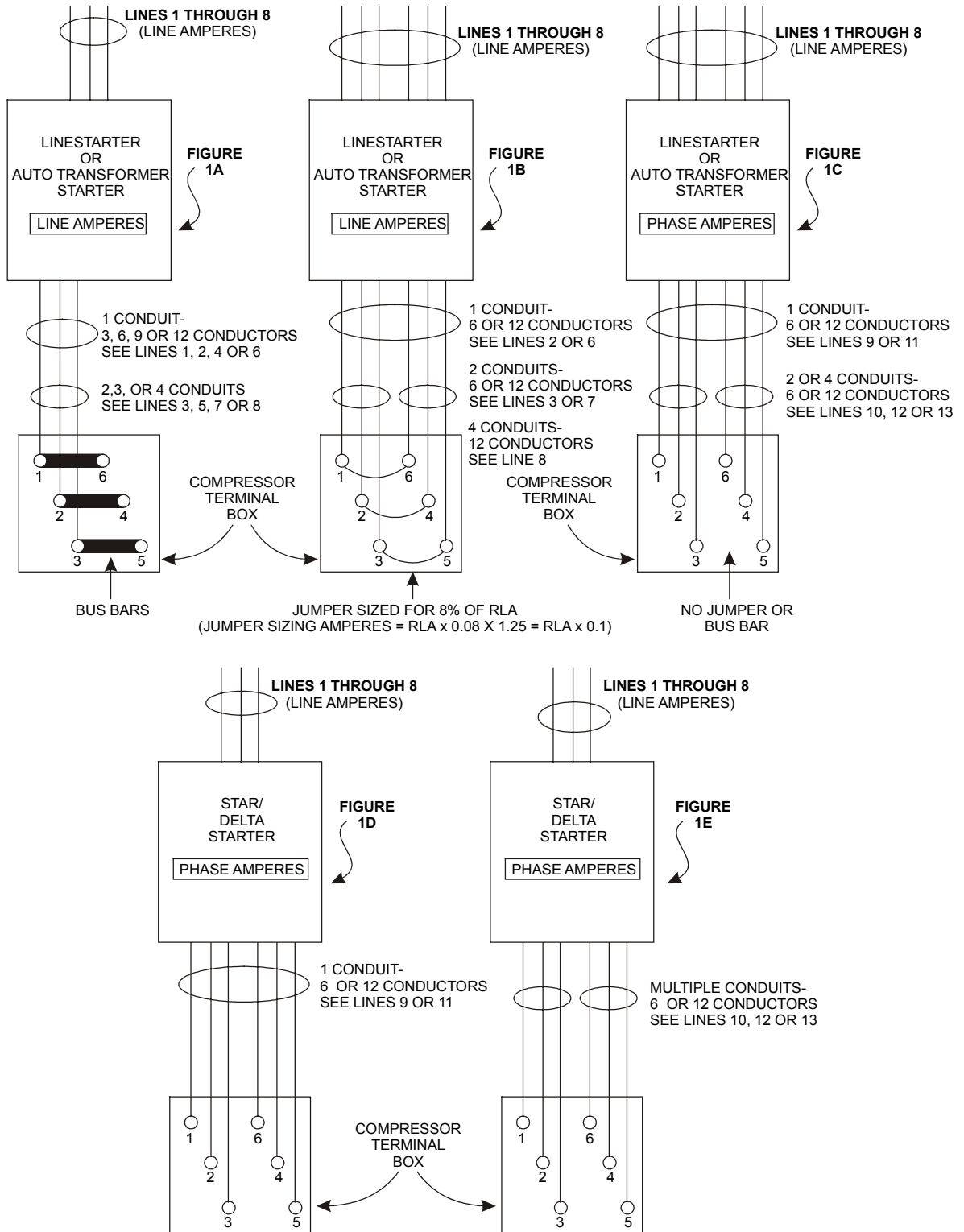



Chart 1, Wire and Fuse Data #1 (See Item 1 on Page 3)

**INSULATED COPPER CONDUCTORS – RATED 75C (167F) – 0 TO 2000 VOLTS – MAXIMUM AMBIENT TEMPERATURE 86F (30C)**

**RANGE - 0 TO 440 AMPERES**

TYPE CURRENT	STARTER TYPE	LINE NO.	NUMBER OF CONDUCTORS	NUMBER OF CONDUITS	RATED LOAD AMPERES (Item 3 on page 3)																							
					20	40	60	80	100	120	140	160	180	200	220	240	260	280	300	320	340	360	380	400	420			
LINE	LINESTART OR AUTO TRANSFORMER	1	3	1		10	8	6	4	3	2	1	1/0	2/0	3/0	4/0	250	300	350	400	500	600	700	750	800	900	1000	
		2	6	1			10	8	6	4	3	2	1	0	00	000	0000	250	300	350	400							
		3	6	2			10	8	6	4	3	2	1	1/0	2/0	3/0	4/0	250	300	350	400							
		4	9	1			10	8	6	4	3	2	1	1/0	2/0	3/0	4/0	250	300	350	400							
		5	9	3				10	8	6	4	3	2	1	1/0	2/0	3/0	4/0	250	300	350	400						
		6	12	1			10	8	6	4	3	2	1	1/0	2/0	3/0	4/0	250	300	350	400							
		7	12	2				10	8	6	4	3	2	1	1/0	2/0	3/0	4/0	250	300	350	400						
		8	12	4					10	8	6	4	3	2	1	1/0	2/0	3/0	4/0	250	300	350	400					
PHASE	STAR-DELTA	9	6	1		10	8	6	4	3	2	1	1/0	2/0	3/0	4/0	250	300	350	400	500	600						
		10	6	2		10	8	6	4	3	2	1	1/0	2/0	3/0	4/0	250	300	350	400	500	600						
		11	12	1		10	8	6	4	3	2	1	1/0	2/0	3/0	4/0	250	300	350	400	500	600						
		12	12	2			10	8	6	4	3	2	1	1/0	2/0	3/0	4/0	250	300	350	400	500	600					
		13	12	4				10	8	6	4	3	2	1	1/0	2/0	3/0	4/0	250	300	350	400	500	600				
FUSE SIZE – AMPERES (MAX)					35	40	45	50	60	70	80	90	100	110	125	150	175	200	225	250	300	350	400	450	500	600	700	
RATED LOAD AMPERES					<b>20</b>	<b>40</b>	<b>60</b>	<b>80</b>	<b>100</b>	<b>120</b>	<b>140</b>	<b>160</b>	<b>180</b>	<b>200</b>	<b>220</b>	<b>240</b>	<b>260</b>	<b>280</b>	<b>300</b>	<b>320</b>	<b>340</b>	<b>360</b>	<b>380</b>	<b>400</b>	<b>420</b>			

**RANGE - 400 TO 840 AMPERES**

TYPE CURRENT	STARTER TYPE	LINE NO.	NUMBER OF CONDUCTORS	NUMBER OF CONDUITS	RATED LOAD AMPERES (Item 3 on page 3)																					
					420	440	460	480	500	520	540	560	580	600	620	640	660	680	700	720	740	760	780	800	820	
LINE	LINESTART OR AUTO TRANSFORMER	1	3	1	900	1000	1250	1500	1750	2000																
		2	6	1	400	500	600	700	750																	
		3	6	2	300	350	400	500	600	700	750															
		4	9	1	250	300	350	400	500	600	700	750														
		5	9	3	2/0	3/0	4/0	500	600	700	750															
		6	12	1	300	350	400	500	600	700	750															
		7	12	2	2/0	3/0	4/0	500	600	700	750															
		8	12	4	1	1/0	2/0	3/0	4/0	500	600	700	750													
PHASE	STAR-DELTA	9	6	1	500	600	700	750																		
		10	6	2	350	400	500	600	700	750																
		11	12	1	350	400	500	600	700	750																
		12	12	2	3/0	4/0	500	600	700	750																
		13	12	4	1/0	2/0	3/0	4/0	500	600	700	750														
FUSE SIZE – AMPERES (MAX)					700	800	1000	1200																		
RATED LOAD AMPERES					<b>420</b>	<b>440</b>	<b>460</b>	<b>480</b>	<b>500</b>	<b>520</b>	<b>540</b>	<b>560</b>	<b>580</b>	<b>600</b>	<b>620</b>	<b>640</b>	<b>660</b>	<b>680</b>	<b>700</b>	<b>720</b>	<b>740</b>	<b>760</b>	<b>780</b>	<b>800</b>	<b>820</b>	

Chart 2, Wire and Fuse Data #2 (Item 1 on page 3)

**INSULATED COPPER CONDUCTORS – RATED 75C (167F) – 0 TO 2000 VOLTS – MAXIMUM AMBIENT TEMPERATURE 86F (30C)**

**RANGE - 800 TO 1240 AMPERES**

TYPE CURRENT	STARTER TYPE	LINE NO.	NUMBER OF CONDUCTORS	NUMBER OF CONDUITS	RATED LOAD AMPERES (Item 3 on page 3)																																					
					820	840	860	880	900	920	940	960	980	1000	1020	1040	1060	1080	1100	1120	1140	1160	1180	1200	1220																	
LINE	LINESTART OR AUTO TRANSFORMER	1	3	1																																						
		2	6	1																																						
		3	6	2																																						
		4	9	1																																						
		5	9	3	500				600				700				750		800		900																					
		6	12	1																																						
		7	12	2	400				500				600				700				750		800																			
		8	12	4	250	300				350				400				500				600																				
PHASE	STAR-DELTA	9	6	1																																						
		10	6	2																																						
		11	12	1																																						
		12	12	2	500				600				700				750																									
		13	12	4	350				400				500				600				700																					
FUSE SIZE – AMPERES (MAX)					1200						1600						2000																									
RATED LOAD AMPERES					820	840	860	880	900	920	940	960	980	1000	1020	1040	1060	1080	1100	1120	1140	1160	1180	1200	1220																	

**RANGE - 1200 to 1640 AMPERES**

TYPE CURRENT	STARTER TYPE	LINE NO.	NUMBER OF CONDUCTORS	NUMBER OF CONDUITS	RATED LOAD AMPERES (Item 3 on page 3)																						
					1220	1240	1260	1280	1300	1320	1340	1360	1380	1400	1420	1440	1460	1480	1500	1520	1540	1560	1580	1600	1620		
LINE	LINESTART OR AUTO TRANSFORMER	5	9	3																							
		6	12	1																							
		7	12	2	750																						
		8	12	4	500	600				700				750													
PHASE	STAR-DELTA	11	12	1																							
		12	12	2																							
		13	12	4	700				750																		
FUSE SIZE – AMPERES (MAX)					2000										2500												
RATED LOAD AMPERES					1220	1240	1260	1280	1300	1320	1340	1360	1380	1400	1420	1440	1460	1480	1500	1520	1540	1560	1580	1600	1620		

RANGE – 0 TO 400 AMPERES

**HIGH VOLTAGE COPPER CONDUCTORS – 2001 TO 5000 VOLTS  
 90C RATED COPPER CONDUCTORS OR CABLE – MAXIMUM AMBIENT AIR TEMPERATURE 104F (40C)  
 MINIMUM CONDUCTOR SIZES – BASED ON OVERLOAD RELAY TRIP OF 1.25 X RATED LOAD AMPERES  
 CONDUCTOR AMPACITIES BASED ON NATIONAL ELECTRICAL CODE TABLES 310-71, 310-73 AND 310-75**

LINE NO.	CONDUCTOR ARRANGEMENT	HOW CONDUCTORS ARE RUN	RATED LOAD AMPERES (Item 3 on page 3)																				
			20	40	60	80	100	120	140	160	180	200	220	240	260	280	300	320	340	360	380	400	420
1	3 CONDUCTOR CABLE	ISOLATED IN AIR	8	6	4	2	1	1/0	2/0	3/0	4/0	250	350	500	750								
2	3 SINGLE CONDUCTORS	IN ISOLATED CONDUIT IN AIR	8	6	4	2	1	1/0	2/0	3/0	4/0	250	350	500	750								
3	3 CONDUCTOR CABLE	IN ISOLATED CONDUIT IN AIR	8	6	4	2	1	1/0	2/0	3/0	4/0	250	350	500	750								

Line 2 ampacities also apply to an insulated triplexed cable.

# Maximum Conductor Length

**Table 7, Maximum Conductor Length, Based on 3% Voltage Drop**

**(3 Phase Copper Conductors – Maximum Length Factor)**

Wire Size (AWG, KCMIL)	Z to Neu Per 1000' @ 0.85pf	3 Phase Voltage (L-L)										
		208	220	230	240	440	460	480	550	575	2300	4160
10	1.1	3.3	3.5	3.6	3.8	6.9	7.2	7.6	8.7	9.1	36.2	65.5
8	0.7	5.1	5.4	5.7	5.9	10.9	11.4	11.9	13.6	14.2	56.9	102.9
6	0.45	8.0	8.5	8.9	9.2	16.9	17.7	18.5	21.2	22.1	88.5	160.1
4	0.3	12.0	12.7	13.3	13.9	25.4	26.6	27.7	31.8	33.2	132.8	240.2
3	0.24	15.0	15.9	16.6	17.3	31.8	33.2	34.6	39.7	41.5	166.0	300.2
2	0.2	18.0	19.1	19.9	20.8	38.1	39.8	41.6	47.6	49.8	199.2	360.3
1	0.16	22.5	23.8	24.9	26.0	47.6	49.8	52.0	59.5	62.2	249.0	450.3
1/0	0.13	27.7	29.3	30.6	32.0	58.6	61.3	64.0	73.3	76.6	306.4	554.3
2/0	0.11	32.8	34.6	36.2	37.8	69.3	72.4	75.6	86.6	90.5	362.2	655.0
3/0	0.094	38.3	40.5	42.4	44.2	81.1	84.8	88.4	101.3	106.0	423.8	766.5
4/0	0.08	45.0	47.6	49.8	52.0	95.3	99.6	103.9	119.1	124.5	498.0	900.7
250	0.073	49.4	52.2	54.6	56.9	104.4	109.1	113.9	130.5	136.4	545.7	987.1
300	0.065	55.4	58.6	61.3	64.0	117.2	122.6	127.9	146.6	153.2	612.9	1108.5
350	0.06	60.0	63.5	66.4	69.3	127.0	132.8	138.6	158.8	166.0	664.0	1200.9
400	0.056	64.3	68.0	71.1	74.2	136.1	142.3	148.5	170.1	177.8	711.4	1286.7
500	0.05	72.1	76.2	79.7	83.1	152.4	159.4	166.3	190.5	199.2	796.8	1441.1
600	0.047	76.7	81.1	84.8	88.4	162.2	169.5	176.9	202.7	211.9	847.6	1533.1
700	0.0443	81.3	86.0	89.9	93.8	172.0	179.9	187.7	215.0	224.8	899.3	1626.5
750	0.043	83.8	88.6	92.6	96.7	177.2	185.3	193.4	221.5	231.6	926.5	1675.7

**Table 8, Maximum Conductor Length, Based on 3% Voltage Drop**

**(1 Phase Copper Conductors – Maximum Length Factor)**

Wire Size (AWG, KCMIL)	Z to Neu Per 1000' @ 0.85pf	Single Phase Voltage (L-N)				
		120	208	220	230	240
14	2.7	0.667	1.156	1.222	1.278	1.333
12	1.7	1.059	1.835	1.941	2.029	2.118
10	1.1	1.636	2.836	3.000	3.136	3.273
8	0.7	2.571	4.457	4.714	4.929	5.143
6	0.45	4.000	6.933	7.333	7.667	8.000

Notes:

1. The maximum allowable voltage drop in the conductors between the power source and the motor is 3 percent. The factors shown in the above tables may be used to calculate the maximum one way length between the power source and the motor for the conductor sizes and voltages listed.
2. The maximum one way conductor length calculated using the factors above is the maximum distance in feet between components (Such as the disconnect-starter), which will result in a 3 percent voltage drop.
3. To obtain the maximum one-way length in feet between the power source-disconnect, disconnect-starter, starter-motor, see the example on page 14.

## USE OF MAXIMUM LENGTH FACTORS

### Example:

Calculate the total conductor voltage drop between the power source and the motor for a centrifugal unit where the following information applies.

1. Rated load amperes = 236 at 480 volts
2. Type of motor starter – linestarter
3. Number and size of conductors power source to disconnect – three, 350 MCM
4. Number and size of conductors disconnect to starter - three, 350 MCM
5. Number and size of conductors starter to motor - six, 1/0, in 2 conduits
6. Distances one way
  - a. Power source to disconnect ..... = 375 feet
  - b. Disconnect to starter ..... = 150 feet
  - c. Starter to motor ..... = 50 feet

### Solution:

$$1. \text{ Maximum Allowed Length} = \frac{\text{Maximum Length Factor} \times 1000}{\text{RLA} \times \text{Amp Factor (Table 3 or Table 4)}}$$

$$\begin{aligned} \text{Power Source to Disconnect} &= \frac{138.6 \times 1000}{236 \times 1.0} \\ \text{(3 – 350 MCM Conductors)} &= 587 \text{ Feet} \end{aligned}$$

$$\begin{aligned} \text{Disconnect to Starter} &= \frac{138.6 \times 1000}{236 \times 1.0} \\ \text{(3 – 350 MCM Conductors)} &= 587 \text{ Feet} \end{aligned}$$

$$\begin{aligned} \text{Starter to Motor} &= \frac{64 \times 1000}{236 \times 0.5} \\ &= 542 \text{ Feet} \end{aligned}$$

$$2. \text{ Voltage Drop} = \frac{\text{Actual Run (Feet)} \times 0.03}{\text{Allowable Run (Feet)}}$$

3. Total Conductor Voltage Drop in percent from power source to motor is obtained by adding percentage of voltage drops between components.

$$\begin{aligned} \text{Voltage Drop} &= \left( \frac{375}{587} \times 0.03 \right) + \left( \frac{150}{587} \times 0.03 \right) + \left( \frac{50}{542} \times 0.03 \right) \\ &= 0.0192 + 0.0077 + 0.0028 \\ &= 0.0297 = 2.97 \text{ percent} \end{aligned}$$

The voltage drop power source to the motor is within the allowable limit of three percent.

# Conductors in Rigid Metal Conduit

**Table 9, Conductors in Rigid Metal Conduit**

CONDUCTORS													
TYPE	CONDUCTOR SIZE (AWG/kcmil)	Trade Size (in.)											
		½	¾	1	1 ¼	1 ½	2	2 ½	3	3 ½	4	5	6
RH, RHH RHW RHW-2	10	3	5	8	14	19	31	44	68	91	118	185	267
	8	1	2	4	7	10	16	23	36	48	61	97	139
	6	1	1	3	6	8	13	18	29	38	49	77	112
	4	1	1	2	4	6	10	14	22	30	38	60	87
	3	1	1	2	4	5	9	12	19	26	34	53	76
	2	1	1	1	3	4	7	11	17	23	29	46	66
	1	0	1	1	1	3	5	7	11	15	19	30	44
	1/0	0	1	1	1	2	4	6	10	13	17	26	38
	2/0	0	1	1	1	2	4	5	8	11	14	23	33
	3/0	0	0	1	1	1	3	4	7	10	12	20	28
	4/0	0	0	1	1	1	3	4	6	8	11	17	24
	250	0	0	0	1	1	1	3	4	6	8	13	18
	300	0	0	0	1	1	1	2	4	5	7	11	16
	350	0	0	0	1	1	1	2	4	5	6	10	15
	400	0	0	0	1	1	1	1	3	4	6	9	13
	500	0	0	0	1	1	1	1	3	4	5	8	11
600	0	0	0	0	1	1	1	2	3	4	6	9	
700	0	0	0	0	1	1	1	1	3	4	6	8	
750	0	0	0	0	0	1	1	1	3	3	5	8	
TW	14	9	15	25	44	59	98	140	216	288	370	581	839
	12	7	12	19	33	45	75	107	165	221	284	446	644
	10	5	9	14	25	34	56	80	123	164	212	332	480
	8	3	5	8	14	19	31	44	68	91	118	185	267
RHH*, RHW*, RHW-2*, THHW, THW, THW-2	14	6	10	17	29	39	65	93	143	191	246	387	558
RHH*, RHW*, RHW-2*, THHW, THW	12	5	8	13	23	32	52	75	115	154	198	311	448
	10	3	6	10	18	25	41	58	90	120	154	242	350
RHH*, RHW*, RHW-2*, THHW, THW, THW-2	8	1	4	6	11	15	24	35	54	72	92	145	209
RHH*, RHW*, RHW-2*, TW, THW THHW, THW-2	6	1	3	5	8	11	18	27	41	55	71	111	160
	4	1	1	3	6	8	14	20	31	41	53	83	120
	3	1	1	3	5	7	12	17	26	35	45	71	103
	2	1	1	2	4	6	10	14	22	30	38	60	87
	1	1	1	1	3	4	7	10	15	21	27	42	61
	1/0	0	1	1	2	3	6	8	13	18	23	36	52
	2/0	0	1	1	2	3	5	7	11	15	19	31	44
	3/0	0	1	1	1	2	4	6	9	13	16	26	37
	4/0	0	0	1	1	1	3	5	8	10	14	21	31
	250	0	0	1	1	1	3	4	6	8	11	17	25
	300	0	0	1	1	1	2	3	5	7	9	15	22
	350	0	0	0	1	1	1	3	5	6	8	13	19
400	0	0	0	1	1	1	3	4	6	7	12	17	
500	0	0	0	1	1	1	2	3	5	6	10	14	

Table 9, Continued (Maximum Number Of Conductors In Rigid Metal Conduit)

TYPE	CONDUCTOR SIZE (AWG/kcmil)	Trade Size (in.)												
		½	¾	1	1 ¼	1 ½	2	2 ½	3	3 ½	4	5	6	
	600	0	0	0	1	1	1	1	3	4	5	8	12	
	700	0	0	0	0	1	1	1	2	3	4	7	10	
	750	0	0	0	0	1	1	1	2	3	4	7	10	
THHN, THWN, THWN-2	14	13	22	36	63	85	140	200	309	412	531	833	1202	
	12	9	16	26	46	62	102	146	225	301	387	608	877	
	10	6	10	17	29	39	64	92	142	189	244	383	552	
	8	3	6	9	16	22	37	53	82	109	140	221	318	
	6	2	4	7	12	16	27	38	59	79	101	159	230	
	4	1	2	4	7	10	16	23	36	48	62	98	141	
	3	1	1	3	6	8	14	20	31	41	53	83	120	
	2	1	1	3	5	7	11	17	26	34	44	70	100	
	1	1	1	1	4	5	8	12	19	25	33	51	74	
	1/0	1	1	1	3	4	7	10	16	21	27	43	63	
	2/0	0	1	1	2	3	6	8	13	18	23	36	52	
	3/0	0	1	1	1	3	5	7	11	15	19	30	43	
	4/0	0	1	1	1	2	4	6	9	12	16	25	36	
	250	0	0	1	1	1	3	5	7	10	13	20	29	
	300	0	0	1	1	1	3	4	6	8	11	17	25	
	350	0	0	1	1	1	2	3	5	7	10	15	22	
	400	0	0	1	1	1	2	3	5	7	8	13	20	
	500	0	0	0	1	1	1	2	4	5	7	11	16	
	600	0	0	0	1	1	1	1	3	4	6	9	13	
	700	0	0	0	1	1	1	1	3	4	5	8	11	
	750	0	0	0	0	1	1	1	3	4	5	7	11	
	FEP, FEPB, PFA, PFAH, TFE	14	12	22	35	61	83	136	194	300	400	515	808	1166
		12	9	16	26	44	60	99	142	219	292	376	590	851
		10	6	11	18	32	43	71	102	157	209	269	423	610
8		3	6	10	18	25	41	58	90	120	154	242	350	
6		2	4	7	13	17	29	41	64	85	110	172	249	
4		1	3	5	9	12	20	29	44	59	77	120	174	
3		1	2	4	7	10	17	24	37	50	64	100	145	
2		1	1	3	6	8	14	20	31	41	53	83	120	
PFA, PFAH, TFE	1	1	1	2	4	6	9	14	21	28	37	57	83	
PFA, PFAH, TFE, Z	1/0	1	1	1	3	5	8	11	18	24	30	48	69	
	2/0	1	1	1	3	4	6	9	14	19	25	40	57	
	3/0	0	1	1	2	3	5	8	12	16	21	33	47	
	4/0	0	1	1	1	2	4	6	10	13	17	27	39	
Z	14	15	26	42	73	100	164	234	361	482	621	974	1405	
	12	10	18	30	52	71	116	166	256	342	440	691	997	
	10	6	11	18	32	43	71	102	157	209	269	423	610	
	8	4	7	11	20	27	45	64	99	132	170	267	386	
	6	3	5	8	14	19	31	45	69	93	120	188	271	
	4	1	3	5	9	13	22	31	48	64	82	129	186	
	3	1	2	4	7	9	16	22	35	47	60	94	136	
	2	1	1	3	6	8	13	19	29	39	50	78	113	
1	1	1	2	5	6	10	15	23	31	40	63	92		

Table 9, Continued (Maximum Number Of Conductors In Rigid Metal Conduit)													
TYPE	CONDUCTOR SIZE (AWG/kcmil)	Trade Size (in.)											
		½	¾	1	1 ¼	1 ½	2	2 ½	3	3 ½	4	5	6
XHH, XHHW, XHHW-2, ZW	14	9	15	25	44	59	98	140	216	288	370	581	839
	12	7	12	19	33	45	75	107	165	221	284	446	644
	10	5	9	14	25	34	56	80	123	164	212	332	480
	8	3	5	8	14	19	31	44	68	91	118	185	267
	6	1	3	6	10	14	23	33	51	68	87	137	197
	4	1	2	4	7	10	16	24	37	49	63	99	143
	3	1	1	3	6	8	14	20	31	41	53	84	121
	2	1	1	3	5	7	12	17	26	35	45	70	101
XHH, XHHW,	1	1	1	1	4	5	9	12	19	26	33	52	76
XHHW-2	1/0	1	1	1	3	4	7	10	16	22	28	44	64
	2/0	0	1	1	2	3	6	9	13	18	23	37	53
	3/0	0	1	1	1	3	5	7	11	15	19	30	44
	4/0	0	1	1	1	2	4	6	9	12	16	25	36
	250	0	0	1	1	1	3	5	7	10	13	20	30
	300	0	0	1	1	1	3	4	6	9	11	18	25
	350	0	0	1	1	1	2	3	6	7	10	15	22
	400	0	0	1	1	1	2	3	5	7	9	14	20
	500	0	0	0	1	1	1	2	4	5	7	11	16
	600	0	0	0	1	1	1	1	3	4	6	9	13
	700	0	0	0	1	1	1	1	3	4	5	8	11
	750	0	0	0	0	1	1	1	3	4	5	7	11

Notes:

1. Information was obtained from the National Electrical Code®, 2002 Edition, Chapter 9, Table C8.
2. Reprinted with permission from NFPA 70-2002, National Electrical Code, Copyright ©, 2002, National Fire Protection Association, Quincy, Mass. 02269. This reprinted material is not the complete and official position of the NFPA on the referenced subject which is represented only by the standard in its entirety.

## Wire Type Letters for Different Temperature Ratings

---

**Table 10, Wire Temperature Rating**

WIRE TEMPERATURE RATING		
60°C (140°F)	75°C (167°)	90°C (194°)
TW	FEPW	TBS
UF	RH	SA
	RHW	SIS
	THHW	FEP
	THW	FEPB
	THWN	MI
	XHHW	RHH
	USE	RHW-2
	ZW	THHN
		THHW
		THW-2
		THWN-2
		USE-2
		XHH
		XHHW
		XHHW-2
		ZW-2

Source of wire identifications 2002 Edition of N.E.C.

---

**NOTE:** This publication is a guideline and is not intended to take the place of the national or local Electrical Codes in whole or in part. The final determination for correctness of the information contained in this manual, where applicable, is the latest edition of the national and/or local Electrical Codes®.

---

