



Form 090.020-M (JUNE 2011)

MAINTENANCE

File: SERVICE MANUAL - Section 90
Replaces: 090-020 M (NOV 2010)
Dist: 3, 3a, 3b, 3c

MAINTENANCE

**FRICK[®] QUANTUM[™] LX
COMPRESSOR
CONTROL PANEL
Version 7.0x**

TABLE OF CONTENTS

SECTION 1

INTRODUCTION TO THE QUANTUM™ CONTROL SYSTEM.....	8
INTRODUCTION.....	8
Quantum™ Controller.....	8
Power Supply.....	8
Digital Input / Output Boards.....	8
Analog Input / Output Boards.....	8
Operator Interface.....	8
THE CONTROL PANEL ENCLOSURE.....	8
GENERAL INFORMATION.....	8
WHAT TO DO BEFORE CALLING THE FACTORY.....	9

SECTION 2

Q5

INTRODUCTION.....	12
FEATURES.....	12
WHAT SHOULD OCCUR WHEN APPLYING POWER.....	12
WHAT IF THE OPERATING STATUS SCREEN IS NOT SHOWN.....	12
BATTERY FUNCTION AND REPLACEMENT.....	13
Q5 INTERFACE BOARD.....	13
Q5 BOARD PICTORIAL.....	14
Q5 JUMPERS, LED'S AND CONNECTORS.....	15
Jumper Table.....	15
LED Definition Table.....	15
Connector Pinout Table.....	15
Q5 INTERFACE BOARD PICTORIAL.....	16
COMM 1 Jumpers.....	16
COMM 2 Jumpers.....	16
Q5 INTERCONNECTIONS.....	17
POWER SUPPLY.....	18
DESCRIPTION	18
POWER DISTRIBUTION.....	18
MEASURING VOLTAGES.....	18
ADJUSTMENT.....	19
+5VDC.....	19
+12VDC.....	19
+24VDC.....	19
POWER SUPPLY REPLACEMENT.....	19
Q5 FLOW DIAGRAM.....	20
Q5 RDB / RWB II / RWF / RXF (58 - 101) CONTROL CENTER ASSEMBLY.....	21
Q5 I/O & D.C. POWER HARNESS.....	25
Q5 A. C. POWER HARNESS.....	26
Q5 COMPRESSOR REPLACEMENT PARTS.....	28

SECTION 3

QUANTUM 4

INTRODUCTION.....	32
WHAT SHOULD OCCUR WHEN APPLYING POWER.....	32
WHAT IF THE OPERATING STATUS SCREEN IS NOT SHOWN.....	32
BATTERY FUNCTION AND REPLACEMENT.....	33
QUANTUM 4 BOARD PICTORIAL.....	34
QUANTUM 4 BOARD SETTINGS.....	35
Processor Board Jumpers.....	35
Communications Board Jumpers.....	35
Com-1 (TB1).....	35
Com-2 (TB2 - TB3).....	35
POWER SUPPLY.....	36
DESCRIPTION	36
MEASURING VOLTAGES.....	36
FUSE REPLACEMENT.....	37

ADJUSTMENT.....	38
POWER SUPPLY REPLACEMENT.....	39
+5 DC VOLTAGE MEASUREMENT LOCATION.....	40
DC POWER SUPPLY PIN ASSIGNMENTS.....	40
QUANTUM 4 FLOW DIAGRAM	
36 & 48 INCH PANELS.....	40
22 & 28 INCH PANELS.....	41
QUANTUM 4 RDB / RWB II / RWF / RXF (58 - 101) CONTROL CENTER ASSEMBLY.....	42
QUANTUM 4 I/O & D.C. POWER HARNESS (36 AND 48 INCH PANELS).....	46
QUANTUM 4 I/O & D.C. POWER HARNESS (22 AND 28 INCH PANELS).....	47
QUANTUM 4 COMPRESSOR REPLACEMENT PARTS.....	48

SECTION 4

DIGITAL BOARD.....	52
INFORMATION.....	52
DIGITAL BOARD DESCRIPTION.....	52
COMMUNICATIONS LED'S.....	52
CONNECTIONS TO THE QUANTUM 4.....	52
LOGIC VOLTAGE (POWER) LED.....	53
ACTIVE LED.....	53
DIGITAL INPUTS.....	53
DIGITAL OUTPUTS.....	54
CHECKING THE DIGITAL INPUTS AND OUTPUTS.....	54
FUSE TESTING AND REPLACEMENT.....	54
INPUT AND OUTPUT MODULE TESTING AND REPLACEMENT.....	54
TROUBLESHOOTING AN OUTPUT.....	54
TROUBLESHOOTING AN INPUT.....	55
REPLACING A DEFECTIVE DIGITAL BOARD.....	55
DIGITAL I/O BOARD #1 PICTORIAL.....	56
DIGITAL I/O BOARD #2 PICTORIAL.....	57
DIGITAL BOARD SETTINGS.....	58
COMMUNICATIONS SETTINGS.....	58
DIPSWITCH SETTINGS.....	58

SECTION 5

ANALOG BOARD.....	60
OVERVIEW.....	60
ANALOG BOARD VERSIONS.....	60
ANALOG BOARD DESCRIPTION.....	60
COMMUNICATIONS LED'S.....	60
CONNECTIONS TO THE QUANTUM™.....	61
LOGIC VOLTAGE (POWER) LED'S.....	61
ACTIVE LED.....	61
ANALOG INPUTS.....	61
ANALOG BOARD INPUT CONFIGURATION TABLE.....	62
ANALOG OUTPUTS.....	63
TROUBLESHOOTING THE ANALOG INPUTS AND OUTPUTS.....	63
REPLACING A DEFECTIVE ANALOG BOARD.....	63
PHD VIBRATION ANALYSIS.....	64
CURRENT TRANSFORMER (MOTOR AMPS).....	65
ANALOG BOARD #1 PICTORIAL.....	66
ANALOG BOARD #2 PICTORIAL.....	67
ANALOG BOARD SETTINGS.....	68
Communications.....	68
Current Transformer (CT).....	68
Vibration.....	68
Dipswitch Settings (Used To Set The Board Address).....	68
Analog Board Comparison Chart.....	68

SECTION 6

OPERATOR INTERFACE.....	70
DESCRIPTION.....	70

Display Assembly.....	70
Identifying The Type of Display.....	70
Display Replacement.....	70
QUANTUM 4 SPECIFIC INFORMATION.....	71
Q5 SPECIFIC INFORMATION.....	71
KEYPAD.....	72
Keypad Troubleshooting.....	72
Keypad Replacement.....	73

SECTION 7

SERVICE SCREENS.....	76
Digital Board Inputs and Outputs.....	76
Analog Board Inputs and Outputs.....	76
Motor Bump.....	77
Software Maintenance.....	78
SYSTEM STATUS	
Maintenance.....	82
CONFIGURATION	
Communications.....	83
MISCELLANEOUS SCREENS	
About.....	84

SECTION 8

TROUBLESHOOTING	
TROUBLESHOOTING A PROBLEM THAT APPEARS UNEXPLAINABLE.....	85
TROUBLESHOOTING CHART FOR FRICK® QUANTUM™ LX CONTROL PANEL.....	87

SECTION 9

SETPOINT DATA SHEETS.....	91
OPERATING VALUES	
Used Defined.....	91
MODE SETUP.....	92
SYSTEM STATUS	
Trending Setup.....	93
Maintenance.....	94
SETPOINTS	
Capacity Control Setpoints	
Mode 1.....	95
Mode 2.....	96
Mode 3.....	97
Mode 4.....	98
Sequencing	
System 1 Setup.....	99
System 2 Setup.....	100
System 3 Setup.....	101
Sequencing Control.....	102
Compressor Safeties Setpoints.....	103
Package Safeties.....	104
Motor (Engine/DBS/Motor/Turbine/Vyper).....	105
Capacity Position.....	107
Condenser Digital Control.....	107
Condenser Analog Control.....	107
Miscellaneous.....	108
Scheduling.....	108
PHD Monitoring.....	109
PID Setup	
Page 1.....	110
Page 2.....	111
Superheat Control Setup.....	112
Discharge Butterfly Setup.....	113
Auxiliary Analog Input Safeties	
Page 1.....	114
Page 2.....	115

Auxiliary Digital Input Configuration.....	116
Auxiliary Digital Output Configuration.....	117
Timed Digital Output Configuration.....	119
Panel.....	119
CALIBRATION	
Pressure.....	120
Temperature.....	122
Capacity/Volume.....	123
Motor/Miscellaneous.....	123
PhD Monitoring.....	125
Analog Outputs (Retransmitting Outputs).....	127
Analog Outputs (VFD / Condenser Outputs).....	128
Analog Output Calibration.....	128
Auxiliaries Analogs (Page 1).....	129
Auxiliaries (Page 2).....	130
CONFIGURATION	
Compressor.....	131
Communications.....	132
Ethernet.....	132
Digital I/O.....	133
SECURITY	135
SESSION	135
ABOUT	135

SECTION 10

QUANTUM™ LX DRAWINGS.....	139
RXF (12-50) RETROFIT MOUNTING.....	140
WIRING DIAGRAM – RWF & RWFII.....	141
WIRING DIAGRAM – RWB II.....	145
WIRING DIAGRAM – RXF (12-101).....	149
WIRING DIAGRAM – RDB.....	153
WIRING DIAGRAM PHD.....	157
WIRING DIAGRAM – DIGITAL I/O BOARD 2.....	158
WIRING DIAGRAM – ANALOG I/O BOARD 2.....	160
ISOLATER REPEATER MODULE.....	162
COMMUNICATIONS WIRING DIAGRAMS.....	163
TO CUSTOMER REMOTE COMPUTER/DCS.....	163
RS-485 COMMUNICATIONS.....	163
RS-422 COMMUNICATIONS.....	163
POINT-TO-POINT FIELD WIRING DIAGRAM.....	164

SECTION 11

TABLES	
PRESSURE TRANSDUCER CONVERSION DATA.....	165
COMPRESSOR MODEL DIFFERENCES.....	165
COMPRESSOR VOLUME RATIO AND CAPACITY INFORMATION.....	166

THE FOLLOWING PUBLICATIONS ARE AVAILABLE FROM THE JOHNSON CONTROLS® WEBSITE jci.com

- 090.022-O Frick® Quantum™ LX Control Panel Operation – Service
- 090.020-CS Frick® Quantum™ LX Control Panel Communications Setup (setup and wiring for data communication using available protocols)
- 090.020-M Frick® Quantum™ LX Control Panel Maintenance (repair and troubleshooting)

NOTES:

SECTION 1

INTRODUCTION TO THE QUANTUM™ CONTROL SYSTEM



INTRODUCTION TO THE QUANTUM™ CONTROL SYSTEM

INTRODUCTION

The Quantum™ LX panel differs from previous Quantum™ LX panel primarily in the software operating system. The hardware portion (with the exception of the new international style keypad and cable) remains the same. The Frick® Quantum™ LX control system consists of five major areas:

- **Quantum™ Controller** - The brains of the system. Currently, there are two versions of Quantum™ board in production, the **Quantum 4** board and the **Q5** board. Both of these boards are discussed in greater detail later in this manual.

The combination of the hardware (Quantum™ board) and the software program that runs on it creates what we call the Quantum™ LX system. The Quantum™ board communicates with all of the Digital and Analog boards. This communication allows the Quantum™ to read the status of all the I/O boards, and display the data on the interface screen. The Quantum™ acts on this data, and provides the necessary control information to the I/O boards to provide the appropriate control of all input and output signals, based upon the configuration of installed features and options of the compressor package. Operator interaction is provided through the keypad, as well as informational status to the display. Interaction to the outside world is provided through industry-standard communications protocols. Additional information about the Quantum™ can be found under the QUANTUM™ CONTROLLER sections found later in this manual.

- **Power Supply** - Provides the necessary operating voltages for the proper operation of all control components. Additional information about the power supply can be found under the POWER SUPPLY sections found later in this manual.
- **Digital Input / Output Boards** - Digital (on/off) signals are sent and received by these boards. The output signals are used for energizing solenoids, valves, contactors, relays, etc., and the input signals are used to sense the condition of switches, relay contacts, auxiliary contacts, etc. This board runs an independent software program from the Quantum™ to control devices, and communicates the status of all devices back to the Quantum™. Additional information about the Digital Boards can be found under the DIGITAL BOARD section found later in this manual.

- **Analog Input / Output Boards** - Analog (variable) signals are sent and received by these boards. The output signals are used for controlling VFDs, modulated valves, etc., and the input signals are used to read the values being sent from pressure transducers, temperature sensors, etc. This board runs an independent software program from the Quantum™ to control devices, and communicates the status of all devices back to the Quantum™. The Analog board has 24 analog inputs, and 8 analog outputs. Additional information about the Analog board can be found under the ANALOG BOARD section found later in this manual.
- **Operator Interface** - This section actually consists of two major components; the Display and the Keypad. The Display is used to show the operator, via a graphical interface, the actual status of all compressor values. Warnings and shutdowns (and history/trending), pressure and temperature values, digital I/O status, setpoints, etc. are viewed on this display. The Keypad is used by the operator to enter data to the Quantum™ controller such as setpoint values, calibration data, etc. Additional information about the Display can be found under the DISPLAY section found later in this manual.

THE CONTROL PANEL ENCLOSURE

The Frick® Quantum™ LX control panel enclosure utilizes available space efficiently and the small size allows it to be used on all of our compressor packages. The panel is also equipped with the necessary posts and hardware to add options in the field. They may also include a second analog and/or digital board, enclosure heater and air-circulating fan.

Dimensions of the standard panel are 18x22x10 inches (WxHxD) and weighs approximately 75 pounds with all options. Typically the panel will be mounted on the package, but it is also designed for easy wall mounting as well. Refer to the Control Center Assembly drawing 649D5151 for the layout for this standard enclosure.

The DC power/communications harness in this panel is color-coded. This will make wire identification much easier. The coding is as follows:

- +5VDC - RED
- +12VDC - YELLOW
- -12VDC - PURPLE
- Common/Ground - BLACK
- +RX/TX - BLUE
- -RX/TX - BLUE w/WHITE stripe

GENERAL INFORMATION

The components within the control panel can be inadvertently damaged by static electricity or mis-handling. Only qualified technicians should directly handle these components.

1. DO NOT attempt to make corrections to the power supply without shutting off the power to the control panel. Accidental shorts can irreparably damage the processor boards or the display screen.
2. DO NOT HANDLE the panel boards when their cables are disconnected without first attaching a properly grounded wrist ground strap to prevent static electrical discharge from your body.

Most problems encountered with the microprocessor and control circuits will be the result of a wiring fault, a blown fuse, faulty I/O module or failure of a peripheral control such as a solenoid coil or a pressure transducer. Faults in the computer, while possible, are unlikely. If a fault develops in the computer, the probability is that all functions will cease and the display screen will go blank. The control system of the compressor consists of an AC (high voltage) side, which can be either 120 volts, or 230 volts, and a DC (low voltage) side. The AC side actuates solenoids, relays, alarms, and other electromechanical functions. The DC side operates the computer and its various sensors.

When working within the panel, the AC high voltage side, which can be either nominal 120 VAC or nominal 230 VAC, CAN CAUSE INJURY OR DEATH.

To troubleshoot the low-voltage side of the control circuits, it is necessary to have the following tools:

1. Accurate digital multimeter (capable of reading to DC/AC, mA to the hundreds place)
2. Small wire stripper
3. Small screwdriver (with insulated shaft)
4. Small snip nose pliers

5. Wrist Grounding strap
6. Static free grounded work surface

Note: Proper panel voltage refers to the AC (high volt-age) that has been supplied to the panel, which could be either nominal 120 VAC or nominal 230 VAC (Reference the Control Panel Power Specifications).

WHAT TO DO BEFORE CALLING THE FACTORY

Many times when a suspected Quantum™ problem is called in to the factory, not enough information is provided for the service personnel to assist in solving the problem. This is because the caller most likely is not aware of the type of information that would be useful to factory personnel in helping to identify and correct the problem. An example of this is the statement that the Quantum™ is not booting (the main processor board is not starting). Unfortunately, this description is usually vague and only means that there is nothing on the display. A blank screen could be the result of many different problems. The following is a list of possible reasons for no display:

- No power
- Loose or Faulty Display Cable or Inverter Cable
- Bad Display
- Bad Backlight Inverter
- Bad Backlight Fluorescent Tube
- Wrong Combination of Display, Cable, Inverter, or Software
- Faulty CPU Board

Before calling the factory for assistance, review the information on the following pages and try to discover and resolve your Quantum™ LX problem. The actual cause of most problems is usually not with the Quantum™ board itself, but with something external. However, on the rare occasion that the problem has been identified as being the Quantum™ board, use the following section as a guideline for replacing it.

NOTES:

SECTION 2

Q5 CONTROLLER

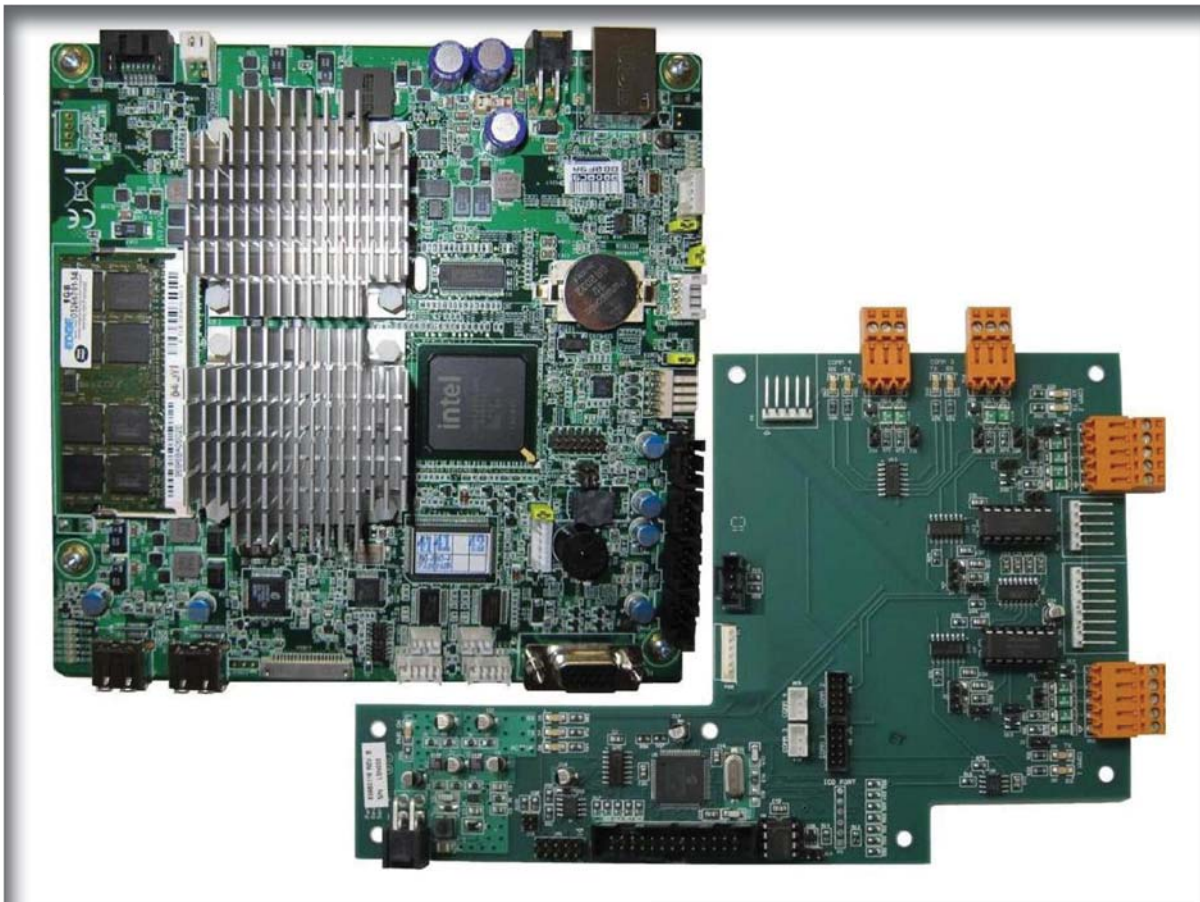

Q5 CONTROLLER BOARD

INTRODUCTION

Frick® Controls has released the latest version of the Quantum™ LX microprocessor board. This board will be referred to as the Q5. A photo of this board appears here:



FEATURES

The Q5 board includes the following features:

- 6 total USB ports (2 are dedicated, 4 are available)
- 10/100/1000 Mbps Ethernet Connection
- 2 RS-422 ports
- 2 RS-485 ports
- External Video monitor connection
- LED indicators to verify proper operation of various on board areas (power, communications, Ethernet connectivity, etc.)
- 2 GB RAM memory
- Battery to maintain date and time

WHAT SHOULD OCCUR WHEN APPLYING POWER

When powering up, the following sequence of events are indicative of a properly working main processor board:

- The six LED's in the lower left corner should turn on solid.
- The on-board "buzzer" should "beep" once.
- The display should show several DOS (text) style screens. A penguin image will appear in the upper left corner of the screen as the boot sequence progresses.

- Just before fully booting, a Loading bar will appear at the bottom of the screen, showing the percent of load that has completed.
- The Operating Status screen will appear.

After the Q5 has properly powered up, the following sequence of events is indicative of proper communication to the analog and digital boards:

- The Analog and Digital I/O boards TX/RX lights should be blinking.
- Each I/O board should have the power LED lighted and the Active LED should be blinking.
- The first thing that should be checked when troubleshooting the Quantum™ 5 board is its powering up sequence.

WHAT IF THE OPERATING STATUS SCREEN IS NOT SHOWN

If the Operating Status screen is not shown, check the following items:

1. If no LED's are lit, then check AC and DC power. Refer to the Power Supply section.
2. Check if the lighting of the LED's is occurring as described in the What Should Occur When Applying Powering section.
 - If the powering up sequence continues to repeat without displaying the Operating Status screen, then there is a booting problem.
3. Check all plugged connectors for proper seating.
4. Check if an error message is displayed when booting.
 - Be sure to write down any error messages exactly as they appear, as well as the top line on the screen where the message appears.
5. Check that the software is OK:
 - Is the correct software installed?
 - Did you just install new software?
6. Check the display. If the Q5 board is booting but you have no display, check the following:
 - Check the LCD backlight tube. Look very closely at the display to see if anything

is visible in the dark screen. Using a beam type source of good lighting, such as a flashlight, look for any ghost type image. If it appears that there is something on the screen but very dark, the problem may be with the LCD backlight tube. There is a sticker on the display mounting plate, that will have a part number that describes the type of display. If there is no sticker, you must take the display apart to identify the display manufacturer.

- Verify that both the display cable and the inverter cable are firmly seated. It may be necessary to remove the video cable from the back of the LCD display and re-seat it to be sure it is connected properly. Note: This is a small connector and caution should be observed so that it is not damaged due to excessive force.
- Refer to the Operator Interface section and check that the LCD, LCD cable, and software versions are matched correctly.

BATTERY FUNCTION AND REPLACEMENT

The Q5 board utilizes a battery to maintain correct date and time for the purpose of stamping warnings and shutdowns with the date and time that they occurred. If the date and time are not being maintained properly, this may indicate that the battery is not functioning, and should be replaced. The battery may be ordered through Baltimore Parts (P/N 333Q0001786) or may be purchased at most electronic shops (manufacturers P/N CR-2032).

The battery is fully assessable, but is surrounded by sensitive electronic components, so care should be

taken when changing.

To replace the battery, ensure that the Control Power switch has been turned OFF.

Locate the Battery socket, as shown on the following drawing:

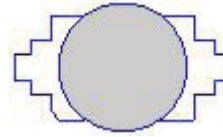

Place your fingernail under the edge of the battery, and gently lift up. The battery should release itself from the socket easily. Take a new battery and place it into the holder in the same orientation as the old battery (the side with the writing must be facing out). Return the Control Power switch back to ON.

Once the Q5 has rebooted, the correct Date and Time must be set.

Q5 INTERFACE BOARD

An interface board has been developed by Frick controls allowing the user to interface exterior connections to the Q5. A photo of this interface board is shown here:



Q5 BOARD

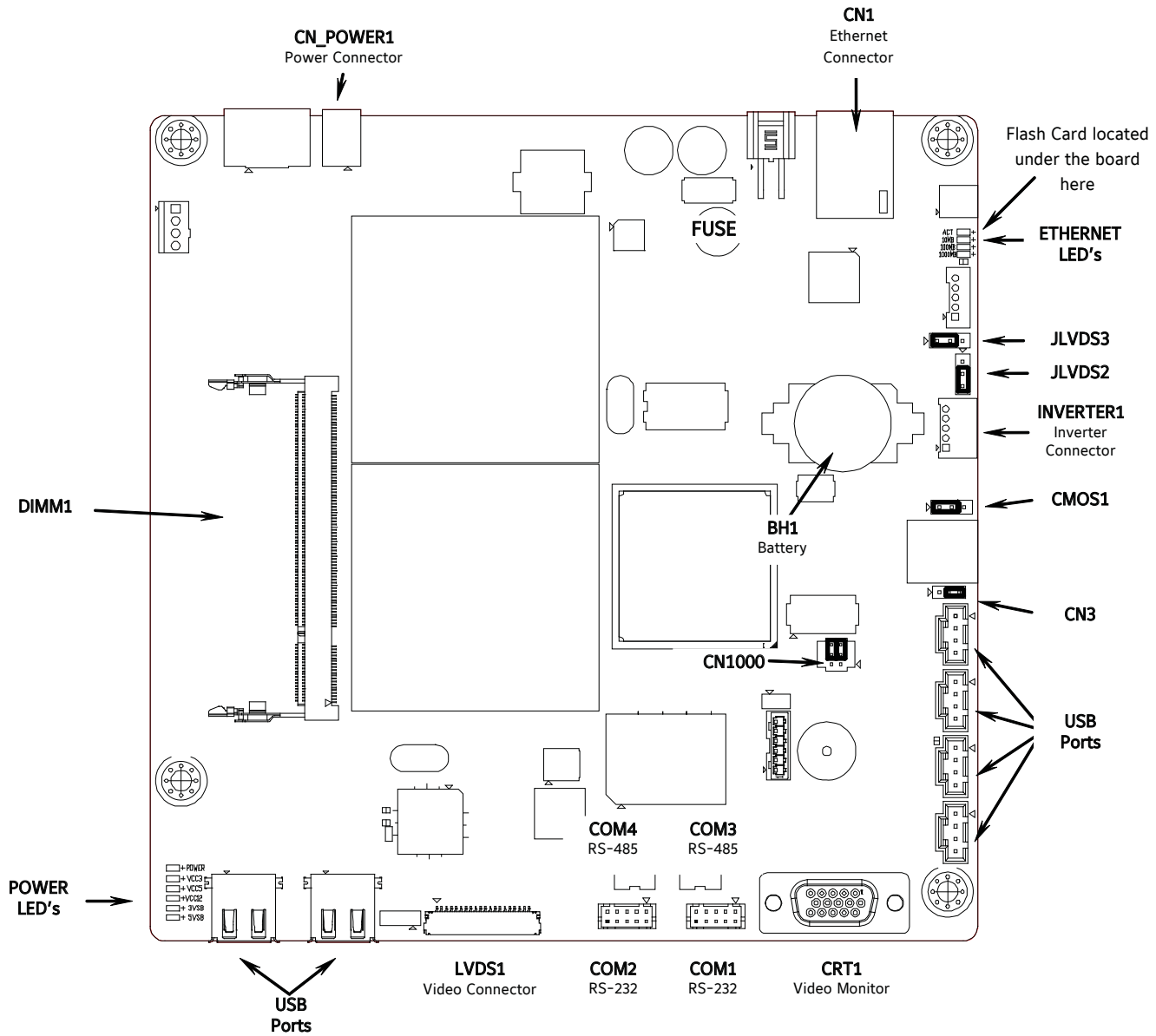

NOTE 1: The triangle symbol (\blacktriangleright) denotes Pin 1 on connectors. Refer to the chart on the following page for jumper settings.



NOTE 2: Do NOT remove the CN4 jumper. Removal of this jumper will cause the processor to not power up.

NOTE 2: Although the Q5 board is the main controller, most of customer connections will be to the Interface board, as shown later.

Q5 BOARD JUMPERS, LED'S AND CONNECTORS

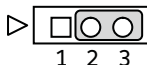
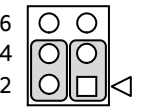
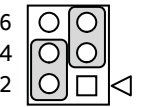
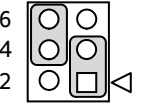
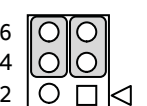
JUMPER TABLE

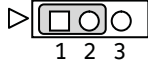
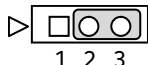
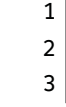
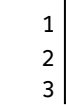
Jumper Title	Function	Jumper Setting	
CMOS1 (CMOS Clear)	Normal (default)		1 - 2 Closed
	Clear CMOS		2 - 3 Closed
CN1000 (LCD Resolution Selector)	24-bit 800x600		1-3 Closed & 2-4 Closed
	24-bit 1024x768		3-5 Closed & 2-4 Closed
	18-bit 800x600		1-3 Closed & 4-6 Closed
	18-bit 640x480 (default)		3-5 Closed & 4-6 Closed

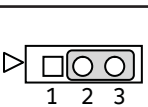
Jumper Title	Function	Jumper Setting	
CN3 (Touch Panel Type Selector)	5-Wire Touch Screen		1-2 Closed
	8-Wire Touch Screen (default)		2-3 Closed
JLVDS2 (Backlight Level Selector)	0- 5V (default)		2-3 Closed
	0 - 2.5V		1-2 Closed
JLVDS3 (Backlight Control Mode)	Voltage Mode (default)		1-2 Closed
	PWM Mode (Pulse Width Modulation)		2-3 Closed

NOTE 1: The triangle symbol (▷) denotes Pin 1 on connectors.

NOTE 2: Jumper CN4 is not shown on this chart, as it must always be installed.

LED DEFINITION TABLE

LED Title	Label	Color	Function
Power LED's	LED1	Red	5VSB
	LED2	Red	3VSB
	LED3	Green	VCC 12V
	LED4	Green	VCC 5V
	LED5	Green	VCC 3V
	LED6	Blue	Power On OK Status
CN1000 (LCD Resolution Selector)	1000MB	Green	Giga - LAN Speed
	100MB	Yellow	100MB - LAN Speed
	10MB	Red	10MB -LAN Speed
	ACT	Green (Blinks)	LINK Activity

CONNECTOR PINOUT TABLE

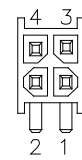
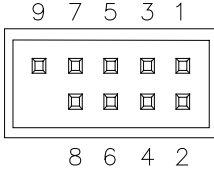
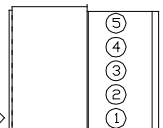
Connector Title	Pin	Function	
CN_PWR1 (Power Input)	1	Ground (GND)	
	2	Ground (GND)	
	3	VCC 12V	
	4	VCC 5V	
COM1 & COM2 (RS-232 Communications)	2	Receive (RX)	
	3	Transmit (TX)	
	5	Ground (GND)	
COM3 & COM4 (RS-485 Communications)	1	-RX/TX	
	2	+RX/TX	
	3	Ground (GND)	

Q5 INTERFACE BOARD

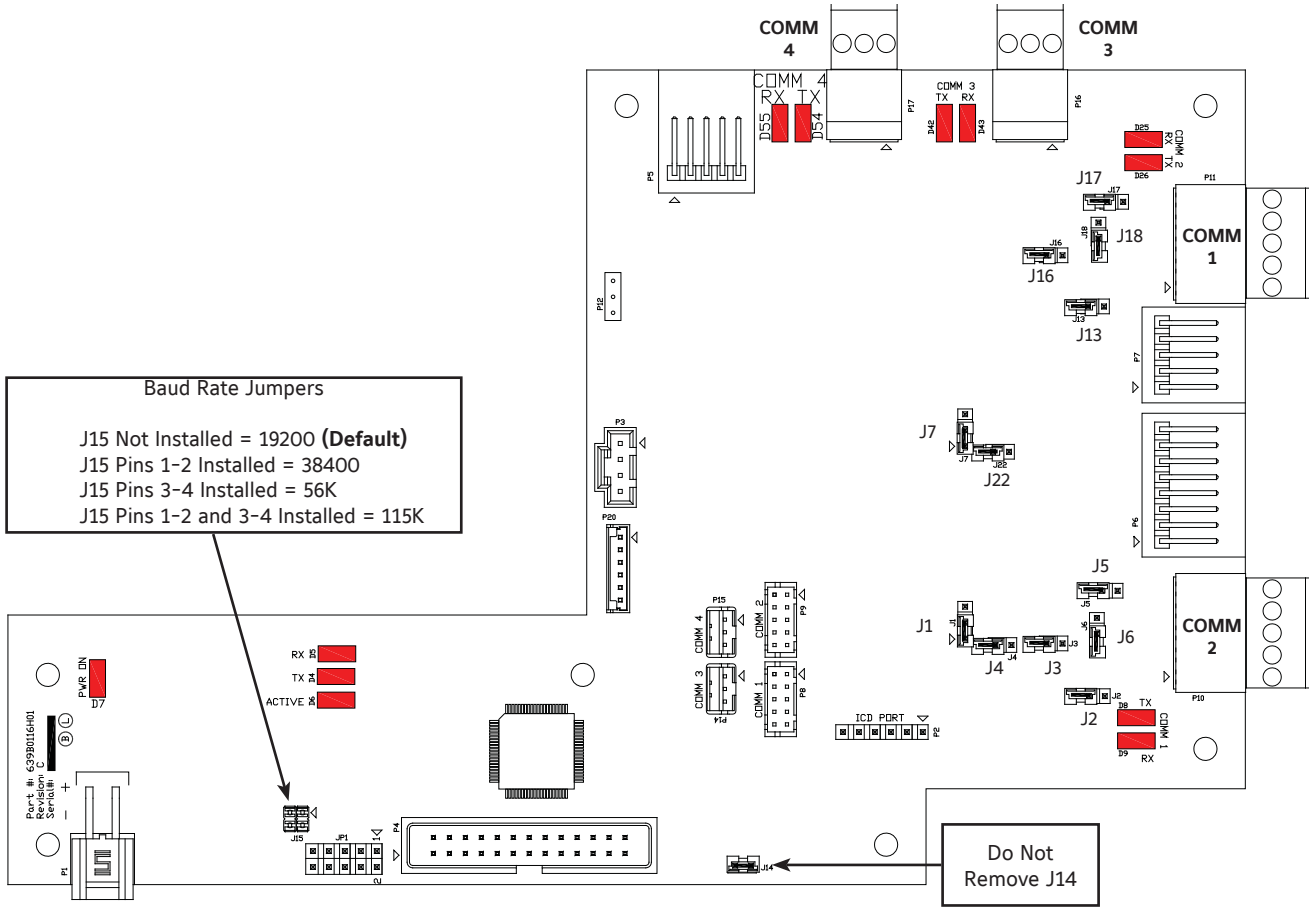

COMM 1 JUMPER SETTINGS

Jumper Title	Function	Jumper Setting	
J1	RS-422 (4-Wire) Default		1 - 2 Closed
	RS-485 (2-Wire)		2 - 3 Closed
J2	Pull Down Default		1 Pin Only
J3	Pull Up Default		1 Pin Only
J4	RS-422 Default		1 Pin Only
J5	Pull Down Default		1 Pin Only
J6	Pull Up Default		1 Pin Only

NOTE: The triangle symbol (◁) denotes Pin 1 on connectors.

COMM 2 JUMPER SETTINGS

Jumper Title	Function	Jumper Setting	
J7	RS-422 (4-Wire) Default		1 - 2 Closed
	RS-485 (2-Wire)		2 - 3 Closed
J13	Pull Down Default		1 Pin Only
J16	Pull Up Default		1 Pin Only
J17	RS-422 Default		1 Pin Only
J18	Pull Down Default		1 Pin Only
J22	Pull Up Default		1 Pin Only

NOTE: The triangle symbol (◁) denotes Pin 1 on connectors.

Q5 INTERCONNECTIONS

The pictorial below depicts the Q5 motherboard, and the necessary interconnects between it and the Interface

board. Each of the interconnecting harnesses must be installed as shown for proper operation.

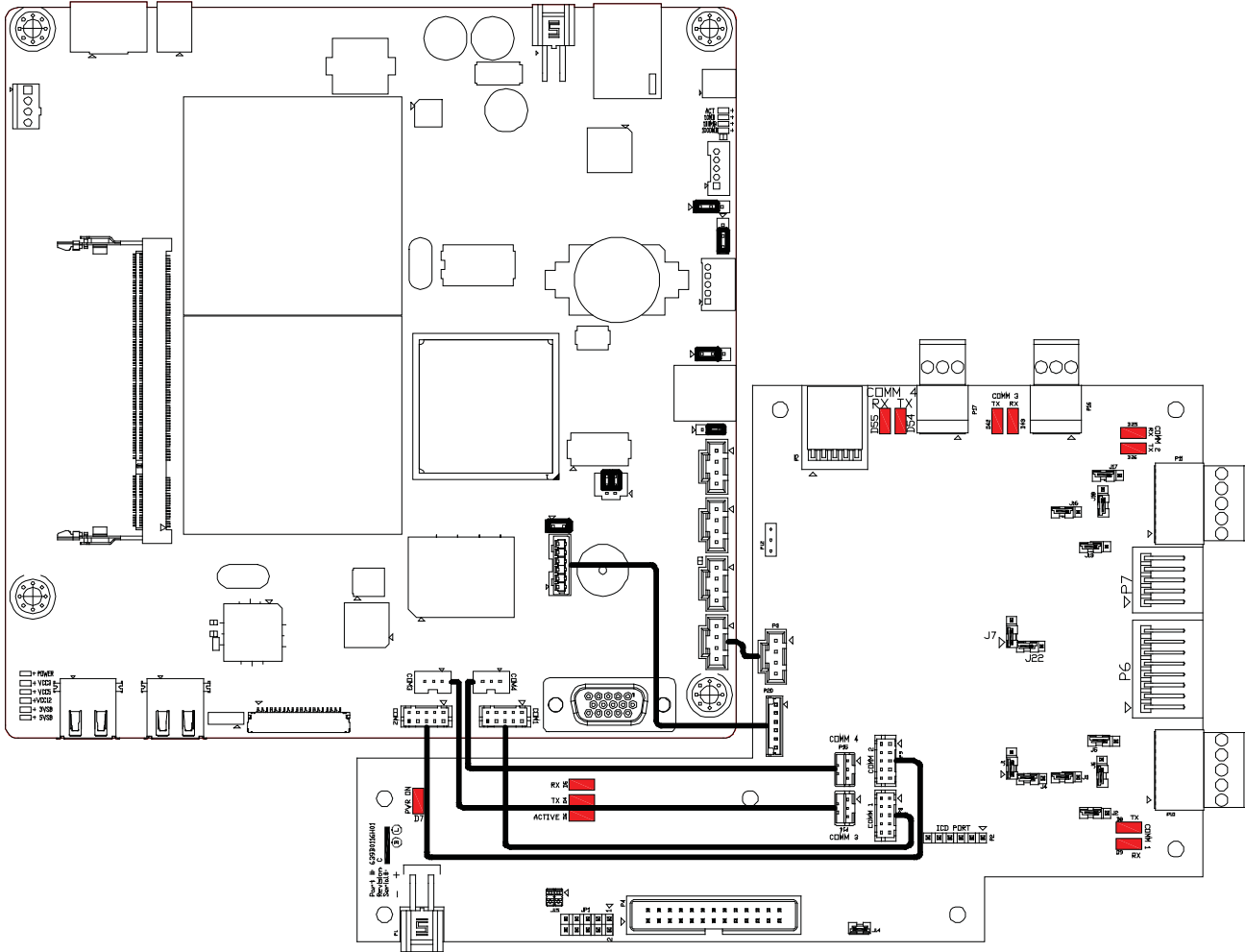

POWER SUPPLY (Q5)

DESCRIPTION

The power supply of the Q5 control panel consists of three independent supplies, and are located on the inside of the front door below the Interface board. They supply the following DC voltages:

- +5 VDC
- +12 VDC
- +24 VDC

All three supplies are adjustable and each has an indicator to show that they are powered. Refer to the following page for the location for the adjustment.

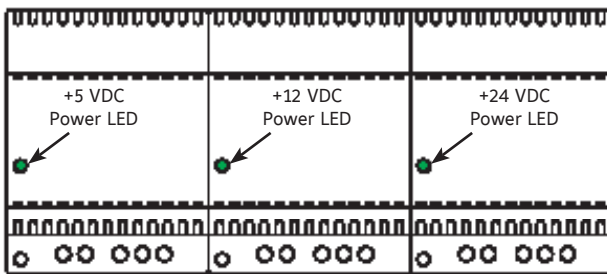

Power Supplies

POWER DISTRIBUTION

DC power coming from the power supplies is wired directly to a series of terminal blocks. The terminals for these voltages are labeled as follows:

- Common (1000)
- +24 VDC (1001)
- +5 VDC (1003)
- +12 VDC (1004)

Power is then distributed to the Q5 processor board, Interface Board, and Digital/Analog I/O boards from these terminals.

MEASURING VOLTAGES

CAUTION! Measuring and adjusting the power supply voltages require the control power switch to be energized. Extreme care must be observed when taking any readings, as 120 or 230 VAC (depending on incoming system voltage) will be present next to the DC voltage connector. Adjusting the supplies requires the use of a small Philips screwdriver inserted into the supply to access an adjusting potentiometer. **CAUTION: It is possible for the screwdriver (and the person making the adjustment) to come into contact with potentially lethal voltages. Proper Personal Protective Equipment (PPE) measures need to be observed.**

All circuit boards within the Q5 control panel require accurately adjusted DC voltages in order to function properly. Periodic measurement and adjustment of

the DC power system is recommended for optimum system operation. Over time, it is possible for temperature, humidity, vibration and component age, to degrade the accuracy of these voltages. When any of the DC voltages begin to stray from their optimum range, mysterious problems can begin to arise.

Even with a perfectly adjusted supply, it is possible for a potential drop in voltage at each connection point. This drop normally is in the millivolt range, but under some conditions, the drop can be much greater (as high as tenths of a volt). By the time the voltage reaches the last board in the daisy chain, and all of these potential voltage drops are considered, the combined drop can be such that problems can be apparent. Some examples of problems could be:

- Loss of or intermittent communications failures.
- A shutdown message stating Digital Board x Reset (where "x" is replaced by the number of the Digital Board that failed).
- An shutdown message stating Digital Board x Comm. Fail - Shutdown (where "x" is replaced by the number of the Digital Board that failed).
- An shutdown message stating Analog Board x Comm. Fail - Shutdown (where "x" is replaced by the number of the Analog Board that failed).
- Numerous sensor fault shutdown messages.
- Q5 reboots for no apparent reason.
- Improper readings of analog pressures and temperatures.
- LED's on the Q5 are lit, but nothing appears on the display.

To perform measurements and adjustments on the power supply voltages, use a reliable, calibrated Digital Volt Meter (DVM). The DVM should be accurate to 1/100 of a volt DC. With the control power switch turned ON, wait until the Operating Screen appears. This is because the graphics required to create this screen will draw more current than when the screen is showing the normal POST (DOS) style messages during a boot up. If the screen never appears however (possibly due to a voltage problem), you will need to proceed regardless of what is or is not displayed.

In order to properly measure the DC power system, it must be checked at the DC power terminal strip.

ADJUSTMENT

Ensure that the meter is set to the proper range (DC, 0-50 V or equivalent), as well as observing proper wire polarity. The power supply drawing shown on the following page applies to all three power supplies. The adjustment access hole for each supply is located on the lower left of the front of the supplies. If an adjustment is required, use a thin, Philips screwdriver, insert the tip into the access hole for the appropriate voltage potentiometer (refer to the diagram on the following page for adjustment location). **NOTE: Extreme care must be used when adjusting the potentiometer. Adjustment should only be performed by qualified personnel. The use of a non-conductive device is recommended.**

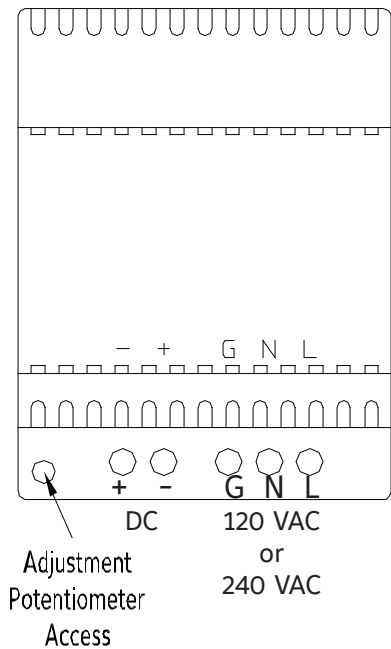

+5 VDC Adjustment

Locate the DC power terminal strip. Terminal 1003 is the +5 VDC, and 1000 is common (COM). Place the negative lead on 1000, and the positive lead on 1003. Verify that the DVM is displaying in the range of +5.08 to +5.12.

If adjustment is required, locate the adjustment access hole on the +5 VDC supply, as previously shown. While watching the DVM, slowly rotate the screwdriver blade clockwise to increase the voltage or counter-clockwise to decrease until the voltage is correctly adjusted.

+12 VDC Adjustment

Locate the DC power terminal strip. Terminal 1004 is the +12 VDC, and 1000 is common (COM). Place the negative lead on 1000, and the positive lead on 1004. Verify that the DVM is displaying in the range of +11.98 to +12.10.

If adjustment is required, locate the adjustment access hole on the +12 VDC supply, as previously shown. While watching the DVM, slowly rotate the screwdriver blade clockwise to increase the voltage or counter-clockwise to decrease until the voltage is correctly adjusted.

+24 VDC Adjustment

Locate the DC power terminal strip. Terminal 1001 is the +24 VDC, and 1000 is common (COM). Place the negative lead on 1000, and the positive lead on 1001. Verify that the DVM is displaying in the range of +23.95 to +24.05.

If adjustment is required, locate the adjustment access hole on the +24 VDC supply, as previously shown. While watching the DVM, slowly rotate the screwdriver blade clockwise to increase the voltage or counter-clockwise to decrease until the voltage is correctly adjusted.

POWER SUPPLY REPLACEMENT

If any of the power supplies are found to be bad, or not capable of acceptable adjustment, the failing supply will need replacing. Refer to the Recommended Spare Parts list for the appropriate part number.

Q5 FLOW DIAGRAM - D.C. VOLTAGE/COMMUNICATIONS HARNESS

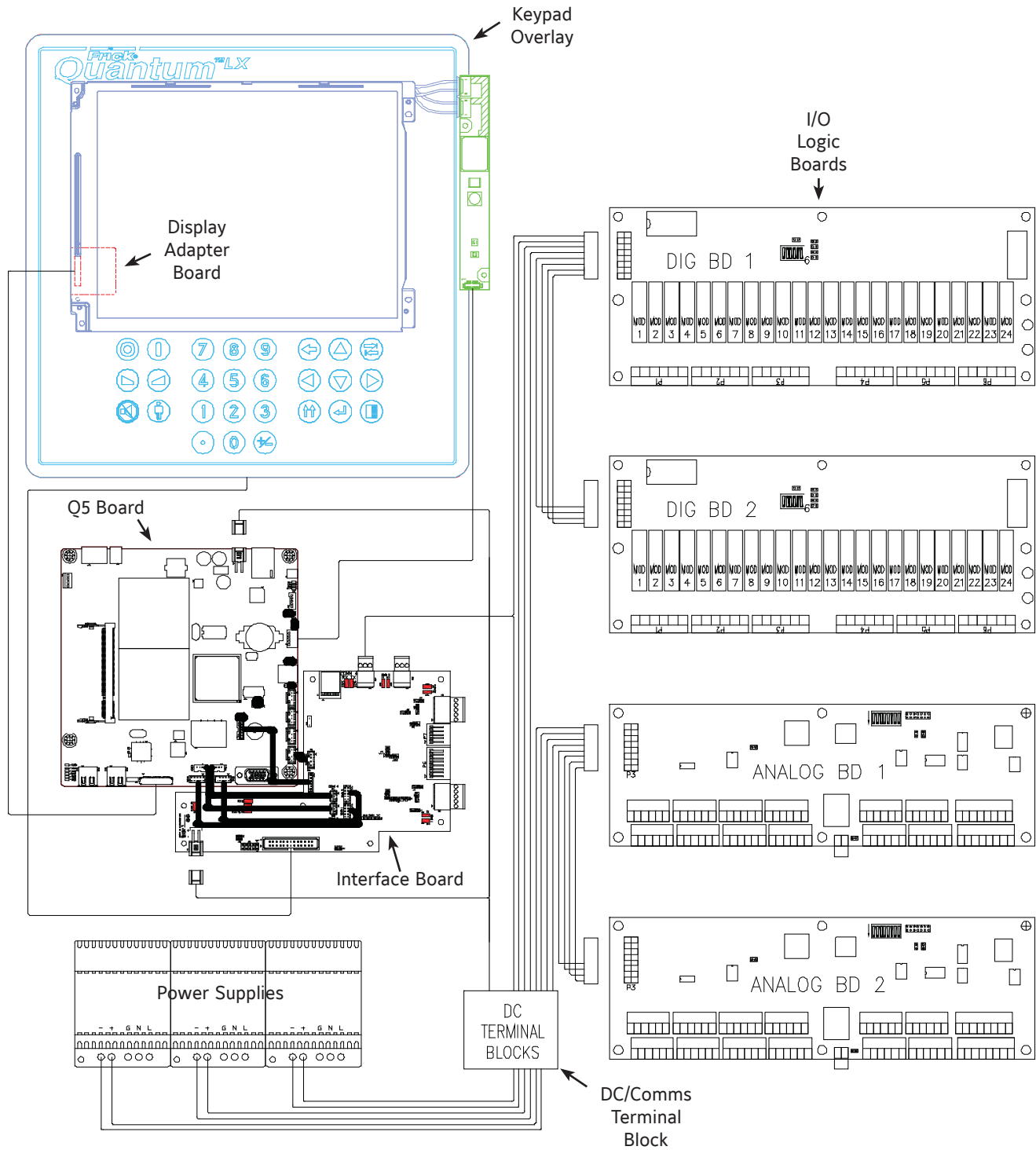

This pictorial represents a typical configuration using the Q5, and is not to scale. Specific units may or may not have both Digital and Analog boards, depending on options. Additionally, exact wiring to and from the DC Power Terminals is for reference only. The pictorial is meant to show the proper interconnection of the D.C. power - I/O communications harness, keyboard cable and display harness and hardware components. Refer to the wiring diagrams later in this manual for exact connections.

**Q5 RDB / RWB II / RWF / RXF (58-101) CONTROL CENTER ASSEMBLY
(SHEET 1 OF 4)**

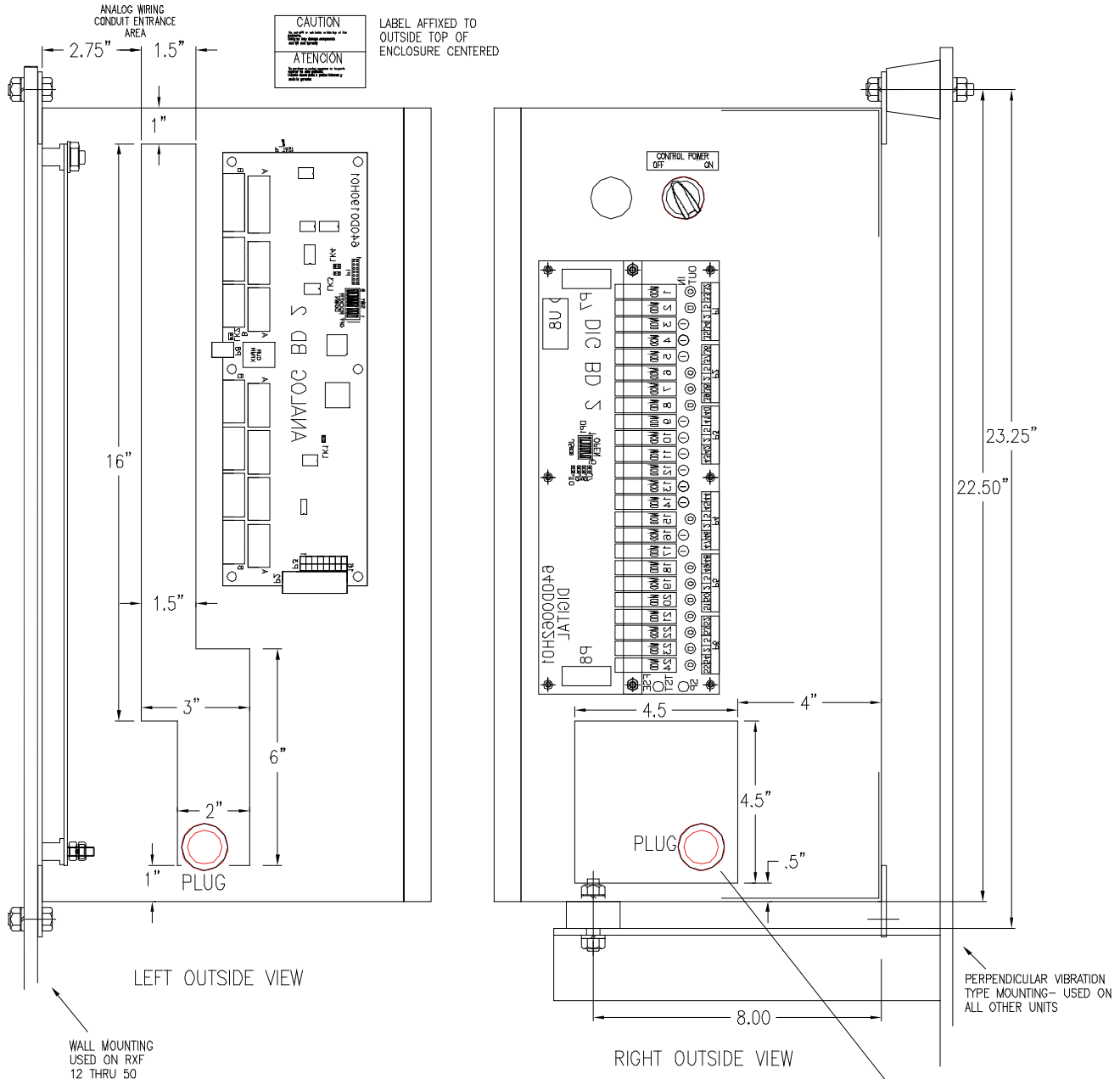

NOTES:
 -ALL REFERENCES TO LEFT & RIGHT SIDE OF PANELS ARE FACING THE PANEL FROM THE FRONT
 -RXF 12 THRU 50 UNITS USE THE BACK MOUNTING FLANGES TO MOUNT ENCLOSURE. PLUG TWO BOTTOM MOUNTING HOLES AT UNIT ASSEMBLY

This drawing appears here for reference purposes only, and is subject to change without notice. When installing, or servicing equipment, always refer to the actual drawings that are included with the control panel for the latest information.

Q5 RDB / RWB II / RWF / RXF (58-101) CONTROL CENTER ASSEMBLY (SHEET 2 OF 4)

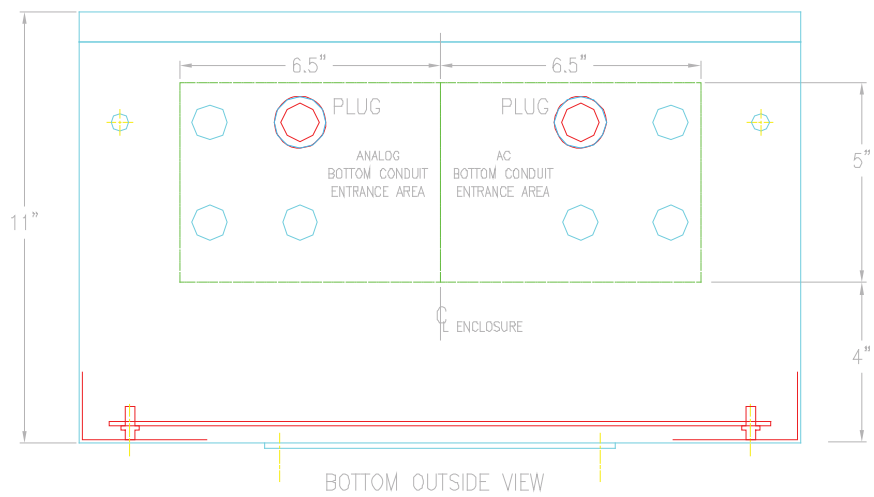
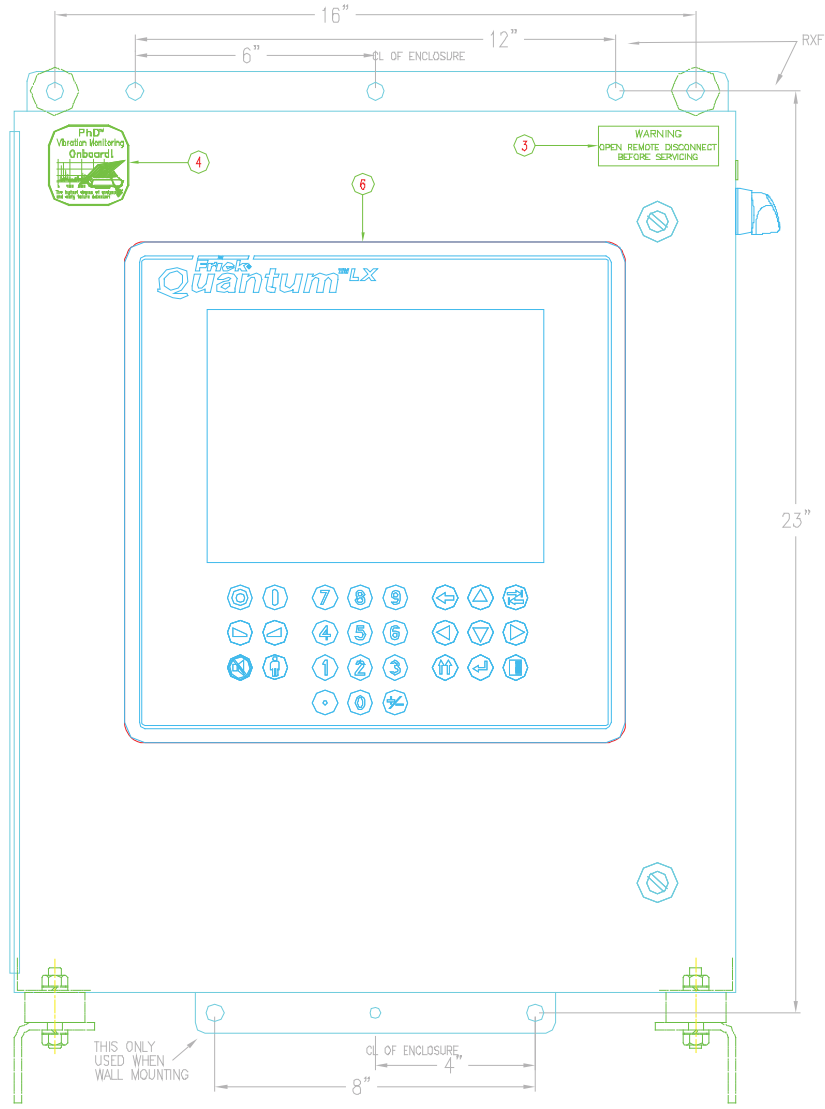

This drawing appears here for reference purposes only, and is subject to change without notice. When installing, or servicing equipment, always refer to the actual drawings that are included with the control panel for the latest information.

**Q5 RDB / RWB II / RWF / RXF (58-101) CONTROL CENTER ASSEMBLY
(SHEET 3 OF 4)**

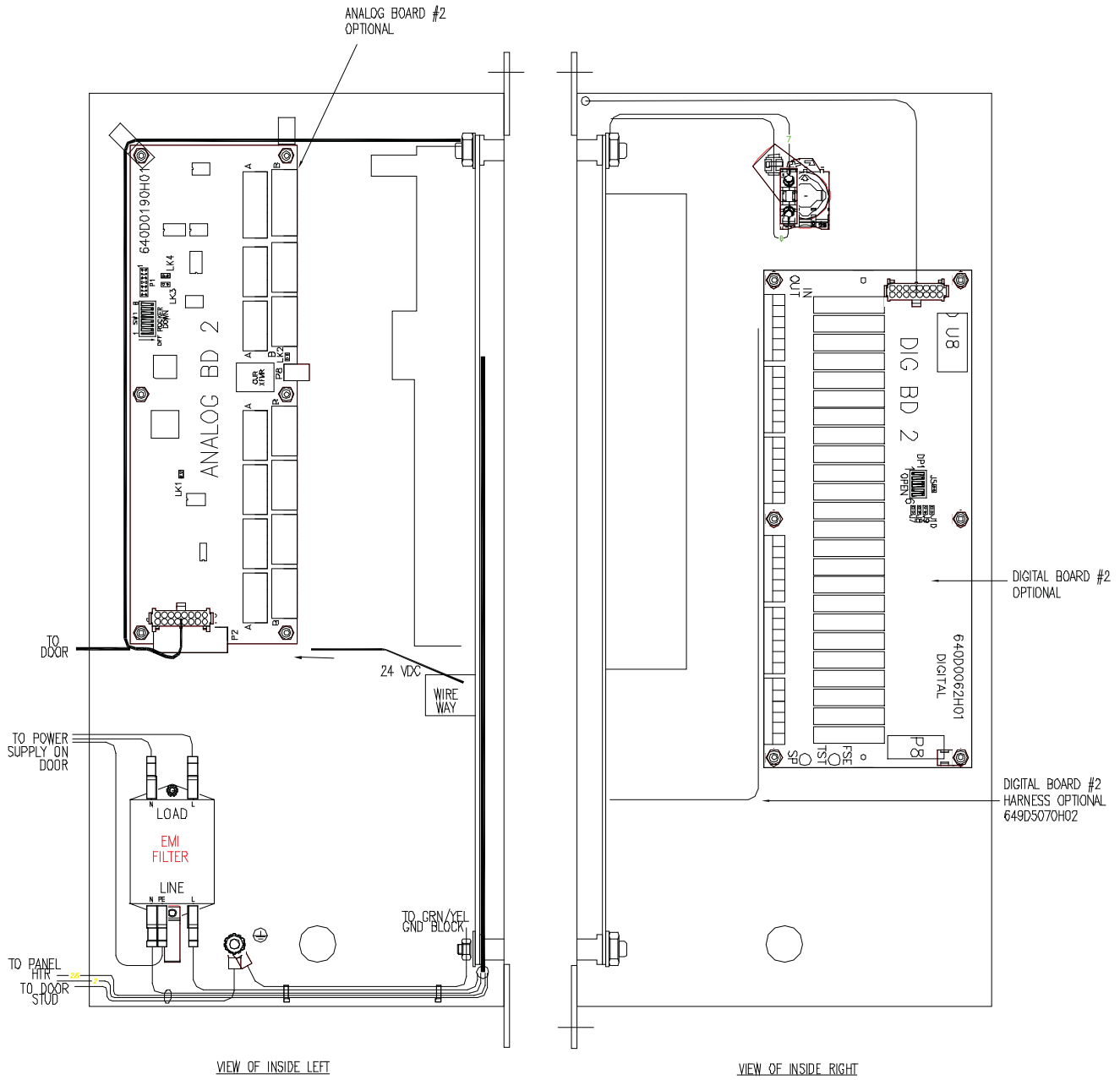

This drawing appears here for reference purposes only, and is subject to change without notice. When installing, or servicing equipment, always refer to the actual drawings that are included with the control panel for the latest information.

Q5 I/O & DC POWER HARNESS

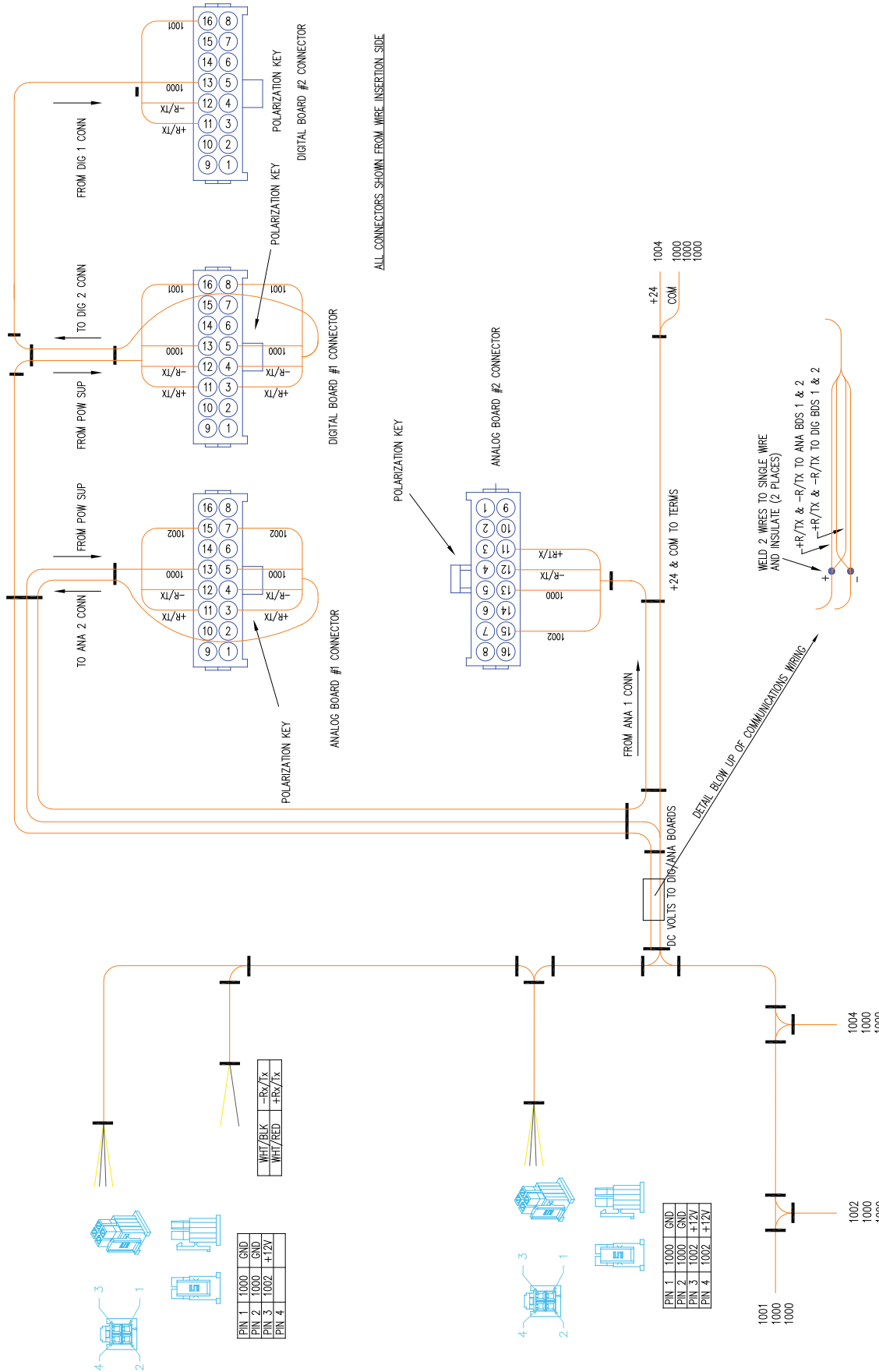

Q5 A.C. POWER HARNESS (DIGITAL BOARD 2)

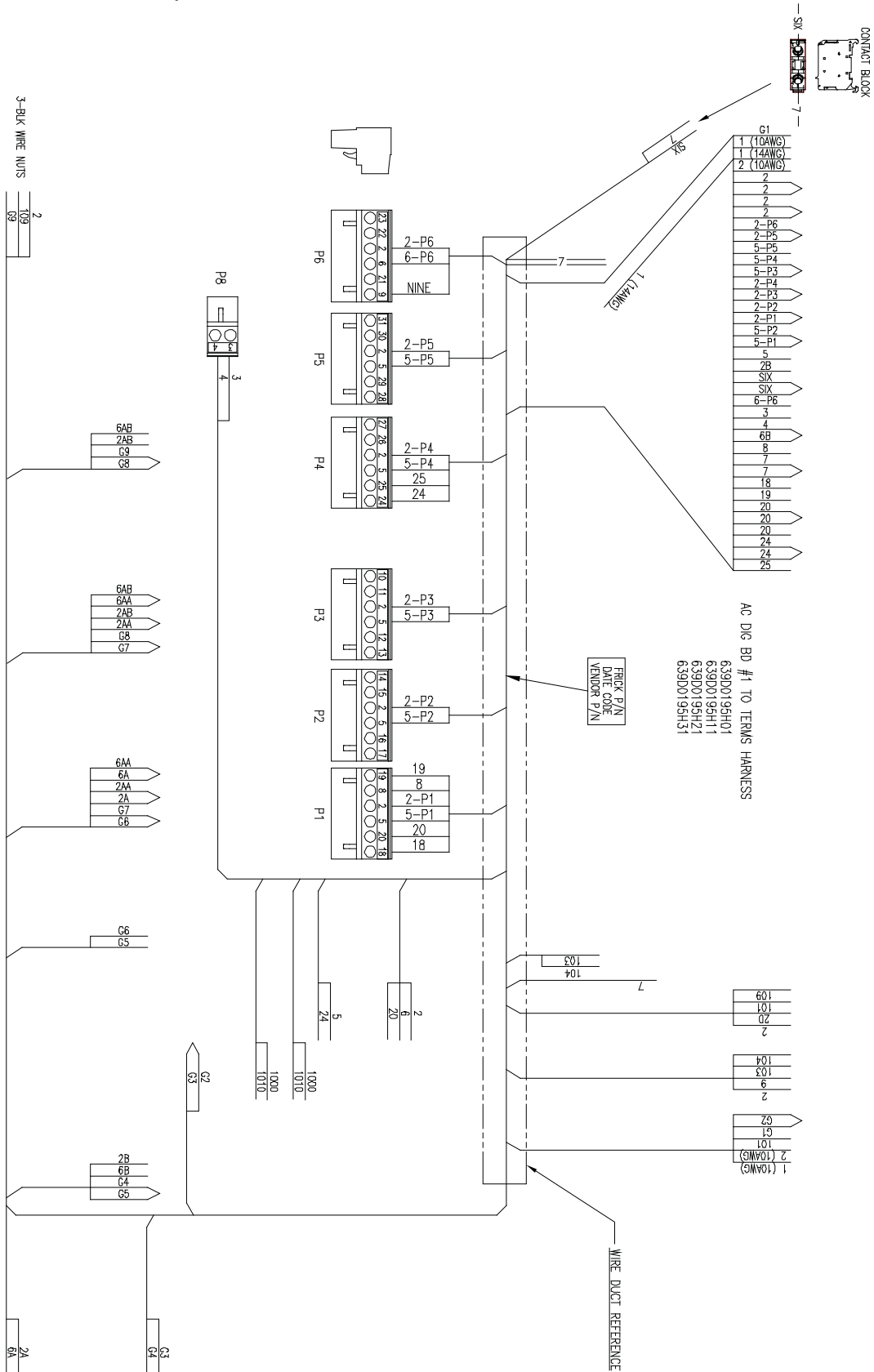

Q5 A.C. POWER HARNESS

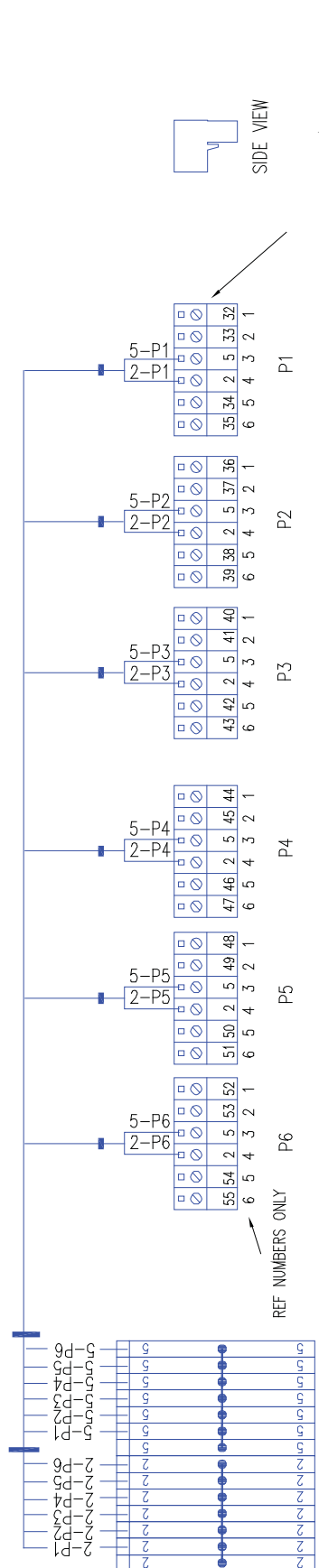

Q5 COMPRESSOR REPLACEMENT PARTS (PAGE 1 OF 2)

Legacy Number	New Number	Description
Analog Boards		
640C0057G01	484532	Analog Board #1 (Replaces existing 32 channel board #1 only - no hardware)
640C0057G02	484533	Analog Board #2 (Replaces existing 32 channel board #2 only - no hardware)
640C0057G11	484534	Analog Board #1 (Field Upgrade Kit - Includes 32 channel board #1, connectors & hardware.)
640C0057G12	484535	Analog Board #2 (Field Upgrade Kit - Includes 32 channel board #2, connectors & hardware.)
Circuit Breakers		
639A0206H10	484050	10 Amp circuit breaker
639A0206H15	484053	15 Amp circuit breaker
639A0206H20	484055	20 Amp circuit breaker
Connectors		
649B0903H01	486156	2-Pole connector (P8 - Analog Board)
333Q0001258	467049	6-Pole connector (P1 through P6 - Digital Board, P4A through P10B - Analog Board)
333Q0001234	467040	8-Pole connector (P11A and P11B - Analog Board)
649B0903H02	486157	9-Pole connector (P2 - Analog Board)
Control Power		
333Q0001418	467096	Filter, Line
333Q0001191	467024	Hour meter
639A0185H10	483963	2-Pos. Selector Switch (Control Power)
639A0185H30	483966	Latch, 3 Across (Attaches contact block to switch mechanism)
639A0185H31	483967	Normally Open Contact Block (for Control Power Switch)
639B0120H51	680313	Socket, Guarded, DPDT
639B0114H51	580348	Socket, Guarded, 3PDT
639B0114H98	580349	Spring Clip Hold Down
639B0120H01	680049	Relay, Control 24VDC, DPDT
639B0120H11	680311	Relay, Control 120VAC, DPDT
639B0120H21	680312	Relay, Control 240VAC, DPDT
639B0114H02	580342	Relay, Control 24VDC, 3PDT
639B0114H12	580345	Relay, Control 120VAC, 3PDT
639B0114H22	580347	Relay, Control 240VAC, 3PDT
639B0120H51	680313	Socket, Guarded, DPDT
111Q0280958	455040	Surge suppresser
Digital Boards		
333Q0001172	467015	Output Module, 24 VDC
111Q0281061	455056	Output Module, 24-280 VAC
333Q0001171	467014	Input Module, 24 VDC
333Q0000116	466842	Input Module, 120 VAC
333Q0000789	466949	Input Module, 230 VAC
333Q0001326	467073	Fuse, 5 amp, 250 V
640C0024G01	484494	Digital Board #1 (Replaces existing board only - no hardware)
640C0024G02	484495	Digital Board #2 (Replaces existing board only - no hardware)
649D5210G11	486364	Digital Board #2 (Field Upgrade Kit- adds a second digital board for 22 x 18 x 10 panels)

Q5 COMPRESSOR REPLACEMENT PARTS (PAGE 2 OF 2)

Legacy Number	New Number	Description
Display Accessories		
333Q0001955	548882	Backlight (Sharp dual-bulb - 4 wire)
639A0261H01	484329	CCFT inverter
639A0278H01	548266	Display Adapter Board (Bat Wing for Q5)
640A0032H02	569676	Plexiglas (mounts in front of display) - Dimensions 7.0" x 8.9" (plate has a notch)
Flash Cards and Software		
649A0884Gxx	N/A	Quantum™ LX Program Flash Card (<i>the xx indicates program version</i>)
649A1063G01	485994	Quantum™ LX program upgrade (USB Drive)
649A1063G99	485995	Quantum™ LX Setpoint Saver (USB Drive)
649D5236G11	486386	Quantum LX upgrade kit (<i>upgrades from Quantum 4 to Quantum™ LX, includes Frick ® logo keypad and flash card</i>)
Harnesses		
639D0193H01	694589	DC power-I/O Comms harness
639D0195H01	694590	AC harness for Digital board # 1
639D0195H02		AC harness for Digital board # 2
639D0191H01	677557	Harness Kit, Interface to Q5 board.
639B0117H01	670741	Display Harness
639B0104H01	552141	Inverter Harness
Keypads		
640D0186H01	484621	Keypad/overlay with Frick logo (Quantum LX)
640D0060H11	484556	Keypad/overlay with Frick logo for upgrading from Quantum to Quantum LX
Miscellaneous		
333Q0001786	N/A	Battery, 3V (located on Q5 board)
Panel Heaters		
640M0007G16	484626	200 W, 115 VAC
640M0007G18	484627	400 W, 115 VAC
640M0007G27	484632	200 W, 220 VAC
640M0007G21	484629	400 W, 220 VAC
Power Supply		
639B0115H01	642307	DC power supply - 5 VDC
639B0115H02	642308	DC power supply - 12 VDC (Same supply is used for +12 and -12 VDC)
639B0115H03	642309	DC power supply - 24 VDC
Q5 Boards		
639C0141G01	686440	Q5 (Advantech Q5)
639B0116H01	677556	Interface Board

REMANUFACTURED PARTS

Legacy Number	New Number	Description
640C0024S01	N/A	Digital I/O Board
640C0057S01	484537	Analog I/O Board (32 Channel)

NOTES:

SECTION 3

QUANTUM 4 CONTROLLER

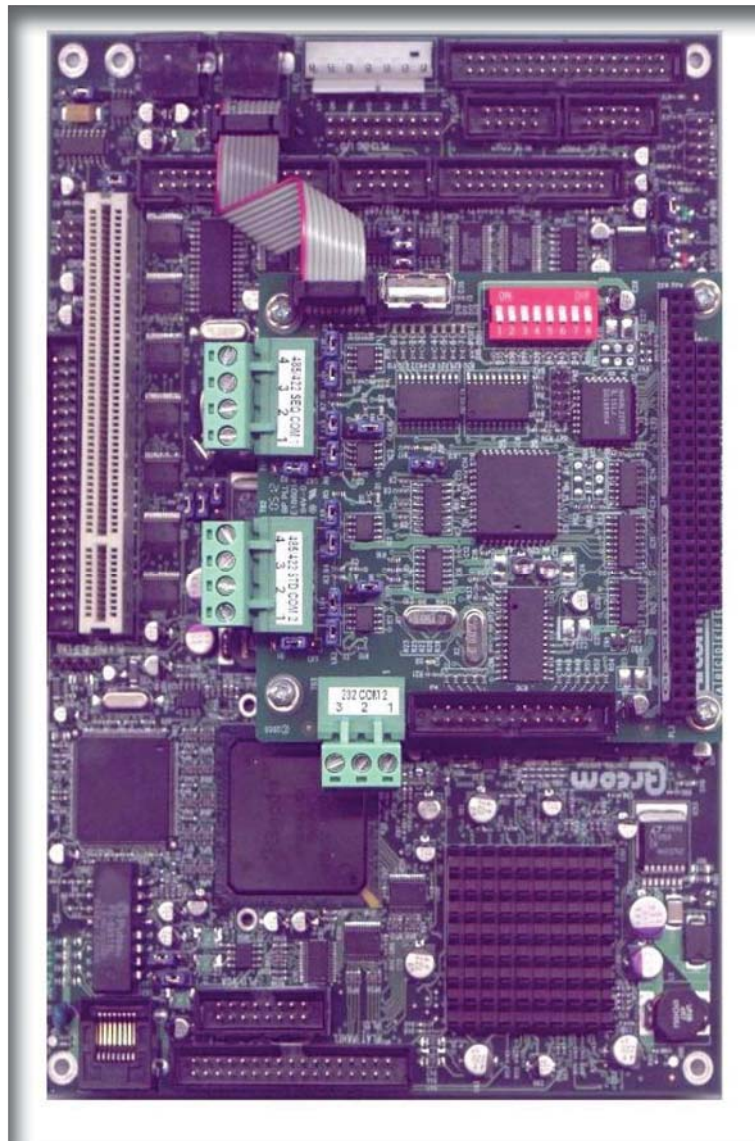

QUANTUM 4 CONTROLLER BOARD

INTRODUCTION

Frick® Controls has strived to remain on the cutting edge of microprocessor technology and development. Because of the ever-increasing speed, memory features, and power of microprocessors, Frick® will continue to introduce the latest advancement in microprocessor control technology.

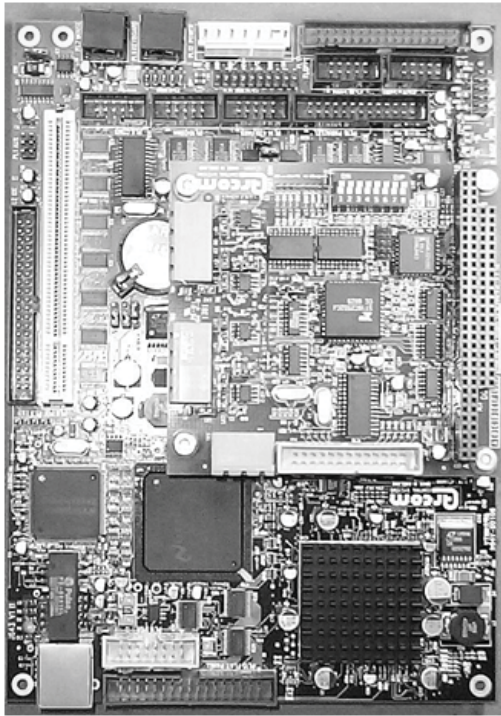

Quantum 4 Board

WHAT SHOULD OCCUR WHEN APPLYING POWER

The first thing that should be checked when troubleshooting the Quantum 4 board is its powering up sequence.

When powering up the Quantum 4, the following sequence of events are indicative of a properly working main processor board:

- Green PWR (Power) LED will turn on solid.
- Red FLASH LED will flash several times early in the boot sequence. It is normally not lit.
- LED D8 (on the smaller board) will start to blink at the rate of about once-per-second. It will continue to blink after the Quantum 4 has booted. The only time that this flashing rate is interrupted, is when a key is pressed on the keypad.
- The display should show several DOS (text) style screens. A penguin image will appear

in the upper left corner of the screen as the boot sequence progresses.

- Just before fully booting, a Loading bar will appear at the bottom of the screen, showing the percent of load that has completed.
- The Operating Status screen will appear.

After the Quantum 4 has properly powered up, the following sequence of events is indicative of proper communication to the analog and digital boards:

- The Analog and Digital I/O boards TX/RX lights should be blinking.
- Each I/O board should have the power LED lighted and the Active LED should be blinking.

WHAT IF THE OPERATING STATUS SCREEN IS NOT SHOWN

If the Operating Status screen is not shown, check the following items:

1. If no LED's are lit, then check AC and DC power. Refer to the Power Supply section.
2. Check if the lighting of the LED's is occurring as described in the What Should Occur When Applying Powering section.
 - If the powering up sequence continues to repeat without displaying the Operating Status screen, then there is a booting problem.
3. Check for bad connections.
4. Check if an error message is displayed when booting.
 - Be sure to write down any error messages exactly as they appear.
5. Check that the software is OK:
 - Is the correct software installed?
 - Did you just install new software?
6. Remove Flashcard and reboot. This will cause the Quantum 4 to boot under a pre-LX operating software. If it boots properly under this older software, then trying re-booting from the Flashcard again. If it doesn't boot with the card, then the Flashcard could be corrupted, and needs to be replaced.

7. Check the display. If the Quantum 4 board is booting but you have no display, check the following:

- Check the LCD backlight tube. Look very closely at the display to see if anything is visible in the dark screen. Using a beam type source of good lighting, such as a flashlight, look for any ghost type image. If it appears that there is something on the screen but very dark, the problem may be with the LCD backlight tube. On the LG Philips, NEC and Sharp displays this tube is field replaceable. On the Samsung LCD display it is not available and the display will have to be replaced. There may be a sticker on the display mounting plate. If there is, it will have a part number that describes the type of display. If there is no sticker, you must take the display apart to identify the display manufacturer.
- Verify that both the display cable and the inverter cable are firmly seated. These cables both originate from the same connector on the Quantum 4. It may be necessary to remove the video cable from the back of the LCD display and re-seat it to be sure it is connected properly. Note: This is a small connector and caution should be observed so that it is not damaged due to excessive force.
- Refer to the Operator Interface section and check that the LCD, LCD cable, and software versions are matched correctly.

BATTERY FUNCTION AND REPLACEMENT

The Quantum 4 board utilizes a battery to maintain correct date and time for the purpose of stamping warnings and shutdowns with the date and time that they occurred. If the date and time are not being maintained properly, it may indicate that the battery is not functioning, and should be replaced. The battery may be ordered through Baltimore Parts (P/N 333Q0001786) or may be purchased at most electronic shops (manufacturers P/N CR-2032).

The battery is partially covered by the communications daughter board, and is located directly beneath the COM1 port (it may be necessary to unplug any connector that is plugged into COM1 to fully access the battery).

To replace the battery, ensure that the Control Power switch has been turned OFF.

Locate the Battery Release Clip on the following drawing:

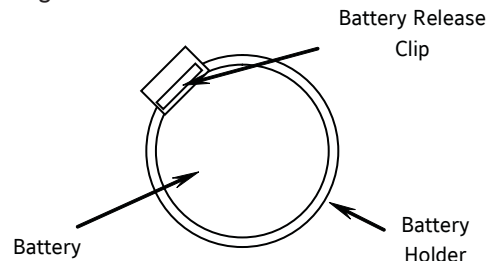

Simply push the clip away from the battery, to release the battery from the holder. Remove the battery, observing the orientation. Take a new battery and place it into the holder in the same orientation as the old battery (the side with the writing must be facing out). Reinstall the COM1 plug (if removed), and return the Control Power switch back to ON.

Once the Quantum 4 has rebooted, the correct Date and Time must be set.

QUANTUM 4 BOARD

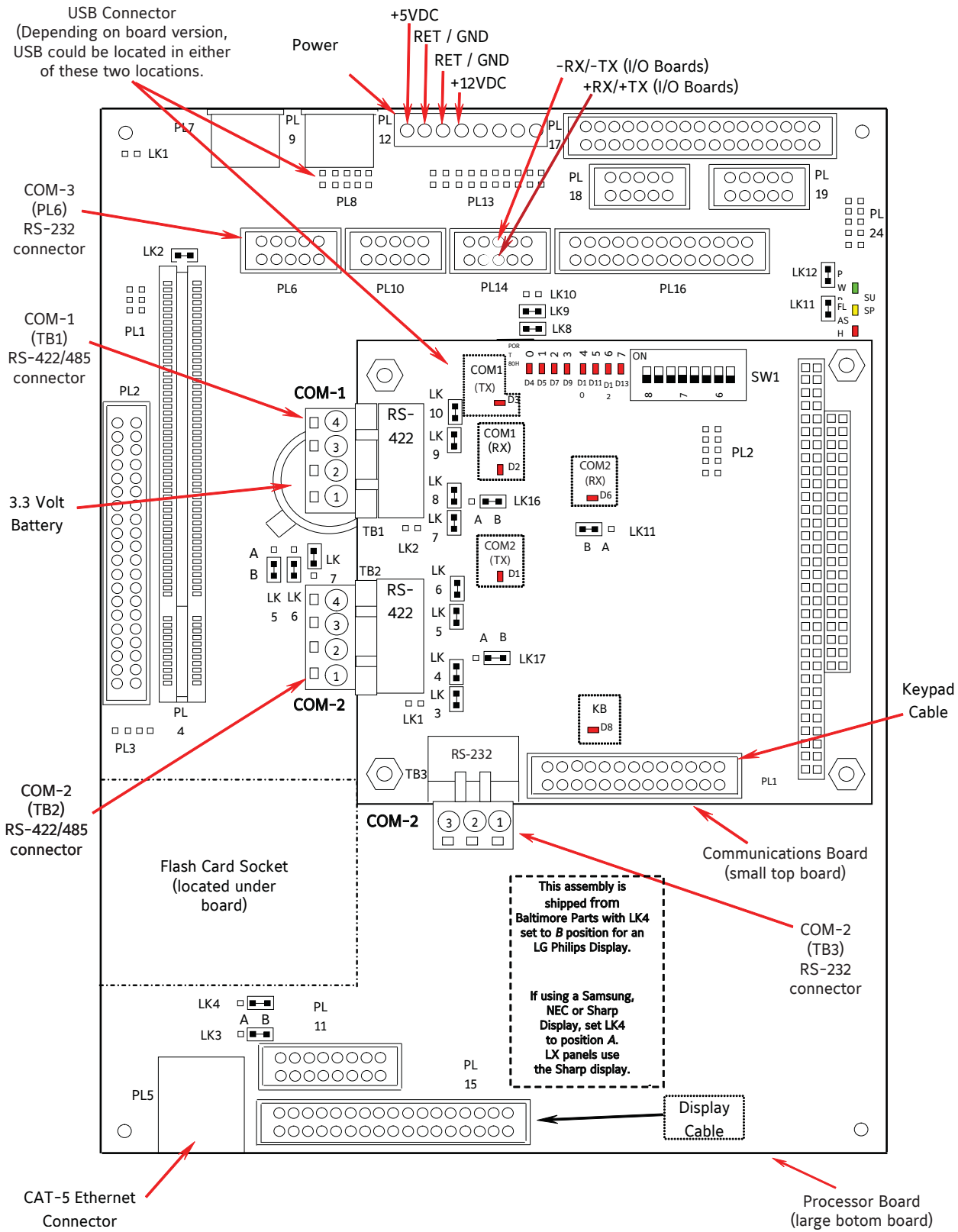

Controller Board Pictorial

Note: There are duplicate numbers for the links on the processor (larger) board and the communications (smaller) board. If you must make a change to a jumper (link), ensure that you modify the correct link.

QUANTUM 4 BOARD SETTINGS

Processor Board Jumpers

LK1	in out*	2 second Watchdog timer timeout 8 second Watchdog timer timeout
LK2	in* out	Watchdog timer Enabled Watchdog timer Disabled
LK3	A B *	+5V Backlight Voltage (not used) +12V Backlight Voltage (all displays)
LK4	A B *	+5V LCD Supply (Samsung, NEC, Sharp) +3.3V LCD Supply (LG Philips Display)
LK5	A B *	COM4 IRQ3 COM4 IRQ10
LK6	A B *	COM3 IRQ4 COM3 IRQ11
LK7	A * B	Battery Backup Enabled Battery Backup Disabled (CMOS Cleared)
LK8	in* out	RS-485 Receiver Enabled RS-485 Receiver Disabled
LK9	in* out	RS-485 Terminated RS-485 Not Terminated
LK10	in out*	RS-422 Terminated RS-422 Not Terminated
LK11	in* out	Bit 1 of 259H "Logic 1" User Application Link Bit 1 of 259H "Logic 0" User Application Link
LK12	in* out	Bit 2 of 259H "Logic 1" User Application Link Bit 2 of 259H "Logic 0" User Application Link

* Standard Setting

Communications Board Jumpers

Com-1 (TB1)

LK2	in out*	Terminate COM1 No termination	RS-422/485
LK7	in out*	Pull down COM1 No pull down	RS-422/485 (Rx-/Tx-)
LK8	in out*	Pull up COM1 No pull up	RS-422/485 (Rx-/Tx+)
LK9	in out*	Pull down COM1 No pull down	RS-422 (Tx-)
LK10	in out*	Pull up COM1 No pull up	RS-422 (Tx+)
LK16	A B*	COM1 RS-422 (TB1) COM1 RS-485 (TB1)	

* Standard Setting

Com-2 (TB2 - TB3)

LK1	in out*	Terminate COM2 No termination	RS-422/485
LK3	in out*	Pull down COM2 No pull down	RS-422/485 (Rx-/Tx-)
LK4	in out*	Pull up COM2 No pull up	RS-422/485 (Rx-/Tx+)
LK5	in out*	Pull down COM2 No pull down	RS-422 (Tx-)
LK6	in out*	Pull up COM2 No pull up	RS-422 (Tx+)
LK11	A B*	Select RS-232 for COM2 (TB2) Select RS-422/RS-485 for COM2 (TB3)	
LK17	A B*	COM2 RS-422 (TB2) COM2 RS-485 (TB2)	

* Standard Setting

QUANTUM 4 POWER SUPPLY

DESCRIPTION

The power supply used in the Quantum 4 control panel is the Condor GLC-75D, and is shown below. This power supply provides the following DC voltages:

- +5 VDC
- +12 VDC
- -12 VDC
- +24 VDC

Of these four voltages, only the +5 VDC may be adjusted. Refer to the following page for the location of this potentiometer adjustment. If either the +12, -12 or +24 VDC is out of acceptable range, first check for short or a blown fuse. If no reason can be found for the loss of any DC voltages, then the power supply will need to be replaced.

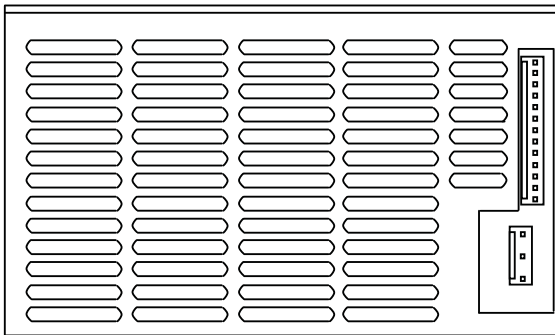

Power Supply

MEASURING VOLTAGES

All circuit boards within the Quantum™ control panel require accurately adjusted DC voltages in order to function properly. These voltages consist of +5 VDC, -12 VDC, +12 VDC and +24 VDC. Periodic measurement and adjustment of the DC power system is highly recommended for optimum system operation. Over time, it is possible for temperature, humidity, vibration and component age, to degrade the accuracy of these voltages. When any of the DC voltages begin to stray from their optimum range (especially +5 VDC), mysterious problems can begin to arise.

All four DC voltages originate from the power supply. They are then daisy-chained to the main board, and then on to all connected Digital and Analog boards. Refer to the Flow Diagrams for the Quantum 4.

Even with a perfectly adjusted supply, it is possible for a potential drop in voltage at each connection point within the daisychain. This drop normally is in the millivolt range, but under some conditions, the drop can be much greater (as high as tenths of a volt). By the time the voltage reaches the last board in the daisy chain, and all of these potential voltages drops are considered, the combined drop can be such that

serious problems can be apparent. Some examples of serious problems could be:

- Loss of or intermittent communications failures.
- A shutdown message stating Digital Board x Reset (where "x" is replaced by the number of the Digital Board that failed).
- An shutdown message stating Digital Board x Comm. Fail - Shutdown (where "x" is replaced by the number of the Digital Board that failed).
- An shutdown message stating Analog Board x Comm. Fail - Shutdown (where "x" is replaced by the number of the Analog Board that failed).
- Numerous sensor fault shutdown messages.
- Quantum 4 reboots for no apparent reason.
- Improper readings of analog pressures and temperatures.
- LED's on the Quantum 4 are lit, but nothing appears on the display.

In order to properly measure the DC power, it must be checked at the Quantum 4 main board, and verified for acceptable total voltage drop at the end of the daisy chain (last I/O board). For the +5 VDC (on either power supply), if the voltage at the Quantum 4 is in the range of +5.15 to +5.20), and the voltage being read at the last I/O board is greater than +5.0 V, it can be assumed that the +5 V power is correctly adjusted. For the +12 VDC, if the range at the last I/O board is between +11.8 and +12.2 VDC (+12.00 is ideal), it can be assumed that the +12 V power is correct. The range for this voltage is not critical at the Quantum 4 main board, and the reading does not need to be taken there.

CAUTION! Measuring and adjusting the power supply voltages require the control power switch to be energized. Extreme care must be observed when taking any readings, as 120 or 230 VAC (depending on incoming system voltage) is present within the power supply. Adjusting the supply requires the use of a small screwdriver with an insulated shaft (refer to NS-10-02) inserted into the supply to access an adjusting potentiometer. It is possible for the screwdriver (and the person making the adjustment) to come into contact with potentially lethal voltages.

FUSE REPLACEMENT

If voltage is NOT present at any of the DC power points, but proper AC voltage is measured at the AC input, one problem could be that there is a short on the DC Power Harness.

To isolate the problem:

1. Turn the Control Power switch to OFF.
2. Unplug the DC power connector from the power supply.
3. Turn the Control Power switch back ON.
4. Measure the voltages on the DC power output connector of the power supply as shown at the end of this section.
5. If the proper voltages are present, the problem is external to the power supply, and further troubleshooting should be performed.

If there are NO DC voltages present, then the problem could be that the internal power supply fuse is blown. To access and replace this fuse, please follow these instructions:

1. Ensure that the Control Power switch has been turned OFF.
2. Remove the AC and DC power connectors from the power supply.
3. The power supply is mounted to a plate. Remove the four mounting plate nuts (one from each corner).

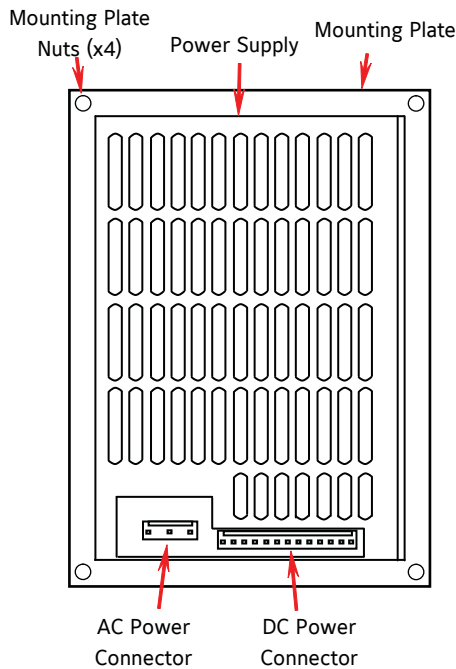

4. Remove the power supply from the enclosure, and turn it over (so power supply is facing down).

5. Four screws attach the power supply to the mounting plate, remove the four screws.

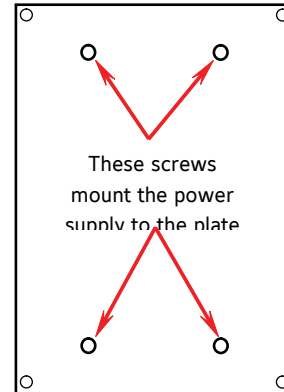

6. Remove the three Philips head screws located on the bottom of the power supply, and two on the side. Notice that there are also three slotted screws on the side of the supply, DO NOT remove these.
7. Carefully lift of the slotted cover. This will expose the circuit board, as shown here:

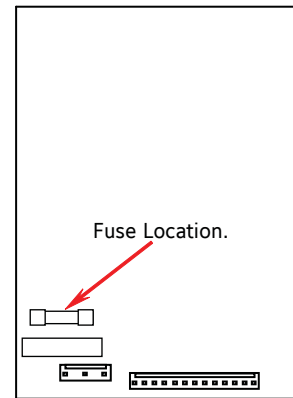

8. Locate the fuse on the circuit board from the above drawing. It is mounted in a clip. Pry up on one end of the fuse and extract the fuse.
9. Verify that the fuse in question is actually bad, and if so, replace the bad fuse with a known good one. Fuses may be ordered from Baltimore Parts (P/N 649A0954H19). This fuse is rated for 3.15 amps @ 250 volts.
10. Reassemble the power supply in the reverse order that it was disassembled.
11. Mount the power supply on to its mounting plate.
12. Place the power supply/mounting plate back onto the studs in the enclosure, and secure with the mounting nuts.
13. Reattach the AC and DC power harnesses.
14. Turn the Control Power switch to ON.
15. Verify that DC voltages are now present on the DC power connector. The 5 VDC may now be adjusted per the adjustment procedure on the following page.

ADJUSTMENT

To perform measurements and adjustments on the power supply voltages, use a reliable, calibrated Digital Volt Meter (DVM). The DVM should be accurate to 1/100 of a volt DC. With the control power switch turned ON, wait until the Operating Screen appears. This is because the graphics required to create this screen will draw more current than when the screen is showing the normal POST style messages during a boot up. If the screen never appears however (possibly due to a voltage problem), you will need to proceed regardless of what is or is not displayed.

Ensure that the meter is set to the proper range (DC, 0-50 V or equivalent), as well as observing proper wire polarity. Measure the +5 VDC first. Place the negative lead on the common (return) pin, and the positive lead on the +5 VDC pin as shown. Verify that the DVM is displaying in the range of +5.15 to +5.20. If the reading is outside of this range, then using a thin, flat bladed, insulated screwdriver, insert the tip into the access hole for the appropriate voltage potentiometer (refer to the diagram on the following page for adjustment location). NOTE: Extreme care must be used when adjusting the +5 VDC potentiometer. Adjustment should only be performed by qualified personnel, using an insulated screwdriver.

While watching the DVM, slowly rotate the screwdriver blade clockwise to increase the voltage or counter-clockwise to decrease. Once the voltage has been adjusted, remove the DVM probes from the Quantum™, and install them into the white connector on the last I/O board in the daisy chain, as shown below:

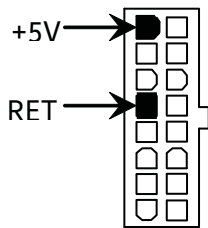

Check the reading on the DVM. If the reading at the Quantum 4 has been adjusted properly, then this reading can be no lower than +5.0 VDC. If the voltage is less, check all of the daisy chain connections on the blue DC-I/O harness. Ensure that all of its connectors are tight. If all connections are good, then go back and start measuring over again, this time beginning at the first board in the daisy chain. Continue checking the voltage at each connection, until you locate the point at which the voltage drop is excessive. This will usually indicate a connection that is not being made properly, or the sockets within the connector are weak. In either case, the DC-I/O wire harness may need replacing.

Next measure the +12 VDC. Perform the same steps as with the +5 VDC measurement, with the exception that you will not need to measure at the Quantum 4. Measure directly at the last connection. If the voltage is low, ensure that there is not an excessive voltage drop in the daisy chain. If the voltage is out of range, then the supply itself may need replaced.

The -12 VDC may be measured the same as the other voltages, however, this voltage is not adjustable on any supply, so if the harness is not the culprit, the supply may need to be replaced.

POWER SUPPLY REPLACEMENT

If the power supply is found to be bad, or not capable of acceptable adjustment, it will need replacing. When ordering this replacement, you will receive an upgrade kit. The purpose of this kit is to allow for the upgrading of the I/O DC power harness, at the same time as replacing the power supply. Refer to the Recommended Spare Parts list for the upgrade part number. This upgrade kit will include the following components:

- Screws (6-32 x 3/8 flat head)
- Power supply (Condor)
- DC power cable harness (this is an improved version of the previous power cable)

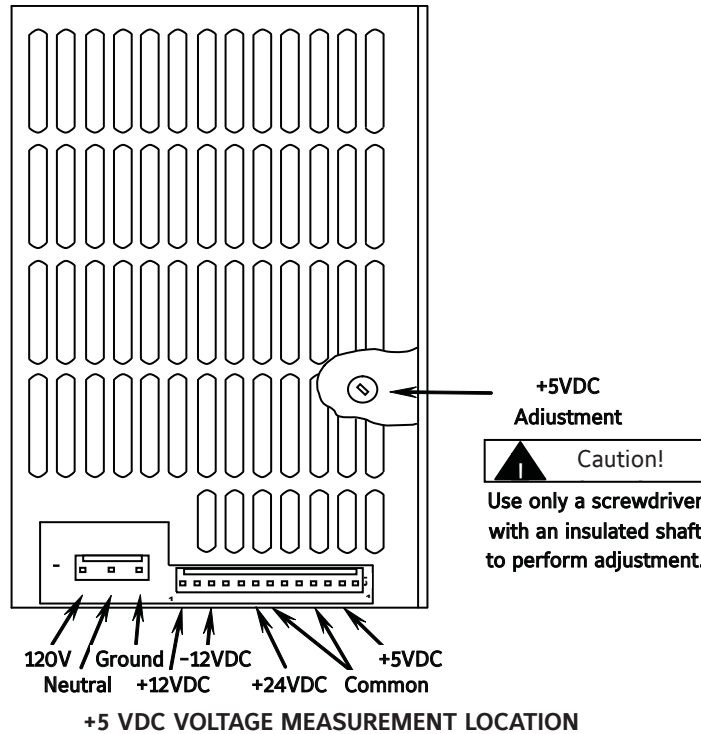
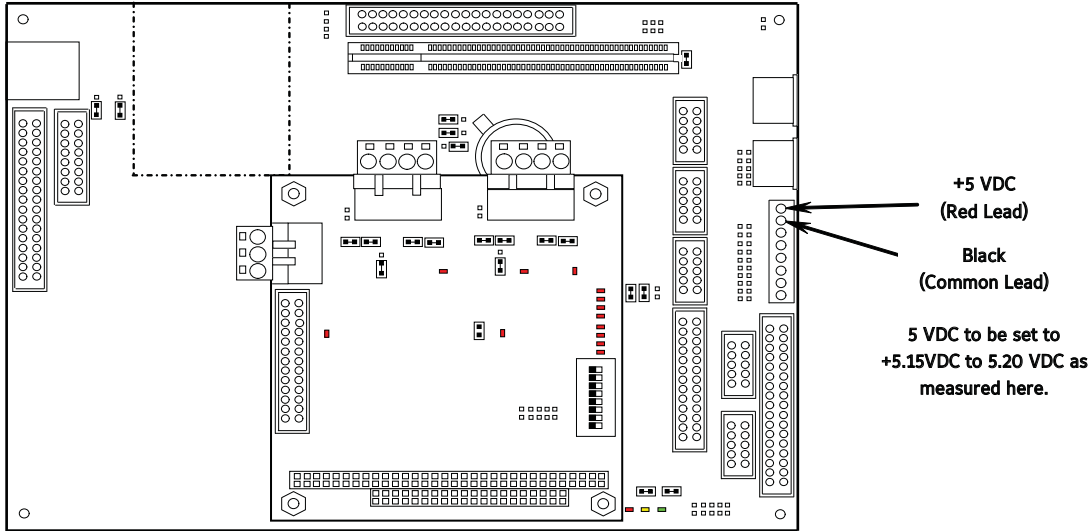

DC POWER SUPPLY PIN ASSIGNMENTS

INPUT: J1			INPUT: J2		
AMP P/N: 640445-5			AMP P/N: 1-640445-3		
.312 CTR CONNECTOR, 3 CIRCUITS			156 CTR CONNECTOR, 13 CIRCUITS		
Pin 1	AC GROUND		PIN 1	OUTPUT #1 (+5.1V)	
Pin 3	AC NEUTRAL		PIN 2	OUTPUT #1 (+5.1V)	
PIN 5	AC LINE		PIN 3	OUTPUT #1 (+5.1V)	
MATING CONNECTORS: MOLEX			PIN 4	COMMON	
	HOUSING	CONTACT	PIN 5	COMMON	
INPUT	26-03-4050	08-52-0113	PIN 6	COMMON	
OUTPUT	26-03-4131	08-52-0113	PIN 7	COMMON	
			PIN 8	OUTPUT #2 (+24V)	
			PIN 9	OUTPUT #2 (+24V)	
			PIN 10	POWER FAIL	
			PIN 11	OUTPUT #3 (-12V)	
			PIN 12	COMMON	
			PIN 13	OUTPUT #4 (+12V)	

QUANTUM 4 FLOW DIAGRAM - D.C. VOLTAGE/COMMUNICATIONS HARNESS (36 & 48 INCH PANELS)

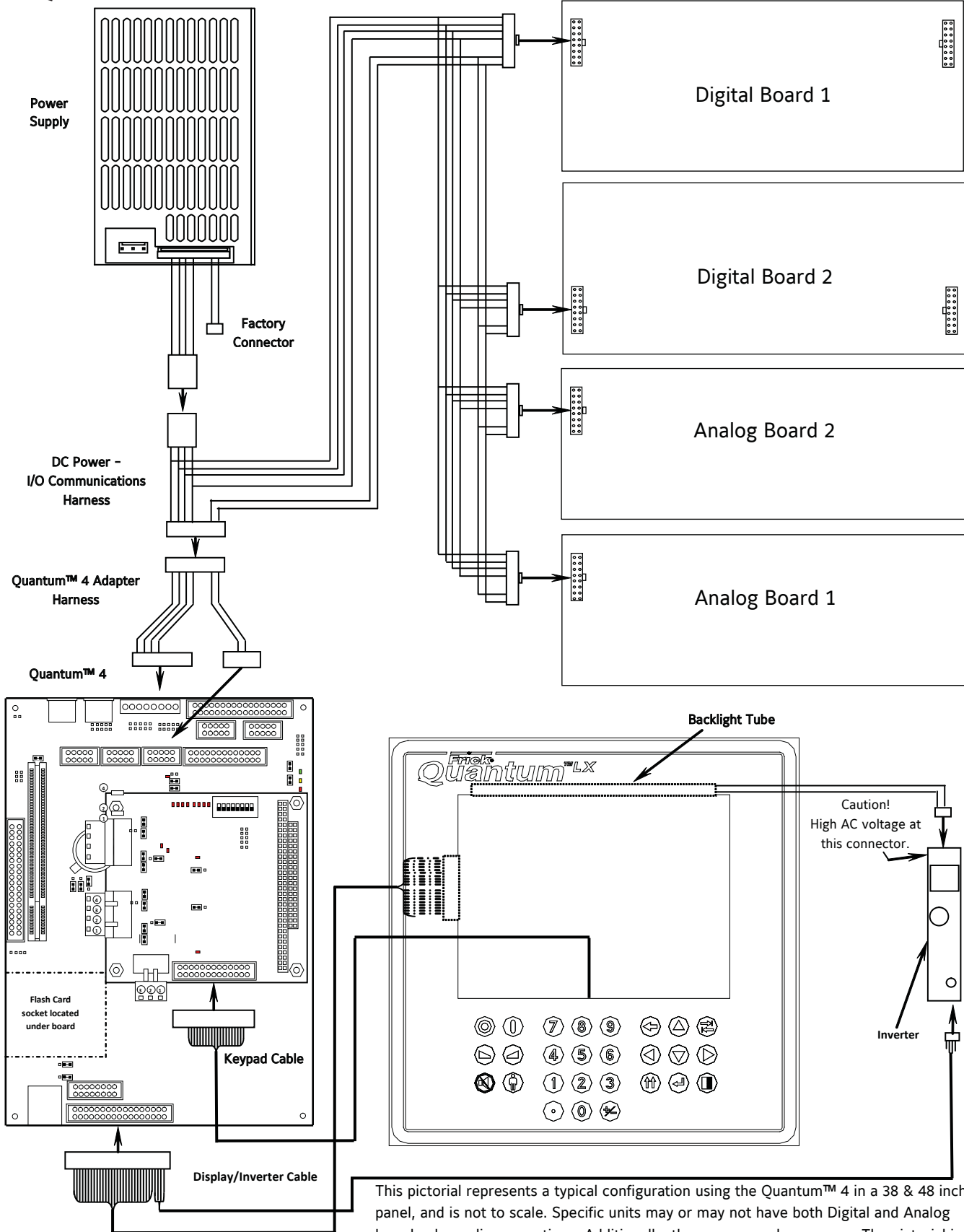

This pictorial represents a typical configuration using the Quantum™ 4 in a 38 & 48 inch panel, and is not to scale. Specific units may or may not have both Digital and Analog boards, depending on options. Additionally, the power supply may vary. The pictorial is meant to show the proper interconnection of the D.C. power - I/O communications harness, keyboard cable and display harness and hardware components.

QUANTUM 4 FLOW DIAGRAM - D.C. VOLTAGE/COMMUNICATIONS HARNESS (22 & 28 INCH PANELS)

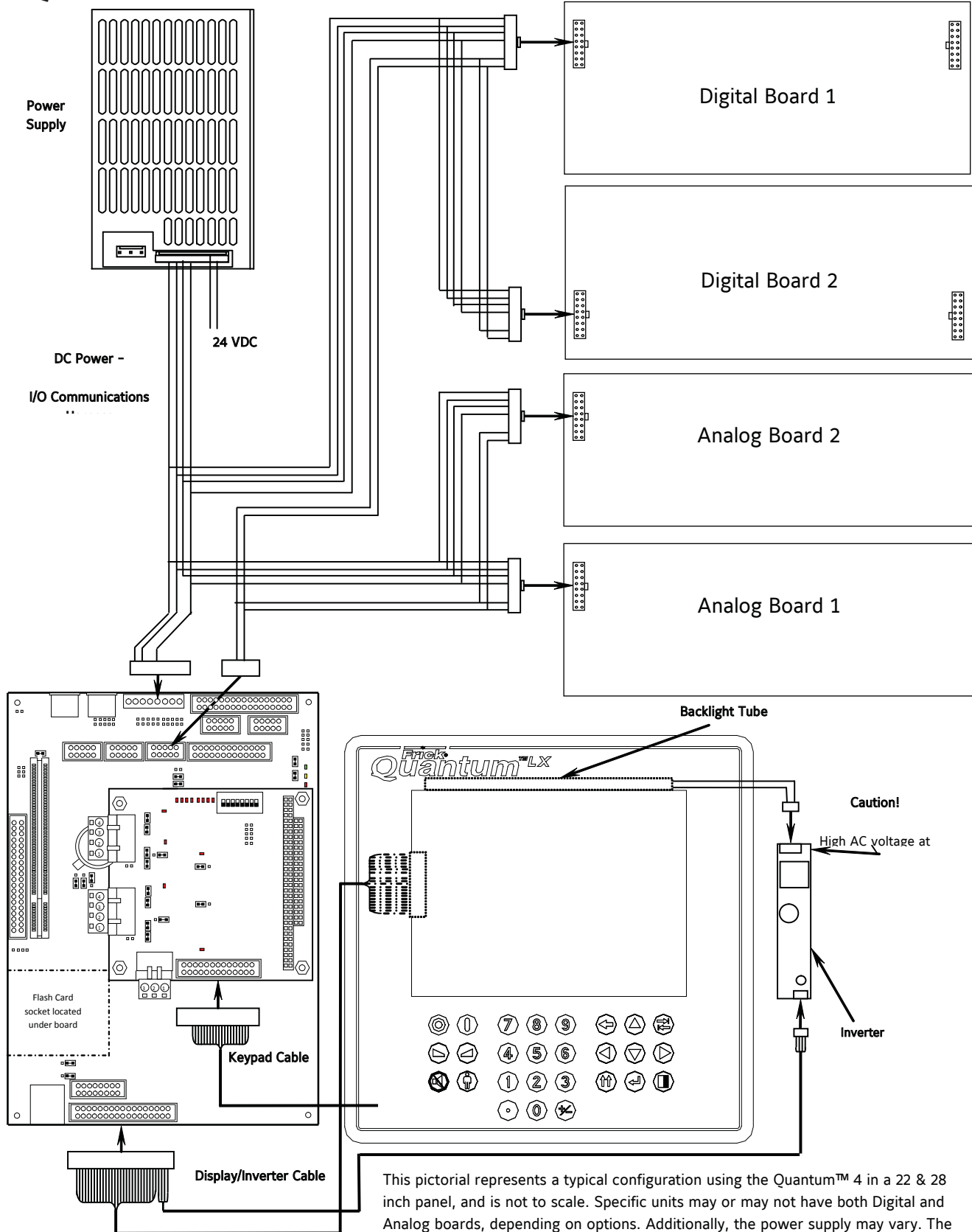

This pictorial represents a typical configuration using the Quantum™ 4 in a 22 & 28 inch panel, and is not to scale. Specific units may or may not have both Digital and Analog boards, depending on options. Additionally, the power supply may vary. The pictorial is meant to show the proper interconnection of the D.C. power - I/O communications harness, keyboard cable and display harness and hardware components.

**QUANTUM 4 RDB / RWB II / RWF / RXF (58 - 101) CONTROL CENTER ASSEMBLY
(Sheet 1 of 4)**

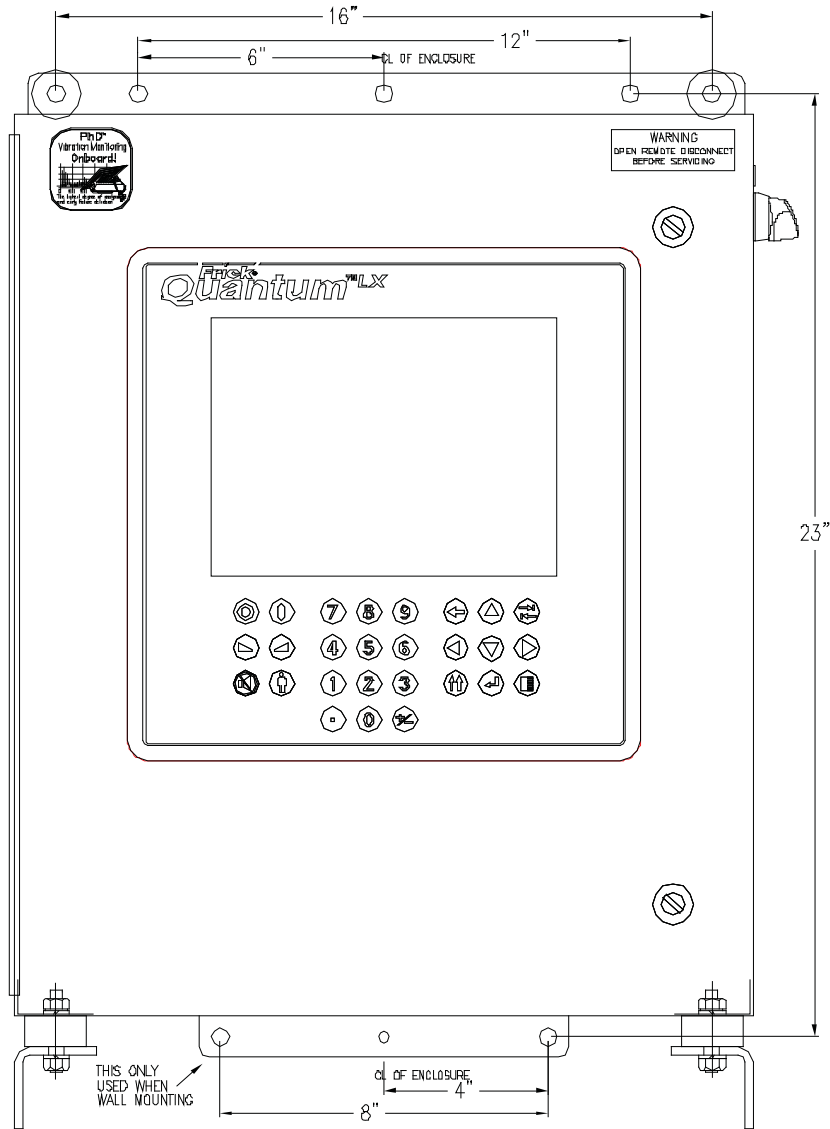

FRONT VIEW

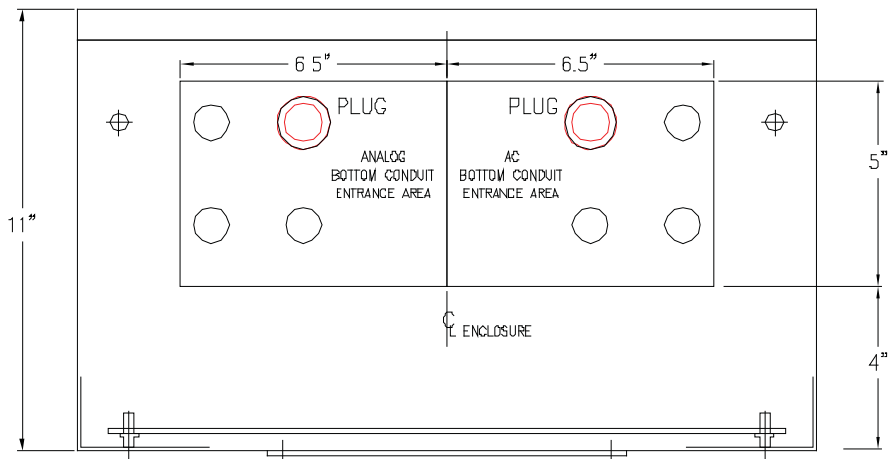

BOTTOM OUTSIDE VIEW

This drawing appears here for reference purposes only, and is subject to change without notice. When installing, or servicing equipment, always refer to the actual drawings that are included with the control panel for the latest information.

QUANTUM 4 RDB / RWB II / RWF / RXF (58 - 101) CONTROL CENTER ASSEMBLY
(Sheet 3 of 4)

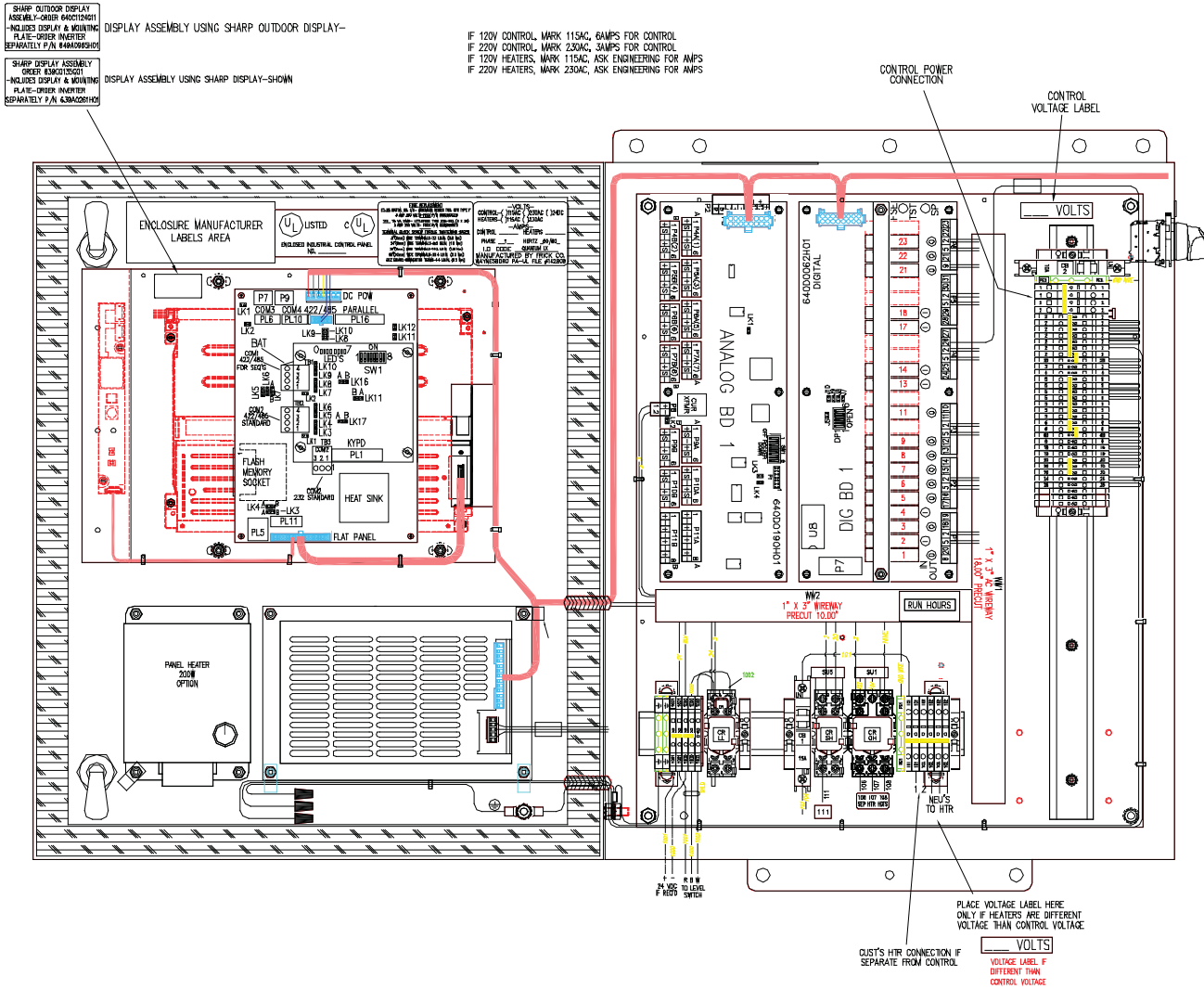

This drawing appears here for reference purposes only, and is subject to change without notice. When installing, or servicing equipment, always refer to the actual drawings that are included with the control panel for the latest information.

**QUANTUM 4 RDB / RWB II / RWF / RXF (58 - 101) CONTROL CENTER ASSEMBLY
(Sheet 4 of 4)**

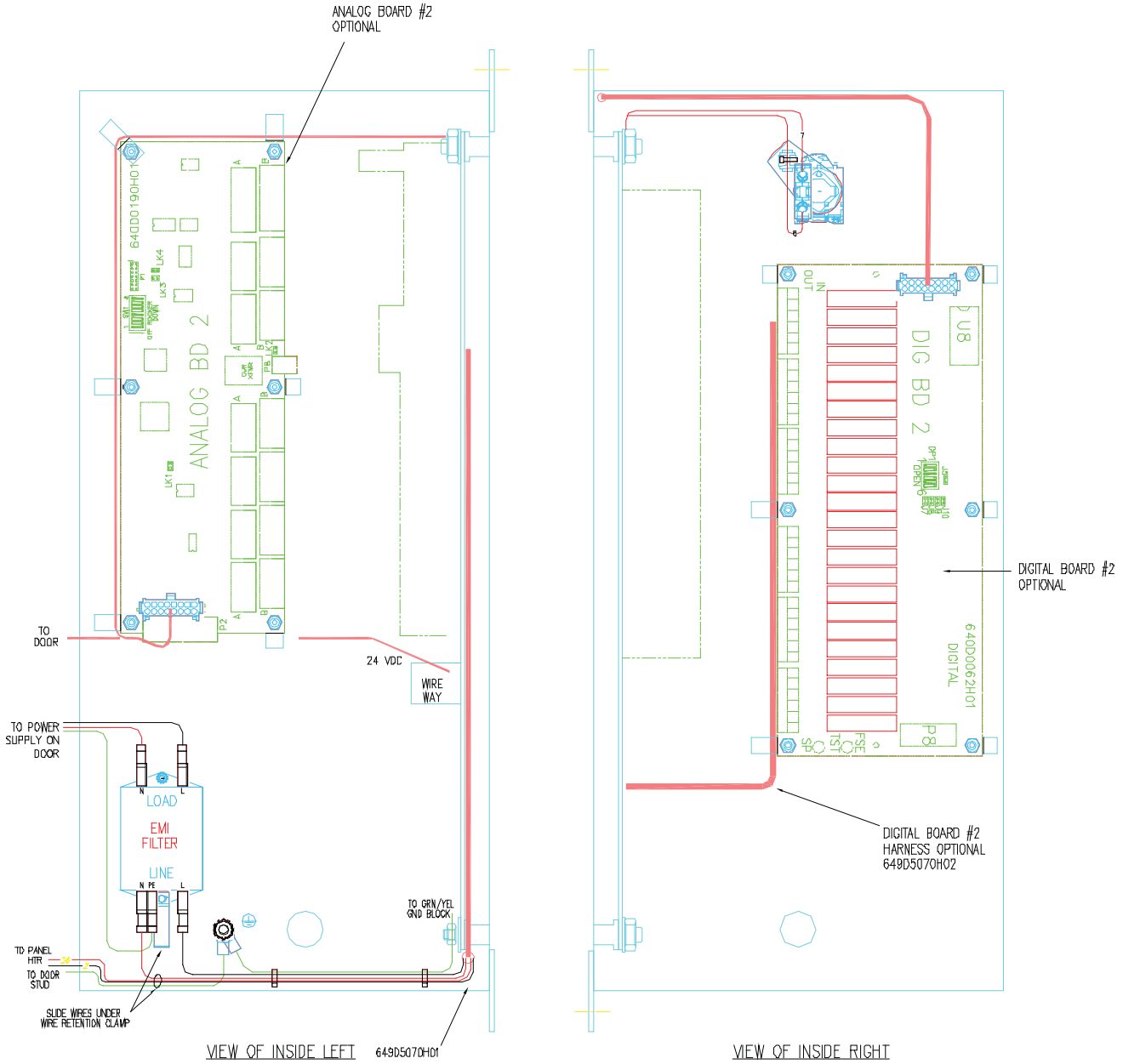

This drawing appears here for reference purposes only, and is subject to change without notice. When installing, or servicing equipment, always refer to the actual drawings that are included with the control panel for the latest information.

QUANTUM 4 I/O & D.C. POWER HARNESS (36 AND 48 INCH PANELS)

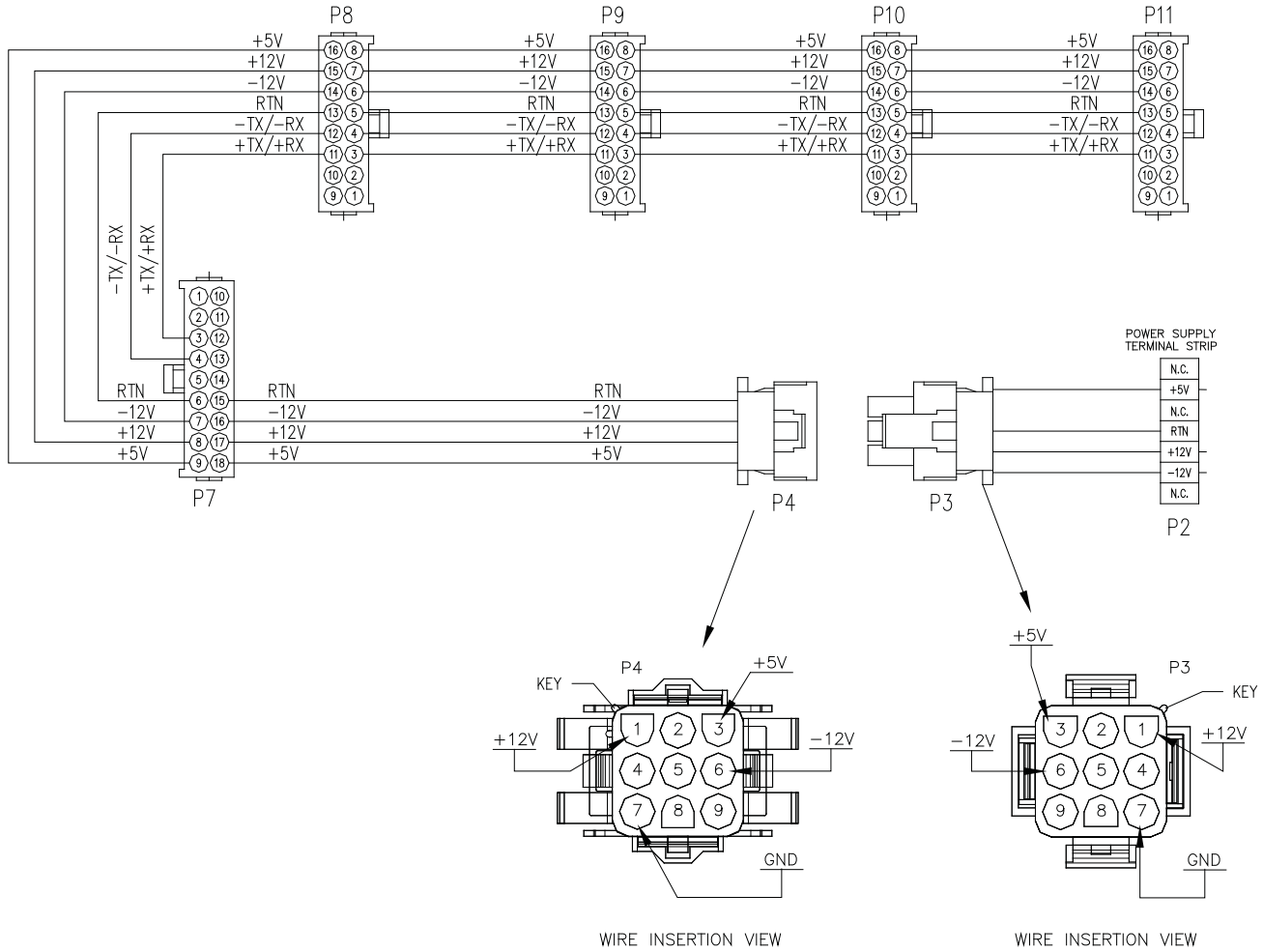

QUANTUM 4 COMPRESSOR REPLACEMENT PARTS (PAGE 1 OF 3)

Legacy Number	New Number	Description
Analog Boards		
640C0057G01	484532	Analog Board #1 (Replaces existing 32 channel board #1 only - no hardware)
640C0057G02	484533	Analog Board #2 (Replaces existing 32 channel board #2 only - no hardware)
640C0057G11	484534	Analog Board #1 (Field Upgrade Kit - Includes 32 channel board #1, connectors & hardware.)
640C0057G12	484535	Analog Board #2 (Field Upgrade Kit - Includes 32 channel board #2, connectors & hardware.)
Circuit Breakers		
639A0206H10	484050	10 Amp circuit breaker
639A0206H15	484053	15 Amp circuit breaker
639A0206H20	484055	20 Amp circuit breaker
Connectors		
649B0903H01	486156	2-Pole connector (P8 - Analog Board)
333Q0001258	467049	6-Pole connector (P1 through P6 - Digital Board, P4A through P10B - Analog Board)
333Q0001234	467040	8-Pole connector (P11A and P11B - Analog Board)
649B0903H02	486157	9-Pole connector (P2 - Analog Board)
Control Power		
333Q0001418	467096	Filter, Line
333Q0001191	467024	Hour meter
639A0185H10	483963	2-Pos. Selector Switch (Control Power)
639A0185H30	483966	Latch, 3 Across (Attaches contact block to switch mechanism)
639A0185H31	483967	Normally Open Contact Block (for Control Power Switch)
639B0120H51	680313	Socket, Guarded, DPDT
639B0114H51	580348	Socket, Guarded, 3PDT
639B0114H98	580349	Spring Clip Hold Down
639B0120H01	680049	Relay, Control 24VDC, DPDT
639B0120H11	680311	Relay, Control 120VAC, DPDT
639B0120H21	680312	Relay, Control 240VAC, DPDT
639B0114H02	580342	Relay, Control 24VDC, 3PDT
639B0114H12	580345	Relay, Control 120VAC, 3PDT
639B0114H22	580347	Relay, Control 240VAC, 3PDT
639B0120H51	680313	Socket, Guarded, DPDT
111Q0280958	455040	Surge suppresser
Digital Boards		
333Q0001172	467015	Output Module, 24 VDC
111Q0281061	455056	Output Module, 24-280 VAC
333Q0001171	467014	Input Module, 24 VDC
333Q0000116	466842	Input Module, 120 VAC
333Q0000789	466949	Input Module, 230 VAC
333Q0001326	467073	Fuse, 5 amp, 250 V
640C0024G01	484494	Digital Board #1 (Replaces existing board only - no hardware)
640C0024G02	484495	Digital Board #2 (Replaces existing board only - no hardware)
649D5210G11	486364	Digital Board #2 (Field Upgrade Kit- adds a second digital board for 22 x 18 x 10 panels)

QUANTUM 4 COMPRESSOR REPLACEMENT PARTS (PAGE 2 OF 3)

Legacy Number	New Number	Description		
Display Accessories				
333Q0001588	N/A	Backlight (Sharp single bulb – 2 wire)		
333Q0001955	548882	Backlight (Sharp dual-bulb – 4 wire)		
639A0261H01	484329	CCFT inverter		
639D0174H01	484428	Display Harness, 10 inch (Quantum 4 or LX processor mounted on display plate)		
639D0174H11	504876	Display Harness, 21 inch (Quantum 4 or LX processor mounted on swing-out door)		
640A0032H01	484437	Plexiglas (mounts in front of display) - Dimensions 6.7" x 8.7" (no notch)		
Display (Indoor - Quantum 4 and Earlier)				
639D0175G01	515456	Display Assembly (when replacing any display other than 639C0135G01) includes:		
			Legacy #	New #
		Display*	639C0132H01	484379
		Inverter	639A0261H01	484329
		Mounting plate	639C0134H01	484382
		Display Harness, for Q1, 2, or 3 Sharp display	640B0045H01	484478
		Display Harness, for Quantum 4 or LX, standard panel	639D0174H01	484428
		Display Harness for Quantum 4 or LX, swing-out door	639D0174H11	504876
		Harness, Inverter	639B0101H01	484345
Hardware				
Display (Outdoor - Quantum 4 and Earlier)				
639C0135G11	530292	Display Assembly, (when replacing a 639C0135G11 or 649C1024G11 display only) includes:		
			Legacy #	New #
		Display*	649C1094H01	486200
		Mounting plate	639C0134H01	484382
Hardware				
Flash Cards and Software				
649A0884Gxx	N/A	Quantum™ LX Program Flash Card (<i>the xx indicates program version</i>)		
649A1063G01	485994	Quantum™ LX program upgrade (USB Drive)		
649A1063G99	485995	Quantum™ LX Setpoint Saver (USB Drive)		
649D5236G11	486386	Quantum LX upgrade kit (<i>upgrades from Quantum 4 to Quantum™ LX, includes Frick ® logo keypad and flash card</i>)		
Harnesses				
649D5070H01	486299	AC harness for Digital board # 1 (22 x 18 x 10 panel)		
649D5070H02	486300	AC harness for Digital board # 2 (22 x 18 x 10 panel)		
640B0038H01	484471	DC power-I/O Comms harness (36 x 30 x 14 panel, blue harness)		
649D5069H01	486298	DC power-I/O Comms harness (22 x 18 x 10 panel, color-coded harness)		
640B0031H01	484470	Keypad cable (used with 640D0060H11 keypad)		
649B0862H01	486153	Quantum 4 Adapter Harness (used with 640B0038H01 harness only)		
640B0039H01	484473	Shunting plug (used with 640B0038H01 harness only)		
649B0915H01	486163	AC Power to Power Supply		

*These parts cannot be ordered separately

QUANTUM 4 COMPRESSOR REPLACEMENT PARTS (PAGE 3 OF 3)

Legacy Number	New Number	Description
Keypads		
640D0186H01	484621	Keypad/overlay with Frick logo (Quantum LX)
640D0060H11	484556	Keypad/overlay with Frick logo for upgrading from Quantum to Quantum LX
Miscellaneous		
333Q0001786	N/A	Battery, 3V (located on Q3, and 4 board)
Panel Heaters		
640M0007G16	484626	200 W, 115 VAC
640M0007G18	484627	400 W, 115 VAC
640M0007G27	484632	200 W, 220 VAC
640M0007G21	484629	400 W, 220 VAC
Power Supply		
640C0022G01	484492	DC power supply – Condor GLC-75D (includes power supply harness)
649A0954H19	485608	Fuse, 3.15A @ 250V (for Condor GLC-75D)
649A1036H08	485887	24 VDC Power Supply, 3 Amp, din-rail mounted (Power Pac)
649A1036H12	485889	24 VDC Power Supply, 5 Amp, din-rail mounted (Power Pac)
Quantum 4 Boards		
649C1091G01	486194	Quantum 4 (Arcom GX1)
639C0130G01	484378	Communications Daughter board only for Quantum 4.
649C1083G01	486181	Upgrade from Quantum 1, 2 or 3 to Quantum 4

REMANUFACTURED PARTS

Legacy Number	New Number	Description
640C0024S01	N/A	Digital I/O Board
640C0022S01	N/A	DC Power Supply (Condor to Condor)
640C0057S01	484537	Analog I/O Board (32 Channel)
649C1091S01	486198	Quantum 4 to Quantum 4

SECTION 4

DIGITAL BOARD



DIGITAL BOARD

INFORMATION

The information that follows in this section can help locate problems that can occur with Digital Input and Output circuit boards.

DIGITAL BOARD DESCRIPTION

The Digital board is a small microprocessor board and is programmed to control discrete outputs, or accept discrete inputs, from external electrical devices. Each Digital board has the capability of 24 independent channels or I/O (Input/Output). Each channel that is used needs a module plugged into it. A yellow module indicates that it is used for Inputs. A black module is used for Outputs. The standard Quantum™ LX compressor control can have up to two Digital boards (depending on options).

COMMUNICATIONS LED'S

The main board is in constant communication with all Digital (and Analog) Boards. You will notice on each Digital and Analog board, that there are a pair of LED's labeled as RX and TX. These letters represent Receive (RX) and Transmit (TX). These LED's should be flashing at a high rate during normal operation. This indicates that the main board, and the Digital board that you are looking at, are properly communicating with each other.

- Reference the JUMPER AND DIPSWITCH SETTINGS section later in this manual. This section contains the dipswitch settings for addressing the Digital I/O boards. When these switches are properly set, the main board is able to serially communicate with each I/O board and provide control signals and data exchange. If these switches are not properly set, the result will be lost or failed communications, or the wrong outputs being energized, or the wrong inputs being received.

CONNECTIONS TO THE QUANTUM™

As stated earlier, the Quantum™ LX standard compressor control system utilizes up to two Digital, and two Analog boards. To connect these boards together so that the Quantum™ LX can control them, they must be interconnected with a wiring harness that provides all of the necessary D.C. voltage requirements, as well as the communications capabilities.

The Digital boards only require the +5 Vdc voltage and the Return (or common) for logic power. The communications signals (RX & TX) are required by all boards.

Three different harnesses have been used and a diagram of each of these wiring harnesses can be found later in this manual (see the Power I/O Wiring Har-

ness drawings). Depending on the type of panel, the following harness will be used:

- **Special Quantum 4 Panel (36 & 48 Inch Panels)** - This harness has an 18-pin connector at one end that plugs into the Quantum™. Another connector plugs into the power supply. The remaining four connectors (16-pin) will plug into each of the Digital and Analog boards in the system. All wires in this harness are blue in color.

Upon close examination of this harness, you will notice that each of the connectors for both the main board and the four I/O boards, have two rows of connections. The wires that are inserted into the positions of one row are internally daisy chained on each I/O board, to continue the voltages and signals to the adjacent row. Therefore, any time that a connector is unplugged from the daisy chain, these voltages and signals cannot continue through the daisy chain to the next board. Whenever a plug is not to be inserted into a board, either for service or if not all boards are present, then a shunting plug (Frick P/N 484473) must be installed onto the open connector.

The four wires that feed from the power supply to the Quantum 4 provide all of the necessary D.C. voltage that is required for the system (+5 VDC, -12 VDC, +12 VDC, and Return or Common). As mentioned previously, the -12VDC and +12VDC are not required for the Digital boards, but they are still daisy-chained on this harness for the Analog boards.

The voltages are passed through the connector on the main board, and two new signals are generated by the main board to be passed on through the daisy chain to the I/O boards. These two signals are the RX (receive) and TX (transmit). These signals are the means by which the main board communicates to the I/O.

- **Standard Quantum 4 Panel (22 & 28 Inch Panels)** - This harness has a 7-pin connector at one end that plugs into the Quantum 4 at PL12, and provides power to the Quantum 4. A second 10-pin connector plugs into PL14 of the Quantum 4, where the communications signals originate. Another connector plugs into the power supply and picks up the DC voltages that are used. The remaining four connectors (16-pin) will plug into each of the Digital and Analog boards in the system (up to four total). This harness varies from the Special panel harness in that

there are two main branches; one feeds the digital boards, the other feeds the analog boards. This harness uses Red, Blue, Yellow and Purple wiring.

- **Q5 Panel** - This harness distributes power and communications from the terminal blocks to the various logic boards. The harness terminates with four, 16 pin connectors, which plug into the digital and analog boards, and two, 4 pin connectors that apply DC power to the Q5 and Interface boards. This harness uses Red, Black, Yellow, Gray, White/Black and White/Red wiring.

LOGIC VOLTAGE (POWER) LED

Located on the Digital Board is a Power LED. This LED will be illuminated as long as the Control Power switch is ON, and the proper voltage is present at the power supply. The power supply generates the +5 Vdc voltage and passes it on through the Power-I/O harness. This LED does not indicate however that the proper voltage is necessarily present at the board, only that the voltage is enough to energize the voltage sensing circuitry. If a voltage related problem is suspected with regard to a Digital Board, the only way to actually determine this is to read the voltage on a Digital Voltage Meter (DVM). This may be accomplished by locating the white power / communications connector on the board. Notice that the Digital Board has one of these connectors on both ends of the board. The associated power / communications harness will only be plugged into one of these connectors. Take the red (positive) probe of the DVM and carefully insert the end into the "+5V" lead, and the black (negative) probe end into the "RET" (Return or Common) lead, as shown below:

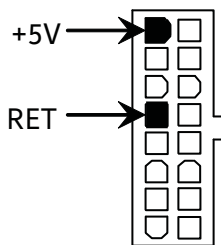

Set the DVM to read DC, and set the proper range. The voltage reading must read a minimum of +5.0 Vdc. The Power-I/O harness will have an associated voltage drop at each board connection. As an example, if you are reading the voltage at the first I/O board in the daisy chain, and it reads 4.98 Vdc, you can be assured that the voltage at the subsequent connections for the remaining boards will be lower yet. The voltage will need to be corrected for proper operation of the system. The cause for a low voltage reading could be:

- The power supply may need adjustment (see the section on power supplies).
- The Power-I/O communications harness has

- a problem (a new harness may be needed).
- A problem may exist with one of the I/O boards (Digital or Analog).
- If the power LED is not lighted, check the cable for proper connectivity. Note: Each board provides the necessary connections to feed all signals to the following connectors. If the auxiliary Analog or Digital Board is not present then a jumper plug (see Recommended Spare Parts List) must be installed to daisy chain the signals.

The most common symptom that is exhibited by a low +5 VDC voltage to the Digital Boards is an alarm message that reads Digital Board Reset Shutdown.

ACTIVE LED

The Digital Boards have an Active LED indicator on the board that blinks when the board's software is running.

If the Active LED is not blinking, check to ensure that the EPROM is installed properly. The EPROM is located in chip slot U8, next to the power connector.

DIGITAL INPUTS

A Digital Input is the portion of the hardware that allows devices such as limit switches, relay contacts, and level switches, to interface with the Quantum™ LX. The software program within the Quantum™ LX is constantly looking at these Input channels, via communications, and based upon whether a control voltage is present or not, will provide the necessary control for an associated Output channel. For instance, if a control voltage is present on the Oil Level Sensor input, the software will determine that the Separator has sufficient oil level for the oil heaters to be energized (if the temperature of the oil is also sensed to be low. Temperature sensing will be discussed in the Analog Input section).

There are two possible varieties of Digital Input modules used on standard compressor control packages. One is for 120 Volt controls, and the other is for 240 volt controls. Both of these module styles are yellow in color. A side profile of these modules is shown below:

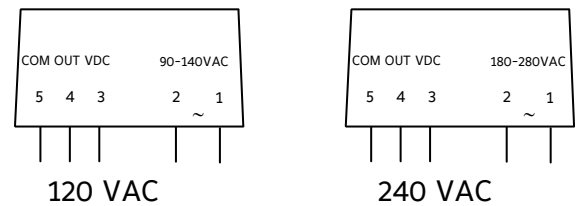

These Input modules, can be identified as to their operating voltage by looking at either the side, as shown above, or from the top. You will notice the module operating voltage printed on the top, and the voltage range printed on the side.

Never plug a 120 Volt Input module into a 240 Volt system, and vice-versa. Never plug an Output module into a position designated for an Input module.

You will notice that when a module is plugged into the Digital board, there is a fuse located directly adjacent to the module. This fuse is of the pluggable variety, and must be plugged into the IN position for an Input module.

DIGITAL OUTPUTS

A Digital Output is the portion of the hardware that the Quantum™ LX is to control (energize). These devices include solenoids, relay coils, and heaters to be energized, based upon the logic within the Quantum™ LX software program.

There is one variety of Digital Output modules used on standard compressor control packages. This one module will handle both 120 Volt controls, and 240 volt controls. This module is black in color. A side profile of this module is shown below:

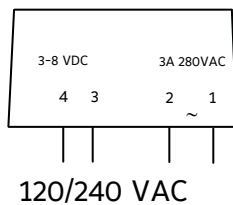

Although this Output module is labeled as 280 VAC on the top, and on the side, it can be used on both 120 and 240 volt applications.

Never plug an Input module into a position designated for an Output module.

You will notice that when a module is plugged into the Digital Board, there is a fuse located directly adjacent to the module. This fuse is of the pluggable variety, and must be plugged into the OUT position for an Output module.

CHECKING THE DIGITAL INPUTS AND OUTPUTS

Some problems that may be encountered involve troubleshooting the digital inputs and outputs. The Digital I/O (Input / Output) Boards have six Digital I/O (DIO) board connectors labeled P1 through P6. The Input and Output modules are wired to a DIO connector plug. Position 3 provides power and position 4 is a neutral on the DIO connectors. Positions 1, 2, 5, and 6 are signal connections, as shown below:

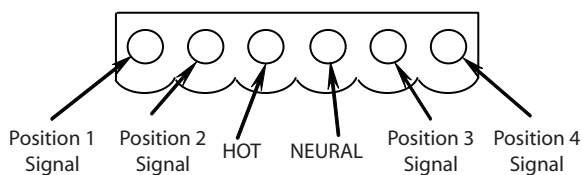

The Digital board's I/O modules are configured by proper module selection, AC or DC, operating voltage, input or output, and moving the fuse to the in or out position. An LED is associated with each module and displays the state of each module. A lit LED represents an Input that is High, receiving a signal or an Output that is On.

If a properly configured Digital I/O is not responding correctly, first look at the Digital Board on the Service Screen and check if the module is on. If it is not on, check if the LED on the Digital Board is also not lit. If the LED is not lit, then check the fuse. If the fuse is OK, then check the module.

FUSE TESTING AND REPLACEMENT

1. Power off the panel.
2. Open the panel door.
3. Remove the questionable fuse.
4. Place the questionable fuse into the fuse tester at the one end of each Digital I/O Board (refer to the Digital Board drawings at the end of this section for exact fuse tester location).
5. Power on the panel.
6. Check the LED on the tester. If the LED is lit, the fuse is OK.
7. Power off the panel.
8. If the fuse is faulty, check for external shorts on the corresponding circuit, then replace the fuse with a new plug-type fuse (refer to Recommended Spare Parts list).

INPUT AND OUTPUT MODULE TESTING AND REPLACEMENT

1. Power off the panel.
2. Open the panel door.
3. Replace the questionable module.
4. Power on the panel.
5. If it is an Output module, check for proper panel voltage on the DIO connector plug. Check the voltage between position 4 (neutral) and the associated position to the Output module.
6. If it is an Input module, check if the associated LED is on when power is applied to the module.

TROUBLESHOOTING AN OUTPUT

1. Make sure the LED associated with the Output is on when power is applied to the module.
2. If the LED is not on when it should be and there is no operating condition preventing it, contact the Frick® Service Department.

3. If the LED is on when it should be, check for proper panel voltage on the DIO connector plug. Check the voltage between the position 4 (neutral) and the associated position to the Output module.
4. If the voltage is OK, check for proper panel voltage between the associated position to the Output module on the DIO connector and the associated position on the terminal strip.
5. If the voltage is OK, check the wiring external to the panel.
6. If voltage is not OK, check the fuse.
7. If the fuse is OK then check the module.
8. If the module is OK, check for proper panel voltage on the DIO connector plug between position 3 (Hot) and position 4 (neutral).

TROUBLESHOOTING AN INPUT

1. Make sure the LED associated with the Input is on when power is applied to the module.
2. If the LED is on then the fuse and Input module are good.
3. If the LED is on and there is no input voltage, replace the Input module.
4. If the LED is not on when power is applied, check the fuse.
5. If the fuse is good, replace the Input module.
6. If you are receiving an Alarm or Shutdown from a digital input in which the adjacent LED indicator light is on, check the Service Screen to see if that channel is turning on and off. If so, replace the input module.

REPLACING A DEFECTIVE DIGITAL BOARD

The procedure to replace a Digital board is outlined below:

1. Shut off control power.
2. Remove the old board from the machine and the new board from its packing and place both on an anti-static surface.
3. Check that all jumpers, dipswitches and components are properly setup on the new board as it was on the old board (refer to the Digital Settings tables near the end of this section).
4. Install the modified replacement board in the panel.

After replacing or installing a Digital Board and powering on the control panel, select **[Re-detect I/O Boards]** from the Menu > Configuration > Communications screen. This selection provides a method to detect all connected Digital and Analog boards. If a board has been removed, a communication error shutdown will be issued until this key is selected. The *About* screen will show what was detected.

DIGITAL I/O BOARD #1 PICTORIAL

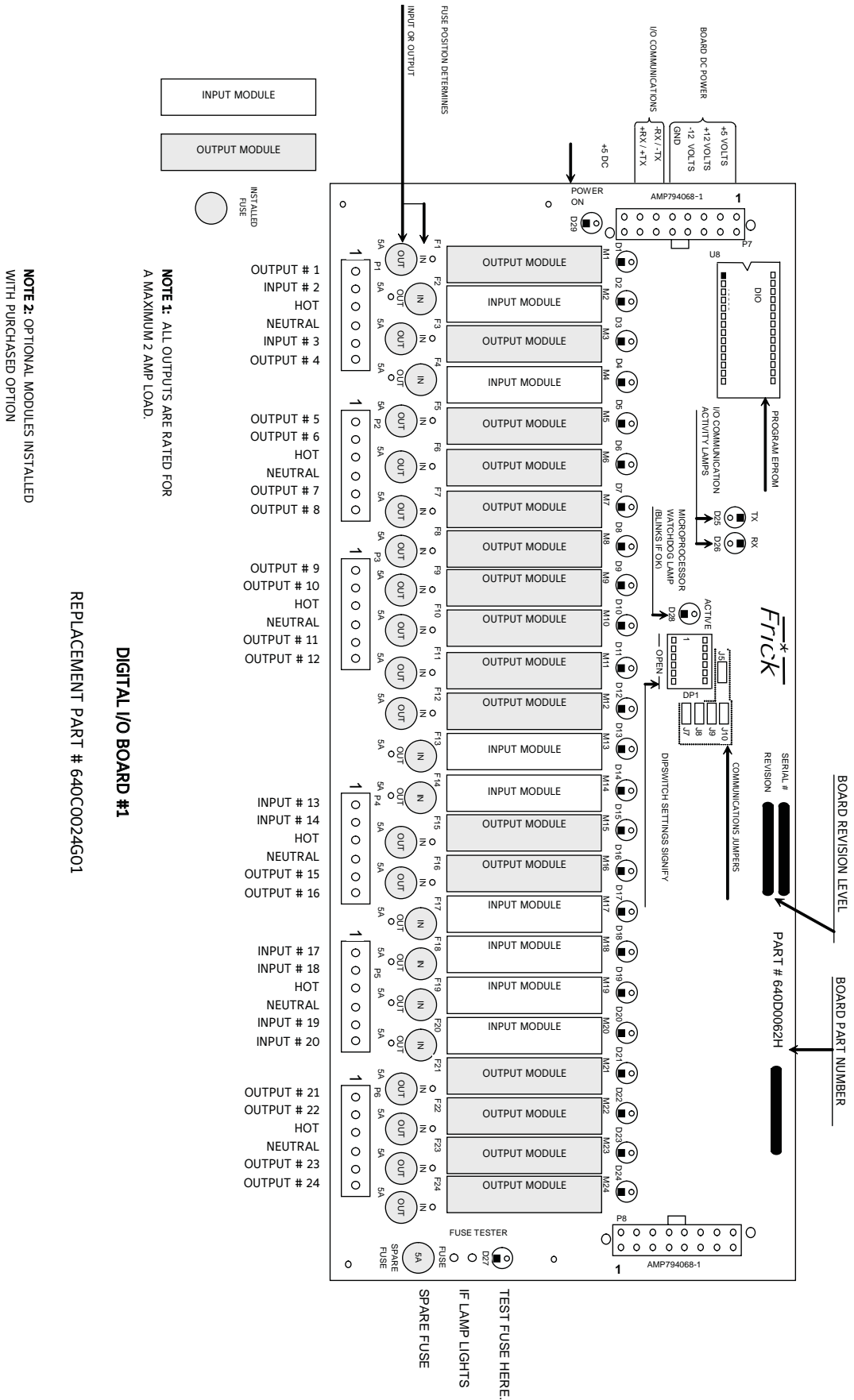

DIGITAL BOARD SETTINGS

COMMUNICATIONS SETTINGS

The following table is to be used when configuring the Quantum™ for external communications.

J5	in	120 ohm long communications line termination.
	out*	No termination.
J7	in	RS-422/485 transmit pull-up for long communications lines.
	out*	No pull-up.
J8	in	RS-422 transmit pull-up for long communications lines.
	out*	No pull-up.
J9	in	RS-422/485 receive pull-down for long communications lines.
	out*	No pull-down.
J10	in	RS-422 receive pull-down for long communications lines.
	out*	No pull-down.

* = standard setting

DIPSWITCH SETTINGS

The following table is to be used to set the digital board addresses. If there is only one board installed, it should be set as board #1, if there are two boards they each need to be set according to the wiring diagrams

	SW1	SW2	SW3	SW4	SW5	SW6
Board #1	on	on	on	on	off	on
Board #2	off	on	on	on	off	on

SECTION 5

ANALOG BOARD

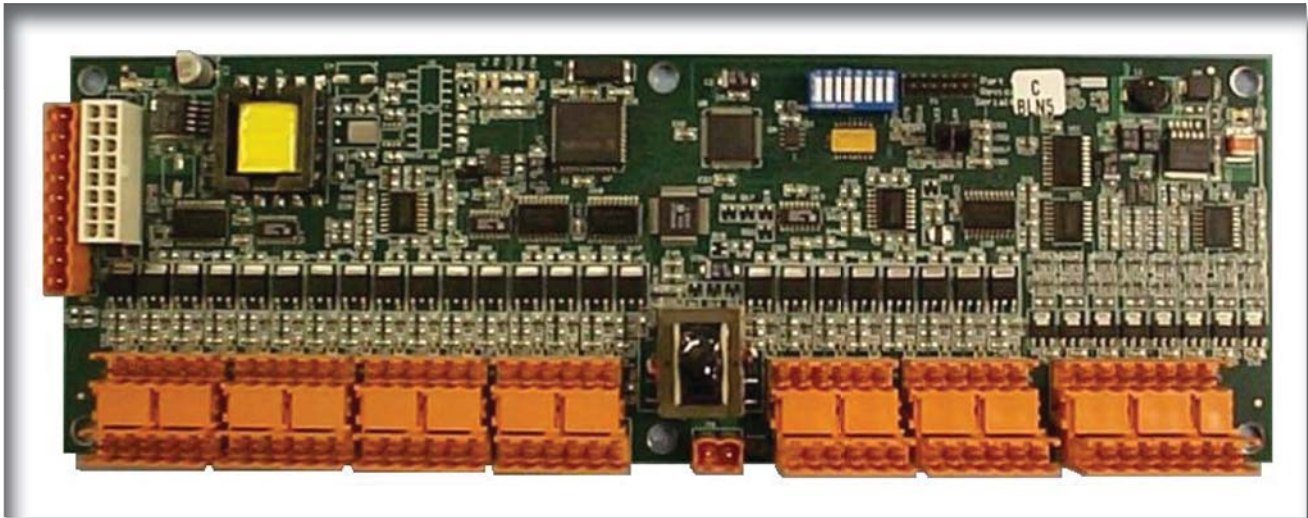

ANALOG BOARD

OVERVIEW

The Frick Quantum™ control panel is capable of reading external analog devices, such as temperature probes and pressure sensors. It uses these input signals for the purpose of monitoring and control. As an example, if an external temperature sensor began to read a higher than expected temperature in some area, the controller would sense this change, and provide the necessary output control signal to remedy the situation. Unlike a digital signal, which is typically either an on or off state, an analog signal can assume a wide variety of states, such as a temperature probe reading a wide range of temperatures.

The method used for receiving (and sending) these signals is the analog board. The analog devices are wired directly to the board, and the on-board software/hardware converts the electrical signals received from these devices into data, which is then sent on to the Quantum™ control board via communications.

It features twenty-four input channels, and eight output channels. Rather than using physical jumpers to configure each channel, this is done through the software. A more detailed description of the operation of this board is provided in the sections that follow.

ANALOG BOARD VERSIONS

There have recently been two different versions of Analog Board which have been used:

- The earlier of these two boards had the root part number of 640D0190H01. It is essentially the same as the current version (640D0193H01) with the exception that there have been several jumpers added. Since this board is no longer in production, and is the same as the current board (with the exception that it doesn't have the additional jumpers), it will not be discussed further. A pictorial of this board is presented here for reference purposes:

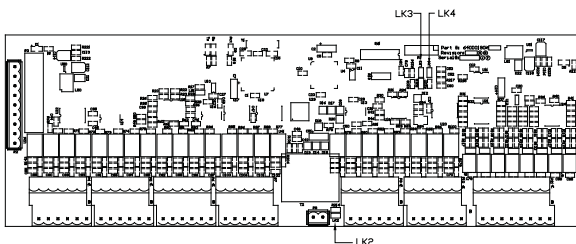

- The current board, root part number 640D0193H01, replaces the previous version

mentioned earlier (640D0190H01). A pictorial of this board is shown here:

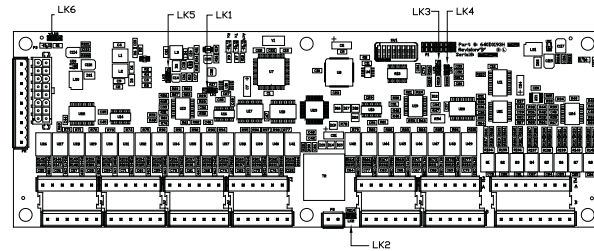

ANALOG BOARD DESCRIPTION

The Analog Board is actually a small microprocessor board and is programmed to control analog outputs, or accept analog inputs, from external electrical devices. Each board has the capability of 24 independent input channels. With the Quantum™ LX Compressor Control, these I/O channels are dedicated through the software and external wiring, as to the function of each channel. The Quantum™ LX controller can utilize up to two separate analog boards (Analog Board #1 and #2), depending on the selected options.

For each of the boards that are installed, they will have specific I/O (Input / Output) functions. For the operating software to distinguish board #1 from #2, each board must be properly addressed as #1 and #2 using the dipswitches on each board (see Analog Board Dipswitch Settings chart for this information). This allows the operating software to know from what channel of which board a signal is being received from.

For example, the first channel of Analog Board #1 is dedicated to reading Suction Temperature. By having the dipswitches set correctly, the software will know which of the two possible boards to look at in order to read the correct channel one.

COMMUNICATIONS LED'S

The Quantum™ controller is in constant communication with the Analog (and Digital) Board(s). You will notice on each Analog and Digital board, that there is a pair of LED's that are labeled as RX and TX. These letters represent receive (RX) and Transmit (TX). These LED's should be flashing at a high rate during normal operation. This indicates that the Quantum™ LX board and the board that you are looking at are properly communicating with each other.

- Refer to the JUMPER AND DIPSWITCH SETTINGS section later in this section. This section contains the dipswitch settings for addressing the Analog I/O Boards. When these switches are properly set, the Quantum™ is able to serially communicate with each I/O board and provide control signals and data

exchange. If these switches are not properly set, the result can be one of the following:

- Lost or failed communications (displayed in the Communications Status box on the Home screen)
- The wrong analog input signals being received
- The wrong analog output signals being sent from the board.

CONNECTIONS TO THE QUANTUM™

Refer to the same titled section in the Digital Board description for the connections.

LOGIC VOLTAGE (POWER) LED'S

Located on the 32 channel Analog Board are two power LED's. The first of these is D1 LED (+5VDC), and will be illuminated as long as the Control Power switch is ON, and the proper +12VDC voltage is present at Analog Board connector P3. The on-board power supply steps the +12VDC down to +5 VDC to power the board. This LED does not indicate however that the proper voltage is necessarily present at the board, only that the voltage is enough to energize the voltage sensing circuitry.

If a voltage related problem is suspected with regard to an Analog Board, the best way to actually determine this is to read the voltage on a DVM (Digital Volt Meter). This may be accomplished by locating the white power / communications connector on the board. Notice that the Analog Board has only one of these connectors. The associated power/communications harness plugs in to it. Take the red (positive) probe of the DVM and carefully insert the end into the +12VDC lead, and the black (negative) probe end into the RET (Return or Common) lead, as shown below:

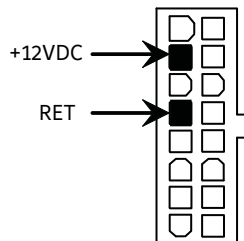

Set the DVM to read DC, and set the proper range. The Ideal voltage range setting for the +12VDC power is 12.10 VDC (+/- 0.05).

The cause for a low voltage reading could be:

- The power supply may need adjustment (see the section on power supplies).
- The Power-I/O communications harness has a problem (a new harness may be needed).

- A problem may exist with one of the I/O boards (Digital or Analog).
- If the power LED is not lighted, check the cable for proper connectivity. **Note: (For the OLD harness only) Each board provides the necessary connections to feed all signals to the following connectors. If the auxiliary Analog or Digital Board is not present then a jumper plug (Part # 640B0039H01) must be installed to daisy chain the signals.**

The second power LED is D5 (+24Vdc). This +24Vdc voltage is generated on the Analog Board from the +12VDC supply being fed from the Quantum™ power supply. If the +12VDC is present as stated earlier, then this LED will illuminate if the on-board +24VDC supply is functioning properly.

ACTIVE LED

The Analog Board has an Active LED indicator that blinks when the board's software is running.

If the Active LED is not blinking, it could be an indication that the internal program is not running. Try powering the Q5 controller off, then back on to see if the Active light starts blinking. If not, a new board may be required.

ANALOG INPUTS

An Analog Input is the portion of the hardware that allows devices such as temperature sensors and pressure transducers to interface with the Quantum™ LX. The software program within the Quantum™ LX is constantly looking at these Input channels, via communications, and based upon what the voltage or current level of the channel is, will provide the necessary control for an associated action. For instance, if the digital input for the Oil Level Sensor is energized, and the Oil Separator Temperature sensor signal causes the value to drop below the setpoint, the Separator will determine that the Oil Heater needs to be energized. (Digital Inputs are discussed in the Digital Input section).

Analog inputs arrive at the board on connectors P4 through P10. Each of these connectors can receive two channels (for a total of twenty-four).

Each of the channels is software configurable to select for the following type of input signals:

Analog Board Input Configuration Table

Channel	ICTD	0-5Vdc	0-10Vdc	0-20mA	POT (Potentiometer)	CT (Motor Current)	Accelerometer (Vibration Monitoring)	RTD (Motor Protection Only)
1	*	*	*	*				*
2	*	*	*	*				*
3	*	*	*	*				*
4	*	*	*	*				*
5	*	*	*	*				*
6	*	*	*	*				*
7	*	*	*	*				*
8	*	*	*	*				*
9	*	*	*	*				*
10	*	*	*	*				*
11	*	*	*	*				*
12	*	*	*	*				*
13	*	*	*	*				*
14	*	*	*	*	*			
15	*	*	*	*	*			
16		*	*	*		*		
17	*	*	*	*			*	*
18	*	*	*	*			*	*
19	*	*	*	*			*	*
20	*	*	*	*			*	*
21	*	*	*	*			*	*
22	*	*	*	*			*	*
23	*	*	*	*			*	*
24	*	*	*	*			*	*

ANALOG OUTPUTS

An Analog Output is the portion of the hardware that the Quantum™ LX uses to provide control. With the Quantum™ LX, this output is dedicated for a 4-20 mA signal that is outputted to an external device, and cannot be changed through the software configuration. This device is usually a customer specific application, such as to simply receive a signal back from the Quantum™ providing the Slide Valve Position to an external application (perhaps a PLC), as an example.

TROUBLESHOOTING THE ANALOG INPUTS AND OUTPUTS

Some problems that are encountered involve troubleshooting the Analog inputs and outputs. The Analog Board has twelve Analog I/O board connectors labeled P4 through P10. The external Analog devices are wired to a connector plug. Position 1 connects to the plus (+) of the external device for channel 1, position 2 connects to the signal (SIG) of the external device for channel 1 and position 3 connects to ground (GND) of the external device for channel 1. Position 4 connects to the plus (+) of the external device for channel 2, position 5 connects to the signal (SIG) of the external device for channel 2 and position 6 connects to ground (GND) of the external device for channel 2, as shown below:

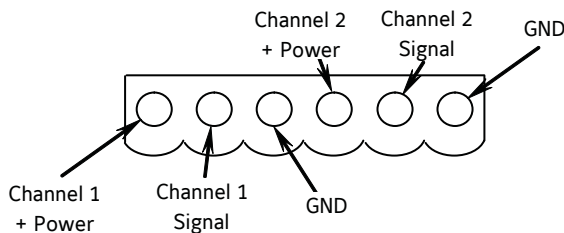

Each channel is setup through software calibration for the proper transducer type and range, and each transducer must be calibrated through the appropriate sensor calibration screen. Improper setup of either the hardware or software will result in improper operation or range.

The most common fault associated with the improper reading of the analog channels other than hardware or software setup problems fall into one of the following categories:

- Sensor fault
- Wiring problem
- Improper grounding of system.

An open wire, shorted wire, or faulty sensor will usually give a reading at either the minimum or maximum end of the range scale. An erratic reading or a reading that seems to float up and down is usually indicative of a grounding problem. When a single transducer or cable is shorted to earth (or system) ground, this can show up as a whole assortment of problem channels. The easiest way to find a short to earth problem is to disconnect all the sensor plugs and ohm out each plug screw terminal to earth for open (infinite) impedance. All sensors should read open to earth with the exception of the CT motor current channel. One side of the CT is grounded in the Motor Control Center (MCC). (The third pin on pressure sensors is ground.)

REPLACING A DEFECTIVE ANALOG BOARD

The procedure to replace an Analog board is outlined below:

1. Shut off control power.
2. Unplug all connectors from the board.
3. Remove the old board from the machine and remove the new board from its packing and place both on an anti-static surface.
4. Check that all jumpers and dipswitches are properly setup on the new board as it was on the old board.
5. Install the modified replacement board in the panel.
6. Plug all connectors back in.
7. Turn on control power.
8. After replacing or installing an Analog Board and powering on the control panel, select **[Redetect I/O Boards]** from the Menu > Configuration > Communications screen. This selection provides a method to detect all connected Analog and Digital boards. If a board has been removed, a communication error shutdown will be issued until this key is selected.

The **[Redetect I/O Boards]** key resets the memory of the processor as to which boards it requires communications from. Therefore, it is important to check the **[About]** screen to see which boards have been detected relative to the I/O boards actually in the panel.

PHD VIBRATION ANALYSIS

The Frick™ 32 channel analog board has the built-in capability to directly receive signals from vibration accelerometers, and motor stator RTDs (100 Ω platinum) which are mounted on the compressor housing and/or the motor/shaft. The purpose of these devices is to monitor compressor motor/shaft vibration and/or motor temperature.

Accelerometers transmit continuous signals to the analog board. The Quantum 4 software monitors these signals, and can detect any variations in the frequency of the vibration. As the vibrations increase over time (due to bearing wear), predefined setpoint limits may be exceeded, and a warning will be generated from the Quantum™ to the display screen, warning the operator of the condition. If the alarm is not addressed, a shutdown will occur to prevent damage

to the compressor. Likewise, if an RTD is used for bearings, it will measure the temperature of the motor bearings and stator, which will increase (due to the failing bearings causing increased friction).

Typically, all PHD related connections will be to Analog Board # 1. However, if Auxiliary Analog monitoring is required also, then this additional wiring would connect to an optional Analog Board # 2. Refer to the drawing at the bottom of this page for the wiring connections of the different possible configurations.

The full wiring diagram may be found later in this manual in the Quantum™ Drawings section. Additional information on PHD vibration monitoring and theory may be found in the Phd Vibration Monitoring System manual (E70.020-TB).

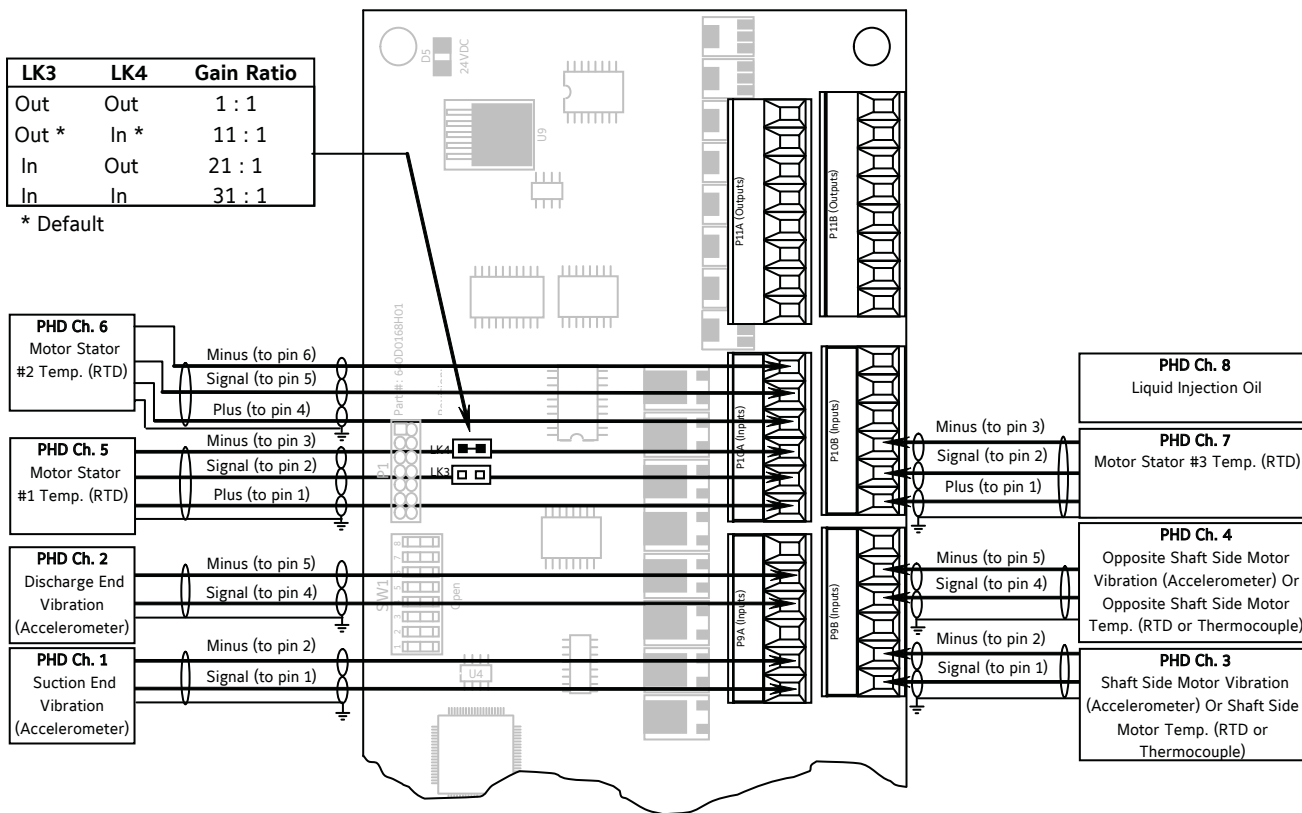

PHD Connections (Analog Board # 1)

CURRENT TRANSFORMER (MOTOR AMPS)

Channel 16 of Analog Board 1 is dedicated to reading motor amps, either through the use of the on board current transformer when using a 0-5 amp CT, or from an external source. When reading motor amps directly at the P8

terminal strip from a CT, the input signal cannot exceed 5 amps. If you are using an external DC Ma or voltage device, remove the jumper at Link 2, and connect the wiring to connector P7B. If you intend on utilizing the on-board current transformer, then install Link 2, and connect the wiring to Channel 16, as shown in the diagram below:

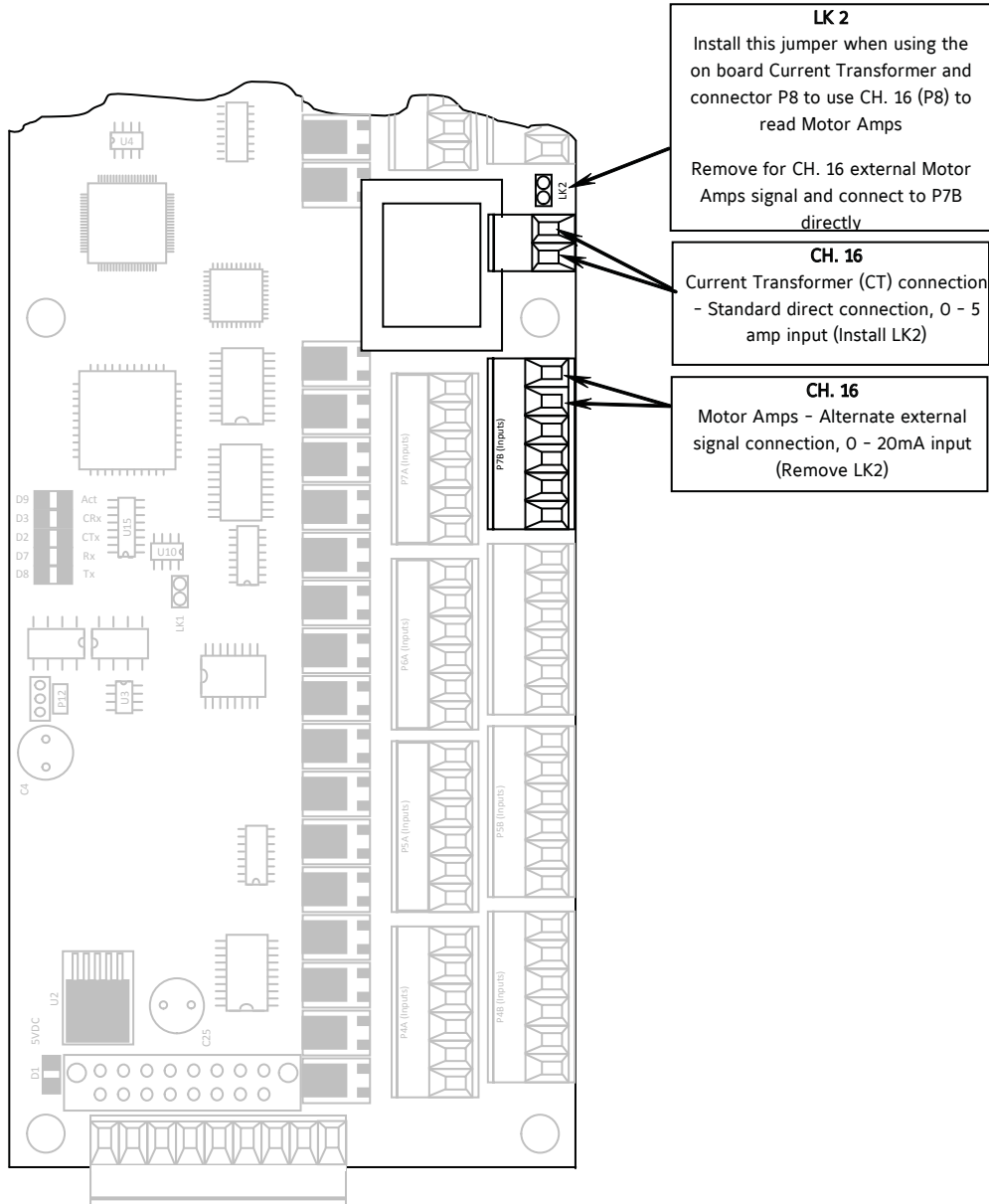

ANALOG BOARD #1 PICTORIAL

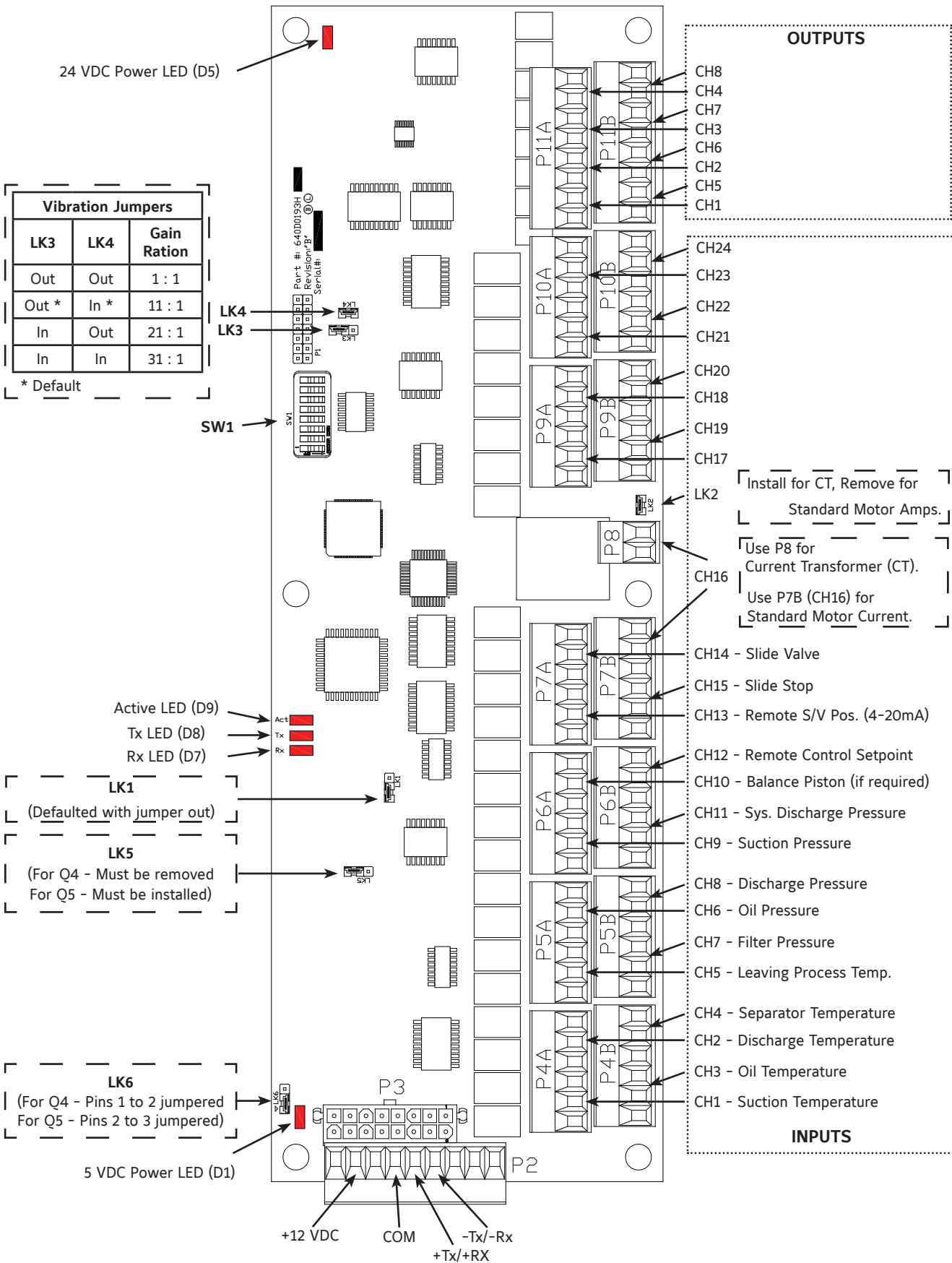

ANALOG BOARD #2 PICTORIAL

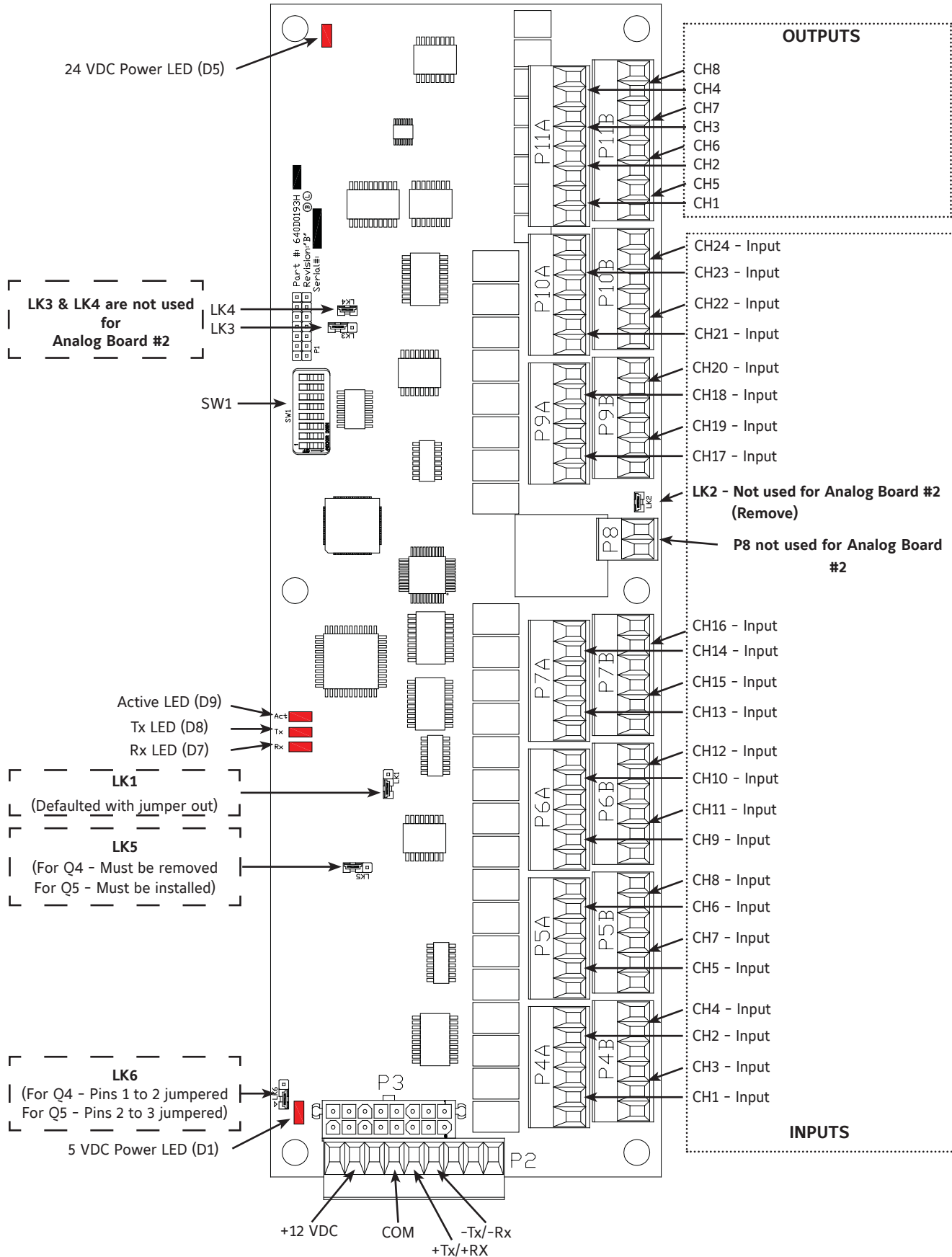

SECTION 6

OPERATOR INTERFACE

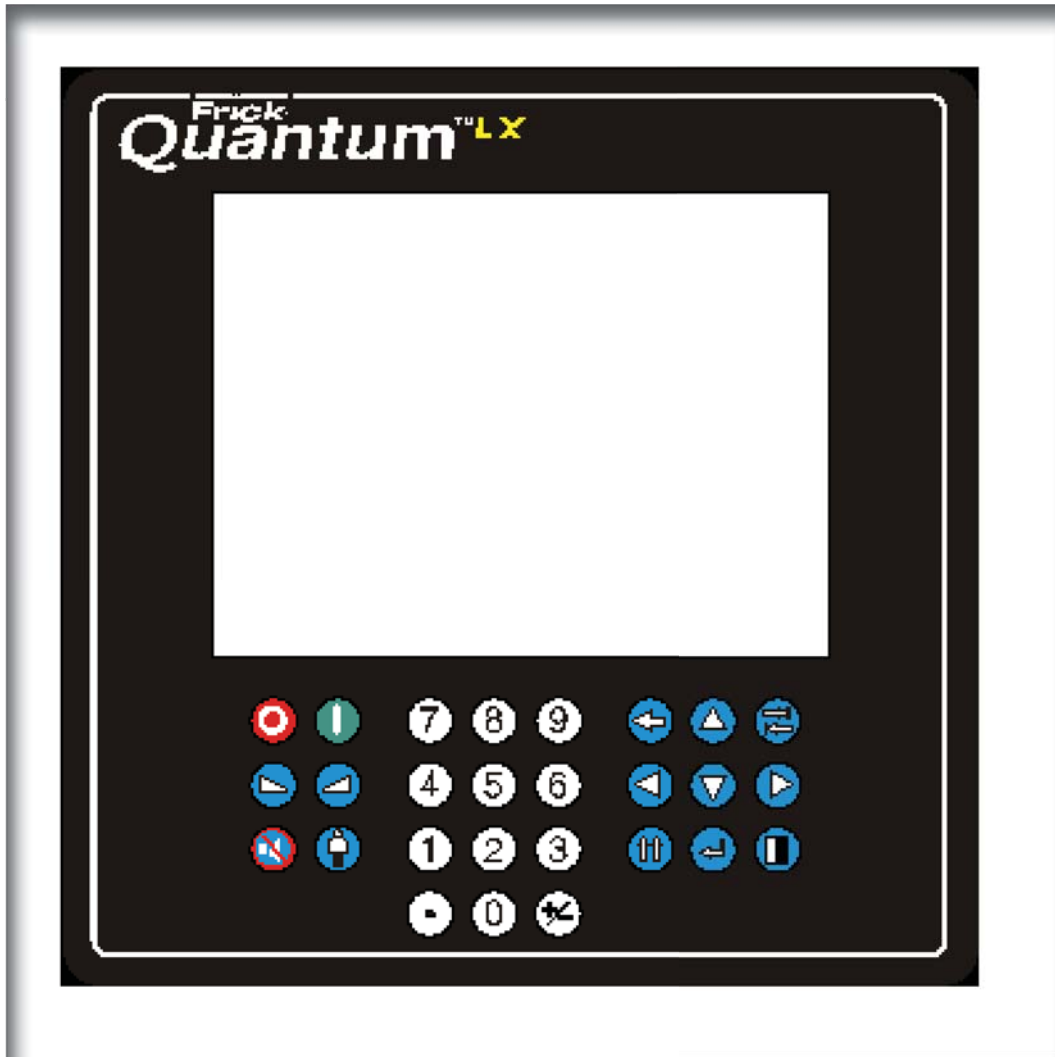

OPERATOR INTERFACE

DESCRIPTION

The Quantum™ LX Operator Interface actually consists of two components: A color 10-1/2" (diagonally measured) graphic display and a membrane touch keypad. The display is used to view information coming from the Quantum™ controller, while the keypad allows the user to enter information into the controller.

DISPLAY ASSEMBLY

The Display assembly consists of a 640 x 480 resolution, LCD screen (which includes a fluorescent backlight tube(s), a backlight inverter circuit board, and a wiring harness). Refer to the Parts List near the end of this manual for specific replacement part numbers.

NOTE: Before replacing a display unit, ensure that the symptom is not actually being caused by a bad fluorescent tube, inverter or harness.

IDENTIFYING THE TYPE OF DISPLAY

Various display manufacturers have been utilized over the years, and although the variations between the displays of these manufacturers is subtle, it needs to be addressed here. If a display related problem is ever encountered and factory service is contacted, they may request the type of display that is being diagnosed. This information can be found on a sticker located on the back of the display mounting plate, and should resemble the following example:

SHARP DISPLAY ASSEMBLY
ORDER 639D0175G01
-INCLUDES DISPLAY & MOUNTING
PLATE-ORDER INVERTER
SEPARATELY P/N 639A0261H01

This sticker will give the part number of the display that is currently installed. Refer to the Spare Parts list at the end of this manual for applicable part numbers.

DISPLAY REPLACEMENT

1. Shut off control power.
2. Carefully unplug all connectors that are attached to the display. Ensure that you are familiar with the relocation of each of these connectors.
3. Loosen the four hex nuts located on the display plate. The location of these nuts is shown on the Quantum 4 and Q5 *Display Mounting Plate* drawings that follow.
4. While supporting the display plate assembly with one hand, carefully remove the four hex nuts

that were loosened in the previous step.

5. Once the four nuts have been removed, carefully remove the display plate. There is a section of plexiglas between the display and the clear viewing window of the keypad assembly. Ensure that this plexiglas does not come out. If it does come out, simply ensure that it is reinstalled before placing the new display in place. Also be sure not to get fingerprints on the plexiglas.
6. Carefully lay the display plate down on a table or bench, with the display side up.
7. If you haven't already done so, remove the connector from the back of the display. There are two variations on the way the display connector is attached depending on whether the unit is a Quantum 4 or Q5. Please refer to the notes provided later in this section as to how to properly perform the cable removal.
8. Remove the four phillips head screws located near the corners of the display.
9. Remove the defective display.
10. Install the new display.
11. Reinstall the four phillips head screws near the four corners of the display. Do not overtighten.
12. Reconnect the display connector on the back of the display. Once again, refer to the two sections shown later as to the proper method to do this.
13. Reinstall the display plate back into position on the panel door, and loosely reinstall the four hex nuts, do not tighten yet.
14. Look at the front of the display from the front of the panel door. Ensure that the display looks centered in the display opening. Once centered, tighten the four hex nuts. Re-centering the display may be necessary after these steps have been completed. If this is the case, simply loosen these four nuts, and re-center the display, then retighten.
15. Reattach all of the connectors that were removed during step 2.
16. Verify the Quantum™ jumper (link) settings per the table shown later in this section.

QUANTUM 4 SPECIFIC INFORMATION

The end of the display cable that plugs into the display has an adapter connector plugged into it, which adapts the display cable to the display. When unplugging the display cable from the back of the display, it is possible that the display cable connector may separate from the display adapter connector. If this occurs, refer to the following drawing to ensure proper connector orientation when plugging the display cable back into the display:

With the display connector held as shown, orient the display harness to plug onto the back pins with the 2 empty wire holes oriented down toward the bottom as shown.

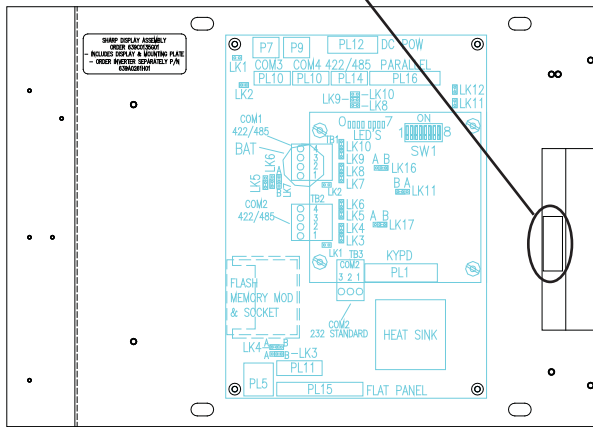
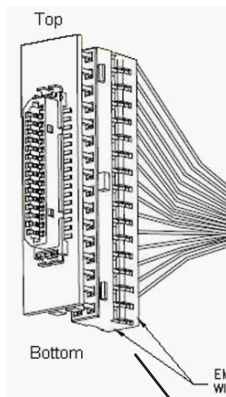

Quantum 4 Motherboard Display Jumpers (links)

Link Number	Link Position	Description
LK3	A	+5V Backlight Voltage (Not used)
	B*	+12V Backlight Voltage (All Displays)
LK4	A*	+5V LCD Supply (Samsung, NEC, Sharp)
	B	+3.3V LCD Supply (LG Philips Display)

* standard setting

(Refer to "Quantum 4 Board Settings" for location of jumpers)

Q5 SPECIFIC INFORMATION

The display for the Q5 utilizes a "bat wing" adapter board that plugs into the display connector, and accepts the display harness from the Q5. This adapter board is keyed so that it cannot be plugged in wrong. The display harness is also keyed, so that its orientation is assured. To aide in accessing this "bat wing" adapter, the Interface board should be removed. A drawing of the "bat wing" adapter and its location is shown here (with Interface board removed):

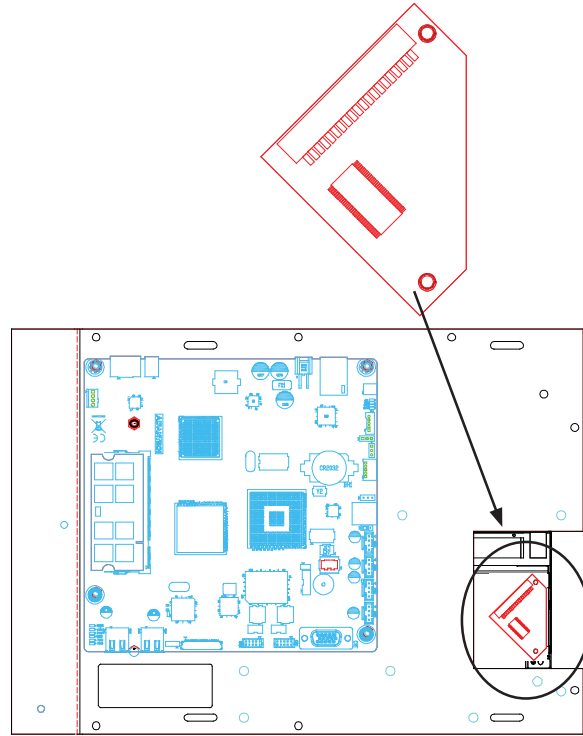

Q5 Motherboard Display Jumpers (links)

Jumper Title	Function	Jumper Setting	
CN1000 (LCD Resolution Selector)	18-bit 640x480 (default)		3-5 Closed & 4-6 Closed
JLVDS2 (Backlight Level Selector)	0- 5V (default)		2-3 Closed
	0 - 2.5V		1-2 Closed
JLVDS3 (Backlight Control Mode)	Voltage Mode (default)		1-2 Closed
	PWM Mode		2-3 Closed

(Refer to "Q5 Board Settings" for location of jumpers)

KEYPAD

The Quantum™ LX keypad is shown here:

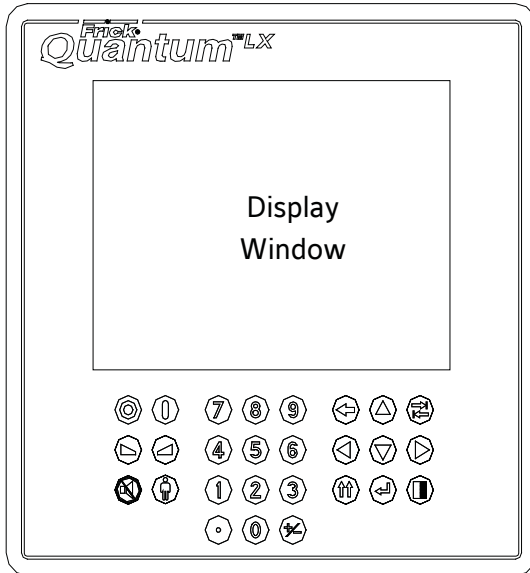

The Keypad consists of two areas, the Display window and the Keypad itself. The Display window is simply a clear portion of the Keypad assembly which the Display is able to be viewed through.

KEYPAD TROUBLESHOOTING

The Keypad area consists of a series of 27 membrane switches. Depressing each switch (key) should result in an audible tactile clicking sound. To ensure that each key is actually functioning:

Quantum 4: Visually inspect the D8 LED located on the control board. This LED will normally

flash on and off at a rate of about once-per-second. Pressing a key on the keypad will interrupt this flash rate, and repeatedly depressing a key will cause the LED to flash each time a key is pressed.

Q5: Visually inspect the D6 (Active) LED located on the Q5 Interface board. This LED will normally flash on and off at a rate of about once-per-second. Pressing a key on the keypad will interrupt this flash rate, and repeatedly depressing a key will cause the LED to flash each time a key is pressed.

If a keypad problem is suspected, or apparent, a USB capable computer keyboard (will have a USB stule connector on the end of the keyboard cable) can be used as a troubleshooting aid. To by-pass the Quantum™ LX keypad, open the control panel door. **NOTE: Always be aware of the presence of live AC voltage!** Depending upon the type of Quantum™ being diagnosed, use the following instructions:

Quantum 4: Locate the USB connection on the controller, and plug the USB end of the keyboard cable in to it.

Q5: Locate the two USB connections on the controller, and plug the USB end of the keyboard cable into either one.

The external USB based keyboard is now active and ready to use. Some of the keyboard keys are mapped so that they will duplicate the functions of the Quantum™ LX keypad. **NOTE: There is a slight variation between the way a Quantum 4 and a Q5 interpret this mapping, but these variations are minor.** To navigate using the external keyboard using Q5 key-board mapping, refer to the following pictorial:

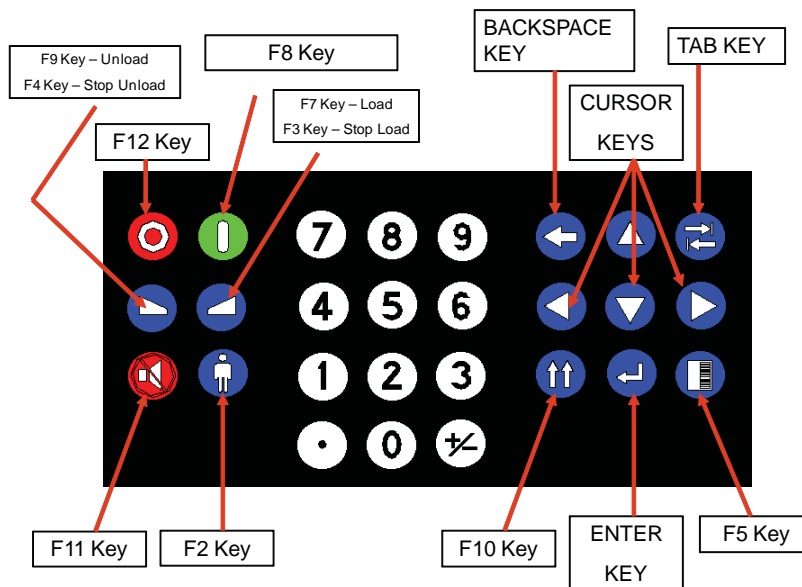

* Numeric Keys, decimal, +/- all the same as a keyboard.

KEYPAD REPLACEMENT

1. Shut off control power.
2. Unplug the defective keypad from the Quantum™ board.
3. The keypad is affixed to the controller door with a double-sided tape film. Start by lifting the keypad at one of the corners. Once the keypad starts to break free from the underlying tape, continue pulling. A carefully used putty knife can help to separate the keypad from the adhesive.
4. Once the keypad has been entirely removed, you will notice that much of the double-backed tape is remaining on the panel door. Carefully using a window scraper style razor will remove most of this tape. Be careful not to scratch the paint outside of the keypad footprint.
5. Take the new keypad, and feed the flat cable through the slotted opening at the bottom of the display area.
6. Remove the paper backing of the keypad to expose the double-backed tape underneath.
7. Carefully align the keypad on the door, ensuring that the display is centered within the window of the keypad. Once you are satisfied with the position, firmly press the keypad into place.
8. Plug the keypad cable back into the Quantum™.
9. Turn Control power back on.
10. Test the new keypad as described earlier.

NOTES:

SECTION 7

SERVICE SCREENS

Digital I/O

<u>Board 1 Channels</u>		<u>Board 2 Channels</u>	
1 Off	13 On	1 Off	13 On
2 Off	14 On	2 Off	14 On
3 Off	15 Off	3 Off	15 Off
4 Off	16 Off	4 Off	16 Off
5 Off	17 On	5 Off	17 On
6 Off	18 On	6 Off	18 On
7 Off	19 On	7 Off	19 On
8 Off	20 On	8 Off	20 On
9 Off	21 Off	9 Off	21 Off
10 Off	22 On	10 Off	22 On
11 Off	23 Off	11 Off	23 Off
12 Off	24 Off	12 Off	24 Off

SERVICE SCREENS

SERVICE - Digital Board Inputs and Outputs

Digital I/O			
Board 1 Channels		Board 2 Channels	
1	Off	13	On
2	Off	14	On
3	Off	15	Off
4	Off	16	Off
5	Off	17	On
6	Off	18	On
7	Off	19	On
8	Off	20	On
9	Off	21	Off
10	Off	22	On
11	Off	23	Off
12	Off	24	Off

ACCESSING:  → Service... → Digital

DESCRIPTION: This Digital Service Screen shows Digital values as ON or OFF

SERVICE - Analog Board Inputs and Outputs

Analog Inputs (data units are Volts DC)			
Board 1 Channels		Board 2 Channels	
1	3.62	13	0.62
2	2.93	14	0.27
3	2.78	15	0.29
4	3.16	16	0.18
5	1.16	17	2.37
6	2.11	18	1.80
7	4.03	19	4.58
8	1.83	20	5.00
9	2.98	21	5.00
10	0.62	22	4.18
11	0.88	23	5.00
12	0.60	24	0.33

Analog Outputs (data units are Volts DC)			
Board 1 Channels		Board 2 Channels	
1	0.00	5	1.00
2	0.00	6	1.00
3	1.22	7	0.00
4	0.00	8	0.00

ACCESSING:  → Service... → Analog

DESCRIPTION: The Analog Service Screen has been provided to view the raw data from an Analog Board. Analog values are converted from binary to show volts. The error factor is +/- .05 volts.

SERVICE - Motor Bump

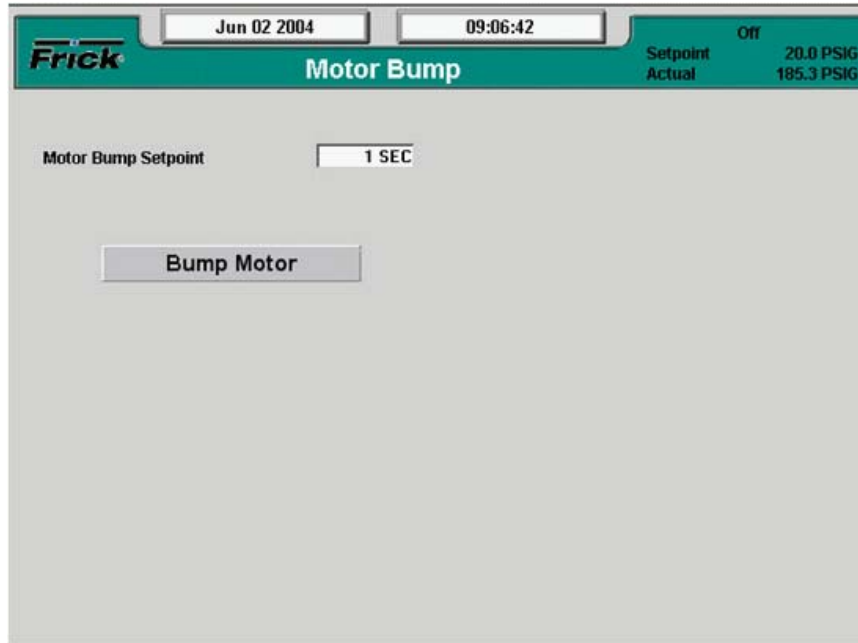

ACCESSING:  → **Service...** → **Motor**

DESCRIPTION: The Motor Bump screen has been provided as a way for the service technician to verify proper motor rotation.

The following setpoint box appears on this screen:

Motor Bump Setpoint - A value from 0 to 15 seconds may be entered here. This value is the amount of time that the compressor motor will be energized for once the Bump Motor toggle switch has been selected.

The following toggle switch has been provided:

Bump Motor - When this button has been highlighted, and the **[Enter]** key pressed, the compressor motor will be energized for the period of time as set

in the Motor Bump Setpoint box. It is during this motor spin time, that the technician can view the motor shaft, for determining proper rotation. **NOTE: Use extreme care in performing this operation. The compressor shaft linkage must be disconnected from the motor prior to performing this test!**

For safety reasons, the **[Bump Motor]** toggle switch only appears in local mode (at the panel itself). It will not appear when viewing this panel remotely.

SERVICE - Software Maintenance

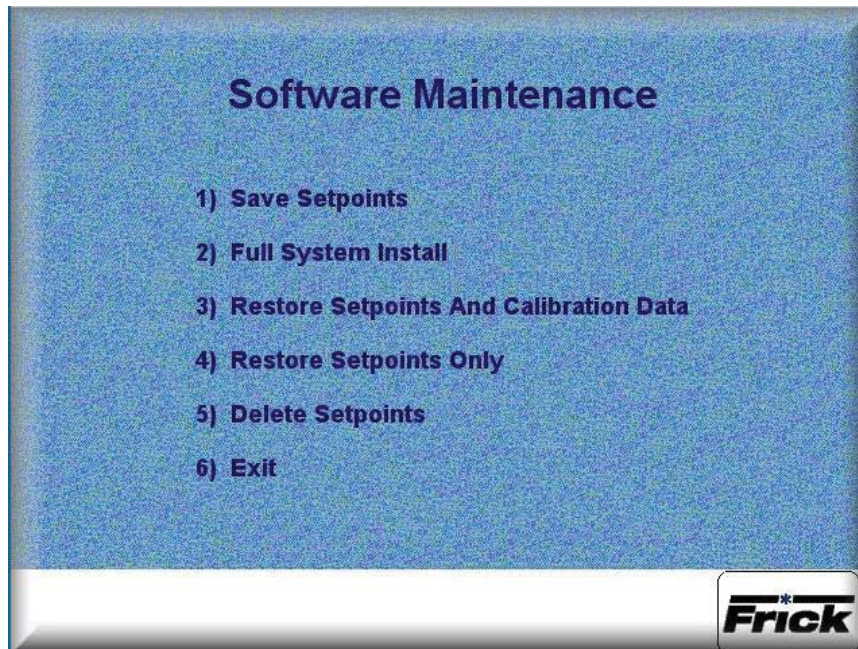

ACCESSING:



Service...

Software Maintenance

DESCRIPTION: The Software Maintenance screen has been provided as a way for the user to upload the operating software to their system, to save setpoints or to restore setpoints. **NOTE:** Before accessing this screen, it is recommended that a USB adapter, with a USB drive device (P/N 649A1063G01) be plugged into the PL8 USB port of the Quantum™.

NOTE: This procedure covers updating from version 6.07 or above. Use caution when accessing this screen remotely with a web browser.

While performing this procedure, one of two dialog boxes will appear. The first of these boxes indicates that a valid USB device has been detected. Any numerals that appear on the center line of this box will represent units that have already been saved (from 0 to 99). If no units have yet been saved, the center line will be blank:

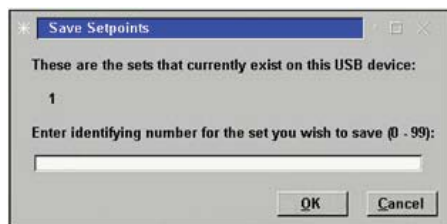

If however, there is no USB device installed, or the device does not contain the operating software, the following dialog box will appear:

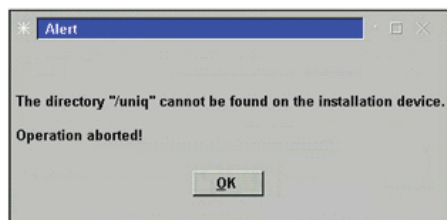

Perform the following steps to prepare the Quantum™ LX for software maintenance:

- Ensure that all setpoint values have been documented as a safety precaution.
- Stop the compressor.
- With power ON, insert the USB device into the provided USB port of the Quantum™.
- Go to User Level 2. The default password is 20.
- Press the **[Menu]** key.
- Cursor down to Service... and press **[Enter]**.
- Cursor down to Software Maintenance and press the **[Enter]** key.

The following selections have been provided:

- 1) **Save Setpoints** - Use this option to save all setpoints and custom text to a USB device as a form of backup:
 - Press **[1]** to Save Setpoints.
 - The program will read the USB device, and display a dialog box.
 - Enter a number on the keypad that corresponds to the unit number that you wish

to save, and then press **[Enter]**. If the unit number has not been saved before, the setpoints will be saved to a file on the USB device (a progress bar will appear asking you to Please Wait... In the future, any time you try to write the setpoints to this number, you will be prompted with a message telling you that the set number already exists – do you wish to overwrite it? Answer by highlighting the Yes button, and pressing **[Enter]** if you do indeed wish to overwrite the values. If you enter a number that does not appear on the center line, no such warning will appear.

- After the file has been written or updated, the dialog boxes will disappear, and you can either exit, or continue with another function.
- 2) Full System Install** – Use this option to install the program:
- Ensure that all setpoint values have been documented as a safety precaution.
 - Press **[2]** to do a Full System Install.
- 3) Restore Setpoints And Calibration Data**– Use this option to re-load previously saved setpoints and custom text to the Quantum™.
- Ensure that all setpoint values have been documented as a safety precaution. Install the previously saved setpoint USB device into the provided connection on the Quantum™.
 - Press **[3]** to Restore Setpoints and Calibration Data.
 - The program will read the USB device, and display a dialog box.
 - Enter a number on the keypad that corresponds to the unit number that you wish to restore, and then press **[Enter]**.
 - A progress bar will appear asking you to Please Wait...
 - After the file has been written or updated, the dialog boxes will disappear, and you can either exit, or continue with another function.
- 4) Restore Setpoints Only** – Use this option to Restore the setpoints only (custom text that has already been changed will not be affected) for a particular unit:
- Ensure that all setpoint values have been documented as a safety precaution. Install the previously saved setpoints USB device into the provided connection on the Quantum™.

tum™.

- Press the **[4]** button.
 - The program will read the USB device, and display a dialog box.
 - Enter a number on the keypad that corresponds to the unit number that you wish to restore, and then press **[Enter]**.
 - Highlight the Yes button, and press **[Enter]**. The dialog box will be updated with a new message stating that Set number (0-99) has been restored.
 - Press **[Enter]** to return to the Software Maintenance menu.
- 5) Delete Setpoints** – Use this option to delete the setpoints and custom text for a particular unit:
- Ensure that all setpoint values have been documented as a safety precaution. Install the previously saved setpoints USB device into the provided connection on the Quantum™.
 - Press the **[5]** button.
 - The program will read the USB device, and display a dialog box.
 - Enter a number on the keypad that corresponds to the unit number that you wish to delete, highlight the Ok button, and then press **[Enter]**. You will be prompted with a new dialog box which will ask you OK to delete set number (0-99)?
 - Highlight the Yes button, and press **[Enter]**. The dialog box will be updated with a new message stating that Set number (0-99) has been deleted!
 - Press **[Enter]** to return to the Software Maintenance menu.
- 6) Exit** – Use this selection to leave this screen:
- While leaving the USB device plugged in, press **[5]** to Exit.
 - During the reboot of the Quantum™ LX, a message will appear that says, “A System Update file has been detected on the mounted USB device. Do you wish to perform this update?” Select **[Yes]**, and a System Update will be performed.
 - At the conclusion of the System Update, a message will appear that says, “The USB device can now be removed and power should be recycled.” Follow these instructions.

Setpoint Defaults When Performing A Quantum™ LX Software Upgrade

The term software upgrade refers to the whole procedure of Saving Setpoints, Full System Installs, and Restoring Setpoints when on the Software Maintenance screen. They get set to these default values even after a Restore Setpoints is performed, so the individual doing the upgrade must then set them manually to what they need to be if they are critical to the application.

To determine the setpoints and their defaults that would be affected by a revision upgrade, find the row or rows corresponding to the Software Version that you will be upgrading to. On that row or rows you can see the setpoints and their related defaults.

Here are some examples:

- If upgrading from 6.48 to 6.51, then both the PowerPAC Flag and the Ethernet Process Enable setpoints will be changed to the defaults shown for each.
- If upgrading from 6.48 to 6.52, then the PowerPAC Flag, Ethernet Process Enable,

Regulation Mode and Max Slide Valve timer setpoints will be changed to the defaults shown for each.

- If upgrading from 6.51 to 6.55 (both shown on this chart), then the PowerPAC Flag, Ethernet Process Enable would have already been changed when you had initially upgraded to 6.51 and will not change again. But now that you are upgrading to 6.55, additionally the Regulation Mode, Max Slide Valve timer, Compressor Type, Pump Type, Process Leaving Temp. Safeties, Compressor Types in the Sequencing Systems and the Compressor Start #'s in the Sequencing Systems setpoints will be changed to the defaults shown for each.

The main message here is ensure that the Setpoint Data Sheets within this manual are filled out, and that when performing any software upgrade, first save your existing setpoints to a Setpoint Saver Card for later use. After completing an upgrade to one of the versions shown here, and then restoring your original setpoints, review this chart and compare the setpoints shown against what the program sees, and make changes to these defaults as necessary.

Setpoint Defaults When Performing a QLX Software Upgrade

Setpoint Description	Default	Software Version
Ethernet Configuration		6.11
PowerPAC Flag	No	6.51
Ethernet Process Enable	Disabled	6.51
Regulation Mode	Mode 1	6.52
Max Slide Valve Timer	30 (tenths of secs)	6.52
Compressor Type	RWF	6.55
Pump Type	Demand	6.55
Process Leaving Temp. Safeties	Disabled	6.55
Compressor Types in the Sequencing Systems	RWF	6.55
Compressor Start #'s in the Sequencing Systems	1	6.55
Filter Differential Calculation	Filter – Oil	6.58
Allen Bradley Checksum Type for Comm 1, 2, & 3	BCC	6.58
Minimum Capacity Position setpoint		Only when versions 6.58-6.61 upgrading to 6.62 or 6.63
Pump Type	Demand	6.59
Added Kw (Kilowatt) capability to Trending list (Real Time & History Trending)	N/A	6.65
Power Assist	30 Sec.	6.82
Low Oil Inj. Pressure Shutdown Delay	180 Sec.	6.82
Vyper Standby Time	20 Min.	6.83
EZ Cool PID Control	Always	6.83
PID Control Point, User Defined and Trending Lists	N/A	7.00
NOTE: The warnings below may appear after upgrading from version 6.53 or below. This is due to a sensor input out of range, usually because the input is not used. If this is the case, you can disable the input (if it is not used) to clear the warning.		
Low Rem Capacity Sensor Warning	Menu > Calibration > Motor Miscellaneous	
Low RPM Sensor Warning	Menu > Calibration > Motor Miscellaneous	
Low Manifold Pressure Sensor Warning	Menu > Calibration > Pressure	
Low Filter Pressure Sensor Warning	Menu > Calibration > Pressure	

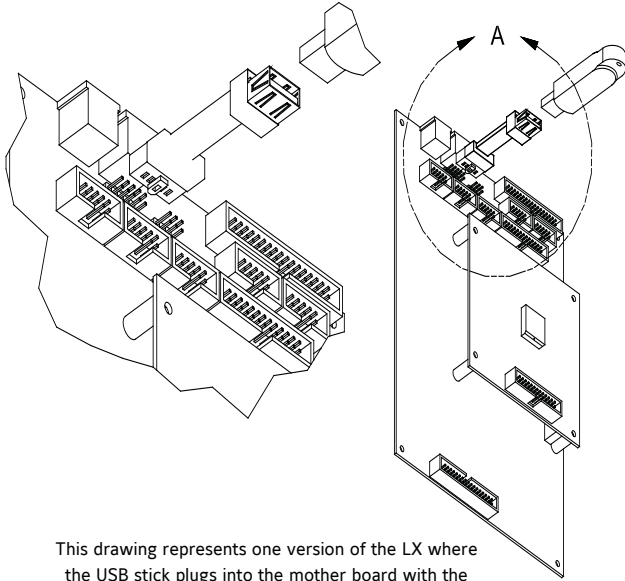

This drawing represents one version of the LX where the USB stick plugs into the mother board with the use of an adapter.

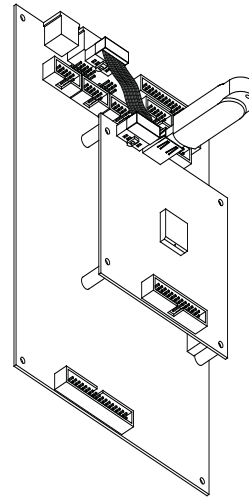

This version of the LX has a USB connector located on the daughter board, no adapter is required.

Quantum 4 USB Plug-in locations

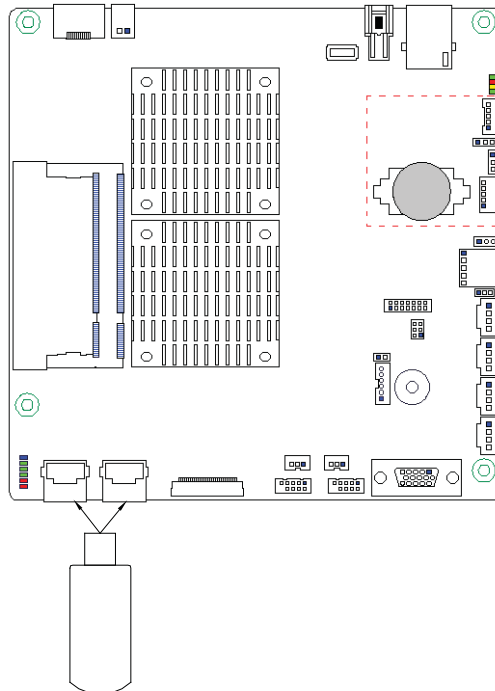

Q5 USB Plug-in locations

SYSTEM STATUS - Maintenance

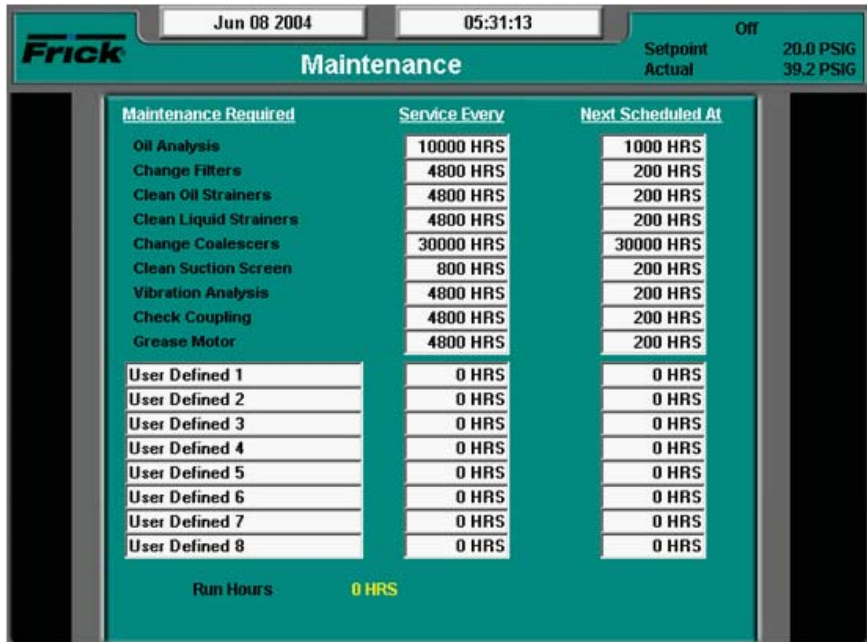

DESCRIPTION: This screen has been provided to aid the service technician with keeping track of system maintenance, and can be accessed from the System Status screen. From here, the service technician can view up to eight (8) user definable maintenance schedules. Each of the schedules may be custom named. This screen is based upon the Maintenance Schedule that is provided in the IOM manual for the specific compressor package. For additional information about this screen, refer to 090.022-O (Operation Manual).

CONFIGURATION - Communications

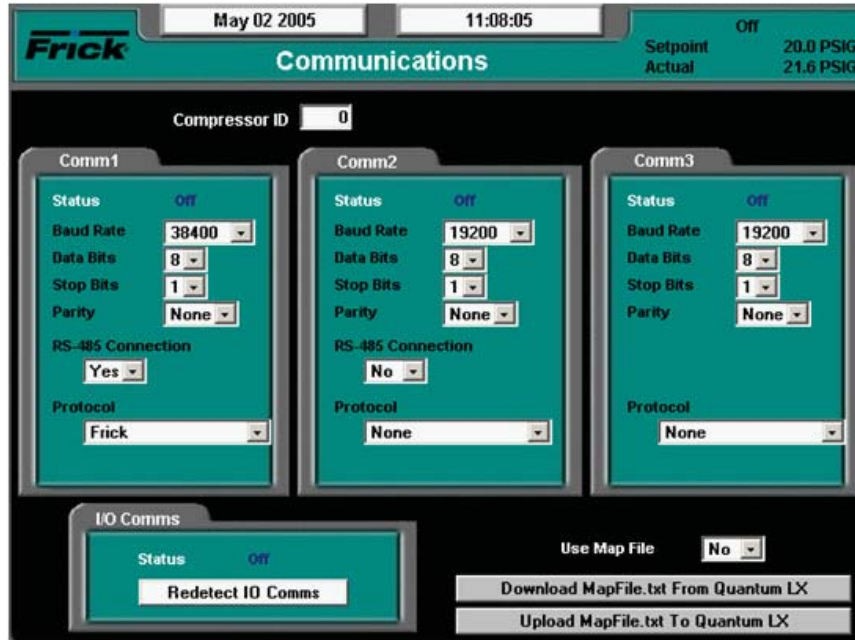

DESCRIPTION: The purpose of this screen being shown here is to indicate where the **[Redetect I/O Comms]** key is located. This selection provides a method to detect all connected Analog and Digital boards. For additional information about this screen, refer to 090.020-CS (Communications Manual).

The following are some of the things that can occur that would cause an I/O board to stop communicating with the Quantum™, and would require that you Redetect I/O Comms:

- A board has been removed, and power was turned on with the board removed. You would need to replace the board, re-power, and then Detect I/O Boards.

- A board has failed in such a way that it cannot properly communicate with the Quantum™ LX.
- A failure with the communications cable which is plugged into the end of each board

If any of these things occur, a communications error shutdown will be issued until this key is selected. You should always view the *About* screen to see what has been detected.

MISCELLANEOUS SCREENS

About



ACCESSING:



About

DESCRIPTION: The About screen shows any Analog and Digital boards that have been detected. If a board has lost communications, a shutdown will be issued. All outputs are turned off on a Digital Board that has lost communications. All inputs will get set to their minimum value range on an Analog Board that has lost communications. A loss of communications to an analog board should result in sensor fault shutdown messages that are associated with the sensors on that board. If the RX LED on the I/O board is blinking but the board was not detected on the About screen, or an I/O Comm failure occurs, check the address of the board.

SECTION 8

TROUBLESHOOTING

TROUBLESHOOTING A PROBLEM THAT APPEARS UNEXPLAINABLE

When there is a problem that makes no sense due to unexplainable things happening, check the following:

1. Is the panel powered by an isolating power source such as a control transformer in the starter panel?
2. Verify that the panel is not powered from a lighting or utility panel.
3. It is important to know if the unit ever worked properly.
4. If the unit used to work properly, try to determine when the problem first showed up.
3. It is important to know if the problem occurs randomly, frequently, or all the time.
4. Check what the temperature is in the engine room and at the panel. Is it very hot or very cold?
 - Make sure that the motor is not blowing exhaust air on the control panel.
5. If it just started to act up, then check if there was recently a severe lightning storm, fire, flood, or a plant accident. If any of the following conditions are possible, then check for it:
 - Has any water, refrigerant, or oil leaked into the panel or conduit?
 - Does the conduit with the Slide Valve or Slide Stop contain liquid?
 - Does the Slide Stop potentiometer cover contain any liquid?
6. If it just started to act up, then check if anything was recently changed in the system (i.e. software or hardware.)
7. If it just started to act up, then check if any service was recently done to the compressor or its electrical system?
8. If there is communication wiring connecting the panel to another panel or device, then check the

following:

- If the Quantum™ is unexplainably shutting down, try disconnecting the communications cable to see if the problem goes away.
 - Check if the communications cable shields are tied to machine ground at only one location. For a PLC or Opto22 based system, the shield should normally be tied only at the PLC or Opto22 panel.
 - Check that you are using the Frick recommended communications cable.
9. If this is an older plant, has the plant wiring been brought up to code?
 10. Do you have power wiring mixed with control, sensor or communications wiring?
 11. Check that the starter panel is grounded to the plant transformer. There are usually four wires: 3 for the 3 phases and 1 for plant ground.
 12. Check that the motor is grounded to the starter panel. There are usually four wires: 3 for the phases and 1 for ground.
 13. Ensure that one side of the motor current transformer is grounded in the motor starter panel. The wire to the control panel terminal #2 is usually the only one grounded.
 14. Check that the pressure transducers are properly grounded. The two types of transducers you may have are as follows: an older type has an 8 to 10 inch 3-conductor pigtail coming out of the transducer. This type will have the attaching cable's shield cut off and insulated at the transducer end. The shield is then tied to a panel ground terminal in the panel. The newer type has the cable as an integral part of the housing and has the shield crimped to the case at the transducer end. This type of transducer has the cable's shield cut off and insulated in the control panel.
 15. Check that the temperature transducers are properly grounded. The temperature probes

usually have two short wires coming out of the sensor, and are tied to a shielded cable at the thermal well head. The shield is insulated at the temperature probe and grounded at the panel end.

16. Check if one of the temperature probes has a signal wire shorted to machine ground. To do this, first pull the orange plug from the micro board and then use a DVM and check each white wire to machine ground and each black wire to machine ground.
17. Check that all inductive loads (i.e. coils, solenoids, or relays, etc.) connected to the I/O output modules have surge suppressers across them, preferably at the devices. Most of the larger factory installed inductive loads should have surge suppressors as well.
18. If the compressor control settings unexplainably change modes, it may be a noise problem affecting the keypad's input circuit. Check if it works OK with the keypad cable disconnected. If it works OK, then check the grounding as de-

scribed above. If the grounding is OK then replace the keypad.

19. Make sure that you have a continuous ground back to the power source. The ground connection must be aluminum or copper. A conduit ground will not work. Do not drive a ground stake at the compressor since extraneous currents will be attracted to the compressor.
22. Make sure that there is no AC wiring lying next to the printed circuit board.
23. Unexplainable compressor auxiliary failures are usually indicative of noise due to wiring problems (i.e. incorrect earth grounds, mixed power and control wiring, unsuppressed coils, etc)
24. If the compressor is unexplainably shutting down, check if the machine shares control transformer power with something else. Make sure each compressor has its own isolation transformer in the motor control center off the three-phase bus with the secondary properly grounded.

**TROUBLESHOOTING CHART FOR FRICK® QUANTUM™ LX CONTROL PANEL
(REFER TO WIRING DIAGRAMS)**

SYMPTOM	PROBABLE CAUSES and CORRECTIONS
DISPLAY IS INOPERATIVE	<p>Check for power at the panel. See if any of the diagnostic lamps on the Main Board are blinking or any lights are blinking on the other boards. If no lights are blinking, make sure the control power switch is switched on. If there are still no lights, then check the circuit breaker (2CB). If the breaker is not tripped, check for power into 2CB. If there is no power, check the external power being supplied. If power from 2CB, check power supply for input AC and output DC level.</p> <p>Shut off power to the panel and first confirm that the display connector is firmly seated. This is a delicate connection and care should be used to reconnect it. Confirm that the connectors at both ends of the backlight inverter are properly connected. Confirm that the display harness is connected properly on the main board.</p> <p>Check the display with a flashlight. If characters are visible, the display is good, but the backlight tube is not on.</p>
OIL PUMP DOES NOT START	<p>The LED (D3) for Output 3 (MOD 3) of Digital I/O Board #1 should be on when Manually On is selected for the oil pump mode. If the pump does not start when the LED is on, check for the proper panel voltage between position 4 and 5 on the P1 DIO connector on Digital I/O board #1. If the proper voltage is not found, check the fuse (F3) and if the fuse is OK, check the output module (MOD 3). If the voltage was OK, check for the proper voltage between position 5 on the P1 DIO connector and position 8 on the terminal strip. If voltage is OK, check for the proper voltage between position 8 and 2 on the terminal strip. If the voltage is OK, check at the oil pump starter. If all of this is OK, then check the Service Screen to see if channel 3 is ON.</p> <p>The Oil Pump #1 Auxiliary Contact switches voltage to Input 4 (MOD 4) of Digital I/O Board #1 when the auxiliary contacts are closed. If the input does not turn on, check if the LED (D4) is lit when it should be. If it isn't, check the fuse (F4) and if the fuse is OK, check the input module (MOD 4). Check the voltage between positions 4 and 6 of the P1 DIO connector. If the LED is ON, check channel 4 on the DIO of Digital Board 1, at the Service Screen.</p>
OIL PUMP IS RUNNING BUT THE COMPRESSOR DOES NOT START	<p>For compressor models with a slide valve: Verify that the Slide Valve has unloaded to or below the Highest Slide Valve Position to allow starting the compressor setpoint. If the slide valve has not unloaded, troubleshoot the hydraulic system. Compressor will not start until the Slide Valve is unloaded. Output 1 (MOD 1) of Digital I/O Board #1 controls the motor starter. If the motor does not start when the LED (D1) is on, check for the proper panel voltage between position 4 and 1 on the P1 DIO connector on Digital I/O board #1. If the proper voltage is not found, check the fuse (F1) and if the fuse is OK, check the output module (MOD 1). If the voltage was OK, check for the proper voltage between position 1 on the P1 DIO connector and position 18 on the terminal strip. If voltage is OK, check for the proper voltage between position 18 and 2 on the terminal strip. If the voltage is OK, check the interposing relay (By others).</p>

SYMPTOM	PROBABLE CAUSES and CORRECTIONS
COMPRESSOR AUXILIARY SHUTDOWN	<p>Output 1 controls the Compressor Start Relay (By others). If the compressor does not start and the LED (D1) for Output 1 (MOD 1) is on, check for the proper panel voltage between position 4 and 1 on the P1 DIO connector on Digital I/O board #1. If the proper voltage is not found, check the fuse (F1) and if the fuse is OK, check the output module (MOD 1). If the voltage was OK, check for the proper voltage between position 1 on the P1 DIO connector and position 18 on the terminal strip. If voltage is OK, check for the proper voltage between position 18 and 2 on the terminal strip. If the voltage is OK, check the interposing relay (By others).</p> <p>The Compressor Starter Auxiliary Contacts turn on Input 2 (MOD 2) of Digital I/O Board #1 when they are closed. These contacts are located on the Compressor Starter. If the input does not turn on check if the LED (D2) is lit when it should be. If it isn't, check the fuse (F2) and if the fuse is OK, check the input module (MOD 2). Check the voltage between positions 2 and 4 of the P1 DIO connector.</p>
OIL HEATERS DO NOT OPERATE	<p>The oil heaters should operate only when the compressor is NOT running and the oil separator temperature is not greater than or equal to the Oil Heater Off Above set-point, and that the Oil Level input is made.</p> <p>If the oil heaters do not work and the LED (D21) for Output 21 (MOD 21) is on, check for the proper panel voltage between position 4 and 1 on the P6 DIO connector on Digital I/O board #1. If the proper voltage is not found, check the fuse (F21) and if the fuse is OK, check the output module (MOD 21). If the voltage was OK, check for the proper voltage between position 1 on the P6 DIO connector and position 9 on the terminal strip. If voltage is OK, check for the proper voltage between position 9 and 2 on the terminal strip. If the voltage is OK, check the Oil Heater Relay (1CR).</p> <p>If the problem hasn't been located, check the circuit breaker (1CB). If the breaker is not tripped, check power into 1CB. If OK check between Wires 103 and 106. If the Oil Heater Relay (1CR) is closed, check for proper panel voltage between wires 106 and 102. If OK, check the Oil Heater.</p>
COMPRESSOR DOES NOT LOAD and/or UNLOAD* (Compressor that steps on Capacity)	<p>For a 4-Step compressor, verify that the 50% SV (Solenoid Valve) is energized BEFORE the 75% SV is energized. For a 3-Step compressor, verify that 75% SV is energized BEFORE the 100% SV. Feel hydraulic tubing to the compressor unloading pistons. If tubing is hot, inspect the unloader pistons for worn parts or improper seating.</p> <p>Check that the hydraulic valves feeding the solenoid valve as well as those feeding the unloader pistons are open.</p> <p>Confirm that hydraulic tubing and wiring is properly connected.</p> <p>Check the solenoid valve coil to see if it has been damaged.</p> <p>NOTE: Verify that the proper capacity control setpoint has been programmed.</p>
COMPRESSOR WILL ONLY PARTIALLY LOAD* (Compressor that steps on Capacity)	<p>With the first SV (solenoid valve) properly energized, verify that the second SV energizes and then check the third SV if there is one for this compressor model.</p> <p>Check that the hydraulic valves feeding the first SV as well as those feeding the compressor unloading pistons are open.</p> <p>Inspect the compressor unloading ports for worn or improperly seated parts.</p>

SYMPTOM	PROBABLE CAUSES and CORRECTIONS
<p>SLIDE VALVE DOES NOT LOAD and/or UNLOAD*</p>	<p>Verify that the Slide Valve is in the AUTO mode and that capacity control is calling for load and/or unload. Output 5 (MOD 5) controls the Slide Valve Load Solenoid. If LED (D5) for Output 5 (MOD 5) is on, check for the proper panel voltage between position 4 and 1 on the P2 DIO connector on Digital I/O board #1. If the proper voltage is not found, check the fuse (F5) and if the fuse is OK, check the output module (MOD 5). If the voltage was OK, check for the proper voltage between position 1 on the P2 DI O connector and position 17 on the terminal strip. If voltage is OK, check for the proper voltage between position 17 and 2 on the terminal strip. If the voltage is OK, check the solenoid valve.</p> <p>Output 6 (MOD 6) controls the Slide Valve Unload Solenoid. If the LED (D1) for Output 6 (MOD 6) is on, check for the proper panel voltage between position 4 and 2 on the P2 DIO connector on Digital I/O board #1. If the proper voltage is not found, check the fuse (F6) and if the fuse is OK, check the output module (MOD 6). If the voltage was OK, check for the proper voltage between position 2 on the P2 DIO connector and position 16 on the terminal strip. If voltage is OK, check for the proper voltage between position 16 and 2 on the terminal strip. If the voltage is OK, check the solenoid valve.</p> <p>NOTE: Verify that the proper capacity control setpoint has been programmed.</p>
<p>SLIDE STOP DOES NOT INCREASE and/or DECREASE*</p>	<p>Verify that the Slide Stop is in the AUTO mode and that the VI Ratio is calling for a VI increase or decrease.</p> <p>Output 7 (MOD 7) controls Slide Stop Increase Solenoid. If the LED (D7) for Output 7 (MOD 7) is on, check for the proper panel voltage between position 4 and 5 on the P2 DIO connector on Digital I/O board #1. If the proper voltage is not found, check the fuse (F7) and if the fuse is OK, check the output module (MOD 7). If the voltage was OK, check for the proper voltage between position 5 on the P2 DIO connector and position 15 on the terminal strip. If voltage is OK, check for the proper voltage between position 15 and 2 on the terminal strip. If the voltage is OK, check the solenoid valve.</p> <p>Output 8 (MOD 8) controls the Slide Stop Decrease Solenoid. If the LED (D8) for Output 8 (MOD 8) is on, check for the proper panel voltage between position 4 and 6 on the P2 DIO connector on Digital I/O board #1. If the proper voltage is not found, check the fuse (F8) and if the fuse is OK, check the output module (MOD 8). If the voltage was OK check for the proper voltage between position 6 on the P2 DIO connector and position 14 on the terminal strip. If voltage is OK, check for the proper voltage between position 14 and 2 on the terminal strip. If the voltage is OK, check the solenoid valve.</p>
<p>LIQUID INJECTION SOLENOID DOES NOT ENERGIZE* (Liquid Injection Refrigerant Cutout - LICO)</p>	<p>Verify that the Liquid Injection TXV is modulating properly and not feeding excessive liquid to LICO the compressor. This solenoid SHOULD be de-energized when the compressor is off. This solenoid should be energized if the Discharge temperature equals or exceeds the "Discharge Temperature On At" setpoint for the delay time.</p> <p>Output 9 controls the Liquid Injection Solenoid. If the LED (D9) for Output 9 (MOD 9) is on, check for the proper panel voltage between position 4 and 1 on the P3 DIO connector on Digital I/O board #1. If the proper voltage is not found, check the fuse (F9) and if the fuse is OK, check the output module (MOD 9). If the voltage was OK, check for the proper voltage between position 1 on the P3 DIO connector and position 13 on the terminal strip. If voltage is OK, check for the proper voltage between position 13 and 2 on the terminal strip. If the voltage is OK, check the solenoid.</p>

SYMPTOM	PROBABLE CAUSES and CORRECTIONS
<p>HI Vi LIQUID INJECTION PORT SOLENOID DOES NOT ENERGIZE*</p>	<p>Output 10 controls the Hi Vi Liquid Injection Port solenoid. If the LED (D10) for Output 10 (MOD 10) is on, check for the proper panel voltage between position 4 and 2 on the P3 DIO connector on Digital I/O board #1. If the proper voltage is not found, check the fuse (F10) and if the fuse is OK, check the output module (MOD 10). If the voltage was OK check for the proper voltage between position 2 on the P3 DIO connector and position 12 on the terminal strip. If voltage is OK, check for the proper voltage between position 12 and 2 on the terminal strip. If the voltage is OK, check the solenoid. NOTE: For an RXB and a GST compressor model, this output should only be on when the Vi is at 5.0.</p>
<p>ECONOMIZER*</p>	<p>Output 11 (MOD 11) controls the Economizer Solenoid Valve. If the LED (D11) for Output 11 (MOD 11) is on, check for the proper panel voltage between position 4 and 5 on the P3 DIO connector on Digital I/O board #1. If the proper voltage is not found, check the fuse (F11) and if the fuse is OK, check the output module (MOD 11). If the voltage was OK, check for the proper voltage between position 5 on the P3 DIO connector and position 11 on the terminal strip. If voltage is OK, check for the proper voltage between position 11 and 2 on the terminal strip. If the voltage is OK, check the solenoid.</p> <p>NOTE: The economizer output will be on based on the Economizer On/Off setpoint.</p>
<p>ALARM CIRCUIT DOES NOT ENERGIZE</p>	<p>Output 22 (MOD 22) controls the Alarm Circuit. The Alarm should turn on only when there is a warning or shutdown. If the Alarm does not occur when these conditions are found and the LED (D22) for Output 22 (MOD 22) is off, check for the proper panel voltage between position 4 and 2 on the P6 DIO connector on Digital I/O board #1. If the proper voltage is not found, check the fuse (F22) and if the fuse is OK, check the output module (MOD 22). If the voltage was OK, check for the proper voltage between position 2 on the P6 DIO connector and position 21 on the terminal strip.</p>
<p>CONTROL PANEL DOES NOT RESPOND TO REMOTE CONTROL SIGNALS</p>	<p>Digital I/O Board 2, Inputs 3 through 5 can be used to operate the compressor from a remote location. NOTE: Check the Operating display to verify that the compressor and the Slide Valve are in REMOTE I/O.</p> <p>If the Input 3 (MOD 3) does not turn on, check if the LED (D3) is lit when it should be. If it isn't, check the fuse (F3) and if the fuse is OK, check the input module (MOD 3).</p> <p>If the Input 4 (MOD 4) does not turn on, check if the LED (D4) is lit when it should be. If it isn't, check the fuse (F4) and if the fuse is OK, check the input module (MOD 4).</p> <p>If the Input 5 (MOD 5) does not turn on, check if the LED (D5) is lit when it should be. If it isn't, check the fuse (F5) and if the fuse is OK, check the input module (MOD 5).</p>
<p>MOTOR LOAD CONTROL(FORCED UNLOAD) OCCURS AT HIGH MOTOR AMPS</p>	<p>The current transformer is used to convert the AC motor amps to a DC voltage signal for the microprocessor. If the %FLA reading from the Operating display is incorrect, contact the Frick® Service Department.</p>

SECTION 9

SETPOINT DATA SHEETS

Quantum™ LX Version 7.0x (06/02/2011)

In most cases, updating software on the Quantum™ LX panel will require clearing the current setpoints and data stored in the nonvolatile memory on the main board. It is suggested that the operator first record all control setpoints prior to performing program upgrades. The setpoint data sheets are useful for recording this information.

The sheets that appear on the following pages are in the order that they are accessed from the Quantum™ LX Menu.

OPERATING VALUES – Used Defined

(Units will be based upon the settings of the Session Screen, defaults are shown here)

Description	Value	Default	User Defined Selections
Status 1		Capacity Slide Position	Capacity Slide Position Volume Slide Position Suction Pressure Discharge Pressure Compressor Oil Pressure Main Oil Injection Pressure Economizer Pressure Filter Pressure Intermediate Pressure Balance Piston Pressure System Discharge Pressure Suction Temperature Discharge Temperature Compressor Oil Temperature Oil Separator Temperature Process/Brine Temperature Leaving Process/Brine Temperature Entering Motor Current RPM Auxiliary Analog 1-10 EZ Cool Feedback % Auxiliary Analog 12-20 Manifold Pressure Compressor Vibration – Suction Compressor Vibration – Discharge Motor Vibration – Shaft Side Motor Vibration – Opposite Shaft Side Motor Temp. – Shaft Side Motor Temp. – Opposite Shaft Side Motor Stator # 1-3 None
Status 2		Capacity Slide Position	
Status 3		Capacity Slide Position	
Status 4		Capacity Slide Position	
Status 5		Capacity Slide Position	
Status 6		Capacity Slide Position	
Status 7		Capacity Slide Position	
Status 8		Capacity Slide Position	
Status 9		Enable User Defined Status 9	
Status 10		Enable User Defined Status 10	
Status 11		Enable User Defined Status 11	
Status 12		Enable User Defined Status 12	
Status 1		Enable User Defined Status 13	
Status 14		Enable User Defined Status 14	
Status 15		Enable User Defined Status 15	
Status 16		Enable User Defined Status 16	
Status 17		Enable User Defined Status 17	
Status 18		Enable User Defined Status 18	
Status 19		Enable User Defined Status 19	
Status 20		Enable User Defined Status 20	

MODE SETUP

(Units will be based upon the settings of the Session Screen, defaults are shown here)

Description	Value	Default	Mode Selections
Compressor		Manual	Manual Automatic Remote Comm Remote I/O Remote Seq Man. Browser
Capacity		Manual	Manual Automatic Remote Comm Remote I/O Remote 4-20 Remote Seq Man. Browser
Volume		Manual	Manual Automatic
Active Mode		Mode 1	Mode 1 Mode 2 Mode 3 Mode 4
Pump <i>(only appears if a Pump type has been selected in Configuration)</i>		Automatic	Manual Automatic
Dual Pump Sequence <i>(only appears if Dual Pumps has been enabled in Configuration)</i>		Pump 1 Lead	Pump 1 Lead Pump 2 Lead

SYSTEM STATUS – Trending Setup

Control	Description	Value	Default	Trending Selections / Ranges
Real Time	Channel 1		Suction Pressure	Capacity Slide Position Volume Slide Position Suction Pressure Discharge Pressure Compressor Oil Pressure Main Oil Injection Pressure Economizer Pressure Filter Pressure
	Channel 2		Discharge Pressure	Intermediate Pressure Balance Piston Pressure System Discharge Pressure Suction Temperature
	Channel 3		Motor Current	Discharge Temperature Compressor Oil Temperature Oil Separator Temperature Process/Brine Temperature Leaving Process/Brine Temperature Entering
	Channel 4		Enable Real Time Trend Channel 4	Motor Current RPM
	Channel 5		Enable Real Time Trend Channel 5	Auxiliary Analog 1-10 EZ Cool Feedback % Auxiliary Analog 12-20 Manifold Pressure
	Channel 6		Enable Real Time Trend Channel 6	Compressor Vibration – Suction Compressor Vibration – Discharge Motor Vibration – Shaft Side Motor Vibration – Opposite Shaft Side
	Channel 7		Enable Real Time Trend Channel 7	Motor Temp. – Shaft Side Motor Temp. – Opposite Shaft Side
	Channel 8		Enable Real Time Trend Channel 8	Motor Stator # 1-3 None
	Recording Interval		10	1.0 to 86400.0 SEC
	Disable Real Time Trending		No	No Yes
History	Channel 1		Suction Pressure	Capacity Slide Position Volume Slide Position Suction Pressure Discharge Pressure Compressor Oil Pressure Main Oil Injection Pressure Economizer Pressure Filter Pressure
	Channel 2		Discharge Pressure	Intermediate Pressure Balance Piston Pressure System Discharge Pressure Suction Temperature
	Channel 3		Motor Current	Discharge Temperature Compressor Oil Temperature Oil Separator Temperature Process/Brine Temperature Leaving Process/Brine Temperature Entering
	Channel 4		Enable History Trend Channel 4	Motor Current RPM
	Channel 5		Enable History Trend Channel 5	Auxiliary Analog 1-10 EZ Cool Feedback % Auxiliary Analog 12-20 Manifold Pressure
	Channel 6		Enable History Trend Channel 6	Compressor Vibration – Suction Compressor Vibration – Discharge Motor Vibration – Shaft Side Motor Vibration – Opposite Shaft Side
	Channel 7		Enable History Trend Channel 7	Motor Temp. – Shaft Side Motor Temp. – Opposite Shaft Side
	Channel 8		Enable History Trend Channel 8	Motor Stator # 1-3 None
	Recording Interval		1	1.0 to 60.0 MIN
	Disable History Trending		No	No Yes

SYSTEM STATUS - Maintenance

Maintenance Required		Service Every		Next Scheduled At		Range	Units
		Default	User Setting	Default	User Setting		
Oil Analysis		10000		1000		0.0 to 100000.0	HRS
Change Filter		4800		200		0.0 to 100000.0	HRS
Clean Oil Strainers		4800		200		0.0 to 100000.0	HRS
Clean Liquid Strainers		4800		200		0.0 to 100000.0	HRS
Change Coalescers		30000		30000		0.0 to 100000.0	HRS
Clean Suction Screen		800		200		0.0 to 100000.0	HRS
Vibration Analysis		4800		200		0.0 to 100000.0	HRS
Check Coupling		4800		200		0.0 to 100000.0	HRS
Grease Motor		1200		200		0.0 to 100000.0	HRS
User Defined 1		0		0		0.0 to 100000.0	HRS
User Defined 2		0		0		0.0 to 100000.0	HRS
User Defined 3		0		0		0.0 to 100000.0	HRS
User Defined 4		0		0		0.0 to 100000.0	HRS
User Defined 5		0		0		0.0 to 100000.0	HRS
User Defined 6		0		0		0.0 to 100000.0	HRS
User Defined 7		0		0		0.0 to 100000.0	HRS
User Defined 8		0		0		0.0 to 100000.0	HRS

SETPOINTS - Capacity Control Setpoints (Mode 1)

(Units will be based upon the settings of the Session Screen, defaults are shown here)

Control	Description		Value	Default	Range	Units		
SUCTION PRESSURE MODE	Capacity Control	Setpoint		20.0	0.0 to 185.3	Pressure	PSIG	
		Proportional Band	High		15.0	0.0 to 100.0	Pressure (Magnitude)	PSIG
			Low					
		Dead Band	High		0.5	0.0 to 20.0		
			Low					
		Cycle Time	High		3	0.0 to 60.0	Time	SEC
			Low					
	VFD Prop. Band	High		15.0	0.0 to 100.0	Pressure	PSIG	
		Low						
	VFD Integ. Time	High		30	0.0 to 999.0	Time	SEC	
		Low						
	Autocycle	Start	Pressure		25.0	0.0 to 185.3	Pressure	PSIG
			Delay		1	0.0 to 60	Time	MIN
		Stop	Pressure		15.0	0.0 to 185.3	Pressure	PSIG
			Delay		1	0.0 to 60	Time	MIN
	Mode Safeties	Load Inhibit			10.0	0.0 to 185.3	Pressure	PSIG
		Force Unload			5.0			
		Warning	Setpoint		2.0	0.0 to 60.0	Time	SEC
			Delay		2			
		Shutdown	Setpoint		0.0	0.0 to 185.3	Pressure	PSIG
Delay				3	0.0 to 60.0	Time	SEC	
ALL OTHER MODES	Capacity Control	Setpoint						
		Proportional Band	High					
			Low					
		Dead Band	High					
			Low					
	Cycle Time	High						
		Low						
	Autocycle	Start	Temp.					
			Delay					
		Stop	Temp.					
			Delay					
	Mode Safeties	Load Inhibit						
		Force Unload						
		Warning	Setpoint					
			Delay					
		Shutdown	Setpoint					
			Delay					
	Low Suction	Load Inhibit						
		Force Unload						
		Warning	Setpoint					
Delay								
Shutdown		Setpoint						
		Delay						

SETPOINTS - Capacity Control Setpoints (Mode 2)

(Units will be based upon the settings of the Session Screen, defaults are shown here)

Control	Description		Value	Default	Range	Units		
SUCTION PRESSURE MODE	Capacity Control	Setpoint		20.0	0.0 to 185.3	Pressure	PSIG	
		Proportional Band	High		15.0	0.0 to 100.0	Pressure (Magnitude)	PSIG
			Low					
		Dead Band	High		0.5	0.0 to 20.0		
			Low					
		Cycle Time	High		3	0.0 to 60.0	Time	SEC
	Low							
	VFD Prop. Band	High		15.0	0.0 to 100.0	Pressure	PSIG	
		Low						
	VFD Integ. Time	High		30	0.0 to 999.0	Time	SEC	
		Low						
	Autocycle	Start	Pressure		25.0	0.0 to 185.3	Pressure	PSIG
			Delay		1	0.0 to 60	Time	MIN
		Stop	Pressure		15.0	0.0 to 185.3	Pressure	PSIG
			Delay		1	0.0 to 60	Time	MIN
	Mode Safeties	Load Inhibit			10.0	0.0 to 185.3	Pressure	PSIG
		Force Unload			5.0			
		Warning	Setpoint		2.0	0.0 to 60.0	Time	SEC
Delay				2				
Shutdown		Setpoint		0.0	0.0 to 185.3	Pressure	PSIG	
		Delay		3	0.0 to 60.0	Time	SEC	
ALL OTHER MODES	Capacity Control	Setpoint						
		Proportional Band	High					
			Low					
		Dead Band	High					
			Low					
		Cycle Time	High					
	Low							
	Autocycle	Start	Temp.					
			Delay					
		Stop	Temp.					
			Delay					
	Mode Safeties	Load Inhibit						
		Force Unload						
		Warning	Setpoint					
			Delay					
		Shutdown	Setpoint					
			Delay					
	Low Suction	Load Inhibit						
Force Unload								
Warning		Setpoint						
		Delay						
Shutdown		Setpoint						
		Delay						

SETPOINTS - Capacity Control Setpoints (Mode 3)

(Units will be based upon the settings of the Session Screen, defaults are shown here)

Control	Description		Value	Default	Range	Units		
SUCTION PRESSURE MODE	Capacity Control	Setpoint			20.0	0.0 to 185.3	Pressure	PSIG
		Proportional Band	High		15.0	0.0 to 100.0	Pressure (Magnitude)	PSIG
			Low					
		Dead Band	High		0.5	0.0 to 20.0		
			Low					
		Cycle Time	High		3	0.0 to 60.0	Time	SEC
			Low					
	VFD Prop. Band	High		15.0	0.0 to 100.0	Pressure	PSIG	
		Low						
	VFD Integ. Time	High		30	0.0 to 999.0	Time	SEC	
		Low						
	Autocycle	Start	Pressure		25.0	0.0 to 185.3	Pressure	PSIG
			Delay		1	0.0 to 60	Time	MIN
		Stop	Pressure		15.0	0.0 to 185.3	Pressure	PSIG
			Delay		1	0.0 to 60	Time	MIN
	Mode Safeties	Load Inhibit			10.0	0.0 to 185.3	Pressure	PSIG
		Force Unload			5.0			
		Warning	Setpoint		2.0	0.0 to 60.0	Time	SEC
			Delay		2			
		Shutdown	Setpoint		0.0	0.0 to 185.3	Pressure	PSIG
Delay				3	0.0 to 60.0	Time	SEC	
ALL OTHER MODES	Capacity Control	Setpoint						
		Proportional Band	High					
			Low					
		Dead Band	High					
			Low					
	Cycle Time	High						
		Low						
	Autocycle	Start	Temp.					
			Delay					
		Stop	Temp.					
			Delay					
	Mode Safeties	Load Inhibit						
		Force Unload						
		Warning	Setpoint					
			Delay					
		Shutdown	Setpoint					
	Delay							
	Low Suction	Load Inhibit						
		Force Unload						
		Warning	Setpoint					
Delay								
Shutdown		Setpoint						
	Delay							

SETPOINTS - Capacity Control Setpoints (Mode 4)

(Units will be based upon the settings of the Session Screen, defaults are shown here)

Control	Description		Value	Default	Range	Units		
SUCTION PRESSURE MODE	Capacity Control	Setpoint			20.0	0.0 to 185.3	Pressure	PSIG
		Proportional Band	High		15.0	0.0 to 100.0	Pressure (Magnitude)	PSIG
			Low					
		Dead Band	High		0.5	0.0 to 20.0		
			Low					
		Cycle Time	High		3	0.0 to 60.0	Time	SEC
			Low					
		VFD Prop. Band	High		15.0	0.0 to 100.0	Pressure	PSIG
			Low					
		VFD Integ. Time	High		30	0.0 to 999.0	Time	SEC
	Low							
	Autocycle	Start	Pressure		25.0	0.0 to 185.3	Pressure	PSIG
			Delay		1	0.0 to 60	Time	MIN
		Stop	Pressure		15.0	0.0 to 185.3	Pressure	PSIG
			Delay		1	0.0 to 60	Time	MIN
	Mode Safeties	Load Inhibit			10.0	0.0 to 185.3	Pressure	PSIG
		Force Unload			5.0			
		Warning	Setpoint		2.0	0.0 to 60.0	Time	SEC
			Delay		2			
		Shutdown	Setpoint		0.0	0.0 to 185.3	Pressure	PSIG
Delay				3	0.0 to 60.0	Time	SEC	
ALL OTHER MODES	Capacity Control	Setpoint						
		Proportional Band	High					
			Low					
		Dead Band	High					
			Low					
		Cycle Time	High					
	Low							
	Autocycle	Start	Temp.					
			Delay					
		Stop	Temp.					
			Delay					
	Mode Safeties	Load Inhibit						
		Force Unload						
		Warning	Setpoint					
			Delay					
		Shutdown	Setpoint					
			Delay					
	Low Suction	Load Inhibit						
		Force Unload						
		Warning	Setpoint					
Delay								
Shutdown		Setpoint						
		Delay						

SETPOINTS – Sequencing (System 1 Setup)

(Units will be based upon the settings of the Session Screen, defaults are shown here)

Control	Description	Value	Default	Range	Units
System 1 Setup	Sequencing		Disabled	Disabled / Enabled	None
	Setpoint		32.0	Same as the range of the Control input	
	Minimum Run Time		20	0.0 to 300.0	Time MIN
	High Stage System Link		None	None / System 2 / System 3	None
1	Sequencing ID		0	0.0 to 255.0	None
	Start #		1	0.0 to 8.0	
	Compressor Mode		Manual	All Available Modes	
	Capacity Mode		Manual		
	Minimum Capacity		0.0	0.0 to 100.0	Percent %
2	Sequencing ID		0	0.0 to 255.0	None
	Start #		1	0.0 to 8.0	
	Compressor Mode		Manual	All Available Modes	
	Capacity Mode		Manual		
	Minimum Capacity		0.0	0.0 to 100.0	Percent %
3	Sequencing ID		0	0.0 to 255.0	None
	Start #		1	0.0 to 8.0	
	Compressor Mode		Manual	All Available Modes	
	Capacity Mode		Manual		
	Minimum Capacity		0.0	0.0 to 100.0	Percent %
4	Sequencing ID		0	0.0 to 255.0	None
	Start #		1	0.0 to 8.0	
	Compressor Mode		Manual	All Available Modes	
	Capacity Mode		Manual		
	Minimum Capacity		0.0	0.0 to 100.0	Percent %
5	Sequencing ID		0	0.0 to 255.0	None
	Start #		1	0.0 to 8.0	
	Compressor Mode		Manual	All Available Modes	
	Capacity Mode		Manual		
	Minimum Capacity		0.0	0.0 to 100.0	Percent %
6	Sequencing ID		0	0.0 to 255.0	None
	Start #		1	0.0 to 8.0	
	Compressor Mode		Manual	All Available Modes	
	Capacity Mode		Manual		
	Minimum Capacity		0.0	0.0 to 100.0	Percent %
7	Sequencing ID		0	0.0 to 255.0	None
	Start #		1	0.0 to 8.0	
	Compressor Mode		Manual	All Available Modes	
	Capacity Mode		Manual		
	Minimum Capacity		0.0	0.0 to 100.0	Percent %
8	Sequencing ID		0	0.0 to 255.0	None
	Start #		1	0.0 to 8.0	
	Compressor Mode		Manual	All Available Modes	
	Capacity Mode		Manual		
	Minimum Capacity		0.0	0.0 to 100.0	Percent %

SETPOINTS – Sequencing (System 2 Setup)

(Units will be based upon the settings of the Session Screen, defaults are shown here)

Control	Description	Value	Default	Range	Units
System 2 Setup	Sequencing		Disabled	Disabled / Enabled	None
	Setpoint		32.0	Same as the range of the Control input	
	Minimum Run Time		20	0.0 to 300.0	Time MIN
	High Stage System Link		None	None / System 1 / System 3	None
1	Sequencing ID		0	0.0 to 255.0	None
	Start #		1	0.0 to 8.0	
	Compressor Mode		Manual	All Available Modes	
	Capacity Mode		Manual		
	Minimum Capacity		0.0	0.0 to 100.0	Percent %
2	Sequencing ID		0	0.0 to 255.0	None
	Start #		1	0.0 to 8.0	
	Compressor Mode		Manual	All Available Modes	
	Capacity Mode		Manual		
	Minimum Capacity		0.0	0.0 to 100.0	Percent %
3	Sequencing ID		0	0.0 to 255.0	None
	Start #		1	0.0 to 8.0	
	Compressor Mode		Manual	All Available Modes	
	Capacity Mode		Manual		
	Minimum Capacity		0.0	0.0 to 100.0	Percent %
4	Sequencing ID		0	0.0 to 255.0	None
	Start #		1	0.0 to 8.0	
	Compressor Mode		Manual	All Available Modes	
	Capacity Mode		Manual		
	Minimum Capacity		0.0	0.0 to 100.0	Percent %
5	Sequencing ID		0	0.0 to 255.0	None
	Start #		1	0.0 to 8.0	
	Compressor Mode		Manual	All Available Modes	
	Capacity Mode		Manual		
	Minimum Capacity		0.0	0.0 to 100.0	Percent %
6	Sequencing ID		0	0.0 to 255.0	None
	Start #		1	0.0 to 8.0	
	Compressor Mode		Manual	All Available Modes	
	Capacity Mode		Manual		
	Minimum Capacity		0.0	0.0 to 100.0	Percent %
7	Sequencing ID		0	0.0 to 255.0	None
	Start #		1	0.0 to 8.0	
	Compressor Mode		Manual	All Available Modes	
	Capacity Mode		Manual		
	Minimum Capacity		0.0	0.0 to 100.0	Percent %
8	Sequencing ID		0	0.0 to 255.0	None
	Start #		1	0.0 to 8.0	
	Compressor Mode		Manual	All Available Modes	
	Capacity Mode		Manual		
	Minimum Capacity		0.0	0.0 to 100.0	Percent %

SETPOINTS – Sequencing (System 3 Setup)

(Units will be based upon the settings of the Session Screen, defaults are shown here)

Control	Description	Value	Default	Range	Units
System 3 Setup	Sequencing		Disabled	Disabled / Enabled	None
	Setpoint		32.0	Same as the range of the Control input	
	Minimum Run Time		20	0.0 to 300.0	Time MIN
	High Stage System Link		None	None / System 1 / System 2	None
1	Sequencing ID		0	0.0 to 255.0	None
	Start #		1	0.0 to 8.0	
	Compressor Mode		Manual	All Available Modes	
	Capacity Mode		Manual		
	Minimum Capacity		0.0	0.0 to 100.0	Percent %
2	Sequencing ID		0	0.0 to 255.0	None
	Start #		1	0.0 to 8.0	
	Compressor Mode		Manual	All Available Modes	
	Capacity Mode		Manual		
	Minimum Capacity		0.0	0.0 to 100.0	Percent %
3	Sequencing ID		0	0.0 to 255.0	None
	Start #		1	0.0 to 8.0	
	Compressor Mode		Manual	All Available Modes	
	Capacity Mode		Manual		
	Minimum Capacity		0.0	0.0 to 100.0	Percent %
4	Sequencing ID		0	0.0 to 255.0	None
	Start #		1	0.0 to 8.0	
	Compressor Mode		Manual	All Available Modes	
	Capacity Mode		Manual		
	Minimum Capacity		0.0	0.0 to 100.0	Percent %
5	Sequencing ID		0	0.0 to 255.0	None
	Start #		1	0.0 to 8.0	
	Compressor Mode		Manual	All Available Modes	
	Capacity Mode		Manual		
	Minimum Capacity		0.0	0.0 to 100.0	Percent %
6	Sequencing ID		0	0.0 to 255.0	None
	Start #		1	0.0 to 8.0	
	Compressor Mode		Manual	All Available Modes	
	Capacity Mode		Manual		
	Minimum Capacity		0.0	0.0 to 100.0	Percent %
7	Sequencing ID		0	0.0 to 255.0	None
	Start #		1	0.0 to 8.0	
	Compressor Mode		Manual	All Available Modes	
	Capacity Mode		Manual		
	Minimum Capacity		0.0	0.0 to 100.0	Percent %
8	Sequencing ID		0	0.0 to 255.0	None
	Start #		1	0.0 to 8.0	
	Compressor Mode		Manual	All Available Modes	
	Capacity Mode		Manual		
	Minimum Capacity		0.0	0.0 to 100.0	Percent %

SETPOINTS - Sequencing Control

(Units will be based upon the settings of the Session Screen, defaults are shown here)

Description	Value	Default	Range	Units	
Average Capacity For Start		90.0	0.0 to 100.0	Percent	%
Full Load Capacity Position		98.0	0.0 to 100.0		
Minimum Capacity Dead Band		1.0	0.0 to 20.0	Time	MIN
Start Failure Reset Delay		12.0	0.0 to 600.0		
Slide Valve Failure Safety		Disabled	Disabled	None	
			Enabled		
Full Load Drive Speed (<i>only with Vyper drive</i>)		98.0	0.0 to 100.0	Percent	%

SETPOINTS - Compressor Safeties Setpoints

(Units will be based upon the settings of the Session Screen, defaults are shown here)

Control	Description		Value	Default	Range	Units		
High Discharge Temp.	Load Inhibit			212.0	32.0 to 250.0	Temp.	F	
	Force Unload							
	Warning	Setpoint		205.0	0. to 60.0	Time	SEC	
		Delay		5				
	Shutdown	Setpoint		212.0	32.0 to 250.0	Temp.	F	
Delay			5					
Misc.	Starting Diff. Press. Below			50.0	0.0 to 380.0	Pressure	PSIG	
High Discharge Pressure	Dual Mode	Enabled/Disabled		Disabled	None		None	
	Load Inhibit	Modes 1 & 3		190.0	0.0 to 270.0	Pres- sure	PSIG	
		Modes 2 & 4		190.0				
	Force Unload	Modes 1 & 3		200.0				
		Modes 2 & 4		200.0				
	Warning	Modes 1 & 3		220.0	0.0 to 5.0	Time	SEC	
		Delay		2				
		Modes 2 & 4		220.0				
	Shutdown	Modes 2 & 4		220.0	0.0 to 270.0	Pressure	PSIG	
		Delay		2				
Modes 1 & 3		270.0						
Modes 2 & 4		225.0						
Misc.	Highest Cap. To Permit Starting			10	0.0 to 100.0	Percent	%	
	Starting Period Before Permitting Cap. Increase			0	0.0 to 999.0	Time	SEC	
	Stopping Period for Capacity Unload			30	0.0 to 300.0			
	Compressor Automatic Mode Min. Capacity			10	0.0 to 100.0	Percent	%	
	Capacity Unload Assist			Disabled	None	None		
	Capacity Unload Assist Rate			2.0	1.0 to 5.0	Percent	%	
	Separator Velocity Reference			0.00	0.0 to 100.0	None		
	Compression Ratio			4.00	1.0 to 30.0			
	Liquid Slugging	Warning			10.0	0.0 to 90.0	Temp.	F
		Shutdown			20.0			
High Suction Pressure	Load Inhibit			105.3	0.0 to 200.0	Pres- sure	PSIG	
	Force Unload			115.3				
	Warning	Setpoint		125.3	0.0 to 60.0	Time	SEC	
		Delay		2				
	Shutdown	Setpoint		135.3	0.0 to 200.0	Pressure	PSIG	
Delay			2					
Econo- mizer	Enabled / Disabled			Disabled	None		None	
	On when above			90.0	0.0 to 100.0	Percent	%	
	Off when below			85.0				
	Override: Discharge Press. < (suction x 1.6^k)			15.0	0.0 to 100.0	Pressure	PSIG	
	Port Value			1.60	0.0 to 5.0	None		
	Pressure Input			Disabled	Disabled/ Fixed Press. Setpoint/ Econo. Analog Value			
	Fixed Pressure Setpoint			12.2 Hg	0.0 to 185.3	Pressure (Positive)	PSIG	
Balance Piston	Enabled / Disabled			Disabled	None		None	
	On			90	0.0 to 100.0	Percent	%	
	Off			85				
	Ignore Delay			5	0.0 to 60.0	Time	MIN	
	Fail Delay			2				
Misc.	Oil Log	Enabled / Disabled		Disabled	None		None	
		Delay			30	0.0 to 300.0	Time	SEC
	Main Oil Injection	On When	Is Above		150.0	32.0 to 212.0	Temp.	F
		Discharge Temp.	For		5	0.0 to 300.0	Time	SEC
Oil Pump Unload Assist			Enabled	Enabled/Disabled		None		

SETPOINTS - Package Safeties

(Units will be based upon the settings of the Session Screen, defaults are shown here)

Control	Description		Value	Default	Range	Units	
Low Oil Separator Temp.	Warning	Setpoint		55.0	49.0 to 100.0	Temp.	F
		Delay		5	0.0 to 60.0	Time	SEC
	Shutdown	Setpoint		49.0	49.0 to 100.0	Temp.	F
		Delay		5	0.0 to 60.0	Time	SEC
Low Comp. Oil Temp.	Warning	Setpoint		55.0	49.0 to 100.0	Temp.	F
		Delay		5	0.0 to 60.0	Time	SEC
	Shutdown	Setpoint		49.0	49.0 to 100.0	Temp.	F
		Delay		5	0.0 to 60.0	Time	SEC
High Comp. Oil Temp.	Warning	Setpoint		158.0	100.0 to 250.0	Temp.	F
		Delay		5	0.0 to 60.0	Time	SEC
	Shutdown	Setpoint		167.0	100.0 to 250.0	Temp.	F
		Delay		5	0.0 to 60.0	Time	SEC
Low Comp. Oil Pressure	Warning	Setpoint		25.0	0.0 to 45.0	Pressure	PSIG
		Delay		600	0.0 to 600.0	Time	SEC
	Shutdown	Setpoint		30.0	0.0 to 45.0	Pressure	PSIG
		Delay		900	0.0 to 600.0	Time	SEC
High Filter Pressure	Warning	Setpoint		25.0	0.0 to 50.0	Pressure (Differential)	PSIG
		Delay		10	0.0 to 60.0	Time	MIN
	Shutdown	Setpoint		30.0	0.0 to 50.0	Pressure (Differential)	PSIG
		Delay		15	0.0 to 60.0	Time	MIN
Main Oil Injection	Enabled / Disabled			Disabled	None		
	Shutdown	Setpoint		15.0	5.0 to 50.0	Pressure	PSIG
		Delay		180	0.0 to 1000.0	Time	SEC
Misc.	Oil Heater Off Above			120.0	100.0 to 150.0	Temp.	F
	High Level Shutdown Delay			5	0.0 to 60.0	Time	SEC
	Low Oil Level Delay			30	0.0 to 30.0		
	Oil Pump Lube Time Before Starting			0	0.0 to 60.0		
	Dual Pump Transition Time			10			
Pull Down	Enabled / Disabled			Disabled	None		
	Capacity Position			5.0	0.0 to 100.0	Percent	%
	Amount of Time			60	0.0 to 900.0	Time	SEC
Pump Down	Enabled / Disabled			Disabled	None		
	On When Suction Above	Setpoint		14.1	0.0 to 185.3	Pressure	PSIG
		Delay		5	0.0 to 60.0	Time	MIN
DX Circuit	#1 Action			Disabled	Disabled DX Circuit On With Compressor DX Circuit On By Capacity Position		
	#2 Action						
	DX Circuit 1	Off When Below		85.0	0.0 to 100.0	Percent	%
		On When Above		90.0	0.0 to 100.0		
	DX Circuit 2	Off When Below		85.0	0.0 to 100.0		
On When Above			90.0	0.0 to 100.0			
Liquid Injection	Enabled / Disabled			Disabled	None		
	On When Above	Setpoint		122.0	100.0 to 180.0	Temp.	F
		Delay		5	0.0 to 60.0	Time	SEC
	Dual Port Transition			4.2	0.0 to 5.0	None	
Misc.	Hot Gas Bypass			0.0	0.0 to 100.0	Percent	%
	Power Assist			30	0.0 to 60.0	Time	SEC

SETPOINTS – Motor (Engine/DBS/Motor/Turbine/Vyper)

(Units will be based upon the settings of the Session Screen, defaults are shown here)

Control	Description	Value	Default	Range	Units		
Name Plate	Motor Amps		100.0	0.0 to 3000.0	Current	AMPS	
	Volts		480.0	0.0 to 9999.0	None		
	Service Factor		1.15	0.0 to 2.0			
	Horse Power		100.0	0.0 to 3000.0			
	CT Factor						
	Recycle Delay		20	20.0 to 255.0	Time	MIN	
High Motor Amps	Load Inhibit		100.0	0.0 to 3000.0	Current	AMPS	
	Force Unload		105.0				
	Warning	Setpoint		110.0	0.0 to 60.0	Time	SEC
		Delay		5			
	Shutdown	Setpoint		115.0	0.0 to 3000.0	Current	AMPS
		Delay		5	0.0 to 60.0	Time	SEC
Low Motor Amps	Shutdown	Setpoint		25.0	0.0 to 750.0	Current	AMPS
		Delay		30	0.0 to 60.0	Time	SEC
	Confirmed Running Motor Amps		20.0	0.0 to 750.0	Current	AMPS	
	Starting Motor Amps Ignore Period		5	0.0 to 30.0	Time	SEC	
	Read Motor Amps From		DBS	DBS or CT	None		
Motor Starter (See DBS Manual)	Locked Rotor Current		*	300.0 to 600.0	Percent	%	
	Stall Time		*	1.0 to 60.0	Time	SEC	
	Jam Current Level		*	100.0 to 600.0	Percent	%	
	Jam Run Delay		*	0.0 to 60.0	Time	SEC	
	Service Factor		*	75.0 to 125.0	Percent	%	
	Current Unbalance	Warning Level		*			2.0 to 25.0
		Warning Delay		*	0.0 to 240.0	Time	SEC
	RTD Temp.	Warning Level		*	32.0 to 500.0	Temp.	F
Trip Level							

* These values are returned from the DBS unit via communications

This Setpoint table continues on the next page.

SETPOINTS - Motor (Engine/DBS/Motor/Turbine/Vyper)

-CONTINUED -

(Units will be based upon the settings of the Session Screen, defaults are shown here)

Description			Value	Default	Range	Units		
Engine / Turbine	Confirmed Running			450.0	0.0 to 750.0	RPM		
	Starting Maximum Delay			5	0.0 to 60.0	Time	MIN	
	Idle Speed			0.0	0.0 to 100.0	Percent	%	
	Cool Down Period Before Stopping			0	0.0 to 999.0	Time	SEC	
	High RPM	Warning	Setpoint		1900	0.0 to 4000	RPM	
			Delay		1	0.0 to 5.0	Time	SEC
		Shutdown	Setpoint		2000	0.0 to 4000.0	RPM	RPM
			Delay		1	0.0 to 5.0	Time	SEC
	Low RPM	Load Inhibit			1100	0.0 to 3000.0	Speed	RPM
		Force Unload			1075			
		Warning	Setpoint		700	0.0 to 180.0	Time	SEC
			Delay		30			
		Shutdown	Setpoint		600	0.0 to 3000	Speed	RPM
			Delay		30	0.0 to 180.0	Time	SEC
Engine	High Manifold Pressure	Load Inhibit			5.9 Hg	0.0 to 31.0	Pressure	PSIG
		Force Unload			5.1 Hg			
	Warning	Setpoint		4.1 Hg	0.0 to 6.0	Time	SEC	
		Delay		3				
	Shutdown	Setpoint		3.1 Hg	0.0 to 31.0	Pressure	PSIG	
		Delay		3	0.0 to 60.0	Time	SEC	
Engine / Turbine / VFD / Vyper	Drive Output	Maximum		100.0	20.0 to 100.0	Percent	%	
		Minimum		50.0				
	Rate of Increase	Setpoint		2.0	0.1 to 25.0	Time	SEC	
		Delay		1.0	0.0 to 30.0			
	Rate of Decrease	Setpoint		2.0	0.1 to 25.0	Percent	%	
		Delay		1.0	0.0 to 30.0	Time	SEC	
	When the S.V. loads to			95.0	20.0 to 100.0	Percent	%	
The Drive Speed will reach			50.0					
Variable Speed Minimum S.V. Position			25.0					
Skip Frequency Bands	Bottom			0.0	0.0 to 100.0	Percent	%	
	Top							
	Bottom							
	Top							
	Bottom							
	Top							
	Bottom							
	Top							
	Bottom							
	Top							

SETPOINTS - Capacity Position

(Units will be based upon the settings of the Session Screen, defaults are shown here)

Description	Value	Default	Range	Units
Maximum Capacity Position		100.0	0.0 to 100.0	None
Minimum Capacity Position		0.0		

SETPOINTS - Condenser Digital Control

(Units will be based upon the settings of the Session Screen, defaults are shown here)

Control	Description	Value	Default	Range	Units		
Condenser Digital Control Setpoints	Condenser Control Setpoint		30 Hg	0.0 to 485.3	Pressure		
	Module A		0	0 to 4	None		
	Module B						
	Module C						
	Module D						
	Step Up	Deadband		0.0	0.0 to 20.0	Pressure (Magnitude)	PSIG
		Delay		0	0.0 to 60.0	Time	SEC
	Step Down	Deadband		0.0	0.0 to 20.0	Pressure (Magnitude)	PSIG
		Delay		0	0.0 to 60.0	Time	SEC
	High Pressure	Override		200.0	0 to 1000.0	Pressure	PSIG
		Delay		0	0.0 to 300.0	Time	SEC

SETPOINTS - Condenser Analog Control

(Units will be based upon the settings of the Session Screen, defaults are shown here)

Control	Description	Value	Default	Range	Units	
Condenser Analog Control Setpoints	Condenser Control Setpoint		30.0 Hg	0.0 to 485.3	Pressure	PSIG
	Analog Output A		Disabled	Disabled or Enabled	None	
	Analog Output B					
	Proportional Band		5.0	0.0 to 100.0	Pressure	PSIG
	Integration Time		30	0.0 to 999.0	Time	SEC
	High Limit		100.0	0.0 to 100.0	Percent	%
	Low Limit		40.0	0.0 to 100.0	Percent	%

SETPOINTS - PHD Monitoring

(Units will be based upon the settings of the Session Screen, defaults are shown here)

Description		Value	Default	Range	Units			
Compressor Bearing	Disabled / Vibration Monitoring			Disabled	None	None		
	Suction End	High Warning		3.5	0.0 to 30.0	(See Manual 070.020-TB)	gF	
		High Warning Delay		99	0.0 to 999.0	Time	SEC	
		High Shutdown		10.0	0.0 to 30.0	(See Manual 070.020-TB)	gF	
		High Shutdown Delay		1	0.0 to 999.0	Time	SEC	
	Discharge End	High Warning		3.5	0.0 to 30.0	(See Manual 070.020-TB)	gF	
		High Warning Delay		99	0.0 to 999.0	Time	SEC	
		High Shutdown		10.0	0.0 to 30.0	(See Manual 070.020-TB)	gF	
		High Shutdown Delay		1	0.0 to 999.0	Time	SEC	
	Motor Bearing	Disabled / Vibration Monitoring / Temperature Monitoring			Disabled	None	None	
		Shaft Side	High Warning		3.5	0.0 to 30.0	(See Manual 070.020-TB)	gF
			High Warning Delay		99	0.0 to 999.0	Time	SEC
High Shutdown				10.0	0.0 to 30.0	(See Manual 070.020-TB)	gF	
High Shutdown Delay				1	0.0 to 999.0	Time	SEC	
Opposite Shaft		High Warning		3.5	0.0 to 30.0	(See Manual 070.020-TB)	gF	
		High Warning Delay		99	0.0 to 999.0	Time	SEC	
		High Shutdown		10.0	0.0 to 30.0	(See Manual 070.020-TB)	gF	
		High Shutdown Delay		1	0.0 to 999.0	Time	SEC	
Motor Stator		Disabled / Temperature Monitoring			Disabled	None	None	
		Stator #1	High Warning		302.0	32.0 to 500.0	Temp.	F
			High Warning Delay		5	0.0 to 999.0	Time	SEC
	High Shutdown			311.0	32.0 to 500.0	Temp.	F	
	High Shutdown Delay			5	0.0 to 999.0	Time	SEC	
	Stator # 2	High Warning		302.0	32.0 to 500.0	Temp.	F	
		High Warning Delay		5	0.0 to 999.0	Time	SEC	
		High Shutdown		311.0	32.0 to 500.0	Temp.	F	
		High Shutdown Delay		5	0.0 to 999.0	Time	SEC	
	Stator # 3	High Warning		302.0	32.0 to 500.0	Temp.	F	
		High Warning Delay		5	0.0 to 999.0	Time	SEC	
		High Shutdown		11.0	32.0 to 500.0	Temp.	F	
		High Shutdown Delay		5	0.0 to 999.0	Time	SEC	

SETPOINTS - PID Setup Page 1 *

(Units will be based upon the settings of the Session Screen, defaults are shown here)

Control	Description	Value	Default *	Range *	Units *				
PID 1	Name		EZ Cool LIOC	Refer to 090.022-0 (Op- eration)	None				
	Control		Always						
	Action		Forward						
	Control Point		Disch. Temp.						
	IO Board		Analog 1						
	Output Channel		1						
	Setpoint		145.0				Based upon Control Point		
	Proportional Band		25.0						
	Integration Time		30.0				0.0 to 1000.0	Time	SEC
	High Limit		100.0				-50.0 to 150.0	Percent	%
	Low Limit		0.0	-50.0 to 150.0					
	When Running Off Value		0.0	0.0 to 100.0					
PID 2	Name		PID # 2	Refer to 090.022-0 (Operation)	None				
	Control		Disabled						
	Action		Forward						
	Control Point		Cap. slide						
	IO Board		Analog 1						
	Output Channel		2						
	Setpoint		0				Based upon Control Point		
	Proportional Band		0						
	Integration Time		30.0				0.0 to 1000.0	Time	SEC
	High Limit		100.0				-50.0 to 150.0	Percent	%
	Low Limit		0.0	-50.0 to 150.0					
	When Running Off Value		0.0	0.0 to 100.0					
PID 3	Name		PID # 3	Refer to 090.022-0 (Operation)	None				
	Control		Disabled						
	Action		Forward						
	Control Point		Cap. slide						
	IO Board		None						
	Output Channel		0						
	Setpoint		0				Based upon Control Point		
	Proportional Band		0						
	Integration Time		30.0				0.0 to 1000.0	Time	SEC
	High Limit		100.0				-50.0 to 150.0	Percent	%
	Low Limit		0.0	-50.0 to 150.0					
	When Running Off Value		0.0	0.0 to 100.0					
PID 4	Name		PID # 4	Refer to 090.022-0 (Operation)	None				
	Control		Disabled						
	Action		Forward						
	Control Point		Cap. slide						
	IO Board		None						
	Output Channel		0						
	Setpoint		0				Based upon Control Point		
	Proportional Band		0						
	Integration Time		30.0				0.0 to 1000.0	Time	SEC
	High Limit		100.0				-50.0 to 150.0	Percent	%
	Low Limit		0.0	-50.0 to 150.0					
	When Running Off Value		0.0	0.0 to 100.0					

* Defaults, ranges and Units will be based upon the setting of the Control Point (settings shown are for the default Control Point setting of Capacity Slide).

SETPOINTS - PID Setup Page 2 *

(Units will be based upon the settings of the Session Screen, defaults are shown here)

Control	Description	Value	Default *	Range *	Units *		
Dis-charge Butterfly Valve	Name		PID # 5	Refer to 090.022-O (Operation)	None		
	Control		Disabled				
	Action		Forward				
	Control Point		Cap. slide				
	IO Board		None				
	Output Channel		0				
	Setpoint		0		Based upon Control Point		
	Proportional Band		0				
	Integration Time		30.0		0.0 to 1000.0	Time	SEC
	High Limit		100.0		-50.0 to 150.0	Percent	%
	Low Limit		0.0		-50.0 to 150.0		
	When Running Off Value		0.0		0.0 to 100.0		
PID 6	Name		PID # 6	Refer to 090.022-O (Operation)	None		
	Control		Disabled				
	Action		Forward				
	Control Point		Cap. slide				
	IO Board		None				
	Output Channel		0				
	Setpoint		0		Based upon Control Point		
	Proportional Band		0				
	Integration Time		30.0		0.0 to 1000.0	Time	SEC
	High Limit		100.0		-50.0 to 150.0	Percent	%
	Low Limit		0.0		-50.0 to 150.0		
	When Running Off Value		0.0		0.0 to 100.0		
PID 7	Name		PID # 7	Refer to 090.022-O (Operation)	None		
	Control		Disabled				
	Action		Forward				
	Control Point		Cap. slide				
	IO Board		None				
	Output Channel		0				
	Setpoint		0		Based upon Control Point		
	Proportional Band		0				
	Integration Time		30.0		0.0 to 1000.0	Time	SEC
	High Limit		100.0		-50.0 to 150.0	Percent	%
	Low Limit		0.0		-50.0 to 150.0		
	When Running Off Value		0.0		0.0 to 100.0		
PID 8	Name		PID # 8	Refer to 090.022-O (Operation)	None		
	Control		Disabled				
	Action		Forward				
	Control Point		Cap. slide				
	IO Board		None				
	Output Channel		0				
	Setpoint		0		Based upon Control Point		
	Proportional Band		0				
	Integration Time		30.0		0.0 to 1000.0	Time	SEC
	High Limit		100.0		-50.0 to 150.0	Percent	%
	Low Limit		0.0		-50.0 to 150.0		
	When Running Off Value		0.0		0.0 to 100.0		

* Defaults, ranges and Units will be based upon the setting of the Control Point (settings shown are for the default Control Point setting of Capacity Slide).

SETPOINTS – Superheat Control Setup*

(Units will be based upon the settings of the Session Screen, defaults are shown here)

Control	Description	Value	Default *	Range *	Units *			
SUPERHEAT # 1	Name		Superheat # 1	Refer to 090.022-O (Operation)	None			
	Control		Disabled					
	Action		Forward					
	Control Pressure		Suction Pressure					
	Control Temperature		Suction Temperature					
	Output Board		None					
	Output Channel		0					
	Setpoint		10.0				Based upon Control Point	
	Proportional Band		2.0					
	Integration Time		30.0				0.0 to 999.0	Time
	High Limit		100.0	-50.0 to 150.0	Percent	%		
	Low Limit		0.0	-50.0 to 150.0				
	When Running Off		0.0	0.0 to 100.0				
SUPERHEAT # 2	Name		Superheat # 2	Refer to 090.022-O (Operation)	None			
	Control		Disabled					
	Action		Forward					
	Control Pressure		Suction Pressure					
	Control Temperature		Discharge Temperature					
	Output Board		None					
	Output Channel		0					
	Setpoint		10.0 F				Based upon Control Point	
	Proportional Band		2.0 F					
	Integration Time		30.0				0.0 to 999.0	Time
	High Limit		100.0	-50.0 to 150.0	Percent	%		
	Low Limit		0.0	-50.0 to 150.0				
	When Running Off		0.0	0.0 to 100.0				
SUPERHEAT # 3	Name		Superheat # 3	Refer to 090.022-O (Operation)	None			
	Control		Disabled					
	Action		Forward					
	Control Pressure		Suction Pressure					
	Control Temperature		Discharge Temperature					
	Output Board		None					
	Output Channel		0					
	Setpoint		10.0 F				Based upon Control Point	
	Proportional Band		2.0 F					
	Integration Time		30.0				0.0 to 999.0	Time
	High Limit		100.0	-50.0 to 150.0	Percent	%		
	Low Limit		0.0	-50.0 to 150.0				
	When Running Off		0.0	0.0 to 100.0				

* Defaults, ranges and Units will be based upon the setting of the Control Point (settings shown are for the default Control Point setting of Capacity Slide).

SETPOINTS - Discharge Butterfly Valve

(Units will be based upon the settings of the Session Screen, defaults are shown here)

Description	Value	Default	Range	Units	
Discharge Butterfly Valve		Disabled	Disabled/ Enabled	None	
I/O Board		None	None Analog Board 1 Analog Board 2		
I/O Channel		0	0 to 999		
Pressure Differential Setpoint		0.0	0.0 to 40.0	Pressure	PSIG
Dead Band		2.0	0.0 to 100.0		
Proportional Band		5.0	0.0 to 100.0		

SETPOINTS - Auxiliary Analog Input Safeties - Page 1

(Units will be based upon the settings of the Session Screen, defaults are shown here)

Control	Description	Value	Default	Range	Units	
Auxiliary Analog 1	Auxiliary Analog 1		Disabled	Disabled/ Enabled	None	
	Low Warning	Setpoint	30 Hg	0.0 to 420.4	Pressure	PSIG
		Delay	0	0.0 to 999.0	Time	SEC
	Low Shutdown	Setpoint	30 Hg	0.0 to 420.4	Pressure	PSIG
		Delay	0	0.0 to 999.0	Time	SEC
	High Warning	Setpoint	30 Hg	0.0 to 420.4	Pressure	PSIG
		Delay	0	0.0 to 999.0	Time	SEC
	High Shutdown	Setpoint	30 Hg	0.0 to 420.4	Pressure	PSIG
		Delay	0	0.0 to 999.0	Time	SEC
	Auxiliary Analog 2	Auxiliary Analog 2		Disabled	Disabled/ Enabled	None
Low Warning		Setpoint	30 Hg	0.0 to 420.4	Pressure	PSIG
		Delay	0	0.0 to 999.0	Time	SEC
Low Shutdown		Setpoint	30 Hg	0.0 to 420.4	Pressure	PSIG
		Delay	0	0.0 to 999.0	Time	SEC
High Warning		Setpoint	30 Hg	0.0 to 420.4	Pressure	PSIG
		Delay	0	0.0 to 999.0	Time	SEC
High Shutdown		Setpoint	30 Hg	0.0 to 420.4	Pressure	PSIG
		Delay	0	0.0 to 999.0	Time	SEC
Auxiliary Analog 3		Auxiliary Analog 3		Disabled	Disabled/ Enabled	None
	Low Warning	Setpoint	30 Hg	0.0 to 420.4	Pressure	PSIG
		Delay	0	0.0 to 999.0	Time	SEC
	Low Shutdown	Setpoint	30 Hg	0.0 to 420.4	Pressure	PSIG
		Delay	0	0.0 to 999.0	Time	SEC
	High Warning	Setpoint	30 Hg	0.0 to 420.4	Pressure	PSIG
		Delay	0	0.0 to 999.0	Time	SEC
	High Shutdown	Setpoint	30 Hg	0.0 to 420.4	Pressure	PSIG
		Delay	0	0.0 to 999.0	Time	SEC
	Auxiliary Analog 4	Auxiliary Analog 4		Disabled	Disabled/ Enabled	None
Low Warning		Setpoint	30 Hg	0.0 to 420.4	Pressure	PSIG
		Delay	0	0.0 to 999.0	Time	SEC
Low Shutdown		Setpoint	30 Hg	0.0 to 420.4	Pressure	PSIG
		Delay	0	0.0 to 999.0	Time	SEC
High Warning		Setpoint	30 Hg	0.0 to 420.4	Pressure	PSIG
		Delay	0	0.0 to 999.0	Time	SEC
High Shutdown		Setpoint	30 Hg	0.0 to 420.4	Pressure	PSIG
		Delay	0	0.0 to 999.0	Time	SEC
Auxiliary Analog 5		Auxiliary Analog 5		Disabled	Disabled/ Enabled	None
	Low Warning	Setpoint	30 Hg	0.0 to 420.4	Pressure	PSIG
		Delay	0	0.0 to 999.0	Time	SEC
	Low Shutdown	Setpoint	30 Hg	0.0 to 420.4	Pressure	PSIG
		Delay	0	0.0 to 999.0	Time	SEC
	High Warning	Setpoint	30 Hg	0.0 to 420.4	Pressure	PSIG
		Delay	0	0.0 to 999.0	Time	SEC
	High Shutdown	Setpoint	30 Hg	0.0 to 420.4	Pressure	PSIG
		Delay	0	0.0 to 999.0	Time	SEC

SETPOINTS - Auxiliary Analog Input Safeties - Page 2

(Units will be based upon the settings of the Session Screen, defaults are shown here)

Control	Description		Value	Default	Range	Units	
Auxiliary Analog 6	Auxiliary Analog 6			Disabled	Disabled/ Enabled	None	
	Low Warning	Setpoint		30 Hg	0.0 to 420.4	Pressure	PSIG
		Delay		0	0.0 to 999.0	Time	SEC
	Low Shutdown	Setpoint		30 Hg	0.0 to 420.4	Pressure	PSIG
		Delay		0	0.0 to 999.0	Time	SEC
	High Warning	Setpoint		30 Hg	0.0 to 420.4	Pressure	PSIG
		Delay		0	0.0 to 999.0	Time	SEC
	High Shutdown	Setpoint		30 Hg	0.0 to 420.4	Pressure	PSIG
		Delay		0	0.0 to 999.0	Time	SEC
	Auxiliary Analog 7	Auxiliary Analog 7			Disabled	Disabled/ Enabled	None
Low Warning		Setpoint		30 Hg	0.0 to 420.4	Pressure	PSIG
		Delay		0	0.0 to 999.0	Time	SEC
Low Shutdown		Setpoint		30 Hg	0.0 to 420.4	Pressure	PSIG
		Delay		0	0.0 to 999.0	Time	SEC
High Warning		Setpoint		30 Hg	0.0 to 420.4	Pressure	PSIG
		Delay		0	0.0 to 999.0	Time	SEC
High Shutdown		Setpoint		30 Hg	0.0 to 420.4	Pressure	PSIG
		Delay		0	0.0 to 999.0	Time	SEC
Auxiliary Analog 8		Auxiliary Analog 8			Disabled	Disabled/ Enabled	None
	Low Warning	Setpoint		30 Hg	0.0 to 420.4	Pressure	PSIG
		Delay		0	0.0 to 999.0	Time	SEC
	Low Shutdown	Setpoint		30 Hg	0.0 to 420.4	Pressure	PSIG
		Delay		0	0.0 to 999.0	Time	SEC
	High Warning	Setpoint		30 Hg	0.0 to 420.4	Pressure	PSIG
		Delay		0	0.0 to 999.0	Time	SEC
	High Shutdown	Setpoint		30 Hg	0.0 to 420.4	Pressure	PSIG
		Delay		0	0.0 to 999.0	Time	SEC
	Auxiliary Analog 9	Auxiliary Analog 9			Disabled	Disabled/ Enabled	None
Low Warning		Setpoint		30 Hg	0.0 to 420.4	Pressure	PSIG
		Delay		0	0.0 to 999.0	Time	SEC
Low Shutdown		Setpoint		30 Hg	0.0 to 420.4	Pressure	PSIG
		Delay		0	0.0 to 999.0	Time	SEC
High Warning		Setpoint		30 Hg	0.0 to 420.4	Pressure	PSIG
		Delay		0	0.0 to 999.0	Time	SEC
High Shutdown		Setpoint		30 Hg	0.0 to 420.4	Pressure	PSIG
		Delay		0	0.0 to 999.0	Time	SEC
Auxiliary Analog 10		Auxiliary Analog 10			Disabled	Disabled/ Enabled	None
	Low Warning	Setpoint		30 Hg	0.0 to 420.4	Pressure	PSIG
		Delay		0	0.0 to 999.0	Time	SEC
	Low Shutdown	Setpoint		30 Hg	0.0 to 420.4	Pressure	PSIG
		Delay		0	0.0 to 999.0	Time	SEC
	High Warning	Setpoint		30 Hg	0.0 to 420.4	Pressure	PSIG
		Delay		0	0.0 to 999.0	Time	SEC
	High Shutdown	Setpoint		30 Hg	0.0 to 420.4	Pressure	PSIG
		Delay		0	0.0 to 999.0	Time	SEC

SETPOINTS – Auxiliary Digital Input Configuration

Control	Description	Value	Default	Range	Units	
Auxiliary Input 1	Name ***		Auxiliary Input 1	None		
	IO Board *		Dig. Bd. 1	*		
	IO Channel		17	None		
	Activity **		Disabled	**		
	Delay		0	0 to 60	Time	SEC
Auxiliary Input 2	Name ***		Auxiliary Input 2	None		
	IO Board *		Dig. Bd. 1	*		
	IO Channel		18	None		
	Activity **		Disabled	**		
	Delay		0	0 to 60	Time	SEC
Auxiliary Input 3	Name ***		Auxiliary Input 3	None		
	IO Board *		Dig. Bd. 2	*		
	IO Channel		9	None		
	Activity **		Disabled	**		
	Delay		0	0 to 60	Time	SEC
Auxiliary Input 4	Name ***		Auxiliary Input 4	None		
	IO Board *		Dig. Bd. 2	*		
	IO Channel		10	None		
	Activity **		Disabled	**		
	Delay		0	0 to 60	Time	SEC
Auxiliary Input 5	Name ***		Auxiliary Input 5	None		
	IO Board *		Dig. Bd. 2	*		
	IO Channel		11	None		
	Activity **		Disabled	**		
	Delay		0	0 to 60	Time	SEC
Auxiliary Input 6	Name ***		Auxiliary Input 6	None		
	IO Board *		Dig. Bd. 2	*		
	IO Channel		12	None		
	Activity **		Disabled	**		
	Delay		0	0 to 60	Time	SEC
Auxiliary Input 7	Name ***		Auxiliary Input 7	None		
	IO Board *		Dig. Bd. 2	*		
	IO Channel		13	None		
	Activity **		Disabled	**		
	Delay		0	0 to 60	Time	SEC
Auxiliary Input 8	Name ***		Auxiliary Input 8	None		
	IO Board *		Dig. Bd. 2	*		
	IO Channel		14	None		
	Activity **		Disabled	**		
	Delay		0	0 to 60	Time	SEC

* IO Board

None
Digital Board 1
Digital Board 2

** Activity

Disabled
Shutdown When Starting/Running
Shutdown When Running
Shutdown Always
Warning When Starting/Running
Warning When Running
Warning Always

*** Name

Chinese version does not have the option to change text for auxiliary input Name – default name only available.

SETPOINTS – Auxiliary Digital Output Configuration

(Units will be based upon the settings of the Session Screen, defaults are shown here)

Control	Description	Value	Default	Range	Units
Output A	Analog Channel		Capacity Slide Position	None	None
	< >		>	< or >	
	On When		0.0	-10000.0 to 10000.0	%
	Off When				
	Control When		Disabled	Disabled Running Always	
	IO Board		Dig. Bd. 2	None	
	IO Channel		7		
Output B	Analog Channel		Capacity Slide Position	None	None
	< >		>	< or >	
	On When		0.0	-10000.0 to 10000.0	%
	Off When				
	Control When		Disabled	Disabled Running Always	
	IO Board		Dig. Bd. 2	None	
	IO Channel		8		
Output C	Analog Channel		Capacity Slide Position	None	None
	< >		>	< or >	
	On When		0.0	-10000.0 to 10000.0	%
	Off When				
	Control When		Disabled	Disabled Running Always	
	IO Board		Dig. Bd. 2	None	
	IO Channel		18		
Output D	Analog Channel		Capacity Slide Position	None	None
	< >		>	< or >	
	On When		0.0	-10000.0 to 10000.0	%
	Off When				
	Control When		Disabled	Disabled Running Always	
	IO Board		None	None	
	IO Channel		0		
Output E	Analog Channel		Capacity Slide Position	None	None
	< >		>	< or >	
	On When		0.0	-10000.0 to 10000.0	%
	Off When				
	Control When		Disabled	Disabled Running Always	
	IO Board		None	None	
	IO Channel		0		

This Setpoint table continues on the next page.

SETPOINTS - Auxiliary Digital Output Configuration

-CONTINUED -

(Units will be based upon the settings of the Session Screen, defaults are shown here)

Control	Description	Value	Default	Range	Units
Output F	Analog Channel		Capacity Slide Position	None	None
	< >		>	< or >	
	On When		0.0	-10000.0 to 10000.0	%
	Off When				
	Control When		Disabled	Disabled Running Always	
	IO Board		None	None	
	IO Channel		0		
Output G	Analog Channel		Capacity Slide Position	None	None
	< >		>	< or >	
	On When		0.0	-10000.0 to 10000.0	%
	Off When				
	Control When		Disabled	Disabled Running Always	
	IO Board		None	None	
	IO Channel		0		
Output H	Analog Channel		Capacity Slide Position	None	None
	< >		>	< or >	
	On When		0.0	-10000.0 to 10000.0	%
	Off When				
	Control When		Disabled	Disabled Running Always	
	IO Board		None	None	
	IO Channel		0		
Output I	Analog Channel		Capacity Slide Position	None	None
	< >		>	< or >	
	On When		0.0	-10000.0 to 10000.0	%
	Off When				
	Control When		Disabled	Disabled Running Always	
	IO Board		None	None	
	IO Channel		0		
Output J	Analog Channel		Capacity Slide Position	None	None
	< >		>	< or >	
	On When		0.0	-10000.0 to 10000.0	%
	Off When				
	Control When		Disabled	Disabled Running Always	
	IO Board		None	None	
	IO Channel		0		

SETPOINTS – Timed Digital Output Configuration

(Units will be based upon the settings of the Session Screen, defaults are shown here)

Control	Description	Value	Default	Range	Units
Output A	On		00 : 00	0.0-23.0 : 0.0-59.0	HR:MIN
	Off		00 : 00		
	Control When		Disabled	Disabled Running Always	
	Which Days		Every Day	Every Day Week Days	
	IO Board		None	None Digital Board 1 Digital Board 2	
	IO Channel		0	None	
Output B	On		00 : 00	0.0-23.0 : 0.0-59.0	HR:MIN
	Off		00 : 00		
	Control When		Disabled	Disabled Running Always	
	Which Days		Every Day	Every Day Week Days	
	IO Board		None	None Digital Board 1 Digital Board 2	
	IO Channel		0	None	
Output C	Run Hour Interval		0	0.0 - 100000.0	HOURS
	On Time		0	0.0 - 100000.0	MINUTES
	IO Board		None	None Digital Board 1 Digital Board 2	
	IO Channel		0	None	

SETPOINTS - Panel

(Units will be based upon the settings of the Session Screen, defaults are shown here)

Description		Value	Default	Range	Units	
Panel Heater	On		53.6	32.0 to 77.0	Temp.	F
	Off		55.4			
Remote Enable Output			Disabled	Disabled Compressor Mode: Remote I/O Compressor and Capacity Modes: Remote I/O Compressor Mode: Remote I/O and Cap. Mode: Remote 4-20		
Input Module Capacity Mode Selection			Disabled	Disabled Enabled		
Permissive Start			Disabled	Disabled Starting Always		
Power Fail Restart	Enabled/Disabled		Disabled	Disabled Enabled		
	Restart Time		0	1.0 to 99.0	Time	MIN
Run Hours			0	0 to 100000		
PLC Interlock			Disabled	Disabled		
Remote Control Setpoint				Enabled		
Recycle Delay <i>(displays only if VFD selected)</i>			Enabled	Disabled Enabled		
Pressure Display Resolution			1 Place	1 Place 2 Place 3 Place		
Browser Automatic Refresh			Disabled	Disabled Enabled		
Extra Digital Auxiliaries			Disabled	Disabled Enabled		
Extra Analog Auxiliaries and Retransmitting Outputs			Disabled	Disabled Enabled		

CALIBRATION – Pressure

(Units will be based upon the settings of the Session Screen, defaults are shown here)

Control	Description	Value	Default	Range	Units
Atmospheric Pressure			14.7	8.0 to 20.0	Pressure PSIG
Suction	Current value			None	None
	Offset		0.0	-30.0 to 30.0	Pressure PSIG
	Range	Low	30.0 Hg	0.0 to 985.3	
		High	185.3		
	Sensor Signal **		1-5V	None	None
	IO Board *		Analog Board 1		
IO Channel		9			
Discharge	Current value			None	None
	Offset		0.0	-30.0 to 30.0	Pressure PSIG
	Range	Low	30.0 Hg	-14.7 to 985.3	
		High	485.3		
	Sensor Signal **		1-5V	None	None
	IO Board *		Analog Board 1		
IO Channel		8			
Oil	Current value			None	None
	Offset		0.0	-30.0 to 30.0	Pressure PSIG
	Range	Low	30.0 Hg	-14.7 to 985.3	
		High	485.3		
	Sensor Signal **		1-5V	None	None
	IO Board *		Analog Board 1		
IO Channel		6			
Filter	Current value			None	None
	Offset		0.0	-30.0 to 30.0	Pressure PSIG
	Range	Low	30.0 Hg	-14.7 to 985.3	
		High	485.3		
	Sensor Signal **		1-5V	None	None
	IO Board *		Analog Board 1		
IO Channel		6			
Economizer	Current value			None	None
	Offset		0.0	-30.0 to 30.0	Pressure PSIG
	Range	Low	30.0 Hg	-14.7 to 985.3	
		High	485.3		
	Sensor Signal **		1-5V	None	None
	IO Board *		Analog Board 1		
IO Channel		6			
Balance Piston	Current value			None	None
	Offset		0.0	-30.0 to 30.0	Pressure PSIG
	Range	Low	30.0 Hg	-14.7 to 985.3	
		High	485.3		
	Sensor Signal **		1-5V	None	None
	IO Board *		None		
IO Channel		10			

This Setpoint table continues on the next page.

CALIBRATION – Pressure

-CONTINUED -

(Units will be based upon the settings of the Session Screen, defaults are shown here)

Control	Description	Value	Default	Range	Units
System Discharge	Current value			None	None
	Offset		0.0	-30.0 to 30.0	Pressure PSIG
	Range	Low	30.0 Hg	-14.7 to 985.3	
		High	485.3		
	Sensor Signal **		1-5V	None	None
	IO Board *		Analog Board 1		
IO Channel		6			
Main Oil Injection	Current value			None	None
	Offset		0.0	-30.0 to 30.0	Pressure PSIG
	Range	Low	30.0 Hg	-14.7 to 985.3	
		High	485.3		
	Sensor Signal **		1-5V	None	None
	IO Board *		Analog Board 1		
IO Channel		6			
Manifold	Current value			None	None
	Offset		0.0	-30.0 to 30.0	Pressure PSIG
	Range	Low	30.0 Hg	-14.7 to 985.3	
		High	485.3		
	Sensor Signal **		1-5V	None	None
	IO Board *		None		
IO Channel		15			

* IO Board:

None
Analog Board 1
Analog Board 2

** Sensor Signal Selections:

None	4-20mA	RTD	Vibration
0-5V	Pot.	CT	1-10V
1-5V	ICTD	RPM	+/- 5V

CALIBRATION – Temperature

(Units will be based upon the settings of the Session Screen, defaults are shown here)

Control	Description	Value	Default	Range	Units
Suction	Current value			None	None
	Offset		0.0	-92.2 to 92.2	Temperature F
	Range	Low	-459.4	-1768 to 1832	
		High	463.1		
	Sensor Signal **		ICTD	None	None
	IO Board *		Analog Board 1		
IO Channel		1			
Discharge	Current value			None	None
	Offset		0.0	-92.2 to 92.2	Temperature F
	Range	Low	-459.4	-1768 to 1832	
		High	463.1		
	Sensor Signal **		ICTD	None	None
	IO Board *		Analog Board 1		
IO Channel		2			
Oil	Current value			None	None
	Offset		0.0	-92.2 to 92.2	Temperature F
	Range	Low	-459.4	-1768 to 1832	
		High	463.1		
	Sensor Signal **		ICTD	None	None
	IO Board *		Analog Board 1		
IO Channel		3			
Separator	Current value			None	None
	Offset		0.0	-92.2 to 92.2	Temperature F
	Range	Low	-459.4	-1768 to 1832	
		High	463.1		
	Sensor Signal **		ICTD	None	None
	IO Board *		Analog Board 1		
IO Channel		4			
Process Leaving	Current value			None	None
	Offset		0.0	-92.2 to 92.2	Temperature F
	Range	Low	-459.4	-1768 to 1832	
		High	463.1		
	Sensor Signal **		ICTD	None	None
	IO Board *		None		
IO Channel		5			
Process Entering	Current value			None	None
	Offset		0.0	-92.2 to 92.2	Temperature F
	Range	Low	-459.4	-1768 to 1832	
		High	463.1		
	Sensor Signal **		ICTD	None	None
	IO Board *		None		
IO Channel		4			
Panel	Current value			0.0 to 45.0	Temperature F
	Offset		0.0		

* IO Board

None
Analog Board 1
Analog Board 2

** Sensor Signal Selections:

None	4-20mA	RTD	Vibration
0-5V	Pot.	CT	1-10V
1-5V	ICTD	RPM	+/- 5V

CALIBRATION – Capacity/Volume

(Units will be based upon the settings of the Session Screen, defaults are shown here)

Control	Description	Value	Default	Range	Units
Capacity	Sensor Signal **		4-20mA	None	None
	IO Board *		Analog Board 1		
	IO Channel		14		
	Travel		196.0	0.0 to 500.0	
Volume	Sensor Signal **		4-20mA	None	None
	IO Board *		Analog Board 1		
	IO Channel		15		
	Bottom of Range		2.2	0.0 to 10.0	
	Top of Range		5.0	0.0 to 10.0	
	Dead Band		0.2	0.0 to 2.0	
	Minimum On Time		0.5	0.0 to 5.0	

* IO Board

None
Analog Board 1
Analog Board 2

** Sensor Signal Selections:

None	4-20mA	RTD	Vibration
0-5V	Pot.	CT	1-10V
1-5V	ICTD	RPM	+/- 5V

CALIBRATION – Motor/Miscellaneous

(Units will be based upon the settings of the Session Screen, defaults are shown here)

Control	Description	Value	Default	Range	Units	
Motor Amps	Current value			None	None	
	Sensor Signal **		CT			
	IO Board *		Analog Board 1			
	IO Channel		16			
Kilowatts	Current value			None	None	
	Offset		0.0	-500.0 to 500.0	Kilowatts	kW
	Range	Low		0.0		
		High		5000.0		
	Sensor Signal **		4-20mA	None	None	
	IO Board *		None			
IO Channel		16				
RPM	Current value			None	None	
	Offset		0.0	-360.0 to 360.0	Speed	RPM
	Range	Low		0.0		
		High		3600 RPM		
	Sensor Signal **		4-20ma	None	None	
	IO Board *		Analog Board 2			
IO Channel		16				
Remote Capacity Position	Current value			None	None	
	Offset		0.0	-10.0 to 10.0	Percent	%
	Range	Low		0.0		
		High		100.0 %		
	Sensor Signal **		4-20Ma	None	None	
	IO Board *		None			
IO Channel		0				
External Input	Current value			None	None	
	Offset		0.0	-75.0 to 75.0	Pressure	PSIG
	Range	Low		-30.0		
		High		485.3 PSIG		
	Sensor Signal **		4-20mA	None	None	
	IO Board *		None			
IO Channel		12				
Control	Description	Value	Default	Range	Units	
Remote Control Setpoint	Current value			None	None	
	Offset		0.0	-30.0 to 30.0	Pressure	PSIG
	Range	Low		30.0		
		High		185.3		
	Sensor Signal **		4-20mA	None	None	
	IO Board *		Analog Board 1			
IO Channel		12				
Liquid Level	Current value			None	None	
	Offset		0.0	-10.0 to 10.0	Percent	%
	Range	Low		0.0		
		High		100.0		
	Sensor Signal **		4-20mA	None	None	
	IO Board *		None			
IO Channel		0				

* IO Board

None
Analog Board 1
Analog Board 2

** Sensor Signal Selections:

None	4-20mA	RTD	Vibration
0-5V	Pot.	CT	1-10V
1-5V	ICTD	RPM	+/- 5V

CALIBRATION - Phd Monitoring

(Units will be based upon the settings of the Session Screen, defaults are shown here)

Control	Description	Value	Default	Range	Units
Compressor Vibration - Suction	Current value			None	gF
	Offset		0.0	-3.0 to 3.0	
	Range (4-20mA only)	Low	0.0	-1000.0 to 1000.0	
		High	30.0		
	Sensor Signal **		Vibration	None	None
	IO Board		None		
IO Channel		17			
Compressor Vibration - Discharge	Current value			None	gF
	Offset		0.0	-3.0 to 3.0	
	Range (4-20mA only)	Low	0.0	-1000.0 to 1000.0	
		High	30.0		
	Sensor Signal **		Vibration	None	None
	IO Board		None		
IO Channel		18			
Motor Vibration - Shaft Side	Current value			None	gF
	Offset		0.0	-3.0 to 3.0	
	Range (4-20mA only)	Low	0.0	-1000.0 to 1000.0	
		High	30.0		
	Sensor Signal **		Vibration	None	None
	IO Board		None		
IO Channel		19			
Motor Vibration - Opposite Shaft Side	Current value			None	gF
	Offset		0.0	-3.0 to 3.0	
	Range (4-20mA only)	Low	0.0	-1000.0 to 1000.0	
		High	30.0		
	Sensor Signal **		Vibration	None	None
	IO Board		None		
IO Channel		20			
Motor Temperature - Shaft Side	Current value			None	F
	Offset		0.0	-92.3 to 92.3	
	Range (4-20mA only)	Low	-459.4	-1768.0 to 1832.0	
		High	463.1		
	Sensor Signal **		RTD	None	None
	IO Board		None		
IO Channel		19			
Motor Temperature - Opposite Shaft Side	Current value			None	F
	Offset		0.0	-92.3 to 92.3	
	Range (4-20mA only)	Low	-459.4	-1768.0 to 1832.0	
		High	463.1		
	Sensor Signal **		RTD	None	None
	IO Board		None		
IO Channel		20			

This Setpoint table continues on the next page.

CALIBRATION - PhD Monitoring

-CONTINUED -

(Units will be based upon the settings of the Session Screen, defaults are shown here)

Control	Description	Value	Default	Range	Units
Motor Stator # 1	Current value			None	F
	Offset		0.0	-92.3 to 92.3	
	Range (4-20mA only)	Low		-459.4	
		High		463.1	
	Sensor Signal **			RTD	None
	IO Board			None	
IO Channel			21		
Motor Stator # 2	Current value			None	F
	Offset		0.0	-92.3 to 92.3	
	Range (4-20mA only)	Low		-459.4	
		High		463.1	
	Sensor Signal **			RTD	None
	IO Board			None	
IO Channel			22		
Motor Stator # 3	Current value			None	F
	Offset		0.0	-92.3 to 92.3	
	Range (4-20mA only)	Low		-459.4	
		High		463.1	
	Sensor Signal **			RTD	None
	IO Board			None	
IO Channel			23		

* IO Board

None
Analog Board 1
Analog Board 2

** Sensor Signal Selections:

None	4-20mA	RTD	Vibration
0-5V	Pot.	CT	1-10V
1-5V	ICTD	RPM	+/- 5V

CALIBRATION - Analog Outputs (Retransmitting Outputs)

Output Channel	Description	Value	Default	Range	Units
A	Input Channel to Retransmit *		Capacity Slide Position	None	None
	IO Board **		Analog Board 1		
	IO Channel		3		
B	Input Channel to Retransmit *		Capacity Slide Position	None	None
	IO Board **		None		
	IO Channel		0		
C	Input Channel to Retransmit *		Capacity Slide Position	None	None
	IO Board **		None		
	IO Channel		0		
D	Input Channel to Retransmit *		Capacity Slide Position	None	None
	IO Board **		None		
	IO Channel		0		
E	Input Channel to Retransmit *		Capacity Slide Position	None	None
	IO Board **		None		
	IO Channel		0		
F	Input Channel to Retransmit *		Capacity Slide Position	None	None
	IO Board **		None		
	IO Channel		0		
G	Input Channel to Retransmit *		Capacity Slide Position	None	None
	IO Board **		None		
	IO Channel		0		
H	Input Channel to Retransmit *		Capacity Slide Position	None	None
	IO Board **		None		
	IO Channel		0		

* Input Channel to Retransmit

Capacity Slide Position	Process/Brine Temperature Entering
Volume Slide Position	Remote Control Setpoint
Suction Pressure	Motor Current
Discharge Pressure	RPM
Compressor Oil Pressure	Auxiliary Analog 1 - 10
Main Oil Injection Pressure	EZ Cool Feedback %
Economizer Pressure	Auxiliary Analog 12- 20
Filter Pressure	Manifold Pressure
Intermediate Pressure	Remote Capacity Position
Balance Piston Pressure	Compressor Vibration - Suction
System Discharge Pressure	Compressor Vibration - Discharge
Suction Temperature	Motor Vibration - Shaft Side
Discharge Temperature	Motor Vibration - Opposite Shaft Side
Compressor Oil Temperature	Motor Temperature - Shaft Side
Oil Separator Temperature	Motor Temperature - Opposite Shaft Side
Process/Brine Temperature Leaving	Motor Stator #1 - #3

** IO Board

None
Analog Board 1
Analog Board 2

CALIBRATION - Analog Outputs (VFD / Condenser Outputs)

Output Channel	Description	Value	Default	Range	Units
Compressor VFD	IO Board *		Analog Board 2	None	None
	IO Channel		3		
Condenser Output A	IO Board *		Analog Board 1	None	None
	IO Channel		5		
Condenser Output B	IO Board *		Analog Board 1	None	None
	IO Channel		6		

* IO Board

None
Analog Board 1
Analog Board 2

CALIBRATION - Analog Output Calibration

Description	Value	Default	Range	Units
Select Analog Board		Analog Board 1	None	None
Select Analog Output Channel to Calibrate		1		

CALIBRATION – Auxiliaries Analogs (Page 1)

(Units will be based upon the settings of the Session Screen, defaults are shown here)

Name	Description	Value	Default	Range	Units
Auxiliary Analog 1	Name		Auxiliary Analog 1		None
	Current value			None	
	Offset		0.0	-75.0 to 75.0	Pressure PSIG
	Range	Low	30.0 Hg	0.0 to 1435.6	
		High	485.3		
Auxiliary Analog 2	Name		Auxiliary Analog 2		None
	Current value			None	
	Offset		0.0	-75.0 to 75.0	Pressure PSIG
	Range	Low	30.0 Hg	0.0 to 1435.6	
		High	485.3		
Auxiliary Analog 3	Name		Auxiliary Analog 3		None
	Current value			None	
	Offset		0.0	-75.0 to 75.0	Pressure PSIG
	Range	Low	30.0 Hg	0.0 to 1435.6	
		High	485.3		
Auxiliary Analog 4	Name		Auxiliary Analog 4		None
	Current value			None	
	Offset		0.0	-75.0 to 75.0	Pressure PSIG
	Range	Low	30.0 Hg	0.0 to 1435.6	
		High	485.3		
Auxiliary Analog 5	Name		Auxiliary Analog 5		None
	Current value			None	
	Offset		0.0	-75.0 to 75.0	Pressure PSIG
	Range	Low	30.0 Hg	0.0 to 1435.6	
		High	485.3		
Auxiliary Analog 6	Name		Auxiliary Analog 6		None
	Current value			None	
	Offset		0.0	-75.0 to 75.0	Pressure PSIG
	Range	Low	30.0 Hg	0.0 to 1435.6	
		High	485.3		
Auxiliary Analog 7	Name		Auxiliary Analog 7		None
	Current value			None	
	Offset		0.0	-75.0 to 75.0	Pressure PSIG
	Range	Low	30.0 Hg	0.0 to 1435.6	
		High	485.3		
Auxiliary Analog 8	Name		Auxiliary Analog 8		None
	Current value			None	
	Offset		0.0	-75.0 to 75.0	Pressure PSIG
	Range	Low	30.0 Hg	0.0 to 1435.6	
		High	485.3		
Auxiliary Analog 9	Name		Auxiliary Analog 9		None
	Current value			None	
	Offset		0.0	-75.0 to 75.0	Pressure PSIG
	Range	Low	30.0 Hg	0.0 to 1435.6	
		High	485.3		
Auxiliary Analog 10	Name		Auxiliary Analog 10		None
	Current value			None	
	Offset		30.0 Hg	-75.0 to 75.0	Pressure PSIG
	Range	Low	0.0	0.0 to 1435.6	
		High	485.3		
EZ Cool Feedback %	Name		EZ Cool Feedback %		None
	Current value			None	
	Offset		0.0	-10.0 to 10.0	Percent %
	Range	Low	0.0	-1000.0 to 10000.0	
		High	100.0		

* Sensor Signal Selections:

None	4-20mA	RTD	Vibration
0-5V	Pot.	CT	1-10V
1-5V	ICTD	RPM	+/- 5V

** Sensor Type

None	Temperature
Pressure	Other

CALIBRATION – Auxiliaries (Page 2)

(Units will be based upon the settings of the Session Screen, defaults are shown here)

Name	Description	Value	Default	Range	Units
Auxiliary Analog 1	IO Board		Auxiliary Analog 2	None	
	IO Channel		5		
	Sensor Signal *		1-5 V		
	Sensor Type **		Pressure		
	Units if Type is Other		None		
Auxiliary Analog 2	IO Board		Auxiliary Analog 2	None	
	IO Channel		6		
	Sensor Signal *		1-5 V		
	Sensor Type **		Pressure		
	Units if Type is Other		None		
Auxiliary Analog 3	IO Board		Auxiliary Analog 2	None	
	IO Channel		7		
	Sensor Signal *		1-5 V		
	Sensor Type **		Pressure		
	Units if Type is Other		None		
Auxiliary Analog 4	IO Board		Auxiliary Analog 2	None	
	IO Channel		8		
	Sensor Signal *		1-5 V		
	Sensor Type **		Pressure		
	Units if Type is Other		None		
Auxiliary Analog 5	IO Board		Auxiliary Analog 2	None	
	IO Channel		9		
	Sensor Signal *		1-5 V		
	Sensor Type **		Pressure		
	Units if Type is Other		None		
Auxiliary Analog 6	IO Board		Auxiliary Analog 2	None	
	IO Channel		10		
	Sensor Signal *		1-5 V		
	Sensor Type **		Pressure		
	Units if Type is Other		None		
Auxiliary Analog 7	IO Board		Auxiliary Analog 2	None	
	IO Channel		11		
	Sensor Signal *		1-5 V		
	Sensor Type **		Pressure		
	Units if Type is Other		None		
Auxiliary Analog 8	IO Board		Auxiliary Analog 2	None	
	IO Channel		12		
	Sensor Signal *		1-5 V		
	Sensor Type **		Pressure		
	Units if Type is Other		None		
Auxiliary Analog 9	IO Board		Auxiliary Analog 2	None	
	IO Channel		13		
	Sensor Signal *		1-5 V		
	Sensor Type **		Pressure		
	Units if Type is Other		None		
Auxiliary Analog 10	IO Board		Auxiliary Analog 2	None	
	IO Channel		14		
	Sensor Signal *		1-5 V		
	Sensor Type **		Pressure		
	Units if Type is Other		None		
EZ Cool Feedback %	IO Board		Auxiliary Analog 1	None	
	IO Channel		24		
	Sensor Signal *		4-20mA		
	Sensor Type **		Other		
	Units if Type is Other		%		

* Sensor Signal Selections:

None	4-20mA	RTD	Vibration
0-5V	Pot.	CT	1-10V
1-5V	ICTD	RPM	+/- 5V

** Sensor Type

None	Temperature
Pressure	Other

CONFIGURATION – Compressor

Control	Description	Value	Default	Range			Units
Misc.	Sequencing		Disabled	Disabled			None
	Condenser		Disabled	Enabled			
	Screen Saver		15	0 to 60			Time MIN
Capacity	Mode 1	Disabled / Enabled		Disabled	Disabled Enabled		None
		Channel *		Suction Pressure	None		
		Direction		Forward	Forward Reverse		
	Mode 2	Disabled / Enabled		Disabled	Disabled Enabled		
		Channel *		Disabled			
		Direction		Forward	Forward Reverse		
	Mode 3	Disabled / Enabled		Disabled	Disabled Enabled		
		Channel *		Disabled			
		Direction		Forward	Forward Reverse		
	Mode 4	Disabled / Enabled		Disabled	Disabled Enabled		
		Channel *		Disabled			
		Direction		Forward	Forward Reverse		
Package	Compressor		RWF	RWF RWBII RXB RXF 12-50 RXF 58-101 RDB 4-Step RDB 3-Step	GSV II GST GSB 3-Step YLC SC York S7 York S5	Other Manuf. Recip-0 Recip-1 Recip-2 Recip-3	None
	Pump		No Pump	No Pump Full Time Demand Shaft w/Auxiliary Shaft			
	Dual Pump		Disabled	Disabled Enabled			
	Drive		Screw w/ Constant Electric	Constant Elec. Drive VFD Engine Drive Turbine DBS Vyper (Ram) Vyper (4-20mA)			
	Refrigerant		R717	R11 R113 R114 R1150 R12 R1270 R13 R134a R13b1 R14 R142b R170	R218 R22 R23 R290 R401a R402a R404a R410a R50 R500 R502 R503	R507 R508 R508B R600 R600a R717 R718 R728 R729 R744 R771 User Defined	

CONFIGURATION – Compressor (Continued)

Control	Description	Value	Default	Range			Units
Package (Cont)	Oil Type (VFD or Vyper only)		None	None Frick #2a Frick #2b Frick #3	Frick #9 Frick #11 Frick #13 Frick #13b	Frick #14 CP-4624-68F Solest 68 Solest 120	
	Model (VFD or Vyper only)		NGC 100A	NGC 100A NGC 100B NGC 100C NGC 100D NGC 150A NGC 150B NGC 150C NGC 150D NGC 200A NGC 200B NGC 200C NGC 200D NGC 250A NGC 250B NGC 250C NGC 250D NGC 300A NGC 300B NGC 300C NGC 300D NGC 400A NGC 400B NGC 400C NGC 400D NGC 400E NGC 400F NGC 450A NGC 450B NGC 450C NGC 450D NGC 450E	NGC 450F SGC 1913 SGC 1918 SGC 2313 SGC 2317 SGC 2321 SGC 2813 SGC 2817 SGC 2821 SGC 2824 SGC 3511 SGC 3515 SGC 3519 SGB 3511 SGB 3515 SGB 3519 SGB 3524 TDSB 355L TDSB 355S TDSB 355U TDSB 355XL TDSH 163L TDSH 163S TDSH 193L TDSH 233L TDSH 233S TDSH 233XL TDSH 283L TDSH 283S TDSH 283SX TDSH 283SX	TDSH 355L TDSH 355S TDSH 355XL TDSL 193L TDSL 193S TDSL 233L TDSL 233S TDSL 283L TDSL 283S TDSL 283XL XJF 120L XJF 120M XJF 120S XJF 151A XJF 151L XJF 151M XJF 151N XJF 151XQ XJF 151XR XJF 151XS XJF 151XT XJF 95L XJF 95M XJF 95S XJS 120L XJS 120M XJS 120S XJS 95L XJS 95M XJS 95S	
	Filter		Disabled	Disabled Filter-Oil Discharge-Oil Discharge-Filter			
	Power Pac		No	No Yes			

* Capacity Channel Range

Capacity Slide Position	Process/Brine Temperature Entering
Volume Slide Position	Remote Control Setpoint
Suction Pressure	Motor Current
Discharge Pressure	RPM
Compressor Oil Pressure	Auxiliary Analog 1 - 10
Main Oil Injection Pressure	EZ Cool Feedback %
Economizer Pressure	Auxiliary Analog 12- 20
Filter Pressure	Manifold Pressure
Intermediate Pressure	Remote Capacity Position
Balance Piston Pressure	Compressor Vibration - Suction
System Discharge Pressure	Compressor Vibration - Discharge
Suction Temperature	Motor Vibration - Shaft Side
Discharge Temperature	Motor Vibration - Opposite Shaft Side
Compressor Oil Temperature	Motor Temperature - Shaft Side
Oil Separator Temperature	Motor Temperature - Opposite Shaft Side
Process/Brine Temperature Leaving	Motor Stator #1 - #3

CONFIGURATION - Communications

Control	Description	Value	Default	Range	Units
Compressor ID			0	0 to 99	
Comm 1	Baud rate		19200	*	* None
	Data Bits		8	7 to 8	
	Stop Bits		1	1 to 2	
	Parity		None	*	
	Protocol				
Comm 2	Baud rate		19200		
	Data Bits		8	7 to 8	
	Stop Bits		1	1 to 2	
	Parity		None	*	
	Protocol				
Comm 3	Baud rate		19200		
	Data Bits		8	7 to 8	
	Stop Bits		1	1 to 2	
	Parity		None	*	
	Protocol				
Map File	Use Map File		No	*	

* Refer to 090.020-CS (Communications Setup) for additional information

CONFIGURATION - Ethernet

Control	Description	Value	Default	Range
IP Data	Address Type		Fixed	Static or Dynamic
	IP Address		*	*
	Gateway Address		*	*
	Subnet Mask		*	*
	Web Server Port		80	0.0 to 99999.0
Naming Data	Host Name		QLX-Host	*
	Workgroup		QLX Compressors	*
	Comment		*	*
Email Data	Email Notification On Shutdown		Disabled	Disabled / Enabled
	Local Email Address		*	*
	Alias Name for Local Email Address			
	Subject			
	SMTTP Server Name OR IP Address		25	0.0 to 99999.0
	SMTTP Server Port Number		*	*
Protocols	ModBus TCP		Disabled	Disabled / Enabled
	Ethernet/IP			
	PROFINET			

* Refer to 090.020-CS (Communications Setup) for additional information

CONFIGURATION – Digital I/O (Page 3)

Input/Output	Description	Value	Default	Range
Liquid Level Increase	IO Board		None	*
	IO Channel		0	None
Liquid Level Decrease	IO Board		None	*
	IO Channel		0	None
PLC Interlock	IO Board		None	*
	IO Channel		0	None
High VI Liquid Injection	IO Board		Digital Board 1	*
	IO Channel		10	None
Shunt Trip	IO Board		Digital Board 1	*
	IO Channel		15	None

* IO Board

None	Digital Board 1	Digital Board 2
------	-----------------	-----------------

SECURITY

Description	Value	Default	Range
Level 1 Password		****	0.0 to 5000.0
Level 2 Password		****	
Level 3 Password		****	
Password For Current Level Or Higher User Level		PSIG	-999999.0 to 999999.0
Remote Internet Acces	User Name		N/A
	Password	****	

Refer to 090.022-O (Operation) for additional information

SESSION

Description	Value	Default	Range	Units
User Level		0	*	*
Password		None		
Language		English		
Pressure Units		PSIG		
Temperature Units		Fahrenheit		
Date Format		US		

* Refer to 090.022-O (Operation) for additional information

ABOUT

Description	Value	Default	Range	Units
Sales Order		0	0.0 to 9999999	None
Item		0	0.0 to 99999	

CONFIGURATION – Digital I/O (Page 1)

Input/Output	Description	Value	Default	Range
Oil Level Switch	IO Board		Digital Board 1	*
	IO Channel		13	None
Capacity Decrease	IO Board		Digital Board 1	*
	IO Channel		6	None
Capacity Increase	IO Board		Digital Board 1	*
	IO Channel		5	None
Volume Decrease	IO Board		Digital Board 1	*
	IO Channel		8	None
Volume Increase	IO Board		Digital Board 1	*
	IO Channel		7	None
Capacity Step #1	IO Board		None	*
	IO Channel		0	None
Capacity Step #2	IO Board		None	*
	IO Channel		0	None
Capacity Step #3	IO Board		None	*
	IO Channel		0	None
Capacity Step #4	IO Board		None	*
	IO Channel		0	None
Capacity Step #5	IO Board		None	*
	IO Channel		0	None
Capacity Step #6	IO Board		None	*
	IO Channel		0	None
Capacity Step #7	IO Board		None	*
	IO Channel		0	None
Economizer	IO Board		Digital Board 1	*
	IO Channel		11	None
Liquid Injection	IO Board		Digital Board 1	*
	IO Channel		9	None
Oil Heater	IO Board		Digital Board 1	*
	IO Channel		21	None
Hot Gas Bypass	IO Board		Digital Board 1	*
	IO Channel		16	None
Compressor Motor Start Signal	IO Board		Digital Board 1	*
	IO Channel		1	None
Compressor Motor Starter Feedback	IO Board		Digital Board 1	*
	IO Channel		2	None
Oil Pump Start Signal	IO Board		Digital Board 1	*
	IO Channel		3	None
Oil Pump Feedback	IO Board		Digital Board 1	*
	IO Channel		4	None
Full Flow Pump Start Signal	IO Board		None	*
	IO Channel		0	None
Oil Pump #2 Start Signal	IO Board		Digital Board 2	*
	IO Channel		15	None
Oil Pump #2 Feedback	IO Board		Digital Board 2	*
	IO Channel		16	None

* IO Board

None	Digital Board 1	Digital Board 2
------	-----------------	-----------------

CONFIGURATION – Digital I/O (Page 2)

Input/Output	Description	Value	Default	Range
High Liquid Level Shutdown	IO Board		Digital Board 1	*
	IO Channel		14	None
Mode Select A	IO Board		Digital Board 1	*
	IO Channel		19	None
Mode Select B	IO Board		Digital Board 1	*
	IO Channel		20	None
Shutdown	IO Board		Digital Board 1	*
	IO Channel		23	None
Warning	IO Board		Digital Board 1	*
	IO Channel		22	None
Balance Piston	IO Board		Digital Board 1	*
	IO Channel		12	None
Panel Heater	IO Board		Digital Board 1	*
	IO Channel		15	None
Permissive Start	IO Board		Digital Board 2	*
	IO Channel		17	None
Ready To Run	IO Board		Digital Board 2	*
	IO Channel		1	None
Remote Enabled	IO Board		Digital Board 2	*
	IO Channel		2	None
Recycle Delay	IO Board		Digital Board 2	*
	IO Channel		6	None
Remote Start/Stop	IO Board		Digital Board 2	*
	IO Channel		3	None
Remote Load	IO Board		Digital Board 2	*
	IO Channel		4	None
Remote Unload	IO Board		Digital Board 2	*
	IO Channel		5	None
Condenser Control Step 1	IO Board		Digital Board 2	*
	IO Channel		21	None
Condenser Control Step 2	IO Board		Digital Board 2	*
	IO Channel		22	None
Condenser Control Step 3	IO Board		Digital Board 2	*
	IO Channel		23	None
Condenser Control Step 4	IO Board		Digital Board 2	*
	IO Channel		24	None
Power Assist	IO Board		Digital Board 1	*
	IO Channel		24	None
Dx Circuit #1	IO Board		Digital Board 2	*
	IO Channel		19	None
Dx Circuit #2	IO Board		Digital Board 2	*
	IO Channel		20	None
Main Oil Injection	IO Board		None	*
	IO Channel		0	None

* IO Board

None	Digital Board 1	Digital Board 2
------	-----------------	-----------------

NOTES:

SECTION 10

QUANTUM™ LX DRAWINGS

This table lists the numbers for the drawings that appear on the following pages. The drawings shown here is the latest revision as of the printing of this manual. These drawings appear here for reference purposes only, and are subject to change without notice. When installing, or servicing equipment, always refer to the actual drawings that are included with the control panel for the latest information.

Wiring Diagrams	Page	Drawing Number
RXF (12-50) RETROFIT MOUNTING	140	N/A
RWF & RWFII	141 - 144	649D5154 Rev. H
RWBII	145- 148	649D5155 Rev. F
RXF 12-101	149 - 152	649D5153 Rev. F
RDB	153 - 156	649D5278 Rev. F
PhD for 32 channel Analog Board	157	649D5050 Rev. D
Digital I/O Board 2	158- 159	649D5210 Rev. C
Analog I/O Board 2	160 - 161	649D5211 Rev. E

Other Drawings	Page	
Isolater Repeater Module (Isolates Communications Signals)	162	639C0133 Rev. A
Communications Wiring Diagrams	163	N/A
Point-to-Point Field Wiring Diagram	164	N/A

RXF (12-50) RETROFIT MOUNTING

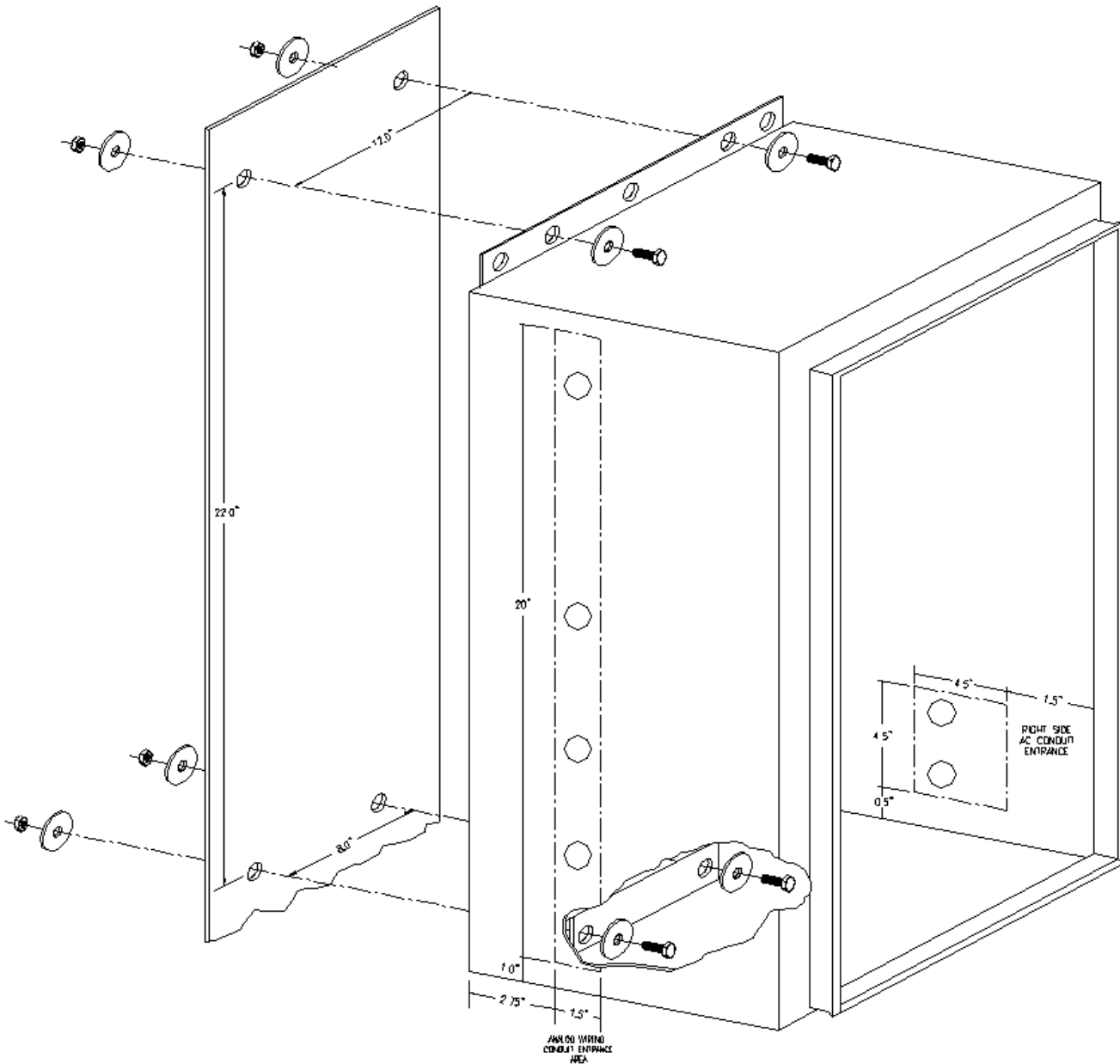

This drawing appears here for reference purposes only, and is subject to change without notice. When installing, or servicing equipment, always refer to the actual drawings that are included with the control panel for the latest information.

WIRING DIAGRAM – RWF & RWF II (Sheet 1 of 4)

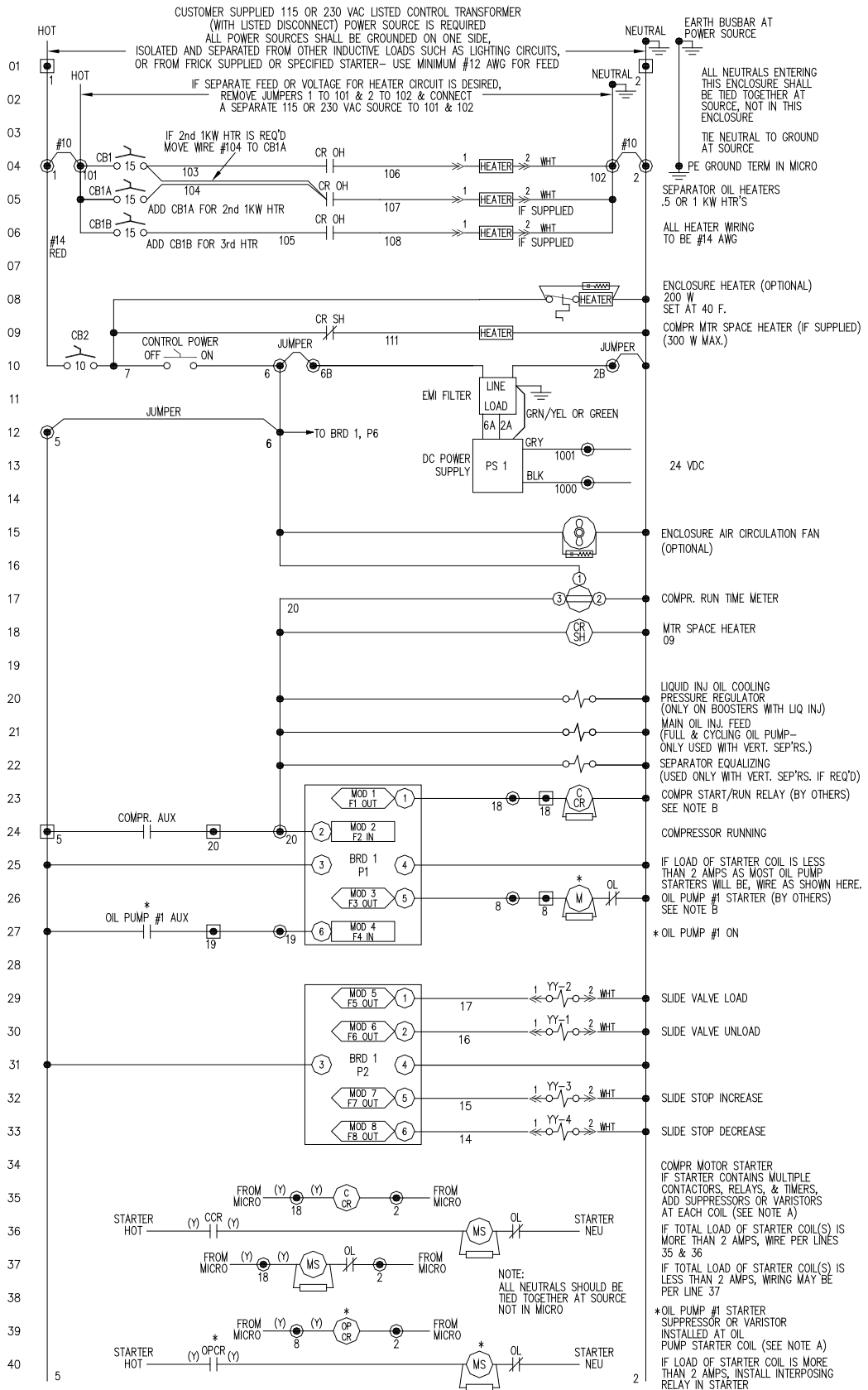

This drawing appears here for reference purposes only, and is subject to change without notice. When installing, or servicing equipment, always refer to the actual drawings that are included with the control panel for the latest information.

WIRING DIAGRAM – RWF & RWF II (Sheet 3 of 4)

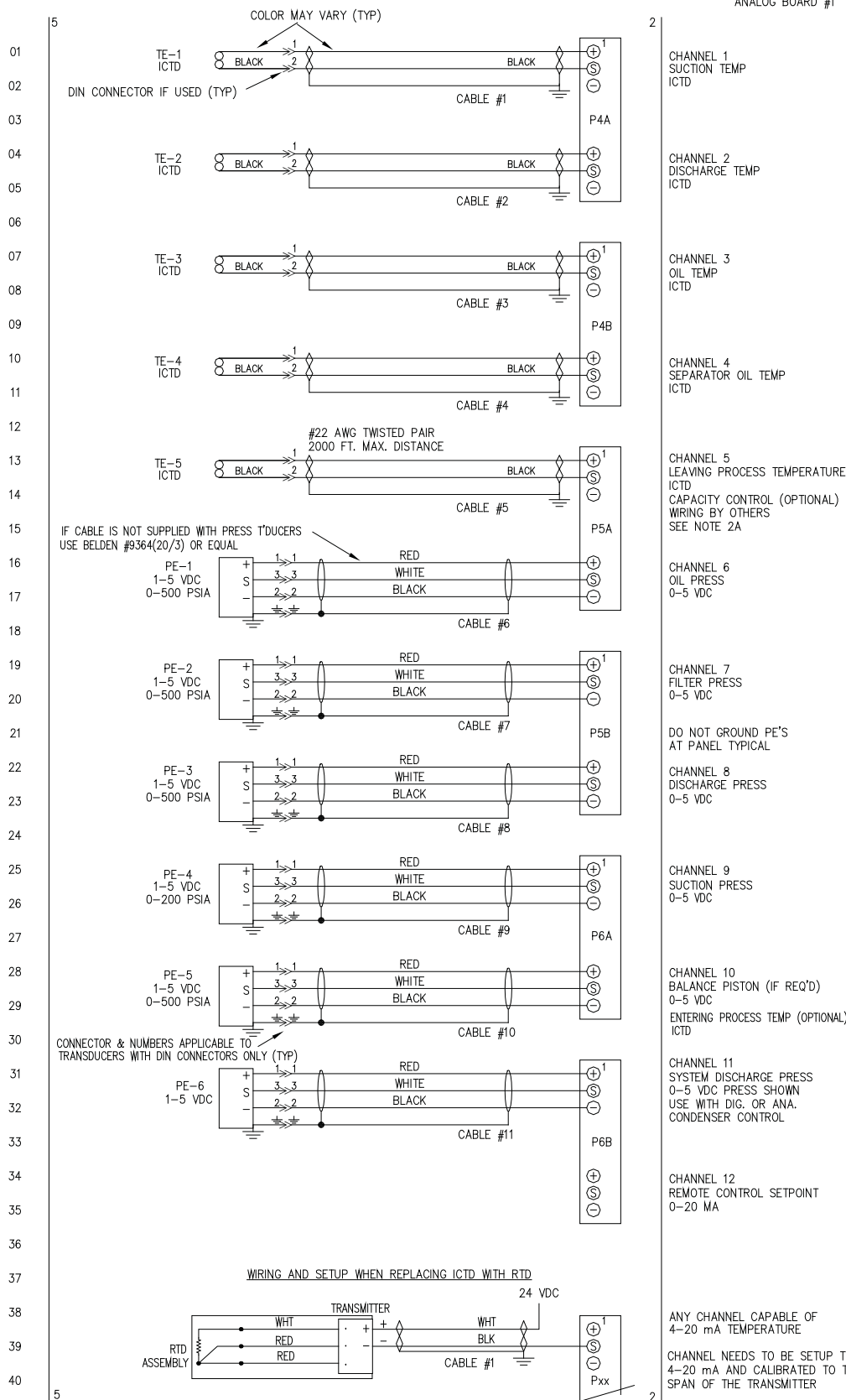

This drawing appears here for reference purposes only, and is subject to change without notice. When installing, or servicing equipment, always refer to the actual drawings that are included with the control panel for the latest information.

WIRING DIAGRAM – RWF & RWF II (Sheet 4 of 4)

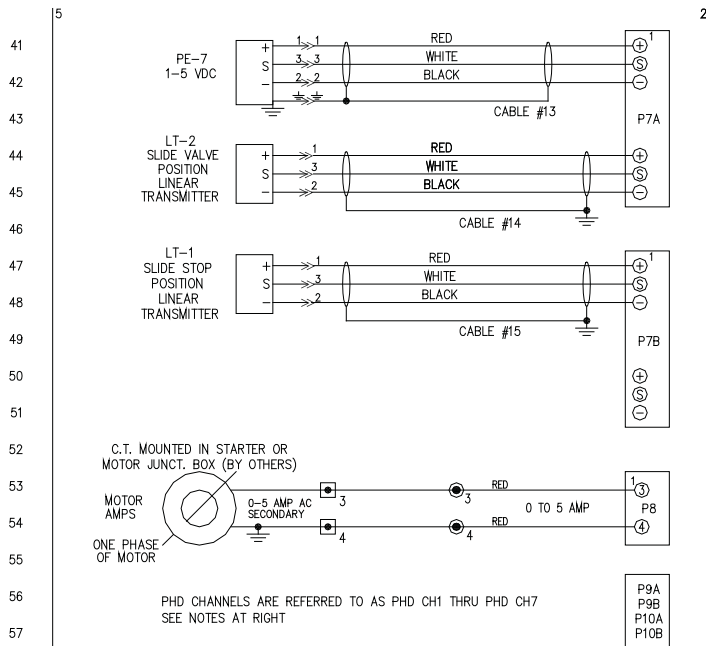

PHD CHANNELS ARE REFERRED TO AS PHD CH1 THRU PHD CH7
SEE NOTES AT RIGHT

ANALOG OUTPUTS

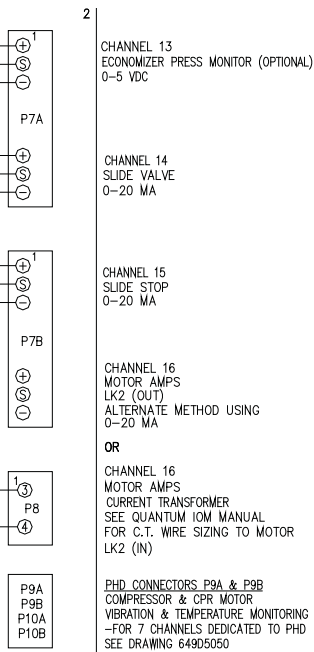

CHANNEL 13
ECONOMIZER PRESS MONITOR (OPTIONAL)
0-5 VDC

CHANNEL 14
SLIDE VALVE
0-20 MA

CHANNEL 15
SLIDE STOP
0-20 MA

CHANNEL 16
MOTOR AMPS
LK2 (OUT)
ALTERNATE METHOD USING
0-20 MA

OR

CHANNEL 16
MOTOR AMPS
CURRENT TRANSFORMER
SEE QUANTUM IOM MANUAL
FOR C.T. WIRE SIZING TO MOTOR
LK2 (IN)

PHD CONNECTORS P9A & P9B
COMPRESSOR & CPR MOTOR
VIBRATION & TEMPERATURE MONITORING
-FOR 7 CHANNELS DEDICATED TO PHD
SEE DRAWING 649D5050

NOTE 1A:
ALL ANALOG LOW VOLTAGE WIRING TO BE RUN IN SEPARATE CONDUIT FROM ALL OTHER WIRING. ALL DRAIN WIRES TO BE INSULATED EITHER TOGETHER OR SEPARATELY WITHIN 2" OR CLOSER OF TERMINATION IF NOT CONFINED OTHERWISE.

NOTE 2A:
TEMPERATURE WIRING SPECIFICATIONS:
MINIMUM CABLE SIZE FOR SENSOR WIRING TO BE 22 AWG, TWISTED PAIR - BELDEN #9320 (20/2) OR EQUAL TWISTED PAIR SUGGESTED IF CABLE HAS A DRAIN WIRE, GROUND DRAIN WIRE AT ONE END ONLY AND INSULATE OTHER END. 2000 FT. MAX. DISTANCE

NOTE 3A:
SPECIFICATIONS FOR TEMPERATURE CAPACITY CONTROL:
-SETPOINT RANGE: -50F. TO 100F.
-TEMPERATURE ASSEMBLY FOR NON-HAZARDOUS LOCATION (FRICK P/N 639A0151G03 WITH 1/2"NPT OR 639A0151G02 FOR CABLE STRAIN RELIEF
-WIRE AS SHOWN IN SEPARATE CONDUIT FROM ALL OTHER WIRING, USE BELDEN #9320(20/2) CABLE OR EQUAL

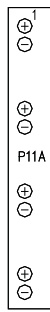

CHANNEL 1 (EZ COOL PID LOOP IF REQ'D)
PID LOOP OR
PROGRAMMABLE SELECTABLE OUTPUT
TO RE-TRANSMIT ANALOG INPUT
4-20 MA

CHANNEL 2
PID LOOP OR
PROGRAMMABLE SELECTABLE OUTPUT
TO RE-TRANSMIT ANALOG INPUT
4-20 MA

CHANNEL 3
PROGRAM SELECTABLE OUTPUT
TO RE-TRANSMIT ANALOG INPUT
SLIDE VALVE POSITION/CAPACITY
4-20 MA

CHANNEL 4
PID, RE-XMITT
ANALOG INPUT
CHANNEL

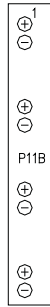

CHANNEL 5
CONDENSER ANALOG OUTPUT A
LOCATE PRESS. TRANSDUCER
ON CHANNEL 11,
ANA. BD. 1

CHANNEL 6
CONDENSER ANALOG OUTPUT B
LOCATE PRESS. TRANSDUCER
ON CHANNEL 11,
ANA. BD. 1

CHANNEL 7
PID, RE-XMITT
ANALOG INPUT
CHANNEL

CHANNEL 8
PID, RE-XMITT
ANALOG INPUT
CHANNEL

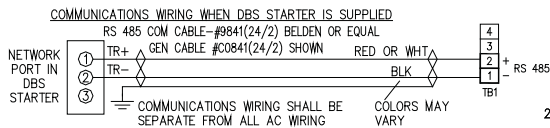
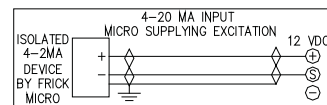
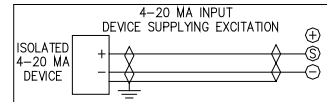
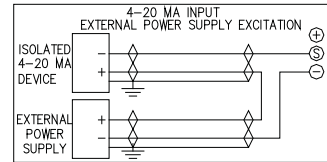

COMMUNICATIONS WIRING WHEN DBS STARTER IS SUPPLIED

RS 485 COM CABLE-#9841(24/2) BELDEN OR EQUAL
GEN CABLE #C0841(24/2) SHOWN
COMMUNICATIONS WIRING SHALL BE SEPARATE FROM ALL AC WIRING
COLORS MAY VARY

TB1 ON TOP BOARD OF CPU COMM 1 PORT LK16 MUST BE IN "B" POSITION

WIRING DIAGRAM - RWB II - (Sheet 1 of 4)

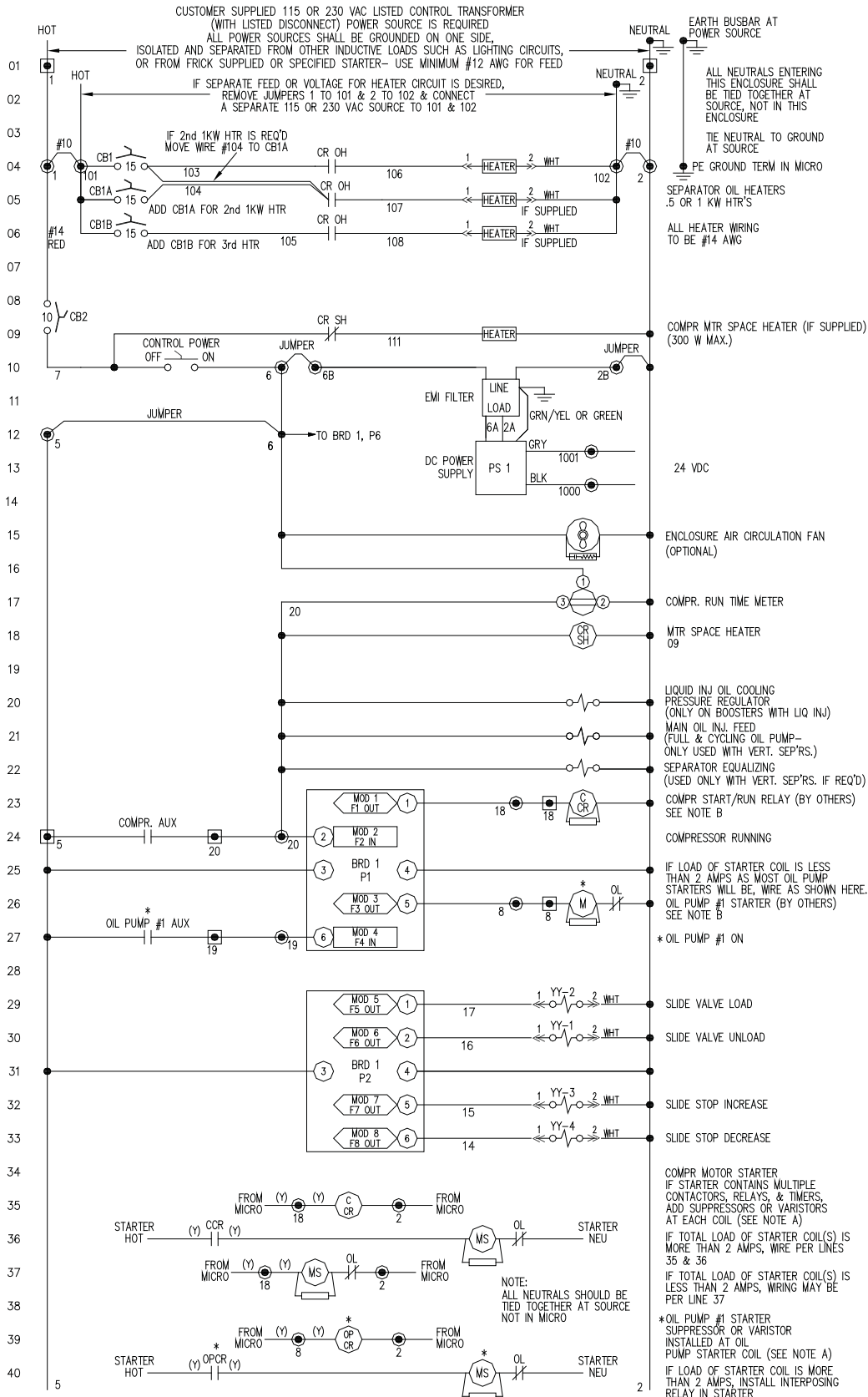

This drawing appears here for reference purposes only, and is subject to change without notice. When installing, or servicing equipment, always refer to the actual drawings that are included with the control panel for the latest information.

WIRING DIAGRAM - RWB II - (Sheet 2 of 4)

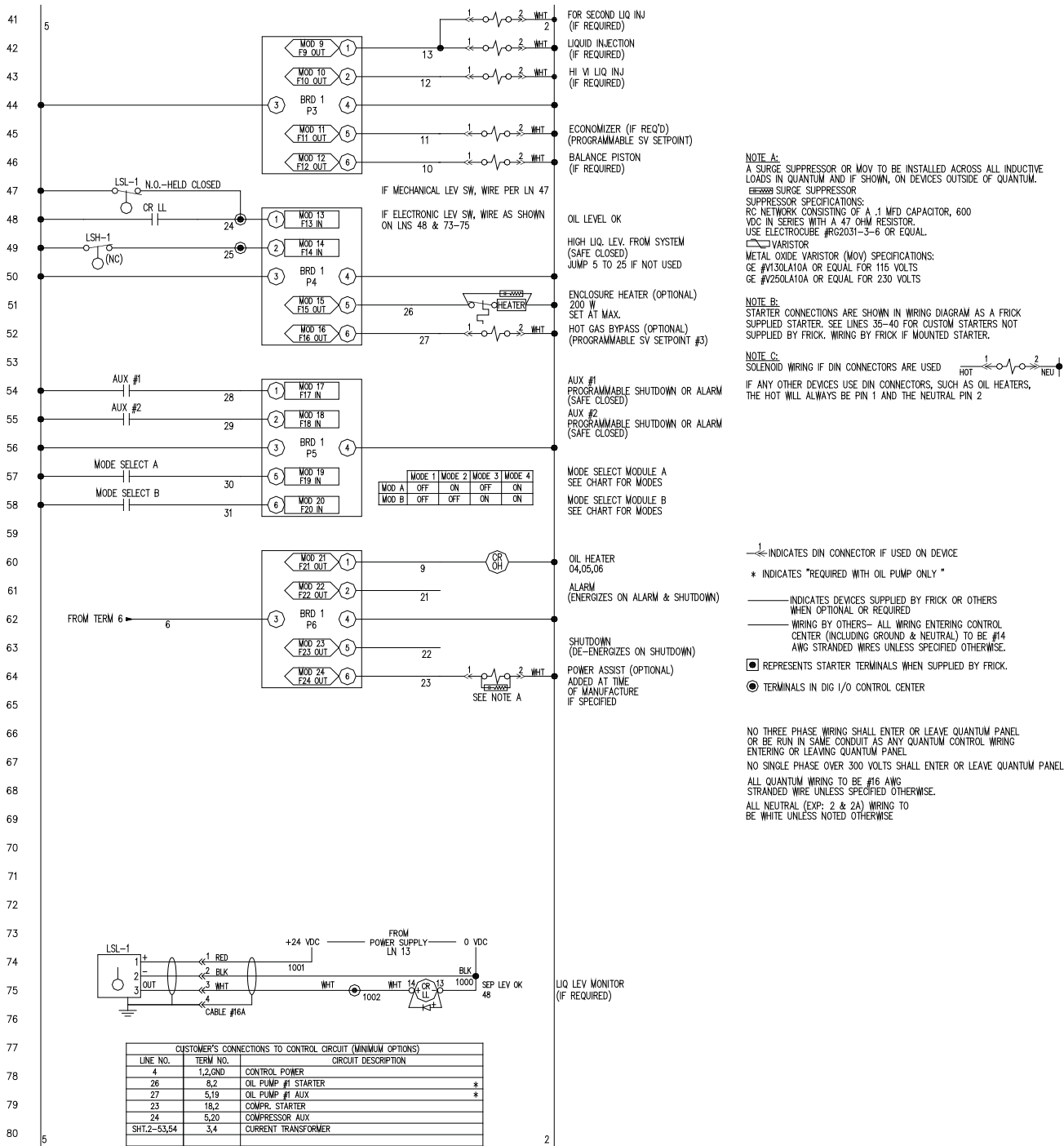

This drawing appears here for reference purposes only, and is subject to change without notice. When installing, or servicing equipment, always refer to the actual drawings that are included with the control panel for the latest information.

WIRING DIAGRAM - RWB II - (Sheet 3 of 4)

ANALOG BOARD #1

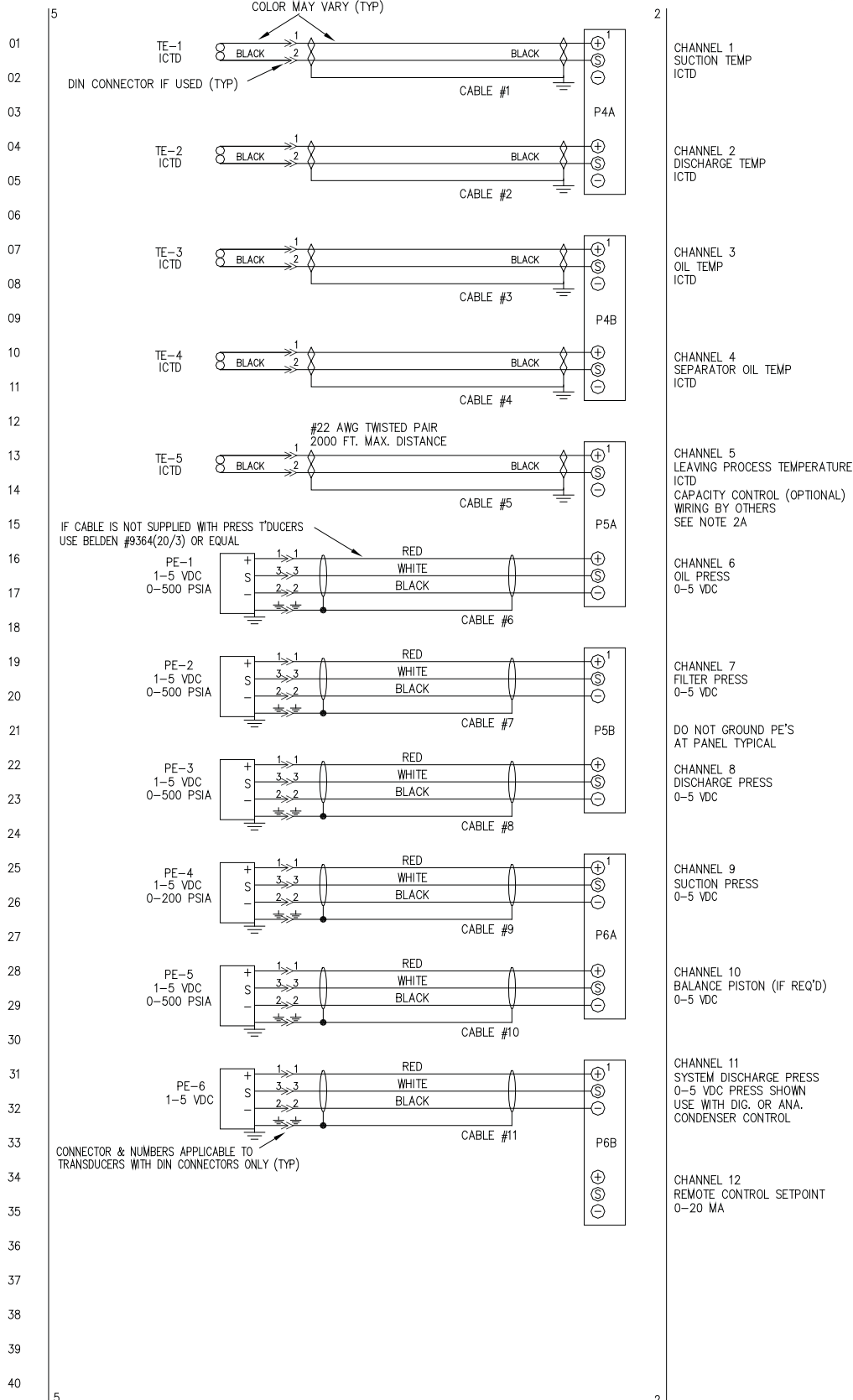

This drawing appears here for reference purposes only, and is subject to change without notice. When installing, or servicing equipment, always refer to the actual drawings that are included with the control panel for the latest information.

WIRING DIAGRAM - RWB II - (Sheet 4 of 4)

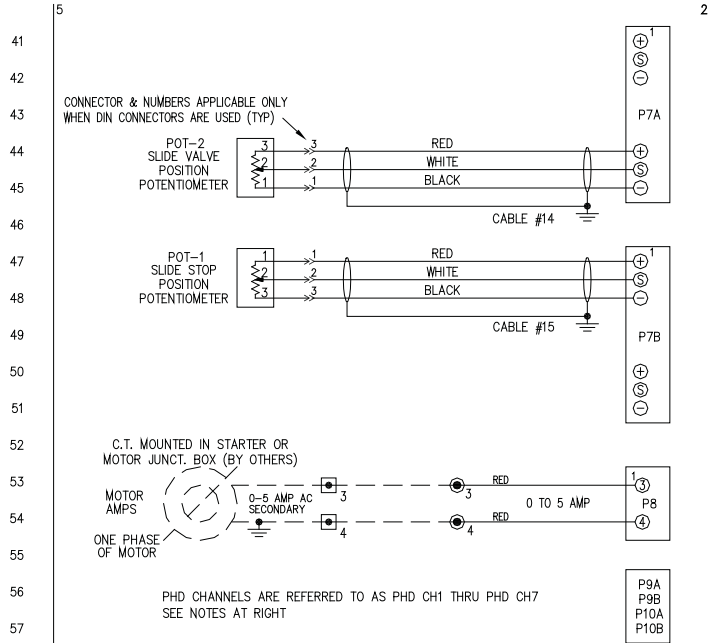

PHD CHANNELS ARE REFERRED TO AS PHD CH1 THRU PHD CH7
SEE NOTES AT RIGHT

ANALOG OUTPUTS

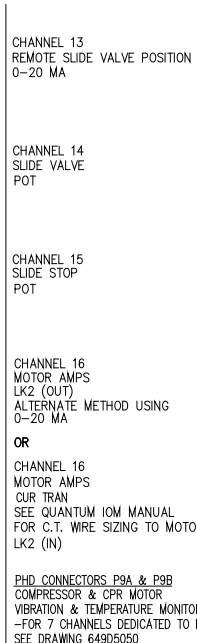

NOTE 1A:
ALL ANALOG LOW VOLTAGE WIRING TO BE RUN IN SEPARATE CONDUIT FROM ALL OTHER WIRING. ALL DRAIN WIRES TO BE INSULATED EITHER TOGETHER OR SEPARATELY WITHIN 2" OR CLOSER OF TERMINATION IF NOT CONFINED OTHERWISE.

NOTE 2A:
TEMPERATURE WIRING SPECIFICATIONS:
MINIMUM CABLE SIZE FOR SENSOR WIRING TO BE 22 AWG, TWISTED PAIR - BELDEN #9320 (20/2) OR EQUAL TWISTED PAIR SUGGESTED IF CABLE HAS A DRAIN WIRE, GROUND DRAIN WIRE AT ONE END ONLY AND INSULATE OTHER END. 2000 FT. MAX. DISTANCE

NOTE 3A:
SPECIFICATIONS FOR TEMPERATURE CAPACITY CONTROL:
-SETPOINT RANGE: -50F. TO 100F.
-TEMPERATURE ASSEMBLY FOR NON-HAZARDOUS LOCATION (FRICK P/N 639A0151003 WITH 1/2"NPT OR 639A0151002 FOR CABLE STRAIN RELIEF)
-WIRE AS SHOWN IN SEPARATE CONDUIT FROM ALL OTHER WIRING, USE BELDEN #9320(20/2) CABLE OR EQUAL

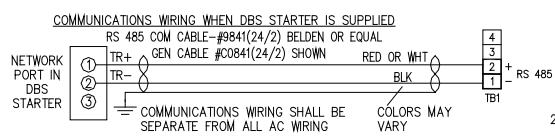
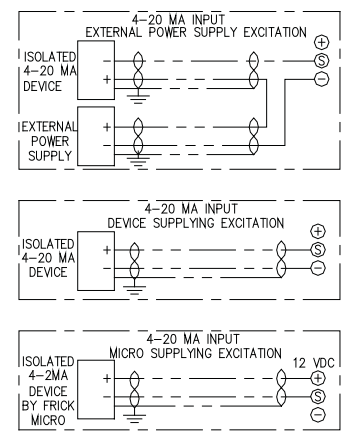
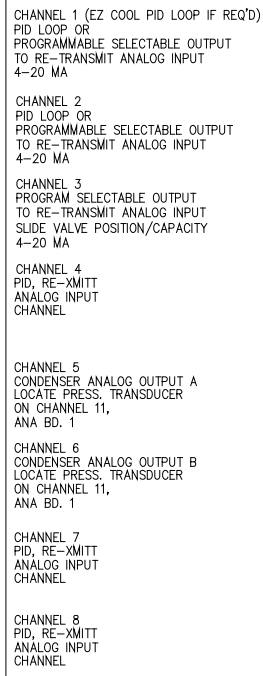

TB1 ON TOP BOARD OF CPU COMM 1 PORT LK16 MUST BE IN "B" POSITION

WIRING DIAGRAM - RXF (12-101) (Sheet 1 of 4)

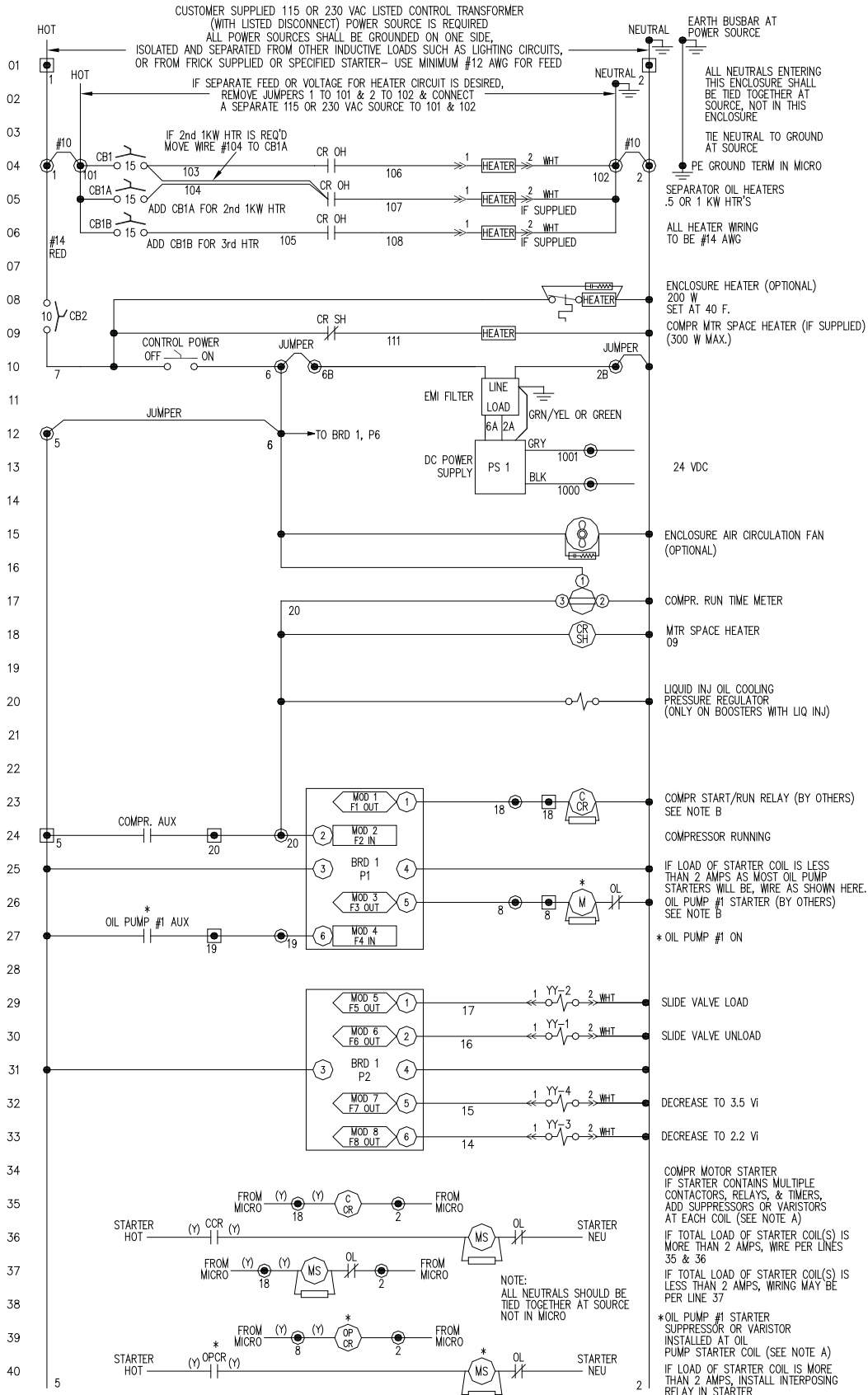

This drawing appears here for reference purposes only, and is subject to change without notice. When installing, or servicing equipment, always refer to the actual drawings that are included with the control panel for the latest information.

WIRING DIAGRAM - RXF (12-101) (Sheet 2 of 4)

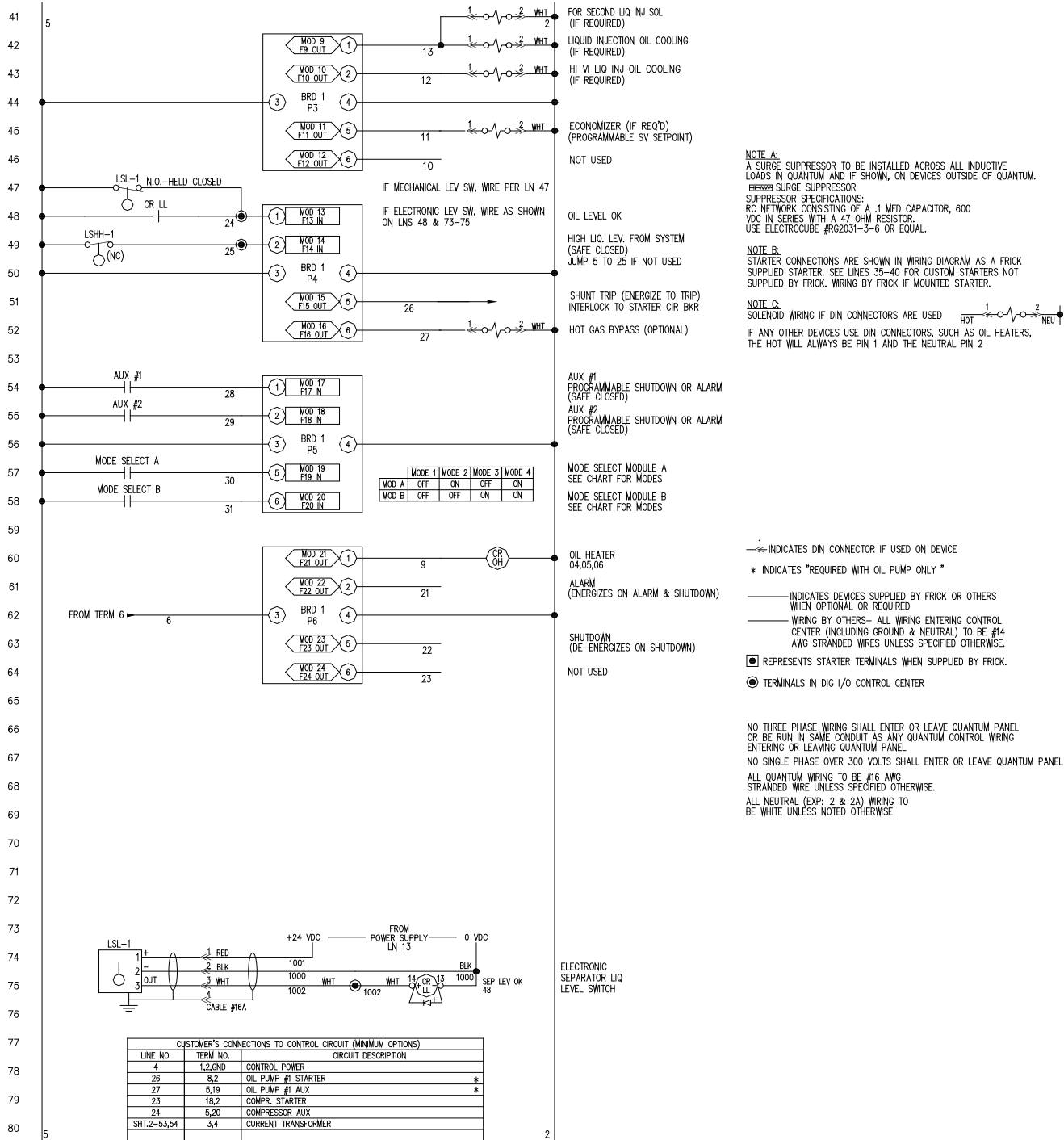

This drawing appears here for reference purposes only, and is subject to change without notice. When installing, or servicing equipment, always refer to the actual drawings that are included with the control panel for the latest information.

WIRING DIAGRAM - RXF (12-101) (Sheet 3 of 4)

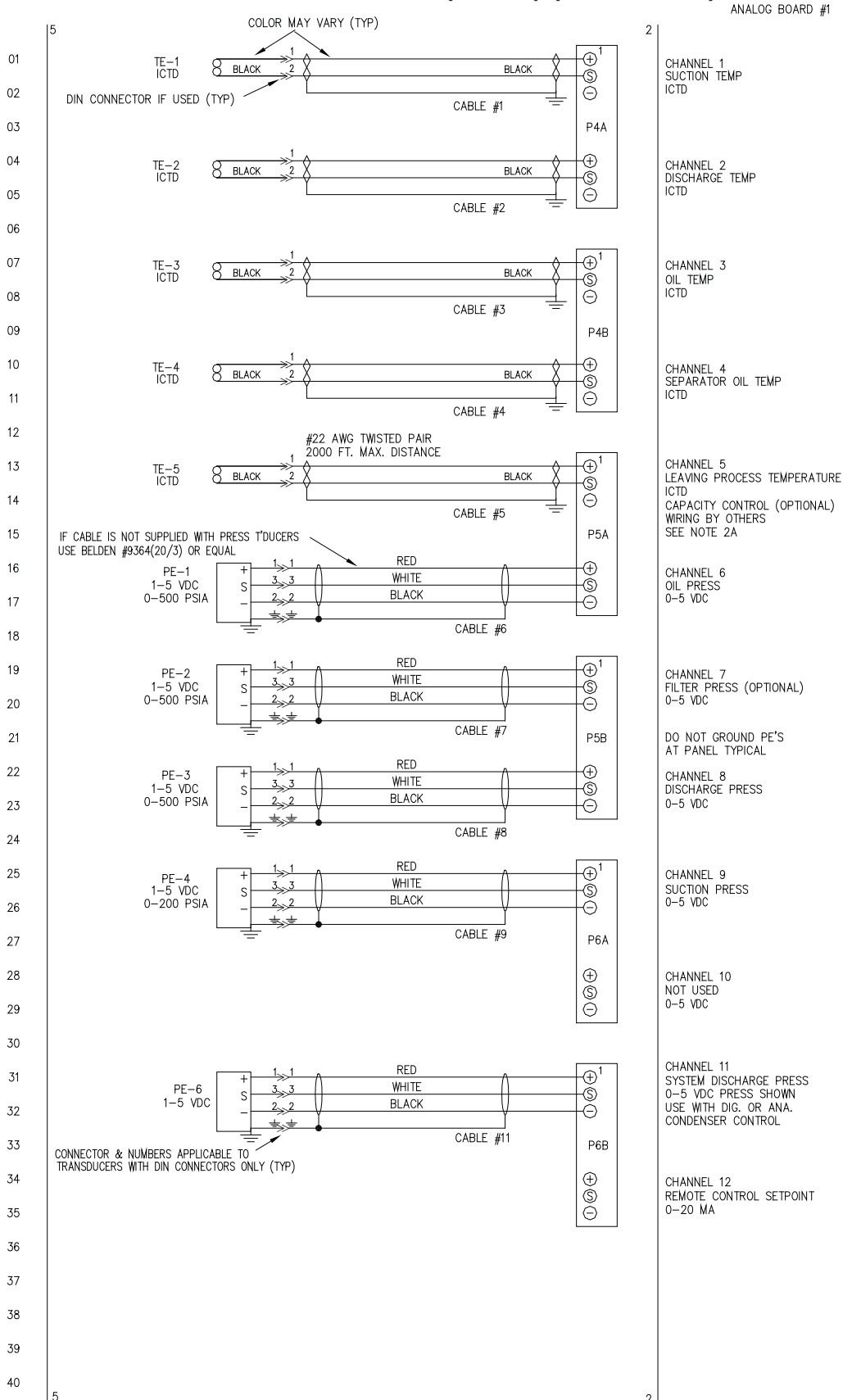

This drawing appears here for reference purposes only, and is subject to change without notice. When installing, or servicing equipment, always refer to the actual drawings that are included with the control panel for the latest information.

WIRING DIAGRAM - RXF (12-101) (Sheet 4 of 4)

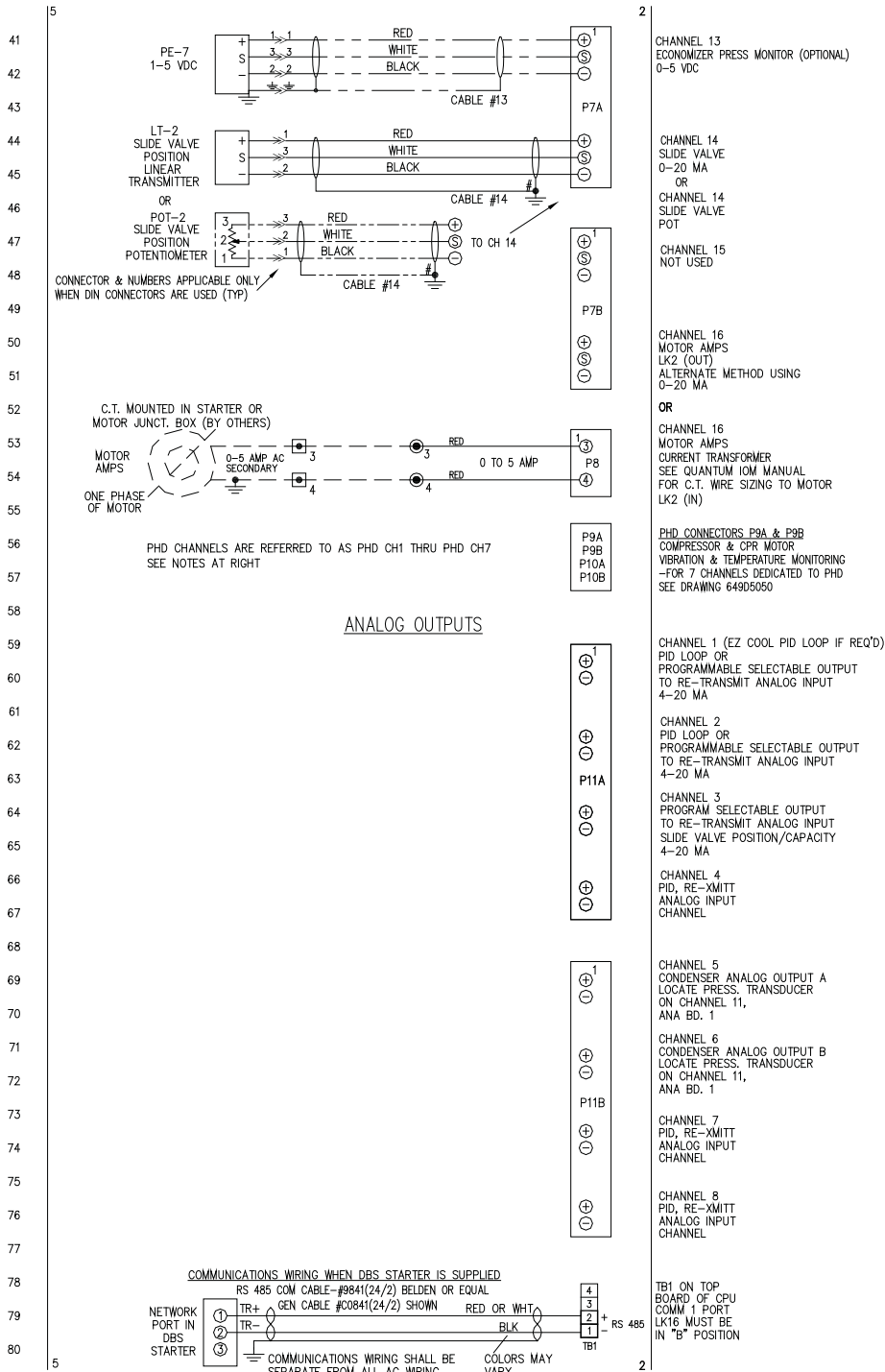

NOTE 1A:
ALL ANALOG LOW VOLTAGE WIRING TO BE RUN IN SEPARATE CONDUIT FROM ALL OTHER WIRING. ALL DRAIN WIRES TO BE INSULATED EITHER TOGETHER OR SEPARATELY WITHIN 2" OR CLOSER OF TERMINATION IF NOT CONFINED OTHERWISE.

NOTE 2A:
TEMPERATURE WIRING SPECIFICATIONS:
MINIMUM CABLE SIZE FOR SENSOR WIRING TO BE 22 AWG, TWISTED PAIR - BELDEN #9320 (20/2) OR EQUAL TWISTED PAIR SUGGESTED IF CABLE HAS A DRAIN WIRE, GROUND DRAIN WIRE AT ONE END ONLY AND INSULATE OTHER END. 2000 FT. MAX. DISTANCE

NOTE 3A:
SPECIFICATIONS FOR TEMPERATURE CAPACITY CONTROL:
-SETPOINT RANGE: -50F. TO 100F.
-TEMPERATURE ASSEMBLY FOR NON-HAZARDOUS LOCATION (FRICK P/N 639A0151G03 WITH 1/2"NPT OR 639A0151G02 FOR CABLE STRAIN RELIEF
-WIRE AS SHOWN IN SEPARATE CONDUIT FROM ALL OTHER WIRING, USE BELDEN #9320(20/2) CABLE OR EQUAL

ANALOG OUTPUTS

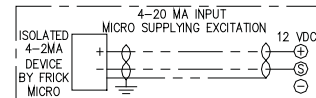
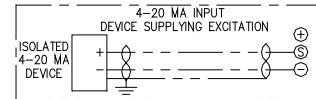
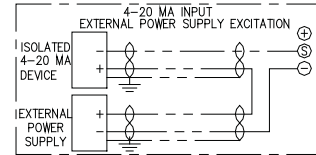

WIRING DIAGRAM - RDB (Sheet 1 of 4)

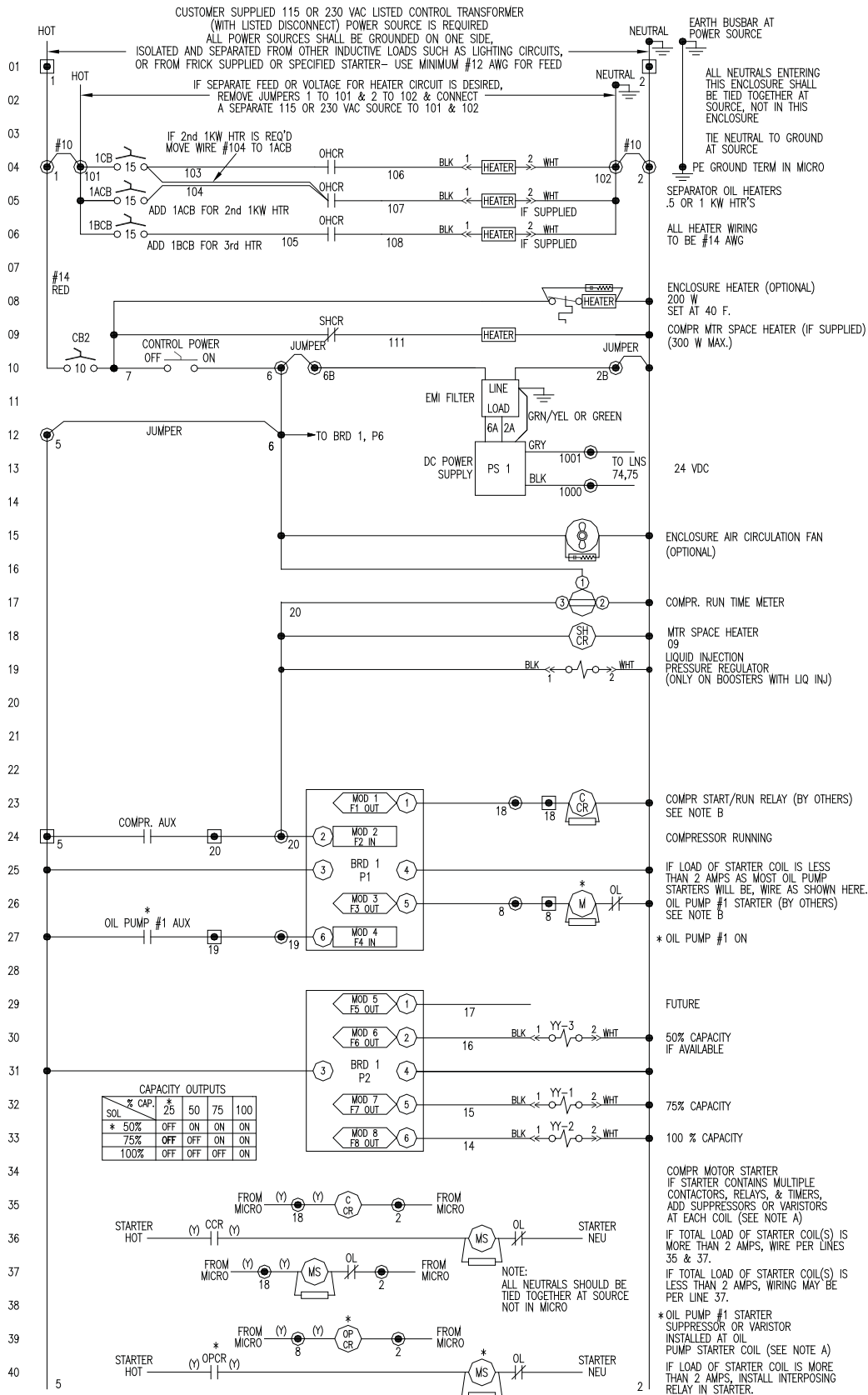

This drawing appears here for reference purposes only, and is subject to change without notice. When installing, or servicing equipment, always refer to the actual drawings that are included with the control panel for the latest information.

WIRING DIAGRAM - RDB (Sheet 2 of 4)

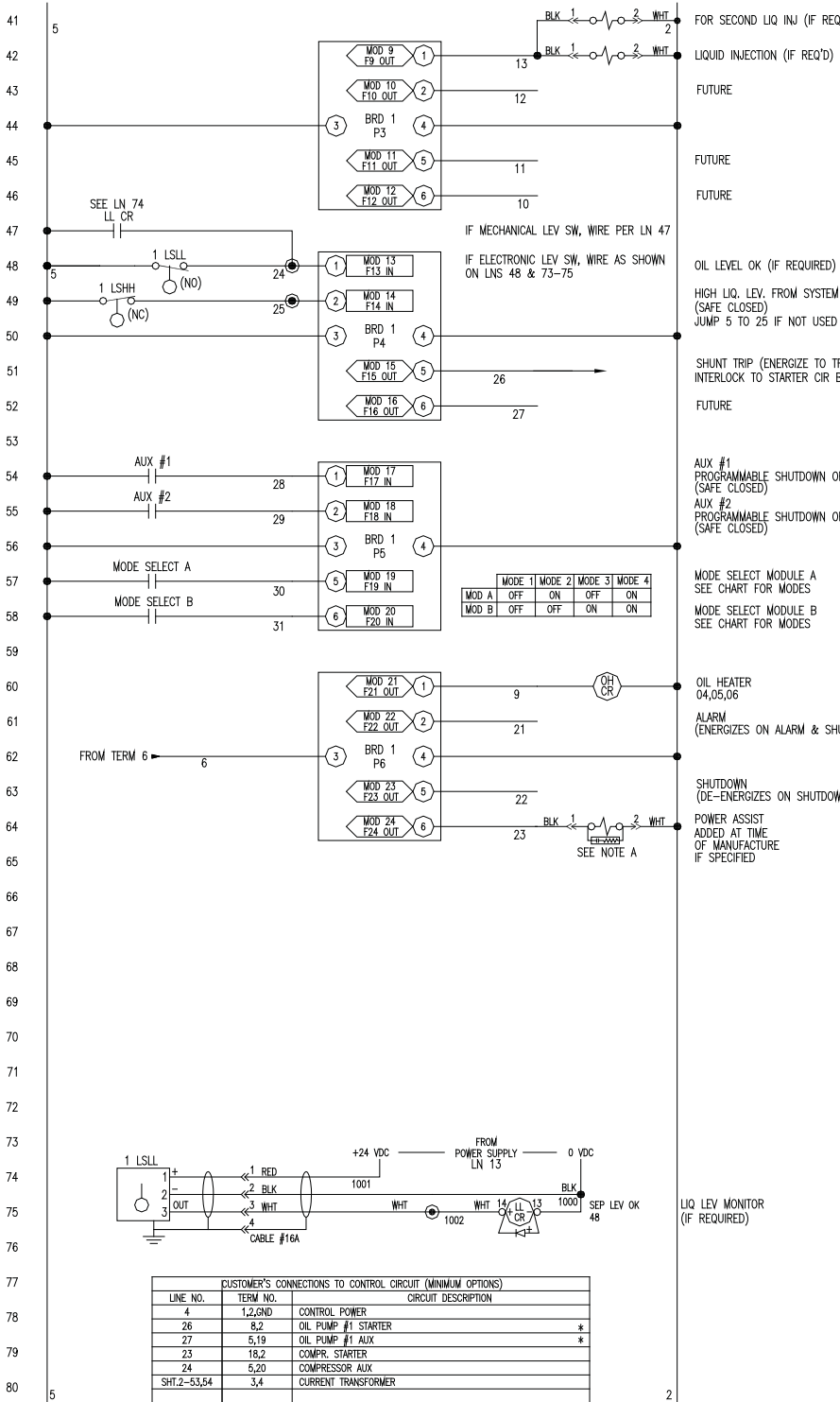

NOTE A:
A SURGE SUPPRESSOR TO BE INSTALLED ACROSS ALL INDUCTIVE LOADS IN QUANTUM AND IF SHOWN, ON DEVICES OUTSIDE OF QUANTUM.
SURGE SUPPRESSOR SPECIFICATIONS:
RC NETWORK CONSISTING OF A .1 MFD CAPACITOR, 600 VDC IN SERIES WITH A 47 OHM RESISTOR.
USE ELECTROCUBE #RG2031-3-6 OR EQUAL.

NOTE B:
STARTER CONNECTIONS ARE SHOWN IN WIRING DIAGRAM AS A FRICK SUPPLIED STARTER. SEE LINES 35-40 FOR CUSTOM STARTERS NOT SUPPLIED BY FRICK. WIRING BY FRICK IF MOUNTED STARTER.

NOTE C:
SOLENOID WIRING IF DIN CONNECTORS ARE USED

IF ANY OTHER DEVICES USE DIN CONNECTORS, SUCH AS OIL HEATERS, THE HOT WILL ALWAYS BE PIN 1 AND THE NEUTRAL PIN 2

— INDICATES DEVICES SUPPLIED BY FRICK OR OTHERS WHEN OPTIONAL OR REQUIRED

— WIRING BY OTHERS— ALL WIRING ENTERING CONTROL CENTER (INCLUDING GROUND & NEUTRAL) TO BE #14 AWG STRANDED WIRES UNLESS SPECIFIED OTHERWISE.

● REPRESENTS STARTER TERMINALS WHEN SUPPLIED BY FRICK.

⊙ TERMINALS IN DIG I/O CONTROL CENTER

—/— INDICATES DIN CONNECTOR IF USED ON DEVICE

* INDICATES "REQUIRED WITH OIL PUMP ONLY"

NO THREE PHASE WIRING SHALL ENTER OR LEAVE QUANTUM PANEL OR BE RUN IN SAME CONDUIT AS ANY QUANTUM CONTROL WIRING ENTERING OR LEAVING QUANTUM PANEL

NO SINGLE PHASE OVER 300 VOLTS SHALL ENTER OR LEAVE QUANTUM PANEL

ALL QUANTUM WIRING TO BE #16 AWG STRANDED WIRE UNLESS SPECIFIED OTHERWISE.

ALL NEUTRAL (EXP: 2 & 2A) WIRING TO BE WHITE UNLESS NOTED OTHERWISE

WIRING DIAGRAM - RDB (Sheet 3 of 4)

ANALOG BOARD #1

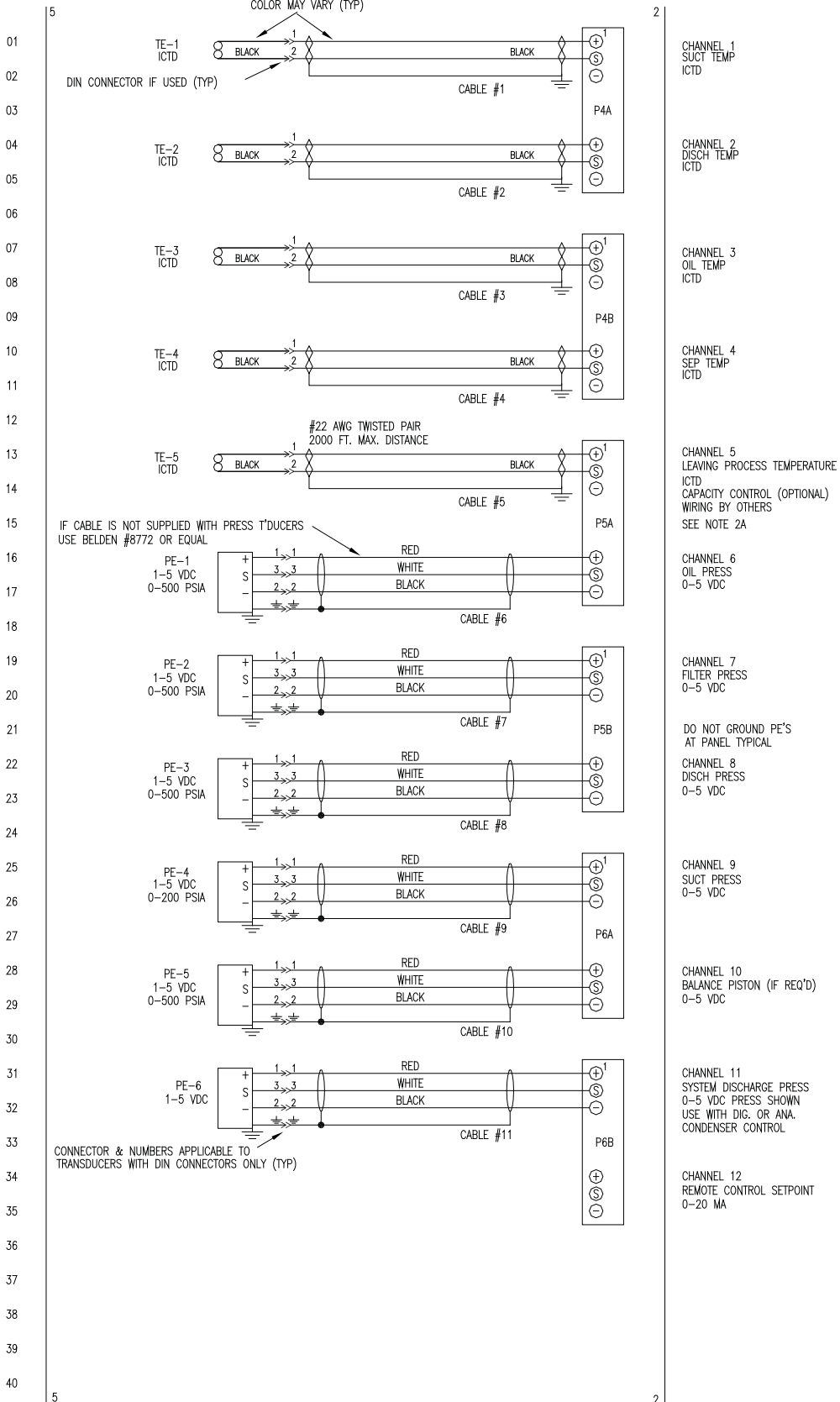

This drawing appears here for reference purposes only, and is subject to change without notice. When installing, or servicing equipment, always refer to the actual drawings that are included with the control panel for the latest information.

WIRING DIAGRAM - RDB (Sheet 4 of 4)

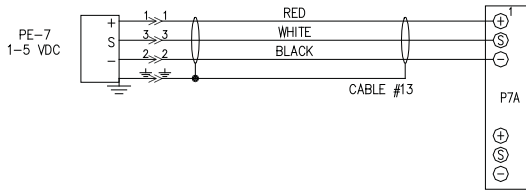

CHANNEL 13
ECONOMIZER PRESS MONITOR (OPTIONAL)
0-5 VDC

CHANNEL 14
(NOT USED)

NOTE 1A:
ALL ANALOG LOW VOLTAGE WIRING TO BE RUN IN SEPARATE CONDUIT FROM ALL OTHER WIRING. ALL DRAIN WIRES TO BE INSULATED EITHER TOGETHER OR SEPARATELY WITHIN 2" OR CLOSER OF TERMINATION IF NOT CONFINED OTHERWISE.

CHANNEL 15
(NOT USED)

NOTE 2A:
TEMPERATURE WIRING SPECIFICATIONS:
MINIMUM CABLE SIZE FOR SENSOR WIRING TO BE 22 AWG, TWISTED PAIR - BELDEN #9320 (20/2) OR EQUAL TWISTED PAIR SUGGESTED IF CABLE HAS A DRAIN WIRE, GROUND DRAIN WIRE AT ONE END ONLY AND INSULATE OTHER END. 2000 FT. MAX. DISTANCE

CHANNEL 16
MOTOR AMPS
LK2 (OUT)
ALTERNATE METHOD USING
0-20 MA

NOTE 3A:
SPECIFICATIONS FOR TEMPERATURE CAPACITY CONTROL:
-SETPOINT RANGE: -50°F. TO 100°F.
-TEMPERATURE ASSEMBLY FOR NON-HAZARDOUS LOCATION (FRICK P/N 639A0151G03 WITH 1/2"NPT OR 639A0151G02 FOR CABLE STRAIN RELIEF
-WIRE AS SHOWN IN SEPARATE CONDUIT FROM ALL OTHER WIRING, USE BELDEN #9320(20/2) CABLE OR EQUAL

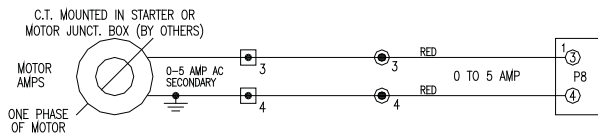

CHANNEL 16
MOTOR AMPS
CUR TRAN
SEE QUANTUM IOM MANUAL
FOR C.T. WIRE SIZING TO MOTOR
LK2 (IN)

PHD CHANNELS ARE REFERRED TO AS PHD CH1 THRU PHD CH7
SEE NOTES AT RIGHT

P9A
P9B
P10A
P10B

PHD CONNECTORS P9A & P9B
COMPRESSOR & CPR MOTOR
VIBRATION & TEMPERATURE MONITORING
-FOR 7 CHANNELS DEDICATED TO PHD
SEE DRAWING 649D5050

ANALOG OUTPUTS

CHANNEL 1 (EZ COOL PID LOOP IF REQ'D)
PID LOOP OR
PROGRAMMABLE SELECTABLE OUTPUT
TO RE-TRANSMIT ANALOG INPUT
4-20 MA

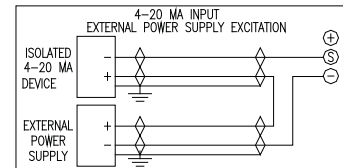

CHANNEL 2
PID LOOP OR
PROGRAMMABLE SELECTABLE OUTPUT
TO RE-TRANSMIT ANALOG INPUT
4-20 MA

CHANNEL 3
PROGRAM SELECTABLE OUTPUT
TO RE-TRANSMIT ANALOG INPUT
SLIDE VALVE POSITION/CAPACITY
4-20 MA

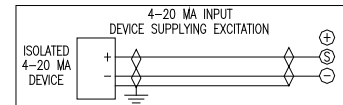

CHANNEL 4
PID, RE-XMITT
ANALOG INPUT
CHANNEL

CHANNEL 5
CONDENSER ANALOG OUTPUT A
LOCATE PRESS. TRANSDUCER
ON CHANNEL 11,
ANA BD. 1

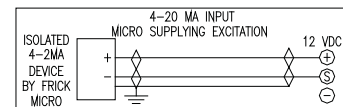

CHANNEL 6
CONDENSER ANALOG OUTPUT B
LOCATE PRESS. TRANSDUCER
ON CHANNEL 11,
ANA BD. 1

CHANNEL 7
PID, RE-XMITT
ANALOG INPUT
CHANNEL

CHANNEL 8
PID, RE-XMITT
ANALOG INPUT
CHANNEL

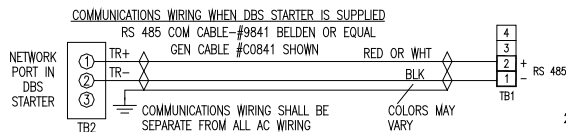

TB1 ON TOP BOARD OF CPU COMM 1 PORT LK16 MUST BE IN "B" POSITION

WIRING DIAGRAM - PHD

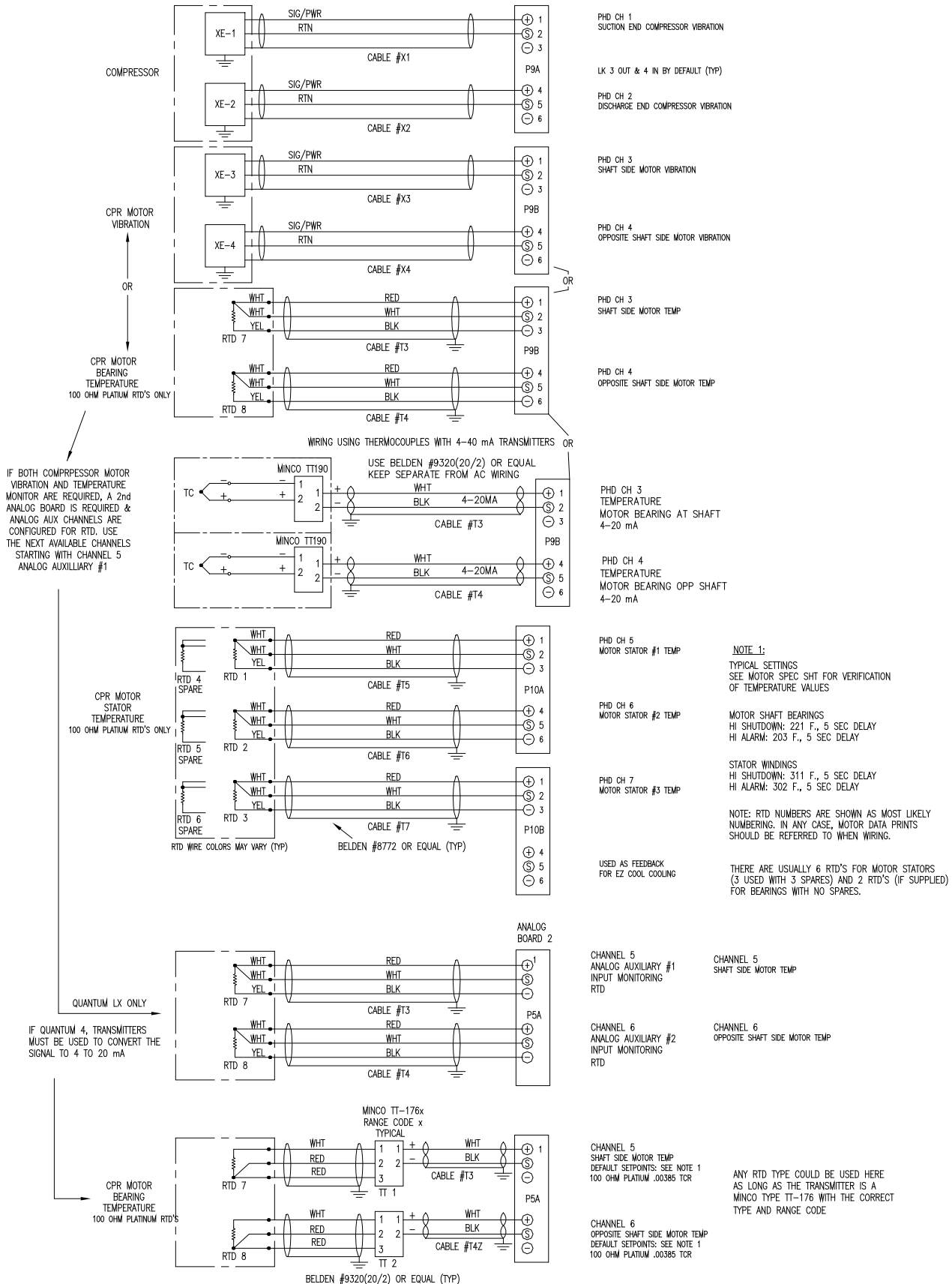

This drawing appears here for reference purposes only, and is subject to change without notice. When installing, or servicing equipment, always refer to the actual drawings that are included with the control panel for the latest information.

WIRING DIAGRAM - DIGITAL I/O BOARD 2 (Sheet 1 of 2)

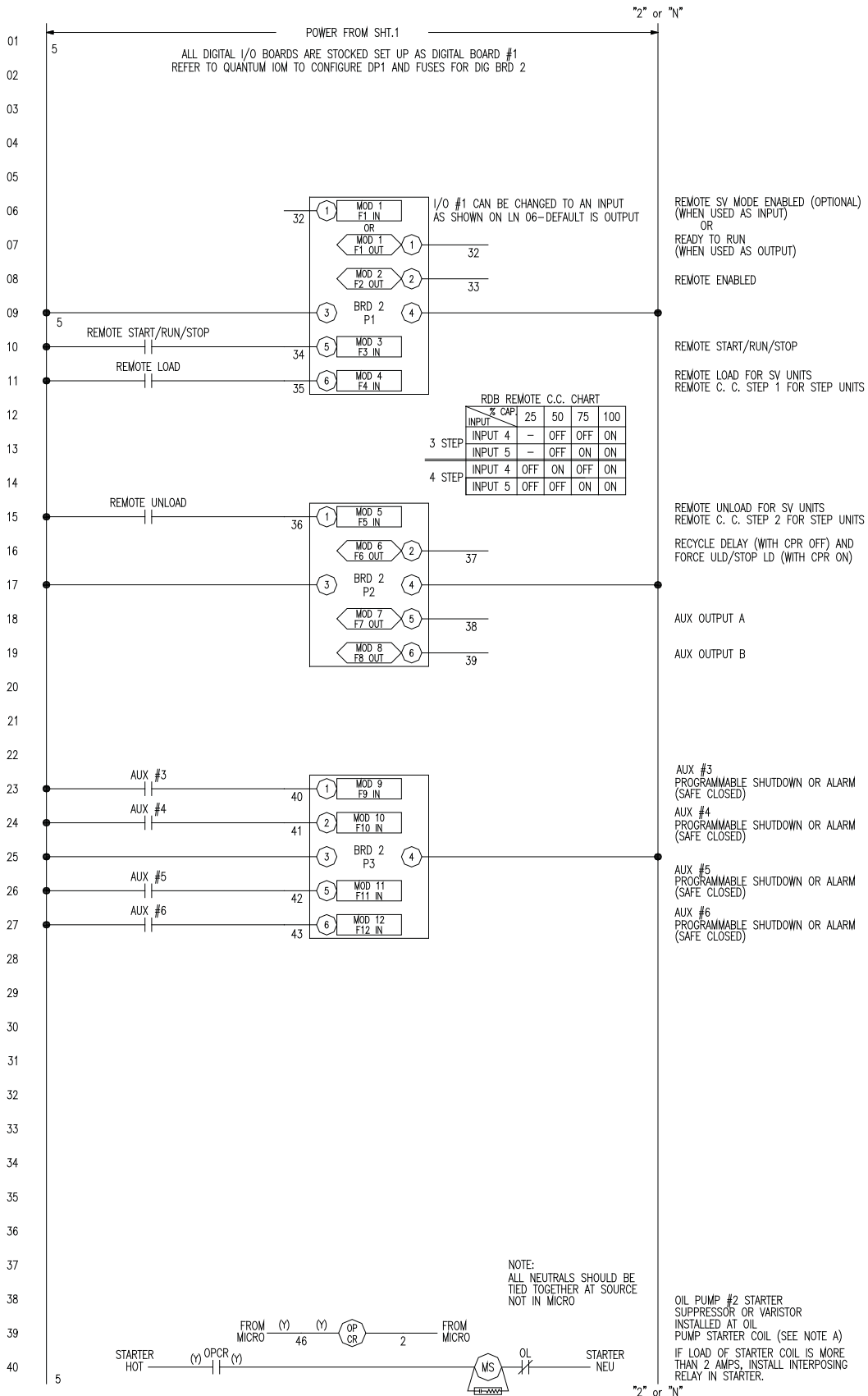

This drawing appears here for reference purposes only, and is subject to change without notice. When installing, or servicing equipment, always refer to the actual drawings that are included with the control panel for the latest information.

WIRING DIAGRAM - DIGITAL I/O BOARD 2 (Sheet 2 of 2)

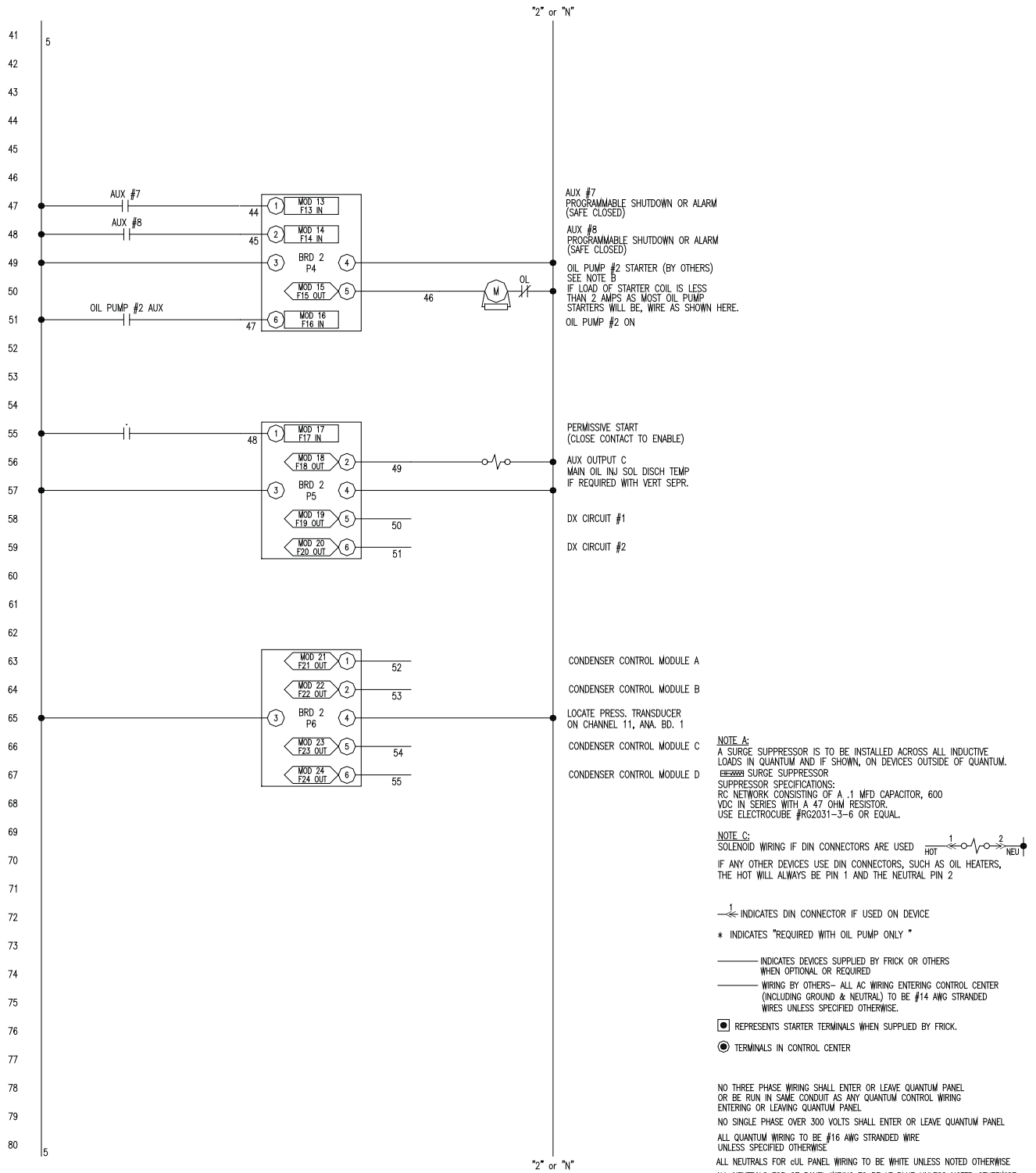

This drawing appears here for reference purposes only, and is subject to change without notice. When installing, or servicing equipment, always refer to the actual drawings that are included with the control panel for the latest information.

WIRING DIAGRAM - ANALOG I/O BOARD 2 (Sheet 2 of 2)

41 5
42
43
44
45
46
47
48
49
50
51
52
53
54
55
56
57
58
59
60
61
62
63
64
65
66
67
68
69
70
71
72
73
74
75
76
77
78
79
80 5

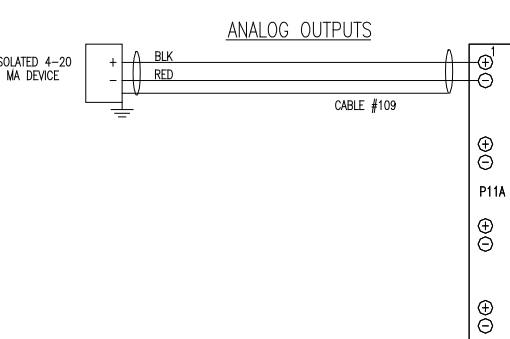
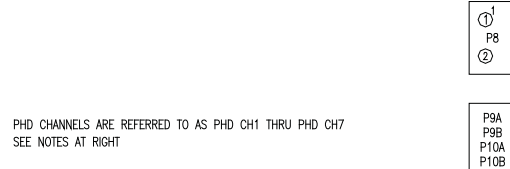
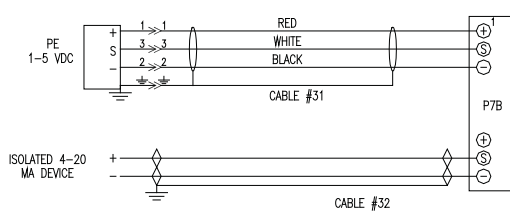

"2" or "N"

CHANNEL 13
ANALOG AUXILIARY #9
INPUT MONITORING
0-5 VDC

CHANNEL 14
ANALOG AUXILIARY #10
INPUT MONITORING
0-5 VDC

CHANNEL 15
MAIN OIL INJECTION
(USED ONLY ON VERT. UNITS
WITH LIQ. INJ. OIL COOLING)
0-5 VDC

CHANNEL 16
KW MONITORING OR
CPR. DRIVE SPEED
0-20 mA OR 0-10 VDC
LK 2 (OUT)

CHANNEL 16
(NOT USABLE)
LK2 (OUT)

PHD CONNECTORS P9A & P9B
COMPRESSOR & CPR MOTOR
VIBRATION & TEMPERATURE MONITORING
-FOR 7 CHANNELS DEDICATED TO PHD
SEE DRAWING 649D5050
THESE CHANNELS ARE ONLY NEEDED
AS PHD IF ANALOG BD 1 IS THE OLDER
TYPE. (640D0063H01)

CHANNEL 1
PID LOOP OR
PROGRAM SELECTABLE OUTPUT
TO RE-TRANSMIT ANALOG INPUT
4-20 MA

CHANNEL 2
PID LOOP OR
PROGRAM SELECTABLE OUTPUT
TO RE-TRANSMIT ANALOG INPUT
4-20 MA

CHANNEL 3
VARIABLE SPEED COMPRESSOR DRIVE
4-20 MA OUT
0-100% OF 0 TO HIGHEST
MOTOR RPM

CHANNEL 4
PID LOOP OR
PROGRAM SELECTABLE OUTPUT
TO RE-TRANSMIT ANALOG INPUT
4-20 MA

CHANNEL 5
PID LOOP OR
PROGRAM SELECTABLE OUTPUT
TO RE-TRANSMIT ANALOG INPUT
4-20 MA

CHANNEL 6
PID LOOP OR
PROGRAM SELECTABLE OUTPUT
TO RE-TRANSMIT ANALOG INPUT
4-20 MA

CHANNEL 7
PID, RE-XMITT
ANALOG INPUT
CHANNEL

CHANNEL 8
PID, RE-XMITT
ANALOG INPUT
CHANNEL

"2" or "N"

NOTE 1
ALL ANALOG LOW VOLTAGE WIRING TO BE RUN IN SEPARATE CONDUIT FROM ALL OTHER WIRING. ALL DRAIN WIRES TO BE INSULATED EITHER TOGETHER OR SEPARATELY WITHIN 2" OR CLOSER OF TERMINATION IF NOT CONFINED OTHERWISE.

NOTE 2
TEMPERATURE WIRING SPECIFICATIONS:
MINIMUM CABLE SIZE FOR SENSOR WIRING TO BE 22 AWG, TWISTED PAIR - BELDEN #9320 OR EQUAL, 20/2 TWISTED PAIR SUGGESTED
-IF CABLE HAS A DRAIN WIRE, GROUND DRAIN WIRE AT ONE END ONLY AND INSULATE OTHER END. 2000 FT. MAX. DISTANCE

NOTE 3
SPECIFICATIONS FOR TEMPERATURE CAPACITY CONTROL:
-SETPOINT RANGE: -50°F. TO 100°F.
-TEMPERATURE ASSEMBLY FOR NON-HAZARDOUS LOCATION (FRICK P/N 639A0151G03 WITH 1/2"NPT OR 639A0151G02 FOR CABLE STRAIN RELIEF
-WIRE AS SHOWN IN SEPARATE CONDUIT FROM ALL OTHER WIRING, USE BELDEN #8761 CABLE OR EQUAL

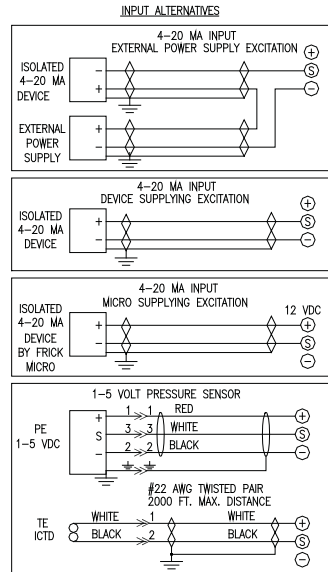

ALL NEUTRALS FOR CUL PANEL WIRING TO BE WHITE UNLESS NOTED OTHERWISE
ALL NEUTRALS FOR CE PANEL WIRING TO BE LT BLUE UNLESS NOTED OTHERWISE

This drawing appears here for reference purposes only, and is subject to change without notice. When installing, or servicing equipment, always refer to the actual drawings that are included with the control panel for the latest information.

ISOLATER REPEATER MODULE (ISOLATES COMMUNICATIONS SIGNALS)

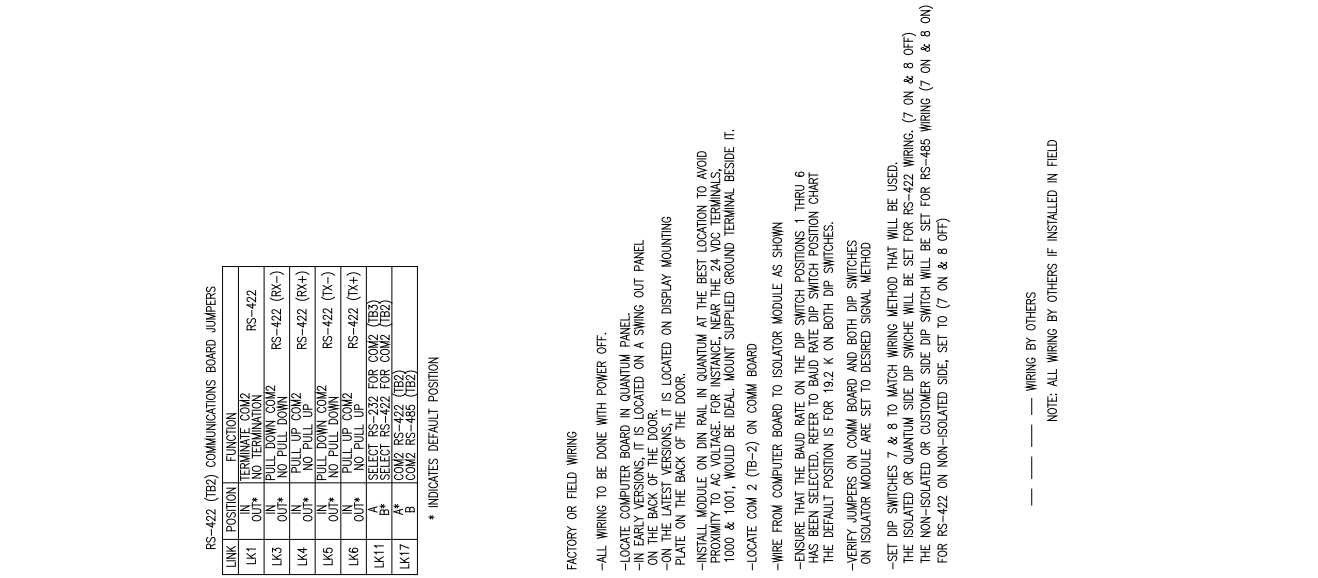

RS-422 (TB2) COMMUNICATIONS BOARD JUMPERS

LINK POSITION	FUNCTION	RS-422
LK1	OUT*	NO TERMINATION
LK3	IN*	PULL DOWN COM2
LK4	OUT*	NO PULL DOWN
LK6	IN*	NO PULL UP
LK6	IN*	PULL DOWN COM2
LK6	OUT*	NO PULL DOWN
LK6	OUT*	PULL UP COM2
LK11	B*	SELECT RS-422 FOR COM2 (TB3)
LK17	A*	COM2 RS-422 (TB2)
	B	COM2 RS-485 (TB2)

* INDICATES DEFAULT POSITION

FACTORY OR FIELD WIRING

- ALL WIRING TO BE DONE WITH POWER OFF.
- LOCATE COMPUTER BOARD IN QUANTUM PANEL.
- IN EARLY VERSIONS, IT IS LOCATED ON A SWING OUT PANEL ON THE BACK OF THE DOOR.
- ON THE LATEST VERSIONS, IT IS LOCATED ON DISPLAY MOUNTING PLATE ON THE BACK OF THE DOOR.
- INSTALL MODULE ON DIN RAIL IN QUANTUM AT THE BEST LOCATION TO AVOID PROXIMITY TO AC VOLTAGE. FOR INSTANCE, NEAR THE 24 VDC TERMINALS, 1000 & 1001, WOULD BE IDEAL. MOUNT SUPPLIED GROUND TERMINAL BESIDE IT.
- LOCATE COM 2 (TB-2) ON COMM BOARD
- WIRE FROM COMPUTER BOARD TO ISOLATER MODULE AS SHOWN
- ENSURE THAT THE BAUD RATE ON THE DIP SWITCH POSITIONS 1 THRU 6 HAS BEEN SELECTED. REFER TO BAUD RATE DIP SWITCH POSITION CHART THE DEFAULT POSITION IS FOR 19.2 K ON BOTH DIP SWITCHES.
- VERIFY JUMPERS ON COMM BOARD AND BOTH DIP SWITCHES ON ISOLATER MODULE ARE SET TO DESIRED SIGNAL METHOD
- SET DIP SWITCHES 7 & 8 TO MATCH WIRING METHOD THAT WILL BE USED. THE ISOLATED OR QUANTUM SIDE DIP SWICHE WILL BE SET FOR RS-422 WIRING. (7 ON & 8 OFF) THE NON-ISOLATED OR CUSTOMER SIDE DIP SWITCH WILL BE SET FOR RS-485 WIRING (7 ON & 8 OFF) FOR RS-422 ON NON-ISOLATED SIDE, SET TO (7 ON & 8 OFF)

NOTE: ALL WIRING BY OTHERS IF INSTALLED IN FIELD

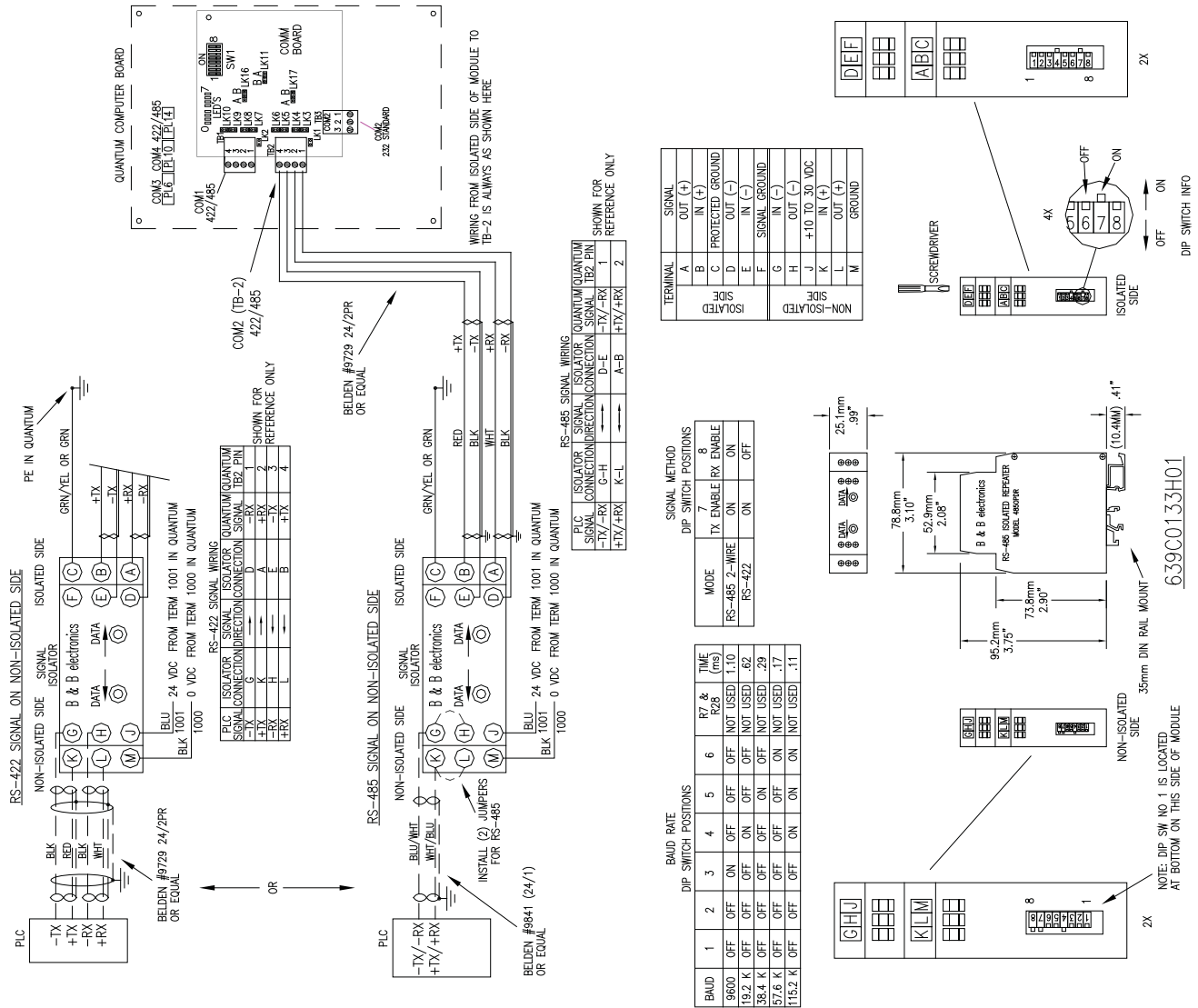

RS-422 SIGNAL WIRING

PLC SIGNAL	ISOLATOR SIGNAL	QUANTUM SIGNAL
-TX	A	1
+TX	B	2
-RX	C	3
+RX	D	4

RS-485 SIGNAL WIRING

PLC SIGNAL	ISOLATOR SIGNAL	QUANTUM SIGNAL
-TX	A	1
+TX	B	2
-RX	C	3
+RX	D	4

TERMINAL SIGNAL

TERMINAL	SIGNAL
A	OUT (+)
B	IN (+)
C	PROTECTED GROUND
D	OUT (-)
E	IN (-)
F	SIGNAL GROUND
G	IN (-)
H	OUT (-)
J	+10 TO 30 VDC
K	IN (+)
L	OUT (+)
M	GROUND

BAUD RATE DIP SWITCH POSITIONS

MODE	TX ENABLE	RX ENABLE
RS-485 2-WIRE	ON	ON
RS-422	ON	OFF

SIGNAL METHOD DIP SWITCH POSITIONS

BAUD RATE	7	8	TIME (ms)
9600	OFF	OFF	NOT USED
19.2 K	OFF	ON	62
38.4 K	OFF	OFF	NOT USED
57.6 K	OFF	OFF	NOT USED
115.2 K	OFF	ON	117

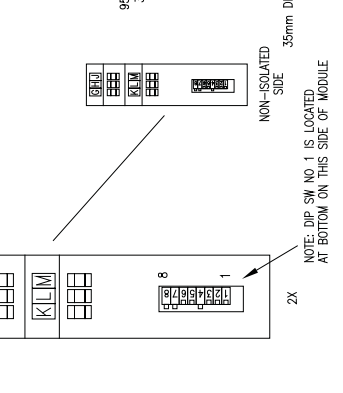
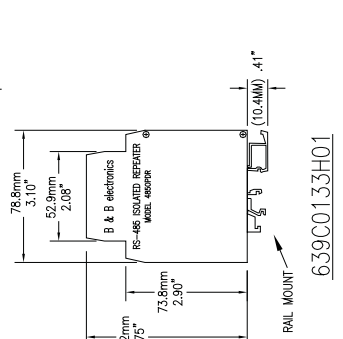
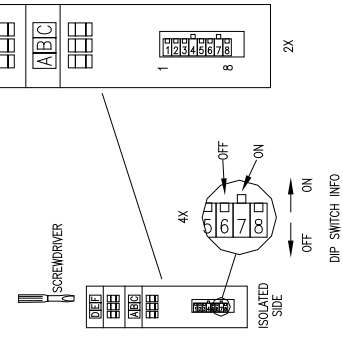

NOTE: DIP SW NO 1 IS LOCATED AT BOTTOM ON THIS SIDE OF MODULE

COMMUNICATIONS WIRING DIAGRAMS

**TO CUSTOMER REMOTE COMPUTER/DCS
RS-485 COMMUNICATIONS**

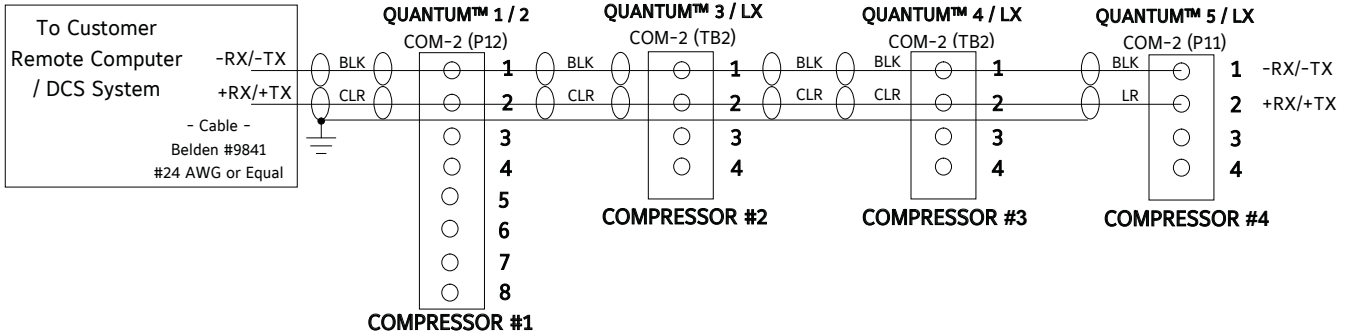

**TO CUSTOMER REMOTE COMPUTER/DCS
RS-422 COMMUNICATIONS**

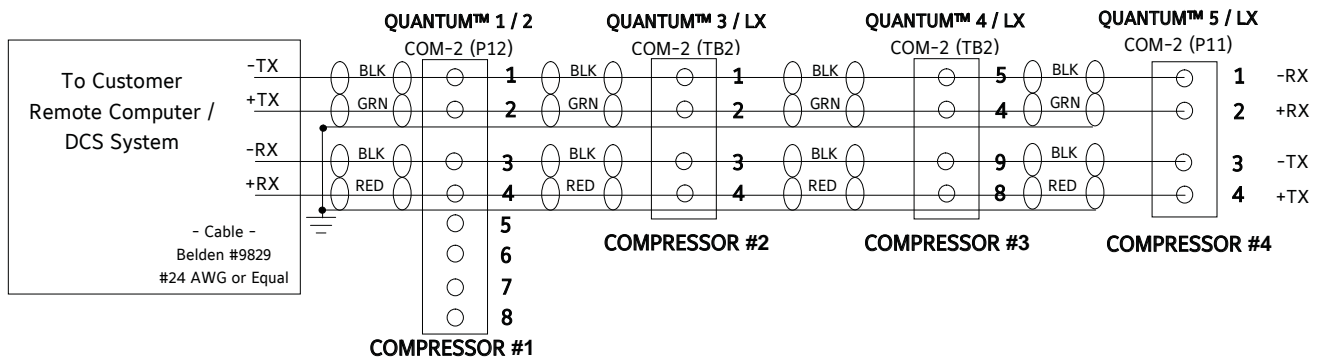

POINT-TO-POINT FIELD WIRING DIAGRAM

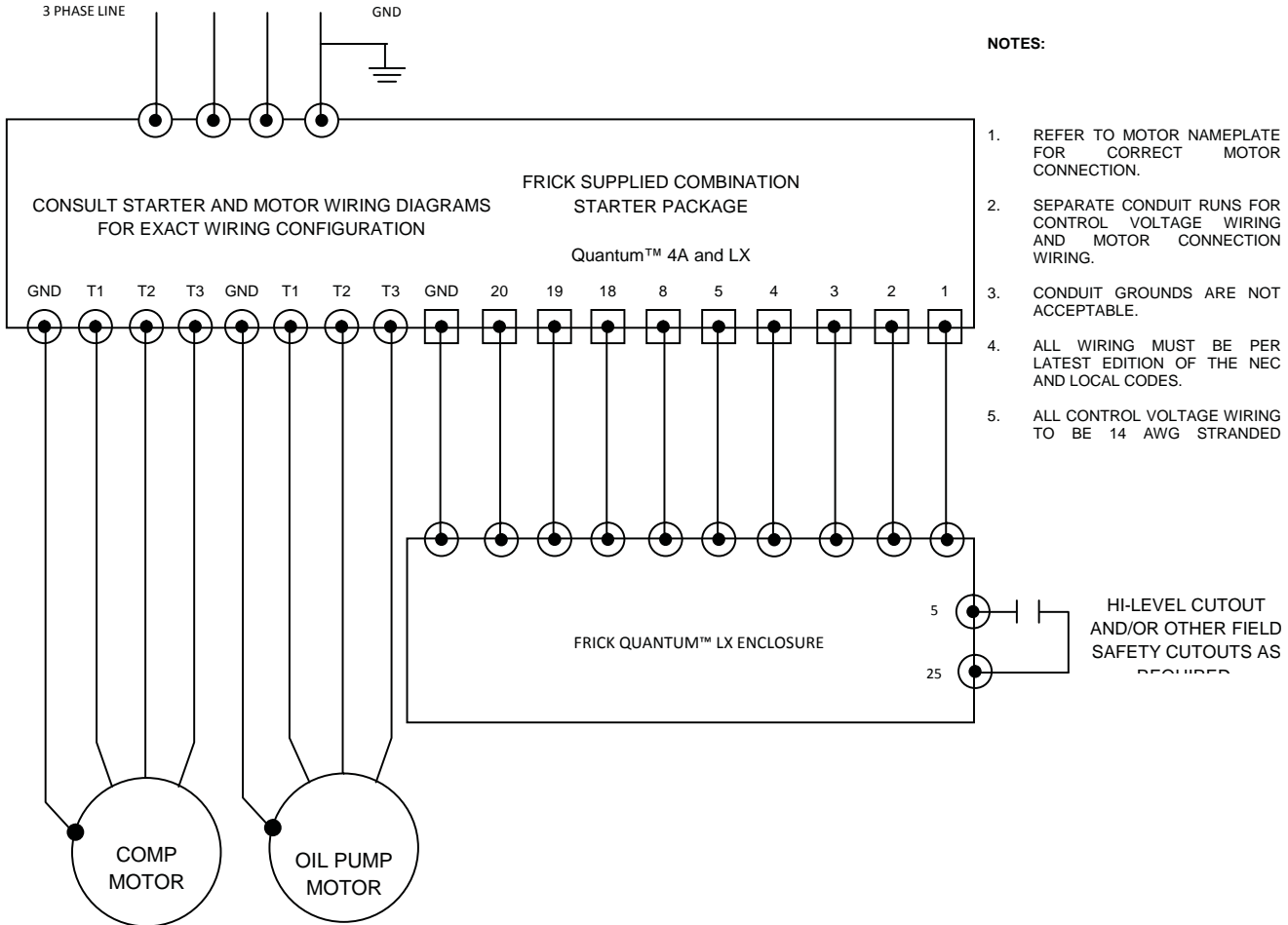

SECTION 11

TABLES

PRESSURE TRANSDUCER CONVERSION DATA

(Data Instruments Model SA)

Sensor Voltage	100 psi Range - psig*		200 psi Range - psig*		300 psi Range - psig*		500 psi Range - psig*	
	Low	High	Low	High	Low	High	Low	High
1.0	29.92"	19.74"	29.92"	9.57"	29.92"	7.0"	29.92"	4.1
1.1	29.92"	14.65"	29.92"	0.3	29.92"	4.1	29.92"	16.6
1.2	29.92"	9.57"	29.92"	5.3	22.3"	11.6	17.1"	29.1
1.3	24.83"	4.48"	19.74"	10.3	7.0"	19.1	4.1	41.6
1.4	19.74"	0.3	9.57"	15.3	4.1	26.6	16.6	54.1
1.5	14.65"	2.8	0.3	20.3	11.6	34.1	29.1	66.6
1.6	9.57"	5.3	5.3	25.3	19.1	41.6	41.6	79.1
1.7	4.48"	7.8	10.3	30.3	26.6	49.1	54.1	91.6
1.8	0.3	10.3	15.3	35.3	34.1	56.6	66.6	104.1
1.9	2.8	12.8	20.3	40.3	41.6	64.1	79.1	116.6
2.0	5.3	15.3	25.3	45.3	49.1	71.6	91.6	129.1
2.1	7.8	17.8	30.3	50.3	56.6	79.1	104.1	141.6
2.2	10.3	20.3	35.3	55.3	64.1	86.6	116.6	154.1
2.3	12.8	22.8	40.3	60.3	71.6	94.1	129.1	166.6
2.4	15.3	25.3	45.3	65.3	79.1	101.6	141.6	179.1
2.5	17.8	27.8	50.3	70.3	86.6	109.1	154.1	191.6
2.6	20.3	30.3	55.3	75.3	94.1	116.6	166.6	204.1
2.7	22.8	32.8	60.3	80.3	101.6	124.1	179.1	216.6
2.8	25.3	35.3	65.3	85.3	109.1	131.6	191.6	229.1
2.9	27.8	37.8	70.3	90.3	116.6	139.1	204.1	241.6
3.0	30.3	40.3	75.3	95.3	124.1	146.6	216.6	254.1
3.1	32.8	42.8	80.3	100.3	131.6	154.1	229.1	266.6
3.2	35.3	45.3	85.3	105.3	139.1	161.6	241.6	279.1
3.3	37.8	47.8	90.3	110.3	146.6	169.1	254.1	291.6
3.4	40.3	50.3	95.3	115.3	154.1	176.6	266.6	304.1
3.5	42.8	52.8	100.3	120.3	161.6	184.1	279.1	316.6
3.6	45.3	55.3	105.3	125.3	169.1	191.6	291.6	329.1
3.7	47.8	57.8	110.3	130.3	176.6	199.1	304.1	341.6
3.8	50.3	60.3	115.3	135.3	184.1	206.6	316.6	354.1
3.9	52.8	62.8	120.3	140.3	191.6	214.1	329.1	366.6
4.0	55.3	65.3	125.3	145.3	199.1	221.6	341.6	379.1
4.1	57.8	67.8	130.3	150.3	206.6	229.1	354.1	391.6
4.2	60.3	70.3	135.3	155.3	214.1	236.6	366.6	404.1
4.3	62.8	72.8	140.3	160.3	221.6	244.1	379.1	416.6
4.4	65.3	75.3	145.3	165.3	229.1	251.6	391.6	429.1
4.5	67.8	77.8	150.3	170.3	236.6	259.1	404.1	441.6
4.6	70.3	80.3	155.3	175.3	244.1	266.6	416.6	454.1
4.7	72.8	82.8	160.3	180.3	251.6	274.1	429.1	466.6
4.8	75.3	85.3	165.3	185.3	259.1	281.6	441.6	479.1
4.9	77.8	87.8	170.3	190.3	266.6	289.1	454.1	491.6
5.0	80.3	90.3	175.3	195.3	274.1	296.6	466.6	504.1
At zero psig	1.388 V	1.788 V	1.094 V	1.494 V	1.046 V	1.346 V	0.968 V	1.268 V

* Below 0 psig measured in inches of mercury.

COMPRESSOR MODEL DIFFERENCES

FRICK GRAM	RWB, SC GSV, YLC	RXB* GST*	RXF	RDB 3-Step GSB 3-Step	RDB 4-Step	Other
Slide Valve Reading	0-100%	0-100%	0-100%	N/A	N/A	0-100%
Slide Valve Setpoints	Yes	Yes	Yes	N/A	N/A	Yes
Slide Valve Calibration	Yes	Yes	Yes	N/A	N/A	Yes
Capacity Reading	N/A	N/A	N/A	50,75,100	25,50,75,100	N/A
Slide Stop Reading	2.2-5.0	2.2,3,5,5.0	2.2,3,5,5.0	N/A	N/A	N/A
Slide Stop Calibration	N/A	N/A	N/A	N/A	N/A	N/A
DX Circuit Option	Yes	Yes	Yes	N/A	N/A	Yes
Hot Gas Bypass/SV Setpoints Option	Yes	Yes	Yes	N/A	N/A	Yes
Remote Slide Valve Position Option	Yes	Yes	Yes	N/A	N/A	Yes
Sequence by Comp. Sequencing	Yes	Yes	Yes	N/A	N/A	Yes
Forced unload Inhibit load delay setpoint	N/A	N/A	N/A	Yes	Yes	N/A

* Or other variable VI

N/A = Not Applicable

COMPRESSOR VOLUME RATIO AND CAPACITY INFORMATION

Bare Model	Package Model	Bare Model Serial Number	Standard Slide Valve		Low Vi Slide Valve		Theoretical Minimum Capacity	Micro Slide Valve Travel	Micro Slide Stop Travel
			Min. Vi	Max. Vi	Min. Vi	Max. Vi			
XJS/XJF 95	RXB/RXF 12, 15, 19	all	2.2, 3.5, 5.0	n/a	n/a	25%			
XJS/XJF 120	RXB/RXF 24,30, 39, 50	all	2.2, 3.5, 5.0	n/a	n/a	25%			
XJF/XJB 151 & 151X	RXF 58, 68, 85, 101	all	2.2, 3.5, 5.0	n/a	n/a	21%			
TDSH 163S	RWB-II 60	all	2.2	5.0	n/a	n/a	12%	195.6	76.2
TDSH 163L	RWB-II 38, 76	all	2.2	5.0	n/a	n/a	12%	195.6	76.2
TDSH 193S	RWB-II 100	all	2.2	5.0	1.7	n/a	12%	195.6	76.2
TDSH 193L	RWB-II 134	all	2.2	5.0	1.7	n/a	12%	195.6	76.2
TDSH 233S	RWB-II 177	all	2.2	5.0	1.7	n/a	12%	195.6	76.2
TDSH 233L	RWB-II 222	all	2.2	5.0	1.7	n/a	12%	195.6	76.2
TDSH 233XL	RWB-II 270	all	2.2	5.0	1.7	n/a	23%	158.6	76.2
TDSH 283S	RWB-II 316	all	2.2	5.0	1.7	n/a	12%	195.6	76.2
TDSH 283L	RWB-II 399	all	2.2	5.0	1.7	n/a	12%	195.6	76.2
TDSH 283LY	YS chiller (S7 compressor)	all	n/a	n/a	1.7	2.5	8%	194.1	56.5
TDSH 283SX	RWB-II 480	all	2.2	4.2	1.7	2.7	23%	165.5	64.8
TDSH/TDSB 355S	RWB-II 496	0153L / 0011SBS and lower	2.2	5.0	1.7	3.0	18%	185.6	76.2
TDSH/TDSB 355S	RWB-II 496	0154L / 0012SBS and higher	2.2	5.0	1.7	3.0	12%	213.9	76.2
TDSH/TDSB 355L	RWB-II 676	0222K / 0025SBL and lower	2.2	5.0	1.7	3.0	18%	185.6	76.2
TDSH/TDSB 355L	RWB-II 676	0223K / 0026SBL and higher	2.2	5.0	1.7	3.0	12%	213.9	76.2
TDSH/TDSB 355XL	RWB-II 856	0109XL / 0052SBXL and lower	2.2	5.0	1.7	3.0	30%	146.5	76.2
TDSH/TDSB 355XL	RWB-II 856	0110XL / 0053SBXL and higher	2.2	5.0	1.7	3.0	18%	184.6	76.2
TDSB 355U	RWB-II 1080	all	2.4	4.5	1.7	2.6	26%	141.5	58.0
TDSH 408S	RWB-II 852	all	2.2	5.0	1.7	3.0	12%	193.0	76.2
TDSH 408L	RWB-II 1179	all	2.2	5.0	1.7	3.0	12%	193.0	76.2
TDSH 408XL	RWB-II 1395	all	2.2	4.3	1.7	2.7	15%	183.9	66.4
API 408S		all	2.2	5.0	1.7	3.0	12%	193.0	76.2
API 408L		all	2.2	5.0	1.7	3.0	12%	193.0	76.2
API 408XL		all	2.2	4.3	1.7	2.7	21%	163.4	66.4
SGC 1913	RWF 100	all	2.2	5.0	1.7	3.0	12%	195.6	76.2
SGC 1918	RWF 134	all	2.2	5.0	1.7	3.0	12%	195.6	76.2
SGC 2313	RWF 177	all	2.2	5.0	1.7	3.0	12%	195.6	76.2
SGC 2317	RWF 222	all	2.2	5.0	1.7	3.0	12%	195.6	76.2
SGC 2321	RWF 270	all	2.2	5.0	1.7	3.0	12%	195.6	76.2
SGC 2813	RWF 316	all	2.2	5.0	1.7	3.0	12%	195.6	76.2
SGC 2817	RWF 399	all	2.2	5.0	1.7	3.0	12%	195.6	76.2
SGC 2821	RWF 480	all	2.2	5.0	1.7	3.0	12%	213.9	76.2
SGC 2824	RWF 546	all	2.0	4.1	n/a	n/a	18%	185.6	76.2
SGC 3511	RWF-II 496	all	2.2	5.0	1.7	3.0	12%	213.9	76.2
SGC 3515	RWF-II 676	all	2.2	5.0	1.7	3.0	12%	213.9	76.2
SGC 3519	RWF-II 856	all	2.2	5.0	1.7	3.0	18%	184.6	76.2
SGC 3524	RWF-II 1080	all	2.4	4.5	1.7	2.6	26%	141.5	58.0
NGC 100		all	2.2	5.0	1.7	3.0	12%	195.6	76.2
NGC 150		all	2.2	5.0	1.7	3.0	12%	195.6	76.2
NGC 200		all	2.2	5.0	1.7	3.0	12%	195.6	76.2
NGC 250		all	2.2	5.0	1.7	3.0	12%	195.6	76.2
NGC 300		all	2.0	4.1	n/a	n/a	15%	197.3	76.2
NGC 400		all	2.2	5.0	n/a	n/a	12%	213.9	76.2
NGC 450		NGC 450E0001Z only	2.0	3.3	n/a	n/a	26%	141.5	58.0
NGC 450		All NGC 450 except E0001Z	2.2	3.9	n/a	n/a	26%	141.5	58.0

NOTE: For 95, 120, and 151mm compressors, the slide stop travel value in parentheses is the travel from Vi=2.2 to Vi=3.5.

NOTES:

NOTES:

