



BY JOHNSON CONTROLS

Form 070-610 SPL (OCT 2010)

SERVICE PARTS LIST

File: SERVICE MANUAL - Section 70
Replaces: 070-610 SPL (MAR 2010)
Dist: 3, 3a, 3b, 3c

RWF II

ROTARY SCREW COMPRESSOR UNITS

WITH

QUANTUM™ LX CONTROL

MODELS: RWF II 100 – 1080

HOW TO USE SERVICE PARTS LIST

This Service Parts List is for standard Frick® RWFII Rotary Screw Compressor Units, Models 100–1080. Units built with special options, modifications, or conversions are not taken into consideration.

This Service Parts List provides identification for detail parts by Figure and Index Number, Part Number and Description. To determine correct replacement item, locate item on Figure 1, 2, etc., note Index number, refer to corresponding Index number in parts list for part number and description. Quantity per assembly is located in QTY. column. Unit of measure is always "each" unless specified otherwise in Quantity column. When Ref. is in QTY. column, this means that the Item Number is for information only and is not necessarily a service replacement part. Contact Baltimore Parts Center for more information. REV. (Revision) column tells the level of the engineering drawing parts were taken from. The P & I REF. column gives the reference number of the item as shown on the Piping and Instrumentation drawing.

The Numerical Parts List can be used to locate a specific item in the Service Parts List. Look for the part by Frick Part Number and it will refer you to the Figure and Index Number where it is located.

Abbreviations found in this manual include:

A/R	As Required	SC	Seal Cap	WIL	Weld-In-Line
BW	Butt Weld	SW	Socket Weld		
HW	Hand Wheel	TSOC	Thermosyphon Oil Cooler		
Ref.	Reference	WCOC	Water Cooled Oil Cooler		

The Unit Data Plate listing model/serial number etc., is attached to the frame below the compressor.

NOTE: PLEASE PROVIDE ORDER NUMBER, UNIT MODEL NUMBER, AND UNIT SERIAL NUMBER WHEN REQUESTING A QUOTATION OR PLACING AN ORDER. FAILURE TO INCLUDE THIS INFORMATION MAY DELAY PROCESSING OF YOUR REQUEST.

TABLE OF CONTENTS

HOW TO USE SERVICE PARTS LIST 2

RECOMMENDED SPARE PARTS - CURRENT DESIGN 3

Figure 1. General Arrangement, Typical 4

Figure 2. Screw Compressor, Typical (1913/1918 shown) 6

Figure 3. Motor Support 193, RWFII 100 & 134 10

Figure 4. Motor Support 233, RWFII 177, 222, & 270 12

Figure 5. Motor Support 283, RWFII 316, 399, 480, & 546 14

Figure 6. Motor Support 355, RWFII 496, 676, 856 & 1080 16

Figure 7. Oil Separator, Typical 18

Figure 8. Oil Filter, Typical 22

Figure 9. Dual Oil Filters, Typical (100/134 shown) 24

Figure 10. Oil Cooler Piping, Typical, 100-546 26

Figure 11. Oil Cooler Piping, Typical, 496-1080 28

Figure 12. Liquid Injection 30

Figure 13. 4-8" Suction/Discharge Stop Valve 32

Figure 14. 10-12" Suction/Discharge Stop Valve, Danfoss 34

Figure 15. 4-8" Discharge Check Valve, Current (Danfoss) 36

Figure 16. Multivalve, 496 & 676 38

Figure 17. Multivalve, 856 & 1080 40

Figure 18. Economizer 42

Figure 19. Oil Pump 44

Figure 20. Coupling Assembly, T. B. Woods, 100 & 134 54

Figure 21. Coupling Assembly, T. B. Woods, 177–1080 55

Figure 22. Piping and Instrumentation, Typical 56

Figure 23. 1913/1918 Compressor Ports Locations 60

Figure 24. 2313/2317 Compressor Ports Locations 61

Figure 25. 2321 Compressor Ports Locations 62

Figure 26. 2813/2817 Compressor Ports Locations 63

Figure 27. 2821/2824 Compressor Ports Locations 64

Figure 28. 3511/3515/3519 Compressor Ports Locations 65

Figure 29. 3524 Compressor Ports Locations 66

193–283 COMPRESSOR PORTS & O-RINGS 67

193–283 COMPRESSOR PORTS & SIZES 67

355 COMPRESSOR PORTS & SIZES 67

RWFII MODEL vs. COMPRESSOR MODEL 67

COMPRESSOR PORTS 100 - 546 68

STRAIGHT ADAPTERS / O-RINGS - STRAIGHT THREAD TO NPTF 68

90° ELBOW ADAPTERS / O-RINGS - STRAIGHT THREAD TO TUBE 68

COMPRESSOR PORTS 496 - 1080 68

FRICK COMPRESSOR OILS 69

FRICK FLANGE GASKETS 69

FRICK BLUE PAINT 70

MISCELLANEOUS TUBING AND CONNECTORS 70

WIRING HARNESSES CHART 71

NUMERICAL PARTS LIST 72

RECOMMENDED SPARE PARTS - CURRENT DESIGN

NOTE: PLEASE PROVIDE FRICK® ORDER NUMBER, UNIT MODEL NUMBER, AND UNIT SERIAL NUMBER WHEN REQUESTING A QUOTATION OR PLACING AN ORDER. FAILURE TO INCLUDE THIS INFORMATION MAY DELAY PROCESSING OF YOUR REQUEST.

DESCRIPTION	QTY	MODEL	PART NUMBER
Temperature Probe, Element Less Well (TE-1-4)	1	ALL	639A0151H01
Transducer, Pressure, 0-200 PSIA (PE-4)	1	ALL	913A0146H01
Transducer, Pressure, 0-500 PSIA (PE-1-3)	1	ALL	913A0146H02
Coil, 120V 60Hz, 110V 50Hz, Yuken Solenoid Valve	2	ALL	951A0114H05
Coil, 220V 50Hz, 240V 60Hz, Yuken Solenoid Valve	2	ALL	951A0114H06
Seal Kit, Yuken Solenoid Valve	1	ALL	951A0113H20
Transmitter, Linear, Slide Valve (less well)	1	ALL	534D1251H03
Transmitter, Linear, Slide Stop (less well)	1	ALL	534C1478H02
Heater, Oil, 1000W, 120V	1	ALL	913A0092G02
Heater, Oil, 1000W, 240V	1	ALL	913A0092G04
Filter, Coalescing	A/R	ALL	531B0099H01
Gasket, Manway For Coalescer	1	ALL	531A0105H04
Element, Oil Filter, SuperFilter™ II, One-Piece (Double Length)	1	100 - 222	531B0100H02
Element, Oil Filter, SuperFilter™ II, One-Piece (Triple Length)	1	270 - 1080	531B0100H03
Gasket, End Cover, For SuperFilter™ II	1	ALL	959A0082H01
Compressor Shaft Seal Replacement Kit - 1913, 1918	1	100 & 134	534M0163G02
Compressor Shaft Seal Replacement Kit - 2313, 2317, 2321	1	177 - 270	534M0163G03
Compressor Shaft Seal Replacement Kit - 2813, 2817, 2821, 2824	1	316 - 480 & 546	534M0163G04
Compressor Shaft Seal Replacement Kit - 3511, 3515, 3519, 3524	1	496 - 1080	534M0163G05

Note: This list is based on one unit. When stocking for more than one unit, the quantity should be adjusted to meet your individual requirements.

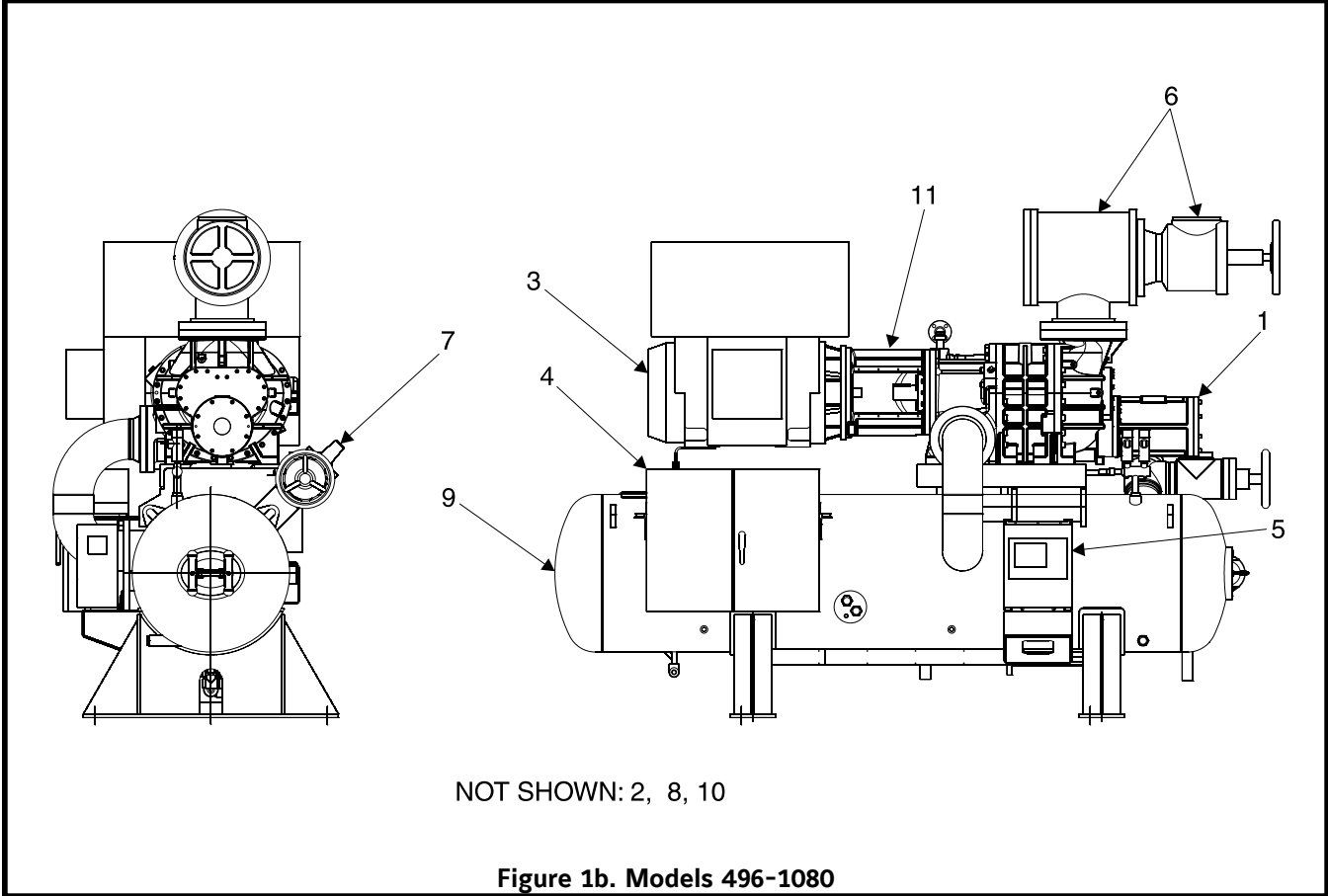
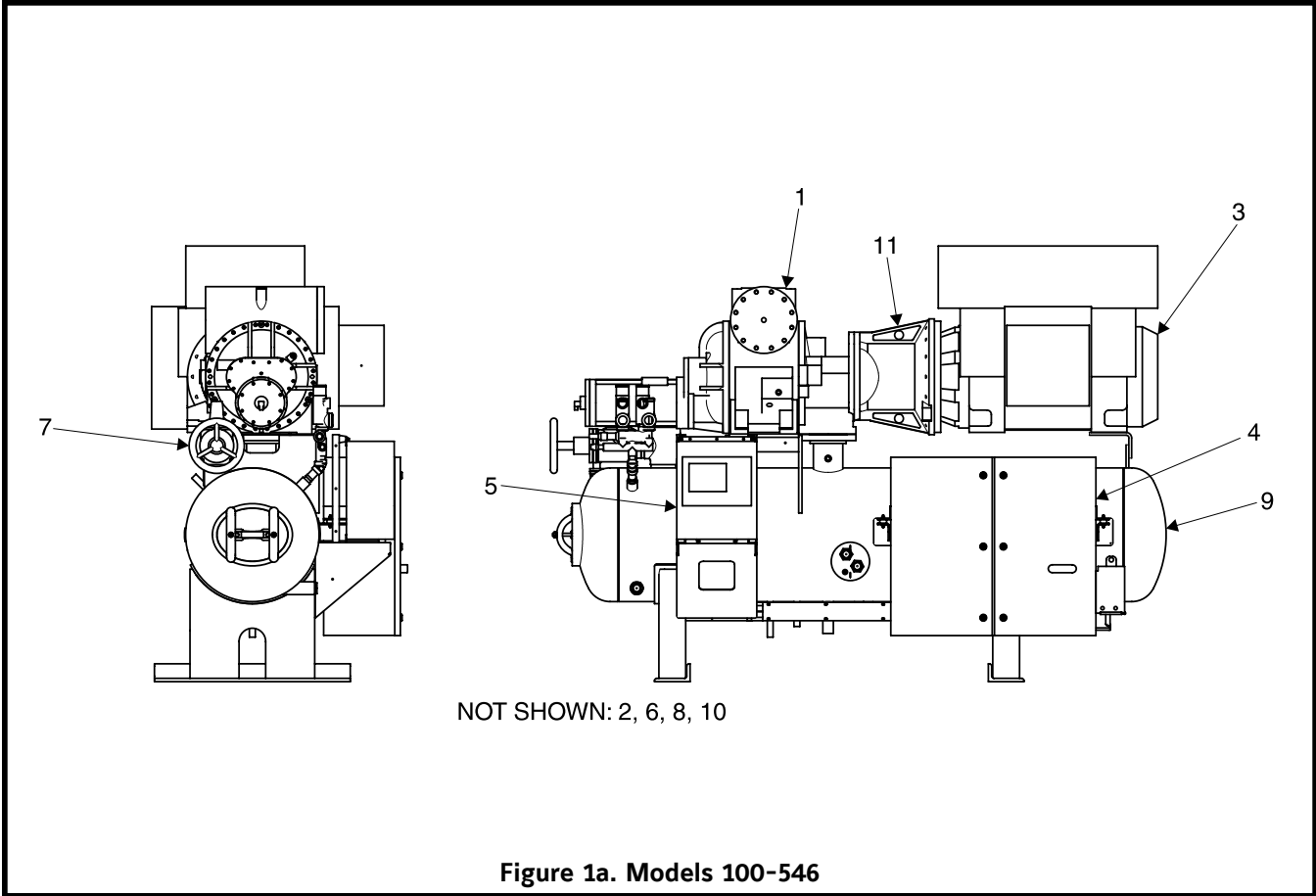
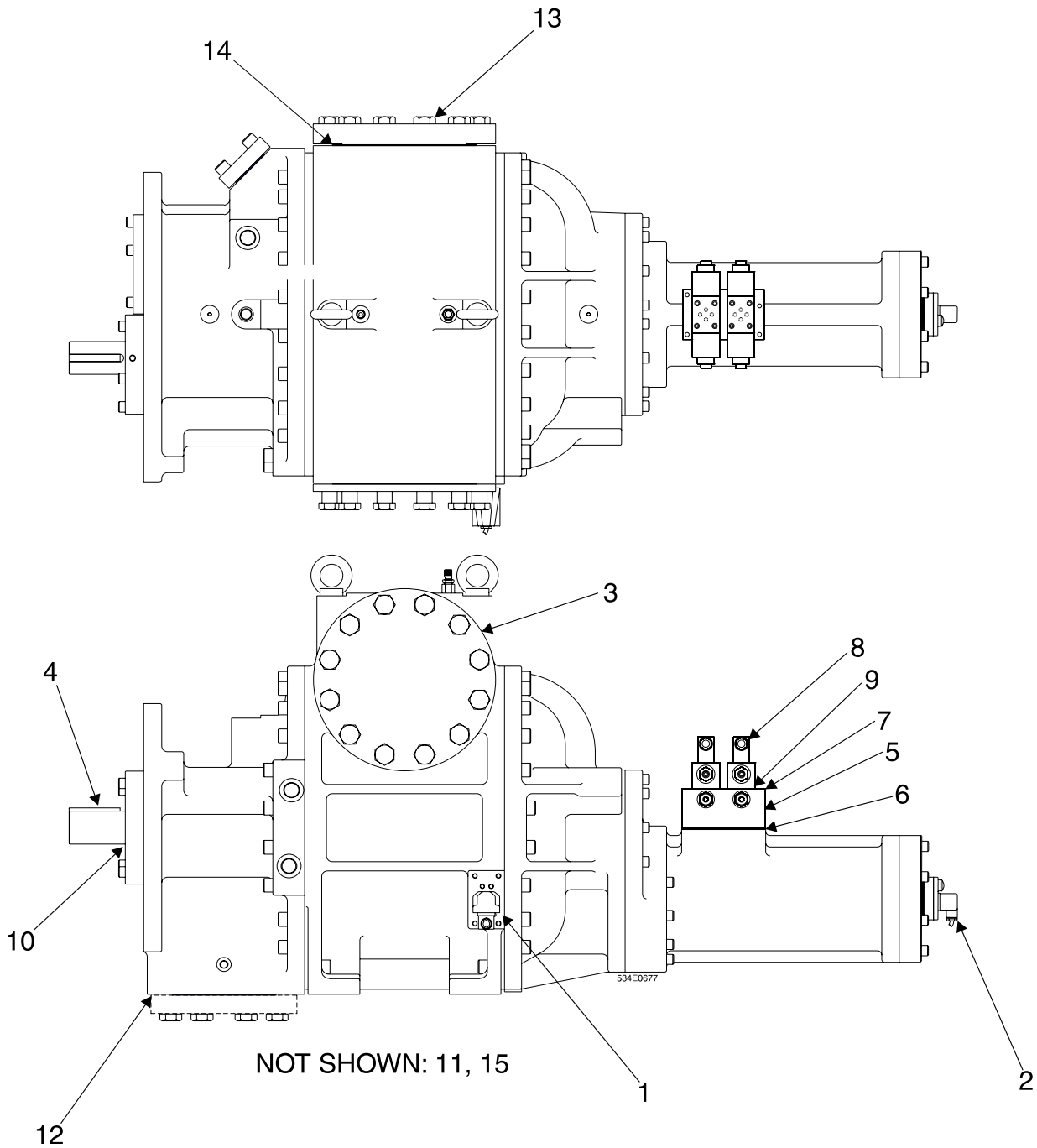

Figure 1. General Arrangement, Typical.

FIG. & INDEX	PART NUMBER	DESCRIPTION	QTY.	REV.	P & I REF.
1a-	-	General Arrangement, RWF II 100 - 546	Ref.		
1b-	-	General Arrangement, RWF II 496 - 1080	Ref.		
-1	-	Compressor, SGC (See Fig. 2)	1		
-2	-	Coupling (See Fig. 20 & 21)	1		
-3	Contact Factory	Motor	1		
-4	Contact Factory	Starter, Solid State	1		
	639A0259H12	Strap, Earth Ground	1		
	720A0052H01	Isolator, Vibration	4		
-5	640D0133G01	Control Panel, Quantum™ LX ⁽¹⁾	1		
-6	950A0240H10	Valve, Angle, Danfoss, 5", HW, WIL (See Fig. 13)	1		
	950A0240H11	Valve, Angle, Danfoss, 6", HW, WIL (See Fig. 13)	1		
	950A0240H12	Valve, Angle, Danfoss, 8", HW, WIL (See Fig. 13)	1		
	950A0283H01	Valve, Angle, Danfoss, 10", HW, WIL (See Fig. 14)	1		
	950A0283H02	Valve, Angle, Danfoss, 12", HW, WIL (See Fig. 14)	1		
	956A0050H03	Valve, Check, 5" (100)	1		
	956A0050H04	Valve, Check, 6" (134-177)	1		
	956A0050H05	Valve, Check, 8" (222-316)	1		
	956A0050H06	Valve, Check, 10" (399-546)	1		
	959A0054H31	Gasket, Flange, 5" (100)	1		
	959A0054H32	Gasket, Flange, 6" (134-177)	1		
	959A0054H33	Gasket, Flange, 8" (222-316)	1		
	959A0098H01	Gasket, Flange, 10" (399-546)	1		
	913A0146H01	Transducer, Pressure, 0-200 PSIA	1		
	649A0890H02	Connector, DIN, 1/2" NPTF ⁽²⁾	1		
	649A0890H11	Gasket, DIN Connector ⁽²⁾	1		
	649D4628H01	Relief, Strain, 1/2" ⁽²⁾	1		
	535D0549G01	Multivalve, 12 x 14" (496-676) (See Fig. 16)	1		
	535D0553G01	Multivalve, 14 x 14" (856-1080) (See Fig. 17)	1		
-7	582C0030G01	Valve Assbly, Disch. Stop/Check, 4" HW (High Stage)	1		
	582C0030G03	Valve Assbly, Disch. Stop/Check, 4" HW (Booster)	1		
	582C0031G01	Valve Assbly, Disch. Stop/Check, 5" HW (High Stage)	1		
	582C0031G03	Valve Assbly, Disch. Stop/Check, 5" HW (Booster)	1		
	582C0032G01	Valve Assbly, Disch. Stop/Check, 6" HW (High Stage)	1		
	582C0032G03	Valve Assbly, Disch. Stop/Check, 6" HW (Booster)	1		
	582C0033G01	Valve Assbly, Disch. Stop/Check, 8" HW (High Stage)	1		
	582C0033G03	Valve Assbly, Disch. Stop/Check, 8" HW (Booster)	1		
	950A0240H09	Valve, Angle, Stop, 4", HW (See Fig. 13)	1		
	950A0240H10	Valve, Angle, Stop, 5", HW (See Fig. 13)	1		
	950A0240H11	Valve, Angle, Stop, 6", HW (See Fig. 13)	1		
	950A0240H12	Valve, Angle, Stop, 8", HW (See Fig. 13)	1		
	956A0045H01	Valve, GVD Check, 4" (High Stage) (See Fig. 15)	1		
	956A0045H02	Valve, GVD Check, 4" (Booster) (See Fig. 15)	1		
	956A0046H01	Valve, GVD Check, 5" (High Stage) (See Fig. 15)	1		
	956A0046H02	Valve, GVD Check, 5" (Booster) (See Fig. 15)	1		
	956A0047H01	Valve, GVD Check, 6" (High Stage) (See Fig. 15)	1		
	956A0047H02	Valve, GVD Check, 6" (Booster) (See Fig. 15)	1		
	956A0048H01	Valve, GVD Check, 8" (High Stage) (See Fig. 15)	1		
	956A0048H02	Valve, GVD Check, 8" (Booster) (See Fig. 15)	1		
-8	-	Assembly, Filter, Oil, Single (See Fig. 8)	Ref.		
	-	Assembly, Filter, Oil, Dual (See Fig. 9)	Ref.		
-9	-	Assembly, Oil Separator (See Fig. 7)	Ref.		
-10	-	Oil Pump, 100 - 1080 (See Fig. 19)	Ref.		
-11	-	Support, Motor (See Figs. 3-6)	Ref.		

1. See Quantum LX Maintenance 090-020 M, Recommended Spare Parts.
2. Not part of Pressure Transducer. Order separately.



NOTE: See Figures 23 - 29 for compressor port locations.

Figure 2. Screw Compressor, Typical (1913/1918 shown).

FIG. & INDEX	PART NUMBER	DESCRIPTION	QTY.	REV.	P & I REF.
2-	534E0672	Screw Compressor, SGC 1913, 1918 (RWFII 100 & 134)	Ref.	P	
	534E0697	Screw Compressor, SGC 2313, 2317 (RWFII 177 & 222)	Ref.	R	
	534E0708	Screw Compressor, SGC 2321 (RWFII 270)	Ref.	N	
	534E0753	Screw Compressor, SGC 2813, 2817 (RWFII 316 & 399)	Ref.	H	
	534D1270	Screw Compressor, SGC 2821 (RWFII 480)	Ref.	E	
	534D1450	Screw Compressor, SGC 2824 (RWFII 546)	Ref.	C	
	534D1436	Screw Compressor, SGCB 3511 (RWFII 496)	Ref.	D	
	534D1444	Screw Compressor, SGCH 3511 (RWFII 496)	Ref.	E	
	534D1439	Screw Compressor, SGCB 3515 (RWFII 676)	Ref.	D	
	534D1445	Screw Compressor, SGCH 3515 (RWFII 676)	Ref.	E	
	534D1442	Screw Compressor, SGCB 3519 (RWFII 856)	Ref.	D	
	534D1443	Screw Compressor, SGCB 3524 (RWFII 1080)	Ref.	D	
	-1	534C1478H01	Assembly, Transmitter, Linear* (Slide Stop)	1	
534C1478H02		Transmitter, Linear (less well)	1		
534C1314H01		Rod, Indicator, 1913, 1918, 2313, 2317, 2321	1		
534C1314H02		Rod, Indicator, 2813, 2817, 2821, 2824	1		
534C1314H03		Rod, Indicator, 3511, 3515, 3519, 3524	1		
534A0032H02		Spring (not part of assembly)	1		
980A0012K62		O-ring (not part of assembly)	1		
-2	534D1251H01	Assembly, Slide Valve Linear Transmitter*	1		
	534D1251H03	Transmitter, Linear (less well)	1		
	980A0012K60	O-ring	1		
-3	534C1264H01	Strainer, Suction, 1913	1		
	959A0054H31	Gasket, Flange, 1913	1		
	534C1264H02	Strainer, Suction, 1918 & 2313	2		
	959A0054H32	Gasket, Flange, 1918 & 2313	1		
	534C1264H03	Strainer, Suction, 2317 & 2321	1-3		
	959A0054H33	Gasket, Flange, 2317 & 2321	1		
	534C1264H05	Strainer, Suction, 2813	2		
	959A0054H33	Gasket, Flange, 2813	1		
	534C1264H04	Strainer, Suction, 2817, 2821, 2824	1		
	959A0054H34	Gasket, Flange, 2817, 2821, 2824	3		
-4	534A0662H02	Key, Square, .50 x 3.50", 1913 & 1918	1		
	534A0662H03	Key, Square, .626 x 3.50", 2313, 2317 & 2321	1		
	534A0662H04	Key, Square, .875 x 4.50", 2813-3524	1		
-5	535E0122H01	Block, Manifold, Yuken	1		
	535E0122H11	Valve, Needle, Flow Regulator, Yuken	5		
-6	980A0012A61	O-ring, Manifold Block to Compressor, Yuken	4		
-7	901A0228H20	Capscrew, SH, (M6x1)x80mm, Manifold to Compressor	4		
-8	951A0114H01	Assembly, Valve, Yuken, 120V 60Hz, 110V 50Hz*	2		
	951A0114H05	Coil, Yuken, 120V 60Hz, 110V 50Hz	4		
	951A0114H02	Assembly, Valve, Yuken, 220V 50Hz, 240V 60Hz, 240V 50Hz*	2		
	951A0114H06	Coil, Yuken, 220V 50Hz, 240V 60Hz	4		
-9	951A0113H20	Seal Kit, Valve, Yuken	2		

* Mounting hardware comes with assembly. DIN Cable Connector: 649A0890H01. DIN Gasket: 649A0890H11

FIG. & INDEX	PART NUMBER	DESCRIPTION	QTY.	REV.	P & I REF.
-10	534M0163G02	Kit, Shaft Seal, 1913 & 1918	1		
	534M0163G03	Kit, Shaft Seal, 2313, 2317 & 2321	1		
	534M0163G04	Kit, Shaft Seal, 2813, 2817, 2821, 2824	1		
	534M0163G05	Kit, Shaft Seal, 3511, 3515, 3519, 3524	1		
-11	913A0146H02	Transducer, Pressure, 0-500 PSIA	1		PE-3
	649A0890H02	Connector, DIN, 1/2" NPTF ⁽¹⁾	1		
	649A0890H11	Gasket, DIN Connector ⁽¹⁾	1		
	649D4628H01	Relief, Strain, 1/2" ⁽¹⁾	1		
-12	959A0054H30	Gasket, Discharge, 4", 1913 & 1918	1		
	959A0054H32	Gasket, Discharge, 6", 2313, 2317, 2321	1		
	959A0054H33	Gasket, Discharge, 8", 2813, 2817, 2821, 2824	1		
	959A0054H34	Gasket, Discharge, 10", 3511-3519, 3524	1		
-13	901A0206H09	Capscrew, Hex Head, (M20x2.5)x65mm, 193-233	A/R		
	901A0192H06	Capscrew, Hex Head, (M22x2.5)x75mm, 233-283 (2317-2813)	A/R		
	901A0207H10	Capscrew, Hex Head, (M24x3.0)x90mm, 283 (2817-2824)	A/R		
	901A0231H01	Capscrew, Hex Head, (M30x3.5)x50mm, 3511-3519, 3524	A/R		
-14	959A0054H31	Gasket, Suction, 5" 300 Class, 193 (1913)	2		
	959A0054H32	Gasket, Suction, 6" 300 Class, 193 (1918)	2		
	959A0054H32	Gasket, Suction, 6" 300 Class, 233 (2313)	2		
	959A0054H33	Gasket, Suction, 8" 300 Class, 233 (2317)	2		
	959A0054H33	Gasket, Suction, 8" 300 Class, 233 (2321)	2		
	959A0054H33	Gasket, Suction, 8" 300 Class, 283 (2813)	2		
	959A0054H34	Gasket, Suction, 10" 300 Class, 283 (2817)	2		
	959A0054H34	Gasket, Suction, 10" 300 Class, 283 (2821)	2		
	959A0054H34	Gasket, Suction, 10" 300 Class, 283 (2824)	2		
	959A0054H34	Gasket, Suction, 10" 300 Class, 283 (2824)	2		
	959A0054H36	Gasket, Suction, 14" 300 Class, 355 (3511-3524)	1		
-15	534E0656C01	Support, Motor, 193, RWFII 100 & 134 (See Fig. 3)	1		
	534E0773C01	Support, Motor, 193, RWFII 100 & 134 ⁽²⁾	1		
	333Q0000738	Washer, Flat, M8	6		
	534A0506H01	Grommet	6		
	534B0149H01	Pin, Dowel, 20 x 70mm	1		
	534B0151H01	Pin, Dowel, 20 x 70mm, Special	1		
	534B0705H01	Cover	1		
	534C1466H01	Cover ⁽²⁾	1		
	901A0190H06	Capscrew, Socket Head, (M8x1.25)x20mm	6		
	901A0224H09	Capscrew, Socket Head, (M12x1.75)x55mm	9		
	534E0684C01	Support, Motor, 233, RWFII 177, 222, & 270 (See Fig. 4)	1		
	534E0684C11	Support, Motor, 233, RWFII 177, 222, & 270 (See Fig. 4) ⁽³⁾	1		
	534B0149H01	Pin, Dowel, 20 x 70mm	1		
	534B0151H01	Pin, Dowel, 20 x 70mm, Special	1		
	901A0224H09	Capscrew, Socket Head, (M12x1.75)x55mm	10		
	534B0723H01	Plate, Cover	1		
	534A0506H01	Grommet	6		
	333Q0000738	Washer, Flat, M8	6		
	901A0190H06	Capscrew, Socket Head, (M8x1.25)x20mm	6		
	534E0731C01	Support, Motor, 283, RWFII 316, 399, 480 & 546 (See Fig. 5)	1		
	534B0149H01	Pin, Dowel, 20 x 70mm	1		
534B0151H01	Pin, Dowel, 20 x 70mm, Special	1			

FIG. & INDEX	PART NUMBER	DESCRIPTION	QTY.	REV.	P & I REF.
	901A0223H08	Capscrew, Socket Head, (M16x2.0)x60mm	12		
	534B0740H01	Plate, Cover	1		
	534A0506H01	Grommet	6		
	333Q0000738	Washer, Flat, M8	6		
	901A0190H06	Capscrew, Socket Head, (M8x1.25)x20mm	6		
	534E0928C01	Support, Motor, 355, RWFII 496, 676, 856, 1080 (See Fig. 6)	1		
	534B1010H01	Gasket, Cover Plate	2		
	534C1699H01	Plate, Cover	1		
	534B0151H01	Pin, Dowel, 20 x 70mm, Special	1		
	901A0224H03	Capscrew, Socket Head, (M12x1.75)x25mm	8		
	901A0222H07	Capscrew, Socket Head, (M20x2.5)x65mm	14		
	534B0149H01	Pin, Dowel, 20 x 70mm	1		
	1. Not part of Pressure Transducer. Order separately. 2. C-Face - 364TSC, 365TSC, 404TSC 3. Ductile Iron				

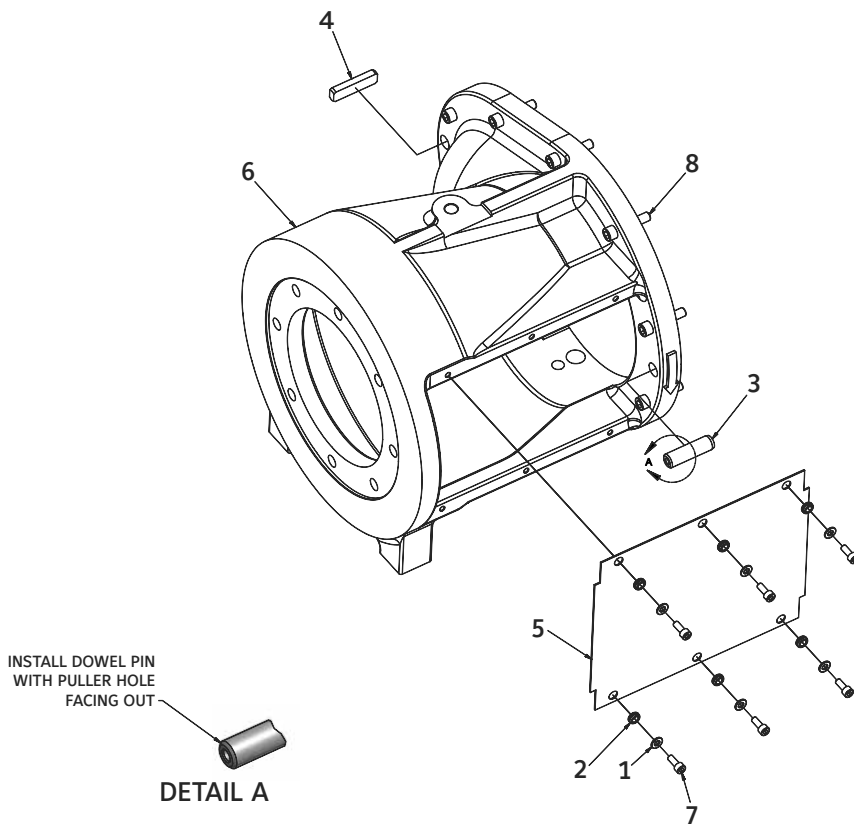
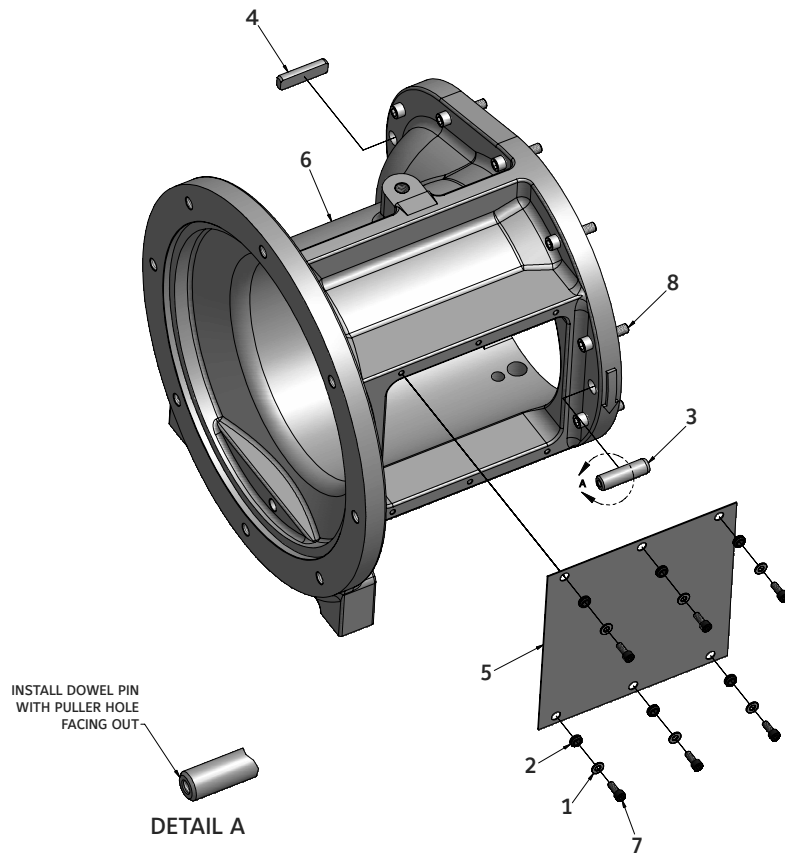

Figure 3. Motor Support 193, RWFII 100 & 134.

FIG. & INDEX	PART NUMBER	DESCRIPTION	QTY.	REV.	P & I REF.
3-	534E0676G01 534E0786G01	Motor Support, RWFII 100 & 134 Motor Support, RWFII 100 & 134 (364TSC, 365TSC, 404TSC) ⁽¹⁾	Ref. Ref.		
-1	333Q0000738	Washer, Flat, M8	6		
-2	534A0506H01	Grommet	6		
-3	534B0149H01	Pin, Dowel, 20 x 70mm	1		
-4	534B0151H01	Pin, Dowel, 20 x 70mm, Special Locating	1		
-5	534B0705H01 534C1466H01	Cover, Support, Motor (100 & 134) Cover, Support, Motor (100 & 134) ⁽¹⁾	1 1		
-6	534E0656C01 534E0773C01	Support, Motor, 193 (100 & 134) Support, Motor, 193 (100 & 134) ⁽¹⁾	1 1		
-7	901A0190H06	Capscrew, Socket Head, (M8x1.25)x20	6		
-8	901A0224H09	Capscrew, Socket Head, (M12x1.75)x55	9		
1. C-Face - 364TSC, 365TSC, 404TSC					

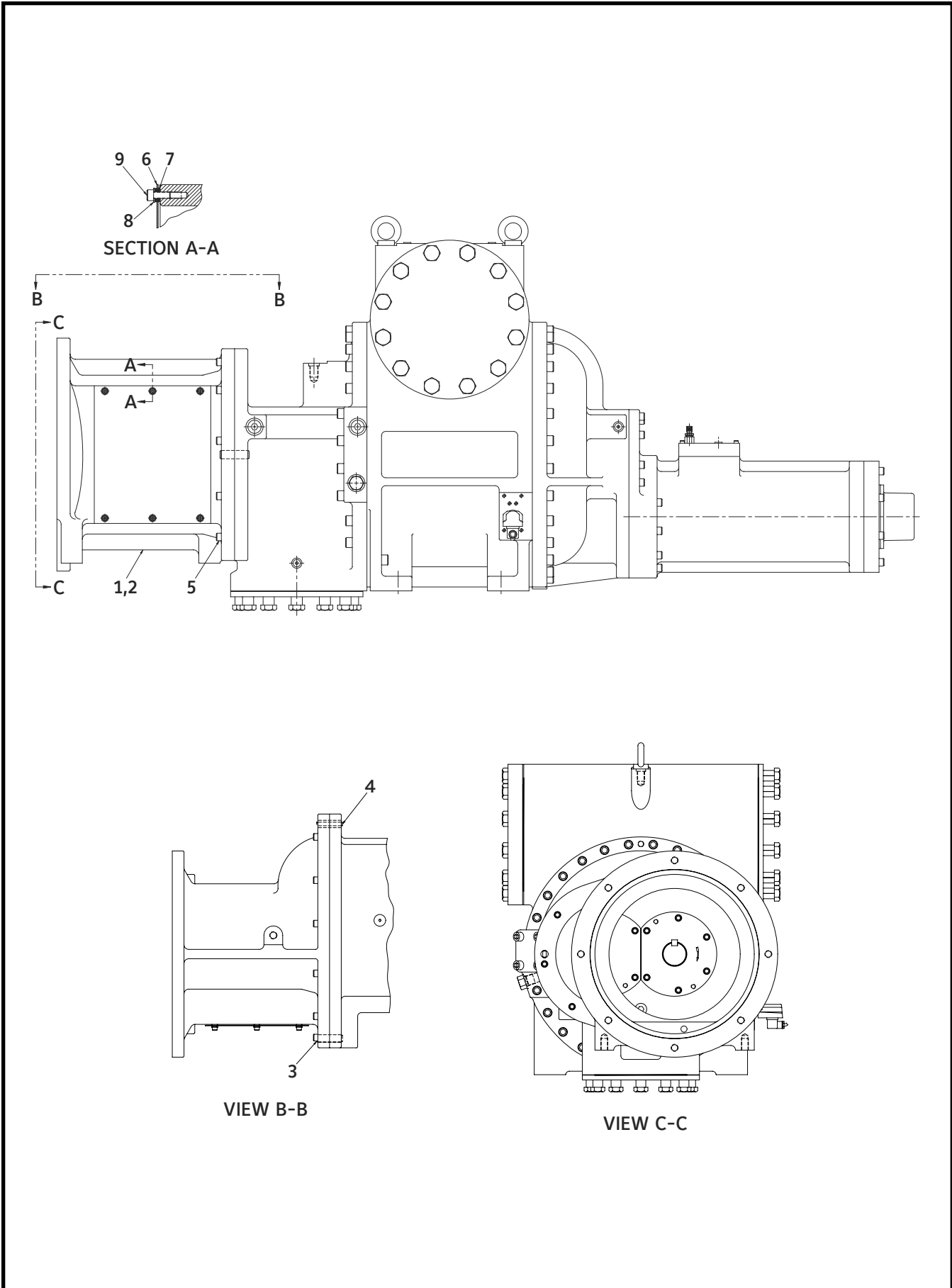

Figure 4. Motor Support 233, RWFII 177, 222, & 270.

FIG. & INDEX	PART NUMBER	DESCRIPTION	QTY.	REV.	P & I REF.
4-	534E0699G01 534E0699G02	Motor Support, RWFII 177, 222, & 270 Motor Support, RWFII 177, 222, & 270 (65-45-12 Ductile Iron)	Ref. Ref.		
-1	534E0684C01	Support, Motor, (177, 222, 270)	1		
-2	534E0684C11	Support, Motor, (177, 222, 270) (Ductile Iron)	1		
-3	534B0149H01	Pin, Dowel, 20 x 70mm	1		
-4	534B0151H01	Pin, Dowel, 20 x 70mm, Special Locating	1		
-5	901A0224H09	Capscrew, Socket Head, (M12x1.75)x55	10		
-6	534B0723H01	Cover, Support, Motor (177, 222, 270)	1		
-7	534A0506H01	Grommet	6		
-8	333Q0000738	Washer, Flat, M8	6		
-9	901A0190H06	Capscrew, Socket Head, (M8x1.25)x20	6		

FIG. & INDEX	PART NUMBER	DESCRIPTION	QTY.	REV.	P & I REF.
5-	534E0758G01	Motor Support, RWFII 316, 399, 480 & 546	Ref.		
-1	534E0731C01	Support, Motor (316, 399, 480, & 546)	1		
-2	534B0149H01	Pin, Dowel, 20 x 70mm	1		
-3	534B0151H01	Pin, Dowel, 20 x 70mm, Special Locating	1		
-4	901A0223H08	Capscrew, Socket Head (M16x2.0)x60mm	12		
-5	534B0740H01	Cover, Support, Motor (316, 399, 480, & 546)	1		
-6	534A0506H01	Grommet	6		
-7	333Q0000738	Washer, Flat, M8	6		
-8	901A0190H06	Capscrew, Socket Head, (M8x1.25)x20	6		

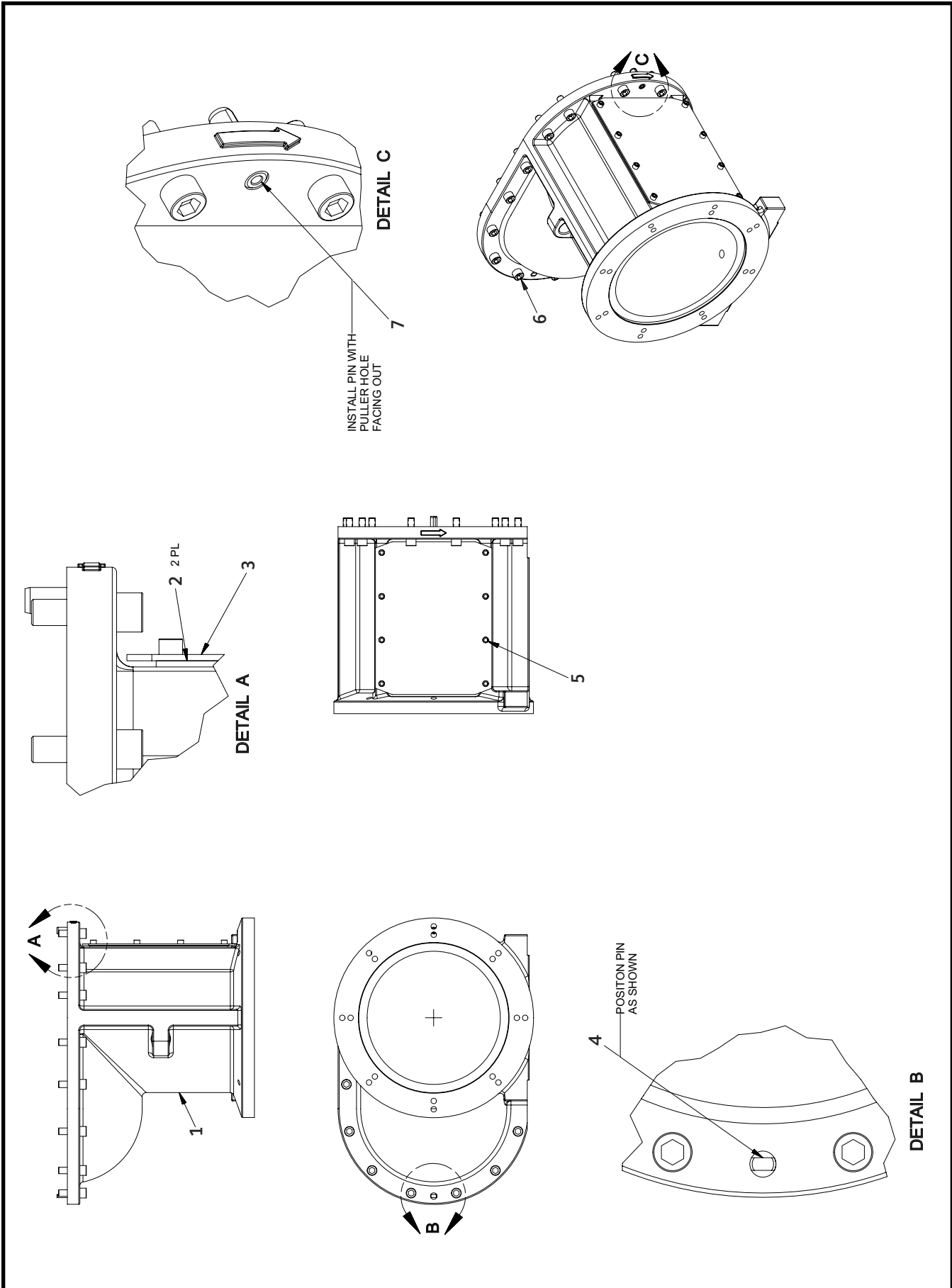

Figure 6. Motor Support 355, RWFII 496, 676, 856 & 1080.

FIG. & INDEX	PART NUMBER	DESCRIPTION	QTY.	REV.	P & I REF.
6-	534C1714G01	Motor Support, RWFII 496, 676, 856 & 1080	Ref.		
-1	534E0928C01	Support, Motor (496, 676, 856 & 1080)	1		
-2	534B1010H01	Gasket, Cover, Support, Motor (496, 676, 856 & 1080)	2		
-3	534C1699H01	Cover, Support, Motor (496, 676, 856 & 1080)	1		
-4	534B0151H01	Pin, Dowel, 20 x 70mm, Special Locating	1		
-5	901A0224H03	Capscrew, Socket Head, (M12x1.75)x25	8		
-6	901A0222H07	Capscrew, Socket Head, (M20x2.5)x65	14		
-7	534B0149H01	Pin, Dowel, 20 x 70mm	1		

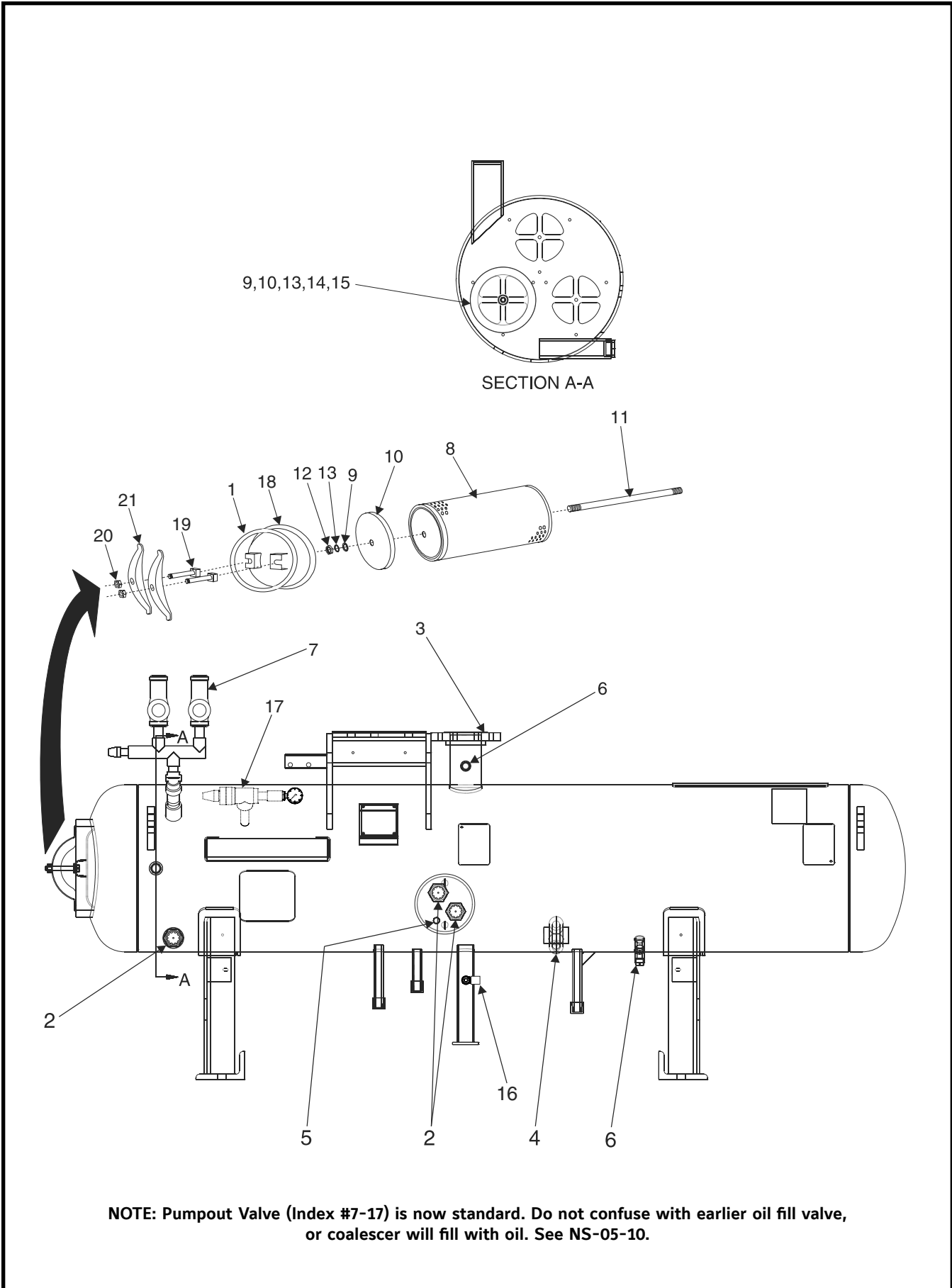

Figure 7. Oil Separator, Typical.

FIG. & INDEX	PART NUMBER	DESCRIPTION	QTY.	REV.	P & I REF.
7-	548E0401G01	Assembly, Oil Separator, 24 x 118 3/8", 300 DWP, 100 & 134 ⁽²⁾	Ref.		
	548E0402G01	Assembly, Oil Separator, 30 x 123 3/8", 300 DWP, 100 & 134 ⁽²⁾	Ref.		
	548E0419G01	Assembly, Oil Separator, 24 x 123 3/8", 400 DWP, 100 & 134 ⁽²⁾	Ref.		
	548E0420G01	Assembly, Oil Separator, 30 x 123 3/8", 400 DWP, 100 & 134 ⁽²⁾	Ref.		
	548E0403G01	Assembly, Oil Separator, 30 x 132 5/8", 300 DWP, 177 & 222 ⁽²⁾	Ref.		
	548E0404G01	Assembly, Oil Separator, 36 x 135 3/4", 300 DWP, 177 & 222 ⁽²⁾	Ref.		
	548E0421G01	Assembly, Oil Separator, 30 x 132 5/8", 400 DWP, 177 & 222 ⁽²⁾	Ref.		
	548E0422G01	Assembly, Oil Separator, 36 x 135 3/4", 400 DWP, 177 & 222 ⁽²⁾	Ref.		
	548E0405G01	Assembly, Oil Separator, 36 x 160 1/2", 300 DWP, 270 ⁽²⁾	Ref.		
	548E0423G01	Assembly, Oil Separator, 36 x 160 1/2", 400 DWP, 270 ⁽²⁾	Ref.		
	548E0406G01	Assembly, Oil Separator, 36 x 160 1/2", 300 DWP, 316 & 399 ⁽²⁾	Ref.		
	548E0407G01	Assembly, Oil Separator, 42 x 163 1/2", 300 DWP, 316 & 399 ⁽²⁾	Ref.		
	548E0424G01	Assembly, Oil Separator, 36 x 160 1/2", 400 DWP, 316 & 399 ⁽²⁾	Ref.		
	548E0425G01	Assembly, Oil Separator, 42 x 163 1/2", 400 DWP, 316 & 399 ⁽²⁾	Ref.		
	548E0408G01	Assembly, Oil Separator, 42 x 170 1/2", 300 DWP, 480 & 546 ⁽²⁾	Ref.		
	548E0426G01	Assembly, Oil Separator, 42 x 170 1/2", 400 DWP, 480 & 546 ⁽²⁾	Ref.		
	548E0409G01	Assembly, Oil Separator, 42 x 179 1/2", 300 DWP, 496 ⁽²⁾	Ref.		
	548E0427G01	Assembly, Oil Separator, 42 x 179 5/8", 400 DWP, 496 ⁽²⁾	Ref.		
	548E0410G01	Assembly, Oil Separator, 48 x 190 5/8", 300 DWP, 676 ⁽²⁾	Ref.		
	548E0428G01	Assembly, Oil Separator, 48 x 190 5/8", 400 DWP, 676 ⁽²⁾	Ref.		
	548E0411G01	Assembly, Oil Separator, 54 x 199 3/4", 300 DWP, 856 & 1080 ⁽²⁾	Ref.		
	548E0429G01	Assembly, Oil Separator, 54 x 199 3/4", 400 DWP, 856 & 1080 ⁽²⁾	Ref.		
-1	531A0105H04	Gasket, Manway, 12 x 16"	1		
-2	947A0003H05	Sightglass, Ball Float, 2-11 1/2 NPT, Silver	3		
	947A0003H07	Sightglass, Ball Float, 1 1/2-11 1/2 NPT, Silver	3		
-3	959A0054H30	Gasket, Compressor to Separator, Class 300, 100 & 134	1		
	959A0054H32	Gasket, Compressor to Separator, Class 300, 177-270	1		
	959A0054H33	Gasket, Compr. to Separator, Class 300, 316/399/480/546	1		
	959A0054H34	Gasket, Compressor to Separator, Class 300, 496-1080	1		
-4	913A0092G02	Assembly, Oil Heater, 1000W/120V	3		HTR
	913A0047H02	Heater, Oil, 1000W/120V	3		
	333Q0001810	Connector, DIN	3		
	913A0092G04	Assembly, Oil Heater, 1000W/240V	3		HTR
	913A0047H04	Heater, Oil, 1000W/240V	3		
	333Q0001810	Connector, DIN	3		
-5	913A0123H01	Assembly, Switch, Oil Level Sensing, 24V	1		
	913A0123H11	Sensor Probe less Well	1		
	913A0123H12	Well only	1		
-6	639A0151G03	Assembly, Temperature Sensor	4		TE
	639A0151H01	Temperature Sensor Probe, less Well	1		
	913A0098H01	Well, with cap	1		
	913A0100H01	Thermal Compound	A/R		
	649A0890H02	Connector, DIN	1		
	649A0890H11	Gasket, DIN Connector	1		
		100-1080 300 PSIG ⁽²⁾			PSV-1
-7	580C0424G10	Assembly, Dual Safety Valve, 1/2", 100-1080	1		
	955B0005H01	Manifold, Valve, 1/2" FPT	1		
	952A0051H10	Valve, Safety, 1/2 x 1" FPT, Shank 813, 300 PSIG	2		
	580C0425G10	Assembly, Dual Safety Valve, 3/4", 100-1080	1		
	955B0005H02	Manifold, Valve, 3/4"	1		
	952A0052H10	Valve, Safety, 3/4 x 1-1/4" FPT, Shank 814, 300 PSIG	2		
	580C0426G10	Assembly, Dual Safety Valve, 1", 100-1080	1		
	955B0005H03	Manifold, Valve, 1"	1		
	952A0053H10	Valve, Safety, 1 x 1-1/2" FPT, Shank 815, 300 PSIG	2		

FIG. & INDEX	PART NUMBER	DESCRIPTION	QTY.	REV.	P & I REF.	
	580C0404G07	Assembly, Dual Safety Valve, 1", 177-1080	1		PSV-1	
	955B0001H02	Manifold, 1-1/4 Pipe x 1" FPT	1			
	952A0055H07	Valve, Safety, 1 x 2" NPT, Shank 851, 300 PSIG	2			
	580C0407G07	Assembly, Dual Safety Valve, 1-1/2" 270-1080	1			
	955B0002H02	Manifold, 2" Pipe x 1-1/2 FPT	1			
	952A0058H07	Valve, Safety, 1-1/2 x 2" FPT, Shank 903, 300 PSIG	2			
		100-546 350 PSIG ⁽²⁾				
	580C0424G12	Assembly, Dual Safety Valve, S813, 350 PSIG	1			
	955B0005H01	Manifold, Valve, 1/2" FPT	1			
	952A0051H12	Valve, Safety, 1/2" Shank, 350 PSIG	2			
	580C0425G12	Assembly, Dual Safety Valve, S814, 350 PSIG	1			
	955B0005H02	Manifold, Valve, 3/4"	1			
	952A0052H12	Valve, Safety, 3/4", Shank, 350 PSIG	2			
	580C0426G12	Assembly, Dual Safety Valve, 1", S815, 350 PSIG	1			
	955B0005H03	Manifold, Valve, 1"	1			
	952A0053H12	Valve, Safety, 1" Shank, 350 PSIG	2			
	580C0404G09	Assembly, Dual Safety Valve, 1", 851, 350 PSIG	1			
	955B0001H02	Manifold, 1-1/4 Pipe x 1" FPT	1			
	955B0001H11	O-rings, Stem	1			
	955B0001H12	O-ring, Cap	1			
	955B0001H13	Gasket, Stem Seal Cap	1			
	952A0055H09	Valve, Safety, 1", Shank, 350 PSIG	1			
	580C0407G09	Assembly, Dual Safety Valve, 903, 1-1/2"	1			
	955B0002H02	Manifold, 1-1/2"	1			
	955B0002H11	O-rings, Stem	1			
	955B0002H12	O-ring, Cap	1			
	955B0002H13	Gasket, Stem Seal Cap	1			
	952A0058H09	Valve, Safety, 1-1/2", Shank, 350 PSIG	2			
		100-546 400 PSIG ⁽²⁾				
	580C0424G14	Assembly, Dual Safety Valve, 813, 400 PSIG	1		PSV-1	
	955B0005H01	Manifold, Valve, 1/2" FPT	1			
	952A0051H14	Valve, Safety, 1/2" FPT, Shank	2			
	580C0425G14	Assembly, Dual Safety Valve, S814, 400 PSIG	1			
	955B0005H02	Manifold, Valve, 3/4"	1			
	952A0052H14	Valve, Safety, 3/4", Shank	2			
	580C0426G14	Assembly, Dual Safety Valve, S815, 400 PSIG	1			
	955B0005H03	Manifold, Valve, 1"	1			
	952A0053H14	Valve, Safety, 1", Shank, 400 PSIG	2			
		496-1080 350 PSIG ⁽²⁾				
	580C0426G12	Assembly, Dual Safety Valve, 1", S815, 350 PSIG	1			PSV-1
	955B0005H03	Valve, Shutoff, 3-Way, 1"	1			
	952A0053H12	Valve, Safety, 1" FPT, Shank, 350 PSIG	2			
	580C0404G09	Assembly, Dual Safety Valve, 1" FPT, 851, 350 PSIG	1			
	955B0001H02	Manifold, 1-1/4 Pipe x 1" FPT	1			
	955B0001H11	O-rings, Stem	1			
	955B0001H12	O-ring, Cap	1			
	955B0001H13	Gasket, Stem Seal Cap	1			
	952A0055H09	Valve, Safety, 1" FPT, Shank, 350 PSIG	2			
	580C0407G09	Assembly, Dual Safety Valve, 1-1/2" FPT, 903, 350 PSIG	1			
	955B0002H02	Manifold, 1-1/2"	1			
	955B0002H11	O-rings, Stem	1			
	955B0002H12	O-ring, Cap	1			
	955B0002H13	Gasket, Stem Seal Cap	1			

FIG. & INDEX	PART NUMBER	DESCRIPTION	QTY.	REV.	P & I REF.
	952A0058H09	Valve, Safety, 1-1/2" FPT, Shank, 350 PSIG 496-1080 400 PSIG ⁽²⁾	2		PSV-1
	580C0426G14	Assembly, Dual Safety Valve, 815, 400 PSIG	1		
	952A0053H14	Valve, Safety, 1" FPT, Shank, 400 PSIG	2		
	955B0005H03	Valve, Shutoff, 3-Way, 1"	1		
-8	531B0099H01	Filter, Coalescing, 100 & 134	2-3		
	531B0099H01	Filter, Coalescing, 177 & 222	3-4		
	531B0099H01	Filter, Coalescing, 270-399	4-5		
	531B0099H01	Filter, Coalescing, 480 & 496 ⁽¹⁾	5-6		
	531B0099H01	Filter, Coalescing, 676 ⁽¹⁾	8-9		
	531B0099H01	Filter, Coalescing, 856 & 1080 ⁽¹⁾	11		
-9	540D0217H06	Washer, Seal	1 per		
-10	540D0217H03	Retainer, Filter (end plate)	1 per		
-11	540D0217G03	Stud 1/2-13NC x 37"	1 per		
-12	902A0021H01	Nut, Hex 1/2-13NC	1 per		
-13	905A0012H05	Washer 1/2"	1 per		
-14	901A0045D04	Capscrew, Hex Head, 1/2 x 1-1/2"	1 per		
	905A0013H05	Washer, Lock, Carbon Steel, 1/2"	1 per		
-15	959A0105H01	Gasket, 9-3/8" OD (for unused coalescer filter opening)	1 per		
-16	950A0292H03	Valve, Angle, SC, Danfoss, 1/2 MPT x 1/2 MPT (oil drain/fill) ⁽³⁾	1		NV
-17	950A0233H02	Valve, Angle, 3/4" SW, SC (pump out) ⁽⁴⁾	1		
	950A0232H21	Kit, Spare Parts, Complete (less stem)	1		
	950A0232H31	Kit, Spare Parts, Packing Gland Assbly.	1		
-18	534A0115H04	Cover, Manway w/Handle	1		
-19	535A0115H06	Bolt, Manway	2		
-20	535A0115H07	Nut, Manway	2		
-21	535A0115H08	Yoke, Manway	2		

1. Quantity of coalescing filters may be different, depending on operating conditions of your unit.
2. 300 DWP is standard. 400 DWP is optional.
3. Oil will now be charged through the drain valve. A pump will be necessary to drive oil flow. See Service Information NS-05-10.
4. Pumpout valve is now standard. Do not confuse with earlier oil fill valve, otherwise coalescer will fill with oil. See NS-05-10.

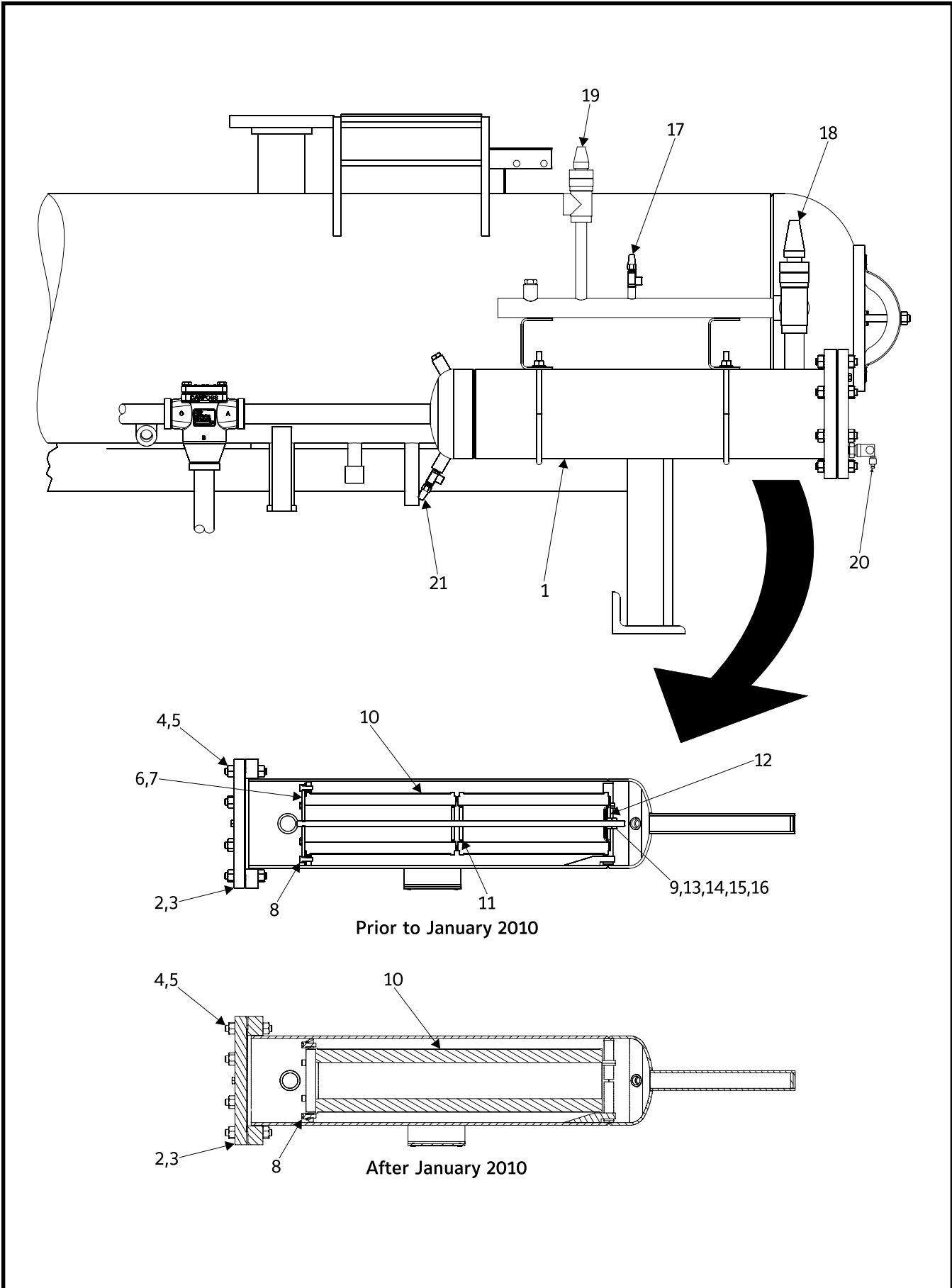

Figure 8. Oil Filter, Typical.

FIG. & INDEX	PART NUMBER	DESCRIPTION	QTY.	REV.	P & I REF.
8-	-	Assembly, Single Oil Filter	Ref.		OF-1
-1	553E0013	Assembly, Filter, 100 & 134 (1-1/2" connections) ⁽¹⁾	1		
	553E0015	Assembly, Filter, 177 & 222 (2" connections) ⁽¹⁾	1		
	553E0014	Assembly, Filter, 270-676 (2-1/2" connections) ⁽²⁾	1		
	553E0020	Assembly, Filter, 856 & 1080 (3" connections) ⁽²⁾	1		
-2	959A0082H01	Gasket	1		
-3	553A0001H01	Cover Plate, End	1		
-4	901A0098H13	Stud, 5/8-11 x 4.5"	8		
-5	902A0021H03	Nut, 5/8-11 UNC	16		
-6	535A0144H01	Plate, Clamping	1		
-7	959A0053H01	Gasket	1		
-8	901A0258H01	Screw, Socket Head, 3/8-16 x 1"	6		
-9	333Q0001268	Rod, Threaded, 1/2-13 x 31-1/2"	1		
-10	531B0100H02	Element, SuperFilter™ II, 28 9/16" overall length ⁽³⁾	1		
	531B0100H03	Element, SuperFilter™ II, 43 5/16" overall length ⁽³⁾	1		
	531A0218H02	Element, SuperFilter™, 14 1/2" overall length ⁽³⁾	2-3		
-11	900A0007H01	Seal, Center	1-2		
-12	900A0008H01	Yoke, Bottom	1		
-13	905A0007H05	Washer, Flat, 1/2"	1		
-14	333Q0001237	Washer, Starlock, 1/2"	1		
-15	902A0021H01	Nut, 1/2-13 UNC	2		
-16	540D0217H06	Washer, Seal, 9/16 ID x 1-7/16 OD x 1/16" Thick	1		
-17	950A0292H01	Valve, Angle, Danfoss, SC, 1/4" MPT x FPT	2		
	913A0146H02	Transducer, Pressure, 0-500 PSIA	2		PE-1,2
	649A0890H02	Connector, DIN, 1/2" NPTF ⁽⁴⁾	1		
	649A0890H11	Gasket, DIN Connector ⁽⁴⁾	1		
	649D4628H01	Relief, Strain, 1/2" ⁽⁴⁾	1		
-18	950A0233H05	Valve, Angle, Danfoss, SC, 1-1/2" SW, 100 & 134	1		
	950A0232H22	Repair Kit, Complete (less stem)	1		
	950A0233H06	Valve, Angle, Danfoss, SC, 2" SW, 177 & 222	1		
	950A0232H23	Repair Kit, Complete (less stem)	1		
	950A0241H07	Valve, Angle, Danfoss, SC, 2-1/2" BW, 270-546, 496, 676	1		
	950A0240H24	Repair Kit, Complete (less stem)	1		
	950A0241H08	Valve, Angle, Danfoss, SC, 3" BW, 856 & 1080	1		
	950A0240H25	Repair Kit, Complete (less stem)	1		
-19	954A0062H02	Valve, Angle, SC, Hand Exp., 3/4" SW/FPT, 100 & 222	1		
	954A0062H27	Repair Kit, Complete (less stem)	1		
	954A0062H03	Valve, Angle, SC, Hand Exp., 1" SW/FPT, 270	1		
	954A0062H28	Repair Kit, Complete (less stem)	1		
	954A0062H04	Valve, Angle, SC, Hand Exp., 1-1/4" SW/FPT, 316 & 399	1		
	954A0062H29	Repair Kit, Complete (less stem)	1		
	954A0075H01	Valve, Angle, SC, Hand Exp., 2" BW, 480-1080	1		
	954A0075H23	Repair Kit, Complete (less stem)	1		
-20	950A0339H01	Valve, Push Button Oil Sampling	1		
-21	950A0292H03	Valve, Angle, SC, Danfoss, 1/2 MPT x 1/2 FPT	1		

1. Prior to January, 2010 contained two of 531A0218H02 element. Replaced with one 531B0100H02 after January, 2010.
2. Prior to January, 2010 contained three of 531A0218H02 element. Replaced with one 531B0100H03 after January, 2010.
3. Current SuperFilter™ II 531B0100H02, and 531B0100H03 replace earlier SuperFilter™ 531A0218H02. One 531B0100H02 replaces two of 531A0218H02. One 531B0100H03 replaces three of 531A0218H02. Required for 1-2-3 Warranty.
4. Not part of Pressure Transducer. Order separately.

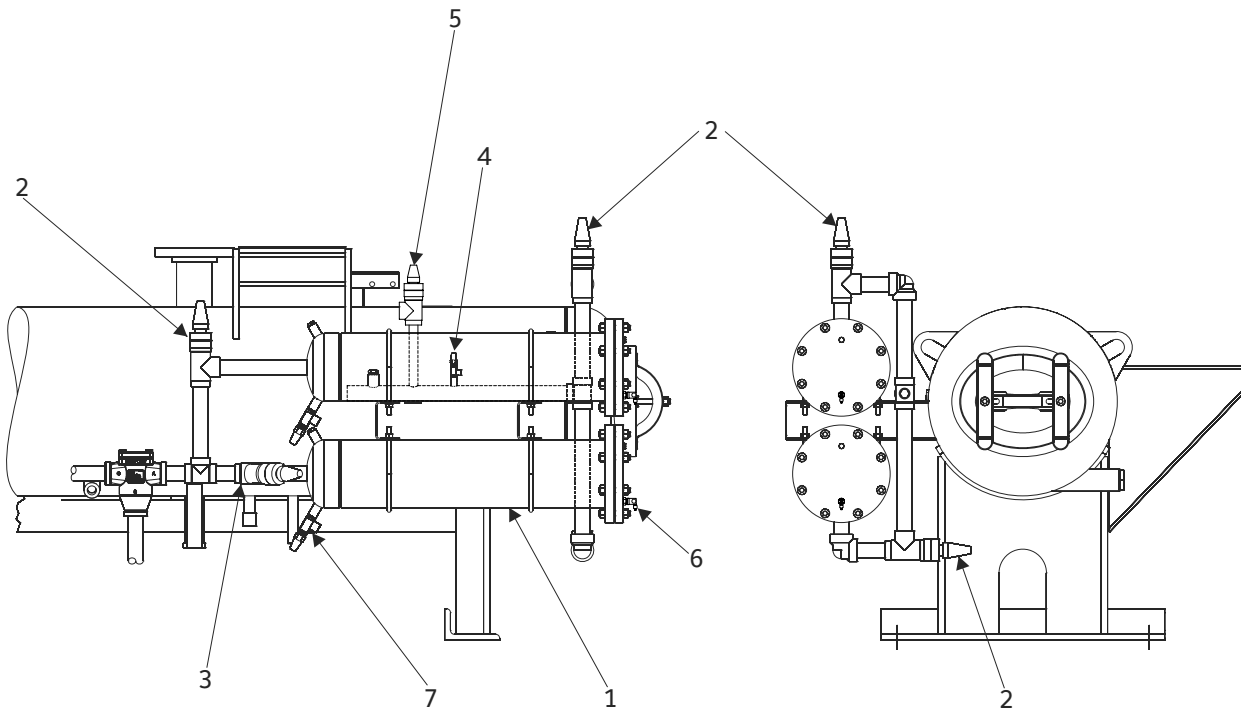

Figure 9. Dual Oil Filters, Typical (100/134 shown).

FIG. & INDEX	PART NUMBER	DESCRIPTION	QTY.	REV.	P & I REF.
9-	720M0475	Dual Oil Filters, 100 and 134	Ref.		
	720M0478	Dual Oil Filters, 177 and 222	Ref.		
	720M0479	Dual Oil Filters, 270	Ref.		
	720M0396	Dual Oil Filters, 316 & 399	Ref.		
	720M0482	Dual Oil Filters, 480 & 546	Ref.		
	720M0485	Dual Oil Filters, 496 & 676	Ref.		
	720M0487	Dual Oil Filters, 856, 1080	Ref.		
-1	553E0013	Assembly, Filter, 100 & 134 (1-1/2" - 2 Element) (See Fig. 8)	2		
	553E0015	Assembly, Filter, 177 & 222 (2" - 2 Element) (See Fig. 8)	2		
	553E0014	Assembly, Filter, 270-676 (2-1/2" - 3 Element) (See Fig. 8)	2		
	553E0020	Assembly, Filter, 856 & 1080 (3" - 3 Element) (See Fig. 8)	2		
-2	950A0233H05	Valve, Angle, Danfoss, SC, 1-1/2" SW, 100 & 134	3		
	950A0232H22	Valve Repair Kit, Complete (less stem)	1		
	950A0233H06	Valve, Angle, Danfoss, SC, 2" SW, 177 & 222	3		
	950A0232H23	Valve Repair Kit, Complete (less stem)	1		
	950A0241H07	Valve, Angle, Danfoss, SC, 2-1/2" BW, 270-676	3		
	950A0240H24	Valve Repair Kit, Complete (less stem)	1		
	950A0241H08	Valve, Angle, Danfoss, SC, 3" BW, 856 & 1080	3		
-3	950A0245H05	Valve, Globe, Danfoss, SC, 1-1/2" SW, 100 & 134	1		
	950A0232H22	Valve Repair Kit, Complete (less stem)	1		
	950A0245H06	Valve, Globe, Danfoss, SC, 2" SW, 177 & 222	1		
	950A0232H23	Valve Repair Kit, Complete (less stem)	1		
	950A0253H07	Valve, Globe, Danfoss, SC, 2-1/2" BW, 270-676	1		
	950A0240H24	Valve Repair Kit, Complete (less stem)	1		
	950A0253H08	Valve, Globe, Danfoss, SC, 3" BW, 856 & 1080	1		
-4	950A0292H01	Valve, Angle, Danfoss, SC, 1/4" NPT	2		
	913A0146H02	Transducer, Pressure, 0-500 PSIA	2		
	649A0890H02	Connector, DIN, 1/2" NPTF ⁽¹⁾	1		
	649A0890H11	Gasket, DIN Connector ⁽¹⁾	1		
	649D4628H01	Relief, Strain, 1/2" ⁽¹⁾	1		
-5	954A0062H02	Valve, Angle, SC, Hand Exp., 3/4" SW/FPT, 100-222	1		
	954A0062H27	Repair Kit, Complete (less stem)	1		
	954A0062H03	Valve, Angle, SC, Hand Exp., 1" SW/FPT, 270	1		
	954A0062H28	Valve Repair Kit, Complete (less stem)	1		
	954A0062H04	Valve, Angle, SC, Hand Exp., 1-1/4" SW/FPT, 316 & 399	1		
	954A0062H29	Valve Repair Kit, Complete (less stem)	1		
	954A0075H01	Valve, Angle, SC, Danfoss, Hand Exp., 2" BW, 480-1080	1		
	954A0075H23	Repair Kit, Complete (less stem)	1		
-6	950A0339H01	Valve, Push Button Oil Sampling	2		
-7	950A0292H03	Valve, Angle, SC, Danfoss, 1/2 MPT x 1/2 FPT	1		
1. Not part of Pressure Transducer. Order separately.					

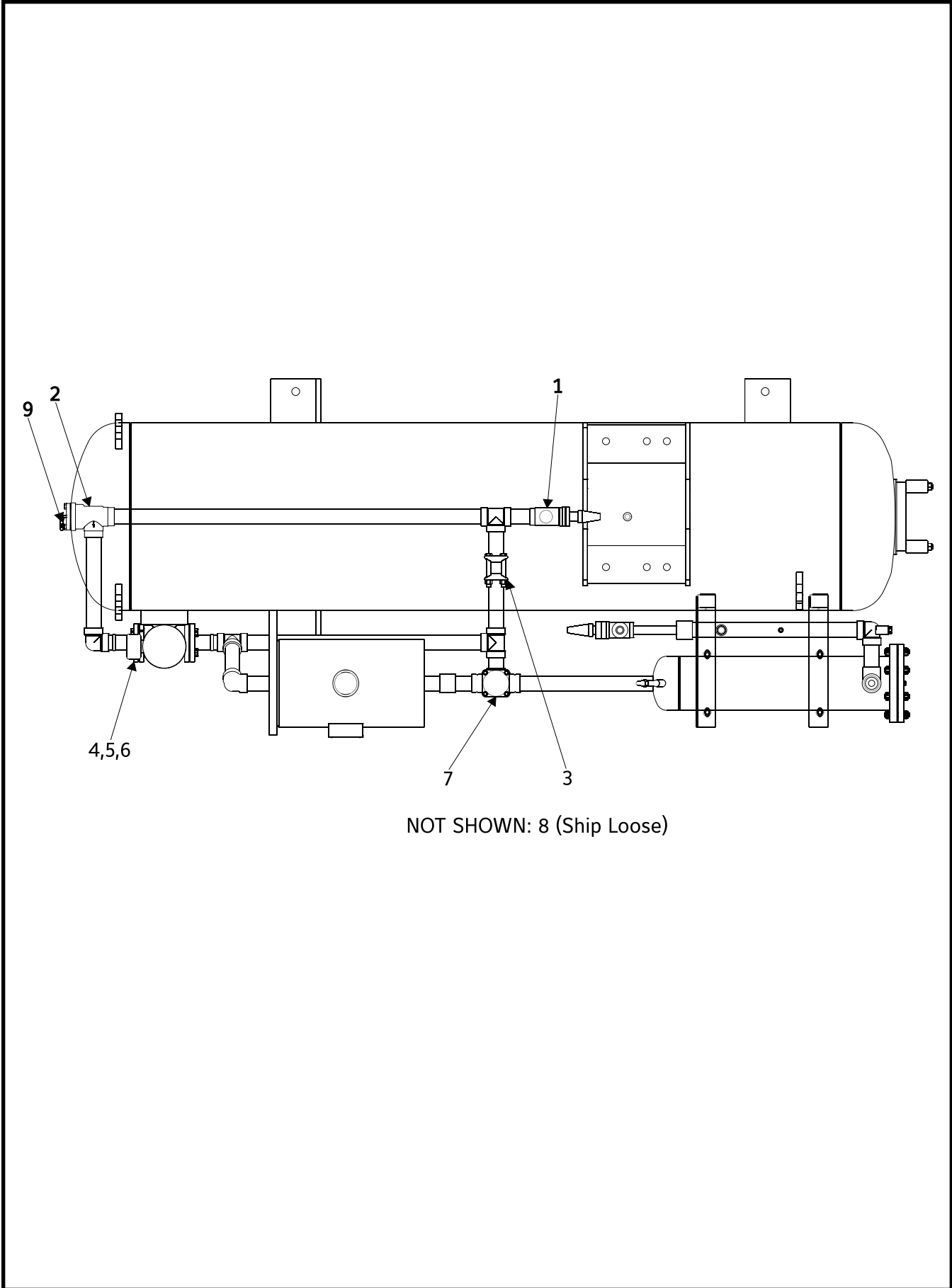

Figure 10. Oil Cooler Piping, Typical, 100-546.

FIG. & INDEX	PART NUMBER	DESCRIPTION	QTY.	REV.	P & I REF.
10-	720M0437	Plate Oil Cooler w/Pump & Temp. Control Valve, 100-134	Ref.		
	720M0438	Plate Oil Cooler w/Pump & Temp. Control Valve, 177-222	Ref.		
	720M0440	Plate Oil Cooler w/Pump & Temp. Control Valve, 270	Ref.		
	720M0458	Plate Oil Cooler w/Pump & Temp. Control Valve, 316-399	Ref.		
	720M0467	Plate Oil Cooler w/Pump & Temp. Control Valve, 480-546	Ref.		
-1	950A0233H06	Valve, Angle, Danfoss, Shutoff, 2" SW, SC	1		
	950A0232H23	Valve Repair Kit, Complete (less stem)	1		
	950A0241H07	Valve, Angle, Danfoss, Shutoff, 2-1/2" BW, SC	1		
	950A0240H24	Repair Kit, Complete (less stem)	1		
-2	950A0320H05	Strainer, Angle, 1-1/2", SW	1		
	950A0320H15	Kit, Strainer & Gasket, 1-1/2"	1		
	950A0320H06	Strainer, Angle, 2", SW	1		
	950A0320H16	Kit, Strainer & Gasket, 2"	1		
	950A0329H01	Valve, Angle, 2-1/2" BW	1		
	950A0329H11	Kit, Strainer & Gasket, 2-1/2"	1		
-3	956A0012G03	Valve, Check, 1-1/2" SW	1		
	956A0012G01	Valve, Check, 2" SW	1		
	956A0012G05	Valve, Check, 2-1/2" SW	1		
-4	944A0108H05	Flange, 1-1/2" SW, 300#	2		
	944A0108H07	Flange, 2-1/2" SW, 300#	2		
	944A0108H08	Flange, 3" SW, 300#	2		
-5	959A0054H25	Gasket, 1-1/2" SW, 300# Flange	2		
	959A0054H27	Gasket, 2-1/2" SW, 300# Flange	2		
	959A0054H28	Gasket, 3" SW, 300# Flange	2		
-6	901A0172H03	Kit, Flange Bolt, 1-1/2", 300#	2		
	901A0172H05	Kit, Flange Bolt, 2-1/2", 300#	2		
	901A0172H06	Kit, Flange Bolt, 3", 300#	2		
-7	950A0294H01	Valve, Temperature Control, 1-1/2"	1		
	950A0294H11	Kit, Service, Temperature Control Valve, 1-1/2 & 2" *	1		
	950A0294H02	Valve, Temperature Control, 2"	1		
	950A0294H11	Kit, Service, Temperature Control Valve, 1-1/2 & 2" *	1		
	950A0297H01	Valve, Temperature Control, 2-1/2"	1		
	950A0297H11	Kit, Service, Temperature Control Valve, 2-1/2" *	1		
-8	950A0328H06	Strainer, Straight, 2", Danfoss, SW	1		
	950A0320H16	Service Kit, 2", Strainer Element and Cover Gasket	1		
	950A0330H02	Strainer, Straight, 3", Danfoss, BW	1		
	950A0329H12	Service Kit, 3", Strainer Element and Cover Gasket	1		
-9	950A0292H01	Valve, Angle, Danfoss, 1/4" MPT x FPT, SC	1		

* Kit includes thermostat and gasket

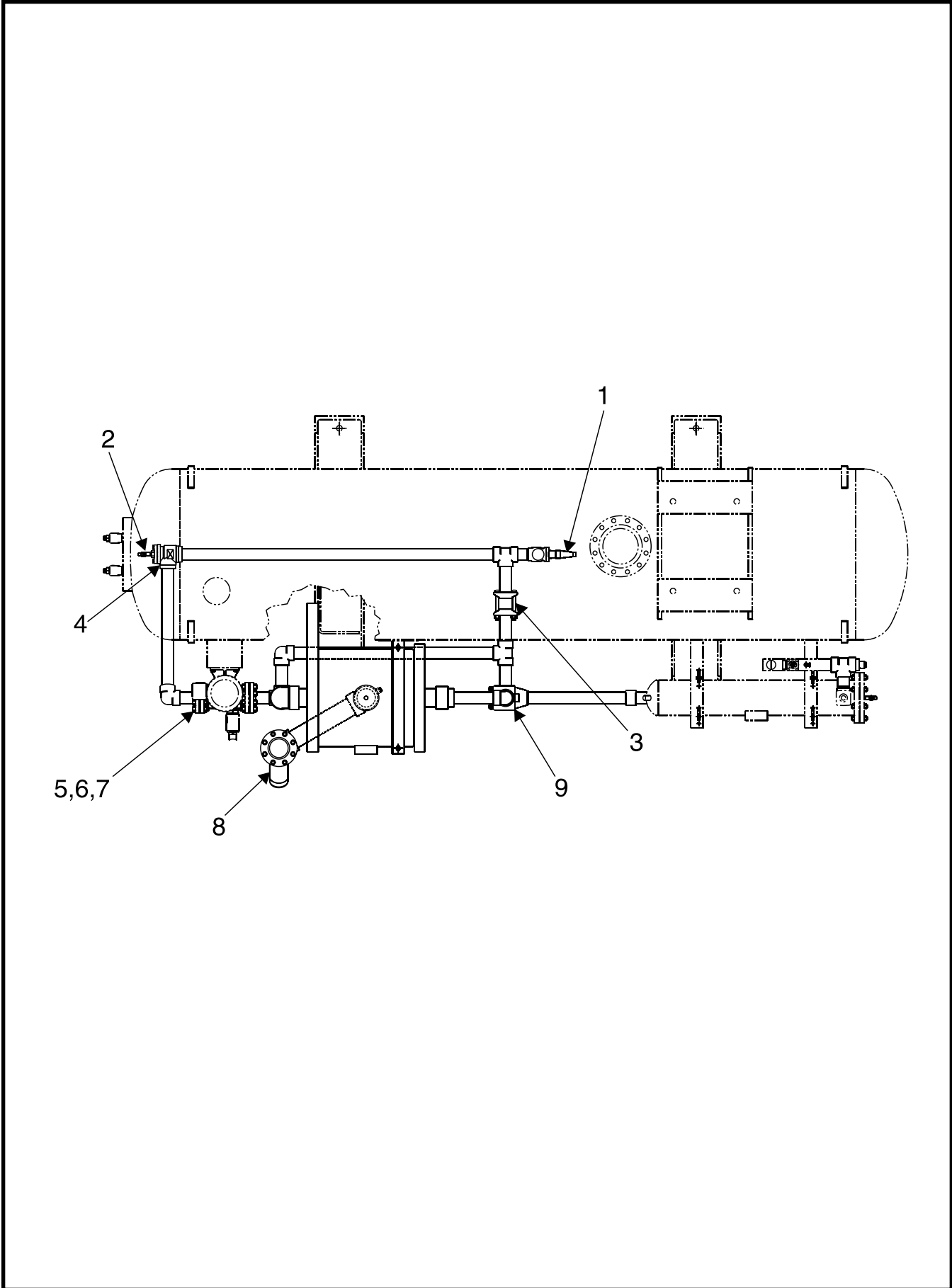

Figure 11. Oil Cooler Piping, Typical, 496-1080.

FIG. & INDEX	PART NUMBER	DESCRIPTION	QTY.	REV.	P & I REF.
11-	720M0469 720M0470	Plate Oil Cooler w/Pump & Temp. Control Valve, 496 & 676 Plate Oil Cooler w/Pump & Temp. Control Valve, 856 & 1080	Ref. Ref.		
-1	950A0241H07 950A0240H24 950A0241H08 950A0240H25	Valve, Angle, Danfoss, 2-1/2", BW, SC Valve Repair Kit, Complete (less stem) Valve, Angle, Danfoss, 3", BW, SC Valve Repair Kit, Complete (less stem)	1 1 1 1		
-2	950A0292H01	Valve, Angle, Danfoss, 1/4" MPT x FPT, SC	1		
-3	956A0012G05 956A0012G02	Valve, Check, R/S, 2-1/2", SW Valve, Check, R/S, 3", SW	1 1		
-4	950A0329H01 950A0329H11 950A0329H02 950A0329H12	Strainer, 3", SW, Danfoss Kit, Service, Strainer Element & Gasket Strainer, 3", BW, Danfoss Kit, Service, Strainer Element & Gasket	1 1 1 1		
-5	944A0108H08	Flange, 3" SW, 300#	2		
-6	959A0054H28	Gasket, 3" SW, 300# Flange	2		
-7	901A0172H06	Kit, Flange, Bolt, 3", 300#	2		
-8	950A0328H06 950A0320H16 950A0330H02 950A0329H12 950A0330H03 950A0329H13	Strainer, Straight, 2", Danfoss, SW Kit, Service, 2", Strainer Element & Cover Gasket Strainer, Straight, 3", Danfoss, BW Kit, Service, 3", Strainer Element & Cover Gasket Strainer, Straight, 4", Danfoss, BW Service Kit, 4", Strainer Element & Cover Gasket	1 1 1 1 1 1		
-9	950A0294H02 950A0294H11 950A0297H01 950A0297H11	Valve, Temperature Control, 2" SW Kit, Service, Temperature Control Valve, 1-1/2 & 2" * Valve, Temperature Control, 2-1/2" SW Kit, Service, Temperature Control Valve, 2-1/2" *	1 1 1 1		
* Kit includes thermostat and gasket					

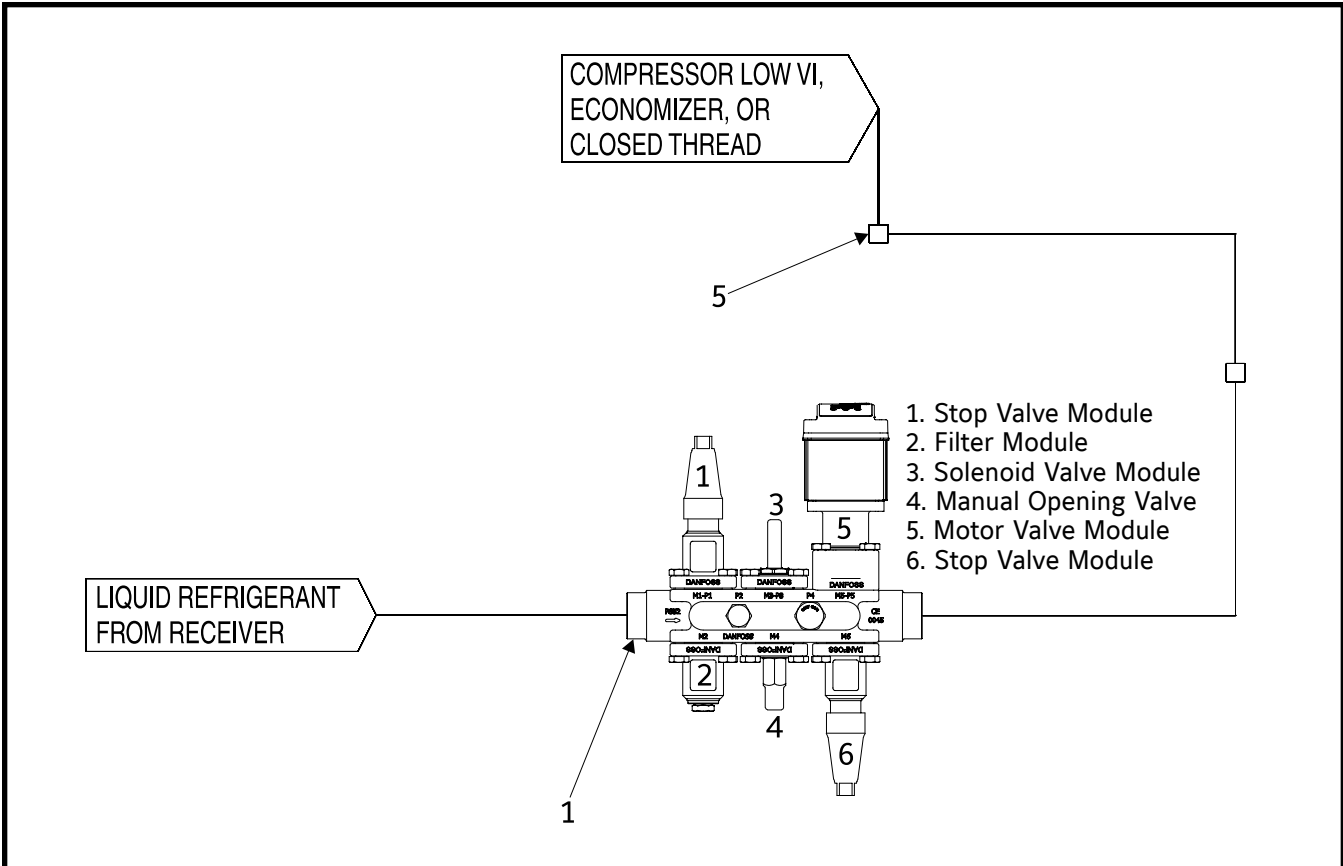

Figure 12a. Liquid Injection, Single Port/Booster.

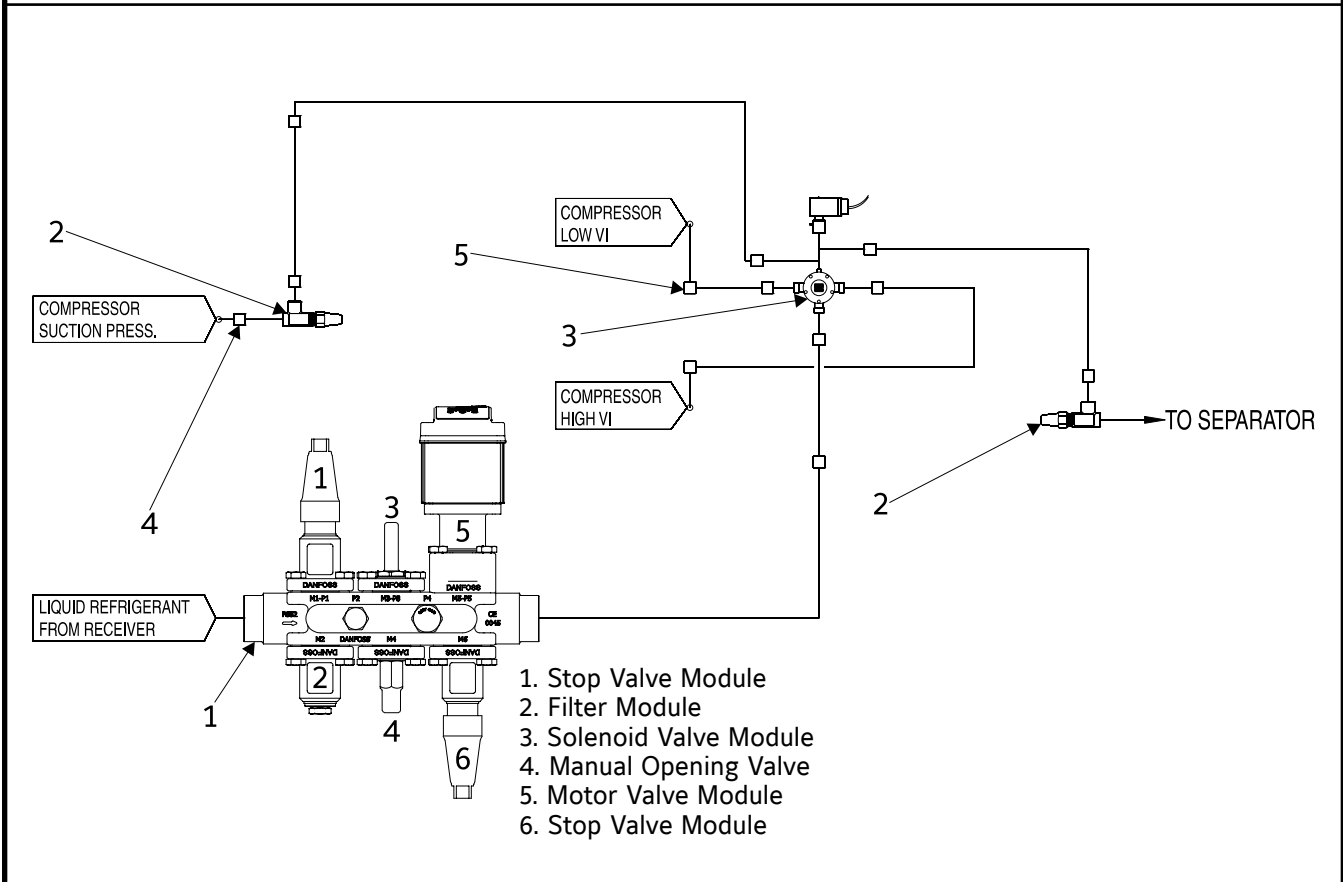

Figure 12b. Liquid Injection, Dual Port.

Figure 12. Liquid Injection.

FIG. & INDEX	PART NUMBER	DESCRIPTION	QTY.	REV.	P & I REF.
12-	720M0275	Liquid Injection, Socket Weld	Ref.		
	720M0314	Liquid Injection, Oil Piping	Ref.		
	720M0433	Liquid Injection Kit	Ref.		
-1	950A0327H01	Valve and Motor Assembly, ICF 20A, 3/4" SW (R-717)	1		
	950A0327H02	Valve and Motor Assembly, ICF 20B, 3/4" SW (R-717)	1		
	950A0327H03	Valve and Motor Assembly, ICF 20C, 1" SW (R-717)	1		
	950A0327H11	Module, Stop Valve, ICFS 20 ⁽¹⁾	2		
	950A0232H31	Gland, Packing, ICFS 20	2		
	950A0327H13	Handwheel, ICFS 20	2		
	950A0327H14	Gasket Kit, Bonnet	6		
	950A0327H15	Element, Filter, ICFF	1		
	950A0327H16	Module, Solenoid Valve, ICFE 20 ⁽¹⁾	1		
	950A0293H01	Coil, 240 AC, 60 Hz (not shown) ⁽²⁾	1		
	950A0293H02	Coil, 120 AC, 60 Hz (not shown) ⁽²⁾	1		
	950A0293H03	Coil, 24 DC, 60 Hz (not shown) ⁽²⁾	1		
	640D0121H01	Cable Assembly	1		
	950A0327H17	Module, Manual Opening, ICFO 20 ⁽¹⁾	1		
	950A0327H18	Module, Motor Valve, ICM 20A ⁽¹⁾	1		
	950A0327H19	Module, Motor Valve, ICM 20B ⁽¹⁾	1		
	950A0327H20	Module, Motor Valve, ICM 20C ⁽¹⁾	1		
	950A0327H21	Actuator, ICAD 600	1		
	950A0327H22	Sight Glass, 3/8" NPT	2		
	950A0327H23	Valve, Bleed, 3/8" FPT (not shown)	1		
	950A0334H01	Valve and Motor Assembly, ICF 20A, 3/4" SW (R-22)	1		
	950A0334H02	Valve and Motor Assembly, ICF 20B, 3/4" SW (R-22)	1		
	950A0334H03	Valve and Motor Assembly, ICF 20C, 1" SW (R-22)	1		
	950A0327H11	Module, Stop Valve, ICFS 20 ⁽¹⁾	2		
	950A0232H31	Gland, Packing, ICFS 20	2		
	950A0327H13	Handwheel, ICFS 20	2		
	950A0327H14	Gasket Kit, Bonnet	6		
	950A0327H15	Element, Filter, ICFF	1		
	950A0327H16	Module, Solenoid Valve, ICFE 20 ⁽¹⁾	1		
	950A0293H01	Coil, 240 AC, 60 Hz (not shown) ⁽²⁾	1		
	950A0293H02	Coil, 120 AC, 60 Hz (not shown) ⁽²⁾	1		
	950A0293H03	Coil, 24 DC, 60 Hz (not shown) ⁽²⁾	1		
	640D0121H01	Cable Assembly	1		
	950A0327H17	Module, Manual Opening, ICFO 20 ⁽¹⁾	1		
	950A0334H18	Module, Motor Valve, ICM 20A ⁽¹⁾	1		
	950A0334H19	Module, Motor Valve, ICM 20B ⁽¹⁾	1		
	950A0334H20	Module, Motor Valve, ICM 20C ⁽¹⁾	1		
	950A0327H21	Actuator, ICAD 600	1		
	950A0327H22	Sight Glass, 3/8" NPT	2		
	950A0327H23	Valve, Bleed, 3/8" FPT (not shown)	1		
-2	950A0292H01	Valve, Angle, SC, Danfoss, 1/4" MPT x 1/4" FPT	1		
-3	951A0053G01	Valve, Solenoid, 3-Way, R-717, R-22 (Plus Fittings)	1		
	951A0053H01	Valve, Solenoid, 3-Way, Less Coil (Plus Fittings)	1		
	951A0054H01	Coil, 120V	1		
	951A0053G11	Repair Kit consisting of:	1		
	951A0053G01	Valve, Solenoid, 3-Way, R-717, R-22	1		
	944A0117H01	Fitting, Connector, Female	1		
-4	980A0012K60	O-ring, Reducer	1		
-5	980A0012K66	O-ring, Elbow	1		
	980A0012K69	O-ring, Elbow	1		

1. Modules include a gasket and 4 bolts.
2. Coil sold separately from valve assembly.

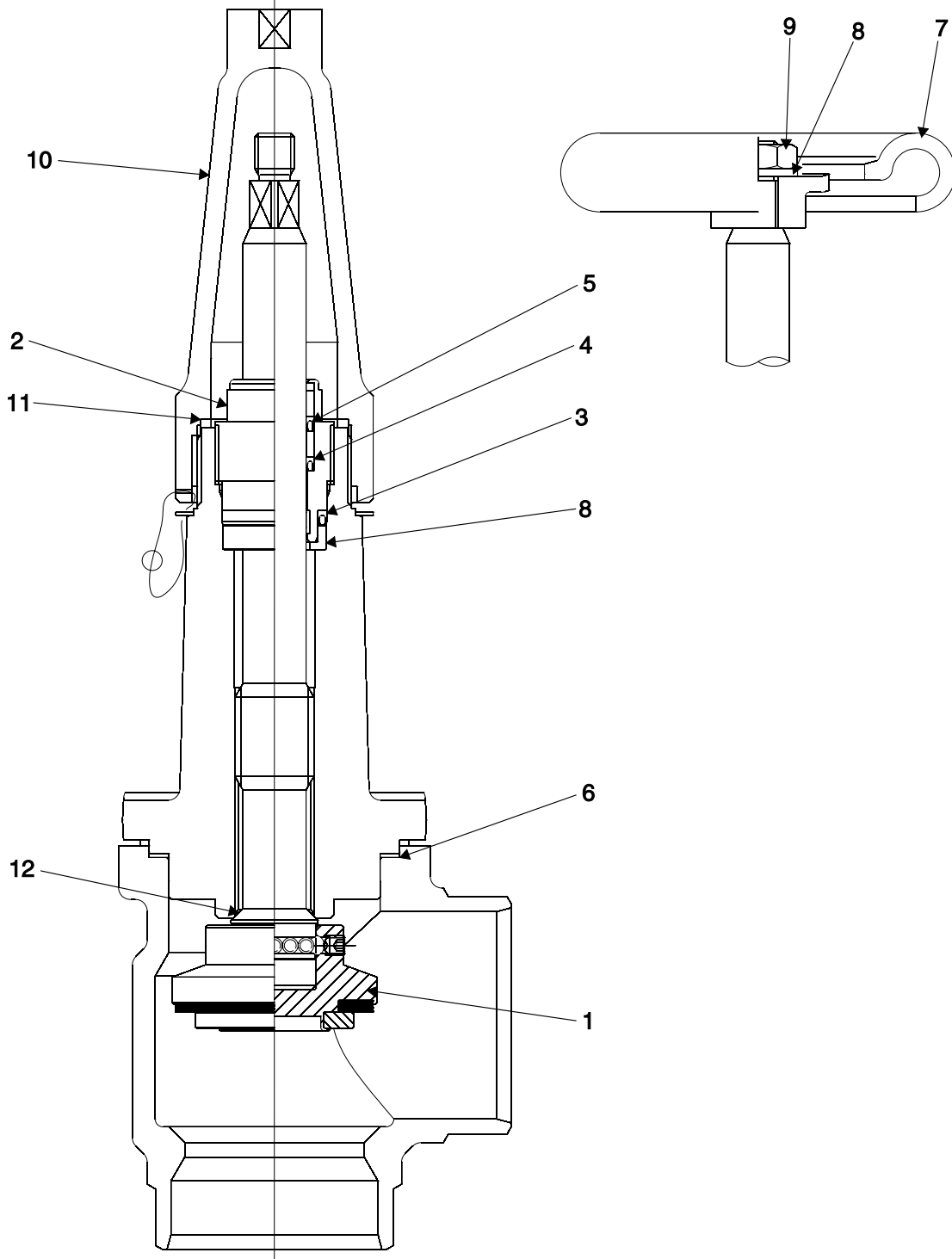

Figure 13. 4-8" Suction/Discharge Stop Valve.

FIG. & INDEX	PART NUMBER	DESCRIPTION	QTY.	REV.	P & I REF.
13-	950A0240 950A0241	4-8" Suction/Discharge Stop Valve, HW (See chart below) 4-8" Suction/Discharge Stop Valve, SC (See chart below)			
-1	Kit 1, 3	Cone Complete w/Cone Seal			
-2	Kit 1, 2	Packing Gland incl. Gaskets			
-3	-	Packing Washer			
-4	Kit 1, 2	O-Ring			
-5	Kit 1, 2	O-Ring			
-6	Kit 1, 3	O-Ring, Housing/Bonnet			
-7	Kit 4	Handwheel			
-8	Kit 4	Washer			
-9	Kit 4	Nut			
-10	Kit 5	Cap			
-11	Kit 1, 5	Gasket for Cap			
-12	Kit 1, 5	Soft Backseal			

4-8" SUCTION/DISCHARGE STOP VALVE							
VALVE	DESCR.	SIZE	1. COMPLETE SPARES KIT ⁽¹⁾	2. PACKING GLAND KIT ⁽²⁾	3. CONE KIT ⁽³⁾	4. HW/SC KIT ⁽⁴⁾	5. CAP & BONNET KIT ⁽⁵⁾
950A0240H09	BW - HW	4	950A0240H26	950A0240H34	950A0240H46	950A0240H55	N/A
950A0240H10	BW - HW	5	950A0240H27	950A0240H35	950A0240H47	950A0240H56	N/A
950A0240H11	BW - HW	6	950A0240H28	950A0240H35	950A0240H48	950A0240H56	N/A
950A0240H12	BW - HW	8	950A0240H29	950A0240H36	950A0240H49	950A0240H57	N/A
950A0241H09	BW - SC	4	950A0240H26	950A0240H34	950A0240H46	950A0241H63	950A0241H56
950A0241H10	BW - SC	5	950A0240H27	950A0240H35	950A0240H47	950A0241H64	950A0241H57
950A0241H11	BW - SC	6	950A0240H28	950A0240H35	950A0240H48	950A0241H64	950A0241H58
950A0241H12	BW - SC	8	950A0240H29	950A0240H36	950A0240H49	950A0241H65	950A0241H59

1. Consists of Cone complete incl. steel balls and Allen screw, Packing Gland incl. Gaskets, O-ring for Housing/Bonnet, Cap Gasket, and Back Seal.
2. Consists of Packing Gland, incl. Gaskets, with O-rings.
3. Consists of Cone Complete incl. Steel Balls & Allen Screw, O-ring for Housing/Bonnet.
4. HW Kit Consists of Handwheel, Nut/Washer (Nut/Washer numbers are: 4" 950A0240H61/950A0240H64, 5-6" 950A0240H62/950A0240H65, 8" 950A0240H63/950A0240H66. SC Kit consists of Cap and Gasket.
5. Consists of Seal Cap Gasket, O-ring for Housing/Bonnet, and Soft Back Seal.

DISCHARGE STOP VALVE SIZE & APPLICATION		
APPLICATION	SIZE	STOP VALVE
HIGH STAGE HW	4	950A0240H09
HIGH STAGE SC	4	950A0241H09
BOOSTER HW	4	950A0240H09
BOOSTER SC	4	950A0241H09
HIGH STAGE HW	5	950A0240H10
HIGH STAGE SC	5	950A0241H10
BOOSTER HW	5	950A0240H10
BOOSTER SC	5	950A0241H10
HIGH STAGE HW	6	950A0240H11
HIGH STAGE SC	6	950A0241H11
BOOSTER HW	6	950A0240H11
BOOSTER SC	6	950A0241H11
HIGH STAGE HW	8	950A0240H12
HIGH STAGE SC	8	950A0241H12
BOOSTER HW	8	950A0240H12
BOOSTER SC	8	950A0241H12

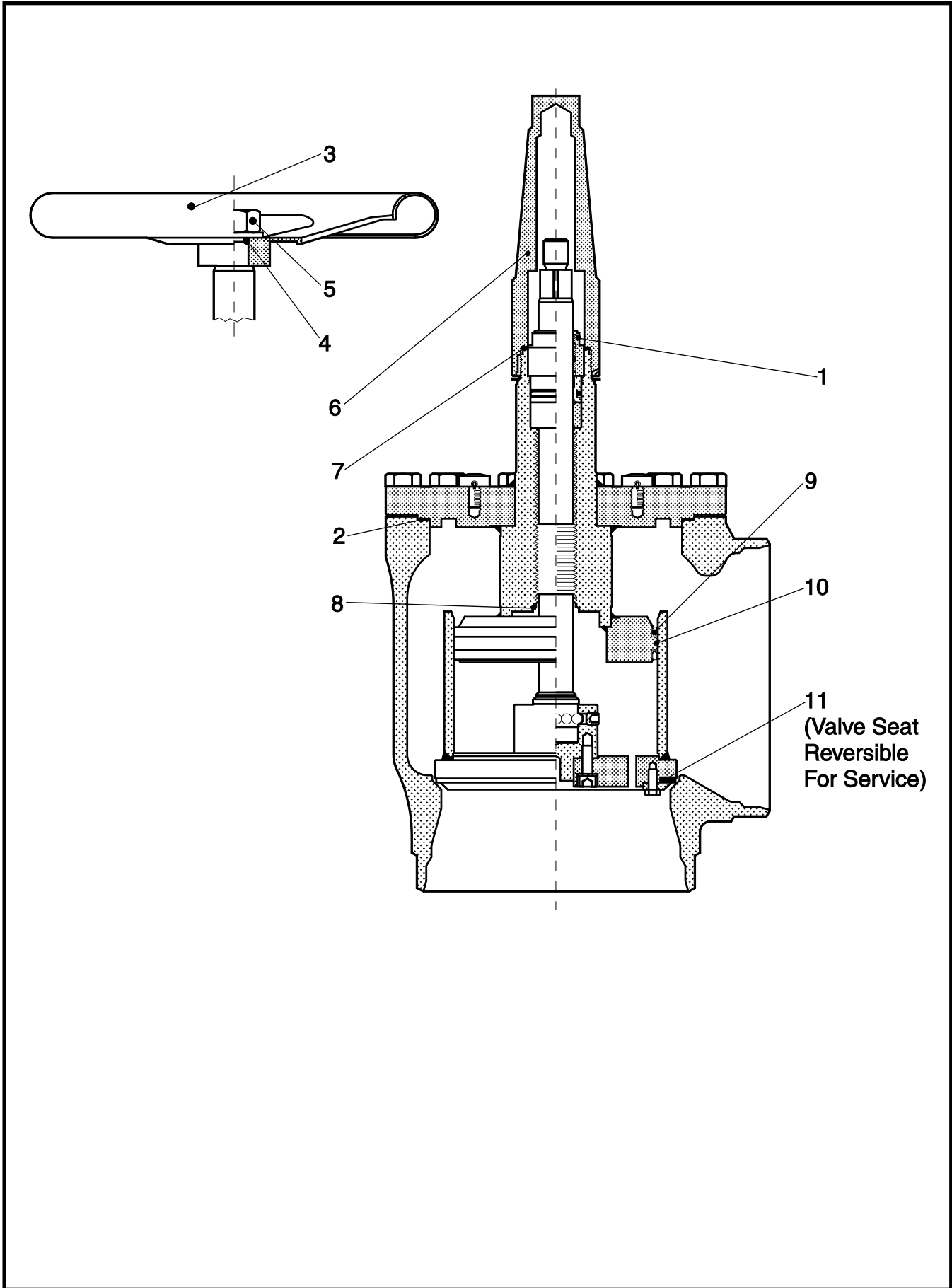

Figure 14. 10-12" Suction/Discharge Stop Valve, Danfoss.

FIG. & INDEX	PART NUMBER	DESCRIPTION	QTY.	REV.	P & I REF.
14-	950A0283 950A0284	10-12" Suction/Discharge Stop Valve, HW Danfoss 10-12" Suction/Discharge Stop Valve, SC Danfoss	Ref. Ref.		
-1	Kit 1, 2	Packing Gland Complete			
-2	Kit 1	Gasket for Bonnet			
-3	Kit 4	Handwheel			
-4	Kit 4	Washer			
-5	Kit 4	Nut			
-6	Kit 4, 5	Cap			
-7	Kit 1, 5	Gasket			
-8	Kit 1, 5	Gasket for backseat			
-9	Kit 1, 3	Gasket for Cone (U-sleeve)			
-10	Kit 1, 3	Wear Ring for Cone			
-11	Kit 1, 3	Gasket for Cone (valve seat) (Note - Valve Seat is reversible for service)			

10-12" SUCTION/DISCHARGE STOP VALVE							
VALVE	DESCR.	SIZE	1. COMPLETE SPARES KIT ⁽¹⁾	2. PACKING GLAND KIT ⁽²⁾	3. CONE KIT ⁽³⁾	4. HW/SC KIT ⁽⁴⁾	5. CAP & BONNET KIT ⁽⁵⁾
950A0283H01	BW - HW	10	950A0283H21	950A0283H31	950A0283H41	950A0283H51	N/A
950A0283H02	BW - HW	12	950A0283H22	950A0283H31	950A0283H42	950A0283H52	N/A
950A0284H01	BW - SC	10	950A0283H21	950A0283H31	950A0284H41	950A0284H61	950A0284H51
950A0284H02	BW - SC	12	950A0283H22	950A0283H31	950A0284H42	950A0284H61	950A0284H52

1. Consists of Packing Gland complete, Five Gaskets, Wear Ring for Cone.
2. Consists of Packing Gland complete.
3. Consists of Gasket for Cone (u-sleeve), Wear ring for Cone, Gasket for Cone (valve seat)
4. HW Kit Consists of Handwheel, Washer, and Nut. SC Kit consists of Cap and Gasket.
5. Consists of Cap and Gasket, and Gasket for backseat.

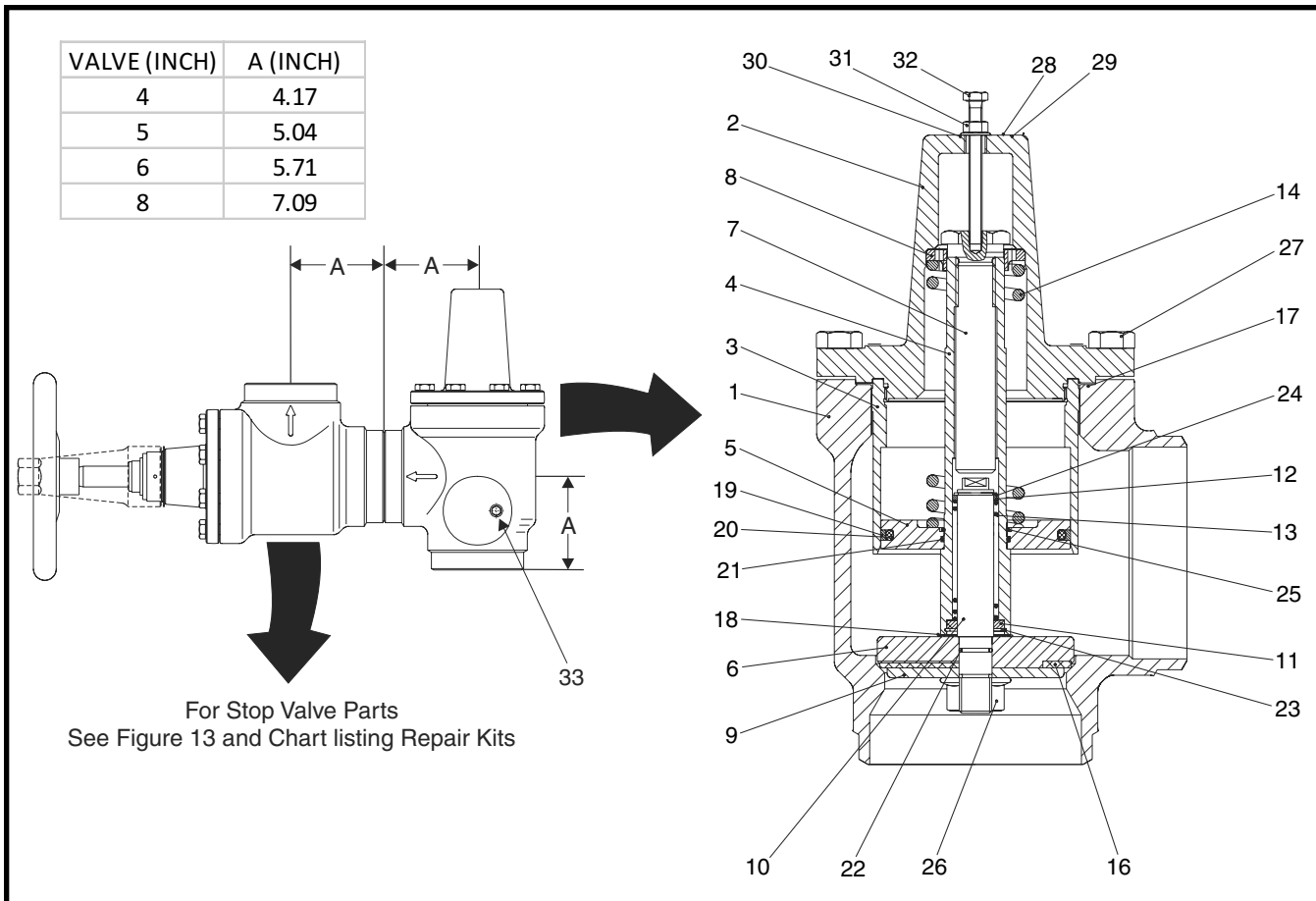

Figure 15. 4-8" Discharge Check Valve, Current (Danfoss).

CHECK VALVE ONLY (See Index next page)						
VALVE	APPLICATION	SIZE	BONNET GASKET	SEAL KIT ⁽¹⁾	14.5 PSI SPRING KIT ⁽²⁾	29 PSI SPRING KIT ⁽²⁾
956A0045H01	HIGH STAGE	4	956A0045H11	956A0045H12	N/A	956A0045H14
956A0045H02	BOOSTER	4	956A0045H11	956A0045H12	956A0045H15	N/A
956A0046H01	HIGH STAGE	5	956A0046H11	956A0046H12	N/A	956A0046H14
956A0046H02	BOOSTER	5	956A0046H11	956A0046H12	956A0046H15	N/A
956A0047H01	HIGH STAGE	6	956A0047H11	956A0047H12	N/A	956A0047H14
956A0047H02	BOOSTER	6	956A0047H11	956A0047H12	956A0047H15	N/A
956A0048H01	HIGH STAGE	8	956A0048H11	956A0048H12	N/A	956A0048H14
956A0048H02	BOOSTER	8	956A0048H11	956A0048H12	956A0048H15	N/A

1. Consists of Teflon Ring, Housing Gasket, Nylon Washer, Glyde Ring, and 3 O-rings.
2. Consists of Spring, Marking Plate, and Rivet.

FIG. & INDEX	PART NUMBER	DESCRIPTION	QTY.	REV.	P & I REF.
15-	-	4-8" Discharge Check Valve, Class 300	Ref.		
	-	Check Valve (See Chart previous page and below)	Ref.		
-1	-	Housing	1		
-2	-	Bonnet	1		
-3	-	Piston Cylinder	1		
-4	-	Piston Rod	1		
-5	-	Piston	1		
-6	-	Cone	1		
-7	-	Spring Screw	1		
-8	-	Spring Bushing	1		
-9	-	Cone Plate	1		
-10	-	Cone Rod	1		
-11	-	Rear Bushing	1		
-12	-	Front Bushing	1		
-13	-	Spring	1		
-14	Spring Kit*	Spring	1		
-15	-	Plug (not shown)	1		
-16	Seal Kit*	Teflon Ring	1		
-17	Seal Kit*	Bonnet Gasket	1		
-18	Seal Kit*	Nylon Washer	1		
-19	Seal Kit*	Glyde Ring	1		
-20	Seal Kit*	O-Ring	1		
-21	Seal Kit*	O-Ring	1		
-22	Seal Kit*	O-Ring	1		
-23	-	Spring Ring	1		
-24	-	Spring Ring	1		
-25	-	Spring Ring	1		
-26	-	Nut	1		
-27	-	Set Screw	A/R		
-28	Spring Kit*	Marking Plate	1		
-29	Spring Kit*	Rivet	1		
-30	-	Washer	1		
-31	-	Nut	1		
-32	-	Screw	1		
-33	950A0292H01	Valve, Angle, SC, Danfoss, 1/4" MPT x 1/4" FPT	1		

* See Check Valve Chart, previous page.

DISCHARGE CHECK VALVE APPLICATION & SIZE		
APPLICATION	SIZE	CHECK VALVE
HIGH STAGE HW	4	956A0045H01
HIGH STAGE SC	4	956A0045H01
BOOSTER HW	4	956A0045H02
BOOSTER SC	4	956A0045H02
HIGH STAGE HW	5	956A0046H01
HIGH STAGE SC	5	956A0046H01
BOOSTER HW	5	956A0046H02
BOOSTER SC	5	956A0046H02
HIGH STAGE HW	6	956A0047H01
HIGH STAGE SC	6	956A0047H01
BOOSTER HW	6	956A0047H02
BOOSTER SC	6	956A0047H02
HIGH STAGE HW	8	956A0048H01
HIGH STAGE SC	8	956A0048H01
BOOSTER HW	8	956A0048H02
BOOSTER SC	8	956A0048H02

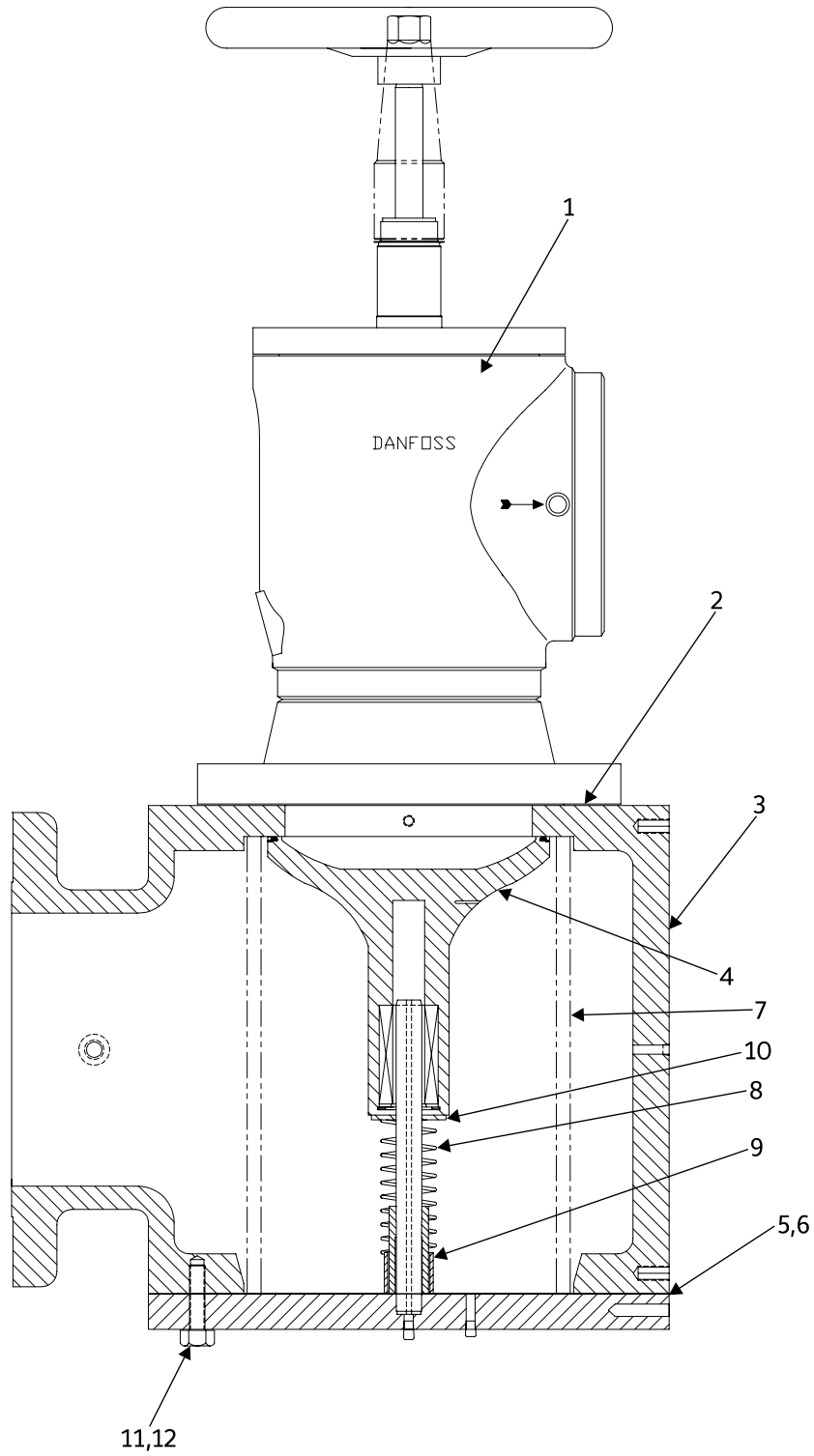

Figure 16. Multivalve, 496 & 676.

FIG. & INDEX	PART NUMBER	DESCRIPTION	QTY.	REV.	P & I REF.
16-	535D0549G01 535D0549G02	Assembly, Multivalve, 12" In x 14" Out, 300 Class, HW Assembly, Multivalve, 12" In x 14" Out, 300 Class, SC	Ref. Ref.		
-1	950A0286G01 950A0283H02 950A0286G02 950A0284H02 901A0050D02 905A0013H10	Valve, Angle, 12", HW - Flanged Assbly. Valve, Angle, 12", HW ⁽¹⁾ Valve, Angle, 12", SC - Flanged Assbly. Valve, Angle, 12", SC ⁽¹⁾ Capscrew, Hex Head, 1-1/8 NC x 3-1/4" LG. (not shown) Lock Washer, 1-1/8" (not shown)	1 1 1 1 16 16		
-2	959A0062H26	Gasket, Multi-Valve, 12"	1		
-3	535D0548G01	Suction Trap Body, 12"	1		
-4	580B0240G08 111Q0452525 580B0243G01 111Q0019409 580A0235H03 580B0243H01 580C0264C01 581A0026H04 980A0012H87	Assembly, Sliding Button Ring, Retaining Assembly, Bearing Mount Liner, Split Body, Bearing Button Washer, Seal O-ring	1 1 1 2 2 1 1 1 1		
-5	580B0246G09 580A0232H02 580B0273H08 580C0394H01 944A0008H02	Subassembly, End Cover Spacer Shaft Cover, End Plug, Pipe, 1/4"	1 1 1 1 2		
-6	959A0061H05	Gasket, End Cover	1		
-7	580C0269H01	Strainer, Double Screen	1		
-8	580A0230H01	Spring, Return	1		
-9	580A0234H02	Adjuster, Spring	1		
-10	111Q0940164	Washer	1		
-11	901A0048D09	Cap Screw, Hex Head, 7/8" NC x 3" LG.	20		
-12	905A0013H08	Washer, Lock, 7/8"	20		
1. See Figure 14 for service parts kits.					

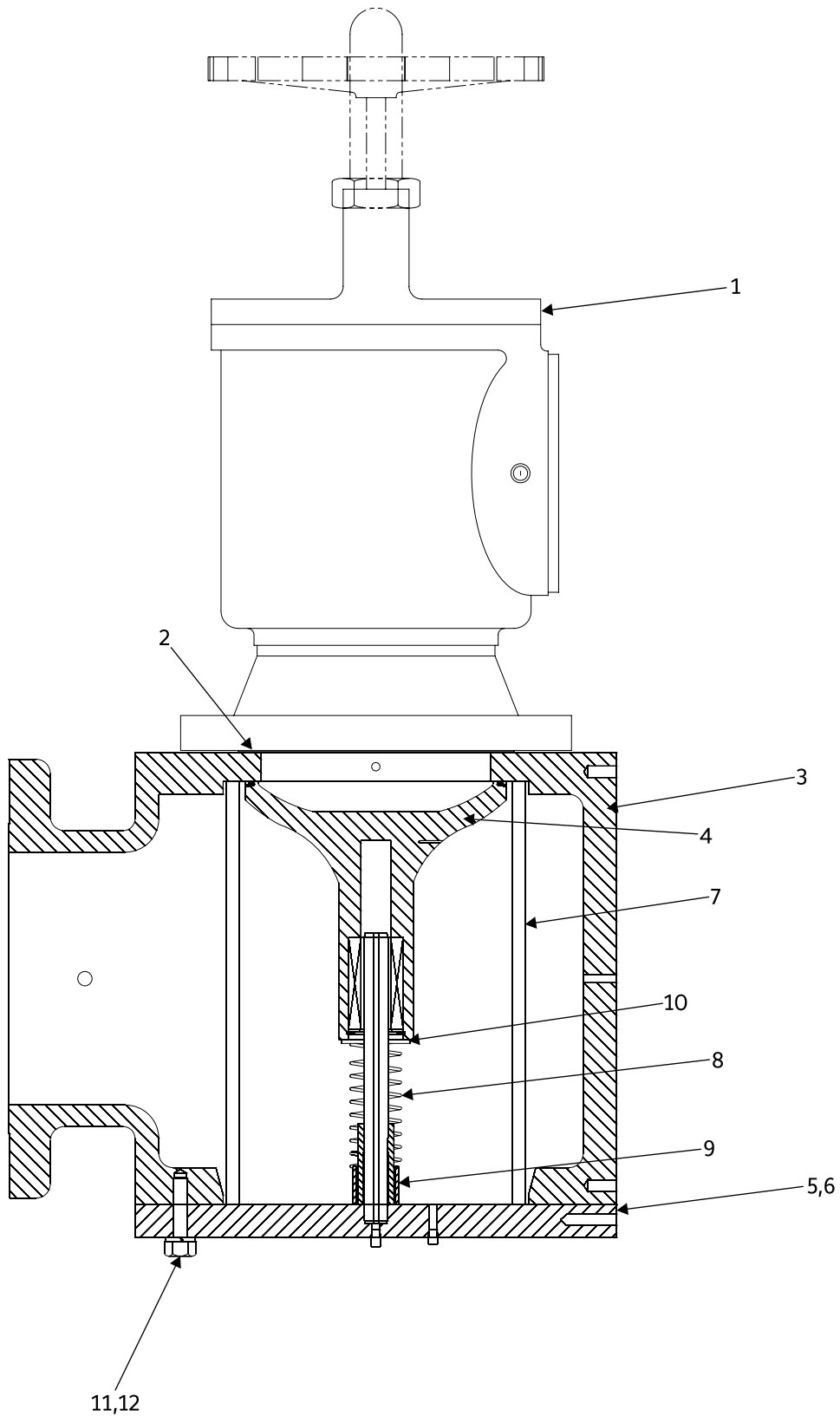

Figure 17. Multivalve, 856 & 1080.

FIG. & INDEX	PART NUMBER	DESCRIPTION	QTY.	REV.	P & I REF.
17-	535D0553G01	Assembly, Multivalve, 14" IN x 14" OUT, 300 Class, HW	Ref.		
-1	950A0185G01	Valve, Angle, 14", HW - Flanged Assbly.	1		
	950A0169G01	Valve, Angle, 14", HW, Hansen ⁽¹⁾	1		
	901A0050D02	Capscrew, Hex Head, 1-1/8 NC x 3-1/4" LG. (not shown)	20		
	905A0013H10	Lock Washer, 1-1/8" (not shown)	20		
-2	959A0062H27	Gasket, Multi-Valve, 14"	1		
-3	535D0193C04	Body, Suction Trap, 14"	1		
-4	580B0240G08	Assembly, Sliding Button	1		
	111Q0452525	Ring, Retaining	1		
	580B0243G01	Assembly, Bearing	1		
	111Q0019409	Mount	2		
	580A0235H03	Liner, Split	2		
	580B0243H01	Body, Bearing	1		
	580C0264C01	Button	1		
	581A0026H04	Washer, Seal	1		
	980A0012H87	O-ring	1		
-5	580B0246G09	Subassembly, End Cover	1		
	580A0232H02	Spacer	1		
	580B0273H08	Shaft	1		
	580C0394H01	Cover, End	1		
	944A0008H02	Plug, Pipe, 1/4"	2		
-6	959A0061H05	Gasket, End Cover	1		
-7	580C0269H01	Strainer, Double Screen	1		
-8	580A0230H01	Spring, Return	1		
-9	580A0234H02	Adjuster, Spring	1		
-10	111Q0940164	Washer	1		
-11	901A0048D09	Cap Screw, Hex Head, 7/8" NC x 3" LG.	20		
-12	905A0013H08	Washer, Lock, 7/8"	20		

1. Contact factory for service information.

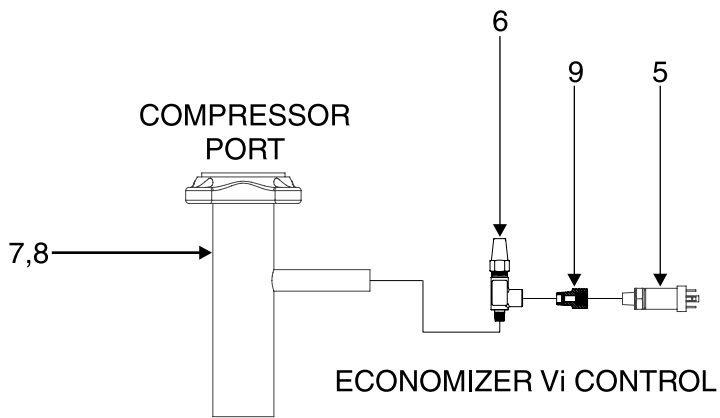
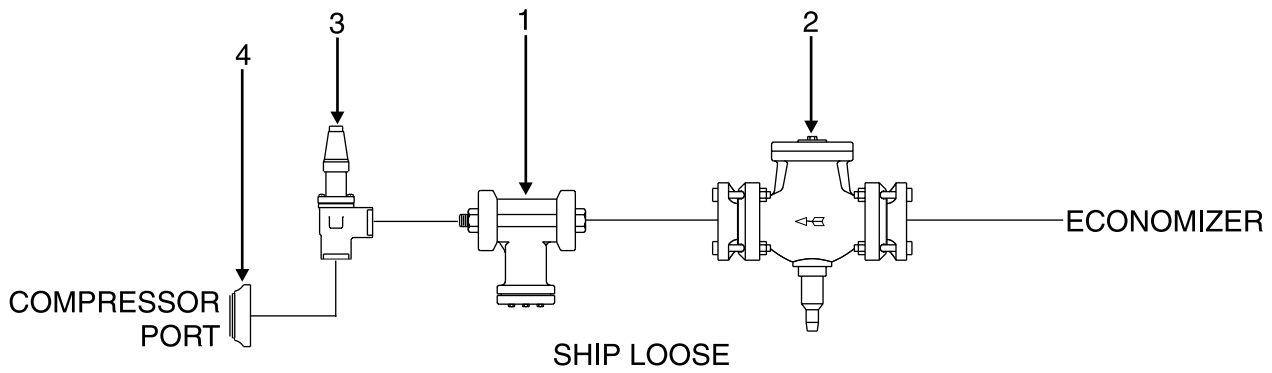

Figure 18. Economizer.

FIG. & INDEX	PART NUMBER	DESCRIPTION	QTY.	REV.	P & I REF.
18-	535M0001G03	Kit, Economizer, 100 & 134	Ref.		
	535M0001G04	Kit, Economizer, 177 - 270	Ref.		
	535M0001G06	Kit, Economizer, 316 & 399	Ref.		
	535M0001G07	Kit, Economizer, 480 & 546	Ref.		
	535M0001G05	Kit, Economizer, 496 & 676	Ref.		
-1	950A0001H08	Strainer, 1½", 100 & 134	1		
	950A0001H27	Kit, Repair (includes screen, spring & gasket)	1		
	950A0001H06	Strainer, 2", 177 - 270, 316 & 399	1		
	950A0001H25	Kit, Repair (includes screen, spring & gasket)	1		
	950A0001H09	Strainer, 3", 480 - 676	1		
	950A0001H28	Kit, Repair (includes screen, spring & gasket)	1		
-2	956A0025H23	Valve, Check, Modified, 1½", 100 & 134	1		
	956A0025H24	Valve, Check, Modified, 2", 177 - 270, 316 & 399	1		
	956A0025H25	Valve, Check, Modified, 3", 480 - 676	1		
-3	950A0233H05	Valve, Angle, Danfoss, SC, 1½" SW, 100 & 134	1		
	950A0232H22	Valve Repair Kit, Complete (less stem)	1		
	950A0233H06	Valve, Angle, Danfoss, SC, 2" SW, 177 - 270, 316 & 399	1		
	950A0232H23	Valve Repair Kit, Complete (less stem)	1		
	950A0241H07	Valve, Angle, Danfoss, SC, 2½" BW, 480 & 546	1		
	950A0240H24	Valve Repair Kit, Complete (less stem)	1		
	950A0241H08	Valve, Angle, Danfoss, SC 3" BW, 496 & 676	1		
	950A0240H25	Valve Repair Kit, Complete (less stem)	1		
-4	959A0057H05	Gasket, 1½" Bolt Flange, 100 & 134	1		
	959A0057H07	Gasket, 2" Bolt Flange, 177 - 270	1		
	959A0057H06	Gasket, 2½" Bolt Flange, 316 - 546	1		
	959A0057H18	Gasket, 3" Bolt Flange, 480 - 676	1		
	944A0358H02	Flange, SW, Square, 1½", 100 & 134	1		
	944A0358H03	Flange, SW, Square, 2", 177 - 270	1		
	944A0358H04	Flange, SW, Square, 2½", 316 - 546	1		
	944A0358H05	Flange, SW, Square, 3", 480 - 676	1		
	720M0532	Kit, Piping, Economizer Vi Control	Ref.		
-5	913A0146G22	Transducer, Pressure, 0-500 PSIA w/DIN Conn. & Str. Relief	1		
	913A0146H02	Transducer, Pressure, 0-500 PSIA	1		
	649A0890H02	Connector, DIN 1/2" NPTF	1		
	649A0890H11	Gasket, DIN Connector	1		
	649D4628H01	Relief, Strain, 1/2"	1		
-6	950A0292H01	Valve, Angle, SC, Stop/Needle, 1/4" MPT x 1/4" FPT	1		
-7	720C0189G01	Assembly, Economizer 1½" Inlet Pipe, 100 & 134	1		
	720C0189G02	Assembly, Economizer 2" Inlet Pipe, 177, 222, & 270	1		
	720C0189G03	Assembly, Economizer 2½" Inlet Pipe, 316, 399, 480, 546	1		
	720C0189G04	Assembly, Economizer 3" Inlet Pipe, 496, 676, 856, 1080	1		
-8	959A0057H05	Gasket, 1½" Bolt Flange, 100 & 134	1		
	959A0057H07	Gasket, 2" Bolt Flange, 177 - 270	1		
	959A0057H06	Gasket, 2½" Bolt Flange, 316 - 546	1		
	959A0057H18	Gasket, 3" Bolt Flange, 496 - 1080	1		
-9	944A0255H01	Fitting, Snubber, Gauge Protector, 1/4 MPT x 1/4 FPT ⁽¹⁾	1		
		1. Porous sintered metal element. Pulsating gas protection.			

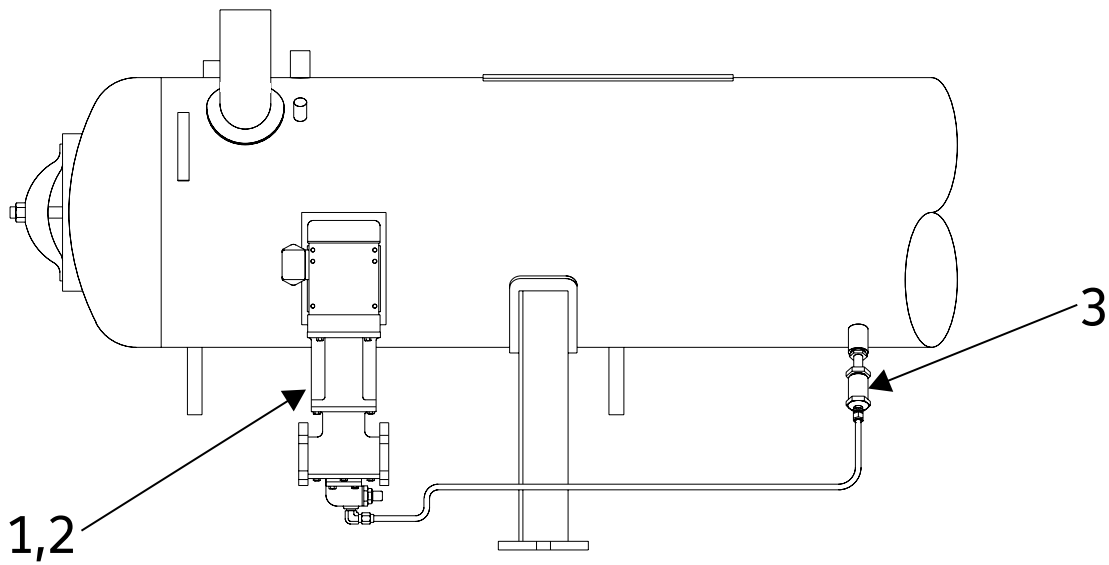

Figure 19. Oil Pump.

FIG. & INDEX	PART NUMBER	DESCRIPTION	QTY.	REV.	P & I REF.
19-	-	Oil Pump Mounting, 100-1080 (300#, 350#, & 400# DWP)	Ref.		
-1		300 PSI DWP (except #11 Oil)			
	960A0082G01	Assembly, Pump, 1 HP, 1150 RPM / 954 RPM ^{(1) (4)}	1		
	960A0082H01	Pump only, HJ495M ⁽²⁾	1		
	914A0015H18	Motor only, 208/230/460-3-60, 190/380-3-50	1		
	960A0066H11	Coupling only	1		
	960A0082G02	Assembly, Pump, 1 HP, 1150 RPM ^{(1) (4)}	1		
	960A0082H01	Pump only, HJ495M ⁽²⁾	1		
	914A0015H19	Motor only, 575-3-60	1		
	960A0066H11	Coupling only	1		
	960A0082G03	Assembly, Pump, 1 HP, 954 RPM ^{(1) (4)}	1		
	960A0082H01	Pump only, HJ495M ⁽²⁾	1		
	914A0015H20	Motor only, 415-3-50	1		
	960A0066H11	Coupling only	1		
	960A0082G07	Assembly, Pump, 1-1/2 HP, 1750 RPM ^{(1) (4)}	1		
	960A0082H01	Pump only, HJ495M ⁽²⁾	1		
	914A0015H02	Motor only, 208/230/460-3-60	1		
	960A0066H11	Coupling only	1		
	960A0082G08	Assembly, Pump, 1-1/2 HP, 1450 RPM ^{(1) (4)}	1		
	960A0082H01	Pump only, HJ495M ⁽²⁾	1		
	914A0015H02	Motor only, 190/380-3-50	1		
	960A0066H11	Coupling only	1		
	960A0082G09	Assembly, Pump, 1-1/2 HP, 1750 RPM ^{(1) (4)}	1		
	960A0082H01	Pump only, HJ495M ⁽²⁾	1		
	914A0015H02	Motor only, 575-3-60	1		
	960A0066H11	Coupling only	1		
	960A0082G10	Assembly, Pump, 1-1/2 HP, 1450 RPM ^{(1) (4)}	1		
	960A0082H01	Pump only, HJ495M ⁽²⁾	1		
	914A0015H02	Motor only, 415-3-50	1		
	960A0066H11	Coupling only	1		
	960A0082G04	Assembly, Pump, 3 HP, 1750 RPM / 1450 RPM ^{(1) (4)}	1		
	960A0082H02	Pump only, HL495M ⁽²⁾	1		
	914A0015H03	Motor only, 230/460-3-60 / 190/380-3-50	1		
	960A0066H12	Coupling only	1		
	960A0082G05	Assembly, Pump, 3 HP, 1750 RPM ^{(1) (4)}	1		
	960A0082H02	Pump only, HL495M ⁽²⁾	1		
	914A0015H03	Motor only, 575-3-60	1		
	960A0066H12	Coupling only	1		
	960A0082G06	Assembly, Pump, 3 HP, 1450 RPM ^{(1) (4)}	1		
	960A0082H02	Pump only, HL495M ⁽²⁾	1		
	914A0015H03	Motor only, 415-3-50	1		
	960A0066H12	Coupling only	1		
	960A0083G01	Assembly, Pump, 5 HP, 1450 RPM ⁽¹⁾	1		
	960A0083H01	Pump only, AS495M ⁽²⁾	1		
	914A0016H02	Motor only, 190/380-3-50	1		
	960A0067H13	Coupling only	1		
	960A0083G02	Assembly, Pump, 5 HP, 1750 RPM ⁽¹⁾	1		
	960A0083H01	Pump only, AS495M ⁽²⁾	1		
	914A0016H02	Motor only, 230/460-3-60	1		
	960A0067H13	Coupling only	1		
	960A0083G03	Assembly, Pump, 5 HP, 1450 RPM ⁽¹⁾	1		
	960A0083H01	Pump only, AS495M ⁽²⁾	1		
	914A0016H20	Motor only, 415-3-50	1		
	960A0067H13	Coupling only	1		

FIG. & INDEX	PART NUMBER	DESCRIPTION	QTY.	REV.	P & I REF.
	960A0083G04	Assembly, Pump, 5 HP, 1750 RPM ⁽¹⁾	1		
	960A0083H01	Pump only, AS495M ⁽²⁾	1		
	914A0016H23	Motor only, 575-3-60	1		
	960A0067H13	Coupling only	1		
	960A0083G07	Assembly, Pump, 7-1/2 HP, 1150 RPM ⁽¹⁾	1		
	960A0083H03	Pump only, AL495M ⁽²⁾	1		
	914A0016H05	Motor only, 230/460-3-60	1		
	960A0067H12	Coupling only	1		
	960A0083G08	Assembly, Pump, 7-1/2 HP, 1150 RPM ⁽¹⁾	1		
	960A0083H03	Pump only, AL495M ⁽²⁾	1		
	914A0016H22	Motor only, 575-3-60	1		
	960A0067H12	Coupling only	1		
	960A0083G09	Assembly, Pump, 7-1/2 HP, 380-3-50 ⁽¹⁾	1		
	960A0083H03	Pump only, AL495M ⁽²⁾	1		
	914A0016H18	Motor only, 380-3-50	1		
	960A0067H12	Coupling only	1		
	960A0083G10	Assembly, Pump, 7-1/2 HP, 954 RPM ⁽¹⁾	1		
	960A0083H03	Pump only, AL495M ⁽²⁾	1		
	914A0016H05	Motor only, 190/380-3-50	1		
	960A0067H12	Coupling only	1		
		300 PSI DWP w/BUNA N (Nitrile) Seals for #11 Oil			
	960A0103G01	Assembly, Pump, 1 HP, 1150 RPM / 954 RPM	1		
	960A0103H01	Pump only, HJ495M ⁽³⁾	1		
	914A0015H18	Motor only, 230/460-3-60 / 190/380-3-50	1		
	960A0066H11	Coupling only	1		
	960A0103H30	Kit, Bypass Valve	1		
	960A0103G02	Assembly, Pump, 1 HP, 1150 RPM	1		
	960A0103H01	Pump only, HJ495M ⁽³⁾	1		
	914A0015H19	Motor only, 575-3-60	1		
	960A0066H11	Coupling only	1		
	960A0103H30	Kit, Bypass Valve	1		
	960A0103G03	Assembly, Pump, 1 HP, 954 RPM	1		
	960A0103H01	Pump only, HJ495M ⁽³⁾	1		
	914A0015H20	Motor only, 415-3-50	1		
	960A0066H11	Coupling only	1		
	960A0103H30	Kit, Bypass Valve	1		
	960A0103G04	Assembly, Pump, 3 HP, 1750 RPM / 1450 RPM	1		
	960A0103H02	Pump only, HJ495M ⁽³⁾	1		
	914A0015H03	Motor only, 230/460-3-60 / 190/380-3-50	1		
	960A0066H12	Coupling only	1		
	960A0103H30	Kit, Bypass Valve	1		
	960A0103G05	Assembly, Pump, 3 HP, 1750 RPM	1		
	960A0103H02	Pump only, HJ495M ⁽³⁾	1		
	914A0015H10	Motor only, 575-3-60	1		
	960A0066H12	Coupling only	1		
	960A0103H30	Kit, Bypass Valve	1		
	960A0103G06	Assembly, Pump, 3 HP, 1450 RPM	1		
	960A0103H02	Pump only, HJ495M ⁽³⁾	1		
	914A0015H09	Motor only, 415-3-50	1		
	960A0066H12	Coupling only	1		
	960A0103H30	Kit, Bypass Valve	1		
	960A0103G07	Assembly, Pump, 1 1/2 HP, 1750 RPM	1		
	960A0103H01	Pump only, HJ495M ⁽³⁾	1		
	914A0015H02	Motor only, 230/460-3-60	1		
	960A0066H11	Coupling only	1		

FIG. & INDEX	PART NUMBER	DESCRIPTION	QTY.	REV.	P & I REF.
	960A0103H30	Kit, Bypass Valve	1		
	960A0103G08	Assembly, Pump, 1 1/2 HP, 1450 RPM	1		
	960A0103H01	Pump only, HJ495M ⁽³⁾	1		
	914A0015H04	Motor only, 190/380-3-50	1		
	960A0066H11	Coupling only	1		
	960A0103H30	Kit, Bypass Valve	1		
	960A0103G09	Assembly, Pump, 1 1/2 HP, 1750 RPM	1		
	960A0103H01	Pump only, HJ495M ⁽³⁾	1		
	914A0015H08	Motor only, 575-3-60	1		
	960A0066H11	Coupling only	1		
	960A0103H30	Kit, Bypass Valve	1		
	960A0103G10	Assembly, Pump, 1 1/2 HP, 1450 RPM	1		
	960A0103H01	Pump only, HJ495M ⁽³⁾	1		
	914A0015H07	Motor only, 415-3-50	1		
	960A0066H11	Coupling only	1		
	960A0103H30	Kit, Bypass Valve	1		
	960A0103G11	Assembly, Pump, 2 HP, 1750 RPM	1		
	960A0103H01	Pump only, HJ495M ⁽³⁾	1		
	914A0015H13	Motor only, 230/460-3-60	1		
	960A0066H11	Coupling only	1		
	960A0103H30	Kit, Bypass Valve	1		
	960A0103G12	Assembly, Pump, 2 HP, 1450 RPM	1		
	960A0103H01	Pump only, HJ495M ⁽³⁾	1		
	914A0015H14	Motor only, 190/380-3-50	1		
	960A0066H11	Coupling only	1		
	960A0103H30	Kit, Bypass Valve	1		
	960A0103G13	Assembly, Pump, 2 HP, 1750 RPM	1		
	960A0103H01	Pump only, HJ495M ⁽³⁾	1		
	914A0015H15	Motor only, 575-3-60	1		
	960A0066H11	Coupling only	1		
	960A0103H30	Kit, Bypass Valve	1		
	960A0103G14	Assembly, Pump, 2 HP, 1450 RPM	1		
	960A0103H01	Pump only, HJ495M ⁽³⁾	1		
	914A0015H16	Motor only, 415-3-50	1		
	960A0066H11	Coupling only	1		
	960A0103H30	Kit, Bypass Valve	1		
	960A0103G14	Assembly, Pump, 2 HP, 1450 RPM	1		
	960A0103H01	Pump only, HJ495M ⁽³⁾	1		
	914A0015H16	Motor only, 415-3-50	1		
	960A0066H11	Coupling only	1		
	960A0103H30	Kit, Bypass Valve	1		
	960A0104G01	Assembly, Pump, 5 HP, 1450 RPM	1		
	960A0104H01	Pump only, AS495M ⁽³⁾	1		
	914A0016H02	Motor only, 190/380-3-50	1		
	960A0067H13	Coupling only	1		
	960A0104H30	Kit, Bypass Valve	1		
	960A0104G02	Assembly, Pump, 5 HP, 1750 RPM	1		
	960A0104H01	Pump only, AS495M ⁽³⁾	1		
	914A0016H02	Motor only, 230/460-3-60	1		
	960A0067H13	Coupling only	1		
	960A0104H30	Kit, Bypass Valve	1		
	960A0104G03	Assembly, Pump, 5 HP, 1450 RPM	1		
	960A0104H01	Pump only, AS495M ⁽³⁾	1		
	914A0016H20	Motor only, 415-3-50	1		
	960A0067H13	Coupling only	1		

FIG. & INDEX	PART NUMBER	DESCRIPTION	QTY.	REV.	P & I REF.
	960A0104H30	Kit, Bypass Valve	1		
	960A0104G04	Assembly, Pump, 5 HP, 1750 RPM	1		
	960A0104H01	Pump only, AS495M ⁽³⁾	1		
	914A0016H23	Motor only, 575-3-60	1		
	960A0067H13	Coupling only	1		
	960A0104H30	Kit, Bypass Valve	1		
	960A0104G05	Assembly, Pump, 7 1/2 HP, 1450 RPM	1		
	960A0104H02	Pump only, AK495M ⁽³⁾	1		
	914A0016H04	Motor only, 190/380-3-50	1		
	960A0067H11	Coupling only	1		
	960A0104H30	Kit, Bypass Valve	1		
	960A0104G06	Assembly, Pump, 7 1/2 HP, 1450 RPM	1		
	960A0104H02	Pump only, AK495M ⁽³⁾	1		
	914A0016H12	Motor only, 415-3-50	1		
	960A0067H11	Coupling only	1		
	960A0104H30	Kit, Bypass Valve	1		
	960A0104G07	Assembly, Pump, 7 1/2 HP, 1150 RPM	1		
	960A0104H03	Pump only, AL495M ⁽³⁾	1		
	914A0016H05	Motor only, 230/460-3-60	1		
	960A0067H12	Coupling only	1		
	960A0104H30	Kit, Bypass Valve	1		
	960A0104G08	Assembly, Pump, 7 1/2 HP, 1150 RPM	1		
	960A0104H03	Pump only, AL495M ⁽³⁾	1		
	914A0016H22	Motor only, 575-3-60	1		
	960A0067H12	Coupling only	1		
	960A0104H30	Kit, Bypass Valve	1		
	960A0104G09	Assembly, Pump, 7 1/2 HP, 1150 RPM	1		
	960A0104H03	Pump only, AL495M ⁽³⁾	1		
	914A0016H18	Motor only, 380-3-60	1		
	960A0067H12	Coupling only	1		
	960A0104H30	Kit, Bypass Valve	1		
	960A0104G10	Assembly, Pump, 7 1/2 HP, 954 RPM	1		
	960A0104H03	Pump only, AL495M ⁽³⁾	1		
	914A0016H24	Motor only, 190/380-3-50	1		
	960A0067H12	Coupling only	1		
	960A0104H30	Kit, Bypass Valve	1		
	960A0104G21	Assembly, Pump, 7 1/2 HP, 1450 RPM	1		
	960A0104H02	Pump only, AK495M ⁽³⁾	1		
	914A0016H04	Motor only, 190/380-3-50	1		
	960A0067H11	Coupling only	1		
	960A0104H30	Kit, Bypass Valve	1		
	960A0104G22	Assembly, Pump, 7 1/2 HP, 1450 RPM	1		
	960A0104H02	Pump only, AK495M ⁽³⁾	1		
	914A0016H12	Motor only, 415-3-50	1		
	960A0067H11	Coupling only	1		
	960A0104H30	Kit, Bypass Valve	1		
	960A0104G23	Assembly, Pump, 7 1/2 HP, 1150 RPM	1		
	960A0104H03	Pump only, AL495M ⁽³⁾	1		
	914A0016H05	Motor only, 230/460-3-60	1		
	960A0067H12	Coupling only	1		
	960A0104H30	Kit, Bypass Valve	1		
	960A0104G24	Assembly, Pump, 7 1/2 HP, 1150 RPM	1		
	960A0104H03	Pump only, AL495M ⁽³⁾	1		
	914A0016H22	Motor only, 575-3-60	1		
	960A0067H12	Coupling only	1		

FIG. & INDEX	PART NUMBER	DESCRIPTION	QTY.	REV.	P & I REF.
	960A0104H30	Kit, Bypass Valve	1		
	960A0104G25	Assembly, Pump, 7 1/2 HP, 1150 RPM	1		
	960A0104H03	Pump only, AL495M ⁽³⁾	1		
	914A0016H18	Motor only, 380-3-60	1		
	960A0067H12	Coupling only	1		
	960A0104H30	Kit, Bypass Valve	1		
	960A0104G26	Assembly, Pump, 7 1/2 HP, 954 RPM	1		
	960A0104H03	Pump only, AL495M ⁽³⁾	1		
	914A0016H24	Motor only, 190/380-3-50	1		
	960A0067H12	Coupling only	1		
	960A0104H30	Kit, Bypass Valve	1		
	960A0105G01	Assembly, Pump, 1 HP, 1750 RPM / 1450 RPM	1		
	960A0105H01	Pump only, GG495M ⁽³⁾	1		
	914A0015H01	Motor only, 230/460-3-60 / 190/380-3-50	1		
	960A0068H11	Coupling only	1		
	960A0105H30	Kit, Bypass Valve	1		
	960A0105G02	Assembly, Pump, 1 HP, 1450 RPM	1		
	960A0105H01	Pump only, GG495M ⁽³⁾	1		
	914A0015H05	Motor only, 415-3-50	1		
	960A0068H11	Coupling only	1		
	960A0105H30	Kit, Bypass Valve	1		
	960A0105G03	Assembly, Pump, 1 HP, 1750 RPM	1		
	960A0105H01	Pump only, GG495M ⁽³⁾	1		
	914A0015H06	Motor only, 575-3-60	1		
	960A0068H11	Coupling only	1		
	960A0105H30	Kit, Bypass Valve	1		
		350 & 400 DWP (except #11 Oil)			
	960A0100G01	Assembly, Pump, 1 HP, 1200 RPM / 1000 RPM ⁽¹⁾	1		
	960A0100H01	Pump only, HJ495M ⁽²⁾	1		
	914A0015H01	Motor only, 230/460-3-60 / 190/380-3-50	1		
	960A0066H11	Coupling only	1		
	960A0100G02	Assembly, Pump, 1 HP, 1200 RPM ⁽¹⁾	1		
	960A0100H01	Pump only, HJ495M ⁽²⁾	1		
	914A0015H06	Motor only, 575-3-60	1		
	960A0066H11	Coupling only	1		
	960A0100G03	Assembly, Pump, 1 HP, 415-3-50 ⁽¹⁾	1		
	960A0100H01	Pump only, HJ495M ⁽²⁾	1		
	914A0015H05	Motor only, 415-3-50	1		
	960A0066H11	Coupling only	1		
	960A0100G04	Assembly, Pump, 3 HP, 1750 RPM / 1450 RPM ⁽¹⁾	1		
	960A0100H02	Pump only, HL495M ⁽²⁾	1		
	914A0015H03	Motor only, 230/460-3-60 / 190/380-3-50	1		
	960A0066H12	Coupling only	1		
	960A0100G05	Assembly, Pump, 3 HP, 1750 RPM ⁽¹⁾	1		
	960A0100H02	Pump only, HL495M ⁽²⁾	1		
	914A0015H10	Motor only, 575-3-60	1		
	960A0066H12	Coupling only	1		
	960A0100G06	Assembly, Pump, 3 HP, 1450 RPM ⁽¹⁾	1		
	960A0100H02	Pump only, HL495M ⁽²⁾	1		
	914A0015H09	Motor only, 415-3-50	1		
	960A0066H12	Coupling only	1		
	960A0100G07	Assembly, Pump, 1-1/2 HP, 1750 RPM ⁽¹⁾	1		
	960A0100H01	Pump only, HJ495M ⁽²⁾	1		
	914A0015H02	Motor only, 230/460-3-60	1		
	960A0066H11	Coupling only	1		

FIG. & INDEX	PART NUMBER	DESCRIPTION	QTY.	REV.	P & I REF.
	960A0100G08	Assembly, Pump, 1-1/2 HP, 1450 RPM ⁽¹⁾	1		
	960A0100H01	Pump only, HJ495M ⁽²⁾	1		
	914A0015H04	Motor only, 190/380-3-50	1		
	960A0066H11	Coupling only	1		
	960A0100G09	Assembly, Pump, 1-1/2 HP, 1750 RPM ⁽¹⁾	1		
	960A0100H01	Pump only, HJ495M ⁽²⁾	1		
	914A0015H08	Motor only, 575-3-60	1		
	960A0066H11	Coupling only	1		
	960A0101G07	Assembly, Pump, 7-1/2 HP, 1150 RPM ⁽¹⁾	1		
	960A0101H07	Pump only, AL495M ⁽²⁾	1		
	914A0016H05	Motor only, 230/460-3-60	1		
	960A0067H12	Coupling only	1		
	960A0101G08	Assembly, Pump, 7-1/2 HP, 1150 RPM ⁽¹⁾	1		
	960A0101H08	Pump only, AL495M ⁽²⁾	1		
	914A0016H22	Motor only, 575-3-60	1		
	960A0067H12	Coupling only	1		
	960A0101G10	Assembly, Pump, 7-1/2 HP, 954 RPM ⁽¹⁾	1		
	960A0101H10	Pump only, AL495M ⁽²⁾	1		
	914A0016H05	Motor only, 190/380-3-50	1		
	960A0067H12	Coupling only	1		
		400 PSI DWP w/BUNA N (Nitrile) Seals for #11 Oil			
	960A0106G01	Assembly, Pump, 1 HP, 1150 RPM / 954 RPM	1		
	960A0106H01	Pump only, HJ495M ⁽³⁾	1		
	914A0015H18	Motor only, 230/460-3-60 / 190/380-3-50	1		
	960A0066H11	Coupling only	1		
	960A0106H30	Kit, Bypass Valve	1		
	960A0106G02	Assembly, Pump, 1 HP, 1150 RPM	1		
	960A0106H01	Pump only, HJ495M ⁽³⁾	1		
	914A0015H19	Motor only, 575-3-60	1		
	960A0066H11	Coupling only	1		
	960A0106H30	Kit, Bypass Valve	1		
	960A0106G03	Assembly, Pump, 1 HP, 954 RPM	1		
	960A0106H01	Pump only, HJ495M ⁽³⁾	1		
	914A0015H20	Motor only, 415-3-50	1		
	960A0066H11	Coupling only	1		
	960A0106H30	Kit, Bypass Valve	1		
	960A0106G04	Assembly, Pump, 3 HP, 1750 RPM / 1450 RPM	1		
	960A0106H02	Pump only, HL495M ⁽³⁾	1		
	914A0015H03	Motor only, 230/460-3-60 / 190/380-3-50	1		
	960A0066H12	Coupling only	1		
	960A0106H30	Kit, Bypass Valve	1		
	960A0106G05	Assembly, Pump, 3 HP, 1750 RPM	1		
	960A0106H02	Pump only, HL495M ⁽³⁾	1		
	914A0015H10	Motor only, 575-3-60	1		
	960A0066H12	Coupling only	1		
	960A0106H30	Kit, Bypass Valve	1		
	960A0106G06	Assembly, Pump, 3 HP, 1450 RPM	1		
	960A0106H02	Pump only, HL495M ⁽³⁾	1		
	914A0015H09	Motor only, 415-3-50	1		
	960A0066H12	Coupling only	1		
	960A0106H30	Kit, Bypass Valve	1		
	960A0106G07	Assembly, Pump, 1 1/2 HP, 1750 RPM	1		
	960A0106H01	Pump only, HJ495M ⁽³⁾	1		
	914A0015H02	Motor only, 230/460-3-60	1		
	960A0066H11	Coupling only	1		

FIG. & INDEX	PART NUMBER	DESCRIPTION	QTY.	REV.	P & I REF.
	960A0106H30	Kit, Bypass Valve	1		
	960A0106G08	Assembly, Pump, 1 1/2 HP, 1450 RPM	1		
	960A0106H01	Pump only, HJ495M ⁽³⁾	1		
	914A0015H04	Motor only, 190/380-3-50	1		
	960A0066H11	Coupling only	1		
	960A0106H30	Kit, Bypass Valve	1		
	960A0106G09	Assembly, Pump, 1 1/2 HP, 1750 RPM	1		
	960A0106H01	Pump only, HJ495M ⁽³⁾	1		
	914A0015H08	Motor only, 575-3-50	1		
	960A0066H11	Coupling only	1		
	960A0106H30	Kit, Bypass Valve	1		
	960A0106G10	Assembly, Pump, 1 1/2 HP, 1450 RPM	1		
	960A0106H01	Pump only, HJ495M ⁽³⁾	1		
	914A0015H07	Motor only, 415-3-50	1		
	960A0066H11	Coupling only	1		
	960A0106H30	Kit, Bypass Valve	1		
	960A0106G11	Assembly, Pump, 2 HP, 1750 RPM	1		
	960A0106H01	Pump only, HJ495M ⁽³⁾	1		
	914A0015H13	Motor only, 230/460-3-60	1		
	960A0066H11	Coupling only	1		
	960A0106H30	Kit, Bypass Valve	1		
	960A0106G12	Assembly, Pump, 2 HP, 1450 RPM	1		
	960A0106H01	Pump only, HJ495M ⁽³⁾	1		
	914A0015H14	Motor only, 190/380-3-50	1		
	960A0066H11	Coupling only	1		
	960A0106H30	Kit, Bypass Valve	1		
	960A0106G13	Assembly, Pump, 2 HP, 1750 RPM	1		
	960A0106H01	Pump only, HJ495M ⁽³⁾	1		
	914A0015H15	Motor only, 575-3-60	1		
	960A0066H11	Coupling only	1		
	960A0106H30	Kit, Bypass Valve	1		
	960A0106G14	Assembly, Pump, 2 HP, 1450 RPM	1		
	960A0106H01	Pump only, HJ495M ⁽³⁾	1		
	914A0015H16	Motor only, 415-3-50	1		
	960A0066H11	Coupling only	1		
	960A0106H30	Kit, Bypass Valve	1		
	960A0107G01	Assembly, Pump, 5 HP, 1450 RPM	1		
	960A0107H01	Pump only, AS495M ⁽³⁾	1		
	914A0016H02	Motor only, 190/380-3-50	1		
	960A0067H13	Coupling only	1		
	960A0107H30	Kit, Bypass Valve	1		
	960A0107G02	Assembly, Pump, 5 HP, 1750 RPM	1		
	960A0107H01	Pump only, AS495M ⁽³⁾	1		
	914A0016H25	Motor only, 230/460-3-60	1		
	960A0067H13	Coupling only	1		
	960A0107H30	Kit, Bypass Valve	1		
	960A0107G03	Assembly, Pump, 5 HP, 1450 RPM	1		
	960A0107H01	Pump only, AS495M ⁽³⁾	1		
	914A0016H25	Motor only, 415-3-50	1		
	960A0067H13	Coupling only	1		
	960A0107H30	Kit, Bypass Valve	1		
	960A0107G04	Assembly, Pump, 5 HP, 1750 RPM	1		
	960A0107H01	Pump only, AS495M ⁽³⁾	1		
	914A0016H23	Motor only, 575-3-60	1		
	960A0067H13	Coupling only	1		

FIG. & INDEX	PART NUMBER	DESCRIPTION	QTY.	REV.	P & I REF.
	960A0107H30	Kit, Bypass Valve	1		
	960A0107G05	Assembly, Pump, 7 1/2 HP, 1450 RPM	1		
	960A0107H02	Pump only, AK495M ⁽³⁾	1		
	914A0016H04	Motor only, 190/380-3-50	1		
	960A0067H11	Coupling only	1		
	960A0107H30	Kit, Bypass Valve	1		
	960A0107G06	Assembly, Pump, 7 1/2 HP, 1450 RPM	1		
	960A0107H02	Pump only, AK495M ⁽³⁾	1		
	914A0016H12	Motor only, 415-3-50	1		
	960A0067H11	Coupling only	1		
	960A0107H30	Kit, Bypass Valve	1		
	960A0107G07	Assembly, Pump, 7 1/2 HP, 1150 RPM	1		
	960A0107H03	Pump only, AL495M ⁽³⁾	1		
	914A0016H05	Motor only, 230/460-3-60	1		
	960A0067H12	Coupling only	1		
	960A0107H30	Kit, Bypass Valve	1		
	960A0107G08	Assembly, Pump, 7 1/2 HP, 1150 RPM	1		
	960A0107H03	Pump only, AL495M ⁽³⁾	1		
	914A0016H22	Motor only, 575-3-60	1		
	960A0067H12	Coupling only	1		
	960A0107H30	Kit, Bypass Valve	1		
	960A0107G09	Assembly, Pump, 7 1/2 HP, 1150 RPM	1		
	960A0107H03	Pump only, AL495M ⁽³⁾	1		
	914A0016H18	Motor only, 380-3-60	1		
	960A0067H12	Coupling only	1		
	960A0107H30	Kit, Bypass Valve	1		
	960A0107G10	Assembly, Pump, 7 1/2 HP, 954 RPM	1		
	960A0107H03	Pump only, AL495M ⁽³⁾	1		
	914A0016H24	Motor only, 190/380-3-50	1		
	960A0067H12	Coupling only	1		
	960A0107H30	Kit, Bypass Valve	1		
	960A0107G21	Assembly, Pump, 7 1/2 HP, 1450 RPM	1		
	960A0107H02	Pump only, AK495M ⁽³⁾	1		
	914A0016H04	Motor only, 190/380-3-50	1		
	960A0067H11	Coupling only	1		
	960A0107H30	Kit, Bypass Valve	1		
	960A0107G22	Assembly, Pump, 7 1/2 HP, 1450 RPM	1		
	960A0107H02	Pump only, AK495M ⁽³⁾	1		
	914A0016H12	Motor only, 415-3-50	1		
	960A0067H11	Coupling only	1		
	960A0107H30	Kit, Bypass Valve	1		
	960A0107G23	Assembly, Pump, 7 1/2 HP, 1150 RPM	1		
	960A0107H03	Pump only, AL495M ⁽³⁾	1		
	914A0016H05	Motor only, 230/460-3-60	1		
	960A0067H12	Coupling only	1		
	960A0107H30	Kit, Bypass Valve	1		
	960A0107G24	Assembly, Pump, 7 1/2 HP, 1150 RPM	1		
	960A0107H03	Pump only, AL495M ⁽³⁾	1		
	914A0016H22	Motor only, 575-3-60	1		
	960A0067H12	Coupling only	1		
	960A0107H30	Kit, Bypass Valve	1		
	960A0107G25	Assembly, Pump, 7 1/2 HP, 1150 RPM	1		
	960A0107H03	Pump only, AL495M ⁽³⁾	1		
	914A0016H18	Motor only, 380-3-60	1		
	960A0067H12	Coupling only	1		

FIG. & INDEX	PART NUMBER	DESCRIPTION	QTY.	REV.	P & I REF.
	960A0107H30	Kit, Bypass Valve	1		
	960A0107G26	Assembly, Pump, 7 1/2 HP, 954 RPM	1		
	960A0107H03	Pump only, AL495M ⁽³⁾	1		
	914A0016H24	Motor only, 190/380-3-50	1		
	960A0067H12	Coupling only	1		
	960A0107H30	Kit, Bypass Valve	1		
	960A0108G01	Assembly, Pump, 1 HP, 1750 RPM / 1450 RPM	1		
	960A0108H01	Pump only, GG495M ⁽³⁾	1		
	914A0015H01	Motor only, 230/460-3-60 / 190/380-3-50	1		
	960A0068H11	Coupling only	1		
	960A0108H30	Kit, Bypass Valve	1		
	960A0108G02	Assembly, Pump, 1 HP, 1450 RPM	1		
	960A0108H01	Pump only, GG495M ⁽³⁾	1		
	914A0015H05	Motor only, 415-3-50	1		
	960A0068H11	Coupling only	1		
	960A0108H30	Kit, Bypass Valve	1		
	960A0108G03	Assembly, Pump, 1 HP, 1750 RPM	1		
	960A0108H01	Pump only, GG495M ⁽³⁾	1		
	914A0015H06	Motor only, 575-3-60	1		
	960A0068H11	Coupling only	1		
	960A0108H30	Kit, Bypass Valve	1		
-2	959A0054H23	Gasket, Flange, 1" (GG495M)	2		
	959A0054H25	Gasket, Flange, 1 1/2" (HJ495M, HL495M)	2		
	959A0054H27	Gasket, Flange, 2 1/2" (AS495M, AK495M)	2		
	959A0054H28	Gasket, Flange, 3" (AL495M)	2		
-3	956A0014H01	Valve, Check, In-line, 3/4" FPT (100 - 222)	1		
	956A0014H02	Valve, Check, In-line, 1" FPT (270 - 546)	1		
	956A0012G04	Valve, Check, 1-1/4" FPT Flanges (496 - 1080)	1		
	<p>1. 960A0082 Pumps are used on Models 100/134/177/222/270. 960A0083 Pumps are used on Models 316/399/480/546/496/676/856/1080. 960A0100 Pumps are used on Models 100/134/177/222/270. 960A0101 Pumps are used on Models 316/399/480/546.</p>				
	<p>2. 960A0082 Pumps use Shaft Seal Kit 960A0076H41. Kit consists of Shaft Seal, O-ring, Bearings and Locknut. 960A0083 Pumps use Shaft Seal Kit 960A0077H41. Kit consists of Shaft Seal, O-ring, Bearings and Locknut. 960A0100 Pumps use Shaft Seal Kit 960A0100H41. Kit consists of Shaft Seal, O-ring, Bearings and Locknut. 960A0101 Pumps use Shaft Seal Kit 960A0101H41. Kit consists of Shaft Seal, O-ring, Bearings and Locknut.</p>				
	<p>3. 960A0103 Pumps use Shaft Seal Kit 960A0103H41. 960A0104 Pumps use Shaft Seal Kit 960A0104H41 960A0105 Pumps use Shaft Seal Kit 960A0105H41 960A0106 Pumps use Shaft Seal Kit 960A0106H41 960A0107 Pumps use Shaft Seal Kit 960A0107H41 960A0108 Pumps use Shaft Seal Kit 960A0108H41</p>				
	<p>4. Bypass Valve Kit - 960A0082H30</p>				

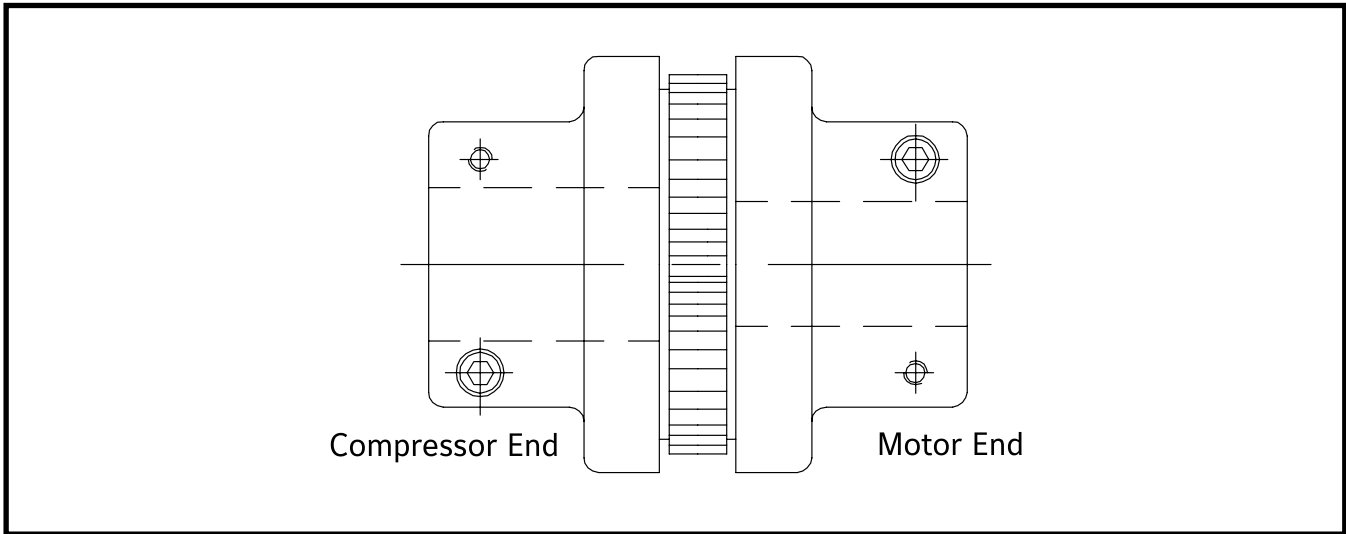

Figure 20. Coupling Assembly, T. B. Woods, 100 & 134.

SIZE 9C			
FLANGE	BORE	KEYWAY	PART NUMBER
Compressor End	2.25	1/2 x 1/4	930A0127H01
Compressor End	2.5	5/8 x 5/16	930A0127H02
Motor End	2.375	5/8 x 5/16	930A0127H03
Motor End	1.875	1/2 x 1/4	930A0127H04
Motor End	2.125	1/2 x 1/4	930A0127H05

SIZE 10C			
FLANGE	BORE	KEYWAY	PART NUMBER
Compressor End	2.25	1/2 x 1/4	930A0127H10
Compressor End	2.5	5/8 x 5/16	930A0127H11
Motor End	2.375	5/8 x 5/16	930A0127H12
Motor End	2.125	1/2 x 1/4	930A0127H13

SIZE 11C			
FLANGE	BORE	KEYWAY	PART NUMBER
Compressor End	2.25	1/2 x 1/4	930A0127H20
Compressor End	2.5	5/8 x 5/16	930A0127H21
Motor End	3.25	7/8 x 7/16	930A0127H22
Motor End	1.875	5/8 x 5/16	930A0127H23
Motor End	2.625	5/8 x 5/16	930A0127H24

CENTER SLEEVE	
9C	930A0093H05
10C	930A0093H11
11C	930A0093H17

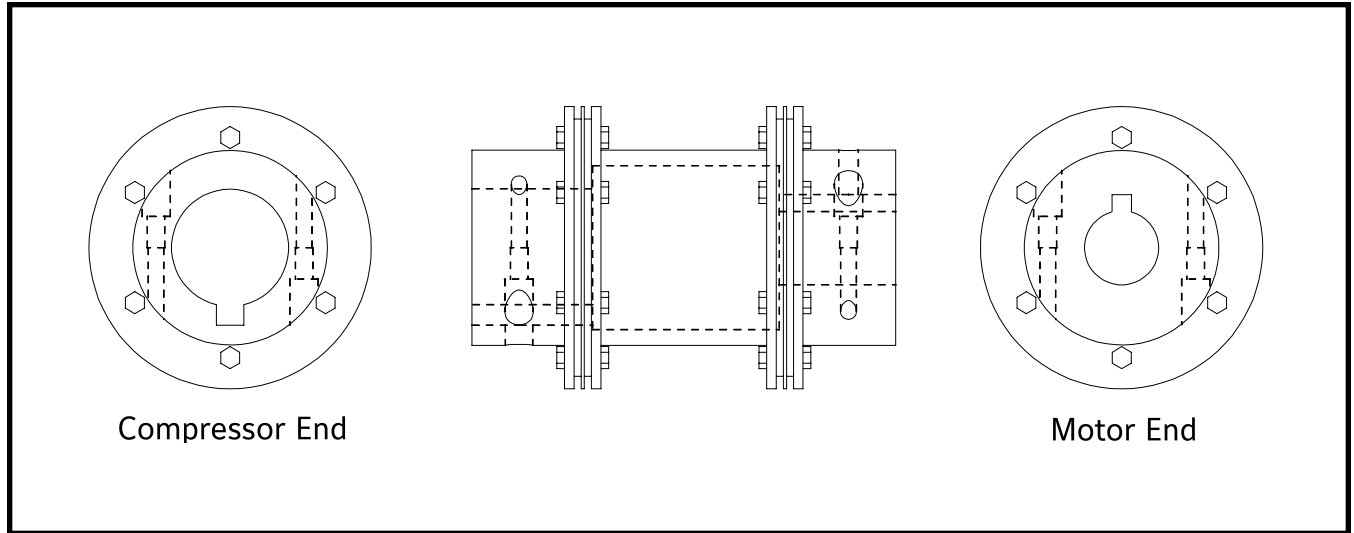

Figure 21. Coupling Assembly, T. B. Woods, 177-1080.

FIG. & INDEX	PART NUMBER	DESCRIPTION	QTY.	REV.	P & I REF.
21-	720C0167	Coupling, Motor to Compressor, 177, 222, 270	Ref.	A	
	720C0166	Coupling, Motor to Compressor, 316, 399, 480, 496, 546	Ref.	A	
	720C0165	Coupling, Motor to Compressor, 496, 676, 856, 1080	Ref.	A	
-1	720C0167H01	Assbly, Coupling, 2 3/8" Motor Bore/2 1/2" Compr. Bore	1		
	720C0167H13	Assbly, Coupling, 2 3/8" Motor Bore/2 1/2" Compr. Bore	1		
	720C0167H25	Assbly, Coupling, 2 3/8" Motor Bore/2 1/2" Compr. Bore	1		
	720C0167H37	Assbly, Coupling, 2 3/8" Motor Bore/2 1/2" Compr. Bore	1		
	720C0166H13	Assbly, Coupling, 2 3/8" Motor Bore/3 1/4" Compr. Bore	1		
	720C0166H25	Assbly, Coupling, 2 3/8" Motor Bore/3 1/4" Compr. Bore	1		
	720C0166H38	Assbly, Coupling, 2 3/8" Motor Bore/3 1/4" Compr. Bore	1		
	720C0165H58	Assbly, Coupling, 2 3/8" Motor Bore/3 3/4" Compr. Bore	1		
	720C0165H90	Assbly, Coupling, 2 3/8" Motor Bore/3 3/4" Compr. Bore	1		
	720C0165P03	Assbly, Coupling, 2 3/8" Motor Bore/3 3/4" Compr. Bore	1		

P/N	RWFII MODEL	COMPRESSOR	SIZE
720C0167H01	177, 222, 270	233	BP 38
720C0167H13	177, 222, 270	233	BP 43
720C0167H25	177, 222, 270	233	BP 48
720C0167H37	270	233	BP 53
720C0166H13	316, 399, 480, 496	283, 355	BP 48
720C0166H25	316, 399, 480, 546	283	BP 53
720C0166H38	316, 399, 480, 546	283	BP 58
720C0165H58	496, 676, 856, 1080	355	BP 58
720C0165H90	496, 676, 856, 1080	355	BP 48
720C0165P03	496, 676, 856, 1080	355	BP 53

COMPRESSOR FLANGE KEYS		
Compressor	Compressor Key	Key Dimensions
SGC 193	534E0662H02	.500 x 3.50"
SGC 233	534E0662H03	.625 x 3.50"
SGC 283 & 355	534E0662H04	.875 x 4.50"

MOTOR FLANGE KEYS
Supplied with motor

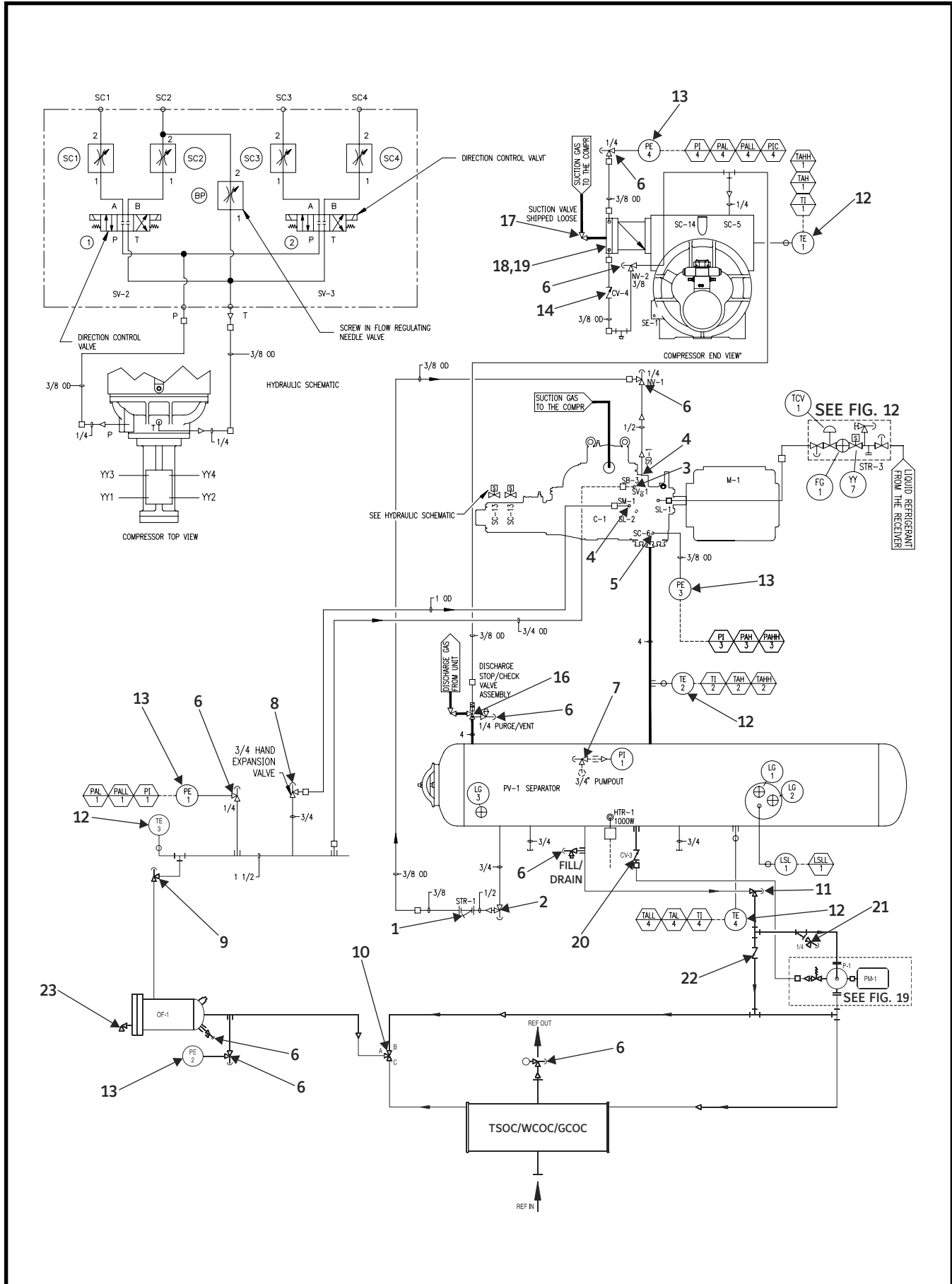

Figure 22. Piping and Instrumentation, Typical.

FIG. & INDEX	PART NUMBER	DESCRIPTION	QTY.	REV.	P & I REF.
22-	-	Piping Package Parts	Ref.		
-1	720B0030H05	Strainer	1		STR-1
	720B0030H21	Kit, Strainer Service, Cover Gasket and Basket	1		
	720B0055H02	Gaskets (Service Kit 720B0030H23 includes 2 gaskets)	3		
	720B0030H08	Flange, 3/8" FPT	2		
	720B0055H01	Bolt & Nut Set	2		
-2	950A0233H03	Valve, SW, Angle, SC, 1"	1		
	950A0232H22	Valve Repair Kit, Complete (less stem)	1		
-3	980A0012K66	O-ring, Port SB-3, Oil Supply	1		
-4	980A0012K66	O-ring, Ports SM-1 & SD-1	2		
-5	980A0012K60	O-ring, Port SC-6, Discharge Pressure	1		
-6	950A0292H01	Valve, Angle, SC, Danfoss, 1/4 MPT x 1/4 FPT	A/R		NV
	950A0292H02	Valve, Angle, SC, Danfoss, 3/8 MPT x 3/8 FPT	A/R		NV
	950A0292H03	Valve, Angle, SC, Danfoss, 1/2 MPT x 1/2 MPT (fill/drain) ⁽¹⁾	A/R		NV
-7	950A0233H02	Valve, Angle, SC, 3/4" SW (pumpout) ⁽²⁾	1		
	950A0232H21	Valve Repair Kit, Complete (less stem)	1		
-8	950A0062H02	Valve, Angle, Hand Expansion, SC, 3/4" SW/FPT, 100-222	1		
	954A0062H27	Valve Repair Kit, Complete (less stem)	1		
	954A0062H03	Valve, Angle, Hand Expansion, SC, 1" SW/FPT, 270	1		
	954A0062H28	Valve Repair Kit, Complete (less stem)	1		
	954A0062H04	Valve, Angle, Hand Expansion, SC, 1-1/4" SW/FPT, 316-399	1		
	954A0062H29	Valve Repair Kit, Complete (less stem)	1		
	954A0075H01	Valve, Angle, Hand Expansion, SC, 2" BW, 480-1080	1		
	954A0075H23	Valve Repair Kit, Complete (less stem)	1		
-9	950A0233H05	Valve, Angle, Danfoss, SC, 1-1/2" SW, 100 & 134	3		
	950A0232H22	Valve Repair Kit, Complete (less stem)	1		
	950A0233H06	Valve, Angle, Danfoss, SC, 2" SW, 177 & 222	3		
	950A0232H23	Valve Repair Kit, Complete (less stem)	1		
	950A0241H07	Valve, Angle, Danfoss, SC, 2-1/2" BW, 270-546, 496, 676	3		
	950A0240H24	Valve Repair Kit, Complete (less stem)	1		
	950A0241H08	Valve, Angle, Danfoss, SC, 3" BW, 856 & 1080	1		
	950A0240H25	Valve Repair Kit, Complete (less stem)	1		
-10	950A0294H01	Valve, Temperature Control, 1-1/2"	1		TCV-1
	950A0294H11	Kit, Service, Temperature Control Valve, 1-1/2 & 2" ⁽³⁾	1		
	950A0294H02	Valve, Temperature Control, 2"	1		TCV-1
	950A0294H11	Kit, Service, Temperature Control Valve, 1-1/2 & 2" ⁽³⁾	1		
	950A0297H01	Valve, Temperature Control, 2-1/2"	1		TCV-1
	950A0297H11	Kit, Service, Temperature Control Valve, 2-1/2" ⁽³⁾	1		
-11	950A0233H06	Valve, Angle, Danfoss, Shutoff, 2" SW, SC	1		
	950A0232H23	Valve Repair Kit, Complete (less stem)	1		
	950A0241H07	Valve, Angle, Danfoss, Shutoff, 2-1/2" BW, SC	1		
	950A0240H24	Valve Repair Kit, Complete (less stem)	1		
-12	639A0151G03	Assembly, Temperature Sensor	4		TE
	639A0151H01	Temperature Sensor Probe, less Well	1		
	913A0098H01	Well, with cap	1		
	913A0100H01	Thermal Compound	A/R		
	649A0890H02	Connector, DIN	1		
	649A0890H11	Gasket, DIN Connector	1		

1. Oil will now be charged through the drain valve. A pump will be necessary to drive oil flow. See Service Information NS-05-10.
2. Pumpout valve is now standard. Do not confuse with earlier oil fill valve, otherwise coalescer will fill with oil. See NS-05-10.
3. See Figures 10, 11, and 12.

RWFII ROTARY SCREW COMPRESSOR UNIT
SERVICE PARTS LIST



FIG. & INDEX	PART NUMBER	DESCRIPTION	QTY.	REV.	P & I REF.
-13	913A0146H01	Transducer, Pressure, 0-200	4		PE
	913A0146H02	Transducer, Pressure, 0-500	4		PE
	649A0890H02	Connector, DIN, 1/2" NPTF ⁽¹⁾	1		
	649A0890H11	Gasket, DIN Connector ⁽¹⁾	1		
	649D4628H01	Relief, Strain, 1/2" ⁽¹⁾	1		
-14	956A0052H01	Valve, Check, 3/8" NPTF (Booster - 20 PSIG)	1		CV-4
	956A0052H02	Valve, Check, 3/8" NPTF (High Stage - 45 PSIG)	1		CV-4
-15	not used				
-16	582C0030G01	Valve, Discharge Stop/Check, 4" (High Stage) ⁽²⁾	1		
	582C0030G03	Valve, Discharge Stop/Check, 4" (Booster or Swing) ⁽²⁾	1		
	582C0031G01	Valve, Discharge Stop/Check, 5" (High Stage) ⁽²⁾	1		
	582C0031G03	Valve, Discharge Stop/Check, 5" (Booster or Swing) ⁽²⁾	1		
	582C0032G01	Valve, Discharge Stop/Check, 6" (High Stage) ⁽²⁾	1		
	582C0032G03	Valve, Discharge Stop/Check, 6" (Booster or Swing) ⁽²⁾	1		
	582C0033G01	Valve, Discharge Stop/Check, 8" (High Stage) ⁽²⁾	1		
	582C0033G03	Valve, Discharge Stop/Check, 8" (Booster or Swing) ⁽²⁾	1		
-17	950A0240H10	Valve, Angle, Danfoss, 5", HW, WIL	1		
	950A0240H27	Valve Repair Kit, Complete (less stem)	1		
	950A0240H11	Valve, Angle, Danfoss, 6", HW, WIL	1		
	950A0240H28	Valve Repair Kit, Complete (less stem)	1		
	950A0240H12	Valve, Angle, Danfoss, 8", HW, WIL	1		
	950A0240H29	Valve Repair Kit, Complete (less stem)	1		
	950A0283H01	Valve, Angle, Danfoss, 10", HW, WIL	1		
	950A0283H21	Valve Repair Kit, Complete (less stem)	1		
	950A0283H02	Valve, Angle, Danfoss, 12", HW, WIL	1		
	950A0283H22	Valve Repair Kit, Complete (less stem)	1		
-18	956A0050H03	Valve, Check, 5" (100)	1		
	956A0050H04	Valve, Check, 6" (134-177)	1		
	956A0050H05	Valve, Check, 8" (222-316)	1		
	956A0050H06	Valve, Check, 10" (399-546)	1		
-19	959A0054H31	Gasket, Flange, 5" (100)	1		
	959A0054H32	Gasket, Flange, 6" (134-177)	1		
	959A0054H33	Gasket, Flange, 8" (222-316)	1		
	959A0054H34	Gasket, Flange, 10" (399-546)	1		
-20	956A0014H01	Valve, Check, In-line, 3/4" FPT (100-222)	1		CV-3
	956A0014H02	Valve, Check, In-line, 1" FPT (270-546)	1		CV-3
	956A0012G04	Valve, Check, 1-1/4" NPT Flanges (496-1080)	1		CV-3
-21	950A0320H05	Strainer, Angle, 1-1/2", SW	1		
	950A0320H15	Kit, Strainer & Gasket, 1-1/2"	1		
	950A0320H06	Strainer, Angle, 2", SW	1		
	950A0320H16	Kit, Strainer & Gasket, 2"	1		
	950A0329H01	Valve, Angle, 2-1/2" BW	1		
	950A0329H11	Kit, Strainer & Gasket, 2-1/2"	1		
-22	956A0012G03	Valve, Check, 1-1/2" NPT Flanges (100 - 134)	1		
	956A9912G01	Valve, Check, 2" NPT Flanges (177 - 222)	1		
	956A0012G05	Valve, Check, 2-1/2" SW (270-480, 496, 676)	1		
	956A0012G02	Valve, Check, 3", SW (856 & 1080)	1		
-23	950A0339H01	Valve, Oil Sampling, Push Button	1		

1. Not included with Pressure Transducer.
2. See Figures 13-17.

This page left blank intentionally.

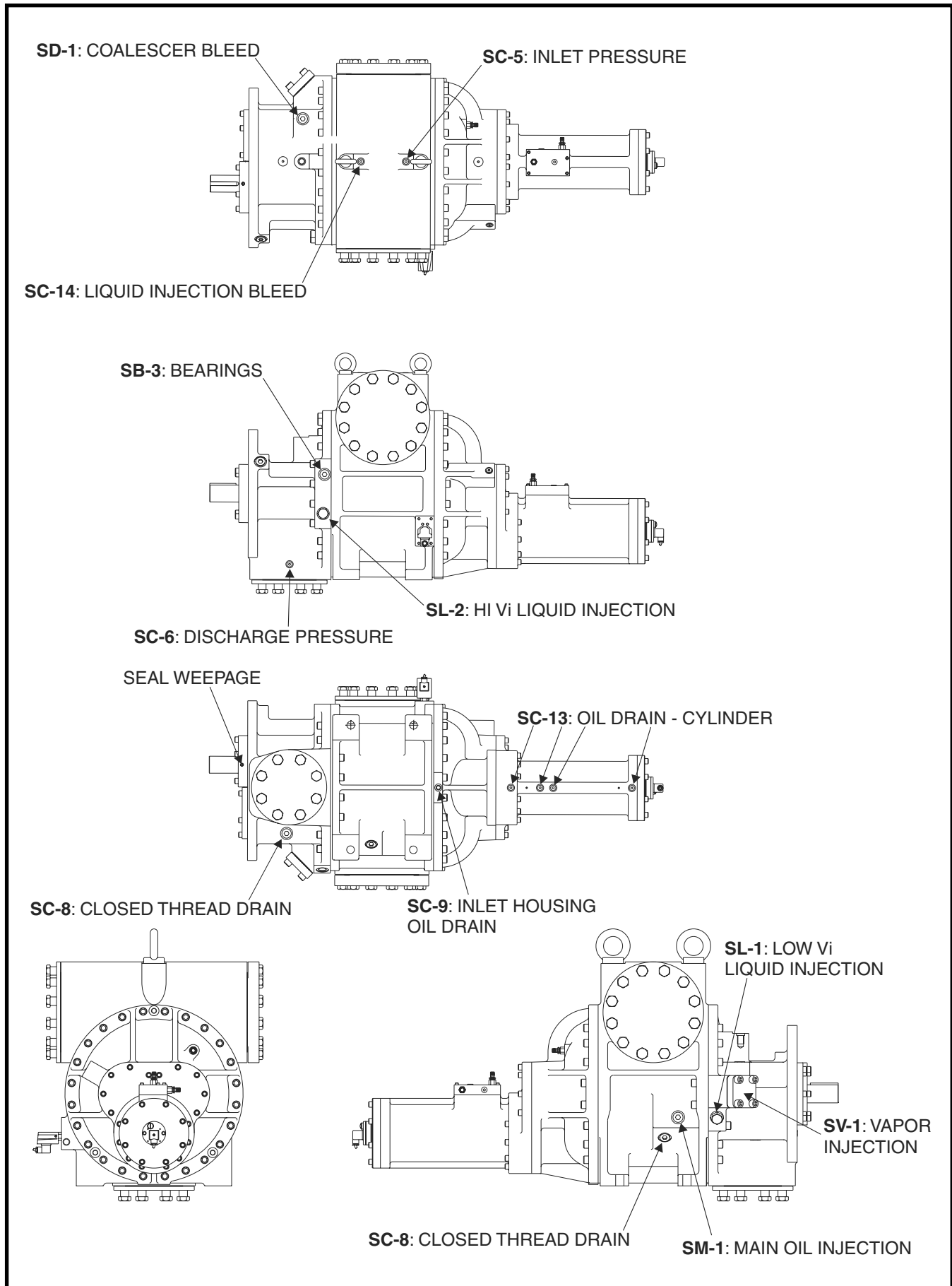

Figure 23. 1913/1918 Compressor Ports Locations.

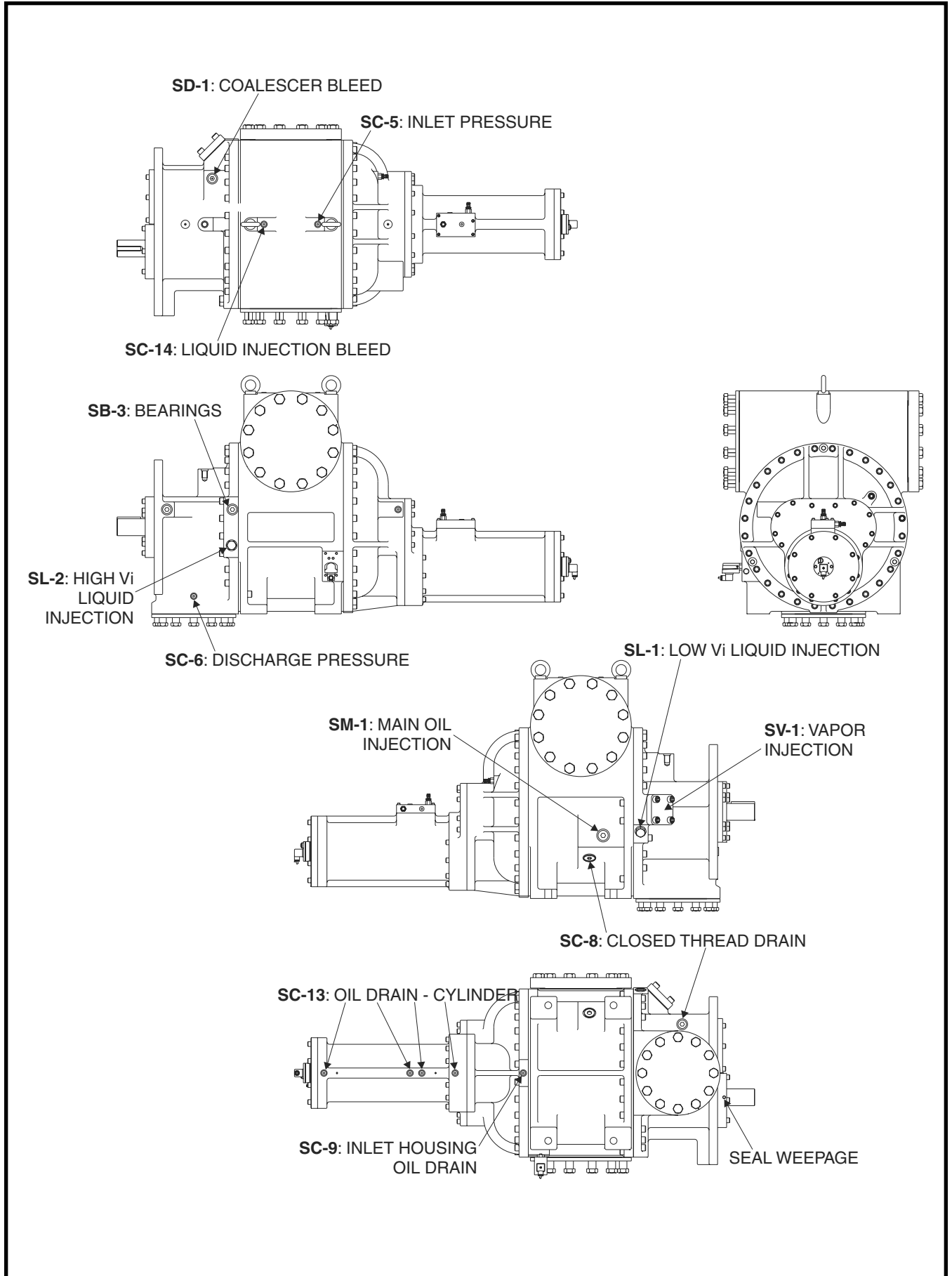

Figure 24. 2313/2317 Compressor Ports Locations.

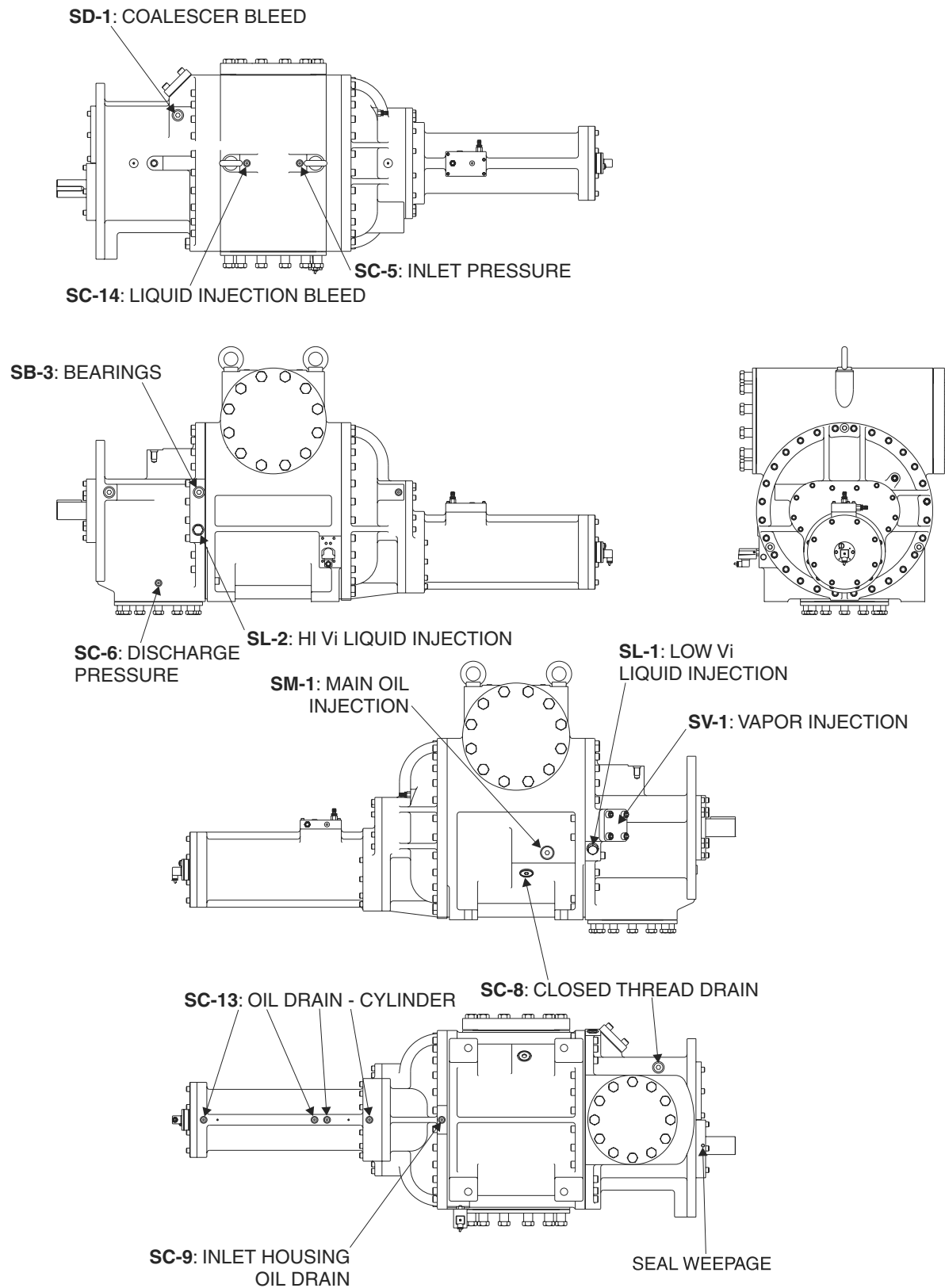

Figure 25. 2321 Compressor Ports Locations.

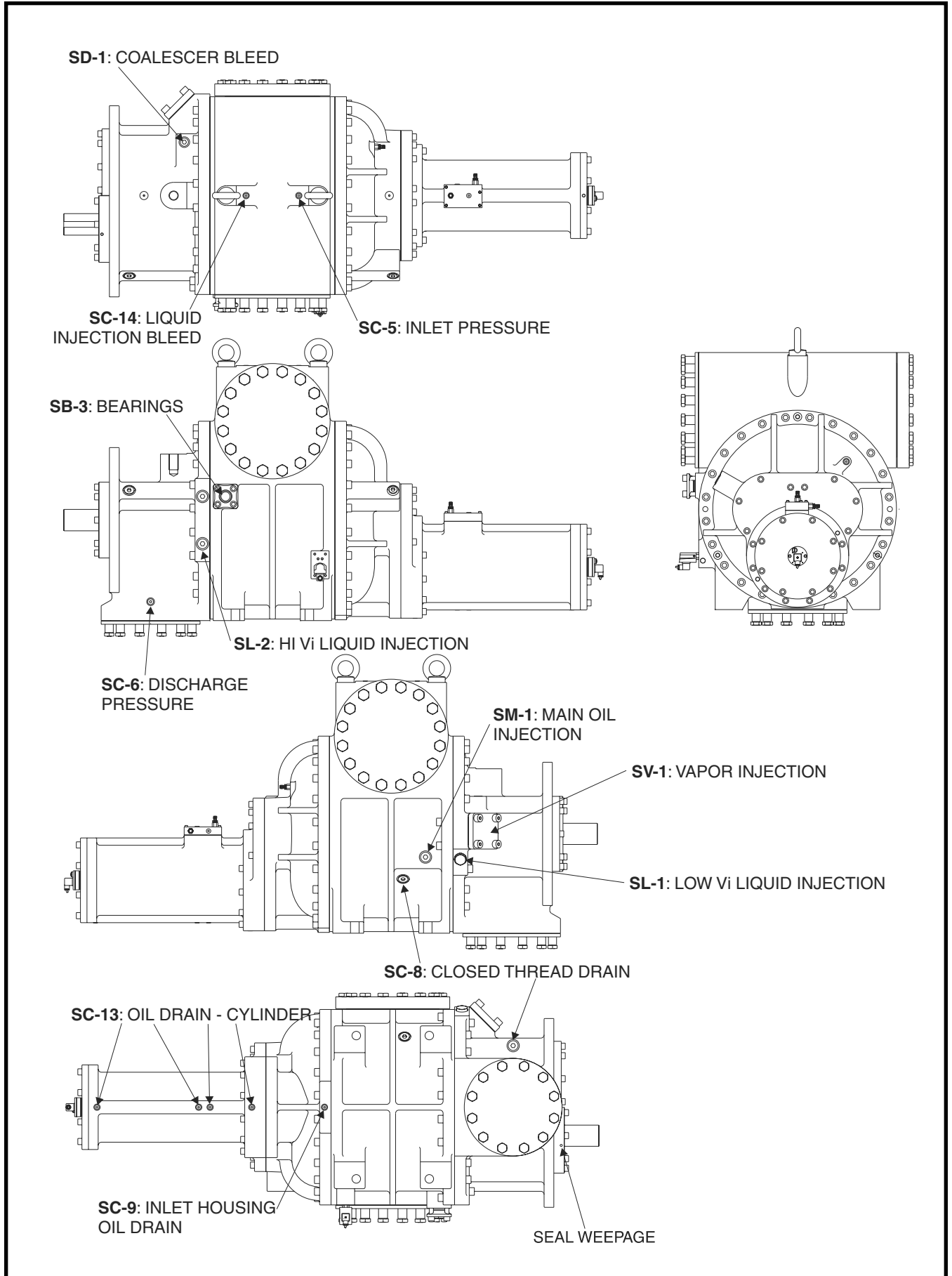

Figure 26. 2813/2817 Compressor Ports Locations.

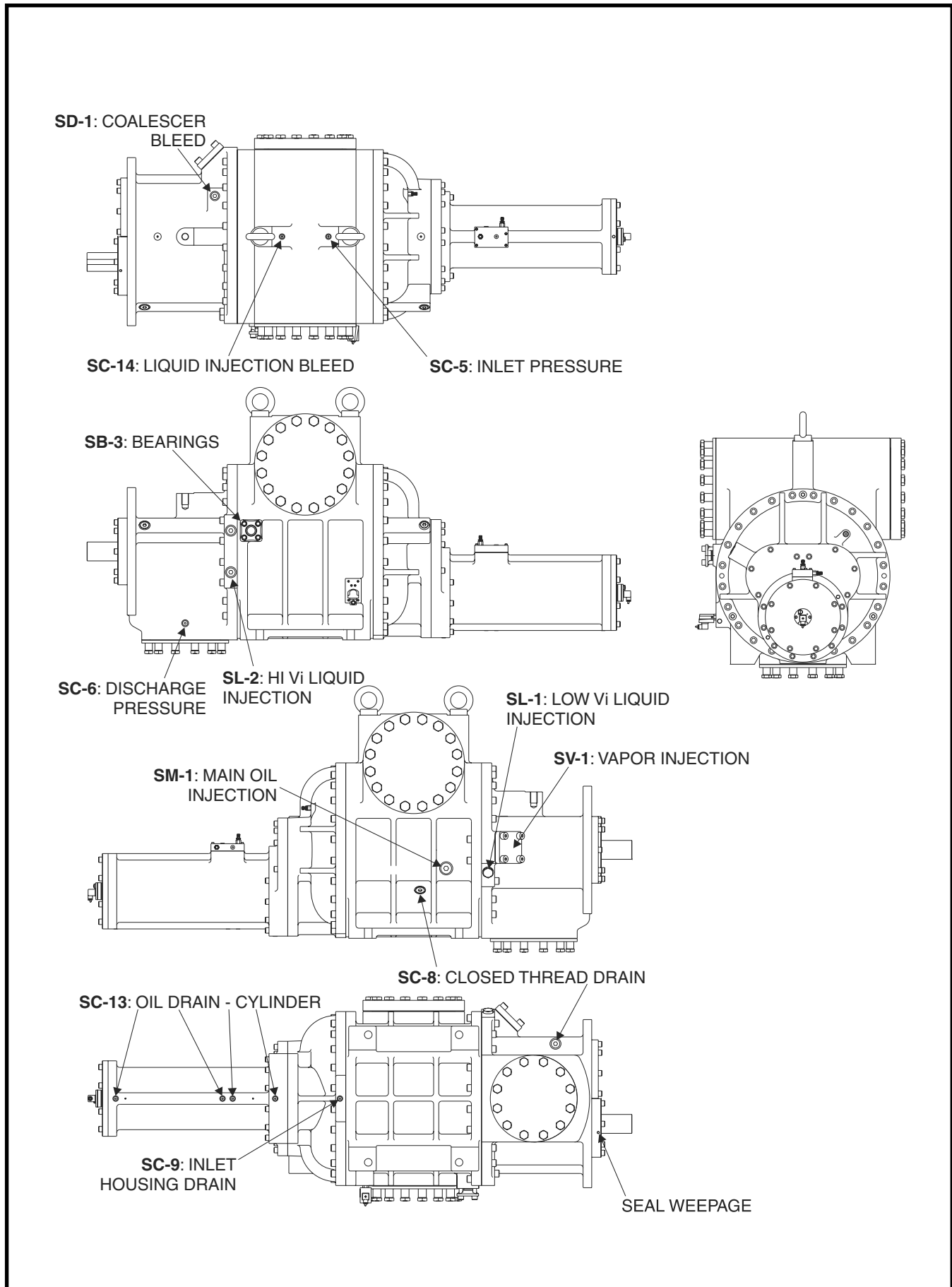

Figure 27. 2821/2824 Compressor Ports Locations.

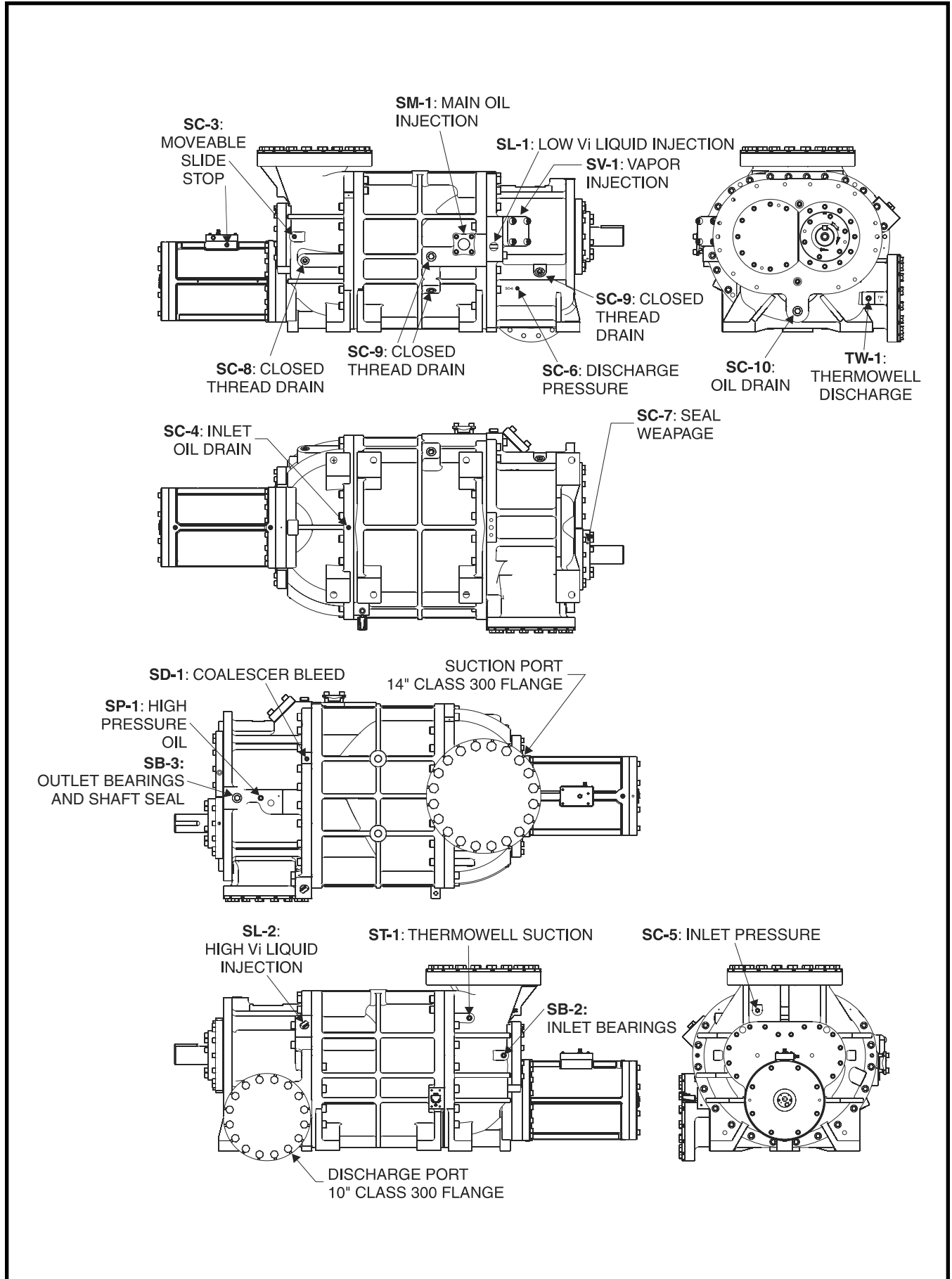

Figure 28. 3511/3515/3519 Compressor Ports Locations.

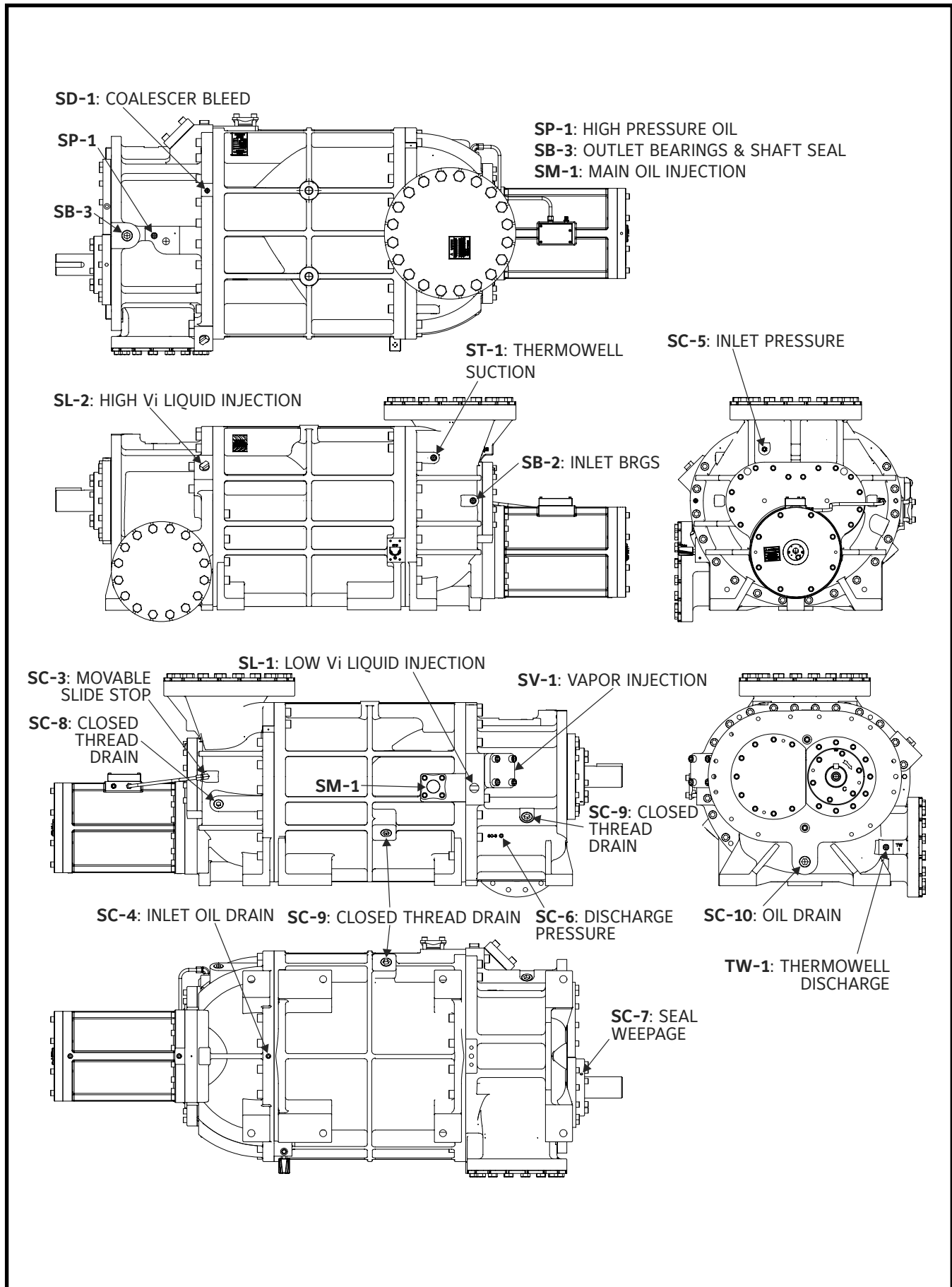

Figure 29. 3524 Compressor Ports Locations.

193-283 COMPRESSOR PORTS & O-RINGS						
PORT	DESCRIPTION	1913-1918 O-RING	2313-2317 O-RING	2321 O-RING	2813-2817 O-RING	2821-2824 O-RING
SB-3	Bearings	980A0012K66	980A0012K66	980A0012K66	980A0012K69	N/A
SC-5	Inlet Pressure	980A0012K60	980A0012K60	980A0012K60	980A0012K60	980A0012K60
SC-6	Discharge Pressure	980A0012K60	980A0012K60	980A0012K60	980A0012K60	980A0012K60
SC-8	Closed Thrd Drain	980A0012K66	980A0012K66	980A0012K66	980A0012K69	980A0012K69
SC-9	Inlet Hsg Oil Drain	980A0012K60	980A0012K60	980A0012K60	980A0012K60	980A0012K60
SC-13	Oil Drain Cylinder	980A0012K60	980A0012K60	980A0012K60	980A0012K60	980A0012K60
SC-14	Liquid Inj Bleed	980A0012K60	980A0012K60	980A0012K60	980A0012K60	980A0012K60
SD-1	Coalescer Bleed	980A0012K66	980A0012K66	980A0012K66	980A0012K66	980A0012K66
SL-1	Low Vi Liq Injection	980A0012K66	980A0012K66	980A0012K66	980A0012K69	980A0012K69
SL-2	High Vi Liq Injection	980A0012K66	980A0012K66	980A0012K66	980A0012K69	980A0012K69
SM-1	Main Oil Injection	980A0012K66	980A0012K66	980A0012K69	980A0012K69	980A0012K71
SV-1	Vapor Injection	N/A	N/A	N/A	N/A	N/A

193-283 COMPRESSOR PORTS & SIZES						
PORT	DESCRIPTION	1913-1918 STRGHT THD ⁽¹⁾	2313-2317 STRGHT THD ⁽¹⁾	2321 STRGHT THD ⁽¹⁾	2813-2817 STRGHT THD ⁽¹⁾	2821-2824 STRGHT THD ⁽¹⁾
SB-3	Bearings	1 1/16-12UN-2B	1 1/16-12UN-2B	1 1/16-12UN-2B	1 1/4 Sq Flg	1 1/4 Sq Flg
SC-5	Inlet Pressure	9/16-18UNF-2B	9/16-18UNF-2B	9/16-18UNF-2B	3/4-16UNF-2B	3/4-16UNF-2B
SC-6	Discharge Pressure	9/16-18UNF-2B	9/16-18UNF-2B	9/16-18UNF-2B	9/16-18UNF-2B	9/16-18UNF-2B
SC-8	Closed Thrd Drain	1 1/16-12UN-2B	1 1/16-12UN-2B	1 1/16-12UN-2B	1 5/16-12UN-2B1	5/16-12UN-2B
SC-9	Inlet Hsg Oil Drain	9/16-18UNF-2B	9/16-18UNF-2B	9/16-18UNF-2B	9/16-18UNF-2B	9/16-18UNF-2B
SC-13	Oil Drain Cylinder	9/16-18UNF-2B	9/16-18UNF-2B	9/16-18UNF-2B	9/16-18UNF-2B	9/16-18UNF-2B
SC-14	Liquid Inj Bleed	9/16-18UNF-2B	9/16-18UNF-2B	9/16-18UNF-2B	9/16-18UNF-2B	9/16-18UNF-2B
SD-1	Coalescer Bleed	1 1/16-12UN-2B	1 1/16-12UN-2B	1 1/16-12UN-2B	1 1/16-12UN-2B	1 1/16-12UN-2B
SL-1	Low Vi Liq Injection	1 1/16-12UN-2B	1 1/16-12UN-2B	1 1/16-12UN-2B	1 5/16-12UN-2B	1 5/16-12UN-2B
SL-2	High Vi Liq Injection	1 1/16-12UN-2B	1 1/16-12UN-2B	1 1/16-12UN-2B	1 5/16-12UN-2B	1 5/16-12UN-2B
SM-1	Main Oil Injection	1 1/16-12UN-2B	1 5/16-12UN-2B	1 5/16-12UN-2B	1 5/16-12UN-2B	1 5/8-12UN-2B
SV-1	Vapor Injection	1 1/2 Sq Flg	2 Sq Flg	2 Sq Flg	2 1/2 Sq Flg	2 1/2 Sq Flg

355 COMPRESSOR PORTS & SIZES		
PORT	DESCRIPTION	3511-3524 NPTF SIZE ⁽¹⁾
SB-2	Inlet Bearings	3/4-14
SB-3	Outlet Brgs. / Shaftseal	1 1/2-11 1/2
SC-3	Moveable Slide Stop	1/2-14
SC-4	Inlet Oil Drain	1/2-14
SC-5	Inlet Pressure	3/8-18
SC-6	Discharge Pressure	3/8-18
SC-8	Closed Thread Drain	1 1/4-11 1/2
SC-9	Closed Thread Drain	1 1/2-11 1/2
SC-10	Oil Drain	1 1/2-11 1/2
SD-1	Coalescer Bleed	1/2-14
SL-1	Low Vi Liq Injection	1 1/4-11 1/2
SL-2	High Vi Liq Injection	1 1/4-11 1/2
SM-1	Main Oil Injection	2 Sq Flg
SP-1	High Pressure Oil	3/4-14
ST-1	Thermowell Suction	3/4-14
SV-1	Vapor Injection	3 Sq Flg
TW-1	Thermowell Discharge	3/4-14

RWFII MODEL vs. COMPRESSOR MODEL	
RWFII MODEL	COMPRESSOR MODEL
RWFII 100 & 134	SGC 1913 (193)
RWFII 177 & 222	SGC 2313 (233)
RWFII 270	SGC 2321 (233)
RWFII 316 & 399	SGC 2813 (283)
RWFII 480	SGC 2821 (283)
RWFII 546	SGC 2824 (283)
RWFII 496	SGCB 3511 (355)
RWFII 496	SGCH 3511 (355)
RWFII 676	SGCB 3515 (355)
RWFII 676	SGCH 3515 (355)
RWFII 856	SGCB 3519 (355)
RWFII 1080	SGCB 3524 (355)

1. In Inches

STRAIGHT ADAPTERS / O-RINGS - STRAIGHT THREAD TO NPTF			
Straight Thread Size ⁽¹⁾	NPTF Size ⁽¹⁾	Frick Part Number	O-ring
9/16-18	1/4-18	944A0246H01	980A0012K60
3/4-16	1/4-18	944A0246H02	980A0012K62
3/4-16	3/8-18	944A0246H03	980A0012K62
3/4-16	1/2-14	944A0246H04	980A0012K62
7/8-14	1/4-18	944A0246H05	980A0012K64
7/8-14	3/8-18	944A0246H06	980A0012K64
7/8-14	1/2-14	944A0246H07	980A0012K64
7/8-14	3/4-14	944A0246H08	980A0012K64
1 1/16-12	1/2-14	944A0246H09	980A0012K66
1 1/16-12	3/4-14	944A0246H10	980A0012K66
1 3/16-12	1/2-14	944A0246H11	980A0012K68
1 3/16-12	3/4-14	944A0246H12	980A0012K68
1 5/16-12	1/2-14	944A0246H13	980A0012K69
1 5/16-12	3/4-14	944A0246H14	980A0012K69
1 5/16-12	1-11 1/2	944A0246H15	980A0012K69
1 5/8-12	1-11 1/2	944A0246H16	980A0012K71
1 5/8-12	1 1/4-11 1/2	944A0246H17	980A0012K71
1 7/8-12	1-11 1/2	944A0246H18	980A0012K72
1 7/8-12	1 1/2-11 1/2	944A0246H19	980A0012K72
7/16-20	1/4-18	944A0246H20	980A0012K58

90° ELBOW ADAPTERS / O-RINGS - STRAIGHT THREAD TO TUBE				
NUMBER	TUBE OD ⁽¹⁾	TUBE END UN/UNF-2A ⁽¹⁾	PORT THD UN/UNF-2A ⁽¹⁾	O-RING
944A0288H01	1/2	3/4-16	3/4-16	980A0012K62
944A0288H02	1/2	3/4-16	9/16-18	980A0012K60
944A0288H03	1/2	3/4-16	7/8-14	980A0012K64
944A0288H04	1/2	3/4-16	1 1/16-12	980A0012K66
944A0288H05	5/8	7/8-14	7/8-14	980A0012K64
944A0288H06	5/8	7/8-14	3/4-16	980A0012K62
944A0288H07	5/8	7/8-14	1 1/16-12	980A0012K66
944A0288H08	3/4	1 1/16-12	1 1/16-12	980A0012K66
944A0288H09	3/4	1 1/16-12	3/4-16	980A0012K62
944A0288H10	3/4	1 1/16-12	7/8-14	980A0012K64
944A0288H11	3/4	1 1/16-12	1 5/16-12	980A0012K69
944A0288H12	7/8	1 3/16-12	1 3/16-12	980A0012K68
944A0288H13	1	1 5/8-12	1 5/16-12	980A0012K69
944A0288H14	1	1 5/16-12	1 1/16-12	980A0012K66
944A0288H15	1 1/4	1 5/8-12	1 5/8-12	980A0012K71
944A0288H16	1 1/2	1 7/8-12	1 7/8-12	980A0012K72

COMPRESSOR PORTS 100 - 546	
PORT	DESCRIPTION
SB-3	Compr Oil Supply
SC-5	Inlet Pressure
SC-6	Discharge Pressure
SC-8	Closed Thrd Drain
SC-9	Inlet Hsg Oil Drain
SC-13	Oil Drain Cylinder
SC-14	Liquid Inj Bleed
SD-1	Coalescer Bleed
SL-1	Low Vi Liq Injection
SL-2	High Vi Liq Injection
SM-1	Main Oil Injection
SV-1	Vapor Injection

COMPRESSOR PORTS 496 - 1080	
PORT	DESCRIPTION
SB-2	Inlet Bearings & Balance Piston
SB-3	Discharge Bearings
SC-3	Movable Slide Stop
SC-4	Inlet Oil Drain
SC-5	Inlet Pressure
SC-6	Discharge Pressure
SC-7	Seal Weepage
SC-8	Closed Thread Drain
SC-9	Closed Thread Drain
SC-10	Oil Drain
SD-1	Coalescer Drain
SL-1	Low Vi Liquid Injection
SL-2	High Vi Liquid Injection
SM-1	Main Oil Injection
ST-1	Thermowell Suction
SV-1	Vapor Injection
TW-1	Thermowell Discharge
SP-1	High Pressure Oil

1. In Inches

FRICK FLANGE GASKETS			
GASKET NO.	FLANGE SIZE ⁽¹⁾	ID ⁽¹⁾	OD ⁽¹⁾
959A0057H01	1/4	29/32	1-11/32
959A0057H02	3/8 & 1/2	1-9/32	1-23/32
959A0057H03	3/4 & 1	1-21/32	2-3/32
959A0057H04	1-1/4	1-27/32	2-9/32
959A0057H05	1-1/2	2-1/8	2-3/4
959A0057H06	2-1/2	3	3-3/4
959A0057H07	2	2-1/2	3-1/4
959A0057H08	3-1/2	4-1/8	4-7/8
959A0057H09	4	4-3/4	5-1/2
959A0057H10	5	6-1/4	7
959A0057H11	6	7-3/8	8-1/8
959A0057H12	8	9-9/16	10-1/2
959A0057H13	10	11-7/8	12-15/16
959A0057H14	12	13-1/4	14-1/4
959A0057H15	14	14-3/4	16-1/32
959A0057H16	3/4	1-5/16	1-13/16
959A0057H18	3	3-5/8	4-3/8

1. Measurements in inches.

FRICK COMPRESSOR OILS				
Number	1 Gallon	5 Gallon	55 Gallon	330 Gallon
2A	—	111Q0550019	111Q0550020	333Q0001866
3	333Q0001842	111Q0550001	111Q0550010	333Q0001861
4	—	—	111Q0550005	—
5	—	111Q0550008	111Q0550009	—
6	—	333Q0000940	333Q0000941	—
7	—	111Q0550024	111Q0550025	—
9	—	333Q0000850	333Q0000849	333Q0001862
9ST	—	333Q0001905	333Q0001904	—
10	333Q0000741	333Q0000740	333Q0000739	—
11	—	333Q0000852	333Q0000851	333Q0001863
11ST	—	333Q0001907	333Q0001906	—
12	333Q0001140	333Q0001141	333Q0001142	—
12B	—	333Q0001883	333Q0001884	—
13	333Q0000511	333Q0001253	333Q0001254	—
13B	333Q0001939	333Q0001938	333Q0001937	—
14	333Q0001143	333Q0001144	333Q0001145	—
18	—	—	333Q0001892	—
19	—	333Q0001900	333Q0001899	—
20	—	333Q0001902	333Q0001903	—
NG 1	—	—	333Q0001850	—
NG 2	—	—	333Q0001851	—
NG 3	—	—	333Q0001852	—

Oil Analysis Kit - 333Q0001853
Tube of ODP Motor Grease - 333Q0001860

RWFII ROTARY SCREW COMPRESSOR UNIT
SERVICE PARTS LIST



FRICK BLUE PAINT	
Size Each	Part Number
1 PT.	993A0001H01*
1 GAL.	333Q0000404
2 GAL.	333Q0000724**

* Spray Can

** Matte finish epoxy paint. One gallon each of resin and cure that require mixing.

MISCELLANEOUS TUBING AND CONNECTORS	
PART NUMBER	DESCRIPTION
941A0021H02	Tubing, S. S., 3/8 x .035"
941A0035H08	Tubing, 1/2 x .049" wall
941A0035H09	Tubing, 3/4 x .065" wall
941A0035H10	Tubing 1 x .083" wall
941A0035H11	Tubing, 1-1/4 x .120" wall
944A0114H10	Ell, C. S., 1-1/4 ODT x 1-1/4 FPT
944A0116H09	Conn, 1-1/2 ODT x 3/8 MPT
944A0117H08	Conn, C. S., 1/2 ODT x 1/2 FPT
944A0117H10	Conn, C. S., 1-1/4 ODT x 1-1/4 FPT
944A0439H01	Nipple, S. S., 1/4-18 NPT x 1-1/2"
944A0439H02	Nipple, S. S., 1/4-18 NPT x 2"
944A0439H03	Nipple, S. S., 1/4-18 NPT x 3"
944A0439H04	Nipple, S. S., 3/8-18 NPT x 2"

WIRING HARNESES CHART**Model Number DESCRIPTION**

RWFII 100/134

649D5195G01	HARNESS INSTALLATION DRAWING
649D5195G02	HARNESS INSTALLATION DRAWING "STARTER OPTION"
649D5127H01	WIRE TRAY
649D5118H01	WIRE HARNESS AC
649D5117H01	WIRE HARNESS DC

RWFII 177/222

649D5231G01	HARNESS INSTALLATION DRAWING
649D5231G02	HARNESS INSTALLATION DRAWING "STARTER OPTION"
649D5230H01	WIRE TRAY
649D5232H01	WIRE HARNESS AC
649D5233H01	WIRE HARNESS DC

RWFII 270/316/399

649D5263G01	HARNESS INSTALLATION DRAWING
649D5263G02	HARNESS INSTALLATION DRAWING "STARTER OPTION"
649D5262H01	WIRE TRAY
649D5261H01	WIRE HARNESS AC
649D5260H01	WIRE HARNESS DC

RWFII 480/546

649D5225G01	HARNESS INSTALLATION DRAWING
649D5225G02	HARNESS INSTALLATION DRAWING "STARTER OPTION"
649D5226H01	WIRE TRAY
649D5227H01	WIRE HARNESS AC
649D5228H01	WIRE HARNESS DC

RWFII 496 OS/676

649D5265G01	HARNESS INSTALLATION DRAWING
649D5219G02	HARNESS INSTALLATION DRAWING "STARTER OPTION"
649D5186H01	WIRE TRAY
649D5189H01	WIRE HARNESS AC
649D5264H01	WIRE HARNESS DC

RWFII 676 OS/856

649D5219G01	HARNESS INSTALLATION
649D5219G02	HARNESS INSTALLATION DRAWING "STARTER OPTION"
649D5186H01	WIRE TRAY
649D5189H01	WIRE HARNESS AC
649D5190H01	WIRE HARNESS DC

RWFII 1080

649D5219G01	HARNESS INSTALLATION DRAWING
649D5219G02	HARNESS INSTALLATION DRAWING "STARTER OPTION"
649D5186H01	WIRE TRAY
649D5189H01	WIRE HARNESS AC
649D5190H01	WIRE HARNESS DC

RWFII ROTARY SCREW COMPRESSOR UNIT
NUMERICAL PARTS LIST



PART NUMBER	FIG. & INDEX NO.	PART NUMBER	FIG. & INDEX NO.	PART NUMBER	FIG. & INDEX NO.
553E0013	8-1	534C1314H01	2-1	580C0264C01	17-4
553E0013	9-1	534C1314H02	2-1	580C0269H01	16-7
553E0014	8-1	534C1314H03	2-1	580C0269H01	17-7
553E0014	9-1	534C1466H01	3-5	580C0394H01	16-5
553E0015	8-1	534C1478H01	2-1	580C0394H01	17-5
553E0015	9-1	534C1478H02	2-1	580C0404G07	7-7
553E0020	8-1	534C1699H01	2-15	580C0404G09	7-7
553E0020	9-1	534C1699H01	6-3	580C0407G07	7-7
111Q0019409	16-4	534D1251H01	2-2	580C0407G09	7-7
111Q0019409	17-4	534D1251H03	2-2	580C0424G10	7-7
111Q0452525	16-4	534E0656C01	2-15	580C0424G12	7-7
111Q0452525	17-4	534E0656C01	3-6	580C0424G14	7-7
111Q0940164	16-10	534E0684C01	4-1	580C0425G10	7-7
111Q0940164	17-10	534E0684C11	2-15	580C0425G12	7-7
333Q0000738	2-15	534E0684C11	4-2	580C0425G14	7-7
333Q0000738	3-1	534E0731C01	2-15	580C0426G10	7-7
333Q0000738	4-8	534E0731C01	5-1	580C0426G12	7-7
333Q0000738	5-7	534E0773C01	3-6	580C0426G14	7-7
333Q0001237	8-14	534E0928C01	2-15	581A0026H04	16-4
333Q0001268	8-9	534E0928C01	6-1	581A0026H04	17-4
333Q0001810	7-4	534M0163G02	2-10	582C0030G01	1-7
531A0105H04	7-1	534M0163G03	2-10	582C0030G01	22-16
531A0218H02	8-10	534M0163G04	2-10	582C0030G03	1-7
531B0099H01	7-8	534M0163G05	2-10	582C0030G03	22-16
531B0100H02	8-10	535A0115H06	7-19	582C0031G01	1-7
531B0100H03	8-10	535A0115H07	7-20	582C0031G01	22-16
534A0032H02	2-1	535A0115H08	7-21	582C0031G03	1-7
534A0115H04	7-18	535A0144H01	8-6	582C0031G03	22-16
534A0506H01	2-15	535D0193C04	17-3	582C0032G01	1-7
534A0506H01	3-2	535D0548G01	16-3	582C0032G01	22-16
534A0506H01	4-7	535D0549G01	1-6	582C0032G03	1-7
534A0506H01	5-6	535D0553G01	1-6	582C0032G03	22-16
534A0662H02	2-4	535E0122H01	2-5	582C0033G01	1-7
534A0662H03	2-4	535E0122H11	2-5	582C0033G01	22-16
534A0662H04	2-4	540D0217G03	7-11	582C0033G03	1-7
534B0149H01	2-15	540D0217H03	7-10	582C0033G03	22-16
534B0149H01	3-3	540D0217H06	7-9	639A0151G03	7-6
534B0149H01	4-3	540D0217H06	8-16	639A0151G03	22-12
534B0149H01	5-2	553A0001H01	8-3	639A0151H01	7-6
534B0149H01	6-7	580A0230H01	16-8	639A0151H01	22-12
534B0151H01	2-15	580A0230H01	17-8	639A0259H12	1-4
534B0151H01	3-4	580A0232H02	16-5	640D0121H01	12-1
534B0151H01	4-4	580A0232H02	17-5	640D0133G01	1-5
534B0151H01	5-3	580A0234H02	16-9	649A0890H02	1-6
534B0151H01	6-4	580A0234H02	17-9	649A0890H02	2-11
534B0705H01	2-15	580A0235H03	16-4	649A0890H02	7-6
534B0705H01	3-5	580A0235H03	17-4	649A0890H02	8-17
534B0723H01	2-15	580B0240G08	16-4	649A0890H02	9-4
534B0723H01	4-6	580B0240G08	17-4	649A0890H02	18-5
534B0740H01	2-15	580B0243G01	16-4	649A0890H02	22-12
534B0740H01	5-5	580B0243G01	17-4	649A0890H02	22-13
534B1010H01	2-15	580B0243H01	16-4	649A0890H11	1-6
534B1010H01	6-2	580B0243H01	17-4	649A0890H11	2-11
534C1264H01	2-3	580B0246G09	16-5	649A0890H11	7-6
534C1264H02	2-3	580B0246G09	17-5	649A0890H11	8-17
534C1264H03	2-3	580B0273H08	16-5	649A0890H11	9-4
534C1264H04	2-3	580B0273H08	17-5	649A0890H11	18-5
534C1264H05	2-3	580C0264C01	16-4	649A0890H11	22-12

PART NUMBER	FIG. & INDEX NO.	PART NUMBER	FIG. & INDEX NO.	PART NUMBER	FIG. & INDEX NO.
649A0890H11	22-13	901A0258H01	8-8	914A0016H23	19-1
649D4628H01	1-6	902A0021H01	7-12	914A0016H24	19-1
649D4628H01	2-11	902A0021H01	8-15	914A0016H25	19-1
649D4628H01	8-17	902A0021H03	8-5	944A0008H02	16-5
649D4628H01	9-4	905A0007H05	8-13	944A0008H02	17-5
649D4628H01	18-5	905A0012H05	7-13	944A0108H05	10-4
649D4628H01	22-13	905A0013H05	7-14	944A0108H07	10-4
720A0052H01	1-4	905A0013H08	16-12	944A0108H08	10-4
720B0030H05	22-1	905A0013H08	17-12	944A0108H08	11-5
720B0030H08	22-1	905A0013H10	16-1	944A0117H01	12-3
720B0030H21	22-1	905A0013H10	17-1	944A0255H01	18-9
720B0055H01	22-1	913A0047H02	7-4	944A0358H02	18-4
720B0055H02	22-1	913A0047H04	7-4	944A0358H03	18-4
720C0165H58	21-1	913A0092G02	7-4	944A0358H04	18-4
720C0165H90	21-1	913A0092G04	7-4	944A0358H05	18-4
720C0165P03	21-1	913A0098H01	7-6	947A0003H05	7-2
720C0166H13	21-1	913A0098H01	22-12	947A0003H07	7-2
720C0166H25	21-1	913A0100H01	7-6	950A0001H06	18-1
720C0166H38	21-1	913A0100H01	22-12	950A0001H08	18-1
720C0167H01	21-1	913A0123H01	7-5	950A0001H09	18-1
720C0167H13	21-1	913A0123H11	7-5	950A0001H25	18-1
720C0167H25	21-1	913A0123H12	7-5	950A0001H27	18-1
720C0167H37	21-1	913A0146G22	18-5	950A0001H28	18-1
720C0189G01	18-7	913A0146H01	1-6	950A0062H02	22-8
720C0189G02	18-7	913A0146H01	22-13	950A0169G01	17-1
720C0189G03	18-7	913A0146H02	2-11	950A0185G01	17-1
720C0189G04	18-7	913A0146H02	8-17	950A0232H21	7-17
720M0532	18-4	913A0146H02	9-4	950A0232H21	22-7
900A0007H01	8-11	913A0146H02	18-5	950A0232H22	8-18
900A0008H01	8-12	913A0146H02	22-13	950A0232H22	9-2
901A0045D04	7-14	914A0015H01	19-1	950A0232H22	9-3
901A0048D09	16-11	914A0015H02	19-1	950A0232H22	18-3
901A0048D09	17-11	914A0015H03	19-1	950A0232H22	22-2
901A0050D02	16-1	914A0015H04	19-1	950A0232H22	22-9
901A0050D02	17-1	914A0015H05	19-1	950A0232H23	8-18
901A0098H13	8-4	914A0015H06	19-1	950A0232H23	9-2
901A0172H03	10-6	914A0015H07	19-1	950A0232H23	9-3
901A0172H05	10-6	914A0015H08	19-1	950A0232H23	10-1
901A0172H06	10-6	914A0015H09	19-1	950A0232H23	18-3
901A0172H06	11-7	914A0015H10	19-1	950A0232H23	22-9
901A0190H06	2-15	914A0015H13	19-1	950A0232H23	22-11
901A0190H06	3-7	914A0015H14	19-1	950A0232H31	7-17
901A0190H06	4-9	914A0015H15	19-1	950A0232H31	12-1
901A0190H06	5-8	914A0015H16	19-1	950A0232H31	12-1
901A0192H06	2-13	914A0015H18	19-1	950A0233H02	7-17
901A0206H09	2-13	914A0015H19	19-1	950A0233H02	22-7
901A0207H10	2-13	914A0015H20	19-1	950A0233H03	22-2
901A0222H07	2-15	914A0016H02	19-1	950A0233H05	8-18
901A0222H07	6-6	914A0016H04	19-1	950A0233H05	9-2
901A0223H08	2-15	914A0016H04	19-1	950A0233H05	18-3
901A0223H08	5-4	914A0016H04	19-1	950A0233H05	22-9
901A0224H03	2-15	914A0016H04	19-1	950A0233H06	8-18
901A0224H03	6-5	914A0016H05	19-1	950A0233H06	9-2
901A0224H09	2-15	914A0016H05	19-1	950A0233H06	10-1
901A0224H09	3-8	914A0016H12	19-1	950A0233H06	18-3
901A0224H09	4-5	914A0016H18	19-1	950A0233H06	22-9
901A0228H20	2-7	914A0016H20	19-1	950A0233H06	22-11
901A0231H01	2-13	914A0016H22	19-1	950A0240H09	1-7

PART NUMBER	FIG. & INDEX NO.	PART NUMBER	FIG. & INDEX NO.	PART NUMBER	FIG. & INDEX NO.
950A0240H10	1-6	950A0292H03	7-16	950A0329H13	11-8
950A0240H10	1-7	950A0292H03	8-21	950A0330H02	10-8
950A0240H10	22-17	950A0292H03	9-7	950A0330H02	11-8
950A0240H11	1-6	950A0292H03	22-6	950A0330H03	11-8
950A0240H11	1-7	950A0293H01	12-1	950A0334H01	12-1
950A0240H11	22-17	950A0293H02	12-1	950A0334H02	12-1
950A0240H12	1-6	950A0293H03	12-1	950A0334H03	12-1
950A0240H12	1-7	950A0294H01	10-7	950A0334H18	12-1
950A0240H12	22-17	950A0294H01	22-10	950A0334H19	12-1
950A0240H24	8-18	950A0294H02	10-7	950A0334H20	12-1
950A0240H24	9-2	950A0294H02	11-9	950A0339H01	8-20
950A0240H24	9-3	950A0294H02	22-10	950A0339H01	9-6
950A0240H24	10-1	950A0294H11	10-7	950A0339H01	22-23
950A0240H24	11-1	950A0294H11	10-7	951A0053G01	12-3
950A0240H24	18-3	950A0294H11	11-9	951A0053G11	12-3
950A0240H24	22-9	950A0294H11	22-10	951A0053H01	12-3
950A0240H24	22-11	950A0297H01	10-7	951A0054H01	12-3
950A0240H25	8-18	950A0297H01	11-9	951A0113H20	2-9
950A0240H25	11-1	950A0297H01	22-10	951A0114H01	2-8
950A0240H25	18-3	950A0297H11	10-7	951A0114H02	2-8
950A0240H25	22-9	950A0297H11	11-9	951A0114H05	2-8
950A0240H27	22-17	950A0297H11	22-10	951A0114H06	2-8
950A0240H28	22-17	950A0320H05	10-2	952A0051H10	7-7
950A0240H29	22-17	950A0320H05	22-21	952A0051H12	7-7
950A0241H07	8-18	950A0320H06	10-2	952A0051H14	7-7
950A0241H07	9-2	950A0320H06	22-21	952A0052H10	7-7
950A0241H07	10-1	950A0320H15	10-2	952A0052H12	7-7
950A0241H07	11-1	950A0320H15	22-21	952A0052H14	7-7
950A0241H07	18-3	950A0320H16	10-2	952A0053H10	7-7
950A0241H07	22-9	950A0320H16	10-8	952A0053H12	7-7
950A0241H07	22-11	950A0320H16	11-8	952A0053H12	7-7
950A0241H08	8-18	950A0320H16	22-21	952A0053H14	7-7
950A0241H08	9-2	950A0327H01	12-1	952A0053H14	7-7
950A0241H08	11-1	950A0327H02	12-1	952A0055H07	7-7
950A0241H08	18-3	950A0327H03	12-1	952A0055H09	7-7
950A0241H08	22-9	950A0327H11	12-1	952A0055H09	7-7
950A0245H05	9-3	950A0327H13	12-1	952A0058H07	7-7
950A0245H06	9-3	950A0327H14	12-1	952A0058H09	7-7
950A0253H07	9-3	950A0327H15	12-1	952A0058H09	7-7
950A0253H08	9-3	950A0327H16	12-1	954A0062H02	8-19
950A0283H01	1-6	950A0327H17	12-1	954A0062H02	9-5
950A0283H01	22-17	950A0327H18	12-1	954A0062H03	8-19
950A0283H02	1-6	950A0327H19	12-1	954A0062H03	9-5
950A0283H02	16-1	950A0327H20	12-1	954A0062H03	22-8
950A0283H02	22-17	950A0327H21	12-1	954A0062H04	8-19
950A0283H21	22-17	950A0327H22	12-1	954A0062H04	9-5
950A0283H22	22-17	950A0328H06	10-8	954A0062H04	22-8
950A0284H02	16-1	950A0328H06	11-8	954A0062H27	8-19
950A0286G01	16-1	950A0329H01	10-2	954A0062H27	9-5
950A0286G02	16-1	950A0329H01	11-4	954A0062H27	22-8
950A0292H01	8-17	950A0329H01	22-21	954A0062H28	8-19
950A0292H01	9-4	950A0329H02	11-4	954A0062H28	9-5
950A0292H01	10-9	950A0329H11	10-2	954A0062H28	22-8
950A0292H01	11-2	950A0329H11	11-4	954A0062H29	8-19
950A0292H01	12-2	950A0329H11	22-21	954A0062H29	9-5
950A0292H01	18-6	950A0329H12	10-8	954A0062H29	22-8
950A0292H01	22-6	950A0329H12	11-4	954A0075H01	8-19
950A0292H02	22-6	950A0329H12	11-8	954A0075H01	9-5

PART NUMBER	FIG. & INDEX NO.	PART NUMBER	FIG. & INDEX NO.	PART NUMBER	FIG. & INDEX NO.
954A0075H01	22-8	959A0054H28	11-6	960A0082G10	19-1
954A0075H23	8-19	959A0054H28	19-2	960A0082H01	19-1
954A0075H23	9-5	959A0054H30	2-12	960A0082H02	19-1
954A0075H23	22-8	959A0054H30	7-3	960A0083G01	19-1
955B0001H02	7-7	959A0054H31	1-6	960A0083G02	19-1
955B0001H11	7-7	959A0054H31	2-3	960A0083G03	19-1
955B0001H12	7-7	959A0054H31	2-14	960A0083G04	19-1
955B0001H13	7-7	959A0054H31	22-19	960A0083G07	19-1
955B0002H02	7-7	959A0054H32	1-6	960A0083G08	19-1
955B0002H11	7-7	959A0054H32	2-3	960A0083G09	19-1
955B0002H12	7-7	959A0054H32	2-12	960A0083G10	19-1
955B0002H13	7-7	959A0054H32	2-14	960A0083H01	19-1
955B0005H01	7-7	959A0054H32	2-14	960A0083H03	19-1
955B0005H02	7-7	959A0054H32	7-3	960A0100G01	19-1
955B0005H03	7-7	959A0054H32	22-19	960A0100G02	19-1
956A0012G01	10-3	959A0054H33	1-6	960A0100G03	19-1
956A0012G02	11-3	959A0054H33	2-3	960A0100G04	19-1
956A0012G02	22-22	959A0054H33	2-3	960A0100G05	19-1
956A0012G03	10-3	959A0054H33	2-12	960A0100G06	19-1
956A0012G03	22-22	959A0054H33	2-14	960A0100G07	19-1
956A0012G04	19-3	959A0054H33	7-3	960A0100G08	19-1
956A0012G04	22-20	959A0054H33	22-19	960A0100G09	19-1
956A0012G05	10-3	959A0054H34	2-3	960A0100H01	19-1
956A0012G05	11-3	959A0054H34	2-12	960A0100H01	19-1
956A0012G05	22-22	959A0054H34	2-14	960A0100H02	19-1
956A0014H01	19-3	959A0054H34	7-3	960A0101G07	19-1
956A0014H01	22-20	959A0054H34	22-19	960A0101G08	19-1
956A0014H02	19-3	959A0054H36	2-14	960A0101G10	19-1
956A0014H02	22-20	959A0057H05	18-4	960A0101H07	19-1
956A0025H23	18-2	959A0057H05	18-8	960A0101H08	19-1
956A0025H24	18-2	959A0057H06	18-4	960A0101H10	19-1
956A0025H25	18-2	959A0057H06	18-8	960A0103G01	19-1
956A0045H01	1-7	959A0057H07	18-4	960A0103G02	19-1
956A0045H02	1-7	959A0057H07	18-8	960A0103G03	19-1
956A0046H01	1-7	959A0057H18	18-4	960A0103G04	19-1
956A0046H02	1-7	959A0057H18	18-8	960A0103G05	19-1
956A0047H01	1-7	959A0061H05	16-6	960A0103G06	19-1
956A0047H02	1-7	959A0061H05	17-6	960A0103G07	19-1
956A0048H01	1-7	959A0062H26	16-2	960A0103G08	19-1
956A0048H02	1-7	959A0062H27	17-2	960A0103G09	19-1
956A0050H03	1-6	959A0082H01	8-2	960A0103G10	19-1
956A0050H03	22-18	959A0098H01	1-6	960A0103G11	19-1
956A0050H04	1-6	959A0105H01	7-15	960A0103G12	19-1
956A0050H04	22-18	960A0066H11	19-1	960A0103G13	19-1
956A0050H05	1-6	960A0066H12	19-1	960A0103G14	19-1
956A0050H05	22-18	960A0067H11	19-1	960A0103H01	19-1
956A0050H06	1-6	960A0067H12	19-1	960A0103H02	19-1
956A0050H06	22-18	960A0067H13	19-1	960A0103H30	19-1
956A0052H01	22-14	960A0068H11	19-1	960A0104G01	19-1
956A0052H02	22-14	960A0082G01	19-1	960A0104G02	19-1
956A9912G01	22-22	960A0082G02	19-1	960A0104G03	19-1
959A0053H01	8-7	960A0082G03	19-1	960A0104G04	19-1
959A0054H23	19-2	960A0082G04	19-1	960A0104G05	19-1
959A0054H25	10-5	960A0082G05	19-1	960A0104G06	19-1
959A0054H25	19-2	960A0082G06	19-1	960A0104G07	19-1
959A0054H27	10-5	960A0082G07	19-1	960A0104G08	19-1
959A0054H27	19-2	960A0082G08	19-1	960A0104G09	19-1
959A0054H28	10-5	960A0082G09	19-1	960A0104G10	19-1

RWFII ROTARY SCREW COMPRESSOR UNIT
NUMERICAL PARTS LIST



PART NUMBER	FIG. & INDEX NO.	PART NUMBER	FIG. & INDEX NO.	PART NUMBER	FIG. & INDEX NO.
960A0104G21	19-1	980A0012H87	16-4		
960A0104G22	19-1	980A0012H87	17-4		
960A0104G23	19-1	980A0012K60	2-2		
960A0104G24	19-1	980A0012K60	12-4		
960A0104G25	19-1	980A0012K60	22-5		
960A0104G26	19-1	980A0012K62	2-1		
960A0104H01	19-1	980A0012K66	12-5		
960A0104H02	19-1	980A0012K66	22-3		
960A0104H03	19-1	980A0012K66	22-4		
960A0104H30	19-1	980A0012K69	12-5		
960A0105G01	19-1				
960A0105G02	19-1				
960A0105G03	19-1				
960A0105H01	19-1				
960A0105H30	19-1				
960A0106G01	19-1				
960A0106G02	19-1				
960A0106G03	19-1				
960A0106G04	19-1				
960A0106G05	19-1				
960A0106G06	19-1				
960A0106G07	19-1				
960A0106G08	19-1				
960A0106G09	19-1				
960A0106G10	19-1				
960A0106G11	19-1				
960A0106G12	19-1				
960A0106G13	19-1				
960A0106G14	19-1				
960A0106H01	19-1				
960A0106H02	19-1				
960A0106H30	19-1				
960A0107G01	19-1				
960A0107G02	19-1				
960A0107G03	19-1				
960A0107G04	19-1				
960A0107G05	19-1				
960A0107G06	19-1				
960A0107G07	19-1				
960A0107G08	19-1				
960A0107G09	19-1				
960A0107G10	19-1				
960A0107G21	19-1				
960A0107G22	19-1				
960A0107G23	19-1				
960A0107G24	19-1				
960A0107G25	19-1				
960A0107G26	19-1				
960A0107H01	19-1				
960A0107H02	19-1				
960A0107H03	19-1				
960A0107H30	19-1				
960A0108G01	19-1				
960A0108G02	19-1				
960A0108G03	19-1				
960A0108H01	19-1				
960A0108H30	19-1				
980A0012A61	2-6				

NOTES

NOTES

NOTES

Form 070-610 SPL (2010-10)
Supersedes: 070-610 SPL (2010-03)
Subject to change without notice
Published in USA - GUI

© 2010 Johnson Controls Inc. - ALL RIGHTS RESERVED



JOHNSON CONTROLS
100 CV Avenue • P.O. Box 997
Waynesboro, PA USA 17268-0997
Phone: 717-762-2121 • FAX: 717-762-8624
www.johnsoncontrols.com/frick