



S70-410 SM/JAN 2003

File: SERVICE MANUAL - Section 70
Replaces: NOTHING (New Information)
Dist: 3, 3a, 3b, 3c

RXF

REPLACEMENT MOTOR & COMPRESSOR MOUNTING PROCEDURES

Purpose:

The purpose of this procedure is to outline the process for mounting replacement motors and compressors on RXF packages in the field. The goal is to ensure a stress-free compressor and motor arrangement to assure the designed life of the bearings and shaft seals. In addition, a stress-free arrangement will yield proper slide valve operation and minimize vibration.

Replacement Motor Mounting Procedure:

1. Prior to removing the motor from the RXF package, the compressor must be blocked up and properly supported. The entire weight of the compressor and tunnel must be supported. Reference Appendix B for compressor weights. Do not unbolt the compressor from the oil separator.
2. Remove the bolts between the motor and the compressor tunnel while supporting the motor weight. Then lift the motor from the compressor package. Reference Appendix A for motor weights.
3. Using a spring scale, weigh the replacement motor prior to assembly to the compressor. Reference Figure 1. If a spring scale is not available, contact Frick or the motor manufacture for the weight of the motor (Appendix A may also be used as a guide).



Figure 1. Weigh replacement motor.

4. Align the D-flange or C-face motor holes to the compressor tunnel holes while supporting the weight of the motor.
5. Insert the bolts through the flanged motor holes and into the compressor tunnel and tighten by hand.
6. Continue to support the motor weight by maintaining the same weight on the spring scale. If a spring scale and/or overhead support is not available, then a hydraulic piston may be used underneath the motor. Reference Figure 2. (Contact the Frick Baltimore Parts Center for a piston type lifting kit, Ph:800-336-7264)

NOTE: The motor weight must be supported to avoid stressing the compressor or motor. Do not over or under support the motor. The scale or pressure gage reading must be within +/- 10% of the motor weight.

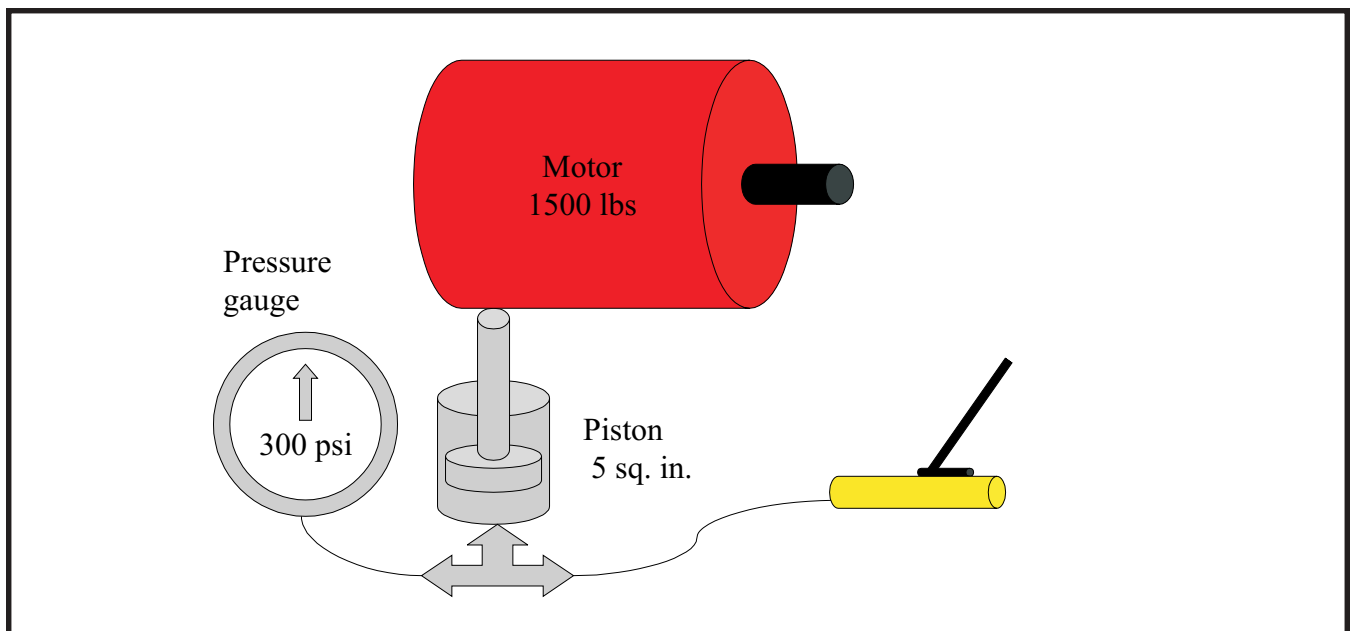

Figure 2. Hydraulic piston supports motor weight.

7. If a hydraulic piston is used, then proceed with the following guidelines:
 - A. Determine the area of the piston (Piston Area = $\Pi * \text{Diameter}^2 / 4$).
 - B. Calculate the required pressure (Pressure = Weight of motor / Piston Area)
 - C. Using a pressure gage between the hydraulic piston and pump, increase the pressure until the gage reaches the calculated required pressure.

8. Torque the bolts between the motor and compressor tunnel to the required specification. Reference Appendix C.
9. While the motor is still supported, shim the motor feet to less than .002 inch gap between each motor foot and the support base. Then, bolt the motor to the mounting base and torque the motor mounting bolts to 250 ft-lb. Reference Figure 3.

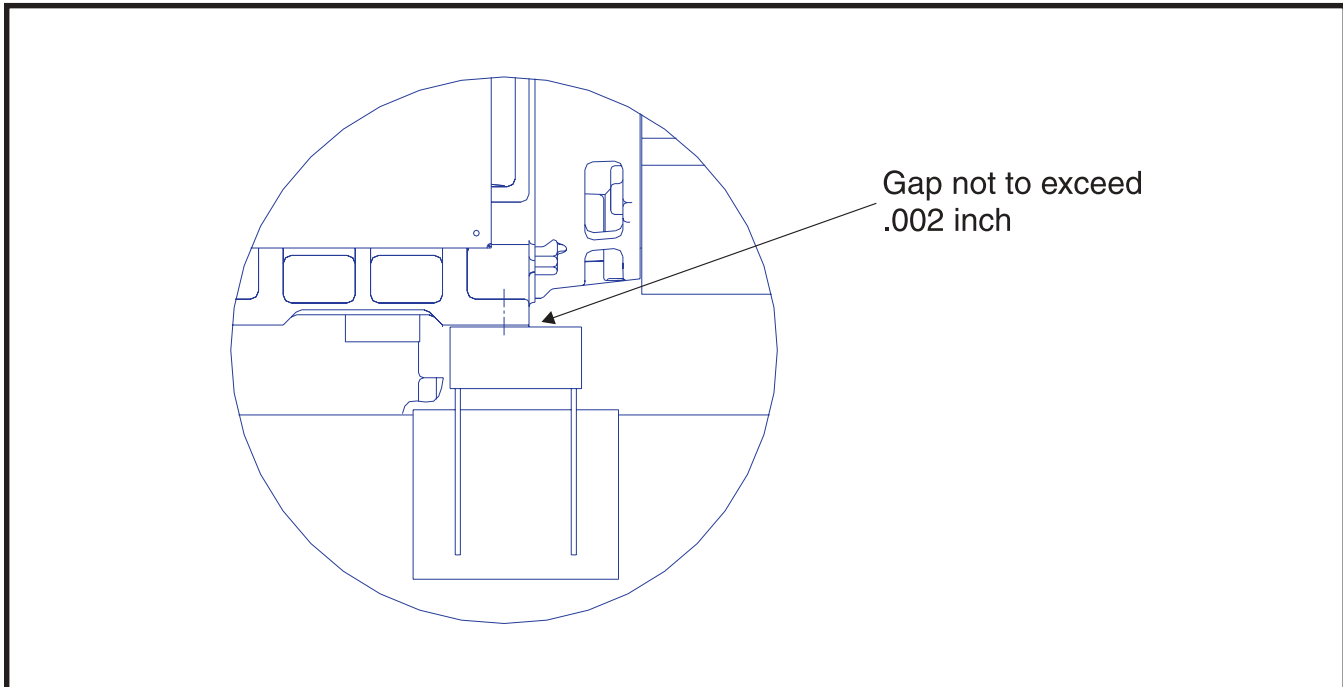

Figure 3. Shim motor feet to less than .002 inch gap.

10. The overhead support or hydraulic piston may now be removed. The blocks supporting the compressor may also be removed.

Replacement Compressor Mounting Procedure:

1. If the compressor needs to be removed from the RXF package, then the entire motor and compressor assembly must be removed.
2. Disconnect all tubing and pipe connections from the compressor and all wiring from the motor. Support the assembly, remove the bolts and lift the compressor and motor assembly from the package. Reference Appendix A and B for compressor and motor weights.

3. Place a new gasket on the oil separator flange. (*Contact the Frick Baltimore Parts Center for replacement gaskets, Ph:800-336-7264*)
4. Set the replacement compressor and motor assembly on the separator flange and align the oil separator flange bolt holes to the compressor discharge flange bolt holes while supporting the assembly with a hydraulic piston underneath the motor. Reference Figure 4. The hydraulic piston must support the motor weight plus $\frac{1}{2}$ the compressor weight. Reference appendix A and B for motor and compressor weights. Follow the guidelines as outlined in step 7 of the motor mounting procedure above.
5. Insert the bolts through the oil separator flange and into the compressor discharge flange and torque the bolts to the required specification (Reference appendix C).

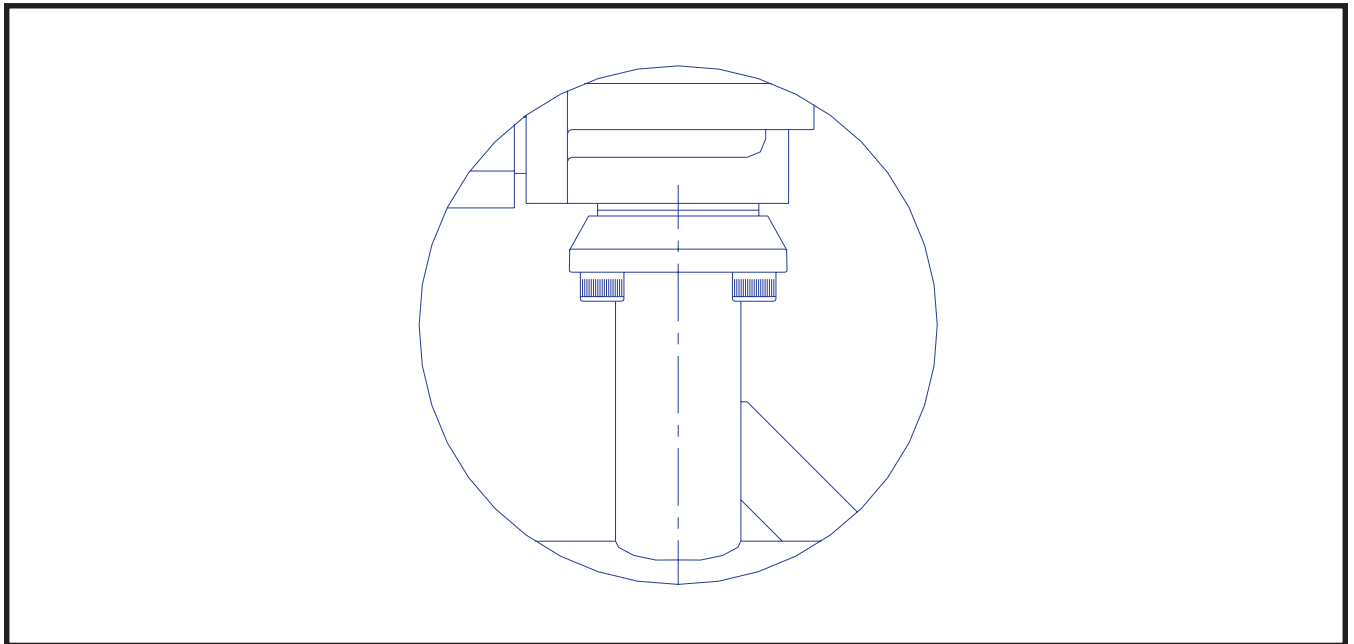

Figure 4. Set replacement compressor and motor assembly on separator flange.

6. The motor feet should rise above the support base. If not, remove the compressor, add another gasket on top of the oil separator flange and repeat steps 4 & 5.
7. While the assembly is still supported, shim the motor feet to less than .002 inch gap between each motor foot and the support base. Then, bolt the motor to the mounting base and torque the motor mounting bolts to 250 ft-lb. Reference Figure 3.
8. Reconnect all tubing and pipe connections to the compressor and all wiring to the motor.
9. Remove the hydraulic piston.

RXF REPLACEMENT MOTOR & COMPRESSOR
MOUNTING PROCEDURES



Motor HP	Frame	Approximate Wt. (lbs.)
75	364TSC	630
100	365TSC	730
125	404TSC	930
125	LN405TDZ	1000
134	LN405TDZ	1000
150	405TSC	1060
150	LN405TDZ	1070
154	LN405TDZ	1070
175	LN405TDZ	1080
200	LN405TDZ	1080
235	LN445TDZ	1440
250	LN445TDZ	1540
263	LN445TDZ	1540
284	LN447TDZ	1630
300	LN447TDZ	1730
305	LN447TDZ	1730
335	LN447TDZ	1730
350	LN447TDZ	1880
368	LN447TDZ	1880
400	LN449TDZ	2180
407	LN449TDZ	2180
437	LN449TDZ	2180
450	LN449TDZ	2310

Appendix A.

Note: The weights listed are for reference only, and are approximate, based on standard open drip proof motors operating at 60 Hz. Contact Frick or the motor manufacture to confirm the motor weight.

Package Model	Compressor Model	Approximate Wt. (lbs.)
RXF 12	XJF 95S	600
RXF 15	XJF 95M	600
RXF 19	XJF 95L	600
RXF 24	XJF 120S	845
RXF 30	XJF 120M	845
RXF 39	XJF 120L	845
RXF 50	XJF 120S	845
RXF 58	XJF 151A	1210
RXF 68	XJF 151M	1210
RXF 85	XJF 151L	1210
RXF 101	XJF 151N	1210

Appendix B.

Note: Weights do not include the drive coupling.

Package Model	Compressor Model	Motor Flange to Compressor Tunnel		Compressor Flange to Separator Flange	
		Bolt Size (in.)	Torque (ft-lb.)	Bolt Size	Torque (ft-lb.)
RXF 12	XJF 95S	1/2 or 5/8	58	M20 X 2.5	107
RXF 15	XJF 95M	1/2 or 5/8	58	M20 X 2.5	107
RXF 19	XJF 95L	1/2 or 5/8	58	M20 X 2.5	107
RXF 24	XJF 120S	1/2 or 5/8	58	M20 X 2.5	150
RXF 30	XJF 120M	1/2 or 5/8	58	M20 X 2.5	150
RXF 39	XJF 120L	1/2 or 5/8	58	M20 X 2.5	150
RXF 50	XJF 120S	1/2 or 5/8	58	M20 X 2.5	150
RXF 58	XJF 151A	5/8 or 3/4	144	M22 X 2.5	167
RXF 68	XJF 151M	5/8 or 3/4	144	M22 X 2.5	167
RXF 85	XJF 151L	5/8 or 3/4	144	M22 X 2.5	167
RXF 101	XJF 151N	5/8 or 3/4	144	M22 X 2.5	167

Appendix C.

NOTE:

1. The bolt torque requirements for the motor flange to compressor tunnel are based on metal to metal contact.
2. The bolt torque requirements for the compressor flange to separator flange are based on:
 - a. Gaskets: Garlock blugard 3300
 - b. Bolts: class 8.8 or stronger hex head bolts, lightly oiled and clean



YORK Refrigeration
100 CV Avenue • P.O. Box 997 • Waynesboro, Pennsylvania USA 17268-0997
Phone: 717-762-2121 • FAX: 717-762-8624 • www.frickcold.com