

# YASKAWA AC Drive Z1000

## AC Drive for HVAC Fan and Pump

### User Manual

Type: CIMR-ZU□A □□□□

Models: 200 V Class: 2.2 to 110 kW (3 to 150 HP)  
400 V Class: 2.2 to 370 kW (3 to 500 HP)

To properly use the product, read this manual thoroughly and retain for easy reference, inspection, and maintenance. Ensure the end user receives this manual.

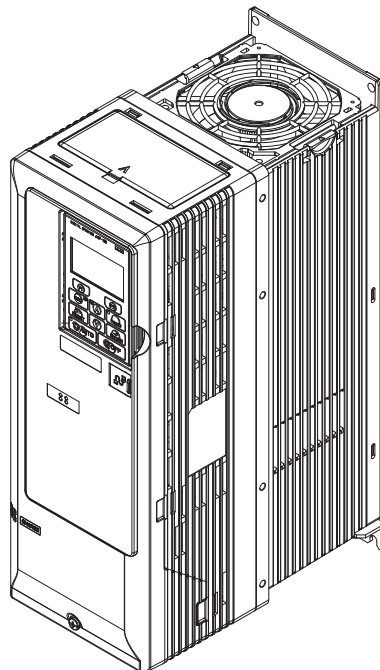

Receiving **1**

Mechanical Installation **2**

Electrical Installation **3**

Start-Up Programming & Operation **4**

Troubleshooting **5**

Peripheral Devices & Options **6**

Specifications **A**

Parameter List **B**

BACnet Communications **C**

Standards Compliance **D**

Quick Reference Sheet **E**

---

**This Page Intentionally Blank**

Copyright © 2011 YASKAWA ELECTRIC CORPORATION. All rights reserved.

No part of this publication may be reproduced, stored in a retrieval system, or transmitted, in any form or by any means, mechanical, electronic, photocopying, recording, or otherwise, without the prior written permission of Yaskawa. No patent liability is assumed with respect to the use of the information contained herein. Moreover, because Yaskawa is constantly striving to improve its high-quality products, the information contained in this manual is subject to change without notice. Every precaution has been taken in the preparation of this manual. Yaskawa assumes no responsibility for errors or omissions. Neither is any liability assumed for damages resulting from the use of the information contained in this publication.

# Table of Contents

---

<b>i. PREFACE &amp; GENERAL SAFETY</b> .....	<b>11</b>
<b>i.1 Preface</b> .....	<b>12</b>
Applicable Documentation.....	12
Symbols.....	12
Terms and Abbreviations .....	12
Trademarks .....	12
<b>i.2 General Safety</b> .....	<b>14</b>
Supplemental Safety Information .....	14
Safety Messages.....	15
General Application Precautions .....	17
Motor Application Precautions.....	18
Drive Label Warning Example.....	20
Warranty Information.....	21
<b>1. RECEIVING</b> .....	<b>23</b>
<b>1.1 Section Safety</b> .....	<b>24</b>
<b>1.2 General Description</b> .....	<b>25</b>
Z1000 Model Selection.....	25
Control Mode Selection .....	26
<b>1.3 Model Number and Nameplate Check</b> .....	<b>27</b>
Drive Nameplate.....	27
<b>1.4 Drive Models and Enclosure Types</b> .....	<b>29</b>
<b>1.5 Component Names</b> .....	<b>30</b>
IP20/NEMA Type 1 Enclosure.....	30
IP00/Open-Type Enclosure .....	33
Front Views .....	37
<b>2. MECHANICAL INSTALLATION</b> .....	<b>39</b>
<b>2.1 Section Safety</b> .....	<b>40</b>
<b>2.2 Mechanical Installation</b> .....	<b>42</b>
Installation Environment .....	42
Transporting the Drive.....	42
Installation Orientation and Spacing.....	43
Instructions on Installation Using the Eye Bolts .....	43
Panel Cut-Out Dimensions.....	45
HOA Keypad Remote Usage .....	46
Exterior and Mounting Dimensions .....	49

<b>3. ELECTRICAL INSTALLATION .....</b>	<b>59</b>
<b>3.1 Section Safety.....</b>	<b>60</b>
<b>3.2 Standard Connection Diagram.....</b>	<b>62</b>
<b>3.3 Main Circuit Connection Diagram.....</b>	<b>65</b>
Three-Phase 200 V Class (2A0011 to 2A0273)	
Three-Phase 400 V Class (4A0005 to 4A0302).....	65
Three-Phase 200 V Class (2A0343 and 2A0396)	
Three-Phase 400 V Class (4A0361 to 4A0590).....	65
12-Pulse/18-Pulse Rectification .....	65
Wiring to -/+1 Terminals (2A0343 to 2A0396 and 4A0361 to 4A0590) .....	66
<b>3.4 Terminal Block Configuration .....</b>	<b>68</b>
<b>3.5 Terminal Cover .....</b>	<b>70</b>
Models 2A0143 to 2A0396 and 4A0124 to 4A0590 .....	70
<b>3.6 HOA Keypad and Front Cover.....</b>	<b>72</b>
Removing/Reattaching the HOA Keypad .....	72
Removing/Reattaching the Front Cover .....	73
<b>3.7 Top Protective Cover .....</b>	<b>79</b>
Removing the Top Protective Cover .....	79
Reattaching the Top Protective Cover .....	80
<b>3.8 Main Circuit Wiring.....</b>	<b>81</b>
Factory Recommended Branch Circuit Protection .....	81
Main Circuit Terminal Functions.....	81
Protecting Main Circuit Terminals .....	82
Wire Gauges and Tightening Torque .....	83
Main Circuit Terminal and Motor Wiring .....	86
<b>3.9 Control Circuit Wiring .....</b>	<b>91</b>
Control Circuit Connection Diagram.....	91
Control Circuit Terminal Block Functions .....	91
Terminal Configuration .....	93
Wiring the Control Circuit Terminal .....	95
Switches and Jumpers on the Control Board .....	99
<b>3.10 Control I/O Connections .....</b>	<b>100</b>
Sinking/Sourcing Mode Switch for Digital Inputs.....	100
Input Signal Selection for Terminals A1 and A2.....	100
Terminal FM/AM Signal Selection .....	101
MEMOBUS/Modbus Termination .....	101
<b>3.11 Connect to a PC.....</b>	<b>102</b>
<b>3.12 External Interlock .....</b>	<b>103</b>
Drive Ready.....	103
<b>3.13 Wiring Checklist .....</b>	<b>104</b>
<b>4. START-UP PROGRAMMING &amp; OPERATION.....</b>	<b>105</b>
<b>4.1 Section Safety.....</b>	<b>106</b>
<b>4.2 Using the HOA Keypad .....</b>	<b>107</b>
Keys and Displays.....	107
LCD Display .....	108
ALARM (ALM) LED Displays.....	109
AUTO LED and HAND LED Indications .....	109

Menu Structure for HOA Keypad.....	111
<b>4.3 The Drive, Programming, and Clock Adjustment Modes .....</b>	<b>112</b>
Real-Time Clock (RTC) .....	112
Clock Adjustment .....	112
Changing Parameter Settings or Values .....	115
Verifying Parameter Changes: Verify Menu .....	116
Simplified Setup Using the Setup Group.....	117
<b>4.4 Start-Up Flowcharts .....</b>	<b>119</b>
Flowchart A: Basic Start-Up and Motor Tuning .....	120
Subchart A-1: Simple Motor Setup Using V/f Control.....	121
Subchart A-2: Operation with Permanent Magnet Motors.....	122
<b>4.5 Powering Up the Drive .....</b>	<b>123</b>
Powering Up the Drive and Operation Status Display.....	123
<b>4.6 Application Selection .....</b>	<b>124</b>
HVAC Application Parameters .....	124
Setting 1: Fan Application .....	124
Setting 2: Fan with PI Control Application .....	125
Setting 3: Return Fan with PI Control Application .....	125
Setting 4: Cooling Tower Fan Application .....	125
Setting 5: Cooling Tower Fan with PI Control Application .....	126
Setting 6: Pump (Secondary) Application.....	126
Setting 7: Pump with PI Control Application.....	126
<b>4.7 Basic Drive Setup Adjustments .....</b>	<b>127</b>
<b>4.8 Auto-Tuning .....</b>	<b>142</b>
Types of Auto-Tuning .....	142
Before Auto-Tuning the Drive .....	143
Auto-Tuning Interruption and Fault Codes .....	144
Auto-Tuning Operation Example .....	144
T1: Parameter Settings during Induction Motor Auto-Tuning .....	146
T2: Parameter Settings during PM Motor Auto-Tuning .....	147
<b>4.9 No-Load Operation Test Run.....</b>	<b>150</b>
No-Load Operation Test Run .....	150
<b>4.10 Test Run with Load Connected.....</b>	<b>151</b>
Test Run with the Load Connected .....	151
<b>4.11 Verifying Parameter Settings and Backing Up Changes .....</b>	<b>152</b>
Backing Up Parameter Values: o2-03 .....	152
Parameter Access Level: A1-01 .....	152
Password Settings: A1-04, A1-05 .....	152
Copy Function .....	153
<b>4.12 Test Run Checklist .....</b>	<b>154</b>
<b>4.13 Advanced Drive Setup Adjustments .....</b>	<b>155</b>
U1: Operation Status Monitors .....	192
U2: Fault Trace.....	192
U3: Fault History.....	192
U4: Maintenance Monitors .....	192
U5: PI Monitors.....	192
U6: Operation Status Monitors .....	193
<b>5. TROUBLESHOOTING.....</b>	<b>195</b>

<b>5.1</b>	<b>Section Safety</b> .....	<b>196</b>
<b>5.2</b>	<b>Motor Performance Fine-Tuning</b> .....	<b>198</b>
	Fine-Tuning V/f Control .....	198
	Fine-Tuning Open Loop Vector Control for PM Motors .....	199
	Parameters to Minimize Motor Hunting and Oscillation .....	200
<b>5.3</b>	<b>Drive Alarms, Faults, and Errors</b> .....	<b>201</b>
	Types of Alarms, Faults, and Errors .....	201
	Alarm and Error Displays .....	202
<b>5.4</b>	<b>Fault Detection</b> .....	<b>205</b>
	Fault Displays, Causes, and Possible Solutions .....	205
<b>5.5</b>	<b>Alarm Detection</b> .....	<b>218</b>
	Alarm Codes, Causes, and Possible Solutions .....	218
<b>5.6</b>	<b>Programming Errors</b> .....	<b>225</b>
	Programming Error Codes, Causes, and Possible Solutions .....	225
<b>5.7</b>	<b>Auto-Tuning Fault Detection</b> .....	<b>229</b>
	Auto-Tuning Codes, Causes, and Possible Solutions .....	229
<b>5.8</b>	<b>Copy Function Related Displays</b> .....	<b>231</b>
	Tasks, Errors, and Troubleshooting .....	231
<b>5.9</b>	<b>Diagnosing and Resetting Faults</b> .....	<b>233</b>
	Fault Occurs Simultaneously with Power Loss .....	233
	If the Drive Still has Power After a Fault Occurs .....	233
	Viewing Fault Trace Data After Fault .....	233
	Fault Reset Methods .....	234
<b>5.10</b>	<b>Troubleshooting without Fault Display</b> .....	<b>235</b>
	Common Problems.....	235
	Cannot Change Parameter Settings .....	235
	Motor Does Not Rotate Properly after Pressing AUTO Button or after Entering External Run	
	Command .....	236
	Motor is Too Hot.....	237
	oPE02 Error Occurs When Lowering the Motor Rated Current Setting .....	238
	Motor Stalls during Acceleration or Acceleration Time is Too Long .....	238
	Drive Frequency Reference Differs from the Controller Frequency Reference Command .....	239
	Excessive Motor Oscillation and Erratic Rotation.....	239
	Deceleration Takes Longer than Expected .....	239
	Noise From Drive or Motor Cables When the Drive is Powered On .....	239
	Ground Fault Circuit Interrupter (GFCI) Trips During Run .....	239
	Connected Machinery Vibrates When Motor Rotates .....	240
	PI Output Fault .....	240
	Motor Rotates After the Drive Output is Shut Off (Motor Rotates During DC Injection Braking).....	240
	Output Frequency is Not as High as Frequency Reference .....	241
	Sound from Motor.....	241
	Unstable Motor Speed when Using PM .....	241
	Motor Does Not Restart after Power Loss.....	241
<b>6.</b>	<b>PERIPHERAL DEVICES &amp; OPTIONS</b> .....	<b>243</b>
<b>6.1</b>	<b>Section Safety</b> .....	<b>244</b>
<b>6.2</b>	<b>Drive Options and Peripheral Devices</b> .....	<b>246</b>
<b>6.3</b>	<b>Connecting Peripheral Devices</b> .....	<b>247</b>

<b>6.4</b>	<b>Option Installation .....</b>	<b>248</b>
	Prior to Installing the Option .....	248
	Installing the Option.....	248
<b>6.5</b>	<b>Installing Peripheral Devices .....</b>	<b>252</b>
	Installing a Molded Case Circuit Breaker (MCCB) or Ground Fault Circuit Interrupter (GFCI) .....	252
	Installing a Magnetic Contactor at the Power Supply Side.....	253
	Connecting an AC Reactor.....	253
	Connecting a Surge Absorber .....	253
	Attachment for External Heatsink Mounting .....	255
	Installing a Motor Thermal Overload (oL) Relay on the Drive Output .....	263
<b>A.</b>	<b>SPECIFICATIONS .....</b>	<b>265</b>
<b>A.1</b>	<b>Power Ratings .....</b>	<b>266</b>
	Three-Phase 200 V Class Drive Models 2A0011 to 2A0088 .....	266
	Three-Phase 200 V Class Drive Models 2A0114 to 2A0396 .....	267
	Three-Phase 400 V Class Drive Models 4A0005 to 4A0027 .....	268
	Three-Phase 400 V Class Drive Models 4A0034 to 4A0096 .....	269
	Three-Phase 400 V Class Drive Models 4A0124 to 4A0302 .....	270
	Three-Phase 400 V Class Drive Models 4A0361 to 4A0590 .....	271
<b>A.2</b>	<b>Drive Specifications .....</b>	<b>272</b>
<b>A.3</b>	<b>Drive Watt Loss Data .....</b>	<b>274</b>
<b>A.4</b>	<b>Drive Derating Data .....</b>	<b>276</b>
	Carrier Frequency Derating.....	276
	Temperature Derating .....	277
	Altitude Derating.....	278
<b>B.</b>	<b>PARAMETER LIST.....</b>	<b>279</b>
<b>B.1</b>	<b>A: Initialization Parameters .....</b>	<b>280</b>
	A1: Initialization .....	280
	A2: User Parameters.....	281
<b>B.2</b>	<b>b: Application.....</b>	<b>282</b>
	b1: Operation Mode Selection.....	282
	b2: DC Injection Braking and Short Circuit Braking.....	282
	b3: Speed Search.....	283
	b4: Timer Function .....	284
	b5: PI Control .....	284
	b8: Energy Saving .....	288
<b>B.3</b>	<b>C: Tuning.....</b>	<b>289</b>
	C1: Acceleration and Deceleration Times .....	289
	C2: S-Curve Characteristics.....	289
	C4: Torque Compensation .....	289
	C6: Carrier Frequency.....	290
<b>B.4</b>	<b>d: References.....</b>	<b>291</b>
	d1: Frequency Reference.....	291
	d2: Frequency Upper/Lower Limits .....	291
	d3: Jump Frequency.....	292
	d4: Frequency Reference Hold Function.....	292
	d6: Field Weakening.....	292
	d7: Offset Frequency.....	293

<b>B.5 E: Motor Parameters .....</b>	<b>294</b>
E1: V/f Pattern for Motor 1 .....	294
E2: Motor Parameters .....	295
E5: PM Motor Settings .....	295
<b>B.6 F: Communication Option Parameters .....</b>	<b>297</b>
F6, F7: Communication Option Card .....	297
<b>B.7 H Parameters: Multi-Function Terminals .....</b>	<b>300</b>
H1: Multi-Function Digital Inputs .....	300
H2: Multi-Function Digital Outputs .....	304
H3: Multi-Function Analog Inputs .....	306
H4: Analog Outputs .....	307
H5: MEMOBUS/Modbus Serial Communication .....	308
<b>B.8 L: Protection Function .....</b>	<b>309</b>
L1: Motor Protection .....	309
L2: Momentary Power Loss Ride-Thru .....	310
L3: Stall Prevention .....	311
L4: Speed Detection .....	312
L5: Fault Restart .....	312
L6: Torque Detection .....	313
L8: Drive Protection .....	313
<b>B.9 n: Special Adjustment .....</b>	<b>316</b>
n1: Hunting Prevention .....	316
n3: High Slip Braking (HSB) and Overexcitation Braking .....	316
n8: PM Motor Control Tuning .....	317
<b>B.10 o: Operator-Related Settings .....</b>	<b>318</b>
o1: HOA Keypad Display Selection .....	318
o2: HOA Keypad Functions .....	319
o3: Copy Function .....	320
o4: Maintenance Monitor Settings .....	320
<b>B.11 S: Special Application .....</b>	<b>321</b>
S1: Dynamic Noise Control Function .....	321
S2: Sequence Timers .....	321
S3: Secondary PI (PI2) Control .....	323
S4: Bypass Operation .....	325
S5: HOA Keypad Parameters .....	325
S6: Z1000 Protection .....	326
<b>B.12 T: Motor Tuning .....</b>	<b>327</b>
T1: Induction Motor Auto-Tuning .....	327
T2: PM Motor Auto-Tuning .....	327
<b>B.13 U: Monitors .....</b>	<b>329</b>
U1: Operation Status Monitors .....	329
U2: Fault Trace .....	330
U3: Fault History .....	331
U4: Maintenance Monitors .....	333
U5: PI Monitors .....	334
U6: Operation Status Monitors .....	335
<b>C. BACNET COMMUNICATIONS .....</b>	<b>337</b>
<b>C.1 BACnet Configuration .....</b>	<b>338</b>

<b>C.2</b>	<b>Communication Specifications</b> .....	<b>339</b>
<b>C.3</b>	<b>Connecting to a Network</b> .....	<b>340</b>
	Network Cable Connection.....	340
	Wiring Diagram for Multiple Connections .....	341
	Network Termination .....	341
<b>C.4</b>	<b>BACnet Setup Parameters</b> .....	<b>342</b>
	BACnet Serial Communication.....	342
<b>C.5</b>	<b>Drive Operations by BACnet</b> .....	<b>346</b>
	Observing the Drive Operation.....	346
	Controlling the Drive.....	346
<b>C.6</b>	<b>Communications Timing</b> .....	<b>347</b>
	Command Messages from Master to Drive.....	347
	Response Messages from Drive to Master .....	347
<b>C.7</b>	<b>BACnet Objects Supported</b> .....	<b>348</b>
	Present Value Access .....	348
	Supported Properties of Objects .....	348
	Analog Input Objects .....	349
	Analog Output Objects .....	349
	Analog Value Objects.....	349
	Binary Input Objects .....	350
	Binary Output Objects .....	351
	Binary Value Objects.....	351
	Device Object .....	352
<b>C.8</b>	<b>Accessing Drive Parameters and the Enter Command</b> .....	<b>353</b>
	Reading Drive Parameters .....	353
	Writing Drive Parameters .....	353
	Enter Command .....	353
<b>C.9</b>	<b>Communication Errors</b> .....	<b>354</b>
<b>C.10</b>	<b>Self-Diagnostics</b> .....	<b>355</b>
<b>C.11</b>	<b>BACnet Protocol Implementation Conformance Statement</b> .....	<b>356</b>
<b>D.</b>	<b>STANDARDS COMPLIANCE</b> .....	<b>359</b>
<b>D.1</b>	<b>Section Safety</b> .....	<b>360</b>
<b>D.2</b>	<b>European Standards</b> .....	<b>362</b>
	CE Low Voltage Directive Compliance.....	362
	EMC Guidelines Compliance .....	363
<b>D.3</b>	<b>UL/cUL Standards</b> .....	<b>368</b>
	UL Standards Compliance .....	368
	Drive Motor Overload Protection .....	371
	Precautionary Notes on External Heatsink (IP00/Open-Type Enclosure).....	372
<b>E.</b>	<b>QUICK REFERENCE SHEET</b> .....	<b>373</b>
<b>E.1</b>	<b>Drive and Motor Specifications</b> .....	<b>374</b>
	Drive Specifications.....	374
	Motor Specifications .....	374
<b>E.2</b>	<b>Basic Parameter Settings</b> .....	<b>375</b>
	Basic Setup .....	375
	Motor Setup.....	375

## Table of Contents

---

Multi-Function Digital Inputs .....	375
Analog Inputs .....	375
Multi-Function Digital Outputs .....	376
Monitor Outputs.....	376
<b>E.3 User Setting Table.....</b>	<b>377</b>
<b>INDEX .....</b>	<b>383</b>

# Preface & General Safety

---

This section provides safety messages pertinent to this product that, if not heeded, may result in fatality, personal injury, or equipment damage. Yaskawa is not responsible for the consequences of ignoring these instructions.

<b>i.1</b>	<b>PREFACE.....</b>	<b>12</b>
<b>i.2</b>	<b>GENERAL SAFETY.....</b>	<b>14</b>

## i.1 Preface

Yaskawa manufactures products used as components in a wide variety of industrial systems and equipment. The selection and application of Yaskawa products remain the responsibility of the equipment manufacturer or end user. Yaskawa accepts no responsibility for the way its products are incorporated into the final system design. Under no circumstances should any Yaskawa product be incorporated into any product or design as the exclusive or sole safety control. Without exception, all controls should be designed to detect faults dynamically and fail safely under all circumstances. All systems or equipment designed to incorporate a product manufactured by Yaskawa must be supplied to the end user with appropriate warnings and instructions as to the safe use and operation of that part. Any warnings provided by Yaskawa must be promptly provided to the end user. Yaskawa offers an express warranty only as to the quality of its products in conforming to standards and specifications published in the Yaskawa manual. **NO OTHER WARRANTY, EXPRESS OR IMPLIED, IS OFFERED.** Yaskawa assumes no liability for any personal injury, property damage, losses, or claims arising from misapplication of its products.

This manual is designed to ensure correct and suitable application of Z1000-series drives. Read this manual before attempting to install, operate, maintain, or inspect a drive and keep it in a safe, convenient location for future reference. Be sure you understand all precautions and safety information before attempting application.

### ◆ Applicable Documentation

The following manuals are available for Z1000-series drives:

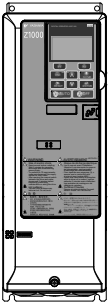
	<p><b>Z1000-Series AC Drive User Manual (TOEPC71061645)</b></p> <p>Read this manual first. This manual is packaged together with the product and contains basic information required to install and wire the drive. It also gives detailed information on fault diagnostics, parameter settings, and BACnet specifications. The purpose of this manual is to prepare the drive for a trial run with an application and for basic operation. This manual is available for download on our documentation website, <a href="http://www.yaskawa.com">www.yaskawa.com</a>.</p>
	<p><b>Z1000-Series AC Drive Programming Manual (SIEPC71061645)</b></p> <p>This manual provides detailed information on parameter settings, drive functions, maintenance, and MEMOBUS/Modbus specifications. Use this manual to expand drive functionality. This manual is available for download on our documentation website, <a href="http://www.yaskawa.com">www.yaskawa.com</a>.</p>

### ◆ Symbols

**Note:** Indicates a supplement or precaution that does not cause drive damage.



Indicates a term or definition used in this manual.

### ◆ Terms and Abbreviations



- **Drive:** Yaskawa Z1000-Series Drive
- **H:** Hexadecimal Number Format
- **IGBT:** Insulated Gate Bipolar Transistor
- **kbps:** Kilobits per Second
- **MAC:** Media Access Control
- **r/min:** Revolutions per Minute
- **V/f:** V/f Control
- **OLV/PM:** Open Loop Vector Control for PM
- **PM motor:** Permanent Magnet Synchronous motor (an abbreviation for IPM motor or SPM motor)
- **IPM motor:** Interior Permanent Magnet Motor (e.g., Yaskawa SSR1 Series and SST4 Series motors)
- **SPM motor:** Surface mounted Permanent Magnet Motor (e.g., Yaskawa SMRA Series motors)

### ◆ Trademarks

- APOGEE® FLN is a registered trademark of Siemens Building Technologies, Inc.
- APOGEE® Anywhere™ is a trademark of Siemens Building Technologies, Inc.
- BACnet is a trademark of the American Society of Heating, Refrigerating, and Air-Conditioning Engineers (ASHRAE).
- GPD is a trademark of Yaskawa, Inc.

- Metasys® N2 is a trademark of Johnson Controls, Inc.
- MODBUS® is a registered trademark of Schneider Automation, Inc.
- Other companies and product names mentioned in this manual are trademarks of those companies.

## i.2 General Safety

### ◆ Supplemental Safety Information

#### General Precautions

- The diagrams in this manual may be indicated without covers or safety shields to show details. Replace the covers or shields before operating the drive and run the drive according to the instructions described in this manual.
- Any illustrations, photographs, or examples used in this manual are provided as examples only and may not apply to all products to which this manual is applicable.
- The products and specifications described in this manual or the content and presentation of the manual may be changed without notice to improve the product and/or the manual.
- When ordering a new copy of the manual due to damage or loss, contact your Yaskawa representative or the nearest Yaskawa sales office and provide the manual number shown on the front cover.
- If nameplate becomes worn or damaged, order a replacement from your Yaskawa representative or the nearest Yaskawa sales office.

#### **WARNING**

Read and understand this manual before installing, operating or servicing this drive. The drive must be installed according to this manual and local codes.

The following conventions are used to indicate safety messages in this manual. Failure to heed these messages could result in serious or fatal injury or damage to the products or to related equipment and systems.

#### **DANGER**

Indicates a hazardous situation, which, if not avoided, will result in death or serious injury.

#### **WARNING**

Indicates a hazardous situation, which, if not avoided, could result in death or serious injury.

**WARNING!** may also be indicated by a bold key word embedded in the text followed by an italicized safety message.

#### **CAUTION**

Indicates a hazardous situation, which, if not avoided, could result in minor or moderate injury.

**CAUTION!** may also be indicated by a bold key word embedded in the text followed by an italicized safety message.

#### **NOTICE**

Indicates a property damage message.

**NOTICE:** may also be indicated by a bold key word embedded in the text followed by an italicized safety message.

## ◆ Safety Messages

### DANGER

#### **Heed the safety messages in this manual.**

Failure to comply will result in death or serious injury.

The operating company is responsible for any injuries or equipment damage resulting from failure to heed the warnings in this manual.

#### **Electrical Shock Hazard**

##### **Do not connect or disconnect wiring while the power is on.**

Failure to comply will result in death or serious injury.

Before servicing, disconnect all power to the equipment. The internal capacitor remains charged even after the power supply is turned off. After shutting off the power, wait for at least the amount of time specified on the drive before touching any components.

### WARNING

#### **Sudden Movement Hazard**

##### **System may start unexpectedly upon application of power, resulting in death or serious injury.**

Clear all personnel from the drive, motor and machine area before applying power. Secure covers, couplings, shaft keys and machine loads before applying power to the drive.

#### **Electrical Shock Hazard**

##### **Do not attempt to modify or alter the drive in any way not explained in this manual.**

Failure to comply could result in death or serious injury.

Yaskawa is not responsible for any modification of the product made by the user. This product must not be modified.

##### **Do not allow unqualified personnel to use equipment.**

Failure to comply could result in death or serious injury.

Maintenance, inspection, and replacement of parts must be performed only by authorized personnel familiar with installation, adjustment and maintenance of AC drives.

##### **Do not remove covers or touch circuit boards while the power is on.**

Failure to comply could result in death or serious injury.

##### **Make sure the protective earthing conductor complies with technical standards and local safety regulations.**

Because the leakage current exceeds 3.5 mA, IEC/EN 61800-5-1 states that either the power supply must be automatically disconnected in case of discontinuity of the protective earthing conductor or a protective earthing conductor with a cross-section of at least 10 mm<sup>2</sup> (Cu) or 16 mm<sup>2</sup> (Al) must be used. Failure to comply may result in death or serious injury.

##### **Always use appropriate equipment for Ground Fault Circuit Interrupters (GFCIs).**

The drive can cause a residual current with a DC component in the protective earthing conductor. Where a residual current operated protective or monitoring device is used for protection in case of direct or indirect contact, always use a type B GFCI according to IEC/EN 60755.

#### **Fire Hazard**

##### **Install adequate branch circuit protection according to applicable local codes and this manual.**

Failure to comply could result in fire and damage to the drive or injury to personnel. The device is suitable for use on a circuit capable of delivering not more than 100,000 RMS symmetrical amperes, 240 Vac (200 V class) and 480 Vac (400 V class), when protected by branch circuit protection devices specified in this manual.

### **WARNING**

Branch circuit protection shall be provided by any of the following: Non-time delay Class J, T, or CC fuses sized at 300% of the drive input rating, or Time delay Class J, T, or CC fuses sized at 175% of the drive input rating, or MCCB sized at 200% maximum of the drive input rating.

**Do not use an improper voltage source.**

Failure to comply could result in death or serious injury by fire.

Verify that the rated voltage of the drive matches the voltage of the incoming power supply before applying power.

### **CAUTION**

#### **Crush Hazard**

**Do not carry the drive by the front cover.**

Failure to comply may result in minor or moderate injury from the main body of the drive falling.

### **NOTICE**

**Observe proper electrostatic discharge procedures (ESD) when handling the drive and circuit boards.**

Failure to comply may result in ESD damage to the drive circuitry.

**Do not perform a withstand voltage test on any part of the drive.**

Failure to comply could result in damage to the sensitive devices within the drive.

**Do not operate damaged equipment.**

Failure to comply could result in further damage to the equipment.

Do not connect or operate any equipment with visible damage or missing parts.

**Do not expose the drive to halogen group disinfectants.**

Failure to comply may cause damage to the electrical components in the drive.

Do not pack the drive in wooden materials that have been fumigated or sterilized.

Do not sterilize the entire package after the product is packed.

**Do not use screws of different sizes in SW1 and SW2.**

Failure to comply may cause overheating and electrical damage.

## ◆ General Application Precautions

### ■ Selection

#### Installing a Reactor

Use an AC reactor in the following situations:

- to suppress harmonic current.
- when the drive is running from a power supply system with thyristor converters.

#### Drive Capacity

For specialized motors, make sure that the motor rated current is less than the rated output current for the drive.

When running more than one motor in parallel from a single drive, the capacity of the drive should be larger than [total motor rated current  $\times$  1.1].

#### Starting Torque

The overload rating for the drive determines the starting and accelerating characteristics of the motor. Expect lower torque than when running from line power. To get more starting torque, use a larger drive or increase both the motor and drive capacity.

#### Emergency Stop

During a drive fault condition, the output shuts off but the motor does not stop immediately. A mechanical brake may be required when it is necessary to stop the motor faster than the ability of the Fast Stop function of the drive.

#### Options

**NOTICE:** The -M, +M, -, +1, and +3 terminals are used to connect optional Z1000-compatible devices only. Connecting non-Yaskawa-approved devices to these terminals may damage the drive.

### ■ Installation

#### Enclosure Panels

Keep the drive in a clean environment by installing the drive in an enclosure panel. Be sure to leave the required space between drives to provide for cooling, and take proper measures so the ambient temperature remains within allowable limits and keep flammable materials away from the drive. Yaskawa offers protective designs for drives that must be used in areas subjected to oil mist and excessive vibration. Contact Yaskawa or your Yaskawa agent for details.

#### Installation Direction

**NOTICE:** Install the drive upright as specified in the manual. [Refer to Mechanical Installation on page 42](#) for more information on installation. Failure to comply may damage the drive due to improper cooling.

### ■ Settings

#### Upper Limits

**NOTICE:** The drive is capable of running the motor up to 240 Hz. Be sure to set the upper limit for the frequency of the drive to prevent the possible danger of accidentally operating equipment at higher than rated speed. The default setting for the maximum output frequency is 60 Hz.

#### DC Injection Braking

**NOTICE:** Excessive current during DC Injection Braking and excessive duration of DC Injection Braking can cause motor overheating.

#### Acceleration/Deceleration Times

Acceleration and deceleration times are affected by the amount of torque generated by the motor, the load torque, and the inertia moment. Set a longer accel/decel time when Stall Prevention is enabled. The accel/decel times are lengthened for as long as the Stall Prevention function is in operation. Install one of the available braking options or increase the capacity of the drive for faster acceleration and deceleration.

### ■ General Handling

#### Wiring Check

**NOTICE:** Do not connect power supply lines to output terminals U/T1, V/T2, or W/T3. Failure to comply will destroy the drive. Be sure to perform a final check of all sequence wiring and other connections before turning on the power and also check for short circuits on the control terminals, which may damage the drive.

#### Selecting a Circuit Breaker or Circuit Interrupter

Yaskawa recommends installing a Ground Fault Circuit Interrupter (GFCI) to the power supply side. The GFCI should be designed for use with AC drives (e.g., Type B according to IEC/EN 60755).

## i.2 General Safety

Select a Molded Case Circuit Breaker (MCCB) or GFCI with a rated current 1.5 to 2 times higher than the drive rated current to avoid nuisance trips caused by harmonics in the drive input current. *Refer to [Installing a Molded Case Circuit Breaker \(MCCB\) or Ground Fault Circuit Interrupter \(GFCI\) on page 252](#)* for more information.

### Magnetic Contactor Installation

**WARNING! Fire Hazard, Sudden Movement Hazard.** Shut off the drive with a magnetic contactor (MC) when a fault occurs in external equipment. *Refer to [Installing a Magnetic Contactor at the Power Supply Side on page 253](#)*. Failure to comply may cause serious injury or death due to fire or inadvertent equipment movement.

**NOTICE:** To get the full performance life out of the electrolytic capacitors and circuit relays, refrain from switching the drive power supply off and on more than once every 30 minutes. Frequent use can damage the drive. Use the drive to stop and start the motor.

### Inspection and Maintenance

**WARNING! Electrical Shock Hazard.** Capacitors in the drive do not immediately discharge after shutting off the power. Wait for at least the amount of time specified on the drive before touching any components after shutting off the power. Failure to comply may cause injury to personnel from electrical shock.

**WARNING! Electrical Shock Hazard.** When a drive is running a PM motor, voltage continues to be generated at the motor terminals after the drive is shut off while the motor coasts to stop. Take the precautions described below to prevent shock and injury:

- In applications where the machine can still rotate after the drive has fully stopped a load, install a switch to the drive output side to disconnect the motor and the drive.
- Do not allow an external force to rotate the motor beyond the maximum allowable speed or to rotate the motor when the drive has been shut off.
- Wait for at least the time specified on the warning label after opening the load switch on the output side before inspecting the drive or performing any maintenance.
- Do not open and close the load switch while the motor is running.
- If the motor is coasting, make sure the power to the drive is turned on and the drive output has completely stopped before closing the load switch.

**WARNING! Burn Hazard.** Because the heatsink can get very hot during operation, take proper precautions to prevent burns. When replacing the cooling fan, shut off the power and wait at least 15 minutes to be sure that the heatsink has cooled down. Failure to comply may cause burn injury to personnel.

### Wiring

Yaskawa recommends using ring terminals on all drive models. Drive models 2A0031 to 2A0396 and 4A0034 to 4A0590 require the use of ring terminals for UL/cUL compliance. Use only the tools recommended by the terminal manufacturer for crimping.

### Transporting the Drive

**NOTICE:** Never steam clean the drive. During transport, keep the drive from coming into contact with salts, fluorine, bromine, phthalate ester, and other such harmful chemicals.

## ◆ Motor Application Precautions

### ■ Standard Induction Motors

#### Low-Speed Range

The cooling fan of a standard motor should sufficiently cool the motor at the rated speed. As the self-cooling capability of such a motor reduces with the speed, applying full torque at low speed will possibly damage the motor. Reduce the load torque as the motor slows to prevent motor damage from overheating. *Figure i.1* shows the allowable load characteristics for a Yaskawa standard motor. Use a motor designed specifically for operation with a drive when 100% continuous torque is needed at low speeds.

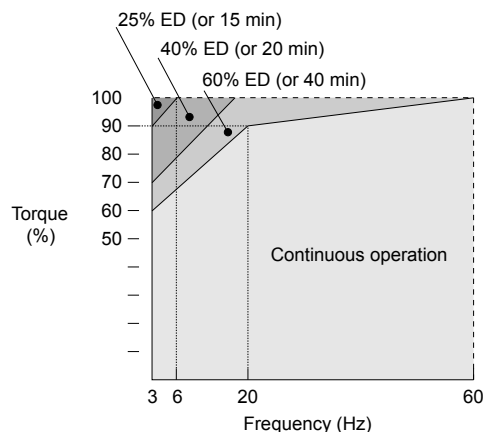

Figure i.1 Allowable Load Characteristics for a Yaskawa Motor

### Insulation Tolerance

**NOTICE:** Consider motor voltage tolerance levels and motor insulation in applications with an input voltage of over 440 V or particularly long wiring distances.

### High-Speed Operation

**NOTICE:** Problems may occur with the motor bearings and dynamic balance of the machine when operating a motor beyond its rated speed. Contact the motor or machine manufacturer.

### Torque Characteristics

Torque characteristics differ compared to operating the motor directly from line power. The user should have a full understanding of the load torque characteristics for the application.

### Vibration and Shock

The drive allows selection of high carrier PWM control and low carrier PWM. Selecting high carrier PWM can help reduce motor oscillation.

Take particular caution when adding a variable speed drive to an application running a motor from line power at a constant speed. If resonance occurs, install shock-absorbing rubber around the base of the motor and enable the Jump frequency selection to prevent continuous operation in the resonant frequency range.

### Audible Noise

The audible noise of the motor varies based on the carrier frequency setting. However, drive current derating may be required. When using a high carrier frequency, audible noise from the motor is comparable to the motor noise generated when running from line power.

## ■ Synchronous Motors

- Contact Yaskawa or a Yaskawa agent when planning to use a synchronous motor not endorsed by Yaskawa.
- Use a standard induction motor when running multiple synchronous motors simultaneously. A single drive does not have this capability.
- A synchronous motor may rotate slightly in the opposite direction of the Run command at start depending on parameter settings and rotor position.
- The amount of generated starting torque differs depending on the control mode and motor type. Set up the motor with the drive after verifying the starting torque, allowable load characteristics, impact load tolerance, and speed control range.

Contact Yaskawa or a Yaskawa agent when planning to use a motor that does not fall within these specifications:

- In Open Loop Vector Control for PM motors, braking torque is less than 125% when running between 20% and 100% speed. Braking torque drops to less than 50% when running at less than 20% speed.
- In Open Loop Vector Control for PM motors, the allowable load inertia moment is approximately 50 times higher than the motor inertia moment.

Contact Yaskawa or a Yaskawa agent for questions concerning applications with a larger inertia moment.

- To restart a coasting motor rotating below 100 Hz, use the Speed Search function if the motor cable is not too long. If the motor cable is relatively long, stop the motor using Short Circuit Braking.

## ■ Specialized Motors

### Multi-Pole Motor

The rated current of a multi-pole motor differs from that of a standard motor, so be sure to check the maximum current when selecting a drive. Always stop the motor before switching between the number of motor poles. The motor will coast to stop if a regen overvoltage (ov) fault occurs or if overcurrent (oC) protection is triggered.

### Submersible Motor

The rated current of a submersible motor is greater than that of a standard motor, so select the drive capacity accordingly. Use a motor cable large enough to avoid decreasing the maximum torque level from voltage drop caused by a long motor cable.

### Explosion-Proof Motor

The motor and the drive must be tested together to be certified as explosion-proof. The drive is not designed for explosion-proof areas.

### Geared Motor

Make sure that the gear and the lubricant are rated for the desired speed range to avoid gear damage when operating at low speeds or very high speeds. Consult with the manufacturer for applications that require operation outside the rated speed range of the motor or gear box.

## i.2 General Safety

### Single-Phase Motor

Variable speed drives are not designed to operate with single phase motors. Using capacitors to start the motor causes excessive current to flow and can damage drive components. A split-phase start or a repulsion start can burn out the starter coils because the internal centrifugal switch is not activated. The drive is for use with three-phase motors only.

### Motor with Brake

Take caution when using the drive to operate a motor with a built-in holding brake. If the brake is connected to the output side of the drive, it may not release at start due to low voltage levels, so be sure to install a separate power supply for the motor brake. Note that motors with built-in brakes tend to generate a fair amount of noise when running at low speeds.

### ◆ Drive Label Warning Example

Always heed the warning information listed in *Figure i.2* in the position shown in *Figure i.3*.

**⚠ WARNING**

**⚡ Risk of electric shock.**

- Read manual before installing.
- Wait 5 minutes for capacitor discharge after disconnecting power supply.
- To conform to CE requirements, make sure to ground the supply neutral for 400V class.
- After opening the manual switch between the drive and motor, please wait 5 minutes before inspecting, performing maintenance or wiring the drive.

**🔥 Hot surfaces**

- Top and Side surfaces may become hot. Do not touch.

Figure i.2 Warning Information Example

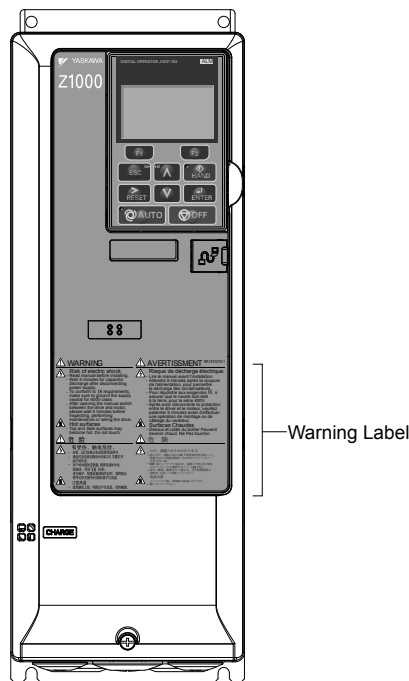

Figure i.3 Warning Information Position

## ◆ Warranty Information

### ■ Warranty Period

This drive is warranted for 12 months from the date of delivery to the customer or 18 months from the date of shipment from the Yaskawa factory, whichever comes first.

### ■ Scope of Warranty

#### Inspections

Customers are responsible for periodic inspections of the drive. Upon request, a Yaskawa representative will inspect the drive for a fee. If the Yaskawa representative finds the drive to be defective due to Yaskawa workmanship or materials and the defect occurs during the warranty period, this inspection fee will be waived and the problem remedied free of charge.

#### Repairs

If a Yaskawa product is found to be defective due to Yaskawa workmanship or materials and the defect occurs during the warranty period, Yaskawa will provide a replacement, repair the defective product, and provide shipping to and from the site free of charge.

However, if the Yaskawa Authorized Service Center determines that the problem with the drive is not due to defective workmanship or materials, the customer will be responsible for the cost of any necessary repairs. Some problems that are outside the scope of this warranty are:

Problems due to improper maintenance or handling, carelessness, or other reasons where the customer is determined to be responsible.

Problems due to additions or modifications made to a Yaskawa product without Yaskawa's understanding.

Problems due to the use of a Yaskawa product under conditions that do not meet the recommended specifications.

Problems caused by natural disaster or fire.

After the free warranty period elapses.

Replenishment or replacement of consumables or expendables.

Defective products due to packaging or fumigation.

Other problems not due to defects in Yaskawa workmanship or materials.

Warranty service is only applicable within the country where the product was purchased. However, after-sales service is available for customers outside of the country where the product was purchased for a reasonable fee.

Contact your local Yaskawa representative for more information.

#### Exceptions

Any inconvenience to the customer or damage to non-Yaskawa products due to Yaskawa's defective products whether within or outside of the warranty period are NOT covered by warranty.

### ■ Restrictions

The drive is not designed or manufactured for use in devices or systems that may directly affect or threaten human lives or health.

Customers who intend to use the product described in this manual for devices or systems relating to transportation, health care, space aviation, atomic power, electric power, or in underwater applications must first contact their Yaskawa representatives or the nearest Yaskawa sales office.

**WARNING!** *Injury to Personnel. This product has been manufactured under strict quality-control guidelines. However, if this product is to be installed in any location where failure of this product could involve or result in a life-and-death situation or loss of human life or in a facility where failure may cause a serious accident or physical injury, safety devices must be installed to minimize the likelihood of any accident.*

**This Page Intentionally Blank**

## Receiving

---

This chapter explains how to inspect the drive upon receipt, and gives an overview of the different enclosure types and components.

<b>1.1</b>	<b>SECTION SAFETY.....</b>	<b>24</b>
<b>1.2</b>	<b>GENERAL DESCRIPTION.....</b>	<b>25</b>
<b>1.3</b>	<b>MODEL NUMBER AND NAMEPLATE CHECK.....</b>	<b>27</b>
<b>1.4</b>	<b>DRIVE MODELS AND ENCLOSURE TYPES.....</b>	<b>29</b>
<b>1.5</b>	<b>COMPONENT NAMES.....</b>	<b>30</b>

## 1.1 Section Safety

### CAUTION

**Do not carry the drive by the front cover or the terminal cover.**

Failure to comply may cause the main body of the drive to fall, resulting in minor or moderate injury.

### NOTICE

**Observe proper electrostatic discharge procedures (ESD) when handling the drive and circuit boards.**

Failure to comply may result in ESD damage to the drive circuitry.

**A motor connected to a PWM drive may operate at a higher temperature than a utility-fed motor and the operating speed range may reduce motor cooling capacity.**

Ensure that the motor is suitable for drive duty and/or the motor service factor is adequate to accommodate the additional heating with the intended operating conditions.

## 1.2 General Description

### ◆ Z1000 Model Selection

Refer to [Table 1.1](#) for drive selection depending on the motor power.

**Note:** The models and capacities in shown here are based on standard settings and operation conditions. Higher carrier frequencies and higher ambient temperatures require derating.

**Table 1.1 Z1000 Models**

Motor Capacity kW (HP)	Three-Phase 200 V Class	
	Model CIMR-Z□	Rated Output Current (A)
2.2 (3)	2A0011	10.6 <1>
3.7 (5)	2A0017	16.7 <1>
5.5 (7.5)	2A0024	24.2 <1>
7.5 (10)	2A0031	30.8 <1>
11 (15)	2A0046	46.2 <1>
15 (20)	2A0059	59.4 <1>
18.5 (25)	2A0075	74.8 <1>
22 (30)	2A0088	88 <1>
30 (40)	2A0114	114 <1>
37 (50)	2A0143	143 <1>
45 (60)	2A0169	169 <1>
55 (75)	2A0211	211 <1>
75 (100)	2A0273	273 <1>
90 (125)	2A0343	343 <2>
110 (150)	2A0396	396 <2>

<1> Assumes the carrier frequency is set to 5 kHz.

<2> Assumes the carrier frequency is set to 2 kHz.

Motor Capacity kW (HP)		Three-Phase 400 V Class	
Input Voltage < 460 V	Input Voltage ≥ 460 V	Model CIMR-Z□	Rated Output Current (A)
1.5 (2)	2.2 (3)	4A0005	4.8 <1>
3.0 (4)	3.7 (5)	4A0008	7.6 <1>
4.0 (5)	5.5 (7.5)	4A0011	11 <1>
5.5 (7.5)	7.5 (10)	4A0014	14 <1>
7.5 (10)	11 (15)	4A0021	21 <1>
11 (15)	15 (20)	4A0027	27 <1>
15 (20)	18.5 (25)	4A0034	34 <1>
18.5 (25)	22 (30)	4A0040	40 <1>
22 (30)	30 (40)	4A0052	52 <1>
30 (40)	37 (50)	4A0065	65 <1>
37 (50)	45 (60)	4A0077	77 <1>
45 (60)	55 (75)	4A0096	96 <1>
55 (75)	75 (100)	4A0124	124 <1>
75 (100)	90 (125)	4A0156	156 <1>
90 (125)	110 (150)	4A0180	180 <1>
110 (150)	150 (200)	4A0240	240 <2>
160 (220)	185 (250)	4A0302	302 <2>

## 1.2 General Description

Motor Capacity kW (HP)		Three-Phase 400 V Class	
Input Voltage < 460 V	Input Voltage ≥ 460 V	Model CIMR-Z□	Rated Output Current (A)
185 (250)	220 (300)	4A0361	361 <3>
220 (300)	260 (350)	4A0414	414 <3>
250 (340)	300 (400)	4A0480	480 <3>
300 (400)	370 (500)	4A0590	590 <3>

<1> Assumes the carrier frequency is set to 5 kHz.

<2> Assumes the carrier frequency is set to 4 kHz.

<3> Assumes the carrier frequency is set to 2 kHz.

**Note:** Current derating is required when setting the carrier frequency higher.

## ◆ Control Mode Selection

Table 1.2 gives an overview of the Z1000 control modes and the various features associated with those control modes.

**Table 1.2 Control Modes and Features**

Motor Type		Induction Motors	Permanent Magnet Motors	Comments
Control Mode		V/f	OLV/PM	–
Parameter Setting		A1-02 = 0	A1-02 = 5	Default Setting is V/f control (A1-02 = 0)
Basic Description		V/f control	Open Loop Vector control for PM motors	–
Type of Applications	Motor Type	IM	PM	–
	Multi Motor	YES	–	–
	Motor data unknown	YES	–	–
	High Speed Accuracy	–	YES	–
Control Characteristics	Speed Control Range	1:40	1:20	May fluctuate with characteristics and motor temperature.
	Speed Accuracy	±2 to 3%	±0.2%	Speed deviation when operating at constant speed may fluctuate with characteristics and motor temperature.
	Speed Response	3 Hz (approx.)	10 Hz	Max. frequency of a speed reference signal that the drive can follow may fluctuate with characteristics and motor temperature.
	Starting Torque	140% at 3 Hz	100% at 5% speed	Starting torque may fluctuate with characteristics and motor temperature. Performance may differ by capacity.
Application-Specific	Auto-Tuning	<ul style="list-style-type: none"> <li>Energy Saving Tuning</li> <li>Line to line resistance</li> </ul>	<ul style="list-style-type: none"> <li>Stationary</li> <li>Line to line resistance</li> </ul>	Automatically adjusts parameter settings that concern electrical characteristics of the motor.
	Speed Search	YES	YES	Bi-directional speed detection of a coasting motor to restart it without stopping.
	Energy-Saving Control	YES	–	Saves energy by always operating the motor at its maximum efficiency.
	High Slip Braking	YES	–	Increases motor loss to allow for faster deceleration. Effectiveness may vary based on motor characteristics.
	Kinetic Energy Buffering	YES	YES	Decelerates the drive to allow it to ride through a momentary power loss and continue operation.
	Overexcitation Deceleration	YES	–	Allows faster deceleration without overvoltage trip.
	Overvoltage Suppression	YES	YES	Prevents overvoltage by increasing speed during regeneration.

# 1.3 Model Number and Nameplate Check

Please perform the following tasks after receiving the drive:

- Inspect the drive for damage.
- If the drive appears damaged upon receipt, contact the shipper immediately.
- Verify receipt of the correct model by checking the information on the nameplate.
- If you have received the wrong model or the drive does not function properly, contact your supplier.

## ◆ Drive Nameplate

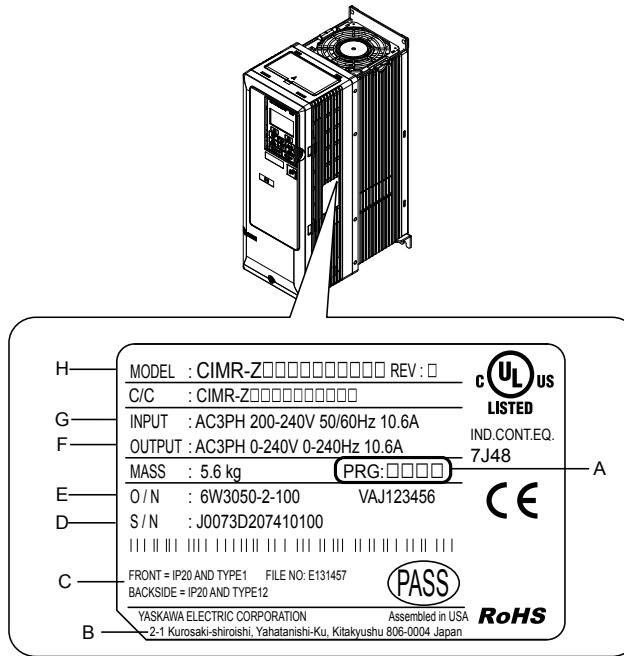

- A – Software version
- B – Address <1>
- C – Enclosure type
- D – Serial number
- E – Lot number
- F – Output specifications
- G – Input specifications
- H – AC drive model

Figure 1.1 Drive Nameplate Information Example

<1> The address of the head office of Yaskawa Electric Corporation (responsible for product liability) is shown on the nameplate.

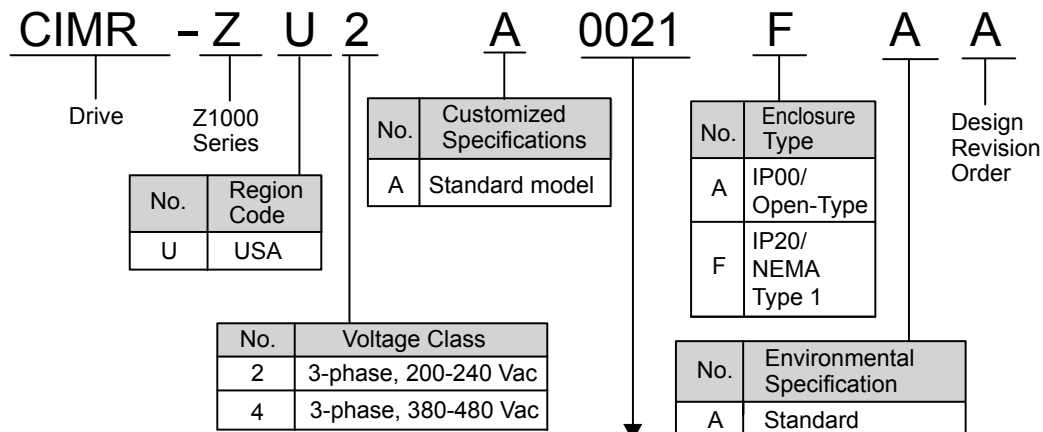

Refer to the following table

### 1.3 Model Number and Nameplate Check

#### ■ Three-Phase 200 V

No.	Max Motor Capacity kW (HP)	Rated Output Current A
0011	2.2 (3)	10.6
0017	3.7 (5)	16.7
0024	5.5 (7.5)	24.2
0031	7.5 (10)	30.8
0046	11 (15)	46.2
0059	15 (20)	59.4
0075	18.5 (25)	74.8
0088	22 (30)	88
0114	30 (40)	114
0143	37 (50)	143
0169	45 (60)	169
0211	55 (75)	211
0273	75 (100)	273
0343	90 (125)	343
0396	110 (150)	396

#### ■ Three-Phase 400 V

No.	Max Motor Capacity kW (HP)		Rated Output Current A
	Input Voltage < 460 V	Input Voltage ≥ 460 V	
0005	1.5 (2)	2.2 (3)	4.8
0008	3.0 (4)	3.7 (5)	7.6
0011	4.0 (5)	5.5 (7.5)	11
0014	5.5 (7.5)	7.5 (10)	14
0021	7.5 (10)	11 (15)	21
0027	11 (15)	15 (20)	27
0034	15 (20)	18.5 (25)	34
0040	18.5 (25)	22 (30)	40
0052	22 (30)	30 (40)	52
0065	30 (40)	37 (50)	65
0077	37 (50)	45 (60)	77
0096	45 (60)	55 (75)	96
0124	55 (75)	75 (100)	124
0156	75 (100)	90 (125)	156
0180	90 (125)	110 (150)	180
0240	110 (150)	150 (200)	240
0302	160 (220)	185 (250)	302
0361	185 (250)	220 (300)	361
0414	220 (300)	260 (350)	414
0480	250 (340)	300 (400)	480
0590	300 (400)	370 (500)	590

## 1.4 Drive Models and Enclosure Types

The following enclosure types are offered for Z1000 drives:

- IP20/NEMA Type 1 enclosure models mount to an indoor wall or in an enclosure panel.
- IP00/Open-Type enclosure models are designed for installation in an enclosure panel that serves to protect personnel from injury caused by accidentally touching live parts.

**Table 1.3** describes drive enclosures and models.

**Table 1.3 Drive Models and Enclosure Types**

Voltage Class	Enclosure Type	
	IP20/NEMA Type 1 Enclosure <sup>&lt;1&gt;</sup> Drive Model CIMR-Z□	IP00/Open-Type Enclosure Drive Model CIMR-Z□
Three-Phase 200 V Class	2A0011F	–
	2A0017F	–
	2A0024F	–
	2A0031F	–
	2A0046F	–
	2A0059F	–
	2A0075F	–
	2A0088F	–
	2A0114F	–
	2A0143F	–
	2A0169F	–
	2A0211F	–
	2A0273F	–
	–	2A0343A
–	2A0396A	
Three-Phase 400 V Class	4A0005F	–
	4A0008F	–
	4A0011F	–
	4A0014F	–
	4A0021F	–
	4A0027F	–
	4A0034F	–
	4A0040F	–
	4A0052F	–
	4A0065F	–
	4A0077F	–
	4A0096F	–
	4A0124F	–
	4A0156F	–
	4A0180F	–
	4A0240F	–
	4A0302F	–
	–	4A0361A
	–	4A0414A
	–	4A0480A
–	4A0590A	

<1> Removing the top protective cover from an IP20/NEMA Type 1 drive voids the NEMA Type 1 protection while maintaining IP20 conformity; removing the bottom conduit bracket voids the NEMA Type 1 protection and IP20 conformity.

## 1.5 Component Names

This section gives an overview of the drive components described in this manual.

- Note:**
1. Refer to *Using the HOA Keypad on page 107* for a description of the HOA keypad.
  2. The drive may have multiple cooling fans depending on the model.

### ◆ IP20/NEMA Type 1 Enclosure

- Three-Phase AC 200 V 2A0011F to 2A0059F
- Three-Phase AC 400 V 4A0005F to 4A0052F

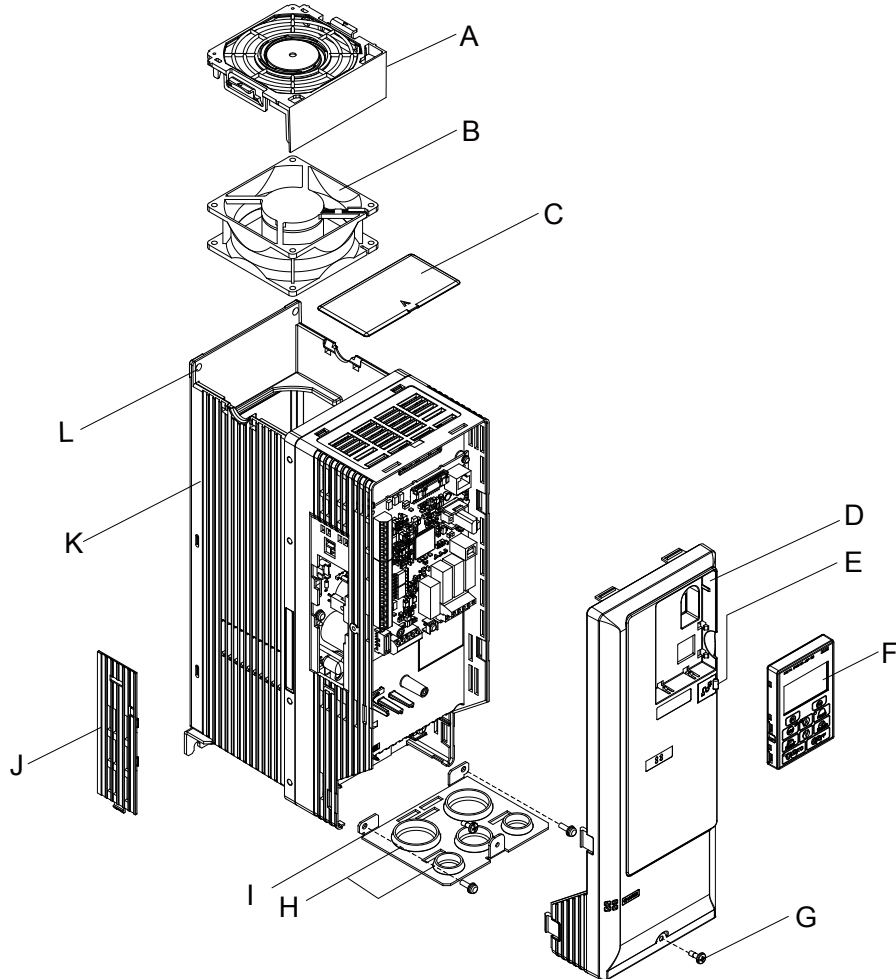

- |                          |   |
|--------------------------|---|
| A – Fan finger guard     | G – Screw   |
| B – Cooling fan          | H – Rubber bushing                                |
| C – Top protective cover | I – Conduit bracket                               |
| D – Front cover          | J – Optional 24 V DC power supply connector cover |
| E – USB port (type-B)    | K – Heatsink                                      |
| F – HOA keypad           | L – Mounting hole                                 |

Figure 1.2 Exploded View of IP20/NEMA Type 1 Components (2A0011F)

■ Three-Phase AC 200 V 2A0075F to 2A0114F  
 Three-Phase AC 400 V 4A0065F to 4A0096F

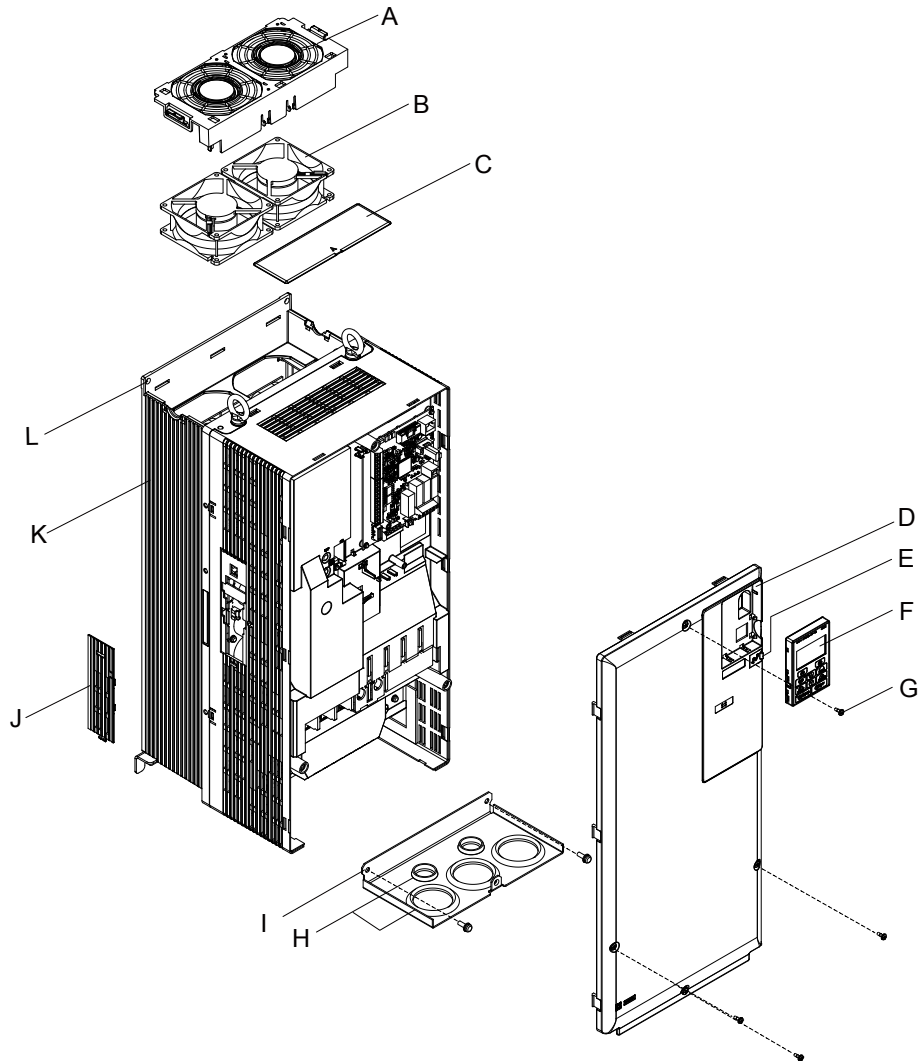

A – Fan finger guard  
 B – Cooling fan  
 C – Top protective cover  
 D – Front cover  
 E – USB port (type-B)  
 F – HOA keypad

G – Screw  
 H – Rubber bushing  
 I – Conduit bracket  
 J – Optional 24 V DC power supply  
 connector cover  
 K – Heatsink  
 L – Mounting hole

Figure 1.3 Exploded View of IP20/NEMA Type 1 Enclosure Components (4A0096F)

## 1.5 Component Names

### ■ Three-Phase AC 200 V 2A0143F to 2A0273F Three-Phase AC 400 V 4A0124F to 4A0302F

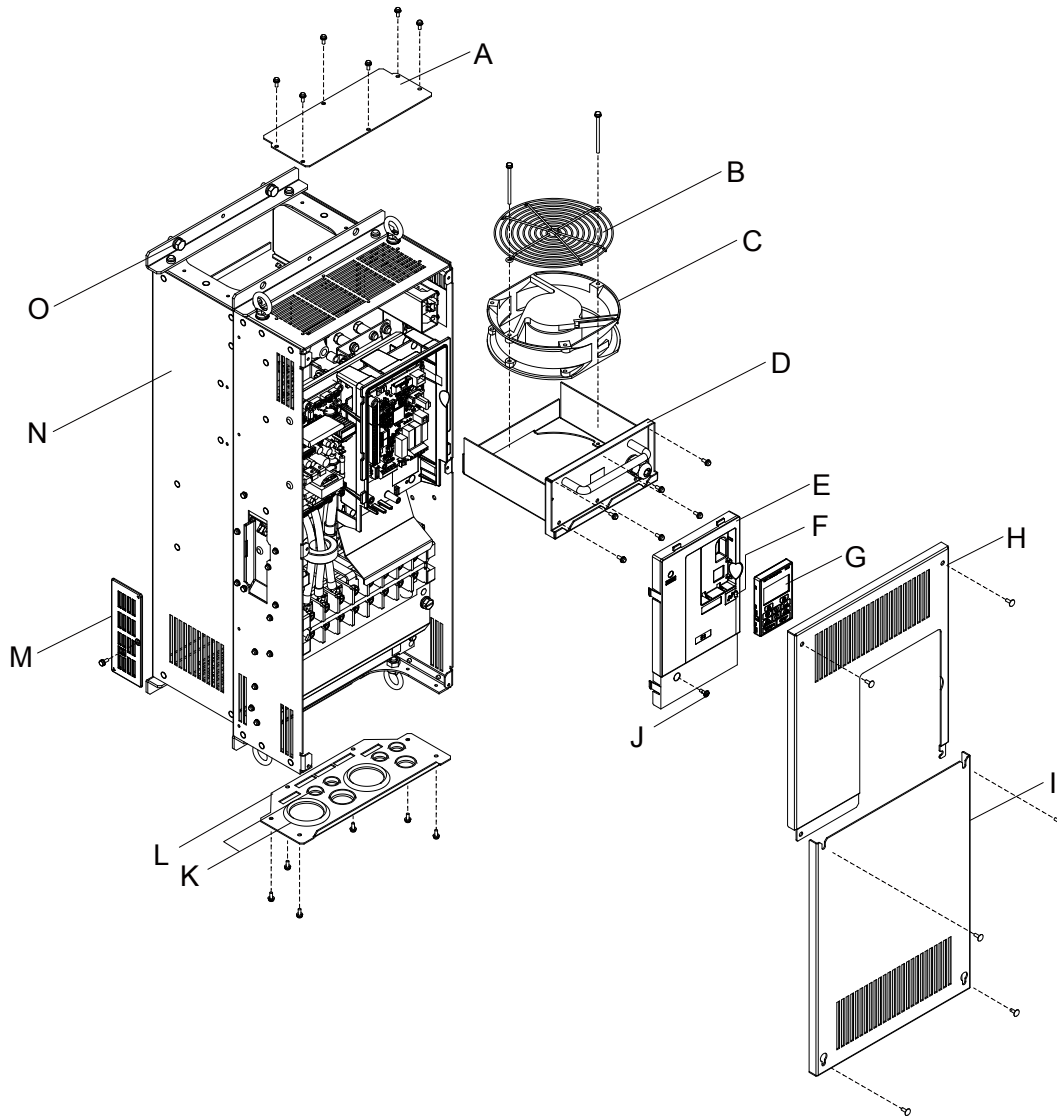

A – Top protective cover

B – Fan guard

C – Cooling fan

D – Fan bracket

E – Front cover

F – USB port (type-B)

G – HOA keypad

H – Drive cover

I – Terminal cover

J – Screw

K – Rubber bushing

L – Conduit bracket

M – Optional 24 V DC power supply  
connector cover

N – Heatsink

O – Mounting hole

Figure 1.4 Exploded view of IP20/NEMA Type 1 Enclosure Components (4A0124F)

## ◆ IP00/Open-Type Enclosure

## ■ Three-Phase AC 200 V 2A0343A, 2A0396A

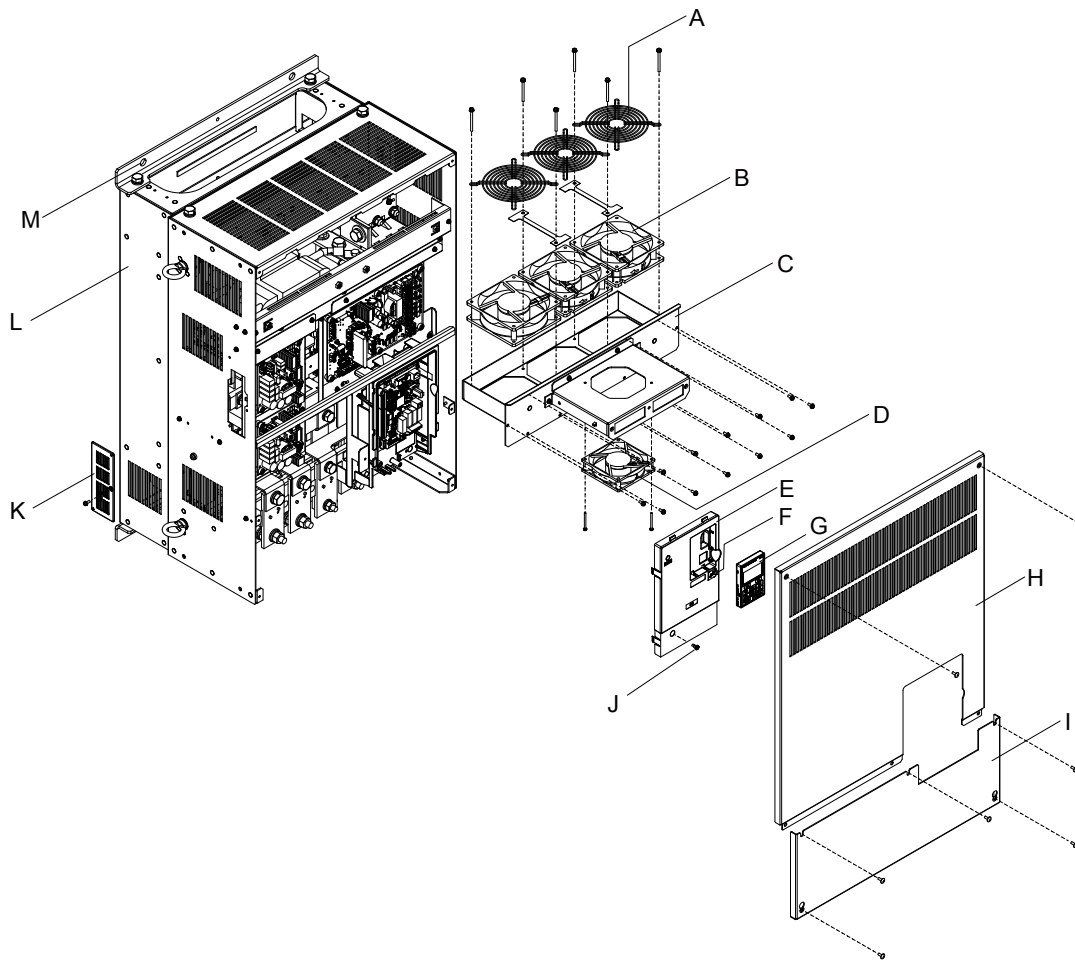

A – Fan guard  
 B – Cooling fan  
 C – Fan bracket  
 D – Circulation fan <1>  
 E – Front cover  
 F – USB port (type-B)  
 G – HOA keypad

H – Drive cover  
 I – Terminal cover  
 J – Screw  
 K – Optional 24 V DC power supply  
 connector cover  
 L – Heatsink  
 M – Mounting hole

Figure 1.5 Exploded view of IP00/Open-Type Enclosure Components (2A0343A)

<1> Drive models 2A0343 and 2A0396 have a built-in circulation fan.

## 1.5 Component Names

### ■ Three-Phase AC 400 V 4A0361A

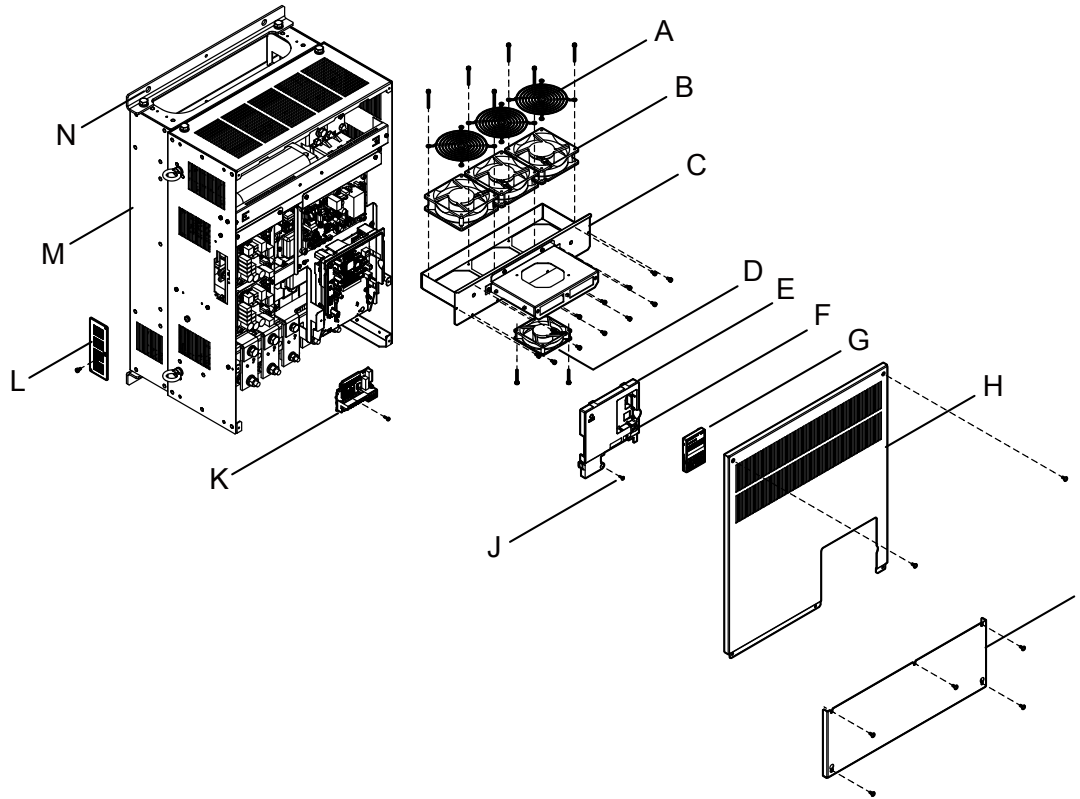

A – Fan guard  
B – Cooling fan  
C – Fan bracket  
D – Circulation fan  
E – Front cover  
F – USB port (type-B)  
G – HOA Keypad

H – Drive cover  
I – Terminal cover  
J – Front cover screw  
K – Terminal board  
L – Optional 24 V DC power supply  
connector cover  
M – Heatsink  
N – Mounting hole

Figure 1.6 Exploded view of IP00/Open-Type Enclosure Components (4A0361A)

### ■ Three-Phase AC 400 V 4A0414A

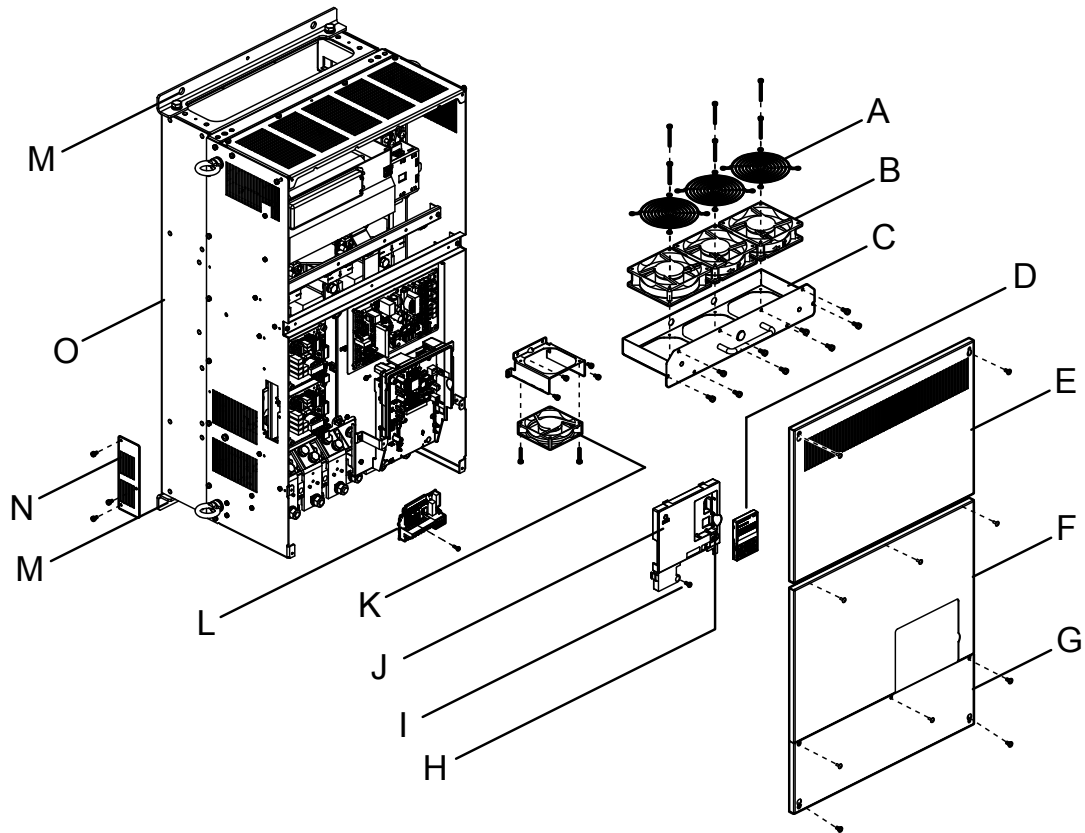

A – Fan guard  
 B – Cooling fan  
 C – Fan bracket  
 D – HOA Keypad  
 E – Drive cover 1  
 F – Drive cover 2  
 G – Terminal cover  
 H – USB port (type-B)

I – Front cover screw  
 J – Front cover  
 K – Circulation fan  
 L – Terminal board  
 M – Mounting hole  
 N – Optional 24 V DC power supply  
 connector cover  
 O – Heatsink

Figure 1.7 Exploded view of IP00/Open Type Enclosure Components (4A0414A)

### ■ Three-Phase AC 400 V 4A0480A to 4A0590A

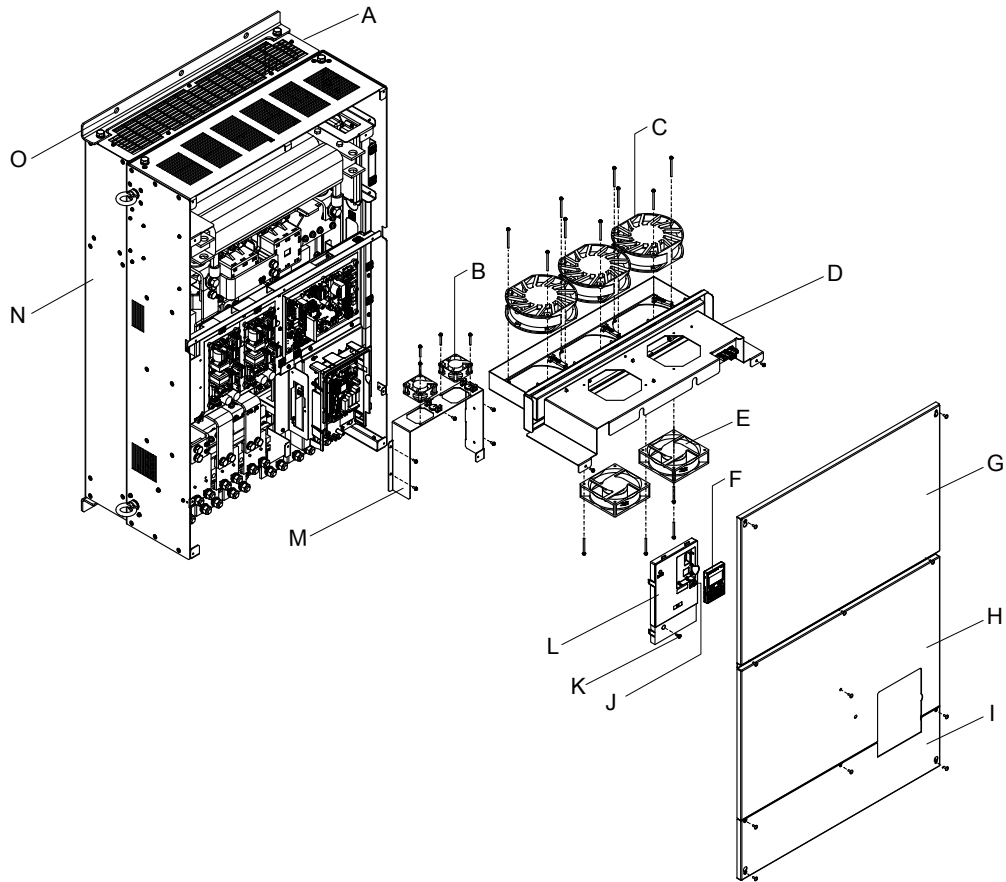

- |                               |   |
|-------------------------------|---|
| A – Fan guard                 | I – Terminal cover                      |
| B – Circuit board cooling fan | J – USB port (type-B)                   |
| C – Cooling fan               | K – Screw                               |
| D – Fan bracket               | L – Front cover                         |
| E – Circulation Fan           | M – Circuit board cooling fan unit case |
| F – HOA keypad                | N – Heatsink                            |
| G – Drive cover 1             | O – Mounting hole                       |
| H – Drive cover 2             |   |

Figure 1.8 Exploded view of IP00/Open-Type Enclosure Components (4A0480A)

◆ Front Views

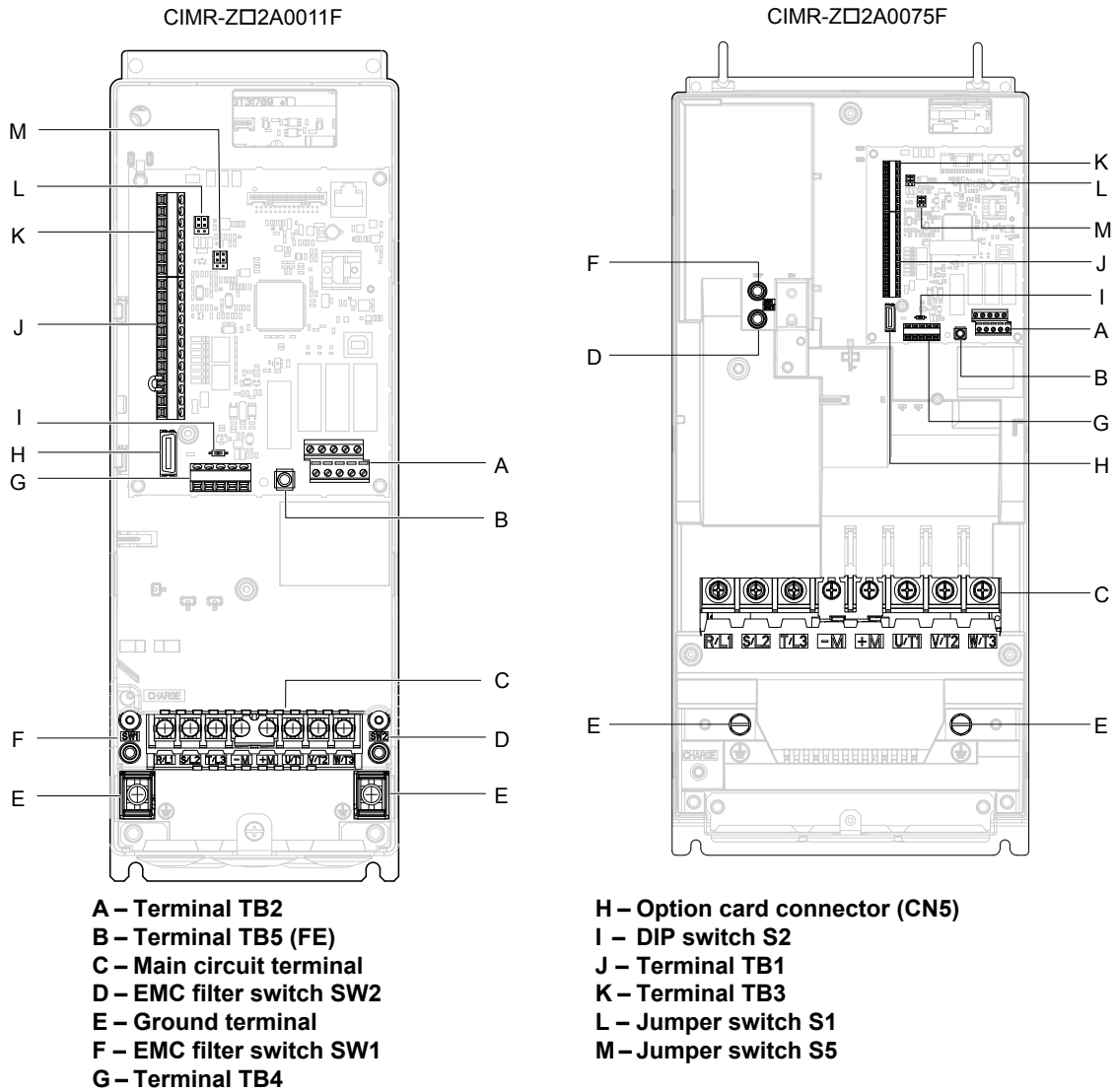

Figure 1.9 Front View of Drives

**This Page Intentionally Blank**

## Mechanical Installation

---

This chapter explains how to properly mount and install the drive.

<b>2.1</b>	<b>SECTION SAFETY.....</b>	<b>40</b>
<b>2.2</b>	<b>MECHANICAL INSTALLATION.....</b>	<b>42</b>

## 2.1 Section Safety

### WARNING

#### Fire Hazard

**Provide sufficient cooling when installing the drive inside an enclosed panel or cabinet.**

Failure to comply could result in overheating and fire.

When multiple drives are placed inside the same enclosure panel, install proper cooling to ensure air entering the enclosure does not exceed 40 °C.

#### Crush Hazard

**Use a dedicated lifter when transporting the drive by a lifter.**

Failure to comply may result in serious injury or death from falling equipment.

**Only use vertical suspension to temporarily lift the drive during installation to an enclosure panel. Do not use vertical suspension to transport the drive.**

Failure to comply may result in serious injury or death from falling equipment.

**Use screws to securely affix the drive front cover, terminal blocks, and other drive components prior to vertical suspension.**

Failure to comply may result in serious injury or death from falling equipment.

**Do not subject the drive to vibration or impact greater than 1.96 m/s<sup>2</sup> (0.2 G) while it is suspended by the cables.**

Failure to comply may result in serious injury or death from falling equipment.

**Do not attempt to flip the drive over or leave the drive unattended while it is suspended by the wires.**

Failure to comply may result in serious injury or death from falling equipment.

### CAUTION

#### Crush Hazard

**Do not carry the drive by the front cover or the terminal cover.**

Failure to comply may result in minor or moderate injury from the main body of the drive falling.

### NOTICE

#### Equipment Hazard

**Prevent foreign matter such as metal shavings or wire clippings from falling into the drive during drive installation and project construction.**

Failure to comply could result in damage to the drive. Place a temporary cover over the top during installation. Be sure to remove the temporary cover before start-up, as the cover will reduce ventilation and cause the unit to overheat.

**Observe proper electrostatic discharge (ESD) procedures when handling the drive.**

Failure to comply could result in ESD damage to the drive circuitry.

**Operating the motor in the low-speed range diminishes the cooling effects, increases motor temperature, and may lead to motor damage by overheating.**

Reduce the motor torque in the low-speed range whenever using a standard blower cooled motor. If 100% torque is required continuously at low speed, consider using a special drive or vector-control motor. Select a motor that is compatible with the required load torque and operating speed range.

**The speed range for continuous operation differs according to the lubrication method and motor manufacturer.**

If the motor is to be operated at a speed higher than the rated speed, consult with the manufacturer.

Continuously operating an oil-lubricated motor in the low-speed range may result in burning.

**NOTICE**

**When the input voltage is 440 V or higher or the wiring distance is greater than 100 meters, pay special attention to the motor insulation voltage or use a drive-rated motor with reinforced insulation.**

Failure to comply could lead to motor winding failure.

**Motor vibration may increase when operating a machine in variable-speed mode, if that machine previously operated at a constant speed.**

Install vibration-proof rubber on the motor base or use the frequency jump function to skip a frequency resonating the machine.

**The motor may require more acceleration torque with drive operation than with a commercial power supply.**

Set a proper V/f pattern by checking the load torque characteristics of the machine to be used with the motor.

**The rated input current of submersible motors is higher than the rated input current of standard motors.**

Select an appropriate drive according to its rated output current. When the distance between the motor and drive is long, use a cable thick enough to connect the motor to the drive to prevent motor torque reduction.

**The current rating differs for a motor with variable pole pitches differs from a standard motor.**

Check the maximum current of the motor before selecting the drive capacity. Only switch motor poles when the motor is stopped. Switching between motor during run will trigger overcurrent protection circuitry or result in overvoltage from regeneration, and the motor will simply coast to stop.

**When using an explosion-proof motor, it must be subject to an explosion-proof test in conjunction with the drive.**

This is also applicable when an existing explosion-proof motor is to be operated with the drive. Since the drive itself is not explosion-proof, always install it in a safe place.

**Never lift the drive up while the cover is removed.**

This can damage the terminal board and other components.

# 2.2 Mechanical Installation

This section outlines specifications, procedures, and the environment for proper mechanical installation of the drive.

### ◆ Installation Environment

Install the drive in an environment matching the conditions below to prolong the optimum performance life of the drive.

**Table 2.1 Installation Environment**

Environment	Conditions
Installation Area	Indoors
Ambient Temperature	-10 °C to +40 °C (14 to 104 °F) IP20/NEMA Type 1 Enclosure, External Heatsink (2A0011 to 2A0273 and 4A0005 to 4A0302) -10 °C to +50 °C (14 to 122 °F) IP00/Open Type Enclosure (2A0343 and 2A0396, and 4A0361 to 4A0590) <b>Note:</b> 1. To install a heatsink on the outside of a panel, design the panel to keep the air temperature inside the panel within 10 °C (18 °F) [5 °C (9 °F) for 2A0273 and 4A0124] of the outside air temperature. 2. Ambient temperature range for continuous operations is -10 to +40 °C (14 to 104 °F) when external heatsink installation method is applied for models 2A0343 and 2A0396 and 4A0361 to 4A0590.
Humidity	95% RH or less and free of condensation
Storage Temperature	-20 to +70 °C (-4 to +158 °F)
Surrounding Area	Install the drive in an area free from: <ul style="list-style-type: none"> <li>• oil mist and dust</li> <li>• metal shavings, oil, water, or other foreign materials</li> <li>• radioactive materials</li> <li>• combustible materials (e.g., wood)</li> <li>• harmful gases and liquids</li> <li>• excessive vibration</li> <li>• chlorides</li> <li>• direct sunlight.</li> </ul>
Altitude	Up to 1000 meters without derating. Up to 3000 meters with output current and voltage derating
Vibration	10 to 20 Hz at 9.8 m/s <sup>2</sup> 20 to 55 Hz at 5.9 m/s <sup>2</sup> (2A0011 to 2A0031 and 4A0005 to 4A0027) or 2.0 m/s <sup>2</sup> (2A0046 to 2A00396 and 4A0034 to 4A0590)
Orientation	Install the drive vertically to maintain maximum cooling effects.

**NOTICE:** Avoid placing drive peripheral devices, transformers, or other electronics near the drive as the noise created can lead to erroneous operation. If such devices must be used in close proximity to the drive, take proper steps to shield the drive from noise.

**NOTICE:** Prevent foreign matter such as metal shavings and wire clippings from falling into the drive during installation. Failure to comply could result in damage to the drive. Place a temporary cover over the top of the drive during installation. Remove the temporary cover before drive start-up, as the cover will reduce ventilation and cause the drive to overheat.

### ◆ Transporting the Drive

**CAUTION!** Do not lift drive models 2A0011 to 2A0114 and 4A0005 to 4A0096 by the front cover. Failure to comply might result in minor or moderate injury if the main body of the drive falls.

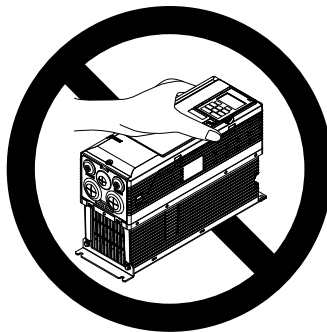

**Figure 2.1 Incorrect Way to Transport the Drive**

## ◆ Installation Orientation and Spacing

Install the drive upright as illustrated in *Figure 2.2* to maintain proper cooling.

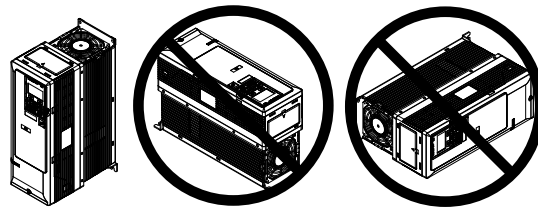

Figure 2.2 Correct Installation Orientation

## ■ Single Drive Installation

*Figure 2.3* shows the installation distance required to maintain sufficient space for airflow and wiring. Install the heatsink against a closed surface to avoid diverting cooling air around the heatsink.

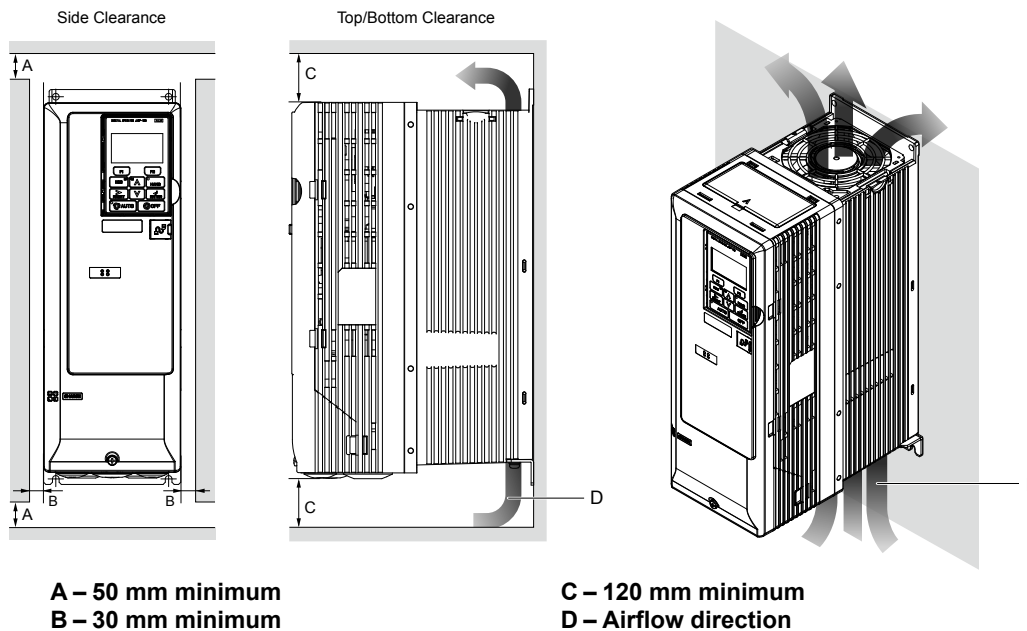

Figure 2.3 Correct Installation Spacing

**Note:** IP20/NEMA Type 1 enclosure and IP00/Open-Type enclosure models require the same amount of space above and below the drive for installation.

## ◆ Instructions on Installation Using the Eye Bolts

Eye bolts are used to install the drive or to temporarily lift the drive when replacing it. Using the eye bolts, the drive can be installed in an enclosure panel or on a wall. Do not leave the drive suspended by the wires in a horizontal or vertical position for long periods of time. Do not transport the drive over long distances. Read the following precautions and instructions before installing the drive.

**WARNING! Crush Hazard.** Observe the following instructions and precautions. Failure to comply could result in serious injury or death from falling equipment.

Only use vertical suspension to temporarily lift the drive during installation to an enclosure panel. Do not use vertical suspension to transport the drive.

Use screws to securely affix the drive front cover, terminal blocks, and other drive components prior to vertical suspension.

Do not subject the drive to vibration or impact greater than  $1.96 \text{ m/s}^2$  (0.2 G) while it is suspended by the wires.

Do not leave the drive unattended while it is suspended by the wires.

Do not attempt to flip the drive over while it is suspended by the wires.

## 2.2 Mechanical Installation

### ■ Horizontal Suspension of Drive Models 2A0343A, 2A0396A, and 4A0361A to 4A0590A

To make a wire hanger or frame for use when lifting the drive with a crane, lay the drive in a horizontal position and pass a wire through the holes of the four eye bolts.

**NOTICE:** *Damage to Equipment.* When lifting the drive, confirm that the spring washer is fully closed. Failure to comply may deform or damage the drive when lifted.

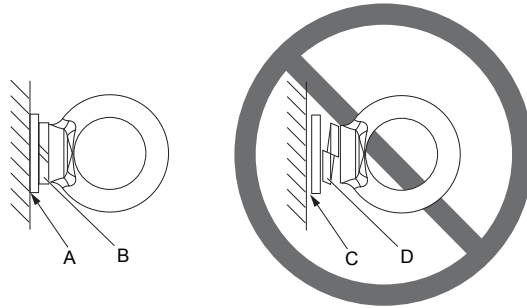

A – No space between drive and washer  
B – Spring washer fully closed

C – Space between drive and washer  
D – Spring washer open

Figure 2.4 Spring Washer

### ■ Vertical Suspension of Drive Models 2A0343A, 2A0396A, and 4A0361A to 4A0590A

When vertical suspension of the drive is required in an enclosure panel, change the orientation of the eye bolts for these models by turning the eye bolts counterclockwise 90 degrees.

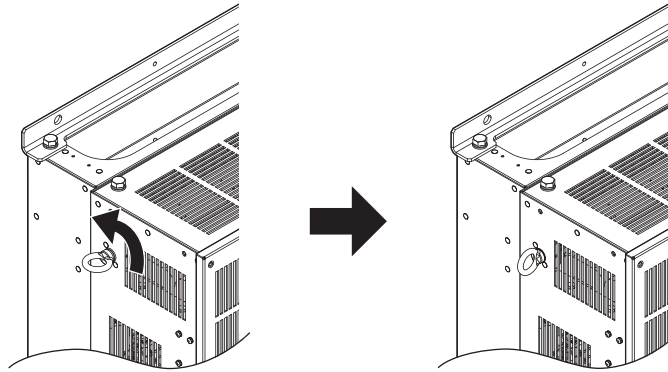

Figure 2.5 Adjusting Angle of Eye Bolts

◆ Panel Cut-Out Dimensions

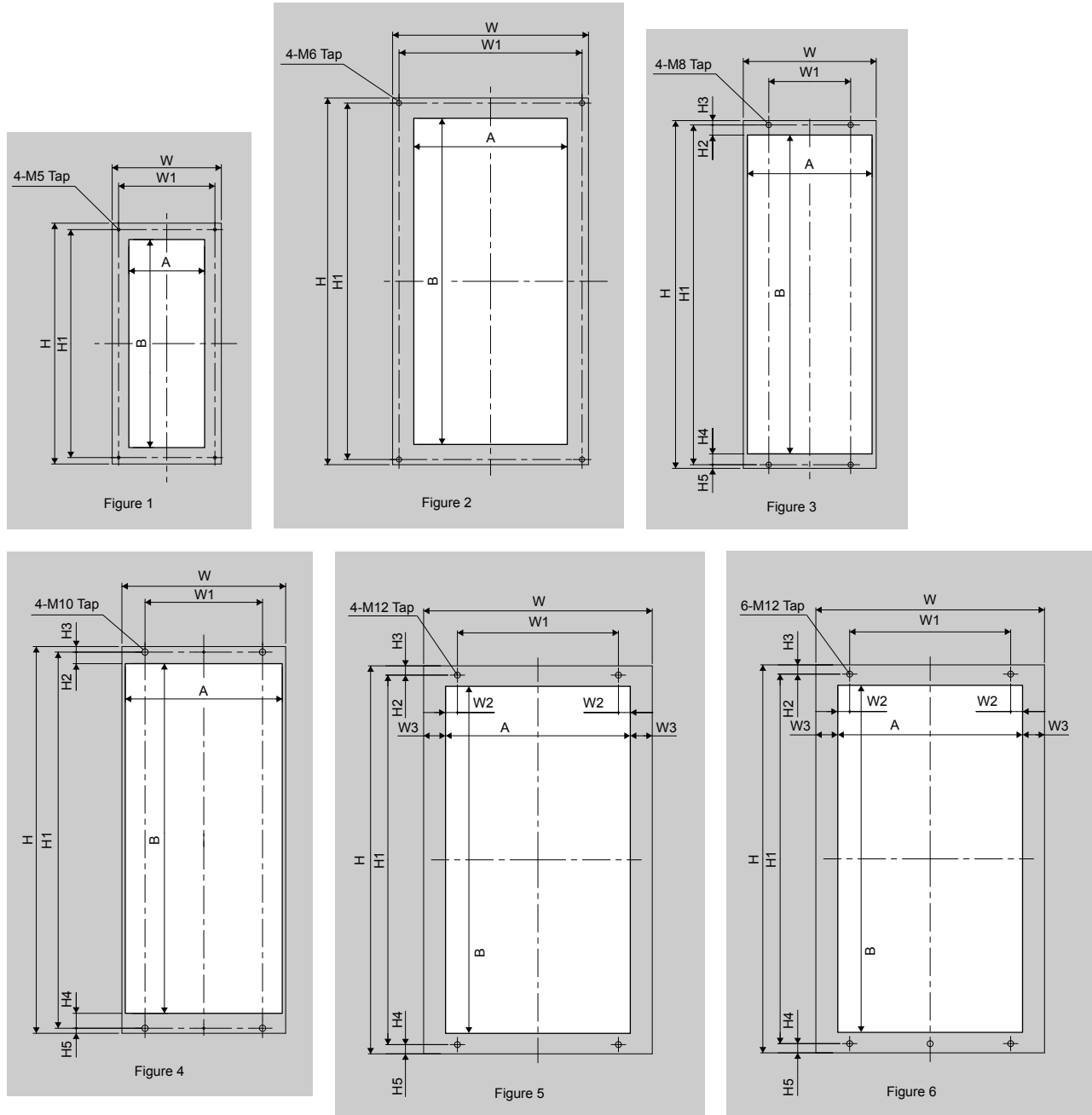

Table 2.2 Panel Cut-Out Dimensions

Drive Model	Dimensions (in)												
	Figure	W	H	W1	W2	W3	H1	H2	H3	H4	H5	A	B
<b>200 V Class</b>													
2A0011 2A0017	1	6.7	14.8	5.9	–	–	14	–	–	–	–	4.6	12.8
2A0024 2A0031	1	6.7	18.3	5.9	–	–	17.5	–	–	–	–	4.6	16.3
2A0046 2A0059	2	7.9	21.1	5.1	–	–	20.5	–	–	–	–	7.6	18.6
2A0075 2A0088 2A0114	2	12	22.5	11.2	–	–	21.9	–	–	–	–	9.4	20

## 2.2 Mechanical Installation

Drive Model	Dimensions (in)												
	Figure	W	H	W1	W2	W3	H1	H2	H3	H4	H5	A	B
2A0143 2A0169 2A0211 2A0273	4	13.4	31.6	9.6	–	–	30.7	0.9	0.5	1.2	0.4	12.8	28.6
2A0343 2A0396	5	19.7	31.5	14.6	2.2	0.3	30.4	0.6	0.6	0.7	0.5	19.1	29.1
<b>400 V Class</b>													
4A0005 4A0008 4A0011	1	6.7	14.8	5.9	–	–	14	–	–	–	–	4.6	12.8
4A0014 4A0021 4A0027	1	6.7	18.3	5.9	–	–	17.5	–	–	–	–	4.6	16.3
4A0034 4A0040 4A0052□□B	2	7.9	21.1	5.1	–	–	20.5	–	–	–	–	7.6	18.6
4A0052□□A 4A0065 4A0077 4A0096	2	12	22.5	11.2	–	–	21.9	–	–	–	–	9.4	20
4A0124	3	10.9	28.4	6.7	–	–	27.8	0.8	0.4	0.9	0.3	10.2	26.1
4A0156 4A0180 4A0240	4	13.4	31.6	9.6	–	–	30.7	0.9	0.5	1.2	0.4	12.8	28.6
4A0302	5	17.9	41.9	12.8	–	–	40.9	1.1	0.6	1.1	0.5	17.1	38.6
4A0361 4A0414 4A0480	5	19.7	31.5	14.6	2.2	0.3	30.4	0.6	0.6	0.7	0.5	19.1	29.1
		19.7	37.4	14.6	2.2	0.3	36.3	0.6	0.6	0.7	0.5	19.1	35.0
		26.4	44.9	17.3	4.2	0.3	43.7	0.7	0.6	0.7	0.6	25.7	42.2
4A0590	6	26.4	44.9	17.3	4.2	0.3	43.7	0.7	0.6	0.7	0.6	25.7	42.2

### ◆ HOA Keypad Remote Usage

#### ■ Remote Operation

The HOA keypad mounted on the drive can be removed and connected to the drive using an extension cable up to 3 m (9.8 ft.) long to facilitate operation when the drive is installed in a location where it can not be easily accessed.

The HOA keypad can also be permanently mounted remote locations such as panel doors using an extension cable and an installation support set (depending on the installation type).

**Note:** Refer to *Peripheral Devices & Options on page 243* for information on extension cables and installation support sets.

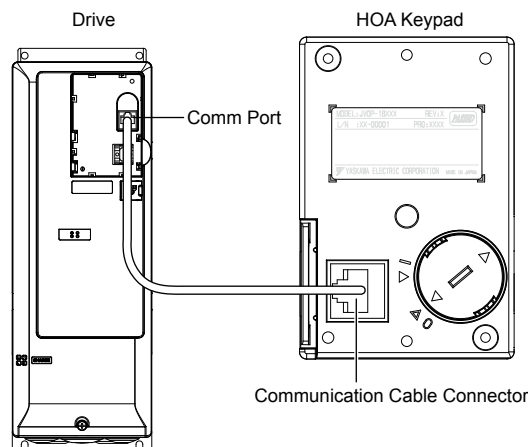

Figure 2.6 Communication Cable Connection

## HOA Keypad Remote Installation

### HOA Keypad Dimensions

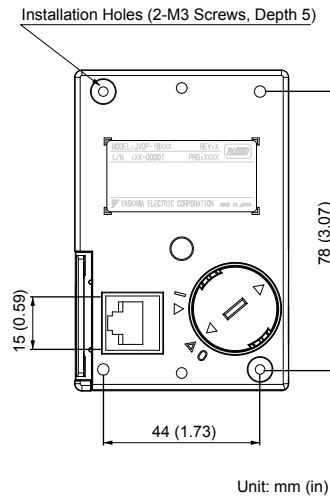

Figure 2.7 HOA Keypad Dimensions

### Installation Types and Required Materials

The HOA keypad mounts to an enclosure two different ways:

- **External/face-mount** installs the HOA keypad outside the enclosure panel
- **Internal/flush-mount** installs the HOA keypad inside the enclosure panel

Table 2.3 HOA Keypad Installation Methods and Required Tools

Installation Method	Description	Installation Support Sets	Model	Required Tools
External/ Face-Mount	Simplified installation with the HOA keypad is mounted on the outside of the panel with two screws.	-	-	Phillips screwdriver (#1)
Internal/ Flush-Mount	Encloses the HOA keypad in the panel. The front of the HOA keypad is flush with the outside of the panel.	Installation Support Set A (for mounting with screws through holes in the panel)	EZZ020642A	Phillips screwdriver (#1, #2)
		Installation Support Set B (for use with threaded studs that are fixed to the panel)	EZZ020642B	Phillips screwdriver (#1) Wrench (7 mm)

**NOTICE:** Prevent foreign matter such as metal shavings or wire clippings from falling into the drive during installation and project construction. Failure to comply could result in damage to the drive. Place a temporary cover over the top of the drive during installation. Remove the temporary cover before drive start-up, as the cover will reduce ventilation and cause the drive to overheat.

### External/Face-Mount

1. Cut an opening in the enclosure panel for the HOA keypad as shown in [Figure 2.8](#).
2. Position the HOA keypad so the display faces outwards, and mount it to the enclosure panel as shown in [Figure 2.9](#).

## 2.2 Mechanical Installation

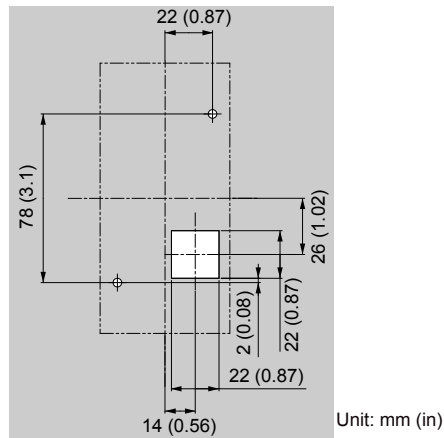

**Figure 2.8 Panel Cut-Out Dimensions (External/Face-Mount Installation)**

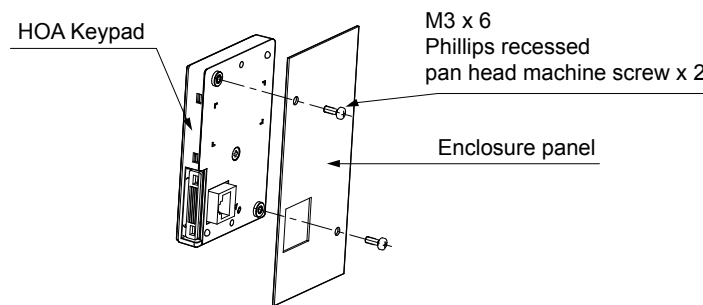
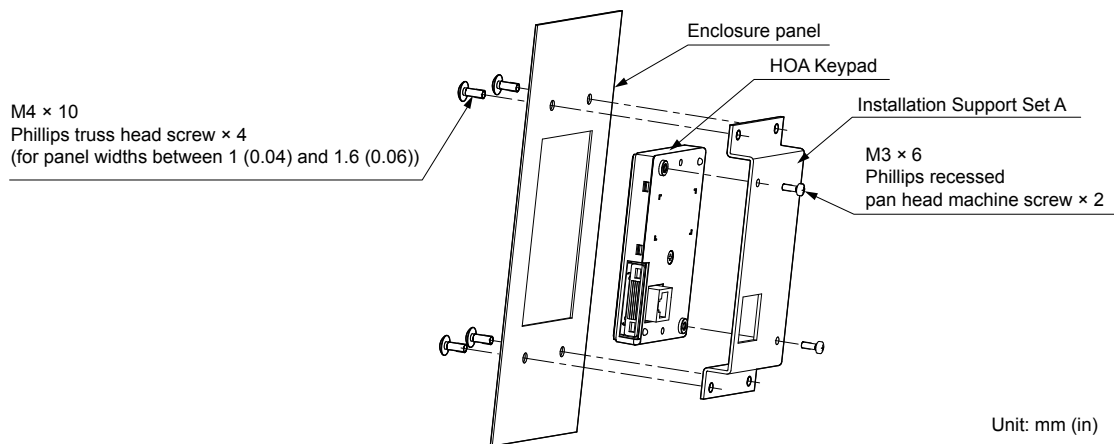

**Figure 2.9 External/Face-Mount Installation**

### Internal/Flush-Mount

An internal/flush-mount requires an installation support set that must be purchased separately. Contact Yaskawa to order an installation support set and mounting hardware. **Figure 2.10** illustrates how to attach the Installation Support Set A.

1. Cut an opening in the enclosure panel for the HOA keypad as shown in **Figure 2.11**.
2. Mount the HOA keypad to the installation support.
3. Mount the installation support set and HOA keypad to the enclosure panel.



**Figure 2.10 Internal/Flush Mount Installation**

**Note:** Use a gasket between the enclosure panel and the HOA keypad in environments with a significant amount of dust or other airborne debris.

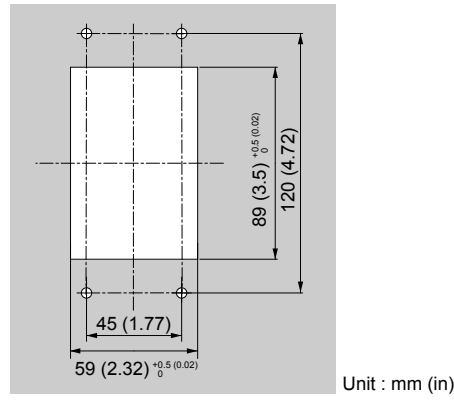

Figure 2.11 Panel Cut-Out Dimensions (Internal/Flush-Mount Installation)

◆ Exterior and Mounting Dimensions

Table 2.4 Drive Models and Types

Protective Design	Drive Model		Page
	Three-Phase 200 V Class	Three-Phase 400 V Class	
IP20/NEMA Type 1 Enclosure	2A0011F	4A0005F	50
	2A0017F	4A0008F	
	2A0024F	4A0011F	
	2A0031F	4A0014F	
	2A0046F	4A0021F	
	2A0059F	4A0027F	
	2A0075F	4A0034F	
	2A0088F	4A0040F	
	2A0114F	4A0052F	
	2A0143F	4A0065F	
	2A0169F	4A0077F	
	2A0211F	4A0096F	
	2A0273F	4A0124F	
		4A0156F	
	4A0180F		
IP00/Open-Type Enclosure	2A0343A	4A0240F	57
	2A0396A	4A0302F	
		4A0361A	
		4A0414A	
	4A0480A		
	4A0590A		

Mechanical Installation

## 2.2 Mechanical Installation

### ■ IP20/NEMA Type 1 Enclosure Drives

**Note:** Removing the top protective cover or bottom conduit bracket from an IP20/NEMA Type 1 enclosure drive voids NEMA Type 1 protection while maintaining IP20 conformity.

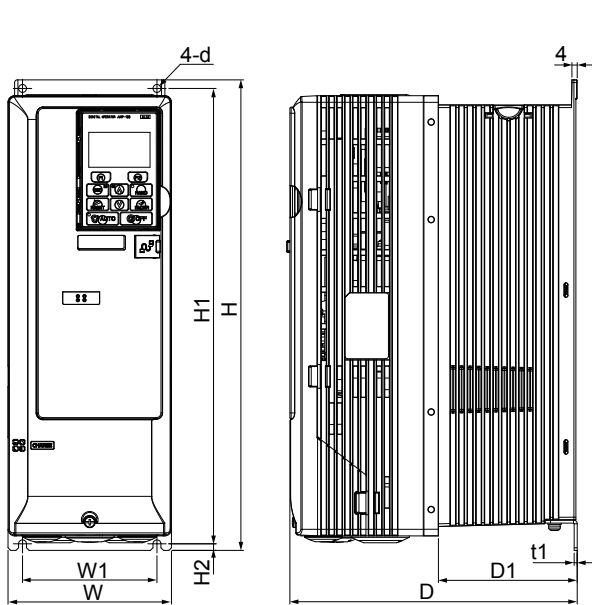

Figure 1

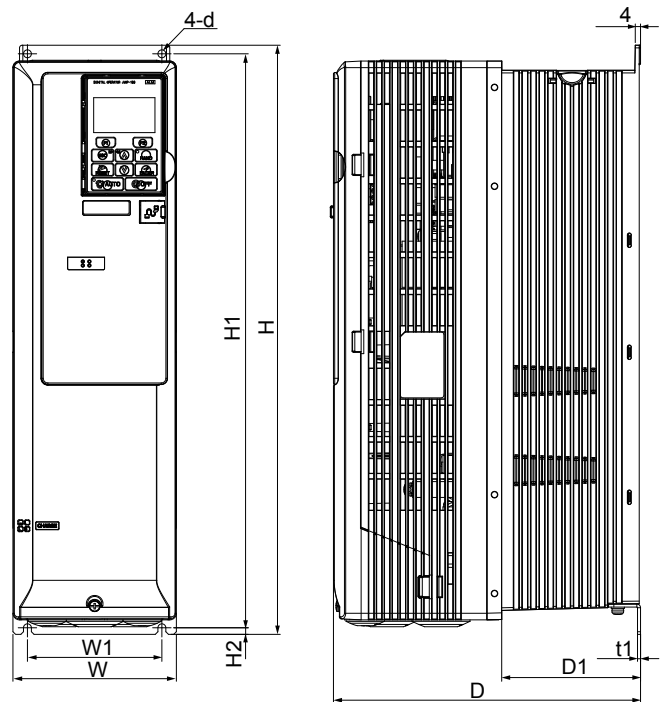

Figure 2

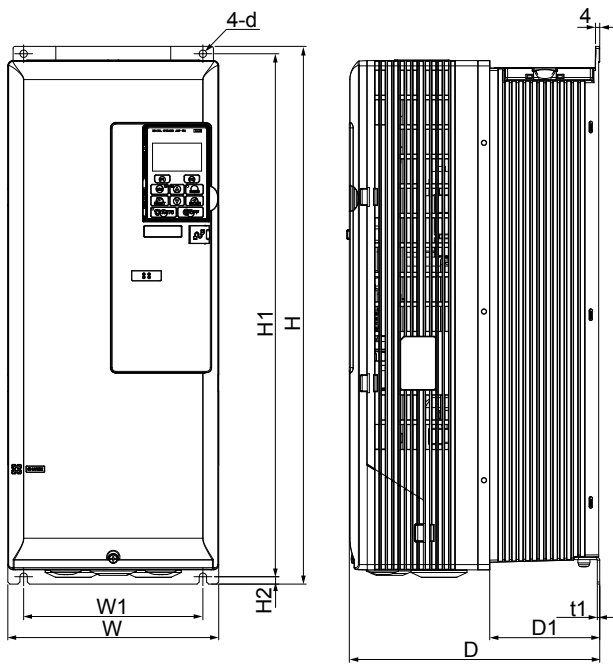

Figure 3

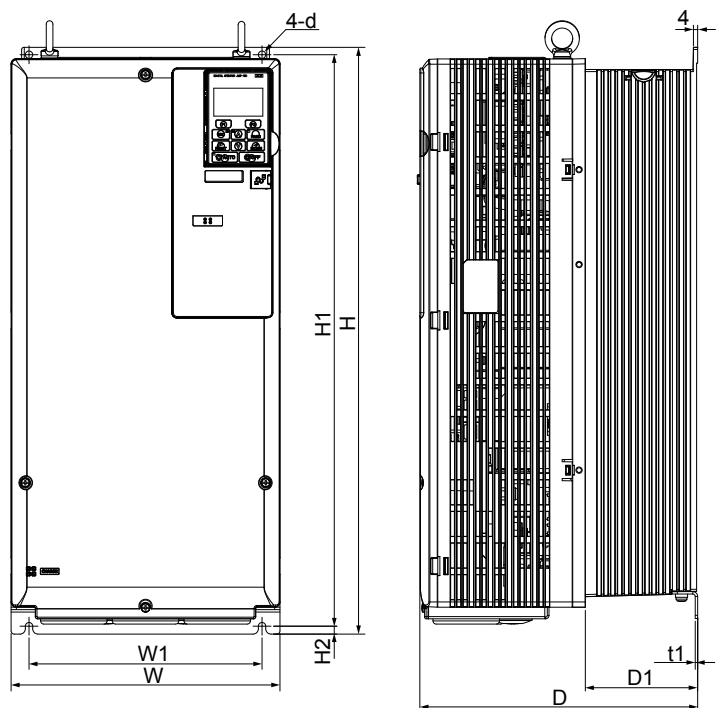

Figure 4

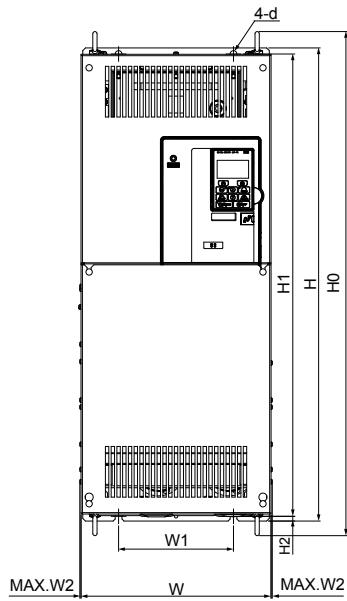

Figure 5

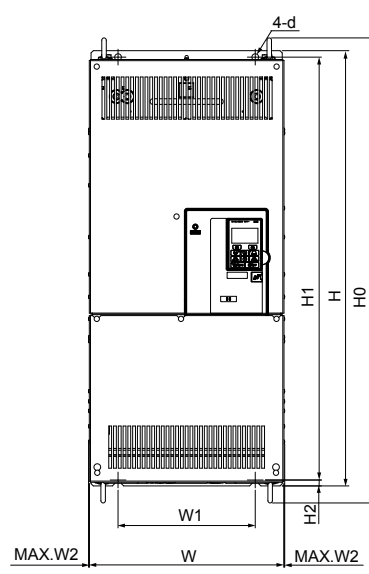
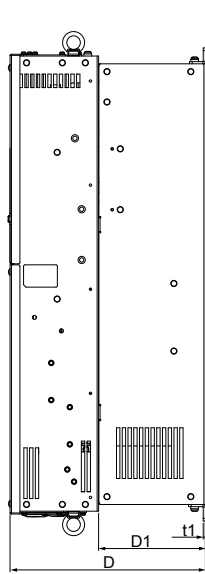

Figure 6

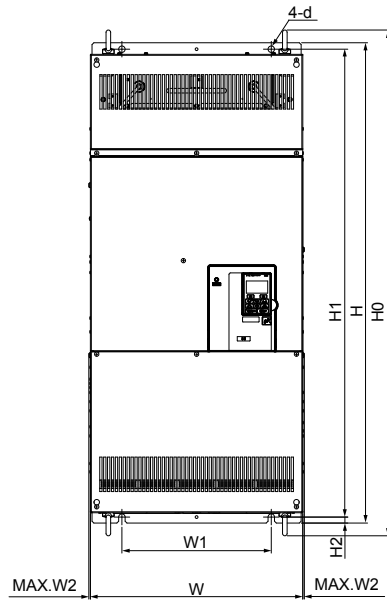
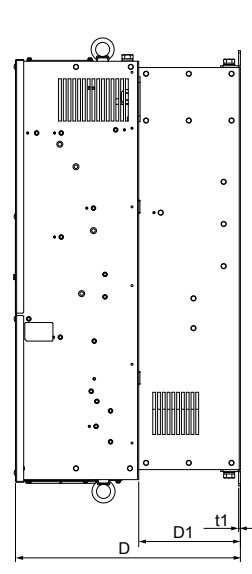
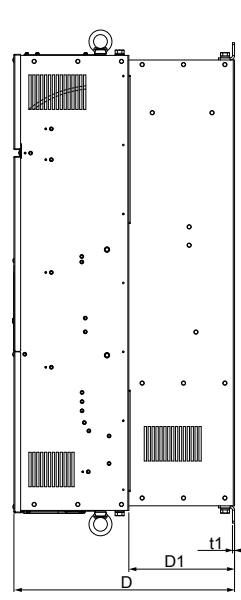

Figure 7



## 2.2 Mechanical Installation

**Table 2.5 Dimensions for IP20/NEMA Type 1 Enclosure: 200 V Class**

Drive Model	Figure	Dimensions (in)										Screw Size	Wt. (lb)
		W	H	D	W1	W2	H0	H1	H2	D1	t1	d	
2A0011 <1>	1	124 (4.88)	357 (14.06)	218 (8.58)	102 (4.02)	-	-	345 (13.60)	5 (0.20)	105 (4.15)	2 (0.09)	M5	6 (12.3)
2A0017 <1>		124 (4.88)	357 (14.06)	218 (8.58)	102 (4.02)	-	-	345 (13.60)	5 (0.20)	105 (4.15)	2 (0.09)	M5	6 (13.0)
2A0024 <1>	2	124 (4.88)	447 (17.60)	233 (9.17)	102 (4.02)	-	-	436 (17.15)	5 (0.20)	105 (4.15)	2 (0.09)	M5	7 (16.3)
2A0031 <1>		124 (4.88)	447 (17.60)	233 (9.17)	102 (4.02)	-	-	436 (17.15)	5 (0.20)	105 (4.15)	2 (0.09)	M5	8 (17.2)
2A0046 <1>	3	200 (7.87)	510 (20.08)	237 (9.35)	170 (6.69)	-	-	496 (19.53)	7 (0.28)	104 (4.11)	2 (0.09)	M6	12 (26.5)
2A0059 <1>		200 (7.87)	510 (20.08)	237 (9.35)	170 (6.69)	-	-	496 (19.53)	7 (0.28)	104 (4.11)	2 (0.09)	M6	13 (28.7)
2A0075 <1>	4	255 (10.04)	542 (21.33)	263 (10.37)	221 (8.70)	-	-	527 (20.76)	8 (0.30)	106 (4.19)	2 (0.09)	M6	27 (59.5)
2A0088 <1>		255 (10.04)	542 (21.33)	263 (10.37)	221 (8.70)	-	-	527 (20.76)	8 (0.30)	106 (4.19)	2 (0.09)	M6	28 (61.7)
2A0114 <1>		255 (10.04)	542 (21.33)	263 (10.37)	221 (8.70)	-	-	527 (20.76)	8 (0.30)	106 (4.19)	2 (0.09)	M6	29 (63.9)
2A0143 <1>	6	340 (13.39)	774 (30.47)	400 (15.75)	244 (9.61)	6 (0.23)	827 (32.56)	752 (29.61)	10 (0.41)	181 (7.12)	3 (0.13)	M10	65 (143.3)
2A0169 <1>		340 (13.39)	774 (30.47)	400 (15.75)	244 (9.61)	6 (0.23)	827 (32.56)	752 (29.61)	10 (0.41)	181 (7.12)	3 (0.13)	M10	68 (149.9)
2A0211 <1>		340 (13.39)	774 (30.47)	400 (15.75)	244 (9.61)	6 (0.23)	827 (32.56)	752 (29.61)	10 (0.41)	181 (7.12)	3 (0.13)	M10	70 (154.3)
2A0273 <1>		340 (13.39)	774 (30.47)	400 (15.75)	244 (9.61)	6 (0.23)	827 (32.56)	752 (29.61)	10 (0.41)	181 (7.12)	3 (0.13)	M10	73 (160.9)

<1> Removing the top protective cover from an IP20/NEMA Type 1 drive voids the NEMA Type 1 protection while maintaining IP20 conformity; removing the bottom conduit bracket voids the NEMA Type 1 protection and IP20 conformity.

**Table 2.6 Dimensions for IP20/NEMA Type 1 Enclosure: 400 V Class**

Drive Model	Figure	Dimensions (in)										Screw Size	Wt. (lb)
		W	H	D	W1	W2	H0	H1	H2	D1	t1	d	
4A0005 <1>	1	124 (4.88)	357 (14.06)	218 (8.58)	102 (4.02)	-	-	345 (13.60)	5 (0.20)	105 (4.15)	2 (0.09)	M5	5 (11.9)
4A0008 <1>		124 (4.88)	357 (14.06)	218 (8.58)	102 (4.02)	-	-	345 (13.60)	5 (0.20)	105 (4.15)	2 (0.09)	M5	6 (12.6)
4A0011 <1>		124 (4.88)	357 (14.06)	218 (8.58)	102 (4.02)	-	-	345 (13.60)	5 (0.20)	105 (4.15)	2 (0.09)	M5	6 (13.4)
4A0014 <1>	2	124 (4.88)	447 (17.60)	233 (9.17)	102 (4.02)	-	-	436 (17.15)	5 (0.20)	105 (4.15)	2 (0.09)	M5	7 (16.1)
4A0021 <1>		124 (4.88)	447 (17.60)	233 (9.17)	102 (4.02)	-	-	436 (17.15)	5 (0.20)	105 (4.15)	2 (0.09)	M5	8 (16.8)
4A0027 <1>		124 (4.88)	447 (17.60)	233 (9.17)	102 (4.02)	-	-	436 (17.15)	5 (0.20)	105 (4.15)	2 (0.09)	M5	8 (18.5)
4A0034 <1>	3	200 (7.87)	510 (20.08)	237 (9.35)	170 (6.69)	-	-	497 (19.53)	7 (0.28)	104 (4.11)	2 (0.09)	M6	13 (28.7)
4A0040 <1>		200 (7.87)	510 (20.08)	237 (9.35)	170 (6.69)	-	-	497 (19.53)	7 (0.28)	104 (4.11)	2 (0.09)	M6	13 (28.7)
4A0052□□B <1>		200 (7.87)	510 (20.08)	237 (9.35)	170 (6.69)	-	-	497 (19.53)	7 (0.28)	104 (4.11)	2 (0.09)	M6	13 (28.7)

Drive Model	Figure	Dimensions (in)										Screw Size	Wt. (lb)
		W	H	D	W1	W2	H0	H1	H2	D1	t1	d	
4A0052□□A <1>	4	255 (10.04)	542 (21.33)	263 (10.37)	221 (8.70)	-	-	527 (20.76)	8 (0.30)	106 (4.19)	2 (0.09)	M6	27 (59.5)
4A0065 <1>		255 (10.04)	542 (21.33)	263 (10.37)	221 (8.70)	-	-	527 (20.76)	8 (0.30)	106 (4.19)	2 (0.09)	M6	29 (63.9)
4A0077 <1>		255 (10.04)	542 (21.33)	263 (10.37)	221 (8.70)	-	-	527 (20.76)	8 (0.30)	106 (4.19)	2 (0.09)	M6	31 (68.3)
4A0096 <1>		255 (10.04)	542 (21.33)	263 (10.37)	221 (8.70)	-	-	527 (20.76)	8 (0.30)	106 (4.19)	2 (0.09)	M6	32 (70.5)
4A0124 <1>	5	276 (10.87)	700 (27.56)	289 (11.38)	170 (6.69)	6 (0.23)	746 (29.36)	684 (26.93)	7 (0.28)	157 (6.22)	3 (0.13)	M8	46 (101.4)
4A0156 <1>	6	340 (13.39)	774 (30.47)	400 (15.75)	244 (9.61)	6 (0.23)	827 (32.56)	752 (29.61)	10 (0.41)	181 (7.12)	3 (0.13)	M10	73 (160.9)
4A0180 <1>		340 (13.39)	774 (30.47)	400 (15.75)	244 (9.61)	6 (0.23)	827 (32.56)	752 (29.61)	10 (0.41)	181 (7.12)	3 (0.13)	M10	76 (167.6)
4A0240 <1>		340 (13.39)	774 (30.47)	400 (15.75)	244 (9.61)	6 (0.23)	827 (32.56)	752 (29.61)	10 (0.41)	181 (7.12)	3 (0.13)	M10	79 (174.2)
4A0302 <1>	7	455 (17.91)	1045 (41.14)	480 (18.90)	325 (12.80)	7 (0.28)	1094 (43.07)	1018 (40.08)	13 (0.51)	230 (9.06)	5 (0.18)	M12	130 (286.6)

<1> Removing the top protective cover from an IP20/NEMA Type 1 drive voids the NEMA Type 1 protection while maintaining IP20 conformity; removing the bottom conduit bracket voids the NEMA Type 1 protection and IP20 conformity.

## 2.2 Mechanical Installation

### IP20/NEMA Type 1 Enclosure Conduit Bracket Dimensions

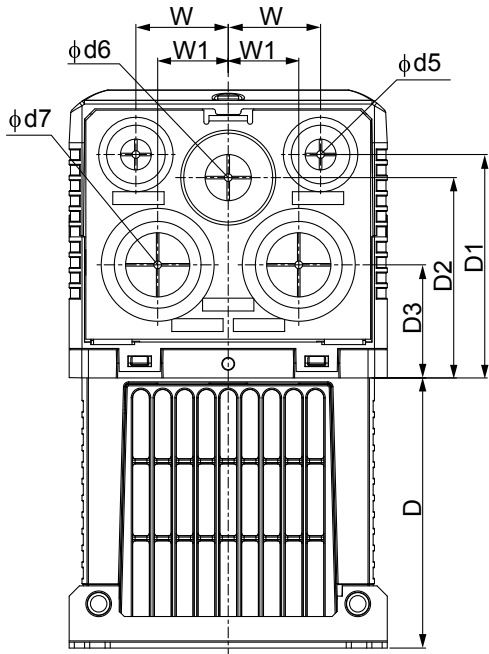

Figure 1

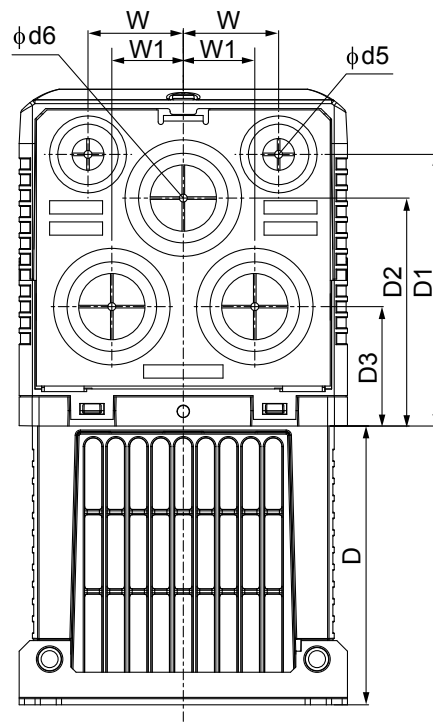

Figure 2

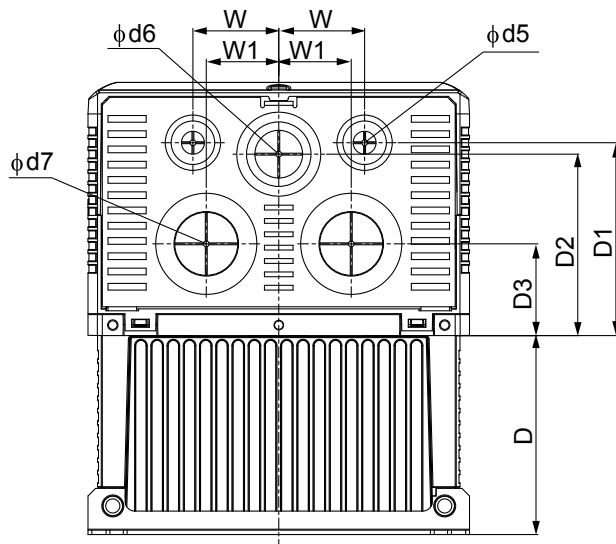

Figure 3

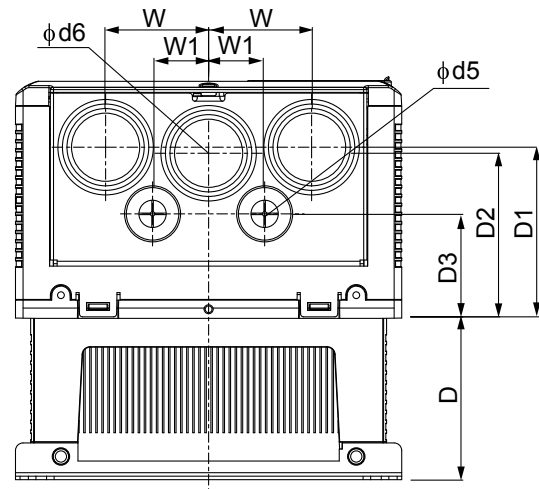

Figure 4

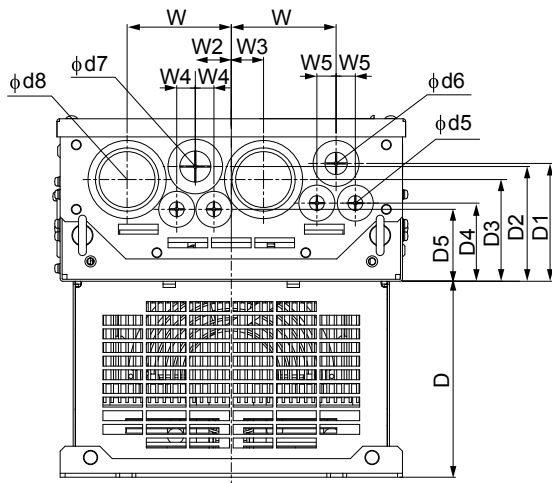

Figure 5

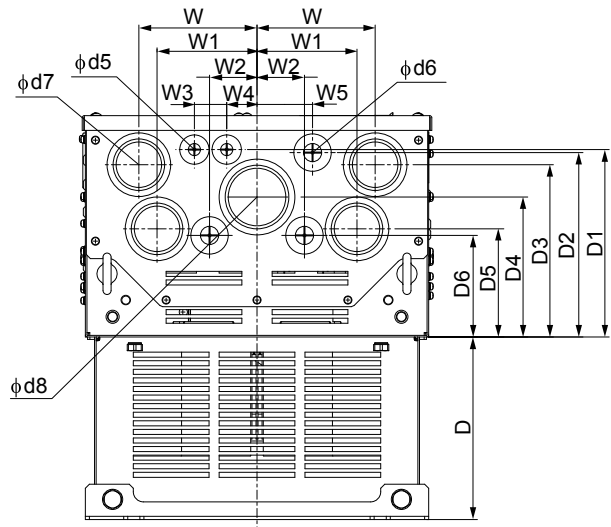

Figure 6

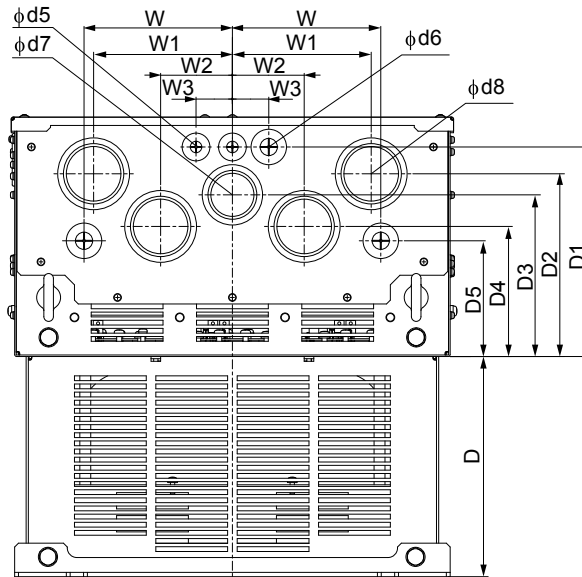

Figure 7

Table 2.7 Conduit Bracket Dimensions for IP20/NEMA Type 1

Drive Model	Figure	Dimensions (in)													Diameter (in)			
		W	D	W1	W2	W3	W4	W5	D1	D2	D3	D4	D5	D6	d5	d6	d7	d8
<b>200 V Class</b>																		
2A0011F	1	1.42	4.15	1.08	-	-	-	-	3.43	3.07	1.74	-	-	-	0.87	1.10	1.38	-
2A0017F		1.42	4.15	1.08	-	-	-	-	3.43	3.07	1.74	-	-	-	0.87	1.10	1.38	-
2A0024F		2	1.42	4.15	1.06	-	-	-	-	4.04	3.39	1.78	-	-	-	0.87	1.38	-
2A0031F	1.42		4.15	1.06	-	-	-	-	4.04	3.39	1.78	-	-	-	0.87	1.38	-	-
2A0046F	3	1.77	4.11	1.50	-	-	-	-	3.98	3.74	1.89	-	-	-	0.87	1.38	1.73	-
2A0059F		1.77	4.11	1.50	-	-	-	-	3.98	3.74	1.89	-	-	-	0.87	1.38	1.73	-
2A0075F	4	2.68	4.19	1.46	-	-	-	-	4.45	4.29	2.72	-	-	-	1.10	1.97	-	-
2A0088F		2.68	4.19	1.46	-	-	-	-	4.45	4.29	2.72	-	-	-	1.10	1.97	-	-
2A0114F		2.68	4.19	1.46	-	-	-	-	4.45	4.29	2.72	-	-	-	1.10	1.97	-	-
2A0143F	6	4.61	7.12	3.90	1.85	1.26	1.18	2.17	7.32	7.20	6.73	5.47	4.21	3.98	0.87	1.10	1.97	2.44
2A0169F		4.61	7.12	3.90	1.85	1.26	1.18	2.17	7.32	7.20	6.73	5.47	4.21	3.98	0.87	1.10	1.97	2.44
2A0211F		4.61	7.12	3.90	1.85	1.26	1.18	2.17	7.32	7.20	6.73	5.47	4.21	3.98	0.87	1.10	1.97	2.44
2A0273F		4.61	7.12	3.90	1.85	1.26	1.18	2.17	7.32	7.20	6.73	5.47	4.21	3.98	0.87	1.10	1.97	2.44

## 2.2 Mechanical Installation

Drive Model	Figure	Dimensions (in)													Diameter (in)			
		W	D	W1	W2	W3	W4	W5	D1	D2	D3	D4	D5	D6	d5	d6	d7	d8
<b>400 V Class</b>																		
4A0005F	1	1.42	4.15	1.08	-	-	-	-	3.43	3.07	1.74	-	-	-	0.87	1.10	1.38	-
4A0008F		1.42	4.15	1.08	-	-	-	-	3.43	3.07	1.74	-	-	-	0.87	1.10	1.38	-
4A0011F		1.42	4.15	1.08	-	-	-	-	3.43	3.07	1.74	-	-	-	0.87	1.10	1.38	-
4A0014F	2	1.42	4.15	1.06	-	-	-	-	4.04	3.39	1.78	-	-	-	0.87	1.38	-	-
4A0021F		1.42	4.15	1.06	-	-	-	-	4.04	3.39	1.78	-	-	-	0.87	1.38	-	-
4A0027F		1.42	4.15	1.06	-	-	-	-	4.04	3.39	1.78	-	-	-	0.87	1.38	-	-
4A0034F	3	1.77	4.11	1.50	-	-	-	-	3.98	3.74	1.89	-	-	-	0.87	1.38	1.73	-
4A0040F		1.77	4.11	1.50	-	-	-	-	3.98	3.74	1.89	-	-	-	0.87	1.38	1.73	-
4A0052F□B		1.77	4.11	1.50	-	-	-	-	3.98	3.74	1.89	-	-	-	0.87	1.38	1.73	-
4A0052F□A	4	2.68	4.19	1.46	-	-	-	-	4.45	4.29	2.72	-	-	-	1.10	1.97	-	-
4A0065F		2.68	4.19	1.46	-	-	-	-	4.45	4.29	2.72	-	-	-	1.10	1.97	-	-
4A0077F		2.68	4.19	1.46	-	-	-	-	4.45	4.29	2.72	-	-	-	1.10	1.97	-	-
4A0096F		2.68	4.19	1.46	-	-	-	-	4.45	4.29	2.72	-	-	-	1.10	1.97	-	-
4A0124F	5	3.31	6.22	3.33	1.14	1.02	0.59	0.61	3.74	3.64	3.23	2.48	2.28	-	0.87	1.10	1.38	1.97
4A0156F	6	4.61	7.12	3.90	1.85	1.26	1.18	2.17	7.32	7.20	6.73	5.47	4.21	3.98	0.87	1.10	1.97	2.44
4A0180F		4.61	7.12	3.90	1.85	1.26	1.18	2.17	7.32	7.20	6.73	5.47	4.21	3.98	0.87	1.10	1.97	2.44
4A0240F		4.61	7.12	3.90	1.85	1.26	1.18	2.17	7.32	7.20	6.73	5.47	4.21	3.98	0.87	1.10	1.97	2.44
4A0302F	7	6.10	9.06	5.71	2.95	1.50	-	-	8.62	7.52	6.65	5.35	4.76	-	0.87	1.10	1.97	2.44

■ IP00/Open-Type Enclosure Drives

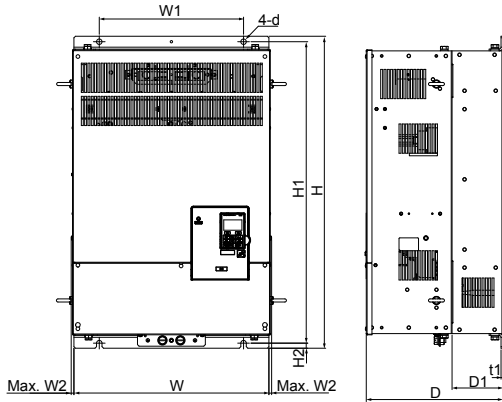

Figure 1

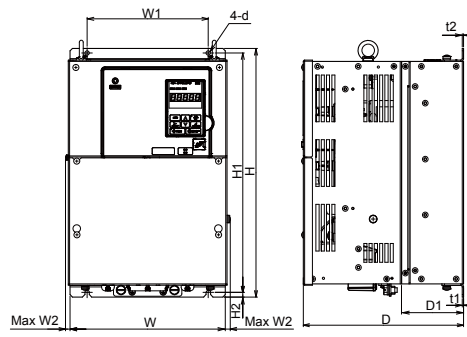

Figure 2

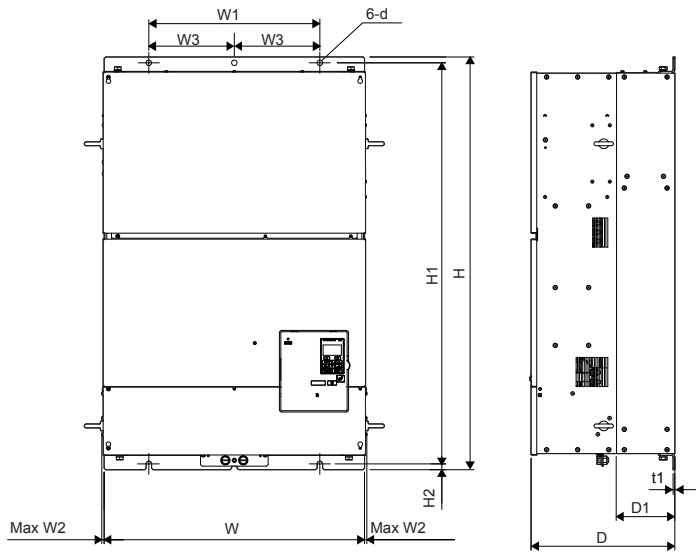

Figure 3

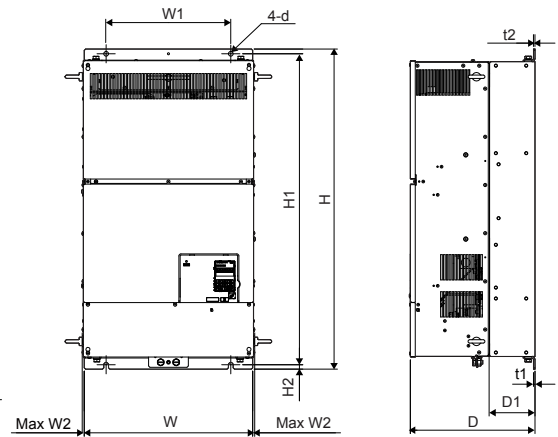

Figure 4

## 2.2 Mechanical Installation

**Table 2.8 Dimensions for IP00/Open-Type Enclosure: 200 V Class**

Drive Model	Figure	Dimensions (in)										Screw Size	Wt. (lb)
		W	H	D	W1	W2	W3	H1	H2	D1	t1	d	
2A0343A	1	500 (19.69)	800 (31.50)	350 (13.78)	370 (14.57)	8 (0.30)	–	773 (30.43)	13 (0.51)	130 (5.12)	5 (0.18)	M12	98 (216.1)
2A0396A		500 (19.69)	800 (31.50)	350 (13.78)	370 (14.57)	8 (0.30)	–	773 (30.43)	13 (0.51)	130 (5.12)	5 (0.18)	M12	99 (218.3)

**Table 2.9 Dimensions for IP00/Open-Type Enclosure: 400 V Class**

Drive Model	Figure	Dimensions (in)											Screw Size	Wt. (lb)
		W	H	D	W1	W2	W3	H1	H2	D1	t1	t2	d	
4A0361A	2	500 (19.69)	800 (31.50)	350 (13.78)	370 (14.57)	10 (0.39)	–	773 (30.43)	13 (0.51)	130 (5.12)	5 (0.18)	5 (0.18)	M12	107 (235.9)
4A0414A	4	500 (19.69)	950 (37.40)	350 (14.57)	370 (14.57)	8 (0.31)	–	923 (36.34)	13 (0.51)	135 (5.31)	5 (0.18)	5 (0.18)	M12	216 (476.2)
4A0480A	3	670 (26.38)	1140 (44.88)	370 (14.57)	440 (17.32)	6 (0.24)	220 (8.66)	1110 (43.70)	15 (0.59)	150 (5.91)	5 (0.18)	–	M12	216 (476.2)
4A0590A		670 (26.38)	1140 (44.88)	370 (14.57)	440 (17.32)	6 (0.24)	220 (8.66)	1110 (43.70)	15 (0.59)	150 (5.91)	5 (0.18)	–	M12	221 (487.2)

# Electrical Installation

---

This chapter explains the proper procedures for wiring the control circuit terminals, motor, and power supply.

<b>3.1</b>	<b>SECTION SAFETY.....</b>	<b>60</b>
<b>3.2</b>	<b>STANDARD CONNECTION DIAGRAM.....</b>	<b>62</b>
<b>3.3</b>	<b>MAIN CIRCUIT CONNECTION DIAGRAM.....</b>	<b>65</b>
<b>3.4</b>	<b>TERMINAL BLOCK CONFIGURATION.....</b>	<b>68</b>
<b>3.5</b>	<b>TERMINAL COVER.....</b>	<b>70</b>
<b>3.6</b>	<b>HOA KEYPAD AND FRONT COVER.....</b>	<b>72</b>
<b>3.7</b>	<b>TOP PROTECTIVE COVER.....</b>	<b>79</b>
<b>3.8</b>	<b>MAIN CIRCUIT WIRING.....</b>	<b>81</b>
<b>3.9</b>	<b>CONTROL CIRCUIT WIRING.....</b>	<b>91</b>
<b>3.10</b>	<b>CONTROL I/O CONNECTIONS.....</b>	<b>100</b>
<b>3.11</b>	<b>CONNECT TO A PC.....</b>	<b>102</b>
<b>3.12</b>	<b>EXTERNAL INTERLOCK.....</b>	<b>103</b>
<b>3.13</b>	<b>WIRING CHECKLIST.....</b>	<b>104</b>

## 3.1 Section Safety

### WARNING

#### Electrical Shock Hazard

**Do not connect or disconnect wiring while the power is on.**

Failure to comply may result in death or serious injury.

Before servicing, disconnect all power to the equipment. The internal capacitor remains charged even after the power supply is turned off. The charge indicator LED will extinguish when the DC bus voltage is below 50 Vdc. To prevent electric shock, wait for at least the time specified on the warning label, once all indicators are OFF, measure for unsafe voltages to confirm the drive is safe prior to servicing.

**Do not operate equipment with covers removed.**

Failure to comply could result in death or serious injury.

The diagrams in this section may show drives without covers or safety shields to show details. Be sure to reinstall covers or shields before operating the drives and run the drives according to the instructions described in this manual.

**Make sure the protective earthing conductor complies with technical standards and local safety regulations.**

Because the leakage current exceeds 3.5 mA, IEC/EN 61800-5-1 states that either the power supply must be automatically disconnected in case of discontinuity of the protective earthing conductor or a protective earthing conductor with a cross-section of at least 10 mm<sup>2</sup> (Cu) or 16 mm<sup>2</sup> (Al) must be used. Failure to comply may result in death or serious injury.

**Always use appropriate equipment for Ground Fault Circuit Interrupters (GFCIs).**

The drive can cause a residual current with a DC component in the protective earthing conductor. Where a residual current operated protective or monitoring device is used for protection in case of direct or indirect contact, always use a type B GFCI according to IEC/EN 60755.

**Always ground the motor-side grounding terminal.**

Improper equipment grounding could result in death or serious injury by contacting the motor case.

**Do not perform work on the drive while wearing loose clothing, jewelry or without eye protection.**

Failure to comply could result in death or serious injury.

Remove all metal objects such as watches and rings, secure loose clothing, and wear eye protection before beginning work on the drive.

**Do not remove covers or touch circuit boards while the power is on.**

Failure to comply could result in death or serious injury.

**Do not allow unqualified personnel to perform work on the drive.**

Failure to comply could result in death or serious injury.

Installation, maintenance, inspection, and servicing must be performed only by authorized personnel familiar with installation, adjustment, and maintenance of AC drives.

**Do not touch any terminals before the capacitors have fully discharged.**

Failure to comply could result in death or serious injury.

Before servicing, disconnect all power to the equipment. The internal capacitor remains charged even after the power supply is turned off. The charge indicator LED will extinguish when the DC bus voltage is below 50 Vdc. To prevent electric shock, wait for at least the time specified on the warning label, once all indicators are OFF, measure for unsafe voltages to confirm the drive is safe prior to servicing.

#### Fire Hazard

**Tighten all terminal screws to the specified tightening torque.**

Loose electrical connections could result in death or serious injury by fire due to overheating of electrical connections.

**Do not use improper combustible materials.**

Failure to comply could result in death or serious injury by fire.

Do not install the drive to a combustible surface. Never place combustible materials on the drive.

**⚠ WARNING****Do not use an improper voltage source.**

Failure to comply could result in death or serious injury by fire.

Verify that the rated voltage of the drive matches the voltage of the incoming power supply before applying power.

**Properly handle the HOA keypad battery.**

Improper use of the battery may cause fire by explosion and personal injury.

Correctly install the battery, paying attention to polarity (+/-).

Do not attempt to charge the battery or improperly disassemble the HOA keypad.

**⚠ CAUTION****Do not carry the drive by the front cover or the terminal cover.**

Failure to comply may cause the main body of the drive to fall, resulting in minor or moderate injury.

**NOTICE****Observe proper electrostatic discharge procedures (ESD) when handling the drive and circuit boards.**

Failure to comply may result in ESD damage to the drive circuitry.

**Never connect or disconnect the motor from the drive while the drive is outputting voltage.**

Improper equipment sequencing could result in damage to the drive.

**Do not use unshielded cable for control wiring.**

Failure to comply may cause electrical interference resulting in poor system performance. Use shielded, twisted-pair wires and ground the shield to the ground terminal of the drive.

**Do not allow unqualified personnel to use the product.**

Failure to comply could result in damage to the drive.

**Do not modify the drive circuitry.**

Failure to comply could result in damage to the drive and will void warranty.

Yaskawa is not responsible for any modification of the product made by the user. This product must not be modified.

**Check all the wiring to ensure that all connections are correct after installing the drive and connecting any other devices.**

Failure to comply could result in damage to the drive.

**Do not heat or throw the battery into fire.**

The battery remains in use even when power to the drive has been shut off. Be sure to also remove the battery in the HOA keypad when the drive will be shut off for long periods of time.

A dead battery left inside the HOA keypad may leak and damage the keypad and drive. Be sure to replace the battery with a new one immediately after the expected lifespan has passed or when the “bAT” error is displayed on the HOA keypad.

**Be sure to observe the Perchlorate Best Management Practices (BMPs).**

BMPs apply to primary lithium (manganese dioxide) coin batteries sold or distributed in California. Perchlorate Material-special handling may apply, please refer to: [www.dtsc.ca.gov/hazardouswaste/perchlorate](http://www.dtsc.ca.gov/hazardouswaste/perchlorate).

### 3.2 Standard Connection Diagram

Connect the drive and peripheral devices as shown in [Figure 3.1](#). It is possible to set and run the drive via the HOA keypad without connecting digital I/O wiring. This section does not discuss drive operation; [Refer to Start-Up Programming & Operation on page 105](#) for instructions on operating the drive.

**WARNING! Fire Hazard.** Install adequate branch circuit protection according to applicable local codes and this manual. Failure to comply could result in fire and damage to the drive or injury to personnel. The device is suitable for use on a circuit capable of delivering not more than 100,000 RMS symmetrical amperes, 240 Vac (200 V class) and 480 Vac (400 V class), when protected by branch circuit protection devices specified in this manual.

Branch circuit protection shall be provided by any of the following: Non-time delay Class J, T, or CC fuses sized at 300% of the drive input rating, or Time delay Class J, T, or CC fuses sized at 175% of the drive input rating, or MCCB sized at 200% maximum of the drive input rating.

**NOTICE:** When the input voltage is 440 V or higher or the wiring distance is greater than 100 meters, pay special attention to the motor insulation voltage or use a drive duty motor. Failure to comply could lead to motor insulation breakdown.

**NOTICE:** Do not connect AC control circuit ground to drive enclosure. Improper drive grounding can cause control circuit malfunction.

**Note:** The minimum load for the relay outputs M1-M2, M3-M4, M5-M6, and MA-MB-MC is 10 mA.

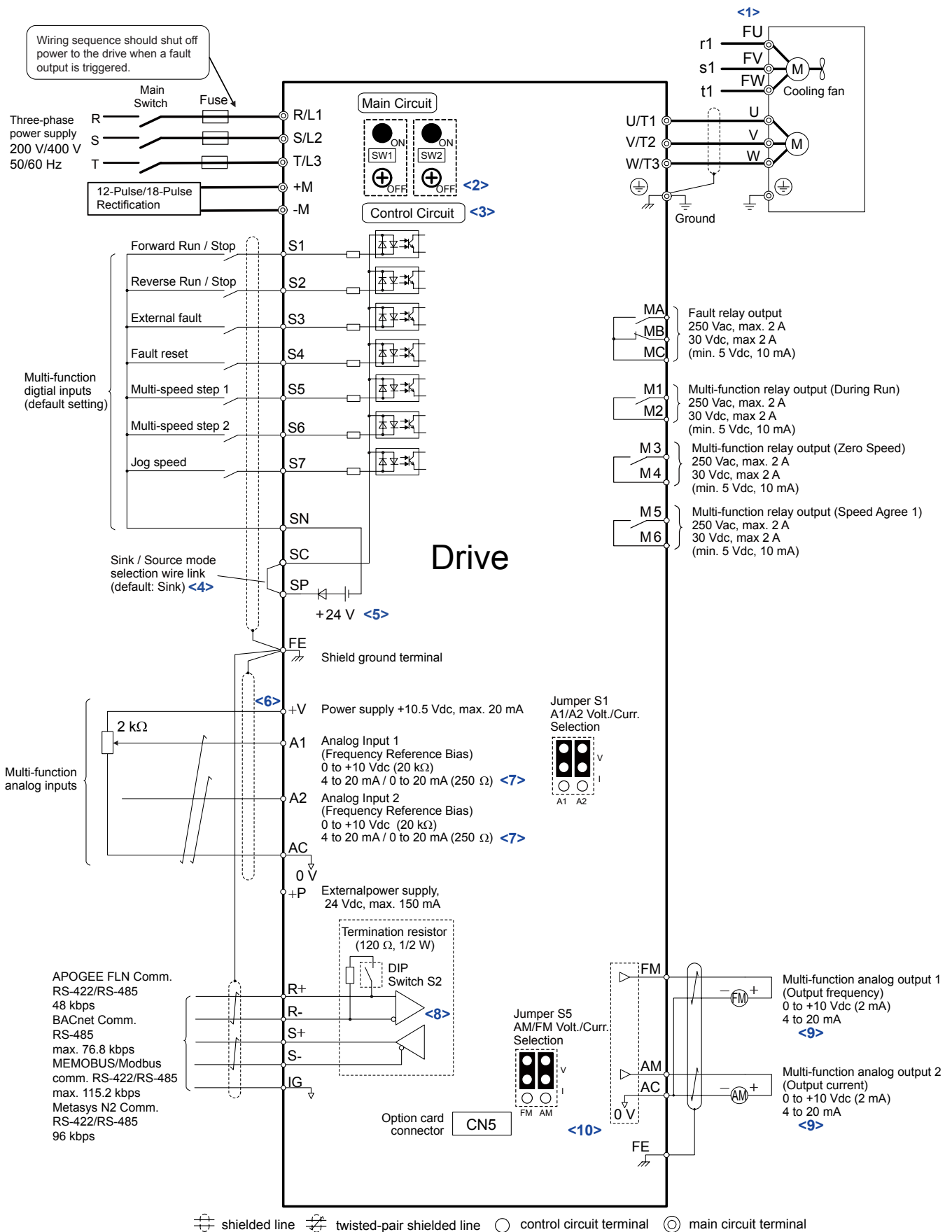

Figure 3.1 Drive Standard Connection Diagram (example: 2A0011)

<1> Self-cooling motors do not require the same wiring necessary for motors with cooling fans.

## 3.2 Standard Connection Diagram

---

- <2> For floating, impedance grounded, or asymmetrically grounded networks, disconnect the internal EMC filter by moving the SW1 and SW2 screws to the OFF position.
- <3> A 24 V power supply option is required to supply power to the to the control circuit separately from the main circuit.
- <4> This figure illustrates an example of a sequence input to S1 through S7 using a non-powered relay or an NPN transistor. Install the wire link between terminals SC-SP for Sink mode, between SC-SN for Source mode, or leave the link out for external power supply. Never short terminals SP and SN, as it will damage the drive.
- <5> This voltage source supplies a maximum current of 150 mA.
- <6> The maximum output current capacity for the +V terminal on the control circuit is 20 mA. Never short terminals +V and AC, as it can cause erroneous operation or damage the drive.
- <7> Use jumper S1 to select between a voltage or current input signal to terminals A1 and A2. The default setting is for voltage input.
- <8> Set DIP switch S2 to the ON position to enable the termination resistor in the last drive in a MEMOBUS/Modbus network.
- <9> Monitor outputs work with devices such as analog frequency meters, ammeters, voltmeters, and wattmeters. They are not intended for use as a feedback-type signal.
- <10> Use jumper S5 to select between voltage or current output signals at terminals FM and AM. Set parameters H4-07 and H4-08 accordingly.

**WARNING!** *Sudden Movement Hazard. Do not close the wiring for the control circuit unless the multifunction input terminal parameters are properly set. Improper sequencing of run/stop circuitry could result in death or serious injury from moving equipment.*

**WARNING!** *Sudden Movement Hazard. Ensure start/stop and safety circuits are wired properly and in the correct state before energizing the drive. Failure to comply could result in death or serious injury from moving equipment. When programmed for 3-Wire control, a momentary closure on terminal S1 may cause the drive to start.*

**WARNING!** *Sudden Movement Hazard. When using a 3-Wire sequence, set the drive to 3-Wire sequence prior to wiring the control terminals and set parameter b1-17 to 0 so the drive will not accept a Run command at power up (default). If the drive is wired for a 3-Wire sequence but set up for a 2-Wire sequence (default), and parameter b1-17 is set to 1 so the drive accepts a Run command at power up, the motor will rotate in reverse direction at drive power up and may cause injury.*

**WARNING!** *Sudden Movement Hazard. Confirm the drive I/O signals and external sequence before executing the application preset function. Executing the application preset function or setting A1-06 ≠ 0 will change the drive I/O terminal functions and may cause unexpected equipment operation. Failure to comply may cause death or serious injury.*

**NOTICE:** *When using the automatic fault restart function with wiring designed to shut off the power supply upon drive fault, make sure the drive does not trigger a fault output during fault restart (L5-02 = 0, default). Failure to comply will prevent the automatic fault restart function from working properly.*

### 3.3 Main Circuit Connection Diagram

Refer to diagrams in this section when wiring the main circuit of the drive. Connections may vary based on drive capacity. The DC power supply for the main circuit also provides power to the control circuit.

#### ◆ Three-Phase 200 V Class (2A0011 to 2A0273) Three-Phase 400 V Class (4A0005 to 4A0302)

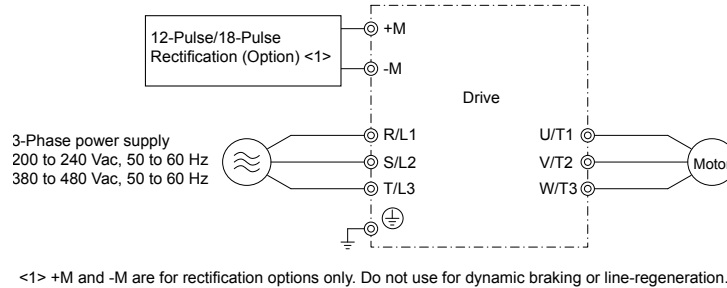

Figure 3.2 Connecting Main Circuit Terminals

#### ◆ Three-Phase 200 V Class (2A0343 and 2A0396) Three-Phase 400 V Class (4A0361 to 4A0590)

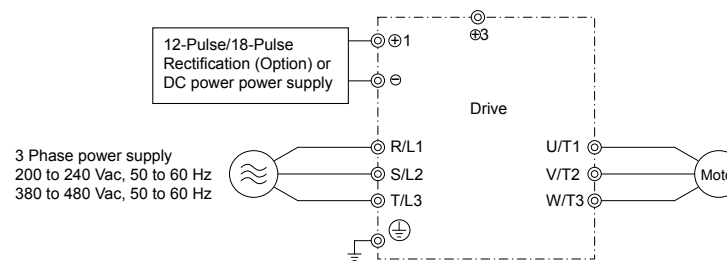

Figure 3.3 Connecting Main Circuit Terminals

#### ◆ 12-Pulse/18-Pulse Rectification

Operation with 12-pulse/18-pulse rectification requires the user to separately prepare a 3-winding/4-winding transformer for the power supply. Contact Yaskawa or your nearest sales representative for the transformer specifications.

#### ■ Wiring to -M/+M Terminals (2A0011 to 2A0273 and 4A0005 to 4A0302)

Access the -M/+M terminals by cutting off the protection cover on models 2A0011 to 2A0114 and 4A0005 to 4A0096 or by removing the protection sheet on -M/+M terminals on models 2A0143 to 2A0273 and 4A0124 to 4A0302.

-M/+M are for rectification options only. Do not use for dynamic braking or line-regeneration.

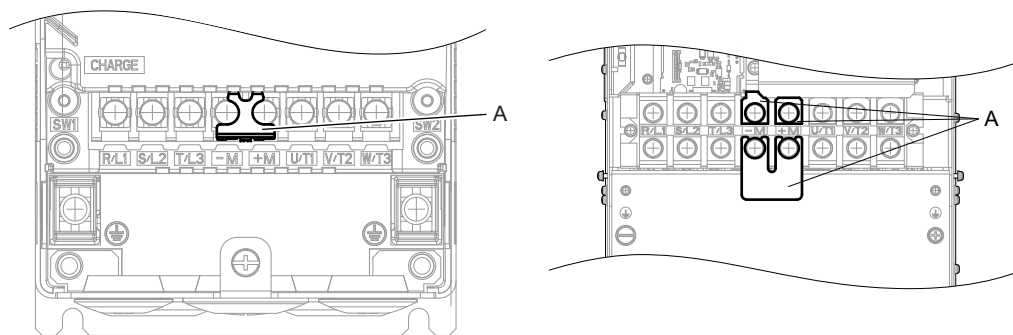

A -Protective covering over -M/+M terminals

Figure 3.4 -M/+M Terminals

### 3.3 Main Circuit Connection Diagram

#### ◆ Wiring to -/+1 Terminals (2A0343 to 2A0396 and 4A0361 to 4A0590)

Wire directly to the -/+1 terminals.

#### ■ Connection Diagrams

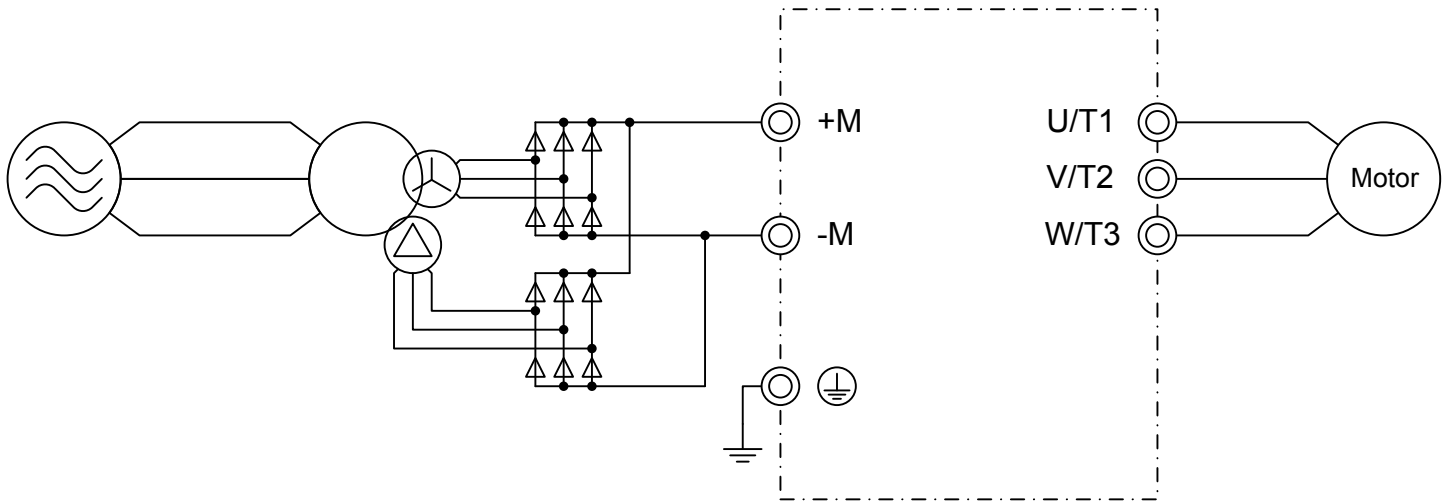

Figure 3.5 12-Pulse Connection Diagram (2A0011 to 2A0273 and 4A0005 to 4A0302)

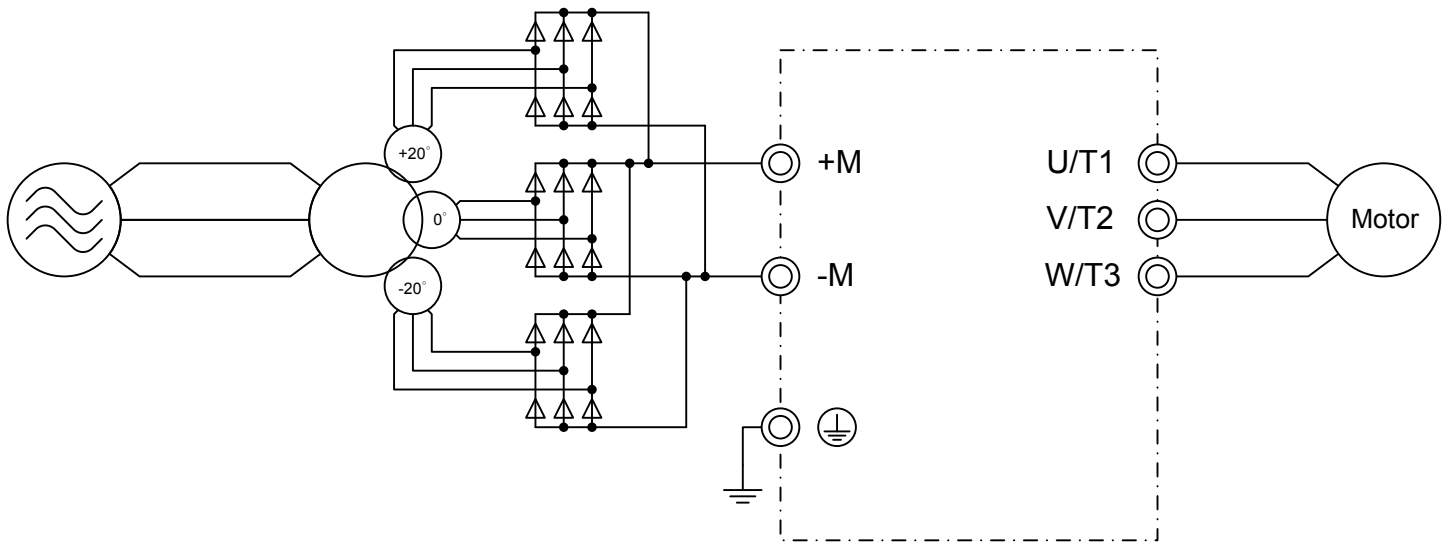

Figure 3.6 18-Pulse Connection Diagram (2A0011 to 2A0273 and 4A0005 to 4A0302)

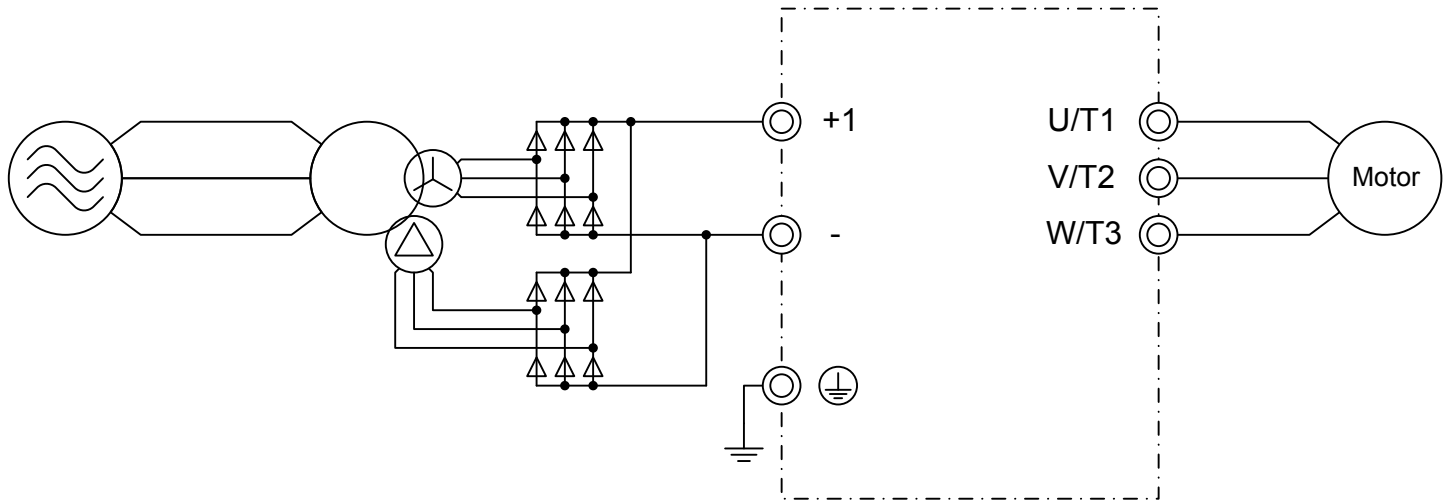

Figure 3.7 12-Pulse Connection Diagram (2A0343, 2A0396, and 4A0361 to 4A0590)

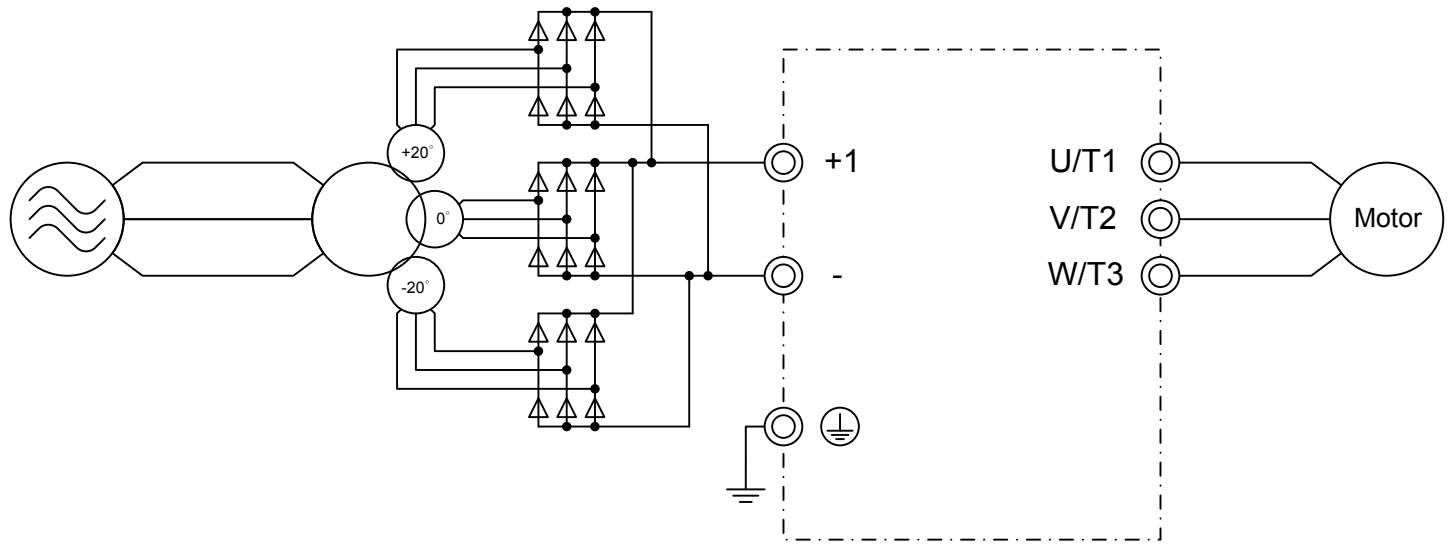

Figure 3.8 18-Pulse Connection Diagram (2A0343, 2A0396, and 4A0361 to 4A0590)

## 3.4 Terminal Block Configuration

Figure 3.9 and Figure 3.10 show the different main circuit terminal arrangements for the drive capacities.

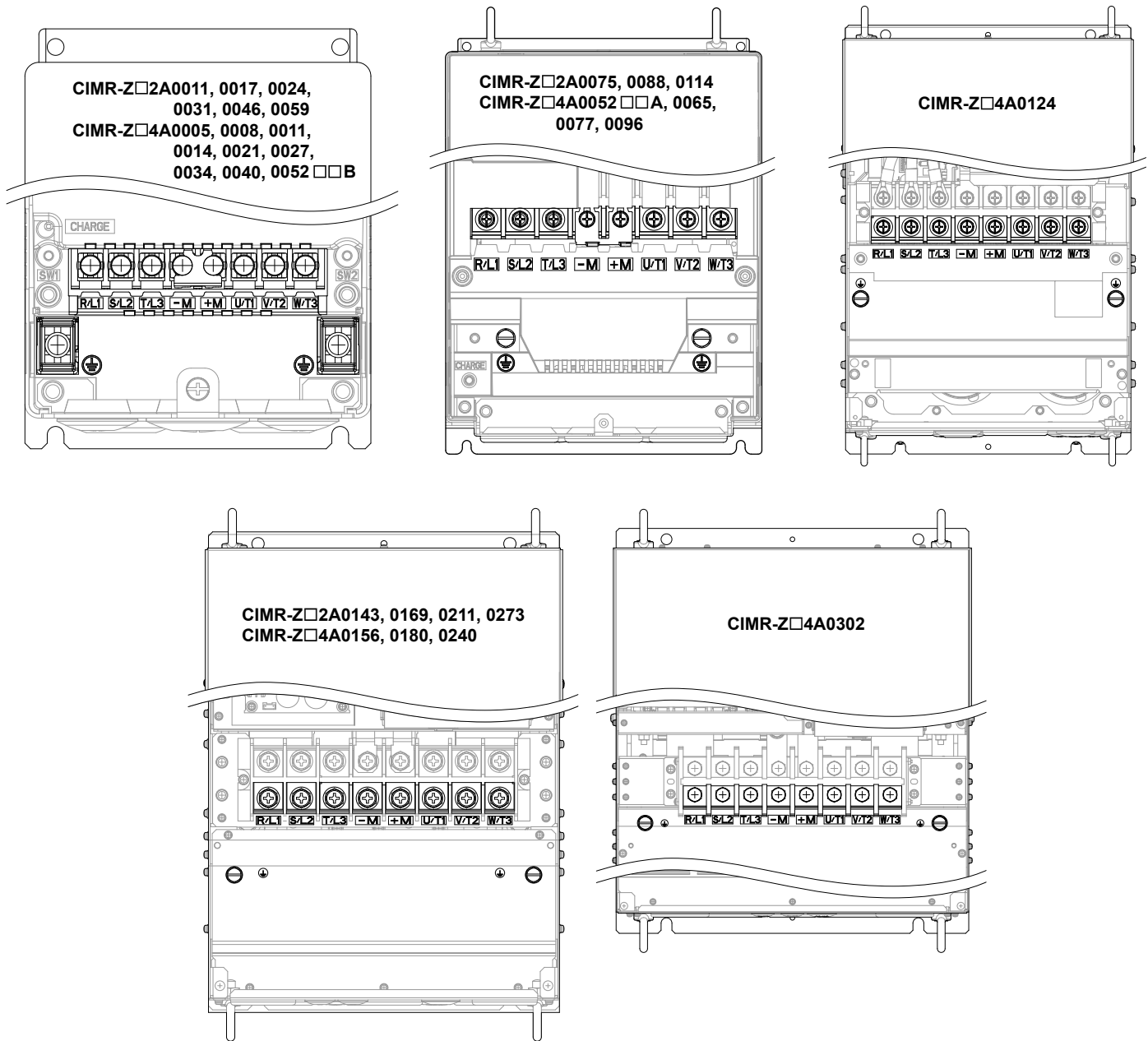

Figure 3.9 Main Circuit Terminal Block Configuration

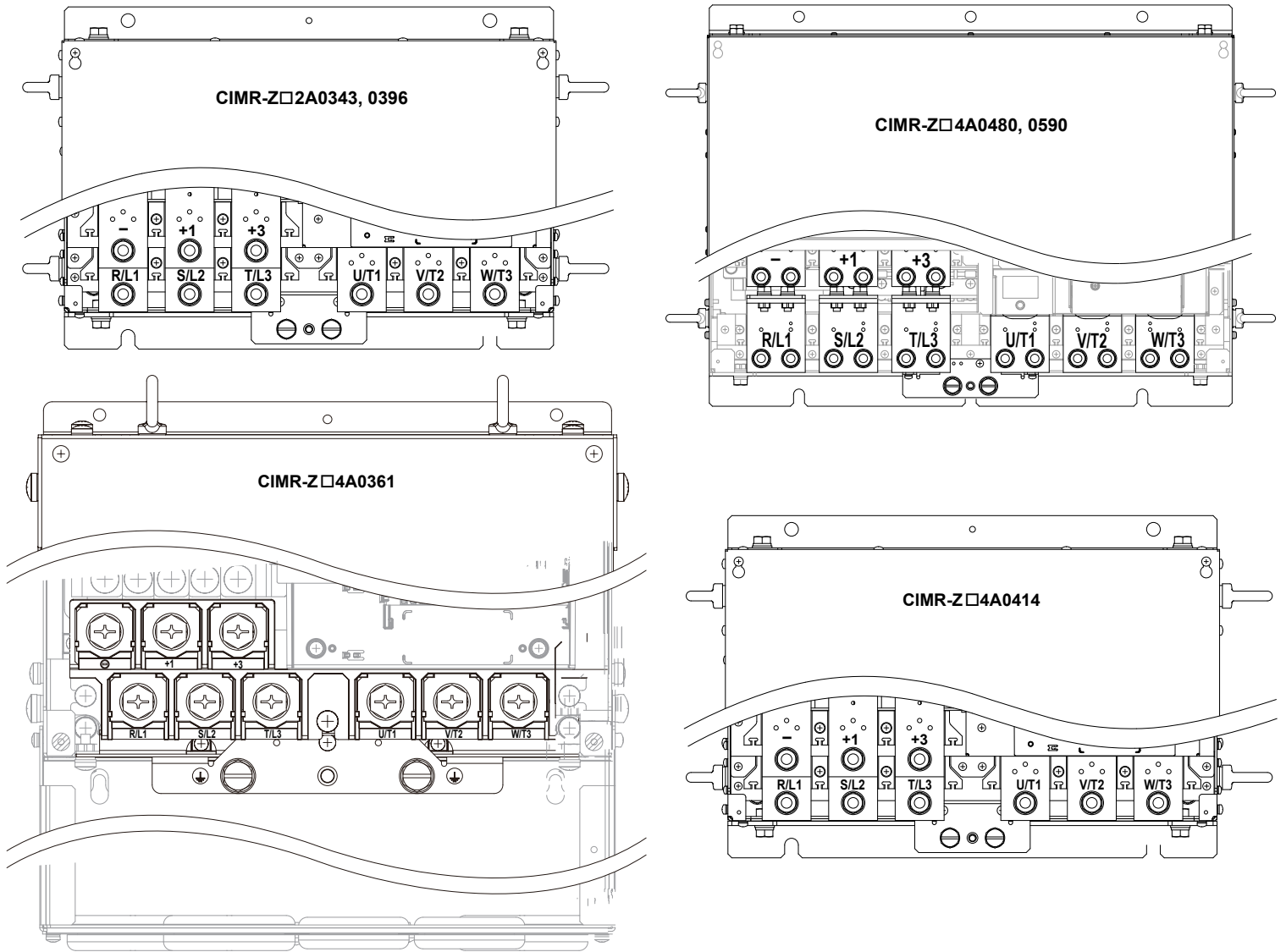

Figure 3.10 Main Circuit Terminal Block Configuration (continued)

### 3.5 Terminal Cover

Follow the procedure below to remove the terminal cover for wiring and to reattach the terminal cover after wiring is complete.

#### ◆ Models 2A0143 to 2A0396 and 4A0124 to 4A0590

##### ■ Removing the Terminal Cover

1. Loosen the screws on the terminal cover, then pull down on the cover.

**Note:** The terminal cover and the number of terminal cover screws differ depending on the drive model.

**CAUTION!** Do not completely remove the cover screws, just loosen them. If the cover screws are removed completely, the terminal cover may fall off causing an injury.

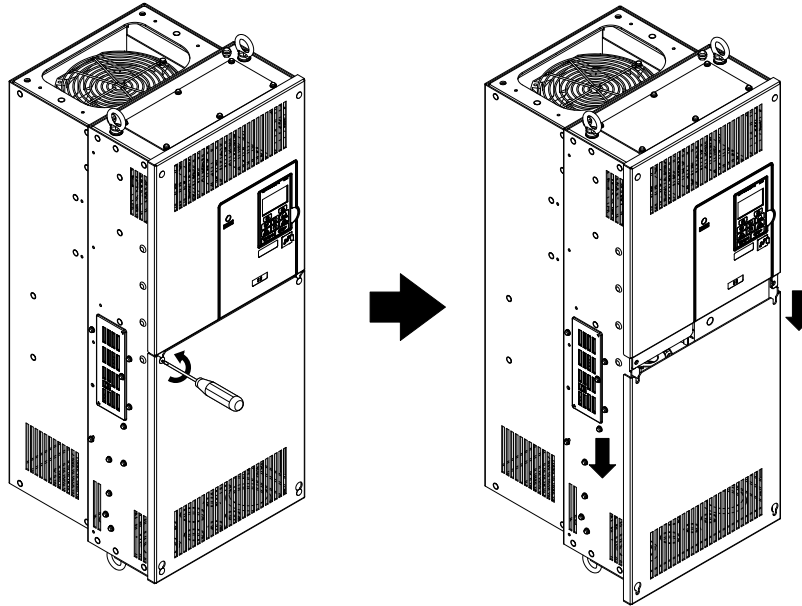

Figure 3.11 Removing the Terminal Cover

2. Pull forward on the terminal cover to free it from the drive.

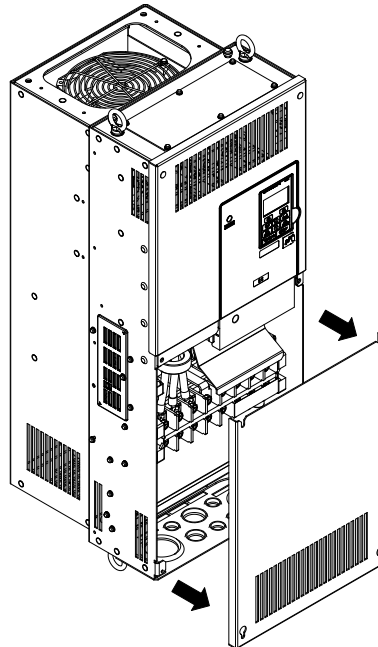
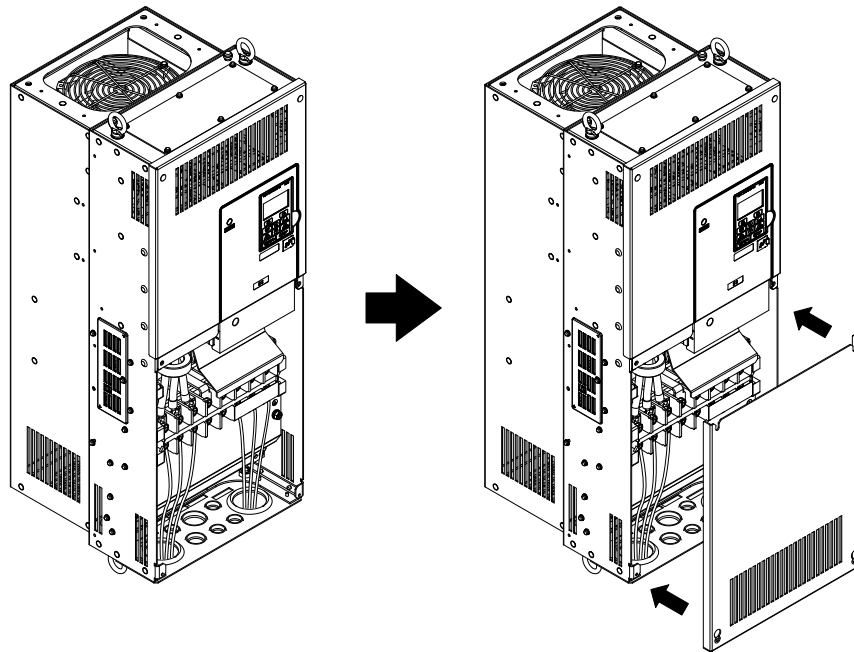

Figure 3.12 Removing the Terminal Cover

## ■ Reattaching the Terminal Cover

After wiring the terminal board and other devices, double-check connections and reattach the terminal cover. *Refer to Wiring the Main Circuit Terminal on page 90* and *Wiring the Control Circuit Terminal on page 95* for details on wiring.



**Figure 3.13** Reattaching the Terminal Cover

**Note:** Connect the ground wiring first, then the main circuit wiring, and finally the control circuit wiring.

## 3.6 HOA Keypad and Front Cover

Detach the HOA keypad from the drive for remote operation or when opening the front cover to install an option card.

**NOTICE:** Be sure to remove the HOA keypad prior to opening or reattaching the front cover. Leaving the HOA keypad plugged into the drive when removing the front cover can result in erroneous operation caused by a poor connection. Firmly fasten the front cover back into place before reattaching the HOA keypad.

### ◆ Removing/Reattaching the HOA Keypad

#### ■ Removing the HOA Keypad

While pressing on the tab located on the right side of the HOA keypad, pull the HOA keypad forward to remove it from the drive.

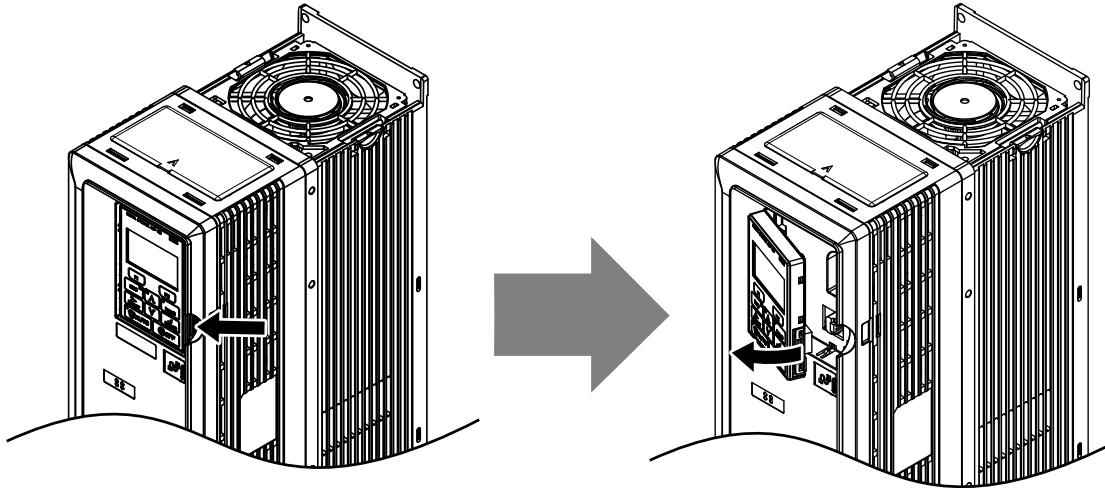

Figure 3.14 Removing the HOA Keypad

#### ■ Reattaching the HOA Keypad

Insert the HOA keypad into the opening in the top cover while aligning it with the notches on the left side of the opening. Next, press gently on the right side of the keypad until it clicks into place.

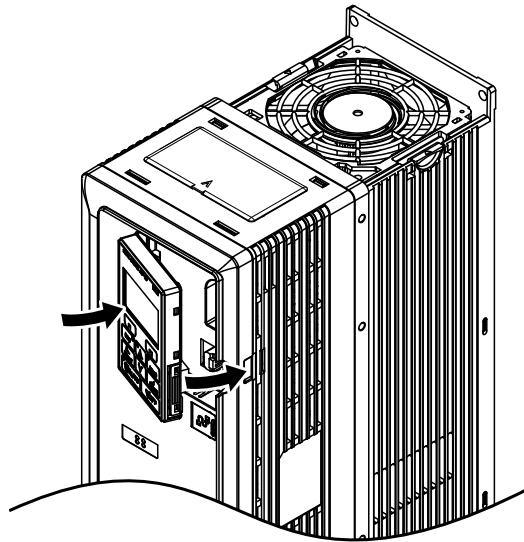

Figure 3.15 Reattaching the HOA Keypad

## ◆ Removing/Reattaching the Front Cover

### ■ Removing the Front Cover

Drive Models 2A0011 to 2A0059, 4A0005 to 4A0040, and 4A0052□□B

1. Remove the HOA keypad.
2. Loosen the front cover screw using a #2 Phillips screwdriver. Screw sizes vary by drive model.

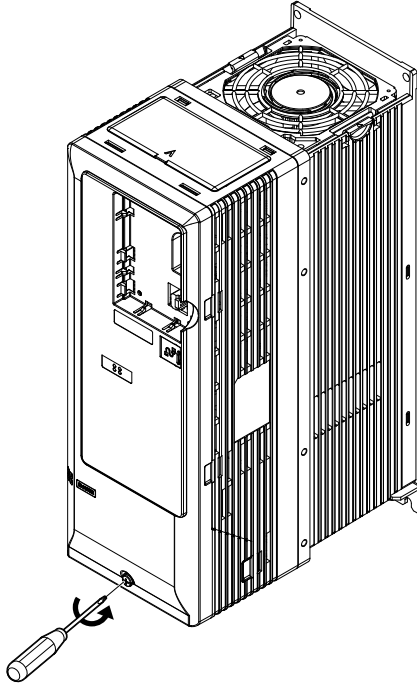

Figure 3.16 Remove the Front Cover (2A0011 to 2A0059, 4A0005 to 4A0040, and 4A0052□□B)

3. Push in on the tab located on the bottom of the front cover and gently pull forward to remove the front cover.

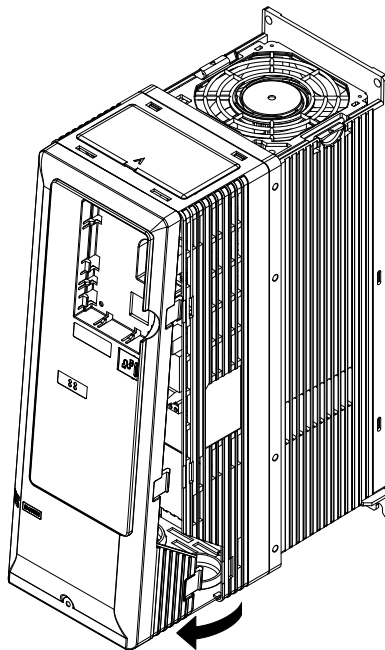
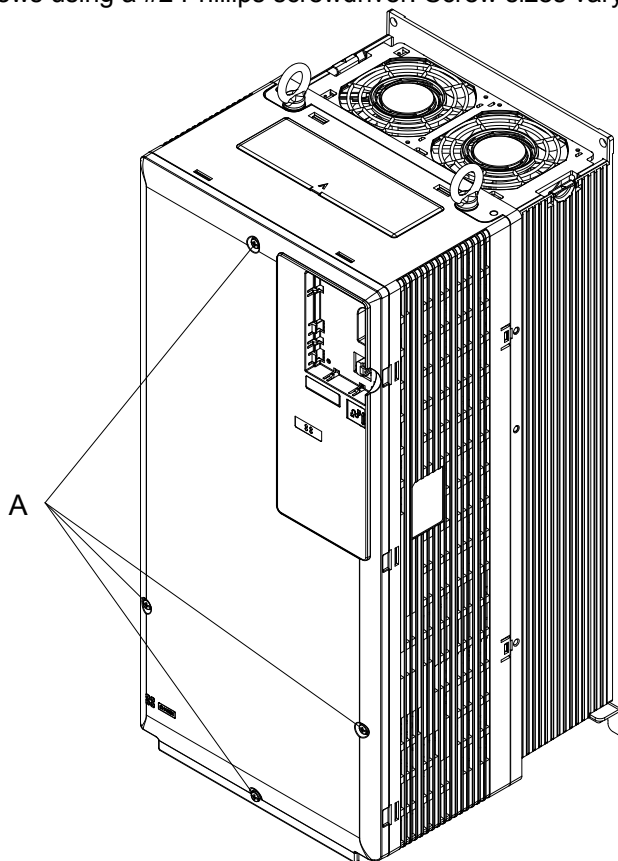

Figure 3.17 Remove the Front Cover (2A0011 to 2A0059, 4A0005 to 4A0040, and 4A0052□□B)

### 3.6 HOA Keypad and Front Cover

Drive Models 2A0075 to 2A0114, 4A0052□□A, and 4A0065 to 4A0096

1. Remove the HOA keypad.
2. Loosen the front cover screws using a #2 Phillips screwdriver. Screw sizes vary by drive model.



A –Front cover screw locations

Figure 3.18 Remove the Front Cover (2A0075 to 2A0114, 4A0052□□A, and 4A0065 to 4A0096)

3. Pinch the tabs located on the bottom of the front cover and gently pull forward to remove the front cover.

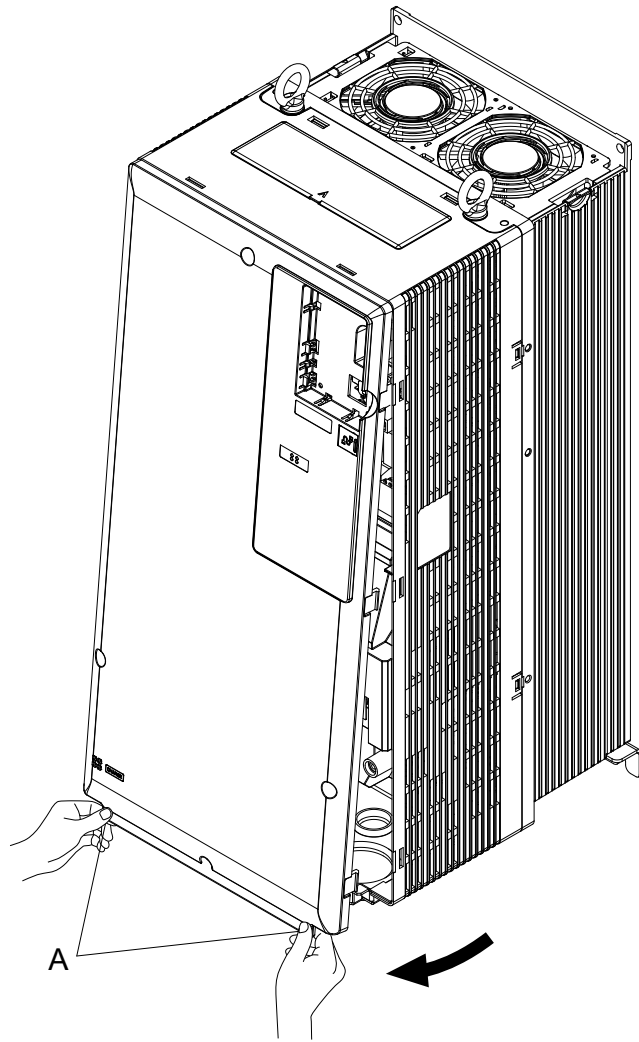

A –Location of tabs on front cover

Figure 3.19 Remove the Front Cover (2A0075 to 2A0114, 4A0052□□A, and 4A0065 to 4A0096)

### 3.6 HOA Keypad and Front Cover

#### Drive Models 2A0143 to 2A0396 and 4A0124 to 4A0590

1. Remove the terminal cover and the HOA keypad.
2. Loosen the installation screw on the front cover.

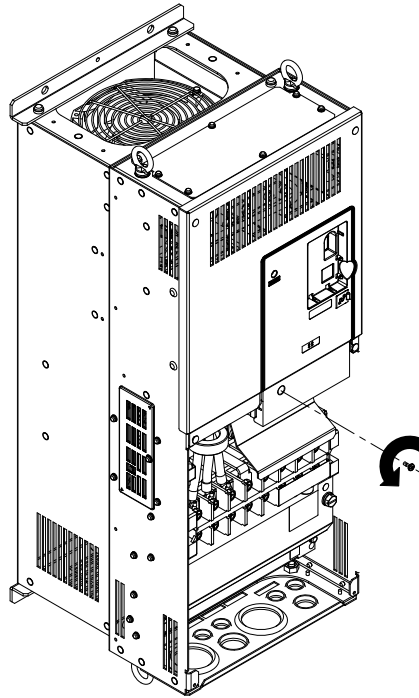

Figure 3.20 Loosen the Installation Screw (2A0143 to 2A0396 and 4A0124 to 4A0590)

3. Push the hooks on each side of the cover that hold it in place.

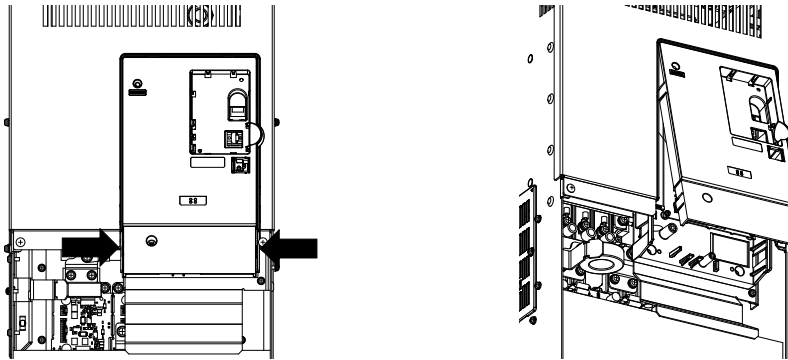

Figure 3.21 Remove the Front Cover (2A0143 to 2A0396 and 4A0124 to 4A0590)

## ■ Reattaching the Front Cover

### Drive Models 2A0011 to 2A0114 and 4A0005 to 4A0096

Reverse the instructions given in *Removing the Front Cover* (2A0011 to 2A0059, 4A0005 to 4A0040, and 4A0052□□B) on page 73 and *Removing the Front Cover* (2A0075 to 2A0114, 4A0052□□A, and 4A0065 to 4A0096) on page 74 to reattach the front cover. Pinch inwards on the hooks found on each side of the front cover while guiding it back into the drive. Make sure it clicks firmly into place.

Power lines and signal wiring should pass through the opening provided. [Refer to \*Wiring the Main Circuit Terminal\* on page 90](#) and [Wiring the Control Circuit Terminal](#) on page 95 for details on wiring.

Reattach the front cover after completing the wiring to the drive and other devices.

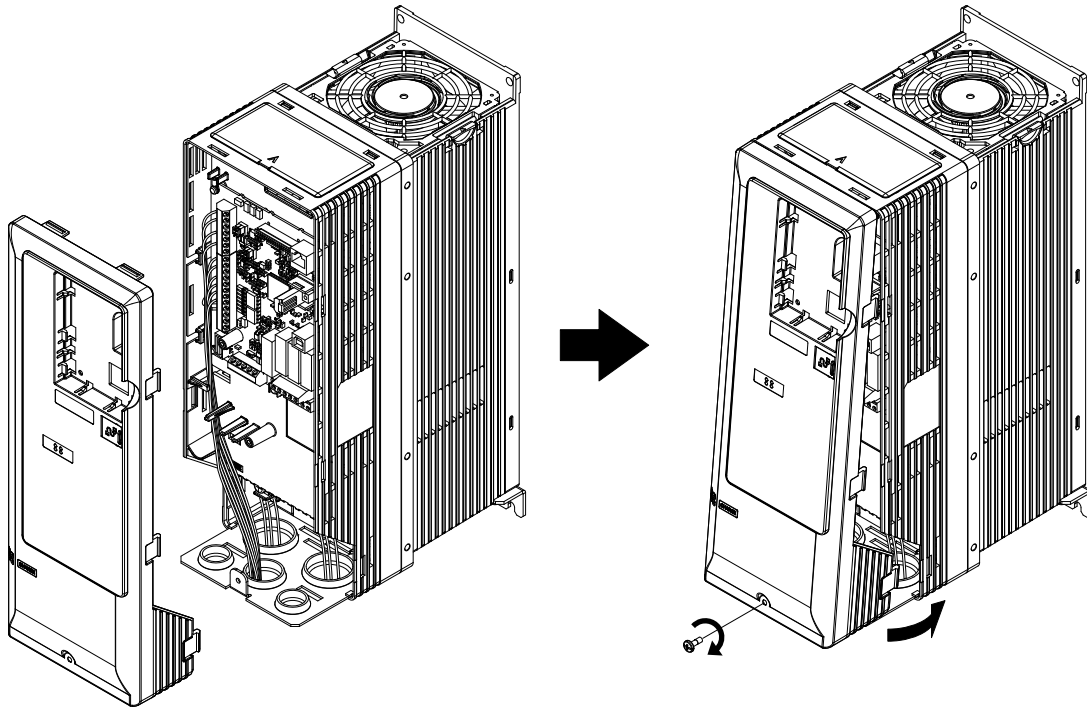

Figure 3.22 Reattach the Front Cover 2A0011 to 2A0114 and 4A0005 to 4A0096)

### Drive Models 2A0143 to 2A0396 and 4A0124 to 4A0590

1. Slide the front cover so the hooks on the top connect to the drive.

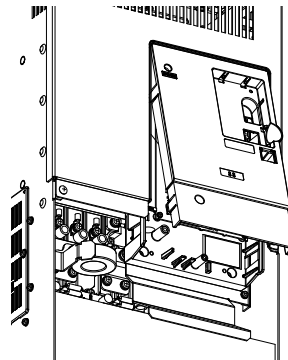
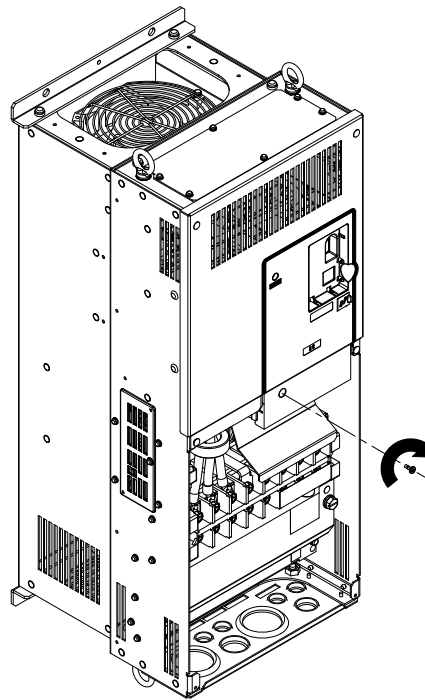

Figure 3.23 Reattach the Front Cover (2A0143 to 2A0396 and 4A0124 to 4A0590)

2. After connecting the hooks to the drive, press firmly on the cover to lock it into place.



**Figure 3.24 Lock the Cover into Place (2A0143 to 2A0396 and 4A0124 to 4A0590)**

## 3.7 Top Protective Cover

Drive models 2A0011 to 2A0273 and 4A0011 to 4A0302 are designed to IP20/NEMA Type 1 specifications with a protective cover on the top. Removing this top protective cover voids the NEMA Type 1 protection while maintaining IP20 conformity; removing the bottom conduit bracket voids the NEMA Type 1 protection and IP20 conformity.

### ◆ Removing the Top Protective Cover

#### ■ Removing the Top Protective Cover: 2A0011 to 2A0114 and 4A0005 to 4A0096

Insert the tip of a straight-edge screwdriver into the small opening located on the front edge of the top protective cover. Gently apply pressure as shown in the figure below to free the cover from the drive.

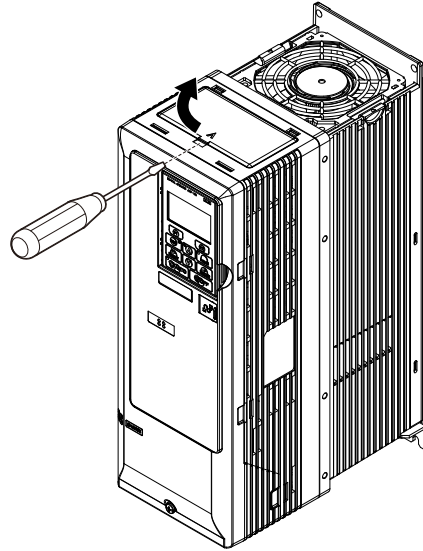

Figure 3.25 Remove the Top Protective Cover (2A0011 to 2A0114 and 4A0005 to 4A0096)

#### ■ Removing the Top Protective Cover: 2A0143 to 2A0273 and 4A0124 to 4A0302

Remove the bolts to remove the top protective cover from the drive.

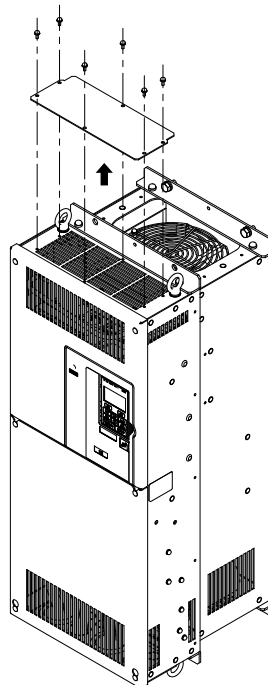

Figure 3.26 Remove the Top Protective Cover (2A0143 to 2A0273 and 4A0124 to 4A0302)

### ◆ Reattaching the Top Protective Cover

#### ■ Reattaching the Top Protective Cover: 2A0011 to 2A0114 and 4A0005 to 4A0096

Insert the two small protruding hooks on the rear side of the top protective cover into the provided mounting holes near the back of the drive, then press down on the front side of the top protective cover to fasten the cover into place.

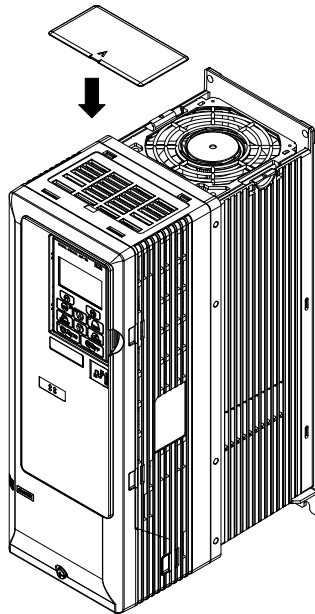

Figure 3.27 Reattach the Protective Cover (2A0011 to 2A0114 and 4A0005 to 4A0096)

#### ■ Reattaching the Top Protective Cover: 2A0143 to 2A0273 and 4A0124 to 4A0302

Reverse the procedure to reattach the top protective cover.

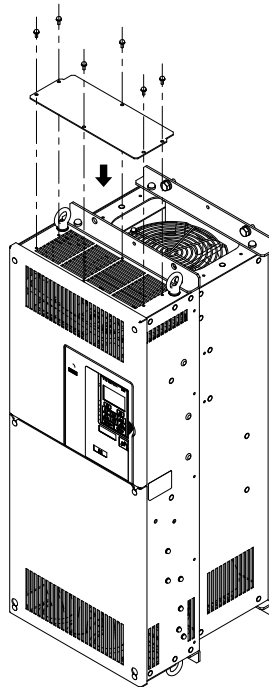

Figure 3.28 Reattach the Protective Cover (2A0143 to 2A0273 and 4A0124 to 4A0302)

## 3.8 Main Circuit Wiring

This section describes the functions, specifications, and procedures required to safely and properly wire the main circuit in the drive.

**NOTICE:** Do not solder the ends of wire connections to the drive. Soldered wiring connections can loosen over time. Improper wiring practices could result in drive malfunction due to loose terminal connections.

**NOTICE:** Do not switch the drive input to start or stop the motor. Frequently switching the drive on and off shortens the life of the DC bus charge circuit and the DC bus capacitors, and can cause premature drive failures. For the full performance life, refrain from switching the drive on and off more than once every 30 minutes.

### ◆ Factory Recommended Branch Circuit Protection

**WARNING! Fire Hazard.** Install adequate branch circuit protection according to applicable local codes and this manual. Failure to comply could result in fire and damage to the drive or injury to personnel. The device is suitable for use on a circuit capable of delivering not more than 100,000 RMS symmetrical amperes, 240 Vac (200 V class) and 480 Vac (400 V class), when protected by branch circuit protection devices specified in this manual.

Branch circuit protection shall be provided by any of the following: Non-time delay Class J, T, or CC fuses sized at 300% of the drive input rating, or Time delay Class J, T, or CC fuses sized at 175% of the drive input rating, or MCCB sized at 200% maximum of the drive input rating.

Yaskawa recommends installing branch circuit protection according to maintain compliance with UL508C. Semiconductor protective type fuses are preferred. Alternate branch circuit protection devices are also listed in this manual. [Refer to Factory Recommended Z1000 AC Drive Branch Circuit Protection on page 254](#) for details.

### ◆ Main Circuit Terminal Functions

Table 3.1 Main Circuit Terminal Functions

Terminal		Type		Function	Page
200 V Class	Drive Model	2A0011 to 2A0273	2A0343 and 2A0396		
400 V Class		4A0005 to 4A0302	4A0361 to 4A0590		
R/L1		Main circuit power supply input		Connects line power to the drive	63
S/L2					
T/L3					
U/T1		Drive output		Connects to the motor	63
V/T2					
W/T3					
+1		–	DC power supply input (+1 and –) or 12/18 pulse rectification	For connecting peripheral devices	–
–		–		–	–
+3 <1>		–	–	–	–
+M		12/18 pulse rectification <2>	–	Input for 12/18 pulse rectification	–
–M					
⊕		For 200 V class: 100 Ω or less For 400 V class: 10 Ω or less		Grounding terminal	87

<1> Not used.

<2> +M and –M are for rectification purposes only. Do not use for dynamic braking or line-regeneration.

### ◆ Protecting Main Circuit Terminals

#### ■ Insulation Caps or Sleeves

Use insulation caps or sleeves when wiring the drive with crimp terminals. Take particular care to ensure that the wiring does not touch nearby terminals or the surrounding case.

#### ■ Insulation Barrier

Insulation barriers are packaged with drive models 4A0361 through 4A0590 to provide added protection between terminals. Yaskawa recommends using the provided insulation barriers to ensure proper wiring. Refer to [Figure 3.29](#) for instructions on placement of the insulation barriers.

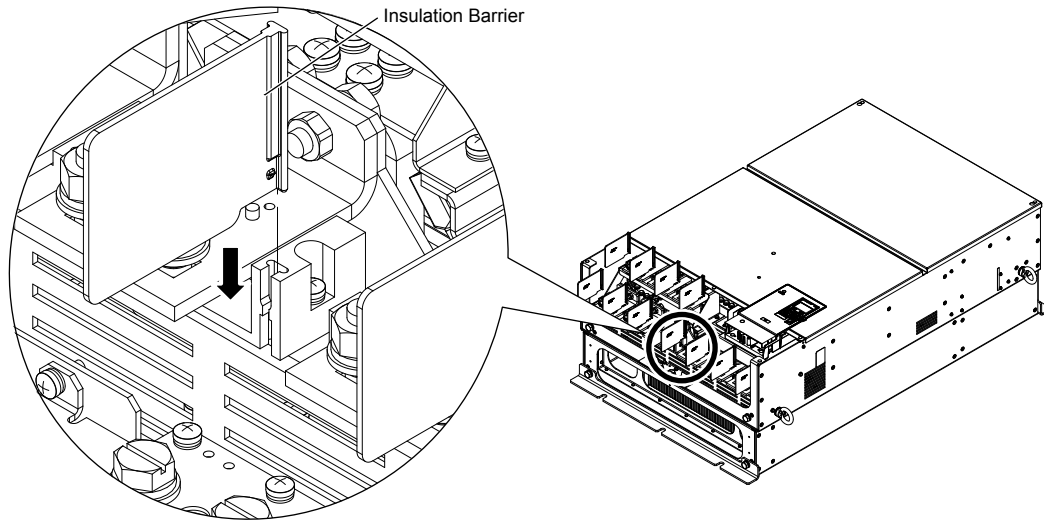
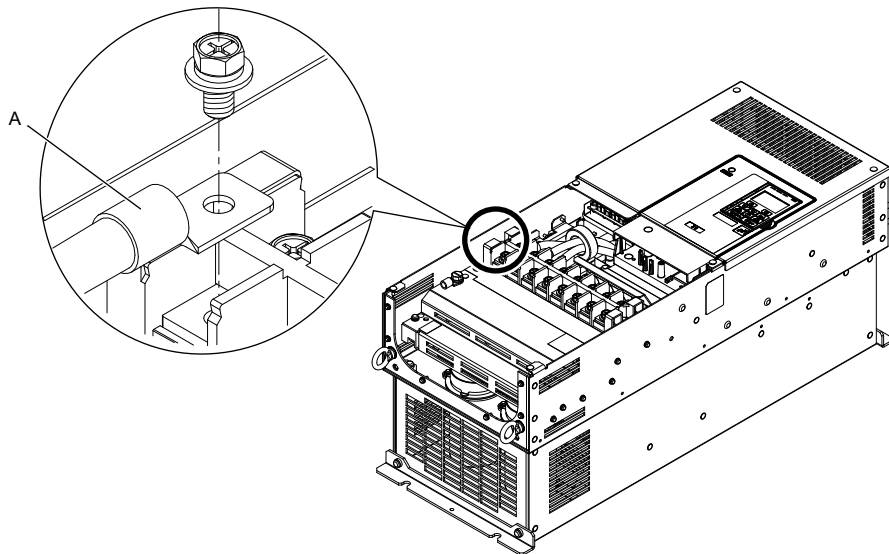

Figure 3.29 Installing Insulation Barriers

When wiring 4A0124, make sure the crimp terminals on the main circuit are connected so that they are facing in the correct direction as shown in [Figure 3.30](#).



A –Crimp terminals in correct position

Figure 3.30 Crimp Terminals

## ◆ Wire Gauges and Tightening Torque

Use the tables in this section to select the appropriate wires and crimp terminals.

Gauges listed in the tables are for use in the United States.

- Note:**
1. Wire gauge recommendations based on drive continuous current ratings using 75 °C 600 Vac vinyl-sheathed wire assuming ambient temperature within 40 °C and wiring distance less than 100 m.
  2. Terminal +3 is not used. Do not connect devices or wiring to this terminal.
- Consider the amount of voltage drop when selecting wire gauges. Increase the wire gauge when the voltage drop is greater than 2% of motor rated voltage. Ensure the wire gauge is suitable for the terminal block. Use the following formula to calculate the amount of voltage drop:

$$\text{Line drop voltage (V)} = \sqrt{3} \times \text{wire resistance } (\Omega/\text{km}) \times \text{wire length (m)} \times \text{current (A)} \times 10^{-3}$$

- **Refer to UL Standards Compliance on page 368** for information on UL compliance.

Yaskawa recommends using closed-loop crimp terminals on all drive models. To maintain UL/cUL approval, UL Listed closed-loop crimp terminals are specifically required when wiring the drive main circuit terminals on models 2A0031 to 2A0396 and 4A0034 to 4A0590. Use only the tools recommended by the terminal manufacturer for crimping. **Refer to Closed-Loop Crimp Terminal Size on page 368** for closed-loop crimp terminal recommendations.

The wire gauges listed in the following tables are Yaskawa recommendations. Refer to NEC table 310-16 for proper wire gauge selection for terminals -M, +M, -1, +3, and ground.

### ■ Three-Phase 200 V Class

Table 3.2 Wire Gauge and Torque Specifications (Three-Phase 200 V Class)

Model	Terminal	Recomm. Gauge AWG, kcmil	Wire Range AWG, kcmil	Screw Size	Tightening Torque N·m (lb. in.)
2A0011	R/L1, S/L2, T/L3	14	14 to 8	M4	1.6 to 1.8 (14 to 16)
	U/T1, V/T2, W/T3	14			
	-M, +M	–		M5	2.7 to 3.0 (24 to 27)
	⊕	–			
2A0017	R/L1, S/L2, T/L3	10	14 to 8	M4	1.6 to 1.8 (14 to 16)
	U/T1, V/T2, W/T3	10			
	-M, +M	–		M5	2.7 to 3.0 (24 to 27)
	⊕	–			
2A0024	R/L1, S/L2, T/L3	8	14 to 8	M4	1.6 to 1.8 (14 to 16)
	U/T1, V/T2, W/T3	8			
	-M, +M	–		M5	2.7 to 3.0 (24 to 27)
	⊕	–			
2A0031 </>	R/L1, S/L2, T/L3	8	14 to 8	M4	1.6 to 1.8 (14 to 16)
	U/T1, V/T2, W/T3	8			
	-M, +M	–		M5	2.7 to 3.0 (24 to 27)
	⊕	–			
2A0046 </>	R/L1, S/L2, T/L3	6	10 to 4	M5	2.7 to 3.0 (24 to 27)
	U/T1, V/T2, W/T3	6			
	-M, +M	–			
	⊕	–			
2A0059 </>	R/L1, S/L2, T/L3	4	10 to 4	M5	2.7 to 3.0 (24 to 27)
	U/T1, V/T2, W/T3	4			
	-M, +M	–			
	⊕	–			
2A0075 </>	R/L1, S/L2, T/L3	3	8 to 2/0	M8	5.4 to 6.0 (48 to 53)
	U/T1, V/T2, W/T3	3			
	-M, +M	–			
	⊕	–			

### 3.8 Main Circuit Wiring

Model	Terminal	Recomm. Gauge AWG, kcmil	Wire Range AWG, kcmil	Screw Size	Tightening Torque N·m (lb. in.)
2A0088 <1>	R/L1, S/L2, T/L3	2	8 to 2/0	M8	5.4 to 6.0 (48 to 53)
	U/T1, V/T2, W/T3	2			
	-M, +M	-			
	⊕	-			
2A0114 <1>	R/L1, S/L2, T/L3	1/0	8 to 2/0	M8	5.4 to 6.0 (48 to 53)
	U/T1, V/T2, W/T3	1/0			
	-M, +M	-			
	⊕	-			
2A0143 <1>	R/L1, S/L2, T/L3	3 × 2	1/0 to 3/0	M8	13.5 to 15.0 (120 to 133)
	U/T1, V/T2, W/T3	3 × 2			
	-M, +M	-			
	⊕	-			
2A0169 <1>	R/L1, S/L2, T/L3	2 × 2	1/0 to 3/0	M8	13.5 to 15.0 (120 to 133)
	U/T1, V/T2, W/T3	2 × 2			
	-M, +M	-			
	⊕	-			
2A0211 <1>	R/L1, S/L2, T/L3	1/0 × 2	1/0 to 3/0	M8	13.5 to 15.0 (120 to 133)
	U/T1, V/T2, W/T3	1/0 × 2			
	-M, +M	-			
	⊕	-			
2A0273 <1>	R/L1, S/L2, T/L3	2/0 × 2	1/0 to 4/0	M10	27.0 to 30.0 (239 to 266)
	U/T1, V/T2, W/T3	2/0 × 2		M8	13.5 to 15.0 (120 to 133)
	-M, +M	-			
	⊕	-			
2A0343 <1>	R/L1, S/L2, T/L3	4/0 × 2	3/0 to 350	M12	32.0 to 40.0 (283 to 354)
	U/T1, V/T2, W/T3	4/0 × 2		M10	18.0 to 23.0 (159 to 204)
	- , +1	-			
	+3	-			
	⊕	-			
2A0396 <1>	R/L1, S/L2, T/L3	250 × 2	3/0 to 350	M12	32.0 to 40.0 (283 to 354)
	U/T1, V/T2, W/T3	250 × 2		M10	18.0 to 23.0 (159 to 204)
	- , +1	-			
	+3	-			
	⊕	-			

<1> Drive models 2A0046 to 2A0396 require the use of closed-loop crimp terminals for UL/cUL compliance. Use only the tools recommended by the terminal manufacturer for crimping.

### ■ Three-Phase 400 V Class

Table 3.3 Wire Gauge and Torque Specifications (Three-Phase 400 V Class)

Model	Terminal	Recomm. Gauge AWG, kcmil	Wire Range AWG, kcmil	Screw Size	Tightening Torque N·m (lb.in.)
4A0005 4A0008 4A0011	R/L1, S/L2, T/L3	14	14 to 8	M4	1.6 to 1.8 (14 to 16)
	U/T1, V/T2, W/T3	14			
	-M, +M	–		M5	2.7 to 3.0 (24 to 27)
	⊕	–			
4A0014	R/L1, S/L2, T/L3	12	14 to 8	M4	1.6 to 1.8 (14 to 16)
	U/T1, V/T2, W/T3	12			
	-M, +M	–		M5	2.7 to 3.0 (24 to 27)
	⊕	–			
4A0021	R/L1, S/L2, T/L3	10	14 to 8	M4	1.6 to 1.8 (14 to 16)
	U/T1, V/T2, W/T3	10			
	-M, +M	–		M5	2.7 to 3.0 (24 to 27)
	⊕	–			
4A0027	R/L1, S/L2, T/L3	8	14 to 8	M4	1.6 to 1.8 (14 to 16)
	U/T1, V/T2, W/T3	8			
	-M, +M	–		M5	2.7 to 3.0 (24 to 27)
	⊕	–			
4A0034 </>	R/L1, S/L2, T/L3	8	10 to 4	M5	2.7 to 3.0 (24 to 27)
	U/T1, V/T2, W/T3	8			
	-M, +M	–			
	⊕	–			
4A0040 4A0052□□B </>	R/L1, S/L2, T/L3	8	10 to 4	M5	2.7 to 3.0 (24 to 27)
	U/T1, V/T2, W/T3	8			
	-M, +M	–			
	⊕	–			
4A0052□□A </>	R/L1, S/L2, T/L3	6	8 to 2/0	M8	5.4 to 6.0 (48 to 53)
	U/T1, V/T2, W/T3	6			
	-M, +M	–			
	⊕	–			
4A0065 </>	R/L1, S/L2, T/L3	4	8 to 2/0	M8	5.4 to 6.0 (48 to 53)
	U/T1, V/T2, W/T3	4			
	-M, +M	–			
	⊕	–			
4A0077 </>	R/L1, S/L2, T/L3	3	8 to 2/0	M8	5.4 to 6.0 (48 to 53)
	U/T1, V/T2, W/T3	3			
	-M, +M	–			
	⊕	–			
4A0096 </>	R/L1, S/L2, T/L3	1	8 to 2/0	M8	5.4 to 6.0 (48 to 53)
	U/T1, V/T2, W/T3	1			
	-M, +M	–			
	⊕	–			
4A0124 </>	R/L1, S/L2, T/L3	2/0	8 to 2/0	M8	5.4 to 6.0 (48 to 53)
	U/T1, V/T2, W/T3	2/0			
	-M, +M	–			
	⊕	–			

### 3.8 Main Circuit Wiring

Model	Terminal	Recomm. Gauge AWG, kcmil	Wire Range AWG, kcmil	Screw Size	Tightening Torque N·m (lb.in.)
4A0156 <1>	R/L1, S/L2, T/L3	3 × 2	1/0 to 3/0	M8	13.5 to 15.0 (120 to 133)
	U/T1, V/T2, W/T3	3 × 2			
	-M, +M	–			
	⊕	–			
4A0180 <1>	R/L1, S/L2, T/L3	2 × 2	1/0 to 3/0	M8	13.5 to 15.0 (120 to 133)
	U/T1, V/T2, W/T3	2 × 2			
	-M, +M	–			
	⊕	–			
4A0240 <1>	R/L1, S/L2, T/L3	1/0 × 2	1/0 to 3/0	M8	13.5 to 15.0 (120 to 133)
	U/T1, V/T2, W/T3	1/0 × 2			
	-M, +M	–			
	⊕	–			
4A0302 <1>	R/L1, S/L2, T/L3	3/0 × 2	1/0 to 4/0	M10	27.0 to 30.0 (239 to 266)
	U/T1, V/T2, W/T3	3/0 × 2			
	-M, +M	–			
	⊕	–			
4A0361 <1>	R/L1, S/L2, T/L3	4/0 × 2	3/0 to 600	M12	32.0 to 40.0 (283 to 354)
	U/T1, V/T2, W/T3	4/0 × 2	3/0 to 600		
	–, +1	–	4/0 to 600	M10	18 to 23 (159 to 204)
	+3	–	3/0 to 600		
	⊕	1	1 to 350		
4A0414 <1>	R/L1, S/L2, T/L3	300 × 2	4/0 to 300	M12	32.0 to 40.0 (283 to 354)
	U/T1, V/T2, W/T3	300 × 2	4/0 to 300		
	–, +1	–	3/0 to 300		
	+3	–	3/0 to 300		
	⊕	1	1 to 3/0		
4A0480 <1>	R/L1, S/L2, T/L3	1/0 × 4	3/0 to 300	M12	32.0 to 40.0 (283 to 354)
	U/T1, V/T2, W/T3	1/0 × 4			
	–, +1	–			
	+3	–			
	⊕	–			
4A0590 <1>	R/L1, S/L2, T/L3	3/0 × 4	3/0 to 300	M12	32.0 to 40.0 (283 to 354)
	U/T1, V/T2, W/T3	3/0 × 4			
	–, +1	–			
	+3	–			
	⊕	–			

<1> Drive models 4A0034 to 4A0590 require the use of closed-loop crimp terminals for UL/cUL compliance. Use only the tools recommended by the terminal manufacturer for crimping.

### ◆ Main Circuit Terminal and Motor Wiring

This section outlines the various steps, precautions, and checkpoints for wiring the main circuit terminals and motor terminals.

**WARNING!** *Electrical Shock Hazard. Do not connect the AC power line to the output terminals of the drive. Failure to comply could result in death or serious injury by fire as a result of drive damage from line voltage application to output terminals.*

**NOTICE:** *When connecting the motor to the drive output terminals U/T1, V/T2, and W/T3, the phase order for the drive and motor should match. Failure to comply with proper wiring practices may cause the motor to run in reverse if the phase order is backward.*

**NOTICE:** *Route motor leads U/T1, V/T2, and W/T3 separate from all other leads to reduce possible interference related issues. Failure to comply may result in abnormal operation of drive and nearby equipment.*

**NOTICE:** *Do not connect phase-advancing capacitors or LC/RC noise filters to the output circuits. Failure to comply could result in damage to the drive, phase-advancing capacitors, LC/RC noise filters or ground fault circuit interrupters.*

## ■ Cable Length Between Drive and Motor

Voltage drop along the motor cable may cause reduced motor torque when the wiring between the drive and the motor is too long, especially at low frequency output. This can also be a problem when motors are connected in parallel with a fairly long motor cable. Drive output current will increase as the leakage current from the cable increases. An increase in leakage current may trigger an overcurrent situation and weaken the accuracy of the current detection.

Adjust the drive carrier frequency according to [Table 3.4](#). If the motor wiring distance exceeds 100 m because of the system configuration, reduce the ground currents. [Refer to C6-02: Carrier Frequency Selection on page 133](#).

**Table 3.4 Cable Length Between Drive and Motor**

Cable Length	50 m or less	100 m or less	Greater than 100 m
Carrier Frequency	12.5 kHz or less	5 kHz or less	2 kHz or less

- Note:**
1. When setting carrier frequency for drives running multiple motors, calculate cable length as the total wiring distance to all connected motors.
  2. The maximum cable length when using OLV/PM (A1-02 = 5) is 100 m.
  3. Do not use a long distance shielded line if there is an overvoltage problem at start. Either lower the carrier frequency or switch on the internal EMC filter if the power supply has a neutral ground.

## ■ Ground Wiring

Follow the precautions below when wiring the ground for one drive or a series of drives.

**DANGER!** *Electrical Shock Hazard. Do not touch SW1 or SW2 screws while power is applied to the drive. Failure to comply will result in death or serious injury.*

**WARNING!** *Electrical Shock Hazard. Make sure the protective earthing conductor complies with technical standards and local safety regulations. Because the leakage current exceeds 3.5 mA, IEC/EN 61800-5-1 states that either the power supply must be automatically disconnected in case of discontinuity of the protective earthing conductor or a protective earthing conductor with a cross-section of at least 10 mm<sup>2</sup> (Cu) or 16 mm<sup>2</sup> (Al) must be used. Failure to comply may result in death or serious injury.*

**WARNING!** *Electrical Shock Hazard. Always use a ground wire that complies with technical standards on electrical equipment and minimize the length of the ground wire. Improper equipment grounding may cause dangerous electrical potentials on equipment chassis, which could result in death or serious injury.*

**WARNING!** *Electrical Shock Hazard. Be sure to ground the drive ground terminal (200 V class: ground to 100 Ω or less and 400 V class: ground to 10 Ω or less). Improper equipment grounding could result in death or serious injury by contacting ungrounded electrical equipment.*

**NOTICE:** *Do not share the ground wire with other devices such as welding machines or large-current electrical equipment. Improper equipment grounding could result in drive or equipment malfunction due to electrical interference.*

**NOTICE:** *When using more than one drive, ground multiple drives according to instructions. Improper equipment grounding could result in abnormal operation of drive or equipment.*

Refer to [Figure 3.31](#) when using multiple drives. Do not loop the ground wire.

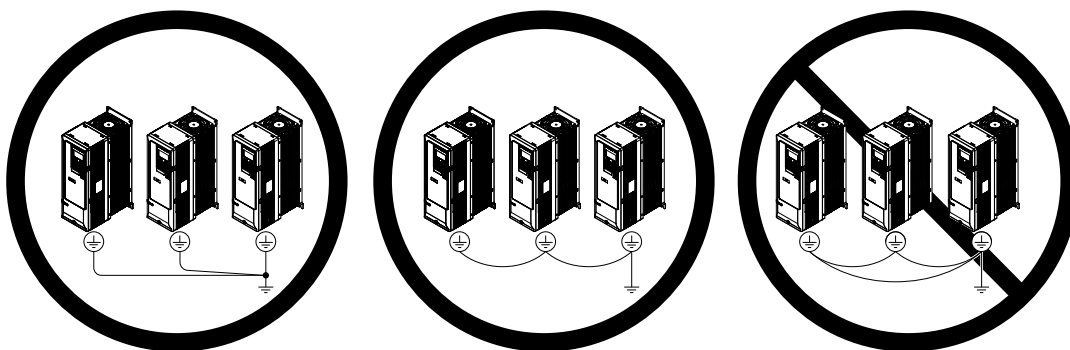

**Figure 3.31 Ground Wiring for Multiple Drives**

### 3.8 Main Circuit Wiring

#### ■ Enable the Internal EMC Filter

**DANGER!** *Electrical Shock Hazard. Do not touch SW1 or SW2 screws while power is applied to the drive. Failure to comply will result in death or serious injury.*

**WARNING!** *Electrical Shock Hazard. Connect the ground cable correctly. Failure to comply may result in death or serious injury.*

**NOTICE:** *When disabling the internal EMC filter, move the screws from ON to OFF and then tighten to the specified torque. Completely removing the screws or tightening the screws to an incorrect torque may cause drive failure.*

**NOTICE:** *Keep SW1/SW2 screws positioned together (ON/ON or OFF/OFF). Screws at different positions may cause drive failure.*

**Note:** For floating, impedance grounded, or asymmetrically grounded networks, disconnect the internal EMC filter by moving the SW1/SW2 screws to the OFF position.

**Table 3.5** shows asymmetrical grounded networks. Asymmetrical networks require first moving the SW1 and SW2 screws to disconnect the internal ground connection. (Drives are shipped with SW1 and SW2 screws installed at the OFF position.)

**Table 3.5 Asymmetrical Grounded Network**

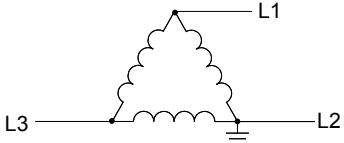
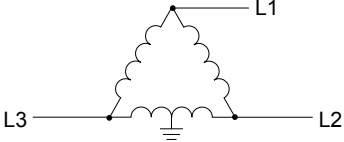
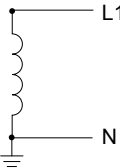
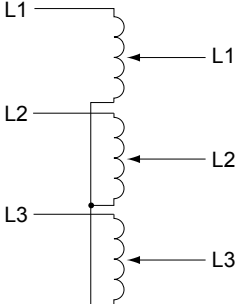
Grounded at the corner of the delta	
Grounded at the middle of the side	
Single-phase, grounded at the end point	
Three-phase variable transformer without solidly grounded neutral	

If EMC is a concern and the network is grounded symmetrically, install the SW1 and SW2 screws to the ON position. Installing the SW1 and SW2 screws enables the internal EMC filter (Drives are shipped with SW1/SW2 screws installed at the OFF position).

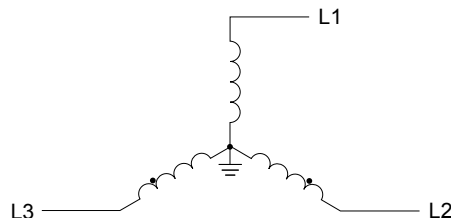

**Figure 3.32 Symmetrical Grounded Network**

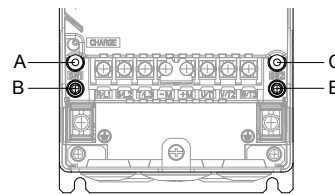

A – SW1 (ON)  
B – Screw (OFF)

C – SW2 (ON)

Figure 3.33 EMC Filter Switch Location (2A0011 to 2A0059, 4A0005 to 4A0040, and 4A0052□□B)

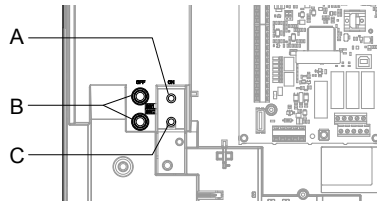

A – SW1 (ON)  
B – Screw (OFF)

C – SW2 (ON)

Figure 3.34 EMC Filter Switch Location (2A0075 to 2A0114, 4A0052□□A, and 4A0065 to 4A0096)

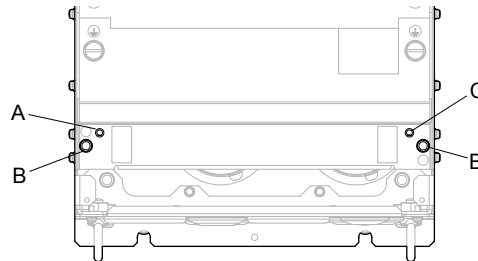

A – SW1 (ON)  
B – Screw (OFF)

C – SW2 (ON)

Figure 3.35 EMC Filter Switch Location (4A0124)

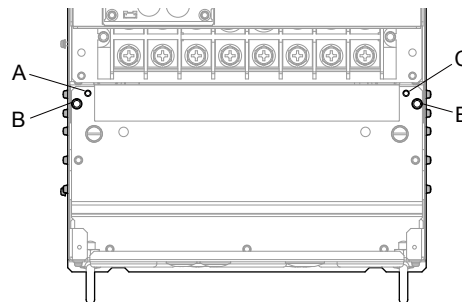

A – SW1 (ON)  
B – Screw (OFF)

C – SW2 (ON)

Figure 3.36 EMC Filter Switch Location (2A0143 to 2A0273 and 4A0156 to 4A0240)

### 3.8 Main Circuit Wiring

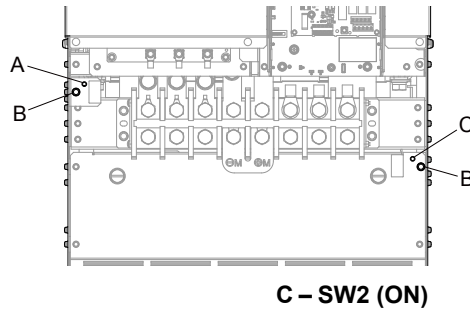

A – SW1 (ON)  
B – Screw (OFF)

C – SW2 (ON)

Figure 3.37 EMC Filter Switch Location (4A0302)

If the SW1/SW2 screws are missing, install proper size screws with the proper tightening torque as shown in [Table 3.6](#).

**NOTICE:** Do not use screws of different sizes in SW1 and SW2. Failure to comply may cause overheating.

Table 3.6 SW1/SW2 Screw Sizes and Tightening Torques

Drive Model		SW1/SW2 Screw Size	Tightening Torque
2A0011 2A0017	4A0005 4A0008 4A0011	M3 × 16	0.5 to 0.6 N•m
2A0024 2A0031	4A0014 4A0021 4A0027	M3 × 16	0.5 to 0.6 N•m
2A0046 2A0059	4A0034 4A0040 4A0052□□B	M3 × 16	0.5 to 0.6 N•m
2A0075 2A0088 2A0114	4A0052□□A 4A0065 4A0077 4A0096	M5 × 30	2 to 2.5 N•m
–	4A0124	M5 × 25	2 to 2.5 N•m
2A0143 2A0169 2A0211 2A0273	4A0156 4A0180 4A0240	M5 × 25	2 to 2.5 N•m
–	4A0302	M5 × 25	2 to 2.5 N•m

#### ■ Wiring the Main Circuit Terminal

**WARNING!** Electrical Shock Hazard. Shut off the power supply to the drive before wiring the main circuit terminals. Failure to comply may result in death or serious injury.

Wire the main circuit terminals after the terminal board has been properly grounded.

Models 2A0011 to 2A0273 and 4A0005 to 4A0302 have a cover placed over the 12/18 rectification terminals prior to shipment to help prevent miswiring. Use wire cutters to cut away covers as needed for terminals.

Refer to [Figure 3.4](#) on page 65 for details.

#### ■ Main Circuit Connection Diagram

Refer to [Main Circuit Connection Diagram on page 65](#) when wiring terminals on the main power circuit of the drive.

## 3.9 Control Circuit Wiring

### ◆ Control Circuit Connection Diagram

Refer to [Figure 3.1](#) on page [63](#) when wiring terminals on the drive control circuit.

### ◆ Control Circuit Terminal Block Functions

Drive parameters determine which functions apply to the multi-function digital inputs (S1 to S7), multi-function digital outputs (M1 to M6), multi-function analog inputs (A1 and A2), and multi-function analog monitor output (FM, AM). The default setting is listed next to each terminal in [Figure 3.1](#) on page [63](#).

**WARNING!** *Sudden Movement Hazard. Always check the operation and wiring of control circuits after being wired. Operating a drive with untested control circuits could result in death or serious injury.*

**WARNING!** *Sudden Movement Hazard. Confirm the drive I/O signals and external sequence before starting test run. Setting parameter A1-06 may change the I/O terminal function automatically from the default setting. Failure to comply may result in death or serious injury.*

### ■ Input Terminals

[Table 3.7](#) lists the input terminals on the drive. Text in parenthesis indicates the default setting for each multi-function input.

**Table 3.7 Control Circuit Input Terminals**

Type	No.	Terminal Name (Function)	Function (Signal Level) Default Setting	Page
Multi-Function Digital Inputs	S1	Multi-function input 1 (Closed: Forward run, Open: Stop)	<ul style="list-style-type: none"> <li>Photocoupler</li> <li>24 Vdc, 8 mA</li> <li>Set the wire jumper to select between sinking, sourcing mode, and the power supply. <a href="#">Refer to Sinking/Sourcing Mode Switch for Digital Inputs on page 100.</a></li> </ul>	300
	S2	Multi-function input 2 (Closed: Reverse run, Open: Stop)		
	S3	Multi-function input 3 (External fault, N.O.)		
	S4	Multi-function input 4 (Fault reset)		
	S5	Multi-function input 5 (Multi-step speed reference 1)		
	S6	Multi-function input 6 (Multi-step speed reference 2)		
	S7	Multi-function input 7 (Jog reference)		
	SC	Multi-function input common	Multi-function input common	
	SP	Digital input power supply +24 Vdc	24 Vdc power supply for digital inputs, 150 mA max	100
SN	Digital input power supply 0 V	<b>NOTICE:</b> Do not jumper or short terminals SP and SN. Failure to comply will damage the drive.	100	
Frequency Reference Inputs	+V	Power supply for analog inputs	10.5 Vdc (max allowable current 20 mA)	127
	A1	Multi-function analog input 1 (Frequency reference bias)	<ul style="list-style-type: none"> <li>0 to 10 Vdc/100% (input impedance: 20 kΩ)</li> <li>4 to 20 mA/100%, 0 to 20 mA/100% (input impedance: 250 Ω)</li> <li>Voltage or current input must be selected by Jumper S1 and H3-01.</li> </ul>	127 174
	A2	Multi-function analog input 2 (Frequency reference bias)	<ul style="list-style-type: none"> <li>0 to 10 Vdc/100% (input impedance: 20 kΩ)</li> <li>4 to 20 mA/100%, 0 to 20 mA/100% (input impedance: 250 Ω)</li> <li>Voltage or current input must be selected by Jumper S1 and H3-09.</li> </ul>	127 127 175
	AC	Frequency reference common	0 V	127
	FE	Ground for shielded lines and option cards	–	–

### 3.9 Control Circuit Wiring

#### ■ Output Terminals

**Table 3.8** lists the output terminals on the drive. Text in parenthesis indicates the default setting for each multi-function output.

**Table 3.8 Control Circuit Output Terminals**

Type	No.	Terminal Name (Function)	Function (Signal Level) Default Setting	Page
Fault Relay Output	MA	N.O.	30 Vdc, 10 mA to 2 A; 250 Vac, 10 mA to 2 A Minimum load: 5 Vdc, 10 mA	–
	MB	N.C. output		
	MC	Fault output common		
Multi-Function Digital Output <1>	M1	Multi-function digital output (During run)	30 Vdc, 10 mA to 2 A; 250 Vac, 10 mA to 2 A Minimum load: 5 Vdc, 10 mA	–
	M2			
	M3	Multi-function digital output (Zero speed)		
	M4			
	M5	Multi-function digital output (Speed Agree 1)		
M6				
Monitor Output	FM	Analog monitor output 1 (Output frequency)	0 to 10 V / 0 to 100% 4 to 20 mA / 0 to 100%	307
	AM	Analog monitor output 2 (Output current)	Voltage or current output must be selected by Jumper S5 and H4-07 for FM and H4-08 for AM.	
	AC	Monitor common	0 V	–
External Power Supply	+P	External Power Supply	24 V (Max. 150 mA)	–

<1> Refrain from assigning functions to digital relay outputs that involve frequent switching, as doing so may shorten relay performance life. Switching life is estimated at 100,000 times (assumes 2 A, resistive load).

#### ■ Serial Communication Terminals

**Table 3.9 Control Circuit Terminals: Serial Communications**

Type	No.	Signal Name	Function (Signal Level)
Serial Communication (APOGEE FLN, BACnet, MEMOBUS/Modbus, or Metasys N2) <1>	R+	Communications input (+)	APOGEE FLN, BACnet, MEMOBUS/Modbus, or Metasys N2 communication: Use an RS-422 or RS-485 cable to connect the drive.
	R-	Communications input (-)	
	S+	Communications output (+)	
	S-	Communications output (-)	<ul style="list-style-type: none"> <li>• APOGEE FLN Comm. RS-422/RS-485, 4.8 kbps</li> <li>• BACnet Comm. RS-485, max. 76.8 kbps</li> <li>• MEMOBUS/Modbus Comm. RS-422/RS-485, max. 115.2 kbps</li> <li>• Metasys N2 Comm. RS-422/RS-485, 9.6 kbps</li> </ul>
	IG	Communications ground	0 V
	FE	Option card ground	–

<1> Enable the termination resistor in the last drive in an APOGEE FLN, BACnet, MEMOBUS/Modbus, or Metasys N2 network by setting DIP switch S2 to the ON position. [Refer to Control I/O Connections on page 100](#) for more information on the termination resistor.

### ◆ Terminal Configuration

The control circuit terminals are arranged as shown in *Figure 3.38*.

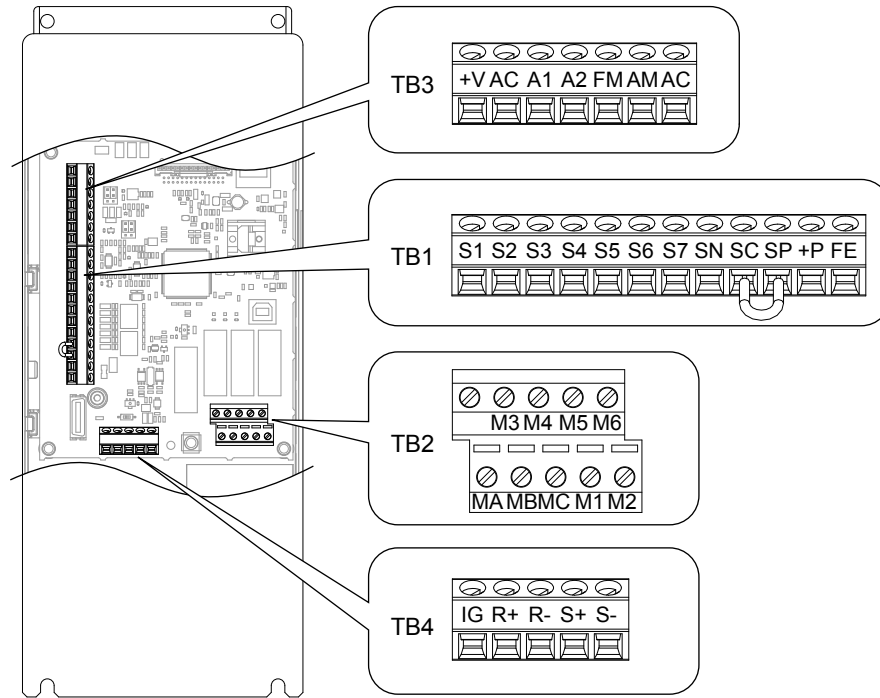

Figure 3.38 Control Circuit Terminal Arrangement

### ■ Wire Size and Torque Specifications

Select appropriate wire type and gauges from *Table 3.10*. For simpler and more reliable wiring, use crimp ferrules on the wire ends. Refer to *Table 3.11* for ferrule terminal types and sizes.

Table 3.10 Wire Gauges

Terminal	Screw Size	Tightening Torque N·m (lb. in)	Bare Wire Terminal		Ferrule-Type Terminal		Wire Type
			Applicable wire size mm <sup>2</sup> (AWG)	Recomm. wire size mm <sup>2</sup> (AWG)	Applicable wire size mm <sup>2</sup> (AWG)	Recomm. wire size mm <sup>2</sup> (AWG)	
S1-S7, SC, SN, SP	M3	0.5 to 0.6 (4.4 to 5.3)	Stranded wire: 0.2 to 1.0 (24 to 16) Solid wire: 0.2 to 1.5 (24 to 16)	0.75 (18)	0.25 to 0.5 (24 to 20)	0.5 (20)	Shielded wire, etc.
+V, A1, A2, AC							
MA, MB, MC							
M1-M6							
FM, AM, AC							
R+, R-, S+, S-, IG							

## 3.9 Control Circuit Wiring

### ■ Ferrule-Type Wire Terminals

Yaskawa recommends using CRIMPFOX 6, a crimping tool manufactured by PHOENIX CONTACT, to prepare wire ends with insulated sleeves before connecting to the drive. See [Table 3.11](#) for dimensions.

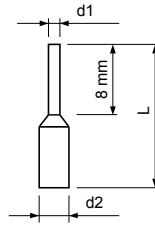

Figure 3.39 Ferrule Dimensions

Table 3.11 Ferrule Terminal Types and Sizes

Size mm <sup>2</sup> (AWG)	Type	L (mm)	d1 (mm)	d2 (mm)	Manufacturer
0.25 (24)	AI 0.25-8YE	12.5	0.8	1.8	PHOENIX CONTACT
0.34 (22)	AI 0.34-8TQ	10.5	0.8	1.8	
0.5 (20)	AI 0.5-8WH or AI 0.5-8OG	14	1.1	2.5	

## ◆ Wiring the Control Circuit Terminal

This section describes the proper procedures and preparations for wiring the control terminals.

**WARNING!** *Electrical Shock Hazard. Do not remove covers or touch the circuit boards while the power is on. Failure to comply could result in death or serious injury.*

**NOTICE:** *Separate control circuit wiring from main circuit wiring (terminals R/L1, S/L2, T/L3, -M, +M, -, +1, +3, U/T1, V/T2, W/T3) and other high-power lines. Improper wiring practices could result in drive malfunction due to electrical interference.*

**NOTICE:** *Separate wiring for digital output terminals MA, MB, MC, and M1 to M6 from wiring to other control circuit lines. Improper wiring practices could result in drive or equipment malfunction or nuisance trips.*

**NOTICE:** *Use a class 2 power supply when connecting to the control terminals. Improper application of peripheral devices could result in drive performance degradation due to improper power supply. Refer to NEC Article 725 Class 1, Class 2, and Class 3 Remote-Control, Signaling, and Power Limited Circuits for requirements concerning class 2 power supplies.*

**NOTICE:** *Insulate shields with tape or shrink tubing to prevent contact with other signal lines and equipment. Improper wiring practices could result in drive or equipment malfunction due to short circuit.*

**NOTICE:** *Connect the shield of shielded cable to the appropriate ground terminal. Improper equipment grounding could result in drive or equipment malfunction or nuisance trips.*

Wire the control circuit only after terminals have been properly grounded and main circuit wiring is complete. [Refer to Terminal Wiring Guide on page 95](#) for details. Prepare the ends of the control circuit wiring as shown in [Figure 3.46](#). [Refer to Wire Gauges on page 93](#).

**NOTICE:** *Do not tighten screws beyond the specified tightening torque. Failure to comply may result in erroneous operation, damage to the terminal block, or cause a fire.*

**NOTICE:** *Use shielded twisted-pair cables as indicated to prevent operating faults. Improper wiring practices could result in drive or equipment malfunction due to electrical interference.*

Connect control wires as shown in [Figure 3.40](#) and [Figure 3.41](#).

Yaskawa recommends Phoenix Contact screwdriver model SZF 0-0.4 x 2.5 or equivalent to wire the terminal block.

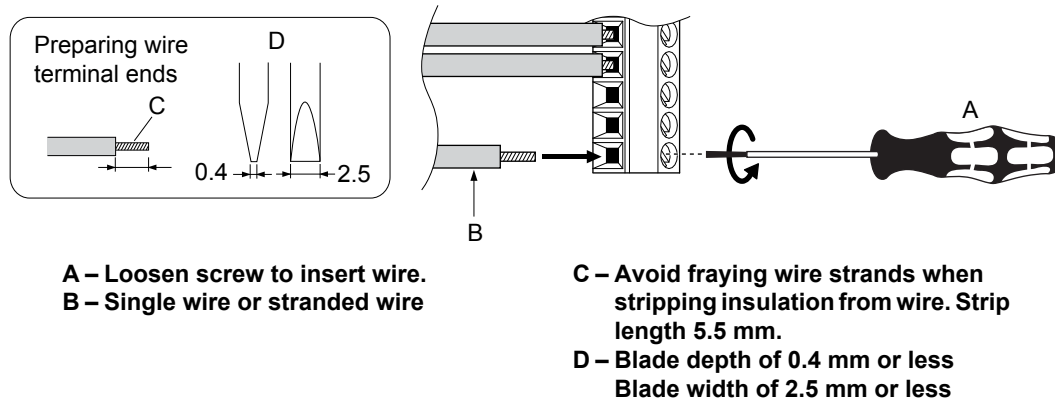
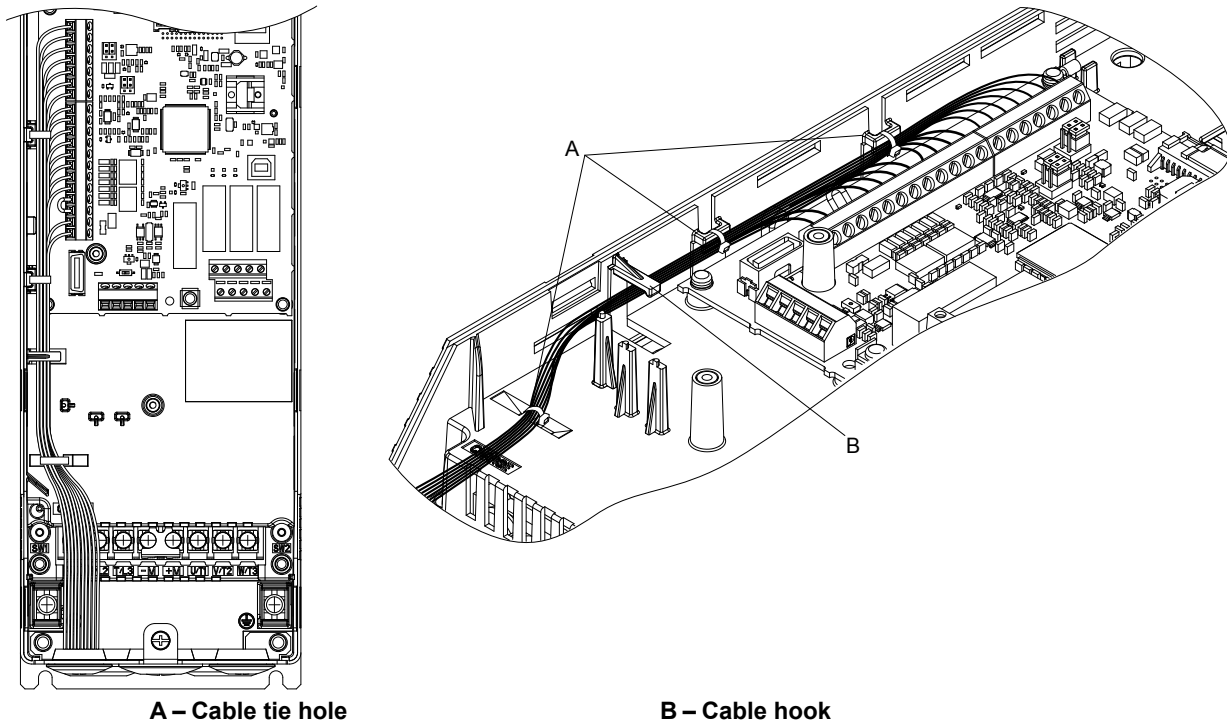

Figure 3.40 Terminal Wiring Guide

Use the cable tie holes and cable hooks when wiring control terminals.

**Note:** Take proper precautions when wiring the cables so that the front covers will easily fit back onto the drive. Make sure cables are not pinched between the front covers and the drive when replacing the covers.

### 3.9 Control Circuit Wiring



A – Cable tie hole

B – Cable hook

Figure 3.41 Control Terminal Wiring (2A0011 to 2A0031 and 4A0005 to 4A0027)

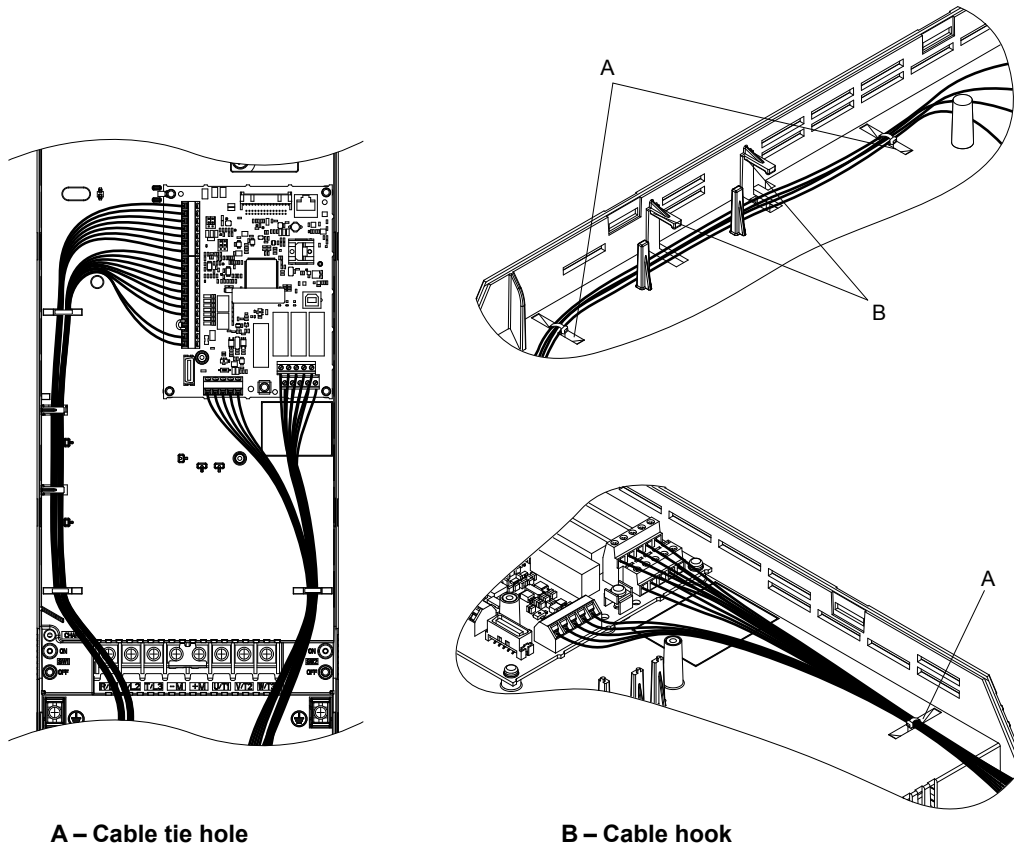

A – Cable tie hole

B – Cable hook

Figure 3.42 Control Terminal Wiring (2A0046, 2A0059, 4A0034, 4A0040, and 4A0052□□B)

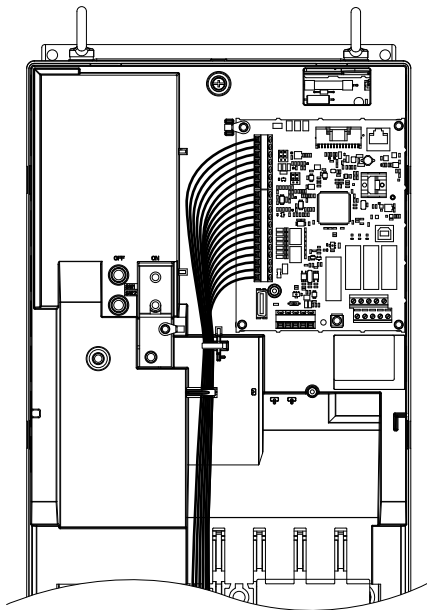

A – Cable tie hole

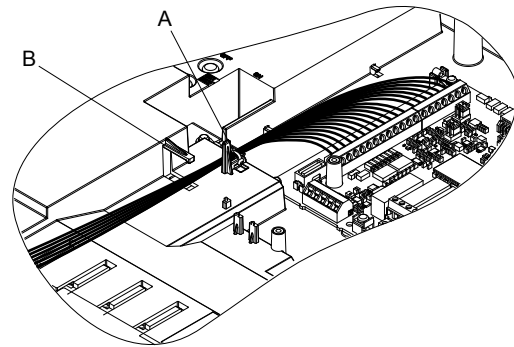

B – Cable hook

Figure 3.43 Control Terminal Wiring (2A0075 to 2A0114, 4A0052□□A, and 4A0065 to 4A0096)

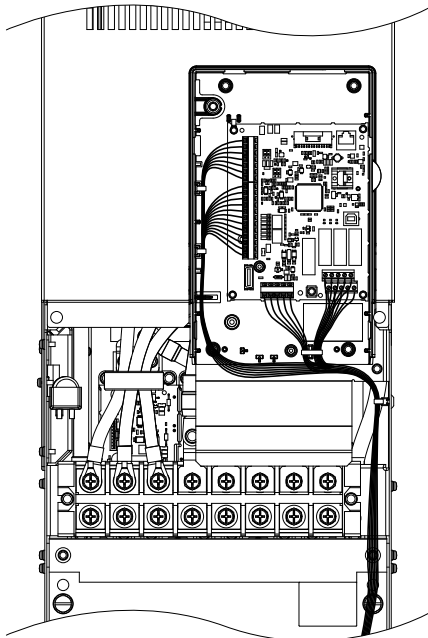

A – Cable hook  
B – Cable tie hole

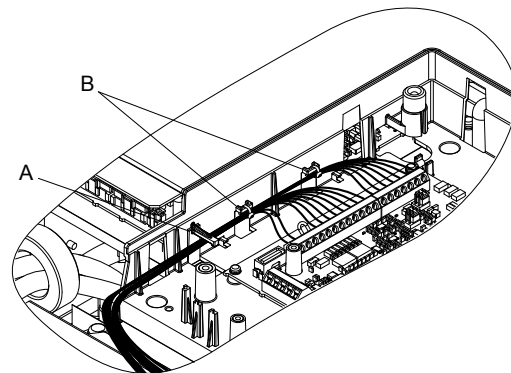
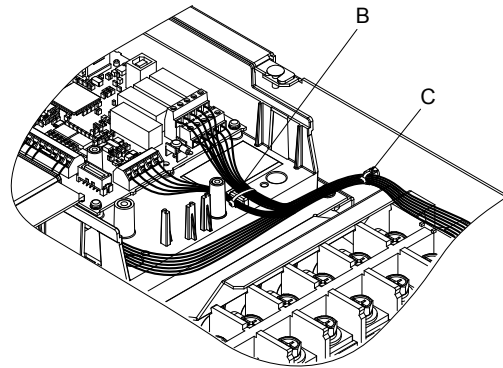

C – Cable anchor

Figure 3.44 Control Terminal Wiring (4A0124)

### 3.9 Control Circuit Wiring

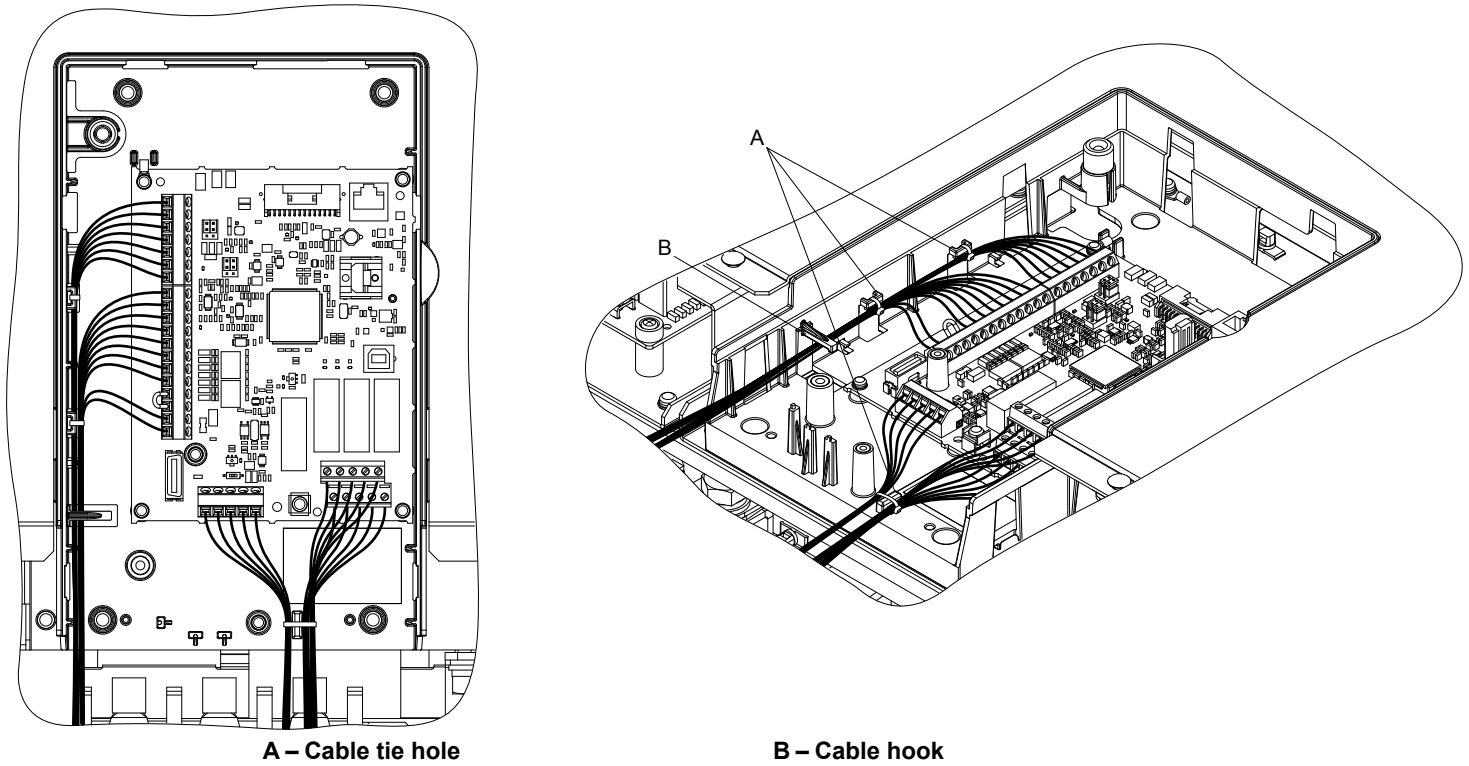

A – Cable tie hole

B – Cable hook

Figure 3.45 Control Terminal Wiring (2A0143 to 2A0396 and 4A0156 to 4A0590)

When setting the frequency by analog reference from an external potentiometer, use shielded twisted-pair wires (preparing wire ends as shown in [Figure 3.46](#)) and connect the shield to the ground terminal of the drive.

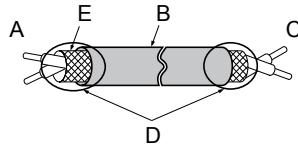

A – Drive side

B – Connect shield to ground terminal of drive.

C – Insulation

D – Control device side

E – Shield sheath (insulate with tape)

F – Shield

Figure 3.46 Preparing the Ends of Shielded Cables

**NOTICE:** The analog signal wiring between the drive and the operator station or peripheral equipment should not exceed 50 meters when using an analog signal from a remote source to supply the frequency reference. Failure to comply could result in poor system performance.

## ◆ Switches and Jumpers on the Control Board

The control board is equipped with several switches used to adapt the drive I/Os to the external control signals. *Figure 3.47* shows the location of these switches. *Refer to Control I/O Connections on page 100* for setting instructions.

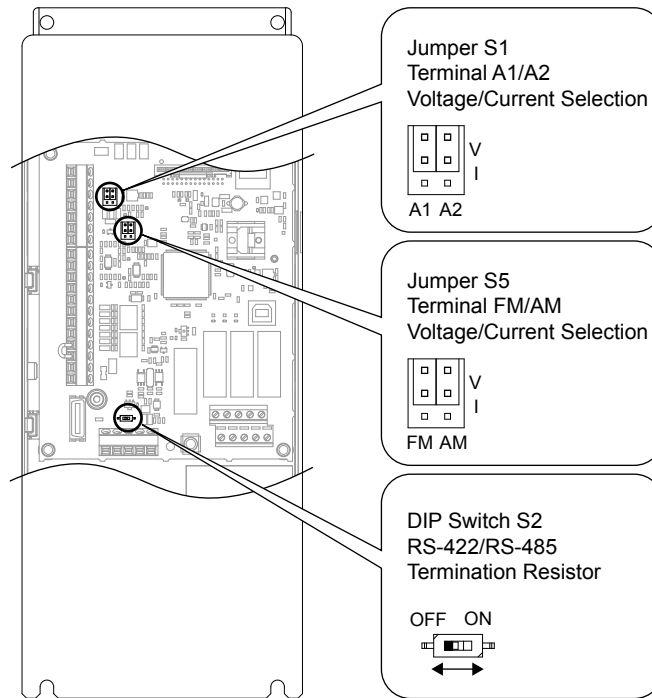

Figure 3.47 Locations of Jumpers and Switches on the Control Board

## 3.10 Control I/O Connections

### ◆ Sinking/Sourcing Mode Switch for Digital Inputs

Use the wire jumper between terminals SC and SP or SC and SN to select between Sink mode, Source mode or external power supply for the digital inputs S1 to S7 as shown in [Table 3.12](#) (Default: Sink mode, internal power supply).

**NOTICE:** Do not short terminals SP and SN. Failure to comply will damage the drive.

**Table 3.12 Digital Input Sink/Source/External Power Supply Selection**

Mode	Drive Internal Power Supply (Terminals SN and SP)	External 24 Vdc Power Supply
Sinking Mode (NPN)		
Sourcing Mode (PNP)		

### ◆ Input Signal Selection for Terminals A1 and A2

Terminals A1 and A2 can be used to input either a voltage or a current signal. Select the signal type using jumper S1 as explained in [Table 3.13](#). Set parameters H3-01 and H3-09 accordingly as shown in [Table 3.14](#).

**Note:** If terminals A1 and A2 are both set for frequency bias (H3-02 = 0 and H3-10 = 0), both input values will be combined to create the frequency reference.

**Table 3.13 Jumper S1 Settings**

Terminal	Voltage Output	Current Output
Terminal A1		
Terminal A2		

Table 3.14 Parameters H3-01 and H3-09 Details

No.	Parameter Name	Description	Setting Range	Default Setting
H3-01	Terminal A1 signal level selection	Selects the signal level for terminal A1. 0: 0 to 10 V with Zero Limit 1: 0 to 10 V without Zero Limit 2: 4 to 20 mA Current Input 3: 0 to 20 mA Current Input	0 to 3	0
H3-09	Terminal A2 signal level selection	Selects the signal level for terminal A2. 0: 0 to 10 V with Zero Limit 1: 0 to 10 V without Zero Limit 2: 4 to 20 mA Current Input 3: 0 to 20 mA Current Input	0 to 3	0

### ◆ Terminal FM/AM Signal Selection

The signal type for terminals FM and AM can be set to either voltage or current output using jumper S5 on the terminal board as explained in [Table 3.15](#). When changing the setting of jumper S5, parameters H4-07 and H4-08 must be set accordingly. The default selection is voltage output for both terminals.

Table 3.15 Jumper S5 Settings





Terminal	Voltage Output	Current Output
Terminal FM		
Terminal AM		

Table 3.16 Parameter H4-07 and H4-08 Details

No.	Parameter Name	Description	Setting Range	Default Setting
H4-07	Terminal FM signal level selection	0: 0 to 10 Vdc	0, 2	0
H4-08	Terminal AM signal level selection	2: 4 to 20 mA		

### ◆ MEMOBUS/Modbus Termination

This drive is equipped with a built-in termination resistor for the RS-422/RS-485 communication connector. DIP switch S2 enables or disabled the termination resistor as shown in [Table 3.17](#). The OFF position is the default. The termination resistor should be placed to the ON position when the drive is the last in a series of slave drives. [Refer to Switches and Jumpers on the Control Board on page 99](#) to locate switch S2.

Table 3.17 MEMOBUS/Modbus Termination Switch S2 Settings

S2 Position	Description
ON	Internal termination resistor ON
OFF	Internal termination resistor OFF (default setting)

## 3.11 Connect to a PC

This drive is equipped with a USB port (type-B).

The drive can connect to a USB port on a PC using a USB 2.0, AB-type cable (sold separately).

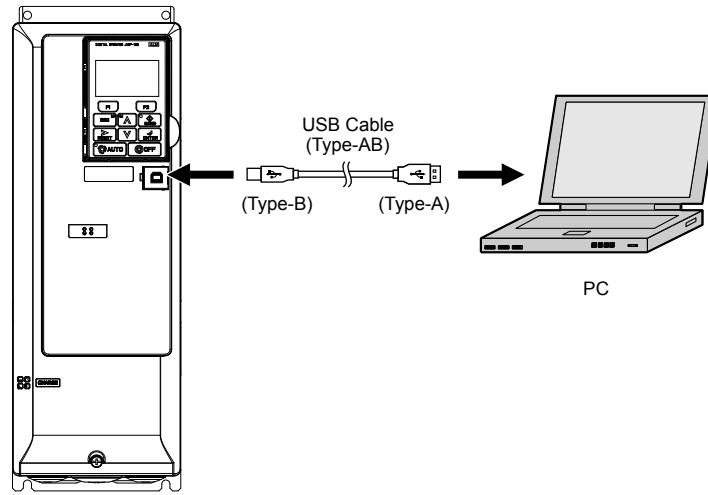

Figure 3.48 Connecting to a PC (USB)

## 3.12 External Interlock

Systems that may be affected during drive fault conditions should be interlocked with the drive fault output and ready signal.

### ◆ Drive Ready

When the “Drive ready” signal has been set to one of the multi-function contact outputs, that output will close whenever the drive is ready to accept a Run command or is already running. Under the following conditions the Drive ready signal will switch off and remain off, even if a Run command is entered:

- when the power supply is shut off
- during a fault
- when there is problem with the control power supply
- when a parameter setting error makes the drive unable to run even if a Run command has been entered
- when a fault such as overvoltage or undervoltage is triggered as soon as the Run command is entered
- when the drive is in the Programming mode and will not accept a Run command even when entered

### ■ Interlock Circuit Example

Two drives running a single application might interlock with the controller using the Drive Ready and Fault output signals as shown below. *Figure 3.49* illustrates how the application would not be able to run if either drive experiences a fault or is unable to supply a Drive Ready signal.

Terminal	Output Signal	Parameter Setting
MA, MB, MC	Fault	–
M1-M2	Drive Ready	H2-01 = 06

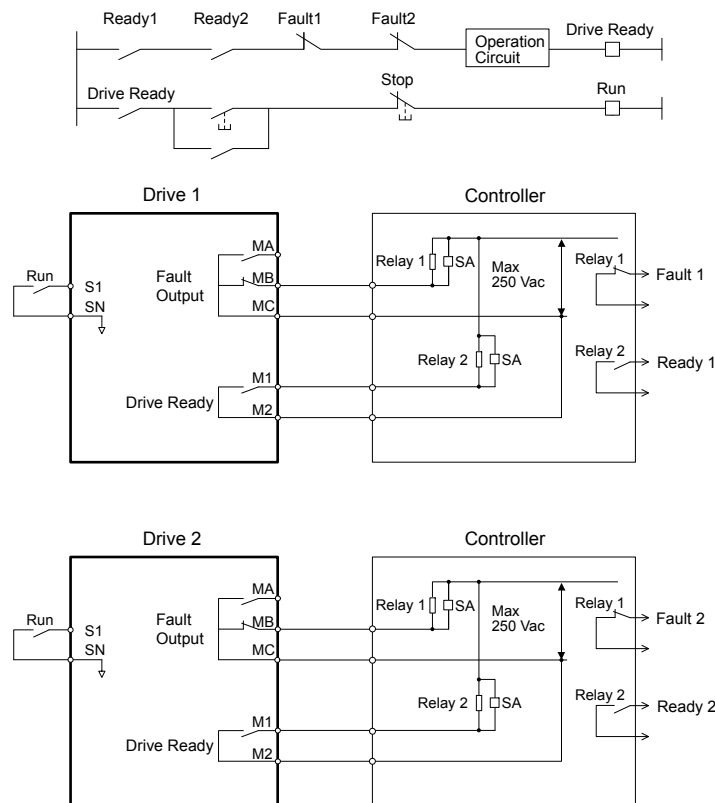

Figure 3.49 Interlock Circuit Example

## 3.13 Wiring Checklist

<input checked="" type="checkbox"/>	No.	Item	Page(s)
<b>Drive, Peripherals, Option Cards</b>			
<input type="checkbox"/>	1	Check drive model number to ensure receipt of correct model.	27
<input type="checkbox"/>	2	Make sure you have the correct noise filters and other peripheral devices.	–
<input type="checkbox"/>	3	Check the option card model number.	–
<b>Installation Area and Physical Setup</b>			
<input type="checkbox"/>	4	Ensure that the area surrounding the drive complies with specifications.	42
<b>Power Supply Voltage, Output Voltage</b>			
<input type="checkbox"/>	5	The voltage from the power supply should be within the input voltage specification range of the drive.	134
<input type="checkbox"/>	6	The voltage rating for the motor should match the drive output specifications.	27
<input type="checkbox"/>	7	Verify that the drive is properly sized to run the motor.	327
<b>Main Circuit Wiring</b>			
<input type="checkbox"/>	8	Confirm proper branch circuit protection as specified by national and local codes.	62
<input type="checkbox"/>	9	Properly wire the power supply to drive terminals R/L1, S/L2, and T/L3.	65
<input type="checkbox"/>	10	Properly wire the drive and motor together. The motor lines and drive output terminals U/T1, V/T2, and W/T3 should match in order to produce the desired phase order. If the phase order is incorrect, the drive will rotate in the opposite direction.	86
<input type="checkbox"/>	11	Confirm that the crimp terminals are in the correct position.	82
<input type="checkbox"/>	12	Use 600 Vac vinyl-sheathed wire for the power supply and motor lines.	83
<input type="checkbox"/>	13	Use the correct wire gauges for the main circuit. <ul style="list-style-type: none"> <li>• Consider the amount of voltage drop when selecting wire gauges. Increase the wire gauge when the voltage drop is greater than 2% of motor rated voltage. Ensure the wire gauge is suitable for the terminal block. Use the following formula to calculate the amount of voltage drop: Line drop voltage (V) = <math>\sqrt{3} \times \text{wire resistance } (\Omega/\text{km}) \times \text{wire length (m)} \times \text{current (A)} \times 10^{-3}</math></li> <li>• If the cable between the drive and motor exceeds 50 m, adjust the carrier frequency set to C6-02 accordingly.</li> </ul>	83
<input type="checkbox"/>	14	For floating, impedance grounded, or asymmetrically grounded networks, disconnect the internal EMC filter by moving the SW1 and SW2 screws to the OFF position.	88
<input type="checkbox"/>	15	Properly ground the drive.	87
<input type="checkbox"/>	16	Tighten control circuit and grounding terminal screws.	83
<input type="checkbox"/>	17	Set up overload protection circuits when running multiple motors from a single drive. <div style="text-align: center; margin: 10px 0;"> <p style="font-size: small; margin: 0;">MC1 - MCn ... magnetic contactor OL 1 - OLn ... thermal relay</p> </div> <p><b>Note:</b> Close MC1 – MCn before operating the drive. MC1 – MCn cannot be switched off during run.</p>	–
<input type="checkbox"/>	18	Verify phase advancing capacitors, input noise filters, or GFCIs are NOT installed on the output side of the drive.	–
<b>Control Circuit Wiring</b>			
<input type="checkbox"/>	19	Use twisted-pair line for all drive control circuit wiring.	95
<input type="checkbox"/>	20	Ground the shields of shielded wiring to the GND ⊕ terminal.	95
<input type="checkbox"/>	21	For 3-Wire sequence, set parameters for multi-function contact input terminals S1 to S7, and wire control circuits.	–
<input type="checkbox"/>	22	Properly wire the option card.	95
<input type="checkbox"/>	23	Check for any other wiring mistakes. Only use a multimeter to check wiring.	–
<input type="checkbox"/>	24	Properly fasten drive control circuit terminal screws.	83
<input type="checkbox"/>	25	Pick up all wire clippings.	–
<input type="checkbox"/>	26	Ensure that no frayed wires on the terminal block are touching other terminals or connections.	–
<input type="checkbox"/>	27	Properly separate control circuit wiring and main circuit wiring.	–
<input type="checkbox"/>	28	Analog signal line wiring should not exceed 50 m.	–

# Start-Up Programming & Operation

---

This chapter explains HOA keypad functions and gives instructions on programming the drive for initial operation.

<b>4.1</b>	<b>SECTION SAFETY.....</b>	<b>106</b>
<b>4.2</b>	<b>USING THE HOA KEYPAD.....</b>	<b>107</b>
<b>4.3</b>	<b>THE DRIVE, PROGRAMMING, AND CLOCK ADJUSTMENT MODES.....</b>	<b>112</b>
<b>4.4</b>	<b>START-UP FLOWCHARTS.....</b>	<b>119</b>
<b>4.5</b>	<b>POWERING UP THE DRIVE.....</b>	<b>123</b>
<b>4.6</b>	<b>APPLICATION SELECTION.....</b>	<b>124</b>
<b>4.7</b>	<b>BASIC DRIVE SETUP ADJUSTMENTS.....</b>	<b>127</b>
<b>4.8</b>	<b>AUTO-TUNING.....</b>	<b>142</b>
<b>4.9</b>	<b>NO-LOAD OPERATION TEST RUN.....</b>	<b>150</b>
<b>4.10</b>	<b>TEST RUN WITH LOAD CONNECTED.....</b>	<b>151</b>
<b>4.11</b>	<b>VERIFYING PARAMETER SETTINGS AND BACKING UP CHANGES.....</b>	<b>152</b>
<b>4.12</b>	<b>TEST RUN CHECKLIST.....</b>	<b>154</b>
<b>4.13</b>	<b>ADVANCED DRIVE SETUP ADJUSTMENTS.....</b>	<b>155</b>

## 4.1 Section Safety

### DANGER

#### Electrical Shock Hazard

**Do not connect or disconnect wiring while the power is on.**

Failure to comply will result in death or serious injury.

### WARNING

#### Electrical Shock Hazard

**Do not operate equipment with covers removed.**

Failure to comply could result in death or serious injury.

The diagrams in this section may include drives without covers or safety shields to illustrate details. Be sure to reinstall covers or shields before operating the drives and run the drives according to the instructions described in this manual.

**Do not remove covers or touch circuit boards while the power is on.**

Failure to comply could result in death or serious injury.

**Prepare a separate holding brake.**

Wire the holding brake so when a fault occurs, it is activated by an external sequence and shuts the power off or triggers an emergency switch. Failure to comply could result in death or serious injury.

## 4.2 Using the HOA Keypad

Use the HOA keypad to enter OFF commands, switch AUTO or HAND Mode, change parameters, and display data including fault and alarm information.

### ◆ Keys and Displays

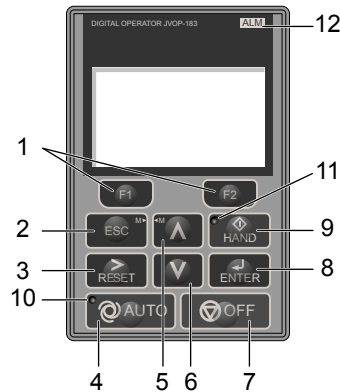

Figure 4.1 Keys and Displays on the HOA Keypad

No.	Display	Name	Function
1		Function Key (F1, F2)	The functions assigned to F1 and F2 vary depending on the currently displayed menu. The name of each function appears in the lower half of the display window.
2		ESC Key	<ul style="list-style-type: none"> <li>Returns to the previous display.</li> <li>Moves the cursor one space to the left.</li> <li>Pressing and holding this button will return to the Frequency Reference display.</li> </ul>
3		RESET Key	<ul style="list-style-type: none"> <li>Moves the cursor to the right.</li> <li>Resets the drive to clear a fault situation.</li> </ul>
4		AUTO Key	Selects the source of Run command and frequency reference. <ul style="list-style-type: none"> <li>Set the drive to AUTO mode.</li> <li>Run command input source depends on b1-02.</li> <li>Frequency reference input source depends on b1-01.</li> </ul>
5		Up Arrow Key	Scrolls up to display the next item, selects parameter numbers, and increments setting values.
6		Down Arrow Key	Scrolls down to display the previous item, selects parameter numbers, and decrements setting values.
7		OFF Key	Follows the stopping method set in b1-03 to stop drive operation.
8		ENTER Key	<ul style="list-style-type: none"> <li>Enters parameter values and settings.</li> <li>Selects a menu item to move between displays.</li> </ul>
9		HAND Key	The drive runs at a selectable frequency reference source by b1-12. <ul style="list-style-type: none"> <li>Set the drive to HAND mode.</li> <li>When b1-13 is set to 1, HAND and AUTO mode can be switched while the drive is running.</li> </ul>
10		AUTO Light	Lit while the drive is in AUTO mode. Refer to page 109 for details.
11		HAND Light	Lit while the drive is in HAND mode. Refer to page 109 for details.
12		ALM LED Light	<i>Refer to ALARM (ALM) LED Displays on page 109.</i>

◆ LCD Display

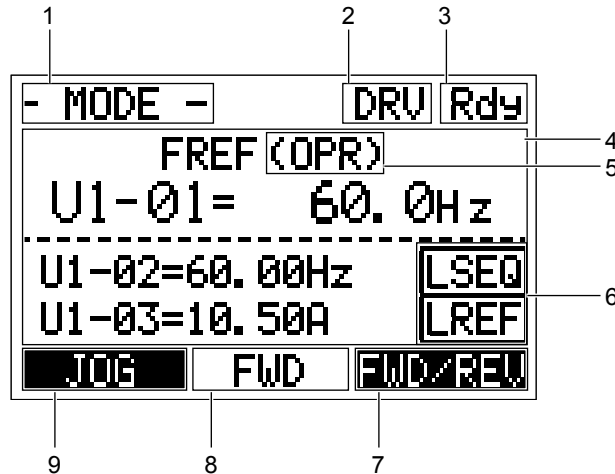







Figure 4.2 LCD Display

Table 4.1 Display and Contents

No.	Name	Display	Content
1	Operation Mode Menus	MODE	Displayed when in Mode Selection.
		MONITR	Displayed when in Monitor Mode.
		VERIFY	Indicates the Verify Menu.
		PRMSET	Displayed when in Parameter Setting Mode.
		A.TUNE	Displayed during Auto-Tuning.
		SETUP	Displayed when in Setup Mode.
2	Mode Display Area	DRV	Displayed when in Drive Mode.
		PRG	Displayed when in Programming Mode.
3	Ready	Rdy	Indicates the drive is ready to run.
4	Data Display	—	Displays specific data and operation data.
5	Frequency Reference Assignment </>	OPR	Displayed when the frequency reference is assigned to the HOA keypad.
		COM	Displayed when the frequency reference is assigned to the MEMOBUS/Modbus Communication Inputs of the drive.
		OP	Displayed when the frequency reference is assigned to option card connected to the drive.
		AI	Displayed when the function reference is assigned to an analog input.
		OFF	Displayed when HAND mode is OFF.
6	LOCAL/REMOTE Display </>	RSEQ	Displayed when the run command is supplied from a remote source.
		LSEQ	Displayed when the run command is supplied from the operator keypad.
		RREF	Displayed when the run command is supplied from a remote source.
		LREF	Displayed when the run command is supplied from the operator keypad.
7	Function Key 2 (F2)	FWD/REV	Pressing  switches between forward and reverse.
		DATA	Pressing  scrolls to the next display.
		→	Pressing  scrolls the cursor to the right.
		RESET	Pressing  resets the existing drive fault error.
		Monitor	Pressing  switches Monitor mode.
		DRV/BYP	The multi-function relay selected Drive/Bypass contact will be toggled.
		RUNBYP	The multi-function relay selected to RUN Bypass will be toggled.
RLY	The multi-function relay selected to Relay operator control will be toggled.		



No.	Name	Display	Content
8	FWD/REV	FWD	Indicates forward motor operation.
		REV	Indicates reverse motor operation.
9	Function Key 1 (F1)	JOG	Pressing  executes the Jog function.
		HELP	Pressing  displays the Help menu.
		←	Pressing  scrolls the cursor to the left.
		HOME	Pressing  returns to the top menu (Frequency Reference).
		ESC	Pressing  returns to the previous display.
		Monitor	Pressing  switches Monitor mode.
		DRV/BYP	The multi-function relay selected Drive/Bypass contact will be toggled.
		RUNBYP	The multi-function relay selected to RUN Bypass will be toggled.
		RLY	The multi-function relay selected to Relay operator control will be toggled.

<1> Displayed when in Frequency Reference Mode.

<2> Displayed when in Frequency Reference Mode and Monitor Mode.



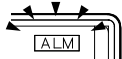











### ◆ ALARM (ALM) LED Displays

Table 4.2 ALARM (ALM) LED Status and Contents

State	Content	Display
Illuminated	When the drive detects an alarm or error.	
Flashing	<ul style="list-style-type: none"> <li>When an alarm occurs.</li> <li>When an oPE is detected.</li> <li>When a fault or error occurs during Auto-Tuning.</li> </ul>	
Off	Normal operation (no fault or alarm).	

### ◆ AUTO LED and HAND LED Indications

Table 4.3 AUTO LED and HAND LED Indications

AUTO LED	HAND LED	State
 Off	 Off	OFF mode
 Off	 On solid	HAND mode
 Off	 Long blink (50% duty)	HAND mode when the Frequency Reference is 0 and/or decelerating in HAND mode.
 On solid	 Off	Running in AUTO mode
 Long blink (50% duty)	 Off	Running in AUTO mode when the Frequency Reference is 0 and/or decelerating in AUTO mode.
 Short blink (15% duty)	 Off	AUTO mode, Ready, No run command input.
 Double blink	 Off	AUTO mode, stopped by a Fast- Stop from a Multi-Function Digital Input.

## 4.2 Using the HOA Keypad

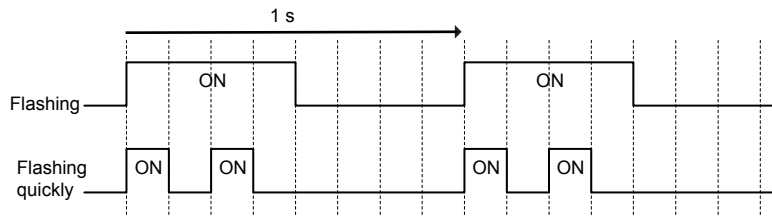

Figure 4.3 AUTO LED and OFF LED Status and Meaning

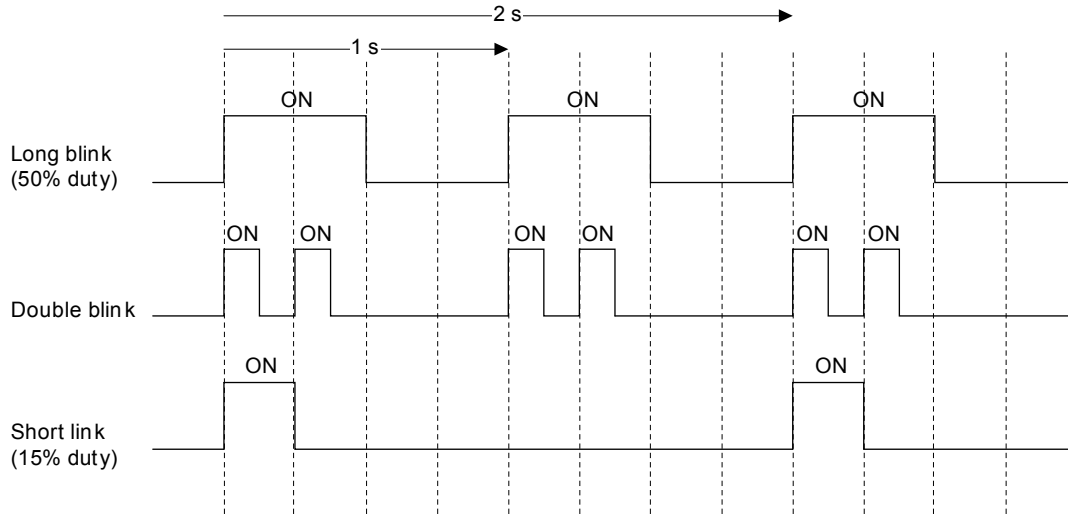

Figure 4.4 LEDs and Drive Operation in AUTO Mode

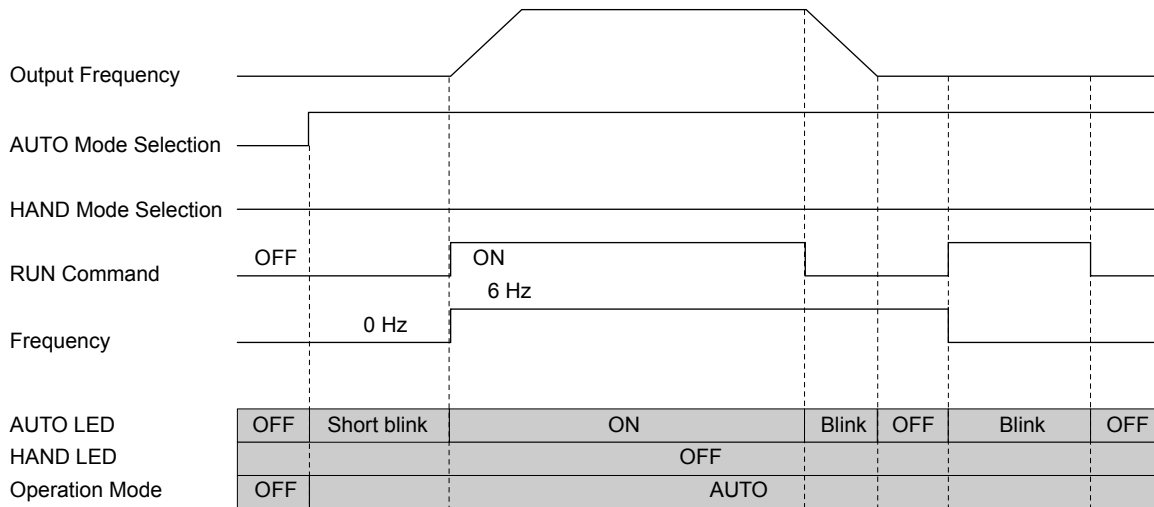

Figure 4.5 LEDs and Drive Operation in HAND Mode

## ◆ Menu Structure for HOA Keypad

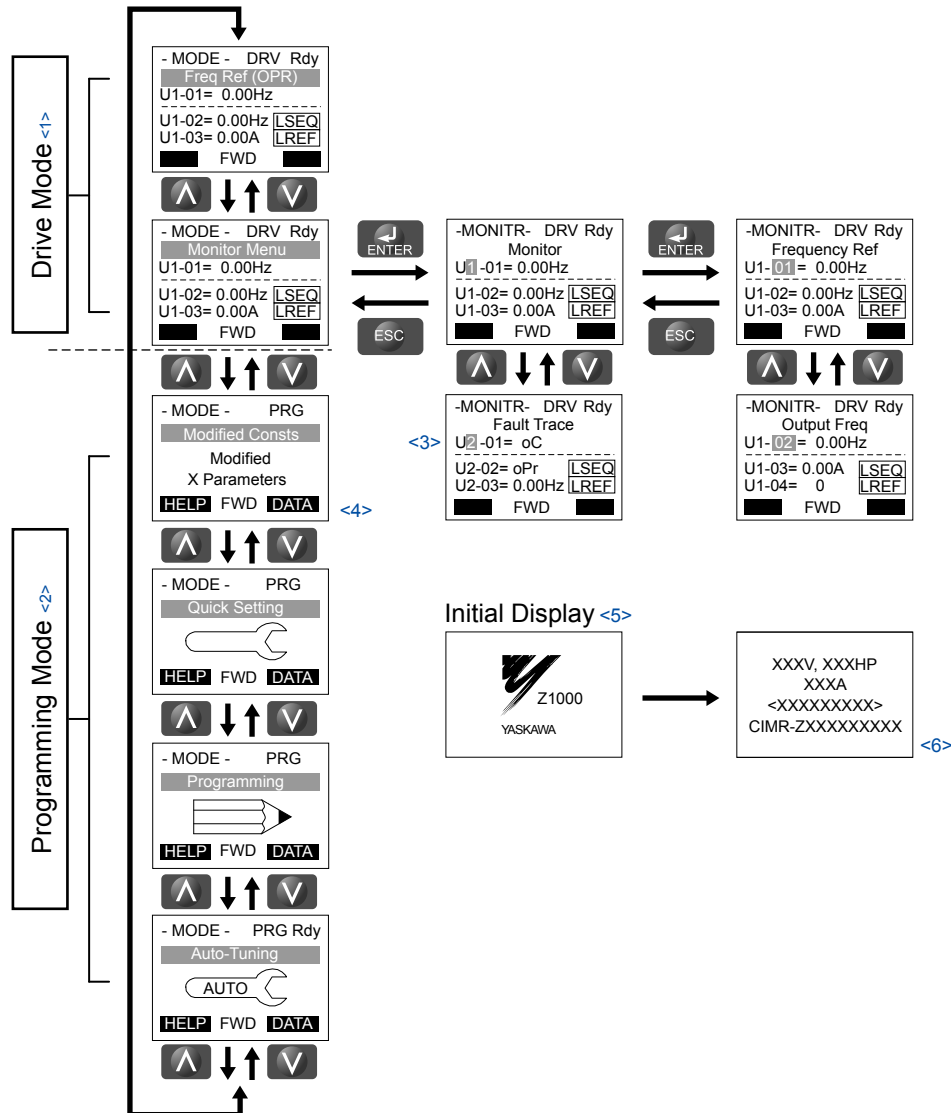

Figure 4.6 HOA Keypad Menu and Screen Structure

- <1> Pressing or will start the motor.
- <2> Drive cannot operate motor.
- <3> Flashing characters are shown with white letters on gray background. (Example: )
- <4> “X” characters are used as examples in this manual. The HOA keypad will display the actual setting values.
- <5> The Frequency Reference appears after the initial display that shows the product name.
- <6> The information that appears on the display will vary depending on the drive.

## 4.3 The Drive, Programming, and Clock Adjustment Modes

The drive has a Drive Mode to operate the motor, a Programming Mode to edit parameter settings, and a Clock Adjustment Mode to adjust the Real Time Clock.

**Drive Mode:** In Drive Mode the user can operate the motor and observe U Monitor parameters. Parameter settings cannot be edited or changed when in Drive Mode.

**Programming Mode:** In Programming Mode the user can edit and verify parameter settings and perform Auto-Tuning. When the drive is in Programming Mode it will not accept a Run command unless b1-08 is set to 1.

- Note:**
1. If b1-08 is set to 0, the drive will only accept a Run command in Drive Mode. After editing parameters, the user must exit the Programming Mode and enter Drive Mode before operating the motor.
  2. Set b1-08 to 1 to allow motor operation from the drive while in Programming Mode.

### ◆ Real-Time Clock (RTC)

The drive has a Clock Adjustment Mode to set and adjust the Real-Time Clock.

**Clock Adjustment Mode:** When o4-17 is set to 1, the HOA keypad will show the Clock Adjustment display. In Clock Adjustment Mode, the user can adjust the Real-Time Clock. When the drive is in Clock Adjustment Mode, it will not accept a Run command.

### ◆ Clock Adjustment

The HOA keypad will display the Real Time Clock Adjustment Display in [Figure 4.7](#) when the drive is powered up for the first time. [Refer to Manual Clock Adjustment Procedure by Setting o4-17 to 1 on page 113](#) for the Real-Time Clock setting procedure.

- Note:** Setting the Real-Time Clock will clear a “TIM” alarm.

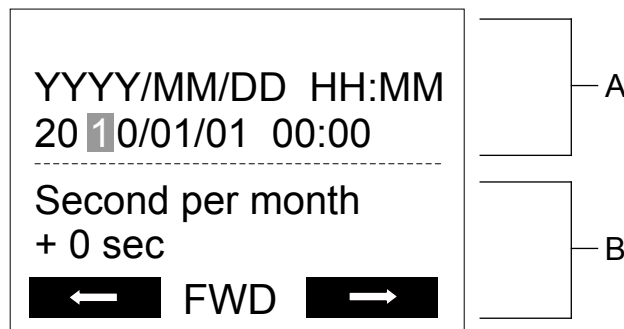

A – Real Time Clock Setting Display      B – Gain/Loss Adjustment Display  
**Figure 4.7 Real Time Clock Adjustment Display**

Display	Description
YYYY	Set the year with the last two digits.
MM	Set the month with two digits.
DD	Set the day with two digits.
HH:MM	Set the hours and minutes, with two digits for each.
Second per month	Set the gain or loss in seconds per month.

#### Moving the Cursor

Pressing the F2 key or the RESET key will move the cursor to the digit on the right. Pressing the F1 key will move the cursor to the left.

#### Changing Settings

- **Changing YYYY/MM/DD HH:MM:** Pressing the up arrow key will increase the number selected by the cursor from 0 to 9. Pressing the down arrow key will decrease the number selected by the cursor from 0 to 9.
- **Setting the Seconds per Month:** Pressing the up arrow key will increase the number selected by the cursor from -504 to +488 in increments of 8. Pressing the down arrow key will decrease the number selected by the cursor from -504 to +488 in increments of 8.

**Verifying the New Time Setting**

After pressing ENTER , the display will indicate “Entry accepted” and the new time value will be saved to the Real-Time Clock (RTC).

If there is a problem with the entered time, the operator will indicate “Input error” and the screen will return to the time setting display.

**Canceling the Input**

Pressing the ESC key will display “Aborted” on the operator, and no value will be saved to the RTC. Pressing OFF will abort the setting process without any display, and no setting changes will be saved to the RTC.

**Exiting from the Time Setting Screen Without Making Any Changes**

If no changes are entered, the display will exit Real Time Clock Adjustment Display after a few seconds and no changes will be saved.

**Real-Time Clock Setting at Initial Power-up of a New Drive**

Setting the Real-time clock is required at power-up of a new drive or after HOA keypad battery replacement.

Table 4.4 illustrates how to set the Real-Time Clock at initial power-up of a new drive.

**Table 4.4 Clock Adjustment Procedure at Power-up of a New Drive**

Procedure		Display
1	Turn the power on. The Real Time Clock Adjustment Display will appear. Use the right arrow key to select the desired digit, then set the correct date and time using the up and down arrow keys.	
2	After entering the Real-Time Clock data, press the ENTER key to save the changes. The display will indicate “Entry Accepted” and return to the initial display in step 3 and the alarm LED will be OFF.	
3	Initial display.	

**Manual Clock Adjustment by Setting o4-17 to 1**

The following actions are possible in the Clock Adjustment Mode:

- Set the current time
- Check the time set to the drive Real-Time Clock

Table 4.5 illustrates how to set the Real-Time Clock manually.

**Table 4.5 Manual Clock Adjustment Procedure by Setting o4-17 to 1**

Procedure		Display
1	The “Time Not Set” (TIM) display will appear if the Real-Time Clock data is not entered within 30 seconds of power-up on a new drive. Refer to <i>Fault Displays, Causes, and Possible Solutions on page 205</i> for more details on the TIM display.	
2	Use the up and down arrow keys to scroll through display menu until the screen displays “Programming”.	

### 4.3 The Drive, Programming, and Clock Adjustment Modes

Procedure		Display
3	Press the ENTER key to enter select the parameter setting mode.	
4	Use the up and down arrow keys to scroll through display menu until parameter o4-17 appears.	
5	Press the ENTER key until "0" flashes.	
6	Press the up arrow key so that the display changes to "1".	
7	Press the ENTER key and the time setting screen will appear. Use the right arrow key to select the desired digit, then set the correct date and time using the up and down arrow keys.	
8	After entering the correct time, press the ENTER key to save the changes. The display will return to the display shown in step 5 and the alarm LED will be OFF.	

#### ■ o4-17: Set/Reset Real Time Clock

The time setting screen will appear.

Z1000 Software Version	No. (Addr. Hex)	LCD Display	Name	Description	Values
PRG: 1012 and earlier	o4-17 (3100)	Set Time 0: Disabled 1: Enabled	Set/Reset Real Time Clock	Sets the current date and time for the Real Time Clock. 0: Disabled 1: Enabled	Default: 0 Range: 0, 1
PRG: 1013 and later	o4-17 (3100)	Set Time 0: — — 1: Set 2: Reset	Set/Reset Real Time Clock	Sets the current date and time for the Real Time Clock. 0: — — No Setting 1: Real Time Clock Set 2: Real Time Clock Reset	Default: 0 Range: 0 to 2

#### Setting 0: — —

No Setting

#### Setting 1: Set

The HOA keypad shows the Clock Adjustment display. In Clock Adjustment Mode the user can adjust the Real Time Clock.

#### Setting 2: Reset

The Real-Time Clock data is cleared. A TIM fault will occur until o4-17 is set to 1 to set the Real Time Clock.

### ■ Drive Mode Details

The following actions are possible in the Drive Mode:

- Run and stop the drive
- Monitor the operation status of the drive (frequency reference, output frequency, output current, output voltage, etc.)
- View information on an alarm
- View a history of alarms that have occurred

### ■ Programming Mode Details

The following actions are possible in the Programming Mode:





- **Parameter Setting Mode:** Access and edit all parameter settings.
- **Verify Menu:** View a list of parameters that have been changed from the default values.
- **Setup Group:** Access a list of commonly used parameters to simplify setup (*Refer to Simplified Setup Using the Setup Group on page 117*).
- **Auto-Tuning Mode:** Automatically calculate and set motor parameters to optimize drive performance.

### ◆ Changing Parameter Settings or Values

This example explains changing C1-02 (Deceleration Time 1) from 30.0 seconds (default) to 20.0 seconds.

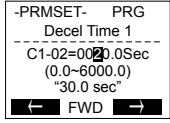
Step		Display/Result
1.	Turn on the power to the drive. The initial display appears.	
2.	Press  or  until the Parameter Setting Mode screen appears.	
3.	Press  to enter the parameter menu tree.	
4.	Press  or  to select the C parameter group.	
5.	Press  two times.	
6.	Press  or  to select parameter C1-02.	
7.	Press  to view the current setting value (10.0 s). The leftmost digit flashes.	
8.	Press  ,  , or  until the desired number is selected. "1" flashes.	

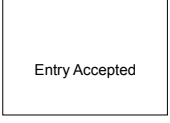
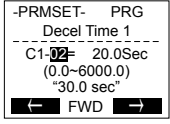
### 4.3 The Drive, Programming, and Clock Adjustment Modes

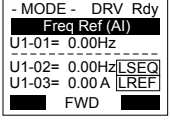
Step			Display/Result
9.	Press  and enter 0020.0.	→	
10.	Press  to confirm the change.	→	
11.	The display automatically returns to the screen shown in Step 4.	→	
12.	Press  as many times as necessary to return to the initial display.	→	







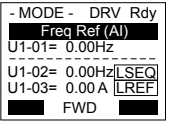

#### ◆ Verifying Parameter Changes: Verify Menu

The Verify Menu lists edited parameters from the Programming Mode or as a result of Auto-Tuning. The Verify Menu helps determine which settings have been changed, and is particularly useful when replacing a drive. If no settings have been changed, the Verify Menu will read “None”. The Verify Menu also allows users to quickly access and re-edit any parameter settings that have been changed.

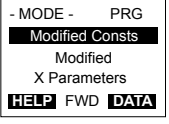
**Note:** The Verify Menu will not display parameters from the A1 group (except for A1-02) even if those parameters have been changed from their default settings.

The following example is a continuation of the steps above. Here, parameter C1-02 is accessed using the Verify Menu, and is changed again from 30.0 s to 20.0 s.

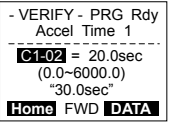
To check the list of edited parameters:

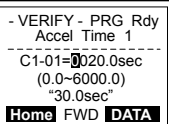
Step			Display/Result
1.	Turn on the power to the drive. The initial display appears.	→	
2.	Press  or  until the display shows the top of the Verify Menu.	→	
3.	Press  to enter the list of parameters that have been edited from their original default settings. If parameters other than C1-02 have been changed, use  or  to scroll until C1-02 appears.	→	
4.	Press  to access the setting value. The most significant digit flashes.	→	

### ◆ Simplified Setup Using the Setup Group

The Setup Group lists the basic parameters necessary to set up the drive for an application. This group expedites the startup process for an application by showing only the most important parameters for the application.

#### ■ Using the Setup Group

Figure 4.8 illustrates how to enter and how to change parameters in the Setup Group.

The first display shown when entering the Setup Group is the Application Selection menu. Skipping this display will keep the current Setup Group parameter selection. The default setting for the Setup Group is a group of parameters most commonly use in general-purpose applications. Pressing the ENTER key from the Application Selection menu and selecting an Application Preset will change the Setup Group to parameters optimal for the application selected. Refer to Application Selection on page 124.

In this example, the Setup Group is accessed to change b1-01 from 1 to 0. This changes the source of the frequency reference from the control circuit terminals to the HOA keypad.

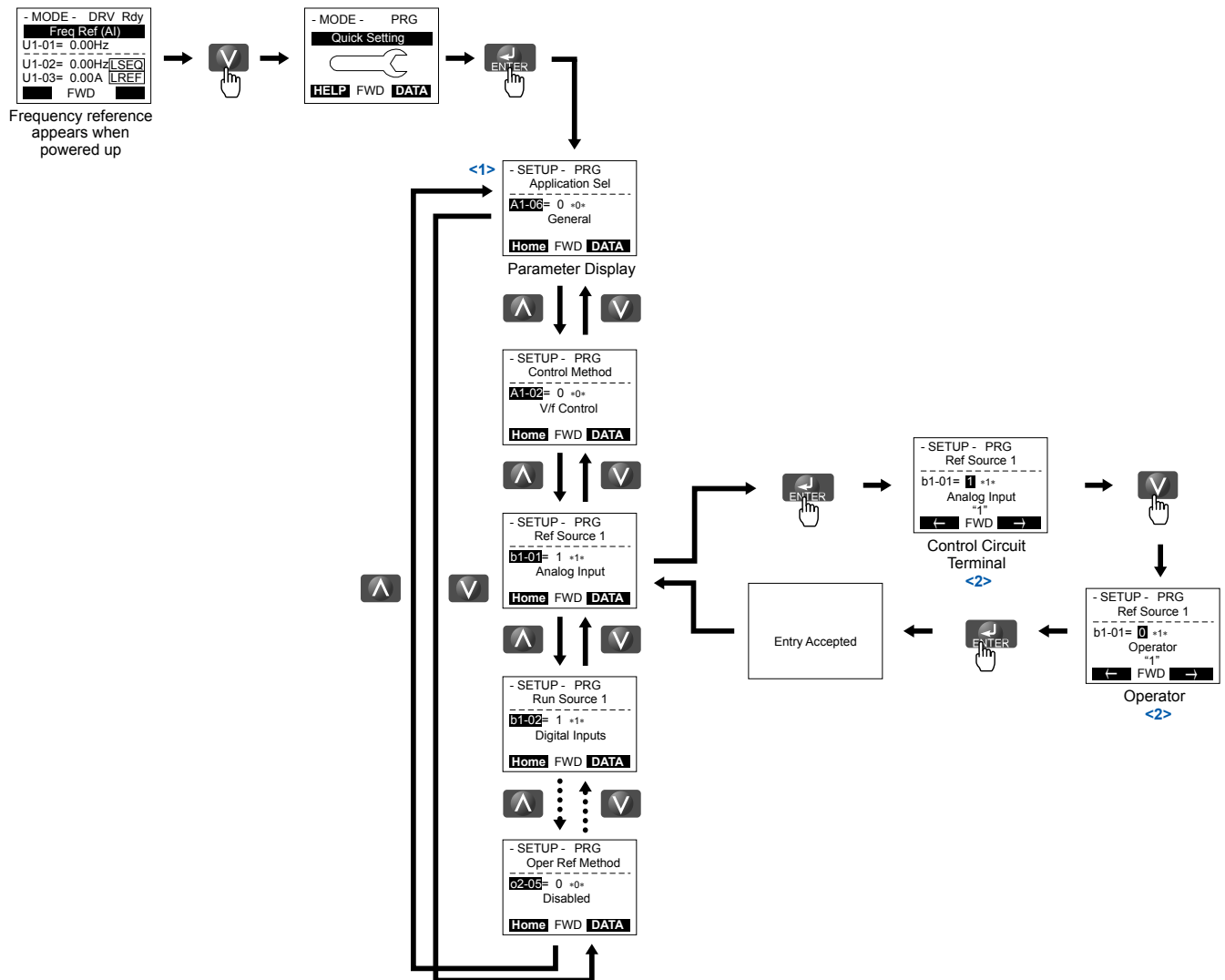

Figure 4.8 Setup Group Example

- <1> Use the up and down arrow keys to scroll through the Setup Group. Press the ENTER key to view or change parameter settings.
- <2> To return to the previous menu without saving changes, press the ESC key.

### 4.3 The Drive, Programming, and Clock Adjustment Modes

#### ■ Setup Group Parameters

*Table 4.6* lists the parameters available by default in the Setup Group. Selecting an Application Preset in parameter A1-06 or from the Application Selection Menu of the Setup Group automatically changes the parameters selected for the Setup Group. *Refer to Application Selection on page 124* for more information.

Use the Programming Mode to access parameters not displayed in the Setup Group.

**Table 4.6 Setup Group Parameters**

Parameter	Name	Parameter	Name
A1-02	Control Method Selection	H3-03	Terminal A1 Gain Setting
b1-01	Frequency Reference Selection 1	H3-04	Terminal A1 Bias Setting
b1-02	Run Command Selection 1	H3-11	Terminal A2 Gain Setting
b1-03	Stopping Method Selection	H3-12	Terminal A2 Bias Setting
C1-01	Acceleration Time 1	L2-01	Momentary Power Loss Operation Selection
C1-02	Deceleration Time 1	L2-02	Momentary Power Loss Ride-Thru Time
C6-02	Carrier Frequency Selection	L4-05	Frequency Reference Loss Detection Selection
d2-01	Frequency Reference Upper Limit	L4-06	Frequency Reference at Reference Loss
d2-02	Frequency Reference Lower Limit	L5-01	Number of Auto Restart Attempts
E1-01	Input Voltage Setting	L5-03	Fault Reset Interval Time
E1-04	Maximum Output Frequency	L6-01	Torque Detection Selection 1
E1-05	Maximum Voltage	L6-02	Torque Detection Level 1
E1-06	Base Frequency	L6-03	Torque Detection Time 1
E2-01	Motor Rated Current	o2-03	User Parameter Default Value
E2-11	Motor Rate Power	o2-05	Frequency Reference Setting Method Selection
F6-01	Communications Error Operation Selection		

## 4.4 Start-Up Flowcharts

These flowcharts summarize steps required to start the drive. Use the flowcharts to determine the most appropriate start-up method for a given application. The charts are quick references to help familiarize the user with start-up procedures.

**Note:** Refer to *Application Selection on page 124* to set up the drive using one of the Application Presets.

Flowchart	Subchart	Objective	Page
A	–	Basic start-up procedure and motor tuning	<a href="#">120</a>
–	A-1	Simple motor setup using V/f mode	<a href="#">121</a>
	A-2	Setting up the drive to run a permanent magnet (PM) motor	<a href="#">122</a>

### ◆ Flowchart A: Basic Start-Up and Motor Tuning

Flowchart A in *Figure 4.9* describes a basic start-up sequence that varies slightly depending on the application. Use the drive default parameter settings in simple applications that do not require high precision.

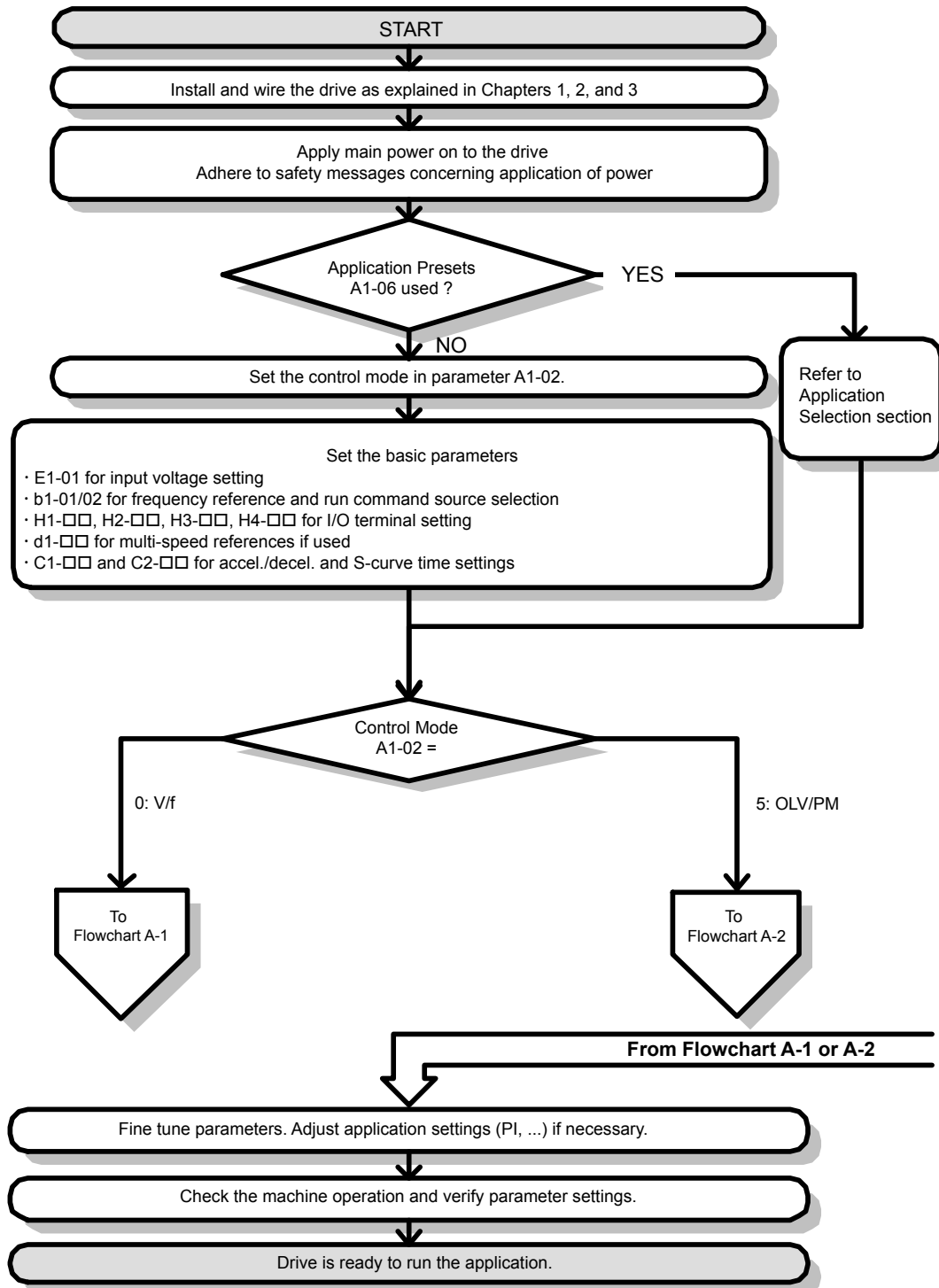

**Figure 4.9 Basic Start-Up**

- Note:**
1. Execute Stationary Auto-Tuning for Line-to-Line Resistance if the drive has been Auto-Tuned and then moved to a different location where the motor cable length exceeds 50 m.
  2. Perform Auto-Tuning again after installing an AC reactor or other such components to the output side of the drive.

### ◆ Subchart A-1: Simple Motor Setup Using V/f Control

Flowchart A-1 in *Figure 4.10* describes simple motor setup for V/f Control. V/f Control is suited for more basic applications such as fans and pumps. This procedure illustrates Energy Savings and Speed Estimation Speed Search.

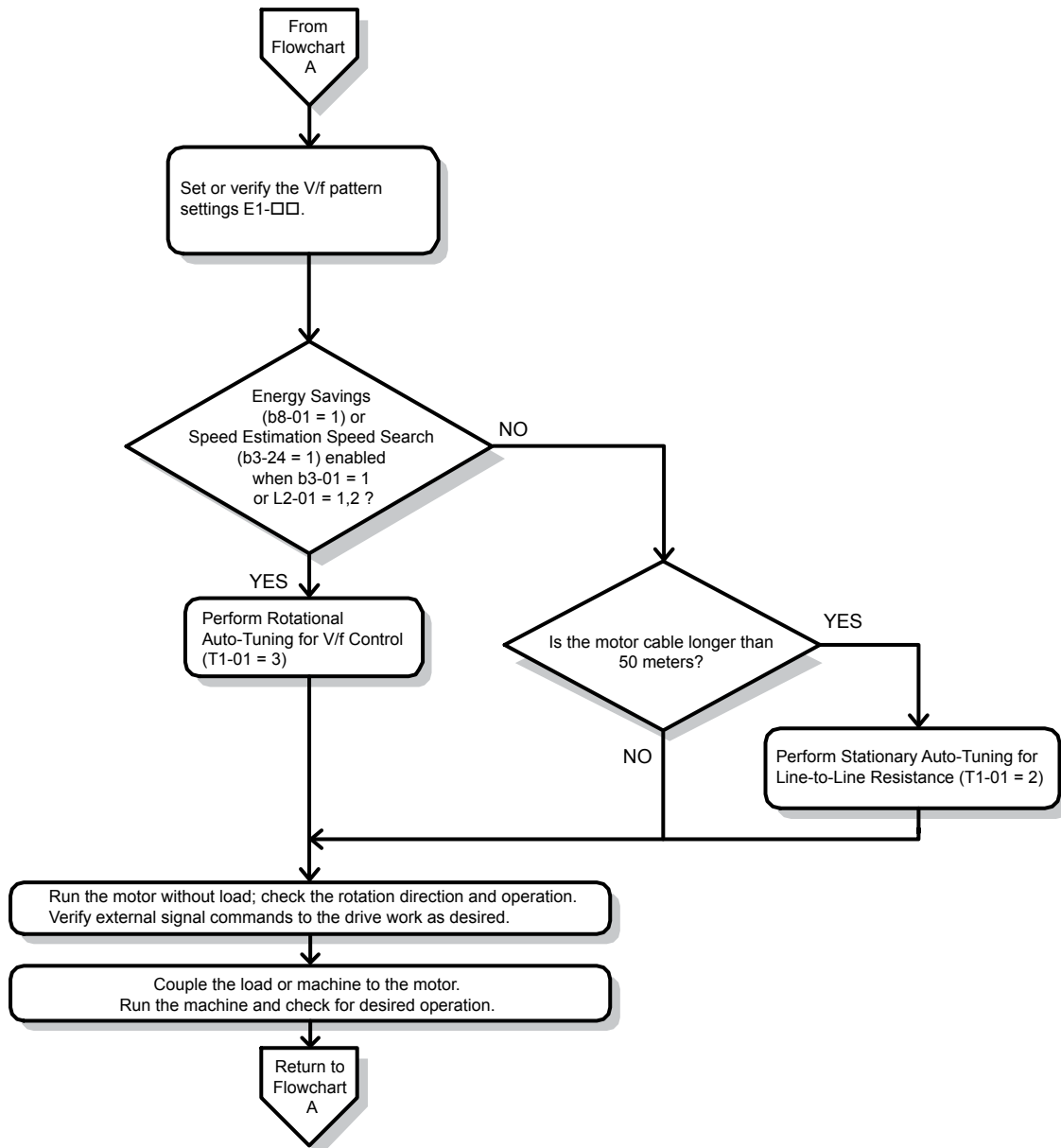

Figure 4.10 Simple Motor Setup with Energy Savings or Speed Search

### ◆ Subchart A-2: Operation with Permanent Magnet Motors

Flowchart A-2 in [Figure 4.11](#) describes the setup procedure for running a PM motor in Open Loop Vector Control. PM motors can be used for more energy-efficient operation in reduced or variable torque applications.

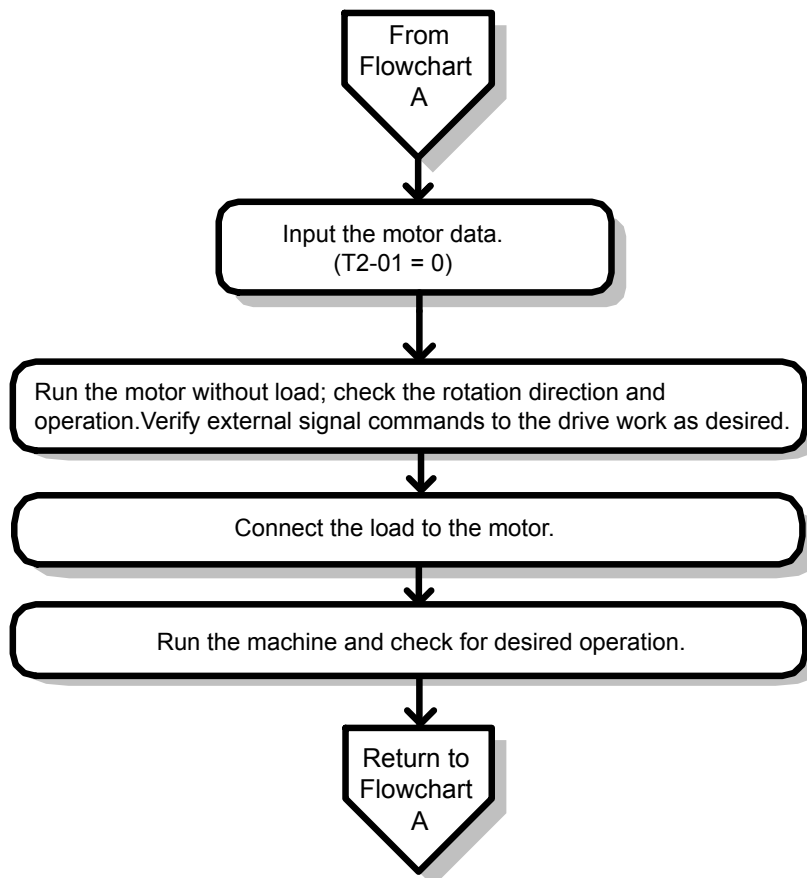

Figure 4.11 Operation with Permanent Magnet Motors

## 4.5 Powering Up the Drive

### ◆ Powering Up the Drive and Operation Status Display

#### ■ Powering Up the Drive

Review the following checklist before turning the power on.

Item to Check	Description
Power supply voltage	200 V class: Three-phase 200 to 240 Vac 50/60 Hz 400 V class: Three-phase 380 to 480 Vac 50/60 Hz
	Properly wire the power supply input terminals (R/L1, S/L2, T/L3).
	Check for proper grounding of drive and motor.
Drive output terminals and motor terminals	Properly wire drive output terminals U/T1, V/T2, and W/T3 with motor terminals U, V, and W.
Control circuit terminals	Check control circuit terminal connections.
Drive control terminal status	Open all control circuit terminals (off).
Status of the load and connected machinery	Decouple the motor from the load.

#### ■ Status Display

When the power supply to the drive is turned on, the HOA keypad lights will appear as follows:

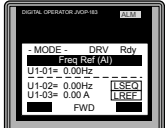
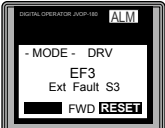
Status	Name	Description
Normal Operation		The data display area displays the frequency reference. <b>[DRV]</b> is lit.
Fault	 External fault (example)	Data displayed varies by the type of fault. <i>Refer to Fault Displays, Causes, and Possible Solutions on page 205</i> for more information. <b>[ALM]</b> and <b>[DRV]</b> are lit.

### 4.6 Application Selection

Several Application Presets are available to facilitate drive setup for commonly used applications. Selecting one of these Application Presets automatically assigns functions to the input and output terminals, and sets certain parameters to values appropriate for the application that was selected.

An Application Preset can either be selected from the Application Selection display in the Setup Group (*Refer to Using the Setup Group on page 117*) or in parameter A1-06. The following presets can be selected:

**Note:** An Application Preset can only be selected if all drive parameters are on at their original default settings. It may be necessary to initialize the drive by setting A1-03 to “2220” or “3330” prior to selecting an Application Preset.

**WARNING!** Confirm the drive I/O signals and external sequence before performing a test run. Setting parameter A1-06 may change the I/O terminal function automatically from the default setting. Failure to comply may result in death or serious injury.

No.	Parameter Name	Setting Range	Default
A1-06	Application Presets	0: Standard 1: Fan 2: Fan with PI Control 3: Return Fan with PI Control 4: Cooling Tower Fan 5: Cooling Tower Fan with PI Control 6: Pump (Secondary) 7: Pump with PI Control	0

### ◆ HVAC Application Parameters

In addition, the application parameters most likely to be changed for fan and pump applications are assigned to the group of User Parameters, A2-01 through A2-32. User Parameters provide quicker access to by eliminating the need to scroll through multiple menus.

**Table 4.7 User Parameters (A2-01 to A2-32)**

No.	Parameter Name	No.	Parameter Name
b1-03	Stopping Method Selection	C1-01	Acceleration Time 1
b1-04	Reverse Operation Selection	d2-03	Master Speed Reference Lower Limit
b2-09	Motor Pre-Heat Current 2	H1-07	Multi-Function Digital Input Terminal S7 Function Selection
b5-01	PI Function Setting	H3-01	Terminal A1 Signal Level Selection
b5-03	Integral Time Setting (I)	H3-02	Terminal A1 Function Selection
b5-08	PI Primary Delay Time Constant	H3-10	Terminal A2 Function Selection
b5-09	PI Output Level Selection	L5-01	Number of Auto Restart Attempts
b5-13	PI Feedback Low Detection Level	L6-01	Stall Prevention Selection during Deceleration
b5-14	PI Feedback Low Detection Time	o1-06	User Monitor Selection Mode
b5-15	PI Sleep Function Start Level	o1-07	Second Line Monitor Selection
b5-16	PI Sleep Delay Time	o1-08	Third Line Monitor Selection

### ◆ Setting 1: Fan Application

**Table 4.8 Fan: Parameter Settings**

No.	Name	Default Setting
b1-03	Stopping Method Selection	1: Coast to Stop
b1-04	Reverse Operation Selection	1: Reverse operation disabled
C1-01	Acceleration Time 1	60 s
L5-01	Number of Auto Restart Attempts	10
L6-01	Torque Detection Selection 1	5: UL3 at speed agree (Alarm)

## ◆ Setting 2: Fan with PI Control Application

Table 4.9 Fan with PI Control: Parameter Settings

No.	Parameter Name	Default Setting
b1-03	Stopping Method Selection	1: Coast to Stop
b1-04	Reverse Operation Selection	1: Reverse operation disabled
b5-01	PI Function Setting	1: Output frequency = PI output 1
b5-03	Integral Time Setting (I)	30 s
b5-08	PI Primary Delay Time Constant	2 s
b5-13	PI Feedback Low Detection Level	2%
b5-14	PI Feedback Low Detection Time	25 s
C1-01	Acceleration Time 1	60 s
L5-01	Number of Auto Restart Attempts	10
L6-01	Stall Prevention Selection during Deceleration	5: UL3 at speed agree (Alarm)

## ◆ Setting 3: Return Fan with PI Control Application

Table 4.10 Return Fan with PI Control: Parameter Settings

No.	Parameter Name	Default Setting
b1-03	Stopping Method Selection	1: Coast to Stop
b1-04	Reverse Operation Selection	1: Reverse operation disabled
b5-01	PI Function Setting	1: Output frequency = PI output 1
b5-03	Integral Time Setting (I)	30 s
b5-08	PI Primary Delay Time Constant	2 s
b5-13	PI Feedback Low Detection Level	2%
b5-14	PI Feedback Low Detection Time	25 s
C1-01	Acceleration Time 1	60 s
H3-01	Terminal A1 Signal Level Selection	2: 4 to 20 mA
H3-02	Terminal A1 Function Selection	B: PI feedback
H3-10	Terminal A2 Function Selection	16: Differential PI feedback
L5-01	Number of Auto Restart Attempts	10
L6-01	Stall Prevention Selection during Deceleration	5: UL3 at speed agree (Alarm)
o1-07	Second Line Monitor Selection	505: PI Differential Feedback

## ◆ Setting 4: Cooling Tower Fan Application

Table 4.11 Cooling Tower Fan: Parameter Settings

No.	Parameter Name	Default Setting
b1-03	Stopping Method Selection	1: Coast to Stop
b1-04	Reverse Operation Selection	0: Reverse operation enabled
b2-09	Motor Pre-Heat Current 2	10%
C1-01	Acceleration Time 1	60 s
d2-03	Master Speed Reference Lower Limit	30%
H1-07	Multi-Function Digital Input Terminal S7 Function Selection	60: Motor Pre-Heat 1
L5-01	Number of Auto Restart Attempts	10
L6-01	Stall Prevention Selection during Deceleration	5: UL3 at speed agree (Alarm)

## 4.6 Application Selection

### ◆ Setting 5: Cooling Tower Fan with PI Control Application

Table 4.12 Cooling Tower Fan with PI Control: Parameter Settings

No.	Parameter Name	Default Setting
b1-03	Stopping Method Selection	1: Coast to Stop
b1-04	Reverse Operation Selection	0: Reverse operation enabled
b2-09	Motor Pre-Heat Current 2	10%
b5-01	PI Function Setting	1: Output frequency = PI output 1
b5-03	Integral Time Setting (I)	30 s
b5-08	PI Primary Delay Time Constant	2 s
b5-09	PI Output Level Selection	1: Reverse Output
b5-13	PI Feedback Low Detection Level	2%
b5-14	PI Feedback Low Detection Time	25 s
b5-15	PI Sleep Function Start Level	10.8 Hz
b5-16	PI Sleep Delay Time	25.5 s
C1-01	Acceleration Time 1	60 s
d2-03	Master Speed Reference Lower Limit	30%
H1-07	Multi-Function Digital Input Terminal S7 Function Selection	60: Motor Pre-Heat 1
L5-01	Number of Auto Restart Attempts	10
L6-01	Stall Prevention Selection during Deceleration	5: UL3 at speed agree (Alarm)

### ◆ Setting 6: Pump (Secondary) Application

Table 4.13 Pump (Secondary): Parameter Settings

No.	Parameter Name	Default Setting
b1-04	Reverse Operation Selection	1: Reverse operation disabled
C1-01	Acceleration Time 1	20 s
d2-03	Master Speed Reference Lower Limit	20%
L5-01	Number of Auto Restart Attempts	10
L6-01	Stall Prevention Selection during Deceleration	5: UL3 at speed agree (Alarm)

### ◆ Setting 7: Pump with PI Control Application

Table 4.14 Pump with PI Control: Parameter Settings

No.	Parameter Name	Default Setting
b1-04	Reverse Operation Selection	1: Reverse operation disabled
b5-01	PI Function Setting	1: Enabled (PI output becomes output frequency reference)
b5-03	Integral Time Setting (I)	15 s
b5-08	PI Primary Delay Time Constant	10.0 s
b5-13	PI Feedback Low Detection Level	2%
b5-14	PI Feedback Low Detection Time	25 s
b5-15	PI Sleep Function Start Level	72%
b5-16	PI Sleep Delay Time	25.5 s
C1-01	Acceleration Time 1	20 s
d2-03	Master Speed Reference Lower Limit	20%
L5-01	Number of Auto Restart Attempts	10
L6-01	Stall Prevention Selection during Deceleration	5: UL3 at speed agree (Alarm)

## 4.7 Basic Drive Setup Adjustments

This section explains the basic settings required for initial drive operation. Checking these basic parameter settings will help to ensure a successful drive start-up. *Refer to Parameter List on page 279* for a complete listing of drive parameters if more information is required for parameters not listed in this section or in *4.13 Advanced Drive Setup Adjustments*.

### ■ A1-02: Control Method Selection

Selects the Control Method (also referred to as the control mode) that the drive uses to operate the motor. Parameter A1-02 determines the control mode for the motor.

**Note:** When changing control modes, all parameter settings depending upon the setting of A1-02 will be reset to the default.

No.	Parameter Name	Setting Range	Default
A1-02	Control Method Selection	0, 5	0

### Setting 0: V/f Control for Induction Motors

Use this mode for simple speed control and for multiple motor applications with low demands to dynamic response or speed accuracy. The speed control range is 1:40.

### Setting 5: Open Loop Vector Control for PM

Use this mode when running a PM motor in variable torque applications that benefit from energy efficiency. The drive can control an SPM or IPM motor with a speed range of 1:20 in this control mode.

### ■ b1-01: Frequency Reference Selection for AUTO Mode

Selects the frequency reference source 1.

**Note:** If a Run command is input to the drive, but the frequency reference entered is 0 or below the minimum frequency, the AUTO or HAND indicator LED on the HOA keypad will light and the OFF indicator will flash.

No.	Parameter Name	Setting Range	Default
b1-01	Frequency Reference Selection for AUTO Mode	0 to 3	1

### Setting 0: HOA Keypad

Using this setting, the frequency reference can be input by:

- switching between the multi-speed references from d1-01 to d1-04.
- entering the frequency reference on the operator keypad.

### Setting 1: Terminals (Analog Input Terminals)

Using this setting, an analog frequency reference can be entered as a voltage or current signal from terminals A1 or A2.

#### Voltage Input

Voltage input can be used at any of the two analog input terminals. Make the settings as described in *Table 4.15* for the input used.

**Table 4.15 Analog Input Settings for Frequency Reference Using Voltage Signals**

Terminal	Signal Level	Parameter Settings				Notes
		Signal Level Selection	Function Selection	Gain	Bias	
A1	0 to 10 V with Zero Limit	H3-01 = 0	H3-02 = 0 (Frequency Reference Bias)	H3-03	H3-04	Set Jumper S1 on the terminal board to "V" for voltage input.
	0 to 10 V without Zero Limit	H3-01 = 1				
A2	0 to 10 V with Zero Limit	H3-09 = 0	H3-10 = 0 (Frequency Reference Bias)	H3-11	H3-12	
	0 to 10 V without Zero Limit	H3-09 = 1				

## 4.7 Basic Drive Setup Adjustments

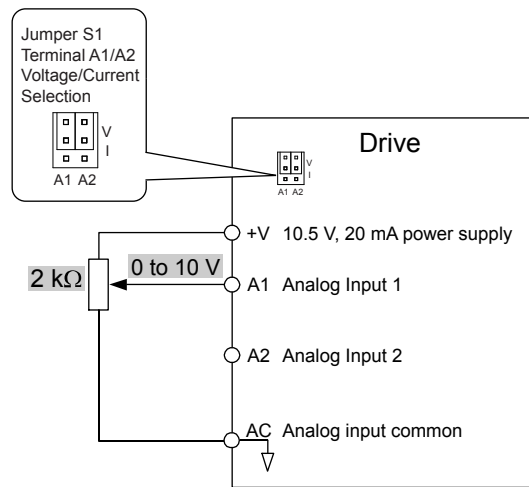

**Figure 4.12** Setting the Frequency Reference as a Voltage Signal at Terminal A1

Use the wiring example shown in [Figure 4.12](#) for any other analog input terminals. When using input terminals A1 and A2, make sure Jumper S1 is set for voltage input.

### Current Input

Input terminals A1 and A2 can accept a current input signal. Refer to [Table 4.16](#) to set terminals A1 and A2 for current input.

**Table 4.16** Analog Input Settings for Frequency Reference Using a Current Signal

Terminal	Signal Level	Parameter Settings				Notes
		Signal Level Selection	Function Selection	Gain	Bias	
A1	4 to 20 mA	H3-01 = 2	H3-02 = 0 (Frequency Reference Bias)	H3-03	H3-04	Make sure to set Jumper S1 on the terminal board to “I” for current input.
	0 to 20 mA	H3-01 = 3				
A2	4 to 20 mA	H3-09 = 2	H3-10 = 0 (Frequency Bias)	H3-11	H3-12	
	0 to 20 mA	H3-09 = 3				

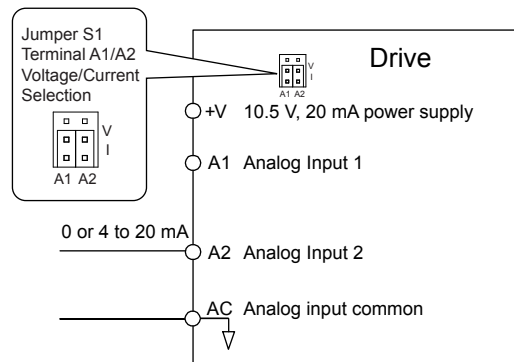

**Figure 4.13** Setting the Frequency Reference as a Current Signal to Terminal A2

### Switching between Main/Auxiliary Frequency References

The frequency reference input can be switched between the analog terminals A1 and A2 using multi-speed inputs. [Refer to Multi-Step Speed Selection on page 170](#) for details on using this function.

### Setting 2: Serial Communication (APOGEE FLN, BACnet, MEMOBUS/Modbus, Metasys N2)

This setting requires entering the frequency reference via the RS-422/RS-485 serial communications port (control terminals R+, R-, S+, and S-).

**Setting 3: Option Card**

This setting requires entering the frequency reference via an option board plugged into connector CN5 on the drive control board. Consult the option card manual for instructions on integrating the drive with the communication system.

**Note:** If the frequency reference source is set for Option PCB (b1-01 = 3), but an option board is not installed, an oPE05 Programming Error will be displayed on the HOA keypad and the drive will not run.

**■ b1-02: Run Command Selection for AUTO Mode**

Determines the Run command selection for AUTO mode.

No.	Parameter Name	Setting Range	Default
b1-02	Run Command Selection for AUTO Mode	1 to 3	1

**Setting 1: Control Circuit Terminal**

This setting requires entering the Run command via the digital input terminals using one of following sequences:

- 2-Wire sequence 1:

Two inputs (FWD/Stop-REV/Stop). Set A1-03 to 2220 to initialize the drive and preset terminals S1 and S2 to these functions. This is the default setting of the drive.

- 2-Wire sequence 2:

Two inputs (Start/Stop-FWD/REV).

- 3-Wire sequence:

Three inputs (Start-Stop-FWD/REV). Set A1-03 to 3330 to initialize the drive and preset terminals S1, S2, and S5 to these functions.

**Setting 2: Serial Communication (APOGEE FLN, BACnet, MEMOBUS/Modbus, Metasys N2)**

This setting requires entering the Run command via serial communications by connecting the RS-422/RS-485 serial communication cable to control terminals R+, R-, S+, and S- on the terminal block.

**Setting 3: Option Card**

This setting requires entering the Run command via the communication option board by plugging a communication option board into the CN5 port on the control PCB. Refer to the option card manual for instructions on integrating the drive into the communication system.

**Note:** If b1-02 is set to 3, but an option card is not installed in CN5, an oPE05 Programming Error will be displayed on the HOA keypad and the drive will not run.

**■ b1-03: Stopping Method Selection**

Selects how the drive stops the motor when the Run command is removed or when a Stop command is entered.

No.	Parameter Name	Setting Range	Default
b1-03	Stopping Method Selection	0 to 3	1

**Setting 0: Ramp to Stop**

When the Run command is removed, the drive will decelerate the motor to stop. The deceleration rate is determined by the active deceleration time. The default deceleration time is set to parameter C1-02.

When the output frequency falls below the level set in parameter b2-01, the drive will start DC injection or Short Circuit Braking depending on the selected control mode. *Refer to b2-01: DC Injection Braking Start Frequency on page 157* for details.

**Setting 1: Coast to Stop**

When the Run command is removed, the drive will shut off its output and the motor will coast (uncontrolled deceleration) to stop. The stopping time is determined by the inertia and the friction in the driven system.

## 4.7 Basic Drive Setup Adjustments

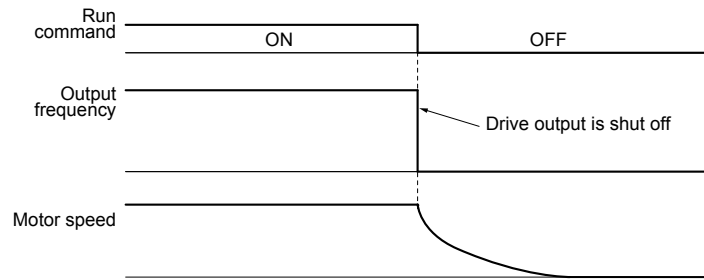

**Figure 4.14 Coast to Stop**

**Note:** After a stop is initiated, any subsequent Run command entered will be ignored until the minimum baseblock time (L2-03) has expired. Do not enter Run command until it has come to a complete stop. Use DC Injection at Start ([Refer to b2: DC Injection Braking and Short Circuit Braking on page 282](#)) or Speed Search ([Refer to b3: Speed Search on page 283](#)) to restart the motor before it has completely stopped.

### Setting 2: DC Injection Braking to Stop

When the Run command is removed, the drive will enter baseblock (turn off its output) for the minimum baseblock time (L2-03). When the minimum baseblock time has expired, the drive will inject the amount DC current set in parameter b2-02 into the motor windings to brake the motor. The stopping time in DC Injection Braking to Stop is significantly faster compared to Coast to Stop.

**Note:** This function is not available in OLV/PM control mode (A1-02 = 5).

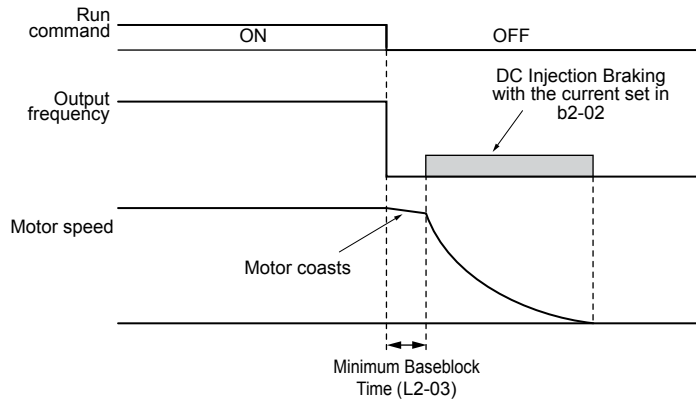

**Figure 4.15 DC Injection Braking to Stop**

DC Injection Braking time is determined by the value set to b2-04 and the output frequency at the time the Run command is removed. It can be calculated by:

$$\text{DC Injection brake time} = \frac{(b2-04) \times 10 \times \text{Output frequency}}{\text{Max. output frequency (E1-04)}}$$

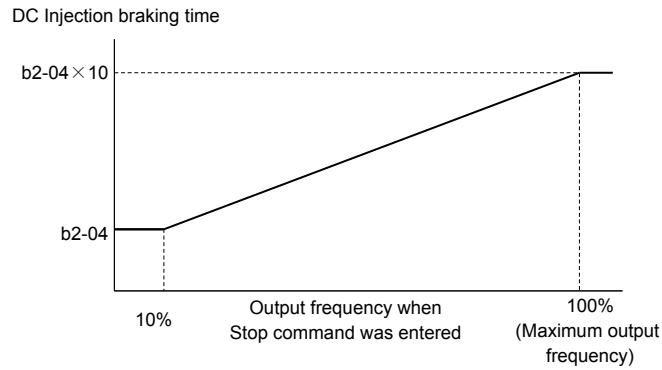

Figure 4.16 DC Injection Braking Time Depending on Output Frequency

**Note:** If an overcurrent (oC) fault occurs during DC Injection Braking to Stop, lengthen the minimum baseblock time (L2-03) until the fault no longer occurs.

**Setting 3: Coast with Timer**

When the Run command is removed, the drive will turn off its output and the motor will coast to stop. The drive will not start if a Run command is input before the time  $t$  (C1-02) has expired. Cycle the Run command that was activated during time  $t$  after  $t$  has expired to start the drive.

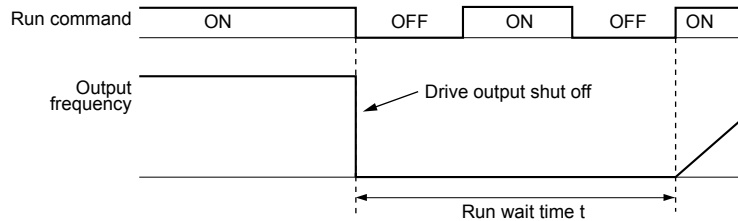

Figure 4.17 Coast with Timer

The wait time  $t$  is determined by the output frequency when the Run command is removed and by the active deceleration time.

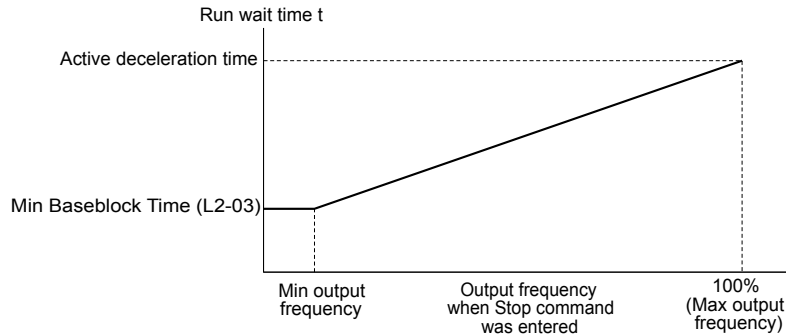

Figure 4.18 Run Wait Time Depending on Output Frequency

## 4.7 Basic Drive Setup Adjustments

### ■ C1-01 to C1-04: Accel, Decel Times 1 and 2

Four different sets of acceleration and deceleration times can be set in the drive by digital inputs, motor selection, or switched automatically.

Acceleration time parameters always set the time to accelerate from 0 Hz to the maximum output frequency (E1-04). Deceleration time parameters always set the time to decelerate from maximum output frequency to 0 Hz. C1-01 and C1-02 are the default active accel/decel settings.

No.	Parameter Name	Setting Range	Default
C1-01	Acceleration Time 1	0.1 to 6000.0 s	30.0 s
C1-02	Deceleration Time 1		
C1-03	Acceleration Time 2		
C1-04	Deceleration Time 2		

#### Switching Acceleration Times by Digital Input

Accel/decel times 1 are active by default if no input is set.

Table 4.17 Accel/Decel Time Selection by Digital Input

Accel/Decel Time Sel. 1 H1-□□ = 7	Active Times	
	Acceleration	Deceleration
0	C1-01	C1-02
1	C1-03	C1-04

Figure 4.19 shows an operation example for changing accel/decel. times. The example below requires that the stopping method be set for “Ramp to stop” (b1-03 = 0).

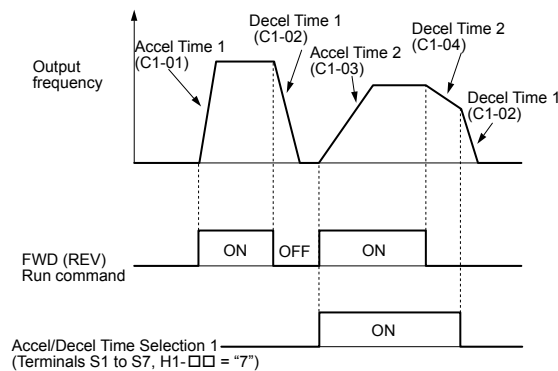

Figure 4.19 Timing Diagram of Accel/Decel Time Change

#### Switching Accel/Decel Times by a Frequency Level

The drive can switch between different acceleration and deceleration times automatically. The drive will switch from accel/decel time 2 in C1-03 and C1-04 to the default accel/decel time in C1-01 and C1-02 when the output frequency exceeds the frequency level set in parameter C1-11. When the frequency falls below this level, the accel/decel times are switched back.

Figure 4.20 shows an operation example.

**Note:** Acceleration and deceleration times selected by digital inputs have priority over the automatic switching by the frequency level set to C1-11. For example, if accel/decel time 2 is selected, the drive will use only accel/decel time 2; it will not switch from accel/decel time 2 to the selected time.

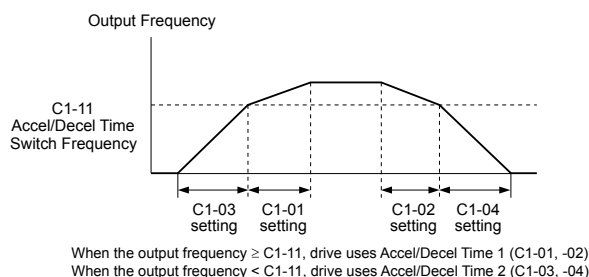

Figure 4.20 Accel/Decel Time Switching Frequency

### ■ C6-02: Carrier Frequency Selection

Sets the switching frequency of the drive output transistors. Changes to the switching frequency lower audible noise and reduce leakage current.

**Note:** Increasing the carrier frequency above the default value automatically lowers the drive current rating.

No.	Parameter Name	Setting Range	Default
C6-02	Carrier Frequency Selection	1 to 9; A to F	Determined by A1-02 and o2-04

#### Settings:

C6-02	Carrier Frequency	C6-02	Carrier Frequency	C6-02	Carrier Frequency
1	2.0 kHz	5	12.5 kHz	9	Swing PWM 3
2	5.0 kHz	6	15.0 kHz	A	Swing PWM 4
3	8.0 kHz	7	Swing PWM 1	B to E	No setting possible
4	10.0 kHz	8	Swing PWM 2	F	User defined

**Note:** Swing PWM uses a carrier frequency of 2.0 kHz as a base, then applies a special PWM pattern to reduce the audible noise.

#### Guidelines for Carrier Frequency Parameter Setup

Symptom	Remedy
Speed and torque are unstable at low speeds	Lower the carrier frequency.
Noise from the drive affects peripheral devices	
Excessive leakage current from the drive	
Wiring between the drive and motor is too long <1>	Increase the carrier frequency or use Swing PWM.
Audible motor noise is too loud	

<1> The carrier frequency may need to be lowered if the motor cable is too long. Refer to the following table.

Wiring Distance	Up to 50 m	Up to 100 m	Greater than 100 m
Recommended setting value for C6-02	1 to F (up to 15 kHz)	1 to 2 (up to 5 kHz), 7 (Swing PWM)	1 (up to 2 kHz), 7 (Swing PWM)

**Note:** The maximum cable length is 100 m when using OLV/PM (A1-02 = 5).

### ■ d2-01: Frequency Reference Upper Limit

Sets the maximum frequency reference as a percentage of the maximum output frequency. This limit applies to all frequency references.

Even if the frequency reference is set to a higher value, the drive internal frequency reference will not exceed this value.

No.	Parameter Name	Setting Range	Default
d2-01	Frequency Reference Upper Limit	0.0 to 110.0%	100.0%

### ■ d2-02: Frequency Reference Lower Limit

Sets the minimum frequency reference as a percentage of the maximum output frequency. This limit applies to all frequency references.

If a lower reference than this value is entered, the drive will run at the limit set to d2-02. If the drive is started with a lower reference than d2-02, it will accelerate up to d2-02.

No.	Parameter Name	Setting Range	Default
d2-02	Frequency Reference Lower Limit	0.0 to 110.0%	0.0%

## 4.7 Basic Drive Setup Adjustments

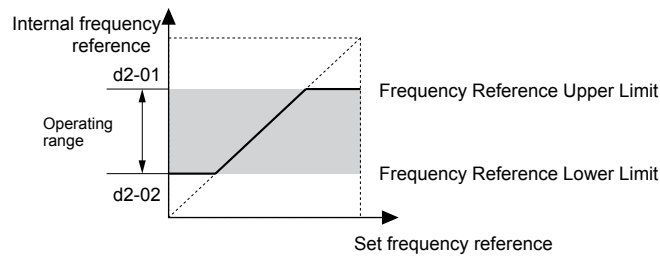

Figure 4.21 Frequency Reference: Upper and Lower Limits

### ■ E1-01: Input Voltage Setting

Adjusts the levels of some protective features of the drive (overvoltage, Stall Prevention, etc.). Set this parameter to the nominal voltage of the AC power supply.

**NOTICE:** Set parameter E1-01 to match the input voltage of the drive. Drive input voltage (not motor voltage) must be set in E1-01 for the protective features to function properly. Failure to set the correct drive input voltage will result in improper drive operation.

No.	Parameter Name	Setting Range	Default
E1-01	Input Voltage Setting	190 to 240 V <1>	230 V <1>

<1> Values shown are specific to 200 V class drives. Double the value for 400 V class drives.

#### E1-01 Related Values

The input voltage setting determines the overvoltage and undervoltage detection levels, the KEB function, and the overvoltage suppression function.

Voltage	Setting Value of E1-01	(Approximate Values)
		Uv Detection Level (L2-05)
200 V Class	All settings	190 V
400 V Class	Setting > 460 V	440 V
	Setting ≥ 400 V	380 V
	Setting < 400 V	350 V

### ■ V/f Pattern Settings E1-04 to E1-13

If E1-03 is set to a preset V/f pattern (i.e., a value other than F), the user can monitor the V/f pattern in parameters E1-04 through E1-13. To create a new V/f pattern, set E1-03 to F. [Refer to V/f Pattern on page 135](#) for an example custom V/f pattern.

**Note:** Certain E1-□□ parameters might not be visible depending on the control mode. [Refer to Parameter List on page 279](#) for details.

No.	Parameter Name	Setting Range	Default
E1-04	Maximum Output Frequency	40.0 to 240.0 Hz	<1>
E1-05	Maximum Voltage	0.0 to 255.0 V <2>	<1>
E1-06	Base Frequency	0.0 to 240.0 kHz	<1>
E1-07	Middle Output Frequency	0.0 to 240.0 kHz	<1>
E1-08	Middle Output Frequency Voltage	0.0 to 255.0 V <2>	<1>
E1-09	Minimum Output Frequency	0.0 to 240.0 kHz	<1>
E1-10	Minimum Output Frequency Voltage	0.0 to 255.0 V <2>	<1>
E1-11	Middle Output Frequency 2	0.0 to 240.0 kHz	0.0 Hz <3>
E1-12	Middle Output Frequency Voltage 2	0.0 to 255.0 V <2>	0.0 V <3>
E1-13	Base Voltage	0.0 to 255.0 V <2>	0.0 V

<1> Default setting is determined by the control mode.

<2> Values shown are specific to 200 V class drives. Double the value for 400 V class drives.

<3> Parameter ignored when E1-11 and E1-12 are set to 0.0.

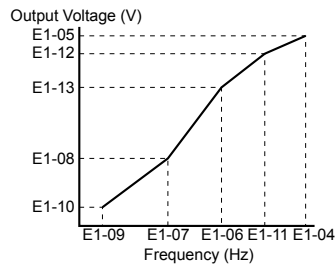

Figure 4.22 V/f Pattern

- Note:**
1. The following condition must be true when setting up the V/f pattern:  $E1-09 \leq E1-07 < E1-06 \leq E1-11 \leq E1-04$
  2. To make the V/f pattern a straight line below E1-06, set E1-09 equal to E1-07. In this case the E1-08 setting is disregarded.
  3. E1-03 is unaffected when the drive is initialized, but E1-04 through E1-13 return to their default values.
  4. Only use E1-11, E1-12, and E1-13 to fine-tune the V/f pattern in the constant output range. These parameters rarely need to be changed.

### ■ E2-01: Motor Rated Current

Provides motor control, protects the motor, and calculates torque limits. Set E2-01 to the full load amps (FLA) stamped on the motor nameplate.

No.	Parameter Name	Setting Range	Default
E2-01	Motor Rated Current	10% to 200% of the drive rated current	Determined by o2-04

- Note:**
1. The number of decimal places in the parameter value depends on the drive model. This value has two decimal places (0.01 A) if the drive is set for a maximum applicable motor capacity up to and including 11 kW, 2A0031, 4A0021 (input voltage of 460 V or higher) or 4A0027 (input voltage of lower than 460 V) and one decimal place (0.1 A) if the maximum applicable motor capacity is higher than 11 kW, 2A0046, 4A0027 (input voltage 460 V or higher) or 4A0034 (input voltage lower than 460 V).
  2. An oPE02 error will occur if the motor rated current in E2-01 is set lower than the motor no-load current in E2-03. Set E2-03 correctly to prevent this error.

### ■ E2-11: Motor Rated Power

Sets the motor rated power in kW. If Auto-Tuning completes successfully, the value entered to T1-02 will automatically be saved to E2-11.

No.	Parameter Name	Setting Range	Default
E2-11	Motor Rated Power	0.00 to 370.00 kW	Determined by o2-04

### ■ E5-02: Motor Rated Power

Sets the rated power of the motor. Determined by the value set to T2-04 during Stationary Auto-Tuning for PM motors.

No.	Parameter Name	Setting Range	Default
E5-02	Motor Rated Power	0.10 to 370.00 kW	Determined by o2-04

### ■ E5-03: Motor Rated Current

Sets the motor rated current in amps. Automatically set when the value is entered to T2-06 during Auto-Tuning.

No.	Parameter Name	Setting Range	Default
E5-03	Motor Rated Current	10 to 200% of drive rated current	Determined by o2-04

- Note:** The number of decimal places in the parameter value depends on the drive model. This value has two decimal places (0.01 A) if the drive is set for a maximum applicable motor capacity up to and including 11 kW, and one decimal place (0.1 A) if the maximum applicable motor capacity is higher than 11 kW.

## 4.7 Basic Drive Setup Adjustments

### ■ E5-04: Number of Motor Poles

Sets the number of motor poles. Automatically set when the value is entered to T2-08 during Auto-Tuning.

No.	Parameter Name	Setting Range	Default
E5-04	Number of Motor Poles	2 to 48	Determined by o2-04

### ■ E5-05: Motor Stator Resistance (r1)

Set the resistance for one motor phase. Do not enter the line-to-line resistance into E5-05 when measuring the resistance manually.

No.	Parameter Name	Setting Range	Default
E5-05	Motor Stator Resistance	0.000 to 65.000 Ω	Determined by o2-04

### ■ E5-06: Motor d-Axis Inductance (Ld)

Sets the d-Axis inductance in 0.01 mH units.

No.	Parameter Name	Setting Range	Default
E5-06	Motor d-Axis Inductance	0.00 to 300.00 mH	Determined by o2-04

### ■ E5-07: Motor q-Axis Inductance (Lq)

Sets the q-Axis inductance in 0.01 mH units.

No.	Parameter Name	Setting Range	Default
E5-07	Motor q-Axis Inductance	0.00 to 600.00 mH	Determined by o2-04

### ■ E5-09: Motor Induction Voltage Constant 1 (Ke)

Sets the induced peak voltage per phase in units of 0.1 mV/(rad/s) [electrical angle]. Set this parameter when using an IPM motor with variable torque.

No.	Parameter Name	Setting Range	Default
E5-09	Motor Induction Voltage Constant 1	0.0 to 2000.0 mV/(rad/s)	Determined by o2-04

**Note:** Set E5-24 to 0 when setting E5-09. However, setting both E5-09 and E5-24 to 0 will trigger an alarm. An alarm will also be triggered if neither E5-09 nor E5-24 are set to 0.

### ■ E5-24: Motor Induction Voltage Constant 2 (Ke)

Set the induced phase-to-phase rms voltage in units of 0.1 mV/(r/min) [mechanical angle]. Set this parameter when using an SPM Motor.

No.	Parameter Name	Setting Range	Default
E5-24	Motor Induction Voltage Constant 2	0.0 to 6500.0 mV/(r/min)	Determined by o2-04

**Note:** Set E5-24 to 0.0 when setting E5-09. However, setting both E5-09 and E5-24 to 0.0 will trigger an alarm. An alarm will also be triggered if neither E5-09 nor E5-24 are set to 0.0.

### ■ H3-03, H3-04: Terminal A1 Gain and Bias Settings

Parameter H3-03 sets the level of the selected input value that is equal to 10 Vdc (20 mA) input at terminal A1 (gain).

Parameter H3-04 sets the level of the selected input value that is equal to 0 V (4 mA, 0 mA) input at terminal A1 (bias).

Use both parameters to adjust the characteristics of the analog input signal to terminal A1.

No.	Name	Setting Range	Default
H3-03	Terminal A1 Gain Setting	-999.9 to 999.9%	100.0%
H3-04	Terminal A1 Bias Setting	-999.9 to 999.9%	0.0%

**Setting Examples**

- Gain H3-03 = 200%, bias H3-04 = 0, terminal A1 as frequency reference input (H3-02 = 0):

A 10 Vdc input is equivalent to a 200% frequency reference and 5 Vdc is equivalent to a 100% frequency reference. Since the drive output is limited by the maximum frequency parameter (E1-04), the frequency reference will be equal to E1-04 above 5 Vdc.

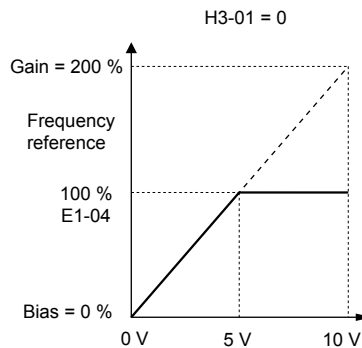
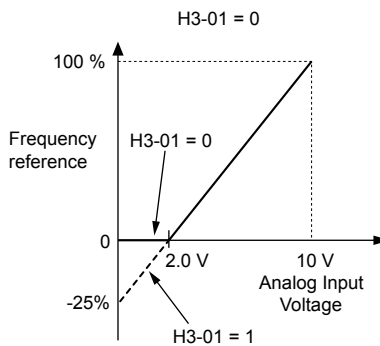

**Figure 4.23 Frequency Reference Setting by Analog Input with Increased Gain**

- Gain H3-03 = 100%, bias H3-04 = -25%, terminal A1 as frequency reference input:

An input of 0 Vdc will be equivalent to a -25% frequency reference.

When parameter H3-01 = 0, the frequency reference is 0% between 0 and 2 Vdc input.



**Figure 4.24 Frequency Reference Setting by Analog Input with Negative Bias**

**■ H3-11, H3-12: Terminal A2 Gain and Bias Setting**

Parameter H3-11 sets the level of the input value selected that is equal to 10 Vdc input or 20 mA input to terminal A2.

Parameter H3-12 sets the level of the input value selected that is equal to 0 V, 4 mA or 0 mA input at terminal A2.

Use both parameters to adjust the characteristics of the analog input signal to terminal A2. The setting works in the same way as parameters H3-03 and H3-04 for analog input A1.

No.	Name	Setting Range	Default
H3-11	Terminal A2 Gain Setting	-999.9 to 999.9%	100.0%
H3-12	Terminal A2 Bias Setting	-999.9 to 999.9%	0.0%

**■ L2-01: Momentary Power Loss Operation Selection**

When a momentary power loss occurs (DC bus voltage falls below the level set in L2-05), the drive can automatically return to the operation it was performing prior to the power loss based on certain conditions.

No.	Name	Setting Range	Default
L2-01	Momentary Power Loss Operation Selection	0 to 2	0

**Setting 0: Disabled**

If power is not restored within 15 ms, a Uv1 fault will result and the motor coasts to stop.

## 4.7 Basic Drive Setup Adjustments

### Setting 1: Recover within L2-02

When a momentary power loss occurs, the drive output will be shut off. If the power returns within the time set to parameter L2-02, the drive will perform Speed Search and attempt to resume operation. If the power does not return within this time, it will trigger a Uv1 fault.

### Setting 2: Recover as long as CPU Has Power

When a momentary power loss occurs, the drive output will be shut off. If the power returns and the drive control circuit has power, the drive will attempt to perform Speed Search and resume the operation. This will not trigger a Uv1 fault.

#### Notes on Settings 1 and 2

- “Uv” will flash on the operator while the drive is attempting to recover from a momentary power loss. A fault signal is not output at this time.
- When using a magnetic contactor between the motor and the drive, keep the magnetic contactor closed as long as the drive attempts to restart with Speed Search.

### ■ L2-02: Momentary Power Loss Ride-Thru Time

Sets the maximum time allowed to ride through a power loss. If power loss operation exceeds this time, the drive will attempt to accelerate back to the frequency reference. This parameter is valid if L2-01 = 1.

**Note:** The amount of time the drive is capable of recovering after a power loss is determined by the capacity of the drive. Drive capacity determines the upper limit for L2-02.

No.	Name	Setting Range	Default
L2-02	Momentary Power Loss Ride-Thru Time	0.0 to 25.5 s	Determined by o2-04

### ■ L4-05: Frequency Reference Loss Detection Selection

The drive can detect a loss of an analog frequency reference from input A1 or A2. Frequency reference loss is detected when the frequency reference drops below 10% of the reference or below 5% of the maximum output frequency within 400 ms.

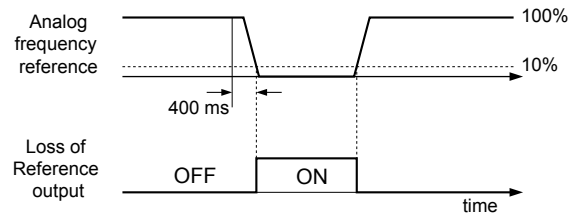

Figure 4.25 Loss of Reference Function

Parameter L4-05 selects the operation when a frequency reference loss is detected.

No.	Name	Setting Range	Default
L4-05	Frequency Reference Loss Detection Selection	0, 1	1

#### Setting 0: Stop

Drive follows the frequency reference (which is no longer present) and stops the motor.

#### Setting 1: Continue Operation with Reduced Frequency Reference

The drive will continue operation at the percent of the previous frequency value set to parameter L4-06. When the external frequency reference value is restored, the operation is continued with the frequency reference.

### ■ L4-06: Frequency Reference at Reference Loss

Sets the frequency reference level at which the drive runs when L4-05 = 1 and when detecting a reference loss. The value is set as a percentage of the frequency reference before the loss was detected.

No.	Name	Setting Range	Default
L4-06	Frequency Reference at Reference Loss	0.0 to 100.0%	80.0%

### ■ L5-01: Number of Auto Restart Attempts

Sets the number of times that the drive may attempt to restart itself.

Parameter L5-05 determines the method of incrementing the restart counter. When the counter reaches the number set to L5-01, the operation stops and the fault must be manually cleared and reset.

The restart counter is incremented at each restart attempt, regardless of whether the attempt was successful. When the counter reaches the number set to L5-01, the operation stops and the fault must be manually cleared and reset.

The number of fault restarts is reset to zero when:

- The drive operates normally for 10 minutes following a fault restart.
- A fault is cleared manually after protective functions are triggered.
- The power supply is cycled.

No.	Name	Setting Range	Default
L5-01	Number of Auto Restart Attempts	0 to 10 Times	0 Times

### ■ L5-03: Time to Continue Making Fault Restarts (enabled only when L5-05 = 0)

Although the drive will continue to execute fault restarts, this parameter will cause a fault if a fault restart cannot occur after the time set to L5-03 passes.

All major faults will cause the drive to stop. For some faults it is possible to configure the drive to attempt a restart automatically. After the fault occurs, the drive baseblocks for L2-03 seconds. After the baseblock is removed, the drive checks if a fault condition still exists. If no fault condition exists, the drive will attempt to restart the motor. If the restart is successful, the drive performs a Speed Search (Regardless of the status of b3-01 "Speed Search Selection") from the set speed command and the Auto Restart Attempts count is increased by one. Even if the restart fails, the restart count is increased by one as long as the drive attempted to rotate the motor. The restart count will not be incremented if the restart is not attempted due to a continuing fault condition, (i.e., an ov fault). The drive waits L5-03 seconds before attempting another restart.

No.	Name	Setting Range	Default
L5-03	Time to Continue Making Fault Restarts	0.00 to 600.0 s	180.0 s

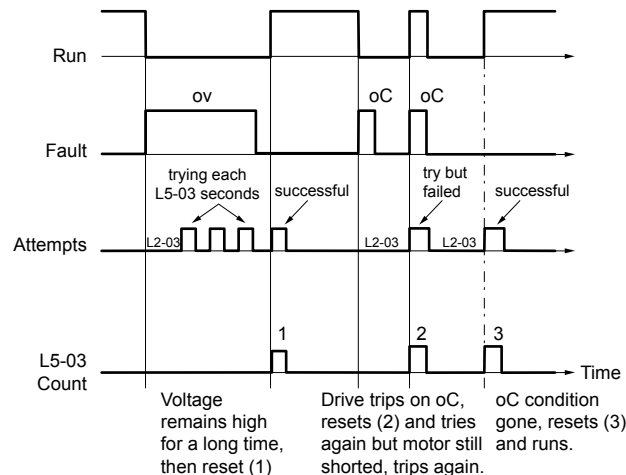

Figure 4.26 Automatic Restart Timing Diagram

The auto restart count is reset back to 0 if any of the following occur:

- No further faults for 10 minutes after the last retry.
- The drive power is turned off (the drive must be without power long enough to let control power dissipate).
- The RESET key is pushed after the last reset attempt.

The setting of parameter L5-02 determines whether the fault output (MA-MB) will be closed during an auto restart attempt.

The setting of L5-02 can be important when using the drive with other equipment.

The following faults will allow the Auto Restart function to initiate:

- oC (Overcurrent)
- LF (Output Phase Loss)

## 4.7 Basic Drive Setup Adjustments

- PF (Input Phase Loss)
- oL1 (Motor Overload)
- oL3 (Overtorque Detection 1)
- oL2 (Drive Overload)
- ov (Overvoltage)
- GF (Ground Fault)
- Uv1 (Undervoltage)
- oH1 (Heatsink Overheat)

In order for auto restart after a Uv1 fault, Momentary Power Loss Ride-thru must be enabled (L2-01= 1: “Power Loss Ridethru Time”). Setting H2-01, H2-02 or H2-03 to 1E configures a digital output as “Restart Enabled” to signal if an impending auto restart is possible.

### ■ L6-01: Torque Detection Selection 1

The torque detection function is triggered when the current or torque exceed the levels set to L6-02 for longer than the time set to L6-03. L6-01 selects the conditions for detection and the operation that follows.

No.	Name	Setting Range	Default
L6-01	Torque Detection Selection 1	0 to 12	0

#### Setting 0: Disabled

#### Setting 1: oL3 at Speed Agree (Alarm)

Overtorque detection is active only when the output speed is equal to the frequency reference (i.e., no detection during acceleration and deceleration). The operation continues after detecting overtorque and triggering an oL3 alarm.

#### Setting 2: oL3 at Run (Alarm)

Overtorque detection works as long as the Run command is active. The operation continues after detecting overtorque and triggering an oL3 alarm.

#### Setting 3: oL3 at Speed Agree (Fault)

Overtorque detection is active only when the output speed is equal to the frequency reference (i.e., no detection during acceleration and deceleration). The operation stops and triggers an oL3 fault.

#### Setting 4: oL3 at Run (Fault)

Overtorque detection works as long as a Run command is active. The operation stops and triggers an oL3 fault.

#### Setting 5: UL3 at Speed Agree (Alarm)

Undertorque detection is active only when the output speed is equal to the frequency reference (i.e., no detection during acceleration and deceleration). The operation continues after detecting overtorque and triggering a UL3 alarm.

#### Setting 6: UL3 at Run (Alarm)

Undertorque detection works as long as the Run command is active. The operation continues after detecting overtorque and triggering a UL3 alarm.

#### Setting 7: UL3 at Speed Agree (Fault)

Undertorque detection is active only when the output speed is equal to the frequency reference (i.e., no detection during acceleration and deceleration). The operation stops and triggers a UL3 fault.

#### Setting 8: UL3 at Run (Fault)

Undertorque detection works as long as a Run command is active. The operation stops and triggers a UL3 fault.

#### Setting 9: UL6 at Speed Agree (Alarm)

Motor Underload detection is active only when the output speed is equal to the frequency reference (i.e., no detection during acceleration and deceleration). The operation continues after detection and triggers a UL6 alarm.

#### Setting 10: UL6 at Run (Alarm)

Motor Underload detection works as long as the Run command is active. The operation continues after detection and triggers a UL6 alarm.

**Setting 11: UL6 at Speed Agree (Fault)**

Motor Underload detection is active only when the output speed is equal to the frequency reference (i.e., no detection during acceleration and deceleration). The operation stops and triggers a UL6 fault.

**Setting 12: UL6 at Run (Fault)**

Motor Underload detection works as long as a Run command is active. The operation stops and triggers a UL6 fault.

**■ L6-02: Torque Detection Level 1**

Sets the detection levels for torque detection function 1 as a percentage of the drive rated output current.

No.	Name	Setting Range	Default
L6-02	Torque Detection Level 1	0 to 300%	15%

**Note:** The torque detection level 1 (L6-02) can also be supplied by an analog input terminal set to H3-□□ = 7. Here, the analog value has priority and the setting in L6-02 is disregarded.

**■ L6-03: Torque Detection Time 1**

Determines the time required to trigger an alarm or fault after exceeding the level in L6-02.

No.	Name	Setting Range	Default
L6-03	Torque Detection Time 1	0.0 to 10.0 s	10.0 s

**■ o2-03: User Parameter Default Value**

After completely setting up drive parameters, save the values as user-set defaults with parameter o2-03. After saving the values, parameter A1-03 (Initialize Parameters) will offer the choice of "1110: User Initialize". Selecting 1110 resets all parameters to the user-set default values. *Refer to A1-03: Initialize Parameters on page 156* for details on drive initialization.

No.	Name	Setting Range	Default
o2-03	User Parameter Default Value	0 to 2	0

**Setting 0: No Change (Awaiting Command)****Setting 1: Set User Initialize Values**

The current parameter settings are saved as user-set default for a later User Initialization. Setting o2-03 to 1 and pressing the ENTER key saves the values and returns the display to 0.

**Setting 2: Clear User Initialize Values**

All user-set defaults for "User Initialize" are cleared. Setting o2-03 to 2 and pressing the ENTER key erases the values and returns the display to 0.

**■ o2-05: Frequency Reference Setting Method Selection**

Determines if the ENTER key must be pressed after changing the frequency reference using the HOA keypad while in Drive Mode.

No.	Name	Setting Range	Default
o2-05	Frequency Reference Setting Method Selection	0, 1	0

**Setting 0: ENTER Key Required**

The ENTER key must be pressed every time the frequency reference is changed using the HOA keypad for the drive to accept the change.

**Setting 1: ENTER Key not Required**

The output frequency changes immediately when the reference is changed by the up or down arrow keys on the HOA keypad. The ENTER key does not need to be pressed. The frequency reference (Fref) is saved to memory after remaining unchanged for 5 seconds.

## 4.8 Auto-Tuning

### ◆ Types of Auto-Tuning

The drive offers different types of Auto-Tuning for induction motors and permanent magnet motors. The type of Auto-Tuning used differs further based on the control mode and other operating conditions. Refer to the tables below to select the type of Auto-Tuning that best suits the application. [Refer to Start-Up Flowcharts on page 119](#) for directions on executing Auto-Tuning.

**Note:** The drive will only show Auto-Tuning parameters that are valid for the control mode that has been set in A1-02. If the control mode is for an induction motor, the Auto-Tuning parameters for PM motors will not be available.

### ■ Auto-Tuning for Induction Motors

This feature automatically sets the V/f pattern and motor parameters E1-□□ and E2-□□ for an induction motor.

**Table 4.18 Types of Auto-Tuning for Induction Motors**

Type	Setting	Application Conditions and Benefits	Control Mode
			V/f
<b>Stationary Auto-Tuning for Line-to-Line Resistance</b>	T1-01 = 2	<ul style="list-style-type: none"> <li>The drive is used in V/f Control and other Auto-Tuning selections are not possible.</li> <li>Drive and motor capacities differ.</li> <li>Tunes the drive after the cable between the drive and motor has been replaced with a cable over 50 m long. Assumes Auto-Tuning has already been performed.</li> <li>Should not be used for any vector control modes unless the motor cable has changed.</li> </ul>	YES
<b>Rotational Auto-Tuning for V/f Control</b>	T1-01 = 3	<ul style="list-style-type: none"> <li>Recommended for applications using Speed Estimation Speed Search or using the Energy Saving function in V/f Control.</li> <li>Assumes motor can rotate while Auto-Tuning is executed. Increases accuracy for certain functions like torque compensation, slip compensation, Energy Saving, and Speed Search.</li> </ul>	YES

[Table 4.19](#) lists the data that must be entered for Auto-Tuning. Make sure this data is available before starting Auto-Tuning. The necessary information is usually listed on the motor nameplate or in the motor test report provided by the motor manufacturer. Also refer to page [121](#) for details on Auto-Tuning processes and selections.

**Table 4.19 Auto-Tuning Input Data**

Input Value	Input Parameter	Unit	Tuning Type (T1-01)	
			2 Line-to-Line Resistance	3 Rotational for V/f Control
Motor rated power	T1-02	kW	YES	YES
Motor rated voltage	T1-03	Vac	–	YES
Motor rated current	T1-04	A	YES	YES
Motor rated frequency	T1-05	Hz	–	YES
Number of motor poles	T1-06	–	–	YES
Motor rated Speed	T1-07	r/min	–	YES
Motor iron loss	T1-11	W	–	YES

## ■ Auto-Tuning for Permanent Magnet Motors

Automatically sets the V/f pattern and motor parameters E1-□□ and E5-□□ when a PM motor is used.

**Table 4.20 Types of Auto-Tuning for Permanent Magnet Motors**

Type	Setting	Application Conditions and Benefits	Control Mode
			OLV/PM
PM Motor Parameter Settings	T2-01 = 0	<ul style="list-style-type: none"> <li>Motor does not rotate during Auto-Tuning.</li> <li>Motor test report or motor data similar to <a href="#">Table 4.21</a> are available.</li> </ul>	YES

[Table 4.21](#) lists the data that must be entered for Auto-Tuning. Make sure the data is available before starting Auto-Tuning. The necessary information is usually listed on the motor nameplate or in the motor test report provided by the motor manufacturer. Also refer to page [122](#) for details on the Auto-Tuning process and selection.

**Table 4.21 Auto-Tuning Input Data**

Input Value	Input Parameter	Unit	Tuning Type (T2-01)
			0 Motor Parameter Settings
<b>Control Mode</b>	<b>A1-02</b>	–	<b>5</b>
Motor Type	T2-03	–	–
Motor Rated Power	T2-04	kW	YES
Motor Rated Voltage	T2-05	Vac	YES
Motor Rated Current	T2-06	A	YES
Motor Rated Frequency	T2-07	Hz	YES
Number of Motor Poles	T2-08	–	YES
Stator Single-phase Resistance	T2-10	Ω	YES
d-Axis Inductance	T2-11	mH	YES
q-Axis Inductance	T2-12	mH	YES
Induced Voltage Constant Unit Selection <1>	T2-13	mVs/rad (elec.)	YES
Voltage Constant <1> <2>	T2-14	mVmin (mech.)	YES
Tuning Pull-in Current	T2-15	A	–
T2 Tuning Start	T2-18	–	YES

<1> It is only necessary to input either T2-13 or T2-14. Select one and leave the other empty.

<2> Dependent upon T2-13 setting.

## ◆ Before Auto-Tuning the Drive

Check the items below before Auto-Tuning the drive.

### ■ Basic Auto-Tuning Preparations

- Auto-Tuning requires the user to input data from the motor nameplate or motor test report. Make sure this data is available before Auto-Tuning the drive.
- For best performance, the drive input supply voltage must be at least equal to or greater than the motor rated voltage.
 

**Note:** Better performance is possible when using a motor with a base voltage that is lower than the input supply voltage (20 V for 200 V class models and 40 V for 400 V class models). This is particularly important when operating the motor above 90% of base speed, where high torque precision is required.
- To cancel Auto-Tuning, press the OFF key on the HOA keypad.
- When using a motor contactor, make sure it is closed throughout the Auto-Tuning process.

**Table 4.22 Auto-Tuning Input Data**

Motor Type	Auto-Tuning Type	Digital Input	Digital Output
Induction Motor	Stationary Auto-Tuning for Line-to-Line Resistance	Digital input functions are disabled.	Maintains the status at the start of Auto-Tuning
	Rotational Auto-Tuning for V/f Control		Functions the same as during normal operation
PM Motor	PM Motor Parameter Settings		Digital output functions are disabled.

## 4.8 Auto-Tuning

### ■ Notes on Stationary Auto-Tuning

Stationary Auto-Tuning modes analyze motor characteristics by injecting current into the motor for approximately one minute.

**WARNING! Electrical Shock Hazard.** When executing stationary Auto-Tuning, voltage is applied to the motor before the motor rotates. Do not touch the motor until Auto-Tuning is completed. Failure to comply may result in injury or death from electrical shock.

**WARNING! Sudden Movement Hazard.** If installed, do not release the mechanical brake during Stationary Auto-Tuning. Inadvertent brake release may cause damage to equipment or injury to personnel. Ensure that the mechanical brake release circuit is not controlled by the drive multi-function digital outputs.

#### Stationary Auto-Tuning for Line-to-Line Resistance

- Perform when entering motor data manually while using motor cables longer than 50 m.
- If the motor cables have been replaced with cables more than 50 m long after Auto-Tuning has already been performed, use Stationary Auto-Tuning for line-to-line resistance.

### ◆ Auto-Tuning Interruption and Fault Codes

If tuning results are abnormal or the OFF key is pressed before completion, Auto-Tuning will be interrupted and a fault code will appear on the HOA keypad.

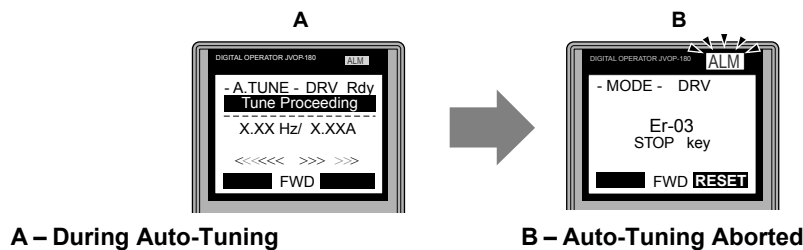

Figure 4.27 Auto-Tuning Aborted Display

### ◆ Auto-Tuning Operation Example

The following example demonstrates Rotational Auto-Tuning for V/f.

#### ■ Selecting the Type of Auto-Tuning

Step		Display/Result
1.	Turn on the power to the drive. The initial display appears.	
2.	Press  or  until the Auto-Tuning display appears.	
3.	Press  to begin setting parameters.	
4.	Press  to display the value for T1-01.	
5.	Save the setting by pressing .	

Step			Display/Result
6.	The display automatically returns to the display shown in Step 3.	→	

### ■ Enter Data from the Motor Nameplate

After selecting the type of Auto-Tuning, enter the data required from the motor nameplate.

**Note:** These instructions continue from Step 6 in “Selecting the Type of Auto-Tuning”.

Step			Display/Result
1.	Press  to access the motor output power parameter T1-02.	→	
2.	Press  to view the default setting.	→	
3.	Press  left,  right,  , , and  to enter the motor power nameplate data in kW.	→	
4.	Press  to save the setting.	→	
5.	The display automatically returns to the display in Step 1.	→	
6.	Repeat Steps 1 through 5 to set the following parameters: <ul style="list-style-type: none"> <li>• T1-03, Motor Rated Voltage</li> <li>• T1-04, Motor Rated Current</li> <li>• T1-05, Motor Base Frequency</li> <li>• T1-06, Number of Motor Poles</li> <li>• T1-07, Motor Base Frequency</li> </ul>	→	

**Note:** To execute Stationary Auto-Tuning for line-to-line resistance only, set parameters T1-02 and T1-04.

## 4.8 Auto-Tuning

### ■ Starting Auto-Tuning



**WARNING! Sudden Movement Hazard.** The drive and motor may start unexpectedly during Auto-Tuning, which could result in death or serious injury. Ensure the area surrounding the drive motor and load are clear before proceeding with Auto-Tuning.

**WARNING! Electrical Shock Hazard.** High voltage will be supplied to the motor when Stationary Auto-Tuning is performed even with the motor stopped, which could result in death or serious injury. Do not touch the motor until Auto-Tuning has been completed.

**NOTICE:** Rotational Auto-Tuning will not function properly if a holding brake is engaged on the load. Failure to comply could result in improper operation of the drive. Ensure the motor can freely spin before beginning Auto-Tuning.

Enter the required information from the motor nameplate. Press  to proceed to the Auto-Tuning start display.

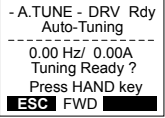
**Note:** These instructions continue from Step 6 in “Enter Data from the Motor Nameplate”.

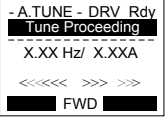
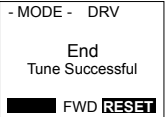
Step		Display/Result
1.	After entering the data listed on the motor nameplate, press  to confirm.	
2.	Press  to activate Auto-Tuning. <b>DRV</b> flashes. The drive begins by injecting current into the motor for about 1 min, and then starts to rotate the motor.	
3.	Auto-Tuning finishes in approximately one to two minutes.	

### ◆ T1: Parameter Settings during Induction Motor Auto-Tuning

The T1-□□ parameters set the Auto-Tuning input data for induction motor tuning.

**Note:** For motors operating in the field weakening range, first perform the Auto-Tuning with the base data. After Auto-Tuning is complete, change E1-04, Maximum Output Frequency, to the desired value.

#### ■ T1-01: Auto-Tuning Mode Selection

Sets the type of Auto-Tuning to be used. [Refer to Auto-Tuning for Induction Motors on page 142](#) for details on the different types of Auto-Tuning.

No.	Name	Setting Range	Default
T1-01	Auto-Tuning Mode Selection	2, 3 (V/f)	2 (V/f)

#### Setting 2: Stationary Auto-Tuning for Line-to-Line Resistance

#### Setting 3: Rotational Auto-Tuning for V/f Control Energy Saving

#### ■ T1-02: Motor Rated Power

Sets the motor rated power according to the motor nameplate value.

**Note:** Use the following formula to convert HP to kW: kW = HP x 0.746.

No.	Name	Setting Range	Default
T1-02	Motor Rated Power	0.00 to 650.00 kW	Determined by o2-04

#### ■ T1-03: Motor Rated Voltage

Sets the motor rated voltage according to the motor nameplate value. Enter the voltage base speed when the motor operates above base speed. Enter the voltage needed to operate the motor under no-load conditions at rated speed to T1-03.

No.	Name	Setting Range	Default
T1-03	Motor Rated Voltage	0.0 to 255.0 V <1>	200.0 V <1>

<1> Values shown are specific to 200 V class drives. Double value for 400 V class drives.

### ■ T1-04: Motor Rated Current

Sets the motor rated current according to the motor nameplate value. Enter the current at the motor base speed.

No.	Name	Setting Range	Default
T1-04	Motor Rated Current	10.0 to 300.0% of drive rated current	Determined by o2-04

### ■ T1-05: Motor Base Frequency

Sets the motor rated frequency according to the motor nameplate value. If a motor with an extended speed range is used or the motor is used in the field weakening area, enter the maximum frequency to E1-04 after Auto-Tuning is complete.

No.	Name	Setting Range	Default
T1-05	Motor Base Frequency	0.0 to 240.0 Hz	60.0 Hz

### ■ T1-06: Number of Motor Poles

Sets the number of motor poles according to the motor nameplate value.

No.	Name	Setting Range	Default
T1-06	Number of Motor Poles	2 to 48	4

### ■ T1-07: Motor Base Speed

Sets the motor rated speed according to the motor nameplate value. Enter the speed at base frequency when using a motor with an extended speed range or if using the motor in the field weakening area.

No.	Name	Setting Range	Default
T1-07	Motor Base Speed	0 to 14400 r/min	1750 r/min

### ■ T1-11: Motor Iron Loss

Provides iron loss information to determine the Energy Saving coefficient. T1-11 will first display the value for the motor iron loss that the drive automatically calculated when the motor capacity was entered to T1-02. Enter the motor iron loss value listed to T1-11 if the motor test report is available.

No.	Name	Setting Range	Default
T1-11	Motor Iron Loss	0 to 65535 W	14 W

### ■ T1-12: T1 Tuning Start

Set T1-12 to 0 to start IM Auto-Tuning.

No.	Name	Setting Range	Default
T1-12	T1 Tuning Start	0	–

## ◆ T2: Parameter Settings during PM Motor Auto-Tuning

The T2-□□ parameters are used to set the Auto-Tuning input data for PM motor tuning.

### ■ T2-01: PM Motor Auto-Tuning Mode Selection

No.	Name	Setting Range	Default
T2-01	PM Motor Auto-Tuning Mode Selection	0	0

#### Setting 0: PM Motor Parameter Settings

## 4.8 Auto-Tuning

### ■ T2-03: PM Motor Type

Selects the type of PM motor the drive will operate.

No.	Name	Setting Range	Default
T2-03	PM Motor Type	0, 1	1

Setting 0: IPM motor

Setting 1: SPM motor

### ■ T2-04: PM Motor Rated Power

Specifies the motor rated power in kilowatts.

No.	Name	Setting Range	Default
T2-04	PM Motor Rated Power	0.00 to 650.00 kW	Determined by o2-04 and C6-01

### ■ T2-05: PM Motor Rated Voltage

Sets the motor rated voltage.

No.	Name	Setting Range	Default
T2-05	PM Motor Rated Voltage	0.0 to 255.0 V <1>	200.0 V <1>

<1> Values shown are specific to 200 V class drives; double the value for 400 V class drives.

### ■ T2-06: PM Motor Rated Current

Enter the motor rated current in amps.

No.	Name	Setting Range	Default
T2-06	PM Motor Rated Current	0.0% to 300.0% of the drive rated current.	Determined by o2-04

### ■ T2-07: PM Motor Base Frequency

Enter the motor base frequency in Hz.

**Note:** T2-07 will be displayed when in OLV/PM.

No.	Name	Setting Range	Default
T2-07	PM Motor Base Frequency	0.0 to 240.0 Hz	87.5 Hz

### ■ T2-08: Number of PM Motor Poles

Enter the number of motor poles.

No.	Name	Setting Range	Default
T2-08	Number of PM Motor Poles	2 to 48	6

### ■ T2-10: PM Motor Stator Resistance

Enter the motor stator resistance per motor phase.

No.	Name	Setting Range	Default
T2-10	PM Motor Stator Resistance	0.000 to 65.000 Ω	Determined by T2-02

### ■ T2-11: PM Motor d-Axis Inductance

Enter the d-Axis inductance per motor phase.

No.	Name	Setting Range	Default
T2-11	PM Motor d-Axis Inductance	0.00 to 600.00 mH	Determined by T2-02

### ■ T2-12: PM Motor q-Axis Inductance

Enter the q-Axis inductance per motor phase.

No.	Name	Setting Range	Default
T2-12	PM Motor q-Axis Inductance	0.00 to 600.00 mH	Determined by T2-02

### ■ T2-13: Induced Voltage Constant Unit Selection

Selects the units used for setting the induced voltage coefficient.

No.	Name	Setting Range	Default
T2-13	Induced Voltage Constant Unit Selection	0, 1	0

**Setting 0: mV (r/min)**

**Setting 1: mV (rad/sec)**

**Note:** If T2-13 is set to 0, then the drive will use E5-24 (Motor Induction Voltage Constant 2), and will automatically set E5-09 (Motor Induction Voltage Constant 1) to 0.0. If T2-13 is set to 1, then the drive will use E5-09 and will automatically set E5-25 to 0.0.

### ■ T2-14: PM Motor Induced Voltage Constant (Ke)

Enter the motor induced voltage constant (Ke).

No.	Name	Setting Range	Default
T2-14	PM Motor Induced Voltage Constant	0.0 to 2000.0	Determined by T2-02

### ■ T2-15: Pull-In Current Level for PM Motor Tuning

Sets the amount of pull-in current. Set as a percentage of the motor rated current.

No.	Name	Setting Range	Default
T2-15	Pull-In Current Level for PM Motor Tuning	0 to 120%	30%

### ■ T2-18: T2 Tuning Start

Set T2-18 to 0 to start PM motor Auto-Tuning.

No.	Name	Setting Range	Default
T2-18	T2 Tuning Start	0	–

## 4.9 No-Load Operation Test Run

### ◆ No-Load Operation Test Run

This section explains how to operate the drive with the motor decoupled from the load during a test run.

#### ■ Before Starting the Motor

Check the following items before operation:

- Ensure the area around the motor is safe.
- Ensure external emergency stop circuitry is working properly and other safety precautions have been taken.

#### ■ During Operation

Check the following items during operation:

- The motor should rotate smoothly (i.e., no abnormal noise or oscillation).
- The motor should accelerate and decelerate smoothly.

#### ■ No-Load Operation Instructions

The following example illustrates a test run procedure using the HOA keypad.

Step			Display/Result
1.	Before starting the motor, set parameter d1-01, Frequency Reference, to 6 Hz. The Run command from AUTO mode must be OFF.	—	—
2.	Turn on the power to the drive. The initial display appears.	➔	
3.	Press  to give the drive a Run command from HAND mode. The HAND light will turn on and the motor will rotate at 6 Hz.	➔	
4.	Ensure the motor is rotating in the correct direction and that no faults or alarms occur.	➔	
5.	If there is no error in step 3, press  to increase the frequency reference. Increase the frequency in increments of 10 Hz, verifying smooth operation at all speeds. For each frequency, check the drive output current using monitor U1-03. The current should be well below the motor rated current.	—	—
6.	The drive should operate normally. Press  to stop the motor. The HAND light is OFF and the motor coasts to stop.	➔	

## 4.10 Test Run with Load Connected

### ◆ Test Run with the Load Connected

After performing a no-load test run, connect the motor and proceed to run the motor and load together.

### ■ Precautions for Connected Machinery

**WARNING!** *Sudden Movement Hazard. Clear all personnel from the drive, motor, and machine area before applying power. System may start unexpectedly upon application of power, causing death or serious injury.*

**WARNING!** *Sudden Movement Hazard. Always check the operation of any fast stop circuits after they are wired. Fast stop circuits are required to provide safe and quick shutdown of the drive. Prepare to initiate an emergency stop during the test run. Operating a drive with untested emergency circuits could result in death or serious injury.*

- The motor should come to a complete stop without problems.
- Connect the load and machinery to the motor.
- Fasten all installation screws properly and check that the motor and connected machinery are held in place.

### ■ Checklist Before Operation

- The motor should rotate in the proper direction.
- The motor should accelerate and decelerate smoothly.

### ■ Operating the Motor under Loaded Conditions

Test run the application similarly to the no-load test procedure when connecting the machinery to the motor.

- Monitor U1-03 for overcurrent during operation.
- If the application permits running the load in the reverse direction, change the motor direction and the frequency reference while watching for abnormal motor oscillation or vibration.
- Correct any problems that occur with hunting, oscillation, and other control-related issues.

## 4.11 Verifying Parameter Settings and Backing Up Changes

Use the Verify Menu to check all changes to parameter settings. *Refer to Verifying Parameter Changes: Verify Menu on page 116.*

Save the verified parameter settings. Change the access level or set a password to the drive to prevent accidental modification of parameter settings.

### ◆ Backing Up Parameter Values: o2-03

Setting o2-03 to 1 saves all parameter settings before resetting o2-03 to 0. The drive can now recall all the saved parameters by performing a User Initialization (A1-03 = 1110).

No.	Parameter Name	Description	Setting Range	Default Setting
o2-03	User Parameter Default Values	Lets the user create a set of default settings for a User Initialization. 0: Saved/Not Set 1: Set Defaults - Saves current parameter settings as the default values for a User Initialization. 2: Clear All - Clears the currently saved user settings. After saving the user parameter set value, the items of 1110 (User Initialization) are displayed in A1-03 (User Parameter Default Value).	0 to 2	0
A1-03	Initialize Parameters	Selects a method to initialize the parameters. 0: No Initialize 1110: User Initialization (The user must first program and store desired settings using parameter o2-03) 2220: 2-Wire Initialization (parameter initialized prior to shipment) 3330: 3-Wire Initialization 3410: HVAC Initialization 3420: OEM Bypass Initialization	0 to 3420	0

### ◆ Parameter Access Level: A1-01



Setting the Access Level for “Operation only” (A1-01 = 0) allows the user to access parameters A1-□□ and U□-□□ only. Other parameters are not displayed.

Setting the Access Level for “User Parameters” (A1-01 = 1) allows the user to access only the parameters that have been previously saved as User Parameters. This is helpful when displaying only the relevant parameters for a specific application.

No.	Parameter Name	Description	Setting Range	Default
A1-01	Access Level Selection	Selects which parameters are accessible via the HOA keypad. 0: Operation only. A1-01 and A1-04 can be set and monitored, and U□-□□ parameters can also be viewed. 1: User Parameters. Only recently changed parameters from application parameters A2-01 to A2-16 and A2-17 to A2-32 can be set and monitored. 2: Advanced Access Level. All parameters can be set and monitored.	0 to 2	2
A2-01 to A2-32	User Parameters 1 to 32	Parameters selected by the user are saved as User Parameters, including recently viewed parameters and parameters specifically selected for quick access. If parameter A2-33 is set to 1, recently viewed parameters will be listed between A2-17 and A2-32. Parameters A2-01 through A2-16 must be manually selected by the user. If A2-33 is set to 0, recently viewed parameters will not be saved to the group of User Parameters. A2-□□ parameters are now available for manual programming.	b1-01 to o□-□□	-
A2-33	User Parameter Automatic Selection	0: Parameters A2-01 through A2-32 are reserved for the user to create a group of User Parameters. 1: Save history of recently viewed parameters. Recently edited parameters will be saved to A2-17 through A2-32 for quick access. The most recently changed parameter is saved to A2-17. The second most recently changed parameter is saved to A2-18, etc.	0, 1	1

### ◆ Password Settings: A1-04, A1-05

The user can set a password in parameter A1-05 to restrict access to the drive. The password must be entered to A1-04 to unlock parameter access (i.e., parameter setting A1-04 must match the value programmed into A1-05). The following parameters cannot be viewed or edited until the value entered to A1-04 correctly matches the value set to A1-05: A1-01, A1-02, A1-03, A1-06, and A2-01 through A2-33.

**Note:** Parameter A1-05 is hidden from view. To display A1-05, access parameter A1-04 and press  and  simultaneously.

### ◆ Copy Function

Parameter settings can be copied to another drive to simplify parameter restoration or multiple drive setup. The drive supports the following copy options:

- **HOA Keypad (standard in all models)**

The HOA keypad used to operate the drive supports copying, importing, and verifying parameter settings.

- **USB Copy Unit and CopyUnitManager**

The copy unit is an external option connected to the drive to copy parameter settings from one drive and save those settings to another drive. Refer to the manual supplied with the USB Copy Unit for instructions.

The CopyUnitManager is a PC software tool. It allows the user to load parameter settings from the Copy Unit onto a PC, or from the PC onto a Copy Unit. This is useful when managing parameters for various drives or applications. Refer to the manual supplied with the CopyUnitManager for instructions.

# 4.12 Test Run Checklist

Review the checklist before performing a test run. Check each item that applies.

<input checked="" type="checkbox"/>	No.	Checklist	Page
<input type="checkbox"/>	1	Thoroughly read the manual before performing a test run.	–
<input type="checkbox"/>	2	Turn the power on.	123
<input type="checkbox"/>	3	Set the voltage for the power supply to E1-01.	134

Check the items that correspond to the control mode being used.

**WARNING!** *Sudden Movement Hazard. Ensure start/stop and safety circuits are wired properly and in the correct state before energizing the drive. Failure to comply could result in death or serious injury from moving equipment. When programmed for 3-Wire control, a momentary closure on terminal S1 may cause the drive to start.*

<input checked="" type="checkbox"/>	No.	Checklist	Page
V/f Control (A1-02 = 0)			
<input type="checkbox"/>	4	Select the best V/f pattern according to the application and motor characteristics.	–
<input type="checkbox"/>	5	Perform Rotational Auto-Tuning for V/f Control if using Energy Saving functions.	142
Open Loop Vector Control for PM (A1-02 = 5)			
<input type="checkbox"/>	6	Perform Auto-Tuning as described.	142

## 4.13 Advanced Drive Setup Adjustments

This section explains advanced settings and parameters that may be required for drive operation. *Refer to Parameter List on page 279* for a complete listing of drive parameters if more information is required for parameters not listed in this section or in *4.7 Basic Drive Setup Adjustments*.

### ■ A1-00: Language Selection

Selects the display language for the HOA keypad.

**Note:** This parameter is not reset when the drive is initialized using parameter A1-03.

No.	Parameter Name	Setting Range	Default
A1-00	Language Selection	0, 1, 3, 5, 6	0

**Setting 0: English**

**Setting 1: Japanese**

**Setting 3: French**

**Setting 5: Spanish**

**Setting 6: Portuguese**

### ■ A1-01: Access Level Selection

Allows or restricts access to drive parameters.

No.	Parameter Name	Setting Range	Default
A1-01	Access Level Selection	0 to 2	2

**Setting 0: Operation Only**

Access to only parameters A1-01, A1-04, and all U monitor parameters.

**Setting 1: User Parameters**

Access to only a specific list of parameters set to A2-01 through A2-32. These User Parameters can be accessed using the Setup Mode of the HOA keypad.

**Setting 2: Advanced Access Level (A)**

All parameters can be viewed and edited.

#### Notes on Parameter Access

- If the drive parameters are password protected by A1-04 and A1-05, parameters A1-00 through A1-03, and all A2 parameters cannot be modified.
- If a digital input terminal programmed for “Program lockout” (H1-□□ = 1B) is enabled, parameter values cannot be modified, even if A1-01 is set to 1 or 2.
- If parameters are changed via serial communication, it will not be possible to edit or change parameter settings with the HOA keypad until an Enter command is issued to the drive from the serial communication.

## 4.13 Advanced Drive Setup Adjustments

### ■ A1-03: Initialize Parameters

Resets parameters to default values. After initialization, the setting for A1-03 automatically returns to 0.

No.	Parameter Name	Setting Range	Default
A1-03	Initialize Parameters	0, 1110, 2220, 3330, 3410, 3420	0

#### Setting 0: No Initialize

#### Setting 1110: User Initialize

Resets parameters to the values selected by the user as User Settings. User Settings are stored when parameter o2-03 is set to “1: Set defaults”.

**Note:** User Initialization resets all parameters to a user-defined set of default values previously saved to the drive. Set parameter o2-03 to 2 to clear the user-defined default values.

#### Setting 2220: 2-Wire Initialization

Resets parameters to default settings with digital inputs S1 and S2 configured as Forward run and Reverse run, respectively.

#### Setting 3330: 3-Wire Initialization

Resets parameters to default settings with digital inputs S1, S2, and S5 configured as Run, Stop, and Forward/Reverse respectively.

#### Setting 3410: HVAC Initialization

Resets parameters to default settings. The following parameters are not reset:

H1-03: b1 (Customer Safeties)

H1-04: b2 (BAS Interlock)

H1-05: AF (Emergency Override Forward Run)

H2-03: b2 (BAS Interlock Relay Contact)

**Note:** After performing an HVAC Initialization, H1-03 to H1-05 and H2-03 will be displayed in the Modified Parameters list.

#### Setting 3420: OEM Bypass Initialization

Resets parameters to default settings. The following parameters are not reset:

H1-03: A7 (BP Customer Safeties)

H1-04: A6 (BP BAS Interlock)

H1-05: A4 (BP Emergency Override)

H1-06: AE (BP Bypass Run)

H2-01: A4 (BP Drive Relay)

H2-02: A5 (BP Bypass Relay)

H2-03: A6 (BP BAS Interlock)

o1-16: 2 (Drive/Bypass)

**Note:** After performing an OEM Bypass Initialization, H1-03 to H1-05, H2-01 to H2-03, and o1-16 will be displayed in the Modified Parameters list.

#### Notes on Parameter Initialization

The parameters shown in [Table 4.23](#) will not be reset when the drive is initialized by setting A1-03 = 2220 or 3330. Although the control mode in A1-02 is not reset when A1-03 is set to 2220 or 3330, it may change when an application preset is selected.

**Table 4.23 Parameters Not Changed by Drive Initialization**

No.	Parameter Name
A1-00	Language Selection
A1-02	Control Method Selection
E1-03	V/f Pattern Selection
F6-08	Communication Parameter Reset
L8-35	Installation Selection

No.	Parameter Name
o2-04	Drive/kVA Selection

### ■ A1-06: Application Preset

Several Application Presets are available to facilitate drive setup for commonly used applications. Selecting one of these Application Presets automatically assigns functions to the input and output terminals and sets a predefined group of parameters to values appropriate for the selected application.

In addition, the parameters most likely to be changed are assigned to the group of User Parameters, A2-01 through A2-16. User Parameters are part of the Setup Group, which provides quicker access by eliminating the need to scroll through multiple menus.

### ■ b1-04: Reverse Operation Selection

Enables and disables Reverse operation. For some applications, reverse motor rotation is not appropriate and may cause problems (e.g., air handling units, pumps, etc.).

No.	Parameter Name	Setting Range	Default
b1-04	Reverse Operation Selection	0, 1	1

#### Setting 0: Reverse Enabled

Possible to operate the motor in both forward and reverse directions.

#### Setting 1: Reverse Disabled

Drive disregards a Reverse run command or a negative frequency reference.

### ■ b1-14: Phase Order Selection

Sets the phase order for drive output terminals U/T1, V/T2, and W/T3.

Switching motor phases will reverse the direction of the motor.

No.	Parameter Name	Setting Range	Default
b1-14	Phase Order Selection	0, 1	0

#### Setting 0: Standard

#### Setting 1: Switch Phase Order

The direction of the motor is reversed.

### ■ b1-17: Run Command at Power Up

Determines whether an external Run command that is active during power up will start the drive.

No.	Parameter Name	Setting Range	Default
b1-17	Run Command at Power Up	0, 1	1

#### Setting 0: Disregarded

A new Run command must be issued after power up. Cycle the Run command to start the drive.

**Note:** For safety reasons, the drive is initially programmed not to accept a Run command at power up (b1-17 = 0). If a Run command is issued at power up, the RUN indicator LED will flash quickly.

#### Setting 1: Allowed

The motor will start immediately after a power up if a Run command is already enabled.

**WARNING!** Sudden Movement Hazard. If b1-17 is set to 1 and an external Run command is active during power up, the motor will begin rotating as soon as the power is switched on. Proper precautions must be taken to ensure that the area around the motor is safe prior to powering up the drive. Failure to comply may cause serious injury.

### ■ b2-01: DC Injection Braking Start Frequency

Active when “Ramp to Stop” is selected as the stopping method (b1-03 = 0).

No.	Name	Setting Range	Default
b2-01	DC Injection Braking Start Frequency	0.0 to 10.0 Hz	Determined by A1-02

The function triggered by parameter b2-01 depends on the control mode that has been selected.

## 4.13 Advanced Drive Setup Adjustments

### V/f (A1-02 = 0)

For these control modes, parameter b2-01 sets the starting frequency for DC Injection Braking at Stop. When the output frequency falls below the setting of b2-01, DC Injection Braking is enabled for the time set in parameter b2-04.

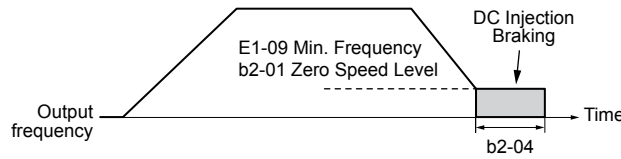

Figure 4.28 DC Injection Braking at Stop for V/f

**Note:** If b2-01 is set to a smaller value than parameter E1-09 (minimum frequency), then DC Injection Braking will begin as soon as the frequency falls to the value set to E1-09.

### OLV/PM (A1-02 = 5)

For these control modes, parameter b2-01 sets the starting frequency for Short-Circuit Braking at stop. When the output frequency falls below the setting of b2-01, Short-Circuit Braking is enabled for the time set in parameter b2-13. If DC Injection Braking time is enabled at stop, then DC Injection Braking is performed for the time set in b2-04 after Short-Circuit Braking is complete.

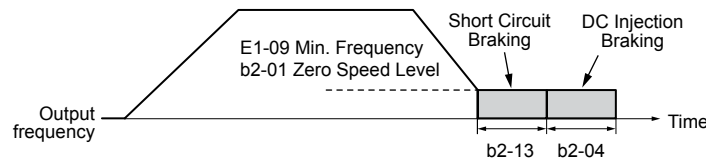

Figure 4.29 Short-Circuit Braking at Stop in OLV/PM

**Note:** If b2-01 is set to a smaller value than parameter E1-09 (minimum frequency), then DC Injection Braking will begin as soon as the frequency falls to the value set to E1-09.

### ■ b2-02: DC Injection Braking Current

Sets the DC Injection Braking current as a percentage of the drive rated current. The carrier frequency is automatically reduced to 1 kHz when this parameter is set to more than 50%.

No.	Name	Setting Range	Default
b2-02	DC Injection Braking Current	0 to 100%	50%

The level of DC Injection Braking current affects the strength of the magnetic field attempting to lock the motor shaft. Increasing the current level will increase the amount of heat generated by the motor windings. Do not set this parameter higher than the level necessary to hold the motor shaft.

### ■ b2-03: DC Injection Braking Time at Start

Sets the time of DC Injection Braking at start. Used to stop a coasting motor before restarting it or to apply braking torque at start. Disabled when set to 0.00 s.

No.	Name	Setting Range	Default
b2-03	DC Injection Braking Time at Start	0.00 to 10.00 s	0.00 s

**Note:** Before starting an uncontrolled rotating motor (e.g., a fan motor driven by windmill effect), use DC Injection or Speed Search to stop the motor or detect motor speed before starting it. Otherwise, motor stalling and other faults can occur.

### ■ b2-04: DC Injection Braking Time at Stop

Sets the time of DC Injection Braking at stop. Used to completely stop a motor with high inertia load after ramp down. Increase the value if the motor still coasts by inertia after it should have stopped. Disabled when set to 0.00 s.

No.	Name	Setting Range	Default
b2-04	DC Injection Braking Time at Stop	0.00 to 10.00 s	0.00 s

### ■ b3-01: Speed Search Selection at Start

Determines if Speed Search is automatically performed when a Run command is issued.

No.	Parameter Name	Setting Range	Default
b3-01	Speed Search Selection at Start	0, 1	Determined by A1-02

#### Setting 0: Disabled

This setting starts operating the drive at the minimum output frequency when the Run command is entered. If external Speed Search 1 or 2 is already enabled by a digital input, the drive will start operating with Speed Search.

#### Setting 1: Enabled

This setting performs Speed Search when the Run command is entered. The drive begins running the motor after Speed Search is complete.

### ■ b3-02: Speed Search Deactivation Current

Sets the operating current for Speed Search as a percentage of the drive rated current. Normally there is no need to change this setting. Lower this value if the drive has trouble restarting.

No.	Name	Setting Range	Default
b3-02	Speed Search Deactivation Current	0 to 200%	Determined by A1-02

**Note:** When parameter A1-02 = 0 (V/f Control) the factory default setting is 120.

### ■ b3-03: Speed Search Deceleration Time

Sets the output frequency reduction ramp used by Current Detection Speed Search (b3-24 = 0) and by the Current Injection Method of Speed Estimation (b3-24 = 1). The time entered into b3-03 will be the time to decelerate from maximum frequency (E1-04) to minimum frequency (E1-09).

No.	Name	Setting Range	Default
b3-03	Speed Search Deceleration Time	0.1 to 10.0 s	2.0 s

### ■ b3-04: V/f Gain during Speed Search

During Speed Search, the output voltage calculated from the V/f pattern is multiplied with this value. Changing this value can help reduce the output current during Speed Search.

No.	Name	Setting Range	Default
b3-04	V/f Gain during Speed Search	10 to 100%	Determined by o2-04

### ■ b3-05: Speed Search Delay Time

In cases where an output contactor is used between the drive and the motor, the contactor must be closed before Speed Search can be performed. This parameter can be used to delay the Speed Search operation, giving the contactor enough time to close completely.

No.	Name	Setting Range	Default
b3-05	Speed Search Delay Time	0.0 to 100.0 s	0.2 s

### ■ b3-06: Output Current 1 during Speed Search

Sets the current injected to the motor at the beginning of Speed Estimation Speed Search as a factor of the motor rated current set in E2-01. If the motor speed is relatively slow when the drive starts to perform Speed Search after a long period of baseblock, it may be helpful to increase the setting value. The output current during Speed Search is automatically limited by the drive rated current.

No.	Name	Setting Range	Default
b3-06	Output Current 1 during Speed Search	0.0 to 2.0	Determined by o2-04

**Note:** Use Current Detection Speed Search if Speed Estimation is not working correctly even after adjusting b3-06.

## 4.13 Advanced Drive Setup Adjustments

### ■ b3-10: Speed Search Detection Compensation Gain

Sets the gain for the detected motor speed of the Speed Estimation Speed Search. Increase the setting only if an overvoltage fault occurs when the drive restarts the motor.

No.	Name	Setting Range	Default
b3-10	Speed Search Detection Compensation Gain	1.00 to 1.20	1.05

### ■ b3-14: Bi-Directional Speed Search Selection

Sets how the drive determines the motor rotation direction when performing Speed Estimation Speed Search.

No.	Parameter Name	Setting Range	Default
b3-14	Bi-Directional Speed Search Selection	0, 1	1

#### Setting 0: Disabled

The drive uses the frequency reference to determine the direction of motor rotation to restart the motor.

#### Setting 1: Enabled

The drive detects the motor rotation direction to restart the motor.

### ■ b3-17: Speed Search Restart Current Level

Sets the current level at which Speed Estimation is restarted as a percentage of drive rated current to avoid overcurrent and overvoltage problems since a large current can flow into the drive if the difference between the estimated frequency and the actual motor speed is too big when performing Speed Estimation.

No.	Name	Setting Range	Default
b3-17	Speed Search Restart Current Level	0 to 200%	110%

### ■ b3-18: Speed Search Restart Detection Time

Sets the time for which the current must be above the level set in b3-17 before restarting Speed Search.

No.	Name	Setting Range	Default
b3-18	Speed Search Restart Detection Time	0.00 to 1.00 s	0.10 s

### ■ b3-19: Number of Speed Search Restarts

Sets the number of times the drive should attempt to find the speed and restart the motor. If the number of restart attempts exceeds the value set to b3-19, the SEr fault will occur and the drive will stop.

No.	Name	Setting Range	Default
b3-19	Number of Speed Search Restarts	0 to 10	3

### ■ b3-24: Speed Search Method Selection

Sets the Speed Search method.

No.	Parameter Name	Setting Range	Default
b3-24	Speed Search Method Selection	0, 1	0

#### Setting 0: Current Detection

#### Setting 1: Speed Estimation

### ■ b3-25: Speed Search Wait Time

Sets the wait time between Speed Search restarts. Increase the wait time if problems occur with overcurrent, overvoltage, or if the SEr fault occurs.

No.	Name	Setting Range	Default
b3-25	Speed Search Wait Time	0.0 to 300.0 s	0.5 s

### ■ b3-27: Start Speed Search Select

Selects a condition to activate Speed Search Selection at Start (b3-01) or External Speed Search Command 1 or 2 from the multi-function input.

No.	Name	Setting Range	Default
b3-27	Start Speed Search Select	0, 1	0

**Setting 0: Triggered when a Run Command Is Issued (Normal)**

**Setting 1: Triggered when an External Baseblock Is Released**

### ■ b5-01: PI Function Setting

Enables or disables the PI operation and selects the PI operation mode.

No.	Parameter Name	Setting Range	Default
b5-01	PI Function Setting	0, 1, 3	0

**Setting 0: PI Disabled**

**Setting 1: Output Frequency = PI Output 1**

The PI controller is enabled and the PI output builds the frequency reference.

**Setting 3: Output Frequency = Frequency Reference + PI Output 1**

The PI controller is enabled and the PI output is added to the frequency reference.

### ■ b5-02: Proportional Gain Setting (P)

Sets the P gain applied to the PI input. Larger values will tend to reduce the error but may cause oscillations if set too high, while lower values may allow too much offset between the setpoint and feedback.

No.	Name	Setting Range	Default
b5-02	Proportional Gain Setting (P)	0.00 to 25.00	2.00

### ■ b5-03: Integral Time Setting (I)

Sets the time constant used to calculate the integral of the PI input. The shorter the integral time set to b5-03, the faster the offset will be eliminated. If the integral time is set too short, however, overshoot or oscillation may occur. To turn off the integral time, set b5-03 to 0.00.

No.	Name	Setting Range	Default
b5-03	Integral Time Setting (I)	0.0 to 360.0 s	0.5 s

### ■ b5-04: Integral Limit Setting

Sets the maximum output possible from the integral block as a percentage of the maximum frequency (E1-04).

No.	Name	Setting Range	Default
b5-04	Integral Limit Setting	0.0 to 100.0%	100.0%

**Note:** On some applications, especially those with rapidly varying loads, the output of the PI function may show a fair amount of oscillation. Program b5-04 to apply a limit to the integral output and suppress this oscillation.

### ■ b5-06: PI Output Limit

Sets the maximum output possible from the entire PI controller as a percentage of the maximum frequency (E1-04).

No.	Name	Setting Range	Default
b5-06	PI Output Limit	0.0 to 100.0%	100.0%

### ■ b5-07: PI Offset Adjustment

Sets the offset added to the PI controller output as a percentage of the maximum frequency (E1-04).

No.	Name	Setting Range	Default
b5-07	PI Offset Adjustment	-100.0 to 100.0%	0.0%

## 4.13 Advanced Drive Setup Adjustments

### ■ b5-08: PI Primary Delay Time Constant

Sets the time constant for the filter applied to the output of the PI controller. Normally, change is not required.

No.	Name	Setting Range	Default
b5-08	PI Primary Delay Time Constant	0.00 to 10.00 s	0.00 s

**Note:** Useful when there is a fair amount of oscillation or when rigidity is low. Set to a value larger than the cycle of the resonant frequency. Increasing this time constant may reduce the responsiveness of the drive.

### ■ b5-09: PI Output Level Selection

Reverses the sign of the PI controller output signal. Normally a positive PI input (feedback smaller than setpoint) leads to positive PI output.

No.	Parameter Name	Setting Range	Default
b5-09	PI Output Level Selection	0, 1	0

#### Setting 0: Normal Output

A positive PI input causes an increase in the PI output (direct acting).

#### Setting 1: Reverse Output

A positive PI input causes a decrease in the PI output (reverse acting).

### ■ b5-10: PI Output Gain Setting

Applies a gain to the PI output and can be helpful when the PI function is used to trim the frequency reference (b5-01 = 3 or 4).

No.	Name	Setting Range	Default
b5-10	PI Output Gain Setting	0.00 to 25.00	1.00

### ■ b5-11: PI Output Reverse Selection

Determines whether a negative PI output reverses the direction of drive operation. This parameter has no effect when the PI function trims the frequency reference (b5-01 = 3) and the PI output will not be limited (same as b5-11 = 1).

No.	Parameter Name	Setting Range	Default
b5-11	PI Output Reverse Selection	0, 1	0

#### Setting 0: Reverse Disabled

Negative PI output will be limited to 0 and the drive output will be stopped.

#### Setting 1: Reverse Enabled

Negative PI output will cause the drive to run in the opposite direction.

### ■ b5-12: PI Feedback Loss Detection Selection

Enables or disables the feedback loss detection and sets the operation when a feedback loss is detected.

No.	Parameter Name	Setting Range	Default
b5-12	PI Feedback Loss Detection Selection	0 to 5	0

**Note:** b5-12 setting range is 0 to 2 in drive software PRG: 1013 and earlier.

#### Setting 0: Digital Output Only (Remains active when PI is disabled by digital input)

A digital output set for “PI feedback low” (H2-□□ = 3E) will be triggered if the PI feedback value is below the detection level set to b5-13 for the time set to b5-14 or longer. A digital output set for “PI feedback high” (H2-□□ = 3F) will be triggered if the PI feedback value is beyond the detection level set to b5-36 for longer than the time set to b5-37. Neither a fault nor an alarm is displayed on the HOA keypad and the drive will continue operation. The output resets when the feedback value leaves the loss detection range. Detection remains active when PI is disabled by digital input (H1-□□ = 19).

#### Setting 1: Feedback Loss Alarm (Remains active when PI is disabled by digital input)

If the PI feedback value falls below the level set to b5-13 for longer than the time set to b5-14, a “FBL - Feedback Low” alarm will be displayed and a digital output set for “PI feedback low” (H2-□□ = 3E) will be triggered. If the PI feedback value exceeds the level set to b5-36 for longer than the time set to b5-37, a “FBH - Feedback High” alarm will be displayed and a

digital output set for “PI feedback high” (H2-□□ = 3F) will be triggered. Both events trigger an alarm output (H1-□□ = 10). The drive will continue operation. The alarm and outputs reset when the feedback value leaves the loss detection range. Detection remains active when PI is disabled by digital input (H1-□□ = 19).

**Setting 2: Feedback Loss Fault (Remains active when PI is disabled by digital input)**

If the PI feedback value falls below the level set to b5-13 for longer than the time set to b5-14, a “FbL - Feedback Low” fault will be displayed. If the PI feedback value exceeds the level set to b5-36 for longer than the time set to b5-37, a “FbH - Feedback High” fault will be displayed. Both events trigger a fault output (H1-□□ = E) and cause the drive to stop the motor. Detection remains active when PI is disabled by digital input (H1-□□ = 19).

**Setting 3: Digital Output Only**

A digital output set for “PI feedback low” (H2-□□ = 3E) will be triggered if the PI feedback value is below the detection level set to b5-13 for the time set to b5-14 or longer. A digital output set for “PI feedback high” (H2-□□ = 3F) will be triggered if the PI feedback value is beyond the detection level set to b5-36 for longer than the time set to b5-37. Neither a fault nor an alarm is displayed on the HOA keypad and the drive will continue operation. The output resets when the feedback value leaves the loss detection range. Detection is disabled when PI is disabled by digital input (H1-□□ = 19).

**Setting 4: Feedback Loss Alarm**

If the PI feedback value falls below the level set to b5-13 for longer than the time set to b5-14, a “FBL - Feedback Low” alarm will be displayed and a digital output set for “PI feedback low” (H2-□□ = 3E) will be triggered. If the PI feedback value exceeds the level set to b5-36 for longer than the time set to b5-37, a “FBH - Feedback High” alarm will be displayed and a digital output set for “PI feedback high” (H2-□□ = 3F) will be triggered. Both events trigger an alarm output (H1-□□ = 10). The drive will continue operation. The alarm and outputs reset when the feedback value leaves the loss detection range. Detection is disabled when PI is disabled by digital input (H1-□□ = 19).

**Setting 5: Feedback Loss Fault**

If the PI feedback value falls below the level set to b5-13 for longer than the time set to b5-14, a “FbL - Feedback Low” fault will be displayed. If the PI feedback value exceeds the level set to b5-36 for longer than the time set to b5-37, a “FbH - Feedback High” fault will be displayed. Both events trigger a fault output (H1-□□ = E) and cause the drive to stop the motor. Detection is disabled when PI is disabled by digital input (H1-□□ = 19).

■ **b5-13: PI Feedback Low Detection Level**

Sets the feedback level used for PI feedback low detection. The PI feedback must fall below this level for longer than the time set to b5-14 before feedback loss is detected.

No.	Name	Setting Range	Default
b5-13	PI Feedback Low Detection Level	0 to 100%	0%

■ **b5-14: PI Feedback Low Detection Time**

Sets the time that the PI feedback has to fall below b5-13 before feedback loss is detected.

No.	Name	Setting Range	Default
b5-14	PI Feedback Low Detection Time	0.0 to 25.5 s	1.0 s

■ **b5-15: PI Sleep Function Start Level**

Sets the level that triggers PI Sleep/Snooze.

The drive goes into Sleep/Snooze mode if the PI output or frequency reference is smaller than b5-15 for longer than the time set to b5-16. The drive resumes operation when the PI output or frequency reference is above b5-15 for longer than the time set to b5-16.

No.	Name	Setting Range	Default
b5-15	PI Sleep Function Start Level	0.0 to 240.0 Hz	0.0 Hz

■ **b5-16: PI Sleep Delay Time**

Sets the delay time to activate or deactivate the PI Sleep/Snooze function.

No.	Name	Setting Range	Default
b5-16	PI Sleep Delay Time	0.0 to 25.5 s	0.0 s

## 4.13 Advanced Drive Setup Adjustments

### ■ b5-17: PI Accel/Decel Time

The PI acceleration/deceleration time is applied on the PI setpoint value.

When the setpoint changes quickly, the normal C1-□□ acceleration times reduce the responsiveness of the system as they are applied after the PI output. The PI accel/decel time helps avoid the hunting and overshoot and undershoot that can result from the reduced responsiveness.

The PI acceleration/deceleration time can be canceled using a digital input programmed for “PI SFS cancel” (H1-□□ = 34).

No.	Name	Setting Range	Default
b5-17	PI Accel/Decel Time	0.0 to 6000.0 s	0.0 s

### ■ b5-18: PI Setpoint Selection

Enables or disables parameter b5-19 for PI setpoint.

No.	Parameter Name	Setting Range	Default
b5-18	PI Setpoint Selection	0, 1	0

#### Setting 0: Disabled

Parameter b5-19 is not used as the PI setpoint.

#### Setting 1: Enabled

Parameter b5-19 is used as PI setpoint.

### ■ b5-19: PI Setpoint Value

Used as the PI setpoint if parameter b5-18 = 1.

No.	Name	Setting Range	Default
b5-19	PI Setpoint Value	0.00 to 600.00%	0.00%

**Note:** Unit and resolution for b5-19 is determined by b5-20, b5-39, and b5-46.

The following conditions apply to drives with software PRG: 1014 and later. Parameter b5-19 is internally limited to b5-38. Changing b5-20, b5-38 and b5-39 will not automatically update the value of b5-19.

### ■ b5-20: PI Setpoint Scaling

Determines the units for the PI Setpoint Value (b5-19) and monitors U5-01 and U5-04.

No.	Parameter Name	Setting Range	Default
b5-20	PI Setpoint Scaling	0 to 3	1

#### Setting 0: Hz

The setpoint and PI monitors are displayed in Hz with a resolution of 0.01 Hz.

#### Setting 1: %

The setpoint and PI monitors are displayed as a percentage with a resolution of 0.01%.

#### Setting 2: r/min

The setpoint and PI monitors are displayed in r/min with a resolution of 1 r/min.

#### Setting 3: User Defined

Parameters b5-38 and b5-39 determine the units and resolution used to display the values the setpoint in b5-19, and PI monitors U5-01 and U5-04.

### ■ b5-21: PI Sleep Input Source

Selects the Sleep Function characteristic action. When b5-21 is set to 1, the Sleep Function Start Level (b5-15) is compared to the output of the drive (Speed Command after PI Block). Use this setting for open loop control.

The Sleep Function Start Level (b5-15) can be compared to the drive input or setpoint by setting b5-21 to 0.

When b5-21 is set to 2, a variation of the Sleep Function called “Snooze” is enabled. See parameters b5-22 to b5-27 for details.

No.	Parameter Name	Setting Range	Default
b5-21	PI Sleep Input Source	0 to 2	1

**Setting 0: PI Setpoint****Setting 1: SFS Input****Setting 2: Snooze****■ b5-22: PI Snooze Level**

Sets the PI Snooze function start level as a percentage of maximum frequency.

No.	Parameter Name	Setting Range	Default
b5-22	PI Snooze Level	0 to 100%	0%

**■ b5-23: PI Snooze Delay Time**

Sets the PI Snooze function delay time in seconds.

No.	Parameter Name	Setting Range	Default
b5-23	PI Snooze Delay Time	0 to 2600 s	0 s

**■ b5-24: PI Snooze Deactivation Level**

When the PI feedback drops below this level, normal operation starts again. Sets as a percentage of maximum frequency.

No.	Parameter Name	Setting Range	Default
b5-24	PI Snooze Deactivation Level	0 to 100%	0%

**■ b5-25: PI Setpoint Boost Setting**

Temporary increase of PI setpoint to create an overshoot of the intended PI setpoint.

No.	Parameter Name	Setting Range	Default
b5-25	PI Setpoint Boost Setting	0 to 100%	0%

**■ b5-26: PI Maximum Boost Time**

Associated with the Snooze Function. In cases where the temporary PI Setpoint (intended PI setpoint + PI Setpoint Boost) cannot be reached within the PI Maximum Boost Time (b5-26), the Setpoint Boost is interrupted and the Drive output is turned off.

No.	Parameter Name	Setting Range	Default
b5-26	PI Maximum Boost Time	0 to 2600 s	0 s

**■ b5-27: PI Snooze Feedback Level**

The second method of initiating the Snooze Function. The drive output shuts off when the PI feedback level exceeds the PI Snooze Feedback Level (b5-27).

Normal drive and PI operation return after the PI feedback drops below the PI Snooze Deactivation Level (b5-24). Snooze activates when both b5-22 and b5-27 conditions are met. There is no time delay for deactivation.

Sets as a percentage of maximum frequency.

No.	Parameter Name	Setting Range	Default
b5-27	PI Snooze Feedback Level	0 to 100%	60%

**■ b5-28: PI Feedback Function Selection**

When b5-28 is set to 1, the square root of the PI feedback is compared to the PI Setpoint to determine appropriate drive output to properly regulate the system.

This is helpful in cases where the measured feedback is pressure, but the PI loop needs to regulate flow.

No.	Parameter Name	Setting Range	Default
b5-28	PI Feedback Function Selection	0, 1	0

## 4.13 Advanced Drive Setup Adjustments

0: Disabled

1: Square Root

### ■ b5-29: PI Square Root Gain

A multiplier applied to the square root of the feedback. If the PI Function is regulating the flow of a closed loop system by using a pressure feedback, it may be convenient to view the square root of the PI output using monitor U1-37.

No.	Parameter Name	Setting Range	Default
b5-29	PI Square Root Gain	0.00 to 2.00	0.00

### ■ b5-30: PI Feedback Offset

Sets PI feedback Offset as a percentage of maximum frequency.

No.	Parameter Name	Setting Range	Default
b5-30	PI Feedback Offset	0.00 to 100.00%	0.00%

### ■ b5-34: PI Output Lower Limit

Sets the minimum possible PI controller output as a percentage of the maximum output frequency (E1-04). The lower limit is disabled when set to 0.00%

No.	Name	Setting Range	Default
b5-34	PI Output Lower Limit	-100.0 to 100.0%	0.0%

### ■ b5-35: PI Input Limit

Sets the maximum allowed PI input as a percentage of the maximum output frequency (E1-04). Parameter b5-35 acts as a bipolar limit.

No.	Name	Setting Range	Default
b5-35	PI Input Limit	0 to 1000.0%	1000.0%

### ■ b5-36: PI Feedback High Detection Level

Sets the feedback level used for PI feedback high detection. The PI feedback must exceed this level for longer than the time set to b5-37 before feedback loss is detected.

No.	Name	Setting Range	Default
b5-36	PI Feedback High Detection Level	0 to 100%	100%

### ■ b5-37: PI Feedback High Detection Time

Sets the time that the PI feedback must exceed the value set to b5-36 before feedback loss is detected.

No.	Name	Setting Range	Default
b5-37	PI Feedback High Detection Time	0.0 to 25.5 s	1.0 s

### ■ b5-38, b5-39: PI Setpoint User Display, PI Setpoint Display Digits

When parameter b5-20 is set to 3, parameters b5-38 and b5-39 set a user-defined display for the PI setpoint (b5-19) and PI feedback monitors (U5-01, U5-04).

Parameter b5-38 determines the display value when the maximum frequency is output and parameter b5-39 determines the number of digits. The setting value is equal to the number of decimal places.

No.	Name	Setting Range	Default
b5-38	PI Setpoint User Display	1 to 60000	Determined by b5-20
b5-39	PI Setpoint Display Digits	0 to 3	Determined by b5-20

### ■ b5-40: Frequency Reference Monitor Content During PI

Sets the content of the frequency reference monitor display (U1-01) when PI control is active.

No.	Name	Setting Range	Default
b5-40	Frequency Reference Monitor Content During PI	0, 1	0

**Setting 0: Frequency Reference after PI**

Monitor U1-01 displays the frequency reference increased or reduced for the PI output.

**Setting 1: Frequency Reference**

Monitor U1-01 displays the frequency reference value.

**■ b5-41: PI Unit Selection**

Sets the display units in U5-14 and U5-15.

No.	Name	Setting Range	Default
b5-41	PI Unit Selection	0 to 14	0

**Setting 0: WC (Inch of Water)****Setting 1: PSI (Pounds per Square Inch)****Setting 2: GPM (Gallons per Minute)****Setting 3: F (Degrees Fahrenheit)****Setting 4: CFM (Cubic Feet per Minute)****Setting 5: CMH (Cubic Meters per Hour)****Setting 6: LPH (Liters per Hour)****Setting 7: LPS (Liters per Second)****Setting 8: Bar (Bar)****Setting 9: Pa (Pascal)****Setting 10: C (Degrees Celsius)****Setting 11: Mtr (Meters)****Setting 12: Ft (Feet)****Setting 13: LPM (Liters per Minute)****Setting 14: CMM (Cubic Meters per Minute)****■ b5-42: PI Output Monitor Calculation Method**

No.	Name	Setting Range	Default
b5-42	PI Output Monitor Calculation Method	0 to 3	0

**Setting 0: Linear**

The monitor displays PI output.

**Setting 1: Square Root**

The monitor displays square root PI output.

**Setting 2: Quadratic**

The monitor displays  $1/(\text{PI output})^2$

**Setting 3: Cubic**

The monitor displays  $1/(\text{PI output})^3$

**■ b5-43/b5-44: Custom PI Output Monitor Setting 1/2**

Set the maximum monitor value at maximum frequency. U5-14 and U5-15 show Custom PI output. U5-14 shows the upper 4 digits and U5-15 shows the lower 4 digits. It shows 999999.99 maximum.

No.	Name	Setting Range	Default
b5-43	Custom PI Output Monitor Setting 2	0 to 9999	0
b5-44	Custom PI Output Monitor Setting 2	0.00 to 99.99	0.00

## 4.13 Advanced Drive Setup Adjustments

### ■ b5-45: Custom PI Output Monitor Setting 3

b5-14 shows Custom PI Output. b5-45 sets the minimum display value at zero speed. This function is effective when b5-42 is set to 0 (Linear).

No.	Name	Setting Range	Default
b5-45	Custom PI Output Monitor Setting 3	0	999.9

### ■ b5-46: PI Setpoint Monitor Unit Selection

Sets the HOA keypad display units in U5-01 and U5-04 when b5-20 is set to 3.

No.	Name	Setting Range	Default
b5-46	PI Setpoint Monitor Unit Selection	0 to 14	0

**Setting 0: WC (Inch of Water)**

**Setting 1: PSI (Pounds per Square Inch)**

**Setting 2: GPM (Gallons per Minute)**

**Setting 3: F (Degrees Fahrenheit)**

**Setting 4: CFM (Cubic Feet per Minute)**

**Setting 5: CMH (Cubic Meters per Hour)**

**Setting 6: LPH (Liters per Hour)**

**Setting 7: LPS (Liters per Second)**

**Setting 8: Bar (Bar)**

**Setting 9: Pa (Pascal)**

**Setting 10: C (Degrees Celsius)**

**Setting 11: Mtr (Meters)**

**Setting 12: Ft (Feet)**

**Setting 13: LPM (Liters per Minute)**

**Setting 14: CMM (Cubic Meters per Minute)**

### ■ b5-47: Reverse Operation Selection 2 by PI Output

Determines whether a negative PI output reverses the direction of drive operation. When the PI function is used to trim the frequency reference (b5-01 = 3), this parameter has no effect and the PI output will not be limited (same as b5-11 = 1).

No.	Name	Setting Range	Default
b5-47	Reverse Operation Selection 2 by PI Output	0, 1	1

**Setting 0: Reverse Disabled**

Negative PI output will be limited to zero and the drive output will be stopped.

**Setting 1: Reverse Enabled**

Negative PI output will cause the drive to run in the opposite direction.

### ■ C2-01 and C2-02: S-Curve Characteristics

C2-01 and C2-02 set separate S-curves for each section of the acceleration or deceleration.

No.	Parameter Name	Setting Range	Default
C2-01	S-Curve Characteristic at Accel Start	0.00 to 10.00 s	Determined by A1-02
C2-02	S-Curve Characteristic at Accel End		0.20 s

*Figure 4.30* illustrates S-curve application.

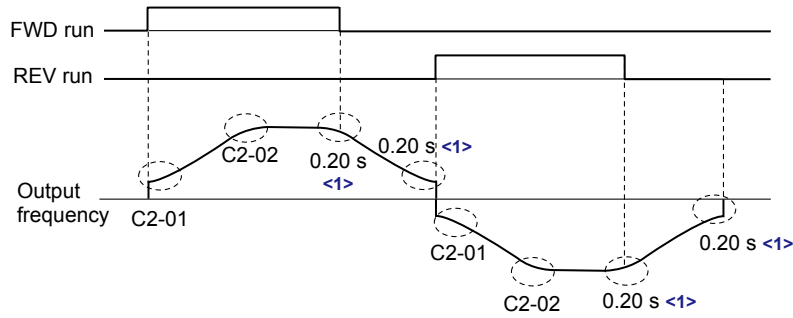

<1> S-Curve characteristic at Decel Start/End is fixed to 0.20 s.

Figure 4.30 S-Curve Timing Diagram - FWD/REV Operation

Setting the S-curve will increase the acceleration and deceleration times.

$$\text{Actual accel time} = \text{accel time setting} + (C2-01 + C2-02) / 2$$

■ **C6-03, C6-04, C6-05: Carrier Frequency Upper Limit, Lower Limit, Proportional Gain**

Note: C6-04 and C6-05 are available in V/f Control mode only.

These parameters set a user-defined or a variable carrier frequency. Set C6-02 to F to set the upper and lower limits and the carrier frequency proportional gain.

No.	Parameter Name	Setting Range	Default
C6-03	Carrier Frequency Upper Limit	1.0 to 15.0 kHz	Determined by C6-02
C6-04	Carrier Frequency Lower Limit (V/f Control only)	1.0 to 15.0 kHz	
C6-05	Carrier Frequency Proportional Gain (V/f Control only)	0 to 99	

**Setting a Fixed User-Defined Carrier Frequency**

A carrier frequency between the fixed selectable values can be entered in parameter C6-03 when C6-02 is set to F. In V/f Control, adjust parameter C6-04 to the same value as C6-03.

**Setting a Variable Carrier Frequency (V/f Control)**

In V/f Control, the carrier frequency can be set up to change linearly with the output frequency by setting the upper and lower limits for the carrier frequency and the carrier frequency proportional gain (C6-03, C6-04, C6-05) as shown in Figure 4.31.

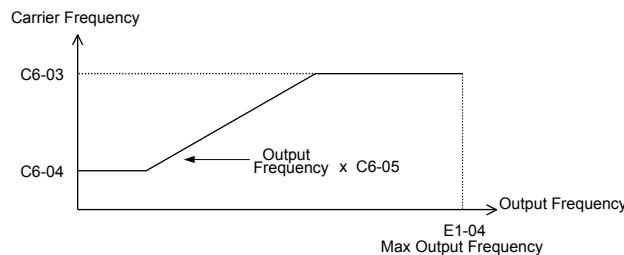

Figure 4.31 Carrier Frequency Changes Relative to Output Frequency

Note: When C6-05 is set lower than 7, C6-04 is disabled and the carrier frequency will be fixed to the value set in C6-03.

■ **d1-01 to d1-04, d1-16, and d1-17: Frequency References 1 to 4, 16, and Jog Frequency Reference**

The drive lets the user switch between up to 5 preset frequency references during run (including the Jog reference) through the digital input terminals. The drive uses the acceleration and deceleration times that have been selected when switching between each frequency reference.

The Jog frequency overrides all other frequency references and must be selected by a separate digital input.

The multi-speed references 1 and 2 can be provided by analog inputs.

## 4.13 Advanced Drive Setup Adjustments

No.	Parameter Name	Setting Range	Default
d1-01 to d1-04	Frequency Reference 1 to 4	0.00 to 240.00 Hz <1> <2>	0.00 Hz <2>
d1-16	Frequency Reference 16	0.00 to 240.00 Hz <1> <2>	0.00 Hz <2>
d1-17	Jog Frequency Reference	0.00 to 240.00 Hz <1> <2>	6.00 Hz <2>

<1> The upper limit is determined by the maximum output frequency (E1-04) and upper limit for the frequency reference (d2-01).

<2> Setting units are determined by parameter o1-03. The default is “Hz” (o1-03 = 0).

### Multi-Step Speed Selection

To use several speed references for a multi-step speed sequence, set the H1-□□ parameters to 3 and 4. To assign the Jog reference to a digital input, set H1-□□ to 6.

Notes on using analog inputs as Multi-Speed 1 and 2:

- The first frequency reference (Multi-Speed 1) comes from the source specified in b1-01. When using an analog input terminal to supply the frequency reference, assign the frequency reference source to the control terminals (b1-01 = 1).
- When an analog input is set to “Auxiliary frequency 1” (H3-02 or H2-06 = 2), the value set to this input will be used as the Multi-Step Speed 2 instead of the value set to parameter d1-02. If no analog inputs are set for “Auxiliary frequency 1”, then d1-02 becomes the reference for Multi-Step Speed 2.

Select the different speed references as shown in [Table 4.24](#). [Figure 4.32](#) illustrates the multi-step speed selection.

**Table 4.24 Multi-Step Speed Reference and Terminal Switch Combinations**

Reference	Multi-Step Speed H1-□□ = 3	Multi-Step Speed 2 H1-□□ = 4	Jog Reference H1-□□ = 6
Frequency Reference 1 (set in b1-01)	OFF	OFF	OFF
Frequency Reference 2 (d1-02 or input terminal A1, A2)	ON	OFF	OFF
Frequency Reference 3 (d1-03 or input terminal A1, A2)	OFF	ON	OFF
Frequency Reference 4 (d1-04)	ON	ON	OFF
Jog Frequency Reference (d1-17) <1>	–	–	ON

<1> The Jog frequency overrides all other frequency references.

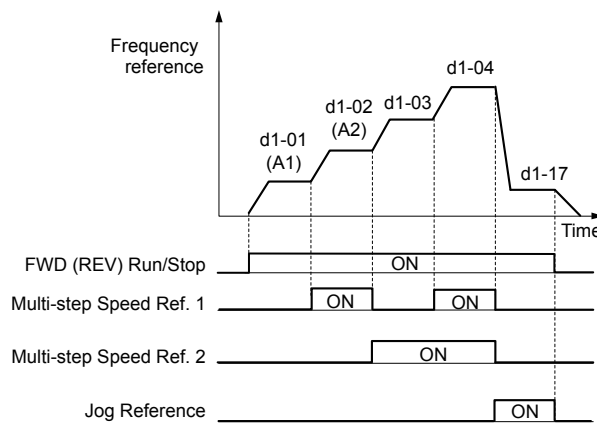

**Figure 4.32 Preset Reference Timing Diagram**

### ■ d2-03: Master Speed Reference Lower Limit

Sets a lower limit as a percentage of the maximum output frequency that will only affect a frequency reference entered from the analog input terminals (A1 or A2) as the master speed reference. This is unlike parameter d2-02, which affects all frequency references regardless of their source.

**Note:** When lower limits are set to both parameters d2-02 and d2-03, the drive uses the greater of those two values as the lower limit.

No.	Parameter Name	Setting Range	Default
d2-03	Master Speed Reference Lower Limit	0.0 to 110.0%	0.0%

**d3-01 to d3-04: Jump Frequencies 1, 2, 3 and Jump Frequency Width**

The Jump frequencies are frequency ranges at which the drive will not operate. The drive can be programmed with three separate Jump frequencies to avoid operating at speeds that cause resonance in driven machinery. If the speed reference falls within a Jump frequency dead band, the drive will clamp the frequency reference just below the dead band and only accelerate past it when the frequency reference rises above the upper end of the dead band.

Setting parameters d3-01 through d3-03 to 0.0 Hz disables the Jump frequency function.

No.	Parameter Name	Setting Range	Default
d3-01	Jump Frequency 1	0.0 to 240.0 Hz	0.0 Hz
d3-02	Jump Frequency 2	0.0 to 240.0 Hz	0.0 Hz
d3-03	Jump Frequency 3	0.0 to 240.0 Hz	0.0 Hz
d3-04	Jump Frequency Width	0.0 to 20.0 Hz	1.0 Hz

Figure 4.33 shows the relationship between the Jump frequency and the output frequency.

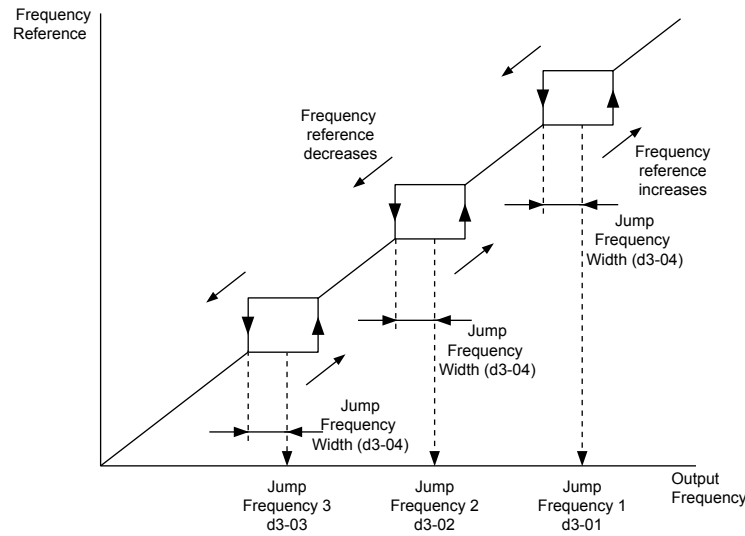

Figure 4.33 Jump Frequency Operation

- Note:**
1. The drive will use the active accel/decel time to pass through the specified dead band range, but will not allow continuous operation in that range.
  2. When setting more than one Jump frequency, make sure that  $d3-01 \geq d3-02 \geq d3-03$ .

**E1-03: V/f Pattern Selection**

Selects the V/f pattern for the drive and motor from 15 predefined patterns or creates a custom V/f pattern.

No.	Parameter Name	Setting Range	Default
E1-03	V/f Pattern Selection	0 to F <I>	F <2>

- <1> Settings 0 through E are not available in OLV/PM (A1-02 = 5).
- <2> Parameter is not reset to the default value when the drive is initialized using A1-03.

**Setting a Predefined V/f Pattern (Setting 0 to F)**

Choose the V/f pattern that best meets the application demands from the table below. These settings are available only in V/f Control modes. Set the correct value to E1-03. Parameters E1-04 to E1-13 can only be monitored, not changed.

- Note:**
1. Setting an improper V/f pattern may result in low motor torque or increased current due to overexcitation.
  2. Drive initialization does not reset parameter E1-03.

## 4.13 Advanced Drive Setup Adjustments

**Table 4.25 Predefined V/f Patterns**

Setting	Specification	Characteristic	Application
0	50 Hz	Constant torque	For general purpose applications. Torque remains constant regardless of changes to speed.
1	60 Hz		
2	60 Hz (with 50 Hz base)		
3	72 Hz (with 60 Hz base)		
4	50 Hz, Variable torque 1	Variable torque	For fans, pumps, and other applications where the required torque changes as a function of the speed.
5	50 Hz, Variable torque 2		
6	50 Hz, Variable torque 3		
7	50 Hz, Variable torque 4		
8	50 Hz, Mid starting torque	High starting torque	Select high starting torque when: <ul style="list-style-type: none"> <li>• Wiring between the drive and motor exceeds 150 m.</li> <li>• A large amount of starting torque is required.</li> <li>• An AC reactor is installed.</li> </ul>
9	50 Hz, High starting torque		
A	60 Hz, Mid starting torque		
B	60 Hz, High starting torque		
C	90 Hz (with 60 Hz base)	Constant output	Output voltage is constant when operating at greater than 60 Hz.
D	120 Hz (with 60 Hz base)		
E	180 Hz (with 60 Hz base)		
F <I>	60 Hz		

<I> Setting F enables a custom V/f pattern by changing parameters E1-04 to E1-13. When the drive is shipped, the default values for parameters E1-04 to E1-13 are equal to predefined V/f pattern 1.

The following tables show details on predefined V/f patterns.

### Predefined V/f Patterns for Models 2A0011 to 2A0017 and 4A0005 to 4A0011

The values in the following graphs are specific to 200 V class drives. Double the values for 400 V class drives.

**Table 4.26 Constant Torque Characteristics, Settings 0 to 3**

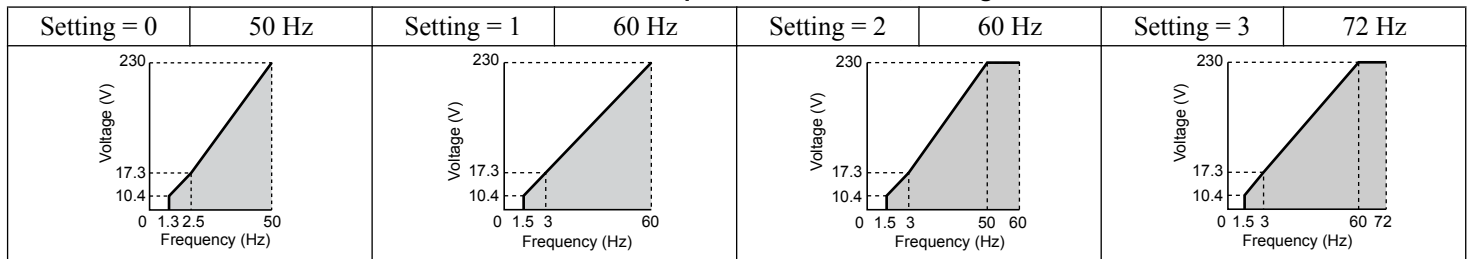

**Table 4.27 Variable Torque Characteristics, Settings 4 to 7**

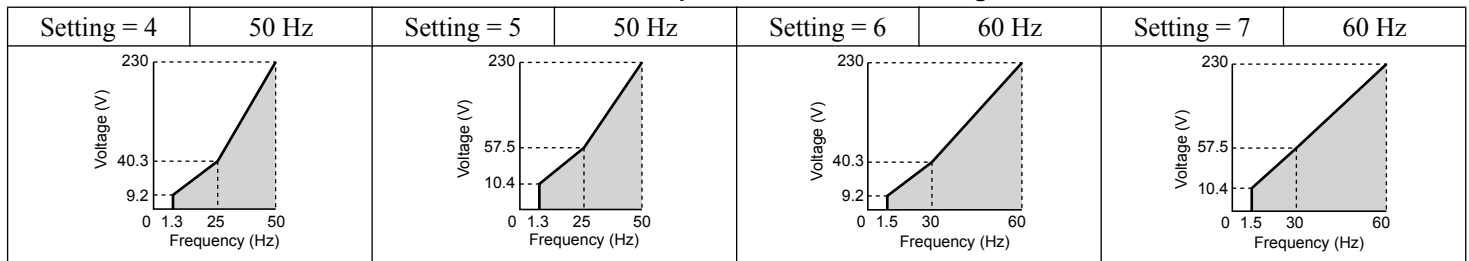

**Table 4.28 High Starting Torque, Settings 8 to B**

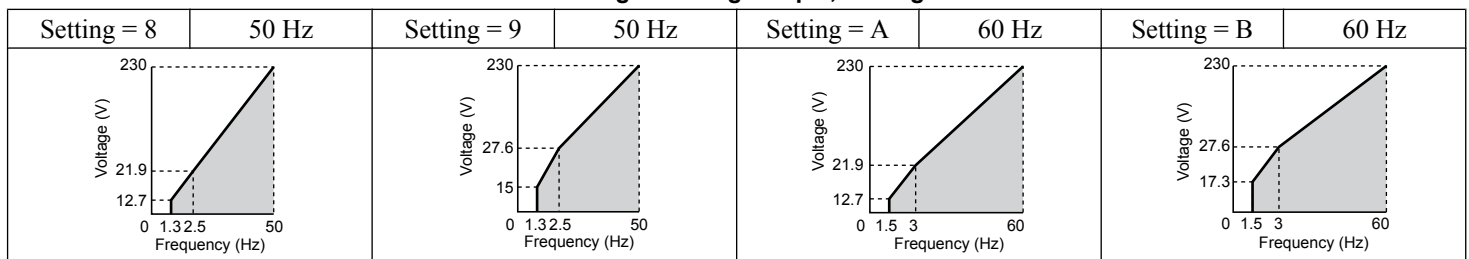
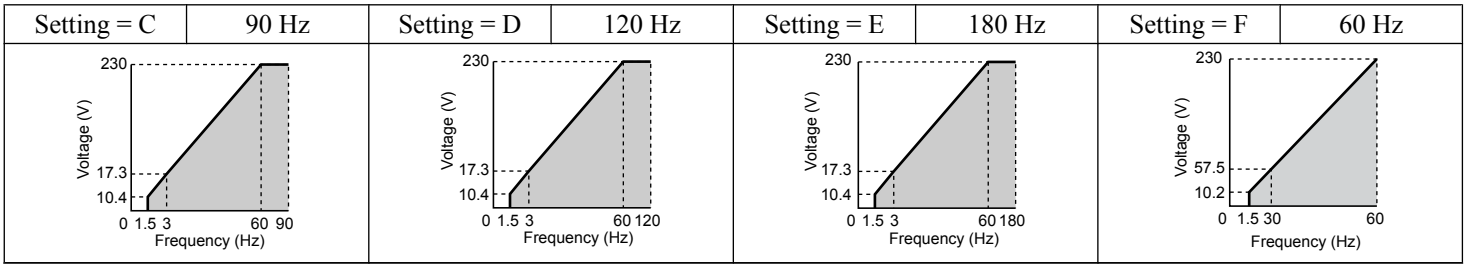

Table 4.29 Rated Output Operation, Settings C to F



**Predefined V/f Patterns for Models 2A0024 to 2A0169 and 4A0014 to 4A0096**

The values in the following graphs are specific to 200 V class drives. Double the values for 400 V class drives.

Table 4.30 Rated Torque Characteristics, Settings 0 to 3

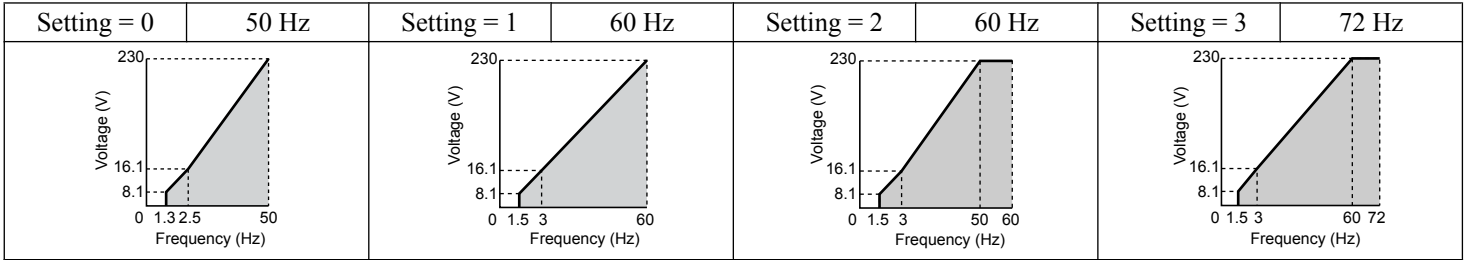

Table 4.31 Variable Torque Characteristics, Settings 4 to 7

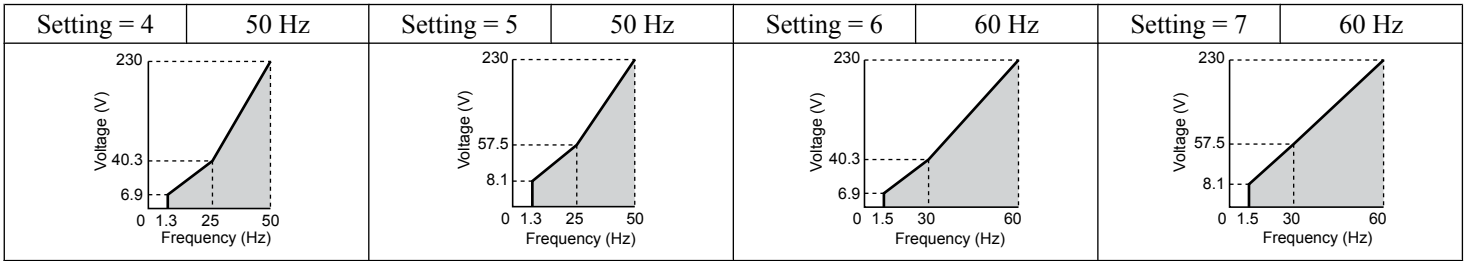

Table 4.32 High Starting Torque, Settings 8 to B

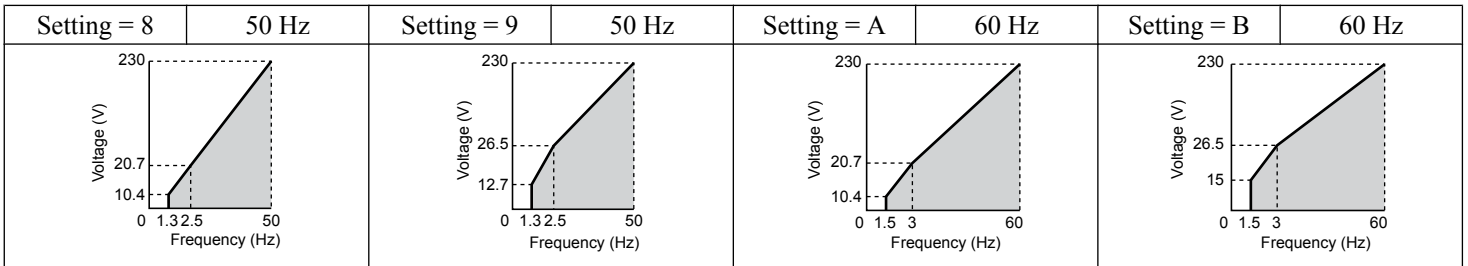
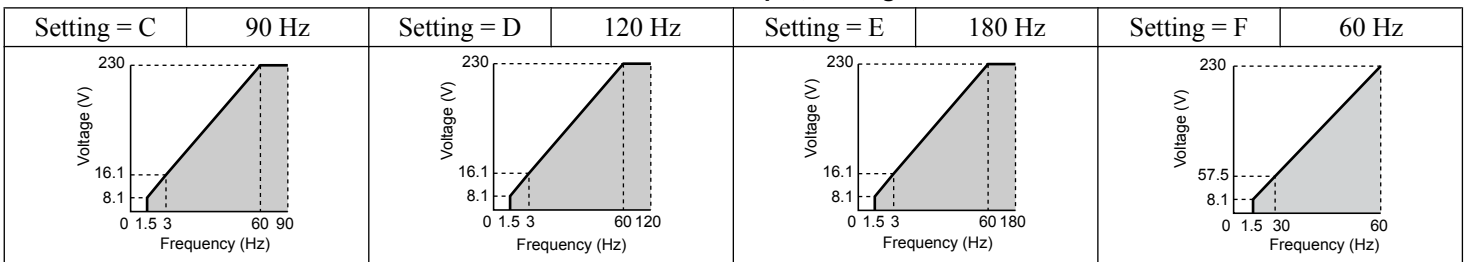

Table 4.33 Constant Output, Settings C to F



## 4.13 Advanced Drive Setup Adjustments

### Predefined V/f Patterns for Models 2A0211 to 2A0396 and 4A0124 to 4A0590

The values in the following graphs are specific to 200 V class drives. Double the values for 400 V class drives.

**Table 4.34 Rated Torque Characteristics, Settings 0 to 3**

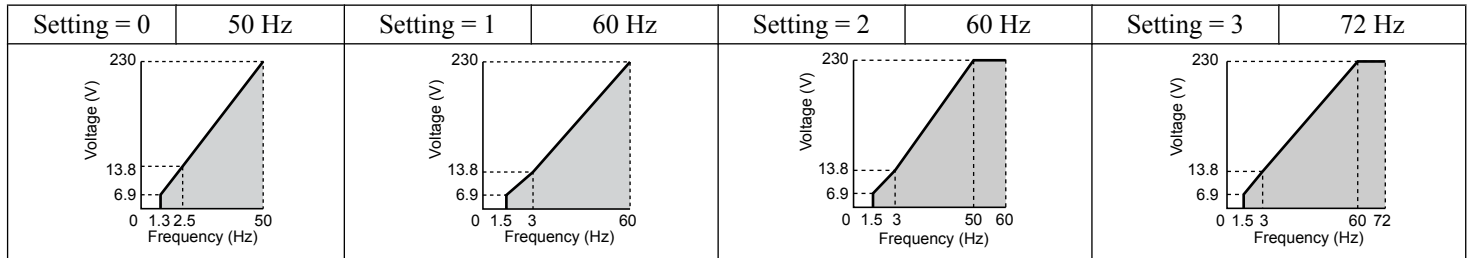

**Table 4.35 Variable Torque Characteristics, Settings 4 to 7**

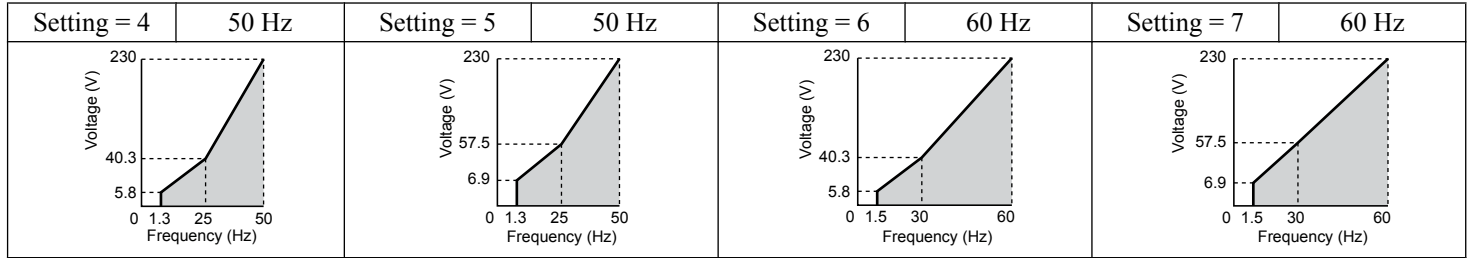

**Table 4.36 High Starting Torque, Settings 8 to B**

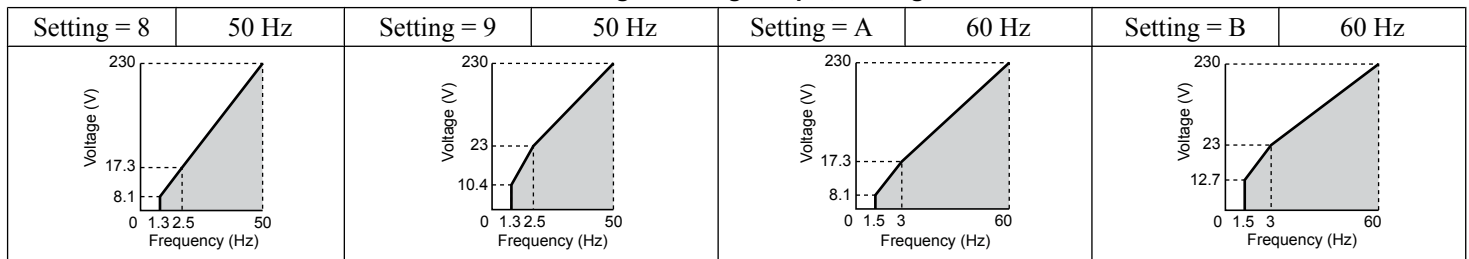

**Table 4.37 Constant Output, Settings C to F**

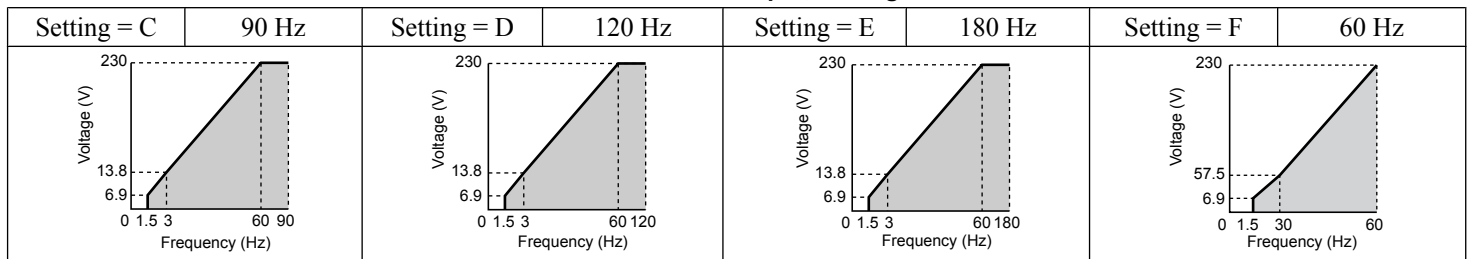

### ■ H3-01: Terminal A1 Signal Level Selection

Selects the input signal level for analog input A1. Set jumper S1 on the terminal board accordingly for voltage input or current input.

No.	Name	Setting Range	Default
H3-01	Terminal A1 Signal Level Selection	0 to 3	0

#### Setting 0: 0 to 10 V with Zero Limit

The input level is 0 to 10 Vdc with zero limit. The minimum input level is limited to 0%, so that a negative input signal due to gain and bias settings will be read as 0%.

#### Setting 1: 0 to 10 V without Zero Limit

The input level is 0 to 10 Vdc without zero limit. If the resulting voltage is negative after being adjusted by gain and bias settings, then the motor will rotate in reverse.

#### Setting 2: 4 to 20 mA Current Input

The input level is 4 to 20 mA. Negative input values by negative bias or gain settings are limited to 0%.

**Setting 3: 0 to 20 mA Current Input**

The input level is 0 to 20 mA. Negative input values by negative bias or gain settings are limited to 0%.

■ **H3-02: Terminal A1 Function Selection**

Selects the input signal level for analog input A1.

No.	Name	Setting Range	Default
H3-02	Terminal A1 Function Selection	0 to 41	0

■ **H3-09: Terminal A2 Signal Level Selection**

Selects the input signal level for analog input A2. Set Jumper S1 on the terminal board accordingly for a voltage input or current input.

No.	Name	Setting Range	Default
H3-09	Terminal A2 Signal Level Selection	0 to 3	2

**Setting 0: 0 to 10 V with Zero Limit**

The input level is 0 to 10 Vdc. Negative input values will be limited to 0. *Refer to Setting 0: 0 to 10 V with Zero Limit on page 174.*

**Setting 1: 0 to 10 V without Zero Limit**

The input level is 0 to 10 Vdc. Negative input values will be accepted. *Refer to Setting 1: 0 to 10 V without Zero Limit on page 174.*

**Setting 2: 4 to 20 mA Current Input**

The input level is 4 to 20 mA. Negative input values by negative bias or gain settings will be limited to 0%.

**Setting 3: 0 to 20 mA Current Input**

The input level is 0 to 20 mA. Negative input values by negative bias or gain settings will be limited to 0%.

■ **H3-10: Terminal A2 Function Selection**

Determines the function assigned to analog input terminal A2.

No.	Name	Setting Range	Default
H3-10	Terminal A2 Function Selection	0 to 26	0

■ **Multi-Function Analog Input Terminal Settings**

See [Table 4.38](#) for information on how H3-02 and H3-10 determine functions for terminals A1 and A2.

**Note:** The scaling of all input functions depends on the gain and bias settings for the analog inputs. Set these to appropriate values when selecting and adjusting analog input functions.

**Table 4.38 Multi-Function Analog Input Terminal Settings**

Setting	Function	Page	Setting	Function	Page
0	Frequency Bias	<a href="#">175</a>	9	Output Frequency Lower Limit Level	–
1	Frequency Gain	<a href="#">176</a>	B	PI Feedback	<a href="#">176</a>
2	Auxiliary Frequency Reference 1	<a href="#">176</a>	C	PI Setpoint	<a href="#">176</a>
3	Auxiliary Frequency Reference 2	<a href="#">176</a>	D	Frequency Bias	<a href="#">176</a>
4	Output Voltage Bias	–	E	Motor Temperature (PTC Input)	<a href="#">176</a>
5	Accel/Decel Time Gain	–	F	Through Mode	<a href="#">176</a>
6	DC Injection Braking Current	–	16	Differential PI Feedback	<a href="#">176</a>
7	Overtorque/Undertorque Detection Level	–	25	Secondary PI Setpoint	–
8	Stall Prevention Level During Run	–	26	Secondary PI Feedback	–

**Setting 0: Frequency Bias**

The input value of an analog input set to this function will be added to the analog frequency reference value. When the frequency reference is supplied by a different source other than the analog inputs, this function will have no effect. Use this setting also when only one of the analog inputs is used to supply the frequency reference.

By default, analog inputs A1 and A2 are set for this function. Simultaneously using A1 and A2 increases the frequency reference by the total of all inputs.

## 4.13 Advanced Drive Setup Adjustments

Example: If the analog frequency reference from analog input terminal A1 is 50% and a bias of 20% is applied by analog input terminal A2, the resulting frequency reference will be 70% of the maximum output frequency.

### Setting 1: Frequency Gain

The input value of an analog input set to this function will be multiplied with the analog frequency reference value.

Example: If the analog frequency reference from analog input terminal A1 is 80% and a gain of 50% is applied from analog input terminal A2, the resulting frequency reference will be 40% of the maximum output frequency.

### Setting 2: Auxiliary Reference 1

Sets the auxiliary frequency reference 1 when multi-step speed operation is selected. [Refer to Multi-Step Speed Selection on page 170](#) for details.

### Setting 3: Auxiliary Reference 2

Sets the auxiliary frequency reference 2 when multi-step speed operation is selected. [Refer to Multi-Step Speed Selection on page 170](#) for details.

### Setting B: PI Feedback

Supplies the PI feedback value. This setting requires PI operation to be enabled in b5-01.

### Setting C: PI Setpoint

Supplies the PI setpoint value and makes the frequency reference selected in parameter b1-01 no longer the PI setpoint. PI operation to be enabled in b5-01 to use this setting.

### Setting D: Frequency Bias

The input value of an analog input set to this function will be added to the frequency reference. This function can be used with any frequency reference source.

### Setting E: Motor Temperature

In addition to motor overload fault detection oL1, it is possible to use a PTC (Positive Temperature Coefficient) thermistor for motor insulation protection.

### Setting F: Through Mode

When set to F, an input does not affect any drive function, but the input level can still be read out by a PLC via APOGEE FLN, BACnet, MEMOBUS/Modbus, or Metasys N2 communications.

### Setting 16: Differential PI Feedback

If an analog value is set for this function, the PI controller is set for differential feedback. The difference of the PI feedback input value and the differential feedback input value builds the feedback value used to calculate the PI input.

## ■ H5-01: Drive Slave Address

Sets the drive slave address used for communications.

**Note:** Cycle the power after changing this parameter to enable the new setting.

No.	Name	Setting Range	Default
H5-01	Drive Slave Address	0 to FFH	1FH

Each slave drive must be assigned a unique slave address for serial communications to work. Slave addresses do not need to be assigned in sequential order, but no two drives may share the same address.

## ■ H5-02: Communication Speed Selection

Sets the communications speed for APOGEE FLN, BACnet, MEMOBUS/Modbus, and Metasys N2.

- Note:**
1. Cycle the power after changing this parameter to enable the new setting.
  2. When Metasys N2 communications are selected (H5-08 = 1), selecting a baud rate other than 9600 bps will trigger an oPE29 error.
  3. When APOGEE FLN (P1) communications are selected (H5-08 = 2), selecting a baud rate other than 4800 bps will trigger an oPE29 error.
  4. When BACnet communications are selected (H5-08 = 3), selecting 115200 bps (Setting 8) will trigger an oPE29 error.

No.	Name	Setting Range	Default
H5-02	Communication Speed Selection	0 to 8	<1>

<1> Default depends on H5-08 setting:

H5-08 = 0, MEMOBUS/Modbus; default: 3  
 H5-08 = 1, N2 (Metasys); default: 3  
 H5-08 = 2, P1 (APOGEE FLN); default: 2  
 H5-08 = 3, BACnet; default: 3

H5-02	Communication Speed	H5-02	Communication Speed
0 <1>	1200 bps	5 <1>	38400 bps
1 <1>	2400 bps	6 <1>	57600 bps
2	4800 bps	7 <1>	76800 bps
3 <1>	9600 bps	8 <1> <2>	115200 bps
4 <1>	19200 bps		

<1> Not available when H5-08 is set to 2 P1 (APOGEE FLN).  
 <2> Not available when H5-08 is set to 0 (MEMOBUS/Modbus) or 1 (Metasys N2).

### ■ H5-03: Communication Parity Selection

Sets the parity used for communications.

**Note:** Cycle the power after changing this parameter to enable the new setting.

No.	Name	Setting Range	Default
H5-03	Communication Parity Selection	0 to 2	0

**Setting 0: No parity**

**Setting 1: Even parity**

**Setting 2: Odd parity**

### ■ H5-04: Stopping Method after Communication Error

Selects the stopping method after a communications error (CE) has occurred.

No.	Name	Setting Range	Default
H5-04	Stopping Method after CE	0 to 4	3

**Setting 0: Ramp to Stop**

Uses the deceleration time currently enabled.

**Setting 1: Coast to Stop**

**Setting 2: Fast Stop**

**Setting 3: Alarm Only - Operation Continues**

**Setting 4: Run at d1-04**

### ■ H5-05: Communication Fault Detection Selection

Enables or disables the CE detection for communications.

No.	Name	Setting Range	Default
H5-05	Communication Fault Detection Selection	0 or 1	1

**Setting 0: Disabled**

No communication error detection. The drive continues operation.

**Setting 1: Enabled**

If the drive does not receive data from the master for longer than the time set to H5-09, then a CE fault will be triggered and the drive will operate as determined by parameter H5-04.

### ■ H5-06: Drive Transmit Wait Time

Sets the time the drive waits after receiving data from a master until responding data.

No.	Name	Setting Range	Default
H5-06	Drive Transmit Wait Time	5 to 65 ms	5 ms

## 4.13 Advanced Drive Setup Adjustments

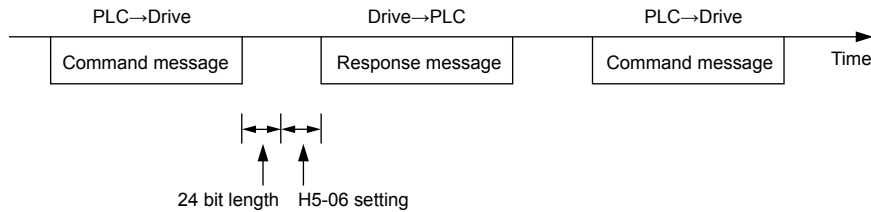

Figure 4.34 Drive Transmit Wait Time Setting

### ■ H5-07: RTS Control Selection

Enables or disables RTS control.

No.	Name	Setting Range	Default
H5-07	RTS Control Selection	0 or 1	1

**Setting 0: Disabled. RTS is always on.**

Use this setting with point-to-point RS-422 communications.

**Setting 1: Enabled. RTS switches while sending.**

Use this setting with RS-485 communications or when using multi-drop RS-422 communications.

### ■ H5-08: Communications Protocol Selection

Selects the communications protocol.

No.	Name	Setting Range	Default
H5-08	Communications Protocol Selection	0 to 3	0

**Setting 0: MEMOBUS/Modbus**

**Setting 1: N2 (Metasys)**

**Setting 2: P1 (APOGEE FLN)**

**Setting 3: BACnet**

### ■ H5-09: Communications Fault Detection Time

Sets the time the communications must be lost before the drive triggers a CE fault.

No.	Name	Setting Range	Default
H5-09	Communications Fault Detection Time	0.0 to 10.0 s	2.0 s

### ■ H5-10: Unit Selection for MEMOBUS/Modbus Register 0025H

Sets the unit for the output voltage monitor value in MEMOBUS/Modbus register 0025H.

No.	Name	Setting Range	Default
H5-10	Unit Selection for MEMOBUS/Modbus Register 0025H	0 or 1	0

**Setting 0: 0.1 V units**

**Setting 1: 1 V units**

### ■ H5-11: Communications Enter Function Selection

Selects whether an Enter command is necessary to change parameter values via MEMOBUS/Modbus communications. *Refer to Enter Command on page 353.*

No.	Name	Setting Range	Default
H5-11	Communications Enter Function Selection	0 or 1	0

**Setting 0: Enter command necessary**

Parameter changes become effective after an Enter command. An Enter command must only be sent after the last parameter change, not for each single parameter.

**Setting 1: Enter command not necessary**

Parameter value changes become effective immediately without the need to send an Enter command.

**■ H5-12: Run Command Method Selection**

Selects the type of sequence used when the Run command source is set to MEMOBUS/Modbus communications (b1-02, b1-16 = 2).

No.	Name	Setting Range	Default
H5-12	Run Command Method Selection	0 or 1	0

**Setting 0: FWD/Stop, REV/Stop**

Setting bit 0 of MEMOBUS/Modbus register 0001H will start and stop the drive in the forward direction. Setting bit 1 will start and stop the drive in reverse.

**Setting 1: Run/Stop, FWD/REV**

Setting bit 0 of MEMOBUS/Modbus register 0001H will start and stop the drive. Setting bit 1 changes the direction.

**■ L5-02: Auto Restart Fault Output Operation Selection**

Determines if a fault output is triggered (H2-□□ = E) when the drive attempts to restart.

No.	Name	Setting Range	Default
L5-02	Auto Restart Fault Output Operation Selection	0, 1	0

**Setting 0: No Fault Output****Setting 1: Fault Output Is Set****■ L5-04: Fault Reset Interval Time**

Determines the amount of time to wait between restart attempts when parameter L5-05 is set to 1.

No.	Name	Setting Range	Default
L5-04	Fault Reset Interval Time	0.5 to 600.0 s	10.0 s

**■ L5-05: Fault Reset Operation Selection**

No.	Name	Setting Range	Default
L5-05	Fault Reset Operation Selection	0, 1	1

**Setting 0: Count Successful Restarts**

The drive will continuously attempt to restart. If it restarts successfully, the restart counter is increased. This operation is repeated each time a fault occurs until the counter reaches the value set to L5-01.

**Setting 1: Count Restart Attempts**

The drive will attempt to restart using the time interval set to parameter L5-04. A record is kept of the number of attempts to restart to the drive, regardless of whether those attempts were successful. When the number of attempted restarts exceeds the value set to L5-01, the drive stops attempting to restart.

**■ L6-13: Motor Underload Protection Selection**

Sets Motor Underload Protection (UL6) based on motor load and determines whether the level of L6-02 refers to fbase or fmax.

Selects the operation of underload detection UL6. Underload is detected when the output current falls below the underload detection level defined by L6-14 and L2-02.

No.	Name	Setting Range	Default
L6-13	Motor Underload Protection Selection	0, 1	0

## 4.13 Advanced Drive Setup Adjustments

### Setting 0: Fbase Motor Load Enabled

### Setting 1: Fmax Base Motor Load Enabled

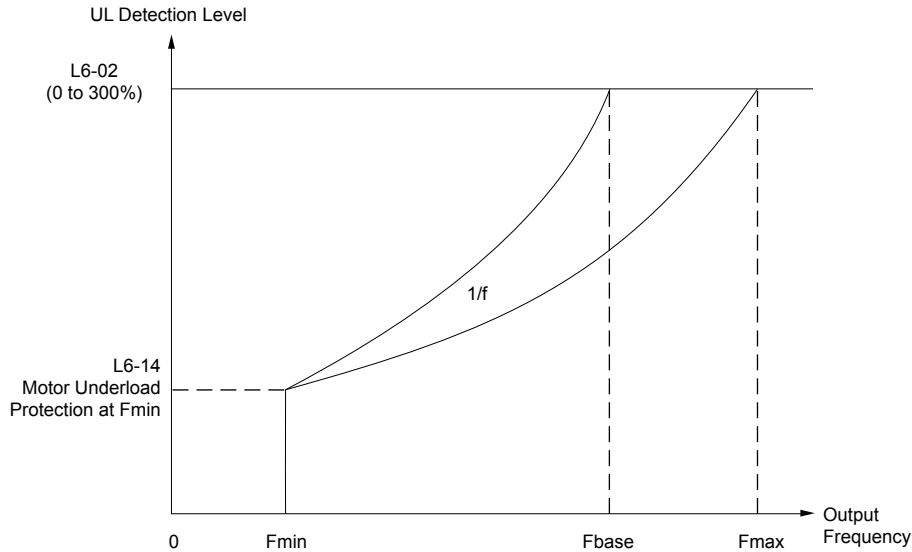

Figure 4.35 Motor Underload Protection

### ■ L6-14: Motor Underload Protection Level at Minimum Frequency

Sets the UL6 detection level at minimum frequency by percentage of drive rated current

No.	Name	Setting Range	Default
L6-14	Motor Underload Protection Level at Minimum Frequency	0 to 300%	15%

### ■ L8-02: Overheat Alarm Level

Sets the overheat alarm (oH) detection level.

The drive outputs an alarm when the heatsink temperature exceeds the overheat alarm level. If the drive is set to continue operation after this alarm occurs (L8-03 = 4) and the temperature reaches the overheat fault level, the drive will trigger an oH1 fault and stop operation.

When an output terminal is set for the oH pre-alarm (H2-□□ = 20), the switch will close when the heatsink temperature rises above L8-02.

No.	Name	Setting Range	Default
L8-02	Overheat Alarm Level	50 to 130 °C	Determined by o2-04

### ■ L8-03: Overheat Pre-Alarm Operation Selection

Sets the operation when an overheat pre-alarm is detected.

**Note:** Change L8-03 setting only when necessary.

No.	Name	Setting Range	Default
L8-03	Overheat Pre-Alarm Operation Selection	0 to 4	4

#### Setting 0: Ramp to Stop

If an overheat alarm occurs, the drive decelerates to stop using the currently selected deceleration time. If a digital output is programmed for “fault” (H2-□□ = E), this output will be triggered.

#### Setting 1: Coast to Stop

If an overheat alarm occurs, the drive switches off the output and the motor coasts to stop. If a digital output is programmed for “fault” (H2-□□ = E), this output will be triggered.

**Setting 2: Fast Stop**

If an overheat alarm occurs, the drive decelerates to stop using the Fast Stop time (C1-09). If a digital output is programmed for “fault” (H2-□□ = E), this output will be triggered.

**Setting 3: Alarm Only**

If an overheat alarm occurs, an alarm is output and the drive continues operation.

**Setting 4: Operation with Reduced Speed**

If an overheat alarm occurs, the operation continues with the speed reduced to the level set to parameter L8-19. If the oH alarm is still present after 10 s, the speed is reduced again. The amount of speed reduction depends on how often the alarm repeats. If the oH alarm disappears while the drive is operating at a reduced speed, the drive will switch to the previous speed in 10 s increments until reaching base frequency. *Figure 4.36* explains the operation with reduced speed during an oH alarm. A digital output programmed for 4D is switched when the oH alarm is still active after ten reduction cycles.

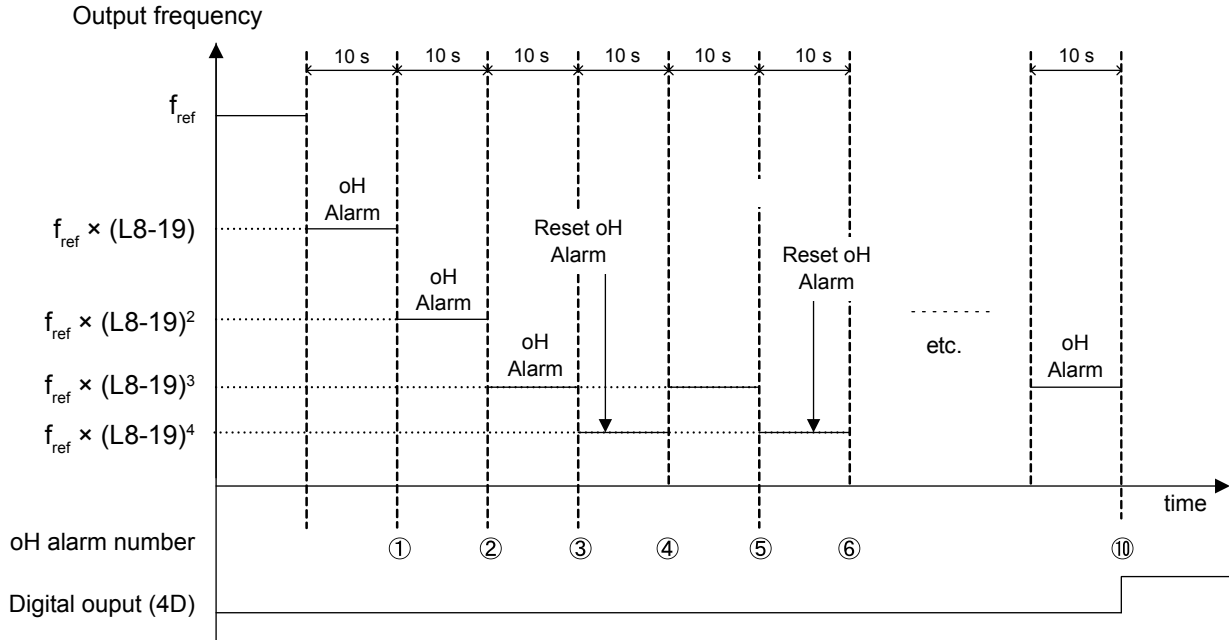

Figure 4.36 Output Frequency Reduction During Overheat Alarm

**■ L8-05: Input Phase Loss Protection Selection**

Enables or disables the input phase loss detection.

No.	Name	Setting Range	Default
L8-05	Input Phase Loss Protection Selection	0, 1	1

**Setting 0: Disabled**

**Setting 1: Enabled**

Enables input phase loss detection. Since measuring the DC bus ripple detects input phase loss, a power supply voltage imbalance or main circuit capacitor deterioration may also trigger a phase loss fault (PF).

Detection is disabled if:

- The drive is decelerating.
- No Run command is active.
- Output current is less than or equal to 30% of the drive rated current.

**■ L8-06: Input Phase Loss Detection Level**

Sets the Input Phase Loss Detection (PF) Level.

Triggers PF fault when there is an imbalance larger than the value set to L8-06 in the drive input power voltage.

$$\text{Detection Level} = 100\% = \text{Voltage Class} \times \sqrt{2}$$

## 4.13 Advanced Drive Setup Adjustments

No.	Name	Setting Range	Default
L8-06	Input Phase Loss Detection Level	0.0 to 25.0%	Determined by o2-04

### ■ L8-07: Output Phase Loss Protection Selection

Enables or disables the output phase loss detection triggered when the output current falls below 5% of the drive rated current.

- Note:**
1. Output phase loss detection can mistakenly be triggered if the motor rated current is very small compared to the drive rating. Disable this parameter in such cases.
  2. Output phase loss detection is not possible when the drive is running a PM motor with light load.

No.	Name	Setting Range	Default
L8-07	Output Phase Loss Protection Selection	0 to 2	1

#### Setting 0: Disabled

#### Setting 1: Fault when One Phase Is Lost

An output phase loss fault (LF) is triggered when one output phase is lost. The output shuts off and the motor coasts to stop.

#### Setting 2: Fault when Two Phases Are Lost

An output phase loss fault (LF) is triggered when two or more output phases are lost. The output shuts off and the motor coasts to stop.

### ■ L8-09: Output Ground Fault Detection Selection

Enables or disables the output ground fault detection.

No.	Name	Setting Range	Default
L8-09	Output Ground Fault Detection Selection	0, 1	Determined by o2-04

#### Setting 0: Disabled

Ground faults are not detected.

#### Setting 1: Enabled

A ground fault (GF) is triggered when high leakage current or a ground short circuit occurs in one or two output phases.

### ■ L8-10: Heatsink Cooling Fan Operation Selection

Selects the heatsink cooling fan operation.

No.	Name	Setting Range	Default
L8-10	Heatsink Cooling Fan Operation Selection	0, 1	0

#### Setting 0: Run with Timer

The fan is switched on when a Run command is active and switched off with the delay set to parameter L8-11 after releasing the Run command. This setting extends the fan lifetime.

#### Setting 1: Run Always

The fan runs when power is supplied to the drive.

### ■ L8-11: Heatsink Cooling Fan Off-Delay Time

Sets the cooling fan switch off-delay time if parameter L8-10 is set to 0.

No.	Name	Setting Range	Default
L8-11	Heatsink Cooling Fan Off-Delay Time	0 to 300 s	300 s

### ■ L8-12: Ambient Temperature Setting

Automatically adapts the drive rated current to safe values when used with parameter L8-35. This eliminates the need to reduce the drive rated current when the temperature where the drive is mounted is above the specified values.

No.	Name	Setting Range	Default
L8-12	Ambient Temperature Setting	40 to 60 °C	40 °C

### ■ L8-15: oL2 Characteristics Selection at Low Speeds

Selects whether the drive overload capability (oL fault detection level) is reduced at low speeds to prevent premature output transistor failures.

**Note:** Contact Yaskawa for consultation before disabling this function. Disabling this function may shorten the operating life of the power transistors.

No.	Name	Setting Range	Default
L8-15	oL2 Characteristics Selection at Low Speed	0, 1	1

#### Setting 0: Protection Disabled at Low Speed

The overload protection level is not reduced. Frequently operating the drive with high output current at low speed can lead to premature drive faults.

#### Setting 1: Protection Enabled at Low Speed

The overload protection level (oL2 fault detection level) is automatically reduced at speeds below 6 Hz. At zero speed, the overload is derated by 50%.

### ■ L8-18: Software Current Limit Selection

Enables and disables the Software Current Limit (CLA) protection function to prevent main circuit transistor failures caused by high current.

**Note:** Do not change this setting unless absolutely necessary.

No.	Name	Setting Range	Default
L8-18	Software Current Limit Selection	0, 1	0

#### Setting 0: Software CLA Disabled

The drive may trip on an oC fault if the load is too heavy or the acceleration is too short.

#### Setting 1: Software CLA Enabled

When the Software CLA current level is reached, the drive reduces the output voltage to reduce the current. Normal operation continues when the current level drops below the Software CLA level.

### ■ L8-19: Frequency Reduction Rate during Overheat Pre-Alarm

Specifies the output frequency reduction when L8-03 is set to 4 and an oH alarm is present. Set as a factor of the maximum output frequency.

No.	Name	Setting Range	Default
L8-19	Frequency Reduction Rate During Overheat Pre-Alarm	0.0 to 100.0%	20.0%

### ■ L8-27: Overcurrent Detection Gain

Adjusts the overcurrent detection level in OLV/PM control mode. A setting of 100% is equal to the motor rated current. When the drive rated current is considerably higher than the motor rated current, use this parameter to decrease the overcurrent level and prevent motor demagnetization from high current.

Overcurrent detection uses the lower value between the overcurrent level for the drive and the motor rated current multiplied by L8-27.

No.	Name	Setting Range	Default
L8-27	Overcurrent Detection Gain	0.0 to 300.0%	300.0%

### ■ L8-29: Current Unbalance Detection (LF2)

Enables or disables output current unbalance detection in OLV/PM control mode. Current unbalance can heat a PM motor and demagnetize the magnets. The current unbalance detection function monitors output current and triggers the LF2 fault to prevent such motor damage.

No.	Name	Setting Range	Default
L8-29	Current Unbalance Detection (LF2)	0, 1	1

#### Setting 0: Disabled

No current unbalance protection is provided to the motor.

## 4.13 Advanced Drive Setup Adjustments

### Setting 1: Enabled

The LF2 fault is triggered if an output current unbalance is detected. Drive output shuts off and the motor coasts to stop.

### ■ L8-32: Main Contactor and Cooling Fan Power Supply Failure Selection

Determines drive operation when a FAn fault occurs.

No.	Name	Setting Range	Default
L8-32	Main Contactor and Cooling Fan Power Supply Failure Selection	0 to 4	1

### Setting 0: Ramp to Stop

The drive stops the motor using the deceleration time set in parameter C1-02.

### Setting 1: Coast to Stop

The drive output is switched off and the motor coasts to a stop.

### Setting 2: Fast stop

The drive stops the motor using the Fast stop time set in parameter C1-09.

### Setting 3: Alarm only

The operation is continued and a FAn alarm is displayed on the HOA keypad.

### Setting 4: Operation with Reduced Speed

The operation is continued, but the speed is reduced to the level set in parameter L8-19.

**Note:** “FAn” is detected as an error when Settings 0 or 2 are selected; it is detected as an alarm when Settings 3 or 4 are selected.

### ■ L8-35: Installation Method Selection

Selects the type of installation for the drive and changes the drive overload (oL2) limits accordingly.

- Note:**
1. Initialization does not reset this parameter.
  2. The value is preset to the appropriate value when the drive is shipped. Change the value only when using Side-by-Side installation or when mounting a standard drive with the heatsink outside the cabinet.

No.	Name	Setting Range	Default
L8-35	Installation Method Selection	0, 2, 3	Determined by o2-04 <1>

<1> Default setting is determined by drive model.

Setting 2: Models 2A0011 to 2A0211 and 4A0005 to 4A0096

Setting 0: Models 2A0273 to 2A0396 and 4A0124 to 4A0590.

### Setting 0: IP00/Open-Chassis Enclosure

For an Open Type enclosure drive installed with at a minimum of 30 mm space to the next drive or a cabinet wall.

### Setting 2: IP20/NEMA Type 1 Enclosure

For drives compliant with IP20/NEMA Type 1 enclosure specifications.

### Setting 3: External Heatsink Installation

For standard drives mounted with the heatsink outside the cabinet or enclosure panel.

### ■ L8-38: Carrier Frequency Reduction Selection

Selects the operation of the carrier frequency reduction function. Reduces the carrier frequency when the output current exceeds a certain level. This temporarily increases the overload capability (oL2 detection), allowing the drive to run through transient load peaks without tripping.

No.	Name	Setting Range	Default
L8-38	Carrier Frequency Reduction Selection	0 to 2	Determined by A1-02 and o2-04

### Setting 0: Disabled

No carrier frequency reduction at high current.

**Setting 1: Enabled for Output Frequencies below 6 Hz**

The carrier frequency is reduced at speeds below 6 Hz when the current exceeds 100% of the drive rated current. The drive returns to the normal carrier frequency when the current falls below 88% or the output frequency exceeds 7 Hz.

**Setting 2: Enabled for Entire Frequency Range**

The carrier frequency is reduced at the following speeds:

- Below 6 Hz when the current exceeds 100% of the drive rated current.
- Above 7 Hz when the current exceeds 112% of the drive rated current.

The drive uses the delay time set in parameter L8-40 and a hysteresis of 12% when switching the carrier frequency back to the set value.

■ **L8-40: Carrier Frequency Reduction Off-Delay Time**

Sets a hold time before returning to the original carrier frequency setting after the carrier frequency has been temporarily derated as determined by L8-38. The carrier frequency reduction function is disabled when this value is 0.00 s.

No.	Name	Setting Range	Default
L8-40	Carrier Frequency Reduction Off-Delay Time	0.00 to 2.00 s	0.50 s

■ **L8-41: High Current Alarm Selection**

Triggers a high current alarm (HCA) when the output current exceeds 150% of the drive rated current.

No.	Name	Setting Range	Default
L8-41	High Current Alarm Selection	0, 1	0

**Setting 0: Disabled**

No alarm is detected.

**Setting 1: Enabled**

An alarm is triggered when the output current exceeds 150% of the drive rated current. A digital output set for an alarm (H2-□□ = 10) will close.

■ **o1-01: Drive Mode Unit Monitor Selection**

The frequency reference display appears when the drive is powered up. Pressing the up arrow key will display the following data: frequency reference → rotational direction → output frequency → output current → o1-01 selection.

Parameter o1-01 selects the content of the last monitor in this sequence.

No.	Name	Setting Range	Default
o1-01	Drive Mode Unit Monitor Selection	104 to 699 U1-04 (Control Mode) to U6-99 (Option Monitors 20) </>	106 (U1-06)

<1> U2-□□ and U3-□□ parameters cannot be selected.

■ **o1-02: User Monitor Selection after Power Up**

Selects which monitor parameter is displayed upon power up by entering the 1- □□ part of U1-□□. Certain monitors are not available in some control modes.

No.	Name	Setting Range	Default
o1-02	User Monitor Selection after Power Up	1 to 5	1

**Setting 1: Frequency Reference (U1-01)**

**Setting 2: Motor Direction**

**Setting 3: Output Frequency (U1-02)**

**Setting 4: Output Current (U1-03)**

**Setting 5: User Monitor**

The monitor value selected by o1-01 will be displayed.

## 4.13 Advanced Drive Setup Adjustments

### ■ o1-03: HOA Keypad Display Selection

Sets the units used to display the frequency reference and output frequency. Set o1-03 to 3 for user-set units before setting parameters o1-10 and o1-11.

No.	Name	Setting Range	Default
o1-03	HOA Keypad Display Selection	0 to 3	0

**Setting 0: 0.01 Hz Units**

**Setting 1: 0.01% Units (100% = Max Output Frequency)**

**Setting 2: r/min Units (Calculated by the Max Output Frequency and the Number of Motor Poles)**

**Setting 3: User-set Units (Use o1-10, o1-11)**

Set the value used for the maximum frequency reference to o1-10. Set the placement of the decimal point in this number to o1-11.

For example, to have the maximum output frequency displayed as “100.00”, set o1-10 = 1000 and o1-11 = 2 (i.e., 1000 with 2 decimal points).

- Note:**
1. Parameter o1-03 allows the programmer to change the units used in the following parameters and monitors:  
U1-01: frequency reference  
U1-02: output frequency  
U1-16: output frequency after softstarter (accel/decel ramp generator)  
d1-01 to d1-17: frequency references
  2. Setting o1-03 to 2 requires entering the number of motor poles to E2-04 and E5-04.

### ■ o1-06: User Monitor Selection Mode

Normally the monitors shown directly below the active monitor are the next two sequential monitors. If o1-06 (User Monitor Selection Mode) is set to 1: “3 Mon Selectable”, those two monitors are locked as specified by parameters o1-07 and o1-08 and will not change as the top parameter is scrolled with the Up/Down Arrow keys.

No.	Name	Setting Range	Default
o1-06	User Monitor Selection Mode	0, 1	0

**Setting 0: 3 Monitor Sequential (Displays the Next 2 Sequential Monitors)**

**Setting 1: 3 Monitor Selectable (o1-07, and o1-08 Selected Monitor Is Shown)**

### ■ o1-07: Second Line Monitor Selection

Selects which monitor will be displayed in the second line. The monitor parameter number is entered into the spaces provided: U□-□□.

For example, set “403” to display monitor parameter U4-03.

No.	Name	Setting Range	Default
o1-07	Second Line Monitor Selection	101 to 699	102

### ■ o1-08: Third Line Monitor Selection

Selects which monitor will be displayed in the third line. The monitor parameter number is entered into the spaces provided: U□-□□.

For example, set “403” to display monitor parameter U4-03.

No.	Name	Setting Range	Default
o1-08	Third Line Monitor Selection	101 to 699	103

### ■ o1-09: Frequency Reference Display Units

Sets unit display for the frequency reference parameters and frequency related monitors when o1-03 > 40.

No.	Name	Setting Range	Default
o1-09	Frequency Reference Display Units	0 to 16	16

- Setting 0: Inch of Water (WC)
- Setting 1: Pounds per Square Inch (PSI)
- Setting 2: Gallons per Minute (GPM)
- Setting 3: Degrees Fahrenheit (F)
- Setting 4: Cubic Feet per Minute (CFM)
- Setting 5: Cubic Meters per Hour (CMH)
- Setting 6: Liters per Hour (LPH)
- Setting 7: Liters per Second (LPS)
- Setting 8: Bar (Bar)
- Setting 9: Pascals (Pa)
- Setting 10: Degrees Celsius (C)
- Setting 11: Meters (Mtr)
- Setting 12: Ft (Feet)
- Setting 13: Liters per Minute (LPM)
- Setting 14: Cubic Meters per Minute (CMM) No unit
- Setting 15: Custom Units (Determined by o1-12)
- Setting 16: None

■ **o1-10: User-Set Display Units Maximum Value**

Determines the display value that is equal to the maximum output frequency.

No.	Name	Setting Range	Default
o1-10	User-Set Display Units Maximum Value	1 to 60000	Determined by o1-03

■ **o1-11: User-Set Display Units Decimal Display**

Determines how many decimal points should be used to set and display the frequency reference.

No.	Name	Setting Range	Default
o1-11	User-Set Display Units Decimal Display	0 to 3	Determined by o1-03

- Setting 0: No Decimal Point
- Setting 1: One Decimal Point
- Setting 2: Two Decimal Points
- Setting 3: Three Decimal Points

■ **o1-13 to o1-15: Frequency Reference and Frequency Related Monitor Custom Units 1 to 3**

Sets the customer specified unit display for the frequency reference parameters and frequency related monitors when o1-03 is set to 3 and o1-09 is set to 15 as custom units.

The custom units consist of three characters selected from o1-13 to o1-15. Each character is selected by ASCII code from 30Hex to 7AHex.

No.	Name	Setting Range	Default
o1-13	Frequency Reference and Frequency Related Monitor Custom Units 1	30H to 7AH	41H
o1-14	Frequency Reference and Frequency Related Monitor Custom Units 2		
o1-15	Frequency Reference and Frequency Related Monitor Custom Units 3		

■ **o1-16, o1-17: F1/F2 Key Function Selection**

The HOA Keypad multi-function keys F1 and F2 can be set for different HVAC specific functions. Selects the functions of the F1/F2 keys and the LCD display text above the F1/F2 keys.

**Note:** Parameters o1-16 and o1-17 cannot be set to the same value (except for setting 0).

## 4.13 Advanced Drive Setup Adjustments

No.	Name	Setting Range	Default
o1-16	F1 Key Function Selection	0 to 4	0
o1-17	F2 Key Function Selection		0

**Setting 0: Standard**

**Setting 1: Monitor**

**Setting 2: Drive/Bypass (DRV/BYP)**

**Setting 3: Bypass Run (RUN BYP)**

**Setting 4: Toggle Relay Output (RLY)**

### ■ o1-18, o1-19: User-Defined Parameter Upper/Lower

Allows the user to set values that can be used as reference information.

No.	Name	Setting Range	Default
o1-18	User-Defined Parameter Upper	0 to 999	0
o1-19	User-Defined Parameter Lower		

### ■ o2-02: OFF Key Function Selection

Determines if the OFF key on the HOA keypad will stop drive operation when the drive is controlled from a remote source (i.e., not from HOA keypad).

No.	Name	Setting Range	Default
o2-02	OFF Key Function Selection	0, 1	1

**Setting 0: Disabled**

**Setting 1: Enabled**

The OFF key will terminate drive operation even if the Run command source is not assigned to the HOA keypad. Cycle the Run command to restart the drive if the drive has been stopped by pressing the OFF key.

### ■ o2-04: Drive Model Selection

Set this parameter when replacing the control board or the terminal board.

**NOTICE:** Drive performance will suffer and protective functions will not operate properly if the correct drive capacity is not set to o2-04.

No.	Name	Setting Range	Default
o2-04	Drive Model Selection	-	Determined by drive capacity

**Note:** Change o2-04 setting only when necessary.

### ■ o2-06: Operation Selection when HOA Keypad is Disconnected

Determines whether the drive will stop when the HOA keypad is removed in HAND mode or when b1-02 or b1-16 is set to 0. When the operator is reconnected, the display will indicate that it was disconnected.

No.	Name	Setting Range	Default
o2-06	Operation Selection when HOA Keypad is Disconnected	0, 1	1

**Setting 0: Continue Operation**

The operation continues.

**Setting 1: Trigger a Fault**

The operation stops and triggers an oPr fault. The motor coasts to stop.

### ■ o2-07: Motor Direction at Power Up when Using Operator

Determines the direction the motor will rotate after the drive is powered up and the Run command is given from the HOA keypad.

**Note:** This parameter is effective only when the Run command is set to be given from the HOA keypad (b1-02, b1-16 = 0).

No.	Name	Setting Range	Default
o2-07	Motor Direction at Power Up when Using Operator	0, 1	0

**Setting 0: Forward****Setting 1: Reverse****■ o3-01: Copy Function Selection**

Instructs the drive to Read, Write, or Verify parameter settings.

No.	Name	Setting Range	Default
o3-01	Copy Function Selection	0 to 3	0

**Setting 0: Copy Select (No Function)****Setting 1: INV --> OP READ**

Copies all parameters from the drive to the HOA keypad.

**Note:** The copy protection for the HOA keypad is enabled by default. Set o3-01 to 1 to unlock copy protection.

**Setting 2: OP --> INV WRITE**

Copies all parameters from the HOA keypad to the drive.

**Setting 3: OP<-->INV VERIFY**

Compares the parameters in the drive with the parameter settings saved on the HOA keypad for matches.

**■ o3-02: Copy Allowed Selection**

Allows and restricts the use of the Copy function.

No.	Name	Setting Range	Default
o3-02	Copy Allowed Selection	0, 1	0

**Setting 0: Disabled****Setting 1: Enabled****■ o4-01: Cumulative Operation Time Setting**

Sets the cumulative operation time of the drive. The user can also manually set this parameter to begin keeping track of operation time from some desired value. Total operation time can be viewed in monitor U4-01.

**Note:** The value in o4-01 is set in 10 h units. For example, a setting of 30 will set the cumulative operation time counter to 300 h. 300 h will also be displayed in monitor U4-01.

No.	Name	Setting Range	Default
o4-01	Cumulative Operation Time Setting	0 to 9999 h	0 h

**■ o4-02: Cumulative Operation Time Selection**

Selects the conditions for how the drive keeps track of its total operation time. This time log can be viewed in monitor U4-01.

No.	Name	Setting Range	Default
o4-02	Cumulative Operation Time Selection	0, 1	1

**Setting 0: Power on Time**

The drive logs the time it is connected to a power supply, regardless of whether the motor is running.

**Setting 1: Run Time**

The drive logs the time that the output is active including when the Run command is active (even if the motor is not rotating) and when there is voltage output.

**■ o4-03: Cooling Fan Operation Time Setting**

Sets the value for how long the cooling fan has been operating. This value can be viewed in monitor U4-03. Parameter o4-03 also sets the base value used for the cooling fan maintenance, which is displayed in U4-04. Reset this parameter to 0 after replacing the cooling fan.

- Note:**
1. The value in o4-03 increases after every 10 hours of use. A setting of 30 will set the cooling fan operation time counter to 300 h. "300" will be displayed in monitor U4-03.
  2. The cooling fan may require maintenance at an earlier date in harsher environments.

No.	Name	Setting Range	Default
o4-03	Cooling Fan Operation Time Setting	0 to 9999 h	0 h

## 4.13 Advanced Drive Setup Adjustments

### ■ o4-05: Capacitor Maintenance Setting

Sets value of the maintenance monitor for the DC bus capacitors displayed in U4-05 as a percentage of the total expected performance life. Reset this value to 0 after replacing the DC bus capacitors.

**Note:** The actual maintenance time will depend on the environment where the drive is used.

No.	Name	Setting Range	Default
o4-05	Capacitor Maintenance Setting	0 to 150%	0%

### ■ o4-07: DC Bus Pre-Charge Relay Maintenance Setting

Sets the value of the softcharge bypass relay maintenance time displayed in U4-06 as a percentage of the total expected performance life. Reset this value to 0 after replacing the bypass relay.

**Note:** The actual maintenance time will depend on the environment where the drive is used.

No.	Name	Setting Range	Default
o4-07	DC Bus Pre-charge Relay Maintenance Setting	0 to 150%	0%

### ■ o4-11: U2, U3 Initialization

Resets the fault trace and fault history monitors (U2-□□ and U3-□□). Initializing the drive using A1-03 does not reset these monitors.

No.	Name	Setting Range	Default
o4-11	U2, U3 Initialization	0, 1	0

#### Setting 0: No Action

The drive keeps the previously saved record concerning fault trace and fault history.

#### Setting 1: Reset Fault Data

Resets the data for the U2-□□ and U3-□□ monitors. Setting o4-11 to 1 and pressing the ENTER key erases fault data and returns the display to 0.

### ■ o4-12: kWh Monitor Initialization

Manually resets kWh monitors U4-10 and U4-11. Initializing the drive or cycling the power will not reset these monitors.

No.	Name	Setting Range	Default
o4-12	kWh Monitor Initialization	0, 1	0

#### Setting 0: No Action

The kWh data are maintained.

#### Setting 1: Reset kWh Data

Resets the kWh counter. The monitors U4-10 and U4-11 will display “0” after they are initialized. Setting o4-12 to 1 and pressing the ENTER erases kWh data and returns the display to 0.

### ■ o4-13: Number of Run Commands Counter Initialization

Resets the Run command counter displayed in U4-02. Initializing the drive or cycling the power does not reset this monitor.

No.	Name	Setting Range	Default
o4-13	Number of Run Commands Counter Initialization	0, 1	0

#### Setting 0: No Action

The Run command data are kept.

#### Setting 1: Number of Run Commands Counter

Resets the Run command counter. The monitor U4-02 will show 0. Setting o4-13 to 1 and pressing the ENTER key erases the counter value and returns the display to 0.

### ■ o4-17: Set/Reset Real Time Clock

The time setting screen will appear.

Z1000 Software Version	No. (Addr. Hex)	LCD Display	Name	Description	Values
PRG: 1012 and earlier	o4-17 (3100)	Set Time 0: Disabled 1: Enabled	Set/Reset Real Time Clock	Sets the current date and time for the Real Time Clock. 0: Disabled 1: Enabled	Default: 0 Range: 0, 1
PRG: 1013 and later	o4-17 (3100)	Set Time 0: — — 1: Set 2: Reset	Set/Reset Real Time Clock	Sets the current date and time for the Real Time Clock. 0: — — No Setting 1: Real Time Clock Set 2: Real Time Clock Reset	Default: 0 Range: 0 to 2

**Setting 0: — —**

No Setting

**Setting 1: Set**

The HOA keypad shows the Clock Adjustment display. In Clock Adjustment Mode the user can adjust the Real Time Clock.

**Setting 2: Reset**

The Real-Time Clock data is cleared. A TIM fault will occur until o4-17 is set to 1 to set the Real Time Clock.

**■ T1-01: Auto-Tuning Mode Selection**

Sets the type of Auto-Tuning to be used. *Refer to Auto-Tuning for Induction Motors on page 142* for details on the different types of Auto-Tuning.

No.	Name	Setting Range	Default
T1-01	Auto-Tuning Mode Selection	2, 3 (V/f)	2 (V/f)

**Setting 2: Stationary Auto-Tuning for Line-to-Line Resistance**

**Setting 3: Rotational Auto-Tuning for V/f Control Energy Saving**

**■ T1-02: Motor Rated Power**

Sets the motor rated power according to the motor nameplate value.

**Note:** Use the following formula to convert HP to kW: kW = HP x 0.746.

No.	Name	Setting Range	Default
T1-02	Motor Rated Power	0.00 to 650.00 kW	Determined by o2-04

**■ T1-03: Motor Rated Voltage**

Sets the motor rated voltage according to the motor nameplate value. Enter the voltage base speed when the motor operates above base speed. Enter the voltage needed to operate the motor under no-load conditions at rated speed to T1-03.

No.	Name	Setting Range	Default
T1-03	Motor Rated Voltage	0.0 to 255.0 V </>	200.0 V </>

<1> Values shown are specific to 200 V class drives. Double value for 400 V class drives.

**■ T1-04: Motor Rated Current**

Sets the motor rated current according to the motor nameplate value. Enter the current at the motor base speed.

No.	Name	Setting Range	Default
T1-04	Motor Rated Current	10.0 to 300.0% of drive rated current	Determined by o2-04

**■ T1-05: Motor Base Frequency**

Sets the motor rated frequency according to the motor nameplate value. If a motor with an extended speed range is used or the motor is used in the field weakening area, enter the maximum frequency to E1-04 after Auto-Tuning is complete.

No.	Name	Setting Range	Default
T1-05	Motor Base Frequency	0.0 to 240.0 Hz	60.0 Hz

**■ T1-06: Number of Motor Poles**

Sets the number of motor poles according to the motor nameplate value.

## 4.13 Advanced Drive Setup Adjustments

No.	Name	Setting Range	Default
T1-06	Number of Motor Poles	2 to 48	4

### ■ T1-07: Motor Base Speed

Sets the motor rated speed according to the motor nameplate value. Enter the speed at base frequency when using a motor with an extended speed range or if using the motor in the field weakening area.

No.	Name	Setting Range	Default
T1-07	Motor Base Speed	0 to 14400 r/min	1750 r/min

### ■ T1-11: Motor Iron Loss

Provides iron loss information to determine the Energy Saving coefficient. T1-11 will first display the value for the motor iron loss that the drive automatically calculated when the motor capacity was entered to T1-02. Enter the motor iron loss value listed to T1-11 if the motor test report is available.

No.	Name	Setting Range	Default
T1-11	Motor Iron Loss	0 to 65535 W	14 W

## ◆ U1: Operation Status Monitors

Status monitors display drive status data such as output frequency and output current. [Refer to U1: Operation Status Monitors on page 329](#) for a complete list of U1-□□ monitors and descriptions.

## ◆ U2: Fault Trace

Use these monitor parameters to view the status of various drive aspects when a fault occurs.

This information is helpful for determining the cause of a fault. [Refer to U2: Fault Trace on page 330](#) for a complete list of U2-□□ monitors and descriptions.

U2-□□ monitors are not reset when the drive is initialized. [Refer to o4-11: U2, U3 Initialization on page 190](#) for instructions on how to reset these monitor values.

**Note:** Fault histories are not kept when CPF00, CPF01, CPF06, CPF24, oFA00, oFb00, oFC00, Uv1, Uv2, or Uv3 occur.

## ◆ U3: Fault History

These parameters display faults that have occurred during operation as well as the drive operation time when those faults occurred. [Refer to U3: Fault History on page 331](#) for a complete list of U3-□□ monitors and descriptions.

U3-□□ monitors are not reset when the drive is initialized. [Refer to o4-11: U2, U3 Initialization on page 190](#) for instructions on how to reset these monitor values.

**Note:** Fault histories are not kept when CPF00, CPF01, CPF06, CPF24, oFA00, oFb00, oFC00, Uv1, Uv2, or Uv3 occur.

## ◆ U4: Maintenance Monitors

Maintenance monitors show:

- Runtime data of the drive and cooling fans and number of Run commands issued
- Maintenance data and replacement information for various drive components
- kWh data
- Highest peak current that has occurred and output frequency at the time the peak current occurred
- Motor overload status information
- Detailed information about the present Run command and frequency reference source selection

[Refer to U4: Maintenance Monitors on page 333](#) for a complete list of U4-□□ monitors and descriptions.

## ◆ U5: PI Monitors

These monitors display various aspects of PI control. [Refer to U5: PI Monitors on page 334](#) for a complete list of U5-□□ monitors and descriptions.

## ◆ U6: Operation Status Monitors

These monitors display reference data for the output voltage and vector control and the offset value added to the frequency reference by the frequency offset function.

*Refer to U6: Operation Status Monitors on page 335* for a complete list of U6-□□ monitors and descriptions.

**This Page Intentionally Blank**

# Troubleshooting

---

This chapter provides descriptions of the drive faults, alarms, errors, related displays, and guidance for troubleshooting. This chapter can also serve as a reference guide for tuning the drive during a trial run.

<b>5.1</b>	<b>SECTION SAFETY.....</b>	<b>196</b>
<b>5.2</b>	<b>MOTOR PERFORMANCE FINE-TUNING.....</b>	<b>198</b>
<b>5.3</b>	<b>DRIVE ALARMS, FAULTS, AND ERRORS.....</b>	<b>201</b>
<b>5.4</b>	<b>FAULT DETECTION.....</b>	<b>205</b>
<b>5.5</b>	<b>ALARM DETECTION.....</b>	<b>218</b>
<b>5.6</b>	<b>PROGRAMMING ERRORS.....</b>	<b>225</b>
<b>5.7</b>	<b>AUTO-TUNING FAULT DETECTION.....</b>	<b>229</b>
<b>5.8</b>	<b>COPY FUNCTION RELATED DISPLAYS.....</b>	<b>231</b>
<b>5.9</b>	<b>DIAGNOSING AND RESETTING FAULTS.....</b>	<b>233</b>
<b>5.10</b>	<b>TROUBLESHOOTING WITHOUT FAULT DISPLAY.....</b>	<b>235</b>

## 5.1 Section Safety

### WARNING

#### Electrical Shock Hazard

**Do not connect or disconnect wiring while the power is on.**

Failure to comply could result in death or serious injury.

Before servicing, disconnect all power to the equipment. The internal capacitor remains charged even after the power supply is turned off. The charge indicator LED will extinguish when the DC bus voltage is below 50 Vdc. To prevent electric shock, wait for at least the time specified on the warning label; after all indicators are OFF, measure for unsafe voltages to confirm the drive is safe prior to servicing.

**Do not operate equipment with covers removed.**

Failure to comply could result in death or serious injury.

The diagrams in this section may illustrate drives without covers or safety shields to display details. Be sure to reinstall covers or shields before operating the drives and run the drives according to the instructions described in this manual.

**Always ground the motor-side grounding terminal.**

Improper equipment grounding could result in death or serious injury by contacting the motor case.

**Do not touch terminals before the capacitors have fully discharged.**

Failure to comply could result in death or serious injury.

Before servicing, disconnect all power to the equipment. The internal capacitor remains charged even after the power supply is turned off. The charge indicator LED will extinguish when the DC bus voltage is below 50 Vdc. To prevent electric shock, wait for at least the time specified on the warning label; after all indicators are OFF, measure for unsafe voltages to confirm the drive is safe prior to servicing.

**After blowing a fuse or tripping a GFCI, do not attempt to restart the drive or operate peripheral devices until five minutes pass and CHARGE lamp is OFF.**

Failure to comply could result in death, serious injury, and damage to the drive.

Check wiring and peripheral device ratings to identify the cause of trips.

Contact your supplier if the cause cannot be identified.

**Do not allow unqualified personnel to perform work on the drive.**

Failure to comply could result in death or serious injury.

Installation, maintenance, inspection and servicing must be performed only by authorized personnel familiar with installation, adjustment and maintenance of AC drives.

**Do not perform work on the drive while wearing loose clothing, jewelry, or without eye protection.**

Failure to comply could result in death or serious injury.

Remove all metal objects such as watches and rings, secure loose clothing and wear eye protection before beginning work on the drive.

**Do not remove covers or touch circuit boards while the power is on.**

Failure to comply could result in death or serious injury.

#### Fire Hazard

**Tighten all terminal screws to the specified tightening torque.**

Loose electrical connections could result in death or serious injury by fire due to overheating of electrical connections.

**Do not use an improper voltage source.**

Failure to comply could result in death or serious injury by fire.

Verify that the rated voltage of the drive matches the voltage of the incoming drive input power before applying power.

**⚠ WARNING****Do not use improper combustible materials.**

Failure to comply could result in death or serious injury by fire.

Attach the drive to metal or other noncombustible material.

**NOTICE****Observe proper electrostatic discharge procedures (ESD) when handling the drive and circuit boards.**

Failure to comply may result in ESD damage to the drive circuitry.

**Never connect or disconnect the motor from the drive while the drive is outputting voltage.**

Improper equipment sequencing could result in damage to the drive.

**Do not use unshielded cable for control wiring.**

Failure to comply may cause electrical interference resulting in poor system performance. Use shielded twisted-pair wires and ground the shield to the ground terminal of the drive.

**Do not modify the drive circuitry.**

Failure to comply could result in damage to the drive and will void warranty.

Yaskawa is not responsible for modification of the product made by the user.

**Check all the wiring after installing the drive and connecting other devices to ensure that all connections are correct.**

Failure to comply could result in damage to the drive.

# 5.2 Motor Performance Fine-Tuning

This section offers helpful information for counteracting oscillation, hunting, and other problems that occur while performing a trial run. Refer to the section below that corresponds to the motor control method used.

**Note:** This section describes commonly edited parameters that may be set incorrectly. Consult Yaskawa for more information on detailed settings and for fine-tuning the drive.

### ◆ Fine-Tuning V/f Control

**Table 5.1 Parameters for Fine-Tuning Performance in V/f**

Problem	Parameter No.	Corrective Action	Default	Suggested Setting
Motor hunting and oscillation at speeds between 10 and 40 Hz	Hunting Prevention Gain (n1-02)	<ul style="list-style-type: none"> <li>Reduce the setting if insufficient motor torque relative to the size of the load causes hunting.</li> <li>Increase the setting when motor hunting and oscillation occur with a light load.</li> <li>Reduce the setting if hunting occurs when using a motor with a relatively low inductance, such as a high-frequency motor or a motor with a larger frame size.</li> </ul>	1.00	0.10 to 2.00
<ul style="list-style-type: none"> <li>Motor noise</li> <li>Motor hunting and oscillation at speeds up to 40 Hz</li> </ul>	Carrier Frequency Selection (C6-02)	<ul style="list-style-type: none"> <li>Increase the carrier frequency If the motor noise is too loud.</li> <li>Lower the carrier frequency when motor hunting and oscillation occur at speeds up to 40 Hz.</li> <li>The default setting for the carrier frequency depends on the drive capacity (o2-04).</li> </ul>	1 (2 kHz)	1 to max. setting
<ul style="list-style-type: none"> <li>Poor torque or speed response</li> <li>Motor hunting and oscillation</li> </ul>	Torque Compensation Primary Delay Time (C4-02)	<ul style="list-style-type: none"> <li>Reduce the setting if motor torque and speed response are too slow.</li> <li>Increase the setting if motor hunting and oscillation occur.</li> </ul>	Depends on o2-04, Drive Model Selection	100 to 1000 ms
<ul style="list-style-type: none"> <li>Poor motor torque at speeds below 10 Hz</li> <li>Motor hunting and oscillation</li> </ul>	Torque Compensation Gain (C4-01)	<ul style="list-style-type: none"> <li>Increase the setting if motor torque is insufficient at speeds below 10 Hz.</li> <li>Reduce the setting if motor hunting and oscillation with a relatively light load.</li> </ul>	1.00	0.50 to 1.50
<ul style="list-style-type: none"> <li>Poor motor torque at low speeds</li> <li>Motor instability at motor start</li> </ul>	Mid Output Voltage A (E1-08) Minimum Output Voltage (E1-10)	<ul style="list-style-type: none"> <li>Increase the setting if motor torque is insufficient at speeds below 10 Hz.</li> <li>Reduce the setting If motor instability occurs at motor start.</li> </ul>	Depends on A1-02, E1-03, and o2-04	Default setting $\pm 5$ V

◆ Fine-Tuning Open Loop Vector Control for PM Motors

Table 5.2 Parameters for Fine-Tuning Performance in OLV/PM

Problem	Parameter No.	Corrective Action	Default	Suggested Setting
Undesirable motor performance	Motor parameters (E1-□□, E5-□□)	<ul style="list-style-type: none"> <li>Check the settings for base and maximum frequency in the E1-□□ parameters.</li> <li>Check E5-□□ parameters and set motor data correctly. Do not enter line-to-line data where single-phase data is required, and vice versa.</li> <li>Perform Auto-Tuning.</li> </ul>	-	-
Poor motor torque and speed response	Load Inertia Ratio (n8-55)	Adjust parameter n8-55 to meet the load inertia ratio of the machine.	0	Close to the actual load inertia ratio
	Speed Feedback Detection Gain (n8-45)	Increase the speed feedback detection gain (n8-45).	0.80	Increase in increments of 0.05
	Torque Compensation (C4-01)	Enable torque compensation. <b>Note:</b> Setting this value too high can cause overcompensation and motor oscillation.	0.00	1.00
Oscillation at start or the motor stalls	Pull-In Current during Accel/Decel (n8-51)	Increase the pull-in current in n8-51	50%	Increase in steps of 5%
	DC Injection Braking Current (b2-02), DC Injection Time at Start (b2-03)	Use DC Injection Braking at start to align the rotor. This may cause a short reverse rotation at start.	b2-02 = 50% b2-03 = 0.00 s	b2-03 = 0.5 s Increase b2-02 if needed
	Load Inertia Ratio (n8-55)	Increase the load inertia ratio. <b>Note:</b> Setting this value too high can cause overcompensation and motor oscillation.	0	Close to the actual load inertia ratio
Stalling or oscillation occur when load is applied during constant speed	Pull-In Current Compensation Time Constant (n8-47)	Reduce n8-47 if hunting occurs during constant speed	5.0 s	Reduce in increments of 0.2 s
	Pull-In Current (n8-48)	Increase the pull-in current in n8-48.	30%	Increase in increments of 5%
	Load Inertia Ratio (n8-55)	Increase the load inertia ratio.	0	Close to the actual load inertia ratio
Hunting or oscillation occur	Speed feedback Detection Gain (n8-45)	Reduce the speed feedback detection gain in n8-45.	0.80	Increase in increments 0.05
STo fault trips when the load is not excessively high	Induced Voltage Constant (E5-09 or E5-24)	<ul style="list-style-type: none"> <li>Check and adjust the induced voltage constant.</li> <li>Check the motor nameplate and the data sheet or contact the motor manufacturer.</li> </ul>	Depends on drive capacity	Refer to the motor data sheet or the nameplate.
Stalling or STo occurs at high speed as the output voltage becomes saturated	Output Voltage Limit (n8-62)	Set the value of the input voltage to parameter n8-62	200 Vac (200 V class) 400 Vac (400 V class)	Set equal to input voltage

### ◆ Parameters to Minimize Motor Hunting and Oscillation

In addition to the parameters discussed on pages 198 and 199, parameters in [Table 5.3](#) indirectly affect motor hunting and oscillation.

**Table 5.3 Parameters that Affect Control Performance in Applications**

Name (Parameter No.)	Application
Accel/Decel Time (C1-01 through C1-11)	Adjusting accel and decel times will affect the torque presented to the motor during acceleration or deceleration.
S-Curve Characteristics (C2-01 and C2-02)	Prevents shock at the beginning and end of acceleration and deceleration.
Jump Frequency (d3-01 through d3-04)	Skips over the resonant frequencies of connected machinery.
Analog Filter Time Constant (H3-13)	Prevents fluctuation in the analog input signal due to noise.
Stall Prevention (L3-01 through L3-06, L3-11)	<ul style="list-style-type: none"><li>• Prevents motor speed loss and overvoltage when the load is too heavy or during sudden acceleration/ deceleration.</li><li>• Adjustment is not normally necessary because Stall Prevention is enabled as a default.</li></ul>

## 5.3 Drive Alarms, Faults, and Errors

### ◆ Types of Alarms, Faults, and Errors

Check the HOA keypad for information about possible faults if the drive or motor fails to operate. *Refer to Using the HOA Keypad on page 107.*

If problems occur that are not covered in this manual, contact the nearest Yaskawa representative with the following information:

- Drive model
- Software version
- Date of purchase
- Description of the problem

*Table 5.4* contains descriptions of the various types of alarms, faults, and errors that may occur while operating the drive.

**Table 5.4 Types of Alarms, Faults, and Errors**

Type	Drive Response
<b>Faults</b>	<p>When the drive detects a fault:</p> <ul style="list-style-type: none"> <li>• The HOA keypad displays text indicating the specific fault and the ALM indicator LED remains lit until the fault is reset.</li> <li>• The fault interrupts drive output and the motor coasts to a stop.</li> <li>• Some faults allow the user to select the stopping method when the fault occurs.</li> <li>• Fault output terminals MA-MC will close, and MB-MC will open.</li> </ul> <p>The drive will remain inoperable until the fault is cleared. <i>Refer to Fault Reset Methods on page 234.</i></p>
<b>Minor Faults and Alarms</b>	<p>When the drive detects an alarm or a minor fault:</p> <ul style="list-style-type: none"> <li>• The HOA keypad displays text indicating the specific alarm or minor fault, and the ALM indicator LED flashes.</li> <li>• The drive continues running the motor, although some alarms allow the user to select a stopping method when the alarm occurs.</li> <li>• A multi-function contact output set to be tripped by a minor fault (H2- □□ = 10) closes. If the output is set to be tripped by an alarm, the contact will not close.</li> <li>• The HOA keypad displays text indicating a specific alarm and the ALM indicator LED flashes.</li> </ul> <p>Remove the cause of the problem to reset a minor fault or alarm.</p>
<b>Operation Errors</b>	<p>An operation error occurs when parameter settings conflict or do not match hardware settings (such as with an option card). When the drive detects an operation error:</p> <ul style="list-style-type: none"> <li>• The HOA keypad displays text indicating the specific error.</li> <li>• Multi-function contact outputs do not operate.</li> </ul> <p>The drive will not operate the motor until the error has been reset. Correct the settings that caused the operation error to clear the error.</p>
<b>Tuning Errors</b>	<p>Tuning errors occur while performing Auto-Tuning. When the drive detects a tuning error:</p> <ul style="list-style-type: none"> <li>• The HOA keypad displays text indicating the specific error.</li> <li>• Multi-function contact outputs do not operate.</li> <li>• Motor coasts to stop.</li> </ul> <p>Remove the cause of the error and repeat the Auto-Tuning process.</p>
<b>Copy Function Errors</b>	<p>Copy Function Errors occur when using the HOA keypad or the USB Copy Unit to copy, read, or verify parameter settings.</p> <ul style="list-style-type: none"> <li>• The HOA keypad displays text indicating the specific error.</li> <li>• Multi-function contact outputs do not operate.</li> </ul> <p>Pressing any key on the HOA keypad will clear the fault. Investigate the cause of the problem (such as model incompatibility) and try again.</p>

### ◆ Alarm and Error Displays

#### ■ Faults

**Table 5.5** gives an overview of possible fault codes. Conditions such as overvoltages can trip faults and alarms. It is important to distinguish between faults and alarms to determine the proper corrective actions.

When the drive detects a fault, the ALM indicator LED lights, the fault code appears on the HOA keypad, and the fault contact MA-MB-MC triggers. An alarm is present if the ALM LED blinks and the fault code on the HOA keypad flashes. *Refer to [Minor Faults and Alarms on page 203](#)* for a list of alarm codes.

**Table 5.5 Fault Displays**

HOA Keypad Display	Name	Page	HOA Keypad Display	Name	Page
bAT	HOA Keypad Battery Voltage Low	<a href="#">205</a>	oFA05, oFA06	Option Card Error (CN5)	<a href="#">211</a>
bUS	Option Communication Error	<a href="#">205</a>	oFA10, oFA11	Option Card Error (CN5)	<a href="#">211</a>
CE	MEMOBUS/Modbus Communication Error	<a href="#">205</a>	oFA12 to oFA17	Option Card Connection Error (CN5)	<a href="#">211</a>
CoF	Current Offset Fault	<a href="#">205</a>	oFA30 to oFA43	Comm Option Card Connection Error (CN5)	<a href="#">211</a>
CPF00, CPF01 <1>	Control Circuit Error	<a href="#">206</a>	oH	Heatsink Overheat	<a href="#">211</a>
CPF02	A/D Conversion Error	<a href="#">206</a>	oH1	Heatsink Overheat	<a href="#">211</a>
CPF03	Control Board Connection Error	<a href="#">206</a>	oH3	Motor Overheat Alarm (PTC input)	<a href="#">211</a>
CPF06	EEPROM Memory Data Error	<a href="#">206</a>	oH4	Motor Overheat Fault (PTC input)	<a href="#">212</a>
CPF07, CPF08	Terminal Board Connection Error	<a href="#">206</a>	oL1	Motor Overload	<a href="#">212</a>
CPF20, CPF21 <2>	Control Circuit Error	<a href="#">206</a>	oL2	Drive Overload	<a href="#">213</a>
CPF22	Hybrid IC Error	<a href="#">207</a>	oL3	Overtorque Detection 1	<a href="#">213</a>
CPF23	Control Board Connection Error	<a href="#">207</a>	oL7	High Slip Braking oL	<a href="#">213</a>
CPF24	Drive Unit Signal Fault	<a href="#">207</a>	oPr	Operator Connection Fault	<a href="#">213</a>
EF0	Option Card External Fault	<a href="#">207</a>	ov	Overvoltage	<a href="#">214</a>
EF1 to EF7	External Fault (input terminal S1 to S7)	<a href="#">207</a>	ov2	Overvoltage 2	<a href="#">214</a>
Err	EEPROM Write Error	<a href="#">208</a>	PF	Input Phase Loss	<a href="#">214</a>
FAn	Internal Fan Fault	<a href="#">207</a>	SEr	Too Many Speed Search Restarts	<a href="#">215</a>
Fn1	External Fan Fault	<a href="#">208</a>	STo	Pull-Out Detection	<a href="#">215</a>
FbH	Excessive PI Feedback	<a href="#">208</a>	TdE	Time Data Error	<a href="#">215</a>
FbL	PI Feedback Loss	<a href="#">208</a>	TIM	Time Not Set	<a href="#">215</a>
GF	Ground Fault	<a href="#">209</a>	UL3	Undertorque Detection 1	<a href="#">215</a>
LF	Output Phase Loss	<a href="#">209</a>	UL6	Motor Underload	<a href="#">216</a>
LF2	Current Imbalance	<a href="#">209</a>	Uv1	Undervoltage	<a href="#">216</a>
nSE	Node Setup Error	<a href="#">209</a>	Uv2	Control Power Supply Undervoltage	<a href="#">216</a>
oC	Overcurrent	<a href="#">210</a>	Uv3	Soft Charge Circuit Fault	<a href="#">216</a>
oFA00	Option Card Connection Error (CN5)	<a href="#">210</a>	voF	Output Voltage Detection Fault	<a href="#">217</a>
oFA01	Option Card Fault (CN5)	<a href="#">211</a>			

<1> Displayed as CPF00 when occurring at drive power up. When one of the faults occurs after successfully starting the drive, the display will show CPF01.

<2> Displayed as CPF20 when occurring at drive power up. When one of the faults occurs after successfully starting the drive, the display will show CPF21.

■ Minor Faults and Alarms

Refer to [Table 5.6](#) for an overview of possible alarm codes. Conditions such as overvoltages can trip faults and alarms. It is important to distinguish between faults and alarms to determine the proper corrective actions.

When the drive detects an alarm, the ALM indicator LED blinks and the alarm code display flashes. Most alarms trigger a digital output programmed for alarm output (H2-□□ = 10). A fault (not an alarm) is present if the ALM LED lights without blinking. [Refer to Faults on page 202](#) for information on fault codes.

Table 5.6 Minor Fault and Alarm Displays

HOA Keypad Display	Name	Minor Fault Output (H2-□□ = 10)	Page	HOA Keypad Display	Name	Minor Fault Output (H2-□□ = 10)	Page
bAT	HOA Keypad Battery Voltage Low	YES	<a href="#">205</a>	LT-2	Capacitor Maintenance Time	No output <2>	<a href="#">221</a>
bb	Drive Baseblock	No output	<a href="#">218</a>	LT-3	Soft Charge Bypass Relay Maintenance Time	No output <2>	<a href="#">221</a>
bUS	Option Card Communications Error	YES	<a href="#">218</a>	oH	Heatsink Overheat	YES	<a href="#">221</a>
CALL	Serial Communication Transmission Error	YES	<a href="#">218</a>	oH2	Drive Overheat	YES	<a href="#">222</a>
CE	MEMOBUS/Modbus Communication Error	YES	<a href="#">218</a>	oH3	Motor Overheat	YES	<a href="#">222</a>
CrST	Cannot Reset	YES	<a href="#">219</a>	oL3	Overtorque 1	YES	<a href="#">222</a>
dnE	Drive Disabled	YES	<a href="#">219</a>	ov	Overvoltage	YES	<a href="#">222</a>
EF	Run Command Input Error	YES	<a href="#">219</a>	PASS	MEMOBUS/Modbus Test Mode Complete	No output	<a href="#">223</a>
EF0	Option Card External Fault	YES	<a href="#">219</a>	SAFE	Customer Safety	No output	<a href="#">223</a>
EF1 to EF7	External Fault (input terminal S1 to S7)	YES	<a href="#">220</a>	SE	MEMOBUS/Modbus Test Mode Fault	YES	<a href="#">223</a>
FAn	Internal Fan Fault	YES	<a href="#">207</a>	TdE	Thermistor Disconnect	YES	<a href="#">223</a>
FbH	Excessive PI Feedback	YES	<a href="#">220</a>	TIM	Time Not Set	YES	<a href="#">215</a>
FbL	PI Feedback Loss	YES	<a href="#">220</a>	UL3	Undertorque 1	YES	<a href="#">223</a>
Fn1	External Fan Fault	YES	<a href="#">208</a>	UL6	Undertorque 6	YES	<a href="#">223</a>
inTLK </>	Interlock Open	No output	<a href="#">221</a>	Uv	Undervoltage	YES	<a href="#">223</a>
LT-1	Cooling Fan Maintenance Time	No output <2>	<a href="#">221</a>	voF	Output Voltage Detection Fault	YES	<a href="#">224</a>
				WrUn	Waiting for Run	YES	<a href="#">224</a>

- <1> ALM LED will not blink.
- <2> Output when H2-□□ = 2F.

■ Operation Errors

Table 5.7 Operation Error Displays

HOA Keypad Display	Name	Page	HOA Keypad Display	Name	Page
oPE01	Drive Unit Setting Error	<a href="#">225</a>	oPE09	PI Control Selection Error	<a href="#">227</a>
oPE02	Parameter Setting Range Error	<a href="#">225</a>	oPE10	V/f Data Setting Error	<a href="#">227</a>
oPE03	Multi-Function Input Setting Error	<a href="#">225</a>	oPE11	Carrier Frequency Setting Error	<a href="#">227</a>
oPE05	Run Command Selection Error	<a href="#">226</a>	oPE16	Energy Saving Constants Error	<a href="#">227</a>
oPE07	Multi-Function Analog Input Selection Error	<a href="#">226</a>	oPE27	BP Program Error	<a href="#">228</a>
oPE08	Parameter Selection Error	<a href="#">226</a>	oPE28	Sequence Timer Error	<a href="#">228</a>

### ■ Auto-Tuning Errors

Table 5.8 Auto-Tuning Error Displays

HOA Keypad Display	Name	Page	HOA Keypad Display	Name	Page
End3	Rated Current Setting Alarm	<a href="#">229</a>	Er-03	OFF Button Input	<a href="#">230</a>
End4	Adjusted Slip Value Fell Below Lower Limit	<a href="#">229</a>	Er-04	Line-to-Line Resistance Error	<a href="#">230</a>
End5	Resistance Between Lines Error	<a href="#">229</a>	Er-05	No-Load Current Error	<a href="#">230</a>
End7	No-Load Current Alarm	<a href="#">229</a>	Er-08	Rated Slip Error	<a href="#">230</a>
Er-01	Motor Data Error	<a href="#">229</a>	Er-09	Acceleration Error	<a href="#">230</a>
Er-02	Alarm	<a href="#">229</a>	Er-12	Current Detection Error	<a href="#">230</a>

### ■ Errors and Displays When Using the Copy Function

Table 5.9 Copy Errors

HOA Keypad Display	Name	Page	HOA Keypad Display	Name	Page
CoPy	Writing parameter settings (flashing)	<a href="#">231</a>	ndAT	Model, voltage class, capacity mismatch	<a href="#">232</a>
CPeR	Control mode mismatch	<a href="#">231</a>	rdEr	Error reading data	<a href="#">232</a>
CPyE	Error writing data	<a href="#">231</a>	rEAd	Reading parameter settings (flashing)	<a href="#">232</a>
CSEr	Copy unit error	<a href="#">231</a>	vAEr	Voltage class, capacity mismatch	<a href="#">232</a>
dFPS	Drive model mismatch	<a href="#">231</a>	vFyE	Parameter setting mismatch	<a href="#">232</a>
End	Task complete	<a href="#">231</a>	vrFy	Comparing parameter settings (flashing)	<a href="#">232</a>
iFEr	Communication error	<a href="#">231</a>			

## 5.4 Fault Detection

### ◆ Fault Displays, Causes, and Possible Solutions

Faults are detected for drive protection, and cause the drive to stop while triggering the fault output terminal MA-MB-MC. Remove the cause of the fault and manually clear the fault before attempting to run the drive again.

**Table 5.10 Detailed Fault Displays, Causes, and Possible Solutions**

HOA Keypad Display	Fault Name
bAT	HOA Keypad Battery Voltage Low
Cause	Possible Solution
The HOA keypad battery is low	Replace the HOA keypad battery.
HOA Keypad Display	Fault Name
bUS	Option Communication Error
	<ul style="list-style-type: none"> <li>The connection was lost after establishing initial communication.</li> <li>Only detected when the run command frequency reference is assigned to an option card.</li> </ul>
Cause	Possible Solution
No signal was received from the PLC	<ul style="list-style-type: none"> <li>Check for faulty wiring.</li> </ul>
Faulty communications wiring or an existing short circuit	<ul style="list-style-type: none"> <li>Correct the wiring.</li> <li>Check for disconnected cables and short circuits and repair as needed.</li> </ul>
Communication data error occurred due to noise	<ul style="list-style-type: none"> <li>Check the various options available to minimize the effects of noise.</li> <li>Counteract noise in the control circuit, main circuit, and ground wiring.</li> <li>Ensure that other equipment such as switches or relays do not cause noise. Use surge absorbers if necessary.</li> <li>Use only recommended cables or other shielded line. Ground the shield on the controller side or the drive input power side.</li> <li>Separate all communication wiring from drive power lines.</li> </ul>
The option card is damaged	Replace the option card if there are no problems with the wiring and the error continues to occur.
The option card is not properly connected to the drive	<ul style="list-style-type: none"> <li>The connector pins on the option card do not line up properly with the connector pins on the drive.</li> <li>Reinstall the option card.</li> </ul>
HOA Keypad Display	Fault Name
CE	MEMOBUS/Modbus Communication Error
	Control data was not received for the CE detection time set to H5-09.
Cause	Possible Solution
Faulty communications wiring or an existing short circuit	<ul style="list-style-type: none"> <li>Check for faulty wiring.</li> <li>Correct the wiring.</li> <li>Check for disconnected cables and short circuits and repair as needed.</li> </ul>
Communication data error occurred due to noise	<ul style="list-style-type: none"> <li>Check the various options available to minimize the effects of noise.</li> <li>Counteract noise in the control circuit, main circuit, and ground wiring.</li> <li>Use only recommended cables or other shielded line. Ground the shield on the controller side or the drive input power side.</li> <li>Ensure that other equipment such as switches or relays do not cause noise. Use surge suppressors if required.</li> <li>Separate all communication wiring from drive power lines.</li> </ul>
HOA Keypad Display	Fault Name
CoF	Current Offset Fault
Cause	Possible Solution
The drive tried to adjust the current offset value beyond the allowable range. This is due to residual induction current in the motor (e.g., during sudden deceleration or when coasting) when the drive attempted to start the motor.	<ul style="list-style-type: none"> <li>Create a motor restart sequence that allows enough time for residual induction voltage to dissipate.</li> <li>Enable Speed Search at start (b3-01 = 1). Use the multi-function terminals to execute External Speed Search 1 and 2 (H1-□□ = 61 or 62).</li> </ul> <p><b>Note:</b> When using a PM motor, External Speed Searches 1 and 2 perform the same operation.</p>
The current sensor in the drive is damaged	If the problem continues, replace the control board or the entire drive. Contact Yaskawa or a Yaskawa representative for instructions on replacing the control board.

## 5.4 Fault Detection

HOA Keypad Display	Fault Name
CPF00 or CPF01	Control Circuit Error
<b>Cause</b>	<b>Possible Solution</b>
There is a self-diagnostic error in the control circuit	<ul style="list-style-type: none"> <li>• Cycle power to the drive.</li> <li>• If the problem continues, replace the control board or the entire drive. Contact Yaskawa or a Yaskawa representative for instructions on replacing the control board.</li> </ul>
Connector on the operator is damaged	Replace the operator.

HOA Keypad Display	Fault Name
CPF02	A/D Conversion Error
	An A/D conversion error or control circuit error occurred.
<b>Cause</b>	<b>Possible Solution</b>
Control circuit is damaged	<ul style="list-style-type: none"> <li>• Cycle power to the drive.</li> <li>• If the problem continues, replace the control board or the entire drive. Contact Yaskawa or a Yaskawa representative for instructions on replacing the control board.</li> </ul>

HOA Keypad Display	Fault Name
CPF03	Control Board Connection Error
	Connection error between the control board and the drive
<b>Cause</b>	<b>Possible Solution</b>
There is a connection error	<ul style="list-style-type: none"> <li>• Turn off the power and check the connection between the control board and the drive.</li> <li>• If the problem continues, replace the control board or the entire drive. Contact Yaskawa or a Yaskawa representative for instructions on replacing the control board.</li> </ul>
Drive fails to operate properly due to noise interference	<ul style="list-style-type: none"> <li>• Check the various options available to minimize the effects of noise.</li> <li>• Counteract noise in the control circuit, main circuit, and ground wiring.</li> <li>• Use only recommended cables or other shielded line. Ground the shield on the controller side or the drive input power side.</li> <li>• Ensure that other equipment such as switches or relays do not cause noise. Use surge suppressors if required.</li> <li>• Separate all communication wiring from drive power lines.</li> </ul>

HOA Keypad Display	Fault Name
CPF06	EEPROM Memory Data Error
	Error in the data saved to EEPROM
<b>Cause</b>	<b>Possible Solution</b>
There is an error in EEPROM control circuit	<ul style="list-style-type: none"> <li>• Turn off the power and check the connection between the control board and the drive.</li> <li>• If the problem continues, replace the control board or the entire drive. Contact Yaskawa or a Yaskawa representative for instructions on replacing the control board.</li> </ul>
The power supply was switched off while parameters were being saved to the drive	Reinitialize the drive using parameter A1-03.

HOA Keypad Display	Fault Name
CPF07	Terminal Board Connection Error
CPF08	
<b>Cause</b>	<b>Possible Solution</b>
There is a faulty connection between the terminal board and the control board	<ul style="list-style-type: none"> <li>• Turn off the power and check the connection between the control board and the drive.</li> <li>• If the problem continues, replace the control board or the entire drive. Contact Yaskawa or a Yaskawa representative for instructions on replacing the control board.</li> </ul>

HOA Keypad Display	Fault Name
CPF20 or CPF21	Control Circuit Error
<b>Cause</b>	<b>Possible Solution</b>
Hardware is damaged	<ul style="list-style-type: none"> <li>• Cycle power to the drive.</li> <li>• If the problem continues, replace the control board or the entire drive. Contact Yaskawa or a Yaskawa representative for instructions on replacing the control board.</li> </ul>

HOA Keypad Display	Fault Name
CPF22	Hybrid IC Failure
<b>Cause</b>	<b>Possible Solution</b>
Hybrid IC failure on the power board	<ul style="list-style-type: none"> <li>• Cycle power to the drive.</li> <li>• If the problem continues, replace the power board or the entire drive. Contact Yaskawa or a Yaskawa representative for instructions on replacing the power board.</li> </ul>

HOA Keypad Display	Fault Name
CPF23	Control Board Connection Error
	Connection error between the control board and the drive
<b>Cause</b>	<b>Possible Solution</b>
Hardware is damaged	<ul style="list-style-type: none"> <li>• Turn off the power and check the connection between the control board and the drive.</li> <li>• If the problem continues, replace the control board or the entire drive. Contact Yaskawa or a Yaskawa representative for instructions on replacing the control board.</li> </ul>

HOA Keypad Display	Fault Name
CPF24	Drive Unit Signal Fault
	The drive capacity cannot be detected correctly (drive capacity is checked when the drive is powered up).
<b>Cause</b>	<b>Possible Solution</b>
Hardware is damaged	If the problem continues, replace the control board or the entire drive. Contact Yaskawa or a Yaskawa representative for instructions on replacing the control board.

HOA Keypad Display	Fault Name
EF0	Option Card External Fault
	An external fault condition is present.
<b>Cause</b>	<b>Possible Solution</b>
An external fault was received from the PLC and F6-03 is set to a value other than 3	<ul style="list-style-type: none"> <li>• Remove the cause of the external fault.</li> <li>• Remove the external fault input from the PLC.</li> </ul>
Problem with the PLC program	Check the PLC program and correct problems.

HOA Keypad Display	Fault Name
EF1	External Fault (input terminal S1)
	External fault at multi-function input terminal S1.
EF2	External Fault (input terminal S2)
	External fault at multi-function input terminal S2.
EF3	External Fault (input terminal S3)
	External fault at multi-function input terminal S3.
EF4	External Fault (input terminal S4)
	External fault at multi-function input terminal S4.
EF5	External Fault (input terminal S5)
	External fault at multi-function input terminal S5.
EF6	External Fault (input terminal S6)
	External fault at multi-function input terminal S6.
EF7	External Fault (input terminal S7)
	External fault at multi-function input terminal S7.
<b>Cause</b>	<b>Possible Solution</b>
An external device tripped an alarm function	Remove the cause of the external fault and reset the fault.
Wiring is incorrect	<ul style="list-style-type: none"> <li>• Properly connect the signal lines to the terminals assigned for external fault detection (H1-□□ = 20 to 2F).</li> <li>• Reconnect the signal line.</li> </ul>
Multi-function contact input setting is incorrect	<ul style="list-style-type: none"> <li>• Check for unused terminals set for H1-□□ = 20 to 2F (External Fault).</li> <li>• Change the terminal settings.</li> </ul>

## 5.4 Fault Detection

HOA Keypad Display	Fault Name
Err	EEPROM Write Error
	Data cannot be written to the EEPROM
<b>Cause</b>	<b>Possible Solution</b>
Noise has corrupted data while writing to the EEPROM	<ul style="list-style-type: none"> <li>• Press “ENTER” on the HOA keypad.</li> <li>• Correct the parameter setting.</li> <li>• Cycle power to the drive.</li> <li>• If the problem continues, replace the control board or the entire drive. Contact Yaskawa or a Yaskawa representative for instructions on replacing the control board.</li> </ul>
Hardware problem	If the problem continues, replace the control board or the entire drive. Contact Yaskawa or a Yaskawa representative for instructions on replacing the control board.

HOA Keypad Display	Fault Name
FAn	Internal Fan Fault
	Fan or magnetic contactor failure
<b>Cause</b>	<b>Possible Solution</b>
Internal cooling fan has malfunctioned	<ul style="list-style-type: none"> <li>• Cycle power to the drive.</li> <li>• Check for fan operation.</li> <li>• Verify the cumulative operation time of the fan with monitor U4-03, and verify the cumulative operation time of the fan maintenance timer with U4-04.</li> <li>• If the cooling fan has exceeded its expected performance life or is damaged in any other way, follow the replacement instructions in the <i>Peripheral Devices &amp; Options</i> chapter.</li> </ul>
Fault detected in the internal cooling fan or magnetic contactor to the power supply	<ul style="list-style-type: none"> <li>• Cycle power to the drive.</li> <li>• If the fault continues to occur, replace the power board/gate drive board or the entire drive.</li> <li>• Contact Yaskawa or a Yaskawa representative for instructions on replacing the power board/gate drive board.</li> </ul>

HOA Keypad Display	Fault Name
Fn1	External Fan Fault
	External fan failure
<b>Cause</b>	<b>Possible Solution</b>
External cooling fan has malfunctioned	<ul style="list-style-type: none"> <li>• Cycle power to the drive.</li> <li>• Check for fan operation.</li> <li>• Verify the cumulative operation time of the fan with monitor U4-03, and verify the cumulative operation time of the fan maintenance timer with U4-04.</li> <li>• If the cooling fan has exceeded its expected performance life or is damaged in any other way, follow the replacement instructions in the <i>Peripheral Devices &amp; Options</i> chapter.</li> </ul>

HOA Keypad Display	Fault Name
FbH	Excessive PI Feedback
	PI feedback input is greater than the level set to b5-36 for longer than the time set to b5-37. Set b5-12 to 2 or 5 to enable fault detection.
<b>Cause</b>	<b>Possible Solution</b>
Parameters are set inappropriately	Check b5-36 and b5-37 settings.
Incorrect PI feedback wiring	Correct the wiring.
There is a problem with the feedback sensor	<ul style="list-style-type: none"> <li>• Check the sensor on the control side.</li> <li>• Replace the sensor if damaged.</li> </ul>

HOA Keypad Display	Fault Name
FbL	PI Feedback Loss
	This fault occurs when PI feedback loss detection is programmed to trigger a fault (b5-12 = 2) and the PI feedback level is below the detection level set to b5-13 for longer than the time set to b5-14.
<b>Cause</b>	<b>Possible Solution</b>
Parameters are set inappropriately	Check b5-13 and b5-14 settings.
Incorrect PI feedback wiring	Correct the wiring.

There is a problem with the feedback sensor	<ul style="list-style-type: none"> <li>• Check the sensor on the control side.</li> <li>• Replace the sensor if damaged.</li> </ul>
---	---

HOA Keypad Display	Fault Name
GF	Ground Fault
	<ul style="list-style-type: none"> <li>• A current short to ground exceeded 50% of rated current on the output side of the drive.</li> <li>• Setting L8-09 to 1 enables ground fault detection in models 2A0075 to 2A0396, 4A0052□□A, and 4A0065 to 4A0590.</li> </ul>
<b>Cause</b>	<b>Possible Solution</b>
Motor insulation is damaged	<ul style="list-style-type: none"> <li>• Check the insulation resistance of the motor.</li> <li>• Replace the motor.</li> </ul>
A damaged motor cable is creating a short circuit	<ul style="list-style-type: none"> <li>• Check the motor cable.</li> <li>• Remove the short circuit and reapply power to the drive</li> </ul>
	<ul style="list-style-type: none"> <li>• Check the resistance between the cable and the ground terminal ⊕.</li> <li>• Replace the cable.</li> </ul>
Excessive leakage current at the drive output	<ul style="list-style-type: none"> <li>• Reduce the carrier frequency.</li> <li>• Reduce the amount of stray capacitance.</li> </ul>
The drive started to run during a current offset fault or while coasting to a stop	<ul style="list-style-type: none"> <li>• The set value exceeds the allowable setting range while the drive automatically adjusts the current offset. This only happens when attempting to restart a PM motor that is coasting to stop.</li> <li>• Set b3-01 to 1 to enable Speed Search at Start.</li> <li>• Perform Speed Search 1 or 2 (H1-□□ = 61 or 62) via one of the external terminals.</li> </ul> <p><b>Note:</b> Speed Searches 1 and 2 are the same when using OLV/PM.</p>
Hardware problem	If the problem continues, replace the control board or the entire drive. Contact Yaskawa or a Yaskawa representative for instructions on replacing the control board.

HOA Keypad Display	Fault Name
LF	Output Phase Loss
	<ul style="list-style-type: none"> <li>• Phase loss on the output side of the drive.</li> <li>• Setting L8-07 to 1 or 2 enables Phase Loss Detection.</li> </ul>
<b>Cause</b>	<b>Possible Solution</b>
The output cable is disconnected	<ul style="list-style-type: none"> <li>• Check for wiring errors and properly connect the output cable.</li> <li>• Correct the wiring.</li> </ul>
The motor winding is damaged	<ul style="list-style-type: none"> <li>• Check the resistance between motor lines.</li> <li>• Replace the motor if the winding is damaged.</li> </ul>
The output terminal is loose	<ul style="list-style-type: none"> <li>• Apply the tightening torque specified in this manual to fasten the terminals. <i>Refer to Wire Gauges and Tightening Torque on page 83</i> for details.</li> </ul>
The rated current of the motor being used is less than 5% of the drive rated current	Check the drive and motor capacities.
An output transistor is damaged	If the problem continues, replace the control board or the entire drive. Contact Yaskawa or a Yaskawa representative for instructions on replacing the control board.
A single-phase motor is being used	The drive cannot operate a single phase motor.

HOA Keypad Display	Fault Name
LF2	Output Current Imbalance
	One or more of the phases in the output current are lost.
<b>Cause</b>	<b>Possible Solution</b>
Phase loss has occurred on the output side of the drive	<ul style="list-style-type: none"> <li>• Check for faulty wiring or poor connections on the output side of the drive.</li> <li>• Correct the wiring.</li> </ul>
Terminal wires are loose on the output side of the drive	Apply the tightening torque specified in this manual to fasten the terminals. <i>Refer to Wire Gauges and Tightening Torque on page 83</i> for details.
The output circuit is damaged	If the problem continues, replace the control board or the entire drive. Contact Yaskawa or a Yaskawa representative for instructions on replacing the control board.
Motor impedance or motor phases are uneven	<ul style="list-style-type: none"> <li>• Measure the line-to-line resistance for each motor phase. Ensure all values match.</li> <li>• Replace the motor.</li> </ul>

## 5.4 Fault Detection

HOA Keypad Display	Fault Name
nSE	Node Setup Error
	A terminal assigned to the node setup function closed during run.
Cause	Possible Solution
The node setup terminal closed during run	Stop the drive when using the node setup function.
A Run command was issued while the node setup function was active	

HOA Keypad Display	Fault Name
oC	Overcurrent
	Drive sensors detected an output current greater than the specified overcurrent level.
Cause	Possible Solution
The motor has been damaged due to overheating or the motor insulation is damaged	<ul style="list-style-type: none"> <li>• Check the insulation resistance.</li> <li>• Replace the motor.</li> </ul>
One of the motor cables has shorted out or there is a grounding problem	<ul style="list-style-type: none"> <li>• Check the motor cables.</li> <li>• Remove the short circuit and reapply power to the drive.</li> </ul>
	<ul style="list-style-type: none"> <li>• Check the resistance between the motor cables and the ground terminal ⊕.</li> <li>• Replace damaged cables.</li> </ul>
The load is too heavy	<ul style="list-style-type: none"> <li>• Measure the current flowing into the motor.</li> <li>• Replace the drive with a larger capacity drive if the current value exceeds the rated current.</li> <li>• Determine if there is sudden fluctuation in the current level.</li> <li>• Reduce the load to avoid sudden changes in the current level or switch to a larger drive.</li> </ul>
The acceleration or deceleration times are too short	Calculate the torque needed during acceleration relative to the load inertia and the specified acceleration time. If it is not possible to set the proper amount of torque, make the following changes: <ul style="list-style-type: none"> <li>• Increase the acceleration time (C1-01 and C1-03)</li> <li>• Increase the S-curve characteristics (C2-01 and C2-02)</li> <li>• Increase the capacity of the drive.</li> </ul>
The drive is attempting to operate a specialized motor or a motor larger than the maximum size allowed	<ul style="list-style-type: none"> <li>• Check the motor capacity.</li> <li>• Ensure that the rated capacity of the drive is greater than or equal to the capacity rating found on the motor nameplate.</li> </ul>
Magnetic contactor (MC) on the output side of the drive has turned on or off	Set up the operation sequence so the MC does not trip while the drive is outputting current.
V/f setting is not operating as expected	<ul style="list-style-type: none"> <li>• Check the ratios between the voltage and frequency.</li> <li>• Set parameters E1-04 through E1-10 appropriately.</li> <li>• Lower the voltage if it is too high relative to the frequency.</li> </ul>
Excessive torque compensation	<ul style="list-style-type: none"> <li>• Check the amount of torque compensation.</li> <li>• Reduce the torque compensation gain (C4-01) until there is no speed loss and less current.</li> </ul>
Drive fails to operate properly due to noise interference	<ul style="list-style-type: none"> <li>• Review the possible solutions provided for handling noise interference.</li> <li>• Review the section on handling noise interference and check the control circuit lines, main circuit lines, and ground wiring.</li> </ul>
Overexcitation gain is set too high	<ul style="list-style-type: none"> <li>• Check if the fault occurs simultaneously with overexcitation function operation.</li> <li>• Consider motor flux saturation and reduce the value of n3-13 (Overexcitation Deceleration Gain).</li> </ul>
Run command was applied while motor was coasting	<ul style="list-style-type: none"> <li>• Set b3-01 to 1 to enable Speed Search at Start.</li> <li>• Program the Speed Search command input through one of the multi-function contact input terminals (H1-□□ = 61 or 62).</li> </ul>
The motor control method and motor do not match	<ul style="list-style-type: none"> <li>• Check the control mode.</li> <li>• For IM motors, set A1-02 to 0.</li> <li>• For PM motors, set A1-02 to 5.</li> </ul>
The rated output current of the drive is too small	Use a larger drive.

HOA Keypad Display	Fault Name
oFA00	Option Card Connection Error at Option Port CN5
	Option compatibility error
Cause	Possible Solution
The option card installed into port CN5 is incompatible with the drive	Check if the drive supports the option card to be installed. Contact Yaskawa for assistance.

HOA Keypad Display	Fault Name
oFA01	Option Card Fault at Option Port CN5
	Option not properly connected
<b>Cause</b>	<b>Possible Solution</b>
The option card connection to port CN5 is faulty	<ul style="list-style-type: none"> <li>• Turn off the power and reconnect the option card.</li> <li>• Check if the option card is properly plugged into the option port. Make sure the card is fixed properly.</li> </ul>

HOA Keypad Display	Fault Name
oFA05, oFA06	Option Card Error Occurred at Option Port CN5
oFA10, oFA11	
oFA12 to oFA17	Option Card Connection Error (CN5)
oFA30 to oFA43	Communication Option Card Connection Error (CN5)
<b>Cause</b>	<b>Possible Solution</b>
Option card or hardware is damaged	<ul style="list-style-type: none"> <li>• Cycle power to the drive.</li> <li>• If the problem continues, replace the control board or the entire drive. Contact Yaskawa or a Yaskawa representative for instructions on replacing the control board.</li> </ul>

HOA Keypad Display	Fault Name
oH	Heatsink Overheat
	The heatsink temperature exceeded the overheat pre-alarm level set to L8-02. The default value for L8-02 is determined by drive capacity (o2-04).
<b>Cause</b>	<b>Possible Solution</b>
Surrounding temperature is too high	<ul style="list-style-type: none"> <li>• Check the temperature surrounding the drive. Verify temperature is within drive specifications.</li> <li>• Improve the air circulation within the enclosure panel.</li> <li>• Install a fan or air conditioner to cool the surrounding area.</li> <li>• Remove anything near the drive that might be producing excessive heat.</li> </ul>
Load is too heavy	<ul style="list-style-type: none"> <li>• Measure the output current.</li> <li>• Decrease the load.</li> <li>• Lower the carrier frequency (C6-02).</li> </ul>
External cooling fan is stopped	<ul style="list-style-type: none"> <li>• Replace the cooling fan.</li> <li>• After replacing the cooling fan, set parameter o4-03 to 0 to reset the cooling fan maintenance.</li> </ul>

HOA Keypad Display	Fault Name
oH1	Overheat 1 (Heatsink Overheat)
	The heatsink temperature exceeded the drive overheat level. Overheat level is determined by drive capacity (o2-04).
<b>Cause</b>	<b>Possible Solution</b>
Surrounding temperature is too high	<ul style="list-style-type: none"> <li>• Check the temperature surrounding the drive.</li> <li>• Improve the air circulation within the enclosure panel.</li> <li>• Install a fan or air conditioner to cool the surrounding area.</li> <li>• Remove anything near the drive that might be producing excessive heat.</li> </ul>
Load is too heavy	<ul style="list-style-type: none"> <li>• Measure the output current.</li> <li>• Lower the carrier frequency (C6-02).</li> <li>• Reduce the load.</li> </ul>

HOA Keypad Display	Fault Name
oH3	Motor Overheat Alarm (PTC Input)
	<ul style="list-style-type: none"> <li>• The motor overheat signal to analog input terminals A1 or A2 exceeded the alarm detection level.</li> <li>• Detection requires setting multi-function analog inputs H3-02 or H3-10 to E.</li> </ul>
<b>Cause</b>	<b>Possible Solution</b>

## 5.4 Fault Detection

Motor has overheated	<ul style="list-style-type: none"> <li>• Check the size of the load, the accel/decel times, and the cycle times.</li> <li>• Decrease the load.</li> <li>• Increase the acceleration and deceleration times (C1-01 through C1-04).</li> </ul>
	<ul style="list-style-type: none"> <li>• Adjust the preset V/f pattern (E1-04 through E1-10) by reducing E1-08 and E1-10.</li> <li>• Do not set E1-08 and E1-10 too low. This reduces load tolerance at low speeds.</li> </ul>
	<ul style="list-style-type: none"> <li>• Check the motor rated current.</li> <li>• Enter the motor rated current to parameter E2-01 as indicated on the motor nameplate.</li> <li>• Ensure the motor cooling system is operating normally.</li> <li>• Repair or replace the motor cooling system.</li> </ul>

HOA Keypad Display	Fault Name
oH4	Motor Overheat Fault (PTC Input)
	<ul style="list-style-type: none"> <li>• The motor overheat signal to analog input terminal A1 or A2 exceeded the fault detection level.</li> <li>• Detection requires setting multi-function analog inputs H3-02 or H3-10 to E.</li> </ul>
Cause	Possible Solution
Motor has overheated	<ul style="list-style-type: none"> <li>• Check the size of the load, the accel/decel times, and the cycle times.</li> <li>• Decrease the load.</li> <li>• Increase the acceleration and deceleration times (C1-01 through C1-04).</li> </ul>
	<ul style="list-style-type: none"> <li>• Adjust the preset V/f pattern (E1-04 through E1-10) by reducing E1-08 and E1-10.</li> <li>• Do not set E1-08 and E1-10 too low. This reduces load tolerance at low speeds.</li> </ul>
	<ul style="list-style-type: none"> <li>• Check the motor rated current.</li> <li>• Enter the motor rated current to parameter E2-01 as indicated on the motor nameplate.</li> <li>• Ensure the motor cooling system is operating normally.</li> <li>• Repair or replace the motor cooling system.</li> </ul>

HOA Keypad Display	Fault Name
oL1	Motor Overload
	The electronic motor overload protection tripped
Cause	Possible Solution
Load is too heavy	Reduce the load.
Cycle times are too short during acceleration and deceleration	Increase the acceleration and deceleration times (C1-01 through C1-04).
A general-purpose motor is driven below the rated speed with a high load	<ul style="list-style-type: none"> <li>• Reduce the load.</li> <li>• Increase the speed.</li> <li>• If the motor is supposed to operate at low speeds, either increase the motor capacity or use a motor specifically designed to operate in the desired speed range.</li> </ul>
The output voltage is too high	<ul style="list-style-type: none"> <li>• Adjust the user-set V/f pattern (E1-04 through E1-10) by reducing E1-08 and E1-10.</li> <li>• Do not set E1-08 and E1-10 too low. This reduces load tolerance at low speeds.</li> </ul>
The wrong motor rated current is set to E2-01	<ul style="list-style-type: none"> <li>• Check the motor-rated current.</li> <li>• Enter the motor rated current to parameter E2-01 as indicated on the motor nameplate.</li> </ul>
The maximum output frequency is set incorrectly	<ul style="list-style-type: none"> <li>• Check the rated frequency indicated on the motor nameplate.</li> <li>• Enter the rated frequency to E1-06 (Base Frequency).</li> </ul>
Multiple motors are running off the same drive	Set L1-01 to 0 to disable the motor protection function and then install a thermal relay to each motor.
The electrical thermal protection characteristics and motor overload characteristics do not match	<ul style="list-style-type: none"> <li>• Check the motor characteristics.</li> <li>• Correct the type of motor protection that has been selected (L1-01).</li> <li>• Install an external thermal relay.</li> </ul>
The electrical thermal relay is operating at the wrong level	<ul style="list-style-type: none"> <li>• Check the current rating listed on the motor nameplate.</li> <li>• Check the value set for the motor rated current (E2-01).</li> </ul>
Motor overheated by overexcitation operation	<ul style="list-style-type: none"> <li>• Overexcitation increases the motor loss and the motor temperature. Excessive duration of overexcitation may cause motor damage. Prevent excessive overexcitation operation or apply proper cooling to the motor.</li> <li>• Reduce the excitation deceleration gain (n3-13).</li> <li>• Set L3-04 (Stall Prevention during Deceleration) to a value other than 4.</li> </ul>
Parameters related to Speed Search are set incorrectly	<ul style="list-style-type: none"> <li>• Check values set to Speed Search related parameters.</li> <li>• Adjust the Speed Search current and Speed Search deceleration times (b3-02 and b3-03 respectively).</li> </ul>

Output current fluctuation due to input phase loss	Check the power supply for phase loss.
--	--

HOA Keypad Display	Fault Name
oL2	Drive Overload
	The thermal sensor of the drive triggered overload protection.
Cause	Possible Solution
Load is too heavy	Reduce the load.
Acceleration or deceleration time is too short	Increase the settings for the acceleration and deceleration times (C1-01 through C1-04).
The output voltage is too high	<ul style="list-style-type: none"> <li>Adjust the preset V/f pattern (E1-04 through E1-10) by reducing E1-08 and E1-10.</li> <li>Do not lower E1-08 and E1-10 excessively. This reduces load tolerance at low speeds.</li> </ul>
Drive capacity is too small	Replace the drive with a larger model.
Overload occurred when operating at low speeds	<ul style="list-style-type: none"> <li>Reduce the load when operating at low speeds.</li> <li>Replace the drive with a model that is one frame size larger.</li> <li>Lower the carrier frequency (C6-02).</li> </ul>
Excessive torque compensation	Reduce the torque compensation gain in parameter C4-01 until there is no speed loss but less current.
Parameters related to Speed Search are set incorrectly	<ul style="list-style-type: none"> <li>Check the settings for all Speed Search related parameters.</li> <li>Adjust the current used during Speed Search (b3-03) and the Speed Search deceleration time (b3-02).</li> <li>After Auto-Tuning, set b3-24 to 1 to enable Speed Estimation Speed Search.</li> </ul>
Output current fluctuation due to input phase loss	Check the power supply for phase loss.

HOA Keypad Display	Fault Name
oL3	Overtorque Detection 1
	The current has exceeded the value set for torque detection (L6-02) for longer than the allowable time (L6-03).
Cause	Possible Solution
Parameter settings are not appropriate for the load	Check L6-02 and L6-03 settings.
Fault on the machine side (e.g., machine is locked up)	Check the status of the load. Remove the cause of the fault.

HOA Keypad Display	Fault Name
oL7	High Slip Braking oL
	The output frequency stayed constant for longer than the time set to n3-04 during High Slip Braking.
Cause	Possible Solution
Excessive load inertia	Reduce deceleration times in parameters C1-02 and C1-04 for applications that do not use High Slip Braking.
Motor is driven by the load	
Something on the load side is restricting deceleration	
The overload time during High Slip Braking is too short	<ul style="list-style-type: none"> <li>Increase parameter n3-04 (High-slip Braking Overload Time).</li> <li>Install a thermal relay and increase the setting of n3-04 to maximum value.</li> </ul>

HOA Keypad Display	Fault Name
oPr	HOA Keypad Connection Fault
	The HOA keypad has been disconnected from the drive. An oPr fault will occur when all of the following conditions are true: <ul style="list-style-type: none"> <li>Output is interrupted when the keypad is disconnected (o2-06 = 1).</li> <li>The Run command is assigned to the keypad (b1-02 = 0 and OFF mode has been selected).</li> <li>Drive software versions PRG: 1014 and later detect an oPr fault when the HOA keypad is removed from the drive while the sequence timer is active, even when oPr error detection is disabled (o2-06 = 0).</li> </ul>
	Cause
External operator is not properly connected to the drive	<ul style="list-style-type: none"> <li>Check the connection between the operator and the drive.</li> <li>Replace the cable if damaged.</li> <li>Turn off the drive input power and disconnect the operator. Reconnect the operator and reapply drive input power.</li> </ul>

## 5.4 Fault Detection

HOA Keypad Display	Fault Name
ov	Overvoltage
	Voltage in the DC bus has exceeded the overvoltage detection level. <ul style="list-style-type: none"> <li>For 200 V class drives: approximately 410 V</li> <li>For 400 V class drives: approximately 820 V (740 V when E1-01 is less than 400)</li> </ul>
Cause	Possible Solution
Deceleration time is too short and regenerative energy is flowing from the motor into the drive	<ul style="list-style-type: none"> <li>Increase the deceleration time (C1-02 and C1-04).</li> <li>Set L3-04 to 1 to enable stall prevention during deceleration. Stall Prevention is enabled as the default setting.</li> </ul>
Fast acceleration time causes the motor to overshoot the speed reference	<ul style="list-style-type: none"> <li>Check if sudden drive acceleration triggers an overvoltage alarm.</li> <li>Increase the acceleration time.</li> <li>Use longer S-curve acceleration and deceleration times.</li> <li>Enable the Overvoltage Suppression function (L3-11 = 1).</li> <li>Lengthen the S-curve at acceleration end.</li> </ul>
Ground fault in the output circuit causes the DC bus capacitor to overcharge	<ul style="list-style-type: none"> <li>Check the motor wiring for ground faults.</li> <li>Correct grounding shorts and reapply power.</li> </ul>
Improper parameters related to Speed Search (including Speed Search after a momentary power loss and after a fault restart)	<ul style="list-style-type: none"> <li>Check the settings for Speed Search-related parameters.</li> <li>Enable Speed Search restart function (b3-19 greater than or equal to 1 to 10).</li> <li>Adjust the current level during Speed Search and the deceleration time (b3-02 and b3-03 respectively).</li> <li>Perform Stationary Auto-Tuning for line-to-line resistance and then set b3-14 to 1 to enable Speed Estimation Speed Search.</li> </ul>
Drive input power voltage is too high	<ul style="list-style-type: none"> <li>Check the voltage.</li> <li>Lower drive input power voltage within the limits listed in the specifications.</li> </ul>
Drive fails to operate properly due to noise interference	<ul style="list-style-type: none"> <li>Review the list of possible solutions provided for controlling noise.</li> <li>Review the section on handling noise interference and check the control circuit lines, main circuit lines, and ground wiring.</li> </ul>
Load inertia is set incorrectly	<ul style="list-style-type: none"> <li>Check the load inertia settings when using KEB, overvoltage suppression, or Stall Prevention during deceleration.</li> <li>Adjust the load inertia ratio in L3-25 to better match the load.</li> </ul>
Motor hunting occurs	<ul style="list-style-type: none"> <li>Adjust the parameters that control hunting.</li> <li>Set the gain for Hunting Prevention (n1-02).</li> <li>Adjust the speed feedback detection suppression gain for PM motors (n8-45) and the time constant for pull-in current (n8-47).</li> </ul>

HOA Keypad Display	Fault Name
ov2	Overvoltage 2
	Bus voltage is boosted because the motor cable is too long.
Cause	Possible Solution
The wiring is too long	<ul style="list-style-type: none"> <li>Shorten the shielded motor cable</li> <li>Lower the carrier frequency</li> <li>Switch on the internal EMC filter if the power supply has a neutral ground</li> </ul>

HOA Keypad Display	Fault Name
PF	Input Phase Loss
	Drive input power has an open phase or has a large imbalance of voltage between phases. Detected when L8-05 is set 1 (enabled).
Cause	Possible Solution
There is phase loss in the drive input power	<ul style="list-style-type: none"> <li>Check for wiring errors in the main circuit drive input power.</li> <li>Correct the wiring.</li> </ul>
There is loose wiring in the drive input power terminals	<ul style="list-style-type: none"> <li>Ensure the terminals are tightened properly.</li> <li>Apply the tightening torque as specified in this manual. <i>Refer to Wire Gauges and Tightening Torque on page 83</i> for details.</li> </ul>
There is excessive fluctuation in the drive input power voltage	<ul style="list-style-type: none"> <li>Check the voltage from the drive input power.</li> <li>Review the possible solutions for stabilizing the drive input power.</li> </ul>
There is poor balance between voltage phases	Stabilize drive input power or disable phase loss detection.

The main circuit capacitors are worn	<ul style="list-style-type: none"> <li>• Check the maintenance time for the capacitors (U4-05).</li> <li>• Replace the capacitor if U4-05 is greater than 90%. For instructions on replacing the capacitor, contact Yaskawa or a Yaskawa representative.</li> </ul>
	Check for problems with the drive input power. If drive input power appears normal but the alarm continues to occur, replace either the control board or the entire drive. For instructions on replacing the control board, contact Yaskawa or a Yaskawa representative.

HOA Keypad Display	Fault Name
SEr	Too Many Speed Search Restarts
	The number of Speed Search restarts exceeded the value set to b3-19.
Cause	Possible Solution
Parameters related to Speed Search are set to the wrong values	<ul style="list-style-type: none"> <li>• Reduce the detection compensation gain during Speed Search (b3-10).</li> <li>• Increase the current level when attempting Speed Search (b3-17).</li> <li>• Increase the detection time during Speed Search (b3-18).</li> </ul>
The motor is coasting in the opposite direction of the Run command	Set b3-14 to 1 to enable Bi-Directional Speed Search.

HOA Keypad Display	Fault Name
STo	Motor Pull Out or Step Out Detection
	Motor pull out or step out has occurred. Motor has exceeded its pull-out torque.
Cause	Possible Solution
Load is too heavy	<ul style="list-style-type: none"> <li>• Increase the load inertia for PM motor (n8-55).</li> <li>• Increase the pull-in current during accel/decel (n8-51).</li> <li>• Reduce the load.</li> <li>• Increase the motor or drive capacity.</li> </ul>
Load inertia is too heavy	Increase the load inertia for PM motor (n8-55).
Acceleration and deceleration times are too short	<ul style="list-style-type: none"> <li>• Increase the acceleration and deceleration times (C1-01 to C1-04).</li> <li>• Increase the S-curve acceleration and deceleration times (C2-01).</li> </ul>
Speed response is too slow	Increase the load inertia for PM motor (n8-55).

HOA Keypad Display	Fault Name
TdE	Time Data Error
Cause	Possible Solution
An error has occurred in the Real-Clock Time function of the HOA keypad	Replace the HOA keypad. For instructions on replacing the HOA keypad, contact Yaskawa or your nearest sales representative.
A communication error has occurred with the Real-Clock Time function of the HOA keypad	

HOA Keypad Display	Fault Name
TIM	Time Not Set
Cause	Possible Solution
The Real-Time Clock for the HOA keypad is not set in parameter o4-17	Set the time for the HOA keypad. Parameter o4-17=1.
<ul style="list-style-type: none"> <li>• The drive is a new drive, first power-up condition</li> <li>• o4-17 was set to (2: Reset), by the user, manually clearing the Real-Time Clock data.</li> </ul>	<ul style="list-style-type: none"> <li>• For drive software PRG: 1012 and less, the drive will display the "TIM" alarm (Time Not Set) whenever the Real time Clock is not set.</li> <li>• For drive software PRG: 1013 and greater, the drive will display the "TIM" alarm (Time Not Set) whenever the Real time Clock is not set. Additionally, at power up, if the "TIM" condition is present, the drive will automatically switch to the time setting screen (o4-17=1) for 30 seconds to prompt the user to set the Real-Time Clock.</li> </ul>
The user did not set the Real Time Clock when prompted following power-up.	Cycle power to the drive and set the Real Time Clock within 30 seconds of power-up, or set the clock manually via parameter o4-17.
The HOA keypad battery is low or the battery has been replaced	Replace the HOA keypad battery and set the Real-Time Clock.
An error has occurred in the Real-Time Clock function of the HOA keypad	Replace the HOA keypad. For instructions on replacing the HOA keypad, contact Yaskawa or your nearest sales representative.

HOA Keypad Display	Fault Name
UL3	Undertorque Detection 1
	The current has fallen below the minimum value set for torque detection (L6-02) for longer than the allowable time (L6-03).

## 5.4 Fault Detection

Cause	Possible Solution
Parameter settings are not appropriate for the load	Check the settings of parameters L6-02 and L6-03.
There is a fault on the machine side	Check the load for any problems.

HOA Keypad Display	Fault Name
UL6	Motor Underload
	The weight of the load has fallen below the underload curve defined in L6-14.
Cause	Possible Solution
The output current has fallen below the motor underload curve defined in L6-14 for longer than the time set to L6-03	Adjust the value set to L6-14 so that output current remains above the motor underload curve during normal operation.

HOA Keypad Display	Fault Name
Uv1	DC Bus Undervoltage
	Voltage in the DC bus fell below the undervoltage detection level (L2-05). <ul style="list-style-type: none"> <li>For 200 V class drives: approximately 190 V</li> <li>For 400 V class drives: approximately 440 when using input voltages 460 V or higher (350 V when E1-01 is less than 400, and 380 V when <math>400V \leq E1-01 &lt; 460 V</math>)</li> </ul> The fault is output only if L2-01 is set to 0 or 1 and the DC bus voltage has fallen below the level set to L2-05 for longer than the time set to L2-02.
Cause	Possible Solution
Input power phase loss	<ul style="list-style-type: none"> <li>The main circuit drive input power is wired incorrectly.</li> <li>Correct the wiring.</li> </ul>
One of the drive input power wiring terminals is loose	<ul style="list-style-type: none"> <li>Ensure there are no loose terminals.</li> <li>Apply the tightening torque specified in this manual to fasten the terminals. <i>Refer to Wire Gauges and Tightening Torque on page 83</i> for details.</li> </ul>
There is a problem with the voltage from the drive input power	<ul style="list-style-type: none"> <li>Check the voltage.</li> <li>Correct the voltage to be within the range listed in drive input power specifications.</li> <li>If there is no problem with the power supply to the main circuit, check for problems with the main circuit magnetic contactor.</li> </ul>
The power has been interrupted	Correct the drive input power.
The main circuit capacitors are worn	<ul style="list-style-type: none"> <li>Check the maintenance time for the capacitors (U4-05).</li> <li>Replace either the control board or the entire drive if U4-05 exceeds 90%. For instructions on replacing the control board, contact Yaskawa or a Yaskawa representative.</li> </ul>
The relay or contactor on the soft-charge bypass circuit is damaged	<ul style="list-style-type: none"> <li>Cycle power to the drive and see if the fault reoccurs.</li> <li>If the problem continues, replace either the control board or the entire drive. For instructions on replacing the control board, contact Yaskawa or a Yaskawa representative.</li> <li>Check monitor U4-06 for the performance life of the soft-charge bypass.</li> <li>Replace either the control board or the entire drive if U4-06 exceeds 90%. For instructions on replacing the control board, contact Yaskawa or a Yaskawa representative.</li> </ul>

HOA Keypad Display	Fault Name
Uv2	Control Power Supply Voltage Fault
	Voltage is too low for the control drive input power.
Cause	Possible Solution
Internal circuitry is damaged	<ul style="list-style-type: none"> <li>Cycle power to the drive. Check if the fault reoccurs.</li> <li>If the problem continues, replace either the control board or the entire drive. For instructions on replacing the control board, contact Yaskawa or a Yaskawa representative.</li> </ul>

HOA Keypad Display	Fault Name
Uv3	Undervoltage 3 (Soft-Charge Circuit Fault)
	The soft-charge bypass circuit failed.
Cause	Possible Solution
The relay or contactor on the soft-charge bypass circuit is damaged	<ul style="list-style-type: none"> <li>Cycle power to the drive and see if the fault reoccurs.</li> <li>If the problem continues, replace either the control board or the entire drive. For instructions on replacing the control board, contact Yaskawa or a Yaskawa representative.</li> <li>Check monitor U4-06 for the performance life of the soft-charge bypass.</li> <li>Replace either the control board or the entire drive if U4-06 exceeds 90%. For instructions on replacing the control board, contact Yaskawa or a Yaskawa representative.</li> </ul>

HOA Keypad Display	Fault Name
voF	Output Voltage Detection Fault
	Problem detected with the voltage on the output side of the drive.
Cause	Possible Solution
Hardware is damaged	Replace the control board or the entire drive. For instructions on replacing the control board, contact Yaskawa or a Yaskawa representative.

## 5.5 Alarm Detection

### ◆ Alarm Codes, Causes, and Possible Solutions

Alarms are drive protection functions that do not necessarily cause the drive to stop. Once the cause of an alarm is removed, the drive will return to the same status it was before the alarm occurred.

When an alarm has been triggered, the ALM light on the HOA keypad display blinks and the alarm code display flashes. If a multi-function output is set for an alarm (H2-□□ = 10), that output terminal will be triggered.

**Note:** If a multi-function output is set to close when an alarm occurs (H2-□□ = 10), it will also close when maintenance periods are reached, triggering alarms LT-1 through LT-4 (triggered only if H2-□□ = 2F).

**Table 5.11 Alarm Codes, Causes, and Possible Solutions**

HOA Keypad Display	Minor Fault Name
bb	Baseblock
	Drive output interrupted as indicated by an external baseblock signal.
<b>Cause</b>	<b>Possible Solutions</b>
External baseblock signal was entered via one of the multi-function input terminals (S1 to S7)	Check external sequence and baseblock signal input timing.

HOA Keypad Display	Minor Fault Name
bUS	Option Communication Error
	<ul style="list-style-type: none"> <li>The connection was lost after initial communication was established.</li> <li>Assign a Run command frequency reference to the option.</li> </ul>
<b>Cause</b>	<b>Possible Solutions</b>
Connection is broken or master controller stopped communicating	<ul style="list-style-type: none"> <li>Check for faulty wiring.</li> <li>Correct the wiring.</li> <li>Check for disconnected cables and short circuits. Repair as needed.</li> </ul>
Option is damaged	If there are no problems with the wiring and the fault continues to occur, replace the option.
The option is not properly connected to the drive	<ul style="list-style-type: none"> <li>The connector pins on the option are not properly lined up with the connector pins on the drive.</li> <li>Reinstall the option.</li> </ul>
A data error occurred due to noise	<ul style="list-style-type: none"> <li>Check options available to minimize the effects of noise.</li> <li>Take steps to counteract noise in the control circuit wiring, main circuit lines and ground wiring.</li> <li>Try to reduce noise on the controller side.</li> <li>Use surge absorbers on magnetic contactors or other equipment causing the disturbance.</li> <li>Use recommended cables or some other type of shielded line. Ground the shield to the controller side or on the input power side.</li> <li>Separate the wiring for communication devices from the drive input power lines.</li> </ul>

HOA Keypad Display	Minor Fault Name
CALL	Serial Communication Transmission Error
	Communication has not yet been established.
<b>Cause</b>	<b>Possible Solutions</b>
Communications wiring is faulty, there is a short circuit, or something is not connected properly	<ul style="list-style-type: none"> <li>Check for wiring errors.</li> <li>Correct the wiring.</li> <li>Check for disconnected cables and short circuits. Repair as needed.</li> </ul>
Programming error on the master side	Check communications at start-up and correct programming errors.
Communications circuitry is damaged	<ul style="list-style-type: none"> <li>Perform a self-diagnostics check.</li> <li>If the problem continues, replace either the control board or the entire drive. For instructions on replacing the control board, contact Yaskawa or your nearest sales representative.</li> </ul>
Termination resistor setting is incorrect	Install a termination resistor at both ends of a communication line. Set the internal termination resistor switch correctly on slave drives. Place DIP switch S2 to the ON position.

HOA Keypad Display	Minor Fault Name
CE	MEMOBUS/Modbus Communication Error
	Control data was not received correctly for two seconds.
<b>Cause</b>	<b>Possible Solutions</b>

A data error occurred due to noise	<ul style="list-style-type: none"> <li>• Check options available to minimize the effects of noise.</li> <li>• Take steps to counteract noise in the control circuit wiring, main circuit lines, and ground wiring.</li> <li>• Reduce noise on the controller side.</li> <li>• Use surge absorbers for the magnetic contactors or other components that may be causing the disturbance.</li> <li>• Use only recommended shielded line. Ground the shield on the controller side or on the drive input power side.</li> <li>• Separate all wiring for communication devices from drive input power lines.</li> </ul>
Communication protocol is incompatible	<ul style="list-style-type: none"> <li>• Check the H5 parameter settings and the protocol setting in the controller.</li> <li>• Ensure settings are compatible.</li> </ul>
The CE detection time (H5-09) is set shorter than the time required for a communication cycle to take place	<ul style="list-style-type: none"> <li>• Check the PLC.</li> <li>• Change the software settings in the PLC.</li> <li>• Set a longer CE detection time using parameter H5-09.</li> </ul>
Incompatible PLC software settings or there is a hardware problem	<ul style="list-style-type: none"> <li>• Check the PLC.</li> <li>• Remove the cause of the error on the controller side.</li> </ul>
Communications cable is disconnected or damaged	<ul style="list-style-type: none"> <li>• Check the connector to make sure the cable has a signal.</li> <li>• Replace the communications cable.</li> </ul>

HOA Keypad Display	Minor Fault Name
CrST	Cannot Reset
<b>Cause</b>	<b>Possible Solutions</b>
Fault reset was being executed when a Run command was entered	<ul style="list-style-type: none"> <li>• Ensure that a Run command cannot be entered from the external terminals or option during fault reset.</li> <li>• Turn off the Run command.</li> </ul>

HOA Keypad Display	Minor Fault Name
dnE	Drive Disabled
<b>Cause</b>	<b>Possible Solutions</b>
“Drive Enable” is set to a multi-function contact input (H1-□□ = 6A) and that signal was switched off	Check the operation sequence.

HOA Keypad Display	Minor Fault Name
EF	Forward/Reverse Run Command Input Error
	Both forward run and reverse run closed simultaneously for longer than 0.5 s.
<b>Cause</b>	<b>Possible Solutions</b>
Sequence error	Check the forward and reverse command sequence and correct the problem. <b>Note:</b> When minor fault EF detected, motor ramps to stop.

HOA Keypad Display	Minor Fault Name
EF0	Option Card External Fault
	An external fault condition is present.
<b>Cause</b>	<b>Possible Solutions</b>
An external fault was received from the PLC with F6-03 set to 3, which allows the drive to continue running after an external fault occurs	<ul style="list-style-type: none"> <li>• Remove the cause of the external fault.</li> <li>• Remove the external fault input from the PLC.</li> </ul>
There is a problem with the PLC program	Check the PLC program and correct problems.

## 5.5 Alarm Detection

HOA Keypad Display	Minor Fault Name
EF1	External Fault (Input Terminal S1)
	External fault at multi-function input terminal S1.
EF2	External fault (input terminal S2)
	External fault at multi-function input terminal S2.
EF3	External fault (input terminal S3)
	External fault at multi-function input terminal S3.
EF4	External fault (input terminal S4)
	External fault at multi-function input terminal S4.
EF5	External fault (input terminal S5)
	External fault at multi-function input terminal S5.
EF6	External fault (input terminal S6)
	External fault at multi-function input terminal S6.
EF7	External fault (input terminal S7)
	External fault at multi-function input terminal S7.
<b>Cause</b>	<b>Possible Solutions</b>
An external device has tripped an alarm function	Remove the cause of the external fault and reset the multi-function input value.
Wiring is incorrect	<ul style="list-style-type: none"> <li>• Ensure the signal lines have been connected properly to the terminals assigned for external fault detection (H1-□□ = 20 to 2F).</li> <li>• Reconnect the signal line.</li> </ul>
Multi-function contact inputs are set incorrectly	<ul style="list-style-type: none"> <li>• Check if the unused terminals have been set for H1-□□ = 20 to 2F (External Fault).</li> <li>• Change the terminal settings.</li> </ul>

HOA Keypad Display	Minor Fault Name
FbH	Excessive PI Feedback
	The PI feedback input is higher than the level set to b5-36 for longer than the time set to b5-37, and b5-12 is set to 1 or 4.
<b>Cause</b>	<b>Possible Solutions</b>
Parameter settings for b5-36 and b5-37 are incorrect	Check parameters b5-36 and b5-37.
PI feedback wiring is faulty	Correct the wiring.
Feedback sensor has malfunctioned	Check the sensor and replace it if damaged.
Feedback input circuit is damaged	Replace either the control board or the entire drive. For instructions on replacing the control board, contact Yaskawa or your nearest sales representative.

HOA Keypad Display	Minor Fault Name
FbL	PI Feedback Loss
	The PI feedback input is lower than the level set to b5-13 for longer than the time set to b5-14, and b5-12 is set to 1 or 4.
<b>Cause</b>	<b>Possible Solutions</b>
Parameter settings for b5-13 and b5-14 are incorrect	Check parameters b5-13 and b5-14.
PI feedback wiring is faulty	Correct the wiring.
Feedback sensor has malfunctioned	Check the sensor and replace it if damaged.
Feedback input circuit is damaged	Replace either the control board or the entire drive. For instructions on replacing the control board, contact Yaskawa or your nearest sales representative.

HOA Keypad Display	Minor Fault Name
HCA	Current Alarm
	Drive current exceeded overcurrent warning level (150% of the rated current).
<b>Cause</b>	<b>Possible Solutions</b>
Load is too heavy	Reduce the load for applications with repetitive operations (i.e., stops and starts), or replace the drive.

Acceleration and deceleration times are too short	<ul style="list-style-type: none"> <li>Calculate the torque required during acceleration and for the inertia moment.</li> <li>If the torque level is not right for the load, take the following steps: <ul style="list-style-type: none"> <li>Increase the acceleration and deceleration times (C1-01 to C1-04).</li> <li>Increase the capacity of the drive.</li> </ul> </li> </ul>
A special-purpose motor is being used, or the drive is attempting to run a motor greater than the maximum allowable capacity	<ul style="list-style-type: none"> <li>Check the motor capacity.</li> <li>Use a motor appropriate for the drive. Ensure the motor is within the allowable capacity range.</li> </ul>
The current level increased due to Speed Search after a momentary power loss or while attempting to perform a fault restart	The alarm will only appear briefly. There is no need to take action to prevent the alarm from occurring in such instances.

HOA Keypad Display	Minor Fault Name
inTLK	Interlock Open ALM LED will not blink
<b>Cause</b>	<b>Possible Solutions</b>
BAS Interlock multi-function input is open	Check the cause of interlock.

HOA Keypad Display	Minor Fault Name
LT-1	Cooling Fan Maintenance Time The cooling fan has reached its expected maintenance period and may need to be replaced. <b>Note:</b> An alarm output (H2-□□ = 10) will only be triggered if both (H2-□□ = 2F and H2-□□ = 10) are set.
<b>Cause</b>	<b>Possible Solutions</b>
The cooling fan has reached 90% of its expected performance life	Replace the cooling fan and set o4-03 to 0 to reset the Maintenance Monitor.

HOA Keypad Display	Minor Fault Name
LT-2	Capacitor Maintenance Time The main circuit and control circuit capacitors are nearing the end of their expected performance life. <b>Note:</b> An alarm output (H2-□□ = 10) will only be triggered if H2-□□ = 2F.
<b>Cause</b>	<b>Possible Solutions</b>
The main circuit and control circuit capacitors have reached 90% of their expected performance lives	Replace either the control board or the entire drive. For instructions on replacing the control board, contact Yaskawa or your nearest sales representative.

HOA Keypad Display	Minor Fault Name
LT-3	Soft Charge Bypass Relay Maintenance Time The DC bus soft charge relay is nearing the end of its expected performance life. <b>Note:</b> An alarm output (H2-□□ = 10) will only be triggered if H2-□□ = 2F.
<b>Cause</b>	<b>Possible Solutions</b>
The DC bus soft charge relay has reached 90% of expected performance life	Replace either the control board or the entire drive. For instructions on replacing the control board, contact Yaskawa or your nearest sales representative.

HOA Keypad Display	Minor Fault Name
LT-4	IGBT Maintenance Time (50%) IGBTs have reached 50% of their expected performance life. <b>Note:</b> An alarm output (H2-□□ = 10) will only be triggered if H2-□□ = 2F.
<b>Cause</b>	<b>Possible Solutions</b>
IGBTs have reached 50% of their expected performance life	Check the load, carrier frequency, and output frequency.

HOA Keypad Display	Minor Fault Name
oH	Heatsink Overheat The temperature of the heatsink exceeded the overheat pre-alarm level set to L8-02 (90-100 °C). Default value for L8-02 is determined by drive capacity (o2-04).
<b>Cause</b>	<b>Possible Solutions</b>

## 5.5 Alarm Detection

Surrounding temperature is too high	<ul style="list-style-type: none"> <li>• Check the surrounding temperature.</li> <li>• Improve the air circulation within the enclosure panel.</li> <li>• Install a fan or air conditioner to cool surrounding area.</li> <li>• Remove anything near drive that may cause extra heat.</li> </ul>
Internal cooling fan has stopped	<ul style="list-style-type: none"> <li>• Replace the cooling fan.</li> <li>• After replacing the drive, set parameter o4-03 to 0 to reset the cooling fan operation time.</li> </ul>
Airflow around the drive is restricted	<ul style="list-style-type: none"> <li>• Provide proper installation space around the drive as indicated in the manual. <i>Refer to Installation Orientation and Spacing on page 43</i> for details.</li> <li>• Allow for the proper space and ensure that there is sufficient circulation around the control panel.</li> </ul>
	<ul style="list-style-type: none"> <li>• Check for dust or other foreign materials clogging the cooling fan.</li> <li>• Clear debris caught in the fan that restricts air circulation.</li> </ul>

HOA Keypad Display	Minor Fault Name
oH2	Drive Overheat Warning
	“Drive Overheat Warning” was input to a multi-function input terminal, S1 through S7 (H1-□□= B).
Cause	Possible Solutions
An external device triggered an overheat warning in the drive	Search for the device that tripped the overheat warning. Remove the cause of the problem.

HOA Keypad Display	Minor Fault Name
oH3	Motor Overheat
	The motor overheat signal entered to a multi-function analog input terminal exceeded the alarm level (H3-02 or H3-10 = E).
Cause	Possible Solutions
Motor thermostat wiring is faulty (PTC input).	Repair the PTC input wiring.
There is a fault on the machine side (e.g., the machine is locked up)	<ul style="list-style-type: none"> <li>• Check the status of the machine.</li> <li>• Remove the cause of the fault.</li> </ul>
Motor has overheated	<ul style="list-style-type: none"> <li>• Check the load size, accel/decel times, and cycle times.</li> <li>• Decrease the load.</li> <li>• Increase accel and decel times (C1-01 to C1-08).</li> <li>• Adjust the preset V/f pattern (E1-04 through E1-10). This involves reducing E1-08 and E1-10.</li> </ul> <p><b>Note:</b> Refrain from lowering E1-08 and E1-10 excessively to prevent a reduction in load tolerance at low speeds.</p> <ul style="list-style-type: none"> <li>• Check the motor-rated current.</li> <li>• Enter motor-rated current on motor nameplate (E2-01).</li> <li>• Ensure the motor cooling system is operating normally.</li> <li>• Repair or replace the motor cooling system.</li> </ul>

HOA Keypad Display	Minor Fault Name
oL3	Overtorque 1
	Drive output current was greater than L6-02 for longer than the time set to L6-03.
Cause	Possible Solutions
Inappropriate parameter settings	Check parameters L6-02 and L6-03.
There is a fault on the machine side (e.g., the machine is locked up)	<ul style="list-style-type: none"> <li>• Check the status of the machine.</li> <li>• Remove the cause of the fault.</li> </ul>

HOA Keypad Display	Minor Fault Name
ov	DC Bus Overvoltage
	The DC bus voltage exceeded the trip point.
	<ul style="list-style-type: none"> <li>• For 200 V class drives: approximately 410 V</li> <li>• For 400 V class drives: approximately 820 V (740 V when E1-01 is less than 400)</li> </ul>
Cause	Possible Solutions
Surge voltage present in the drive input power	<ul style="list-style-type: none"> <li>• Install an AC reactor.</li> <li>• Voltage surge can result from a thyristor convertor and a phase advancing capacitor operating on the same drive input power system.</li> </ul>

The motor is short-circuited	<ul style="list-style-type: none"> <li>• Check the motor power cable, relay terminals and motor terminal box for short circuits.</li> <li>• Correct grounding shorts and turn the power back on.</li> </ul>
Ground current has overcharged the main circuit capacitors via the drive input power	
Noise interference causes the drive to operate incorrectly	<ul style="list-style-type: none"> <li>• Review possible solutions for handling noise interference.</li> <li>• Review section on handling noise interference and check control circuit lines, main circuit lines and ground wiring.</li> <li>• If the magnetic contactor is identified as a source of noise, install a surge protector to the MC coil.</li> </ul>
	Set number of fault restarts (L5-01) to a value other than 0.

HOA Keypad Display	Minor Fault Name
PASS	MEMOBUS/Modbus Comm. Test Mode Complete
<b>Cause</b>	<b>Possible Solutions</b>
MEMOBUS/Modbus test has finished normally	This verifies that the test was successful.

HOA Keypad Display	Minor Fault Name
SAFE	Customer Safety
	Customer Safeties multi-function input is open. This alarm has display priority over the Interlock Open (inTLK).
<b>Cause</b>	<b>Possible Solutions</b>
External contact from customer wiring is open.	Check the cause of the open safety.

HOA Keypad Display	Minor Fault Name
SE	MEMOBUS/Modbus Communication Test Mode Error
	<b>Note:</b> This alarm will not trigger a multi-function output terminal that is set for alarm output (H2-□□ = 10).
<b>Cause</b>	<b>Possible Solutions</b>
A digital input set to 67H (MEMOBUS/Modbus test) was closed while the drive was running	Stop the drive and run the test again.

HOA Keypad Display	Minor Fault Name
TrPC	IGBT Maintenance Time (90%)
	IGBTs have reached 90% of their expected performance life.
<b>Cause</b>	<b>Possible Solutions</b>
IGBTs have reached 90% of their expected performance life	Replace the drive.

HOA Keypad Display	Minor Fault Name
UL3	Undertorque Detection 1
	Drive output current less than L6-02 for longer than L6-03 time.
<b>Cause</b>	<b>Possible Solutions</b>
Inappropriate parameter settings	Check parameters L6-02 and L6-03.
Load has dropped or decreased significantly	Check for broken parts in the transmission system.

HOA Keypad Display	Minor Fault Name
UL6	Undertorque Detection 6
	<b>Possible Solutions</b>
The load has dropped or decreased under the motor underload curve	Check parameters L6-13 and L6-14.

HOA Keypad Display	Minor Fault Name
Uv	Undervoltage
	One of the following conditions was true when the drive was stopped and a Run command was entered: <ul style="list-style-type: none"> <li>• DC bus voltage dropped below the level specified in L2-05.</li> <li>• Contactor to suppress inrush current in the drive was opened.</li> <li>• Low voltage in the control drive input power. This alarm outputs only if L2-01 is not 0 and DC bus voltage is under L2-05.</li> </ul>
<b>Cause</b>	<b>Possible Solutions</b>

## 5.5 Alarm Detection

Phase loss in the drive input power	Check for wiring errors in the main circuit drive input power. Correct the wiring.
Loose wiring in the drive input power terminals	<ul style="list-style-type: none"> <li>• Ensure the terminals have been properly tightened.</li> <li>• Apply the tightening torque to the terminals as specified. <i>Refer to Wire Gauges and Tightening Torque on page 83.</i></li> </ul>
There is a problem with the drive input power voltage	<ul style="list-style-type: none"> <li>• Check the voltage.</li> <li>• Lower the voltage of the drive input power so that it is within the limits listed in the specifications.</li> </ul>
Drive internal circuitry is worn	<ul style="list-style-type: none"> <li>• Check the maintenance time for the capacitors (U4-05).</li> <li>• Replace either the control board or the entire drive if U4-05 exceeds 90%. For instructions on replacing the control board, contact Yaskawa or your nearest sales representative.</li> </ul>
The drive input power transformer is too small and voltage drops when the power is switched on	<ul style="list-style-type: none"> <li>• Check for an alarm when the magnetic contactor, line breaker, and leakage breaker are closed.</li> <li>• Check the capacity of the drive input power transformer.</li> </ul>
Air inside the drive is too hot	Check the temperature inside the drive.
The CHARGE light is broken or disconnected	Replace either the control board or the entire drive. For instructions on replacing the control board, contact Yaskawa or your nearest sales representative.

HOA Keypad Display	Minor Fault Name
voF	Output Voltage Detection Fault
	There is a problem with the output voltage.
Cause	Possible Solutions
Hardware is damaged	Replace either the control board or the entire drive. For instructions on replacing the control board, contact Yaskawa or your nearest sales representative.

HOA Keypad Display	Minor Fault Name
WrUn	Waiting for Run
	A Run command has been issued and the drive is waiting to begin running the motor.
Cause	Possible Solutions
After a Run command has been entered, the drive must wait for the time set to b1-11 to pass before it can begin to operate the motor	This is not an error.

## 5.6 Programming Errors

### ◆ Programming Error Codes, Causes, and Possible Solutions

A Programming Error (oPE) occurs when a contradictory parameter is set or an individual parameter is set to an inappropriate value.

The drive will not operate until the parameter or parameters causing the problem are set correctly. An oPE, however, does not trigger an alarm or fault output. If an oPE occurs, investigate the cause and refer to [Table 5.12](#) for the appropriate action. When an oPE appears on the HOA keypad display, press the ENTER button to view U1-18 and see which parameter is causing the oPE.

**Table 5.12 oPE Codes, Causes, and Possible Solutions**

HOA Keypad Display	Error Name
oPE01	Drive Capacity Setting Fault
	Drive capacity and the value set to o2-04 do not match.
<b>Cause</b>	<b>Possible Solutions</b>
The drive model selection (o2-04) and the actual capacity of the drive are not the same	Correct the value set to o2-04.
HOA Keypad Display	Error Name
oPE02	Parameter Range Setting Error
	Use U1-18 to find parameters set outside the range.
<b>Cause</b>	<b>Possible Solutions</b>
Parameters were set outside the possible setting range	Set parameters to the proper values.
<b>Note:</b> When multiple errors occur simultaneously, other errors are given precedence over oPE02	
HOA Keypad Display	Error Name
oPE03	Multi-Function Input Selection Error
	A contradictory setting is assigned to multi-function contact inputs H1-01 to H1-07.
<b>Cause</b>	<b>Possible Solutions</b>
<ul style="list-style-type: none"> <li>The same function is assigned to two multi-function inputs</li> <li>Excludes “Not used” and “External Fault”</li> </ul>	<ul style="list-style-type: none"> <li>Ensure all multi-function inputs are assigned to different functions.</li> <li>Re-enter the multi-function settings to ensure this does not occur.</li> </ul>
The Up command was set but the Down command was not, or vice versa (settings 10 vs. 11)	Properly set the functions that required for use in combination with other functions.
<ul style="list-style-type: none"> <li>Run/Stop command for a 2-wire sequence was set (H1-□□ = 42), but Forward/Reverse command (H1-□□ = 43) was not</li> <li>“Drive Enable” is set to multi-function input S1 or S2 (H1-01 = 6A or H1-02 = 6A)</li> </ul>	Properly set the functions that required for use in combination with other functions.
Two of the following functions are set simultaneously: <ul style="list-style-type: none"> <li>Up/Down Command (10 vs. 11)</li> <li>Hold Accel/Decel Stop (A)</li> <li>Analog Frequency Reference Sample/Hold (1E)</li> <li>Offset Frequency 1, 2, 3 Calculations (44, 45, 46)</li> </ul>	<ul style="list-style-type: none"> <li>Check if contradictory settings have simultaneously been assigned to the multi-function input terminals.</li> <li>Correct setting errors.</li> </ul>
The Up/Down command (10, 11) and PI control (b5-01) are enabled simultaneously	Set b5-01 to 0 to disable control PI or disable the Up/Down command.

## 5.6 Programming Errors

<p>Settings for N.C. and N.O. input for the following functions were selected simultaneously:</p> <ul style="list-style-type: none"> <li>External Search Command 1 and External Search Command 2 (61 vs. 62)</li> <li>Fast Stop N.O. and Fast Stop N.C. (15 vs. 17)</li> <li>KEB for Momentary Power Loss and High Slip Braking (65, 66, 7A, 7B vs. 68)</li> <li>KEB Command 1 and KEB Command 2 (65, 66 vs. 7A, 7B)</li> <li>FWD Run Command (or REV) and FWD/REV Run Command (2-wire) (40, 41 vs. 42, 43)</li> <li>Drive Enable (60 vs. 6A)</li> </ul>	<ul style="list-style-type: none"> <li>Check if contradictory settings have simultaneously been assigned to the multi-function input terminals.</li> <li>Correct setting errors.</li> </ul>
<p>One of the following settings was entered while H1-□□ = 2 (External Reference 1/2):</p> <ul style="list-style-type: none"> <li>b1-15 = 4 (Pulse Train Input) but the pulse train input selection is not set for the frequency reference (H6-01 &gt; 0)</li> <li>b1-15 or b1-16 set to 3 but no option card is connected</li> <li>Although b1-15 = 1 (Analog Input) and H3-02 or H3-10 are set to 0 (Frequency Bias)</li> </ul>	Correct the settings for the multi-function input terminal parameters.
H2-□□ is set to 38 (Drive Enabled) and H1-□□ is not set to 6A (Drive Enable)	

HOA Keypad Display	Error Name
oPE05	Run Command/Frequency Reference Source Selection Error
<b>Cause</b>	<b>Possible Solutions</b>
Frequency reference is assigned to an option card (b1-01 = 3) and an input option card is not connected to the drive	Reconnect the input option card to the drive.
The Run command is assigned to an option card (b1-02 = 3) and an input option card is not connected to the drive	

HOA Keypad Display	Error Name
oPE07	Multi-Function Analog Input Selection Error
<b>Cause</b>	A contradictory setting is assigned to multi-function analog inputs H3-02 or H3-10 and PI functions conflict.
At least two analog input terminals are set to the same function (i.e., at least two of these parameters have the same setting: H3-02 or H3-10)	Change the settings to H3-02 and H3-10 so that functions no longer conflict.
The following simultaneous contradictory settings: H3-02 or H3-10 = C (PI Target Value) while b5-18 = 1 (enables b5-19 as the target PI value)	<b>Note:</b> Both 0 (Frequency Reference Bias) and F (Not Used) can be set to H3-02 and H3-10 simultaneously.
	Disable one of the PI selections.

HOA Keypad Display	Error Name
oPE08	Parameter Selection Error
<b>Cause</b>	A function has been set that cannot be used in the motor control method selected.
In OLV/PM, parameters E5-02 to E5-07 are set to 0	<b>Possible Solutions</b>
The following settings have occurred in OLV/PM: <ul style="list-style-type: none"> <li>E5-03 does not equal 0</li> <li>E5-09 and E5-24 are both equal to 0, or neither equals 0</li> </ul>	<ul style="list-style-type: none"> <li>When using a special-purpose motor, set E5-□□ in accordance with the test report provided.</li> <li>Set E5-09 or E5-24 to the correct value, and set the other to 0.</li> <li>Set the motor rated current for PM to 0 (E5-03).</li> </ul>
<b>Note:</b>	Use U1-18 to find parameters that are set outside the specified setting range. When multiple errors occur simultaneously, other errors are given precedence over oPE08.

HOA Keypad Display	Error Name
oPE09	PI Control Selection Fault
	PI control function selection is incorrect. Requires that PI control is enabled (b5-01 = 1 or 3).
<b>Cause</b>	<b>Possible Solutions</b>
The following simultaneous contradictory settings have occurred: <ul style="list-style-type: none"> <li>b5-15 is not set to 0.0 (PI Sleep Function Operation Level)</li> <li>The stopping method is set to either DC Injection Braking or coast to stop with a timer (b1-03 = 2 or 3)</li> </ul>	<ul style="list-style-type: none"> <li>Set b5-15 to a value other than 0.0.</li> <li>Set the stopping method to coast to stop or ramp to stop (b1-03 = 0 or 1).</li> </ul>
b5-01 is set to 1, enabling PI control, but the lower limit for the frequency reference (d2-02) is not set to 0 while reverse output is enabled (b5-11 = 1)	Correct the parameter settings.
b5-01 is set to 3, enabling PI control, but the lower limit for the frequency reference (d2-01) is not 0	Correct the parameter settings.

HOA Keypad Display	Error Name
oPE10	V/f Data Setting Error
	One of the following setting errors has occurred: E1-04 $\geq$ E1-06 E1-06 $\geq$ E1-07 E1-07 $\geq$ E1-09 or E1-09 $\geq$ E1-11
<b>Cause</b>	<b>Possible Solutions</b>
V/f pattern setting error	Correct the settings for E1-04, E1-06, E1-07, E1-09, and E1-11.

HOA Keypad Display	Error Name
oPE11	Carrier Frequency Setting Error
	Correct the setting for the carrier frequency.
<b>Cause</b>	<b>Possible Solutions</b>
The following simultaneous contradictory settings have occurred: C6-05 > 6 and C6-04 > C6-03 (carrier frequency lower limit is greater than the upper limit) If C6-05 $\leq$ 6, the drive operates at C6-03	Correct the parameter settings.
The upper and lower limits between C6-02 and C6-05 are contradictory	

HOA Keypad Display	Error Name
oPE16	Energy Saving Constants Error
<b>Cause</b>	<b>Possible Solutions</b>
The following contradictory settings are true: A1-02 = 0, S1-01 = 1, and b8-01 = 1	Correct the parameter settings.

## 5.6 Programming Errors

HOA Keypad Display	Error Name
oPE27	BP Program Error
	Bypass mode is not correctly configured.
<b>Cause</b>	<b>Possible Solutions</b>
If digital inputs A4, A5, or A7 or digital outputs A4 or A5 are programmed, then all must be programmed	Correct the parameter settings.
Digital inputs A4, A5, or A7 and digital outputs A4 or A5 are programmed and one of the following conditions is true: <ul style="list-style-type: none"> <li>• H1-0□ = 0 (3-Wire Sequence)</li> <li>• L5-01 &gt; 0 and S4-01 = 1 (Auto Transfer of Fault)</li> <li>• H1-□□ ≤ A6 and H2-□□ = A6</li> <li>• H1-□□ = A6 and H2-□□ ≤ A6</li> </ul>	
HOA Keypad Display	Error Name
oPE28	Sequence Timer Error
	One or more of the sequence timers is not set in the correct order.
<b>Cause</b>	<b>Possible Solutions</b>
One of the following contradictory settings is true: <ul style="list-style-type: none"> <li>• S2-01 &gt; S2-02</li> <li>• S2-06 &gt; S2-07</li> <li>• S2-11 &gt; S2-12</li> <li>• S2-16 &gt; S2-17</li> </ul>	Correct the parameter settings.

## 5.7 Auto-Tuning Fault Detection

Auto-Tuning faults in this section are displayed on the digital operator and will cause the motor to coast to a stop. Auto-Tuning faults do not trigger a multi-function digital output set for fault or alarm output.

An End□ error on the digital operator display indicates Auto-Tuning has successfully completed with discrepancies in the calculations. Check the cause of the End□ error using the tables in this section and perform Auto-Tuning again after fixing the cause.

The drive may be used in the application if no cause can be identified despite the existence of an End□ error.

An Er□ error indicates that Auto-Tuning has not completed successfully. Check for the cause of the error using the tables in this section, and perform Auto-Tuning again after fixing the cause.

### ◆ Auto-Tuning Codes, Causes, and Possible Solutions

Table 5.13 Auto-Tuning Codes, Causes, and Possible Solutions

HOA Keypad Display	Error Name
End3	Rated Current Setting Alarm (displayed after Auto-Tuning is complete)
<b>Cause</b>	<b>Possible Solutions</b>
The correct current rating printed on the motor nameplate was not entered into T1-04	<ul style="list-style-type: none"> <li>• Check the setting of parameter T1-04.</li> <li>• Check the motor data and repeat Auto-Tuning.</li> </ul>
HOA Keypad Display	Error Name
End4	Adjusted Slip Calculation Error
<b>Cause</b>	<b>Possible Solutions</b>
The calculated slip is outside the allowable range	Make sure the data entered for Auto-Tuning is correct.
HOA Keypad Display	Error Name
End5	Resistance Tuning Error
<b>Cause</b>	<b>Possible Solutions</b>
The calculated resistance value is outside the allowable range	<ul style="list-style-type: none"> <li>• Double-check the data entered for the Auto-Tuning process.</li> <li>• Check the motor and motor cable connection for faults.</li> </ul>
HOA Keypad Display	Error Name
End7	No-Load Current Alarm
<b>Cause</b>	<b>Possible Solutions</b>
The entered no-load current value was outside the allowable range	Check and correct faulty motor wiring.
Auto-Tuning results were less than 5% of the motor rated current	Double-check the data entered for the Auto-Tuning process.
HOA Keypad Display	Error Name
Er-01	Motor Data Error
<b>Cause</b>	<b>Possible Solutions</b>
Motor data or data entered during Auto-Tuning was incorrect	<ul style="list-style-type: none"> <li>• Check that the motor data entered to T1 parameters matches motor nameplate input before Auto-Tuning.</li> <li>• Restart Auto-Tuning and enter the correct information.</li> </ul>
Motor output power and motor-rated current settings (T1-02 and T1-04) do not match	<ul style="list-style-type: none"> <li>• Check the drive and motor capacities.</li> <li>• Correct the settings of parameters T1-02 and T1-04.</li> </ul>
Motor rated current and detected no-load current are inconsistent	<ul style="list-style-type: none"> <li>• Check the motor rated current and no-load current.</li> <li>• Correct the settings of parameters T1-04 and E2-03.</li> </ul>
Base frequency and motor rated speed (T1-05 and T1-07) do not match	<ul style="list-style-type: none"> <li>• Correct the settings of parameters T1-05 and T1-07.</li> <li>• Check that the correct number of poles were entered to T1-06.</li> </ul>
HOA Keypad Display	Error Name
Er-02	Minor Fault
<b>Cause</b>	<b>Possible Solutions</b>
An alarm was triggered during Auto-Tuning	Exit the Auto-Tuning menu, check the alarm code, remove the alarm cause, and repeat Auto-Tuning.

## 5.7 Auto-Tuning Fault Detection

HOA Keypad Display	Error Name
Er-03	OFF Button Input
Cause	Possible Solutions
Auto-Tuning canceled by pressing the OFF button	Auto-Tuning did not complete properly. Restart Auto-Tuning.

HOA Keypad Display	Error Name
Er-04	Line-to-Line Resistance Error
Cause	Possible Solutions
Motor data entered during Auto-Tuning was incorrect	<ul style="list-style-type: none"> <li>Make sure the data entered to the T1 parameters match the information written on the motor nameplate.</li> <li>Restart Auto-Tuning and enter the correct information.</li> </ul>
Results from Auto-Tuning are outside the parameter setting range or the tuning process took too long	Check and correct faulty motor wiring.
Faulty motor cable or cable connection	

HOA Keypad Display	Error Name
Er-05	No-Load Current Error
Cause	Possible Solutions
Motor data entered during Auto-Tuning was incorrect	<ul style="list-style-type: none"> <li>Make sure the data entered to the T1 parameters match the information written on the motor nameplate.</li> <li>Restart Auto-Tuning and enter the correct information.</li> </ul>
Results from Auto-Tuning are outside the parameter setting range or the tuning process took too long	Check and correct faulty motor wiring.

HOA Keypad Display	Error Name
Er-08	Rated Slip Error
Cause	Possible Solutions
Motor data entered during Auto-Tuning was incorrect	<ul style="list-style-type: none"> <li>Make sure the data entered to the T1 parameters match the information written on the motor nameplate.</li> <li>Restart Auto-Tuning and enter the correct information.</li> </ul>
Results from Auto-Tuning are outside the parameter setting range or the tuning process took too long	Check and correct faulty motor wiring.

HOA Keypad Display	Error Name
Er-09	Acceleration Error
Cause	Possible Solutions
The motor did not accelerate for the specified acceleration time	<ul style="list-style-type: none"> <li>Increase the acceleration time (C1-01).</li> <li>Disconnect the machine from the motor if possible.</li> </ul>

HOA Keypad Display	Error Name
Er-12	Current Detection Error
Cause	Possible Solutions
One of the motor phases is missing: (U/T1, V/T2, W/T3)	Check motor wiring and correct any problems.
The current exceeded the current rating of the drive	<ul style="list-style-type: none"> <li>Check motor wiring for a short between motor lines.</li> <li>Close any magnetic contactors used between motors.</li> <li>Replace the control board or the entire drive. For instructions on replacing the control board, contact Yaskawa or your nearest sales representative.</li> </ul>
The current is too low	
Attempted Auto-Tuning without motor connected to the drive	Connect the motor and restart Auto-Tuning.
Current detection signal error	Replace the control board or the entire drive. For instructions on replacing the control board, contact Yaskawa or your nearest sales representative.

## 5.8 Copy Function Related Displays

### ◆ Tasks, Errors, and Troubleshooting

The table below lists the messages and errors that may appear when using the Copy function.

When executing the tasks offered by the Copy function, the HOA keypad will indicate the task being performed. When an error occurs, a code appears on the HOA keypad to indicate the error. Note that errors related to the Copy function do not trigger a multi-function output terminal that has been set up to close when a fault or alarm occurs. Press any key on the HOA keypad to clear an error; the error display will disappear.

**Table 5.14** lists the corrective action that can be taken when an error occurs.

- Note:**
1. Whenever using the copy function, the drive should be fully stopped.
  2. The drive will not accept a Run command while the Copy function is being executed.
  3. Parameters can only be saved to a drive when the voltage class, capacity, control mode, and software version match.

**Table 5.14 Copy Function Task and Error Displays**

HOA Keypad Display	Task
CoPy	Writing Parameter Settings (flashing)
Cause	Possible Solutions
Parameters are being written to the drive.	This is not an error.
HOA Keypad Display	Error
CPEr	Control Mode Mismatch
Cause	Possible Solutions
Control mode of the parameters to be loaded onto the drive and the control mode set to the drive do not match.	<ul style="list-style-type: none"> <li>• Verify the control mode for the parameters to be loaded onto the drive and the control mode on drive to which those parameters will be written.</li> <li>• Set the same control mode using parameter A1-02 and retry.</li> </ul>
HOA Keypad Display	Error
CPyE	Error Writing Data
Cause	Possible Solutions
Failed writing parameters	Attempt to write parameters again.
HOA Keypad Display	Error
CSEr	Copy Unit Error
Cause	Possible Solutions
Hardware fault	Replace the operator or the USB Copy Unit.
HOA Keypad Display	Error
dFPS	Drive Model Mismatch
Cause	Possible Solutions
The drives used in the copy and write process are not the same model. <ul style="list-style-type: none"> <li>• The drive from which the parameters were copied is a different model.</li> <li>• The drive to be written to is a different model.</li> </ul>	<ul style="list-style-type: none"> <li>• Verify the model number of the drive from which the parameters were copied and the model of the drive to which those parameters will be written.</li> <li>• Make sure the two drives are the same model and have the same software version.</li> </ul>
HOA Keypad Display	Task
End	Task Complete
Cause	Possible Solutions
Finished reading, writing, or verifying parameters.	This is not an error.
HOA Keypad Display	Error
iFEr	Communication Error
Cause	Possible Solutions
A communication error occurred between the drive and the operator or the USB copy unit.	Check the cable connection.

## 5.8 Copy Function Related Displays

A non-compatible cable is being used to connect the USB Copy Unit and the drive.	Use the cable originally packaged with the USB Copy Unit.
<b>HOA Keypad Display</b>	<b>Error</b>
ndAT	Model, Voltage Class, Capacity Mismatch
<b>Cause</b>	<b>Possible Solutions</b>
The drive from which the parameters were copied and the drive to which the parameters will be written have different electrical specifications, capacities, are set to different control modes, or are different models.	Make sure model numbers and specifications are the same for both drives.
The device being used to write the parameters is blank and does not have any parameters saved on it.	Make sure all connections are correct, and copy the parameter settings onto the USB Copy Unit or the operator.
<b>HOA Keypad Display</b>	<b>Error</b>
rdEr	Error Reading Data
<b>Cause</b>	<b>Possible Solutions</b>
Failed while attempting to read parameter settings from the drive.	Press and hold the READ key on the USB Copy Unit for at least one second to have the unit read parameters from the drive.
<b>HOA Keypad Display</b>	<b>Task</b>
rEAd	Reading Parameter Settings (flashing)
<b>Cause</b>	<b>Possible Solutions</b>
Displayed while the parameter settings are being read onto the USB Copy Unit.	This is not an error.
<b>HOA Keypad Display</b>	<b>Error</b>
vAEr	Voltage Class, Capacity Mismatch
<b>Cause</b>	<b>Possible Solutions</b>
The drive from which the parameters were copied and the drive on which the Verify mode is being performed have different electrical specifications or are a different capacity.	Make sure electrical specifications and capacities are the same for both drives.
<b>HOA Keypad Display</b>	<b>Error</b>
vFyE	Parameter settings in the drive and those saved to the copy function are not the same
<b>Cause</b>	<b>Possible Solutions</b>
Indicates that the parameter settings that have been Read and loaded onto the Copy Unit or HOA Keypad are different.	To synchronize parameters, either write the parameters saved on the USB Copy Unit or HOA keypad onto the drive, or Read the parameter settings on the drive onto the USB Copy Unit.
<b>HOA Keypad Display</b>	<b>Task</b>
vrFy	Comparing Parameter Settings (flashing)
<b>Cause</b>	<b>Possible Solutions</b>
The Verify mode has confirmed that parameters settings on the drive and parameters read to the copy device are identical.	This is not an error.

## 5.9 Diagnosing and Resetting Faults

When a fault occurs and the drive stops, follow the instructions below to remove whatever conditions triggered the fault, then restart the drive.

**Note:** An oC/SC fault will be displayed in the event of an IGBT failure. It may not be possible to reset this fault until the IGBT problem is corrected.

### ◆ Fault Occurs Simultaneously with Power Loss

**WARNING!** *Electrical Shock Hazard. Ensure there are no short circuits between the main circuit terminals (R/L1, S/L2, and T/L3) or between the ground and main circuit terminals before restarting the drive. Failure to comply may result in serious injury or death and will cause damage to equipment.*

1. Turn on the drive input power.
2. Use monitor parameters U2-□□ to display data on the operating status of the drive just before the fault occurred.
3. Remove the cause of the fault and reset.

**Note:**

1. To find out what faults were triggered, check the fault history in U2-02. Information on drive status when the fault occurred such as the frequency, current, and voltage can be found in U2-03 through U2-32. [Refer to Viewing Fault Trace Data After Fault on page 233](#) for information on how to view fault data.
2. When the fault continues to be displayed after cycling power, remove the cause of the fault and reset.

### ◆ If the Drive Still has Power After a Fault Occurs



1. Look at the HOA keypad for information on the fault that occurred.
2. [Refer to Fault Displays, Causes, and Possible Solutions on page 205.](#)
3. Reset the fault. [Refer to Fault Reset Methods on page 234.](#)

### ◆ Viewing Fault Trace Data After Fault

Step		Display/Result
1. Turn on the drive input power. The first screen displays.	→	
2. Press  or  until the monitor screen is displayed.	→	
3. Press  to display the parameter setting screen.	→	
4. Press  and  to scroll to monitor U2-02. The fault code shown in U2-02 is the fault that occurred most recently.	→	
5. Press  to view drive status information when fault occurred. Parameters U2-03 through U2-32 help determine the cause of a fault. Parameters to be monitored differ depending on the control mode.	→	

### ◆ Fault Reset Methods

When a fault occurs, the cause of the fault must be removed and the drive must be restarted. The table below lists the different ways to restart the drive.

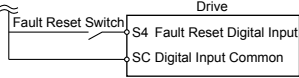
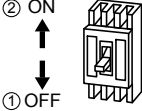
After the Fault Occurs	Procedure	
Fix the cause of the fault, restart the drive, and reset the fault	Press  on the HOA keypad.	
Resetting via Fault Reset Digital Input S4	Close then open the fault signal digital input via terminal S4. S4 is set for "Fault Reset" as default (H1-04 = 14).	
Turn off the main power supply if the above methods do not reset the fault. Reapply power after the HOA keypad display has turned off. When an "SC" error occurs, contact Yaskawa or a Yaskawa agent before cycling the power to the drive.		

**Note:** If the Run command is present, the drive will disregard any attempts to reset the fault. Remove the Run command before attempting to clear a fault situation.

## 5.10 Troubleshooting without Fault Display

This section describes troubleshooting problems that do not trip an alarm or fault.

The following symptoms indicate that the drive is not set correctly for proper performance with the motor. *Refer to Motor Performance Fine-Tuning on page 198* for guidance on troubleshooting.

- Motor hunting and oscillation
- Poor motor torque
- Poor speed precision
- Poor motor torque and speed response
- Motor noise



### ◆ Common Problems

Common Problems		Page
Cannot Change Parameter Settings		235
Motor Does Not Rotate Properly after Pressing the AUTO Button or after Entering External Run Command	Motor Does Not Rotate	236
	Motor Rotates in the Opposite Direction from the Run Command	237
	Motor Rotates in One Direction Only	237
Motor is Too Hot		237
oPE02 Error Occurs When Lowering the Motor Rated Current Setting		238
Motor Stalls During Acceleration or With Large Loads		238
Drive Frequency Reference Differs from the Controller Frequency Reference Command		239
Excessive Motor Oscillation and Erratic Rotation		239
Deceleration Takes Longer Than Expected		239
Noise From Drive or Motor Cables When the Drive is Powered On		239
Ground Fault Circuit Interrupter (GFCI) Trips During Run		239
Connected Machinery Vibrates When Motor Rotates	Unexpected Noise from Connected Machinery	240
	Oscillation or Hunting	240
PI Output Fault		240
Motor Rotates After the Drive Output is Shut Off (Motor Rotates During DC Injection Braking)		240
Output Frequency is not as High as Frequency Reference		241
Sound from Motor		241
Unstable Motor Speed when Using PM		241
Motor Does Not Restart after Power Loss		241

### ◆ Cannot Change Parameter Settings



Cause	Possible Solutions
The drive is running the motor (i.e., the Run command is present).	<ul style="list-style-type: none"> <li>• Stop the drive and switch over to the Programming Mode.</li> <li>• Most parameters cannot be edited during run.</li> </ul>
The Access Level is set to restrict access to parameter settings.	<ul style="list-style-type: none"> <li>• Set the Access Level to allow parameters to be edited (A1-01 = 2).</li> </ul>
The operator is not in the Parameter Setup Mode (the screen will display “PAR”).	<ul style="list-style-type: none"> <li>• See what mode the operator is currently set for.</li> <li>• Parameters cannot be edited when in the Setup Mode (“STUP”). Switch modes so that “PAR” appears on the screen. <i>Refer to The Drive, Programming, and Clock Adjustment Modes on page 112.</i></li> </ul>
A multi-function contact input terminal is set to allow or restrict parameter editing (H1-01 through H1-07 = 1B).	<ul style="list-style-type: none"> <li>• When the terminal is open, parameters cannot be edited.</li> <li>• Turn on the multi-function contact input set to 1B.</li> </ul>



## 5.10 Troubleshooting without Fault Display

Cause	Possible Solutions
The wrong password was entered.	<ul style="list-style-type: none"> <li>If the password entered to A1-04 does not match the password saved to A1-05, then drive settings cannot be changed.</li> <li>Reset the password.</li> </ul> <p>If you cannot remember the password:</p> <ul style="list-style-type: none"> <li>Scroll to A1-04. Press  and  simultaneously. Parameter A1-05 will appear.</li> <li>Set a new password to parameter A1-05.</li> </ul>
Undervoltage was detected.	<ul style="list-style-type: none"> <li>Check the drive input power voltage by looking at the DC bus voltage (U1-07).</li> <li>Check all main circuit wiring.</li> </ul>

### ◆ Motor Does Not Rotate Properly after Pressing AUTO Button or after Entering External Run Command

#### ■ Motor Does Not Rotate

Cause	Possible Solutions
The drive is not in the Drive Mode.	<ul style="list-style-type: none"> <li>Check if the DRV light on the HOA keypad is lit.</li> <li>Enter the Drive Mode to begin operating the motor. <i>Refer to The Drive, Programming, and Clock Adjustment Modes on page 112.</i></li> </ul>
 was pressed.	<p>Stop the drive and check if the correct frequency reference source is selected. If the operator keypad shall be the source, the LO/RE button LED must be on. If the source is REMOTE, it must be off.</p> <p>Take the following steps to solve the problem:</p> <ul style="list-style-type: none"> <li>Press .</li> </ul>
Auto-Tuning has just completed.	<ul style="list-style-type: none"> <li>When Auto-Tuning completes, the drive is switched back to the Programming Mode. The Run command will not be accepted unless the drive is in the Drive Mode.</li> <li>Use the HOA keypad to enter the Drive Mode. <i>Refer to The Drive, Programming, and Clock Adjustment Modes on page 112.</i></li> </ul>
A Fast Stop was executed and has not yet been reset.	Reset the Fast Stop command.
Settings are incorrect for the source that provides the Run command.	<p>Check parameter b1-02 (Run Command Selection). Set b1-02 so that it corresponds with the correct Run command source.</p> <p>0: HOA keypad 1: Control circuit terminal (default setting) 2: MEMOBUS/Modbus communications 3: Option card</p>
There is faulty wiring in the control circuit terminals.	<ul style="list-style-type: none"> <li>Check the wiring for the control terminal.</li> <li>Correct wiring mistakes.</li> <li>Check the input terminal status monitor (U1-10).</li> </ul>
The drive has been set to accept the frequency reference from the incorrect source.	<p>Check parameter b1-01 (Frequency Reference Selection 1). Set b1-01 to the correct source of the frequency reference.</p> <p>0: HOA keypad 1: Control circuit terminal (default setting) 2: MEMOBUS/Modbus communications 3: Option card</p>
The terminal set to accept the main speed reference is set to the incorrect voltage and/or current.	If the frequency reference is set at terminal A1, check parameter H3-01 for the correct signal level selection. If terminal A2 is used, check parameter H3-09. <i>Refer to Input Signal Selection for Terminals A1 and A2 on page 100.</i>
Selection for the sink/source mode and the internal/external power supply is incorrect.	Check wire jumper connection between terminals SC and SP. <i>Refer to Sinking/Sourcing Mode Switch for Digital Inputs on page 100.</i>
Frequency reference is too low.	<ul style="list-style-type: none"> <li>Check the frequency reference monitor (U1-01).</li> <li>Increase the frequency by changing the maximum output frequency (E1-09).</li> </ul>
Multi-function analog input is set up to accept gain for the frequency reference, but no voltage (current) has been provided.	<ul style="list-style-type: none"> <li>Check the multi-function analog input settings.</li> <li>Check if analog inputs A1 or A2 are set for frequency reference gain (H3-02, H3-10 = 1). If so, check if the correct signal is applied to the terminal. The gain and the frequency reference will be 0 if no signal is applied to the gain input.</li> <li>Check if H3-02 and H3-10 have been set to the proper values.</li> <li>Check if the analog input value has been set properly. (U1-13 and U1-14)</li> </ul>

Cause	Possible Solutions
 was pressed when the drive was started from a REMOTE source.	<ul style="list-style-type: none"> <li>Pressing  will decelerate the drive to stop.</li> <li>Switch off the Run command and then re-enter a new Run command.</li> <li>Set o2-02 to 0 to disable .</li> </ul>
Motor starting torque is too low.	<i>Refer to Motor Performance Fine-Tuning on page 198.</i>
Frequency reference value is too low or the drive does not accept the value entered.	Enter a value that is above the minimum output frequency determined by E1-09.
The sequence Start/Stop sequence is set up incorrectly.	<ul style="list-style-type: none"> <li>If the drive is supposed to be set up for a 2-wire sequence, then ensure parameters H1-03 through H1-07 are not set to 0.</li> <li>If the drive is supposed to be set up for a 3-wire sequence, then one of the parameters H1-03 through H1-07 must be set to 0. Terminal S1 will become the Start, terminal S2 will become the Stop input.</li> </ul>

■ **Motor Rotates in the Opposite Direction from the Run Command**

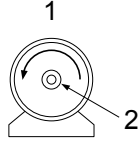
Cause	Possible Solutions
Phase wiring between the drive and motor is incorrect.	<ul style="list-style-type: none"> <li>Check the motor wiring.</li> <li>Switch two motor cables (U, V, and W) to reverse motor direction.</li> <li>Connect drive output terminals U/T1, V/T2, and W/T3 in the right order to match motor terminals U, V, and W.</li> <li>Change the setting of parameter b1-14.</li> </ul>
The forward direction for the motor is set up incorrectly.	Typically, forward is designated as being counterclockwise when looking from the motor shaft (see figure below). <div style="text-align: center;">  </div> <ol style="list-style-type: none"> <li>Forward Rotating Motor (looking down the motor shaft)</li> <li>Motor Shaft</li> </ol>
The motor is running at almost 0 Hz and the Speed Search estimated the speed to be in the opposite direction.	<ul style="list-style-type: none"> <li>Disable bi-directional search (b3-14 = 0) so that Speed Search is performed only in the specified direction.</li> </ul>

**Note:** Check the motor specifications for the forward and reverse directions. The motor specifications will vary depending on the manufacturer of the motor.

■ **Motor Rotates in One Direction Only**

Cause	Possible Solutions
The drive prohibits reverse rotation.	<ul style="list-style-type: none"> <li>Check parameter b1-04.</li> <li>Set parameter b1-04 to 0 to allow the motor to rotate in reverse.</li> </ul>
A Reverse run signal has not been entered, although 3-Wire sequence is selected.	<ul style="list-style-type: none"> <li>Make sure that one of the input terminals S3 to S7 used for the 3-Wire sequence has been set for reverse.</li> </ul>

◆ **Motor is Too Hot**

Cause	Possible Solutions
The load is too heavy.	If the load is too heavy for the motor, the motor will overheat as it exceeds its rated torque value for an extended period of time. Keep in mind that the motor also has a short-term overload rating in addition to the possible solutions provided below: <ul style="list-style-type: none"> <li>Reduce the load.</li> <li>Increase the acceleration and deceleration times.</li> <li>Check the values set for the motor protection (L1-01, L1-02) as well as the motor rated current (E2-01).</li> <li>Increase motor capacity.</li> </ul>
The air around the motor is too hot.	<ul style="list-style-type: none"> <li>Check the ambient temperature.</li> <li>Cool the area until it is within the specified temperature range.</li> </ul>

## 5.10 Troubleshooting without Fault Display

Cause	Possible Solutions
Insufficient voltage insulation between motor phases.	<p>When the motor cable is long, high voltage surges occur between the motor coils and drive switching. Normally, surges can reach up to three times the drive input power supply voltage.</p> <ul style="list-style-type: none"> <li>• Use a motor with a voltage tolerance higher than the max voltage surge.</li> <li>• Use an inverter-duty motor rated for use with AC drives when using the motor on drives rated higher than 200 V class.</li> <li>• Install an AC reactor on the output side of the drive. The carrier frequency should be set to 2 kHz when installing an AC reactor.</li> </ul>
The motor fan has stopped or is clogged.	Check the motor fan.
The carrier frequency is too low.	Increase the carrier frequency to lower the current harmonic distortion and lower the motor temperature.

### ◆ oPE02 Error Occurs When Lowering the Motor Rated Current Setting

Cause	Possible Solutions
Motor rated current and the motor no-load current setting in the drive are incorrect.	<ul style="list-style-type: none"> <li>• The user is trying to set the motor rated current in E2-01 to a value lower than the no-load current set in E2-03.</li> <li>• Make sure that value set in E2-01 is higher than E2-03.</li> <li>• If it is necessary to set E2-01 lower than E2-03, first lower the value set to E2-03, then change the setting in E2-01 as needed.</li> </ul>

### ◆ Motor Stalls during Acceleration or Acceleration Time is Too Long

Cause	Possible Solutions
Current suppression prevents the drive from accelerating.	<p>Take the following steps to resolve the problem:</p> <ul style="list-style-type: none"> <li>• Reduce the load.</li> <li>• Increase motor capacity.</li> </ul> <p><b>Note:</b> Although the drive has a Stall Prevention function and a Torque Compensation function, accelerating too quickly or trying to drive an excessively large load can exceed the capabilities of the motor.</p>
Load is too heavy.	
Frequency reference is too low.	<ul style="list-style-type: none"> <li>• Check the maximum output frequency (E1-04).</li> <li>• Increase E1-04 if it is set too low.</li> </ul> <p>Check U1-01 for proper frequency reference.</p> <p>Check if a frequency reference signal switch has been set to one of the multi-function input terminals.</p> <p>Check for low gain level set to terminals A1 or A2 (H3-03 or H3-11).</p>
Load is too heavy.	<p>Reduce the load so that the output current remains within the motor rated current.</p> <ul style="list-style-type: none"> <li>• Increase the acceleration time.</li> <li>• Check if the mechanical brake is fully releasing as it should.</li> </ul>
Acceleration time has been set too long.	Check if the acceleration time parameters have been set too long (C1-01, C1-03).
Motor characteristics and drive parameter settings are incompatible with one another.	<ul style="list-style-type: none"> <li>• Set the correct V/f pattern so that it matches the characteristics of the motor being used.</li> <li>• Check the V/f pattern set to E1-03.</li> </ul>
Incorrect frequency reference setting.	<ul style="list-style-type: none"> <li>• Check the multi-function analog input settings. Multi-function analog input terminals A1 or A2 are set for frequency gain (H3-02 or H3-10 are set to 1), but there is no voltage or current input provided.</li> <li>• Make sure H3-02 and H3-10 are set to the proper values.</li> <li>• See if the analog input value is set to the right value (U1-13 and U1-14).</li> </ul>
The Stall Prevention level during acceleration and deceleration set too low.	<ul style="list-style-type: none"> <li>• Check the Stall Prevention level during acceleration (L3-02).</li> <li>• If L3-02 is set too low, acceleration may be taking too long.</li> <li>• Increase L3-02.</li> </ul>
The Stall Prevention level during run has been set too low.	<ul style="list-style-type: none"> <li>• Check the Stall Prevention level during run (L3-06).</li> <li>• If L3-06 is set too low, speed will drop as the drive outputs torque.</li> <li>• Increase the setting value.</li> </ul>
Drive reached the limitations of the V/f motor control method.	<ul style="list-style-type: none"> <li>• The motor cable may be long enough (over 50 m) to require Auto-Tuning for line-to-line resistance.</li> <li>• Be aware that V/f Control is comparatively limited when it comes to producing torque at low speeds.</li> </ul>

### ◆ Drive Frequency Reference Differs from the Controller Frequency Reference Command

Cause	Possible Solutions
The analog input gain and bias for the frequency reference input are set to incorrect values.	<ul style="list-style-type: none"> <li>Check the gain and bias settings for the analog inputs that are used to set the frequency reference. Check parameters H3-03 and H3-04 for input A1 and check parameters H3-11 and H3-12 for input A2.</li> <li>Set these parameters to the appropriate values.</li> </ul>
A frequency bias signal is being entered via analog input terminals A1 to A2.	<ul style="list-style-type: none"> <li>If multi-function analog inputs A1 and A2 are set for frequency reference bias (H3-02 or H3-10 is set to 0), then the sum of all signals builds the frequency reference.</li> <li>Make sure that H3-02 and H3-10 are set appropriately.</li> <li>Check the input level set for terminals A1 and A2 (U1-13 and U1-14).</li> </ul>
PI control is enabled, and the drive is consequently adjusting the output frequency to match the PI setpoint. The drive will only accelerate to the maximum output frequency set in E1-04 while PI control is active.	If PI control is not necessary for the application, disable it by setting b5-01 to 0.

### ◆ Excessive Motor Oscillation and Erratic Rotation

Cause	Possible Solutions
Poor balance between motor phases.	Check drive input power voltage to ensure that it provides stable power.
Hunting prevention function is disabled.	Set n1-01 to 1 to enable Hunting Prevention.

### ◆ Deceleration Takes Longer than Expected

Cause	Possible Solutions
L3-04 is set incorrectly.	Check the Stall Prevention level during deceleration (L3-04).
The deceleration time is set too long.	Set deceleration to more appropriate time (C1-02 and C1-04).
Insufficient motor torque.	<ul style="list-style-type: none"> <li>Assuming parameter settings are normal and that no overvoltage occurs when there is insufficient torque, it is likely that the demand on the motor has exceeded the motor capacity.</li> <li>Use a larger motor.</li> </ul>
Load exceeded the internal torque limit determined by the drive rated current.	Switch to a larger capacity drive.

### ◆ Noise From Drive or Motor Cables When the Drive is Powered On

Cause	Possible Solutions
Relay switching in the drive generates excessive noise.	<ul style="list-style-type: none"> <li>Lower the carrier frequency (C6-02).</li> <li>Install a noise filter on the input side of drive input power.</li> <li>Install a noise filter on the output side of the drive.</li> <li>Place the wiring inside a metal conduit to shield it from switching noise.</li> <li>Ground the drive and motor properly.</li> <li>Separate the main circuit wiring and the control lines.</li> <li>Make sure wires and the motor have been properly grounded.</li> </ul>

### ◆ Ground Fault Circuit Interrupter (GFCI) Trips During Run

Cause	Possible Solutions
Excessive leakage current trips GFCI.	<ul style="list-style-type: none"> <li>Check the wiring and rating of peripheral devices.</li> <li>Increase the GFCI sensitivity or use GFCI with a higher threshold.</li> <li>Lower the carrier frequency (C6-02).</li> <li>Reduce the length of the cable used between the drive and the motor.</li> <li>Install a noise filter or reactor on the output side of the drive. Set the carrier frequency to 2 kHz when connecting a reactor.</li> <li>Disable the internal EMC filter.</li> </ul>

## 5.10 Troubleshooting without Fault Display

### ◆ Connected Machinery Vibrates When Motor Rotates

#### ■ Unexpected Noise from Connected Machinery

Cause	Possible Solutions
The carrier frequency is at the resonant frequency of the connected machinery.	Adjust the carrier frequency using parameters C6-02 through C6-05.
The drive output frequency is the same as the resonant frequency of the connected machinery.	<ul style="list-style-type: none"> <li>Adjust the parameters used for the Jump frequency function (d3-01 through d3-04) to skip the problem-causing bandwidth.</li> <li>Place the motor on a rubber pad to reduce vibration.</li> </ul>

**Note:** The drive may have trouble assessing the status of the load due to white noise generated from using Swing PWM (C6-02 = 7 to A).

#### ■ Oscillation or Hunting

Cause	Possible Solutions
Gain is too low when using PI control.	<i>Refer to b5: PI Control on page 284</i> for details.
The frequency reference is assigned to an external source and the signal is noisy.	<ul style="list-style-type: none"> <li>Ensure that noise is not affecting the signal lines.</li> <li>Separate main circuit wiring and control circuit wiring.</li> <li>Use twisted-pair cables or shielded wiring for the control circuit.</li> <li>Increase the analog input time filter constant (H3-13).</li> </ul>
The cable between the drive and motor is too long.	<ul style="list-style-type: none"> <li>Perform Auto-Tuning for line-to-line resistance.</li> <li>Reduce the length of the cable.</li> </ul>

### ◆ PI Output Fault

Cause	Possible Solutions
No PI feedback input.	<ul style="list-style-type: none"> <li>Check the multi-function analog input terminal settings.</li> <li>Set multi-function analog input terminal A1 or, A2 for PI feedback (H3-02 or H3-10 = B).</li> <li>A signal input to the terminal selection for PI feedback is needed.</li> <li>Check the connection of the feedback signal.</li> <li>Check the various PI-related parameter settings.</li> <li>No PI feedback input to the terminal causes the value detected to be 0, causing a PI fault and the drive to operate at max frequency.</li> </ul>
The level of detection and the target value do not correspond with each other.	<ul style="list-style-type: none"> <li>PI control keeps the difference between target and detection values at 0. Set the input level for the values relative to one another.</li> <li>Use analog input gains H3-03 and H3-11 to adjust PI target and feedback signal scaling.</li> </ul>
Reverse drive output frequency and speed detection. When output frequency rises, the sensor detects a speed decrease.	Set PI output for reverse characteristics (b5-09 = 1).
PI parameter setting adjustments are insufficient.	<i>Refer to b5: PI Control on page 284</i> for details.

### ◆ Motor Rotates After the Drive Output is Shut Off (Motor Rotates During DC Injection Braking)

Cause	Possible Solutions
DC Injection Braking is set too low and the drive cannot decelerate properly.	<ul style="list-style-type: none"> <li>Adjust the DC Injection braking settings.</li> <li>Increase the current level for DC Injection Braking (b2-02).</li> <li>Increase the DC Injection Braking time at stop (b2-04).</li> </ul>
The stopping method is set so that the drive coasts to stop.	Set b1-03 (Stopping Method Selection) to 0 or 2.

### ◆ Output Frequency is Not as High as Frequency Reference

Cause	Possible Solutions
Frequency reference is set within the range of the Jump frequency.	<ul style="list-style-type: none"> <li>Adjust the parameters used for the Jump frequency function (d3-01, d3-02, d3-03).</li> <li>Enabling the Jump frequency prevents the drive from outputting the frequencies specified in the Jump range.</li> </ul>
Upper limit for the frequency reference has been exceeded.	<ul style="list-style-type: none"> <li>Set the maximum output frequency and the upper limit for the frequency reference to more appropriate values (E1-04, d2-01).</li> <li>The following calculation yields the upper value for the output frequency:  <math>E1-04 \times d2-01 / 100</math></li> </ul>
Large load triggered Stall Prevention function during acceleration.	<ul style="list-style-type: none"> <li>Reduce the load.</li> <li>Adjust the Stall Prevention level during acceleration (L3-02).</li> </ul>

### ◆ Sound from Motor

Cause	Possible Solutions
Exceeded 110% of the rated output current of the drive while operating at low speeds.	<ul style="list-style-type: none"> <li>If the output current rises too high at low speeds, the carrier frequency is automatically reduced and causes a whining or buzzing sound.</li> <li>If the sound is coming from the motor, disable carrier frequency derating (L8-38 = 0).</li> <li>Disabling the automatic carrier frequency derating increases the chances of an overload fault (oL2). Switch to a larger capacity motor if oL2 faults occur too frequently.</li> </ul>

### ◆ Unstable Motor Speed when Using PM

Cause	Possible Solutions
Drive is attempting to operate the motor beyond the speed control range listed in the specifications.	Check the speed control range and adjust the speed accordingly.
Motor hunting occurs.	<i>Refer to Motor Performance Fine-Tuning on page 198</i> for details.
Hunting occurs at start.	Increase the S-curve time at the start of acceleration (C2-01).
Too much current is flowing through the drive.	For special-purpose motors, enter the correct data to all E5 parameters according to the test report provided for the motor.

### ◆ Motor Does Not Restart after Power Loss

Cause	Possible Solutions
The Run command was not issued again when power was restored.	<ul style="list-style-type: none"> <li>Check the sequence and wiring that has been set up to enter the Run command.</li> <li>A relay should be set up to make sure the Run command remains enabled throughout any power loss.</li> </ul>
The relay that is supposed to maintain the Run command has been switched off.	Check wiring and circuitry for the relay intended to keep the Run command enabled.

**This Page Intentionally Blank**

# Peripheral Devices & Options

---

This chapter explains the installation of peripheral devices and options available for the drive.

<b>6.1</b>	<b>SECTION SAFETY.....</b>	<b>244</b>
<b>6.2</b>	<b>DRIVE OPTIONS AND PERIPHERAL DEVICES.....</b>	<b>246</b>
<b>6.3</b>	<b>CONNECTING PERIPHERAL DEVICES.....</b>	<b>247</b>
<b>6.4</b>	<b>OPTION INSTALLATION.....</b>	<b>248</b>
<b>6.5</b>	<b>INSTALLING PERIPHERAL DEVICES.....</b>	<b>252</b>

## 6.1 Section Safety

### DANGER

#### Electrical Shock Hazard

**Do not connect or disconnect wiring while the power is on.**

Failure to comply will result in death or serious injury.

The internal capacitor remains charged even after the power supply is turned off. After shutting off the power, wait for at least the amount of time specified on the drive before touching any components.

### WARNING

#### Electrical Shock Hazard

**Do not operate equipment with covers removed.**

Failure to comply could result in death or serious injury.

The diagrams in this section may show drives without covers or safety shields to show details. Be sure to reinstall covers or shields before operating the drives and run the drives according to the instructions described in this manual.

**Do not remove covers or touch circuit boards while the power is on.**

Failure to comply could result in death or serious injury.

**Do not allow unqualified personnel to perform work on the drive.**

Failure to comply could result in death or serious injury.

Installation, maintenance, inspection and servicing must be performed only by authorized personnel familiar with installation, adjustment and maintenance of AC drives.

**Do not perform work on the drive while wearing loose clothing, jewelry or without eye protection.**

Failure to comply could result in death or serious injury.

Remove all metal objects such as watches and rings, secure loose clothing and wear eye protection before beginning work on the drive.

**Always ground the motor-side grounding terminal.**

Improper equipment grounding could result in death or serious injury by contacting the motor case.

**Do not remove covers or touch circuit boards while the power is on.**

Failure to comply could result in death or serious injury.

**Do not use damaged wires, place excessive stress on wiring, or damage the wire insulation.**

Failure to comply could result in death or serious injury.

#### Fire Hazard

**Tighten all terminal screws to the specified tightening torque.**

Loose electrical connections could result in death or serious injury by fire due to overheating of electrical connections.

**NOTICE**

**Observe proper electrostatic discharge procedures (ESD) when handling the drive and circuit boards.**

Failure to comply may result in ESD damage to the drive circuitry.

**Never connect or disconnect the motor from the drive while the drive is outputting voltage.**

Improper equipment sequencing could result in damage to the drive.

**If a fuse is blown or a Ground Fault Circuit Interrupter (GFCI) is tripped, check the wiring and the selection of the peripheral devices.**

Contact your supplier if the cause cannot be identified after checking the above.

**Do not restart the drive or immediately operate the peripheral devices if a fuse is blown or a GFCI is tripped.**

Check the wiring and the selection of peripheral devices to identify the cause. Contact your supplier before restarting the drive or the peripheral devices if the cause cannot be identified.

**Do not operate damaged equipment.**

Failure to comply could result in further damage to the equipment.

Do not connect or operate any equipment with visible damage or missing parts.

**Do not use unshielded wire for control wiring.**

Failure to comply may cause electrical interference resulting in poor system performance. Use shielded twisted-pair wires and ground the shield to the ground terminal of the drive.

**Properly connect all pins and connectors.**

Failure to comply may prevent proper operation and possibly damage equipment.

**Check all the wiring to ensure that all connections are correct after installing the option and connecting any other devices.**

Failure to comply could result in damage to the option.

### 6.2 Drive Options and Peripheral Devices

The following table of peripheral devices lists the names of the various accessories and options available for Yaskawa drives. Contact Yaskawa or your Yaskawa agent to order these peripheral devices.

- **Peripheral Device Selection:** Refer to the Yaskawa catalog for selection and part numbers.
- **Peripheral Device Installation:** Refer to the corresponding option manual for installation instructions.

**Table 6.1 Available Peripheral Devices**

Option	Model Number	Description
<b>Power Options</b>		
AC Reactor	–	Protects the drive when operating from a large power supply and improves the power factor by suppressing harmonic distortion. Highly recommended for power supplies that exceed 600 kVA.
<b>Communication Option Cards</b>		
Modbus TCP/IP	SI-EM3	Connects to a Modbus TCP/IP network.
EtherNet/IP	SI-EN3	Connects to an EtherNet/IP network.
LONWORKS	SI-W3	Connects to a LONWORKS network.
<b>Interface Options</b>		
Remote Operator Cable	UWR000051, 1 m cable UWR000052, 2 m cable	RJ-45, 8-pin straight through, UTP CAT5e, extension cable (1 m or 2 m) to connect the HOA keypad for remote operation
USB Copy Unit	JVOP-181	<ul style="list-style-type: none"> <li>• Allows the user to copy and verify parameter settings between drives</li> <li>• Functions as an adapter to connect the drive to a USB port on a PC</li> </ul>
<b>Mechanical Options</b>		
Attachment for External Heatsink	Installation kit for mounting the drive with the heatsink outside of the panel. NEMA Type 1 and NEMA Type 12 attachments are available. NEMA Type 12 attachments are available only for rev. B products or later.	
<b>Others</b>		
24 V Power Supply	PS-A10LB, PS-A10HB	Supplies the drive controller with 24 Vdc power during main power loss.

## 6.3 Connecting Peripheral Devices

Figure 6.1 illustrates how to configure the drive and motor to operate with various peripheral devices. Refer to the specific manual for the devices shown below for more detailed installation instructions.

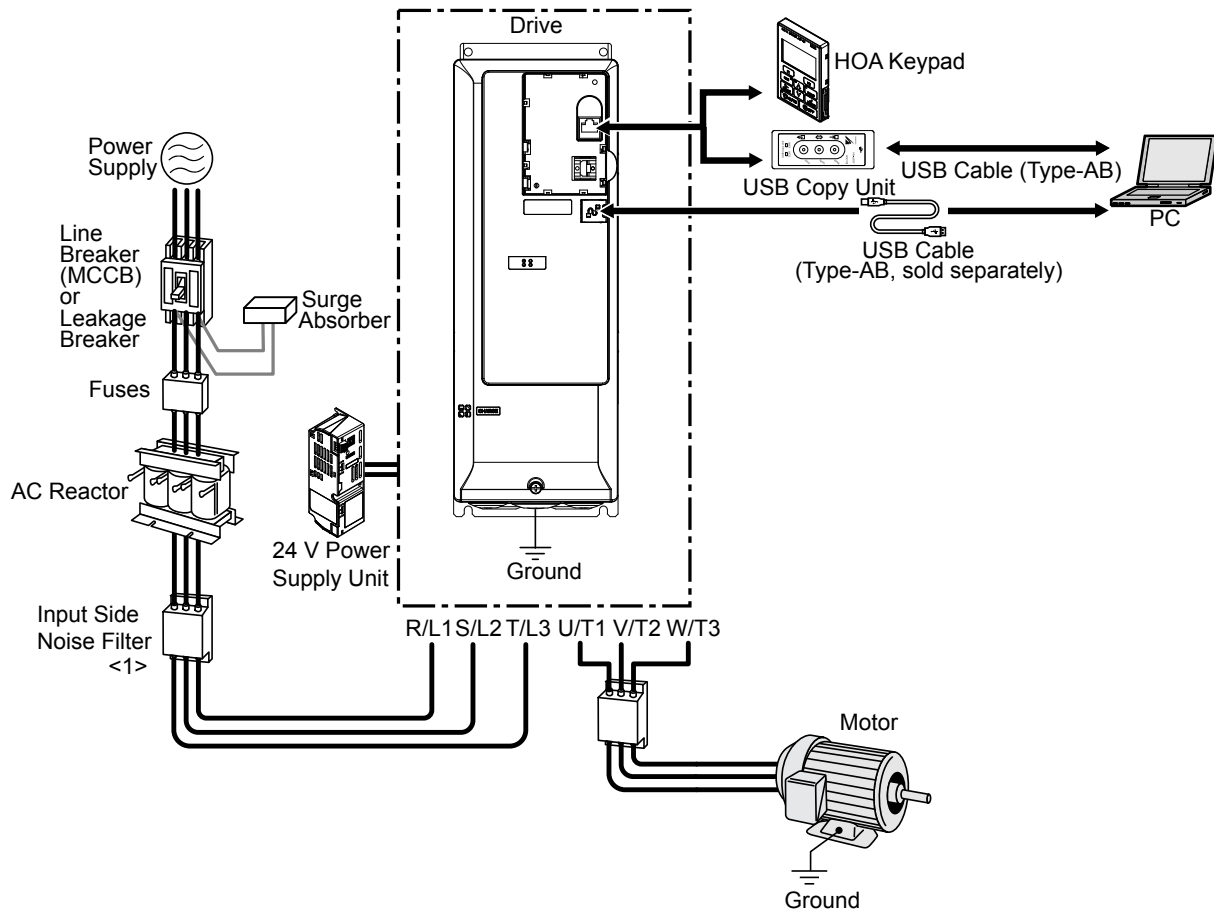

<1> An input side noise filter is built into models CIMR-Z□2A0011 to 2A0273 and 4A0005 to 4A0302.

**Figure 6.1 Connecting Peripheral Devices**

**Note:** If the drive is set to trigger a fault output when the fault restart function is activated ( $L5-02 = 1$ ), then a sequence to interrupt power when a fault occurs will turn off the power to the drive while the drive attempts to restart. The default setting for L5-02 is 0 (fault output active during restart).

## 6.4 Option Installation

This section provides instructions on installing the options in [Table 6.2](#).

### ◆ Prior to Installing the Option

Prior to installing the option, wire the drive, make necessary connections to the drive terminals, and verify that the drive functions normally without the option installed.

[Table 6.2](#) below lists the number of options that can be connected to the drive and the drive ports for connecting those options.

**Table 6.2 Option Installation**

Option	Port/Connector
SI-W3, SI-EM3, SI-EN3	CN5

[Figure 6.2](#) shows an exploded view of the drive with the option and related components for reference.

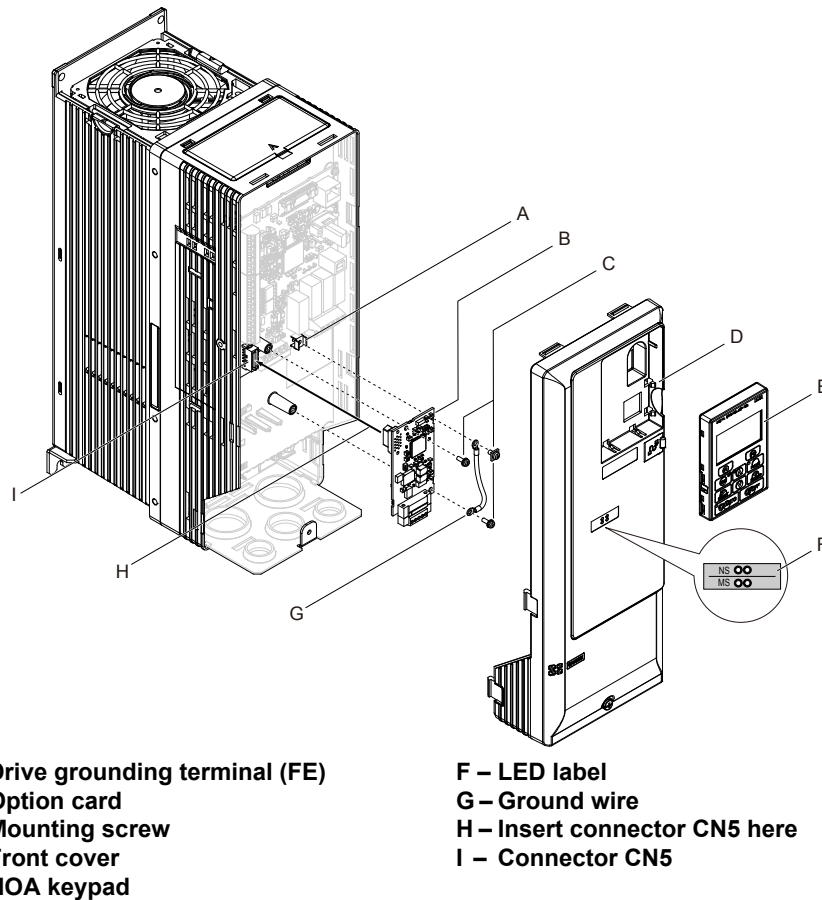

**Figure 6.2 Drive Components with Option**

### ◆ Installing the Option

Refer to the instructions below to install the option.

**DANGER!** *Electrical Shock Hazard. Disconnect all power to the drive and wait at least the amount of time specified on the drive front cover safety label. After all indicators are off, measure the DC bus voltage to confirm safe level, and check for unsafe voltages before servicing to prevent electric shock. The internal capacitor remains charged even after the power supply is turned off.*

**WARNING!** *Electrical Shock Hazard. Do not allow unqualified personnel to perform work on the drive. Failure to comply could result in death or serious injury. Maintenance, inspection, and replacement of parts must be performed only by authorized personnel familiar with installation, adjustment and maintenance of AC drives and option cards.*

**NOTICE:** *Damage to Equipment. Observe proper electrostatic discharge procedures (ESD) when handling the option card, drive, and circuit boards. Failure to comply may result in ESD damage to circuitry.*

**NOTICE:** *Damage to Equipment. Tighten all terminal screws to the specified tightening torque. Failure to comply may cause the application to operate incorrectly or damage the drive.*

1. Shut off power to the drive, wait the appropriate amount of time for voltage to dissipate, then remove the HOA keypad (E) and front cover (D).

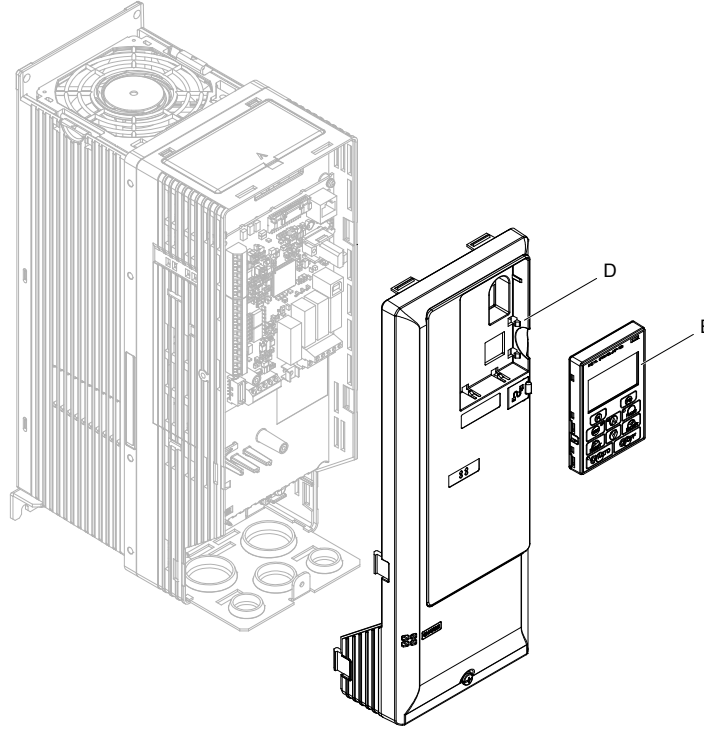

**Figure 6.3 Remove the Front Cover and HOA Keypad**

2. With the front cover and HOA keypad removed, apply the LED label (F) in the appropriate position on the drive front cover (D).

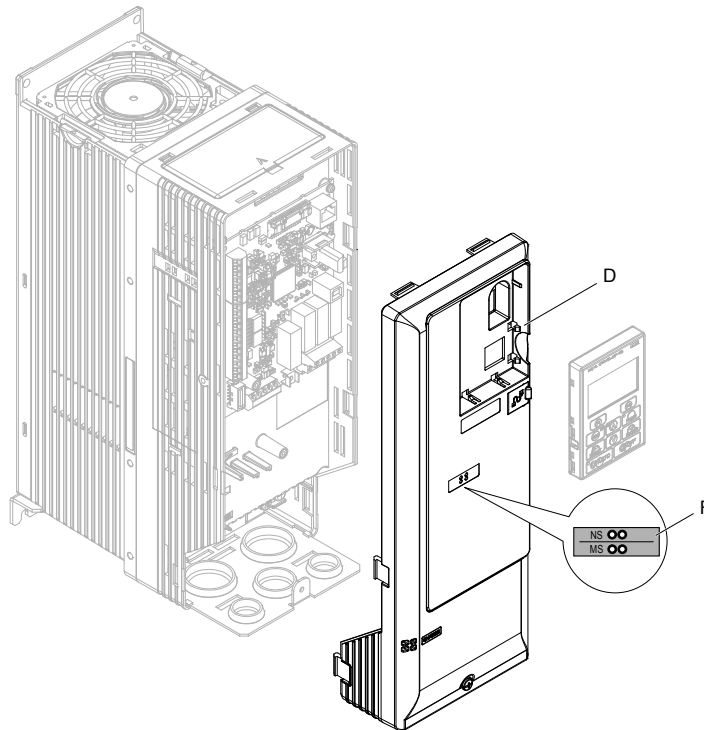

**Figure 6.4 Apply the LED Label**

## 6.4 Option Installation

3. Insert the CN5 connector on the option card (B) into the matching CN5 connector on the drive (I), then fasten it into place using one of the screws (C) included with the option card.

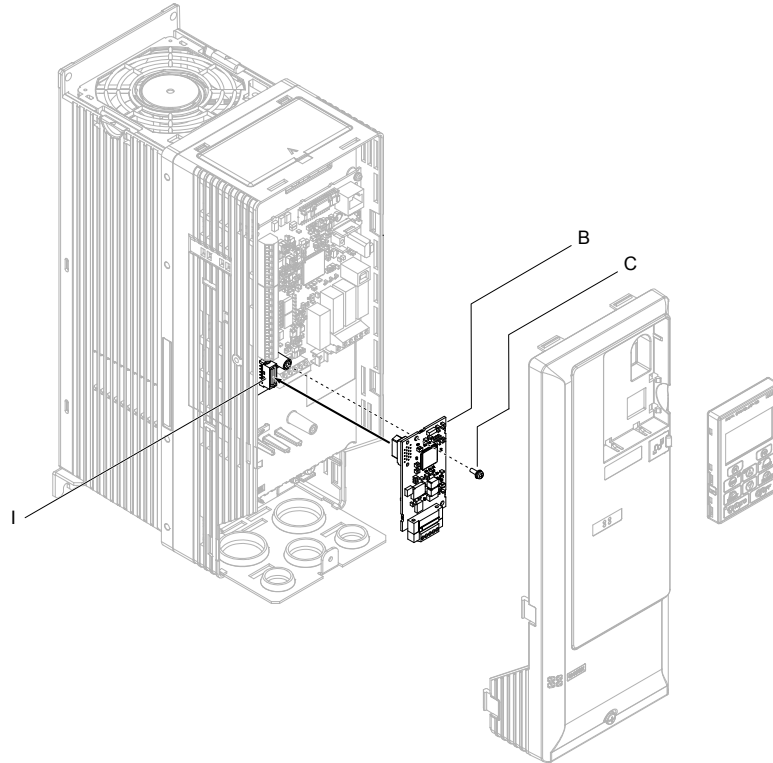

Figure 6.5 Insert the Option Card

4. Connect the ground wire (G) to the ground terminal (A) using one of the remaining provided screws (C). Connect the other end of the ground wire (G) to the ground terminal and installation hole on the option using the last remaining provided screw (C).

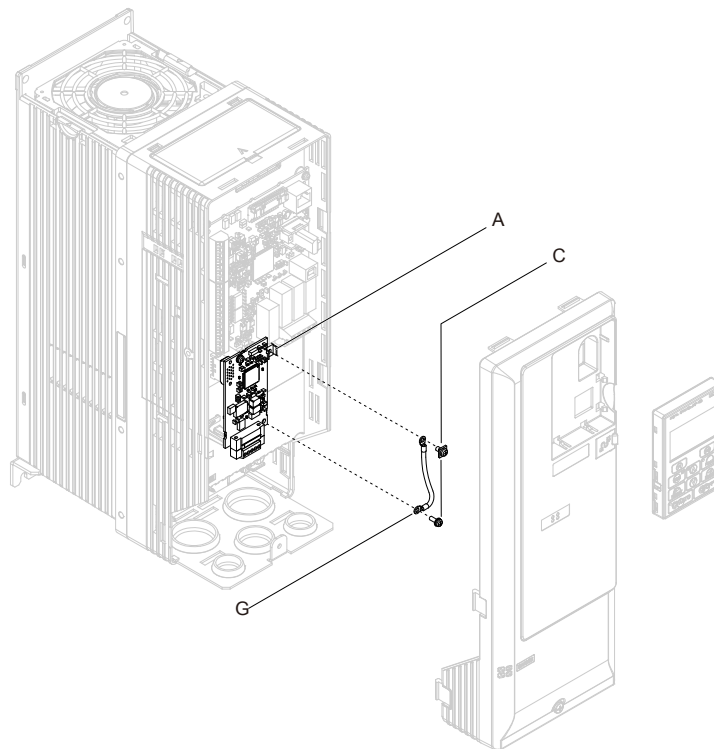
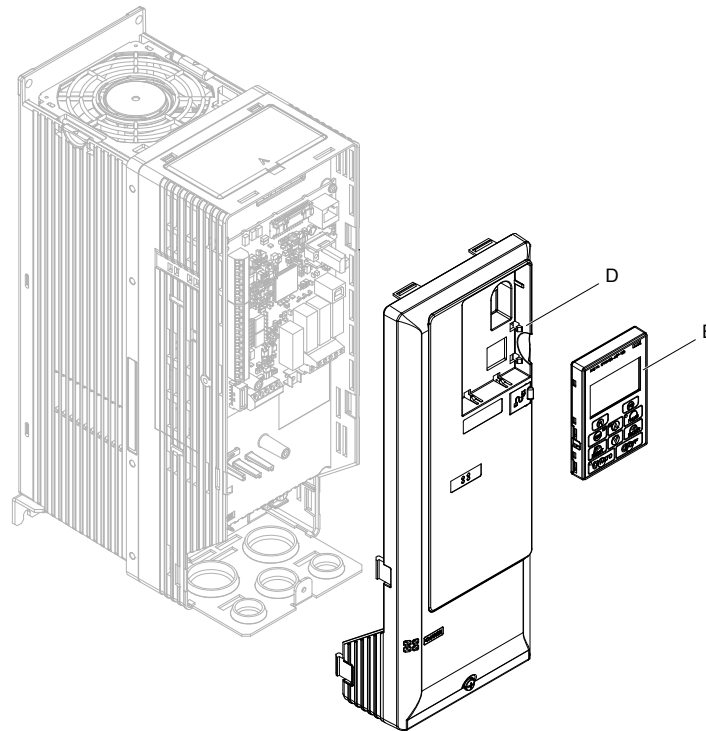

Figure 6.6 Connect the Ground Wire

**5.** Wire the communication cables.

**Note:** Separate communication cables from main circuit wiring and other electrical lines.

**6.** Replace and secure the front cover of the drive (D) and replace the HOA Keypad (F).

**Figure 6.7** Replace the Front Cover and HOA Keypad

**Note:** Leave enough space when wiring to easily reattach the front cover. Make sure no wires get caught between the front cover and the drive.

## 6.5 Installing Peripheral Devices

This section describes the proper steps and precautions to take when installing or connecting various peripheral devices to the drive.

**NOTICE:** Use a class 2 power supply when connecting to the control terminals. Improper application of peripheral devices could result in drive performance degradation due to improper power supply. Refer to NEC Article 725 Class 1, Class 2, and Class 3 Remote-Control, Signaling, and Power Limited Circuits for requirements concerning class 2 power supplies.

### ◆ Installing a Molded Case Circuit Breaker (MCCB) or Ground Fault Circuit Interrupter (GFCI)

Install an MCCB or GFCI for line protection between the power supply and the main circuit power supply input terminals R/L1, S/L2, and T/L3. This protects the main circuit and devices wired to the main circuit while also providing overload protection.

Consider the following when selecting and installing an MCCB or GFCI:

- The capacity of the MCCB or GFCI should be 1.5 to 2 times the rated output current of the drive. Use an MCCB or GFCI to keep the drive from faulting out instead of using overheat protection (110% for one minute at the rated output current).
- If several drives are connected to one MCCB or GFCI that is shared with other equipment, use a sequence that shuts the power OFF when errors are output by using magnetic contactor (MC) as shown in [Figure 6.8](#).

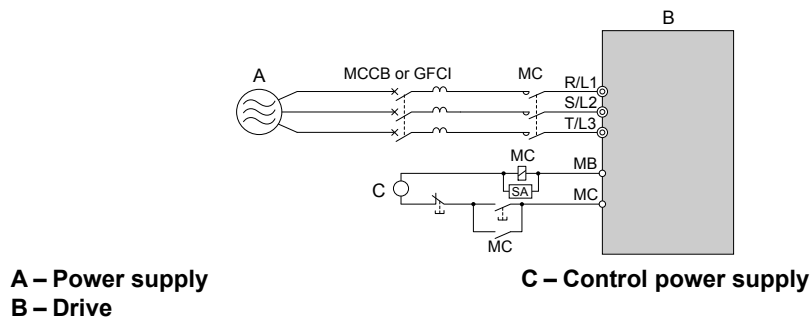

Figure 6.8 Power Supply Interrupt Wiring (Example)

**WARNING!** Electrical Shock Hazard. Disconnect the MCCB (or GFCI) and MC before wiring terminals. Failure to comply may result in serious injury or death.

### ■ Application Precautions when Installing a GFCI

Drive outputs generate high-frequency leakage current as a result of high-speed switching. Install a GFCI on the input side of the drive to switch off potentially harmful leakage current.

Factors in determining leakage current:

- Size of the AC drive
- AC drive carrier frequency
- Motor cable type and length
- EMI/RFI filter

If the GFCI trips spuriously, consider changing these items or use a GFCI with a higher trip level.

**Note:** Choose a GFCI designed specifically for an AC drive. The operation time should be at least 0.1 s with sensitivity amperage of at least 200 mA per drive. The output waveform of the drive and built-in EMC filter may cause an increase in leakage current. This may in turn cause the leakage breaker to malfunction. Increase the sensitivity amperage or lower the carrier frequency to correct the problem.

## ◆ Installing a Magnetic Contactor at the Power Supply Side

Install a magnetic contactor (MC) to the drive input for the purposes explained below.

### ■ Disconnecting the Power Supply

Shut off the drive with an MC when a fault occurs in external equipment.

**NOTICE:** Do not connect electromagnetic switches or MCs to the output motor circuits without proper sequencing. Improper sequencing of output motor circuits could result in damage to the drive.

**NOTICE:** Install an MC on the input side of the drive when the drive should not automatically restart after power loss. To get the full performance life out of the electrolytic capacitors and circuit relays, refrain from switching the drive power supply off and on more than once every 30 minutes. Frequent use can damage the drive. Use the drive to stop and start the motor.

**NOTICE:** Use a magnetic contactor (MC) to ensure that power to the drive can be completely shut off when necessary. The MC should be wired so that it opens when a fault output terminal is triggered.

- Note:**
1. Install an MC to the drive input side to prevent the drive from restarting automatically when power is restored after momentary power loss.
  2. Set up a delay that prevents the MC from opening prematurely to continue operating the drive through a momentary power loss.

## ◆ Connecting an AC Reactor

AC reactors suppress surges in current and improve the power factor on the input side of the drive.

Use an AC reactor in the following situations:

- To suppress harmonic current or improve the power factor of the power supply.
- When using a phase advancing capacitor switch.
- With a large capacity power supply transformer (over 600 kVA).

**Note:** Use an AC reactor when also connecting a thyristor converter (such as a DC drive) to the same power supply system, regardless of the conditions of the power supply.

### ■ Connecting an AC Reactor

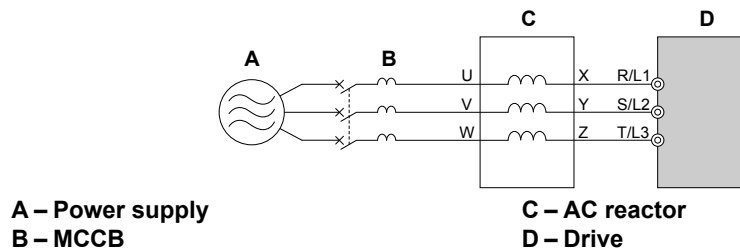

Figure 6.9 Connecting an AC Reactor

## ◆ Connecting a Surge Absorber

A surge absorber suppresses surge voltage generated from switching an inductive load near the drive. Inductive loads include magnetic contactors, relays, valves, solenoids, and brakes. Always use a surge absorber or diode when operating with an inductive load.

**WARNING! Fire Hazard.** Due to surge absorber short circuit on drive output terminals U/T1, V/T2, and W/T3, do not connect surge absorbers to the drive output power terminals. Failure to comply may result in serious injury or death by fire or flying debris.

## 6.5 Installing Peripheral Devices

### ■ Factory Recommended Branch Circuit Protection

**WARNING! Fire Hazard.** Install adequate branch circuit protection according to applicable local codes and this manual. Failure to comply could result in fire and damage to the drive or injury to personnel. The device is suitable for use on a circuit capable of delivering not more than 100,000 RMS symmetrical amperes, 240 Vac (200 V class) and 480 Vac (400 V class), when protected by branch circuit protection devices specified in this manual.

Branch circuit protection shall be provided by any of the following: Non-time delay Class J, T, or CC fuses sized at 300% of the drive input rating, or Time delay Class J, T, or CC fuses sized at 175% of the drive input rating, or MCCB sized at 200% maximum of the drive input rating.

Yaskawa recommends installing one of the following types of branch circuit protection to maintain compliance with UL508C. Semiconductor protective type fuses are preferred. Alternate branch circuit protection devices are also listed in [Table 6.3](#).

**Table 6.3 Factory Recommended Z1000 AC Drive Branch Circuit Protection**

Model	Nominal Output Power (HP)	AC Drive Input (A)	MCCB Rating (A) <1>	Time Delay Fuse Rating (A) <2>	Non-time Delay Fuse Rating (A) <3>	Bussmann Semiconductor Fuse Model (Fuse Ampere) <4>
<b>Three-Phase 200 V Class</b>						
2A0011	3	10.6	20	17.5	30	FWH-40B (40)
2A0017	5	16.7	30	25	50	FWH-50B (50)
2A0024	7.5	24.2	40	40	70	FWH-80B (80)
2A0031	10	30.8	60	50	90	FWH-100B (100)
2A0046	15	46.2	90	80	125	FWH-150B (150)
2A0059	20	59.4	110	100	175	FWH-175B (175)
2A0075	25	74.8	150	125	200	FWH-225A (225)
2A0088	30	88	175	150	250	FWH-225A (225)
2A0114	40	114	225	175	300	FWH-250A (250)
2A0143	50	143	250	250	400	FWH-275A (275)
2A0169	60	169	300	275	500	FWH-350A (350)
2A0211	75	211	400	350	600	FWH-400A (400)
2A0273	10	273	500	450	<5>	FWH-450A (450)
2A0343	125	343	600	600		FWH-600A (600)
2A0396	150	396	700	<5>		FWH-600A (600)
<b>Three-Phase 400 V Class</b>						
4A0005	3	4.8	15	8	12	FWH-40B (40)
4A0008	5	7.6	15	12	20	FWH-40B (40)
4A0011	7.5	11	20	17.5	30	FWH-45B (45)
4A0014	10	14	25	20	40	FWH-45B (45)
4A0021	15	21	40	35	60	FWH-60B (60)
4A0027	20	27	50	45	80	FWH-60B (60)
4A0034	25	34	60	50	100	FWH-125B(125)
4A0040	30	40	75	70	110	FWH-150B (150)
4A0052	40	52	100	90	150	FWH-200B (200)
4A0065	50	65	125	110	175	FWH-225A (225)
4A0077	60	77	150	125	225	FWH-225A (225)
4A0096	75	96	175	150	275	FWH-225A (225)
4A0124	100	124	225	200	350	FWH-250A(250)
4A0156	125	156	300	250	450	FWH-300A (300)
4A0180	150	180	350	300	500	FWH-350A (350)
4A0240	200	240	450	400	<5>	FWH-400A (400)
4A0302	250	302	600	500		FWH-600A (600)
4A0361	300	346	600	600	1000 <6>	FWH-800A (800)
4A0414	350	410	800	700	1200 <6>	FWH-800A (800)

Model	Nominal Output Power (HP)	AC Drive Input (A)	MCCB Rating (A) <1>	Time Delay Fuse Rating (A) <2>	Non-time Delay Fuse Rating (A) <3>	Bussmann Semiconductor Fuse Model (Fuse Ampere) <4>
4A0480	400	480	900	<5>	<5>	FWH-700A (700)
4A0590	500	590	1100			FWH-1000A (1000)

- <1> Maximum MCCB rating is 15 A, or 200% of drive input current rating, whichever value is larger. MCCB voltage rating must be 600 Vac or greater.
- <2> Maximum Time delay fuse is 175% or drive input current rating. This covers any Class J, T, or CC fuse.
- <3> Maximum Non-time delay fuse is 300% of drive input current rating. This covers any Class J, T, or CC fuse.
- <4> When using semiconductor fuses, Bussmann FWH fuses are required for UL compliance.
- <5> Consult factory.
- <6> Class L fuse is also approved for this rating.

### ◆ Attachment for External Heatsink Mounting

An external attachment can be used to project the heatsink outside of an enclosure to ensure that there is sufficient air circulation around the heatsink.

#### ■ NEMA Type 1 Heatsink-External Mounting Attachment

Table 6.4 shows the heatsink-external mounting attachment for a NEMA Type 1 enclosure.

Order parts according to the corresponding product codes in Table 6.4 and install them according to document EZZ021811. Refer to Table 6.6 for panel cut-out dimensions.

**NOTICE:** Tighten the installation screws for the bracket and the attachment to the specified tightening torque. Dust can enter if the screw is loose, and may cause the drive to break down.

**NOTICE:** If the environment outside the diecast case is relatively harsh, then use either a sealant or a gasket to ensure that the attachment is firmly affixed. Refer to Table 6.6 for installation details.

**NOTICE:** The bracket and attachment must match the direction of the installation. Water and dust can enter when the bracket and attachment are installed incorrectly, and may cause the drive to break down.

Table 6.4 NEMA Type 1 Attachment Code List

Model	Product Code	Product Text	Parts List	Weight kg (lb)	Recommended Mounting Hardware (Not Provided)	
					Screw Size	Tightening Torque N·m (lb. in.)
<b>Three-Phase 200 V Class</b>						
2A0011 2A0017	100-067-550	72606 -EZZ021811A	Bracket (Qty. 2) Screw M5x14+S+W (Qty. 8)	0.4 (0.9)	Screw M5x14 (Qty. 4)	2.0 to 2.5 (17.7 to 22.1)
2A0024 2A0031	100-067-551	72606 -EZZ021811B	Bracket (Qty. 2) Screw M5x14+S+W (Qty. 8)	0.6 (1.3)	Screw M5x14 (Qty. 4)	2.0 to 2.5 (17.7 to 22.1)
2A0046 2A0059	100-067-552	72606 -EZZ021811C	Bracket (Qty. 2) Screw M5x14+S+W (Qty. 4)	0.3 (0.7)	Screw M6x14 (Qty. 4)	4.0 to 4.9 (35.4 to 43.3)
2A0075 2A0088 2A0114	100-067-553	72606 -EZZ021811D	Bracket (Qty. 2) Screw M5x14+S+W (Qty. 2) Screw M6x14+S+W (Qty. 2)	0.4 (0.9)	Screw M6x14 (Qty. 4)	4.0 to 4.9 (35.4 to 43.3)
2A0143 2A0169 2A0211 2A0273	–	–	–	–	Screw M10x20 (Qty. 4)	17.7 to 22.5 (156.7 to 199.1)
<b>Three-Phase 400 V Class</b>						
4A0005 4A0008 4A0011	100-067-550	72606 -EZZ021811A	Bracket (Qty. 2) Screw M5x14+S+W (Qty. 8)	0.4 (0.9)	Screw M5x14 (Qty. 4)	2.0 to 2.5 (17.7 to 22.1)
4A0014 4A0021 4A0027	100-067-551	72606 -EZZ021811B	Bracket (Qty. 2) Screw M5x14+S+W (Qty. 8)	0.6 (1.3)	Screw M5x14 (Qty. 4)	2.0 to 2.5 (17.7 to 22.1)
4A0034 4A0040	100-067-552	72606 -EZZ021811C	Bracket (Qty. 2) Screw M5x14+S+W (Qty. 4)	0.3 (0.7)	Screw M6x14 (Qty. 4)	4.0 to 4.9 (35.4 to 43.3)

## 6.5 Installing Peripheral Devices

Model	Product Code	Product Text	Parts List	Weight kg (lb)	Recommended Mounting Hardware (Not Provided)	
					Screw Size	Tightening Torque N·m (lb. in.)
4A0052 4A0065 4A0077 4A0096	100-067-553	72606 -EZZ021811D	Bracket (Qty. 2) Screw M5x14+S+W (Qty. 2) Screw M6x14+S+W (Qty. 2)	0.4 (0.9)	Screw M6x14 (Qty. 4)	4.0 to 4.9 (35.4 to 43.3)
4A0124	–	–	–	–	Screw M8x20 (Qty. 4)	9.0 to 10.7 (79.7 to 94.6)
4A0156 4A0180 4A0240	–	–	–	–	Screw M10x20 (Qty. 4)	17.7 to 22.5 (156.7 to 199.1)
4A0302	–	–	–	–	Screw M12x20 (Qty. 4)	31.4 to 39.2 (277.9 to 346.9)

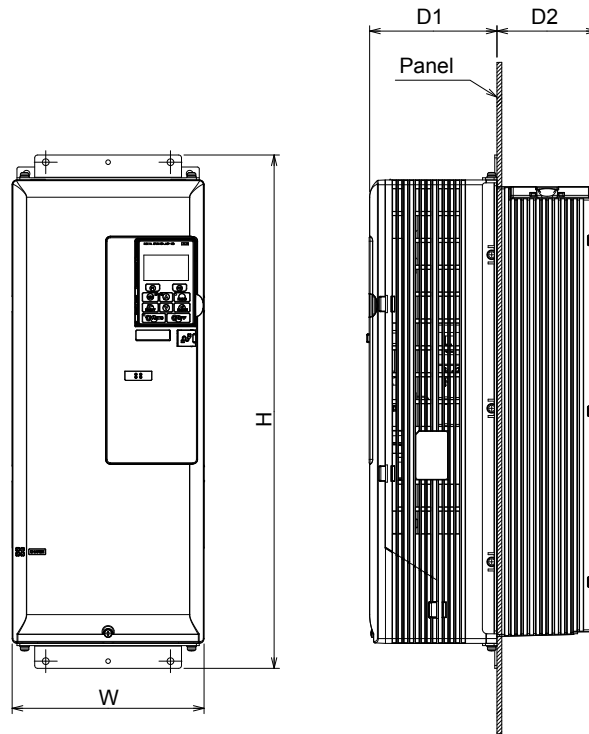
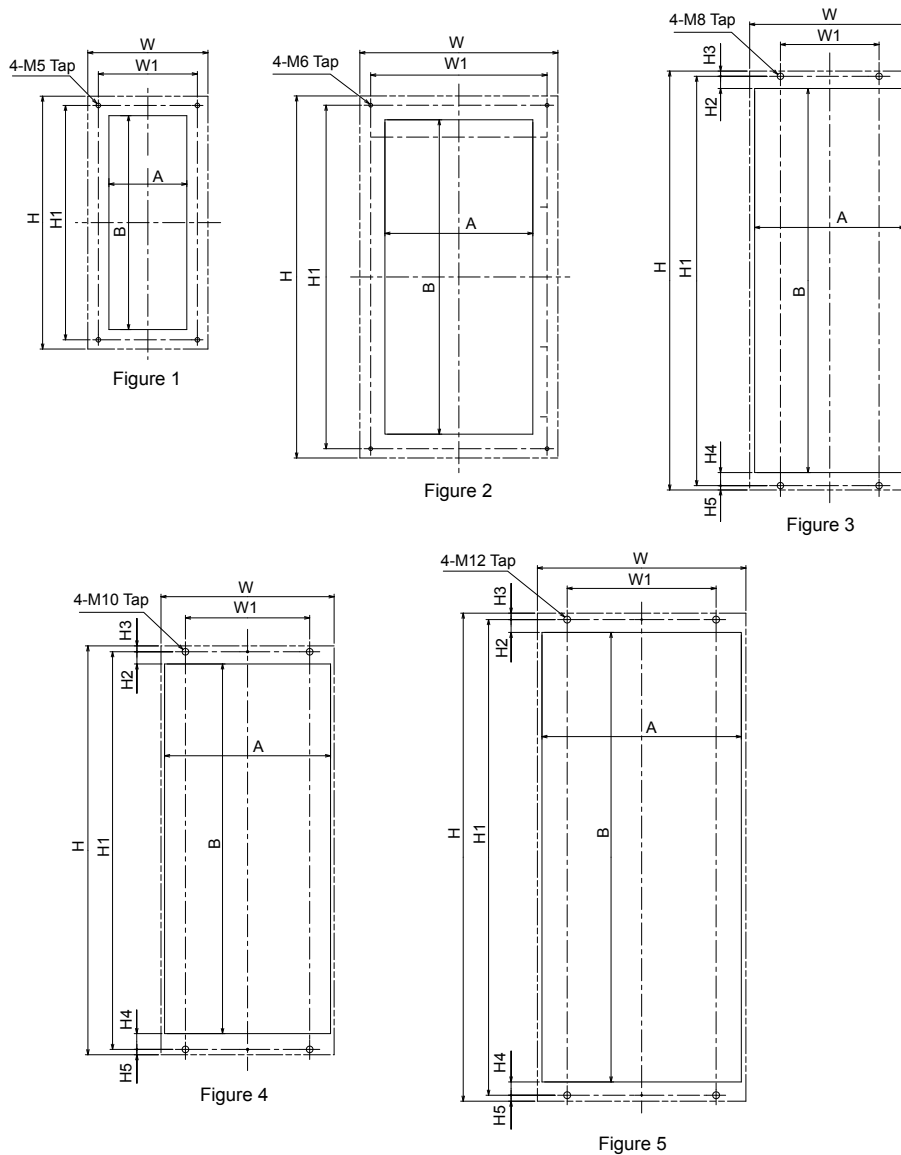

Table 6.5 NEMA Type 1 Drive Dimensions with Attachment Installed

Model	Dimensions mm (in)			
	W	H	D1	D2
<b>Three-Phase 200 V Class</b>				
2A0011 2A0017	170 (6.69)	375 (14.76)	112.5 (4.43)	105.5 (4.15)
2A0024 2A0031	170 (6.69)	465 (18.31)	127.5 (5.02)	105.5 (4.15)
2A0046 2A0059	200 (7.87)	533 (20.98)	133 (5.24)	104.5 (4.11)
2A0075 2A0088 2A0114	305 (12.01)	570 (22.44)	157 (6.18)	106.5 (4.19)
2A0143 2A0169 2A0211 2A0273	340 (13.39)	803 (31.61)	219.2 (8.63)	180.8 (7.12)
<b>Three-Phase 400 V Class</b>				
4A0005 4A0008 4A0011	170 (6.69)	375 (14.76)	112.5 (4.43)	105.5 (4.15)

Model	Dimensions mm (in)			
	W	H	D1	D2
4A0014 4A0021 4A0027	170 (6.69)	465 (18.31)	127.5 (5.02)	105.5 (4.15)
4A0034 4A0040	200 (7.87)	533 (20.98)	133 (5.24)	104.5 (4.11)
4A0052 4A0065 4A0077 4A0096	305 (12.01)	570 (22.44)	157 (6.18)	106.5 (4.19)
4A0124	276 (10.87)	721.4 (28.40)	131 (5.16)	158 (6.22)
4A0156 4A0180 4A0240	340 (13.39)	803 (31.61)	219.2 (8.63)	180.8 (7.12)
4A0302	455 (17.91)	1065 (41.93)	250.2 (9.85)	230 (9.06)

## 6.5 Installing Peripheral Devices



**Table 6.6 NEMA Type 1 Panel Cut-Out Dimensions**

Model	Dimensions mm (in)										
	Figure	W	H	W1	H1	H2	H3	H4	H5	A	B
<b>Three-Phase 200 V Class</b>											
2A0011 2A0017	1	170 (6.69)	375 (14.76)	150 (5.91)	355 (13.98)	–	–	–	–	118 (4.65)	324 (12.76)
2A0024 2A0031	1	170 (6.69)	465 (18.31)	150 (5.91)	445 (17.52)	–	–	–	–	118 (4.65)	414 (16.30)
2A0046 2A0059	2	200 (7.87)	533 (20.98)	130 (5.12)	520 (20.47)	–	–	–	–	194 (7.64)	473 (18.62)
2A0075 2A0088 2A0114	2	305 (12.01)	570 (22.44)	285 (11.22)	555 (21.85)	–	–	–	–	239 (9.41)	508 (20.00)
2A0143 2A0169 2A0211 2A0273	4	340 (13.39)	803 (31.61)	244 (9.61)	781 (30.75)	24.2 (0.95)	11.5 (0.45)	30.8 (1.21)	10.5 (0.41)	326 (12.83)	726 (28.58)
<b>Three-Phase 400 V Class</b>											
4A0005 4A0008 4A0011	1	170 (6.69)	375 (14.76)	150 (5.91)	355 (13.98)	–	–	–	–	118 (4.65)	324 (12.76)

Model	Dimensions mm (in)										
	Figure	W	H	W1	H1	H2	H3	H4	H5	A	B
4A0014 4A0021 4A0027	1	170 (6.69)	465 (18.31)	150 (5.91)	445 (17.52)	–	–	–	–	118 (4.65)	414 (16.30)
4A0034 4A0040	2	200 (7.87)	533 (20.98)	130 (5.12)	520 (20.47)	–	–	–	–	194 (7.64)	473 (18.62)
4A0052 4A0065 4A0077 4A0096	2	305 (12.01)	570 (22.44)	285 (11.22)	555 (21.85)	–	–	–	–	239 (9.41)	508 (20.00)
4A0124	3	276 (10.87)	721.4 (28.40)	170 (6.69)	705.4 (27.77)	20.5 (0.81)	9 (0.35)	21.9 (0.86)	7 (0.28)	259 (10.20)	663 (26.10)
4A0156 4A0180 4A0240	4	340 (13.39)	803 (31.61)	244 (9.61)	781 (30.75)	24.2 (0.95)	11.5 (0.45)	30.8 (1.21)	10.5 (0.41)	326 (12.83)	726 (28.58)
4A0302	5	455 (17.91)	1065 (41.93)	325 (12.80)	1038 (40.87)	28 (1.10)	14 (0.55)	29 (1.14)	13 (0.51)	435 (17.13)	981 (38.62)

■ NEMA Type 12 Heatsink-External Mounting Attachment

Table 6.7 shows the heatsink-external mounting attachment for a NEMA Type 12 enclosure.

Order parts according to the corresponding product codes in Table 6.7 and install them according to document EZZ021642. NEMA Type 12 attachments are available only for rev.B or later products. Contact a Yaskawa sales representative for product revisions. Refer to Table 6.9 for panel cut-out dimensions.

**NOTICE:** Tighten the installation screws for the bracket and the attachment to the specified tightening torque. Dust can enter if the screw is loose, and may cause the drive to break down.

**NOTICE:** Do not damage the gasket when installing the bracket and attachment. Water and dust can enter when the bracket and attachment are installed incorrectly, and may cause the drive to break down.

**NOTICE:** The bracket and attachment must match the direction of the installation. Water and dust can enter when the bracket and attachment are installed incorrectly, and may cause the drive to break down.

Table 6.7 NEMA Type 12 Attachment Code List

Model	Product Code	Product Text	Parts List	Weight kg (lb)	Recommended Mounting Hardware (Not Provided)	
					Screw Size	Tightening Torque N·m (lb. in.)
<b>Three-Phase 200 V Class</b>						
2A0011 2A0017	100-065-941	72606 -EZZ021642A	Bracket (Qty. 2) Attachment (Qty. 1) Screw M5x14+S+W (Qty. 8)	1.1 (2.43)	Screw M5x14 (Qty. 10)	2.0 to 2.5 (17.7 to 22.1)
2A0024 2A0031	100-065-942	72606 -EZZ021642B	Bracket (Qty. 2) Attachment (Qty. 1) Screw M5x14+S+W (Qty. 8)	1.4 (3.09)	Screw M5x14 (Qty. 12)	2.0 to 2.5 (17.7 to 22.1)
2A0046 2A0059	100-065-943	72606 -EZZ021642C	Bracket 1 (Qty. 2) Bracket 2 (Qty. 2) Attachment (Qty. 1) Screw M4x10+S+W (Qty. 2) Screw M5x14+S+W (Qty. 10)	1.9 (4.19)	Screw M6x14 (Qty. 12)	4.0 to 4.9 (35.4 to 43.3)
2A0075 2A0088 2A0114	100-065-944	72606 -EZZ021642D	Bracket 1 (Qty. 1) Bracket 2 (Qty. 1) Bracket 3 (Qty. 1) Bracket 4 (Qty. 1) Attachment (Qty. 1) Screw M4x10+S+W (Qty. 2) Screw M5x14+S+W (Qty. 8) Screw M6x14+S+W (Qty. 2)	2.4 (5.29)	Screw M6x14 (Qty. 14)	4.0 to 4.9 (35.4 to 43.3)
2A0143 2A0169 2A0211 2A0273	100-065-946	72606 -EZZ021642F	Bracket 1 (Qty. 1) Bracket 2 (Qty. 1) Attachment (Qty. 1) Screw M4x10+S+W (Qty. 12) Screw M5x14+S+W (Qty.12)	4.8 (10.58)	Screw M5x20 (Qty. 12) Screw M10x20 (Qty. 4)	M5: 2.0 to 2.5 (17.7 to 22.1) M10: 17.7 to 22.5 (156.7 to 199.1)

## 6.5 Installing Peripheral Devices

Model	Product Code	Product Text	Parts List	Weight kg (lb)	Recommended Mounting Hardware (Not Provided)	
					Screw Size	Tightening Torque N·m (lb. in.)
<b>Three-Phase 400 V Class</b>						
4A0005 4A0008 4A0011	100-065-941	72606 -EZZ021642A	Bracket (Qty. 2) Attachment (Qty. 1) Screw M5x14+S+W (Qty. 8)	1.1 (2.43)	Screw M5x14 (Qty. 10)	2.0 to 2.5 (17.7 to 22.1)
4A0014 4A0021 4A0027	100-065-942	72606 -EZZ021642B	Bracket (Qty. 2) Attachment (Qty. 1) Screw M5x14+S+W (Qty. 8)	1.4 (3.09)	Screw M5x14 (Qty. 12)	2.0 to 2.5 (17.7 to 22.1)
4A0034 4A0040	100-065-943	72606 -EZZ021642C	Bracket 1 (Qty. 2) Bracket 2 (Qty. 2) Attachment (Qty. 1) Screw M4x10+S+W (Qty. 2) Screw M5x14+S+W (Qty. 10)	1.9 (4.19)	Screw M6x14 (Qty. 12)	4.0 to 4.9 (35.4 to 43.3)
4A0052 4A0065 4A0077 4A0096	100-065-944	72606 -EZZ021642D	Bracket 1 (Qty. 1) Bracket 2 (Qty. 1) Bracket 3 (Qty. 1) Bracket 4 (Qty. 1) Attachment (Qty. 1) Screw M4x10+S+W (Qty. 2) Screw M5x14+S+W (Qty. 8) Screw M6x14+S+W (Qty. 2)	2.4 (5.29)	Screw M6x14 (Qty. 14)	4.0 to 4.9 (35.4 to 43.3)
4A0124	100-065-945	72606 -EZZ021642E	Bracket 1 (Qty. 1) Bracket 2 (Qty. 1) Attachment (Qty. 1) Screw M4x10+S+W (Qty. 11) Screw M5x14+S+W (Qty. 10)	4.2 (9.26)	Screw M5x20 (Qty. 12) Screw M8x20 (Qty. 4)	M5: 2.0 to 2.5 (17.7 to 22.1) M8: 9.0 to 10.7 (79.7 to 94.6)
4A0156 4A0180 4A0240	100-065-946	72606 -EZZ021642F	Bracket 1 (Qty. 1) Bracket 2 (Qty. 1) Attachment (Qty. 1) Screw M4x10+S+W (Qty. 12) Screw M5x14+S+W (Qty. 12)	4.8 (10.58)	Screw M5x20 (Qty. 12) Screw M10x20 (Qty. 4)	M5: 2.0 to 2.5 (17.7 to 22.1) M10: 17.7 to 22.5 (156.7 to 199.1)
4A0302	100-065-947	72606 -EZZ021642G	Bracket 1 (Qty. 1) Bracket 2 (Qty. 1) Attachment (Qty. 1) Screw M4x10+S+W (Qty. 16) Screw M5x14+S+W (Qty. 16)	6.8 (14.99)	Screw M5x20 (Qty. 16) Screw M12x20 (Qty. 4)	M5: 2.0 to 2.5 (17.7 to 22.1) M12: 31.4 to 39.2 (277.9 to 346.9)

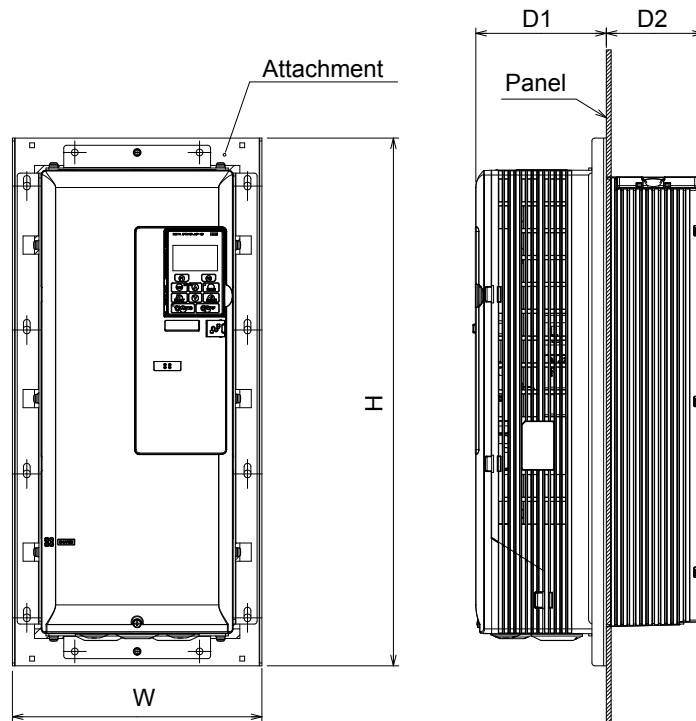
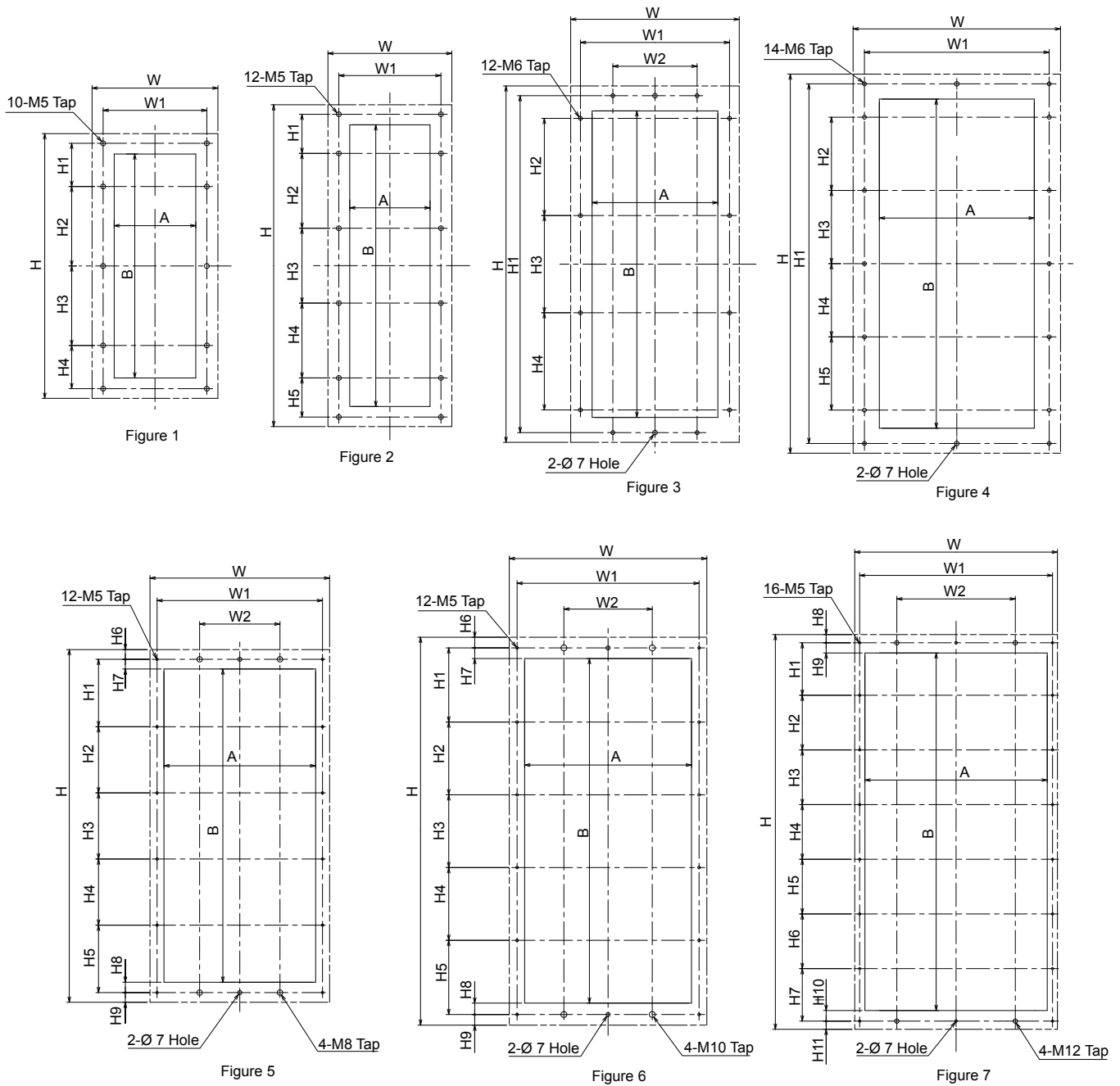

Table 6.8 NEMA Type 12 Drive Dimensions with Attachment Installed

Model	Dimensions mm (in)			
	W	H	D1	D2
<b>Three-Phase 200 V Class</b>				
2A0011 2A0017	182 (7.17)	383 (15.08)	113.5 (4.47)	104.5 (4.11)
2A0024 2A0031	182 (7.17)	473 (18.62)	128.5 (5.06)	104.5 (4.11)
2A0046 2A0059	260 (10.24)	550 (21.65)	134 (5.28)	103.5 (4.07)
2A0075 2A0088 2A0114	320 (12.60)	585 (23.03)	157.8 (6.21)	105.7 (4.16)
2A0143 2A0169 2A0211 2A0273	444 (17.48)	824 (32.44)	220.2 (8.67)	179.8 (7.08)
<b>Three-Phase 400 V Class</b>				
4A0005 4A0008 4A0011	182 (7.17)	383 (15.08)	113.5 (4.47)	104.5 (4.11)
4A0014 4A0021 4A0027	182 (7.17)	473 (18.62)	128.5 (5.06)	104.5 (4.11)
4A0034 4A0040	260 (10.24)	550 (21.65)	134 (5.28)	103.5 (4.07)
4A0052 4A0065 4A0077 4A0096	320 (12.60)	585 (23.03)	157.8 (6.21)	105.7 (4.16)
4A0124	380 (14.96)	746.4 (29.39)	132 (5.20)	157 (6.18)
4A0156 4A0180 4A0240	444 (17.48)	824 (32.44)	220.2 (8.67)	179.8 (7.08)
4A0302	556 (21.89)	1082 (42.60)	251 (9.88)	229 (9.02)

## 6.5 Installing Peripheral Devices



**Table 6.9 NEMA Type 12 Panel Cut-Out Dimensions**

Model	Dimensions mm (in)																	
	Fig.	W	H	W1	W2	H1	H2	H3	H4	H5	H6	H7	H8	H9	H10	H11	A	B
<b>Three-Phase 200 V Class</b>																		
2A0011 2A0017	1	182 (7.17)	383 (15.08)	150 (5.91)	-	62.5 (2.46)	115 (4.53)	115 (4.53)	62.5 (2.46)	-	-	-	-	-	-	-	118 (4.65)	324 (12.76)
2A0024 2A0031	2	182 (7.17)	473 (18.62)	150 (5.91)	-	57.5 (2.26)	110 (4.33)	110 (4.33)	110 (4.33)	57.5 (2.26)	-	-	-	-	-	-	118 (4.65)	414 (16.30)
2A0046 2A0059	3	260 (10.24)	550 (21.65)	230 (9.06)	130 (5.12)	520 (20.47)	150 (5.91)	150 (5.91)	150 (5.91)	-	-	-	-	-	-	-	194 (7.64)	473 (18.62)
2A0075 2A0088 2A0114	4	320 (12.60)	585 (23.03)	285 (11.22)	-	555 (21.85)	113 (4.45)	113 (4.45)	113 (4.45)	113 (4.45)	-	-	-	-	-	-	239 (9.41)	508 (20.00)

Model	Dimensions mm (in)																	
	Fig.	W	H	W1	W2	H1	H2	H3	H4	H5	H6	H7	H8	H9	H10	H11	A	B
2A0143 2A0169 2A0211 2A0273	6	444 (17.48)	824 (32.44)	414 (16.30)	244 (9.61)	156.5 (6.16)	156 (6.14)	156 (6.14)	156 (6.14)	156.5 (6.16)	21.5 (0.85)	24.2 (0.95)	30.8 (1.21)	21.5 (0.85)	-	-	385 (15.16)	726 (28.58)
<b>Three-Phase 400 V Class</b>																		
4A0005 4A0008 4A0011	1	182 (7.17)	383 (15.08)	150 (5.91)	-	62.5 (2.46)	115 (4.53)	115 (4.53)	62.5 (2.46)	-	-	-	-	-	-	-	118 (4.65)	324 (12.76)
4A0014 4A0021 4A0027	2	182 (7.17)	473 (18.62)	150 (5.91)	-	57.5 (2.26)	110 (4.33)	110 (4.33)	110 (4.33)	57.5 (2.26)	-	-	-	-	-	-	118 (4.65)	414 (16.30)
4A0034 4A0040	3	260 (10.24)	550 (21.65)	230 (9.06)	130 (5.12)	520 (20.47)	150 (5.91)	150 (5.91)	150 (5.91)	-	-	-	-	-	-	-	194 (7.64)	473 (18.62)
4A0052 4A0065 4A0077 4A0096	4	320 (12.60)	585 (23.03)	285 (11.22)	-	555 (21.85)	113 (4.45)	113 (4.45)	113 (4.45)	113 (4.45)	-	-	-	-	-	-	239 (9.41)	508 (20.00)
4A0124	5	380 (14.96)	746.4 (29.39)	350 (13.78)	170 (6.69)	142.7 (5.62)	140 (5.51)	140 (5.51)	140 (5.51)	142.7 (5.62)	20.5 (0.81)	20.5 (0.81)	21.9 (0.86)	20.5 (0.81)	-	-	320 (12.60)	663 (26.10)
4A0156 4A0180 4A0240	6	444 (17.48)	824 (32.44)	414 (16.30)	244 (9.61)	156.5 (6.16)	156 (6.14)	156 (6.14)	156 (6.14)	156.5 (6.16)	21.5 (0.85)	24.2 (0.95)	30.8 (1.21)	21.5 (0.85)	-	-	385 (15.16)	726 (28.58)
4A0302	7	556 (21.89)	1083 (42.64)	529 (20.83)	325 (12.80)	144 (5.67)	150 (5.91)	150 (5.91)	150 (5.91)	150 (5.91)	150 (5.91)	144 (5.67)	22.5 (0.89)	28 (1.10)	29 (1.14)	22.5 (0.89)	499 (19.65)	981 (38.62)

### ◆ Installing a Motor Thermal Overload (oL) Relay on the Drive Output

Motor thermal overload relays protect the motor by disconnecting power lines to the motor due to a motor overload condition.

Install a motor thermal overload relay between the drive and motor:

- When operating multiple motors on a single AC drive.
- When using a power line bypass to operate the motor directly from the power line.

It is not necessary to install a motor thermal overload relay when operating a single motor from a single AC drive. The AC drive has UL recognized electronic motor overload protection built into the drive software.

- Note:**
1. Disable the motor protection function (L1-01 = 0) when using an external motor thermal overload relay.
  2. The relay should shut off main power on the input side of the main circuit when triggered.

### ■ General Precautions when Using Thermal Overload Relays

Consider the following application precautions when using motor thermal overload relays on the output of AC drives to prevent nuisance trips or overheat of the motor at low speeds:

1. Low speed motor operation
2. Use of multiple motors on a single AC drive
3. Motor cable length
4. Nuisance tripping resulting from high AC drive carrier frequency.

#### Low Speed Operation and Motor Thermal oL Relays

Generally, thermal relays are applied on general-purpose motors. When general-purpose motors are driven by AC drives, the motor current is approximately 5% to 10% greater than if driven by a commercial power supply. In addition, the cooling capacity of a motor with a shaft-driven fan decreases when operating at low speeds. Even if the load current is within the motor rated value, motor overheating may occur. A thermal relay cannot effectively protect the motor due to the reduction of cooling at low speeds. For this reason, apply the UL recognized electronic thermal overload protection function built into the drive whenever possible.

#### UL Recognized Electronic Thermal Overload Function of the Drive

Speed-dependent heat characteristics are simulated using data from standard motors and force-ventilated motors. The motor is protected from overload using this function.

#### Using a Single Drive to Operate Multiple Motors

Set parameter L1-01 to 0 to disable thermal overload protection for the drive.

- Note:** The UL recognized electronic thermal overload function cannot be applied when operating multiple motors with a single drive.

## 6.5 Installing Peripheral Devices

---

### Long Motor Cables

When a high carrier frequency and long motor cables are used, nuisance tripping of the thermal relay may occur due to increased leakage current. To avoid this, reduce the carrier frequency or increase the tripping level of the thermal overload relay.

### Nuisance Tripping Due to a High AC Drive Carrier Frequency

Current waveforms generated by high carrier frequency PWM drives tend to increase the temperature in overload relays. It may be necessary to increase the trip level setting when encountering nuisance triggering of the relay.

**WARNING! Fire Hazard.** *Confirm an actual motor overload condition is not present prior to increasing the thermal oL trip setting. Check local electrical codes before making adjustments to motor thermal overload settings. Failure to comply could result in death or serious injury.*

# Appendix: A

## Specifications

---

<b>A.1</b>	<b>POWER RATINGS.....</b>	<b>266</b>
<b>A.2</b>	<b>DRIVE SPECIFICATIONS.....</b>	<b>272</b>
<b>A.3</b>	<b>DRIVE WATT LOSS DATA.....</b>	<b>274</b>
<b>A.4</b>	<b>DRIVE DERATING DATA.....</b>	<b>276</b>

## A.1 Power Ratings

### ◆ Three-Phase 200 V Class Drive Models 2A0011 to 2A0088

Table A.1 Power Ratings (Three-Phase 200 V Class)

Item		Specification							
CIMR-Z□2A		0011	0017	0024	0031	0046	0059	0075	0088
Maximum Applicable Motor Capacity <1>	HP	3	5	7.5	10	15	20	25	30
	kW	2.2	3.7	5.5	7.5	11	15	18.5	22
Input	Input Current (A) <2>	10.6	16.7	24.2	30.8	46.2	59.4	74.8	88
	Rated Voltage Rated Frequency	Three-phase 200 to 240 Vac 50/60 Hz							
	Allowable Voltage Fluctuation	-15 to 10%							
	Allowable Frequency Fluctuation	±5%							
	Minimum Power Supply Capacity (kVA)	5	7	11	13	20	25	32	37
Output	Rated Output Capacity (kVA) <3>	4.2	6.7	10	12	18	24	30	35
	Rated Output Current (A)	10.6 <4>	16.7 <4>	24.2 <4>	30.8 <4>	46.2 <4>	59.4 <4>	74.8 <4>	88 <4>
	Overload Tolerance	110% of rated output current for 60 s 140% of rated output current for 0.5 s							
	Carrier Frequency	User adjustable between 1 and 12.5 kHz (Maximum Frequency varies with Rated Output Capacity)							
	Maximum Output Voltage (V)	Three-phase 200 to 240 V (proportional to input voltage)							
	Maximum Output Frequency (Hz)	240 Hz							
Harmonics Reduction	DC Link Choke	Built-in							
EMC	Filter (IEC/EN 61800-3 Category 2)	Built-in							

- <1> The motor capacity (HP) refers to an NEC Table 430.250 208 V motor. The rated output current of the drive output amps should be equal to or greater than the motor current. Select the appropriate capacity drive if operating the motor continuously above motor nameplate current.
- <2> Assumes operation at the rated output current. Input current rating varies depending on the power supply transformer, input reactor, wiring connections, and power supply impedance.
- <3> Rated motor capacity is calculated with a rated output voltage of 230 V.
- <4> Carrier frequency is set to 5 kHz. Current derating is required to raise the carrier frequency.

## ◆ Three-Phase 200 V Class Drive Models 2A0114 to 2A0396

Table A.2 Power Ratings Continued (Three-Phase 200 V Class)

Item		Specification						
CIMR-Z□2A		0114	0143	0169	0211	0273	0343	0396
Maximum Applicable Motor Capacity <1>	HP	40	50	60	75	100	125	150
	kW	30	37	45	55	75	90	110
Input	Input Current (A) <2>	114	143	169	211	273	343	396
	Rated Voltage Rated Frequency	Three-phase 200 to 240 Vac 50/60 Hz						
	Allowable Voltage Fluctuation	-15 to 10%						
	Allowable Frequency Fluctuation	±5%						
	Minimum Power Supply Capacity (kVA)	48	60	71	88	114	143	165
Output	Rated Output Capacity (kVA) <3>	45	57	67	84	109	137	158
	Rated Output Current (A)	114 <4>	143 <4>	169 <4>	211 <4>	273 <4>	343 <4>	396 <5>
	Overload Tolerance	110% of rated output current for 60 s 140% of rated output current for 0.5 s						
	Carrier Frequency	User adjustable between 1 and 12.5 kHz (Maximum Frequency varies with Rated Output Capacity)						
	Maximum Output Voltage (V)	Three-phase 200 to 240 V (proportional to input voltage)						
	Maximum Output Frequency (Hz)	240 Hz						
Harmonics Reduction	DC Link Choke	Built-in						
EMC	Filter (IEC/EN 61800-3 Category 2)	Built-in					External	

- <1> The motor capacity (HP) refers to an NEC Table 430.250 208 V motor. The rated output current of the drive output amps should be equal to or greater than the motor current. Select the appropriate capacity drive if operating the motor continuously above motor nameplate current.
- <2> Assumes operation at the rated output current. Input current rating varies depending on the power supply transformer, input reactor, wiring connections, and power supply impedance.
- <3> Rated motor capacity is calculated with a rated output voltage of 230 V.
- <4> Carrier frequency is set to 5 kHz. Current derating is required to raise the carrier frequency.
- <5> Carrier frequency is set to 2 kHz. Current derating is required to raise the carrier frequency.

◆ Three-Phase 400 V Class Drive Models 4A0005 to 4A0027

Table A.3 Power Ratings (Three-Phase 400 V Class)

Item			Specification					
CIMR-Z□4A			0005	0008	0011	0014	0021	0027
Maximum Applicable Motor Capacity	Input Voltage 460 V or higher <1>	HP	3	5	7.5	10	15	20
		kW	2.2	3.7	5.5	7.5	11	15
	Input Voltage lower than 460 V <2>	HP	2	4	5	7.5	10	15
		kW	1.5	3.0	4.0	5.5	7.5	11
Input	Input Current (A) <3>		4.8	7.6	11	14	21	27
	Rated Voltage Rated Frequency		Three-phase 380 to 480 Vac 50/60 Hz / 510 to 680 Vdc					
	Allowable Voltage Fluctuation		-15 to 10%					
	Allowable Frequency Fluctuation		±5%					
	Minimum Power Supply Capacity (kVA)		4	7	10	12	18	23
Output	Rated Output Capacity (kVA)	Input Voltage 460 V or higher <4>	3.8	6.1	8.8	11	17	22
		Input Voltage lower than 460 V <5>	3.3	5.3	7.6	9.7	14.5	18.7
	Rated Output Current (A)		4.8 <6>	7.6 <6>	11 <6>	14 <6>	21 <6>	27 <6>
	Overload Tolerance		110% of rated output current for 60 s 140% of rated output current for 0.5 s					
	Carrier Frequency		User adjustable between 1 and 12.5 kHz (Maximum Frequency varies with Rated Output Capacity)					
	Maximum Output Voltage (V)		Three-phase 380 to 480 V (proportional to input voltage)					
	Maximum Output Frequency (Hz)		240 Hz					
Harmonics Reduction	DC Link Choke		Built-in					
EMC	Filter (IEC/EN 61800-3 Category 2)		Built-in					

- <1> The motor capacity (HP) refers to an NEC Table 430.250 208 V motor. The rated output current of the drive output amps should be equal to or greater than the motor current. Select the appropriate capacity drive if operating the motor continuously above motor nameplate current.
- <2> The motor capacity (HP) refers to a Yaskawa 4-pole motor. The rated output current of the drive output amps should be equal to or greater than the motor current. Select the appropriate capacity drive if operating the motor continuously above motor nameplate current.
- <3> Assumes operation at the rated output current. Input current rating varies depending on the power supply transformer, input reactor, wiring connections, and power supply impedance.
- <4> Rated motor capacity is calculated with a rated output voltage of 460 V.
- <5> Rated motor capacity is calculated with a rated output voltage of 400 V.
- <6> Carrier frequency is set to 5 kHz. Current derating is required to raise the carrier frequency.

### ◆ Three-Phase 400 V Class Drive Models 4A0034 to 4A0096

Table A.4 Power Ratings Continued (Three-Phase 400 V Class)

Item			Specification					
CIMR-Z□4A			0034	0040	0052	0065	0077	0096
Maximum Applicable Motor Capacity	Input Voltage 460 V or higher <1>	HP	25	30	40	50	60	75
		kW	18.5	22	30	37	45	55
	Input Voltage lower than 460 V <2>	HP	20	25	30	40	50	60
		kW	15	18.5	22	30	37	45
Input	Input Current (A) <3>		34	40	52	65	77	96
	Rated Voltage Rated Frequency		Three-phase 380 to 480 Vac 50/60 Hz / 510 to 680 Vdc					
	Allowable Voltage Fluctuation		-15 to 10%					
	Allowable Frequency Fluctuation		±5%					
	Minimum Power Supply Capacity (kVA)		29	34	44	55	65	80
Output	Rated Output Capacity (kVA)	Input Voltage 460 V or higher <4>	27	32	41	52	61	76
		Input Voltage lower than 460 V <5>	23.6	28	36	45	53	67
	Rated Output Current (A)		34 <6>	40 <6>	52 <6>	65 <6>	77 <6>	96 <6>
	Overload Tolerance		110% of rated output current for 60 s 140% of rated output current for 0.5 s					
	Carrier Frequency		User adjustable between 1 and 12.5 kHz (Maximum Frequency varies with Rated Output Capacity)					
	Maximum Output Voltage (V)		Three-phase 380 to 480 V (proportional to input voltage)					
	Maximum Output Frequency (Hz)		240 Hz					
Harmonics Reduction	DC Link Choke		Built-in					
EMC	Filter (IEC/EN 61800-3 Category 2)		Built-in					

- <1> The motor capacity (HP) refers to an NEC Table 430.250 208 V motor. The rated output current of the drive output amps should be equal to or greater than the motor current. Select the appropriate capacity drive if operating the motor continuously above motor nameplate current.
- <2> The motor capacity (HP) refers to a Yaskawa 4-pole motor. The rated output current of the drive output amps should be equal to or greater than the motor current. Select the appropriate capacity drive if operating the motor continuously above motor nameplate current.
- <3> Assumes operation at the rated output current. Input current rating varies depending on the power supply transformer, input reactor, wiring connections, and power supply impedance.
- <4> Rated motor capacity is calculated with a rated output voltage of 460 V.
- <5> Rated motor capacity is calculated with a rated output voltage of 400 V.
- <6> Carrier frequency is set to 5 kHz. Current derating is required to raise the carrier frequency.

**◆ Three-Phase 400 V Class Drive Models 4A0124 to 4A0302**

**Table A.5 Power Ratings Continued (Three-Phase 400 V Class)**

Item			Specification				
CIMR-Z□4A			0124	0156	0180	0240	0302
Maximum Applicable Motor Capacity	Input Voltage 460 V or higher <1>	HP	100	125	150	200	250
		kW	75	90	110	150	185
	Input Voltage lower than 460 V <2>	HP	75	100	125	150	220
		kW	55	75	90	110	160
Input	Input Current (A) <3>		124	156	180	240	302
	Rated Voltage Rated Frequency		Three-phase 380 to 480 Vac 50/60 Hz / 510 to 680 Vdc				
	Allowable Voltage Fluctuation		-15 to 10%				
	Allowable Frequency Fluctuation		±5%				
	Minimum Power Supply Capacity (kVA)		104	130	150	200	252
Output	Rated Output Capacity (kVA)	Input Voltage 460 V or higher <4>	99	124	143	191	241
		Input Voltage lower than 460 V <5>	86	108	125	166	209
	Rated Output Current (A)		124 <6>	156 <6>	180 <6>	240 <7>	302 <7>
	Overload Tolerance		110% of rated output current for 60 s 140% of rated output current for 0.5 s				
	Carrier Frequency		User adjustable between 1 and 10 kHz (Maximum Frequency varies with Rated Output Capacity)				
	Maximum Output Voltage (V)		Three-phase 380 to 480 V (proportional to input voltage)				
	Maximum Output Frequency (Hz)		240 Hz				
Harmonics Reduction	DC Link Choke		Built-in				
EMC	Filter (IEC/EN 61800-3 Category 2)		Built-in				

- <1> The motor capacity (HP) refers to an NEC Table 430.250 208 V motor. The rated output current of the drive output amps should be equal to or greater than the motor current. Select the appropriate capacity drive if operating the motor continuously above motor nameplate current.
- <2> The motor capacity (HP) refers to a Yaskawa 4-pole motor. The rated output current of the drive output amps should be equal to or greater than the motor current. Select the appropriate capacity drive if operating the motor continuously above motor nameplate current.
- <3> Assumes operation at the rated output current. Input current rating varies depending on the power supply transformer, input reactor, wiring connections, and power supply impedance.
- <4> Rated motor capacity is calculated with a rated output voltage of 460 V.
- <5> Rated motor capacity is calculated with a rated output voltage of 400 V.
- <6> Carrier frequency is set to 5 kHz. Current derating is required to raise the carrier frequency.
- <7> Carrier frequency is set to 4 kHz. Current derating is required to raise the carrier frequency.

## ◆ Three-Phase 400 V Class Drive Models 4A0361 to 4A0590

Table A.6 Power Ratings Continued (Three-Phase 400 V Class)

Item			Specification			
CIMR-Z□4A			0361	0414	0480	0590
Maximum Applicable Motor Capacity	Input Voltage 460 V or higher <1>	HP	300	350	400	500
		kW	220	260	300	370
	Input Voltage lower than 460 V <2>	HP	250	300	340	400
		kW	185	220	250	300
Input	Input Current (A) <3>		361	414	480	590
	Rated Voltage Rated Frequency		Three-phase 380 to 480 Vac 50/60 Hz / 510 to 680 Vdc			
	Allowable Voltage Fluctuation		-15 to 10%			
	Allowable Frequency Fluctuation		±5%			
	Minimum Power Supply Capacity (kVA)		316	375	400	491
Output	Rated Output Capacity (kVA)	Input Voltage 460 V or higher <4>	276	316	382	470
		Input Voltage lower than 460 V <5>	250	287	333	409
	Rated Output Current (A)		362 <6>	414 <6>	480 <6>	590 <6>
	Overload Tolerance		110% of rated output current for 60 s 140% of rated output current for 0.5 s			
	Carrier Frequency		User adjustable between 1 and 5 kHz (Maximum Frequency varies with Rated Output Capacity)			
	Maximum Output Voltage (V)		Three-phase 380 to 480 V (proportional to input voltage)			
	Maximum Output Frequency (Hz)		240 Hz			
Harmonics Reduction	DC Link Choke		Built-in			
EMC	Filter (IEC/EN 61800-3 Category 2)		External			

- <1> The motor capacity (HP) refers to an NEC Table 430.250 208 V motor. The rated output current of the drive output amps should be equal to or greater than the motor current. Select the appropriate capacity drive if operating the motor continuously above motor nameplate current.
- <2> The motor capacity (HP) refers to a Yaskawa 4-pole motor. The rated output current of the drive output amps should be equal to or greater than the motor current. Select the appropriate capacity drive if operating the motor continuously above motor nameplate current.
- <3> Assumes operation at the rated output current. Input current rating varies depending on the power supply transformer, input reactor, wiring connections, and power supply impedance.
- <4> Rated motor capacity is calculated with a rated output voltage of 460 V.
- <5> Rated motor capacity is calculated with a rated output voltage of 400 V.
- <6> Carrier frequency is set to 2 kHz. Current derating is required to raise the carrier frequency.

## A.2 Drive Specifications

- Note:**
1. Perform rotational Auto-Tuning to obtain the performance specifications given below.
  2. For optimum performance life of the drive, install the drive in an environment that meets the required specifications.

Item		Specification
<b>Control Characteristics</b>	<b>Control Method</b>	The following control methods can be set using drive parameters: <ul style="list-style-type: none"> <li>• V/f Control (V/f)</li> <li>• Open Loop Vector Control for PM (OLV/PM)</li> </ul>
	<b>Frequency Control Range</b>	0.01 to 240 Hz
	<b>Frequency Accuracy (Temperature Fluctuation)</b>	Digital input: within $\pm 0.01\%$ of the max output frequency (-10 to +50 °C [14 to 122 °F]) Analog input: within $\pm 0.1\%$ of the max output frequency (25 °C $\pm 10$ °C [77 $\pm 50$ °F])
	<b>Frequency Setting Resolution</b>	Digital inputs: 0.01 Hz Analog inputs: 1/1000 of the maximum output frequency setting (10 bit unsigned)
	<b>Output Frequency Resolution</b>	0.001 Hz
	<b>Frequency Setting Signal</b>	0 to 10 V, 0 to 20 mA, 4 to 20 mA
	<b>Starting Torque</b> <f>	V/f: 140% at 3 Hz OLV/PM: 50% at 6 Hz
	<b>Speed Control Range</b> <f>	V/f: 1:40 OLV/PM: 1:20
	<b>Speed Response</b> <f>	OLV/PM: 10 Hz
	<b>Accel/Decel Time</b>	0.0 to 6000.0 s (4 selectable combinations of independent acceleration and deceleration settings)
	<b>Braking Torque</b>	Approximately 20%
	<b>V/f Characteristics</b>	User-selected programs and V/f preset patterns possible
	<b>Main Control Functions</b>	Momentary Power Loss Ride-Thru, Speed Search, Overtorque/Undertorque Detection, 4 Step Speed (max), Accel/Decel Switch, S-curve Accel/decel, 3-Wire Sequence, Auto-Tuning (Stationary for Line-to-Line Resistance, Rotational for V/f Control), Cooling Fan on/off Switch, Slip Compensation, Torque Compensation, Frequency Jump, Upper/lower Limits for Frequency Reference, DC Injection Braking at Start and Stop, Overexcitation Braking, High Slip Braking, PI Control (with sleep function), Energy Saving Control, APOGEE FLN Comm. (RS-422/RS-485 4.8 kbps), BACnet Comm. (RS-485 max. 76.8 kbps), MEMOBUS/Modbus Comm. (RS-422/RS-485 max. 115.2 kbps), Metasys N2 Comm. (RS-422/RS-485 9.6 kbps), Fault Restart, Application Presets, KEB, Overexcitation Deceleration, Overvoltage Suppression, Sequence Timer Operation, Secondary PI Control, Bypass Operation, HOA Keypad, Dynamic Noise Control
<b>Protection Functions</b>	<b>Motor Protection</b>	Electronic thermal overload relay
	<b>Momentary Overcurrent Protection</b>	Drive stops when rated output current exceeds 175%
	<b>Overload Protection</b>	Drive stops after 60 s at 110% of rated output current <f> Drive stops after 0.5 s at 140% of rated output current <f>
	<b>Overvoltage Protection</b>	200 V class: Stops when DC bus voltage exceeds approx. 410 V 400 V class: Stops when DC bus voltage exceeds approx. 820 V

Item		Specification
Protection Functions	Undervoltage Protection	200 V class: Stops when DC bus voltage falls below approx. 190 V 400 V class: Stops when DC bus voltage falls below approximately 350 V when using an input voltage lower than 400V Stops when DC bus voltage falls below approximately 380 V when using an input voltage lower than 460 V Stops when DC bus voltage falls below approximately 440 V when using an input voltage of 460 V or higher
	Momentary Power Loss Ride-Thru	Immediately stop after 15 ms or longer power loss <3> Continuous operation during power loss shorter than 2 s by speed search function <4>
	Heatsink Overheat Protection	Thermistor
	Stall Prevention	Stall Prevention is available during acceleration, deceleration, and during run.
	Ground Protection	Electronic circuit protection <5> <6>
	DC Bus Charge LED	Remains lit until DC bus voltage falls below 50 V
Environment	Area of Use	Indoors
	Ambient Temperature	-10 °C to +40 °C (14 to 104 °F) IP20/NEMA Type 1 Enclosure, External Heatsink (2A0011 to 2A0273 and 4A0005 to 4A0302) -10 °C to +50 °C (14 to 122 °F) IP00/Open Type Enclosure (2A0343 and 2A0396, and 4A0361 to 4A0590) <b>Note:</b> <ol style="list-style-type: none"> <li>To install a heatsink on the outside of a panel, design the panel to keep the air temperature inside the panel within 10 °C (18 °F) [5 °C (9 °F) for 2A0273 and 4A0124] of the outside air temperature.</li> <li>Ambient temperature range for continuous operations is -10 to +40 °C (14 to 104 °F) when external heatsink installation method is applied for models 2A0343 and 2A0396 and 4A0361 to 4A0590.</li> </ol>
	Humidity	95% RH or less (no condensation)
	Storage Temperature	-20 °C to +70 °C (-4 to +158 °F) (short-term temperature during transportation)
	Altitude	Up to 1000 meters without derating, up to 3000 m with output current and voltage derating. <i>Refer to Altitude Derating on page 278</i> for details.
	Vibration/Shock	10 to 20 Hz at 9.8 m/s <sup>2</sup> 20 to 55 Hz at 5.9 m/s <sup>2</sup> (2A0011 to 2A0031 and 4A0005 to 4A0027) or 2.0 m/s <sup>2</sup> (2A0046 to 2A0396 and 4A0034 to 4A0590)
Standards	IEC/EN 61800-5-1	
Protection Design	IP00/Open Type enclosure, IP20/NEMA Type 1 enclosure <7>	

- <1> The accuracy of these values depends on motor characteristics, ambient conditions, and drive settings. Specifications may vary with different motors and with changing motor temperature. Contact Yaskawa for consultation.
- <2> Overload protection may be triggered when operating with 100% of the rated output current if the output frequency is less than 6 Hz.
- <3> May be shorter due to load conditions and motor speed.
- <4> A 24 V power supply Unit (Model Nos. PS-A10LB, PS-A10HB) is required for models 2A0011 to 2A0059 and 4A0005 to 4A0052 if the application must continue running for up to 2 seconds during a momentary power loss.
- <5> Ground protection cannot be provided when the impedance of the ground fault path is too low, or when the drive is powered up while a ground fault is present at the output.
- <6> Setting L8-09 to 1 enables ground fault detection in models 2A0075 to 2A0396, 4A0052□□A, and 4A0065 to 4A0590.
- <7> Drive models 2A0011 to 2A0273 and 4A0011 to 4A0302 are designed to IP20/NEMA Type 1 specifications with a protective cover on the top. Removing this top protective cover voids the NEMA Type 1 protection while maintaining IP20 conformity; removing the bottom conduit bracket voids the NEMA Type 1 protection and IP20 conformity.

## A.3 Drive Watt Loss Data

Table A.7 Watt Loss 200 V Class Three-Phase Models

Model	Rated Amps (A)	Heatsink Loss (W)	Interior Unit Loss (W)	Total Loss (W)
2A0011	10.6 <1>	121	28	148
2A0017	16.7 <1>	176	37	214
2A0024	24.2 <1>	280	55	335
2A0031	30.8 <1>	378	73	451
2A0046	46.2 <1>	396	86	482
2A0059	59.4 <1>	542	116	658
2A0075	74.8 <1>	557	132	688
2A0088	88 <1>	670	157	827
2A0114	114 <1>	864	200	1064
2A0143	143 <1>	1191	307	1499
2A0169	169 <1>	1447	365	1811
2A0211	211 <1>	1753	471	2224
2A0273	273 <1>	2378	625	3003
2A0343	343 <2>	1964	655	2620
2A0396	396 <2>	2435	829	3264

<1> Value assumes the carrier frequency is set to 5 kHz or less.

<2> Value assumes the carrier frequency is set to 2 kHz.

Table A.8 Watt Loss 400 V Class Three-Phase Models

Model	Rated Amps (A)	Heatsink Loss (W)	Interior Unit Loss (W)	Total Loss (W)
4A0005	4.8 <1>	93	24	117
4A0008	7.6 <1>	146	33	178
4A0011	11 <1>	184	38	222
4A0014	14 <1>	231	52	283
4A0021	21 <1>	306	69	375
4A0027	27 <1>	390	85	475
4A0034	34 <1>	457	105	562
4A0040	40 <1>	558	118	677
4A0052□□B	52 <1>	584	151	734
4A0052□□A	52 <1>	463	130	594
4A0065	65 <1>	576	161	737
4A0077	77 <1>	891	225	1116
4A0096	96 <1>	1131	288	1419
4A0124	124 <1>	1581	398	1979
4A0156	156 <1>	1929	535	2464
4A0180	180 <1>	2342	621	2963
4A0240	240 <2>	2863	790	3653
4A0302	302 <2>	3278	929	4207
4A0361	361 <3>	3009	1157	4166
4A0414	414 <3>	3206	1633	4840
4A0480	480 <3>	3881	2011	5893
4A0590	590 <3>	4130	1964	6094

<1> Value assumes the carrier frequency is set to 5 kHz or less.

<2> Value assumes the carrier frequency is set to 4 kHz or less.

<3> Value assumes the carrier frequency is set to 2 kHz.

## A.4 Drive Derating Data

The drive can be operated at above the rated temperature, altitude, and default carrier frequency by derating the drive capacity.

### ◆ Carrier Frequency Derating

Derate the drive according to [Figure A.1](#) to [Figure A.5](#) as the carrier frequency increases above the factory default setting.

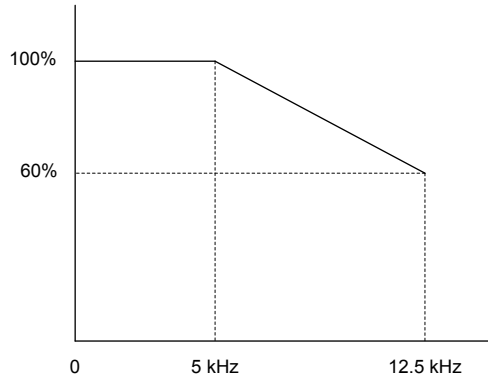

Figure A.1 Carrier Frequency Derating (2A0011 to 2A0114 and 4A0005 to 4A0096)

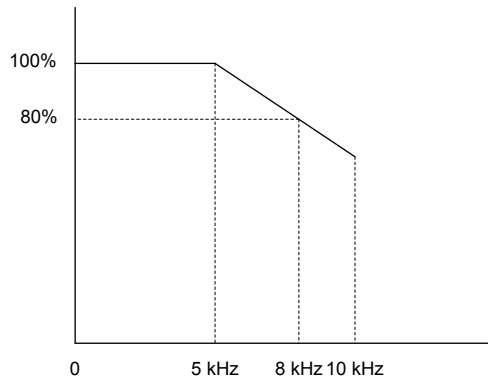

Figure A.2 Carrier Frequency Derating (2A0143 to 2A0273 and 4A0124 to 4A0180)

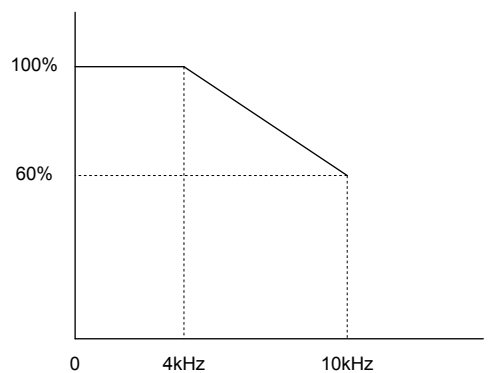

Figure A.3 Carrier Frequency Derating (4A0240 and 4A0302)

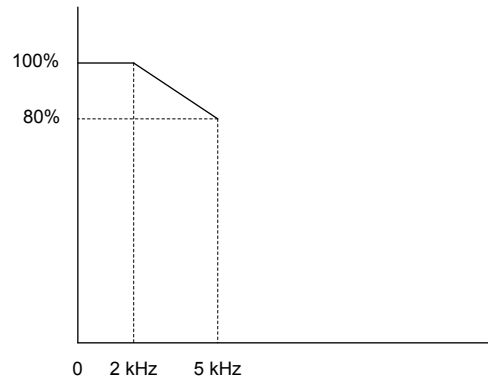

Figure A.4 Carrier Frequency Derating (2A0343 to 2A0396 and 4A0414 to 4A0590)

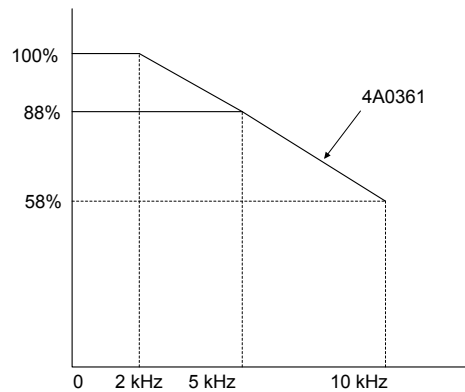

Figure A.5 Carrier Frequency Derating (4A0361)

### ◆ Temperature Derating

To ensure the maximum performance life, the drive output current must be derated as shown in *Figure A.6* when the drive is installed in areas with high ambient temperature or if drives are mounted in a cabinet. In order to ensure reliable drive overload protection, set parameters L8-12 and L8-35 according to the installation conditions.

**Note:** To install a heatsink on the outside of a panel, design the panel to keep the air temperature inside the panel within 10 °C (18 °F) [5 °C (9 °F) for 2A0273 and 4A0124] of the outside air temperature.

### ■ Parameter Settings

No.	Name	Description	Range	Def.
L8-12	Ambient Temperature Setting	Adjust the drive overload (oL2) protection level when the drive is installed in an environment that exceeds its ambient temperature rating.	40 to 60	30 °C
L8-35	Installation Method Selection	0: IP00/Open-Chassis Enclosure 2: IP20/NEMA Type 1 Enclosure 3: External Heatsink Installation	0, 2, 3	2

#### IP00/Open-Chassis Enclosure

Drive operation between -10 °C and +50 °C (14 and 122 °F) allows 100% continuous current without derating.

#### IP20/NEMA Type 1 Enclosure

Drive operation between -10 °C and +40 °C (14 and 104 °F) allows 100% continuous current without derating. Operation between 40 °C and 50 °C (104 and 122 °F) requires output current derating.

**Note:** The temperature derating remains unchanged when removing the top protective cover and the bottom conduit bracket to change an IP20/NEMA Type 1 enclosure drive to an IP00/Open-Type enclosure drive (derating required for temperatures over 40 °C [104 °F]).

#### External Heatsink Installation

Drive operation between -10 °C and +40 °C (14 and 104 °F) allows 100% continuous current without derating. Operation between 40 °C and 50 °C (104 and 122 °F) requires output current derating.

## A.4 Drive Derating Data

---

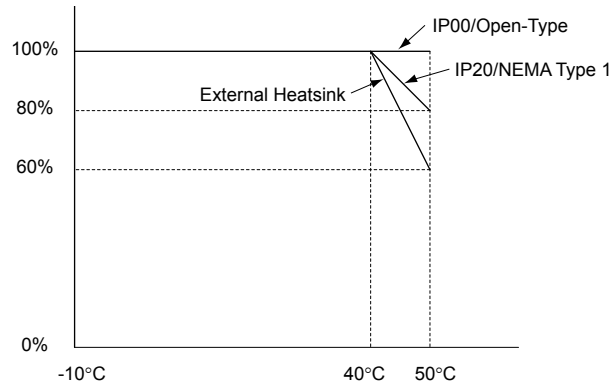

Figure A.6 Ambient Temperature and Installation Method Derating

---

### ◆ Altitude Derating

The drive standard ratings are valid for installation altitudes up to 1000 m. For installations from 1000 m to 3000 m, the drive rated output current must be derated for 0.2% per 100 m.

# Appendix: B

## Parameter List



---

This appendix contains a full listing of all parameters and settings available in the drive.

<b>B.1</b>	<b>A: INITIALIZATION PARAMETERS.....</b>	<b>280</b>
<b>B.2</b>	<b>B: APPLICATION.....</b>	<b>282</b>
<b>B.3</b>	<b>C: TUNING.....</b>	<b>289</b>
<b>B.4</b>	<b>D: REFERENCES.....</b>	<b>291</b>
<b>B.5</b>	<b>E: MOTOR PARAMETERS.....</b>	<b>294</b>
<b>B.6</b>	<b>F: COMMUNICATION OPTION PARAMETERS.....</b>	<b>297</b>
<b>B.7</b>	<b>H PARAMETERS: MULTI-FUNCTION TERMINALS.....</b>	<b>300</b>
<b>B.8</b>	<b>L: PROTECTION FUNCTION.....</b>	<b>309</b>
<b>B.9</b>	<b>N: SPECIAL ADJUSTMENT.....</b>	<b>316</b>
<b>B.10</b>	<b>O: OPERATOR-RELATED SETTINGS.....</b>	<b>318</b>
<b>B.11</b>	<b>S: SPECIAL APPLICATION.....</b>	<b>321</b>
<b>B.12</b>	<b>T: MOTOR TUNING.....</b>	<b>327</b>
<b>B.13</b>	<b>U: MONITORS.....</b>	<b>329</b>



## B.1 A: Initialization Parameters

Table B.1 Symbols and Icons Used in Parameter Descriptions

Symbol	Description
	Parameter can be changed during run.
	Parameter is ONLY available when operating the drive with Open Loop Vector for PM motors.

The A parameter group creates the operating environment for the drive. This includes the parameter Access Level, Motor Control Method, Password, User Parameters and more.

### ◆ A1: Initialization

No. (Addr. Hex)	Name	LCD Display	Description	Values	Page
A1-00 (100)  <1>	Language Selection	Select Language 0: English 1: ニホンゴ (Japanese) 3: Français 5: Español 6: Portuguêsêse	0: English 1: Japanese 3: French 5: Spanish 6: Portuguese	Default: 0 Range: 0 to 6	155
A1-01 (101)  <2>	Access Level Selection	Access Level 0: Operation Only 1: User Parameters 2: Advanced Level	0: View and set A1-01 and A1-04. U□-□□ parameters can also be viewed. 1: User Parameters (access to a set of parameters selected by the user, A2-01 to A2-32) 2: Advanced Access (access to view and set all parameters)	Default: 2 Range: 0 to 2	155
A1-02 (102) <1>	Control Method Selection	Control Method 0: V/F Control 5: PM OpenLoop Vect	0: V/f Control 5: Open Loop Vector Control for PM	Default: 0 Range: 0, 5	127
A1-03 (103)	Initialize Parameters	Init Parameters 0: No Initialize 1110: User Initialize 2220: 2-Wire Initial 3330: 3-Wire Initial 3410: SELVAL HVAC Initialize 3420: SELVAL OEM Bypass Init	0: No initialization 1110: User Initialize (parameter values must be stored using parameter o2-03) 2220: 2-Wire Initialization 3330: 3-Wire Initialization 3410: HVAC Initialization 3420: OEM Bypass Initialization	Default: 0 Range: 0 to 3420	156
A1-04 (104)	Password	Enter Password	When the value set into A1-04 does not match the value set into A1-05, parameters A1-01 through A1-03, A1-06, and A2-01 through A2-33 cannot be changed.	Default: 0000 Min.: 0000 Max.: 9999	–
A1-05 (105)	Password Setting	Select Password	When the value set into A1-04 does not match the value set into A1-05, parameters A1-01 through A1-03, A1-06, and A2-01 through A2-33 cannot be changed.	Default: 0000 Min.: 0000 Max.: 9999	–
A1-06 (127)	Application Preset	Application Sel 0: General 1: Fan General 2: Fan PI 3: Fan ReturnAir/PI 4: Cooling Tower 5: Cooling Tower/PI 6: Pump Secondary 7: Pump PI	0: Standard 1: Fan 2: Fan with PI Control 3: Return Fan with PI Control 4: Cooling Tower Fan 5: Cooling Tower Fan with PI Control 6: Pump (Secondary) 7: Pump with PI Control	Default: 0 Range: 0 to 7	157

<1> Parameter setting value is not reset to the default value when the drive is initialized.

<2> Default setting value is dependent on the Application Preset selected with parameter A1-06.

## ◆ A2: User Parameters

No. (Addr. Hex)	Name	LCD Display	Description	Values	Page
A2-01 to A2-32 (106 to 125)	User Parameters 1 to 32	User Param 1 - 32	Recently edited parameters are listed here. The user can also select parameters to appear here for quicker access.	Default: <1> Range: A1-00 to S6-07	–
A2-33 (126)	User Parameter Automatic Selection	User Parms Sel 0: Disabled 1: Enabled	0: Parameters A2-01 to A2-32 are reserved for the user to create a list of User Parameters. 1: Save history of recently viewed parameters. Recently edited parameters will be saved to A2-17 through A2-32 for quicker access.	Default: 1 <2> Range: 0, 1	–

<1> Default setting value is dependent on the Application Preset selected with parameter A1-06.

<2> Default setting value is dependent on parameter A1-06. Default is 0 when A1-06 = 0, and 1 when A1-06 ≠ 0.

## B.2 b: Application

Application parameters configure the source of the Run command, DC Injection Braking, Speed Search, timer functions, PI control, Energy Savings, and a variety of other application-related settings.

### ◆ b1: Operation Mode Selection

No. (Addr. Hex)	Name	LCD Display	Description	Values	Page
b1-01 (180)	Frequency Reference Selection for AUTO mode	Ref Source 1 0: Operator 1: Analog Input 2: Serial Com 3: Option PCB	0: HOA keypad 1: Terminals (Analog Input Terminals) 2: Serial communications (APOGEE FLN, BACnet, MEMOBUS/Modbus, or Metasys N2) 3: Option card	Default: 1 Range: 0 to 3	127
b1-02 (181)	Run Command Selection for AUTO mode	Run Source 1 1: Digital Inputs 2: Communication 3: Option PCB	1: Control Circuit Terminal 2: Serial communications (APOGEE FLN, BACnet, MEMOBUS/Modbus, or Metasys N2) 3: Option card	Default: 1 Range: 1 to 3	129
b1-03 (182)	Stopping Method Selection	Stopping Method 0: Ramp to Stop 1: Coast to Stop 2: DCInj to Stop 3: Coast w/Timer	0: Ramp to stop 1: Coast to stop 2: DC Injection Braking to stop 3: Coast with timer	Default: 1 Range: 0 to 3	129
b1-04 (183)	Reverse Operation Selection	Reverse Oper 0: Reverse Enabled 1: Reverse Disabled	0: Reverse enabled 1: Reverse disabled	Default: 1 Range: 0, 1	157
b1-08 (187)	Run Command Selection in Programming Mode	RUN dur PRG Mode 0: Run Disabled@PRG 1: ModeRun Enabled@PRG 2: Prg only @ Stop	0: Run command is not accepted while in Programming Mode 1: Run command is accepted while in Programming 2: Prohibit entering Programming Mode during Run	Default: 0 Range: 0 to 2	–
b1-11 (1DF)	Drive Delay Time Setting	Run Delay Time	After a Run command is entered, the drive output waits until this delay time has passed before starting.	Default: 0 s Min.: 0 Max.: 600	–
b1-14 (1C3)	Phase Order Selection	Rotation Sel 0: Standard 1: SwitchPhaseOrder	0: Standard 1: Switch phase order (reverses the direction of the motor)	Default: 0 Range: 0, 1	157
b1-17 (1C6)	Run Command at Power Up	Run Cmd @ Pwr On 0: Cycle Ext Run 1: Accept Ext Run	0: Disregarded. A new Run command must be issued after power up. 1: Allowed. Motor will start immediately after power up if a Run command is already enabled.	Default: 1 Range: 0, 1	157

### ◆ b2: DC Injection Braking and Short Circuit Braking

No. (Addr. Hex)	Name	LCD Display	Description	Values	Page
b2-01 (189)	DC Injection Braking Start Frequency	DCInj Start Freq	Sets the frequency at which DC Injection Braking starts when “Ramp to stop” (b1-03 = 0) is selected.	Default: <I> Min.: 0.0 Hz Max.: 10.0 Hz	157
b2-02 (18A)	DC Injection Braking Current	DCInj Current	Sets the DC Injection Braking current as a percentage of the drive rated current.	Default: 50% Min.: 0 Max.: 100	158
b2-03 (18B)	DC Injection Braking Time at Start	DCInj Time@Start	Sets DC Injection Braking time at start. Disabled when set to 0.00 seconds.	Default: 0.00 s Min.: 0.00 Max.: 10.00	158
b2-04 (18C)	DC Injection Braking Time at Stop	DCInj Time@Stop	Sets DC Injection Braking time at stop.	Default: 0.00 s Min.: 0.00 Max.: 10.00	158
b2-09 (1E1)	Motor Pre-Heat Current 2	Preheat Current	Determines the percentage of motor rated output current used for the motor pre-heat function.	Default: 5% Min.: 0 Max.: 100	–

No. (Addr. Hex)	Name	LCD Display	Description	Values	Page
b2-12 (1BA)	Short Circuit Brake Time at Start	SC Brake T@Start	<b>OLV/PM</b> Sets the time for Short Circuit Braking operation at start.	Default: 0.00 s Min.: 0.00 Max.: 25.50	–
b2-13 (1BB)	Short Circuit Brake Time at Stop	SC Brake T@Stop	<b>OLV/PM</b> Sets the Short Circuit Braking operation time at stop.	Default: 0.50 s Min.: 0.00 Max.: 25.50	–
b2-18 (177)	Short Circuit Braking Current	Shrt Cir Brk	<b>OLV/PM</b> Determines the current level for Short Circuit Braking. Set as a percentage of the motor rated current.	Default: 100.0% Min.: 0.0 Max.: 200.0	–

<1> Default setting is determined by parameter A1-02, Control Method Selection.

### ◆ b3: Speed Search

No. (Addr. Hex.)	Name	LCD Display	Description	Values	Page
b3-01 (191)	Speed Search Selection at Start	SpdSrch at Start 0: Disabled 1: Enabled	0: Disabled 1: Enabled	Default: <1> Range: 0, 1	159
b3-02 (192)	Speed Search Deactivation Current	SpdSrch DeactCur	Sets the current level at which the speed is assumed to be detected and Speed Search is ended. Set as a percentage of the drive rated current.	Default: <1> Min.: 0% Max.: 200%	159
b3-03 (193)	Speed Search Deceleration Time	SpdSrch Dec Time	Sets output frequency reduction time during Speed Search.	Default: 2.0 s Min.: 0.1 Max.: 10.0	159
b3-04 (194)	V/f Gain during Speed Search	SpdSrch V/f	Determines how much to lower the V/f ratio during Speed Search. Output voltage during Speed Search equals the V/f setting multiplied by b3-04.	Default: <2> Min.: 10% Max.: 100%	159
b3-05 (195)	Speed Search Delay Time	Search Delay	When using an external contactor on the output side, b3-05 delays executing Speed Search after a momentary power loss to allow time for the contactor to close.	Default: 0.2 s Min.: 0.0 Max.: 100.0	–
b3-06 (196)	Output Current 1 during Speed Search	Srch Im Lvl1	Sets the current injected to the motor at the beginning of Speed Estimation Speed Search. Set as a coefficient for the motor rated current.	Default: <2> Min.: 0.0 Max.: 2.0	159
b3-07 (197)	Output Current 2 during Speed Search (Speed Estimation Type)	Srch Im Lvl2	Sets the amount of output current during Speed Estimation Speed Search as a coefficient for the no-load current (output current during Speed Search is automatically limited by the drive rated current). Increase this setting value in increments of 0.1 if the drive fails to perform Speed Estimation.	Default: 1.0 Min.: 0.0 Max.: 5.0	–
b3-08 (198)	Current Control Gain during Speed Search (Speed Estimation Type)	Srch ACR P Gain	Sets the proportional gain for the current controller during Speed Search.	Default: <1> <2> Min.: 0.00 Max.: 6.00	–
b3-09 (199)	Current Control Integral Time during Speed Search (Speed Estimation Type)	Srch ACR I Time	Sets the Integral Time for the current controller during Speed Search.	Default: <1> Min.: 0.0 ms Max.: 1000.0 ms	–
b3-10 (19A)	Speed Search Detection Compensation Gain	Srch Detect Comp	Sets the gain which is applied to the speed detected by Speed Estimation Speed Search before the motor is reaccelerated. Increase this setting if ov occurs when performing Speed Search after a relatively long period of baseblock.	Default: 1.05 Min.: 1.00 Max.: 1.20	160
b3-11 (19B)	Speed Search Method Switching Level (Speed Estimation Type)	Srch Mthd Sw Lvl	Uses the amount of voltage remaining in the motor to automatically switch the search method within the type of speed measurement. (200 V class at 100% = 200 V; 400 V class at 100% = 400 V)	Default: 5.0% Min.: 0.5 Max.: 100.0	–
b3-12 (19C)	Minimum Current Detection Level during Speed Search	Srch I Deadband	Sets the minimum current detection level during Speed Search. Increase this setting value in increments of 0.1 if the drive fails to perform Speed Estimation.	Default: <2> Min.: 2.0 Max.: 10.0	–

## B.2 b: Application

No. (Addr Hex.)	Name	LCD Display	Description	Values	Page
b3-14 (19E)	Bi-Directional Speed Search Selection	Bidir Search Sel 0: Disabled 1: Enabled	0: Disabled (uses the direction of the frequency reference) 1: Enabled (drive detects which way the motor is rotating)	Default: <1> Range: 0, 1	160
b3-17 (1F0)	Speed Search Restart Current Level	SrchRestart Lvl	Sets the Speed Search restart current level as a percentage of the drive rated current.	Default: 110% Min.: 0 Max.: 200	160
b3-18 (1F1)	Speed Search Restart Detection Time	SrchRestart Time	Sets the time to detect Speed Search restart.	Default: 0.10 s Min.: 0.00 Max.: 1.00	160
b3-19 (1F2)	Number of Speed Search Restarts	Num of SrchRestr	Sets the number of times the drive can attempt to restart when performing Speed Search.	Default: 3 Min.: 0 Max.: 10	160
b3-24 (1C0)	Speed Search Method Selection	SpdSrch Method 0: CurrentDetection 1: Speed Estimation	0: Current Detection 1: Speed Estimation	Default: 0 Range: 0, 1	160
b3-25 (1C8)	Speed Search Wait Time	SpdSrch WaitTime	Sets the time the drive must wait between each Speed Search restart attempt.	Default: 0.5 s Min.: 0.0 Max.: 300.0	160
b3-27 (1C9)	Start Speed Search Select	Start srch sel 0: Start from 0 1: Start Fref>Fmin	Selects a condition to activate Speed Search Selection at Start (b3-01) or External Speed Search Command 1 or 2 from the multi-function input. 0: Triggered when a Run command is issued. (normal). 1: Triggered when an external baseblock is released.	Default: 0 Range: 0, 1	161
b3-33 (0B3F) <2>	Speed Search Selection when Run Command is Given during Uv	SpdSrch Start UV 0: Disabled 1: Enabled	Activates and deactivates Speed Search at start in accordance with whether a Run command was issued during an undervoltage (Uv) condition. Function is active when a momentary power loss (L2-01 = 1 or 2), Speed Search at start (b3-01 = 1), and coasting to a stop (b1-03 = 1) are enabled. 0: Disabled 1: Enabled	Default: 0 Range: 0, 1	–

<1> Default setting is determined by parameter A1-02, Control Method Selection.

<2> Default setting is dependent on parameter o2-04, Drive Model Selection.

<3> Available in drive software versions PRG: 1016 and later.

### ◆ b4: Timer Function

No. (Addr. Hex)	Name	Description	Values	Page
b4-01 (1A3)	Timer Function On-Delay Time	Sets the on-delay and off-delay times for a digital timer output (H2-□□=12). The output is triggered by a digital input programmed to H1-□□=18).	Default: 0.0 s Min.: 0.0 Max.: 3000.0	–
b4-02 (1A4)	Timer Function Off-Delay Time		Default: 0.0 s Min.: 0.0 Max.: 3000.0	–

### ◆ b5: PI Control

No. (Addr. Hex)	Name	LCD Display	Description	Values	Page
b5-01 (1A5)	PI Function Setting	PID Mode 0: Disabled 1: Enabled D=Fdbk 3: Fref+PID D=Fdbk	0: Disabled 1: Enabled (PI output becomes output frequency reference) 3: Enabled (PI output added to frequency reference)	Default: 0 Range: 0, 1, 3	161
b5-02 (1A6) [RUN]	Proportional Gain Setting (P)	PID Gain	Sets the proportional gain of the PI controller.	Default: 2.00 Min.: 0.00 Max.: 25.00	161
b5-03 (1A7) [RUN]	Integral Time Setting (I)	PID I Time	Sets the integral time for the PI controller.	Default: 0.5 s Min.: 0.0 Max.: 360.0	161

No. (Addr. Hex)	Name	LCD Display	Description	Values	Page
b5-04 (1A8) <input type="checkbox"/> RUN	Integral Limit Setting	PID I Limit	Sets the maximum output possible from the integrator as a percentage of the maximum output frequency.	Default: 100.0% Min.: 0.0 Max.: 100.0	161
b5-06 (1AA) <input type="checkbox"/> RUN	PI Output Limit	PID Limit	Sets the maximum output possible from the entire PI controller as a percentage of the maximum output frequency.	Default: 100.0% Min.: 0.0 Max.: 100.0	161
b5-07 (1AB) <input type="checkbox"/> RUN	PI Offset Adjustment	PID Offset	Applies an offset to the PI controller output. Set as a percentage of the maximum output frequency.	Default: 0.0% Min.: -100.0 Max.: 100.0	161
b5-08 (1AC) <input type="checkbox"/> RUN	PI Primary Delay Time Constant	PID Delay Time	Sets a low pass filter time constant on the output of the PI controller.	Default: 0.00 s Min.: 0.00 Max.: 10.00	162
b5-09 (1AD)	PI Output Level Selection	Output Level Sel 0: Normal Character 1: Rev Character	0: Normal output (direct acting) 1: Reverse output (reverse acting)	Default: 0 Range: 0, 1	162
b5-10 (1AE)	PI Output Gain Setting	Output Gain	Sets the gain applied to the PI output.	Default: 1.00 Min.: 0.00 Max.: 25.00	162
b5-11 (1AF)	PI Output Reverse Selection	Output Rev Sel 0: 0 limit 1: Reverse	0: Negative PI output triggers zero limit. 1: Rotation direction reverses with negative PI output. <b>Note:</b> When using setting 1, make sure reverse operation is permitted by b1-04.	Default: 0 Range: 0, 1	162
b5-12 (1B0)	PI Feedback Loss Detection Selection	Fb loss Det Sel 0: DO Only - Always 1: Alarm - Always 2: Fault - Always 3: DO Only@PID Enbl 4: Alarm @ PID Enbl 5: Fault @ PID Enbl	0: Digital Output Only (Remains active when PI is disabled by digital input) 1: Alarm output, drive continues operation (Remains active when PI is disabled by digital input) 2: Fault output, drive output is shut off (Remains active when PI is disabled by digital input) 3: Digital output only. No detection when PI is disabled by digital input. 4: Alarm detection. No detection when PI is disabled by digital input. 5: Fault detection. No detection when PI is disabled by digital input.	Default: 0 Range: 0 to 5	162
b5-13 (1B1)	PI Feedback Loss Detection Level	Fb loss Det Lvl	Sets the PI feedback loss detection level as a percentage of the maximum output frequency.	Default: 0% Min.: 0 Max.: 100	163
b5-14 (1B2)	PI Feedback Loss Detection Time	Fb loss Det Time	Sets a delay time for PI feedback loss.	Default: 1.0 s Min.: 0.0 Max.: 25.5	163
b5-15 (1B3)	PI Sleep Function Start Level	PID Sleep Level	Sets the frequency level that triggers the sleep/snooze function.	Default: <I> Min.: 0.0 Hz Max.: 240.0 Hz	163
b5-16 (1B4)	PI Sleep Delay Time	PID Sleep Time	Sets a delay time before the sleep/snooze function is triggered.	Default: 0.0 s Min.: 0.0 Max.: 25.5	163
b5-17 (1B5)	PI Accel/Decel Time	PID Acc/Dec Time	Sets the acceleration and deceleration time to PI setpoint.	Default: 0.0 s Min.: 0.0 Max.: 6000.0	164
b5-18 (1DC)	PI Setpoint Selection	PID Setpoint Sel 0: Disabled 1: Enabled	0: Disabled 1: Enabled	Default: 0 Range: 0, 1	164
b5-19 (1DD) <input type="checkbox"/> RUN	PI Setpoint Value	PID Setpoint	Sets the PI target value when b5-18 = 1. Set as a percentage of the maximum output frequency.	Default: 0.00% Min.: 0.00 Max.: 600.00 <?>	164
b5-20 (1E2)	PI Setpoint Scaling	PID Disp Scaling 0: 0.01Hz units 1: 0.01% units 2: r/min 3: User Units	0: 0.01 Hz units 1: 0.01% units (100% = max output frequency) 2: r/min (number of motor poles must entered) 3: User-set (set scaling to b5-38 and b5-39)	Default: 1 Range: 0 to 3	164

## B.2 b: Application

No. (Addr. Hex)	Name	LCD Display	Description	Values	Page
b5-21 (1E3)	PI Sleep Input Source	PI Sleep Ref 0: PI Setpoint 1: Frequency Ref 2: Snooze Func	Input source selection for Sleep Function mode. 0: PI Setpoint 1: SFS Input 2: Snooze	Default: 1 Range: 0 to 2	164
b5-22 (1E4)	PI Snooze Level	Snooze Level	Sets the PI Snooze Function start level as a percentage of the maximum frequency.	Default: 0% Min.: 0 Max.: 100	165
b5-23 (1E5)	PI Snooze Delay Time	Snooze DelayTime	Sets the PI Snooze Function delay time in seconds.	Default: 0s Min.: 0 Max.: 2600	165
b5-24 (1E6)	PI Snooze Deactivation Level	SnoozeRestartLvl	When the PI feedback level drops below this level, the drive returns to normal operation. Set as a percentage of the maximum frequency.	Default: 0% Min.: 0 Max.: 100	165
b5-25 (1E7)	PI Setpoint Boost Setting	SetpointBoostLvl	Temporarily increases the PI setpoint to create an overshoot of the intended PI setpoint.	Default: 0% Min.: 0 Max.: 100	165
b5-26 (1E8)	PI Maximum Boost Time	SetpointBoostTim	Sets the maximum boost time when PI feedback does not reach boost level. The Snooze Function starts when the PI feedback exceeds the boost setting level or when the boost time expires.	Default: 0s Min.: 0 Max.: 2600	165
b5-27 (1E9)	PI Snooze Feedback Level	Snooze Reset Lvl	Sets the PI feedback level above which Snooze mode is activated. Set as a percentage of the maximum frequency.	Default: 60% Min.: 0 Max.: 100	165
b5-28 (1EA)	PI Feedback Function Selection	PI Fdbk Sqrt Sel 0: Disabled 1: Enabled	0: Disabled 1: Square root	Default: 0 Range: 0, 1	165
b5-29 (1EB)	PI Square Root Gain	PI Fdbk SqrtGain	A multiplier applied to the square root of the feedback.	Default: 0.00 Min.: 0.00 Max.: 2.00	166
b5-30 (1EC)	PI Feedback Offset	PI Fdbk Offset	PI feedback offset set as a percentage of the maximum frequency.	Default: 0.00 Min.: 0.00 Max.: 100.00	166
b5-34 (19F) RUN	PI Output Lower Limit	PID Out Low Lim	Sets the minimum output possible from the PI controller as a percentage of the maximum output frequency.	Default: 0.0% Min.: -100.0 Max.: 100.0	166
b5-35 (1A0) RUN	PI Input Limit	PID Input Limit	Limits the PI control input (deviation signal) as a percentage of the maximum output frequency. Acts as a bipolar limit.	Default: 1000.0% Min.: 0.0 Max.: 1000.0	166
b5-36 (1A1)	PI Feedback High Detection Level	Fb High Det Lvl	Sets the PI feedback high detection level as a percentage of the maximum output frequency.	Default: 100% Min.: 0 Max.: 100	166
b5-37 (1A2)	PI Feedback High Detection Time	Fb High Dly Time	Sets the PI feedback high level detection delay time.	Default: 1.0 s Min.: 0.0 Max.: 25.5	166
b5-38 (1FE)	PI Setpoint User Display	PID UsrDspMaxVal	Sets the display value of U5-01 and U5-04 when the maximum frequency is output.	Default: <> Min.: 1 Max.: 60000	166
b5-39 (1FF)	PI Setpoint Display Digits	PID UsrDspDigits 0: No Dec (XXXXX) 1: 1 Dec (XXXX.X) 2: 2 Dec (XXX.XX) 3: 3 Dec (XX.XXX)	0: No decimal places 1: One decimal place 2: Two decimal places 3: Three decimal places	Default: <> Range: 0 to 3	166
b5-40 (17F)	Frequency Reference Monitor Content during PI	Fref Mon Sel@PID 0: Fref Mon w PID 1: Fref Mon w/o PID	0: Display the frequency reference (U1-01) after PI compensation has been added. 1: Display the frequency reference (U1-01) before PI compensation has been added.	Default: 0 Range: 0, 1	166

No. (Addr. Hex)	Name	LCD Display	Description	Values	Page
b5-41 (160)	PI Unit Selection	PI Mon Unit Sel 0: WC 1: PSI 2: GPM 3: °F 4: CFM 5: CMH 6: LPH 7: LPS 8: Bar 9: Pa 10: °C 11: Mtr 12: Ft 13: LPM 14: CMM	0: WC (Inch of water) 1: PSI (Pounds per square inch) 2: GPM (Gallons per minute) 3: F (Degrees Fahrenheit) 4: CFM (Cubic feet per minute) 5: CMH (Cubic meters per hour) 6: LPH (Liters per hour) 7: LPS (Liters per second) 8: Bar (Bar) 9: Pa (Pascal) 10: C (Degrees Celsius) 11: Mtr (Meters) 12: Ft (Feet) 13: LPM (Liters per minute) 14: CMM (Cubic meters per minute)	Default: 0 Range: 0 to 14	167
b5-42 (161) RUN	PI Output Monitor Calculation Method	PI Out Calc Mode 0: Linear 1: Square root 2: 1/f <sup>2</sup> 3: 1/f <sup>3</sup>	0: Linear - the monitor displays PI output 1: Square root - the monitor displays square root PI output 2: Quadratic - the monitor displays 1/(PI output) 3: Cubic - the monitor displays 1/(PI output)	Default: 0 Range: 0 to 3	167
b5-43 (162) RUN	Custom PI Output Monitor Setting 1	PI Out MonMax U4	Set maximum monitor value at maximum frequency. U5-07 and U5-08 show Custom PI output. U5-43 shows the upper four digits and U5-44 shows the lower four digits. It shows 999999.99 maximum.	Default: 0 Min.: 0 Max.: 9999	167
b5-44 (163) RUN	Custom PI Output Monitor Setting 2	PI Out MonMax L4	Sets the minimum display value at zero speed. b5-07 and b5-08 show Custom PI output. This function is effective when b5-42 is set to 1 (Linear unit)	Default: 0 Min.: 0 Max.: 99.99	167
b5-45 (164) RUN	Custom PI Output Monitor Setting 3	PI Out MonMin		Default: 0 Min.: 0 Max.: 999.9	168
b5-46 (165)	PI Setpoint Monitor Unit Selection	PI Mon Unit Sel 0: WC 1: PSI 2: GPM 3: °F 4: CFM 5: CMH 6: LPH 7: LPS 8: Bar 9: Pa 10: °C 11: Mtr 12: Ft 13: LPM 14: CMM	0: WC (Inch of water) 1: PSI (Pounds per square inch) 2: GPM (Gallons per minute) 3: F (Degrees Fahrenheit) 4: CFM (Cubic feet per minute) 5: CMH (Cubic meters per hour) 6: LPH (Liters per hour) 7: LPS (Liters per second) 8: Bar (Bar) 9: Pa (Pascal) 10: C (Degrees Celsius) 11: Mtr (Meters) 12: Ft (Feet) 13: LPM (Liters per minute) 14: CMM (Cubic meters per minute)	Default: 0 Range: 0 to 14	168
b5-47 (17D)	Reverse Operation Selection 2 by PI Output	Output Rev Sel2 0: 0 limit 1: Reverse	Reverse operation selection when b5-01 = 3 0: Reverse Disabled 1: Reverse Enabled	Default: 1 Range: 0, 1	168

<1> Default setting is determined by parameter A1-02, Control Method Selection.

<2> Internally limited to the value of b5-38 in drive software versions PRG: 1014 and later. Changing b5-20, b5-38, and b5-39 will not automatically update the value of this parameter.

<3> Default setting is dependent on parameter b5-20, PI Setpoint Scaling.

### ◆ b8: Energy Saving

No. (Addr. Hex)	Name	LCD Display	Description	Values	Page
b8-01 (1CC)	Energy Saving Control Selection	Energy Save Sel 0: Disabled 1: Enabled	0: Disabled 1: Enabled	Default: <1> Range: 0, 1	–
b8-04 (1CF)	Energy Saving Coefficient Value	Energy Save COEF	Determines the level of maximum motor efficiency. Setting range is 0.0 to 2000.0 for drives 3.7 kW and smaller.	Default: <2> <3> Min.: 0.00 Max.: 655.00	–
b8-05 (1D0)	Power Detection Filter Time	kW Filter Time	Sets a time constant filter for output power detection.	Default: 20 ms Min.: 0 Max.: 2000	–
b8-06 (1D1)	Search Operation Voltage Limit	Search V Limit	Sets the limit for the voltage search operation as a percentage of the motor rated voltage.	Default: 0% Min.: 0 Max.: 100	–

<1> Default setting is determined by parameter A1-02, Control Method Selection.

<2> Default setting is determined by parameters A1-02, Control Method Selection, and o2-04, Drive Model Selection.

<3> Parameter value changes automatically if E2-11 is manually changed or changed by Auto-Tuning.

## B.3 C: Tuning

C parameters are used to adjust the acceleration and deceleration times, S-curves, torque compensation, and carrier frequency selections.

### ◆ C1: Acceleration and Deceleration Times

No. (Addr. Hex)	Name	LCD Display	Description	Values	Page
C1-01 (200) RUN	Acceleration Time 1	Accel Time 1	Sets the time to accelerate from 0 to maximum frequency.	Default: 30.0 s Min.: 0.1 Max.: 6000.0	132
C1-02 (201) RUN	Deceleration Time 1	Decel Time 1	Sets the time to decelerate from maximum frequency to 0.		132
C1-03 (202) RUN	Acceleration Time 2	Accel Time 2	Sets the time to accelerate from 0 to maximum frequency.	Default: 30.0 s Min.: 0.1 Max.: 6000.0	132
C1-04 (203) RUN	Deceleration Time 2	Decel Time 2	Sets the time to decelerate from maximum frequency to 0.		132
C1-09 (208)	Fast Stop Time	Fast Stop Time	Sets the time for the Fast Stop function.	Default: 10.0 s Min.: 0.1 Max.: 6000.0	–
C1-11 (20A)	Accel/Decel Time Switching Frequency	Acc/Dec SW Freq	Sets the frequency to switch between accel/decel time settings. Setting units are determined by parameter A1-02, Control Method Selection.	Default: 0.0 Hz Min.: 0.0 Max.: 240.0	–

### ◆ C2: S-Curve Characteristics

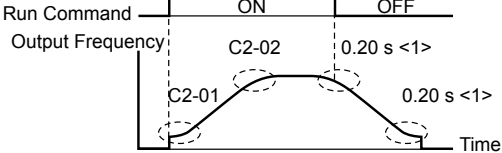
No. (Addr. Hex)	Name	LCD Display	Description	Values	Page
C2-01 (20B)	S-Curve Characteristic at Accel Start	SCrv Acc @ Start	The S-curve can be controlled at the four points shown below. 	Default: <1> Min.: 0.00 s Max.: 10.00 s	168
C2-02 (20C)	S-Curve Characteristic at Accel End	SCrv Acc @ End		Default: 0.20 s Min.: 0.00 Max.: 10.00	168

<1> S-curve characteristics at decel start/end are fixed to 0.20 s.

<2> Default setting is determined by parameter A1-02, Control Method Selection.

### ◆ C4: Torque Compensation

No. (Addr. Hex)	Name	LCD Display	Description	Values	Page
C4-01 (215) RUN	Torque Compensation Gain	Torq Comp Gain	Sets the gain for the automatic torque (voltage) boost function and helps to produce better starting torque. Used for motor 1.	Default: <1> Min.: 0.00 Max.: 2.50	–
C4-02 (216) RUN	Torque Compensation Primary Delay Time 1	Torq Comp Time	Sets the torque compensation filter time.	Default: <2> Min.: 0 ms Max.: 60000 ms	–

<1> Default setting is determined by parameter A1-02, Control Method Selection.

<2> Default setting is determined by parameters A1-02, Control Method Selection, and o2-04, Drive Model Selection.

**◆ C6: Carrier Frequency**

No. (Addr. Hex)	Name	LCD Display	Description	Values	Page
C6-02 (224)	Carrier Frequency Selection	CarrierFreq Sel 1: 2.0 kHz 2: 5.0 kHz 3: 8.0 kHz 4: 10.0 kHz 5: 12.5 kHz 6: 15.0 kHz 7: Swing PWM1 (Audible sound 1) 8: Swing PWM2 (Audible sound 2) 9: Swing PWM3 (Audible sound 3) A: Swing PWM4 (Audible sound 4) B to E: No setting possible F: Program	1: 2.0 kHz 2: 5.0 kHz 3: 8.0 kHz 4: 10.0 kHz 5: 12.5 kHz 6: 15.0 kHz 7: Swing PWM1 (Audible sound 1) 8: Swing PWM2 (Audible sound 2) 9: Swing PWM3 (Audible sound 3) A: Swing PWM4 (Audible sound 4) B to E: No setting possible F: User-defined (determined by C6-03 through C6-05)	Default: <1> Range: 1 to 9; A, F	133
C6-03 (225)	Carrier Frequency Upper Limit	CarrierFreq Max	<p>Determines the upper and lower limits for the carrier frequency.</p>	Default: <2> Min.: 1.0 kHz Max.: 15.0 kHz	169
C6-04 (226)	Carrier Frequency Lower Limit	CarrierFreq Min		Default: <2> Min.: 1.0 kHz Max.: 15.0 kHz	169
C6-05 (227)	Carrier Frequency Proportional Gain	CarrierFreq Gain		Default: <2> Min.: 0 Max.: 99	169







<1> Default setting value is dependent on parameters A1-02, Control Method Selection and o2-04, Drive Model Selection.

<2> Default setting value is dependent on parameter C6-02, Carrier Frequency Selection.

## B.4 d: References

Reference parameters set the various frequency reference values during operation.

### ◆ d1: Frequency Reference

No. (Addr. Hex)	Name	LCD Display	Description	Values	Page
d1-01 (280) 	Frequency Reference 1	Reference 1	Sets the frequency reference for the drive. Setting units are determined by parameter o1-03.	Default: 0.00 Hz Min.: 0.00 Max.: 240.00 <I>	169
d1-02 (281) 	Frequency Reference 2	Reference 2	Sets the frequency reference for the drive. Setting units are determined by parameter o1-03.	Default: 0.00 Hz Min.: 0.00 Max.: 240.00 <I>	169
d1-03 (282) 	Frequency Reference 3	Reference 3	Sets the frequency reference for the drive. Setting units are determined by parameter o1-03.	Default: 0.00 Hz Min.: 0.00 Max.: 240.00 <I>	169
d1-04 (283) 	Frequency Reference 4	Reference 4	Sets the frequency reference for the drive. Setting units are determined by parameter o1-03.	Default: 0.00 Hz Min.: 0.00 Max.: 240.00 <I>	169
d1-16 (291) 	Frequency Reference 16	Reference 16	Sets the frequency reference for the drive. Setting units are determined by parameter o1-03.	Default: 0.00 Hz Min.: 0.00 Max.: 240.00 <I>	169
d1-17 (292) 	Jog Frequency Reference	Jog Reference	Sets the Jog frequency reference. Setting units are determined by parameter o1-03.	Default: 6.00 Hz Min.: 0.00 Max.: 240.0 <I>	169

<I> Range upper limit is determined by parameters d2-01, Frequency Reference Upper Limit, and E1-04, Maximum Output Frequency.

### ◆ d2: Frequency Upper/Lower Limits

No. (Addr. Hex.)	Name	LCD Display	Description	Setting	Page
d2-01 (289)	Frequency Reference Upper Limit	Ref Upper Limit	Sets the frequency reference upper limit as a percentage of the maximum output frequency.	Default: 100.0% Min.: 0.0 Max.: 110.0	133
d2-02 (28A)	Frequency Reference Lower Limit	Ref Lower Limit	Sets the frequency reference lower limit as a percentage of the maximum output frequency.	Default: 0.0% Min.: 0.0 Max.: 110.0	133
d2-03 (293)	Master Speed Reference Lower Limit	Ref1 Lower Limit	Sets the lower limit for frequency references from analog inputs as a percentage of the maximum output frequency.	Default: 0.0% Min.: 0.0 Max.: 110.0	170

◆ d3: Jump Frequency

No. (Addr. Hex)	Name	LCD Display	Description	Values	Page
d3-01 (294)	Jump Frequency 1	Jump Freq 1	Eliminates problems with resonant vibration of the motor/machine by avoiding continuous operation in predefined frequency ranges. The drive accelerates and decelerates the motor through the prohibited frequency ranges. Setting 0.0 disables this function. Parameters must be set so that $d3-01 \geq d3-02 \geq d3-03$ .	Default: 0.0 Hz Min.: 0.0 Max.: 240.0	171
d3-02 (295)	Jump Frequency 2	Jump Freq 2	Eliminates problems with resonant vibration of the motor/machine by avoiding continuous operation in predefined frequency ranges. The drive accelerates and decelerates the motor through the prohibited frequency ranges. Setting 0.0 disables this function. Parameters must be set so that $d3-01 \geq d3-02 \geq d3-03$ .	Default: 0.0 Hz Min.: 0.0 Max.: 240.0	171
d3-03 (296)	Jump Frequency 3	Jump Freq 3	Eliminates problems with resonant vibration of the motor/machine by avoiding continuous operation in predefined frequency ranges. The drive accelerates and decelerates the motor through the prohibited frequency ranges. Setting 0.0 disables this function. Parameters must be set so that $d3-01 \geq d3-02 \geq d3-03$ .	Default: 0.0 Hz Min.: 0.0 Max.: 240.0	171
d3-04 (297)	Jump Frequency Width	Jump Bandwidth	Sets the dead-band width around each selected prohibited frequency reference point.	Default: 1.0 Hz Min.: 0.0 Max.: 20.0	171

◆ d4: Frequency Reference Hold Function

No. (Addr. Hex)	Name	LCD Display	Description	Values	Page
d4-01 (298)	Frequency Reference Hold Function Selection	Fref Hold Sel 0: Disabled 1: Enabled	0: Disabled. Drive starts from zero when the power is switched on. 1: Enabled. At power up, the drive starts the motor at the Hold frequency that was saved.	Default: 0 Range: 0, 1	–
d4-10 (2B6)	Up/Down Frequency Reference Limit Selection	Up/Dn LowLim Sel 0: D2-02 or Analog 1: D2-02 Only	0: The lower limit is determined by d2-02 or an analog input. 1: The lower limit is determined by d2-02.	Default: 0 Range: 0, 1	–

◆ d6: Field Weakening

No. (Addr. Hex)	Name	LCD Display	Description	Values	Page
d6-01 (2A0)	Field Weakening Level	Field-Weak Lvl	Sets the drive output voltage for the Field Weakening function as a percentage of the maximum output voltage. Enabled when a multi-function input is set for Field Weakening (H1-□□ = 63).	Default: 80% Min.: 0 Max.: 100	–
d6-02 (2A1)	Field Weakening Frequency Limit	Field-Weak Freq	Sets the lower limit of the frequency range where Field Weakening control is valid. The Field Weakening command is valid only at frequencies above this setting and only when the output frequency matches the frequency reference (speed agree).	Default: 0.0 Hz Min.: 0.0 Max.: 240.0	–

## ◆ d7: Offset Frequency

No. (Addr. Hex)	Name	LCD Display	Description	Setting	Page
d7-01 (2B2) <u>RUN</u>	Offset Frequency 1	Offset Freq 1	Added to the frequency reference when the digital input "Frequency offset 1" (H1-□□ = 44) is switched on.	Default: 0.0% Min.: -100.0 Max.: 100.0	–
d7-02 (2B3) <u>RUN</u>	Offset Frequency 2	Offset Freq 2	Added to the frequency reference when the digital input "Frequency offset 2" (H1-□□ = 45) is switched on.	Default: 0.0% Min.: -100.0 Max.: 100.0	–
d7-03 (2B4) <u>RUN</u>	Offset Frequency 3	Offset Freq 3	Added to the frequency reference when the digital input "Frequency offset 3" (H1-□□ = 46) is switched on.	Default: 0.0% Min.: -100.0 Max.: 100.0	–

## B.5 E: Motor Parameters

### ◆ E1: V/f Pattern for Motor 1

No. (Addr. Hex)	Name	LCD Display	Description	Values	Page
E1-01 (300)	Input Voltage Setting	Input Voltage	This parameter must be set to the power supply voltage. <b>WARNING!</b> <i>Electrical Shock Hazard. Drive input voltage (not motor voltage) must be set in E1-01 for the protective features of the drive to function properly. Failure to do so may result in equipment damage and/or death or personal injury.</i>	Default: 230 V <I> Min.: 190 Max.: 240 <I>	134
E1-03 (302)	V/f Pattern Selection	V/F Selection 0: 50 Hz 1: 60 Hz Saturation 2: 60 Hz Saturation 3: 72 Hz 4: 50 Hz VT1 5: 50 Hz VT2 6: 60 Hz VT1 7: 60 Hz VT2 8: 50 Hz HST1 9: 50 Hz HST2 A: 60 Hz HST1 B: 60 Hz HST2 C: 90 Hz D: 120 Hz E: 180 Hz F: Custom V/F	0: 50 Hz, Constant torque 1 1: 60 Hz, Constant torque 2 2: 60 Hz, Constant torque 3 (50 Hz base) 3: 72 Hz, Constant torque 4 (60 Hz base) 4: 50 Hz, Variable torque 1 5: 50 Hz, Variable torque 2 6: 60 Hz, Variable torque 3 7: 60 Hz, Variable torque 4 8: 50 Hz, High starting torque 1 9: 50 Hz, High starting torque 2 A: 60 Hz, High starting torque 3 B: 60 Hz, High starting torque 4 C: 90 Hz (60 Hz base) D: 120 Hz (60 Hz base) E: 180 Hz (60 Hz base) F: Custom V/f E1-04 through E1-13 settings define the V/f pattern	Default: F <>> Range: 0 to 9; A to F	171
E1-04 (303)	Maximum Output Frequency	Max Frequency	<p>These parameters are only applicable when E1-03 is set to F. To set linear V/f characteristics, set the same values for E1-07 and E1-09.</p> <p>In this case, the setting for E1-08 will be disregarded. Ensure that the four frequencies are set according to these rules:  <math>E1-09 \leq E1-07 &lt; E1-06 \leq E1-11 \leq E1-04</math>                      Output Voltage (V)</p> <p>Frequency (Hz)</p>	Default: <>> <>> Min.: 40.0 Hz Max.: 240.0 Hz	134
E1-05 (304)	Maximum Voltage	Max Voltage		Default: <>> <>> Min.: 0.0 V Max.: 255.0 V <I>	134
E1-06 (305)	Base Frequency	Base Frequency		Default: <>> <>> Min.: 0.0 Hz Max.: 240.0 Hz	134
E1-07 (306)	Middle Output Frequency	Mid Frequency A		Default: <>> Min.: 0.0 Hz Max.: 240.0 Hz	134
E1-08 (307)	Middle Output Frequency Voltage	Mid Voltage A		Default: <>> Min.: 0.0 V Max.: 255.0 V <I>	134
E1-09 (308)	Minimum Output Frequency	Min Frequency		Default: <>> <>> Min.: 0.0 Hz Max.: 240.0 Hz	134
E1-10 (309)	Minimum Output Frequency Voltage	Min Voltage		Default: <>> Min.: 0.0 V Max.: 255.0 V <I>	134
E1-11 (30A) <6>	Middle Output Frequency 2	Mid Frequency B		Default: 0.0 Hz Min.: 0.0 Max.: 240.0	134
E1-12 (30B) <6>	Middle Output Frequency Voltage 2	Mid Voltage B		Default: 0.0 V Min.: 0.0 Max.: 255.0 <I>	134
E1-13 (30C)	Base Voltage	Base Voltage		Default: 0.0 V <>> Min.: 0.0 Max.: 255.0 <I>	134

**Note:** E1-07, E1-08, and E1-10 to E1-13 are not available in OLV/PM control mode.

- <1> Values shown are specific to 200 V class drives. Double the value for 400 V class drives.
- <2> Parameter setting value is not reset to the default value when the drive is initialized.
- <3> Default setting is dependent on parameters A1-02, Control Model Selection and o2-04, Drive Model Selection.
- <4> Default setting is dependent on parameter o2-04, Drive Model Selection.
- <5> When Auto-Tuning is performed, E1-13 and E1-05 will be set to the same value.
- <6> Parameter ignored when E1-11 (Motor 1 Mid Output Frequency 2) and E1-12 (Motor 1 Mid Output Frequency Voltage 2) are set to 0.0.

◆ E2: Motor Parameters

No. (Addr. Hex)	Name	LCD Display	Description	Values	Page
E2-01 (30E)	Motor Rated Current	Motor Rated FLA	Sets the motor nameplate full load current in amps. Automatically set during Auto-Tuning.	Default: <1> Min.: 10% of drive rated current Max.: 200% of drive rated current <2>	135
E2-02 (30F)	Motor Rated Slip	Motor Rated Slip	Sets the motor rated slip. Automatically set during Auto-Tuning.	Default: <1> Min.: 0.00 Hz Max.: 20.00 Hz	–
E2-03 (310)	Motor No-Load Current	No-Load Current	Sets the no-load current for the motor. Automatically set during Auto-Tuning.	Default: <1> Min.: 0 A Max.: E2-01 <2>	–
E2-04 (311)	Number of Motor Poles	Number of Poles	Sets the number of motor poles. Automatically set during Auto-Tuning.	Default: 4 Min.: 2 Max.: 48	–
E2-05 (312)	Motor Line-to-Line Resistance	Term Resistance	Sets the phase-to-phase motor resistance. Automatically set during Auto-Tuning.	Default: <1> Min.: 0.000 Ω Max.: 65.000 Ω	–
E2-10 (317)	Motor Iron Loss for Torque Compensation	Motor Iron Loss	Sets the motor iron loss.	Default: <1> Min.: 0 W Max.: 65535 W	–
E2-11 (318)	Motor Rated Power	Mtr Rated Power	Sets the motor rated power in kilowatts (1 HP = 0.746 kW). Automatically set during Auto-Tuning.	Default: <1> Min.: 0.00 kW Max.: 370.00 kW	135

- <1> Default setting is dependent on parameter o2-04, Drive Model Selection.
- <2> The number of decimal places in the parameter value depends on the drive model. This value has two decimal places (0.01 A) if the drive is set for a maximum applicable motor capacity up to and including 11 kW, 2A0031, 4A0021 (input voltage 460 V or higher) or 4A0027 (input voltage lower than 460 V) and one decimal place (0.1 A) if the maximum applicable motor capacity is higher than 11 kW, 2A0046, 4A0027 (input voltage 460 V or higher) or 4A0034 (input voltage lower than 460 V) .

◆ E5: PM Motor Settings

No. (Addr. Hex)	Name	LCD Display	Description	Values	Page
E5-02 (32A) <1>	Motor Rated Power	PM Mtr Capacity	<b>OLV/PM</b> Sets the rated capacity of the motor.	Default: <2> Min.: 0.10 kW Max.: 370.00 kW	135
E5-03 (32B) <1>	Motor Rated Current	PM Mtr Rated FLA	<b>OLV/PM</b> Sets the motor rated current.	Default: <2> Min: 10% of drive rated current Max: 200% of drive rated current <3>	135
E5-04 (32C) <1>	Number of Motor Poles	PM Motor Poles	<b>OLV/PM</b> Sets the number of motor poles.	Default: <2> Min.: 2 Max.: 48	136

## B.5 E: Motor Parameters

No. (Addr. Hex)	Name	LCD Display	Description	Values	Page
E5-05 (32D) </>	Motor Stator Resistance	PM Mtr Arm Ohms	<b>OLV/PM</b> Set the resistance for each motor phase.	Default: </> Min.: 0.000 Ω Max.: 65.000 Ω	136
E5-06 (32E) </>	Motor d-Axis Inductance	PM Mtr d Induct	<b>OLV/PM</b> Sets the d-Axis inductance for the PM motor.	Default: </> Min.: 0.00 mH Max.: 300.00 mH	136
E5-07 (32F) </>	Motor q-Axis Inductance	PM Mtr q Induct	<b>OLV/PM</b> Sets the q-Axis inductance for the PM motor.	Default: </> Min.: 0.00 mH Max.: 600.00 mH	136
E5-09 (331) </>	Motor Induction Voltage Constant 1	PM Mtr Ind V 1	<b>OLV/PM</b> Sets the induced peak voltage per phase in units of 0.1 mV/(rad/s) [electrical angle]. Set this parameter when using an IPM motor with variable torque. Set E5-24 to 0 when setting this parameter.	Default: </> Min.: 0.0 mV/(rad/s) Max.: 2000.0 mV/(rad/s)	136
E5-24 (353) </>	Motor Induction Voltage Constant 2	PM Mtr Ind V 2	<b>OLV/PM</b> Sets the induced phase-to-phase rms voltage in units of 0.1 mV/(r/min) [mechanical angle].	Default: </> Min.: 0.0 mV/(r/min) Max.: 6500.0 mV/(r/min)	136

<1> Selections may vary depending on the setting entered to o2-04.

<2> Default setting is dependent on parameter o2-04, Drive Model Selection.

<3> The number of decimal places in the parameter value depends on the drive model. This value has two decimal places (0.01 A) if the drive is set for a maximum applicable motor capacity up to and including 11 kW, and one decimal place (0.1 A) if the maximum applicable motor capacity is higher than 11 kW.

## B.6 F: Communication Option Parameters

### ◆ F6, F7: Communication Option Card

Parameters F6-01 through F6-03 and F6-06 through F6-08 are used for EtherNet/IP, Modbus TCP/IP, and LONWORKS options. F7 parameters are used for the EtherNet/IP and Modbus TCP/IP options.

No. (Addr. Hex)	Name	LCD Display	Description	Values	Page
F6-01 (3A2)	Communications Error Operation Selection	Comm Bus Flt Sel 0: Ramp to Stop 1: Coast to Stop 2: Fast-Stop 3: Alarm Only 4: Alarm (d1-04)	0: Ramp to stop. Decelerate to stop using the deceleration time in C1-02. 1: Coast to stop. 2: Fast Stop. Decelerate to stop using the deceleration time in C1-09. 3: Alarm only. </> 4: Alarm only. Continue operation using the frequency reference set in d1-04. </> </>	Default: 1 Range: 0 to 4	–
F6-02 (3A3)	External Fault from Comm. Option Detection Selection	EF0 Detection 0: Always Detected 1: Only During Run	0: Always detected. 1: Detection during run only.	Default: 0 Range: 0, 1	–
F6-03 (3A4)	External Fault from Comm. Option Operation Selection	EF0 Fault Action 0: Ramp to Stop 1: Coast to Stop 2: Fast-Stop 3: Alarm Only	0: Ramp to stop. Decelerate to stop using the deceleration time in C1-02. 1: Coast to stop. 2: Fast Stop. Decelerate to stop using the deceleration time in C1-09. 3: Alarm only. </>	Default: 1 Range: 0 to 3	–
F6-06 (3A7)	Torque Reference/Torque Limit Selection from Comm. Option	Torq Ref/Lmt Sel 0: Disabled 1: Enabled	<b>OLV/PM</b> 0: Disabled. Torque reference/limit from option board disabled. 1: Enabled. Torque reference/limit from option board enabled.	Default: 0 Range: 0, 1	–
F6-07 (3A8)	Multi-Step Speed Enable/Disable Selection when NefRef/ComRef is Selected	Fref PrioritySel 0: Net/Com REF 1: MultiStep Speed	0: Multi-step reference disabled (same as F7) 1: Multi-step reference enabled (same as V7)	Default: 0 Range: 0, 1	–
F6-08 (36A) </>	Reset Communication Parameters	Com Prm Init Sel 0: Init Com Prms 1: No Init Com Prms	0: Communication-related parameters (F6-□□) are not reset when the drive is initialized using A1-03. 1: Reset all communication-related parameters (F6-□□) when the drive is initialized using A1-03.	Default: 0 Range: 0, 1	–
F7-01 (3E5) </> </> </>	IP Address 1	IP Address 1	Sets the most significant octet of network static IP address.	Default: 192 Min.: 0 Max.: 255	–
F7-02 (3E6) </> </> </>	IP Address 2	IP Address 2	Sets the second most significant octet of network static IP address.	Default: 168 Min.: 0 Max.: 255	–
F7-03 (3E7) </> </> </>	IP Address 3	IP Address 3	Sets the third most significant octet of network static IP address.	Default: 1 Min.: 0 Max.: 255	–
F7-04 (3E8) </> </> </>	IP Address 4	IP Address 4	Sets the fourth most significant octet of network static IP address.	Default: 20 Min.: 0 Max.: 255	–
F7-05 (3E9) </>	Subnet Mask 1	Subnet Mask 1	Sets the most significant octet of network static Subnet Mask.	Default: 255 Min.: 0 Max.: 255	–
F7-06 (3EA) </>	Subnet Mask 2	Subnet Mask 2	Sets the second most significant octet of network static Subnet Mask.	Default: 255 Min.: 0 Max.: 255	–
F7-07 (3EB) </>	Subnet Mask 3	Subnet Mask 3	Sets the third most significant octet of network static Subnet Mask.	Default: 255 Min.: 0 Max.: 255	–

## B.6 F: Communication Option Parameters

No. (Addr. Hex)	Name	LCD Display	Description	Values	Page
F7-08 (3EC) <6>	Subnet Mask 4	Subnet Mask 4	Sets the fourth most significant octet of network static Subnet Mask.	Default: 0 Min.: 0 Max.: 255	–
F7-09 (3ED) <6>	Gateway Address 1	Gateway IP Add 1	Sets the most significant octet of network Gateway address.	Default: 192 Min.: 0 Max.: 255	–
F7-10 (3EE) <6>	Gateway Address 2	Gateway IP Add 2	Sets the second most significant octet of network Gateway address.	Default: 168 Min.: 0 Max.: 255	–
F7-11 (3EF) <6>	Gateway Address 3	Gateway IP Add 3	Sets the third most significant octet of network Gateway address.	Default: 1 Min.: 0 Max.: 255	–
F7-12 (3E0) <6>	Gateway Address 4	Gateway IP Add 4	Sets the fourth most significant octet of network Gateway address.	Default: 1 Min.: 0 Max.: 255	–
F7-13 (3F1)	Address Mode at Startup	IP Add Mode Sel 0: User Defined 1: BOOTP 2: DHCP	Select the option address setting method 0: Static <5> <6> 1: BOOTP 2: DHCP	Default: 2 Range: 0 to 2	–
F7-14 (3F2)	Duplex Mode Selection	Duplex Select 0: Half Duplex 1: Auto Negotiate 2: Full Duplex	Selects duplex mode setting. 0: Half duplex forced <7> 1: Auto-negotiate duplex mode and communication speed 2: Full duplex forced <7>	Default: 1 Range: 0 to 2	–
F7-15 (3F3) <7>	Communication Speed Selection	Baud Rate 10: 10 Mbps 100: 100 Mbps	Sets the communication speed 10: 10 Mbps 100: 100 Mbps	Default: 10 Range: 10, 100	–
F7-16 (3F4)	Communication Loss Timeout	CommLoss Tout	Sets the timeout value in tenths of a second for communication loss detection. Example: Setting this parameter to 100 represents 10.0 seconds. Setting this parameter to 0 disables the connection timeout.	Default: 0 Min.: 0 Max.: 300	–
F7-17 (3F5)	EtherNet/IP Speed Scaling Factor	EN Speed Scale	Sets the scaling factor for the speed monitor in EtherNet/IP Class ID 2AH Object.	Default: 0 Min.: -15 Max.: 15	–
F7-18 (3F6)	EtherNet/IP Current Scaling Factor	EN Current Scale	Sets the scaling factor for the output current monitor in EtherNet/IP Class ID 2AH Object.	Default: 0 Min.: -15 Max.: 15	–
F7-19 (3F7)	EtherNet/IP Torque Scaling Factor	EN Torque Scale	Sets the scaling factor for the torque monitor in EtherNet/IP Class ID 2AH Object.	Default: 0 Min.: -15 Max.: 15	–
F7-20 (3F8)	EtherNet/IP Power Scaling Factor	EN Power Scale	Sets the scaling factor for the power monitor in EtherNet/IP Class ID 2AH Object.	Default: 0 Min.: -15 Max.: 15	–
F7-21 (3F9)	EtherNet/IP Voltage Scaling Factor	EN Voltage Scale	Sets the scaling factor for the voltage monitor in EtherNet/IP Class ID 2AH Object.	Default: 0 Min.: -15 Max.: 15	–
F7-22 (3FA)	EtherNet/IP Time Scaling	EN Time Scale	Sets the scaling factor for the time monitor in EtherNet/IP Class ID 2AH Object.	Default: 0 Min.: -15 Max.: 15	–
F7-23 to F7-32 (3FB to 374)	Dynamic Output Assembly Parameters	–	Parameters used in Output Assembly 116. Each parameter contains a MEMOBUS/Modbus address. The value received for Output Assembly 116 will be written to this corresponding MEMOBUS/Modbus address. A MEMOBUS/Modbus address value of 0 means that the value received for Output Assembly 116 will not be written to any MEMOBUS/Modbus register.	Default: 0	–
F7-33 to F7-42 (375 to 37E)	Dynamic Input Assembly Parameters	–	Parameters used in Input Assembly 166. Each parameter contains a MEMOBUS/Modbus address. The value sent for Input Assembly 166 will be read from this corresponding MEMOBUS/Modbus address. A MEMOBUS/Modbus address value of 0 means that the value sent for Input Assembly 166 is not defined by the user, therefore the option default register value will be returned.	Default: 0	–

<1> When using this setting, be sure to take safety measures, such as installing an emergency stop switch. The drive will continue to operate when a fault is detected.

- <2> Available in drive software versions PRG: 1017 and later.
- <3> Parameter setting value is not reset to the default value when the drive is initialized.
- <4> Cycle power for setting changes to take effect.
- <5> When setting F7-13 to 0, all IP addresses (F7-01 to F7-04) must be unique.
- <6> When setting F7-13 to 0, also set parameters F7-01 to F7-12.
- <7> When F7-14 is set to 0 or 2, be sure to also set F7-15.

## B.7 H Parameters: Multi-Function Terminals

H parameters assign functions to the multi-function input and output terminals.

### ◆ H1: Multi-Function Digital Inputs

No. (Addr. Hex)	Name	LCD Display	Description	Values	Page
H1-01 (438)	Multi-Function Digital Input Terminal S1 Function Selection	Term S1 Func Sel	Assigns a function to the multi-function digital inputs. Refer to pages 300 to 303 for descriptions of setting values. <b>Note:</b> Set unused terminals to F.	Default: 40 (F) </> Min.: 1 Max.: B2	–
H1-02 (439)	Multi-Function Digital Input Terminal S2 Function Selection	Term S2 Func Sel	Assigns a function to the multi-function digital inputs. Refer to pages 300 to 303 for descriptions of setting values. <b>Note:</b> Set unused terminals to F.	Default: 41 (F) </> Min.: 1 Max.: B2	–
H1-03 (400)	Multi-Function Digital Input Terminal S3 Function Selection	Term S3 Func Sel	Assigns a function to the multi-function digital inputs. Refer to pages 300 to 303 for descriptions of setting values. <b>Note:</b> Set unused terminals to F.	Default: 24 Min.: 0 Max.: B2	–
H1-04 (401)	Multi-Function Digital Input Terminal S4 Function Selection	Term S4 Func Sel	Assigns a function to the multi-function digital inputs. Refer to pages 300 to 303 for descriptions of setting values. <b>Note:</b> Set unused terminals to F.	Default: 14 Min.: 0 Max.: B2	–
H1-05 (402)	Multi-Function Digital Input Terminal S5 Function Selection	Term S5 Func Sel	Assigns a function to the multi-function digital inputs. Refer to pages 300 to 303 for descriptions of setting values. <b>Note:</b> Set unused terminals to F.	Default: 3 (0) </> Min.: 0 Max.: B2	–
H1-06 (403)	Multi-Function Digital Input Terminal S6 Function Selection	Term S6 Func Sel	Assigns a function to the multi-function digital inputs. Refer to pages 300 to 303 for descriptions of setting values. <b>Note:</b> Set unused terminals to F.	Default: 4 (3) </> Min.: 0 Max.: B2	–
H1-07 (404)	Multi-Function Digital Input Terminal S7 Function Selection	Term S7 Func Sel	Assigns a function to the multi-function digital inputs. Refer to pages 300 to 303 for descriptions of setting values. <b>Note:</b> Set unused terminals to F.	Default: 6 (4) </> Min.: 0 Max.: B2	–

</> Value in parenthesis is the default setting when a 3-Wire initialization is performed (A1-03 = 3330).

H1 Multi-Function Digital Input Selections					
H1-□□ Setting	Function	LCD Display	Description	Page	
0	3-Wire sequence	3-Wire Control	Closed: Reverse rotation (only if the drive is set up for 3-Wire sequence) Terminals S1 and S2 are automatically set up for the Run command and Stop command.	–	
3	Multi-Step Speed Reference 1	Multi-Step Ref 1	When input terminals are set to Multi-Step Speed References 1 through 3, switching combinations of those terminals will create a multi-step speed sequence using the frequency references set in d1-01 through d1-08.	–	
4	Multi-Step Speed Reference 2	Multi-Step Ref 2	When input terminals are set to Multi-Step Speed References 1 through 3, switching combinations of those terminals will create a multi-step speed sequence using the frequency references set in d1-01 through d1-08.	–	
6	Jog reference selection	jog Freq Ref	Closed: Jog frequency reference (d1-17) selected. Jog has priority over all other reference sources.	–	
7	Accel/decel time selection 1	Multi-Acc/Dec 1	Used to switch between accel/decel time 1 (set in C1-01, C1-02) and accel/decel time 2 (set in C1-03, C1-04).	–	
8	Baseblock command (N.O.)	Ext BaseBlk N.O.	Closed: No drive output	–	
9	Baseblock command (N.C.)	Ext BaseBlk N.C.	Open: No drive output	–	
A	Accel/decel ramp hold	Acc/Dec RampHold	Open: Accel/decel is not held Closed: The drive pauses during acceleration or deceleration and maintains the output frequency.	–	
B	Drive overheat alarm (oH2)	OH2 Alarm Signal	Closed: Closes when an oH2 alarm occurs	–	
C	Analog terminal input selection	Term A2 Enable	Open: Function assigned by H3-14 is disabled. Closed: Function assigned by H3-14 is enabled.	–	

H1 Multi-Function Digital Input Selections				
H1-□□ Setting	Function	LCD Display	Description	Page
F	Through mode	Term Not Used	Select this setting when using the terminal in a pass-through mode. The terminal does not trigger a drive function, but it can be used as digital input for the controller to which the drive is connected.	–
10	Up command	Up Command 1	The drive accelerates when the Up command terminal closes, and decelerates when the Down command closes. When both terminals are closed or both are open, the drive holds the frequency reference. The Up and Down commands must always be used in conjunction with one another.	–
11	Down command	Down Command 1	The drive accelerates when the Up command terminal closes, and decelerates when the Down command closes. When both terminals are closed or both are open, the drive holds the frequency reference. The Up and Down commands must always be used in conjunction with one another.	–
12	Forward Jog	Forward Jog	Closed: Runs forward at the Jog frequency d1-17.	–
13	Reverse Jog	Reverse Jog	Closed: Runs reverse at the Jog frequency d1-17.	–
14	Fault reset	Fault Reset	Closed: Resets faults if the cause is cleared and the Run command is removed.	–
15	Fast Stop (N.O.)	Fast-Stop N.O.	Closed: Decelerates at the Fast Stop time set to C1-09.	–
17	Fast Stop (N.C.)	Fast-Stop N.C.	Open: Decelerates to stop at the Fast Stop time set to C1-09.	–
18	Timer function input	Timer function	Triggers the timer set up by parameters b4-01 and b4-02. Must be set in conjunction with the timer function output (H2-□□ = 12).	–
19	PI disable	PID Disable	Open: PI control enabled Closed: PI control disabled	–
1B	Program lockout	Program Lockout	Open: Parameters cannot be edited (except for U1-01 if the reference source is assigned to the HOA keypad). Closed: Parameters can be edited and saved.	–
1E	Reference sample hold	Ref Sample Hold	Closed: Samples the analog frequency reference and operates the drive at that speed.	–
20 to 2F	External fault	External fault 20: NO/Always Det, Ramp to Stop 21: NC/Always Det, Ramp to Stop 22: NO/During RUN, Ramp to Stop 23: N.C., During run, ramp to stop 24: NO/ Always Det, Coast to Stop 25: NC/Always Det, Coast to Stop 26: NO/During RUN, Coast to Stop 27: NC/During RUN, Coast to Stop 28: NO/Always Det, Fast-Stop 29: NC/Always Det, Fast-Stop 2A: NO/During RUN, Fast-Stop 2B: NC/During RUN, Fast-Stop 2C: NO/Always Det, Alarm Only 2D: NC/Always Det, Alarm Only 2E: NO/ During RUN, Alarm Only 2F: NC/During RUN, Alarm Only	20: N.O., Always detected, ramp to stop 21: N.C., Always detected, ramp to stop 22: N.O., During run, ramp to stop 23: N.C., During run, ramp to stop 24: N.O., Always detected, coast to stop 25: N.C., Always detected, coast to stop 26: N.O., During run, coast to stop 27: N.C., During run, coast to stop 28: N.O., Always detected, Fast Stop 29: N.C., Always detected, Fast Stop 2A: N.O., During run, Fast Stop 2B: N.C., During run, Fast Stop 2C: N.O., Always detected, alarm only (continue running) 2D: N.C., Always detected, alarm only (continue running) 2E: N.O., During run, alarm only (continue running) 2F: N.C., During run, alarm only (continue running)	–
30	PI integral reset	PID Intgrl Reset	Closed: Resets the PI control integral value.	–
31	PI integral hold	PID Intgrl Hold	Open: Performs integral operation. Closed: Maintains the current PI control integral value.	–
34	PI soft starter cancel	PID SFS Cancel	Open: PI soft starter is enabled. Closed: Disables the PI soft starter b5-17.	–
35	PI input level selection	PID Input Invert	Closed: Inverts the PI input signal.	–

## B.7 H Parameters: Multi-Function Terminals

H1 Multi-Function Digital Input Selections				
H1-□□ Setting	Function	LCD Display	Description	Page
40	Forward run command (2-Wire sequence)	FwdRun 2Wire Seq	Open: Stop Closed: Forward run <b>Note:</b> Cannot be set together with settings 42 or 43.	–
41	Reverse run command (2-Wire sequence)	RevRun 2WireSeq	Open: Stop Closed: Reverse run <b>Note:</b> Cannot be set together with settings 42 or 43.	–
42	Run command (2-Wire sequence 2)	Run/Stp 2WireSeq	Open: Stop Closed: Run <b>Note:</b> Cannot be set together with settings 40 or 41.	–
43	FWD/REV command (2-Wire sequence 2)	FWD/REV 2WireSeq	Open: Forward Closed: Reverse <b>Note:</b> Determines motor direction, but does not issue a Run command. Cannot be set together with settings 40 or 41.	–
44	Offset frequency 1	Offset Freq 1	Closed: Adds d7-01 to the frequency reference.	–
45	Offset frequency 2	Offset Freq 2	Closed: Adds d7-02 to the frequency reference.	–
46	Offset frequency 3	Offset Freq 3	Closed: Adds d7-03 to the frequency reference.	–
50	Motor Pre-Heat 2	Motor Preheat 2	Closed: Triggers Motor Pre-Heat 2.	–
51	Sequence Timer Disable	SeqTimer Disable	Closed: Drive ignores sequence timers and runs normally.	–
52	Sequence Timer Cancel	SeqTimer Cancel	Closed: Sequence Timer Cancel .	–
60	Motor pre-heat 1	DCInj Activate	Closed: Triggers Motor pre-heat 1.	–
61	External Speed Search command 1	Speed Search 1	Closed: Activates Current Detection Speed Search from the maximum output frequency (E1-04).	–
62	External Speed Search command 2	Speed Search 2	Closed: Activates Current Detection Speed Search from the frequency reference.	–
63	Field weakening	Field Weak	Closed: The drive performs Field Weakening control as set for d6-01 and d6-02.	–
65	KEB Ride-Thru 1 (N.C.)	KEB Ridethru NC	Open: KEB Ride-Thru 1 enabled.	–
66	KEB Ride-Thru 1 (N.O.)	KEB Ridethru NO	Closed: KEB Ride-Thru 1 enabled.	–
67	Communications test mode	Comm Test Mode	Tests the MEMOBUS/Modbus RS-422/RS-485 interface. Displays “PASS” if the test completes successfully.	–
68	High slip braking	HighSlipBraking	Closed: Activates High Slip Braking to stop the drive during a Run command.	–
69	Jog 2	Jog 2	Cause the drive to ramp to the jog frequency (d1-17).	–
6A	Drive enable	Drive Enable	Open: Drive disabled. If this input is opened during run, the drive will stop as specified by b1-03. Closed: Ready for operation.	–
6D	AUTO mode select	AUTO Mode Sel	Legacy Operation Mode (S5-04 = 0) • Open: HAND reference is selected (based on S5-01) • Closed: AUTO reference is selected (based on b1-01) Normal Operation Mode (S5-04 ≠ 0) • Open: Drive is in OFF or HAND mode. • Closed: Drive is in AUTO mode (when HAND mode select input is open)	–
6E	HAND mode select	HAND Mode Se	Legacy Operation Mode (S5-04 = 0) • Open: AUTO reference is selected (based on b1-01) • Closed: HAND reference is selected (based on S5-01) Normal Operation Mode (S5-04 ≠ 0) • Open: Drive is in OFF or AUTO mode. • Closed: Drive is in HAND mode. (when AUTO mode select input is open)	–
70	Drive Enable2	Drive Enable 2	Prevents the Drive from executing a Run command until the Drive Enable2 input is closed. When the Drive Enable2 input is open and a Run command is closed, the digital operator will display “dnE”. The drive will run when the Run and Drive Enable2 inputs are both closed. If the Drive Enable2 input is opened while the drive is running, the drive will stop using the method set by parameter b1-03.	–
7A	KEB Ride-Thru 2 (N.C.)	KEB Ridethru2NC	Open: KEB Ride-Thru 2 enabled. Drive disregards L2-29 and performs Single Drive KEB Ride-Thru 2.	–

H1 Multi-Function Digital Input Selections				
H1-□□ Setting	Function	LCD Display	Description	Page
7B	KEB Ride-Thru 2 (N.O.)	KEB Ridethru2NO	Closed: KEB Ride-Thru 2 enabled. Drive disregards L2-29 and performs Single Drive KEB Ride-Thru 2.	–
7C	Short circuit braking (N.O.)	SC Brake (NO)	Closed: Short Circuit Braking enabled	–
7D	Short circuit braking (N.C.)	SC Brake (NC)	<b>OLV/PM</b> Open: Short Circuit Braking enabled	–
A4	BP Customer Safeties	BP Emg Override	Closed: Indicates that customer safeties are in place.	–
A5	BP Drive/Bypass Select	BP Drv/Bypass Sel	Open: Bypass mode. Closed: Drive mode.	–
A6	BP BAS Interlock Input	BP BAS Interlock	Closed: Indicates that the dampers are open	–
A7	BP Customer Safeties	BP Cust Safeties	Closed: Indicates that customer safeties are in place.	–
A8	Secondary PI Disable (N.O.)	PI2 Disable N.O.	Closed: Disables the secondary PI controller. Output behavior depends on the setting of S3-12.	–
A9	Secondary PI Disable (N.C.)	PI2 Disable N.C.	Closed: Enables the secondary PI controller. Output behavior depends on the setting of S3-12 when open.	–
AA	Secondary PI Inverse Operation	PI2 Invert	Closed: Changes the sign of the secondary PI controller input (reverse acting PI control).	–
AB	Secondary PI Integral Reset	PI2 Intgrl Reset	Closed: Resets the secondary PI controller integral value.	–
AC	Secondary PI Integral Hold	PI2 Intgrl Hold	Closed: Locks the value of the secondary PI controller integral value.	–
AD	Select Secondary PI Parameters	Select PI2 Parm	Closed: Uses the secondary PI controller Proportional and Integral adjustments (S3-06 and S3-07) instead of the primary PI controller Proportional and Integral adjustments (b5-02 and b5-03). Only valid when S3-01 = 0 (secondary PI controller disabled).  <b>Note:</b> This multi-function input has no effect on the secondary PI controller. It is only used for the primary PI controller (b5-□□).	–
AE	BP Bypass Run	BP Bypass Run	Closed: Commands a Run (via closing the BP Bypass Relay multi-function output) when in Bypass mode.	–
AF	Emergency Override Forward Run	EmergOverrideFWD	Closed: Emergency Override Forward Run	–
B0	Emergency Override Reverse Run	EmergOverrideREV	Closed: Emergency Override Reverse Run	–
B1	Customer Safeties	CustomerSafeties	The functionality is identical to Drive Enable 2 (H1-□□ = 70), except for the following characteristics: <ul style="list-style-type: none"> <li>The stopping method is forced to Coast to Stop when the input is open</li> <li>The drive will display a “SAFE” alarm if the input is open when a Run command is present. It will not display “dnE”.</li> </ul> Open: Customer Safeties are open. Drive will not run. Stopping method is Coast to Stop. Closed: Customer Safeties are in place.	–
B2	BAS Interlock	BAS Interlock	Open: Damper interlock is not closed. Drive output is shut off (baseblocked). The drive displays an "inTLK" message if a Run command is present. It will not display "dnE". Closed: Damper interlock is closed. Drive operates normally.  <b>Note:</b> The state of the BAS Interlock multi-function input has no effect on the Emergency Override multi-function inputs (H1-□□ = AF, B0). The Emergency Override command is accepted when the BAS Interlock digital input is open or closed.	–

**◆ H2: Multi-Function Digital Outputs**

No. (Addr. Hex)	Name	LCD Display	Description	Values	Page
H2-01 (40B)	Terminal M1-M2 function selection (relay)	M1-M2 Func Sel	Refer to H2 Multi-Function Digital Output Settings on pages <a href="#">304</a> to <a href="#">305</a> for descriptions of setting values.	Default: 0 Range: 0 to 1B2	–
H2-02 (40C)	Terminal M3-M4 function selection (relay)	P1/PC Func Sel		Default: 1 Range: 0 to 1B2	–
H2-03 (40D)	Terminal M5-M6 function selection (relay)	P2/PC Func Sel		Default: 2 Range: 0 to 1B2	–

**H2 Multi-Function Digital Output Settings**

H2-□□ Setting	Function	LCD Display	Description	Page
0	During run	During RUN 1	Closed: A Run command is active or voltage is output.	–
1	Zero speed	Zero Speed	Open: Output frequency is above the minimum output frequency set in E1-09. Closed: Output frequency is below the minimum output frequency set in E1-09.	–
2	Speed agree 1	Fref/Fout Agree1	Closed: Output frequency equals the speed reference (plus or minus the hysteresis set to L4-02).	–
3	User-set speed agree 1	Fref/Set Agree 1	Closed: Output frequency and speed reference equal L4-01 (plus or minus the hysteresis set to L4-02).	–
4	Frequency detection 1	Freq Detect 1	Closed: Output frequency is less than or equal to the value in L4-01 with hysteresis determined by L4-02.	–
5	Frequency detection 2	Freq Detect 2	Closed: Output frequency is greater than or equal to the value in L4-01 with hysteresis determined by L4-02.	–
6	Drive ready	Drive Ready	Closed: Power up is complete and the drive is ready to accept a Run command.	–
7	DC bus undervoltage	DC Bus Undervolt	Closed: DC bus voltage is below the Uv trip level set in L2-05.	–
8	During baseblock (N.O.)	BaseBlk 1	Closed: Drive has entered the baseblock state (no output voltage).	–
9	Frequency reference source	Ref Source	Open: External Reference 1 or 2 supplies the frequency reference (set in b1-01 or b1-15). Closed: HOA keypad supplies the frequency reference.	–
A	Run command source	Run Cmd Source	Open: External Reference 1 or 2 supplies the Run command (set in b1-02 or b1-16). Closed: HOA keypad supplies the Run command.	–
B	Torque detection 1 (N.O.)	Trq Det 1 N.O.	Closed: An overtorque or undertorque situation has been detected.	–
C	Frequency reference loss	Loss of Ref	Closed: Analog frequency reference has been lost.	–
E	Fault	Fault	Closed: Fault occurred.	–
F	Through mode	Not Used	Set this value when using the terminal in the pass-through mode.	–
10	Minor fault	Minor Fault	Closed: An alarm has been triggered, or the IGBTs have reached 90% of their expected life span.	–
11	Fault reset command active	Reset Cmd Active	Closed: A command has been entered to clear a fault via the input terminals or from the serial network.	–
12	Timer output	Timer Output	Closed: Timer output.	–
13	Speed agree 2	Fref/Fout Agree2	Closed: When drive output frequency equals the frequency reference $\pm$ L4-04.	–
14	User-set speed agree 2	Fref/Set Agree 2	Closed: When the drive output frequency is equal to the value in L4-03 $\pm$ L4-04.	–
15	Frequency detection 3	Freq Detect 3	Closed: When the drive output frequency is less than or equal to the value in L4-03 $\pm$ L4-04.	–
16	Frequency detection 4	Freq Detect 4	Closed: When the output frequency is greater than or equal to the value in L4-03 $\pm$ L4-04.	–
17	Torque detection 1 (N.C.)	Trq Det 1 N.C.	Open: Overtorque or undertorque has been detected.	–
1A	During Reverse	Reverse Dir	Closed: Drive is running in the reverse direction.	–
1B	During baseblock (N.C.)	BaseBlk 2	Open: Drive has entered the baseblock state (no output voltage).	–
1E	Restart enabled	Dur Flt Restart	Closed: An automatic restart is performed	–
1F	Motor overload alarm (oL1)	Overload (OL1)	Closed: oL1 is at 90% of its trip point or greater. An oH3 situation also triggers this alarm.	–

H2 Multi-Function Digital Output Settings				
H2-□□ Setting	Function	LCD Display	Description	Page
20	Drive overheat pre-alarm (oH)	OH Prealarm	Closed: Heatsink temperature exceeds the parameter L8-02 value.	–
2F	Maintenance period	Maintenance	Closed: Cooling fan, electrolytic capacitors, IGBTs, or the soft charge bypass relay may require maintenance.	–
37	During frequency output	During RUN 2	Open: Either the drive has stopped or baseblock, DC Injection Braking, or Initial Excitation is being performed. Closed: Drive is running the motor (not in a baseblock state and DC Injection is not being performed).	–
38	Drive enabled	Drive Enable	Closed: Multi-function input set for “Drive enable” is closed (H1-□□ = 6A)	–
39	Watt hour pulse output	Watt-hour Pulse	Output units are determined by H2-06. Outputs a pulse every 200 ms to indicate the kWh count.	–
3A	Drive overheat alarm	OH Alarm 2	Closed: An external device triggered an overheat warning in the drive.	–
3D	During speed search	During SpdSrch	Closed: Speed Search is being executed.	–
3E	PI feedback low	PID Feedback Low	Closed: PI feedback level is too low.	–
3F	PI feedback high	PID FeedbackHigh	Closed: The PI feedback level is too high.	–
4A	During KEB Ride-Thru	During KEB	Closed: KEB Ride-Thru is being performed.	–
4B	During short circuit braking	During SC Brake	<b>OLV/PM</b> Closed: Short Circuit Braking is active.	–
4C	During fast stop	During Fast Stop	Closed: A Fast Stop command has been entered from the operator or input terminals.	–
4D	oH Pre-alarm time limit	OH Pre-Alarm	Closed: oH pre-alarm time limit has passed.	–
50	Waiting for run	Waiting for Run	Closed: Delay executing any run command until the time set to b1-11 has expired.	–
51	Sequence timer 1 active	SeqTimer Disable	Closed: Sequence timer 1 is active.	–
52	Sequence timer 2 active	SeqTimer Cancel	Closed: Sequence timer 2 is active.	–
53	Sequence timer 3 active	Sequence timer 3	Closed: Sequence timer 3 is active.	–
54	Sequence timer 4 active	Sequence Timer 4	Closed: Sequence timer 4 is active.	–
58	Underload detection	UL6	Closed: Underload is detected.	–
60	Internal cooling fan alarm	Fan Alrm Det	Closed: Internal cooling fan alarm	–
71	Secondary PI Feedback Low	PI2 Feedback Low	Closed: PI2 feedback level is too low.	–
72	Secondary PI Feedback High	PI2 FeedbackHigh	Closed: The PI2 feedback level is too high.	–
A4	BP Drive Relay Contact	BP Emg Override	Closed: Line voltage is being supplied to the drive, and the motor is being run via the drive.	–
A5	BP Bypass Relay Contact	BP Drv/Byppss Sel	Closed: Line voltage is being supplied directly to the motor.	–
A6	BP BAS Interlock Relay Contact	BP BAS Interlock	Closed: Actuation signal for options dampers.	–
A9	Relay Operator Control	PI2 Disable N.C.	Closed: F1 (F2) key toggle relay output.	–
B2	BAS Interlock Relay Contact	BAS Interlock	A Run command is active or voltage is output. Actuation signal for damper.	–
100 to 1B2	Function 0 to b2 with inverse output Note: A prefix of “!” is added to represent inverse functions on the LCD keypad display. Example: “!Zero speed”	–	Inverts the output switching of the multi-function output functions. Set the last two digits of 1□□ to reverse the output signal of that specific function.	–

**◆ H3: Multi-Function Analog Inputs**

No. (Addr. Hex)	Name	LCD Display	Description	Values	Page
H3-01 (410)	Terminal A1 Signal Level Selection	Term A1 Level 0: 0-10V, (LowLim=0) 1: 0-10V, (BipolRef) 2: 4-20 mA 3: 0-20 mA	0: 0 to 10 V with zero limit 1: 0 to 10 V without zero limit 2: 4-20 mA 3: 0-20 mA  <b>Note:</b> Use jumper switch S1 to set input terminal A1 for current or voltage.	Default: 0 Range: 0 to 3	<a href="#">174</a>
H3-02 (434)	Terminal A1 Function Selection	Term A1 FuncSel	Sets the function of terminal A1.	Default: 0 Range: 0 to 26	<a href="#">175</a>
H3-03 (411) <input type="checkbox"/> RUN	Terminal A1 Gain Setting	Terminal A1 Gain	Sets the level of the input value selected in H3-02 when 10 V is input at terminal A1.	Default: 100.0% Min.: -999.9 Max.: 999.9	<a href="#">136</a>
H3-04 (412) <input type="checkbox"/> RUN	Terminal A1 Bias Setting	Terminal A1 Bias	Sets the level of the input value selected in H3-02 when 0 V is input at terminal A1.	Default: 0.0% Min.: -999.9 Max.: 999.9	<a href="#">136</a>
H3-09 (417)	Terminal A2 Signal Level Selection	Term A2 Level 0: 0-10V, (LowLim=0) 1: 0-10V, (BipolRef) 2: 4-20 mA 3: 0-20 mA	0: 0 to 10 V with zero limit 1: 0 to 10 V without zero limit 2: 4 to 20 mA 3: 0 to 20 mA  <b>Note:</b> Use jumper switch S1 to set input terminal A2 for current or voltage input signal.	Default: 2 Range: 0 to 3	<a href="#">175</a>
H3-10 (418)	Terminal A2 Function Selection	Term A2 FuncSel	Sets the function of terminal A2.	Default: 0 Range: 0 to 26	<a href="#">175</a>
H3-11 (419) <input type="checkbox"/> RUN	Terminal A2 Gain Setting	Terminal A2 Gain	Sets the level of the input value selected in H3-10 when 10 V (20 mA) is input at terminal A2.	Default: 100.0% Min.: -999.9 Max.: 999.9	<a href="#">137</a>
H3-12 (41A) <input type="checkbox"/> RUN	Terminal A2 Bias Setting	Terminal A2 Bias	Sets the level of the input value selected in H3-10 when 0 V (0 or 4 mA) is input at terminal A2.	Default: 0.0% Min.: -999.9 Max.: 999.9	<a href="#">137</a>
H3-13 (41B)	Analog Input Filter Time Constant	A1/A2 Filter T	Sets a primary delay filter time constant for terminals A1 and A2. Used for noise filtering.	Default: 0.03 s Min.: 0.00 Max.: 2.00	–
H3-14 (41C)	Analog Input Terminal Enable Selection	A1/A2 Sel 1: A1 Available 2: A2 Available 3: A1/A2 Available	Determines which analog input terminals will be enabled when a digital input programmed for “Analog input enable” (H1-□□ = C) is activated. 1: Terminal A1 only 2: Terminal A2 only 3: Terminals A1 and A2	Default: 2 Range: 1 to 3	–
H3-16 (2F0)	Terminal A1 Offset	Term A1 Offset	Adds an offset when the analog signal to terminal A1 is at 0 V.	Default: 0 Min.: -500 Max.: 500	–
H3-17 (2F1)	Terminal A2 Offset	Term A2 Offset	Adds an offset when the analog signal to terminal A2 is at 0 V.	Default: 0 Min.: -500 Max.: 500	–

**H3 Multi-Function Analog Input Settings**

H3-□□ Setting	Function	LCD Display	Description	Page
0	Frequency bias	Freq Ref Bias	10 V = E1-04 (maximum output frequency)	<a href="#">175</a>
1	Frequency gain	Freq Ref Gain	0 to 10 V signal allows a setting of 0 to 100%. -10 to 0 V signal allows a setting of -100 to 0%.	<a href="#">176</a>
2	Auxiliary frequency reference 1 (used as a Multi-Step Speed 2)	Aux Reference1	10 V = E1-04 (maximum output frequency)	<a href="#">176</a>
3	Auxiliary frequency reference 2 (3rd step analog)	Aux Reference2	10 V = E1-04 (maximum output frequency)	<a href="#">176</a>

H3 Multi-Function Analog Input Settings				
H3-□□ Setting	Function	LCD Display	Description	Page
4	Output voltage bias	Voltage Bias	10 V = E1-05 (motor rated voltage)	–
5	Accel/decel time gain	Acc/Dec Change	10 V = 100%	–
6	DC Injection Braking current	DC Brake Current	10 V = Drive rated current	–
7	Overtorque/undertorque detection level	Torque Det Level	10 V = Drive rated current (V/f) 10 V = Motor rated torque (OLV/PM)	–
8	Stall Prevention level during run	Stall Prev Level	10 V = Drive rated current	–
9	Output frequency lower limit level	Ref Lower Limit	10 V = E1-04 (maximum output frequency)	–
B	PI feedback	PID Feedback1	10 V = 100%	176
C	PI setpoint	PID Set Point	10 V = 100%	176
D	Frequency bias	Freq Ref Bias 2	10 V = E1-04 (maximum output frequency)	176
E	Motor temperature (PTC input)	Motor PTC	10 V = 100%	–
F	Through mode	Not Used	Set this value when using the terminal in the pass-through mode.	–
16	Differential PI feedback	PID Feedback 2	10 V = 100%	–
25	Secondary PI Setpoint	PI2 Setpoint	10 V = S3-02 (maximum output frequency)	–
26	Secondary PI Feedback	PI2 Feedback	10 V = S3-02 (maximum output frequency)	–

◆ H4: Analog Outputs

No. (Addr. Hex)	Name	LCD Display	Description	Values	Page
H4-01 (41D)	Multi-Function Analog Output Terminal FM Monitor Selection	Term FM FuncSel	Selects the data to be output through multi-function analog output terminal FM. Set the desired monitor parameter to the digits available in U□-□□. For example, enter “103” for U1-03.	Default: 102 Range: 000 to 655	–
H4-02 (41E) <span style="border: 1px solid black; padding: 1px;">RUN</span>	Multi-Function Analog Output Terminal FM Gain	Terminal FM Gain	Sets the signal level at terminal FM that is equal to 100% of the selected monitor value.	Default: 100.0% Min.: -999.9 Max.: 999.9	–
H4-03 (41F) <span style="border: 1px solid black; padding: 1px;">RUN</span>	Multi-Function Analog Output Terminal FM Bias	Terminal FM Bias	Sets the signal level at terminal FM that is equal to 0% of the selected monitor value.	Default: 0.0% Min.: -999.9 Max.: 999.9	–
H4-04 (420)	Multi-Function Analog Output Terminal AM Monitor Selection	Terminal AM Sel	Selects the data to be output through multi-function analog output terminal AM. Set the desired monitor parameter to the digits available in U□-□□. For example, enter “103” for U1-03.	Default: 103 Range: 000 to 655	–
H4-05 (421) <span style="border: 1px solid black; padding: 1px;">RUN</span>	Multi-Function Analog Output Terminal AM Gain	Terminal AM Gain	Sets the signal level at terminal AM that is equal to 100% of the selected monitor value.	Default: 50.0% Min.: -999.9 Max.: 999.9	–
H4-06 (422) <span style="border: 1px solid black; padding: 1px;">RUN</span>	Multi-Function Analog Output Terminal AM Bias	Terminal AM Bias	Sets the signal level at terminal AM that is equal to 0% of the selected monitor value.	Default: 0.0% Min.: -999.9 Max.: 999.9	–
H4-07 (423)	Multi-Function Analog Output Terminal FM Signal Level Selection	Level Select1 0: 0-10 VDC 2: 4-20 mA	0: 0 to 10 V 2: 4 to 20 mA	Default: 0 Range: 0, 2	–
H4-08 (424)	Multi-Function Analog Output Terminal AM Signal Level Selection	AO Level Select2 0: 0-10 VDC 2: 4-20 mA	0: 0 to 10 V 2: 4 to 20 mA	Default: 0 Range: 0, 2	–

**◆ H5: MEMOBUS/Modbus Serial Communication**

No. (Addr. Hex)	Name	LCD Display	Description	Values	Page
H5-01 (425) <1>	Drive Slave Address	Serial Comm Adr	Selects drive station slave number (address) for MEMOBUS/Modbus terminals R+, R-, S+, S-. Cycle power for the setting to take effect.	Default: 1F (Hex) Min.: 0 Max.: FF	176
H5-02 (426)	Communication Speed Selection	Serial Baud Rate 0: 1200 bps 1: 2400 bps 2: 4800 bps 3: 9600 bps 4: 19.2 kbps 5: 38.4 kbps 6: 57.6 kbps 7: 76.8 kbps 8: 115.2 kbps	0: 1200 bps 1: 2400 bps 2: 4800 bps 3: 9600 bps 4: 19200 bps 5: 38400 bps 6: 57600 bps 7: 76800 bps 8: 115200 bps Cycle power for the setting to take effect.	Default: 3 Range: 0 to 8	176
H5-03 (427)	Communication Parity Selection	Serial Com Sel 0: No parity 1: Even parity 2: Odd parity	0: No parity 1: Even parity 2: Odd parity Cycle power for the setting to take effect.	Default: 0 Range: 0 to 2	177
H5-04 (428)	Stopping Method after Communication Error (CE)	Serial Fault Sel 0: Ramp to Stop 1: Coast to Stop 2: Fast-Stop 3: Alarm Only 4: Alarm(d1-04)	0: Ramp to stop 1: Coast to stop 2: Fast Stop 3: Alarm only 4: Run at d1-04	Default: 3 Range: 0 to 4	177
H5-05 (429)	Communication Fault Detection Selection	Serial Flt Dtct 0: Disabled 1: Enabled	0: Disabled 1: Enabled If communication is lost for more than two seconds, a CE fault will occur.	Default: 1 Range: 0, 1	177
H5-06 (42A)	Drive Transmit Wait Time	Transmit WaitTIM	Set the wait time between receiving and sending data.	Default: 5 ms Min.: 5 Max.: 65	177
H5-07 (42B)	RTS Control Selection	RTS Control Sel 0: Disabled 1: Enabled	0: Disabled. RTS is always on. 1: Enabled. RTS turns on only when sending.	Default: 1 Range: 0, 1	178
H5-08 (62D)	Communication Protocol Selection	Protocol Select 0: MEMOBUS 1: N2 2: P1 3: BACnet	Selects the communication protocol. 0: MEMOBUS/Modbus 1: N2 (Metasys) 2: P1 (APOGEE FLN) 3: BACnet	Default: 0 Range: 0 to 3	178
H5-09 (435)	CE Detection Time	CE Detect Time	Sets the time required to detect a communications error. Adjustment may be needed when networking several drives.	Default: 2.0 s Min.: 0.0 Max.: 10.0	178
H5-10 (436)	Unit Selection for MEMOBUS/Modbus Register 0025H	CommReg 25h Unit 0: 0.1 V 1: 1 V	0: 0.1 V units 1: 1 V units	Default: 0 Range: 0, 1	178
H5-11 (43C)	Communications ENTER Function Selection	Enter CommandSel 0: Enter Required 1: No EnterRequired	0: Drive requires an Enter command before accepting any changes to parameter settings. 1: Parameter changes are activated immediately without the Enter command (same as V7).	Default: 0 Range: 0, 1	178
H5-12 (43D)	Run Command Method Selection	Run CommandSel 0: FWD Run &REV Run 1: Run & FWD/REV	0: FWD/Stop, REV/Stop 1: Run/Stop, FWD/REV	Default: 0 Range: 0, 1	179
H5-14 (310D)	BAC Dev Obj ID 0	BAC Dev Obj Id 0	BACnet device object ID	Default: 1 Range: 0 to FFFF	179
H5-15 (310E)	BAC Dev Obj ID 1	BAC Dev Obj Id 1	BACnet device object ID	Default: 0 Range: 0 to 3F	179

<1> If this parameter is set to 0, the drive will be unable to respond to MEMOBUS/Modbus commands.

## B.8 L: Protection Function

L parameters provide protection to the drive and motor, including control during momentary power loss, Stall Prevention, frequency detection, fault restarts, overtorque detection, and other types of hardware protection.

### ◆ L1: Motor Protection

No. (Addr. Hex)	Name	LCD Display	Description	Values	Page
L1-01 (480)	Motor Overload Protection Selection	Mtr OL Charact 0: OL1 Disabled 1: VT Motor 4: PM Motor	0: Disabled 1: General purpose motor (standard fan cooled) 4: PM motor with variable torque The drive may not be able to provide protection when using multiple motors, even if overload is enabled in L1-01. Set L1-01 to 0 and install separate thermal relays to each motor.	Default: <1> Range: 0, 1, 4	–
L1-02 (481)	Motor Overload Protection Time	MOL Time Const	Sets the motor thermal overload protection (oL1) time.	Default: 1.0 min Min.: 1.0 Max.: 5.0	–
L1-03 (482)	Motor Overheat Alarm Operation Selection (PTC input)	Mtr OH Alarm Sel 0: Ramp to Stop 1: Coast to Stop 2: Fast-Stop 3: Alarm only	Sets operation when the motor temperature analog input (H3-02 or H3-10 = E) exceeds the alarm level. 0: Ramp to stop 1: Coast to stop 2: Fast Stop (decelerate to stop using the deceleration time in C1-09) 3: Alarm only (“oH3” will flash)	Default: 3 Range: 0 to 3	–
L1-04 (483)	Motor Overheat Fault Operation Selection (PTC input)	Mtr OH Fault Sel 0: Ramp to Stop 1: Coast to Stop 2: Fast-Stop	Sets stopping method when the motor temperature analog input (H3-02, or H3-10 = E) exceeds the oH4 fault level. 0: Ramp to stop 1: Coast to stop 2: Fast Stop (decelerate to stop using the deceleration time in C1-09)	Default: 1 Range: 0 to 2	–
L1-05 (484)	Motor Temperature Input Filter Time (PTC input)	Mtr Temp Filter	Adjusts the filter for the motor temperature analog input (H3-02, or H3-10 = E).	Default: 0.20 s Min.: 0.00 Max.: 10.00	–
L1-08 (1103) <2>	oL1 Current Level	oL1 Current Lvl	Sets the reference current for motor thermal overload detection for the motor in amperes.	Default: <3> Min.: 10% of drive rated current Max.: 150% of drive rated current <4>	–
L1-13 (46D)	Continuous Electrothermal Operation Selection	Mtr OL Mem Sel 0: Disabled 1: Enabled 2: Enabled(RTC)	0: Disabled 1: Enabled 2: Enable using Real Time Clock	Default: 1 Range: 0 to 2	–

<1> Default setting is determined by parameter A1-02, Control Method Selection.

<2> Available in drive software versions PRG: 1016 and later.

<3> Default setting is determined by parameters o2-04, Drive Model Selection, and C6-01, Drive Duty Selection.

<4> The number of decimal places in the parameter value depends on the drive model. This value has two decimal places (0.01 A) if the drive is set for a maximum applicable motor capacity up to and including 11 kW, 2A0031, 4A0021 (input voltage 460 V or higher) or 4A0027 (input voltage lower than 460 V) and one decimal place (0.1 A) if the maximum applicable motor capacity is higher than 11 kW, 2A0046, 4A0027 (input voltage 460 V or higher) or 4A0034 (input voltage lower than 460 V) .

**◆ L2: Momentary Power Loss Ride-Thru**

No. (Addr. Hex)	Name	LCD Display	Description	Values	Page
L2-01 (485)	Momentary Power Loss Operation Selection	PwrL Selection 0: Disabled 1: Enbl with Timer 2: Enbl whl CPU act	0: Disabled. Drive trips on Uv1 fault when power is lost. 1: Recover within the time set in L2-02. Uv1 will be detected if power loss is longer than L2-02. 2: Recover as long as CPU has power. Uv1 is not detected.	Default: 0 Range: 0 to 2	137
L2-02 (486)	Momentary Power Loss Ride-Thru Time	PwrL Ridethru t	Sets the Power Loss Ride-Thru time. Enabled only when L2-01 = 1 or 3.	Default: <1> Min.: 0.0 s Max.: 25.5 s	138
L2-03 (487)	Momentary Power Loss Minimum Baseblock Time	PwrL Baseblock t	Sets the minimum wait time for residual motor voltage decay before the drive output reenergizes after performing Power Loss Ride-Thru. Increasing the time set to L2-03 may help if overcurrent or overvoltage occur during Speed Search or during DC Injection Braking.	Default: <1> Min.: 0.1 s Max.: 5.0 s	–
L2-04 (488)	Momentary Power Loss Voltage Recovery Ramp Time	PwrL V/F Ramp t	Sets the time for the output voltage to return to the preset V/f pattern during Speed Search.	Default: <1> Min.: 0.0 s Max.: 5.0 s	–
L2-05 (489)	Undervoltage Detection Level (Uv1)	PUV Det Level	Sets the DC bus undervoltage trip level.	Default: 190 Vdc <2> <3> Min.: 150 Vdc Max.: 220 Vdc <3>	–
L2-06 (48A)	KEB Deceleration Time	KEB Decel Time	Sets the time required to decelerate from the speed when KEB was activated to zero speed.	Default: 0.00 s Min.: 0.00 Max.: 6000.0	–
L2-07 (48B)	KEB Acceleration Time	KEB Accel Time	Sets the time to accelerate to the frequency reference when momentary power loss is over. If set to 0.0, the active acceleration time is used.	Default: 0.00 s Min.: 0.00 Max.: 6000.0	–
L2-08 (48C)	Frequency Gain at KEB Start	KEB Freq Red	Sets the percentage of output frequency reduction at the beginning of deceleration when the KEB Ride-Thru function is started. Reduction = (slip frequency before KEB) × L2-08 × 2	Default: 100% Min.: 0 Max.: 300	–
L2-10 (48E)	KEB Detection Time (Minimum KEB Time)	KEB Detect Time	Sets the time to perform KEB Ride-Thru.	Default: 50 ms Min.: 0 Max.: 2000	–
L2-11 (461)	DC Bus Voltage Setpoint during KEB	KEB DC Bus Level	Sets the desired value of the DC bus voltage during KEB Ride-Thru.	Default: <2> [E1-01] × 1.22 Min.: 150 Vdc Max.: 400 Vdc <3>	–
L2-29 (475)	KEB Method Selection	KEB Mode Sel 0: Single Mode KEB1 1: Single Mode KEB2	0: Single Drive KEB Ride-Thru 1 1: Single Drive KEB Ride-Thru 2	Default: 0 Range: 0, 1	–

<1> Default setting is dependent on parameter o2-04, Drive Model Selection.

<2> Default setting is dependent on parameter E1-01, Input voltage Setting.

<3> Values shown are specific to 200 V class drives. Double the value for 400 V class drives.

◆ L3: Stall Prevention

No. (Addr. Hex)	Name	LCD Display	Description	Values	Page
L3-01 (48F)	Stall Prevention Selection during Acceleration	StallP Accel Sel 0: Disabled 1: General purpose 2: Intelligent	0: Disabled. 1: General purpose. Acceleration is paused as long as the current is above the L3-02 setting. 2: Intelligent. Accelerate in the shortest possible time without exceeding the L3-02 level. <b>Note:</b> Setting 2 is not available when using OLV/PM.	Default: 1 Range: 0 to 2	–
L3-02 (490)	Stall Prevention Level during Acceleration	StallP Accel Lvl	Used when L3-01 = 1 or 2. 100% is equal to the drive rated current.	Default: </> Min.: 0% Max.: 150% </>	–
L3-03 (491)	Stall Prevention Limit during Acceleration	StallPAcc LowLim	Sets Stall Prevention lower limit during acceleration when operating in the constant power range. Set as a percentage of drive rated current.	Default: 50% Min.: 0 Max.: 100	–
L3-04 (492)	Stall Prevention Selection during Deceleration	StallP Decel Sel 0: Disabled 1: General purpose 2: Intelligent 4: High Flux Brake 5: High Flux Brake2	0: Disabled. Deceleration at the active deceleration rate. An ov fault may occur. 1: General purpose. Deceleration is paused when the DC bus voltage exceeds the Stall Prevention level. 2: Intelligent. Decelerate as fast as possible while avoiding ov faults. 4: Overexcitation Deceleration. Decelerates while increasing the motor flux 5: Overexcitation Deceleration 2. Adjust the deceleration rate according to the DC bus voltage.	Default: 1 Range: 0 to 2; 4, 5 </>	–
L3-05 (493)	Stall Prevention Selection during Run	StallP Run Sel 0: Disabled 1: Decel time 2: Decel time 2	0: Disabled. Drive runs at a set frequency. A heavy load may cause speed loss. 1: Decel time 1. Uses the deceleration time set to C1-02 while Stall Prevention is performed. 2: Decel time 2. Uses the deceleration time set to C1-04 while Stall Prevention is performed.	Default: 1 Range: 0 to 2	–
L3-06 (494)	Stall Prevention Level during Run	StallP Run Level	Enabled when L3-05 is set to 1 or 2. 100% is equal to the drive rated current.	Default: </> Min.: 30% Max.: 150% </>	–
L3-11 (4C7)	Overvoltage Suppression Function Selection	OV Inhibit Sel 0: Disabled 1: Enabled	Enables or disables the ov suppression function, which allows the drive to change the output frequency as the load changes to prevent an ov fault. 0: Disabled 1: Enabled	Default: 0 Range: 0, 1	–
L3-17 (462)	Target DC Bus Voltage for Overvoltage Suppression and Stall Prevention	DC Bus Reg Level	Sets the desired value for the DC bus voltage during overvoltage suppression and Stall Prevention during deceleration.	Default: 370 Vdc </> </> Min.: 150 Max.: 400 </>	–
L3-20 (465)	DC Bus Voltage Adjustment Gain	DC Bus P Gain	Determines the proportional gain used by overvoltage suppression (L3-11 = 1), Single drive KEB 2 (L2-29 = 1), KEB Ride-Thru 2 (H1-□□ = 7A or 7B), and Intelligent Stall Prevention during Deceleration (L3-04 = 2) to control the DC bus voltage in OLV/PM.	Default: </> Min.: 0.00 Max.: 5.00	–
L3-21 (466)	Accel/Decel Rate Calculation Gain	Acc/Dec P Gain	Sets the proportional gain used to calculate the deceleration rate during KEB Ride-Thru, ov suppression function, and Stall Prevention during deceleration (L3-04 = 2).	Default: </> Min.: 0.00 Max.: 200.00	–
L3-22 (4F9)	Deceleration Time at Stall Prevention during Acceleration	PM Acc Stall P T	Sets the deceleration time used for Stall Prevention during acceleration in OLV/PM.	Default: 0.0 s Min.: 0.0 Max.: 6000	–
L3-23 (4FD)	Automatic Reduction Selection for Stall Prevention during Run	CHP Stall P Sel 0: Lv1 set in L3-06 1: Autom. Reduction	0: Sets the Stall Prevention level set in L3-04 that is used throughout the entire frequency range. 1: Automatic Stall Prevention level reduction in the constant output range. The lower limit value is 40% of L3-06.	Default: 0 Range: 0, 1	–
L3-24 (46E)	Motor Acceleration Time for Inertia Calculations	Mtr Accel Time	<b>OLV/PM</b> Sets the time needed to accelerate the uncoupled motor at rated torque from stop to the maximum frequency.	Default: </> </> Min: 0.001 s Max: 10.000 s	–
L3-25 (46F)	Load Inertia Ratio	Load Inertia Rat	<b>OLV/PM</b> Sets the ratio between the motor and machine inertia.	Default: 1.0 Min.: 1.0 Max.: 1000.0	–

Parameter List

B

## B.8 L: Protection Function

No. (Addr. Hex)	Name	LCD Display	Description	Values	Page
L3-26 (455)	Additional DC Bus Capacitors	ExtDC busCapSize	When DC bus capacitors have been added externally, be sure to add those values to the internal capacitor table for proper DC bus calculations.	Default: 0 $\mu$ F Min.: 0 Max.: 65000	–
L3-27 (456)	Stall Prevention Detection Time	Stl Prev DetTime	Sets the time the current must exceed the Stall Prevention level to activate Stall Prevention.	Default: 50 ms Min.: 0 Max.: 5000	–

- <1> Upper limit is dependent on parameter L8-38, Frequency Reduction Selection.
- <2> The setting range is 0 to 2 in OLV/PM control mode.
- <3> Default setting is dependent on parameter E1-01, Input voltage Setting.
- <4> Values shown are specific to 200 V class drives. Double the value for 400 V class drives.
- <5> Default setting is determined by parameter A1-02, Control Mode Setting.
- <6> Parameter value changes automatically if E2-11 is manually changed or changed by Auto-Tuning.
- <7> Default setting is dependent on parameter o2-04, Drive Model Selection.

## ◆ L4: Speed Detection

No. (Addr. Hex)	Name	LCD Display	Description	Values	Page
L4-01 (499)	Speed Agreement Detection Level	Spd Agree Level	L4-01 sets the frequency detection level for digital output functions H2-□□ = 2, 3, 4, 5.	Default: 0.0 Hz Min.: 0.0 Max.: 240.0	–
L4-02 (49A)	Speed Agreement Detection Width	Spd Agree Width	L4-02 sets the hysteresis or allowable margin for speed detection.	Default: 2.0 Hz Min.: 0.0 Max.: 20.0	–
L4-03 (49B)	Speed Agreement Detection Level (+/-)	Spd Agree Lvl+-	L4-03 sets the frequency detection level for digital output functions H2-□□ = 13, 14, 15, 16.	Default: 0.0 Hz Min.: -240.0 Max.: 240.0	–
L4-04 (49C)	Speed Agreement Detection Width (+/-)	Spd Agree Wdth+-	L4-04 sets the hysteresis or allowable margin for speed detection.	Default: 2.0 kHz Min.: 0.0 Max.: 20.0	–
L4-05 (49D)	Frequency Reference Loss Detection Selection	Ref Loss Sel 0: Stop 1: Run@L4-06PrevRef	0: Stop. Drive stops when the frequency reference is lost. 1: Run. Drive runs at a reduced speed when the frequency reference is lost.	Default: 1 Range: 0, 1	<a href="#">138</a>
L4-06 (4C2)	Frequency Reference at Reference Loss	Fref at Floss	Sets the percentage of the frequency reference that the drive should run with when the frequency reference is lost.	Default: 80.0% Min.: 0.0 Max.: 100.0	<a href="#">138</a>
L4-07 (470)	Speed Agreement Detection Selection	Freq Detect Sel 0: No Detection @BB 1: Always Detected	0: No detection during baseblock. 1: Detection always enabled.	Default: 0 Range: 0, 1	–

## ◆ L5: Fault Restart

No. (Addr. Hex)	Name	LCD Display	Description	Values	Page
L5-01 (49E)	Number of Auto Restart Attempts	Num of Restarts	Sets the number of times the drive may attempt to restart after the following faults occur: GF, LF, oC, ov, PF, oL1, oL2, oL3, STo, Uv1.	Default: 0 Min.: 0 Max.: 10	<a href="#">139</a>
L5-02 (49F)	Auto Restart Fault Output Operation Selection	Restart Sel 0: Flt Outp Disabld 1: Flt Outp Enabled	0: Fault output not active. 1: Fault output active during restart attempt.	Default: 0 Range: 0, 1	<a href="#">179</a>
L5-03 (4A0)	Time to Continue Making Fault Restarts	Max Restart Time	Enabled only when L5-05 is set to 0. Causes a fault if a fault restart cannot occur after the set time passes.	Default: 180.0 s Min.: 0.0 Max.: 600.0	<a href="#">139</a>
L5-04 (46C)	Fault Reset Interval Time	Flt Reset Wait T	Sets the amount of time to wait between performing fault restarts.	Default: 10.0 s Min.: 0.5 Max.: 600.0	<a href="#">179</a>

No. (Addr. Hex)	Name	LCD Display	Description	Values	Page
L5-05 (467)	Fault Reset Operation Selection	Fault Reset Sel 0: Continuous 1: Use L5-04 Time	0: Continuously attempt to restart while incrementing restart counter only at a successful restart (same as F7 and G7). 1: Attempt to restart with the interval time set in L5-04 and increment the restart counter with each attempt (same as V7).	Default: 1 Range: 0, 1	179

◆ L6: Torque Detection

No. (Addr. Hex)	Name	LCD Display	Description	Values	Page
L6-01 (4A1)	Torque Detection Selection 1	Torq Det 1 Sel 0: Disabled 1: OL Alm at SpdAgr 2: OL Alm dur RUN 3: OL Flt at SpdAgr 4: OL Flt dur RUN 5: UL Alm at SpdAgr 6: UL Alm dur RUN 7: UL Flt at SpdAgr 8: UL Flt dur RUN 9: UL6Alm at SpdAgr 10: UL6Alm dur RUN 11: UL6Flt at SpdAgr 12: UL6Flt dur RUN	0: Disabled 1: oL3 detection only active during speed agree, operation continues after detection 2: oL3 detection always active during run, operation continues after detection 3: oL3 detection only active during speed agree, output shuts down on an oL3 fault 4: oL3 detection always active during run, output shuts down on an oL3 fault 5: UL3 detection only active during speed agree, operation continues after detection 6: UL3 detection always active during run, operation continues after detection 7: UL3 detection only active during speed agree, output shuts down on an oL3 fault 8: UL3 detection always active during run, output shuts down on an oL3 fault 9: UL6 at speed agree (alarm) 10: UL6 at run (alarm) 11: UL6 at speed agree (fault) 12: UL6 at run (fault)	Default: 0 Range: 0 to 12	140
L6-02 (4A2)	Torque Detection Level 1	Torq Det 1 Lvl	Sets the overtorque and undertorque detection level.	Default: 15% Min.: 0 Max.: 300	141
L6-03 (4A3)	Torque Detection Time 1	Torq Det 1 Time	Sets the time an overtorque or undertorque condition must exist to trigger torque detection 1.	Default: 10.0 s Min.: 0.0 Max.: 10.0	141
L6-13 (62E)	Motor Underload Protection Selection	Underload Select 0: Base Freq Enable 1: Max Freq Enable	Sets the motor underload protection (UL□) based on motor load. 0: Overtorque/undertorque detection enabled 1: Base frequency motor load enabled	Default: 0 Range: 0, 1	140
L6-14 (62F)	Motor Underload Protection Level at Minimum Frequency	Underload Level	Sets the UL6 detection level at minimum frequency by percentage of drive rated current.	Default: 15% Min.: 0 Max.: 300	140

◆ L8: Drive Protection

No. (Addr. Hex)	Name	LCD Display	Description	Values	Page
L8-02 (4AE)	Overheat Alarm Level	OH Pre-Alarm Lvl	An overheat alarm occurs when heatsink temperature exceeds the L8-02 level.	Default: </> Min.: 50 °C Max.: 150 °C	180
L8-03 (4AF)	Overheat Pre-Alarm Operation Selection	OH Pre-Alarm Sel 0: Ramp to stop 1: Coast to stop 2: Fast-Stop 3: Alarm only 4: Run@L8-19 Rate	0: Ramp to stop. A fault is triggered. 1: Coast to stop. A fault is triggered. 2: Fast Stop. Decelerate to stop using the deceleration time in C1-09. A fault is triggered. 3: Continue operation. An alarm is triggered. 4: Continue operation at reduced speed as set in L8-19.	Default: 4 Range: 0 to 4	180
L8-05 (4B1)	Input Phase Loss Protection Selection	Inp Ph Loss Det 0: Disabled 1: Enabled	Selects the detection of input current phase loss, power supply voltage imbalance, or main circuit electrolytic capacitor deterioration. 0: Disabled 1: Enabled	Default: 1 Range: 0, 1	181

## B.8 L: Protection Function

No. (Addr. Hex)	Name	LCD Display	Description	Values	Page
L8-06 (4B2)	Input Phase Detection Level	Inp Ph Loss Lvl	When ripple is observed in the DC bus, expansion of the input bias is calculated. This value becomes the input phase if the difference between the maximum and minimum values of the ripple is greater than the value set to L8-06. Detection Level = 100% = Voltage class x $\sqrt{2}$	Default: </> Min.: 0.0% Max.: 50.0%	181
L8-07 (4B3)	Output Phase Loss Protection Selection	Outp Ph Loss Det 0: Disabled 1: 1PH Loss Det 2: 2/3PH Loss Det	0: Disabled 1: Enabled (triggered by a single phase loss) 2: Enabled (triggered when two phases are lost)	Default: 1 Range: 0 to 2	182
L8-09 (4B5)	Output Ground Fault Detection Selection	Grnd Flt Det Sel 0: Disabled 1: Enabled	0: Disabled 1: Enabled	Default: </> Range: 0, 1	182
L8-10 (4B6)	Heatsink Cooling Fan Operation Selection	Fan On/Off Sel 0: Dur Run (OffDly) 1: Always On	0: During run only. Fan operates only during run for L8-11 seconds after stop. 1: Fan always on. Cooling fan operates whenever the drive is powered up.	Default: 0 Range: 0, 1	182
L8-11 (4B7)	Heatsink Cooling Fan Off Delay Time	Fan Delay Time	Sets a delay time to shut off the cooling fan after the Run command is removed when L8-10 = 0.	Default: 300 s Min.: 0 Max.: 300	182
L8-12 (4B8)	Ambient Temperature Setting	Ambient Temp	Enter the ambient temperature. This value adjusts the oL2 detection level.	Default: 40 °C Min.: 40 Max.: 60	182
L8-15 (4BB)	oL2 Characteristics Selection at Low Speeds	OL2 Sel @ L-Spd 0: Disabled 1: Enabled	0: No oL2 level reduction below 6 Hz. 1: oL2 level is reduced linearly below 6 Hz. It is halved at 0 Hz.	Default: 1 Range: 0, 1	183
L8-18 (4BE)	Software Current Limit Selection	Soft CLA Sel 0: Disabled 1: Enabled	0: Disabled 1: Enabled	Default: 0 Range: 0, 1	183
L8-19 (4BF)	Frequency Reduction Rate during Overheat Pre-Alarm	Fc Red dur OHAlm	Specifies the frequency reference reduction gain at overheat pre-alarm when L8-03 = 4.	Default: 20.0% Min.: 0.0 Max.: 100.0	183
L8-27 (4DD)	Overcurrent Detection Gain	OC Level	Sets the gain for overcurrent detection as a percentage of the motor rated current. Overcurrent is detected using the lower value between the overcurrent level of the drive or the value set to L8-27.	Default: 300.0% Min.: 0.0 Max.: 300.0	183
L8-29 (4DF)	Current Unbalance Detection (LF2)	LF2 Flt Det Sel 0: Disabled 1: Enabled	0: Disabled 1: Enabled	Default: 1 Range: 0, 1	183
L8-32 (4E2)	Main Contactor and Cooling Fan Power Supply Failure Selection	MC/FAN PS FltSel 0: Ramp to stop 1: Coast to stop 2: Fast-Stop 3: Alarm only 4: Run@L8-19 Rate	Determines drive response when a fault occurs with the internal cooling fan. 0: Ramp to stop 1: Coast to stop 2: Fast stop (Decelerate to stop using the deceleration time set to C1-09) 3: Alarm only ("FAn" will flash) 4: Continue operation at reduced speed as set to L8-19.	Default: 1 Range: 0 to 4	184
L8-35 (4EC)	Installation Method Selection	Installation Sel 0: IP00/OpenChassis 2: IP20/Nema Type 1 3: ExternalHeatsink	0: IP00/Open-Chassis enclosure 2: IP20/NEMA Type 1 enclosure 3: External Heatsink Installation	Default: </> </> </> Range: 0, 2, 3	184
L8-38 (4EF)	Carrier Frequency Reduction	Fc Reduct dur OL 0: Disabled 1: Active below 6Hz 2: Active @ any Spd	0: Disabled 1: Enabled below 6 Hz 2: Enabled for the entire speed range	Default: </> Range: 0 to 2	184
L8-40 (4F1)	Carrier Frequency Reduction Off Delay Time	Fc Reduct Time	Sets the time that the drive continues running with reduced carrier frequency after the carrier reduction condition is gone. Setting 0.00 s disables the carrier frequency reduction time.	Default: 0.50 s Min.: 0.00 Max.: 2.00	185
L8-41 (4F2)	High Current Alarm Selection	High Cur Alm Sel 0: Disabled 1: Enabled	0: Disabled 1: Enabled. An alarm is triggered at output currents above 150% of drive rated current.	Default: 0 Range: 0, 1	185
L8-97 (3104)	Carrier Frequency Reduction Selection during oH Pre-Alarm	FC Sel dur OHAlm 0: Disabled 1: Enabled	Carrier frequency reduction protection selection. It is reduced to the carrier frequency at oH pre-alarm. 0: Disabled 1: Enabled	Default: 0 Range: 0, 1	-

- <1> Default setting is dependent on parameter o2-04, Drive Model Selection.
- <2> Parameter setting value is not reset to the default value when the drive is initialized.
- <3> Default setting is determined by the drive model:
  - Setting 2: Models 2A0011 to 2A0211 and 4A0005 to 4A0096
  - Setting 0: Models 2A0273 to 2A0396 and 4A0124 to 4A0590
- <4> Default setting is dependent on parameters A1-02, Control Method Selection, and o2-04, Drive Model Selection.

## B.9 n: Special Adjustment

The n parameters adjust more advanced performance characteristics such as Hunting Prevention, speed feedback detection, High Slip Braking, and Online Tuning for motor line-to-line resistance.

### ◆ n1: Hunting Prevention

No. (Addr. Hex)	Name	LCD Display	Description	Values	Page
n1-01 (580)	Hunting Prevention Selection	Hunt Prev Select 0: Disabled 1: Enabled	0: Disabled 1: Enabled	Default: 1 Range: 0, 1	–
n1-02 (581)	Hunting Prevention Gain Setting	Hunt Prev Gain	If the motor vibrates while lightly loaded, increase the gain by 0.1 until vibration ceases. If the motor stalls, decrease the gain by 0.1 until the stalling ceases.	Default: 1.00 Min.: 0.00 Max.: 2.50	–
n1-03 (582)	Hunting Prevention Time Constant	Hunt Prev Time	Sets the time constant used for Hunting Prevention.	Default: <1> Min.: 0 ms Max.: 500 ms	–
n1-05 (530)	Hunting Prevention Gain while in Reverse	Hprev Gain @Rev	Sets the gain used for Hunting Prevention. If set to 0, the gain set to n1-02 is used for operation in reverse.	Default: 0.00 Min.: 0.00 Max.: 2.50	–

<1> Default setting is dependent on parameter o2-04, Drive Model Selection.

### ◆ n3: High Slip Braking (HSB) and Overexcitation Braking

No. (Addr. Hex)	Name	LCD Display	Description	Values	Page
n3-01 (588)	High-Slip Braking Deceleration Frequency Width	HSB DecStepWidth	Sets the output frequency reduction step width for when the drive stops the motor using HSB. Set as a percentage of the maximum output frequency. Increase this setting if overvoltage occurs during HSB.	Default: 5% Min.: 1 Max.: 20	–
n3-02 (589)	High-Slip Braking Current Limit	HSB Current Lim	Sets the current limit during HSB as a percentage of the motor rated current.	Default: <1> Min.: 0% Max.: 200%	–
n3-03 (58A)	High-Slip Braking Dwell Time at Stop	HSB DwellTim@Stp	Sets the time the drive will run with minimum frequency (E1-09) at the end of deceleration. If this time is set too low, the machine inertia can cause the motor to rotate slightly after HSB.	Default: 1.0 s Min.: 0.0 Max.: 10.0	–
n3-04 (58B)	High-Slip Braking Overload Time	HSB OL Time	Sets the time required for an HSB overload fault (oL7) to occur when the drive output frequency does not change during an HSB stop. This parameter does not typically require adjustment.	Default: 40 s Min.: 30 Max.: 1200	–
n3-13 (531)	Overexcitation Deceleration Gain	Hflux Brake Gain	Sets the gain applied to the V/f pattern during Overexcitation Deceleration (L3-04 = 4).	Default: 1.10 Min.: 1.00 Max.: 1.40	–
n3-21 (579)	High-Slip Suppression Current Level	Hflux I Supp Lvl	Sets output current level at which the drive will start reducing the overexcitation gain in order to prevent a too high motor slip during Overexcitation Deceleration. Set as a percentage of the drive rated current.	Default: 100% Min.: 0 Max.: 150	–
n3-23 (57B)	Overexcitation Operation Selection	Hflux Brake Sel 0: Enabled-Both Dir 1: Enabled-Fwd only 2: Enabled-Rev only	0: Enabled in both directions 1: Enabled only when rotating forward 2: Enabled only when in reverse	Default: 0 Range: 0 to 2	–

<1> Default setting is dependent on parameter L8-38, Frequency Reduction Selection.

## ◆ n8: PM Motor Control Tuning

No. (Addr. Hex)	Name	LCD Display	Description	Values	Page
n8-45 (538)	Speed Feedback Detection Control Gain	PM Spd Fdbk Gain	<b>OLV/PM</b> Increase this setting if hunting occurs. Decrease to lower the response.	Default: 0.80 Min.: 0.00 Max.: 10.00	–
n8-47 (53A)	Pull-In Current Compensation Time Constant	PM Pull-in I Tc	<b>OLV/PM</b> Sets the time constant to make the pull-in current reference and actual current value agree. Decrease the value if the motor begins to oscillate, and increase the value if it takes too long for the current reference to equal the output current.	Default: 5.0 s Min.: 0.0 Max.: 100.0	–
n8-48 (53B)	Pull-In Current	PM No-load Curr	<b>OLV/PM</b> Defines the d-Axis current reference during no-load operation at a constant speed. Set as a percentage of the motor rated current. Increase this setting if hunting occurs while running at constant speed.	Default: 30% Min.: 20 Max.: 200	–
n8-49 (53C)	d-Axis Current for High Efficiency Control	EnergySav ID Lvl	<b>OLV/PM</b> Sets the d-Axis current reference when running a high load at constant speed. Set as a percentage of the motor rated current.	Default: <1> Min.: -200.0% Max.: 0.0%	–
n8-51 (53E)	Acceleration/Deceleration Pull-In Current	PM Pull-in I@Acc	<b>OLV/PM</b> Sets the d-Axis current reference during acceleration/deceleration as a percentage of the motor rated current. Set to a high value when more starting torque is needed.	Default: 50% Min.: 0 Max.: 200	–
n8-54 (56D)	Voltage Error Compensation Time Constant	PM V Error CompT	<b>OLV/PM</b> Adjusts the value when hunting occurs at low speed. If hunting occurs with sudden load changes, increase n8-54 in increments of 0.1. Reduce this setting if oscillation occurs at start.	Default: 1.00 s Min.: 0.00 Max.: 10.00	–
n8-55 (56E)	Load Inertia	PMLoad wk2 Ratio 0: Less than 1:10 1: 1:10 to 1:30 2: 1:30 to 1:50 3: More than 1:50	<b>OLV/PM</b> Sets the ratio between motor and machine inertia. 0: Lower than 1:10 1: Between 1:10 to 1:30 2: Between 1:30 to 1:50 3: Higher than 1:50	Default: 0 Min.: 0 Max.: 3	–
n8-62 (57D)	Output Voltage Limit	PM Vout Limit	<b>OLV/PM</b> Prevents output voltage saturation. Should be set just below the voltage provided by the input power supply.	Default: 200.0 V <2> Min.: 0.0 Max.: 230.0 <2>	–
n8-65 (65C)	Speed Feedback Detection Control Gain during ov Suppression	SFdbk G @OV Supp	<b>OLV/PM</b> Sets the gain used for internal speed feedback detection during ov suppression.	Default: 1.50 Min.: 0.00 Max.: 10.00	–

<1> Default setting is dependent on parameter o2-04, Drive Model Selection.

<2> Values shown are specific to 200 V class drives. Double the value for 400 V class drives.

## B.10 o: Operator-Related Settings

The o parameters set up the HOA keypad displays.

### ◆ o1: HOA Keypad Display Selection

No. (Addr. Hex)	Name	LCD Display	Description	Values	Page
o1-01 (500) [RUN]	Drive Mode Unit Monitor Selection	User Monitor Sel	Selects the content of the last monitor that is shown when scrolling through Drive Mode display. Enter the last three digits of the monitor parameter number to be displayed: U□-□□.	Default: 106 Range: 104 to 699	<a href="#">185</a>
o1-02 (501) [RUN]	User Monitor Selection after Power Up	Power-On Monitor 1: Frequency Ref 2: FWD/REV 3: Output Freq 4: Output Current 5: User Monitor	1: Frequency reference (U1-01) 2: Direction 3: Output frequency (U1-02) 4: Output current (U1-03) 5: User Monitor	Default: 1 Range: 1 to 5	<a href="#">185</a>
o1-03 (502)	HOA Keypad Operator Display Selection	Display Unit Sel 0: 0.01 Hz 1: 0.01% 2: r/min 3: User Units	Sets the units the drive should use to display the frequency reference and motor speed monitors. 0: 0.01 Hz 1: 0.01% (100% = E1-04) 2: r/min (calculated using the number of motor poles setting in E2-04, E4-04, or E5-04) 3: User-selected units (set by o1-10 and o1-11)	Default: 0 Range: 0 to 3	<a href="#">186</a>
o1-06 (517)	User Monitor Selection Mode	Monitor Mode Sel 0: 3 Mon Sequential 1: 3 Mon Selectable	0: 3 Monitor Sequential (Displays the next two sequential monitors) 1: 3 Monitor Selectable (o1-07 and o1-08 selected monitor are shown)	Default: 0 Range: 0, 1	<a href="#">186</a>
o1-07 (518)	Second Line Monitor Selection	2nd Monitor Sel	Selects the monitor that is shown in the second line. Enter the last three digits of the monitor parameter number to be displayed: U□-□□. For example, set "403" to display monitor parameter U4-03.	Default: 102 Range: 101 to 699	<a href="#">186</a>
o1-08 (519)	Third Line Monitor Selection	3rd Monitor Sel	Selects the monitor that is shown in the third line. Enter the last three digits of the monitor parameter number to be displayed: U□-□□. For example, set "403" to display monitor parameter U4-03.	Default: 103 Range: 101 to 699	<a href="#">186</a>
o1-09 (51C)	Frequency Reference Display Units	Fref Disp Unit 0: WC 1: PSI 2: GPM 3: °F 4: CFM 5: CMH 6: LPH 7: LPS 8: Bar 9: Pa 10: °C 11: Mtr 12: Ft 13: LPM 14: CMM 15: Custom unit 16: No Unit	Sets unit display for the frequency reference parameters and frequency related monitors when o1-03 > 40. 0: WC (Inch of water) 1: PSI (Pounds per square inch) 2: GPM (Gallons per minute) 3: F (Degrees Fahrenheit) 4: CFM (Cubic feet per minute) 5: CMH (Cubic meters per hour) 6: LPH (Liters per hour) 7: LPS (Liters per second) 8: Bar (Bar) 9: Pa (Pascal) 10: C (Degrees Celsius) 11: Mtr (Meters) 12: Ft (Feet) 13: LPM (Liters per minute) 14: CMM (Cubic meters per minute) 15: Custom units (Determined by o1-12) 16: None	Default: 16 Range: 0 to 16	<a href="#">186</a>
o1-10 (520)	User-Set Display Units Maximum Value	UserDisp Scaling	These settings define the display values when o1-03 is set to 3. o1-10 sets the display value that is equal to the maximum output frequency. o1-11 sets the position of the decimal position.	Default: </> Range: 1 to 60000	<a href="#">187</a>
o1-11 (521)	User-Set Display Units Decimal Display	UserDisp Dec		Default: </> Range: 0 to 3	<a href="#">187</a>
o1-13 (3105)	Frequency Reference and Frequency Related Monitor Custom Units 1	Fref Cust Unit 1	Sets the customer-specified unit display for the frequency reference parameters and frequency related monitors when o1-03 = 3 and o1-09 = 15 as custom units.	Default: 41 Range: 30 to 7A	<a href="#">187</a>
o1-14 (3106)	Frequency Reference and Frequency Related Monitor Custom Units 2	Fref Cust Unit 2	Sets the customer-specified unit display for the frequency reference parameters and frequency related monitors when o1-03 = 3 and o1-09 = 15 as custom units	Default: 41 Range: 30 to 7A	<a href="#">187</a>

No. (Addr. Hex)	Name	LCD Display	Description	Values	Page
o1-15 (3107)	Frequency Reference and Frequency Related Monitor Custom Units 3	Fref Cust Unit 3	Sets the customer-specified unit display for the frequency reference parameters and frequency related monitors when o1-03 = 3 and o1-09 = 15 as custom units	Default: 41 Range: 30 to 7A	187
o1-16 (3108)	F1 Key Function Selection	F1 Key Func Sel 0: Standard 1: Mon 2: DRV/BYP 3: RUN BYP 4: RLY	Selects the function of the F1 key and the LCD display text above the F1 key. 0: Standard 1: Monitor 2: Drive/Bypass (DRV/BYP) 3: Bypass Run Command (RUN BYP) 4: Toggle Relay Output (RLY)	Default: 0 Range: 0 to 4	187
o1-17 (3109)	F2 Key Function Selection	F2 Key Func Sel 0: Standard 1: Mon 2: DRV/BYP 3: RUN BYP 4: RLY	Selects the function of the F1 key and the LCD display text above the F1 key. 0: Standard 1: Monitor 2: Drive/Bypass (DRV/BYP) 3: Bypass Run Command (RUN BYP) 4: Toggle Relay Output (RLY)	Default: 0 Range: 0 to 4	187
o1-18 (310A)	User Defined Parameter Upper	Userdefined par1	Allows the user to set values that can be used as reference information.	Default: 0 Range: 0 to 999	187
o1-19 (310B)	User Defined Parameter Lower	Userdefined par2	Allows the user to set values that can be used as reference information.	Default: 0 Range: 0 to 999	187

<1> Default setting is dependent on parameter o1-03, HOA Keypad Display Selection.

## ◆ o2: HOA Keypad Functions

No. (Addr. Hex)	Name	LCD Display	Description	Values	Page
o2-02 (506)	OFF Key Function Selection	Oper STOP Key 0: Disabled 1: Enabled	0: Disabled. OFF key is disabled in REMOTE operation. 1: Enabled. OFF key is always enabled.	Default: 1 Range: 0, 1	188
o2-03 (507)	User Parameter Default Value	User Default Sel 0: No Change 1: Save User Init 2: Clear User Init	0: No change. 1: Set defaults. Saves parameter settings as default values for a User Initialization. 2: Clear all. Clears the default settings that have been saved for a User Initialization.	Default: 0 Range: 0 to 2	141
o2-04 (508)	Drive Model Selection	Inverter Model #	Enter the drive model. Setting required only if installing a new control board.	Default: Determined by drive capacity	188
o2-05 (509)	Frequency Reference Setting Method Selection	Oper Ref Method 0: Disabled 1: Enabled	0: ENTER key must be pressed to enter a frequency reference. 1: ENTER key is not required. The frequency reference can be adjusted using the up and down arrow keys only.	Default: 0 Range: 0, 1	141
o2-06 (50A)	Operation Selection when HOA Keypad is Disconnected	Oper Discon Det 0: Disabled 1: Enabled	0: The drive continues operating if the HOA keypad is disconnected. 1: An oPr fault is triggered and the motor coasts to stop.	Default: 1 Range: 0, 1	188
o2-07 (527)	Motor Direction at Power Up when Using Operator	For/RevSel@PwrUp 0: Forward 1: Reverse	0: Forward 1: Reverse This parameter requires assigning drive operation to the HOA keypad.	Default: 0 Range: 0, 1	188
o2-19 (61F)	Selection of Parameter Write during Uv	ParameterSet Sel 0: Disabled 1: Enabled	Selects whether parameter settings can be changed during a DC bus undervoltage condition. Used with 24 V Power Supply (PS-A10L, PS-A10H). 0: Disabled 1: Enabled	Default: 0 Range: 0, 1	-

## B.10 o: Operator-Related Settings

### ◆ o3: Copy Function

No. (Addr. Hex)	Name	LCD Display	Description	Values	Page
o3-01 (515)	Copy Function Selection	COPY SELECT 0: COPY SELECT 1: INV→OP READ 2: OP→INV WRITE 3: OP←→INV VERIFY	0: No action 1: Read parameters from the drive, saving them onto the HOA keypad. 2: Copy parameters from the digital operator, writing them to the drive. 3: Verify parameter settings on the drive to check if they match the data saved on the HOA keypad.	Default: 0 Range: 0 to 3	<a href="#">189</a>
o3-02 (516)	Copy Allowed Selection	Read Allowable 0: Disabled 1: Enabled	0: Read operation prohibited 1: Read operation allowed	Default: 0 Range: 0, 1	<a href="#">189</a>

### ◆ o4: Maintenance Monitor Settings

No. (Addr. Hex)	Name	LCD Display	Description	Values	Page
o4-01 (50B)	Cumulative Operation Time Setting	DrvElapsTimeCnt	Sets the value for the cumulative operation time of the drive in units of 10 h.	Default: 0 h Min.: 0 Max.: 9999	<a href="#">189</a>
o4-02 (50C)	Cumulative Operation Time Selection	ElapsTimeCntSet 0: Power-On Time 1: Running Time	0: Logs power-on time 1: Logs operation time when the drive output is active (output operation time).	Default: 1 Range: 0, 1	<a href="#">189</a>
o4-03 (50E)	Cooling Fan Operation Time Setting	FanElapsTimeCn	Sets the value of the fan operation time monitor U4-03 in units of 10 h.	Default: 0 h Min.: 0 Max.: 9999	<a href="#">189</a>
o4-05 (51D)	Capacitor Maintenance Setting	BusCap Maint Set	Sets the value of the Maintenance Monitor for the capacitors. See U4-05 to check when the capacitors may need to be replaced.	Default: 0% Min.: 0 Max.: 150	<a href="#">190</a>
o4-07 (523)	DC Bus Pre-Charge Relay Maintenance Setting	ChrgCircMaintSet	Sets the value of the Maintenance Monitor for the soft charge bypass relay. See U4-06 to check when the bypass relay may need to be replaced.	Default: 0% Min.: 0 Max.: 150	<a href="#">190</a>
o4-11 (510)	U2, U3 Initialization	Fault Data Init 0: No Reset 1: Reset	0: U2-□□ and U3-□□ monitor data is not reset when the drive is initialized (A1-03). 1: U2-□□ and U3-□□ monitor data is reset when the drive is initialized (A1-03).	Default: 0 Range: 0, 1	<a href="#">190</a>
o4-12 (512)	kWh Monitor Initialization	kWh Monitor Init 0: No Reset 1: Reset	0: U4-10 and U4-11 monitor data is not reset when the drive is initialized (A1-03). 1: U4-10 and U4-11 monitor data is reset when the drive is initialized (A1-03).	Default: 0 Range: 0, 1	<a href="#">190</a>
o4-13 (528)	Number of Run Commands Counter Initialization	Run Counter Init 0: No Reset 1: Reset	0: Number of Run commands counter is not reset when the drive is initialized (A1-03). 1: Number of Run commands counter is reset when the drive is initialized (A1-03).	Default: 0 Range: 0, 1	<a href="#">190</a>
o4-17 (3100) <1>	Set/Reset Real Time Clock	Set Time 0: Disabled 1: Enabled	Sets the current date and time for the Real Time Clock. 0: Disabled 1: Enabled	Default: 0 Range: 0, 1	<a href="#">190</a>
o4-17 (3100) <2>	Set/Reset Real Time Clock	Set Time 0: — — 1: Set 2: Reset	Sets the current date and time for the Real Time Clock. 0: — — No Setting 1: Real Time Clock Set 2: Real Time Clock Reset	Default: 0 Range: 0 to 2	<a href="#">190</a>

<1> Available in drive software versions PRG: 1012 and earlier.

<2> Available in drive software versions PRG: 1013 and later.

## B.11 S: Special Application

### ◆ S1: Dynamic Noise Control Function

No. (Addr. Hex)	Name	LCD Display	Description	Values	Page
S1-01 (3200)	Dynamic Audible Noise Control Function Selection	Dyn Noise Ctrl 0: Disabled 1: Enabled	Reduces audible noise by decreasing the output voltage in variable torque applications with light loads. 0: Disabled 1: Enabled	Default: 1 Range: 0, 1	–
S1-02 (3201)	Voltage Reduction Rate	Volt Reduce Amt	Sets the rate at which the output voltage will be reduced as a percentage of the V/f pattern when operating with no load.	Default: 50.0% Min.: 50.0 Max.: 100.0	–
S1-03 (3202)	Voltage Restoration Level	V Reduce On Lvl	Sets the level when the drive should start restoring the voltage as a percentage of the drive rated torque.	Default: 20.0% Min.: 0.0 Max.: 90.0	–
S1-04 (3203)	Voltage Restoration Complete Level	V Reduce Off Lvl	Sets the level at which voltage restoration for the V/f pattern is complete as a percentage of the drive rated torque. If the output torque rises above the value of S1-04, then the voltage will be controlled in a manner specified by the V/f pattern setting.	Default: 50.0% Min.: S1-03 + 10.0 Max.: 100.0	–
S1-05 (3204)	Voltage Restoration Sensitivity Time Constant	Sensitivity Time	Sets the level of sensitivity of the output torque and LPF time constant for the voltage reduction rate. The level of sensitivity can be adjusted in accordance with the load response.	Default: 1.000 s Min.: 0.000 Max.: 3.000	–
S1-06 (3205)	Voltage Restoration Time Constant at Impact	Impact Load Time	Sets the voltage restoration time constant if an impact load is added.	Default: 0.050 s Min.: 0.000 Max.: 1.000	–

### ◆ S2: Sequence Timers

No. (Addr. Hex)	Name	LCD Display	Description	Values	Page
S2-01 (3206)	Sequence Timer 1 Start Time	Tmr 1 Start Time	Sets the start time for timer 1. The value must be set less than or equal to S2-02.	Default: 00:00 Min.: 00:00 Max.: 24:00	–
S2-02 (3207)	Sequence Timer 1 Stop Time	Tmr 1 Stop Time	Sets the stop time for timer 1. The value must be set greater than or equal to S2-01.	Default: 00:00 Min.: 00:00 Max.: 24:00	–
S2-03 (3208)	Sequence Timer 1 Day Selection	Tmr 1 Day Sel 0: Timer disabled 1: Daily 2: Mon - Fri 3: Sat - Sun 4: Monday 5: Tuesday 6: Wednesday 7: Thursday 8: Friday 9: Saturday 10: Sunday	Sets the days for which sequence timer 1 is active. 0: Timer disabled 1: Daily 2: Mon - Fri 3: Sat - Sun 4: Monday 5: Tuesday 6: Wednesday 7: Thursday 8: Friday 9: Saturday 10: Sunday	Default: 0 Range: 0 to 10	–
S2-04 (3209)	Sequence Timer 1 Selection	Tmr 1 Seq Sel 0: Digital out only 1: Run 2: Run - PI Disable	Sets the action that occurs when sequence timers 1 is active. 0: Digital output only 1: Run 2: Run - PI disable	Default: 0 Range: 0 to 2	–
S2-05 (320A)	Sequence Timer 1 Reference Source	Tmr 1 Ref Source 0: Operator (d1-01) 1: Operator (d1-02) 2: Operator (d1-03) 3: Operator (d1-04) 4: Terminals 5: Serial com 6: Option PCB	Selects the frequency reference source used for running the drive when sequence timer 1 is active (only applicable when S2-04 is set to 1 or 2). 0: Operator (d1-01) 1: Operator (d1-02) 2: Operator (d1-03) 3: Operator (d1-04) 4: Terminals 5: Serial communication 6: Option card	Default: 0 Range: 0 to 6	–

## B.11 S: Special Application

No. (Addr. Hex)	Name	LCD Display	Description	Values	Page
S2-06 (320B)	Sequence Timer 2 Start Time	Tmr 2 Start Time	Sets the start time for timer 2. The value must be set less than or equal to S2-07.	Default: 00:00 Min.: 00:00 Max.: 24:00	–
S2-07 (320C)	Sequence Timer 2 Stop Time	Tmr 2 Stop Time	Sets the stop time for timer 2. The value must be set greater than or equal to S2-06.	Default: 00:00 Min.: 00:00 Max.: 24:00	–
S2-08 (320D)	Sequence Timer 2 Day Selection	Tmr 2 Day Sel 0: Timer disabled 1: Daily 2: Mon - Fri 3: Sat - Sun 4: Monday 5: Tuesday 6: Wednesday 7: Thursday 8: Friday 9: Saturday 10: Sunday	Sets the days for which sequence timer 2 is active. 0: Timer disabled 1: Daily 2: Mon - Fri 3: Sat - Sun 4: Monday 5: Tuesday 6: Wednesday 7: Thursday 8: Friday 9: Saturday 10: Sunday	Default: 0 Range: 0 to 10	–
S2-09 (320E)	Sequence Timer 2 Selection	Tmr 2 Seq Sel 0: Digital out only 1: Run 2: Run - PI Disable	Sets the action that occurs when sequence timers 2 is active. 0: Digital output only 1: Run 2: Run - PI disable	Default: 0 Range: 0 to 2	–
S2-10 (320F)	Sequence Timer 2 Reference Source	Tmr 2 Ref Source 0: Operator (d1-01) 1: Operator (d1-02) 2: Operator (d1-03) 3: Operator (d1-04) 4: Terminals 5: Serial com 6: Option PCB	Selects the frequency reference source used for running the drive when sequence timer 2 is active (only applicable when S2-09 is set to 1 or 2). 0: Operator (d1-01) 1: Operator (d1-02) 2: Operator (d1-03) 3: Operator (d1-04) 4: Terminals 5: Serial communication 6: Option card	Default: 0 Range: 0 to 6	–
S2-11 (3210)	Sequence Timer 3 Start Time	Tmr 3 Start Time	Sets the start time for timer 3. The value must be set less than or equal to S2-12.	Default: 00:00 Min.: 00:00 Max.: 24:00	–
S2-12 (3211)	Sequence Timer 3 Stop Time	Tmr 3 Stop Time	Sets the stop time for timer 3. The value must be set greater than or equal to S2-11.	Default: 00:00 Min.: 00:00 Max.: 24:00	–
S2-13 (3212)	Sequence Timer 3 Day Selection	Tmr 3 Day Sel 0: Timer disabled 1: Daily 2: Mon - Fri 3: Sat - Sun 4: Monday 5: Tuesday 6: Wednesday 7: Thursday 8: Friday 9: Saturday 10: Sunday	Sets the days for which sequence timer 3 is active. 0: Timer disabled 1: Daily 2: Mon - Fri 3: Sat - Sun 4: Monday 5: Tuesday 6: Wednesday 7: Thursday 8: Friday 9: Saturday 10: Sunday	Default: 0 Range: 0 to 10	–
S2-14 (3213)	Sequence Timer 3 Selection	Tmr 3 Seq Sel 0: Digital out only 1: Run 2: Run - PI Disable	Sets the action that occurs when sequence timer 3 is active. 0: Digital output only 1: Run 2: Run - PI disable	Default: 0 Range: 0 to 2	–
S2-15 (3214)	Sequence Timer 3 Reference Source	Tmr 3 Ref Source 0: Operator (d1-01) 1: Operator (d1-02) 2: Operator (d1-03) 3: Operator (d1-04) 4: Terminals 5: Serial com 6: Option PCB	Selects the frequency reference source used for running the drive when sequence timer 3 is active (only applicable when S2-14 is set to 1 or 2). 0: Operator (d1-01) 1: Operator (d1-02) 2: Operator (d1-03) 3: Operator (d1-04) 4: Terminals 5: Serial communication 6: Option card	Default: 0 Range: 0 to 6	–
S2-16 (3215)	Sequence Timer 4 Start Time	Tmr 4 Start Time	Sets the start time for timer 4. The value must be set less than or equal to S2-17.	Default: 00:00 Min.: 00:00 Max.: 24:00	–

No. (Addr. Hex)	Name	LCD Display	Description	Values	Page
S2-17 (3216)	Sequence Timer 4 Stop Time	Tmr 4 Stop Time	Sets the stop time for timer 4. The value must be set greater than or equal to S2-16.	Default: 00:00 Min.: 00:00 Max.: 24:00	–
S2-18 (3217)	Sequence Timer 4 Day Selection	Tmr 4 Day Sel 0: Timer disabled 1: Daily 2: Mon - Fri 3: Sat - Sun 4: Monday 5: Tuesday 6: Wednesday 7: Thursday 8: Friday 9: Saturday 10: Sunday	Sets the days for which sequence timer 4 is active. 0: Timer disabled 1: Daily 2: Mon - Fri 3: Sat - Sun 4: Monday 5: Tuesday 6: Wednesday 7: Thursday 8: Friday 9: Saturday 10: Sunday	Default: 0 Range: 0 to 10	–
S2-19 (3218)	Sequence Timer 4 Selection	Tmr 4 Seq Sel 0: Digital out only 1: Run 2: Run - PI Disable	Sets the action that occurs when sequence timer 4 is active. 0: Digital output only 1: Run 2: Run - PI disable	Default: 0 Range: 0 to 2	–
S2-20 (3219)	Sequence Timer 4 Reference Source	Tmr 4 Ref Source 0: Operator (d1-01) 1: Operator (d1-02) 2: Operator (d1-03) 3: Operator (d1-04) 4: Terminals 5: Serial com 6: Option PCB	Selects the frequency reference source used for running the drive when sequence timer 4 is active (only applicable when S2-19 is set to 1 or 2). 0: Operator (d1-01) 1: Operator (d1-02) 2: Operator (d1-03) 3: Operator (d1-04) 4: Terminals 5: Serial communication 6: Option card	Default: 0 Range: 0 to 6	–

◆ S3: Secondary PI (PI2) Control

No. (Addr. Hex)	Name	LCD Display	Description	Values	Page
S3-01 (321A) RUN	Secondary PI Enable Selection	PI2 Enable Sel 0: Disabled 1: Always 2: Drive running 3: Motor running	0: Secondary PI disabled 1: Always 2: Drive running 3: Motor running	Default: 0 Range: 0 to 3	–
S3-02 (321B) RUN	Secondary PI User Display	PI2 UsrDspMaxVal	Sets the scale value of 100% PI input.	Default: 10000 Min.: 0 Max.: 60000	–
S3-03 (321C) RUN	Secondary PI Display Digits	PI2 UsrDspDigits 0: No Dec (XXXXX) 1: 1 Dec (XXXX.X) 2: 2 Dec (XXX.XX) 3: 3 Dec (XX.XXX)	0: No decimal places 1: One decimal place 2: Two decimal places 3: Three decimal places	Default: 2 Range: 0 to 3	–
S3-04 (321D) RUN	Secondary PI Unit Selection	PI2 Unit Sel 0: WC 1: PSI 2: GPM 3: °F 4: CFM 5: CMH 6: LPH 7: LPS 8: Bar 9: Pa 10: °C 11: Mtr 12: LPM 13: CMM 14: No unit 15: %	0: Inch of water (WC) 1: Pounds per square inch (PSI) 2: Gallons per minute (GPM) 3: Degrees Fahrenheit (F) 4: Cubic feet per minute (CFM) 5: Cubic meters per hour (CMH) 6: Liters per hour (LPH) 7: Liters per second (LPS) 8: Bar (Bar) 9: Pascals (Pa) 10: Degrees Celsius (C) 11: Meters (Mtr) (Ft: Feet) 12: Liters per minute (LPM) 13: Cubic meters per minute (CMM) 14: No unit 15: Percentage (%)	Default: 15 Range: 0 to 15	–

## B.11 S: Special Application

No. (Addr. Hex)	Name	LCD Display	Description	Values	Page
S3-05 (321E) <input type="button" value="RUN"/>	Secondary PI Setpoint Value	PI2 Setpoint	Sets the secondary PI controller target value	Default: 0.00 <1> Min.: 0.00 Max.: 600.00 <2>	–
S3-06 (321F) <input type="button" value="RUN"/>	Secondary PI Proportional Gain Setting	PI2 Gain	Sets the proportional gain of the secondary PI controller. A setting of 0.00 disables P control.	Default: 1.00 Min.: 0.00 Max.: 25.00	–
S3-07 (3220) <input type="button" value="RUN"/>	Secondary PI Integral Time Setting	PI2 I Time	Sets the integral time for the secondary PI controller. A setting of 0.0s disables integral control.	Default: 1.0 s Min.: 0.0 Max.: 360.0	–
S3-08 (3221) <input type="button" value="RUN"/>	Secondary PI Integral Limit Setting	PI2 I Limit	Sets the maximum output possible from the integrator.	Default: 100.0% Min.: 0.0 Max.: 100.0	–
S3-09 (3222) <input type="button" value="RUN"/>	Secondary PI Output Upper Limit	PI2 Upper Limit	Sets the maximum output possible from the secondary PI controller.	Default: 100.0% Min.: 0.0 Max.: 100.0	–
S3-10 (3223) <input type="button" value="RUN"/>	Secondary PI Output Lower Limit	PI2 Lower Lim	Sets the minimum output possible from the secondary PI controller.	Default: 0.00% Min.: -100.00 Max.: 100.00	–
S3-11 (3224) <input type="button" value="RUN"/>	Secondary PI Output Level Selection	PI2 Out Lvl Sel 0: Normal Character 1: Rev Character	0: Normal Output (direct acting) 1: Reverse Output (reverse acting)	Default: 0 Range: 0, 1	–
S3-12 (3225) <input type="button" value="RUN"/>	Secondary PI Disable Mode	PI2 Disable Mode 0: No output 1: Lower Limit (S3-10) 2: Setpoint	0: No output (0%) 1: Lower Limit (S3-10) 2: Setpoint	Default: 0 Range: 0 to 2	–
S3-13 (3226) <input type="button" value="RUN"/>	Secondary PI Low Feedback Detection Level	PI2 Low FB Lvl	Sets the secondary PI low feedback detection level.	Default: 0.00 <1> Min.: 0.00 Max.: 600.00 <2>	–
S3-14 (3227) <input type="button" value="RUN"/>	Secondary PI Low Feedback Detection Time	PI2 Low FB Time	Sets the secondary PI low feedback detection delay time in seconds.	Default: 1.0 s Min.: 0.0 Max.: 25.5	–
S3-15 (3228) <input type="button" value="RUN"/>	Secondary PI High Feedback Level	PI2 High FB Lvl	Sets the secondary PI high feedback detection level.	Default: 100.00 <1> Min.: 0.00 Max.: 600.00 <2>	–
S3-16 (3229) <input type="button" value="RUN"/>	Secondary PI High Feedback Detection Time	PI2 High FB Tim	Sets the secondary PI high feedback detection delay time in seconds.	Default: 1.0 s Min.: 0.0 Max.: 25.5	–
S3-17 (322A) <input type="button" value="RUN"/>	Secondary PI Feedback Detection Selection	PI2 FB Det Sel 0: PI2 Enabled 1: Always	0: Secondary PI enabled 1: Always	Default: 0 Range: 0, 1	–

<1> Unit is determined by S3-04.

<2> Upper limit is S3-02, decimal placeholder is determined by S3-03.

## ◆ S4: Bypass Operation

No. (Addr. Hex)	Name	LCD Display	Description	Values	Page
S4-01 (322B) <input type="checkbox"/> RUN	BP Auto Transfer on Fault Enable	BP Fault Trnsfer 0: Disabled 1: Enabled	0: No transfer after fault 1: Transfer to bypass after fault	Default: 1 Range: 0, 1	–
S4-02 (322C) <input type="checkbox"/> RUN	Secondary PI User Display	BP Enrgy Sav Lvl	Delta used to determine when to switch into Energy Save Bypass. This allows for lower frequency output values to also trigger Energy Save Bypass functionality.	Default: 0 Hz Min.: 0 Max.: 20	–
S4-03 (322D) <input type="checkbox"/> RUN	BP Energy Save Bypass Timer	BP Enrgy Sav TMR	Sets the time in seconds that the drive should run at the specified speed before entering Energy Save Bypass mode.	Default: 60 s Min.: 10 Max.: 60000	–
S4-04 (322E) <input type="checkbox"/> RUN	BP Energy Save Bypass Speed Increase	BP Enrgy Sav Inc	Sets the value in Hz that the drive will increase the output frequency above E1-04 before performing an Energy Save transfer to bypass.	Default: 6 Hz Min.: 0 Max.: 10	–

## ◆ S5: HOA Keypad Parameters

No. (Addr. Hex)	Name	LCD Display	Description	Values	Page
S5-01 (322F)	HAND Frequency Reference Selection	HAND Fref Source 0: Operator 1: Terminals 2: d1-16 3: S5-05 4: Set by b1-01	0: HOA keypad 1: Terminals 2: d1-16 3: S5-05 4: Determined by b1-01	Default: 0 Range: 0 to 4	–
S5-02 (3230)	HAND/AUTO During Run Selection	HAND/AUTO @Run 0: Disabled 1: Enabled	0: Disabled 1: Enabled	Default: 1 Range: 0, 1	–
S5-03 (3231) <input type="checkbox"/> RUN	HAND Mode PI Selection	HAND Mode PI Sel 0: Disabled 1: Enabled	0: Disabled 1: Enabled	Default: 1 Range: 0, 1	–
S5-04 (3232)	HAND Mode Behavior Selection	HAND BehaviorSel 0: Legacy 1: Normal 2: Normal w/ Memory	0: Legacy operation mode 1: Normal operation mode 2: Normal with memory  <b>Note:</b> The drive will always be in AUTO mode at power up with S5-04 = 1.	Default: 1 Range: 0 to 2	–
S5-05 (3233) <input type="checkbox"/> RUN	HAND Frequency Reference 1	HAND Freq Ref 2	Sets the frequency reference used in HAND mode when S5-01 is set to 2.	Default: 0.00 Hz Min.: 0.00 Max.: 240.00	–
S5-07 (3235)	HAND Key Function Selection (HOA Keypad)	Oper HAND Key 0: Disabled 1: Enabled	Determines whether the HAND key on the HOA keypad will be enabled for switching between HAND and AUTO. 0: Disabled 1: Enabled	Default: 1 Range: 0, 1	–

**◆ S6: Z1000 Protection**

No. (Addr. Hex)	Name	LCD Display	Description	Values	Page
S6-01 (3236)	Emergency Override Speed	E Override Speed	Sets the speed command used in Emergency Override mode when S6-02 = 0.	Default: 0.00 Hz Min.: 0.00 Max.: 240.00	–
S6-02 (3237)	Emergency Override Reference Selection	E OverrideRefSel 0: Use S6-01 Ref 1: Use AUTO Ref	Selects the frequency reference source for the Emergency Override function (H1-□□= AF or B0). 0: Use S6-01 Reference 1: Use AUTO Reference  <b>Note:</b> In drive software versions PRG: 1013 and earlier, if the CALL alarm is displayed, the Emergency Override Forward (H1-0□ = AF) and Emergency Override Reverse (H1-0□ = B0) inputs are ignored. In drive software versions PRG: 1014 and later, the Emergency Override inputs will function even if the CALL alarm is displayed.	Default: 0 Range: 0, 1	–
S6-03 (3238)	ov2 Detect Time	ov2 Detect Time	Sets the detection time of ov2 in 0.1 s increments.	Default: 10.0 s Min.: 0.0 Max.: 1200.0	–
S6-04 (3239)	Main Contactor and Cooling Fan Power Supply Failure	FAN1 Fault Sel 0: Ramp to Stop 1: Coast to stop 2: Fast-Stop	Determines the action the drive should take when a fault occurs with the external cooling fan. 0: Ramp to stop 1: Coast to Stop 2: Fast Stop (decelerate to stop using the deceleration time in C1-09)	Default: 1 Range: 0 to 2	–
S6-07 (323C)	Output Phase Loss Detection Level for Dynamic Audible Noise Control	Outp Ph Loss Lv1	Sets the output phase loss detection level for Dynamic Audible Noise Control. Decrease the setting in steps of 10% when output phase loss is detected erroneously. This setting rarely needs to be changed.	Default: 100.0% Min.: 10.0 Max.: 100.0	–

## B.12 T: Motor Tuning

Enter data into the following parameters to tune the motor and drive for optimal performance.

### ◆ T1: Induction Motor Auto-Tuning

No. (Addr. Hex)	Name	LCD Display	Description	Values	Page
T1-01 (701) <1>	Auto-Tuning Mode Selection	Tuning Mode Sel 2: Term Resistance 3: On-DelayCompTune	2: Stationary Auto-Tuning for Line-to-Line Resistance 3: Rotational Auto-Tuning for V/f Control Energy Saving	Default: 2 Range: 2, 3	146
T1-02 (702)	Motor Rated Power	Mtr Rated Power	Sets the motor rated power as specified on the motor nameplate. <b>Note:</b> Use the following formula to convert horsepower into kilowatts: 1HP = 0.746 kW.	Default: <2> Min.: 0.00 kW Max.: 650.00 kW	146
T1-03 (703)	Motor Rated Voltage	Rated Voltage	Sets the motor rated voltage as specified on the motor nameplate.	Default: 200.0 V <3> Min: 0.0 Max: 255.0 <3>	146
T1-04 (704)	Motor Rated Current	Rated Current	Sets the motor rated current as specified on the motor nameplate.	Default: <2> Min.: 10% of drive rated current Max.: 200% of drive rated current	147
T1-05 (705)	Motor Base Frequency	Rated Frequency	Sets the rated frequency of the motor as specified on the motor nameplate.	Default: 60.0 Hz Min.: 0.0 Max.: 240.0	147
T1-06 (706)	Number of Motor Poles	Number of Poles	Sets the number of motor poles as specified on the motor nameplate.	Default: 4 Min.: 2 Max.: 48	147
T1-07 (707)	Motor Base Speed	Rated Speed	Sets the rated speed of the motor as specified on the motor nameplate.	Default: 1750 r/min Min.: 0 Max.: 14400	147
T1-11 (70B)	Motor Iron Loss	Mtr Iron Loss(W)	Sets the iron loss for determining the Energy Saving coefficient. The value is set to E2-10 (motor iron loss) set when the power is cycled. If T1-02 is changed, a default value appropriate for the motor capacity that was entered will appear.	Default: 14 W <4> Min.: 0 Max.: 65535	147
T1-12 (FFF0)	T1 Tuning Start	Tuning Ready	The drive starts tuning.	No setting available	147

<1> The availability of certain Auto-Tuning methods depends on the control mode selected for the drive.

<2> Default setting is dependent on parameter o2-04, Drive Model Selection.

<3> Values shown are specific to 200 V class drives. Double the value for 400 V class drives.

<4> Default setting value differs depending on the motor code value and motor parameter settings.

### ◆ T2: PM Motor Auto-Tuning

No. (Addr. Hex)	Name	LCD Display	Description	Values	Page
T2-01 (750)	PM Motor Auto-Tuning Mode Selection	PM Tuning Mode 0: Standard Tuning	<b>OLV/PM</b> 0: PM Motor Parameter Settings	Default: 0 Range: 0	–
T2-03 (752)	PM Motor Type	PM Motor Type 0: IPM motor 1: SPM motor	<b>OLV/PM</b> 0: IPM motor 1: SPM motor	Default: 1 Range: 0, 1	–

## B.12 T: Motor Tuning

No. (Addr. Hex)	Name	LCD Display	Description	Values	Page
T2-04 (730)	PM Motor Rated Power	Mtr Rated Power	<b>OLV/PM</b> Sets the motor rated power. <b>Note:</b> Use the following formula to convert horsepower into kilowatts: 1 HP = 0.746 kW.	Default: <1> Min.: 0.00 kW Max.: 650.00 kW	–
T2-05 (732)	PM Motor Rated Voltage	Rated Voltage	<b>OLV/PM</b> Enter the motor rated voltage as indicated on the motor nameplate.	Default: 200.0 V <2> Min.: 0.0 Max.: 255.0 <2>	–
T2-06 (733)	PM Motor Rated Current	Rated Current	<b>OLV/PM</b> Enter the motor rated current as indicated on the motor nameplate.	Default: <3> Min.: 10% of drive rated current Max.: 200% of drive rated current	–
T2-07 (753)	PM Motor Base Frequency	Base Frequency	<b>OLV/PM</b> Enter the motor base frequency as indicated on the motor nameplate.	Default: 87.5 Hz Min.: 0.0 Max.: 240.0	–
T2-08 (734)	Number of PM Motor Poles		<b>OLV/PM</b> Enter the number of motor poles for the PM motor as indicated on the motor nameplate.	Default: 6 Min.: 2 Max.: 48	–
T2-10 (754)	PM Motor Stator Resistance	Arm Resistance	<b>OLV/PM</b> Enter the rotor resistance for the PM motor as indicated on the motor nameplate.	Default: <3> Min.: 0.000 Ω Max.: 65.000 Ω	–
T2-11 (735)	PM Motor d-Axis Inductance	d-Axis Induct	<b>OLV/PM</b> Enter the d-axis inductance for the PM motor as indicated on the motor nameplate.	Default: <3> Min.: 0.00 mH Max.: 600.00 mH	–
T2-12 (736)	PM Motor q-Axis Inductance	q-Axis Induct	<b>OLV/PM</b> Enter the q-axis inductance for the PM motor as indicated on the motor nameplate.	Default: <3> Min.: 0.00 mH Max.: 600.00 mH	–
T2-13 (755)	Induced Voltage Constant Unit Selection	Induct Volt Unit 0: mV/RPM 1: mV/(rad/sec)	<b>OLV/PM</b> 0: mV/(r/min). E5-09 will automatically be set to 0.0, and E5-24 will be used. 1: mV/(rad/sec). E5-24 will automatically be set to 0.0, and E5-09 will be used.	Default: 0 Range: 0, 1	–
T2-14 (737)	PM Motor Induced Voltage Constant	Induct Volt Coef	<b>OLV/PM</b> Enter the induced voltage coefficient for the PM motor as indicated on the motor nameplate. Setting units are determined by parameter T2-13, Induced Voltage Constant Unit Selection.	Default: <3> Min.: 0.1 Max.: 2000.0	–
T2-15 (756)	Pull-In Current Level for PM Motor Tuning	Pull-In I Lvl	<b>OLV/PM</b> Sets the amount of pull-in current to use for Auto-Tuning as a percentage of the motor rated current. Increase this setting for high inertia loads.	Default: 30% Min.: 0 Max.: 120	–
T2-18 (FFF1)	T2 Tuning Start	T2 Tuning Start	<b>OLV/PM</b> The drive starts tuning.	No setting available	–

<1> Default setting is dependent on parameter o2-04, Drive Model Selection.

<2> Values shown are specific to 200 V class drives. Double the value for 400 V class drives.

<3> Default setting is dependent on parameter T2-02, PM Motor Code Selection, and the drive capacity.

## B.13 U: Monitors

Monitor parameters allow the user to view drive status, fault information, and other data concerning drive operation.

### ◆ U1: Operation Status Monitors

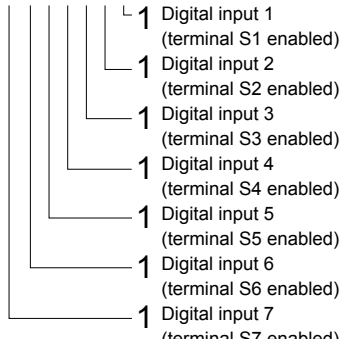
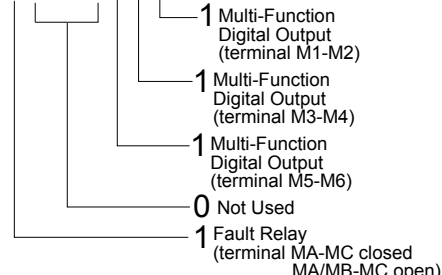
No. (Addr. Hex)	Name	LCD Display	Description	Analog Output Level	Unit
U1-01 (40)	Frequency Reference	Frequency Ref	Monitors the frequency reference. Display units are determined by o1-03.	10 V: Max frequency	0.01 Hz
U1-02 (41)	Output Frequency	Output Freq	Displays the output frequency. Display units are determined by o1-03.	10 V: Max frequency	0.01 Hz
U1-03 (42)	Output Current	Output Current	Displays the output current.	10 V: Drive rated current	<I> <I>
U1-04 (43)	Control Method	Control Method	0: V/f Control	No signal output available	-
U1-06 (45)	Output Voltage Reference	Output Voltage	Displays the output voltage.	10 V: 200 Vrms <3>	0.1 Vac
U1-07 (46)	DC Bus Voltage	DC Bus Voltage	Displays the DC bus voltage.	10 V: 400 V <3>	1 Vdc
U1-08 (47)	Output Power	Output kWatts	Displays the output power (this value is calculated internally).	10 V: Drive rated power (kW)	<4>
U1-10 (49)	Input Terminal Status	Input Term Sts	Displays the input terminal status. <b>U1 - 10 = 00000000</b>  <ul style="list-style-type: none"> <li>1 Digital input 1 (terminal S1 enabled)</li> <li>1 Digital input 2 (terminal S2 enabled)</li> <li>1 Digital input 3 (terminal S3 enabled)</li> <li>1 Digital input 4 (terminal S4 enabled)</li> <li>1 Digital input 5 (terminal S5 enabled)</li> <li>1 Digital input 6 (terminal S6 enabled)</li> <li>1 Digital input 7 (terminal S7 enabled)</li> </ul>	No signal output available	-
U1-11 (4A)	Output Terminal Status	Output Term Sts	Displays the output terminal status. <b>U1 - 11 = 00000000</b>  <ul style="list-style-type: none"> <li>1 Multi-Function Digital Output (terminal M1-M2)</li> <li>1 Multi-Function Digital Output (terminal M3-M4)</li> <li>1 Multi-Function Digital Output (terminal M5-M6)</li> <li>0 Not Used</li> <li>1 Fault Relay (terminal MA-MC closed MA/MB-MC open)</li> </ul>	No signal output available	-

## B.13 U: Monitors

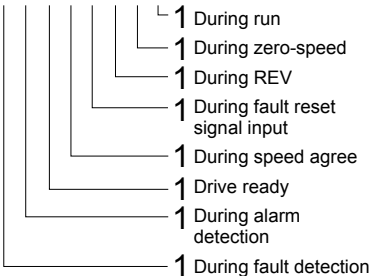
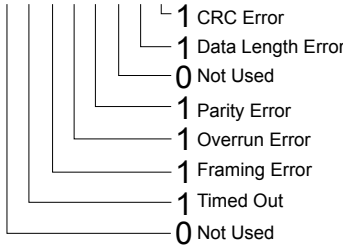
No. (Addr. Hex)	Name	LCD Display	Description	Analog Output Level	Unit
U1-12 (4B)	Drive Status	Int Ctl Sts 1	Verifies the drive operation status. <b>U1 - 12=00000000</b> 	No signal output available	–
U1-13 (4E)	Terminal A1 Input Level	Term A1 Level	Displays the signal level to analog input terminal A1.	10 V: 100%	0.1%
U1-14 (4F)	Terminal A2 Input Level	Term A2 Level	Displays the signal level to analog input terminal A2.	10 V: 100%	0.1%
U1-16 (53)	Output Frequency after Soft Starter	SFS Output	Displays output frequency with ramp time and S-curves. Units determined by o1-03.	10 V: Max frequency	0.01 Hz
U1-18 (61)	oPE Fault Parameter	OPE Error Code	Displays the parameter number that caused the oPE□□ or Err (EEPROM write error) error.	No signal output available	–
U1-19 (66)	MEMOBUS/Modbus Error Code	Transmit Err	Displays the contents of a MEMOBUS/Modbus error. <b>U1 - 19=00000000</b> 	No signal output available	–
U1-25 (4D)	Software Number (Flash)	CPU 1 SW Number	FLASH ID	No signal output available	–
U1-26 (5B)	Software No. (ROM)	CPU 2 SW Number	ROM ID	No signal output available	–
U1-27 (7A8)	Message ID (OPR)	MessageID (OPR)	OPR ID	No signal output available	–
U1-28 (7A9)	Message ID (INV)	MessageID (INV)	INV ID	No signal output available	–

<1> The number of decimal places in the parameter value depends on the drive model. This value has two decimal places (0.01 A) if the drive is set for a maximum applicable motor capacity up to and including 11 kW, and one decimal place (0.1 A) if the maximum applicable motor capacity is higher than 11 kW.

<2> When reading the value of this monitor via MEMOBUS/Modbus, a value of 8192 is equal to 100% of the drive rated output current.

<3> Values shown are specific to 200 V class drives. Double the value for 400 V class drives.

<4> This value has two decimal places (0.01 kW) if the drive is set for a maximum applicable motor capacity up to and including 11 kW, and one decimal place (0.1 kW) if the maximum applicable motor capacity is higher than 11 kW.

## ◆ U2: Fault Trace

No. (Addr. Hex)	Name	LCD Display	Description	Analog Output Level	Unit
U2-01 (80)	Current Fault	Current Fault	Displays the current fault.	No signal output available	–
U2-02 (81)	Previous Fault	Last Fault	Displays the previous fault.	No signal output available	–

No. (Addr. Hex)	Name	LCD Display	Description	Analog Output Level	Unit
U2-03 (82)	Frequency Reference at Previous Fault	Frequency Ref	Displays the frequency reference at the previous fault.	No signal output available	0.01 Hz
U2-04 (83)	Output Frequency at Previous Fault	Output Freq	Displays the output frequency at the previous fault.	No signal output available	0.01 Hz
U2-05 (84)	Output Current at Previous Fault	Output Current	Displays the output current at the previous fault.	No signal output available	<1> <2>
U2-07 (86)	Output Voltage at Previous Fault	Output Voltage	Displays the output voltage at the previous fault.	No signal output available	0.1 Vac
U2-08 (87)	DC Bus Voltage at Previous Fault	DC Bus Voltage	Displays the DC bus voltage at the previous fault.	No signal output available	1 Vdc
U2-09 (88)	Output Power at Previous Fault	Output kWatts	Displays the output power at the previous fault.	No signal output available	0.1 kW
U2-11 (8A)	Input Terminal Status at Previous Fault	Input Term Sts	Displays the input terminal status at the previous fault. Displayed as in U1-10.	No signal output available	–
U2-12 (8B)	Output Terminal Status at Previous Fault	Output Term Sts	Displays the output status at the previous fault. Displays the same status displayed in U1-11.	No signal output available	–
U2-13 (8C)	Drive Operation Status at Previous Fault	Inverter Status	Displays the operation status of the drive at the previous fault. Displays the same status displayed in U1-12.	No signal output available	–
U2-14 (8D)	Cumulative Operation Time at Previous Fault	Elapsed time	Displays the cumulative operation time at the previous fault.	No signal output available	1 h
U2-15 (7E0)	Soft Starter Speed Reference at Previous Fault	SFS Output	Displays the speed reference for the soft starter at the previous fault.	No signal output available	0.01 Hz
U2-16 (7E1)	Motor q-Axis Current at Previous Fault	Motor Iq Current	Displays the q-axis current for the motor at the previous fault.	No signal output available	0.10%
U2-17 (7E2)	Motor d-Axis Current at Previous Fault	Motor Id Current	<b>OLV/PM</b> Displays the d-axis current for the motor at the previous fault.	No signal output available	0.10%
U2-20 (8E)	Heatsink Temperature at Previous Fault	Actual Fin Temp	Displays the temperature of the heatsink when the most recent fault occurred.	No signal output available	1 °C
U2-30 (3008)	Date Year at Previous Fault	Date Year YYYY	Displays the year when the most recent fault occurred.	No signal output available	–
U2-31 (3009)	Date Month and Day at Previous Fault	Date Mo Day MMDD	Displays the date and day when the most recent fault occurred.	No signal output available	–
U2-32 (300A)	Time Hours and Minutes at Previous Fault	Time Hr Min HHMM	Displays the time when the most recent fault occurred.	No signal output available	–

<1> This value has two decimal places (0.01 A) if the drive is set for a maximum applicable motor capacity up to and including 11 kW, and one decimal place (0.1 A) if the maximum applicable motor capacity is higher than 11 kW.

<2> When reading the value of this monitor via MEMOBUS/Modbus, a value of 8192 is equal to 100% of the drive rated output current.

### ◆ U3: Fault History

No. (Addr. Hex)	Name	LCD Display	Description	Analog Output Level	Unit
U3-01 to U3-04 (90 to 93 (800 to 803))	First to 4th Most Recent Fault	Fault Message <input type="checkbox"/>	Displays the first to the fourth most recent faults.	No signal output available	–
U3-05 to U3-10 (804 to 809)	5th to 10th Most Recent Fault	Fault Message <input type="checkbox"/>	Displays the fifth to the tenth most recent faults. After ten faults, data for the oldest fault is deleted. The most recent fault appears in U3-01, with the next most recent fault appearing in U3-02. The data is moved to the next monitor parameter each time a fault occurs.	No signal output available	–
U3-11 to U3-14 (94 to 97 (80A to 80D))	Cumulative Operation Time at 1st to 4th Most Recent Fault	Elapsed Time <input type="checkbox"/>	Displays the cumulative operation time when the first to the fourth most recent faults occurred.	No signal output available	1 h

## B.13 U: Monitors

No. (Addr. Hex)	Name	LCD Display	Description	Analog Output Level	Unit
U3-15 to U3-20 (80E to 813)	Cumulative Operation Time at 5th to 10th Most Recent Fault	Elapsed Time □	Displays the cumulative operation time when the fifth to the tenth most recent faults occurred.	No signal output available	1 h
U3-21 (300B)	Date Year at Most Recent Fault	Fault 1 YYYY	Displays the year when the most recent fault occurred.	No signal output available	–
U3-22 (300C)	Date Month and Day at Most Recent Fault	Fault 1 MMDD	Displays the date and day when the most recent faults occurred.	No signal output available	–
U3-23 (300D)	Time Hours and Minutes at Most Recent Fault	Fault 1 HHMM	Displays the time when the most recent fault occurred.	No signal output available	–
U3-24 (300E)	Date Year at 2nd Most Recent Fault	Fault 2 YYYY	Displays the year when the second most recent fault occurred.	No signal output available	–
U3-25 (300F)	Date Month and Day at 2nd Most Recent Fault	Fault 2 MMDD	Displays the date and day when the second most recent fault occurred.	No signal output available	–
U3-26 (3010)	Time Hours and Minutes at 2nd Most Recent Fault	Fault 2 HHMM	Displays the time when the second most recent fault occurred.	No signal output available	–
U3-27 (3011)	Date Year at 3rd Most Recent Fault	Fault 3 YYYY	Displays the year when the most third recent fault occurred.	No signal output available	–
U3-28 (3012)	Date Month and Day at 3rd Most Recent Fault	Fault 3 MMDD	Displays the date and day when the third most recent fault occurred.	No signal output available	–
U3-29 (3013)	Time Hours and Minutes at 3rd Most Recent Fault	Fault 3 HHMM	Displays the time when the third most recent fault occurred.	No signal output available	–
U3-30 (3014)	Date Year at 4th Most Recent Fault	Fault 4 YYYY	Displays the year when the fourth most recent fault occurred.	No signal output available	–
U3-31 (3015)	Date Month and Day at 4th Most Recent Fault	Fault 4 MMDD	Displays the date and day when the fourth most recent fault occurred.	No signal output available	–
U3-32 (3016)	Time Hours and Minutes at 4th Most Recent Fault	Fault 4 HHMM	Displays the time when the fourth most recent fault occurred.	No signal output available	–
U3-33 (3017)	Date Year at 5th Most Recent Fault	Fault 5 YYYY	Displays the year when the fifth most recent fault occurred.	No signal output available	–
U3-34 (3018)	Date Month and Day at 5th Most Recent Fault	Fault 5 MMDD	Displays the date and day when the fifth most recent fault occurred.	No signal output available	–
U3-35 (3019)	Time Hours and Minutes at 5th Most Recent Fault	Fault 5 HHMM	Displays the time when the fifth most recent fault occurred.	No signal output available	–
U3-36 (301A)	Date Year at 6th Most Recent Fault	Fault 6 YYYY	Displays the year when the sixth most recent fault occurred.	No signal output available	–
U3-37 (301B)	Date Month and Day at 6th Most Recent Fault	Fault 6 MMDD	Displays the date and day when the sixth most recent fault occurred.	No signal output available	–
U3-38 (301C)	Time Hours and Minutes at 6th Most Recent Fault	Fault 6 HHMM	Displays the time when the most sixth recent fault occurred.	No signal output available	–
U3-39 (301D)	Date Year at 7th Most Recent Fault	Fault 7 YYYY	Displays the year when the most seventh recent fault occurred.	No signal output available	–
U3-40 (301E)	Date Month and Day at 7th Most Recent Fault	Fault 7 MMDD	Displays the date and day when the seventh most recent fault occurred.	No signal output available	–
U3-41 (301F)	Time Hours and Minutes at 7th Most Recent Fault	Fault 7 HHMM	Displays the time when the seventh most recent fault occurred.	No signal output available	–
U3-42 (3020)	Date Year at 8th Most Recent Fault	Fault 8 YYYY	Displays the year when the eighth most recent fault occurred.	No signal output available	–
U3-43 (3021)	Date Month and Day at 8th Most Recent Fault	Fault 8 MMDD	Displays the date and day when the eighth most recent fault occurred.	No signal output available	–
U3-44 (3022)	Time Hours and Minutes at 8th Most Recent Fault	Fault 8 HHMM	Displays the time when the eighth most recent fault occurred.	No signal output available	–
U3-45 (3023)	Date Year at 9th Most Recent Fault	Fault 9 YYYY	Displays the year when the ninth most recent fault occurred.	No signal output available	–
U3-46 (3024)	Date Month and Day at 9th Most Recent Fault	Fault 9 MMDD	Displays the date and day when the ninth most recent fault occurred.	No signal output available	–
U3-47 (3025)	Time Hours and Minutes at 9th Most Recent Fault	Fault 9 HHMM	Displays the time when the ninth most recent fault occurred.	No signal output available	–

No. (Addr. Hex)	Name	LCD Display	Description	Analog Output Level	Unit
U3-48 (3026)	Date Year at 10th Most Recent Fault	Fault 10 YYYY	Displays the year when the tenth most recent fault occurred.	No signal output available	–
U3-49 (3027)	Date Month and Day at 10th Most Recent Fault	Fault 10 MMDD	Displays the date and day when the tenth most recent fault occurred.	No signal output available	–
U3-50 (3028)	Time Hours and Minutes at 10th Most Recent	Fault 10 HHMM	Displays the time when the tenth most recent fault occurred.	No signal output available	–

#### ◆ U4: Maintenance Monitors

No. (Addr. Hex)	Name	LCD Display	Description	Analog Output Level	Unit
U4-01 (4C)	Cumulative Operation Time	Drv Elapsed Time	Displays the cumulative operation time of the drive. The value for the cumulative operation time counter can be reset in parameter o4-01. Use parameter o4-02 to determine if the operation time should start as soon as the power is switched on or only while the Run command is present. The maximum number displayed is 99999, after which the value is reset to 0.	No signal output available	1 h
U4-02 (75)	Number of Run Commands	RUN Cmd Counter	Displays the number of times the Run command is entered. Reset the number of Run commands using parameter o4-13. This value will reset to 0 and start counting again after reaching 65535.	No signal output available	1 Time
U4-03 (67)	Cooling Fan Operation Time	Fan Elapsed Time	Displays the cumulative operation time of the cooling fan. The default value for the fan operation time is reset in parameter o4-03. This value will reset to 0 and start counting again after reaching 99999.	No signal output available	1 h
U4-04 (7E)	Cooling Fan Maintenance	Fan Life Mon	Displays main cooling fan usage time as a percentage of its expected performance life. Parameter o4-03 can be used to reset this monitor.	No signal output available	1%
U4-05 (7C)	Capacitor Maintenance	Cap Life Mon	Displays main circuit capacitor usage time as a percentage of their expected performance life. Parameter o4-05 can be used to reset this monitor.	No signal output available	1%
U4-06 (7D6)	Soft Charge Bypass Relay Maintenance	ChgCirc Life Mon	Displays the soft charge bypass relay maintenance time as a percentage of its estimated performance life. Parameter o4-07 can be used to reset this monitor.	No signal output available	1%
U4-08 (68)	Heatsink Temperature	Heatsink Temp	Displays the heatsink temperature.	10 V: 100 °C	1 °C
U4-09 (5E)	LED Check	LED Oper Check	Lights all segments of the LED to verify that the display is working properly.	No signal output available	–
U4-10 (5C)	kWh, Lower 4 Digits	kWh Lower 4 dig	Monitors the drive output power. The value is shown as a 9-digit number displayed across two monitor parameters, U4-10 and U4-11. Example: 12345678.9 kWh is displayed as: U4-10: 678.9 kWh U4-11: 12345 MWh	No signal output available	1 kWh
U4-11 (5D)	kWh, Upper 5 Digits	kWh Upper 5 dig		No signal output available	1 MWh
U4-13 (7CF)	Peak Hold Current	Current PeakHold	Displays the highest current value that occurred during run.	No signal output available	0.01 A </>
U4-14 (7D0)	Peak Hold Output Frequency	Freq@ I PeakHold	Displays the output frequency when the current value shown in U4-13 occurred.	No signal output available	0.01 Hz
U4-16 (7D8)	Motor Overload Estimate (oL1)	Motor OL1 Level	Shows the value of the motor overload detection accumulator. 100% is equal to the oL1 detection level.	10 V: 100%	0.1%

## B.13 U: Monitors

No. (Addr. Hex)	Name	LCD Display	Description	Analog Output Level	Unit
U4-18 (7DA)	Frequency Reference Source Selection	Reference Source	Displays the source for the frequency reference as XY-nn. <b>X: indicates which reference is used:</b> 0 = OFF 1 = AUTO 2 = HAND <b>Y-nn: indicates the reference source</b> 0-01 = HOA keypad 1-00 = Analog (not assigned) 1-01 = Analog (terminal A1) 1-02 = Analog (terminal A2) 2-02 to 17 = Multi-step speed (d1-02 to 17) 3-01 = MEMOBUS/Modbus communications 4-01 = Communication option card 9-01 = Up/Down	No signal output available	–
U4-19 (7DB)	Frequency Reference from MEMOBUS/Modbus Comm.	MEMOBUS Freq Ref	Displays the frequency reference provided by MEMOBUS/Modbus (decimal).	No signal output available	0.01%
U4-20 (7DC)	Option Frequency Reference	Option Freq Ref	Displays the frequency reference input by an option card (decimal).	No signal output available	–
U4-21 (7DD)	Run Command Source Selection	Run Cmd Source	Displays the source for the Run command as XY-nn. <b>X: Indicates which Run source is used:</b> 0 = OFF 1 = AUTO 2 = HAND <b>Y: Input power supply data</b> 0 = HOA keypad 1 = External terminals 3 = Serial communications (APOGEE FLN, BACnet, MEMOBUS/Modbus, or Metasys N2) 4 = Communication option card <b>nn: Run command limit status data</b> 00: No limit status. 01: Run command was left on when stopped in the PRG mode 02: Run command was left on when switching from LOCAL to REMOTE operation 03: Waiting for soft charge bypass contactor after power up (Uv or Uv1 flashes after 10 s) 04: Waiting for “Run command prohibited” time period to end 05: Fast Stop (digital input, HOA keypad) 06: b1-17 (Run command given at power-up) 07: During baseblock while coast to stop with timer 08: Frequency reference is below minimal reference during baseblock 09: Waiting for Enter command	No signal output available	–
U4-22 (7DE)	MEMOBUS/Modbus Communications Reference	MEMOBUS Ref Reg	Displays the drive control data set by MEMOBUS/Modbus communications register no. 0001H as a four-digit hexadecimal number.	No signal output available	–
U4-23 (7DF)	Communication Option Card Reference	Option Ref Reg	Displays drive control data set by an option card as a four-digit hexadecimal number.	No signal output available	–

<1> When reading the value of this monitor via MEMOBUS/Modbus, a value of 8192 is equal to 100% of the drive rated output current.

## ◆ U5: PI Monitors

No. (Addr. Hex)	Name	LCD Display	Description	Analog Output Level	Unit
U5-01 (57)	PI Feedback	PID Feedback 1	Displays the PI feedback value.	10 V: 100%	0.01%
U5-02 (63)	PI Input	PID Input	Displays the amount of PI input (deviation between PI setpoint and feedback).	10 V: 100%	0.01%
U5-03 (64)	PI Output	PID Output	Displays PI control output.	10 V: 100%	0.01%
U5-04 (65)	PI Setpoint	PID Setpoint	Displays the PI setpoint.	10 V: 100%	0.01%
U5-05 (7D2)	PI Differential Feedback	PID Feedback 2	Displays the second PI feedback value if differential feedback is used (H3-□□ = 16).	10 V: 100%	0.01%

No. (Addr. Hex)	Name	LCD Display	Description	Analog Output Level	Unit
U5-06 (7D3)	PI Adjusted Feedback	PID Diff Fdbk	Displays the difference of both feedback values if differential feedback is used (U5-01 - U5-05). If differential feedback is not used, then U5-01 and U5-06 will be the same.	10 V: 100%	0.01%
U5-07 (72)	AUTO Mode Frequency Reference Value	AUTO mode Fref	Displays the Frequency reference value at AUTO Mode.	No signal output available	0.01 Hz
U5-08 (73)	HAND Mode Frequency Reference Value	HAND mode Fref	Displays the Frequency reference value at HAND Mode.	No signal output available	0.01 Hz
U5-14 (86B)	PI Output Upper 4 Digits	PI Output U4	Displays Custom PI output. U5-14 shows the upper 4 digits.	10V: (b5-43 x 10000) + b5-44 </>	1
U5-15 (86C)	PI Output Lower 4 Digits	PI Output L4	Displays Custom PI output. U5-15 shows the lower 4 digits.	No signal output available	0.01
U5-17 (302A)	PI2 Setpoint	PI2 Set-point	Displays the secondary PI setpoint.	10 V: Max frequency	0.01%
U5-18 (302B)	PI2 Feedback	PI2 Feedback	Displays the secondary PI feedback value.	10 V: Max frequency	0.01%
U5-19 (302C)	PI2 Input	PI2 Input	Displays the secondary PI input (deviation between PI target and feedback).	10 V: Max frequency	0.01%
U5-20 (302D)	PI2 Output	PI2 Output	Displays the secondary PI control output.	10 V: Max frequency	0.01%
U5-30 (3000)	Time Hr Min HHMM	Time Hr Min HHMM	Displays the current time (Hours and Minutes).	No signal output available	1
U5-31 (3001)	Date Year	Date Year	Displays the current year.	No signal output available	1
U5-32 (3002)	Date Mo Day MMDD	Date Mo Day MMDD	Displays the current date (Month and Day).	No signal output available	1
U5-33 (3003)	Day of the Week	Date Week 0: Sun 1: Mon 2: Tues 3: Wed 4: Thur 5: Fri 6: Sat	Displays the current day of the week. 0: Sunday 1: Monday 2: Tuesday 3: Wednesday 4: Thursday 5: Friday 6: Saturday	No signal output available	1

<1> Analog Output selection text is: "PI Output 2".

## ◆ U6: Operation Status Monitors

No. (Addr. Hex)	Name	LCD Display	Description	Analog Output Level	Unit
U6-01 (51)	Motor Secondary Current (Iq)	Mot SEC Current	Displays the value of the motor secondary current (Iq). Motor rated secondary current is 100%.	10 V: Motor secondary rated current	0.1%
U6-02 (52)	Motor Excitation Current (Id)	Mot EXC Current	<b>OLV/PM</b> Displays the value calculated for the motor excitation current (Id). Motor rated secondary current is 100%.	10 V: Motor secondary rated current	0.1%
U6-05 (59)	Output Voltage Reference (Vq)	Voltage Ref (Vq)	<b>OLV/PM</b> Output voltage reference (Vq) for the q-Axis.	10 V: 200 Vrms </>	0.1 Vac
U6-06 (5A)	Output Voltage Reference (Vd)	Voltage Ref (Vd)	<b>OLV/PM</b> Output voltage reference (Vd) for the d-Axis.	10 V: 200 Vrms </>	0.1 Vac
U6-21 (7D5)	Offset Frequency	Offset Frequency	Displays the frequency added to the main frequency reference.	–	0.1%
U6-80 to U6-99 (7B0 to 7F9)	Option Monitors 1 to 20	–	Output monitor for option card. Refer to Option Instruction manual for details	No signal output available.	–

<1> Values shown are specific to 200 V class drives. Double the values for 400 V class drives.

**This Page Intentionally Blank**

# Appendix: C

## BACnet Communications

---

<b>C.1</b>	<b>BACNET CONFIGURATION.....</b>	<b>338</b>
<b>C.2</b>	<b>COMMUNICATION SPECIFICATIONS.....</b>	<b>339</b>
<b>C.3</b>	<b>CONNECTING TO A NETWORK.....</b>	<b>340</b>
<b>C.4</b>	<b>BACNET SETUP PARAMETERS.....</b>	<b>342</b>
<b>C.5</b>	<b>DRIVE OPERATIONS BY BACNET.....</b>	<b>346</b>
<b>C.6</b>	<b>COMMUNICATIONS TIMING.....</b>	<b>347</b>
<b>C.7</b>	<b>BACNET OBJECTS SUPPORTED.....</b>	<b>348</b>
<b>C.8</b>	<b>ACCESSING DRIVE PARAMETERS AND THE ENTER COMMAND.....</b>	<b>353</b>
<b>C.9</b>	<b>COMMUNICATION ERRORS.....</b>	<b>354</b>
<b>C.10</b>	<b>SELF-DIAGNOSTICS.....</b>	<b>355</b>
<b>C.11</b>	<b>BACNET PROTOCOL IMPLEMENTATION CONFORMANCE STATEMENT....</b>	<b>356</b>

### C.1 BACnet Configuration

Drives can be monitored and controlled by a controller on a Building Automation and Control network (BACnet) using RS-485 technology and MS-TP (Master-Slave/Token-Passing) protocol. The drives conform to the BACnet application specific controller (B-ASC) device profile.

Up to 127 drives can communicate on a single BACnet MS-TP network. If more drives or BACnet devices are required, then a BACnet router is required to allow another MS-TP network to be available with up to another 127 drives.

The BACnet node address is configurable by a parameter in the drive. This defines the physical address of the drive on the MS-TP network. In addition, both the Device Object instance ID and the Device Object Name are configurable. These allow the drive to have a virtual address, thus simplifying controller configuration.

Once the addressing is set, a controller can initiate communication to the drive. The drive will perform the specified function and then send a response back to the controller. The drive will usually respond immediately, but may delay its response until it gets the token for commands that may take extra local processing time.

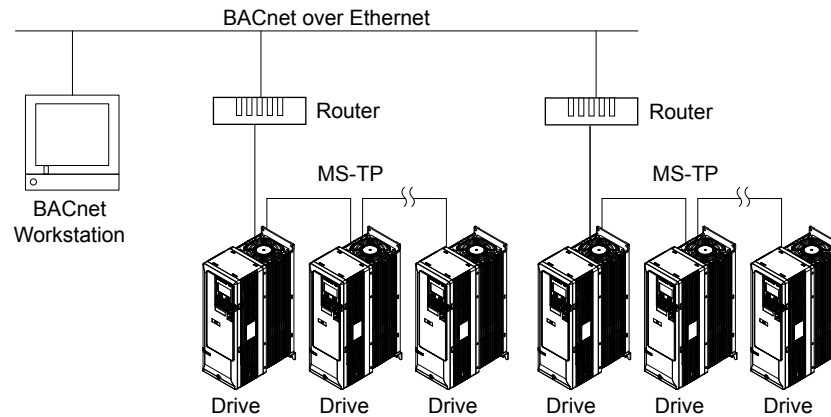

Figure C.1 Connecting Multiple Drives to a BACnet Workstation

## C.2 Communication Specifications

BACnet specifications appear in the following table:

Item	Specifications
Interface	MS-TP (Master-Slave/Token-Passing) RS-485
Communication Parameters	Communication Speeds: 1200, 2400, 4800, 9600, 19200, 38400, 57600, 76800 bps Data Length: 8-bit (fixed) Parity: Select Even, Odd, or None Stop Bit: 1-bit (fixed)
Protocol	BACnet MS-TP
Max Number of Drives	127 per MS-TP Network Segment

### C.3 Connecting to a Network

This section explains how to connect the drive to a BACnet network and the network termination required for a connection.

#### ◆ Network Cable Connection

Follow the instructions below to connect the drive to a BACnet network.

1. With the power shut off, connect the communications cable to the drive and the master. Use terminal TB4 for BACnet.

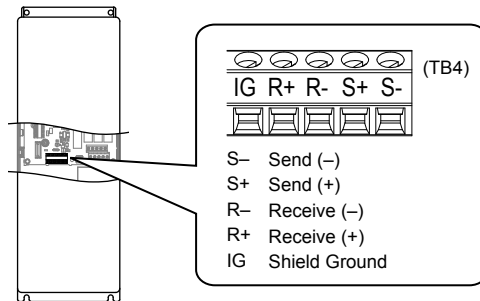

**Figure C.2 Serial Communications Cable Connection Terminal (TB4)**

- Note:** Separate the communications cables from the main circuit cables and other wiring and power cables. Use shielded cables for the communications cables, and properly shielded clamps to prevent problems with noise. When using RS-485 communications, connect S+ to R+, and S- to R- as shown in the diagram below.
2. Check or set the termination resistor selection at all slaves. Use the description in [Network Termination](#) on page [341](#) for slaves that are Z1000 drives.
  3. Switch the power on.
  4. Set the parameters needed for serial communications (H5-01 through H5-12) using the digital operator.
  5. Shut the power off and wait until the display on the digital operator goes out completely.
  6. Turn the power back on.
  7. The drive is now ready to begin communicating with the master.

## ◆ Wiring Diagram for Multiple Connections

*Figure C.3* explains the wiring diagrams for multiple connections using BACnet communication.

### ■ RS-485 Interface

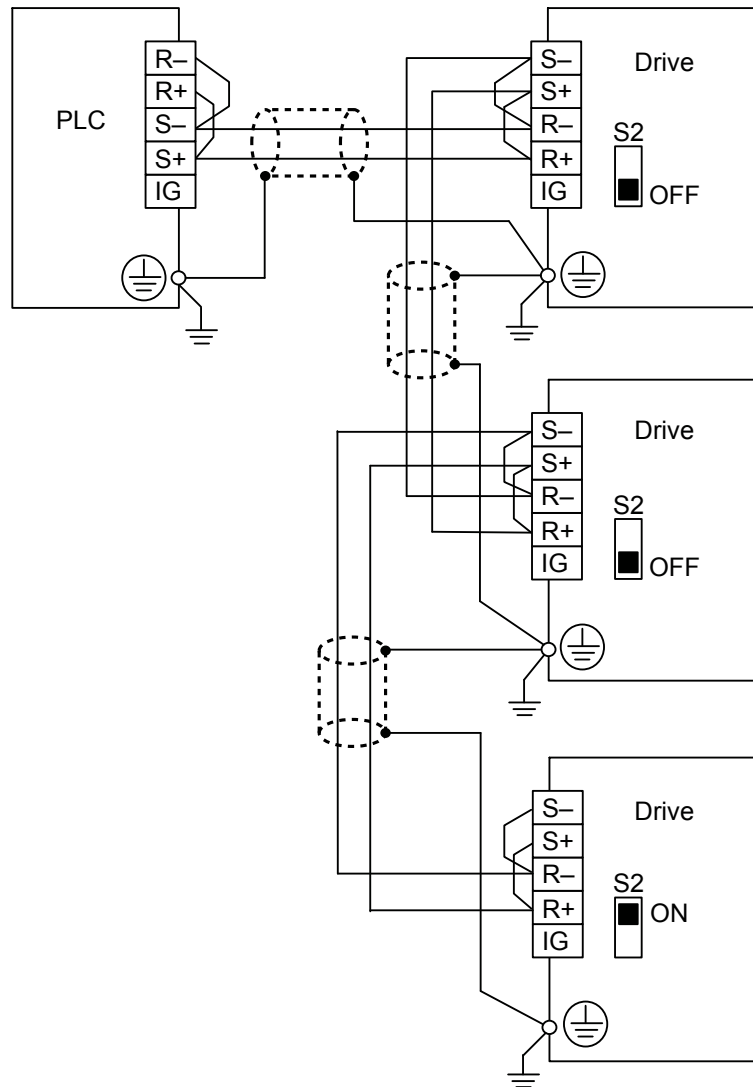

**Figure C.3 RS-485 Interface**

- Note:**
1. Set DIP switch S2 to the ON position on the drive located at the end of the network. Set DIP switch S2 to the OFF positions on all other slave devices.
  2. Set H5-07 to 1 when using the RS-485 interface.

## ◆ Network Termination

The two ends of the BACnet network line have to be terminated. The drive has a built in termination resistor that can be enabled or disabled using DIP switch S2. If a drive is located at the end of a network line, enable the termination resistor by setting DIP switch S2 to the ON position. Disable the termination resistor on all slaves that are not located at the network line end.

## C.4 BACnet Setup Parameters

### ◆ BACnet Serial Communication

This section describes parameters necessary to set up BACnet communications.

#### ■ H5-01: Drive Slave Address

Sets the drive slave address used for communications.

**Note:** Cycle the power after changing this parameter to enable the new setting.

No.	Name	Setting Range	Default
H5-01	Drive Slave Address	0 to FFH	1FH

Each slave drive must be assigned a unique slave address for serial communications to work. Slave addresses do not need to be assigned in sequential order, but no two drives may share the same address.

#### ■ H5-02: Communication Speed Selection

Sets the communications speed for APOGEE FLN, BACnet, MEMOBUS/Modbus, and Metasys N2.

- Note:**
1. Cycle the power after changing this parameter to enable the new setting.
  2. When Metasys N2 communications are selected (H5-08 = 1), selecting a baud rate other than 9600 bps will trigger an oPE29 error.
  3. When APOGEE FLN (P1) communications are selected (H5-08 = 2), selecting a baud rate other than 4800 bps will trigger an oPE29 error.
  4. When BACnet communications are selected (H5-08 = 3), selecting 115200 bps (Setting 8) will trigger an oPE29 error.

No.	Name	Setting Range	Default
H5-02	Communication Speed Selection	0 to 8	<1>

- <1> Default depends on H5-08 setting:  
 H5-08 = 0, MEMOBUS/Modbus; default: 3  
 H5-08 = 1, N2 (Metasys); default: 3  
 H5-08 = 2, P1 (APOGEE FLN); default: 2  
 H5-08 = 3, BACnet; default: 3

H5-02	Communication Speed	H5-02	Communication Speed
0 <1>	1200 bps	5 <1>	38400 bps
1 <1>	2400 bps	6 <1>	57600 bps
2	4800 bps	7 <1>	76800 bps
3 <1>	9600 bps	8 <1> <2>	115200 bps
4 <1>	19200 bps		

- <1> Not available when H5-08 is set to 2 P1 (APOGEE FLN).  
 <2> Not available when H5-08 is set to 0 (MEMOBUS/Modbus) or 1 (Metasys N2).

#### ■ H5-03: Communication Parity Selection

Sets the parity used for communications.

**Note:** Cycle the power after changing this parameter to enable the new setting.

No.	Name	Setting Range	Default
H5-03	Communication Parity Selection	0 to 2	0

- Setting 0: No parity**  
**Setting 1: Even parity**  
**Setting 2: Odd parity**

#### ■ H5-04: Stopping Method after Communication Error

Selects the stopping method after a communications error (CE) has occurred.

No.	Name	Setting Range	Default
H5-04	Stopping Method after CE	0 to 4	3

**Setting 0: Ramp to Stop**

Uses the deceleration time currently enabled.

**Setting 1: Coast to Stop**

**Setting 2: Fast Stop**

**Setting 3: Alarm Only - Operation Continues**

**Setting 4: Run at d1-04**

■ **H5-05: Communication Fault Detection Selection**

Enables or disables the CE detection for communications.

No.	Name	Setting Range	Default
H5-05	Communication Fault Detection Selection	0 or 1	1

**Setting 0: Disabled**

No communication error detection. The drive continues operation.

**Setting 1: Enabled**

If the drive does not receive data from the master for longer than the time set to H5-09, then a CE fault will be triggered and the drive will operate as determined by parameter H5-04.

■ **H5-06: Drive Transmit Wait Time**

Sets the time the drive waits after receiving data from a master until responding data.

No.	Name	Setting Range	Default
H5-06	Drive Transmit Wait Time	5 to 65 ms	5 ms

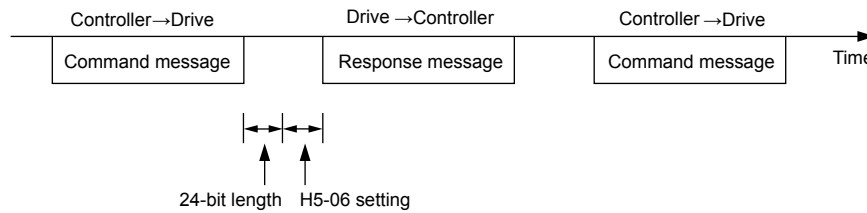

Figure C.4 Drive Transmit Wait Time Setting

■ **H5-07: RTS Control Selection**

Enables or disables RTS control.

No.	Name	Setting Range	Default
H5-07	RTS Control Selection	0 or 1	1

**Setting 0: Disabled. RTS is always on.**

Use this setting with point-to-point RS-422 communications.

**Setting 1: Enabled. RTS switches while sending.**

Use this setting with RS-485 communications or when using multi-drop RS-422 communications.

## C.4 BACnet Setup Parameters

### ■ H5-08: Communications Protocol Selection

Selects the communications protocol.

No.	Name	Setting Range	Default
H5-08	Communications Protocol Selection	0 to 3	0

**Setting 0: MEMOBUS/Modbus**

**Setting 1: N2 (Metasys)**

**Setting 2: P1 (APOGEE FLN)**

**Setting 3: BACnet**

### ■ H5-09: Communications Fault Detection Time

Sets the time the communications must be lost before the drive triggers a CE fault.

No.	Name	Setting Range	Default
H5-09	Communications Fault Detection Time	0.0 to 10.0 s	2.0 s

### ■ H5-10: Unit Selection for MEMOBUS/Modbus Register 0025H

Sets the unit for the output voltage monitor value in MEMOBUS/Modbus register 0025H.

No.	Name	Setting Range	Default
H5-10	Unit Selection for MEMOBUS/Modbus Register 0025H	0 or 1	0

**Setting 0: 0.1 V units**

**Setting 1: 1 V units**

### ■ H5-11: Communications Enter Function Selection

Selects whether an Enter command is necessary to change parameter values via MEMOBUS/Modbus communications. *Refer to Enter Command on page 353.*

No.	Name	Setting Range	Default
H5-11	Communications Enter Function Selection	0 or 1	0

**Setting 0: Enter command necessary**

Parameter changes become effective after an Enter command. An Enter command must only be sent after the last parameter change, not for each single parameter.

**Setting 1: Enter command not necessary**

Parameter value changes become effective immediately without the need to send an Enter command.

### ■ H5-12: Run Command Method Selection

Selects the type of sequence used when the Run command source is set to MEMOBUS/Modbus communications (b1-02, b1-16 = 2).

No.	Name	Setting Range	Default
H5-12	Run Command Method Selection	0 or 1	0

**Setting 0: FWD/Stop, REV/Stop**

Setting bit 0 of MEMOBUS/Modbus register 0001H will start and stop the drive in the forward direction. Setting bit 1 will start and stop the drive in reverse.

**Setting 1: Run/Stop, FWD/REV**

Setting bit 0 of MEMOBUS/Modbus register 0001H will start and stop the drive. Setting bit 1 changes the direction.

### ■ H5-14, H5-15: BACnet Device Object Identifiers 0 and 1

These parameters set the Instance Identifier of the BACnet Device Object, where the H5-14 value is the least significant word and the H5-15 value is the most significant word.

No.	Name	Setting Range	Default
H5-14	BACnet Device Object Identifier 0	0 to FFFFH	1
H5-15	BACnet Device Object Identifier 1	0 to 3FH	0

Example 1: Set Device Object Instance Identifier of “1234”

1234 decimal is equal to 4D2H (hexadecimal)

Set H5-14 to 4D2H and set H5-15 to 0.

Example 2: Set Device Object Instance Identifier of “1234567”

12334567 decimal is equal to 12D687H

Set H5-14 to D687H and set H5-15 to 12H.

## C.5 Drive Operations by BACnet

The drive operations that can be performed by BACnet communication depend on drive parameter settings. This section explains the functions that can be used and related parameter settings.

### ◆ Observing the Drive Operation

A controller can perform the following actions with BACnet communications at any time regardless of parameter settings (except for H5-□□parameters):

- Observe drive status and drive control terminal status from a controller
- Read and write parameters
- Set and reset faults
- Set multi-function inputs.

**Note:** Input settings from the input terminals S□ and from BACnet communications are both linked by a logical OR operation.

### ◆ Controlling the Drive

Select an external reference and adjust the parameters in [Table C.1](#) accordingly to start and stop the drive or set the frequency reference using BACnet communications.

**Table C.1 Setting Parameters for Drive Control from BACnet**

Reference Source	Parameter	Name	Required Setting
External Reference 1	b1-01	Frequency Reference Selection 1	2
	b1-02	Run Command Selection 1	2
External Reference 2	b1-15	Frequency Reference Selection 2	2
	b1-16	Run Command Selection 2	2

*Refer to b1-01: Frequency Reference Selection for AUTO Mode on page 127 and Refer to b1-02: Run Command Selection for AUTO Mode on page 129 for details on external reference parameter selections.*

## C.6 Communications Timing

To prevent a communications overrun in the slave drive, the master should wait a certain time between sending messages to the same drive. In the same way, the slave drive must wait before sending response messages to prevent an overrun in the master. This section explains the message timing.

### ◆ Command Messages from Master to Drive

The master must wait for a specified time between receiving a response and resending the same type of command to the same slave drive to prevent overrun and data loss. The minimum wait time depends on the command as shown in [Table C.2](#).

**Table C.2 Minimum Wait Time for Sending Messages**

Command Type	Example	Minimum Wait Time
1	<ul style="list-style-type: none"> <li>Control command (Run, Stop)</li> <li>Set inputs/outputs</li> <li>Read monitors and parameter values</li> </ul>	5 ms </>
2	Write parameters	H5-11 = 0: 50 ms H5-11 = 1: 200 ms </>
3	Save changes using an Enter command	200 ms to 2 s, depending on the number of parameters that were changed </>
4	Enter with storage to drive EEPROM after initialization	5 s

<1> If the drive receives command type 1 data during the minimum wait time, it will perform the command and then respond. However, if it receives a command type 2 or 3 during that time, either a communication error will result or the command will be ignored.

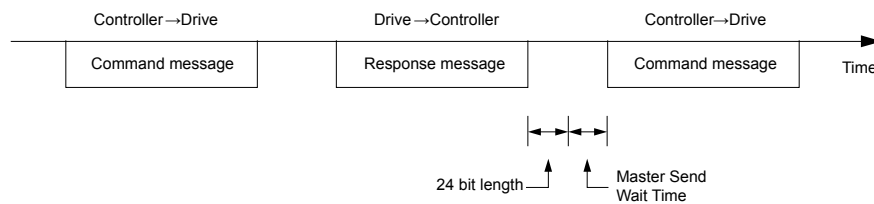
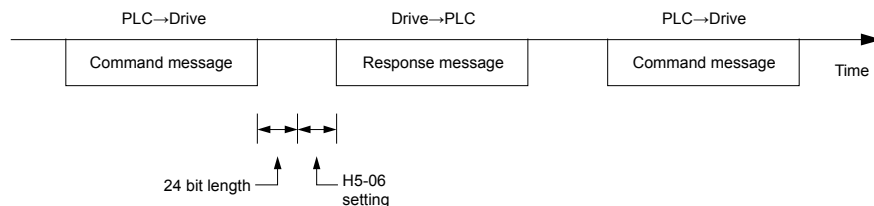

**Figure C.5 Minimum Wait Time for Sending Messages**

Set a timer in the master to check how long it takes for the slave drive(s) to respond to the master. If no response is received within a certain amount of time, the master should try resending the message.

### ◆ Response Messages from Drive to Master

If the drive receives a command from the master, it will process the data received and wait for the time set in H5-06 until it responds. Increase H5-06 if the drive response causes overrun in the master.



**Figure C.6 Minimum Response Wait Time**

## C.7 BACnet Objects Supported

### ◆ Present Value Access

The Present Value (PV) of BACnet objects can always be read. In addition, some PVs can be written or commanded. A commandable PV is similar to writing the value, but the value is actually written into a priority array. The value occupying the highest priority in the array will be used by the drive. The convention for showing how the PV is accessed is shown in [Table C.3](#) and will be noted for the PV of each object.

Table C.3 Present Value Access Values

PV Access	Name	Description
C	Commandable	Value written to a priority array. The highest priority value in the array is then written to the drive.
R	Readable	Value is read-only
W	Writable	Value written to the drive

### ◆ Supported Properties of Objects

Table C.4 Object Properties

Property	Object Type						
	Device	Analog Input	Analog Output	Analog Value	Binary Output	Binary Output	Binary Value
Object_Identifier	Yes	Yes	Yes	Yes	Yes	Yes	Yes
Object_Name	Yes	Yes	Yes	Yes	Yes	Yes	Yes
Object_Type	Yes	Yes	Yes	Yes	Yes	Yes	Yes
System_Status	Yes	–	–	–	–	–	–
Vendor_Name	Yes	–	–	–	–	–	–
Vendor_Identifier	Yes	–	–	–	–	–	–
Model_Name	Yes	–	–	–	–	–	–
Firmware_Revision	Yes	–	–	–	–	–	–
Protocol_Version	Yes	–	–	–	–	–	–
Protocol_Revision	Yes	–	–	–	–	–	–
Protocol_Services_Supported	Yes	–	–	–	–	–	–
Protocol_Object_Types_Supported	Yes	–	–	–	–	–	–
Object_List	Yes	–	–	–	–	–	–
Max_ADPU_Length_Accepted	Yes	–	–	–	–	–	–
Segmentation_Supported	Yes	–	–	–	–	–	–
Local_Time	Yes	–	–	–	–	–	–
Local_Date	Yes	–	–	–	–	–	–
ADPU_Timeout	Yes	–	–	–	–	–	–
Number_Of_ADPU_Retries	Yes	–	–	–	–	–	–
Max_Masters	Yes	–	–	–	–	–	–
Max_Info_Frames	Yes	–	–	–	–	–	–
Device_Address_Binding	Yes	–	–	–	–	–	–
Database_Revision	Yes	–	–	–	–	–	–
Present_Value	–	Yes	Yes	Yes	Yes	Yes	Yes
Status_Flags	–	Yes	Yes	Yes	Yes	Yes	Yes
Event_State	–	Yes	Yes	Yes	Yes	Yes	Yes
Reliability	–	Yes	Yes	Yes	Yes	Yes	Yes
Out_Of_Service	–	Yes	Yes	Yes	Yes	Yes	Yes
Units	–	Yes	Yes	Yes	–	–	–
Priority_Array	–	–	Yes </>	Yes </>	–	Yes	Yes
Relinquish_Default	–	–	Yes </>	Yes </>	–	Yes	Yes
Polarity	–	–	–	–	Yes	Yes	–

Property	Object Type						
	Device	Analog Input	Analog Output	Analog Value	Binary Output	Binary Output	Binary Value
Inactive_Text	-	-	-	-	Yes	Yes	Yes
Active_Text	-	-	-	-	Yes	Yes	Yes

<1> For Commandable Object Instances only.

### ◆ Analog Input Objects

Table C.5 Analog Input Objects

Object ID	Object Name	Modbus Address	Precision	Range	Units	PV Access
AI1	Analog Input 1 Level	004EH	XXXX.X	-	%	R
AI2	Analog Input 2 Level	004FH	XXXX.X	-	%	R
AI3	Not used	-	-	-	-	-
AI4	Not used	-	-	-	-	-
AI5	Not used	-	-	-	-	-
AI6	Display Format o1-03	0502H	XXXXXX	-	-	R
AI7	Scale Format b5-20	01E2H	XXXXXX	-	-	R
AI8	Inverter Model o2-04	0508F	XXXXXX	-	-	R
AI9	Rated Current n9-01	05D0H	XXXX.X	-	Amps	R

### ◆ Analog Output Objects

Table C.6 Analog Output Objects

Object ID	Object Name	Modbus Address	Precision	Range	Units	PV Access
AO1	Analog Output 1 Level	0007H	XXXX.X	0 to 100.0	%	C
AO2	Analog Output 2 Level	0008H	XXXX.X	0 to 100.0	%	C

### ◆ Analog Value Objects

Table C.7 Analog Value Objects

Object ID	Object Name	Modbus Address	Precision	Range	Units	PV Access
AV1	Not used	-	-	-	-	-
AV2	Frequency Command	0002H	XXX.XX Depends on o1-03	0.00 to 600.00	Hz Depends on o1-03	C
AV3	PI Setpoint	0006H	XXX.XX	0.00 to 100.00	%	C
AV4	Not used	-	-	-	-	-
AV5	Not used	-	-	-	-	-
AV6	Not used	-	-	-	-	-
AV7	Not used	-	-	-	-	-
AV8	Not used	-	-	-	-	-
AV9	Frequency Reference	0040H	XXX.XX Depends on o1-03	-	Hz Depends on o1-03	R
AV10	Output Frequency	0041H	XXX.XX Depends on o1-03	-	Hz Depends on o1-03	R
AV11	Output Voltage	0045H	XXXX.X	-	Volts	R

## C.7 BACnet Objects Supported

Object ID	Object Name	Modbus Address	Precision	Range	Units	PV Access
AV12	Output Current	0042H	XXXX.X (for drives rated above 11 kVA) XXX.XX (for drives rated 11 kVA or lower)	–	Amps	R
AV13	Output Power	0047H	XXXX.X (for drives rated above 11 kVA) XXX.XX (for drives rated 11 kVA or lower)	–	Watts	R
AV14	Torque Reference	0048H	XXXX.X	–	%	R
AV15	Not used	–	–	–	–	–
AV16	Not used	–	–	–	–	–
AV17	Not used	–	–	–	–	–
AV18	DC Bus Voltage	0031H	XXXX.X	–	Volts	R
AV19	PI Feedback Level	0038H	XXXX.X	–	%	R
AV20	PI Input Level	0039H	XXXX.X	–	%	R
AV21	PI Output Level	003AH	XXXX.X	–	%	R
AV22	CPU Software	005BH	XXXXX	–	–	R
AV23	Flash Number	004DH	XXXXX	–	–	R
AV24	Not used	–	–	–	–	–
AV25	kVA Setting	003EH	XXXXX	–	–	R
AV26	Control Method	003FH	XXXXX	–	–	R
AV27	Accel Time	0200H	XXXX.X (when C1-10=1) XXX.XX (when C1-10=0)	0.0 to 6000.0 (when C1-10=1) 0.00 to 600.00 (when C1-10=0)	Sec	W
AV28	Decel Time	0201H	XXXX.X (when C1-10=1) XXX.XX (when C1-10=0)	0.0 to 6000.0 (when C1-10=1) 0.00 to 600.00 (when C1-10=0)	Sec	W
AV29 <I>	Param Number	–	XXXXX	0 to FFFFH	–	W
AV30 <I>	Param Data	–	XXXXX	0 to FFFFH	–	W

<I> Refer to [Accessing Drive Parameters and the Enter Command on page 353](#) for an explanation of how to read and write drive parameters not listed in the analog or binary objects.

## ◆ Binary Input Objects

Table C.8 Binary Input Objects

Object ID	Object Name	Modbus Address	Active Text	Inactive Text	PV Access
BI1	Input Terminal 1	002BH:bit 0	ON	OFF	R
BI2	Input Terminal 2	002BH:bit 1	ON	OFF	R
BI3	Input Terminal 3	002BH:bit 2	ON	OFF	R
BI4	Input Terminal 4	002BH:bit 3	ON	OFF	R
BI5	Input Terminal 5	002BH:bit 4	ON	OFF	R
BI6	Input Terminal 6	002BH:bit 5	ON	OFF	R
BI7	Input Terminal 7	002BH:bit 6	ON	OFF	R
BI8	Multi-Function Out 1	0020H:bit 5	ON	OFF	R
BI9	Multi-Function Out 2	0020H:bit 6	ON	OFF	R

## ◆ Binary Output Objects

Table C.9 Binary Output Objects

Object ID	Object Name	Modbus Address	Active Text	Inactive Text	PV Access
BO1	MF Output M1-M2	0009H:bit 0	ON	OFF	C
BO2	MF Output M3-M4	0009H:bit 1	ON	OFF	C
BO3	MF Output MA-MC	0009H:bit 2	ON	OFF	C
BO4	Ref Sel: PI Setpoint	000FH:bit 1	ON	OFF	C
BO5	Ref Sel: Term S5 IN	000FH:bit 12	ON	OFF	C
BO6	Ref Sel: Term S6 IN	000FH:bit 13	ON	OFF	C
BO7	Refl Sel: Term S7 IN	000FH:bit 14	ON	OFF	C

## ◆ Binary Value Objects

Table C.10 Binary Value Objects

Object ID	Object Name	Modbus Address	Active Text	Inactive Text	PV Access
BV1	RUN FWD	0001H:bit 0	RUN	OFF	C
BV2	RUN REV	0001H:bit 1	REV	OFF	C
BV3	EXT FAULT	0001H:bit 2	FAULT	OFF	C
BV4	FAULT RESET	0001H:bit 3	RESET	OFF	C
BV5	COM NET	0001H:bit 4	COM	LOCAL	C
BV6	COM CNTRL	0001H:bit 5	COM	LOCAL	C
BV7	MF Input 3 Cmd	0001H:bit 6	ON	OFF	C
BV8	MF Input 4 Cmd	0001H:bit 7	ON	OFF	C
BV9	MF Input 5 Cmd	0001H:bit 8	ON	OFF	C
BV10	MF Input 6 Cmd	0001H:bit 9	ON	OFF	C
BV11	MF Input 7 Cmd	0001H:bit 10	ON	OFF	C
BV12	Set Fault Contact Cmd	0009H:bit 6	ENABLE	OFF	C
BV13	RUN-STOP	0020H:bit 0	RUN	OFF	R
BV14	REV-FWD	0020H:bit 1	REV	FWD	R
BV15	READY	0020H:bit 2	READY	OFF	R
BV16	FAULT	0020H:bit 3	FAULTED	OFF	R
BV17	Data Set Error	0020H:bit 4	ERROR	OFF	R
BV18	Overcurrent – Ground Fault	0021H:bit 0	OC-GF	OFF	R
BV19	Main Circuit Overvoltage	0021H:bit 1	OV	OFF	R
BV20	Drive Overload	0021H:bit 2	OL2	OFF	R
BV21	Drive Overheat	0021H:bit 3	OH1-OH2	OFF	R
BV22	Fuse Blown	0021H:bit 5	PUF	OFF	R
BV23	PI Feedback Loss	0021H:bit 6	FBL	OFF	R
BV24	External Fault	0021H:bit 7	EF0-EF	OFF	R
BV25	Hardware Error	0021H:bit 8	CPF	OFF	R
BV26	Mtr Ovrld-OvrTorque	0021H:bit 9	OL1-OL3	OFF	R
BV27	Overspeed	0021H:bit 10	OS-DEV	OFF	R
BV28	Main CKT Undervoltage	0021H:bit 11	UV	OFF	R
BV29	MCU, Cntl Pwr Sy Err	0021H:bit 12	UV1-2-3	OFF	R
BV30	Output Phase Loss	0021H:bit 13	LF	OFF	R
BV31	Communication Error	0021H:bit 14	CE	OFF	R
BV32	Operator Disconnect	0021H:bit 15	OPR	OFF	R
BV33	Operating	002CH:bit 0	OPERATING	OFF	R
BV34	Aero Speed	002CH:bit 1	ON	OFF	R

## C.7 BACnet Objects Supported

Object ID	Object Name	Modbus Address	Active Text	Inactive Text	PV Access
BV35	Frequency Agree	002CH:bit 2	ON	OFF	R
BV36	Desired Frequency Agree	002CH:bit 3	ON	OFF	R
BV37	Frequency Detect 1	002CH:bit 4	ON	OFF	R
BV38	Frequency Detect 2	002CH:bit 5	ON	OFF	R
BV39	Drive Startup Complete	002CH:bit 6	ON	OFF	R
BV40	Low Voltage Detect	002CH:bit 7	ON	OFF	R
BV41	Base Block	002CH:bit 8	ON	OFF	R
BV42	Frequency Reference Mode	002CH:bit 9	COM	LOCAL	R
BV43	Run Command Mode	002CH:bit 10	COM	LOCAL	R
BV44	Overtorque Detect	002CH:bit 11	ON	OFF	R
BV45	Frequency Refer Lost	002CH:bit 12	ON	OFF	R
BV46	Retry Error	002CH:bit 13	ON	OFF	R
BV47	Modbus Comms Error	002CH:bit 14	ON	OFF	R
BV48	Modbus Timeout Error	002CH:bit 15	ON	OFF	R
BV49	CRC Error	003DH:bit 0	ON	OFF	R
BV50	Invalid Data Length	003DH:bit 1	ON	OFF	R
BV51	Parity Error	003DH:bit 3	ON	OFF	R
BV52	Overrun Error	003DH:bit 4	ON	OFF	R
BV53	Framing Error	003DH:bit 5	ON	OFF	R
BV54	Timeout Error	003DH:bit 6	ON	OFF	R
BV55 </>	Parameter Accept	0910H:bit 0	ON	OFF	W
BV56 </>	Parameter Enter	0900H:bit 0	ON	OFF	W
BV57	Drive Comm Error	-	ON	OFF	R

<1> [Refer to Accessing Drive Parameters and the Enter Command on page 353](#) for an explanation of how to read and write drive parameters not listed in the analog or binary objects.

### ◆ Device Object

The Device Object fully describes the BACnet device to the network. Notable is that the Device Object Instance ID and the Device Object Name are configurable.

The Device Object Instance ID is a unique internetwork-wide numerical value. It is a 22-bit value that can range from 0 to 4,194,303. It is configurable by parameters H5-14 and H5-15. Any changes to these parameters will not take effect until the power is cycled to the drive.

The Device Object Name is a unique internetwork-wide character string. It is a 20-character string. It is writable from the BACnet network. Any new string written will not take effect until the power is cycled to the drive.

## C.8 Accessing Drive Parameters and the Enter Command

### ◆ Reading Drive Parameters

Reading drive parameters not listed in the analog or digital objects is accomplished using AV29 and AV30 as shown below:

1. In decimal, write the desired Modbus register to AV29.
2. In decimal, read the value at the given register from AV30.

For example, to read the Frequency Reference Upper Limit, read from parameter d2-01.

Parameter d2-01 is located at Modbus register 0289H, which is decimal 649.

Set AV29 to “649”

Read AV30 to get the value.

### ◆ Writing Drive Parameters

Writing drive parameters not listed in the analog or digital objects is accomplished using AV29, AV30, and BV55 or BV56 as shown below:

1. In decimal, write the desired Modbus register to AV29.
2. In decimal, write the value to be written into AV30.
3. At this point the value is written to the drive, but the location is pending. If necessary, write in more values this way, then the drive will accept these settings by one of two methods:

Set BV55 to “ON” to move data to active memory.

Set BV56 to “ON” to move data into active memory and save to non-volatile memory.

For example, to reset the KWH Monitor, write a value of “1” to parameter o1-12.

Parameter o1-12 is located at Modbus register 0512H, which is decimal 1298.

Set AV29 to “1298”

Set AV30 to “1”

Set BV55 to “ON”.

### ◆ Enter Command

Enter Commands are only required when using AV29 and AV30 to access drive parameters. An Enter command is not required when reading or writing to the other BACnet objects.

When writing parameters to the drive from a controller using BACnet communications, parameter H5-11 determines if an Enter command must be issued to enable these parameters. This section describes the types and functions of the Enter commands.

### ■ Enter Command Types

The drive supports two types of Enter commands as shown in [Table C.11](#).

**Table C.11 Enter Command Types**

BACnet Object	Modbus Address	Description
BV55 (Write “ON”)	0910H (Write 0)	Writes data in the RAM only. Parameter changes are lost when the drive is shut off.
BV56 (Write “ON”)	0900H (Write 0)	Simultaneously writes data into the EEPROM (non-volatile memory) of the drive and enables the data in RAM. Parameter changes remain after cycling power.

**Note:** The EEPROM can only be written to 100,000 times, so it is recommended to limit the number of times writing to the EEPROM. The Enter command registers 0900H and 0910H are write-only and if these registers are read, the register address will be invalid. However, BACnet objects BV55 and BV56 can be read without error.

### C.9 Communication Errors

Errors that may occur when accessing drive parameters using the BACnet objects are shown in [Table C.12](#).

**Table C.12 MEMOBUS to BACnet Error Conversion**

Error Code	Description
03d	BN_ERR_DEVICE_IS_BUSY Writing to a parameter was attempted while the drive was saving parameters to non-volatile memory.
27d	BN_ERR_READ_ACCESS_DENIED Invalid parameter register number used when reading.
37d	BN_ERR_VALUE_OUT_OF_RANGE Value written to the parameter is out of the valid range.
40d	BN_ERR_WRITE_ACCESS_DENIED An invalid parameter register number was used when writing. Writing to a parameter was attempted while the drive was in a mode that disables writing (i.e., writing while the drive was Auto-Tuning). Writing to a parameter was attempted while the DC Bus had an Undervoltage (Uv) fault

## C.10 Self-Diagnostics

The drive has a built-in self-diagnosing function of the serial communication interface circuits. To perform the self-diagnosis function, use the following procedure.

**DANGER! Electrical Shock Hazard.** Do not connect or disconnect wiring while the power is on. Failure to comply will result in death or serious injury. Before servicing, disconnect all power to the equipment. The internal capacitor remains charged even after the power supply is turned off. The charge indicator LED will extinguish when the DC bus voltage is below 50 Vdc. To prevent electric shock, wait at least one minute after all indicators are OFF and measure the DC bus voltage level to confirm safe level.

1. Turn on the power to the drive.
2. Note the present terminal S6 function selection setting (H1-06) and set it for the communications test mode (H1-06 = 67).
3. Turn off the power to the drive.
4. With the power off, wire the drive as shown in the following diagram, connecting terminals R+ and S+, R- and S-, and S6 and SP.

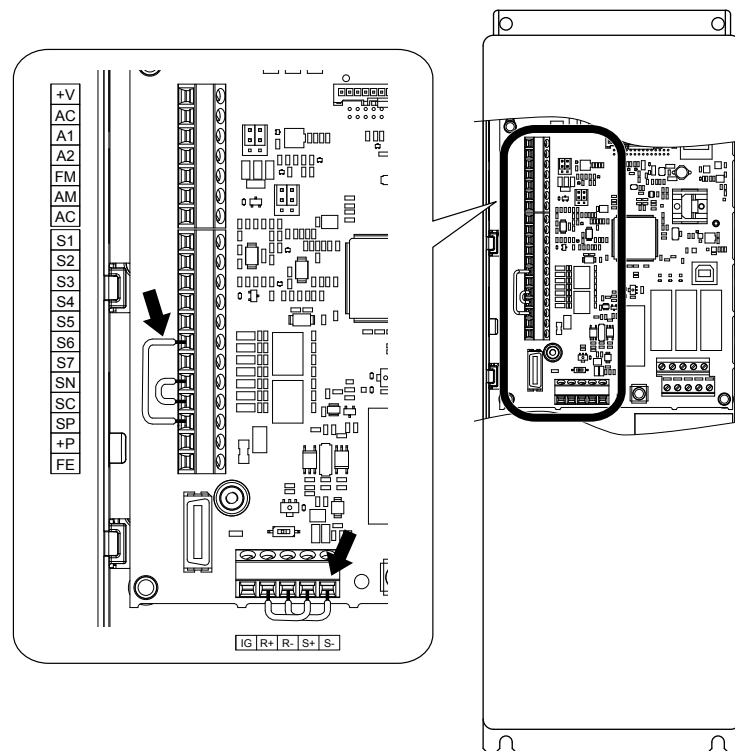

Figure C.7 Terminal Connections for Communication Self-Diagnostics

5. Connect a wire jumper between terminals SN and SC to change to source mode.
6. Turn the power to the drive back on.
7. During normal operation, the drive will display “Pass” to indicate that the communications test mode is operating normally.  
When a fault occurs, the drive will display “CE” on the keypad display.
8. Turn off the power supply.
9. Remove the wire jumpers from terminal R+, R-, S+, S-, and S6-SP. Reset the wire jumper to its original position and set terminal S6 to its original function.
10. Return to normal operation.

# C.11 BACnet Protocol Implementation Conformance Statement

Date: 1/4/2011 Vendor Name: Yaskawa America, Inc.

Product Name: AC Motor Controller Product

Model Number: CIMR-ZU□A-□□□□

Application Software Version: 1.3 / Firmware Revision: VSE90101X / BACnet Protocol Revision: 4

Product Description:

The Yaskawa Z1000 Drive and Bypass products are high performance products specifically designed for commercial building automation applications. The Yaskawa BACnet feature connects the Z1000 Drive and Bypass products to a standard BACnet MS/TP network. These products may be fully controlled and monitored over BACnet. All drive parameters are available for reading and writing

BACnet Standardized Device Profile (Annex L):

- BACnet Operator Workstation (B-OWS)
- BACnet Building Controller (B-BC)
- BACnet Advanced Application Controller (B-AAC)
- BACnet Application Specific Controller (B-ASC)
- BACnet Smart Sensor (B-SS)
- BACnet Smart Actuator (B-SA)

List all BACnet Interoperability Building Blocks Supported (Annex K):

- Data Sharing-ReadProperty-B (DS-RP-B)
- Data Sharing-WriteProperty-B (DS-WP-B)
- Data Sharing - ReadProperty Multiple - B (DS-RPM-B)
- Data Sharing - WriteProperty Multiple - B (DS-WPM-B)
- Device Management-Dynamic Device Binding-B (DM-DDB-B)
- Device Management-Dynamic Object Binding-B (DM-DOB-B)
- Device Management-DeviceCommunicationControl-B (DM-DCC-B)
- Device Management-ReinitializeDevice-B (DM-RD-B)
- Device Management-TimeSynchronization-B (DM-TS-B)

Segmentation Capability:

- Segmented requests supported / Window Size
- Segmented responses supported / Window Size

Standard Object Types Supported:

- Device Object
- Analog Input Object
- Analog Output Object
- Analog Value Object
- Binary Input Object
- Binary Output Object
- Binary Value Object

Data Link Layer Options:

- BACnet IP, (Annex J)
- BACnet IP, (Annex J), Foreign Device
- ISO 8802-3, Ethernet (Clause 7)
- ANSI/ATA 878.1, 2.5 Mb. ARCNET (Clause 8)
- ANSI/ATA 878.1, RS-485 ARCNET (Clause 8), baud rate(s)
- MS/TP master (Clause 9), baud rate(s): 1200, 2400, 4800, 9600, 19200, 38400, 57600, 76800, 115200
- MS/TP slave (Clause 9), baud rate(s):

Point-To-Point, EIA 232 (Clause 10), baud rate(s):

Point-To-Point, modem, (Clause 10), baud rate(s):

LonTalk, (Clause 11), medium:

Other:

Device Address Binding:

Is static device binding supported? (This is currently necessary for two-way communication with MS/TP slaves and certain other devices.)  Yes  No

Networking Options:

Router, Clause 6 - List all routing configurations, e.g., ARCNET-Ethernet, Ethernet-MS/TP, etc.

Annex H, BACnet Tunneling Router over IP

BACnet/IP Broadcast Management Device (BBMD)

Does the BBMD support registrations by Foreign Devices?  Yes  No

Character Sets Supported:

Indicating support for multiple character sets does not imply that they can all be supported simultaneously.

ANSI X3.4

IBM/Microsoft

DBCS

ISO 8859-1

ISO 10646 (UCS-2)

ISO 10646 (UCS-4)

JIS C 6226

If this product is a communication gateway, describe the types of non-BACnet equipment/networks(s) that the gateway supports: Not supported

**This Page Intentionally Blank**

# Appendix: D

## Standards Compliance

---

This appendix explains the guidelines and criteria for maintaining CE and UL standards.

<b>D.1</b>	<b>SECTION SAFETY.....</b>	<b>360</b>
<b>D.2</b>	<b>EUROPEAN STANDARDS.....</b>	<b>362</b>
<b>D.3</b>	<b>UL/CUL STANDARDS.....</b>	<b>368</b>

## D.1 Section Safety

### WARNING

#### Electrical Shock Hazard

**Do not connect or disconnect wiring while the power is on.**

Failure to comply could result in death or serious injury.

Before servicing, disconnect all power to the equipment. The internal capacitor remains charged even after the power supply is turned off. The charge indicator LED will extinguish when the DC bus voltage is below 50 Vdc. To prevent electric shock, wait for at least the time specified on the warning label; After all indicators are OFF, measure the DC bus voltage level to confirm it has reached a safe level.

**Do not operate equipment with covers removed.**

Failure to comply could result in death or serious injury.

The diagrams in this section may show drives without covers or safety shields to show details. Be sure to reinstall covers or shields before operating the drives and run the drives according to the instructions described in this manual.

**Always ground the motor-side grounding terminal.**

Improper equipment grounding could result in death or serious injury by contacting the motor case.

**Do not touch any terminals before the capacitors have fully discharged.**

Failure to comply could result in death or serious injury.

Before wiring terminals, disconnect all power to the equipment. The internal capacitor remains charged even after the power supply is turned off. After shutting off the power, wait for at least the amount of time specified on the drive before touching any components.

**Do not allow unqualified personnel to perform work on the drive.**

Failure to comply could result in death or serious injury.

Installation, maintenance, inspection, and servicing must be performed only by authorized personnel familiar with installation, adjustment and maintenance of AC drives.

**Do not perform work on the drive while wearing loose clothing, jewelry or without eye protection.**

Failure to comply could result in death or serious injury.

Remove all metal objects such as watches and rings, secure loose clothing, and wear eye protection before beginning work on the drive.

**Do not remove covers or touch circuit boards while the power is on.**

Failure to comply could result in death or serious injury.

#### Fire Hazard

**Tighten all terminal screws to the specified tightening torque.**

Loose electrical connections could result in death or serious injury by fire due to overheating of electrical connections.

**Do not use an improper voltage source.**

Failure to comply could result in death or serious injury by fire.

Verify that the rated voltage of the drive matches the voltage of the incoming power supply before applying power.

**Do not use improper combustible materials.**

Failure to comply could result in death or serious injury by fire.

Attach the drive to metal or other noncombustible material.

**NOTICE**

**Observe proper electrostatic discharge procedures (ESD) when handling the drive and circuit boards.**

Failure to comply may result in ESD damage to the drive circuitry.

**Never connect or disconnect the motor from the drive while the drive is outputting voltage.**

Improper equipment sequencing could result in damage to the drive.

**Do not use unshielded wire for control wiring.**

Failure to comply may cause electrical interference resulting in poor system performance. Use shielded twisted-pair wires and ground the shield to the ground terminal of the drive.

**Do not modify the drive circuitry.**

Failure to comply could result in damage to the drive and will void warranty.

Yaskawa is not responsible for modification of the product made by the user. This product must not be modified.

**Check all the wiring to ensure that all connections are correct after installing the drive and connecting other devices.**

Failure to comply could result in damage to the drive.

**If a fuse is blown or a Ground Fault Circuit Interrupter (GFCI) is tripped, check the wiring and the selection of the peripheral devices.**

Contact your supplier if the cause cannot be identified after checking the above.

**Do not restart the drive immediately operate the peripheral devices if a fuse is blown or a GFCI is tripped.**

Check the wiring and the selection of peripheral devices to identify the cause. Contact your supplier before restarting the drive or the peripheral devices if the cause cannot be identified.

## D.2 European Standards



Figure D.1 CE Mark

The CE mark indicates compliance with European safety and environmental regulations. It is required for engaging in business and commerce in Europe.

European standards include the Machinery Directive for machine manufacturers, the Low Voltage Directive for electronics manufacturers, and the EMC guidelines for controlling noise.

This drive displays the CE mark based on the EMC guidelines and the Low Voltage Directive.

- **Low Voltage Directive:** 2006/95/EC
- **EMC Guidelines:** 2004/108/EC

Devices used in combination with this drive must also be CE certified and display the CE mark. When using drives displaying the CE mark in combination with other devices, it is ultimately the responsibility of the user to ensure compliance with CE standards. After setting up the device, verify that conditions meet European standards.

### ◆ CE Low Voltage Directive Compliance

This drive has been tested according to European standard IEC/EN 61800-5-1, and it fully complies with the Low Voltage Directive.

To comply with the Low Voltage Directive, be sure to meet the following conditions when combining this drive with other devices:

#### ■ Area of Use

Do not use drives in areas with pollution higher than severity 2 and overvoltage category 3 in accordance with IEC/EN 664.

#### ■ Installing Fuses on the Input Side

Always install input fuses. Select fuses according to the table below.

**WARNING! Fire Hazard.** Install adequate branch circuit protection according to applicable local codes and this manual. Failure to comply could result in fire and damage to the drive or injury to personnel. The device is suitable for use on a circuit capable of delivering not more than 100,000 RMS symmetrical amperes, 240 Vac (200 V class) and 480 Vac (400 V class), when protected by branch circuit protection devices specified in this manual.

Branch circuit protection shall be provided by any of the following: Non-time delay Class J, T, or CC fuses sized at 300% of the drive input rating, or Time delay Class J, T, or CC fuses sized at 175% of the drive input rating, or MCCB sized at 200% maximum of the drive input rating.

Table D.1 Recommended Input Fuse Selection

Model	Manufacturer: Bussmann	
	Model	Fuse Ampere Rating (A)
<b>Three-Phase 200 V Class</b>		
2A0011	FWH-40B	40
2A0017	FWH-50B	50
2A0024	FWH-80B	80
2A0031	FWH-100B	100
2A0046	FWH-150B	150
2A0059	FWH-175B	175
2A0075	FWH-225A	225
2A0088	FWH-225A	225
2A0114	FWH-250A	250
2A0143	FWH-275A	275
2A0169	FWH-350A	350
2A0211	FWH-400A	400
2A0273	FWH-450A	450

Model	Manufacturer: Bussmann	
	Model	Fuse Ampere Rating (A)
2A0343	FWH-600A	600
2A0396	FWH-600A	600
<b>Three-Phase 400 V Class</b>		
4A0005	FWH-40B	40
4A0008	FWH-40B	40
4A0011	FWH-45B	45
4A0014	FWH-45B	45
4A0021	FWH-60B	60
4A0027	FWH-60B	60
4A0034	FWH-125B	125
4A0040	FWH-150B	150
4A0052	FWH-200B	200
4A0065	FWH-225A	225
4A0077	FWH-225A	225
4A0096	FWH-225A	225
4A0124	FWH-250A	250
4A0156	FWH-300A	300
4A0180	FWH-350A	350
4A0240	FWH-400A	400
4A0302	FWH-600A	600
4A0361	FWH-800A	800
4A0414	FWH-800A	800
4A0480	FWH-700A	700
4A0590	FWH-1000A	1000

## ■ Grounding

The drive is designed to be used in T-N (grounded neutral point) networks. If installing the drive in other types of grounded systems, contact your Yaskawa representative for instructions.

## ■ Guarding Against Harmful Materials

When installing IP00/Open Type enclosure drives, use an enclosure that prevents foreign material from entering the drive from above or below.

## ◆ EMC Guidelines Compliance

This drive is tested according to European standards IEC/EN 61800-3: 2004.

### ■ EMC Filter Installation

**Note:** Drive models CIMR-Z□2A0011 to 2A0273 and 4A0005 to 4A0302 have a built-in EMC filter.

The following conditions must be met to ensure continued compliance with guidelines. [Refer to EMC Filters on page 367](#) for EMC filter selection.

#### Installation Method for CIMR-Z□2A0011 to 2A0273 and 4A0005 to 4A0302

Verify the following installation conditions to ensure that other devices and machinery used with this drive comply with EMC guidelines.

1. Move the screws to the ON position to enable the internal EMC filter.
2. Use braided shield cable for the drive and motor wiring, or run the wiring through a metal conduit.
3. Keep wiring as short as possible. Ground the shield on both the drive side and the motor side.

#### Installation Method for CIMR-Z□2A0343, 2A0396, and 4A0361 to 4A0590

Verify the following installation conditions to ensure that other devices and machinery used in combination with this drive also comply with EMC guidelines.

1. Install an EMC noise filter to the input side specified by Yaskawa for compliance with European standards.

## D.2 European Standards

2. Place the drive and EMC noise filter in the same enclosure.
3. Use braided shield cable for the drive and motor wiring, or run the wiring through a metal conduit.
4. Keep wiring as short as possible. Ground the shield on both the drive side and the motor side.

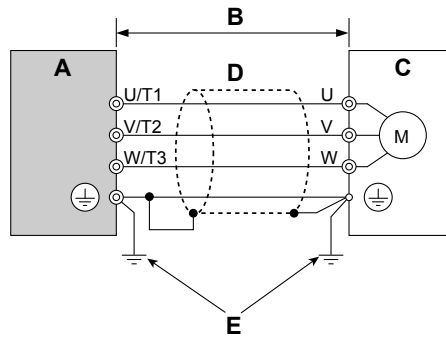

A – Drive

B – 10 m max. cable length between  
drive and motor

C – Motor

D – Metal conduit

E – Ground wire should be as short as  
possible.

Figure D.2 Installation Method

5. Make sure the protective earthing conductor complies with technical standards and local safety regulations.

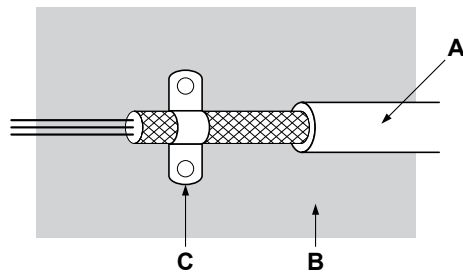

A – Braided shield cable

B – Metal panel

C – Cable clamp (conductive)

Figure D.3 Ground Area

Three-Phase 200 V / 400 V Class (2A0011 to 2A0273 and 4A0011 to 4A0302)

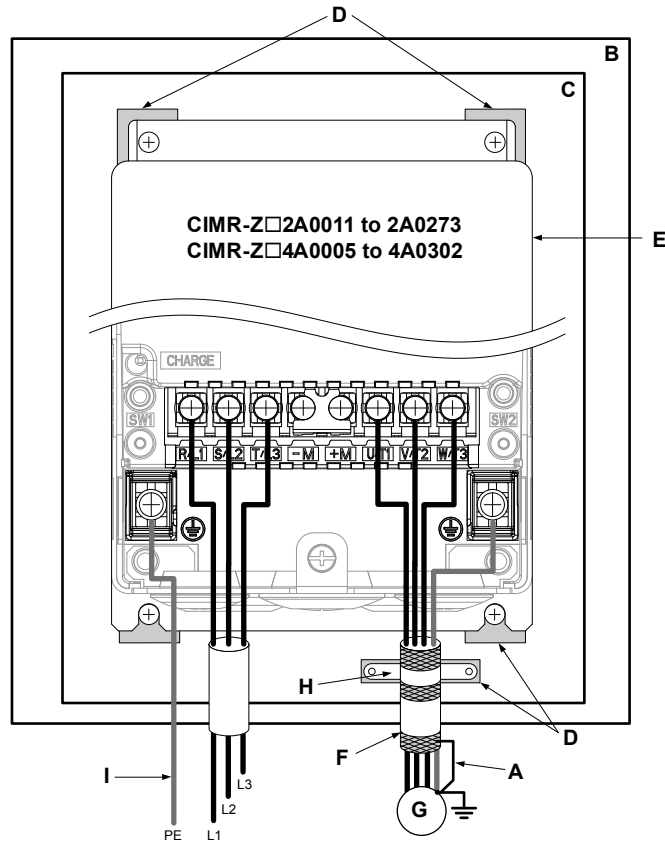

- |  |  |
|--|--|
| <b>A</b> – Ground the cable shield                         | <b>F</b> – Motor cable (braided shield cable, max. 10 m) |
| <b>B</b> – Enclosure panel                                 | <b>G</b> – Motor   |
| <b>C</b> – Metal plate                                     | <b>H</b> – Cable Clamp                                   |
| <b>D</b> – Grounding surface (remove any paint or sealant) | <b>I</b> – Make sure the ground wire is grounded         |
| <b>E</b> – Drive   |  |

Figure D.4 EMC Filter and Drive Installation for CE Compliance (2A0011 to 2A0273 and 4A0011 to 4A0302)

## D.2 European Standards

### Three-Phase 200 V / 400 V Class (2A0343, 2A0396, and 4A0361 to 4A0590)

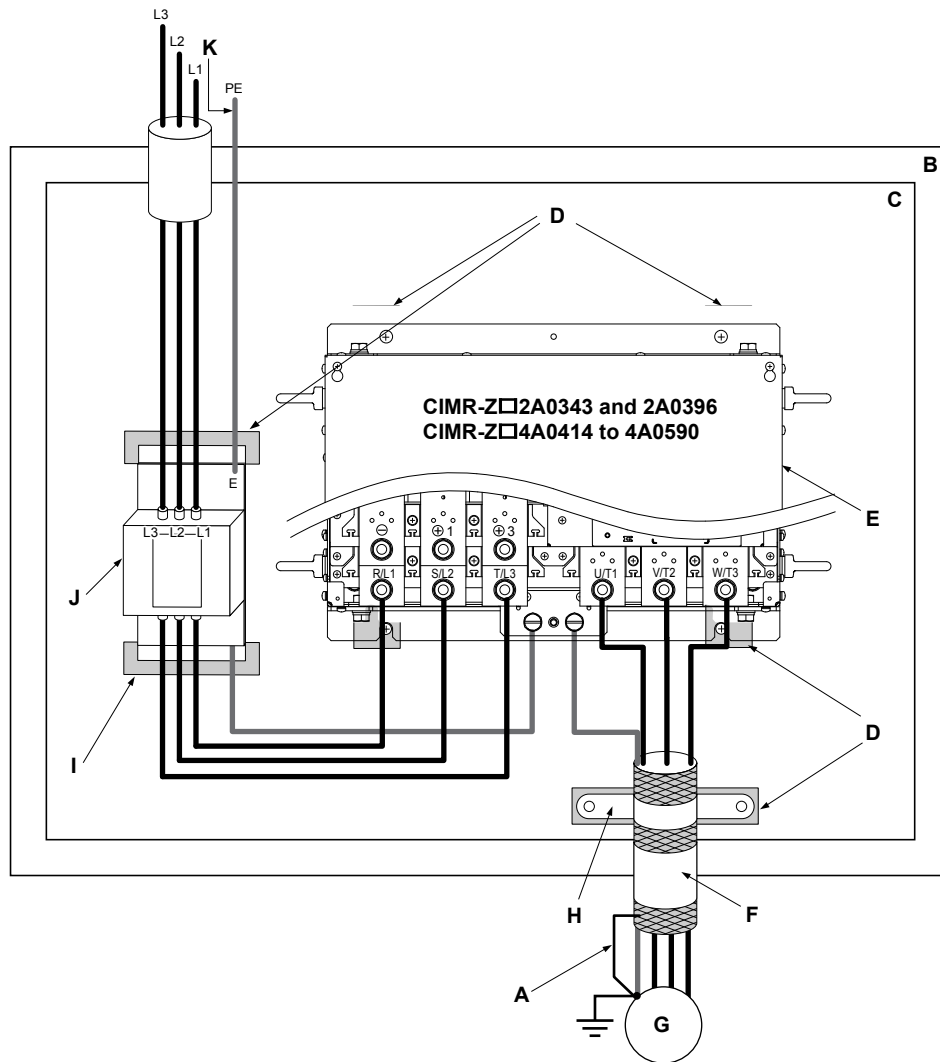

- |  |  |
|--|--|
| <b>A</b> – Ground the cable shield                         | <b>G</b> – Motor                                       |
| <b>B</b> – Enclosure panel                                 | <b>H</b> – Cable Clamp                                 |
| <b>C</b> – Metal plate                                     | <b>I</b> – Ground plate (scrape off any visible paint) |
| <b>D</b> – Grounding surface (remove any paint or sealant) | <b>J</b> – EMC noise filter                            |
| <b>E</b> – Drive   | <b>K</b> – Make sure the ground wire is grounded       |
| <b>F</b> – Motor cable (braided shield cable, max. 10 m)   |  |

Figure D.5 EMC Filter and Drive Installation for CE Compliance (2A0343, 2A0396, and 4A0361 to 4A0590)

■ EMC Filters

Install the drive with the EMC filters listed below for 2A0343, 2A0396, and 4A0361 to 4A0590.

Table D.2 IEC/EN 61800-3 Filters

Model	Filter Data (Manufacturer: Schaffner)				
	Type	Rated Current (A)	Weight (lb)	Dimensions [W x D x H] (in)	Y x X (in)
<b>Three-Phase 200 V Class</b>					
2A0343 2A0396	FS5972-600-99	600	24.3	10.2 × 5.3 × 15.2	9.3 × 4.7
<b>Three-Phase 400 V Class</b>					
4A0361	FS5972-410-99	410	23.1	10.2 × 4.5 × 15.2	9.3 × 4.7
4A0414 4A0480	FS5972-600-99	600	24.3	10.2 × 5.3 × 15.2	9.3 × 4.7
4A0590	FS5972-800-99	800	69.4	11.8 × 6.3 × 28.2	10.8 × 8.3

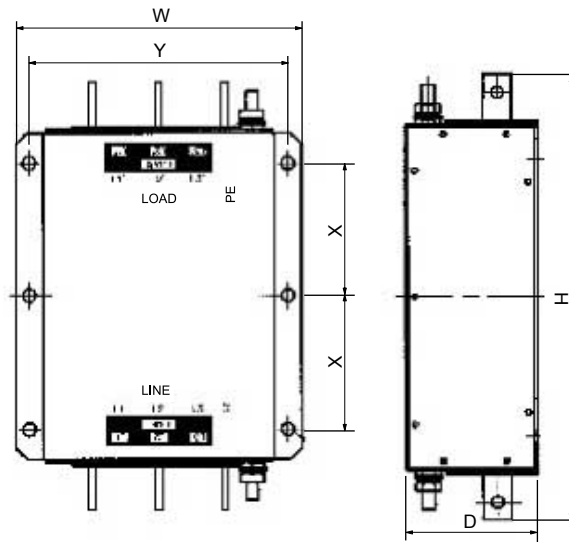

Figure D.6 EMC Filter Dimensions

## D.3 UL/cUL Standards

### ◆ UL Standards Compliance

The UL/cUL mark applies to products in the United States and Canada. It indicates that UL has performed product testing and evaluation, and determined that their stringent standards for product safety have been met. For a product to receive UL certification, all components inside that product must also receive UL certification.



Figure D.7 UL/cUL Mark

This drive is tested in accordance with UL standard UL508C and complies with UL requirements. The conditions described below must be met to maintain compliance when using this drive in combination with other equipment:

#### ■ Installation Area

Do not install the drive to an area greater than pollution degree 2 (UL standard).

#### ■ Ambient Temperature

IP20/NEMA Type 1 Enclosure, External Heatsink (2A0011 to 2A0073 and 4A0005 to 4A0302): -10 to +40 °C (14 to 104 °F)

IP00/Open Type Enclosure (2A0343 and 2A0396 and 4A0361 to 4A0590): -10 to +50 °C (14 to 122 °F)

#### ■ Main Circuit Terminal Wiring

Yaskawa recommends using closed-loop crimp terminals on all drive models. To maintain UL/cUL approval, UL Listed closed-loop crimp terminals are specifically required when wiring the drive main circuit terminals on models 2A0031 to 2A0396 and 4A0034 to 4A0590. Use only the tools recommended by the terminal manufacturer for crimping. *Refer to Closed-Loop Crimp Terminal Size on page 368* for closed-loop crimp terminal recommendations.

The wire gauges listed in the following tables are Yaskawa recommendations. Refer to NEC table 310-16 for proper wire gauge selection for terminals -M, +M, -1, +3, and ground.

#### Wire Gauges and Tightening Torques

*Refer to Wire Gauges and Tightening Torque on page 83* to select the appropriate wires and crimp terminals for use in the United States.

**Note:** The ⊕ mark indicates the terminals for protective ground connection as defined in IEC/EN 60417-5019.  
 Grounding impedance:  
 200 V: 100 Ω or less  
 400 V: 10 Ω or less

#### Closed-Loop Crimp Terminal Recommendations

Yaskawa recommends using closed-loop crimp terminals on all drive models. To maintain UL/cUL approval, UL Listed closed-loop crimp terminals are specifically required when wiring the drive main circuit terminals on models 2A0031 to 2A0396 and 4A0034 to 4A0590. Use only the tools recommended by the terminal manufacturer for crimping. Yaskawa recommends crimp terminals made by JST and Tokyo DIP (or equivalent) for the insulation cap.

*Table D.3* matches the wire gauges and terminal screw sizes with Yaskawa-recommended crimp terminals, tools, and insulation caps. Refer to the appropriate Wire Gauge and Torque Specifications table for the wire gauge and screw size for your drive model. Place orders with a Yaskawa representative or the Yaskawa sales department. Refer to local codes for proper selections.

Table D.3 Closed-Loop Crimp Terminal Size

Wire Gauge	Terminal Screws	Crimp Terminal Model Number	Tool		Insulation Cap Model No.	Code <1>
			Machine No.	Die Jaw		
2 mm <sup>2</sup> 14 AWG	M4	R2-4	YA-4	AD-900	TP-003	100-054-028
3.5 / 5.5 mm <sup>2</sup> 12 / 10 AWG	M4	5.5-4NS	YA-4	AD-900	TP-005	100-064-248

Wire Gauge	Terminal Screws	Crimp Terminal Model Number	Tool		Insulation Cap Model No.	Code <1>
			Machine No.	Die Jaw		
8 mm <sup>2</sup> 8 AWG	M4	8-4NS	YA-4	AD-901	TP-008	100-064-249
	M5	R8-5	YA-4	AD-901	TP-008	100-054-032
14 mm <sup>2</sup> 6 AWG	M5	R14-5	YA-4	AD-902	TP-014	100-054-034
	M8	R14-8	YA-5	AD-952	TP-014	100-054-035
22 mm <sup>2</sup> 4 AWG	M5	22-5NS	YA-5	AD-953	TP-022	100-051-262
	M8	R22-8	YA-5	AD-953	TP-022	100-051-263
30 / 38 mm <sup>2</sup> 3 / 2 AWG	M8	R38-8	YA-5	AD-954	TP-038	100-051-264
50 / 60 mm <sup>2</sup> 1 AWG 1/0 AWG 1/0 AWG × 2P	M8	R60-8	YA-5	AD-955	TP-060	100-051-265
70 mm <sup>2</sup> 2/0 AWG 2/0 AWG × 2P	M8	CB70-S8	YF-1 YET-300-1	TD-322,TD-311	TP-080	100-064-417
		70-8				100-064-250
80 mm <sup>2</sup> 3/0 AWG × 2P 3/0 AWG × 4P	M10	70-10	YF-1 YET-300-1	TD-322,TD-311	TP-080	100-064-251
	M12	80-10	YF-1 YET-300-1	TD-323,TD-312	TP-080	100-051-267
100 mm <sup>2</sup> 4/0 AWG × 2P 4/0 AWG × 4P	M12	80-L12	YF-1 YET-300-1	TD-323,TD-312	TP-080	100-051-558
		100-L12				TD-324,TD-312
150 mm <sup>2</sup> 250 kcmil × 2P 300 kcmil × 2P	M12	150-L12	YF-1 YET-300-1	TD-325,TD-313	TP-150	100-051-562

<1> Codes refer to a set of three crimp terminals and three insulation caps. Prepare input and output wiring using two sets for each connection.  
 Example 1: Models with 300 kcmil for both input and output require one set for input terminals and one set for output terminals, so the user should order two sets of [100-051-272].  
 Example 2: Models with 4/0 AWG × 2P for both input and output require two sets for input terminals and two sets for output terminals, so the user should order four sets of [100-051-560].

**Note:** Use crimp insulated terminals or insulated shrink tubing for wiring connections. Wires should have a continuous maximum allowable temperature of 75 °C 600 Vac UL-approved vinyl-sheathed insulation.

### ■ Factory Recommended Branch Circuit Protection

**WARNING! Fire Hazard.** Install adequate branch circuit protection according to applicable local codes and this manual. Failure to comply could result in fire and damage to the drive or injury to personnel. The device is suitable for use on a circuit capable of delivering not more than 100,000 RMS symmetrical amperes, 240 Vac (200 V class) and 480 Vac (400 V class), when protected by branch circuit protection devices specified in this manual.  
 Branch circuit protection shall be provided by any of the following: Non-time delay Class J, T, or CC fuses sized at 300% of the drive input rating, or Time delay Class J, T, or CC fuses sized at 175% of the drive input rating, or MCCB sized at 200% maximum of the drive input rating.

Yaskawa recommends installing one of the following types of branch circuit protection to maintain compliance with UL508C. Semiconductor protective type fuses are preferred. Alternate branch circuit protection devices are also listed in [Table 6.3](#).

**Table D.4 Factory Recommended Z1000 AC Drive Branch Circuit Protection**

Model	Nominal Output Power (HP)	AC Drive Input (A)	MCCB Rating (A) <1>	Time Delay Fuse Rating (A) <2>	Non-time Delay Fuse Rating (A) <3>	Bussmann Semiconductor Fuse Model (Fuse Ampere) <4>
<b>Three-Phase 200 V Class</b>						
2A0011	3	10.6	20	17.5	30	FWH-40B (40)
2A0017	5	16.7	30	25	50	FWH-50B (50)
2A0024	7.5	24.2	40	40	70	FWH-80B (80)
2A0031	10	30.8	60	50	90	FWH-100B (100)
2A0046	15	46.2	90	80	125	FWH-150B (150)
2A0059	20	59.4	110	100	175	FWH-175B (175)
2A0075	25	74.8	150	125	200	FWH-225A (225)

### D.3 UL/cUL Standards

Model	Nominal Output Power (HP)	AC Drive Input (A)	MCCB Rating (A) <1>	Time Delay Fuse Rating (A) <2>	Non-time Delay Fuse Rating (A) <3>	Bussmann Semiconductor Fuse Model (Fuse Ampere) <4>
2A0088	30	88	175	150	250	FWH-225A (225)
2A0114	40	114	225	175	300	FWH-250A (250)
2A0143	50	143	250	250	400	FWH-275A (275)
2A0169	60	169	300	275	500	FWH-350A (350)
2A0211	75	211	400	350	600	FWH-400A (400)
2A0273	10	273	500	450	<5>	FWH-450A (450)
2A0343	125	343	600	600		FWH-600A (600)
2A0396	150	396	700	<5>		FWH-600A (600)
<b>Three-Phase 400 V Class</b>						
4A0005	3	4.8	15	8	12	FWH-40B (40)
4A0008	5	7.6	15	12	20	FWH-40B (40)
4A0011	7.5	11	20	17.5	30	FWH-45B (45)
4A0014	10	14	25	20	40	FWH-45B (45)
4A0021	15	21	40	35	60	FWH-60B (60)
4A0027	20	27	50	45	80	FWH-60B (60)
4A0034	25	34	60	50	100	FWH-125B(125)
4A0040	30	40	75	70	110	FWH-150B (150)
4A0052	40	52	100	90	150	FWH-200B (200)
4A0065	50	65	125	110	175	FWH-225A (225)
4A0077	60	77	150	125	225	FWH-225A (225)
4A0096	75	96	175	150	275	FWH-225A (225)
4A0124	100	124	225	200	350	FWH-250A(250)
4A0156	125	156	300	250	450	FWH-300A (300)
4A0180	150	180	350	300	500	FWH-350A (350)
4A0240	200	240	450	400	<5>	FWH-400A (400)
4A0302	250	302	600	500		FWH-600A (600)
4A0361	300	346	600	600	1000 <6>	FWH-800A (800)
4A0414	350	410	800	700	1200 <6>	FWH-800A (800)
4A0480	400	480	900	<5>	<5>	FWH-700A (700)
4A0590	500	590	1100			FWH-1000A (1000)

<1> Maximum MCCB rating is 15 A, or 200% of drive input current rating, whichever value is larger. MCCB voltage rating must be 600 Vac or greater.

<2> Maximum Time delay fuse is 175% or drive input current rating. This covers any Class J, T, or CC fuse.

<3> Maximum Non-time delay fuse is 300% of drive input current rating. This covers any Class J, T, or CC fuse.

<4> When using semiconductor fuses, Bussmann FWH fuses are required for UL compliance.

<5> Consult factory.

<6> Class L fuse is also approved for this rating.

#### ■ Low Voltage Wiring for Control Circuit Terminals

Wire low voltage wires with NEC Class 1 circuit conductors. Refer to national state or local codes for wiring. The external power supply shall be a UL listed Class 2 power supply source or equivalent only. Refer to NEC Article 725 Class 1, Class 2, and Class 3 Remote-Control, Signaling, and Power Limited Circuits for requirements concerning class 1 circuit conductors and class 2 power supplies.

**Table D.5 Control Circuit Terminal Power Supply**

Input / Output	Terminal Signal	Power Supply Specifications
Multi-function digital inputs	S1, S2, S3, S4, S5, S6, S7, SC, SP, SN	Use the internal control power supply of the drive or an external class 2 power supply.
Multi-function analog inputs	+V, A1, A2, AC, FM, AM	

## ■ Drive Short Circuit Rating

The drive is suitable for use on a circuit capable of delivering not more than 100,000 RMS symmetrical Amperes, 240 Vac maximum (200 V Class) and 480 Vac maximum (400 V Class), when protected by Bussmann Type FWH or FWP fuses as specified in *Installing Fuses on the Input Side* on page 362.

## ◆ Drive Motor Overload Protection

Set parameter E2-01 (motor rated current) to the appropriate value to enable motor overload protection. The internal motor overload protection is UL listed and in accordance with the NEC and CEC.

### ■ E2-01: Motor Rated Current

Setting Range: Model-dependent

Default Setting: Model-dependent

Parameter E2-01 protects the motor when parameter L1-01 is not set to 0. The default for L1-01 is 1, which enables protection for standard induction motors.

If Auto-Tuning has been performed successfully, the motor data entered to T1-04 is automatically written to parameter E2-01. If Auto-Tuning has not been performed, manually enter the correct motor rated current to parameter E2-01.

### ■ L1-01: Motor Overload Protection Selection

The drive has an electronic overload protection function (oL1) based on time, output current, and output frequency that protects the motor from overheating. The electronic thermal overload function is UL-recognized, so it does not require an external thermal relay for single motor operation.

This parameter selects the motor overload curve used according to the type of motor applied.

**Table D.6 Overload Protection Settings**

Setting	Description	
0	Disabled	Disabled the internal motor overload protection of the drive.
1	Standard fan-cooled motor	Selects protection characteristics for a standard self-cooled motor with limited cooling capabilities when running below the rated speed. The motor overload detection level (oL1) is automatically reduced when running below the motor rated speed.
4	Permanent Magnet motor with variable torque	Selects protection characteristics for a variable torque PM motor. The motor overload detection level (oL1) is automatically reduced when running below the motor rated speed.

When connecting the drive to more than one motor for simultaneous operation, disable the electronic overload protection (L1-01 = 0) and wire each motor with its own motor thermal overload relay.

Enable motor overload protection (L1-01 = 1, 2, or 4) when connecting the drive to a single motor, unless another motor overload preventing device is installed. The drive electronic thermal overload function causes an oL1 fault, which shuts off the output of the drive and prevents additional overheating of the motor. The motor temperature is continually calculated while the drive is powered up.

### ■ L1-02: Motor Overload Protection Time

Setting Range: 0.1 to 5.0 min

Factory Default: 1.0 min

Parameter L1-02 determines how long the motor is allowed to operate before the oL1 fault occurs when the drive is running a hot motor at 60 Hz and at 150% of the full load amp rating (E2-01) of the motor. Adjusting the value of L1-02 can shift the set of oL1 curves up the y axis of the diagram below, but will not change the shape of the curves.

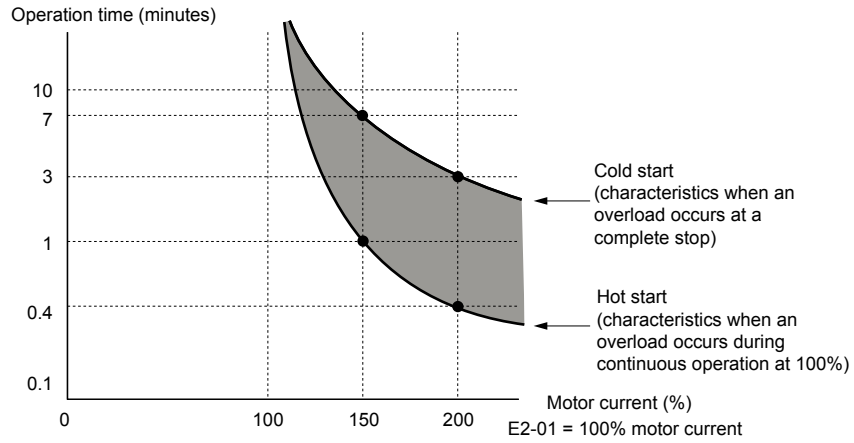

Figure D.8 Motor Overload Protection Time

◆ **Precautionary Notes on External Heatsink (IP00/Open-Type Enclosure)**

When using an external heatsink, UL compliance requires covering exposed capacitors in the main circuit to prevent injury to surrounding personnel.

The portion of the external heatsink that projects out can be protected with the enclosure or with the appropriate capacitor cover after completing drive installation. Use [Table D.7](#) to match drive models with available capacitor covers. Order capacitor covers from a Yaskawa representative or directly from the Yaskawa sales department.

Table D.7 Capacitor Cover

Model CIMR-Z□	Code Number	Model	Figure
2A0343	100-061-278	ECAT31698-11	<i>Figure D.9</i>
2A0396			
4A0361	100-061-278	ECAT31698-11	
4A0414	100-061-279	ECAT31740-11	
4A0480	100-061-280	ECAT31746-11	
4A0590			

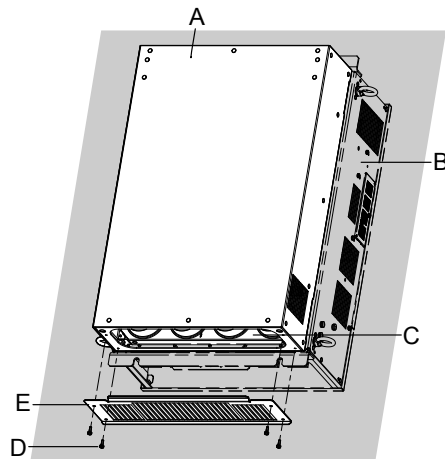

- A – Drive (outside panel)
- B – Drive (inside panel)
- C – Opening to capacitors
- D – Installation screws
- E – Capacitor cover

Figure D.9 Capacitor Cover

# Appendix: E

## Quick Reference Sheet

---

This section provides tables to keep record of the drive specifications, motor specifications, and drive settings. Fill in the table data after commissioning the application and have them ready when contacting Yaskawa for technical assistance.

<b>E.1</b>	<b>DRIVE AND MOTOR SPECIFICATIONS.....</b>	<b>374</b>
<b>E.2</b>	<b>BASIC PARAMETER SETTINGS.....</b>	<b>375</b>
<b>E.3</b>	<b>USER SETTING TABLE.....</b>	<b>377</b>

## E.1 Drive and Motor Specifications

### ◆ Drive Specifications

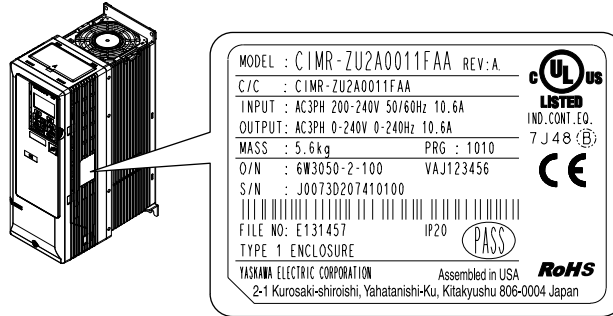

Items	Description
Model	CIMR-Z
Serial Number	
Software Version (PRG)	
Options used	
Date of Usage	

### ◆ Motor Specifications

#### ■ Induction Motor

Items	Description	Items	Description
Manufacturer		Motor Rated Current (T1-04)	A
Model		Motor Base Frequency (T1-05)	Hz
Motor Rated Power (T1-02)	HP	Number of Motor Poles (T1-06)	
Motor Rated Voltage (T1-03)	V	Motor Base Speed (T1-07)	r/min

Note: These values must be entered as part of the Auto-Tuning process.

#### ■ Permanent Magnet Motor

Items	Description	Items	Description
Manufacturer		Induction Voltage Constant	mVs/rad
Model		Induction Voltage Constant	mV/(r/min)
PM Motor Rated Power (T2-04)	HP	PM Motor Rated Current (T2-06)	A
PM Motor Rated Voltage (T2-05)	V	PM Motor Base Frequency (T2-07)	Hz
q-Axis Inductance	mH	Number of PM Motor Poles (T2-08)	
d-Axis Inductance	mH		

Note: These values must be entered as part of the Auto-Tuning process.

## E.2 Basic Parameter Settings

Use the following tables to keep records of important parameters. Have this data available when contacting Yaskawa technical support.

### ◆ Basic Setup

Item	Setting Value	Memo
Control Mode	A1-02 =	
Input Voltage Setting	E1-01=	

### ◆ Motor Setup

Motor Type	Item	Setting Value	Memo
Induction	Motor Rated Current	E2-01 =	
	Motor Rated Slip	E2-02 =	
	Motor No-Load Current	E2-03 =	
	No. of Motor Poles	E2-04 =	
	Line-to-Line Resistance	E2-05 =	
Permanent Magnet	Motor Rated Power	E5-02 =	
	Motor Rated Current	E5-03 =	
	No. of Motor Poles	E5-04 =	
	Motor Stator Resistance	E5-05 =	
	Motor d-Axis Inductance	E5-06 =	
	Motor q-Axis Inductance	E5-07 =	
	Induction Volt. Const. 1	E5-09 =	
Induction Volt. Const. 2	E5-24 =		

### ◆ Multi-Function Digital Inputs

Terminal	Input Used	Setting Value and Function Name	Memo
S1		H1-01 =	
S2		H1-02 =	
S3		H1-03 =	
S4		H1-04 =	
S5		H1-05 =	
S6		H1-06 =	
S7		H1-07 =	

### ◆ Analog Inputs

Terminal	Input Used	Setting Value and Function Name	Memo
A1		H3-02 =	
A2		H3-10 =	

### ◆ Multi-Function Digital Outputs

Terminal	Output Used	Setting Value and Function Name	Memo
M1-M2		H2-01 =	
M3-M4		H2-02 =	
M5-M6		H2-03 =	

### ◆ Monitor Outputs

Terminal	Output Used	Setting Value and Function Name	Memo
FM		H4-01 =	
AM		H4-04 =	

## E.3 User Setting Table

Use the Verify Menu to see which parameters have been changed from their original default settings

RUN below the parameter number indicates that the parameter setting can be changed during run.

Parameter names in **bold face type** are included in the Setup Group of parameters.

No.	Name	User Setting	No.	Name	User Setting
A1-00 <span style="border: 1px solid black; padding: 1px;">RUN</span>	Language Selection		b3-24	Speed Search Method Selection	
A1-01 <span style="border: 1px solid black; padding: 1px;">RUN</span>	Access Level Selection		b3-25	Speed Search Wait Time	
A1-02	<b>Control Method Selection</b>		b3-27	Start Speed Search Select	
A1-03	Initialize Parameters		b3-33	Speed Search Selection when Run Command is Given during Uv	
A1-04	Password		b4-01	Timer Function On-Delay Time	
A1-05	Password Setting		b4-02	Timer Function Off-Delay Time	
A1-06	Application Preset		b5-01	PI Function Setting	
A2-01 to A2-32	User Parameters, 1 to 32		b5-02 <span style="border: 1px solid black; padding: 1px;">RUN</span>	Proportional Gain Setting (P)	
A2-33	User Parameter Automatic Selection		b5-03 <span style="border: 1px solid black; padding: 1px;">RUN</span>	Integral Time Setting (I)	
b1-01	<b>Frequency Reference Selection 1</b>		b5-04 <span style="border: 1px solid black; padding: 1px;">RUN</span>	Integral Limit Setting	
b1-02	<b>Run Command Selection 1</b>		b5-06 <span style="border: 1px solid black; padding: 1px;">RUN</span>	PI Output Limit	
b1-03	<b>Stopping Method Selection</b>		b5-07 <span style="border: 1px solid black; padding: 1px;">RUN</span>	PI Offset Adjustment	
b1-04	Reverse Operation Selection		b5-08 <span style="border: 1px solid black; padding: 1px;">RUN</span>	PI Primary Delay Time Constant	
b1-08	Run Command Selection while in Programming Mode		b5-09	PI Output Level Selection	
b1-11	Drive Delay Time Setting		b5-10	PI Output Gain Setting	
b1-14	Phase Order Selection		b5-11	PI Output Reverse Selection	
b1-15	Frequency Reference Selection 2		b5-12	PI Feedback Loss Detection Selection	
b1-16	Run Command Selection 2		b5-13	PI Feedback Loss Detection Level	
b1-17	Run Command at Power Up		b5-14	PI Feedback Loss Detection Time	
b1-18	HAND Frequency Reference 1		b5-15	PI Sleep Function Start Level	
b1-19	HAND Frequency Reference 2		b5-16	PI Sleep Delay Time	
b2-01	DC Injection Braking Start Frequency		b5-17	PI Accel/Decel Time	
b2-02	DC Injection Braking Current		b5-18	PI Setpoint Selection	
b2-03	DC Injection Braking Time at Start		b5-19 <span style="border: 1px solid black; padding: 1px;">RUN</span>	PI Setpoint Value	
b2-04	DC Injection Braking Time at Stop		b5-20	PI Setpoint Scaling	
b2-09	Motor Pre-Heat Current 2		b5-21	PI Sleep Input Source	
b2-12	Short Circuit Brake Time at Start		b5-22	PI Snooze Level	
b2-13	Short Circuit Brake Time at Stop		b5-23	PI Snooze Delay Time	
b2-18	Short Circuit Braking Current		b5-24	PI Snooze Deactivation Level	
b3-01	Speed Search Selection at Start		b5-25	PI Setpoint Boost Setting	
b3-02	Speed Search Deactivation Current		b5-26	PI Maximum Boost Time	
b3-03	Speed Search Deceleration Time		b5-27	PI Snooze Feedback Level	
b3-04	V/f Gain during Speed Search		b5-28	PI Feedback Function Selection	
b3-05	Speed Search Delay Time		b5-29	PI Square Root Gain	
b3-06	Output Current 1 during Speed Search		b5-30	PI Feedback Offset	
b3-10	Speed Search Detection Compensation Gain				
b3-14	Bi-Directional Speed Search Selection				
b3-17	Speed Search Restart Current Level				
b3-18	Speed Search Restart Detection Time				
b3-19	Number of Speed Search Restarts				

### E.3 User Setting Table

No.	Name	User Setting	No.	Name	User Setting
b5-34 <input type="checkbox"/> RUN	PI Output Lower Limit		d1-02 <input type="checkbox"/> RUN	Frequency Reference 2	
b5-35 <input type="checkbox"/> RUN	PI Input Limit		d1-03 <input type="checkbox"/> RUN	Frequency Reference 3	
b5-36	PI Feedback High Detection Level		d1-04 <input type="checkbox"/> RUN	Frequency Reference 4	
b5-37	PI Feedback High Detection Time		d1-16 <input type="checkbox"/> RUN	Frequency Reference 16	
b5-38	PI Setpoint User Display		d1-17 <input type="checkbox"/> RUN	Jog Frequency Reference	
b5-39	PI Setpoint Display Digits		d2-01	<b>Frequency Reference Upper Limit</b>	
b5-40	Frequency Reference Monitor Content during PI		d2-02	<b>Frequency Reference Lower Limit</b>	
b5-41	PI Unit Selection		d2-03	Master Speed Reference Lower Limit	
b5-42 <input type="checkbox"/> RUN	PI Output Monitor Calculation Method		d3-01	Jump Frequency 1	
b5-43 <input type="checkbox"/> RUN	Custom PI Output Monitor 1		d3-02	Jump Frequency 2	
b5-44 <input type="checkbox"/> RUN	Custom PI Output Monitor 2		d3-03	Jump Frequency 3	
b5-45 <input type="checkbox"/> RUN	Custom PI Output Monitor 3		d3-04	Jump Frequency Width	
b5-46	PI Setpoint Monitor Unit Selection		d4-01	Frequency Reference Hold Function Selection	
b5-47	Reverse Operation Selection 2 by PI Output		d4-10	Up/Down Frequency Reference Limit Selection	
b5-48	PI 4-20 mA Feedback Loss Detection Level		d6-01	Field Weakening Level	
b5-49	PI 4-20 mA Feedback Loss Detection Time		d6-02	Field Weakening Frequency Limit	
b8-01	Energy Saving Control Selection		d7-01 <input type="checkbox"/> RUN	Offset Frequency 1	
b8-04	Energy Saving Coefficient Value		d7-02 <input type="checkbox"/> RUN	Offset Frequency 2	
b8-05	Power Detection Filter Time		d7-03 <input type="checkbox"/> RUN	Offset Frequency 3	
b8-06	Search Operation Voltage Limit		E1-01	<b>Input Voltage Setting</b>	
C1-01 <input type="checkbox"/> RUN	<b>Acceleration Time 1</b>		E1-03	V/f Pattern Selection	
C1-02 <input type="checkbox"/> RUN	<b>Deceleration Time 1</b>		E1-04	<b>Maximum Output Frequency</b>	
C1-03 <input type="checkbox"/> RUN	Acceleration Time 2		E1-05	<b>Maximum Voltage</b>	
C1-04 <input type="checkbox"/> RUN	Deceleration Time 2		E1-06	<b>Base Frequency</b>	
C1-09	Fast-Stop Time		E1-07	Middle Output Frequency	
C1-11	Accel/Decel Time Switching Frequency		E1-08	Middle Output Frequency Voltage	
C2-01	S-Curve Characteristic at Accel Start		E1-09	Minimum Output Frequency	
C2-02	S-Curve Characteristic at Accel End		E1-10	Minimum Output Frequency Voltage	
C4-01 <input type="checkbox"/> RUN	Torque Compensation Gain		E1-11	Middle Output Frequency 2	
C4-02 <input type="checkbox"/> RUN	Torque Compensation Primary Delay Time		E1-12	Middle Output Frequency Voltage 2	
C6-02	<b>Carrier Frequency Selection</b>		E1-13	Base Voltage	
C6-03	Carrier Frequency Upper Limit		E2-01	<b>Motor Rated Current</b>	
C6-04	Carrier Frequency Lower Limit		E2-02	Motor Rated Slip	
C6-05	Carrier Frequency Proportional Gain		E2-03	Motor No-Load Current	
d1-01 <input type="checkbox"/> RUN	Frequency Reference 1		E2-04	Number of Motor Poles	
			E2-05	Motor Line-to-Line Resistance	
			E2-10	Motor Iron Loss for Torque Compensation	
			E2-11	<b>Motor Rated Power</b>	
			E5-02	Motor Rated Power	
			E5-03	Motor Rated Current	
			E5-04	Number of Motor Poles	

No.	Name	User Setting	No.	Name	User Setting
E5-05	Motor Stator Resistance		H4-07	Multi-Function Analog Output Terminal FM Signal Level Selection	
E5-06	Motor d-Axis Inductance		H4-08	Multi-Function Analog Output Terminal AM Signal Level Selection	
E5-07	Motor q-Axis Inductance		H5-01	Drive Slave Address	
E5-09	Motor Induction Voltage Constant 1		H5-02	Communication Speed Selection	
E5-24	Motor Induction Voltage Constant 2		H5-03	Communication Parity Selection	
H1-01	Multi-Function Digital Input Terminal S1 Function Selection		H5-04	Stopping Method After Communication Error (CE)	
H1-02	Multi-Function Digital Input Terminal S2 Function Selection		H5-05	Communication Fault Detection Selection	
H1-03	Multi-Function Digital Input Terminal S3 Function Selection		H5-06	Drive Transmit Wait Time	
H1-04	Multi-Function Digital Input Terminal S4 Function Selection		H5-07	RTS Control Selection	
H1-05	Multi-Function Digital Input Terminal S5 Function Selection		H5-08	Communication Protocol Selection	
H1-06	Multi-Function Digital Input Terminal S6 Function Selection		H5-09	CE Detection Time	
H1-07	Multi-Function Digital Input Terminal S7 Function Selection		H5-10	Unit Selection for MEMOBUS/Modbus Register 0025H	
H2-01	Multi-Function Contact Output (terminal M1-M2)		H5-11	Communications ENTER Function Selection	
H2-02	Multi-Function Contact Output 2 (terminal M3-M4)		H5-12	Run Command Method Selection	
H2-03	Multi-Function Contact Output 3 (terminal M5-M6)		H5-14	BACnet Device Object ID	
H3-01	Terminal A1 Signal Level Selection		H5-15	BACnet Device Object ID	
H3-02	Terminal A1 Function Selection		L1-01	Motor Overload Protection Selection	
H3-03	<b>Terminal A1 Gain Setting</b>		L1-02	Motor Overload Protection Time	
H3-04	<b>Terminal A1 Bias Setting</b>		L1-03	Motor Overheat Alarm Operation Selection (PTC input)	
H3-09	Terminal A2 Signal Level Selection		L1-04	Motor Overheat Fault Operation Selection (PTC input)	
H3-10	Terminal A2 Function Selection		L1-05	Motor Temperature Input Filter Time (PTC input)	
H3-11	<b>Terminal A2 Gain Setting</b>		L1-08	oL1 Current Level	
H3-12	<b>Terminal A2 Bias Setting</b>		L1-13	Continuous Electrothermal Operation Selection	
H3-13	Analog Input Filter Time Constant		L2-01	<b>Momentary Power Loss Operation Selection</b>	
H3-14	Analog Input Terminal Enable Selection		L2-02	<b>Momentary Power Loss Ride-Thru Time</b>	
H3-16	Terminal A1 Offset		L2-03	Momentary Power Loss Minimum Baseblock Time	
H3-17	Terminal A2 Offset		L2-04	Momentary Power Loss Voltage Recovery Ramp Time	
H4-01	Multi-Function Analog Output Terminal FM Monitor Selection		L2-05	Undervoltage Detection Level (Uv1)	
H4-02	Multi-Function Analog Output Terminal FM Gain		L2-06	KEB Deceleration Time	
H4-03	Multi-Function Analog Output Terminal FM Bias		L2-07	KEB Acceleration Time	
H4-04	Multi-Function Analog Output Terminal AM Monitor Selection		L2-08	Frequency Gain at KEB Start	
H4-05	Multi-Function Analog Output Terminal AM Gain		L2-10	KEB Detection Time (Minimum KEB Time)	
H4-06	Multi-Function Analog Output Terminal AM Bias		L2-11	DC Bus Voltage Setpoint during KEB	
			L2-29	KEB Method Selection	
			L3-01	Stall Prevention Selection during Acceleration	
			L3-02	Stall Prevention Level during Acceleration	
			L3-03	Stall Prevention Limit during Acceleration	
			L3-04	Stall Prevention Selection during Deceleration	
			L3-05	Stall Prevention Selection during Run	
			L3-06	Stall Prevention Level during Run	
			L3-11	Overvoltage Suppression Function Selection	
			L3-17	Target DC Bus Voltage for Overvoltage Suppression and Stall Prevention	
			L3-20	DC Bus Voltage Adjustment Gain	
			L3-21	Accel/Decel Rate Calculation Gain	

## E.3 User Setting Table

No.	Name	User Setting	No.	Name	User Setting
L3-22	Deceleration Time at Stall Prevention during Acceleration		n1-05	Hunting Prevention Gain while in Reverse	
L3-23	Automatic Reduction Selection for Stall Prevention during Run		n3-01	High-Slip Braking Deceleration Frequency Width	
L3-24	Motor Acceleration Time for Inertia Calculations		n3-02	High-Slip Braking Current Limit	
L3-25	Load Inertia Ratio		n3-03	High-Slip Braking Dwell Time at Stop	
L3-26	Additional DC Bus Capacitors		n3-04	High-Slip Braking Overload Time	
L3-27	Stall Prevention Detection Time		n3-13	Overexcitation Deceleration Gain	
L4-01	Speed Agreement Detection Level		n3-21	High-Slip Suppression Current Level	
L4-02	Speed Agreement Detection Width		n3-23	Overexcitation Operation Selection	
L4-03	Speed Agreement Detection Level (+/-)		n8-45	Speed Feedback Detection Control Gain	
L4-04	Speed Agreement Detection Width (+/-)		n8-47	Pull-In Current Compensation Time Constant	
L4-05	<b>Frequency Reference Loss Detection Selection</b>		n8-48	Pull-In Current	
L4-06	<b>Frequency Reference at Reference Loss</b>		n8-49	d-Axis Current for High Efficiency Control	
L4-07	Speed Agreement Detection Selection		n8-51	Acceleration/Deceleration Pull-In Current	
L5-01	<b>Number of Auto Restart Attempts</b>		n8-54	Voltage Error Compensation Time Constant	
L5-02	Auto Restart Fault Output Operation Selection		n8-55	Load Inertia	
L5-03	<b>Time to Continue Making Fault Restarts</b>		n8-62	Output Voltage Limit	
L5-04	Fault Reset Interval Time		n8-65	Speed Feedback Detection Control Gain during ov Suppression	
L5-05	Fault Reset Operation Selection		o1-01	Drive Mode Unit Monitor Selection	
L6-01	<b>Torque Detection Selection 1</b>		<input type="checkbox"/> RUN		
L6-02	<b>Torque Detection Level 1</b>		o1-02	User Monitor Selection After Power Up	
L6-03	<b>Torque Detection Time 1</b>		<input type="checkbox"/> RUN		
L6-13	Motor Underload Protection Selection		o1-03	Digital Operator Display Selection	
L6-14	Motor Underload Protection Level at Minimum Frequency		o1-06	User Monitor Selection Mode	
L8-02	Overheat Alarm Level		o1-07	Second Line Monitor Selection	
L8-03	Overheat Pre-Alarm Operation Selection		o1-08	Third Line Monitor Selection	
L8-05	Input Phase Loss Protection Selection		o1-09	Frequency Reference Display Units	
L8-06	Input Phase Loss Detection Level		o1-10	User-Set Display Units Maximum Value	
L8-07	Output Phase Loss Protection		o1-11	User-Set Display Units Decimal Display	
L8-09	Output Ground Fault Detection Selection		o1-13	Frequency Reference and Frequency Related Monitor Custom Units 1	
L8-10	Heatsink Cooling Fan Operation Selection		o1-14	Frequency Reference and Frequency Related Monitor Custom Units 2	
L8-11	Heatsink Cooling Fan Off Delay Time		o1-15	Frequency Reference and Frequency Related Monitor Custom Units 3	
L8-12	Ambient Temperature Setting		o1-16	F1 Key Function Selection	
L8-15	oL2 Characteristics Selection at Low Speeds		o1-17	F2 Key Function Selection	
L8-18	Software Current Limit Selection		o1-18	User-Defined Parameter Upper	
L8-19	Frequency Reduction Rate during Overheat Pre-Alarm		o1-19	User-Defined Parameter Lower	
L8-27	Overcurrent Detection Gain		o2-02	STOP Key Function Selection	
L8-29	Current Unbalance Detection (LF2)		o2-03	<b>User Parameter Default Value</b>	
L8-32	Main Contactor and Cooling Fan Power Supply Failure Selection		o2-04	Drive Model Selection	
L8-35	Installation Method Selection		o2-05	<b>Frequency Reference Setting Method Selection</b>	
L8-38	Carrier Frequency Reduction Selection		o2-06	Operation Selection when Digital Operator is Disconnected	
L8-40	Carrier Frequency Reduction Off-Delay Time		o2-07	Motor Direction at Power Up when Using Operator	
L8-41	High Current Alarm Selection		o2-15	HAND Key Function Selection	
L8-97	Carrier Frequency Reduction Selection during oH Pre-Alarm		o2-19	Selection of Parameter Write during Uv	
n1-01	Hunting Prevention Selection		o3-01	Copy Function Selection	
n1-02	Hunting Prevention Gain Setting		o3-02	Copy Allowed Selection	
n1-03	Hunting Prevention Time Constant		o4-01	Cumulative Operation Time Setting	

No.	Name	User Setting	No.	Name	User Setting
o4-02	Cumulative Operation Time Selection		S3-08	Secondary PI Integral Limit Setting	
o4-03	Cooling Fan Maintenance Operation Time Setting		<input type="checkbox"/> RUN		
o4-05	Capacitor Maintenance Setting		S3-09	Secondary PI Output Upper Limit	
o4-07	DC Bus Pre-charge Relay Maintenance Setting		<input type="checkbox"/> RUN		
o4-09	IGBT Maintenance Setting		S3-10	Secondary PI Output Lower Limit	
o4-11	U2, U3 Initialize Selection		<input type="checkbox"/> RUN		
o4-12	kWh Monitor Initialization		S3-11	Secondary PI Output Level Selection	
o4-13	Number of Run Commands Counter Initialization		<input type="checkbox"/> RUN		
o4-17	Real Time Clock Setting		S3-12	Secondary PI Disable Mode	
S1-01	Stillness Control Selection		<input type="checkbox"/> RUN		
S1-02	Voltage Reduction Rate		S3-13	Secondary PI Low Feedback Detection Level	
S1-03	Voltage Restoration Level		<input type="checkbox"/> RUN		
S1-04	Voltage Restoration Complete Level		S3-14	Secondary PI Low Feedback Detection Time	
S1-05	Voltage Restoration Sensitivity Time Constant		<input type="checkbox"/> RUN		
S1-06	Voltage Restoration Time Constant at Impact		S3-15	Secondary PI High Feedback Level	
S2-01	Sequence Timer 1 Start Time		<input type="checkbox"/> RUN		
S2-02	Sequence Timer 1 Stop Time		S3-16	Secondary PI High Feedback Detection Time	
S2-03	Sequence Timer 1 Day Selection		<input type="checkbox"/> RUN		
S2-04	Sequence Timer 1 Selection		S3-17	Secondary PI Feedback Detection Selection	
S2-05	Sequence Timer 1 Reference Source		<input type="checkbox"/> RUN		
S2-06	Sequence Timer 2 Start Time		S4-01	BP Auto Transfer on Fault Enable	
S2-07	Sequence Timer 2 Stop Time		<input type="checkbox"/> RUN		
S2-08	Sequence Timer 2 Day Selection		S4-02	BP Energy Save Bypass Trigger Level	
S2-09	Sequence Timer 2 Selection		<input type="checkbox"/> RUN		
S2-10	Sequence Timer 2 Reference Source		S4-03	BP Energy Save Bypass Timer	
S2-11	Sequence Timer 3 Start Time		<input type="checkbox"/> RUN		
S2-12	Sequence Timer 3 Stop Time		S4-04	BP Energy Save Bypass Speed Increase	
S2-13	Sequence Timer 3 Day Selection		<input type="checkbox"/> RUN		
S2-14	Sequence Timer 3 Selection		S5-01	HAND Frequency Reference Selection	
S2-15	Sequence Timer 3 Reference Source		S5-02	HAND/AUTO During Run Selection	
S2-16	Sequence Timer 4 Start Time		S5-03	HAND Mode PI Selection	
S2-17	Sequence Timer 4 Stop Time		<input type="checkbox"/> RUN		
S2-18	Sequence Timer 4 Day Selection		S5-04	HAND Mode Behavior Selection	
S2-19	Sequence Timer 4 Selection		S5-05	HAND Frequency Reference 1	
S2-20	Sequence Timer 4 Reference Source		<input type="checkbox"/> RUN		
S3-01	Secondary PI Enable Selection		S5-07	HAND Key Function Selection (HOA Keypad)	
<input type="checkbox"/> RUN			S6-01	Emergency Override Speed	
S3-02	Secondary PI User Display		S6-02	Emergency Override Reference Selection	
<input type="checkbox"/> RUN			S6-03	ov2 Detect Time	
S3-03	Secondary PI Display Digits		S6-04	Main Contactor and Cooling Fan Power Supply Failure	
<input type="checkbox"/> RUN			S7-01	oH1 Detection Selection for Cooling Fan Failure	
S3-04	Secondary PI Unit Selection		S7-02	Carrier Frequency Reduction Rate during oH Pre-Alarm	
<input type="checkbox"/> RUN			T1-01	Auto-Tuning Mode Selection	
S3-05	Secondary PI Setpoint Value		T1-02	Motor Rated Power	
<input type="checkbox"/> RUN			T1-03	Motor Rated Voltage	
S3-06	Secondary PI Proportional Gain Setting		T1-04	Motor Rated Current	
<input type="checkbox"/> RUN					
S3-07	Secondary PI Integral Time Setting				
<input type="checkbox"/> RUN					

### E.3 User Setting Table

No.	Name	User Setting	No.	Name	User Setting
T1-05	Motor Base Frequency		T2-06	PM Motor Rated Current	
T1-06	Number of Motor Poles		T2-07	PM Motor Base Frequency	
T1-07	Motor Base Speed		T2-08	Number of PM Motor Poles	
T1-11	Motor Iron Loss		T2-10	PM Motor Stator Resistance	
T2-01	PM Motor Auto-Tuning Mode Selection		T2-11	PM Motor d-Axis Inductance	
T2-02	PM Motor Code Selection		T2-12	PM Motor q-Axis Inductance	
T2-03	PM Motor Type		T2-13	Induced Voltage Constant Unit Selection	
T2-04	PM Motor Rated Power		T2-14	PM Motor Induced Voltage Constant	
T2-05	PM Motor Rated Voltage		T2-15	Pull-In Current Level for PM Motor Tuning	

# Index

+	Auto Restart Fault Output Operation Selection.....	179
+V.....	Auto Restart Operation Selection.....	312
	Auto-Tuning.....	142, 143, 146
<b>Numerics</b>	Auto-Tuning Codes.....	229
24 V Power Supply.....	Auto-Tuning Errors.....	204
2-Wire Initialization.....	Auto-Tuning Fault Codes.....	144
3-Wire Initialization.....	Auto-Tuning Fault Detection.....	229
5th Most Recent Fault.....	Auto-Tuning Fault Solutions.....	229
<b>A</b>	Auto-Tuning for Induction Motors.....	142
A/D Conversion Error.....	Auto-Tuning for Permanent Magnet Motors.....	143
A1.....	Auto-Tuning Input Data.....	142, 143
A1-01.....	Auto-Tuning Interruption Codes.....	144
A1-03.....	Auto-Tuning Mode Selection.....	146, 191, 327
A1-04.....	<b>B</b>	
A1-05.....	b2-02.....	240
A2.....	b2-04.....	240
A2-01.....	Backing Up Parameter Values.....	152
A2-32.....	BACnet Configuration.....	338
A2-33.....	BACnet Objects Supported.....	348
AC.....	BACnet Serial Communication.....	342
Accel/Decel Time.....	BACnet Setup Parameters.....	342
Acceleration Error.....	BACnet Specifications.....	339
Acceleration Time.....	Baseblock.....	218
Acceleration Time Pull-In Current.....	Base Frequency.....	134
Access Level Selection.....	Base Voltage.....	134
Adjusted Slip Calculation Error.....	Basic Auto-Tuning Preparations.....	143
Alarms and Errors.....	Basic Start-up and Motor Tuning.....	120
Allowable Frequency Fluctuation.....	bAT.....	205
Allowable Voltage Fluctuation.....	bb.....	218
ALM LED Light.....	Bi-Directional Speed Search Selection.....	160
Altitude.....	Binary Input Objects.....	350
AM.....	Binary Output Objects.....	351
Ambient Temperature.....	Binary Value Objects.....	351
Ambient Temperature and Installation Method Derating.....	BP Auto Transfer on Fault Enable.....	325
Ambient Temperature Setting.....	BP Energy Save Bypass Speed Increase.....	325
Analog Filter Time Constant.....	BP Energy Save Bypass Timer.....	325
Analog Input Objects.....	BP Program Error.....	228
Analog Output Objects.....	Braking Torque.....	272
Analog Value Objects.....	bUS.....	205, 218
Application Presets.....	<b>C</b>	
Application Selection.....	C2-01 and C2-02.....	200
Attachment for External Heatsink.....	C4-01.....	198
AUTO Key.....	C4-02.....	198
AUTO LED and HAND LED Indications.....	C6-02.....	104, 198, 239, 240
AUTO Light.....	C6-05.....	240
Automatic Reduction Selection for Stall Prevention during Run.....	Cable Length Between Drive and Motor.....	87

CALL.....	218	Control Mode Selection.....	26
Cannot Change Parameter Settings.....	235	Control Power Supply Voltage Fault.....	216
Cannot Reset.....	219	Cooling Fan.....	30, 32, 33, 34, 35, 36
Capacitor Maintenance.....	333	Cooling Fan Maintenance.....	333
Capacitor Maintenance Setting.....	190, 320	Cooling Fan Maintenance Setting (Operation Time).....	320
Capacitor Maintenance Time.....	221	Cooling Fan Maintenance Time.....	221
Carrier Frequency.....	266, 267, 268, 269, 270, 271	Cooling Fan Operation Time.....	333
Carrier Frequency Derating.....	276	Cooling Fan Operation Time Setting.....	189
Carrier Frequency Lower Limit.....	169	Cooling Tower Fan Application.....	125
Carrier Frequency Proportional Gain.....	169	Cooling Tower Fan with PI Control Application.....	126
Carrier Frequency Reduction.....	314	CoPy.....	231
Carrier Frequency Reduction Off-Delay Time.....	185	Copy Allowed Selection.....	189
Carrier Frequency Reduction Off Delay Time.....	314	Copy Function.....	153
Carrier Frequency Reduction Selection.....	184	Copy Function Errors.....	201
Carrier Frequency Reduction Selection during oH Pre-Alarm.....	314	Copy Function Selection.....	189
Carrier Frequency Selection.....	87, 198	Copy Unit Error.....	231
Carrier Frequency Setting Error.....	227	CopyUnitManager.....	153
Carrier Frequency Upper Limit.....	169	CPEr.....	231
CE.....	205, 218	CPF00 or CPF01.....	206
CE Detection Time.....	178, 344	CPF02.....	206
CE Low Voltage Directive Compliance.....	362	CPF03.....	206
CE mark.....	362	CPF06.....	206
Changing Parameter Settings or Values.....	115	CPF07.....	206
Circulation Fan.....	36	CPF08.....	206
Clock Adjustment Mode.....	112	CPF20.....	206
Closed-Loop Crimp Terminal Size.....	83	CPF21.....	206
Coast to stop.....	129	CPF22.....	207
Coast with Timer.....	131	CPF23.....	207
CoF.....	205	CPF24.....	207
Comm. option card connection error (CN5).....	211	CPyE.....	231
Command Messages from Master to Drive.....	347	CrST.....	219
Communication Error.....	231	CSEr.....	231
Communication Errors.....	354	Cumulative Operation Time.....	333
Communication Fault Detection Selection.....	177, 343	Cumulative Operation Time at 5th Most Recent Fault.....	332
Communication Option Card Reference.....	334	Cumulative Operation Time at Most Recent Fault.....	331
Communication Parity Selection.....	177, 342	Cumulative Operation Time at Previous Fault.....	331
Communications Enter Function Selection.....	178, 344	Cumulative Operation Time Selection.....	189, 320
Communication Speed Selection.....	176, 342	Cumulative Operation Time Setting.....	189, 320
Communications Protocol Selection.....	178, 344	Current Alarm.....	220
Communications Timing.....	347	Current Detection Error.....	230
Comparing Parameter Settings.....	232	Current Fault.....	330
Component Names.....	30	Current Offset Fault.....	205
Conduit bracket.....	30, 31	Current Unbalance Detection (LF2).....	183, 314
Conduit Bracket Dimensions for IP20/NEMA Type 1.....	55	Customer Safety.....	223
Connected Machinery Vibrates When Motor Rotates.....	240	Custom PI Output Monitor Setting 1/2.....	167
Connecting an AC Reactor.....	253	Custom PI Output Monitor Setting 3.....	168
Connecting a Surge Absorber.....	253		
Connecting Peripheral Devices.....	247	<b>D</b>	
Connecting to a BACnet Network.....	340	d2-01.....	241
Connecting to a PC (USB).....	102	d3-01.....	240
Continuous Electrothermal Operation Selection.....	309	d3-01 through d3-04.....	200
Control Board Connection Error.....	206, 207	d3-04.....	240
Control Circuit Error.....	206	DC Bus Overvoltage.....	222
Control Circuit Input Terminals.....	91	DC Bus Pre-Charge Relay Maintenance Setting.....	190
Control Circuit Output Terminals.....	92	DC Bus Undervoltage.....	216
Control Circuit Terminal Block Functions.....	91	DC Bus Voltage.....	329
Control Method Selection.....	127	DC Bus Voltage Adjustment Gain.....	311
Control Mode.....	127, 329	DC Bus Voltage at Previous Fault.....	331
Control Mode Mismatch.....	231	DC Injection Braking at Stop.....	240
Control Modes and their Features.....	26	DC Injection Braking Current.....	158, 240

DC Injection Braking Start Frequency.....	129	EMC Filters.....	363
DC Injection Braking Time at Start.....	158	EMC filter switch SW1.....	37
DC Injection Braking Time at Stop.....	158	EMC filter switch SW2.....	37
DC Injection Braking to Stop.....	130	EMC Guidelines.....	362
Deceleration Rate Calculation Gain.....	311	EMC Guidelines Compliance.....	363
Deceleration Time.....	132	Emergency Override Reference Selection.....	326
Deceleration Time at Stall Prevention during Acceleration.....	311	Emergency Override Speed.....	326
Desired DC Bus Voltage during KEB.....	310	Enclosure Types.....	29
Device Object.....	352	End.....	231
dFPS.....	231	End3.....	229
Diagnosing and Resetting Faults.....	233	End4.....	229
Dimensions for IP00/Open-Type Enclosure: 200 V Class.....	58	End5.....	229
Dimensions for IP00/Open-Type Enclosure: 400 V Class.....	58	End7.....	229
Dimensions for IP20/NEMA Type 1 Enclosure: 200 V Class.....	52	Energy Saving Constants Error.....	227
Dimensions for IP20/NEMA Type 1 Enclosure: 400 V Class.....	52	Enter Command.....	178
DIP Switch S2.....	37	Enter command necessary.....	178, 344
dnE.....	219	Enter command not necessary.....	179, 344
Down Arrow Key.....	107	Enter Command Types.....	353
Drive/kVA Selection.....	319	Enter Data from the Motor Nameplate.....	145
Drive Capacity Setting Fault.....	225	ENTER Key.....	107
Drive Cover.....	32, 33, 34, 35, 36	Er-01.....	229
Drive Derating Data.....	276	Er-02.....	229
Drive Disabled.....	219	Er-03.....	230
Drive Mode.....	112, 115	Er-04.....	230
Drive Model Mismatch.....	231	Er-05.....	230
Drive Models and Types.....	49	Er-08.....	230
Drive Model Selection.....	188	Er-09.....	230
Drive Mode Unit Monitor Selection.....	185, 318	Er-12.....	230
Drive Nameplate.....	27	Err.....	208
Drive Operations by BACnet.....	346	Error Reading Data.....	232
Drive Operation Status at Previous Fault.....	331	Errors and Displays When Using the Copy Function.....	204
Drive Overheat Warning.....	222	Error Writing Data.....	231
Drive Overload.....	213	European Standards.....	362
Drive Ready.....	103	Excessive Motor Oscillation and Erratic Rotation.....	239
Drive Slave Address.....	176, 342	Excessive PI Feedback.....	208, 220
Drive Specifications.....	272	Exterior and Mounting Dimensions.....	49
Drive Status.....	330	External Fault.....	207, 220
Drive Transmit Wait Time.....	177, 343	External Interlock.....	103
Drive Unit Signal Fault.....	207	<b>F</b>	
Drive Watt Loss Data.....	274	F1/F2 Key Function Selection.....	187
Dynamic Audible Noise Control Function Selection.....	321	F1 Key Function Selection.....	319
<b>E</b>		F2 Key Function Selection.....	319
E1-04.....	241	FAn.....	208
E1-08.....	198	Fan Application.....	124
E1-10.....	198	Fan Bracket.....	32, 33, 34, 35
E2-03.....	229	Fan Cover.....	30
EEPROM Memory Data Error.....	206	Fan Finger Guard.....	30
EEPROM Write Error.....	208	Fan Guard.....	32, 33, 34, 35, 36
EF.....	219	Fan with PI Control Application.....	125
EF0.....	207, 219	Fault Causes and Solutions.....	205
EF1.....	207, 220	Fault Detection.....	205
EF2.....	207, 220	Fault Displays.....	205
EF3.....	207, 220	Fault History.....	192
EF4.....	207, 220	Fault Relay Output.....	92
EF5.....	207, 220	Fault Reset Interval Time.....	179, 312
EF6.....	207, 220	Fault Reset Methods.....	201
EF7.....	207, 220	Fault Reset Operation Selection.....	179, 313
EMC Filter and Drive Installation for CE Compliance.....	365, 366	Faults.....	201, 202
EMC Filter Installation.....	363	Fault Trace.....	192, 233

FbH .....	208, 220	HAND Key Function Selection (HOA Keypad) .....	325
FbL .....	208, 220	HAND Light .....	107
FE .....	91	HAND Mode Behavior Selection .....	325
Ferrule Dimensions .....	94	HAND Mode PI Selection .....	325
Ferrule Terminal Types and Sizes .....	94	HCA .....	220
Ferrule-Type Wire Terminals .....	94	Heatsink .....	30, 31, 32, 33, 34, 35, 36
Fine-Tuning Open Loop Vector Control for PM Motors .....	199	Heatsink Cooling Fan Off-Delay Time .....	182
Fine-Tuning V/f Control .....	198	Heatsink Cooling Fan Operation Delay Time .....	314
FM .....	92	Heatsink Cooling Fan Operation Selection .....	182, 314
Fn1 .....	208	Heatsink Overheat .....	211, 221
Forward/Reverse Run Command Input Error .....	219	Heatsink Temperature .....	333
Frequency Accuracy (Temperature Fluctuation) .....	272	High Current Alarm Selection .....	185, 314
Frequency Control Range .....	272	High-Slip Braking Current Limit .....	316
Frequency Reduction Rate during Overheat Pre-Alarm .....	183, 314	High-Slip Braking Deceleration Frequency Width .....	316
Frequency Reference .....	329	High-Slip Braking Dwell Time at Stop .....	316
Frequency Reference and Frequency Related Monitor Custom Units 1 .....	318	High-slip Braking oL .....	213
Frequency Reference and Frequency Related Monitor Custom Units 1 to 3 .....	187	High-Slip Braking Overload Time .....	316
Frequency Reference and Frequency Related Monitor Custom Units 2 .....	318	High-Slip Suppression Current Level .....	316
Frequency Reference and Frequency Related Monitor Custom Units 3 .....	319	HOA Keypad .....	34, 35, 30
Frequency Reference at Previous Fault .....	331	HOA keypad .....	30, 31, 32, 33, 36
Frequency Reference at Reference Loss .....	138, 312	HOA Keypad Battery Voltage Low .....	205
Frequency Reference Display Units .....	318	HOA Keypad Connection Fault .....	213
Frequency Reference from MEMOBUS/Modbus Comm. ....	334	HOA Keypad Dimensions .....	47
Frequency Reference Inputs .....	91	HOA Keypad Display Selection .....	186, 318
Frequency Reference Loss Detection Selection .....	138, 312	HOA Keypad Installation Methods and Required Tools .....	47
Frequency Reference Lower Limit .....	133	HOA Keypad Menu and Screen Structure .....	111
Frequency Reference Monitor Content During PI .....	166	HOA Keypad Remote Installation .....	47
Frequency Reference Selection 1 .....	236	HOA Keypad Remote Usage .....	46
Frequency Reference Selection for AUTO Mode .....	127	Humidity .....	42
Frequency Reference Selection for AUTO mode .....	282	Hunting Prevention Gain .....	198
Frequency Reference Setting / Decimal Display .....	318	Hunting Prevention Gain Setting .....	316
Frequency Reference Setting and User-Set Display .....	318	Hunting Prevention Gain while in Reverse .....	316
Frequency Reference Setting Method Selection .....	141, 319	Hunting Prevention Selection .....	316
Frequency Reference Source Selection .....	334	Hunting Prevention Time Constant .....	316
Frequency Reference Upper Limit .....	133	Hybrid IC Failure .....	207
Frequency Setting Resolution .....	272		
Frequency Setting Signal .....	272	<b>I</b>	
Front Cover .....	30, 31, 32, 33, 34, 35, 36	I/O Connections .....	92
Front Cover Screw .....	34, 35	IEC/EN 61800-3 Filters .....	367
Fuse Selection .....	81, 362, 369	iFEr .....	231
		IG .....	92
<b>G</b>		IGBT Maintenance Time (50%) .....	221
General Safety Information .....	14	IGBT Maintenance Time (90%) .....	223
GF .....	209	Induced Voltage Constant Unit Selection .....	149
Ground Fault .....	209	Initialize Parameters .....	152, 141
Ground Terminal .....	37	Initial Operation .....	119
Ground Wiring .....	87	Input Current .....	266, 267, 268, 269, 270, 271
Ground Wiring for Multiple Drives .....	87	Input Fuses .....	81, 362, 369
		Input Phase Detection Level .....	314
<b>H</b>		Input Phase Loss .....	214
H1 Multi-Function Digital Input Selections .....	300	Input Phase Loss Detection Level .....	181
H3-01 .....	101	Input Phase Loss Protection Selection .....	181, 313
H3-09 .....	101	Input Terminal Status .....	329
H3-13 .....	200, 240	Input Terminal Status at Previous Fault .....	331
H3 Multi-Function Analog Input Settings .....	306	Input Voltage Setting .....	134
HAND/AUTO During Run Selection .....	325	Inrush Prevention Circuit Fault .....	216
HAND Frequency Reference 1 .....	325	Inrush Prevention Relay Maintenance Setting .....	320
HAND Frequency Reference Selection .....	325	Installation Area .....	42
HAND Key .....	107	Installation Environment .....	42
		Installation Method Selection .....	184, 314

Installation Orientation ..... 43

Installation Orientation and Spacing ..... 43

Installation Spacing ..... 43

Installing a GFCI ..... 252

Installing a Magnetic Contactor ..... 18

Installing a Molded Case Circuit Breaker (MCCB) ..... 18

Installing a Motor Thermal Overload (oL) Relay on the Drive Output ..... 263

Installing Peripheral Devices ..... 252

Integral Limit Setting ..... 161

Integral Time Setting (I) ..... 161

Interlock Circuit Example ..... 103

Interlock Open ..... 221

inTLK ..... 221

IP00/Open-Type Enclosure ..... 29

IP20/NEMA Type 1 Enclosure ..... 29

**J**

Jog Frequency Reference ..... 169

Jumper S1 Settings ..... 100

Jumper switch S1 ..... 37

Jumper switch S5 ..... 37

Jump Frequency ..... 200

Jump Frequency Width ..... 171

**K**

KEB Acceleration Time ..... 310

KEB Deceleration Time ..... 310

KEB Start Output Frequency Reduction ..... 310

Keys and Displays on the HOA Keypad ..... 107

kWh ..... 333

kWh, Lower 4 Digits ..... 333

kWh, Upper 5 Digits ..... 333

kWh Monitor Initialization ..... 190

kWh Monitor Initial Value Selection ..... 320

**L**

L3-01 through L3-06 ..... 200

L3-02 ..... 241

L3-04 ..... 239

L3-11 ..... 200

L8-12 ..... 277

L8-35 ..... 277

L8-38 ..... 241

Language Selection ..... 155

LCD Display ..... 108

LED Check ..... 333

LF ..... 209

LF2 ..... 209

Line-to-Line Resistance Error ..... 230

Load Current ..... 317

Load Inertia ..... 317

Load Inertia Ratio ..... 311

Loss of Reference Function ..... 138

Low Voltage Directive ..... 362

Low Voltage Wiring for Control Circuit Terminals ..... 370

LT-1 ..... 221

LT-2 ..... 221

LT-3 ..... 221

LT-4 ..... 221

**M**

M1 ..... 92

M2 ..... 92

M3 ..... 92

M4 ..... 92

M5 ..... 92

M6 ..... 92

MA ..... 92

Main Circuit Connection Diagram ..... 65, 90

Main Circuit Terminal ..... 37

Main Circuit Terminal and Motor Wiring ..... 86

Main Circuit Terminal Block Configuration ..... 68

Main Circuit Terminal Functions ..... 81

Main Circuit Terminal Wiring ..... 71

Main Circuit Wiring ..... 81

Main Contactor and Cooling Fan Power Supply Failure ..... 326

Main Contactor and Cooling Fan Power Supply Failure Selection ..... 314

Maintenance Monitors ..... 192

Master Speed Reference Lower Limit ..... 170

Maximum Applicable Motor Capacity ..... 266, 267, 268, 269, 270, 271

Maximum Output Frequency ..... 134, 266, 267, 268, 269, 270, 271

Maximum Output Voltage ..... 266, 267, 268, 269, 270, 271

Maximum Voltage ..... 134

MB ..... 92

MC ..... 92

MEMOBUS/Modbus Comm. Test Mode Complete ..... 223

MEMOBUS/Modbus Communication Error ..... 205, 218

MEMOBUS/Modbus Communications Reference ..... 334

MEMOBUS/Modbus Error Code ..... 330

MEMOBUS/Modbus Switch Settings ..... 101

MEMOBUS/Modbus Termination ..... 101

Menu Structure for HOA Keypad ..... 111

Message ID (INV) ..... 330

Message ID (OPR) ..... 330

Middle Output Frequency ..... 134

Middle Output Frequency 2 ..... 134

Middle Output Frequency Voltage ..... 134

Middle Output Frequency Voltage 2 ..... 134

Mid Output Voltage A ..... 198

Minimum Output Frequency ..... 134

Minimum Output Frequency Voltage ..... 134

Minimum Output Voltage ..... 198

Minimum Power Supply Capacity ..... 266, 267, 268, 269, 270, 271

Minimum Wait Time for Sending Messages ..... 347

Minor Alarms ..... 202

Minor Fault ..... 229

Minor Fault and Alarm Displays ..... 203

Minor Faults ..... 202

Minor Faults and Alarms ..... 201, 202

Model, Voltage Class, Capacity Mismatch ..... 232

Model Number and Nameplate Check ..... 27

Modes ..... 112

Momentary Overcurrent Protection ..... 272

Momentary Power Loss Minimum Baseblock Time ..... 310

Momentary Power Loss Operation Selection ..... 137, 310

Momentary Power Loss Ride-Thru ..... 273

Momentary Power Loss Ride-Thru Time ..... 138, 310

Momentary Power Loss Voltage Recovery Ramp Time ..... 310

Monitor Output ..... 92

Monitor Parameters.....	329	Noise From the Drive or Motor Cables When the Drive is Powered On 239	
Most Recent Fault .....	331	No-Load Current Alarm .....	229
Motor Acceleration Time for Inertia Calculations .....	311	No-Load Current Error .....	230
Motor Base Frequency .....	145, 147, 191, 327	No-Load Operation .....	150
Motor Base Speed .....	147, 192, 327	No-Load Operation Test Run .....	150
Motor Data Error.....	229	Notes on Stationary Auto-Tuning .....	144
Motor d-Axis Current at Previous Fault .....	331	nSE .....	210
Motor d-Axis Inductance .....	136	Number of Auto Restart Attempts.....	139, 312
Motor Direction at Power Up when Using Operator.....	188, 319	Number of Motor Poles .....	136, 147, 191, 327
Motor Does Not Rotate .....	236	Number of PM Motor Poles .....	148
Motor Excitation Current (Id) .....	335	Number of Run Commands .....	333
Motor Hunting and Oscillation Control Parameters .....	200	Number of Run Commands Counter Initialization.....	190, 320
Motor Induction Voltage Constant 1 .....	136	Number of Speed Search Restarts .....	160
Motor Induction Voltage Constant 2 .....	136	<b>O</b>	
Motor Iron Loss.....	147, 192, 327	o2-03.....	152
Motor is Too Hot .....	237	oC .....	210
Motor Overheat .....	222	oFA00 .....	210
Motor Overheat Alarm (PTC Input).....	211	oFA01 .....	211
Motor Overheat Alarm Operation Selection .....	309	oFA05, oFA06 .....	211
Motor Overheat Fault (PTC Input).....	212	oFA10 .....	211
Motor Overheat Fault Operation Selection.....	309	oFA11 .....	211
Motor Overload .....	212	oFA12 to oFA17 .....	211
Motor Overload Estimate (oL1) .....	333	oFA30 to oFA43 .....	211
Motor Overload Protection Selection .....	309, 371	OFF button Input .....	230
Motor Overload Protection Time.....	309, 371	OFF Key .....	107
Motor Performance Fine-Tuning .....	198	OFF Key Function Selection.....	319
Motor Poles.....	145	Offset Frequency.....	335
Motor Pull Out or Step Out Detection .....	215	oH.....	211, 221
Motor q-Axis Current at Previous Fault .....	331	oH1 .....	211
Motor q-Axis Inductance .....	136	oH2 .....	222
Motor Rated Current .....	135, 145, 147, 191, 327, 371	oH3 .....	211, 222
Motor Rated Power.....	135, 146, 191, 327	oH4 .....	212
Motor Rated Voltage.....	145, 146, 191, 327	oL1.....	212
Motor Rotates After the Drive Output is Shut Off.....	240	oL1 Current Level .....	309
Motor Rotates Faster Than the Frequency Reference.....	239	oL2.....	213, 241
Motor Rotates in One Direction Only.....	237	oL2 Characteristics Selection at Low Speeds.....	183, 314
Motor Secondary Current (Iq) .....	335	oL3.....	213, 222
Motor Stalls During Acceleration or With Large Loads .....	238	oL7.....	213
Motor Stator Resistance.....	136	oPE .....	225
Motor Temperature Input Filter Time.....	309	oPE01 .....	225
Motor Underload.....	216	oPE02 .....	225
Motor Underload Protection Level at Minimum Frequency.....	180, 313	oPE03 .....	225
Motor Underload Protection Selection.....	179, 313	oPE05 .....	226
Motor Wiring.....	86	oPE07 .....	226
Mounting Hole .....	32, 33, 34, 35, 36	oPE08 .....	226
Mounting hole.....	30, 31	oPE09 .....	227
Multi-Function Analog Input Selection Error.....	226	oPE10 .....	227
Multi-Function Analog Input Terminal Settings .....	175	oPE11 .....	227
Multi-Function Digital Inputs.....	91	oPE16 .....	227
Multi-Function Digital Output .....	92	oPE27 .....	228
Multi-Function Input Selection Error .....	225	oPE28 .....	228
Multi-Step Speed Selection.....	128	oPE Fault Parameter.....	330
E2-01 .....	371	Open Loop Vector Control for PM Motors .....	26
L1-01 .....	371	Open Loop Vector Control Mode Tuning Parameters .....	199
<b>N</b>		Operating with the Load Connected.....	151
n1-02.....	198	Operation Errors .....	201, 203
ndAT.....	232	Operation Selection when HOA Keypad is Disconnected .....	188, 319
Network Termination .....	340	Operation Status Monitors.....	192, 193
		Operation with Permanent Magnet Motors.....	122

oPr .....	213	Parameter Selection Error .....	226
Optional 24 V DC power supply connector cover ....	30, 31, 32, 33, 34, 35	Parameter Settings .....	115
Option card connection error (CN5) .....	211	Parameters to Minimize Motor Hunting and Oscillation .....	200
Option Card Connection Error at Option Port CN5 .....	210	PASS .....	223
Option card connector (CN5) .....	37	Password .....	152
Option card error occurred at option port CN5 .....	211	Password Settings .....	152
Option Card External Fault .....	207, 219	Peak Hold Current .....	333
Option Card Fault at Option Port CN5 .....	211	Peak Hold Output Frequency .....	333
Option Communication Error .....	205, 218	Permanent Magnet Motor Control .....	122
Option Frequency Reference .....	334	PF .....	214
Option Installation .....	248	Phase Order Selection .....	157
Option Monitors 1 to 20 .....	335	PI Accel/Decel Time .....	164
Oscillation or Hunting .....	240	PI Feedback .....	334
Output Current .....	329	PI Feedback Function Selection .....	165
Output Current 1 during Speed Search .....	159	PI Feedback High Detection Level .....	166
Output Current at Previous Fault .....	331	PI Feedback High Detection Time .....	166
Output Current Imbalance .....	209	PI Feedback Loss .....	208, 220
Output Frequency .....	329	PI Feedback Loss Detection Selection .....	162
Output Frequency after Soft Start .....	330	PI Feedback Low Detection Level .....	163
Output Frequency at Previous Fault .....	331	PI Feedback Low Detection Time .....	163
Output Frequency is not as High as Frequency Reference .....	241	PI Feedback Offset .....	166
Output Frequency Reduction During Overheat Alarm .....	181	PI Function Setting .....	161
Output Frequency Resolution .....	272	PI Input (feedback) .....	334
Output Ground Fault Detection Selection .....	182, 314	PI Input Limit .....	166
Output Phase Loss .....	209	PI Maximum Boost Time .....	165
Output Phase Loss Detection Level for Dynamic Audible Noise Control .....	326	PI Monitors .....	192
Output Phase Loss Protection .....	314	PI Offset Adjustment .....	161
Output Phase Loss Protection Selection .....	182	PI Output .....	334
Output Power .....	329	PI Output Fault .....	240
Output Power at Previous Fault .....	331	PI Output Gain Setting .....	162
Output Terminal Status .....	329	PI Output Level Selection .....	162
Output Terminal Status at Previous Fault .....	331	PI Output Limit .....	161
Output Voltage at Previous Fault .....	331	PI Output Lower Limit .....	166
Output Voltage Detection Fault .....	217, 224	PI Output Monitor Calculation Method .....	167
Output Voltage Reference .....	329	PI Output Reverse Selection .....	162
Output Voltage Reference (Vd) .....	335	PI Primary Delay Time Constant .....	162
Output Voltage Reference (Vq) .....	335	PI Setpoint .....	334
ov .....	214, 222	PI Setpoint Boost Setting .....	165
ov2 .....	214	PI Setpoint Display Digits .....	166
ov2 Detect Time .....	326	PI Setpoint Monitor Unit Selection .....	168
Overcurrent .....	210	PI Setpoint Scaling .....	164
Overcurrent Detection Gain .....	183, 314	PI Setpoint Selection .....	164
Overexcitation Deceleration Gain .....	316	PI Setpoint User Display .....	166
Overexcitation Operation Selection .....	316	PI Setpoint Value .....	164
Overheat 1 (Heatsink Overheat) .....	211	PI Sleep Delay Time .....	163
Overheat Alarm Level .....	180, 313	PI Sleep Function Start Level .....	163
Overheat Pre-Alarm Operation Selection .....	180, 313	PI Sleep Input Source .....	164
Overload Protection .....	272	PI Snooze Deactivation Level .....	165
Overload Tolerance .....	266, 267, 268, 269, 270, 271	PI Snooze Delay Time .....	165
Overtorque 1 .....	222	PI Snooze Feedback Level .....	165
Overtorque Detection 1 .....	213	PI Snooze Level .....	165
Overvoltage .....	214	PI Square Root Gain .....	166
Overvoltage 2 .....	214	PI Unit Selection .....	167
Overvoltage Protection .....	272	PM Motor Auto-Tuning Mode Selection .....	147
ov Suppression Function Selection .....	311	PM Motor Base Frequency .....	148
<b>P</b>		PM Motor d-Axis Inductance .....	148
Panel Cut-Out Dimensions .....	45	PM Motor Induced Voltage Constant .....	149
Parameter Access Level .....	152	PM Motor Parameter Settings .....	143
Parameter Range Setting Error .....	225	PM Motor q-Axis Inductance .....	149
		PM Motor Rated Current .....	148

PM Motor Rated Power .....	148	Run Command/Frequency Reference Source Selection Error .....	226
PM Motor Rated Voltage .....	148	Run Command at Power Up .....	157
PM Motor Stator Resistance .....	148	Run Command Method Selection .....	179, 344
PM Motor Type .....	148	Run Command Selection .....	236
Powering Up the Drive .....	123	Run Command Selection 1 .....	129
Power Ratings (Three-Phase 200 V Class) .....	266, 267, 268, 269, 270	RUN Command Selection for AUTO mode .....	282
Power Ratings (Three-Phase 400 V Class) .....	271	Run Command Source Selection .....	334
Predefined V/f Patterns .....	172	<b>S</b>	
Preface .....	12	S- .....	92
Preparing the Ends of Shielded Cables .....	98	S: Special Parameters .....	321
Present Value Access .....	348	S/L2 .....	81
Preset Reference Timing Diagram .....	170	S+ .....	92
Previous Fault .....	330	S1 .....	91
Programming Errors .....	225	S1: Dynamic Noise Control Function .....	321
Programming Mode .....	112, 115	S2 .....	91
Proportional Gain Setting (P) .....	161	S2: Sequence Timers .....	321
Protective Cover .....	79	S3 .....	91
Protective Covers, Reattaching .....	71	S4 .....	91
Protective Covers, Removing .....	70	S5 .....	91
Pull-In Current .....	317	S6 .....	91
Pull-In Current Compensation Time Constant .....	317	S7 .....	91
Pull-In Current during Accel/Decel for PM .....	215	SAFE .....	223
Pull-In Current Level for PM Motor Tuning .....	149	Safety Hazard Definitions .....	14
Pump (Secondary) Application .....	126	Safety Information .....	14
Pump with PI Control Application .....	126	SC .....	91
<b>R</b>		Screw .....	30, 32, 33, 36
R- .....	92	S-Curve Characteristics .....	200
R/L1 .....	81	SE .....	223
R+ .....	92	Secondary PI Disable Mode .....	324
Ramp to stop .....	129	Secondary PI Display Digits .....	323
Rated Current Setting Alarm .....	229	Secondary PI Enable Selection .....	323
Rated Output Capacity .....	266, 267, 268, 269, 270, 271	Secondary PI Feedback Detection Selection .....	324
Rated Output Current .....	266, 267, 268, 269, 270, 271	Secondary PI High Feedback Detection Time .....	324
Rated Slip Error .....	230	Secondary PI High Feedback Level .....	324
Rated Voltage, Rated Frequency .....	266, 267, 268, 269, 270, 271	Secondary PI Integral Limit Setting .....	324
rdEr .....	232	Secondary PI Integral Time Setting .....	324
READ .....	189	Secondary PI Low Feedback Detection Level .....	324
rEAd .....	232	Secondary PI Low Feedback Detection Time .....	324
Reading BACnet Drive Parameters .....	353	Secondary PI Output Level Selection .....	324
Reading Parameter Settings .....	232	Secondary PI Output Lower Limit .....	324
Real Time Clock Setting .....	114, 190	Secondary PI Output Upper Limit .....	324
Reattaching the Front Cover .....	77	Secondary PI Proportional Gain Setting .....	324
Reattaching the HOA Keypad .....	72	Secondary PI Setpoint Value .....	324
Reattaching the Protective Cover .....	80	Secondary PI Unit Selection .....	323
Reattaching the Terminal Cover .....	71	Secondary PI User Display .....	323, 325
Removing the Front Cover .....	73	Second Line Monitor Selection .....	186, 318
Removing the HOA Keypad .....	72	Selecting the Type of Auto-Tuning .....	144
Removing the Protective Cover .....	79	Selection of Parameter Write during Uv .....	319
Removing the Terminal Cover .....	70	Self-Diagnostics .....	355
RESET Key .....	107	Sequence Timer 1 Day Selection .....	321
Resistance Tuning Error .....	229	Sequence Timer 1 Reference Source .....	321
Response Messages from Drive to Master .....	347	Sequence Timer 1 Selection .....	321
Return Fan with PI Control Application .....	125	Sequence Timer 1 Start Time .....	321
Reverse Operation Selection .....	157	Sequence Timer 1 Stop Time .....	321
Reverse Operation Selection 2 by PI Output .....	168	Sequence Timer 2 Day Selection .....	322
Rotational Auto-Tuning for V/f Control .....	142	Sequence Timer 2 Reference Source .....	322
RS-485 Interface .....	341	Sequence Timer 2 Selection .....	322
RTS Control Selection .....	178, 343	Sequence Timer 2 Start Time .....	322
Rubber Bushing .....	30	Sequence Timer 2 Stop Time .....	322

Sequence Timer 3 Day Selection .....	322	Stationary Auto-Tuning .....	144
Sequence Timer 3 Reference Source .....	322	Stationary Auto-Tuning for Line-to-Line Resistance .....	142
Sequence Timer 3 Selection .....	322	Status Display .....	123
Sequence Timer 3 Start Time .....	322	STo .....	215
Sequence Timer 3 Stop Time .....	322	STOP Key Function Selection .....	188
Sequence Timer 4 Day Selection .....	323	Stopping Method after Communication Error .....	177, 342
Sequence Timer 4 Reference Source .....	323	Stopping Method Selection .....	129
Sequence Timer 4 Selection .....	323	Storage Temperature .....	42
Sequence Timer 4 Start Time .....	322	Supported Properties of Objects .....	348
Sequence Timer 4 Stop Time .....	323	Surrounding Area .....	42
Sequence Timer Error .....	228	Swing PWM .....	133
SEr .....	215	<b>T</b>	
Serial Comms Cable Connection Terminal .....	340	T/L3 .....	81
Serial Communication Terminals .....	92	T1-03 .....	145
Serial Communication Transmission Error .....	218	T1-04 .....	145
Set Time .....	114, 191, 320	T1-05 .....	145
Setup Group .....	117	T1-06 .....	145
Setup Group Parameters .....	118	T1-07 .....	145, 146
Setup Mode .....	115	T1 Tuning Start .....	327
Shielded Twisted-Pair Cables .....	98	T2 Tuning Start .....	149
Simple Motor Setup Using V/f Control .....	121	Task Complete .....	231
Simplified Setup Using the Setup Group .....	115	TdE .....	215
Sinking/Sourcing Mode Switch for Digital Inputs .....	91	Temperature Derating .....	277
SN .....	91	Terminal A1 Bias Setting .....	136
Soft Charge Bypass Relay Maintenance .....	333	Terminal A1 Function Selection .....	175
Soft Charge Bypass Relay Maintenance Time .....	221	Terminal A1 Gain Setting .....	136
Soft CLA Selection .....	314	Terminal A1 Signal Level Selection .....	174
Soft Starter Speed Reference at Previous Fault .....	331	Terminal A2 Bias Setting .....	137
Software Current Limit Selection .....	183	Terminal A2 Function Selection .....	175
Software No. (Flash) .....	330	Terminal A2 Gain Setting .....	137
Software No. (ROM) .....	330	Terminal A2 Signal Level Selection .....	175
Software version .....	27	Terminal Block Configuration .....	68
Sound from Motor .....	241	Terminal Board .....	34, 35
Speed Agreement Detection Level .....	312	Terminal Board Connection Error .....	206
Speed Agreement Detection Level (+/-) .....	312	Terminal Connections for Communication Self-Diagnostics .....	355
Speed Agreement Detection Width .....	312	Terminal Cover .....	32, 33, 34, 35, 36, 70
Speed Agreement Detection Width (+/-) .....	312	Terminal TB1 .....	37
Speed Control Range .....	272	Terminal TB2 .....	37
Speed Feedback Detection Control Gain .....	317	Terminal TB3 .....	37
Speed Response .....	272	Terminal TB4 .....	37
Speed Search Deactivation Current .....	159	Terminal TB5 .....	37
Speed Search Deceleration Time .....	159	Test Run .....	143, 146
Speed Search Delay Time .....	159	Test Run Checklist .....	154
Speed Search Detection Compensation Gain .....	160	Test Run with Load Connected .....	151
Speed Search Method Selection .....	160	Third Line Monitor Selection .....	186, 318
Speed Search Restart Current Level .....	160	Tightening Torque .....	83
Speed Search Restart Detection Time .....	160	TIM .....	215
Speed Search Selection at Start .....	159	Time Data Error .....	215
Speed Search Wait Time .....	160	Time Not Set .....	215
Stall Prevention .....	200	Time to Continue Making Fault Restarts .....	312
Stall Prevention Level during Acceleration .....	311	Too Many Speed Search Restarts .....	215
Stall Prevention Level during Run .....	311	Torque Compensation Gain .....	198
Stall Prevention Limit during Acceleration .....	311	Torque Compensation Primary Delay Time .....	198
Stall Prevention Selection during Acceleration .....	311	Torque Detection Level 1 .....	141, 313
Stall Prevention Selection during Deceleration .....	311	Torque Detection Selection 1 .....	140, 313
Stall Prevention Selection during Run .....	311	Torque Detection Time 1 .....	141, 313
Standard Connection Diagram .....	62	Torque Specifications, Three Phase 200 V Class .....	83
Standards .....	273	Torque Specifications, Three Phase 400 V Class .....	85
Starting Torque .....	272	Troubleshooting without Fault Display .....	235
Start-Up Flowcharts .....	119		

## Index

TrPC	223	vFyE	232
Tuning Errors	201	voF	217, 224
Types of Alarms, Faults, and Errors	201	Voltage Class, Capacity Mismatch	232
Types of Auto-Tuning for Induction Motors	142	Voltage drop calculation formula	83
Types of Auto-Tuning for Permanent Magnet Motors	143	Voltage Reduction Rate	321
<b>U</b>		Voltage Restoration Complete Level	321
U/T1	81	Voltage Restoration Level	321
U1-01	238	Voltage Restoration Sensitivity Time Constant	321
U1-07	236	Voltage Restoration Time Constant at Impact	321
U2, U3 Initialization	190	vrFy	232
U2, U3 Initial Value Selection	320	<b>W</b>	
UL3	215, 223	W/T3	81
UL6	216, 223	Waiting for Run	224
UL Standards	368	Warranty Information	21
UL Standards Compliance	83	Watt Loss 200 V Class Three Phase Models	274
Undertorque Detection 1	215, 223	Watt Loss 400 V Class Three Phase Models	274
Undertorque Detection 6	223	Wire Gauge, Three Phase 200 V Class	83
Undervoltage	223	Wire Gauge, Three Phase 400 V Class	85
Undervoltage 3	216	Wire Gauges	83
Undervoltage 3 (Soft-Charge Circuit Fault)	216	Wiring Checklist	104
Undervoltage Detection Level (Uv1)	310	Wiring Distance	133
Undervoltage Protection	273	Wiring the Control Circuit Terminal	71
Unexpected Noise from Connected Machinery	240	WRITE	189
Unit Code	188	Writing BACnet Drive Parameters	353
Unit Selection for MEMOBUS/Modbus Register 0025H	178, 344	Writing Parameter Settings	231
Unstable Motor Speed when Using PM	241	WrUn	224
Up Arrow Key	107	<b>Z</b>	
USB Copy Unit	153, 246	Z1000 Models	25
USB port (type-B)	30, 31, 32, 33, 34, 35, 36, 102		
User Defined Parameter Lower	319		
User Defined Parameter Upper	319		
User-Defined Parameter Upper/Lower	188		
User Monitor Selection after Power Up	185, 318		
User Monitor Selection Mode	186, 318		
User Parameter Automatic Selection	152, 281		
User Parameter Default Value	141, 319		
User Parameter Default Values	152		
User Parameters	152		
User Parameters 1 to 32	152, 281		
User-Set Display Units Decimal Display	187		
User-Set Display Units Maximum Value	187		
Uv	223		
Uv1	216		
Uv2	216		
Uv3	216		
<b>V</b>			
V/f Characteristics	272		
V/f Control	26		
V/f Control Mode Tuning	198		
V/f Control Mode Tuning Parameters	198		
V/f Data Setting Error	227		
V/f Gain During Speed Search	159		
V/f Pattern Selection	171, 238		
V/T2	81		
vAEr	232		
VERIFY	189		
Verifying Parameter Changes	116		
Verify Menu	116		

---

**This Page Intentionally Blank**





## Revision History

The revision dates and the numbers of the revised manuals appear on the bottom of the back cover.

MANUAL NO. TOEP C710616 45B

Published in U.S.A. May 2011 11-3 

└─ Date of original publication  
└─ Date of publication

Date of Publication	Revision Number	Section	Revised Content
October 2013		All	Updated documentation for software versions PRG: 1016 and PRG: 1017 Addition: Model 4A0052□□B
		Chapter 2	Addition: Instructions on installation using the eye bolts
		Chapter 6	Addition: NEMA Type 1 and NEMA Type 12 External Heatsink Mounting data
November 2012		All	Revision: Reviewed and corrected entire documentation
		Chapter 4	Addition: Parameter settings according to software version PRG: 1015 H5-08: Settings 1 (Metasys N2) and 2 (APOGEE FLN P1)
		Appendix B	Addition: Parameter settings according to software version PRG: 1015 H5-08: Settings 1 (Metasys N2) and 2 (APOGEE FLN P1)
September 2012		–	Removed references to model 4A0515 throughout book Updated documentation for software versions PRG: 1013 and 1014 Updated technical specifications for 4A0361 and 4A0414 models throughout book
		Chapter 4	Addition: Technical data for Real Time Clock function
May 2011		Chapter 1	Addition: Component names
		Chapter 2	Addition: Panel cut-out dimensions
		Chapter 4	Addition: Parameter settings according to software version PRG: 1012 A1-03: Settings 3410 (HVAC Initialization) and 3420 (OEM Bypass Initialization)
		Chapter 5	Addition: Alarm codes according to software version PRG: 1012 Interlock Open (inTLK) Customer Safety (SAFE)
		Appendix B	Addition: Parameter settings according to software version PRG: 1012 A1-03: Settings 3410 (HVAC Initialization) and 3420 (OEM Bypass Initialization) H1-□□: Settings b1 (Customer Safeties) and b2 (BAS Interlock) H2-□□: Setting b2 (BAS Interlock)
March 2011	–	–	First Edition. This manual supports drive software version PRG: 1011

# YASKAWA AC Drive Z1000

## AC Drive for HVAC Fan and Pump

### User Manual

---

**YASKAWA AMERICA, INC.**

2121 Norman Drive South, Waukegan, IL 60085, U.S.A.  
Phone: 1-800-YASKAWA (927-5292) or 1-847-887-7000 Fax: 1-847-887-7310  
<http://www.yaskawa.com>

**DRIVE CENTER (INVERTER PLANT)**

2-13-1, Nishimiyaichi, Yukuhashi, Fukuoka, 824-8511, Japan  
Phone: 81-930-25-3844 Fax: 81-930-25-4369  
<http://www.yaskawa.co.jp>

**YASKAWA ELECTRIC CORPORATION**

New Pier Takeshiba South Tower, 1-16-1, Kaigan, Minatoku, Tokyo, 105-6891, Japan  
Phone: 81-3-5402-4502 Fax: 81-3-5402-4580  
<http://www.yaskawa.co.jp>

**YASKAWA ELÉTRICO DO BRASIL LTDA.**

Avenida Piraporinha 777, Diadema, São Paulo, 09950-000, Brasil  
Phone: 55-11-3585-1100 Fax: 55-11-3585-1187  
<http://www.yaskawa.com.br>

**YASKAWA EUROPE GmbH**

Hauptstrasse 185, 65760 Eschborn, Germany  
Phone: 49-6196-569-300 Fax: 49-6196-569-398  
<http://www.yaskawa.eu.com>

**YASKAWA ELECTRIC KOREA CORPORATION**

9F, Kyobo Securities Bldg., 26-4, Yeouido-dong, Yeongdeungpo-gu, Seoul, 150-737, Korea  
Phone: 82-2-784-7844 Fax: 82-2-784-8495  
<http://www.yaskawa.co.kr>

**YASKAWA ELECTRIC (SINGAPORE) PTE. LTD.**

151 Lorong Chuan, #04-02A, New Tech Park, 556741, Singapore  
Phone: 65-6282-3003 Fax: 65-6289-3003  
<http://www.yaskawa.com.sg>

**YASKAWA ELECTRIC (CHINA) CO., LTD.**

12F, Carlton Bld., No.21 HuangHe Road, HuangPu District, Shanghai 200003, China  
Phone: 86-21-5385-2200 Fax: 86-21-5385-3299  
<http://www.yaskawa.com.cn>

**YASKAWA ELECTRIC (CHINA) CO., LTD. BEIJING OFFICE**

Room 1011, Tower W3 Oriental Plaza, No. 1 East Chang An Ave.,  
Dong Cheng District, Beijing, 100738, China  
Phone: 86-10-8518-4086 Fax: 86-10-8518-4082

**YASKAWA ELECTRIC TAIWAN CORPORATION**

9F, 16, Nanking E. Rd., Sec. 3, Taipei, 104, Taiwan  
Phone: 886-2-2502-5003 Fax: 886-2-2505-1280

**YASKAWA INDIA PRIVATE LIMITED**

#17/A Electronics City, Hosur Road Bangalore 560 100 (Karnataka), India  
Phone: 91-80-4244-1900 Fax: 91-80-4244-1901  
<http://www.yaskawaindia.in>



YASKAWA ELECTRIC CORPORATION

In the event that the end user of this product is to be the military and said product is to be employed in any weapons systems or the manufacture thereof, the export will fall under the relevant regulations as stipulated in the Foreign Exchange and Foreign Trade Regulations. Therefore, be sure to follow all procedures and submit all relevant documentation according to any and all rules, regulations and laws that may apply.

Specifications are subject to change without notice for ongoing product modifications and improvements.

© 2011-2013 YASKAWA ELECTRIC CORPORATION. All rights reserved.



\*10LPC7107164\*

MANUAL NO. TOEP C710616 45E

Published in Japan October 2013 11-3   
13-7-12\_YAI