



Allen-Bradley

***1336 IMPACT™
Adjustable Frequency
AC Drive
Series A***

*A007 – A015
B015 – B030
C015 – C020*

Troubleshooting Guide

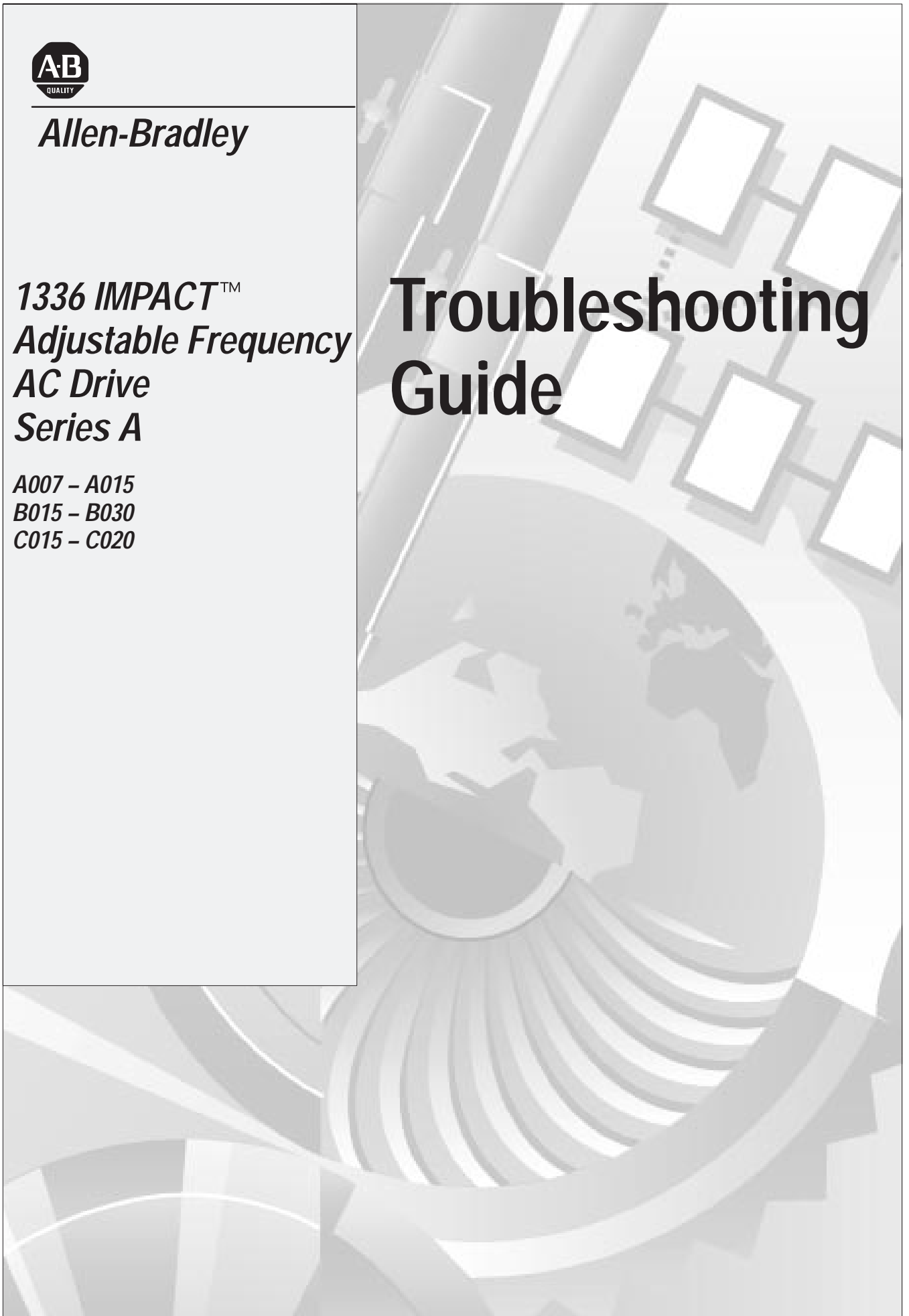

Important User Information

Because of the variety of uses for the products described in this publication, those responsible for the application and use of this control equipment must satisfy themselves that all necessary steps have been taken to assure that each application and use meets all performance and safety requirements, including any applicable laws, regulations, codes and standards.

The illustrations, charts, sample programs and layout examples shown in this guide are intended solely for purposes of example. Since there are many variables and requirements associated with any particular installation, Rockwell Automation does not assume responsibility or liability (to include intellectual property liability) for actual use based upon the examples shown in this publication.

Rockwell Automation publication SGI-1.1, *Safety Guidelines for the Application, Installation, and Maintenance of Solid-State Control* (available from your local Rockwell Automation office), describes some important differences between solid-state equipment and electromechanical devices that should be taken into consideration when applying products such as those described in this publication.

Reproduction of the contents of this copyrighted publication, in whole or in part, without written permission of Rockwell International Corporation, is prohibited.

Throughout this manual we use notes to make you aware of safety considerations:



ATTENTION: Identifies information about practices or circumstances that can lead to personal injury or death, property damage or economic loss.

Attention statements help you to:

- identify a hazard
- avoid the hazard
- recognize the consequences

Important: Identifies information that is critical for successful application and understanding of the product.



We Want Our Manuals to be the Best!

You can help! Our manuals must meet the needs of you, the user. This is your opportunity to make sure they do just that. By filling out this form you can help us provide the most useful, thorough, and accurate manuals available. Please take a few minutes to tell us what you think. Then mail or FAX this form.

FAX: to your local Allen-Bradley Sales Office or 414/512-8579.

PUBLICATION NAME _____

PUBLICATION NUMBER, DATE AND PART NUMBER (IF PRESENT) _____

✓ **CHECK THE FUNCTION THAT MOST CLEARLY DESCRIBES YOUR JOB.**

- SUGGEST / RESPONSIBLE FOR THE PURCHASE OF EQUIPMENT MAINTAIN / OPERATE PROGRAMMABLE MACHINERY
- DESIGN / IMPLEMENT ELECTRICAL SYSTEMS TRAIN/EDUCATE MACHINE USERS
- SUPERVISE FLOOR OPERATIONS

✓ **WHAT LEVEL OF EXPERIENCE DO YOU HAVE WITH EACH OF THE FOLLOWING PRODUCTS?**

	NONE	LITTLE	MODERATE	EXTENSIVE
PROGRAMMABLE CONTROL	<input type="checkbox"/>	<input type="checkbox"/>	<input type="checkbox"/>	<input type="checkbox"/>
AC / DC DRIVES	<input type="checkbox"/>	<input type="checkbox"/>	<input type="checkbox"/>	<input type="checkbox"/>
PERSONAL COMPUTERS	<input type="checkbox"/>	<input type="checkbox"/>	<input type="checkbox"/>	<input type="checkbox"/>
NC / CNC CONTROLS	<input type="checkbox"/>	<input type="checkbox"/>	<input type="checkbox"/>	<input type="checkbox"/>
DATA COMMUNICATIONS / LAN	<input type="checkbox"/>	<input type="checkbox"/>	<input type="checkbox"/>	<input type="checkbox"/>

✓ **RATE THE OVERALL QUALITY OF THIS MANUAL BY CIRCLING YOUR RESPONSE BELOW. (1) = POOR (5) = EXCELLENT**

HELPFULNESS OF INDEX / TABLE OF CONTENTS	1	2	3	4	5
CLARITY	1	2	3	4	5
EASE OF USE	1	2	3	4	5
ACCURACY AND COMPLETENESS	1	2	3	4	5
QUALITY COMPARED TO OTHER COMPANIES' MANUALS	1	2	3	4	5
QUALITY COMPARED TO OTHER ALLEN-BRADLEY MANUALS	1	2	3	4	5

✓ **WHAT DID YOU LIKE MOST ABOUT THIS MANUAL?**

✓ **WHAT DID YOU LIKE LEAST ABOUT THIS MANUAL?**

✓ **PLEASE LIST ANY ERRORS YOU FOUND IN THIS MANUAL (REFERENCE PAGE, TABLE, OR FIGURE NUMBERS).**

✓ **DO YOU HAVE ANY ADDITIONAL COMMENTS?**

✓ **COMPLETE THE FOLLOWING.**

NAME _____ COMPANY _____

TITLE _____ DEPARTMENT _____

STREET _____ CITY _____ STATE _____ ZIP _____

TELEPHONE _____ DATE _____

CUT ALONG DOTTED LINE 

FOLD HERE

FOLD HERE



NO POSTAGE
NECESSARY
IF MAILED
IN THE
UNITED STATES

BUSINESS REPLY MAIL

FIRST CLASS PERMIT NO. 413 MEQUON, WI

POSTAGE WILL BE PAID BY ADDRESSEE

ALLEN-BRADLEY

Attn: Marketing Communications
P.O. Box 760
Mequon, WI 53092-9907

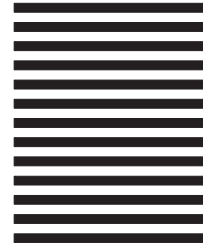

Summary of Changes

The information below summarizes the changes to the company-wide templates since the last release.

Updated Information

No changes have been made to this manual.

Preface

Manual Objective	P-1
Who Should Use This Manual	P-1
Safety Precautions	P-1
Electrostatic Discharge Precautions	P-2
1336 IMPACT Product Identification	P-3
Drive Nameplate Location	P-3
Drive and Option Identification	P-4
1336 IMPACT Drive Catalog Numbers	P-4
Drive Rating Qualifications	P-7
Enclosure Type	P-8
Conventions	P-8
Auxiliary Input	P-8
Auxiliary Interlock	P-8
Bit	P-8
Check	P-9
Connector	P-9
Default	P-9
Enable Input	P-9
False	P-9
Jumper	P-9
L Option Board	P-10
Parameter	P-10
Press	P-10
True	P-10
Related Publications	P-10

Control Logic Wiring and Adapters

Chapter 1

Chapter Objectives	1-1
Chapter Overview	1-1
L Option Board	1-3
L Option Board Jumpers	1-3
Available Inputs	1-4
Local Programming	1-4
Human Interface Module (HIM)	1-9
Description	1-9
Removing the HIM	1-11
HIM Operation	1-12
Graphic Programming Terminal	1-13
GPT Description	1-13
DriveTools	1-14
Control Firmware Function	1-14

Troubleshooting and Error Codes

Chapter 2

Chapter Objectives	2-1
Fault/Warning Handling	2-1
Viewing the Fault and Warning Queues on the HIM	2-3
What Are the Fault Descriptions	2-4
Diagnostic Procedures by Symptom	2-17
Drive Will Not Start or Jog	2-17
No HIM Display	2-18
HIM Displays "Running"	2-19
Motor Response Not Where You Want It	2-20
Start Up Troubleshooting Procedures	2-21
Miscellaneous Troubleshooting Procedures	2-21
Encoderless Troubleshooting Procedures	2-24

Disassembly and Access Procedures

Chapter 3

Chapter Objectives	3-1
Disassembly and Access Overview	3-1
Electrostatic Discharge Precautions	3-1
Tools	3-2
Fastener Torque Specifications	3-2
Torque Sequence	3-2
Two-Point Mounting	3-2
Four-Point Mounting	3-3
Torque Specifications	3-4
Disassembly and Access Procedures	3-5
Opening the Drive Enclosure	3-5
Removal	3-5
Installation	3-6
Removing the L Option Board	3-7
Removal	3-7
Installation	3-8
Removing the Main Control Board Mounting Plate	3-9
Removal	3-9
Installation	3-10
Removing the Main Control Board	3-11
Removal	3-11
Installation	3-12
Removing the Gate Driver/Power Supply Board	3-13
Removal	3-14
Installation	3-16
Accessing Chassis Power Components	3-16

Component Test Procedures

Chapter 4

Chapter Objectives	4-1
Component Test Overview	4-1

Electrostatic Discharge Precautions	4-2
Tools	4-2
Test 1 – Testing Bridge Rectifier BR1	4-3
Test 2 – Testing the Bus Capacitors	4-5
Test 3 – Testing Transistor Modules Q1, Q2, and Q3	4-8
Test 4 – Testing the Precharge Module	4-11
Test 5 – Testing the Gate Driver/Power Supply Board	4-14

Part Replacement Procedures

Chapter 5

Chapter Objective	5-1
Part Replacement Overview	5-1
Safety Precautions	5-1
Electrostatic Discharge Precautions	5-1
Tools	5-2
Major Component Replacement	5-2
Detailed Product Identification	5-2
Precharge Module	5-4
Removal	5-4
Installation	5-5
Thermistor	5-6
Removal	5-6
Installation	5-7
Transistor Modules	5-8
Removal	5-8
Installation	5-9
Bridge Rectifier BR1	5-10
Removal	5-10
Installation	5-11
Fan	5-12
Removal	5-12
Installation	5-13
DC Bus Inductor	5-14
Removal	5-15
Installation	5-16
Bus Capacitors	5-17
Removal	5-17
Installation	5-18

Replacement Parts List

Chapter 6

Chapter Objectives	6-1
Ordering Replacement Parts	6-1
Replacement Parts Listing	6-2

**Schematics — 15 – 30 HP
1336 IMPACT Drives**

Chapter 7

Index

Preface

Manual Objective

The information in this manual is designed to help troubleshoot or repair an Allen-Bradley 1336 IMPACT Adjustable Frequency AC Drive with ratings A007 – A015, B015 – B030, and C015 – C020.

Who Should Use This Manual

This manual is intended for qualified service personnel responsible for repairing the 1336 IMPACT Adjustable Frequency AC Drive. You should:

- Read this entire manual before performing maintenance or repairs to drives.
- Have previous experience with, and basic understanding of, electrical terminology, procedures, required troubleshooting equipment, equipment protection procedures and methods, and safety precautions.

This manual describes equipment, troubleshooting, and disassembly procedures. You begin with general illustrations and end with greater detail concerning replacement parts and part locations on the drives. Later chapters may refer you back to earlier chapters for information on basic equipment and steps necessary to perform detailed diagnostics and part replacement.

Safety Precautions



ATTENTION: Some printed circuit boards and drive components may contain hazardous voltage levels. Remove and lock out power before you disconnect or reconnect wires and before you remove or replace fuses and circuit boards. Verify bus voltage by measuring the voltage between +DC and –DC on terminal block TB1. Do not attempt to service the drive until the bus voltage has discharged to zero volts.



ATTENTION: Potentially fatal voltages may result from improper usage of oscilloscope and other test equipment. The oscilloscope chassis may be at a potentially fatal voltage if not properly grounded. If an oscilloscope is used to measure high voltage waveforms, use only a dual channel oscilloscope in the differential mode with X 100 probes. It is recommended that the oscilloscope be used in the A minus B Quasi-differential mode with the oscilloscope chassis correctly grounded to an earth ground.



ATTENTION: Only personnel familiar with the 1336 IMPACT Adjustable Frequency AC Drive and associated machinery should plan or implement the installation, start-up and subsequent maintenance of the system. Failure to comply may result in personal injury and/or equipment damage.

Electrostatic Discharge Precautions



ATTENTION: This assembly contains parts and sub-assemblies that are sensitive to electrostatic discharge. Static control precautions are required when servicing this assembly. Component damage may result if you ignore electrostatic discharge control procedures. If you are not familiar with static control procedures, reference Rockwell Automation Publication 8000-4.5.2, Guarding Against Electrostatic Damage, or any other applicable ESD protection handbook.

Electrostatic discharge generated by static electricity can damage the complementary metallic oxide semiconductor devices on various drive boards. It is recommended that you perform these procedures to guard against this type of damage when circuit boards are removed or installed:

- Wear a wrist-type grounding strap that is grounded to the drive chassis.
- Attach the wrist strap before removing the new circuit board from the conductive packet.
- Remove boards from the drive and immediately insert them into their conductive packets.

1336 IMPACT Product Identification

Drive Nameplate Location

The drive nameplate is located on the face of the Main Control Board Mounting Plate. The drive nameplate contains the drive's catalog number and other important drive information. Reference the catalog number when ordering replacement parts.

Figure P.1
Drive Nameplate Location

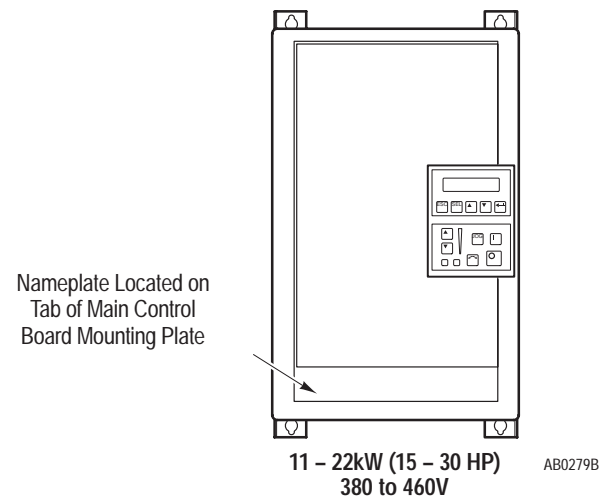

Drive and Option Identification

The following is an explanation of the catalog numbering system for 1336 IMPACT Adjustable Frequency AC Drives and options. The catalog number is coded to identify the drive power rating and can be found on the drive shipping carton and nameplate.

1336 IMPACT Drive Catalog Numbers

Table P.A

1336E	- A007-AN	- EN	- L6	- HA1	- GM1	
Bulletin No.	Rating-Enclosure (Must Be Specified)	Language Module ¹ (Must Be Specified)	L Option ¹ (Optional)	Human Interface ¹ (Optional)	Communication Card ¹ (Optional)	
200 – 240V AC Input						
Drive Rating²			Enclosures			
			Open IP00 No Enclosure	NEMA Type 1 IP20 General Purpose	NEMA Type 4 IP65 Resist Water, Dust	NEMA Type 12 IP54 Industrial Use
Frame Designation	Output Amps	Nominal HP	Code	Code ³	Code	Code
B	27.2	7.5	A007-AN	A007-AA, -AE	A007-AF	A007-AJ
	33.7	10	A010-AN	A010-AA, -AE	A010-AF	A010-AJ
	48.2	15	A015-AN	A015-AA, -AE	A015-AF	A015-AJ

¹ Refer to the Language Module and Options tables following these Catalog Number tables.

² Drive rating is based on a carrier frequency of 4kHz maximum, an altitude of 1,000 meters or less, and a maximum ambient temperature of 40°. Refer to Drive Rating Qualifications on page P-7.

³ Refer to Table P.I for explanation of "AE" rating.

Table P.B

1336E	- B007-AA	- EN	- L6	- HA1	- GM1
Bulletin No.	Rating-Enclosure (Must Be Specified)	Language Module ^[1] (Must Be Specified)	L Option ^[1] (Optional)	Human Interface ^[1] (Optional)	Communication Card ^[1] (Optional)

380 – 480V AC Input

Drive Rating ^[2]			Enclosures			
			Open IP00 No Enclosure	NEMA Type 1 IP20 General Purpose	NEMA Type 4 IP56 Resist Water, Dust	NEMA Type 12 IP54 Industrial Use
Frame Designation	Output Amps	Nominal HP	Code	Code ^[3]	Code	Code
B	27.2	15	B015-AN	B015-AA, -AE	B015-AF	B015-AJ
	33.7	20	B020-AN	B020-AA, -AE	B020-AF	B020-AJ
	41.8	25	B025-AN	B025-AA, -AE	B025-AF	B025-AJ
	48.2	30	B030-AN	B030-AA, -AE	B030-AF	B030-AJ

^[1] Refer to the Language Module and Options tables following these Catalog Number tables.

^[2] Drive rating is based on a carrier frequency of 4kHz maximum, an altitude of 1,000 meters or less, and a maximum ambient temperature of 40°. Refer to Drive Rating Qualifications on page P-7.

^[3] Refer to Table P.I for explanation of "E" rating.

Table P.C

1336E	- C007-AA	- EN	- L6	- HA1	- GM1
Bulletin No.	Rating-Enclosure (Must Be Specified)	Language Module ^[1] (Must Be Specified)	L Option ^[1] (Optional)	Human Interface ^[1] (Optional)	Communication Card ^[1] (Optional)

500 – 600V AC Input

Drive Rating ^[2]			Enclosures			
			Open IP00 No Enclosure	NEMA Type 1 IP20 General Purpose	NEMA Type 4 IP65 Resist Water, Dust	NEMA Type 12 IP54 Industrial Use
Frame Designation	Output Amps	Nominal HP	Code	Code ^[3]	Code	Code
B	19	15	C015-AN	C015-AA, -AE	C015-AF	C015-AJ
	24	20	C020-AN	C020-AA, -AE	C020-AF	C020-AJ

^[1] Refer to the Language Module and Options tables following these Catalog Number tables.

^[2] Drive rating is based on a carrier frequency of 4kHz maximum, an altitude of 1,000 meters or less, and a maximum ambient temperature of 40°. Refer to Drive Rating Qualifications on page P-7.

^[3] Refer to Table P.I for explanation of "E" rating.

Table P.D

Language Modules	
Description	Option Code
English/English	EN
English/French [†]	FR
English/German [†]	DE
English/Italian [†]	IT
English/Japanese [†]	JP
English/Spanish [†]	ES

[†] Currently not available.

Table P.E

Options			
Code	Description [†]	Code	Description
Human Interface Modules, NEMA Type 1 (IP20)		Communication Options	
HAB	Blank – No Functionality	GM1	Single Point Remote I/O
HAP	Programmer Only	GM2	RS-232/422/485, DF1
HA1	Programmer/Controller with Analog Pot	GM3	RS-232/422/485, DH485
HA2	Programmer/Controller with Digital Pot		
Human Interface Modules, NEMA Type 4/12 (IP65/54)		L Option Boards	
HJP	Programmer Only	L4	Contact Closure
HJ2	Programmer/Controller with Digital Pot	L7E	Contact Closure & Encoder Feedback
		L5	+24V AC/DC
		L8E	+24V AC/DC & Encoder Feedback
		L6	115V AC
		L9E	115V AC & Encoder Feedback

[†] For a more functionally complete description of each option, refer to Publication 1336 IMPACT-1.0.

Table P.F
200 – 240 Drives¹

Catalog Number	Maximum Amp Rating ¹	Derate Curve ^{1 2}	Heat Dissipation Drive Watts ^{2 3}	Heat Sink Watts	Total Watts
A007	27	⁴	156	486	642
A010	34	⁵	200	721	921
A015	48	⁵	205	819	1024

Table P.G
380 – 480 Drives¹

Catalog Number	Maximum Amp Rating ¹	Derate Curve ^{1 2}	Heat Dissipation Drive Watts ^{2 3}	Heat Sink Watts	Total Watts
B015	27	⁴	117	486	603
B020	34	⁵	140	628	768
B025	42	⁵	141	720	861
B030	48	⁵	141	820	961

Table P.H
500 – 600 Drives¹

Catalog Number	Maximum Amp Rating ¹	Derate Curve ^{1 2}	Heat Dissipation Drive Watts ^{2 3}	Heat Sink Watts	Total Watts
C015	19	⁴	117	360	477
C020	24	⁴	140	467	607

¹ Amp Rating is at 4kHz. If carrier frequencies above 4kHz are selected, drive Amp Rating must be derated. Refer to the User Manual for carrier frequency vs. Amp deratings.

² Drive Ambient Temperature Rating is 40°C. If ambient exceeds 40°C, the drive must be derated.

³ Drive Rating is based on altitudes of 1,000m (3,000 ft) or less. If installed at higher altitude, drive must be derated.

⁴ Not available.

⁵ Refer to the 1336 IMPACT Drive User Manual.

Drive Rating Qualifications

Several factors can affect drive rating. If more than one factor exists, derating percentages must be multiplied. For example, if a 14-amp drive is installed at a 2km (6,600 ft.) altitude and has a 2% high-input line voltage, the actual amp rating is:

14 x 94% altitude derating x 96% high-input line derating = 12.6 amps.

Enclosure Type

The first character, A, indicates the Enclosure Code.

The second character indicates the type of enclosure shipped from the factory:

Table P.1
Enclosure Type Code Descriptions

Enclosure Type Code	Description
N	Open style (IP 00)
A	NEMA Type 1 (IP 20)
E	NEMA Type 1 (IP 20) "CE" Metal Cover
F	NEMA Type 4 (IP 56)
J	NEMA Type 12 (IP 54)

Conventions

To help differentiate parameter names and display text from other text in this manual, the following conventions will be used:

- Parameter Names will appear in *italics*.
- Display Text will appear in "quotes".

The following is a list of conventions used throughout this manual, and definitions of the conventions. For a list of terminology and definitions, refer to the Glossary in the back of this manual.

Auxiliary Interlock

The Auxiliary Interlock is a user supplied circuit consisting of reset, overload, or other interlocking circuitry. The Interlock is wired to the drive Not External Fault input.

Bit

A bit is a single character or status point used in programmable logic. Eight bits form a BYTE, 16 bits form a word. Drive parameters are actually eight bits or 16 bit words.

Check

To check means to examine either the physical condition of something or the setting of some control, such as a Parameter. Checking a drive board or component may also require measurements and tests.

Connector

A connector joins one drive board to another. Connectors come in two designs, male and female. Male connectors are stationary and contain pins, which are sometimes joined by jumpers. Female connectors are at the ends of wires or ribbon cables and plug into male connectors.

Default

When a drive function defaults, it automatically changes to a pre-programmed setting.

Enable Input

The Enable Input is a terminal connection on the L Option Board. This connection provides an external input to enable or disable the Drive Output section. It must be true to permit the drive to operate.

False

False refers to a logical false state. For instance, an L Option signal on TB3 is false when the input contact is open or the appropriate voltage is not applied to the L Option Board.

Jumper

A jumper completes a circuit between two pins within a male connector on a drive board. In the absence of certain optional equipment using female connectors, jumpers are applied to certain pins within a male connector to complete specific and necessary circuits.

L Option Board

An L Option Board plugs into connectors J2 and J3, located on the lower portion of the Main Control Board. This board is identified as L4, L5, L6, L7E, L8E, or L9E and provides optional control wiring configurations for a drive.

Not External Fault Input

The Not External Fault Input is a terminal connection on the L Option Board. This connection provides an external input for use as an Auxiliary Interlock. Unless this interlock is closed, the drive will be faulted with an External Fault.

Parameter

Parameters are programmable drive functions that define various operating functions or status displays of a drive. Refer to the 1336 IMPACT Adjustable Frequency AC Drive User Manual for parameter details.

Press

Press a button on the Human Interface Module to change parameter settings and drive functions.

True

True refers to a logical true state. For instance, an L Option signal on TB3 is true when: L4/L7E contact input is closed, L5/L8E input terminal registers 24V, or L6/L9E input terminal registers 115V AC.

Related Publications

The following lists other Allen-Bradley publications that apply to the 1336 IMPACT Adjustable Frequency AC Drives:

- Product Data DriveTools Software (9303-2.0)
- Bulletin 1201 Graphic Programming Terminal User Manual (1201-5.0)
- Product Pricing Bulletin (1336 IMPACT-3.0)
- 1336 IMPACT User Manual (1336 IMPACT-5.0)
- Renewal Parts List^[1]
- Options Manuals/Instructions

^[1] Current 1336 IMPACT spare parts information, including recommended parts, catalog numbers, and pricing, can be obtained from the following sources.

- Allen-Bradley home page on the World Wide Web at:

<http://www.ab.com>

Select **Drives**, and the select **Information for Drives, Including Part Lists . . .** Select documents **1060.pdf** (230V drives) and/or **1070.pdf** (460 & 575V drives).

- Standard Drives "AutoFax" service—an automated system that you can call to request a "faxed" copy of the spare parts information (or other technical documentation).

Simply call **444-646-6701** and follow the phone prompts to request document(s) **1060** (230V drives) and/or **1070** (460 & 575V drives).

Control Logic Wiring and Adapters

Chapter Objectives

This chapter introduces you to terminal block locations and wiring and adapter locations and functions.

Chapter Overview

This chapter also illustrates and describes:

- L Options L4, L5, L6, L7E, L8E, and L9E including terminal block TB3
- TB3 L Option Mode selections and functions
- TB3 terminal designations

Important: All printed circuit boards, except the Main Control Board assembly, are referenced to negative ground (-bus).



ATTENTION: Some printed circuit boards and drive components may contain hazardous voltage levels. Remove power before you disconnect or reconnect wires and before you remove or replace fuses and circuit boards. Verify bus voltage by measuring the voltage between +DC and -DC on terminal block TB1. Do not attempt to service the drive until the bus voltage has discharged to zero volts.



ATTENTION: This assembly contains parts and sub-assemblies that are sensitive to electrostatic discharge. Static control precautions are required when servicing this assembly. Component damage may result if you ignore electrostatic discharge control procedures. If you are not familiar with static control procedures, reference Rockwell Automation Publication 8000-4.5.2, Guarding Against Electrostatic Discharge, or any other applicable ESD protection handbook.

Figure 1.1
Terminal Block Locations

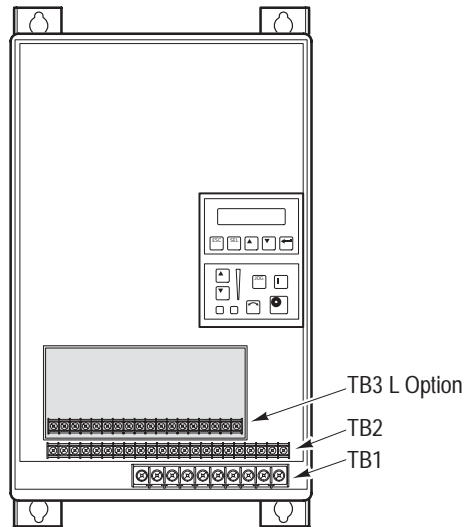

11-22k (15-30 HP)

AB0318A



ATTENTION: The National Electrical Code (NEC) and local codes outline provisions for safely installing electrical equipment. Installation must comply with specifications regarding wire types, conductor sizes, branch circuit protection and disconnect devices. Failure to do so may result in personal injury and/or equipment damage.

L Option Board

The L Option Board provides a means of interfacing various signals and commands to the 1336 IMPACT drive by using contact closures.

Six different versions of the option are available:

L4	Contact Closure Interface ¹
L7E	Contact Closure Interface with Encoder Feedback ¹
L5	+24V AC/DC Interface
L8E	+24V AC/DC Interface with Encoder Feedback
L6	115V AC Interface
L9E	115V AC Interface with Encoder Feedback

¹ Uses internal +5V DC supply.

The user inputs are connected to the L Option Board through TB3. The L4, L5, and L6 options each have nine inputs: seven user-configurable inputs and two factory-defined control inputs. The function of each input must be selected through programming as explained later in this section. The L7E, L8E, and L9E options are similar to L4, L5, and L6 with the addition of encoder feedback inputs.

L Option Board Jumpers

Important: If the L Option Board is being installed, Main Control Board jumpers at pins 3 & 4 and 17 & 18 of J2 must be removed. If these jumpers are removed, they can be stored on the “Spares” location on the Main Control Board. If this board is removed, these jumpers must be reinstalled and the *L Option Mode* parameter (parameter 116) must be programmed to “1”.

Figure 1.2
Jumper Locations

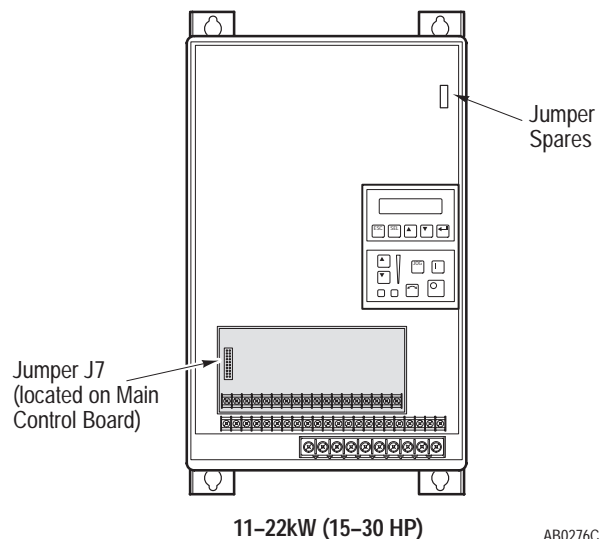

Available Inputs

The L Option allows the combination of the following functions:

Accel/Decel Rates	Process Trim
Digital Potentiometer (MOP)	Ramp
Enable	Reset
Flux Enable	Run Forward
Forward/Reverse	Run Reverse
Jog	Speed Selects
Local Control	Speed Torque Selections
Not Ext Flt	Start
Not Stop, Clear Fault	Stop Mode Selects

The available combinations are shown in Figure 1.4. Programming the *L Option Mode* parameter to one of the L Option Mode numbers listed selects that combination of input functions.

Important: The *L Option Mode* parameter can be changed at any time; however, programming changes will not take effect until power has been cycled to the drive. When changing an L Option Mode, it is important to note that the corresponding inputs to TB3 may also change.

The programming options of the L Option Board allow the user to select an input combination to meet the needs of a specific installation. Appropriate selection of a combination may be done by using Table 1.A. First determine the type of start/stop/direction control desired. Then select the remaining control functions available. After selecting a group of L Option modes, use Table 1.A for specific mode selection. Record the selected mode number below.

Selected Mode Number: _____

Local Programming

For local programming and control information, refer to the 1336 IMPACT Drive User Manual.

Table 1.A
L Option Mode Selection

Start/Stop Type	Direction Control	Communication Compatibility	Mode(s) to Use
Stop & Enable Only	None	Control must be provided by HIM or Communication Option.	1
Momentary Pushbutton (3 Wire)	Maintained Switch (Open-Forward, Closed-Reverse) Single-Source	Start/Stop – works like the HIM and Communication Options. Direction Control will not work with HIM or Communication Options. User must select direction control from either HIM and Communication Options or TB3 input.	2 – 6, 17, and 18, and 27 ^[2]
Momentary Pushbutton (3 Wire)	Momentary Pushbuttons (Forward and Reverse) Multi-Source	Start/Stop – works in parallel with HIM and Communication Options. Direction – works in parallel with HIM or Communication Options.	7 – 11 and 19 – 22 and 28, 29 ^[2]
Maintained switches for combined run and direction control (2 wire, Run Forward, Run Reverse)		Start – works differently than three-wire control. ^[1] Direction – works differently than three-wire control. ^[1] Stop – always works.	12 – 16 and 23 – 26 and 30 ^[2]

^[1] Refer to two-, three-wire notes in the User Manual.

^[2] Diodes 27–30 are available with versions 2.02 and later.

Figure 1.3 provides the terminal designations for TB3. The maximum and minimum wire sizes accepted by TB3 are 2.1 and 0.30 mm² (14 and 22 AWG). Maximum torque for all terminals is 1.36 N-m (12 lb-in.). Use copper wire only.

Figure 1.3
TB3 Terminal Designations

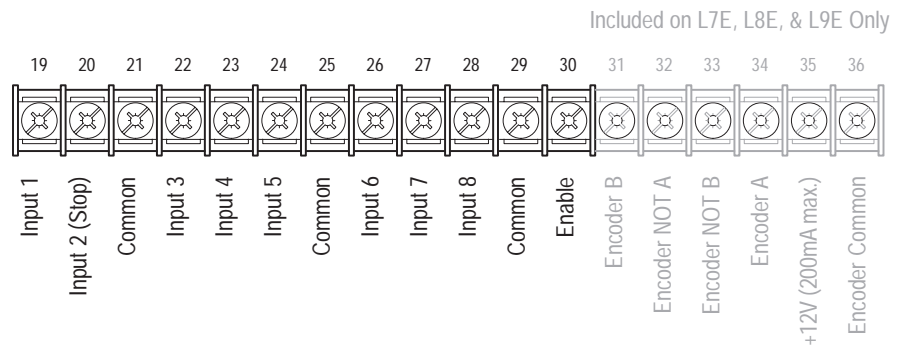

AB0293B

Figure 1.4
L Option Mode Selection and Typical TB3 Connections

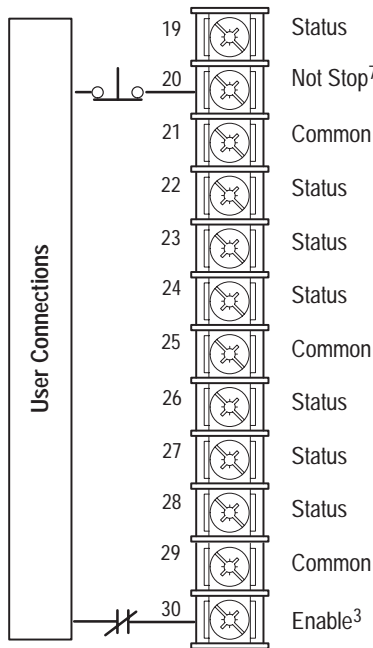
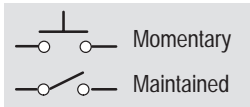

L Option Mode (parameter 116) = 1
Factory Default

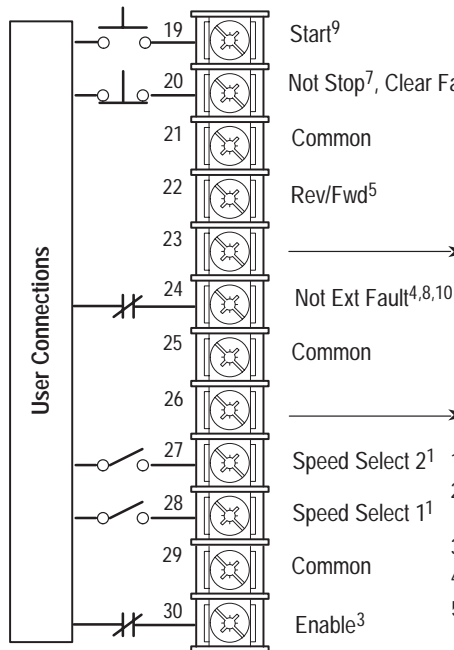

L Option Mode (parameter 116) = 2 - 6, 17, 18, and 27
Single-Source, Three-Wire Control

	Mode								
	2	3	4	5 ¹¹	6	17	18	27 ^{11,12}	
Jog	Jog	Stop Type ⁷	2nd/1st Accel	Digital Pot Up	Jog	Proc Trim	Flux En	Digital Pot Up	
Speed Select 3 ¹	Speed Select 3 ¹	Speed Select 3 ¹	2nd/1st Decel	Digital Pot Dn	Local Control ²	Ramp	Reset	Digital Pot Dn	

- 1 See Table 1.B.
- 2 Drive must be stopped to take Local Control. Control by all other adapters is disabled (except Stop).
- 3 These inputs must be present before drive will start.
- 4 For Common Bus, this becomes Precharge Enable.
- 5 Bit 11 of *Logic Options* (parameter 17) must be 0 for reverse direction control.
- 6 For soft faults only. You need to recycle power to the drive or reset to clear. For hard faults, refer to the troubleshooting chapter.
- 7 To configure the stop type, refer to *Logic Options* (parameter 17).
- 8 This input must be present before the fault can be cleared and the drive will start. This can be disabled through *Fault Select 2* (parameter 22) and *Warning Select 2* (parameter 23).
- 9 Latched starts require a stop to stop the drive.
- 10 This input must be present or masked out before drive will start.
- 11 In mode 5, the MOP value is not reset to 0 when you stop. In mode 27, the MOP Value is reset when you stop.
- 12 Available in versions 2.02 and later.

AB0290B

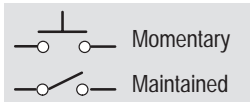

L Option Mode (parameter 116) = 7 – 11 and 19 – 22, 28, 29
Multi-Source, Three-Wire Control

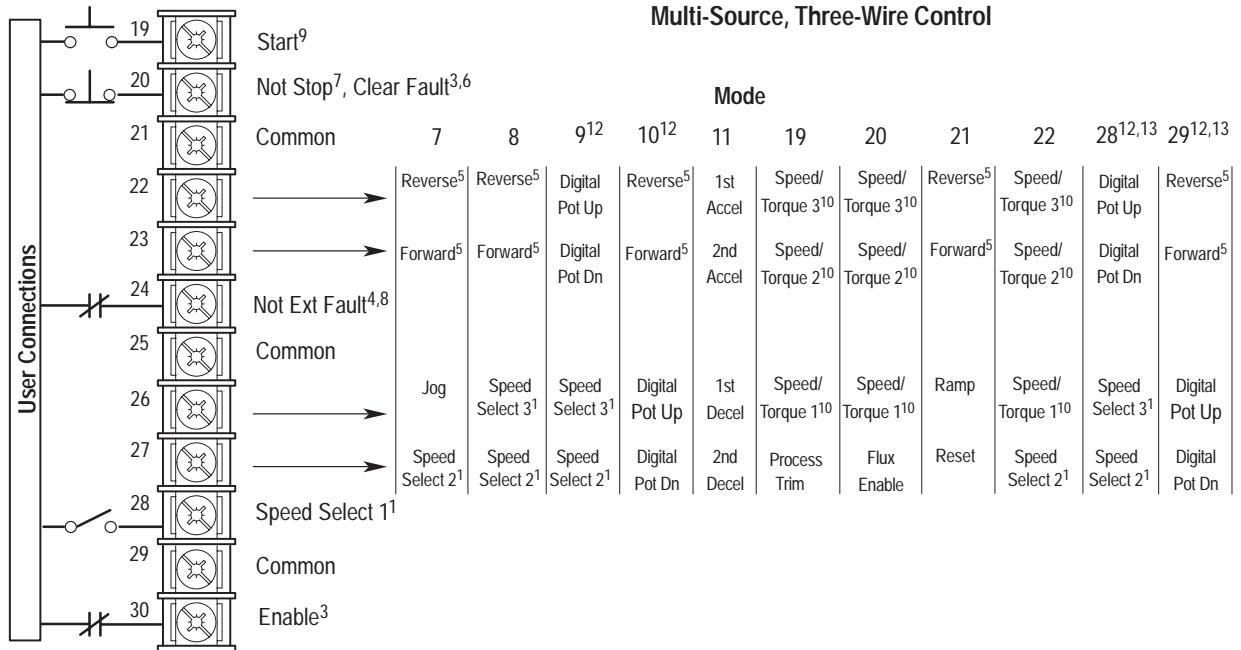

L Option Mode (parameter 116) = 12 – 16 and 23 – 26, 30
Single-Source, Two-Wire Control

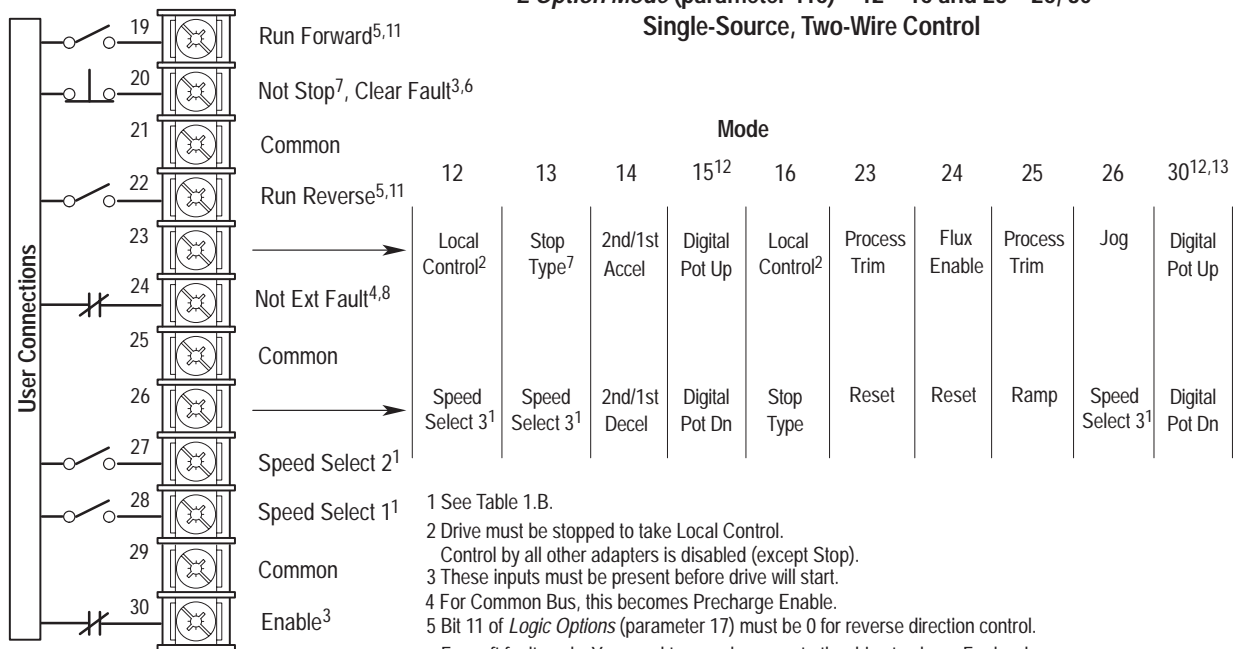

- 1 See Table 1.B.
- 2 Drive must be stopped to take Local Control. Control by all other adapters is disabled (except Stop).
- 3 These inputs must be present before drive will start.
- 4 For Common Bus, this becomes Precharge Enable.
- 5 Bit 11 of *Logic Options* (parameter 17) must be 0 for reverse direction control.
- 6 For soft faults only. You need to recycle power to the drive to clear. For hard faults, refer to the troubleshooting chapter.
- 7 To configure the stop type, refer to *Logic Options* (parameter 17).
- 8 This input must be present before the fault can be cleared and the drive will start. This can be disabled through *Fault Select 2* (parameter 22) and *Warning Select 2* (parameter 23).
- 9 Latched starts require a stop to stop the drive.
- 10 See Speed/Torque Select table.
- 11 Unlatched start.
- 12 In modes 9, 10, and 15, the MOP value is not reset to 0 when you stop.
- 13 In modes 28, 29, and 30, the MOP Value is reset when you stop.

AB0291B

Table 1.B defines the input state of the Speed Select inputs for a desired speed reference source.

Table 1.B
Speed Select/Speed Reference

Speed Select 3	Speed Select 2	Speed Select 1	Speed Reference Source
0	0	0	Speed Ref 1
0	0	X	Speed Ref 2
0	X	0	Speed Ref 3
0	X	X	Speed Ref 4
X	0	0	Speed Ref 5
X	0	X	Speed Ref 6
X	X	0	Speed Ref 7
X	X	X	Last State

O = Open = Removed = 0

X = Closed = Applied = 1

Table 1.C defines the input state of the Speed/Torque Mode Select inputs for a desired speed/torque mode.

Table 1.C
Speed/Torque Select

Speed/Torque Mode Select 3	Speed/Torque Mode Select 2	Speed/Torque Mode Select 1	Speed/Torque Mode
0	0	0	Zero Torque
0	0	X	Speed Regulate
0	X	0	Torque Regulate
0	X	X	Minimum Torque/Speed
X	0	0	Maximum Torque/Speed
X	0	X	Sum of the Torque and Speed
X	X	0	Zero Torque
X	X	X	Zero Torque

O = Open = Removed = 0

X = Closed = Applied = 1

Human Interface Module (HIM)

Description

When the drive-mounted HIM is supplied, it will be connected as SCANport Adapter 1 (refer to Figure 1.6) and visible from the front of the drive. The HIM can be divided into two sections; Display Panel and Control Panel. The Display Panel provides a means of programming the drive and viewing the various operating parameters. The Control Panel allows different drive functions to be controlled. For HIM operation, refer to the 1336 IMPACT Drive User Manual.

Important: The operation of HIM functions depends upon drive parameter settings. Default parameter values allow full HIM functionality.

Figure 1.5
Human Interface Module

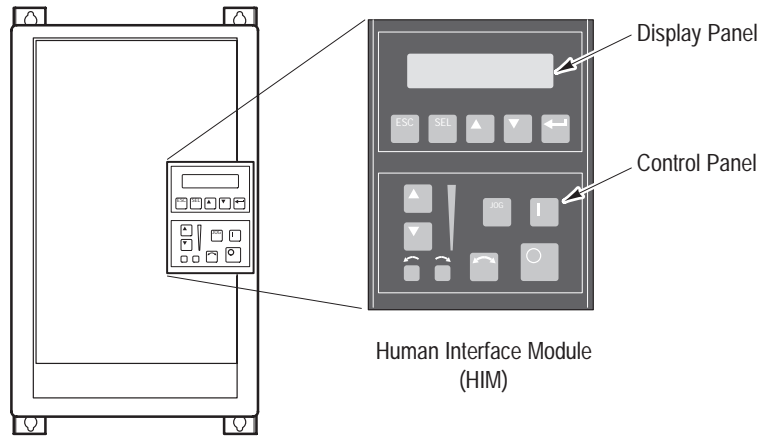

AB0268B

Figure 1.6
Adapter Locations

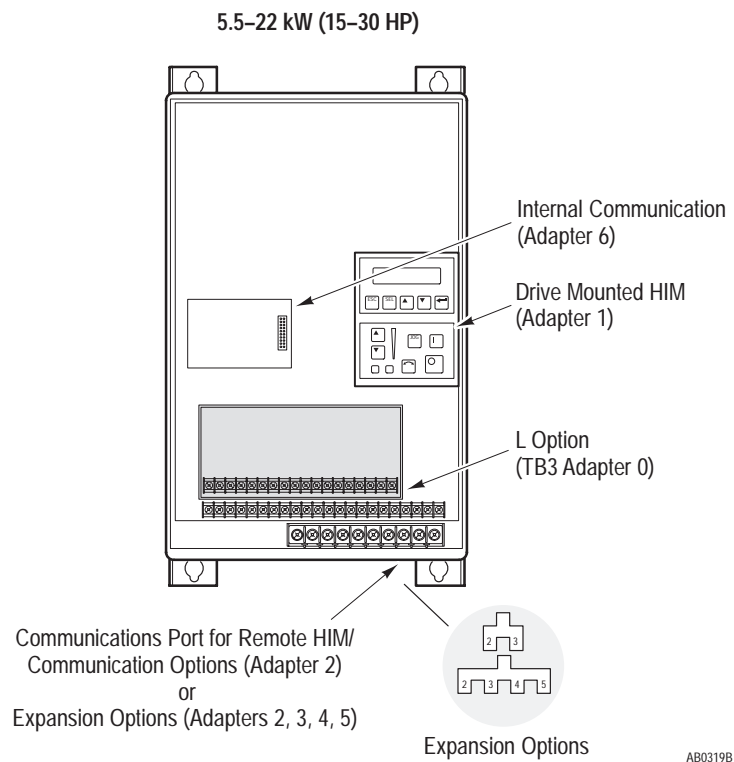

AB0319B

Removing the HIM

For handheld operation, you can remove the module and place it up to 10 meters (33 feet) from the 1336 IMPACT drive. (You do need a cable for this.)



ATTENTION: Some voltages present behind the drive front cover are at incoming line potential. To avoid an electric shock hazard, use extreme caution when removing/replacing the HIM.

Important: Removing a HIM (or other SCANport device) from a drive while power is applied causes a Serial Fault, unless *SP Enable Mask* (parameter 124) or *Fault Select 1* (parameter 20) have been set to disable this fault or *Control Logic* (from the *Control Status* menu) has been disabled (only available on a Series A, version 3.0 or Series B HIM). Setting bit 1 of *SP Enable Mask* to 0 disables Serial Fault from a HIM on port 1. It also disables all HIM control functions except Stop. Setting bit 9 of *Fault Select 1* to 0 disables the serial fault from the HIM on port 1 but still allows HIM control.



ATTENTION: Hazard of personal injury or equipment damage exist. If you initiate a command to start motor rotation (command a start or jog) and then disconnect the programming device, the drive will not fault if you have the SCANport communications fault set to be ignored for that port.

To remove the HIM, you need to:

1. Either remove the power or clear the port but, which corresponds to the port the HIM is attached to, in *SP Enable Mask* (parameter 124) or *Fault Select 1* (parameter 20) to prevent the drive from faulting.
2. Remove the front cover of the drive.
3. Push release at the bottom of the HIM cradle and slide the module down out of its cradle.

To use the module from anywhere up to 10 meters (33 feet) from the drive, you need to:

1. Connect the appropriate cable between the HIM and the communications port (adapter 2, 3, 4, or 5) or adapter 1 (the HIM cradle).
2. Set *SP Enable Mask* to enable the port that you plugged the HIM into and/or *Fault Select 1* (parameter 20).

To replace the module, follow these steps:

1. Slide the module up into its cradle.
2. Replace the front cover of the drive.
3. Apply power, set *SP Enable Mask* or set *Fault Select 1*.

HIM Operation

When power is first applied to the drive, the HIM will cycle through a series of displays. These displays will show the drive name, ID, and communication status. Upon completion, the Status Display (refer to Figure 1.7) will be shown. This display shows the current status of the drive (i.e. Stopped, Running, etc.) or any faults that may be present (Not Enabled, etc.).

For HIM operation, refer to the 1336 IMPACT Drive User Manual.

Figure 1.7
Status Display



Graphic Programming Terminal

GPT Description

The optional GPT (Figure 1.8) is a remote device with a 1.8 meter (6 foot) long cable. The GPT offers a 40 by 8 character display that can also be used as a graphics display. For GPT operation, refer to the 1201 GPT User Manual.

Important: Main Menu screens are dynamic and will change based on functionality provided by adapter and drive status.

Figure 1.8
Graphic Programming Terminal

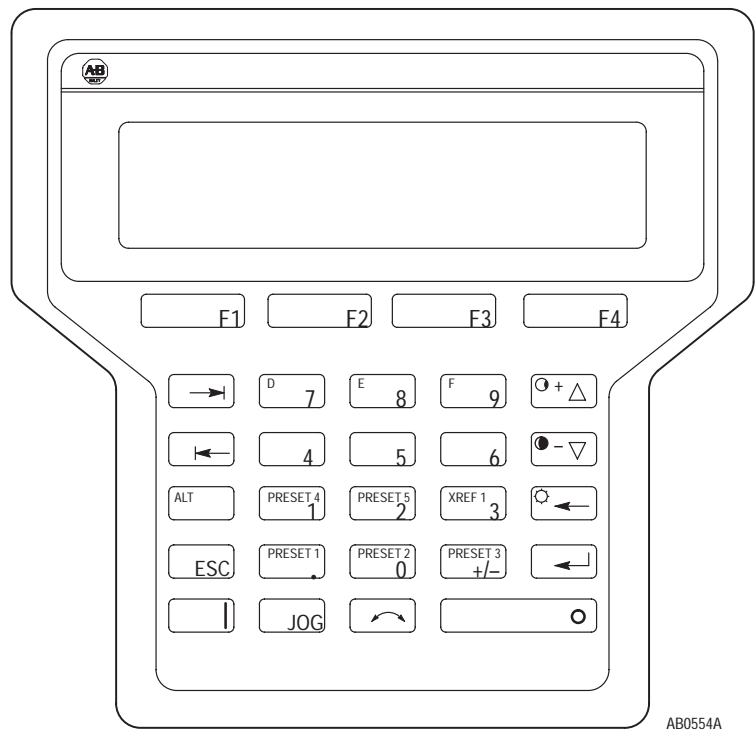

DriveTools

DriveTools software is a Windows 3.1 compatible family of application programs allowing the user to perform programming, monitoring, and diagnostic operations on Allen-Bradley AC and DC digital drive products. The software consists of five Windows applications. For operation, refer to the Product Data DriveTools Software manual.

Control Firmware Function

All control functions in the 1336 IMPACT drive are performed through the use of parameters that can be changed with a programming terminal or DriveTools. Refer to the overview Block Diagram of the Control Firmware Function in the 1336 IMPACT Drive User Manual.

Feedback information is derived from hardware devices as part of the process equipment used. Analog signals are converted to digital signals for use by the drive. Control signals may be provided to the drive by the Main Control Board.

All setup and operation information used by the drive is stored in a system parameter table. Every parameter, including Setup and Configuration parameters (Sources and Destinations), has an entry in the parameter table. For example, parameter 29 is named the [Speed Ref 1] parameter and contains a number value representing the speed reference. The speed reference can originate from an external control device such as a potentiometer connected to the analog input of the Main Control Board. Refer to the 1336 IMPACT Drive User Manual, Publication 1336 IMPACT-5.0.

Troubleshooting and Error Codes

Chapter Objectives

This chapter provides information to help troubleshoot your 1336 IMPACT drive.



ATTENTION: Do not troubleshoot or maintain the 1336 IMPACT drive unless you are familiar with your drive system and the associated machinery. You may be injured and/or the equipment may be damaged if you do not comply.

During the start-up procedure, you should have recorded board jumper settings for each board, board software version numbers, and the drive and motor nameplate data in Table 6.A of the *1336 IMPACT™ Adjustable Frequency AC Drive User Manual*. If this information was not recorded, record it before beginning any troubleshooting sequences.

Fault/Warning Handling

When a problem occurs with your drive, check the VP and CP lights on your drive on the main control board. Figure 2.1 shows the location of the VP and CP lights.

Figure 2.2
VP and CP LED Locations

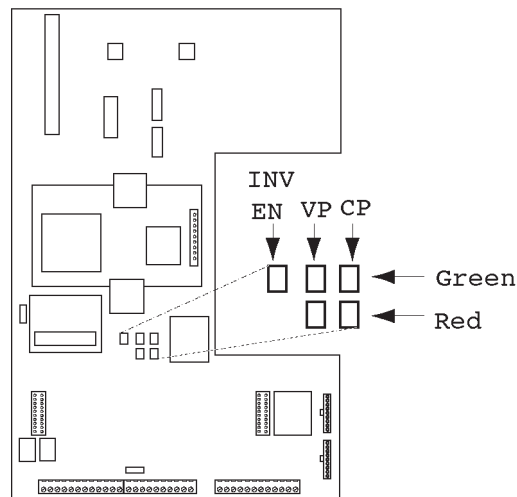

Frames B – H

The lights on the motor control board indicate the status of the velocity processor (VP) and current processor (CP):

If the VP or CP LED is:	Then, for that processor:
Solid green	No fault occurred.
Flashing green	A drive warning occurred.
Flashing red	A drive soft fault occurred.
Solid red	A drive hard fault occurred.

Faults fall into three basic categories:

This type of fault:	Has the following definition:	To remove this fault, you need to:
Hard	Trips the drive causing it to stop. You cannot regain control until you reset the drive.	Perform a <i>Drive Reset</i> command or cycle drive power.
Soft	Trips the drive causing it to stop.	1 Address the condition that caused the fault. 2 Perform a <i>Clear Faults</i> command.
Warning	Indicates an undesirable condition. The drive will not stop, but the condition may lead to a fault that will stop the drive.	Address the condition that caused the warning.

Faults are annunciated on the Human Interface Module (HIM) at the time they occur. Warnings are not annunciated on the HIM.

To help troubleshoot your 1336 IMPACT drive, the drive logs any faults or warnings in either the fault or warning queue. The faults and warnings that are contained in the queues are either configurable or non-configurable.

This fault type:	Refers to faults that you:
Configurable	Can set up to either trip the drive or provide only a visual warning while the drive continues to operate.
Non-configurable	Cannot disable. These faults are the result of a condition that could damage the drive if allowed to persist.



You can reset the soft faults by pressing the stop button on the HIM.

Viewing the Fault and Warning Queues on the HIM

You can use the HIM to view the fault and warning queues. To view the fault queue, you need to:

1. Press the *Escape* key until you reach the *Choose Mode* level.
2. Use the *Increment* or *Decrement* key to scroll through the *Choose Mode* options until *Control Status* is displayed.
3. Press the *Enter* key.

4. Use the *Increment* or *Decrement* key to scroll through the *Control Status* options until *Fault Queue* is displayed.
5. Press the *Enter* key.
6. Press the *Enter* key when *View Queue* is displayed.

The fault queue can contain up to 32 faults. The 1336 IMPACT drive reports the faults using the following format:

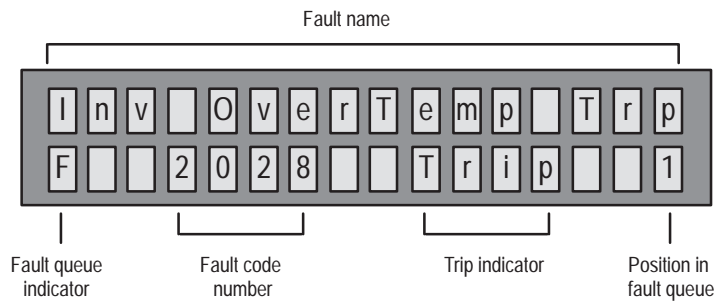

The trip indicator is only present if this fault caused the drive to trip.

The last number (1) indicates the position of this fault within the fault queue.

A marker is placed in the queue when the first fault occurs after a power up sequence. This power up marker is as shown.



The 1336 IMPACT drive tracks the time that has elapsed since power up. The drive uses this information as a time stamp so that you can tell when a fault occurred in relation to when the drive was powered up.

To clear the fault queue, select *Clear Queue* from the *Fault Queue* options.

To view the warning queue, select *Warning Queue* from the *Control Status* options. The remaining steps are the same as for the fault queue.

What Are the Fault Descriptions

When a fault occurs, the fault is displayed until you initiate a *Drive Reset* or a *Clear Faults* command. A *Drive Reset* clears all faults, while a *Clear Faults* command only clears soft and warning faults. You can perform a *Drive Reset* and *Clear Faults* either through bits in *Logic Input Sts* (parameter 14) or with a terminal.

The fault codes are defined as shown in Table 1.A.

Table 2.A
Table 2.B
Fault Descriptions

Fault Code and Text	LED Information	Fault Type	Description	Suggested Action
01027 <i>Autotune Diag</i>	VP, Flashing red	Soft	The drive encountered a problem while running the autotune tests. When this condition occurs, the drive coasts to a stop regardless of the selected stop type.	Check <i>Autotune Errors</i> (parameter 176). For additional information about <i>Autotune Errors</i> , refer to Chapter 13, <i>Understanding the Autotuning Procedure</i> , in the user manual.
01051 <i>MtrOvrlD Pnd</i>	VP, Flashing red	Soft	A motor overload is pending. The drive has reached 95% of the level required for a motor overload trip (see fault 01052).	Check for possible motor overheating. <ul style="list-style-type: none"> • If the motor temperature is excessive, reduce the accel/decel times (parameters 42–45) or reduce the load. • If the motor temperature is acceptable, increase the value of <i>Motor Overload %</i> (parameter 26). If you do not want this condition to be reported as a fault, change bit 3 in <i>Fault Select 2</i> (parameter 22) to 0.
01052 <i>MtrOvrlD Trp</i>	VP, Flashing red	Soft	Motor overload tripped. The drive has reached the level of accumulated motor current over time as set by <i>Motor Overload %</i> (parameter 26).	Check for possible motor overheating. <ul style="list-style-type: none"> • If the motor temperature is excessive, reduce the accel/decel times (parameters 42–45) or reduce the load. • If the motor temperature is acceptable, increase the value of <i>Motor Overload %</i> (parameter 26). If you do not want this condition to be reported as a fault, change bit 4 in <i>Fault Select 2</i> (parameter 22) to 0.
01053 <i>Mtr Stall</i>	VP, Flashing red	Soft	The drive is in a limit condition for a period of time in excess of the value specified in <i>Motor Stall Time</i> (parameter 25) with the motor at zero speed.	Check <i>Torque Limit Sts</i> (parameter 87) to see which limit has occurred. Increase the appropriate limit parameter or reduce the load. If you do not want this condition to be reported as a fault, change bit 5 in <i>Fault Select 2</i> (parameter 22) to 0.
01083 <i>MtrOvrlD Pend</i>	VP, Flashing green	Warning	Motor overload pending. The drive has reached 95% of the level required for a motor overload trip (see fault 01084).	Check for possible motor overheating. <ul style="list-style-type: none"> • If the motor temperature is excessive, reduce the accel/decel times (parameters 42–45) or reduce the load. • If the motor temperature is acceptable, increase the value of <i>Motor Overload %</i> (parameter 26). If you do not want this condition to be reported as a warning, change bit 3 in <i>Warning Select 2</i> (parameter 23) to 0.

Fault Code and Text	LED Information	Fault Type	Description	Suggested Action
01084 <i>MtrOvrlD Trp</i>	VP, Flashing green	Warning	Motor overload tripped. The drive has reached the level of accumulated motor current over time as set by <i>Motor Overload %</i> (parameter 26).	<p>Check for possible motor overheating.</p> <ul style="list-style-type: none"> • If the motor temperature is excessive, reduce the accel/decel times (parameters 42–45) or reduce the load. • If the motor temperature is acceptable, increase the value of <i>Motor Overload %</i> (parameter 26). <p>If you do not want this condition to be reported as a warning, change bit 4 in <i>Warning Select 2</i> (parameter 23) to 0.</p>
01085 <i>Mtr Stall</i>	VP, Flashing green	Warning	The drive is in a limit condition for a period of time in excess of the value specified in <i>Motor Stall Time</i> (parameter 25) with the motor at zero speed.	<p>Check <i>Torque Limit Sts</i> (parameter 87) to see which limit has occurred. Increase the appropriate limit parameter or reduce the load.</p> <p>If you do not want this condition to be reported as a warning, change bit 5 in <i>Warning Select 2</i> (parameter 23) to 0.</p>
02028 <i>Inv Overtemp Trp</i>	VP, Flashing red	Soft	<p>Inverter overtemperature trip. There is excessive temperature at the heatsink.</p> <p>When this condition occurs, the drive coasts to a stop regardless of the selected stop type.</p>	<p>Check the cabinet filters, drive fans, and heatsinks.</p> <p>Check the thermal sensor and sensor wiring (connector).</p> <p>Reduce the load or duty cycle if possible.</p> <p>Lower the value of <i>PWM Frequency</i> (parameter 10).</p>
02049 <i>Inv Overtemp Pnd</i>	VP, Flashing red	Soft	<p>An inverter overtemperature is pending. The inverter heatsink temperature is approaching the trip level.</p>	<p>Check the cabinet filters, drive fans, and heatsinks.</p> <p>Check the thermal sensor and sensor wiring (connector).</p> <p>Reduce the load or duty cycle if possible.</p> <p>Lower the value of <i>PWM Frequency</i> (parameter 10).</p> <p>If you do not want this condition to be reported as a fault, change bit 1 in <i>Fault Select 2</i> (parameter 22) to 0.</p>
02061 <i>InvOvld Pend</i>	VP, Flashing red	Soft	<p>An inverter (IT) overload is pending. The inverter current has been in excess of 105% of <i>Inverter Amps</i> (parameter 11) too long. Continued operation at this load level will cause an overload.</p>	<p>Reduce the load or duty cycle if possible.</p> <p>If you do not want this condition to be reported as a fault, change bit 13 in <i>Fault Select 2</i> (parameter 22) to 0.</p>
02063 <i>Inv Overload</i>	VP, Flashing red	Soft	<p>Inverter (IT) overload. The inverter current has been in excess of 105% of <i>Inverter Amps</i> (parameter 11) too long.</p>	<p>Reduce the load or duty cycle if possible.</p> <p>If you do not want this condition to be reported as a fault, change bit 15 in <i>Fault Select 2</i> (parameter 22) to 0.</p>

Fault Code and Text	LED Information	Fault Type	Description	Suggested Action
02081 <i>Inv Overtemp Pnd</i>	VP, Flashing green	Warning	An inverter overtemperature is pending. The inverter heatsink temperature is approaching the trip level.	<p>Check the cabinet filters, drive fans, and heatsinks.</p> <p>Check the thermal sensor and sensor wiring (connector).</p> <p>Reduce the load or duty cycle if possible.</p> <p>Lower the value of <i>PWM Frequency</i> (parameter 10).</p> <p>If you do not want this condition to be reported as a warning, change bit 1 in <i>Warning Select 2</i> (parameter 23) to 0.</p>
02093 <i>InvOvld Pend</i>	VP, Flashing green	Warning	An inverter (IT) overload is pending. The inverter current has been in excess of 105% of <i>Inverter Amps</i> (parameter 11) too long. Continued operation at this load level will cause an overload.	<p>Reduce the load or duty cycle if possible.</p> <p>If you do not want this condition to be reported as a warning, change bit 13 in <i>Warning Select 2</i> (parameter 23) to 0.</p>
02095 <i>Inv Overload</i>	VP, Flashing green	Warning	Inverter (IT) overload. The inverter current has been in excess of 105% of <i>Inverter Amps</i> (parameter 11) too long.	<p>Reduce the load or duty cycle if possible.</p> <p>If you do not want this condition to be reported as a warning, change bit 15 in <i>Warning Select 2</i> (parameter 23) to 0.</p>
03008 <i>HW Malfunction</i>	VP, Red 1 blink	Hard	<p>A hardware malfunction was detected on power up or reset.</p> <p>When this condition occurs, the drive coasts to a stop regardless of the selected stop type.</p>	<p>Recycle the power. If the fault does not clear, replace the main control board.</p>
03009 <i>HW Malfunction</i>	VP, Red 2 blink	Hard	<p>A hardware malfunction was detected on power up or reset.</p> <p>When this condition occurs, the drive coasts to a stop regardless of the selected stop type.</p>	<p>Recycle the power. If the fault does not clear, replace the main control board.</p>
03010 <i>HW Malfunction</i>	VP, Red 3 blink	Hard	<p>A hardware malfunction was detected on power up or reset.</p> <p>When this condition occurs, the drive coasts to a stop regardless of the selected stop type.</p>	<p>Recycle the power. If the fault does not clear, replace the main control board.</p>
03011 <i>HW Malfunction</i>	VP, Red 4 blink	Hard	<p>A hardware malfunction was detected on power up or reset.</p> <p>When this condition occurs, the drive coasts to a stop regardless of the selected stop type.</p>	<p>Recycle the power. If the fault does not clear, replace the main control board.</p>
03012 <i>HW Malfunction</i>	VP, Red 5 blink	Hard	<p>A hardware malfunction was detected on power up or reset.</p> <p>When this condition occurs, the drive coasts to a stop regardless of the selected stop type.</p>	<p>Recycle the power. If the fault does not clear, replace the main control board.</p>

Fault Code and Text	LED Information	Fault Type	Description	Suggested Action
03014 <i>EE Checksum</i>	VP, Flashing red	Soft	The parameter database is corrupt.	Initialize parameters or: <ul style="list-style-type: none"> • Perform a Recall Values operation. • Perform a Save Values operation. • Verify the parameters. • Reset the drive. If the fault still occurs, replace the main control board.
03015 <i>HW Malfunction</i>	VP, Flashing red	Soft	A hardware malfunction has occurred.	Recycle the power. If the fault does not clear, replace the main control board.
03022 <i>Diff Drv Type</i>	VP, Flashing red	Soft	The main control board has been initialized on a different size drive.	Issue a <i>Reset Defaults</i> command to set the drive parameters back to the default values.
03023 <i>SW Malfunction</i>	VP, Solid red	Hard	A software malfunction has occurred.	Recycle the power. If the fault does not clear, replace the main control board. If the fault still occurs, replace the gate driver board.
03024 <i>SW Malfunction</i>	VP, Solid red	Hard	A software malfunction has occurred. When this condition occurs, the drive coasts to a stop regardless of the selected stop type.	Recycle the power. If the fault does not clear, replace the main control board.
03025 <i>Absolute Overspd</i>	VP, Flashing red	Soft	The motor speed has exceeded the speed limit plus <i>Absolute Overspd</i> (parameter 24) settings. When this condition occurs, the drive coasts to a stop regardless of the selected stop type.	If operating in torque mode, check if the load is allowing excessive motor speed. Check if the setting of <i>Absolute Overspd</i> (parameter 24) or the speed limits (parameters 40 and 41) are too low.
03026 <i>Analog Spply Tol</i>	VP, Flashing red	Soft	The analog supply tolerance voltage is outside of the 13V to 18V range. When this condition occurs, the drive coasts to a stop regardless of the selected stop type.	Possible faulty analog 15V power supply. The gate driver board or the main control board may require replacement.
03029 <i>SW Malfunction</i>	VP, Solid red	Hard	A software malfunction has occurred.	Recycle the power. If the fault does not clear, replace the main control board.
03030 <i>SW Malfunction</i>	VP, Solid red	Hard	A software malfunction has occurred. When this condition occurs, the drive coasts to a stop regardless of the selected stop type.	Recycle the power. If the fault does not clear, replace the main control board.
03031 <i>SW Malfunction</i>	VP, Solid red	Hard	A software malfunction has occurred.	Recycle the power. If the fault does not clear, replace the main control board.
03040 <i>mA Input</i>	VP, Flashing red	Soft	A loss of 4–20mA input has occurred.	Check your wiring and connections. If the fault does not clear, replace the main control board. If you do not want this condition to be reported as a fault, change bit 8 in <i>Fault Select 1</i> (parameter 20) to 0.

Fault Code and Text	LED Information	Fault Type	Description	Suggested Action
03057 <i>Param Limit</i>	VP, Flashing red	Soft	A parameter limit has occurred.	Examine the parameter limit testpoints to determine the exact cause. Refer to the <i>Understanding Parameter Limit Faults</i> section in the troubleshooting chapter of the user manual. If you do not want this condition to be reported as a fault, change bit 9 in <i>Fault Select 2</i> (parameter 22) to 0.
03058 <i>Math Limit</i>	VP, Flashing red	Soft	A math limit has occurred.	Examine the math limit testpoints to determine the exact cause. Refer to the <i>Understanding Math Limit Faults</i> section in the troubleshooting chapter of the user manual. If you do not want this condition to be reported as a fault, change bit 10 in <i>Fault Select 2</i> (parameter 22) to 0.
03072 <i>mA Input</i>	VP, Flashing green	Warning	A loss of 4–20mA input has occurred.	Check your wiring and connections. If you do not want this condition to be reported as a warning, change bit 8 in <i>Warning Select 1</i> (parameter 21) to 0.
03089 <i>Param Limit</i>	VP, Flashing green	Warning	A parameter limit has occurred.	Examine the parameter limit testpoints to determine the exact cause. Refer to the <i>Understanding Parameter Limit Faults</i> section in the troubleshooting chapter of the user manual. If you do not want this condition to be reported as a warning, change bit 9 in <i>Warning Select 2</i> (parameter 23) to 0.
03090 <i>Math Limit</i>	VP, Flashing green	Warning	A math limit has occurred.	Examine the math limit testpoints to determine the exact cause. Refer to the <i>Understanding Math Limit Faults</i> section in the troubleshooting chapter of the user manual. If you do not want this condition to be reported as a warning, change bit 10 in <i>Warning Select 2</i> (parameter 23) to 0.
05048 <i>Spd Fdbk Loss</i>	VP, Flashing red	Soft	A loss of feedback occurred.	Check the encoder wiring. Verify that the encoder signals are free of noise. If you do not want this condition to be reported as a fault, change bit 0 in <i>Fault Select 2</i> (parameter 22) to 0.
05054 <i>External Flt In</i>	VP, Flashing red	Soft	The external fault input from the L Option board is open.	Check the external circuit for cause of an open input signal. If you do not want this condition to be reported as a fault, change bit 6 in <i>Fault Select 2</i> (parameter 22) to 0.

Fault Code and Text	LED Information	Fault Type	Description	Suggested Action
05080 <i>Spd Fdbk Loss</i>	VP, Flashing green	Warning	A loss of feedback occurred.	<p>Check the encoder wiring.</p> <p>Verify that the encoder signals are free of noise.</p> <p>If you do not want this condition to be reported as a warning, change bit 0 in <i>Warning Select 2</i> (parameter 23) to 0.</p>
05086 <i>External Flt In</i>	VP, Flashing green	Warning	The external fault input from the L Option board is open.	<p>Check the external circuit for cause of an open input signal.</p> <p>If you do not want this condition to be reported as a warning, change bit 6 in <i>Warning Select 2</i> (parameter 23) to 0.</p>
06041 <i>SP 1 Timeout</i>	VP, Flashing red	Soft	The SCANport adapter at port 1 has been disconnected and the logic mask bit for port 1 is set (1).	<p>If the adapter was not intentionally disconnected:</p> <ul style="list-style-type: none"> • Check the wiring to the SCANport adapters. • Replace wiring, SCANport expander, SCANport adapters, and main control board. • Replace drive, if required. <p>If you do not want this condition to be reported as a fault, change bit 9 in <i>Fault Select 1</i> (parameter 20) to 0.</p>
06042 <i>SP 2 Timeout</i>	VP, Flashing red	Soft	The SCANport adapter at port 2 has been disconnected and the logic mask bit for port 2 is set (1).	<p>If the adapter was not intentionally disconnected:</p> <ul style="list-style-type: none"> • Check the wiring to the SCANport adapters. • Replace wiring, SCANport expander, SCANport adapters, and main control board. • Replace drive, if required. <p>If you do not want this condition to be reported as a fault, change bit 10 in <i>Fault Select 1</i> (parameter 20) to 0.</p>
06043 <i>SP 3 Timeout</i>	VP, Flashing red	Soft	The SCANport adapter at port 3 has been disconnected and the logic mask bit for port 3 is set (1).	<p>If the adapter was not intentionally disconnected:</p> <ul style="list-style-type: none"> • Check the wiring to the SCANport adapters. • Replace wiring, SCANport expander, SCANport adapters, and main control board. • Replace drive, if required. <p>If you do not want this condition to be reported as a fault, change bit 11 in <i>Fault Select 1</i> (parameter 20) to 0.</p>

Fault Code and Text	LED Information	Fault Type	Description	Suggested Action
06044 <i>SP 4 Timeout</i>	VP, Flashing red	Soft	The SCANport adapter at port 4 has been disconnected and the logic mask bit for port 4 is set (1).	<p>If the adapter was not intentionally disconnected:</p> <ul style="list-style-type: none"> •Check the wiring to the SCANport adapters. •Replace wiring, SCANport expander, SCANport adapters, and main control board. •Replace drive, if required. <p>If you do not want this condition to be reported as a fault, change bit 12 in <i>Fault Select 1</i> (parameter 20) to 0.</p>
06045 <i>SP 5 Timeout</i>	VP, Flashing red	Soft	The SCANport adapter at port 5 has been disconnected and the logic mask bit for port 5 is set (1).	<p>If the adapter was not intentionally disconnected:</p> <ul style="list-style-type: none"> •Check the wiring to the SCANport adapters. •Replace wiring, SCANport expander, SCANport adapters, and main control board. •Replace drive, if required. <p>If you do not want this condition to be reported as a fault, change bit 13 in <i>Fault Select 1</i> (parameter 20) to 0.</p>
06046 <i>SP 6 Timeout</i>	VP, Flashing red	Soft	The SCANport adapter at port 6 has been disconnected and the logic mask bit for port 6 is set (1).	<p>If the adapter was not intentionally disconnected:</p> <ul style="list-style-type: none"> •Check the wiring to the SCANport adapters. •Replace wiring, SCANport expander, SCANport adapters, and main control board. •Replace drive, if required. <p>If you do not want this condition to be reported as a fault, change bit 14 in <i>Fault Select 1</i> (parameter 20) to 0.</p>
06047 <i>SP Error</i>	VP, Flashing red	Soft	SCANport communications have been interrupted.	<p>If the adapter was not intentionally disconnected:</p> <ul style="list-style-type: none"> •Check the amount of noise on the system. •Check the wiring to the SCANport adapters. •Replace wiring, SCANport expander, SCANport adapters, and main control board. •Replace drive, if required. <p>If you do not want this condition to be reported as a fault, change bit 15 in <i>Fault Select 1</i> (parameter 20) to 0.</p>

Fault Code and Text	LED Information	Fault Type	Description	Suggested Action
06073 <i>SP 1 Timeout</i>	VP, Flashing green	Warning	The SCANport adapter at port 1 has been disconnected and the logic mask bit for port 1 is set (1).	<p>If the adapter was not intentionally disconnected:</p> <ul style="list-style-type: none"> • Check the wiring to the SCANport adapters. • Replace wiring, SCANport expander, SCANport adapters, and main control board. • Replace drive, if required. <p>If you do not want this condition to be reported as a warning, change bit 9 in <i>Warning Select 1</i> (parameter 21) to 0.</p>
06074 <i>SP 2 Timeout</i>	VP, Flashing green	Warning	The SCANport adapter at port 2 has been disconnected and the logic mask bit for port 2 is set (1).	<p>If the adapter was not intentionally disconnected:</p> <ul style="list-style-type: none"> • Check the wiring to the SCANport adapters. • Replace wiring, SCANport expander, SCANport adapters, and main control board. • Replace drive, if required. <p>If you do not want this condition to be reported as a warning, change bit 10 in <i>Warning Select 1</i> (parameter 21) to 0.</p>
06075 <i>SP 3 Timeout</i>	VP, Flashing green	Warning	The SCANport adapter at port 3 has been disconnected and the logic mask bit for port 3 is set (1).	<p>If the adapter was not intentionally disconnected:</p> <ul style="list-style-type: none"> • Check the wiring to the SCANport adapters. • Replace wiring, SCANport expander, SCANport adapters, and main control board. • Replace drive, if required. <p>If you do not want this condition to be reported as a warning, change bit 11 in <i>Warning Select 1</i> (parameter 21) to 0.</p>
06076 <i>SP 4 Timeout</i>	VP, Flashing green	Warning	The SCANport adapter at port 4 has been disconnected and the logic mask bit for port 4 is set (1).	<p>If the adapter was not intentionally disconnected:</p> <ul style="list-style-type: none"> • Check the wiring to the SCANport adapters. • Replace wiring, SCANport expander, SCANport adapters, and main control board. • Replace drive, if required. <p>If you do not want this condition to be reported as a warning, change bit 12 in <i>Warning Select 1</i> (parameter 21) to 0.</p>

Fault Code and Text	LED Information	Fault Type	Description	Suggested Action
06077 <i>SP 5 Timeout</i>	VP, Flashing green	Warning	The SCANport adapter at port 5 has been disconnected and the logic mask bit for port 5 is set (1).	<p>If the adapter was not intentionally disconnected:</p> <ul style="list-style-type: none"> • Check the wiring to the SCANport adapters. • Replace wiring, SCANport expander, SCANport adapters, and main control board. • Replace drive, if required. <p>If you do not want this condition to be reported as a warning, change bit 13 in <i>Warning Select 1</i> (parameter 21) to 0.</p>
06078 <i>SP 6 Timeout</i>	VP, Flashing green	Warning	The SCANport adapter at port 6 has been disconnected and the logic mask bit for port 6 is set (1).	<p>If the adapter was not intentionally disconnected:</p> <ul style="list-style-type: none"> • Check the wiring to the SCANport adapters. • Replace wiring, SCANport expander, SCANport adapters, and main control board. • Replace drive, if required. <p>If you do not want this condition to be reported as a warning, change bit 14 in <i>Warning Select 1</i> (parameter 21) to 0.</p>
06079 <i>SP Error</i>	VP, Flashing green	Warning	SCANport communications have been interrupted.	<p>If the adapter was not intentionally disconnected:</p> <ul style="list-style-type: none"> • Check the amount of noise on the system. • Check the wiring to the SCANport adapters. • Replace wiring, SCANport expander, SCANport adapters, and main control board. • Replace drive, if required. <p>If you do not want this condition to be reported as a warning, change bit 15 in <i>Warning Select 1</i> (parameter 21) to 0.</p>
12016 <i>Overvoltage</i>	CP, Solid red	Soft	<p>The DC bus voltage has exceeded the maximum value.</p> <p>When this condition occurs, the drive coasts to a stop regardless of the selected stop type.</p>	<p>Monitor the AC line for high line voltage or transient conditions.</p> <p>Increase the deceleration time or install the dynamic brake option because motor regeneration can also cause bus overvoltages. Refer to the user manual for a description of <i>Bus Options</i> (parameter 13) for additional information about bus overvoltages.</p> <p>If you are using flux braking, refer to Chapter 9, <i>Applications</i>, in the user manual for information about flux braking.</p>
12017 <i>Desaturation</i>	CP, Solid red	Soft	<p>There was too much current in the system.</p> <p>When this condition occurs, the drive coasts to a stop regardless of the selected stop type.</p>	<p>Run the power structure diagnostics.</p> <p>Check for a shorted motor or motor wiring.</p> <p>Replace the drive.</p>

Fault Code and Text	LED Information	Fault Type	Description	Suggested Action
12018 <i>Ground Fault</i>	CP, Solid red	Soft	<p>A current path to earth ground in excess of drive rated current has been detected at one or more of the drive output terminals.</p> <p>When this condition occurs, the drive coasts to a stop regardless of the selected stop type.</p>	<p>Run the power structure diagnostics.</p> <p>Check the motor and external wiring to the drive output terminals for a grounded condition.</p> <p>Replace the drive.</p>
12019 <i>Overcurrent</i>	CP, Solid red	Soft	<p>There was too much current in the system.</p> <p>When this condition occurs, the drive coasts to a stop regardless of the selected stop type.</p>	<p>Run the power structure diagnostics.</p> <p>Check for shorted motor or motor wiring.</p> <p>Replace drive.</p>
12032 <i>RidethruTime</i>	CP, Flashing red	Soft	<p>There was a bus voltage drop of 150V and power did not return within 2 seconds.</p>	<p>Check the incoming power and fuses.</p> <p>Refer to the <i>Understanding Precharge and Ridethrough Faults</i> section in the troubleshooting chapter of the user manual for more information.</p> <p>If you do not want this condition to be reported as a fault, change bit 0 in <i>Fault Select 1</i> (parameter 20) to 0.</p>
12033 <i>Prechg Time</i>	CP, Flashing red	Soft	<p>The precharge function could not complete within 30 seconds.</p>	<p>Refer to the <i>Understanding Precharge and Ridethrough Faults</i> section in the troubleshooting chapter of the user manual for more information.</p> <p>If you do not want this condition to be reported as a fault, change bit 1 in <i>Fault Select 1</i> (parameter 20) to 0.</p>
12034 <i>Bus Drop</i>	CP, Flashing red	Soft	<p>The bus voltage dropped 150V below the bus tracker voltage.</p>	<p>Monitor the incoming AC line for low voltage or line power interruption.</p> <p>Refer to the <i>Understanding Precharge and Ridethrough Faults</i> section in the troubleshooting chapter of the user manual for more information.</p> <p>If you do not want this condition to be reported as a fault, change bit 2 in <i>Fault Select 1</i> (parameter 20) to 0.</p>
12035 <i>Bus Undervlt</i>	CP, Flashing red	Soft	<p>The DC bus voltage fell below the trip value (388V DC at 460V AC input).</p>	<p>Monitor the incoming AC line for low voltage or line power interruption.</p> <p>Refer to the <i>Understanding Precharge and Ridethrough Faults</i> section in the troubleshooting chapter of the user manual for more information.</p> <p>If you do not want this condition to be reported as a fault, change bit 3 in <i>Fault Select 1</i> (parameter 20) to 0 or decrease the bus undervoltage setpoint.</p>

Fault Code and Text	LED Information	Fault Type	Description	Suggested Action
12036 <i>Bus Cycle>5</i>	CP, Flashing red	Soft	At least 5 ridethrough cycles have occurred within a 20 second period. This indicates a converter problem or a problem with the incoming power.	<p>Monitor the incoming AC line for low voltage or line power interruption.</p> <p>Refer to the <i>Understanding Precharge and Ridethrough Faults</i> section in the troubleshooting chapter of the user manual for more information.</p> <p>If you do not want this condition to be reported as a fault, change bit 4 in <i>Fault Select 1</i> (parameter 20) to 0.</p>
12037 <i>Open Circuit</i>	CP, Flashing red	Soft	The fast flux up current is less than 50% of commanded.	<p>Make sure the motor is properly connected.</p> <p>Refer to the <i>Understanding Precharge and Ridethrough Faults</i> section in the troubleshooting chapter of the user manual for more information.</p> <p>If you do not want this condition to be reported as a fault, change bit 5 in <i>Fault Select 1</i> (parameter 20) to 0.</p>
12064 <i>RidethruTime</i>	CP, Solid green	Warning	There was a drop of 150V and power did not return within 2 seconds.	<p>Check the incoming power and fuses.</p> <p>Refer to the <i>Understanding Precharge and Ridethrough Faults</i> section in the troubleshooting chapter of the user manual for more information.</p> <p>If you do not want this condition to be reported as a warning, change bit 0 in <i>Warning Select 1</i> (parameter 21) to 0.</p>
12065 <i>Prechrg Time</i>	CP, Solid green	Warning	The precharge function could not complete within 30 seconds.	<p>Refer to the <i>Understanding Precharge and Ridethrough Faults</i> section in the troubleshooting chapter of the user manual for more information.</p> <p>If you do not want this condition to be reported as a warning, change bit 1 in <i>Warning Select 1</i> (parameter 21) to 0.</p>
12066 <i>Bus Drop</i>	CP, Solid green	Warning	The bus voltage dropped 150V below the bus tracker voltage.	<p>Monitor the incoming AC line for low voltage or line power interruption.</p> <p>Refer to the <i>Understanding Precharge and Ridethrough Faults</i> section in the troubleshooting chapter of the user manual for more information.</p> <p>If you do not want this condition to be reported as a warning, change bit 2 in <i>Warning Select 1</i> (parameter 21) to 0.</p>

Fault Code and Text	LED Information	Fault Type	Description	Suggested Action
12067 <i>Bus Undervlt</i>	CP, Solid green	Warning	The DC bus voltage fell below the minimum value (388V DC at 460V AC input).	<p>Monitor the incoming AC line for low voltage or line power interruption.</p> <p>Refer to the <i>Understanding Precharge and Ridethrough Faults</i> section in the troubleshooting chapter of the user manual for more information.</p> <p>If you do not want this condition to be reported as a warning, change bit 3 in <i>Warning Select 1</i> (parameter 21) to 0.</p>
12068 <i>Bus Cycle>5</i>	CP, Solid green	Warning	At least 5 ridethrough cycles have occurred within a 20 second period. This indicates a converter problem or a problem with the incoming power.	<p>Monitor the incoming AC line for low voltage or line power interruption.</p> <p>Refer to the <i>Understanding Precharge and Ridethrough Faults</i> section in the troubleshooting chapter of the user manual for more information.</p> <p>If you do not want this condition to be reported as a warning, change bit 4 in <i>Warning Select 1</i> (parameter 21) to 0.</p>
12069 <i>Open Circuit</i>	CP, Solid green	Warning	The fast flux up current is less than 50% of commanded.	<p>Make sure the motor is properly connected.</p> <p>Refer to the <i>Understanding Precharge and Ridethrough Faults</i> section in the troubleshooting chapter of the user manual for more information.</p> <p>If you do not want this condition to be reported as a warning, change bit 5 in <i>Warning Select 1</i> (parameter 21) to 0.</p>
13000 <i>HW Malfunction</i>	CP, Solid red	Hard	A hardware malfunction occurred.	Recycle the power. If the fault does not clear, replace the main control board.
13001 <i>HW Malfunction</i>	CP, Solid red	Hard	A hardware malfunction occurred.	Recycle the power. If the fault does not clear, replace the main control board.
13002 <i>HW Malfunction</i>	CP, Solid red	Hard	A hardware malfunction occurred.	Recycle the power. If the fault does not clear, replace the main control board.
13003 <i>HW Malfunction</i>	CP, Solid red	Hard	A hardware malfunction occurred.	Recycle the power. If the fault does not clear, replace the main control board.
13004 <i>HW Malfunction</i>	CP, Solid red	Hard	A hardware malfunction occurred.	Recycle the power. If the fault does not clear, replace the main control board.

Diagnostic Procedures by Symptom

The following charts list drive symptoms, symptom descriptions, and recommended actions.

Drive Will Not Start or Jog

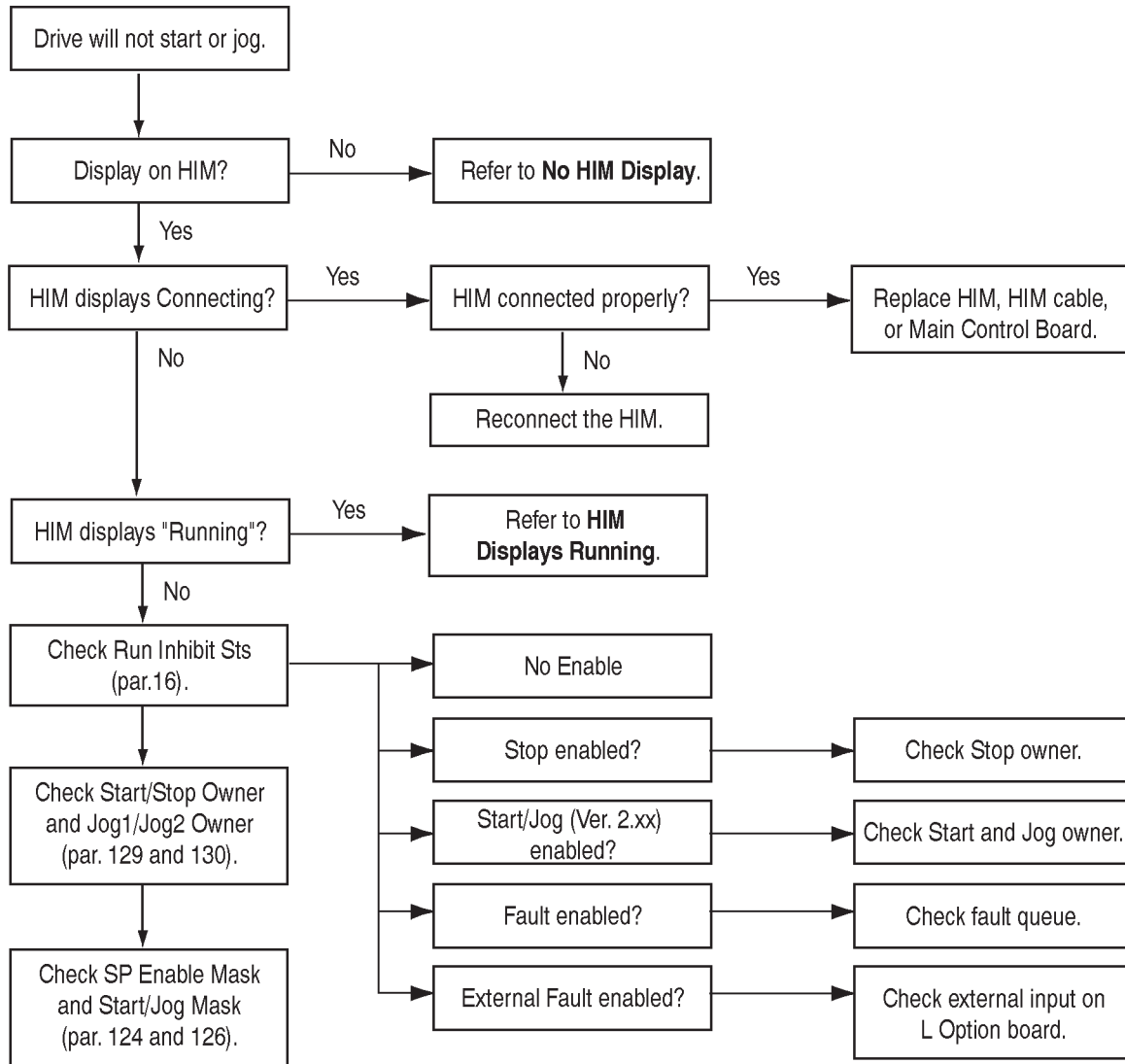

No HIM Display

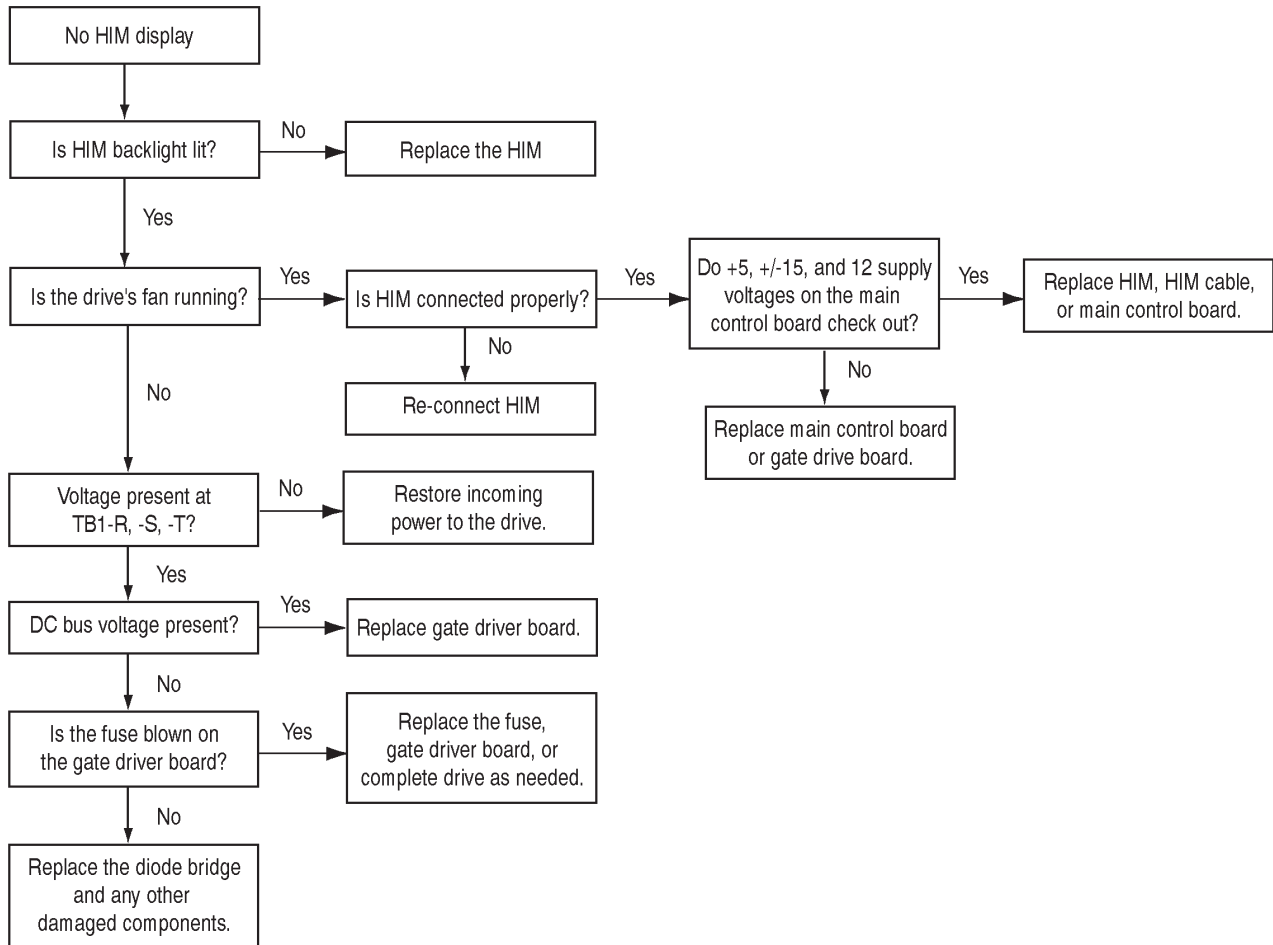

HIM Displays "Running"

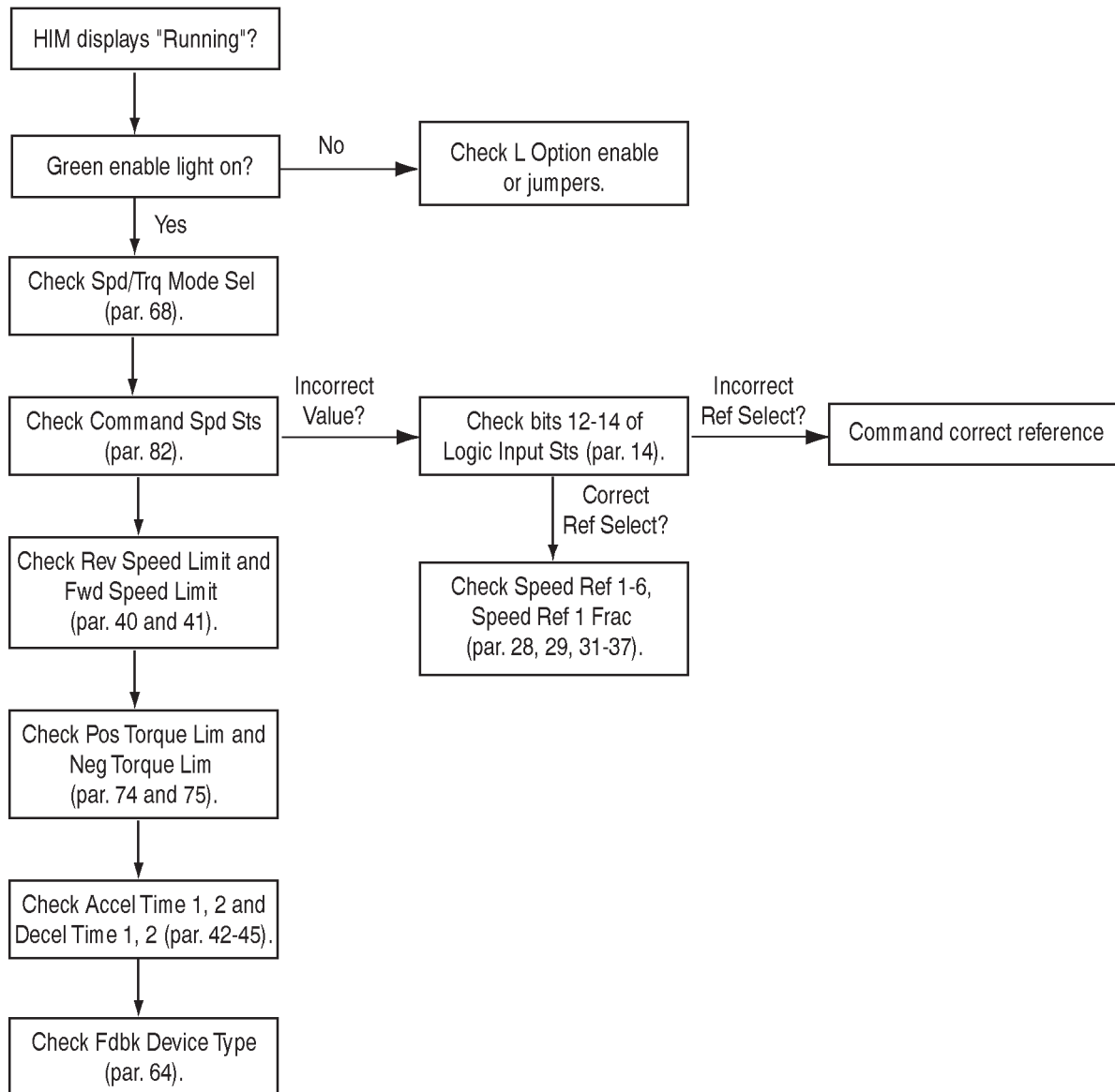

Motor Response Not Where You Want It

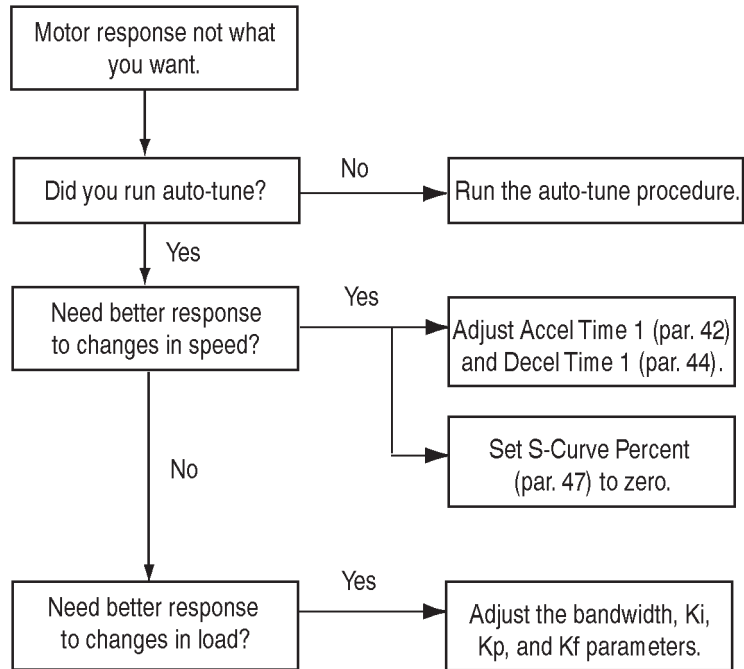

Start Up Troubleshooting Procedures

If you are having problems with the start up procedure, refer to this table for possible solutions before calling for help.

If:	Then:
You powered up your drive and cannot access the start up routine.	The start up procedure is not supported on a Series A Human Interface Module (HIM). To verify that you have a Series A HIM, check the series letter located on the back side of the HIM or check the HIM version when you first power up your drive.
You got a <i>Feedback Loss Fault</i> .	You have specified that an encoder is on the system but it has been disconnected.
The motor does not turn during the phase rotation test.	Remove the load from the motor and try running the autotune tests again. Afterwards, you will need to attach the load again and run the inertia test manually.
During the phase rotation test you were asked to swap the encoder leads. You changed the leads and ran start up again. You were asked to swap the leads again.	<p>The drive is not getting any speed feedback information. You need to:</p> <ul style="list-style-type: none"> • Check the connection between the encoder and the motor. • Run the phase rotation test again and escape out to the status display at the first question. Check the motor speed. It should ramp to 3 Hz (90 rpm) for a 60 Hz 4 pole motor. If the motor speed is 0 rpm, you should: <ul style="list-style-type: none"> • Check the encoder wiring. • Check the encoder itself.

Miscellaneous Troubleshooting Procedures

If you are having problems with how your 1336 IMPACT drive is operating, refer to this table for possible solutions before calling for help.

If:	Then you should:
The drive starts and then stops.	<ul style="list-style-type: none"> • Check if the mode specified in <i>L Option Mode</i> (parameter 116) is 2 or 3 wire. • Check <i>SP 2 Wire Enable</i> (parameter 181). • Check to see if the HIM displays a fault message. • Check the L Option Board wiring. • Check the settings on your gateway (communications module).
There is a delay before the stop command takes effect.	<ul style="list-style-type: none"> • Check the value of <i>Stop Dwell Time</i> (parameter 18).
The motor waits before starting.	<ul style="list-style-type: none"> • Check <i>Start Dwell Time</i> (parameter 194). • Check <i>Pos Torque Lim</i> (parameter 74) and <i>Neg Torque Lim</i> (parameter 75). • Check <i>Fast Flux Level</i> (parameter 78) and bit 8 of <i>Bus/Brake Opts</i> (parameter 13). • Check <i>S-Curve Percent</i> (parameter 47).
The drive coasts on stop.	<ul style="list-style-type: none"> • Check the stop type bits in <i>Logic Options</i> (parameter 17). • Check <i>Zero Speed Tol</i> (parameter 19).

If:	Then you should:
You cannot clear faults.	<ul style="list-style-type: none"> • Check if the port is enabled in <i>SP Enable Mask</i> (parameter 124). • Check if clear faults is enabled in <i>Clr Flt/Res Mask</i> (parameter 127). • Check if clear fault owners in <i>Ramp/ClFlt Owner</i> (parameter 131) is set. If set, check stop owners in <i>Start/Stop Owner</i> (parameter 129) and remove stop conditions. • The fault is a hard fault which requires a power cycle or drive reset.
The motor does not turn or run at the correct speed.	<ul style="list-style-type: none"> • Check which speed reference the drive is following in <i>Drive/Inv Status</i> (parameter 15) bits 13–15. • Check if <i>Spd/Trq Mode Sel</i> (parameter 68) is set correctly. • Check if <i>Spd Desired BW</i> (parameter 161) is non-zero. • Set the drive defaults and run start up again to tune the drive.
The HIM pot does not control motor speed.	<ul style="list-style-type: none"> • Check if <i>SP An In1 Select</i> (parameter 133) or <i>SP An In2 Select</i> (parameter 136) is set to the HIM port number. • Check if <i>SP An In1 Scale</i> (parameter 135) or <i>SP An In2 Scale</i> (parameter 138) is 0.125. • Check if a <i>Speed Ref 1–7</i> (parameters 29 through 36) is linked to <i>SP An In1 Value</i> (parameter 134) or <i>SP An In2 Value</i> (parameter 137). • Check which speed reference the drive is following in <i>Drive/Inv Status</i> (parameter 15) bits 13–15. The speed reference should be set to the speed reference that <i>SP An In1 Value</i> (parameter 134) or <i>SP An In2 Value</i> (parameter 137) is linked to.
The drive will not change direction.	<ul style="list-style-type: none"> • Check if the port is enabled in <i>SP Enable Mask</i> (parameter 124). • Check if Direction is enabled in <i>Dir/Ref Mask</i> (parameter 125). • Check if Direction owner in <i>Dir/Ref Owner</i> (parameter 128) has any bit set. If so, remove the command direction. • Check to make sure that bit 11 in <i>Logic Options</i> (parameter 17) is clear (0).
You cannot change the speed reference.	<ul style="list-style-type: none"> • Check if the port is enabled in <i>SP Enable Mask</i> (parameter 124). • Check if Reference is enabled in <i>Dir/Ref Mask</i> (parameter 125). • Check if Reference owner in <i>Dir/Ref Owner</i> (parameter 128) has any bit set. If so, remove the command reference. If bit 0 (for the L Option control) is set, you need to do one of the following to remove ownership: <ul style="list-style-type: none"> • Clear bit 0 in <i>Dir/Ref Mask</i> (parameter 125). • If <i>L Option Mode</i> (parameter 116) is 2, 3, 8, 9, 23, 24, or 26, close the L Option inputs for speed references 1, 2, and 3.
The drive does not run correct torque.	<ul style="list-style-type: none"> • Set the drive defaults and run start up again to tune the drive. • Check <i>Spd/Trq Mode Sel</i> (parameter 68) and <i>Slave Torque %</i> (parameter 70).
The drive cannot control current and trips on an overcurrent fault.	<ul style="list-style-type: none"> • If you are using an encoder, check that you have entered the correct PPR into <i>Encoder PPR</i> (parameter 8).
The MOP does not work.	<ul style="list-style-type: none"> • Check <i>L Option Mode</i> (parameter 116). • Make sure that <i>Mop Value</i> (parameter 119) is linked to a speed reference.

If:	Then you should:
The pulse input does not work.	<ul style="list-style-type: none"> • Make sure that the pulse input jumper is set correctly. • Make sure that the input is differential and not single ended. • Check the values of <i>Pulse In PPR</i> (parameter 120), <i>Pulse In Scale</i> (parameter 121), and <i>Pulse In Offset</i> (parameter 122). • Check the link on <i>Pulse In Value</i> (parameter 123).
The external fault does not work.	<ul style="list-style-type: none"> • Check the mode in <i>L Option Mode</i> (parameter 116). • Check bit 6 in <i>Fault Select 2</i> (parameter 22) and <i>Warning Select 2</i> (parameter 23).
You keep getting motor overload trips.	<ul style="list-style-type: none"> • Reduce the load. • Check bits 3 and 4 in <i>Fault Select 2</i> (parameter 22) and <i>Warning Select 2</i> (parameter 23). • Check <i>Motor Overload %</i> (parameter 26).
The motor reduced the speed range.	<ul style="list-style-type: none"> • Check <i>SP An In1 Scale</i> (parameter 135) or <i>SP An In2Scale</i> (parameter 138) if your speed input is coming from the HIM pot. • Check <i>An In 1 Offset</i> (parameter 97), <i>An In 1 Scale</i> (parameter 98), <i>An In 2 Offset</i> (parameter 100), <i>An In 2 Scale</i> (parameter 101), <i>mA Input Offset</i> (parameter 103), and <i>mA Input Scale</i> (parameter 104) if your speed input is coming from the analog inputs. • Check <i>Speed Scale 1</i> (parameter 30) or <i>Speed Scale 7</i> (parameter 37). • Check <i>Absolute Overspd</i> (parameter 24). • Check <i>Min Speed Limit</i> (parameter 215).

Encoderless Troubleshooting Procedures

If you are having problems with encoderless mode, refer to this table for possible solutions before calling for help.

If:	Then you should:
<p>The motor will not accelerate or does not start smoothly</p>	<ul style="list-style-type: none"> • Increase the bandwidth in <i>Spd Desired BW</i> (parameter 161). If the bandwidth is too low, the motor may not accelerate, although the current increases to current limit. • If the regen power limit is 0, increase it to at least -5%. • Increase the torque and current limits to the maximum. • Increase the value of <i>Kp Freq Reg</i> (parameter 178).
<p>The motor oscillates after it is up to speed</p>	<ul style="list-style-type: none"> • Decrease the bandwidth in <i>Spd Desired BW</i> (parameter 161) if the process will allow. If this does not help, depending on your application, you need to either increase or decrease the value of <i>Error Filter BW</i> (parameter 162).
<p>The inverter trips on absolute overspeed during starting</p>	<ul style="list-style-type: none"> • Increase the acceleration time. • If the overspeed occurs during a fast acceleration, increase the value of <i>Kp Freq Reg</i> (parameter 178) until the trip stops occurring. • Increase the bandwidth in <i>Spd Desired BW</i> (parameter 161). • If the overspeed occurs during a reversal, increase the deceleration time (slower deceleration).

Disassembly and Access Procedures

Chapter Objectives

This chapter describes general disassembly procedures required to access internal drive components.

Disassembly and Access Overview



ATTENTION: Some printed circuit boards and drive components may contain hazardous voltage levels. Remove and lock out power before you disconnect or reconnect wires and before you remove or replace fuses and circuit boards. Verify bus voltage by measuring the voltage between +DC and –DC on terminal block TB1. Do not attempt to service the drive until the bus voltage has discharged to zero volts.



ATTENTION: Servicing energized industrial control equipment can be hazardous. Electrical shock, burns, or unintentional actuation of controlled industrial equipment may cause death or serious injury. Follow the safety-related practices of NFPA 70E, Electrical Safety for Employee Workplaces, when working on or near energized equipment. Do not work alone on energized equipment.

Electrostatic Discharge Precautions



ATTENTION: This assembly contains parts and sub-assemblies that are sensitive to electrostatic discharge. Static control precautions are required when servicing this assembly. Component damage may result if you ignore electrostatic discharge control procedures. If you are not familiar with static control procedures, reference Rockwell Automation Publication 8000-4.5.2, Guarding Against Electrostatic Discharge, or any other applicable ESD protection handbook.

Electrostatic discharge generated by static electricity can damage the complementary metallic oxide semiconductor devices on various drive boards. It is recommended that you perform these procedures to guard against this type of damage when circuit boards are removed or installed:

- Wear a wrist-type grounding strap that is grounded to the chassis.
- Attach the wrist strap before removing the new circuit board from the conductive packet.
- Remove boards from the drive and immediately insert them into their conductive packets.

Tools

You need the following tools to disassemble and assemble the drive:

- Pliers
- #2 Phillips screwdriver
- 5/16-inch or 8mm socket
- Torque wrench, metered in lb-in. or N-m

Fastener Torque Specifications

Torque Sequence

When mounting components to a drive's heat sink, component-fastener torque sequences and tolerances are crucial to component-to-heat sink heat dissipation.



ATTENTION: Component can be damaged if temporary tightening procedure is not performed to specification.

Two-Point Mounting

The following illustrates temporary and final tightening sequences for components fastened to a heat sink using two screws. Temporary torque is 1/3 (33%) of final torque. The numeric illustration labels are for your assistance. Drive components do not carry these labels.

Figure 3.1
Two-Point Mounting

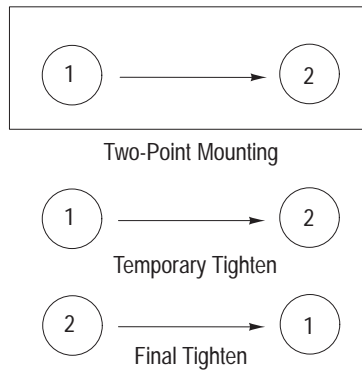

AB0016A

Four-Point Mounting

The following illustrates temporary and final tightening sequences for components fastened to a heat sink using four screws. Temporary torque is 1/3 (33%) of final torque. The numeric illustration labels are for your assistance. Drive components do not carry these labels.

Figure 3.2
Four-Point Mounting

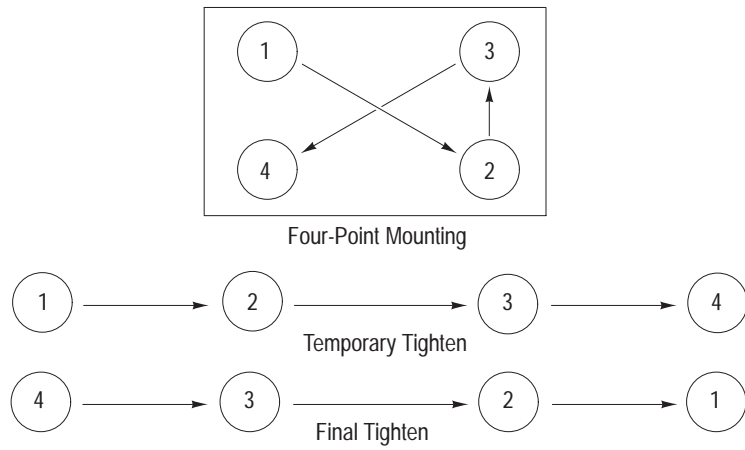

AB0017A

Torque Specifications

The following table lists fastener locations by component, how the fasteners are used, and torque specifications. Refer to Torque Sequence in this chapter for fastening two-point and four-point components to the heat sink.

Table 3.A
Fastener Torque Specifications

Component	Fastener Application	Torque, lb-in.	Torque, N-m
Bus Capacitor Ass'y	Ass'y to chassis	22 – 30	2.5 – 3.4
Gate Driver Board	Driver board to capacitors	22 – 30	2.5 – 3.4
Gate Driver Board	Driver board to inductor	22 – 30	2.5 – 3.4
Gate Driver Board	Module (M5 screw)	22 – 30	2.5 – 3.4
Gate Driver Board	Module (M6 screw)	30 – 39	3.4 – 4.4
Bridge Rectifier BR1	BR1 to Driver board	22 – 30	2.5 – 3.4
Bridge Rectifier BR1	BR1 to heat sink	25 – 31	2.8 – 3.5
Precharge Module	M1 to heat sink	22 – 30	2.5 – 3.4
Precharge Module	M1 to Driver board	22 – 30	2.5 – 3.4
Transistor Modules Q1 – Q3	Module to heat sink	25 – 31	2.8 – 3.5
Inductor	Inductor to chassis	22 – 30	2.5 – 3.4
TB1	Wires to TB1	16	1.8
TB3	Wires to TB3	8 – 10	0.9 – 1.1

Disassembly and Access Procedures

Opening the Drive Enclosure

Figure 3.3
Opening the Drive Enclosure

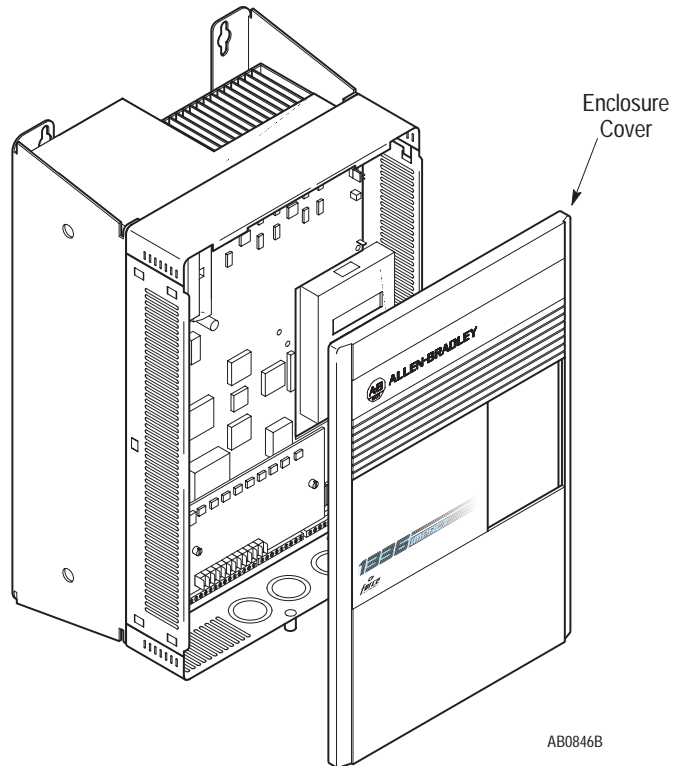

Removal



ATTENTION: Disconnect and lock out power from the drive before disassembling the drive. Failure to disconnect power may result in death or serious injury. Verify bus voltage by measuring the voltage between +DC and -DC on terminal block TB1. Do not attempt to service the drive until the bus voltage has discharged to zero volts.



ATTENTION: Wear a wrist-type grounding strap when servicing 1336 IMPACT drives. Failure to protect drive components against ESD may damage drive components. Refer to Electrostatic Discharge Precautions at the beginning of this chapter.

1. Remove power from the drive.
2. Remove the screws fastening the enclosure cover to the bottom of the Enclosure frame.
3. Pull the bottom of the cover outward to clear the enclosure frame, and then lift the cover upward to remove the cover.
4. Check for zero volts at TB1 terminals +DC and –DC.
5. Check for the absence of control voltage at:
 - TB10
 - TB11
 - L Option Board (if used)
6. Remove the customer-supplied wiring from the drive.
7. Remove the screws from the enclosure frame top and bottom panels to remove the panels.

Installation

Install the Enclosure in reverse order of removal.



ATTENTION: Replace all guards and insulators before applying power to the drive. Failure to replace guards may result in death or serious injury.

Removing the L Option Board

Figure 3.4
L Option Board

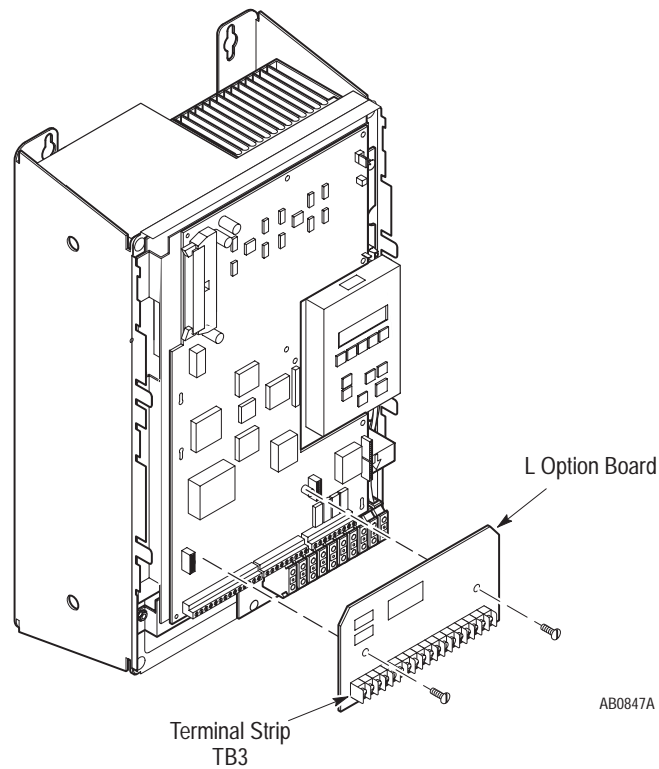

Removal



ATTENTION: Disconnect and lock out power from the drive before disassembling the drive. Failure to disconnect power may result in death or serious injury. Verify bus voltage by measuring the voltage between +DC and -DC on terminal block TB1. Do not attempt to service the drive until the bus voltage has discharged to zero volts.



ATTENTION: Wear a wrist-type grounding strap when servicing 1336 IMPACT drives. Failure to protect drive components against ESD may damage drive components. Refer to Electrostatic Discharge Precautions at the beginning of this chapter.

Important: Before you remove connections and wires from the drive components, mark the connections and wires to correspond with their component connections and terminals to prevent incorrect wiring during assembly.

1. Remove power from the drive.
2. Open the enclosure cover. Refer to Opening the Drive Enclosure in this chapter.
3. Check for zero volts at TB1 terminals +DC and -DC.
4. Check for the absence of control voltage at:
 - TB10
 - TB11
 - L Option Board (if used)
5. Remove all wires from the terminals on TB3.
6. Loosen the two captive screws fastening the L Option Board to the Main Control Board.
7. Grip the right and left sides of the L Option Board and pull the board straight outward from the Main Control Board.

Installation

Install the L Option Board in reverse order of removal.



ATTENTION: Replace all guards and insulators before applying power to the drive. Failure to replace guards may result in death or serious injury.

Removing the Main Control Board Mounting Plate

Figure 3.5
Control Board Mounting Plate

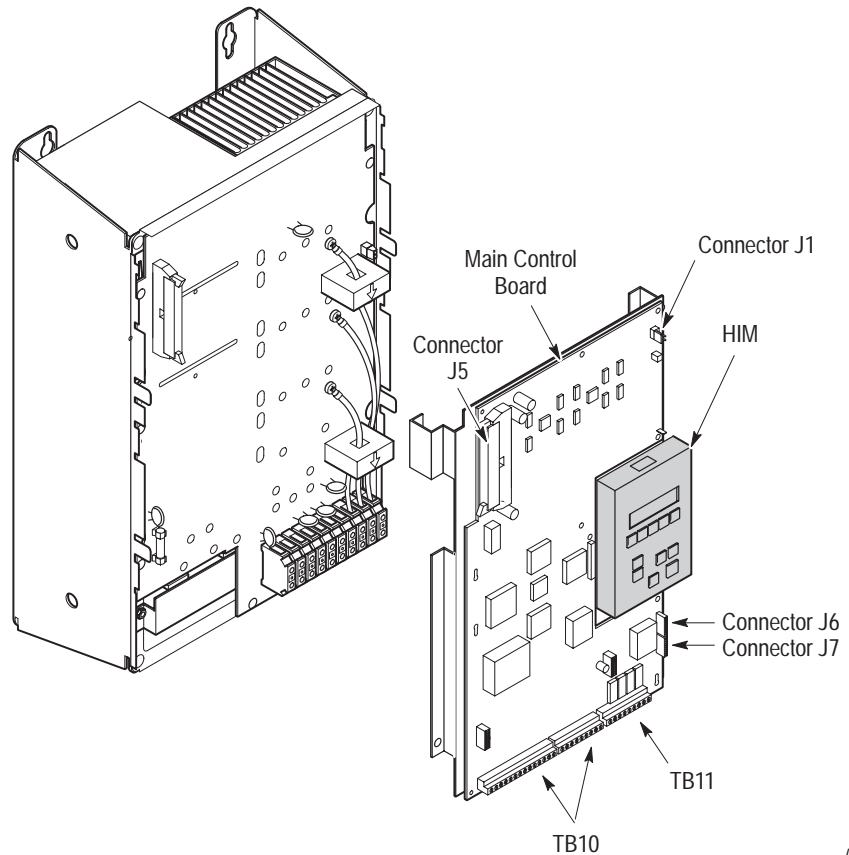

AB0848A

Removal



ATTENTION: Disconnect and lock out power from the drive before disassembling the drive. Failure to disconnect power may result in death or serious injury. Verify bus voltage by measuring the voltage between +DC and -DC on terminal block TB1. Do not attempt to service the drive until the bus voltage has discharged to zero volts.



ATTENTION: Wear a wrist-type grounding strap when servicing 1336 IMPACT drives. Failure to protect drive components against ESD may damage drive components. Refer to Electrostatic Discharge Precautions at the beginning of this chapter.

Important: Before you remove connections and wires from the drive components, mark the connections and wires to correspond with their component connections and terminals to prevent incorrect wiring during assembly.

1. Remove power from the drive.
2. Open the enclosure cover. Refer to Opening the Drive Enclosure in this chapter.
3. Check for zero volts at TB1 terminals +DC and -DC.
4. Check for the absence of control voltage at:
 - TB10
 - TB11
 - L Option Board (if used)
5. Disconnect the following from the Main Control Board:
 - J1 connector
 - J5 ribbon cable connector
 - J7 connector
 - Ground wires from terminal strip TE
 - Chassis ground wire at the top-right corner of the Main Control Board Mounting Plate
6. Loosen the two captive screws near the bottom of the Main Control Board Mounting Plate.
7. Pull the Main Control Board Mounting Plate out about two inches, then slide it downward.

Installation

Install the Main Control Board Mounting Plate in reverse order of removal.



ATTENTION: Replace all guards and insulators before applying power to the drive. Failure to replace guards may result in death or serious injury.

Removing the Main Control Board

Figure 3.6
Main Control Board and Mounting Plate

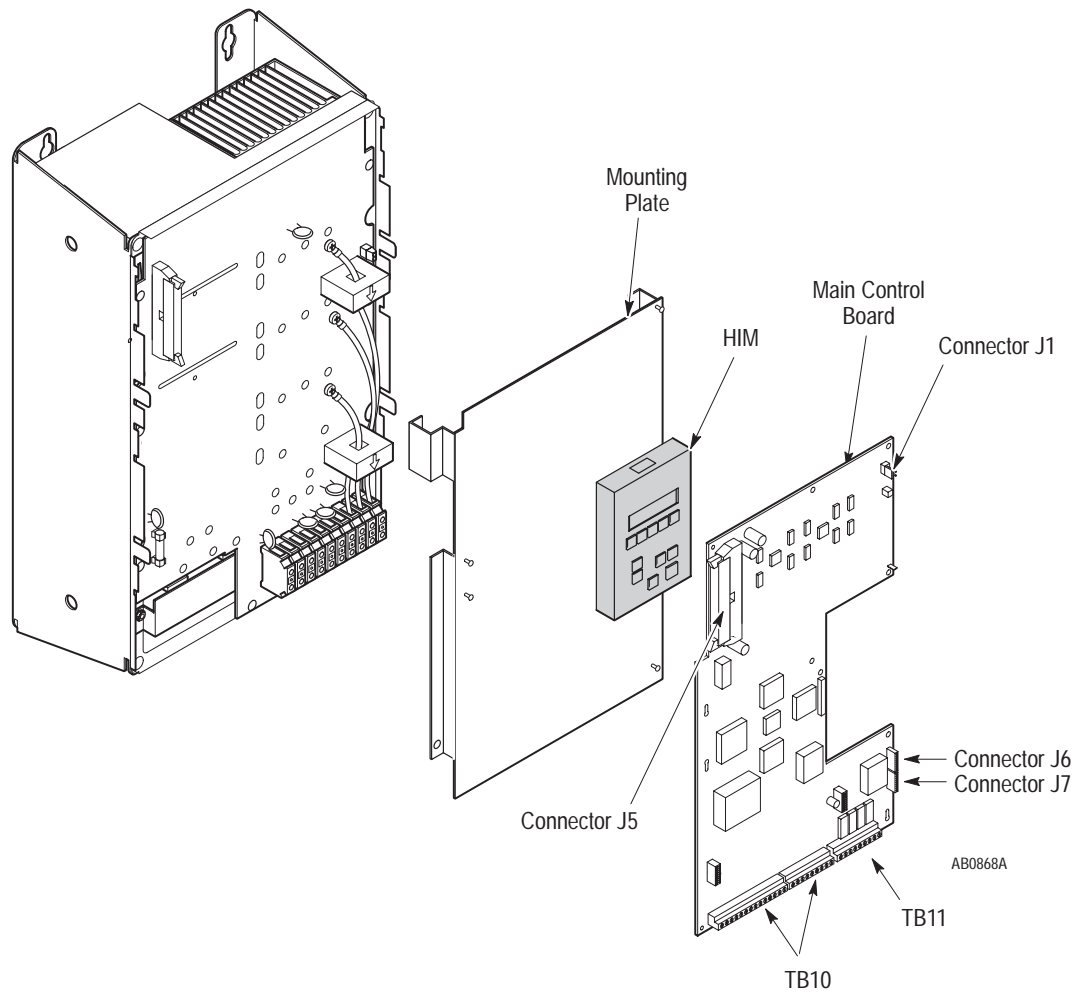

Removal



ATTENTION: Disconnect and lock out power from the drive before disassembling the drive. Failure to disconnect power may result in death or serious injury. Verify bus voltage by measuring the voltage between +DC and -DC on terminal block TB1. Do not attempt to service the drive until the bus voltage has discharged to zero volts.



ATTENTION: Wear a wrist-type grounding strap when servicing 1336 IMPACT drives. Failure to protect drive components against ESD may damage drive components. Refer to Electrostatic Discharge Precautions at the beginning of this chapter.

Important: Before you remove connections and wires from the drive components, mark the connections and wires to correspond with their component connections and terminals to prevent incorrect wiring during assembly.

1. Remove power from the drive.
2. Open the enclosure cover. Refer to Opening the Drive Enclosure in this chapter.
3. Check for zero volts at TB1 Terminals +DC and –DC.
4. Check for the absence of control voltage at:
 - TB10
 - TB11
 - L Option Board (if used)
5. Remove all wires from Terminal Strip TB3 if an L Option Board is used.
6. Disconnect the following from the Main Control Board:
 - J1 connector
 - J5 ribbon cable connector
 - J6 connector
 - J7 connector
 - Ground wire at Stake-on connector
 - All wires from the terminals on TB10 and TB11
7. Remove the screws fastening the Main Control Board to the Main Control Board Mounting Plate.
8. Lift the Main Control Board upward to release it from the slide-mount stand-offs.
9. Pull the Main Control Board away from the Mounting Plate.

Installation

Install the Main Control Board in reverse order of removal.



ATTENTION: Replace all guards and insulators before applying power to the drive. Failure to replace guards may result in death or serious injury.

Removing the Gate Driver/Power Supply Board

Figure 3.7
Gate Driver/Power Supply Board

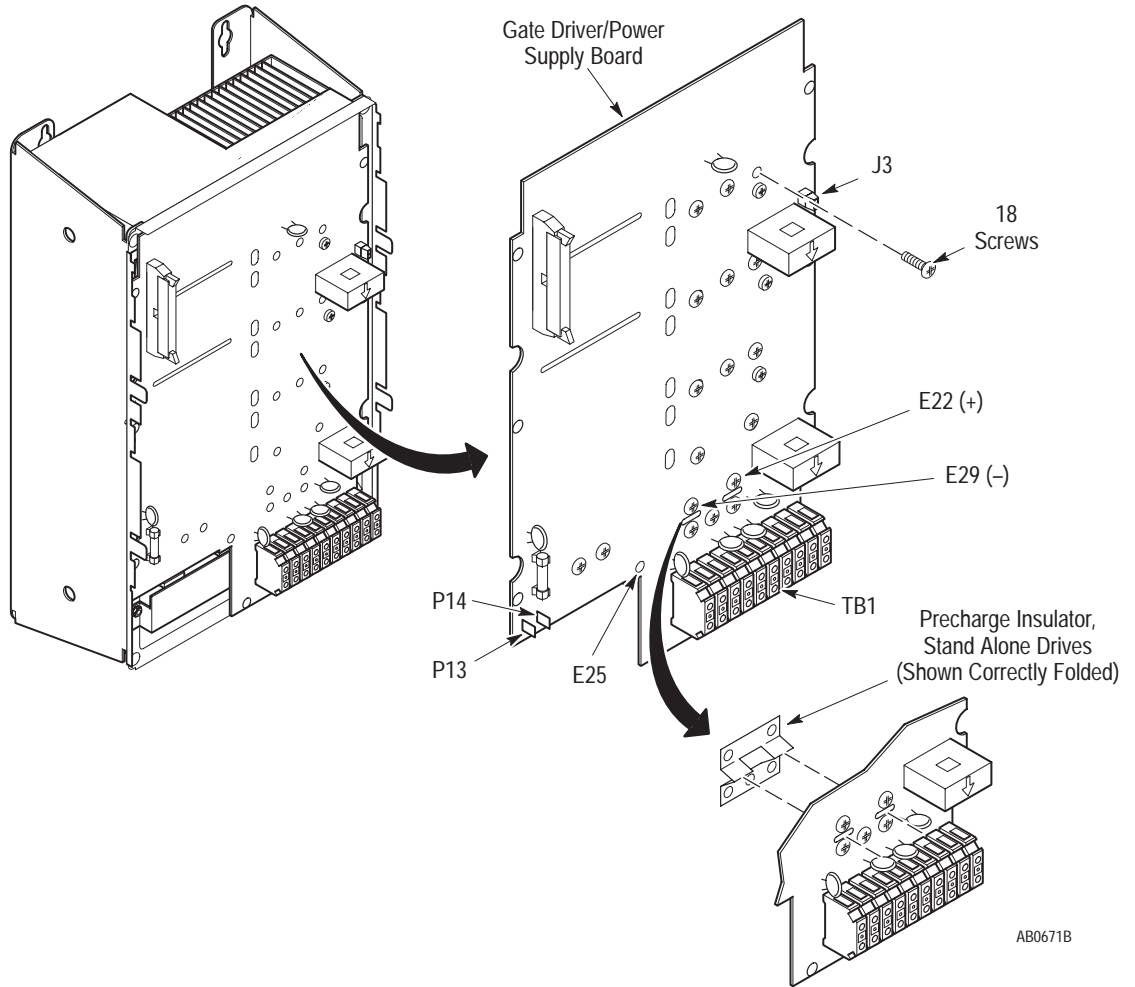

AB0671B

Figure 3.8
Gate Driver/Power Supply Board A007, B015, and C015
Drives

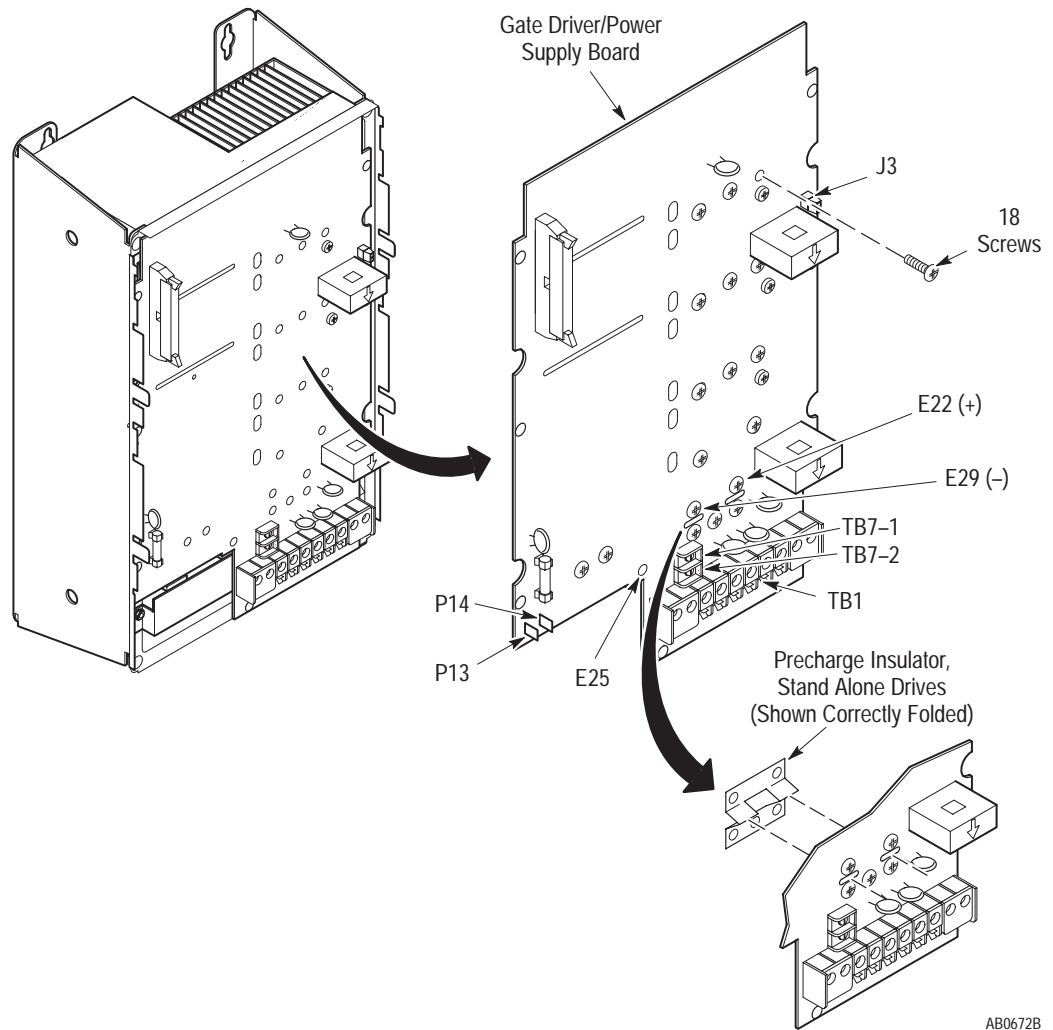

AB0672B

Removal



ATTENTION: Disconnect and lock out power from the drive before disassembling the drive. Failure to disconnect power may result in death or serious injury. Verify bus voltage by measuring the voltage between +DC and -DC on terminal block TB1. Do not attempt to service the drive until the bus voltage has discharged to zero volts.



ATTENTION: Wear a wrist-type grounding strap when servicing 1336 IMPACT drives. Failure to protect drive components against ESD may damage drive components. Refer to Electrostatic Discharge Precautions at the beginning of this chapter.

Important: Before you remove connections and wires from the drive components, mark the connections and wires to correspond with their component connections and terminals to prevent incorrect wiring during assembly.

1. Remove power from the drive.
2. Open the enclosure cover. Refer to Opening the Drive Enclosure in this chapter.
3. Check for zero volts at TB1 terminals +DC and -DC.
4. Check for the absence of control voltage at:
 - TB10
 - TB11
 - L Option Board (if used)
5. Remove the Main Control Board Mounting Plate. Refer to Removing the Main Control Board Mounting Plate in this chapter.
6. Disconnect the following from the Gate Driver/Power Supply Board:
 - P13 stake-on connector
 - P14 stake-on connector
 - E29 – DC Bus Inductor wire
 - E22 + DC Bus Inductor wire
 - DC Bus Inductor wires from TB7
 - E25 ground wire
 - J3 connector fan wires
 - All incoming power wires at terminal block TB1
7. Remove all screws connecting the Gate Driver/Power Supply Board to the power components.

Installation

Install the Gate Driver/Power Supply Board in reverse order of removal. Refer to Table 3.A – Fastener Torque Specifications.

Important: Before positioning the Gate Driver/Power Supply Board in the drive, fold and install the Precharge Insulator through the back of the Gate Driver/Power Supply Board. Refer to Figures 3.7 and 3.8.



ATTENTION: Replace all guards and insulators before applying power to the drive. Failure to replace guards may result in death or serious injury.

Accessing Chassis Power Components

To access the power components located on the chassis, refer to the appropriate Removing the Gate Driver/Power Supply Board section in this chapter.

Component Test Procedures

Chapter Objectives

The following tests help you troubleshoot A007 – A015, B015 – B030, and C015 – C020 drives.

Component Test Overview

In some cases, different tests troubleshoot components of the same name. These similar tests vary according to the rating of the drive being tested. Verify that the rating on the drive matches the rating for the test you are performing.

The procedures in this chapter assume that the drive you are servicing either has no enclosure or that the enclosure is opened. For more information on opening the drive enclosure, refer to Chapter 3 – Disassembly and Access Procedures, Opening the Drive Enclosure.



ATTENTION: Some printed circuit boards and drive components may contain hazardous voltage levels. Remove and lock out power before you disconnect or reconnect wires and before you remove or replace fuses and circuit boards. Verify bus voltage by measuring the voltage between +DC and – DC on terminal block TB1. Do not attempt to service the drive until the bus voltage has discharged to zero volts.



ATTENTION: Servicing energized industrial control equipment can be hazardous. Electrical shock, burns, or unintentional actuation of controlled industrial equipment may cause death or serious injury. Follow the safety-related practices of NFPA 70E, Electrical Safety for Employee Workplaces, when working on or near energized equipment. Do not work alone on energized equipment.

Electrostatic Discharge Precautions



ATTENTION: This assembly contains parts and sub-assemblies that are sensitive to electrostatic discharge. Static control precautions are required when servicing this assembly. Component damage may result if you ignore electrostatic discharge control procedures. If you are not familiar with static control procedures, reference Rockwell Automation Publication 8000-4.5.2, Guarding Against Electrostatic Discharge, or any other applicable ESD protection handbook.

Electrostatic discharge generated by static electricity can damage the complementary metallic oxide semiconductor devices on various drive boards. It is recommended that you perform these procedures to guard against this type of damage when circuit boards are removed or installed:

- Wear a wrist-type grounding strap that is grounded to the chassis.
- Attach the wrist strap before removing the new circuit board from the conductive packet.
- Remove boards from the drive and immediately insert them into their conductive packets.

Tools

You need the following tools to disassemble and assemble the drive:

- Pliers
- #2 Phillips screwdriver
- 5/16-inch or 8mm socket
- Torque wrench, metered in lb-in. or N-m

Test 1 – Testing Bridge Rectifier BR1

Bridge Rectifier BR1 is located on the bottom right of the heat sink.

Figure 4.1
Bridge Rectifier Test

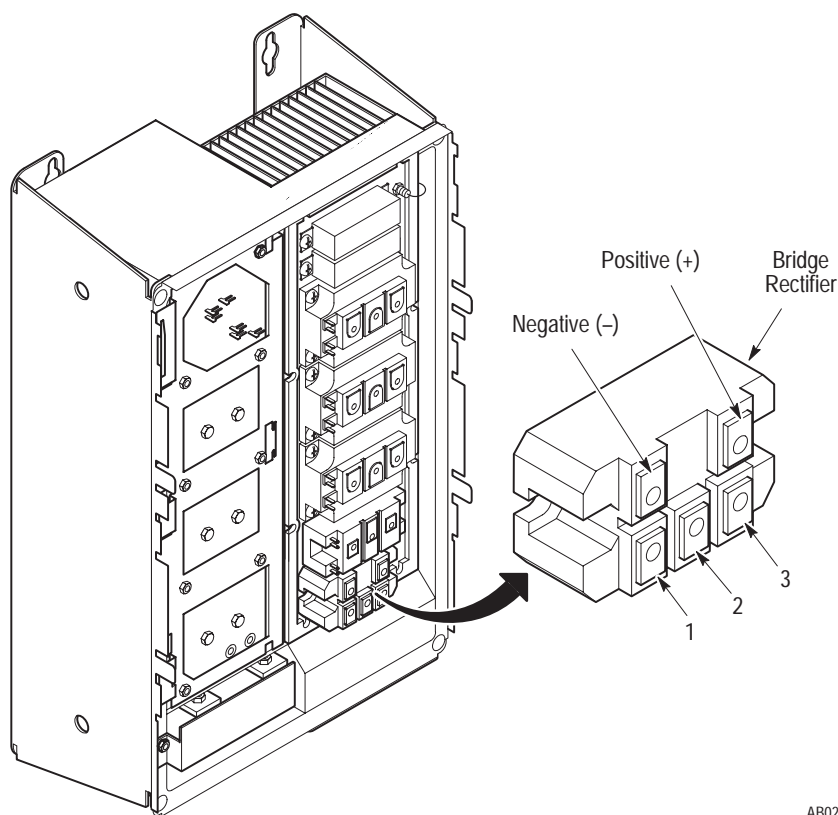

AB0297A



ATTENTION: Disconnect and lock out power from the drive before disassembling the drive. Failure to disconnect power may result in death or serious injury. Verify bus voltage by measuring the voltage between +DC and –DC on terminal block TB1. Do not attempt to service the drive until the bus voltage has discharged to zero volts.

Important: Before you remove connections and wires from the drive components, mark the connections and wires to correspond with their component connections and terminals to prevent incorrect wiring during assembly.

1. Remove power from the drive.
2. Check for zero volts at TB1 terminals +DC and –DC.

3. Check for the absence of control voltage at:
 - TB10
 - TB11
 - L Option Board (if used)
4. Remove the Gate Driver/Power Supply Board. Refer to Chapter 3 – Disassembly and Access Procedures, Removing the Gate Driver/Power Supply Board.
5. Set your meter to test diodes.
6. The following table shows meter connections and ideal meter readings for those connections. Refer to the previous illustration for meter connection locations.

Table 4.A
Bridge Rectifier BR1 Test

Meter (+) Lead	Meter (-) Lead	Nominal Meter Reading
1	+	0.43
2	+	0.43
3	+	0.43
+	1	Infinite
+	2	Infinite
+	3	Infinite
-	1	0.43
-	2	0.43
-	3	0.43
1	-	Infinite
2	-	Infinite
3	-	Infinite

7. Replace BR1 if any readings are not as shown above.
 - Clean all surfaces between the rectifier and the heat sink using a soft, clean cloth.
 - Replace the Preform between the rectifier and the chassis.
 - Fasten the mounting screws. Refer to Chapter 3 – Disassembly and Access Procedures, Table 3.A – Fastener Torque Specifications.
8. If the rectifier shorted, check:
 - Transistor Modules for possible damage.
 - MOV1 for an open/shorted condition.
9. Replace and secure the Gate Driver/Power Supply Board and Main Control Board Mounting Plate.

Test 2 – Testing the Bus Capacitors

The Bus Capacitors are located on the left side of the Main Chassis.

Figure 4.2
Bus Capacitor Test

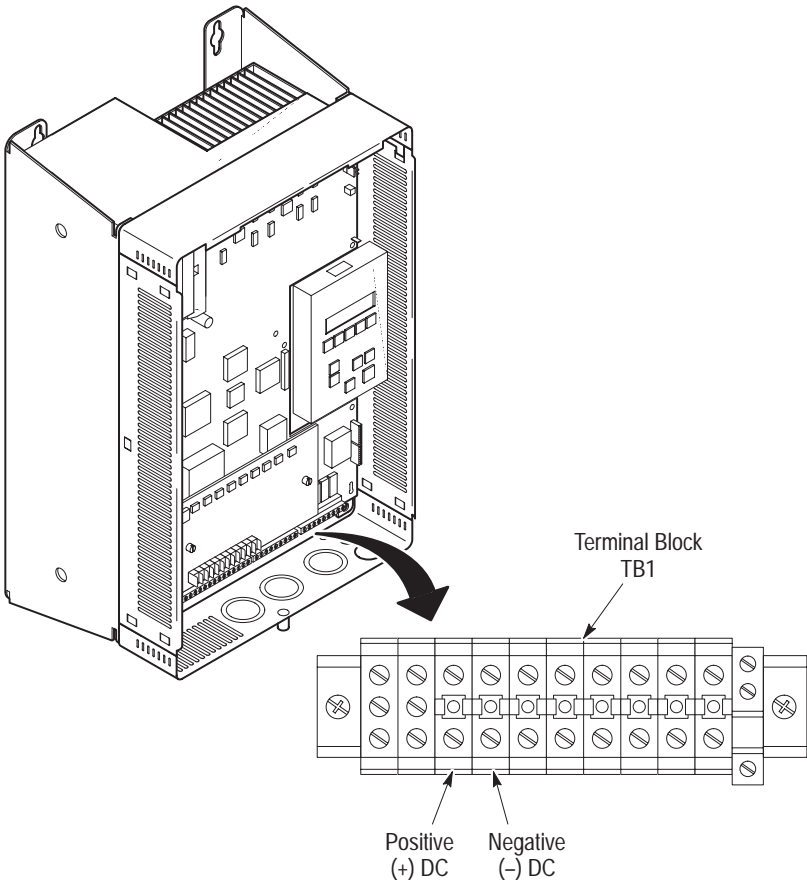

AB0849A



ATTENTION: Disconnect and lock out power from the drive before disassembling the drive. Failure to disconnect power may result in death or serious injury. Verify bus voltage by measuring the voltage between +DC and -DC on terminal block TB1. Do not attempt to service the drive until the bus voltage has discharged to zero volts.

Important: Before you remove connections and wires from the drive components, mark the connections and wires to correspond with their component connections and terminals to prevent incorrect wiring during assembly.

1. Remove power from the drive.
2. Check for zero volts at TB1 terminals +DC and -DC.

3. Check for the absence of control voltage at:
 - TB10
 - TB11
 - L Option Board (if used)
4. Inspect the capacitors for deformation, discoloration, or other indications of high temperature. Replace if damaged. Otherwise, go to Step 5.
5. Set your meter to test voltage.
6. Connect the negative lead of your meter to the (–) DC Bus terminal on TB1 and the positive lead to the (+) DC Bus terminal. Refer to the previous illustration for TB1 terminal locations.



ATTENTION: Servicing energized industrial control equipment can be hazardous. Electrical shock, burns, or unintentional actuation of controlled industrial equipment may cause death or serious injury. Follow the safety-related practices of NFPA 70E, Electrical Safety for Employee Workplaces, when working on or near energized equipment. Do not work alone on energized equipment.

7. Apply power **AFTER** the meter is connected; otherwise, your meter will read zero volts. Expand readings for all input voltage ratings.

Table 4.B
Bus Capacitor Group Test

Drive Rating	Input Volts	Meter Reading
A	200	282V DC +/-5%
	230	325V DC +/-5%
	240	339V DC +/-5%
B	380	537V DC +/-5%
	415	586V DC +/-5%
	480	478V DC +/-5%
C	500	707V DC +/-5%
	575	813V DC +/-5%
	600	850V DC +/-5%

8. If the voltage is out of tolerance, check the following:
 - An open condition at Bridge Rectifier BR1.
 - A voltage drop due to Inductor L1 resistance.
 - A voltage drop between Bridge Rectifier BR1 and the bus capacitors due to loose or resistive wires or connections.
 - Precharge Circuit problems.

-
9. If the above check did not reveal a problem, replace the capacitors and balancing resistors. The balancing resistors are located on the top-right of the heat sink.
 10. Install the nuts fastening the capacitor assembly. Refer to Chapter 3 – Disassembly and Access Procedures, Table 3.A – Fastener Torque Specifications.



ATTENTION: Replace all guards and insulators before applying power to the drive. Failure to replace guards may result in death or serious injury.

Test 3 – Testing Transistor Modules Q1, Q2, and Q3

Transistor Modules Q1, Q2, and Q3 are located near the center of the heat sink.

Figure 4.3
Transistor Module Test

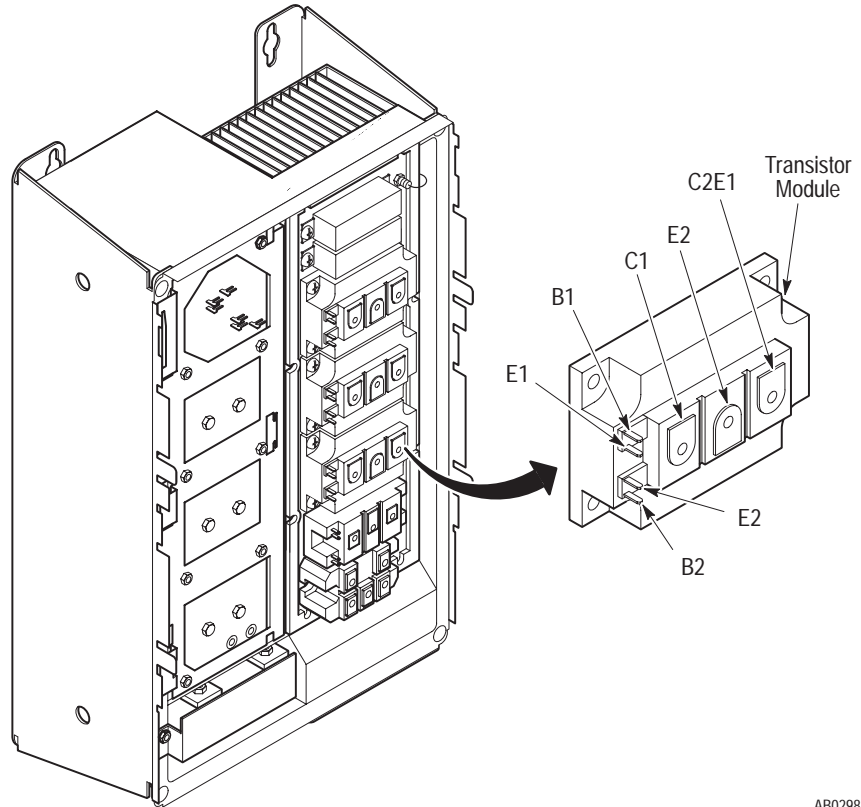

AB0298A



ATTENTION: Disconnect and lock out power from the drive before disassembling the drive. Failure to disconnect power may result in death or serious injury. Verify bus voltage by measuring the voltage between +DC and –DC on terminal block TB1. Do not attempt to service the drive until the bus voltage has discharged to zero volts.

Important: Before you remove connections and wires from the drive components, mark the connections and wires to correspond with their component connections and terminals to prevent incorrect wiring during assembly.

1. Remove power from the drive.
2. Check for zero volts at TB1 terminals +DC and –DC.

3. Check for the absence of control voltage at:
 - TB10
 - TB11
 - L Option Board (if used)
4. Remove the Gate Driver/Power Supply Board. Refer to Chapter 3 – Disassembly and Access Procedures, Removing the Gate Driver/Power Supply Board.
5. Set your meter to test diodes.
6. The following tables show meter connections and ideal meter readings for those connections. Refer to the previous illustration for meter connection locations.

Table 4.C
A007 – A005, B007 – B015, and C007 – C015 Q1, Q2, and Q3 Test

Meter (+) Lead	Meter (-) Lead	Nominal Meter Reading
C2E1	E2	Infinite
E2	C2E1	0.36
C1	C2E1	Infinite
C2E1	C1	0.36
B1	E1	Infinite
B2	E2	Infinite

Table 4.D
B020 – B030 and C020 Q1, Q2, and Q3 Test

Meter (+) Lead	Meter (-) Lead	Nominal Meter Reading	Maximum Meter Reading
C2E1	E2	Infinite/O.L.	-
E2	C2E1	0.34	0.6
C1	C2E1	Infinite/O.L.	-
C2E1	C1	0.34	0.6
B1	E1	Infinite	Infinite
B2	E2	Infinite	Infinite

Important: Check the Transistor Module casings and replace if deformed.

7. If your readings do not match the table readings, replace Transistor Module Q1, Q2, or Q3.
 - Clean all surfaces between the transistor and the heat sink using a soft, clean cloth.
 - Replace the Preform between the transistor and the heat sink.
 - Install the screws fastening the Transistor Module to the heat sink. Refer to Chapter 3 – Disassembly and Access Procedures, Table 3.A – Fastener Torque Specifications.
8. If a Transistor Module is replaced, replace the Precharge Module. Refer to Test 4 – Testing the Precharge Module. You must also test the Gate Driver/Power Supply Board. Refer to Test 5 – Testing the Gate Driver/Power Supply Board.
9. Replace and secure the Gate Driver/Power Supply Board and Main Control Board Mounting Plate.

Test 4 – Testing the Precharge Module

The Precharge Module is located near the bottom of the heat sink.

Figure 4.4
Precharge Module Test

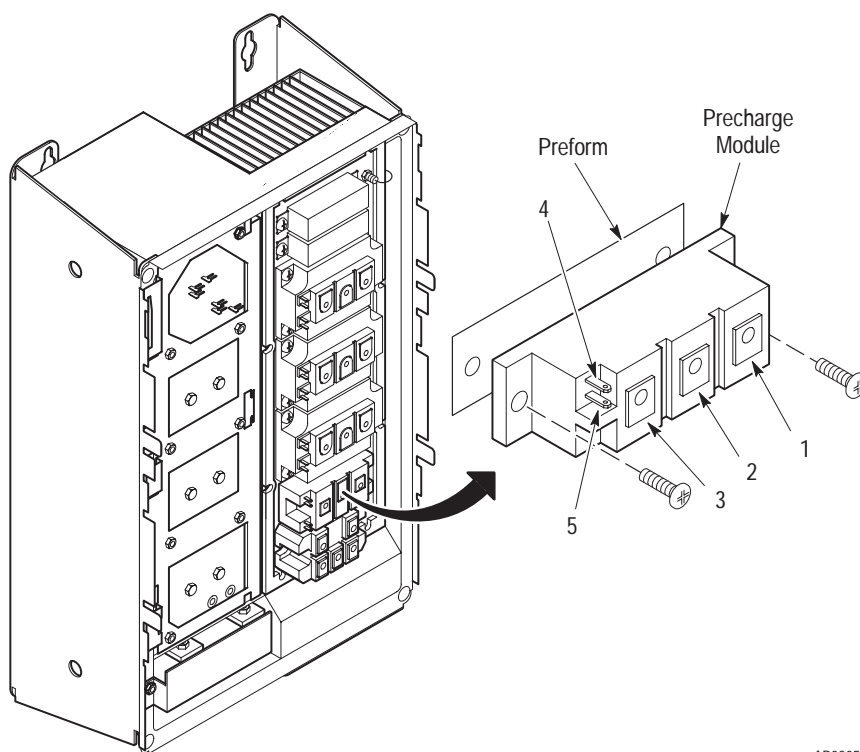

AB0305B



ATTENTION: Disconnect and lock out power from the drive before disassembling the drive. Failure to disconnect power may result in death or serious injury. Verify bus voltage by measuring the voltage between +DC and –DC on terminal block TB1. Do not attempt to service the drive until the bus voltage has discharged to zero volts.

Important: Before you remove connections and wires from the drive components, mark the connections and wires to correspond with their component connections and terminals to prevent incorrect wiring during assembly.

1. Remove power from the drive.
2. Check for zero volts at TB1 Terminals +DC and –DC.
3. Check for the absence of control voltage at:
 - TB10
 - TB11
 - L Option Board (if used)

4. Remove the Gate Driver/Power Supply Board. Refer to Chapter 3 – Disassembly and Access Procedures, Removing the Gate Driver/Power Supply Board.
5. Set your meter to test diodes.
6. Test the module. The following table shows meter connections at the module and ideal meter readings for those connections. Refer to the previous illustration for meter connection locations.

Table 4.E
Precharge Module Diode Test

Meter (+) Lead	Meter (-) Lead	Nominal Meter Reading
1	3	Infinite
3	1	0.42
1	2	Infinite
2	1	Infinite
2	3	Infinite
3	2	Infinite

7. Set your meter to test resistance.
8. Test the module. The following table shows meter connections at the module and ideal meter readings for those connections. Refer to the previous illustration for meter connection locations.

Table 4.F
Precharge Module Resistance Test

Meter (+) Lead	Meter (-) Lead	Nominal Meter Reading
5	4	15
4	5	15
5	3	≈ 23M
5	2	0.00
2	5	0.00
4	2	15
5	1	≈ 10M
4	3	≈ 23M
4	1	≈ 10M

9. If your readings do not match the table readings, replace the Precharge Module.
 - Clean the surfaces between the Precharge Module and the heat sink using a soft, clean cloth.
 - Replace the Preform between the Precharge Module and the heat sink.
 - Fasten the Precharge Module to the heat sink using two screws. Refer to Chapter 3 – Disassembly and Access Procedures, Table 3.A – Fastener Torque Specifications.
10. Replace and secure the Gate Driver/Power Supply Board and Main Control Board Mounting Plate.

Test 5 – Testing the Gate Driver/Power Supply Board

The Gate Driver/Power Supply Board is located between the Main Control Board and the Main Chassis. If one or more Transistor Modules Q1, Q2, or Q3 has been replaced, you must test the Gate Driver/Power Supply Board.

Figure 4.5
Gate Driver/Power Supply Board Test

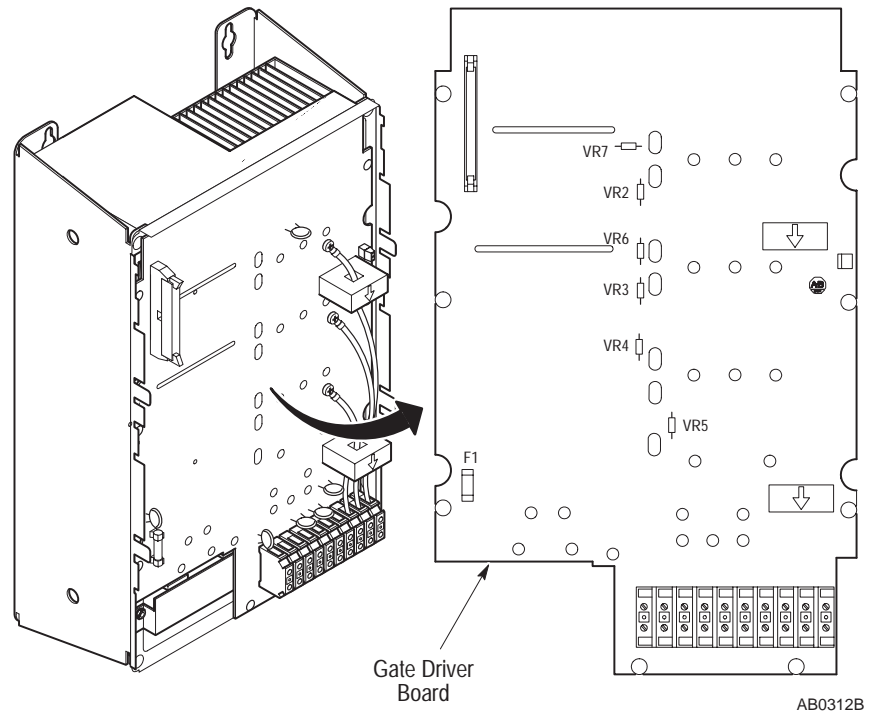

ATTENTION: Disconnect and lock out power from the drive before disassembling the drive. Failure to disconnect power may result in death or serious injury. Verify bus voltage by measuring the voltage between +DC and –DC on terminal block TB1. Do not attempt to service the drive until the bus voltage has discharged to zero volts.

Important: Before you remove connections and wires from the drive components, mark the connections and wires to correspond with their component connections and terminals to prevent incorrect wiring during assembly.

1. Remove power from the drive.
2. Check for zero volts at TB1 terminals +DC and –DC.

3. Check for the absence of control voltage at:
 - TB10
 - TB11
 - L Option Board (if used)
4. Remove the Main Control Board Mounting Plate. Refer to Chapter 3 – Disassembly and Access Procedures, Removing the Main Control Board Mounting Plate.
5. Unplug the connectors from the Gate Driver/Power Supply Board.
6. Set your meter to test resistance.
7. Check Fuse F1, located on the lower left side of the Gate Driver/Power Supply Board, for continuity. Replace the fuse if it shows an open condition.
8. Set your meter to test diodes.
9. Test VR2 through VR7. The following table shows meter connections at the components and ideal meter readings for those connections. Refer to the previous illustration for meter connection locations.

Table 4.G
Gate Driver Board Test

Component	Meter (+) Lead	Meter (-) Lead	Nominal Meter Reading
VR2 - VR7	+	-	1.2
	-	+	2.5

Important: Typical malfunction is shorted in both directions.

10. If your readings do not match the table readings, replace the Gate Driver/Power Supply Board.

Part Replacement Procedures

Chapter Objective

This chapter describes procedures required to replace drive components. This chapter references Chapter 3 – Disassembly and Access Procedures for basic drive component access.

Part Replacement Overview

The part replacement procedures in this chapter assume that the drive you are servicing either has no enclosure or that the enclosure is open. For more information on opening the drive enclosure, refer to Chapter 3 – Disassembly and Access Procedures, Opening the Drive Enclosure.

Safety Precautions



ATTENTION: Some printed circuit boards and drive components may contain hazardous voltage levels. Remove power before you disconnect or reconnect wires and before you remove or replace fuses and circuit boards. Verify bus voltage by measuring the voltage between +DC and –DC on terminal block TB1. Do not attempt to service the drive until the bus voltage has discharged to zero volts.

Electrostatic Discharge Precautions



ATTENTION: This assembly contains parts and sub-assemblies that are sensitive to electrostatic discharge. Static control precautions are required when servicing this assembly. Component damage may result if you ignore electrostatic discharge control procedures. If you are not familiar with static control procedures, reference Rockwell Automation Publication 8000-4.5.2, Guarding Against Electrostatic Discharge, or any other applicable ESD protection handbook.

Electrostatic discharge generated by static electricity can damage the complementary metallic oxide semiconductor devices on various drive boards. It is recommended that you perform these procedures to guard against this type of damage when circuit boards are removed or installed:

- Wear a wrist type grounding strap that is grounded to the chassis.
- Attach the wrist strap before removing the new circuit board from the conductive packet.
- Remove boards from the drive and immediately insert them into their conductive packets.

Tools

You need the following tools to disassemble and assemble the drive:

- Pliers
- #2 Phillips screwdriver
- 5/16-inch or 8mm socket
- Torque wrench, metered in lb-in. or N-m

Major Component Replacement

This section explains in detail how to replace the following drive components:

- Precharge Module
- Thermistor
- Transistor Modules
- Bridge Rectifier BR1
- Fan
- DC Bus Inductor L1
- Bus Capacitors

For Gate Driver/Power Supply Board, Main Control Board, and L Option Board installation and removal procedures, refer to Chapter 3 – Disassembly and Access Procedures.

Detailed Product Identification

Allen-Bradley Adjustable Frequency AC Drives are modular by design to enhance troubleshooting and spare parts replacement, thereby helping reduce production down-time.

The following illustration calls out the main components of a typical drive. Component designs vary slightly among the different drive ratings, but component locations are identical.

Figure 5.1
Main Drive Components

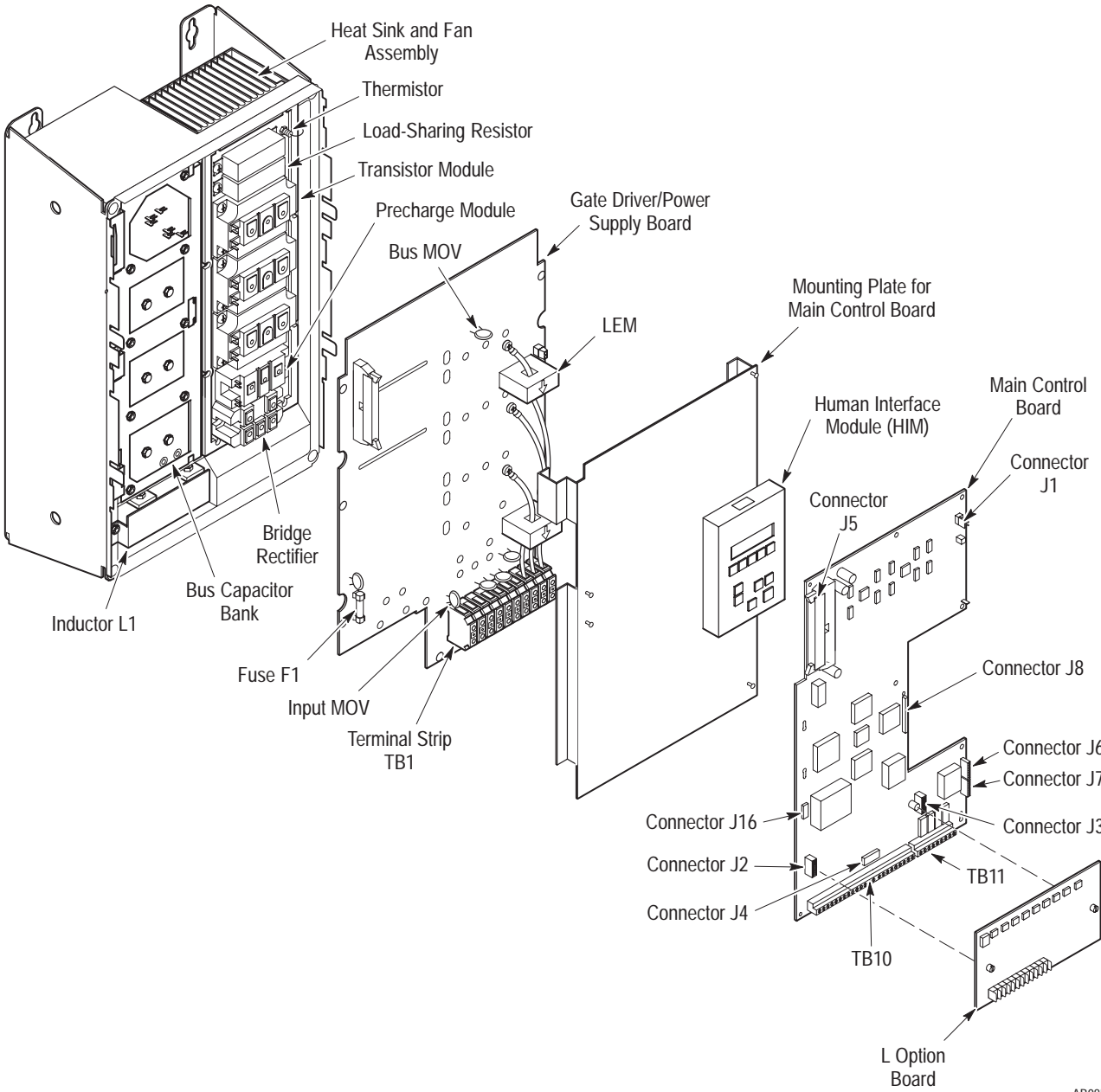

AB0850B

Precharge Module

The Precharge Module is located near the bottom of the heat sink. If one or more Transistor Modules has been replaced, you must replace the Precharge Module.

Figure 5.2
Precharge Module

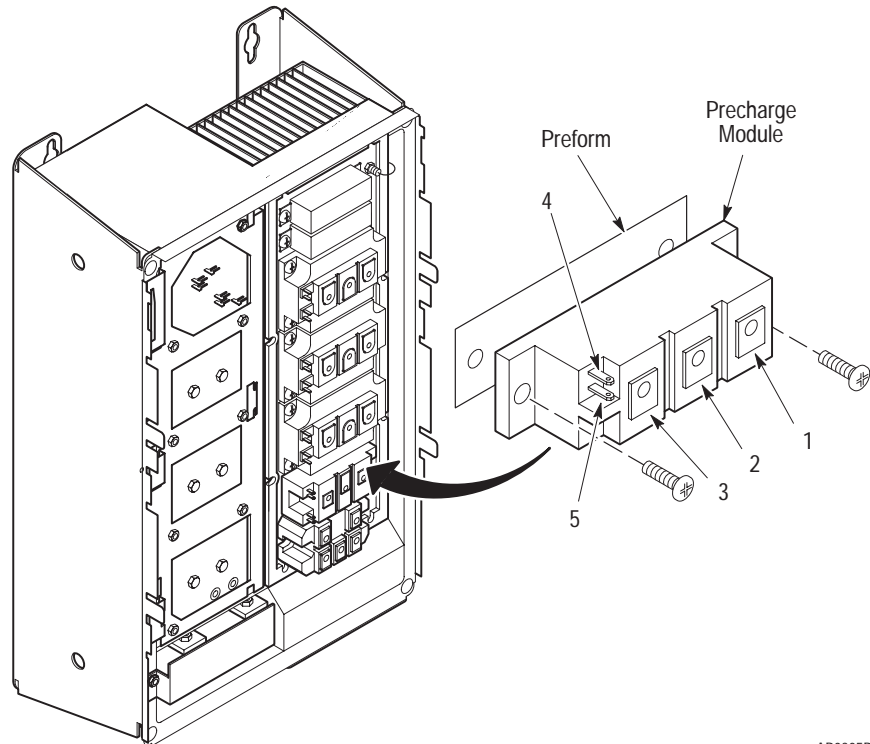

AB0305B

Removal



ATTENTION: Disconnect and lock out power from the drive before disassembling the drive. Failure to disconnect power may result in death or serious injury. Verify bus voltage by measuring the voltage between +DC and -DC on terminal block TB1. Do not attempt to service the drive until the bus voltage had discharged to zero volts.



ATTENTION: Wear a wrist-type grounding strap when servicing 1336 IMPACT drives. Failure to protect drive components against ESD may damage drive components. Refer to Electrostatic Discharge Precautions at the beginning of this chapter.

Important: Before you remove connections and wires from the drive components, mark the connections and wires to correspond with their component connections and terminals to prevent incorrect wiring during assembly.

1. Remove power from the drive.
2. Check for zero volts at TB1 Terminals +DC and –DC.
3. Check for the absence of control voltage at:
 - TB10
 - TB11
 - L Option Board (if used)
4. Remove the Gate Driver/Power Supply Board. Refer to Chapter 3 – Disassembly and Access Procedures, Removing the Gate Driver/Power Supply Board.
5. Remove the two round-head screws fastening the Precharge Module to the heat sink.
6. Remove the Precharge Module from the drive.

Installation

1. Clean surfaces between the Precharge Module and the heat sink.
2. Replace the Preform between the Precharge Module and the heat sink.
3. Install the Precharge Module in reverse order of removal. Refer to Chapter 3 – Disassembly and Access Procedures, Table 3.A – Fastener Torque Specifications.



ATTENTION: Replace all guards and insulators before applying power to the drive. Failure to replace guards may result in death or serious injury.

Thermistor

The Thermistor is fastened to the upper right corner of the heat sink.

Figure 5.3
Thermistor

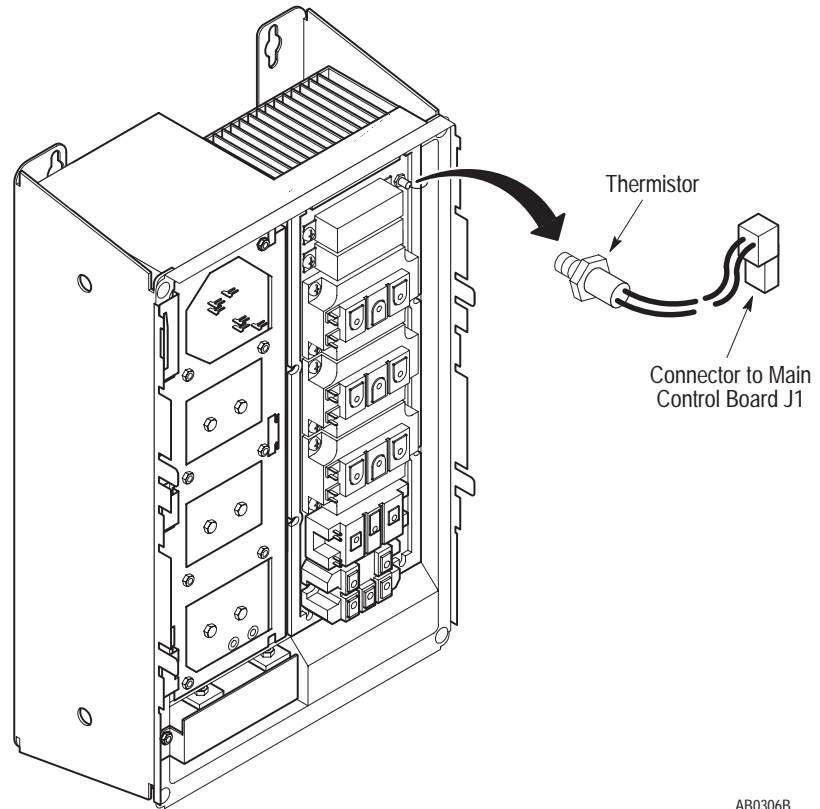

Removal



ATTENTION: Disconnect and lock out power from the drive before disassembling the drive. Failure to disconnect power may result in death or serious injury. Verify bus voltage by measuring the voltage between +DC and -DC on terminal block TB1. Do not attempt to service the drive until the bus voltage has discharged to zero volts.



ATTENTION: Wear a wrist-type grounding strap when servicing 1336 IMPACT drives. Failure to protect drive components against ESD may damage drive components. Refer to Electrostatic Discharge Precautions at the beginning of this chapter.

1. Remove power from the drive.
2. Check for zero volts at TB1 Terminals +DC and –DC.
3. Check for the absence of control voltage at:
 - TB10
 - TB11
 - L Option Board (if used)
4. Remove the Gate Driver/Power Supply Board. Refer to Chapter 3 – Disassembly and Access Procedures, Removing the Gate Driver/Power Supply Board.
5. Unscrew the Thermistor from the heat sink.

Installation

Install the Thermistor in reverse order of removal.

Important: When fastening the Thermistor to the heat sink, hand-tighten the Thermistor to avoid damaging the porcelain Thermistor body.



ATTENTION: Replace all guards and insulators before applying power to the drive. Failure to replace guards may result in death or serious injury.

Transistor Modules

Transistor Modules Q1, Q2, and Q3 are located on the center of the heat sink.

Figure 5.4
Transistor Modules

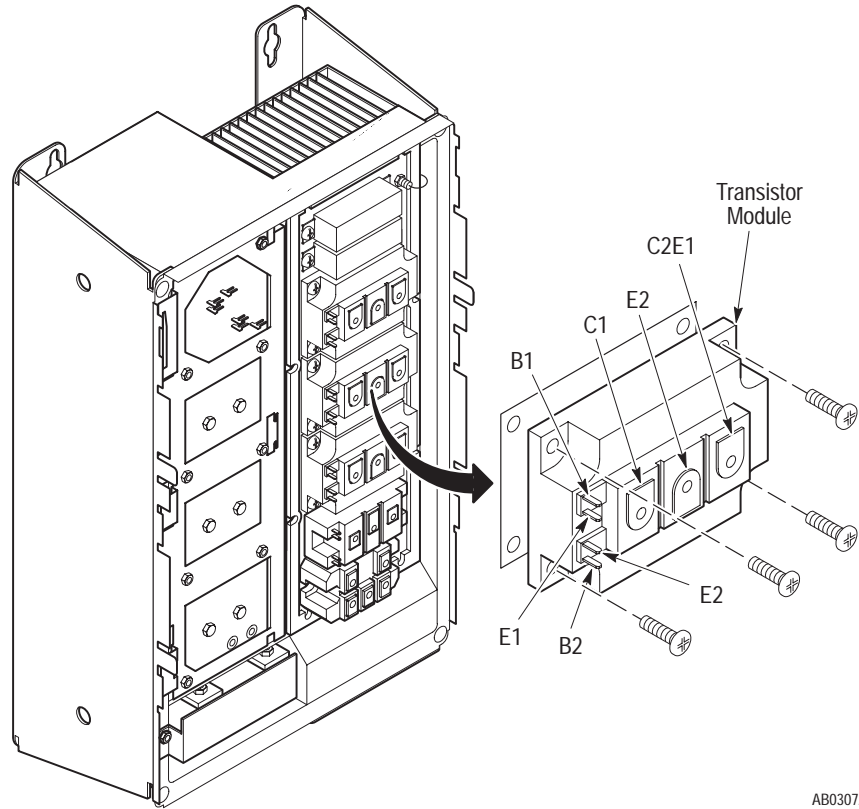

AB0307A

Removal



ATTENTION: Disconnect and lock out power from the drive before disassembling the drive. Failure to disconnect power may result in death or serious injury. Verify bus voltage by measuring the voltage between +DC and -DC on terminal block TB1. Do not attempt to service the drive until the bus voltage has discharged to zero volts.



ATTENTION: Wear a wrist-type grounding strap when servicing 1336 IMPACT drives. Failure to protect drive components against ESD may damage drive components. Refer to Electrostatic Discharge Precautions at the beginning of this chapter.

Important: Before you remove connections and wires from the drive components, mark the connections and wires to correspond with their component connections and terminals to prevent incorrect wiring during assembly.

1. Remove power from the drive.
2. Check for zero volts at TB1 Terminals +DC and -DC.
3. Check for the absence of control voltage at:
 - TB10
 - TB11
 - L Option Board (if used)
4. Remove the Gate Driver/Power Supply Board from the drive. Refer to Chapter 3 – Disassembly and Access Procedures, Removing the Gate Driver/Power Supply Board.
5. Remove all wires connected to the transistor module terminals.
6. Remove the screws fastening the transistor to the heat sink.

Installation

1. Clean all surfaces between the transistor and the heat sink using a soft, clean cloth.
2. Replace the Preform between the transistor and the heat sink.
3. Install the transistor modules in reverse order of removal.
4. Fasten the mounting screws. Refer to Chapter 3 – Disassembly and Access Procedures, Table 3.A – Fastener Torque Specifications.
5. Fasten the terminal screws. Refer to Chapter 3 – Disassembly and Access Procedures, Table 3.A – Fastener Torque Specifications.



ATTENTION: Replace all guards and insulators before applying power to the drive. Failure to replace guards may result in death or serious injury.

Bridge Rectifier BR1

Bridge Rectifier BR1 is located at the bottom of the heat sink.

Figure 5.5
Bridge Rectifier BR1

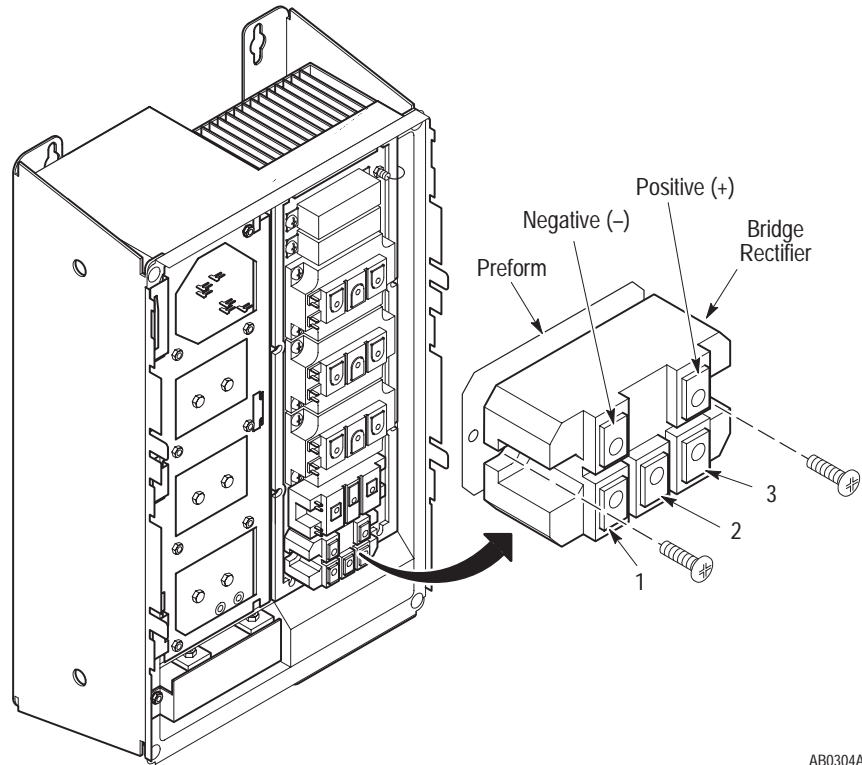

AB0304A

Removal



ATTENTION: Disconnect and lock out power from the drive before disassembling the drive. Failure to disconnect power may result in death or serious injury. Verify bus voltage by measuring the voltage between +DC and -DC on terminal block TB1. Do not attempt to service the drive until the bus voltage has discharged to zero volts.



ATTENTION: Wear a wrist-type grounding strap when servicing 1336 IMPACT drives. Failure to protect drive components against ESD may damage drive components. Refer to Electrostatic Discharge Precautions at the beginning of this chapter.

Important: Before you remove connections and wires from the drive components, mark the connections and wires to correspond with their component connections and terminals to prevent incorrect wiring during assembly.

1. Remove power from the drive.
2. Check for zero volts at TB1 Terminals +DC and –DC.
3. Check for the absence of control voltage at:
 - TB10
 - TB11
 - L Option Board (if used)
4. Remove the Gate Driver/Power Supply Board from the drive. Refer to Chapter 3 – Disassembly and Access Procedures, Removing the Gate Driver/Power Supply Board.
5. Remove the two screws fastening the bridge rectifier to the heat sink.
6. Remove the rectifier from the heat sink.

Installation

1. Clean all surfaces between Bridge Rectifier BR1 and the heat sink using a soft, clean cloth.
2. Replace the Preform between the rectifier and the heat sink.
3. Install the rectifier in reverse order of removal.
4. Fasten the mounting screws. Refer to Chapter 3 – Disassembly and Access Procedures, Table 3.A – Fastener Torque Specifications.
5. Fasten the terminal screws. Refer to Chapter 3 – Disassembly and Access Procedures, Table 3.A – Fastener Torque Specifications.



ATTENTION: Replace all guards and insulators before applying power to the drive. Failure to replace guards may result in death or serious injury.

Fan

The Fan is located behind and to the bottom of the heat sink.

Figure 5.6
Fan

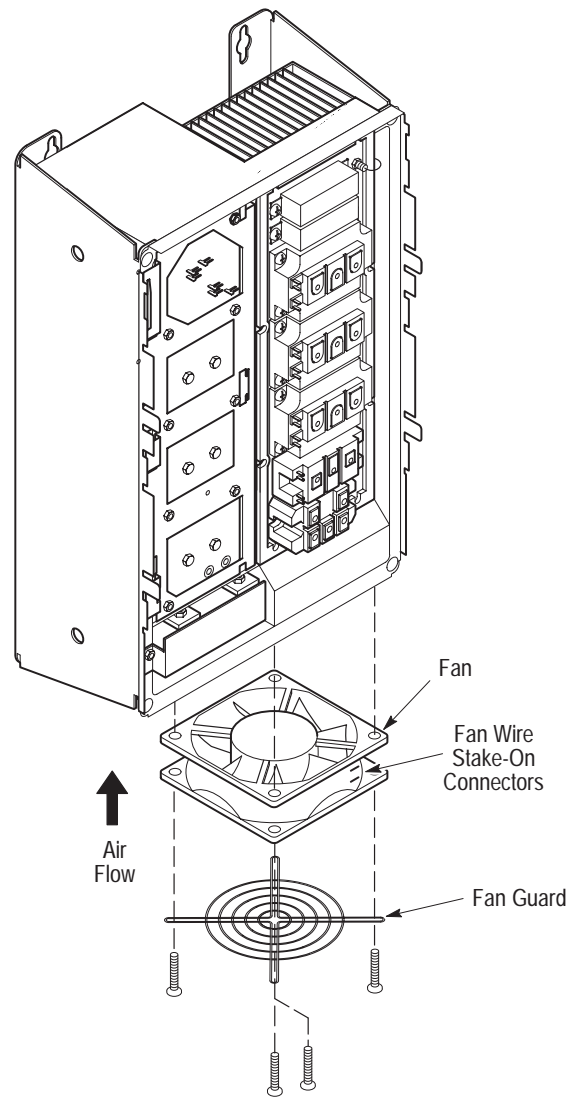

AB0301A

Removal



ATTENTION: Disconnect and lock out power from the drive before disassembling the drive. Failure to disconnect power may result in death or serious injury. Verify bus voltage by measuring the voltage between +DC and -DC on terminal block TB1. Do not attempt to service the drive until the bus voltage has discharged to zero volts.



ATTENTION: Wear a wrist-type grounding strap when servicing 1336 IMPACT drives. Failure to protect drive components against ESD may damage drive components. Refer to Electrostatic Discharge Precautions at the beginning of this chapter.

Important: Before you remove connections and wires from the drive components, mark the connections and wires to correspond with their component connections and terminals to prevent incorrect wiring during assembly.

1. Remove power from the drive.
2. Check for zero volts at TB1 terminals +DC and -DC.
3. Check for the absence of control voltage at:
 - TB10
 - TB11
 - L Option Board (if used)
4. Remove the wire connectors from the terminals on the fan.
5. Remove the four round-head screws fastening the top and bottom of the fan guard to the heat sink.
6. Pull the fan guard and fan away from the heat sink.

Installation

Install the fan in reverse order of removal.

Important: When fastening the fan to the cover plate, position the air flow arrow, located on the top of the fan near the connectors, so it points to the top of the drive. Position the fan connectors to the front, away from DC Bus Inductor L1. Connect the red wire to the positive fan terminal and the black wire to the negative terminal.



ATTENTION: Replace all guards and insulators before applying power to the drive. Failure to replace guards may result in death or serious injury.

DC Bus Inductor

DC Bus Inductor is located on the lower left-hand corner of the Main Chassis.

Figure 5.7
DC Bus Inductor and Gate Driver/Power Supply Board

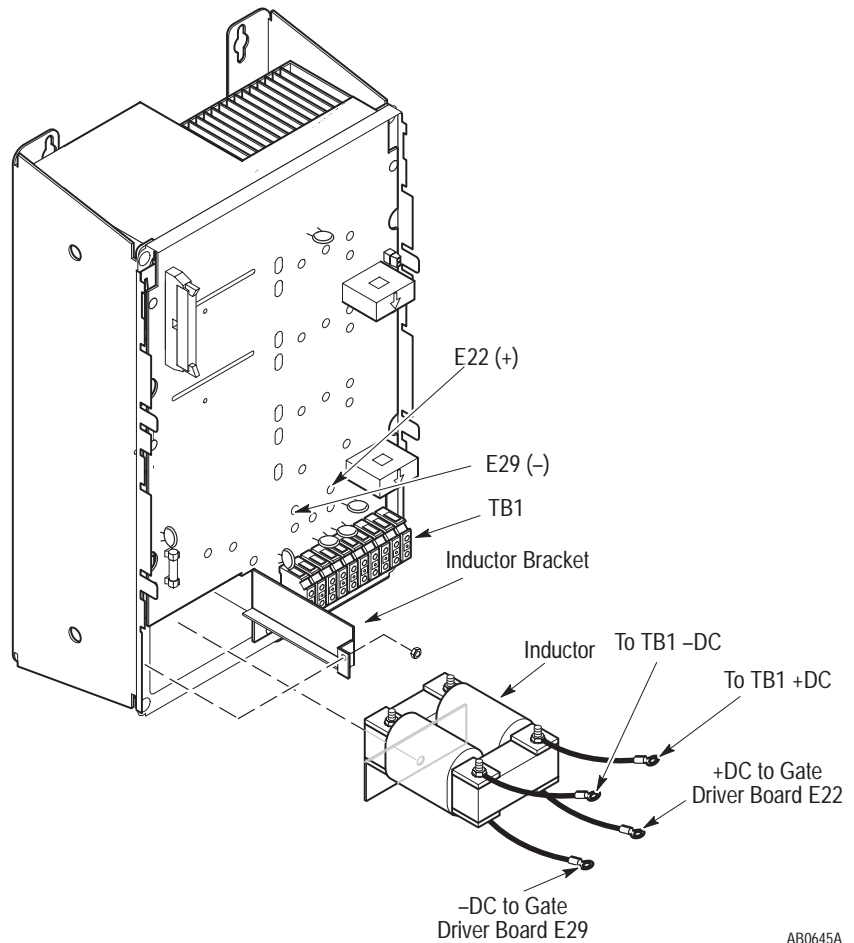

AB0645A

Figure 5.8
DC Bus Inductor and Gate Driver/Power Supply Board,
A007 – A015, B015 – B030, and C015 – C020 Drives.

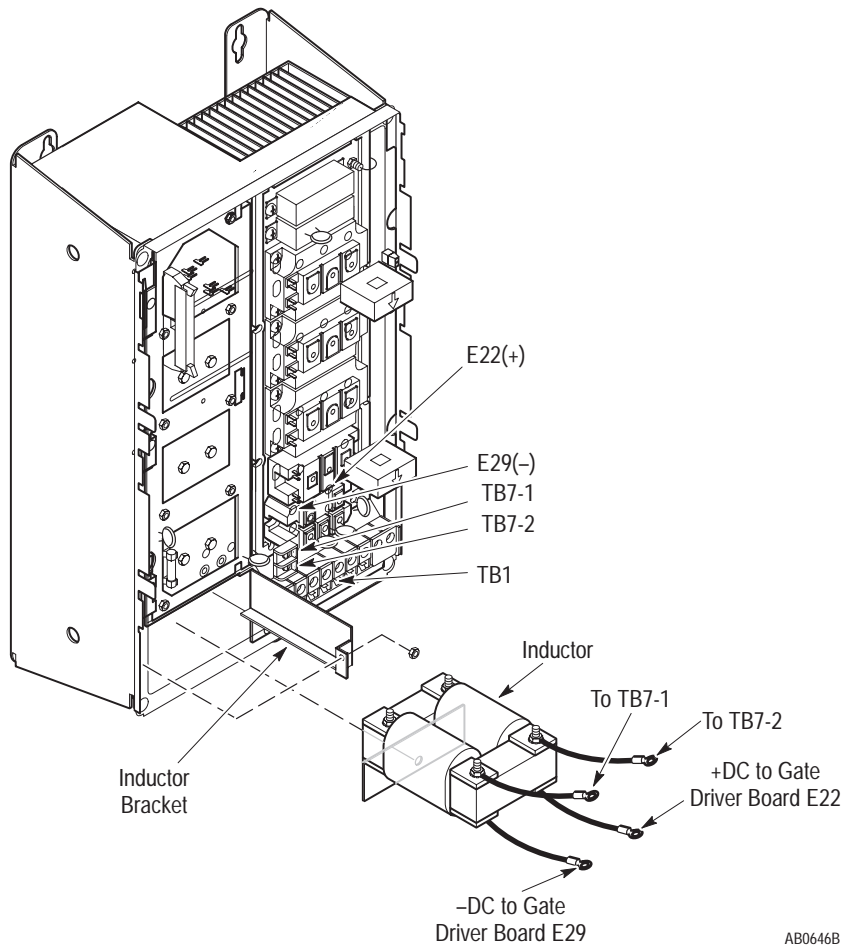

AB0646B

Removal



ATTENTION: Disconnect and lock out power from the drive before disassembling the drive. Failure to disconnect power may result in death or serious injury. Verify bus voltage by measuring the voltage between +DC and –DC on terminal block TB1. Do not attempt to service the drive until the bus voltage has discharged to zero volts.



ATTENTION: Wear a wrist-type grounding strap when servicing 1336 IMPACT drives. Failure to protect drive components against ESD may damage drive components. Refer to Electrostatic Discharge Precautions at the beginning of this chapter.

1. Remove power from the drive.
2. Check for zero volts at TB1 Terminals +DC and –DC.
3. Check for the absence of control voltage at:
 - TB10
 - TB11
 - L Option Board (if used)
4. Remove the Main Control Board Mounting Plate. Refer to Chapter 3 – Disassembly and Access Procedures, Removing the Main Control Board Mounting Plate.
5. Remove the DC Bus Inductor wires from TB1 –DC and TB1 +DC.
6. Remove the nut fastening the inductor bracket to the chassis.
7. Remove the bracket from the DC Bus Inductor to remove the inductor.

Installation

1. Lower the DC Bus Inductor into the Main Chassis. Align the hole in the bottom inductor bracket with the peg on the chassis.

Important: The DC Bus Inductor insulator may shift when the inductor is removed. Before installing the inductor, check the insulator position.

2. Install the DC Bus Inductor in reverse order of removal.



ATTENTION: Replace all guards and insulators before applying power to the drive. Failure to replace guards may result in death or serious injury.

Bus Capacitors

The Bus Capacitors are located on the left side of the Main Chassis. Bus Capacitor sizes and quantities vary according to drive ratings.

Figure 5.9
Bus Capacitors

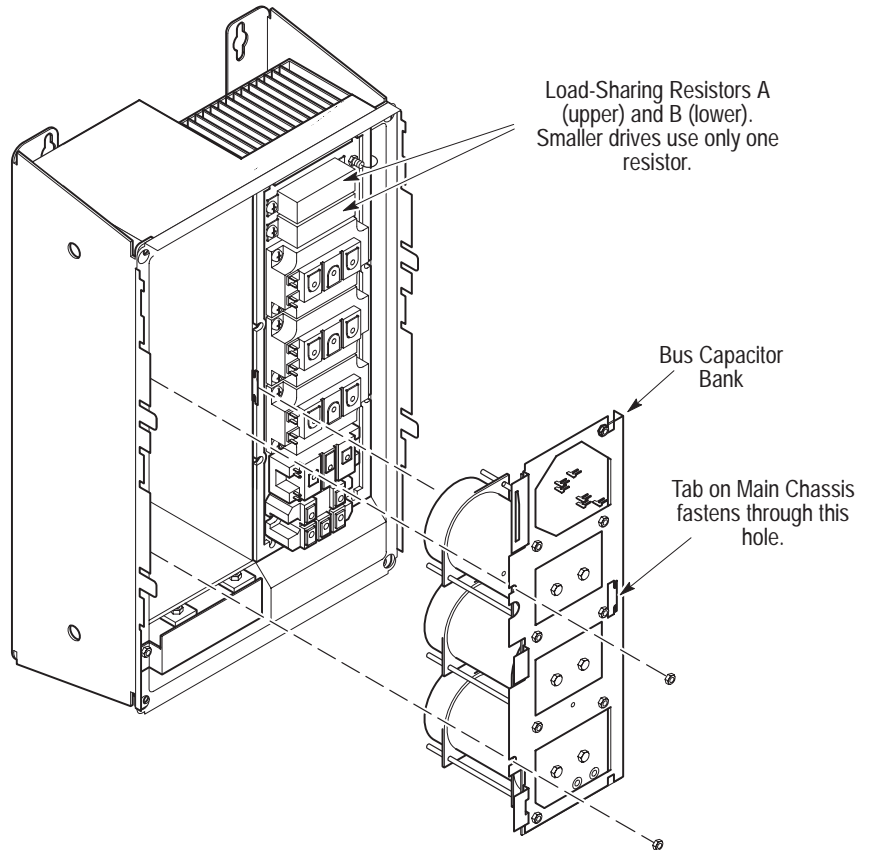

AB0302B

Removal



ATTENTION: Disconnect and lock out power from the drive before disassembling the drive. Failure to disconnect power may result in death or serious injury. Verify bus voltage by measuring the voltage between +DC and -DC on terminal block TB1. Do not attempt to service the drive until the bus voltage has discharged to zero volts.



ATTENTION: Wear a wrist-type grounding strap when servicing 1336 IMPACT drives. Failure to protect drive components against ESD may damage drive components. Refer to Electrostatic Discharge Precautions at the beginning of this chapter.

Important: Before you remove connections and wires from the drive components, mark the connections and wires to correspond with their component connections and terminals to prevent incorrect wiring during assembly.

1. Remove power from the drive.
2. Check for zero volts at TB1 Terminals +DC and -DC.
3. Check for the absence of control voltage at:
 - TB10
 - TB11
 - L Option Board (if used)
4. Remove the Gate Driver/Power Supply Board. Refer to Chapter 3 – Disassembly and Access Procedures, Removing the Gate Driver/Power Supply Board.
5. Remove the Load-Sharing Resistor wires from the connectors on the Bus Capacitor Bank.
6. Remove the two nuts fastening the Bus Capacitor assembly to the chassis.
7. Remove the Bus Capacitor assembly from the Main Chassis.

Installation

1. Fasten the capacitor assembly to the Main Chassis using the two nuts on the left side. Refer to Chapter 3 – Disassembly and Access Procedures, Table 3.A – Fastener Torque Specifications.
2. Connect the Load-Sharing Resistors to the Bus Capacitors according to the following diagrams.

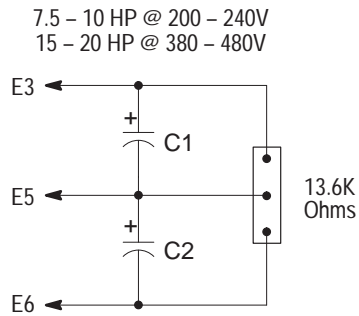
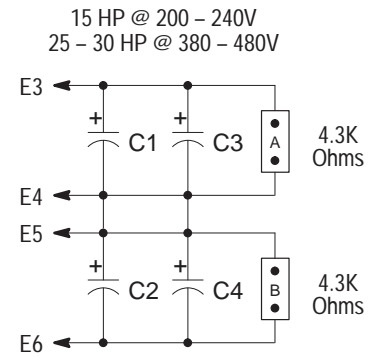
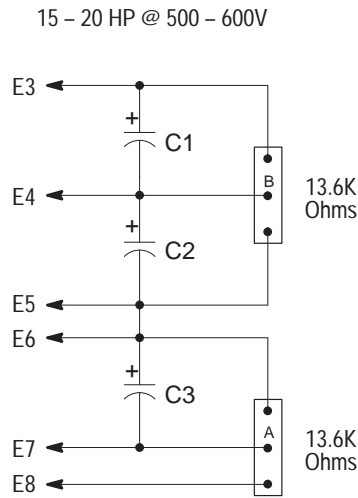

Figure 5.10
Load-Sharing Resistor Connections to Bus Capacitors



AB0313A



ATTENTION: The Capacitor Bus PCB must connect a positive (+) capacitor terminal to a negative (-) capacitor terminal. Capacitors not connected correctly will explode and cause death or serious injury.

Replacement Parts List

Chapter Objectives

This chapter illustrates and lists replacement parts for the 1336 IMPACT Drives rated A007 – A015, B015 – B030, and C015 – C020 and describes replacement parts ordering procedures.

The following illustration and table show you parts, part names, locations, and chapters for replacement procedures.

Ordering Replacement Parts

For your convenience, the Rockwell Automation Drives Division and the Rockwell Automation Support Division provide efficient and convenient repair and exchange for eligible equipment.

A product service report number is required to return any equipment for repair. Your local Rockwell Automation distributor or area sales and support office can provide you with a product service report number.

You should return equipment to be repaired to the area sales and support center nearest you. Reference the product service report number on the carton and packing slip. Include:

- Your company name
- Your company address
- The repair purchase order number
- A brief description of the problem

Contact your local Rockwell Automation distributor or sales office for a complete listing of area sales and support centers near you.

For parts catalog numbers, refer to the 1336 IMPACT Spare Parts Pricing publication included with your drive documentation set. See next page for more information.

Spare Parts Information

Current 1336 IMPACT drive spare parts information including recommended parts, catalog numbers and pricing can be obtained from the following sources:

Allen-Bradley home page on the World Wide Web at

<http://www.ab.com>

then select . . .

“Drives and Motors” *followed by . . .*

“1336 IMPACT from the Product Directory” *and . . .*

“Terchnical Support . . .”

Select "Parts List"

Replacement Parts Listing

Figure 6.1
Parts for A007 – A015, B015 – B030, and C015 – C020 Drives

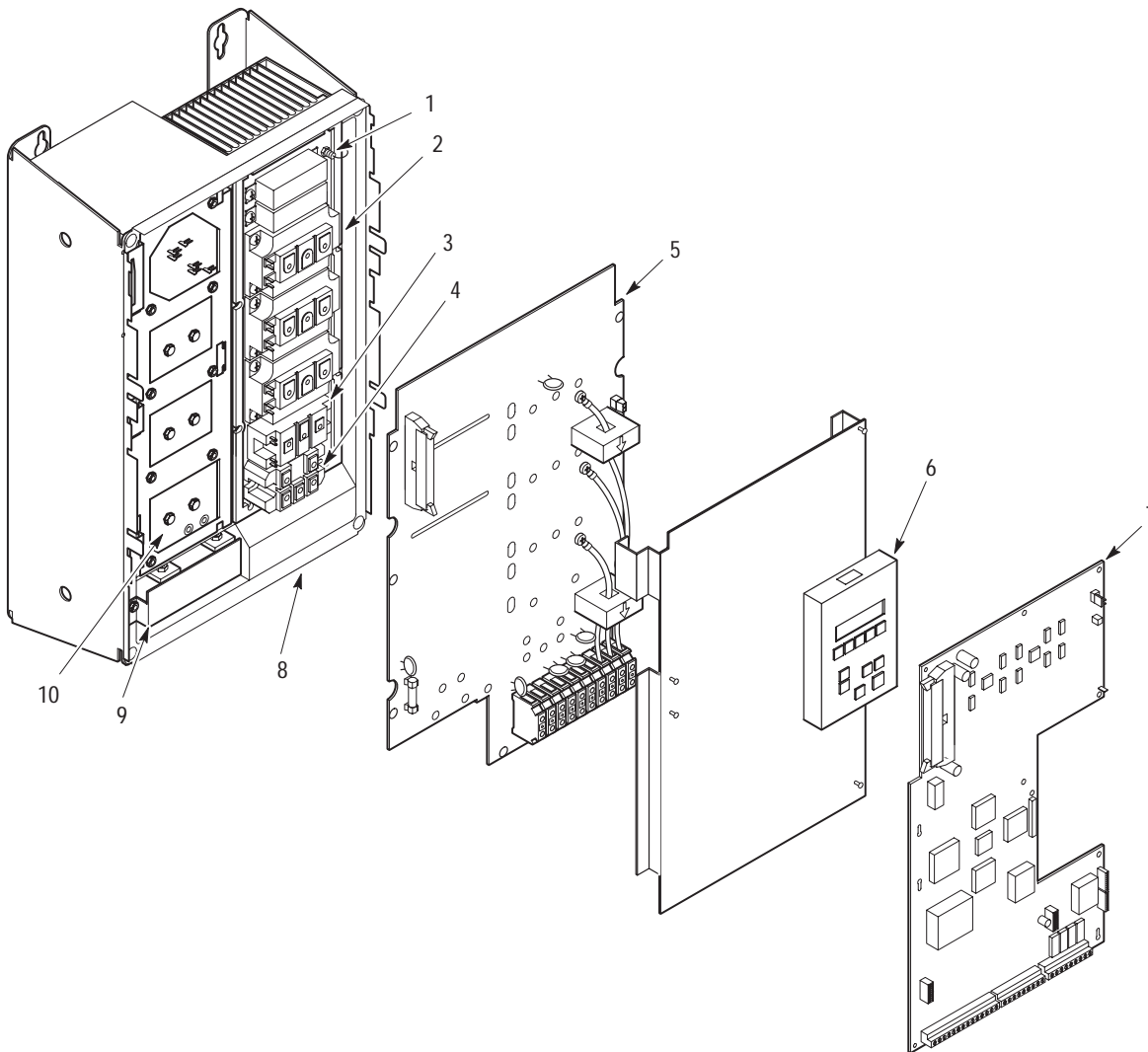

AB0851B

Table 6.A
Replacement Parts for A007 – A015, B015 – B030, and
C015 – C020 Drives

Callout	Symbol	Description	Location	Replacement Procedures
1	ST	Thermistor	Main Chassis	Chapter 5, Thermistor
2	Q1 – 3	Transistor	Main Chassis	Chapter 5, Transistor Modules
3	M1	Precharge Module	Main Chassis	Chapter 5, Precharge Module
4	BR1	Bridge Rectifier	Main Chassis	Chapter 5, Bridge Rectifier BR1
5	BASEDR/ PWRSPPLY	Gate Driver/Power Supply PCB	–	Chapter 3, Removing the Gate Driver/Power Supply Board
6	LOCAL DIS	Human Interface Module	Main Control Board Mounting Plate	Chapter 3, Removing the HIM
7	MAIN CTL	Main Control PCB	Main Control Board Mounting Plate	Chapter 3, Removing the Main Control Board
8	FAN	Fan	Main Chassis	Chapter 5, Fan
9	L1	DC Bus Inductor	Main Chassis	Chapter 5, DC Bus Inductor L1
10	C1 – C4	Bus Capacitors	Main Chassis	Chapter 5, Bus Capacitors

**Schematics — 15 – 30 HP 1336 IMPACT
Drives**

CAP BANK DETAILS

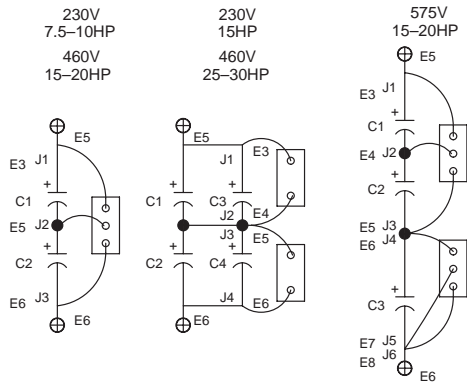

ALL CAPS ARE CONNECTED TOGETHER BY PCB ARTWORK

STANDALONE CONFIGURATION

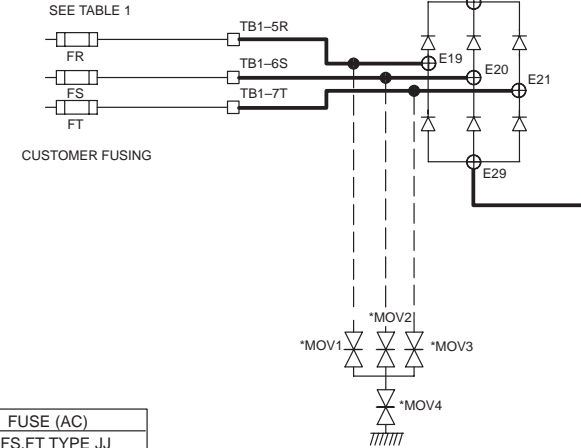

HP	VOLTAGE	FUSE (AC)
		FR,FS,FT TYPE JJ
7.5	230	35
10	230	45
15	230	70
15CT 20VT	380/460	35
20CT 25VT	380/460	45
25CT 30VT	380/460	60
30CT 30IEC	380/460	70
15	575	25
20	575	35

STAND ALONE UNIT
 BULLETIN 1336 IMPACT
 200-240 Volt: 5.5-11 kW (7.5-15 HP)
 380-480 Volt: 11-22kW (15-30 HP)
 500-600 Volt: 11-15KW (15-20 HP)

AB0753A

Main Control Board

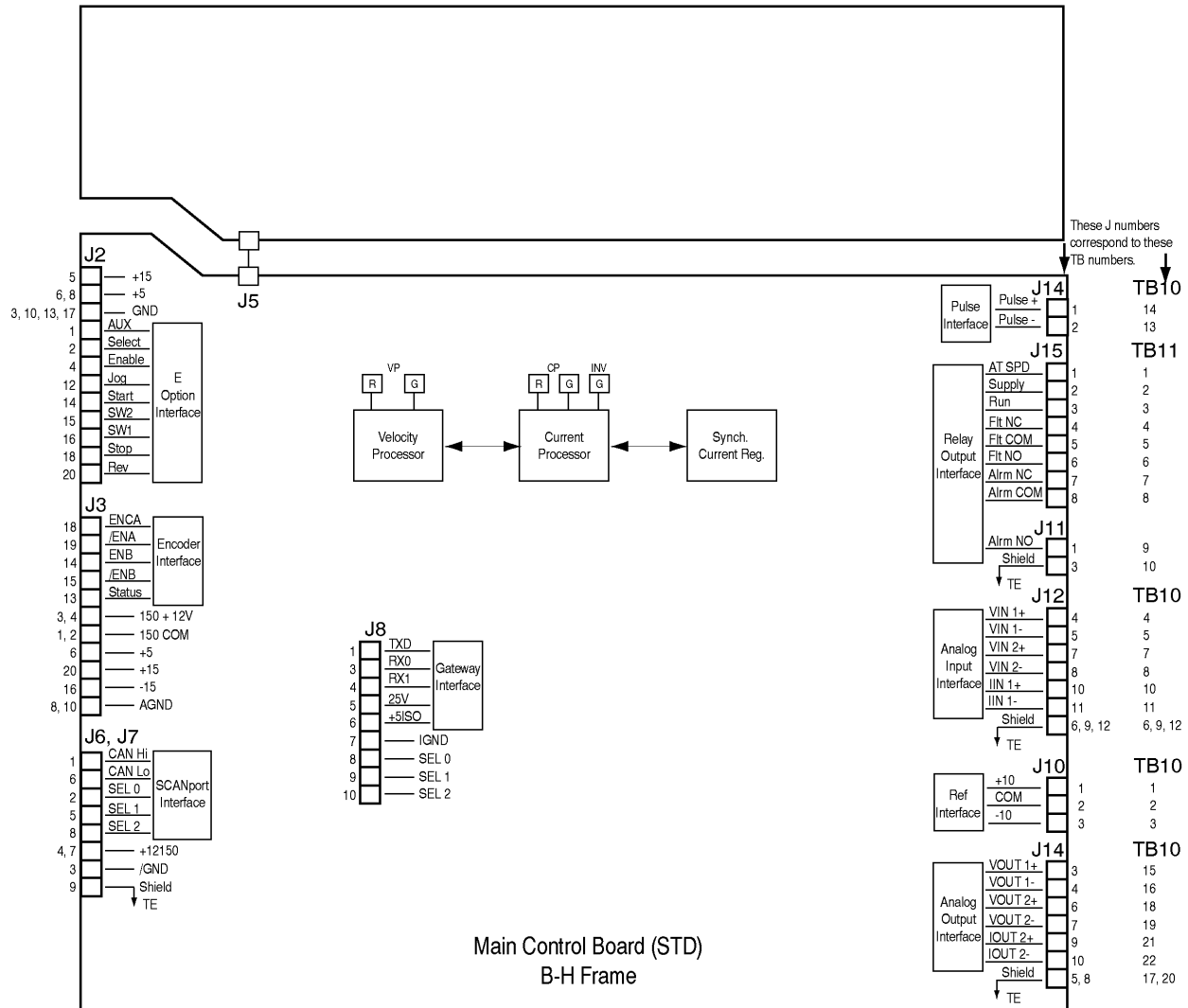

A

Adapter Locations, 1–10
Audience for this Manual, P–1
Auxiliary Interlock, Definition, P–8

B

Bit, Definition, P–8
Bridge Rectifier
 Illustration, 5–10
 Installation, 5–11
 Removal, 5–10
 Test, 4–3
Bus Capacitor
 Illustration, 5–17
 Installation, 5–18
 Removal, 5–17
 Test, 4–5

C

Check, Definition, P–8
Component Test Procedures, 4–1
Connector, Definition, P–9
Control Firmware Function, 1–14
Control Interface L Option Board. *See* L
 Option Board
Control Logic Wiring, 1–1
Conventions in this Manual, P–8

D

DC Bus Inductor (Series C and D)
 Illustration, 5–14
 Installation, 5–16
 Removal, 5–15
Default, Definition, P–9
Drive
 Enclosure Type, P–8
 Identification, P–4
 Illustration, 5–3
 Nameplate Location, P–3
 Rating, P–7
Drive Enclosure
 Illustration, 3–5
 Installation, 3–6
 Removal, 3–5
DriveTools, 1–14

E

Electrostatic Discharge, P–2
Enable Input, Definition, P–9
Enclosure Type, P–8
Encoderless, 2–23
ESD, P–2

F

False, Definition, P–9
Fan
 Illustration, 5–12
 Installation, 5–13
 Removal, 5–12
Faults, 2–1
 Absolute Overspd, 2–7
 Analog Sply Tol, 2–7
 Autotune Diag, 2–4
 Bus Cycle >5, 2–14
 Bus Drop, 2–13
 Bus Undervlt, 2–13
 Clear Queue, 2–3
 Desaturation, 2–12
 Diff Drv Type, 2–7
 EE Checksum, 2–7
 External Flt In, 2–8
 Feedback Loss, 2–20
 Ground Fault, 2–13
 HW Malfunction, 2–6, 2–15
 Inv Overload, 2–5
 Inv Overtmp Pnd, 2–5
 Inv Overtmp Trp, 2–5
 InvOvld Pend, 2–5
 mA Input, 2–7
 Math Limit, 2–8
 Mtr Stall, 2–4
 MtrOvrd Pnd, 2–4
 MtrOvrd Trp, 2–4
 Open Circuit, 2–14
 Overcurrent, 2–13
 Overvoltage, 2–12
 Param Limit, 2–8
 Prechg Time, 2–13
 Ridethru Time, 2–13
 SP 1 Timeout, 2–9
 SP 2 Timeout, 2–9
 SP 3 Timeout, 2–9
 SP 4 Timeout, 2–10
 SP 5 Timeout, 2–10
 SP 6 Timeout, 2–10

- SP Error, 2-10
- Spd Fdbk Loss, 2-8
- SW Malfunction, 2-7
- Viewing Queue with HIM, 2-2
- Feedback Loss Fault, 2-20
- Four-Point Mounting, 3-3

G

- Gate Driver/Power Supply Board, Test, 4-14
- Gate Driver/Power Supply Board (Series C and D)
 - Illustration, 3-13, 3-14
 - Installation, 3-16
 - Removal, 3-14
- GPT. *See* Graphic Programming Terminal
- Graphic Programming Terminal
 - Description, 1-13
 - Illustration, 1-13

H

- Human Interface Module (HIM)
 - Adapter Locations, 1-10
 - Description, 1-9
 - Illustration, 1-10
 - Operation, 1-12
 - Removal, 1-11
 - Viewing Fault/Warning Queues, 2-2

I

- Identification, Product, P-3
- Input Mode. *See* L Option Mode
- Inputs, Available, 1-4

J

- Jumper, Definition, P-9

L

- L Option Board, 1-3
 - Definition, P-9
 - Illustration, 3-7
 - Inputs, 1-4
 - Installation, 3-8
 - Jumper Locations, 1-3
 - Options, 1-3
 - Removal, 3-7
- L Option Mode
 - Factory Default, 1-6

- Programming, 1-4
- Selection, 1-5
- Three-Wire Control, Multi-Source Reversing, 1-7
- Three-Wire Control, Single-Source Reversing, 1-6
- Two-Wire Control, Single-Source Control, 1-7
- Load-Sharing Resistor Connections, 5-19
- Local Programming, 1-4

M

- Main Control Board
 - Illustration, 3-11
 - Installation, 3-12
 - Removal, 3-11
- Main Control Board Mounting Plate
 - Illustration, 3-9
 - Installation, 3-10
 - Removal, 3-9
- Manual
 - Audience, P-1
 - Conventions, P-8
 - Objective, P-1
 - Related Publications, P-10
- Motor Control Board
 - Illustration, 3-11
 - Installation, 3-12
 - Removal, 3-11
- Motor Control Board Mounting Plate
 - Illustration, 3-9
 - Installation, 3-10
 - Removal, 3-9
- Mounting
 - Four-Point, 3-3
 - Two-Point, 3-2

N

- Nameplate Location, P-3
- Not External Fault Input, Definition, P-10

O

- Objective of this Manual, P-1
- Operation, Human Interface Module, 1-12
- Option
 - Control Interface, 1-3
 - Identification, P-4

P

Parameter, Definition, P-10

Precautions

- Electrostatic Discharge, P-2
- Safety, P-1

Precharge Module (Series C and D)

- Illustration, 5-4
- Installation, 5-5
- Removal, 5-4
- Test, 4-11

Press, Definition, P-10

Procedures

- Accessing Internal Drive Components, 3-1
- Bridge Rectifier Installation, 5-11
- Bridge Rectifier Removal, 5-10
- Bridge Rectifier Test, 4-3
- Bus Capacitor Installation, 5-18
- Bus Capacitor Removal, 5-17
- Bus Capacitor Test, 4-5
- Component Test, 4-1
- Control Board Installation, 3-12
- Control Board Mounting Plate Installation, 3-10
- Control Board Mounting Plate Removal, 3-9
- Control Board Removal, 3-11
- DC Bus Inductor (Series C and D) Installation, 5-16
- DC Bus Inductor (Series C and D) Removal, 5-15
- Drive Enclosure Installation, 3-6
- Drive Enclosure Removal, 3-5
- Fan Installation, 5-13
- Fan Removal, 5-12
- Gate Driver/Power Supply Board (Series C and D) Installation, 3-16
- Gate Driver/Power Supply Board (Series C and D) Removal, 3-13
- Gate Driver/Power Supply Board Test, 4-14
- L Option Board Installation, 3-8
- L Option Board Removal, 3-7
- Main Control Board Installation, 3-12
- Main Control Board Mounting Plate Installation, 3-10
- Main Control Board Mounting Plate Removal, 3-9
- Main Control Board Removal, 3-11
- Precharge Module (Series C and D) Installation, 5-5
- Precharge Module (Series C and D) Removal, 5-4
- Precharge Module (Series C and D) Test, 4-11
- Replacement Part, 5-1

- Thermistor Installation, 5-7
- Thermistor Removal, 5-6
- Transistor Module Installation, 5-9
- Transistor Module Removal, 5-8
- Transistor Module Test, 4-8

Product Identification, P-3

Programming

- L Option Mode, 1-4
- Local, 1-4

R

Rating, Drive, P-7

Related Publications, P-10

Removal Procedures. *See* Procedures

Removal, Human Interface Module, 1-11

Replacement Part Procedures, 5-1

Replacement Parts, 6-1

S

Safety Precautions, P-1

Schematics, 7-1

Speed Select/Speed Reference, 1-8

T

TB3 Terminal Designations, 1-5

Terminal Block Locations, 1-2

Terminal Designations, TB3, 1-5

Thermistor

- Illustration, 5-6
- Installation, 5-7
- Removal, 5-6

Tools, Required for Service, 3-2, 4-2, 5-2

Torque

- Four-Point Mounting Sequence, 3-3
- Maximum for TB Terminals, 1-5
- Specifications, 3-4
- Two-Point Mounting Sequence, 3-2

Transistor Module

- Illustration, 5-8
- Installation, 5-9
- Removal, 5-8
- Test, 4-8

Troubleshooting

- Component Test Procedures, 4-1
- Encoderless, 2-23
- Start Up, 2-16, 2-20

True, Definition, P-10

Two-Point Mounting, 3-2

W

Warnings, 2-1

Bus Cycle>5, 2-15

Bus Drop, 2-14

Bus Undervlt, 2-15

External Flt In, 2-9

Inv Overload, 2-6

Inv Overtmp Pnd, 2-6

InvOvld Pend, 2-6

mA Input, 2-8

Math Limit, 2-8

Mtr Stall, 2-5

MtrOvrd Pend, 2-4

MtrOvrd Trp, 2-5

Open Circuit, 2-15

Param Limit, 2-8

Prechrg Time, 2-14

Ridethru Time, 2-14

SP 1 Timeout, 2-11

SP 2 Timeout, 2-11

SP 3 Timeout, 2-11

SP 4 Timeout, 2-11

SP 5 Timeout, 2-12

SP 6 Timeout, 2-12

SP Error, 2-12

Spd Fdbk Loss, 2-9

Viewing Queue with HIM, 2-2

Wire Sizes, 1-5

1336 IMPACT, ControlNet, and SCANport are trademarks of Rockwell International Corporation.

PLC is a registered trademark of Rockwell International Corporation.



Allen-Bradley, a Rockwell Automation Business, has been helping its customers improve productivity and quality for more than 90 years. We design, manufacture and support a broad range of automation products worldwide. They include logic processors, power and motion control devices, operator interfaces, sensors and a variety of software. Rockwell is one of the world's leading technology companies.

Worldwide representation.



Argentina • Australia • Austria • Bahrain • Belgium • Brazil • Bulgaria • Canada • Chile • China, PRC • Colombia • Costa Rica • Croatia • Cyprus • Czech Republic • Denmark • Ecuador • Egypt • El Salvador • Finland • France • Germany • Greece • Guatemala • Honduras • Hong Kong • Hungary • Iceland • India • Indonesia • Ireland • Israel • Italy • Jamaica • Japan • Jordan • Korea • Kuwait • Lebanon • Malaysia • Mexico • Netherlands • New Zealand • Norway • Pakistan • Peru • Philippines • Poland • Portugal • Puerto Rico • Qatar • Romania • Russia-CIS • Saudi Arabia • Singapore • Slovakia • Slovenia • South Africa, Republic • Spain • Sweden • Switzerland • Taiwan • Thailand • Turkey • United Arab Emirates • United Kingdom • United States • Uruguay • Venezuela • Yugoslavia

Allen-Bradley Headquarters, 1201 South Second Street, Milwaukee, WI 53204 USA, Tel: (1) 414 382-2000 Fax: (1) 414 382-4444