



Allen-Bradley

***1336 IMPACT™
Adjustable Frequency
AC Drive
(Series A)***

*A75 – A125
B150 – B250
C150 – C250*

Troubleshooting Guide



Important User Information

Because of the variety of uses for the products described in this publication, those responsible for the application and use of this control equipment must satisfy themselves that all necessary steps have been taken to assure that each application and use meets all performance and safety requirements, including any applicable laws, regulations, codes and standards.

The illustrations, charts, sample programs and layout examples shown in this guide are intended solely for purposes of example. Since there are many variables and requirements associated with any particular installation, Rockwell Automation does not assume responsibility or liability (to include intellectual property liability) for actual use based upon the examples shown in this publication.

Rockwell Automation publication SGI-1.1, *Safety Guidelines for the Application, Installation, and Maintenance of Solid-State Control* (available from your local Rockwell Automation office), describes some important differences between solid-state equipment and electromechanical devices that should be taken into consideration when applying products such as those described in this publication.

Reproduction of the contents of this copyrighted publication, in whole or in part, without written permission of Rockwell Automation, is prohibited.

Throughout this manual we use notes to make you aware of safety considerations:



ATTENTION: Identifies information about practices or circumstances that can lead to personal injury or death, property damage or economic loss.

Attention statements help you to:

- identify a hazard
- avoid the hazard
- recognize the consequences

Important: Identifies information that is critical for successful application and understanding of the product.



We Want Our Manuals to be the Best!

You can help! Our manuals must meet the needs of you, the user. This is your opportunity to make sure they do just that. By filling out this form you can help us provide the most useful, thorough, and accurate manuals available. Please take a few minutes to tell us what you think. Then mail or FAX this form.

FAX: to your local Allen-Bradley Sales Office or 414/512-8579.

PUBLICATION NAME _____

PUBLICATION NUMBER, DATE AND PART NUMBER (IF PRESENT) _____

✓ **CHECK THE FUNCTION THAT MOST CLEARLY DESCRIBES YOUR JOB.**

- SUGGEST / RESPONSIBLE FOR THE PURCHASE OF EQUIPMENT MAINTAIN / OPERATE PROGRAMMABLE MACHINERY
- DESIGN / IMPLEMENT ELECTRICAL SYSTEMS TRAIN/EDUCATE MACHINE USERS
- SUPERVISE FLOOR OPERATIONS

✓ **WHAT LEVEL OF EXPERIENCE DO YOU HAVE WITH EACH OF THE FOLLOWING PRODUCTS?**

	NONE	LITTLE	MODERATE	EXTENSIVE
PROGRAMMABLE CONTROL	<input type="checkbox"/>	<input type="checkbox"/>	<input type="checkbox"/>	<input type="checkbox"/>
AC / DC DRIVES	<input type="checkbox"/>	<input type="checkbox"/>	<input type="checkbox"/>	<input type="checkbox"/>
PERSONAL COMPUTERS	<input type="checkbox"/>	<input type="checkbox"/>	<input type="checkbox"/>	<input type="checkbox"/>
NC / CNC CONTROLS	<input type="checkbox"/>	<input type="checkbox"/>	<input type="checkbox"/>	<input type="checkbox"/>
DATA COMMUNICATIONS / LAN	<input type="checkbox"/>	<input type="checkbox"/>	<input type="checkbox"/>	<input type="checkbox"/>

✓ **RATE THE OVERALL QUALITY OF THIS MANUAL BY CIRCLING YOUR RESPONSE BELOW. (1) = POOR (5) = EXCELLENT**

HELPFULNESS OF INDEX / TABLE OF CONTENTS		1	2	3	4	5
CLARITY		1	2	3	4	5
EASE OF USE		1	2	3	4	5
ACCURACY AND COMPLETENESS		1	2	3	4	5
QUALITY COMPARED TO OTHER COMPANIES' MANUALS		1	2	3	4	5
QUALITY COMPARED TO OTHER ALLEN-BRADLEY MANUALS	1	2	3	4	5	

✓ **WHAT DID YOU LIKE MOST ABOUT THIS MANUAL?**

✓ **WHAT DID YOU LIKE LEAST ABOUT THIS MANUAL?**

✓ **PLEASE LIST ANY ERRORS YOU FOUND IN THIS MANUAL (REFERENCE PAGE, TABLE, OR FIGURE NUMBERS).**

✓ **DO YOU HAVE ANY ADDITIONAL COMMENTS?**

✓ **COMPLETE THE FOLLOWING.**

NAME _____ COMPANY _____

TITLE _____ DEPARTMENT _____

STREET _____ CITY _____ STATE _____ ZIP _____

TELEPHONE _____ DATE _____

CUT ALONG DOTTED LINE

FOLD HERE

FOLD HERE



NO POSTAGE
NECESSARY
IF MAILED
IN THE
UNITED STATES

BUSINESS REPLY MAIL
FIRST CLASS PERMIT NO. 413 MEQUON, WI

POSTAGE WILL BE PAID BY ADDRESSEE



ALLEN-BRADLEY
Attn: Marketing Communications
P.O. Box 760
Mequon, WI 53092-9907



Summary of Changes

The information below summarizes the changes to the company-wide templates since the last release.

Updated Information

No changes have been made to this manual.

Table of Contents

Preface

Manual Objective	P-1
Who Should Use This Manual	P-1
Safety Precautions	P-1
Electrostatic Discharge Precautions	P-2
1336 IMPACT Product Identification	P-3
Drive Nameplate Location	P-3
Drive and Option Identification	P-3
1336 IMPACT Drive Catalog Numbers	P-4
Drive Rating Qualifications	P-9
Enclosure Type	P-9
Conventions	P-10
Auxiliary Interlock	P-10
Bit	P-10
Check	P-10
Connector	P-10
Default	P-10
Enable Input	P-11
False	P-11
Jumper	P-11
L Option Board	P-11
Not External Fault Input	P-11
Parameter	P-11
Press	P-12
True	P-12
Related Publications	P-12

Control Logic Wiring and Adapters

Chapter 1

Chapter Objectives	1-1
Chapter Overview	1-1
L Option Board	1-3
L Option Board Jumpers	1-4
Available Inputs	1-5
Local Programming	1-5
Human Interface Module (HIM)	1-10
Description	1-10
Removing the HIM	1-11
HIM Operation	1-12
Graphic Programming Terminal	1-13
GPT Description	1-13
DriveTools	1-14
Control Firmware Function	1-14

Troubleshooting and Error Codes

Chapter 2

Chapter Objectives	2-1
Fault/Warning Handling	2-1
Viewing the Fault and Warning Queues on the HIM	2-3
What Are the Fault Descriptions	2-4
Diagnostic Procedures by Symptom	2-14
Start Up Troubleshooting Procedures	2-18
Miscellaneous Troubleshooting Procedures	2-18
Encoderless Troubleshooting Procedures	2-20

Disassembly and Access Procedures

Chapter 3

Chapter Objectives	3-1
Disassembly and Access Overview	3-1
Electrostatic Discharge Precautions	3-1
Tools	3-2
Fastener Torque Specifications	3-3
Torque Sequence	3-3
Torque Specifications	3-4
Disassembly and Access Procedures	3-6
Opening the Drive Enclosure	3-6
Removal	3-6
Installation	3-7
Removing the High Voltage Guard	3-8
Removal	3-8
Installation	3-9
Removing the L Option Board	3-10
Removal	3-10
Installation	3-11
Removing the Main Control Board Mounting Plate	3-12
Removal	3-12
Installation	3-13
Removing the Main Control Board	3-14
Removal	3-14
Installation	3-15
Removing The Gate Driver Board Mounting Plate	3-16
Removal	3-16
Installation	3-17
Removing the Gate Driver Board	3-19
Removal	3-19
Installation	3-20
Removing the Precharge Board Mounting Plate	3-21
Removal	3-21
Installation	3-22

Removing the Precharge Board	3-24
Removal	3-24
Installation	3-25
Removing a Power Module Snubber Board	3-26
Removal	3-27
Installation	3-28
Removing an Input Rectifier Snubber Board	3-29
Removal	3-29
Installation	3-30
Accessing Power Plane Components	3-30

Component Test Procedures

Chapter 4

Chapter Objectives	4-1
Component Test Overview	4-1
Electrostatic Discharge Precautions	4-2
Tools	4-2
Test 1 – Testing the Gate Driver Board	4-3
Test 2 – Testing the Precharge Board	4-5
Test 3 – Testing the Power Modules	4-7
Test 4 – Testing the Bus Capacitors	4-10
Test 5 – Testing the Input Rectifiers	4-13

Part Replacement Procedures

Chapter 5

Chapter Objective	5-1
Part Replacement Overview	5-1
Safety Precautions	5-1
Electrostatic Discharge Precautions	5-1
Tools	5-2
Major Component Replacement	5-2
Detailed Product Identification	5-3
Bus Capacitor Bank	5-4
Removal	5-4
Installation	5-6
Thermistor	5-7
Removal	5-7
Installation	5-8
Power Modules	5-9
Removal	5-9
Installation	5-11
Input Rectifiers	5-12
Removal	5-12
Installation	5-14
Fan and Transformer Assembly	5-15
Removal	5-16
Installation	5-18

DC Bus Inductor L1	5-19
Removal	5-19
Installation	5-21
Ground Sense CT	5-22
Removal	5-22
Installation	5-24
Bus Fuse F1	5-25
Removal	5-25
Installation	5-26
LEMs	5-27
Removal	5-27
Installation	5-29
MOV Surge Suppressor	5-30
Removal	5-31
Installation	5-31

Replacement Parts List

Chapter 6

Chapter Objectives	6-1
Ordering Replacement Parts	6-1
Replacement Parts Listing	6-2

Schematics — 150 – 300 HP 1336 IMPACT Drives

Chapter 7

Index

Preface

Manual Objective

The information in this manual is designed to help troubleshoot or repair an Allen-Bradley 1336 IMPACT Adjustable Frequency AC Drive with ratings A75 – A125, B150 – B250, and C150 – C250.

Who Should Use This Manual

This manual is intended for qualified service personnel responsible for troubleshooting and repairing the 1336 IMPACT Adjustable Frequency AC Drive. You should:

- Read this entire manual before performing maintenance or repairs to drives.
- Have previous experience with, and basic understanding of, electrical terminology, procedures, required equipment, equipment protection procedures and methods, and safety precautions.

This manual describes equipment, troubleshooting, and disassembly procedures. You begin with general illustrations and end with greater detail concerning replacement parts and part locations on the drives. Later chapters may refer you back to earlier chapters for information on basic equipment and steps necessary to perform detailed diagnostics and part replacement.

Safety Precautions



ATTENTION: Some printed circuit boards and drive components may contain hazardous voltage levels. Remove and lock out power before you disconnect or reconnect wires, and before you remove or replace fuses and circuit boards. Verify bus voltage by measuring the voltage between +DC and –DC on Terminal Block TB1. Do not attempt to service the drive until the bus voltage has discharged to zero volts.



ATTENTION: Potentially fatal voltages may result from improper usage of oscilloscope and other test equipment. The oscilloscope chassis may be at a potentially fatal voltage if not properly grounded. If an oscilloscope is used to measure high voltage waveforms, use only a dual channel oscilloscope in the differential mode with X 100 probes. It is recommended that the oscilloscope be used in the A minus B Quasi-differential mode with the oscilloscope chassis correctly grounded to an earth ground.



ATTENTION: Only personnel familiar with the 1336 IMPACT Adjustable Frequency AC Drive and associated machinery should plan or implement the installation, start-up and subsequent maintenance of the system. Failure to comply may result in personal injury and/or equipment damage.

Electrostatic Discharge Precautions



ATTENTION: This assembly contains parts and sub-assemblies that are sensitive to electrostatic discharge. Static control precautions are required when servicing this assembly. Component damage may result if you ignore electrostatic discharge control procedures. If you are not familiar with static control procedures, reference Rockwell Automation Publication 8000-4.5.2, Guarding Against Electrostatic Damage, or any other applicable ESD protection handbook.

Electrostatic discharge generated by static electricity can damage the complementary metallic oxide semiconductor devices on various drive boards. It is recommended that you perform these procedures to guard against this type of damage when circuit boards are removed or installed:

- Wear a wrist-type grounding strap that is grounded to the drive chassis.
- Attach the wrist strap before removing the new circuit board from the conductive packet.
- Remove boards from the drive and immediately insert them into their conductive packets.

1336 IMPACT Product Identification

Drive Nameplate Location

The drive nameplate is located on the face of the Main Control Board Mounting Plate. The drive nameplate contains the drive's catalog number and other important drive information. Reference the catalog number when ordering replacement parts.

Figure P.1
Drive Nameplate Location

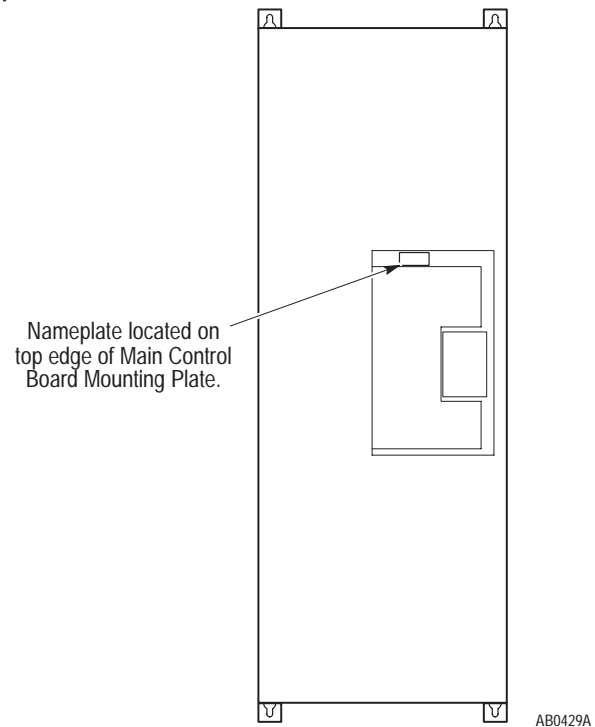

Drive and Option Identification

The following is an explanation of the catalog numbering system for 1336 IMPACT Adjustable Frequency AC Drives and options. The catalog number is coded to identify the drive power rating and can be found on the drive shipping carton and nameplate.

1336 IMPACT Drive Catalog Numbers

Table P.A

1336E	– A075-AN		– EN	– L6	– HA1	– GM1
Bulletin No.	Rating-Enclosure (Must Be Specified)		Language Module ^[3] (Must Be Specified)	L Option ^[3] (Optional)	Human Interface ^[3] (Optional)	Communication Card ^[3] (Optional)
200 – 240V AC Input						
Drive Rating^[1]			Enclosures			
			Open IP00 No Enclosure	NEMA Type 1 IP20 General Purpose	NEMA Type 4 IP56 Resist Water, Dust	NEMA Type 12 IP54 Industrial Use
Frame Designation	Constant Torque		Code	Code	Code	Code
	Output Amps	Nominal HP				
E	240.0 291.4 327.4	75 100 125	A075-AN A100-AN B125-AN	A075-AA, -AE A100-AA, -AE A125-AA, -AE	^[2] ^[2] ^[2]	A075C-AJ A100C-AJ A125C-AJ

^[1] Drive rating is based on a carrier frequency of 2kHz maximum, an altitude of 1,000 meters or less, and a maximum ambient temperature of 40°C. Refer to Drive Rating Qualifications on page P-9.

^[2] Not available.

^[3] Refer to the Language Module and Options tables following these Catalog Number tables.

Table P.B

1336E	- B150-AN	- EN	- L6	- HA1	- GM1	
Bulletin No.	Rating-Enclosure (Must Be Specified)	Language Module ^③ (Must Be Specified)	L Option ^③ (Optional)	Human Interface ^③ (Optional)	Communication Card ^③ (Optional)	
380 – 480V AC Input						
Drive Rating^①			Enclosures			
			Open IP00 No Enclosure	NEMA Type 1 IP20 General Purpose	NEMA Type 4 IP56 Resist Water, Dust	NEMA Type 12 IP54 Industrial Use
Frame Designation	Constant Torque		Code	Code	Code	Code
	Output Amps	Nominal HP				
E	240.0 291.4 327.4	150 200 250	B150-AN B200-AN B250-AN	B150-AA, -AE B200-AA, -AE B250-AA, -AE	^② ^② ^②	B150C-AJ B200C-AJ B250C-AJ

^① Drive rating is based on a carrier frequency of 2kHz maximum, an altitude of 1,000 meters or less, and a maximum ambient temperature of 40°C. Refer to Drive Rating Qualifications on page P-9.

^② Not available.

^③ Refer to the Language Module and Options tables following these Catalog Number tables.

Table P.C

1336E	- C150-AN		- EN	- L6	- HA1	- GM1
Bulletin No.	Rating-Enclosure (Must Be Specified)		Language Module ^③ (Must Be Specified)	L Option ^③ (Optional)	Human Interface ^③ (Optional)	Communication Card ^③ (Optional)
500 – 600V AC Input						
Drive Rating ^①			Enclosures			
			Open IP00 No Enclosure	NEMA Type 1 IP20 General Purpose	NEMA Type 4 IP56 Resist Water, Dust	NEMA Type 12 IP54 Industrial Use
Frame Designation	Constant Torque		Code	Code	Code	Code
	Output Amps	Nominal HP				
E	159.7 252.6 283.6	150 200 250	C150-AN C200-AN C250-AN	C150-AA C200-AA C250-AA	② ② ②	C150C-AJ C200C-AJ C250C-AJ

^① Drive rating is based on a carrier frequency of 2kHz maximum, an altitude of 1,000 meters or less, and a maximum ambient temperature of 40°C. Refer to Drive Rating Qualifications on page P-9.

^② Not available.

^③ Refer to the Language Module and Options tables following these Catalog Number tables.

Table P.D

Language Modules	
Description	Option Code
English/English	EN
English/French [□]	FR
English/German [□]	DE
English/Italian [□]	IT
English/Japanese [□]	JP
English/Spanish [□]	ES

[□] Not available at time of printing.

Table P.E

Options			
Code	Description [□]	Code	Description [□]
Human Interface Modules, NEMA Type 1 (IP20)		Communication Options	
HAB	Blank – No Functionality	GM1	Single Point Remote I/O
HAP	Programmer Only	GM2	RS-232/422/485, DF1 & DH485 Protocol
HA1	Programmer/Controller with Analog Pot	GM3	DeviceNet
HA2	Programmer/Controller with Digital Pot		
Human Interface Modules, NEMA Type 4 (IP56)		L Option Boards	
HFP	Programmer Only	L4	Contact Closure
HF2	Programmer/Controller with Digital Pot	L7E	Contact Closure & Encoder Feedback
Human Interface Modules, NEMA Type 12 (IP54)		L5	+24V AC/DC
HJP	Programmer Only	L8E	24V AC/DC & Encoder Feedback
HJ2	Programmer/Controller with Digital Pot	L6	115V AC
		L9E	115V AC & Encoder Feedback

[□] For a more functionally complete description of each option, refer to Publication 1336 IMPACT-1.0.

Table P.F
200 – 240V Drives

Catalog Number	Maximum Amp Rating ¹	Derate Curve ^{2 3}	Heat Dissipation Drive Watts ^{2 3 4}	Heat Sink Watts ²	Total Watts ²
A075	240	5	606	2769	3375
A100	291	5	755	3700	4455
A125	325	5	902	4100	5002

Table P.G
380 – 480V Drives

Catalog Number	Maximum Amp Rating ¹	Derate Curve ^{2 3}	Heat Dissipation Drive Watts ^{2 3 4}	Heat Sink Watts ²	Total Watts ²
B150	240	5	606	2769	3375
B200	291	5	755	3700	4455
B250	325	5	902	4100	5002

Table P.H
500 – 600V Drives

Catalog Number	Maximum Amp Rating ¹	Derate Curve ^{2 3}	Heat Dissipation Drive Watts ^{2 3 4}	Heat Sink Watts ²	Total Watts ²
C150	168	5	6	6	6
C200	252	5	755	3065	3820
C250	284	5	890	3625	4515

¹ Maximum Amp Ratings are based on nominal voltage (240, 480, or 600V). If input voltage exceeds Drive Rating, Drive Output must be derated.

² Rating is at 4kHz for 224 – 448 kW/300 – 600 HP, 500 – 600V. If carrier frequencies above 4kHz are selected, drive rating must be derated.

³ Drive Ambient Temperature Rating is 40°C. If ambient exceeds 40°C, the drive must be derated.

⁴ Drive Rating is based on altitudes of 1,000m (3,000 ft) or less. If installed at higher altitude, drive must be derated.

⁵ Refer to the 1336 IMPACT User Manual.

⁶ Not Available.

Drive Rating Qualifications

Several factors can affect drive rating:

- Altitude
- High-input line voltage
- Line transients
- Extreme ambient temperature

If more than one factor exists, consult Rockwell Automation.

Enclosure Type

The first character, A, indicates the Enclosure Code.

The second character indicates the type of enclosure shipped from the factory:

Table P.1
Enclosure Type Code Description

Enclosure Type Code	Description
N	Open style (IP00)
A	NEMA Type 1 (IP20)
E	NEMA Type 1 (IP20)/EMC
F	NEMA Type 4 (IP56)
J	NEMA Type 12 (IP54)

Conventions

To help differentiate parameter names and display text from other text in this manual, the following conventions will be used:

- Parameter Names will appear in *italics*.
- Display Text will appear in “quotes”.

The following is a list of conventions used throughout this manual, and definitions of the conventions. For a list of terminology and definitions, refer to the Glossary in the back of this manual.

Auxiliary Interlock

The Auxiliary Interlock is a user supplied circuit consisting of reset, overload, or other interlocking circuitry. The Interlock is wired to the drive Not External Fault Input.

Bit

A bit is a single character or status point used in programmable logic. Eight bits form a BYTE, 16 bits form a word. Drive parameters are actually eight-bit or 16-bit words.

Check

To check means to examine either the physical condition of something or the setting of some control, such as a Parameter. Checking a drive board or component may also require measurements and tests.

Connector

A connector connects one drive board to another. Connectors come in two designs, male and female. Male connectors are stationary and contain pins, which are sometimes joined by jumpers. Female connectors are at the ends of wires or ribbon cables and plug into male connectors.

Default

When a drive function defaults, it automatically changes to a pre-programmed setting.

Enable Input

The Enable Input is a terminal connection on the L Option Board. This connection provides an external input to enable or disable the Drive Output section. It must be a logic “true” to permit the drive to operate.

False

False refers to a logical false state. For instance, an L Option signal on TB3 is false when the input contact is open or the appropriate voltage is not applied to the L Option Board.

Jumper

A jumper completes a circuit between two pins within a male connector on a drive board. In the absence of certain optional equipment using female connectors, jumpers are applied to certain pins within a male connector to complete specific and necessary circuits.

L Option Board

An L Option Board plugs into connectors J7 and J9, located on the lower portion of the Main Control Board. This board is identified as L4, L5, L6, L7E, L8E, or L9E and provides optional control wiring configurations for a drive.

Not External Fault Input

The Not External Fault Input is a terminal connection on the L Option Board. This connection provides an external input for use as an Auxiliary Interlock. Unless this interlock is closed, the drive will be faulted with an External Fault.

Parameter

Parameters are programmable drive functions that define various operating functions or status displays of a drive. Refer to Bulletin 1336 IMPACT Adjustable Frequency AC Drive User Manual for parameter details.

Press

Press a button on the Human Interface Module to change parameter settings and drive functions.

True

True refers to a logical true state. For instance, an L Option signal on TB3 is true when: L4/L7E contact input is closed, L5/L8E input terminal registers 24V, or L6/L9E input terminal registers 115V AC.

Related Publications

The following lists other Allen-Bradley publications that apply to the 1336 IMPACT Adjustable Frequency AC Drives:

- Product Pricing Bulletin (1336 IMPACT-3.0)
- User Manual (1336 IMPACT-5.0)
- Renewal Parts List[□]
- Options Manuals/Instructions
- Product Data DriveTools Software (9303-2.0)
- Bulletin 1201 Graphic Programming Terminal User Manual (1201-5.0)

[□] Current 1336 IMPACT spare parts information, including recommended parts, catalog numbers, and pricing, can be obtained from the following sources.

- Allen-Bradley home page on the World Wide Web at:

<http://www.ab.com>

Select **Drives**, and the select **Information for Drives, Including Part Lists . . .** Select documents **1060.pdf** (230V drives) and/or **1070.pdf** (460 & 575V drives).

- Standard Drives "AutoFax" service – an automated system that you can call to request a "faxed" copy of the spare parts information (or other technical documentation).

Simply call **444-646-6701** and follow the phone prompts to request document(s) **1060** (230V drives) and/or **1070** (460 & 575V drives).

Control Logic Wiring and Adapters

Chapter Objectives

This chapter introduces you to terminal block locations and wiring and to adapter locations and functions.

Chapter Overview

This chapter illustrates and describes:

- L Option Options L4, L5, L6, L7E, L8E, and L9E including terminal block TB3
- TB3 L Option mode selections and functions
- TB3 terminal designations

Important: All printed circuit boards, except the Main Control Board assembly, are referenced to negative ground (–bus).



ATTENTION: Some printed circuit boards and drive components may contain hazardous voltage levels. Remove power before you disconnect or reconnect wires and before you remove or replace fuses and circuit boards. Verify bus voltage by measuring the voltage between +DC and –DC on terminal block TB1. Do not attempt to service the drive until the bus voltage has discharged to zero volts.



ATTENTION: This assembly contains parts and sub-assemblies that are sensitive to electrostatic discharge. Static control precautions are required when servicing this assembly. Component damage may result if you ignore electrostatic discharge control procedures. If you are not familiar with static control procedures, reference Rockwell Automation Publication 8000-4.5.2, Guarding Against Electrostatic Discharge, or any other applicable ESD protection handbook.

Figure 1.1
Terminal Block Locations

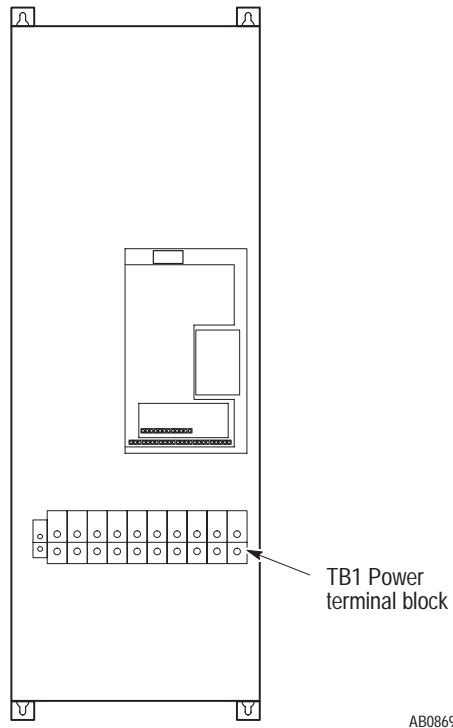

ATTENTION: The National Electrical Code (NEC) and local codes outline provisions for safely installing electrical equipment. Installation must comply with specifications regarding wire types, conductor sizes, branch circuit protection and disconnect devices. Failure to do so may result in personal injury and/or equipment damage.

L Option Board

The L Option Board provides a means of interfacing various signals and commands to the 1336 IMPACT Drive by using contact closures.

Six different versions of the L Option are available:

L4	Contact Closure Interface ¹
L7E	Contact Closure Interface with Encoder Feedback ¹
L5	+24V AC/DC Interface
L8E	+24V AC/DC Interface with Encoder Feedback ¹
L6	115V AC Interface
L9E	115V AC Interface with Encoder Feedback ¹

¹ Uses internal +5V DC supply.

The user inputs are connected to the L Option Board through TB3. The L4, L5, and L6 options each have nine inputs: seven user-configurable inputs and two factory-defined control inputs. The function of each input must be selected through programming as explained later in this section. The L7E, L8E, and L9E options are similar to L4, L5, and L6 with the addition of encoder feedback inputs.

L Option Board Jumpers

Important: If the L Option Board is being installed, Main Control Board jumpers at pins 3 & 4 and 17 & 18 of J2 (J7 on 7.5 – 30 HP drives) must be removed. If the jumpers are removed, they can be stored on the “spares” location on the Main Control Board. If this board is removed, these jumpers must be reinstalled and the *L Option Mode* parameter must be programmed to “1”.

Figure 1.2
Jumper Locations

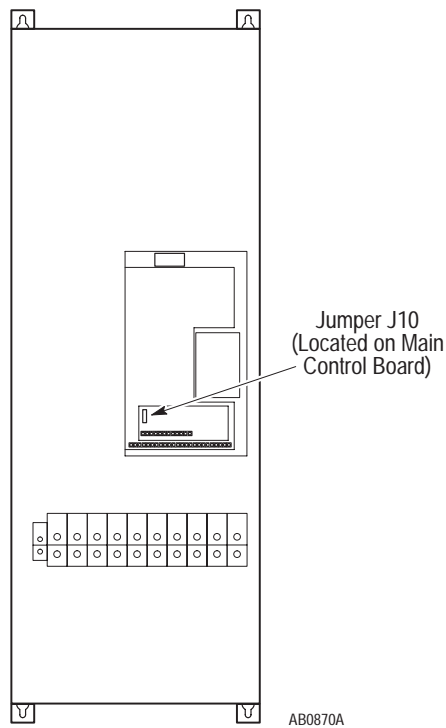

Available Inputs

The L Option allows the combination of the following functions:

Accel/Decel Rates	Process Trim
Digital Potentiometer (MOP)	Ramp
Enable	Reset
Flux Enable	Run Forward
Forward/Reverse	Run Reverse
Jog	Speed Selects
Local Control	Speed Torque Selections
Not Ext Flt	Start
Not Stop, Clear Fault	Stop Mode Selects

The available combinations are shown in Figure 1.4. Programming the *L Option Mode* parameter to one of the L Option Mode numbers listed selects that combination of input functions.

Important: The *L Option Mode* parameter can be changed at any time; however, programming changes will not take affect until power has been cycled to the drive. When changing an input mode, it is important to note that the corresponding inputs to TB3 may also change.

The programming options of the L Option Board allow the user to select an input combination to meet the needs of a specific installation. Appropriate selection of a combination may be done by using Table 1.A. First determine the type of start/stop/direction control desired. Then select the remaining control functions available. After selecting a group of L Option Modes, use Table 1.A for specific mode selection. Record the selected mode number below.

Selected Mode Number: _____

Local Programming

For local programming and control information, refer to the 1336 IMPACT User Manual.

Table 1.A
L Option Mode Selection

Start/Stop Type	Direction Control	Communication Compatibility	Mode(s) to Use
Stop & Enable Only	None	Control must be provided by HIM or Communication Option.	1
Momentary Pushbutton (3 Wire)	Maintained Switch (Open-Forward, Closed-Reverse)	Start/Stop – works like the HIM and Communication Options. Direction Control will not work with HIM or Communication Options. User must select direction control from either HIM and Communication Options or TB3 input.	2 – 6, 17, 18, and 27 ^[1]
Momentary Pushbutton (3 Wire)	Momentary Pushbuttons (Forward and Reverse)	Start/Stop – works in parallel with HIM and Communication Options. Direction – works in parallel with HIM or Communication Options.	7 – 11, 9 – 22, and 28, 29
Maintained switches for combined run and direction control (2 wire, Run Forward, Run Reverse)		Start – works differently than three-wire control. ^[2] Direction – works differently than three-wire control. ^[2] Stop – always works.	12 – 16 23 – 25, and 30

^[1] Diodes 27 – 30 are available with versions 2.02 and later.

^[2] Refer to two-, three-wire notes in the user manual.

Figure 1.3 provides the terminal designations for TB3. The maximum and minimum wire sizes accepted by TB3 are 2.1 and 0.30 mm² (14 and 22 AWG). Maximum torque for all terminals is 1.36 N-m (12 lb-in.). Use copper wire only.

Figure 1.3
TB3 Terminal Designations

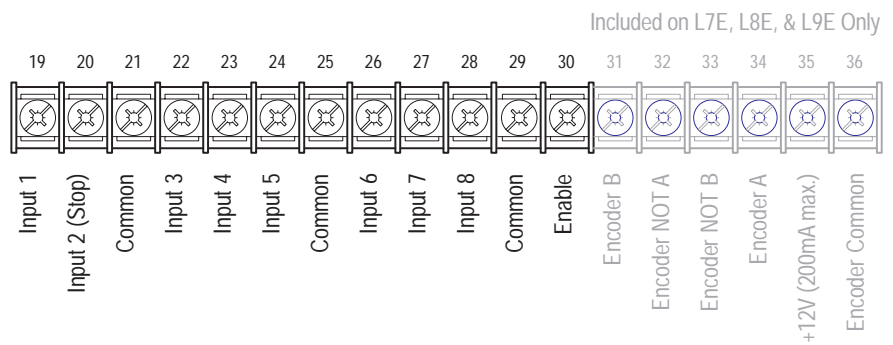

AB0293B

Figure 1.4
L Option Mode Selection and Typical TB3 Connections

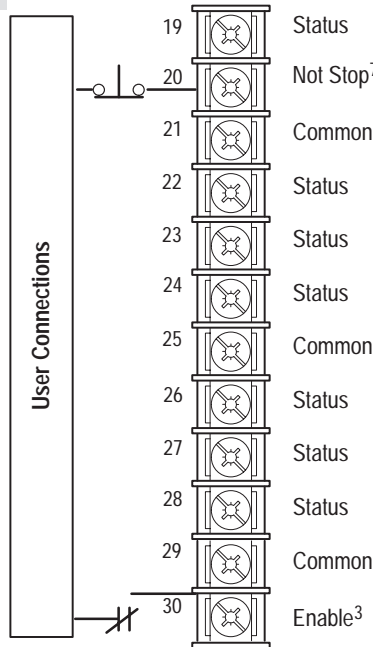
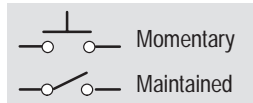

L Option Mode (parameter 116) = 1
Factory Default

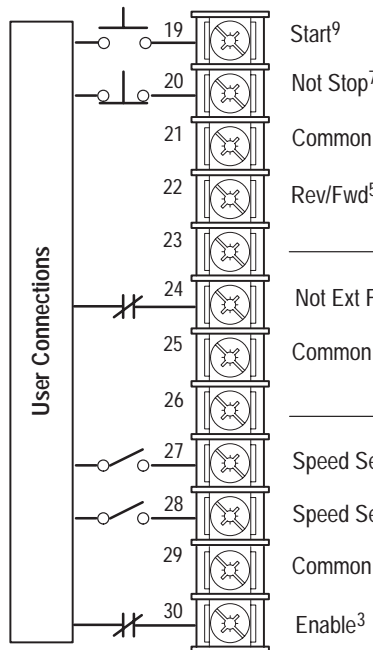

L Option Mode (parameter 116) = 2 - 6, 17, 18, and 27
Single-Source, Three-Wire Control

	Mode								
	2	3	4	5	6	17	18	27 ^{11, 12}	
Jog		Stop Type ⁷	2nd/1st Accel	Digital Pot Up	Jog	Proc Trim	Flux En	Digital Pot Up	
Speed Select 3 ¹	Speed Select 3 ¹	Speed Select 3 ¹	2nd/1st Decel	Digital Pot Dn	Local Control ²	Ramp	Reset	Digital Pot Dn	

- 1 See Table 1.B.
- 2 Drive must be stopped to take Local Control. Control by all other adapters is disabled (except Stop).
- 3 These inputs must be present before drive will start.
- 4 For Common Bus, this becomes Precharge Enable.
- 5 Bit 11 of *Logic Options* (parameter 17) must be 0 for reverse direction control.
- 6 For soft faults only. You need to recycle power to the drive or reset to clear. For hard faults, refer to the troubleshooting chapter.
- 7 To configure the stop type, refer to *Logic Options* (parameter 17).
- 8 This input must be present before the fault can be cleared and the drive will start. This can be disabled through *Fault Select 2* (parameter 22) and *Warning Select 2* (parameter 23).
- 9 Latched starts require a stop to stop the drive.
- 10 This input must be present or masked out before drive will start.
- 11 In mode 5, the MOP value is not reset to 0 when you stop. In mode 27, the MOP value is reset when you stop.
- 12 Available in versions 2.02 and later.

AB0290B

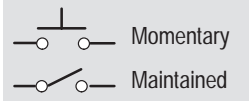

L Option Mode (parameter 116) = 7 – 11, 19 – 22, 28, and 29
Multi-Source, Three-Wire Control

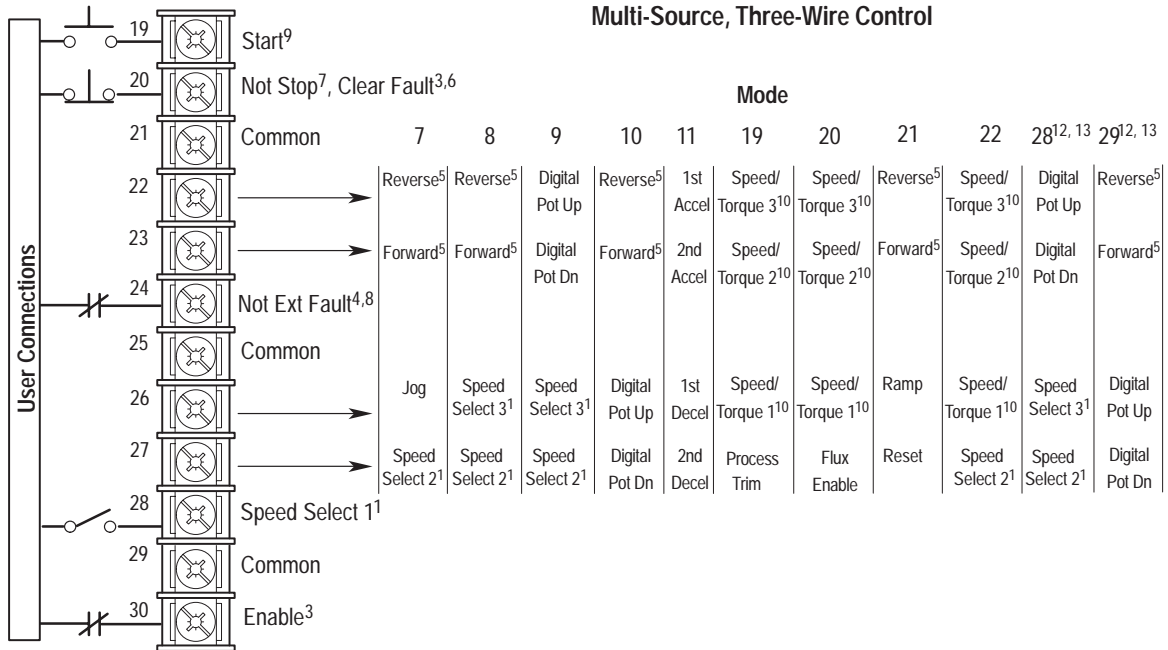

L Option Mode (parameter 116) = 12 – 16, 23 – 26, and 30
Single-Source, Two-Wire Control

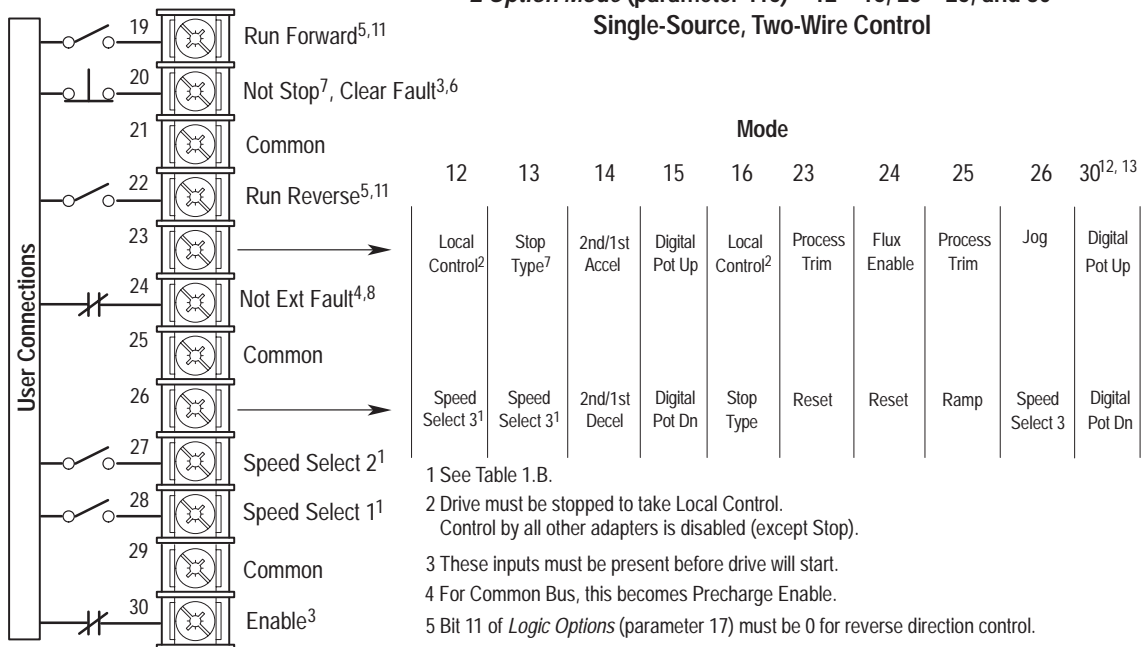

- 1 See Table 1.B.
- 2 Drive must be stopped to take Local Control. Control by all other adapters is disabled (except Stop).
- 3 These inputs must be present before drive will start.
- 4 For Common Bus, this becomes Precharge Enable.
- 5 Bit 11 of *Logic Options* (parameter 17) must be 0 for reverse direction control.
- 6 For soft faults only. You need to recycle power to the drive to clear. For hard faults, refer to the troubleshooting chapter.
- 7 To configure the stop type, refer to *Logic Options* (parameter 17).
- 8 This input must be present before the fault can be cleared and the drive will start. This can be disabled through *Fault Select 2* (parameter 22) and *Warning Select 2* (parameter 23).
- 9 Latched starts require a stop to stop the drive.
- 10 See Speed/Torque Select table.
- 11 Unlatched start.
- 12 In modes 9, 10, and 15, the MOP value is not reset to 0 when you stop. In modes 28, 29, and 30, the MOP value is reset when you stop.
- 13 Available in versions 2.02 and later.

The following table defines the input state of the Speed Select inputs for a desired speed reference source.

Table 1.B
Speed Select/Speed Reference

Speed Select 3	Speed Select 2	Speed Select 1	Frequency Source
O	O	O	Speed Ref 1
O	O	X	Speed Ref 2
O	X	O	Speed Ref 3
O	X	X	Speed Ref 4
X	O	O	Speed Ref 5
X	O	X	Speed Ref 6
X	X	O	Speed Ref 7
X	X	X	Last State

O = Open = Removed = 0

X = Closed = Applied = 1

Table 1.C defines the input state of the speed/torque mode select inputs for a desired speed/torque mode.

Table 1.C
Speed/Torque Select

Speed/ Torque Mode Select 3	Speed/ Torque Mode Select 2	Speed/ Torque Mode Select 2	Speed/Torque Mode:
O	O	O	Zero Torque
O	O	X	Speed Regulate
O	X	O	Torque Regulate
O	X	X	Minimum Torque/Speed
X	O	O	Maximum Torque/Speed
X	O	X	Sum of the Torque and Speed
X	X	O	Zero Torque
X	X	X	Zero Torque

O = Open = Removed = 0

X = Closed = Applied = 1

Human Interface Module (HIM)

Description

When the drive-mounted HIM is supplied, it will be connected as SCANport Adapter 1 (refer to Figure 1.6) and visible from the front of the drive. The HIM can be divided into two sections: Display Panel and Control Panel. The Display Panel provides a means of programming the drive and viewing the various operating parameters. The Control Panel allows different drive functions to be controlled. Refer to the 1336 IMPACT User Manual for HIM operation.

Important: The operation of HIM functions depends upon drive parameter settings. Default parameter values allow full HIM functionality.

Figure 1.5
Human Interface Module

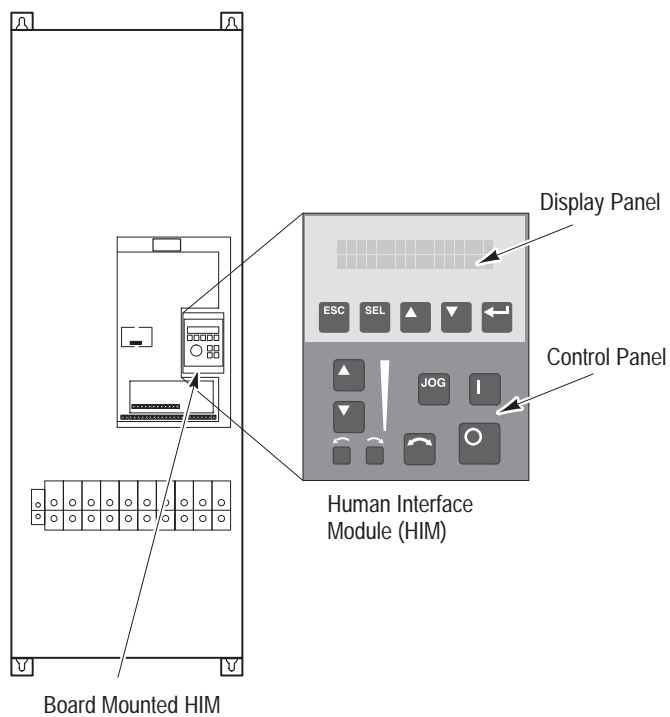

AB0751A

Figure 1.6
Adapter Locations

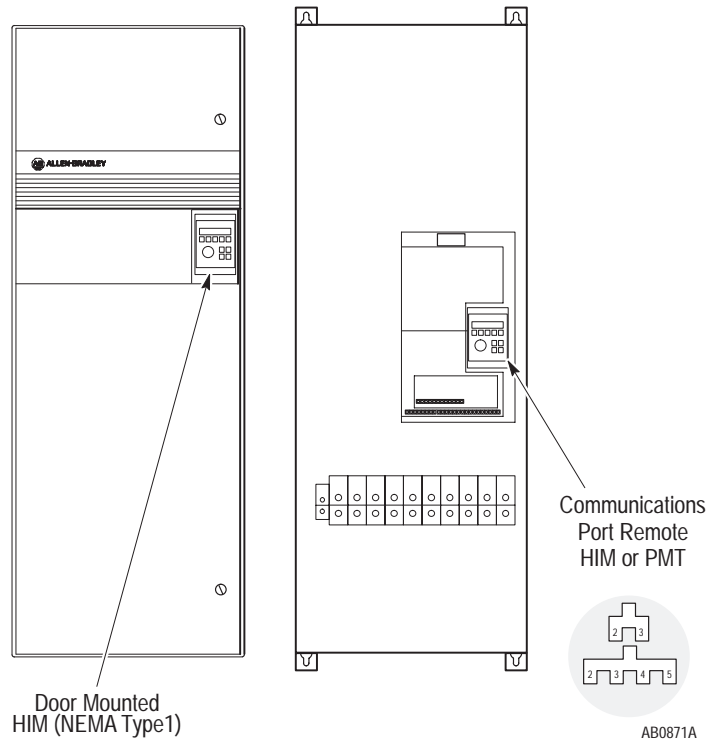

Removing the HIM

For handheld operation, you can remove the module and place it up to 10 meters (33 feet) from the 1336 IMPACT drive. (You do need a cable to do this.)



ATTENTION: Some voltages present behind the drive front cover are at incoming line potential. To avoid an electrical shock hazard, use extreme caution when removing/replacing the HIM.

Important: Removing a HIM (or other SCANport device) from a drive while power is applied causes a Serial Fault, unless *SP Enable Mask* (parameter 124) or *Fault Select 1* (parameter 20) have been set to disable this fault or *Control Logic* (from the *Control Status* menu) has been disabled (only available on a Series A, version 3.0 or Series B HIM). Setting bit 1 of *SP Enable Mask* to 0 disables Serial Fault from a HIM on port 1. It also disables all HIM control functions except Stop. Setting bit 9 of *Fault Select 1* to 0 disables the serial fault from the HIM on port 1 but still allows HIM control.



ATTENTION: Hazard of personal injury or equipment damage exist. If you initiate a command to start motor rotation (command a start or jog) and then disconnect the programming device, the drive will not fault if you have the SCANport communications fault set to be ignored for that port.

To remove the HIM, you need to:

1. Either remove the power or clear the port bit, which corresponds to the port the HIM is attached to, in *SP Enable Mask* (parameter 124) or *Fault Select 1* (parameter 20) to prevent the drive from faulting.
2. Remove the front cover of the drive.
3. Slide the module down out of its cradle.

To use the module from anywhere up to 10 meters (33 feet) from your drive, you need to:

1. Connect the appropriate cable between the HIM and the communications port (adapter 2, 3, 4, or 5) or adapter 1 (the HIM cradle).
2. Set *SP Enable Mask* (parameter 124) and/or *Fault Select 1* (parameter 20) to enable the port into which you plugged the HIM.

To replace the module, follow these steps;

1. Slide the module up into its cradle.
2. Replace the front cover of the drive.
3. Apply power, set *SP Enable Mask* or set *Fault Select 1*.

HIM Operation

When power is first applied to the drive, the HIM will cycle through a series of displays. These displays will show drive ID and communication status. Upon completion, the Status Display (refer to Figure 1.7) will be shown. This display shows the current status of the drive (i.e. Stopped, Running, etc.) or any faults that may be present (Not Enabled, etc.).

Refer to the 1336 IMPACT User Manual for HIM operation.

Figure 1.7
Status Display



Graphic Programming Terminal

GPT Description

The optional GPT (Figure 1.8) is a remote device with a 1.8 meter (6 foot) long cable. The GPT offers a 40- by 8-character display that can also be used as a graphics display. For GPT operation, refer to the 1201 GPT User Manual.

Important: Main Menu screens are dynamic and will change based on functionality provided by adapter and drive status.

Figure 1.8
Graphic Programming Terminal

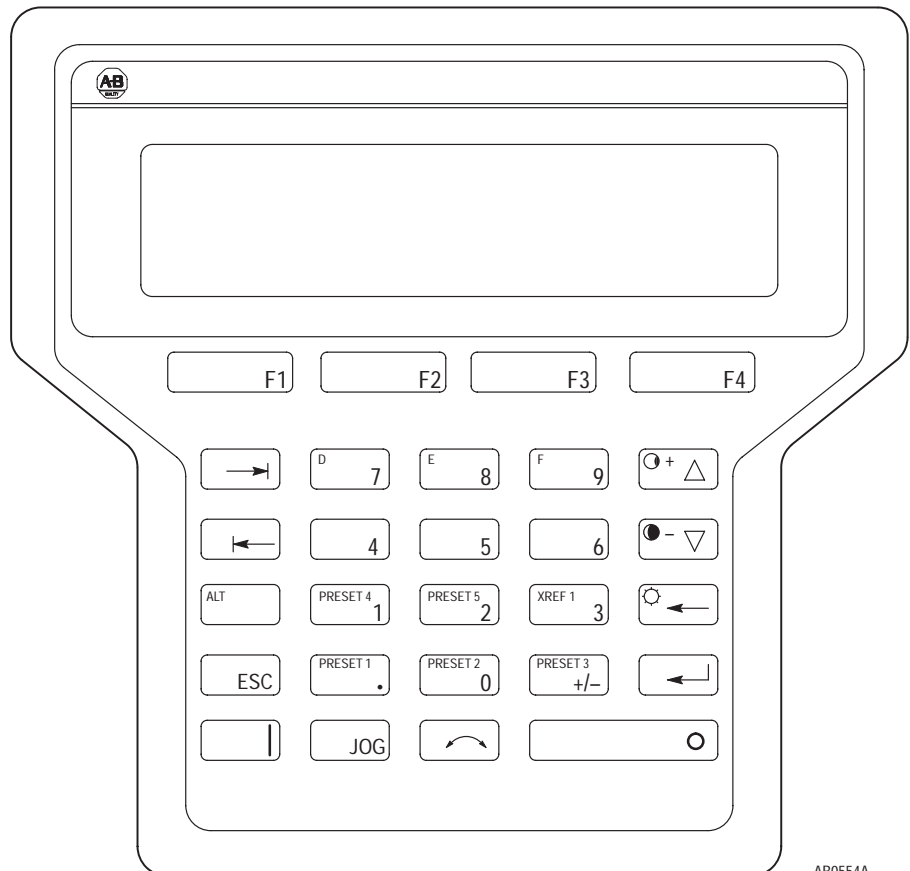

AB0554A

DriveTools

DriveTools software is a Windows 3.1 compatible family of application programs allowing the user to perform programming, monitoring, and diagnostic operations on Rockwell Automation AC and DC digital drive products. The software consists of five Windows applications. For operation, refer to the Product Data DriveTools Software manual.

Control Firmware Function

All control functions in the 1336 IMPACT Drive are performed through the use of parameters that can be changed with a programming terminal or DriveTools. Refer to an overview Block Diagram of the Control Firmware Function in the 1336 IMPACT User Manual.

Feedback information is derived from hardware devices as part of the process equipment used. Analog signals are converted to digital signals for use by the drive. Control signals may be provided to the drive by the Main Control Board.

All setup and operation information used by the drive is stored in a system parameter table. Every parameter, including Setup and Configuration parameters (Sources and Destinations), has an entry in the parameter table. For example, parameter 29 is named the *Speed Ref 1* parameter and contains a number value representing the speed reference. The speed reference can originate from an external control device such as a potentiometer connected to the analog input of the Main Control Board. Refer to the 1336 IMPACT User Manual, Publication 1336 IMPACT-5.0.

Troubleshooting and Error Codes

Chapter Objectives

This chapter provides information to help troubleshoot your 1336 IMPACT drive.



ATTENTION: Do not troubleshoot or maintain the 1336 IMPACT drive unless you are familiar with your drive system and the associated machinery. You may be injured and/or the equipment may be damaged if you do not comply.

During the start-up procedure, you should have recorded board jumper settings for each board, board software version numbers, and the drive and motor nameplate data in Table 6.A of the *1336 IMPACT™ Adjustable Frequency AC Drive User Manual*. If this information was not recorded, record it before beginning any troubleshooting sequences.

Fault/Warning Handling

When a problem occurs with your drive, check the VP and CP lights on your drive on the main control board. Figure 2.1 shows the location of the VP and CP lights.

Figure 2.1
VP and CP LED Locations

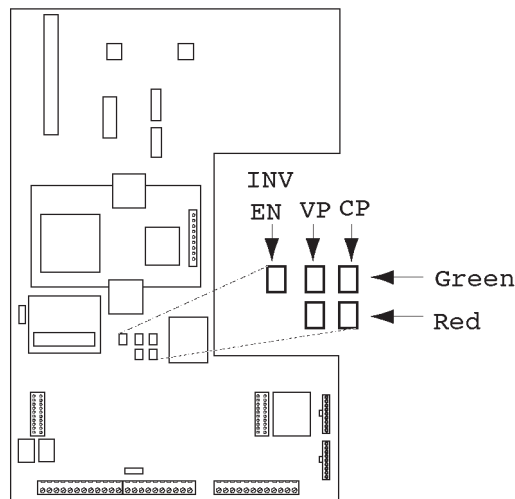

Frames B – H

The lights on the motor control board indicate the status of the velocity processor (VP) and current processor (CP):

Table 2.A

If the VP or CP LED is:	Then, for that processor:
Solid green	No fault occurred.
Flashing green	A drive warning occurred.
Flashing red	A drive soft fault occurred.
Solid red	A drive hard fault occurred.

Faults fall into three basic categories:

Table 2.B

This type of fault:	Has the following definition:	To remove this fault, you need to:
Hard	Trips the drive causing it to stop. You cannot regain control until you reset the drive.	Perform a <i>Drive Reset</i> command or cycle drive power.
Soft	Trips the drive causing it to stop.	1 Address the condition that caused the fault. 2 Perform a <i>Clear Faults</i> command.
Warning	Indicates an undesirable condition. The drive will not stop, but the condition may lead to a fault that will stop the drive.	Address the condition that caused the warning.

Faults are annunciated on the Human Interface Module (HIM) at the time they occur. Warnings are not annunciated on the HIM.

To help troubleshoot your 1336 IMPACT drive, the drive logs any faults or warnings in either the fault or warning queue. The faults and warnings that are contained in the queues are either configurable or non-configurable.

Table 2.C

This fault type:	Refers to faults that you:
Configurable	Can set up to either trip the drive or provide only a visual warning while the drive continues to operate.
Non-configurable	Cannot disable. These faults are the result of a condition that could damage the drive if allowed to persist.



You can reset the soft faults by pressing the stop button on the HIM.

Viewing the Fault and Warning Queues on the HIM

You can use the HIM to view the fault and warning queues. To view the fault queue, you need to:

1. Press the *Escape* key until you reach the *Choose Mode* level.
2. Use the *Increment* or *Decrement* key to scroll through the *Choose Mode* options until *Control Status* is displayed.
3. Press the *Enter* key.
4. Use the *Increment* or *Decrement* key to scroll through the *Control Status* options until *Fault Queue* is displayed.
5. Press the *Enter* key.
6. Press the *Enter* key when *View Queue* is displayed.

The fault queue can contain up to 32 faults. The 1336 IMPACT drive reports the faults using the following format:

Figure 2.2

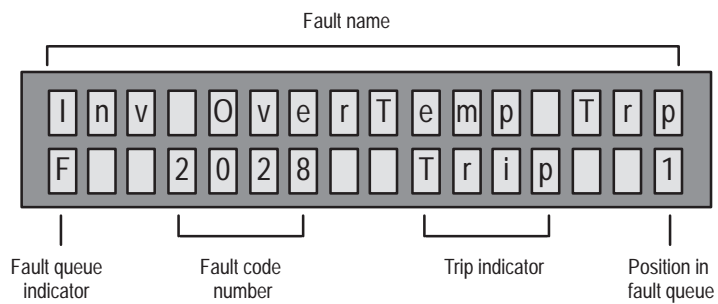

The trip indicator is only present if this fault caused the drive to trip.

The last number (1) indicates the position of this fault within the fault queue.

A marker is placed in the queue when the first fault occurs after a power up sequence. This power up marker is as shown.

Figure 2.3

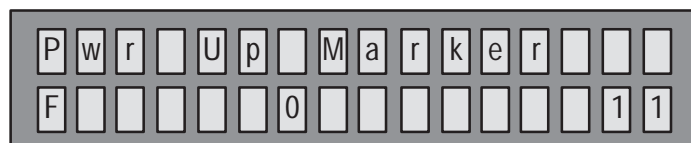

The 1336 IMPACT drive tracks the time that has elapsed since power up. The drive uses this information as a time stamp so that you can tell when a fault occurred in relation to when the drive was powered up.

To clear the fault queue, select *Clear Queue* from the *Fault Queue* options.

To view the warning queue, select *Warning Queue* from the *Control Status* options. The remaining steps are the same as for the fault queue.

What Are the Fault Descriptions

When a fault occurs, the fault is displayed until you initiate a *Drive Reset* or a *Clear Faults* command. A *Drive Reset* clears all faults, while a *Clear Faults* command only clears soft and warning faults. You can perform a *Drive Reset* and *Clear Faults* either through bits in *Logic Input Sts* (parameter 14) or with a terminal.

The fault codes are defined as shown in Table 2.D.

Table 2.D
Fault Descriptions

Fault Code and Text	LED Information	Fault Type	Description	Suggested Action
01027 <i>Autotune Diag</i>	VP, Flashing red	Soft	The drive encountered a problem while running the autotune tests. When this condition occurs, the drive coasts to a stop regardless of the selected stop type.	Check <i>Autotune Errors</i> (parameter 176). For additional information about <i>Autotune Errors</i> , refer to Chapter 13, <i>Understanding the Autotuning Procedure</i> , in the user manual.
01051 <i>MtrOvrlD Pnd</i>	VP, Flashing red	Soft	A motor overload is pending. The drive has reached 95% of the level required for a motor overload trip (see fault 01052).	Check for possible motor overheating. <ul style="list-style-type: none"> • If the motor temperature is excessive, reduce the accel/decel times (parameters 42 – 45) or reduce the load. • If the motor temperature is acceptable, increase the value of <i>Motor Overload %</i> (parameter 26). If you do not want this condition to be reported as a fault, change bit 3 in <i>Fault Select 2</i> (parameter 22) to 0.
01052 <i>MtrOvrlD Trp</i>	VP, Flashing red	Soft	Motor overload tripped. The drive has reached the level of accumulated motor current over time as set by <i>Motor Overload %</i> (parameter 26).	Check for possible motor overheating. <ul style="list-style-type: none"> • If the motor temperature is excessive, reduce the accel/decel times (parameters 42 – 45) or reduce the load. • If the motor temperature is acceptable, increase the value of <i>Motor Overload %</i> (parameter 26). If you do not want this condition to be reported as a fault, change bit 4 in <i>Fault Select 2</i> (parameter 22) to 0.
01053 <i>Mtr Stall</i>	VP, Flashing red	Soft	The drive is in a limit condition for a period of time in excess of the value specified in <i>Motor Stall Time</i> (parameter 25) with the motor at zero speed.	Check <i>Torque Limit Sts</i> (parameter 87) to see which limit has occurred. Increase the appropriate limit parameter or reduce the load. If you do not want this condition to be reported as a fault, change bit 5 in <i>Fault Select 2</i> (parameter 22) to 0.

Fault Code and Text	LED Information	Fault Type	Description	Suggested Action
01083 <i>MtrOvrlD Pend</i>	VP, Flashing green	Warning	Motor overload pending. The drive has reached 95% of the level required for a motor overload trip (see fault 01084).	Check for possible motor overheating. <ul style="list-style-type: none"> • If the motor temperature is excessive, reduce the accel/decel times (parameters 42 – 45) or reduce the load. • If the motor temperature is acceptable, increase the value of <i>Motor Overload %</i> (parameter 26). If you do not want this condition to be reported as a warning, change bit 3 in <i>Warning Select 2</i> (parameter 23) to 0.
01084 <i>MtrOvrlD Trp</i>	VP, Flashing green	Warning	Motor overload tripped. The drive has reached the level of accumulated motor current over time as set by <i>Motor Overload %</i> (parameter 26).	Check for possible motor overheating. <ul style="list-style-type: none"> • If the motor temperature is excessive, reduce the accel/decel times (parameters 42 – 45) or reduce the load. • If the motor temperature is acceptable, increase the value of <i>Motor Overload %</i> (parameter 26). If you do not want this condition to be reported as a warning, change bit 4 in <i>Warning Select 2</i> (parameter 23) to 0.
01085 <i>Mtr Stall</i>	VP, Flashing green	Warning	The drive is in a limit condition for a period of time in excess of the value specified in <i>Motor Stall Time</i> (parameter 25) with the motor at zero speed.	Check <i>Torque Limit Sts</i> (parameter 87) to see which limit has occurred. Increase the appropriate limit parameter or reduce the load. If you do not want this condition to be reported as a warning, change bit 5 in <i>Warning Select 2</i> (parameter 23) to 0.
02028 <i>Inv Overtemp Trp</i>	VP, Flashing red	Soft	Inverter overtemperature trip. There is excessive temperature at the heatsink. When this condition occurs, the drive coasts to a stop regardless of the selected stop type.	Check the cabinet filters, drive fans, and heatsinks. Check the thermal sensor and sensor wiring (connector). Reduce the load or duty cycle if possible. Lower the value of <i>PWM Frequency</i> (parameter 10).
02049 <i>Inv Overtemp Pnd</i>	VP, Flashing red	Soft	An inverter overtemperature is pending. The inverter heatsink temperature is approaching the trip level.	Check the cabinet filters, drive fans, and heatsinks. Check the thermal sensor and sensor wiring (connector). Reduce the load or duty cycle if possible. Lower the value of <i>PWM Frequency</i> (parameter 10). If you do not want this condition to be reported as a fault, change bit 1 in <i>Fault Select 2</i> (parameter 22) to 0.
02061 <i>InvOvld Pend</i>	VP, Flashing red	Soft	An inverter (IT) overload is pending. The inverter current has been in excess of 105% of <i>Inverter Amps</i> (parameter 11) too long. Continued operation at this load level will cause an overload.	Reduce the load or duty cycle if possible. If you do not want this condition to be reported as a fault, change bit 13 in <i>Fault Select 2</i> (parameter 22) to 0.
02063 <i>Inv Overload</i>	VP, Flashing red	Soft	Inverter (IT) overload. The inverter current has been in excess of 105% of <i>Inverter Amps</i> (parameter 11) too long.	Reduce the load or duty cycle if possible. If you do not want this condition to be reported as a fault, change bit 15 in <i>Fault Select 2</i> (parameter 22) to 0.

Fault Code and Text	LED Information	Fault Type	Description	Suggested Action
02081 <i>Inv Overtemp Pnd</i>	VP, Flashing green	Warning	An inverter overtemperature is pending. The inverter heatsink temperature is approaching the trip level.	Check the cabinet filters, drive fans, and heatsinks. Check the thermal sensor and sensor wiring (connector). Reduce the load or duty cycle if possible. Lower the value of <i>PWM Frequency</i> (parameter 10). If you do not want this condition to be reported as a warning, change bit 1 in <i>Warning Select 2</i> (parameter 23) to 0.
02093 <i>InvOvld Pend</i>	VP, Flashing green	Warning	An inverter (IT) overload is pending. The inverter current has been in excess of 105% of <i>Inverter Amps</i> (parameter 11) too long. Continued operation at this load level will cause an overload.	Reduce the load or duty cycle if possible. If you do not want this condition to be reported as a warning, change bit 13 in <i>Warning Select 2</i> (parameter 23) to 0.
02095 <i>Inv Overload</i>	VP, Flashing green	Warning	Inverter (IT) overload. The inverter current has been in excess of 105% of <i>Inverter Amps</i> (parameter 11) too long.	Reduce the load or duty cycle if possible. If you do not want this condition to be reported as a warning, change bit 15 in <i>Warning Select 2</i> (parameter 23) to 0.
03008 <i>HW Malfunction</i>	VP, Red 1 blink	Hard	A hardware malfunction was detected on power up or reset. When this condition occurs, the drive coasts to a stop regardless of the selected stop type.	Recycle the power. If the fault does not clear, replace the main control board.
03009 <i>HW Malfunction</i>	VP, Red 2 blink	Hard	A hardware malfunction was detected on power up or reset. When this condition occurs, the drive coasts to a stop regardless of the selected stop type.	Recycle the power. If the fault does not clear, replace the main control board.
03010 <i>HW Malfunction</i>	VP, Red 3 blink	Hard	A hardware malfunction was detected on power up or reset. When this condition occurs, the drive coasts to a stop regardless of the selected stop type.	Recycle the power. If the fault does not clear, replace the main control board.
03011 <i>HW Malfunction</i>	VP, Red 4 blink	Hard	A hardware malfunction was detected on power up or reset. When this condition occurs, the drive coasts to a stop regardless of the selected stop type.	Recycle the power. If the fault does not clear, replace the main control board.
03012 <i>HW Malfunction</i>	VP, Red 5 blink	Hard	A hardware malfunction was detected on power up or reset. When this condition occurs, the drive coasts to a stop regardless of the selected stop type.	Recycle the power. If the fault does not clear, replace the main control board.
03014 <i>EE Checksum</i>	VP, Flashing red	Soft	The parameter database is corrupt.	Initialize parameters or: <ul style="list-style-type: none"> • Perform a Recall Values operation. • Perform a Save Values operation. • Verify the parameters. • Reset the drive. If the fault still occurs, replace the main control board.
03015 <i>HW Malfunction</i>	VP, Flashing red	Soft	A hardware malfunction has occurred.	Recycle the power. If the fault does not clear, replace the main control board.

Fault Code and Text	LED Information	Fault Type	Description	Suggested Action
03022 <i>Diff Drv Type</i>	VP, Flashing red	Soft	The main control board has been initialized on a different size drive.	Issue a <i>Reset Defaults</i> command to set the drive parameters back to the default values.
03023 <i>SW Malfunction</i>	VP, Solid red	Hard	A software malfunction has occurred.	Recycle the power. If the fault does not clear, replace the main control board. If the fault still occurs, replace the gate driver board.
03024 <i>SW Malfunction</i>	VP, Solid red	Hard	A software malfunction has occurred. When this condition occurs, the drive coasts to a stop regardless of the selected stop type.	Recycle the power. If the fault does not clear, replace the main control board.
03025 <i>Absolute Overspd</i>	VP, Flashing red	Soft	The motor speed has exceeded the speed limit plus <i>Absolute Overspd</i> (parameter 24) settings. When this condition occurs, the drive coasts to a stop regardless of the selected stop type.	If operating in torque mode, check if the load is allowing excessive motor speed. Check if the setting of <i>Absolute Overspd</i> (parameter 24) or the speed limits (parameters 40 and 41) are too low.
03026 <i>Analog Spplly Tol</i>	VP, Flashing red	Soft	The analog supply tolerance voltage is outside of the 13V to 18V range. When this condition occurs, the drive coasts to a stop regardless of the selected stop type.	Possible faulty analog 15V power supply. The gate driver board or the main control board may require replacement.
03029 <i>SW Malfunction</i>	VP, Solid red	Hard	A software malfunction has occurred.	Recycle the power. If the fault does not clear, replace the main control board.
03030 <i>SW Malfunction</i>	VP, Solid red	Hard	A software malfunction has occurred. When this condition occurs, the drive coasts to a stop regardless of the selected stop type.	Recycle the power. If the fault does not clear, replace the main control board.
03031 <i>SW Malfunction</i>	VP, Solid red	Hard	A software malfunction has occurred.	Recycle the power. If the fault does not clear, replace the main control board.
03040 <i>mA Input</i>	VP, Flashing red	Soft	A loss of 4 – 20mA input has occurred.	Check your wiring and connections. If the fault does not clear, replace the main control board. If you do not want this condition to be reported as a fault, change bit 8 in <i>Fault Select 1</i> (parameter 20) to 0.
03057 <i>Param Limit</i>	VP, Flashing red	Soft	A parameter limit has occurred.	Examine the parameter limit testpoints to determine the exact cause. Refer to the <i>Understanding Parameter Limit Faults</i> section in the troubleshooting chapter of the user manual. If you do not want this condition to be reported as a fault, change bit 9 in <i>Fault Select 2</i> (parameter 22) to 0.
03058 <i>Math Limit</i>	VP, Flashing red	Soft	A math limit has occurred.	Examine the math limit testpoints to determine the exact cause. Refer to the <i>Understanding Math Limit Faults</i> section in the troubleshooting chapter of the user manual. If you do not want this condition to be reported as a fault, change bit 10 in <i>Fault Select 2</i> (parameter 22) to 0.

Fault Code and Text	LED Information	Fault Type	Description	Suggested Action
03072 <i>mA Input</i>	VP, Flashing green	Warning	A loss of 4 – 20mA input has occurred.	Check your wiring and connections. If you do not want this condition to be reported as a warning, change bit 8 in <i>Warning Select 1</i> (parameter 21) to 0.
03089 <i>Param Limit</i>	VP, Flashing green	Warning	A parameter limit has occurred.	Examine the parameter limit testpoints to determine the exact cause. Refer to the <i>Understanding Parameter Limit Faults</i> section in the troubleshooting chapter of the user manual. If you do not want this condition to be reported as a warning, change bit 9 in <i>Warning Select 2</i> (parameter 23) to 0.
03090 <i>Math Limit</i>	VP, Flashing green	Warning	A math limit has occurred.	Examine the math limit testpoints to determine the exact cause. Refer to the <i>Understanding Math Limit Faults</i> section in the troubleshooting chapter of the user manual. If you do not want this condition to be reported as a warning, change bit 10 in <i>Warning Select 2</i> (parameter 23) to 0.
05048 <i>Spd Fdbk Loss</i>	VP, Flashing red	Soft	A loss of feedback occurred.	Check the encoder wiring. Verify that the encoder signals are free of noise. If you do not want this condition to be reported as a fault, change bit 0 in <i>Fault Select 2</i> (parameter 22) to 0.
05054 <i>External Flt In</i>	VP, Flashing red	Soft	The external fault input from the L Option board is open.	Check the external circuit for cause of an open input signal. If you do not want this condition to be reported as a fault, change bit 6 in <i>Fault Select 2</i> (parameter 22) to 0.
05080 <i>Spd Fdbk Loss</i>	VP, Flashing green	Warning	A loss of feedback occurred.	Check the encoder wiring. Verify that the encoder signals are free of noise. If you do not want this condition to be reported as a warning, change bit 0 in <i>Warning Select 2</i> (parameter 23) to 0.
05086 <i>External Flt In</i>	VP, Flashing green	Warning	The external fault input from the L Option board is open.	Check the external circuit for cause of an open input signal. If you do not want this condition to be reported as a warning, change bit 6 in <i>Warning Select 2</i> (parameter 23) to 0.
06041 <i>SP 1 Timeout</i>	VP, Flashing red	Soft	The SCANport adapter at port 1 has been disconnected and the logic mask bit for port 1 is set (1).	If the adapter was not intentionally disconnected: <ul style="list-style-type: none"> • Check the wiring to the SCANport adapters. • Replace wiring, SCANport expander, SCANport adapters, and main control board. • Replace drive, if required. If you do not want this condition to be reported as a fault, change bit 9 in <i>Fault Select 1</i> (parameter 20) to 0.

Fault Code and Text	LED Information	Fault Type	Description	Suggested Action
06042 <i>SP 2 Timeout</i>	VP, Flashing red	Soft	The SCANport adapter at port 2 has been disconnected and the logic mask bit for port 2 is set (1).	<p>If the adapter was not intentionally disconnected:</p> <ul style="list-style-type: none"> • Check the wiring to the SCANport adapters. • Replace wiring, SCANport expander, SCANport adapters, and main control board. • Replace drive, if required. <p>If you do not want this condition to be reported as a fault, change bit 10 in <i>Fault Select 1</i> (parameter 20) to 0.</p>
06043 <i>SP 3 Timeout</i>	VP, Flashing red	Soft	The SCANport adapter at port 3 has been disconnected and the logic mask bit for port 3 is set (1).	<p>If the adapter was not intentionally disconnected:</p> <ul style="list-style-type: none"> • Check the wiring to the SCANport adapters. • Replace wiring, SCANport expander, SCANport adapters, and main control board. • Replace drive, if required. <p>If you do not want this condition to be reported as a fault, change bit 11 in <i>Fault Select 1</i> (parameter 20) to 0.</p>
06044 <i>SP 4 Timeout</i>	VP, Flashing red	Soft	The SCANport adapter at port 4 has been disconnected and the logic mask bit for port 4 is set (1).	<p>If the adapter was not intentionally disconnected:</p> <ul style="list-style-type: none"> • Check the wiring to the SCANport adapters. • Replace wiring, SCANport expander, SCANport adapters, and main control board. • Replace drive, if required. <p>If you do not want this condition to be reported as a fault, change bit 12 in <i>Fault Select 1</i> (parameter 20) to 0.</p>
06045 <i>SP 5 Timeout</i>	VP, Flashing red	Soft	The SCANport adapter at port 5 has been disconnected and the logic mask bit for port 5 is set (1).	<p>If the adapter was not intentionally disconnected:</p> <ul style="list-style-type: none"> • Check the wiring to the SCANport adapters. • Replace wiring, SCANport expander, SCANport adapters, and main control board. • Replace drive, if required. <p>If you do not want this condition to be reported as a fault, change bit 13 in <i>Fault Select 1</i> (parameter 20) to 0.</p>
06046 <i>SP 6 Timeout</i>	VP, Flashing red	Soft	The SCANport adapter at port 6 has been disconnected and the logic mask bit for port 6 is set (1).	<p>If the adapter was not intentionally disconnected:</p> <ul style="list-style-type: none"> • Check the wiring to the SCANport adapters. • Replace wiring, SCANport expander, SCANport adapters, and main control board. • Replace drive, if required. <p>If you do not want this condition to be reported as a fault, change bit 14 in <i>Fault Select 1</i> (parameter 20) to 0.</p>
06047 <i>SP Error</i>	VP, Flashing red	Soft	SCANport communications have been interrupted.	<p>If the adapter was not intentionally disconnected:</p> <ul style="list-style-type: none"> • Check the amount of noise on the system. • Check the wiring to the SCANport adapters. • Replace wiring, SCANport expander, SCANport adapters, and main control board. • Replace drive, if required. <p>If you do not want this condition to be reported as a fault, change bit 15 in <i>Fault Select 1</i> (parameter 20) to 0.</p>

Fault Code and Text	LED Information	Fault Type	Description	Suggested Action
06073 <i>SP 1 Timeout</i>	VP, Flashing green	Warning	The SCANport adapter at port 1 has been disconnected and the logic mask bit for port 1 is set (1).	If the adapter was not intentionally disconnected: <ul style="list-style-type: none"> • Check the wiring to the SCANport adapters. • Replace wiring, SCANport expander, SCANport adapters, and main control board. • Replace drive, if required. If you do not want this condition to be reported as a warning, change bit 9 in <i>Warning Select 1</i> (parameter 21) to 0.
06074 <i>SP 2 Timeout</i>	VP, Flashing green	Warning	The SCANport adapter at port 2 has been disconnected and the logic mask bit for port 2 is set (1).	If the adapter was not intentionally disconnected: <ul style="list-style-type: none"> • Check the wiring to the SCANport adapters. • Replace wiring, SCANport expander, SCANport adapters, and main control board. • Replace drive, if required. If you do not want this condition to be reported as a warning, change bit 10 in <i>Warning Select 1</i> (parameter 21) to 0.
06075 <i>SP 3 Timeout</i>	VP, Flashing green	Warning	The SCANport adapter at port 3 has been disconnected and the logic mask bit for port 3 is set (1).	If the adapter was not intentionally disconnected: <ul style="list-style-type: none"> • Check the wiring to the SCANport adapters. • Replace wiring, SCANport expander, SCANport adapters, and main control board. • Replace drive, if required. If you do not want this condition to be reported as a warning, change bit 11 in <i>Warning Select 1</i> (parameter 21) to 0.
06076 <i>SP 4 Timeout</i>	VP, Flashing green	Warning	The SCANport adapter at port 4 has been disconnected and the logic mask bit for port 4 is set (1).	If the adapter was not intentionally disconnected: <ul style="list-style-type: none"> • Check the wiring to the SCANport adapters. • Replace wiring, SCANport expander, SCANport adapters, and main control board. • Replace drive, if required. If you do not want this condition to be reported as a warning, change bit 12 in <i>Warning Select 1</i> (parameter 21) to 0.
06077 <i>SP 5 Timeout</i>	VP, Flashing green	Warning	The SCANport adapter at port 5 has been disconnected and the logic mask bit for port 5 is set (1).	If the adapter was not intentionally disconnected: <ul style="list-style-type: none"> • Check the wiring to the SCANport adapters. • Replace wiring, SCANport expander, SCANport adapters, and main control board. • Replace drive, if required. If you do not want this condition to be reported as a warning, change bit 13 in <i>Warning Select 1</i> (parameter 21) to 0.
06078 <i>SP 6 Timeout</i>	VP, Flashing green	Warning	The SCANport adapter at port 6 has been disconnected and the logic mask bit for port 6 is set (1).	If the adapter was not intentionally disconnected: <ul style="list-style-type: none"> • Check the wiring to the SCANport adapters. • Replace wiring, SCANport expander, SCANport adapters, and main control board. • Replace drive, if required. If you do not want this condition to be reported as a warning, change bit 14 in <i>Warning Select 1</i> (parameter 21) to 0.

Fault Code and Text	LED Information	Fault Type	Description	Suggested Action
06079 <i>SP Error</i>	VP, Flashing green	Warning	SCANport communications have been interrupted.	<p>If the adapter was not intentionally disconnected:</p> <ul style="list-style-type: none"> • Check the amount of noise on the system. • Check the wiring to the SCANport adapters. • Replace wiring, SCANport expander, SCANport adapters, and main control board. • Replace drive, if required. <p>If you do not want this condition to be reported as a warning, change bit 15 in <i>Warning Select 1</i> (parameter 21) to 0.</p>
12016 <i>Overvoltage</i>	CP, Solid red	Soft	<p>The DC bus voltage has exceeded the maximum value.</p> <p>When this condition occurs, the drive coasts to a stop regardless of the selected stop type.</p>	<p>Monitor the AC line for high line voltage or transient conditions.</p> <p>Increase the deceleration time or install the dynamic brake option because motor regeneration can also cause bus overvoltages. Refer to the user manual for a description of <i>Bus Options</i> (parameter 13) for additional information about bus overvoltages.</p> <p>If you are using flux braking, refer to Chapter 9, <i>Applications</i>, in the user manual for information about flux braking.</p>
12017 <i>Desaturation</i>	CP, Solid red	Soft	<p>There was too much current in the system.</p> <p>When this condition occurs, the drive coasts to a stop regardless of the selected stop type.</p>	<p>Run the power structure diagnostics. Check for a shorted motor or motor wiring. Replace the drive.</p>
12018 <i>Ground Fault</i>	CP, Solid red	Soft	<p>A current path to earth ground in excess of drive rated current has been detected at one or more of the drive output terminals.</p> <p>When this condition occurs, the drive coasts to a stop regardless of the selected stop type.</p>	<p>Run the power structure diagnostics. Check the motor and external wiring to the drive output terminals for a grounded condition. Replace the drive.</p>
12019 <i>Overcurrent</i>	CP, Solid red	Soft	<p>There was too much current in the system.</p> <p>When this condition occurs, the drive coasts to a stop regardless of the selected stop type.</p>	<p>Run the power structure diagnostics. Check for shorted motor or motor wiring. Replace drive.</p>
12032 <i>RidethruTime</i>	CP, Flashing red	Soft	<p>There was a bus voltage drop of 150V and power did not return within 2 seconds.</p>	<p>Check the incoming power and fuses. Refer to the <i>Understanding Precharge and Ridethrough Faults</i> section in the troubleshooting chapter of the user manual for more information.</p> <p>If you do not want this condition to be reported as a fault, change bit 0 in <i>Fault Select 1</i> (parameter 20) to 0.</p>
12033 <i>Prechrg Time</i>	CP, Flashing red	Soft	<p>The precharge function could not complete within 30 seconds.</p>	<p>Refer to the <i>Understanding Precharge and Ridethrough Faults</i> section in the troubleshooting chapter of the user manual for more information.</p> <p>If you do not want this condition to be reported as a fault, change bit 1 in <i>Fault Select 1</i> (parameter 20) to 0.</p>

Fault Code and Text	LED Information	Fault Type	Description	Suggested Action
12034 <i>Bus Drop</i>	CP, Flashing red	Soft	The bus voltage dropped 150V below the bus tracker voltage.	Monitor the incoming AC line for low voltage or line power interruption. Refer to the <i>Understanding Precharge and Ridethrough Faults</i> section in the troubleshooting chapter of the user manual for more information. If you do not want this condition to be reported as a fault, change bit 2 in <i>Fault Select 1</i> (parameter 20) to 0.
12035 <i>Bus Undervlt</i>	CP, Flashing red	Soft	The DC bus voltage fell below the trip value (388V DC at 460V AC input).	Monitor the incoming AC line for low voltage or line power interruption. Refer to the <i>Understanding Precharge and Ridethrough Faults</i> section in the troubleshooting chapter of the user manual for more information. If you do not want this condition to be reported as a fault, change bit 3 in <i>Fault Select 1</i> (parameter 20) to 0 or decrease the bus undervoltage setpoint.
12036 <i>Bus Cycle>5</i>	CP, Flashing red	Soft	At least 5 ridethrough cycles have occurred within a 20 second period. This indicates a converter problem or a problem with the incoming power.	Monitor the incoming AC line for low voltage or line power interruption. Refer to the <i>Understanding Precharge and Ridethrough Faults</i> section in the troubleshooting chapter of the user manual for more information. If you do not want this condition to be reported as a fault, change bit 4 in <i>Fault Select 1</i> (parameter 20) to 0.
12037 <i>Open Circuit</i>	CP, Flashing red	Soft	The fast flux up current is less than 50% of commanded.	Make sure the motor is properly connected. Refer to the <i>Understanding Precharge and Ridethrough Faults</i> section in the troubleshooting chapter of the user manual for more information. If you do not want this condition to be reported as a fault, change bit 5 in <i>Fault Select 1</i> (parameter 20) to 0.
12064 <i>RidethruTime</i>	CP, Solid green	Warning	There was a drop of 150V and power did not return within 2 seconds.	Check the incoming power and fuses. Refer to the <i>Understanding Precharge and Ridethrough Faults</i> section in the troubleshooting chapter of the user manual for more information. If you do not want this condition to be reported as a warning, change bit 0 in <i>Warning Select 1</i> (parameter 21) to 0.
12065 <i>Prechrg Time</i>	CP, Solid green	Warning	The precharge function could not complete within 30 seconds.	Refer to the <i>Understanding Precharge and Ridethrough Faults</i> section in the troubleshooting chapter of the user manual for more information. If you do not want this condition to be reported as a warning, change bit 1 in <i>Warning Select 1</i> (parameter 21) to 0.

Fault Code and Text	LED Information	Fault Type	Description	Suggested Action
12066 <i>Bus Drop</i>	CP, Solid green	Warning	The bus voltage dropped 150V below the bus tracker voltage.	Monitor the incoming AC line for low voltage or line power interruption. Refer to the <i>Understanding Precharge and Ridethrough Faults</i> section in the troubleshooting chapter of the user manual for more information. If you do not want this condition to be reported as a warning, change bit 2 in <i>Warning Select 1</i> (parameter 21) to 0.
12067 <i>Bus Undervlt</i>	CP, Solid green	Warning	The DC bus voltage fell below the minimum value (388V DC at 460V AC input).	Monitor the incoming AC line for low voltage or line power interruption. Refer to the <i>Understanding Precharge and Ridethrough Faults</i> section in the troubleshooting chapter of the user manual for more information. If you do not want this condition to be reported as a warning, change bit 3 in <i>Warning Select 1</i> (parameter 21) to 0.
12068 <i>Bus Cycle>5</i>	CP, Solid green	Warning	At least 5 ridethrough cycles have occurred within a 20 second period. This indicates a converter problem or a problem with the incoming power.	Monitor the incoming AC line for low voltage or line power interruption. Refer to the <i>Understanding Precharge and Ridethrough Faults</i> section in the troubleshooting chapter of the user manual for more information. If you do not want this condition to be reported as a warning, change bit 4 in <i>Warning Select 1</i> (parameter 21) to 0.
12069 <i>Open Circuit</i>	CP, Solid green	Warning	The fast flux up current is less than 50% of commanded.	Make sure the motor is properly connected. Refer to the <i>Understanding Precharge and Ridethrough Faults</i> section in the troubleshooting chapter of the user manual for more information. If you do not want this condition to be reported as a warning, change bit 5 in <i>Warning Select 1</i> (parameter 21) to 0.
13000 <i>HW Malfunction</i>	CP, Solid red	Hard	A hardware malfunction occurred.	Recycle the power. If the fault does not clear, replace the main control board.
13001 <i>HW Malfunction</i>	CP, Solid red	Hard	A hardware malfunction occurred.	Recycle the power. If the fault does not clear, replace the main control board.
13002 <i>HW Malfunction</i>	CP, Solid red	Hard	A hardware malfunction occurred.	Recycle the power. If the fault does not clear, replace the main control board.
13003 <i>HW Malfunction</i>	CP, Solid red	Hard	A hardware malfunction occurred.	Recycle the power. If the fault does not clear, replace the main control board.
13004 <i>HW Malfunction</i>	CP, Solid red	Hard	A hardware malfunction occurred.	Recycle the power. If the fault does not clear, replace the main control board.

Diagnostic Procedures by Symptom

The following charts list drive symptoms, symptom descriptions, and recommended actions.

Figure 2.4
Drive Will Not Start or Jog

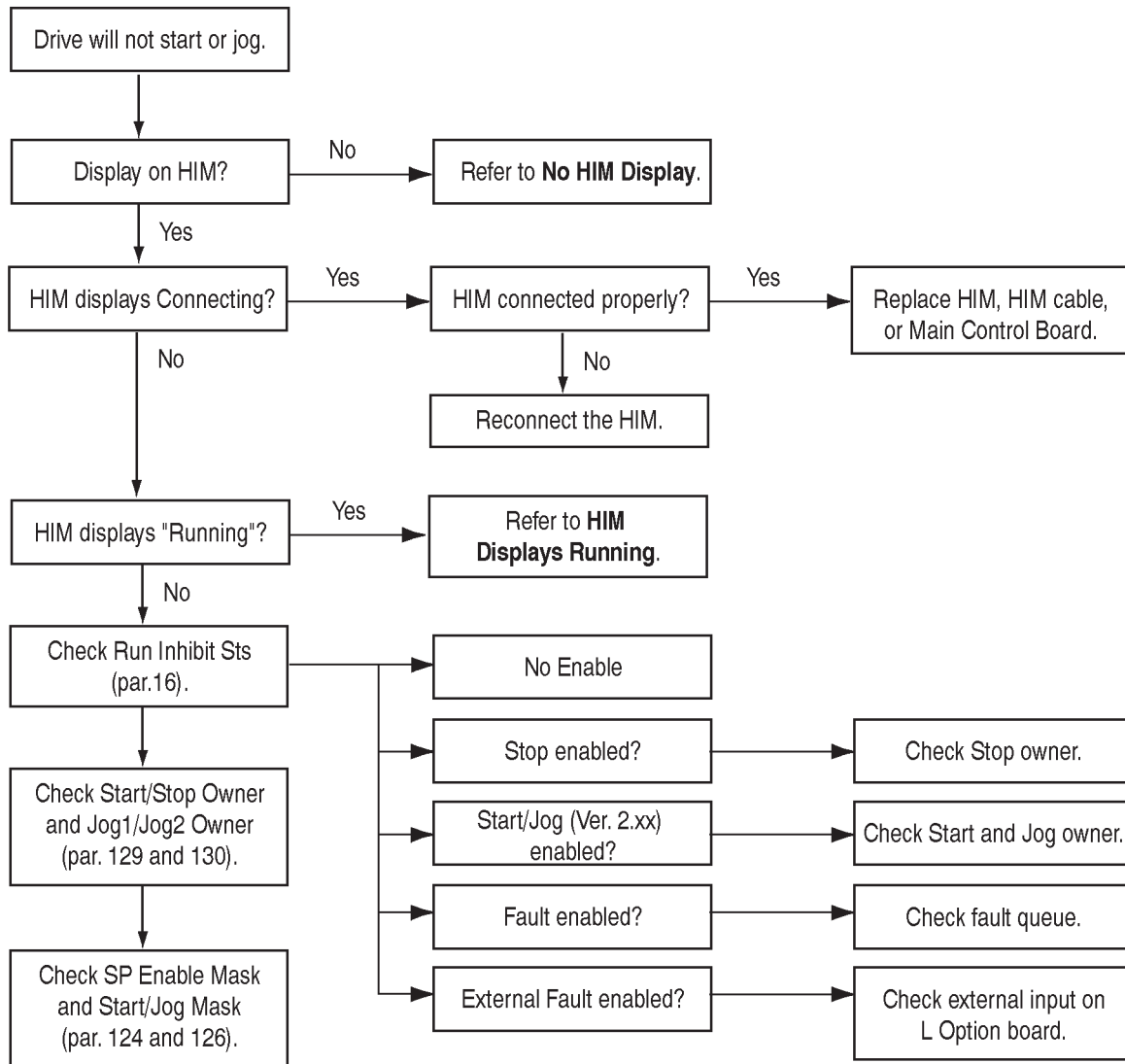

Figure 2.5
No HIM Display

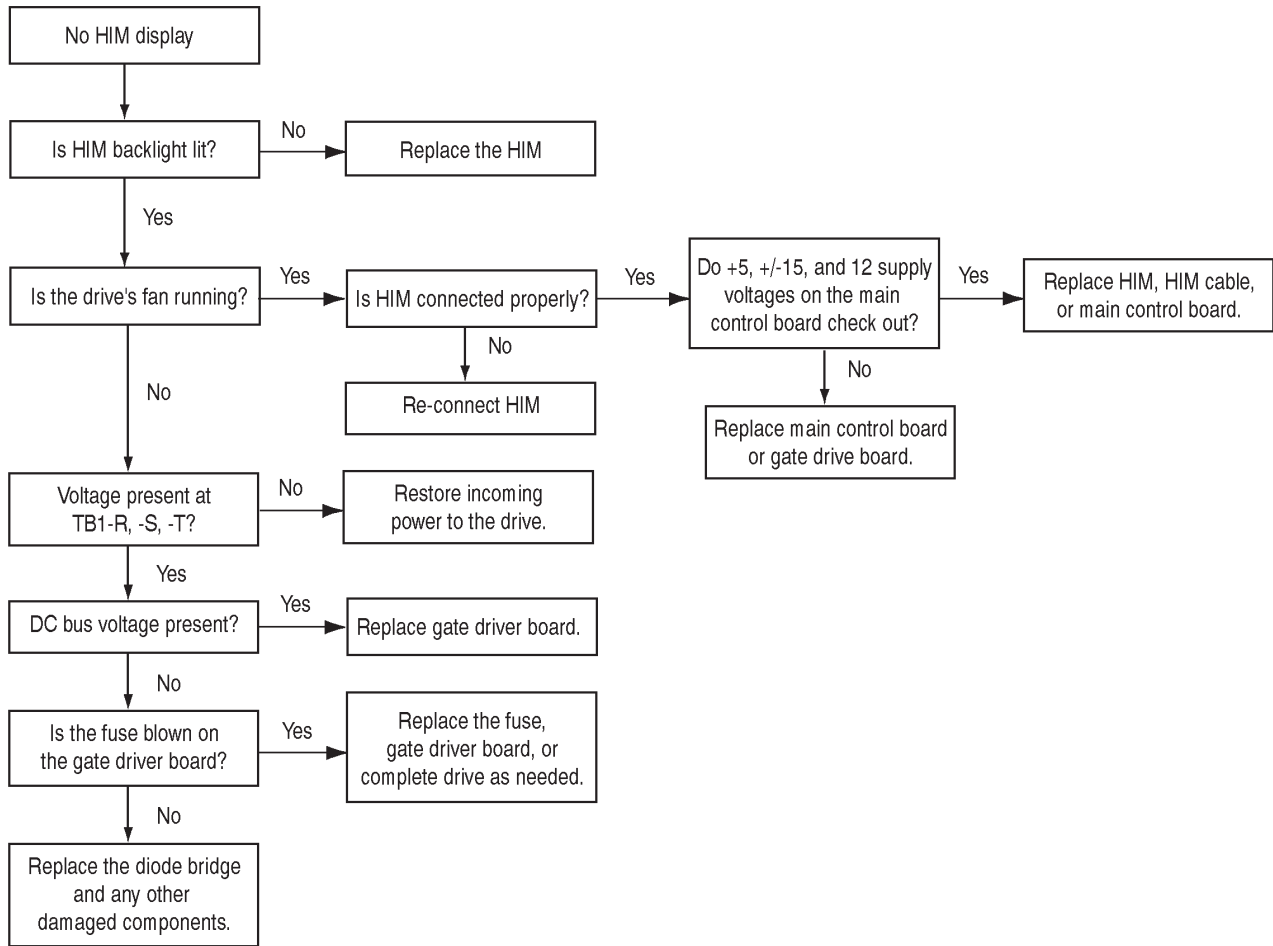

Figure 2.6
HIM Displays "Running"

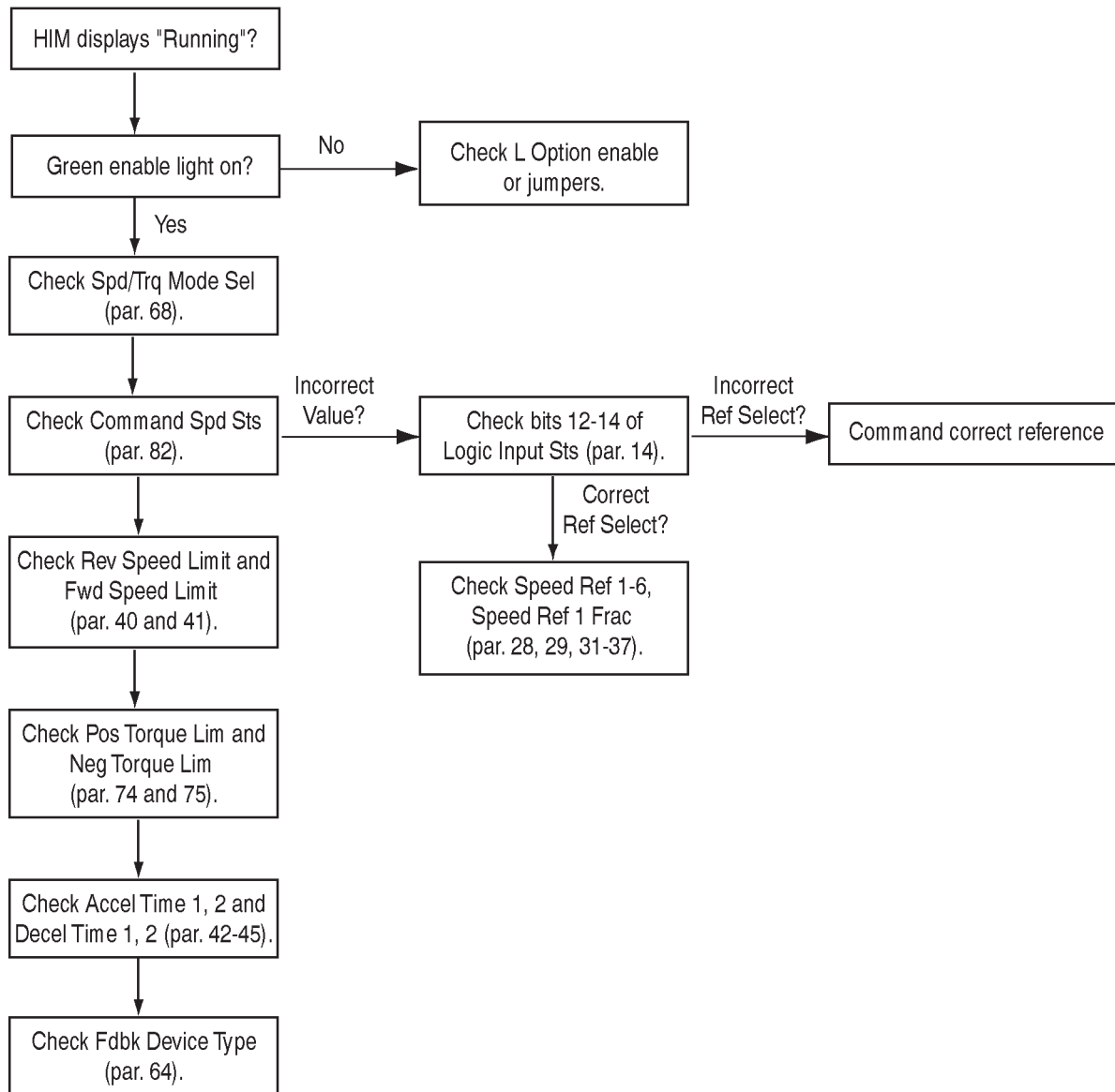
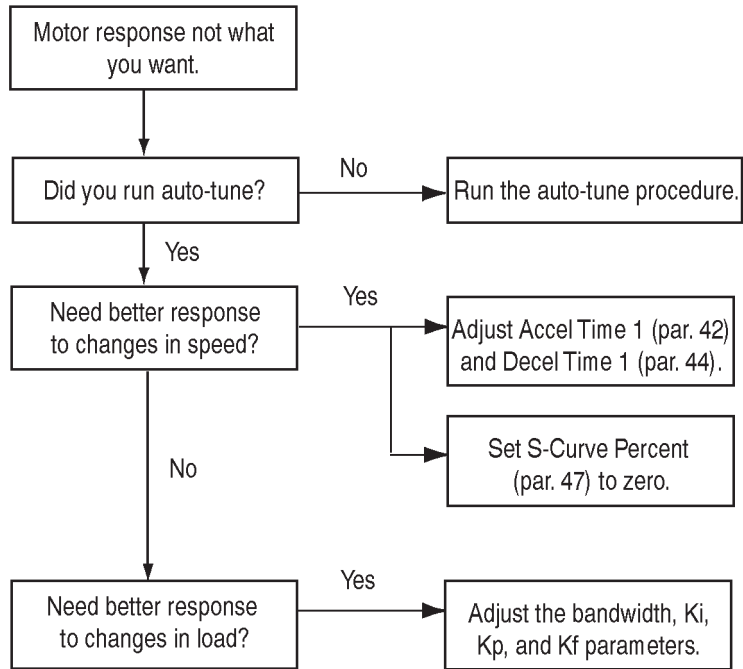

Figure 2.7
Motor Response Not Where You Want It



Start Up Troubleshooting Procedures

If you are having problems with the start up procedure, refer to this table for possible solutions before calling for help.

Table 2.E

If:	Then:
You powered up your drive and cannot access the start up routine.	The start up procedure is not supported on a Series A Human Interface Module (HIM). To verify that you have a Series A HIM, check the series letter located on the back side of the HIM or check the HIM version when you first power up your drive.
You got a <i>Feedback Loss Fault</i> .	You have specified that an encoder is on the system but it has been disconnected.
The motor does not turn during the phase rotation test.	Remove the load from the motor and try running the autotune tests again. Afterwards, you will need to attach the load again and run the inertia test manually.
During the phase rotation test you were asked to swap the encoder leads. You changed the leads and ran start up again. You were asked to swap the leads again.	The drive is not getting any speed feedback information. You need to: <ul style="list-style-type: none"> • Check the connection between the encoder and the motor. • Run the phase rotation test again and escape out to the status display at the first question. Check the motor speed. It should ramp to 3 Hz (90 rpm) for a 60 Hz 4 pole motor. If the motor speed is 0 rpm, you should: <ul style="list-style-type: none"> • Check the encoder wiring. • Check the encoder itself.

Miscellaneous Troubleshooting Procedures

If you are having problems with how your 1336 IMPACT drive is operating, refer to this table for possible solutions before calling for help.

Table 2.F

If:	Then you should:
The drive starts and then stops.	<ul style="list-style-type: none"> • Check if the mode specified in <i>L Option Mode</i> (parameter 116) is 2 or 3 wire. • Check <i>SP 2 Wire Enable</i> (parameter 181). • Check to see if the HIM displays a fault message. • Check the L Option Board wiring. • Check the settings on your gateway (communications module).
There is a delay before the stop command takes effect.	<ul style="list-style-type: none"> • Check the value of <i>Stop Dwell Time</i> (parameter 18).
The motor waits before starting.	<ul style="list-style-type: none"> • Check <i>Start Dwell Time</i> (parameter 194). • Check <i>Pos Torque Lim</i> (parameter 74) and <i>Neg Torque Lim</i> (parameter 75). • Check <i>Fast Flux Level</i> (parameter 78) and bit 8 of <i>Bus/Brake Opts</i> (parameter 13). • Check <i>S-Curve Percent</i> (parameter 47).
The drive coasts on stop.	<ul style="list-style-type: none"> • Check the stop type bits in <i>Logic Options</i> (parameter 17). • Check <i>Zero Speed Tol</i> (parameter 19).
You cannot clear faults.	<ul style="list-style-type: none"> • Check if the port is enabled in <i>SP Enable Mask</i> (parameter 124). • Check if clear faults is enabled in <i>Clr Flt/Res Mask</i> (parameter 127). • Check if clear fault owners in <i>Ramp/CIFlt Owner</i> (parameter 131) is set. If set, check stop owners in <i>Start/Stop Owner</i> (parameter 129) and remove stop conditions. • The fault is a hard fault which requires a power cycle or drive reset.
The motor does not turn or run at the correct speed.	<ul style="list-style-type: none"> • Check which speed reference the drive is following in <i>Drive/Inv Status</i> (parameter 21) bits 13 – 15. • Check if <i>Spd/Trq Mode Sel</i> (parameter 68) is set correctly. • Check if <i>Spd Desired BW</i> (parameter 161) is non-zero. • Set the drive defaults and run start up again to tune the drive.

If:	Then you should:
The HIM pot does not control motor speed.	<ul style="list-style-type: none"> • Check if <i>SP An In1 Select</i> (parameter 133) or <i>SP An In2 Select</i> (parameter 136) is set to the HIM port number. • Check if <i>SP An In1 Scale</i> (parameter 135) or <i>SP An In2 Scale</i> (parameter 138) is 0.125. • Check if a <i>Speed Ref 1 – 7</i> (parameters 29 through 36) is linked to <i>SP An In1 Value</i> (parameter 134) or <i>SP An In2 Value</i> (parameter 137). • Check which speed reference the drive is following in <i>Drive/Inv Status</i> (parameter 21) bits 13 – 15. The speed reference should be set to the speed reference that <i>SP An In1 Value</i> (parameter 134) or <i>SP An In2 Value</i> (parameter 137) is linked to.
The drive will not change direction.	<ul style="list-style-type: none"> • Check if the port is enabled in <i>SP Enable Mask</i> (parameter 124). • Check if Direction is enabled in <i>Dir/Ref Mask</i> (parameter 125). • Check if Direction owner in <i>Dir/Ref Owner</i> (parameter 128) has any bit set. If so, remove the command direction. • Check to make sure that bit 11 in <i>Logic Options</i> (parameter 17) is clear (0).
You cannot change the speed reference.	<ul style="list-style-type: none"> • Check if the port is enabled in <i>SP Enable Mask</i> (parameter 124). • Check if Reference is enabled in <i>Dir/Ref Mask</i> (parameter 125). • Check if Reference owner in <i>Dir/Ref Owner</i> (parameter 128) has any bit set. If so, remove the command reference. If bit 0 (for the L Option control) is set, you need to do one of the following to remove ownership: <ul style="list-style-type: none"> • Clear bit 0 in <i>Dir/Ref Mask</i> (parameter 125). • If <i>L Option Mode</i> (parameter 116) is 2, 3, 8, 9, 23, 24, or 26, close the L Option inputs for speed references 1, 2, and 3.
The drive does not run correct torque.	<ul style="list-style-type: none"> • Set the drive defaults and run start up again to tune the drive. • Check <i>Spd/Trq Mode Sel</i> (parameter 68) and <i>Slave Torque %</i> (parameter 70).
The drive cannot control current and trips on an overcurrent fault.	<ul style="list-style-type: none"> • If you are using an encoder, check that you have entered the correct PPR into <i>Encoder PPR</i> (parameter 8).
The MOP does not work.	<ul style="list-style-type: none"> • Check <i>L Option Mode</i> (parameter 116). • Make sure that <i>Mop Value</i> (parameter 119) is linked to a speed reference.
The pulse input does not work.	<ul style="list-style-type: none"> • Make sure that the pulse input jumper is set correctly. • Make sure that the input is differential and not single ended. • Check the values of <i>Pulse In PPR</i> (parameter 120), <i>Pulse In Scale</i> (parameter 121), and <i>Pulse In Offset</i> (parameter 122). • Check the link on <i>Pulse In Value</i> (parameter 123).
The external fault does not work.	<ul style="list-style-type: none"> • Check the mode in <i>L Option Mode</i> (parameter 116). • Check bit 6 in <i>Fault Select 2</i> (parameter 22) and <i>Warning Select 2</i> (parameter 23).
You keep getting motor overload trips.	<ul style="list-style-type: none"> • Reduce the load. • Check bits 3 and 4 in <i>Fault Select 2</i> (parameter 22) and <i>Warning Select 2</i> (parameter 23). • Check <i>Motor Overload %</i> (parameter 26).
The motor reduced the speed range.	<ul style="list-style-type: none"> • Check <i>SP An In1 Scale</i> (parameter 135) or <i>SP An In2Scale</i> (parameter 138) if your speed input is coming from the HIM pot. • Check <i>An In 1 Offset</i> (parameter 97), <i>An In 1 Scale</i> (parameter 98), <i>An In 2 Offset</i> (parameter 100), <i>An In 2 Scale</i> (parameter 101), <i>mA Input Offset</i> (parameter 103), and <i>mA Input Scale</i> (parameter 104) if your speed input is coming from the analog inputs. • Check <i>Speed Scale 1</i> (parameter 30) or <i>Speed Scale 7</i> (parameter 37). • Check <i>Absolute Overspd</i> (parameter 24). • Check <i>Min Speed Limit</i> (parameter 215).

Encoderless Troubleshooting Procedures

If you are having problems with encoderless mode, refer to this table for possible solutions before calling for help.

Table 2.G

If:	Then you should:
The motor will not accelerate or does not start smoothly	<ul style="list-style-type: none"> • Increase the bandwidth in <i>Spd Desired BW</i> (parameter 161). If the bandwidth is too low, the motor may not accelerate, although the current increases to current limit. • If the regen power limit is 0, increase it to at least -5%. • Increase the torque and current limits to the maximum. • Increase the value of <i>Kp Freq Reg</i> (parameter 178).
The motor oscillates after it is up to speed	<ul style="list-style-type: none"> • Decrease the bandwidth in <i>Spd Desired BW</i> (parameter 161) if the process will allow. If this does not help, depending on your application, you need to either increase or decrease the value of <i>Error Filter BW</i> (parameter 162).
The inverter trips on absolute overspeed during starting	<ul style="list-style-type: none"> • Increase the acceleration time. • If the overspeed occurs during a fast acceleration, increase the value of <i>Kp Freq Reg</i> (parameter 178) until the trip stops occurring. • Increase the bandwidth in <i>Spd Desired BW</i> (parameter 161). • If the overspeed occurs during a reversal, increase the deceleration time (slower deceleration).

Disassembly and Access Procedures

Chapter Objectives

This chapter describes general disassembly procedures required to access internal drive components.

Disassembly and Access Overview



ATTENTION: Some printed circuit boards and drive components may contain hazardous voltage levels. Remove and lock out power before you disconnect or reconnect wires and before you remove or replace fuses and circuit boards. Verify bus voltage by measuring the voltage between +DC and –DC on terminal block TB1. Do not attempt to service the drive until the bus voltage has discharged to zero volts.



ATTENTION: Servicing energized industrial control equipment can be hazardous. Electrical shock, burns, or unintentional actuation of controlled industrial equipment may cause death or serious injury. Follow the safety-related practices of NFPA 70E, Electrical Safety for Employee Workplaces, when working on or near energized equipment. Do not work alone on energized equipment.

Electrostatic Discharge Precautions



ATTENTION: This assembly contains parts and sub-assemblies that are sensitive to electrostatic discharge. Static control precautions are required when servicing this assembly. Component damage may result if you ignore electrostatic discharge control procedures. If you are not familiar with static control procedures, reference Rockwell Automation Publication 8000-4.5.2, Guarding Against Electrostatic Discharge, or any other applicable ESD protection handbook.

Electrostatic discharge generated by static electricity can damage the complementary metallic oxide semiconductor devices on various drive boards. It is recommended that you perform these procedures to guard against this type of damage when circuit boards are removed or installed:

- Wear a wrist-type grounding strap that is grounded to the chassis.
- Attach the wrist strap before removing the new circuit board from the conductive packet.
- Remove boards from the drive and immediately insert them into their conductive packets.

Tools

You need the following tools to disassemble and assemble the drive:

- Pliers
- Phillips screwdrivers (small, medium, and large)
- Standard screwdrivers (small, medium, and large)
- 25/64-inch or 10 mm socket
- 7/16-inch or 11 mm socket
- 33/64-inch or 13 mm deep-well socket
- 5/16-inch or 8 mm open-end wrench
- Torque wrench, metered in lb-in. or N-m
- Nylon tie wraps

Fastener Torque Specifications

Torque Sequence

When mounting components to a drive's heat sink, component-fastener torque sequences and tolerances are crucial to component-to-heat sink heat dissipation.



ATTENTION: Component can be damaged if temporary tightening procedure is not performed to specification.

The following illustrates temporary and final tightening sequences for components fastened to a heat sink using two, four, and six screws. Temporary torque is 1/3 (33%) of final torque, except six-point mountings, which require 0.5 N-m (4 lb-in.). The numeric illustration labels are for your assistance. Drive components do not carry these labels.

Figure 3.1
Two-Point Mounting

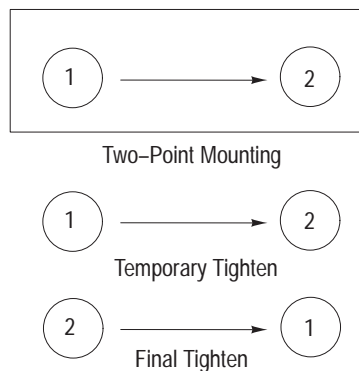

AB0016A

Figure 3.2
Four-Point Mounting

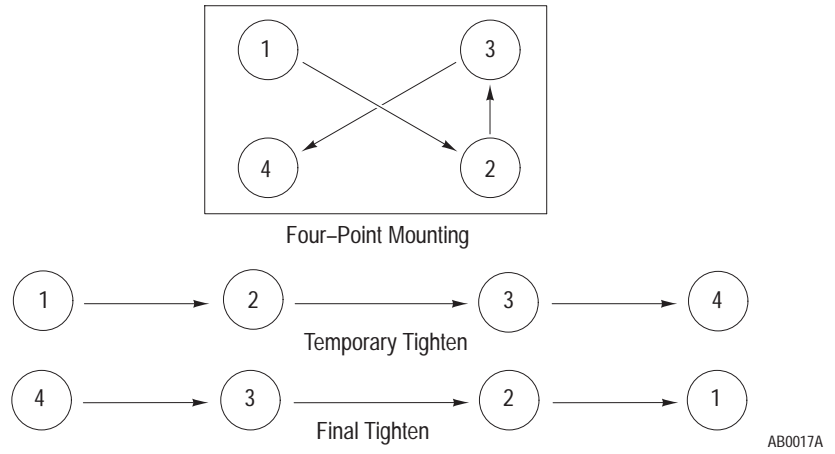
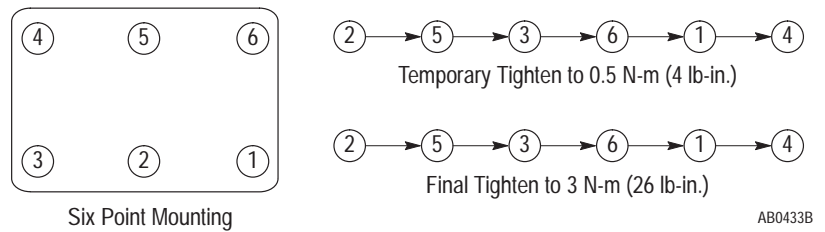

Figure 3.3
Six-Point Mounting



Do not exceed 0.5 Newton-meters (4 lb-in.) on initial torque of all six screws.

Torque Specifications

The following table lists fastener locations by component, how the fasteners are used, and torque specifications. Refer to Torque Sequence in this chapter for fastening two-point, four-point and six-point components to the heat sink.

Table 3.A
Fastener Torque Specifications

Component	Fastener Application	Torque lb-in.	Torque N-m
Fan Motor	Motor to Fan Cover Assembly	14	2
Fan Cover Assembly	Assembly to chassis	26	3
Fan Transformer	Transformer to chassis	26	3
Fan Capacitor	Capacitor to chassis	Hand-tighten	
MOV Surge Suppressor	MOV to chassis	14	2
Snubber Resistor	Resistor to heat sink	26	3
Snubber Resistor	Wires to Capacitor Bus Bar Assembly	50	6
Snubber Bracket	Bracket to Power Module	80	9
Snubber Board	Board to Brackets	50	6
Snubber Board	Board to Input Rectifier	50	6
Volt Sharing Resistor	Resistor to heat sink	26	3
Volt Sharing Resistor	Wires to Capacitor Bus Bar Assembly	50	6
Thermistor	Thermistor to heatsink	14	2
Bus Capacitor Holder	Holder to Bus Capacitors	26	3
Capacitor Bus Bar Assembly	Assembly to Bus Capacitors	50	6
Power Module Gate Interface Board	Board to Power Modules	14	2
Power Module Bus Bar	Bus Bar to Power Modules	80	9
Power Module	Module to heat sink	Refer to Figure 3.3	
DIN Rail (TB1)	Rail to chassis	50	6
PE Shortening Bar	Bar to TB1	80	9
Input Rectifier	Rectifier to heat sink	50	6
Transitional Bus Bar Assembly	Assembly to Power Module Bus Bar Assembly	80	9
Bus Fuse F1	Fuse to Transitional Bus Bar Assembly	80	9
DC Bus Inductor L1	Inductor to chassis	50	6
Bus Bar Cable Adaptor	Adaptor to Transitional Bus Bar Assembly and DC Bus Inductor	80	9
Converter Bus and Motor Bus Bars	Bus Bars to all connections	80	9
Wires (PE)	Wires to Ground Stud	80	9
Wires	Wires to TB1	80	9
Wire (TE)	Wire to TB1	50	6
Wires	Wires to TB3	8 – 10	0.9 – 1.13
LEM Mounting Plate	Mounting Plate to LEM Clamping Plate	14	2
LEM Clamping Plate	Clamping Plate to Bus Bar	26	3
Power Cables	Cables to terminals	80	9
Main Control, Gate Driver, Precharge Board Mounting Plates	Plates to chassis	26	3
High Voltage Guard	Guard to chassis	26	3

Disassembly and Access Procedures

Opening the Drive Enclosure

Figure 3.4
Drive Enclosure

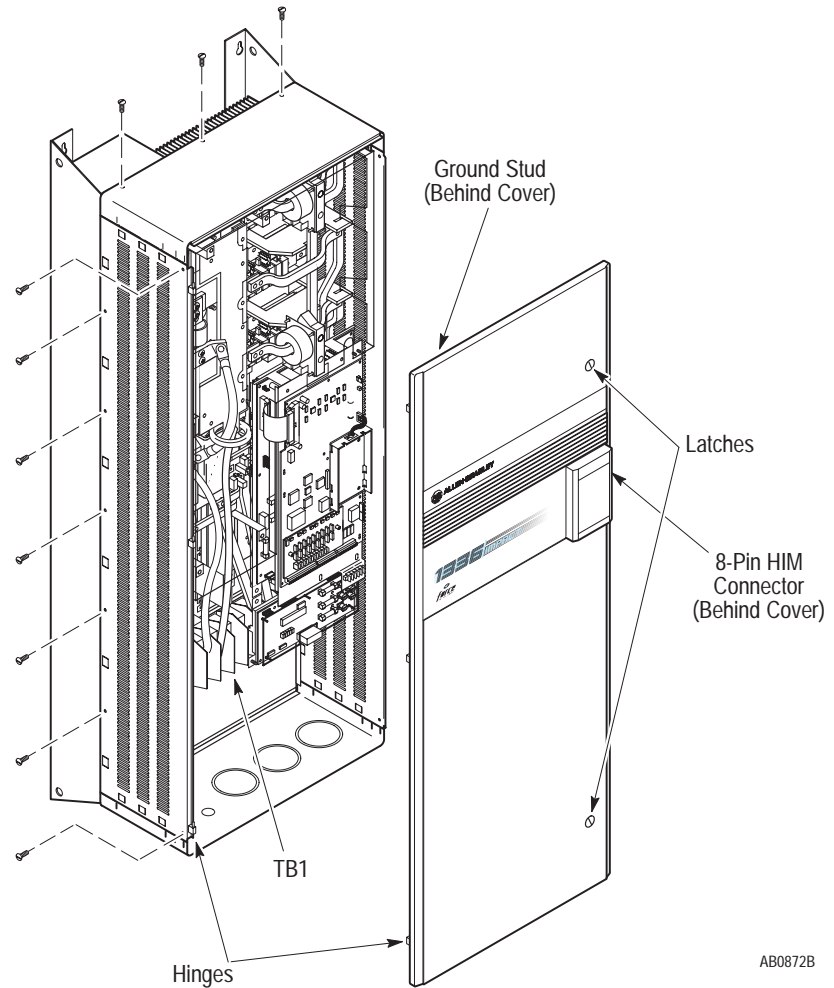

AB0872B

Removal



ATTENTION: Disconnect and lock out power from the drive before disassembling the drive. Failure to disconnect power may result in death or serious injury. Verify bus voltage by measuring the voltage between +DC and -DC on terminal block TB1. Do not attempt to service the drive until the bus voltage has discharged to zero volts.



ATTENTION: Wear a wrist-type grounding strap when servicing 1336 IMPACT drives. Failure to protect drive components against ESD may damage drive components. Refer to Electrostatic Discharge Precautions at the beginning of this chapter.

1. Remove power from the drive.
2. Turn the Enclosure Cover latches, located on the right side of the cover, 90 degrees clockwise.
3. Open the Enclosure door.
4. Check for zero volts at TB1 terminals +DC and –DC.
5. Check for the absence of control voltage at:
 - TB10
 - TB11
 - L Option Board (if used)
6. Remove the 8-pin HIM connector from the HIM holder and the ground wire from the ground stud on the inside of the door.
7. Disconnect the HIM cable and the ground wire from the clips inside the door.
8. Lift the cover up toward the top of the drive to disengage the cover from the hinges.
9. Remove the customer-supplied wiring from the drive.
10. Remove the Enclosure top and bottom panels.
11. Remove the Enclosure side panels.

Installation

Install the Enclosure in reverse order of removal.



ATTENTION: Replace all guards before applying power to the drive. Failure to replace guards may result in death or serious injury.

Removing the High Voltage Guard

The High Voltage Guard is a clear plastic guard covering the LEMs, Bus Capacitor Bank, and DC Bus Inductor.

Figure 3.5
High Voltage Guard

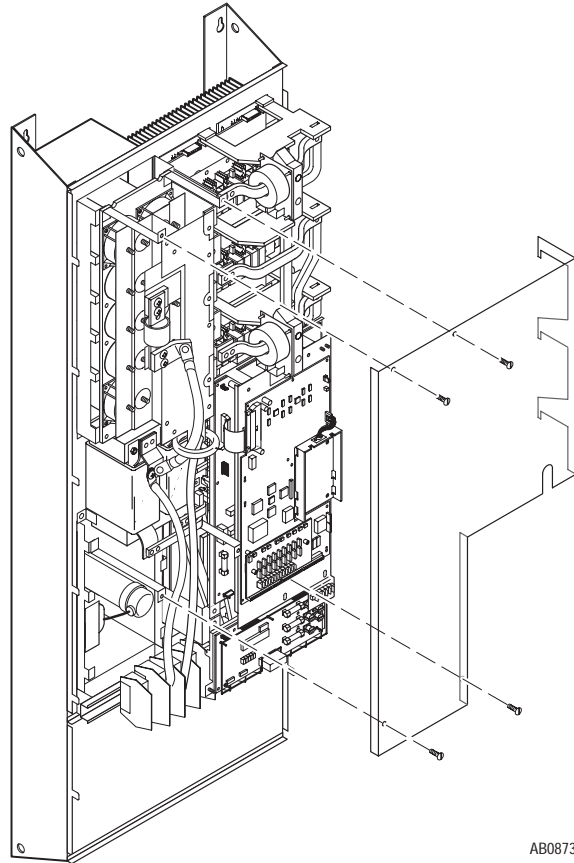

Removal



ATTENTION: Disconnect and lock out power from the drive before disassembling the drive. Failure to disconnect power may result in death or serious injury. Verify bus voltage by measuring the voltage between +DC and -DC on terminal block TB1. Do not attempt to service the drive until the bus voltage has discharged to zero volts.



ATTENTION: Wear a wrist-type grounding strap when servicing 1336 IMPACT drives. Failure to protect drive components against ESD may damage drive components. Refer to Electrostatic Discharge Precautions at the beginning of this chapter.

1. Remove power from the drive.
2. Open the Enclosure cover if the drive has an enclosure. Refer to Opening the Drive Enclosure in this chapter.
3. Check for zero volts at TB1 terminals +DC and –DC.
4. Check for the absence of control voltage at:
 - TB10
 - TB11
 - L Option Board (if used)
5. Remove the screws fastening the High Voltage Guard to the standoffs.
6. Lift the guard upward to disengage the tabs on the right side from the bus bar supports.
7. Pull the guard away from the drive.

Installation

Install the High Voltage Guard in reverse order of removal. Refer to Table 3.A – Fastener Torque Specifications.



ATTENTION: Replace all guards before applying power to the drive. Failure to replace guards may result in death or serious injury.

Removing the L Option Board

Figure 3.6
L Option Board

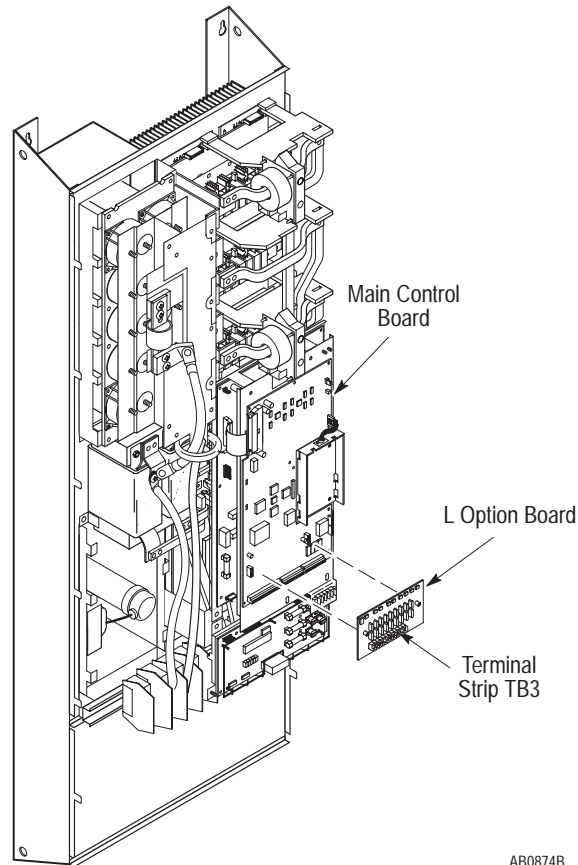

AB0874B

Removal



ATTENTION: Disconnect and lock out power from the drive before disassembling the drive. Failure to disconnect power may result in death or serious injury. Verify bus voltage by measuring the voltage between +DC and -DC on terminal block TB1. Do not attempt to service the drive until the bus voltage has discharged to zero volts.



ATTENTION: Wear a wrist-type grounding strap when servicing 1336 IMPACT drives. Failure to protect drive components against ESD may damage drive components. Refer to Electrostatic Discharge Precautions at the beginning of this chapter.

Important: Before you remove connections and wires from the drive components, mark the connections and wires to correspond with their component connections and terminals to prevent incorrect wiring during assembly.

1. Remove power from the drive.
2. Open the Enclosure cover if the drive has an enclosure. Refer to Opening the Drive Enclosure in this chapter.
3. Check for zero volts at TB1 terminals +DC and –DC.
4. Check for the absence of control voltage at:
 - TB10
 - TB11
 - L Option Board (if used)
5. Remove all wires from the terminals on TB3.
6. Loosen the two captive screws fastening the L Option Board to the Main Control Board.
7. Grip the right and left sides of the L Option Board and pull the board straight out from the Main Control Board.

Installation

Install the L Option Board in reverse order of removal.



ATTENTION: Replace all guards before applying power to the drive. Failure to replace guards may result in death or serious injury.

Removing the Main Control Board Mounting Plate

Figure 3.7
Main Control Board Mounting Plate

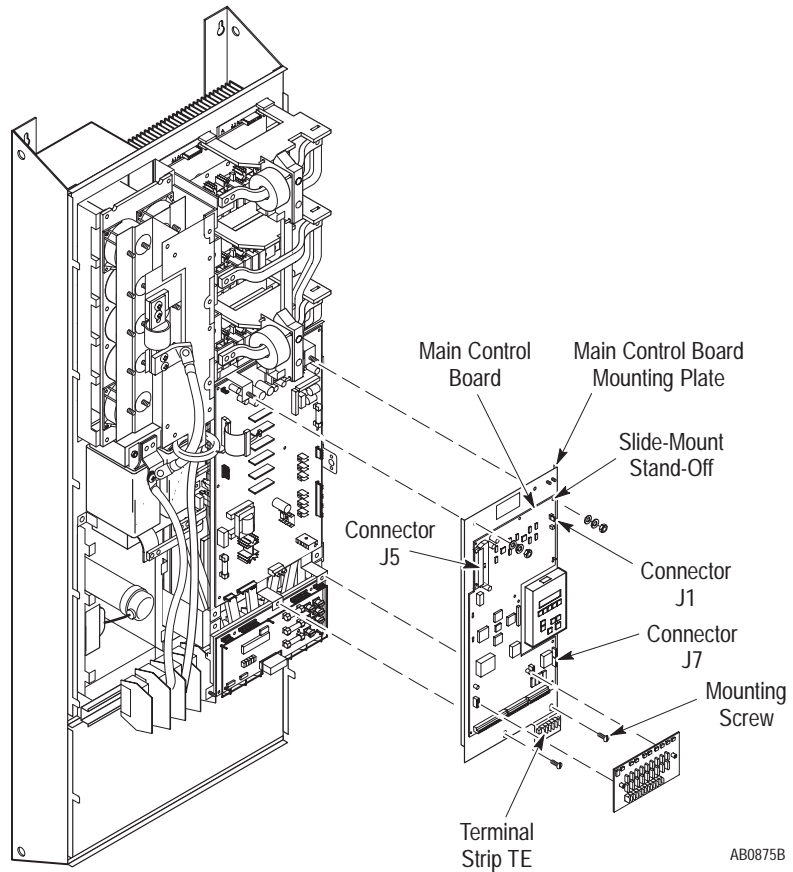

Removal



ATTENTION: Disconnect and lock out power from the drive before disassembling the drive. Failure to disconnect power may result in death or serious injury. Verify bus voltage by measuring the voltage between +DC and -DC on terminal block TB1. Do not attempt to service the drive until the bus voltage has discharged to zero volts.



ATTENTION: Wear a wrist-type grounding strap when servicing 1336 IMPACT drives. Failure to protect drive components against ESD may damage drive components. Refer to Electrostatic Discharge Precautions at the beginning of this chapter.

Important: Before you remove connections and wires from the drive components, mark the connections and wires to correspond with their component connections and terminals to prevent incorrect wiring during assembly.

1. Remove power from the drive.
2. Open the Enclosure cover if the drive has an enclosure. Refer to Opening the Drive Enclosure in this chapter.
3. Check for zero volts at TB1 terminals +DC and –DC.
4. Check for the absence of control voltage at:
 - TB10
 - TB11
 - L Option Board (if used)
5. Disconnect the following from the Main Control Board:
 - J1 connector
 - J5 ribbon cable connector
 - J7 connector
 - Ground wires from terminal strip TE
 - Chassis ground wire at the top-right corner of the Main Control Board Mounting Plate
6. Slide the LEM harness out of the clip located at the top-left of the Main Control Board.
7. Remove the two screws fastening the bottom of the Main Control Board to the standoffs.
8. Remove the nuts fastening the top of the Main Control Board to the Gate Driver Board Mounting Plate.
9. Lift the Main Control Board Mounting Plate out of the drive.

Installation

Install the Main Control Board Mounting Plate in reverse order of removal. Refer to Table 3.A – Fastener Torque Specifications.



ATTENTION: Replace all guards before applying power to the drive. Failure to replace guards may result in death or serious injury.

Removing the Main Control Board

Figure 3.8
Main Control Board

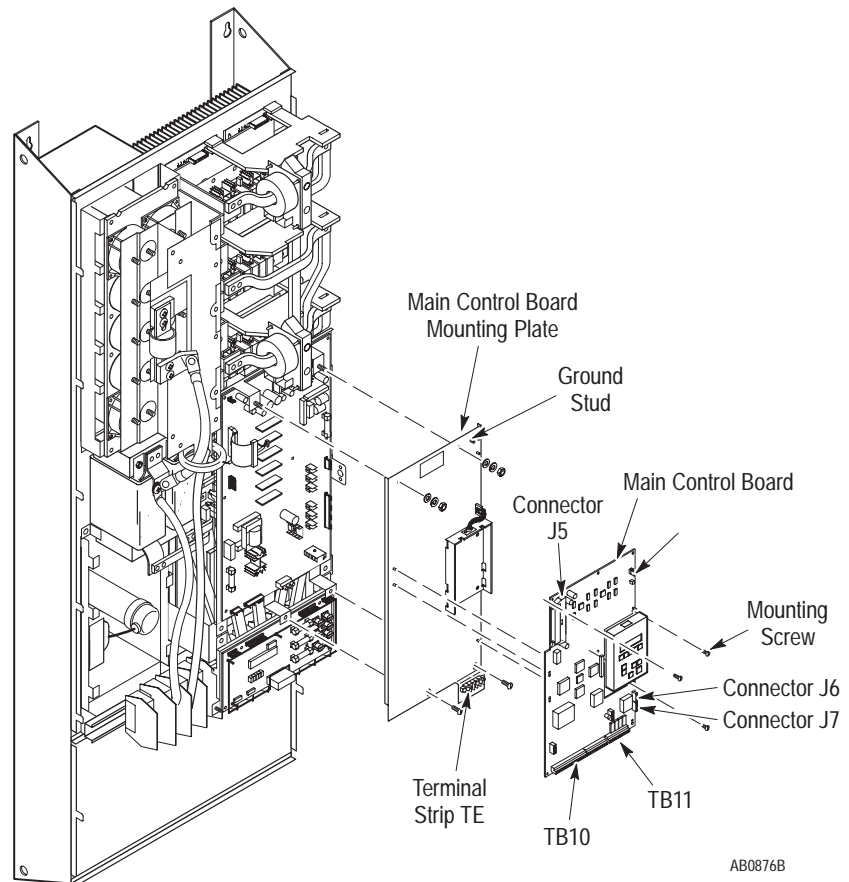

Removal



ATTENTION: Disconnect and lock out power from the drive before disassembling the drive. Failure to disconnect power may result in death or serious injury. Verify bus voltage by measuring the voltage between +DC and -DC on terminal block TB1. Do not attempt to service the drive until the bus voltage has discharged to zero volts.



ATTENTION: Wear a wrist-type grounding strap when servicing 1336 IMPACT drives. Failure to protect drive components against ESD may damage drive components. Refer to Electrostatic Discharge Precautions at the beginning of this chapter.

Important: Before you remove connections and wires from the drive components, mark the connections and wires to correspond with their component connections and terminals to prevent incorrect wiring during assembly.

1. Remove power from the Drive.
2. Open the Enclosure cover. Refer to Opening the Drive Enclosure in this chapter.
3. Check for zero volts at TB1 Terminals +DC and –DC.
4. Check for the absence of control voltage at:
 - TB10
 - TB11
 - L Option Board (if used)
5. Remove all wires from Terminal Strip TB3 if a L Option Board is used.
6. Disconnect the following from the Main Control Board:
 - J1 connector
 - J5 ribbon cable connector
 - J6 connector
 - J7 connector
 - Ground wire at stake-on connector
 - All wires from the terminals on TB10 and TB11
7. Remove the five screws fastening the Main Control Board to the mounting plate.
8. Slide the Main Control Board upward to release it from the slide-mount stand-offs.
9. Lift the Main Control Board away from the mounting plate.

Installation

Install the Main Control Board in reverse order of removal.



ATTENTION: Replace all guards before applying power to the drive. Failure to replace guards may result in death or serious injury.

Removing The Gate Driver Board Mounting Plate

Figure 3.9
Gate Driver Board Mounting Plate

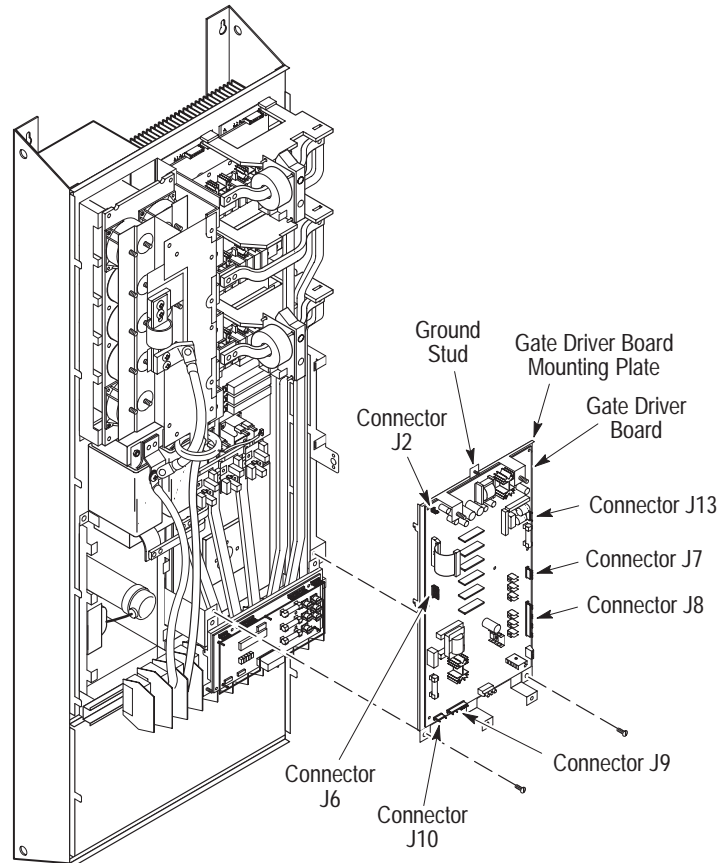

AB0439A

Removal



ATTENTION: Disconnect and lock out power from the drive before disassembling the drive. Failure to disconnect power may result in death or serious injury. Verify bus voltage by measuring the voltage between +DC and -DC on terminal block TB1. Do not attempt to service the drive until the bus voltage has discharged to zero volts.



ATTENTION: Wear a wrist-type grounding strap when servicing 1336 IMPACT drives. Failure to protect drive components against ESD may damage drive components. Refer to Electrostatic Discharge Precautions at the beginning of this chapter.

Important: Before you remove connections and wires from the drive components, mark the connections and wires to correspond with their component connections and terminals to prevent incorrect wiring during assembly.

1. Remove power from the drive.
2. Open the Enclosure cover. Refer to Opening the Drive Enclosure in this chapter.
3. Check for zero volts at TB1 terminals +DC and –DC.
4. Check for the absence of control voltage at:
 - TB10
 - TB11
 - L Option Board (if used)
5. Remove the Main Control Board Mounting Plate. Refer to Removing the Main Control Board Mounting Plate in this chapter.
6. Disconnect the following from the Gate Driver Board:
 - J2 connector
 - J6 connector
 - J7 connector
 - J8 connector
 - J9 connector
 - J10 connector
 - J13 connector
 - Ground wire from the top of the Gate Driver Board Mounting Plate
7. Remove the screws fastening the bottom of the Gate Driver Board Mounting Plate to the chassis.
8. Slide the plate toward the top of the drive to disengage the mounting plate tabs from the slots on the chassis.

Installation

Install the Gate Driver Board Mounting Plate in reverse order of removal. Refer to Table 3.A – Fastener Torque Specifications.



ATTENTION: When removing the entire wire harness connecting Gate Driver Board connector J9 to Precharge Board connector J3, align the wires on the harness terminals with the pins on the board connectors. Incorrect harness connection may result in faulty drive operation and may damage the equipment.



ATTENTION: Replace all guards before applying power to the drive. Failure to replace guards may result in death or serious injury.

Removing the Gate Driver Board

Figure 3.10
Gate Driver Board and Mounting Plate

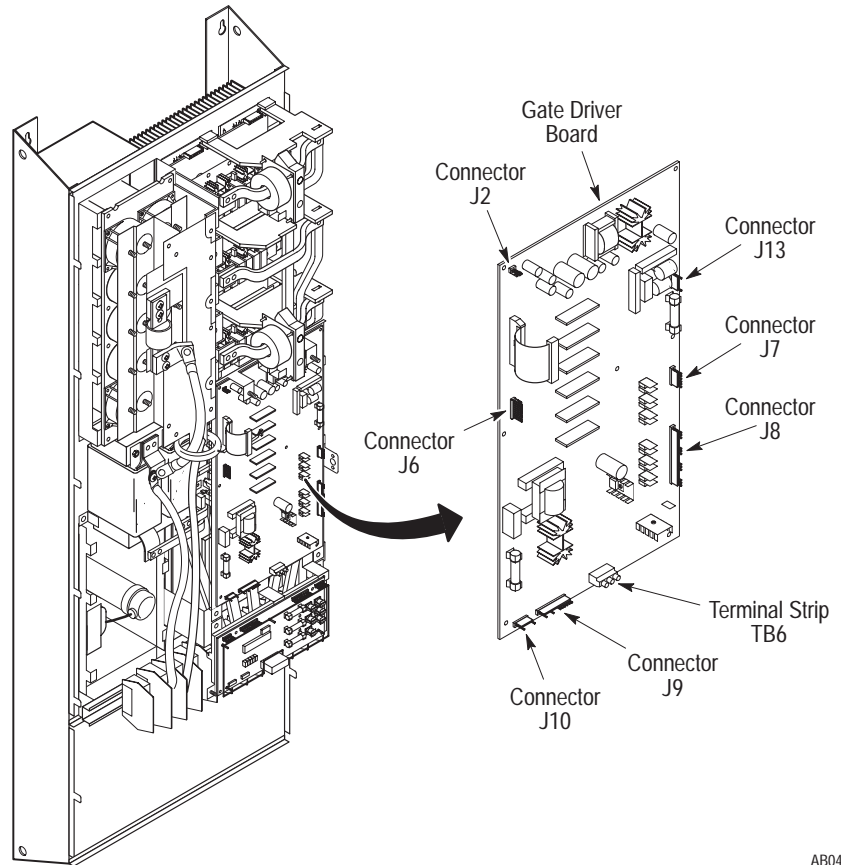

AB0440A

Removal



ATTENTION: Disconnect and lock out power from the drive before disassembling the drive. Failure to disconnect power may result in death or serious injury. Verify bus voltage by measuring the voltage between +DC and -DC on terminal block TB1. Do not attempt to service the drive until the bus voltage has discharged to zero volts.



ATTENTION: Wear a wrist-type grounding strap when servicing 1336 IMPACT drives. Failure to protect drive components against ESD may damage drive components. Refer to Electrostatic Discharge Precautions at the beginning of this chapter.

Important: Before you remove connections and wires from the drive components, mark the connections and wires to correspond with their component connections and terminals to prevent incorrect wiring during assembly.

1. Remove power from the drive.
2. Open the Enclosure if the drive has an Enclosure. Refer to Opening the Drive Enclosure in this chapter.
3. Check for zero volts at TB1 terminals +DC and -DC.
4. Check for the absence of control voltage at:
 - TB10
 - TB11
 - L Option Board (if used)
5. Remove the Main Control Board Mounting Plate. Refer to Removing the Main Control Board Mounting Plate in this chapter.
6. Disconnect the following from the Gate Driver Board:
 - J2 connector
 - J6 connector
 - J7 connector
 - J8 connector
 - J9 connector
 - J10 connector
 - J13 connector
 - TB6 High Voltage Aux. Input
 - Ground wire from the top of the Gate Driver Board Mounting Plate
7. Turn the eight standoff screws, fastening the Gate Driver Board to the Mounting Plate, 1/4 turn counterclockwise.
8. Pull the Gate Driver Board away from the Gate Driver Board Mounting Plate.

Installation

Install the Gate Driver Board in reverse order of removal.



ATTENTION: When removing the entire wire harness connecting Gate Driver Board connector J9 to Precharge Board connector J3, align the wires on the harness terminals with the pins on the board connectors. Incorrect harness connection may result in faulty drive operation and may damage the equipment.



ATTENTION: Replace all guards before applying power to the drive. Failure to replace guards may result in death or serious injury.

Removing the Precharge Board Mounting Plate

Figure 3.11
Precharge Board Mounting Plate

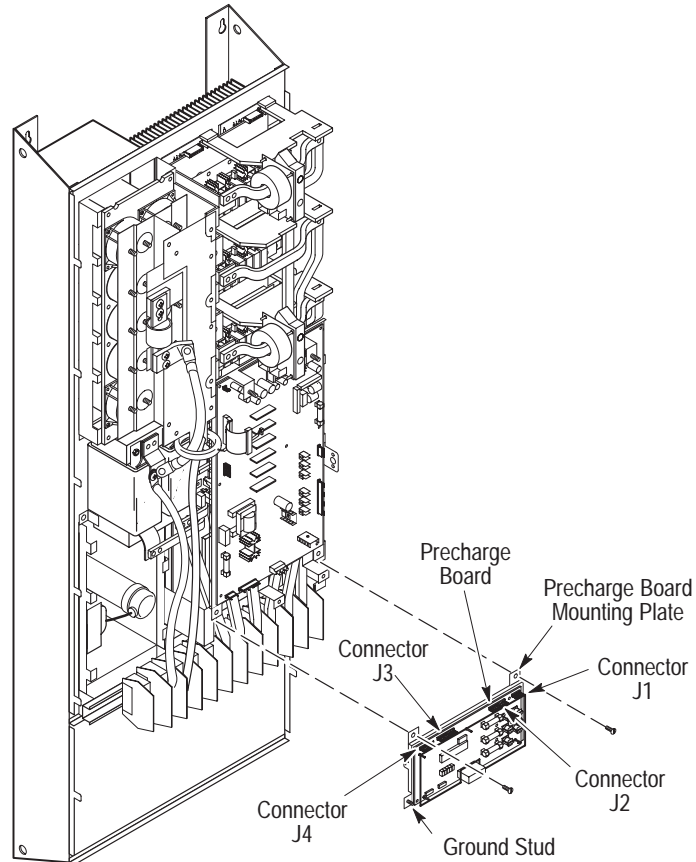

AB0438A

Removal



ATTENTION: Disconnect and lock out power from the drive before disassembling the drive. Failure to disconnect power may result in death or serious injury. Verify bus voltage by measuring the voltage between +DC and -DC on terminal block TB1. Do not attempt to service the drive until the bus voltage has discharged to zero volts.



ATTENTION: Wear a wrist-type grounding strap when servicing 1336 IMPACT drives. Failure to protect drive components against ESD may damage drive components. Refer to Electrostatic Discharge Precautions at the beginning of this chapter.

Important: Before you remove connections and wires from the drive components, mark the connections and wires to correspond with their component connections and terminals to prevent incorrect wiring during assembly.

1. Remove power from the drive.
2. Open the Enclosure if the drive has an Enclosure. Refer to Opening the Drive Enclosure in this chapter.
3. Check for zero volts at TB1 terminals +DC and -DC.
4. Check for the absence of control voltage at:
 - TB10
 - TB11
 - L Option Board (if used)
5. Remove the High Voltage Guard.
6. Disconnect the following from the Precharge Board:
 - J1 connector
 - J2 connector
 - J3 connector
 - J4 connector
 - Ground wire from the stud at the bottom left of the mounting plate
7. Remove the screws fastening the top of the Precharge Board Mounting Plate to the chassis.
8. Slide the Precharge Board Mounting Plate toward the bottom of the drive to disengage the tabs from the slots in the chassis.
9. Pull the Precharge Board Mounting Plate out of the enclosure.

Installation

Install the Precharge Board Mounting Plate in reverse order of removal. Refer to Table 3.A – Fastener Torque Specifications.



ATTENTION: When removing the entire wire harness connecting Gate Driver Board connector J9 to Precharge Board connector J3, align the wires on the harness terminals with the pins on the board connectors. Incorrect harness connection may result in faulty drive operation and may damage the equipment.



ATTENTION: Replace all guards before applying power to the drive. Failure to replace guards may result in death or serious injury.

Removing the Precharge Board

Figure 3.12
Precharge Board

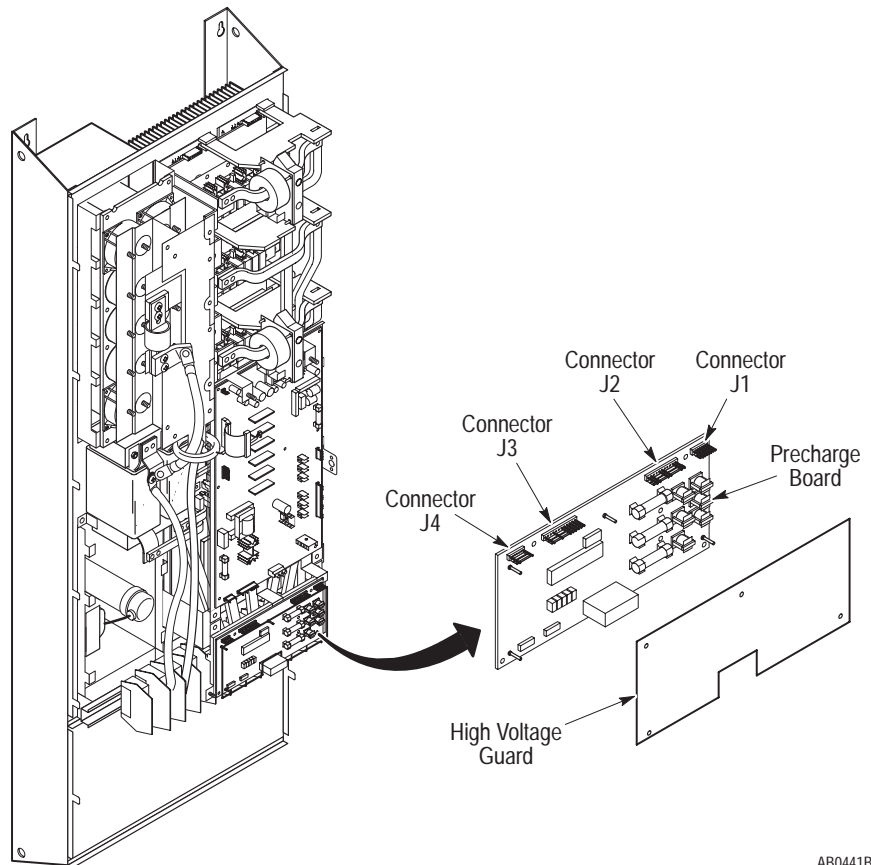

AB0441B

Removal



ATTENTION: Disconnect and lock out power from the drive before disassembling the drive. Failure to disconnect power may result in death or serious injury. Verify bus voltage by measuring the voltage between +DC and -DC on terminal block TB1. Do not attempt to service the drive until the bus voltage has discharged to zero volts.



ATTENTION: Wear a wrist-type grounding strap when servicing 1336 IMPACT drives. Failure to protect drive components against ESD may damage drive components. Refer to Electrostatic Discharge Precautions at the beginning of this chapter.

Important: Before you remove connections and wires from the drive components, mark the connections and wires to correspond with their component connections and terminals to prevent incorrect wiring during assembly.

1. Remove power from the drive.
2. Open the Enclosure if the drive has an Enclosure. Refer to Opening the Drive Enclosure in this chapter.
3. Check for zero volts at TB1 terminals +DC and -DC.
4. Check for the absence of control voltage at:
 - TB10
 - TB11
 - L Option Board (if used)
5. Remove the High Voltage Guard. Refer to Removing the High Voltage Guard in this chapter
6. Disconnect the following from the Precharge Board:
 - J1 connector
 - J2 connector
 - J3 connector
 - J4 connector
7. Turn the six standoff screws, fastening the Precharge Board to the Precharge Board Mounting Plate, 1/4 turn counterclockwise.
8. Pull the Precharge Board away from the Precharge Board Mounting Plate.

Installation

Install the Precharge Board in reverse order of removal.



ATTENTION: When removing the entire wire harness connecting Gate Driver Board connector J9 to Precharge Board connector J3, align the wires on the harness terminals with the pins on the board connectors. Incorrect harness connection may result in faulty drive operation and may damage the equipment.



ATTENTION: Replace all guards before applying power to the drive. Failure to replace guards may result in death or serious injury.

Removing a Power Module Snubber Board

The Power Module Snubber Boards are located under the Motor Bus Bars and LEMs.

Figure 3.13
Power Module Snubber Board

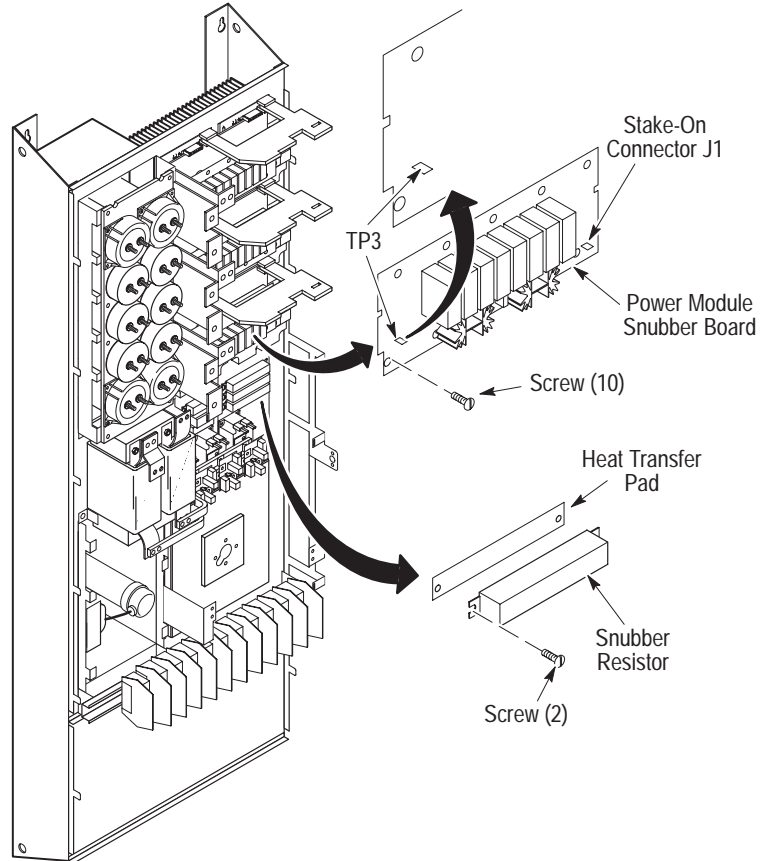

AB0443B

Removal



ATTENTION: Disconnect and lock out power from the drive before disassembling the drive. Failure to disconnect power may result in death or serious injury. Verify bus voltage by measuring the voltage between +DC and –DC on terminal block TB1. Do not attempt to service the drive until the bus voltage has discharged to zero volts.



ATTENTION: Hazard of electric shock exists. Up to 1,600 VDC will be on J1 if the Snubber Resistor is open. Measure for zero (0)VDC from Snubber Board terminal TP3 to plus (+) bus before removing connector J1. Use a resistor greater than 1 ohm and less than 100 ohm, rated for 25 watts minimum, between TP3 and plus (+) bus to discharge any voltage.



ATTENTION: Wear a wrist-type grounding strap when servicing 1336 IMPACT drives. Failure to protect drive components against ESD may damage drive components. Refer to Electrostatic Discharge Precautions at the beginning of this chapter.

Important: Before you remove connections and wires from the drive components, mark the connections and wires to correspond with their component connections and terminals to prevent incorrect wiring during assembly.

1. Remove power from the drive.
2. Open the Enclosure if the drive has an Enclosure. Refer to Opening the Drive Enclosure in this chapter.
3. Check for zero volts at TB1 terminals +DC and –DC.
4. Check for the absence of control voltage at:
 - TB10
 - TB11
 - L Option Board (if used)
5. Remove the Main Control Board Mounting Plate. Refer to Removing the Main Control Board Mounting Plate in this chapter.
6. Remove the Gate Driver Board Mounting Plate. Refer to Removing the Gate Driver Board Mounting Plate in this chapter.

7. Remove the Precharge Board Mounting Plate. Refer to Removing the Precharge Board Mounting Plate in this chapter.
8. Remove the wires from the connectors on the LEMs.
9. Remove the Motor Bus Bars. LEMs are attached to two of these bars.
10. Remove the Motor Bus Bars from TB1 terminals U-M1, V-M2, and W-M3.
11. Slide the notches in the Motor Bus Bars away from the slots in the Motor Bus Bar Support to remove the Motor Bus Bars from the Drive.
12. Remove the Snubber Resistor wire from the Power Module Snubber Board stake-on connector J1.
13. Remove the screws fastening the Power Module Snubber Board to the Snubber Bracket to remove the Snubber Boards.
14. Check the Snubber Resistor with a VOM. The reading should be 8 ohms. If open, replace the Snubber Resistor.

Installation



ATTENTION: Do not substitute longer or shorter hardware when fastening the Power Module components to the Power Modules. Use the same size fastener to fasten the components as was originally used. Using different fastener lengths will damage the Power Modules.

Install the Power Module Snubber Board in reverse order of removal. Refer to Table 3.A – Fastener Torque Specifications.

Important: Install washers on TB1 terminals with the serrated side facing toward you.



ATTENTION: Replace all guards before applying power to the drive. Failure to replace guards may result in death or serious injury.

Removing an Input Rectifier Snubber Board

The Input Rectifier Snubber Boards are located under the Gate Driver Board Mounting Plate.

Figure 3.14
Input Rectifier Snubber Board

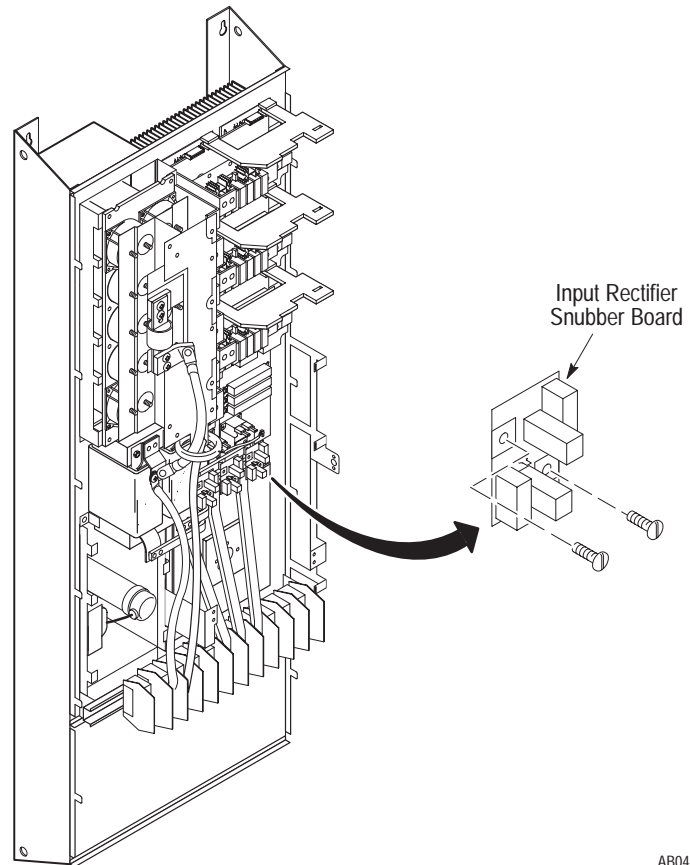

Removal



ATTENTION: Disconnect and lock out power from the drive before disassembling the drive. Failure to disconnect power may result in death or serious injury. Verify bus voltage by measuring the voltage between +DC and -DC on terminal block TB1. Do not attempt to service the drive until the bus voltage has discharged to zero volts.



ATTENTION: Wear a wrist-type grounding strap when servicing 1336 IMPACT drives. Failure to protect drive components against ESD may damage drive components. Refer to Electrostatic Discharge Precautions at the beginning of this chapter.

Important: Before you remove connections and wires from the drive components, mark the connections and wires to correspond with their component connections and terminals to prevent incorrect wiring during assembly.

1. Remove power from the drive.
2. Open the Enclosure if the drive has an Enclosure. Refer to Opening the Drive Enclosure in this chapter.
3. Check for zero volts at TB1 terminals +DC and -DC.
4. Check for the absence of control voltage at:
 - TB10
 - TB11
 - L Option Board (if used)
5. Remove the Main Control Board Mounting Plate. Refer to Removing the Main Control Board Mounting Plate in this chapter.
6. Remove the Gate Driver Board Mounting Plate. Refer to Removing the Gate Driver Board Mounting Plate in this chapter.
7. Remove the wire from Input Rectifier Snubber Board stake-on connector J1.
8. Remove the two screws fastening the Input Rectifier Snubber Input Rectifier Board to the Converter Snubber "Z" bracket.

Installation

Install the snubber board in reverse order of removal. Refer to Table 3.A – Fastener Torque Specifications.



ATTENTION: Replace all guards before applying power to the drive. Failure to replace guards may result in death or serious injury.

Accessing Power Plane Components

To access the power plane components located on the chassis, refer to Removing a Power Module Snubber Board in this chapter.

Component Test Procedures

Chapter Objectives

The following tests help you troubleshoot A75 – A125, B150 – B250, and C150 – C250 drives.

Component Test Overview

In some cases, different tests troubleshoot components of the same name. These similar tests vary according to the rating of the drive being tested. Verify that the rating on the drive matches the rating for the test you are performing.

The procedures in this chapter assume that the drive you are servicing either has no enclosure or that the enclosure is opened. For more information on opening the Drive Enclosure, refer to Chapter 3 – Disassembly and Access Procedures, Opening the Drive Enclosure.



ATTENTION: Some printed circuit boards and drive components may contain hazardous voltage levels. Remove and lock out power before you disconnect or reconnect wires, and before you remove or replace fuses and circuit boards. Verify bus voltage by measuring the voltage between +DC and –DC on terminal block TB1. Do not attempt to service the drive until the bus voltage has discharged to zero volts.



ATTENTION: Servicing energized industrial control equipment can be hazardous. Electrical shock, burns, or unintentional actuation of controlled industrial equipment may cause death or serious injury. Follow the safety-related practices of NFPA 70E, Electrical Safety for Employee Workplaces, when working on or near energized equipment. Do not work alone on energized equipment.

Electrostatic Discharge Precautions



ATTENTION: This assembly contains parts and sub-assemblies that are sensitive to electrostatic discharge. Static control precautions are required when servicing this assembly. Component damage may result if you ignore electrostatic discharge control procedures. If you are not familiar with static control procedures, reference Rockwell Automation Publication 8000-4.5.2, Guarding Against Electrostatic Discharge, or any other applicable ESD protection handbook.

Electrostatic discharge generated by static electricity can damage the complementary metallic oxide semiconductor devices on various drive boards. It is recommended that you perform these procedures to guard against this type of damage when circuit boards are removed or installed:

- Wear a wrist-type grounding strap that is grounded to the chassis.
- Attach the wrist strap before removing the new circuit board from the conductive packet.
- Remove boards from the drive and immediately insert them into their conductive packets.

Tools

You need the following tools to disassemble and assemble the drive:

- Pliers
- Phillips screwdrivers (medium and large)
- Standard screwdrivers (small, medium, and large)
- 25/64-inch or 10 mm socket
- 7/16-inch or 11 mm socket
- 33/64-inch or 13 mm deep-well socket
- 5/16-inch or 8 mm open-end wrench
- Torque wrench, metered in lb-in. or N-m
- Nylon tie wraps

Test 1 – Testing the Gate Driver Board

The Gate Driver Board is located between the Main Control Board and the Main Chassis. If modules have been replaced, you must test the Gate Driver Board.

Figure 4.1
Gate Driver Board Test

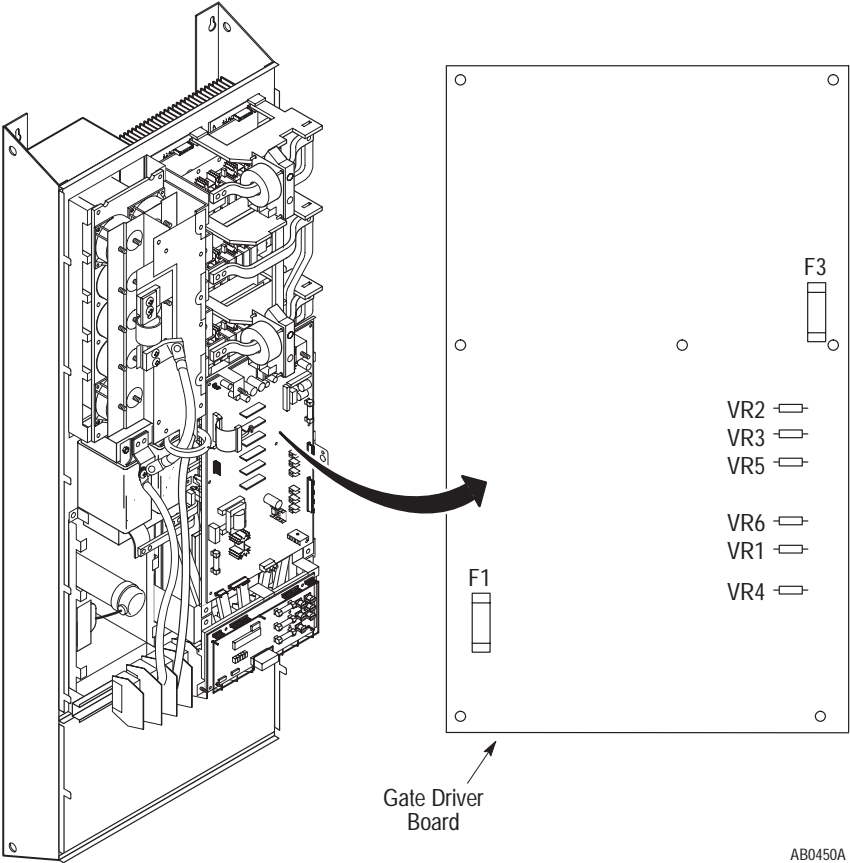

AB0450A



ATTENTION: Disconnect and lock out power from the drive before disassembling the drive. Failure to disconnect power may result in death or serious injury. Verify bus voltage by measuring the voltage between +DC and -DC on terminal block TB1. Do not attempt to service the drive until the bus voltage has discharged to zero volts.

Important: Before you remove connections and wires from the drive components, mark the connections and wires to correspond with their component connections and terminals to prevent incorrect wiring during assembly.

1. Remove power from the drive.
2. Check for zero volts at TB1 terminals +DC and –DC.
3. Check for the absence of control voltage at:
 - TB10
 - TB11
 - L Option Board (if used)
4. Remove the Main Control Board Mounting Plate. Refer to Chapter 3 – Disassembly and Access Procedures, Removing the Main Control Board Mounting Plate.
5. Unplug the connectors from the Gate Driver Board.
6. Set your meter to test resistance.
7. Test Fuses F1 and F3 for an open condition. Replace the Gate Driver Board if either fuse shows an open condition.
8. Set your meter to test diodes.
9. Test VR1 – VR6. The following table shows meter connections at the components and ideal meter readings for those connections. Refer to the former illustration for component locations.

Table 4.A
Gate Driver Board Test

Component	Meter (+) Lead	Meter (-) Lead	Nominal Meter Reading*
VR1 – VR6	+	–	1.06
	–	+	1.8

Important: Typical malfunction is shorted in both directions.

* Meter Used: Fluke® Model 87, set to “Diode” range.

10. Replace the Gate Driver Board if your readings do not match the table readings. Refer to Chapter 3 – Disassembly and Access Procedures, Removing the Gate Driver Board.
11. Assemble the drive in reverse order of disassembly.



ATTENTION: Replace all guards before applying power to the drive. Failure to replace guards may result in death or serious injury.

Test 2 – Testing the Precharge Board

If modules have been replaced, you must check the Power Module Snubber Board and the Precharge Board. Refer to Chapter 3 – Disassembly and Access Procedures, Removing a Power Module Snubber Board and Removing the Precharge Board Mounting Plate.

Figure 4.2
Precharge Board Test

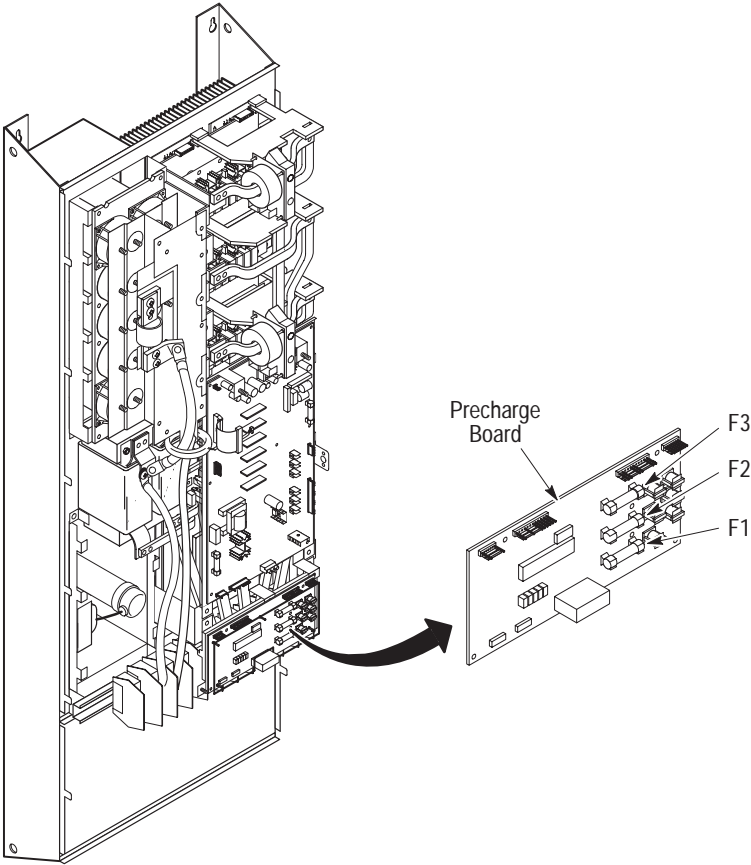

AB0451A



ATTENTION: Disconnect and lock out power from the drive before disassembling the drive. Failure to disconnect power may result in death or serious injury. Verify bus voltage by measuring the voltage between +DC and – audition DC on terminal block TB1. Do not attempt to service the drive until the bus voltage has discharged to zero volts.

Important: Before you remove connections and wires from the drive components, mark the connections and wires to correspond with their component connections and terminals to prevent incorrect wiring during assembly.

1. Remove power from the drive.
2. Check for zero volts at TB1 terminals +DC and -DC.
3. Check for the absence of control voltage at:
 - TB10
 - TB11
 - L Option Board (if used)
4. Set your meter to test resistance.
5. Test fuses F1, F2, and F3 for open conditions.
6. Replace the Precharge Board if any fuse shows an open condition. Refer to Chapter 3 – Disassembly and Access Procedures, Removing the Precharge Board.



ATTENTION: Replace all guards before applying power to the drive. Failure to replace guards may result in death or serious injury.

Test 3 – Testing the Power Modules

The Power Modules are located near the top of the heat sink. If modules have been replaced, you must check the Power Module Snubber Board. Refer to Chapter 3 – Disassembly and Access Procedures, Removing a Power Module Snubber Board.



ATTENTION: Hazard of electric shock exists. Up to 1,600 VDC will be on J1 if the Snubber Resistor is open. Measure for zero VDC from Snubber Board terminal TP3 to plus (+) bus before removing connector J1. Use a resistor greater than 1 ohm and less than 100 ohm, rated for 25 watts minimum, between TP3 and plus (+) bus to discharge any voltage. Refer to Chapter 3 – Disassembly and Access Procedures, Removing a Power Module Snubber Board.

Figure 4.3
Power Module Test

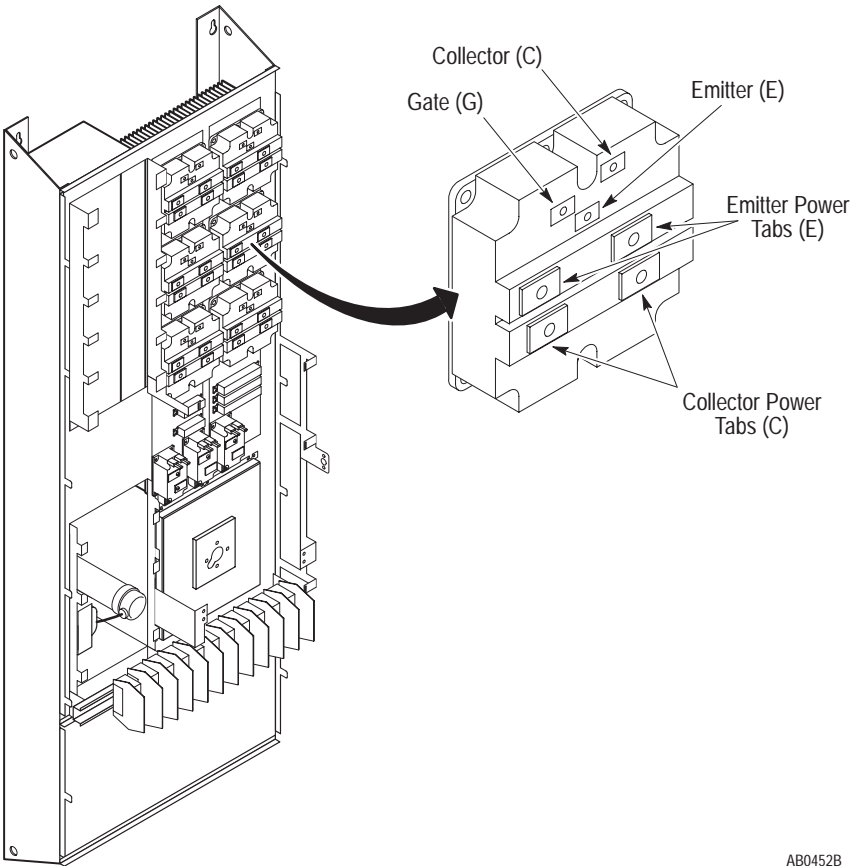

AB0452B



ATTENTION: Disconnect and lock out power from the drive before disassembling the drive. Failure to disconnect power may result in death or serious injury. Verify bus voltage by measuring the voltage between +DC and –DC on terminal block TB1. Do not attempt to service the drive until the bus voltage has discharged to zero volts.

Important: Before you remove connections and wires from the drive components, mark the connections and wires to correspond with their component connections and terminals to prevent incorrect wiring during assembly.

1. Remove power from the drive.
2. Check for zero volts at TB1 terminals +DC and –DC.
3. Check for the absence of control voltage at:
 - TB10
 - TB11
 - L Option Board (if used)
4. Remove the Main Control Board Mounting Plate. Refer to Chapter 3 – Disassembly and Access Procedures, Removing the Main Control Board Mounting Plate.
5. Remove the Gate Driver Board Mounting Plate. Refer to Chapter 3 – Disassembly and Access Procedures, Removing the Gate Driver Board Mounting Plate.
6. Remove the Power Module Snubber Boards. Refer to Chapter 3 – Disassembly and Access Procedures, Removing a Power Module Snubber Board.
7. Set your meter to test diodes.
8. Test the Power Modules. The following table shows meter connections and ideal meter readings for those connections. Refer to the former illustration for meter connection locations.

Table 4.B
Power Modules

Meter (+) Lead	Meter (-) Lead	Nominal Meter Reading
E	C	0.318
E	G	Infinite
C	E	Infinite
C	G	Infinite
G	E	Infinite
G	C	Infinite

9. Replace a Power Module if meter readings are not as shown. Refer to Chapter 5 – Part Replacement Procedures, Power Modules.

10. If one or more Power Modules is replaced, test the Gate Driver Board. Refer to Testing the Gate Driver Board in this chapter.

11. Assemble the drive in reverse order of disassembly.



ATTENTION: Replace all guards before applying power to the drive. Failure to replace guards may result in death or serious injury.

Test 4 – Testing the Bus Capacitors

The Bus Capacitor Bank is located on the left side of the Main Chassis.

Figure 4.4
Bus Capacitor Bank Test

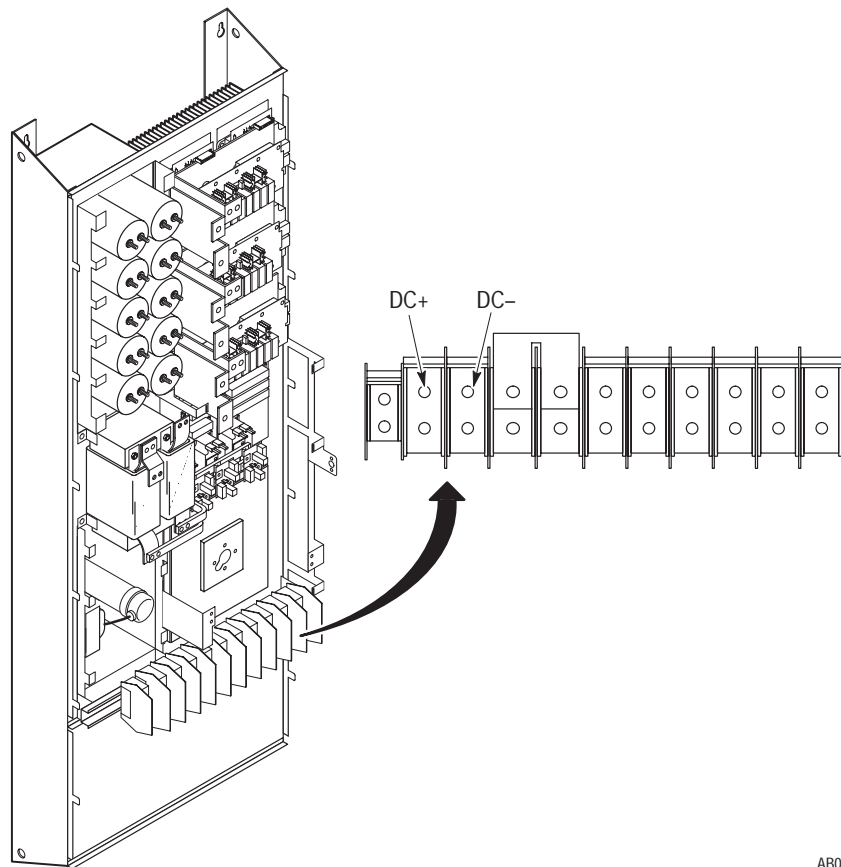

AB0453B



ATTENTION: Disconnect and lock out power from the drive before disassembling the drive. Failure to disconnect power may result in death or serious injury. Verify bus voltage by measuring the voltage between +DC and –DC on terminal block TB1. Do not attempt to service the drive until the bus voltage has discharged to zero volts.

Important: Before you remove connections and wires from the drive components, mark the connections and wires to correspond with their component connections and terminals to prevent incorrect wiring during assembly.

1. Remove power from the drive.
2. Check for zero volts at TB1 terminals +DC and –DC.
3. Check for the absence of control voltage at:
 - TB10
 - TB11
 - L Option Board (if used)
4. Set your meter to test voltage.
5. Connect the negative (–) lead of your meter to the (–) DC Bus terminal on TB1 and the positive (+) lead to the (+) DC Bus terminal. Refer to the following tables and former illustration for meter readings and terminal locations.



ATTENTION: Servicing energized industrial control equipment can be hazardous. Electrical shock, burns, or unintentional actuation of controlled industrial equipment may cause death or serious injury. Follow the safety-related practices of NFPA 70E, Electrical Safety for Employee Workplaces, when working on or near energized equipment. Do not work alone on energized equipment.

6. Apply power **AFTER** the meter is connected, otherwise your meter will read zero volts. Expand readings for all input voltage ratings.

Table 4.C
Bus Capacitor Bank Test

Drive Rating	Input Volts	Meter Reading
A	200	280V DC +/-10%
	230	322V DC +/-10%
	240	336V DC +/-10%
B	380	535V DC +/-10%
	415	580V DC +/-10%
	480	650V DC +/-10%
C	500	700V DC +/-10%
	575	800V DC +/-10%
	600	850V DC +/-10%

7. If the voltage is out of tolerance, check the following:
 - An open condition at an Input Rectifier.
 - A voltage drop due to Bus Inductor L1 resistance.
 - A voltage drop between an Input Rectifier and the bus capacitors due to loose or resistive wires or connections.
 - Precharge circuit problems.
8. If the above check does not reveal a problem, replace the Bus Capacitor Bank and Load-Sharing Resistors. Refer to Chapter 5 – Part Replacement Procedures, Bus Capacitor Bank.



ATTENTION: Replace all guards before applying power to the drive. Failure to replace guards may result in death or serious injury.

Test 5 – Testing the Input Rectifiers

The Input Rectifiers are located on the bottom of the heat sink.

Figure 4.5
Input Rectifier Test

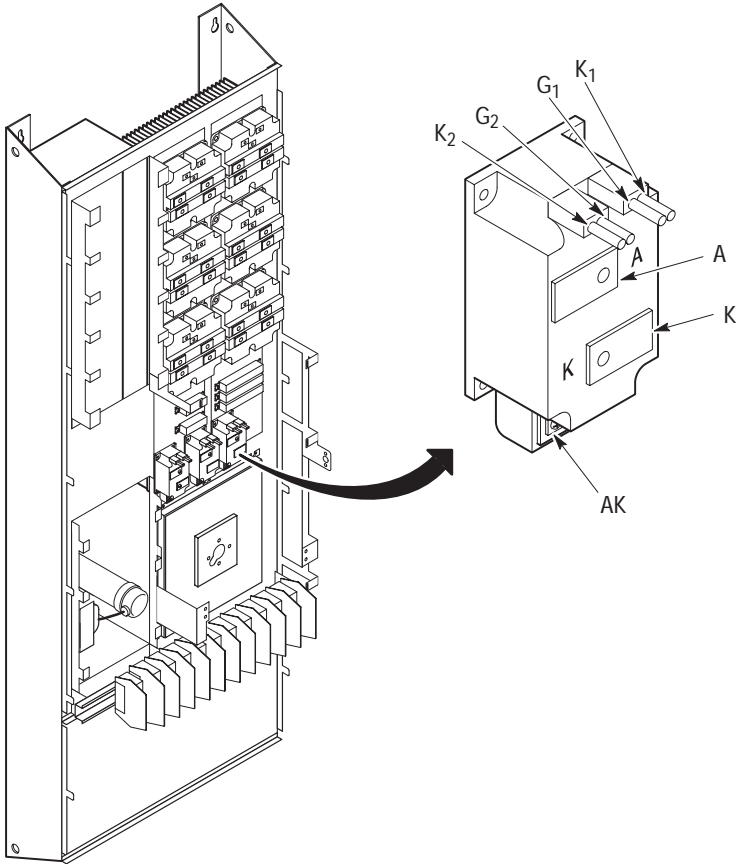

AB0454B



ATTENTION: Disconnect and lock out power from the drive before disassembling the drive. Failure to disconnect power may result in death or serious injury. Verify bus voltage by measuring the voltage between +DC and -DC on terminal block TB1. Do not attempt to service the drive until the bus voltage has discharged to zero volts.

Important: Before you remove connections and wires from the drive components, mark the connections and wires to correspond with their component connections and terminals to prevent incorrect wiring during assembly.

1. Remove power from the drive.
2. Check for zero volts at TB1 terminals +DC and –DC.
3. Check for the absence of control voltage at:
 - TB10
 - TB11
 - L Option Board (if used)
4. Remove the Main Control Board and Mounting Plate. Refer to Chapter 3 – Disassembly and Access Procedures, Removing the Main Control Board Mounting Plate.
5. Remove the Gate Driver Board Mounting Plate. Refer to Chapter 3 – Disassembly and Access Procedures, Removing the Gate Driver Board Mounting Plate.
6. Remove the Input Rectifier Snubber Board. Refer to Chapter 3 – Disassembly and Access Procedures, Removing an Input Rectifier Snubber Board.
7. Set your meter to test diodes.
8. The following table shows meter connections and ideal meter readings for those connections. Refer to the former illustration for meter connection locations.

Table 4.D
Input Rectifier Test

Meter (+) Lead	Meter (-) Lead	Nominal Meter Reading
AK	K	Infinite
AK	A	Infinite
K	A	Infinite
K	AK	Infinite
A	AK	Infinite
A	K	Infinite
G1	K1	0.011
K1	G1	0.011
G2	K2	0.011
K2	G2	0.011

9. Replace the Input Rectifier if any meter readings are not as shown. Refer to Chapter 5 – Part Replacement Procedures, Input Rectifiers.
10. If the Input Rectifier shorted, check the Power Modules for damage. Refer to Testing the Power Modules in this chapter.

Part Replacement Procedures

Chapter Objective

This chapter describes procedures required to replace drive components. This chapter references Chapter 3 – Disassembly and Access Procedures for basic drive component access.

Part Replacement Overview

The part replacement procedures in this chapter assume that the drive you are servicing either has no enclosure or that the enclosure is open. For more information on opening the Drive Enclosure, refer to Chapter 3 – Disassembly and Access Procedures, Opening the Drive Enclosure.

Safety Precautions



ATTENTION: Some printed circuit boards and drive components may contain hazardous voltage levels. Remove power before you disconnect or reconnect wires, and before you remove or replace fuses and circuit boards. Verify bus voltage by measuring the voltage between +DC and –DC on terminal block TB1. Do not attempt to service the drive until the bus voltage has discharged to zero volts.

Electrostatic Discharge Precautions



ATTENTION: This assembly contains parts and sub-assemblies that are sensitive to electrostatic discharge. Static control precautions are required when servicing this assembly. Component damage may result if you ignore electrostatic discharge control procedures. If you are not familiar with static control procedures, reference Rockwell Automation Publication 8000-4.5.2, Guarding Against Electrostatic Discharge, or any other applicable ESD protection handbook.

Electrostatic discharge generated by static electricity can damage the complementary metallic oxide semiconductor devices on various drive boards. It is recommended that you perform these procedures to guard against this type of damage when circuit boards are removed or installed:

- Wear a wrist-type grounding strap that is grounded to the chassis.
- Attach the wrist strap before removing the new circuit board from the conductive packet.
- Remove boards from the drive and immediately insert them into their conductive packets.

Tools

You need the following tools to disassemble and assemble the drive:

- Pliers
- Phillips screwdrivers (small, medium, and large)
- Standard screwdrivers (small, medium, and large)
- 25/64-inch or 10 mm socket
- 7/16-inch or 11 mm socket
- 33/64-inch or 13 mm deep-well socket
- 5/16-inch or 8 mm open-end wrench
- Torque wrench, metered in lb-in. or N-m
- Nylon tie wraps

Major Component Replacement

This section explains in detail how to replace the following drive components:

- Bus Capacitor Bank
- Thermistor
- Power Modules
- Input Rectifiers
- Fan and Transformer Assembly
- DC Bus Inductor L1
- Ground Sense CT
- Bus Fuse F1
- LEMs
- MOV Surge Suppressor

For Gate Driver Board, Main Control Board, Snubber Boards, and L Option Board installation and removal procedures, refer to Chapter 3.

Detailed Product Identification

Rockwell Automation Adjustable Frequency AC Drives are modular by design to enhance troubleshooting and spare parts replacement, thereby helping reduce production down-time.

The following illustration calls out the main components of a typical drive. Component designs vary slightly among the different drive ratings, but component locations are identical.

Figure 5.1
Main Drive Components

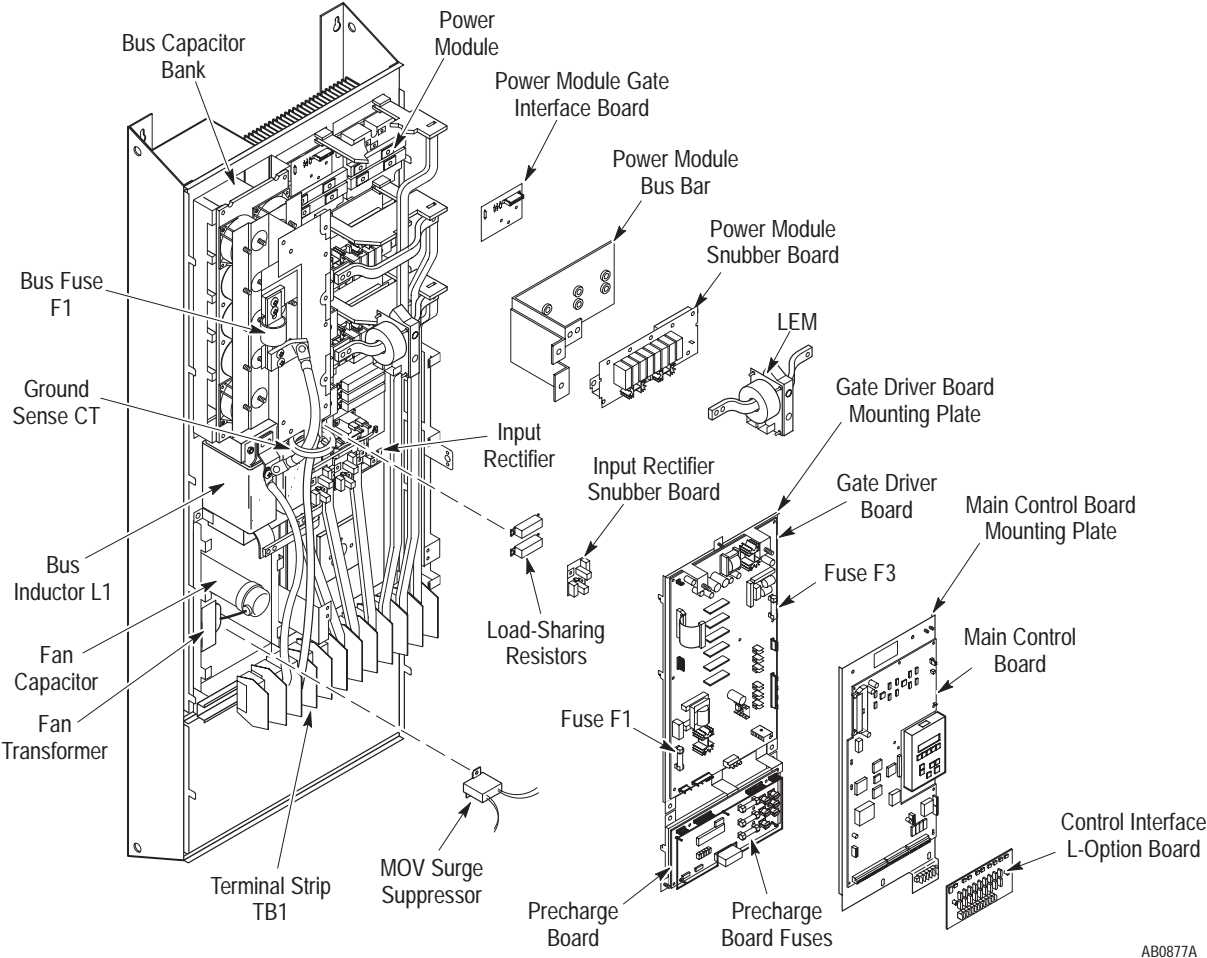

AB0877A

Bus Capacitor Bank

The Bus Capacitor Bank is located on the left side of the Main Chassis.

Figure 5.2
Bus Capacitor Bank

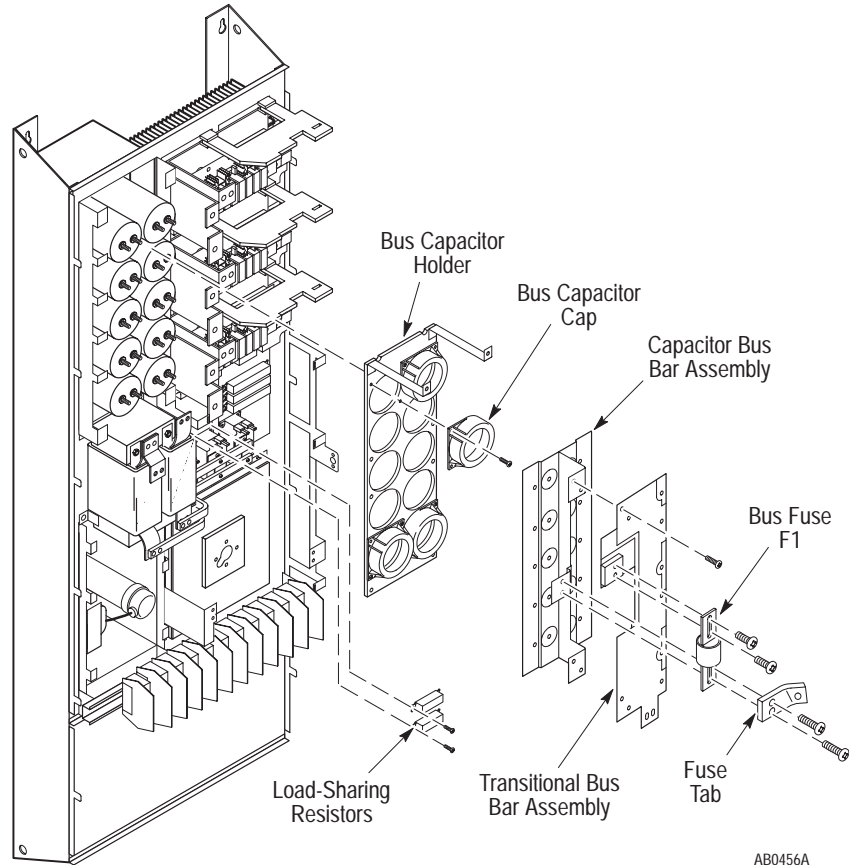

Removal



ATTENTION: Disconnect and lock out power from the drive before disassembling the drive. Failure to disconnect power may result in death or serious injury. Verify bus voltage by measuring the voltage between +DC and -DC on terminal block TB1. Do not attempt to service the drive until the bus voltage has discharged to zero volts.



ATTENTION: Wear a wrist-type grounding strap when servicing 1336 IMPACT drives. Failure to protect drive components against ESD may damage drive components. Refer to Electrostatic Discharge Precautions at the beginning of this chapter.

Important: Before you remove connections and wires from the drive components, mark the connections and wires to correspond with their component connections and terminals to prevent incorrect wiring during assembly.

Access the Main Chassis:

1. Remove power from the drive.
2. Check for zero volts at TB1 terminals +DC and –DC.
3. Check for the absence of control voltage at:
 - TB10
 - TB11
 - L Option Board (if used)
4. Remove the High Voltage Guard from the drive. Refer to Chapter 3 – Disassembly and Access Procedures, Removing the High Voltage Guard.
5. Remove the Main Control Board Mounting Plate. Refer to Chapter 3 – Disassembly and Access Procedures, Removing the Main Control Board Mounting Plate.
6. Remove the Gate Driver Board Mounting Plate. Refer to Chapter 3 – Disassembly and Access Procedures, Removing the Gate Driver Board Mounting Plate.
7. Remove the Precharge Board Mounting Plate. Refer to Chapter 3 – Disassembly and Access Procedures, Removing the Precharge Board Mounting Plate.

Access the Bus Capacitor Bank:

1. Remove the screws fastening the Transitional Bus Bar Assembly to the Power Module Bus Bars, DC Bus Inductor, and Capacitor Bus Bar Assembly.
2. Remove the Bus Fuse. Refer to Bus Fuse F1 in this chapter.
3. Slide the Transitional Bus Bar Assembly to the left to remove it from the drive.
4. Remove the screws fastening the wires to the Capacitor Bus Bar Assembly.

5. Remove the nuts fastening the Capacitor Bus Bar Assembly to the Bus Capacitors.
6. Remove the Capacitor Bus Bar Assembly from the drive.
7. Remove the screws fastening the Bus Capacitor Holder to the chassis. Remove the Capacitor Holder and the two Cover Support Brackets at the top of the Bus Capacitor Holder from the drive.
8. Remove the Bus Capacitors from the Drive.

Installation

1. Fasten the capacitor assembly in reverse order of removal. Refer to Chapter 3 – Disassembly and Access Procedures, Fastener Torque Specifications.

Important: Orient the notch and vent hole on the Bus Capacitors to the top of the drive.

2. Connect the Load-Sharing Resistors to the Bus Capacitors according to the following diagram. Refer to the schematic diagrams in this manual for more information on component configurations.

Important: Check the Load-Sharing Resistors for an open condition and replace any open resistors. Resistors must measure within 20 percent tolerance of their marked resistance value.

Important: If the drive is equipped with PEM nuts on the Cap Bus bar, use them instead of capacitor studs to make the electrical connection.

Figure 5.3
Load-Sharing Resistor Connections to Bus Capacitors

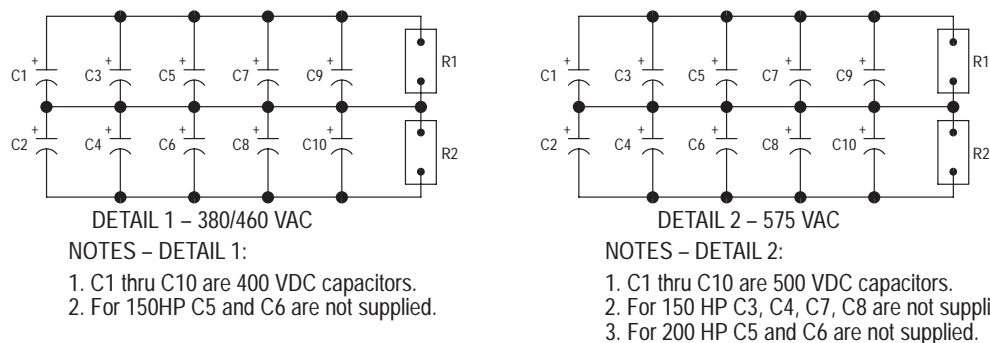

AB0752A



ATTENTION: Capacitors not installed correctly will explode or vent and could cause injury and equipment damage. Observe correct polarities.

Thermistor

The Thermistor is located on the heat sink at the top-middle of the drive.

Figure 5.4
Thermistor

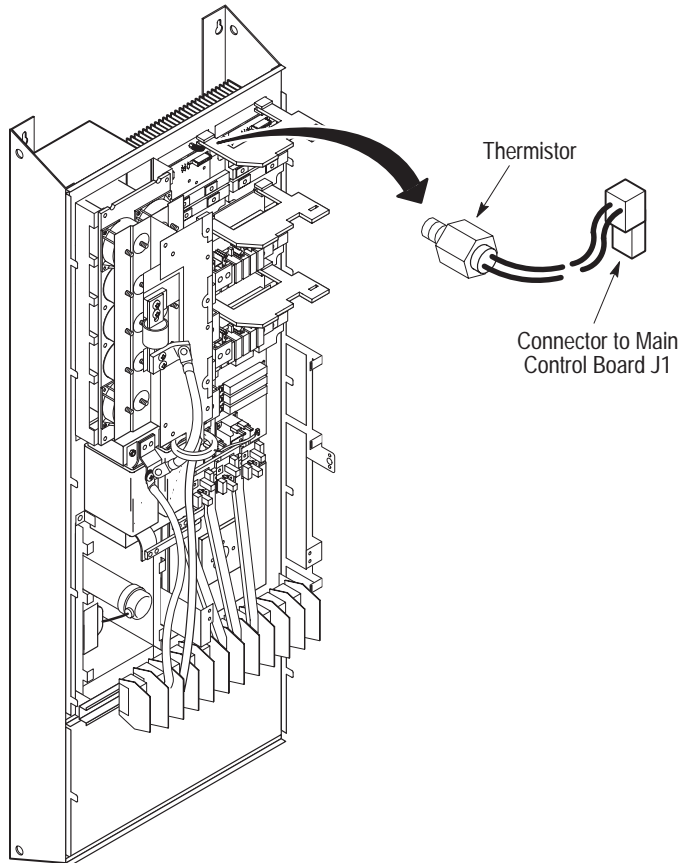

AB0458A

Removal



ATTENTION: Disconnect and lock out power from the drive before disassembling the drive. Failure to disconnect power may result in death or serious injury. Verify bus voltage by measuring the voltage between +DC and -DC on terminal block TB1. Do not attempt to service the drive until the bus voltage has discharged to zero volts.



ATTENTION: Wear a wrist-type grounding strap when servicing 1336 IMPACT drives. Failure to protect drive components against ESD may damage drive components. Refer to Electrostatic Discharge Precautions at the beginning of this chapter.

Important: Before you remove connections and wires from the drive components, mark the connections and wires to correspond with their component connections and terminals to prevent incorrect wiring during assembly.

1. Remove power from the drive.
2. Check for zero volts at TB1 terminals +DC and -DC.
3. Check for the absence of control voltage at:
 - TB10
 - TB11
 - L Option Board (if used)
4. Remove the screws fastening the High Voltage Guard to the drive. Refer to Chapter 3 – Disassembly and Access Procedures, Removing the High Voltage Guard.
5. Disconnect the Thermistor connector at J1 on the Main Control Board.
6. Unscrew the Thermistor from the heat sink.

Installation

Install the Thermistor in reverse order of removal. Refer to Chapter 3 – Disassembly and Access Procedures, Fastener Torque Specifications.



ATTENTION: Replace all guards before applying power to the drive. Failure to replace guards may result in death or serious injury.

Power Modules

The Power Modules are located near the top of the heat sink. If one or more Power Modules is replaced, you must check the Power Module Snubber Board and the Precharge Board. Refer to Chapter 3 – Disassembly and Access Procedures, Removing the Precharge Board Mounting Plate.

Figure 5.5
Power Modules

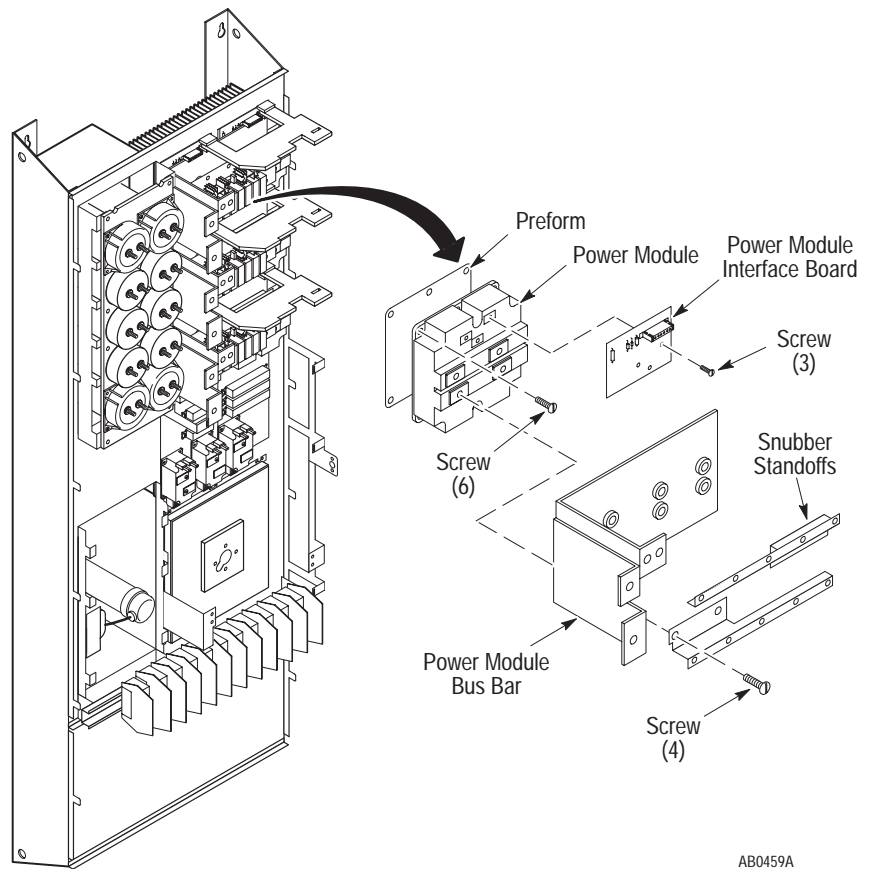

AB0459A

Removal



ATTENTION: Disconnect and lock out power from the drive before disassembling the drive. Failure to disconnect power may result in death or serious injury. Verify bus voltage by measuring the voltage between +DC and -DC on terminal block TB1. Do not attempt to service the drive until the bus voltage has discharged to zero volts.



ATTENTION: Hazard of electric shock exists. Up to 1,600 VDC will be on J1 if the Snubber Resistor is open. Measure for zero VDC from Snubber Board terminal TP3 to plus (+) bus before removing connector J1. Use a resistor greater than 1 ohm and less than 100 ohm, rated for 25 watts minimum, between TP3 and plus (+) bus to discharge any voltage. Refer to Chapter 3 – Disassembly and Access Procedures, Removing a Power Module Snubber Board.



ATTENTION: Wear a wrist-type grounding strap when servicing 1336 IMPACT drives. Failure to protect drive components against ESD may damage drive components. Refer to Electrostatic Discharge Precautions at the beginning of this chapter.

Important: Before you remove connections and wires from the drive components, mark the connections and wires to correspond with their component connections and terminals to prevent incorrect wiring during assembly.

Access the Power Module:

1. Remove power from the drive.
2. Check for zero volts at TB1 terminals +DC and –DC.
3. Check for the absence of control voltage at:
 - TB10
 - TB11
 - L Option Board (if used)
4. Remove the High Voltage Guard from the drive. Refer to Chapter 3 – Disassembly and Access Procedures, Removing the High Voltage Guard.
5. Remove the Main Control Board Mounting Plate. Refer to Chapter 3 – Disassembly and Access Procedures, Removing the Main Control Board Mounting Plate.
6. Remove the Gate Driver Board Mounting Plate. Refer to Chapter 3 – Disassembly and Access Procedures, Removing the Gate Driver Board Mounting Plate.
7. Remove the Precharge Board Mounting Plate. Refer to Chapter 3 – Disassembly and Access Procedures, Removing the Precharge Board Mounting Plate.

Remove the Power Module:

1. Remove the Power Module Snubber Boards. Refer to Chapter 3 – Disassembly and Access Procedures, Removing a Power Module Snubber Board.
2. Remove the screws fastening the Snubber standoffs to the Power Module Bus Bar to remove the standoffs.
3. Remove the screws fastening the Power Module Bus Bar to the Power Modules and the Transitional Bus Bar assembly.
4. Slide the Power Module Bus Bar toward the right side of the drive to remove.
5. Remove the wiring harness from Power Module Gate Interface Board Connector J1.
6. Remove the screws fastening the Power Module Gate Interface Boards to the Power Modules.
7. Remove the Power Module Gate Interface Boards.
8. Remove the screws fastening the Power Modules to the heat sink.

Installation

1. Clean all surfaces between the Power Module and the heat sink using a soft, clean cloth.
2. Replace the Preform between the Power Module and the heat sink.
3. Install the Power Module in reverse order of removal. Refer to Chapter 3 – Disassembly and Access Procedures, Fastener Torque Specifications.



ATTENTION: Do not substitute longer or shorter hardware when fastening the Power Module components to the Power Modules. Use the same size fastener to fasten the components as was originally used. Using different fastener lengths will damage the Power Modules.



ATTENTION: Replace all guards before applying power to the drive. Failure to replace guards may result in death or serious injury.

Input Rectifiers

The Input Rectifiers are located toward the bottom of the heat sink.

Figure 5.6
Input Rectifiers

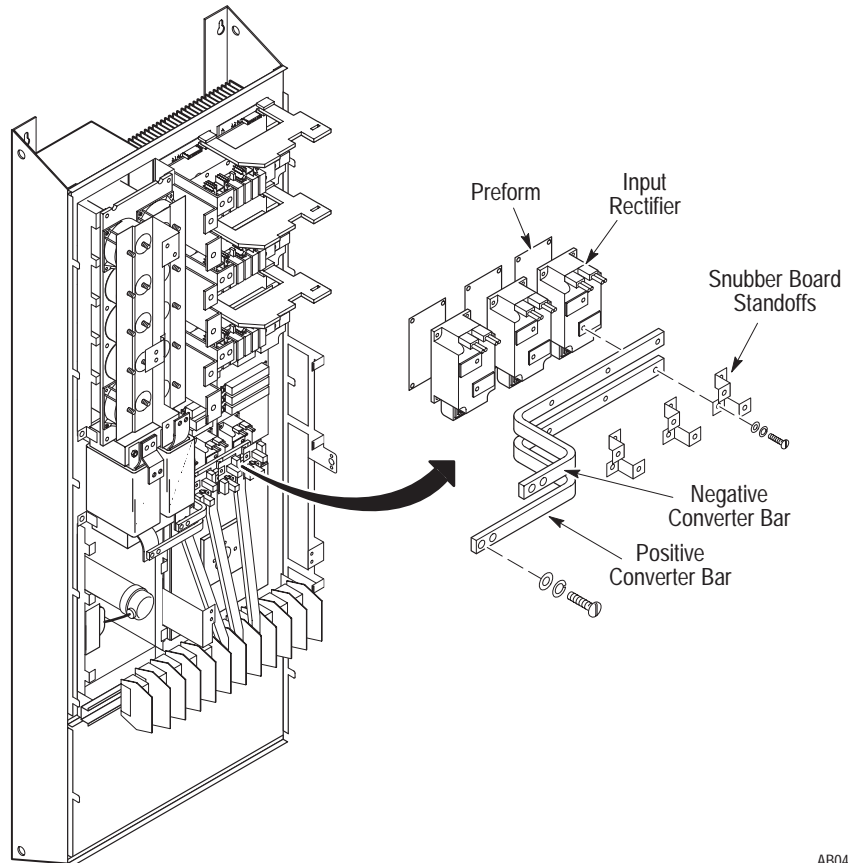

AB0460A

Removal



ATTENTION: Disconnect and lock out power from the drive before disassembling the drive. Failure to disconnect power may result in death or serious injury. Verify bus voltage by measuring the voltage between +DC and -DC on terminal block TB1. Do not attempt to service the drive until the bus voltage has discharged to zero volts.



ATTENTION: Wear a wrist-type grounding strap when servicing 1336 IMPACT drives. Failure to protect drive components against ESD may damage drive components. Refer to Electrostatic Discharge Precautions at the beginning of this chapter.

Important: Before you remove connections and wires from the drive components, mark the connections and wires to correspond with their component connections and terminals to prevent incorrect wiring during assembly.

Access the Input Rectifiers:

1. Remove power from the drive.
2. Check for zero volts at TB1 terminals +DC and –DC.
3. Check for the absence of control voltage at:
 - TB10
 - TB11
 - L Option Board (if used)
4. Remove the High Voltage Guard from the drive. Refer to Chapter 3 – Disassembly and Access Procedures, Removing the High Voltage Guard.
5. Remove the Main Control Board Mounting Plate. Refer to Chapter 3 – Disassembly and Access Procedures, Removing the Main Control Board Mounting Plate.
6. Remove the Gate Driver Board Mounting Plate. Refer to Chapter 3 – Disassembly and Access Procedures, Removing the Gate Driver Board Mounting Plate.

Remove the Input Rectifiers:

1. Remove the Input Rectifier Snubber Boards. Refer to Chapter 3 – Disassembly and Access Procedures, Removing an Input Rectifier Snubber Board.
2. Remove the screws fastening the Input Rectifier standoffs to the rectifiers.
3. Remove the screws fastening the Positive and Negative Converter Bars to the DC Bus Inductor.
4. Remove the TB1 Input Bus Bars and the Precharge Board Wiring Harnesses from the Rectifiers.
5. Remove the screws fastening the Input Rectifiers to the heat sink.

Installation

1. Clean all surfaces between the Input Rectifier and the heat sink using a soft, clean cloth.
2. Replace the Preform between the Input Rectifier and the heat sink.
3. Install the Input Rectifier in reverse order of removal. Refer to Chapter 3 – Disassembly and Access Procedures, Fastener Torque Specifications.

Important: Install washers on TB1 terminals with the serrated side facing toward you.



ATTENTION: Replace all guards before applying power to the drive. Failure to replace guards may result in death or serious injury.

Fan and Transformer Assembly

The Fan is located in the chassis and under TB1 at the bottom of the heat sink. The Fan Transformer and Fan Capacitor are located in the bottom left corner of the chassis.

Figure 5.7
Fan and Transformer

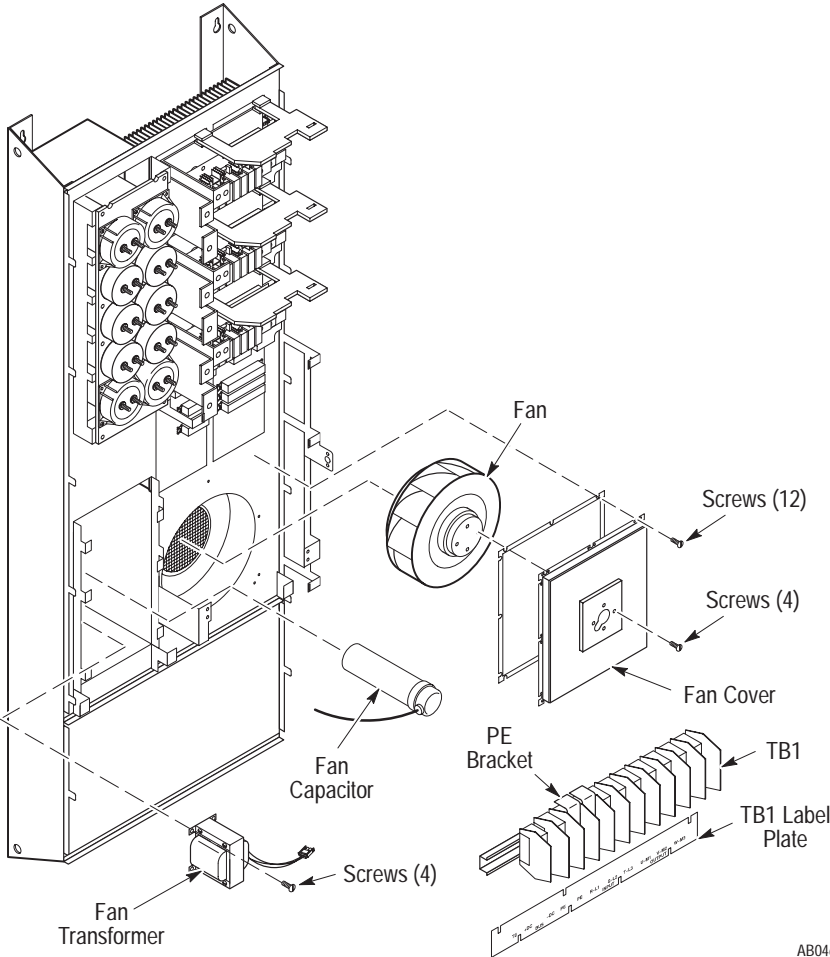

AB0461A

Removal



ATTENTION: Disconnect and lock out power from the drive before disassembling the drive. Failure to disconnect power may result in death or serious injury. Verify bus voltage by measuring the voltage between +DC and –DC on terminal block TB1. Do not attempt to service the drive until the bus voltage has discharged to zero volts.



ATTENTION: Hazard of electric shock exists. Up to 1,600 VDC will be on J1 if the Snubber Resistor is open. Measure for zero (0) VDC from Snubber Board terminal TP3 to plus (+) bus before removing connector J1. Use a resistor greater than 1 ohm and less than 100 ohm, rated for 25 watts minimum between TP3 and plus (+) bus to discharge any voltage. Refer to Chapter 3 – Disassembly and Access Procedures, Removing a Power Module Snubber Board.



ATTENTION: Wear a wrist-type grounding strap when servicing 1336 IMPACT drives. Failure to protect drive components against ESD may damage drive components. Refer to Electrostatic Discharge Precautions at the beginning of this chapter.

Important: Before you remove connections and wires from the drive components, mark the connections and wires to correspond with their component connections and terminals to prevent incorrect wiring during assembly.

Access the Main Chassis:

1. Remove power from the drive.
2. Check for zero volts at TB1 terminals +DC and –DC.
3. Check for the absence of control voltage at:
 - TB10
 - TB11
 - L Option Board (if used)
4. Remove the High Voltage Guard from the drive. Refer to Chapter 3 – Disassembly and Access Procedures, Removing the High Voltage Guard.

5. Remove the Main Control Board Mounting Plate. Refer to Chapter 3 – Disassembly and Access Procedures, Removing the Main Control Board Mounting Plate.
6. Remove the Gate Driver Board Mounting Plate. Refer to Chapter 3 – Disassembly and Access Procedures, Removing the Gate Driver Board Mounting Plate.
7. Remove the Precharge Board Mounting Plates. Refer to Chapter 3 – Disassembly and Access Procedures, Removing the Precharge Board Mounting Plate.
8. Remove the Motor Bus Bars. Refer to Chapter 3 – Disassembly and Access Procedures, Removing the Power Module Snubber Boards.
9. Remove all wires from PE, TE, MOV and Fan Transformer at TB1.
10. Remove the TB1 Input Bus Bars from the Input Rectifiers.
11. Remove the Bus PE Bracket from TB1 PE partitions.

Remove TB1 and Mounting Rail:

1. Loosen the screws on the Terminal End Stops on each end of the TB1 Mounting Rail.
2. Slide the left End Stop off the TB1 Mounting Rail.
3. Remove the screw fastening the left side of the Mounting Rail to the chassis.
4. Slide the right End Stop off the TB1 Mounting Rail.
5. Slide the first partition toward the right end of the rail.
6. Remove the screw fastening the right side of the Mounting Rail to the chassis.
7. Slide the two PE partitions apart and toward opposite ends of the TB1 Mounting Rail.
8. Remove the screw fastening the Mounting Rail to the chassis.
9. Remove the TB1 Mounting Rail and the Label Plate.

Remove the Fan:

1. Disconnect the Fan wiring harness.
2. Remove the screws fastening the Fan Cover to the chassis.
3. Pull the Fan Cover assembly away from the Drive.
4. Remove the screws fastening the Fan to the Fan Cover to remove the Fan.
5. Disconnect the Fan Capacitor from the Fan Wiring Harness.

6. Unscrew the Fan Capacitor from the chassis by hand.
7. Disconnect the Fan Transformer from the Fan Wiring Harness and from TB1.
8. Remove the screws fastening the Fan Transformer to the chassis.

Installation

Install the Fan Assembly in reverse order of removal, with the following exceptions:

- Thread the Fan wiring connector through the hole in the Fan Cover.
- Refer to Chapter 3 – Disassembly and Access Procedures, Fastener Torque Specifications.
- Install the Fan Capacitor to the chassis with M8 split washer and hand tighten.
- Connect the Fan Transformer red wire to TB1 terminal S-L2 and the black wire to TB1 terminal R-L1.

Important: Install washers on TB1 terminals with the serrated side facing toward you.



ATTENTION: Replace all guards before applying power to the drive. Failure to replace guards may result in death or serious injury.

DC Bus Inductor L1

DC Bus Inductor L1 is located on the lower left corner of the drive.

Figure 5.8
DC Bus Inductor L1

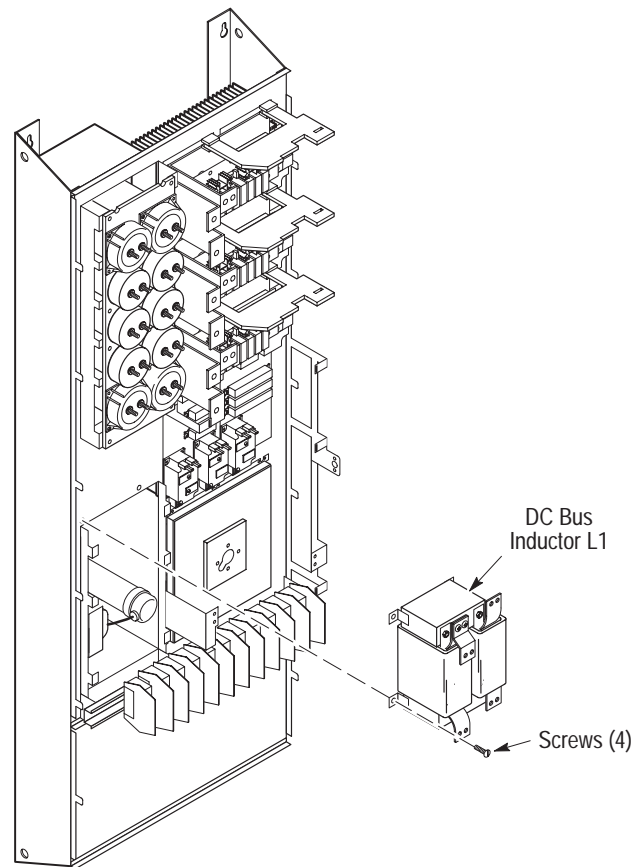

AB0462A

Removal



ATTENTION: Disconnect and lock out power from the drive before disassembling the drive. Failure to disconnect power may result in death or serious injury. Verify bus voltage by measuring the voltage between +DC and -DC on terminal block TB1. Do not attempt to service the drive until the bus voltage has discharged to zero volts.



ATTENTION: Wear a wrist-type grounding strap when servicing 1336 IMPACT drives. Failure to protect drive components against ESD may damage drive components. Refer to Electrostatic Discharge Precautions at the beginning of this chapter.

Important: Before you remove connections and wires from the drive components, mark the connections and wires to correspond with their component connections and terminals to prevent incorrect wiring during assembly.

1. Remove power from the drive.
2. Check for zero volts at TB1 terminals +DC and -DC.
3. Check for the absence of control voltage at:
 - TB10
 - TB11
 - L Option Board (if used)
4. Remove the High Voltage Guard from the drive. Refer to Chapter 3 – Disassembly and Access Procedures, Removing the High Voltage Guard.
5. Remove the Gate Driver Board Mounting Plate. Refer to Chapter 3 – Disassembly and Access Procedures, Removing the Gate Driver Board Mounting Plate.
6. Remove the Fuse and TB1 cables from the DC Bus Inductor.
7. Remove the screws fastening the DC Bus Inductor to the Transitional Bus Bar Assembly.
8. Remove the Positive and Negative Converter Bars. Refer to Input Rectifiers in this chapter.
9. Remove the screws fastening the Bus Bar Cable Adapters to the DC Bus Inductor terminals.
10. Remove screws fastening the DC Bus Inductor to the chassis.



ATTENTION: The DC Bus Inductor is heavy and may fall during disassembly. A falling inductor may result in death or serious injury.

Important: Note the position and orientation of the Ground Sense CT (CT3) around the (-)Bus terminal at the top of the Bus inductor. This CT will come off when the inductor is removed. Re-install the CT in the same position, and make sure the (+)Bus cable to the fuse passes through the Ground Sense CT during assembly.

11. Remove the Bus Inductor from the Drive.

Installation

Install DC Bus Inductor L1 in reverse order of removal. Refer to Chapter 3 – Disassembly and Access Procedures, Fastener Torque Specifications.



ATTENTION: Replace all guards before applying power to the drive. Failure to replace guards may result in death or serious injury.

Ground Sense CT

The Ground Sense CT is located between DC Bus Inductor L1 and the Transitional Bus Bar Assembly.

Figure 5.9
Ground Sense CT

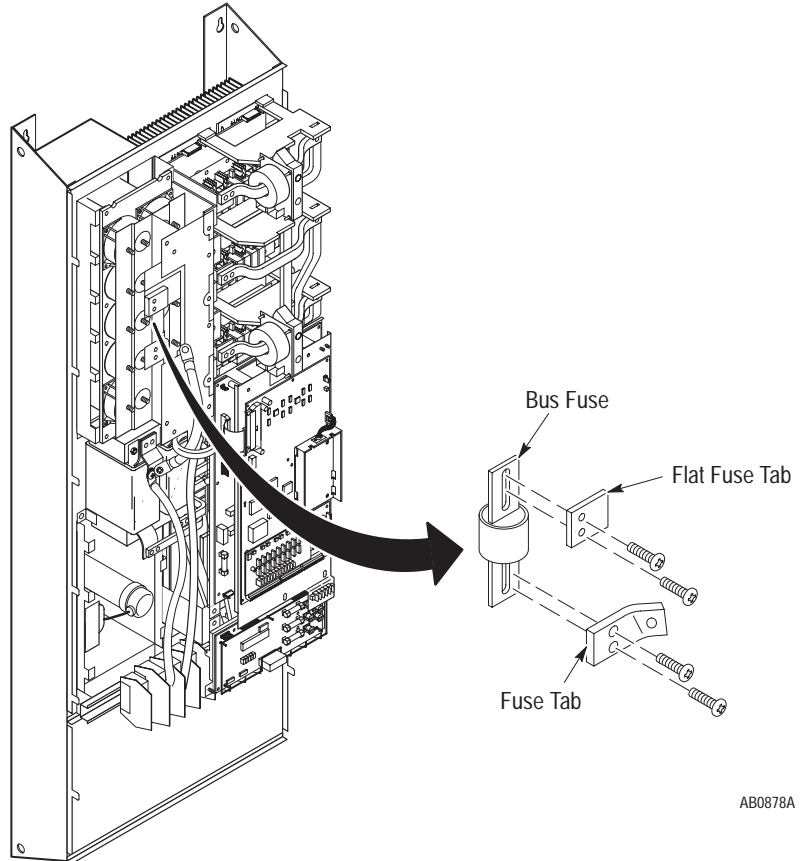

Removal



ATTENTION: Disconnect and lock out power from the drive before disassembling the drive. Failure to disconnect power may result in death or serious injury. Verify bus voltage by measuring the voltage between +DC and -DC on terminal block TB1. Do not attempt to service the drive until the bus voltage has discharged to zero volts.



ATTENTION: Wear a wrist-type grounding strap when servicing 1336 IMPACT drives. Failure to protect drive components against ESD may damage drive components. Refer to Electrostatic Discharge Precautions at the beginning of this chapter.

Important: Before you remove connections and wires from the drive components, mark the connections and wires to correspond with their component connections and terminals to prevent incorrect wiring during assembly.

1. Remove power from the drive.
2. Check for zero volts at TB1 terminals +DC and -DC.
3. Check for the absence of control voltage at:
 - TB10
 - TB11
 - L Option Board (if used)
4. Remove the High Voltage Guard from the drive. Refer to Chapter 3 – Disassembly and Access Procedures, Removing the High Voltage Guard.
5. Disconnect the Ground Sense CT from Gate Driver Board connector J2.
6. Remove the screws from the wire passing through Ground Sense CT. One screw is located at Bus Fuse F1, and one at the DC Bus Inductor.
7. Remove the screws fastening the bottom of Bus Fuse F1 to the Capacitor Bus Bar Assembly.
8. Remove the screws fastening the Transitional Bus Bar Assembly to the Power Module Bus Bars, DC Bus Inductor, and Capacitor Bus Bar Assembly.
9. Slide the Transitional Bus Bar Assembly to the left to remove it from the Drive.

Installation

Install the Ground Sense CT in reverse order of removal, inserting the wire, connecting Bus Fuse F1 to DC Bus Inductor, through the center of the Ground Sense CT. Refer to Chapter 3 – Disassembly and Access Procedures, Fastener Torque Specifications.



ATTENTION: A possible short-circuit hazard exists. Position the fuse-to-inductor wire with the shrink-wrapped end of the wire connected to the Bus Inductor. Failure to position the wire as illustrated may result in serious injury or equipment damage.



ATTENTION: Replace all guards before applying power to the drive. Failure to replace guards may result in death or serious injury.

Bus Fuse F1

The Bus Fuse is located on the Transitional Bus Bar Assembly.

Figure 5.10
Bus Fuse F1

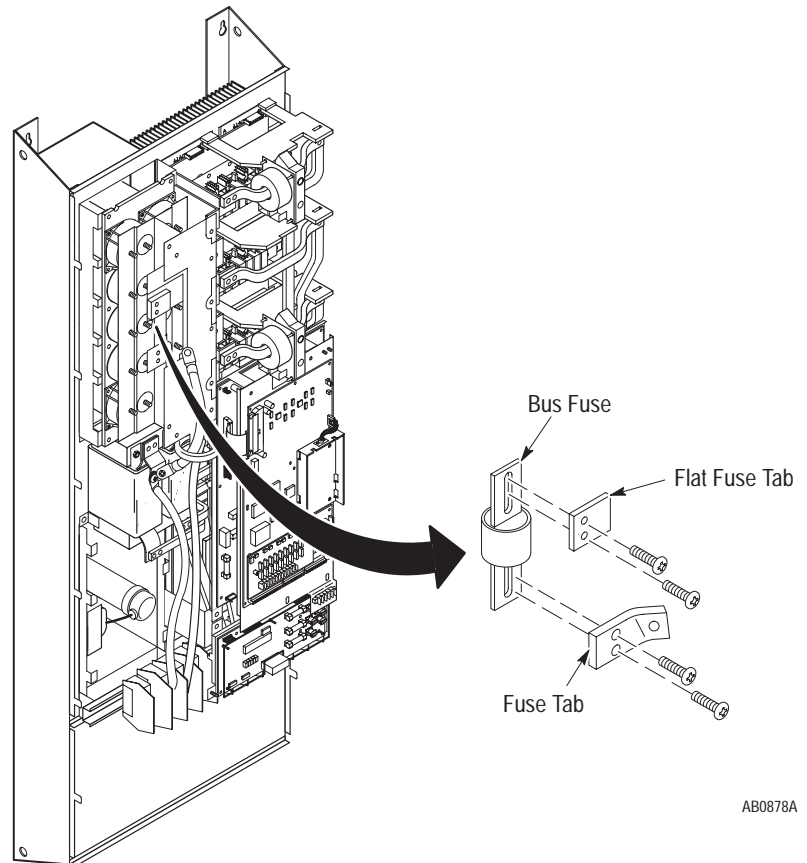

Removal



ATTENTION: Disconnect and lock out power from the drive before disassembling the drive. Failure to disconnect power may result in death or serious injury. Verify bus voltage by measuring the voltage between +DC and -DC on terminal block TB1. Do not attempt to service the drive until the bus voltage has discharged to zero volts.



ATTENTION: Wear a wrist-type grounding strap when servicing 1336 IMPACT drives. Failure to protect drive components against ESD may damage drive components. Refer to Electrostatic Discharge Precautions at the beginning of this chapter.

Important: Before you remove connections and wires from the drive components, mark the connections and wires to correspond with their component connections and terminals to prevent incorrect wiring during assembly.

1. Remove power from the drive.
2. Check for zero volts at TB1 terminals +DC and -DC.
3. Check for the absence of control voltage at:
 - TB10
 - TB11
 - L Option Board (if used)
4. Remove the High Voltage Guard from the drive. Refer to Chapter 3 – Disassembly and Access Procedures, Removing the High Voltage Guard.
5. Remove the screws fastening the Bus Fuse to the drive.

Installation

Install the Bus Fuse in reverse order of removal. Refer to Chapter 3 – Disassembly and Access Procedures, Fastener Torque Specifications.



ATTENTION: Replace all guards before applying power to the drive. Failure to replace guards may result in death or serious injury.

LEMs

Figure 5.11
LEMs

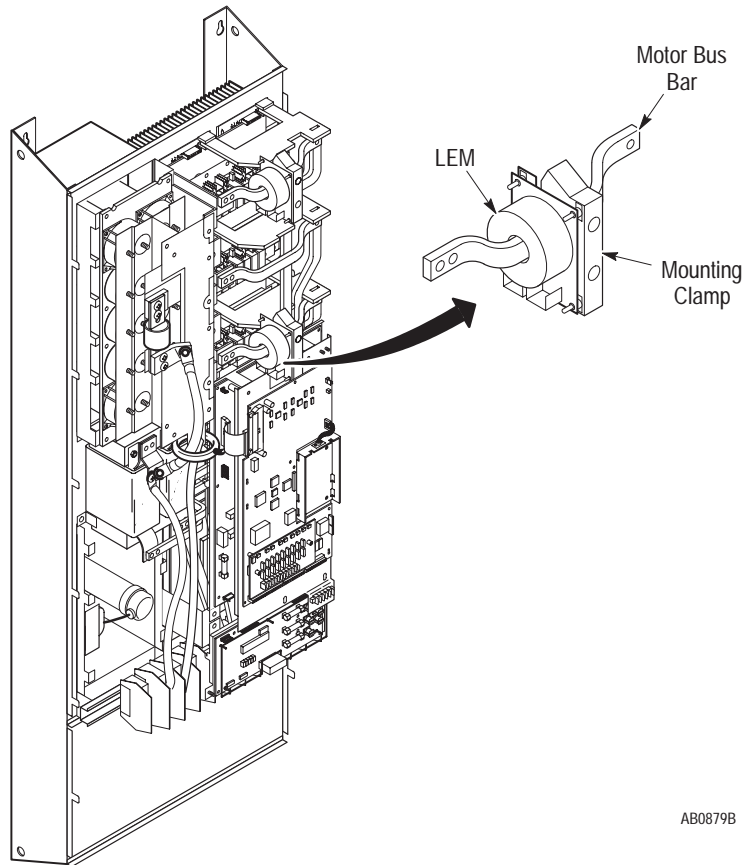

Removal



ATTENTION: Disconnect and lock out power from the drive before disassembling the drive. Failure to disconnect power may result in death or serious injury. Verify bus voltage by measuring the voltage between +DC and -DC on terminal block TB1. Do not attempt to service the drive until the bus voltage has discharged to zero volts.



ATTENTION: Hazard of electric shock exists. Up to 1,600 VDC will be on J1 if the Snubber Resistor is open. Measure for zero (0) VDC from Snubber Board terminal TP3 to plus (+) bus before removing connector J1. Use a resistor greater than 1 ohm and less than 100 ohm, rated for 25 watts minimum, between TP3 and plus (+) bus to discharge any voltage. Refer to Chapter 3 – Disassembly and Access Procedures, Removing a Power Module Snubber Board.



ATTENTION: Wear a wrist-type grounding strap when servicing 1336 IMPACT drives. Failure to protect drive components against ESD may damage drive components. Refer to Electrostatic Discharge Precautions at the beginning of this chapter.

Important: Before you remove connections and wires from the drive components, mark the connections and wires to correspond with their component connections and terminals to prevent incorrect wiring during assembly.

1. Remove power from the drive.
2. Check for zero volts at TB1 terminals +DC and –DC.
3. Check for the absence of control voltage at:
 - TB10
 - TB11
 - L Option Board (if used)
4. Remove the High Voltage Guard from the drive. Refer to Chapter 3 – Disassembly and Access Procedures, Removing the High Voltage Guard.
5. Remove the wires from the connectors on the LEMs.
6. Remove the screws fastening the LEM Motor Bus Bars to the Output Motor Bus Bars.
7. Remove the two screws and the clamping plate holding the LEM mounting clamp around the Motor Bus Bar.
8. Pull the LEMs away from the mounting plates.

Installation

Install the LEMs in reverse order of removal. Refer to Chapter 3 – Disassembly and Access Procedures, Fastener Torque Specifications.



ATTENTION: Replace all guards before applying power to the drive. Failure to replace guards may result in death or serious injury.

MOV Surge Suppressor

The MOV Surge Suppressor is located in the bottom-left corner of the Drive near the Fan Transformer and Fan Capacitor.

The MOV protects the drive from high voltage surges above approximately 1,000 volts. Replace it if it is burned, expanded, or ruptured after such events as a lightning strike or inadvertent connection of the drive input to a voltage source substantially above nameplate voltage.

Figure 5.12
MOV Surge Suppressor

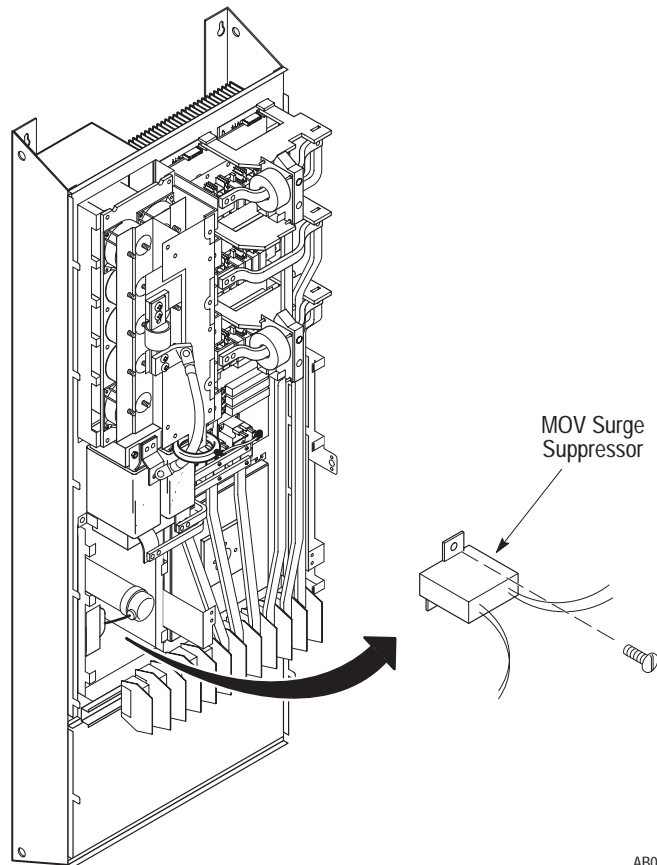

AB0469A

Removal



ATTENTION: Wear a wrist-type grounding strap when servicing 1336 IMPACT drives. Failure to protect drive components against ESD may damage drive components. Refer to Electrostatic Discharge Precautions at the beginning of this chapter.

Important: Before you remove connections and wires from the drive components, mark the connections and wires to correspond with their component connections and terminals to prevent incorrect wiring during assembly.

1. Remove power from the drive.
2. Check for zero volts at TB1 terminals +DC and –DC.
3. Check for the absence of control voltage at:
 - TB10
 - TB11
 - L Option Board (if used)
4. Remove the nut fastening the MOV Surge Suppressor ground wire to the ground stud on the chassis.
5. Remove the MOV Surge Suppressor wires from TB1 terminals R-L1, S-L2, and T-L3.
6. Remove the screw fastening the MOV Surge Suppressor to the chassis.
7. Remove the MOV Surge Suppressor from the Drive.

Installation

Install the MOV Surge Suppressor in reverse order of removal. Refer to Chapter 3 – Disassembly and Access Procedures, Fastener Torque Specifications.

Important: Install washers on TB1 terminals with the serrated side facing toward you.



ATTENTION: Replace all guards before applying power to the drive. Failure to replace guards may result in death or serious injury.

This Page Intentionally Left Blank

Replacement Parts List

Chapter Objectives

This chapter illustrates and lists replacement parts for the 1336 IMPACT Drives rated A75 – A125, B150 – B250, and C150 – C250 and describes replacement parts ordering procedures.

The following illustration and table show you parts, part names, locations, and chapters for replacement procedures.

Ordering Replacement Parts

For your convenience, the Rockwell Automation Drives Division and the Rockwell Automation Support Division provide efficient and convenient repair and exchange for eligible equipment.

A product service report number is required to return any equipment for repair. Your local Rockwell Automation distributor or area sales and support office can provide you with a product service report number.

You should return equipment to be repaired to the area sales and support center nearest you. Reference the product service report number on the carton and packing slip. Include:

- Your company name
- Your company address
- The repair purchase order number
- A brief description of the problem

Contact your local Rockwell Automation distributor or sales office for a complete listing of area sales and support centers near you.

For parts catalog numbers, refer to the 1336 IMPACT Spare Parts Pricing publication included with your drive documentation set. Or see next page for more information.

Spare Parts Information

Current 1336 IMPACT drive spare parts information including recommended parts, catalog numbers and pricing can be obtained from the following sources:

Allen-Bradley home page on the World Wide Web at

<http://www.ab.com>

then select . . .

"Drives and Motors" *followed by . . .*

"1336 IMPACT" *from the Product Directory" and . . .*

"Technical Support . . ."

Select "Parts List"

Replacement Parts Listing

Figure 6.1
Parts for B150 – B250 and C150 – C250 Drives

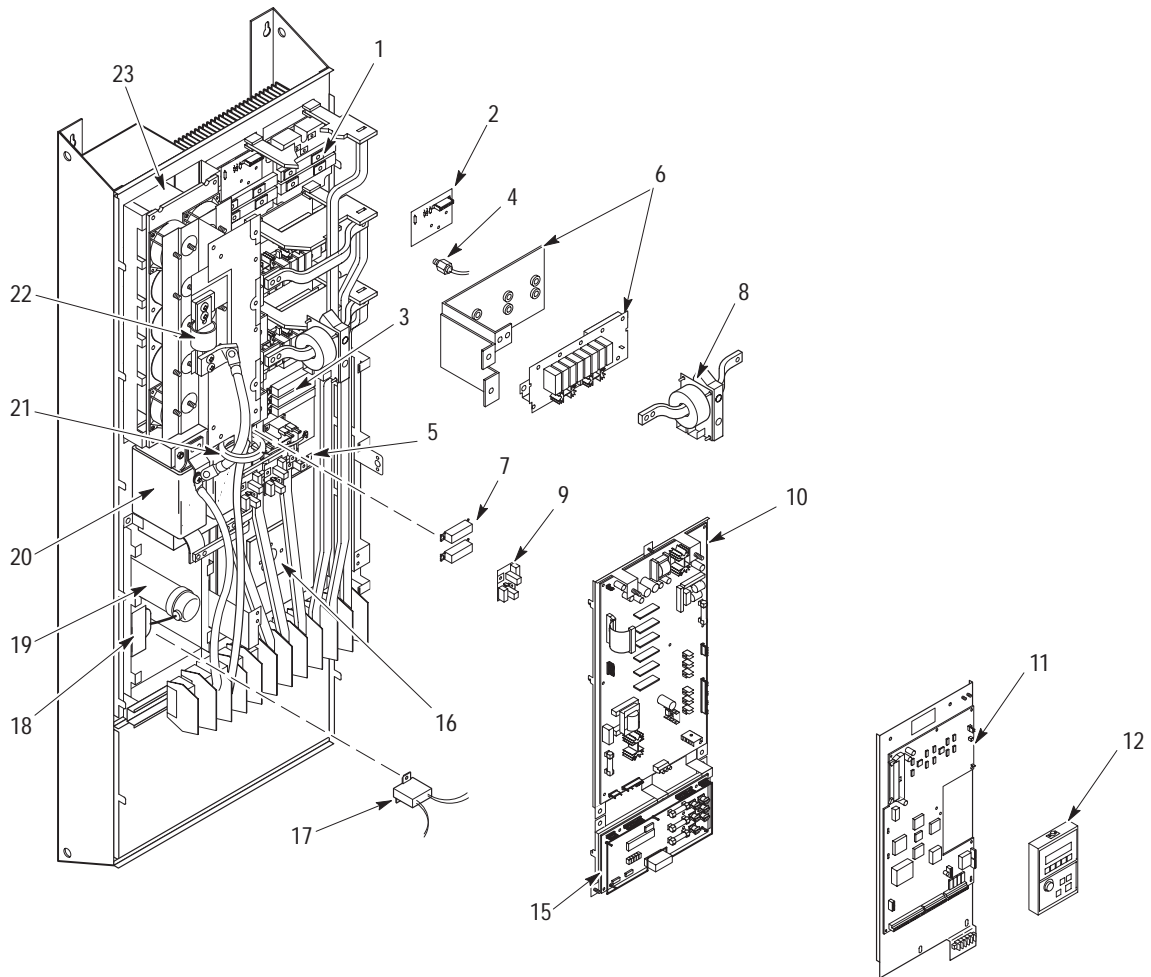

AB0880A

Table 6.A
Replacement Parts for B150 – B250 and C150 – C250, C250
and CX 300 Drives

Callout	Symbol	Description	Location	Replacement Procedures
1	Q1 – Q6	Transistor (Power Module)	Heat Sink	Chapter 5, Power Modules
2	A23 – A28	Power Module Gate Interface Board	Power Module	Chapter 5, Power Modules
3	R20 – R22	Power Module Snubber Resistor	Heat Sink	Chapter 3, Removing a Power Module Snubber Board
4	ST	Thermistor	Heat Sink	Chapter 5, Thermistor
5	SCR1 – SCR3	Input Rectifier	Heat Sink	Chapter 5, Input Rectifiers
6	SNUBBER BOARD	Power Module Bus Bar and Snubber Board	Power Module	Chapter 3, Removing a Power Module Snubber Board
7	R1 – R3	Load-Sharing Resistor	Heat Sink	Chapter 5, Bus Capacitor Bank
8	CT1, CT2	LEM	Bus Bar	Chapter 5, LEMs
9	SCR SNUBBER BOARD	Input Rectifier Snubber Board	Input Rectifier	Chapter 3, Removing the Input Rectifier Snubber Board
10	BASEDR/PWRSPLY	Gate Driver Board	Gate Driver Board Mounting Plate	Chapter 3, Removing the Gate Driver Board
11	MAIN CONTROL BOARD	Main Control Board	Main Control Board Mounting Plate	Chapter 3, Removing the Main Control Board from the Mounting Plate
12	HIM	Human Interface Module	Enclosure Cover	Chapter 1, Module Removal
13	A10	Precharge Board	Precharge Board Mounting Plate	Chapter 3, Removing the Precharge Board
14	FAN	Fan	Main Chassis	Chapter 5, Fan and Transformer
15	MOV1	MOV Surge Suppressor	Main Chassis	Chapter 5, Fan and Transformer
16	T1	Fan Transformer	Main Chassis	Chapter 3, Removing the Input Rectifier Snubber Board
17	C-HB1	Fan Capacitor	Main Chassis	Chapter 5, Fan and Transformer
18	L1	DC Bus Inductor	Main Chassis	Chapter 5, DC Bus Inductor L1
19	CT3	Ground Sense CT	—	Chapter 5, Ground Sense CT
20	F1	Bus Fuse	—	Chapter 5, Bus Fuse F1
21	C1 – C10	Bus Capacitors	Main Chassis	Chapter 5, Bus Capacitor Bank

This Page Intentionally Left Blank

**Schematics — 150 – 300 HP 1336
IMPACT Drives**

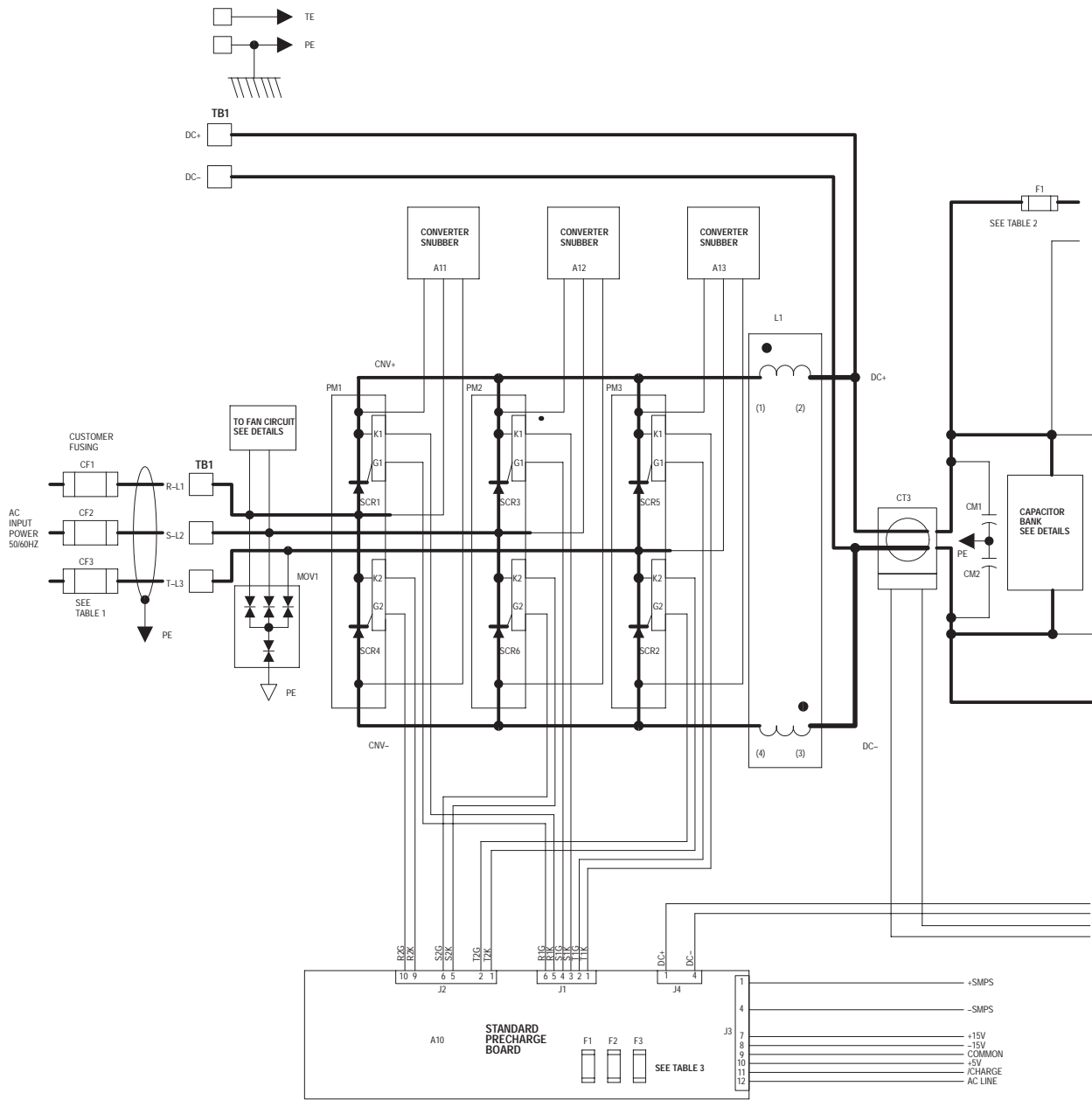

SCHEMATIC DIAGRAM
 STAND ALONE UNIT
 BULLETIN 1336 IMPACT
 150 – 250 HP 380/460 VAC
 150 – 300 HP 575 VAC

AB0720A

Fan Circuit Detail

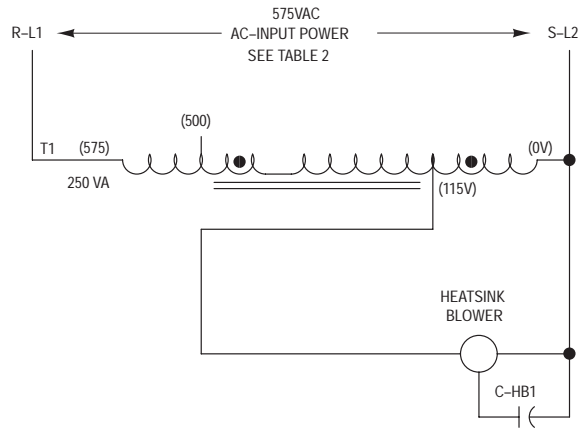
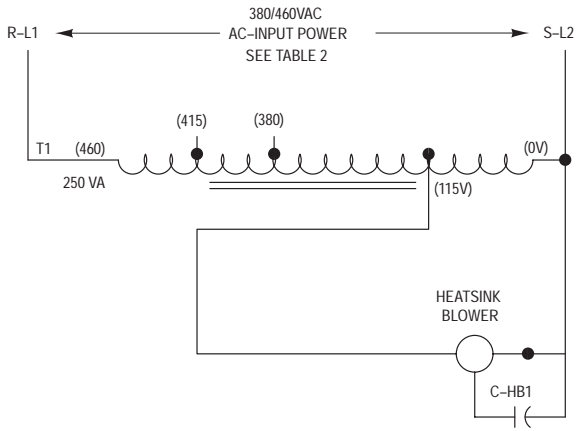

Capacitor Detail

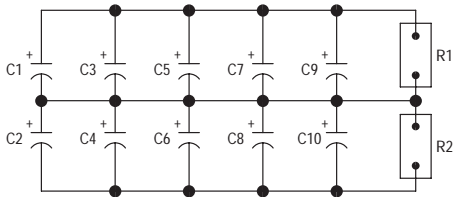

DETAIL 1 – 380/460 VAC

NOTES: – DETAIL 1:

1. C1 THRU C10 ARE 400 VDC CAPACITORS.
2. FOR 150HP C5 AND C6 ARE NOT SUPPLIED.

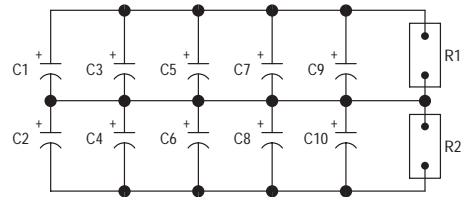

DETAIL 2 – 575 VAC

NOTES: – DETAIL 2:

1. C1 THRU C10 ARE 500 VDC CAPACITORS.
2. FOR 150 HP C3, C4, C7, C8 ARE NOT SUPPLIED.
3. FOR 200 HP C5 AND C6 ARE NOT SUPPLIED.

AB0721A

Main Control Board

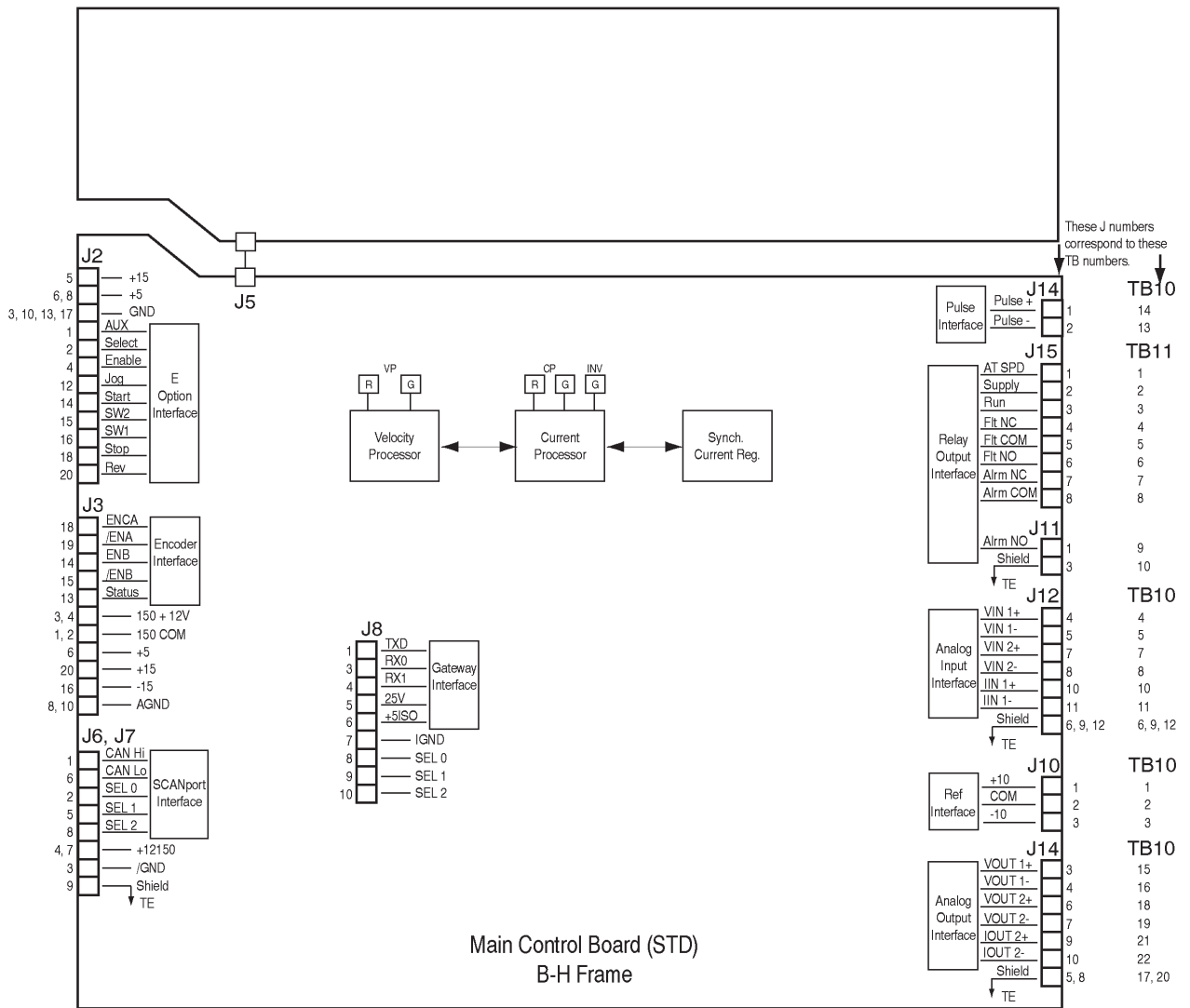

Note 1: Customer fusing.

Based on maximum drive rating the following fuses or approved equivalent must be used:

HORSEPOWER	380/460VAC FUSE CURRENT/TYPE	575VAC FUSE CURRENT/TYPE
150	300A/UL CLASS CC, T OR J	225A/UL CLASS CC, T OR J
200	400A/UL CLASS CC, T OR J	350A/UL CLASS CC, T OR J
250	450A/UL CLASS CC, T OR J	400A/UL CLASS CC, T OR J
300	NOT APPLICABLE	400A/UL CLASS SPP,FWP OR A70Q

Note 2: The inverter DC + bus fuse will remain one amp rating.

For all unites in this frame, the table below defines the fuse rating.

DRIVE HORSEPOWER, INPUT VOLTAGE	FUSE INFORMATION		
	RATING	TYPE	P/N
150/200/250 HP – 380/460/575 VAC	600A	A70Q600-4	25178-310-19
300 HP – 575 VAC	600A	A70Q600-4	25178-310-19

Note 3: The following is a listing of all printed circuit assemblies versus fuse & documentation information.

ITEM	B/M	SCHEMATIC DIAGRAM	FUSE INFORMATION			
			DESIGNATOR	RATING	TYPE	P/N
A1	74101-169-XX	74101-167	F1	1.0A/600V	KTK-R-1	25172-260-08
			F3	1.5A/600V	KTK-R-1.5	25172-260-09
A10	74101-181-XX	74101-179	F1-F3	1.5A/600V	KTK-R-1.5	25172-260-09
A11-13	74101-367-XX	74101-365	NONE			
A20-22	74101-363-XX	74101-361	NONE			
A23-28	74101-371-XX	74101-369	NONE			

AB0722A

A

Audience for this Manual, P-1
Auxiliary Interlock, Definition, P-10

B

Bit, Definition, P-10
Bus Capacitor Bank
 Illustration, 5-4
 Installation, 5-6
 Removal, 5-4
 Test, 4-10
Bus Fuse
 Illustration, 5-25
 Installation, 5-26
 Removal, 5-25

C

Check, Definition, P-10
Component Test Procedures, 4-1
Connector, Definition, P-10
Control Firmware Function, 1-14
Control Interface L-Option Board. *See*
 L Option Board
Control Logic Wiring and Adapters, 1-1
Conventions in this Manual, P-10

D

DC Bus Inductor L1
 Illustration, 5-19
 Installation, 5-21
 Removal, 5-19
Default, Definition, P-10
Drive
 Enclosure Type, P-9
 Identification, P-3
 Illustration, 5-3
 Nameplate Location, P-3
 Rating, P-9
Drive Enclosure
 Illustration, 3-6
 Installation, 3-7
 Removal, 3-6
DriveTools, 1-14

E

Electrostatic Discharge, P-2
Enable Input, Definition, P-11
Enclosure Type, P-9
Encoderless, 2-20
ESD, P-2

F

False, Definition, P-11
Fan and Transformer
 Illustration, 5-15
 Installation, 5-18
 Removal, 5-16
Faults, 2-1
 Absolute Overspd, 2-7
 Analog Spply Tol, 2-7
 Autotune Diag, 2-4
 Bus Cycle >5, 2-12
 Bus Drop, 2-12
 Bus Undervlt, 2-12
 Clear Queue, 2-3
 Desaturation, 2-11
 Diff Drv Type, 2-7
 EE Checksum, 2-6
 External Flt In, 2-8
 Feedback Loss, 2-18
 Ground Fault, 2-11
 HW Malfunction, 2-6, 2-13
 Inv Overload, 2-5
 Inv Overtmp Pnd, 2-5
 Inv Overtmp Trp, 2-5
 InvOvld Pend, 2-5
 mA Input, 2-7
 Math Limit, 2-7
 Mtr Stall, 2-4
 MtrOvrd Pnd, 2-4
 MtrOvrd Trp, 2-4
 Open Circuit, 2-12
 Overcurrent, 2-11
 Overvoltage, 2-11
 Param Limit, 2-7
 Prechg Time, 2-11
 Ridethru Time, 2-11
 SP 1 Timeout, 2-8
 SP 2 Timeout, 2-9
 SP 3 Timeout, 2-9
 SP 4 Timeout, 2-9
 SP 5 Timeout, 2-9

- SP 6 Timeout, 2-9
- SP Error, 2-9
- Spd Fdbk Loss, 2-8
- SW Malfunction, 2-7
- Viewing Queue with HIM, 2-3

Feedback Loss Fault, 2-18

Four-Point Mounting, 3-4

G

Gate Driver Board

- Illustration, 3-19
- Installation, 3-20
- Removal, 3-19
- Test, 4-3

Gate Driver Board Mounting Plate

- Illustration, 3-16
- Installation, 3-17
- Removal, 3-16

GPT. *See* Graphic Programming Terminal

Graphic Programming Terminal

- Description, 1-13
- Illustration, 1-13

Ground Sense CT

- Illustration, 5-22
- Installation, 5-24
- Removal, 5-22

H

High Voltage Guard

- Illustration, 3-8
- Installation, 3-9
- Removal, 3-8

HIM. *See* Human Interface Module

Human Interface Module

- Adapter Locations, 1-10
- Description, 1-10
- Illustration, 1-10
- Operation, 1-12
- Removal, 1-11

Human Interface Module (HIM), Viewing

- Fault/Warning Queues, 2-3

I

Input Mode. *See* L Option Mode

Input Rectifier

- Illustration, 5-12
- Installation, 5-14
- Removal, 5-12
- Test, 4-13

Input Rectifier Snubber Board

- Illustration, 3-29
- Installation, 3-30
- Removal, 3-29

Inputs, Available, 1-5

Installation Procedures. *See* Procedures

J

Jumper, Definition, P-11

L

L Option Board, 1-3

- Definition, P-11
- Illustration, 3-10
- Inputs, 1-5
- Installation, 3-11
- Jumper Locations, 1-4
- Options, 1-3
- Removal, 3-10

L Option Mode, 1-3

- Factory Default, 1-7
- Programming, 1-5
- Selection, 1-6
- Three-Wire Control, Multi-Source

 - Reversing, 1-8

- Three-Wire Control, Single-Source

 - Reversing, 1-7

- Two-Wire Control, Single-Source

 - Reversing, 1-8

LEMs

- Illustration, 5-27, 5-30
- Installation, 5-29
- Removal, 5-27

Load-Sharing Resistor Connections, 5-6

Local Programming, 1-5

M

Main Control Board

- Illustration, 3-14
- Installation, 3-15
- Removal, 3-14

Main Control Board Mounting Plate

- Illustration, 3-12
- Installation, 3-13
- Removal, 3-12

Major Component Replacement. *See* Procedures

- Manual
 - Audience, P-1
 - Conventions, P-10
 - Objective, P-1
 - Related Publications, P-12
- Mounting
 - Four-Point, 3-4
 - Six-Point, 3-4
 - Two-Point, 3-3
- MOV Surge Suppressor
 - Illustration, 5-30
 - Installation, 5-31
 - Removal, 5-31
- N**
- Nameplate Location, P-3
- Not External Fault Input, Definition, P-11
- O**
- Objective of this Manual, P-1
- Operation, Human Interface Module, 1-12
- Option
 - Identification, P-3
 - L Option Board, 1-3
- P**
- Parameter, Definition, P-11
- Power Module
 - Illustration, 5-9
 - Installation, 5-11
 - Removal, 5-9
 - Test, 4-7
- Power Module Snubber Board
 - Illustration, 3-26
 - Installation, 3-28
 - Removal, 3-27
- Precautions
 - Electrostatic Discharge, P-2
 - Safety, P-1
- Precharge Board
 - Illustration, 3-24
 - Installation, 3-25
 - Removal, 3-24
 - Test, 4-5
- Precharge Board Mounting Plate
 - Illustration, 3-21
 - Installation, 3-22
 - Removal, 3-21
- Press, Definition, P-12
- Procedures
 - Accessing Internal Drive Components, 3-1
 - Bus Capacitor Bank Installation, 5-6
 - Bus Capacitor Bank Removal, 5-4
 - Bus Capacitor Bank Test, 4-10
 - Bus Fuse, 5-25, 5-26
 - Component Test, 4-1
 - Control Board Installation, 3-15
 - Control Board Mounting Plate
 - Installation, 3-13
 - Control Board Removal, 3-14
 - DC Bus Inductor L1 Installation, 5-21
 - DC Bus Inductor L1 Removal, 5-19
 - Drive Enclosure Installation, 3-7
 - Drive Enclosure Removal, 3-6
 - Fan Installation, 5-18
 - Fan Removal, 5-16
 - Gate Driver Board Installation, 3-20
 - Gate Driver Board Removal, 3-19
 - Gate Driver Board Test, 4-3
 - Ground Sense CT, 5-22, 5-24
 - High Voltage Guard Installation, 3-9
 - High Voltage Guard Removal, 3-8
 - Input Rectifier Installation, 5-14
 - Input Rectifier Removal, 5-12
 - Input Rectifier Test, 4-13
 - L Option Board Installation, 3-11
 - L Option Board Removal, 3-10
 - Main Control Board Mounting Plate
 - Removal, 3-12
 - Major Component Replacement, 5-2
 - MOV Surge Suppressor Removal, 5-31
 - Power Module Installation, 5-11
 - Power Module Removal, 5-9
 - Power Module Snubber Board
 - Installation, 3-28
 - Power Module Snubber Board Removal, 3-26
 - Power Module Test, 4-7
 - Precharge Board Installation, 3-25
 - Precharge Board Mounting Plate
 - Installation, 3-22
 - Precharge Board Mounting Plate
 - Removal, 3-21
 - Precharge Board Removal, 3-24
 - Precharge Board Test, 4-5
 - Replacement Part, 5-1
 - Thermistor Installation, 5-8
 - Thermistor Removal, 5-7
- Programming
 - L Option Mode, 1-5
 - Local, 1-5

R

Rating, Drive, P-9
 Related Publications, P-12
 Removal Procedures. *See* Procedures
 Replacement Part Procedures, 5-1
 Replacement Parts, 6-1

S

Safety Precautions, P-1
 Schematics, 7-1
 Six-Point Mounting, 3-4
 Snubber Board, Input Rectifier
 Illustration, 3-29
 Installation, 3-30
 Removal, 3-29
 Snubber Board, Power Module
 Illustration, 3-26
 Installation, 3-28
 Removal, 3-27
 Speed Select, Input State, 1-9

T

Terminal Block Locations, 1-2
 Thermistor
 Illustration, 5-7
 Installation, 5-8
 Removal, 5-7
 Tools, Required for Service, 3-2, 4-2, 5-2
 Torque
 Four-Point Mounting Sequence, 3-4
 Maximum for TB Terminals, 1-6
 Six-Point Mounting Sequence, 3-4
 Specifications, 3-4

Two-Point Mounting Sequence, 3-3
 Troubleshooting, Component Test
 Procedures, 4-1
 Troubleshooting
 Encoderless, 2-20
 Start Up, 2-14, 2-18
 True, Definition, P-12
 Two-Point Mounting, 3-3

W

Warnings, 2-1
 Bus Cycle>5, 2-13
 Bus Drop, 2-13
 Bus Undervolt, 2-13
 External Flt In, 2-8
 Inv Overload, 2-6
 Inv Overtemp Pnd, 2-6
 InvOvld Pend, 2-6
 mA Input, 2-8
 Math Limit, 2-8
 Mtr Stall, 2-5
 MtrOvrd Pend, 2-5
 MtrOvrd Trp, 2-5
 Open Circuit, 2-13
 Param Limit, 2-8
 Prechrg Time, 2-12
 Ridethru Time, 2-12
 SP 1 Timeout, 2-10
 SP 2 Timeout, 2-10
 SP 3 Timeout, 2-10
 SP 4 Timeout, 2-10
 SP 5 Timeout, 2-10
 SP 6 Timeout, 2-10
 SP Error, 2-11
 Spd Fdbk Loss, 2-8
 Viewing Queue with HIM, 2-3
 Wire Sizes, 1-6

1336 IMPACT, ControlNet, and SCANport are trademarks of Rockwell Automation Company, Inc.

PLC is a registered trademark of Rockwell Automation Company, Inc.



Allen-Bradley, a Rockwell Automation Business, has been helping its customers improve productivity and quality for more than 90 years. We design, manufacture and support a broad range of automation products worldwide. They include logic processors, power and motion control devices, operator interfaces, sensors and a variety of software. Rockwell is one of the world's leading technology companies.

Worldwide representation.



Argentina • Australia • Austria • Bahrain • Belgium • Brazil • Bulgaria • Canada • Chile • China, PRC • Colombia • Costa Rica • Croatia • Cyprus • Czech Republic • Denmark • Ecuador • Egypt • El Salvador • Finland • France • Germany • Greece • Guatemala • Honduras • Hong Kong • Hungary • Iceland • India • Indonesia • Ireland • Israel • Italy • Jamaica • Japan • Jordan • Korea • Kuwait • Lebanon • Malaysia • Mexico • Netherlands • New Zealand • Norway • Pakistan • Peru • Philippines • Poland • Portugal • Puerto Rico • Qatar • Romania • Russia-CIS • Saudi Arabia • Singapore • Slovakia • Slovenia • South Africa, Republic • Spain • Sweden • Switzerland • Taiwan • Thailand • Turkey • United Arab Emirates • United Kingdom • United States • Uruguay • Venezuela • Yugoslavia

Allen-Bradley Headquarters, 1201 South Second Street, Milwaukee, WI 53204 USA, Tel: (1) 414 382-2000 Fax: (1) 414 382-4444