



Allen-Bradley

PowerFlex[®] **700H**

Adjustable Frequency AC Drive

High Power

Firmware Versions

xxx.x - 1.002

Programming Manual

**Rockwell
Automation**

Important User Information

Solid state equipment has operational characteristics differing from those of electromechanical equipment. *Safety Guidelines for the Application, Installation and Maintenance of Solid State Controls* (Publication SGI-1.1 available from your local Rockwell Automation sales office or online at <http://www.ab.com/manuals/gi>) describes some important differences between solid state equipment and hard-wired electromechanical devices. Because of this difference, and also because of the wide variety of uses for solid state equipment, all persons responsible for applying this equipment must satisfy themselves that each intended application of this equipment is acceptable.

In no event will Rockwell Automation, Inc. be responsible or liable for indirect or consequential damages resulting from the use or application of this equipment.

The examples and diagrams in this manual are included solely for illustrative purposes. Because of the many variables and requirements associated with any particular installation, Rockwell Automation, Inc. cannot assume responsibility or liability for actual use based on the examples and diagrams.

No patent liability is assumed by Rockwell Automation, Inc. with respect to use of information, circuits, equipment, or software described in this manual.

Reproduction of the contents of this manual, in whole or in part, without written permission of Rockwell Automation, Inc. is prohibited.

Throughout this manual we use notes to make you aware of safety considerations.



WARNING: Identifies information about practices or circumstances that can cause an explosion in a hazardous environment, which may lead to personal injury or death, property damage, or economic loss.

Important: Identifies information that is critical for successful application and understanding of the product.



ATTENTION: Identifies information about practices or circumstances that can lead to personal injury or death, property damage, or economic loss. Attentions help you:

- identify a hazard
 - avoid the hazard
 - recognize the consequences
-



Shock Hazard labels may be located on or inside the drive to alert people that dangerous voltage may be present.



Burn Hazard labels may be located on or inside the drive to alert people that surfaces may be at dangerous temperatures.

Preface	Overview	
	Who Should Use this Manual?	P-1
	What Is Not in this Manual	P-1
	Reference Materials	P-1
	Manual Conventions	P-2
	General Precautions	P-2
Chapter 1	Start Up	
	Prepare For Drive Start-Up	1-1
	Status Indicators	1-2
	Start-Up Routines	1-3
	Running S.M.A.R.T. Start	1-3
	Running an Assisted Start Up	1-4
Chapter 2	Programming and Parameters	
	About Parameters	2-1
	How Parameters are Organized	2-3
	Monitor File	2-6
	Motor Control File	2-7
	Speed Command File	2-10
	Dynamic Control File	2-15
	Utility File	2-19
	Communication File	2-26
	Inputs/Outputs File	2-29
	Parameter Cross Reference – by Name	2-34
	Parameter Cross Reference – by Number	2-36
Chapter 3	Troubleshooting	
	Faults and Alarms	3-1
	Drive Status	3-2
	Manually Clearing Faults	3-3
	Fault & Alarm Descriptions	3-3
	Clearing Alarms	3-8
	Common Symptoms and Corrective Actions	3-9
Appendix A	HIM Overview	
	External and Internal Connections	A-1
	LCD Display Elements	A-2
	ALT Functions	A-2
	Menu Structure	A-3
	Viewing and Editing Parameters	A-5
	Removing/Installing the HIM	A-6

Appendix B

Application Notes

External Brake Resistor..... B-1
Minimum Speed..... B-1
Motor Control Technology B-2
Motor Overload B-3
Overspeed B-5
Power Loss Ride Through..... B-6
Process PI..... B-7
Reverse Speed Limit B-9
Skip Frequency B-10
Sleep Wake Mode B-11
Start At PowerUp..... B-12
Stop Modes B-13
Voltage Tolerance..... B-14

Index

Overview

The purpose of this manual is to provide you with the basic information needed to start-up, program and troubleshoot the PowerFlex 700H Adjustable Frequency AC Drive.

For information on . . .	See page . . .
Who Should Use this Manual?	P-1
What Is Not in this Manual	P-1
Reference Materials	P-1
Manual Conventions	P-2
General Precautions	P-2

Who Should Use this Manual?

This manual is intended for qualified personnel. You must be able to program and operate Adjustable Frequency AC Drive devices. In addition, you must have an understanding of the parameter settings and functions.

What Is Not in this Manual

The *PowerFlex 700H Programming Manual* is designed to provide basic start-up, programming and fault information. For installation information, refer to the *PowerFlex 700H/700S Installation Instructions*. Detailed drive information can be found in the *PowerFlex Reference Manual*.

Reference Materials

The following manuals are recommended for general drive information:

Title	Publication	Available Online at . . .
Industrial Automation Wiring and Grounding Guidelines	1770-4.1	www.ab.com/manuals/gi
Preventive Maintenance of Industrial Control and Drive System Equipment	DRIVES-TD001A-EN-E	www.ab.com/manuals/dr
Safety Guidelines for the Application, Installation and Maintenance of Solid State Control	SGI-1.1	www.ab.com/manuals/gi
A Global Reference Guide for Reading Schematic Diagrams	0100-2.10	www.ab.com/manuals/ms
Guarding Against Electrostatic Damage	8000-4.5.2	www.ab.com/manuals/dr

For detailed PowerFlex 700H information:

Title	Publication	Available . . .
PowerFlex Reference Manual	PFLEX-RM001	on the CD supplied with the drive or at www.ab.com/manuals/dr
PowerFlex 700H/700S Installation Instructions	PFLEX-IN001	on the CD supplied with the drive or at www.ab.com/manuals/dr

For Allen-Bradley Drives Technical Support:

Title	Online at . . .
Allen-Bradley Drives Technical Support	www.ab.com/support/abdrives

Manual Conventions

- In this manual we refer to the PowerFlex 700H Adjustable Frequency AC Drive as; drive, PowerFlex 700H or PowerFlex 700H Drive.
- To help differentiate parameter names and LCD display text from other text, the following conventions will be used:
 - Parameter Names will appear in [brackets].
For example: [DC Bus Voltage].
 - Display Text will appear in “quotes.” For example: “Enabled.”
- The following words are used throughout the manual to describe an action:

Word	Meaning
Can	Possible, able to do something
Cannot	Not possible, not able to do something
May	Permitted, allowed
Must	Unavoidable, you must do this
Shall	Required and necessary
Should	Recommended
Should Not	Not recommended

General Precautions



ATTENTION: This drive contains ESD (Electrostatic Discharge) sensitive parts and assemblies. Static control precautions are required when installing, testing, servicing or repairing this assembly. Component damage may result if ESD control procedures are not followed. If you are not familiar with static control procedures, reference A-B publication 8000-4.5.2, “Guarding Against Electrostatic Damage” or any other applicable ESD protection handbook.



ATTENTION: An incorrectly applied or installed drive can result in component damage or a reduction in product life. Wiring or application errors, such as, undersizing the motor, incorrect or inadequate AC supply, or excessive ambient temperatures may result in malfunction of the system.



ATTENTION: Only qualified personnel familiar with adjustable frequency AC drives and associated machinery should plan or implement the installation, start-up and subsequent maintenance of the system. Failure to comply may result in personal injury and/or equipment damage.



ATTENTION: To avoid an electric shock hazard, verify that the voltage on the bus capacitors has discharged before performing any work on the drive. Measure the DC bus voltage at the +DC & –DC terminals (refer to the Installation Manual for location). The voltage must be zero.



ATTENTION: Risk of injury or equipment damage exists. DPI host products must not be directly connected together via 1202 cables. Unpredictable behavior can result if two or more devices are connected in this manner.



ATTENTION: The “adjust freq” portion of the bus regulator function is extremely useful for preventing nuisance overvoltage faults resulting from aggressive decelerations, overhauling loads, and eccentric loads. It forces the output frequency to be greater than commanded frequency while the drive's bus voltage is increasing towards levels that would otherwise cause a fault. However, it can also cause either of the following two conditions to occur.

1. Fast positive changes in input voltage (more than a 10% increase within 6 minutes) can cause uncommanded positive speed changes. However an “OverSpeed Limit” fault will occur if the speed reaches [Max Speed] + [Overspeed Limit]. If this condition is unacceptable, action should be taken to 1) limit supply voltages within the specification of the drive and, 2) limit fast positive input voltage changes to less than 10%. Without taking such actions, if this operation is unacceptable, the “adjust freq” portion of the bus regulator function must be disabled (see parameters 161 and 162).
2. Actual deceleration times can be longer than commanded deceleration times. However, a “Decel Inhibit” fault is generated if the drive stops decelerating altogether. If this condition is unacceptable, the “adjust freq” portion of the bus regulator must be disabled (see parameters 161 and 162). In addition, installing a properly sized dynamic brake resistor will provide equal or better performance in most cases.

Important: These faults are not instantaneous. Test results have shown that they can take between 2-12 seconds to occur.

Notes

Start Up

This chapter describes how you start up the PowerFlex 700H Drive. Refer to [Appendix A](#) for a brief description of the LCD HIM (Human Interface Module).

For information on . . .	See page . . .
Prepare For Drive Start-Up	1-1
Status Indicators	1-2
Start-Up Routines	1-3
Running S.M.A.R.T. Start	1-3
Running an Assisted Start Up	1-4



ATTENTION: Power must be applied to the drive to perform the following start-up procedure. Some of the voltages present are at incoming line potential. To avoid electric shock hazard or damage to equipment, only qualified service personnel should perform the following procedure. Thoroughly read and understand the procedure before beginning. If an event does not occur while performing this procedure, **Do Not Proceed.**

Remove Power including user supplied control voltages. User supplied voltages may exist even when main AC power is not applied to then drive. Correct the malfunction before continuing.

Prepare For Drive Start-Up Before Applying Power to the Drive

- 1. Confirm that all inputs are connected to the correct terminals and are secure.
- 2. Verify that AC line power at the disconnect device is within the rated value of the drive.
- 3. Verify that control power voltage is correct.

The remainder of this procedure requires that a HIM be installed. If an operator interface is not available, remote devices should be used to start up the drive.

Applying Power to the Drive

- ❑ 4. Apply AC power and control voltages to the drive.

If any of the six digital inputs are configured to “Stop – CF” (CF = Clear Fault) or “Enable,” verify that signals are present or reconfigure [Digital Inx Sel]. If an I/O option is not installed (i.e. no I/O terminal block), verify that [Digital Inx Sel] is not configured to “Stop – CF” or “Enable.” If this is not done, the drive will not start. Refer to [Fault & Alarm Descriptions on page 3-3](#) for a list of potential digital input conflicts. If a fault code appears, refer to [Chapter 3](#).

- ❑ 5. Proceed to Start-Up Routines.

Status Indicators

Figure 1.1 Drive Status Indicators

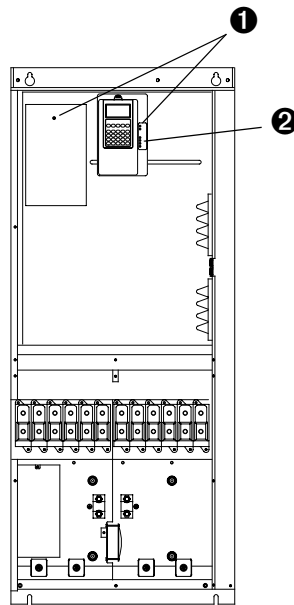

#	Name	Color	State	Description
❶	PWR (Power)	Green	Steady	Illuminates when power is applied to the drive.
❷	PORT	Green	–	Status of DPI port internal communications (if present).
	MOD	Yellow	–	Status of communications module (when installed).
	NET A	Red	–	Status of network (if connected).
	NET B	Red	–	Status of secondary network (if connected).

Start-Up Routines

The PowerFlex 700H is designed so that start up is simple and efficient. If you have an LCD HIM, two start-up methods are provided, allowing the user to select the desired level needed for the application.

- **S.M.A.R.T. Start**

This routine allows you to quickly set up the drive by programming values for the most commonly used functions (see below).

- **Assisted Start Up**

This routine prompts you for information that is needed to start up a drive for most applications, such as line and motor data, commonly adjusted parameters and I/O.

Important Information

Power must be applied to the drive when viewing or changing parameters. Previous programming may affect the drive status and operation when power is applied.

Figure 1.2 PowerFlex 700H Start Up Menu

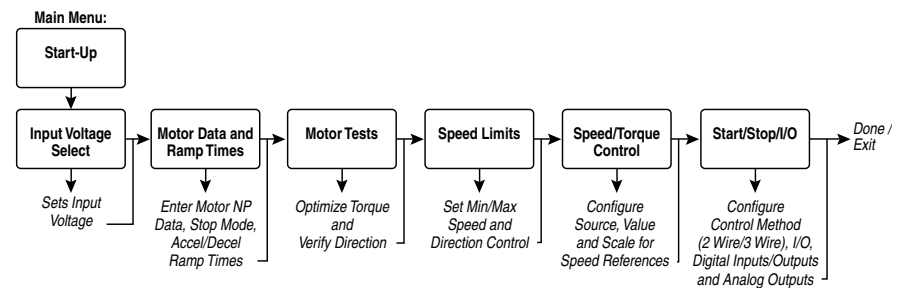

Running S.M.A.R.T. Start

During a Start Up, the majority of applications require changes to only a few parameters. The LCD HIM on a PowerFlex 700H drive offers S.M.A.R.T. start, which displays the most commonly changed parameters. With these parameters, you can set the following functions:

- S - Start Source and Stop Mode
- M - Minimum and Maximum Speed
- A - Accel Time 1 and Decel Time 1
- R - Reference Source
- T - Thermal Motor Overload

To run a S.M.A.R.T. start routine:

<ol style="list-style-type: none"> 1. Press ALT and then Esc (S.M.A.R.T.). The S.M.A.R.T. start screen appears. 2. View and change parameter values as desired. For HIM information, see Appendix A. 3. Press Esc to exit the S.M.A.R.T. start. 		<pre> F-> Stopped Auto ----- ----- ----- SMART List: Digital In2 Sel Stop Mode A Minimum Speed </pre>
--	--	--

Running an Assisted Start Up

Important: This start-up routine requires an LCD HIM.

The Assisted start-up routine asks simple yes or no questions and prompts you to input required information. Access Assisted Start Up by selecting “Start Up” from the Main Menu.

To perform an Assisted Start-Up

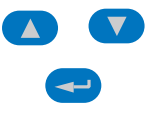
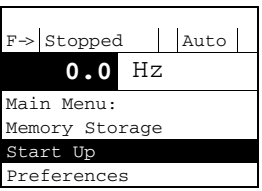
<ol style="list-style-type: none">1. In the Main Menu, press the Up Arrow or Down Arrow to scroll to “Start Up”.2. Press Enter.		
--	--	---

Programming and Parameters

Chapter 2 provides a complete listing and description of the PowerFlex 700H parameters. The parameters can be programmed (viewed/edited) using an LCD HIM (Human Interface Module). As an alternative, programming can also be performed using DriveExplorer™ or DriveExecutive™ software and a personal computer. Refer to the Installation Manual for a brief description of the LCD HIM.

For information on . . .	See page . . .
About Parameters	2-1
How Parameters are Organized	2-3
Monitor File	2-6
Motor Control File	2-7
Speed Command File	2-10
Dynamic Control File	2-15
Utility File	2-19
Communication File	2-26
Inputs/Outputs File	2-29
Parameter Cross Reference – by Name	2-34
Parameter Cross Reference – by Number	2-36

About Parameters

To configure a drive to operate in a specific way, drive parameters may have to be set. Three types of parameters exist:

- **ENUM Parameters**
ENUM parameters allow a selection from a list of items. The LCD HIM will display a text message for each item.
- **Bit Parameters**
Bit parameters have individual bits associated with features or conditions. If the bit is 0, the feature is off or the condition is false. If the bit is 1, the feature is on or the condition is true.
- **Numeric Parameters**
These parameters have a single numerical value (i.e. 0.1 Volts).

The example on the following page shows how each parameter type is presented in this manual.

1	2	3	4	5	6
File	Group	No.	Parameter Name & Description	Values	Related
UTILITY	Drive ...	198	[Load Frm Usr Set] Loads a previously saved set of parameter values from a selected user set location in drive nonvolatile memory to active drive memory.	Default: 0 "Ready" Options: 0 "Ready" 1 "User Set 1" 2 "User Set 2" 3 "User Set 3"	199 7
		216	[Dig In Status] Status of the digital inputs. 	Read Only	361 thru 366
MOTOR ...	Motor Data	044	[Motor NP RPM] Set to the motor nameplate rated RPM.	Default: 1750.0 RPM Min/Max: 60.0/19200.0 RPM Units: 1.0 RPM	

No.	Description																
1	File – Lists the major parameter file category.																
2	Group – Lists the parameter group within a file.																
3	No. – Parameter number. = Parameter value can not be changed until drive is stopped.																
4	Parameter Name & Description – Parameter name as it appears on an LCD HIM, with a brief description of the parameters function.																
5	Values – Defines the various operating characteristics of the parameter. Three types exist. <table border="1"> <tr> <td>ENUM</td> <td>Default:</td> <td>Lists the value assigned at the factory. "Read Only" = no default.</td> </tr> <tr> <td></td> <td>Options:</td> <td>Displays the programming selections available.</td> </tr> <tr> <td>Bit</td> <td>Bit:</td> <td>Lists the bit place holder and definition for each bit.</td> </tr> <tr> <td rowspan="3">Numeric</td> <td>Default:</td> <td>Lists the value assigned at the factory. "Read Only" = no default.</td> </tr> <tr> <td>Min/Max:</td> <td>The range (lowest and highest setting) possible for the parameter.</td> </tr> <tr> <td>Units:</td> <td>Unit of measure and resolution as shown on the LCD HIM.</td> </tr> </table> <p>Important: Some parameters will have two unit values:</p> <ul style="list-style-type: none"> Analog inputs can be set for current or voltage with [Anlg In Config], param. 320. Setting [Speed Units], parameter 79 selects Hz or RPM. <p>Important: When sending values through DPI ports, simply remove the decimal point to arrive at the correct value (i.e. to send "5.00 Hz," use "500").</p>	ENUM	Default:	Lists the value assigned at the factory. "Read Only" = no default.		Options:	Displays the programming selections available.	Bit	Bit:	Lists the bit place holder and definition for each bit.	Numeric	Default:	Lists the value assigned at the factory. "Read Only" = no default.	Min/Max:	The range (lowest and highest setting) possible for the parameter.	Units:	Unit of measure and resolution as shown on the LCD HIM.
ENUM	Default:	Lists the value assigned at the factory. "Read Only" = no default.															
	Options:	Displays the programming selections available.															
Bit	Bit:	Lists the bit place holder and definition for each bit.															
Numeric	Default:	Lists the value assigned at the factory. "Read Only" = no default.															
	Min/Max:	The range (lowest and highest setting) possible for the parameter.															
	Units:	Unit of measure and resolution as shown on the LCD HIM.															
6	Related – Lists parameters (if any) that interact with the selected parameter. The symbol 7 indicates that additional parameter information is available in Appendix B .																

How Parameters are Organized

The LCD HIM displays parameters in a **File-Group-Parameter** or **Numbered List** view order. To switch display mode, access the Main Menu, press ALT, then Sel while cursor is on the parameter selection. In addition, using [\[Param Access Lvl\]](#), the user has the option to display *all* parameters, commonly used parameters or diagnostic parameters.

File-Group-Parameter Order







This simplifies programming by grouping parameters that are used for similar functions. The parameters are organized into 6 files in Basic Parameter view or 7 files in Advanced Parameter view. Each file is divided into groups, and each parameter is an element in a group. By default, the LCD HIM displays parameters by File-Group-Parameter view.

Numbered List View

All parameters are in numerical order.





Basic Parameter View



Parameter 196 [Param Access Lvl] set to option 0 “Basic.”

File	Group	Parameters					
	Metering	Output Freq	001				
		Commanded Speed	002				
		Output Current	003				
		Torque Current	004				
		DC Bus Voltage	012				
	Motor Data	Motor NP Volts	041	Motor NP RPM	044	Motor OL Hertz	047
		Motor NP FLA	042	Motor NP Power	045	Motor Poles	049
		Motor NP Hertz	043	Mtr NP Pwr Units	046		
	Torq Attributes	Motor Cntl Sel	053				
		Maximum Freq	055				
		Autotune	061				
	Spd Mode/Limits	Speed Units	079	Minimum Speed	081	Rev Speed Limit	454
		Feedback Select	080	Maximum Speed	082		
	Speed References	Speed Ref A Sel	090	Speed Ref B Sel	093	TB Man Ref Sel	096
		Speed Ref A Hi	091	Speed Ref B Hi	094	TB Man Ref Hi	097
		Speed Ref A Lo	092	Speed Ref B Lo	095	TB Man Ref Lo	098
	Discrete Speeds	Jog Speed 1	100	Jog Speed 2	108		
		Preset Speed 1-7	101-107				
	Ramp Rates	Accel Time 1	140	Decel Time 1	142	S-Curve %	146
		Accel Time 2	141	Decel Time 2	143		
	Load Limits	Current Lmt Sel	147	Current Lmt Val	148		
	Stop/Brake Modes	Stop/BRK Mode A	155	DC Brake Level	158	Bus Reg Mode B	162
		Stop/BRK Mode B	156	DC Brake Time	159	DB Resistor Type	163
		DC Brk Lvl Sel	157	Bus Reg Mode A	161		
	Restart Modes	Start At PowerUp	168	Auto Rstrt Tries	174	Auto Rstrt Delay	175
	Power Loss	Power Loss Mode	184	Power Loss Time	185	Power Loss Volts	186
		Direction Config	Direction Mode	190			
Drive Memory		Param Access Lvl	196	Load Frm Usr Set	198	Language	201
		Reset To Defaults	197	Save To User Set	199		
Diagnostics		Start Inhibits	214	Dig In Status	216	Dig Out Status	217
Faults		Fault Config 1	238				
Alarms		Alarm Config 1	259				
	Analog Inputs	Anlg In Config	320	Analog In1 Lo	323	Analog In2 Lo	326
		Analog In1 Hi	322	Analog In2 Hi	325		
	Analog Outputs	Analog Out1, 2 Sel	342	Analog Out1, 2 Lo	344	Analog Out2 Hi	346
		Analog Out1 Hi	343	Analog Out1, 2 Sel	345	Analog Out1, 2 Lo	347
	Digital Inputs	Digital In1-6 Sel	361-366				
	Digital Outputs	Digital Out1-3 Sel	380, 384, 388	Dig Out1-3 Level	381, 385, 389		

Advanced Parameter View

Parameter 196 [Param Access Lvl] set to option 1 “Advanced.”

File	Group	Parameters						
	Metering	Output Freq	001	Output Power	007	DC Bus Memory	013	
		Commanded Speed	002	Output Powr Fctr	008	Analog In1 Value	016	
		Output Current	003	Elapsed MWh	009	Analog In2 Value	017	
		Torque Current	004	Elapsed Run Time	010	Ramped Speed	022	
		Flux Current	005	MOP Reference	011	Speed Reference	023	
		Output Voltage	006	DC Bus Voltage	012	Speed Feedback	025	
	Drive Data	Rated kW	026	Rated Amps	028			
		Rated Volts	027	Control SW Ver	029			
		Motor Data	Motor Type	040	Motor NP RPM	044	Motor OL Factor	048
			Motor NP Volts	041	Motor NP Power	045	Motor Poles	049
Motor NP FLA			042	Mtr NP Pwr Units	046			
Motor NP Hertz			043	Motor OL Hertz	047			
Torq Attributes		Motor Cntl Sel	053	SV Boost Filter	059			
		Maximum Freq	055	Autotune	061			
		Flux Up Mode	057	IR Voltage Drop	062			
		Flux Up Time	058	Flux Current Ref	063			
Volts per Hertz		Start/Acc Boost	069	Break Voltage	071	Break Frequency	072	
	Spd Mode/Limits	Speed Units	079	Overspeed Limit	083	Skip Freq Band	087	
		Feedback Select	080	Skip Frequency 1	084	Speed/Torque Mod	088	
		Minimum Speed	081	Skip Frequency 2	085	Rev Speed Limit	454	
		Maximum Speed	082	Skip Frequency 3	086			
	Speed References	Speed Ref A Sel	090	Speed Ref B Hi	094	TB Man Ref Sel	096	
		Speed Ref A Hi	091	Speed Ref B Lo	095	TB Man Ref Hi	097	
		Speed Ref A Lo	092	Speed Ref B Sel	093	TB Man Ref Lo	098	
	Discrete Speeds	Jog Speed 1	100	Preset Speed 1-7	101-107	Jog Speed 2	108	
	Speed Trim	Trim In Select	117	Trim Hi	119			
Trim Out Select		118	Trim Lo	120				
Slip Comp	Slip RPM @ FLA	121	Slip RPM Meter	123				
Process PI	PI Configuration	124	PI Lower Limit	131	PI Output Meter	138		
	PI Control	125	PI Upper Limit	132	PI Reference Hi	460		
	PI Reference Sel	126	PI Preload	133	PI Reference Lo	461		
	PI Setpoint	127	PI Status	134	PI Feedback Hi	462		
	PI Feedback Sel	128	PI Ref Meter	135	PI Feedback Lo	463		
	PI Integral Time	129	PI Fdback Meter	136				
	PI Prop Gain	130	PI Error Meter	137				
	Ramp Rates	Accel Time 1, 2	140,141	Decel Time 1, 2	142,143	S Curve %	146	
	Load Limits	Current Lmt Sel	147	Current Lmt Gain	149	PWM Frequency	151	
		Current Lmt Val	148	Drive OL Mode	150	Droop RPM @ FLA	152	
	Stop/Brake Modes	Stop/BRK Mode A	155	DC Brake Time	159	DB Resistor Type	163	
		Stop/BRK Mode B	156	Bus Reg Ki	160	Bus Reg Kp	164	
		DC Brk Lvl Sel	157	Bus Reg Mode A	161	Bus Reg Kd	165	
		DC Brake Level	158	Bus Reg Mode B	162			
	Restart Modes	Start At PowerUp	168	Sleep-Wake Mode	178	Sleep Level	182	
		Flying Start En	169	Sleep-Wake Ref	179	Sleep Time	183	
		Auto Rstrt Tries	174	Wake Level	180	Powerup Delay	167	
Auto Rstrt Delay		175	Wake Time	181				
Power Loss	Power Loss Mode	184	Power Loss Time	185	Power Loss Volts	186		
	Direction Config	Direction Mode	190					
	HIM Ref Config	Save HIM Ref	192	Man Ref Preload	193			
	MOP Config	Save MOP Ref	194	MOP Rate	195			
	Drive Memory	Param Access Lvl	196	Save To User Set	199	Drive Checksum	203	
		Reset To Defaults	197	Reset Meters	200			
		Load Frm Usr Set	198	Language	201			
	Diagnostics	Drive Status 1, 2	209,210	Dig In Status	216	Fault Amps	225	
		Drive Alarm 1, 2	211,212	Dig Out Status	217	Fault Bus Volts	226	
		Speed Ref Source	213	Drive Temp	218	Status 1,2 @ Fault	227,228	
		Start Inhibits	214	Motor OL Count	220	Alarm 1,2 @ Fault	229,230	
Last Stop Source		215	Fault Frequency	224				
Faults	Fault Config 1	238	Fault Clear Mode	241	Fault 1-8 Code	243-257		
	Fault Clear	240	Power Up Marker	242	Fault 1-8 Time	244-258		
Alarms	Alarm Config 1	259	Alarm Clear	261	Alarm1-8 Code	262-269		

File	Group	Parameters						
Communication 	Comm Control	Drive Logic Rslt	271	Drive Ramp Rslt	273	DPI Port Value	275	
		Drive Ref Rslt	272	DPI Port Sel	274			
	Masks/Owners	Logic Mask	276	Fault Clr Mask	283	Reference Owner	292	
		Start Mask	277	MOP Mask	284	Accel Owner	293	
		Jog Mask	278	Local Mask	285	Decel Owner	294	
		Direction Mask	279	Stop Owner	288	Fault Clr Owner	295	
		Reference Mask	280	Start Owner	289	MOP Owner	296	
		Accel Mask	281	Jog Owner	290	Local Owner	297	
		Decel Mask	282	Direction Owner	291			
	Datalinks	Data In A1-D2	300-307	Data Out A1-D2	310-317			
	Inputs/Outputs 	Analog Inputs	Anlg In Config	320	Analog In1, 2 Hi	322,325	Analog In1, 2 Loss	324,327
			Anlg In Sqr Root	321	Analog In1, 2 Lo	323,326		
		Analog Outputs	Anlg Out Config	340	Analog Out1, 2 Hi	343,346	Anlg Out1,2 Scal	354,355
			Anlg Out Absolut	341	Analog Out1, 2 Lo	344,347	Anlg1,2 Out Setpt	377,378
			Analog Out1, 2 Sel	342,345				
Digital Inputs		Digital In1-6 Sel	361-366					
Digital Outputs		Dig Out Setpt	379	Digital Out2 Sel	384	Digital Out3 Sel	388	
		Digital Out1 Sel	380	Dig Out2 Level	385	Dig Out3 Level	389	
		Dig Out1 Level	381	Dig Out2 OnTime	386	Dig Out3 OnTime	390	
		Dig Out1 OnTime	382	Dig Out2 OffTime	387	Dig Out3 OffTime	391	
		Dig Out1 OffTime	383					

Monitor File

File	Group	No.	Parameter Name & Description	Values	Related
MONITOR	Metering	001	[Output Freq] Output frequency present at U/T1, V/T2 & W/T3.	Default: Read Only Min/Max: -/+ [Maximum Freq] Units: 0.1 Hz	
		002	[Commanded Speed] Value of the active Speed/Frequency Reference. Displayed in Hz or RPM, depending on value of [Speed Units].	Default: Read Only Min/Max: -/+ [Maximum Speed] Units: 0.1 Hz 0.1 RPM	079
		003	[Output Current] The total output current present at U/T1, V/T2 & W/T3.	Default: Read Only Min/Max: 0.0/Drive Rated Amps x 2 Units: 0.1 Amps	
		004	[Torque Current] Based on the motor, the amount of current that is in phase with the fundamental voltage component.	Default: Read Only Min/Max: Drive Rating x -2/+2 Units: 0.1 Amps	
		005	[Flux Current] Amount of current that is out of phase with the fundamental voltage component.	Default: Read Only Min/Max: Drive Rating x -2/+2 Units: 0.1 Amps	
		006	[Output Voltage] Output voltage present at terminals U/T1, V/T2 & W/T3.	Default: Read Only Min/Max: 0.0/Drive Rated Volts Units: 0.1 VAC	
		007	[Output Power] Output power present at U/T1, V/T2 & W/T3.	Default: Read Only Min/Max: 0.0/Drive Rated kW x 2 Units: 0.1 kW	
		008	[Output Powr Fctr] Output power factor.	Default: Read Only Min/Max: 0.00/1.00 Units: 0.01	
		009	[Elapsed MWh] Accumulated output energy of the drive.	Default: Read Only Min/Max: 0.0/429496729.5 MWh Units: 0.1 MWh	
		010	[Elapsed Run Time] Accumulated time drive is outputting power.	Default: Read Only Min/Max: 0.0/214748364.0 Hrs Units: 0.1 Hrs	
		011	[MOP Reference] Value of the signal at MOP (Motor Operated Potentiometer).	Default: Read Only Min/Max: -/+ [Maximum Speed] Units: 0.1 Hz 0.1 RPM	079
		012	[DC Bus Voltage] Present DC bus voltage level.	Default: Read Only Min/Max: 0.0/Based on Drive Rating Units: 0.1 VDC	
		013	[DC Bus Memory] Approximate full load DC bus voltage level.	Default: Read Only Min/Max: 0.0/Based on Drive Rating Units: 0.1 VDC	
		016	[Analog In1 Value]	Default: Read Only	
		017	[Analog In2 Value] Value of the signal at the analog inputs.	Min/Max: 0.000/20.000 mA -/+10.000V Units: 0.001 mA 0.001 Volt	

File	Group	No.	Parameter Name & Description	Values	Related
MONITOR	Metering	022	[Ramped Speed] Value of commanded speed after Accel/Decel, and S-Curve are applied.	Default: Read Only Min/Max: -/+320.0 Hz -/+19200.0 RPM Units: 0.1 Hz 0.1 RPM	079
		023	[Speed Reference] Summed value of ramped speed, process PI and droop.	Default: Read Only Min/Max: -/+320.0 Hz -/+19200.0 RPM Units: 0.1 Hz 0.1 RPM	079
		025	[Speed Feedback] This parameter displays the estimated value of actual motor speed.	Default: Read Only Min/Max: -/+320.0 Hz -/+19200.0 RPM Units: 0.1 Hz 0.1 RPM	
	Drive Data	026	[Rated kW] Drive power rating.	Default: Read Only Min/Max: 0.00/3000.00 kW Units: 0.01 kW	
		027	[Rated Volts] The drive input voltage class (208, 240, 400 etc.).	Default: Read Only Min/Max: 0.0/690.0 VAC Units: 0.1 VAC	
		028	[Rated Amps] The drive rated output current.	Default: Read Only Min/Max: 0.0/6553.5 Amps Units: 0.1 Amps	
		029	[Control SW Ver] Main Control Board software version.	Default: Read Only Min/Max: 0.000/255.255 Units: 0.001	



Motor Control File

File	Group	No.	Parameter Name & Description	Values	Related
MOTOR CONTROL	Motor Data	040	[Motor Type] Set to match the type of motor connected.	Default: 0 "Induction" Options: 0 "Induction"	053
		041	[Motor NP Volts] Set to the motor nameplate rated volts.	Default: Based on Drive Rating Min/Max: 0.0/[Rated Volts] Units: 0.1 VAC	
		042	[Motor NP FLA] Set to the motor nameplate rated full load amps.	Default: Based on Drive Rating Min/Max: 0.0/[Rated Amps] × 2 Units: 0.1 Amps	047 048
		043	[Motor NP Hertz] Set to the motor nameplate rated frequency.	Default: Based on Drive Cat. No. Min/Max: 5.0/320.0 Hz Units: 0.1 Hz	
		044	[Motor NP RPM] Set to the motor nameplate rated RPM.	Default: 1750.0 RPM Min/Max: 60.0/19200.0 RPM Units: 1.0 RPM	
		045	[Motor NP Power] Set to the motor nameplate rated power.	Default: Based on Drive Rating Min/Max: 0.00/5000.00 Units: 0.01 kW/HP See [Mtr NP Pwr Units]	046

File	Group	No.	Parameter Name & Description	Values	Related
MOTOR CONTROL	Motor Data	046	[Mtr NP Pwr Units] <input checked="" type="radio"/> Selects the motor power units to be used. "Convert HP" = converts all power units to Horsepower. "Convert kW" = converts all power units to kilowatts.	Default: Drive Rating Based Options: 0 "Horsepower" 1 "kiloWatts" 2 "Convert HP" 3 "Convert kW"	
		047	[Motor OL Hertz] <input checked="" type="radio"/> Selects the output frequency below which the motor operating current is derated. The motor thermal overload will generate a fault at lower levels of current below this output frequency.	Default: Motor NP Hz/3 Min/Max: 0.0/Motor NP Hz Units: 0.1 Hz	042 220
		048	[Motor OL Factor] <input checked="" type="radio"/> Sets the operating level for the motor overload. $\text{Motor FLA} \times \text{OL Factor} = \text{Operating Level}$	Default: 1.00 Min/Max: 0.20/2.00 Units: 0.01	042 220
		049	[Motor Poles] <input checked="" type="radio"/> Defines the number of poles in the motor.	Default: 4 Min/Max: 2/12 Units: 1 Pole	
	Torq Attributes	053	[Motor Cntl Sel] <input checked="" type="radio"/> Sets the method of motor control used in the drive.	Default: 0 "Sensrls Vect" Options: 0 "Sensrls Vect" 1 "SV Economize" 2 "Custom V/Hz" 3 "Fan/Pmp V/Hz"	
		055	[Maximum Freq] <input checked="" type="radio"/> Sets the highest frequency the drive will output. Refer to parameter 083 [Overspeed Limit].	Default: 60.0 or 70.0 Hz Min/Max: 5.0/320.0 Hz Units: 0.1 Hz	083
		057	[Flux Up Mode] Auto = Flux is established for a calculated time period based on motor nameplate data. [Flux Up Time] is not used. Manual = Flux is established for [Flux Up Time] before acceleration.	Default: 0 "Manual" Options: 0 "Manual" 1 "Automatic"	053 058
		058	[Flux Up Time] Sets the amount of time the drive will use to try and achieve full motor stator flux. When a Start command is issued, DC current at current limit level is used to build stator flux before accelerating.	Default: 0.0 Secs Min/Max: 0.0/5.0 Secs Units: 0.1 Secs	053 058
		059	[SV Boost Filter] Sets the amount of filtering used to boost voltage during Sensorless Vector operation.	Default: 55 Min/Max: 0/32767 Units: 1	

File	Group	No.	Parameter Name & Description	Values	Related	
MOTOR CONTROL	Torq Attributes	061	[Autotune] Provides a manual or automatic method for setting [IR Voltage Drop], [Flux Current Ref] and [Ixo Voltage Drop].	Default: 3 "Calculate" Options: 0 "Ready" 1 "Static Tune" 2 "Rotate Tune" 3 "Calculate"	053 062	
		<p>"Ready" (0) = Parameter returns to this setting following a "Static Tune" or "Rotate Tune." It also permits manually setting [IR Voltage Drop], [Ixo Voltage Drop] and [Flux Current Ref].</p> <p>"Static Tune" (1) = A temporary command that initiates a non-rotational motor stator resistance test for the best possible automatic setting of [IR Voltage Drop], [Break Voltage] and [Break Frequency] in all modes. A start command is required within 20 seconds following initiation of this setting. The parameter returns to "Ready" (0) following the test, at which time another start transition is required to operate the drive in normal mode. Used when motor cannot be rotated.</p> <p>"Rotate Tune" (2) = A temporary command that initiates a "Static Tune" followed by a rotational test for the best possible automatic setting of [Flux Current Ref] and [Start Boost]. A start command is required following initiation of this setting. The parameter returns to "Ready" (0) following the test, at which time another start transition is required to operate the drive in normal mode. Important: Used when motor is uncoupled from the load. Results may not be valid if a load is coupled to the motor during this procedure.</p>				
		<p> ATTENTION: Rotation of the motor in an undesired direction can occur during this procedure. To guard against possible injury and/or equipment damage, it is recommended that the motor be disconnected from the load before proceeding.</p>				
	<p>"Calculate" (3) = This setting uses motor nameplate data to automatically set [IR Voltage Drop], [Flux Current Ref] and [Slip RPM @ FLA].</p>					
			062	[IR Voltage Drop] Value of voltage drop across the resistance of the motor stator at rated motor current.	Default: Based on Drive Rating Min/Max: 0.0/[Motor NP Volts]× 0.50 Units: 0.1 VAC	053 061
			063	[Flux Current Ref] Value of amps for full motor flux.	Default: Based on Drive Rating Min/Max: 0.00/[Motor NP FLA] Units: 0.01 Amps	053 061
			069	[Start Boost] Sets the voltage boost level for starting and acceleration. Refer to parameter 083 [Overspeed Limit].	Default: Based on Drive Rating Min/Max: 0.0/[Motor NP Volts]× 0.25 Units: 0.1 VAC	053
		071	[Break Voltage] Sets the voltage the drive will output at [Break Frequency]. Refer to parameter 083 [Overspeed Limit].	Default: [Motor NP Volts] × 0.25 Min/Max: 0.0/[Motor NP Volts] Units: 0.1 VAC	053 072	
		072	[Break Frequency] Sets the frequency the drive will output at [Break Voltage]. Refer to parameter 083.	Default: [Motor NP Hz] × 0.25 Min/Max: 0.0/[Maximum Freq] Units: 0.1 Hz	053 071	

Speed Command File

File	Group	No.	Parameter Name & Description	Values	Related
SPEED COMMAND	Spd Mode/Limits	079	[Speed Units] <input checked="" type="radio"/> Selects the units to be used for all speed related parameters. Options 0 & 1 indicate status only. Options 2 & 3 will convert/configure the drive for that selection. "Convert Hz" (2) - converts all speed based parameters to Hz, and changes the value proportionately (i.e. 1800 RPM = 60 Hz). "Convert RPM" (3) - converts all speed based parameters to RPM, and changes the value proportionately.	Default: 0 "Hz" Options: 0 "Hz" 1 "RPM" 2 "Convert Hz" 3 "Convert RPM"	
		080	[Feedback Select] <input checked="" type="radio"/> Selects the source for motor speed feedback. "Open Loop" (0) - no encoder is present, and slip compensation is not needed. "Slip Comp" (1) - tight speed control is needed, and encoder is not present.	Default: 0 "Open Loop" Options: 0 "Open Loop" 1 "Slip Comp"	152
		081	[Minimum Speed] <input checked="" type="radio"/> Sets the low limit for speed reference after scaling is applied. Refer to parameter 083 [Overspeed Limit].	Default: 0.0 Min/Max: 0.0/[Maximum Speed] Units: 0.1 Hz 0.1 RPM	079 083 092 095
		082	[Maximum Speed] <input checked="" type="radio"/> Sets the high limit for speed reference after scaling is applied. Refer to parameter 083 [Overspeed Limit].	Default: 50.0 or 60.0 Hz (volt class) [Motor NP RPM] Min/Max: 5.0/320.0 Hz 75.0/19200.0 RPM Units: 0.1 Hz 0.1 RPM	055 079 083 091 094
		083	[Overspeed Limit] <input checked="" type="radio"/> Sets the incremental amount of the output frequency (above [Maximum Speed]) allowable for functions such as slip compensation. [Maximum Speed] + [Overspeed Limit] must be \leq [Maximum Freq]	Default: 10.0 Hz 300.0 RPM Min/Max: 0.0/20.0 Hz 0.0/600.0 RPM Units: 0.1 Hz 0.1 RPM	055 079 082 
		084	[Skip Frequency 1]	Default: 0.0 Hz	087
085	[Skip Frequency 2]	Default: 0.0 Hz			
086	[Skip Frequency 3]	Default: 0.0 Hz			
			Sets a frequency at which the drive will not operate. [Skip Frequency 1-3] and [Skip Frequency Band] must not equal 0.	Min/Max: -/+ [Maximum Speed] Units: 0.1 Hz	

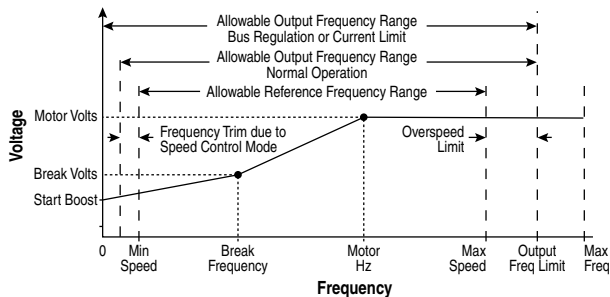



File	Group	No.	Parameter Name & Description	Values	Related	
SPEED COMMAND	Spd Mode/Limits	087	[Skip Freq Band] Determines the bandwidth around a skip frequency. [Skip Freq Band] is split, applying 1/2 above and 1/2 below the actual skip frequency. The same bandwidth applies to all skip frequencies.	Default: 0.0 Hz Min/Max: 0.0/30.0 Hz Units: 0.1 Hz	084 085 086	
		088	<input checked="" type="radio"/> [Speed/Torque Mod] Selects the torque reference source. "Speed Reg" (1) - drive operates as a speed regulator.	Default: 1 "Speed Reg" Options: 1 "Speed Reg"	053	
		454	[Rev Speed Limit] Sets a limit on speed in the negative direction. Used in bipolar mode only. A value of zero disables this parameter and uses [Min Speed] for minimum speed.	Default: 0.0 RPM Min/Max: -[Max Speed]/0.0 Hz -[Max Speed]/0.0 RPM Units: 0.0 Hz 0.0 RPM		
	Speed References	<input checked="" type="radio"/>	090	[Speed Ref A Sel] Selects the source of the speed reference to the drive unless [Speed Ref B Sel] or [Preset Speed 1-7] is selected. (1) See Installation Manual for DPI port locations.	Default: 2 "Analog In 2" Options: 1 "Analog In 1" 2 "Analog In 2" 3-8 "Reserved" 9 "MOP Level" 10 "Reserved" 11 "Preset Spd1" 12 "Preset Spd2" 13 "Preset Spd3" 14 "Preset Spd4" 15 "Preset Spd5" 16 "Preset Spd6" 17 "Preset Spd7" 18 "DPI Port 1" ⁽¹⁾ 19 "DPI Port 2" ⁽¹⁾ 20 "DPI Port 3" ⁽¹⁾ 21 "DPI Port 4" ⁽¹⁾ 22 "DPI Port 5" ⁽¹⁾	002 091 thru 093 101 thru 107 117 thru 120 192 thru 194 213 272 273 320 361 thru 366
			091	[Speed Ref A Hi] Scales the upper value of the [Speed Ref A Sel] selection when the source is an analog input.	Default: [Maximum Speed] Min/Max: -/+ [Maximum Speed] Units: 0.1 Hz 0.01 RPM	079 082
			092	[Speed Ref A Lo] Scales the lower value of the [Speed Ref A Sel] selection when the source is an analog input.	Default: 0.0 Min/Max: -/+ [Maximum Speed] Units: 0.1 Hz 0.01 RPM	079 081
			093	[Speed Ref B Sel] <input checked="" type="radio"/> See [Speed Ref A Sel] .	Default: 11 "Preset Spd1" Options: See [Speed Ref A Sel]	090
			094	[Speed Ref B Hi] Scales the upper value of the [Speed Ref B Sel] selection when the source is an analog input.	Default: [Maximum Speed] Min/Max: -/+ [Maximum Speed] Units: 0.1 Hz 0.01 RPM	079 093
			095	[Speed Ref B Lo] Scales the lower value of the [Speed Ref B Sel] selection when the source is an analog input.	Default: 0.0 Min/Max: -/+ [Maximum Speed] Units: 0.1 Hz 0.01 RPM	079 090 093

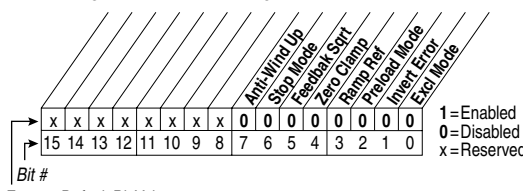

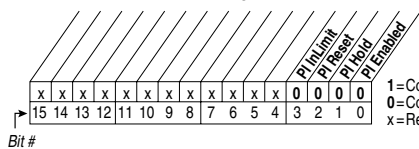

File	Group	No.	Parameter Name & Description	Values	Related
SPEED COMMAND	Speed References	096	[TB Man Ref Sel] Sets the manual speed reference source when a digital input is configured for "Auto/Manual." (1) "Analog In 2" is not a valid selection if it was selected for any of the following: - [Trim In Select] - [PI Feedback Sel] - [PI Reference Sel] - [Current Lmt Sel] - [Sleep-Wake Ref]	Default: 1 "Analog In 1" Options: 1 "Analog In 1" 2 "Analog In 2" ⁽¹⁾ 3-8 "Reserved" 9 "MOP Level"	097 098
		097	[TB Man Ref Hi] Scales the upper value of the [TB Man Ref Sel] selection when the source is an analog input.	Default: [Maximum Speed] Min/Max: -/[Maximum Speed] Units: 0.1 Hz 0.01 RPM	079 096
		098	[TB Man Ref Lo] Scales the lower value of the [TB Man Ref Sel] selection when the source is an analog input.	Default: 0.0 Min/Max: -/[Maximum Speed] Units: 0.1 Hz 0.01 RPM	079 096
	Discrete Speeds	100	[Jog Speed 1] Sets the output frequency when Jog Speed 1 is selected.	Default: 10.0 Hz 300.0 RPM Min/Max: -/[Maximum Speed] Units: 0.1 Hz 1 RPM	079
		101	[Preset Speed 1]	Default: 5.0 Hz/150 RPM	079
		102	[Preset Speed 2]	10.0 Hz/300 RPM	090
		103	[Preset Speed 3]	20.0 Hz/600 RPM	093
		104	[Preset Speed 4]	30.0 Hz/900 RPM	
		105	[Preset Speed 5]	40.0 Hz/1200 RPM	
		106	[Preset Speed 6]	50.0 Hz/1500 RPM	
107	[Preset Speed 7]	60.0 Hz/1800 RPM			
Speed Trim	108	[Jog Speed 2] Sets the output frequency when Jog Speed 2 is selected.	Default: 10.0 Hz 300.0 RPM Min/Max: -/[Maximum Speed] Units: 0.1 Hz 1 RPM		
	117	[Trim In Select] Specifies which analog input signal is being used as a trim input.	Default: 2 "Analog In 2" Options: See [Speed Ref A Sel]	090 093	
	118	[Trim Out Select] Specifies which speed references are to be trimmed.		1 = Trimmed/% 0 = Not Trimmed/Add x = Reserved	117 119 120
	* Vector firmware 3.001 & later. Factory Default Bit Values				





File	Group	No.	Parameter Name & Description	Values	Related	
SPEED COMMAND	Speed Trim	119	[Trim Hi] Scales the upper value of the [Trim In Select] selection when the source is an analog input.	Default: 60.0 Hz Min/Max: -/[Maximum Speed] Units: 0.1 Hz 1 RPM	079 082 117	
		120	[Trim Lo] Scales the lower value of the [Trim In Select] selection when the source is an analog input.	Default: 0.0 Hz Min/Max: -/[Maximum Speed] Units: 0.1 Hz 1 RPM	079 117	
	Slip Comp	Important: Parameters in the Slip Comp Group are used to enable and tune the Slip Compensation Regulator. In order to allow the Slip Compensation Regulator to control drive operation, parameter 080 [Feedback Select] must be set to 1 "Slip Comp".				
		121	[Slip RPM @ FLA] Sets the amount of compensation to drive output at motor FLA.	Default: Based on [Motor NP RPM] Min/Max: 0.0/1200.0 RPM Units: 0.1 RPM	061 080 123	
		123	[Slip RPM Meter] Displays the present amount of adjustment being applied as slip compensation.	Default: Read Only Min/Max: -/+300.0 RPM Units: 0.1 RPM	080 121	
	Process PI	124	[PI Configuration]  Sets configuration of the PI regulator.		124 thru 138	
		125	[PI Control] Controls the PI regulator.		080	
		126	[PI Reference Sel] Selects the source of the PI reference.	Default: 0 "PI Setpoint" Options: 0 "PI Setpoint" 1 "Analog In 1" 2 "Analog In 2" 3-8 "Reserved" 9 "MOP Level" 10 "Master Ref" 11-17 "Preset Spd1-7" 18-22 "DPI Port 1-5"	124 thru 138	
		127	[PI Setpoint] Provides an internal fixed value for process setpoint when [PI Reference Sel] is set to "PI Setpoint."	Default: 50.0% Min/Max: -/+100.0% of Maximum Process Value Units: 0.1%	124 thru 138	
		128	[PI Feedback Sel] Selects the source of the PI feedback.	Default: 2 "Analog In 2" Options: See [PI Reference Sel] .	124 thru 138	





File	Group	No.	Parameter Name & Description	Values	Related
SPEED COMMAND	Process PI	129	[PI Integral Time] Time required for the integral component to reach 100% of [PI Error Meter]. Not functional when the PI Hold bit of [PI Control] = "1" (enabled).	Default: 2.0 Secs Min/Max: 0.00/100.00 Secs Units: 0.01 Secs	124 thru 138
		130	[PI Prop Gain] Sets the value for the PI proportional component. PI Error x PI Prop Gain = PI Output	Default: 1.0 Min/Max: 0.00/100.00 Units: 0.01	124 thru 138
		131	[PI Lower Limit] Sets the lower limit of the PI output.	Default: -[Maximum Freq] 100% Min/Max: -/+800.0% Units: 0.1%	079 124 thru 138
		132	[PI Upper Limit] Sets the upper limit of the PI output.	Default: +[Maximum Freq] 100% Min/Max: -/+800.0% Units: 0.1%	079 124 thru 138
		133	[PI Preload] Sets the value used to preload the integral component on start or enable.	Default: 0.0 Hz 100% Min/Max: -/+800.0% Units: 0.1%	079 124 thru 138
		134	[PI Status] Status of the Process PI regulator.  Legend: 1=Condition True, 0=Condition False, x=Reserved	Read Only	124 thru 138
		135	[PI Ref Meter] Present value of the PI reference signal.	Default: Read Only Min/Max: -/+100.0% Units: 0.1%	124 thru 138
		136	[PI Fdback Meter] Present value of the PI feedback signal.	Default: Read Only Min/Max: -/+100.0% Units: 0.1%	124 thru 138
		137	[PI Error Meter] Present value of the PI error.	Default: Read Only Min/Max: -/+100.0% Units: 0.1%	124 thru 138
		138	[PI Output Meter] Present value of the PI output.	Default: Read Only Min/Max: -/+100.0 Hz -/+100.0% Units: 0.1 Hz 0.1%	124 thru 138
		460	[PI Reference Hi] Scales the upper value of [PI Reference Sel] of the source.	Default: 100.0% Min/Max: -/+100.0% Units: 0.1%	
		461	[PI Reference Lo] Scales the lower value of [PI Reference Sel] of the source.	Default: -100.0% Min/Max: -/+100.0% Units: 0.1%	
		462	[PI Feedback Hi] Scales the upper value of [PI Feedback] of the source.	Default: 100.0% Min/Max: -/+100.0% Units: 0.1%	
		463	[PI Feedback Lo] Scales the lower value of [PI Feedback] of the source.	Default: 0.0% Min/Max: -/+100.0% Units: 0.1%	



Dynamic Control File

File	Group	No.	Parameter Name & Description	Values	Related	
DYNAMIC CONTROL	Ramp Rates	140	[Accel Time 1]	Default: 10.0 Secs	142	
		141	[Accel Time 2]	10.0 Secs	143	
			Sets rate of accel for all speed increases. $\frac{\text{Max Speed}}{\text{Accel Time}} = \text{Accel Rate}$	Min/Max: 0.1/3276.7 Secs Units: 0.1 Secs	146 361 thru 366	
			142	[Decel Time 1]	Default: 10.0 Secs	140
			143	[Decel Time 2]	10.0 Secs	141
				Sets rate of decel for all speed decreases. $\frac{\text{Max Speed}}{\text{Decel Time}} = \text{Decel Rate}$	Min/Max: 0.1/3276.7 Secs Units: 0.1 Secs	146 361 thru 366
			146	[S Curve %]	Default: 0% Min/Max: 0/100% Units: 1%	140 thru 143
			147	[Current Lmt Sel] 	Default: 0 "Cur Lim Val" Options: 0 "Cur Lim Val" 1 "Analog In 1" 2 "Analog In 2"	146 149
			148	[Current Lmt Val] Defines the current limit value when [Current Lmt Sel] = "Cur Lim Val."	Default: [Rated Amps] × 1.5 (Equation yields approximate default value.) Min/Max: Based on Drive Rating Units: 0.1 Amps	147 149
			149	[Current Lmt Gain] Sets the responsiveness of the current limit.	Default: 1000 Min/Max: 0/32767 Units: 1	147 148
		Load Limits	150	[Drive OL Mode] Selects drive response to increasing drive temperature.	Default: 3 "Both-PWM 1st" Options: 0 "Reserved" 1 "Reduce Clim" 2 "Reserved" 3 "Both-PWM 1st"	
			151	[PWM Frequency] Sets the carrier frequency for the PWM output. Drive derating may occur at higher carrier frequencies.	Default: 2 kHz Min/Max: 1/Based on Drive Rating Units: 1 kHz	
			152	[Droop RPM @ FLA] Selects amount of droop that the speed reference is reduced when at full load torque. Zero disables the droop function. Important: Selecting "Slip Comp" with param. 080 in conjunction with parameter 152, may produce undesirable results.	Default: 0.0 RPM Min/Max: 0.0/200.0 RPM Units: 0.1 RPM	
		Stop/Brake Modes	155	[Stop/Brk Mode A]	Default: 1 "Ramp"	157
			156	[Stop/Brk Mode B] Active stop mode. [Stop Mode A] is active unless [Stop Mode B] is selected by inputs. ⁽¹⁾ When using options 1 or 2, refer to the Attention statements at [DC Brake Level].	Default: 0 "Coast" Options: 0 "Coast" 1 "Ramp" ⁽¹⁾ 2 "Ramp to Hold" ⁽¹⁾ 3 "DC Brake"	158 159 
		157	[DC Brake Lvl Sel] Selects the source for [DC Brake Level].	Default: 0 "DC Brake Lvl" Options: 0 "DC Brake Lvl" 1 "Analog In 1" 2 "Analog In 2"	155 156 158 159	

File	Group	No.	Parameter Name & Description	Values	Related
DYNAMIC CONTROL	Stop/Brake Modes	158	<p>[DC Brake Level]</p> <p>Defines the DC brake current level injected into the motor when "DC Brake" is selected as a stop mode.</p> <p>The DC braking voltage used in this function is created by a PWM algorithm and may not generate the smooth holding force needed for some applications.</p> <hr/> <p> ATTENTION: If a hazard of injury due to movement of equipment or material exists, an auxiliary mechanical braking device must be used.</p> <p>ATTENTION: This feature should not be used with synchronous or permanent magnet motors. Motors may be demagnetized during braking.</p>	Default: [Rated Amps] Min/Max: 0/[Rated Amps] Units: 0.1 Amps	
		159	<p>[DC Brake Time]</p> <p>Sets the amount of time DC brake current is "injected" into the motor.</p>	Default: 0.0 Secs Min/Max: 0.0/90.0 Secs Units: 0.1 Secs	155 thru 158 
		160	<p>[Bus Reg Ki]</p> <p>Sets the responsiveness of the bus regulator.</p>	Default: 30 Min/Max: 0/5000 Units: 1	161 162
		161 162	<p>[Bus Reg Mode A] [Bus Reg Mode B]</p> <p> Sets the method and sequence of the DC bus voltage regulator. Choices are dynamic brake, frequency adjust or both. Options 2 & 3 only appear when a dynamic brake is installed in the drive.</p> <p>Dynamic Brake Setup If a dynamic brake resistor is connected to the drive, both of these parameters must be set to either option 2 or 3.</p> <p>Refer to the Attention statement on page P-3 for important information on bus regulation.</p> <hr/> <p> ATTENTION: The drive does not offer protection for externally mounted brake resistors. A risk of fire exists if external braking resistors are not protected. External resistor packages must be self-protected from over temperature or the protective circuit shown in Figure B.2 on page B-6 (or equivalent) must be supplied.</p>	Default: 1 "Adjust Freq" 0 "Disabled" Options: 0 "Disabled" 1 "Adjust Freq" 2 "Dynamic Brak" 3 "Both-DB 1st"	160 163 
		163	<p>[DB Resistor Type]</p> <p>Selects whether an external DB resistor will be used.</p>	Default: 0 "None" Options: 0 "None" 1 "External Res"	161 162
		164	<p>[Bus Reg Kp]</p> <p>Proportional gain for the bus regulator. Used to adjust regulator response.</p>	Default: 610 Min/Max: 0/10000 Units: 1	
		165	<p>[Bus Reg Kd]</p> <p>Derivative gain for the bus regulator. Used to control regulator overshoot.</p>	Default: 4000 Min/Max: 0/10000 Units: 1	



File	Group	No.	Parameter Name & Description	Values	Related	
DYNAMIC CONTROL	Restart Modes	167	[Powerup Delay] Defines the programmed delay time, in seconds, before a start command is accepted after a power up.	Default: 0.0 Secs Min/Max: 0.0/30.0 Secs Units: 0.1 Secs		
		168	[Start At PowerUp] Enables/disables a feature to issue a Start or Run command and automatically resume running at commanded speed after drive input power is restored. Requires a digital input configured for Run or Start and a valid start contact.	Default: 0 "Disabled" Options: 0 "Disabled" 1 "Enabled"		
		 ATTENTION: Equipment damage and/or personal injury may result if this parameter is used in an inappropriate application. Do not use this function without considering applicable local, national and international codes, standards, regulations or industry guidelines.				
		169	[Flying Start En] Enables/disables the function which reconnects to a spinning motor at actual RPM when a start command is issued.	Default: 0 "Disabled" Options: 0 "Disabled" 1 "Enabled"		
		174	[Auto Rstrt Tries] Sets the maximum number of times the drive attempts to reset a fault and restart.	Default: 0 Min/Max: 0/9 Units: 1		175
 ATTENTION: Equipment damage and/or personal injury may result if this parameter is used in an inappropriate application. Do not use this function without considering applicable local, national and international codes, standards, regulations or industry guidelines.						
		175	[Auto Rstrt Delay] Sets the time between restart attempts when [Auto Rstrt Tries] is set to a value other than zero.	Default: 1.0 Secs Min/Max: 0.5/30.0 Secs Units: 0.1 Secs	174	

File	Group	No.	Parameter Name & Description	Values	Related																										
DYNAMIC CONTROL	Restart Modes	178	<p>[Sleep-Wake Mode]</p> <p> Enables/disables the Sleep/Wake function. Important: When enabled, the following conditions must be met:</p> <ul style="list-style-type: none"> • A proper minimum value must be programmed for [Sleep Level]. • A speed reference must be selected in [Speed Ref A Sel]. • At least one of the following must be programmed (and input closed) in [Digital Inx Sel]; "Enable," "Stop=CF," "Run," "Run Forward," "Run Reverse." 	<p>Default: 0 "Disabled"</p> <p>Options: 0 "Disabled" 1 "Direct" (Enabled)</p>	168																										
		<p> ATTENTION: Enabling the Sleep-Wake function can cause unexpected machine operation during the Wake mode. Equipment damage and/or personal injury can result if this parameter is used in an inappropriate application. Do Not use this function without considering the table below and applicable local, national & international codes, standards, regulations or industry guidelines.</p>																													
		<p>Conditions Required to Start Drive ⁽¹⁾⁽²⁾⁽³⁾</p> <table border="1"> <thead> <tr> <th>Input</th> <th>After Power-Up</th> <th>After a Drive Fault</th> <th colspan="2">After a Stop Command</th> </tr> <tr> <td></td> <td></td> <td><i>Reset by Stop-CF, HIM or TB</i></td> <td><i>Reset by Clear Faults (TB)</i></td> <td><i>HIM or TB</i></td> </tr> </thead> <tbody> <tr> <td>Stop</td> <td>Stop Closed Wake Signal</td> <td>Stop Closed Wake Signal New Start or Run Cmd.⁽⁴⁾</td> <td>Stop Closed Wake Signal</td> <td>Stop Closed Analog Sig. > Sleep Level⁽⁶⁾ New Start or Run Cmd.⁽⁴⁾</td> </tr> <tr> <td>Enable</td> <td>Enable Closed Wake Signal⁽⁴⁾</td> <td>Enable Closed Wake Signal New Start or Run Cmd.⁽⁴⁾</td> <td>Enable Closed Wake Signal</td> <td>Enable Closed Analog Sig. > Sleep Level⁽⁶⁾ New Start or Run Cmd.⁽⁴⁾</td> </tr> <tr> <td>Run Run For. Run Rev.</td> <td>Run Closed Wake Signal</td> <td>New Run Cmd.⁽⁵⁾ Wake Signal</td> <td>Run Closed Wake Signal</td> <td>New Run Cmd.⁽⁵⁾ Wake Signal</td> </tr> </tbody> </table>					Input	After Power-Up	After a Drive Fault	After a Stop Command				<i>Reset by Stop-CF, HIM or TB</i>	<i>Reset by Clear Faults (TB)</i>	<i>HIM or TB</i>	Stop	Stop Closed Wake Signal	Stop Closed Wake Signal New Start or Run Cmd. ⁽⁴⁾	Stop Closed Wake Signal	Stop Closed Analog Sig. > Sleep Level ⁽⁶⁾ New Start or Run Cmd. ⁽⁴⁾	Enable	Enable Closed Wake Signal ⁽⁴⁾	Enable Closed Wake Signal New Start or Run Cmd. ⁽⁴⁾	Enable Closed Wake Signal	Enable Closed Analog Sig. > Sleep Level ⁽⁶⁾ New Start or Run Cmd. ⁽⁴⁾	Run Run For. Run Rev.	Run Closed Wake Signal	New Run Cmd. ⁽⁵⁾ Wake Signal	Run Closed Wake Signal	New Run Cmd. ⁽⁵⁾ Wake Signal
		Input	After Power-Up	After a Drive Fault	After a Stop Command																										
				<i>Reset by Stop-CF, HIM or TB</i>	<i>Reset by Clear Faults (TB)</i>	<i>HIM or TB</i>																									
Stop	Stop Closed Wake Signal	Stop Closed Wake Signal New Start or Run Cmd. ⁽⁴⁾	Stop Closed Wake Signal	Stop Closed Analog Sig. > Sleep Level ⁽⁶⁾ New Start or Run Cmd. ⁽⁴⁾																											
Enable	Enable Closed Wake Signal ⁽⁴⁾	Enable Closed Wake Signal New Start or Run Cmd. ⁽⁴⁾	Enable Closed Wake Signal	Enable Closed Analog Sig. > Sleep Level ⁽⁶⁾ New Start or Run Cmd. ⁽⁴⁾																											
Run Run For. Run Rev.	Run Closed Wake Signal	New Run Cmd. ⁽⁵⁾ Wake Signal	Run Closed Wake Signal	New Run Cmd. ⁽⁵⁾ Wake Signal																											
<p>(1) When power is cycled, if all conditions are present after power is restored, restart will occur.</p> <p>(2) The drive only starts <u>after</u> Sleep-Wake Mode is "enabled" and a valid signal is received.</p> <p>(3) The active speed reference is determined as explained in "Reference Control" in the Installation Manual. The Sleep/Wake function and the speed reference may be assigned to the same input.</p> <p>(4) Command must be issued from HIM, TB or network.</p> <p>(5) Run Command must be cycled.</p> <p>(6) Signal does not need to be greater than wake level.</p>																															
		179	<p>[Sleep-Wake Ref]</p> <p> Selects the source of the input controlling the Sleep-Wake function.</p>	<p>Default: 2 "Analog In 2"</p> <p>Options: 1 "Analog In 1" 2 "Analog In 2" 3-6 "Reserved"</p>																											
		180	<p>[Wake Level]</p> <p> Defines the analog input level that will start the drive.</p>	<p>Default: 6.000 mA, 6.000 Volts</p> <p>Min/Max: [Sleep Level]/20.000 mA 10.000 Volts</p> <p>Units: 0.001 mA 0.001 Volts</p>	181																										
		181	<p>[Wake Time]</p> <p>Defines the amount of time at or above [Wake Level] before a Start is issued.</p>	<p>Default: 0.0 Secs</p> <p>Min/Max: 0.0/1000.0 Secs</p> <p>Units: 0.1 Secs</p>	180																										
		182	<p>[Sleep Level]</p> <p> Defines the analog input level that will stop the drive.</p>	<p>Default: 5.000 mA, 5.000 Volts</p> <p>Min/Max: 4.000 mA/[Wake Level] 0.000 Volts/[Wake Level]</p> <p>Units: 0.001 mA 0.001 Volts</p>	183																										

File Group	No.	Parameter Name & Description	Values	Related
DYNAMIC CONTROL	Restart Modes	183	[Sleep Time] Defines the amount of time at or below [Sleep Level] before a Stop is issued.	Default: 0.0 Secs Min/Max: 0.0/1000.0 Secs Units: 0.1 Secs 182
	Power Loss	184	[Power Loss Mode] Sets the reaction to a loss of input power. Power loss is recognized when: <ul style="list-style-type: none"> DC bus voltage is $\leq 73\%$ of [DC Bus Memory] and [Power Loss Mode] is set to "Coast". DC bus voltage is $\leq 82\%$ of [DC Bus Memory] and [Power Loss Mode] is set to "Decel". 	Default: 0 "Coast" Options: 0 "Coast" 1 "Decel" 2 "Continue" 013 185
		185	[Power Loss Time] Sets the time that the drive will remain in power loss mode before a fault is issued.	Default: 0.5 Secs Min/Max: 0.0/60.0 Secs Units: 0.1 Secs 184
		186	[Power Loss Volts] Sets the level at which the [Power Loss Mode] selection will occur. The drive can use the percentages referenced in [Power Loss Mode] or a trigger point can be set at [Power Loss Volts]. A digital input (programmed to "29, Pwr Loss Lvl") is used to toggle between fixed percentages and the [Power Loss Volts] level.  ATTENTION: Drive damage can occur if proper input impedance is not provided as explained below. If the value for [Power Loss Volts] is less than 82% of the nominal DC bus voltage, the user must provide a minimum line impedance to limit inrush current when the power line recovers. The input impedance should be equal to or greater than the equivalent of a 5% transformer with a VA rating 5 times the drives input VA rating.	Default: Based on Drive Rated Volts Min/Max: 170.0/780.0 VDC Units: 0.1 VDC 

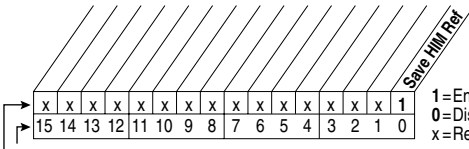
Utility File

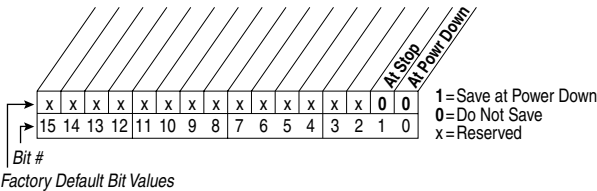
File Group	No.	Parameter Name & Description	Values	Related								
UTILITY	Direction Config	190	[Direction Mode] Selects the method for changing drive direction. <table border="1"> <tr> <th>Mode</th> <th>Direction Change</th> </tr> <tr> <td>Unipolar</td> <td>Drive Logic</td> </tr> <tr> <td>Bipolar</td> <td>Sign of Reference</td> </tr> <tr> <td>Reverse Dis</td> <td>Not Changeable</td> </tr> </table>	Mode	Direction Change	Unipolar	Drive Logic	Bipolar	Sign of Reference	Reverse Dis	Not Changeable	Default: 0 "Unipolar" Options: 0 "Unipolar" 1 "Bipolar" 2 "Reverse Dis" 320 thru 327 361 thru 366
	Mode	Direction Change										
Unipolar	Drive Logic											
Bipolar	Sign of Reference											
Reverse Dis	Not Changeable											
HIM Ref Config	192	[Save HIM Ref] Enables a feature to save the present frequency reference value issued by the HIM to Drive memory on power loss. Value is restored to the HIM on power up.  <p>Bit # Factory Default Bit Values</p> <p>1 = Enabled 0 = Disabled x = Reserved</p>										

File	Group	No.	Parameter Name & Description	Values	Related		
UTILITY	HIM Ref Config	193	[Man Ref Preload] Enables/disables a feature to automatically load the present "Auto" frequency reference value into the HIM when "Manual" is selected. Allows smooth speed transition from "Auto" to "Manual."	Default: 0 "Disabled" Options: 0 "Disabled" 1 "Enabled"			
		194	[Save MOP Ref] Enables/disables the feature that saves the present MOP frequency reference at power down or at stop. 				
	MOP Config	195	[MOP Rate] Sets rate of change of the MOP reference in response to a digital input.	Default: 1.0 Hz/s 30.0 RPM/s Min/Max: 0.2/[Maximum Speed] 6.0/[Maximum Speed] Units: 0.1 Hz/s 0.1 RPM/s			
		196	[Param Access Lvl] Selects the parameter display level. Basic = Reduced param. set Advanced = Full param. set	Default: 0 "Basic" Options: 0 "Basic" 1 "Advanced" 2 "Reserved"			
		197	[Reset To Defaults]  Resets parameters to factory defaults except [Language] & [Param Access Lvl] (params 196 & 201). Important: The drive will reset after a reset to defaults.	Default: 0 "Ready" Options: 0 "Ready" 1 "Factory" 2 "Low Voltage" 3 "High Voltage"	041 thru 047 055 062 063 069 thru 072 082 148 158		
		198	[Load Frm Usr Set]  Loads a previously saved set of parameter values from a selected user set location in drive nonvolatile memory to active drive memory.	Default: 0 "Ready" Options: 0 "Ready" 1 "User Set 1" 2 "User Set 2" 3 "User Set 3"	199		
		199	[Save To User Set] Saves the parameter values in active drive memory to a user set in drive nonvolatile memory.	Default: 0 "Ready" Options: 0 "Ready" 1 "User Set 1" 2 "User Set 2" 3 "User Set 3"	198		
		200	[Reset Meters] Resets selected meters to zero.	Default: 0 "Ready" Options: 0 "Ready" 1 "MWh" 2 "Elapsed Time"			
		Drive Memory					

File	Group	No.	Parameter Name & Description	Values	Related																																																																																																																																																															
UTILITY	Drive Memory	201	[Language] Selects the display language when using an LCD HIM. This parameter is not functional with an LED HIM. Options 6, 8 and 9 are "Reserved."	Default: 0 "Not Selected" Options: 0 "Not Selected" 1 "English" 2 "Français" 3 "Español" 4 "Italiano" 5 "Deutsch" 7 "Português" 10 "Nederlands"																																																																																																																																																																
		202	[Voltage Class] Displays the last "Reset to Defaults" operation.	Default: Read Only Options: 0 "Low Voltage" 1 "High Voltage"																																																																																																																																																																
		203	[Drive Checksum] Provides a checksum value that indicates whether or not a change in drive programming has occurred.	Default: Read Only Min/Max: 0/65535 Units: 1																																																																																																																																																																
UTILITY	Diagnostics	209	[Drive Status 1] Present operating condition of the drive.	Read Only	210																																																																																																																																																															
		<p>Bit #</p> <table border="1"> <tr> <td>15</td><td>14</td><td>13</td><td>12</td><td>11</td><td>10</td><td>9</td><td>8</td><td>7</td><td>6</td><td>5</td><td>4</td><td>3</td><td>2</td><td>1</td><td>0</td> </tr> <tr> <td>0</td><td>0</td><td>0</td><td>0</td><td>1</td><td>1</td><td>1</td><td>0</td><td>0</td><td>0</td><td>0</td><td>0</td><td>1</td><td>1</td><td>0</td><td>0</td> </tr> </table> <p>1=Condition True 0=Condition False x=Reserved</p>			15	14	13	12	11	10	9	8	7	6	5	4	3	2	1	0	0	0	0	0	1	1	1	0	0	0	0	0	1	1	0	0																																																																																																																																
		15	14	13	12	11	10	9	8	7	6	5	4	3	2	1	0																																																																																																																																																			
0	0	0	0	1	1	1	0	0	0	0	0	1	1	0	0																																																																																																																																																					
<table border="1"> <thead> <tr> <th colspan="4">Bits⁽²⁾</th> <th>Description</th> <th colspan="3">Bits⁽¹⁾</th> <th>Description</th> </tr> <tr> <th>15</th><th>14</th><th>13</th><th>12</th> <th></th> <th>11</th><th>10</th><th>9</th> <th></th> </tr> </thead> <tbody> <tr><td>0</td><td>0</td><td>0</td><td>0</td><td>Ref A Auto</td><td>0</td><td>0</td><td>0</td><td>Port 0 (TB)</td></tr> <tr><td>0</td><td>0</td><td>0</td><td>1</td><td>Ref B Auto</td><td>0</td><td>0</td><td>1</td><td>Port 1</td></tr> <tr><td>0</td><td>0</td><td>1</td><td>0</td><td>Preset 2 Auto</td><td>0</td><td>1</td><td>0</td><td>Port 2</td></tr> <tr><td>0</td><td>0</td><td>1</td><td>1</td><td>Preset 3 Auto</td><td>0</td><td>1</td><td>1</td><td>Port 3</td></tr> <tr><td>0</td><td>1</td><td>0</td><td>0</td><td>Preset 4 Auto</td><td>1</td><td>0</td><td>0</td><td>Port 4</td></tr> <tr><td>0</td><td>1</td><td>0</td><td>1</td><td>Preset 5 Auto</td><td>1</td><td>0</td><td>1</td><td>Port 5</td></tr> <tr><td>0</td><td>1</td><td>1</td><td>0</td><td>Preset 6 Auto</td><td>1</td><td>1</td><td>0</td><td>Port 6</td></tr> <tr><td>0</td><td>1</td><td>1</td><td>1</td><td>Preset 7 Auto</td><td>1</td><td>1</td><td>1</td><td>No Local Control</td></tr> <tr><td>1</td><td>0</td><td>0</td><td>0</td><td>TB Manual</td><td></td><td></td><td></td><td></td></tr> <tr><td>1</td><td>0</td><td>0</td><td>1</td><td>Port 1 Manual</td><td></td><td></td><td></td><td></td></tr> <tr><td>1</td><td>0</td><td>1</td><td>0</td><td>Port 2 Manual</td><td></td><td></td><td></td><td></td></tr> <tr><td>1</td><td>0</td><td>1</td><td>1</td><td>Port 3 Manual</td><td></td><td></td><td></td><td></td></tr> <tr><td>1</td><td>1</td><td>0</td><td>0</td><td>Port 4 Manual</td><td></td><td></td><td></td><td></td></tr> <tr><td>1</td><td>1</td><td>0</td><td>1</td><td>Port 5 Manual</td><td></td><td></td><td></td><td></td></tr> <tr><td>1</td><td>1</td><td>1</td><td>0</td><td>Port 6 Manual</td><td></td><td></td><td></td><td></td></tr> <tr><td>1</td><td>1</td><td>1</td><td>1</td><td>Jog Ref</td><td></td><td></td><td></td><td></td></tr> </tbody> </table>			Bits ⁽²⁾				Description	Bits ⁽¹⁾			Description	15	14	13	12		11	10	9		0	0	0	0	Ref A Auto	0	0	0	Port 0 (TB)	0	0	0	1	Ref B Auto	0	0	1	Port 1	0	0	1	0	Preset 2 Auto	0	1	0	Port 2	0	0	1	1	Preset 3 Auto	0	1	1	Port 3	0	1	0	0	Preset 4 Auto	1	0	0	Port 4	0	1	0	1	Preset 5 Auto	1	0	1	Port 5	0	1	1	0	Preset 6 Auto	1	1	0	Port 6	0	1	1	1	Preset 7 Auto	1	1	1	No Local Control	1	0	0	0	TB Manual					1	0	0	1	Port 1 Manual					1	0	1	0	Port 2 Manual					1	0	1	1	Port 3 Manual					1	1	0	0	Port 4 Manual					1	1	0	1	Port 5 Manual					1	1	1	0	Port 6 Manual					1	1	1	1	Jog Ref				
Bits ⁽²⁾				Description	Bits ⁽¹⁾			Description																																																																																																																																																												
15	14	13	12		11	10	9																																																																																																																																																													
0	0	0	0	Ref A Auto	0	0	0	Port 0 (TB)																																																																																																																																																												
0	0	0	1	Ref B Auto	0	0	1	Port 1																																																																																																																																																												
0	0	1	0	Preset 2 Auto	0	1	0	Port 2																																																																																																																																																												
0	0	1	1	Preset 3 Auto	0	1	1	Port 3																																																																																																																																																												
0	1	0	0	Preset 4 Auto	1	0	0	Port 4																																																																																																																																																												
0	1	0	1	Preset 5 Auto	1	0	1	Port 5																																																																																																																																																												
0	1	1	0	Preset 6 Auto	1	1	0	Port 6																																																																																																																																																												
0	1	1	1	Preset 7 Auto	1	1	1	No Local Control																																																																																																																																																												
1	0	0	0	TB Manual																																																																																																																																																																
1	0	0	1	Port 1 Manual																																																																																																																																																																
1	0	1	0	Port 2 Manual																																																																																																																																																																
1	0	1	1	Port 3 Manual																																																																																																																																																																
1	1	0	0	Port 4 Manual																																																																																																																																																																
1	1	0	1	Port 5 Manual																																																																																																																																																																
1	1	1	0	Port 6 Manual																																																																																																																																																																
1	1	1	1	Jog Ref																																																																																																																																																																
210	[Drive Status 2] Present operating condition of the drive.	Read Only	209																																																																																																																																																																	
<p>Bit #</p> <table border="1"> <tr> <td>15</td><td>14</td><td>13</td><td>12</td><td>11</td><td>10</td><td>9</td><td>8</td><td>7</td><td>6</td><td>5</td><td>4</td><td>3</td><td>2</td><td>1</td><td>0</td> </tr> <tr> <td>x</td><td>x</td><td>0</td><td>0</td><td>0</td><td>0</td><td>0</td><td>0</td><td>0</td><td>0</td><td>0</td><td>0</td><td>0</td><td>0</td><td>0</td><td>0</td> </tr> </table> <p>1=Condition True 0=Condition False x=Reserved</p> <p>* Vector firmware 3.001 & later</p>			15	14	13	12	11	10	9	8	7	6	5	4	3	2	1	0	x	x	0	0	0	0	0	0	0	0	0	0	0	0	0	0																																																																																																																																		
15	14	13	12	11	10	9	8	7	6	5	4	3	2	1	0																																																																																																																																																					
x	x	0	0	0	0	0	0	0	0	0	0	0	0	0	0																																																																																																																																																					
211	[Drive Alarm 1] Alarm conditions that currently exist in the drive.	Read Only	212																																																																																																																																																																	
<p>Bit #</p> <table border="1"> <tr> <td>15</td><td>14</td><td>13</td><td>12</td><td>11</td><td>10</td><td>9</td><td>8</td><td>7</td><td>6</td><td>5</td><td>4</td><td>3</td><td>2</td><td>1</td><td>0</td> </tr> <tr> <td>x</td><td>x</td><td>0</td><td>0</td><td>0</td><td>0</td><td>0</td><td>x</td><td>x</td><td>0</td><td>0</td><td>0</td><td>0</td><td>0</td><td>0</td><td>0</td> </tr> </table> <p>1=Condition True/E 0=Condition False/I x=Reserved</p>			15	14	13	12	11	10	9	8	7	6	5	4	3	2	1	0	x	x	0	0	0	0	0	x	x	0	0	0	0	0	0	0																																																																																																																																		
15	14	13	12	11	10	9	8	7	6	5	4	3	2	1	0																																																																																																																																																					
x	x	0	0	0	0	0	x	x	0	0	0	0	0	0	0																																																																																																																																																					

File	Group	No.	Parameter Name & Description	Values	Related
UTILITY	Diagnostics	212	[Drive Alarm 2] Alarm conditions that currently exist in the drive.	Read Only 	211
		213	[Speed Ref Source] Displays the source of the speed reference to the drive.	Default: Read Only Options: 0 "PI Output" 1 "Analog In 1" 2 "Analog In 2" 3-8 "Reserved" 9 "MOP Level" 10 "Jog Speed 1" 11-17 "Preset Spd1-7" 18-22 "DPI Port 1-5" 23 ""Reserved" 24 "Auto Tune" 25 "Jog Speed 2"	090 093 096 101
		214	[Start Inhibits] Displays the inputs currently preventing the drive from starting.	Read Only 	
		215	[Last Stop Source] Displays the source that initiated the most recent stop sequence. It will be cleared (set to 0) during the next start sequence.	Default: Read Only Options: 0 "Pwr Removed" 1-5 "DPI Port 1-5" 6 "Reserved" 7 "Digital In" 8 "Fault" 9 "Not Enabled" 10 "Sleep" 11 "Jog" 12 "Autotune" 13 "Precharge"	361 362 363 364 365 366
		216	[Dig In Status] Status of the digital inputs.	Read Only 	361 thru 366

File	Group	No.	Parameter Name & Description	Values	Related
UTILITY	Diagnostics	217	[Dig Out Status] Status of the digital outputs.	Read Only 	380 384 388 thru 380 384 388
		218	[Drive Temp] Present operating temperature of the drive power section.	Default: Read Only Min/Max: 0.0/100.0% Units: 0.1%	
		220	[Motor OL Count] Accumulated percentage of motor overload. Continuously operating the motor over 100% of the motor overload setting will increase this value to 100% and cause a drive fault.	Default: Read Only Min/Max: 0.0/100.0% Units: 0.1%	047 048
		224	[Fault Frequency] Captures and displays the output speed of the drive at the time of the last fault.	Default: Read Only Min/Max: 0.0/[Maximum Freq] Units: 0.1 Hz	079 225 thru 230
		225	[Fault Amps] Captures and displays motor amps at the time of the last fault.	Default: Read Only Min/Max: 0.0/[Rated Amps] × 2 Units: 0.1 Amps	224 thru 230
		226	[Fault Bus Volts] Captures and displays the DC bus voltage of the drive at the time of the last fault.	Default: Read Only Min/Max: 0.0/Max Bus Volts Units: 0.1 VDC	224 thru 230
		227	[Status 1 @ Fault] Captures and displays [Drive Status 1] bit pattern at the time of the last fault.	Read Only 	209 224 thru 230
		228	[Status 2 @ Fault] Captures and displays [Drive Status 2] bit pattern at the time of the last fault.	Read Only 	210 224 thru 230
229	[Alarm 1 @ Fault] Captures and displays [Drive Alarm 1] at the time of the last fault.	Read Only 	211 224 thru 230		









File	Group	No.	Parameter Name & Description	Values	Related
UTILITY	Diagnostics	230	[Alarm 2 @ Fault] Captures and displays [Drive Alarm 2] at the time of the last fault.	Read Only 	212 224 thru 230
		238	[Fault Config 1] Enables/disables annunciation of the listed faults.	<p>Factory Default Bit Values</p>	
	Faults	240	[Fault Clear] Resets a fault and clears the fault queue.	Default: 0 "Ready" Options: 0 "Ready" 1 "Clear Faults" 2 "Clr Fit Que"	
		241	[Fault Clear Mode] Enables/disables a fault reset (clear faults) attempt from any source. This does not apply to fault codes which are cleared indirectly via other actions.	Default: 1 "Enabled" Options: 0 "Disabled" 1 "Enabled"	
		242	[Power Up Marker] Elapsed hours since initial drive power up. This value will rollover to 0 after the drive has been powered on for more than the max value shown. For relevance to most recent power up see [Fault x Time].	Default: Read Only Min/Max: 0.0000/429496.7295 Hr Units: 0.1 Hr	244 246 248 250 252 254 256 258
		243	[Fault 1 Code]	Default: Read Only	
		245	[Fault 2 Code]	Min/Max: 0/65535	
247	[Fault 3 Code]	Units: 0			
249	[Fault 4 Code]				
251	[Fault 5 Code]				
253	[Fault 6 Code]				
255	[Fault 7 Code]				
257	[Fault 8 Code]				
			A code that represents the fault that tripped the drive. The codes will appear in these parameters in the order they occur ([Fault 1 Code] = the most recent fault).		

File	Group	No.	Parameter Name & Description	Values	Related	
UTILITY	Faults	244	[Fault 1 Time]	Default: Read Only Min/Max: 0.0000/429496.7295 Hr Units: 0.0001 Hr	242	
		246	[Fault 2 Time]			
		248	[Fault 3 Time]			
		250	[Fault 4 Time]			
		252	[Fault 5 Time]			
		254	[Fault 6 Time]			
		256	[Fault 7 Time]			
		258	[Fault 8 Time]			
					The time between initial drive power up and the occurrence of the associated trip fault. Can be compared to [Power Up Marker] for the time from the most recent power up. [Fault x Time] – [Power Up Marker] = Time difference to the most recent power up. A negative value indicates fault occurred before most recent power up. A positive value indicates fault occurred after most recent power up.	
		259	[Alarm Config 1]	Enables/disables alarm conditions that will initiate an active drive alarm.		
Alarms	261	[Alarm Clear]	Resets all [Alarm 1-8 Code] parameters to zero.	Default: 0 "Ready" Options: 0 "Ready" 1 "Clr Alrm Que"	262 263 264 265 266 267 268 269	
	262	[Alarm 1 Code]	A code that represents a drive alarm. The codes will appear in the order they occur (first 4 alarms in – first 4 out alarm queue). A time stamp is not available with alarms.	Default: Read Only Min/Max: 0/65535 Units: 1	261	
	263	[Alarm 2 Code]				
	264	[Alarm 3 Code]				
	265	[Alarm 4 Code]				
266	[Alarm 5 Code]					
267	[Alarm 6 Code]					
268	[Alarm 7 Code]					
269	[Alarm 8 Code]					

Communication File

File	Group	No.	Parameter Name & Description	Values	Related																																
COMMUNICATION	Comm Control	271	<p>[Drive Logic Rslt]</p> <p>The final logic command resulting from the combination of all DPI and discrete inputs. This parameter has the same structure as the product-specific logic command received via DPI and is used in peer to peer communications.</p> <p>Bit #</p> <table border="1"> <tr> <td>15</td><td>14</td><td>13</td><td>12</td><td>11</td><td>10</td><td>9</td><td>8</td><td>7</td><td>6</td><td>5</td><td>4</td><td>3</td><td>2</td><td>1</td><td>0</td> </tr> <tr> <td>0</td><td>0</td><td>0</td><td>0</td><td>1</td><td>1</td><td>1</td><td>0</td><td>1</td><td>0</td><td>0</td><td>0</td><td>1</td><td>1</td><td>0</td><td>0</td> </tr> </table> <p>1 = Condition True 0 = Condition False x = Reserved</p>	15	14	13	12	11	10	9	8	7	6	5	4	3	2	1	0	0	0	0	0	1	1	1	0	1	0	0	0	1	1	0	0	Read Only	
		15	14	13	12	11	10	9	8	7	6	5	4	3	2	1	0																				
		0	0	0	0	1	1	1	0	1	0	0	0	1	1	0	0																				
		272	<p>[Drive Ref Rslt]</p> <p>Present frequency reference scaled as a DPI reference for peer to peer communications. The value shown is the value prior to the accel/decel ramp and the corrections supplied by slip comp, PI, etc.</p>	Default: Read Only Min/Max: $-/+32767$ Units: 1																																	
		273	<p>[Drive Ramp Rslt]</p> <p>Present frequency reference scaled as a DPI reference for peer to peer communications. The value shown is the value after the accel/decel ramp, but prior to any corrections supplied by slip comp, PI, etc.</p>	Default: Read Only Min/Max: $-/+32767$ Units: 1																																	
274	<p>[DPI Port Sel]</p> <p>Selects which DPI port reference value will appear in [DPI Port Value].</p>	Default: "DPI Port 1" Options: 1 "DPI Port 1" 2 "DPI Port 2" 3 "DPI Port 3" 4 "DPI Port 4" 5 "DPI Port 5"																																			
275	<p>[DPI Port Value]</p> <p>Value of the DPI reference selected in [DPI Port Sel].</p>	Default: Read Only Min/Max: $-/+32767$ Units: 1																																			
Masks/Owners		276	<p>[Logic Mask]</p> <p> Determines which adapters can control the drive. If the bit for an adapter is set to "0," the adapter will have no control functions except for stop.</p> <p>Bit #</p> <table border="1"> <tr> <td>15</td><td>14</td><td>13</td><td>12</td><td>11</td><td>10</td><td>9</td><td>8</td><td>7</td><td>6</td><td>5</td><td>4</td><td>3</td><td>2</td><td>1</td><td>0</td> </tr> <tr> <td>x</td><td>x</td><td>x</td><td>x</td><td>x</td><td>x</td><td>x</td><td>x</td><td>x</td><td>1</td><td>1</td><td>1</td><td>1</td><td>1</td><td>1</td><td>1</td> </tr> </table> <p>1 = Control Permitted 0 = Control Masked x = Reserved</p> <p>Factory Default Bit Values</p>	15	14	13	12	11	10	9	8	7	6	5	4	3	2	1	0	x	x	x	x	x	x	x	x	x	1	1	1	1	1	1	1		288 thru 297
15	14	13	12	11	10	9	8	7	6	5	4	3	2	1	0																						
x	x	x	x	x	x	x	x	x	1	1	1	1	1	1	1																						

File	Group	No.	Parameter Name & Description	Values	Related
COMMUNICATION	Masks/Owners	277	[Start Mask] Controls which adapters can issue start commands.	See [Logic Mask] .	288 thru 297
		278	[Jog Mask] Controls which adapters can issue jog commands.	See [Logic Mask] .	288 thru 297
		279	[Direction Mask] Controls which adapters can issue forward/reverse direction commands.	See [Logic Mask] .	288 thru 297
		280	[Reference Mask] Controls which adapters can select an alternate reference; [Speed Ref A, B Sel] or [Preset Speed 1-7].	See [Logic Mask] .	288 thru 297
		281	[Accel Mask] Controls which adapters can select [Accel Time 1, 2].	See [Logic Mask] .	288 thru 297
		282	[Decel Mask] Controls which adapters can select [Decel Time 1, 2].	See [Logic Mask] .	288 thru 297
		283	[Fault Clr Mask] Controls which adapters can clear a fault.	See [Logic Mask] .	288 thru 297
		284	[MOP Mask] Controls which adapters can issue MOP commands to the drive.	See [Logic Mask] .	288 thru 297
		285	[Local Mask] Controls which adapters are allowed to take exclusive control of drive logic commands (except stop). Exclusive "local" control can only be taken while the drive is stopped.	See [Logic Mask] .	288 thru 297
		288	[Stop Owner] Adapters that are presently issuing a valid stop command. Bit #	Read Only	276 thru 285
		289	[Start Owner] Adapters that are presently issuing a valid start command.	See [Stop Owner] .	276 thru 285
		290	[Jog Owner] Adapters that are presently issuing a valid jog command.	See [Stop Owner] .	276 thru 285
		291	[Direction Owner] Adapter that currently has exclusive control of direction changes.	See [Stop Owner] .	276 thru 285
292	[Reference Owner] Adapter that has the exclusive control of the command frequency source selection.	See [Stop Owner] .	276 thru 285		

File	Group	No.	Parameter Name & Description	Values	Related
COMMUNICATIONS	Masks/Owners	293	[Accel Owner] Adapter that has exclusive control of selecting [Accel Time 1, 2].	See [Stop Owner] .	140 276 thru 285
		294	[Decel Owner] Adapter that has exclusive control of selecting [Decel Time 1, 2].	See [Stop Owner] .	142 276 thru 285
		295	[Fault Clr Owner] Adapter that is presently clearing a fault.	See [Stop Owner] .	276 thru 285
		296	[MOP Owner] Adapters that are currently issuing increases or decreases in MOP command frequency.	See [Stop Owner] .	276 thru 285
		297	[Local Owner] Adapter that has requested exclusive control of all drive logic functions. If an adapter is in local lockout, all other functions (except stop) on all other adapters are locked out and non-functional. Local control can only be obtained when the drive is not running.	See [Stop Owner] .	276 thru 285
COMMUNICATIONS	Datalinks	300 301 	[Data In A1] - Link A Word 1 [Data In A2] - Link A Word 2 Parameter number whose value will be written from a communications device data table. Value will not be updated until drive is stopped. Refer to your communications option manual for datalink information.	Default: 0 (0 = "Disabled") Min/Max: 0/486 Units: 1	
		302 303 	[Data In B1] - Link B Word 1 [Data In B2] - Link B Word 2	See [Data In A1] - Link A Word 1 [Data In A2] - Link A Word 2 .	
		304 305 	[Data In C1] - Link C Word 1 [Data In C2] - Link C Word 2	See [Data In A1] - Link A Word 1 [Data In A2] - Link A Word 2 .	
		306 307 	[Data In D1] - Link D Word 1 [Data In D2] - Link D Word 2	See [Data In A1] - Link A Word 1 [Data In A2] - Link A Word 2 .	
		310 311 	[Data Out A1] - Link A Word 1 [Data Out A2] - Link A Word 2 Parameter number whose value will be written to a communications device data table.	Default: 0 (0 = "Disabled") Min/Max: 0/544 Units: 1	
		312 313 	[Data Out B1] - Link B Word 1 [Data Out B2] - Link B Word 2	See [Data Out A1] - Link A Word 1 [Data Out A2] - Link A Word 2 .	
		314 315 	[Data Out C1] - Link C Word 1 [Data Out C2] - Link C Word 2	See [Data Out A1] - Link A Word 1 [Data Out A2] - Link A Word 2 .	
		316 317 	[Data Out D1] - Link D Word 1 [Data Out D2] - Link D Word 2	See [Data Out A1] - Link A Word 1 [Data Out A2] - Link A Word 2 .	

Inputs/Outputs File

File	Group	No.	Parameter Name & Description	Values	Related
INPUTS/OUTPUTS	Analog Inputs	320	[Anlg In Config] Selects the mode for the analog inputs.	<p>Bit #</p> <p>Factory Default Bit Values</p>	322 325 323 326
		321	[Anlg In Sqr Root] Enables/disables the square root function for each input.	<p>Bit #</p> <p>Factory Default Bit Values</p>	
		322	[Analog In 1 Hi]	Default: 10.000 Volt	091
		325	[Analog In 2 Hi] Sets the highest input value to the analog input x scaling block. [Anlg In Config], parameter 320 defines if this input will be -/+10V or 4-20 mA.	10.000 Volt Min/Max: 4.000/20.000mA -/+10.000V 0.000/10.000V Units: 0.001 mA 0.001 Volt	092
		323	[Analog In 1 Lo]	Default: 0.000 Volt	091
		326	[Analog In 2 Lo] Sets the lowest input value to the analog input x scaling block. [Anlg In Config], parameter 320 defines if this input will be -/+10V or 4-20 mA.	0.000 Volt Min/Max: 4.000/20.000mA -/+10.000V 0.000/10.000V Units: 0.001 mA 0.001 Volt	092
		324	[Analog In 1 Loss]	Default: 0 "Disabled"	091
327	[Analog In 2 Loss] Selects drive action when an analog signal loss is detected. Signal loss is defined as an analog signal less than 1V or 2mA. The signal loss event ends and normal operation resumes when the input signal level is greater than or equal to 1.5V or 3mA.	0 "Disabled" Options: 0 "Disabled" 1 "Fault" 2 "Hold Input" 3 "Set Input Lo" 4 "Set Input Hi" 5 "Goto Preset1" 6 "Hold OutFreq"	092		
	Analog Outputs	340	[Anlg Out Config] Selects the mode for the analog outputs.	<p>Bit #</p> <p>Factory Default Bit Values</p>	

File	Group	No.	Parameter Name & Description	Values	Related																																																																									
INPUTS/OUTPUTS	Analog Outputs	341	[Anlg Out Absolut] Selects whether the signed value or absolute value of a parameter is used before being scaled to drive the analog output. <div style="text-align: center;"> <p>Bit #</p> <p>Factory Default Bit Values</p> </div>																																																																											
		342	[Analog Out1 Sel] [Analog Out2 Sel] Selects the source of the value that drives the analog output.	Default: 0 "Output Freq" Options: See Table	001 002 003 004 005 007 006 012 135 136 137 138 220																																																																									
			<table border="1"> <thead> <tr> <th rowspan="2">Options</th> <th colspan="2">[Analog Out1 Lo] Value</th> <th rowspan="2">[Analog Out1 Hi] Value</th> </tr> <tr> <th>Param. 341 = Signed</th> <th>Param. 341 = Absolute</th> </tr> </thead> <tbody> <tr> <td>0 "Output Freq"</td> <td>-[Maximum Speed]</td> <td>0 Hz</td> <td>+[Maximum Speed]</td> </tr> <tr> <td>1 "Command Spd"</td> <td>-[Maximum Speed]</td> <td>0 Hz/RPM</td> <td>+[Maximum Speed]</td> </tr> <tr> <td>2 "Output Amps"</td> <td>0 Amps</td> <td>0 Amps</td> <td>200% Rated</td> </tr> <tr> <td>3 "Torque Amps"</td> <td>-200% Rated</td> <td>0 Amps</td> <td>200% Rated</td> </tr> <tr> <td>4 "Flux Amps"</td> <td>0 Amps</td> <td>0 Amps</td> <td>200% Rated</td> </tr> <tr> <td>5 "Output Power"</td> <td>0 kW</td> <td>0 kW</td> <td>200% Rated</td> </tr> <tr> <td>6 "Output Volts"</td> <td>0 Volts</td> <td>0 Volts</td> <td>120% Rated Input Volts</td> </tr> <tr> <td>7 "DC Bus Volts"</td> <td>0 Volts</td> <td>0 Volts</td> <td>200% Rated Input Volts</td> </tr> <tr> <td>8 "PI Reference"</td> <td>-100%</td> <td>0%</td> <td>100%</td> </tr> <tr> <td>9 "PI Feedback"</td> <td>-100%</td> <td>0%</td> <td>100%</td> </tr> <tr> <td>10 "PI Error"</td> <td>-100%</td> <td>0%</td> <td>100%</td> </tr> <tr> <td>11 "PI Output"</td> <td>-100%</td> <td>0%</td> <td>100%</td> </tr> <tr> <td>12 "%Motor OL"</td> <td>0%</td> <td>0%</td> <td>100%</td> </tr> <tr> <td>13-15 "Reserved"</td> <td>-</td> <td>-</td> <td>-</td> </tr> <tr> <td>16 "Speed Ref"</td> <td>-[Maximum Speed]</td> <td>0 Hz</td> <td>+[Maximum Speed]</td> </tr> <tr> <td>17-23 "Reserved"</td> <td>-</td> <td>-</td> <td>-</td> </tr> <tr> <td>24 "Param Cntl"</td> <td>-</td> <td>-</td> <td>-</td> </tr> </tbody> </table>	Options	[Analog Out1 Lo] Value		[Analog Out1 Hi] Value	Param. 341 = Signed	Param. 341 = Absolute	0 "Output Freq"	-[Maximum Speed]	0 Hz	+[Maximum Speed]	1 "Command Spd"	-[Maximum Speed]	0 Hz/RPM	+[Maximum Speed]	2 "Output Amps"	0 Amps	0 Amps	200% Rated	3 "Torque Amps"	-200% Rated	0 Amps	200% Rated	4 "Flux Amps"	0 Amps	0 Amps	200% Rated	5 "Output Power"	0 kW	0 kW	200% Rated	6 "Output Volts"	0 Volts	0 Volts	120% Rated Input Volts	7 "DC Bus Volts"	0 Volts	0 Volts	200% Rated Input Volts	8 "PI Reference"	-100%	0%	100%	9 "PI Feedback"	-100%	0%	100%	10 "PI Error"	-100%	0%	100%	11 "PI Output"	-100%	0%	100%	12 "%Motor OL"	0%	0%	100%	13-15 "Reserved"	-	-	-	16 "Speed Ref"	-[Maximum Speed]	0 Hz	+[Maximum Speed]	17-23 "Reserved"	-	-	-	24 "Param Cntl"	-	-	-	
		Options	[Analog Out1 Lo] Value		[Analog Out1 Hi] Value																																																																									
			Param. 341 = Signed	Param. 341 = Absolute																																																																										
		0 "Output Freq"	-[Maximum Speed]	0 Hz	+[Maximum Speed]																																																																									
		1 "Command Spd"	-[Maximum Speed]	0 Hz/RPM	+[Maximum Speed]																																																																									
		2 "Output Amps"	0 Amps	0 Amps	200% Rated																																																																									
		3 "Torque Amps"	-200% Rated	0 Amps	200% Rated																																																																									
		4 "Flux Amps"	0 Amps	0 Amps	200% Rated																																																																									
5 "Output Power"	0 kW	0 kW	200% Rated																																																																											
6 "Output Volts"	0 Volts	0 Volts	120% Rated Input Volts																																																																											
7 "DC Bus Volts"	0 Volts	0 Volts	200% Rated Input Volts																																																																											
8 "PI Reference"	-100%	0%	100%																																																																											
9 "PI Feedback"	-100%	0%	100%																																																																											
10 "PI Error"	-100%	0%	100%																																																																											
11 "PI Output"	-100%	0%	100%																																																																											
12 "%Motor OL"	0%	0%	100%																																																																											
13-15 "Reserved"	-	-	-																																																																											
16 "Speed Ref"	-[Maximum Speed]	0 Hz	+[Maximum Speed]																																																																											
17-23 "Reserved"	-	-	-																																																																											
24 "Param Cntl"	-	-	-																																																																											
343	[Analog Out1 Hi] [Analog Out2 Hi] Sets the analog output value when the source value is at maximum.	Default: 20.000 mA, 10.000 Volts Min/Max: 4.000/20.000mA -/+10.000V 0.000/10.000V Units: 0.001 mA 0.001 Volt	340 342 345																																																																											
344	[Analog Out1 Lo] [Analog Out2 Lo] Sets the analog output value when the source value is at minimum.	Default: 0.000 mA, 0.000 Volts Min/Max: 4.000/20.000mA -/+10.000V 0.000/10.000V Units: 0.001 mA 0.001 Volt	340 342 345																																																																											
354	[Anlg Out1 Scale] [Anlg Out2 Scale] Sets the high value for the range of analog out scale. Entering 0.0 will disable this scale and max scale will be used. Example: If [Analog Out Sel] = "Commanded Trq," a value of 150 = 150% scale in place of the default 800%.	Default: 0.0 Min/Max: [Analog Out1 Sel] Units: 0.1	342 345																																																																											
377	[Anlg1 Out Setpt] [Anlg2 Out Setpt] Sets the analog output value from a communication device. Example: Set [Data In Ax] to "377" (value from communication device). Then set [Analog Outx Sel] to "Param Cntl."	Default: 0.000 mA, 0.000 Volts Min/Max: 0.000/20.000mA -/+10.000V Units: 0.001 mA 0.001 Volt	342 345																																																																											

File	Group	No.	Parameter Name & Description	Values	Related																																				
INPUTS/OUTPUTS	Digital Inputs	361	[Digital In1 Sel]	Default: 4 "Stop – CF"																																					
		362	[Digital In2 Sel]	Default: 5 "Start"																																					
		363	[Digital In3 Sel]	Default: 18 "Auto/ Manual"																																					
		364	[Digital In4 Sel]	Default: 15 "Speed Sel 1"																																					
		365	[Digital In5 Sel]	Default: 16 "Speed Sel 2"																																					
		366	[Digital In6 Sel] ⁽⁹⁾	Default: 17 "Speed Sel 3"																																					
		☉	<p>Selects the function for the digital inputs.</p> <p>(1) Speed Select Inputs.</p> <table border="1" style="margin-left: 20px;"> <thead> <tr> <th>3</th> <th>2</th> <th>1</th> <th>Auto Reference Source</th> </tr> </thead> <tbody> <tr><td>0</td><td>0</td><td>0</td><td>Reference A</td></tr> <tr><td>0</td><td>0</td><td>1</td><td>Reference B</td></tr> <tr><td>0</td><td>1</td><td>0</td><td>Preset Speed 2</td></tr> <tr><td>0</td><td>1</td><td>1</td><td>Preset Speed 3</td></tr> <tr><td>1</td><td>0</td><td>0</td><td>Preset Speed 4</td></tr> <tr><td>1</td><td>0</td><td>1</td><td>Preset Speed 5</td></tr> <tr><td>1</td><td>1</td><td>0</td><td>Preset Speed 6</td></tr> <tr><td>1</td><td>1</td><td>1</td><td>Preset Speed 7</td></tr> </tbody> </table> <p>To access Preset Speed 1, set [Speed Ref x Sel] to "Preset Speed 1".</p> <p>Type 2 Alarms - Some digital input programming may cause conflicts that will result in a Type 2 alarm. Example: [Digital In1 Sel] set to "5, Start" in 3-wire control and [Digital In2 Sel] set to 7 "Run" in 2-wire.</p> <p>Refer to Table 3.A for information on resolving this type of conflict.</p> <p>(2) When [Digital Inx Sel] is set to option 2 "Clear Faults" the Stop button cannot be used to clear a fault condition.</p> <p>(3) Typical 3-Wire Inputs - Requires that only 3-wire functions are chosen. Including 2-wire selections will cause a type 2 alarm.</p> <p>(4) Typical 2-Wire Inputs - Requires that only 2-wire functions are chosen. Including 3-wire selections will cause a type 2 alarm. See Table 3.A for conflicts.</p> <p>(5) Auto/Manual - Refer to the Installation Manual for details.</p> <p>(6) Opening an "Enable" input will cause the motor to coast-to-stop, ignoring any programmed Stop modes.</p> <p>(7) A "Dig In ConflictB" alarm will occur if a "Start" input is programmed without a "Stop" input.</p> <p>(8) Refer to the Sleep-Wake Mode Attention statement on page 2-18.</p> <p>(9) A dedicated hardware enable input is available via a jumper selection. Refer to Installation Manual for further information.</p>	3	2	1	Auto Reference Source	0	0	0	Reference A	0	0	1	Reference B	0	1	0	Preset Speed 2	0	1	1	Preset Speed 3	1	0	0	Preset Speed 4	1	0	1	Preset Speed 5	1	1	0	Preset Speed 6	1	1	1	Preset Speed 7	<p>Options:</p> <p>0 "Not Used"</p> <p>1 "Enable"⁽⁶⁾⁽⁸⁾</p> <p>2 "Clear Faults"(CF)⁽²⁾</p> <p>3 "Aux Fault"</p> <p>4 "Stop – CF"⁽⁸⁾</p> <p>5 "Start"⁽³⁾⁽⁷⁾</p> <p>6 "Fwd/ Reverse"⁽³⁾</p> <p>7 "Run"⁽⁴⁾⁽⁸⁾</p> <p>8 "Run Forward"⁽⁴⁾</p> <p>9 "Run Reverse"⁽⁴⁾</p> <p>10 "Jog1"⁽³⁾</p> <p>11 "Jog Forward"⁽⁴⁾</p> <p>12 "Jog Reverse"⁽⁴⁾</p> <p>13 "Stop Mode B"</p> <p>14 "Bus Reg Md B"</p> <p>15-17 "Speed Sel 1-3"⁽¹⁾</p> <p>18 "Auto/ Manual"⁽⁵⁾</p> <p>19 "Local"</p> <p>20 "Acc2 & Dec2"</p> <p>21 "Accel 2"</p> <p>22 "Decel 2"</p> <p>23 "MOP Inc"</p> <p>24 "MOP Dec"</p> <p>25 "Excl Link"</p> <p>26 "PI Enable"</p> <p>27 "PI Hold"</p> <p>28 "PI Reset"</p> <p>29 "Pwr Loss Lvl"</p> <p>30-33 Reserved</p> <p>34 "Jog 2"</p> <p>35 "PI Invert"</p>	<p>100</p> <p>156</p> <p>162</p> <p>096</p> <p>141</p> <p>143</p> <p>195</p> <p>194</p> <p>124</p>
3	2	1	Auto Reference Source																																						
0	0	0	Reference A																																						
0	0	1	Reference B																																						
0	1	0	Preset Speed 2																																						
0	1	1	Preset Speed 3																																						
1	0	0	Preset Speed 4																																						
1	0	1	Preset Speed 5																																						
1	1	0	Preset Speed 6																																						
1	1	1	Preset Speed 7																																						
	Digital Outputs	379	<p>[Dig Out Setpt]</p> <p>Sets the digital output value from a communication device.</p> <p>Example</p> <p>Set [Data In B1] to "379." The first three bits of this value will determine the setting of [Digital Outx Sel] which should be set to "24, Param Cntl."</p> <div style="text-align: center;"> </div> <p>1 = Output Energized 0 = Output De-energized x = Reserved</p>		<p>380</p> <p>384</p> <p>388</p>																																				

File	Group	No.	Parameter Name & Description	Values	Related
INPUTS/OUTPUTS Digital Outputs		380	[Digital Out1 Sel]	Default: 1 "Fault"	381
		384	[Digital Out2 Sel]	4 "Run"	385
		388	[Digital Out3 Sel]	4 "Run"	389
			Selects the drive status that will energize a (CRx) output relay.	Options: 1 "Fault" ⁽¹⁾	382
				2 "Alarm" ⁽¹⁾	386
				3 "Ready"	390
				4 "Run"	383
				5 "Forward Run"	
				6 "Reverse Run"	
				7 "Auto Restart"	
				8 "Powerup Run"	
				9 "At Speed"	
				10 "At Freq" ⁽²⁾	002
				11 "At Current" ⁽²⁾	001
				12 "At Torque" ⁽²⁾	003
				13 "At Temp" ⁽²⁾	004
				14 "At Bus Volts" ⁽²⁾	218
				15 "At PI Error" ⁽²⁾	012
				16 "DC Braking"	137
				17 "Curr Limit"	157
				18 "Reserved"	147
				19 "Motor Overld"	053
				20 "Power Loss"	048
				21-26 "Input 1-6 Link"	184
				27 "PI Enable"	
				28 "PI Hold"	
				29 "Reserved"	
				30 "Param Cntl" ⁽³⁾	

Selected Option Definitions – [Analog Outx Sel], [Digital Inx Sel], [Digital Outx Sel]

Option	Description	Related
At Speed	Relay changes state when drive has reached commanded speed.	380 384 388
Excl Link	Links digital input to a digital output if the output is set to "Input 1-6 Link." This does not need to be selected in the Vector option.	361
Input 1-6 Link	When Digital Output 1 is set to one of these (i.e. Input 3 Link) in conjunction with Digital Input 3 set to "Excl Link," the Digital Input 3 state (on/off) is echoed in the Digital Output 1.	380 384 388
MOP Dec	Decrements speed reference as long as input is closed.	361
MOP Inc	Increments speed reference as long as input is closed.	361
Param Cntl	Parameter controlled analog output allows PLC to control analog outputs through data links. Set in [AnlgX Out Setpt], par. 377-378.	342 345
Param Cntl	Parameter controlled digital output allows PLC to control digital outputs through data links. Set in [Dig Out Setpt], parameter 379.	380 384 388
PI Reference	Reference for PI block (see page B-7).	342 345

File	Group	No.	Parameter Name & Description	Values	Related	
INPUTS/OUTPUTS	Digital Outputs	381	[Dig Out1 Level]	Default: 0.0	380	
		385	[Dig Out2 Level]	0.0	384	
		389	[Dig Out3 Level]	0.0	388	
		Sets the relay activation level for options 10 – 15 in [Digital Outx Sel]. Units are assumed to match the above selection (i.e. "At Freq" = Hz, "At Torque" = Amps).			Min/Max: 0.0/1500.0 Units: 0.1	
		382	[Dig Out1 OnTime]	Default: 0.00 Secs	380	
		386	[Dig Out2 OnTime]	0.00 Secs	384	
		390	[Dig Out3 OnTime]	0.00 Secs	388	
		Sets the "ON Delay" time for the digital outputs. This is the time between the occurrence of a condition and activation of the relay.			Min/Max: 0.00/163.00 Secs Units: 0.01 Secs	
		383	[Dig Out1 OffTime]	Default: 0.00 Secs	380	
387	[Dig Out2 OffTime]	0.00 Secs	384			
391	[Dig Out3 OffTime]	0.00 Secs	388			
Sets the "OFF Delay" time for the digital outputs. This is the time between the disappearance of a condition and de-activation of the relay.			Min/Max: 0.00/163.00 Secs Units: 0.01 Secs			

Parameter Cross Reference – by Name

Parameter Name	Number	Group	Page
Accel Mask	281	Masks/Owners	2-27
Accel Owner	293	Masks/Owners	2-28
Accel Time X	140, 141	Ramp Rates	2-15
Alarm Clear	261	Alarms	2-25
Alarm Config 1	259	Alarms	2-25
Alarm X @ Fault	229, 230	Diagnostics	2-23
Alarm X Code	262-269	Alarms	2-25
Analog In X Hi	322, 325	Analog Inputs	2-29
Analog In X Lo	323, 326	Analog Inputs	2-29
Analog In X Loss	324, 327	Analog Inputs	2-29
Analog In1 Value	016	Metering	2-6
Analog In2 Value	017	Metering	2-6
Analog OutX Hi	343, 346	Analog Outputs	2-30
Analog OutX Lo	344, 347	Analog Outputs	2-30
Analog OutX Sel	342, 345	Analog Outputs	2-30
Anlg In Config	320	Analog Inputs	2-29
Anlg In Sqr Root	321	Analog Inputs	2-29
Anlg Out Absolut	341	Analog Outputs	2-30
Anlg Out Config	340	Analog Outputs	2-29
Anlg OutX Scale	354, 355	Analog Outputs	2-30
Anlg OutX Setpt	377, 378	Analog Outputs	2-30
Auto Rstrt Delay	175	Restart Modes	2-17
Auto Rstrt Tries	174	Restart Modes	2-17
Autotune	061	Torq Attributes	2-9
Break Frequency	072	Volts per Hertz	2-9
Break Voltage	071	Volts per Hertz	2-9
Bus Reg Kd	165	Stop/Brake Modes	2-16
Bus Reg Ki	160	Stop/Brake Modes	2-16
Bus Reg Kp	164	Stop/Brake Modes	2-16
Bus Reg Mode X	161, 162	Stop/Brake Modes	2-16
Commanded Speed	002	Metering	2-6
Control SW Ver	029	Drive Data	2-7
Current Lmt Gain	149	Load Limits	2-15
Current Lmt Sel	147	Load Limits	2-15
Current Lmt Val	148	Load Limits	2-15
Data In XX	300-307	Datalinks	2-28
Data Out XX	310-317	Datalinks	2-28
DB Resistor Type	163	Stop/Brake Modes	2-16
DC Brake Level	158	Stop/Brake Modes	2-16
DC Brake Time	159	Stop/Brake Modes	2-16
DC Brk Lvl Sel	157	Stop/Brake Modes	2-15
DC Bus Memory	013	Metering	2-6
DC Bus Voltage	012	Metering	2-6
Decel Mask	282	Masks/Owners	2-27
Decel Owner	294	Masks/Owners	2-28
Decel Time X	142, 143	Ramp Rates	2-15
Dig In Status	216	Diagnostics	2-22
Dig Out Setpt	379	Digital Outputs	2-31
Dig Out Status	217	Diagnostics	2-23
Dig OutX Level	381, 385, 389	Digital Outputs	2-33
Dig OutX OffTime	383, 387, 391	Digital Outputs	2-33
Dig OutX OnTime	382, 386, 390	Digital Outputs	2-33
Digital InX Sel	361-366	Digital Inputs	2-31
Digital OutX Sel	380, 384, 388	Digital Outputs	2-32
Direction Mask	279	Masks/Owners	2-27
Direction Mode	190	Direction Config	2-19
Direction Owner	291	Masks/Owners	2-27
DPI Port Sel	274	Comm Control	2-26
DPI Port Value	275	Comm Control	2-26
Drive Alarm X	211, 212	Diagnostics	2-21
Drive Checksum	203	Drive Memory	2-21
Drive Logic Rslt	271	Comm Control	2-26
Drive OL Mode	150	Load Limits	2-15
Drive Ramp Rslt	273	Comm Control	2-26
Drive Ref Rslt	272	Comm Control	2-26
Drive Status X	209, 210	Diagnostics	2-21
Drive Temp	218	Diagnostics	2-23

Parameter Name	Number	Group	Page
Droop RPM @ FLA	152	Load Limits	2-15
Elapsed MWh	009	Metering	2-6
Elapsed Run Time	010	Metering	2-6
Fault 1 Code	243	Faults	2-24
Fault 1 Time	244	Faults	2-25
Fault 2 Code	245	Faults	2-24
Fault 2 Time	246	Faults	2-25
Fault 3 Code	247	Faults	2-24
Fault 3 Time	248	Faults	2-25
Fault 4 Code	249	Faults	2-24
Fault 4 Time	250	Faults	2-25
Fault 5 Code	251	Faults	2-24
Fault 5 Time	252	Faults	2-25
Fault 6 Code	253	Faults	2-24
Fault 6 Time	254	Faults	2-25
Fault 7 Code	255	Faults	2-24
Fault 7 Time	256	Faults	2-25
Fault 8 Code	257	Faults	2-24
Fault 8 Time	258	Faults	2-25
Fault Amps	225	Diagnostics	2-23
Fault Bus Volts	226	Diagnostics	2-23
Fault Clear	240	Faults	2-24
Fault Clear Mode	241	Faults	2-24
Fault Clr Mask	283	Masks/Owners	2-27
Fault Clr Owner	295	Masks/Owners	2-28
Fault Config 1	238	Faults	2-24
Fault Frequency	224	Diagnostics	2-23
Feedback Select	080	Spd Mode/Limits	2-10
Flux Current	005	Metering	2-6
Flux Current Ref	063	Torq Attributes	2-9
Flux Up Mode	057	Torq Attributes	2-8
Flux Up Time	058	Torq Attributes	2-8
Flying Start En	169	Restart Modes	2-17
IR Voltage Drop	062	Torq Attributes	2-9
Jog Mask	278	Masks/Owners	2-27
Jog Owner	290	Masks/Owners	2-27
Jog Speed 1	100	Discrete Speeds	2-12
Jog Speed 2	108	Discrete Speeds	2-12
Language	201	Drive Memory	2-21
Last Stop Source	215	Diagnostics	2-22
Load Frm Usr Set	198	Drive Memory	2-20
Local Mask	285	Masks/Owners	2-27
Local Owner	297	Masks/Owners	2-28
Logic Mask	276	Masks/Owners	2-26
Man Ref Preload	193	HIM Ref Config	2-20
Maximum Freq	055	Torq Attributes	2-8
Maximum Speed	082	Spd Mode/Limits	2-10
Minimum Speed	081	Spd Mode/Limits	2-10
MOP Mask	284	Masks/Owners	2-27
MOP Owner	296	Masks/Owners	2-28
MOP Rate	195	MOP Config	2-20
MOP Reference	011	Metering	2-6
Motor Cntl Sel	053	Torq Attributes	2-8
Motor NP FLA	042	Motor Data	2-7
Motor NP Hertz	043	Motor Data	2-7
Motor NP Power	045	Motor Data	2-7
Motor NP RPM	044	Motor Data	2-7
Motor NP Volts	041	Motor Data	2-7
Motor OL Count	220	Diagnostics	2-23
Motor OL Factor	048	Motor Data	2-8
Motor OL Hertz	047	Motor Data	2-8
Motor Poles	049	Motor Data	2-8
Motor Type	040	Motor Data	2-7
Mtr NP Pwr Units	046	Motor Data	2-8
Output Current	003	Metering	2-6
Output Freq	001	Metering	2-6
Output Power	007	Metering	2-6
Output Powr Fctr	008	Metering	2-6
Output Voltage	006	Metering	2-6
Overspeed Limit	083	Spd Mode/Limits	2-10
Param Access Lvl	196	Drive Memory	2-20

Parameter Name	Number	Group	Page
PI Configuration	124	Process PI	2-13
PI Control	125	Process PI	2-13
PI Error Meter	137	Process PI	2-14
PI Fdback Meter	136	Process PI	2-14
PI Feedback Hi	462	Process PI	2-14
PI Feedback Lo	463	Process PI	2-14
PI Feedback Sel	128	Process PI	2-13
PI Integral Time	129	Process PI	2-14
PI Lower Limit	131	Process PI	2-14
PI Output Meter	138	Process PI	2-14
PI Preload	133	Process PI	2-14
PI Prop Gain	130	Process PI	2-14
PI Ref Meter	135	Process PI	2-14
PI Reference Hi	460	Process PI	2-14
PI Reference Lo	461	Process PI	2-14
PI Reference Sel	126	Process PI	2-13
PI Setpoint	127	Process PI	2-13
PI Status	134	Process PI	2-14
PI Upper Limit	132	Process PI	2-14
Power Loss Volts	186	Power Loss	2-19
Power Loss Mode	184	Power Loss	2-19
Power Loss Time	185	Power Loss	2-19
Power Up Marker	242	Faults	2-24
Powerup Delay	167	Restart Modes	2-17
Preset Speed X	101-107	Discrete Speeds	2-12
PWM Frequency	151	Load Limits	2-15
Ramped Speed	022	Metering	2-7
Rated Amps	028	Drive Data	2-7
Rated kW	026	Drive Data	2-7
Rated Volts	027	Drive Data	2-7
Reference Mask	280	Masks/Owners	2-27
Reference Owner	292	Masks/Owners	2-27
Reset Meters	200	Drive Memory	2-20
Reset To Defaults	197	Drive Memory	2-20
Rev Speed Limit	454	Speed Regulator	2-11
S Curve %	146	Ramp Rates	2-15
Save HIM Ref	192	HIM Ref Config	2-19
Save MOP Ref	194	MOP Config	2-20
Save To User Set	199	Drive Memory	2-20
Skip Freq Band	087	Spd Mode/Limits	2-11
Skip Frequency X	084-086	Spd Mode/Limits	2-10
Sleep Level	182	Restart Modes	2-18
Sleep Time	183	Restart Modes	2-19
Sleep-Wake Mode	178	Restart Modes	2-18
Sleep-Wake Ref	179	Restart Modes	2-18
Slip RPM @ FLA	121	Slip Comp	2-13
Slip RPM Meter	123	Slip Comp	2-13
Speed Feedback	025	Metering	2-7
Speed Ref Source	213	Diagnostics	2-22
Speed Ref X Hi	091, 094	Speed Reference	2-11
Speed Ref X Lo	092, 095	Speed Reference	2-11
Speed Ref X Sel	090, 093	Speed Reference	2-11
Speed Reference	023	Metering	2-7
Speed Units	079	Spd Mode/Limits	2-10
Speed/Torque Mod	088	Spd Mode/Limits	2-11
Start At PowerUp	168	Restart Modes	2-17
Start Inhibits	214	Diagnostics	2-22
Start Mask	277	Masks/Owners	2-27
Start Owner	289	Masks/Owners	2-27
Start/Acc Boost	069	Volts per Hertz	2-9
Status X @ Fault	227, 228	Diagnostics	2-23
Stop Owner	288	Masks/Owners	2-27
Stop/BRK Mode X	155, 156	Stop/Brake Modes	2-15
SV Boost Filter	059	Torq Attributes	2-8
TB Man Ref Hi	097	Speed Reference	2-12
TB Man Ref Lo	098	Speed Reference	2-12
TB Man Ref Sel	096	Speed Reference	2-12
Torque Current	004	Metering	2-6
Trim Hi	119	Speed Trim	2-13
Trim In Select	117	Speed Trim	2-12
Trim Lo	120	Speed Trim	2-13

Parameter Name	Number	Group	Page
Trim Out Select	118	Speed Trim	2-12
Wake Level	180	Restart Modes	2-18
Wake Time	181	Restart Modes	2-18
Voltage Class	202	Drive Memory	2-21

Parameter Cross Reference – by Number

Number	Parameter Name	Group	Page
001	Output Freq	Metering	2-6
002	Commanded Speed	Metering	2-6
003	Output Current	Metering	2-6
004	Torque Current	Metering	2-6
005	Flux Current	Metering	2-6
006	Output Voltage	Metering	2-6
007	Output Power	Metering	2-6
008	Output Powr Fctr	Metering	2-6
009	Elapsed MWh	Metering	2-6
010	Elapsed Run Time	Metering	2-6
011	MOP Reference	Metering	2-6
012	DC Bus Voltage	Metering	2-6
013	DC Bus Memory	Metering	2-6
016	Analog In1 Value	Metering	2-6
017	Analog In2 Value	Metering	2-6
022	Ramped Speed	Metering	2-7
023	Speed Reference	Metering	2-7
025	Speed Feedback	Metering	2-7
026	Rated kW	Drive Data	2-7
027	Rated Volts	Drive Data	2-7
028	Rated Amps	Drive Data	2-7
029	Control SW Ver	Drive Data	2-7
040	Motor Type	Motor Data	2-7
041	Motor NP Volts	Motor Data	2-7
042	Motor NP FLA	Motor Data	2-7
043	Motor NP Hertz	Motor Data	2-7
044	Motor NP RPM	Motor Data	2-7
045	Motor NP Power	Motor Data	2-7
046	Mtr NP Pwr Units	Motor Data	2-8
047	Motor OL Hertz	Motor Data	2-8
048	Motor OL Factor	Motor Data	2-8
049	Motor Poles	Motor Data	2-8
053	Motor Cntl Sel	Torq Attributes	2-8
055	Maximum Freq	Torq Attributes	2-8
057	Flux Up Mode	Torq Attributes	2-8
058	Flux Up Time	Torq Attributes	2-8
059	SV Boost Filter	Torq Attributes	2-8
061	Autotune	Torq Attributes	2-9
062	IR Voltage Drop	Torq Attributes	2-9
063	Flux Current Ref	Torq Attributes	2-9
069	Start/Acc Boost	Volts per Hertz	2-9
071	Break Voltage	Volts per Hertz	2-9
072	Break Frequency	Volts per Hertz	2-9
079	Speed Units	Spd Mode/Limits	2-10
080	Feedback Select	Spd Mode/Limits	2-10
081	Minimum Speed	Spd Mode/Limits	2-10
082	Maximum Speed	Spd Mode/Limits	2-10
083	Overspeed Limit	Spd Mode/Limits	2-10
084-086	Skip Frequency X	Spd Mode/Limits	2-10
087	Skip Freq Band	Spd Mode/Limits	2-11
088	Speed/Torque Mod	Spd Mode/Limits	2-11
090, 093	Speed Ref X Sel	Speed Reference	2-11
091, 094	Speed Ref X Hi	Speed Reference	2-11
092, 095	Speed Ref X Lo	Speed Reference	2-11
096	TB Man Ref Sel	Speed Reference	2-12
097	TB Man Ref Hi	Speed Reference	2-12
098	TB Man Ref Lo	Speed Reference	2-12
100	Jog Speed 1	Discrete Speeds	2-12
101-107	Preset Speed X	Discrete Speeds	2-12
108	Jog Speed 2	Discrete Speeds	2-12
117	Trim In Select	Speed Trim	2-12
118	Trim Out Select	Speed Trim	2-12
119	Trim Hi	Speed Trim	2-13
120	Trim Lo	Speed Trim	2-13
121	Slip RPM @ FLA	Slip Comp	2-13
123	Slip RPM Meter	Slip Comp	2-13
124	PI Configuration	Process PI	2-13
125	PI Control	Process PI	2-13
126	PI Reference Sel	Process PI	2-13

Number	Parameter Name	Group	Page
127	PI Setpoint	Process PI	2-13
128	PI Feedback Sel	Process PI	2-13
129	PI Integral Time	Process PI	2-14
130	PI Prop Gain	Process PI	2-14
131	PI Lower Limit	Process PI	2-14
132	PI Upper Limit	Process PI	2-14
133	PI Preload	Process PI	2-14
134	PI Status	Process PI	2-14
135	PI Ref Meter	Process PI	2-14
136	PI Fdback Meter	Process PI	2-14
137	PI Error Meter	Process PI	2-14
138	PI Output Meter	Process PI	2-14
140, 141	Accel Time X	Ramp Rates	2-15
142, 143	Decel Time X	Ramp Rates	2-15
146	S Curve %	Ramp Rates	2-15
147	Current Lmt Sel	Load Limits	2-15
148	Current Lmt Val	Load Limits	2-15
149	Current Lmt Gain	Load Limits	2-15
150	Drive OL Mode	Load Limits	2-15
151	PWM Frequency	Load Limits	2-15
152	Droop RPM @ FLA	Load Limits	2-15
155, 156	Stop/BRK Mode X	Stop/Brake Modes	2-15
157	DC Brk Lvl Sel	Stop/Brake Modes	2-15
158	DC Brake Level	Stop/Brake Modes	2-16
159	DC Brake Time	Stop/Brake Modes	2-16
160	Bus Reg Ki	Stop/Brake Modes	2-16
161, 162	Bus Reg Mode X	Stop/Brake Modes	2-16
163	DB Resistor Type	Stop/Brake Modes	2-16
164	Bus Reg Kp	Stop/Brake Modes	2-16
165	Bus Reg Kd	Stop/Brake Modes	2-16
167	Powerup Delay	Restart Modes	2-17
168	Start At PowerUp	Restart Modes	2-17
169	Flying Start En	Restart Modes	2-17
174	Auto Rstrt Tries	Restart Modes	2-17
175	Auto Rstrt Delay	Restart Modes	2-17
178	Sleep-Wake Mode	Restart Modes	2-18
179	Sleep-Wake Ref	Restart Modes	2-18
180	Wake Level	Restart Modes	2-18
181	Wake Time	Restart Modes	2-18
182	Sleep Level	Restart Modes	2-18
183	Sleep Time	Restart Modes	2-19
184	Power Loss Mode	Power Loss	2-19
185	Power Loss Time	Power Loss	2-19
186	Power Loss Volts	Power Loss	2-19
190	Direction Mode	Direction Config	2-19
192	Save HIM Ref	HIM Ref Config	2-19
193	Man Ref Preload	HIM Ref Config	2-20
194	Save MOP Ref	MOP Config	2-20
195	MOP Rate	MOP Config	2-20
196	Param Access Lvl	Drive Memory	2-20
197	Reset To Defaults	Drive Memory	2-20
198	Load Frm Usr Set	Drive Memory	2-20
199	Save To User Set	Drive Memory	2-20
200	Reset Meters	Drive Memory	2-20
201	Language	Drive Memory	2-21
202	Voltage Class	Drive Memory	2-21
203	Drive Checksum	Drive Memory	2-21
209, 210	Drive Status X	Diagnostics	2-21
211, 212	Drive Alarm X	Diagnostics	2-21
213	Speed Ref Source	Diagnostics	2-22
214	Start Inhibits	Diagnostics	2-22
215	Last Stop Source	Diagnostics	2-22
216	Dig In Status	Diagnostics	2-22
217	Dig Out Status	Diagnostics	2-23
218	Drive Temp	Diagnostics	2-23
220	Motor OL Count	Diagnostics	2-23
224	Fault Frequency	Diagnostics	2-23
225	Fault Amps	Diagnostics	2-23
226	Fault Bus Volts	Diagnostics	2-23
227, 228	Status X @ Fault	Diagnostics	2-23
229, 230	Alarm X @ Fault	Diagnostics	2-23

Number	Parameter Name	Group	Page
238	Fault Config 1	Faults	2-24
240	Fault Clear	Faults	2-24
241	Fault Clear Mode	Faults	2-24
242	Power Up Marker	Faults	2-24
243	Fault 1 Code	Faults	2-24
244	Fault 1 Time	Faults	2-25
245	Fault 2 Code	Faults	2-24
246	Fault 2 Time	Faults	2-25
247	Fault 3 Code	Faults	2-24
248	Fault 3 Time	Faults	2-25
249	Fault 4 Code	Faults	2-24
250	Fault 4 Time	Faults	2-25
251	Fault 5 Code	Faults	2-24
252	Fault 5 Time	Faults	2-25
253	Fault 6 Code	Faults	2-24
254	Fault 6 Time	Faults	2-25
255	Fault 7 Code	Faults	2-24
256	Fault 7 Time	Faults	2-25
257	Fault 8 Code	Faults	2-24
258	Fault 8 Time	Faults	2-25
259	Alarm Config 1	Alarms	2-25
261	Alarm Clear	Alarms	2-25
262-269	Alarm X Code	Alarms	2-25
271	Drive Logic Rslt	Comm Control	2-26
272	Drive Ref Rslt	Comm Control	2-26
273	Drive Ramp Rslt	Comm Control	2-26
274	DPI Port Sel	Comm Control	2-26
275	DPI Port Value	Comm Control	2-26
276	Logic Mask	Masks/Owners	2-26
277	Start Mask	Masks/Owners	2-27
278	Jog Mask	Masks/Owners	2-27
279	Direction Mask	Masks/Owners	2-27
280	Reference Mask	Masks/Owners	2-27
281	Accel Mask	Masks/Owners	2-27
282	Decel Mask	Masks/Owners	2-27
283	Fault Clr Mask	Masks/Owners	2-27
284	MOP Mask	Masks/Owners	2-27
285	Local Mask	Masks/Owners	2-27
288	Stop Owner	Masks/Owners	2-27
289	Start Owner	Masks/Owners	2-27
290	Jog Owner	Masks/Owners	2-27
291	Direction Owner	Masks/Owners	2-27
292	Reference Owner	Masks/Owners	2-27
293	Accel Owner	Masks/Owners	2-28
294	Decel Owner	Masks/Owners	2-28
295	Fault Clr Owner	Masks/Owners	2-28
296	MOP Owner	Masks/Owners	2-28
297	Local Owner	Masks/Owners	2-28
300-307	Data In XX	Datalinks	2-28
310-317	Data Out XX	Datalinks	2-28
320	Anlg In Config	Analog Inputs	2-29
321	Anlg In Sqr Root	Analog Inputs	2-29
322, 325	Analog In X Hi	Analog Inputs	2-29
323, 326	Analog In X Lo	Analog Inputs	2-29
324, 327	Analog In X Loss	Analog Inputs	2-29
340	Anlg Out Config	Analog Outputs	2-29
341	Anlg Out Absolut	Analog Outputs	2-30
342, 345	Analog OutX Sel	Analog Outputs	2-30
343, 346	Analog OutX Hi	Analog Outputs	2-30
344, 347	Analog OutX Lo	Analog Outputs	2-30
354, 355	Anlg OutX Scale	Analog Outputs	2-30
361-366	Digital InX Sel	Digital Inputs	2-31
377, 378	Anlg OutX Setpt	Analog Outputs	2-30
379	Dig Out Setpt	Digital Outputs	2-31
380, 384, 388	Digital OutX Sel	Digital Outputs	2-32
381, 385, 389	Dig OutX Level	Digital Outputs	2-33
382, 386, 390	Dig OutX OnTime	Digital Outputs	2-33

Number	Parameter Name	Group	Page
383, 387, 391	Dig OutX OffTime	Digital Outputs	2-33
454	Rev Speed Limit	Speed Regulator	2-11
460	PI Reference Hi	Process PI	2-14
461	PI Reference Lo	Process PI	2-14
462	PI Feedback Hi	Process PI	2-14
463	PI Feedback Lo	Process PI	2-14

Notes

Troubleshooting

Chapter 3 provides information to guide you in troubleshooting the PowerFlex 700H. Included is a listing and description of drive faults (with possible solutions, when applicable) and alarms.

For information on...	See page...
Faults and Alarms	3-1
Drive Status	3-2
Manually Clearing Faults	3-3
Fault & Alarm Descriptions	3-3
Clearing Alarms	3-8
Common Symptoms and Corrective Actions	3-9

Faults and Alarms

A fault is a condition that stops the drive. There are three fault types.

Type	Fault Description
①	Auto-Reset Run When this type of fault occurs, and [Auto Rstrt Tries] (see page 2-17) is set to a value greater than "0," a user-configurable timer, [Auto Rstrt Delay] (see page 2-17) begins. When the timer reaches zero, the drive attempts to automatically reset the fault. If the condition that caused the fault is no longer present, the fault will be reset and the drive will be restarted.
②	Non-Resettable This type of fault normally requires drive or motor repair. The cause of the fault must be corrected before the fault can be cleared. The fault will be reset on power up after repair.
③	User Configurable These faults can be enabled/disabled to annunciate or ignore a fault condition.

An alarm is a condition that, if left untreated, may stop the drive. There are two alarm types.

Type	Alarm Description
①	User Configurable These alarms can be enabled or disabled through [Alarm Config 1] on page 2-25 .
②	Non-Configurable These alarms are always enabled.

Refer to [Fault & Alarm Descriptions on page 3-3](#).

Drive Status

The condition or state of your drive is constantly monitored. Any changes will be indicated through the LEDs and/or the HIM (if present).

Front Panel LED Indications

Figure 3.1 Drive Status Indicators

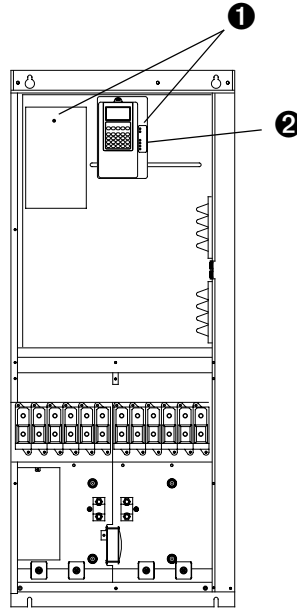

#	Name	Color	State	Description
1	PWR (Power)	Green	Steady	Illuminates when power is applied to the drive.
2	PORT ⁽¹⁾	Green	–	Status of DPI port internal communications (if present).
	MOD ⁽¹⁾	Yellow	–	Status of communications module (when installed).
	NET A ⁽¹⁾	Red	–	Status of network (if connected).
	NET B ⁽¹⁾	Red	–	Status of secondary network (if connected).

⁽¹⁾ Refer to the Communication Option User Manual for details.

HIM Indication

The LCD HIM also provides visual notification of a fault or alarm condition.

Drive is indicating a fault.

The LCD HIM immediately reports the fault condition by displaying the following.

- “Faulted” appears in the status line
- Fault number
- Fault name
- Time that has passed since fault occurred

Press Esc to regain HIM control.

```

F> | Faulted | | Auto |
    | 00 Hz |
    | - Fault - F | 5 |
    | OverVoltage |
    | Time Since Fault |
    | 0000:23:52 |
                    
```

<p>Drive is indicating an alarm.</p> <p>The LCD HIM immediately reports the alarm condition by displaying the following.</p> <ul style="list-style-type: none"> • Alarm name (Type 2 alarms only) • Alarm bell graphic 	F> Power Loss Auto
	0.0 Hz
	Main Menu: Diagnostics Parameter Device Select

Manually Clearing Faults

<ol style="list-style-type: none"> 1. Press Esc to acknowledge the fault. The fault information will be removed so that you can use the HIM. 	
<ol style="list-style-type: none"> 2. Address the condition that caused the fault. The cause must be corrected before the fault can be cleared. 	
<ol style="list-style-type: none"> 3. After corrective action has been taken, clear the fault by one of these methods. <ul style="list-style-type: none"> • Press Stop • Cycle drive power • Set parameter 240 [Fault Clear] to "1." • "Clear Faults" on the HIM Diagnostic menu. 	

Fault & Alarm Descriptions

Table 3.A Fault/Alarm Types, Descriptions and Actions

No.	Name	Fault	Alarm	Description	Action (if appropriate)
1	PrechargeActv			Drive received a start command while in the DC bus precharge state.	
2	Auxiliary In	①		Auxiliary input interlock is open.	Check remote wiring.
3	Power Loss	① ③		DC bus voltage remained below [Power Loss Volts] for longer than [Power Loss Time]. Enable/Disable with [Fault Config 1] on page 2-24 .	Monitor the incoming AC line for low voltage or line power interruption.
4	UnderVoltage	① ③		DC bus voltage fell below the minimum value of 333V for 400/480V drives and 461V for 600/ 690V drives. Enable/Disable with [Fault Config 1] (page 2-24).	Monitor the incoming AC line for low voltage or power interruption.
5	OverVoltage	①		DC bus voltage exceeded maximum value.	Monitor the AC line for high line voltage or transient conditions. Bus overvoltage can also be caused by motor regeneration. Extend the decel time or install dynamic brake option.
6	Motor Stall	②		Motor is operating at high current and low frequency and is not accelerating.	<ol style="list-style-type: none"> 1. Run Autotune 2. Reduce Load

No.	Name	Fault	Alarm	Description	Action (if appropriate)
7	MotorOverload	① ③		Internal electronic overload trip. Enable/Disable with [Fault Config 1] on page 2-24 .	<ol style="list-style-type: none"> 1. Run Autotune 2. Verify settings of [Motor Overload Factor] and [Motor Overload Frequency]. 3. Reduce load so drive output current does not exceed the current set by [Motor NP FLA].
8	HeatsinkOvrTp	②	❶	Heatsink temperature exceeds maximum allowable value. 85 degrees C = Alarm 90 degrees C = Fault	<ol style="list-style-type: none"> 1. Verify that maximum ambient temperature has not been exceeded. 2. Check fan. 3. Check for excess load. 4. Check carrier frequency
9	IGBT OverTemp	①		Output transistors have exceeded their maximum operating temperature due to excessive load.	<ol style="list-style-type: none"> 1. Verify that maximum ambient temperature has not been exceeded. 2. Check fan. 3. Check for excess load.
10	System Fault	②		Hardware problem exists in the power structure.	<ol style="list-style-type: none"> 1. Cycle power. 2. Replace drive.
12	OverCurrent	①		The drive output current has exceeded the hardware current limit.	Check programming. Check for excess load, improper DC boost setting, DC brake volts set too high or other causes of excess current. Check for shorted motor leads or shorted motor.
13	Ground Fault	①		A current path to earth ground greater than 25% of drive rating. Ground fault level is 50% of the drive's heavy duty current rating. The current must appear for 800ms before the drive will fault.	Check the motor and external wiring to the drive output terminals for a grounded condition.
14	InverterFault	②		Hardware problem in the power structure.	<ol style="list-style-type: none"> 1. Cycle power. 2. Replace drive.
15	Load Loss	③	❶		
16	Motor Therm	③	❶	Option board thermistor input is greater than limit.	
17	Input Phase	③	❶	One input line phase missing.	<ol style="list-style-type: none"> 1. Check user-supplied fuses 2. Check AC input line voltage.
21	OutPhasMissng	②		Zero current in one output motor phase.	<ol style="list-style-type: none"> 1. Check motor wiring. 2. Check motor for open phase.
22	NP Hz Cnflct		②	Fan/pump mode is selected in [Motor Cntl Sel] and the ratio of [Motor NP Hertz] to [Maximum Freq] is greater than 26.	
23	MaxFreqCnflct		②	The sum of [Maximum Speed] and [Overspeed Limit] exceeds [Maximum Freq]. Raise [Maximum Freq] or lower [Maximum Speed] and/or [Overspeed Limit] so that the sum is less than or equal to [Maximum Freq].	
24	Decel Inhibit	③	❶	Drive cannot follow commanded decel due to bus limiting.	<ol style="list-style-type: none"> 1. Verify that input voltage is within specified limits. 2. Verify that system ground impedance follows proper grounding techniques. 3. Disable bus regulation and/or add dynamic brake resistor and/or extend deceleration time.

No.	Name	Fault	Alarm	Description	Action (if appropriate)
25	OverSpd Limit	①		Functions such as Slip Compensation or Bus Regulation have attempted to add an output frequency adjustment greater than that programmed in [Overspeed Limit].	Remove excessive load or overhauling conditions or increase [Overspeed Limit].
26	VHz Neg Slope		②	[Motor Cntl Sel] = "Custom V/Hz" & the V/Hz slope is negative.	
27	SpdRef Cnflct		②	[Speed Ref x Sel] or [PI Reference Sel] is set to "Reserved".	
28	BrakResMissing		②	No brake resistor detected.	1. Program [Bus Reg Mode x] to not use brake. 2. Install brake resistor.
29	Anlg In Loss	① ③	①	An analog input is configured to fault on signal loss. A signal loss has occurred. Configure with [Anlg In 1, 2 Loss] on page 2-29 .	1. Check parameters. 2. Check for broken/loose connections at inputs.
30	MicroWatchdog		②	Microprocessor watchdog timeout.	1. Cycle Power. 2. Replace control.
32	Fan Cooling		②	Fan is not energized at start command.	
33	AutoReset Lim		③	Drive unsuccessfully attempted to reset a fault and resume running for the programmed number of [Fit RstRun Tries]. Enable/Disable with [Fault Config 1] on page 2-24 .	Correct the cause of the fault and manually clear.
34	CAN Bus Flt		②	Sent message not acknowledged.	1. Cycle Power. 2. Replace control.
37	HeatsinkUndTp		①	Ambient temperature is too low.	Raise ambient temperature.
44	Device Change		②	New power unit or option board installed of different type.	Clear fault and reset drive to factory defaults.
45	Device Add		②	New option board added.	Clear fault.
47	NvsReadChksum		②	Error reading [Elapsed MWh] and [Elapsed Run Time] from EEPROM.	
48	ParamsDefault		②	The drive was commanded to write default values to EEPROM.	1. Clear the fault or cycle power to the drive. 2. Program the drive parameters as needed.
50	MotorCalcData		②	Incorrect motor nameplate data.	Check motor nameplate data.
54	Zero Divide		②	This event called from arithmetical functions if divider is zero.	1. Cycle Power. 2. Replace control.
63	Shear Pin		③	Programmed [Current Lmt Val] has been exceeded. Enable/Disable with [Fault Config 1] on page 2-24 .	Check load requirements and [Current Lmt Val] setting.
65	I/O Removed		②	Option board removed.	

No.	Name	Fault Alarm	Description	Action (if appropriate)
70	Power Unit	②	One or more of the output transistors were operating in the active region instead of desaturation. This can be caused by excessive transistor current or insufficient base drive voltage.	1. Clear fault.
71	Periph Loss	②	The communications card has a fault on the network side.	1. Check DPI device event queue and corresponding fault information for the device.
81	Port DPI Loss	②	DPI port stopped communicating. A SCANport device was connected to a drive operating DPI devices at 500k baud.	1. If adapter was not intentionally disconnected, check wiring to the port. Replace wiring, port expander, adapters, Main Control Board or complete drive as required. 2. Check HIM connection. 3. If an adapter was intentionally disconnected and the [Logic Mask] bit for that adapter is set to "1", this fault will occur. To disable this fault, set the [Logic Mask] bit for the adapter to "0."
94	Hardware Enbl		Enable signal missing from control terminal block.	1. Check control wiring. 2. Check position of hardware enable jumper. 3. Check digital input programming.
95	AutoT Rs Stat	②	Autotune Rs Static Test failed.	1. Verify that motor is not rotating when autotune is enabled. 2. Check motor connections.
96	AutoT Lm Rot	②	Autotune Lm rotate test failed.	1. Check motor nameplate data. 2. Check motor connections. 3. Verify that Accel Time < (Base Speed/40) x 33 sec. Note: 33 sec. = time limit to bring motor to 40 Hz.
97	AutoT MagRot	②	Autotune magnetizing current rotate test failed.	1. Check motor nameplate data. 2. Check motor connections. 3. Verify that Accel Time < (Base Speed/40) x 33 sec. (see above).
98	AutoT Saturat	②	Autotune saturation curve test failed.	1. Check motor nameplate data. 2. Check motor connections.
99	UserSet Timer	②	User Set load or save not completed in less than 5 sec.	Replace main control.
100	Param Chksum	②	The checksum read from the board does not match the checksum calculated.	1. Restore defaults. 2. Cycle power. 3. Reload User Set if used.
104	PwrBrd Chksum	②	The checksum read from the EEPROM does not match the checksum calculated from the EEPROM data.	1. Cycle power. 2. Replace drive.
106	MCB-PB Config	②	Drive rating information stored on the power board is incompatible with the main control board.	1. Reset fault or cycle power. 2. Replace control board.
107	New IO Option	②	New option board added to control.	1. Restore defaults. 2. Reprogram parameters.
113	Fatal App	②	Fatal Application error.	1. Replace control board.

No.	Name	Fault Alarm	Description	Action (if appropriate)																																																																																																				
114	AutoT Enable	②	Autotune enabled but not started.	Press the Start key within 20 seconds of enabling autotune.																																																																																																				
120	I/O Change	②	Option board replaced.	Reset Fault.																																																																																																				
121	I/O Comm Loss	②	I/O Board lost communications with the Main Control Board.	Check connector. Check for induced noise. Replace I/O board or Main Control Board.																																																																																																				
133	DigIn CnflctA	②	<p>Digital input functions are in conflict. Combinations marked with a “⚡” will cause an alarm.</p> <p>* Jog 1 and Jog 2</p> <table border="1"> <thead> <tr> <th></th> <th>Acc2/Dec2</th> <th>Accel 2</th> <th>Decel 2</th> <th>Jog*</th> <th>Jog Fwd</th> <th>Jog Rev</th> <th>Fwd/Rev</th> </tr> </thead> <tbody> <tr> <td>Acc2 / Dec2</td> <td></td> <td>⚡</td> <td>⚡</td> <td></td> <td></td> <td></td> <td></td> </tr> <tr> <td>Accel 2</td> <td>⚡</td> <td></td> <td></td> <td></td> <td></td> <td></td> <td></td> </tr> <tr> <td>Decel 2</td> <td>⚡</td> <td></td> <td></td> <td></td> <td></td> <td></td> <td></td> </tr> <tr> <td>Jog*</td> <td></td> <td></td> <td></td> <td></td> <td>⚡</td> <td>⚡</td> <td></td> </tr> <tr> <td>Jog Fwd</td> <td></td> <td></td> <td></td> <td></td> <td></td> <td></td> <td>⚡</td> </tr> <tr> <td>Jog Rev</td> <td></td> <td></td> <td></td> <td></td> <td></td> <td></td> <td>⚡</td> </tr> <tr> <td>Fwd/Rev</td> <td></td> <td></td> <td></td> <td></td> <td>⚡</td> <td>⚡</td> <td></td> </tr> </tbody> </table>		Acc2/Dec2	Accel 2	Decel 2	Jog*	Jog Fwd	Jog Rev	Fwd/Rev	Acc2 / Dec2		⚡	⚡					Accel 2	⚡							Decel 2	⚡							Jog*					⚡	⚡		Jog Fwd							⚡	Jog Rev							⚡	Fwd/Rev					⚡	⚡																																						
	Acc2/Dec2	Accel 2	Decel 2	Jog*	Jog Fwd	Jog Rev	Fwd/Rev																																																																																																	
Acc2 / Dec2		⚡	⚡																																																																																																					
Accel 2	⚡																																																																																																							
Decel 2	⚡																																																																																																							
Jog*					⚡	⚡																																																																																																		
Jog Fwd							⚡																																																																																																	
Jog Rev							⚡																																																																																																	
Fwd/Rev					⚡	⚡																																																																																																		
134	DigIn CnflctB	②	<p>A digital Start input has been configured without a Stop input or other functions are in conflict. Combinations that conflict are marked with a “⚡” and will cause an alarm.</p> <p>* Jog 1 and Jog 2</p> <table border="1"> <thead> <tr> <th></th> <th>Start</th> <th>Stop-CF</th> <th>Run</th> <th>Run Fwd</th> <th>Run Rev</th> <th>Jog*</th> <th>Jog Fwd</th> <th>Jog Rev</th> <th>Fwd/Rev</th> </tr> </thead> <tbody> <tr> <td>Start</td> <td></td> <td></td> <td>⚡</td> <td>⚡</td> <td>⚡</td> <td></td> <td>⚡</td> <td>⚡</td> <td></td> </tr> <tr> <td>Stop-CF</td> <td></td> <td></td> <td></td> <td></td> <td></td> <td></td> <td></td> <td></td> <td></td> </tr> <tr> <td>Run</td> <td>⚡</td> <td></td> <td></td> <td>⚡</td> <td>⚡</td> <td></td> <td>⚡</td> <td>⚡</td> <td></td> </tr> <tr> <td>Run Fwd</td> <td>⚡</td> <td></td> <td>⚡</td> <td></td> <td></td> <td>⚡</td> <td></td> <td></td> <td>⚡</td> </tr> <tr> <td>Run Rev</td> <td>⚡</td> <td></td> <td>⚡</td> <td></td> <td></td> <td>⚡</td> <td></td> <td></td> <td>⚡</td> </tr> <tr> <td>Jog*</td> <td></td> <td></td> <td></td> <td>⚡</td> <td>⚡</td> <td></td> <td></td> <td></td> <td></td> </tr> <tr> <td>Jog Fwd</td> <td>⚡</td> <td></td> <td>⚡</td> <td></td> <td></td> <td></td> <td></td> <td></td> <td></td> </tr> <tr> <td>Jog Rev</td> <td>⚡</td> <td></td> <td>⚡</td> <td></td> <td></td> <td></td> <td></td> <td></td> <td></td> </tr> <tr> <td>Fwd/Rev</td> <td></td> <td></td> <td></td> <td>⚡</td> <td>⚡</td> <td></td> <td></td> <td></td> <td></td> </tr> </tbody> </table>		Start	Stop-CF	Run	Run Fwd	Run Rev	Jog*	Jog Fwd	Jog Rev	Fwd/Rev	Start			⚡	⚡	⚡		⚡	⚡		Stop-CF										Run	⚡			⚡	⚡		⚡	⚡		Run Fwd	⚡		⚡			⚡			⚡	Run Rev	⚡		⚡			⚡			⚡	Jog*				⚡	⚡					Jog Fwd	⚡		⚡							Jog Rev	⚡		⚡							Fwd/Rev				⚡	⚡					
	Start	Stop-CF	Run	Run Fwd	Run Rev	Jog*	Jog Fwd	Jog Rev	Fwd/Rev																																																																																															
Start			⚡	⚡	⚡		⚡	⚡																																																																																																
Stop-CF																																																																																																								
Run	⚡			⚡	⚡		⚡	⚡																																																																																																
Run Fwd	⚡		⚡			⚡			⚡																																																																																															
Run Rev	⚡		⚡			⚡			⚡																																																																																															
Jog*				⚡	⚡																																																																																																			
Jog Fwd	⚡		⚡																																																																																																					
Jog Rev	⚡		⚡																																																																																																					
Fwd/Rev				⚡	⚡																																																																																																			
135	DigIn CnflctC	②	<p>More than one physical input has been configured to the same input function. Multiple configurations are not allowed for the following input functions.</p> <p>Forward/Reverse Run Reverse Bus Regulation Mode B Speed Select 1 Jog Forward Acc2 / Dec2 Speed Select 2 Jog Reverse Accel 2 Speed Select 3 Run Decel 2 Run Forward Stop Mode B</p>																																																																																																					
136	BipolarCnflct	②	<p>Parameter 190 [Direction Mode] is set to “Bipolar” or “Reverse Dis” and one or more of the following digital input functions is configured: “Fwd/Reverse,” “Run Forward,” “Run Reverse,” “Jog Forward” or “Jog Reverse.”</p>																																																																																																					
143	TB Man Conflict	②	[TB Man Ref Sel] is using an analog input that is programmed for another function.	Check parameter settings to avoid problem.																																																																																																				
147	Start AtPwrUp	①	[Start At PowerUp] is enabled. Drive may start at any time within 10 seconds of drive powerup.																																																																																																					
148	IntDB OvrHeat	①	The drive has temporarily disabled the DB regulator because the resistor temperature has exceeded a predetermined value.																																																																																																					
149	Waking	①	The Wake timer is counting toward a value that will start the drive.																																																																																																					
150	Sleep Config	②	<p>Sleep/Wake configuration error. With [Sleep-Wake Mode] = “Direct,” possible causes include: drive is stopped and [Wake Level] < [Sleep Level]. “Stop=CF,” “Run,” “Run Forward,” or “Run Reverse.” is not configured in [Digital Inx Sel].</p>																																																																																																					

Table 3.B Fault/Alarm Cross Reference

Name	No.	Fault	Alarm
Anlg In Loss	29	✓	✓
AutoReset Lim	33	✓	
AutoT Enable	114	✓	
AutoT Lm Rot	96	✓	
AutoT MagRot	97	✓	
AutoT Rs Stat	95	✓	
AutoT Saturat	98	✓	
Auxiliary In	2	✓	
BipolarCnflct	136		✓
BrakResMissng	28	✓	
CAN Bus Flt	34	✓	
Decel Inhibit	24	✓	✓
Device Add	45	✓	
Device Change	44	✓	
DigIn CnflctA	133		✓
DigIn CnflctB	134		✓
DigIn CnflctC	135		✓
Fan Cooling	32	✓	
Fatal App	113	✓	
Ground Fault	13		
Hardware Enbl	94	✓	
HeatsinkOvrTp	8	✓	
HeatsinkUndTp	37	✓	
I/O Change	120	✓	
I/O Comm Loss	121	✓	
I/O Removed	65	✓	
IGBT OverTemp	9	✓	
Input Phase	17	✓	✓
IniDB OvrHeat	148		✓
InverterFault	14	✓	
Load Loss	15	✓	✓
MaxFreqCnflct	23		✓
Name	No.	Fault	Alarm
MCB-PB Config	106	✓	
MicroWatchdog	30	✓	
Motor Stall	6	✓	
Motor Therm	16	✓	✓
MotorCalcData	50	✓	
MotorOverload	7	✓	
New IO Option	107	✓	
NP Hz Cnflct	22		✓
NvsReadChksum	47	✓	
OutPhasMissng	21	✓	
OverCurrent	12	✓	
OverSpd Limit	25	✓	
OverVoltage	5	✓	
Param Chksum	100	✓	
ParamsDefault	48	✓	
Periph Loss	71	✓	
Port DPI Loss	81	✓	
Power Loss	3	✓	✓
Power Unit	70	✓	
PrechargeActv	1		✓
PwrBrd Chksum	104	✓	
Shear Pin	63	✓	
Sleep Config	150		✓
SpdRef Cnflct	27		✓
Start AtPwrUp	147		✓
System Fault	10	✓	
TB Man Conflict	143		✓
UnderVoltage	4	✓	✓
UserSet Timer	99	✓	
VHz Neg Slope	26		✓
Waking	149		✓
Zero Divide	54	✓	

Clearing Alarms

Alarms are automatically cleared when the condition that caused the alarm is no longer present.

Common Symptoms and Corrective Actions

Drive does not Start from Start or Run Inputs wired to the terminal block.

Cause(s)	Indication	Corrective Action
Drive is Faulted	Flashing red status light	Clear fault. <ul style="list-style-type: none"> • Press Stop • Cycle power • Set [Fault Clear] to 1 (See page 2-24) • “Clear Faults” on the HIM Diagnostic menu.
Incorrect input wiring. See pages Installation Manual for wiring examples. <ul style="list-style-type: none"> • 2 wire control requires Run, Run Forward, Run Reverse or Jog input. • 3 wire control requires Start and Stop inputs. • Jumper from terminal 25 to 26 is required. 	None	Wire inputs correctly and/or install jumper.
Incorrect digital input programming. <ul style="list-style-type: none"> • Mutually exclusive choices have been made (i.e., Jog and Jog Forward). • 2 wire and 3 wire programming may be conflicting. • Exclusive functions (i.e, direction control) may have multiple inputs configured. • Stop is factory default and is not wired. 	None	Program [Digital Inx Sel] for correct inputs. (See page 2-31) Start or Run programming may be missing.
	Flashing yellow status light and “DigIn CflctB” indication on LCD HIM. [Drive Status 2] shows type 2 alarm(s).	Program [Digital Inx Sel] to resolve conflicts. (See page 2-31) Remove multiple selections for the same function. Install stop button to apply a signal at stop terminal.

Drive does not Start from HIM.

Cause(s)	Indication	Corrective Action
Drive is programmed for 2 wire control. HIM Start button is disabled for 2 wire control.	None	If 2 wire control is required, no action needed. If 3 wire control is required, program [Digital Inx Sel] for correct inputs. (See page 2-31)

Drive does not respond to changes in speed command.

Cause(s)	Indication	Corrective Action
No value is coming from the source of the command.	LCD HIM Status Line indicates “At Speed” and output is 0 Hz.	1. If the source is an analog input, check wiring and use a meter to check for presence of signal. 2. Check [Commanded Speed] for correct source. (See page 2-6)
Incorrect reference source has been programmed.	None	3. Check [Speed Ref Source] for the source of the speed reference. (See page 2-22) 4. Reprogram [Speed Ref A Sel] for correct source. (See page 2-11)
Incorrect Reference source is being selected via remote device or digital inputs.	None	5. Check [Drive Status 1], page 2-21 , bits 12 and 13 for unexpected source selections. 6. Check [Dig In Status], page 2-22 to see if inputs are selecting an alternate source. 7. Reprogram digital inputs to correct “Speed Sel x” option. (See page 2-31)

Motor and/or drive will not accelerate to commanded speed.

Cause(s)	Indication	Corrective Action
Acceleration time is excessive.	None	Reprogram [Accel Time x]. (See page 2-15)
Excess load or short acceleration times force the drive into current limit, slowing or stopping acceleration.	None	Check [Drive Status 2], bit 10 to see if the drive is in Current Limit. (See page 2-21) Remove excess load or reprogram [Accel Time x]. (See page 2-15)
Speed command source or value is not as expected.	None	Check for the proper Speed Command using Steps 1 through 7 above.
Programming is preventing the drive output from exceeding limiting values.	None	Check [Maximum Speed] (See page 2-10) and [Maximum Freq] (See page 2-8) to assure that speed is not limited by programming.

Motor operation is unstable.

Cause(s)	Indication	Corrective Action
Motor data was incorrectly entered or Autotune was not performed.	None	1. Correctly enter motor nameplate data. 2. Perform "Static" or "Rotate" Autotune procedure. (Param #061, page 2-9) 3. Set gain parameters to default values.

Drive will not reverse motor direction.

Cause(s)	Indication	Corrective Action
Digital input is not selected for reversing control.	None	Check [Digital Inx Sel], page 2-31 . Choose correct input and program for reversing mode.
Digital input is incorrectly wired.	None	Check input wiring.
Direction mode parameter is incorrectly programmed.	None	Reprogram [Direction Mode], page 2-19 for analog "Bipolar" or digital "Unipolar" control.
Motor wiring is improperly phased for reverse.	None	Switch two motor leads.
A bipolar analog speed command input is incorrectly wired or signal is absent.	None	1. Use meter to check that an analog input voltage is present. 2. Check wiring. Positive voltage commands forward direction. Negative voltage commands reverse direction.

Stopping the drive results in a Decel Inhibit fault.

Cause(s)	Indication	Corrective Action
The bus regulation feature is enabled and is halting deceleration due to excessive bus voltage. Excess bus voltage is normally due to excessive regenerated energy or unstable AC line input voltages. Internal timer has halted drive operation.	Decel Inhibit fault screen. LCD Status Line indicates "Faulted".	1. See Attention statement on page P-3 . 2. Reprogram parameters 161/162 to eliminate any "Adjust Freq" selection. 3. Disable bus regulation (parameters 161 & 162) and add a dynamic brake. 4. Correct AC input line instability or add an isolation transformer. 5. Reset drive.

HIM Overview

For information on . .	See page . .
External and Internal Connections	A-1
LCD Display Elements	A-2
ALT Functions	A-2
Menu Structure	A-3
Viewing and Editing Parameters	A-5
Removing/Installing the HIM	A-6

External and Internal Connections

The PowerFlex 700H provides a number of cable connection points

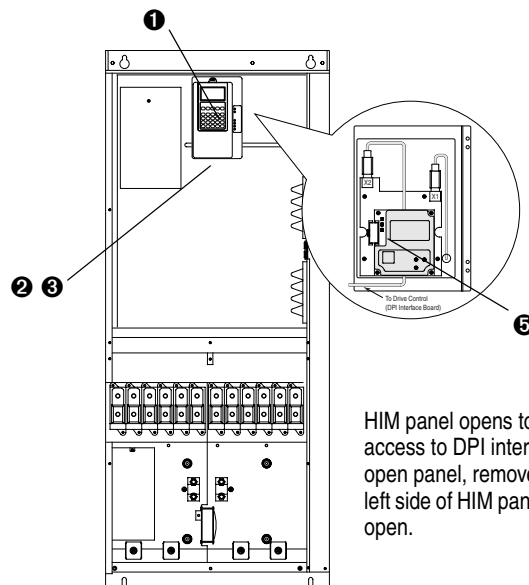

No.	Connector	Description
❶	DPI Port 1	HIM connection when installed in drive.
❷	DPI Port 2	Cable connection for handheld and remote options.
❸	DPI Port 3 or 2	Splitter cable connected to DPI Port 2 provides additional port.
❹	DPI Port 4	Not available.
❺	DPI Port 5	Cable connection for communications adapter.



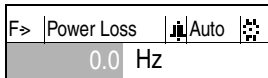





LCD Display Elements

Display	Description
	Direction Drive Status Alarm Auto/Man Information Commanded or Output Frequency
Main Menu: Diagnostics Parameter Device Select	Programming / Monitoring / Troubleshooting

ALT Functions

To use an ALT function, press the ALT key, release it, then press the programming key associated with one of the following functions:

Table A.A ALT Key Functions

ALT Key and then ...	Performs this function ...
 S.M.A.R.T.	Displays the S.M.A.R.T. screen.
 View	Allows the selection of how parameters will be viewed or detailed information about a parameter or component.
 Lang	Displays the language selection screen.
 Auto / Man	Switches between Auto and Manual Modes.
  Remove	Allows HIM removal without causing a fault if the HIM is not the last controlling device and does not have Manual control of the drive.
 Exp	Allows value to be entered as an exponent. (Not available on PowerFlex 700.)
  Param #	Allows entry of a parameter number for viewing/editing.

Menu Structure

Figure A.1 HIM Menu Structure

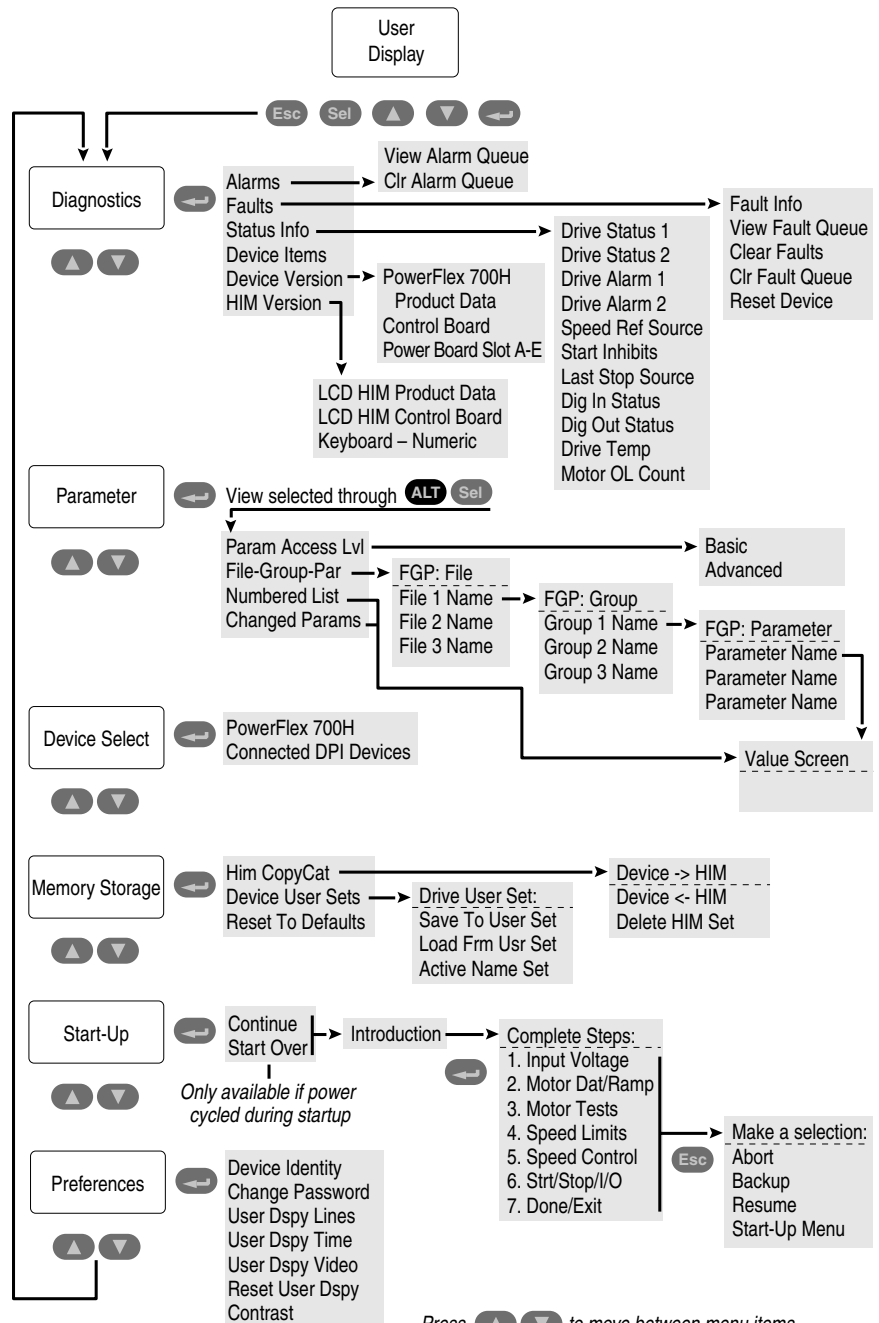

Press **▲ ▼** to move between menu items

Press **←** to select a menu item

Press **Esc** to move 1 level back in the menu structure

Press **ALT Sel** to select how to view parameters

Diagnostics Menu

When a fault trips the drive, use this menu to access detailed data about the drive.

Option	Description
Faults	View fault queue or fault information, clear faults or reset drive.
Status Info	View parameters that display status information about the drive.
Device Version	View the firmware version and hardware series of components.
HIM Version	View the firmware version and hardware series of the HIM.

Parameter Menu

Refer to [Viewing and Editing Parameters on page A-5](#).

Device Select Menu

Use this menu to access parameters in connected peripheral devices.

Memory Storage Menu

Drive data can be saved to, or recalled from, User and HIM sets. *User sets* are files stored in permanent nonvolatile drive memory. *HIM sets* are files stored in permanent nonvolatile HIM memory.

Option	Description
HIM Copycat Device -> HIM Device <- HIM	Save data to a HIM set, load data from a HIM set to active drive memory or delete a HIM set.
Device User Sets	Save data to a User set, load data from a User set to active drive memory or name a User set.
Reset To Defaults	Restore the drive to its factory-default settings.

Start Up Menu

See [Chapter 1](#).

Preferences Menu













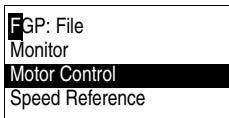

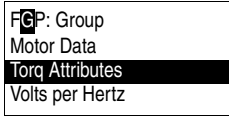

The HIM and drive have features that you can customize.

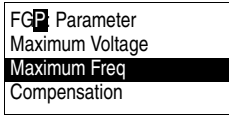
Option	Description
Drive Identity	Add text to identify the drive.
Change Password	Enable/disable or modify the password.
User Dspy Lines	Select the display, parameter, scale and text for the User Display. The User Display is two lines of user-defined data that appears when the HIM is not being used for programming.
User Dspy Time	Set the wait time for the User Display or enable/disable it.
User Dspy Video	Select Reverse or Normal video for the Frequency and User Display lines.
Reset User Dspy	Return all the options for the User Display to factory default values.

The PowerFlex 700H drive is initially set to Basic Parameter View. To view all parameters, set parameter 196 [Param Access Lvl] to option 1 “Advanced”.

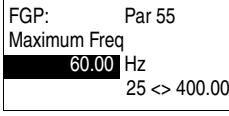
Viewing and Editing Parameters

LCD HIM

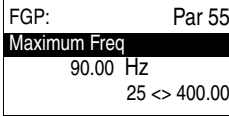

Step	Key(s)	Example Displays
1. In the Main Menu, press the Up Arrow or Down Arrow to scroll to "Parameter."	 or 	
2. Press Enter. "FGP File" appears on the top line and the first three files appear below it.		
3. Press the Up Arrow or Down Arrow to scroll through the files.	 or 	
4. Press Enter to select a file. The groups in the file are displayed under it.		
5. Repeat steps 3 and 4 to select a group and then a parameter. The parameter value screen will appear.		
6. Press Enter to edit the parameter.		
7. Press the Up Arrow or Down Arrow to change the value. If desired, press Sel to move from digit to digit, letter to letter, or bit to bit. The digit or bit that you can change will be highlighted.	 or  	
8. Press Enter to save the value. If you want to cancel a change, press Esc.		
9. Press the Up Arrow or Down Arrow to scroll through the parameters in the group, or press Esc to return to the group list.	 or  	

Numeric Keypad Shortcut

If using a HIM with a numeric keypad, press the ALT key and the +/- key to access the parameter by typing its number.

Removing/Installing the HIM The HIM can be removed or installed while the drive is powered.

Important: HIM removal is only permissible in Auto mode. If the HIM is removed while in Manual mode or the HIM is the only remaining control device, a fault will occur.

Step	Key(s)	Example Displays
To remove the HIM . . . 1. Press ALT and then Enter (Remove). The Remove HIM confirmation screen appears. 2. Press Enter to confirm that you want to remove the HIM. 3. Remove the HIM from the drive.	 + 	<div data-bbox="1081 422 1300 531" style="border: 1px solid black; padding: 5px;"> - Remove HIM - Do you wish to continue? Press Enter </div>
To install HIM . . . 1. Insert into drive or connect cable.		

Application Notes

For information on . .	See page . .
External Brake Resistor	B-1
Minimum Speed	B-1
Motor Control Technology	B-2
Motor Overload	B-3
Overspeed	B-5
Power Loss Ride Through	B-6
Process PI	B-7

For information on . .	See page . .
Reverse Speed Limit	B-9
Skip Frequency	B-10
Sleep Wake Mode	B-11
Start At PowerUp	B-12
Stop Modes	B-13
Voltage Tolerance	B-14

External Brake Resistor

Figure B.1 External Brake Resistor Circuitry

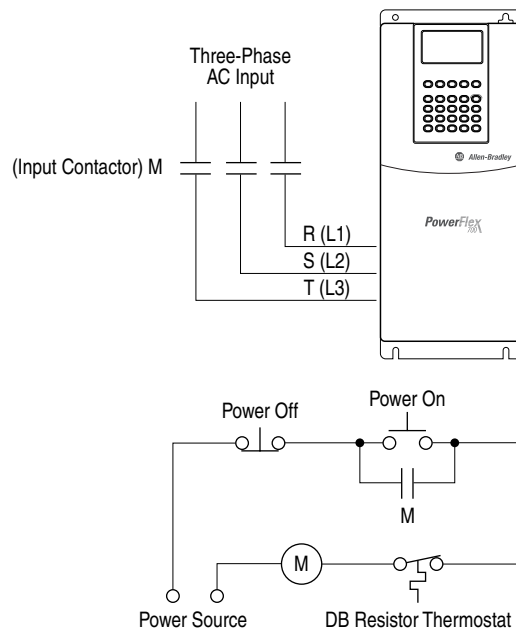

Minimum Speed

Refer to [Reverse Speed Limit on page B-9](#)

Motor Control Technology

Within the PowerFlex family there are several motor control technologies:

- Torque Producers
- Torque Controllers
- Speed Regulators

Torque Producers

Volts/Hertz

This technology follows a specific pattern of voltage and frequency output to the motor, regardless of the motor being used. The shape of the V/Hz curve can be controlled a limited amount, but once the shape is determined, the drive output is fixed to those values. Given the fixed values, each motor will react based on its own speed/torque characteristics.

This technology is good for basic centrifugal fan/pump operation and for most multi-motor applications. Torque production is generally good.

Sensorless Vector

This technology combines the basic Volts/Hertz concept with known motor parameters such as Rated FLA, HP, Voltage, stator resistance and flux producing current. Knowledge of the individual motor attached to the drive allows the drive to adjust the output pattern to the motor and load conditions. By identifying motor parameters, the drive can maximize the torque produced in the motor and extend the speed range at which that torque can be produced.

This technology is excellent for applications that require a wider speed range and applications that need maximum possible torque for breakaway, acceleration or overload. Centrifuges, extruders, conveyors and others are candidates.

Torque Controllers

Vector

This technology differs from the two above, because it actually controls or regulates torque. Rather than allowing the motor and load to actually determine the amount of torque produced, Vector technology allows the drive to regulate the torque to a defined value. By independently identifying and controlling both flux and torque currents in the motor, true control of torque is achieved. High bandwidth current regulators remain active with or without encoder feedback to produce outstanding results.

This technology is excellent for those applications where torque control, rather than mere torque production, is key to the success of the process. These include web handling, demanding extruders and lifting applications such as hoists or material handling.

Vector Control can operate in one of two configurations:

1. Encoderless

Not to be confused with Sensorless Vector above, Encoderless Vector based on Allen-Bradley's patented Field Oriented Control technology means that a feedback device is not required. Torque control can be achieved across a significant speed range without feedback.

2. Closed Loop (with Encoder)



Vector Control with encoder feedback utilizes Allen-Bradley's Force Technology™. This industry leading technology allows the drive to control torque over the entire speed range, including zero speed. For those applications that require smooth torque regulation at very low speeds or full torque at zero speed, Closed Loop Vector Control is the answer.

Speed Regulators

Any of the PowerFlex drives, regardless of their motor control technology (Volts/Hz, Sensorless Vector or Vector) can be set up to regulate speed. Speed regulation and torque regulation must be separated to understand drive operation.

The PowerFlex 70/700 with Standard Control and the PowerFlex 700H can be programmed to regulate speed using the slip compensation feature. Slip compensation reacts to load changes by adjusting the drive output frequency to maintain motor speed. Torque production operates independently. This feature produces speed regulation of about 0.5% of base speed over a specified speed range (40:1 for V/Hz and 80:1 for Sensorless Vector). These drives do not have the capability to extend the speed range or tighten the speed regulation below 0.5% because they do not have connections for a feedback device.

Motor Overload

For single motor applications the drive can be programmed to protect the motor from overload conditions. An electronic thermal overload I^2T function emulates a thermal overload relay. This operation is based on three parameters; [Motor NP FLA], [Motor OL Factor] and [Motor OL Hertz] (parameters 042, 048 and 047, respectively).

[Motor NP FLA] is multiplied by [Motor OL Factor] to allow the user to define the continuous level of current allowed by the motor thermal overload. [Motor OL Hertz] is used to allow the user to adjust the frequency below which the motor overload is derated.

The motor can operate up to 102% of FLA continuously. If the drive had just been activated, it will run at 150% of FLA for 180 seconds. If the motor had been operating at 100% for over 30 minutes, the drive will run at 150% of FLA for 60 seconds. These values assume the drive is operating above [Motor OL Hertz], and that [Motor OL Factor] is set to 1.00.

Operation below 100% current causes the temperature calculation to account for motor cooling.

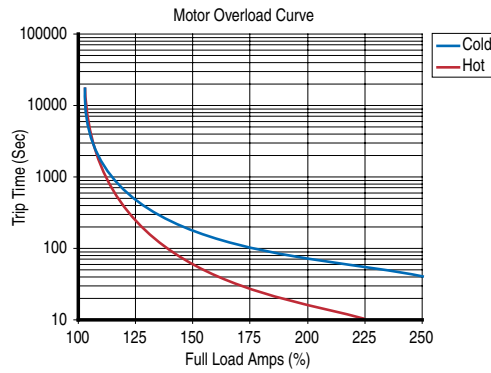

[Motor OL Hertz] defines the frequency where motor overload capacity derate should begin. The motor overload capacity is reduced when operating below [Motor OL Hertz]. For all settings of [Motor OL Hertz] other than zero, the overload capacity is reduced to 70% at an output frequency of zero.

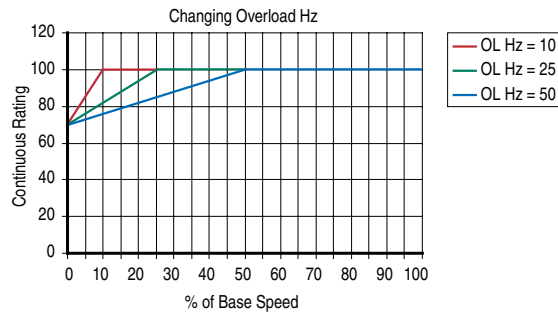

[Motor NP FLA] is multiplied by [Motor OL Factor] to select the rated current for the motor thermal overload. This can be used to raise or lower the level of current that will cause the motor thermal overload to trip. The effective overload factor is a combination of [Motor OL Hertz] and [Motor OL Factor].

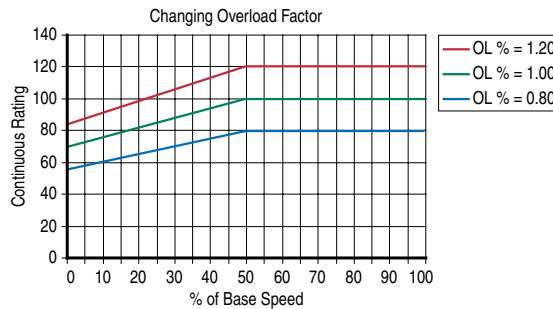

Overspeed

Overspeed Limit is a user programmable value that allows operation at maximum speed, but also provides an “overspeed band” that will allow a speed regulator such as encoder feedback or slip compensation to increase the output frequency above maximum speed in order to maintain maximum motor speed.

The figure below illustrates a typical Custom V/Hz profile. Minimum Speed is entered in Hertz and determines the lower speed reference limit during normal operation. Maximum Speed is entered in Hertz and determines the upper speed reference limit. The two “Speed” parameters only limit the speed reference and not the output frequency.

The actual output frequency at maximum speed reference is the sum of the speed reference plus “speed adder” components from functions such as slip compensation.

The Overspeed Limit is entered in Hertz and added to Maximum Speed and the sum of the two (Speed Limit) limit the output frequency. This sum (Speed Limit) must be compared to Maximum Frequency and an alarm is initiated which prevents operation if the Speed Limit exceeds Maximum Frequency.

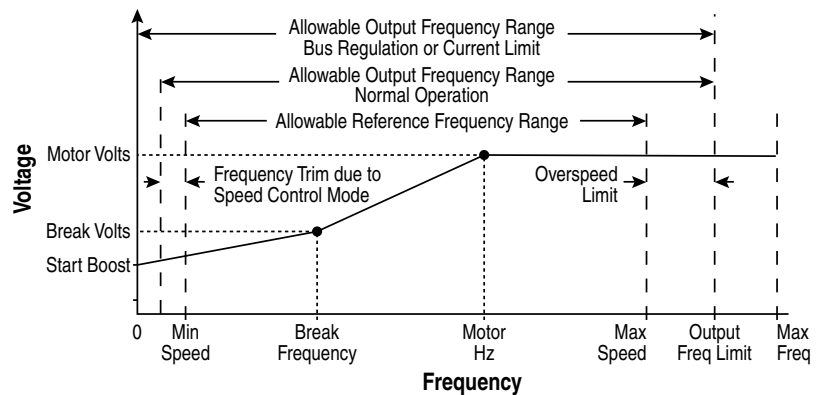

Power Loss Ride Through

When AC input power is lost, energy is being supplied to the motor from the DC bus capacitors. The energy from the capacitors is not being replaced (via the AC line), thus, the DC bus voltage will fall rapidly. The drive must detect this fall and react according to the way it is programmed.

There are three possible methods of dealing with low bus voltages:

1. “Coast” – Disable the transistors and allow the motor to coast.
2. “Decel” – Decelerate the motor at just the correct rate so that the energy absorbed from the mechanical load balances the losses.
3. “Continue” – Allow the drive to power the motor down to the undervoltage trip level.

Two parameters display DC bus voltage:

- [DC Bus Voltage] – displays the instantaneous value.
- [DC Bus Memory] – displays an estimate of the full-load DC bus voltage.

All drive reactions to power loss are based on either a fixed percentage of [DC Bus Memory], a fixed DC bus voltage, or a user-programmable DC bus voltage. The selected power loss mode determines which trigger levels are available, and the choice of voltage levels is made by “toggling” a digital input programmed to “Pwr Loss Lvl.”

If “Continue” is selected, the drive will ignore a loss of DC bus voltage and continue to run the motor until the drive trips on an Undervoltage Fault (F004).

If “Decel” is selected, there is a choice of two levels for recognizing a power loss. If a digital input is programmed for “Pwr Loss Lvl” but is not energized, or no input is programmed, the drive will recognize a power loss at 80% of [DC Bus Memory]. If a digital input is programmed for “Pwr Loss Lvl” and the input is energized, a power loss will be recognized at the value of [Power Loss Volts].

If “Coast” is selected, there is a choice of two levels for recognizing a power loss. If a digital input is programmed for “Pwr Loss Lvl” but is not energized, or no input is programmed, the drive will recognize a power loss at 73% of [DC Bus Memory]. If a digital input is programmed for “Power Loss Lvl” and the input is energized, a power loss will be recognized at the value of [Power Loss Volts].

Figure B.2 Power Loss Mode = Coast

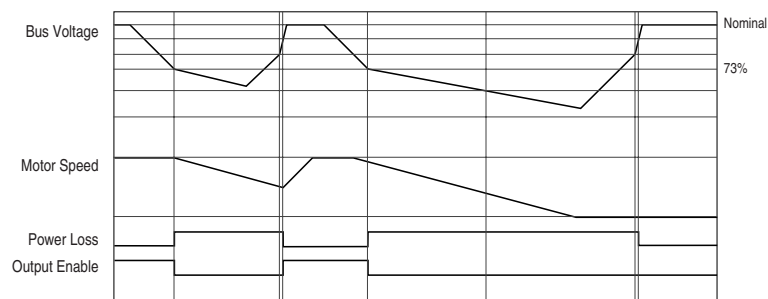
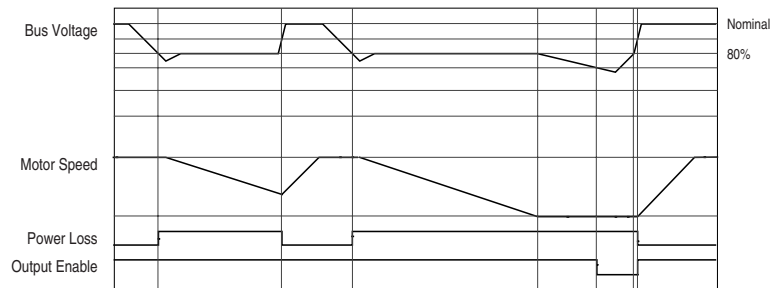

Figure B.3 Power Loss Mode = Decel

Process PI

The internal PI function of the PowerFlex 700 provides closed loop process control with proportional and integral control action. The function is designed for use in applications that require simple control of a process without external control devices. The PI function allows the microprocessor of the drive to follow a single process control loop.

The PI function reads a process variable input to the drive and compares it to a desired setpoint stored in the drive. The algorithm will then adjust the output of the PI regulator, changing drive output frequency to try and make the process variable equal the setpoint.

It can operate as trim mode by summing the PI loop output with a master speed reference.

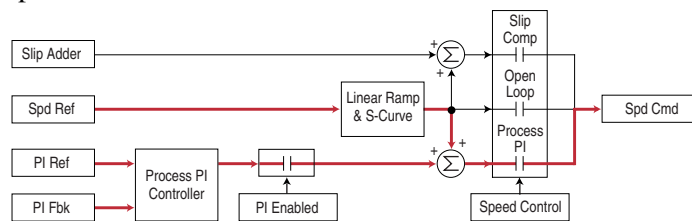

Or, it can operate as control mode by supplying the entire speed reference. This method is identified as “exclusive mode”

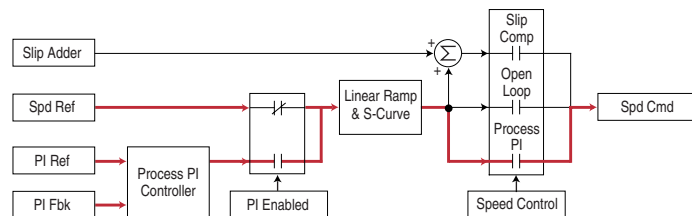

PI Enable

The output of the PI loop can be turned on (enabled) or turned off (disabled). This control allows the user to determine when the PI loop is providing part or all of the commanded speed. The logic for enabling the PI loop is shown below.

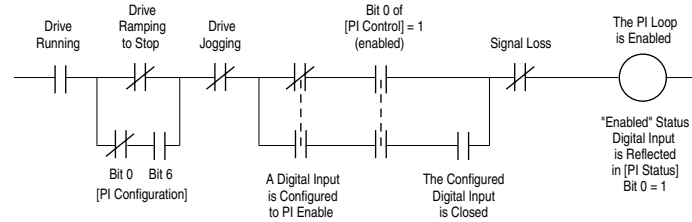

The drive must be running for the PI loop to be enabled. The loop will be disabled when the drive is ramping to a stop (unless “Stop Mode” is configured in [PI Configuration]), jogging or the signal loss protection for the analog input(s) is sensing a loss of signal.

If a digital input has been configured to “PI Enable,” two events are required to enable the loop: the digital input must be closed AND bit 0 of the PI Control parameter must be = 1.

If no digital input is configured to “PI Enable,” then only the Bit 0 = 1 condition must be met. If the bit is permanently set to a “1”, then the loop will become enabled as soon as the drive goes into “run”.

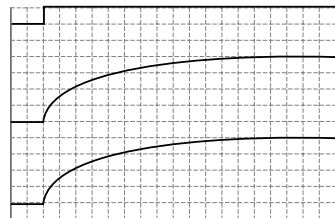

PI Pre-load Value = 0

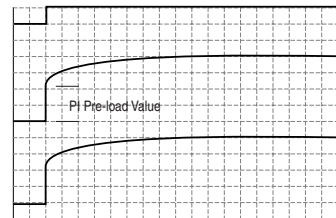

PI Pre-load Value > 0

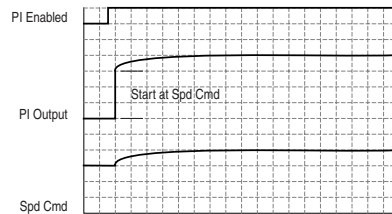

Pre-load to Command Speed

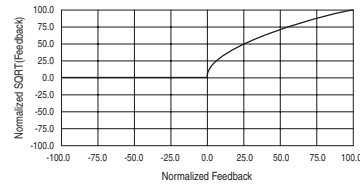
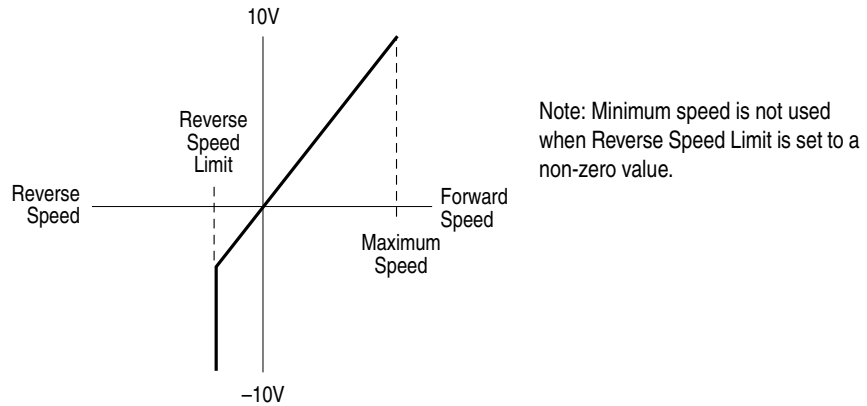
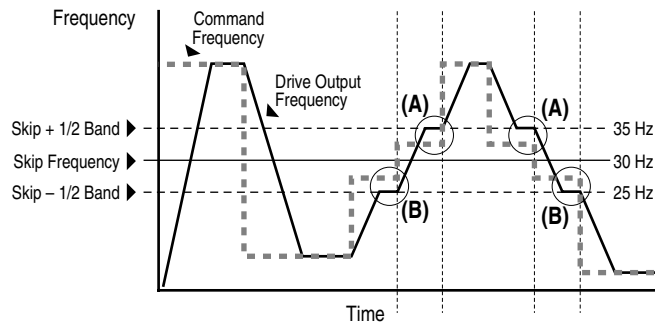

Figure B.5 [Rev Speed Limit], parameter 454 set to a non-zero Value



Skip Frequency

Figure B.6 Skip Frequency



Some machinery may have a resonant operating frequency that must be avoided to minimize the risk of equipment damage. To assure that the motor cannot continuously operate at one or more of the points, skip frequencies are used. Parameters 084-086, ([Skip Frequency 1-3]) are available to set the frequencies to be avoided.

The value programmed into the skip frequency parameters sets the center point for an entire “skip band” of frequencies. The width of the band (range of frequency around the center point) is determined by parameter 87, [Skip Freq Band]. The range is split, half above and half below the skip frequency parameter.

If the commanded frequency of the drive is greater than or equal to the skip (center) frequency and less than or equal to the high value of the band (skip plus 1/2 band), the drive will set the output frequency to the high value of the band. See (A) in [Figure B.6](#).

If the commanded frequency is less than the skip (center) frequency and greater than or equal to the low value of the band (skip minus 1/2 band), the drive will set the output frequency to the low value of the band. See (B) in [Figure B.6](#).

Acceleration and deceleration are not affected by the skip frequencies. Normal accel/decel will proceed through the band once the commanded frequency is greater than the skip frequency. See (A) & (B) in [Figure B.6](#). This function affects only continuous operation within the band.

Skip Frequency Examples

The skip frequency will have hysteresis so the output does not toggle between high and low values. Three distinct bands can be programmed. If none of the skip bands touch or overlap, each band has its own high/low limit.

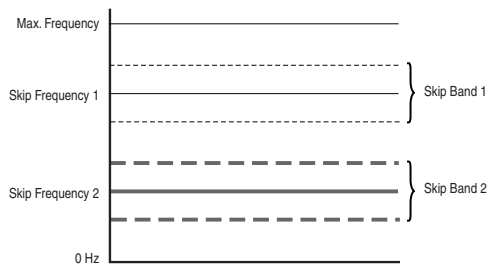

If skip bands overlap or touch, the center frequency is recalculated based on the highest and lowest band values.

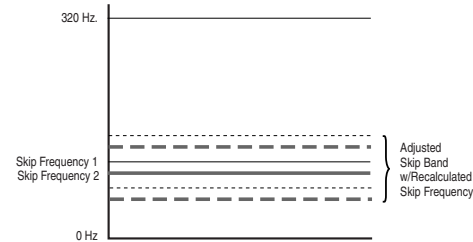

If a skip band(s) extend beyond the max frequency limits, the highest band value will be clamped at the max frequency limit. The center frequency is recalculated based on the highest and lowest band values.

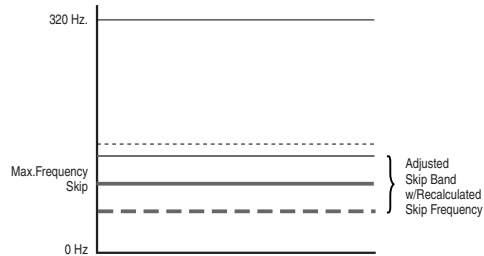

If the band is outside the limits, the skip band is inactive.

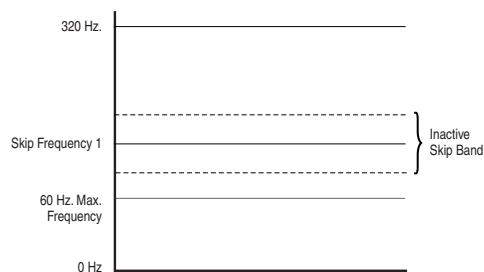

Sleep Wake Mode

This function stops (sleep) and starts (wake) the drive based on separately configurable analog input levels rather than discrete start and stop signals. The drive will start (wake) when an analog signal is greater than or equal to the user specified [Wake Level], and stop the drive when an analog signal is less than or equal to the user specified [Sleep Level].

Definitions

- Wake - A start command generated when the analog input value remains above [Wake Level] for a time greater than [Wake Time].
- Sleep - A Stop command generated when the analog input value remains below [Sleep Level] for a time greater than [Sleep Time].
- Speed Reference – The active speed command to the drive as selected by drive logic and [Speed Ref x Sel].
- Start Command - A command generated by pressing the Start button on the HIM, closing a digital input programmed for Start, Run, Run Forward or Run Reverse.

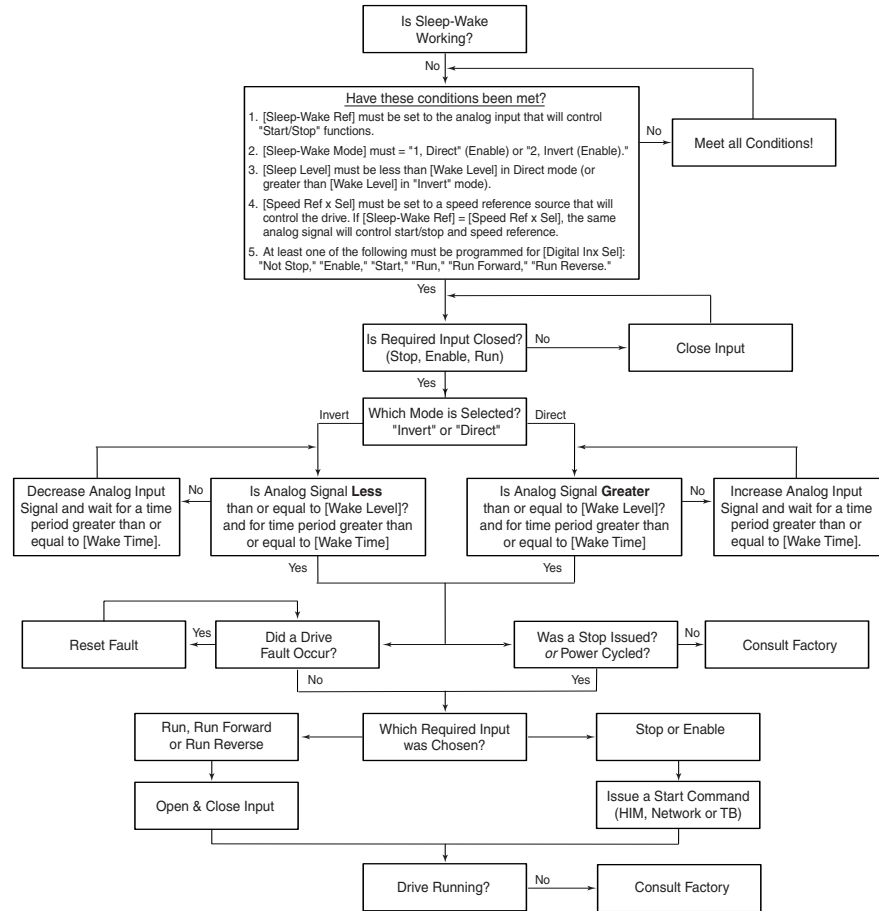

Start At PowerUp

A powerup delay time of up to 30 seconds can be programmed through [Powerup Delay], parameter 167. After the time expires, the drive will start if all of the start permissive conditions are met. Before that time, restart is not possible.

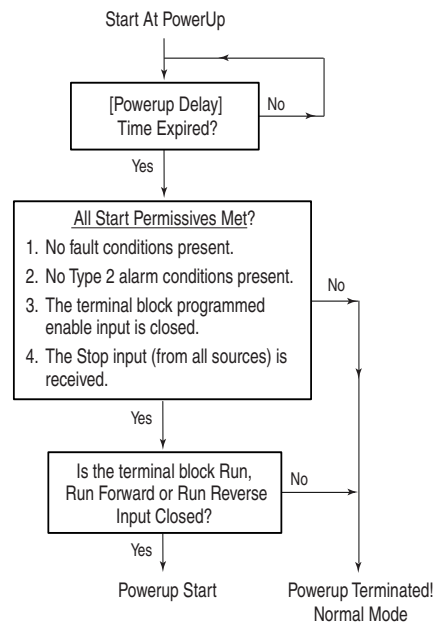

Stop Modes

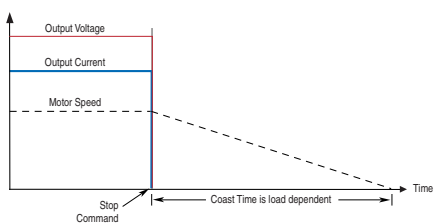
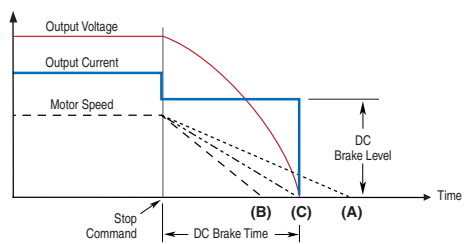
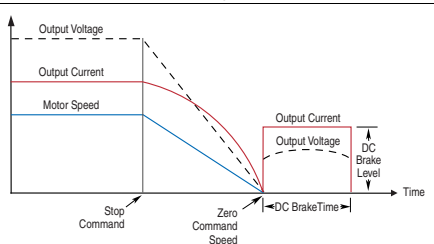
Mode	Description
Coast	 <p>This method releases the motor and allows the load to stop by friction.</p> <ol style="list-style-type: none"> 1. On Stop, the drive output goes immediately to zero (off). 2. No further power is supplied to the motor. The drive has released control. 3. The motor will coast for a time that is dependent on the mechanics of the system (inertia, friction, etc).
DC Brake	 <p>This method uses DC injection of the motor to Stop and/or hold the load.</p> <ol style="list-style-type: none"> 1. On Stop, 3 phase drive output goes to zero (off) 2. Drive outputs DC voltage on the last used phase at the level programmed in [DC Brake Level] Par 158. This voltage causes a “stopping” brake torque. If the voltage is applied for a time that is longer than the actual possible stopping time, the remaining time will be used to attempt to hold the motor at zero speed. 3. DC voltage to the motor continues for the amount of time programmed in [DC Brake Time] Par 159. Braking ceases after this time expires. 4. After the DC Braking ceases, no further power is supplied to the motor. The motor may or may not be stopped. The drive has released control. 5. The motor, if rotating, will coast from its present speed for a time that is dependent on the mechanics of the system (inertia, friction, etc).
Ramp	 <p>This method uses drive output reduction to stop the load.</p> <ol style="list-style-type: none"> 1. On Stop, drive output will decrease according to the programmed pattern from its present value to zero. The pattern may be linear or squared. The output will decrease to zero at the rate determined by the programmed [Maximum Freq] and the programmed active [Decel Time x] 2. The reduction in output can be limited by other drive factors such as such as bus or current regulation. 3. When the output reaches zero the output is shut off. 4. DC voltage is applied to the motor for a time equal to [DC Brake Time] at [DC Brake Level].

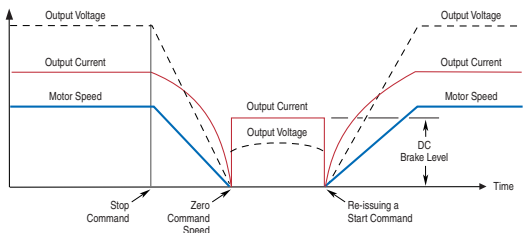
Mode	Description
Hold	 <p>This method combines two of the methods above. It uses drive output reduction to stop the load and DC injection to hold the load at zero speed once it has stopped.</p> <ol style="list-style-type: none"> 1. On Stop, drive output will decrease according to the programmed pattern from its present value to zero. The pattern may be linear or squared. The output will decrease to zero at the rate determined by the programmed [Maximum Freq] and the programmed active [Decel Time x] 2. The reduction in output can be limited by other drive factors such as bus or current regulation. 3. When the output reaches zero 3 phase drive output goes to zero (off) and the drive outputs DC voltage on the last used phase at the level programmed in [DC Brake Level] Par 158. This voltage causes a “holding” brake torque. 4. DC voltage to the motor continues until a Start command is reissued or the drive is disabled. 5. If a Start command is reissued, DC Braking ceases and the drive returns to normal AC operation. If an Enable command is removed, the drive enters a “not ready” state until the enable is restored.

Voltage Tolerance

Drive Rating	Nominal Line Voltage	Nominal Motor Voltage	Drive Full Power Range	Drive Operating Range
200-240	200	200†	200-264	180-264
	208	208	208-264	
	240	230	230-264	
380-400	380	380†	380-528	342-528
	400	400	400-528	
	480	460	460-528	
500-600	600	575†	575-660	432-660

Drive Full Power Range = Nominal Motor Voltage to Drive Rated Voltage + 10%.
 Rated current is available across the entire Drive Full Power Range.

Drive Operating Range = Lowest† Nominal Motor Voltage - 10% to Drive Rated Voltage + 10%.
 Drive Output is linearly derated when Actual Line Voltage is less than the Nominal Motor Voltage.

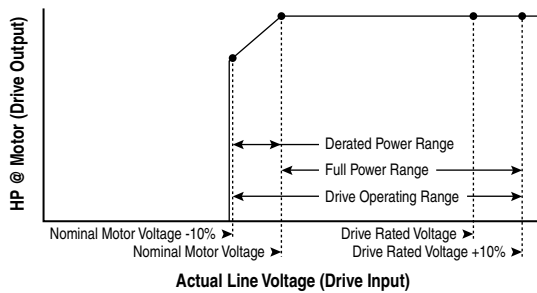

Example:

Calculate the maximum power of a 5 HP, 460V motor connected to a 480V rated drive supplied with 342V Actual Line Voltage input.

- Actual Line Voltage / Nominal Motor Voltage = 74.3%
- $74.3\% \times 5 \text{ HP} = 3.7 \text{ HP}$
- $74.3\% \times 60 \text{ Hz} = 44.6 \text{ Hz}$

At 342V Actual Line Voltage, the maximum power the 5 HP, 460V motor can produce is 3.7 HP at 44.6 Hz.

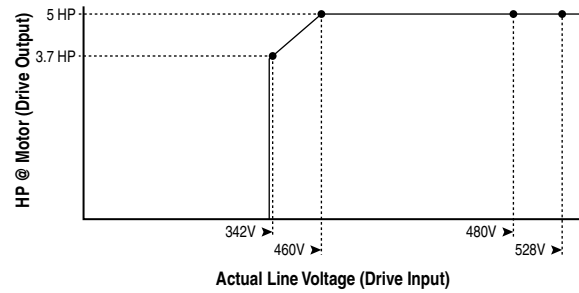

Notes

A

Accel Mask, **2-27**
Accel Owner, **2-28**
Accel Time x, **2-15**
Alarm & Fault Types, **3-1**
Alarm 1 @ Fault, **2-23**
Alarm 2 @ Fault, **2-24**
Alarm Clear, **2-25**
Alarm Config 1, **2-25**
Alarm x Code, **2-25**
Alarms Group, **2-25**
Alarms, Clearing, **3-8**
ALT Key
 Functions, **A-2**
ALT Key Functions, **A-2**
Analog In x Hi, **2-29**
Analog In x Lo, **2-29**
Analog Inputs Group, **2-29**
Analog Inx Value, **2-6**
Analog Out Scale, **2-30**
Analog Out1 Hi, **2-30**
Analog Out1 Lo, **2-30**
Analog Out1 Sel, **2-30**
Analog Out2 Lo, **2-30**
Analog Out2 Sel, **2-30**
Analog Outputs Group, **2-29**
Anlg In Config, **2-29**
Anlg In Loss, **2-29**
Anlg In Sqr Root, **2-29**
Anlg Out Absolut, **2-30**
Anlg Out Config, **2-29**
Anlg Out Setpt, **2-30**
Assisted Start Up, **1-3**
Auto Rstrt Delay, **2-17**
Auto Rstrt Tries, **2-17**
Auto-Reset/Start, **3-1**
Autotune, **2-9**

B

Before Applying Power, **1-1**
Brake
 Dynamic, **2-16**
Break Frequency, **2-9**

Break Voltage, **2-9**
Bus Capacitors, Discharging, **P-2**
Bus Reg Kd, **2-16**
Bus Reg Ki, **2-16**
Bus Reg Kp, **2-16**
Bus Reg Mode A, **2-16**
Bus Reg Mode B, **2-16**

C

Capacitors
 Bus, Discharging, **P-2**
Checklist, Start-Up, **1-1**
Clear Fault Owner, **2-28**
Clearing Alarms, **3-8**
Clearing Faults, **3-3**
Comm Control Group, **2-26**
Commanded Speed, **2-6**
Common Symptoms and Corrective Action,
 3-9
Communication File, **2-26**
Control SW Ver, **2-7**
Conventions, Manual, **P-2**
Copycat, **A-4**
Cross Reference, Parameter
 by Name, **2-34**
 by Number, **2-36**
Current Lmt Gain, **2-15**
Current Lmt Sel, **2-15**
Current Lmt Val, **2-15**

D

Data In Ax, **2-28**
Data Out Ax, **2-28**
Data, Saving, **A-4**
Datalinks Group, **2-28**
DB Resistor Type, **2-16**
DC Brake Level, **2-16**
DC Brake Time, **2-16**
DC Brk Levl Sel, **2-15**
DC Bus Memory, **2-6**
DC Bus Voltage, **2-6**
Decel Mask, **2-27**
Decel Owner, **2-28**

Decel Time x, **2-15**
Diagnostic Data, Viewing, **A-4**
Diagnostics Group, **2-21**
Dig In Status, **2-2, 2-22**
Dig Out Setpt, **2-31**
Dig Out Status, **2-23**
Dig Outx Level, **2-33**
Dig Outx OffTime, **2-33**
Dig Outx OnTime, **2-33**
Digital Inputs Group, **2-31**
Digital Inx Sel, **2-31**
Digital Outputs Group, **2-31**
Digital Outx Sel, **2-32**
Direction Config Group, **2-19**
Direction Mask, **2-27**
Direction Mode, **2-19**
Direction Owner, **2-27**
DPI Port Locations, **A-1**
DPI Port Sel, **2-26**
DPI Port Value, **2-26**
Drive Alarm 1, **2-21**
Drive Alarm 2, **2-21, 2-22**
Drive Checksum, **2-21**
Drive Data Group, **2-7**
Drive Logic Rslt, **2-26**
Drive Memory Group, **2-20**
Drive OL Mode, **2-15**
Drive Ramp Rslt, **2-26**
Drive Ref Rslt, **2-26**
Drive Status 1, **2-21**
Drive Temp, **2-23**
DriveExecutive, **2-1**
DriveExplorer, **2-1**
Droop RPM @ FLA, **2-15**
Dynamic Brake
 Resistor Selection, **2-16**
 Setup, **2-16**
Dynamic Control File, **2-15**

E

Editing Parameters, **2-1**
Elapsed MWH, **2-6**
Elapsed Run Time, **2-6**
ESD, Static Discharge, **P-2**

External Brake Resistor, **B-1**

F

Fault & Alarm Types, **3-1**
Fault 1 Time, **2-25**
Fault Amps, **2-23**
Fault Bus Volts, **2-23**
Fault Clear, **2-24**
Fault Clear Mode, **2-24**
Fault Clr Mask, **2-27**
Fault Config x, **2-24**
Fault Descriptions, **3-3**
Fault Frequency, **2-23**
Fault Queue, **A-4**
Fault x Code, **2-24**
Faults Group, **2-24**
Faults, Clearing, **3-3**
Feedback Select, **2-10**
FGP, **2-3**
File
 Communication, **2-26**
 Dynamic Control, **2-15**
 Inputs & Outputs, **2-29**
 Monitor, **2-6**
 Motor Control, **2-7**
 Speed Command, **2-10**
 Utility, **2-19**
File-Group-Parameter, **2-3**
Flux Current, **2-6**
Flux Current Ref, **2-9**
Flux Up Mode, **2-8**
Flux Up Time, **2-8**
Flying Start En, **2-17**
Functions, ALT Key, **A-2**

G

General Precautions, **P-2**
Group
 Alarms, **2-25**
 Analog Inputs, **2-29**
 Analog Outputs, **2-29**
 Comm Control, **2-26**
 Datalinks, **2-28**
 Diagnostics, **2-21**
 Digital Inputs, **2-31**
 Digital Outputs, **2-31**

Direction Config, **2-19**
Drive Data, **2-7**
Drive Memory, **2-20**
Faults, **2-24**
HIM Ref Config, **2-19**
Load Limits, **2-15**
Masks & Owners, **2-26**
Metering, **2-6**
MOP Config, **2-20**
Motor Data, **2-7**
Power Loss, **2-19**
Process PI, **2-13**
Ramp Rates, **2-15**
Restart Modes, **2-17**
Slip Comp, **2-13**
Spd Mode & Limits, **2-10**
Speed References, **2-11**
Speed Trim, **2-12**
Stop/Brake Modes, **2-15**
Torq Attributes, **2-8**
Volts per Hertz, **2-9**

H

HIM Menu Structure, **A-4**
HIM Menus
 Diagnostics, **A-4**
 Memory Storage, **A-4**
 Preferences, **A-4**
HIM Ref Config Group, **2-19**
HIM, Removing/Installing, **A-6**

I

Inputs & Outputs File, **2-29**
IR Voltage Drop, **2-9**

J

Jog Mask, **2-27**
Jog Owner, **2-27**
Jog Speed, **2-12**

L

Language, **2-21**
Last Stop Source, **2-22**
LCD HIM
 Menus, **A-4**
LEDs, **1-2, 3-2**

Linear List, **2-3**
Load Frm Usr Set, **2-2, 2-20**
Load Limits Group, **2-15**
Local Mask, **2-27**
Local Owner, **2-28**
Logic Mask, **2-26**

M

Man Ref Preload, **2-20**
Manual Conventions, **P-2**
Masks & Owners Group, **2-26**
Maximum Freq, **2-8**
Maximum Speed, **2-10**
Menu Structure, HIM, **A-4**
Metering Group, **2-6**
Minimum Speed, **2-10, B-1**
MOD LED, **1-2, 3-2**
Monitor File, **2-6**
MOP Config Group, **2-20**
MOP Mask, **2-27**
MOP Owner, **2-28**
MOP Rate, **2-20**
MOP Reference, **2-6**
Motor Cntl Sel, **2-8**
Motor Control File, **2-7**
Motor Control Technology, **B-2**
Motor Data Group, **2-7**
Motor NP FLA, **2-7**
Motor NP Hertz, **2-7**
Motor NP Power, **2-7**
Motor NP RPM, **2-2, 2-7**
Motor NP Volts, **2-7**
Motor OL Count, **2-23**
Motor OL Factor, **2-8**
Motor OL Hertz, **2-8**
Motor Overload, **B-3**
Motor Poles, **2-8**
Motor Type, **2-7**

N

NET LED, **1-2, 3-2**
Non-Resettable, **3-1**

O

Operator Interface, **A-5**
 Output Current, **2-6**
 Output Freq, **2-6**
 Output Power, **2-6**
 Output Powr Fctr, **2-6**
 Output Voltage, **2-6**
 Overspeed, **B-5**
 Overspeed Limit, **2-10**

P

Param Access Lvl, **2-20**

Parameter

Changing/Editing, **A-5**
 Descriptions, **2-1**
 File-Group-Parameter Organization, **2-3**
 Linear List, **2-3**
 Viewing, **A-5**

Parameter Cross Reference

by Name, **2-34**
 by Number, **2-36**

Parameter View

Advanced
 Vector Control, **2-4**
 Basic
 Vector Control, **2-3**

Parameters

Accel Mask, **2-27**
 Accel Owner, **2-28**
 Accel Time x, **2-15**
 Alarm 1 @ Fault, **2-23**
 Alarm 2 @ Fault, **2-24**
 Alarm Clear, **2-25**
 Alarm Config 1, **2-25**
 Alarm x Code, **2-25**
 Analog In x Hi, **2-29**
 Analog In x Lo, **2-29**
 Analog Inx Value, **2-6**
 Analog Out Scale, **2-30**
 Analog Out1 Hi, **2-30**
 Analog Out1 Lo, **2-30**
 Analog Out1 Sel, **2-30**
 Analog Out2 Hi, **2-30**
 Analog Out2 Lo, **2-30**
 Analog Out2 Sel, **2-30**
 Anlg In Config, **2-29**
 Anlg In Loss, **2-29**
 Anlg In Sqr Root, **2-29**

Anlg Out Absolut, **2-30**
 Anlg Out Config, **2-29**
 Anlg Out Setpt, **2-30**
 Auto Rstrt Delay, **2-17**
 Auto Rstrt Tries, **2-17**
 Autotune, **2-9**
 Break Frequency, **2-9**
 Break Voltage, **2-9**
 Bus Reg Kd, **2-16**
 Bus Reg Ki, **2-16**
 Bus Reg Kp, **2-16**
 Bus Reg Mode A, **2-16**
 Bus Reg Mode B, **2-16**
 Clear Fault Owner, **2-28**
 Commanded Speed, **2-6**
 Control SW Ver, **2-7**
 Current Lmt Gain, **2-15**
 Current Lmt Sel, **2-15**
 Current Lmt Val, **2-15**
 Data In Ax, **2-28**
 Data Out Ax, **2-28**
 DB Resistor Type, **2-16**
 DC Brake Level, **2-16**
 DC Brake Time, **2-16**
 DC Brk Lvl Sel, **2-15**
 DC Bus Memory, **2-6**
 DC Bus Voltage, **2-6**
 Decel Mask, **2-27**
 Decel Owner, **2-28**
 Decel Time x, **2-15**
 Dig In Status, **2-2, 2-22**
 Dig Out Setpt, **2-31**
 Dig Out Status, **2-23**
 Dig Outx Level, **2-33**
 Dig Outx OffTime, **2-33**
 Dig Outx OnTime, **2-33**
 Digital Inx Sel, **2-31**
 Digital Outx Sel, **2-32**
 Direction Mask, **2-27**
 Direction Mode, **2-19**
 Direction Owner, **2-27**
 DPI Port Sel, **2-26**
 DPI Port Value, **2-26**
 Drive Alarm 1, **2-21**
 Drive Alarm 2, **2-21, 2-22**
 Drive Checksum, **2-21**
 Drive Logic Rslt, **2-26**
 Drive OL Mode, **2-15**
 Drive Ramp Rslt, **2-26**
 Drive Ref Rslt, **2-26**
 Drive Status 1, **2-21**

Drive Temp, **2-23**
Droop RPM @ FLA, **2-15**
Elapsed MWH, **2-6**
Elapsed Run Time, **2-6**
Fault 1 Time, **2-25**
Fault Amps, **2-23**
Fault Bus Volts, **2-23**
Fault Clear, **2-24**
Fault Clear Mode, **2-24**
Fault Clr Mask, **2-27**
Fault Config x, **2-24**
Fault Frequency, **2-23**
Fault x Code, **2-24**
Feedback Select, **2-10**
Flux Current, **2-6**
Flux Current Ref, **2-9**
Flux Up Mode, **2-8**
Flux Up Time, **2-8**
Flying Start En, **2-17**
IR Voltage Drop, **2-9**
Jog Mask, **2-27**
Jog Owner, **2-27**
Jog Speed, **2-12**
Language, **2-21**
Last Stop Source, **2-22**
Load Frm Usr Set, **2-2, 2-20**
Local Mask, **2-27**
Local Owner, **2-28**
Logic Mask, **2-26**
Man Ref Preload, **2-20**
Maximum Freq, **2-8**
Maximum Speed, **2-10**
Minimum Speed, **2-10**
MOP Mask, **2-27**
MOP Owner, **2-28**
MOP Rate, **2-20**
MOP Reference, **2-6**
Motor Cntl Sel, **2-8**
Motor NP FLA, **2-7**
Motor NP Hertz, **2-7**
Motor NP Power, **2-7**
Motor NP RPM, **2-2, 2-7**
Motor NP Volts, **2-7**
Motor OL Count, **2-23**
Motor OL Factor, **2-8**
Motor OL Hertz, **2-8**
Motor Poles, **2-8**
Motor Type, **2-7**
Output Current, **2-6**
Output Freq, **2-6**
Output Power, **2-6**
Output Powr Fctr, **2-6**
Output Voltage, **2-6**
Overspeed Limit, **2-10**
Param Access Lvl, **2-20**
PI Configuration, **2-13**
PI Control, **2-13**
PI Error Meter, **2-14**
PI Fdback Meter, **2-14**
PI Feedback Hi, **2-14**
PI Feedback Lo, **2-14**
PI Feedback Sel, **2-13**
PI Integral Time, **2-14**
PI Lower Limit, **2-14**
PI Output Meter, **2-14**
PI Preload, **2-14**
PI Prop Gain, **2-14**
PI Ref Meter, **2-14**
PI Reference Hi, **2-14**
PI Reference Lo, **2-14**
PI Reference Sel, **2-13**
PI Setpoint, **2-13**
PI Status, **2-14**
PI Upper Limit, **2-14**
Power Loss Mode, **2-19**
Power Loss Time, **2-19**
Power Loss Volts, **2-19**
Powerup Delay, **2-17**
PowerUp Marker, **2-24**
Preset Speed x, **2-12**
Pulse Input Ref, **2-12**
PWM Frequency, **2-15**
Ramped Speed, **2-7**
Rated Amps, **2-7**
Rated kW, **2-7**
Rated Volts, **2-7**
Reference Mask, **2-27**
Reference Owner, **2-27**
Reset Meters, **2-20**
Reset To Defaults, **2-20**
Rev Speed Limit, **2-11**
S Curve %, **2-15**
Save HIM Ref, **2-19**
Save MOP Ref, **2-20**
Save To User Set, **2-20**
Skip Freq Band, **2-11**
Skip Frequency x, **2-10**
Sleep Level, **2-18**
Sleep Time, **2-19**
Sleep-Wake Mode, **2-18**
Sleep-Wake Ref, **2-18**
Slip RPM @ FLA, **2-13**

- Slip RPM Meter, **2-13**
 - Speed Feedback, **2-7**
 - Speed Ref A Hi, **2-11**
 - Speed Ref A Lo, **2-11**
 - Speed Ref A Sel, **2-11**
 - Speed Ref B Hi, **2-11**
 - Speed Ref B Lo, **2-11**
 - Speed Ref B Sel, **2-11**
 - Speed Ref Source, **2-22**
 - Speed Reference, **2-7**
 - Speed Units, **2-10**
 - Speed/Torque Mod, **2-11**
 - Start At PowerUp, **2-17**
 - Start Inhibits, **2-22**
 - Start Mask, **2-27**
 - Start Owner, **2-27**
 - Start/Acc Boost, **2-9**
 - Status 1 @ Fault, **2-23**
 - Stop Owner, **2-27**
 - Stop/BRK Mode x, **2-15**
 - SV Boost Filter, **2-8**
 - TB Man Ref Hi, **2-12**
 - TB Man Ref Lo, **2-12**
 - TB Man Ref Sel, **2-12**
 - Torque Current, **2-6**
 - Trim Hi, **2-13**
 - Trim In Select, **2-12**
 - Trim Lo, **2-13**
 - Trim Out Select, **2-12**
 - Voltage Class, **2-21**
 - Wake Level, **2-18**
 - Wake Time, **2-18**
 - PI Configuration, **2-13**
 - PI Control, **2-13**
 - PI Error Meter, **2-14**
 - PI Fdback Meter, **2-14**
 - PI Feedback Hi, **2-14**
 - PI Feedback Lo, **2-14**
 - PI Feedback Sel, **2-13**
 - PI Integral Time, **2-14**
 - PI Lower Limit, **2-14**
 - PI Output Meter, **2-14**
 - PI Preload, **2-14**
 - PI Prop Gain, **2-14**
 - PI Ref Meter, **2-14**
 - PI Reference Hi, **2-14**
 - PI Reference Lo, **2-14**
 - PI Reference Sel, **2-13**
 - PI Setpoint, **2-13**
 - PI Status, **2-14**
 - PI Upper Limit, **2-14**
 - PORT LED, **1-2, 3-2**
 - Ports, DPI Type, **A-1**
 - Power Loss Group, **2-19**
 - Power Loss Mode, **2-19**
 - Power Loss Ride Through, **B-6**
 - Power Loss Time, **2-19**
 - Power Loss Volts, **2-19**
 - PowerFlex Reference Manual, **P-1**
 - Powering Up the Drive, **1-1**
 - Powerup Delay, **2-17**
 - PowerUp Marker, **2-24**
 - Precautions, General, **P-2**
 - Preferences, Setting, **A-4**
 - Preset Speed x, **2-12**
 - Process PI
 - Standard Control, **B-7**
 - Process PI Group, **2-13**
 - Programming, **2-1**
 - Publications, Reference, **P-1**
 - Pulse Input Ref, **2-12**
 - PWM Frequency, **2-15**
 - PWR LED, **1-2, 3-2**
- ## R
- Ramp Rates Group, **2-15**
 - Ramped Speed, **2-7**
 - Rated Amps, **2-7**
 - Rated kW, **2-7**
 - Rated Volts, **2-7**
 - Reference Manual, **P-1**
 - Reference Mask, **2-27**
 - Reference Material, **P-1**
 - Reference Owner, **2-27**
 - Reset Meters, **2-20**
 - Reset To Defaults, **2-20**
 - Reset to Defaults, HIM, **A-4**
 - Restart Modes Group, **2-17**
 - Rev Speed Limit, **2-11**
 - Reverse Speed Limit, **B-9**

S

S Curve %, **2-15**
 S.M.A.R.T. Start Up, **1-3**
 Save HIM Ref, **2-19**
 Save MOP Ref, **2-20**
 Save To User Set, **2-20**
 Saving Data, **A-4**
 Setting Preferences, **A-4**
 Skip Freq Band, **2-11**
 Skip Frequency, **B-10**
 Skip Frequency x, **2-10**
 Sleep Level, **2-18**
 Sleep Time, **2-19**
 Sleep Wake Mode, **B-11**
 Sleep-Wake Mode, **2-18**
 Sleep-Wake Ref, **2-18**
 Slip Comp Group, **2-13**
 Slip RPM @ FLA, **2-13**
 Slip RPM Meter, **2-13**
 Spd Mode & Limits Group, **2-10**
 Speed Command File, **2-10**
 Speed Feedback, **2-7**
 Speed Ref A Hi, **2-11**
 Speed Ref A Lo, **2-11**
 Speed Ref A Sel, **2-11**
 Speed Ref B Hi, **2-11**
 Speed Ref B Lo, **2-11**
 Speed Ref B Sel, **2-11**
 Speed Ref Source, **2-22**
 Speed Reference, **2-7**
 Speed References Group, **2-11**
 Speed Trim Group, **2-12**
 Speed Units, **2-10**
 Speed/Torque Mod, **2-11**
 Start At PowerUp, **2-17, B-12**
 Start Inhibits, **2-22**
 Start Mask, **2-27**
 Start Owner, **2-27**
 Start/Acc Boost, **2-9**
 Start-Up
 Assisted, **1-3**
 Checklist, **1-1**
 S.M.A.R.T., **1-3**
 Static Discharge, ESD, **P-2**

Status 1 @ Fault, **2-23**
 Status LEDs, **1-2, 3-2**
 Stop Modes, **B-13**
 Stop Owner, **2-27**
 Stop/Brake Modes Group, **2-15**
 Stop/BRK Mode x, **2-15**
 STS LED, **1-2, 3-2**
 SV Boost Filter, **2-8**

T

TB Man Ref Hi, **2-12**
 TB Man Ref Lo, **2-12**
 TB Man Ref Sel, **2-12**
 Torq Attributes Group, **2-8**
 Torque Current, **2-6**
 Trim Hi, **2-13**
 Trim In Select, **2-12**
 Trim Lo, **2-13**
 Trim Out Select, **2-12**
 Troubleshooting, **3-1**

U

User Configurable Alarm, **3-1**
 User Sets, **A-4**
 Utility File, **2-19**

V

Viewing and Changing Parameters, **A-5**
 Voltage Class, **2-21**
 Voltage Tolerance, **B-14**
 Volts per Hertz Group, **2-9**

W

Wake Level, **2-18**
 Wake Time, **2-18**
 Web Sites, see *WWW, World Wide Web*
 WWW, World Wide Web, **P-1**

Notes

www.rockwellautomation.com

Corporate Headquarters

Rockwell Automation, 777 East Wisconsin Avenue, Suite 1400, Milwaukee, WI, 53202-5302 USA, Tel: (1) 414.212.5200, Fax: (1) 414.212.5201

Headquarters for Allen-Bradley Products, Rockwell Software Products and Global Manufacturing Solutions

Americas: Rockwell Automation, 1201 South Second Street, Milwaukee, WI 53204-2496 USA, Tel: (1) 414.382.2000, Fax: (1) 414.382.4444

Europe/Middle East/Africa: Rockwell Automation SA/NV, Vorstlaan/Boulevard du Souverain 36, 1170 Brussels, Belgium, Tel: (32) 2 663 0600, Fax: (32) 2 663 0640

Asia Pacific: Rockwell Automation, 27/F Citicorp Centre, 18 Whitfield Road, Causeway Bay, Hong Kong, Tel: (852) 2887 4788, Fax: (852) 2508 1846

Headquarters for Dodge and Reliance Electric Products

Americas: Rockwell Automation, 6040 Ponders Court, Greenville, SC 29615-4617 USA, Tel: (1) 864.297.4800, Fax: (1) 864.281.2433

Europe/Middle East/Africa: Rockwell Automation, Brühlstraße 22, D-74834 Elztal-Dallau, Germany, Tel: (49) 6261 9410, Fax: (49) 6261 17741

Asia Pacific: Rockwell Automation, 55 Newton Road, #11-01/02 Revenue House, Singapore 307987, Tel: (65) 6356-9077, Fax: (65) 6356-9011

U.S. Allen-Bradley Drives Technical Support

Tel: (1) 262.512.8176, Fax: (1) 262.512.2222, Email: support@drives.ra.rockwell.com, Online: www.ab.com/support/abdrives