



VS1CTD

Cooling Tower Drive

Any trademarks used in this manual are the property of their respective owners.

Important:

Be sure to check www.baldor.com for the latest software, firmware and drivers for your VS1 product. Also, you can download the latest version of this manual in Adobe Acrobat PDF format.

Chapter 1

Introduction

1.1	Getting Assistance from Baldor	1-1
1.2	Safety Notice	1-1
1.3	Quick Start.....	1-3

Chapter 2

General Information and Ratings

2.1	Limited Warranty.....	2-1
-----	-----------------------	-----

Chapter 3

Installing the Drive

3.1	Receiving & Inspection	3-1
3.2	General Requirements for the Installation Site.....	3-1
3.2.1	Environmental Instructions	3-1
3.2.2	Minimum Mounting Clearances	3-1
3.3	Mounting the Drive.....	3-1
3.3.1	Protecting the Drive from Debris.....	3-2
3.3.2	Watts Loss Data	3-2
3.4	Cover Removal	3-2

Chapter 4

Power Wiring

4.1	Grounding the Drive.....	4-1
4.1.1	Ungrounded Distribution System	4-1
4.1.2	Input Power Conditioning	4-1
4.2	Line Impedance	4-2
4.1.2	Line Reactors.....	4-2
4.1.2	Load Reactors	4-2
4.3	Line Disconnect	4-2
4.4	Protective Devices	4-2
4.5	Reduced Input Voltage Considerations	4-3
4.6	Electrical Installation	4-3
4.7	Optional Filter/Reactor.....	4-3
4.8	3 Phase Power and Motor Connections	4-5
4.9	Operating a 3 Phase Contol on Single Phase Input Power	4-6
4.9.1	Single Phase Power Derating	4-6
4.10	M-Contactor	4-8
4.11	Optional Dynamic Brake Hardware	4-9

4.12	External Trip Input	4-9
Chapter 5		
Control Wiring		
5.1	Control Board Connections.....	5-1
5.2	Analog Inputs.....	5-2
5.2.1	Analog Input 1.....	5-3
5.2.2	Analog Input 2.....	5-3
5.3	Analog Outputs.....	5-4
5.4	Opto Isolated Inputs.....	5-4
5.5	Operating Modes	5-5
5.5.1	Keypad.....	5-5
5.5.2	Standard Run 2Wire	5-6
5.5.3	Standard Run 3Wire	5-7
5.5.4	15 Preset Speeds	5-8
5.5.5	Fan Pump 2Wire.....	5-9
5.5.6	Fan Pump 3Wire.....	5-10
5.5.7	Process Control	5-11
5.5.8	3 Speed Analog 2Wire	5-12
5.5.9	3 Speed Analog 3Wire	5-13
5.5.10	E-POT 2Wire	5-14
5.5.11	E-POT 3Wire	5-15
5.5.12	Network.....	5-16
5.5.13	Profile Run	5-17
5.5.14	Bipolar.....	5-18
5.5.15	PLC.....	5-20
5.5.16	CTD 2Wire	5-21
5.5.17	CTD 3Wire	5-24
5.6	Digital Outputs	5-27
5.7	Relay Outputs.....	5-27
5.8	USB Port.....	5-28

5.9	Communication Expansion Boards	5-29
5.9.1	RS485 Modbus	5-27
5.10	Opto-Isolated Inputs	5-30
5.11	Opto-Isolated Outputs.....	5-30
5.12	Pre-Operation Checklist	5-31
5.13	Powerup Procedure	5-31
5.14	Mint WorkBench	5-32
5.14.1	Install USB Driver	5-32
5.14.2	Install Mint WorkBench	5-33
5.14.3	Update Firmware	5-35

Chapter 6

Using the Keypad

6.1	Keypad Components	6-1
6.1.1	Display Description	6-1
6.1.2	Display features	6-2
6.2	Status Mode.....	6-3
6.3	Menu Display	6-4
6.4	Basic Params	6-5
6.5	Save Parameter Values.....	6-8
6.6	Restore Parameter Values	6-9
6.7	Advanced Prog	6-10
6.7.1	Modified Parameters.....	6-11
6.7.2	Linear List	6-11
6.8	Event Log.....	6-13
6.9	Diagnostics	6-13
6.10	Display Options.....	6-15
6.11	Operating the Control from the Keypad	6-16
6.11.1	Accessing the Keypad JOG Command	6-16
6.11.2	Speed Adjustment using Local Speed Reference	6-16

Chapter 7

Parameter Descriptions

7.1	Level 1 Parameters (ADVANCED PROG, LEVEL 1 BLOCKS).....	7-1
7.2	Level 2 Parameters (ADVANCED PROG, LEVEL 2 BLOCKS)	7-17
7.3	Level 3 Parameters (ADVANCED PROG, LEVEL 3 BLOCKS).....	7-28

Chapter 8	
Customizing for Your Application	
8.1 Customizing for your Application	8-1
Chapter 9	
TroubleShooting	
9.1 Event Log.....	9-1
9.2 Diagnostic Information	9-6
9.3 Fault Messages	9-9
9.4 Electrical Noise Considerations	9-14
Chapter 10	
PLC Mode Description	
10.1 Overview.....	10-1
10.2 Configuring Parameters.....	10-1
10.3 Comparator Function	10-2
10.4 Timers	10-3
10.5 PLC Mode as Standard Run Two Wire	10-11
10.6 PLC Mode as 15 Preset Speed Mode	10-12
10.7 PLC Mode as Process PID Mode	10-13
10.8 PLC Mode as a Modified Process PID Mode	10-14
Chapter 11	
Composite Reference Description	
11.1 Overview.....	11-1
11.2 Composite Reference Examples	11-2
Chapter 12	
Monitor and RTC Description	
12.1 Monitor Parameters (P0001 to P0818).....	12-1
12.2 Real Time Clock (RTC) Overview.....	12-6
Appendix A	
Technical Specifications	
A.1 Specifications for Power Terminal Block Wiring.....	A-4
A.2 Identifying the Drive by Model Number	A-5
A.3 Storage Guidelines.....	A-6
A.4 VS1CTD Ratings, Model Numbers and Frame Sizes	A-6

Appendix B

Parameter Tables

B.1	Level 1 Parameters (Advanced PROG, Level 1 Blocks)	B-1
B.2	Level 2 Parameters (Advanced PROG, Level 2 Blocks)	B-9
B.3	Level 3 Parameters (Advanced PROG, Level 3 Blocks)	B-13

Appendix C

CE Guidelines

CE Guidelines	C-1
---------------	-----

Appendix D

Options and Kits

D.1	Dynamic Braking (DB) Hardware	D-1
D.2	Expansion Boards	D-2
D.3	Keypad Extension Cables	D-3
D.4	Keypad Connector	D-3
D.5	Optional Remote Keypad Installation	D-4

Appendix E

Remote Keypad Mounting Template

Remote Keypad Mounting Template	E-1
---------------------------------	-----

Chapter 1

Introduction

The VS1CTD is a drive designed specifically for controlling cooling tower fans. The PWM control algorithms present in the VS1CTD firmware are unique in their ability to control RPMAC motors utilizing interior permanent magnet (IPM) construction. These motors are designed for direct drive applications thus eliminating the need for right angle gearboxes and long drive shafts with their associated mechanical components. The technology in this drive will operate these motors without the need for an encoder or resolver thus further simplifying the installation, setup and maintenance of the system.

The information in this manual supports firmware version 1.22.

This manual is intended for qualified electrical personnel familiar with installing, programming, and maintaining AC Drives. This manual contains information on:

- Installing and wiring the VS1CTD drive
- Programming the drive
- Troubleshooting the drive

1.1 Getting Assistance from Baldor

For technical assistance, contact your Baldor District Office. Before calling, please review the troubleshooting section of this manual. You will be asked for the drive model number or catalog number that is located on the Nameplate along with the drive serial number.

1.2 Safety Notice

This equipment contains voltages that may be as high as 1000 volts! Electrical shock can cause serious or fatal injury. Only qualified personnel should attempt the start-up procedure or troubleshoot this equipment.

This equipment may be connected to other machines that have rotating parts or parts that are driven by this equipment. Improper use can cause serious or fatal injury. Only qualified personnel should attempt the start-up procedure or troubleshoot this equipment.

Precautions: Classifications of cautionary statements

WARNING: Indicates a potentially hazardous situation which, if not avoided, could result in injury or death.

CAUTION: Indicates a potentially hazardous situation which, if not avoided, could result in damage to property

Precautions

WARNING: Do not touch any circuit board, power device or electrical connection before you first ensure that power has been disconnected and there is no high voltage present from this equipment or other equipment to which it is connected. Electrical shock can cause serious or fatal injury. Only qualified personnel should attempt the start-up procedure or troubleshoot this equipment.

WARNING: Be sure that you are completely familiar with the safe operation of this equipment. This equipment may be connected to other machines that have rotating parts or parts that are controlled by this equipment. Improper use can cause serious or fatal injury. Only qualified personnel should attempt the start-up procedure or troubleshoot this equipment.

- WARNING:** Do not use motor overload relays with an automatic reset feature. These are dangerous since the process may injure someone if a sudden or unexpected automatic restart occurs. If manual reset relays are not available, disable the automatic restart feature using external control wiring.
- WARNING:** This unit has an automatic restart feature that will start the motor whenever input power is applied and a RUN (FWD or REV) command is issued. If an automatic restart of the motor could cause injury to personnel, the automatic restart feature should be disabled.
- WARNING:** Be sure the system is properly grounded before applying power. Do not apply AC power before you ensure that all grounding instructions have been followed. Electrical shock can cause serious or fatal injury.
- WARNING:** Do not remove cover for at least five (5) minutes after AC power is disconnected to allow capacitors to discharge. Dangerous voltages are present inside the equipment. Electrical shock can cause serious or fatal injury.
- WARNING:** Improper operation of control may cause violent motion of the motor shaft and driven equipment. Be certain that unexpected motor shaft movement will not cause injury to personnel or damage to equipment. Certain failure modes of the control can produce peak torque of several times the rated motor torque.
- WARNING:** Motor circuit may have high voltage present whenever AC power is applied, even when motor is not rotating. Electrical shock can cause serious or fatal injury.
- WARNING:** Dynamic brake resistors may generate enough heat to ignite combustible materials. Keep all combustible materials and flammable vapors away from brake resistors.
- WARNING:** The motor shaft will rotate during the autotune procedure. Be certain that unexpected motor shaft movement will not cause injury to personnel or damage to equipment.
- Caution:** Disconnect motor leads (T1, T2 and T3) from control before you perform a dielectric withstand (insulation) test on the motor. Failure to disconnect motor from the control will result in extensive damage to the control. The control is tested at the factory for high voltage/leakage resistance as part of the Underwriters Laboratory requirements.
- Caution:** Suitable for use on a circuit capable of delivering not more than the RMS symmetrical short circuit amperes listed here at rated voltage.
- | <u>Horsepower</u> | <u>RMS Symmetrical Amperes</u> |
|-------------------|--------------------------------|
| 1-50 | 5,000 |
| 51-200 | 10,000 |
| 201-400 | 18,000 |
| 401-600 | 30,000 |
| 601-900 | 42,000 |
- Caution:** Do not connect AC power to the Motor terminals T1, T2 AND T3. Connecting AC power to these terminals may result in damage to the control.
- Caution:** Baldor does not recommend using "Grounded Leg Delta" transformer supplies that may create ground loops. Instead, we recommend using a four wire Wye.
- Caution:** Do not supply any power to the External Trip (motor thermostat) leads at TH1 and TH2. Power on these leads can damage the control. Use a dry contact type that requires no external power to operate.
- Caution:** If the Dynamic Brake (DB) hardware mounting is in any position other than vertical, the DB hardware must be derated by 35% of its rated capacity.

- Caution:** Before external Dynamic Brake Hardware is added, the internal resistor must be disconnected. Remove the resistor from the B+/R1 and R2 terminals and insulate the leads to avoid accidental connection to drive circuitry. The external resistor can be connected across these terminals. Failure to remove the internal resistor will decrease the total resistance (parallel connection) and cause damage.
- Caution:** Do not set Level 2, Drive Configure, Power Input parameter to Common Bus if AC power is connected to L1, L2 or L3. Common Bus requires numerous changes. Contact Baldor for information.
- Caution:** Only Baldor cables should be used to connect the keypad and control. These are special twisted pair cables to protect the control and keypad. Damage associated with other cable types are not covered by the Baldor warranty.
- Caution:** If an M-Contactor is installed, the control must be disabled for at least 200msec before the M-Contactor is opened. If the M-Contactor is opened while the control is supplying voltage and current to the motor, the control may be damaged. Before the control is enabled, the M-Contactor must be closed for at least 200msec.
- Caution:** Use of power correction capacitors on the output of the drive can result in erratic operation of the motor, nuisance tripping, and/or permanent damage to the drive. Remove power correction capacitors before proceeding. Failure to observe this precaution could result in damage to, or destruction of, the equipment.

1.3 Quick Start

If you are an experienced user of Baldor controls, you are probably already familiar with the keypad programming and keypad operation methods. If so, this quick start guide has been prepared for you. This procedure will help get your system up and running in the keypad mode quickly and allows motor and control operation to be verified. This procedure assumes that the Control, Motor and Dynamic Brake hardware are correctly installed (see Chapters 3, 4, and 5 for procedures) and that you have an understanding of the keypad programming and operation procedures. Figure 1-1 shows minimum connection requirements. It is not necessary to wire the terminal strip to operate in Keypad mode (Chapter 5 describes terminal strip wiring procedures).

The quick start procedure is as follows:

1. Read the Safety Notice and Precautions in this Chapter.
2. Mount the control. Refer to Chapters 3, 4, and 5 "Physical Location" procedure.
3. Connect AC power (Figure 1-1).
4. Connect the motor (Figure 1-1). Do not couple the motor shaft to the load until auto tune is complete.
5. Install Dynamic brake hardware, if required. Refer to Chapter 4 "Optional Dynamic Brake Hardware."

Caution: After completing the installation but before you apply power, be sure to check the following electrical items:

1. Verify AC line voltage at source matches control rating.
2. Inspect all power connections for accuracy, workmanship and torques as well as compliance to codes.
3. Verify control and motor are grounded to each other and the control is connected to earth ground.
4. Check all signal wiring for accuracy.
5. Be certain all brake coils, contactors and relay coils have noise suppression. This should be an R-C filter for AC coils and reverse polarity diodes for DC coils. MOV type transient suppression is not adequate.

Caution: Make sure that unexpected operation of the motor shaft during start up will not cause injury to personnel or damage to equipment.

Procedure - Initial Conditions

Be sure the Control, Motor and Dynamic Brake hardware are wired according to the procedures described in Chapters 4 and 5 of this manual. Become familiar with the keypad programming and keypad operation of the control as described in Chapter 6 of this manual.

1. Remove all power from the control.
2. Verify that any enable inputs to J2-8 are open (remove factory jumper from J2-8 to J3-24).
3. Disconnect the motor from the load (including coupling or inertia wheels).
4. Turn power on. Be sure there are no faults displaying.
5. Select "Advanced Prog", "Level 2 Blocks", "Drive Config" and set the parameter "Factory Settings" to "Yes". This will change all parameters to Factory Default.
6. Set the Level 2 Drive Limits block, "OPERATING ZONE" parameter as desired. (STD CONST TQ, STD VAR TQ, QUIET CONST TQ or QUIET VAR TQ).
7. If external dynamic brake hardware is used, set the Level 2 Brake Adjust block "Resistor Ohms" and "Resistor Watts" parameters (see parameter description in Chapter 7 for more information).
8. Enable the control (J2-8 connect to J3-24).

Caution: The motor shaft will rotate during this procedure. Be certain that unexpected motor shaft movement will not cause injury to personnel or damage to equipment.

9. Select Basic Params from the main keypad menu. Perform each step including motor data and "Calc Motor Model".
10. Remove all power from the control.
11. Couple the motor to its load.
12. Verify freedom of motion of motor shaft.
13. Verify the motor coupling is tight without backlash.
14. Verify the holding brakes, if any, are properly adjusted to fully release and set to the desired torque value.
15. Turn power on. Be sure no errors are displayed.
16. Run the drive from the keypad using one of the following: the arrow keys for direct speed control, a keypad entered speed or the JOG mode.
17. Select and program additional parameters to suit your application.

The control is now ready for use in the keypad mode. If a different operating mode is desired, refer to Chapter 5 Operating Modes and Chapter 6 and 7 for Programming and Operation.

For more advanced tuning of the drive speed loop once coupled to the load, see "Speed Loop Tune" in "Autotune Block" in Chapter 7.

Figure 1-1: Minimum Connection Diagram

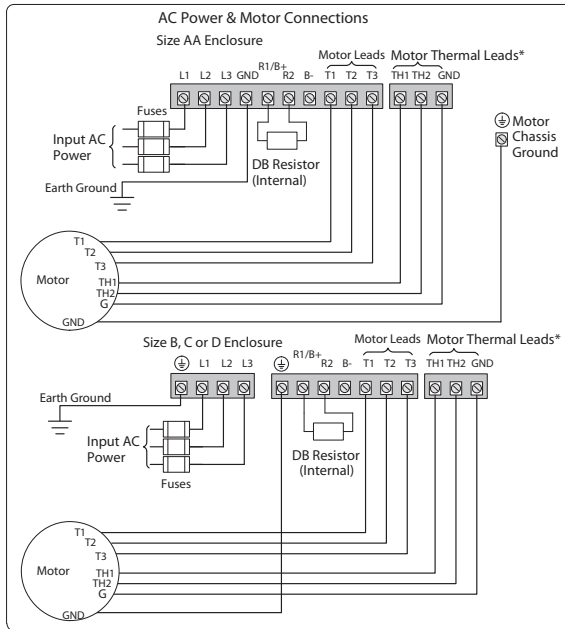
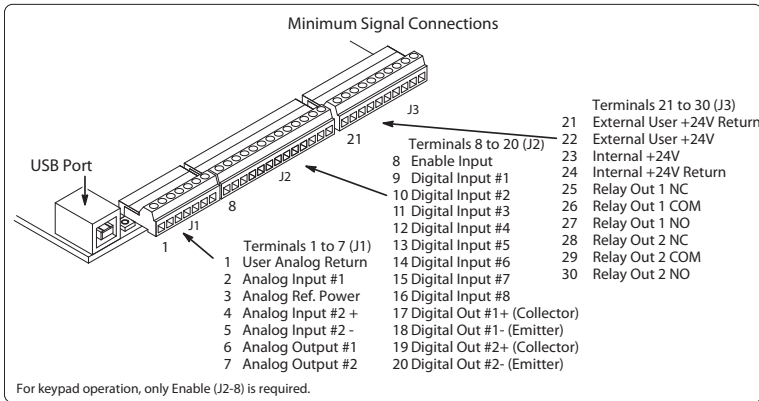

Note: The control enable input must be active to allow operation. Therefore, J2-8 Enable is connected by a factory installed jumper to J3-24. This uses the internal supply and provides an active low at J2-8.

* Remove TH1 and TH2 jumper if Motor Thermal Leads are connected.

Note: An open circuit on these terminals will generate a motor overtemperature fault. Refer to the fault / troubleshooting information provided in Chapter 9.

* See figure 4-3 for terminal arrangement for size E enclosure

Chapter 2

General Information

The VS1CTD control uses flux vector technology. Flux vector technology (sometimes referred to as Field Oriented Control) is a closed loop control scheme using an algorithm to adjust the frequency and phase of voltage and current applied to a three phase interior permanent magnet motor.

The control's rated output power is based on the use of a Baldor IPM Motor and operation at nominal rated input voltage. The control may be programmed by the user to operate in two different operating zones: standard or quiet variable torque. It can also be configured to operate in a number of modes depending upon the application requirements and user preference. It is the responsibility of the user to determine the optimum operating zone and mode to interface the control to the application. These choices are made with the keypad as explained in Chapter 6 of this manual.

Limited Warranty

For a period of two (2) years from the date of original purchase, BALDOR will repair or replace without charge controls and accessories which our examination proves to be defective in material or workmanship. This warranty is valid if the unit has not been tampered with by unauthorized persons, misused, abused, or improperly installed and has been used in accordance with the instructions and/or ratings supplied. This warranty is in lieu of any other warranty or guarantee expressed or implied. BALDOR shall not be held responsible for any expense (including installation and removal), inconvenience, or consequential damage, including injury to any person or property caused by items of our manufacture or sale. (Some states do not allow exclusion or limitation of incidental or consequential damages, so the above exclusion may not apply.) In any event, BALDOR's total liability, under all circumstances, shall not exceed the full purchase price of the control. Claims for purchase price refunds, repairs, or replacements must be referred to BALDOR with all pertinent data as to the defect, the date purchased, the task performed by the control, and the problem encountered. No liability is assumed for expendable items such as fuses.

Goods may be returned only with written notification including a BALDOR Return Authorization Number and any return shipments must be prepaid.

Chapter 3

Installing the Drive

This chapter provides information that must be considered when planning a VS1CTD drive installation and provides drive mounting information and installation site requirements.

3.1 Receiving & Inspection

When you receive your control, there are several things you should do immediately.

1. Observe the condition of the shipping container and report any damage immediately to the commercial carrier that delivered your control.
2. Remove the control from the shipping container and remove all packing materials from the control. The container and packing materials may be retained for future shipment.
3. Verify that the part number of the control you received is the same as the part number listed on your purchase order.
4. Inspect the control for external physical damage that may have been sustained during shipment and report any damage immediately to the commercial carrier that delivered your control.
5. If the control is to be stored for several weeks before use, make sure that it is stored in a location that conforms to published storage humidity and temperature specifications stated in this manual.

3.2 General Requirements for the Installation Site

It is important to ensure that the drive's environment and operating conditions are satisfactory. The area behind the drive must be kept clear of all control and power wiring. Power connections may create electromagnetic fields that may interfere with control wiring or components when run in close proximity to the drive.

Read the recommendations in the following sections before continuing with the drive installation.

3.2.1 Environmental Instructions

Before deciding on an installation site, consider the following guidelines:

- Protect the cooling fan by avoiding dust or metallic particles.
- Do not expose the drive to a corrosive atmosphere.
- Protect the drive from moisture and direct sunlight.
- Verify that the drive location will meet the environmental conditions specified in table 3-1.

Table 3-1: Ambient Temperatures and Mounting Clearances

Ambient Temperature		Enclosure Rating	Minimum Mounting Clearances Top, Bottom, Left & Right Sides
Minimum	Maximum		
-10°C (14°F)	45°C (113°F)	NEMA 1	2 in (50mm)

3.2.2 Minimum Mounting Clearances

Be sure to provide proper top, bottom and side clearance (2" minimum on each side).

3.3 Mounting the Drive

Mount the drive upright on a flat, vertical surface. Avoid mounting the drive in locations that would subject the drive to vibration in excess of the 0.5G RMS rating (e.g. adjacent to a large punch press).

3.3.1 Protecting the Drive from Debris

The drive must be protected from debris falling through the drive vents during installation and operation. The drive is designed to operate in NEMA1 Type installations. The atmosphere must not contain airborne particles that can collect on the internal circuitry of the drive, especially conductive particles.

3.3.2 Watts Loss Data

Table 3-2: Watts Loss Data

Enclosure Size	480VAC	
	4kHz PWM	8.0kHz PWM
AA, B, C, D and E	50Watts + (20 W/Amp)	50Watts + (26 W/Amp)

Example: At 4 kHz, a 30hp, 480VAC control draws 45.1Amps. Watts loss = 50W + (45.1x20) = 952Watts

3.4 Cover Removal

To connect power and signal wires, the cover must be removed. This procedure describes how to access all terminal connections inside the control.

1. Remove the four cover screws shown in Figure 3-1.
2. Lift and remove the cover.
3. Press in the two Cover Releases (Control) and rotate the control cover open as shown.

Figure 3-1: Cover Removal

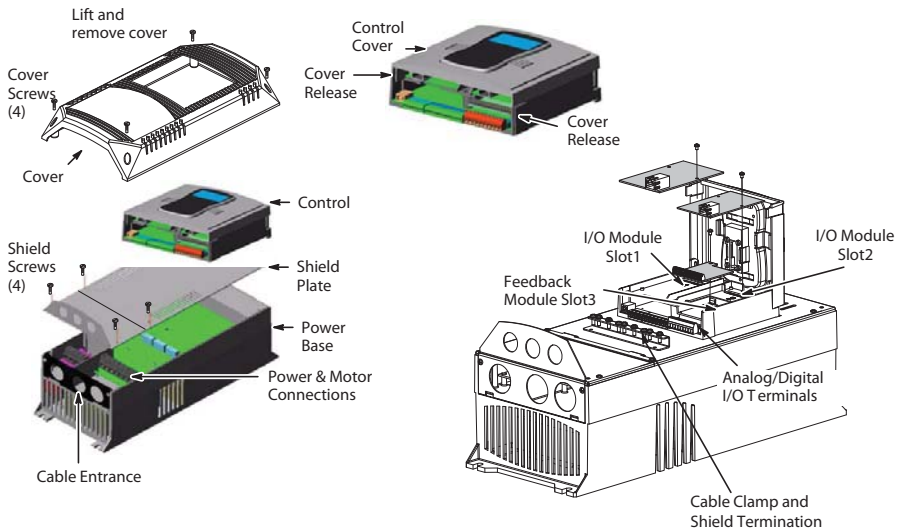

4.1 Grounding the Drive

Baldor does not recommend using “Grounded Leg Delta” transformer power leads that may create ground loops. Instead we recommend using a four wire Wye. Baldor drives are designed to be powered from standard three phase lines that are electrically symmetrical with respect to ground. System grounding is an important step in the overall installation to prevent problems. The recommended grounding method is shown in Figure 4-1.

Figure 4-1: Recommended System Grounding

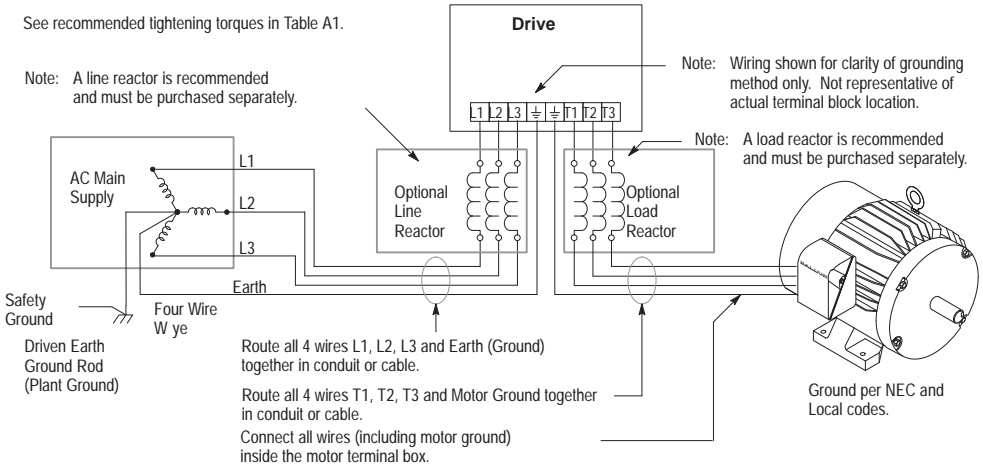

4.1.1 Ungrounded Distribution System

With an ungrounded power distribution system it is possible to have a continuous current path to ground through the MOV devices. To avoid equipment damage, an isolation transformer with a WYE grounded secondary is recommended. This provides three phase AC power that is symmetrical with respect to ground.

4.1.2 Input Power Conditioning

Baldor drives are designed for direct connection to standard three phase lines that are electrically symmetrical with respect to ground. An AC line reactor or an isolation transformer may be required for some power conditions.

- If the feeder or branch circuit that provides power to the drive has permanently connected power factor correction capacitors, an input AC line reactor or an isolation transformer must be connected between the power factor correction capacitors and the drive.
- If the feeder or branch circuit that provides power to the drive has power factor correction capacitors that are switched on line and off line, the capacitors must not be switched while the drive is connected to the AC power line. If the capacitors must be switched while the drive is still connected to the AC power line, additional protection is required. TVSS (Transient Voltage Surge Suppressor) of the proper rating must be installed on the drive input between the drive and any type of input impedance such as an input reactor or drive isolation transformer.

4.2 Line Impedance

The Baldor drives require 1% line impedance minimum. If the impedance of the incoming power does not meet this requirement, a 3 phase line reactor can be used to provide the needed impedance in most cases. The input impedance of the power lines can be determined as follows:

Measure the line to line voltage at no load and at full rated load.

Use these measured values to calculate impedance as follows:

$$\% \text{ Impedance} = ((\text{Volts}_{\text{No Load}} - \text{Volts}_{\text{Full Load}}) / \text{Volts}_{\text{No Load}}) \times 100$$

4.2.1 Line Reactors

Three phase line reactors are available from Baldor. The line reactor to order is based on the full load current of the motor (FLA). If providing your own line reactor, use the following formula to calculate the minimum inductance required.

$$L = \frac{(V_{L-L} \times 0.01)}{(I \times \sqrt{3} \times 377)}$$

Where:	L	Minimum inductance in Henries.
	V_{L-L}	Input volts measured line to line.
	0.01	Desired percentage of input impedance 1%.
	I	Input current rating of drive.
	377	Constant used with 60Hz power. Use 314 if input power is 50Hz.

4.2.2 Load Reactors

Line reactors may be used at the drive output to the motor. When used this way, they are called Load Reactors. Load reactors serve several functions that include:

- Protect the drive from a short circuit at the motor.
- Limit the rate of rise of motor surge currents.
- Slowing the rate of change of power the drive delivers to the motor.

Load reactors should be installed as close to the drive as possible. Selection should be based on the motor nameplate FLA value.

4.3 Line Disconnect

A power disconnect should be installed between the input power service and the drive for a fail safe method to disconnect power. This drive will remain in a powered-up condition until all input power is removed from the drive and the internal bus voltage is depleted.

4.4 Protective Devices

Recommended fuse sizes are based on the following:

115% of maximum continuous current for time delay.

150% of maximum continuous current for Fast or Very Fast action.

Note: These recommendations do not consider harmonic currents or ambient temperatures greater than 45°C. Be sure a suitable input power protection device is installed. Use the recommended fuses and wire sizes shown in Tables 4-1 and 4-2. Wire size is based on the use of copper conductor wire rated at 75 °C. The table is specified for NEMA B motors.

Fast Action Fuses: Buss® KTS to 600A (KTU for 601 to 1200A)

Very Fast Action: Buss® JJS

Semiconductor

Fuses: Ferraz Shawmut A70QS

Buss® is a trademark of Cooper Industries, Inc.

4.5 Reduced Input Voltage Considerations

When operating with other than nominal input voltages or with non-standard motors, the output current rating of the drive must be greater than or equal to the continuous load requirements of the motor when operated under these conditions.

4.6 Electrical Installation

All interconnection wires between the drive, AC power source, motor, host control and any other operator interface stations should be in metal conduits or shielded cable must be used. If the connection being made is on a connection stud or grounding screw, then use listed closed loop connectors that are of appropriate size for wire gauge being used. Connectors are to be installed using crimp tool specified by the manufacturer of the connector. Only class 1 wiring should be used. See Appendix A for conduit hole size for each frame size.

4.7 Optional Filter/Reactor

Figure 4-2 shows the connections for installing an optional Line Filter and AC Reactor.

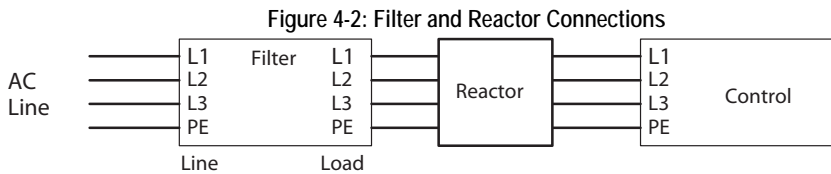

Table 4-1: 480VAC Three Phase Wire Size

Control Rating		Input Fuse (Amps)			Wire Gauge	
HP	Input Amps	Fast Acting (UL)	Fast Acting (CUL)	Semiconductor (CUL)	AWG	mm ²
7.5	11.9	17.5	17.5		14	2.5
10	11.9	25	25		12	4.0
15	23.0	40	40		10	5.3
20	28.9	50	50		8	10.0
25	34.0	60	60		8	10.0
30	45.1	60	*60	A70QS60-4	8	10.0
40	55.3	80	*80	A70QS80-4	6	16.0
50	65.5	100	*100	A70QS100-4	4	25.0
60	90.8	125	125		3	35.0
75	116.6	150	150		1	50.0
100	136.3	200	200		2/0	70.0
125	143.8	250	250		3/0	85.0
150	204.0	300	300		One-4/0 or Two-1/0	One-110.0 or Two-55.0

* Requires custom drive for CUL application using fast fuses.

Note: Wire sizes based on 75°C copper wire. Fuses based on 40°C ambient, max continuous output and no harmonic current.

4.8 3 Phase Power and Motor Connections

Figure 4-3 shows the minimum connections required at the power connector. All cables must be shielded and the shields must be grounded at the cable entrance. The brake resistor and cable must be shielded if installed outside the enclosure.

Figure 4-3: 3 Phase Power Connections

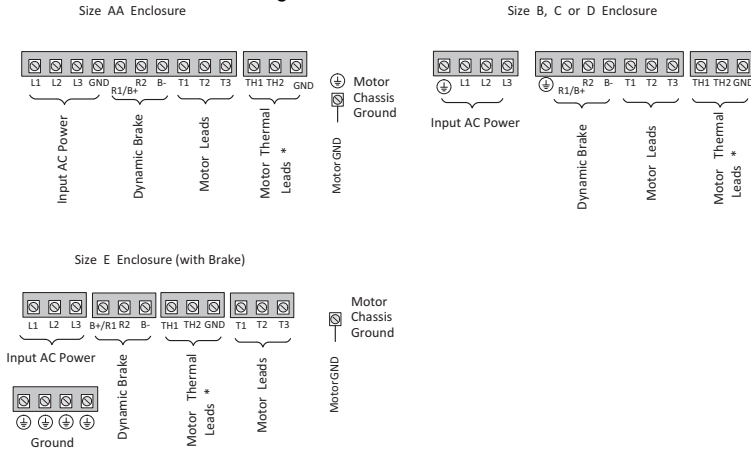

See Recommended Tightening Torques in Table A1.

*Remove TH1 to TH2 jumper if Motor Thermal Leads are connected

1. Access the Power and Motor Terminals (see Cover Removal procedure).
2. Feed the power supply and motor cables into the drive through the cable entrance.
3. Connect the line L1, L2, L3 and GND to the power terminal connectors, Figure 4-4.
4. Connect motor leads to T1, T2, T3 and GND motor terminal connectors.

Figure 4-4: 3 Phase Power Connections

*Optional components not provided with control.

1. See "Protective Devices" described previously in this section.
2. Use same gauge wire for Earth ground as is used for L1, L2 and L3 for AA,B,C frame drives. For D and E frame drives, size the grounding conductor per the local electrical code.
3. Metal conduit should be used. Connect conduits so the use of a Reactor or RC Device does not interrupt EMI/RFI shielding.
4. See Line/Load Reactors described previously in this section. Line Reactors are built-in for size B and larger controls.

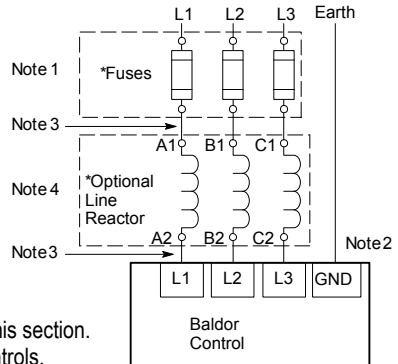

4.9 Operating a 3 Phase Control on Single Phase Input Power

Single phase AC input power can be used to power the control instead of three phase for control sizes AA, B and C. The specifications and control sizes are listed in Appendix A of this manual. If single phase power is to be used, the rated Horsepower of the control may have to be reduced (derated). In addition, power wiring and jumper changes are required. Both connection types are shown in Figures 4-5 and 4-6 . Single phase rating wire size and protection devices are listed in Tables 4-5 and 4-6 .

4.9.1 Single Phase Power Derating:

Single phase power derating requires that the continuous and peak current ratings of the control be reduced by the following percentages:

1. 7.5-30hp 480VAC controls(15-60 HP drive ratings):

Derate output hp by 50% of the nameplate rating.

Table 4-2: Single Phase Wire Size and Protection Devices – 480 VAC Controls

Drive HP	Derated Rating		Input Fuse (Amps)			Wire Gauge	
	Input Amps	HP	Fast Acting (UL)	Fast Acting (CUL)	Semiconductor (CUL)	AWG	mm ²
15	20	7.5	30	30		12	4.0
20	25	10	40	40		10	6.0
30	34	15	50	*50	A70QS50-4	8	10.0
40	44	20	60	*60	A70QS60-4	8	10.0
50	55	25	80	*80	A70QS80-4	6	16.0

*Requires custom drive for CUL application using fast fuses.

Note: All wire sizes are based on 75°C copper wire. Recommended fuses are based on 40°C ambient, maximum continuous control output current and no harmonic current.

Figure 4-5: Size AA Single Phase Power Connections To a 3 Phase Control

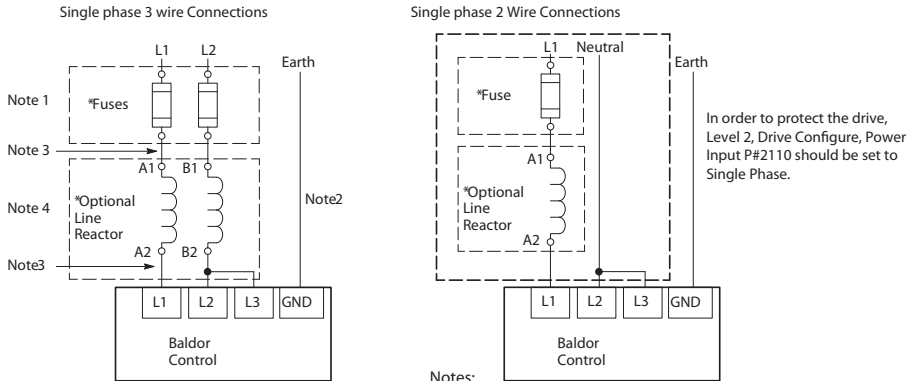

* Optional components are not provided with control.

See Recommended Tightening Torques in Table A.1.

Figure 4-6: Size B and C Single Phase Power Connections To a 3 Phase Control

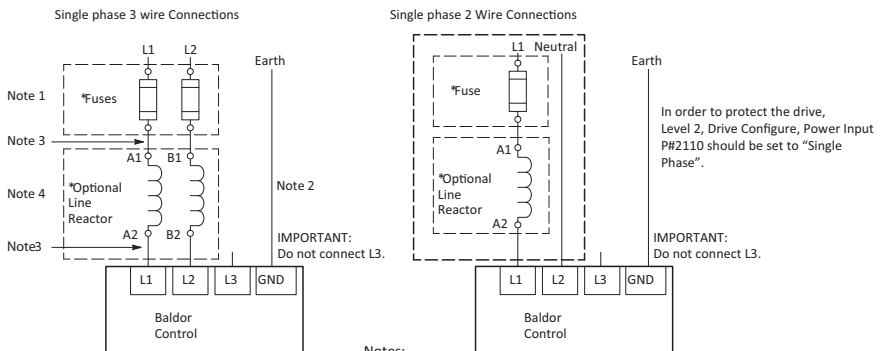

* Optional components not provided with control.

See Recommended Tightening Torque in Table A.1.

4.10 M-Contactor

If required by local codes or for safety reasons, an M-Contactor (motor circuit contactor) may be installed. However, incorrect installation or failure of the M-Contactor or wiring may damage the control.

M-Contactor connections are shown in Figure 4-7.

Caution: If an M-Contactor is installed, the control must be disabled for at least 200msec before the M-Contactor is opened. If the M-Contactor is opened while the control is supplying voltage and current to the motor, the control may be damaged. Before the control is enabled, the M-Contactor must be closed for at least 200msec.

Figure 4-7: Motor Connections and Optional Connections

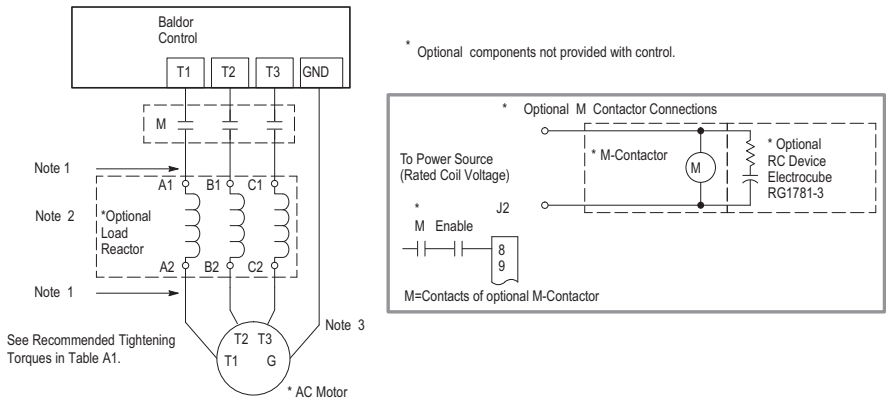

Notes:

1. Metal conduit should be used. Connect conduits so the use of the Load Reactor or RC Device does not interrupt EMI/RFI shielding.
2. See Line/Load Reactors described previously in this section.
3. Use same gauge wire for ground as for T1, T2 and T3 for AA, B, and C controls. For size D and E controls, size the grounding conductor per the local electrical code.

Long Motor Leads

The wire leads that connect the motor to the control are critical in terms of sizing, shielding and the cable characteristics. Short cable runs are usually trouble free but fault-monitoring circuitry can produce numerous faults when long cables (over 100 feet) are used.

- 100+ft (30m): Baldor recommends adding an optional load reactor to the output of the control
- 250+ft (75m): Baldor recommends adding an optional load reactor and common mode choke to the control.

The load reactor and/or common mode choke should be placed in close physical proximity to the control. Unexpected faults may occur due to excessive charging current required for motor cable capacitance. If you use long motor leads and experience unexpected trips due to overload conditions and are not sure how to correctly size and connect the optional load reactors, please contact your Baldor representative.

4.11 Optional Dynamic Brake Hardware

Refer to Figure 4-8 for DB resistor connections. Dynamic Brake (DB) hardware must be installed on a flat, non-flammable, vertical surface for effective cooling and operation.

Caution: Before external Dynamic Brake Hardware is added, the internal resistor must be disconnected. Remove the resistor from the B+/R1 and R2 terminals. The external resistor can be connected across these terminals. Failure to remove the internal resistor will decrease the total resistance (parallel connection) and cause damage.

Figure 4-8: DB Terminal Identification

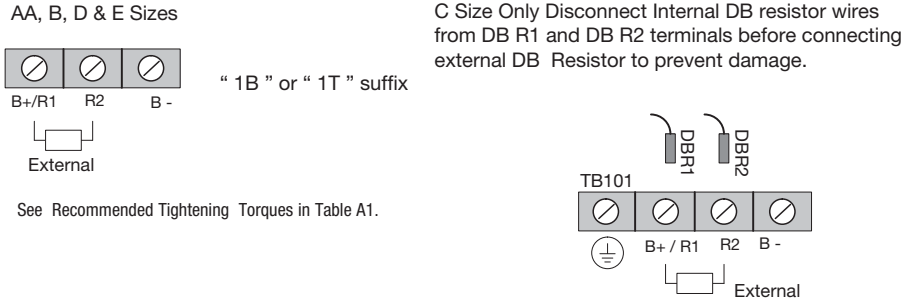

Notes:

1. Wires from the internal Dynamic Brake resistor for size AA, B, C and D controls must be removed before external resistor hardware is installed.
2. E Size Drives do not include an internal Dynamic Brake resistor.
3. Although not shown, metal conduit should be used to shield all power wires and motor leads.

4.12 External Trip Input

Terminal J2-16 is available for connection to a contact that is closed during normal operation. The contact should be a dry contact type. When the contact opens the control will automatically disable its PWM output to the motor and give an External Trip fault. Note that parameter 2201 “External Trip” must be set to the value of “ON” for this input to be active.

5.1 Control Board Connections

The analog and digital inputs and output terminals are shown in Figure 5-1. The signals are described in Tables 5-1, 5-2 and 5-3. Connections will depend upon which of the operating modes are chosen. Each mode described and a connection diagram is provided later in this section.

Figure 5-1: Control I/O Connections

See Recommended Tightening Torques in Table A1.

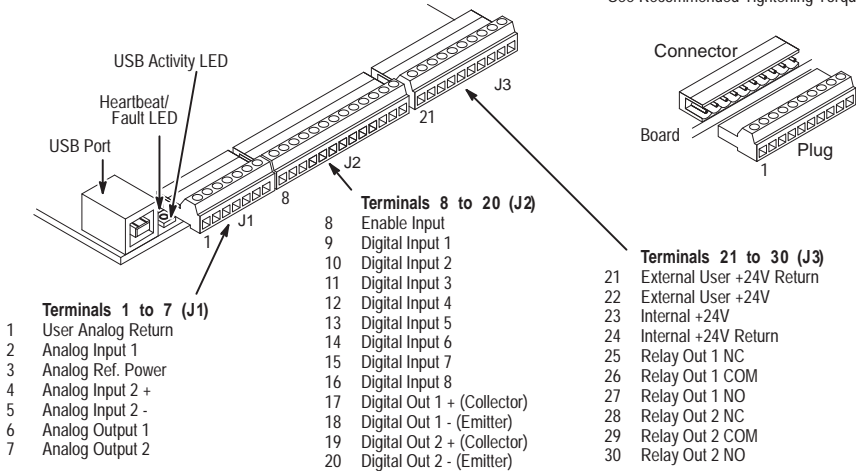

Table 5-1: J1 Connector Definition

Connector Terminal	Signal Description
J1-1	0VDC – Common reference for Analog Inputs and Outputs.
J1-2	AIN1 – Analog Input 1.
J1-3	AREF - Analog reference power (+10V for Analog Input 1).
J1-4	AIN2+ - Analog Input 2+.
J1-5	AIN2- - Analog Input 2-.
J1-6	AOUT1 - Analog Output 1.
J1-7	AOUT2 - Analog Output 2.

Table 5-2: J2 Connector Definition

Connector Terminal	Signal Description
J2-8	Enable Input
J2-9	DIN1 – Digital Input 1.
J2-10	DIN2 – Digital Input 2.
J2-11	DIN3 – Digital Input 3.
J2-12	DIN4 – Digital Input 4.
J2-13	DIN5 – Digital Input 5.
J2-14	DIN6 – Digital Input 6.
J2-15	DIN7 – Digital Input 7.
J2-16	DIN8 – Digital Input 8.
J2-17	Digital Output #1+ (Collector)
J2-18	Digital Output #1 – (Emitter)
J2-19	Digital Output #2+ (Collector)
J2-20	Digital Output #2 – (Emitter)

Table 5-3: J3 Connector Definition

Connector Terminal	Signal Description
J3-21	External User +24V Return
J3-22	External User +24V
J3-23	Internal +24VDC
J3-24	Internal +24VDC Return
J3-25	Relay Output #1 N.C.
J3-26	Relay Output #1 COMMON
J3-27	Relay Output #1 N.O.
J3-28	Relay Output #2 N.C.
J3-29	Relay Output #2 COMMON
J3-30	Relay Output #2 N.O.

5.2 Analog Inputs

Two analog inputs are available: Analog Input 1 (J1-1 and J1-2) and Analog Input 2 (J1-4 and J1-5) as shown in Figure 5-2. Either analog input may be selected in the Level 1 Input block, Command Source Parameter.

Figure 5-2: Analog Inputs

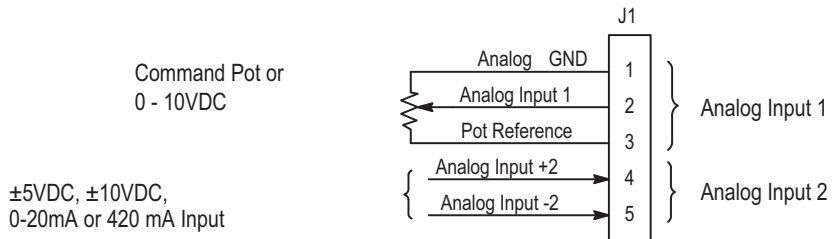

See recommended terminal tightening Torques in Table A-1.

5.2.1 Analog Input 1 (Single Ended)

When using a potentiometer as the speed command, process feedback or setpoint source, the potentiometer should be connected at Analog Input 1. When using Analog Input 1, the respective parameter must be set to “Analog Input 1”.

Note: A potentiometer value of 5kΩ to 10kΩ, 0.5 watt may be used.

Parameter Selection

The single ended Analog Input 1 is typically used in one of three ways:

1. Speed or Torque command (Level 1 Input block, Command Source=Analog Input 1).
2. Process Feedback (Level 2 Process Control block, Process Feedback=Analog Input 1).
3. Setpoint Source (Level 2 Process Control block, Setpoint Source=Analog Input 1).

5.2.2 Analog Input 2 (Differential)

Analog Input 2 accepts a differential command $\pm 5\text{VDC}$, $\pm 10\text{VDC}$, 0-20 mA or 4-20 mA.

If pin J1-4 is positive with respect to pin 5 and P1408= $\pm 5\text{V}$ or $\pm 10\text{V}$, the motor will rotate in the forward direction.

If pin J1-4 is negative with respect to pin 5 and P1408= $\pm 5\text{V}$ or $\pm 10\text{V}$, the motor will rotate in the reverse direction. If forward direction is not correct, change Level 2, Motor Data Reverse Rotation parameter P2415.

Analog Input 2 can be connected for single ended operation by connecting either of the differential terminals to common, provided the common mode voltage range is not exceeded.

Analog Input 2 can be set for voltage or current mode operation. With JP1 as shown in Figure 5-3 , Voltage mode is selected. If JP1 is connected to pins 2 and 3, current mode is selected.

The Level 1 Input Setup Parameter P#1408 can be set to the full scale voltage or current range desired.

Note: The common mode voltage can be measured with a voltmeter. Apply the maximum command voltage to Analog Input 2 (J1-4,5). Measure the AC and DC voltage across J1-1 to J1-4. Add the AC and DC values. Measure the AC and DC voltage from J1-1 to J1-5. Add these AC and DC values.

If either of these measurement totals exceeds a total of ± 15 volts, then the common mode voltage range has been exceeded. To correct this condition, isolate the command signal with a signal isolator, such as Baldor catalog number BC145.

Figure 5-3: Jumper Locations

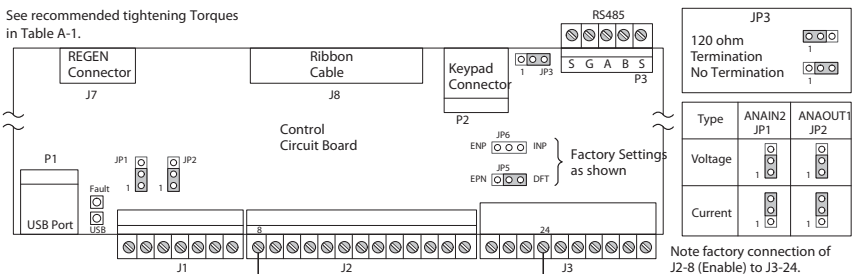

5.3 Analog Outputs

Two programmable analog outputs are provided on J1-6 and J1-7. These outputs are scaled and can be used to provide status of various control conditions. The return for these outputs is J1-1 analog return. Each output function is programmed in the Level 1 Output block, Analog Out1 Signal or Analog Out2 Signal parameter values. Analog Output 1 can be set for voltage or current mode operation. With JP2 as shown in Figure 5-3, Voltage mode is selected. If JP2 is connected to pins 2 and 3, current mode is selected. The Level 1 Output Setup Parameter P#1510 can be set to the full scale voltage or current range desired.

5.4 Opto Isolated Inputs

Logic input connections are made at terminal strip J2 pins 8 to 16. J2 inputs can be wired as active High or active Low as shown in Figure 5-4. Internal or external power source is selected by jumpers JP5 and JP6 shown in Figure 5-4.

Notes for Figure 5-4:

1. These pins are shown wired together. Although this can be done, each input is usually connected to a switch for individual control of each input condition.
2. Factory connection of J2-8 (Enable) is made to J3-24 for Internal, Active Low connection. For other configurations, the wire at J3-24 must be moved to J3-23, J3-21 or J3-22 as needed.

Figure 5-4: Active HIGH (Sourcing)/LOW (Sinking) Relationship

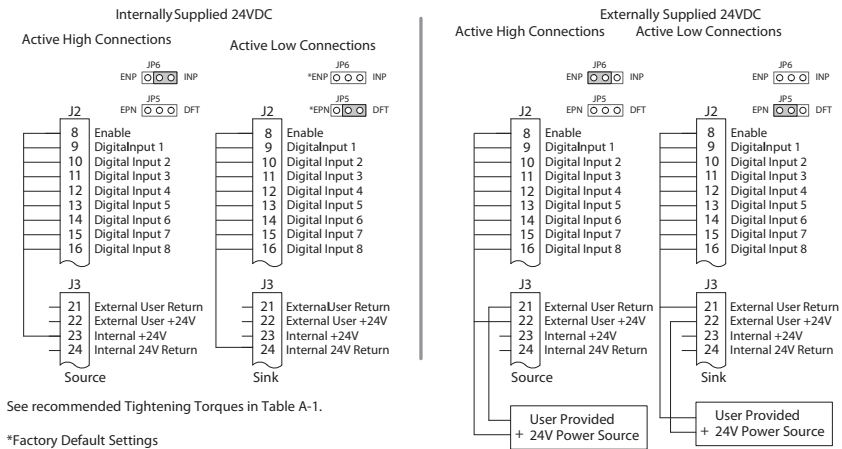

5.5 Operating Modes

The operating modes define the basic motor control setup and the operation of the input and output terminals. After the circuit connections are completed, the operating mode is selected by programming the Operating Mode parameter in the Level 1 Input Setup Programming Block (P# 1401).

Operating modes include:

- Keypad
- Fan Pump 2Wire
- 3 SPD ANA 3Wire
- Profile Run*
- PLC*
- Standard Run, 2Wire
- Fan Pump 3Wire
- Electronic Pot 2Wire
- CTD 2Wire
- Standard Run, 3Wire
- Process Control*
- Electronic Pot 3Wire
- Bipolar
- 15 Preset Speeds
- 3 SPD ANA 2Wire
- Network
- CTD 3Wire

* To view and change parameters associated with these modes, P1401 must be set to the respective mode. This means Process Control parameters will not appear on the keypad for selection unless Level 1, Input Setup, Operating Mode, P1401 is set to "Process Control".

Each mode requires connections to the J1, J2 and J3 terminal strips. The terminal strips are shown in Figure 5-1. The connection of each input or output signal is described in the following pages.

Modbus Notes: In general Modbus coils 35 (network reference source) and 81 (bipolar mode) affect any operating mode that uses the command source parameter. If the command source is driving the mode with the drive in speed mode and with coil 35 on, the drive check coil 81 to determine if the network source is bipolar. The operating mode will then use the network speed reference. The same is true if the drive is in torque mode but the operating mode would use the network torque reference instead.

5.5.1 Keypad

The Keypad mode allows the control to be operated from the keypad. In this mode only Enable is required. However, the Stop and External Trip inputs may optionally be used. All other Digital Inputs remain inactive. The Analog Outputs and Digital Outputs remain active at all times.

Figure 5-5: Keypad Connection Diagram

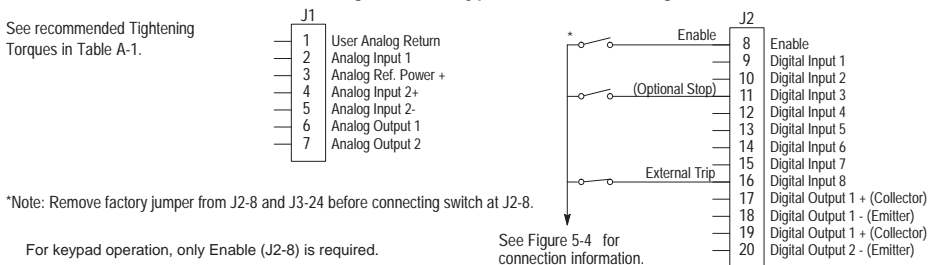

J2-8 CLOSED allows normal control operation.

OPEN disables the control and motor coasts to stop.

J2-11 Optional STOP input (not required). OPEN motor coasts or brakes to stop if Level 1 Keypad Setup block, Local Hot Start parameter is set to "ON".

CLOSED allows normal control operation.

J2-16 Optional External Trip input (not required). If used, you must set Level 2 Drive Protect block, External Trip to "ON".

CLOSED allows normal operation.

OPEN causes an External Trip to be received by the control (when programmed to "ON").

5.5.2 Standard Run 2Wire

In Standard Run 2Wire mode, the control is operated by the digital inputs and the command source. Also, Preset Speed 1 can be selected. The opto inputs can be switches as shown in Figure 5-6 or logic signals from another device.

Figure 5-6: Standard Run 2Wire Connection Diagram

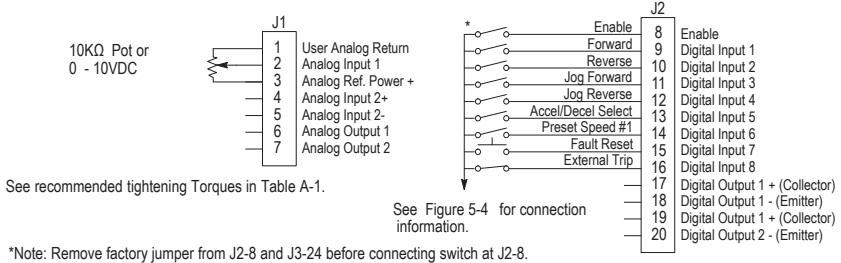

J2-8 CLOSED allows normal operation.

OPEN disables the control and motor coasts to a stop.

J2-9 CLOSED starts motor operation in the Forward direction.

OPEN motor decels to stop. If Level 1, Stop Mode is set to “coast”, motor coasts to stop

J2-10 CLOSED starts motor operation in the Reverse direction.

OPEN motor decels to stop. If Level 1, Stop Mode is set to “coast”, motor coasts to stop

J2-11 CLOSED starts motor JOG operation in the Forward direction.

OPEN motor decels to stop. If Level 1, Stop Mode is set to “coast”, motor coasts to stop

J2-12 CLOSED starts motor JOG operation in the Reverse direction.

OPEN motor decels to stop. If Level 1, Stop Mode is set to “coast”, motor coasts to stop

J2-13 CLOSED selects ACC / DEC / S-ACC / S-DEC group 2.

OPEN selects ACC / DEC / S-ACC / S-DEC group 1.

J2-14 CLOSED selects Preset Speed #1, (J2-11 or 12, will override this Preset Speed).

OPEN allows speed command from the command source (P1402).

J2-15 CLOSED to reset fault.

OPEN to run.

J2-16 Optional External Trip input (not required). If used, you must set Level 2 Drive Protect block, External Trip to “ON”.

CLOSED allows normal operation.

OPEN causes an External Trip to be received by the control (when programmed to “ON”).

Note: When command source is a unipolar signal (0-10V, 0-5V, 4-20ma etc.) and forward or reverse are closed, motion will occur (unless both are closed at the same time).

5.5.3 Standard Run 3Wire

In Standard Run 3Wire mode, the control is operated by the digital inputs and the command source. Also, Preset Speed 1 can be selected. The opto inputs can be switches as shown in Figure 5-7 or logic signals from another device.

Figure 5-7: Standard Run 3Wire Connection Diagram

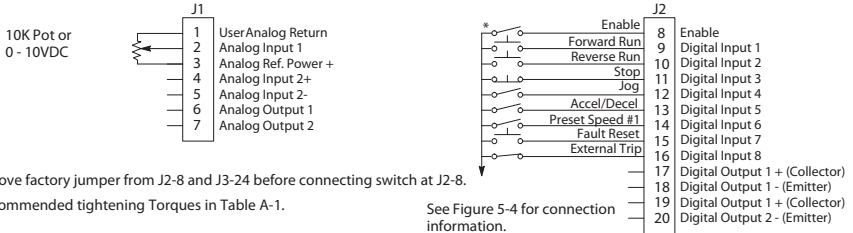

*Note: Remove factory jumper from J2-8 and J3-24 before connecting switch at J2-8.

See recommended tightening Torques in Table A-1.

See Figure 5-4 for connection information.

J2-8 CLOSED allows normal operation.

OPEN disables the control and motor coasts to a stop.

J2-9 MOMENTARY CLOSED starts motor operation in the Forward direction.

In JOG mode (J2-12 CLOSED), continuous closed jogs motor in the Forward direction.

J2-10 MOMENTARY CLOSED starts motor operation in the Reverse direction.

In JOG mode (J2-12 CLOSED), continuous closed jogs motor in the Reverse direction.

J2-11 MOMENTARY OPEN motor decels to stop (depending on Decel time).

J2-12 CLOSED places control in JOG mode, Forward and Reverse run are used to jog the motor.

J2-13 CLOSED selects ACC / DEC / S-ACC / S-DEC group 2.

OPEN selects ACC / DEC / S-ACC / S-DEC group 1.

J2-14 CLOSED selects Preset Speed #1, (J2-12, will override this Preset Speed).

OPEN allows speed command from the command source (P1402).

J2-15 CLOSED to reset fault. OPEN to run.

J2-16 Optional External Trip input (not required). If used, you must set Level 2 Drive Protect block, External Trip to "ON". CLOSED allows normal operation.

OPEN causes an External Trip to be received by the control (when programmed to "ON").

Note: When command source is a unipolar signal (0-10V, 0-5V, 4-20mA etc.) and forward or reverse are closed, motion will occur (unless both are closed at the same time).

5.5.4 15 Preset Speeds

Operation in 15 Preset Speeds 2-Wire mode is controlled by the opto isolated inputs at J2. The values of the Preset Speeds are set in the Level 1 Preset Speeds block, Preset Speed 1 to Preset Speed 15. J2-11 through J2-14 inputs allow selection of 15 Preset Speeds. The opto inputs can be switches as shown in Figure 5-8 or logic signals from another device.

Figure 5-8: 15 Preset Speeds

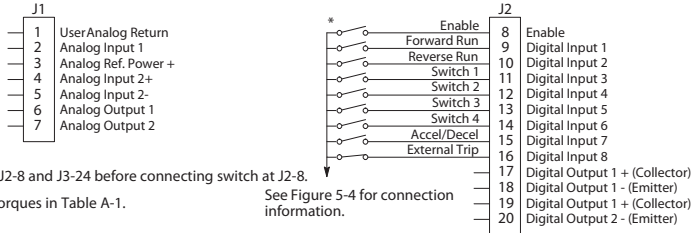

*Note: Remove factory jumper from J2-8 and J3-24 before connecting switch at J2-8.

See recommended tightening Torques in Table A-1.

See Figure 5-4 for connection information.

- J2-8 CLOSED allows normal operation.
OPEN disables the control and motor coasts to a stop.
- J2-9 CLOSED operates the motor in the Forward direction (with J2-10 open).
OPEN motor decels to stop (depending on Decel time).
- J2-10 CLOSED operates motor in the Reverse direction (with J2-9 open).
OPEN motor decels to stop (depending on Decel time).
- J2-1 1-14 Selects programmed Preset Speeds as defined in Table 5-4 .
- J2-15 CLOSED selects ACC / DEC / S-ACC / S-DEC group 2.
OPEN selects ACC / DEC / S-ACC / S-DEC group 1 .
- J2-16 Optional External Trip input (not required). If used, you must set Level 2 Drive Protect block, External Trip to "ON". CLOSED allows normal operation.
OPEN causes an External Trip to be received by the control (when programmed to "ON").

Table 5-4: Switch Truth Table for 15 Speed, 2Wire Control Mode

J2-11	J2-12	J2-13	J2-14	Function
OPEN	OPEN	OPEN	OPEN	Selects Level 1:Preset Speed:Preset Speed 1 (P#1001)
CLOSED	OPEN	OPEN	OPEN	Selects Level 1:Preset Speed:Preset Speed 2 (P#1002)
OPEN	CLOSED	OPEN	OPEN	Selects Level 1:Preset Speed:Preset Speed 3 (P#1003)
CLOSED	CLOSED	OPEN	OPEN	Selects Level 1:Preset Speed:Preset Speed 4 (P#1004)
OPEN	OPEN	CLOSED	OPEN	Selects Level 1:Preset Speed:Preset Speed 5 (P#1005)
CLOSED	OPEN	CLOSED	OPEN	Selects Level 1:Preset Speed:Preset Speed 6 (P#1006)
OPEN	CLOSED	CLOSED	OPEN	Selects Level 1:Preset Speed:Preset Speed 7 (P#1007)
CLOSED	CLOSED	CLOSED	OPEN	Selects Level 1:Preset Speed:Preset Speed 8 (P#1008)
OPEN	OPEN	OPEN	CLOSED	Selects Level 1:Preset Speed:Preset Speed 9 (P#1009)
CLOSED	OPEN	OPEN	CLOSED	Selects Level 1:Preset Speed:Preset Speed 10 (P#10010)
OPEN	CLOSED	OPEN	CLOSED	Selects Level 1:Preset Speed:Preset Speed 11 (P#10011)
CLOSED	CLOSED	OPEN	CLOSED	Selects Level 1:Preset Speed:Preset Speed 12 (P#10012)
OPEN	OPEN	CLOSED	CLOSED	Selects Level 1:Preset Speed:Preset Speed 13 (P#10013)
CLOSED	OPEN	CLOSED	CLOSED	Selects Level 1:Preset Speed:Preset Speed 14 (P#10014)
OPEN	CLOSED	CLOSED	CLOSED	Selects Level 1:Preset Speed:Preset Speed 15 (P#10015)
CLOSED	CLOSED	CLOSED	CLOSED	Fault Reset

5.5.5 Fan Pump 2Wire

Operation in the Fan Pump 2-Wire mode is controlled by the opto isolated inputs at J2-8 through J2-16. The opto inputs can be switches as shown in Figure 5-9 or logic signals from another device.

Figure 5-9: Fan Pump 2Wire Connection Diagram

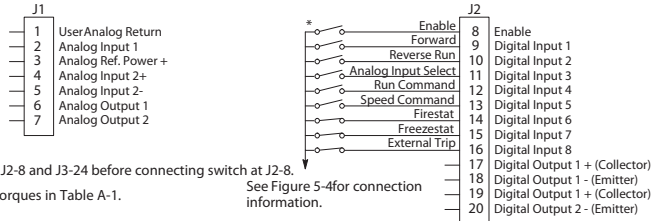

*Note: Remove factory jumper from J2-8 and J3-24 before connecting switch at J2-8.

See recommended tightening Torques in Table A-1.

See Figure 5-4 for connection information.

J2-8 CLOSED allows normal control operation.

OPEN disables the control and the motor coasts to a stop.

J2-9 CLOSED operates the motor in the Forward direction (with J2-10 open).

OPEN motor decels to stop (depending on Decel Time). Note: J2-9 and J2-10 are both closed = Fault Reset.

J2-10 CLOSED operates the motor in the Reverse direction (with J2-9 open).

OPEN motor decels to stop (depending on Decel Time). Note: J2-9 and J2-10 are both closed = Fault Reset.

J2-11 CLOSED selects Analog Input 1 (if J2-13, J2-14 and J2-15 are closed).

OPEN selects Command Source (Level 1, Input, Command Source, if J2-13, J2-14 and J2-15 are closed).

J2-12 CLOSED selects STOP/START and Reset commands from terminal strip.

OPEN selects STOP/START and Reset commands from Keypad.

J2-13 CLOSED allows other selections, see Speed Select Table 5-5 .

OPEN selects speed commanded from Keypad (if J2-14 and J2-15 are closed).

Note: When changing from Terminal Strip to Keypad (J2-12 or J2-13) the motor speed and direction will remain the same after the change.

J2-14 Firestat. Selects Level 1, Preset Speeds, Preset Speed #1.

J2-15 Freezestat. Level 1, Preset Speeds, Preset Speed #2 (if J2-14 is closed).

J2-16 Optional External Trip input (not required). If used, you must set Level 2 Drive Protect block, External Trip to "ON". CLOSED allows normal operation.

OPEN causes an External Trip to be received by the control (when programmed to "ON").

Figure 5-10: Speed Select Table – Fan Pump, 2Wire

J2-11	J2-13	J2-14	J2-15	Command
	OPEN	CLOSED	CLOSED	Keypad Speed Command
		OPEN		Level 1, Preset Speeds, Preset Speed #1
		CLOSED	OPEN	Level 1, Preset Speeds, Preset Speed #2
OPEN	CLOSED	CLOSED	CLOSED	Level 1, Input Setup, Command Source (parameter 1402)
CLOSED	CLOSED	CLOSED	CLOSED	Analog Input 1

Note: When command source is a unipolar signal (0-10V, 0-5V, 4-20ma etc.) and forward or reverse are closed, motion will occur (unless both are closed at the same time).

5.5.6 Fan Pump 3Wire

Operation in the Fan Pump 3-Wire mode is controlled by the opto isolated inputs at J2-8 through J2-16. The opto inputs can be switches as shown in Figure 5-10 or logic signals from another device.

Figure 5-10: Fan Pump 3Wire Connection

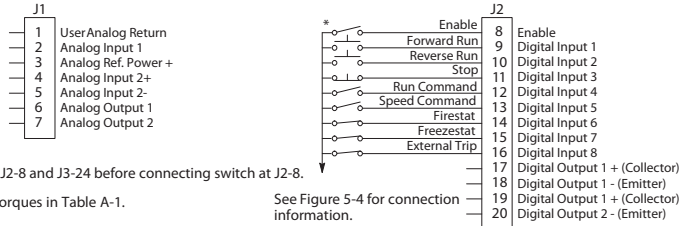

*Note: Remove factory jumper from J2-8 and J3-24 before connecting switch at J2-8.

See recommended tightening Torques in Table A-1.

See Figure 5-4 for connection information.

J2-8 CLOSED allows normal control operation.

OPEN disables the control and the motor coasts to a stop.

J2-9 MOMENTARY CLOSED starts motor operation in the Forward direction.

Note: Closing both J2-9 and J2-10 at the same time will reset a fault.

J2-10 MOMENTARY CLOSED starts motor operation in the Reverse direction.

Note: Closing both J2-9 and J2-10 at the same time will reset a fault.

J2-11 MOMENTARY OPEN motor decels to stop (depending on Decel Time).

J2-12 CLOSED selects STOP/START and Reset commands from terminal strip.

OPEN selects STOP/START and Reset commands from Keypad.

J2-13 CLOSED allows other selections, see Speed Select Table 5-6.

OPEN selects speed commanded from Keypad (if J2-14 and J2-15 are closed).

Note: When changing from Terminal Strip to Keypad (J2-12 or J2-13) the motor speed and direction will remain the same after the change.

J2-14 Firestat. Selects Level 1, Preset Speeds, Preset Speed #1.

J2-15 Freezestat. Level 1, Preset Speeds, Preset Speed #2 (if J2-14 is closed).

J2-16 Optional External Trip input (not required). If used, you must set Level 2 Drive Protect block, External Trip to "ON". CLOSED allows normal operation.

OPEN causes an External Trip to be received by the control (when programmed to "ON").

Table 5-6: Speed Select Table – Fan Pump, 3Wire

J2-13	J2-14	J2-15	Command
	OPEN		Level 1, Preset Speeds, Preset Speed #1
CLOSED	CLOSED	OPEN	Level 1, Preset Speeds, Preset Speed #2
OPEN	CLOSED	CLOSED	Keypad Speed Command
CLOSED	CLOSED	CLOSED	Level 1, Input Setup, Command Source (parameter 1402)

5.5.7 Process Control

The process control mode provides an auxiliary closed loop general purpose PID set point control. The process control loop may be configured in various ways and detailed descriptions of the Process Control are given in MN707 "Introduction to Process Control". The opto inputs can be switches as shown in Figure 5-11 or logic signals from another device.

Figure 5-11: Speed Select Table – Fan Pump, 3Wire

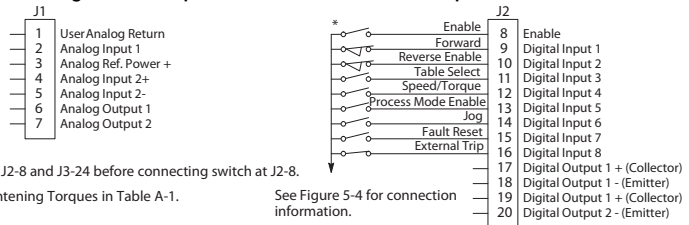

*Note: Remove factory jumper from J2-8 and J3-24 before connecting switch at J2-8.

See recommended tightening Torques in Table A-1.

See Figure 5-4 for connection information.

J2-8 CLOSED allows normal control operation.

OPEN disables the control and the motor coasts to a stop.

J2-9 CLOSED to enable operation in the Forward direction.

OPEN TO DISABLE Forward operation (drive will decel to a stop if a Forward command is still present). Reverse operation is still possible if J2-10 is closed.

J2-10 CLOSED to enable operation in the Reverse direction.

OPEN to disable Reverse operation (drive will decel to a stop if a Reverse command is still present). Forward operation is still possible if J2-9 is closed.

Note: If J2-9 and J2-10 are both opened, the drive will decel to a stop.

J2-11 CLOSED = TABLE 2,

OPEN = TABLE 1. Refer to Table 5-7.

Note: The operating mode P#1401 must be set to a mode that allows table switching in both tables T1 and T2.

J2-12 CLOSED Selects ACC/DEC group 2 (V/F) or selects torque mode (Vector)

OPEN Selects ACC/DEC group 1 (V/F) or selects speed mode (Vector)

Note: If a stop command is issued while in the torque (current) mode, the control will stop but will not maintain position (zero current). This is different than zero speed operation for the velocity mode.

J2-13 CLOSED to enable PID and FF. Feedforward (FF) is from P1402 (Command Source). OPEN to enable FF only. PID is disabled with its integrator reset to zero.

J2-14 CLOSED to enable JOG mode. Jog in either direction is allowed if enabled by J2-9 or J2-10.

J2-15 CLOSED to reset a fault.

OPEN to run.

J2-16 Optional External Trip input (not required). If used, you must set Level 2 Drive Protect block, External Trip to "ON". CLOSED allows normal operation.

OPEN causes an External Trip to be received by the control (when programmed to "ON").

Table 5-7: Table Select – Process Control

J2-11	Command
OPEN	Selects Parameter Table 1
CLOSED	Selects Parameter Table 2

Note: See multiple parameter sets in this section.

5.5.8 3 Speed Analog 2Wire

Provides 2 wire input control and allows selection of 3 Preset Speeds. The values of the Preset Speeds are set in the Level 1 Preset Speeds block, Preset Speed #1, Preset Speed #2 and Preset Speed #3.

The opto inputs can be switches as shown in Figure 5-12 or logic signals from another device.

Figure 5-12: 3 Speed Analog 2Wire Connection Diagram

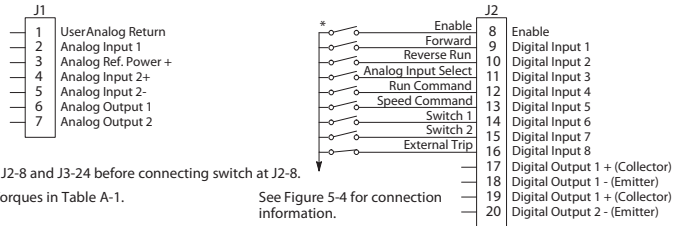

*Note: Remove factory jumper from J2-8 and J3-24 before connecting switch at J2-8.

See recommended tightening Torques in Table A-1.

See Figure 5-4 for connection information.

J2-8 CLOSED allows normal control operation.

OPEN disables the control and the motor coasts to a stop.

J2-9 CLOSED operates the motor in the Forward direction (with J2-10 open).

OPEN motor decels to stop (depending on Decel time).

J2-10 CLOSED operates the motor in the Reverse direction (with J2-10 open).

OPEN motor decels to stop (depending on Decel time).

Note: Closing both J2-9 and J2-10 at the same time will reset a fault.

J2-11 CLOSED selects Analog Input 1.

OPEN selects Level 1 Input block, Command Source parameter.

Note: If Command Source (Level 1 Input block) is set to Analog Input 1, then Analog Input 1 is always selected regardless of this switch position.

J2-12 CLOSED selects STOP/START and Reset Commands from the terminal strip.

OPEN selects STOP/START and Reset Commands from the keypad.

J2-13 CLOSED selects Level 1 Input block, Command Source parameter.

OPEN selects speed commanded from Keypad.

Note: When changing from Terminal Strip to Keypad (J2-12 or J2-13) the motor speed and direction will remain the same after the change.

J2-14 Selects Preset Speeds as defined in the Speed Select Table (Table 5-8).

J2-15 Selects Preset Speeds as defined in the Speed Select Table (Table 5-8).

J2-16 Optional External Trip input (not required). If used, you must set Level 2 Drive Protect block, External Trip to "ON". CLOSED allows normal operation.

OPEN causes an External Trip to be received by the control (when programmed to "ON").

Table 5-8: Speed Select Table

J2-14	J2-15	Command
OPEN	OPEN	Level 1, Input Setup, Command Source (parameter 1402)
CLOSED	OPEN	Preset #1
OPEN	CLOSED	Preset #2
CLOSED	CLOSED	Preset #3

Note: When command source is a unipolar signal (0-10V, 0-5V, 4-20mA, etc.) and forward or reverse are closed, motion will occur (unless both are closed at the same time).

5.5.9 3 Speed Analog 3Wire

Provides 3 wire input control and allows selection of 3 Preset Speeds. The values of the Preset Speeds are set in the Level 1 Preset Speeds block, Preset Speed #1, Preset Speed #2 and Preset Speed #3. The opto inputs can be switches as shown in Figure 5-13 or logic signals from another device.

Figure 5-13: 3 Speed Analog 3Wire Connection Diagram

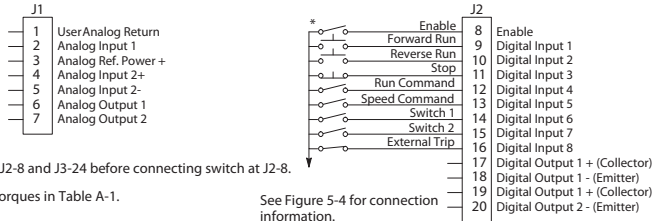

*Note: Remove factory jumper from J2-8 and J3-24 before connecting switch at J2-8.

See recommended tightening Torques in Table A-1.

See Figure 5-4 for connection information.

J2-8 CLOSED allows normal control operation.

OPEN disables the control and the motor coasts to a stop.

J2-9 MOMENTARY CLOSED starts motor operation in the Forward direction.

J2-10 MOMENTARY CLOSED starts motor operation in the Reverse direction.

Note: Closing both J2-9 and J2-10 at the same time will reset a fault.

J2-11 MOMENTARY OPEN motor decels to stop (depending on Decel time).

J2-12 CLOSED selects STOP/START and Reset Commands from the terminal strip.

OPEN selects STOP/START and Reset Commands from the keypad.

J2-13 CLOSED selects Level 1 Input block, Command Source parameter.

OPEN selects speed commanded from Keypad.

Note: When changing from Terminal Strip to Keypad (J2-12 or J2-13) the motor speed and direction will remain the same after the change.

J2-14 Selects Preset Speeds as defined in the Speed Select Table (Table 5-9).

J2-15 Selects Preset Speeds as defined in the Speed Select Table (Table 5-9).

J2-16 Optional External Trip input (not required). If used, you must set Level 2 Drive Protect block, External Trip to "ON". CLOSED allows normal operation.

OPEN causes an External Trip to be received by the control (when programmed to "ON").

Table 5-9: Speed Select Table

J2-14	J2-15	Command
OPEN	OPEN	Level 1, Input Setup, Command Source (parameter 1402)
CLOSED	OPEN	Preset #1
OPEN	CLOSED	Preset #2
CLOSED	CLOSED	Preset #3

5.5.10 E-POT 2Wire

Provides speed Increase and Decrease inputs to allow E-POT (Electronic Potentiometer) operation with 2 wire inputs. The values of the Preset Speeds are set in the Level 1 Preset Speeds block, Preset Speed #1 or Preset Speed #2. The opto inputs can be switches as shown in Figure 5-14 or logic signals from another device.

Figure 5-14: E-POT 2Wire Connection Diagram

Figure 5-14 E-POT 2Wire Connection Diagram

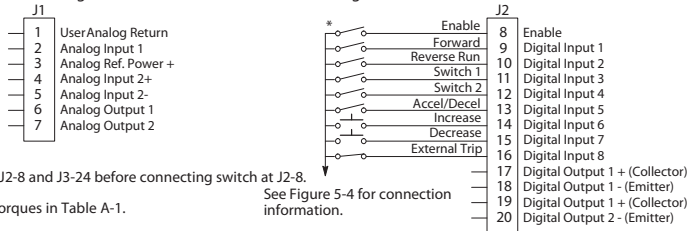

*Note: Remove factory jumper from J2-8 and J3-24 before connecting switch at J2-8.

See recommended tightening Torques in Table A-1.

See Figure 5-4 for connection information.

J2-8 CLOSED allows normal control operation.

OPEN disables the control and the motor coasts to a stop.

J2-9 CLOSED starts motor operation in the Forward direction.

OPEN motor decels to stop (depending on Decel time).

J2-10 CLOSED starts motor operation in the Reverse direction.

OPEN motor decels to stop (depending on Decel time).

J2-11 Selects Preset Speeds as defined in the Speed Select Table (Table 5-10).

J2-12 Selects Preset Speeds as defined in the Speed Select Table (Table 5-10).

J2-13 CLOSED selects ACC / DEC / S-ACC / S-DEC group 2.

OPEN selects ACC / DEC / S-ACC / S-DEC group 1.

J2-14 MOMENTARY CLOSED increases motor speed while contact is closed.

J2-15 MOMENTARY CLOSED decreases motor speed while contact is closed.

J2-16 Optional External Trip input (not required). If used, you must set Level 2 Drive Protect block, External Trip to "ON". CLOSED allows normal operation.

OPEN causes an External Trip to be received by the control (when programmed to "ON").

Table 5-10: Speed Select Table

J2-11	J2-12	Command
OPEN	OPEN	Electronic Pot
CLOSED	OPEN	Level 1, Input Setup, Command Source (parameter 1402)
OPEN	CLOSED	Preset #1
CLOSED	CLOSED	Preset #2

5.5.11 E-POT 3Wire

Provides speed Increase and Decrease inputs to allow E-POT operation with 3 wire inputs. The opto inputs can be switches as shown in Figure 5-15 or logic signals from another device.

Figure 5-15: E-POT 3Wire Connection Diagram

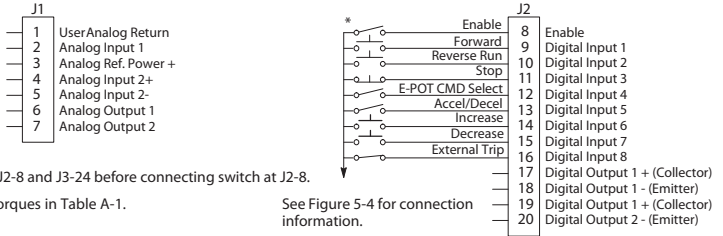

*Note: Remove factory jumper from J2-8 and J3-24 before connecting switch at J2-8.

See recommended tightening Torques in Table A-1.

See Figure 5-4 for connection information.

J2-8 CLOSED allows normal control operation.

OPEN disables the control and the motor coasts to a stop.

J2-9 MOMENTARY CLOSED starts motor operation in the Forward direction.

J2-10 MOMENTARY CLOSED starts motor operation in the Reverse direction.

Note: Closing both J2-9 and J2-10 at the same time will reset a fault.

J2-11 MOMENTARY OPEN motor decels to stop (depending on Decel time).

J2-12 CLOSED selects Level 1 Command Source parameter value.

OPEN selects E-POT.

J2-13 CLOSED selects ACC / DEC / S-ACC /S-DEC group 2.

OPEN selects ACC / DEC / S-ACC /S-DEC group 1.

J2-14 MOMENTARY CLOSED increases motor speed while contact is closed.

J2-15 MOMENTARY CLOSED decreases motor speed while contact is closed.

J2-16 Optional External Trip input (not required). If used, you must set Level 2 Drive Protect block, External Trip to "ON". CLOSED allows normal operation.

OPEN causes an External Trip to be received by the control (when programmed to "ON").

Table 5-10: E-POT 3Wire Connection Diagram

J2-11	J2-12	Command
OPEN	OPEN	Electronic Pot
CLOSED	OPEN	Level 1, Input Setup, Command Source (parameter 1402)
OPEN	CLOSED	Preset #1
CLOSED	CLOSED	Preset #2

5.5.12 Network

Provides bipolar speed or torque control. Preset speeds are set in software.

The opto inputs can be switches as shown in Figure 5-16 or logic signals from another device.

Figure 5-16: Network Connection Diagram

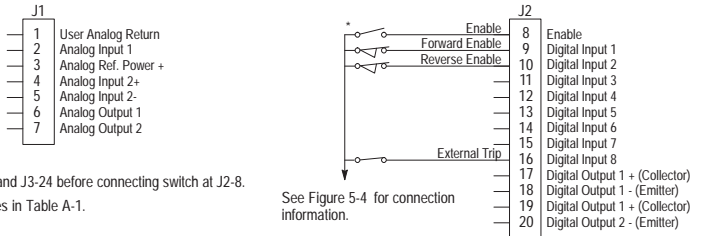

*Note: Remove factory jumper from J2-8 and J3-24 before connecting switch at J2-8.

See recommended tightening Torques in Table A-1.

J2-8 CLOSED allows normal control operation.

OPEN disables the control and the motor coasts to a stop.

J2-9 CLOSED to enable operation in the Forward direction.

OPEN TO DISABLE Forward operation (drive will decel to a stop if a Forward command is still present). Reverse operation is still possible if J2-10 is closed.

J2-10 CLOSED to enable operation in the Reverse direction.

OPEN TO DISABLE Forward operation (drive will decel to a stop if a Reverse command is still present). Forward operation is still possible if J2-9 is closed.

J2-16 Optional External Trip input (not required). If used, you must set Level 2 Drive Protect block, External Trip to "ON". CLOSED allows normal operation.

OPEN causes an External Trip to be received by the control (when programmed to "ON").

Table 5-11: Modbus Coils that Affect this Mode

Coil		Coil	
2	Torque Mode (Vector Only)	15	Jog Mode
3	Speed Mode	33	Keypad reference source (local)
4	Orientation, absolute position orientation (Closed Vector or AC Servo only)	34	Terminal block reference source (remote)
5	Position Command absolute (for future use)	35	Network reference source
6	Position Command incremental (for future use)	42	Select Acc/Dec Group 1
7	Position Command track (for future use)	43	Select Acc/Dec Group 2
8	Position Command external (for future use)	78	Stop, stops the motor
9	Homing (available in Closed Vector or AC Servo Only)	79	Forward Run (terminal J2-4 must also be true)
10	Process Torque	80	Reverse Run (terminal J2-10 must also be true)
11	Process Velocity	81	Bipolar Mode
13	Network current Limiting	82	Network Drive enable and drive hardware enable (terminal J2-8) must both be set else drive is disabled.

5.5.13 Profile Run

Provides a speed profile consisting of seven segments to setup a cyclic operation or test cycle. The opto inputs can be switches as shown in Figure 5-17 or logic signals from another device. Speed settings for Speed curve 1 to speed curve 7 are Preset Speed 1 to Preset Speed 7. See level 3, profile run block for more information

Figure 5-17: Profile Run Connection Diagram

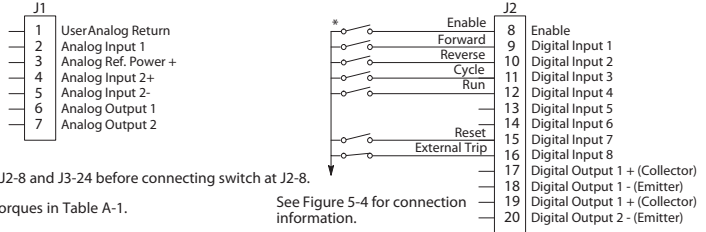

*Note: Remove factory jumper from J2-8 and J3-24 before connecting switch at J2-8.

See recommended tightening Torques in Table A-1.

See Figure 5-4 for connection information.

- J2-8 CLOSED allows normal operation. OPEN disables the control and motor coasts to a stop.
- J2-9 CLOSED to maintain operation in the Forward direction.
OPEN TO DISABLE Forward operation (drive will decel to a stop if a Forward command is still present). Reverse operation is still possible if J2-10 is closed.
- J2-10 CLOSED to maintain operation in the Reverse direction.
OPEN to disable Reverse operation (drive will decel to a stop if a Reverse command is still present). Forward operation is still possible if J2-9 is closed.
- J2-11 CLOSED runs the profile for an indefinite number of cycles. When the Level 3, Profile Run, Number of Cycles (P#3001) cycle count is reached, the counter is reset and the mode restarts (continuous cycling). Example: If P#3001 = 5 the profile runs 5 times, the counter is reset to zero, and will begin running 5 more cycles immediately. As long as pin 11 is closed it will keep resetting the count to zero every time the number of cycles is reached.
OPEN cycle mode is terminated when cycle count is reached.
- J2-12 CLOSED uses Run Command from J2-9 or J2-10.
OPEN uses Run Command from Keypad.
- J2-13 Not used.
- J2-14 Not used.
- J2-15 CLOSED resets an alarm or fault. OPEN normal operation.
- J2-16 Optional External Trip input (not required). If used, you must set Level 2 Drive Protect block, External Trip to "ON". CLOSED allows normal operation.
OPEN causes an External Trip to be received by the control (when programmed to "ON").

5.5.14 Bipolar

Provides bipolar speed or torque control, Vector modes only. Preset Speeds are set in software, the control is operated by the digital inputs and the command source. The opto inputs can be switches as shown in Figure 5-19 or logic signals from another device.

Figure 5-18: Bipolar Connection Diagram

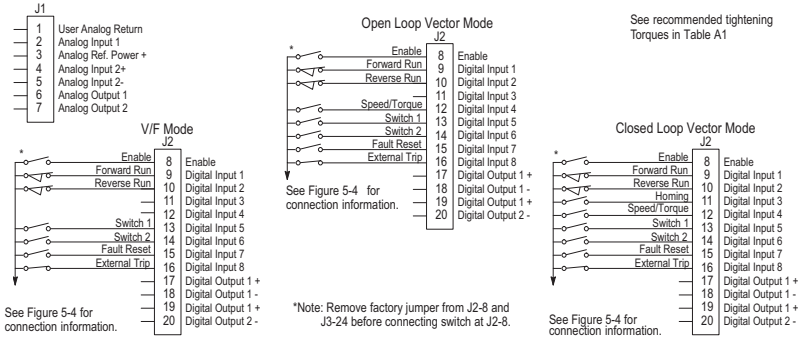

J2-8 CLOSED allows normal control operation.

OPEN disables the control and the motor coasts to a stop.

J2-9 CLOSED to enable operation in Forward direction.

OPEN TO DISABLE Forward operation (drive will decel to a stop if a Forward command is still present). Reverse operation is still possible if J2-10 is closed.

J2-10 CLOSED to enable operation in the Reverse direction.

OPEN to disable Reverse operation (drive will decel to a stop if a Reverse command is still present). Forward operation is still possible if J2-9 is closed.

Note: If J2-9 and J2-10 are both opened, the drive will decel to a stop. J2-11 CLOSED causes the motor to rotate in the forward direction until the load reaches a marker or external switch location. OPEN allows normal operation.

J2-12 CLOSED puts the control in torque command mode, Vector modes only.

OPEN puts the control in speed (velocity) command mode. Note: If a stop command is issued while in the torque (current) mode, the control will stop but will not maintain position (zero current). This is different than zero speed operation for the velocity mode. J2-13 & 14 Select from four parameter tables as defined in Table 5-13 .

J2-15 Momentary CLOSED to reset fault condition.

OPEN allows normal operation.

J2-16 Optional External Trip input (not required). If used, you must set Level 2 Drive Protect block, External Trip to "ON". CLOSED allows normal operation.

OPEN causes an External Trip to be received by the control (when programmed to "ON").

Table 5-13: Bipolar Mode Table Select Truth Table

J2-13	J2-14	Function
OPEN	OPEN	Parameter Table 1 (T1)
CLOSED	OPEN	Parameter Table 2 (T2)
OPEN	CLOSED	Parameter Table 3 (T3)
CLOSED	CLOSED	Parameter Table 4 (T4)

Note: See multiple parameter sets in this section.

Bipolar - Multiple Parameter Sets

The following procedure allows you to program up to four complete sets of parameter values and to use these multiple parameter sets. Each parameter table must be properly initialized before use. Each table must have an operating mode that supports table switching (Process Control, Bipolar or Network) and all motor data and related parameters must be the same in each table if switching tables with the drive enabled. When programming each parameter set, use the ENTER key to accept and automatically save parameter values.

Note: The control can be programmed in the REMOTE mode with the drive enabled. The control must be disabled to change the operating mode parameter. The operating mode is not stored with the other parameters in a parameter table.

1. If this is a new installation, do this procedure after the Pre-Operation Checklist and Power-Up Procedures at the end of this section.
2. Set the Level 1 INPUT block, Operating Mode parameter value to BIPOLAR in each of the parameter sets.
3. Set switches J2-13 and J2-14 to Parameter Table 1 (both switches open). Be sure switches J2-8, J2-9 and J2-10 are OPEN. Select Quick Setup from the main Keypad menu. Perform each step including auto tune. This creates and saves the first parameter set which is numbered Table 1.
4. Set switches J2-13 and J2-14 to Parameter Table 2. Be sure switches J2-8, J2-9 and J2-10 are OPEN. Select Quick Setup from the main Keypad menu. Perform each step including auto tune. This creates and saves the second parameter set which is numbered Table 2.
5. Set switches J2-13 and J2-14 to Parameter Table 3. Be sure switches J2-8, J2-9 and J2-10 are OPEN. Select Quick Setup from the main Keypad menu. Perform each step including auto tune. This creates and saves the third parameter set which is numbered Table 3.
6. Set switches J2-13 and J2-14 to Parameter Table 4. Be sure switches J2-8, J2-9 and J2-10 are OPEN. Select Quick Setup from the main Keypad menu. Perform each step including auto tune. This creates and saves the final parameter set which is numbered Table 4.
7. Remember that to change the value of a parameter in one of the parameter tables, you must first select the table using the switches. You cannot change a value in a table until you have first selected that table.
Note: The active parameter table is selected by Level 2:Drive Configure:Active Parameter Table P# 0052.

Example:

Before attempting to switch parameter tables during operation “on the fly” using the digital inputs J2-13 & 14, the operating mode for each parameter table to be used must be initialized. Specifically, to switch from Table 1 to Table 2 then back to Table 1 both parameter Table 1 and parameter Table 2 must have operating modes that support table switching. Otherwise, once the switch occurs, switching back will not be possible.

To illustrate this, prior to running Bipolar Mode perform the following steps:

1. Use the keypad, set Level 2:Drive Configure:Active Parameter Table to 0 “Table 1”.
2. Go to Level One and set Level 1: Input Setup:Operating Mode to Bipolar.
Repeat the above steps but this time for Table 2.
3. Use the keypad, set Level 2:Drive Configure:Active Parameter Table to 1 “Table 2”.
4. Go to Level One and set Level 1: Input Setup:Operating Mode to Bipolar.

The drive is now properly configured to switch between parameter Table 1 and Table 2.

5.5.15 PLC

Provides control from a PLC device (Programmable Logic Control) as described in Chapter 10 of this manual. Preset speeds are set in software. The opto inputs can be switches as shown in Figure 5-19 or logic signals from another device.

Figure 5-19: PLC Connection Diagram

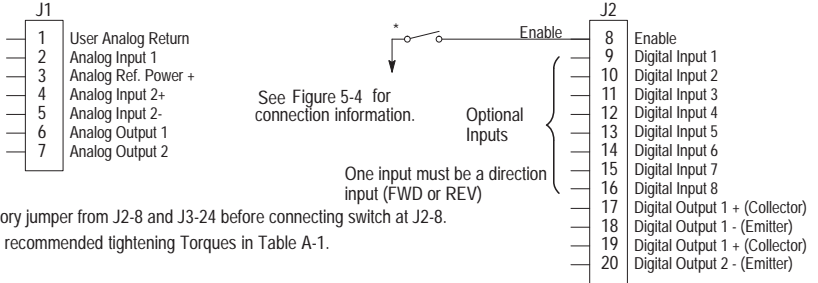

*Note: Remove factory jumper from J2-8 and J3-24 before connecting switch at J2-8.

See recommended tightening Torques in Table A-1.

5.5.16 CTD 2Wire

Operation in the Fan CTD 2-Wire mode is controlled by the opto isolated inputs at J2-8 through J2-16. The opto inputs can be switches as shown in Figure 5-20 or logic signals from another device.

Figure 5-20: Cooling Tower Drive 2Wire Connection Diagram

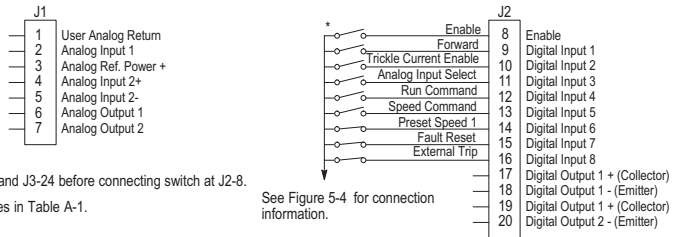

*Note: Remove factory jumper from J2-8 and J3-24 before connecting switch at J2-8.

See recommended tightening Torques in Table A-1.

See Figure 5-4 for connection information.

J2-8 CLOSED allows normal control operation.

OPEN disables the control and the motor coasts to a stop.

J2-9 CLOSED operates the motor in the Forward direction;

OPEN motor decels to stop (depending on Decel Time).

J2-10 CLOSED applies trickle current PWM to cooling tower motor if J2-8 is closed

Drive is not in Run

OPEN trickle current off

J2-11 CLOSED selects Analog Input 1 (if J2-14 is open).

OPEN selects Command Source (Level 1, Input, Command Source, if J2-14 is open).

J2-12 CLOSED selects STOP/START and Reset commands from terminal strip.

OPEN selects STOP/START and Reset commands from Keypad.

J2-13 CLOSED allows selection of speed command via command source (P1402) or via

Preset Speed 1 if J2-14 is closed.

OPEN selects speed command from Keypad

Note: When changing from Terminal Strip to Keypad (J2-12 or J2-13) the motor speed and direction will remain the same after the change.

J2-14 Commands Preset Speed #1

J2-15 CLOSED to reset fault

OPEN to run

J2-16 Optional External Trip input (not required). If used, you must set Level 2 Drive Protect block, External Trip to "ON". CLOSED allows normal operation.

OPEN causes an External Trip to be received by the control (when programmed to "ON").

CTD 2Wire Connection Diagrams

For proper operation in a cooling tower system, the CTD should be used with an "Output /Shorting" contactor or "Output /Shorting" disconnect.

Please see appropriate diagram below and connect CTD to motor and control signals as shown:

CTD 2Wire - Output / Shorting disconnect:

Figure 5-21

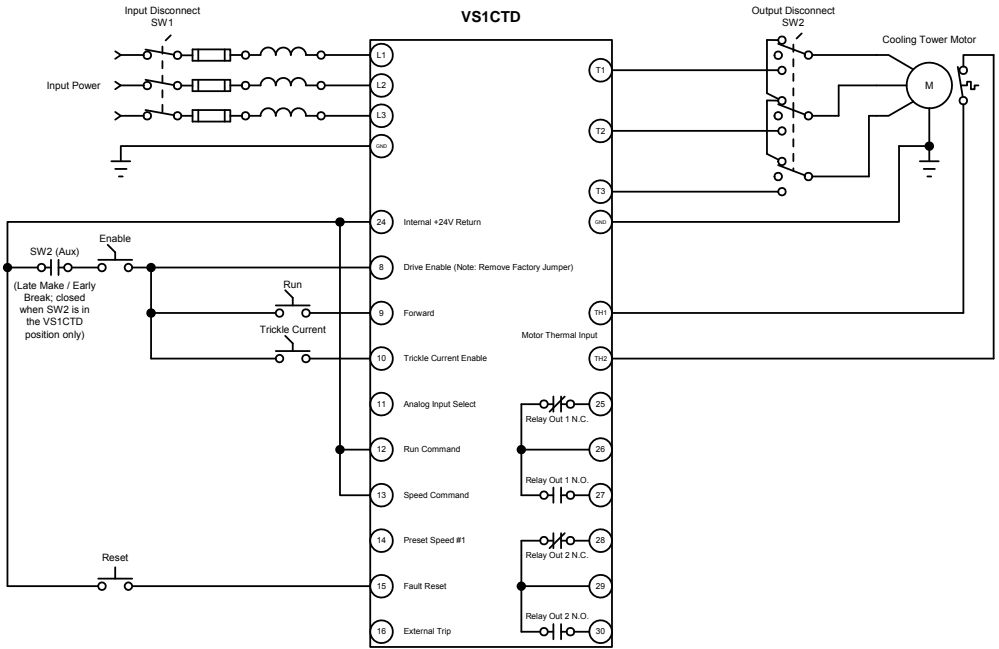

CTD – 2Wire - Output / Shorting Contactor:

Figure 5-22

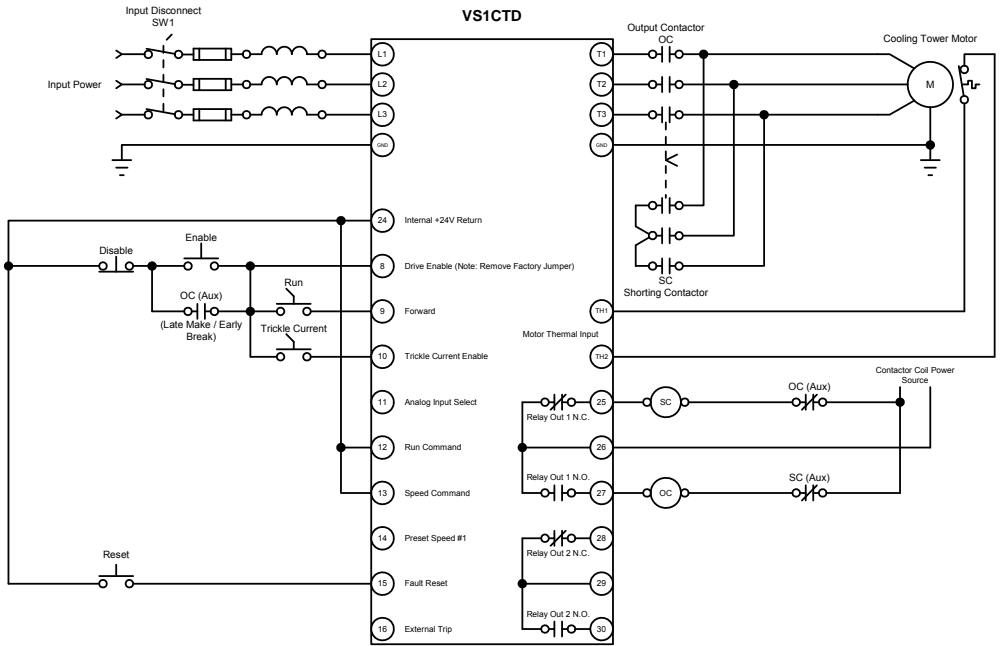

5.5.17 CTD 3Wire

Operation in the Fan Pump 3-Wire mode is controlled by the opto isolated inputs at J2-8 through J2-16. The opto inputs can be switches as shown in Figure 5-23 or logic signals from another device.

Figure 5-23: Cooling Tower Drive 3Wire Connection

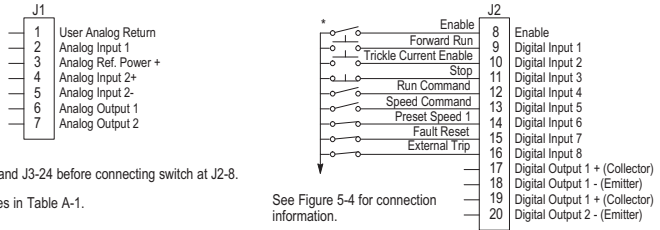

*Note: Remove factory jumper from J2-8 and J3-24 before connecting switch at J2-8.

See recommended tightening Torques in Table A-1.

See Figure 5-4 for connection information.

J2-8 CLOSED allows normal control operation.

OPEN disables the control and the motor coasts to a stop.

J2-9 MOMENTARY CLOSED starts motor operation in the Forward direction.

J2-10 Closed applies trickle current PWM to cooling tower motor if J2-8 is closed and Drive is not in Run, OPEN trickle current is off

J2-11 MOMENTARY OPEN motor decels to stop (depending on Decel Time).

J2-12 CLOSED selects STOP/START and Reset commands from terminal strip.

OPEN selects STOP/START and Reset commands from Keypad.

J2-13 CLOSED allows selection of speed command source (P1402) or via Preset Speed 1 if J2-14 is closed.

OPEN selects speed commanded from Keypad

Note: When changing from Terminal Strip to Keypad (J2-12 or J2-13) the motor speed and direction will remain the same after the change.

J2-14 Commands Preset Speed # 1

J2-15 CLOSED to reset fault.

OPEN to run

J2-16 Optional External Trip input (not required). If used, you must set Level 2 Drive Protect block, External Trip to "ON". CLOSED allows normal operation.

OPEN causes an External Trip to be received by the control (when programmed to "ON").

CTD 3Wire Connection Diagram

For proper operation in a cooling tower system, the CTD should be used with an Output/Shorting disconnect. Please see appropriate diagram and connect CTD to motor and control signals as shown:

CTD 3Wire Output/Shorting Disconnect:

Figure 5-24

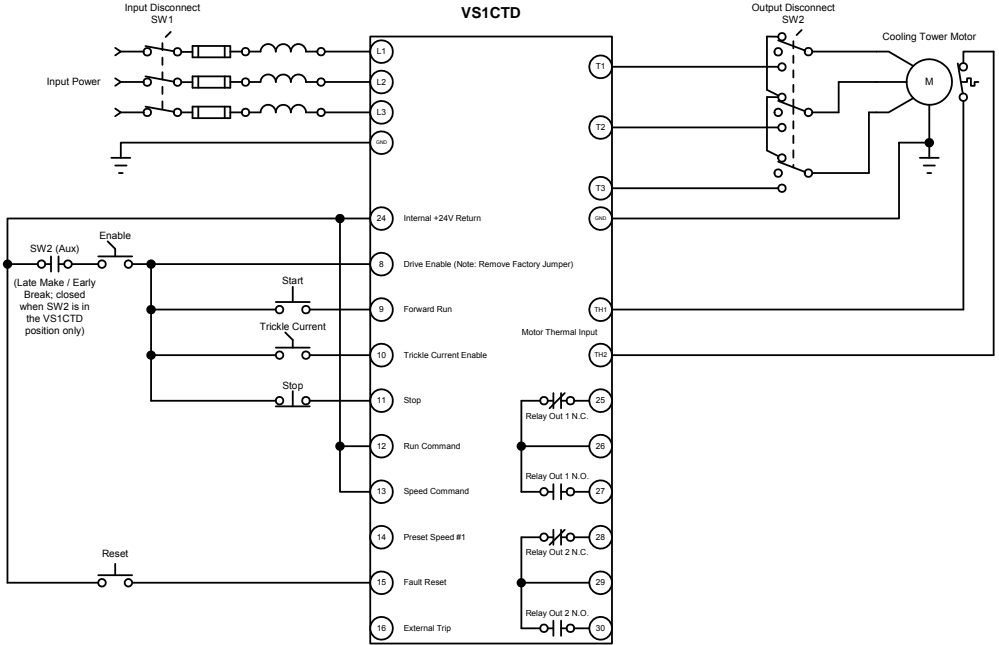

CTD 3Wire Output/Shorting Contactor

Figure 5-25
VS1CTD

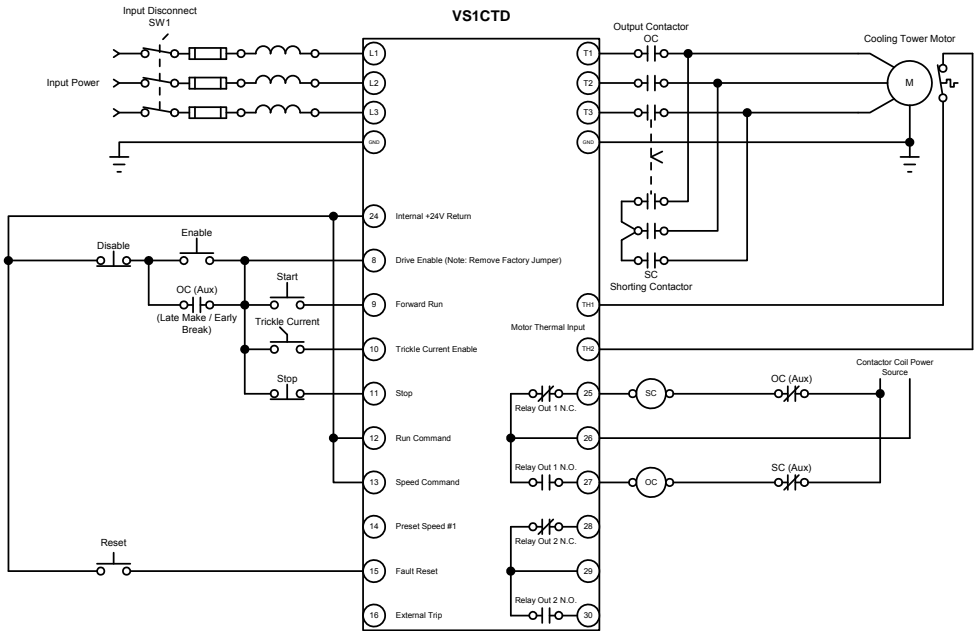

5.6 Digital Outputs

Digital Outputs 1 and 2 are opto isolated. Internal supply or a customer provided, external power source may be used as shown in Figure 5-26. The maximum voltage from Digital Output to common when active is 1.0 VDC.

If the Digital Outputs are used to directly drive a relay, a flyback diode rated at 1A, 100V (IN4002 or equivalent) minimum should be connected across the relay coil. See Figure 5-27. Each opto output is programmed in the Output programming block.

Figure 5-26: Digital Output Power Connections

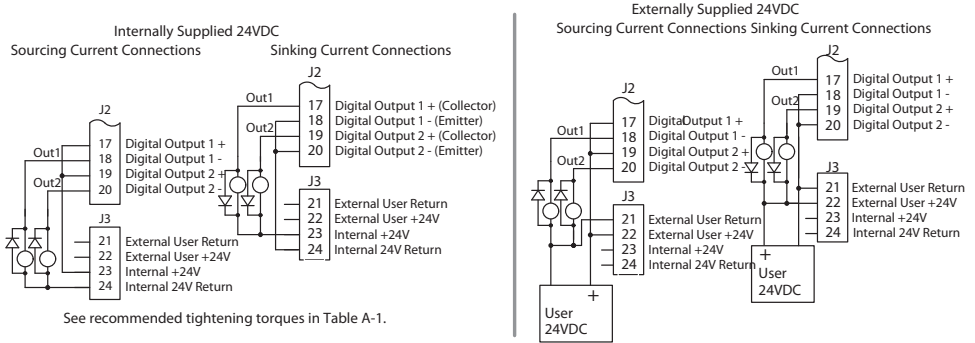

5.7 Relay Outputs

Relay Outputs 1 and 2 provide N.O. and N.C. voltage free contacts. The internal relay function is shown in Figure 5-28.

Figure 5-27: Relay Contacts

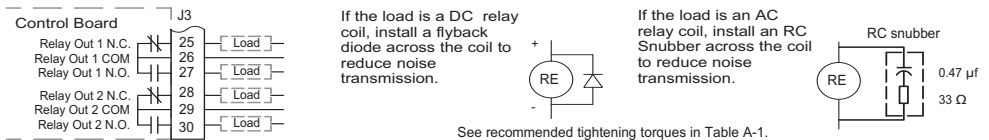

Note: Relay Outputs are rated to 10-30VDC or 240VAC @ 5A resistive (non-inductive).

5.8 USB Port

The USB port shown in Figure 5-29 is a full 12Mbps USB 2.0 compliant port for serial communications. The connections are described in Figure 5-28 and Table 5-14 .

Figure 5-28: USB Receptacle Pin Identification

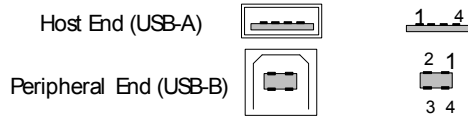

Table 5-14: USB Port Connections

Pin	Signal Name	Description
1	V_{bus}	USB power from the host for monitoring
2	D-	Data Return
3	D+	Data In
4	GND	Power Supply Return

5.9 Communication Expansion Boards

The communication and feedback module slots are shown in Figure 5-29. All option boards are designed as plug-in modules.

Figure 5-29: Expansion Board Location

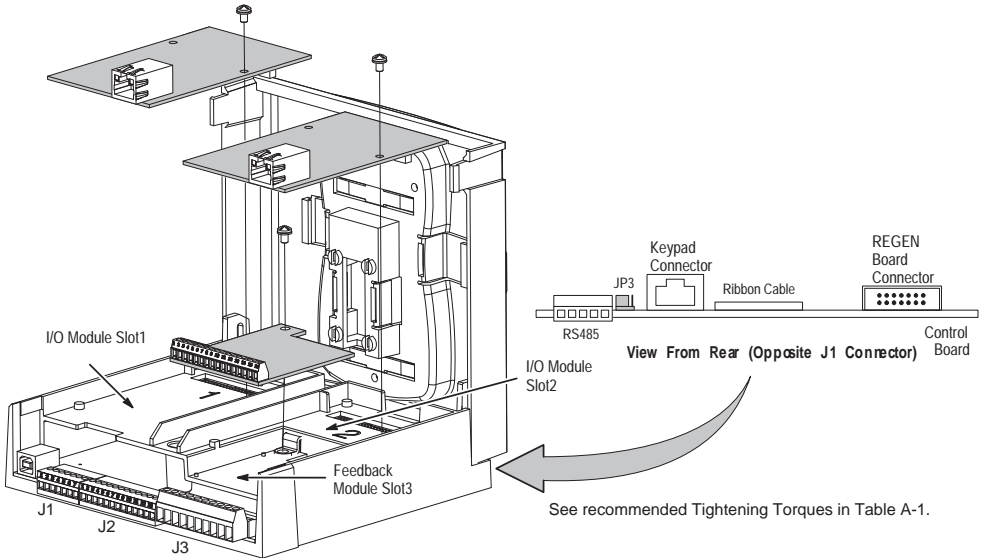

5.9.1 RS485 Modbus

The serial communications port on the control board supports RS485 communications, Figure 5-29. The baud rate and node addresses are selectable from the Keypad. Jump JP3 (Figure 5-29) on the control board sets termination. As shown (pins 2 and 3 jumpered) no terminal resistor is used. Setting the jumper to pins 1 and 2 selects the 120 ohm terminating resistor for the RS485 cable. The RS485 connections are described in Table 5-15. Refer to MN744 for connection and software information.

Table 5-15: RS485 Multi-Drop Port Connections

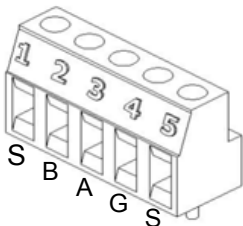

Pin	Signal Name	Description
1	SCR	Screen termination, connected to chassis on the control board
2	B	Data Return
3	A	Data In
4	GND	Power Supply Return
5	SCR	Screen termination, connected to chassis on the control board

5.10 Opto-Isolated Inputs

The equivalent circuit of the nine opto inputs is shown in Figure 5-30. The function of each input depends on the operating mode selected and are described previously in this section. This Figure also shows the connections using the internal opto input Supply.

Figure 5-30: Opto-Input Connections

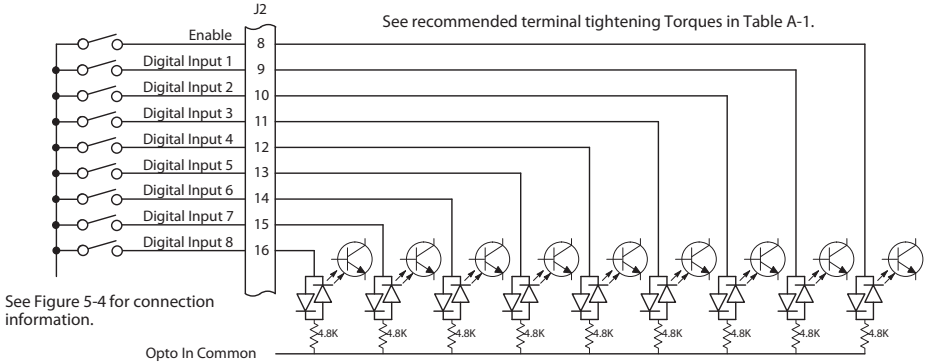

5.11 Opto-Isolated Outputs

The outputs are opto isolated and may be configured for sinking or sourcing. However, all must be configured the same. The maximum voltage from opto output to common when active is 1.0 VDC (TTL compatible). The equivalent circuit for the opto isolated outputs is shown in Figure 5-31 .

Figure 5-31: Opto-Output Equivalent Circuit

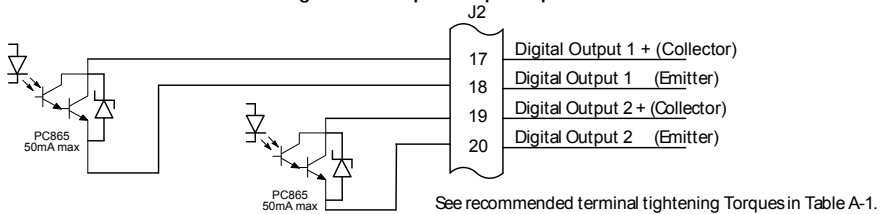

5.12 Pre-Operation Checklist (Check of Electrical Items)

1. Verify AC line voltage at source matches control rating.
2. Inspect all power connections for accuracy, workmanship and tightness and compliance to codes.
3. Verify control and motor are grounded to each other and the control is connected to earth ground.
4. Check all signal wiring for accuracy.
5. Be certain all brake coils, contactors and relay coils have noise suppression. This should be an R-C filter for AC coils and reverse polarity diodes for DC coils. MOV type transient suppression is not adequate.

5.13 Powerup Procedure

1. Remove all power from the control.
2. Verify that any enable inputs to J2-8 are open.
3. Disconnect the motor from the load (including coupling or inertia wheels).
4. Turn power on. Be sure there are no faults.
5. Set the Level 2 Output Limits block, "OPERATING ZONE" parameter as desired (STD CONST TQ, STD VAR TQ, QUIET CONST TQ or QUIET VAR TQ).
6. If external dynamic brake hardware is used, set the Level 2 Brake Adjust block "Resistor Ohms" and "Resistor Watts" parameters.
7. Enable the control (J2-8 connect to J3-24).

WARNING: The motor shaft will rotate during this procedure. Be certain that unexpected motor shaft movement will not cause injury to personnel or damage to equipment.

8. Select basic parameters from the main Keypad menu. Perform each step including "CALC MOTOR MODEL" (P#2414).
9. Select "Advanced Prog", Level 2 Blocks, Auto Tune, "One-Step Tuning" and run all tests.
10. Remove all power from the control.
11. Couple the motor to its load.
12. Verify freedom of motion of motor shaft.
13. Verify the motor coupling is tight without backlash.
14. Verify the holding brakes if any, are properly adjusted to fully release and set to the desired torque value.
15. Turn power on. Be sure no errors are displayed.
16. Execute "Speed Loop Tune"
17. Run the drive from the keypad using one of the following: the arrow keys for direct speed control, a keypad entered speed or the JOG mode.
18. Select and program additional parameters to suit your application.

The control is now ready for use in the keypad mode. If a different operating mode is desired, refer to Chapter 5 Operating Modes and Chapter 6 Programming and Operation.

5.14 Mint WorkBench

As an alternative to using the keypad for programming and setup, Baldor's Mint WorkBench software version 5.5 or greater can be used. When the software is installed and configured, the help topics provide information for how to use the software. The following procedure will help you install and configure the software to minimize difficulty.

Before you can use Mint WorkBench software, it must be installed on your PC's hard drive. Be sure that the USB port of the control is connected to a USB port on your PC. This must be connected to establish communication after the software is installed.

5.14.1 Install USB Driver

The control connects to a PC by using USB cable connection. This procedure installs the USB driver that is required by Windows.

1. The software must be downloaded from the Baldor site: <http://www.baldor.com> Simply log into that web site and select Products then select AC Controls then select VS1 Vector to locate the Software tools.
2. USB Device Driver

Figure 5-32: USB Driver

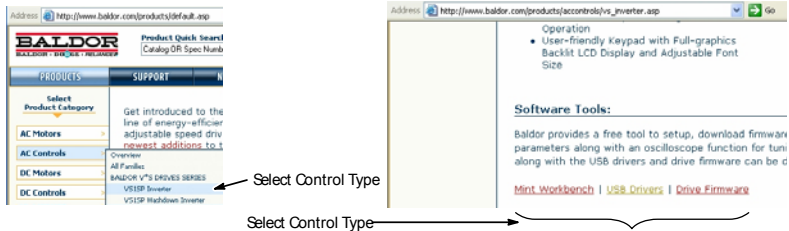

3. Click on USB Device Drive and select Open to view the uncompressed files.



Name	Type	Packe...
Installing the driv...	Text Document	1 KB
USBMotion.Inf	Setup Inform...	1 KB
USBMotion.sys	System file	12 KB

4. Be sure the control is powered up.
5. Connect the USB cable to the control.
6. Install the USB drivers.
 - a. Choose "install from a list or specific location" and click Next.
 - b. Choose "Don't search I will choose the driver to install".
 - c. Click "Have Disk". Then enter the location that you stored the inf and sys file (in step 3) and click Next to install the driver files.

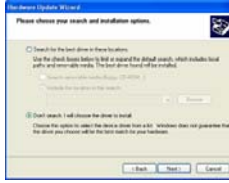

7. Proceed to the Mint WorkBench installation procedure.

5.14.2 Install Mint WorkBench

1. Use the Add/Remove Software feature of the Windows control panel and remove previous versions of Mint WorkBench software.
2. The software must be downloaded from the Baldor site: <http://www.baldor.com>
Simply log into that web site, Figure 5-27 , and locate
 1. Mint WorkBench v X.x
3. Click on Download the software, and run the installation program.
4. When installation is complete, the Mint WorkBench program will start, see Figure 5-28 .
 - a. Click "Start New Project".
 - b. Click "Scan".
 - c. Select "H2" platform from the list.
 - d. Click Select and the Mint WorkBench main menu is displayed, see Figure 5-29.

Figure 5-33: Mint WorkBench Software Set-up

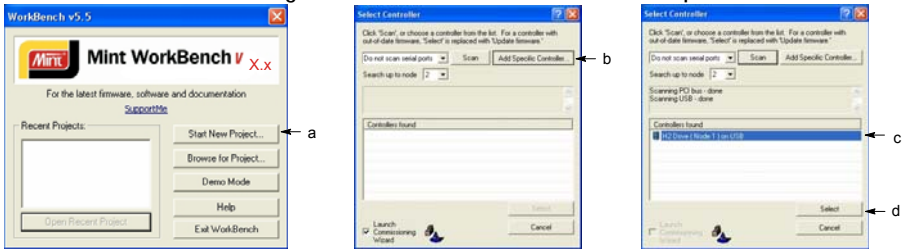
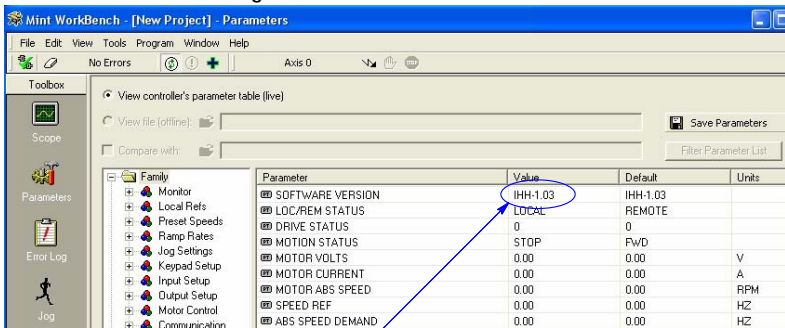

Figure 5-34: Communication Established



Software version is Inverter (IHH) version 1 release 03.

5. Parameter values can be modified as desired.

Figure 5-35: Mint WorkBench Main Menu

Change Parameter Value

Example:

Change Preset Speed 1 to 48RPM.

Click on Preset Speeds Block.

Click in the Value Column for Preset Speed 1.

Type in the new value "48" press enter.

Note that the keypad will instantly display the new value.

If the parameter value is a selection, a list will appear for you to make the selection.

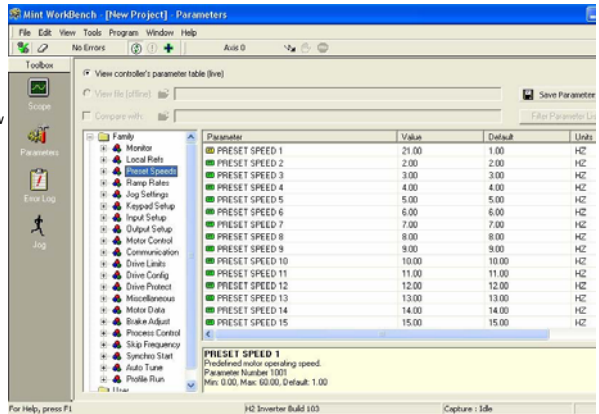
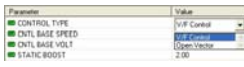

- When all parameter values are as desired, they can be saved to a file. Click File, see Figure 5-31. The pxt file is saved in My Documents\My Mint directory.
- When complete, the entire project can be saved to your PC's hard disk for future use. Click File, Save File, see Figure 5-31. The wbx file is saved in C:\Program Files\Mint Machine Center\Firmware\ you can choose the directory.

Figure 5-36: Save Parameters & Project

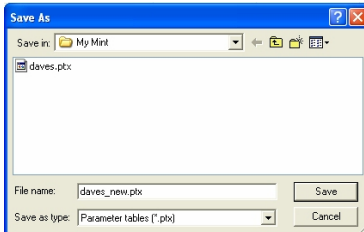

Note:
Enter a filename.
The .pxt extension is automatically added.

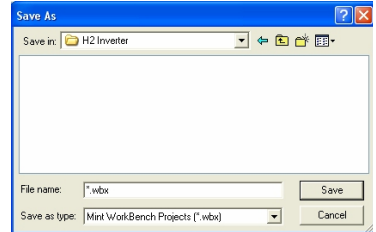

Note: Enter a filename.
The .wbx extension is automatically added.

The help menus provided with the software can be used to explore other features and descriptions of menu choices. As previously stated, either the Mint WorkBench program or the Keypad can be used to adjust parameter values for the application.

5.14.3 Update Firmware

Installing chx Files

(If you are installing msx files skip this procedure and go to “Installing msx Files”).

This procedure erases memory and restores factory settings. All user data will be lost. After the firmware download, all user data values must be reprogrammed.

1. The software must be downloaded from the Baldor site: <http://www.baldor.com>
Simply log into that web site, Figure 5-27 . Locate and click on Drive Firmware
2. Save the firmware file to a location on your hard disk
(for example: C:\Program Files\Mint Machine Center\Firmware\H2 Vector\THH_1_22.chx).

This procedure erases memory and restores factory settings. All user data will be lost. After the firmware download, all user data values must be reprogrammed.

3. Start the Workbench program as before, see Figure 5-32 .
 - a. Select “Download Firmware” from the Tools menu.
 - b. Select “Advanced” then “Download Firmware File”, click “Yes” at the warning to download.
 - c. Select the firmware file to download (for example: THH_1_22chx).
 - d. When complete, the new firmware version is displayed and the control is ready for use.

Note: All user settings and motor parameter values have been over written by factory settings.

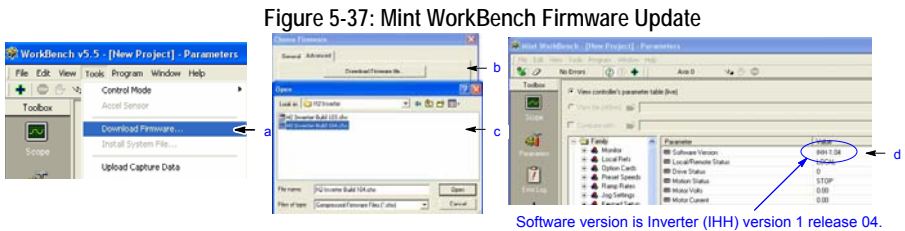

Installing A Mint System (.msx) file

(If you are installing chx files skip this procedure and go to “Installing chx Files”).

This procedure erases memory and restores factory settings. All user data will be lost. After the firmware download, all user data values must be reprogrammed.

1. The msx file must be saved to a location on your hard disk (for example: C:\Program Files\Mint Machine Center\Firmware\H2 Vector\H2 Cooling Tower Build 122.msx). This procedure installs the msx file contents within the same directory (chx, ini and txt files are extracted).
2. Start the WorkBench program as before, see Figure 5-28 .
 - a. Select “Install System File Firmware” from the Tools menu, Figure 5-33 .
 - b. Select the firmware file to download (for example: H2 Cooling Tower Build 122.msx)
 - c. Select OPEN.
 - d. When complete, the install successful message is displayed, click OK.

Figure 5-38: Mint WorkBench Firmware Update

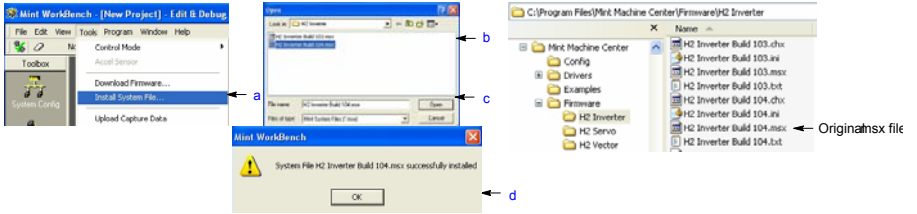

3. This procedure erases memory and restores factory settings. All user data will be lost. After the firmware download, all user data values must be reprogrammed.
 - a. Select “Download Firmware” from the Tools menu, Figure 5-34.
 - b. Select control type and version to download.
 - c. Select Download to control to download the firmware.
 - d. When complete, the new firmware version is displayed and the control is ready for use.

Note: All user settings and motor parameter values have been over written by factory settings.

Figure 5-39: Mint WorkBench Firmware Update

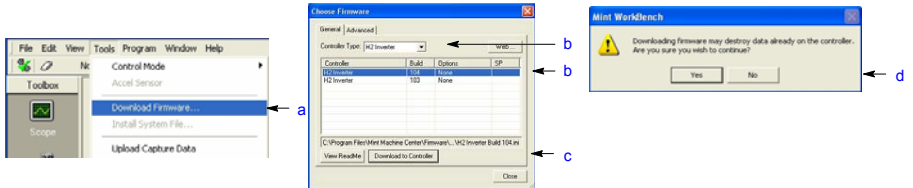

Chapter 6

Using the Keypad

6.1 Keypad Components

The keypad is used to program the control parameters, to operate the motor and to monitor the status and outputs of the control by accessing the display options, the diagnostic menu and the fault log. Additionally drive parameters can be stored in the keypad for future retrieval.

6.1.1 Display Description

Keypad Display – Displays status information during Local or Remote operation. It also displays information during parameter setup and fault or Diagnostic information.

F1 – Alternates or “toggles” between the last two menu choices or function indicated by text displayed directly above key.

Enter – Press ENTER to save parameter value changes. In the display mode the ENTER key is used to directly set the local speed reference. It is also used to select other operations when prompted by the keypad display.

Menu – Selects the menu display. The following menu items are shown: Status, Basic Params, Advanced Prog, Event Log, Diagnostics and Display Options.

REV – When pressed, initiates a reverse direction run command.

Stop – Initiates a stop command.
Note: Pressing the stop key twice in succession will immediately disable the drive placing the motor in a coast stop condition.



Display Diagnostics –
I/O Status
I/O Function configuration
Modified Parameters
Control Operation Data
Custom Units
Fault Display – 10 Faults with Time Stamp

F2 – Clears faults or undo parameter edit changes or function indicated by text displayed directly above key.

- ▲ Up Arrow
- ▼ Down Arrow
- ◀ Left Arrow
- ▶ Right Arrow

Moves cursor to select menu choices.

Local Remote – Switches between local and remote modes.

Help – Provides help at each display screen, setup parameter and fault. Press to view/close help information.

JOG – Initiates Jog mode pressed. Press FWD or REV for motion. Only active in local mode.

FWD – When pressed, initiates a forward direction run command.

Indicator Lights – (on indicated key)
STOP key with red light indicator.
FWD key with green light indicator.
REV key with green light indicator.
JOG key with green light indicator.

6.1.2 Display Features

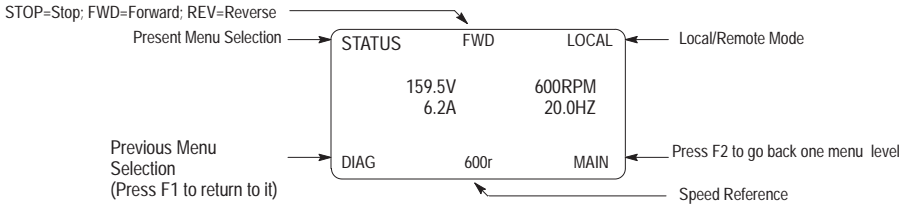

Advanced Prog Mode ONLY Display Features:





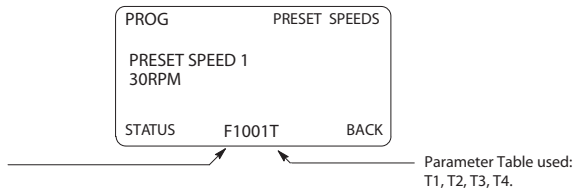











The first character of the parameter number has the following meaning:

- F = Factory Setting (parameter value has not been changed)
- C = Custom value set by user (not factory value)
- V = Parameter value may be Viewed but not changed.
- L = Parameter value is locked, security code required.



6.2 Status Mode

When AC power is applied to the control, the keypad should display the status.

Action	Description	Display	Comments															
Apply Power	Logo is displayed for a short time. The Status screen is then displayed.																	
	Normal status screen at start up. Displays Motor V oltage, Motor Amps, Motor Speed RPM and Motor Frequency Hz.	<table border="1"> <tr> <td>STATUS</td> <td>STOP</td> <td>LOCAL</td> </tr> <tr> <td>0.0V</td> <td>0RPM</td> <td></td> </tr> <tr> <td>0.0A</td> <td>0.0HZ</td> <td></td> </tr> <tr> <td>DIAG</td> <td>0.00r</td> <td>MAIN</td> </tr> </table>	STATUS	STOP	LOCAL	0.0V	0RPM		0.0A	0.0HZ		DIAG	0.00r	MAIN	The display can be changed to several formats by pressing the ► or ◀ keys.			
STATUS	STOP	LOCAL																
0.0V	0RPM																	
0.0A	0.0HZ																	
DIAG	0.00r	MAIN																
Press ► key	Next screen format is displayed.	<table border="1"> <tr> <td>STATUS</td> <td></td> <td>LOCAL</td> </tr> <tr> <td></td> <td>0 RPM</td> <td></td> </tr> <tr> <td></td> <td>0.0 A</td> <td></td> </tr> <tr> <td>DIAG</td> <td>0.00r</td> <td>MAIN</td> </tr> </table>	STATUS		LOCAL		0 RPM			0.0 A		DIAG	0.00r	MAIN				
STATUS		LOCAL																
	0 RPM																	
	0.0 A																	
DIAG	0.00r	MAIN																
Press ► key	Next screen format is displayed.	<table border="1"> <tr> <td>STATUS</td> <td></td> <td>LOCAL</td> </tr> <tr> <td></td> <td>0 RPM</td> <td></td> </tr> <tr> <td></td> <td>0.0 HZ</td> <td></td> </tr> <tr> <td>DIAG</td> <td>0.00r</td> <td>MAIN</td> </tr> </table>	STATUS		LOCAL		0 RPM			0.0 HZ		DIAG	0.00r	MAIN				
STATUS		LOCAL																
	0 RPM																	
	0.0 HZ																	
DIAG	0.00r	MAIN																
Press ► key	Next screen format is displayed.	<table border="1"> <tr> <td>STATUS</td> <td></td> <td>LOCAL</td> </tr> <tr> <td></td> <td>0.0 A</td> <td></td> </tr> <tr> <td></td> <td>0.0 V</td> <td></td> </tr> <tr> <td>DIAG</td> <td>0.00r</td> <td>MAIN</td> </tr> </table>	STATUS		LOCAL		0.0 A			0.0 V		DIAG	0.00r	MAIN				
STATUS		LOCAL																
	0.0 A																	
	0.0 V																	
DIAG	0.00r	MAIN																
Press ► key	Next screen format is displayed.	<table border="1"> <tr> <td>STATUS</td> <td></td> <td>LOCAL</td> </tr> <tr> <td></td> <td>0 RPM</td> <td></td> </tr> <tr> <td></td> <td>0.0 V</td> <td></td> </tr> <tr> <td></td> <td>0.0 A</td> <td></td> </tr> <tr> <td>DIAG</td> <td>0.00r</td> <td>MAIN</td> </tr> </table>	STATUS		LOCAL		0 RPM			0.0 V			0.0 A		DIAG	0.00r	MAIN	
STATUS		LOCAL																
	0 RPM																	
	0.0 V																	
	0.0 A																	
DIAG	0.00r	MAIN																
Press ► key	Next screen format is displayed.	<table border="1"> <tr> <td>STATUS</td> <td></td> <td>LOCAL</td> </tr> <tr> <td></td> <td>0.0 NM</td> <td></td> </tr> <tr> <td></td> <td>0.0 A</td> <td></td> </tr> <tr> <td></td> <td>0 RPM</td> <td></td> </tr> <tr> <td>DIAG</td> <td>0.00r</td> <td>MAIN</td> </tr> </table>	STATUS		LOCAL		0.0 NM			0.0 A			0 RPM		DIAG	0.00r	MAIN	
STATUS		LOCAL																
	0.0 NM																	
	0.0 A																	
	0 RPM																	
DIAG	0.00r	MAIN																
Press ► key	The rst screen format is displayed.	<table border="1"> <tr> <td>STATUS</td> <td>STOP</td> <td>LOCAL</td> </tr> <tr> <td>0.0V</td> <td>0RPM</td> <td></td> </tr> <tr> <td>0.0A</td> <td>0.0HZ</td> <td></td> </tr> <tr> <td>DIAG</td> <td>0 r</td> <td>MAIN</td> </tr> </table>	STATUS	STOP	LOCAL	0.0V	0RPM		0.0A	0.0HZ		DIAG	0 r	MAIN				
STATUS	STOP	LOCAL																
0.0V	0RPM																	
0.0A	0.0HZ																	
DIAG	0 r	MAIN																
Press FWD key	Motor begins to rotate in the forward direction at the preset speed.	<table border="1"> <tr> <td>STATUS</td> <td>FWD</td> <td>LOCAL</td> </tr> <tr> <td>159.5V</td> <td>600RPM</td> <td></td> </tr> <tr> <td>0.2A</td> <td>20.0HZ</td> <td></td> </tr> <tr> <td>DIAG</td> <td>600r</td> <td>MAIN</td> </tr> </table>	STATUS	FWD	LOCAL	159.5V	600RPM		0.2A	20.0HZ		DIAG	600r	MAIN				
STATUS	FWD	LOCAL																
159.5V	600RPM																	
0.2A	20.0HZ																	
DIAG	600r	MAIN																

6.3 Menu Display

After power-up the display shows the Status screen. Press the Menu key to display menu options.

Action	Description	Display	Comments
Status Display		<pre> STATUS STOP LOCAL 0.0V ORPM 0.0A 0.0HZ DIAG 0.00r MAIN </pre>	
Press Menu	Displays top level menu options.	<pre> STATUS BASIC PARAMS ADVANCED PROG EVENT LOG DIAGNOSTICS ▼ DIAG BACK </pre>	Press ▲ or ▼ to move cursor over the desired selection the press "Enter" to select and display the selection.

6.4 Basic Params

From the Menu display screen, select Basic Params and press Enter. **Parameter Status.** All programmable parameters are displayed with an “F” at the bottom center of the display. “F” means it is the factory setting value. “C” means it is a custom value set by the user. “V” means the parameter value may be viewed but not changed while the motor is operating. If the parameter is displayed with an “L”, the value is locked and may not be changed until the security code is entered.

Action	Description	Display	Comments
Basic Params Display	Control type display . The parameter number “1601” is given at the bottom center of the display. “F”1601 indicates it is at the factory setting and has not been changed.		Press Enter to select the parameter and press the ▲ or ▼ keys to change the preset value to a different control type. Press enter when finished to exit and save the new value or F2 to exit without saving.
Press ► to go to the next Basic Params screen.			T1 indicates the Table Number or the parameter list in use. Four parameter tables are available, T1, T2, T3 or T4 (See Level 2, Drive Config, Active Param T able parameter P0052.)
Press ► to go to the next Basic Params screen.			
Press ► to go to the next Basic Params screen.			
Press ► to go to the next Basic Params screen.			
Press ► to go to the next Basic Params screen.			

Basic Params Continued

Action	Description	Display	Comments
Press ▶ to go to the next Basic Params screen.		BASIC MOTOR DATA CALC MOTOR MODEL No STATUS F2414 BACK	
Press ▶ to go to the next Basic Params screen.		BASIC INPUT SETUP OPERATING MODE Keypad STATUS F1401T1 BACK	
Press ▶ to go to the next Basic Params screen.		BASIC RAMP RATES ACCEL TIME 1 3.0 SEC STATUS F1101T1 BACK	
Press ▶ to go to the next Basic Params screen.		BASIC RAMP RATES DECEL TIME 1 3.0 SEC STATUS F1104T1 BACK	
Press ▶ to go to the next Basic Params screen.		BASIC DRIVE LIMITS MIN OUTPUT SPEED 0 RPM STATUS F2002T1 BACK	
Press ▶ to go to the next Basic Params screen.		BASIC DRIVE LIMITS MAX OUTPUT SPEED 1800 RPM STATUS F2003T1 BACK	
Press ▶ to go to the next Basic Params screen.		BASIC END OF BASIC PARAMS STATUS BACK	

How to Change a Value

These are the BASIC screens. To change a value, simply display the desired screen and press Enter and change the value. For example:

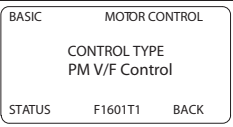
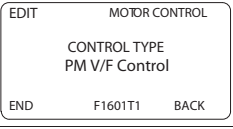
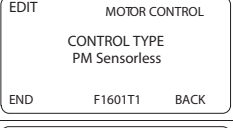
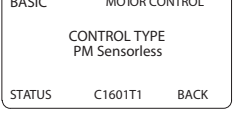
Action	Description	Display	Comments
Press ▶ to go to the next Basic Params screen.	1601 indicates the parameter number and F indicates it is the factory value.		
Press Enter to choose parameter value and edit.			Press "F2" to exit EDIT mode without saving changes.
Press the ▲ or ▼ keys to change parameter value.			
Press Enter to save the parameter value and exit.			

When editing a parameter value, the function of the "F1" key (previous parameter block) shown in the lower left of the display changes to one of the following to help select the parameter value: TOP Press "F1" to display and select the first value in the list of parameter values.

When the first parameter value is displayed, press Enter or scroll to select a different value. END Press "F1" to display and select the last value in the list of parameter values.

When the last parameter value is displayed, press Enter or scroll to select a different value. DEF Press "F1" to display and select the Factory Setting value.

PREV Press "F1" to display and select previous value.

MIN Press "F1" to display and select minimum parameter value.

MAX Press "F1" to display and select maximum parameter value.

Note: When END is displayed, Pressing "F1" will display the last value in the list but then TOP or DEF is displayed. The "F1" key allows you to quickly move through large lists of parameter choices. The value is not selected until you press "Enter".

6.5 Save Parameter Values

The keypad keys and display work with the memory of the control. When a parameter value is displayed, the displayed value is the value stored in control memory. The changes are written to non-volatile memory and are stored even when power is removed. Normal control operation can resume when power is restored.

Keypad memory is only used to backup the four parameter tables stored in control memory. This means that after the parameters are configured for the application and the control operation is as desired, a copy of the parameters can be saved to keypad memory as a backup copy. This backup copy can be restored at any time. This is useful to restore program operation after a firmware update or to make several controls operate the same. It prevents having to make the changes to each control individually.

Action	Description	Display	Comments
Press Menu	Go to the Advanced Prog Level 1 Keypad Setup block.	<pre> PRESET SPEEDS RAMP RATES JOG SETTINGS KEYPAD SETUP INPUT SETUP STATUS BACK </pre>	Press "Enter" to select.
Press Enter to edit Keypad Setup parameters.	Scroll to PARAMS TO KEYPAD	<pre> PROG KEYPAD SETUP PARAMS TO KEYPAD No STATUS F1310 BACK </pre>	Press "Enter" to change parameter value. Note that T1 is missing from the parameter number . It is not part of the stored parameter table values T1, T2, T3 and T4.
Press Enter to edit parameter .		<pre> EDIT KEYPAD SETUP PARAMS TO KEYPAD Yes STATUS F1310 BACK </pre>	Press ▲ to change value to YES.
Press Enter to load the parameter table values from control memory to keypad memory .		<pre> PROG KEYPAD SETUP PARAMS TO KEYPAD No STATUS F1310 BACK </pre>	Press "F2" to return to Keypad Setup menu.

A copy of all four parameter tables have now been saved to non-volatile keypad memory.

6.6 Restore Parameter Values

The keypad keys and display work with the memory of the control. When a parameter value is displayed, the displayed value is the value stored in control memory. The changes are written to non-volatile memory and are stored even when power is removed. Normal control operation can resume when power is restored.

Keypad memory is only used to backup the four parameter tables stored in control memory. This means that after the parameters are configured for the application and the control operation is as desired, a copy of the parameters can be saved to keypad memory as a backup copy. This backup copy can be restored at any time. This is useful to restore program operation after a firmware update or to make several controls operate the same. It prevents having to make the changes to each control individually.

Action	Description	Display	Comments
Press Menu	Go to the Advanced Prog Level 1 Keypad Setup block.	<pre> PRESET SPEEDS RAMP RATES JOG SETTINGS KEYPAD SETUP INPUT SETUP </pre>	Press "Enter" to select.
Press Enter to edit Keypad Setup parameters.	Scroll to DOWNLOAD SELECT and change as desired.	<pre> PROG KEYPAD SETUP DOWNLOAD SELECT ALL STATUS F1311T1 BACK </pre>	ALL =Download all parameters. Motor = Download only Motor Parameters. Other =All parameters other than motor parameters.
	Scroll to KEYPAD TO PARAMS	<pre> PROG KEYPAD SETUP KEYPAD TO PARAMS No STATUS F1312 BACK </pre>	Press "Enter" to change parameter value.
Press Enter to edit parameter .		<pre> EDIT KEYPAD SETUP KEYPAD TO PARAMS Yes STATUS F1312 BACK </pre>	Press ▲ to change value to YES.
Press Enter to load the parameter table values from keypad memory to control memory .		<pre> PROG KEYPAD SETUP KEYPAD TO PARAMS No STATUS F1312 BACK </pre>	Press "F2" to return to Keypad Setup menu.

A copy of all four parameter tables have now been restored to non-volatile memory control.

6.7 Advanced Prog

At the Menu display screen, select ADVANCED PROG and press Enter. This menu provides access to all drive parameters which are organized in blocks that are grouped into one of 3 levels. Examples of tasks accomplished via this menu are:

1. Adjustment of motor data not available in the basic parameters menu.
2. Auto Tune the motor.
3. Customize the drive parameters to your application.

Parameter Status. All programmable parameters are displayed with its parameter number shown at the bottom center of the display. "F" means it is the factory setting value. "C" means it is a custom value set by the user. "V" means the parameter value may be viewed but not changed while the motor is operating. If the parameter is displayed with an "L", the value is locked and may not be changed until the security code is entered.

security code is entered.

Action	Description	Display	Comments
Advanced Prog Display	Top Level Advanced Prog menu.	<pre> LEVEL 1 BLOCKS LEVEL 2 BLOCKS LEVEL 3 BLOCKS MODIFIED PARAMS LINEAR LIST STATUS BACK </pre>	Press enter to program level 1 block parameters. or Press ▼ to view Level 2 blocks. Press ▼ to view Level 3 blocks. Press ▼ to view list of parameters that have been changed from their factory settings or to view a list of parameters organized by number.
Press Enter to edit Level 1 parameters.	Top of Level 1 Advanced Prog Block 1 menu.	<pre> PRESET SPEEDS RAMP RATES JOG SETTINGS KEYPAD SETUP INPUT SETUP STATUS BACK </pre>	Press ▼ to scroll to next level 1 parameter.
Press Enter to select Preset Speeds.	Preset speed 1 value display .	<pre> PROG PRESET SPEEDS PRESET SPEED 1 30 RPM STATUS F1001T1 BACK </pre>	Press ▼ to go to next Preset Speed parameter .
Press Enter to edit Preset Speed 1.	Press ▲ or ▼ to increase or decrease the value highlighted by the cursor .	<pre> EDIT PRESET SPEEDS PRESET SPEED 1 00030 RPM MAX F1001T1 RESET </pre>	Press ▲ or ▼ to move cursor . Press "F1" to select the maximum allowable speed.
	Press ▲ to increase the value.	<pre> EDIT PRESET SPEEDS PRESET SPEED 1 000060 RPM MAX F1001T1 RESET </pre>	Press F2 to exit editing the value without saving or press Enter to exit and save the new value.
Press Enter to save the new value and stop editing.		<pre> PROG PRESET SPEEDS PRESET SPEED 1 60 RPM STATUS C1001T1 BACK </pre>	Press F2 to return to previous screen. Press F1 to go to Status screen.

Parameter values in other Level 1, 2 and 3 blocks can be selected and edited in the same way.

6.7.1 Modified Parameters

Allows viewing of all parameters that have been changed from factory set values.

Action	Description	Display	Comments
Advanced Prog Display	Top Level Advanced Prog menu.	<pre> LEVEL 1 BLOCKS LEVEL 2 BLOCKS LEVEL 3 BLOCKS MODIFIED PARAMS LINEAR LIST </pre>	Press ▼ to scroll to Modified Params. Press enter to view list of parameters that have been changed from their factory settings
Press Enter to select Modified Parameters.	View parameter values that have been changed from factory settings by user selection, autotune, etc.	<pre> PROG PRESET SPEEDS PRESET SPEED 1 40 RPM STATUS C1001T1 BACK </pre>	Press ▶ to go to next modified parameter. Press F2 to return to Advanced Prog menu.
		<pre> PROG INPUT SETUP OPERATING MODE PLC STATUS C1401T1 BACK </pre>	Press ▶ to go to next modified parameter. Press F2 to return to Advanced Prog menu.

6.7.2 Linear List

Action	Description	Display	Comments
Advanced Prog Display	Top Level Advanced Prog menu.	<pre> LEVEL 1 BLOCKS LEVEL 2 BLOCKS LEVEL 3 BLOCKS MODIFIED PARAMS LINEAR LIST </pre>	Press ▼ to scroll to Linear List. Press enter to view list of parameters beginning with 1001.
Press Enter to select sequential view of parameters by parameter number "Linear List".	The number and name of each parameter is displayed in listing format. The first character of the parameter number has the following meaning: F = Factory Setting C = Custom value set by user V = Parameter value may be viewed but not changed L = Parameter value is locked, security code required	<pre> C1001 PRESET SPEED 1 F1002 PRESET SPEED 2 F1003 PRESET SPEED 3 F1004 PRESET SPEED 4 F1005 PRESET SPEED 5 PNUM BACK </pre>	Press ▲ or ▼ keys to scroll to through the parameter list. Press ▶ or ◀ keys to jump to next page. Press F2 to return to previous menu.

Change a parameter value within the linear list as follows:

Action	Description	Display	Comments
Press Enter to select the parameter value to be viewed or modified.	The number and name of each parameter is displayed in listing format.	<pre> C1001PRESET SPEED 1 F1002 PRESET SPEED 2 F1003 PRESET SPEED 3 F1004 PRESET SPEED 4 F1005 PRESET SPEED 5 PNUM BACK </pre>	Press ▲ or ▼ keys to scroll to through the parameter list. Press ► or ◀ keys to jump to next page. Press F2 to return to previous menu.
Press Enter to change the parameter value.	The parameter value can be changed as previously described in Advanced Programming.	<pre> PROG PRESET SPEEDS PRESET SPEED 1 40 RPM STATUS C1001T1 BACK </pre>	Press Enter then use cursor keys to position cursor and increase or decrease each character under the cursor as desired. Press F2 to return to previous menu.

Jump to display a different range of parameters as follows:

Press F1 key (PNUM) to highlight Parameter Number.	The parameter number is highlighted.	<pre> C1001PRESET SPEED 1 F1002 PRESET SPEED 2 F1003 PRESET SPEED 3 F1004 PRESET SPEED 4 F1005 PRESET SPEED 5 PNUM BACK </pre>	Press F1 key (PNUM) to highlight Parameter Number . Press ▲ or ▼ keys to scroll. Press F2 (BACK) to return to previous menu.
Press Enter key to edit the highlight Parameter Number.	The parameter number is highlighted.	<pre> C2001PRESET SPEED 1 F1002 PRESET SPEED 2 F1003 PRESET SPEED 3 F1004 PRESET SPEED 4 F1005 PRESET SPEED 5 PNUM BACK </pre>	Use cursor keys to position cursor and increase or decrease each character under the cursor as desired. Press Enter when finished. Press F2 to return to previous menu.
	The newly selected parameter number range is displayed. These values may be viewed and changed or jump to a different parameter range may be performed.	<pre> F2001OPERATING ZONE F2002 MIN OUTPUT SPEED F2003 MAX OUTPUT SPEED F2004 PWM FREQUENCY F2006 PEAK CURR LEVEL PNUM BACK </pre>	Press ▲ or ▼ keys to scroll to through the parameter list. Press ► or ◀ keys to jump to next page. Press F2 (BACK) to return to previous menu.

6.8 Event Log

From the Menu display screen, select Event Log and press enter. Trace is used to display control conditions present at the time the fault occurred. A separate trace log is recorded for each event. This is described in Chapter 9 of this manual.

Action	Description	Display	Comments
Event Log Display	Displays error name, Entry # and time the error occurred. LOW INITIAL BUS 0 Date Time Entry # DD/MM/YY HH:MM 0-9	EV. LOG STOP LOCAL LOW INITIAL BUS 0 4-Jul-06 09:35:00 STATUS TRACE	Press ▲ or ▼ to view next entry. Press F2 to view Trace log. Press F1 to return to Status Menu. Note: Trace is described in Chapter 9 of this manual.

Trace is used to display control conditions present at the time the fault occurred. Input states, Output states, various voltage and current values etc. can be viewed to help understand the cause of the fault condition. See Chapter 9 of this manual for more information.

6.9 Diagnostics

From the Menu display screen, select Diagnostics and press enter. These are read only values with the exception of the real time clock settings. See Chapter 9 for a more detailed description.

See Chapter 9 for a more detailed description.

Action	Description	Display	Comments
Press Menu	Displays top level menu options.	STATUS BASIC PARAMS ADVANCED PROG EVENT LOG DIAGNOSTICS STATUS BACK	Press ▲ or ▼ to move cursor over the "DIAGNOSTICS" selection. Press Enter to view diagnostic information.
Press to display next group.	Displays active operating mode settings.	DIAG STOP LOCAL OPERATING MODE Keypad Speed PM Sensorless EV. LOG 0.00r MAIN	
Press to display next group.	Bit display of digital inputs, outputs and the voltage present at the internal 24V supply terminals. Note: Enable input=1. Out1=1.	DIAG STOP LOCAL DIGITAL I/O INPUTS 100000000 OUTPUTS 0001 USER 24V 24.9V EV. LOG 0.00r MAIN	Press ► or ◀ to go to the next or previous Diagnostic screen. Press F2 to return to previous menu.

Diagnostic Continued

Action	Description	Display	Comments																		
Press ► to display next group.	OutputFrequency,% Feedforward % Setpoint, % Feedback	<table border="1"> <tr> <td>DIAG</td> <td>STOP</td> <td>LOCAL</td> </tr> <tr> <td colspan="3">PROC CONTROL PID</td> </tr> <tr> <td>0.00HZ</td> <td>0.0FF</td> <td></td> </tr> <tr> <td>0.0SP</td> <td>0.0FB</td> <td></td> </tr> <tr> <td>EV. LOG</td> <td>0.00r</td> <td>MAIN</td> </tr> </table>	DIAG	STOP	LOCAL	PROC CONTROL PID			0.00HZ	0.0FF		0.0SP	0.0FB		EV. LOG	0.00r	MAIN	Press ► or ◀ to go to the next or previous Diagnostic screen. Press F2 to return to previous menu. Note:This screen does not appear unless P#1401 is set to Process Control.			
DIAG	STOP	LOCAL																			
PROC CONTROL PID																					
0.00HZ	0.0FF																				
0.0SP	0.0FB																				
EV. LOG	0.00r	MAIN																			
Diagnostic Display	Displays software version, hp, volts and Amp/Volt ratings.	<table border="1"> <tr> <td>DIAG</td> <td>STOP</td> <td>LOCAL</td> </tr> <tr> <td colspan="3">THH-1.22</td> </tr> <tr> <td>RATED HP</td> <td></td> <td>3HP</td> </tr> <tr> <td>RATED VOLTS</td> <td></td> <td>240.0V</td> </tr> <tr> <td>RATED A/V</td> <td></td> <td>4.0A/V</td> </tr> <tr> <td>EV. LOG</td> <td>0.00r</td> <td>MAIN</td> </tr> </table>	DIAG	STOP	LOCAL	THH-1.22			RATED HP		3HP	RATED VOLTS		240.0V	RATED A/V		4.0A/V	EV. LOG	0.00r	MAIN	Press ► or ◀ to go to the next or previous Diagnostic screen. Press F2 to return to previous menu.
DIAG	STOP	LOCAL																			
THH-1.22																					
RATED HP		3HP																			
RATED VOLTS		240.0V																			
RATED A/V		4.0A/V																			
EV. LOG	0.00r	MAIN																			
Press ► to display next group.		<table border="1"> <tr> <td>DIAG</td> <td>STOP</td> <td>LOCAL</td> </tr> <tr> <td colspan="3">THH-1.22</td> </tr> <tr> <td>RATED CURRE</td> <td></td> <td>9.6A</td> </tr> <tr> <td>RATED PK CU</td> <td></td> <td>16.8A</td> </tr> <tr> <td>EV. LOG</td> <td>0.00r</td> <td>MAIN</td> </tr> </table>	DIAG	STOP	LOCAL	THH-1.22			RATED CURRE		9.6A	RATED PK CU		16.8A	EV. LOG	0.00r	MAIN	Press ► or ◀ to go to the next or previous Diagnostic screen. Press F2 to return to previous menu.			
DIAG	STOP	LOCAL																			
THH-1.22																					
RATED CURRE		9.6A																			
RATED PK CU		16.8A																			
EV. LOG	0.00r	MAIN																			
Press ► to display next group.	Displays: Power Base ID number EE Firmware version FPGA firmware version	<table border="1"> <tr> <td>DIAG</td> <td>STOP</td> <td>LOCAL</td> </tr> <tr> <td colspan="3">POWER BASE VERSION</td> </tr> <tr> <td>ID</td> <td></td> <td>0x000A2003</td> </tr> <tr> <td>EE VER</td> <td></td> <td>0x00000001</td> </tr> <tr> <td>FPGA VER</td> <td></td> <td>0x00000A02</td> </tr> <tr> <td>EV. LOG</td> <td>0.00r</td> <td>MAIN</td> </tr> </table>	DIAG	STOP	LOCAL	POWER BASE VERSION			ID		0x000A2003	EE VER		0x00000001	FPGA VER		0x00000A02	EV. LOG	0.00r	MAIN	Press ► or ◀ to go to the next or previous Diagnostic screen. Press F2 to return to previous menu. 0x=Hexadecimal 0b=Binary
DIAG	STOP	LOCAL																			
POWER BASE VERSION																					
ID		0x000A2003																			
EE VER		0x00000001																			
FPGA VER		0x00000A02																			
EV. LOG	0.00r	MAIN																			
Press ► to display next group.	Displays real time clock values (date and time) and total run time since installation. Press ENTER to set date and time.	<table border="1"> <tr> <td>DIAG</td> <td>STOP</td> <td>LOCAL</td> </tr> <tr> <td colspan="3">REAL TIME CLOCK</td> </tr> <tr> <td colspan="3">Jul 4, 2006</td> </tr> <tr> <td colspan="3">22:07:35</td> </tr> <tr> <td>RUN TIMER</td> <td></td> <td>474.1HR</td> </tr> <tr> <td>EV. LOG</td> <td>0.00r</td> <td>MAIN</td> </tr> </table>	DIAG	STOP	LOCAL	REAL TIME CLOCK			Jul 4, 2006			22:07:35			RUN TIMER		474.1HR	EV. LOG	0.00r	MAIN	Press ► or ◀ to go to the next or previous Diagnostic screen. Press F2 to return to previous menu.
DIAG	STOP	LOCAL																			
REAL TIME CLOCK																					
Jul 4, 2006																					
22:07:35																					
RUN TIMER		474.1HR																			
EV. LOG	0.00r	MAIN																			
Press ► to display next group.	Displays energy cost (based on parameter # 2305 value).	<table border="1"> <tr> <td>DIAG</td> <td>STOP</td> <td>LOCAL</td> </tr> <tr> <td colspan="3">ENERGY</td> </tr> <tr> <td>EST POWER</td> <td></td> <td>0.00KW</td> </tr> <tr> <td>EST ENERGY</td> <td></td> <td>0.0KWH</td> </tr> <tr> <td>EST COST</td> <td></td> <td>0.0\$</td> </tr> <tr> <td>EV. LOG</td> <td>0.00r</td> <td>MAIN</td> </tr> </table>	DIAG	STOP	LOCAL	ENERGY			EST POWER		0.00KW	EST ENERGY		0.0KWH	EST COST		0.0\$	EV. LOG	0.00r	MAIN	Press ► or ◀ to go to the next or previous Diagnostic screen. Press F2 to return to previous menu. Press F1 to go to Status screen.
DIAG	STOP	LOCAL																			
ENERGY																					
EST POWER		0.00KW																			
EST ENERGY		0.0KWH																			
EST COST		0.0\$																			
EV. LOG	0.00r	MAIN																			
Press ► to display next group.	Diagnostic Analog Input values display.	<table border="1"> <tr> <td>DIAG</td> <td>STOP</td> <td>LOCAL</td> </tr> <tr> <td colspan="3">ANALOG INPUTS</td> </tr> <tr> <td>ANA IN1</td> <td></td> <td>1.3v</td> </tr> <tr> <td>ANA IN2</td> <td></td> <td>0.0v</td> </tr> <tr> <td>EV. LOG</td> <td>0.00r</td> <td>MAIN</td> </tr> </table>	DIAG	STOP	LOCAL	ANALOG INPUTS			ANA IN1		1.3v	ANA IN2		0.0v	EV. LOG	0.00r	MAIN	Press ► or ◀ to go to the next or previous Diagnostic screen. Press F2 to return to previous menu.			
DIAG	STOP	LOCAL																			
ANALOG INPUTS																					
ANA IN1		1.3v																			
ANA IN2		0.0v																			
EV. LOG	0.00r	MAIN																			
Press ► to display next group.	Diagnostic Analog Output values display.	<table border="1"> <tr> <td>DIAG</td> <td>STOP</td> <td>LOCAL</td> </tr> <tr> <td colspan="3">ANALOG OUTPUTS</td> </tr> <tr> <td>ANA OUT1</td> <td></td> <td>0.0V</td> </tr> <tr> <td>ANA OUT2</td> <td></td> <td>0.0V</td> </tr> <tr> <td>EV. LOG</td> <td>0.00r</td> <td>MAIN</td> </tr> </table>	DIAG	STOP	LOCAL	ANALOG OUTPUTS			ANA OUT1		0.0V	ANA OUT2		0.0V	EV. LOG	0.00r	MAIN	Press ► or ◀ to go to the next or previous Diagnostic screen. Press F2 to return to previous menu.			
DIAG	STOP	LOCAL																			
ANALOG OUTPUTS																					
ANA OUT1		0.0V																			
ANA OUT2		0.0V																			
EV. LOG	0.00r	MAIN																			

Dagnostic Continued

Action	Description	Display	Comments
Press ▶ to display next group.	Displays keypad software version.	<pre> DIAG STOP LOCAL KEYPAD VERSION KEYPAD SOF 1.1X EV. LOG 0.00r MAIN </pre>	
Press ▶ to display next group.	Diagnostic installed Option Card identification display .	<pre> DIAG STOP LOCAL OPTION BOARDS OPTION 1 ETHERNET OPTION 2 NONE FEEDBACK NONE EV. LOG 0.00r MAIN </pre>	Press ▶ or ◀ previous Diagnostic screen. Press F2 to return to previous menu. Press F1 to go to Status screen.
Press ▶ to display next group.	Displays Composite Reference values.	<pre> DIAG STOP LOCAL COMPOSITE REF COMPONENT A 0.00% COMPONENT B 0.00% REFERENCE 0.00% EV. LOG 0.00r Alarm </pre>	
Press ▶ to display next group.	DC Bus Voltage Drive Heatsink Temperature % Overload (remaining)	<pre> DIAG STOP LOCAL DRIVE BUS VOLTAGE 333.9V DRIVE TEMP 26.1C OVERLOAD O/L L 100.0% EV. LOG 0.00r Alarm </pre>	Press ▶ previous Diagnostic screen. Press F2 to return to previous menu.
Press ▶ to display next group.	Motor Voltage Motor Current % Overload (remaining)	<pre> DIAG STOP LOCAL MOTOR MOTOR VOLTAGE 333.9V MOTOR CURRE 4.8A MOTOR O/L L 100.0% EV. LOG 0.00r Alarm </pre>	Press ▶ or ◀ previous Diagnostic screen. Press F2 to return to previous menu.

6.10 Display Options

From the Menu display screen, select Display Options and press Enter to view or change values.

Action	Description	Display	Comments
		<pre> PROG KEYPAD SETUP KEYPAD CONTRAST 50% DIAG F1313T1 BACK </pre>	Press "Enter" to change parameter value. Press ▶ or ◀ to display next screen. Press "F2" to return to previous menu.
		<pre> PROG KEYPAD SETUP BACKLIGHT On DIAG F1314T1 BACK </pre>	Press "Enter" to change parameter value. Press ▶ or ◀ to display next screen. Press "F2" to return to previous menu.

6.11 Operating the Control from the Keypad

To activate the LOCAL Mode, first press the “STOP” key (if enabled).

Note: Pressing the keypad STOP key (if enabled) will automatically issue a motor stop command and change to LOCAL mode. Selection of LOCAL Mode overrides any remote or serial control inputs except the External Trip input, Local Enable Input or STOP input.

The control can operate the motor from the keypad in two ways.

1. JOG Command.
2. Speed adjustment with Keypad entered values and/or Keypad Up/Down arrow keys.

Note: If the level 1, input block operating mode parameter is set to Keypad, then no other means of operation is permitted other than from the keypad.

6.11.1 Accessing the Keypad JOG Command

Action	Description	Display	Comments
Status Display			
Press JOG key Next, press and hold the FWD or REV key	The JOG LED will light indicating the JOG mode is active. Holding the FWD or REV key starts JOG operation. Releasing FWD or REV key will terminate motor rotation.		To change Jog Speed, Edit Level 1 parameter 1201 (Jog Speed). Press STOP key twice to terminate JOG mode.

6.11.2 Speed Adjustment using Local Speed Reference

Action	Description	Display	Comments
At the Status Display, press ENTER key to access Local Speed Reference.			
			Press ► or ◀ to move cursor . Press ▲ or ▼ to increase or decrease value at cursor . Press ENTER when finished and save the new value.
			Press ► or ◀ to move cursor . Press ▲ or ▼ to increase or decrease value at cursor . Press ENTER when finished and save the new value.
Press FWD or REV key.	The control will turn the motor shaft at the local speed ref speed.		Press STOP key to terminate local speed mode. Press ▲ or ▼ to increase or decrease motor speed during rotation.

Chapter 7

Parameter Descriptions

7.1 Level 1 Parameters (ADVANCED PROG, LEVEL 1 BLOCKS)

Table 7-1: Level 1 Parameter Block Definitions

Block Title	P#	Parameter Name and Description
PRESET SPEEDS	1001, 1015	<p>Preset Speeds 1 - 15 (Range: 0-Max Speed RPM)</p> <p>Allows selection of 15 predefined motor operating speeds. Each speed may be selected using external switches connected to terminals at J2. For motor operation, a motor direction command must be given along with a preset speed command.</p> <p>Preset Value: 1001=30, 1002=60, 1003=90, 1004=120, 1005=150, 1006=180, 1007=210, 1008=240, 1009=270 1010=300, 1011=330, 1012=360, 1013=390, 1014=420, 1015=450</p>
RAMP RATES	1101, 1107	<p>Accel Time 1, 2 (Range: 0.0 to 3600.0 Seconds) Accel time is the number of seconds required for the motor to increase at a linear rate from 0 to "Max Output Speed" parameter in the Level 2 Output Limits block.</p> <p>Preset Value: 1101=3.0, 1107=3.0</p>
	1104, 1110	<p>Decel Time 1, 2 (Range: 0.0 to 3600.0 Seconds)</p> <p>Decel time is the number of seconds required for the motor to decrease at a linear rate from the speed specified in the "Max Output Speed" to 0.</p> <p>Preset Value: 1104=3.0, 1110=3.0</p>
	1102, 1108	<p>Start S-Accel 1, 2 (Range: 0.0 to 100.0%)</p> <p>Start S-Curve Acceleration as a percentage of max speed (% 1 and 2)</p> <p>Preset Value:</p>
	1103, 1109	<p>End S-Accel 1, 2 (Range: 0.0 to 100.0%)</p> <p>End S-Curve Acceleration as a percentage of max speed (% 1 and 2)</p> <p>Preset Value: 1103=0.0, 1109=0.0</p>
	1105, 1111	<p>Start S-Decel 1, 2 (Range: 0.0 to 100.0%)</p> <p>Start S-Curve Deceleration as a percentage of max speed (% 1 and 2)</p> <p>Preset Value: 1105=0.0, 1111=0.0</p>
	1106, 1112	<p>End S-Decel 1, 2 (Range: 0.0 to 100.0%)</p> <p>End S-Curve Deceleration as a percentage of max speed (% 1 and 2)</p> <p>Preset Value: 1106=0.0, 1112=0.0</p>
	1113	<p>Power Loss Decel Time (Range: 0.0 to 3600.0 Seconds)</p> <p>Time to stop the motor from maximum drive speed during a power loss.</p> <p>Preset Value: 1.0</p>

Table 7-1 Continued

Block Title	P#	Parameter Name and Description
Jog Settings	1201	<p>Jog Speed (Range: 0-MAX Speed RPM) Jog Speed is the programmed speed used during jog. Jog can be initiated from the keypad or terminal strip. At the Keypad, press the JOG key then press and hold the direction (FWD or REV). For Standard Run 3Wire mode, close the JOG input (J2-12) at the terminal strip then close and maintain the direction input (J2-9 or J2-10). Process Control mode operation is different. If the terminal strip Process Control Enable input (J2-13) is closed, pressing the Keypad JOG key (or closing J2-14) will cause the drive to move in the direction of the error (without pressing FWD or REV). Preset Value: 210</p>
	1202	<p>Jog Accel Time (Range: 0.0 to 3600.0 Seconds) The accel rate or time to reach max Speed. $Time = (Jog\ Speed / Max\ Speed) \times (Jog\ Accel\ Time)$. Preset Value: 10.0</p>
	1203	<p>Jog Start S-Accel (Range: 0.0 to 100.0%) Start S-Curve Acceleration as a percentage of max speed. Preset Value: 0.0</p>
	1204	<p>Jog End S-Accel (Range: 0.0 to 100.0%) End S-Curve Acceleration as a percentage of max speed. Preset Value: 0.0</p>
	1205	<p>Jog Decel Time (Range: 0.0 to 3600.0 Seconds) The decel rate or time to decel from max Speed. $Time = (Jog\ Speed / Max\ Speed) \times (Jog\ Decel\ Time)$. Preset Value: 10.0</p>
	1206	<p>Jog Start S-Decel (Range: 0.0 to 100.0%) Start S-Curve Deceleration as a percentage of max speed. Preset Value: 0.0</p>
	1207	<p>Jog End S-Decel (Range: 0.0 to 100.0%) End S-Curve Deceleration as a percentage of max speed. Preset Value: 0.0</p>
	1209	<p>Jog Forward (Range: 0-Off, 1-On) Enables Jog in the drive forward direction at Jog speed for keypad mode. Preset Value: 1</p>
	1210	<p>Jog Reverse (Range: 0-Off, 1-On) Enables Jog in the drive reverse direction at Jog speed for keypad mode. Preset Value: 1</p>
	Keypad Setup	1301
1302		<p>Stop Mode (Range: 0-Coast, 1-Regen) Selects if the Stop command causes the motor to COAST to a stop or REGEN to a stop. COAST Motor is turned off and allowed to coast to a stop. REGEN The voltage and frequency to the motor is reduced at a rate set by Decel Time. Preset Value: 1</p>

Table 7-1 Continued

Block Title	P#	Parameter Name and Description
Keypad Setup (Continued)	1303	Run Forward (Range: 0-Off, 1-On) OFF Disables FWD key in Local mode. ON Makes the keypad FWD key active in Local mode. Preset Value: 1
	1304	Run Reverse (Range: 0-Off, 1-On) OFF Disables REV key in Local mode. ON Makes the keypad REV key active in Local mode. Preset Value: 0
	1305	Switch on Fly (Range: 0-Off, 1-On) OFF Disables Switch on Fly. ON Allows switching between Local and Remote while Control is on. Preset Value: 0
	1306	Loc. Hot Start (Range: 0-Off, 1-On) OFF disables the Stop input at J2-11 in the keypad operating mode. ON enables the Stop input at J2-11 in the keypad operating mode. Preset Value: 0
	1307	Speed Increment (Range: 1 to 1800 RPM) Sets the increment of speed change for each key press. (1-3600RPM or 0-60Hz) Preset Value: 30
	1308	Init Local Speed (Range: 0-Zero, 1-Last Speed, 2-Set Speed) At power up, initializes the local speed to 0RPM, the last speed before power down or at Set Speed parameter. Preset Value: 0
	1309	Set Speed (Range: 0-MAX Speed RPM) At power up, initializes the local speed to this preset value if "Init Local Speed" =Set Speed. Preset Value: 30
	1310	Parameters to Keypad (Range: 0-No, 1-Yes) Transfers the parameter settings stored in the control memory (flash) to keypad memory. Preset Value: 0
	1311	Download Select (Range: 0-All, 1-Motor, 2-Other) Selects parameters to download (All, Motor or Other) with the Keypad to Params #1312 parameter. All=All parameters, Motor=Motor parameters only, Other=All parameters except Motor parameters. Preset Value: 0
	1312	Keypad to Parameters (Range: 0-No, 1-Yes) Transfers the parameter settings stored in keypad memory to the control memory (flash). Preset Value: 0
	1313	Keypad Contrast (Range: 0-100% (0=dimmiest, 100=brightest)) Sets LCD contrast: 0=dimmiest, 100=brightest. Preset Value: 50
1314	Backlight (Range: 0-Off, 1-On) Turns On/Off the backlight for the keypad display. Preset Value: 1	
1315	Local Torque Mode (PM Sensorless Only) (Range: 0-Off, 1-On) OFF Disables local torque mode. ON Enables local torque mode operation. Preset Value: 0	
1316	Local Torque Ref (PM Sensorless Only) (Range: -100 to 100%) Local torque mode reference value. Preset Value: 0.00	

Table 7-1 Continued

Block Title	P#	Parameter Name and Description
Input Setup	1401	<p>Operating Mode (Range: 0-KEYPAD 1-STANDARD RUN 2Wire 2-STANDARD RUN 3Wire 3-15 PRESET SPEEDS 4-FAN&PUMP 2WIRE 5-FAN&PUMP 3WIRE 6-PROCESS CONTROL 7-3SPD ANA 2WIRE 8-3SPD ANA 3WIRE 9-E-POT 2WIRE 10-E-POT 3WIRE 11-NETWORK 12-PROFILE RUN 14-BIPOLAR 16-PLC 17-CTD 2Wire 18-CTD 3Wire</p> <p>External connections to the control are made at the control terminal strip (wiring diagrams are shown in Chapter 5 "Operating Modes"). Preset Value: 0</p>
	1402	<p>Command Source (Range: 0-None 1-Analog Input1 2-Analog Input2 3-Keypad 4-Network 5-Composite Ref 6-Opt1 Analn1 7-Opt1 Analn2 8-Opt2 Analn1 9-Opt2 Analn2 10-EXB Pulse FOL)</p> <p>0-None, Command Source is not used. 1-Analog Input1, Connect a 10Kohm pot at J1 or connect a 0-10VDC signal to J1-2 and J1-1. 2-Analog Input2, Connect a 0-5V, 0-10V, $\pm 5V$, $\pm 10V$, 0-20mA or 4-20mA source to J1-4 and 5. 4-20mA should be considered when a long distance (up to 50 ft) between the external device and J1-4 and 5 of the control is necessary. 3-Keypad, Command is from Keypad. 4-Network, Signal source is from a device on the network. 5-Composite Ref, the result of the Level 3 Composite Reference set by the user. 6-OPT1 ANA IN1 Scaled value of option board 1 analog input 1 signal value. 7-OPT1 ANA IN2 Scaled value of option board 1 analog input 1 signal value. 8-OPT2 ANA IN1 Scaled value of option board 1 analog input 1 signal value. 9-OPT2 ANA IN2 Scaled value of option board 1 analog input 1 signal value. 10-EXB Pulse FOL, Signal source is from the EXB Pulse Follower expansion board. Preset Value: 1</p>

Table 7-1 Continued

Block Title	P#	Parameter Name and Description
Input Setup (Continued)	1403	<p>ANA IN1 Type (Range: 0-NONE, 1-POTENTIOMETER)</p> <p>None, input not used. Potentiometer (0-10V signal is used). Preset Value: 1</p>
	1404	<p>ANA IN1 Invert (Range: 0-Off, 1-On)</p> <p>Off -will cause a low input voltage (e.g. 0VDC) to be a low motor speed command and a maximum input voltage (e.g. 10VDC) to be a maximum motor speed command. On -will cause a low input voltage (e.g. 0VDC) to be a maximum motor speed command and a maximum input voltage (e.g. 10VDC) to be a low motor speed command. Preset Value: 0</p>
	1405	<p>ANA IN1 Gain (Range: 0.0% to 300.0%)</p> <p>Allows 0 to 300% gain to be applied (as in $Y=Gain*(X-Offset)$). Preset Value: 100.0%</p>
	1406	<p>ANA IN1 Offset (Range: -100.0% to 100.0%)</p> <p>Provides an offset to the Analog Input to minimize signal drift. For example, if the minimum speed signal is 1VDC (instead of 0VDC) the ANA CMD Offset can be set to -10% so the minimum voltage input is seen by the control as 0VDC. This parameter is automatically adjusted during the auto tune CMD Offset Trim test. Preset Value: 0.0</p>
	1407	<p>ANA IN1 Filter (Range: 0 (No Filter) TO 6 (Max Filter))</p> <p>Amount of signal filtering to use, 0=No filtering, 6= Max filtering. Preset Value: 0</p>
	1408	<p>ANA IN2 Type (Range: 0-None, 1-(-10V to+10V), 2-(-5V to+5V), 3-(4to20mA), 4-(0to20mA), 5-(0to10V), 6-(0-5V))</p> <p>Defines signal being used, None, $\pm 5V$, $\pm 10V$, 0-20mA or 4-20mA, 0-10V and 0-5V. Preset Value: 1</p>
	1409	<p>ANA IN2 Invert (Range: 0-OFF, 1-ON)</p> <p>Off -will cause a low input voltage (e.g. 0VDC) to be a low motor speed command and a maximum input voltage (e.g. 10VDC) to be a maximum motor speed command. On -will cause a low input voltage (e.g. 0VDC) to be a maximum motor speed command and a maximum input voltage (e.g. 10VDC) to be a low motor speed command. Preset Value: 0</p>
	1410	<p>ANA IN2 Gain (Range: 0.0% to 300.0%)</p> <p>Allows 0 to 300% gain to be applied (as in $Y=Gain*(X-offset)$). Preset Value: 100.0</p>
	1411	<p>ANA IN2 Offset (Range: -100.0% to 100.0%)</p> <p>Provides an offset to the Analog Input to minimize signal drift. For example, if the minimum speed signal is 1VDC (instead of 0VDC) the ANA CMD Offset can be set to -10% so the minimum voltage input is seen by the control as 0VDC. This parameter is automatically adjusted during the auto tune CMD Offset Trim test. Preset Value: 0.0</p>

Table 7-1 Continued

Block Title	P#	Parameter Name and Description
Input Setup (Continued)	1412	<p>ANA IN2 Deadband (Range: 0.0% to 75.0%) Allows a defined range of voltage to be a deadband. A command signal within this range will not affect the control output. The deadband value is the voltage above and below the zero command signal level. Preset Value: 0.0</p>
	1413	<p>ANA IN2 Filter (Range: 0 (No Filter) to 6 (Max Filter)) Amount of signal filtering to use, 0=No filtering, 6= Max filtering. Preset Value: 0</p>
	1414	<p>EXT. Current Limit (Only available in PM Sensorless mode. Ignore these parameters for PM V/F Control mode.) (Range: 0-OFF, 1-ON) Off - No input current limit. On - Uses Current Limit Source (P1415) as the external signal source for current limiting in speed mode. Preset Value: 0</p>
	1415	<p>Current Limit Source (Only available in PM Sensorless mode. Ignore these parameters for PM V/F control Mode.) (Range: 0-None, 1-Analog In1, 2-Analog In2, 3-Keypad, 4-Composite, 5-Opt1Ana In1, 6-Opt1Ana In2, 7-Opt2Ana In1, 8-Opt2 Ana In2) Selects the external speed reference to be used. None Turns off external current limit. Analog In1 Connect a 10Kohm pot at J1 or connect a 0-10VDC signal to J1-2 and J1-1. Analog In2 Connect a 0-5V, 0-10V, $\pm 5V$, $\pm 10V$, 0-20mA or 4-20mA source to J1-4 and 5. 4-20mA should be considered when a long distance (up to 50 ft) between the external device and J1-4 and 5 of the control is necessary. Composite see Chapter 11 for more information. Op1Ana In1, Opr1Analn2 – Selects analog input from high resolution analog input/output Expansion Board(EXBHH005) mounted in expansion slot 1. Opt 2Ana In1, Opt2Analn2-Selects analog input/output Expansion Board (EXBHH005) mounted in expansion slot 2 Preset Value: 0</p>
	1416	<p>Sleep Mode (Range: 0-OFF, 1-ON) Disables the control when Command Source is less than CMD Sleep Band (parameter #1417). Active in all speed modes. Preset Value: 0</p>
	1417	<p>CMD Sleep Band (Range: 0.00 to 100.00%) Disables the control when Command Source is less than CMD Sleep Band (parameter #1417). Active in all speed modes. Preset Value: 0.00</p>

Table 7-1 Continued

Block Title	P#	Parameter Name and Description
Input Setup (Continued)	1418	<p>Torque FF Source (Only available or active in PM sensorless mode. Ignore these parameters for PM V/F control mode.) (Range: 0-None, 1-Analog In1, 2-Analog In2, 3-Keypad, 4-Composite, 5-Opt1Ana In1, 6-Opt1Ana In2, 7-Opt2Ana In1, 8-Opt2 Ana In2)</p> <p>Selects the external torque reference to be used.</p> <p>None, Turns off external torque reference</p> <p>Analog In1, Connect a 10Kohm pot at J1 or connect a 0-10VDC signal to J1-2 and J1-1.</p> <p>Analog In2, Connect a 0-5V, 0-10V, $\pm 5V$, $\pm 10V$, 0-20mA or 4-20mA source to J1-4 and 5. 4- 20mA should be considered when a long distance (up to 50 ft) between the external device and J1-4 and 5 of the control is necessary.</p> <p>Keypad, Turns off external torque reference. (Keypad uses Local Keypad Torque Reference as feedforward.)</p> <p>Composite, see Chapter 11 for more information.</p> <p>Opt1Ana In1, Opt1Analn2 – Selects analog input from high resolution analog input/output expansion Board(EXBH005) mounted in expansion slot 1. Opt 2Ana In1, Opt 2Ana In2-Selects analog input/output Expansion Board (EXBH005) mounted in expansion slot 2</p> <p>Preset Value: 0.00</p>

Table 7-1 Continued

Block Title	P#	Parameter Name and Description
Output Setup	1501 - 1504	<p>Digital Output 1-4 (Range: 0-Drive Run, 1-Drive Ready, 2-Drive On, 3-Drive Stopped, 4-Jog, 5-Accelerate, 6-Constant Speed, 7-Decelerate, 8-At Zero Speed, 9-At Speed, 10-At Set Speed, 11-Current Overload, 12-Current Underload, 13-I_{2t} Overload, 14-Keypad Control, 15-Dynamic Brake, 16-Foldback, 17-Fault, 18-Alarm, 19-Command Forward, 20-Command Reverse, 21-Motor Forward, 22-Motor Reverse, 23-Process Error, 24-Network, 25-At Position, 26-In Motion, 27-PLC, 28-RTC, 29-Powered Up)</p> <p>Drive Ready - Active after soft start, when drive is enabled and no faults are present.</p> <p>Drive On - (V/F) Active when drive is "Ready" and producing PWM to motor. (Vector) Active when drive is "Ready" and motor flux is present.</p> <p>Drive Run - Active when drive is "On" and a FWD/REV direction command is present.</p> <p>Drive Stopped - Active when stop command is present and motor is stopped (or coasting to stop).</p> <p>Jog - Active during Jog mode.</p> <p>Accelerate - Active when control is accelerating.</p> <p>Constant Speed-Active when control speed is constant.</p> <p>Decelerate - Active when control is decelerating.</p> <p>At Zero Speed - Active when motor speed is less than the Level 1 Output Setup "Zero SPD Set Pt (P1505)".</p> <p>At Speed - Active when motor speed is within band set by the Level 1 Output Setup "At Speed Band (P1506)".</p> <p>At Set Speed - Active when output speed is at or greater than the Level 1 Output Setup "Set Speed Point (P1507)".</p> <p>Current Overload - Active when motor current is greater than "Overload Set Point (P1508)".</p> <p>Current Underload - Active when motor current is less than "Underload Set Point (P1509)".</p> <p>I_{2t} Overload - Active when overload left is less than 100%.</p> <p>Keypad Control- Active when control is in Local keypad control.</p> <p>Dynamic Brake - Active when Dynamic Brake transistor is turned ON.</p> <p>Foldback - Active when current foldback is active (V/Hz Mode only).</p> <p>Fault - Active when a fault condition is present (will cause trip).</p> <p>Alarm - Active when an Alarm condition is present (but doesn't cause trip).</p> <p>Command Forward - Active during forward run command.</p> <p>Command Reverse - Active during reverse run command.</p> <p>Motor Forward - Active when motor is moving in Drive forward direction.</p> <p>Motor Reverse - Active when motor is moving in Drive reverse direction.</p> <p>Process Error - Active when absolute process error is greater than P2606 (Process Error Tolerance).</p> <p>Network - Active when commanded by network (Modbus). Network device controls this output.</p> <p>At Position - Active when load is at position ($Position\ error \leq P\#1517$) AND ($Motor\ Speed \leq P\#1505$).</p> <p>In Motion - Active when load is moving ($Position\ error > P\#1517$) OR ($Motor\ Speed > P\#1505$).</p>

Table 7-1 Continued

Block Title	P#	Parameter Name and Description
Output Setup (Continued)	1501-1504 Cont.	<p>PLC - Output is controlled by PLC mode.</p> <p>RTC - Output is controlled by RTC module.</p> <p>Powered Up - Active when Bus is "UP" and no faults are present.</p> <p>Preset Value: 1501=1, 1502=8, 1503=9, 1504=17 (See also 1505, 1506, 1507, 1508, 1509, 1517, Chapter 10, Chapter 11, Chapter 12.)</p>
	1505	<p>Zero SPD Set PT (Range: 0-MAX Speed RPM)</p> <p>Zero speed opto output is active when the speed is less than the ZERO SPD SET PT, the opto output becomes active. This is useful when a motor brake is to interlock operation with a motor.</p> <p>Preset Value: 180</p>
	1506	<p>At Speed Band (Range: 0-MAX Speed RPM)</p> <p>At Speed opto output is active when the magnitude of (Speed Ref)-(Speed Demand) is less than P1506.</p> <p>Preset Value: 60</p>
	1507	<p>Set Speed Point (Range: 0-MAX Speed RPM)</p> <p>Sets the speed that the AT Set Speed digital output becomes active (turns on). When the speed is greater than the Level 1 Output SET SPEED parameter, the digital output becomes active. This is useful when another machine must not start or stop until the motor exceeds a predetermined speed.</p> <p>Preset Value: 1800</p>
	1508	<p>Overload Set Point (Range: 0.0-200.0%)</p> <p>Sets the motor current value at which the Overload digital output is active.</p> <p>Preset Value: 150.0</p>
	1509	<p>Underload Set Point (Range: 0.0-200.0%)</p> <p>Sets the motor current value at which the Underload digital output is active.</p> <p>Preset Value: 50.0</p>
	1510	<p>Analog Out1 Type (Range: 0-(0 TO +10V), 1-(0 TO 5V), 2-(4mA TO 20mA), 3-(0mA TO 20mA))</p> <p>Sets the output signal (0-5V, 0-10V, 4-20mA or 0-20mA).</p> <p>Preset Value: 0</p>
	1511, 1514	<p>Analog Out 1 Signal, Analog Out 2 Signal</p> <p>(Range: 0-Speed Ref, 1-Speed Demand, 2-Acc/Dec, 3-Motor Current, 4-Mag Current, 5-Mag Current Command, 6-Load Current, 7-Load Current Command, 8-Power Factor, 9-PH1 Current, 10-PH2 Current, 11-PH3 Current, 12-Motor Voltage, 13-VD Demand, 14-VQ Demand, 15-Bus Voltage, 16-ABS Torque, 17-Torque, 18-Control Temp, 19-Analog Input1, 20-Analog Input2, 21-Opt1 Ana In1, 22-Opt1 Ana In2, 23-Opt2 Ana In1, 24-Opt2 Ana In2, 25-PROC Feedforward, 26-PROC Feedback, 27-Proc Setpoint, 28-Electric Angle, 29-Abs Speed, 30-Velocity, 31-Network, 32-Composite Ref, 33-Power (Kw), 34-Calibrate)</p> <p>Speed Ref - Scaled value of speed reference (input to velocity profiler) (ACC/DEC ramp).</p> <p>Speed Demand - Scaled value of speed reference (output of velocity profiler) (ACC/DEC ramp).</p> <p>Acc/Dec - Scaled value of ACC/DEC rate, range is from 0 to max ACC/DEC rate.</p> <p>Motor Current - Scaled value of Motor Current, range is based on 2 times drive FLA. (Includes both mag and load currents).</p> <p>MAG Current - Scaled value of magnetizing current, range is based on 2 times drive FLA.</p> <p>MAG Current Command - The commanded D-axis PI vector magnetizing current to the current controller, range is based on 2 times drive FLA.</p> <p>Load Current - Scaled value of the load amps, range is based on 2 times drive FLA.</p>

Table 7-1 Continued

Block Title	P#	Parameter Name and Description
Output Setup (Continued)	1511, 1514 (Continued)	<p>Current Cmd - The commanded Q-axis PI vector load current to the current controller, range is based on 2 times drive FLA.</p> <p>Power Factor - Scaled value of power factor, range is from 0 to 1.0.</p> <p>PH1 Current - Scaled value of the phase 1 motor current, range is based on 2 times drive FLA.</p> <p>PH2 Current - Scaled value of the phase 2 motor current, range is based on 2 times drive FLA.</p> <p>PH3 Current - Scaled value of the phase 3 motor current, range is based on 2 times drive FLA.</p> <p>Motor Voltage - Scaled value of the motor voltage, range is based on drive rated voltage.</p> <p>VD Demand - Flux controller output. Used to diagnose control problems.</p> <p>VQ Demand - Load controller output. Used to diagnose control problems.</p> <p>Bus Voltage - Scaled value of the Bus voltage. (Range is based on 123% of drive rated voltage)</p> <p>ABS Torque - Scaled value of the absolute torque, range is based on peak torque (2 x rated torque).</p> <p>Torque - Scaled value of the motor torque (signed), range is based on peak torque (2 x rated torque).</p> <p>Control Temp - Scaled value of the control heatsink temperature, range is -50 to 150C.</p> <p>Analog Input 1 - Scaled value of the analog input 1 signal value.</p> <p>Analog Input 2 - Scaled value of the analog input 2 signal value, range depends on input type P1408.</p> <p>OPT1 ANA IN1 - Scaled value of option board 1 analog input 1 signal value, range depends on input type selected.</p> <p>OPT1 ANA IN2 - Scaled value of option board 1 analog input 2 signal value, range depends on input type selected.</p> <p>OPT2 ANA IN1 - Scaled value of option board 2 analog input 1 signal value, range depends on input type selected.</p> <p>OPT2 ANA IN2 - Scaled value of option board 2 analog input 2 signal value, range depends on input type selected.</p> <p>PROC Feedforward - Scaled value of the process feedforward signal, range is -100% to 100% of Process Feedforward signal.</p> <p>PROC Feedback - Scaled value of the process feedback signal, range is -100% to 100% of Process Feedback signal.</p> <p>PROC Setpoint - Scaled value of the process setpoint source, range is -100% to 100% of Process Setpoint signal.</p> <p>Electric Angle - Scaled value of the electrical angle of shaft, range is from 0-359 degrees.</p> <p>ABS Speed - Scaled value (absolute) of actual motor speed, range is 0-Max Motor Speed P2003.</p> <p>Velocity - Scaled value (signed) of actual motor speed, range is - Max Motor Speed to +Max Motor Speed P2003.</p> <p>Network - Represents the network speed reference, see MN744. Analog 1 holding register is 40014:40013, Analog 2 holding register is 40016:40015.</p> <p>Composite Ref - Scaled value of the Composite Reference output, range is -100% to 100% of composite reference calculation.</p> <p>Power (kW) - Scaling power calculated using nominal output amps and RMS output volts</p> <p>Calibrate - Produces maximum value of selected analog output type.</p> <p>Preset Value: 1511=29, 1514=3</p>

Table 7-1 Continued

Block Title	P#	Parameter Name and Description
Output Setup (Continued)	1512	Analog Out 1 Gain (Range: 0 – 500.0%) Scale factor for analog output (as in $Y=Gain \times X$) Preset Value: 100.
	1513	Analog Out 2 Type (Range: 0-(+/-5V), 1-(+/-10V)) Sets the output signal ($\pm 5V$, $\pm 10V$). Preset Value: 1
	1515	Analog Out 2 Gain (Range: 1-500.0%) Scale factor for analog output (as in $Y=Gain \times X$). Preset Value: 100.0
	1516	Calibrate Analog Output (Range: -100.0% to 100.0%) Scalable output signal used to calibrate output device (-100% to 100% of Analog Out 1 Type). Preset Value: 0.0
Motor Control	1601	Control Type (Range: 0- PM V/F Control, 1-PM Sensorless) Sets the control type to PM V/F Control or PM sensorless Preset Value: 1
	1602	Control Base Speed Only available or active in V/F mode (Range: 0-MAX Speed RPM) The speed at which Field Weakening begins. (Typically set to $(0.925 \times 60 \times (\text{Motor Rated Freq}) / (\text{Pole Pairs}))$) Preset Value: 1800
	1611	Control Base Volt Only available or active in V/F mode. Ignore these parameters for Open Loop Vector mode. (Range: 0- Drive Rated Voltage. Voltage that represents base speed. Typically set to motor rated voltage. Preset Value: CALC
	1612	Static Boost Only available or active in V/F mode. Ignore these parameters for Open Loop Vector mode. (Range: 0.0-15.0%) Additional voltage applied to motor at start-up. Preset Value: 0.0
	1613	Dynamic Boost Cut In Only available or active in V/F mode. Ignore these parameters for Open Loop Vector mode. (Range: 6.00-60.00 Hz) Speed at which dynamic boost takes full effect. Preset Value: 30.00
	1614	Dynamic Boost Only available or active in V/F mode. Ignore these parameters for Open Loop Vector mode. (Range: 0.0-10.0%) The Dynamic Boost parameter can be adjusted to provide more or less running torque from the motor than is available with the factory setting. The boost adjustment alters the output voltage to the motor from the normal voltage value by increasing or decreasing the voltage per frequency unit as defined by the V/F profile. Preset Value: 0.0
	1615	V/F Efficiency Only available or active in V/F mode. Ignore these parameters for Open Loop Vector mode. (Range: 0-OFF, 1-ON) Smooths transitions between static boost and V/F curve. Preset Value: 0

Table 7-1 Continued

Block Title	P#	Parameter Name and Description
Motor Control (Continued)	1616	<p>V/F Profile Only available or active in V/F mode. Ignore these parameters for Open Loop Vector mode. (Range: 0.0-100.0%). Set the Volts/Frequency ratio of the control output (to the motor) for all values of output voltage versus output frequency up to the control base frequency. Because motor voltage is related to motor current, motor voltage can then be related to motor torque. A change in the V/F profile can adjust how much torque is available from the motor at various speeds. 0=Linear, 100= Quadratic Preset Value:</p>  <p>The graph titled "V/F Profile Curve" plots Output Volts on the y-axis against Output Frequency on the x-axis. The y-axis starts at "Static Boost" and goes up to "Max Output". The x-axis starts at "Static Boost" and goes up to "Base Freq.". Three curves are shown: a straight line labeled "0%", a curve labeled "50%", and a curve labeled "100%".</p>
	1617	<p>3 Point Method Only available or active in V/F mode. Ignore these parameters for Open Loop Vector mode. (Range: 0-OFF, 1-3 Point, 2-7 Point) 3PT profile - allows two linear V/F segments by setting the V/F 3PT Volts and V/F 3PT Frequency parameters.</p> <p>7PT Profile – allows 6 linear V/F segments by setting the 7 point frequency and voltage parameters. Preset Value: 0</p>  <p>The graph titled "3 Point Method Curve" plots Output Volts on the y-axis against Output Frequency on the x-axis. The y-axis starts at "Static Boost" and goes up to "Max Output". The x-axis starts at "Static Boost" and goes up to "Base Freq.". The curve is piecewise linear, with a kink at "3 PT Volts" and "3 PT Freq.".</p>
	1618	<p>3 Point Voltage Only available or active in V/F mode. Ignore these parameters for Vector modes. (Range: 0.0-100.0%) The output voltage associated with the 3PT Frequency parameter. Calculated as a percentage of drive rated output voltage. Preset Value: 0.0</p>
	1619	<p>3 Point Frequency Only available or active in V/F mode. Ignore these parameters for Open Loop Vector modes. (Range: 0.00-maximum output speed (P2003 Hz). The output frequency associated with the 3PT Volts parameter. Preset Value: 30.00</p>
	1620	<p>Slip Comp Enable Only available or active in V/F mode. Ignore these parameters for Vector modes. (Range: 0-OFF, 1-ON) Compensates for change in slip due to varying load conditions during normal operation to maintain constant rotor speed. Preset Value: 0</p>
	1621	<p>7 Point Frequency 1: Only available in PM V/F Control. Ignore these parameters for PM Sensorless (Range: 0.00 to maximum output speed (P2003 Hz) Preset Value: 300 RPM</p>
	1622	<p>7 Point Voltage 1: Only available in PM V/F Control. Ignore these parameters for PM Sensorless (Range: 0.00 to maximum output speed (P2003 Hz) Preset Value: 16.7%</p>

Table 7-1 Continued

Block Title	P#	Parameter Name and Description
Motor Control (Continued)	1623	7 Point Frequency 2; Only available in PM V/F Control. Ignore these parameters for PM Sensorless (Range: 0.00 to maximum output speed (P2003 Hz) Preset Value: 600 RPM
	1624	7 Point Voltage 2; Only available in PM V/F Control. Ignore these parameters for PM Sensorless (Range: 0.00 to maximum output speed (P2003 Hz) Preset Value: 33.3%
	1625	7 Point Frequency 3; Only available in PM V/F Control. Ignore these parameters for PM Sensorless (Range: 0.00 to maximum output speed (P2003 Hz) Preset Value: 900 RPM
	1626	7 Point Voltage 3; Only available in PM V/F Control. Ignore these parameters for PM Sensorless (Range: 0.00 to maximum output speed (P2003 Hz) Preset Value: 50%
	1627	7 Point Frequency 4; Only available in PM V/F Control. Ignore these parameters for PM Sensorless (Range: 0.00 to maximum output speed (P2003 Hz) Preset Value: 1200 RPM
	1628	7 Point Voltage 4; Only available in PM V/F Control. Ignore these parameters for PM Sensorless (Range: 0.00 to maximum output speed (P2003 Hz) Preset Value: 66.7%
	1629	7 Point Frequency 5; Only available in PM V/F Control. Ignore these parameters for PM Sensorless (Range: 0.00 to maximum output speed (P2003 Hz) Preset Value: 1500 RPM
	1630	7 Point Voltage 5; Only available in PM V/F Control. Ignore these parameters for PM Sensorless (Range: 0.00 to maximum output speed (P2003 Hz) Preset Value: 83.3%
	1633	Current PROP Gain Only available or active in either Vector mode. Ignore these parameters for V/F mode. (Range: 0.00-150.00) Sets the current loop proportional gain. Preset Value: CALC
	1634	Current INT Gain Only available or active in either Vector mode. Ignore these parameters for V/F mode. (Range: 0.0-3000.00Hz) Sets the current loop integral gain. Preset Value: 150.00
	1635	Speed PROP Gain Only available or active in either Vector mode. Ignore these parameters for V/F mode. (Range: 0.00-1000.00) Sets the speed (velocity) loop proportional gain. Excessive speed prop gain will cause ringing around the set point. Decreasing the speed prop gain will result in slower response and decrease the ringing, but will increase the overshoot. Preset Value: 5.00
	1636	Speed INT Gain Only available or active in either Vector mode. Ignore these parameters for V/F mode. (Range: 0.00-1000.00Hz) Sets the speed (velocity) loop integral gain. Preset Value: 10.00
	1637	Speed DIFF Gain Only available or active in either Vector mode. Ignore these parameters for V/F mode. (Range: 0.00-1.00) Sets the speed (velocity) loop differential gain. Preset Value: 0.00
1639	A.S. Prop Gain Only available or active in either Vector mode. Ignore these parameters for V/F mode. (Range: 0.0-255.0) Sets the anti-saturation proportional gain. Preset Value: 10.0	

Table 7-1 Continued

Block Title	P#	Parameter Name and Description
Motor Control (Continued)	1640	A.S. Integral Gain Only available or active in either Vector mode. Ignore these parameters for V/F mode. (Range: 0.00-200.00Hz) Sets the anti-saturation integral gain. Preset Value: 50.00
	1644	Rotor Time Constant (Range: 0.000-60.000seconds) Sets the rotor time constant value. Preset Value: CALC
	1672	Stator Inductance Only available in PM Sensorless mode. (Range 0 to 1000mH) Per phase stator inductance in mH for IPM motors. Used to tune the current loop gains. Preset Value: CALC
	1673	Stator Resistance Only available in PM Sensorless mode. (Range 0 to 1000 Ohms) Per phase stator resistance in Ohms for IPM motors. Used to tune the current loop gains. Preset Value: CALC
	1674	Voltage Constant of Motor Only available in PM Sensorless mode. (Range 0 to 1500 V/1000RPM) Voltage constant as rms line to line emf at 1000 rpm Preset Value: CALC
	1675	D-axis Stator Inductance Only available in PM Sensorless mode. (Range 0 to 1000 mH) D-axis stator inductance in mH for IPM motors Preset Value: CALC
	1676	Q-axis Stator Inductance Only available in PM Sensorless mode. (Range 0 to 1000 mH) Q-axis stator inductance in mH for IPM motors Preset Value: CALC
	1678	Trickle Current Heating Amps (Range: 0 to 50% of motor FLA); Provides DC current through motor windings when motor is not in use to eliminate condensation Preset Value: 0
1679	Lq at 25 pct load Only available in PM Sensorless mode. Not accessible using the keypad (must use Mint WorkBench). (Range 0 to 1000mH) Motor Lq inductance value in mH at 25% loading or as specified by Iq current level given in parameter 1683. Preset Value: CALC	

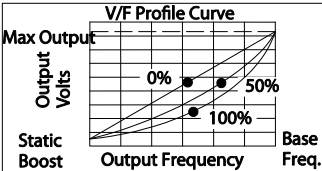
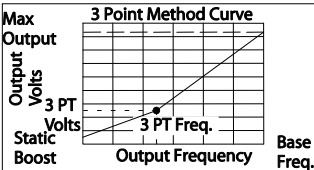
Table 7-1 Continued

Block Title	P#	Parameter Name and Description
Motor Control (Continued)	1680	<p>Lq at 50 pct load</p> <p>Only available in PM Sensorless mode. Not accessible using the keypad (must use Mint WorkBench).</p> <p>(Range 0 to 1000mH)</p> <p>Motor Lq inductance value in mH at 50% loading or as specified by Iq current level given in parameter 1684.</p> <p>Preset Value: CALC</p>
	1681	<p>Lq at 75 pct load</p> <p>Only available in PM Sensorless mode. Not accessible using the keypad (must use Mint WorkBench).</p> <p>(Range 0 to 1000mH)</p> <p>Motor Lq inductance value in mH at 75% loading or as specified by Iq current level given in parameter 1685.</p> <p>Preset Value: CALC</p>
	1682	<p>Lq at 100 pct load</p> <p>Only available in PM Sensorless mode. Not accessible using the keypad (must use Mint WorkBench).</p> <p>(Range 0 to 1000mH)</p> <p>Motor Lq inductance value in mH at 100% loading or as specified by Iq current level given in parameter 1686.</p> <p>Preset Value: CALC</p>
	1683	<p>Iq at 25 pct load</p> <p>Only available in PM Sensorless mode. Not accessible using the keypad (must use Mint WorkBench).</p> <p>(Range 0 to 4000 Amps)</p> <p>Optimum Iq current level in amps at 25% load</p> <p>Preset Value: CALC</p>
	1684	<p>Iq at 50 pct load</p> <p>Only available in PM Sensorless mode. Not accessible using the keypad (must use Mint WorkBench).</p> <p>(Range 0 to 4000 Amps)</p> <p>Optimum Iq current level in amps at 50% load</p> <p>Preset Value: CALC</p>
	1685	<p>Iq at 75 pct load</p> <p>Only available in PM Sensorless mode. Not accessible using the keypad (must use Mint WorkBench).</p> <p>(Range 0 to 4000 Amps)</p> <p>Optimum Iq current level in amps at 75% load</p> <p>Preset Value: CALC</p>

Table 7-1 Continued

Block Title	P#	Parameter Name and Description
Motor Control (Continued)	1686	<p>Iq at 100 pct load Only available in PM Sensorless mode. Not accessible using the keypad (must use Mint WorkBench). (Range 0 to 4000 Amps) Optimum Iq current level in amps at 100% load Preset Value: CALC</p>
	1687	<p>Initial Angle Short Pulse Count Only available in PM Sensorless mode. Not accessible using the keypad (must use Mint WorkBench). (Range 1 to 200 counts) Number of pulse counts used in generating the short pulses for initial angle estimation Preset Value: CALC</p>
	1688	<p>Initial Angle Long Pulse Count Only available in PM Sensorless mode. Not accessible using the keypad (must use Mint WorkBench). (Range 1 to 400 counts) Number of pulse counts used in generating the long pulses for initial angle estimation Preset Value: CALC</p>
Communication	1701	<p>Baud Rate (Range: 0-9600, 1-19200, 2-38400, 3-56000, 4-115200) Sets the communication baud rate. Preset Value: 1</p>
	1702	<p>Parity (Range: 0-None, 1-Odd, 2-Even) Sets communication parity. Preset Value: 0</p>
	1703	<p>Stop Bits (Range: 0-One, 1-Two) Sets the number of stop bits to use. Preset Value: 0</p>
	1704	<p>Drive Address (Range: 1-247) Sets the drive address for communication. Preset Value: 1</p>
	1705	<p>Option Card Reset (Range: 0-OFF, 1-ON) Sends a power up reset command to all expansion boards, slot 1 only, or slot 2 only. Preset Value: 0</p>
	1706	<p>Security Default (Range: 0-NO, 1-YES) Restores factory settings to Browser User ID and Password. Preset Value: 0</p>
	1707	<p>Browser User ID ASCII user ID for the Ethernet Web Browser Option Board if installed. Preset Value: baldor</p>
	1709	<p>Browser Password Password for the Ethernet Web Browser Option Board if installed. Preset Value: baldor</p>
	1720 - 1792	<p>See documentation provided with communications expansion board.</p>

7.2 Level 2 Parameters (Advanced Prog, Level 2 Blocks)

Table 7-2: Level 2 Parameter Block Definitions

Block Title	P#	Parameter Name and Description
Drive Limits	2001	<p>Operating Zone (Range: 0-STD Const Torque, 1-STD Var Torque, 2-Quiet Const Torque, 3-Quiet VAR Torque)</p> <p>Sets the PWM operating zone to Standard 2.5kHz or Quiet 8.0kHz output carrier frequency. Two operating modes are available: Constant Torque and Variable Torque. Constant Torque allows 175% for 3 seconds and 150% for 60 seconds of peak overload capacity. Variable Torque allows 115% peak overload for 60 seconds.</p> <p>Preset Value: 0</p>
	2002	<p>MIN Output Speed (Range: 0-MAX Speed RPM)</p> <p>Sets the minimum motor speed in RPM. During operation, the motor speed will not decrease below this value except for motor starts or during dynamic braking to a stop.</p> <p>Preset Value: 0</p>
	2003	<p>MAX Output Speed (Range: 500-30000 RPM)</p> <p>Sets the maximum motor speed in RPM.</p> <p>Preset Value: Rated Motor Speed</p>
	2004	<p>PWM Frequency (Range: 1000 to 16000Hz)</p> <p>The frequency that the output transistors are switched. PWM (pulse width modulation) frequency is also referred to as "Carrier" frequency. PWM should be as low as possible to minimize stress on the output transistors and motor windings. It is recommended that the PWM frequency be set to approximately 15 times the maximum output frequency of the control. Ratios less than 15 will result in non-Sinusoidal current waveforms.</p> <p>Preset Value: 4000</p>
	2005	<p>Current Rate Limit Only available or active in either Vector mode. Ignore these parameters for V/F mode. (Range: 0.000-10.000 seconds) Limits the rate of torque change in response to a torque command. This parameter sets the time in seconds to change the output torque by 1 times motor rated torque.</p> <p>Preset Value: 0.004</p>
	2006	<p>Peak Current Level (Range: 0- Peak Rated Current) (Vector)</p> <p>Sets maximum motor current level for operation. (V/F) Sets the motor current (including MAG current) where foldback begins.</p> <p>Preset Value: CALC</p>
	2007	<p>REGEN Torque Limit (Range: 0.0-200.0%)</p> <p>Sets the maximum motor current (not including MAG current) allowed during regen.</p> <p>Preset Value: CALC</p>
Drive Configure	2101	<p>Speed Units (Range: 0-Hz, 1-RPM)</p> <p>Sets units to Hz or RPM.</p> <p>Preset Value: 1</p>
	2102	<p>Language Select (Range: 0-English, 1-Other (Spanish, German, Italian, French, or Portuguese))</p> <p>English and one language can be stored (Spanish, German, Italian, French and Portuguese). Standard firmware allows English and Spanish. For other languages, language tables must be loaded into the drive's language flash area.</p> <p>Preset Value: 0</p>
	2103	<p>Factory Settings (Range: 0-NO, 1-YES)</p> <p>Restores factory settings (overwrites all stored values) for all four parameter tables.</p> <p>Preset Value: 0</p>
	2105	<p>Security (Range: 0-Off, 1-Local, 2-Network, 3-Total)</p> <p>Enable security. 0-Off: Security not enabled; 1-Local: Security enabled for keypad only; 2-Network: Security enabled for network only; 3 – Total: Security enabled for both keypad and network</p> <p>Preset Value: 0</p>

Table 7-2 Continued

Block Title	P#	Parameter Name and Description
Drive Configure (Continued)	2114	<p>Torque Enable Sequence (Range: 0 – Torque on Enable; 1 – Torque on Command)</p> <p>This parameter determines whether the drive starts regulating motor torque immediately upon closure of the drive enable input (J2-8) or only after the drive receives a forward/reverse command input. Only effective during remote operation.</p> <p>0 – Torque on Enable: Regulate motor torque any time the drive is enabled</p> <p>1 – Torque on Command: Regulate motor torque only after the drive has received a run forward or run reverse command.</p> <p>Preset Value: 0</p>
Drive Protect	2201	<p>External Trip (Range: 0-OFF, 1-ON)</p> <p>OFF - External Trip is Disabled. ON -External Trip is enabled.</p> <p>If a normally closed contact at J2-16 is opened, an External Trip fault will occur and cause the drive to shut down.</p> <p>Preset Value: 0</p>
	2202	<p>Following Error Only available or active in either Vector mode. Ignore for V/F mode. (Range: 0-OFF, 1-ON)</p> <p>OFF - Control ignores "At Speed Error" from the process.</p> <p>ON - Control monitors the following error from the process. If the process speed is outside the range set in the Level 1 Output block, AT Speed Band parameter, the drive will fault and will disable.</p> <p>Preset Value: 0</p>
	2203	<p>Torque Proving Only available or active in either Vector mode. Ignore for V/F mode. (Range: 0-OFF, 1-ON)</p> <p>OFF - Control ignores unbalanced motor phases.</p> <p>ON - Control looks for balanced output current in all three phases to the motor. Unbalanced output current will cause a trip and create a torque proving fault.</p> <p>This occurs after establishing flux current in the motor .</p> <p>Preset Value: 0</p>
	2204	<p>Feedback Loss Only available in Closed Loop Vector mode. Ignore for Open Loop Vector and V/F modes. (Range: 0-OFF, 1-ON)</p> <p>OFF - Loss of feedback signal is ignored.</p> <p>ON - Loss of feedback signal produces a trip condition to disable the drive.</p> <p>Preset Value: 1</p>
	2205	<p>Foldback Gain Only available or active in V/F mode. Ignore for Vector modes. (Range: 0.000-10.000) Sets the rate of change of output frequency during current limit.</p> <p>Preset Value: 0.010</p>
	2206	<p>Overload (Range: 0-Fault, 1-Foldback, 2-Hold) Sets how the control handles I2T power overloads. When an overload occurs it will either Fault, Foldback, or Hold based on the control output AMPS.</p> <p>Fault –drive will fault and disable PWM to motor if overload capability is exceeded.</p> <p>Foldback – drive attempts to reduce current to 80% of Drive rated current so that time remaining can count back up.</p> <p>Hold – drive attempts to reduce current to 100% of drive rated current so that time remaining can hold at present value.</p> <p>Preset Value: 0</p>
	2207	<p>Overload Trigger Only available or active in V/F mode. Ignore for Open Loop Vector mode. (Range: 0.0-100.0%) Sets the trigger point for an overload condition.</p> <p>Preset Value: 50.0</p>

Table 7-2 Continued

Block Title	P#	Parameter Name and Description
Drive Project (Continued)	2209	Single Phasing Not available for size AA controls. (Range: 0-Derate, 1-Fault) Fault - When input power phase is lost for approximately 10 cycles, control trips on fault. Derate - When an input power phase is lost, single phase operation is assumed and control output is derated by 50% and operation is allowed at the reduced output. Preset Value: 1
	2210	Over Temperature (Range: 0-Derate, 1-Fault) Fault - When control temperature reaches 85°C, control trips on fault. Derate - When control temperature reaches 80°C (standard or 90°C quiet mode), output is derated by 30% (current limiting) and operation is allowed at the reduced value. Operation at full current is allowed when control temperature decreases to 70°C. If control temperature reaches 85°C, control trips on fault. Preset Value: 1
	2211	Pwr Down Options (Range: 0-Fault, 1- Ride Through) Determines how the drive responds to a line loss. Preset Value: Fault
	2212	Cntl Stp Bus Lvl (Range: 200 to 800V) Active during a power loss ride-through. Sets the DC bus level at which a controlled stop may be triggered. Preset Value: CALC
	2213	Cntl Stop Delay (Range: 0 to 3600.0 Seconds) Active during a power loss ride-through. Sets the delay time required after a controlled stop before drive enable. Preset Value: 1.0
	2214	Kp r Ride Through (Range: 0 to 1000.0000) Proportional gain of PI controller for power loss ride through. Preset Value: 10.0000
	2215	Ki Ride Through(Range: 0 to 1000.0000) Integral gain of PI controller for power loss ride through. Preset Value: 1
Miscellaneous	2301	Auto Restart (Range: 0-Manual, 1-At Powerup, 2-After Fault, 3-Both) Manual Power Up Start - If set to MAN and a run command (enable signal & FWD or REV command) is present at power up, the motor will not run. The run command must be removed then reapplied to start operation. The run command refers to the enable plus direction (FWD or REV) signals. Restart after Fault - If a fault occurs during operation, the control must be reset and the run command must be removed then reapplied to start operation. Note: If Restart Fault/Hr is zero, the control must be manually reset. If Restart Fault/Hr. is non-zero, the control will automatically attempt to reset the fault but will not restart until the run command is removed then reapplied to start operation. Automatic At Power Up - If a run command (enable signal & FWD or REV command) is present at power up, the control will automatically start. Auto restarts enabled at power up but disabled after a fault. After Fault - If a fault occurs during operation, the control will automatically reset (after the restart delay time) to resume operation if the Fault/Hr is set to a non zero value. Auto restarts disabled at power up but enabled after a fault. Both - Auto restarts active at power up and after faults. 3 Wire modes, AUTO start after a fault or loss of power will not occur because the momentary contacts are open and the run command must again be applied. The run command refers to the enable plus direction (FWD or REV) lines. Preset Value: 1

Table 7-2 Continued

Block Title	P#	Parameter Name and Description
Miscellaneous (Continued)	2302	Restarts/Hr (Range: 0-10) The maximum number of automatic restart attempts before requiring a manual restart. After one hour without reaching the maximum number of faults or if power is turned off and on again, the fault count is reset to zero. Preset Value: 3
	2303	Restart Delay (Range: 0-3600 seconds) The amount of time allowed after a fault condition for an automatic restart to occur. Useful to allow sufficient time to clear a fault condition before restart is attempted. Preset Value: 3
	2304	PWM Technique (Range: 0-Space Vector, 1-Sine Triangle) Sets the method used to generate the motor voltage PWM signal, Space Vector or Sine Triangle. Preset Value: 1
	2305	Cost of Energy (Range: 0.00-99999.00\$/KWH) Sets the billing cost per KWH charged by the local power utility. Preset Value: 0.10
	2306	Reset Energy (Range: 0-NO, 1-YES) Resets the energy counter (in power base of the control). Preset Value: 0
	2309	Filter Type (Range: 0-None, 1-Low Pass, 2-High Pass, 3-Notch) Sets the auxiliary filter to None, Low pass, High Pass or Notch. Preset Value: 0
	2310	Filter Source (Range: 0-None, 1-Raw Speed, 2-Torque, 3-Analog IN1, 4-Analog IN2, 5-Composite Ref, 6-OPT1 ANA IN 1, 7-OPT1 ANA IN 2, 7-OPT2 ANA IN 1, 8-OPT2 ANA IN 2) Sets the auxiliary filter source to None, Raw speed, Torque, Analog IN1 or Analog IN2, Composite. Preset Value: 0
	2311	Filter Destination (Range: 0-None, 1-Speed Loop, 2-Torque Loop, 3-Speed FFWD, 4-Process FBK, 5-Process FFWD, 6-Process SP) Sets the output of the filter to None, Speed Loop, Torque Loop, Speed Feedforward, Process Feedback, Process Feedforward, or Process Setpoint. Preset Value: 0
	2312	Filter Cutoff (Range: 0.00-1000.00Hz) Sets the cutoff frequency of the auxiliary filter (a low value = slower response). Preset Value: 0.00
	2313	Notch Center Frequency (Range: 0.00-500.00Hz) Sets the center frequency for the notch filter (if Filter Type=Notch). Preset Value: 0.00
2314	Notch Band (Range: 0.00-200.00Hz) Sets the frequency band of the notch filter (if Filter Type=Notch). Preset Value: 0.00	
Motor Data	2401	Motor Rated Volt (Range: 0-1000 Volts) The rated voltage of the motor (listed on the motor nameplate). Preset Value: CALC
	2402	Motor Rated Amps (Range: 0- MAX AMP) The rated current of the motor (listed on the motor nameplate).

Table 7-2 Continued

Block Title	P#	Parameter Name and Description
Motor Data (Continued)	2403	Motor Rated Speed (Range: 0-30000 RPM) The rated speed of the motor (listed on the motor nameplate). Preset Value: 1754
	2404	Motor Rated Frequency (Range: 10.00-500.00) The rated frequency of the motor (listed on the motor nameplate). Preset Value: 60.00
	2406	Instability Frequency Only available or active in V/F mode. Ignore for Open Loop Vector mode. (Range: 0.00-500.00Hz) If the motor exhibits instability (usually no load) this parameter should be set to the center of the instability band. Preset Value: 0.00
	2407	Stability Gain Only available or active in V/F mode. Ignore for Open Loop Vector mode. (Range: 0.000-10.000) Sets the amount of correction to stabilize the motor. Preset Value: 0.000
	2414	Calculate Motor Model (Range: 0-NO, 1-YES) NO - No presets are calculated. YES - This procedure loads preset values into memory that are required to perform auto tune. Preset Value: 0
	2415	Reverse Rotation (Range: 0-OFF, 1-ON) Reverse direction of motor rotation without rewiring the motor or encoder wires. Note: In position mode, if the feedback alignment parameter is changed, the motor will continue to rotate in the same direction for a given position reference. However, if the encoder wires are swapped, motor rotation will reverse. Preset Value: 0
Brake Adjust	2501	Resistor Ohms (Range: 0.00-255.0 Ohms) The dynamic braking resistor value in ohms. Refer to dynamic braking manual for additional information. Preset Value: CALC
	2502	Resistor Watts (Range: 0-999999W) The dynamic braking resistor watts rating. Preset Value: CALC
	2503	Resistor Thermal Time Constant (Range: 20 – 3600 seconds) Sets the time for heat dissipation for the dynamic braking resistor. If 2X watts is dissipated continuously "Regen R Fault" will occur in the time set by this parameter. If 3x watts is dissipated continuously, "Regen R Fault" will occur in ½ the time set by this parameter. Preset Value: CALC

Table 7-2 Continued

Block Title	P#	Parameter Name and Description
Brake Adjust (Continued)	2504	<p>DC Brake Volts Only available or active in V/F mode. Ignore for Open/Closed Loop Vector mode. (Range: 0-20.00%) The amount of DC braking voltage applied to the motor windings during a stop command. Increase this value for more braking torque during stops. The increased braking voltage may cause the motor to overheat for applications that require frequent starts/stops. Be careful in selecting this value.</p> <p>The maximum DC Brake Voltage = (1.414) X (Max Output Volts) X 20%</p> <p>Preset Value: 0.00</p>
	2505	<p>DC Brake Trigger Only available or active in V/F mode. Ignore for Open/Closed Loop Vector mode. (Range: 0.00-50.00 Hz) The frequency at which dc injection braking will begin.</p> <p>Preset Value: 0.00</p>
	2506	<p>Brake On Stop Only available or active in V/F mode. Ignore for Open/Closed Loop Vector mode. (Range: 0-OFF, 1-ON)</p> <p>If set to ON, DC injection braking will begin when a stop command is issued. After a stop command, the DC brake voltage will be applied to the motor windings when the output frequency reaches the DC brake trigger.</p> <p>Preset Value: 0</p>
	2507	<p>Brake On Reverse Only available or active in V/F mode. Ignore for Open/Closed Loop Vector mode. (Range: 0 – OFF, 1 – ON)</p> <p>If set to ON, DC Injection braking will begin after a change-motor-rotation command is issued. After a stop command, the DC brake voltage will be applied to the motor windings when the output frequency reaches the DC brake trigger. Braking continues until the motor is stopped or until stop brake time is exhausted. The motor will then accelerate in the opposite direction.</p> <p>Preset Value: 0</p>
	2508	<p>Stop Brake Time Only available or active in V/F mode. Ignore for Open/Closed Loop Vector mode. (Range: 0.0-60.0 seconds)</p> <p>The maximum number of seconds that DC injection brake voltage will be applied to the motor windings after a stop command. After the time specified by this value, DC injection braking is automatically turned off. If DC injection braking starts at a frequency less than the DC brake trigger parameter, the stop brake time is calculated as follows:</p> <p>Preset Value: 0.0</p> <p>$BrakeTime = StopBrakeTime \times (OutputFrequencyatBraking / DCBrakeTrigger)$</p>
	2509	<p>Brake on Start Only available or active in V/F mode. Ignore for Open/Closed Loop Vector mode. (Range: 0-OFF, 1-ON)</p> <p>ON turns DC injection braking ON for a period of time (Start Brake Time) when a run command is issued. This ensures the motor is not rotating. Braking will automatically turn off and the motor will accelerate at the end of the start brake time.</p> <p>Preset Value: 0</p>
	2510	<p>Start Brake Time Only available or active in V/F mode. Ignore for Open/Closed Loop Vector mode. (Range: 0.0-60.0 seconds)</p> <p>The amount of time that DC injection braking will be applied after a run command is issued. This will only occur if brake on start is set to ON. Braking may cause the motor to overheat for applications that require frequent starts/stops. Be careful in selecting this value. The start brake time should be just long enough to ensure the motor shaft is not rotating when a start command is issued.</p> <p>Preset Value: 0.0</p>

Table 7-2 Continued

Block Title	P#	Parameter Name and Description
Process Control	2601	<p>Process Type (Range: 0-None, 1-Forward Acting, 2-Reverse Acting) None - PID is disabled, however feedforward is always available. Forward Acting - The process error computed as, $PE = (\text{Set Point}) - (\text{Feedback})$. Useful when feedback increases as motor speed increases. Reverse Acting - The process error compute as, $PE = (\text{Feedback}) - (\text{Set Point})$. Useful when feedback decreases as motor speed increases. Sets the type of PID control. Preset Value: 0</p>
	2602	<p>Setpoint Adjust Limit (Range: 0.0-100.0%) Set as a percent of motor speed it limits speed corrections due to process error. Preset Value: 10.0</p>
	2603	<p>Process Feedback (Range: 0-None, 1-Setpoint CMD, 2-Local Speed Ref. 3-Analog In1, 4-Analog In2, 5-Network, 6-Composite, 7-OPT1 ANA IN 1, 8-OPT1 ANA IN 2, 9-OPT2 ANA IN 1, 10-OPT2 ANA IN 2 Sets the type of signal used for the process feedback signal. Preset Value: 0</p>
	2604	<p>Setpoint Source (Range: 0-None, 1-Setpoint CMD, 2-Local Speed Ref. 3-Analog In1, 4-Analog In2, 5-Network, 6-Composite, 7-OPT1 ANA IN 1, 8-OPT1 ANA IN 2, 9-OPT2 ANA IN 1, 10-OPT2 ANA IN 2 Sets the source input signal type to which the process feedback will be compared. If "Setpoint CMD" is selected, the fixed value of the set point is entered in the Setpoint Command parameter value. Preset Value: 0</p>
	2605	<p>Setpoint Command (Range: -100.0% to +100.0%) Sets the value, as a percentage of the process feedback signal, the control will try to maintain by adjusting motor speed. This is only used when the Setpoint Source is a fixed value "Setpoint CMD" under Setpoint Source. Preset Value: 0.0</p>
	2606	<p>Process Error Tolerance (Range: 0.0-100.0%) The band within which the Opto or Relay Output is active (turned ON) indicating the process is within the desired range. Preset Value: 10.0</p>
	2607	<p>Process PROP Gain (Range: 0.0000-9999.9990) Sets the PID loop proportional gain. Determines how much adjustment to motor speed is due to process error. Preset Value: 1.0000</p>
	2608	<p>Process INTG Gain (Range: 0.0000-9999.9990) Sets the PID loop Integral gain. Determines how quickly the motor speed is adjusted to correct long term error. Preset Value: 0.0000</p>
	2609	<p>Process INTG Clamp (Range: 0.0-100.0%) Sets the level of the Integrator clamp as a percentage of maximum motor speed. Preset Value: 100.0</p>
	2610	<p>Process DIFF Gain (Range: 0.0000-9999.9990) Sets the PID loop differential gain. This determines how much adjustment to motor speed is made for transient error. Preset Value: 0.0000</p>

Table 7-2 Continued

Block Title	P#	Parameter Name and Description
Process Control (Continued)	2611	Profile Adjust (Range: 0-OFF, 1-ON) ON - Adjusts the ACC/DEC rate 1 based on process error (P2612). OFF - No adjustment is made. Preset Value: 0
	2612	Profile Adjust Band (Range: 0-200.0%) Active when P2612 is ON. If process error is within this band, ACC/DEC Group 1 is used. If process error is outside this band, ACC/DEC 2 is used. Useful when the PID's response needs to differ when process error is small as compared to when it is large. Preset Value: 50.0
	2613	Process Sleep Band (Range: 0-100.0%) Non-zero - Enables process PID sleep mode. When Process error remains within this band for 5 seconds, sleep mode is active (control is disabled, motor coasts). If at any time the process error moves out of this band, sleep mode is terminated and normal PID operation is resumed. Zero - disables sleep mode. Preset Value: 0.0
	2614	Process Output Filter (Range: 0.0-100.0 seconds) Sets the amount of filtering for the PID process output. Preset Value: 0.00
	2615	Process Output Offset (Range: -100.0-100.0%) Sets the amount of offset for the PID process output. Preset Value: 0.0
	2616	Process Output Gain (Range: 0.0-200.0%) Sets the amount of gain for the PID process output. Preset Value: 100.0
	Skip Frequency	2701, 2703, 2705
2702, 2704, 2706		Skip Band 1-3 (Range: 0-MAX Speed) The width of the band centered about the Skip Frequency. For example, if Skip Frequency #1 is set to 20Hz and Skip Band #1 is set to 5Hz, continuous operation is not allowed in the dead-band of 15Hz to 25Hz. Preset Value: 0.00
Synchro Start		2801
	2802	Synchro Start Reverse (Range: 0-OFF, 1-ON) Synchro Start feature begins scanning motor rotational frequency in the drive reverse direction. If P#2801 is ON, scan always starts in FWD direction even if P# 2802 is ON Preset Value: 0

Table 7-2 Continued

Block Title	P#	Parameter Name and Description
Synchro Start (Continued)	2803	Synchro at MAX Frequency (Range: 0-OFF, 1-ON Allows the Synchro Start feature to begin scanning motor rotational frequency at the MAX Frequency (On) or at the last speed reference command (Off). Preset Value: 1
	2804	Synchro Scan V/F (Range: 1.0-25.0%) Sets the Volts/Hertz ratio for the Synchro Start feature as a percentage of the V/F ratio defined by the "Control Base Volts/Control Base Frequency". This Synchro Scan V/F percentage value is multiplied by the "Control Base Volts/Control Base Frequency" value. If this value is too high, the inverter may fault on Overcurrent. Preset Value: 10.0 % V/F – 10% open vector
	2805	Synchro Setup Time (Range: 0.5-10.0 seconds) The time at max frequency (or last reference) before scanning begins. Allows motor currents to settle before scanning starts. Active in both forward and reverse directions. Preset Value: 0.20 V/F – 0.10 open vector
	2806	Synchro Scan Time (Range: 0.5-10.0 seconds) The time allowed for Synchro Start to scan and detect rotor frequency. Scanning begins at the Start at MAX Frequency to 0Hz. Generally, the shorter the Synchro Scan Time the more likely a false Synchro Start will be detected. This value should be set high enough to eliminate false Synchro Starts. This time applies in each direction. Preset Value: 2.0 V/F – 0.50 open vector
	2807	Synchro Recover (Range: 0.1-10.0 seconds) This time applies after the synchro frequency has been found. It is the amount of time given to ramp the voltage from the synchro start V/F ratio voltage level to the full V/F voltage level required by the motor. Preset Value: 1.0 V/F – 0.10 open vector
Auto Tune	2901	ANA Offset Trim (Range: 0-NO, 1-YES) Measure analog offset for all analog inputs. Preset Value: 0
	2902	One-Step Tuning Only available or active in either Vector mode. Ignore for V/F mode. (Range: 0-NO, 1-YES) Perform one step auto tune. (Prompts for "Press Enter" before a rotational test is performed). Preset Value: 0
	2903	Stator R1 Tune (Range: 0-NO, 1-YES) Measure Stator resistance. Preset Value: 0
	2904	Measure Xm (ROT) (Range: 0-NO, 1-YES) Measure MAG Reactance. This is a rotational test. Load should be decoupled from the motor. Preset Value: 0

Table 7-2 Continued

Block Title	P#	Parameter Name and Description
Auto Tune (Continued)	2905	Measure Leakage (Range: 0-NO, 1-YES) Measure leakage reactance and rotor resistance. Preset Value: 0
	2906	Current Loop Tune (Range: 0-NO, 1-YES) Tune the current controller loop. Preset Value: 0
	2907	Flux CUR Tune (Range: 0-NO, 1-YES) Tune the flux controller loop. This is a rotational test. Preset Value: 0
	2909	Slip Frequency Tune Only available or active in either Vector mode. Ignore for V/F mode. (Range: 0-NO, 1-YES) Tune slip frequency. This is a rotational test. Preset Value: 0
	2910	Speed Loop Tune Only available or active in either Vector mode. Ignore for V/F mode. (Range: 0-NO, 1-YES) Tune the speed controller loop. This is a rotational test. Preset Value: 0

Table 7-3 Continued

Block Title	P#	Parameter Name and Description
Composite Reference	3501	Parameter A Number (Range: 00000 to 10000) (See Chapter 11). Preset Value: 0
	3502	Parameter A Function (Range: 0-Zero, 1-Identity, 2-Absolute Value, 3-Invert, 4-Square, 5-Square Root, 6-Sine 7-Cosine, 8-Ramp Generator, 9-FREQ Generator (See Chapter 11). Preset Value: 0
	3503	Parameter B Number (Range: 00000 to 10000) (See Chapter 11). Preset Value:
	3504	Parameter B Function Range: 0-Zero, 1-Identity, 2-Absolute Value, 3-Invert, 4-Square, 5-Square Root, 6-Sine 7-Cosine, 8-Ramp Generator, 9-FREQ Generator (See Chapter 11). Preset Value: 0
	3505	Operator (Range: 0-Sum, 1-Difference, 2-Multiply, 3-Divide, 4-Maximum, 5-Minimum (See Chapter 11). Preset Value: 0
	3506	Function (Range: 0-Zero, 1-Identity, 2-Absolute Value, 3-Invert, 4-Square, 5-Square Root, 6-Sine 7-Cosine, 8-Ramp Generator, 9-FREQ Generator (See Chapter 11). Preset Value: 1
	3507	Parameter A Gain (Range: -1000.000 to 1000.000 (See Chapter 11). Preset Value: 1.00
	3508	Parameter B Gain (Range: -1000.000 to 1000.000 (See Chapter 11). Preset Value: 1.00
RTC Features	3601	RTC Action 1 - 2 (Range: 0-None, 1-D.Out1 ON, 2-D.Out1 OFF, 3-D.Out2 ON, 4-D.Out2 OFF, 5-R.Out1 ON, 6-R.Out1 Off, 7-R.Out2 ON, 8-R.Out2 Off, 9-Increment, 10-Decrement, 11-Reset, 12-D.Out1 On/IncP107, 13-D.Out1 Off/IncP107, 14-D.Out1 On/DecP107, 15-D.Out1 Off/DecP107, 16-D.Out1 On/Reset, 17-D.Out1 Off/Reset, 18-R.Out1 On/IncP107, 19-R.Out1 Off/IncP107, 20-R.Out1 On/DecP107, 21-R.Out1 Off/DecP107, 22-R.Out1 On/Reset, 23-R.Out1 Off/Reset) See Chapter 12. Preset Value: 3601=0, 3602=0
	3602	
	3603	RTC Message 1- 2 (Range: 0-None, 1-Clean Filter, 2-Change Filter, 3-Apply Oil/Lube, 4-Service Motor, 5-Service Drive, 6-Service Coolant, 7-Service Heating, 8-RTC Alarm) See Chapter 12. Preset Value: 3603=0, 3604=0
	3604	
	3605	Action 1 - 2 Qualifier (Range: 0-Once, 1-Second, 2-Minute, 3-Hourly, 4-Daily, 5-Monthly, 6-Yearly) See Chapter 12. Preset Value: 3605=0, 3606=0
	3606	
	3607	Message 1 - 2 Qualifier (Range: 0-Once, 1-Second, 2-Minute, 3-Hourly, 4-Daily, 5-Monthly, 6-Yearly) See Chapter 12. Preset Value: 3607=0, 3608=0
	3608	
	3609	Action 1 - 2 Date/Time (Range: MM DD, YYYY HH:MM:SS) See Chapter 12. Preset Value: 3609=Jan 01,2000 00:00:00, 3610=Jan 01,2000 00:00:00
	3610	
3611	Message 1 - 2 Date/Time (Range: MM DD, YYYY HH:MM:SS) See Chapter 12. Preset Value: 3609=Jan 01,2000 00:00:00, 3610=Jan 01,2000 00:00:00	
3612		
3630	RTC Counter MAX (Range: 00000-99999 See Chapter 12). Preset Value: 0	
3631	DST Select (Range: 0-OFF, 1-U.S.A, 2-E.U. Daylight Savings Time. See Chapter 12. Preset Value: 0	

Chapter 8

Customizing for Your Application

Manually Tuning the Control

In some applications the drive cannot be accurately auto tuned. In these cases, it is necessary to calculate the values needed to tune the drive and manually enter these calculated parameter values. In case the autotune feature cannot be used, enter the motor rated and magnetizing current parameters as described below and execute "Calc Motor Model". Use the current proportional, current integral and speed gains calculated after this step as the starting point for manual fine-tuning.

Electrical Slip Frequency Parameter

This parameter is located in the Level 2, Motor Data Block. The slip frequency may be calculated from nameplate data or auto tuned.

$$F_{\text{slip}} = \text{Rated Freq} - [(\text{Rated RPM} \times \text{Number of Motor Poles}) / 120]$$

Current Prop Gain Parameter

This parameter is located in the Level 1, Motor Control Block. The value is set at the factory and is recommended to be changed with Auto Tune or "Calc Motor Model". Do not attempt to change the value manually.

Current Int Gain Parameter

The Current Int Gain parameter located in the Level 1 Motor Control Block is factory set and is suitable for most applications.

Speed Prop Gain Parameter

The Speed Prop Gain parameter located in the Level 1 Motor Control Block is factory set to 5. This gain may be increased or decreased to suit the application. Increasing the Speed Prop Gain parameter will result in faster response, excessive proportional gain will cause overshoot and ringing. Decreasing the Speed Prop Gain parameter will cause slower response and decrease overshoot, ringing, and possibly instability resulting in overcurrent faults.

Speed Int Gain Parameter

The Speed Int Gain parameter in the Level 1 Motor Control Block is set to 10 Hz and may be set at any value. See also, PI Controller later in this section. Setting the Speed Int Gain parameter to 0Hz removes integral compensation that results in a proportional rate loop. This selection is for systems where overshoot must be avoided and stiffness (ability of the controller to maintain commanded speed with varying torque loads) is not required.

Increasing values of the Speed Int Gain parameter increases the stiffness of the controller. Typical setting is 10 Hz. If the Speed Prop Gain parameter and the Speed Int Gain parameter are set too high, an overshoot condition can occur.

To manually tune the control, the following procedure is used with the load coupled to the the motor:

1. Set the speed Integral Gain parameter = 0 (remove integral gain).
2. Increase the Speed Prop Gain parameter setting until adequate response to step speed commands is attained.
3. Increase the Speed Integral Gain parameter setting to increase the stiffness of the drive. Note: It is convenient to monitor speed step response with a strip chart recorder or storage oscilloscope connected to J1A-6 or -7 with Level 1, Output Block Analog Out #1 or #2 set to ABS SPEED, 0 VDC = zero speed. See Chapter 5 for a discussion of analog outputs. Additionally, the scope function within Mint WorkBench is a good tool to use while tuning the drive speed loop.

PI Controller

Both the current and rate control loops are of the Proportional plus Integral type. If "E" is defined to be the error signal,

$E = \text{Command} - \text{Feedback}$

then the PI controller operated on "E" as

$\text{Output} = (K_p * E) + (K_i \int E dt)$

where K_p is the proportional gain of the system and K_i is the integral gain of the system.

The transfer function (output /E) of the controller using $1/s$ (Laplace Operator) to denote the integral,

$\text{Output}/E = K_p + K_i / s = K_p (s + K_i/K_p) / s.$

The second equation shows that the ratio of K_i/K_p is a frequency in radians/sec. In the Baldor AC Vector Control, the integral gain has been redefined to be,

$K_i = (K_i / K_p) / (2\pi) \text{ Hz},$

and the transfer function is,

$\text{Output}/E = K_p (s + 2\pi K_i) / s.$

The integral gain is a frequency (in Hz) and should be set to about 1/10 of the bandwidth of the control loop.

The proportional gain sets the open loop gain of the system, the bandwidth (speed of response) of the system.

If the system electrical noise is excessive, the most likely cause is that the proportional gain is set too high.

Chapter 9 Troubleshooting

The VS1CTD continuously monitors its status and operation. When a fault occurs, the event and drive status are captured to help you troubleshoot problems. The following are designed to help in troubleshooting:

- LEDs on the keypad indicate status (Stop etc.)
- Fault Codes displayed on the keypad display as they occur
- A log of these faults and the time each occurred is kept in the Event Log
- A trace log for each event stored in the fault log

9.1 Event Log

From the Menu display screen, select Event Log and press enter. If an error is displayed during operation, press the "Help" key to learn more about the error. If more than one error was logged, access the Event Log and examine each error Entry at the time of the event to learn more about the error.

Action	Description	Display	Comments
Status Display	After power up the display shows the Status screen.	<pre> STATUS FWD LOCAL 159.5V 600RPM 6.2A 20.00HZ DIAG 600r MAIN </pre>	
Press Menu	Displays top level menu options.	<pre> STATUS BASIC PARAMS ADVANCED PROG EVENT LOG DIAGNOSTICS DIAG BACK </pre>	Press ▲ or ▼ to move cursor over the "EVENT LOG" selection. Press Enter to view the event log.
Event Log Display	Displays error name, Entry # and time the error occurred. LOW INITIAL BUS 0 Date Time Entry # DD/MM/YY HH:MM 0-9	<pre> EV. LOG STOP LOCAL LOW INITIAL BUS 0 4-Jul-06 09:35:00 STATUS TRACE </pre>	Press ▲ or ▼ to view next entry. Press F2 to display Trace menu. Press F1 to return to Status Menu.

Trace

Trace is used to display control conditions present at the time the fault occurred. Input states, Output states, various voltage and current values etc. can be viewed to help understand the cause of the fault condition. Each event in the Event log has its own Fault Trace displays that were captured when that event occurred. Scroll through the event log to the event you wish to investigate.

Trace Displays

Action	Description	Display	Comments
Event Log Display	Press ▲ or ▼ to scroll to the event you want to investigate.	<pre> EV. LOG STOP LOCAL ----- LOW INITIAL BUS 3 4-Jul-06 09:42:00 ----- STATUS TRACE </pre>	Press F2 (or press Enter) to show the Fault Trace for the event.
Fault Trace Display	The Fault Latch word is displayed. 0x=Hexadecimal 0b=Binary	<pre> EV. LOG FAULT TRACE ----- FAULT LATCH 0x0000 ----- STATUS T0003 BACK </pre>	Press ▲ or ▼ to view next entry . This is a hex value. The T0003 indicates the Fault Trace for event 3 of the event log is displayed.

FAULT LATCH Word Interpretation

Hexadecimal	Binary	Description
0000	0000 0000 0000 0000	No Fault
0001	0000 0000 0000 0001	Motor Phase U upper Transistor
0002	0000 0000 0000 0010	Motor Phase U lower Transistor
0004	0000 0000 0000 0100	Motor Phase V lower Transistor
0008	0000 0000 0000 1000	Motor Phase V upper Transistor
0010	0000 0000 0001 0000	Motor Phase W lower Transistor
0020	0000 0000 0010 0000	Motor Phase W upper Transistor
0040	0000 0000 0100 0000	Brake Desaturation Fault
0080	0000 0000 1000 0000	Brake IGBT Fault
0100	0000 0001 0000 0000	Not Used
0200	0000 0010 0000 0000	Not Used
0400	0000 0100 0000 0000	Ground Fault
0800	0000 1000 0000 0000	Over Current Fault (Active Low)
1000	0001 0000 0000 0000	Pulse by Pulse fault on Motor Phase 1
2000	0010 0000 0000 0000	Pulse by Pulse fault on Motor Phase 2
4000	0100 0000 0000 0000	Pulse by Pulse fault on Motor Phase 3
8000	1000 0000 0000 0000	Inverter Desaturation Fault

Trace Displays Continued

Action	Description	Display	Comments
Fault Trace Display	The Alarm Latch word is also displayed. The T0003 indicates the Fault Trace for event 3 of the event log is displayed.	<div style="border: 1px solid black; padding: 5px;"> EV. LOG FAULT TRACE ALARM LATCH 0x0000 STATUS T0003 BACK </div>	Press ▲ or ▼ to view next entry. This is a hex value.

ALARM LATCH Word Interpretation

Hexadecimal	Binary	Description
0000	0000 0000 0000 0000	No Alarm
0001	0000 0000 0000 0001	Fan Alarm
0002	0000 0000 0000 0010	Motor Over Temperature
0004	0000 0000 0000 0100	Phase Loss
0008	0000 0000 0000 1000	Line Loss
0010	0000 0000 0001 0000	Line Sag
0020	0000 0000 0010 0000	Power Supply Alarm
0040	0000 0000 0100 0000	Not Used
0080	0000 0000 1000 0000	Powerbase in pulse-by-pulse limiting
0100	0000 0001 0000 0000	Not Used
0200	0000 0010 0000 0000	Not Used
0400	0000 0100 0000 0000	Not Used
0800	0000 1000 0000 0000	Not Used
1000	0001 0000 0000 0000	Not Used
2000	0010 0000 0000 0000	Not Used
4000	0100 0000 0000 0000	Not Used
8000	1000 0000 0000 0000	Not Used

Action	Description	Display	Comments
Fault Trace Display	Third word in the event trace is the Voltage reference for the Analog to Digital Converter.	<div style="border: 1px solid black; padding: 5px;"> EV. LOG FAULT TRACE ADC CURRENT REF 0.000 V STATUS T0003 BACK </div>	Press ▲ or ▼ to view next entry.
Fault Trace Display	Next is the Voltage measurement of the Internal 24V power supply for the Opto Inputs and Outputs.	<div style="border: 1px solid black; padding: 5px;"> EV. LOG FAULT TRACE 24 V REF 0.0 V STATUS T0003 BACK </div>	Press ▲ or ▼ to view next entry.
Fault Trace Display	Next is the status of the nine Digital Input signals. J2 8 (Enable) left most digit=1. J2 16 (DIN#8) right most digit=0.	<div style="border: 1px solid black; padding: 5px;"> EV. LOG FAULT TRACE USER INPUTS 100000000 STATUS T0003 BACK </div>	Press ▲ or ▼ to view next entry. This is a bit display, not a hex value.

Trace Displays Continued

Action	Description	Display	Comments
Fault Trace Display	Next is the status of the Digital Output signals.	<div style="border: 1px solid black; padding: 5px;"> EV. LOG FAULT TRACE DIGITAL OUTPUTS 00000000 STATUS T0003 BACK </div>	Press ▲ or ▼ to view next entry. This is a bit display, not a hex value.

Digital Output Display		Description
Hexadecimal	Binary	
00	0000 0000	No Fault
01	0000 0001	Actual Speed is less than Zero Speed Band
02	0000 0010	Main SCR enable (active low)
04	0000 0100	Dynamic Brake active
08	0000 1000	Soft start (pre-charge) relay active
10	0001 0000	Relay Output 2 (J3-28, 29, 30)
20	0010 0000	Relay Output 1 (J3-25, 26, 27) active
40	0100 0000	Digital Output 2 (J2-19, 20) active
80	1000 0000	Digital Output 1 (J2-17, 18) active

Action	Description	Display	Comments
Fault Trace Display	Next is the voltage present at Analog Input 1.	<div style="border: 1px solid black; padding: 5px;"> EV. LOG FAULT TRACE ANA INPUT 1 0.0 V STATUS T0003 BACK </div>	Press ▲ or ▼ to view next entry.
Fault Trace Display	Next is the voltage present at Analog Input 2.	<div style="border: 1px solid black; padding: 5px;"> EV. LOG FAULT TRACE ANA INPUT 2 0.0 V STATUS T0003 BACK </div>	Press ▲ or ▼ to view next entry.
Fault Trace Display	Next is the Speed Reference Setting.	<div style="border: 1px solid black; padding: 5px;"> EV. LOG FAULT TRACE SPEED REF 0 RPM STATUS T0003 BACK </div>	Press ▲ or ▼ to view next entry.
Fault Trace Display	Next is the AC output current on phase 1.	<div style="border: 1px solid black; padding: 5px;"> EV. LOG FAULT TRACE PH1 CURRENT 0.0 A STATUS T0003 BACK </div>	Press ▲ or ▼ to view next entry.

Trace Displays Continued

Action	Description	Display	Comments
Fault Trace Display	Next is the AC output current on phase 2.	<div style="border: 1px solid black; padding: 5px;"> <p style="text-align: center;">EV. LOG FAULT TRACE</p> <p style="text-align: center;">PH2 CURRENT 0.0 A</p> <p style="text-align: center;">STATUS T0003 BACK</p> </div>	Press ▲ or ▼ to view next entry
Fault Trace Display	Next is the AC output current on phase 3.	<div style="border: 1px solid black; padding: 5px;"> <p style="text-align: center;">EV. LOG FAULT TRACE</p> <p style="text-align: center;">PH3 CURRENT 0.0 A</p> <p style="text-align: center;">STATUS T0003 BACK</p> </div>	Press ▲ or ▼ to view next entry
Fault Trace Display	Next is the Motor Current.	<div style="border: 1px solid black; padding: 5px;"> <p style="text-align: center;">EV. LOG FAULT TRACE</p> <p style="text-align: center;">MOTOR CURRENT 0.0A</p> <p style="text-align: center;">STATUS T0003 BACK</p> </div>	Press ▲ or ▼ to view next entry
Fault Trace Display	Next is the Motor Torque.	<div style="border: 1px solid black; padding: 5px;"> <p style="text-align: center;">EV. LOG FAULT TRACE</p> <p style="text-align: center;">MOTOR TORQUE 0.0 NM</p> <p style="text-align: center;">STATUS T0003 BACK</p> </div>	Press ▲ or ▼ to view next entry
Fault Trace Display	Next is the Motor Voltage.	<div style="border: 1px solid black; padding: 5px;"> <p style="text-align: center;">EV. LOG FAULT TRACE</p> <p style="text-align: center;">MOTOR VOLTS 0.0V</p> <p style="text-align: center;">STATUS T0003 BACK</p> </div>	Press ▲ or ▼ to view next entry
Fault Trace Display	Next is the Motor Speed.	<div style="border: 1px solid black; padding: 5px;"> <p style="text-align: center;">EV. LOG FAULT TRACE</p> <p style="text-align: center;">MOTOR SPEED 0 Hz</p> <p style="text-align: center;">STATUS T0003 BACK</p> </div>	Press ▲ or ▼ to view next entry
Fault Trace Display	Next is Bus Voltage.	<div style="border: 1px solid black; padding: 5px;"> <p style="text-align: center;">EV. LOG FAULT TRACE</p> <p style="text-align: center;">BUS VOLTAGE 0.0 V</p> <p style="text-align: center;">STATUS T0003 BACK</p> </div>	Press ▲ or ▼ to view next entry

Trace Displays Continued

Action	Description	Display	Comments
Fault Trace Display	The control heatsink temperature.	<pre> EV. LOG FAULT TRACE DRIVE TEMP 0.0 C STATUS T0003 BACK </pre>	Press ▲ or ▼ to view next entry.
Fault Trace Display	The fault code for the event.	<pre> EV. LOG FAULT TRACE FAULT LATCH 0x0000 STATUS T0003 BACK </pre>	Press ▲ or ▼ to view next entry.
Fault Trace Display	The alarm code for the event.	<pre> EV. LOG FAULT TRACE ALARM LATCH 0x0000 STATUS T0003 BACK </pre>	Press ▲ or ▼ to view next entry.
Fault Trace Display		<pre> EV. LOG END OF FAULT TRACE STATUS BACK </pre>	Press Enter or F2 to return to the event log.

9.2 Diagnostic Information

After power up, select the Diagnostic Menu to see information from the diagnostic displays.

Action	Description	Display	Comments
Press Menu	Displays top level menu options.	<pre> STATUS BASIC PARAMS ADVANCED PROG EVENT LOG DIAGNOSTICS DISPLAY OPTIONS STATUS BACK </pre>	Press ▲ or ▼ to move cursor over the "DIAGNOSTICS" selection. Press Enter to view diagnostic information.
Press ► to display next group.	Displays active operating mode settings.	<pre> DIAG STOP LOCAL OPERATING MODE Keypad Speed PM Sensorless EV. LOG 0.00r MAIN </pre>	
Press ► to display next group.	Bit display of digital inputs, outputs and the voltage present at the internal 24V supply terminals. Note: Enable input = 1. Out1 =1.	<pre> DIAG STOP LOCAL Digital I/O 100000000 INPUTS 0001 OUTPUTS 24.9V USER 24V 24.9V EV. LOG 0 r MAIN </pre>	Press ► or ◀ to go to the next or previous diagnostics screen. Press F2 to return to previous menu.

Diagnosics Information Continued

Action	Description	Display	Comments
Press ▶ to display next group.	Output Frequency, % Feedforward % Setpoint, % Feedback	<pre> DIAG STOP LOCAL PROC CONTROL PID 0.00HZ 0.0FF 0.0SP 0.0FB EV. LOG or MAIN </pre>	Press ▶ or ◀ to go to the next or previous Diagnostic screen. Press F2 to return to previous menu. Note: This screen does not appear unless P#1401 is set to Process Control.
Diagnostic Display	Displays software version, hp, volts and Amp/V olt ratings.	<pre> DIAG STOP LOCAL THH-1.22 RATED HP 3HP RATED VOLTS 240.0V RATED A/V 4.0A/V EV. LOG or MAIN </pre>	Press ▶ or ◀ to go to the next or previous Diagnostic screen. Press F2 to return to previous menu.
Press ▶ to display next group.		<pre> DIAG STOP LOCAL THH-1.22 RATED CURRE 9.6A RATED PK CU 16.8A EV. LOG or MAIN </pre>	Press ▶ or ◀ to go to the next or previous Diagnostic screen. Press F2 to return to previous menu.
Press ▶ to display next group.	Displays: Power Base ID number EE Firmware version FPGA firmware version	<pre> DIAG STOP LOCAL POWER BASE VERSION ID 0x000A2003 EE VER 0x00000001 FPGA VER 0x00000A02 EV. LOG or MAIN </pre>	Press ▶ or ◀ to go to the next or previous Diagnostic screen. Press F2 to return to previous menu. 0x=Hexadecimal 0b=Binary
Press ▶ to display next group.	Displays real time clock values (date and time) and total run time since installation. Press ENTER to set date and time.	<pre> DIAG STOP LOCAL REAL TIME CLOCK Jul 4, 2006 22:07:35 RUN TIMER 474.1HR EV. LOG or MAIN </pre>	Press ▶ or ◀ to go to the next or previous Diagnostic screen. Press F2 to return to previous menu.
Press ▶ to display next group.	Displays energy cost (based on parameter # 2305 value).	<pre> DIAG STOP LOCAL ENERGY EST POWER 0.00KW EST ENERGY 0.0KWH EST COST 0.0\$ EV. LOG or MAIN </pre>	Press ▶ or ◀ to go to the next or previous Diagnostic screen. Press F2 to return to previous menu. Press F1 to go to Status screen.
Press ▶ to display next group.	Diagnostic Analog Input values display.	<pre> DIAG STOP LOCAL ANALOG INPUTS ANA IN1 1.3v ANA IN2 0.0v EV. LOG or MAIN </pre>	Press ▶ or ◀ to go to the next or previous Diagnostic screen. Press F2 to return to previous menu.
Press ▶ to display next group.	Diagnostic Analog Output values display.	<pre> DIAG STOP LOCAL ANALOG OUTPUTS ANA OUT1 0.0V ANA OUT2 0.0V EV. LOG or MAIN </pre>	Press ▶ or ◀ to go to the next or previous Diagnostic screen. Press F2 to return to previous menu.

Diagnosics Information Continued

Action	Description	Display	Comments																		
Press ▶ to display next group.	Displays keypad software version.	<table border="1"> <tr> <td>DIAG</td> <td>STOP</td> <td>LOCAL</td> </tr> <tr> <td colspan="3">KEYPAD VERSION</td> </tr> <tr> <td>KEYPAD SOF</td> <td>1.1X</td> <td></td> </tr> <tr> <td>EV. LOG</td> <td>0r</td> <td>MAIN</td> </tr> </table>	DIAG	STOP	LOCAL	KEYPAD VERSION			KEYPAD SOF	1.1X		EV. LOG	0r	MAIN							
DIAG	STOP	LOCAL																			
KEYPAD VERSION																					
KEYPAD SOF	1.1X																				
EV. LOG	0r	MAIN																			
Press ▶ to display next group.	Diagnostic installed Option Card identification display .	<table border="1"> <tr> <td>DIAG</td> <td>STOP</td> <td>LOCAL</td> </tr> <tr> <td colspan="3">OPTION BOARDS</td> </tr> <tr> <td>OPTION 1</td> <td></td> <td>Ethernet</td> </tr> <tr> <td>OPTION 2</td> <td></td> <td>None</td> </tr> <tr> <td>FEEDBACK</td> <td></td> <td>None</td> </tr> <tr> <td>EV. LOG</td> <td>0r</td> <td>MAIN</td> </tr> </table>	DIAG	STOP	LOCAL	OPTION BOARDS			OPTION 1		Ethernet	OPTION 2		None	FEEDBACK		None	EV. LOG	0r	MAIN	Press ▶ or ◀ to go to the next or previous Diagnostic screen. Press F2 to return to previous menu. Press F1 to go to Status screen.
DIAG	STOP	LOCAL																			
OPTION BOARDS																					
OPTION 1		Ethernet																			
OPTION 2		None																			
FEEDBACK		None																			
EV. LOG	0r	MAIN																			
Press ▶ to display next group.	Displays Composite Reference values.	<table border="1"> <tr> <td>DIAG</td> <td>STOP</td> <td>LOCAL</td> </tr> <tr> <td colspan="3">COMPOSITE REF</td> </tr> <tr> <td>COMPONENT A</td> <td></td> <td>0.00%</td> </tr> <tr> <td>COMPONENT B</td> <td></td> <td>0.00%</td> </tr> <tr> <td>REFERENCE</td> <td></td> <td>0.00%</td> </tr> <tr> <td>EV. LOG</td> <td>0r</td> <td>Alarm</td> </tr> </table>	DIAG	STOP	LOCAL	COMPOSITE REF			COMPONENT A		0.00%	COMPONENT B		0.00%	REFERENCE		0.00%	EV. LOG	0r	Alarm	
DIAG	STOP	LOCAL																			
COMPOSITE REF																					
COMPONENT A		0.00%																			
COMPONENT B		0.00%																			
REFERENCE		0.00%																			
EV. LOG	0r	Alarm																			
Press ▶ to display next group.	DC Bus V oltag Drive Heatsink T emperature % Overload (remaining)	<table border="1"> <tr> <td>DIAG</td> <td>STOP</td> <td>LOCAL</td> </tr> <tr> <td colspan="3">DRIVE</td> </tr> <tr> <td>BUS VOLTAGE</td> <td></td> <td>333.9V</td> </tr> <tr> <td>DRIVE TEMP</td> <td></td> <td>26.1C</td> </tr> <tr> <td>OVERLOAD O/L L</td> <td></td> <td>100.0%</td> </tr> <tr> <td>EV. LOG</td> <td>0r</td> <td>MAIN</td> </tr> </table>	DIAG	STOP	LOCAL	DRIVE			BUS VOLTAGE		333.9V	DRIVE TEMP		26.1C	OVERLOAD O/L L		100.0%	EV. LOG	0r	MAIN	Press ▶ or ◀ to go to the next or previous Diagnostic screen. Press F2 to return to previous menu.
DIAG	STOP	LOCAL																			
DRIVE																					
BUS VOLTAGE		333.9V																			
DRIVE TEMP		26.1C																			
OVERLOAD O/L L		100.0%																			
EV. LOG	0r	MAIN																			
Press ▶ to display next group.	Motor V oltag Motor Current % Overload (remaining)	<table border="1"> <tr> <td>DIAG</td> <td>STOP</td> <td>LOCAL</td> </tr> <tr> <td colspan="3">MOTOR</td> </tr> <tr> <td>MOTOR VOLTAGE</td> <td></td> <td>333.9V</td> </tr> <tr> <td>MOTOR CURRE</td> <td></td> <td>4.8A</td> </tr> <tr> <td>OVERLOAD O/L L</td> <td></td> <td>100.0%</td> </tr> <tr> <td>EV. LOG</td> <td>0r</td> <td>MAIN</td> </tr> </table>	DIAG	STOP	LOCAL	MOTOR			MOTOR VOLTAGE		333.9V	MOTOR CURRE		4.8A	OVERLOAD O/L L		100.0%	EV. LOG	0r	MAIN	Press ▶ or ◀ to go to the next or previous Diagnostic screen. Press F2 to return to previous menu.
DIAG	STOP	LOCAL																			
MOTOR																					
MOTOR VOLTAGE		333.9V																			
MOTOR CURRE		4.8A																			
OVERLOAD O/L L		100.0%																			
EV. LOG	0r	MAIN																			

9.3 Fault Messages

Table 9-1: Fault Messages

Keypad Text	Type	Fault Number	Description
AC Input High	Fault	69	Check AC Input Line Voltage
ADC Calibr Fault	Fault	57	ADC Calibration Voltages Out of Range. Check analog input wiring for noise. If problem persists, contact factory for further assistance.
Apply Oil/Lub	Alarm	84	Triggered from RTC Module.
Aux Filter Setup	Alarm	51	Incorrect setup. Filter Source should be set to "Raw Speed" when destination is set to SpeedLoop
Brake Over Temp	Alarm	97	Dynamic brake has overheated, check sizing or increase ohms setting for brake
Brk Desat	Fault	65	Dynamic brake de-saturation has occurred. Check that dynamic brake resistor is properly connected to R1 and R2.
Bus Transient	Fault	95	Transient causing unbalanced bus capacitor voltage; cycle power to reset fault. A line surge or bus capacitor failure has resulted in an unbalanced voltage condition as determined by a bus voltage monitoring circuit.
Change Filter(s)	Alarm	83	Triggered from RTC Module.
Clean Filter(s)	Alarm	82	Triggered from RTC Module.
Configuration	Fault	2	Some drive feature or option has failed initial startup tests; parameter(s) out of range after download of improper parameter file settings.
Control EE	Fault	27	Problem reading EEPROM on the control board, please call Baldor for service
Control EE	Fault	29	Problem writing fault log to control board EEPROM, please call Baldor for service
Control EE	Fault	31	Problem writing the header record to the control board EEPROM, please call Baldor for service
Control EE	Fault	32	Problem writing a parameter to the control board EEPROM, please call Baldor for service
Conv Over Temp	Alarm	98	Converter has overheated, decrease loading; check for proper air flow; check for elevated ambient temperature.
Current Ref	Fault	15	Reference volt for current readings out of tolerance. Call Baldor for service
Current Sense	Fault	12	Motor current sensor(s) out of tolerance; cycle power to drive; if problem persists contact factory.
DC Bus High	Fault	19	DC Bus V over 405/810/1000V for 230V/460V/575V units. Check for high input line voltage; increase decel rates; check for correct brake resistor on R1/R2
DC Bus Low	Alarm	20	DC Bus V below 220/440/550V for 230V/460V/575V units. Check for low input line voltage; increase accel rate; verify B+ to B- voltage; verify proper brake resistor.
DC Pk Overvolt	Fault	63	Bus peak voltage rating exceeded. Check AC input lines; sizing of dynamic brake; insure that input does not have power factor correction capacitors or other source of transients.

Keypad Text	Type	Fault Number	Description
Desaturation	Fault	7	Output current exceeds desaturation limit. Check motor and connections for short circuit; verify proper motor load; increase acc/dec; check for conductive debris inside drive.
Download	Fault	54	Parameter download from keypad or network has failed. Verify parameter set compatibility
Drive Disabled	Alarm	66	Motion command given with drive disabled. Check drive enable input
Drive Enabled	Alarm	67	Drive enabled during parameter download. Drive must remain disabled until completion of parameter download.
Drive Low Temp	Fault	76	Heat sink Temperature is lower than allowed. Space heater may be required in cabinet.
Drive Over Tmp	Alarm	21	Heatsink temp exceeded 85/95 C. Verify ambient does not exceed 45°C. Clean fans and heatsink. Add cabinet cooling if ambient is too high.
Dyn Brake Desat	Fault	36	Dynamic braking current limit exceeded. Check for shorted braking resistor circuit or for brake resistor with an ohmic value below the allowed limit for the drive. Check for a short between R1 or R2 and B-.
Encoder Loss	Fault	58	Encoder detected but has poor or no signal. Check encoder wiring; verify shielding, grounding and bonding practices.
Excess Faults/Hr	Alarm	79	The allowed number of faults/hour has been exceeded
External Trip	Fault	22	J1-16 is open. Check remote connection on J1-16. Occurs only when external fault parameter is turned ON
Fan Loss	Alarm	62	Fan circuit is seeing low current or over current. Verify that fan is not blocked and is connected properly.
Flt Log Mem Fail	Fault	28	Problem reading fault log from control board EEPROM, please call Baldor for service
Following Error	Fault	18	Speed error beyond Set Speed Band parameter. Verify motor is not overloaded; increase Set Speed Band.
Ground Fault	Fault	8	Ground currents in output of control. Due to shorts to ground or excessive leakage current to ground. Disconnect motor, meg motor for insulation leakage to ground; check motor leads for shorts to ground; replace motor leads with lower capacitance cable or shorten leads if possible; consider the usage of load reactor.
High Line	Alarm	102	Power grid voltage too high, check power base rating, check input lines
IGBT Thermal	Fault	94	IGBT thermal overload. Check motor loading. Allow time to cool.
Initial Pos	Alarm	70	The initial position reading could not be read or is out of expected range. Check motor feedback wiring. Verify proper wiring, grounding and bonding.
Internal Config	Fault	35	An internal firmware configuration occurred, call Baldor for service
Invalid FB Sel	Alarm	56	Feedback board not installed in selected slot. Select an Encoder/Resolver board as feedback source. Verify selection of correct slot for motor feedback.
Invalid Res Sel	Alarm	71	The feedback source selected is not a resolver board. If resolver feedback utilized, ensure installed feedback board is for resolver feedback. Verify selection of correct slot for motor feedback.
Line Loss	Alarm	37	All 3 input phases lost. Check input circuit breaker, fuses or input contacts

Keypad Text	Type	Fault Number	Description
Line Regen	Fault	34	This fault code is not used, if it occurs call Baldor for service
Line Sag	Alarm	64	All 3 phase input lines have sagged below 70% of nominal. Check input line quality; check line impedance; check for excessive loading on power system.
Logic Supply	Fault	9	Internal logic power supply has dropped below 24V threshold. Replace Power Supply
Low Initial Bus	Fault	11	Bus volt below 200/400/500V on 230/460/575V units at power up. Check input line voltage; check for proper resistor on R1/R2; check for open circuit on TH1-TH2 Terminals
Low Line	Alarm	101	Power grid voltage too low. Check power base rating; check input connections; ensure input voltage is within drive specification.
Lower U Gate	Fault	40	Transistor #1 failed to fire or misfired. Verify IGBT is not shorted. Verify no debris has fallen into drive. Check wiring between drive and motor. Verify motor windings are not shorted.
Lower V Gate	Fault	42	Transistor #2 failed to fire or misfired. Verify IGBT is not shorted. Verify no debris has fallen into drive. Check wiring between drive and motor. Verify motor windings are not shorted.
Lower W Gate	Fault	44	Transistor #3 failed to fire or misfired. Verify IGBT is not shorted. Verify no debris has fallen into drive. Check wiring between drive and motor. Verify motor windings are not shorted.
Macro Cmd Failed	Fault	93	Macro command execution failure. Verify that macro file is correct.
Macro Cmd Inval	Fault	92	Macro command found is invalid. Verify that macro file is correct.
Macro Read	Fault	90	Macro record read failed. Recompile file and download to drive again.
Macro Rec Length	Fault	91	Macro record length is invalid. Recompile file and download to drive again.
Memory	Fault	49	Option card problem, memory failure, contact Baldor for service
Motor Overload	Fault	23	Motor thermal connection at TH1-TH2 open circuit. Motor overheated due to excess load; Ohm connections at TH1-TH2
Motor Overload	Fault	80	Motor overloaded. Check motor load. Verify motor rated amps parameter.
Motor Ovrtmp	Alarm	61	Motor has overheated. Check motor cooling system or blocked air flow; check thermal switch on TH1-TH2 circuit; reduce load on motor.
Network Timeout	Fault	48	Forced network fault. Loss of network communications; watchdog timer expired; user program timing problems.
New Base ID	Fault	5	Control board detected new or a different power base. Press RESET to clear. Factory settings will be restored. Verify all settings and setup custom parameters.
No Fault	Fault	0	No Fault Exist
NV memory Fail	Fault	30	Problem writing a parameter to the control board EEPROM, please call Baldor for service
Opt1 Protocol	Alarm	77	Invalid protocol selected for optional communication card 1. Select a protocol supported by the expansion board that is installed or replace board with a board that supports the desired protocol.

Keypad Text	Type	Fault Number	Description
Opt2 Protocol	Alarm	78	Invalid protocol selected for optional communication card 2. Select a protocol supported by the expansion board that is installed or replace board with a board that supports the desired protocol.
Option Board	Fault	50	Option board not recognized or is not supported. Verify proper firmware version is being used. Download latest firmware from www.baldor.com and install in drive.
Option Not Found	Alarm	74	Option Board for the feature requested is not installed. Verify slot location for expansion board to support desired feature; install appropriate option board for requested feature.
Over Current	Fault	6	Motor current exceeded peak limit. Check motor connections and motor load; increase acc/dec times; verify correct motor data settings; verify proper tuning.
Over Speed	Fault	59	Rotor speed over 110% maximum speed limit. Verify proper drive tuning; ensure drive is not being overhauled by excessive high-speed regenerative load.
Overload - 1 Min	Fault	16	Motor current exceeded 150% for 1 minute. Check motor load. Extend acc/dec times. Verify proper motor data and drive tuning.
Overload - 3 Sec	Fault	17	Motor current exceeded 175% for 3 seconds. Check motor load and resize motor and drive as needed. Extend acc/dec times. Verify proper motor data and drive tuning. Change setting of "Overload" parameter (P2206) to "Foldback" to allow current to automatically limit to a lower level prior to the 3 second time limit.
Param Checksum	Fault	4	Cycle power. If no change, load Factory Settings
Parameter	Fault	55	Parameters momentarily locked. Wait 30 seconds, try again
PB Power Supply	Alarm	68	Power Base Logic Power Supply below acceptable operating levels
PCB Over Temp	Alarm	96	Powerbase signal interface PCB board is over heating, reduce loading or call Baldor for service
PF Setup	Alarm	73	Pulse Follower Option Board Setup. Check Master PPR, Receive, Transmit Ratio and Input Type.
Ph1 (L1) Loss	Alarm	109	Loss of phase 1 (L1), check power grid or wiring connections
Ph1 Pulse	Fault	45	Phase 1 curr limiting via pulse by pulse method; check motor spiking loads, chattering contacts, loose connections.
Ph2 (L2) Loss	Alarm	110	Loss of phase 2 (L2), check power grid or wiring connections
Ph2 Pulse	Fault	46	Phase 2 curr limiting via pulse by pulse method; check motor spiking loads, chattering contacts, loose connections.
Ph3 (L3) Loss	Alarm	111	Loss of phase 3 (L3), check power grid or wiring connections
Ph3 Pulse	Fault	47	Phase 3 curr limiting via pulse by pulse method; check motor spiking loads, chattering contacts, loose connections.
Phase Loss	Alarm	38	Single input phase lost. Check input circuit breaker, fuses or input contacts. Excessive line notching occurring.
PLC Mode Trip	Fault	81	PLC Mode Trip. PLC action has generated this trip. Check input defined in PLC mode for fault trip. Check PLC program logic.

Keypad Text	Type	Fault Number	Description
Pos Cnt Overflow	Fault	75	Position counter has exceeded max or min range. Verify wiring, grounding and bonding of position feedback; verify range of acceptable values.
Power Base	Fault	10	Should occur in conjunction with other faults to indicate that fault was generated by the power base circuitry. This is useful in trouble-shooting to understand that the fault was detected by the power base electronics.
Powerbase EE	Fault	26	Communication error between control board and power base memory. Cycle power. If problem persists, contact factory for assistance.
Powerbase FPGA	Fault	52	Power base communication loss or incompatible firmware. Cycle power. If problem persists, contact factory.
Pre-charge Fault	Fault	60	Dynamic Brake miswired; AC Input too low; Bus Caps shorted or Input Single Phasing. Check motor thermal lead connections to TH1-TH2.
Reac Over Temp	Alarm	99	Reactor has overheated, decrease loading; decrease wire length; verify drive ambient temperature is less than 45°C; verify proper air flow and system cooling capability.
Regen R or PWR	Fault	25	Brake resistor power rating exceeded. Check resistor ratings; extend decel times; increase size of braking kit
Resolver Loss	Fault	72	Resolver signal poor or missing. Verify wiring, grounding, and bonding of resolver feedback.
RTC Alarm	Alarm	89	Triggered from RTC Module.
SCR1 No Fire	Alarm	103	Phase loss due to SCR1 (L1 upper) not firing. Verify SCR gate leads properly connected.
SCR2 No Fire	Alarm	104	Phase loss due to SCR2 (L1 lower) not firing. Verify SCR gate leads properly connected.
SCR3 No Fire	Alarm	105	Phase loss due to SCR3 (L2 upper) not firing. Verify SCR gate leads properly connected.
SCR4 No Fire	Alarm	106	Phase loss due to SCR4 (L2 lower) not firing. Verify SCR gate leads properly connected.
SCR5 No Fire	Alarm	107	Phase loss due to SCR5 (L3 upper) not firing. Verify SCR gate leads properly connected.
SCR6 No Fire	Alarm	108	Phase loss due to SCR6 (L3 lower) not firing. Verify SCR gate leads properly connected.
Sel FB Source	Alarm	53	Feedback Source Not Selected/Feedback Board is absent. Choose an appropriate card for encoder/resolver; verify selection of appropriate feedback source; verify wiring to feedback device. Operate in V/Hz or Open Vector mode if feedback device or board not present.
Sense 1 TA	Alarm	100	Temperature of converter bridge detected by power interface board is too low or too high. Verify drive ambient temperature is between -10°C and 45°C. Verify proper air flow and system cooling capability. Verify proper termination of temperature sensors within drive.
Ser Coolant Sys	Alarm	87	Triggered from RTC Module.
Ser Heating Sys	Alarm	88	Triggered from RTC Module.
Service Drive	Alarm	86	Triggered from RTC Module.

Keypad Text	Type	Fault Number	Description
Service Motor	Alarm	85	Triggered from RTC Module.
Soft Version	Fault	33	This fault code is not used, if it occurs call Baldor for service
SPI Timeout	Fault	3	Comms Error between control board and power board. Remove power from drive, verify proper grounding and bonding techniques. Re-apply power. If persists, call Baldor.
Torque Proving	Fault	24	Failed to read current in all 3 motor phases. Check motor connections or open motor contacts.
Unknown	Fault	1	This fault should not occur. Call Baldor for service
Upper U Gate	Fault	39	Transistor #1 failed to fire or misfired. Verify IGBT is not shorted. Verify no debris has fallen into drive. Check wiring between drive and motor. Verify motor windings are not shorted.
Upper V Gate	Fault	41	Transistor #2 failed to fire or misfired. Verify IGBT is not shorted. Verify no debris has fallen into drive. Check wiring between drive and motor. Verify motor windings are not shorted.
Upper W Gate	Fault	43	Transistor #3 failed to fire or misfired. Verify IGBT is not shorted. Verify no debris has fallen into drive. Check wiring between drive and motor. Verify motor windings are not shorted.
User 24V	Fault	14	User 24V supply out of tolerance. Measure 24V supply using a digital multi-meter at terminals J1-23 and J1-24. If voltage is not correct, remove all external control connections and repeat measurement to determine if problem is with external connections or with the power supply.
User Ref	Fault	13	User analog input reference out of tolerance. Check connections for proper shielding and grounding; check for excessive noise on analog signals. If problem persists, call Baldor for service

9.4 Electrical Noise Considerations

All electronic devices are vulnerable to significant electronic interference signals (commonly called “Electrical Noise”). At the lowest level, noise can cause intermittent operating errors or faults. From a circuit standpoint, 5 or 10 millivolts of noise may cause detrimental operation. For example, analog speed and torque inputs are often scaled at 5 to 10VDC maximum with a typical resolution of one part in 1,000. Thus, noise of only 5 mV represents a substantial error.

At the extreme level, significant noise can cause damage to the drive. Therefore, it is advisable to prevent noise generation and to follow wiring practices that prevent noise generated by other devices from reaching sensitive circuits. In a control, such circuits include inputs for speed, torque, control logic, and speed and position feedback, plus outputs to some indicators and computers.

Relay and Contactor Coils

Among the most common sources of noise are the coils of contactors and relays. When these highly inductive coil circuits are opened, transient conditions often generate spikes of several hundred volts in the control circuit. These spikes can induce several volts of noise in an adjacent wire that runs parallel to a control-circuit wire. Figure 9-1 illustrates noise suppression for AC and DC relay coils.

Figure 9-1: AC and DC Coil Noise Suppression

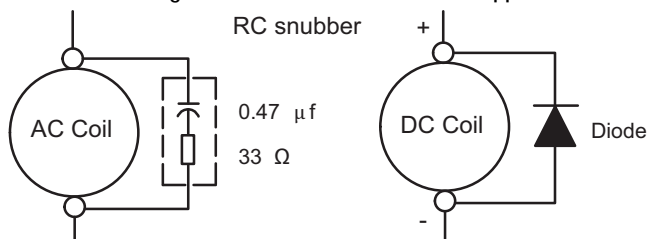

Wires between Controls and Motors

Output leads from a typical 460VAC drive controller contain rapid voltage rises created by power semiconductors switching 650V in less than a microsecond, 1,000 to 16,000 times a second. These noise signals can couple into sensitive drive circuits. If shielded pair cable is used, the coupling is reduced by nearly 90%, compared to unshielded cable. Even input AC power lines contain noise and can induce noise in adjacent wires. In some cases, line reactors may be required. To prevent induced transient noise in signal wires, all motor leads and AC power lines should be contained in rigid metal conduit, or flexible conduit. Do not place line conductors and load conductors in same conduit. Use one conduit for 3 phase input wires and another conduit for the motor leads. The conduits should be grounded to form a shield to contain the electrical noise within the conduit path. Signal wires, even ones in shielded cable, should never be placed in the conduit with motor power wires.

Special Drive Situations

For severe noise situations, it may be necessary to reduce transient voltages in the wires to the motor by adding load reactors. Load reactors are installed between the control and motor. Line and Load Reactors are typically 3% reactance and are designed for the frequencies encountered in PWM drives. For maximum benefit, the reactors should be mounted in the drive enclosure with short leads between the control and the reactors.

Control Enclosures

Motor controls mounted in a grounded enclosure should also be connected to earth ground with a separate conductor to ensure best ground connection. Often grounding the control to the grounded metallic enclosure is not sufficient. Usually painted surfaces and seals prevent solid metallic contact between the control and the panel enclosure. Likewise, conduit should never be used as a ground conductor for motor power wires or signal conductors.

Special Motor Considerations

Motor frames must also be grounded. As with control enclosures, motors must be grounded directly to the control and plant ground with as short a ground wire as possible. Capacitive coupling within the motor windings produces transient voltages between the motor frame and ground. The severity of these voltages increases with the length of the ground wire. Installations with the motor and control mounted on a common frame, and with heavy ground wires less than 10 ft. (3m) long, rarely have a problem caused by these motor-generated transient voltages.

Analog Signal Wires

Analog signals generally originate from speed and torque controls, plus DC tachometers and process controllers. Reliability is often improved by the following noise reduction techniques:

- Use twisted-pair shielded wires with the shield grounded at the drive end only.
- Route analog signal wires away from power or control wires (all other wiring types).
- Cross power and control wires at right angles (90°) to minimize inductive noise coupling.

Chapter 10

PLC Mode Description

10.1 Overview

PLC functionality is selected by setting Level 1, Input Setup block, Operating Mode parameter P#1401 to PLC. PLC mode allows 2-Wire and 3-Wire operating modes to be created using a selection of conditions, logical operators and desired actions. PLC Mode parameters are located in Level 3, PLC block parameters P3401 through P3443.

Simply stated, for each logical statement choose two input conditions from Table 10-1, one logical operation from Table 10-2 and one action from Table 10-3. These 30 logical statements are evaluated every 10 milliseconds, in order from P3401 to 3430. For each statement Condition 1 and Condition 2 are evaluated to True or False, the Logical Operator is applied and the final outcome is either True or False. If True the Action is taken; if False the Alternate Action is taken. Conditions, operators and actions are pre-defined and so cannot be changed.

10.2 Configuration Parameters

The PLC program is contained within 30 statements, PLC CONFIG 1 (P3401) through PLC CONFIG 30 (P3430). Each statement has the same 32 bit word format and structure as the example given in Figure 10-1. If P3401-P3430 are not programmed, the PLC Mode will do nothing. It is also possible to program them so that the motor will not move. This can happen, for instance, if no Forward/Reverse Enables are programmed.

Figure 10-1: Example PLC Configuration Parameters

Parameter Number Format = DDD.CCC.BBB.AAA

Where:

DDD = bits 31-24 Byte 3

CCC = bits 23-16 Byte 2

BBB = bits 15-8 Byte 1

AAA = bits 7-0 Byte 0

Example:

P3401 = 051.000.000.020

051 = Digital Input 2 (from Table 10-1)

000 = OR (from Table 10-2)

000 = False (from Table 10-1)

020 = Forward (from Table 10-3)

Parameter No.	Hex Byte 3	Hex Byte 2	Hex Byte 1	Hex Byte 0
P3401-3430	Condition ID MSD (Table 10-1)	Logical Operator ID (Table 10-2)	Condition ID (Table 10-1)	Action ID LSD (Table 10-3)

A configuration parameter may be disabled (turned off) by setting bit 23 in its configuration word. This is the same as setting the most significant bit of byte 2 (the logical operator ID field). If any field within any of these parameters is invalid, it is ignored at run time. Only one runtime version exists at a time. The runtime version in effect is the one defined by the parameter table active at the time the drive was placed in Remote Mode.

To switch runtime PLC versions perform the following operations:

1. Disable the drive.
2. At the keypad, select "Local" mode.
3. Select the desired parameter table.
4. Enable the drive.
5. At the keypad, select "Remote" mode.

If a parameter table is switched while the drive is enabled the run time PLC version is not affected.

10.3 Comparator Function

Comparator parameters provide a way to monitor real-time signals within the drive and apply them to the PLC Mode's logic. They may be used on the condition definition side of the PLC Mode's logic. Parameters P3431 and P3433 hold parameter numbers (i.e. they point to other parameters, see Monitor and RTC chapter in this manual for these values). P3432 and P3434 hold percents that are applied against P3431 and P3433 maximums, together they provide all that is needed for the following comparison equations:

If $|\text{Value of P3431}| \leq (\text{P3432}/100) * (\text{Max of P3431})$ then True or
If $|\text{Value of P3433}| \leq (\text{P3434}/100) * (\text{Max of P3433})$ then True

In a sense P3431 and P3433 may be viewed as holding addresses for other parameters.

For example: If P3431 = 5 (selects parameter 5 which is Motor Volts = 230V) and P3432=20% then Comparator A is true if $|\text{P5}| = (20/100) * 230 \leq 46\text{V}$. But if the voltage exceeds 46V, Comparator A is false.

If P3433 = 6 (selects parameter 6 Motor Current = 10 Amps) then Comparator B is true if $|\text{P6}| \leq 1 \text{ Amp}$. Any parameter (see Monitor and RTC chapter in this manual for these values) can be used in a comparator.

Note: Don't use P3431 and P3433 since this would create a circular reference and the comparator would fail.

A and B are defined as follows:

$A = (\text{Value of Parameter P3431}) / (\text{Max of Parameter P3431})$

$B = (\text{Value of Parameter P3433}) / (\text{Max of Parameter P3433})$

Then, A & B are signals with the following properties: $-1 \leq A \leq 1$ and $-1 \leq B \leq 1$.

A and B are normalized signals derived from parameters pointed to by P3431 and P3433.

Comparator A

Comparator A is used in Condition 76 and checks the following relationship for true or false:

If $|A - \text{P3435}/100| \leq \text{P3432}/100$

Alternatively, another way of writing the same relation is as follows:

If $(\text{P3435} - \text{P3432})/100 \leq A \leq (\text{P3432} + \text{P3435})/100$

Thus, Comparator A provides a way to determine if a parameter is within a specific range. For example, if P3431=5 (Motor Volts with Max=230V) and P3432=20% and P3435=0% then Comparator A would be true so long as $|\text{P5}| \leq 46\text{V}$ or $|A| \leq 0.20$. That is, motor voltage is monitored and so long as it remains below 46 Volts, the outcome of Comparator A would be True, but if it were to go above 46 Volts, the output of Comparator A would be False.

Comparator B

Comparator B is used in Condition 77 and checks the following relationship for true or false:

If $|B - \text{P3436}/100| \leq \text{P3434}/100$

Alternatively, another way of writing the same relation is as follows:

If $(\text{P3436} - \text{P3434})/100 \leq B \leq (\text{P3436} + \text{P3434})/100$

Thus, Comparator B provides a way to determine if a parameter is within a specific range. For example, if P3433=6 (Motor Current with Max=10Amps) and P3434=10% and P3436=50% then Comparator B would be true so long as: $4 \text{ Amps} \leq \text{P6} \leq 6 \text{ Amps}$ OR $0.4 \leq B \leq 0.60$. That is, motor current is monitored and so long as it remains within 1 Amp of 5 Amps the outcome of Comparator B would be True, but if it were to go above 6 Amps or below 4 Amps the output of Comparator B would be False.

Less than

Less than, Condition 88, uses the following equation: If $A < B$ then True else False For example, if P3431=103 (Analog Input 1 Reference with Max=100%) and P3433=104 (Analog Input 2 Reference with Max=100%) then Condition 88 would be true so long as $P103 < P104$ or so long as Analog Input 1 Reference is less than Analog Input 2 Reference.

Equal

Equal, Condition 89, uses the following equation: If $A = B$ then True else False For example, if P3431=103 (Analog Input 1 Reference with Max=100%) and P3433=104 (Analog Input 2 Reference with Max=100%) then Condition 89 would be true so long as $P103 = P104$ or so long as Analog Input 1 Reference is equal to Analog Input 2 Reference.

Greater than

Greater than, Condition 90, uses the following equation: If $A > B$ then True else False For example, if P3431=103 (Analog Input 1 Reference with Max=100%) and P3433=104 (Analog Input 2 Reference with Max=100%) then

Condition 90 would be true so long as $P103 > P104$ or so long as Analog Input 1 Reference is greater than Analog Input 2 Reference.

10.4 Timers

The PLC Mode uses four general purpose timers: Timer A (P3440), B (P3441), C (P3442) and D (P3443) with units of seconds and resolution of 10ms or 100 counts/sec. They may be used in PLC control and logic statements as defined in the Conditions and Actions Tables. In general there are actions to start and stop the timers as well as conditions to test their contents.

P113, P114, P117 and P118 are read/write monitor parameters that reflect the current state of timers A through D. Since they may be written, they can be used to start a timer by writing zero to it or to stop a timer by writing max counts.

For example, set P3440 to 1.5 sec then upon Timer A timeout,

$P113 = 150 \text{ counts} = (1.5 \text{ sec}) \times (100 \text{ counts/sec})$

Starting timer A also starts P113 ramping from 0 to 150 in 1.5 seconds.

Set P3441 to 10 seconds and start Timer B, P114 then ramps from 0 to 1000 in 10 sec.

These monitor parameters may also be inputs to the Composite Reference block to generate timed ramps or other complex reference signals.

Table 10-1: PLC Conditions

Dec	Description
0	False - This condition is always False
1	True - This condition is always True
2	Reserved (Workbench - Digital Input)
3	Reserved (Workbench - Hard Forward Limit)
4	Reserved (Workbench - Hard Reverse Limit)
5	Reserved (Workbench - Soft Forward Limit)
6	Reserved (Workbench - Soft Reverse Limit)
7	Reserved (Workbench - Move Statue)
8	Reserved (Workbench - Idle)
9	Reserved (Workbench - Position achieved)
10	Reserved (Workbench - At target position)
11	Reserved (Workbench - In Idle Position Window)
12	Reserved (Workbench - Following Error Fatal)
13	Reserved (Workbench - Following Error Warning)
14	At Speed - If the measured speed of the rotor is within the At Speed Band (P1506) of the reference then this condition is True.
15	Reserved - (Workbench - Velocity Error)
16	Velocity Setpoint Minimum - If the measured absolute speed is below the Minimum Output Speed (P2002) then this condition is True.
17	Velocity Setpoint Maximum- If the measured absolute speed is above the Maximum Output Speed (P2003) then this is True.
18	Reserved
19	Motor Overload - If the motor's I2T algorithm has exceeded its integral limit this condition is True.
20	Drive Overload - If the drive's I2T algorithm has exceeded its integral limit this condition is True.
21	Motor Direction - If rotor speed is positive this condition is True
22	Command Direction - If speed demand is positive this condition is True
23	Ready - If soft start is complete, drive hardware enable is on and there are no errors this condition is True.
24	Drive On - If the drive is ready and producing PWM to the motor this condition is True.
25	Fault - If the drive is faulted for any reason this condition is True.
26	Motor Over Temp Trip - If the motor's over temperature trip input has occurred then this condition is True.

Table 10-1: PLC Conditions (Continued)

Dec	Description
27	Drive Over Temp Trip - If the drive's over temperature trip input has occurred then this condition is True.
28	Drive Over Temp Warning - If the drive's temperature has exceeded that defined for the drive then this condition is True.
29	Reserved (Workbench - home status)
50	Digital Input 1 (J2-9) - If digital input 1 is high this condition is true. (Level sensitive)
51	Digital Input 2 (J2-10) - If digital input 2 is high this condition is true. (Level sensitive)
52	Digital Input 3 (J2-11) - If digital input 3 is high this condition is true. (Level sensitive)
53	Digital Input 4 (J2-12) - If digital input 4 is high this condition is true. (Level sensitive)
54	Digital Input 5 (J2-13) - If digital input 5 is high this condition is true. (Level sensitive)
55	Digital Input 6 (J2-14) - If digital input 6 is high this condition is true. (Level sensitive)
56	Digital Input 7 (J2-15) - If digital input 7 is high this condition is true. (Level sensitive)
57	Digital Input 8 (J2-16) - If digital input 8 is high this condition is true. (Level sensitive). When J2-16 is used in PLC Program, Set P2201=OFF to avoid an external trip condition.
58	Drive Run - If the drive is on and has a forward or reverse command this condition is True.
59	Stop - If motion status is stopped this condition is True.
60	Jog - If jog mode is active this condition is True.
61	Accelerating - If absolute speed demand is accelerating this condition is True.
62	Constant Speed - If absolute speed demand is constant this condition is True.
63	Decelerating - If absolute speed demand is decelerating this condition is True.
64	At Zero Speed - If absolute speed demand is below the Zero Speed Set Point (P1505) this condition is True.
65	At Set Speed - If absolute speed demand is above Set Speed Point (P1507) this condition is True.
66	Motor Over Current - If motor RMS current is above the Overload Set Point (P1508) this condition is True.
67	Motor Under Current - If motor RMS current is below the Underload Set Point (P1509) this condition is True.
68	Keypad Control - If the drive is under keypad control this condition is True.
69	Dynamic Brake - If the drive's dynamic brake is on this condition is True.
70	Frequency Foldback - If the drive is in frequency foldback this condition is True.
71	Alarm - If an alarm is active this condition is True.
72	Forward - If the drive has a forward command this condition is True.
73	Reverse - If the drive has a reverse command this condition is True.
74	Process PID Error - If the absolute value of Process PID Error is less than the Process PID Error Tolerance (P2606) this condition is True.
75	Sleep Mode - If the drive's sleep algorithm has put the drive to sleep this condition is True.
76	Comparator A - Monitors a parameter and returns True if the parameter is less than a predefined setpoint. NOTE: See chapter on PLC Comparator Parameters

Table 10-1: PLC Conditions (Continued)

Dec	Description
77	Comparator B - Monitors a parameter and returns True if the parameter is below a predefined setpoint. NOTE: See chapter on PLC Comparator Parameters
78	Parameter Table 1 - If parameter table 1 is active then this condition is True.
79	Parameter Table 2 - If parameter table 2 is active then this condition is True.
80	Parameter Table 3 - If parameter table 3 is active then this condition is True.
81	Parameter Table 4 - If parameter table 4 is active then this condition is True.
82	Digital Output 1- If digital output 1 is On this condition is True.
83	Digital Output 2- If digital output 2 is On this condition is True.
84	Relay Output 1 - If relay output 1 is On this condition is True.
85	Relay Output 2 - If relay output 2 is On this condition is True.
86	Timer A - True if Timer A has expired.
87	Timer B - True if Timer B has expired.
88	Less Than (<) - Monitors two parameters (A & B) and returns True if A<B else False is returned.
89	Equal (=) - Monitors two parameters (A & B) and returns True if A=B else False is returned.
90	Greater Than (>) - Monitors two parameters (A & B) and returns True if A>B else False is returned.
100	Logical Variable A - Logical variable A is tested for True/False
101	Logical Variable B - Logical variable B is tested for True/False
102	Logical Variable C - Logical variable C is tested for True/False
103	Logical Variable D - Logical variable D is tested for True/False
104	Logical Variable E - Logical variable E is tested for True/False
105	Logical Variable F - Logical variable F is tested for True/False
106	Logical Variable G - Logical variable G is tested for True/False
107	Logical Variable H - Logical variable H is tested for True/False
108	Logical Variable I – Logical variable I is tested for True/False
109	Logical Variable J - Logical variable J is tested for True/False
150	Heater – If trickle current running the condition True, else False

Table 10-2: PLC Logical Operators

Dec	Description
0	OR
1	AND
2	XOR
3	NOR
4	NAND
5	Reserved

Table 10-3: PLC Actions

Dec	Description
0	Digital Output 1 - If the input condition is True then Digital Output 1 (J2-17,18) will be active otherwise it is inactive NOTE: Digital output 1 must have been set to "PLC" using P1501
1	Digital Output 2 - If the input condition is True then Digital Output 2 (J2-19,20) will be active otherwise it is inactive NOTE: Digital output 2 must have been set to "PLC" using P1502
2	Relay Output 1 - If the input condition is True then Relay Output 1 (J3-25,26,27) will be active otherwise it is inactive NOTE: Relay output 1 must have been set to "PLC" using P1503
3	Reserved (Workbench - Fault)
4	Drive Enable/Disable - If the condition is True then the drive is capable of producing power. If the condition is False the drive is disabled. NOTE: If not programmed, J2-8 alone enables the drive NOTE: The drive's hardware enable input (J2-8) must be is active for this action.
5	Jog Reverse - If the condition is True then the motor will jog in the reverse direction at the speed set by P1201 if jogging is enabled. NOTE: If both jog forward and reverse are active the motor stops
6	Jog Forward - If the condition is True then the motor will jog in the forward direction at the speed set by P1201 if jogging is enabled. NOTE: If both jog forward and reverse are active the motor stops
7	Reserved (Workbench - Hold)
8	Stop Enable/Disable - If the input condition is True the motor is stopped.
9	Reserved (Workbench - Error Deceleration)
10	Reserved (Workbench - Cancel)
11	Reserved (Workbench - Disable)
12	Reserved (Workbench - Forced Abort)
13	Reserved (Workbench - Fast Gear)
18	Jog Enable - Allows jogging if True else jogging is disabled
19	Fault - If the input condition is True a "PLC Fault" is triggered. If using J2-16 to generate a PLC Fault Condition, P2201 must be set to "OFF" to avoid a conflict with external trip.
20	Forward Enable/Disable - If the input condition is True forward motion is enabled otherwise it is disabled.
21	Reverse Enable/Disable - If the input condition is True reverse motion is enabled otherwise it is disabled.
22	Acc/Dec Group Select - If the input condition is True then Acc/Dec group 2 is selected otherwise group 1 is selected. NOTE: If this action is not programmed Group 1 is active by default.
23	Reset - If the input condition is True a reset request is issued. NOTE: This action is edge triggered on a False to True transition. NOTE: Pre-existing faults/alarms may or may not be cleared.
24	Preset Speed/Analog - If the input condition is True then the Preset Speed Select Table Index sets the speed reference from the Preset Speeds (P1001-P1015) else the Command Source (P1402) selects the speed reference. NOTE: If this action is not programmed P1402 is always active. NOTE: If the Preset Speed Select Table Index is not programmed then P1001 is used.
25	Preset Speed Select Table Index Bit 0 - If the input condition is True then bit 0 of the Preset Speed Select Table Index is set else it is reset. NOTE: If this action is not programmed then bit 0 is reset.

Table 10-3: PLC Actions

Dec	Description
26	Preset Speed Select Table Index Bit 1 - If the input condition is True then bit 1 of the Preset Speed Select Table Index is set else it is reset. NOTE: If this action is not programmed then bit 1 is reset.
27	Preset Speed Select Table Index Bit 2 - If the input condition is True then bit 2 of the Preset Speed Select Table Index is set else it is reset. NOTE: If this action is not programmed then bit 2 is reset.
28	Preset Speed Select Table Index Bit 3 - If the input condition is True then bit 3 of the Preset Speed Select Table Index is set else it is reset. NOTE: If this action is not programmed then bit 3 is reset.
29	Process PID Enable/Disable - If the input condition is True then the Process PID is active otherwise it is inactive. NOTE: The Process PID is automatically set to inactive during keypad control or while jogging.
30	Keypad - If the input condition is True then forward/reverse and stop commands along with the keypad's local speed reference control the drive. The keypad is disabled by default.
31	Electronic Pot - If the input condition is True the Electronic Pot sets the speed reference otherwise it is not active. The pot is disabled by default.
32	Decrease Electronic Pot Speed Reference- If the input condition is True the Electronic Pot speed reference is increased else has no affect. NOTE: E-Pot is non-volatile NOTE: E-Pot is unipolar so direction is determined by forward/reverse commands.
33	Increase Electronic Pot Speed Reference- If the input condition is True the Electronic Pot speed reference is decreased else has no affect. NOTE: E-Pot is non-volatile NOTE: E-Pot is unipolar so direction is determined by forward/reverse commands.
34	Parameter Table Select Enable - If the input condition is True enables parameter table selection through the parameter table select index, else parameter table selection is disabled.
35	Parameter Table Select Index Bit 0 - If the input condition is True then bit 0 of the Parameter Table Select Index is set else it is reset. NOTE: If this action is not programmed then bit 0 is reset NOTE: This index sets the active parameter table
36	Parameter Table Select Index Bit 1 - If the input condition is True then bit 1 of the Parameter Table Select Index is set else it is reset. NOTE: If this action is not programmed then bit 1 is reset NOTE: This index sets the active parameter table
37	Relay Output 2 - If the input condition is True then Relay Output 2 (J3-28,29,30) will be active otherwise it is inactive NOTE: Relay Output 2 must have been set to "PLC" using P1504
38	Torque/Speed Mode - If the input condition is True then the drive controls torque else it controls speed. Default is speed control. NOTE: For V/F, torque control is not supported and is ignored.
39	Seed E-Pot - If the condition is true, the current speed reference is seeded into the E-Pot speed reference. Otherwise, it is not seeded. NOTE: E-Pot must not be the active speed reference for seeding to occur.
40	Logical Variable A - If the input condition is True then logical variable A is set else reset
41	Logical Variable B - If the input condition is True then logical variable B is set else reset
42	Logical Variable C - If the input condition is True then logical variable C is set else reset
43	Logical Variable D - If the input condition is True then logical variable D is set else reset
44	Logical Variable E - If the input condition is True then logical variable E is set else reset
45	Logical Variable F - If the input condition is True then logical variable F is set else reset

Table 10-3: PLC Actions

Dec	Description
46	Logical Variable G - If the input condition is True then logical variable G is set else reset
47	Logical Variable H - If the input condition is True then logical variable H is set else reset
48	Logical Variable I - If the input condition is True then logical variable I is set else reset
49	Logical Variable J - If the input condition is True then logical variable J is set else reset.
50	Start Timer A - If the input condition is True zero Timer A else count up to a timeout.
51	Stop Timer A - If the input condition is True, set Timer A= P3440 counts else do nothing.
52	Start Timer B - If the input condition is True, set Timer B= 0 else count up to a timeout.
53	Stop Timer B - If the input condition is True, set Timer B= P3441 counts else do nothing.
54	Start Timer C - If the input condition is True, set Timer C= 0 else count up to a timeout.
55	Stop Timer C - If the input condition is True, set Timer C= P3442 counts else do nothing.
56	Start Timer D - If the input condition is True, set Timer D= 0 else count up to a timeout.
57	Stop Timer C - If the input condition is True, set Timer D= P3443 counts else do nothing.
58	Pulse Start Timer A –If the input condition is True and timer A has expired then restarts timer A
59	Pulse Start Timer B –If the input condition is True and timer B has expired then restarts timer B
60	Pulse Start Timer C –If the input condition is True and timer C has expired then restarts timer C
61	Pulse Start Timer D –If the input condition is True and timer D has expired then restarts timer D
69	Reset PLC – If the input condition is True then a PLC reset is performed. All timers are expired and all logical variables are set to FALSE. Comparators are not affected.
70-99	Jump 0-29 – If the input condition is True then a jump from the current rung number to the specified rung number is performed. Skipped rungs are not executed. Only forward jumps are allowed. Jumps from high to lower rungs or jumps to the same rung number result in an error.
150	Heater – If the input condition is True then trickle current heating is enabled else it is disabled

Table 10-4: Preset Speed Select Index

PLC Actions					Description
Dec	Binary				
	28	27	26	25	
0	0	0	0	0	Preset Speed 1 (P1001)
1	0	0	0	1	Preset Speed 2 (P1002)
2	0	0	1	0	Preset Speed 3 (P1003)
3	0	0	1	1	Preset Speed 4 (P1004)
4	0	1	0	0	Preset Speed 5 (P1005)
5	0	1	0	1	Preset Speed 6 (P1006)
6	0	1	1	0	Preset Speed 7 (P1007)
7	0	1	1	1	Preset Speed 8 (P1008)
8	1	0	0	0	Preset Speed 9 (P1009)
9	1	0	0	1	Preset Speed 10 (P1010)
10	1	0	1	0	Preset Speed 11 (P1011)
11	1	0	1	1	Preset Speed 12 (P1012)
12	1	1	0	0	Preset Speed 13 (P1013)
13	1	1	0	1	Preset Speed 14 (P1014)
14	1	1	1	0	Preset Speed 15 (P1015)
15	1	1	1	1	Zero Speed (Not Defined)

Table 10-5: Parameter Table Select Index

PLC Actions			Description
Dec	Binary		
	36	35	
0	0	0	Parameter Table 1 (P52 set to T1)
1	0	1	Parameter Table 2 (P52 set to T2)
2	1	0	Parameter Table 3 (P52 set to T3)
3	1	1	Parameter Table 4 (P52 set to T4)

10.5 PLC Mode as Standard Run Two Wire

This example shows how the PLC Mode may operate as the Standard Run Two Wire Mode.

These parameter values are entered from the keypad.

Initialization:

Parameter	Value	Comment
P1401	PLC	PLC operating mode selected

PLC Mode configuration parameters:

Parameter Number	Parameter Dec Value	Byte 3 Condition	Byte 2 Logic	Byte 1 Condition	Byte 0 Action
P3401	050.000.000.020	Input 1 (50)	OR (0)	False (0)	Forward (20)
P3402	051.000.000.021	Input 2 (51)	OR (0)	False (0)	Reverse (21)
P3403	052.000.053.018	Input 3 (52)	OR (0)	Input 4 (53)	Jog Enable (18)
P3404	052.000.000.006	Input 3 (52)	OR (0)	False (0)	Jog Forward (6)
P3405	053.000.000.005	Input 4 (53)	OR (0)	False (0)	Jog Reverse (5)
P3406	054.000.000.022	Input 5 (54)	OR (0)	False (0)	Acc/Dec Group (22)
P3407	055.000.000.024	Input 6 (55)	OR (0)	False (0)	Presets/Analog (24)
P3408	056.000.000.023	Input 7 (56)	OR (0)	False (0)	Reset (23)
P3409	057.003.000.019	Input 8 (57)	NOR (3)	False (0)	Fault (19)

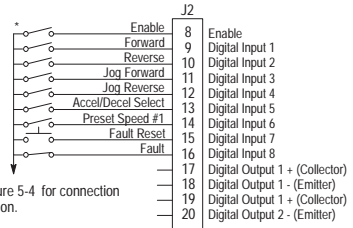
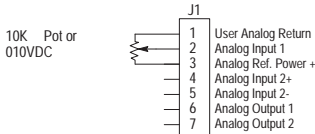

*Note: Remove factory jumper from J2-8 and J3-24 before connecting switch at J2-8.

See recommended tightening torques in table 4.2.

See Figure 5-4 for connection information.

The Parameter Dec Value column can be used when entering the PLC configuration parameters at the keypad (parameters are shown as decimal long values - byte3.byte2.byte1.byte0).

For this mode Enable is active.

Note that Preset Speed 1 is active so the Preset Speed Select Table Index need not be programmed since it automatically follows action 24 (Presets/Analog)

Jog is enabled anytime input 3 or 4 is on while these same inputs set the direction for jog.

The Fault action is programmed to trigger whenever digital input 8 goes low.

10.6 PLC Mode as 15 Preset Speed Mode

This example shows how the PLC Mode creates the 15 Preset Speed Mode.

Initialization:

Parameter	Value	Comment
P1401	PLC	PLC operating mode selected

PLC Mode configuration parameters:

Parameter Number	Parameter Dec Value	Byte 3 Condition	Byte 2 Logic	Byte 1 Condition	Byte 0 Action
P3401	050.000.000.020	Input 1 (50)	OR (0)	False (0)	Forward (20)
P3402	051.000.000.024	Input 2 (51)	OR (0)	False (0)	Reverse (21)
P3403	001.000.000.035	True (1)	OR (0)	False (0)	Presets/Analog (24)
P3404	052.000.000.025	Input 3 (52)	OR (0)	False (0)	Preset Tbl Bit 0 (25)
P3405	053.000.000.026	Input 4 (53)	OR (0)	False (0)	Preset Tbl Bit 1 (26)
P3406	054.000.000.027	Input 5 (54)	OR (0)	False (0)	Preset Tbl Bit 2 (27)
P3407	055.000.000.028	Input 6 (55)	OR (0)	False (0)	Preset Tbl Bit 3(28)
P3408	052.001.053.040	Input 3 (52)	AND (1)	Input 4 (53)	Variable A (40)
P3409	054.001.055.041	Input 5 (54)	AND (1)	Input 6 (55)	Variable B (41)
P3410	100.001.101.023	A (100)	AND (1)	B (101)	Reset (23)
P3411	056.000.000.022	Input 7 (56)	OR (0)	False (0)	Acc/Dec Group (22)
P3412	057.003.000.019	Input 8 (57)	NOR (3)	False (0)	Fault (19)

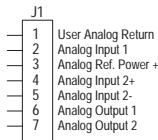

*Note: Remove factory jumper from J2-8 and J3-24 before connecting switch at J2-8.

See recommended tightening torques in table 4.2.

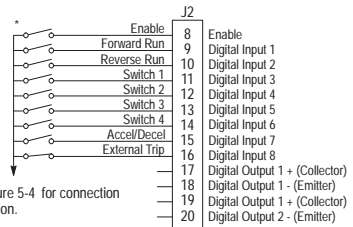

See Figure 5-4 for connection information.

The Parameter Dec Value column can be used when entering the PLC configuration parameters at the keypad (parameters are shown as decimal long values - byte3.byte2.byte1.byte0).

For this mode Enable is active.

Note that Preset Speed 1 is active so the Preset Speed Select Table Index need not be programmed since it automatically follows action 24 (Presets/Analog).

Jog is enabled anytime input 3 or 4 is on while these same inputs set the direction for jog.

The Fault action is programmed to trigger whenever digital input 8 goes low.

10.7 PLC Mode as Process PID Mode

This example shows how the PLC Mode rendered as the Process PID Mode.

Initialization:

Parameter	Value	Comment
P1401	PLC	PLC operating mode selected

PLC Mode configuration parameters:

Parameter Number	Parameter Dec Value	Byte 3 Condition	Byte 2 Logic	Byte 1 Condition	Byte 0 Action
P3401	050.000.000.020	Input 1 (50)	OR (0)	False (0)	Forward (20)
P3402	051.000.000.021	Input 2 (51)	OR (0)	False (0)	Reverse (21)
P3403	001.000.000.034	True (1)	OR (0)	False (0)	Param Table Select (34)
P3404	052.000.000.035	Input 3 (52)	OR (0)	False (0)	Table Select Bit 0 (35)
P3405	053.000.000.038	Input 4 (53)	OR (0)	False (0)	Torque/Speed (38)
P3406	054.000.000.029	Input 5 (54)	OR (0)	False (0)	PID (29)
P3407	055.000.000.018	Input 6 (55)	OR (0)	False (0)	Jog Enable (18)
P3408	055.000.000.006	Input 6 (55)	OR (0)	False (0)	Jog Forward (6)
P3409	056.000.000.023	Input 7 (56)	OR (0)	False (0)	Reset (23)
P3410	057.003.000.019	Input 8 (57)	NOR (3)	False (0)	Fault (19)

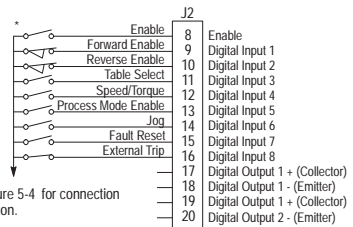
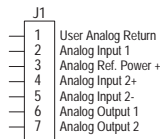

*Note: Remove factory jumper from J2-8 and J3-24 before connecting switch at J2-8.

See recommended tightening torques in table 4.2.

See Figure 5-4 for connection information.

The Parameter Dec Value column can be used when entering the PLC configuration parameters at the keypad (parameters are shown as decimal long values - byte3.byte2.byte1.byte0).

For this mode Enable is active.

The unconditional True statement P3403 enables parameter table select (Table 10-5) at all times.

The Fault action is programmed to trigger whenever digital input 8 goes low.

10.8 PLC Mode as a Modified Process PID Mode

This example shows how the PLC Mode as a modified Process PID Mode.

Initialization:

Parameter	Value	Comment
P1401	PLC	PLC operating mode selected
P1501	PLC	Digital Output 1 Set by PLC Mode Logic
P3431	10	Comparator A monitors absolute speed demand (P10)
P3432	20%	Comparator A's constant (12 Hz for 60 Hz max)
P3440	3.00 sec	Timer A set for 3 seconds

PLC Mode configuration parameters:

Parameter Number	Parameter Dec Value	Byte 3 Condition	Byte 2 Logic	Byte 1 Condition	Byte 0 Action
P3401	076.000.000.040	Comp A (76)	OR (0)	False (0)	A (40)
P3402	050.000.000.020	Input 1 (50)	OR (0)	False (0)	Forward (20)
P3403	051.000.000.021	Input 2 (51)	OR (0)	False (0)	Reverse (21)
P3404	100.000.000.038	A (100)	OR (0)	False (0)	Torque/Speed (38)
P3405	053.002.100.029	Input 4 (53)	XOR (2)	A (100)	PID (29)
P3406	054.000.055.018	Input 5 (54)	OR (0)	Input 6 (55)	Jog Enable (18)
P3407	054.000.000.006	Input 5 (54)	OR (0)	False (0)	Jog Forward (6)
P3408	055.000.000.005	Input 6 (55)	OR (0)	False (0)	Jog Reverse (5)
P3409	056.000.000.023	Input 7 (56)	OR (0)	False (0)	Reset (23)
P3410	057.000.000.050	Input 8 (57)	OR (0)	False (0)	Start Timer (50)
P3411	086.000.000.019	Timer A (86)	OR (0)	False (0)	Fault (19)

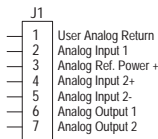

*Note: Remove factory jumper from J2-8 and J3-24 before connecting switch at J2-8.
See recommended tightening torques in table 4.2.

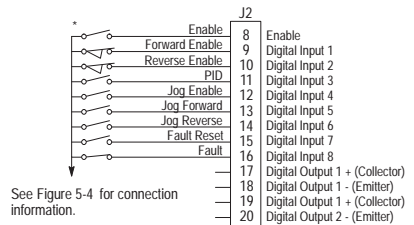

The Parameter Dec Value column can be used when entering the PLC configuration parameters at the keypad (parameters are shown as decimal long values - byte3.byte2.byte1.byte0).

For this mode Enable is active.

Use of logical variables A, B, C or D allows for complex PLC logic.

Variable "A" is set based on the outcome of a comparator and then used as an input condition for the torque/speed select and PID actions.

Note that P3401 is programmed to set logical variable "A" before it is used since statements are executed in order from P3401 through P3410.

Either input 5 or 6 enable jog and they also set jog direction as in P3407 and P3408.

Speed mode is active above 12 Hz but torque mode is active when less than 12Hz.

The PID becomes active above 12 Hz if input 4 is ON.

The PID becomes active at less than 12 Hz when input 4 is OFF.

The Fault action is programmed to trigger after a three second delay following digital input 8 going low.

Timer A is used to implement this action.

Normally P3410 continuously resets Timer A when digital input 8 is high.

If digital input 8 goes low then high in less than three seconds no fault action occurs since Timer A is reset before it has a chance to timeout.

If digital input 8 goes low and stays low for at least 3 seconds then Timer A does timeout and a fault occurs.

Chapter 11

Composite Reference Description

11.1 Overview

This reference is mathematically computed from any two valid drive parameters. Once configured, it can provide a signal to drive the speed loop, torque loop or process PID. In addition, this reference can drive all existing operating modes including the PLC Mode. Composite Ref can be referenced to any valid input:

P1402 - Command Source P2310 - Auxiliary Filter Source P1415 - Current Limit Source
 P2603 - Process PID Feedback Source P1418 -Torque Feedforward Source P2604 - Process PID Setpoint Source

Mathematical operations are performed at each stage in its development providing the ability to add, subtract, multiply or divide any two parameters to form a complex internal reference source. This reference source can influence the operation of all existing operating modes including PLC Mode. The Composite Reference Parameter Block is programmed in the Level 3, Composite REF parameters.

Figure 11-1: Composite Reference Generator Block Diagram

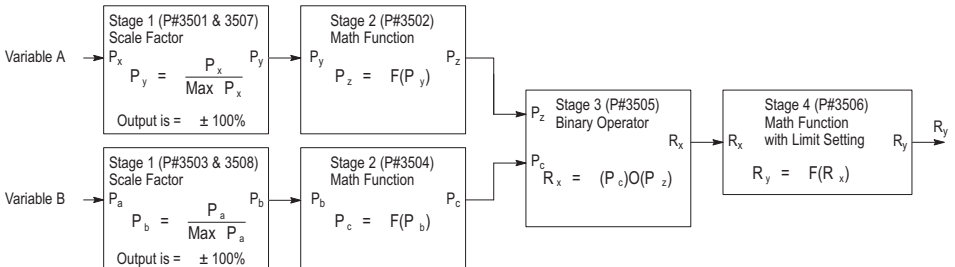

Table 11-1: Math Functions (P#3506)

ID	Function	Description	Notes
0	0	Zero ¹	1. Zero Function, $F(x) = 0$
1	X	Identity ²	2. Identity Function, $F(x) = x$
2	X	Absolute Value ³	3. Where, x is the absolute value function: $ x = x$ for $x \geq 0$
3	1/X	Inversion	$ x = -x$ for $x < 0$
4	X ²	Square	4. The ramp generator is computed as follows: $0.0 \rightarrow 1.0$ for $x > 0$
5	$\sqrt{(X)}$	Square Root ³	Constant output for $x = 0$ $0.0 \rightarrow 1.0$ for $x < 0$
6	Sin(x)	Sine	With time period equal to $1.0/(x \cdot 100)$ Sec
7	Cos(x)	Cosine	
8	Ramp(x)	Ramp Generator ⁴	5. The frequency generator is computed as follows: $y = \text{Ramp}(x)$ $\text{Freq}(x) = \text{Sin}(2\pi y)$ With output frequency equal to $ x \cdot 100$ Hz
9	Freq(x)	Frequency Generator ⁵	

Table 11-2: Binary Operator Selection Parameter (P#3505)

ID	Function	Description	Notes
0	+	Sum	1. Y = Max(x, y) provides the maximum 2. Y = Min(x, y) provides the minimum
1	-	Difference	
2	•	Multiply	
3	/	Divide	
4	Max	Maximum ¹	
5	Min	Minimum ²	

Table 11-3: Composite Reference Parameters

Stage #	P#	Description
1	3501 & 3503	<p>Scale Factor - Monitor a parameter number (Variable A or B) and scales the value into percentage of maximum value for use by the next stage. As an example, P3501=5 Motor Voltage (assume its maximum is 230V) is monitored and internally 20% is computed for P5= 46 V or 10% for P5=23 V. Likewise, with P3503=11 then Speed Demand (assume its maximum is 60 Hz) is monitored and 50% is output when P11=30 Hz or -50% when P11= -30 Hz.</p> <p>P3501 or P3503 can be can be set to any valid drive parameter number. If either is set to an invalid parameter number Py=0% or Pb=0%.</p> <p>P3501 or P3503 only point to a valid parameter number in the active parameter table, never a parameter outside the active table. Switching parameter tables with the drive enabled causes the Composite Reference to be redefined by the parameter values in the new active parameter table.</p>
2 & 4	3502, 3504 & 3506	Math Function - These parameters select the mathematical functions to be applied at the second and fourth stage of the Composite Reference's derivation. Refer to Table 11-1 .
3	3505	Optional Operator - This parameter provides the mathematical operation to be performed at the third stage of the Composite Reference derivation. Refer to Table 11-2 .
1	3507 & 3508	<p>These parameters provide a way to scale up or down the percentage calculation of the first stage. They range from -1000.00 to 1000.00 with default 1.00. Normally, the defaults work so these parameters need not be changed.</p> <p>A simple example of their use is: A 5A motor is connected to a 15A (peak) drive. When the motor is at rated amps only 5/15 or 33.3% is passed on to stage 2, but by setting P3507=3.00, 100% is passed on allowing full use of the motor's current.</p>

11.2 Composite Reference Examples

The following table gives examples of the kinds of Composite References that may be developed.

Table 11-4: Examples

Composite Reference Parameters								Description
P3501	P3503	P3503	P3504	P3505	P3506	P3507	P3508	
P103	Identity	P104	Identity	Sum	Identity	0.5	0.5	Average of Analog Inputs 1&2: $Ry = (A_1+A_2)/2$
P103	Identity	P104	Freq	Multiply	Identity	1.0	1.0	Signal Generator with Magnitude set by A ₁ and Frequency by A ₂ : $Ry = A_1 \times \text{Freq}(A_2)$
P103	Identity	P104	Identity	Divide	Identity	1.0	1.0	Ratio of Analog Inputs 1&2: $Ry = A_1/A_2$
P102	Square	P104	Square	Difference	Square Root	1.0	1.0	Square Root of Difference of Squares of Process Error and Analog2: $Ry = \sqrt{(P_e ^2 - A_2^2)}$

Chapter 12

Monitor and RTC Description

12.1 Monitor Parameters (P0001 to P0818)

Monitor parameters can be viewed using the WorkBench software. Most are read only (P0001) but some (P0052) can be written as well.

Table 12-1: Monitor Parameters Descriptions

P#	Type	Name	Unit	Help
1		SOFTWARE VERSION		Software Version. - Drive firmware version number
2		LOC/REM STATUS		Local/Remote Status. - Source of run/stop commands. Local for keypad or Remote for terminal block
3		DRIVE STATUS		Drive Enable Status. - 0 for disabled, 1 for enabled
4		MOTION STATUS		Motion Status. - Status: stopped, forward, reverse, bipolar, sleep, homing, etc.
5		MOTOR VOLTS	V	Motor Volts. - Estimated line-to-line drive output RMS voltage
6		MOTOR CURRENT	A	Motor Current. - Measured motor RMS current
7		MOTOR ABS SPEED	RPM	Motor Absolute Speed. - Estimated or measured absolute rotor speed
8		POSITION COUNTER	CNT	Position Counter. - Accumulated count in revolutions and counts. Units: encoder counts
9		SPEED REF	Hz	Speed Reference. - Setpoint speed for motor. Command source parameter determines the source
10		ABS SPEED DEMAND	Hz	Absolute Speed Demand. - Absolute speed output from Speed Profiler.
11		SPEED DEMAND	Hz	Speed Demand. - Signed speed output from Speed Profiler
12		ABS MOTOR FREQ	Hz	Absolute Motor Frequency. - Estimated motor electrical frequency
13		MOTOR FREQ	Hz	Motor Frequency. - Signed motor frequency
14		DRIVE TEMP	°C	Drive Temperature. - Measured temperature of drive heat sink
15		BUS VOLTAGE	V	Bus Voltage. - Measured bus voltage. DC bus high fault occurs above 400/820V DC
16		OVERLOAD LEFT	%	Overload Remaining. - Current overload count remaining until overload fault/foldback occurs
17		INPUTS		Digital Inputs. - State of terminal block digital inputs. Off/On indicated by 0/1
18		OUTPUTS		Digital Outputs. - State of the terminal block digital/relay outputs. Off/On indicated by 0/1
19		RATED HP	HP	Rated Horsepower. - Drive rated horsepower
20		RATED CURRENT	A	Rated Current. - Nominal/derated drive continuous RMS current rating
21		RATED PK CURRENT	A	Rated Peak Current. - Nominal/de-rated drive peak, short term, current rating
22		RATED VOLTS	V	Rated Voltage. - Nominal voltage rating of drive
23		ACTIVE FAULTS		Active Faults. - Number of active / simultaneous drive faults
24		ACTIVE FLT CODE		Active Fault Code. - Currently active drive fault code number
25		PROC FEEDFORWARD	%	FF Process Feedforward. - Process PID feed forward signal
26		PROC SETPOINT	%	SP Process Setpoint. - Process PID set point signal
27		PROC FEEDBACK	%	FB Process Feedback. - Process PID feedback signal
28		ADC USER REF	V	ADC User Reference. - Hardware ADC reference voltage for analog inputs
29		ADC CURR REF	V	ADC Current Reference. - Hardware ADC reference voltage for currents
30		USER 24V	V	User 24V. - Measured, internally supplied 24V for I/O
31		MOTOR TORQUE	NM	Motor Torque. - Estimated motor torque from measured currents and motor model

Table 12-1: Monitor Parameters Descriptions

P#	Type	Name	Unit	Help
32		AUTO-TUNE PROG	%	Auto-Tune Progress. - Estimated progress of auto-tune test
33		LINE VOLTAGE		Line Voltage. - Estimated drive input line-to-line RMS voltage
34		RATED A/V	V	Rated Amps/Volt. - Nominal drive current scaling set at the factory
35		MOTOR POLES		Motor Poles. - Calculated /entered number of motor poles
36		RUN TIMER	HR	Run Timer. - Accumulated drive run (non-idle) time in hours
37		ACTIVE ALARMS		Active Alarms. - Number of currently active /simultaneous alarms
38		ACT ALARM CODE		Active Alarm Code. - Currently active alarm code
39		ANA IN1	V	Analog Input 1. - Measured value of analog input #1 on terminal input J1-2 and J1-1
40		ANA IN2	V	Analog Input 2. - Measured value of analog input #2 on terminal input J1-4 and J1-5
41		ANA OUT1	V	Analog Output 1. - Estimated value of analog output #1 on terminal J1-6
42		ANA OUT2	V	Analog Output 2. - Estimated value of analog output #2 on terminal J1-7
43		OPTION1		Option 1. - Option board detected in option slot #1 (left slot)
44		OPTION2		Option 2. - Option board detected in option slot #2 (right slot)
45		FEEDBACK		Feedback. - Feedback board detected in motor feedback board slot
46		DATE AND TIME		Current Date and Time. - Real time clock current reading
47		DST STATUS		DST Status. - Daylight Saving Time status: 0=Not Active 1=Active
48		MOTOR OVERLOAD REMAINING	%	Current overload count remaining until a motor overload fault/overload occurs
49		LAST MOTOR OVERLOAD REMAINING	%	Last reading of motor overload left before power down
50		LAST DRIVE OVERLOAD REMAINING	%	Last reading of drive overload left before power down
51		Speed Measured	RPM	Displays measured speed from encoder or resolver even if control type is V/F or open vector
52		ACTIVE PARAM TBL		Active Parameter Table. - Parameter table currently in use on the drive
53		EE VER		Power Base EEPROM Rev. - Power base EEPROM parameter revision number. Set by factory
54		FPGA VER		Power Base FPGA Rev. - Power base FPGA revision control number. Set by factory
55		ACC/DEC DEMAND	Hz/SEC	Accel/Decel Demand. - Current ramp rate used by the velocity profiler
56		ID CURRENT		ID Current. - D axis measured current proportional to motor flux
57		ID DEMAND	A	ID Demand. - D axis demand current proportional to motor flux
58		IQ CURRENT	A	IQ Current. - Q axis measured current proportional to motor torque
59		IQ DEMAND	A	IQ Demand. - Q demand current proportional to motor torque
60		POWER FACTOR		Power Factor. - Ratio of (real power)/(apparent power)
61		PHASE 1 CURRENT	A	Phase 1(U) Current. - Phase U current
62		PHASE 2 CURRENT	A	Phase 2(V) Current. - Phase V current
63		PHASE 3 CURRENT	A	Phase 3(W) Current. - Phase W current
64		VD DEMAND	V	VD Demand. - D axis voltage demand for setting up motor flux
65		VQ DEMAND	V	VQ Demand. - Q axis voltage demand for setting up motor torque

Table 12-1: Monitor Parameters Descriptions

P#	Type	Name	Unit	Help
66		ELECTRICAL ANGLE	°	Electrical Angle. - Electrical angle used to develop phased voltages to the motor
67		MOTOR SPEED	RPM	Motor Speed. - Current speed of the motor
68		AT TEST DESC		Autotune Test Description. - Description of current autotuning state
69	R/W	APP LAYER ERROR		Application Layer Error. Application layer error code number. The last error that occurred
70		USB TRANSACTIONS		USB Transactions. Total number of USB transactions since start up
71		USB ERRORS		USB Errors. Total number of USB errors since start up
72		TSK STATUS		Task Status. Runtime task overrun status. Bits correspond to tasks that have overrun their time limit
73		TSK ID		Task ID. First task that overran its time slot
74		TSK COUNT		Task Count. Total number of overruns for the first task to overrun its time slot
75		Kp PACKETS		Keypad Packets. Total number of processed keypad packets
76		Kp T-GAPS		Keypad Gaps. Total number of keypad inter-packet time gap errors
77		Kp NAKs		Keypad NAKs. Total number of NAKs sent. High word are received NAKs low word is transmitted NAKs
78		EST POWER	kW	Estimated Power. - Drive power output estimated from measured current and voltages. Units: KW
79		EST ENERGY	kWH	Estimated Energy. - Delivered by drive. Estimated from measured current and voltages. Units: kWH
80		EST COST	\$	Estimated Cost. - Cost of output energy delivered. Estimated from cost of kWH unit parameter
81	R/W	ACCESS KEY		Access Key. - Parameter security access key. Contact Baldor to decode the key code
82	R/W	KEYPAD SOFT VER		Keypad Software Version. - Keypad software version string
83		AUTOTUNE TEST RE		Autotune test result. Use keypad back/forward keys to review results on the keypad
84		AUTOTUNE TEST RE		Autotune test result. Use keypad back/forward keys to review results on the keypad
85		CMD TYPE		Command Type. Operating mode input signal command type
86		FPGA READ ERRORS		FPGA Read Errors. Number of reads Errors when reading FPGA since start up
87		FPGA WRITE ERROR		FPGA Write Errors. Number of writes Errors when writing to FPGA since start up
88		FPGA ALARM REG		FPGA Alarm Register. Alarm Latch Alarm Status of Powerbase FPGA
89		REFRESH REQUEST		Refresh Request. - Refresh parameter list request from drive to host
90		PHASE 1 VOLTAGE	V	Phase 1(U) Voltage. - Phase U RMS voltage
91		PHASE 2 VOLTAGE	V	Phase 2(V) Voltage. - Phase V RMS voltage
92		PHASE 3 VOLTAGE	V	Phase 3(W) Voltage. - Phase W RMS voltage
93		CUSTOM UNITS	CUSTOM	Custom Units. - Shows production rates according to custom units.
94		POS REFERENCE	CNT	Position Reference. - Position Profiler's Current Target Position.
95		POS DEMAND	CNT	Position Demand. - Position Profiler's Current Position Demand.
96		POS ERROR	CNT	Position Following Error. - Difference Between Position Demand and Rotor Position.
97		POS COUNTER	CNT	Position Counter. - Actual 32-bit position of the encoder.
98		LV TEST FEEDBACK		LV test feedback. - Gives feedback on state of test
99		LV TEST FE STATE		Front End State. -Gives feedback on state of front end
100		ID		Power Base ID. - Power Base ID Number. Set by factory

Table 12-1: Monitor Parameters Descriptions

P#	Type	Name	Unit	Help
101		AUTOTUNE TEST ST		Autotune Test State. - Gives feedback on state of Autotune
102		PROC ERROR	%	ER Process Error. - Process PID error signal
103		ANA1 REF	%	Analog Input 1 Reference. - Reference generated from analog input 1
104		ANA2 REF	%	Analog Input 2 Reference. - Reference generated from analog input 2
105		COMPOSITE REF	%	Composite Reference. - Reference generated composite reference parameter block.
106		POS MOVE STATUS		Position Move Status. - 15 Preset Position Mode status. 0x0=inactive, 0x1-0xF=active, 0x101-0x10F=complete
107	R/W	RTC EDGE COUNTER		RTC Edge Counter. - General purpose date/time edge counter used in Real Time Clock Features.
108	R/W	RTC OUTPUTS		RTC Virtual Outputs. - Outputs set by the RTC and mapped to real outputs if enabled.
109	R/W	RTC MSG STATUS		RTC Message Status. - Individual bits are mapped to RTC message when set
110		LAST POWERDOWN		Last Drive Power Down Date. - The date and time the drive was last turned off.
111		COMPONENT A	%	Component A of Composite Reference. - First part of the composite reference signal.
112		COMPONENT B	%	Component B of Composite Reference. - First part of the composite reference signal.
113	R/W	PLC TIMER A		PLC Mode Timer A Counter. - General purpose timer/counter in 10ms clock ticks.
114	R/W	PLC TIMER B		PLC Mode Timer B Counter. - General purpose timer/counter in 10ms clock ticks.
115		ENC POS FB SPEED	%	Speed reference set by Pulse Follower EXB.
116		MACRO STATUS		ID number of last executed macro (none if no macros have been executed).
117	R/W	PLC Timer C		PLC Mode Timer C Counter- General purpose timer/counter in 10ms clock ticks.
118	R/W	PLC Timer D		PLC Mode Timer D Counter - General purpose timer/counter in 10ms clock ticks.
201		LOC SPEED REF	Hz	Local Speed Reference. - Local speed reference from keypad. Reference can be entered in Hz or RPM
202		E-POT SPEED REF	Hz	E-Pot Speed Ref. - Electronic pot speed reference
301		FAULT LOG TIME		Fault Log Time. Time stamp for fault log entries
302		FAULT LOG MSG		Fault Log Message.
501		COUNTS	CNT	Counts. Accumulated position in encoder pulses per revolution
502		REVOLUTIONS	REV	Revolutions. Accumulated revolutions since power up. Encoder PPR parameter sets the revolution count
503		OPT1 ANA IN1	V	Option 1 Analog Input 1. Option board 1 analog input 1
504		OPT1 ANA IN2	V	Option 1 Analog Input 2. Option board 1 analog input 2
505		OPT2 ANA IN1	V	Option 2 Analog Input 1. Option board 2 analog input 1
506		OPT2 ANA IN2	V	Option 2 Analog Input 2. Option board 2 analog input 2
507		OPT1 ANA OUT1	V	Option 1 Analog Output 1. Option board 1 analog output 1
508		OPT1 ANA OUT2	V	Option Board 1 Analog Output 2. Option 1 analog output 2
509		OPT2 ANA OUT1	V	Option 2 Analog Output 1. Option board 2 analog output 1
510		OPT2 ANA OUT2	V	Option 2 Analog Output 2. Option board 2 analog output 2
511		TX CNTS	CNT	PF Tx Counts. PF transmitted accumulated position in encoder pulses per revolution
512		TX REVS		PF Tx Revolutions. PF transmitted accumulated revolutions since power up. Encoder PPR parameter sets the revolution count
513		RX CNTS	CNT	PF Rx Counts. PF received accumulated position in encoder pulses per revolution

Table 12-1: Monitor Parameters Descriptions

P#	Type	Name	Unit	Help
514		RX REVS		PF Rx Revolutions. PF received accumulated revolutions since power up. Encoder PPR parameter sets the revolution count
515		OPT1 CONFIG1		Option Card 1 Configuration Word 1. Slot 1 option card's general purpose config data from its EE
516		OPT1 CONFIG2		Option Card 1 Configuration Word 2. Slot 1 option card's general purpose config data from its EE
517		OPT1 CONFIG3		Option Card 1 Configuration Word 3. Slot 1 option card's general purpose config data from its EE
518		OPT1 CONFIG4		Option Card 1 Configuration Word 4. Slot 1 option card's general purpose config data from its EE
519		OPT2 CONFIG1		Option Card 2 Configuration Word 1. Slot 2 option card's general purpose config data from its EE
520		OPT2 CONFIG2		Option Card 2 Configuration Word 2. Slot 2 option card's general purpose config data from its EE
521		OPT2 CONFIG3		Option Card 2 Configuration Word 3. Slot 2 option card's general purpose config data from its EE
522		OPT2 CONFIG4		Option Card 2 Configuration Word 4. Slot 2 option card's general purpose config data from its EE
530		OPT1 FIRMWARE		Option Card 1 Firmware Version. Option card 1 firmware version string
531		OPT2 FIRMWARE		Option Card 2 Firmware Version. Option card 2 firmware version string
532		OPT1 CONFIG		Option Card 1 Configuration Status. Slot 1 option card's configuration status
533		OPT2 CONFIG		Option Card 2 Configuration Status. Slot 2 option card's configuration status
534		OPT1 RUN STATUS		Option Card 1 Runtime Status. Slot 1 option card's run time status
535		OPT2 RUN STATUS		Option Card 2 Runtime Status. Slot 2 option card's run time status
536		OPT1 ANA1 REF	%	Option Card 1 Analog Input 1 Reference. Reference generated from analog input 1 on option card 1
537		OPT1 ANA2 REF	%	Option Card 1 Analog Input 2 Reference. Reference generated from analog input 2 on option card 1
538		OPT2 ANA1 REF	%	Option Card 2 Analog Input 1 Reference. Reference generated from analog input 1 on option card 2
539		OPT2 ANA2 REF	%	Option Card 2 Analog Input 2 Reference. Reference generated from analog input 2 on option card 2
801		FAULT LATCH		Fault Latch. Fault trace signal: powerbase fault active high latch
802		ALARM LATCH		Alarm Latch. Fault trace signal: powerbase alarm active high latch
803		ADC CURRENT REF	V	ADC Current Reference. Fault trace signal: ADC 1.5V current reference
804		24V REF	V	24V Reference. Fault trace signal: 24v reference
807		USER INPUTS		User Digital Inputs. Fault trace signal: user digital inputs
806		DIGITAL OUTPUTS		Digital Outputs. Fault trace signal: all digital outputs
807		ANA INPUT 1	V	Analog Input 1. Fault trace signal: analog input 1
808		ANA INPUT 2	V	Analog Input 2. Fault trace signal: analog input 2
809		SPEED REF	Hz	Speed Reference. Fault trace signal: speed reference
810		PH1 CURRENT	A	Phase 1(U) Current. Fault trace signal: motor phase 1 current
811		PH2 CURRENT	A	Phase 2(V) Current. Fault trace signal: motor phase 2 current

Table 12-1: Monitor Parameters Descriptions

P#	Type	Name	Unit	Help
812		PH3 CURRENT	A	Phase 3(W) Current. Fault trace signal: motor phase 3 current
813		MOTOR CURRENT	A	Motor Current. Fault trace signal: motor instantaneous RMS current
814		MOTOR TORQUE	NM	Motor Torque. Fault trace signal: motor instantaneous torque
815		MOTOR VOLTS	V	Motor Voltage. Fault trace signal: instantaneous voltage to motor
816		MOTOR SPEED	RPM	Motor Speed. Fault trace signal: motor instantaneous rotor speed
817		BUS VOLTAGE	V	Bus Voltage. Fault trace signal: instantaneous bus voltage
818		DRIVE TEMP	°C	Drive Temperature. Fault trace signal: drive temperature

12.2 Real Time Clock (RTC) Overview

Action Module

Action Module parameters P3601 - 3602 set the actions to be scheduled. Action 2 takes priority over action 1 should both be scheduled to trigger within the same second. So, if action 1 turns on output 1 and action 2 turns off output 1 and they both trigger on the same seconds tick, then output 1 will appear as though to never turn on.

As a rule, once an action is taken it is latched until it is reset by another action.

Action Module selections are shown in Table 12-2 .

Figure 12-1: RTC Features

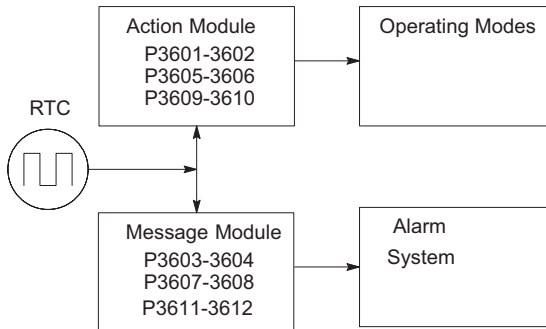

Table 12-2: Actions (P3601 & 3602)

ID	ACTION	DESCRIPTION
0	None	No action assigned. Default setting.
1	Digital Output 1 On	Digital output 1 is turned on. P1501 set to RTC.
2	Digital Output 1 Off	Digital output 1 is turned off. P1501 set to RTC
3	Digital Output 2 On	Digital output 2 is turned on. P1502 set to RTC
4	Digital Output 2 Off	Digital output 2 is turned off. P1502 set to RTC
5	Relay Output 1 On	Relay output 1 is turned on. P1503 set to RTC
6	Relay Output 1 Off	Relay output 1 is turned off. P1503 set to RTC
7	Relay Output 2 On	Relay output 2 is turned on. P1504 set to RTC

Table 12-2: Actions (P3601 & 3602) (Continued)

ID	ACTION	DESCRIPTION
8	Relay Output 2 Off	Relay output 2 is turned off. P1504 set to RTC
9	Increment P107	Increments the RTC counter parameter
10	Decrement P107	Decrements the RTC counter parameter
11	Reset P107	Resets the RTC counter parameter
12	Digital Output 1 On with Inc	Performs digital I/O with P107 increment
13	Digital Output 1 Off with Inc	Performs digital I/O with P107 increment
14	Digital Output 1 On with Dec	Performs digital I/O with P107 decrement
15	Digital Output 1 Off with Dec	Performs digital I/O with P107 decrement
16	Digital Output 1 On with Reset	Performs digital I/O with P107 reset
17	Digital Output 1 Off with Reset	Performs digital I/O with P107 reset
18	Relay Output 1 On with Inc	Performs digital I/O with P107 increment
19	Relay Output 1 Off with Inc	Performs digital IO with P107 increment
20	Relay Output 1 On with Dec	Performs digital IO with P107 decrement
21	Relay Output 1 Off with Dec	Performs digital IO with P107 decrement
22	Relay Output 1 On with Reset	Performs digital IO with P107 reset
23	Relay Output 1 Off with Reset	Performs digital IO with P107 reset

Level 1, Output Setup Block parameters P1501-P1504 select the digital/relay output functions. P107 is the RTC counter parameter.

Message Module (P3603 - 3604)

Message Module parameters P3603 - 3604 set the messages to be scheduled. Message selections are shown in Table 12-3 .

Table 12-3 RTC Message 1&2 Parameters (P3603 & P3604)

ID	MESSAGE	HELP TEXT
0	None (default)	No message active
1	Clean Filter(s)	Time to do periodic cleaning of filter(s)
2	Change Filter(s)	Time to change out the filter(s)
3	Apply Oil/Lubricate	Apply oil and/or lubricant necessary areas of the system
4	Service Motor	Check motor cables, encoder, clean motor etc.
5	Service Drive	Check drive cables, clean panels and keypad display etc.
6	Service Coolant System	Check coolant pressures/levels, check for leaks, top off as needed
7	Service Heating System	Check for gas leaks, clean filters, blowers and connections
8	RTC Alarm	Generic real-time clock alarm

RTC Action/Message Qualifier Parameters (P3605-P3608)

Qualifier parameters shown in Table 12-4 set the interval of time of the actions and messages selected.

Table 12-4 Action/Message Qualifier Parameters (P3605 – P3608)

ID	QUALIFIERS	DESCRIPTION
0	Once	Action/Message is scheduled once to occur on the date and time entered.
1	Second	Action/Message is scheduled every second. Starting on the date and time entered and repeated every second thereafter.
2	Minute	Action/Message is scheduled every minute. Starting on the date and time entered and repeated every minute thereafter at the same seconds into the minute specified in the start date and time.
3	Hourly	Action/Message is scheduled hourly. Starting on the date and time entered and repeated every hour thereafter at the same minutes and seconds into the hour as specified in the start date and time.
4	Daily	Action/Message is scheduled Daily. Starting on the date and time entered and repeated every day thereafter at the same hour, minutes and seconds specified in the start date and time. If the day specified does not exist for that month the action/message is skipped.
5	Monthly	Action/Message is scheduled monthly. Starting on the date and time entered and repeated every month thereafter on the same day, hour, minutes and seconds specified in the start date and time.
6	Yearly	Action/Message is scheduled yearly. Starting on the date and time entered and repeated every year thereafter on the same month, day, hour, minutes and seconds in the start date and time.

RTC Schedule Date Parameters (P3609-P3612)

To each action and message there is an associated start date and time. For Action 1 (P3609) is used; for Action 2 (P3610) and for Messages 1 & 2 (P3611 and P3612) are used respectively. The internal date and time parameter format is shown in Table 12-5 .

Table 12-5 Date and Time Format (P0046)

Bits	31	30	29	28	27	26	25	24	23	22	21	20	19	18	17	16	15	14	13	12	11	10	9	8	7	6	5	4	3	2	1	0
Fields	Year (00–63)						Month (1-12)			Day (1-31)			Hour Bit 5	Hour Bits 4-0 (0-23)			Minutes (0-59)					Seconds (0-59)										

RTC Counter and Maximum Count Parameters (P107 and P3630)

Monitor parameter P107 is a general purpose RTC Counter that can be assigned as the target of a RTC action. This parameter may be incremented, decremented or reset by RTC actions.

Parameter number P3630 sets the maximum for P107, so that: $-P3630 \leq P107 \leq P3630$.

The comparators A&B of the PLC Operating Mode along with the Composite Reference make use of the maximum setting of a parameter for internal scaling of their operations.

RTC Daylight Saving Time Parameter (P3631)

P3631 has three settings: OFF, U.S.A (United States of America) and E.U. (European Union).

Setting it to OFF disables the DST Feature. Setting it to USA enable Daylight Saving Time for US customers. Setting it to EU enables Daylight Saving Time for Europe based countries.

Power Cycles and RTC Edit Changes

The RTC acts like an alarm clock during power cycles, edit changes and DST (Daylight Saving Time) updates. After power up, even though an action/message would have occurred during the power down period no action/message is issued, that action/message is lost. The next regularly scheduled action/message will trigger on the next regularly occurring clock edge after power up. Likewise if the RTC is advanced by some time-offset due to editing or DST action/messages may be lost. For example, digital output 1 is scheduled to turn on at 1:00 PM daily. At 12:15:00 PM the clock is changed to 1:15:00 PM advancing it an hour.

The output will not turn on that day since its triggering edge never occurs. On the other hand, if the clock is receded by one hour, that is, changed at 1:30:00 PM to 12:30:00 PM then two triggers for digital output 1 on will have been generated that day since the RTC will have passed through 1:00 PM twice. Furthermore, if an active RTC message is not acknowledged by an operator and power is cycled that message persists after the cycle. The operator must acknowledge an RTC message even if power is cycled. The same is NOT true for outputs. RTC controlled digital outputs and relays are reset at power up.

RTC Scheduling Examples

The following table gives examples of the kinds scheduled events that may be programmed.

Table 12-6 Scheduled Events Examples

	Action 1	Action 2	Message 1	Message 2
P3601	Digital Out 1 ON			
P3602		Digital Out 1 OFF		
P3603			Change Filters	
P3604				Service Heating System
P3605	Daily			
P3606		Daily		
P3607			Monthly	
P3608				Yearly
P3609	3-Feb-07 01:00:00			
P3610		3-Feb-07 02:00:00		
P3611			10-Jan-06 13:30:00	
P3612				10-Jul-06 13:30:00

For this example assume the drive is in Standard Run Two Wire operating mode with digital output 1 wired to FWD. The drive would then run daily for one hour from 1:00 AM to 2:00 AM starting February 3, 2007. The same drive is scheduled for monthly and yearly service. Filters are to be changed on the tenth of every month after lunch starting January 10, 2006. In addition, once a year on the 10 of July the heating system is serviced after lunch as well.

RTC messages 1&2 are not logged but must be acknowledged before they are cleared.

RTC Keypad Screens

The following templates shows how these parameters are displayed on the keypad.

Keypad Screen											
Line 1	Program				Parameter Block Name						
Line 2	Parameter Name										
Line 3	Parameter List Text ¹							Qualifier ¹			
Line 4	Month ¹		Day ¹	,	Year ¹		Hour ¹	:	Minutes ¹	:	Seconds ¹
Line 5	A	Parameter Number					B				

Note 1: Field is editable

Line 1 holds the screen's name and parameter block name. Line 2 holds a parameter name. Line 3 holds list parameter text and the scheduling qualifier. Line 4 holds the date and time. And line 5 holds the A-Function Key name, a parameter number and the B-Function Key name.

Example one:

Keypad Screen											
Line 1	Prog				RTC						
Line 2	ACTION 1										
Line 3	Digital Output 1 ON							Daily			
Line 4	July		04		2006		01	:	00	:	00
Line 5	Edit	C3601T1					Back				

Action	Description	Display	Comments
At the Level 3 Programming Menu select RTC FEATURES	At the first menu "RTC ACTION 1" press ENTER.	<p>The screenshot shows the 'RTC ACTION 1' screen. At the top, it says 'RTC ACTION 1'. Below that, there are three columns: 'Action' with 'None', 'Date & Time' with 'Jul 04, 2006', and 'Action Qualifier' with 'Once 01:00:00'. At the bottom, there are three buttons: 'MAX', 'F0201', and 'RESET'. Arrows point from the 'EDIT' label to the 'None' and 'Once' options, and from the 'RTC FEATURES' label to the 'Once' and '01:00:00' options.</p>	Press ▲ or ▼ to change value. Press ► or ◀ to move cursor to Action Qualifier. Press ▲ or ▼ to change value. Press ► or ◀ to move cursor to Date & Time. Press ENTER when finished and save the new value. See RTC chapter of this manual for additional details.
Press ► to go to the next RTC screen.	Each RTC parameter can be changed by using the procedure described for RTC ACTION 1.	<p>The screenshot shows the 'RTC ACTION 2' screen. At the top, it says 'RTC ACTION 2'. Below that, there are three columns: 'Action' with 'None', 'Date & Time' with 'Jul 04, 2006', and 'Action Qualifier' with 'Once 01:00:00'. At the bottom, there are three buttons: 'MAX', 'F0201', and 'RESET'. Arrows point from the 'EDIT' label to the 'None' and 'Once' options, and from the 'RTC FEATURES' label to the 'Once' and '01:00:00' options.</p>	Press ▲ or ▼ to change value. Press ► or ◀ to move cursor to Action Qualifier. Press ▲ or ▼ to change value. Press ► or ◀ to move cursor to Date & Time. Press ENTER when finished and save the new value. See RTC chapter of this manual for additional details.

Example two:

Keypad Screen											
Line 1	Prog				RTC						
Line 2	MESSAGE 1										
Line 3	Change Filter(s)							Monthly			
Line 4	Jul		17		2010		13	:	30	:	00
Line 5	Diag	C3603T1					Back				

Appendix A

Technical Specifications

Table A-1: VS1CTD Specifications

Input Ratings	Voltage	480
	Voltage range	340-528
	Phase	Three Phase (single phase with derating)
	Frequency	50/60Hz \pm 5%
	Impedance	1% minimum from mains connection
Output Ratings	Horsepower	7.5-150 HP @ 480VAC, 3PH
	Overload Capacity	Variable Torque (Normal Duty) = 115% for 60 seconds
	Frequency	0-500Hz
	Voltage	0 to maximum input voltage (RMS)
Protective Features	Trip	Missing control power, over current, over voltage, under voltage, motor over speed, over temperature (motor or control), output shorted or grounded, motor overload
	Stall Prevention	Over voltage suppression, over current suppression
	External Output	LED trip condition indicators, 4 assignable logic outputs, 2 assignable analog outputs
	Short Circuit	Phase to phase, phase to ground
Electronic Motor Overload	Meets UL508C (I ² T)	
Environmental Conditions	Temperature	-10 to 45 °C Derate 3% per degree C above 45 to 55 °C maximum ambient temperature
	Cooling	Forced air
	Enclosure	NEMA 1 (-1T, -1B);
	Altitude	Sea level to 3300 Feet (1000 Meters) Derate 2% per 1000 Feet (303 Meters) above 3300 Feet
	Humidity	10 to 90% RH Non-Condensing
	Shock	1G
	Vibration	0.5G at 10Hz to 60Hz
	Storage Temperature	-10 to +65 °C
	Duty Cycle	1.0

Table A-1: VS1CTD Specifications

Keypad Display	Display	LCD Graphical 128x64 Pixel
	Keys	14 key membrane with tactile feedback
	Functions	Output status monitoring Digital speed control Parameter setting and display Diagnostic and Fault log display Motor run and jog Local/Remote toggle
	LED Indicators	Forward run command Reverse run command Stop command Jog active
	Remote Mount	200 feet (60.6m) maximum from control; NEMA 4 rated when remote mounted
	Trip	Separate message and trace log for each trip, last 10 trips retained in memory
Control Specifications	Control Method	Microprocessor controlled PWM output selectable PM V/Hz Control, PM Sensorless, or PM closed loop
	PWM Frequency	Adjustable 4-5kHz STD, 5-16 kHz quiet
	Speed Setting	±5 VDC, 0-5 VDC ±10 VDC, 0-10 VDC, 4-20 mA, 0-20 mA; digital (keypad), Serial Comms/USB 2.0, and Modbus RTU standard
	Accel/Decel	0-3600 seconds
	Motor Matching	Automatic tuning to motor with manual override
	PC Setup Software	Mint WorkBench software available using USB2.0 port for commissioning wizard, firmware download, parameter viewer, scope capture and cloning
	Velocity Loop Bandwidth	Adjustable to 180 Hz (Control only)
	Current Loop Bandwidth	Adjustable to 1200 Hz (Control only)
	Maximum Output Frequency	500 Hz
	Quiet PWM Frequency Version	Full rating 5-8 kHz PWM frequency, Adjustable to 16 kHz with linear derating (between 8 - 16kHz) of 50% at 16 kHz (Size AA and B only)
	Standard PWM Frequency Version	Full rating 4 kHz PWM frequency, Adjustable to 5 kHz with linear derating (between 4 - 5kHz) of 25% at 5 kHz
	Selectable Operating Modes	Keypad Standard Run, 2 Wire Standard Run, 3 Wire 15 Preset Speeds Fan Pump 2 Wire Fan Pump 3 Wire Process Control 3 SPD ANA 2 Wire 3 SPD ANA 3 Wire Electronic Pot 2 Wire Electronic Pot 3 Wire Network Profile Run Bipolar Pulse Follower PLC CTD 2Wire CTD 3Wire

Table A-1: VS1CTD Specifications

Differential Analog Input	Common Mode Rejection	40 db
	Full Scale Range	±5VDC, ±10VDC, 4/20 mA and 0-20 mA
	Resolution	11 bits + sign
	Input Impedance	80 kOhms (Volt mode); 500 Ohms (Current mode)
Single Ended Analog Input	Full Scale Range	0 - 10 VDC
	Resolution	11 bits + sign
	Input Impedance	80 kOhms
Analog Outputs	Analog Outputs	2 Assignable
	Full Scale Range	AOUT1 (0-5V, 0-10V, 0-20mA or 4-20mA), AOUT2 (±5V, ±10V)
	Source Current	1 mA maximum (volt mode), 20mA (current mode)
	Resolution	9 bits + sign
Digital Inputs	Opto-isolated Inputs	8 Assignable, 1 dedicated input (Drive Enable)
	Rated Voltage	10 - 30 VDC (closed contacts std)
	Input Impedance	4.71 k Ohms
	Leakage Current	10 A maximum
	Update Rate	16 msec
Digital Outputs (2 Opto Outputs)	Rated Voltage	5 to 30VDC
	Maximum Current	60 mA Maximum
	ON Voltage Drop	2 VDC Maximum
	OFF Leakage Current	0.1 A Maximum
	Output Conditions	25 Conditions (see Output Setup Block parameter table, Chapter 7)
Digital Outputs (2 Relay Outputs)	Rated Voltage	5 to 30VDC or 240VAC
	Maximum Current	5A Maximum non-inductive
	Output Conditions	25 Conditions (see Output Setup Block parameter table, Chapter 7)

Diagnostic Indications:

Current Sense Fault	Regeneration (db) Overload	Following Error
Ground Fault	Soft Start Fault	PWR Base Fault
Instantaneous Over Current	Under Voltage	Logic Power Fault
Overload	Ready	
Line Power Loss	Parameter Loss	
Microprocessor Failure	Overload	
Over temperature (Motor or Control)	Overvoltage	
Over speed	Torque Proving	

Note: All specifications are subject to change without notice.

A.1 Specifications for Power Terminal Block Wiring

Table A-2: Terminal Tightening Torque Specifications

Catalog No.	Tightening Torque									
	Power TB1		Ground		Control J1, J2, J3		B+/R1; B+; B-; or R2		TH1 and TH2	
	In-lbs	N-M	In-lbs	N-M	In-lbs	N-M	In-lbs	N-M	In-lbs	N-M
VS1CTD47-1B	12	1.36	15	1.7	4.5	0.5	12	1.36	4	0.45
VS1CTD410-1B	12	1.36	15	1.7	4.5	0.5	12	1.36	4	0.45
VS1CTD415-1B	12	1.36	50	5.6	4.5	0.5	12	1.36	4	0.45
VS1CTD420-1B	12	1.36	50	5.6	4.5	0.5	12	1.36	4	0.45
VS1CTD425-1B	12	1.36	50	5.6	4.5	0.5	12	1.36	4	0.45
VS1CTD430-1B	35	4	50	5.6	4.5	0.5	35	4	4	0.45
VS1CTD440-1B	35	4	50	5.6	4.5	0.5	35	4	4	0.45
VS1CTD450-1B	35	4	50	5.6	4.5	0.5	35	4	4	0.45
VS1CTD460-1B	80	9.1	50	5.6	4.5	0.5	80	9.1	6	0.68
VS1CTD475-1B	120	13.6	50	5.6	4.5	0.5	80	9.1	6	0.68
VS1CTD4100-1B	120	13.6	50	5.6	4.5	0.5	100	13.6	6	0.68
VS1CTD4125-1B	120	13.6	50	5.6	4.5	0.5	100	1.36	6	0.68
VS1CTD4150-1T	275	31.1	50	5.6	4.5	0.5	120	13.6	6	0.68

A.2 Identifying the Drive by Model Number

Each drive can be identified by its model number, as shown in Figure A-1. The model number is on the shipping label and the drive nameplate. The model number includes the drive and any options. Drive model numbers for the VS1CTD drive are provided in Table A-2.

Figure A-1: Drive Identification

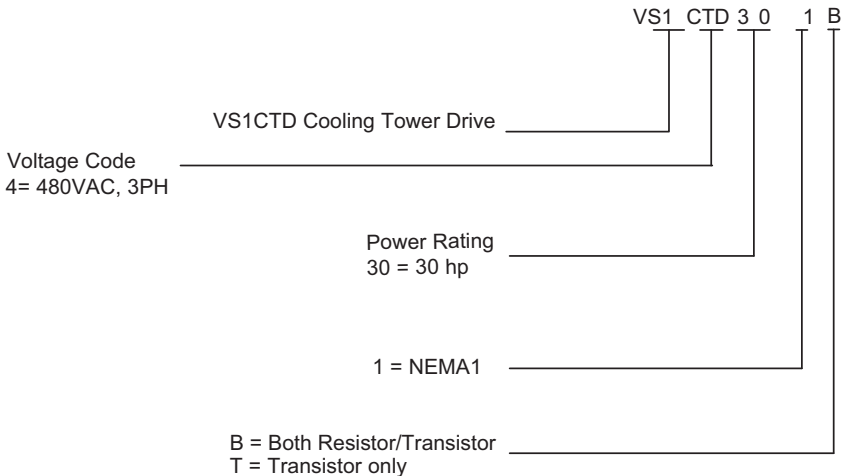

A.3 Storage Guidelines

If you need to store the drive, follow these recommendations to prolong drive life and performance:

- Store the drive within an ambient temperature range of -10°C to +65°C.
- Store the drive within a relative humidity range of 0% to 90%, non-condensing.
- Do not expose the drive to a corrosive atmosphere.

A.4 VS1CTD Drive Ratings, Model Numbers and Frame Sizes

Similar VS1CTD drive sizes are grouped into frame sizes to simplify re-ordering and dimensioning. Refer to Figure A-2 for the dimensions of each frame size.

Table A-3 provides VS1CTD drive ratings, model numbers and frame sizes.

Table A-3: Drive Ratings, Model Numbers and Frame Sizes – Standard 4 kHz PWM

Catalog No.	Input Volt	Frame Size	Standard 4 kHz PWM					
			Normal Duty					
			Input Amp	Output				
				Hp	KW	IC	IP	
VS1CTD47-1B	480	AA	11.0	7 1/2	5.6	11.9	13.7	
VS1CTD410-1B	480	AA	14.0	10	7.5	11.9	13.7	
VS1CTD415-1B	480	B	21.0	15	11	23.0	26.4	
VS1CTD420-1B	480	B	27.0	20	15	28.9	33.2	
VS1CTD425-1B	480	B	34.0	25	18.5	34.0	39.1	
VS1CTD430-1B	480	C	40.0	30	22	44.2	51.9	
VS1CTD440-1B	480	C	52.0	40	30	55.3	63.5	
VS1CTD450-1B	480	C	52.0	50	37	65.5	75.3	
VS1CTD460-1B	480	D	77.0	60	44	90.8	104.4	
VS1CTD475-1B	480	D	116.6	75	56	116.6	134.0	
VS1CTD4100-1B	480	D	136.3	100	75	136.3	156.8	
VS1CTD4125-1B	480	D	143.8	125	93	143.8	165.4	
VS1CTD4150-1T	480	E	204.0	150	112	204.0	234.6	

Note: IC=Continuous Current Rating; IP=Peak Current Capability

Table A-4: Drive Ratings, Model Numbers and Frame Sizes – Quiet 8 kHz PWM

Catalog No.	Input Volt	Frame Size	Quite 8 kHz PWM				
			Normal Duty				
			Input Amp	Output			
				Hp	KW	IC	IP
VSCTD47-1B	480	AA	11.0	7-1/2	5.6	11.0	12.7
VS1CTD10-1B	480	AA	14.0	10	7.4	14.0	16.1
VS1CTD15-1B	480	B	21.0	15	11.0	21.0	24.2
VS1CTD420-1B	480	B	27.0	20	15.0	27.0	31.1
VS1CTD425-1B	480	B	34.0	25	18.7	34.0	39.1
VS1CTD430-1B	480	C	40.0	30	22.4	40.0	46.0
VS1CTD440-1B	480	C	52.0	40	29.8	52.0	59.8
VS1CTD450-1B	480	C	52.0	40	29.8	52.0	59.8
VS1CTD460-1B	480	D	77.0	60	44.8	77.0	88.6
VS1CTD475-1B	480	D	96.0	75	56.0	96.0	110.4
VS1CTD4100-1B*	480	D	124.0	100	74.6	124.0	142.6
VS1CTD4125-1B*	480	D	156.0	125	93.3	156.0	179.4
VS1CTD4150-1T	480	E	156.0	125	93.3	156.0	179.4

Note: IC=Continuous Current Rating; IP=Peak Current Capability

Note: Quite rating for these drives is at 5KHz PWM

Figure A-2: Drive Dimensions and Weights

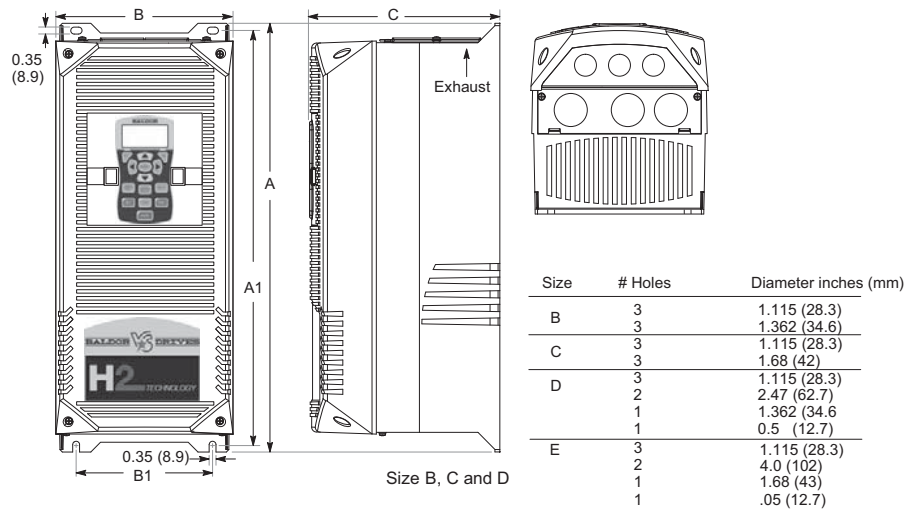
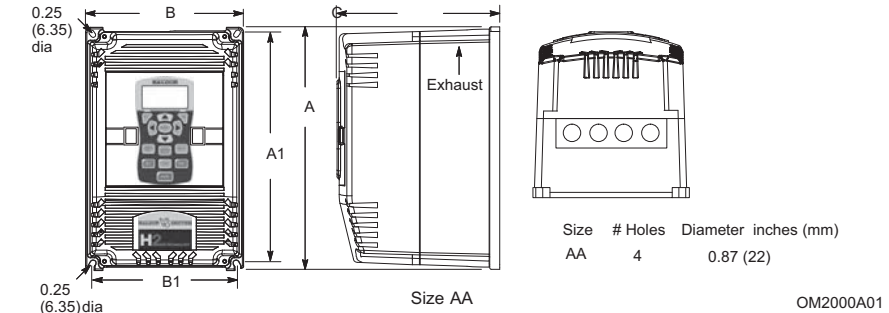

OM2000A00, 02, 04, 05

Size	Dimensions inches (mm)					Weight
	Outside			Mounting		
	Height (A)	Width (B)	Depth (C)	Height (A1)	Width (B1)	lb (kg)
AA	12.27 (311)	7.97 (202)	8.21 (208)	11.75 (298)	7.38 (187)	20 (9.1)
B	18.00 (457)	9.10 (231)	9.75 (248)	17.25 (438)	7.00 (178)	30 (13.6)
C	22.00 (559)	9.10 (231)	9.75 (248)	21.25 (540)	7.00 (178)	60 (27.2)
D	28.00 (711)	11.50 (292)	13.00 (330)	27.25 (692)	9.50 (241)	120 (54.4)
E	42.81 (1087)	18.75 (476)	16.05 (407)	39.75 (1010)	15.75 (400)	250 (113.4)

Appendix B

Parameter Tables

B.1 Level 1 Parameters (Advanced PROG, Level 1 Blocks)

All parameters displayed in this appendix are Parameter Table 1 (T1) factory set values. Setting parameter P2103 to yes will load these values into all four parameter tables. Level 1 & 2 parameters are secured by security access code (P2107).

Table B.1 Parameter Block Values Level 1

Block Title	Parameter	P#	Adjustable Range	Factory	User Setting
PRESET SPEEDS	PRESET SPEED 1	1001	0-MAX Speed	30	
	PRESET SPEED 2	1002	0-MAX Speed	60	
	PRESET SPEED 3	1003	0-MAX Speed	90	
	PRESET SPEED 4	1004	0-MAX Speed	120	
	PRESET SPEED 5	1005	0-MAX Speed	150	
	PRESET SPEED 6	1006	0-MAX Speed	180	
	PRESET SPEED 7	1007	0-MAX Speed	210	
	PRESET SPEED 8	1008	0-MAX Speed	240	
	PRESET SPEED 9	1009	0-MAX Speed	270	
	PRESET SPEED 10	1010	0-MAX Speed	300	
	PRESET SPEED 11	1011	0-MAX Speed	330	
	PRESET SPEED 12	1012	0-MAX Speed	360	
	PRESET SPEED 13	1013	0-MAX Speed	390	
	PRESET SPEED 14	1014	0-MAX Speed	420	
	PRESET SPEED 15	1015	0-MAX Speed	450	
RAMP RATES	ACCEL TIME 1	1101	0.0 to 3600.0 Seconds	3.0	
	START S-ACCEL 1	1102	0.0-100.0%	0.0	
	END S-ACCEL 1	1103	0.0-100.0%	0.0	
	DECEL TIME 1	1104	0.0 to 3600.0 Seconds	3.0	
	START S-DECEL 1	1105	0.0-100.0%	0.0	
	END S-DECEL 1	1106	0.0-100.0%	0.0	
	ACCEL TIME 2	1107	0.0 to 3600.0 Seconds	3.0	
	START S-ACCEL 2	1108	0.0-100.0%	0.0	
	END S-ACCEL 2	1109	0.0-100.0%	0.0	
	DECEL TIME 2	1110	0.0 to 3600.0 Seconds	3.0	
	START S-DECEL 2	1111	0.0-100.0%	0.0	
	END S-DECEL 2	1112	0.0-100.0%	0.0	
	POWER LOSS DECEL TIME	1113	0.0-3600.0 Seconds	1.0	

Table B.1 Parameter Block Values Level 1 (Cont.)

Block Title	Parameter	P#	Adjustable Range	Factory	User Setting
JOG SETTINGS	JOG SPEED	1201	0-MAX Speed	210	
	JOG ACCEL TIME	1202	0.0 to 3600.0 Seconds	10.0	
	JOG START S-ACCEL	1203	0.0-100.0%	0.0	
	JOG END S-ACCEL	1204	0.0-100.0%	0.0	
	JOG DECEL TIME	1205	0.0 to 3600.0 Seconds	10.0	
	JOG START S-DECEL	1206	0.0-100.0%	0.0	
	JOG END S-DECEL	1207	0.0-100.0%	0.0	
	JOG FORWARD	1209	0-OFF , 1-ON	1	
	JOG REVERSE	210	0-OFF , 1-ON	1	
KEYPAD SETUP	STOP KEY	1301	0-OFF (Keypad Stop inactive in remote). 1-ON (Keypad Stop active in remote).	1	
	STOP MODE	1302	0-Coast, 1-Regen	1	
	RUN FORWARD	1303	0-OFF , 1-ON	1	
	SWITCH ON FLY	1305	0-OFF , 1-ON	0	
	LOCAL HOT START	1306	0-OFF , 1-ON	0	
	SPEED INCREMENT	1307	0-MAX Speed	30	
	INIT LOCAL SPEED	1308	0-Zero, 1-Last Speed, 2-Set Speed	0	
	SET SPEED	1309	0-MAX Speed	30	
	PARAMS TO KEYPAD	1310	0-NO, 1-YES	0	
	DOWNLOAD SELECT	1311	0-All, 1-Motor, 2-Other	0	
	KEYPAD TO PARAMS	1312	0-NO, 1-YES	0	
	KEYPAD CONTRAST	1313	0-100% (0=dimmet, 100=brightest)	50	
	BACKLIGHT	1314	0-OFF , 1-ON	1	

[1] Only available or active in Closed/Open Loop Vector mode. Ignore these parameters for V/F mode.

Table B.1 Parameter Block Values Level 1 (Cont.)

Block Title	Parameter	P#	Adjustable Range	Factory	User Setting
INPUT SETUP	OPERATING MODE	1401	0-KEYPAD 1-STANDARD RUN 2-Wire 2-STANDARD RUN 3-Wire 3-15 PRESET SPEEDS 4- FAN&PUMP 2WIRE 5- FAN&PUMP 3WIRE 6-PROCESS CONTROL 7-3SPD ANA 2WIRE 8-3SPD ANA 3WIRE 9-E-POT 2WIRE 10-E-POT 3WIRE 11-NETWORK 12-PROFILE RUN 13-15 PRESET POSITIONS 14-BIOPOLAR 15-PULSE FOLLOWER 16-PLC 17-CTD 2Wire 18-CTD 3Wire	0	
	COMMAND SOURCE	1402	0-NONE, 1-ANALOG INPUT1, 2-ANALOG INPUT2, 3-KEYPAD, 4-NETWORK, 5-COMPOSITE, 6-EXB Pulse FOL	1	
	ANA IN1 TYPE	1403	0-None, 1-Potentiometer	1	
	ANA IN1 INVERT	1404	0-OFF , 1-ON	0	
	ANA IN1 GAIN	1405	0.0% TO 300.0%	100.0	
	ANA IN1 OFFSET	1406	-100.0% TO 100.0%	0.0	
	ANA IN1 FILTER	1407	0 (No Filter) TO 6 (Max Filter)	0	
	ANA IN2 TYPE	1408	0-None, 1-(-10V to+10V), 2-(-5V to+5V), 3-(4 to20mA), 4-(0 to20mA), 5-(0 to 10V), 6-(0 to 5V)	1	
	ANA IN2 INVERT	1409	0-OFF , 1-ON	0	ANA IN2 INVERT
	ANA IN2 GAIN	1410	0.0% TO 300.0%	100.0	ANA IN2 GAIN
	ANA IN2 OFFSET	1411	-100.0% TO 100.0%	0.0	ANA IN2 OFFSET
	ANA IN2 DEADBAND	1412	0.0% TO 75.0%	0.0	ANA IN2 DEADBAND

Table B.1 Parameter Block Values Level 1 (Cont.)

Block Title	Parameter	P#	Adjustable Range	Factory	User Setting
INPUT SETUP (Continued)	ANA IN2 FILTER	1413	0 (No Filter) TO 6 (Max Filter)	0	
	[1] CURRENT LIMIT SOURCE	1415	0-None, 1-Analog In1, 2-Analog In2, 3-Keypad, 4-Composite	0	
	SLEEP MODE	1416	0-OFF , 1-ON	0	
	CMD SLEEP BAND	1417	0.00 TO 100.00%	0.00	
OUTPUT SETUP	DIGITAL OUTPUT 1	1501	0-DRIVE RUN	1	
	DIGITAL OUTPUT 2	1502	1-DRIVE READY	8	
			2-DRIVE ON		
	RELAY OUTPUT 1	1503	3-DRIVE STOPPED	9	
	RELAY OUTPUT 2	1504	4-JOG	17	
			5-ACCELERATE		
			6-CONST ANT SPEED		
			7-DECELERATE		
			8-AT ZERO SPEED		
			9-AT SPEED		
10-AT SET SPEED					
11-CURRENT OVERLOAD					
12-CURRENT UNDERLOAD					
13-I 2T OVERLOAD					
14-KEYPAD CONTROL					
15-DYNAMIC BRAKE					
16-FOLDBACK					
17-FAULT					
18-ALARM					
19-COMMAND FORWARD 20-					
COMMAND REVERSE					
21-MOTOR FORWARD					
22-MOTOR REVERSE					
23-PROCESS ERROR					
24-NETWORK					
25-AT POSITION					
26-IN MOTION					
27-PLC					
28-RTC					
29-POWERED UP					
ZERO SPD SET PT	1505	0-MAX Speed	6.00		
AT SPEED BAND	1506	0-100 RPM	2.00		
SET SPEED POINT	1507	0-MAX Speed	60.00		

[1] Only available or active in Closed/Open Loop Vector mode. Ignore these parameters for V/F mode.

Table B.1 Parameter Block Values Level 1 (Cont.)

Block Title	Parameter	P#	Adjustable Range	Factory	User Setting
OUTPUT SETUP (Continued)	OVERLOAD SET POINT	1508	0.0-200.0%	150.0	
	UNDERLOAD SET POINT	1509	0.0-200.0%	50.0	
	ANALOG OUT1 TYPE	1510	0-(0 TO +10V), 1-(0 TO 5V), 2-(4mA TO 20mA), 3-(0mA TO 20mA)	0	
	ANALOG OUT1 SIGNAL	1511	0-SPEED REF 1-SPEED DEMAND	29	
	ANALOG OUT2 SIGNAL	1514	2-ACC/DEC 3-MOTOR CURRENT 4-MAG CURRENT 5-MAG CURRENT COMMAND 6-LOAD CURRENT 7-LOAD CURRENT COMMAND 8-POWER FACTOR 9-PH1 CURRENT 10-PH2 CURRENT 11-PH3 CURRENT 12-MOTOR VOLTAGE 13-VD DEMAND 14-VQ DEMAND 15-BUS VOLTAGE 16-ABS TORQUE 17-TORQUE 18-CONTROL TEMP 19-ANALOG INPUT 1 20-ANALOG INPUT 2 21-OPT1 ANA IN1 22-OPT1 ANA IN2 23-OPT2 ANA IN1 24-OPT2 ANA IN2 25-PROC FEEDFORWARD 26-PROC FEEDBACK 27-PROC SETPOINT 28-ELECTRIC ANGLE 29-ABS SPEED 30-VELOCITY 31-NETWORK 32-COMPOSITE REF 33-POWER (KW) 34-CALIBRATE	3	
	ANALOG OUT1 GAIN	1512	0.0-200%	100.0	
	ANALOG OUT2 TYPE	1513	0-(+/-5V), 1-(+/-10V)	1	
	ANALOG OUT2 GAIN	1515	0.0-200.0%		
	CALIBRATE ANALOG OUT	1516	-100.0% to 100.0%	0.0	

Table B.1 Parameter Block Values Level 1 (Cont.)

Block Title	Parameter	P#	Adjustable Range	Factory	User Setting
Motor Control	Control Type	1601	0 - PM V/F Control 1- PM Sensorless	1	
	Control Base Speed	1602	30 - 15,000 RPM	1800	
	Control Base Voltage	1611	0 - 480 Vac	460	
	Static Boost	1612	0 - 30 Vac	0	
	Dynamic Boost Cut-In	1613	0 - 1800 RPM	120	
	Dynamic Boost	1614	0 - 10 Vac	0	
	V/F Efficiency	1615	0 - Off 1 - On	0	
	V/F Profile	1616	0 - 100%	0	
	Custom V/F Curve	1617	0- Off 1- 3 Point 2 - 7 Point	0	
	3 Point Voltage	1618	0 - 100%	50	
	3 Point Frequency	1619	0 - 1800 RPM	900	
	Slip Compensation Enable	1620	0 - Off 1 - On	0	
	7 Point Frequency 1	1621	0 - 1800 RPM	300	
	7 Point Voltage 1	1622	0 - 100%	16.7	
	7 Point Frequency 2	1623	0 - 1800 RPM	600	
	7 Point Voltage 2	1624	0 - 100%	33.3	
	7 Point Frequency 3	1625	0 - 1800 RPM	900	
	7 Point Voltage 3	1626	0 - 100%	50	
	7 Point Frequency 4	1627	0 - 1800 RPM	1200	
	7 Point Voltage 4	1628	0 - 100%	66.7	
	7 Point Frequency 5	1629	0 - 1800 RPM	1500	
	7 Point Voltage 5	1630	0 - 100%	83.3	
	Current Loop Proportional Gain	1633	0 - 150	CALC	
	Current Loop Integral Gain	1634	0 - 3000 Hz	150	
Speed Loop Proportional Gain	1635	1 - 1000	5		
Speed Loop Integral Gain	1636	0 - 1000 Hz	10		
Speed Loop Differential Gain	1637	0 - 1	0		

Table B.1 Parameter Block Values Level 1 (Cont.)

Block Title	Parameter	P#	Adjustable Range	Factory	User Setting
Motor Control (Continued)	Anti-Saturation Proportional Gain	1639	0 - 255	10	
	Anti-Saturation Integral Gain	1640	0 - 200 Hz	50	
	Rotor Time Constant	1644	0 - 60 Seconds	CALC	
	Stator Inductance	1672	0 to 1000mH	CALC	
	Stator Resistance	1673	0 to 1000 Ohms	CALC	
	Voltage Constant of Motor	1674	0 to 1500 V/1000RPM	CALC	
	D-axis Stator Inductance	1675	0 to 1000 mH	CALC	
	Q-axis Stator Inductance	1676	0 to 1000 mH	CALC	
	Trickle Current Heating Amps	1678	0 - 50% Motor FLA	0	
	Lq at 25 pct load	1679	0 to 1000 mH	CALC	
	Lq at 50 pct load	1680	0 to 1000 mH	CALC	
	Lq at 75 pct load	1681	0 to 1000 mH	CALC	
	Lq at 100 pct load	1682	0 to 1000 mH	CALC	
	Iq at 25 pct load	1683	0 to 4000 Amps	CALC	
	Iq at 25 pct load	1684	0 to 4000 Amps	CALC	
	Iq at 25 pct load	1685	0 to 4000 Amps	CALC	
	Iq at 25 pct load	1686	0 to 4000 Amps	CALC	
	Initial Angle Short Pulse Count	1687	1 to 200 counts	CALC	
	Initial Angle Long Pulse Count	1688	1 to 400 counts	CALC	

Table B.1 Parameter Block Values Level 1 (Cont.)

Block Title	Parameter	P#	Adjustable Range	Factory	User Setting
COMMUNICATION	BAUD RATE	1701	0-9600, 1-19200, 2-38400, 3-56000, 4-115200	1	
	PARITY	1702	0-None, 1-Odd, 2-Even	0	
	STOP BITS	1703	0-One, 1-Two	0	
	DRIVE ADDRESS	1704	1-247	1	
	OPTION CARD RESET	1705	0-Off, 1-ON	0	
	SECURITY DEFAULT	1706	0-NO, 1-YES	NO	
	BROWSER USER ID	1707		Baldor	
	BROWSER PASSWORD	1709		Baldor	

[1] Only available or active in Closed/Open Loop Vector mode. Ignore these parameters for V/F mode.

[2] Only available or active in V/F mode. Ignore these parameters for Closed/Open Loop mode.

[3] Only available or active in Closed Loop Vector mode. Ignore these parameters for Open Loop or V/F mode.

B.2 Level 2 Parameters (Advanced PROG, Level 2 Blocks)

Table B.2 Parameter Block Values Level 2

Block Title	Parameter	P#	Adjustable Range	Factory	User Setting
DRIVE LIMITS	OPERATING ZONE	2001	0-STD CONST TORQUE 1-STD VAR TORQUE 2-QUIET CONST TORQUE 3-QUIET VAR TORQUE	0	
	MIN OUTPUT SPEED	2002	0-MAX Speed	0.00	
	MAX OUTPUT SPEED	2003	300-15000RPM	1800	
	PWM FREQUENCY	2004	1500 to 16000 Hz	2500	
	PEAK CURRENT LEVEL	2006	0.000 – Peak Rated Currents	CALC	
	REGEN TORQUE LIMIT	2007	0.0 to Peak Amps-Mag	CALC	
DRIVE CONFIGURE	SPEED UNITS	2101	0-Hz,	1	
	LANGUAGE SELECT	2102	0-English 1-Other (Spanish, German, Italian, French, or Portuguese)	0	
	FACTORY SETTINGS	2103	0-NO, 1-YES	0	
	SECURITY	2105	0-Off, 1-Local, 2- Network, 3- Total	0	
	ACCESS TIMEOUT	2106	1.0-600.0 seconds	5.0	
	ACCESS CODE	2107	0-9999	9999	
	ACTIVE PARAM TABLE	0052	0-T1, 1-T2, 2-T3, 3-T4	0	
	CLEAR FAULT LOG	2108	0-NO, 1-YES	0	
	[2] DEAD TIME COMP	2109	0.0-100.0%	100.0	
	POWER INPUT	2110	0-Single Phase, 1-Common Bus Slave 2- Three Phase, 3- Common Bus Master	2	
	EXECUTE MACRO	2112	0-NO, 1-M1, 2-M2, 3-M3, 4- M4, 5-M5	0	
	UNDO MACRO	2113	0-NO, 1-YES	0	
	TORQUE ENABLE SEQUENCE	2114	0-Torque on Enable 1-Torque on Command	0	
DRIVE PROTECT	EXTERNAL TRIP	2201	0-OFF, 1-ON	0	
	[2] FOLDBACK GAIN	2205	0.000-10.000%	0.010	
	OVERLOAD	2206	0-Fault, 1-Foldback, 2-Hold	0	
	[2] OVERLOAD TRIGGER	2207	0.0-100.0%	50.0	
	[4] SINGLE PHASING	2209	0-Derate, 1-Fault	1	
	OVER TEMPERATURE	2210	0-Derate, 1-Fault	1	
	PWR DOWN OPTIONS	2211	0-Fault, 1-Ride Through	0	
	CNTL STP BUS LVL	2212	200-800V	CALC	
	CNTL STOP DELAY	2213	0 to 3600.0 seconds	1.0	

Table B.2 Parameter Block Values Level 2 (Cont.)

Block Title	Parameter	P#	Adjustable Range	Factory	User Setting
DRIVE PROTECT (Continued)	Kp RIDE THROUGH	2214	0 To 1000.0000	1.0000	
	Ki RIDE THROUGH	2215	0 To 1000.0000	0.0010	
MISCELLANEOUS	AUTO RESTART	2301	0-Manual, 1-At Power Up, 3-Both	1	
	RESTARTS/HOUR	2302	0-10	3	
	RESTART DELAY	2303	0-3600 seconds	3	
	COST OF ENERGY	2305	0.00-99999.00\$/KWH	0.10	
	RESET ENERGY	2306	0-NO, 1-YES	0	
	FILTER TYPE	2309	0-None, 1-Low Pass, 2-High Pass, 3-Notch	0	
	FILTER SOURCE	2310	0-None, 1-Raw Speed, 2-Torque, 3-Analog In1, 4-Analog In2, 5-Composite REF, 6-OPT1 ANA IN 1, 7-OPT1 ANA IN 2, 8-OPT2 ANA IN 1, 9-OPT2 ANA IN 2	0	
	FILTER DESTINATION	2311	0-None, 1-Speed Loop, 2-Torque Loop, 3-Speed FFWD, 4-Process FBK, 5-Process FFWD, 6-Process SP	0	
	FILTER CUTOFF	2312	0.00-1000.00Hz	0.00	
	NOTCH CENTER FREQ	2313	0.00-500.00Hz	0.00	
	NOTCH BAND	2314	0.00-200.00Hz	0.00	
	MOTOR DATA	MOTOR RATED VOLT	2401	0-1000 Volts	CALC
MOTOR RATED AMPS		2402	0- AMP	CALC	
MOTOR RATED SPEED		2403	0-30000 RPM	1754	
MOTOR RATED FREQUENCY		2404	0.00-120.00Hz	60.00	
MOTOR MAG AMPS		2405	0-8.6 AMPS	CALC	
[2] INSTABILITY FREQUENCY		2406	0.00-500.00Hz	20.00	
[2] STABILITY GAIN		2407	0.000-10.000	0.300	
[3] RESOLVER SPEED		2411	0-10	0	
[1] ELECTRICAL SLIP FREQ		2412	0.00-20.00Hz	CALC	
CALCULATE MOTOR MODEL		2414	0-NO, 1-YES	0	
REVERSE ROTATION		2415	0-OFF, 1-ON	0	

[1] Only available or active in Closed/Open Loop Vector mode. Ignore these parameters for V/F mode.

[2] Only available or active in V/F mode. Ignore these parameters for Closed/Open Loop mode.

[3] Only available or active in Closed Loop Vector mode. Ignore these parameters for Open Loop or V/F mode.

[4] Not available for size AA Controls.

Table B.2 Parameter Block Values Level 2 (Cont.)

Block Title	Parameter	P#	Adjustable Range	Factory	User Setting
BRAKE ADJUST	RESISTOR OHMS	2501	0-255.0 Ohms	CALC	
	RESISTOR WATTS	2502	0-999999 Watts	CALC	
	RESISTOR THERMAL TIME CONSTANT	2503	20-3600 seconds	CALC	
	[2] DC BRAKE VOLTS	2504	0-20.00%	0.00	
	[2] DC BRAKE TRIGGER	2505	0.00-50.0Hz	0.00	
	[2] BRAKE ON STOP	2506	0-OFF, 1-ON	0	
	[2] STOP BRAKE TIME	2508	0.0-60.0 seconds	0.0	
	[2] BRAKE ON START	2509	0-OFF, 1-ON	0	
[2] START BRAKE TIME	2510	0.0-60.0 seconds	0.0		
PROCESS CONTROL	PROCESS TYPE	2601	0-None, 1-Forward Acting, 2-Reverse Acting	0	
	SETPOINT ADJUST LIMIT	2602	0.0-100.0%	10.0	
	PROCESS FEEDBACK	2603	0-None, 1-Setpoint CMD, 2-Local Speed REF.	0	
	SETPOINT SOURCE	2604	3-Analog In1, 4-Analog In2, 5-Network, 6-Composite 7-OPT1 ANA IN 1, 8-OPT1 ANA IN 2, 9-OPT2 ANA IN 1, 10-OPT2 ANA IN 2	0	
	SETPOINT COMMAND	2605	-100.0% - +100.0%	0.0	
	PROCESS ERROR TOLERANCE	2606	0.0-100.0%	10.0	
	PROCESS PROP GAIN	2607	0.0000-1000.0000	1.0000	
	PROCESS INTG GAIN	2608	0.0000-1000.0000	0.0000	
	PROCESS INTG CLAMP	2609	0.0-100.0%	100.0	
	PROCESS DIFF GAIN	2610	0.0000-1000.0000	0.0000	
	PROFILE ADJUST	2611	0-OFF, 1-ON	0	
	PROFILE AJDUST BAND	2612	0.0-200.0%	50.0	
	PROCESS SLEEP BAND	2613	0.0-100.0%	0.0	
	PROCESS OUTPUT FILTER	2614	0.0-100.0 seconds	0.00	
	PROCESS OUTPUT OFFSET	2615	-100.0-100.0%	0.0	
PROCESS OUTPUT GAIN	2616	0.0-200.0%	100.0		
SKIP FREQUENCY	[2] SKIP FREQ 1	2701	0-MAX Speed	0.00	
	[2] SKIP BAND 1	2702	0-MAX Speed	0.00	
	[2] SKIP FREQ 2	2703	0-MAX Speed	0.00	
	[2] SKIP BAND 2	2704	0-MAX Speed	0.00	
	[2] SKIP FREQ 3	2705	0-MAX Speed	0.00	
	[2] SKIP BAND 3	2706	0-MAX Speed	0.00	

[1] Only available or active in Closed/Open Loop Vector mode. Ignore these parameters for V/F mode.

[2] Only available or active in V/F mode. Ignore these parameters for Closed/Open Loop mode.

Table B.2 Parameter Block Values Level 2 (Cont.)

Block Title	Parameter	P#	Adjustable Range	Factory	User Setting
SYNCHRO START	[4] SYNC START FWD	2801	0-OFF, 1- ON	0	
	[4] SYNC START REV	2802	0-OFF, 1- ON	0	
	[4] SYNC AT MAX FREQ	2803	0-OFF, 1- ON	1	
	[4] SYNCHRO SCAN V/F	2804	1.0-100.0%	10.0/10.0	
	[4] SYNC SETUP TIME	2805	0.0-5.00 seconds	0.20/0.10	
	[4] SYNC SCAN TIME	2806	0.5-10.0 seconds	2.0/0.50	
	[4] SYNC RECOVER	2807	0.5-10.0 seconds	1.0/0.10	
AUTO TUNE	ANALOG OFFSET TRIM	2901	0-NO, 1-YES	0	
	ONE-STEP TUNING	2902	0-NO, 1-YES	0	
	[1] STATOR R1 TUNE	2903	0-NO, 1-YES	0	
	[1] MEASURE XM	2904	0-NO, 1-YES	0	
	[1] MEASURE LEAKAGE	2905	0-NO, 1-YES	0	
	[1]1 CURRENT LOOP TUNE	2906	0-NO, 1-YES	0	
	[1] FLUX CUR TUNE	2907	0-NO, 1-YES	0	
	[3] FEEDBACK TEST	2908	0-NO, 1-YES	0	

[1] Only available or active in Closed/Open Loop Vector mode. Ignore these parameters for V/F mode.

[2] Only available or active in V/F mode. Ignore these parameters for Closed/Open Loop mode.

[3] Only available or active in Closed Loop Vector mode. Ignore these parameters for Open Loop or V/F mode.

[4] Only available or active in V/F or Open Vector mode. Factory settings are different depending on mode (V/F or Open Vector). Note: In Open Vector mode, it is recommended that these values remain at the factory settings

B.3 Level 3 Parameters (Advanced PROG, Level 3 Blocks)

Table B.3 Parameter Block Values Level 3

Block Title	Parameter	P#	Adjustable Range	Factory	User Setting
PULSE FOLLOWER	MASTER PPR	3101	50-20000 counts	1024	
	INPUT VOLTS	3102	0-5V, 1-12V	0	
	INPUT TYPE	3103	0-None, 1-Quadrature, 2-Speed	1	
	TRACK MODE	3104	0-Velocity, 1-Position, 2-Position Sync	0	
	INCREMENT STEP	3105	1-1024	1	
	RX RATIO INPUT	3106	1-20000	1024	
	RX RATIO OUTPUT 1	3107	1-20000	1024	
	RX RATIO OUTPUT 2	3108	1-20000	1024	
	RX RATIO OUTPUT 3	3109	1-20000	1024	
	RX RATIO OUTPUT 4	3110	1-20000	1024	
	OUTPUT TYPE	3111	0-Quadrature, 1-Speed	0	
	TX RATIO INPUT	3112	1-1048576	1024	
	TX RATION OUTPUT	3113	1-20000	1024	
CUSTOM UNITS	MAX DECIMAL PLACES	3201	0-5	1	
	VALUE AT SPEED	3202	X.X; YRPM	0.0	
	UNITS OF MEASURE	3203		CUSTOM See Section 4	
PLC MODE	PLC CONFIG 1	3401	0 to 255.255.255.255	000.128.000.000	
	PLC CONFIG 2	3402	0 to 255.255.255.255	000.128.000.000	
	PLC CONFIG 3	3403	0 to 255.255.255.255	000.128.000.000	
	PLC CONFIG 4	3404	0 to 255.255.255.255	000.128.000.000	
	PLC CONFIG 5	3405	0 to 255.255.255.255	000.128.000.000	
	PLC CONFIG 6	3406	0 to 255.255.255.255	000.128.000.000	
	PLC CONFIG 7	3407	0 to 255.255.255.255	000.128.000.000	
	PLC CONFIG 8	3408	0 to 255.255.255.255	000.128.000.000	
	PLC CONFIG 9	3409	0 to 255.255.255.255	000.128.000.000	
	PLC CONFIG 10	3410	0 to 255.255.255.255	000.128.000.000	
	PLC CONFIG 11	3411	0 to 255.255.255.255	000.128.000.000	
	PLC CONFIG 12	3412	0 to 255.255.255.255	000.128.000.000	
	PLC CONFIG 13	3413	0 to 255.255.255.255	000.128.000.000	
	PLC CONFIG 14	3414	0 to 255.255.255.255	000.128.000.000	
	PLC CONFIG 15	3415	0 to 255.255.255.255	000.128.000.000	
	PLC CONFIG 16	3416	0 to 255.255.255.255	000.128.000.000	
	PLC CONFIG 17	3417	0 to 255.255.255.255	000.128.000.000	
	PLC CONFIG 18	3418	0 to 255.255.255.255	000.128.000.000	
	PLC CONFIG 19	3419	0 to 255.255.255.255	000.128.000.000	
	PLC CONFIG 20	3420	0 to 255.255.255.255	000.128.000.000	
	PLC CONFIG 21	3421	0 to 255.255.255.255	000.128.000.000	
	PLC CONFIG 22	3422	0 to 255.255.255.255	000.128.000.000	
	PLC CONFIG 23	3423	0 to 255.255.255.255	000.128.000.000	
	PLC CONFIG 24	3424	0 to 255.255.255.255	000.128.000.000	
	PLC CONFIG 25	3425	0 to 255.255.255.255	000.128.000.000	

Table B.3 Parameter Block Values Level 3 (Continued)

	PLC CONFIG 26	3426	0 to 255.255.255.255	000.128.000.000	
	PLC CONFIG 27	3427	0 to 255.255.255.255	000.128.000.000	
	PLC CONFIG 28	3428	0 to 255.255.255.255	000.128.000.000	
	PLC CONFIG 29	3429	0 to 255.255.255.255	000.128.000.000	
	PLC CONFIG 30	3430	0 to 255.255.255.255	000.128.000.000	
	COMPARE A PARAMETER	3431	00000 to 1000	0	
	COMPARE A CONSTANT1	3432	0.00 to 100.00%	0.00	
	COMPARE A CONSTANT2	3433	0.00 to 100.00%	0.00	
	COMPARE B PARAMETER	3434	00000 to 1000	0	
	COMPARE B CONSTANT1	3435	0.00 to 100.00%	0.00	
	COMPARE B CONSTANT 2	3436	0.00 to 100.00%	0.00	
	TIMER A DURATION	3440	0.00 to 999.99 seconds	0.00	
	TIMER B DURATION	3441	0.00 to 999.99 seconds	0.00	
	TIMER C DURATION	3442	0.00 to 999.99 seconds	0.00	
	TIMER D DURATION	3443	0.00 to 999.99 seconds	0.00	
COMPOSITE REF	PARAMETER A NUMBER	3501	0.000 to 1000.000	0	
	PARAMETER B NUMBER	3502	0.000 to 1000.000	0	
	PARAMETER A FUNCTION	3503	0-ZERO	ZERO	
	PARAMETER B FUNCTION	3504	1-IDENTITY	ZERO	
			2-ABSOLUTE VALUE	ZERO	
	FUNCTION	3505	3-INVERT	ZERO	
			4-SQUARE		
			5-SQUARE ROOT		
			6-SINE		
			7-COSINE		
8-RAMP GENERATOR 9-FREQ GENERATOR					
OPERATOR	3506	0-SUM 1-DIFFERENCE 2-MULTIPLY 3-DIVIDE 4-MAXIMUM 5-MINIMUM	SUM		
PARAMETER A GAIN	3507	0.000 to 1000.000	1.000		
PARAMETER B GAIN	3508	0.000 to 1000.000	1.000		

Table B.3 Parameter Block Values Level 3 (Continued)

RTC FEATURES (Real Time Clock)	RTC ACTION 1	3601	0-None, 1-D.Out1 ON, 2-D.Out1 OFF, 3-D.Out2 ON, 4-D.Out2 OFF, 5-R.Out1 ON, 6-R.Out1 Off, 7-R.Out2 ON, 8-R.Out2 Off, 9-Increment, 10-Decrement, 11-Reset, 12-D.Out1 On/IncP107, 13-D.Out1 Off/IncP107, 14-D.Out1 On/DecP107, 15-D.Out1 Off/DecP107, 16-D.Out1 On/Reset, 17-D.Out1 Off/Reset, 18-R.Out1 On/IncP107, 19-R.Out1 Off/IncP107, 20-R.Out1 On/DecP107, 21-R.Out1 Off/DecP107, 22-R.Out1 On/Reset, 23-R.Out1 Off/Reset	None	
	RTC ACTION 2	3602		None	
	RTC MESSAGE 1	3603	0-None, 1-Clean Filter, 2-Change Filter, 3-Apply	None	
	RTC MESSAGE 2	3604	Oil/Lube, 4-Service Motor, 5-Service Drive, 6-Service Coolant, 7-Service Heating, 8-RTC Alarm	None	
	ACTION 1 QUALIFIER	3605	0-Once, 1-Second, 2-Minute,	Once	
	ACTION 2 QUALIFIER	3606	3-Hourly, 4-Daily, 5-Monthly,	Once	
	MESSAGE 1 QUALIFIER	3607	6-Yearly	Once	
	MESSAGE 2 QUALIFIER	3608		Once	
	ACTION 1 DATE/TIME	3609	MM DD, YYYY HH:MM:SS	Jan 01,2000 00:00:00	
	ACTION 2 DATE/TIME	3610	MM DD, YYYY HH:MM:SS	Jan 01,2000 00:00:00	
	MESSAGE 1 DATE/TIME	3611	MM DD, YYYY HH:MM:SS	Jan 01,2000 00:00:00	
	MESSAGE 2 DATE/TIME	3612	MM DD, YYYY HH:MM:SS	Jan 01,2000 00:00:00	
	RTC COUNTER MAX	3630	00000-99999	60	
	Daylight Saving Time SELECT	3631	0-OFF, 1-U.S.A., 2-E.U.	OFF	

[1] The adjustable range of each Preset Position parameter is x:y where

x = -499999 to 499999 REV

y = -4095 to 4395 counts

Note: In Mint WorkBench, each position is displayed as individual parameters. For example, Preset POS 2 is 3301(x) and 2217(y).

CE Declaration of Conformity

Baldor indicates that the products are only components and not ready for immediate or instant use within the meaning of "Safety law of appliance", "EMC Law" or "Machine directive". The final mode of operation is defined only after installation into the user's equipment. It is the responsibility of the user to verify compliance.

EMC - Conformity and CE - Marking

The information contained herein is for your guidance only and does not guarantee that the installation will meet the requirements of the council directive 89/336/EEC.

The purpose of the EEC directives is to state a minimum technical requirement common to all the member states within the European Union. In turn, these minimum technical requirements are intended to enhance the levels of safety both directly and indirectly.

Council directive 89/336/EEC relating to Electro Magnetic Compliance (EMC) indicates that it is the responsibility of the system integrator to ensure that the entire system complies with all relative directives at the time of installing into service.

Motors and controls are used as components of a system, per the EMC directive. Hence all components, installation of the components, interconnection between components, and shielding and grounding of the system as a whole determines EMC compliance.

The CE mark does not inform the purchaser which directive the product complies with. It rests upon the manufacturer or his authorized representative to ensure the item in question complies fully with all the relative directives in force at the time of installing into service, in the same way as the system integrator previously mentioned. Remember, it is the instructions of installation and use, coupled with the product, that comply with the directive.

Wiring of Shielded (Screened) Cables

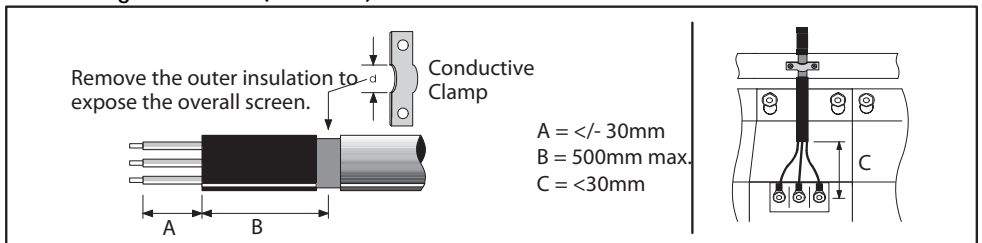

Shielded Couplings

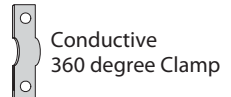
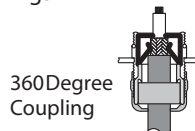
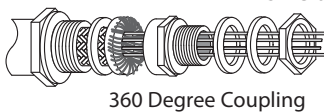

EMC Installation Options

When installed for Class A or Class B operation, the control is compliant with EN55011 (1991)/ EN55022 (1994) for radiated emissions as described.

Grounding for Wall Mounting (Class A) also see Chapter 4

Top cover must be installed.

- A single-star point (earth) is required.
- The protective earth connection (PE) to the motor must be run inside the screened cable or conduit between the motor and control and be connected to the protective earth terminal at the control.
- The internal/external AC supply filter must be permanently earthed.
- The signal/control cables must be screened.

Grounding for Enclosure Mounting (Class B) also see Chapter 4

- The unit is installed for Class B operation when mounted inside an enclosure that has 10dB attenuation from 30 to 100MHz (typically the attenuation provided by a metal cabinet with no opening greater than 0.15m), using the recommended AC supply filter and having met all cable requirements.

Note: Radiated magnetic and electric fields inside the cubicle will be high and components installed inside must be sufficiently immune.

- The control, external filter and associated equipment are mounted onto a conducting, metal panel. Do not use enclosures that use insulating mounting panels or undefined mounting structures. Cables between the control and motor must be screened or in conduit and terminated at the control.

Using CE approved components will not guarantee a CE compliant system!

1. The components used in the drive, installation methods used, materials selected for interconnection of components are important.
2. The installation methods, interconnection materials, shielding, filtering and grounding of the system as a whole will determine CE compliance.
3. The responsibility of CE mark compliance rests entirely with the party who offers the end system for sale (such as an OEM or system integrator).

Baldor products which meet the EMC directive requirements are indicated with a "CE" mark. A signed CE declaration of conformity is provided in this section.

EMC Wiring Technique

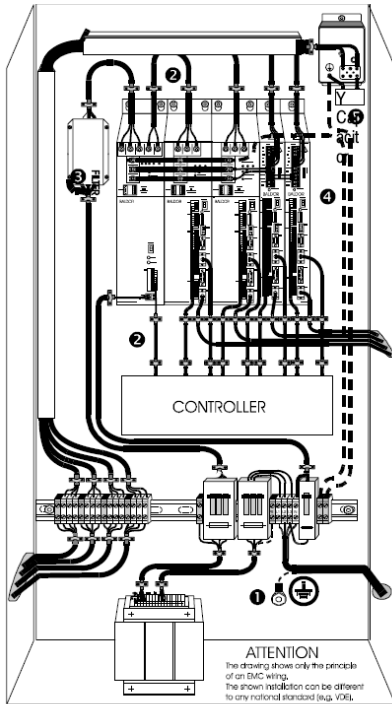

1 CABINET

The drawing shows an electroplated zinc coated enclosure, which is connected to ground.

This enclosure has the following advantages:

- All parts mounted on the back plane are connected to ground.
- All shield (screen) connections are connected to ground.

Within the cabinet there should be a spatial separation between power wiring (motor and AC power cables) and control wiring.

2 SCREEN CONNECTIONS

All connections between components must use shielded cables. The cable shields must be connected to the enclosure. Use conductive clamps to ensure good ground connection. With this technique, a good ground shield can be achieved.

3 EMC - FILTER

The EMI or main filter should be mounted next to the power supply (here BPS). For the connection to and from the main filter screened cables should be used. The cable screens should be connected to screen clamps on both sides. (Exception: Analog Command Signal).

4 Grounding (Earth)

For safety reasons (VDE0160), all BALDOR components must be connected to ground with a separate wire. The diameter of the wire must be at minimum AWG#6 (10mm²). Ground connections (dashed lines) must be made from the central ground to the regen resistor enclosure and from the central ground to the Shared Power Supply.

5 Y-CAP ACITOR

The connection of the regeneration resistor can cause RFI (radio frequency interference) to be very high. To minimize RFI, a Y-capacitor is used. The capacitor should only be connected between the dynamic brake resistor housing and terminal pin R1

EMC Installation Instructions

To ensure electromagnetic compatibility (EMC), the following installation instructions should be completed. These steps help to reduce interference.

Consider the following:

- Grounding of all system elements to a central ground point
- Shielding of all cables and signal wires
- Filtering of power lines

A proper enclosure should have the following characteristics:

- A) All metal conducting parts of the enclosure must be electrically connected to the back plane. These connections should be made with a grounding strap from each element to a central grounding point. [1]
- B) Keep the power wiring (motor and power cable) and control wiring separated. If these wires must cross, be sure they cross at 90 degrees to minimize noise due to induction.
- C) The shield connections of the signal and power cables should be connected to the screen rails or clamps. The screen rails or clamps should be conductive clamps fastened to the cabinet. [2]
- D) The cable to the regeneration resistor must be shielded. The shield must be connected to ground at both ends.

- E) The location of the AC mains filter has to be situated close to the drive so the AC power wires are as short as possible.
- F) Wires inside the enclosure should be placed as close as possible to conducting metal, cabinet walls and plates. It is advised to terminate unused wires to chassis ground. [1]
- G) To reduce ground current, use at least a 10mm² (6 AWG) solid wire for ground connections.

[1] Grounding in general describes all metal parts which can be connected to a protective conductor, e.g. housing of cabinet, motor housing, etc. to a central ground point. This central ground point is then connected to the main plant (or building) ground.

[2] Or run as twisted pair at minimum.

Example Cable Screens Grounding

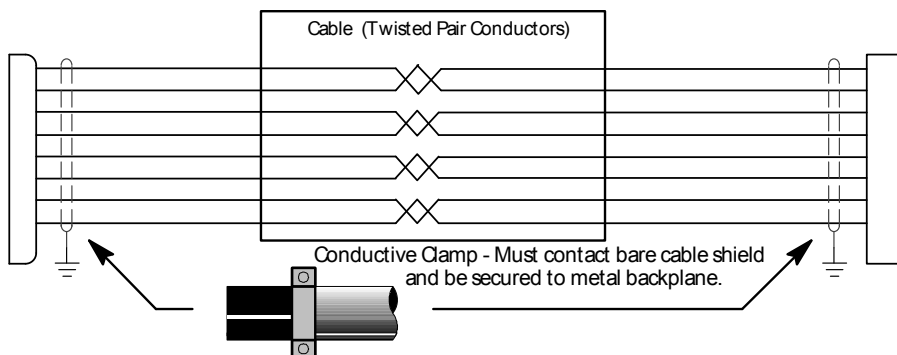

Appendix D

Options and Kits

D.1 Dynamic Braking (DB) Hardware

Whenever a motor is abruptly stopped or forced to slow down quicker than if allowed to coast to a stop, the motor becomes a generator. This energy appears on the DC Bus of the control and must be dissipated using dynamic braking hardware. Dynamic braking resistors are completely assembled and mounted in a NEMA 1 enclosure. A listing of available RGA assemblies is provided in Table D-1. Select the braking resistor that has correct ohm value for the control and adequate continuous watts capacity to meet load requirements.

Table D-1: Dynamic Braking Resistor Assemblies (RGA)

Input Volts	HP	Total* Ohms	Continuous Rated Watts						
			600	1200	2400	4800	6400	9600	14200
460	1-3	120	RGA6120	RGA12120	RGA24120				
	5-10	60	RGA660	RGA1260	RGA2460	RGA4860			
	15-25	20	RGA620	RGA1220	RGA2420	RGA4820			
	30-50	10		RGA1210	RGA2410	RGA4810			
	60-125	4		RGA1204	RGA2404	RGA4804	RGA6404	RGA9604	RGA14204
	150	2				RGA4802	RGA6402	RGA9602	RGA14202

*Note: Total Ohms column indicates the minimum resistance that the output transistors can drive. For example, if the Total Ohms column indicates 6 ohms and a 6 ohm resistor is unavailable, an 8 ohm can be used but not a 4 ohm resistor.

D.2 Expansion Boards

Baldor offers a wide variety of plug-in expansion boards for their Controls. Expansion boards allow a control to be compatible with various inputs and outputs. Each control can accept up to two expansion boards. Chapter 3 of this manual describes the locations of the connectors for these expansion boards.

Table D-2: Expansion Board Descriptions

Catalog Number	Description														
EXBHH001A01 or later	Ethernet Server Expansion Board Uses standard RJ-45 female terminal for Ethernet connection. Provides easy connection to any PC based Web Browser that has an Ethernet connection. Allows you to quickly access all drive parameters for setup and review. Download parameter values, operating conditions, and fault log data for review and archive.														
EXBHH003A01 or later	Isolated Input Expansion Board Contains 9 isolated inputs, jumper configurable for 90-130 VAC. All inputs must be the same voltage. One side of all inputs is common. This board replaces all the opto inputs on the main control board. Uses screw terminals for connection.														
EXBHH005A01 or later	High resolution analog board Allows two inputs with up to 16 bits resolution. DC inputs: $\pm 10V$, 0-10V, $\pm 5V$, 0-5V, with 300 microvolt resolution. Current inputs: 4-20 mA, with 0.6 microamps resolution. <table border="1" style="margin-left: auto; margin-right: auto;"> <thead> <tr> <th>Input</th> <th>Resolution</th> </tr> </thead> <tbody> <tr> <td>$\pm 10 V$</td> <td>16 bit</td> </tr> <tr> <td>0 - 10 V</td> <td>15 bit</td> </tr> <tr> <td>$\pm 5 V$</td> <td>15 bit</td> </tr> <tr> <td>0 - 5 V</td> <td>14 bit</td> </tr> <tr> <td>0 - 20 mA</td> <td>15 bit</td> </tr> <tr> <td>4 - 20 mA</td> <td>15 bit</td> </tr> </tbody> </table> <p>Both the 0-10 V and 4-20 mA inputs may be inverted to 10-0 V and 20-4 mA. Two outputs, each with $\pm 10 VDC$, 0-10 VDC or 4-20 mA with inverting capability. These are in addition to the two analog outputs on the main control board (4 total). Uses screw terminals for connection.</p>	Input	Resolution	$\pm 10 V$	16 bit	0 - 10 V	15 bit	$\pm 5 V$	15 bit	0 - 5 V	14 bit	0 - 20 mA	15 bit	4 - 20 mA	15 bit
Input	Resolution														
$\pm 10 V$	16 bit														
0 - 10 V	15 bit														
$\pm 5 V$	15 bit														
0 - 5 V	14 bit														
0 - 20 mA	15 bit														
4 - 20 mA	15 bit														
EXBHH007A01 or later	Master Pulse Reference / Isolated Pulse Follower Jumper selection of the following modes: <ol style="list-style-type: none"> 1. Accepts a 5VDC or 12VDC quadrature pulse train input or pulse and direction input to use as a master reference. 2. Re-transmits the input pulse train at 5VDC for ratios from 1:20 up to 65535:1. (Scaled output). 3. Can be used as a auxiliary encoder input to the control. 4. A CANopen port with an RJ-45 female connector for adding an additional I/O breakout box or CAN HMI terminal. 														
EXBHH013A01 or later	DeviceNet Expansion Board / Ethernet IP Communications Expansion Board. Allows connection to DeviceNet Communications Bus. Allows connection to Ethernet IP Communications Bus. Uses plug-in terminals for connection.														
EXBHH014A01 or later	Profibus DP Expansion Board Allows connection to Profibus Communications Bus. Uses plug-in terminals for connection.														
EXBHH015A01	BACnet Expansion Board Allows connection to a BACnet Communications Network Uses 9-pin D-shell for connection														
EXBHH017A01 or later	Metasys N2 Communications Expansion Board Allows connection to or N2 communications network Uses plug-in terminals for connection														

D.3 Keypad Extension Cable

For the convenience of our customers, we offer a connector plug/cable assembly. This assembly provides the connectors from the keypad to the control for remote keypad operation.

Caution: Only use cables manufactured by Baldor. Cables purchased from other sources may not be properly wired and may damage the control or keypad and void the warranty.

Table D-3: Keypad Extension Cable Selection

Catalog Number	Length
CBLHH015KP	5 ft (1.5m)
CBLHH030KP	10 ft (3.0m)
CBLHH046KP	15 ft (4.6m)
CBLHH061KP	20 ft (6.1m)
CBLHH091KP	30 ft (9.1m)
CBLHH152KP	50 ft (15.2m)
CBLHH229KP	75 ft (22.9m)
CBLHH305KP	100 ft (30.5m)
CBLHH457KP	150 ft (45.7m)
CBLHH610KP	200 ft (61.0m)

D.4 Keypad Connector

The keypad connector referenced in Figure D-1 and Table D-4 is an RJ-11 type wired as half duplex FS485. Twisted pair wire must be used to connect the keypad and control for remote mounting of the keypad.

Figure D-1: Connector Connection

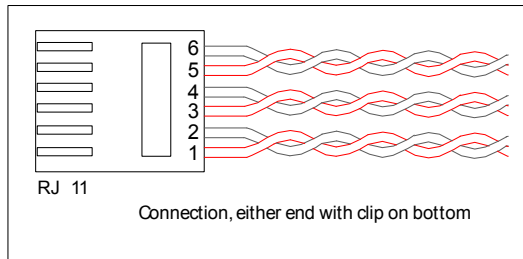

Table D-4: Cable Connections

Pin	Signal Name	Description
1	A	RS485 Line A
2	B	RS485 Line B
3	KP_PS_GND	Power Supply Return
4	+8V	Power Supply +
5	KP_PS_GND	Power Supply Return
6	+8V	Power Supply +

D.5 Optional Remote Keypad Installation

The keypad may be remotely mounted using optional Baldor keypad extension cable (refer to Table D-3). When the keypad is properly mounted to a NEMA Type 4X enclosure, it retains the the Type 4X rating. The mounting/drill template is located in Appendix E of this manual.

Caution: Only use cables manufactured by Baldor. Cables purchased from other sources may not be properly wired and may damage the control or keypad and void the warranty.

Tools Required:

- Center punch, tap handle, screwdrivers (Phillips and straight)
- #27 drill bit
- 1-3/8" standard knockout punch
- RTV Sealant
- (3) 6-32x3/8" screws
- (3) #6 Flat Washers

Mounting Instructions: For clearance mounting holes

1. Locate a flat 4" wide x 5.5" minimum high mounting surface. Material should be sufficient thickness (14 gauge minimum).
2. Place the template on the mounting surface or mark the holes as shown on the template.
3. Accurately center punch the 3 mounting holes and the large knockout.
4. Drill three #27 clearance holes.
5. Locate the 1 1/8" knockout center and punch using the manufacturers instructions.
6. Debur knockout and mounting holes making sure the panel stays clean and flat.
7. Apply RTV to the three #27 clearance holes.
8. Assemble the keypad to the panel. Use 6-32 screws and flat washers.
9. From the inside of the panel, apply RTV over each of the three mounting screws and nuts. Cover a 3/4" area around each screw making sure to completely encapsulate the screw head and washer.
10. Refer to Appendix A for selection of cables designed to be used for remote mounting of keypad. Be sure that only Baldor cables are used. Route the keypad cable into the control and connect to P2 of the control board, Figure D-2 .

Figure D-2: Connector Locations

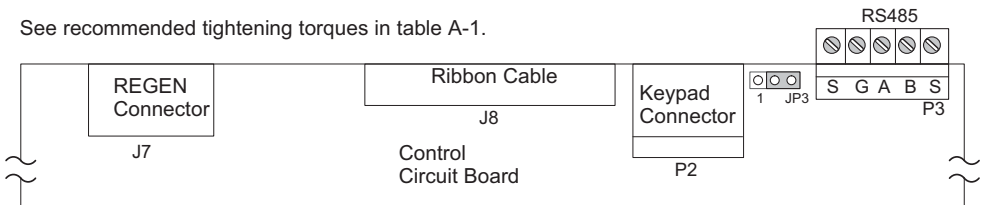

Appendix E

Remote Keypad Mounting Template

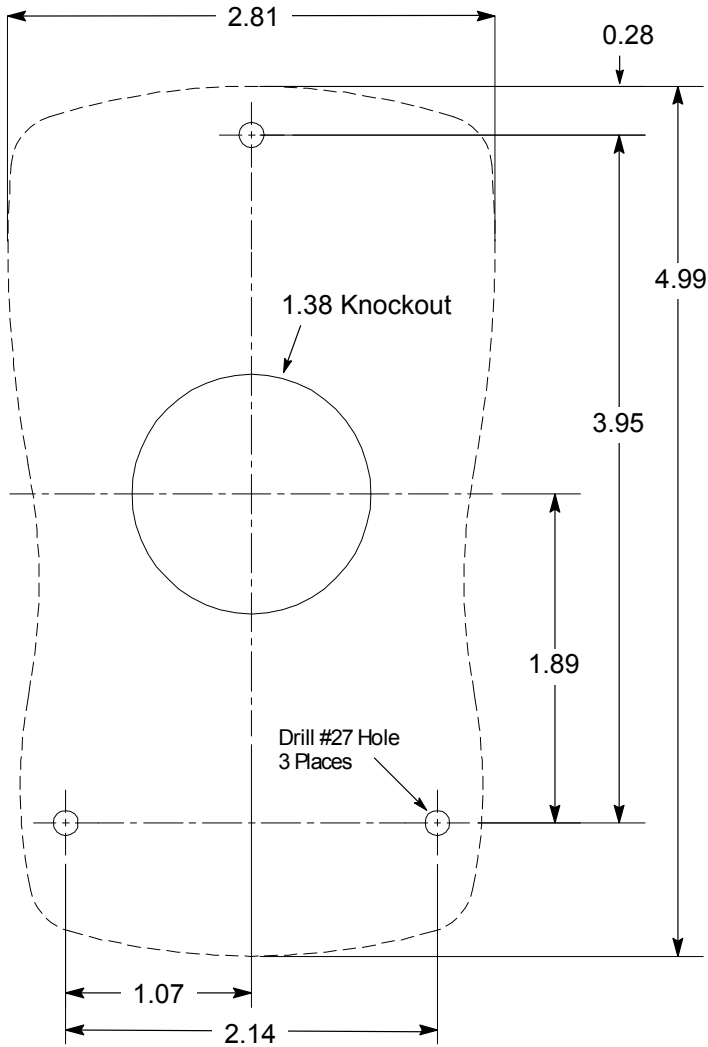

Note: Template may be distorted due to reproduction. (KP0030A00)

Baldor District Offices

UNITED STATES

ARIZONA

PHOENIX
4211 S 43RD PLACE
PHOENIX, AZ 85040
PHONE: 602-470-0407
FAX: 602-470-0464

ARKANSAS

CLARKSVILLE
1001 COLLEGE AVE.
CLARKSVILLE, AR 72830
PHONE: 479-754-9108
FAX: 479-754-9205

CALIFORNIA

LOS ANGELES
6160 FLOTTILA
COMMERCE, CA 90040
PHONE: 323-724-6771
FAX: 323-721-8859

HAYWARD

21056 FORBES STREET
HAYWARD, CA 94546
PHONE: 510-785-9900
FAX: 510-785-9910

COLORADO

DENVER
3855 FOREST STREET
DENVER, CO 80207
PHONE: 303-623-0127
FAX: 303-595-3772

9980 PARK MEADOWS DRIVE
SUITE 214
LONE TREE, CO 80124-6739
PHONE: 303-339-9629
FAX: 303-339-9633

CONNECTICUT

WALLINGFORD
65 SOUTH TURNPIKE ROAD
WALLINGFORD, CT 06492
PHONE: 203-289-1564
FAX: 203-289-5485

FLORIDA

TAMPA/PUERTO RICO/
VIRGIN ISLANDS
3905 EAST 11TH AVENUE
TAMPA, FL 33605
PHONE: 813-249-0578
FAX: 813-247-2984

GEORGIA

ATLANTA
62 TECHNOLOGY DR.
ALPHARETTA, GA 30005
PHONE: 770-772-7000
FAX: 770-772-7200

5480 MCGINNIS FERRY PLACE
SUITE 133
ALPHARETTA, GA 30005
PHONE: 770-752-4254
FAX: 770-752-4257

ILLINOIS

CHICAGO
4 SAMMONS COURT
BOLINGBROOK, IL 60440
PHONE: 630-296-1400
FAX: 630-226-9420

INDIANA

COLUMBUS
3300 TENTH ST
COLUMBUS, IN 47201
PHONE: 317-378-2556
FAX: 317-378-2555

INDIANAPOLIS

5525 W. MINNESOTA STREET
INDIANAPOLIS, IN 46241
PHONE: 317-246-5100
FAX: 317-246-5110

IOWA

DES MOINES
1800 DIXON STREET, SUITE C
DES MOINES, IA 50316
PHONE: 515-263-8929
FAX: 515-263-8515

KANSAS

5030 BOB BILLINGS PKWY STE B
LAWRENCE, KS 66049
PHONE: 785-748-4339
FAX: 785-748-4217

MARYLAND

BALTIMORE
6660 SANTA BARBARA RD.
SUITE 22.24
ELK RIDGE, MD 21075
PHONE: 410-579-2135
FAX: 410-579-2677

MASSACHUSETTS

BOSTON
6 PULLMAN STREET
WORCESTER, MA 01606
PHONE: 508-854-0708
FAX: 508-854-0291

MICHIGAN

DETROIT
33782 STERLING PONDS BLVD.
STERLING HEIGHTS, MI 48312
PHONE: 588-978-9800
FAX: 588-978-9869

GRAND RAPIDS
668 THREE MILE ROAD NW
GRAND RAPIDS, MI 49504
PHONE: 616-785-1784
FAX: 616-785-1788

MINNESOTA

MINNEAPOLIS
21080 134TH AVE. NORTH
ROGERS, MN 55374
PHONE: 763-428-3633
FAX: 763-428-4551

MISSOURI

ST LOUIS
422 INDUSTRIAL DRIVE
MARYLAND HEIGHTS, MO 63043
PHONE: 314-298-1800
FAX: 314-298-7660

KANSAS CITY
1501 BEDFORD AVENUE
NORTH KANSAS CITY, MO 64116
PHONE: 816-587-0272
FAX: 816-587-3735

NEW YORK

AUBURN
ONE ELLIS DRIVE
AUBURN, NY 13021
PHONE: 315-255-3403
FAX: 315-253-9923

NORTH CAROLINA

GREENSBORO
1220 ROTHERWOOD ROAD
GREENSBORO, NC 27406
PHONE: 336-272-6104
FAX: 336-273-6628

OHIO

CINCINNATI
2929 CRESCENTVILLE ROAD
WEST CHESTER, OH 45069
PHONE: 513-771-2600
FAX: 513-772-2219

CLEVELAND

8929 FREEWAY DRIVE
MACEDONIA, OH 44056
PHONE: 330-489-4777
FAX: 330-489-4779

26525 CHAGRIN BLVD SUITE 208
CLEVELAND, OH 44122
PHONE: 216-360-8296
FAX: 216-360-4172

OKLAHOMA

TULSA
2 EAST DAWES
BIXBY, OK 74008
PHONE: 918-368-3320
FAX: 918-366-8338

OREGON

PORTLAND
20383 SW AVERY COURT
TUALATIN, OR 97062
PHONE: 503-891-3010
FAX: 503-891-3012

PENNSYLVANIA

KING OF PRUSSIA
1060 FIRST AVE STE 400
KING OF PRUSSIA, PA 19406
PHONE: 610-768-8018
FAX: 215-672-5759

PHILADELPHIA

1036 THOMAS BUSCH
MEMORIAL HIGHWAY
PENNSAUKEN, NJ 08110
PHONE: 856-661-1442
FAX: 856-663-6363

PITTSBURGH

153 PROMINENCE DRIVE
NEW KENSINGTON, PA 15088
PHONE: 724-889-0092
FAX: 724-889-0094

TENNESSEE

MEMPHIS
4000 WINCHESTER ROAD
MEMPHIS, TN 38118
PHONE: 901-365-2020
FAX: 901-365-3914

TEXAS

ADDISON
3939 BELT LINE ROAD #250
ADDISON, TX 75001
PHONE: 972-499-7746, 499-7747
FAX: 972-242-1505

DALLAS

3040 QUEBEC
DALLAS, TX 75247
PHONE: 214-634-7271
FAX: 214-634-8874

HOUSTON

4647 PINE TIMBERS
SUITE # 135
HOUSTON, TX 77041
PHONE: 713-895-7062
FAX: 713-690-4540

UTAH

SALT LAKE CITY
2230 SOUTH MAIN STREET
SALT LAKE CITY, UT 84115
PHONE: 801-832-0127
FAX: 801-832-8911

VIRGINIA

RICHMOND
6767 FOREST HILL AVE STE 305
RICHMOND, VA 23225
PHONE: 804-545-8848
FAX: 804-545-8840

WASHINGTON

KIRKLAND, WA
550 KIRKLAND WAY STE 205
KIRKLAND, WA 98033
PHONE: 425-962-5000
FAX: 775-255-8019

WISCONSIN

MILWAUKEE
2725 SOUTH 163RD STREET
NEW BERLIN, WI 53151
PHONE: 262-784-5940
FAX: 262-784-1215

WAUKESHA

N14 W23777 STONE RIDGE DRIVE
SUITE 170
WAUKESHA, WI 53188
PHONE: 262-347-2000
FAX: 262-347-0258

INTERNATIONAL SALES

FORT SMITH, AR
P.O. BOX 2400
FORT SMITH, AR 72902
PHONE: 479-646-4711
FAX: 479-648-8995

CANADA

EDMONTON, ALBERTA
4053-92 STREET
EDMONTON, ALBERTA T6E 6R8
PHONE: 780-434-4900
FAX: 780-438-2600

11428-168 STREET

EDMONTON, ALBERTA T5M 3T9
PHONE: 780-822-7865
FAX: 780-822-7878

MISSISSAUGA, ONTARIO
244 BRITANNIA ROAD EAST
MISSISSAUGA, ONTARIO L4Z 1S6
PHONE: 905-890-5110
FAX: 905-890-5540

OKAYVILLE, ONTARIO

2750 COWERTY ROAD
OKAYVILLE, ONTARIO L6H 6R1
PHONE: 905-829-3301
FAX: 905-829-3302

DORVAL, QUEBEC

95 RUE LINDSAY
DORVAL, QUEBEC H9P 2S6
PHONE: 514-422-8818
FAX: 514-422-8982

MONTREAL, QUEBEC

1844 WILLIAM STREET
MONTREAL, QUEBEC H3J 1R5
PHONE: 514-933-2711
FAX: 514-933-8639

VANCOUVER,

BRITISH COLUMBIA
1538 KEBET WAY
PORT COQUITLAM
BRITISH COLUMBIA V3C 5M5
PHONE: 604-421-2822
FAX: 604-421-3113

WINNIPEG, MANITOBA

54 PRINCESS STREET
WINNIPEG, MANITOBA R3B 1K2
PHONE: 204-942-5205
FAX: 204-956-4251

AUSTRALIA

UNIT 3, 6 STANTON ROAD
SEVEN HILLS, NSW 2147, AUSTRALIA
PHONE: (61) 2 9674 5455
FAX: (61) 2 9674 2495

UNIT 8, 5 KELLETTS ROAD

ROWVILLE, VICTORIA, 3178
AUSTRALIA
PHONE: (61) (3) 9753 4355
FAX: (61) (3) 9753 4366

EL SALVADOR

RESIDENCIAL PINARES DE SUIZA
P.O. 15 444,
NVA. SAN SALVADOR, EL SALVADOR
PHONE: +503 2288-1519
FAX: +503 2288-1518

CHILE

LUIS THAYER OJEDA 166,
OF 402 - PROVIDENCIA
SANTIAGO, CHILE
PHONE: 56-2-290-0762
FAX: 56-2-290-0762

CHINA

5299 BEI SONG ROAD
SONGJIANG
201611 SHANGHAI, CHINA
PHONE: +86 21 5760 5335
FAX: +86 21 5760 5336

UNIT 905, 9TH FLOOR,

TOWER B WANDA PLAZA
NO. 93 JIANGSU ROAD,
CHAOYANG DISTRICT
BEIJING, 100022, CHINA
PHONE: +86 (010) 58205516
FAX: +86 (010) 58204231

GERMANY

DIESELSTRASSE 22
D-85551 KIRCHHEIM
MUNICH, GERMANY
PHONE: +49 89 90 5080
FAX: +49 89 90 50 8492

HERMANN-HEINRICH-GOSSEN-
STRASSE 3
D-50658 KÖLN, GERMANY
PHONE: 49 2234 37941 0
FAX: 49 2234 37941 64

INDIA

14 COMMERCE AVENUE
MAHAGANESH COLONY
PAUD ROAD
PUNE - 411038
MAHARASHTRA, INDIA
PHONE: 91 20 25452717, 25452718
FAX: 91 20 25452719

ITALY

BALDOR ASP AG
SUICORSALE DI MENDRISIO
VIA BORROMINI, 20A
CH-6850 MENDRISIO
SWITZERLAND
PHONE: 0041 91 640 99 50
FAX: 0041 91 630 26 33

JAPAN

DIA BLDG 802,
2-21-1 TSURUVA-CHO,
KANAGAWA-KU
YOKOHAMA, 221-0835, JAPAN
PHONE: 81-45-412-4506
FAX: 81-45-412-4507

KOREA

RW 1715, SUSEO TOWER, 725,
SUSEO-DONG, GANGNAM-GU,
SEOUL 135-757 KOREA
TEL: (82) 2 2226 9369
FAX: (82) 2 2226 9368

MEXICO

LEON, GUANAJUATO
KM. 2.0 BLVD. AEROPUERTO
LEON 37545, GUANAJUATO, MEXICO
PHONE: 52 477 751 2030
FAX: 52 477 761 2010

MIDDLE EAST & NORTH AFRICA

VSE INTERNATIONAL CORP.
P. O. BOX 5618
BUFFALO GROVE, IL 60089-5618
PHONE: 847 590 5547
FAX: 847 590 5587

SINGAPORE

18, KAKI BUKIT ROAD 3
#03-09 ENTREPRENEUR
BUSINESS CENTRE
SINGAPORE 415978
PHONE: (65) 6744 2572
FAX: (65) 6747 1708

PANAMA

AVE. RICARDO J. ALFARO
EDIFICIO SUN TOWERS MALL
PISO 2, LOCAL 55
CIUDAD DE PANAMA, PANAMA
PHONE: +507 236-5165
FAX: +507 261-5355

SWITZERLAND

POSTFACH 73
SCHUTZENSTRASSE 69
CH-8245 FEUERHAISEN
SWITZERLAND
PHONE: +41 52 647 4700
FAX: +41 52 659 2394

TAIWAN

1F, NO 126 WENSHAN 3RD STREET,
NANTUNG DISTRICT,
TAICHUNG CITY 408
TAIWAN R.O.C.
PHONE: (886) 4 238 04235
FAX: (886) 4 238 04463

UNITED KINGDOM

6 BRISTOL DISTRIBUTION PARK
HAWKLEY DRIVE
BRISTOL BS32 0BF U.K.
PHONE: +44 1454 850000
FAX: +44 1454 859001

VENEZUELA

AV. ROMA, QTA EL MILAGRO, URB.
CALIFORNIA NORTE
CARACAS, 1070 VENEZUELA
PHONE: 58-414-114-8623
FAX: 58-414-322-5750



BALDOR ELECTRIC COMPANY
World Headquarters
P.O. Box 2400 Fort Smith, AR 72901-2400
(479) 646-4711 Fax (479) 648-5792
www.baldor.com