

AUTOMATION STARTER A C S S A INSTRUCTION MANUAL

INSTRUCTION MANUAL
Document number: BOOK0923

Date of release: January 2001

OPERATING AND MAINTENANCE PERSONNEL

1. Read the whole Instruction Manual before installing and putting the equipment into operation.
2. During all work (operation, maintenance, repairs, etc.) observe the safety procedures given in this manual as well as any other operating instructions for the driven machine or system. See Emergency below.
3. The operator must avoid any conditions which reduce the safety of the device.
4. The operator must do what he can to ensure the device is not operated by unauthorized personnel.
5. The operator must immediately report any changes to the device which may reduce its safety to the user.

INSTALLATION OF SPARE PARTS

We expressly point out that any spare parts and accessories not supplied by Boston Gear have also not been tested or approved by Boston Gear.

Installing and/or using such products can have a negative effect on the characteristics designed for your device. The manufacturer is not liable for damage arising as a result of using non-original parts and accessories.

EMERGENCY

The starter may be safely shut down in an emergency by disconnecting the power supply at both the main disconnect and any control voltage source.

DISMANTLING AND SCRAPPING

The enclosure of the starter is made of recyclable material as aluminum, iron and plastic. Legal requirements for disposal and recycling of these materials must be complied with.

The starter contains a number of components demanding special treatment, as for example SCR's. The circuit board contains small amounts of tin and lead. Legal requirements for disposal and recycling of these materials must be complied with.

1. SAFETY	8
1.1 Integrated Safety Systems	8
1.2 Safety Measures	8
1.3 Notes to the Instruction Manual	8
1.4 Standards	8
2. INSPECTION	9
2.1 Transport and Packing	9
2.1.1 Check on Receipt:	9
2.1.2 Is the packaging damaged?	9
2.1.3 If You Have Cause for Complaint	9
2.1.4 Packaging for Returning the Device	9
2.1.5 Intermediate Storage	9
3. DESCRIPTION	10
3.1 General	10
3.1.1 Features	10
3.1.2 Special Application	11
3.1.3 Auxiliary Relays and Displays	11
3.1.4 Applications for the Starter	11
3.1.5 Connection – Minimum Wiring	12
3.2 Function of the Starter	13
3.3 Overview of Starter Operation	14
4. MOUNTING / WIRING	15
4.1 Mounting / Wiring	15
4.2 Installation of the Starter in a Cabinet	15
4.3 Connections	15
4.4 Standard Wiring	18
4.5 Wiring Example	19
4.5.1 Bypass	19
5. QUICK SET-UP	21
5.1 Checklist	22
5.2 Basic Parameter Setting	22
5.2.1 Parameters 007 and 008	22
5.2.2 Motor Nameplate Voltage [041]	23
5.2.3 Motor Nameplate FLA [042]	23
5.2.4 Motor Nameplate Power [043]	23
5.2.5 Motor Nameplate RPM [044]	23
5.2.6 Motor Power Factor [045]	23
5.2.7 Input Frequency [046]	24
5.2.8 Initial Voltage at Start Ramp 1 [001]	24
5.2.9 Start Time Ramp 1 [002]	24
5.2.10 Stop Time Ramp 1 [004]	24
5.3 Starting	25
5.3.1 Start/Stop/Reset from Keypad [006]	25
5.4 Current Read-out	25
5.4.1 RMS Current Read-out [005]	25

6. OPERATION	26
6.1 General Description of User Interface	26
6.1.1 The Keypad	26
6.1.2 LED Display	27
6.1.3 The Menu Structure	27
6.1.4 The Keys	28
6.1.5 Keypad Lock	28
6.1.6 The Three Built-in Relays	28
6.1.7 Overview of Starter Operation	28
6.2 Description of Functions	29
6.2.1 Parameter Groups / Monitor Functions	29
6.2.2 Detailed Function / Parameter Description	30
6.2.3 Reset to Factory Setting [199]	31
6.2.4 Function and Combination Matrix	31
6.3 Start / Stop / Reset	32
6.3.1 Control Mode Selection [006]	32
6.3.2 2-Wire Start / Stop with Automatic Reset at Start	33
6.3.3 2-Wire Start / Stop with Separate Reset	33
6.3.4 3-Wire Start / Stop with Automatic Reset at Start	33
6.4 Motor Data Setting	33
6.4.1 Motor Data	33
6.4.2 Motor Nameplate Voltage [041]	33
6.4.3 Motor Nameplate FLA [042]	34
6.4.4 Motor Nameplate Power [043]	34
6.4.5 Motor Nameplate RPM [044]	34
6.4.6 Motor Nameplate Power Factor [045]	34
6.4.7 Input Frequency [046]	34
6.5 Start / Stop Ramp Parameters	35
6.5.1 Setting Initial Voltage [001]	35
6.5.2 Setting Start Ramp Time [002]	35
6.5.3 Setting Stop Ramp Time [004]	35
6.5.4 Setting Step Down Voltage at Stop [003]	36
6.5.5 RMS Current Read Out [005]	36
6.5.6 Starting	36
6.6 Menu Expansion Settings	37
6.6.1 Setting of Menu Expansion for Monitor Functions [007]	37
6.6.2 Setting of Menu Expansion to Reach Extended Functions [008]	37
6.7 Dual Voltage Ramp at Start and Stop	38
6.7.1 Setting Initial Voltage 2 [011]	38
6.7.2 Setting Start Ramp Time 2 [012]	38
6.7.3 Setting of Step Down Voltage 2 [013]	39
6.7.4 Setting of Stop Ramp Time 2 [014]	39
6.8 Torque Control	39
6.8.1 Torque Control at Start / Stop [025]	39
6.8.2 Initial Torque at Start [016]	40
6.8.3 Max Torque at Start [017]	40
6.8.4 End Torque at Stop [018]	40
6.9 Current Limit Functions	41
6.9.1 Voltage Ramp with Current Limit [020]	41
6.9.2 Current Limit [021]	42
6.10 Pump Control	42
6.10.1 Setting of Pump Control [022]	42
6.11 Analog Input Control	43
6.11.1 Selecting Analog Input Control [023]	43
6.12 Full Voltage Start	44
6.12.1 Setting of Full Voltage Start [024]	44

6.13	Kick Start	44
6.13.1	Kick Start Active Time [030]	44
6.13.2	Kick Start Current Limit [031]	45
6.14	Bypass	45
6.14.1	Setting of Bypass Function [032]	45
6.15	Energy Saver	46
6.15.1	Setting of Energy Saver Control [033]	46
6.16	DC-brake	46
6.16.1	DC-brake Active Time [034]	46
6.16.2	DC-brake Current Limit [035]	47
6.17	Slow Speed	47
6.17.1	Slow Speed Torque [037]	47
6.17.2	Slow Speed with JOG Buttons [103 & 104]	47
6.17.3	Slow Speed During a Selected Time [038 & 039]	48
6.17.4	Slow Speed Controlled by an External Signal [036]	48
6.17.5	DC-brake After Slow Speed at Stop	49
6.18	Programmable Relay K1 and K2	50
6.18.1	Setting of Relay K1 Indication [051]	50
6.18.2	Setting of Relay K2 Indication [052]	50
6.19	Analog Output	51
6.20	Parameter Set	52
6.20.1	Parameter Set [061]	52
6.21	Automatic Return Parameter	53
7.	PROTECTION AND ALARM	54
7.1	Alarm Description	54
7.1.1	Alarm with Stop Requiring a Separate Reset	54
7.1.2	Alarm with Stop Requiring only a New Start Command	54
7.1.3	Alarm without Stop	54
7.2	Alarm Overview	55
7.3	Line Power Monitor / Protection (Alarm F1, F8, F9 and F10)	56
7.3.1	Phase Loss Failure	56
7.3.2	Run at Phase Loss Failure [101]	56
7.3.3	Voltage Unbalance [081]	56
7.3.4	Response Delay Voltage Unbalance [082]	57
7.3.5	Over Voltage [083]	57
7.3.6	Response Delay Over Voltage [084]	57
7.3.7	Under Voltage [085]	58
7.3.8	Response Delay Under Voltage [086]	58
7.4	Motor Overload Protection (F2 alarm)	58
7.4.1	Motor RTD Input [071]	58
7.4.2	Thermal Overload Protection [072]	59
7.4.3	Used Thermal Capacity [073]	59
7.5	Starter Over-Temperature (F3 alarm)	59
7.6	Current Limit Start Alarm (F4 alarm)	60
7.6.1	Full Speed not Reached at Set Current Limit and Start Time [102]	60
7.7	Locked Rotor (F5 alarm)	60
7.7.1	Locked Rotor [075]	60
7.8	Load monitor Max and Min / Protection (F6 and F7 alarms)	61
7.8.1	Output Power In % [090]	61
7.8.2	Auto Set Power Limit [089]	61
7.8.3	Start Delay for Power Limits [091]	61
7.8.4	Max Power Alarm Limit [092]	62
7.8.5	Max Alarm Response Delay [093]	62
7.8.6	Min Power Alarm Limit [098]	62
7.8.7	Min Alarm Response Delay [099]	63

TABLE OF CONTENTS

7.9	Starts / Hour Limitation Function (F11 alarm)	63
7.9.1	Starts / Hour Limitation [074]	63
7.10	Phase Sequence Alarm (F16 alarm)	64
7.10.1	Phase Sequence Alarm [088]	64
7.10.2	Phase Sequence [087]	64
7.11	Alarm List	64
7.12	Pre-Alarms	65
7.12.1	Max Power Pre-Alarm Limit [094]	65
7.12.2	Max Pre-Alarm Response Delay [095]	65
7.12.3	Min Power Pre-Alarm Limit [096]	66
7.12.4	Min Pre-Alarm Response Delay [097]	66
8.	VIEW OPERATION	67
8.1	General	67
8.2	Measured Values	67
8.3	Viewing of the Measured Values	67
8.3.1	RMS Current [201]	67
8.3.2	Line Voltage [202]	67
8.3.3	Output Power [203]	68
8.3.4	Power Factor [204]	68
8.3.5	Total Power Consumption [205]	68
8.3.6	Reset of Power Consumption [206]	68
8.3.7	Motor Shaft Torque [207]	69
8.3.8	Elapsed Time [208]	69
8.3.9	Current Phase L1 [211]	69
8.3.10	Current Phase L2 [212]	69
8.3.11	Current Phase L3 [213]	70
8.3.12	Line Voltage L1-L2 [214]	70
8.3.13	Line Voltage L1-L3 [215]	70
8.3.14	Line Voltage L2-L3 [216]	70
9.	TROUBLESHOOTING	71
9.1	Fault, Possible Cause and Solution	71
10.	SPECIAL CONDITIONS	73
10.1	Small Motor or Low Load	73
10.2	Ambient Temperature Below 0°C	73
10.3	Power Factor Correction Capacitors	73
10.4	Reversing and Two Speed Contactors	73
10.5	Shielded Motor Cable	73
10.6	Slip Ring / Wound Rotor Motors	73
10.7	Starting into Back Spinning Loads	73
10.8	Running Motors in Parallel	73
10.9	Insulation Test on Motor	73
11.	MAINTENANCE	74
12.	TECHNICAL DATA	75
13.	PARAMETERS	77

LIST OF TABLES

Table 1	Overview of Starter Operation and Parameter Set-up.	14
Table 2	PCB Terminals	17
Table 3	Combination Matrix	31
Table 4	Start / Stop Combination	32

LIST OF FIGURES

Fig. 1	The Keypad and Menu Structure.	10
Fig. 2	Connection - Minimum Wiring	12
Fig. 3	Relay Logic Sequence	13
Fig. 4	Connection of ACSSA420 to ACSSA450.....	15
Fig. 5	Connection of ACSSA475 to ACSSA4100	16
Fig. 6	Connections on the PCB, Control Card.	17
Fig. 7	Connection - Standard Wiring	18
Fig. 8	Connection - Standard Wiring with Bypass	19
Fig. 9	Current Transformer Position on ACSSA420 to ACSSA4100 with Bypass	20
Fig. 10	Current Transformer Position on ACSSA4150 to ACSSA4600 with Bypass	20
Fig. 11	Connection - Standard Wiring	21
Fig. 12	Automation Starter ACSSA Models	26
Fig. 13	Keypad	26
Fig. 14	LED Indication Sequence	27
Fig. 15	Menu Structure	27
Fig. 16	Parameter Numbers for Start / Stop Ramps	35
Fig. 17	Parameter Numbers for Dual Voltage Ramps	38
Fig. 18	Torque Control at Start / Stop	39
Fig. 19	Wiring for Analog Input	43
Fig. 20	Selecting Voltage or Current for Analog Input	43
Fig. 21	Kick Start in Voltage Ramp Mode	44
Fig. 22	Slow Speed at Start / Stop During a Selected Time.....	48
Fig. 23	Selecting Voltage Input	49
Fig. 24	Slow Speed External Input Connection	49
Fig. 25	Slow Speed Controlled by an External Signal	49
Fig. 26	K1 / K2 Relay Function "Operation" and "Full voltage"	50
Fig. 27	Analog Output Connections	51
Fig. 28	Selecting Current or Voltage Output	51
Fig. 29	Parameter Overview	52
Fig. 30	Selection of Parameter Sets Via External Inputs	52

1.1 INTEGRATED SAFETY SYSTEMS

The unit comes standard with a complete diagnostic package that monitors and provides protection for:

- Over temperature.
- Voltage imbalance.
- Over and under voltage.
- Phase reversal (selectable)
- Phase loss
- Motor overload and RTD input.
- Motor load monitor, protecting machine or process max or min alarm
- Starts per hour limitation

1.2 SAFETY MEASURES

These instructions are an integral part of the device and must be:

- Available to competent personnel at all times.
- Read prior to installation of the device.
- Observed with regard to safety, warnings and information given.

The tasks in these instructions are described so that they can be understood by people trained in electrical engineering. Such personnel must have appropriate tools and testing instruments available. Such personnel must have been trained in safe working methods.

The user must obtain any general and local operating permits and meet any requirements regarding:

- Safety of personnel.
- Product disposal.
- Environmental protection.

NOTE! *The safety measures must remain in force at all times. Should questions or uncertainties arise, please contact your local distributor.*

1.3 NOTES TO THE INSTRUCTION MANUAL



WARNING! Warnings are marked with a warning triangle.

IMPORTANT

For all inquiries and spare parts orders, please quote the correct name of the device and serial number to ensure that your inquiry or order is dealt with correctly and swiftly.

1.4 STANDARDS

The device is manufactured in accordance with EC regulations.

- IEC 947-4-2
- EN 60 204-1 Electrical equipment of machines, part 1, General requirements and VDE 0113.
- EN 50081-2, EMC Emission
- EN 50081-1, EMC Emission with bypass
- EN 50082-2, EMC Immunity
- cUL usa

2.1 TRANSPORT AND PACKING

The device is packed in a carton or plywood box for delivery. The outer packaging can be returned. The devices are carefully checked and packed before dispatch, but transport damage cannot be ruled out.

2.1.1 Check on Receipt:

- Check that the shipment is complete as listed on the packing slip, see part no., rating, etc. on the nameplate.

2.1.2 Is the packaging damaged?

- Check the goods for damage (visual check).

2.1.3 If You Have Cause for Complaint

If the goods have been damaged in transport:

- Contact the transport company immediately.
- Keep the packaging (for inspection by the transport company or for returning the device).

2.1.4 Packaging for Returning the Device

- Pack the device so that it is shock-resistant.

2.1.5 Intermediate Storage

After delivery or after it has been unpacked, the device can be stored before further use in a dry room.

3.1 GENERAL

The Automation Starter ACSSA is installed directly between the branch disconnect and the motor.

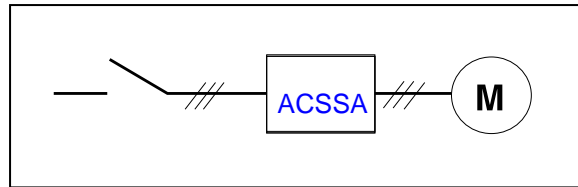

The starter is developed for soft starting and stopping three-phase motors. After adjustment of appropriate parameters, a microprocessor will calculate all necessary output voltage values. The output voltage has three-phase control.

On the front of the starter there is a built-in operator panel with an LED character display and a keypad. The functions of the keypad are organized in a simple "One Level" menu structure. Controlling the motor (i.e. start/stop) is done either from the keypad, through remote control inputs, or through the serial interface. To get the function and performance expected, a number of parameters have to be set:

- The "Quick Set-up" allows the soft start to be programmed for operation by setting only 9 parameters.
- To optimize system performance it is possible to access and adjust up to 71 parameters.

When using the default start mode of the starter via "Voltage Ramp Function":

- The motor voltage is controlled from the starting voltage through to full supply voltage and vice versa.
- The starting current of the motor is thus reduced. A typical starting current of a starter using the ramp function amounts to about 300-400% of the rated current, compared with 600-800% of rated current in across-the-line starting. As a rule, the starting current is half of that required for an across-the-line start.

3.1.1 Features

As mentioned above ACSSA AUTOMATION starters offer you several features and the following functions are available:

- Torque controlled start and stop
- Current limit control at start
- "Pump" start
- External analog input control
- Kick start at start
- Full voltage start
- Dual voltage ramp at start and stop
- Bypass
- DC-brake
- Slow speed at start and stop
- Jogging forward and reverse
- Four parameter sets
- Analog output indicating current, power or voltage
- Viewing of current, voltage, power, torque, power consumption, elapsed time etc.
- Integrated safety system as discussed in section 1.1, page 8, with an alarm list.

As an option, a serial interface is also available. This option, as well as all other options and accessories, can be added and delivered either separately or as part of the package.

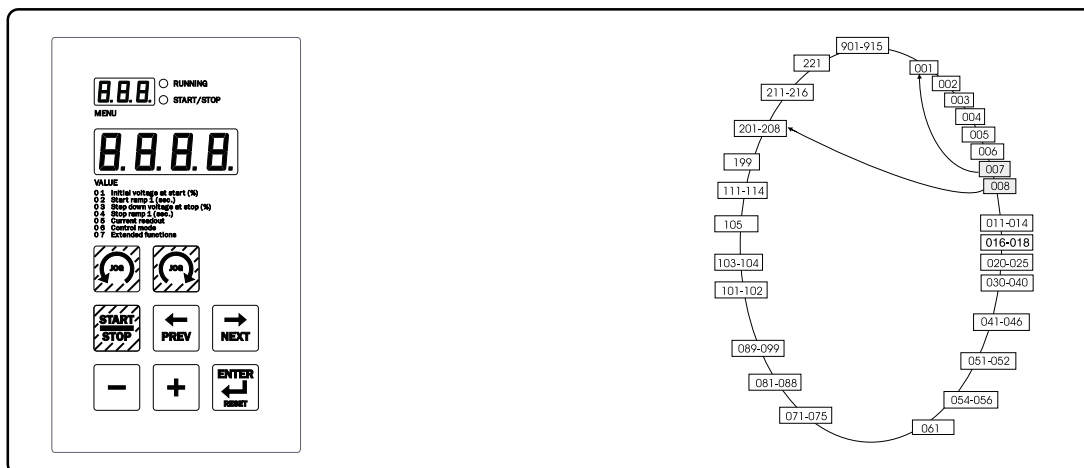

Fig. 1 The keypad and the menu structure.

3.1.2 Special Application

Special ramp functions can be performed as required via the integrated external analog control input 0-10/2-10 VDC alt. 0-20/4-20 mA DC.

NOTE! *To avoid thermal overloads at the motor, consult your sales representative before using this function.*

3.1.3 Auxiliary Relays and Displays

The starter has three built-in auxiliary relays (K1, K2 and K3) to signal Operation, Full voltage, DC-brake contactor and Alarm. K3 is always used as an alarm relay.

The other two relays are programmable, but the factory default for K1 is Operation and K2 is Full voltage. On the front of the starter there is a built-in LED display showing power on, status and alarm.

3.1.4 Applications for the Starter

Typical equipment used with the starter are:

- Ventilators, fans
- Pumps
- Conveyor belts
- Compressors
- Presses
- Centrifuges
- Saw mills
- Overhead cranes
- Water and waste water equipment
- Grinders
- Rock crushers
- Mixers

- And more

CHAPTER 3: DESCRIPTION

3.1.5 Connection – Minimum Wiring

Fig. 2 shows the minimum wiring of the starter for operation. Control of the motor is done either from the keypad, or through the remote control inputs, terminals 11 - 13:

1. To start/stop the starter from the keypad, parameter 006 must be set to 01.
2. To start/stop from the remote control inputs, terminals 11 - 13, parameter 006 must be set to 02 (Factory Default is 02). Connect 11 and 12, for 2-wire start/stop. (See 6.3, page 32)

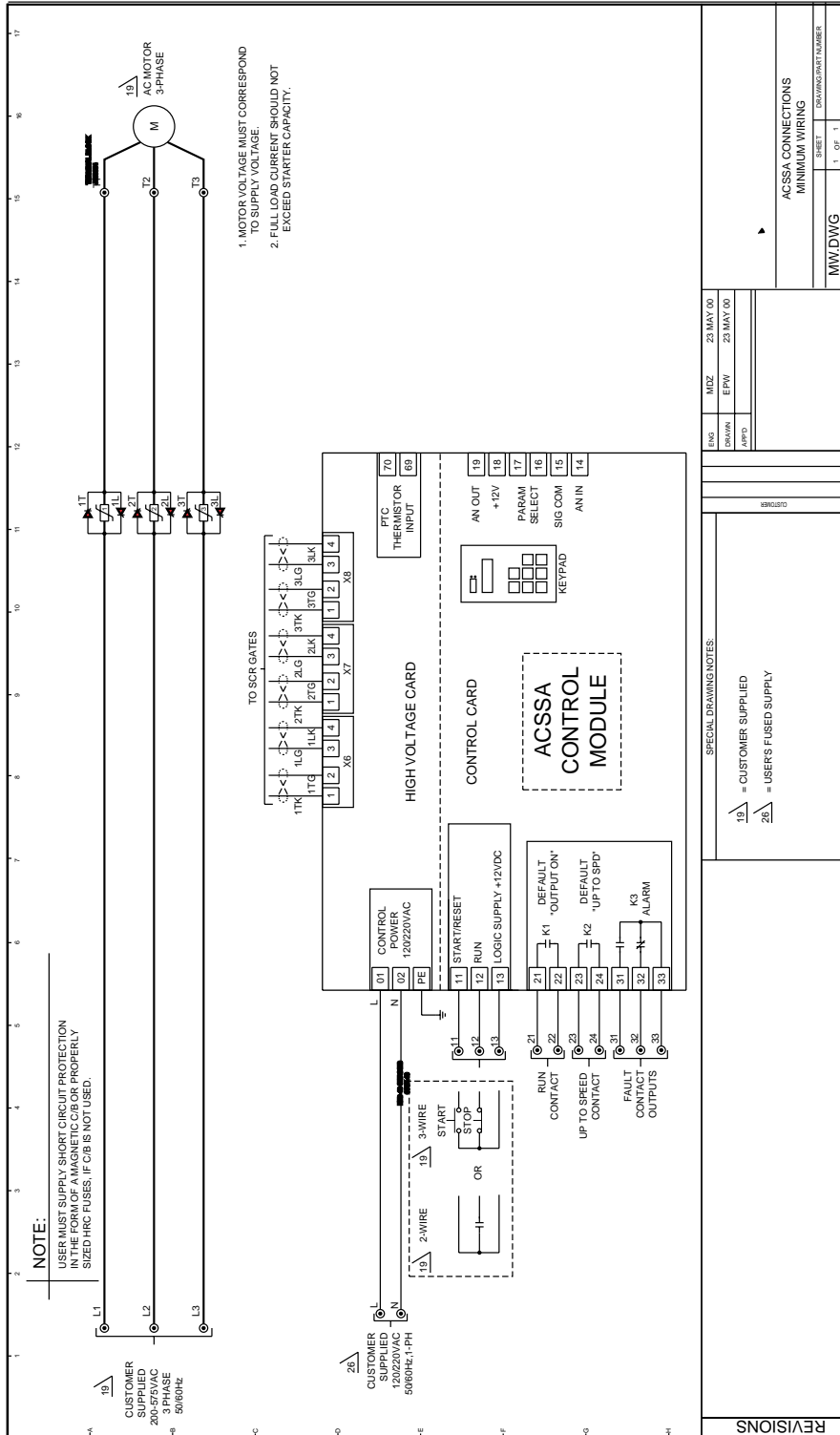

Fig. 2 Connection – Minimum Wiring.

3.2 FUNCTION OF THE STARTER

Below is a functional description of the starter (with Factory Default settings).

The device is started and stopped as shown in Fig. 3.

- The ramp times are set separately for starting and stopping by means of the built-in keypad on the front of the starter. Start ramp can be set from 1 to 60 sec. in parameter 002 and stop ramp from 2 to 120 sec. in parameter 004. Step down voltage at stop can be set in parameter 003, if required. These ramp times relate to the voltage ramp mode.
- The starter starts the motor when an external dry contact has closed at terminals 12–13. Starting/stopping of the motor can also be done at the keypad. To start/stop from the keypad the parameter 006 must be set to 01. See Section 5.3, page 25.
- The output voltage increases according to the ramp settings and the initial voltage, parameter 001.
- As the voltage increases the motor shaft starts to rotate.

The output voltage increases until full voltage has been reached. The acceleration and deceleration times result from the amount of voltage and current being supplied to the motor, and from the amount of torque the motor must generate to drive the load. To reduce the starting time when the load torque is high, the start curve can be optimized by raising the initial voltage. While operating, the starter continuously checks the power and load conditions.

After the external contact (term. 12-13) has been opened, or a stop command given from the keypad, the motor is stopped according to the stop ramp. If a step down voltage value is set, terminals the output motor voltage follows the step down ramp, otherwise the stop ramp commences from full voltage.

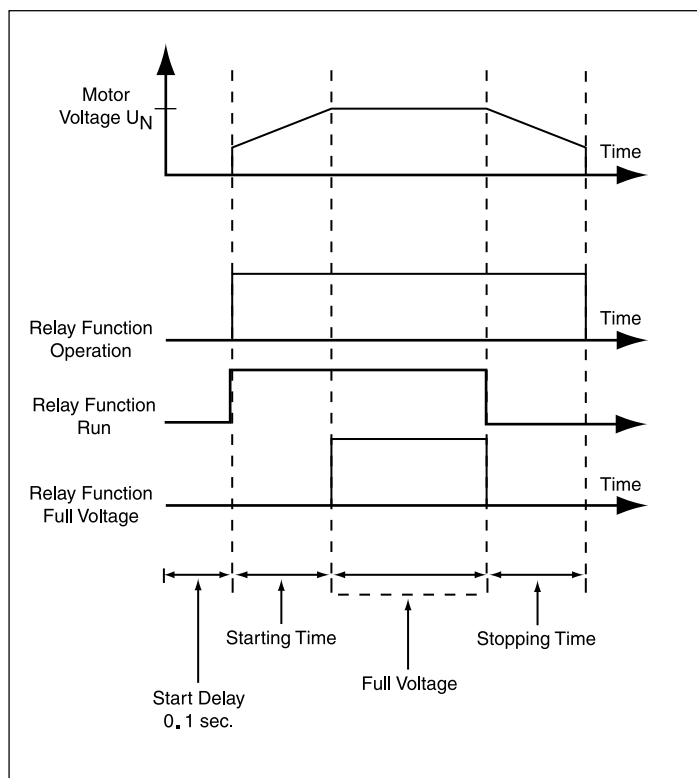

Fig. 3. Relay logic sequence.

The unit has three built-in relays: K1, K2 and K3. Relay K3 is always used as an alarm relay. The other two relays are programmable. Relay K1 and K2 are factory set according to description below.

- Relay K1 is used for indication of operation. K1 is activated by the external contact, terminals 12–13, or a start command from keypad (see Fig. 3). It de-energizes upon completion of the stop ramp.
- Relay K2 is used for indication of full voltage, it closes when the start ramp is completed and remains closed until a stop command is given (terminals 12-13 opened or stop command from keypad).
- To change the programming of Relay K1 or K2, see 6.18, page 50.

3.3 OVERVIEW OF STARTER OPERATION

Table 1 shows what source is active for programming and operating the ACSSA (whether it accepts keypad, terminals, or serial communication input). The control mode is selected in parameter 006.

Control Mode	Start / Stop	Jog Fwd / Rev	Alarm Reset
Keypad Menu 006 = 1	Keypad	Keypad	Keypad
Remote Menu 006 = 2	Remote	-	Remote and Keypad
Serial Communication Menu 006 = 3	Serial Communication	-	Serial Communication and Keypad

Table 1 Overview of starter operation and parameter set-up.

4.1 MOUNTING / WIRING

Mounting and wiring of the unit must be carried out by trained personnel:

- In accordance with the local regulations.
- In accordance with any requirements per the local power company.
- In accordance with the National Electrical Code.

Care must be taken to ensure that personnel do not come into contact with live circuit components.



WARNING! Never operate the starter with the front cover removed.

4.2 INSTALLATION OF THE STARTER IN A CABINET

When installing the starter:

- Ensure that the cabinet will be sufficiently ventilated after the installation.
- Ensure that air can flow freely from the bottom to the top.

NOTE! When installing the starter, make sure it does not come into contact with live components. The heat generated must be dispersed via the cooling fins to prevent damage to the SCR's (free circulation of air).

4.3 CONNECTIONS

Connection of ACSSA420 to ACSSA450

Device connections

1. Ground, (PE), Line power, Motor (on the right and left inside of the cabinet)
2. Ground, (PE), Control voltage
3. Control voltage connection 01, 02
4. Line power L1, L2, L3
5. Motor leads T1, T2, T3

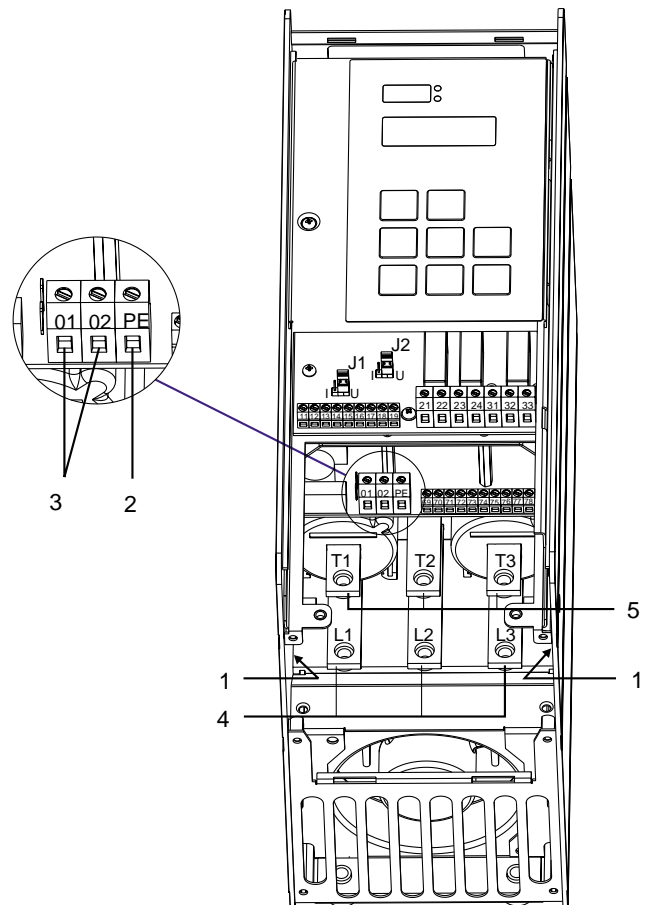

Fig. 4 Connection of ACSSA420 to ACSSA450.

Connection and setting on the PCB control card

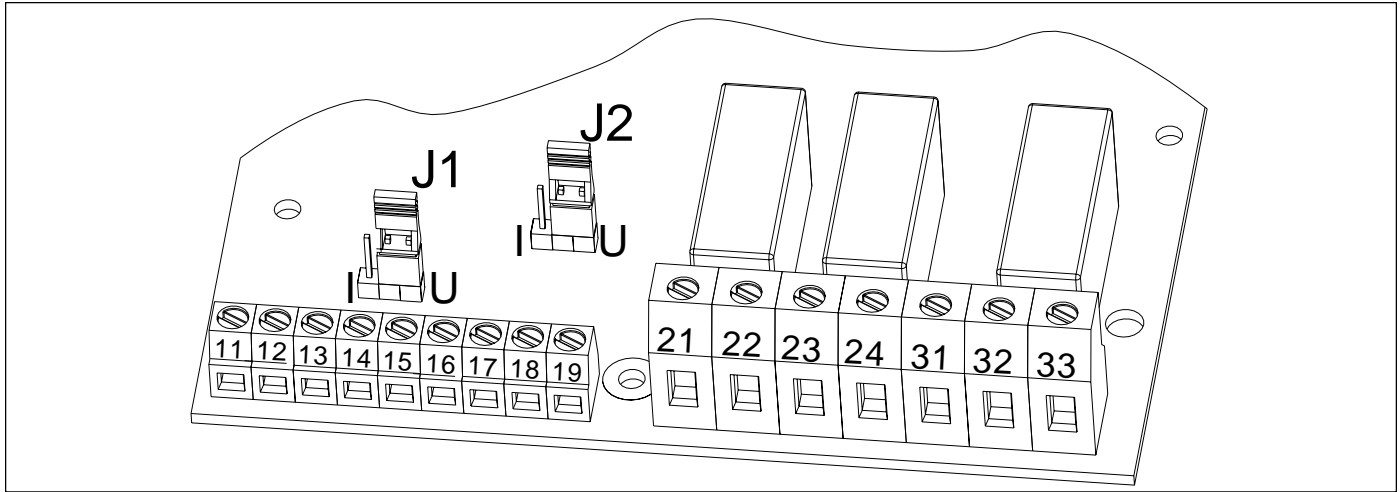

Fig. 6 Connections on the PCB, control card.

Terminal	Function	Electrical Characteristics
01	Control Voltage	100 - 240 VAC ±10%
02		
PE	Ground	
11	Digital inputs for start / stop and reset	0-3 V → 0; 8-27 V → 1. Max 37 V for 10 sec. Impedance to 0 VDC: 2.2 kΩ
12		
13	Supply / control voltage to PCB terminals 11 and 12, 10 kV potentiometer, etc.	+12 VDC ±5% , Max. current from + 12 VDC: 50 mA. Short circuit proof
14	Remote analog input control, 0-10 V, 2-10 V, 0-20 mA and 4-20 mA	Impedance to terminal 15 (0 VDC) voltage signal: 125 kΩ , current signal: 100V
15	Ground (common)	0 VDC
16	Digital inputs for selection of parameter set	0-3 V → 0; 8-27 V → 1. Max 37 V for 10 sec. Impedance to 0 VDC: 2.2 kΩ
17		
18	Supply / control voltage to PCB terminals 16 and 17, 10 kV potentiometer, etc.	+12 VDC ±5% , Max. current from + 12 VDC: 50 mA. Short circuit proof
19	Remote analog output control	0-20 mA and 4-20 mA, 0-10 V, 2-10 V
21	Programmable relay K1. Factory setting is "Operation" indication by closing terminals 21-22	1-pole closing contact, 250 VAC 8 A or 24 VDC 8 A resistive, 250 VAC, 3 A inductive
22		
23	Programmable relay K2. Factory setting is "Full Voltage" indication by closing terminals 23-24	1-pole closing contact, 250 VAC 8 A or 24 VDC 8 A resistive, 250 VAC, 3 A inductive
24		
31	Alarm relay K3, closed to 33 at alarm	1-pole change over contact, 250 VAC 8 A or 24 VDC 8 A resistive, 250 VAC, 3 A inductive
32	Alarm relay K3, opened at alarm	
33	Alarm relay K3, common terminal	
69-70	PTC Thermistor input	Alarm level 2.4 kV switch back level 2.2 kΩ
75	Current transformer input, cable S1	Connection of L1 or T1 phase current transformer
76	Current transformer input, cable S1	Connection of L3, T3 phase (ACSSA420 - ACSSA4100) or L2, T2 phase (ACSSA4150 - ACSSA4600)
77	Current transformer input, cable S2	Common connection for terminal 75 and 76
*78	Fan connection	24 VDC
*79	Fan connection	0 VDC

Table 2 PCB Terminals

*Internal connection, no customer use.

4.4 STANDARD WIRING

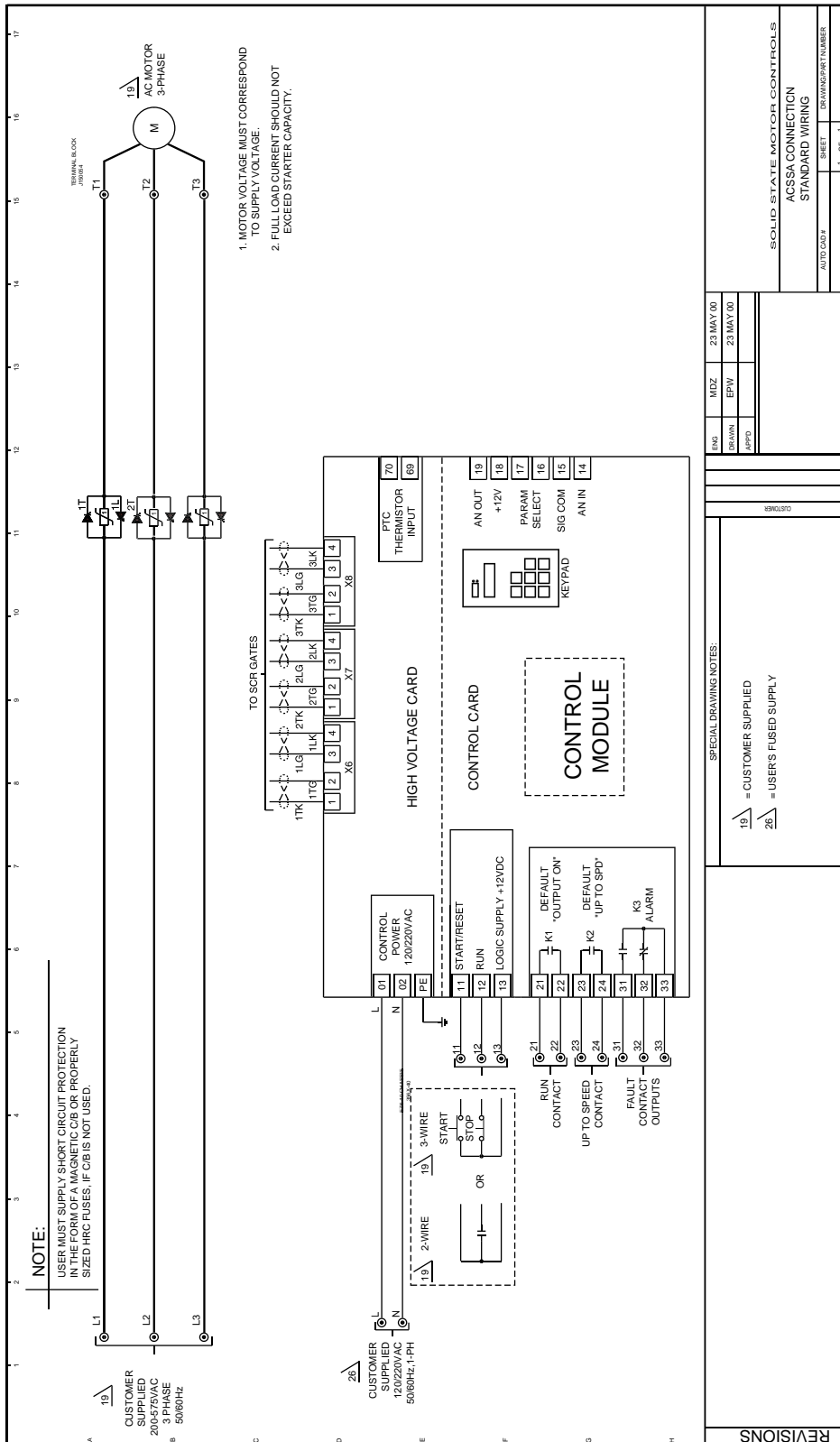

Figure 7 shows the “standard wiring”.

1. Connect Ground (PE) to earth screw marked (PE).
2. Connect the starter between the 3-phase line power and the motor. On the starter the line side is marked with L1, L2 and L3 and the motor side with T1, T2 and T3.
3. Connect the control voltage (100-240 VAC) at terminals 01 and 02.
4. Connect PCB terminals 12 and 13 (terminals 11-12 must be linked for two wire control) to, e.g. a 2-position switch (on/off) or a PLC, etc. (For start/stop command from keypad parameter 006 must be set to 01).
5. Ensure the installation complies with the appropriate local regulations.

Fig. 7 Connection - Standard Wiring

4.5 WIRING EXAMPLE

4.5.1 Bypass

Note: Bypass contactor can be used to shunt the motor current once the motor is up to speed.

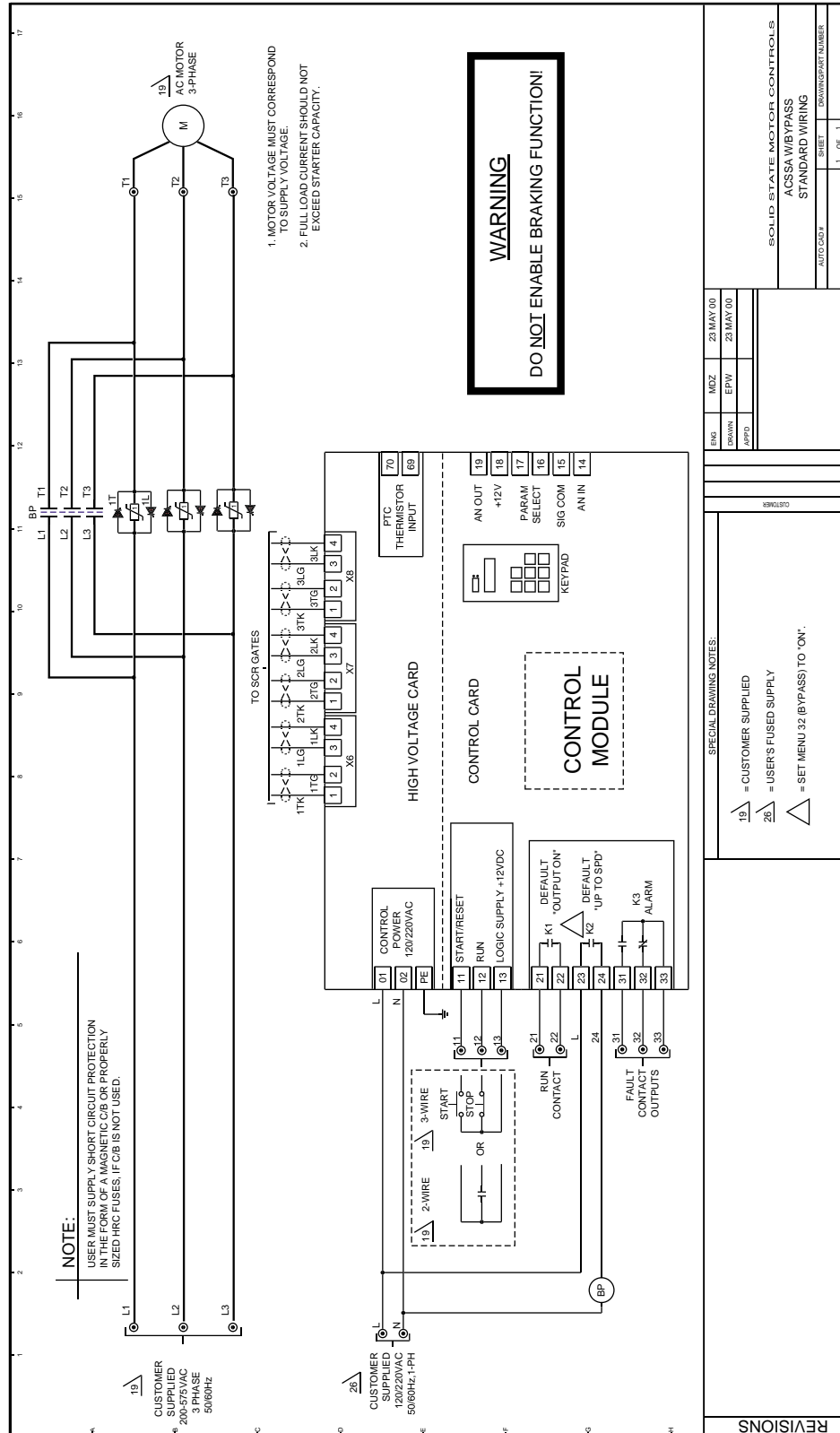

Fig. 8 Connection - Standard Wiring with Bypass

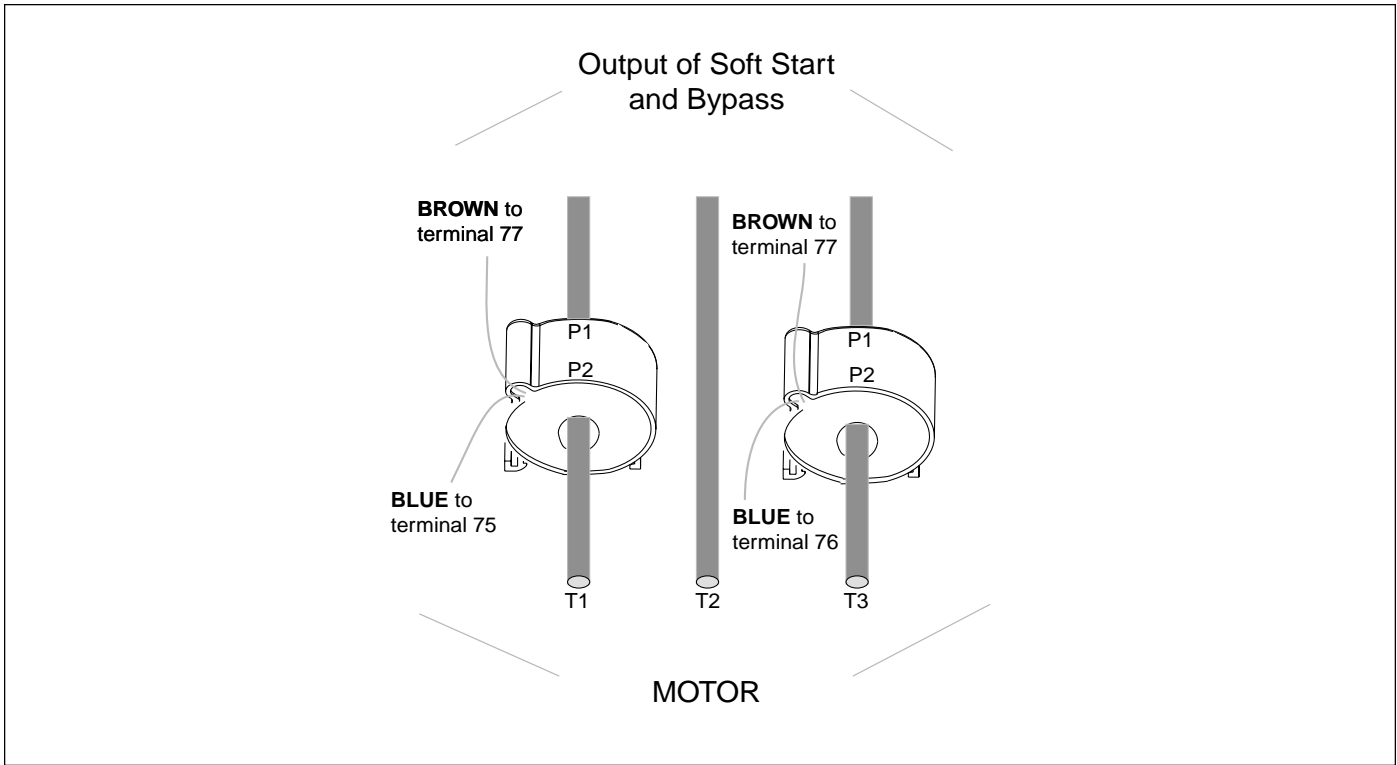

Fig. 9 Current transformer position on ACSSA420 to ACSSA4100 with a bypass.

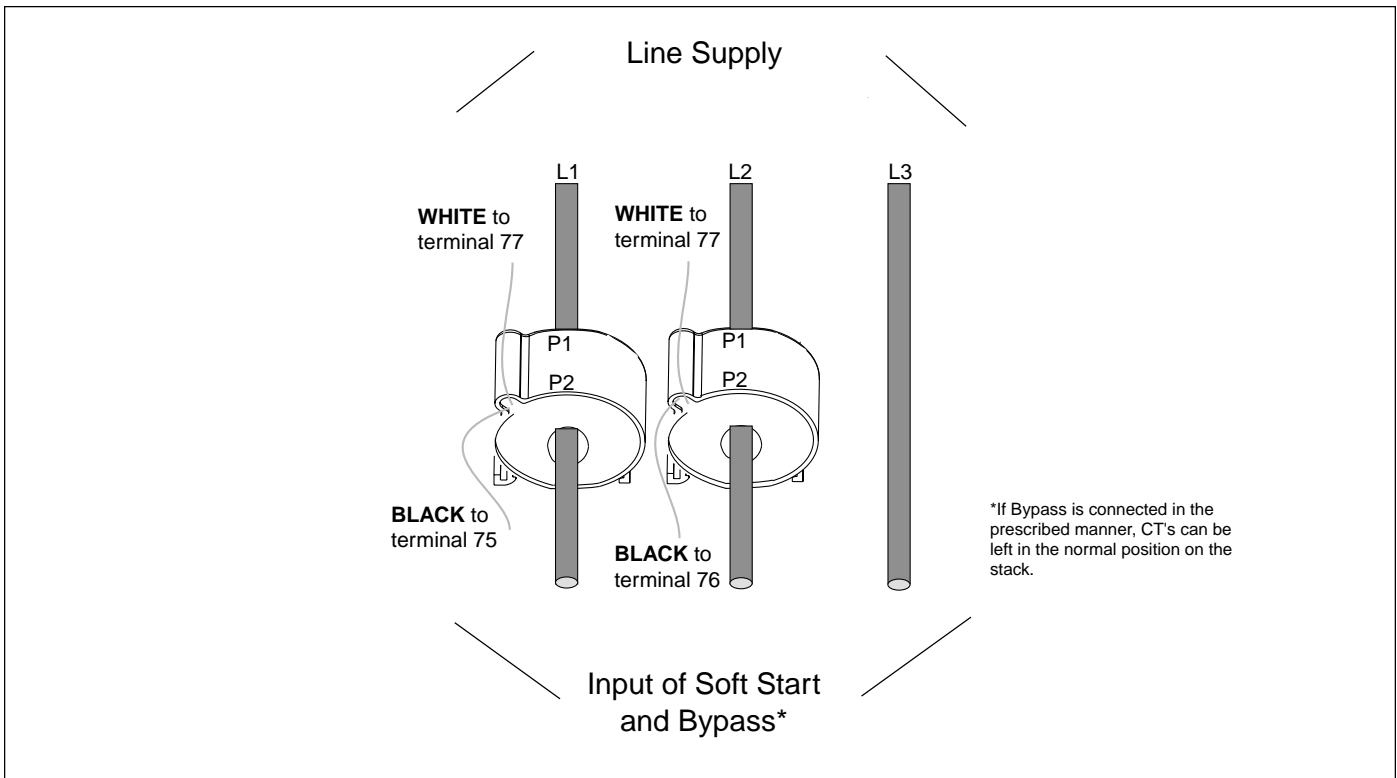

Fig. 10 Current transformer position on ACSSA4150 to ACSSA4600 with a bypass.

5.1 CHECKLIST

- Mount the starter in accordance with chapter 4, page 15.
- Consider the power loss at rated current when dimensioning a cabinet, max. ambient temperature is 50°C (see chapter 12, page 75).
- Connect the motor circuit.
- Connect the ground.
- Connect the control voltage to terminals 01 and 02 (100 - 240 VAC).
- Connect PCB terminals 12 and 13 to, e.g., a 2-way switch or a PLC, etc. (The parameter 006 must be put to 01 for start/stop command from keypad.)
- Check that the motor and supply voltage corresponds to values on the starter's rating plate.
- Ensure the installation complies with the appropriate local regulations.

5.2 BASIC PARAMETER SETTING



WARNING! *Make sure that all safety measures have been taken before applying power.*

Apply control power, all segments in the display and the two LED's will be illuminated for a few seconds. Then the display will show parameter 001. An illuminated display indicates there is supply voltage on the PCB. Check that you have line power on L1, L2, and L3. The basic parameters can now be set as follows:

5.2.1 Parameters 007 and 008

The first step in the settings is to set parameter 007 and 008 to "on". This allows the programmer to be able to reach all parameters and enter the required data.

5.2.2 Motor Nameplate Voltage [041]

NOTE! Parameters 041-046 must be set correctly for motor to be protected.

041		Motor Voltage
460		
Default:	460 V	
Range:	200 - 700 V	

5.2.3 Motor Nameplate FLA [042]

042		Motor FLA
45		
Default:	Nominal starter current	
Range:	25% - 150% of starter current	

5.2.4 Motor Nameplate Power [043]

043		Motor Power
22		
Default:	Nominal starter power	
Range:	25% - 150% of starter in HP	

5.2.5 Motor Nameplate RPM [044]

044		Motor RPM
1750		
Default:	1750 RPM	
Range:	500 - 3600 RPM	

5.2.6 Motor Nameplate Power Factor [045]

045		Motor Power Factor
.86		
Default:	0.86	
Range:	0.50 - 1.00	

CHAPTER 5: QUICK SET-UP

5.2.7 Input Frequency [046]

NOTE! To now lock out all parameters except for voltage ramp settings go back to parameter 007 and set it to "off".

<div style="display: flex; align-items: center;"> <div style="border: 1px solid black; padding: 2px; margin-right: 5px;">0</div> <div style="border: 1px solid black; padding: 2px; margin-right: 5px;">4</div> <div style="border: 1px solid black; padding: 2px; margin-right: 5px;">6</div> <div style="margin-left: 10px;">○</div> </div>	
Input Frequency	
<div style="display: flex; align-items: center;"> <div style="border: 1px solid black; padding: 2px; margin-right: 5px;"> </div> <div style="border: 1px solid black; padding: 2px; margin-right: 5px;"> </div> <div style="border: 1px solid black; padding: 2px; margin-right: 5px;">6</div> <div style="border: 1px solid black; padding: 2px;">0</div> </div>	
Default:	60 Hz
Range:	50 / 60 Hz

5.2.8 Initial Voltage at Ramp 1 [001]

<div style="display: flex; align-items: center;"> <div style="border: 1px solid black; padding: 2px; margin-right: 5px;">0</div> <div style="border: 1px solid black; padding: 2px; margin-right: 5px;">0</div> <div style="border: 1px solid black; padding: 2px; margin-right: 5px;">1</div> <div style="margin-left: 10px;">○</div> </div>	
Initial Voltage at Ramp 1	
<div style="display: flex; align-items: center;"> <div style="border: 1px solid black; padding: 2px; margin-right: 5px;"> </div> <div style="border: 1px solid black; padding: 2px; margin-right: 5px;"> </div> <div style="border: 1px solid black; padding: 2px; margin-right: 5px;">3</div> <div style="border: 1px solid black; padding: 2px;">0</div> </div>	
Default:	30 % of line voltage
Range:	25 - 90% of line voltage
<p>Factory Setting: 30% of line voltage, will normally be okay. to increase initial voltage press key "+". To decrease initial voltage press key "-". "ENTER" to confirm new value. "NEXT", "PREV" to change parameter.</p>	

5.2.9 Start Time Ramp 1 [002]

<div style="display: flex; align-items: center;"> <div style="border: 1px solid black; padding: 2px; margin-right: 5px;">0</div> <div style="border: 1px solid black; padding: 2px; margin-right: 5px;">0</div> <div style="border: 1px solid black; padding: 2px; margin-right: 5px;">2</div> <div style="margin-left: 10px;">○</div> </div>	
Start Time Ramp 1	
<div style="display: flex; align-items: center;"> <div style="border: 1px solid black; padding: 2px; margin-right: 5px;"> </div> <div style="border: 1px solid black; padding: 2px; margin-right: 5px;"> </div> <div style="border: 1px solid black; padding: 2px; margin-right: 5px;">1</div> <div style="border: 1px solid black; padding: 2px;">0</div> </div>	
Default:	10 sec
Range:	1 - 60 sec
<p>Estimate the starting time for the motor / machine. Set "Ramp-Up Time" at start (1-60 sec). Key "ENTER" to confirm new value. Key "NEXT", "PREV" to change parameter.</p>	

5.2.10 Stop Time Ramp 1 [004]

<div style="display: flex; align-items: center;"> <div style="border: 1px solid black; padding: 2px; margin-right: 5px;">0</div> <div style="border: 1px solid black; padding: 2px; margin-right: 5px;">0</div> <div style="border: 1px solid black; padding: 2px; margin-right: 5px;">4</div> <div style="margin-left: 10px;">○</div> </div>	
Stop Time Ramp 1	
<div style="display: flex; align-items: center;"> <div style="border: 1px solid black; padding: 2px; margin-right: 5px;"> </div> <div style="border: 1px solid black; padding: 2px; margin-right: 5px;">O</div> <div style="border: 1px solid black; padding: 2px; margin-right: 5px;">F</div> <div style="border: 1px solid black; padding: 2px;">F</div> </div>	
Default:	OFF
Range:	OFF, 2 - 120 sec
<p>Set "Ramp Down Time" at stop (2 - 120 sec). "OFF" if only a ramped start is required.</p>	

5.3 STARTING



WARNING! *Make sure that all safety measures have been taken before starting the motor in order to avoid personal injury. Start the motor by pressing the "START/STOP" key on the built-in keypad or through the remote control, PCB terminals 11, 12 and 13. When the start command is given the motor starts softly.*

If the initial voltage or the ramp time has to be readjusted, repeat the steps in "Parameter 001, 002 and 004" above. When the settings are correct the motor will start slowly and without any jerking motion. The motor will then accelerate smoothly to full speed.

NOTE! *The rated current must not be exceeded during normal operation. "Real start time" can be longer or shorter than the set values depending on the load conditions during start up. Also the stop time can be longer or shorter than the set stop time.*

5.3.1 Start / Stop / Reset from Keypad [006].

<div style="display: flex; align-items: center; justify-content: center;"> <div style="border: 1px solid black; padding: 2px; margin-right: 5px;">006</div> <div style="margin-left: 5px;">○</div> </div>	Selection of Control Mode
<div style="display: flex; align-items: center; justify-content: center;"> <div style="border: 1px solid black; padding: 2px; margin-right: 5px;"> </div> <div style="border: 1px solid black; padding: 2px; margin-right: 5px;"> </div> <div style="border: 1px solid black; padding: 2px; margin-right: 5px;"> </div> <div style="border: 1px solid black; padding: 2px; margin-right: 5px;">2</div> </div>	
Default:	2
Range:	1, 2, 3
Parameter 006 must be set to 1 to operate from keypad	

To start and stop from the keypad, the "START/STOP" key is used.

To reset from the keypad, the "ENTER/RESET" key is used. A reset can be given both when the motor is running and when the motor is stopped. A reset by the keypad will not start or stop the motor.

5.4 CURRENT READ-OUT

The RMS current to the motor during start and while running, can be read on the display.

5.4.1 RMS Current Read-Out [005]

<div style="display: flex; align-items: center; justify-content: center;"> <div style="border: 1px solid black; padding: 2px; margin-right: 5px;">005</div> <div style="margin-left: 5px;">○</div> </div>	RMS Current Read-Out
<div style="display: flex; align-items: center; justify-content: center;"> <div style="border: 1px solid black; padding: 2px; margin-right: 5px;"> </div> <div style="border: 1px solid black; padding: 2px; margin-right: 5px;"> </div> <div style="border: 1px solid black; padding: 2px; margin-right: 5px;">0.0</div> </div>	
Default:	-
Range:	0.0 - 9999 Amp
Select menu 005 before starting to view the starting current. Go to parameter 005 at any time when the motor is running to view current draw.	



Fig. 12 Automation Starter ACSSA Models.

6.1 GENERAL DESCRIPTION OF USER INTERFACE



WARNING! Never operate the starter with the front cover removed.

To obtain the optimum operation, a number of parameters must be set in the starter. Setting/configuration is done either from the built-in keypad or by a computer/control system through the serial interface (option). Controlling the motor is done either from the keypad, through the remote control inputs or through the serial interface (option).

SETTING



WARNING! Make sure that all safety measures have been taken before applying power.

Switch on the control voltage, all segments in the display will light up for a few seconds. Then the display will show parameter 001. An illuminated display indicates there is supply voltage on the PCB. Check that you have voltage at L1, L2, and L3. To be able to use all extended functions and to optimize the performance of the starter, program the motor data.

6.1.1 The Keypad

The keypad is a built-in operator panel with two light emitting diodes and three + four seven-segment LED-displays.

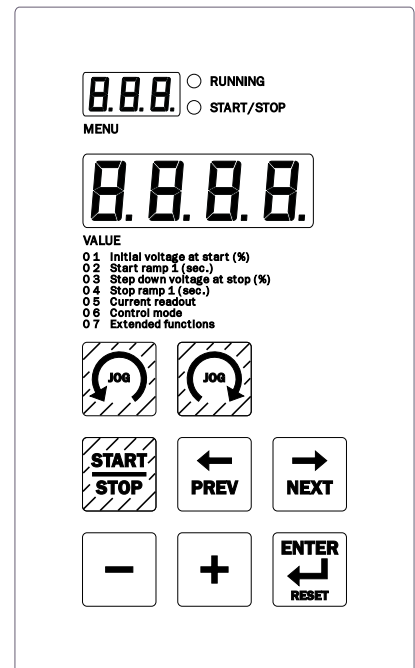

Fig. 13 Keypad.

6.1.2 LED Display

The two light emitting diodes indicate start/stop and running. When a start command is given from the keypad, through the serial interface (option) or through the remote control inputs, the start/stop-LED will be illuminated. At a stop command the start/stop-LED will switch off. When the motor is running, the running-LED is illuminated continuously at full motor voltage and flashes during ramp up or down.

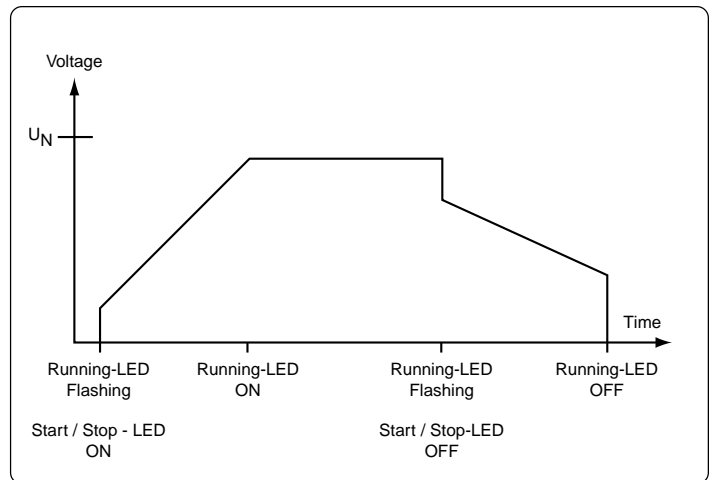

Fig. 14 LED indication sequence.

6.1.3 The Menu Structure

The parameters are organized in a simple one level structure with the possibility to limit the number of accessible parameters by setting the value in parameter 007 to "off" (factory setting). With this setting only the basic parameters 001, 002, 003, 004, 005, 006 and 007 can be reached. This is to simplify the setting when only voltage start/stop ramps are used.

If parameter 007 is "on" and parameter 008 "off" it is possible to reach all viewing parameters and alarm lists as well.

If parameters 007 and 008 are both "on" it is possible to read and adjust all parameters.

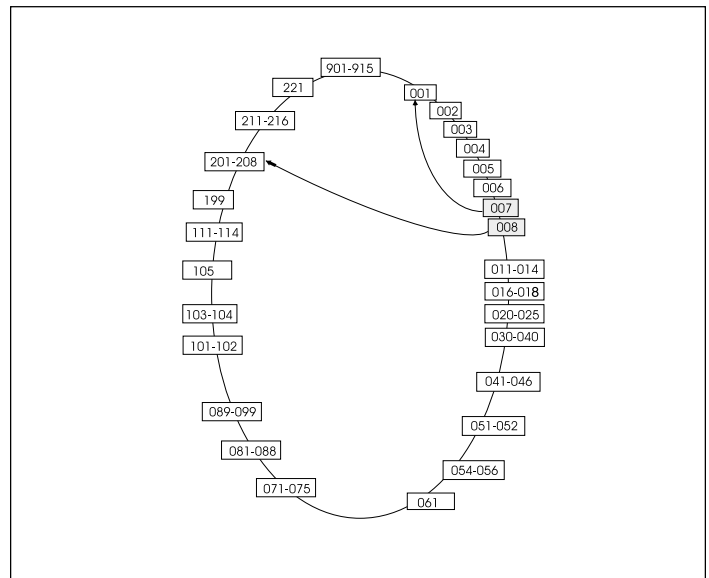











Fig. 15 Menu Structure

CHAPTER 6: OPERATION

6.1.4 The Keys

At power up, parameter 001 is shown automatically. Use the "NEXT" and "PREV" keys to move between parameters. To scroll through parameter numbers, press and hold either the "NEXT" or the "PREV" key. The "+" and "-" keys are used to increase and decrease the value of setting. The value flashes during setting. The "ENTER" key confirms the setting just made, and the value will go from flashing to stable. The "START/STOP" key is only used to start and stop the motor/machine.

The  and  keys are only used for JOG from the keypad. Please note for the JOG to be functional, the user must select "enable" in parameter 103 or 104, see 6.17.2, page 47.

Start/stop motor operation.		Increase value of setting.	
Display previous parameter.		Confirm setting. Alarm reset.	
Display next parameter.		JOG Reverse	
Decrease value of setting.		JOG Forward	

6.1.5 Keypad Lock

The keypad can be locked to prohibit operation and parameter setting by unauthorized personnel. Lock the keypad by pressing both "NEXT" and "ENTER" for at least 2 sec. The message '- Loc' will display when locked. To unlock the keypad press the same 2 buttons "NEXT" and "ENTER" for at least 2 sec. The message 'unlo' will display when unlocked.

In the locked mode it is possible to view all parameters and read-outs, but it is not possible to change parameters or to operate the starter from the keypad.

The message '-Loc' will display if an attempt to change a parameter or operate the starter is made in locked mode.

The keypad status can be read out in parameter 221.

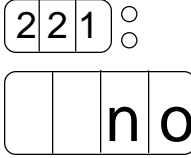
		Keypad Status
Default:	no	
Range:	no, YES	
no	Keypad is not locked	
YES	Keypad is locked	

6.1.6 The Three Built-in Relays.

- Relay K1 is factory set "Operation". The relay is activated by the start/stop-command. Relay K1 can be set to "Operation", "Full voltage" or "Pre-alarm" function.
- Relay K2 is factory set to "Full voltage". The relay is activated once the start ramp is complete. Relay K2 can be set to "Full voltage", "Operation" or "Pre-alarm" function. When a DC-brake time (parameter 034) is chosen, the relay K2 is automatically dedicated to control the external DC-brake contactor.
- The alarm relay, K3, is always an alarm relay and activates when a fault occurs.

6.1.7 Overview of Starter Operation

Control mode is selected in parameter 006.

Control Mode	Start / Stop	Jog Fwd / Rev	Alarm Reset
Keypad Menu 006 = 1	Keypad	Keypad	Keypad
Remote Menu 006 = 2	Remote	-	Remote and Keypad
Serial Comm Menu 006 = 3	Serial Communication	-	Serial Communication and Keypad

6.2 DESCRIPTION OF FUNCTIONS

In the tables below you will find all functions/parameters. At delivery, your starter is programmed according to the column "Factory Setting".

6.2.1 Parameter Groups / Monitor Functions

Function Type	Menu Numbers	Parameter Group	Menu Numbers
Basic	001-006	Voltage control	001-006
Extended	011-199	Voltage control dual ramp	011-014
		Torque control parameters	016-017
		Main functions	020-025
		Additional functions	030-035
		Slow speed and JOG functions	036-040, 103-104
		Nominal motor data	041-046
		Output control functions	051-052, 054-056
		Protection functions	071-075, 081-102
Viewing	201-915	Serial communication	111-114
		Main view	201-208
		RMS currents per phase	211-213
		RMS voltages per phase	214-216
		Alarm list	901-915

Parameter	Function	Range
005	Motor current	0 - 9999 A
073	Used thermal capacity	0 - 150%
087	Phase sequence	L123, L321
090	Output power	0 - 200%
201	Motor current (same as 005)	0 - 9999 A
202	Line voltage	0 - 700 V
203	Output power	0 to ±9999 HP
204	Power factor	0.00 - 1.00
205	Power consumption	0 - 2000 MW hrs
207	Shaft torque	0 to ±9999 ft-lbs
208	Operation time	0 - 9999 days
211 - 3	L1 - L3 currents	0 - 9999 A
214 - 6	L1 - L3 line voltages	0 - 700 V
901 - 15	Alarm list	F1 - F16

Explanation of units:

- V Input line voltage
- Vn Nominal motor voltage.
- In Nominal motor current.
- Pn Nominal motor power.
- Nn Nominal motor speed.
- Tn Nominal shaft torque.
- Insoft Nominal current starter.
- Pnsoft Nominal power starter.
- Nnsoft Nominal speed starter.

Calculation shaft torque:

$$T_n = \frac{P_n}{\left(\frac{N_n}{60} \times 2\pi \right)}$$

NOTE! *Only one start mode, parameters 020-025, can be selected at any given time.*

6.2.2 Detailed Function / Parameter Description

Parameter	Function	Range	Default	Parameter	Function	Range	Default
001	Initial voltage at start ramp 1	25-90% line voltage	30%	054	Analog output	off, 1, 2	off
002	Start time for ramp 1	1 - 60 sec	10 sec	055	Analog output value	1, 2, 3	1
003	Step down voltage decel ramp 1	100 - 40 % line voltage	100%	056	Analog output scaling	5 - 150%	100%
004	Stop time for decel ramp 1	off, 2 - 120 sec	off	061	Parameter set	0, 1, 2, 3, 4	1
006	Control mode	1, 2, 3	2	071	Motor RTD input	no, yes	no
007	Ext function / metering access	off, on	off	072	Overload class	off, 2 - 40 sec	10
008	Extended function access	off, on	off	072	Starts per hour limit	off, 1 - 99 / hr	off
011	Initial voltage at start ramp 2	30 - 90% line voltage	90%	075	Locked rotor alarm	off, 1 - 10 sec	off
012	Start time for ramp 2	off, 1 - 60 sec	off	081	Voltage imbalance alarm	5 - 25% line voltage	10%
013	Stop down voltage decel ramp 2	100 - 40% line voltage	40%	082	Voltage imbalance delay	off, 1 - 60 sec	off
014	Stop time for decel ramp 2	off, 2 - 120 sec	off	083	Overvoltage alarm	100 - 150% line voltage	115%
016	Initial start torque	0 - 200%	10%	084	Overvoltage delay	off, 1 - 60 sec	off
017	Final start torque	50 - 200%	150%	085	Undervoltage alarm	75 - 100% line voltage	85%
018	End stop torque	0 - 100%	0%	086	Undervoltage delay	off, 1 - 60 sec	off
020	Voltage ramp with current limit	off, 150 - 500% A	off	088	Phase reversal	off, on	off
021	Current limit start	off, 150 - 500% A	off	089	Auto set power alarms	no, yes	no
022	Pump control	off, on	off	091	Power alarms start delay	1 - 250 sec	10
023	Analog	off, 1, 2	off	092	Max power alarm level	5 - 200%	115%
024	Full voltage start	off, on	off	093	Max power alarm delay	off, 0.1 - 25 sec	off
025	Torque control	off, 1, 2	off	094	Max power pre-alarm level	5 - 200%	110%
030	Kickstart time	off, 0.1 - 2.0 sec	off	095	Max power pre-alarm delay	off, 0.1 - 25 sec	off
031	Kickstart current limit	300 - 500%	300%	096	Min power pre-alarm level	5 - 200%	90%
032	Bypass enable	off, on	off	097	Min power pre-alarm delay	off, 0.1 - 25 sec	off
033	Energy saver	off, on	off	098	Min power alarm level	5 - 200%	85%
034	DC brake on time	off, 1 - 120 sec	off	099	Min power alarm delay	off, 0.1 - 25 sec	off
035	DC brake current limit	100 - 200%	100%	101	Run at phase loss failure	no, yes	no
036	Slow speed input control	off, 1 - 100	off	102	Run at current limit time-out	no, yes	no
037	Slow speed torque	10 - 100%	10%	103	Jog fwd from keypad enable	off, on	off
038	Slow speed time at start	off, 1 - 60 sec	off	104	Jog rev from keypad enable	off, on	off
039	Slow speed time at stop	off, 1 - 60 sec	off	105	Automatic parameter return	off, 1 - 999	off
040	DC brake at slow speed	off, 1 - 60 sec	off	111	Serial comm address	1 - 247	1
041	Nameplate motor voltage	200 - 575 V	460 V	112	Serial comm baud rate	2.4 - 38.4 kBaud	9.6k
042	Nameplate motor FLA	25 - 150% starter	100%	113	Serial comm parity	0, 1	0
043	Nameplate motor power	25 - 150% starter	100%	114	Serial comm contact failure	off, 1, 2	1
044	Nameplate motor RPM	500 - 3600 RPM	1750	199	Reset to factory defaults	no, yes	no
045	Nameplate power factor	0.50 - 1.00	0.86	206	Reset power consumption	no, yes	no
046	Nameplate frequency	50, 60 Hz	60 Hz	221	Keypad lock	no, yes	no
051	Programmable relay K1	1, 2, 3	1				
052	Programmable relay K2	1, 2, 3, 4	2				

6.2.3 Reset to Factory Setting [199]

When reset to factory settings:

- All parameters in all parameter sets will have default factory settings.
- Parameter 001 will appear on the display.
- Note that the alarm list, the power consumption and the operation time will not have default settings.

NOTE! *Reset to factory settings is not allowed during run.*



WARNING! *If a DC-brake contactor is connected, be sure to select the DC-brake function in parameter 034 before a start, or the SCR's will be short-circuited. This is due to the default value for relay K2 being 2 (full voltage).*

1

9

9

○

Reset to Factory Settings

n

o

Default:	no
Range:	no, YES
no	No reset
YES	Reset all functions to the factory defaults including all 4 Parameter Sets

6.2.4 Function and Combination Matrix

Table 3 gives an overview of the functions available in any given start mode.

1. Select a function in the horizontal "Start mode" column. Only one function can be selected in this column, at a time.
2. In the vertical column "Additional Functions" you will find all available functions that can be used together with your selected start mode.

Start Mode	Additional Functions										
	Dual ramp start	Dual ramp stop	Bypass	Power factor control	DC brake	Torque boost	Jogging with keypad button	Timer controlled slow speed	External controlled slow speed	Complete protection	Parameter sets
Voltage ramp start / stop (default)	X	X	X	X	X	X	X	X	X	X	X
Torque control start / stop (menu 025)			X	X	X	X	X	X	X	X	X
Voltage ramp with current limit (menu 020)		X	X	X	X	X	X	X	X	X	X
Current limit start (menu 021)		X	X	X	X	X	X	X	X	X	X
Pump Control (menu 022)			X							X	X
Analog input (menu 023)										X	X
Direct on line start (menu 024)			X							X	X

Table 3 Combination Matrix

Table 4 shows what stop ramps are available with each of the start modes.

Start Function	Stop Function				
	Voltage ramp stop	Torque control stop	Pump control	Analog input	Coast to stop
Voltage ramp start	X				X
Torque control start		X			X
Current limit start	X				X
Voltage ramp with current limit	X				X
Pump control			X		X
Analog input				X	X
Full voltage start					X

Table 4 Start/Stop Combination.

6.3 START / STOP / RESET

Start/stop of the motor and reset of alarm is done from the keypad, through the remote inputs or through the serial interface (option). The remote inputs start/stop/reset (PCB terminals 11, 12 and 13) can be connected for 2-wire or 3-wire control.



6.3.1 Control Mode Selection [006]

NOTE! A reset via the keypad will not start or stop the motor.

NOTE! Factory default setting is 2, remote control.

To start and stop from the keypad, the "START/STOP" key is used.

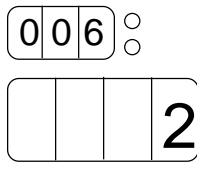
To reset from the keypad, the "ENTER/RESET" key is used. A reset can be given both when the motor is running and when the motor is stopped. A reset from the keypad will not start or stop the motor.

Selection of Control Mode	
	
Default:	2
Range:	1, 2, 3
1	START / STOP / RESET command via the keypad. <ul style="list-style-type: none"> - Press the "START/STOP" key on the keypad to start and stop the starter. - Press the "ENTER / RESET" key to reset a trip condition.
2	START/STOP/RESET Via remote control. The following control methods are possible. <ul style="list-style-type: none"> - 2-wire start/stop with automatic reset, see 6.3.2, page 33. - 2-wire start/stop with separate reset, see 6.3.3, page 33. - 3-wire start/stop with automatic reset at start, see 6.3.4, page 33.
 WARNING! The motor will start if terminals 11, 12, 13 are in start position.	
3	START/STOP/RESET commands via serial interface option. Details are in the operating instructions supplied with this option.

6.3.2 2-Wire Start / Stop with Automatic Reset at Start

Closing PCB terminals 12 and 13, with a jumper between terminal 11 and 12, will give a start command. Opening the terminals will give a stop. If PCB terminals 12 and 13 are closed at power up, a start command is given (automatic start at power up). When a start command is given there will automatically be a reset.

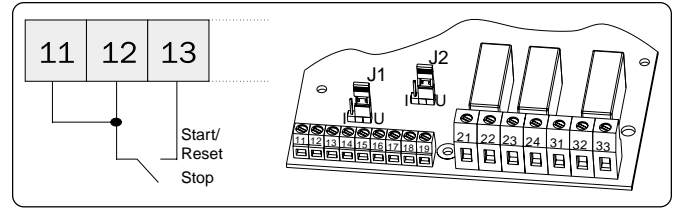

6.3.3 2-Wire Start / Stop with Separate Reset

Closing PCB terminals 11, 12 and 13 will give a start and opening the terminals 12 and 13 will give a stop. If PCB terminals 12 and 13 are closed at power up a start command is given (automatic start at power up). When PCB terminals 11 and 13 are opened and closed again a reset is given. A reset can be given both when the motor is running and stopped and doesn't affect the start/stop.

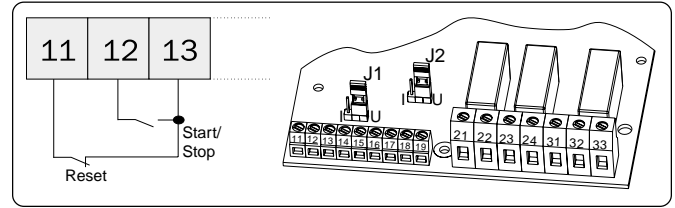

6.3.4 3-Wire Start / Stop with Automatic Reset at Start.

PCB terminals 12 to 13 are normally closed and PCB terminals 11 to 13 are normally open. A start command is given by momentarily closing PCB terminals 11 to 13. To stop, PCB terminals 12 and 13 are momentarily opened. When a start command is given there will automatically be a reset. There will not be an automatic start at power up.

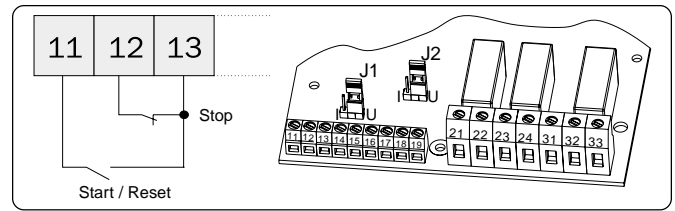

6.4 MOTOR DATA SETTING

6.4.1 Motor Data

The first step is to set parameters 007 and 008 to "on" to be able to reach the parameters 041-046 and enter the motor data.

NOTE! Parameters 041-046 must be set correctly for motor to be protected.

6.4.2 Motor Nameplate Voltage [041]

041	Motor Voltage
460	
Default:	460 V
Range:	200 - 700 V
Make sure the starter's voltage rating is the same as the motor voltage.	

CHAPTER 6: OPERATION

6.4.3 Motor Nameplate FLA [042]

<div style="display: flex; align-items: center;"> <div style="border: 1px solid black; padding: 2px; margin-right: 5px;">0</div> <div style="border: 1px solid black; padding: 2px; margin-right: 5px;">4</div> <div style="border: 1px solid black; padding: 2px; margin-right: 5px;">2</div> <div style="margin-left: 10px;">○</div> </div>		Motor FLA
<div style="display: flex; align-items: center;"> <div style="border: 1px solid black; padding: 2px; margin-right: 5px;"> </div> <div style="border: 1px solid black; padding: 2px; margin-right: 5px;"> </div> <div style="border: 1px solid black; padding: 2px; margin-right: 5px;">1</div> <div style="border: 1px solid black; padding: 2px; margin-right: 5px;">7</div> </div>		
Default:	Nominal starter current	
Range:	25 - 150% of Insoft in Amp	

6.4.4 Motor Nameplate Power [043]

<div style="display: flex; align-items: center;"> <div style="border: 1px solid black; padding: 2px; margin-right: 5px;">0</div> <div style="border: 1px solid black; padding: 2px; margin-right: 5px;">4</div> <div style="border: 1px solid black; padding: 2px; margin-right: 5px;">3</div> <div style="margin-left: 10px;">○</div> </div>		Motor Power
<div style="display: flex; align-items: center;"> <div style="border: 1px solid black; padding: 2px; margin-right: 5px;"> </div> <div style="border: 1px solid black; padding: 2px; margin-right: 5px;"> </div> <div style="border: 1px solid black; padding: 2px; margin-right: 5px;">7</div> <div style="border: 1px solid black; padding: 2px; margin-right: 5px;">.</div> <div style="border: 1px solid black; padding: 2px; margin-right: 5px;">5</div> </div>		
Default:	Nominal starter power	
Range:	25 - 150% of Pnsoft in HP	

6.4.5 Motor Nameplate RPM [044]

<div style="display: flex; align-items: center;"> <div style="border: 1px solid black; padding: 2px; margin-right: 5px;">0</div> <div style="border: 1px solid black; padding: 2px; margin-right: 5px;">4</div> <div style="border: 1px solid black; padding: 2px; margin-right: 5px;">4</div> <div style="margin-left: 10px;">○</div> </div>		Motor RPM
<div style="display: flex; align-items: center;"> <div style="border: 1px solid black; padding: 2px; margin-right: 5px;">1</div> <div style="border: 1px solid black; padding: 2px; margin-right: 5px;">7</div> <div style="border: 1px solid black; padding: 2px; margin-right: 5px;">5</div> <div style="border: 1px solid black; padding: 2px; margin-right: 5px;">0</div> </div>		
Default:	1750 RPM	
Range:	500 - 3600 RPM	

6.4.6 Motor Nameplate Power Factor [045]

<div style="display: flex; align-items: center;"> <div style="border: 1px solid black; padding: 2px; margin-right: 5px;">0</div> <div style="border: 1px solid black; padding: 2px; margin-right: 5px;">4</div> <div style="border: 1px solid black; padding: 2px; margin-right: 5px;">5</div> <div style="margin-left: 10px;">○</div> </div>		Motor Power Factor
<div style="display: flex; align-items: center;"> <div style="border: 1px solid black; padding: 2px; margin-right: 5px;"> </div> <div style="border: 1px solid black; padding: 2px; margin-right: 5px;">.</div> <div style="border: 1px solid black; padding: 2px; margin-right: 5px;">8</div> <div style="border: 1px solid black; padding: 2px; margin-right: 5px;">6</div> </div>		
Default:	0.86	
Range:	0.50 - 1.00	

6.4.7 Input Frequency [046]

<div style="display: flex; align-items: center;"> <div style="border: 1px solid black; padding: 2px; margin-right: 5px;">0</div> <div style="border: 1px solid black; padding: 2px; margin-right: 5px;">4</div> <div style="border: 1px solid black; padding: 2px; margin-right: 5px;">6</div> <div style="margin-left: 10px;">○</div> </div>		Input Frequency
<div style="display: flex; align-items: center;"> <div style="border: 1px solid black; padding: 2px; margin-right: 5px;"> </div> <div style="border: 1px solid black; padding: 2px; margin-right: 5px;"> </div> <div style="border: 1px solid black; padding: 2px; margin-right: 5px;">6</div> <div style="border: 1px solid black; padding: 2px; margin-right: 5px;">0</div> </div>		
Default:	60 Hz	
Range:	50 / 60 Hz	

NOTE! To now lock out all parameters except for voltage ramp settings go back to parameter 007 and set it to "off".

6.5 START / STOP RAMP PARAMETERS

Determine the starting time for the motor/machine.
 When setting the ramp times for starting and stopping, initial voltage at start and step down voltage at stop, proceed as follows:

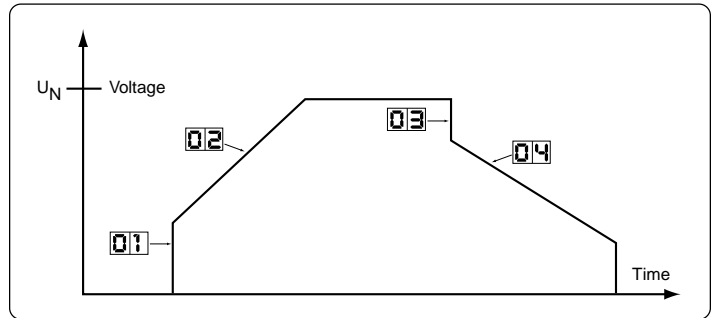

Fig. 16 Parameter numbers for start/stop ramps.

6.5.1 Setting Initial Voltage [001]

001		Initial Voltage at Start Ramp 1
30		
Default:	30%	
Range:	25 - 90%	
Set the initial voltage. Normally the factory setting, 30% of Vn, is a suitable choice.		

6.5.2 Setting Start Ramp Time [002]

002		Start Time Ramp 1
10		
Default:	10 sec.	
Range:	1 - 60 sec	
Set "Ramp Up Time" at start.		

6.5.3 Setting Stop Ramp Time [004]

004		Stop Time Ramp 1
OFF		
Default:	oFF	
Range:	oFF, 2 - 120 sec	
oFF	Stop ramp disabled, coast to stop	
2 - 120	Set "Ramp Down Time" at stop	

CHAPTER 6: OPERATION

6.5.4 Setting Step Down Voltage at Stop [003]

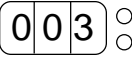
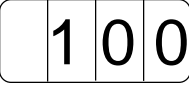
		Setting of Step Down Voltage Stop Ramp 1
		
Default:	100%	
Range:	100 - 40% of Un	
Step down voltage can help eliminate oscillation at the beginning of the stop ramp.		

6.5.5 RMS Current Read Out [005]

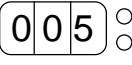
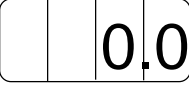
		RMS Current Read Out
		
Default:	-	
Range:	0.0 - 9999 Amp	
Read-out display of the RMS motor current		

NOTE! *This is the same read-out as function 201, see 8.3.1, page 67.*

6.5.6 Starting



WARNING! *Make sure that all safety measures have been taken before starting the motor in order to avoid personal injury.*



Start the motor by pressing the “START/STOP” key on the built-in keypad (parameter 006 must be set to 1, see 6.3.1, page 32) or through the remote input, PCB terminals 11, 12 and 13. When the start command is given the motor will start softly. If the initial voltage or the ramp time has to be readjusted, repeat the steps in “Setting” above. When the settings are correct the motor will start slowly and without any jerking motion. The motor will accelerate smoothly to full speed if the desired ramp-up time has been set.

NOTE! *The rated current must not be exceeded during normal operation. “Actual start time” can be longer or shorter than the set values depending on the load conditions during startup. Also the actual stop time can be longer or shorter than the set stop time.*

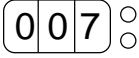

6.6 MENU EXPANSION SETTINGS

In order to use the viewing parameters and/or the extended functions, parameter 007 must be set to "on", allowing parameters 201-915 to be accessed. To be able to set any extended functions in the parameters 011-199 parameter 008 must be set to "on" as well.

6.6.1 Setting of Menu Expansion for Monitor Functions [007]

		Selecting of Extended and Viewing Functions
		
Default:	oFF	
Range:	oFF, ON	
oFF	Only parameters 001 - 007 are visible.	
ON	<ul style="list-style-type: none"> - Monitor functions 201 - 915 are visible - Extended functions (parameter 008) selectable 	

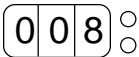
6.6.2 Setting of Menu Expansion to Reach Extended Functions [008]

		Selecting Extended Program Parameters
		
Default:	oFF	
Range:	oFF, ON	
oFF	Only monitor functions 201 - 915 are visible	
ON	All parameters are visible	

NOTE! *Parameter 007 must be "on" to access 008.*

CHAPTER 6: OPERATION

6.7 DUAL VOLTAGE RAMP AT START AND STOP

To further optimize the ramps at start and/or stop, a dual ramp can be used.

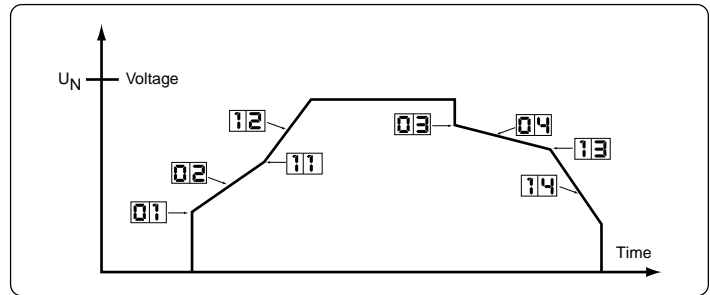

Fig. 17 Parameter numbers for dual voltage ramp at start and stop

The ramp set-up begins with the settings in parameters 001-004 and 007-008 and continues with the following steps:

6.7.1 Setting Initial Voltage 2 [011]

<div style="display: flex; align-items: center;"> <div style="border: 1px solid black; padding: 2px; margin-right: 5px;">0</div> <div style="border: 1px solid black; padding: 2px; margin-right: 5px;">1</div> <div style="border: 1px solid black; padding: 2px; margin-right: 5px;">1</div> <div style="margin-left: 10px;">○</div> </div>		<p>Setting the Initial Voltage at Start Ramp 2</p>
<div style="border: 1px solid black; padding: 2px; display: flex; align-items: center;"> <div style="border: 1px solid black; padding: 2px; margin-right: 5px;"> </div> <div style="border: 1px solid black; padding: 2px; margin-right: 5px;">9</div> <div style="border: 1px solid black; padding: 2px; margin-right: 5px;">0</div> </div>		
Default:	90%	
Range:	30 - 90% Un	
<p>Set the start voltage for start ramp 2. The initial voltage for start ramp 2 is limited to the initial voltage at start (parameter 001), see 6.5.1, page 35.</p>		

6.7.2 Setting Start Ramp Time 2 [012]

<div style="display: flex; align-items: center;"> <div style="border: 1px solid black; padding: 2px; margin-right: 5px;">0</div> <div style="border: 1px solid black; padding: 2px; margin-right: 5px;">1</div> <div style="border: 1px solid black; padding: 2px; margin-right: 5px;">2</div> <div style="margin-left: 10px;">○</div> </div>		<p>Start Time Ramp 2</p>
<div style="border: 1px solid black; padding: 2px; display: flex; align-items: center;"> <div style="border: 1px solid black; padding: 2px; margin-right: 5px;">o</div> <div style="border: 1px solid black; padding: 2px; margin-right: 5px;">F</div> <div style="border: 1px solid black; padding: 2px; margin-right: 5px;">F</div> </div>		
Default:	oFF	
Range:	oFF, 1 - 60 sec	
oFF	Start ramp 2 disabled	
1 - 60	Set the start ramp 2 time. A dual voltage ramp is now active.	

6.7.3 Setting of Step Down Voltage 2 [013]

013	○	Step Down Voltage in Stop Ramp 2
40	○	
Default:	40%	
Range:	100 - 40%	
Set the step down voltage for stop ramp 2. The step down voltage for stop ramp 2 is limited to the step down voltage at stop (parameter 003).		

6.7.4 Setting of Stop Ramp Time 2 [014]

014	○	Stop Ramp Time 2
OFF	○	
Default:	oFF	
Range:	oFF, 2 - 120 sec	
oFF	Start ramp 2 disabled	
1 - 60	Set the start ramp 2 time. A dual voltage ramp is now active.	

6.8 TORQUE CONTROL

This main function can be used to start the motor according to a pre-defined torque reference curve. Two different load characteristics, linear and variable, are selectable.

At start/stop the torque controller will follow the selected characteristic.

The torque start/stop curves can be seen in Fig. 18 below.

The start time must be selected in parameter 002 (see 6.5.2, page 35) and the stop time is selected in parameter 004 (see 6.5.3, page 35).

See 6.2.4, page 31 for additional functions available when torque control mode is used.

6.8.1 Torque Control at Start / Stop [025]

NOTE! Torque control mode is only possible when parameters 020-024 are "oFF".

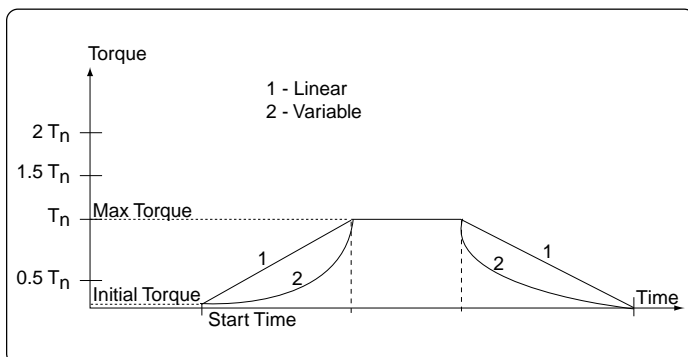

Fig. 18 Torque control at start/stop.

025	○	Torque Control at Start / Stop
OFF	○	
Default:	oFF	
Range:	oFF, 1, 2	
oFF	Torque control is disabled	
1	Torque control with linear torque characteristics	
2	Torque control with variable torque characteristics	

6.8.2 Initial Torque at Start [016]

<div style="display: flex; align-items: center; gap: 5px;"> <div style="border: 1px solid black; padding: 2px 5px;">0</div> <div style="border: 1px solid black; padding: 2px 5px;">1</div> <div style="border: 1px solid black; padding: 2px 5px;">6</div> <div style="font-size: 0.8em;">○</div> </div>	Initial Torque at Start
<div style="display: flex; align-items: center; gap: 5px;"> <div style="border: 1px solid black; width: 20px; height: 20px; margin-right: 5px;"></div> <div style="border: 1px solid black; padding: 2px 5px;">1</div> <div style="border: 1px solid black; padding: 2px 5px;">0</div> </div>	
Default:	10
Range:	0 - 200% of Tn
Set initial torque at start in percent of nominal shaft torque (Tn).	

6.8.3 Max Torque at Start [017]

NOTE! Start time (002) and stop time (004) must also be programmed to desired values.

<div style="display: flex; align-items: center; gap: 5px;"> <div style="border: 1px solid black; padding: 2px 5px;">0</div> <div style="border: 1px solid black; padding: 2px 5px;">1</div> <div style="border: 1px solid black; padding: 2px 5px;">7</div> <div style="font-size: 0.8em;">○</div> </div>	Max Torque at Start
<div style="display: flex; align-items: center; gap: 5px;"> <div style="border: 1px solid black; width: 20px; height: 20px; margin-right: 5px;"></div> <div style="border: 1px solid black; padding: 2px 5px;">1</div> <div style="border: 1px solid black; padding: 2px 5px;">5</div> <div style="border: 1px solid black; padding: 2px 5px;">0</div> </div>	
Default:	150
Range:	50 - 200% of Tn
Set max torque at start in percent of nominal shaft torque (Tn).	

6.8.4 End Torque at Stop [018]

<div style="display: flex; align-items: center; gap: 5px;"> <div style="border: 1px solid black; padding: 2px 5px;">0</div> <div style="border: 1px solid black; padding: 2px 5px;">1</div> <div style="border: 1px solid black; padding: 2px 5px;">8</div> <div style="font-size: 0.8em;">○</div> </div>	End Torque at Stop
<div style="display: flex; align-items: center; gap: 5px;"> <div style="border: 1px solid black; width: 20px; height: 20px; margin-right: 5px;"></div> <div style="border: 1px solid black; padding: 2px 5px;">1</div> <div style="border: 1px solid black; padding: 2px 5px;">0</div> </div>	
Default:	0%
Range:	0 - 100% of Tr
Set end torque of stop ramp. If set lower than initial torque (016) will be reset to that level.	

6.9 CURRENT LIMIT FUNCTIONS

The Current Limit function is used to set the maximum current the motor can draw when starting (150 - 500% of I_n). Current limit is only active during start.

Two kinds of current limit start are available.

- Voltage ramp with current limit.
If current stays below the set current limit, this start will act exactly as a voltage ramp start. Should the current draw reach the limit point the voltage ramp will adjust itself automatically.
- Current limit start.
The starter will limit the current drawn by the motor at the set level until the start is completed or the set start-up time expires.

6.9.1 Voltage Ramp with Current Limit [020]

The settings are carried out as follows:

1. Estimate starting time for the motor/machine and select that time in parameter 002 (see 6.5.2, page 35).
2. Estimate the initial voltage and select this voltage in parameter 001 (see 6.5.1, page 35).
3. Set the current limit to a suitable value e.g. 300% of I_n at parameter 020.
4. Repeat these steps as necessary to achieve desired ramp.

NOTE! *In most applications the voltage ramp with current limit allows for a smoother start.*

NOTE! *For proper ramp response ensure that motor nameplate current in parameter 042 is set correctly.*

NOTE! *Only possible when parameters 021-025 are "oFF".*

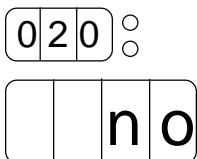
		Voltage Ramp Current Limit at Start
Default:	oFF	
Range:	oFF, 150 - 500% I_n	
oFF	Voltage ramp mode with current limit disabled.	
150 - 500	Current limit level in voltage ramp mode.	

CHAPTER 6: OPERATION

6.9.2 Current Limit [021]

The settings are carried out in two steps:

1. Estimate starting time for the motor/machine and select that time in parameter 002 (see 6.5.2, page 35).
2. Set the current limit to a suitable value e.g. 300% of In at parameter 021.

NOTE! *Increasing the current limit level will allow the motor to start quicker while decreasing the current will extend the time it takes to start the motor.*

NOTE! *Only possible when parameters 020, 022-025 are "oFF".*

NOTE! *Even though the current limit can be set as low as 150% of the motor nameplate current value, this minimum value is normally not effective. Considerations must be given to the starting torque and the motor before setting the appropriate current limit. Actual starting time can be longer or shorter than the set values depending on the load conditions. This applies to both current limit methods.*

If the starting time is exceeded and the starter is still operating at the set current level, an alarm will be activated. It is possible for the starter to either stop the operation or continue as described in section 7.6, page 60.

<div style="display: flex; align-items: center;"> <div style="border: 1px solid black; padding: 2px; margin-right: 10px;">021</div> <div style="margin-left: 10px;">○</div> </div> <div style="display: flex; align-items: center; margin-top: 10px;"> <div style="border: 1px solid black; padding: 2px; margin-right: 10px;">n</div> <div style="border: 1px solid black; padding: 2px; margin-right: 10px;">o</div> </div> <div style="margin-left: 100px;">Current Limit at Start</div>	
Default:	oFF
Range:	oFF, 150 - 500% In
oFF	Current limit mode disabled.
150 - 500	Current limit level in current limit mode.

6.10 PUMP CONTROL

This function is intended to minimize waterhammer in pipelines when using centrifugal pumps by accelerating and decelerating smoothly.

The soft start senses the system variables and reduces the hydraulic shock to the system. The start and stop time must be set, see 6.5.2, page 35 and 6.5.3, page 35. The initial torque must also be set (see 6.8.2, page 40).

6.10.1 Setting of Pump Control [022]

NOTE! *Only possible when parameter 020-021, 023-025 are "oFF".*

<div style="display: flex; align-items: center;"> <div style="border: 1px solid black; padding: 2px; margin-right: 10px;">022</div> <div style="margin-left: 10px;">○</div> </div> <div style="display: flex; align-items: center; margin-top: 10px;"> <div style="border: 1px solid black; padding: 2px; margin-right: 10px;">o</div> <div style="border: 1px solid black; padding: 2px; margin-right: 10px;">F</div> <div style="border: 1px solid black; padding: 2px; margin-right: 10px;">F</div> </div> <div style="margin-left: 100px;">Pump Control</div>	
Default:	oFF
Range:	oFF, ON
oFF	Pump control disabled. Voltage ramp enabled.
ON	Pump control application is enabled.

6.11 ANALOG INPUT CONTROL

Soft starting and stopping can also be controlled via the Analog Input Control. This control makes it possible to connect optional ramp generators or regulators. It can also be used as a variable voltage output for heater control. After the start command is given, the motor voltage is controlled through the remote analog input.



WARNING! *The remote analog control may not be used for continuous speed regulation of standard motors. Only variable voltage motors are designed for this type of input control.*

To use the analog input control, proceed as follows:

1. Connect the control inputs to terminals 14 (+) and 15 (-).

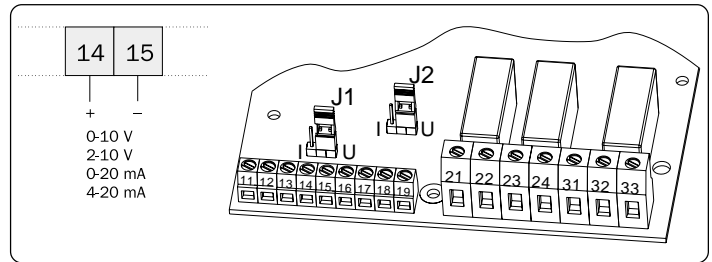

Fig. 19 Wiring for analog input.

2. Set Jumper J1 on the PCB control card to voltage (U) or current (I) position (see Fig. 20). Factory setting is voltage (U).

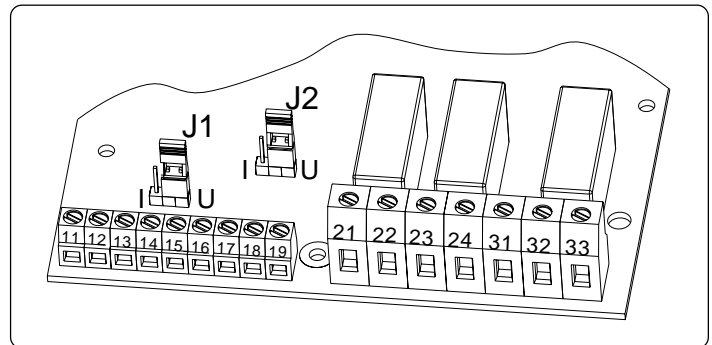

Fig. 20 Selecting voltage or current for analog input.

6.11.1 Selecting Analog Input Control [023]

NOTE! *Only possible when parameter 020-022, 024, 025 are "oFF"*

Selection of Analog Input Control	
0 2 3	oFF
Default:	oFF
Range:	oFF, 1, 2
1	Analog input is set for 0 - 10 V / 0 - 20 mA control signal.
2	Analog input is set for 2 - 10 V / 4 - 20 mA control signal.

CHAPTER 6: OPERATION

6.12 FULL VOLTAGE START

The motor can be accelerated as if it was started through a contactor. Ensure whether the motor can accelerate the required load.

6.12.1 Setting of Full Voltage Start [024]

NOTE! Only possible when parameter 020-023, 025 are "oFF".

<div style="display: flex; align-items: center;"> <div style="border: 1px solid black; padding: 2px; margin-right: 10px;">024</div> <div style="margin-right: 10px;">○</div> <div style="margin-right: 10px;">○</div> </div> <div style="display: flex; align-items: center;"> <div style="border: 1px solid black; padding: 2px; margin-right: 10px;">oFF</div> <div style="margin-right: 10px;">F</div> <div style="margin-right: 10px;">F</div> </div> <div style="text-align: right;"> Setting of Full Voltage Start </div>	
Default:	oFF
Range:	oFF, ON
oFF	Full voltage start disabled.
YES	Full voltage start enabled.

6.13 KICK START

The Kick start enables a high torque to be obtained by providing a high current during the first 0.1 - 2 sec of the start. This enables a soft start of the motor even if the break-away torque is high at start.

When the Kick start function has finished, starting continues according to the selected start mode. This additional function can be used together with most of the main functions (see 6.2.4, page 31).

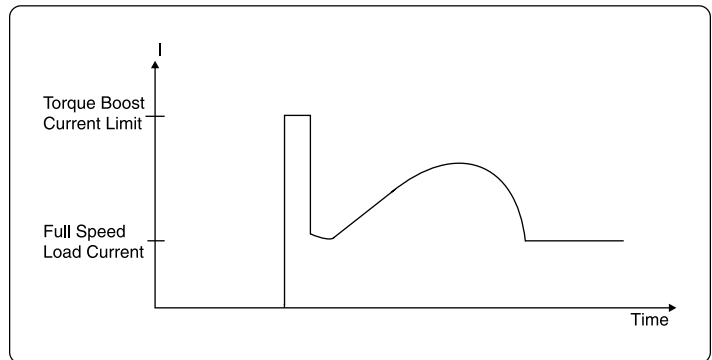

Fig. 21 Kick start in voltage ramp mode.

6.13.1 Kick Start Active Time [030]

<div style="display: flex; align-items: center;"> <div style="border: 1px solid black; padding: 2px; margin-right: 10px;">030</div> <div style="margin-right: 10px;">○</div> <div style="margin-right: 10px;">○</div> </div> <div style="display: flex; align-items: center;"> <div style="border: 1px solid black; padding: 2px; margin-right: 10px;">oFF</div> <div style="margin-right: 10px;">F</div> <div style="margin-right: 10px;">F</div> </div> <div style="text-align: right;"> Kick Start Time </div>	
Default:	oFF
Range:	oFF, 0.1 - 2 sec
oFF	Kick start disabled.
0.1 - 2.0	Kick start time.

6.13.2 Kick Start Current Limit [031]

NOTE! Check whether the motor can accelerate the load using "Kick start", without any harmful mechanical stress.

<div style="display: flex; align-items: center;"> <div style="border: 1px solid black; padding: 2px; margin-right: 5px;">031</div> <div style="margin-left: 10px;">○</div> </div>	
Kick Start Current Limit	
<div style="border: 1px solid black; padding: 5px; display: inline-block;"> <div style="display: flex; align-items: center; gap: 10px;"> <div style="border: 1px solid black; padding: 5px;">3</div> <div style="border: 1px solid black; padding: 5px;">0</div> <div style="border: 1px solid black; padding: 5px;">0</div> </div> </div>	
Default:	300
Range:	300 - 500% of In
<p>The kick start current control uses a selected value as the maximum current reference.</p>	

6.14 BYPASS

The use of a by-pass contactor minimizes the heat generated by the starter at full speed. By using the built-in Full Voltage Relay function, an external contactor can be used to Bypass the starter.

A Bypass contactor is not required as the device is designed for continuous running duty. It does, however, reduce the size of the TENV enclosure required to house the starter.

NOTE! For the protection and monitoring functions to be operable in the bypass mode, the current transformers must be mounted outside of the starter as shown in Fig. 9 and Fig. 10 on page 20.

6.14.1 Setting of Bypass Function [032]



CAUTION! If a bypass is used and parameter 032 is not set to ON, there will be an F12 alarm (shorted SCR) at full speed and the motor will coast to a stop.

<div style="display: flex; align-items: center;"> <div style="border: 1px solid black; padding: 2px; margin-right: 5px;">032</div> <div style="margin-left: 10px;">○</div> </div>	
Setting of Bypass	
<div style="border: 1px solid black; padding: 5px; display: inline-block;"> <div style="display: flex; align-items: center; gap: 10px;"> <div style="border: 1px solid black; padding: 5px;">o</div> <div style="border: 1px solid black; padding: 5px;">F</div> <div style="border: 1px solid black; padding: 5px;">F</div> </div> </div>	
Default:	oFF
Range:	oFF, ON
oFF	Bypass disabled.
ON	Bypass enabled. Use relay K1 (parameter 051 = 2)

6.15 ENERGY SAVER

During operation, the starter continuously monitors the load on the motor. Particularly when idling or when only partially loaded, it is sometimes possible to improve the motor efficiency. If Energy Saver control is selected, the starter reduces the motor voltage when the load is light. Power consumption is reduced and the degree of efficiency improved. If Energy Saver is enabled, bypass contactor will not function.

6.15.1 Setting of Energy Saver Control [033]

<div style="display: flex; align-items: center;"> <div style="border: 1px solid black; padding: 2px; margin-right: 10px;">033</div> <div style="margin-left: 10px;">○ ○</div> </div>		Setting of Energy Saver
<div style="border: 1px solid black; padding: 2px; display: inline-block;">oFF</div>		
Default:	oFF	
Range:	oFF, ON	
oFF	Energy saver disabled	
ON	Energy saver enabled. The full voltage relay function does not work.	

6.16 DC-BRAKE

In some applications braking of high inertia machines is required, i.e. flywheel applications. If the built-in DC-brake function is chosen, the relay K2 will be dedicated to control an external DC-brake contactor. This function can be combined with the ramp stop, but if the ramp stop time is "off", the DC-brake will energize when the stop command is given.

NOTE! *If the motor is D-connected(delta) a DC-brake contactor is not required.*

NOTE! *Both time (1-120 sec) and current (100-300% of In) can be set, to ensure that the braking stops when the motor has reached a standstill. For very high inertia loads, at the end of the maximum 120 sec, the machine coasts to a stop.*

NOTE! *To enable the DC-brake function, the time in parameter 034 is set to 1-120 sec. The relay K2 is then dedicated to control the external DC-brake contactor.*

This additional function can be used together with most of the main functions (see 6.2.4, page 31).

6.16.1 DC Brake Active Time [034]

<div style="display: flex; align-items: center;"> <div style="border: 1px solid black; padding: 2px; margin-right: 10px;">034</div> <div style="margin-left: 10px;">○ ○</div> </div>		DC Brake Active Time
<div style="border: 1px solid black; padding: 2px; display: inline-block;">oFF</div>		
Default:	oFF	
Range:	oFF, 1 - 120 sec	
oFF	DC brake disabled.	
1 - 120	Set the DC brake time.	

6.16.2 DC Brake Current Limit [035]



WARNING! *The SCR's will be shorted together if the DC-brake function in parameter 034 is "off" and the external DC-brake contactor is connected. The SCR's will also be shorted together if the external DC-brake contactor is connected between T1-T2 or T1-T3 instead of properly connected between T2-T3.*

035		DC-Brake Current Limit
100		
Default:	100	
Range:	100 - 300% of In	
<p>The DC brake current control uses a selected value as the DC current reference. A smooth and controlled DC braking is achieved, because closed loop control is used.</p>		

6.17 SLOW SPEED

6.17.1 Slow Speed Torque [037]

The slow speed function can be used as follows:

- Slow speed forward by pressing "JOG ".
- Slow speed reverse by pressing "JOG ".
- Slow speed at start during a selected time.
- Slow speed at stop during a selected time.
- Slow speed at start controlled by an external signal.
- Slow speed at stop controlled by an external signal.

The slow speed forward is always 14% of full speed and slow speed reverse is always 9% of full speed.

037		Slow Speed Torque
10		
Default:	10%	
Range:	10 - 100%	
<p>Select the torque level for slow speed.</p>		

6.17.2 Slow Speed with JOG Buttons [103&104]

Slow speed with the keypad "JOG" buttons is only possible in the keypad control mode. In remote terminal mode and serial communication mode these buttons are ignored. These buttons are also ignored if the starter is running. The slow speed JOG function has to be enabled for the forward and reverse directions in parameters 103 and 104.

103		Jog Forward Button Enabled
OFF		
Default:	oFF	
Range:	oFF, ON	
oFF	JOG forward disabled.	
ON	JOG forward enabled.	

104		Jog Reverse Button Enabled
OFF		
Default:	oFF	
Range:	oFF, ON	
oFF	JOG reverse disabled.	
ON	JOG reverse enabled.	

CHAPTER 6: OPERATION

6.17.3 Slow speed during a selected time [038 & 039]

It is possible to have a slow speed in the forward direction before a start and after a stop. The duration of the slow speed is selectable in parameters 038 and 039, respectively.

It is recommended to select DC brake (see 6.16, page 46) before a slow speed at stop if it is a high inertia load. This slow speed function is possible in all control modes (keypad, remote and serial communication).

038

○ ○

Slow Speed Time at Start

OFF

Default:	oFF
Range:	oFF, 1 - 60 sec
oFF	Slow speed at start is disabled.
1 - 60	Set slow speed time at start.

039

○ ○

Slow Speed Time at Stop

OFF

Default:	oFF
Range:	oFF, 1 - 60 sec
oFF	Slow speed at stop is disabled.
1 - 60	Set slow speed time at stop.

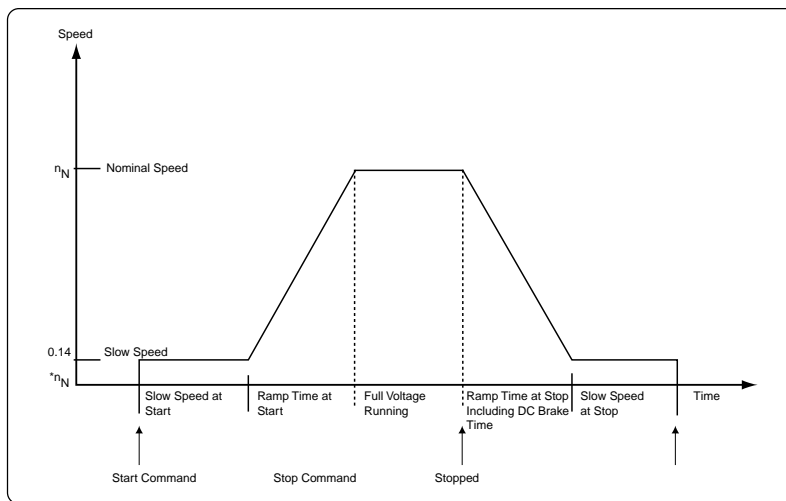

Fig. 22 Slow speed at start/stop during a selected time.

6.17.4 Slow Speed Controlled by an External Signal [036]

This slow speed function is possible in all control modes (keypad, remote and serial communication).

Set up as follows:

1. Set Jumper J1 on the PCB board to the voltage (U) position, see Fig. 23 on page 49.
2. Connect the external input wires to terminals 18(+) and 14 (input). See Fig. 24 on page 49.
3. If slow speed at start is to be controlled, set a time in parameter 038 (see 6.17.3, above). This time will now be the maximum time for slow speed at start, should the external signal not appear.
4. If slow speed at stop is to be controlled, set a time in parameter 039 (see 6.17.3, above). This time will now be the maximum time for slow speed at stop, should the external signal not appear.
5. Select slow speed controlled by external signal in parameter 036.

036

○ ○

Slow Speed External Input Control

OFF

Default:	oFF
Range:	oFF, 1 - 100
oFF	Slow speed at stop is disabled.
1 - 100	Number of edges to be ignored at the slow speed input, before a start or stop is executed from slow speed. The edges are generated by an external sensor (photo cell, micro switch etc.)

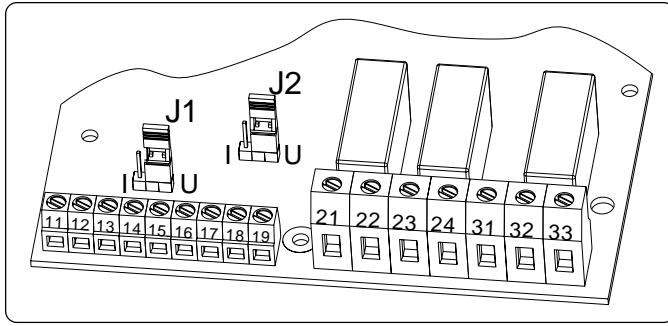

Fig. 23 Selecting voltage input.

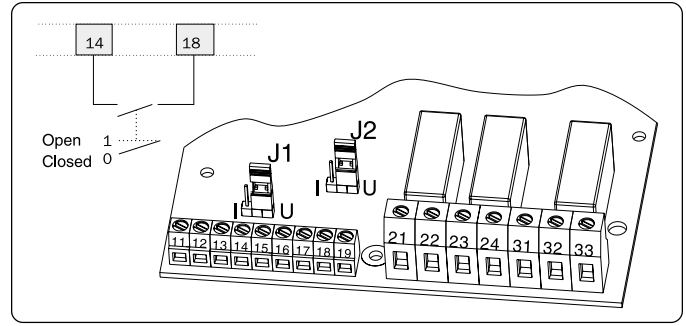

Fig. 24 Slow speed external input connection.

At start, the motor will run in slow speed forward until the number of external pulses reaches the value in parameter 036 or the slow speed time at start expires. At that point, a start according to the selected ramp mode commences.

At stop, the motor will ramp down (if selected) and DC brake (if selected) to a slow speed forward. Slow speed will last until the number of edges on the external input reaches the value in parameter 036 or the slow speed time at stop expires. At that time, voltage is removed from the motor.

In the example in Fig. 25, the parameter 036 is set to 4. DC-brake to slow speed is recommended (see 6.16, page 46) for a high inertia load.

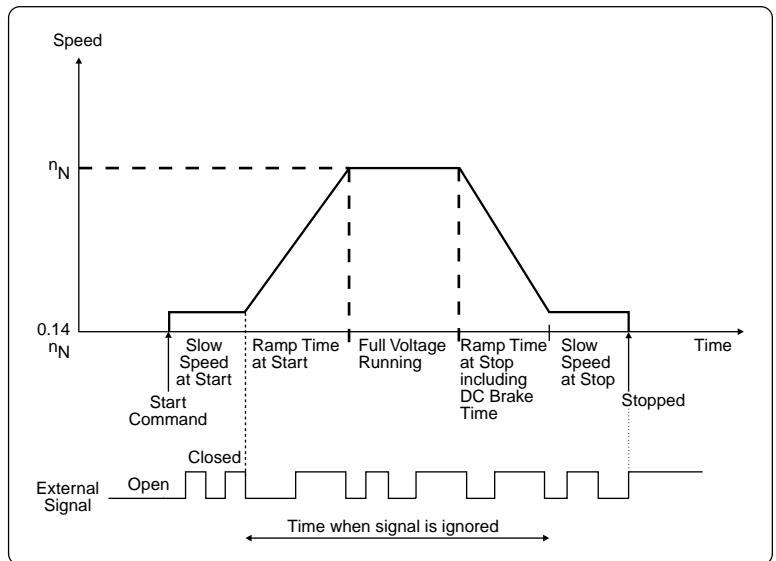

Fig. 25 Slow speed controlled by an external signal.

This function can be used together with most of the main functions (see 6.2.4, page 31).

6.17.5 DC-brake After Slow Speed at Stop [040]

A DC-brake after a slow speed at stop is available for high inertia loads or for more precise stopping. The current is controlled by the reference value for the normal DC-brake function (see 6.16.2, page 46). The duration of the DC-brake is selected in parameter 040. This DC-brake function is not applied when the "JOG" and "JOG" buttons are used.

040	○ ○	DC Brake After Slow Speed
OFF		
Default:	oFF	
Range:	oFF, 1 - 60	
oFF	DC brake after slow speed at stop disabled.	
1 - 60	DC brake duration time after slow speed at stop.	

CHAPTER 6: OPERATION

6.18 PROGRAMMABLE RELAY K1 AND K2

The starter has three built-in auxiliary relays with K3 always used as an alarm relay. The other two relays, K1 and K2 are programmable.

K1 and K2 can be set to "Operation", "Full Voltage" or "Pre-Alarm" indication. If DC-brake is chosen the relay K2 will be dedicated to this function.

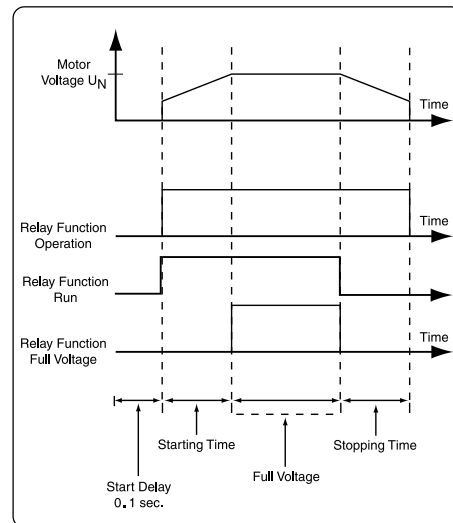

Fig. 26 K1/K2 relay function "Operation" and "Full voltage".

6.18.1 Setting of Relay K1 Indication [051]

051

○

K1 Indication

1

Default:	1
Range:	1, 2, 3
1	K1 is set for "Operation"
2	K1 is set for "Full Voltage"
3	K1 is set for "Power Pre-Alarm"
4	Not Available
5	K1 is set to "RUN". Closes at start command, opens at stop command

6.18.2 Setting of Relay K2 Indication [052]

NOTE! When the time in parameter 034 is set to 1-120 sec., the DC-brake function is chosen and relay K2 is dedicated to control the external DC-brake contactor. Parameter 052 will automatically change to "4" to indicate that K2 is set to control the external DC-brake contactor.

052

○

K2 Indication

2

Default:	2
Range:	1, 2, 3, 4
1	K2 is set for "Operation"
2	K2 is set for "Full Voltage"
3	K2 is set for "Power Pre-Alarm"
4	K2 is set for "DC Brake"
5	K1 is set to "RUN". Closes at start command, opens at stop command.



CAUTION! Ensure that the DC-brake contactor is not connected unless relay K2 (052) is programmed to 4.

6.19 ANALOG OUTPUT

The starter can read out current, voltage and power on an analog output terminal for connection to a recording instrument or a PLC. The output can be configured in 4 different ways, 0-10V, 2-10 V, 0-20 mA, or 4-20 mA. Set up as follows:

1. Connect the monitoring device to terminals 19 (+) and 15 (-). See Fig. 27.
2. Set Jumper J2 on the PCB board to voltage (U) or current (I) signal position. Factory setting is voltage (U). See Fig. 28.
3. Set the parameter in 054.
4. Choose a read-out value in 055.
5. Set analog output gain to adjust the range of analog output selection in parameter 056.

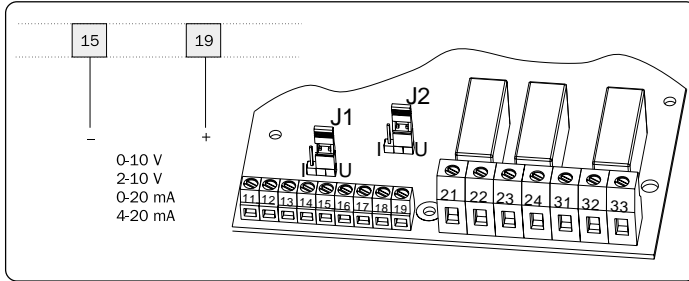

Fig. 27 Analog Output Connection

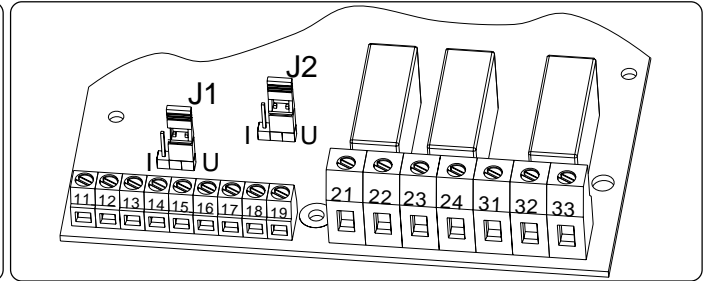

Fig. 28 Selecting Current or Voltage Output.

054		Analog Output	
oFF			
Default:	oFF		
Range:	off, 1, 2		
oFF	Analog output is disabled		
1	Analog output is set to 0 - 10 V / 0 - 20 mA		
2	Analog output is set to 2 - 10 V / 4 - 20 mA		

055		Analog Output Value	
1			
Default:	1		
Range:	1, 2, 3		
1	RMS current, default range 0 - 5x I _n		
2	Line voltage, default range 0 - 532 V		
3	Output power, default range 0 - 2x P _n		

056		Analog Output Gain	
100			
Default:	100%		
Range:	5 - 150%		

EXAMPLE ON SETTINGS:			
Set value	I _{scale}	V _{scale}	P _{scale}
100%	0-5 x I _n	0-532 V	0-2 x P _n
50%	0-2.5 x I _n	0-266 V	0-P _n

CHAPTER 6: OPERATION

6.20 PARAMETER SET

Parameter Set can be useful when starting under varying load conditions. For example, starting and stopping conveyor belts that are loaded or unloaded.

Four sets of parameters can be controlled either from the keypad, the external control inputs or the serial interface (option). Up to 51 different parameters can be selected for each Parameter Set.

When 'Parameter set' in parameter 061 is set to 0 (external selection), only parameters in parameter 006 (Control mode) and 061 (Parameter set) can be changed from the keypad. All other parameters are disabled. It is possible to change parameter sets at stop and while running at full speed.

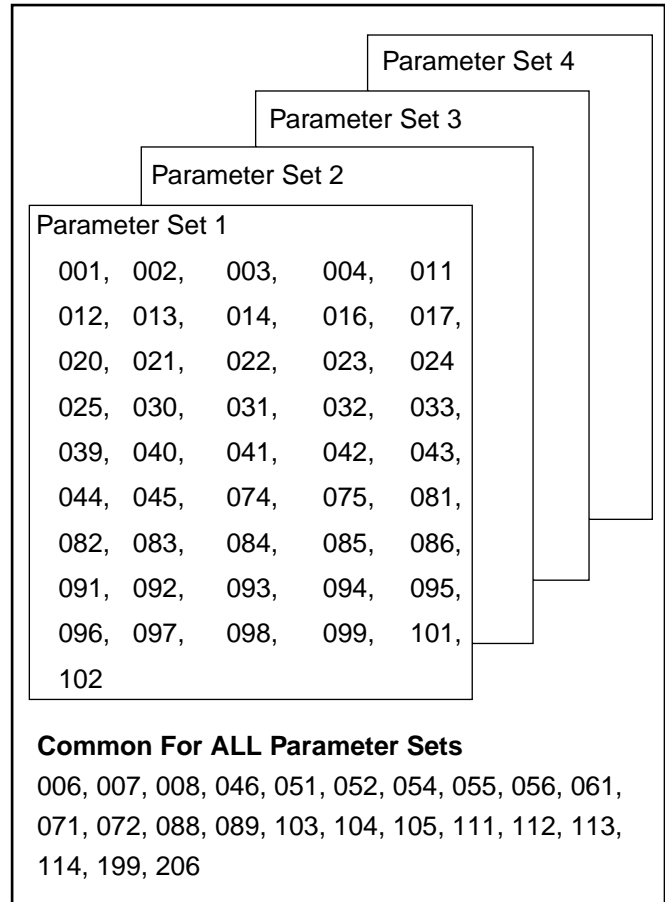

Fig. 29 Parameter overview

6.20.1 Parameter Set [061]

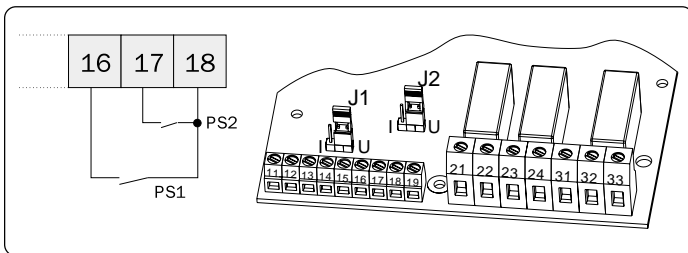

Fig. 30 Selection of parameter sets via external inputs.



<div style="border: 1px solid black; padding: 5px; display: inline-block;"> 061 </div>	
Parameter Set	
<div style="border: 1px solid black; padding: 5px; display: inline-block;"> 1 </div>	
Default:	1
Range:	0, 1, 2, 3, 4
0	Parameter sets are selected by the external input 16 and 17 (fig. 30)
1, 2, 3, 4	Selection of parameter 1 - 4.

Parameter Set	PS1 (16 - 18)	PS2 (17 - 18)
1	Open	Open
2	Closed	Open
3	Open	Closed
4	Closed	Closed

6.21 AUTOMATIC RETURN PARAMETER

Often it is desirable to have a specific parameter on the display during operation, (i.e. RMS current or power consumption). The Automatic return parameter allows the selection of any parameter in the parameter system.

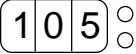
The parameter selected will come up on the display after 60 seconds of keypad inactivity. The alarm messages (F1-F16) have a priority over parameter 105 (as they have for all parameters).

		Automatic Return Menu
		
Default:	oFF	
Range:	oFF, 1 - 999	
1 - 999	“+” / “-” keys will scroll through the parameter system.	

The starter has a protection system for the motor, the machine and for the starter itself.
Three categories of alarm are available:

Category 1

Alarm that stops the motor and needs a separate reset before a new start can be accepted.

Category 2

Alarm that stops the motor and accepts a new start command without any separate reset.

Category 3

Alarm that does not stop the motor.

All alarms, except pre-alarms, will activate the alarm relay output K3, flash a red fault number on the display and be placed in the alarm list. As long as the alarm is active, the display is locked in the alarm indication.

The relay output K3 can be used in the control circuit for interlocking when an alarm occurs.

If more than one alarm is active, it is the last alarm that is on the display.

7.1 ALARM DESCRIPTION

7.1.1 Alarm with Stop Requiring a Separate Reset

Operation will stop for a category 1 alarm. A separate reset is needed before a new start command is accepted. It is possible to reset from keypad (pushing "ENTER/RESET") regardless of selected control mode. It is also possible to reset the alarm from the actual control mode (i.e. if control mode is serial communication, a reset is possible through serial communication).

A reset is accepted only when the alarm source is no longer present.

When a reset is made, the alarm relay output K3 is deactivated, the alarm indication on the display disappears and the original parameter shows.

After a reset is made the system is ready for a new start command.

7.1.2 Alarm with Stop Requiring only a New Start Command

Operation will stop for a category 2 alarm. A restart can be done and will deactivate the alarm relay output K3. The alarm indication on the display will disappear and the original parameter is displayed.

It is still possible to reset the alarm as for category 1 alarms (see 7.1.1), if a start is not required at the time.

7.1.3 Alarm without Stop

Operation will continue run for a category 3 alarm. The alarm can be reset as follows (see remarks for the specific alarms in 7.2):

- Automatic reset when the alarm source goes back to normal.
- Automatic reset when a stop command is given.
- Manual reset during run.

When the reset occurs, the alarm relay output K3 is deactivated, the alarm indication on the display disappears and the original parameter shows.

7.2 ALARM OVERVIEW

Display Indication	Protective Function	Alarm Category	Remark
F1	Phase input failure	Cat 3. Run with auto reset	Indicates phase loss when running if parameter 101 "Run at Phase Loss" = YES. If the lost phase returns, an automatic reset is made.
		Cat 2. Stop with reset at start.	Phase failure at start or if parameter 101 "Run at Phase Loss" = no.
F2	Motor protection, overload.	Cat 1. Stop with manual reset.	If parameter 071 "Motor RTD Input" = YES, cool down the motor. If parameter 071 "Motor RTD Input" = no, the internal O/L has to "COOL" down.
F3	Soft start overheated	Cat 1. Stop with manual reset	Cannot be reset until the unit has cooled sufficiently.
F4	Stall prevention	If parameter 102 "Run at Current Limit Time-Out" = no. Cat 2. Stop with reset in start.	The current limit start is not completed.
		If parameter 102 "Run at Current Limit Time-Out" = YES. Cat 3. Run with manual reset.	When start time expires, a 6 sec ramp is used to reach fill voltage, with no current limit. Reset the alarm with either a manual reset or a stop command.
F5	Locked rotor.	Cat 1. Stop with manual reset.	Motor and / or machine protection.
F6	Above max. power limit.	Cat 1. Stop with manual reset.	Machine protection.
F7	Below min. power limit.	Cat 1. Stop with manual reset.	Machine protection.
F8	Voltage unbalance.	Cat 2. Stop with reset in start.	Motor protection.
F9	Overvoltage	Cat 2. Stop with reset in start.	Motor protection.
F10	Undervoltage	Cat 2. Stop with reset in start.	Motor protection.
F11	Starts / hour exceeded.	Cat 2. Stop with reset in start.	Motor and / or machine protection.
F12	Shorted SCR.	Cat 3. Run with manual reset.	When stop command is given, the stop will be "Coast to Stop" and the starter will be reset. After this fault it is possible to start only in "Full Voltage" mode. One or more SCR's are probably damaged.
F13	Open SCR.	Cat 1. Stop with manual reset.	One or more SCR's probably damaged.
F14	Motor terminal open.	Cat 1. Stop with manual reset.	Check motor connections.
F15	Serial communication broken.	If parameter 114 serial comm. contact broken = 1. Cat 2. Stop with reset in start.	Serial communication broken will stop operation. Run from keypad if necessary.
		If parameter 114 serial comm. contact broken = 2. Cat 3. Run with auto reset.	Serial communication broken will not stop operation. Stop from keypad if necessary.
F16	Phase reversal alarm.	Cat 1. Stop with manual reset.	Incorrect phase order on main voltage input.

7.3 LINE POWER MONITOR / PROTECTION (ALARM F1, F8, F9 AND F10)

7.3.1 Phase Loss Failure

- Multiple phase failure.
Power loss shorter than 100ms is ignored. If failure duration is between 100 ms and 2 sec, operation is temporarily stopped. A soft start is made if the failure disappears before 2 sec. If failure duration is longer than 2 sec, an F1 alarm is given in category 2.
- Single phase failure.
During start up (acceleration) the reaction is the same as the multiple phase failure. When running the alarm action is selectable.

7.3.2 Run at Phase Loss Failure [101]

<div style="display: flex; align-items: center;"> <div style="border: 1px solid black; padding: 2px; margin-right: 5px;">1</div> <div style="border: 1px solid black; padding: 2px; margin-right: 5px;">0</div> <div style="border: 1px solid black; padding: 2px; margin-right: 5px;">1</div> <div style="margin-left: 5px;">○</div> <div style="margin-left: 5px;">○</div> </div> <div style="display: flex; align-items: center;"> <div style="border: 1px solid black; padding: 2px; margin-right: 5px;"></div> <div style="border: 1px solid black; padding: 2px; margin-right: 5px;"></div> <div style="border: 1px solid black; padding: 2px; margin-right: 5px;">n</div> <div style="border: 1px solid black; padding: 2px; margin-right: 5px;">o</div> </div> <div style="margin-left: 20px;">Run at Phase Loss</div>	
Default:	no
Range:	no, YES
no	Start trips if a phase loss is detected. Alarm F1 (category 2) will appear after 2 sec.
YES	Starter continues to run after a single phase loss. <ul style="list-style-type: none"> - Alarm F1 appears after 2 sec. - If the phase turns, the alarm is reset automatically. - If running on 2 phases, a stop command will give a "Coast to Stop"

7.3.3 Voltage Unbalance [081]

<div style="display: flex; align-items: center;"> <div style="border: 1px solid black; padding: 2px; margin-right: 5px;">0</div> <div style="border: 1px solid black; padding: 2px; margin-right: 5px;">8</div> <div style="border: 1px solid black; padding: 2px; margin-right: 5px;">1</div> <div style="margin-left: 5px;">○</div> <div style="margin-left: 5px;">○</div> </div> <div style="display: flex; align-items: center;"> <div style="border: 1px solid black; padding: 2px; margin-right: 5px;"></div> <div style="border: 1px solid black; padding: 2px; margin-right: 5px;"></div> <div style="border: 1px solid black; padding: 2px; margin-right: 5px;">1</div> <div style="border: 1px solid black; padding: 2px; margin-right: 5px;">0</div> </div> <div style="margin-left: 20px;">Voltage Unbalance Alarm</div>	
Default:	10
Range:	5 - 25%
Insert limit in % of motor nameplate voltage. Max. unbalance in voltage between the 3 input phases is compared with the selected value. This is a category 2 alarm.	

7.3.4 Response Delay Voltage Unbalance [082]

<div style="display: flex; align-items: center;"> <div style="border: 1px solid black; padding: 2px; margin-right: 10px;">082</div> <div style="margin-left: 10px;">○</div> </div> <div style="margin-left: 100px;">Response Delay Voltage Unbalance Alarm</div>	
<div style="border: 1px solid black; padding: 5px; display: inline-block; font-size: 24px;">OFF</div>	
Default:	oFF
Range:	off, 1 - 60 sec
oFF	Unbalanced voltage alarm is disabled.
1 - 60	Set the response delay time for unbalanced voltage alarm F1.

7.3.5 Over Voltage [083]

<div style="display: flex; align-items: center;"> <div style="border: 1px solid black; padding: 2px; margin-right: 10px;">083</div> <div style="margin-left: 10px;">○</div> </div> <div style="margin-left: 100px;">Over Voltage Alarm</div>	
<div style="border: 1px solid black; padding: 5px; display: inline-block; font-size: 24px;">115</div>	
Default:	115
Range:	100 - 150% Un
<p>Insert limit in % of motor nameplate voltage. Max. voltage of the 3 input phases is compared with the selected value. This is a category 2 alarm.</p>	

7.3.6 Response Delay Over Voltage [084]

<div style="display: flex; align-items: center;"> <div style="border: 1px solid black; padding: 2px; margin-right: 10px;">084</div> <div style="margin-left: 10px;">○</div> </div> <div style="margin-left: 100px;">Response Delay Over Voltage Alarm</div>	
<div style="border: 1px solid black; padding: 5px; display: inline-block; font-size: 24px;">OFF</div>	
Default:	oFF
Range:	off, 1 - 60 sec
oFF	Over voltage alarm is disabled.
1 - 60	Set the response delay time for over voltage alarm F9.

7.3.7 Under Voltage [085]

<div style="display: flex; align-items: center;"> <div style="border: 1px solid black; padding: 2px; margin-right: 5px;">085</div> <div style="margin-left: 5px;">○</div> </div>	
Under Voltage Alarm	
<div style="border: 1px solid black; padding: 5px; display: inline-block;"> <div style="border: 1px solid black; padding: 2px; margin-right: 5px;">OFF</div> </div>	
Default:	85
Range:	75 - 100 Vn
<p>Insert limit in % of motor nameplate voltage. Min. voltage of the 3 input phases is compared with the selected value. This is a category 2 alarm.</p>	

7.3.8 Response Delay Under Voltage [086]

<div style="display: flex; align-items: center;"> <div style="border: 1px solid black; padding: 2px; margin-right: 5px;">086</div> <div style="margin-left: 5px;">○</div> </div>	
Response Delay Under Voltage Alarm	
<div style="border: 1px solid black; padding: 5px; display: inline-block;"> <div style="border: 1px solid black; padding: 2px; margin-right: 5px;">OFF</div> </div>	
Default:	oFF
Range:	off, 1 - 60 sec
oFF	Unbalanced voltage alarm is disabled.
1 - 60	Set the response delay time for unbalanced voltage alarm F10.

7.4 MOTOR OVERLOAD PROTECTION (F2 ALARM)

The ACSSA starter can use an input RTD signal from the motor, an internal thermal model of the motor or both together at the same time for thermal protection. Slight overload for a long time and several overloads of short duration will be detected with both methods.

7.4.1 Motor RTD Input [071]

<div style="display: flex; align-items: center;"> <div style="border: 1px solid black; padding: 2px; margin-right: 5px;">071</div> <div style="margin-left: 5px;">○</div> </div>	
Motor RTD Input	
<div style="border: 1px solid black; padding: 5px; display: inline-block;"> <div style="border: 1px solid black; padding: 2px; margin-right: 5px;">no</div> </div>	
Default:	no
Range:	no, YES
no	Motor RTD input is disabled.
YES	<p>Motor RTD input is enabled.</p> <ul style="list-style-type: none"> - Connect the RTD to terminals 69 and 70 (see Table 2, page 17). - An overheated motor will give an F2 alarm. The alarm can only be reset after the motor has cooled.

NOTE! *Open terminals 69 and 70 will give an F2 alarm immediately. Make sure the RTD is always connected or the terminals are shorted if parameter 071 is enabled.*

NOTE! *When using the RTD input, the thermal overload protection will still be active if it is not disabled.*

7.4.2 Thermal Overload Protection [072]

NOTE! *If 'Bypass' is used, the current transformers must be placed and connected correctly (see page 20).*

CAUTION! *The used thermal capacity (073) is reset to 0 if the control voltage is removed (terminals 01 and 02). This means that the internal thermal model starts as if with a 'cold' motor, which may not be the case and can lead to motor overheating.*

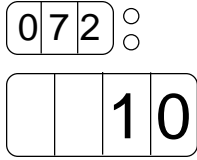
 Thermal Overload Protection	
Default:	10
Range:	oFF, 2 - 40 sec.
oFF	Internal motor protection is disabled.
2 - 40	Selection of the thermal curve. - Check that parameter 042 is set to the proper motor current (see 6.4.3, page 34). - If the current exceeds the selected curve an F2 alarm is activated. - Thermal capacity can be viewed in parameter 073.

7.4.3 Used Thermal Capacity [073]

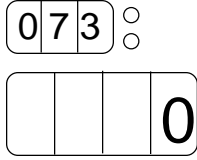
 Used Thermal Capacity	
Default:	-
Range:	0 - 150%
Read-out of the used thermal capacity. If parameter 072 "Thermal Overload Protection" is set to off, the capacity is shown as if the default class 10 was selected.	

7.5 STARTER OVER-TEMPERATURE (F3 ALARM)

Temperature sensing of the starter is necessary to protect the 6 SCR's in the power section. This is a category 1 alarm and a reset is accepted only after a cool down of the heatsink.

7.6 CURRENT LIMIT START ALARM (F4 ALARM)

7.6.1 Full Speed not Reached at Set Current Limit and Start Time [102]

In modes 'Current limit' and 'Voltage ramp with current limit' an alarm is activated if the unit is still at the current limit level when the ramp time is exceeded.

<div style="display: flex; align-items: center;"> <div style="border: 1px solid black; padding: 2px; margin-right: 10px;">102</div> <div style="margin-right: 10px;">○</div> <div style="margin-right: 10px;">○</div> </div> <div style="display: flex; align-items: center;"> <div style="border: 1px solid black; padding: 2px; margin-right: 10px;">no</div> <div style="margin-right: 10px;">○</div> <div style="margin-right: 10px;">○</div> </div> <div style="margin-left: 20px;"> <p>Run at Current Limit Time-Out</p> </div>	
Default:	no
Range:	no
no	Starter trips if the current limit time is exceeded. Alarm F4 (category 2) appears.
YES	<p>Starter continues to run after the current limit time is exceeded:</p> <ul style="list-style-type: none"> - Alarm F4 appears. - The starter ramps up to full voltage with a 6 second ramp and no current limit. - Reset the alarm with either ENTER / RESET key or by giving a stop command.

7.7 LOCKED ROTOR (F5 ALARM)

7.7.1 Locked Rotor [075]

<div style="display: flex; align-items: center;"> <div style="border: 1px solid black; padding: 2px; margin-right: 10px;">075</div> <div style="margin-right: 10px;">○</div> <div style="margin-right: 10px;">○</div> </div> <div style="display: flex; align-items: center;"> <div style="border: 1px solid black; padding: 2px; margin-right: 10px;">oFF</div> <div style="margin-right: 10px;">○</div> <div style="margin-right: 10px;">○</div> </div> <div style="margin-left: 20px;"> <p>Locked Rotor Alarm</p> </div>	
Default:	oFF
Range:	off, 1.0 - 10.0 sec
oFF	Locked rotor alarm is disabled.
1.0 - 10.0	An F5 alarm is given when the rotor locks (500% FLA). The alarm is active during starting and running.

7.8 LOAD MONITOR MAX AND MIN/PROTECTION (F6 AND F7 ALARMS)

The ACSSA has a built-in load monitor based on output power. This is a unique function, which enables protection of machines and processes. Both a Min and Max limit is selectable. This makes for a highly effective system monitor, especially when used in tandem with the pre-alarm functions (see 7.12, page 54). An auto set function is also included for an automatic setting of the alarm limits. A start-up delay time can be selected to avoid nuisance alarms at start-up.

7.8.1 Output Power In % [090]

090		Output Power in %
0		
Default:	-	
Range:	0 - 200%	
Measured output power in % of nominal motor power.		

7.8.2 Auto Set Power Limit [089]

NOTE! System must be running at full speed before an auto set is permitted.

The actual power is regarded as 1.00 x P actual.

The set levels are:

Power max alarm [092]:	1.15 x P actual
Power max pre-alarm [094]:	1.10 x P actual
Power min pre-alarm [096]:	0.90 x P actual
Power min alarm [098]:	0.85 x P actual

A successful auto set shows a message 'Set' for 3 seconds, otherwise a message 'no' will be showed.

089		Auto Set Power Limits
no		
Default:	no	
Range:	no, YES	
no	Auto set is disabled.	
YES	Auto set is activated if ENTER is pressed	

7.8.3 Start Delay for Power Limits [091]

091		Start Delay for Power Limits
10		
Default:	10 sec	
Range:	1 - 250 sec	
After the start command, all power monitor alarms and pre-alarms are disabled for the set time.		

7.8.4 Max Power Alarm Limit [092]

<div style="display: flex; align-items: center;"> <div style="border: 1px solid black; padding: 2px; margin-right: 5px;">0</div> <div style="border: 1px solid black; padding: 2px; margin-right: 5px;">9</div> <div style="border: 1px solid black; padding: 2px; margin-right: 5px;">2</div> <div style="margin-left: 10px;">○</div> </div>		Max Power Alarm Limit
<div style="display: flex; align-items: center;"> <div style="border: 1px solid black; padding: 2px; margin-right: 5px;">1</div> <div style="border: 1px solid black; padding: 2px; margin-right: 5px;">1</div> <div style="border: 1px solid black; padding: 2px; margin-right: 5px;">5</div> </div>		
Default:	115	
Range:	5 - 200% Pn	
<p>Insert limit in % of motor nameplate power. The actual power, in % of motor nameplate power, can be read in parameter 090. If output power exceeds selected limit, an F6 alarm occurs after the response delay time. The "Auto Set" function, in parameter 089 affects this setting even if the alarm is disabled in parameter 093. This is a category 1 alarm.</p>		

7.8.5 Max Alarm Response Delay [093]

<div style="display: flex; align-items: center;"> <div style="border: 1px solid black; padding: 2px; margin-right: 5px;">0</div> <div style="border: 1px solid black; padding: 2px; margin-right: 5px;">9</div> <div style="border: 1px solid black; padding: 2px; margin-right: 5px;">3</div> <div style="margin-left: 10px;">○</div> </div>		Response Delay Max Alarm
<div style="display: flex; align-items: center;"> <div style="border: 1px solid black; padding: 2px; margin-right: 5px;">1</div> <div style="border: 1px solid black; padding: 2px; margin-right: 5px;">1</div> <div style="border: 1px solid black; padding: 2px; margin-right: 5px;">5</div> </div>		
Default:	oFF	
Range:	oFF, 0.1 - 25.0 sec	
oFF	Max alarm is disabled.	
0.1 - 25.0	Sets the response delay of the max. alarm level.	

7.8.6 Min Power Alarm Limit [098]

<div style="display: flex; align-items: center;"> <div style="border: 1px solid black; padding: 2px; margin-right: 5px;">0</div> <div style="border: 1px solid black; padding: 2px; margin-right: 5px;">9</div> <div style="border: 1px solid black; padding: 2px; margin-right: 5px;">8</div> <div style="margin-left: 10px;">○</div> </div>		Min Power Alarm Limit
<div style="display: flex; align-items: center;"> <div style="border: 1px solid black; padding: 2px; margin-right: 5px;"> </div> <div style="border: 1px solid black; padding: 2px; margin-right: 5px;"> </div> <div style="border: 1px solid black; padding: 2px; margin-right: 5px;">8</div> <div style="border: 1px solid black; padding: 2px; margin-right: 5px;">5</div> </div>		
Default:	85	
Range:	5 - 200% Pn	
<p>Insert limit in % of motor nameplate power. The actual power, in % of motor nameplate power can be read out in parameter 090. If output power goes below the selected limit, an F7 alarm occurs after the response delay time. The "Auto Set" function, in parameter 089, affect this limit even if the alarm is disabled in parameter 099. This is a category 1 alarm.</p>		

7.8.7 Min Alarm Response Delay [099]

<div style="display: flex; align-items: center; justify-content: space-between;"> <div style="border: 1px solid black; padding: 2px;">099</div> <div style="font-size: 2em;">○ ○</div> </div> <div style="display: flex; align-items: center; justify-content: space-between; margin-top: 5px;"> <div style="border: 1px solid black; padding: 2px;">OFF</div> <div style="text-align: right;">Min Power Alarm Limit</div> </div>	
Default:	oFF
Range:	oFF, 0.1 - 25.0 sec
oFF	Min alarm is disabled.
0.1 - 25.0	Sets the response delay of the min. alarm lever. The min alarm is disabled during a ramp down.

7.9 STARTS / HOUR LIMITATION FUNCTION (F11 ALARM)

7.9.1 Starts / Hour Limitation [074]

<div style="display: flex; align-items: center; justify-content: space-between;"> <div style="border: 1px solid black; padding: 2px;">074</div> <div style="font-size: 2em;">○ ○</div> </div> <div style="display: flex; align-items: center; justify-content: space-between; margin-top: 5px;"> <div style="border: 1px solid black; padding: 2px;">OFF</div> <div style="text-align: right;">Starts per Hour Limitation</div> </div>	
Default:	oFF
Range:	oFF, 1 - 99 / hour
oFF	Starts per hour limitation is disabled.
1 - 99	Sets the start per hour limitation alarm. If the selected number is exceeded, alarm F11 occurs.

7.10 PHASE SEQUENCE ALARM (F16 ALARM)

7.10.1 Phase Sequence Alarm [088]

NOTE! *The actual phase sequence can be viewed in parameter 087.*

<div style="display: flex; align-items: center;"> <div style="border: 1px solid black; padding: 2px; margin-right: 10px;">088</div> <div style="margin-left: 10px;">○</div> </div> <div style="display: flex; align-items: center; margin-top: 10px;"> <div style="border: 1px solid black; padding: 5px; margin-right: 10px;">OFF</div> <div>Phase Sequence Alarm</div> </div>	
Default:	oFF
Range:	oFF, ON
oFF	Phase sequence alarm is disabled.
ON	Sets the phase sequence alarm. - Apply line power. The phase sequence is stored as the correct sequence. - Set the parameter 088 to "ON". - Any reversal of input phase sequence will cause alarm F16.

7.10.2 Phase Sequence [087]

<div style="display: flex; align-items: center;"> <div style="border: 1px solid black; padding: 2px; margin-right: 10px;">087</div> <div style="margin-left: 10px;">○</div> </div> <div style="display: flex; align-items: center; margin-top: 10px;"> <div style="border: 1px solid black; padding: 5px; margin-right: 10px;">- - - -</div> <div>Phase Sequence</div> </div>	
Default:	-
Range:	L123, L321
L123 is the direct phase sequence. L321 is the reverse phase sequence.	

7.11 ALARM LIST

The alarm list is generated automatically. It shows the latest 15 alarms (F1 - F16). The alarm list can be useful when tracing a failure in the starter or its control circuit. Press key "NEXT" or "PREV" to reach the alarm list in parameters 901-915 (parameter 007 has to be ON).

7.12 PRE-ALARMS

It can be useful to know if the load is changing toward a load alarm limit. It is possible in the ACSSA to insert both a Max and Min pre-alarm limit based on the motor output power. If the load exceeds one of these limits, a pre-alarm condition occurs.

It should be noted that these are not alarms. They will not be stored in the alarm list, activate the alarm relay output K3, be displayed on the alarm display, nor will they stop operation. But it is possible to activate relay K1 or K2 if a pre-alarm condition occurs. To have pre-alarm status on any of these relays, select value 3 in parameter 051 or 052 (see 6.18, page 50).

A start-up delay time can be selected in parameter 091 to avoid nuisance pre-alarms at start-up. Note that this delay time is also shared with Max and Min power alarms.

NOTE! The pre-alarm status is always available on the serial communication.

7.12.1 Max Power Pre-Alarm Limit [094]

094	○	Max Power Pre-Alarm Limit
110	○	
Default:	110	
Range:	5 - 200% Pn	
<p>Insert limit in % of nominal motor power. The actual power in % of motor nameplate power, can be read out in parameter 090. If output power exceeds selected limit, a pre-alarm occurs after the response delay time. The "Auto Set" function, in parameter 089, effects selected limit even if the pre-alarm is disabled in parameter 095.</p>		

7.12.2 Max Pre-Alarm Response Delay [095]

095	○	Max Pre-Alarm Response Delay
OFF	○	
Default:	oFF	
Range:	oFF, 0.1 - 25.0 sec	
oFF	Max pre-alarm is disabled.	
0.1 - 25.0	Sets the response delay of the max pre-alarm level.	

7.12.3 Min Power Pre-Alarm Limit [096]

<div style="display: flex; align-items: center;"> <div style="border: 1px solid black; padding: 2px; margin-right: 10px;">096</div> <div style="margin-right: 10px;">○</div> <div style="margin-right: 10px;">○</div> <div style="text-align: right;"> Min Power Pre-Alarm Limit </div> </div>	
<div style="border: 1px solid black; padding: 5px; display: inline-block;"> 90 </div>	
Default:	90%
Range:	5 - 200% Pn
<p>Insert limit in % of nominal motor power. The actual power in % of motor nameplate power, can be read out in parameter 090. If output power goes below selected limit, a pre-alarm occurs after the response delay time. The "Auto Set" function, in parameter 089, effects selected limit even if the pre-alarm is disabled in parameter 097.</p>	

7.12.4 Min Pre-Alarm Response Delay [097]

<div style="display: flex; align-items: center;"> <div style="border: 1px solid black; padding: 2px; margin-right: 10px;">097</div> <div style="margin-right: 10px;">○</div> <div style="margin-right: 10px;">○</div> <div style="text-align: right;"> Min Pre-Alarm Response Delay </div> </div>	
<div style="border: 1px solid black; padding: 5px; display: inline-block;"> o F F </div>	
Default:	oFF
Range:	oFF, 0.1 - 25.0 sec
oFF	Min pre-alarm is disabled.
0.1 - 25.0	Sets the response delay of the min pre-alarm level.

8.1 GENERAL

The soft start includes, as standard, numerous metering functions, eliminating the need for additional transducers and meters.

8.2 MEASURED VALUES

- Current RMS - 3-phase current and each phase current
- Voltage RMS - 3-phase voltage and each phase voltage
- Output power / torque in kW/Nm
- Power factor
- Power consumption in kWh
- Elapsed time in days

8.3 VIEWING OF THE MEASURED VALUES

After setting motor data and extended functions parameter 008 can be set to "off". When scrolling, the parameters will then move from 008 to parameter 201, the first monitor parameter, eliminating the need to scroll through parameters 011 to 199.

8.3.1 RMS Current [201]

NOTE! This is the same read-out as parameter 005 see 6.5.5, page 36.

<div style="display: flex; align-items: center; justify-content: center;"> <div style="border: 1px solid black; padding: 2px 5px; margin-right: 5px;">201</div> <div style="margin-left: 5px;">○</div> </div>	RMS Current
<div style="display: flex; align-items: center; justify-content: center;"> <div style="border: 1px solid black; padding: 2px 5px; margin-right: 5px;"> </div> <div style="border: 1px solid black; padding: 2px 5px; margin-right: 5px;"> </div> <div style="border: 1px solid black; padding: 2px 5px; margin-right: 5px;">0</div> <div style="border: 1px solid black; padding: 2px 5px;">.0</div> </div>	
Default:	-
Range:	0.0 - 9999 Amp
Read-out of the RMS motor current.	

8.3.2 Line Voltage [202]

<div style="display: flex; align-items: center; justify-content: center;"> <div style="border: 1px solid black; padding: 2px 5px; margin-right: 5px;">202</div> <div style="margin-left: 5px;">○</div> </div>	Line Voltage
<div style="display: flex; align-items: center; justify-content: center;"> <div style="border: 1px solid black; padding: 2px 5px; margin-right: 5px;"> </div> <div style="border: 1px solid black; padding: 2px 5px; margin-right: 5px;"> </div> <div style="border: 1px solid black; padding: 2px 5px; margin-right: 5px;">0</div> <div style="border: 1px solid black; padding: 2px 5px;">.0</div> </div>	
Default:	-
Range:	0 - 600 V
The RMS input line voltage.	

CHAPTER 8: VIEW OPERATION

8.3.3 Output Power [203]

<div style="display: flex; align-items: center;"> <div style="border: 1px solid black; padding: 2px; margin-right: 10px;">203</div> <div style="margin-left: 10px;">○</div> </div>	
Output Power	
<div style="border: 1px solid black; padding: 5px; display: inline-block;"> 0.0 </div>	
Default:	-
Range:	HP
Viewing will show negative value if in regen mode.	

8.3.4 Power Factor [204]

NOTE! *The power factor viewing will not work in bypass even if the current transformers are mounted outside the soft start.*

<div style="display: flex; align-items: center;"> <div style="border: 1px solid black; padding: 2px; margin-right: 10px;">204</div> <div style="margin-left: 10px;">○</div> </div>	
Power Factor	
<div style="border: 1px solid black; padding: 5px; display: inline-block;"> 0.0 </div>	
Default:	-
Range:	0.00 - 1
View the actual power factor.	

8.3.5 Total Power Consumption [205]

<div style="display: flex; align-items: center;"> <div style="border: 1px solid black; padding: 2px; margin-right: 10px;">205</div> <div style="margin-left: 10px;">○</div> </div>	
Total Power Consumption	
<div style="border: 1px solid black; padding: 5px; display: inline-block;"> 0.000 </div>	
Default:	-
Range:	0.000 - 2000 MWh
View the total power consumption.	

8.3.6 Reset of Power Consumption [206]

<div style="display: flex; align-items: center;"> <div style="border: 1px solid black; padding: 2px; margin-right: 10px;">206</div> <div style="margin-left: 10px;">○</div> </div>	
Reset of Power Consumption	
<div style="border: 1px solid black; padding: 5px; display: inline-block;"> no </div>	
Default:	no
Range:	no, YES
no	No reset of power consumption.
YES	Reset power consumption in parameter 205 to 0.000

8.3.7 Motor Shaft Torque [207]

<div style="display: flex; align-items: center;"> <div style="border: 1px solid black; padding: 2px; margin-right: 10px;">207</div> <div style="margin-left: 10px;">○</div> </div>	
Motor Shaft Torque	
<div style="border: 1px solid black; padding: 5px; display: inline-block;"> 0.0 </div>	
Default:	-
Range:	LB-FT
Viewing will show negative value if in regen mode.	

8.3.8 Elapsed Time [208]

<div style="display: flex; align-items: center;"> <div style="border: 1px solid black; padding: 2px; margin-right: 10px;">208</div> <div style="margin-left: 10px;">○</div> </div>	
Elapsed Time	
<div style="border: 1px solid black; padding: 5px; display: inline-block;"> 0.0 </div>	
Default:	-
Range:	0 - 9999 days
<p>By selecting parameter 208, one can view the elapsed time the soft start has been in operation. This time is only calculated when the soft start is in operation, not during bypass operation.</p>	

8.3.9 Current Phase L1 [211]

<div style="display: flex; align-items: center;"> <div style="border: 1px solid black; padding: 2px; margin-right: 10px;">211</div> <div style="margin-left: 10px;">○</div> </div>	
RMS Current in Phase L1	
<div style="border: 1px solid black; padding: 5px; display: inline-block;"> 0.0 </div>	
Default:	-
Range:	0.0 - 9999 Amp
View the current in phase L1.	

8.3.10 Current Phase L2 [212]

<div style="display: flex; align-items: center;"> <div style="border: 1px solid black; padding: 2px; margin-right: 10px;">212</div> <div style="margin-left: 10px;">○</div> </div>	
RMS Current in Phase L2	
<div style="border: 1px solid black; padding: 5px; display: inline-block;"> 0.0 </div>	
Default:	-
Range:	0.0 - 9999 Amp
View the current in phase L2.	

CHAPTER 8: VIEW OPERATION

8.3.11 Current Phase L3 [213]

<div style="display: flex; align-items: center;"> <div style="border: 1px solid black; padding: 2px; margin-right: 5px;">213</div> <div style="margin-left: 5px;">○</div> </div>	
RMS Current in Phase L3	
<div style="border: 1px solid black; padding: 5px; display: inline-block;"> 0.0 </div>	
Default:	-
Range:	0.0 - 9999 Amp
View the current in phase L3.	

8.3.12 Line Voltage L1-L2 [214]

<div style="display: flex; align-items: center;"> <div style="border: 1px solid black; padding: 2px; margin-right: 5px;">214</div> <div style="margin-left: 5px;">○</div> </div>	
Line Voltage L1 - L2	
<div style="border: 1px solid black; padding: 5px; display: inline-block;"> 0 </div>	
Default:	-
Range:	0 - 600 V
View line voltage L1 - L2.	

8.3.13 Line Voltage L1-L3 [215]

<div style="display: flex; align-items: center;"> <div style="border: 1px solid black; padding: 2px; margin-right: 5px;">215</div> <div style="margin-left: 5px;">○</div> </div>	
Line Voltage L1 - L3	
<div style="border: 1px solid black; padding: 5px; display: inline-block;"> 0 </div>	
Default:	-
Range:	0 - 600 V
View line voltage L1 - L3.	

8.3.14 Line Voltage L2-L3 [216]

<div style="display: flex; align-items: center;"> <div style="border: 1px solid black; padding: 2px; margin-right: 5px;">216</div> <div style="margin-left: 5px;">○</div> </div>	
Line Voltage L2 - L3	
<div style="border: 1px solid black; padding: 5px; display: inline-block;"> 0 </div>	
Default:	-
Range:	0 - 600 V
View line voltage L2 - L3.	

9.1 FAULT, POSSIBLE CAUSE AND SOLUTION

Observation	Fault Indication	Possible Causes(s)	Solution
The display is not illuminated.	None	No control voltage.	Switch on the control voltage.
The motor does not run	F1 (Phase input failure)	Fuse defective.	Replace the fuse.
		No line supply.	Check line power.
	F2 (Motor protection, overload)	Bad RTD connection. Incorrect motor current programmed (parameter 042). Motor overloaded.	Check the RTD input if used. If internal protection is used, perhaps next class overload could be used (parameter 072). Cool down the motor and do a reset.
	F3 (Soft start overheated)	Ambient temperature too high. Starter duty cycle exceeded. Fan failure	Check cabinet ventilation. Check the size of the cabinet. Clean the cooling fins. If the fan(s) is not working correctly, contact your local distributor.
	F4 (Full speed not reached at set current limit and start time)	Current limit parameters not matched to the load and motor.	Increase the starting time and / or the current level.
	F5 (Locked rotor)	Foreign material in machine or motor bearing failure.	Check machine and motor bearings. The alarm delay time can be set longer (parameter 075).
	F6 (Above max. power limit)	Overload	Overload. Check machine. The alarm delay time can be set longer (parameter 093).
	F7 (Below min. power limit)	Under-load	Under-load. Check machine. The alarm delay time can be set longer (parameter 099).
	F8 (Voltage unbalance)	Line voltage unbalanced.	Check line supply.
	F9 (Overvoltage)	Line power overvoltage.	Check line supply.
	F10 (Undervoltage)	Line power undervoltage.	Check line supply.
	F11 (Starts / hour exceeded)	Number of starts exceeded according to parameter 074.	Wait and make a new start. The number of starts / hour can be increased in parameter 074.
	F13 (Open SCR)	Damaged SCR.	Make a reset and a restart. If the same alarm appears immediately, contact your local distributor.
	F14 (Motor terminal open)	Open motor contact, cable or motor winding.	If the fault is not found, reset the alarm and inspect the alarm list. If alarm F12 is found, an SCR is probably shorted. Make a restart. If alarm F14 appears immediately, contact your local distributor.
	F15 (Serial communication broken)	Serial communication broken.	Make a reset and try to establish contact. Check contacts, cables and option board. Verify: - System address (parameter 111) - Baud rate (parameter 112) - Parity (parameter 113) If fault is not found, for critical operation, temporarily run the motor with keypad control (set parameter 006 to "1"). See also manual for serial communication.
	F16 (Phase reversal)	Incorrect phase sequence on line supply.	Switch L2 and L3 input phases.
- - - -	Start command problem (i.e.: start from keypad when remote control is selected or faulty start switch).	Give start command from selected source (parameter 006). Check start logic wiring.	
- Loc	System in keypad lock.	Unlock keypad by pressing the buttons "NEXT" and "ENTER" for at least 3 sec.	

Observation	Fault Indication	Possible Causes(s)	Solution
The motor is running, but the alarm is given.	F1 (Phase input failure)	Phase loss. Defective fuse.	Check fuses and line supply. Select "no" in parameter 101, if stop is desired when a phase loss occurs.
	F4 (Full speed not reached at set current limit and start time)	Current limit parameters not matched to the load and motor.	Increase the starting time and / or the current limit level. Select "no" in parameter 102, if stop is desired at current limit time-out.
	F12 (Shorted SCR)	Perhaps a damaged SCR.	When stop command is given, a free wheel stop is made. Make a reset and a restart. If alarm F12 appears immediately, contact your local distributor. If it is critical to re-start the motor, set starter in "Full Voltage" (parameter 024). It is possible to start in this mode.
		Bypass contactor is used but parameter 032 "Bypass" is not set to "on".	Set parameter 032 "Bypass" to "on".
F15 (Serial communication broken)	Serial communication broken.	Make a reset and try to establish contact. Check contacts, cables and option board. Verify: - System address (parameter 111). - Baud rate (parameter 112). - Parity (parameter 113). If the fault is not found, for critical operation, temporarily run the motor with keypad control. See also manual for serial communication.	
The motor jerks etc. When starting, motor reaches full speed, but it jerks or vibrates.	If "Torque Control" or "Pump Control" is selected, it is necessary to input motor data into the system.		Input motor nameplate data in parameters 041-046. Select the proper load characteristic in parameter 025. Select a correct initial and end torque at start in parameters 016 and 017. If "Bypass" is selected, check that the current transformers are correctly connected.
		Starting time is too short.	Increase starting time.
		Starting voltage is too high or low.	Adjust starting voltage.
		Starting ramp not set correctly.	Readjust the start ramp. Select current limit function.
	Starting or stopping time too long or short.	Ramp times not set correctly. Motor too large or too small in relation to load.	Readjust the start and / or stop ramp time. Change to another motor size.
The monitor function does not work.	No alarm or pre-alarm.	It is necessary to input nominal motor data for this function. Incorrect alarm levels.	Input nominal motor data in parameters 041-046. Adjust alarm levels in parameters 091-099. If "Bypass" is selected, check that the current transformers are correctly connected.
Unexplainable alarm.	F5, F6, F7, F8, F9, F10	Alarm delay time is too short.	Adjust the response delay times for the alarms in parameters 075, 082, 086, 093, and 099.
The system seems locked in an alarm.	F2 (Motor protection, overload)	RTD input terminal could be open. Motor could still be too warm. If internal motor protection is used, the cooling takes time.	RTD input terminals should be shorted if not used. Wait until motor RTD gives an OK (not overheated) signal. Wait until the internal cooling is done. Try to reset the alarm.
	F3 (Soft start overheated)	Ambient temperature too high. Fan failure.	Check that the cables from the module are connected in terminals 073, 074, 071 and 072. ACSSA420 to ACSSA4100 should have a short circuit between 071 and 072. Check also that the fan(s) is rotating.
Parameter will not be accepted.	- - - -	If the parameter number is 020-025, only one can be selected.	Ensure only one parameter 020-025 is enabled.
		If parameter 061, "Parameter Set" is set to "0", the system is in a remote parameter selection mode. It is not possible to change most of the parameters.	Set the parameter 061, "Parameter Set" to a value between "1" - "4" and then it is possible to change any parameter.
		During acceleration, deceleration, slow speed, DC brake and energy saver control mode, it is not possible to change parameters.	Set parameters during stop or full voltage running.
		If control source is serial communication, it is not possible to change parameters from keypad and vice versa.	Change parameters from the selected control source.
	- Loc	Keypad is locked.	Unlock keypad by pressing the buttons "NEXT" and "ENTER" for at least 3 sec.

10.1 SMALL MOTOR OR LOW LOAD

The minimum load current for the soft start is 10 % of the rated current of the starter. Example ACSSA4200 rated current = 240 A. Min. Current = 24 A.

10.2 AMBIENT TEMPERATURE BELOW 0°C

For ambient temperatures below 0°C e.g. a space heater should be installed in the cabinet. The soft start can also be relocated as the distance between the motor and the soft start is not critical.

10.3 POWER FACTOR CORRECTION CAPACITORS

If power factor correction capacitors are to be used, they must be connected at the input of the starter and never between the motor and the starter.

10.4 REVERSING AND TWO SPEED CONTACTORS

The contactors should be connected between the output of the starter and the motor.

10.5 SHIELDED MOTOR CABLE

It is not necessary to use shielded wire with soft starts due to the very low radiated emissions.

NOTE! *The starter should be wired with shielded control cable when it is necessary to fulfill EMC regulations.*

10.6 SLIP RING / WOUND ROTOR MOTORS

Slip ring motors can be used together with the starter.

10.7 STARTING INTO BACK SPINNING LOADS

It is possible to start a motor in forward, even if the load is rotating in the reverse direction, such as in a fan. Because the soft start limits the current drawn by the motor, the load can be brought to a stop and accelerated in the forward direction through a normal start sequence.

10.8 RUNNING MOTORS IN PARALLEL

When starting and running motors in parallel the total amount of the motor current must be equal or lower than the connected soft start. Please note that it is not possible to make individual settings for each motor. The start can only be set for an average starting ramp for all the connected motors and the start time may differ from motor to motor. Each motor must have individual thermal overload protection.

10.9 INSULATION TEST ON MOTOR

When megging the motor with high voltage the soft start must be disconnected from the motor. This is due to the fact that the SCR's may be damaged by the high peak voltage.

11.1 MAINTENANCE

In general the starter is maintenance-free. There are however some things which should be checked regularly. Especially if the environment is dusty the unit should be cleaned regularly.



WARNING! *Do not touch parts inside the enclosure when the control and motor voltage is on.*

REGULAR MAINTENANCE:

- Check that nothing in the starter has been damaged by vibration (loose screws or connections).
- Check external wiring, connections and control signals. Tighten terminal screws and busbar bolts if necessary.
- Check that the PCB boards, SCR's and cooling fins are free from dust. Clean with compressed air if necessary. Make sure the PCB boards and SCR's are undamaged.
- Check for signs of overheating (changes in color on PCB boards, oxidation of solder joints etc.). Check that the temperature is within permissible limits.
- Check that the cooling fan(s) permit free air flow. Clean any external air filters if necessary.

3 x 200 = 575 V, 50 / 60 Hz Model	ACSSA420	ACSSA440	ACSSA450	ACSSA4100	ACSSA4150
Max HP @ 480 V	20 HP	40 HP	60 HP	100 HP	150 HP
Rated current of device (A)	30	60	85	145	180
Electrical Data					
Power loss at rated motor load (In)	90 W	180 W	260 W	440 W	540 W
Power consumption control card	20 VA	25 VA	25 VA	25 VA	35 VA
Starts / Hr: In in % and time in sec. at 50% duty, intermittent S4, at max 40°C⁽¹⁾					
450%, 5x	100	100	100	28	90
400%, 10s	65	65	65	28	63
350%, 20s	50	50	50	14	48
300%, 30s	38	38	38	10	36
250%, 60s	28	28	28	8	26
Mechanical Data					
Dimensions H x W x D in Inches (mm)	12.6 x 5 x 10.25 (320 x 126 x 260)		15.75 x 7 x 10.25 (400 x 176 x 260)		33 x 27 x 11 (838 x 658 x 254)
Mounting position (Vertical / Horizontal)	Vertical				
Weight in Lbs (kg)	14.75 (6.7)		27 (12)		65 (30)
Cooling System	Convection	Fan			
General Electrical Data					
Number of fully controlled phases	3				
Voltage tolerance (control and motor)	±10%				
Recommended fuse for control card (A)	Max 10 A				
Frequency	50 / 60 Hz				
Frequency tolerance	±10%				
Switch-on delay	100 ms				
Relay contacts	3 x 8 A, 250 V resistive load, 3 A, 250 VAC inductive (PF = 0.4)				
Type of Protection / Insulation					
Type of casing protection	Chassis				
Other General Data					
Ambient temperatures In operation In storage	0 - 50°C (-25) - (+70)°C				
Relative air humidity	95% non-condensing				
Max. altitude	1000 m				
Norms / Standards, Conform to:					
EMC, Emission	EN 50081-2 (EN50081-1 with bypass contactor)				
EMC, Immunity	EN 50082-2				
Harmonic Distortion	Max. 5% of basic frequency				
(1) For other applications, please contact B. Gear or use application / calculation examples. Starts per hour depends on e.e. average, rated, starting and running current: starting, running and cooling time; ambient temperature etc.					

3 x 200 - 575 V, 50 / 60 Hz Model	ACSSA4200	ACSSA4300	ACSSA4400	ACSSA4600
Max HP @ 480 V	200 HP	300 HP	400 HP	600 HP
Rated current of device (A)	250	360	500	800
Electrical Data				
Power loss at rated motor load (In)	750 W	1100 W	1400 W	2500 W
Power consumption control card	35 VA	35 VA	35 VA	35 VA
Starts / Hr: In in % and time in sec. at 50% duty, intermittent S4, at max 40°C ⁽¹⁾				
450%, 5s	50	38	28	20
400%, 10s	32	25	18	13
350%, 20s	25	23	15	11
300%, 30s	20	19	10	8
250%, 60s	15	11	8	6
Mechanical Data				
Dimensions H x W x D in Inches (mm)	45 x 33 x 11 (1143 x 838 x 279)		57 x 33 x 12.5 (1448 x 838 x 317)	57 x 33 x 16 (1448 x 838 x 406)
Mounting position	Vertical or Horizontal			
Weight Lbs (kg)	102 (46)		160 (73)	206 (93.5)
Cooling system	Fan			
General Electrical Data				
Number of fully controlled phases	3			
Voltage tolerance (control and motor)	±10%			
Recommended fuse for control card (A)	Max 10 A			
Frequency	50 / 60 Hz			
Frequency tolerance	±10%			
Switch-on delay	100 ms			
Relay contacts	3 x 8 A, 250 V resistive load, 3A, 250 VAC inductive (PF = 0.4)			
Type of Protection / Insulation				
Type of casing protection	Chassis			
Other General Data				
Ambient Temperatures In operation In storage	0 - 50°C (-25) - (+70)°C			
Relative air humidity	95% non-condensing			
Max. altitude	1000 m			
Norms / Standards, Conform to:				
EMC, Emission	EN 50081-2, (EN 50081-1 with bypass contactor)			
EMC, Immunity	EN 50082-2			
Harmonic distortion	Max. 5% of basic frequency			
(1) For other applications, please contact B. Gear or use application / calculation examples. Starts per hour depends on i.e. average, rated, starting and running current: starting, running and cooling time; ambient temperature etc.				

Parameter Number	Function / Parameter	Range	Parameter Set	Factory Setting	Page Number
001	Initial voltage at start	25 - 90 % of U	1 - 4	30	35
002	Start time ramp 1	1 - 60 sec	1 - 4	10	35
003	Step down voltage at stop	100 - 40% U	1 - 4	100	36
004	Stop time ramp 1	oFF, 2 - 120 sec	1 - 4	oFF	35
005	Current	0.0 - 9999 Amp	-	-	36
006	Control mode	1, 2, 3	-	2	32
007	Extended functions & metering	oFF, ON	-	oFF	37
008	Extended functions	oFF, ON	-	oFF	37
011	Initial voltage start ramp 2	30 - 90% U	1 - 4	90	38
012	Start time ramp 2	oFF, 1 - 60 sec	1 - 4	oFF	38
013	Step down voltage stop ramp 2	100 - 40% U	1 - 4	40	39
014	Stop time ramp 2	off, 2 - 120 sec	1 - 4	oFF	39
016	Initial torque at start	0 - 200% T _n	1 - 4	10	40
017	End torque at start	50 - 200% T _n	1 - 4	150	40
108	End stop torque	0 - 100%	1 - 4	0%	40
020	Voltage ramp with current limit at start	oFF, 150 - 500% I _n	1 - 4	oFF	41
021	Current limit at start	oFF, 150 - 500% I _n	1 - 4	oFF	42
022	Pump control	oFF, ON	1 - 4	oFF	42
023	Remote analog control	oFF, 1, 2	1 - 4	oFF	43
024	Full voltage start D.O.L.	oFF, ON	1 - 4	oFF	44
025	Torque control	oFF, 1, 2	1 - 4	oFF	39
030	Torque boost active time	oFF, 0.1 - 2.0 sec	1 - 2	oFF	44
031	Torque boost current limit	300 - 500% I _n	1 - 4	300	45
032	Bypass	oFF, ON	1 - 4	oFF	45
033	Power factor control PFC	oFF, ON	1 - 4	oFF	46
034	DC brake active time	oFF, 1 - 120 sec	1 - 4	oFF	46
035	DC brake current limit	100 - 300% I _n	1 - 4	100	47
036	Slow speed digital input control	oFF, 1 - 100	1 - 4	oFF	48
037	Slow speed torque	10 - 100	1 - 4	10	47
038	Slow speed time at start	oFF, 1 - 60 sec	1 - 4	oFF	48
039	Slow speed time at stop	oFF, 1 - 60 sec	1 - 4	oFF	48
040	DC brake at slow speed	oFF, 1 - 60 sec	1 - 4	oFF	49
041	Nominal motor voltage	200 - 700 V	1 - 4	400	33
042	Nominal motor current	25 - 150% I _{nsft} in Amp	1 - 4	I _{nsft} in Amp	34
043	Nominal motor power	25 - 150% P _{nsft} in HP	1 - 4	P _{nsft} in kW	34
044	Nominal speed	500 - 3600 rpm	1 - 4	N _{nsft} in rpm	34
045	Nominal power factor	0.50 - 1.00	1 - 4	0.86	34
046	Nominal frequency	50, 60 Hz	-	50	34
051	Programmable relay K1	1, 2, 3	-	1	50
052	Programmable relay K2	1, 2, 3, 4	-	2	50
054	Analog output	oFF, 1, 2	-	oFF	51
055	Analog output value	1, 2, 3	-	1	51
056	Scaling analog output	5 - 150%	-	100	51
061	Parameter set	0, 1, 2, 3, 4	-	1	52
071	Motor PTC input	no, YES	-	no	58
072	Internal motor thermal protection class	oFF, 2 - 40 sec	-	10	59
073	Used thermal capacity	0 - 150%	-	-	59
074	Starts per hour limitation	oFF, 1 - 99 / hr	1 - 4	oFF	63
075	Locked rotor alarm	oFF, 1.0 - 10.0 sec	1 - 4	oFF	60

Parameter Number	Function / Parameter	Range	Parameter Set	Factory Setting	Page Number
081	Voltage unbalance alarm	5 - 25% U_n	1 - 4	10	56
082	Response delay voltage unbalance alarm	oFF, 1 - 60 sec	1 - 4	oFF	57
083	Over voltage alarm	100 - 150% U_n	1 - 4	115	57
084	Response delay over voltage alarm	oFF, 1 - 60 sec	1 - 4	oFF	57
085	Under voltage alarm	75 - 100% U_n	1 - 4	85	58
086	Response delay under voltage alarm	oFF, 1 - 60 sec	1 - 4	oFF	58
087	Phase sequence	L123, L321	-	-	64
088	Phase reversal alarm	oFF, ON	-	oFF	64
089	Auto set power limits	no, YES	-	no	61
090	Output shaft power	0.0 - 200.0% P_n	-	-	61
091	Start delay power limits	1 - 250 sec	1 - 4	10	61
092	Max power alarm limit	5 - 200% P_n	1 - 4	115	62
093	Max alarm response delay	oFF, 0.1 - 25.0 sec	1 - 4	oFF	62
094	Max power pre-alarm limit	5 - 200% P_n	1 - 4	oFF	65
095	Max pre-alarm response delay	oFF, 0.1 - 25.0 sec	1 - 4	oFF	65
096	Min pre-alarm power limit	5 - 200% P_n	1 - 4	90	66
097	Min pre-alarm response delay	oFF, 0.1 - 25.0 sec	1 - 4	oFF	66
098	Min power alarm limit	5 - 200% P_n	1 - 4	85	62
099	Min alarm response delay	oFF, 0.1 - 25.0 sec	1 - 4	oFF	63
101	Run at single phase input failure	no, YES	1 - 4	no	56
102	Run at current limit time-out	no, YES	1 - 4	no	60
103	Jog forward from keypad enable	oFF, on	-	oFF	47
104	Jog reverse from keypad enable	oFF, on	-	oFF	47
105	Automatic return menu	oFF, 1 - 999	-	oFF	53
111	Serial communication unit address	1 - 247	-	1	
112	Serial communication baud rate	2.4 - 38.4 kBaud	-	9.6	
113	Serial communication parity	0, 1	-	0	
114	Serial communication contact broken	oFF, 1, 2	-	1	
199	Reset to factory settings	no, YES	-	no	31
201	Current	0.0 - 9999 Amp	-	-	67
202	Line main voltage	0 - 700 V	-	-	67
203	Output shaft power	0 to ± 9999 HP	-	-	68
204	Power factor	0.00 - 1.00	-	-	68
205	Power consumption	0.000 - 2000 MWh	-	-	68
206	Reset power consumption	no, YES	-	no	68
207	Shaft torque	0 to ± 9999 ft-lbs	-	-	69
208	Operation time	0.0 - 9999 days	-	-	69
211	Current phase L1	0.0 - 9999 Amp	-	-	69
212	Current phase L2	0.0 - 9999 Amp	-	-	69
213	Current phase L3	0.0 - 9999 Amp	-	-	70
214	Line main voltage L1 - L2	0 - 700 V	-	-	70
215	Line main voltage L1 - L3	0 - 700 V	-	-	70
216	Line main voltage L1 - L3	0 - 700 V	-	-	70
221	Locked keypad info	no, YES	-	no	28
901	Alarm list, latest error	F1 - F16	-	-	71
902 - 915	Alarm list, older error in order	F1 - F16	-	-	71

