



# Cutler-Hammer

## HVX9000 AF Drives

User Manual

April 2005  
Supersedes July 2004





April 2005

**Important Notice – Please Read**

The product discussed in this literature is subject to terms and conditions outlined in Eaton Electrical Inc. selling policies. The sole source governing the rights and remedies of any purchaser of this equipment is the relevant Eaton Electrical Inc. selling policy.

NO WARRANTIES, EXPRESS OR IMPLIED, INCLUDING WARRANTIES OF FITNESS FOR A PARTICULAR PURPOSE OR MERCHANTABILITY, OR WARRANTIES ARISING FROM COURSE OF DEALING OR USAGE OF TRADE, ARE MADE REGARDING THE INFORMATION, RECOMMENDATIONS AND DESCRIPTIONS CONTAINED HEREIN. In no event will Eaton Electrical Inc. be responsible to the purchaser or user in contract, in tort (including negligence), strict liability or otherwise for any special, indirect, incidental or consequential damage or loss whatsoever, including but not limited to damage or loss of use of equipment, plant or power system, cost of capital, loss of power, additional expenses in the use of existing power facilities, or claims against the purchaser or user by its customers resulting from the use of the information, recommendations and descriptions contained herein.

The information contained in this manual is subject to change without notice.

Cover Photo: Cutler-Hammer® HVX IntelliPass Drive



April 2005

## Table of Contents

<b>LIST OF FIGURES — FOR LISTING BY TOPIC SEE APPENDIX D</b>	iv
<b>LIST OF TABLES — FOR LISTING BY TOPIC SEE APPENDIX D</b>	v
<b>SAFETY</b>	
Definitions and Symbols	vii
Hazardous High Voltage	vii
Warnings, Cautions and Notices	viii
<b>CHAPTER 1 — OVERVIEW</b>	
How to Use This Manual	1-1
Receiving and Inspection	1-1
Catalog Numbering System	1-2
<b>CHAPTER 2 — MOUNTING</b>	
Space Requirements	2-1
Environmental Requirements	2-2
Standard Mounting Instructions	2-2
<b>CHAPTER 3 — POWER WIRING</b>	
Guidelines	3-1
UL Compatible Cable Selection and Installation	3-2
Installation Instructions	3-4
Standard Wiring Diagrams and Terminal Locations	3-7
Power and Motor Wiring Terminal Photos	3-10
Checking the Cable and Motor Insulation	3-16
<b>CHAPTER 4 — CONTROL WIRING</b>	
General Information	4-1
Control Wiring Details	4-3
<b>CHAPTER 5 — INTELLIPASS BYPASS OPTION</b>	
Product Description	5-1
Catalog Number Selection	5-1
Dimensions	5-2
Power Wiring	5-5
IntelliPass Control Wiring Instructions	5-9
<b>CHAPTER 6 — MENU INFORMATION</b>	
Keypad Operation	6-1
Menu Navigation	6-4
<b>CHAPTER 7 — START-UP</b>	
Safety Precautions	7-1
Sequence of Operation	7-2
<b>CHAPTER 8 — APPLICATION INFORMATION</b>	
Parameter Menus	8-1
<b>APPENDIX A — TECHNICAL DATA</b>	
Specifications	A-1
Power Ratings	A-3
Power Loss and Switching Frequency	A-4
Dimensions	A-8
EMC Capability	A-17
Declaration of Conformity	A-17
Warranty and Liability Information	A-18
<b>APPENDIX B — PARAMETER TABLES</b>	B-1
<b>APPENDIX C — FAULT AND WARNING CODES</b>	C-1
<b>APPENDIX D — FIGURES AND TABLES BY TOPICS</b>	D-1

## List of Figures — For Listing by Topic see Appendix D

Figure 2-1: Mounting Space Requirements . . . . .	2-1
Figure 3-1: Input Power and Motor Cable Stripping and Wire Lengths . . . . .	3-4
Figure 3-2: Wiring Plate . . . . .	3-5
Figure 3-3: Ground Terminal Locations . . . . .	3-5
Figure 3-4: Cable Protection Plate . . . . .	3-6
Figure 3-5: Principle Wiring Diagram of HVX Power Unit, FR4, FR5 and FR6 . . . . .	3-7
Figure 3-6: Principle Wiring Diagram of HVX Power Unit, FR6, FR7 and FR8 . . . . .	3-8
Figure 3-7: Principle Wiring Diagram of HVX Power Unit, FR9 and FR10 . . . . .	3-9
Figure 3-8: FR4 Power and Motor Wiring Terminals . . . . .	3-10
Figure 3-9: FR5 Power and Motor Wiring Terminals . . . . .	3-11
Figure 3-10: FR6 Power and Motor Wiring Terminals . . . . .	3-12
Figure 3-11: FR7 Power and Motor Wiring Terminals . . . . .	3-13
Figure 3-12: FR8 Power and Motor Wiring Terminals . . . . .	3-14
Figure 3-13: FR9 Power and Motor Wiring Terminals . . . . .	3-15
Figure 4-1: Option Board Slots . . . . .	4-1
Figure 4-2: Option Board A9 Wiring Diagram . . . . .	4-3
Figure 4-3: Option Board A9 Jumper Location and Settings (Slot A) . . . . .	4-5
Figure 4-4: Option Board A2 Wiring Diagram (Slot B) . . . . .	4-5
Figure 4-5: Option Board A2 Terminal Locations . . . . .	4-6
Figure 4-6: Positive/Negative Logic . . . . .	4-6
Figure 5-1: HVX IntelliPass Dimensions . . . . .	5-2
Figure 5-2: HVX Series Enclosed Drive Dimensions . . . . .	5-3
Figure 5-3: HVX Series Enclosed Drive Dimensions . . . . .	5-4
Figure 5-4: IntelliPass Power and Motor Terminal Wiring Example . . . . .	5-8
Figure 5-5: Option Board B5 Wiring Diagram . . . . .	5-9
Figure 5-6: Option Board B5 Terminal Location . . . . .	5-10
Figure 5-7: Operate Menu Navigation . . . . .	5-11
Figure 5-8: Enable Bypass . . . . .	5-12
Figure 6-1: Keypad and Display . . . . .	6-1
Figure 6-2: Main Menu Navigation — 1 of 2 . . . . .	6-4
Figure 6-3: Main Menu Navigation — 2 of 2 . . . . .	6-5
Figure 6-4: Parameter Menu Structure . . . . .	6-6
Figure 6-5: Keypad Control Menu . . . . .	6-6
Figure 6-6: System Menu Structure . . . . .	6-8
Figure 6-7: Expander Board Menu Structure . . . . .	6-15
Figure 6-8: Digital Inputs DIN1, DIN2, DIN3 Status . . . . .	6-17
Figure 6-9: Digital Inputs DIN4, DIN5, DIN6 Status . . . . .	6-17
Figure 6-10: Digital Inputs DO1, RO1, RO2 Status . . . . .	6-17
Figure 6-11: Active Fault Display Example . . . . .	6-17
Figure 6-12: Sample Fault History Display . . . . .	6-19
Figure 6-13: Operate Menu Navigation . . . . .	6-20
Figure 8-1: DC Braking Command . . . . .	8-5
Figure 8-2: AI1 Signal Filtering . . . . .	8-9
Figure 8-3: AI2 Signal Filtering . . . . .	8-10
Figure 8-4: Control Place B with and without Reference Scaling . . . . .	8-11
Figure 8-5: Analog Output Filtering . . . . .	8-14
Figure 8-6: Analog Output Inversion . . . . .	8-14
Figure 8-7: Analog Output Scale . . . . .	8-15
Figure 8-8: Output Frequency Supervision . . . . .	8-22
Figure 8-9: External Brake Control . . . . .	8-24

April 2005

**List of Figures — For Listing by Topic see Appendix D, continued**

Figure 8-10: Acceleration/Deceleration Curve (S-Shaped) . . . . .	8-28
Figure 8-11: DC Braking Time When Stop Mode = Coasting . . . . .	8-30
Figure 8-12: DC Braking Time When Stop Mode = Ramp . . . . .	8-31
Figure 8-13: DC Braking Time at Start . . . . .	8-31
Figure 8-14: Skip Frequency Area Setting . . . . .	8-33
Figure 8-15: Ramp Speed Scaling Between Skip Frequencies . . . . .	8-33
Figure 8-16: Linear and Squared Change of Motor Voltage . . . . .	8-35
Figure 8-17: Programmable V/f Ratio . . . . .	8-36
Figure 8-18: Motor Cooling Power . . . . .	8-40
Figure 8-19: Motor Temperature Calculation . . . . .	8-41
Figure 8-20: Stall Characteristics Settings . . . . .	8-42
Figure 8-21: Minimum Load Setting . . . . .	8-43
Figure 8-22: Underload Time Counter Function . . . . .	8-44
Figure 8-23: Example of Automatic Restart with Two Restarts . . . . .	8-45
Figure 8-24: Frequency Reference Logic of the Fire Mode PID Application When Running in Fire Mode . . . . .	8-48
Figure 8-25: PID Output + Motor Potentiometer Reference . . . . .	8-50
Figure 8-26: Examples of Actual Value Signal Scaling . . . . .	8-51
Figure 8-27: PID Controller D-Time, Example 1 . . . . .	8-53
Figure 8-28: PID Controller D-Time, Example 2 . . . . .	8-54
Figure 8-29: PID Controller D-Time, Example 3 . . . . .	8-54
Figure 8-30: Frequency Converter Sleep Function . . . . .	8-56
Figure A-1: Power Loss as Function of Switching Frequency: 1 – 3 hp 230V, 1-1/2 – 7-1/2 hp 480V . . . . .	A-5
Figure A-2: Power Loss as Function of Switching Frequency: 5 – 10 hp 230V, 10 – 20 hp 480V . . . . .	A-5
Figure A-3: Power Loss as Function of Switching Frequency: 15 – 20 hp 230V, 25 – 40 hp 480V . . . . .	A-6
Figure A-4: Power Loss as Function of Switching Frequency: 50 – 75 hp 480V . . . . .	A-6
Figure A-5: Power Loss as Function of Switching Frequency: 100 – 150 hp 480V . . . . .	A-7
Figure A-6: Power Loss as Function of Switching Frequency: 200 – 250 hp 480V . . . . .	A-7
Figure A-7: NEMA Type 1 and NEMA Type 12 HVX9000 Drive Dimensions, FR4, FR5 and FR6 . . . . .	A-8
Figure A-8: HVX9000 Dimensions, NEMA Type 1 and NEMA Type 12 with Flange Kit, FR4, FR5 and FR6 . . . . .	A-9
Figure A-9: HVX9000 Dimensions, NEMA Type 1 and NEMA Type 12, FR7 . . . . .	A-10
Figure A-10: HVX9000 Dimensions, NEMA Type 1 and NEMA Type 12, FR8 . . . . .	A-11
Figure A-11: HVX9000 Dimensions, NEMA Type 1 and NEMA Type 12, with Flange Kit, FR7 and FR8 . . . . .	A-12
Figure A-12: HVX9000 Dimensions, NEMA Type 1 and NEMA Type 12, FR9 . . . . .	A-13
Figure A-13: HVX9000 Dimensions, NEMA Type 1 and NEMA Type 12 FR9 . . . . .	A-14
Figure A-14: HVX9000 Dimensions, NEMA Type 1 and NEMA Type 12 FR9 with Flange Kit . . . . .	A-15
Figure A-15: HVX9000 Dimensions, FR10 Open Chassis . . . . .	A-16

## List of Tables — For Listing by Topic see Appendix D

Table 1-1: HVX9000 Drive Catalog Numbering System .....	1-2
Table 2-1: Space Requirements for Mounting an HVX9000 Drive .....	2-1
Table 2-2: Cooling Airflow Requirements .....	2-2
Table 3-1: Cable Spacings .....	3-1
Table 3-2: Cable and Fuse Sizes — 208 – 240V Ratings .....	3-2
Table 3-3: Cable and Fuse Sizes — 380 – 500V Ratings .....	3-2
Table 3-4: Cable and Fuse Sizes — 575 – 690V Ratings .....	3-3
Table 3-5: Maximum Symmetrical Supply Current .....	3-3
Table 3-6: Power Connection Tightening Torque .....	3-3
Table 3-7: Power and Motor Cable Stripping Lengths .....	3-4
Table 4-1: Tightening Torques of Terminals .....	4-2
Table 4-2: Control Wiring Instructions .....	4-2
Table 4-3: Option Board A9 Terminal Descriptions .....	4-4
Table 4-4: Option Board A2 Terminal Descriptions .....	4-6
Table 5-1: HVX IntelliPass Drive Catalog Numbering System .....	5-1
Table 5-2: NEMA TYPE 1 IntelliPass Drive Dimensions .....	5-2
Table 5-3: HVX Series TYPE 12 Enclosed IntelliPass Drive Dimensions .....	5-3
Table 5-4: HVX Series TYPE 3R Enclosed IntelliPass Drive Dimensions .....	5-4
Table 5-5: IntelliPass Power Wiring Instructions .....	5-5
Table 5-6: Option Board B5 Terminal Descriptions .....	5-9
Table 5-7: Operate Menu Items — IntelliPass Application Example .....	5-11
Table 6-1: LCD Status Indicators .....	6-2
Table 6-2: LED Status Indicators .....	6-2
Table 6-3: Navigation Buttons .....	6-3
Table 6-4: Total Counters .....	6-13
Table 6-5: Trip Counters .....	6-13
Table 6-6: Software Information .....	6-14
Table 6-7: Application Information .....	6-14
Table 6-8: Hardware Information .....	6-14
Table 6-9: Slot A Expander Board Information .....	6-14
Table 6-10: Monitoring Menu Items .....	6-16
Table 6-11: Fault Types .....	6-18
Table 6-12: Fault Time Data .....	6-19
Table 6-13: Operate Menu Items — IntelliPass Application Example .....	6-20
Table 8-1: Scaling Factor for the Analog Output .....	8-15
Table 8-2: DO1 Function Settings .....	8-16
Table 8-3: RO1 Function Settings .....	8-17
Table 8-4: RO2 Function Settings .....	8-18
Table 8-5: RO3 Content Settings .....	8-20
Table 8-6: Scaling Factor for the Analog Output .....	8-26
Table 8-7: Scaling Factor for the Analog Output .....	8-27
Table 8-8: Binary Inputs for Seven Preset Speeds .....	8-57
Table 8-9: Fieldbus Output Selection Examples .....	8-59
Table A-1: HVX9000 Drive Specifications .....	A-1
Table A-2: 230V VT Output Power Ratings .....	A-3
Table A-3: 480V VT Output Power Ratings .....	A-3
Table A-4: 575V VT Output Power Ratings .....	A-4

April 2005

**List of Tables — For Listing by Topic see Appendix D, continued**

Table A-5: HVX9000 Drive Dimensions .....	A-8
Table A-6: Dimensions for HVX9000, FR4, FR5 and FR6 with Flange Kit .....	A-9
Table A-7: Dimensions for the Flange Opening, FR4 to FR6 .....	A-9
Table A-8: HVX9000 Drive Dimensions, FR7 .....	A-10
Table A-9: HVX9000 Drive Dimensions, FR8 .....	A-11
Table A-10: Dimensions for HVX9000, FR7 and FR8 with Flange Kit .....	A-12
Table A-11: Dimensions for the Flange Opening, FR7/FR8 .....	A-12
Table A-12: HVX9000 Drive Dimensions, FR9 .....	A-13
Table A-13: Dimensions for HVX9000, FR9 .....	A-14
Table A-14: Dimensions for HVX9000, FR9 with Flange Kit .....	A-15
Table A-15: Dimensions for HVX9000, FR10 Open Chassis .....	A-16
Table B-1: Parameter Group G1.1: Basic .....	B-1
Table B-2: Parameter Group G1.2: Input Signals .....	B-2
Table B-3: Parameter Group G1.3: Output Signals .....	B-4
Table B-4: Parameter Group G1.4: Drive Control .....	B-7
Table B-5: Parameter Group G1.5: Skip Frequencies .....	B-8
Table B-6: Parameter Group G1.6: Motor Control .....	B-8
Table B-7: Parameter Group G1.7: Protections .....	B-9
Table B-8: Parameter Group G1.8: Auto-Restart Parameters .....	B-10
Table B-9: Parameter Group G1.9: Fire Mode .....	B-11
Table B-10: Parameter Group G1.10: IntelliPass Parameters .....	B-11
Table B-11: Parameter Group G1.11: PID Control .....	B-12
Table B-12: Parameter Group G1.12: Preset Speeds .....	B-13
Table B-13: Parameter Group G1.13: Communication Bus .....	B-13
Table B-14: Monitoring Menu Items .....	B-14
Table C-1: Fault Codes .....	C-1

## Safety

### Definitions and Symbols

---

** WARNING**

---

This symbol indicates high voltage. It calls your attention to items or operations that could be dangerous to you and other persons operating this equipment. Read the message and follow the instructions carefully.



This symbol is the "Safety Alert Symbol." It occurs with either of two signal words: WARNING or CAUTION as described below.

---

** WARNING**

---

Indicates a potentially hazardous situation which, if not avoided, can result in serious injury or death.

---

** CAUTION**

---

Indicates a potentially hazardous situation which, if not avoided, can result in minor to moderate injury, or serious damage to the equipment. The situation described in the CAUTION may, if not avoided, lead to serious results. Important safety measures are described in CAUTION (as well as WARNING).

### Hazardous High Voltage

---

** WARNING**

---

Motor control equipment and electronic controllers are connected to hazardous line voltages. When servicing drives and electronic controllers, there may be exposed components with housings or protrusions at or above line potential. Extreme care should be taken to protect against shock.

- Stand on an insulating pad and make it a habit to use only one hand when checking components.
- Always work with another person in case an emergency occurs.
- Disconnect power before checking controllers or performing maintenance.
- Be sure equipment is properly grounded.
- Wear safety glasses whenever working on electronic controllers or rotating machinery.

April 2005

## Warnings, Cautions and Notices

Read this manual thoroughly and make sure you understand the procedures before you attempt to install, set up, or operate this Cutler-Hammer® HVX9000 Adjustable Frequency Drive from Eaton's electrical business.

### Warnings

---

** WARNING**

---

Be sure to ground the unit following the instructions in this manual. Ungrounded units may cause electric shock and/or fire.

---

** WARNING**

---

This equipment should be installed, adjusted, and serviced by qualified electrical maintenance personnel familiar with the construction and operation of this type of equipment and the hazards involved. Failure to observe this precaution could result in death or severe injury.

---

** WARNING**

---

Components within the HVX9000 power unit are live when the drive is connected to power. Contact with this voltage is extremely dangerous and may cause death or severe injury.

---

** WARNING**

---

Line terminals (L1, L2, L3), motor terminals (U, V, W) and the DC-link/brake resistor terminals (-/+) are live when the drive is connected to power, even if the motor is not running. Contact with this voltage is extremely dangerous and may cause death or severe injury.

---

** WARNING**

---

Even though the control I/O-terminals are isolated from line voltage, the relay outputs and other I/O-terminals may have dangerous voltage present even when the drive is disconnected from power. Contact with this voltage is extremely dangerous and may cause death or severe injury.

---

** WARNING**

---

The HVX9000 drive has a large capacitive leakage current during operation, which can cause enclosure parts to be above ground potential. Proper grounding, as described in this manual, is required. Failure to observe this precaution could result in death or severe injury.

---

** WARNING**

---

Before applying power to the HVX9000 drive, make sure that the front and cable covers are closed and fastened to prevent exposure to potential electrical fault conditions. Failure to observe this precaution could result in death or severe injury.

---

**⚠ WARNING**

---

An upstream disconnect/protective device must be provided as required by the National Electric Code (NEC). Failure to follow this precaution may result in death or severe injury.

---

**⚠ WARNING**

---

Before opening the HVX9000 drive covers:

- Disconnect all power to the HVX9000 drive.
- Wait a minimum of 5 (five) minutes after all the lights on the keypad are off. This allows time for the DC bus capacitors to discharge.
- A hazardous voltage may still remain in the DC bus capacitors even if the power has been turned off. Confirm that the capacitors have fully discharged by measuring their voltage using a multimeter set to measure DC voltage.

Failure to follow the above precautions may cause death or severe injury.

---

**⚠ WARNING**

---

The HVX9000 output terminals U, V and W correspond to a phase rotation of ABC. If the input terminals L1, L2 and L3 have not been wired for ABC, the motor rotation will be different when powered from the bypass instead of the HVX9000 which can result in personal injury and equipment damage. In this situation the input line wiring must be changed to correspond to ABC rotation.

**Cautions**

---

**⚠ CAUTION**

---

Do not perform any megger or voltage withstand tests on any part of the HVX9000 drive or its components. Improper testing may result in damage.

---

**⚠ CAUTION**

---

Prior to any tests or measurements of the motor or the motor cable, disconnect the motor cable at the HVX9000 output terminals (U, V, W) to avoid damaging the HVX9000 during the motor or cable testing.

---

**⚠ CAUTION**

---

Do not touch any components on the circuit boards. Static voltage discharge may damage the components.

---

**⚠ CAUTION**

---

Any electrical or mechanical modification to this equipment without prior written consent of Eaton will void all warranties and may result in a safety hazard in addition and voiding of the UL listing.

April 2005

---

**⚠ CAUTION**

---

Install the HVX9000 drive on flame-resistant material such as a steel plate to reduce the risk of fire.

---

**⚠ CAUTION**

---

Install the HVX9000 drive on a perpendicular surface that is able to support the weight of the drive and is not subject to vibration, to lessen the risk of the drive falling and being damaged and/or causing personal injury.

---

**⚠ CAUTION**

---

Prevent foreign material such as wire clippings or metal shavings from entering the drive enclosure, as this may cause arcing damage and fire.

---

**⚠ CAUTION**

---

Install the HVX9000 drive in a well-ventilated room that is not subject to temperature extremes, high humidity, or condensation, and avoid locations that are directly exposed to sunlight, or have high concentrations of dust, corrosive gas, explosive gas, inflammable gas, grinding fluid mist, etc. Improper installation may result in a fire hazard.

**Motor and Equipment Safety**

---

**⚠ CAUTION**

---

Before starting the motor, check that the motor is mounted properly and aligned with the driven equipment. Ensure that starting the motor will not cause personal injury or damage equipment connected to the motor.

---

**⚠ CAUTION**

---

Set the maximum motor speed (frequency) in the HVX9000 drive according to the requirements of the motor and the equipment connected to it. Incorrect maximum frequency settings can cause motor or equipment damage and the potential for personal injury.

---

**⚠ CAUTION**

---

Before reversing the motor rotation, ensure that this will not cause personal injury or equipment damage.

---

**⚠ CAUTION**

---

Make sure that no power factor correction capacitors are connected to the HVX9000 output or the motor terminals to prevent HVX9000 malfunction and potential damage.

---

**⚠ CAUTION**

---

Make sure that the HVX9000 output terminals (U, V, W) are not connected to the utility line power as severe damage to the HVX9000 drive and personal injury may occur.



April 2005

## Chapter 1 — Overview

This chapter describes the purpose and contents of this manual, the receiving inspection recommendations and the Cutler-Hammer® HVX9000 catalog numbering system.

### How to Use This Manual

The purpose of this manual is to provide you with information necessary to install, set and customize parameters, start-up, troubleshoot and maintain the Cutler-Hammer HVX9000 drive from Eaton's electrical business. To provide for safe installation and operation of the equipment, read the safety guidelines at the beginning of this manual and follow the procedures outlined in the following chapters before connecting power to the HVX9000 drive. Keep this operating manual handy and distribute to all users, technicians and maintenance personnel for reference.

*Chapter 1 – Overview*

*Chapter 2 – Mounting*

*Chapter 3 – Power Wiring*

*Chapter 4 – Control Wiring*

*Chapter 5 – IntelliPass Bypass Option*

*Chapter 6 – Menu Information*

*Chapter 7 – Start-Up*

*Chapter 8 – Application Information*

*Appendix A – Technical Data*

*Appendix B – Parameter Tables*

*Appendix C – Fault and Warning Codes*

### Receiving and Inspection

The HVX9000 AC drive has met a stringent series of factory quality requirements before shipment. It is possible that packaging or equipment damage may have occurred during shipment. After receiving your HVX9000 drive, please check for the following:

- Check to make sure that the package(s) includes the HVX9000 drive, the User Manual, rubber conduit covers, screws, conduit plate and ground straps.
- Inspect the unit to ensure it was not damaged during shipment.
- Make sure that the part number indicated on the nameplate corresponds with the Catalog Number on your order.

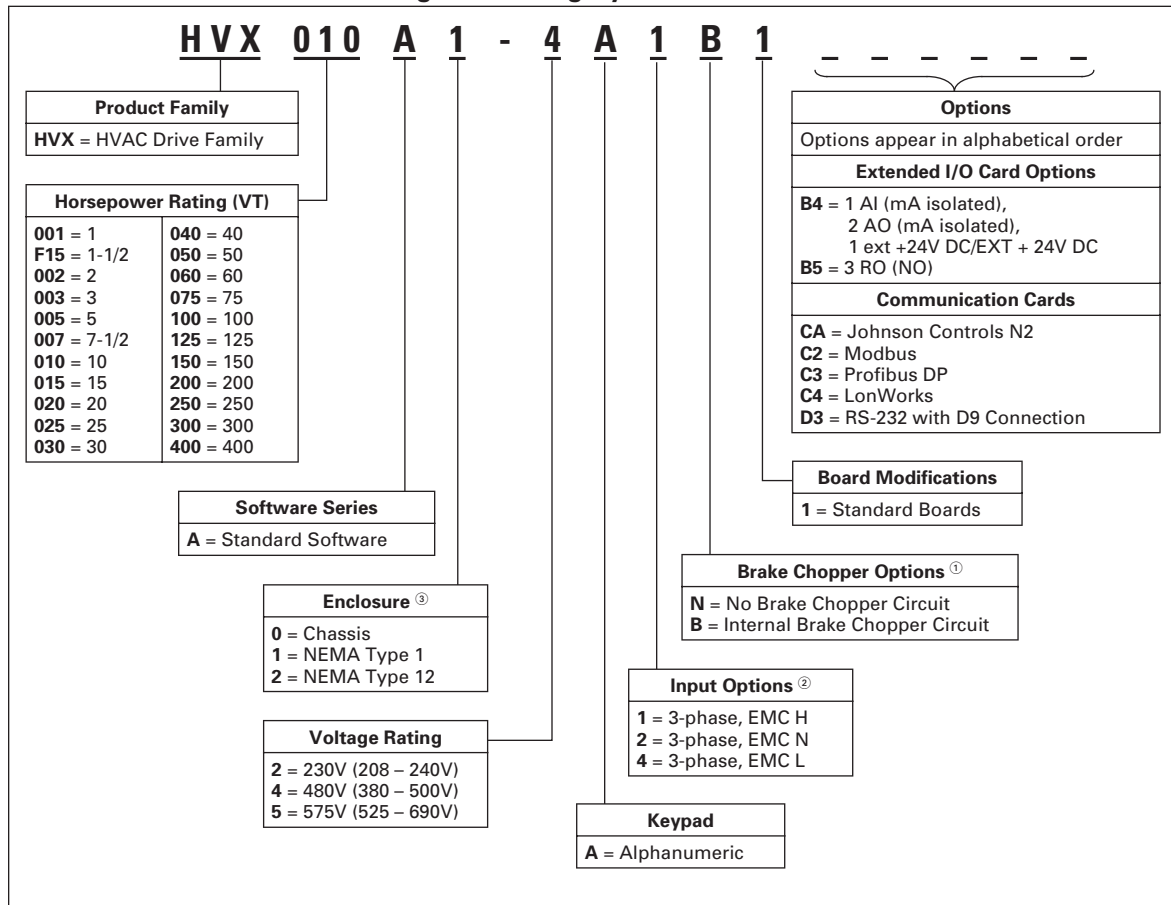
If shipping damage has occurred, please contact and file a claim with the carrier involved immediately.

If the delivery does not correspond to your order, please contact your Eaton representative.

**Note:** Do not destroy the packing. The template printed on the protective cardboard can be used for marking the mounting points of the HVX9000 on the wall or cabinet.

## Catalog Numbering System

**Table 1-1: HVX9000 Drive Catalog Numbering System**



- ① 480V Drives up to 40 hp (VT) are only available with Brake Chopper Option **B**.  
480V Drives 50 hp (VT) or larger are only available with Brake Chopper Option **N**.  
230V Drives up to 20 hp (VT) are only available with Brake Chopper Option **B**.  
575V Drives are standard without Brake Chopper Option **N**.
- ② All 230V Drives and 480V Drives up to 250 hp (VT) are only available with Input Option **1**.  
480V Drives 300 hp (VT) or larger are only available with Input Option **2**. 575V Drives up to 200 hp (VT) are only available with Input Option **4** (EMC Level L).
- ③ 300 and 400 hp (VT), 480V Drives are only available with Enclosure Style **0** (Chassis).

**Note:** Availability —

480V: 1-1/2 – 400 hp, 230V: 1 – 40 hp, 575V: 3 – 200 hp.

April 2005

## Chapter 2 — Mounting

HVX9000 drives may be mounted side-by-side or stacked vertically, as outlined in the following section.

### Space Requirements

To ensure proper air circulation and cooling, follow the guidelines below.

**Table 2-1: Space Requirements for Mounting an HVX9000 Drive**

Drive Type Variable Torque Rating	Approximate Dimensions in Inches (mm) <sup>①</sup>				
	A	A <sub>2</sub>	B	C	D
230V, 1 – 3 hp 480V, 1-1/2 – 7-1/2 hp	0.8 (20)		0.8 (20)	3.9 (100)	2.0 (50)
230V, 5 – 10 hp 480V, 10 – 20 hp	0.8 (20)		0.8 (20)	4.7 (120)	2.4 (60)
230V, 15 – 20 hp 480V, 25 – 40 hp 575V, 3 – 30 hp	1.2 (30)		0.8 (20)	6.3 (160)	3.1 (80)
230V, 25 – 30 hp 480V, 50 – 75 hp 575V, 40 – 50 hp	3.1 (80)		3.1 (80)	11.8 (300)	3.9 (100)
480V, 100 – 150 hp 575V, 60 – 100 hp	3.1 (80)	5.9 (150)	3.1 (80)	11.8 (300)	7.9 (200)
480V, 200 – 250 hp 575V, 125 – 200 hp	2.0 (50)		3.1 (80)	15.7 (400)	9.8 (250) 13.8 <sup>②</sup> (350)

<sup>①</sup> Dimensions represent the minimum clearance needed when mounting a drive. See **Figure 2-1** below.

A = clearance around the HVX9000.

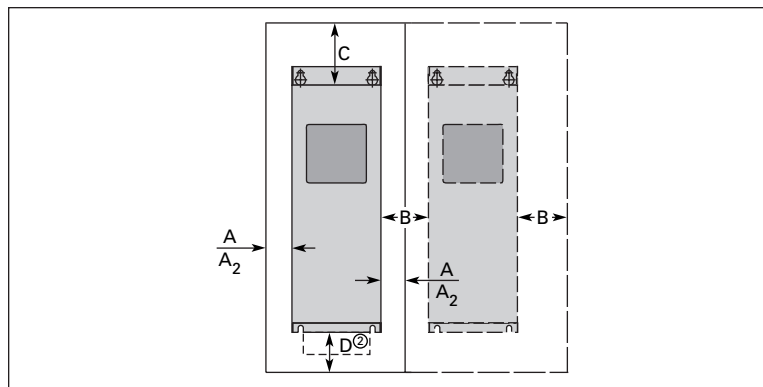
A<sub>2</sub> = clearance needed to change the fan without disconnecting the motor cables.

B = distance between adjacent HVX9000s or between the HVX9000 and an enclosure wall.

C = clearance above the HVX9000.

D = clearance below the HVX9000.

<sup>②</sup> Minimum clearance below the HVX9000 needed to change the fan.



**Figure 2-1: Mounting Space Requirements**

If several units are mounted above each other, the clearance between the drives should equal C + D (see **Table 2-1** and **Figure 2-1** above). In addition, the outlet air used for cooling the lower unit must be directed away from the inlet air used by the upper unit.

## Environmental Requirements

Ensure that the environment meets the requirements listed in **Table A-1** of **Appendix A** for any storage or operating situation.

The following table specifies the minimum airflow required in the area where the drive will be mounted.

**Table 2-2: Cooling Airflow Requirements**

Drive Type Variable Torque Ratings	Cooling Air Required
230V, 1 – 3 hp 480V, 1-1/2 – 7-1/2 hp	41 cfm (70 m <sup>3</sup> /h)
230V, 5 – 10 hp 480V, 10 – 20 hp	112 cfm (190 m <sup>3</sup> /h)
230V, 15 – 20 hp 480V, 25 – 40 hp 575V, 3 – 30 hp	250 cfm (425 m <sup>3</sup> /h)
230V, 25 – 30 hp 480V, 50 – 75 hp 575V, 40 – 50 hp	250 cfm (425 m <sup>3</sup> /h)
480V, 100 – 150 hp 575V, 60 – 100 hp	383 cfm (650 m <sup>3</sup> /h)
480V, 200 – 250 hp 575V, 125 – 200 hp	765 cfm (1300 m <sup>3</sup> /h)

## Standard Mounting Instructions

1. Measure the mounting space to ensure that it allows for the minimum space surrounding the HVX9000 drive. Drive dimensions are in **Appendix A**.
2. Make sure the mounting surface is flat and strong enough to support the drive, is not flammable, and is not subject to excessive motion or vibration.
3. Ensure that the minimum airflow requirements for your drive are met at the mounting location.
4. Mark the location of the mounting holes on the mounting surface, using the template provided on the cover of the cardboard shipping package.
5. Using fasteners appropriate to your drive and mounting surface, securely attach the drive to the mounting surface using all 4 screws or bolts.

April 2005

## Chapter 3 — Power Wiring

### Guidelines

To ensure proper wiring, use the following guidelines:

- Use heat-resistant copper cables only, +75°C or higher.
- The input line cable and line fuses must be sized in accordance with the rated input current of the unit. See **Tables 3-2** and **3-5**.
- Consistent with UL listing requirements, for maximum protection of the HVX9000 drive, UL recognized fuses type RK should be used.
- If motor temperature sensing is used for overload protection, the output wire size may be selected based on the motor specifications.
- If three or more shielded cables are used in parallel for the output on the larger units, every cable must have its own overload protection.
- Avoid placing the motor cables in long parallel lines with other cables.
- If the motor cables run in parallel with other cables, note the minimum distances between the motor cables and other cables given in **Table 3-1** below:

**Table 3-1: Cable Spacings**

Minimum Distance Between Cables in Feet (m)	Shielded Cable Length in Feet (m)
1 (0.3)	≤164 (50)
3.3 (1.0)	≤656 (200)

- The spacings of **Table 3-1** also apply between the motor cables and signal cables of other systems.
- Maximum length of the motor cables is as follows:
  - 1 – 2 hp 230V units, 328 ft. (100m)
  - All other hp units, 984 ft. (300m)
- The motor cables should cross other cables at an angle of 90 degrees.
- If conduit is being used for wiring, use separate conduits for the input power wiring, the output power wiring, the signal wiring, and the control wiring.

## UL Compatible Cable Selection and Installation

Use only copper wire with temperature rating of at least 167°F (75°C).

**Table 3-2: Cable and Fuse Sizes — 208 – 240V Ratings**

hp	Frame Size	NEC I <sub>L</sub> (A)	I <sub>L</sub> (A)	Fuse (A) ①	Wire Size		Terminal Size	
					Power	Ground	Power	Ground
1	FR4	4.2	4.8	10	14	14	16 – 12	16 – 14
1-1/2	FR4	6	6.6	10	14	14	16 – 12	16 – 14
2	FR4	6.8	7.8	10	14	14	16 – 12	16 – 14
3	FR4	9.6	11	15	14	14	16 – 12	16 – 14
5	FR5	15.2	17.5	20	12	12	16 – 8	16 – 8
7-1/2	FR5	22	25	30	10	10	16 – 8	16 – 8
10	FR5	28	31	40	8	8	16 – 8	16 – 8
15	FR6	42	48	60	4	8	14 – 0	10 – 2
20	FR6	54	61	80	2	6	14 – 0	10 – 2
25	FR7	68	75	100	2	6	14 – 0	10 – 00
30	FR7	80	88	110	1	6	14 – 0	10 – 00
40	FR7	104	114	125	1/0	4	14 – 0	10 – 00

① UL recognized type RK.

**Table 3-3: Cable and Fuse Sizes — 380 – 500V Ratings**

hp	Frame Size	NEC I <sub>L</sub> (A)	I <sub>L</sub> (A)	Fuse (A) ①	Wire Size		Terminal Size	
					Power	Ground	Power	Ground
1-1/2	FR4	3	3.3	10	14	14	16 – 12	16 – 14
2	FR4	3.4	4.3	10	14	14	16 – 12	16 – 14
3	FR4	4.8	5.6	10	14	14	16 – 12	16 – 14
5	FR4	7.6	7.6	10	14	14	16 – 12	16 – 14
7-1/2	FR4	11	12	15	12	14	16 – 12	16 – 14
10	FR5	14	16	20	10	12	16 – 8	16 – 8
15	FR5	21	23	30	10	10	16 – 8	16 – 8
20	FR5	27	31	35	8	8	16 – 8	16 – 8
25	FR6	34	38	50	6	8	14 – 0	10 – 2
30	FR6	40	46	60	4	8	14 – 0	10 – 2
40	FR6	52	61	80	2	6	14 – 0	10 – 2
50	FR7	65	72	100	2	6	14 – 0	10 – 00
60	FR7	77	87	110	1	6	14 – 0	10 – 00
75	FR7	96	105	125	1/0	4	14 – 0	10 – 00
100	FR8	124	140	175	3/0	2	4 – 3/0	4 – 000
125	FR8	156	170	200	4/0	0	000 – 350 MCM	4 – 000
150	FR8	180	205	250	300	2/0	000 – 350 MCM	4 – 000
200	FR9	240	261	350	350	3/0	2*000 – 350 MCM	4 – 000
250	FR9	302	300	400	2 X 250	300	2*000 – 350 MCM	4 – 000
300	FR10	361	385	450	2 X 250	300	600 MCM	300 MCM
400	FR10	515	520	600	2 X 350	350	600 MCM	300 MCM

① UL recognized type RK5.

April 2005

**Table 3-4: Cable and Fuse Sizes — 575 – 690V Ratings**

hp	Frame Size	NEC I <sub>l</sub> (A)	I <sub>l</sub> (A)	Fuse (A) <sup>①</sup>	Wire Size		Terminal Size	
					Power	Ground	Power	Ground
3	FR6	3.9	4.5	10	14	14	14 – 0	14 – 2
5	FR6	6.1	7.5	10	14	14	14 – 0	14 – 2
7-1/2	FR6	9	10	10	14	14	14 – 0	14 – 2
10	FR6	11	13.5	15	12	14	14 – 0	14 – 2
15	FR6	17	18	20	10	12	14 – 0	14 – 2
20	FR6	22	22	30	10	10	14 – 0	14 – 2
25	FR6	27	27	35	8	8	14 – 0	14 – 2
30	FR6	32	34	40	8	8	14 – 0	14 – 2
40	FR7	41	41	50	6	8	14 – 0	10 – 0
50	FR7	52	52	60	4	6	14 – 0	10 – 0
60	FR8	62	62	80	2	6	4 – 3/0	4 – 3/0
75	FR8	77	80	100	1	6	4 – 3/0	4 – 3/0
100	FR8	99	100	125	1/0	6	4 – 3/0	4 – 3/0
125	FR9	N/A	125	175	3/0	6	4 – 3/0	4 – 3/0
150	FR9	144	144	200	4/0	2	000 – 350 MCM	4 – 3/0
200	FR9	192	208	250	350	1/0	000 – 350 MCM	4 – 3/0

<sup>①</sup> UL recognized type RK5.

**Table 3-5: Maximum Symmetrical Supply Current**

Product	Voltage	Maximum RMS Symmetrical Amperes on Supply Circuit
1 – 30 hp	230	100,000A
1-1/2 – 250 hp	480	100,000A

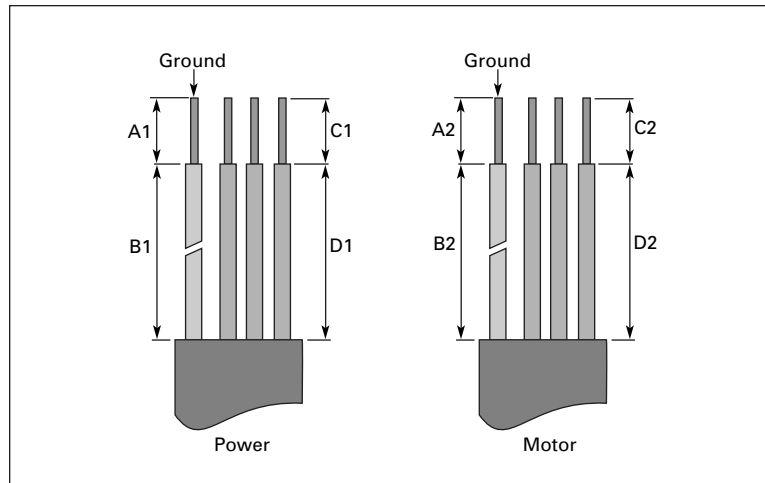
**Table 3-6: Power Connection Tightening Torque**

Rating	Frame Size	Tightening Torque (in-lbs)	Tightening Torque (Nm)
230V, 1 – 3 hp 480V, 1-1/2 – 7-1/2 hp	FR4	5	0.6
230V, 5 – 10 hp 480V, 10 – 20 hp	FR5	13	1.5
230V, 15 – 20 hp 480V, 25 – 40 hp 575V, 3 – 30 hp	FR6	35	4
230V, 25 – 40 hp 480V, 50 – 75 hp 575V, 40 – 50 hp	FR7	88	10
480V, 100 hp	FR8	170/80 <sup>①</sup>	20/9 <sup>①</sup>
480V, 125 – 150 hp 575V, 60 – 100 hp	FR8	354/195 <sup>①</sup>	40/22 <sup>①</sup>
480V, 200 – 250 hp 575V, 125 – 200 hp	FR9	354/195 <sup>①</sup>	40/22 <sup>①</sup>
480V, 300 – 400 hp	FR10	620/354	70/40 <sup>①</sup>

<sup>①</sup> The isolation standoff of the bus bar will not withstand the listed tightening torque. Use a wrench to apply a counter torque when tightening.

## Installation Instructions

- Strip the motor and power cables as shown in **Figure 3-1** and **Table 3-7**.



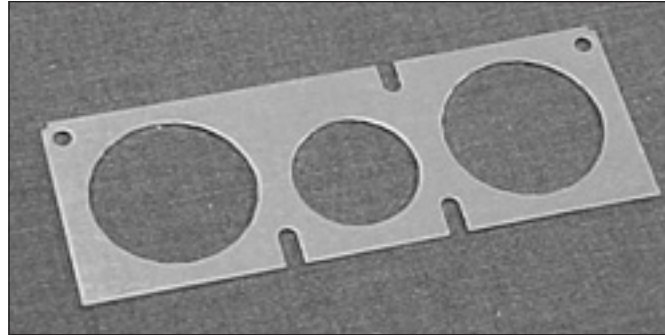
**Figure 3-1: Input Power and Motor Cable Stripping and Wire Lengths**

**Table 3-7: Power and Motor Cable Stripping Lengths**

Product		Frame Size	Power Wiring in Inches (mm)				Motor Wiring in Inches (mm)			
Horsepower	Voltage		A1	B1	C1	D1	A2	B2	C2	D2
1 – 3 1-1/2 – 7-1/2	230 480	FR4	0.59 (15)	1.38 (35)	0.39 (10)	0.79 (20)	0.28 (7)	1.97 (50)	0.28 (7)	1.38 (35)
5 – 10 10 – 20	230 480	FR5	0.79 (20)	1.57 (40)	0.39 (10)	1.18 (30)	0.79 (20)	2.36 (60)	0.39 (10)	1.57 (40)
15 – 20 25 – 40 3 – 30	230 480 575	FR6	0.79 (20)	3.54 (90)	0.59 (15)	2.36 (60)	0.79 (20)	3.54 (90)	0.59 (15)	2.36 (60)
25 – 40 50 – 75 40 – 50	230 480 575	FR7	0.98 (25)	4.72 (120)	0.98 (25)	4.72 (120)	0.98 (25)	4.72 (120)	0.98 (25)	4.72 (120)
100 – 150 60 – 100	480 575	FR8	1.1 (28)	9.45 (240)	1.1 (28)	9.45 (240)	1.1 (28)	9.45 (240)	1.1 (28)	9.45 (240)
200 – 250 125 – 200	480 575	FR9	1.1 (28)	11.61 (295)	1.1 (28)	11.61 (295)	1.1 (28)	11.61 (295)	1.1 (28)	11.61 (295)

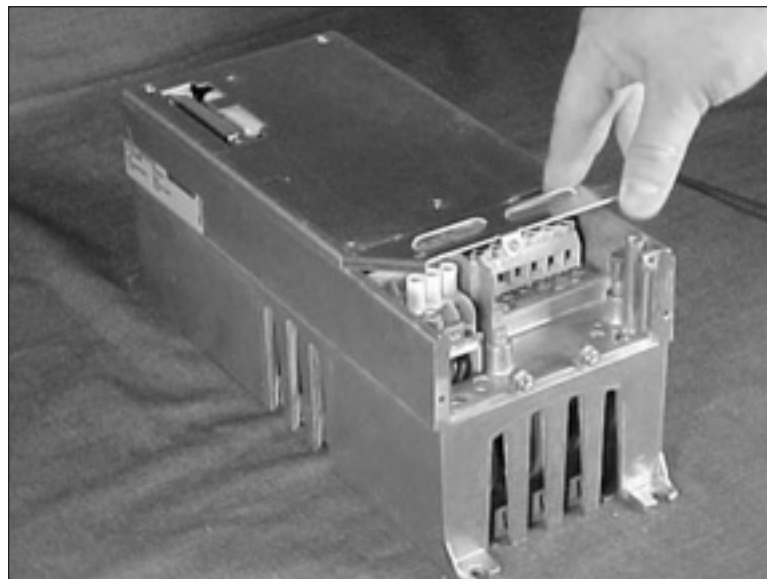
April 2005

2. Locate the plastic bag shipped with the drive containing the wiring plate.



**Figure 3-2: Wiring Plate**

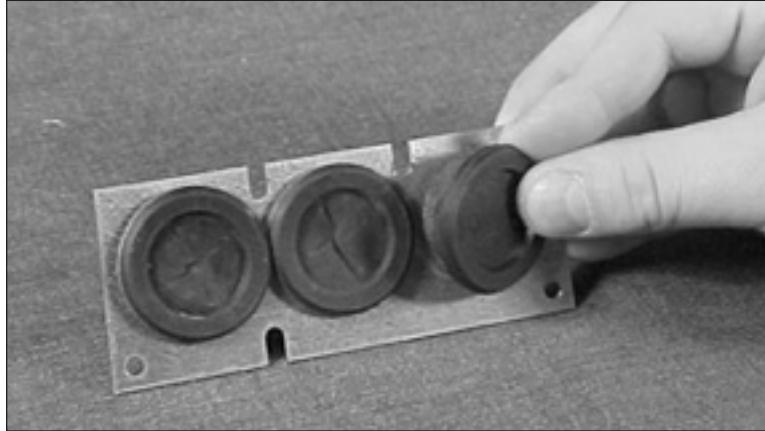
3. If conduit is being used, attach the wiring plate to it.
4. Pass the motor and input power wires/cables through the holes of the wiring plate.
5. Connect the input power and motor wires to their respective terminals according to the wiring diagrams in the following section marked "Standard Wiring Diagrams and Terminal Locations" on **Page 3-7**.
6. If an optional external brake resistor is used, connect its cable to the appropriate terminals. See "Standard Wiring Diagrams and Terminal Locations".
7. If shielded cable is used, connect the shields of the input line power cable and the motor cable to the ground terminals of the HVX9000 drive, the motor and the line power supply.



**Figure 3-3: Ground Terminal Locations**

8. If shielded cable is not used, check the connection of the ground cable to the motor, the HVX9000 drive and the input line power terminals marked with  $\oplus$ .

9. Attach the wiring plate with the screws provided. Ensure that no wires are trapped between the frame and the wiring plate.
10. Insert the rubber grommets into the wiring plate holes that have not been used as illustrated in **Figure 3-4**.



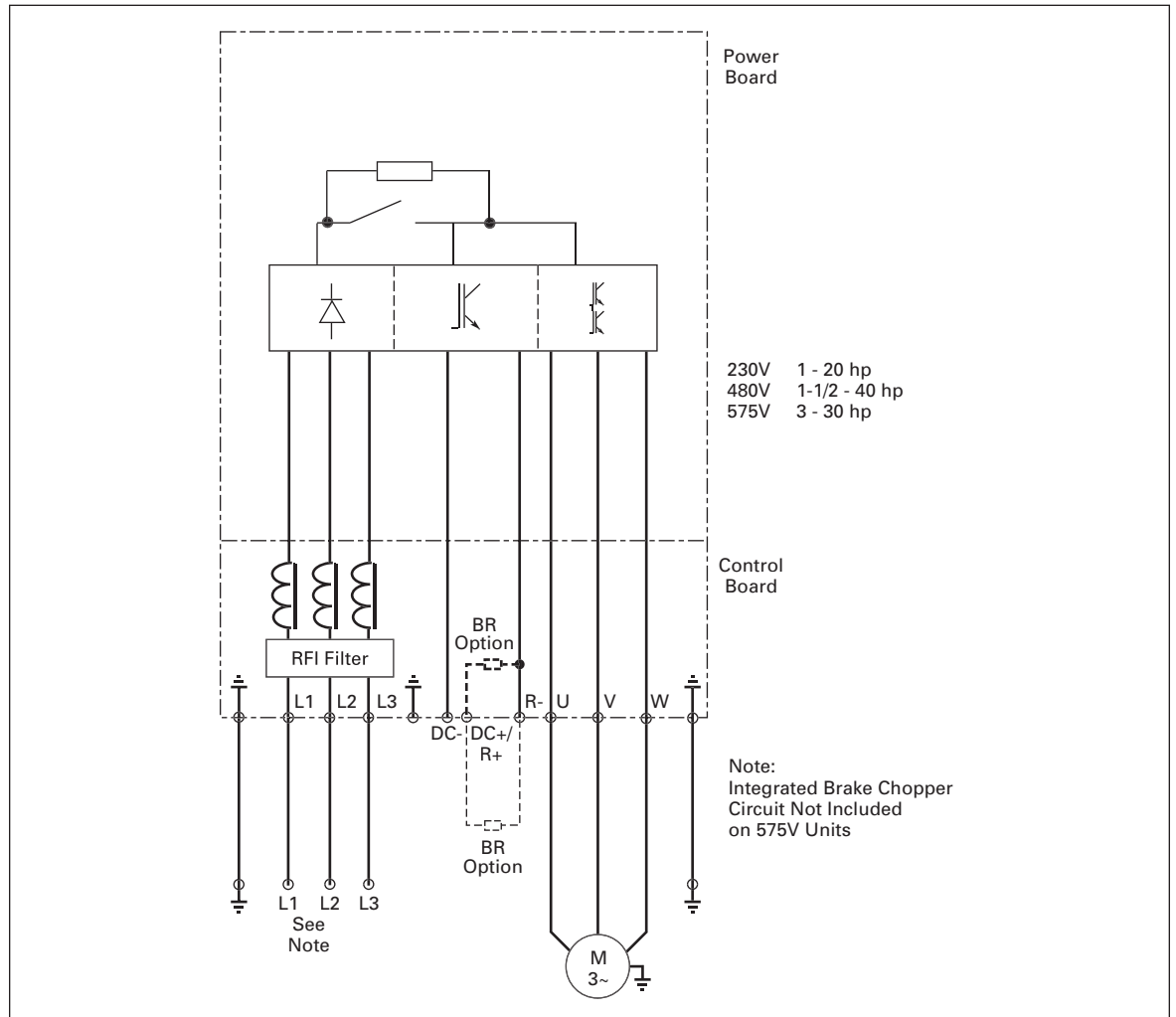
**Figure 3-4: Cable Protection Plate**

April 2005

## Standard Wiring Diagrams and Terminal Locations

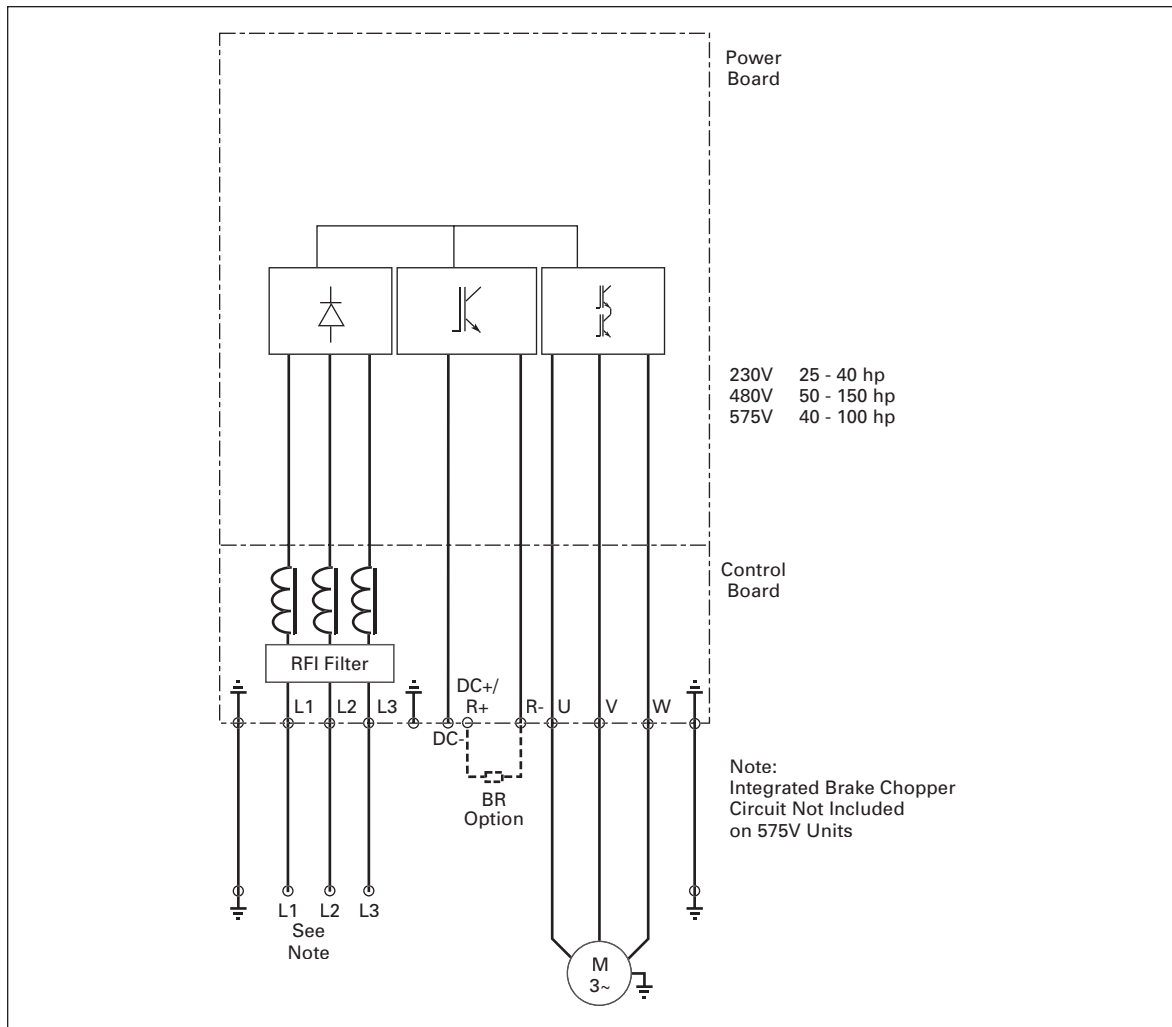
### Power and Motor Wiring Terminal Schematics for HVX9000 Drives

The following wiring diagrams show the line and motor connections of the frequency converter.



**Figure 3-5: Principle Wiring Diagram of HVX Power Unit, FR4, FR5 and FR6**

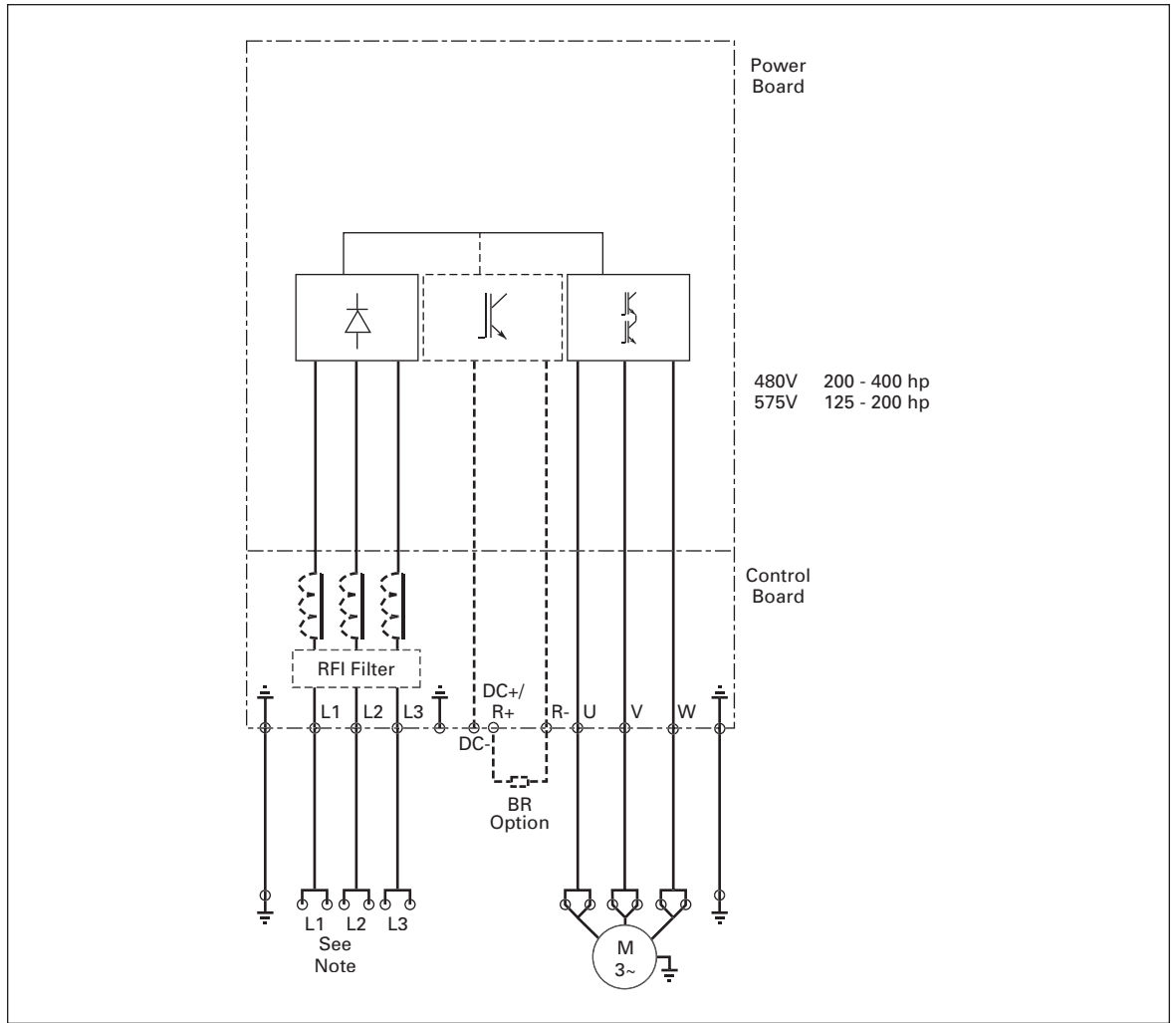
**Note:** When using a 1-phase supply, for units rated for such, connect the input power to terminals L1 and L2. Refer to **Tables A-2, A-3 and A-4** in **Appendix A**.



**Figure 3-6: Principle Wiring Diagram of HVX Power Unit, FR6, FR7 and FR8**

**Note:** When using a 1-phase supply, for units rated for such, connect the input power to terminals L1 and L2. Refer to **Tables A-2, A-3 and A-4** in **Appendix A**.

April 2005



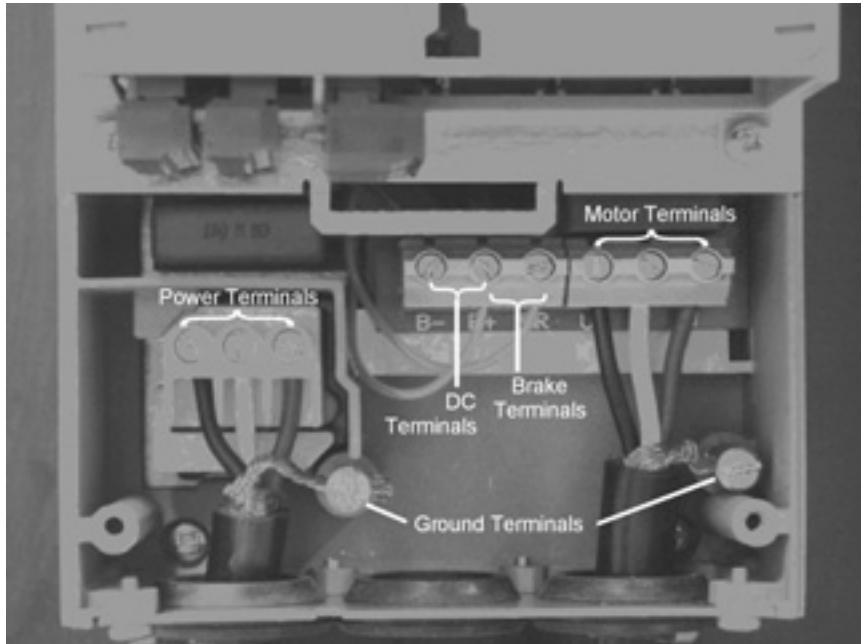
**Figure 3-7: Principle Wiring Diagram of HVX Power Unit, FR9 and FR10**

*The dotted lines refer to components present in FR9 but not in FR10.*

**Note:** When using a 1-phase supply, for units rated for such, connect the input power to terminals L1 and L2. Refer to **Tables A-3 and A-4** in **Appendix A**.

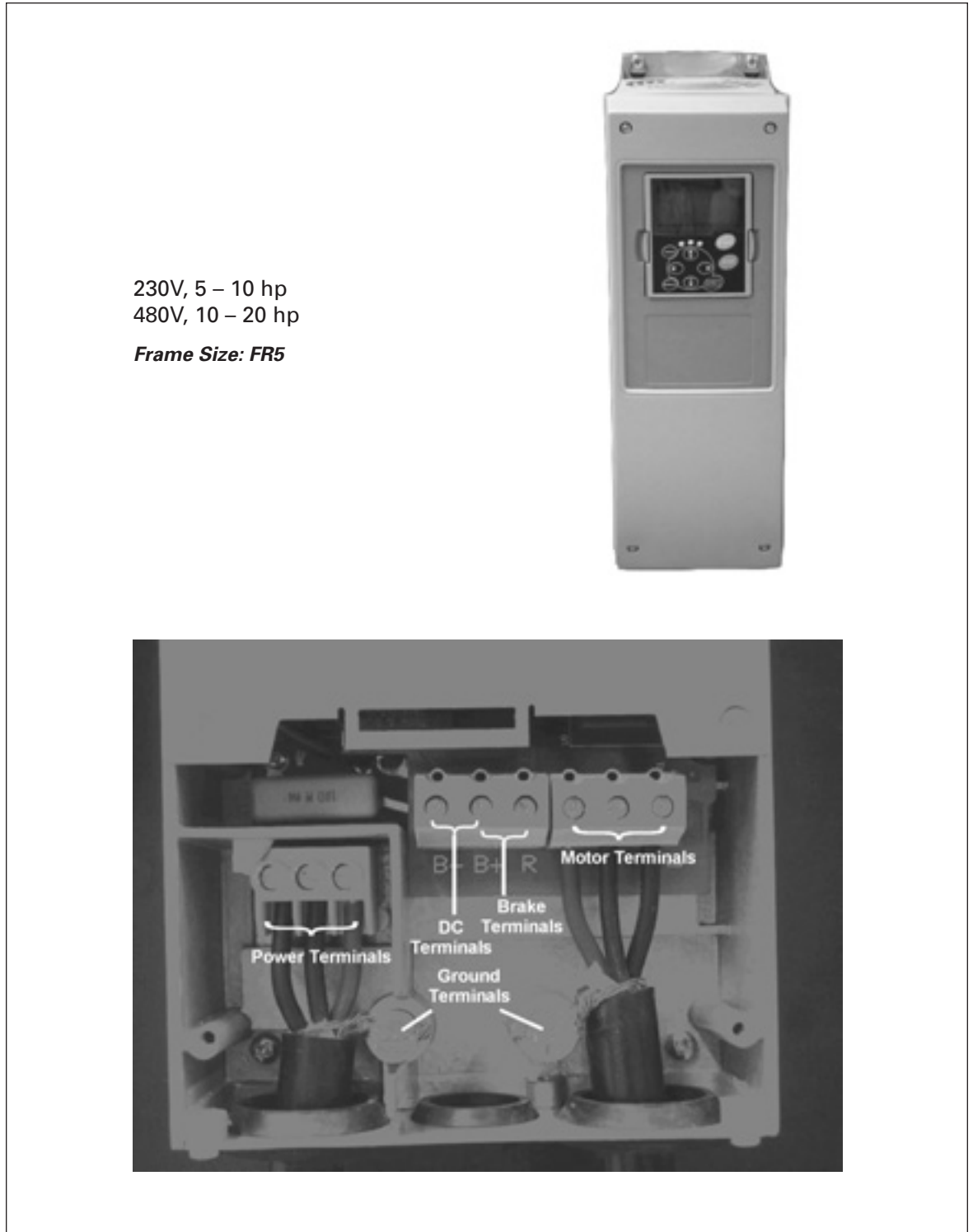
### Power and Motor Wiring Terminal Photos

230V, 1 – 3 hp  
480V, 1-1/2 – 7-1/2 hp  
**Frame Size: FR4**



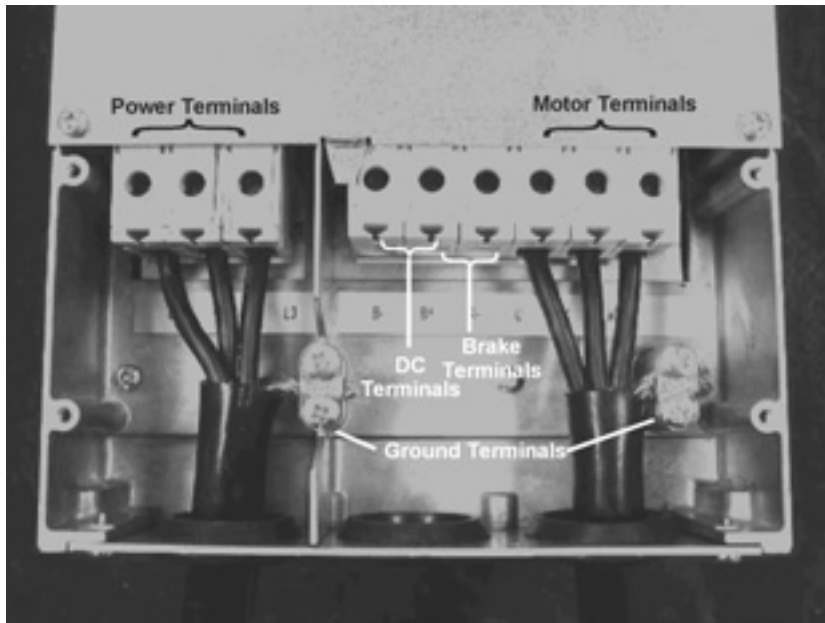
**Figure 3-8: FR4 Power and Motor Wiring Terminals**

April 2005



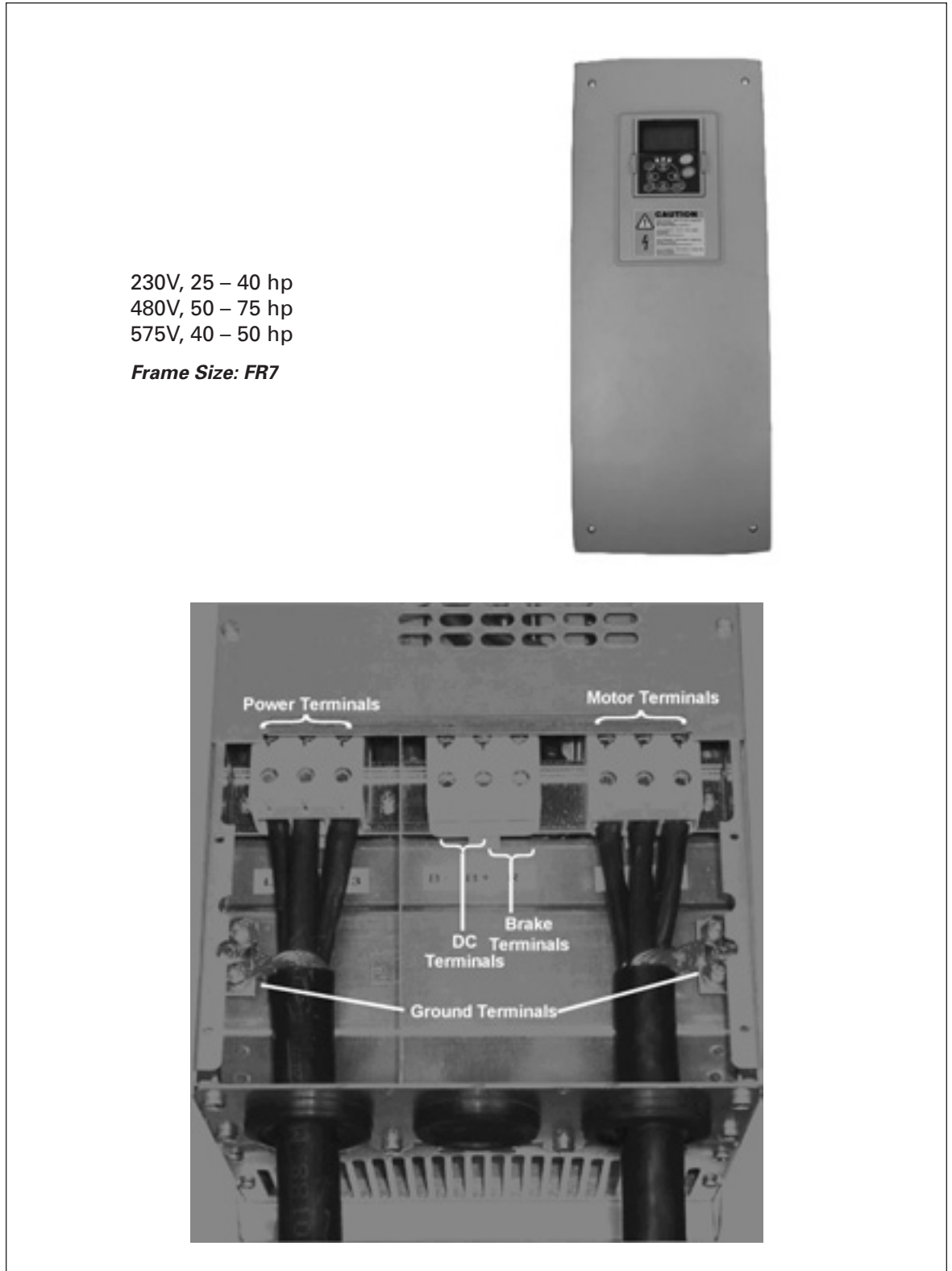
**Figure 3-9: FR5 Power and Motor Wiring Terminals**

230V, 15 – 20 hp  
480V, 25 – 40 hp  
575V, 3 – 30 hp  
**Frame Size: FR6**

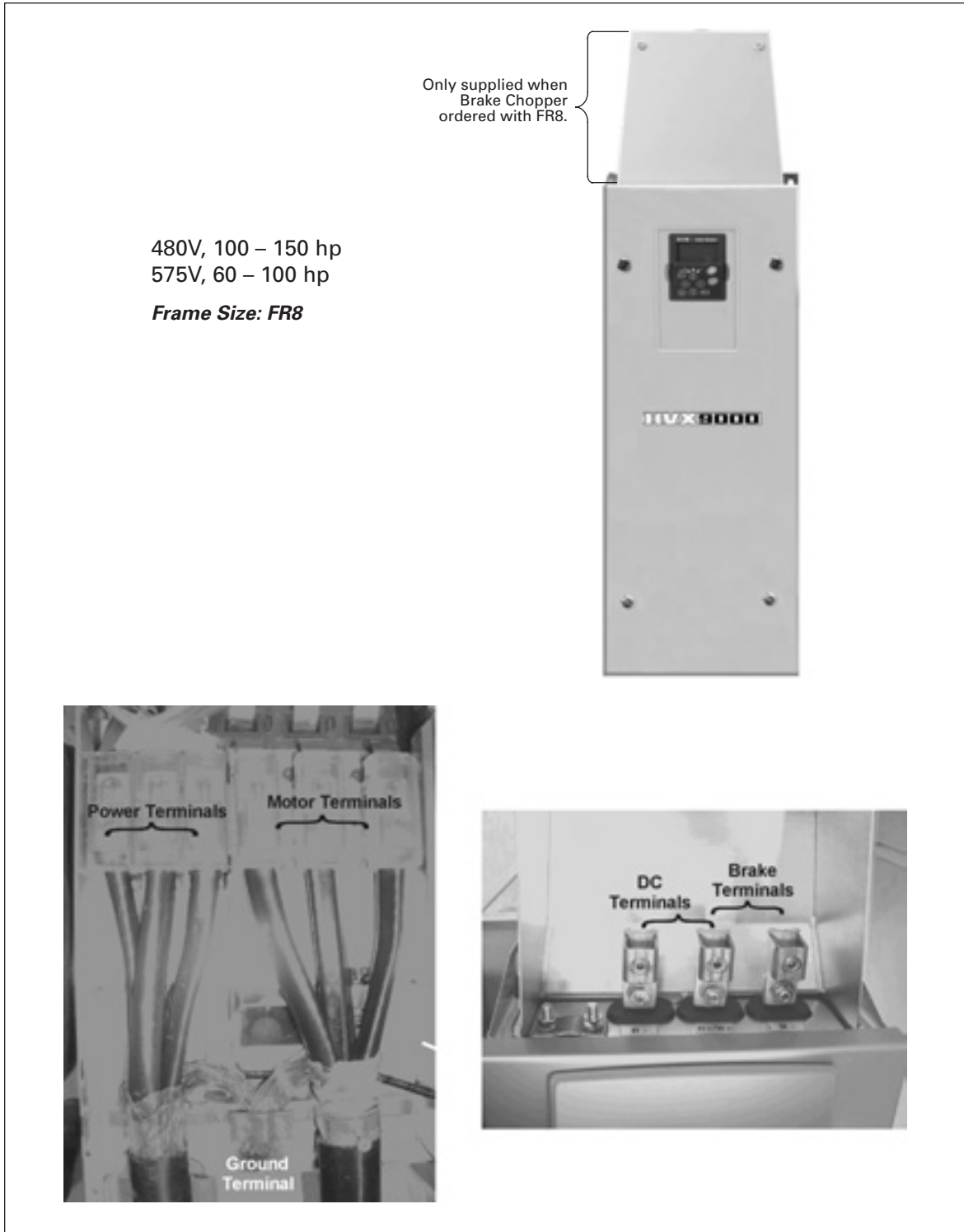


**Figure 3-10: FR6 Power and Motor Wiring Terminals**

April 2005



**Figure 3-11: FR7 Power and Motor Wiring Terminals**



**Figure 3-12: FR8 Power and Motor Wiring Terminals**

April 2005

**Figure 3-13: FR9 Power and Motor Wiring Terminals**

## Checking the Cable and Motor Insulation

1. Check the motor cable insulation as follows:
  - Disconnect the motor cable from terminals U, V and W of the HVX900 and from the motor.
  - Measure the insulation resistance of the motor cable between each phase conductor as well as between each phase conductor and the protective ground conductor.
  - The insulation resistance must be  $>1\text{M}\Omega$ .
2. Check the input power cable insulation as follows:
  - Disconnect the input power cable from terminals L1, L2 and L3 of the HVX9000 and from the utility line feeder.
  - Measure the insulation resistance of the input power cable between each phase conductor as well as between each phase conductor and the protective ground conductor.
  - The insulation resistance must be  $>1\text{M}\Omega$ .
3. Check the motor insulation as follows:
  - Disconnect the motor cable from the motor and open any bridging connections in the motor connection box.
  - Measure the insulation resistance of each motor winding. The measurement voltage must equal at least the motor nominal voltage but not exceed 1000V.
  - The insulation resistance must be  $>1\text{M}\Omega$ .

April 2005

## Chapter 4 — Control Wiring

### General Information

The control unit of the HVX9000 drive consists of the control board and various option boards that plug into the five slot connectors (A to E) of the control board.

Galvanic isolation of the control terminals is provided as follows:

- Control connections are isolated from power, and the GND terminals are permanently connected to ground.
- Digital inputs are galvanically isolated from the I/O ground.
- Relay outputs are double-isolated from each other at 300V AC.

### Option Board General Information

The HVX9000 Series drives can accommodate a wide selection of *expander* and *adapter boards* to customize the drive for your application needs.

The drive's control unit is designed to accept a total of five option boards. Option boards are available for normal analog and digital inputs and outputs, for communication and for additional application-specific hardware.

The HVX9000 factory installed standard option board configuration includes an A9 I/O board and an A2 relay output board, which are installed in slots A and B. For information on additional option boards, see the 9000X Series Drives Option Board Manual.

**Note:** If your HVX9000 has been shipped with a factory installed IntelliPass bypass, the B5 option board is installed in slot C.

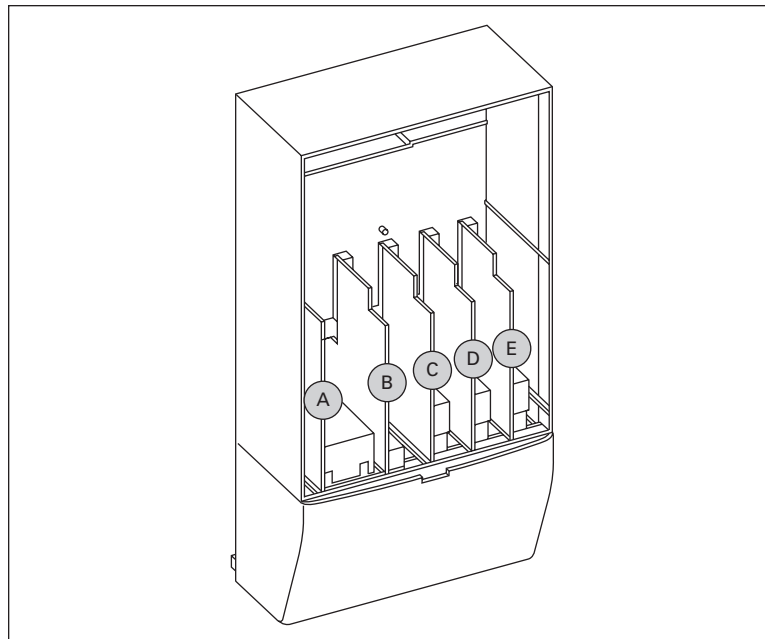


Figure 4-1: Option Board Slots

**Control Wiring Guidelines**

Wire the control terminals using the following guidelines:



- The control wires shall be at least AWG 20 (0.5 mm<sup>2</sup>) shielded cables.
- The maximum wire size is AWG 14 (2.5 mm<sup>2</sup>) for the relay terminals and AWG 16 (1.5 mm<sup>2</sup>) for all other terminals.
- The tightening torques for the option board terminals are listed in **Table 4-1**.

**Table 4-1: Tightening Torques of Terminals**

Terminal Screw	Tightening Torque	
	lb-in	Nm
Relay and thermistor terminals (M3 screw)	4.5	0.5
Other terminals (M2.6 screw)	2.2	0.25

**Control Wiring Instructions**

**Table 4-2: Control Wiring Instructions**

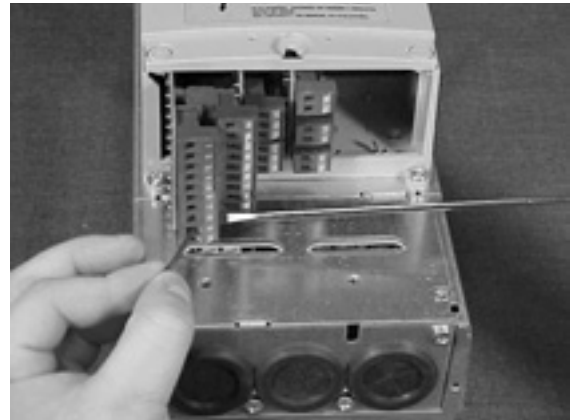
<p>1. Unlock the bottom cover by turning the locking screw 90 degrees counterclockwise.</p>	
<p>2. Remove the bottom cover by rotating the cover towards you on the base hinges, then lifting the cover away from the base.</p>	

April 2005

**Table 4-2: Control Wiring Instructions (Continued)**

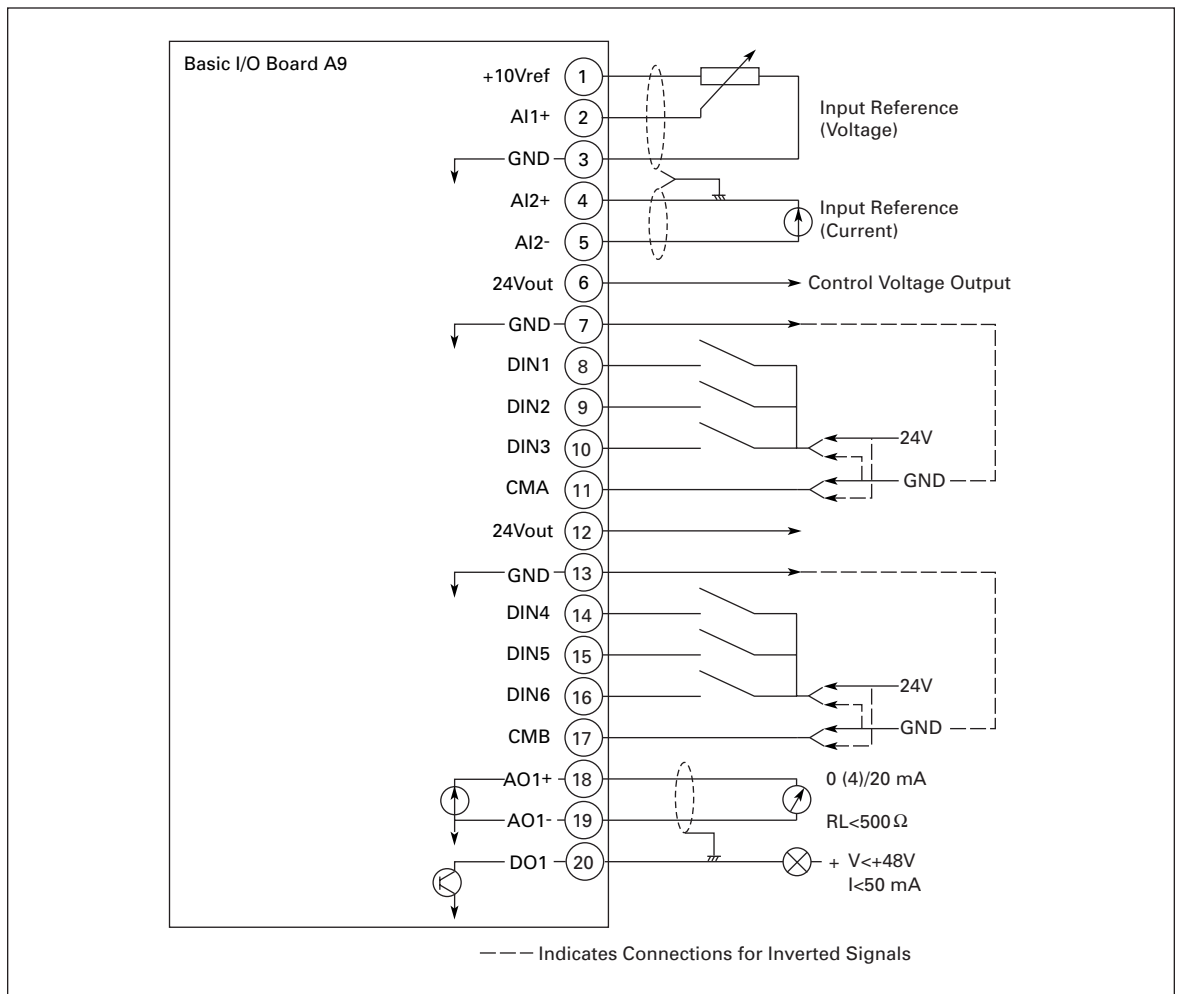
3. Wire the control terminals following the details for the specific option boards shown on the following pages.

**Note:** For ease of access, the option board terminal blocks can be unplugged for wiring.



### Control Wiring Details

#### Wiring Option Board A9



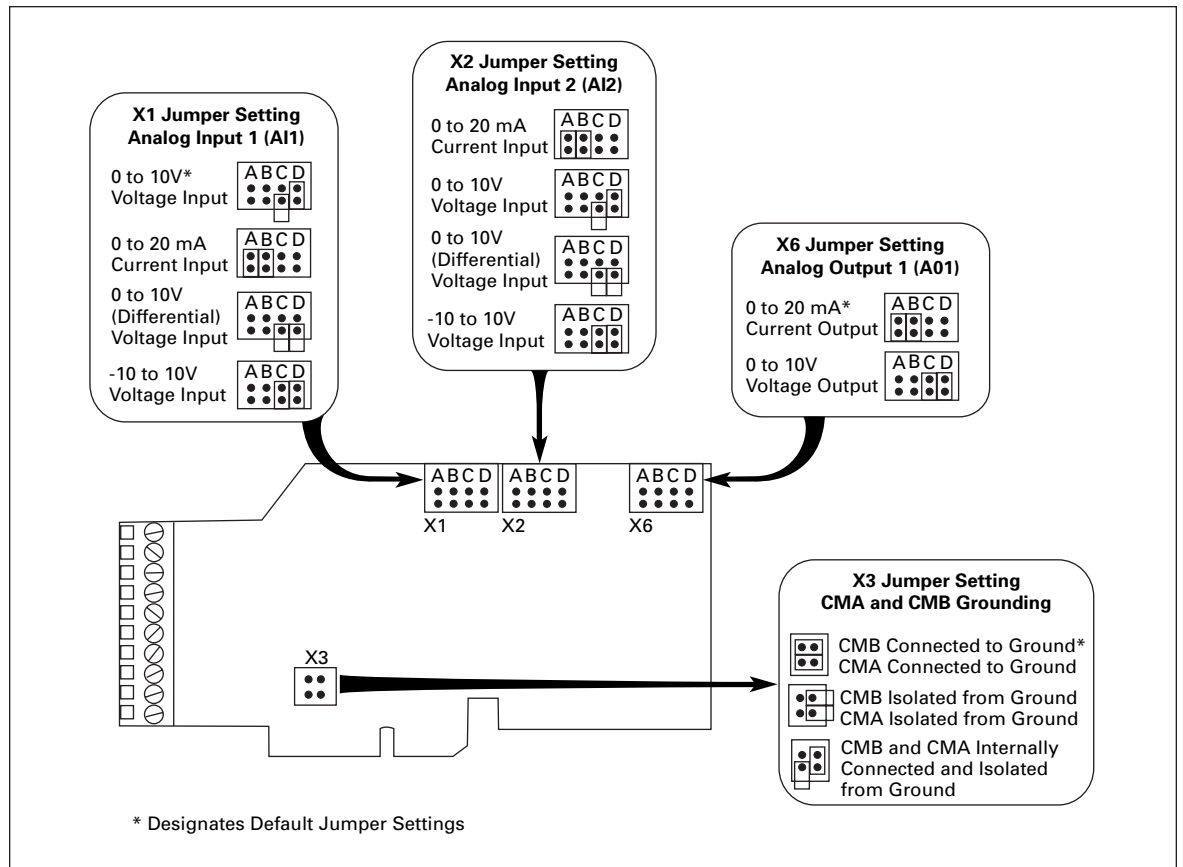
**Figure 4-2: Option Board A9 Wiring Diagram**

**Table 4-3: Option Board A9 Terminal Descriptions**

Terminal	Signal	Description and Parameter Reference
1	+10 V <sub>ref</sub>	Reference voltage Maximum current 10 mA
2	AI1+	Analog input, voltage
3	GND	Analog input common Default: 0 – +10V (R <sub>i</sub> = 200 kΩ; -10V to +10V joystick control) 0 – 20 mA (R <sub>i</sub> = 250 Ω) <i>Select V or mA with jumper block X1 (Figure 4-3)</i> Differential input if not connected to ground; allows ±20V differential mode voltage to GND
4	AI2+	Analog input
5	GND/ AI2-	Analog input common Default: 0 – 20 mA (R <sub>i</sub> = 250 Ω) 0 – +10V (R <sub>i</sub> = 200 kΩ; -10V to +10V joystick control) <i>Select V or mA with jumper block X2 (Figure 4-3)</i> Differential input if not connected to ground; allows ±20V differential mode voltage to GND
6	24 V <sub>out</sub>	24V control voltage (bi-directional) ±15%, 250 mA (all boards total); 150 mA (max. current from single board); Can be used as external power backup for the control (and fieldbus); Galvanically connected to terminal #12
7	GND	I/O ground Ground for reference and controls; Galvanically connected to terminals #13, 19
8	DIN1	Digital input 1   Start R <sub>i</sub> = min. 5 kΩ, Programmable
9	DIN2	Digital input 2   Ext Fault Closed <sup>①</sup> R <sub>i</sub> = min. 5 kΩ, Programmable
10	DIN3	Digital input 3   Fault Reset R <sub>i</sub> = min. 5 kΩ, Programmable
11	CMA	Digital input common A for DIN1, DIN2 and DIN3 Must be connected to GND or 24V of I/O terminal or to external 24V or GND. Selection with jumper block X3. (Figure 4-3)
12	24 V <sub>out</sub>	24V control voltage (bi-directional) Same as terminal #6; Galvanically connected to terminal #6
13	GND	I/O ground Same as terminal #7; Galvanically connected to terminals #7 & 19
14	DIN4	Digital input 4   Accel/Decel Select R <sub>i</sub> = min. 5 kΩ, Programmable
15	DIN5	Digital input 5   PM Setback R <sub>i</sub> = min. 5 kΩ, Programmable
16	DIN6	Digital input 6   Speed Select 3 <sup>①</sup> R <sub>i</sub> = min. 5 kΩ, Programmable
17	CMB	Digital input common B for DIN4, DIN5 and DIN6 Must be connected to GND or 24V of I/O terminal or to external 24V or GND. Select with jumper block X3. (Figure 4-3)
18	A01+	Analog signal (+output) Output signal range: 0 – 10V default Current: 0(4) – 20 mA, RL max 500 Ω or Voltage: 0 – 10V, RL >1 kΩ: default Selection with jumper block X6. (Figure 4-3)
19	A01-	Analog output common Maximum V <sub>in</sub> = 48V DC; Galvanically connected to terminals #7, 13
20	DO1	Digital output1   Ready Open collector, Maximum current = 50 mA

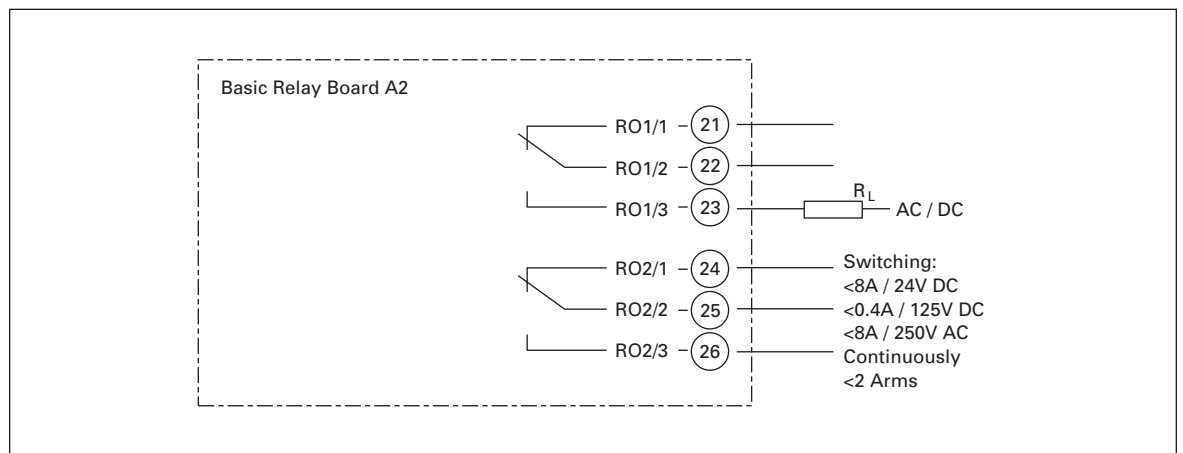
<sup>①</sup> For IntelliPass, this is programmed for Bypass Overload fault. The bypass must be enabled at least once or Parameter P1.10.3, Auto Bypass, must be enabled for software to automatically change DIN6 programmable selection to “Bypass Overload Fault”.

April 2005



**Figure 4-3: Option Board A9 Jumper Location and Settings (Slot A)**

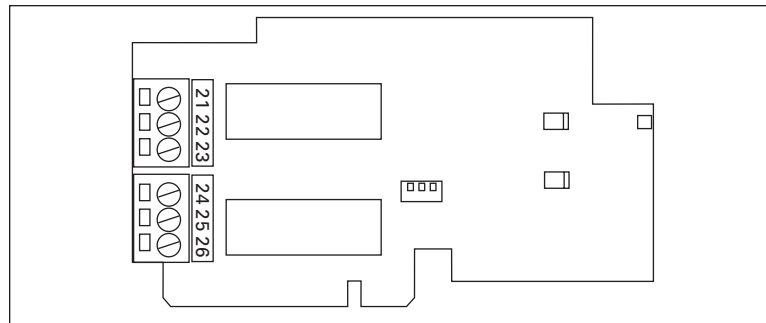
**Wiring Option Board A2**



**Figure 4-4: Option Board A2 Wiring Diagram (Slot B)**

**Table 4-4: Option Board A2 Terminal Descriptions**

Terminal	Signal	Description and Parameter Reference
21	RO1/1	Run Switching Capacity: 24V DC / 8A 250V AC / 8A 125V DC / 0.4Az Min switching load: 5V/10 mA Continuous Capacity: <2 Arms
22	RO1/2	
23	RO1/3	
24	RO2/1	Fault Switching Capacity: 24V DC / 8A 250V AC / 8A 125V DC / 0.4A Min switching load: 5V/10 mA Continuous Capacity: <2 Arms
25	RO2/2	
26	RO2/3	

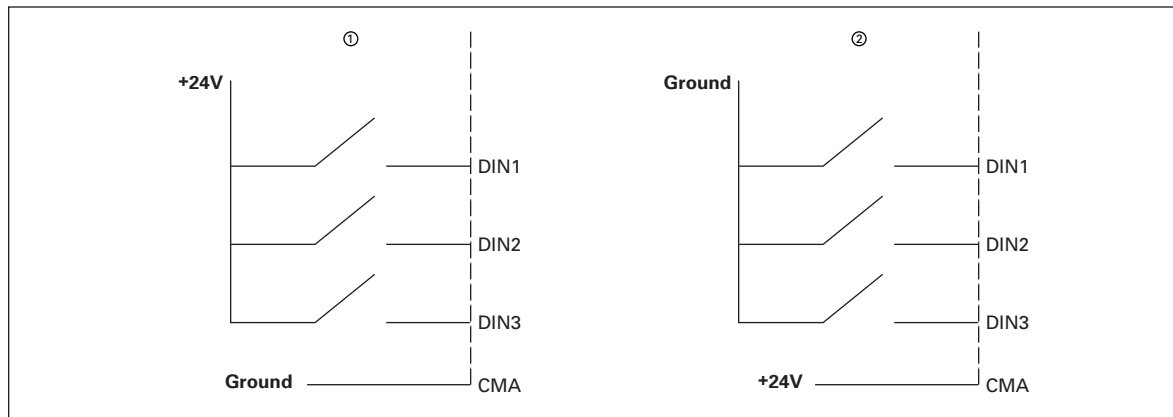


**Figure 4-5: Option Board A2 Terminal Locations**

***Inverting the Digital Input Signal***

The active signal level depends on which potential the common inputs CMA and CMB (terminals 11 and 17) are connected to. The alternatives are either +24V or ground (0V). See **Figure 4-6**.

The 24-volt control voltage and the ground for the digital inputs and the common inputs (CMA, CMB) can be either the internal 24V supply or an external supply.



**Figure 4-6: Positive/Negative Logic**

- ① Positive logic (+24V is the active signal) = the input is active when the switch is closed.
- ② Negative logic (0V is the active signal) = the input is active when the switch is closed.

April 2005

## Chapter 5 — IntelliPass Bypass Option

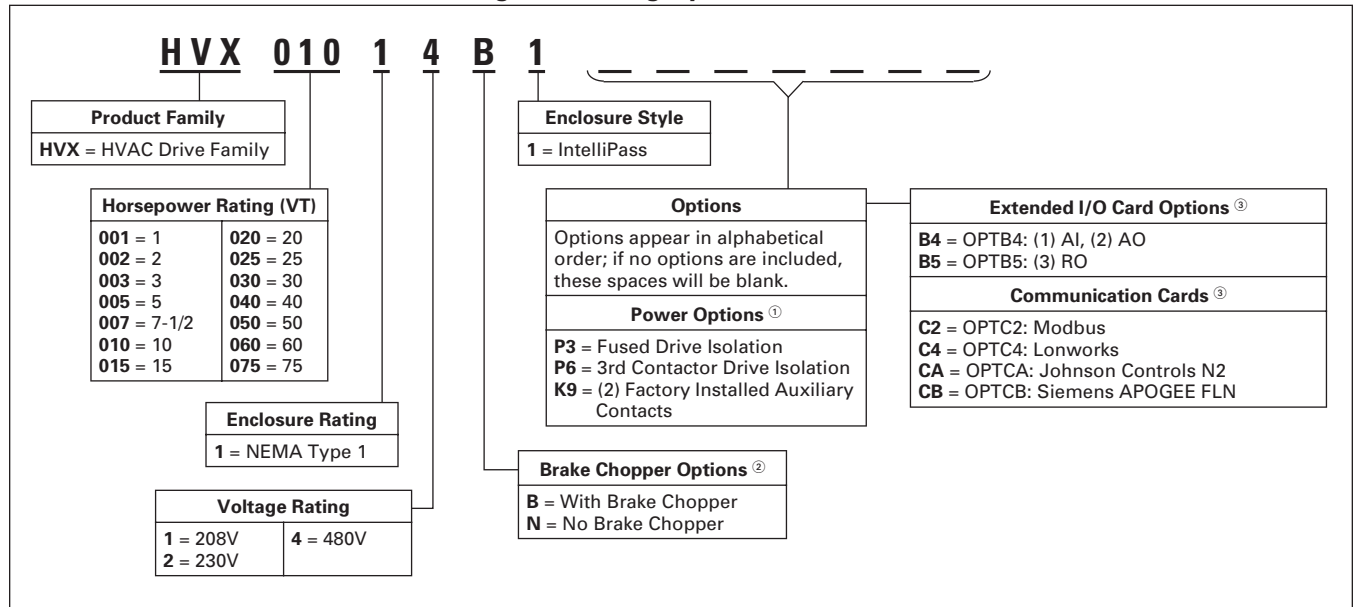
### Product Description

The Cutler-Hammer® IntelliPass Drive continues Eaton’s tradition of providing a premier intelligent drive integrated with a reliable bypass configuration, by taking advantage of the Cutler-Hammer Intelligent Technologies (*IT.*), enclosed control and circuit breaker expertise.

The IntelliPass bypass is a two- or three-contactor design utilizing the Cutler-Hammer 24V DC *IT.* series of contactors and power supplies. The *IT.* features, function and form allow the drive and bypass to become an integrated design, enabling Eaton to manufacture the world’s smallest drive and bypass package. The IntelliPass comes standard with a Cutler-Hammer protective disconnect integrated into the drive and bypass design.

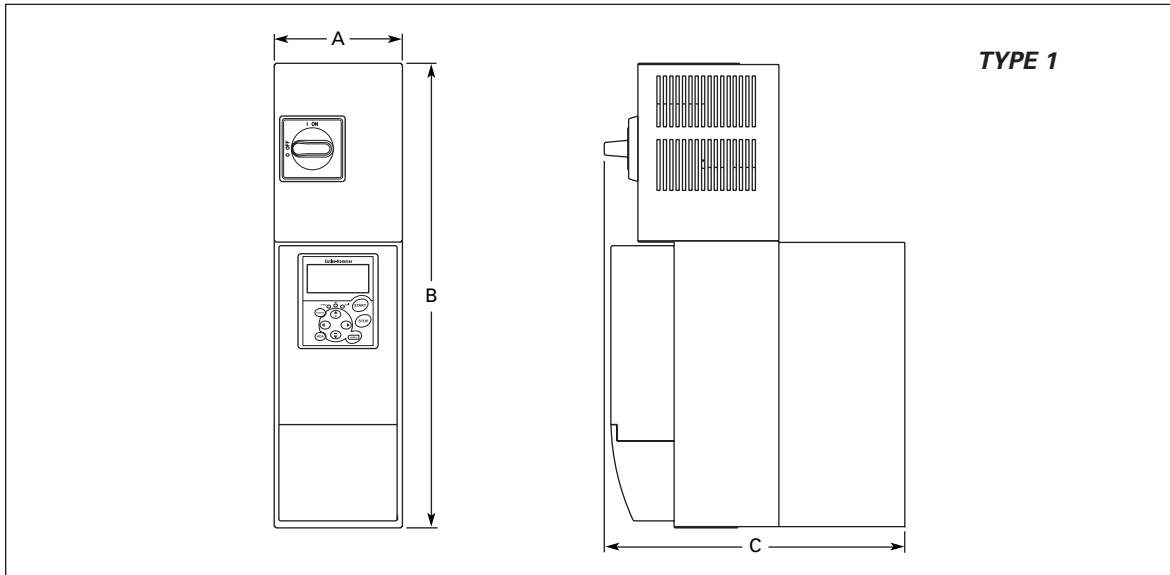
### Catalog Number Selection

**Table 5-1: HVX IntelliPass Drive Catalog Numbering System**



① Power Options **P3** and **P6** cannot be ordered together in the same drive.  
 ② 480V Drives, 50 – 75 hp are only available with Brake Chopper Option **N**. 208/230V Drives, 1 – 20 hp are only available with Brake Chopper Option **N**. 208/230V Drives, 25 hp and 30 hp are only available with Brake Chopper Option **N**.  
 ③ Two slots (D, E) available for expansion cards.

**Dimensions**

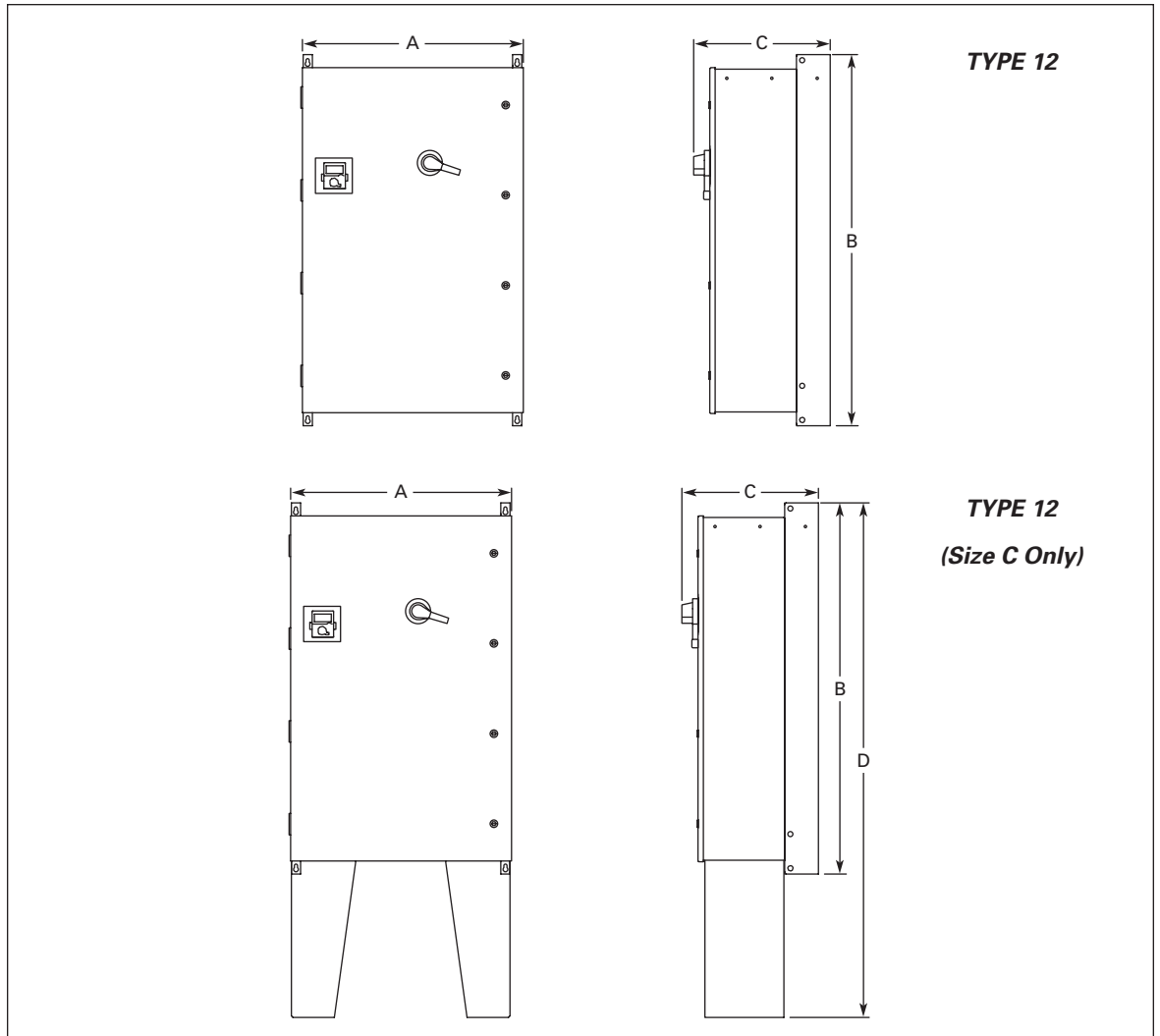


**Figure 5-1: HVX IntelliPass Dimensions**

**Table 5-2: NEMA TYPE 1 IntelliPass Drive Dimensions**

Drive Horsepower (VT)	Frame Size	Approximate Dimensions in Inches (mm)			Weight in Lbs. (kg)
		A	B	C	
230V, 1 – 3 hp 480V, 1 – 7-1/2 hp	FR4	5.04 (128)	18.25 (464)	12.13 (308)	21 (9.5)
230V, 5 – 7-1/2 hp 480V, 10 – 20 hp	FR5	5.50 (140)	23.25 (591)	15.00 (381)	35 (15.9)
230V, 10 – 20 hp 430V, 25 – 40 hp	FR6	7.50 (191)	29.38 (746)	15.25 (387)	67 (30.4)
230V, 25 – 30 hp 480V, 50 – 75 hp	FR7	9.10 (231)	37.53 (953)	16.00 (419)	108 (49.0)

April 2005



**Figure 5-2: HVX Series Enclosed Drive Dimensions**

**Table 5-3: HVX Series TYPE 12 Enclosed IntelliPass Drive Dimensions**

Drive Horsepower (VT)	Frame Size	Enclosure Box	Approximate Dimensions in Inches (mm)			
			A	B	C	D <sup>①</sup>
208V, 1 – 15 hp 230V, 1 – 15 hp 480V, 1 – 30 hp 575V, 3 – 30 hp	FR4 – FR6 FR4 – FR6 FR4 – FR6 FR6	A	16.92 (429.8)	29.00 (736.6)	18.60 (472.4)	—
208V, 20 – 30 hp 230V, 20 – 30 hp 480V, 40 – 75 hp 575V, 40 – 50 hp	FR6 – FR7	B	20.92 (531.3)	40.00 (1016.0)	19.10 (485.1)	—
208V, 40 – 60 hp 230V, 40 – 60 hp 480V, 100 – 150 hp	FR8	C	30.92 (785.3)	52.00 (1320.8)	19.10 (485.1)	72.00 (1828.8)

<sup>①</sup> Floor Stands available on Box C only and can be purchased and shipped separately as kit.

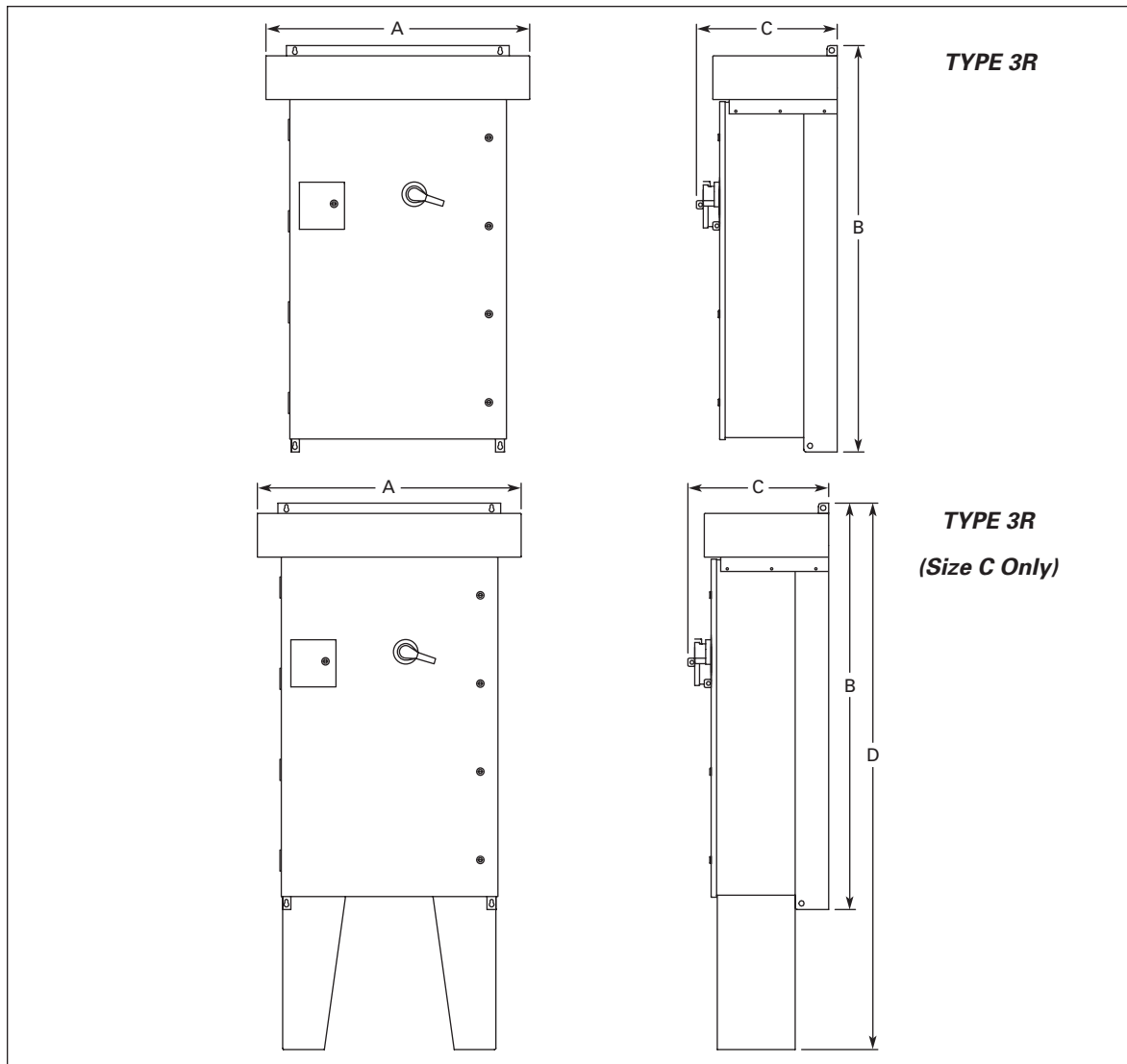


Figure 5-3: HVX Series Enclosed Drive Dimensions

Table 5-4: HVX Series TYPE 3R Enclosed IntelliPass Drive Dimensions

Drive Horsepower (VT)	Frame Size	Enclosure Box	Approximate Dimensions in Inches (mm)			
			A	B	C	D <sup>①</sup>
208V, 1 – 15 hp 230V, 1 – 15 hp 480V, 1 – 30 hp 575V, 3 – 30 hp	FR4 – FR6	A	21.05 (534.7)	33.00 (838.2)	18.60 (472.4)	—
208V, 20 – 30 hp 230V, 20 – 30 hp 480V, 40 – 75 hp 575V, 40 – 50 hp	FR6 – FR7	B	26.31 (668.3)	46.09 (1170.7)	19.10 (482.6)	—
208V, 40 – 60 hp 230V, 40 – 60 hp 480V, 100 – 150 hp	FR8	C	37.73 (958.3)	58.09 (1475.5)	19.10 (482.6)	78.09 (1983.5)

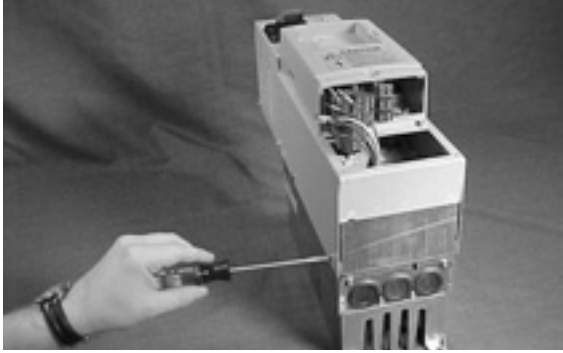


<sup>①</sup> Floor Stands available on Box C only and can be purchased and shipped separately as kit.

April 2005




## Power Wiring

### *IntelliPass Power Wiring Maintenance*

**Table 5-5: IntelliPass Power Wiring Instructions**

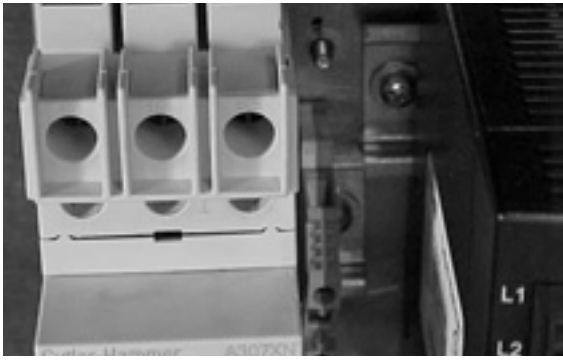
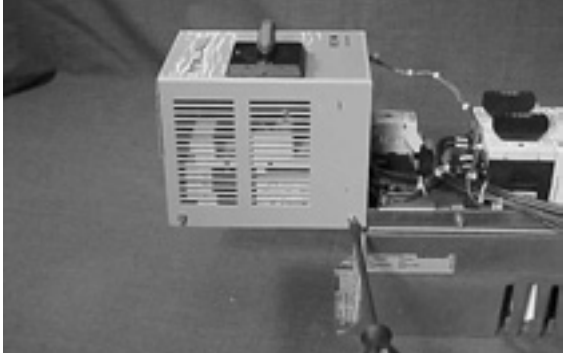
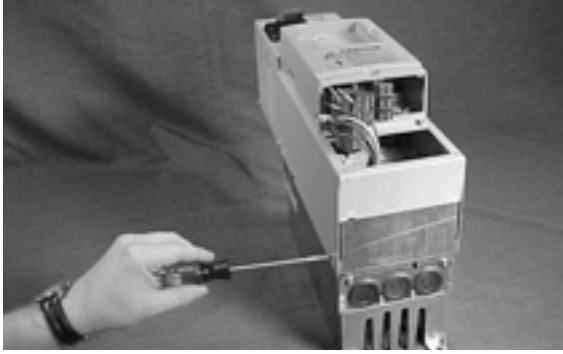

<ol style="list-style-type: none"> <li>1. Loosen the four screws on the side of the bottom bypass cover.</li> <li>2. Lift the bypass cover off of the base.</li> </ol> <p><b>Note:</b> Do not stretch ribbon cable.</p>	
<ol style="list-style-type: none"> <li>3. Hook the cover on the hanger screw on the upper left side of the unit using the keyhole in the side of the bypass cover.</li> </ol> <p><b>Note:</b> Take care not to damage ribbon cable.</p>	
<ol style="list-style-type: none"> <li>4. If using conduit, remove the base plate and attach the conduit connector to the plate. Thread the power and motor wires through separate holes in the conduit plate.</li> </ol>	

**Table 5-5: IntelliPass Power Wiring Instructions, continued**

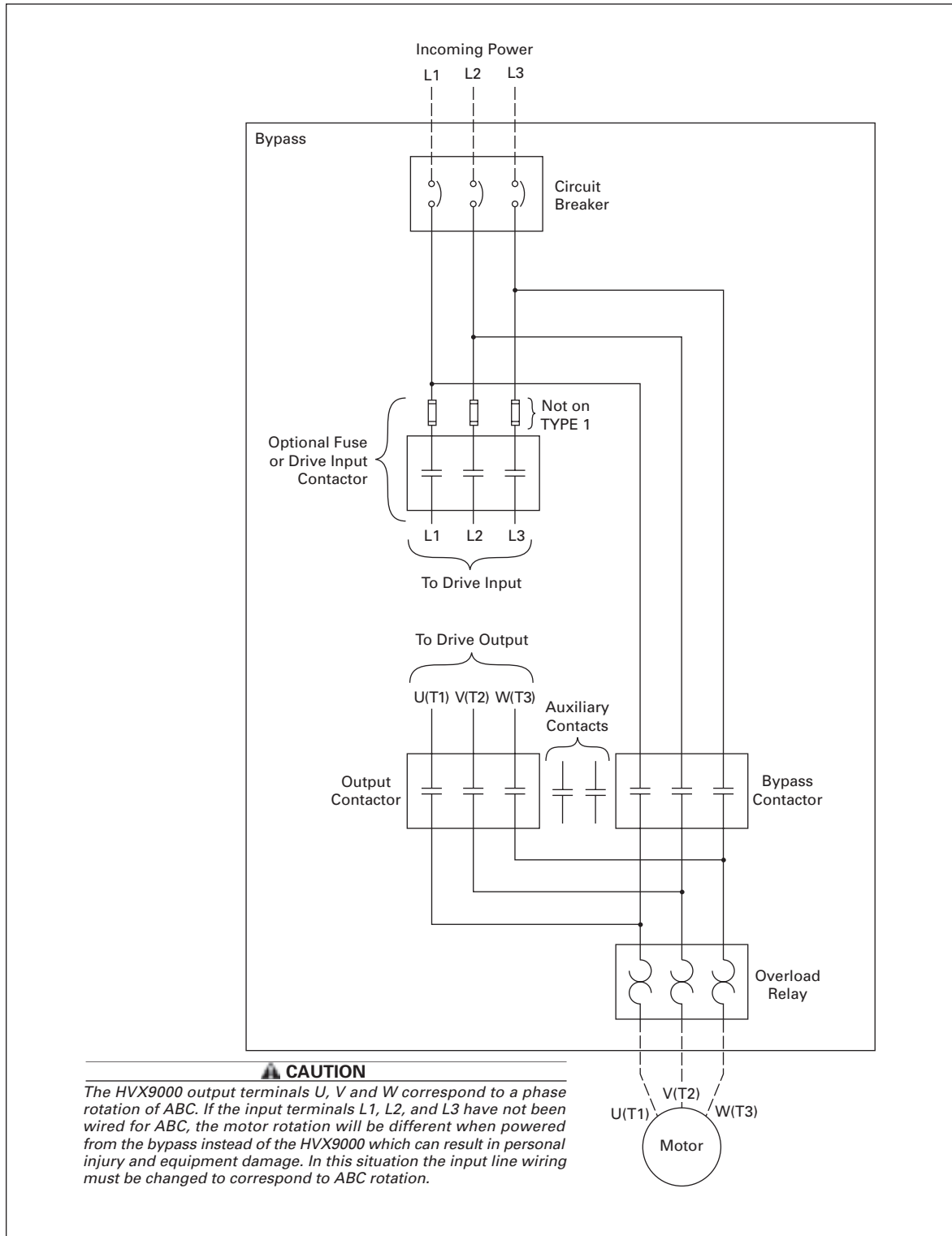
<p>5. Attach the motor wiring to terminals U(T1/2), V(T2/4) and W(T3/5).</p>	
<p>6. Remove the top bypass cover by loosening the four screws on the side of the cover and lifting the cover away from the bypass.</p>	
<p>7. Thread the line power wires through a second hole and pull the wires to the top of the unit and to terminals 1L1, 3L2 and 5L3.</p> <hr/> <p><b>⚠ WARNING</b></p> <p>The HVX9000 output terminals U, V and W correspond to a phase rotation of ABC. If the input terminals L1, L2 and L3 have not been wired for ABC, the motor rotation will be different when powered from the bypass instead of the HVX9000 which can result in personal injury and equipment damage. In this situation the input line wiring must be changed to correspond to ABC rotation.</p>	

April 2005

**Table 5-5: IntelliPass Power Wiring Instructions, continued**

<p>8. Remove the grounding nuts from the package and use them to secure both the motor and input power ground wires to their respective ground posts.</p>	
<p>9. Replace the bypass covers.</p>	
<p>10. Tighten the screws on the sides of the cover(s).</p>	
<p>11. Replace the base plate.</p> <p>Install rubber grommets in any of the wiring plate holes that will not be used.</p>	

**Power and Motor Wiring Schematic**



**Figure 5-4: IntelliPass Power and Motor Terminal Wiring Example**

April 2005

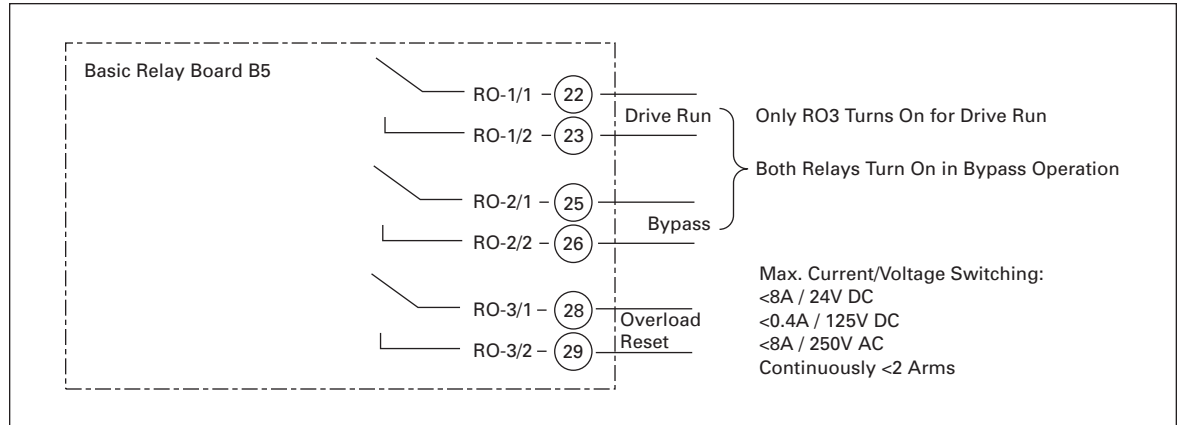
## IntelliPass Control Wiring Instructions

Use the instructions and diagrams in Chapter 4 “Control Wiring” for wiring standard option boards A9 and A2.

In addition to these two boards, the IntelliPass Bypass includes option board B5, which is described in the following section.

### Wiring Option Board B5

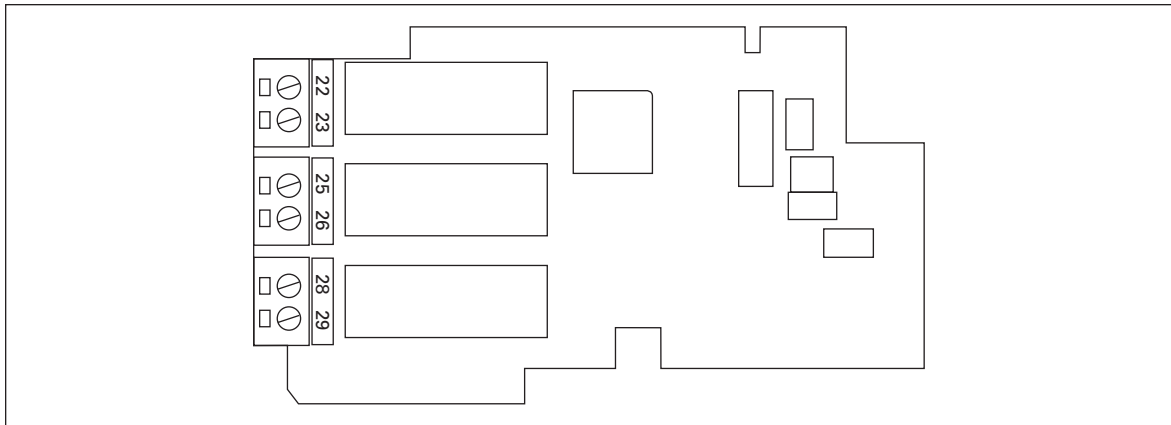
- This board is to be mounted in slot C.



**Figure 5-5: Option Board B5 Wiring Diagram**

**Table 5-6: Option Board B5 Terminal Descriptions**

Terminal	Signal		Description and Parameter Reference
22	RO-1/1	Common	Drive Run Switching Capacity: 24V DC / 8A 250V AC / 8A 125V DC / 0.4A Min Switching Load: 5V/10 mA Continuously: <2 Arms
23	RO-1/2	Normally Open	
25	RO-2/1	Common	Bypass Switching Capacity: 24V DC / 8A 250V AC / 8A 125V DC / 0.4A
26	RO-2/2	Normally Open	
28	RO-3/1	Common	Overload Reset Switching Capacity: 24V DC / 8A 250V AC / 8A 125V DC / 0.4A
29	RO-3/2	Normally Open	



**Figure 5-6: Option Board B5 Terminal Location**

### **Start-Up Wizard**

Upon initial power up, the **Start-Up Wizard** guides the commissioner through the basic HVX9000 setup. The **Start-Up Wizard** may be set to function upon power up by setting parameter P3.5.3, or by pressing the STOP button for 5 seconds. The display will read "Startup Wizard" ACTIVATED after 5 seconds.

Upon power up, the display will read:  
 "Startup wizard"  
 "Press enter"

Upon pressing ENTER, the choice for the language to be used followed by the application desired are presented. Change selection by using the up and down arrow buttons. A selection is confirmed by pressing ENTER. After the application selection, the following text appears:  
 "Setup starts"  
 "Press enter"

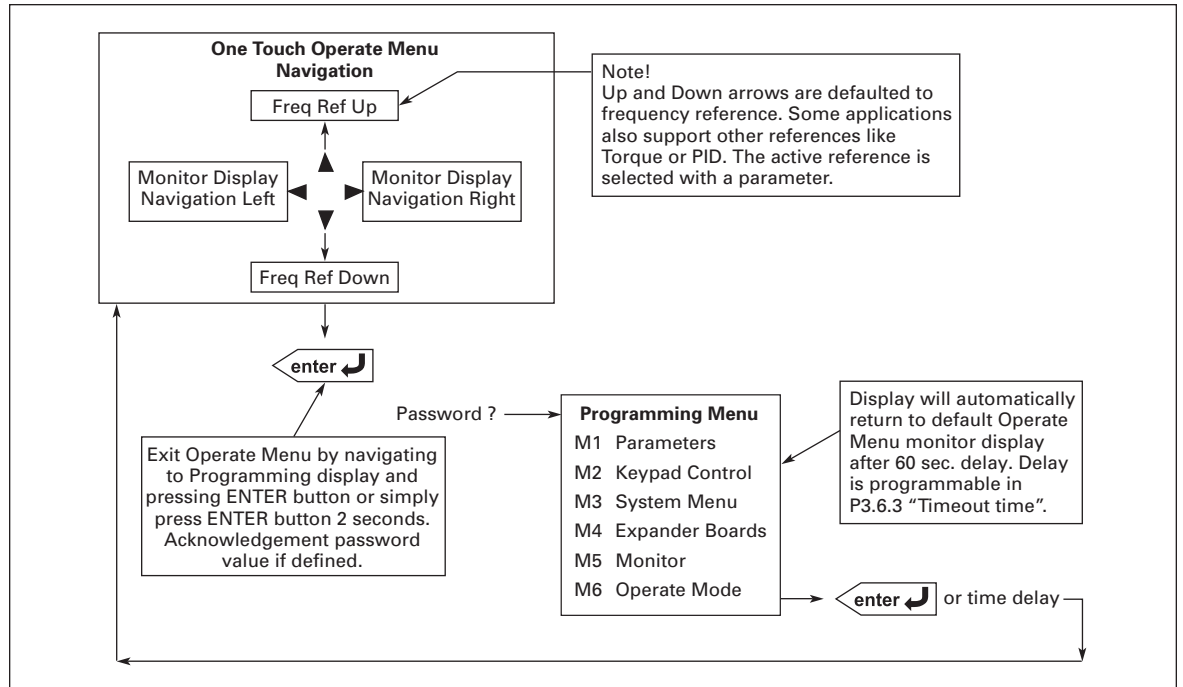
When ENTER is pressed the setup parameter list is presented. The parameter value will be blinking allowing setting by the up and down arrow buttons. The value is confirmed using the ENTER button, after which the next parameter in the list will be displayed.

After the last setup parameter is presented, the following text is displayed:  
 "Repeat setup?"  
 "←No" and "Yes→"

If the right arrow is pressed, the Start-Up Wizard restarts. If the left arrow is pressed, the following is displayed:  
 "Setup done"  
 "Press enter"

After this, the display returns to the default page, normally the Operate Menu.

April 2005



**Figure 5-7: Operate Menu Navigation**

The Operate Menu provides an easy to use method of viewing key numerical Monitoring Menu items. Some applications also support the setting of reference values in this menu. The items displayed vary by application. **Table 5-7** is an example for the Standard application.

**Table 5-7: Operate Menu Items — IntelliPass Application Example**

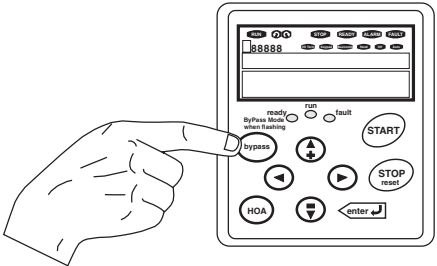
Code	Signal Name	Unit	Description
O.1	Motor Speed	rpm	Calculated motor speed
O.2	Motor Nomspeed	%	Motor nominal speed
O.3	Freq Reference	Hz	Frequency Reference
O.4	Output Frequency	Hz	Output Frequency
O.5	Motor Current	A	Measured Motor Current
O.6	Motor Torque	%	Calculated torque based on nominal motor torque
O.7	Motor Power	%	Calculated motor voltage
O.8	DC-Bus Voltage	V	Measured DC-Bus Voltage
O.9	Unit Temperature	°C	Heatsink temperature
O.10	Calc. MotorTemp	%	Calculated motor temperature based on the motor nameplate information and the calculated motor load
O.11	Analog Input 1	V	Voltage input at Terminals AI1 + and GND

The menu is navigated by using the left and right arrow buttons. If a reference level is available for setting, the up and down arrow buttons adjust the value. To exit the Operate Menu to access the other menus, depress the ENTER button for 2 seconds. While in the other menus, if there is no keypad activity, the display will return to the Operate Menu after 60 seconds. Programmable per P3.6.3 "Timeout Time". **Figure 5-7** illustrates the Operate Menu button function.


**Note:** Once enabled, bypass operation (across the input line) will be controlled through whichever control source is selected. Pressing BYPASS button will not work if HOA (HAND/OFF/AUTO) is in OFF.


### ***Bypass: Enabling, Disabling and Running Motor***

To enable the bypass:  
Press the BYPASS button.




Display Reads:  
"Activate Bypass?"  
"Press Enter"


Press  key.

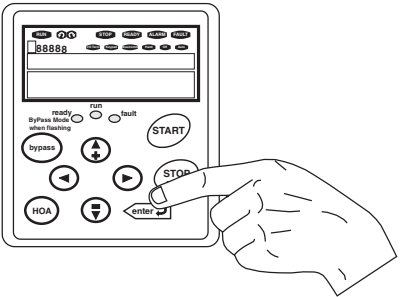
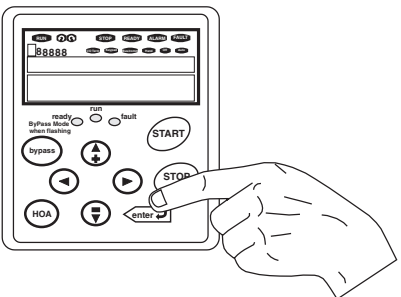
After pressing the  key, display will read "RUN IN BYPASS? Press Start!" You should also observe that "READY LED" is flashing once per second.

This LED indicates that the unit is in "Bypass Mode" and awaiting a start signal. Once Bypass is "running", the LED will flash at a faster rate, twice every second, plus display will read "MOTOR RUNNING IN BYPASS!!"

**IMPORTANT!**  
At this point you have two possible start sources for bypass operation. Whichever control source is indicated on the display such as I/O term or Bus/Comm, plus directly from the keypad.

When you want to leave "Bypass Mode" and return to AFD operation, press the BYPASS button. Display will read "RETURN TO DRIVE? Press Enter!" If "Activate Bypass Press Enter" is displayed, you must press the  key to activate Keypad Bypass Control before pressing the BYPASS button again to return to drive operation.

After pressing the  key, you will be in AFD operation. The "Ready/Bypass Mode when Flashing" LED should now be either solid green or OFF.

**Figure 5-8: Enable Bypass**

**Note:** See Parameter Group 1.10 "IntelliPass Parameters" for more information on customizing bypass operation.

Another way to return to drive operation is to go directly to Parameter 1.10.1 INTELLI-PASS and disable, which also disables the BYPASS in all control sources.

When in doubt as to Mode of Bypass, view status of "Ready/Bypass Mode when flashing" LED along with keypad display.

April 2005

## Chapter 6 — Menu Information

### Keypad Operation

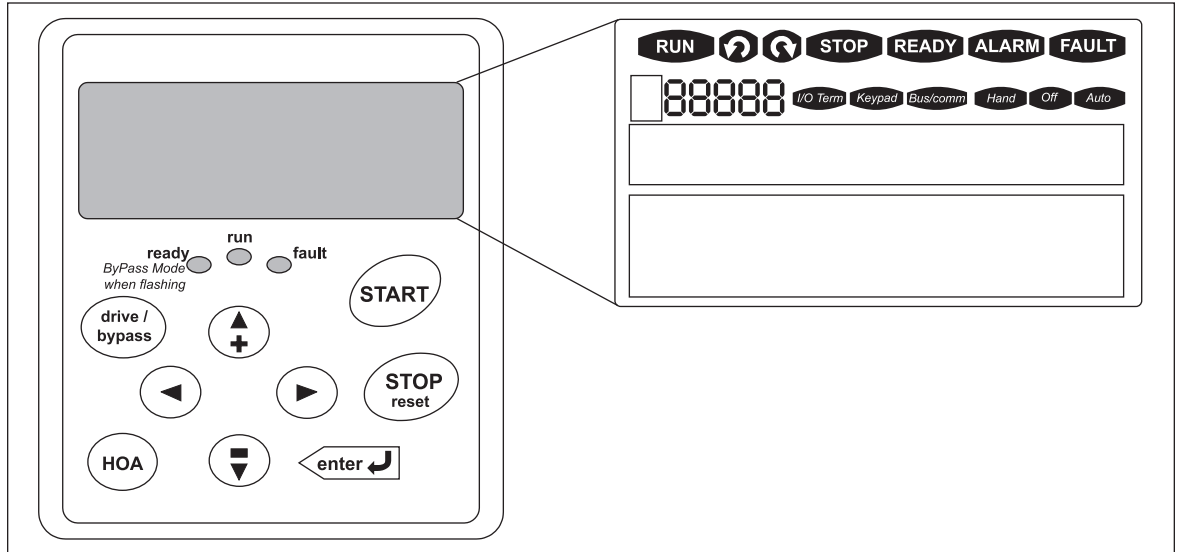















Figure 6-1: Keypad and Display

**Table 6-1: LCD Status Indicators**








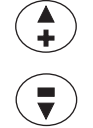
Indicator	Description
	<b>Run</b> Indicates that the HVX9000 is running and controlling the load in Drive or Bypass.
	<b>Counterclockwise Operation</b> The output phase rotation is <b>BAC</b> , corresponding to counterclockwise rotation of most motors.
	<b>Clockwise Operation</b> The output phase rotation is <b>ABC</b> , corresponding to clockwise rotation of most motors.
	<b>Stop</b> Indicates that the HVX9000 is stopped and not controlling the load.
	<b>Ready</b> Indicates that the HVX9000 is ready to be started. Run Enable/INTLK DIN selection will disable "Ready."
	<b>Alarm</b> Indicates that there is one or more active drive alarm(s).
	<b>Fault</b> Indicates that there is one or more active drive fault(s).
	<b>I/O Terminal</b> Indicates that the I/O terminal have been chosen for control.
	<b>Keypad</b> Indicates that the keypad has been chosen for control.
	<b>Bus/Communications</b> Indicates that the communications bus has been chosen for control.
	<b>Hand</b> Indicates that HAND has been chosen in the HOA control mode.
	<b>Off</b> Indicates that the HVX9000 is stopped while in the HOA control mode.
	<b>Auto</b> Indicates that AUTO has been chosen in the HOA control mode.

**Table 6-2: LED Status Indicators**

Indicator	Description
ready	<b>Ready</b> — Steady Illumination Indicates that the HVX9000 is ready to be started. <b>Ready</b> — Flashing once per second, Bypass Mode is enabled and awaiting a start signal. Flashing twice per second, indicates that the HVX9000 is running motor in Bypass.
run	<b>Run</b> Indicates that the HVX9000 or Bypass is operating and controlling the load.
fault	<b>Fault</b> Indicates that there is one or more active drive fault(s).


April 2005

**Table 6-3: Navigation Buttons**

Button	Description
	<p><b>Start</b> This button operates as START button for normal operation when the “Keypad” is selected as the active control.</p>
	<p><b>Enter</b> This button in the parameter edit mode is used to</p> <ul style="list-style-type: none"> <li>• leave the programming mode</li> <li>• leave the parameter group</li> <li>• save the parameter setting and move to the next parameter</li> </ul> <p>This button is also used to reset Fault History</p> <ul style="list-style-type: none"> <li>• Fault History is reset if ENTER is pressed on the “Fault History” menu group in “Monitoring Menu” or</li> <li>• if ENTER is pressed while in the “Fault History” menu</li> </ul>
	<p><b>Stop/Reset</b> This button has three integrated functions. The button operates as the STOP button during normal operation. In the fault mode, it is used as the fault RESET button. It is also used to enter programming mode when pressed for two seconds from the “Operate Menu”.</p> <ul style="list-style-type: none"> <li>• motor STOP from the keypad</li> <li>• used to reset the active fault</li> </ul>
	<p><b>Drive/Bypass</b> Switches between the drive and bypass modes.</p>
	<p><b>HOA</b> Steps through Hand, Off and Auto control modes. Press “Enter” to select mode. If “Enter” is not pressed, control mode will remain in previous control mode.</p>
	<p><b>Left Arrow</b></p> <ul style="list-style-type: none"> <li>• navigation button, movement to left</li> <li>• in display mode, enter parameter group mode</li> <li>• in parameter edit mode, exits mode, backs up one step</li> <li>• cancels edited parameter (exit from a parameter edit mode)</li> </ul>
	<p><b>Right Arrow</b></p> <ul style="list-style-type: none"> <li>• navigation button, movement to right</li> <li>• enter parameter group mode</li> <li>• enter parameter mode from group mode</li> </ul>
	<p><b>Up and Down Arrows</b></p> <ul style="list-style-type: none"> <li>• move either up or down the operating menu list in order to view the desired operating values</li> <li>• move either up or down the parameter group list in order to select the desired group</li> <li>• move either up or down the parameter list in order to select the desired parameter in the group</li> <li>• increase/decrease the reference value of the selected parameter</li> </ul>

## Menu Navigation

### Navigation Tips

- To navigate within one level of menu, use the up and down arrows.
- To move deeper into the menu structure and back out, use the right and left arrows.
- To edit a parameter, navigate to show that parameter's value, and press the right arrow button to enter the edit mode. In edit mode, the parameter value will flash.
- When in edit mode, the parameter value can be changed by pressing the up or down arrow keys.
- When in edit mode, pressing the right arrow a second time will allow you to edit the parameter value digit by digit.
- To confirm the parameter change you must press the ENTER key. *The value will not change unless the ENTER button is pushed.*
- Parameters identified with a  in **Appendix B** can not be changed while the HVX9000 is running. The screen will display LOCKED if you attempt to edit these parameters while the drive is running. Stop the drive to edit these parameters.

### Main Menu

The data on the control keypad are arranged in menus and submenus.

The first menu level consists of menus M1 to M6 and is called the Main menu. These menus and their submenus are illustrated in **Figures 6-2** and **6-3**.

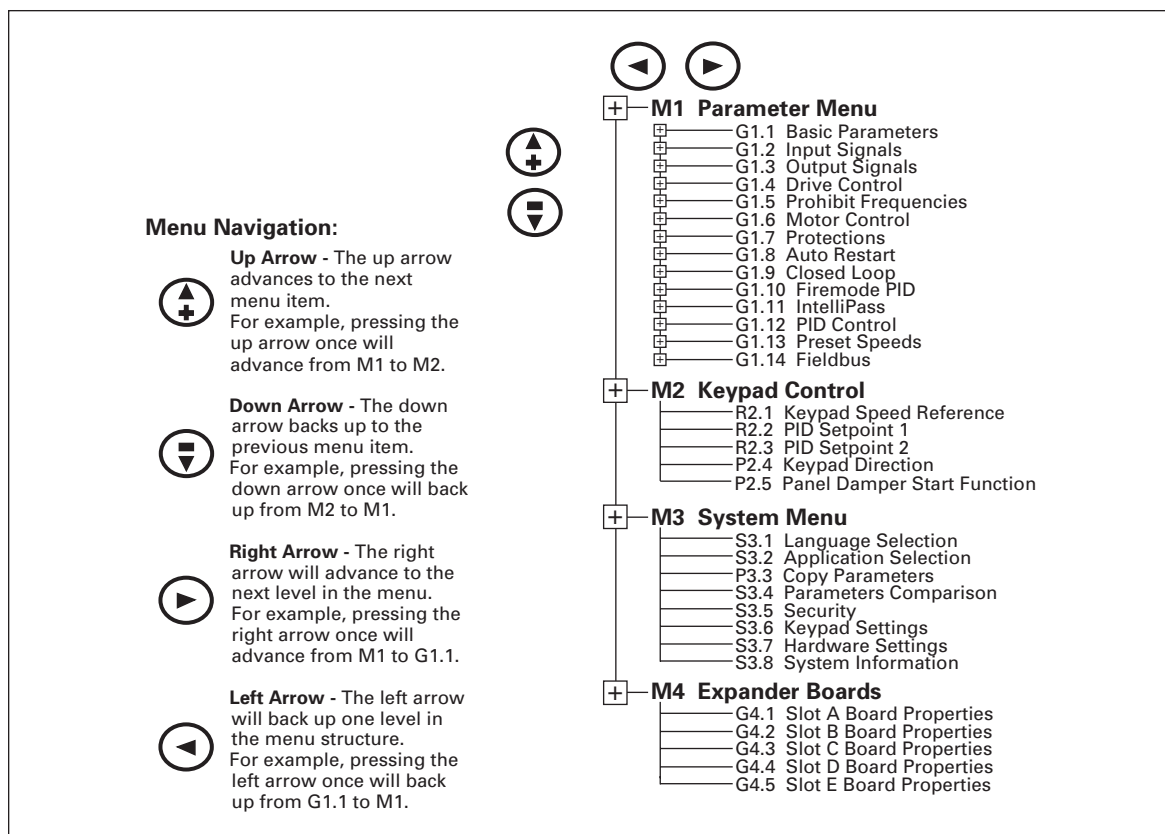


Figure 6-2: Main Menu Navigation — 1 of 2

April 2005

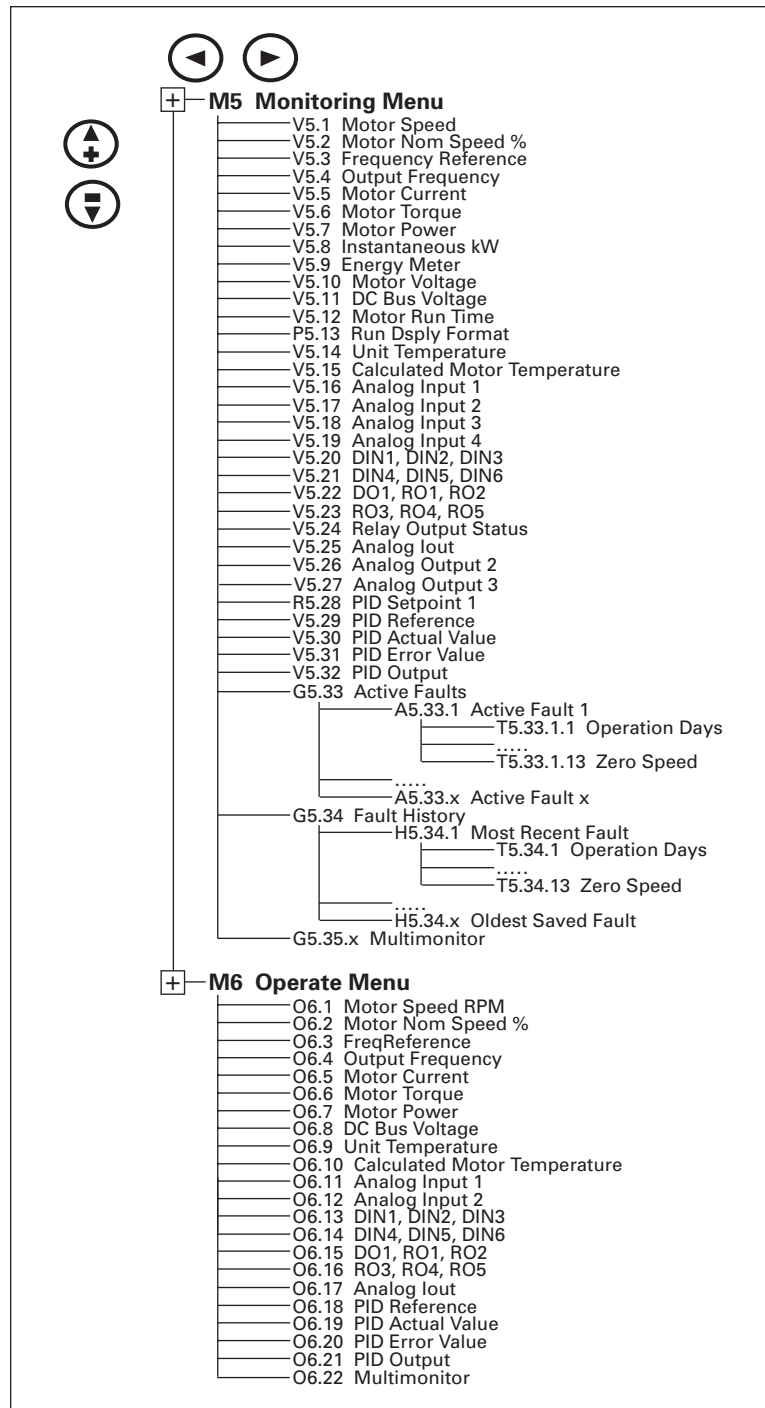
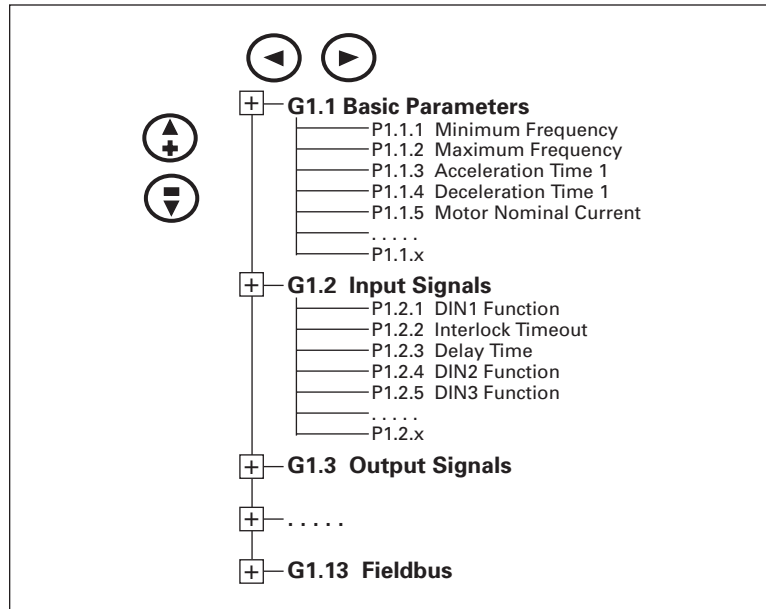


Figure 6-3: Main Menu Navigation — 2 of 2

**Parameter Menu (M1)**

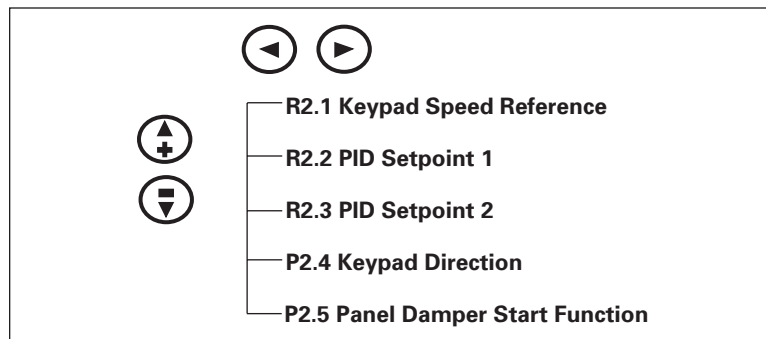
The Parameter Menu is a multi-level menu, arranged by parameter group as illustrated in **Figure 6-4**. Parameters and parameter groups are explained in further detail in **Chapter 8** and **Appendix B**.



**Figure 6-4: Parameter Menu Structure**

**Keypad Control Menu (M2)**

In the Keypad Control Menu, you can set the frequency reference, PID Setpoint and PID Setpoint 2, choose the motor direction for keypad operation and choose the keypad Damper Start Function. See **Figure 6-5**.



**Figure 6-5: Keypad Control Menu**

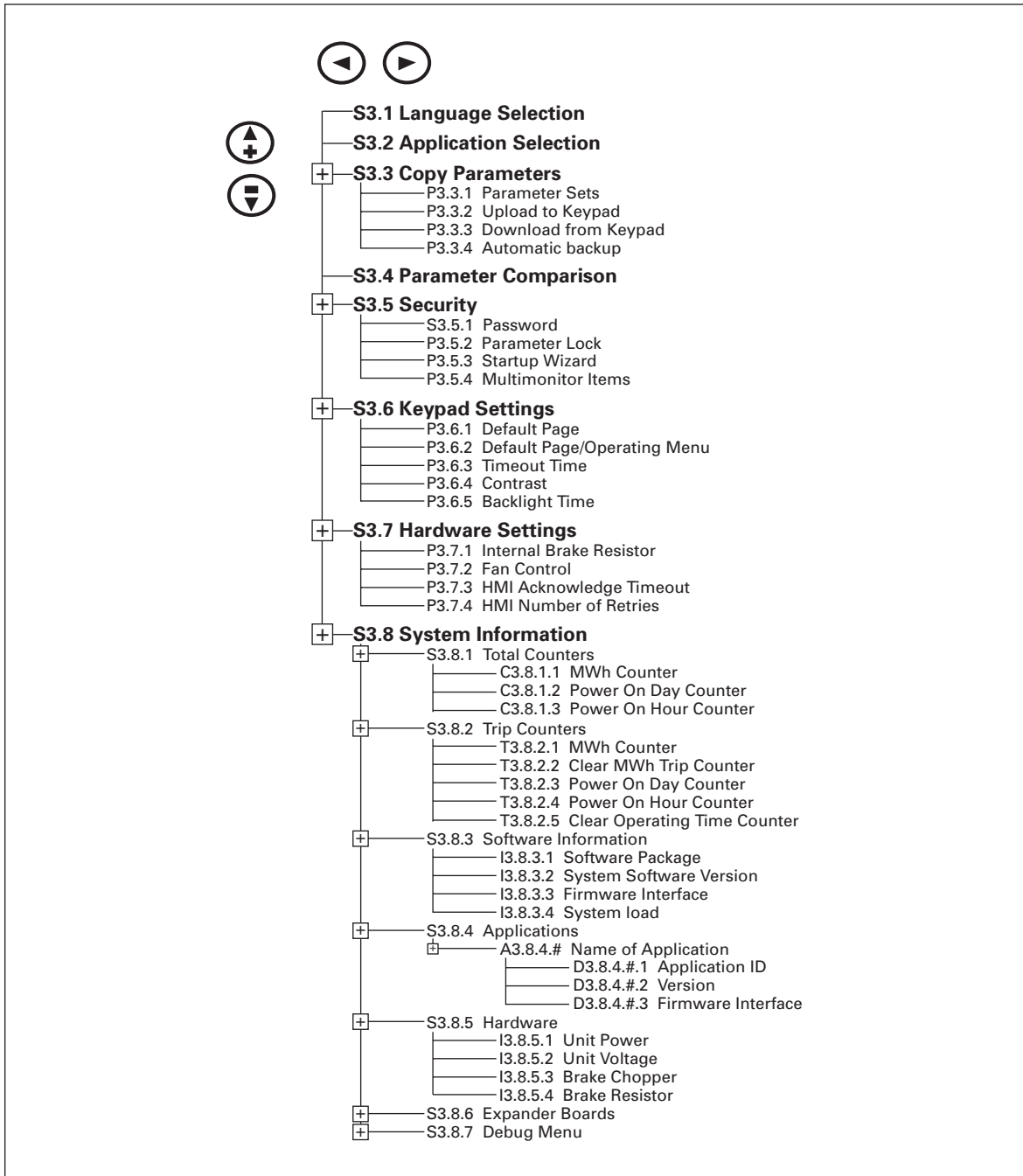
April 2005

<p><b>R2.1</b> <b>Keypad Speed Reference</b></p>	<p>Range: 0.0 – 100.0 Units: Percent <i>KEYPAD SPEED REF</i> The keypad reference displays and allows the operator to edit the motor speed reference. The changes will take place immediately. This reference value will not, however, influence the motor rotation speed unless the keypad has been selected as the active control place. 100% corresponds to <b>Maximum Frequency</b>.</p>
<p><b>R2.2</b> <b>PID Setpoint 1</b></p>	<p>Range: 0.00 – 100.00 Units: Percent <i>PID SETPOINT 1</i> This parameter sets the value of the PID setpoint 1 reference, if the keypad is the active control place.</p>
<p><b>R2.3</b> <b>PID Setpoint 2</b></p>	<p>Range: 0.00 – 100.00 Units: Percent <i>PID SETPOINT 2</i> This parameter sets the value of the PID setpoint 2 reference, if PID Ref2 Sel is enabled in the Digital Inputs.</p>
<p><b>R2.4</b> <b>Keypad Direction</b></p>	<p>Range: Clockwise, Counterclockwise Default: Clockwise <i>KEYPAD DIRECTION</i> The keypad direction displays and allows the operator to change the rotation direction of the motor. This setting will not, however, influence the rotation direction of the motor unless the keypad has been selected as the active control place.</p>
<p><b>R2.5</b> <b>Panel Damper Function</b></p>	<p>Range: 1 – 3 Default: 1 (Interlock Start) <i>PANEL DAMPER FUNCTION</i> Similar to the DIN1 Function only using the keypad or panel start versus the I/O terminal BAS start for P1.2.1 DIN1 Function.</p> <ol style="list-style-type: none"> <li>1 Interlocked Start – To use this, a relay output, RO1 – RO8, needs to be programmed for selections 27 “StrtDelayRly,” and a digital input DIN2 to DIN6 must be programmed for selection 3 “RunEn/INTLK.” The relay output is used to energize an element of the driven system, such as a damper, seal water solenoid, or a pre-lube pump. Upon a return acknowledgement contact closure to the programmed digital input, the HVX9000 will start.</li> <li>2 Interlock Time Start – This functions the same as the Interlocked Start, except that if the return acknowledgement contact is not received within the <b>Interlock Timeout</b>, an “IntlkTimeExpired RestartDrive” message is displayed and the start sequence will need to be restarted.</li> <li>3 Delay Start – This start is similar to the Interlocked Start, except that a return contact is not used. After the “Delay Time” following the relay output closure, the HVX9000 starts.</li> </ol> <p><b>Note:</b> If Run Enable/Interlock opens, the START button must be pressed in order to restart damper open and restart drive. Using I/O BAS start, which is maintained retoggle of DIN1 is unnecessary. Motor will start automatically when Run Enable/Interlock is closed again. <b>Note:</b> Panel Damper uses the same timers P1.2.2 and P1.2.3 that P1.2.1 DIN1 uses.</p>

**System Menu (M3)**

The controls associated with the general use of the drive, such as application selection, customized parameter sets or information about the hardware and software are located in the System Menu.

Descriptions of the system menu parameters are illustrated in **Figure 6-6**.



**Figure 6-6: System Menu Structure**

April 2005

## System Menu Parameters

- S3.1**  
**Language Selection** *LANGUAGE* Default: English
- This parameter offers the ability to control the HVX9000 through the keypad in the language of your choice. Currently available languages are: English, Spanish, French and Portuguese.
- S3.2**  
**Application Selection** *APPLICATION* Default: HVX 7.09
- This parameter sets the active application if multiple applications have been loaded.
- When changing applications, you will be asked if you want the parameters of the new application to be uploaded to the keypad. If you wish to load the new application parameters, push the ENTER button. Pushing any other button saves the parameters of the previously used application in the keypad.

## System Menu Copy Parameter Options (S3.3)

The parameter copy function is used when the operator wants to copy one or all parameter groups from one drive to another. All the parameter groups are first uploaded to the keypad, then the keypad is connected to another drive and then the parameter groups are downloaded to it (or possibly back to the same drive).

**Note:** Before any parameters can successfully be copied from one drive to another, the drive must be stopped when the parameters are downloaded to it.

- S3.3.1**  
**Parameter Sets** *PARAMETER SETS*
- This parameter allows you to reload the factory default parameter values, and to store and load two customized parameter sets.
- S3.3.2**  
**Load Up to Keypad** *UP TO KEYPAD*
- This function uploads all existing parameter groups to the keypad.
- S3.3.3**  
**Download from Keypad** Range: 0 – 3 Default: 0 (All parameters)  
*DOWN FROM KEYPAD*
- This function downloads one or all parameter groups from the keypad to the drive.
- 0 All parameters
  - 1 All, no parameters
  - 2 Application parameters
- S3.3.4**  
**Automatic Backup** Range: Yes, No Default: Yes  
*AUTO. BACKUP*
- This parameter activates and deactivates the parameter backup function. When the Parameter backup function is activated, the keypad makes a copy of the parameters and settings in the currently active application.

## System Menu Parameter Comparison Options (S.3.4)

### S3.4 Parameter Comparison

#### *PARAMCOMPARISON*

With the Parameter Comparison function, you can compare the actual parameter values to the values of your customized parameter sets and those loaded to the control keypad.

The actual parameter values are first compared to those of the customized parameter Set1. If no differences are detected, a "0" is displayed on the lowermost line of the keypad.

If any of the parameter values differ from those of the Set1 parameters, the number of the deviations is displayed together with symbol P (e.g. P1 → P5 = five deviating values).

By pressing the right arrow button once again you will see both the actual value and the value it was compared to. In this display, the value on the Description line (in the middle) is the default value, and the one on the value line (lowermost line) is the edited value. You can also edit the actual value by pushing the Right Arrow button.

Actual values can also be compared to Set2, Factory Settings and Keypad Set values.

## Security Menu Parameter Options (S3.5)

**Note:** The Security submenu is protected with a password.

Store the password in a safe place.

### S3.5.1 Password

Range: 0 – 65,535

Default: 0

#### *PASSWORD*

The application selection can be protected against unauthorized changes with the Password function. When the password function is enabled, the user will be prompted to enter a password before application changes, parameter value changes, or password changes.

By default, the password function is not in use. If you want to activate the password, change the value of this parameter to any number between 1 and 65,535. The password will be activated after the Timeout time (**Timeout Time**) has expired.

To deactivate the password, reset the parameter value to 0.

### S3.5.2 Parameter Lock

Range: ChangeEnable, ChangeDisabl    Default: ChangeEnable

#### *PARAMETER LOCK*

This function allows the user to prohibit changes to the parameters.

If the parameter lock is activated the text *\*LOCKED\** will appear on the display if you try to edit a parameter value.

**Note:** This function does not prevent unauthorized editing of parameter values.

### S3.5.3 Start-Up Wizard

Range: Yes, No

Default: No

#### *START-UP WIZARD*

The Start-Up Wizard facilitates commissioning the HVX9000. If selected active, the Start-Up Wizard prompts the operator for the language and application of his/her choice and then returns to the starting menu or page.

This feature can also be selected by pressing the STOP button for 5 seconds. Display will then show "Start-Up Wizard Activated". Unit must then be powered down and "SUW" will be displayed on powerup.

April 2005

**S3.5.4 Multi-Monitoring Items** Range: ChangeEnable, Change Disabl Default: ChangeEnable  
*MULTIMON. ITEM*

The keypad display where can display three actual monitored values at the same time. This parameter determines if the operator is allowed to replace the values monitored with other values.

### Keypad Settings (S3.6)

There are four parameters (**Default Page** to **Backlight Time**) associated with the keypad operation:

**P3.6.1 Default Page** Default: 0  
*DEFAULT PAGE*

This parameter sets the view to which the display automatically moves as the **Timeout Time** expires or when the keypad power is switched on. If the Default Page value is 0 the function is not activated, i.e. the last displayed page remains on the keypad display.

**P3.6.2 Default Page in the Operating Menu**  
*DEFAULT PAGE/OM*

Here you can set the location in the Operating menu to which the display automatically moves as the set **Timeout Time** expires, or when the keypad power is switched on. See setting of **Default Page** parameter above.

**P3.6.3 Timeout Time** Range: 0 – 65,535 Default: 60  
Units: Seconds  
*TIMEOUT TIME*

The Timeout Time setting defines the time after which the keypad display returns to the **Default Page**.

**Note:** If the Default Page value is 0 the Timeout Time setting has no effect.

**P3.6.4 Contrast Adjustment** Range: 0 – 31 Default: 18  
*CONTRAST ADJUSTMENT*

If the display is not clear, you can adjust the keypad contrast with this parameter.

**P3.6.5 Backlight Time** Range: 1 – 65,535 or Forever Default: 10  
Units: Minutes  
*BACKLIGHT TIME*

This parameter determines how long the backlight stays on before going out. You can select here any time between 1 and 65,535 minutes or "Forever".

### Hardware Settings (S3.7)

The Hardware Settings submenu (S3.7) provides parameters for Internal brake resistor connection, Fan control, HMI acknowledge timeout and HMI retry.

<p><b>P3.7.1</b> <b>Internal Brake Resistor Connection</b></p>	<p>Range: Connected, Not Connected      Default: Not connected</p> <p><i>INTERNBRAKERES</i></p> <p>With this function you can tell the HVX9000 whether the internal brake resistor is connected or not.</p> <p>If your drive has an internal brake resistor, the default value of this parameter is "Connected". However, if it is necessary to increase braking capacity by installing an external brake resistor, or if the internal brake resistor is disconnected, it is advisable to change the value of this function to "Not Connected" in order to avoid unnecessary fault trips.</p> <p><b>Note:</b> The brake resistor is available as an option for all drives. It can be installed internally in frame sizes FR4 to FR6.</p>
<p><b>P3.7.2</b> <b>Fan Control</b></p>	<p>Range: Continuous, Temperature      Default: Continuous</p> <p><i>FAN CONTROL</i></p> <p>This function allows you to control the HVX9000's cooling fan. You can set the fan to run continuously when the power is switched on or to run based on the temperature of the unit. If the latter function has been selected, the fan is switched on automatically when the heatsink temperature reaches 60°C. The fan receives a stop command when the heatsink temperature falls to 55°C. The fan runs for about a minute after receiving the stop command or switching on the power, as well as after changing the value from "Continuous" to "Temperature."</p> <p><b>Note:</b> The fan runs continuously, regardless of this setting, when the HVX9000 is in RUN state.</p>
<p><b>P3.7.3</b> <b>HMI Acknowledge Timeout</b></p>	<p>Range: 200 – 5,000      Default: 200 ms</p> <p>Units: mseconds</p> <p><i>HMI ACK TIMEOUT</i></p> <p>This function allows the user to change the timeout of the HMI acknowledgement time.</p> <p><b>Note:</b> If the HVX9000 has been connected to a PC with a serial cable, the default values of <b>HMI Acknowledge Timeout</b> and <b>Number of Retries to Receive HMI Acknowledgement</b> must not be changed.</p> <p>If the HVX9000 has been connected to a PC via a modem and there is delay in transferring messages, the value of <b>HMI Acknowledge Timeout</b> must be set according to the delay as follows:</p> <p><b>Example:</b></p> <ul style="list-style-type: none"> <li>• Transfer delay between the frequency converter and the PC = 600 ms</li> <li>• The value of <b>HMI Acknowledge Timeout</b> is set to 1200 ms (2 x 600, sending delay + receiving delay)</li> <li>• The corresponding setting shall be entered in the [Misc]-part of the file NCDrive.ini: <ul style="list-style-type: none"> <li>Retries = 5</li> <li>AckTimeOut = 1200</li> <li>TimeOut = 6000</li> </ul> </li> </ul> <p>It must also be considered that intervals shorter than the <b>HMI Acknowledge Timeout</b> time cannot be used in HVX9000 drive monitoring.</p>

April 2005

**P3.7.4  
Number of Retries  
to Receive HMI  
Acknowledgement**

Range: 1 – 10

Default: 5

*HMI RETRY*

With this parameter you can set the number of times the drive will try receive acknowledgement when it has not been received within the acknowledgement time (**HMI Acknowledge Timeout**) or if the received acknowledgement is faulty.

### System Information (S3.8)

This section contains hardware and software information as well as operation information.

**S3.8.1  
Total Counters**

*TOTAL COUNTERS*

In the Total Counters page (**Total Counters**) you can find information related to the HVX9000 operating times, i.e. the total numbers of MWh, operation days and operation hours passed so far. See **Table 6-4**.

Unlike the counters in the Trip Counters, these counters cannot be reset.

**Note:** The Power On time counter (days and hours) runs always, when the power is on.

**Table 6-4: Total Counters**

Number	Name	Description
C3.8.1.1	MWh counter	Megawatt hours total operation time counter.
C3.8.1.2	Power On day counter	Number of days the HVX9000 has been supplied with power.
C3.8.1.3	Power On hour counter	Number of hours the HVX9000 has been supplied with power.

**S3.8.2  
Trip Counters**

*TRIP COUNTERS*

Trip counters are counters the values of which can be reset i.e. restored to zero. You have the following resettable counters at your disposal:

**Table 6-5: Trip Counters**

Number	Name	Description
T3.8.2.1	MWh counter	Megawatts hours since last reset.
T3.8.2.2	Clear MWh counter	Resets megawatts hours counter and clears Energy Meter in the Monitoring Menu (V5.9).
T3.8.2.3	Power On day counter	Number of days since the last reset.
T3.8.2.4	Power On hour counter	Number of hours the HVX9000 has been running a motor since the last reset.
T3.8.2.5	Clear Operation time counter	Resets the day and hour motor or drive running counter and resets the Motor Run Time in the Monitoring Menu (V5.12).

**Note:** The trip counters operate only when the motor is running above 0.00 Hz. The counters can be reset with **Clear MWh counter** and **Clear Operation time counter**.

### S3.8.3 Software Information

#### SOFTWARE

The Software information page includes information on the following software topics:

**Table 6-6: Software Information**

Number	Content
I3.8.3.1	Software package
I3.8.3.2	System software version
I3.8.3.3	Firmware interface
I3.8.3.4	System load

### S3.8.4 Application Information

#### APPLICATIONS

The Application information page includes information on not only the application currently in use but also all other applications loaded into the HVX9000. The information available is:

**Table 6-7: Application Information**

Number	Content
A3.8.4.1	Name of application
D3.8.4.1.1	Application ID
D3.8.4.1.2	Version
D3.8.4.1.3	Firmware interface

### S3.8.5 Hardware Information

#### HARDWARE

The Hardware information page provides information on the following hardware-related topics:

**Table 6-8: Hardware Information**

Number	Content
I3.8.5.1	Power unit type
I3.8.5.2	Nominal voltage of the unit
E3.8.5.3	Brake chopper
E3.8.5.4	Brake resistor
E3.8.5.5	Serial number

### S3.8.6 Expander Board Information

#### EXPANDER BOARDS

This parameter and its sub-items provide information about the basic and option boards plugged into the control board. **Table 6-9** provides an example for slot A.

**Table 6-9: Slot A Expander Board Information**

Number	Content
E3.8.6.1	Slot A board identification
E3.8.6.1.1	Operating state
E3.8.6.1.2	Program version

April 2005

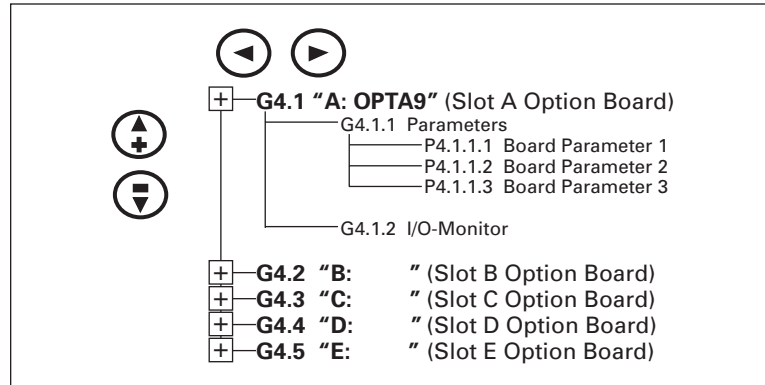
**S3.8.7**  
**Debug Menu**     *DEBUG*

This menu is meant for advanced users and application designers. Contact factory for any assistance needed.

**Expander Board Menu (M4)**

The Expander Board Menu makes it possible for the user to:

- to see what expander boards are connected to the control board and
- to reach and edit the parameters associated with the expander board.



**Figure 6-7: Expander Board Menu Structure**

**Example of Expander Board Parameters for Option Board A9**

<b>P4.1.1.1</b> <b>AI1 Mode</b>	Range: 1 – 5 <i>AI1 MODE</i> Analog Input 1 input options: 1 0 – 20 mA 2 4 – 20 mA 3 0 – 10V 4 2 – 10V 5 -10 – +10V	Default: 3
<b>P4.1.1.2</b> <b>AI2 Mode</b>	Range: 1 – 5 <i>AI2 MODE</i> Analog Input 2 input options: 1 0 – 20 mA 2 4 – 20 mA 3 0 – 10V 4 2 – 10V 5 -10 – +10V	Default: 1
<b>P4.1.1.3</b> <b>AO1 Mode</b>	Range: 1 – 4 <i>AO1 MODE</i> Analog Output 1 output options: 1 0 – 20 mA 2 4 – 20 mA 3 0 – 10V 4 2 – 10V	Default: 1

**Monitoring Menu (M5)**

The Monitoring Menu items are meant for viewing parameter values during operation. Monitored values are updated every 0.3 sec. Monitored items are identified by item numbers V5.1 to V5.32 and G5.35, as listed in **Table 6-10**.

**Table 6-10: Monitoring Menu Items**

Code	Signal Name	Unit	ID #	Description
V5.1	Motor speed	rpm	2	Calculated motor speed
V5.2	Motor speed %	%	1590	Motor Nominal Speed %
V5.3	Frequency reference	Hz	25	Frequency reference setting
V5.4	Output frequency	Hz	1	Frequency to the motor
V5.5	Motor current	A	1780	Measured motor current
V5.6	Motor torque	%	4	Calculated torque based on nominal motor torque
V5.7	Motor power	%	5	Calculated power based on nominal motor power
V5.8	Instantaneous	kW	1888	Calculated power based on output to motor
V5.9	Energy meter	KwH	1666	Kilowatt hours total usage <sup>①</sup>
V5.10	Motor voltage	V	6	Calculated motor voltage
V5.11	DC-bus voltage	V	7	Measured DC-bus voltage
V5.12	Motor run time	Hrs	1701	Motor run time total <sup>①</sup>
P5.13	Run Display Format	—	1565	Changes motor run time between seconds, minutes, hours and days <sup>③</sup>
V5.14	Unit temperature	°C	8	Heatsink temperature
V5.15	Calculated motor temperature	°C	1917	Calculated motor temperature based on the motor nameplate information and the calculated motor load
V5.16	Analog Input 1	V	13	Voltage Input at Terminal AI1+ and GND
V5.17	Analog Input 2	mA	14	Current Input at Terminals AI2+ and AI2-
V5.18	Analog Input 3	mA	1680	Current Input at Terminals AI3+ and AI3-
V5.19	Analog Input 4	mA	1710	Current Input at Terminals AI4+ and AI4-
V5.20	DIN1, DIN2, DIN3	—	15	Digital input status ( <b>Figure 6-8</b> )
V5.21	DIN4, DIN5, DIN6	—	16	Digital input status ( <b>Figure 6-9</b> )
V5.22	DO1, RO1, RO2	—	17	Digital and relay output status ( <b>Figure 6-10</b> )
V5.23	RO3, RO4, RO5	—	1678	Relay output status
V5.24	Relay out status	—	1773	Status of all relay outputs <sup>②</sup>
V5.25	Analog lout	mA	26	Current Output at Terminals AO1+ and AO1-
V5.26	Analog Output 2	mA	1874	Current Output at Terminals AO2+ and AO2-
V5.27	Analog Output 3	mA	1875	Current Output at Terminals AO3+ and AO3-
R5.28	PID Setpoint 1	%	—	PID Setpoint 1 Level
V5.29	PID Reference	%	20	PID Reference Level
V5.30	PID Actual Level	%	21	PID Actual Level
V5.31	PID Error Value	%	22	PID Error Value
V5.32	PID Output	%	23	PID Output
G5.33	Active Faults	—		See <b>Page 6-17</b>
G5.34	Fault History	—		See <b>Page 6-19</b>
G5.35	Multimonitor	—		See <b>Page 6-19</b>

<sup>①</sup> Resettable via S.3.8.2 trip counters.

<sup>②</sup> Includes BIN — Binary to decimal converted value for all digital and relay outputs.

<sup>③</sup> See description on **Page 6-17**.

April 2005

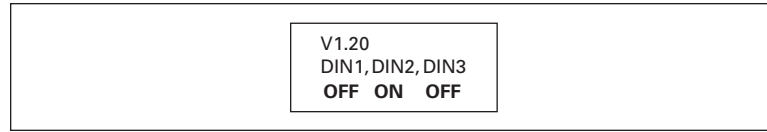


Figure 6-8: Digital Inputs DIN1, DIN2, DIN3 Status

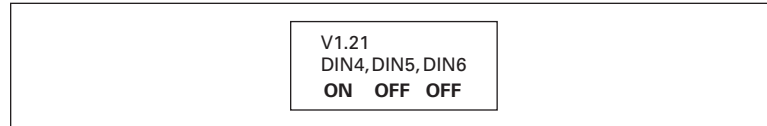


Figure 6-9: Digital Inputs DIN4, DIN5, DIN6 Status

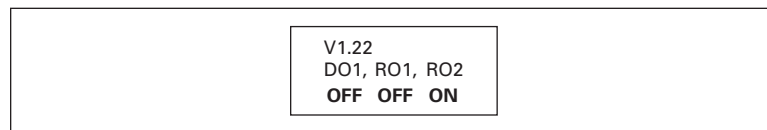


Figure 6-10: Digital Inputs DO1, RO1, RO2 Status

<b>P5.13</b>	Range: 4 – 7	Default: 5 (Minutes)
<b>Run Display Format</b>	<i>RUNDSPLYFORMAT</i>	
	This sets the format of the display for <b>Motor Run Time</b> , V 5.12.	
	4 Seconds	
	5 Minutes	
	6 Hours	
	7 Days	

**Active Faults (G5.33)**

When a fault occurs, the HVX9000 stops. The sequence indication F1, the fault code, a short description of the fault and the fault type symbol will appear on the display. In addition, the indication FAULT or ALARM is displayed and, in case of a FAULT, the red LED on the keypad starts to blink. If several faults occur simultaneously, the sequence of active faults can be browsed with the Browser buttons. See **Figure 6-11**.

The active faults memory can store the maximum of 10 faults in the sequential order of appearance. The display can be cleared with the STOP/RESET button and the readout will return to the same state it was before the fault trip. The fault remains active until it is cleared with the STOP/RESET button or with a reset signal from the I/O terminal.

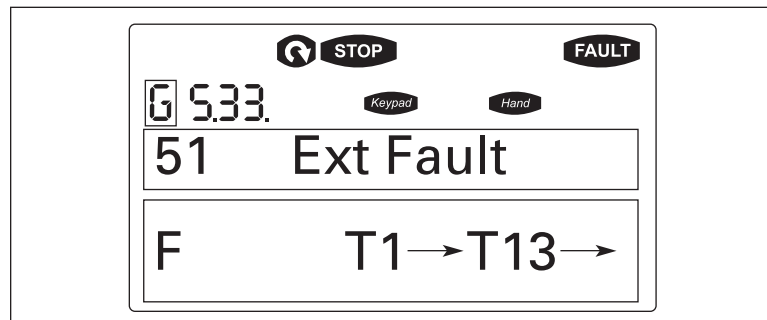


Figure 6-11: Active Fault Display Example

---

**⚠ CAUTION**


---

Remove any External Start signals or permissives before resetting the fault to prevent unintentional restart of the HVX9000, which could result in personal injury or equipment damage.

**Fault Type** Range: A, F, AR, FT  
*FAULT TYPE*  
 There are four different types of faults. These faults and their definitions are given **Table 6-11**.

**Table 6-11: Fault Types**

Fault Type	Fault Name	Description
A	Alarm	This type of fault is a sign of an unusual operating condition. It does not cause the drive to stop, nor does it require any special actions. The "A fault" remains in the display for about 30 seconds.
F	Fault	An "F fault" is a kind of fault that makes the drive stop. Actions need to be taken in order to restart the drive.
AR	Auto-Restart Fault	If an "AR fault" occurs the drive will also stop immediately. The fault is reset automatically and the drive tries to restart the motor. If the restart is not successful, a fault trip (FT) occurs.
FT	Fault Trip	If the drive is unable to restart the motor after an AR fault, an FT fault occurs. The effect of the "FT fault" is the same as that of the F fault — the drive is stopped.

**Fault Code** Range: 1 – 82  
*FAULT CODE*  
 Fault codes indicate the cause of the fault. A list of fault codes, their descriptions, and possible solutions can be found in **Appendix C – Fault and Warning Codes**.

**Fault Time Data** Range: T.1 – T.13  
*FAULT TIME DATA*  
 In this menu, important data recorded at the time the fault is available. This feature is intended to help the user or the service person to determine the cause of fault. **Table 6-12** indicates the information that is recorded.

April 2005

**Table 6-12: Fault Time Data**

Data	Units	Description
T.1 ①	D	Counted operation days (Fault 43: Additional code)
T.2	hh:mm:ss (d)	Counted operation hours (Fault 43: Counted operation days)
T.3	Hz hh:mm:ss	Output frequency (Fault 43: Counted operation hours)
T.4	A	Motor current
T.5	V	Motor voltage
T.6	%	Motor power
T.7	%	Motor torque
T.8	V	DC bus voltage
T.9	°C	Unit temperature
T.10	—	Run status
T.11	—	Direction
T.12	—	Warnings
T.13	—	Zero speed

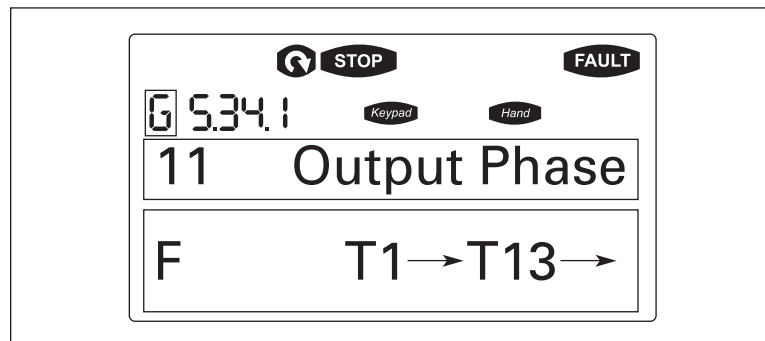
① Real time record:  
If real time is set, T.1 and T.2 will appear as follows:

T.1	yyyy-mm-dd	Counted operation days (Fault 43: Additional code)
T.2	hh:mm:ss.sss	Counted operation hours (Fault 43: Counted operation days)

**Fault History (G5.34)**

All faults are stored in the Fault History Menu, which can be viewed by using the Browser buttons. Additionally, the Fault time data record pages are accessible for each fault as in the Active Faults Menu described above. See **Figure 6-12**.

The HVX9000's memory can store a maximum of 30 faults, in the order of appearance. If there are 30 uncleared faults in the memory, the next occurring fault will erase the oldest fault from the memory.



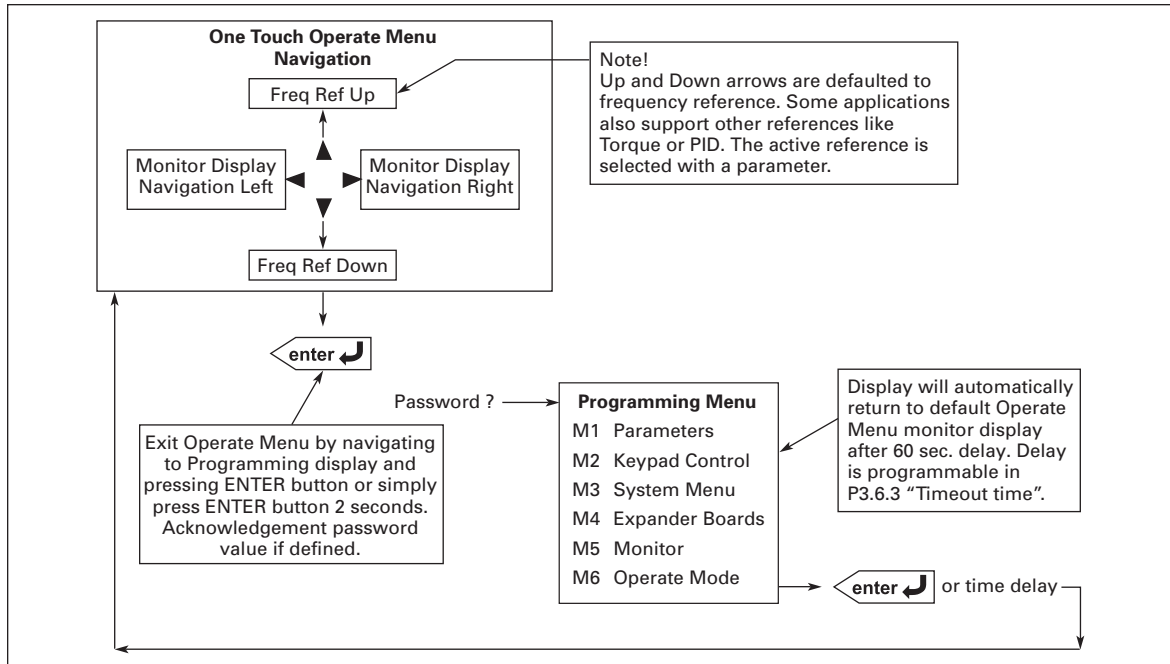
**Figure 6-12: Sample Fault History Display**

**Note:** Pressing the ENTER button for 3 seconds will clear the entire fault history.

**Multimonitor (G5.35)**

This Parameter allows the viewing and selection (if allowed by System menu item, P3.5.4) of three simultaneously monitored items from the Monitored Menu Items illustrated in **Table 6-10**. Use the right arrow key to select the item to be modified and then the up or down arrow keys to select the new item. Press the ENTER key to accept the change.

**Operate Menu**



**Figure 6-13: Operate Menu Navigation**

The Operate Menu provides an easy to use method of viewing key numerical Monitoring Menu items. Some applications also support the setting of reference values in this menu. The items displayed vary by application. **Table 6-13** is an example of the first 11 menu variables for the IntelliPass application.

**Table 6-13: Operate Menu Items — IntelliPass Application Example**

Code	Signal Name	Unit	Description
O.1	Motor Speed	rpm	Calculated motor speed
O.2	Motor Nomspeed	%	Motor nominal speed
O.3	Freq Reference	Hz	Frequency Reference
O.4	Output Frequency	Hz	Output Frequency
O.5	Motor Current	A	Measured Motor Current
O.6	Motor Torque	%	Calculated torque based on nominal motor torque
O.7	Motor Power	%	Calculated motor voltage
O.8	DC-Bus Voltage	V	Measured DC-Bus Voltage
O.9	Unit Temperature	°C	Heatsink temperature
O.10	Calc. MotorTemp	%	Calculated motor temperature based on the motor nameplate information and the calculated motor load
O.11	Analog Input 1	V	Voltage input at Terminals AI1 + and GND

The menu is navigated by using the left and right arrow buttons. If a reference level is available for setting, the up and down arrow buttons adjust the value. To exit the Operate Menu to access the other menus, depress the ENTER button for 2 seconds. While in the other menus, if there is no keypad activity, the display will return to the Operate Menu after 60 seconds programmable per P3.6.3 "Timeout Time" parameter. **Figure 6-13** illustrates the Operate Menu button function.

April 2005

## Chapter 7 — Start-Up

### Safety Precautions

Before start-up, observe the following warnings and safety instructions.

---

 **WARNING**

---

- 1** Internal components and circuit boards (except the isolated I/O terminals) are at utility potential when the HVX9000 is connected to the line. This voltage is extremely dangerous and may cause death or severe injury if you come in contact with it.
- 2** When the HVX9000 is connected to the utility, the motor connections U (T1), V (T2), W (T3) and DC-link/brake resistor connections B-, B+ and R- are live even if the motor is not running.
- 3** Do not make any connections when the HVX9000 drive is connected to the utility line.
- 4** Do not open the cover of the HVX9000 immediately after disconnecting power to the unit, because components within the drive remain at a dangerous voltage potential for some time. Wait until at least five minutes after the cooling fan has stopped and the keypad or cover indicators are dark before opening the HVX9000 cover.
- 5** The control I/O terminals are isolated from the utility potential, but relay outputs and other I/Os may have dangerous external voltages connected even if power is disconnected from the HVX9000.
- 6** Before connecting to the utility make sure that the cover of the HVX9000 is closed.

## Sequence of Operation

1. Read and follow all safety precautions.
2. At installation ensure:
  - a. That the HVX9000 and motor are connected to ground.
  - b. That the utility and motor cables are in accordance with the installation and connection instructions as detailed in **Chapter 3**.
  - c. That the control cables are located as far as possible from the power cables as detailed in **Chapter 4** and **Table 3-1**. That control cable shields are connected to protective ground. That no wires make contact with any electrical components in the HV9000.
  - d. That the common input of digital input groups is connected to +24V or ground of the I/O terminal supply or an external supply as detailed in **Chapter 4** and **Figure 4-6**.
3. Check the quality of the cooling air as detailed in **Chapter 2**.
4. Check that moisture has not condensed inside the HVX9000.
5. Check that all START/STOP switches connected to the I/O terminals are in the STOP state.
6. Connect the HVX9000 to the utility and switch the power on.
7. Ensure that Group G1.1 parameters match the application by setting the following parameters to match the motor nameplate:
  - P1.1.5 = the motor nominal current.
  - P1.1.6 = the nominal voltage of the motor.
  - P1.1.7 = the nominal nameplate frequency of the motor.
  - P1.1.8 = the nominal nameplate full load speed of the motor.
  - P1.1.9 = the motor power factor.

April 2005

8. Perform either Test A or Test B without the motor connected to the HVX9000.

**Test A** — Control from the Control Panel.

- Apply input power to the HVX9000.
- Press HOA button until HAND LCD is flashing, then press ENTER.
- Press the START button.
- Go to the Monitoring Menu and check that the output frequency follows the reference as detailed in **Reference Source Hand**.
- Press the STOP/RESET button.

**Test B** — Control from the I/O Terminals.

- Apply input supply power to the HVX9000.
- Change control from the keypad to the I/O terminals. Press HOA button until AUTO LCD is flashing, then press ENTER. Start drive by closing DIN1.
- Change the frequency reference, from where "Reference Source Auto" (P1.1.15) has been selected.
- Check from the monitoring menu at the control panel that the output frequency follows the frequency reference.
- Stop the drive by opening the start contact at DIN1.

Disconnect all power to the HVX9000. Wait until the cooling fan on the unit stops and the indicators on the panel are not lit. If no keypad is present, check the indicators in the cover. Wait at least five more minutes for the DC bus to discharge. Connect the motor to the HVX9000 and check for correct motor rotation. If possible, perform a start-up test with the motor connected to the HVX9000 but not connected to the process. If the HVX9000 must be tested with the motor connected to the process, perform it under no-load or light load conditions.



April 2005

## Chapter 8 — Application Information

### Parameter Menus

#### Parameter Group G1.1: Basic Parameters

<p><b>P1.1.1</b> <b>Minimum Frequency</b></p>	<p>Range: 0.00 – Max Frequency Units: Hertz <i>MIN FREQUENCY</i></p>	<p>Default: 12.00</p>	<p>Defines the minimum output frequency limit setting.</p>
<p><b>P1.1.2</b> <b>Maximum Frequency</b></p>	<p>Range: Min Frequency – 320.00 Units: Hertz <i>MAX FREQUENCY</i></p>	<p>Default: 60.00</p>	<p>Defines the maximum output frequency limit setting.</p>
<p><b>P1.1.3</b> <b>Acceleration Time 1</b></p>	<p>Range: 0.1 – 3000.0 Units: Seconds <i>ACCEL TIME 1</i></p>	<p>Default: 60.0</p>	<p>This defines the time required for the output frequency to change from the minimum frequency to the maximum frequency as set by <b>Minimum Frequency</b> and <b>Maximum Frequency</b>. With the use of <b>Acceleration Time 1</b> and <b>Acceleration Time 2</b>, two different acceleration times can be used for an application. The active set can be selected with one of the programmable digital inputs DIN2, DIN3, DIN4, DIN5 or DIN6. <b>Note:</b> If the PID-controller is used, <b>Acceleration Time 2/Deceleration Time 2</b> is automatically selected.</p>
<p><b>P1.1.4</b> <b>Deceleration Time 1</b></p>	<p>Range: 0.1 – 3000.0 Units: Seconds <i>DECEL TIME 1</i></p>	<p>Default: 60.0</p>	<p>This defines the time required for the output frequency to change from the maximum frequency to the minimum frequency as set by <b>Maximum Frequency</b> and <b>Minimum Frequency</b>. With the use of <b>Deceleration Time 1</b> and <b>Deceleration Time 2</b>, two different deceleration times can be used for an application. The active set can be selected with one of the programmable digital inputs DIN2, DIN3, DIN4, DIN5 or DIN6. <b>Note:</b> If the PID-controller is used, <b>Acceleration Time 2/Deceleration Time 2</b> is automatically selected.</p>
<p><b>P1.1.5</b> <b>Motor Nominal Current</b></p>	<p>Range: <math>0.3 \times I_{nHVXL} - 2.0 \times I_{nHVXL}</math> Units: Amperes <i>MOTOR NOM CURRNT</i></p>	<p>Default: <math>I_{nHVXL}</math></p>	<p>This is the motor nameplate full load current (<math>I_n</math>).</p>
<p><b>P1.1.6</b> <b>Motor Nominal Voltage</b></p>	<p>Range: 180 – 690 Units: Volts <i>MOTOR NOM VOLTG</i></p>	<p>Default: 230 or 460 (Drive Rating)</p>	<p>This is the motor nameplate base voltage. This parameter sets the voltage at the <b>Field Weakening Point</b> to <math>100\% \times V_n</math>.</p>
<p><b>P1.1.7</b> <b>Motor Nominal Frequency</b></p>	<p>Range: 30.00 – 320.00 Units: Hertz <i>MOTOR NOM FREQ</i></p>	<p>Default: 60.00</p>	<p>This is the motor nameplate base frequency. This parameter sets the <b>Field Weakening Point</b> to the same value.</p>

<b>P1.1.8</b> <b>Motor Nominal Speed</b>	Range: 300 – 20,000 Units: rpm <i>MOTOR NOM SPEED</i> This is the motor nameplate base speed ( $N_n$ ), which is used for displays using motor speed.	Default: 1760
<b>P1.1.9</b> <b>Motor Power Factor</b>	Range: 0.30 – 1.00 <i>MOTORPOWERFACTOR</i> This is the motor nameplate full load power factor from the motor rating nameplate.	Default: 0.85
<b>P1.1.10</b> <b>Current Limit</b>	Range: $0.1 \times I_L - 2.5 \times I_{nHVX}$ Units: Amperes <i>CURRENT LIMIT</i> This parameter determines the maximum motor current allowed from the HVX9000. The parameter value range differs from size to size and is based on the HVX9000 nameplate full load current.	Default: $I_{nHVX}$
<b>P1.1.11</b> <b>HOA Control Source</b>	Range: 0 – 2 <i>HOA CONTROL SRC</i> This parameter determines whether the HOA function is controlled from the keypad or terminal block. 0 Control from keypad 1 Control from I/O terminals 2 Control from communication bus Digital inputs need to be programmed for HAND/AUTO and/or OFF control, along with FB Fixed Control Word bits 4 – 7 corresponding to FB_DIN3-FB_DIN6.	Default: 0
<b>P1.1.12</b> <b>Start Source Hand</b>	Range: 0 – 3 <i>START SRC HAND</i> This parameter determines where the Hand start is controlled from. 0 Keypad 1 BAS 2 I/O terminals 3-wire Start/Stop <sup>①</sup> 3 Panel Damper <sup>②</sup> <sup>①</sup> Digital inputs must be programmed for Run Enable/Interlock for 3-wire control. <sup>②</sup> Digital inputs must be programmed for Run Enable/Interlock and "Damper Output" unless just using "Delay Start".	Default: 0
<b>P1.1.13</b> <b>Reference Source Hand</b>	Range: 0 – 7 <i>REF SOURCE HAND</i> This parameter determines the frequency reference input source when operating in the Hand mode. 0 Analog Input AI1 1 Analog Input AI2 2 Analog Input AI3 3 Analog Input AI4 (Not operational at this time) 4 Keypad reference 5 Communication Bus 6 Motor potentiometer 7 PID-Controller — When selected PID Reference and Actual Value must be programmed in PID Control group.	Default: 4

April 2005

<b>P1.1.14</b> <b>Start Source Auto</b>	Range: 0 – 3 <i>START SRCE AUTO</i> This parameter determines where the Auto start is controlled from. 0 Keypad 1 BAS I/O terminal 2-wire Start/Stop 2 I/O terminals 3-wire Start/Stop <sup>①</sup> 3 Communication bus <sup>①</sup> Digital inputs must be programmed for Run Enable/Interlock for 3-wire control.	Default: 1
<b>P1.1.15</b> <b>Reference Source Auto</b>	Range: 0 – 7 <i>REF SOURCE AUTO</i> This parameter determines the frequency reference input source when operating in the Auto mode. 0 Analog Input AI1 1 Analog Input AI2 2 Analog Input AI3 3 Analog Input AI4 (Not operational at this time) 4 Keypad 5 Communication Bus 6 Motor potentiometer 7 PID-Controller — When selected PID Reference and Actual Value must be programmed in PID Control group.	Default: 0
<b>P1.1.16</b> <b>PM Setback Percentage</b>	Range: 0.0 – 100.0 Units: Percent <i>PM SETBACK PCT</i> This parameter determines the frequency reference for PM setback operation when DIN2, DIN4, DIN5 or DIN6 are set to control PM Setback and closed.	Default: 30.0

**Parameter Group G1.2: Input Signals**

<b>P1.2.1</b> <b>DIN1 Function</b>	Range: 0 – 3 <i>DIN1 FUNCTION</i> This parameter determines the function of digital input DIN1. 0 Start – standard start 1 Interlocked Start – To use this, a relay output, RO1 – RO8, needs to be programmed for selections 27 “StrtDelayRly,” and a digital input DIN2 to DIN6 must be programmed for selection 3 “RunEn/INTLK.” The relay output is used to energize an element of the driven system, such as a damper, seal water solenoid, or a pre-lube pump. Upon a return acknowledgement contact closure to the programmed digital input, the HVX9000 will start. 2 Interlock Time Start – This functions the same as the Interlocked Start, except that if the return acknowledgement contact is not received within the <b>Interlock Timeout</b> , an “IntlkTimeExpired RestartDrive” message is displayed and the start sequence will need to be restarted. 3 Delay Start – This start is similar to the Interlocked Start, except that a return contact is not used. After the “Delay Time” following the relay output closure, the HVX9000 starts. <b>Note:</b> Selections 1 – 3 will only function properly with BAS selected for the “Start Source”.	Default: 0 (Start)
<b>P1.2.2</b> <b>Interlock Timeout</b>	Range: 1 – 32,500 Units: Seconds <i>INTLK TIMEOUT</i> The timeout time used for an Interlocked Time Start, after which the start sequence must be restarted if no acknowledgement contact is received. See <b>DIN1 Function</b> . This parameter is also used for the Panel Damper Function “Interlock Time Start,” P2.5.	Default: 5

**P1.2.3** Range: 1 – 32,500 Default: 5  
**Delay Time** Units: Seconds

*DELAY TIME*

The delay time following a Delay Start, after which the HVX9000 will be started. See **DIN1 Function**. This parameter is also used for the Panel Damper Function "Delay Start", P2.5.

**P1.2.4** Range: 0 – 15 Default: 1  
**DIN2 Function** (Ext fault close)

*DIN2 FUNCTION*

This parameter determines the function of digital input DIN2. If DIN2 is not being used, set this parameter value to 0.

- 0 Not Used
- 1 Ext. Fault Close
- 2 Bypass OvlD Fault
- 3 Run enable/External interlock –  
Contact open: HVX9000 start disabled  
Contact closed: HVX9000 start enabled
- 4 Acceleration or deceleration time selection –  
Contact open: Acceleration/Deceleration time 1 selected  
Contact closed: Acceleration/Deceleration time 2 selected
- 5 Hand/Auto Select – contact closed: Auto control selected
- 6 PID Control – contact closed: PID control selected
- 7 Motor potentiometer down – contact closed: Motor potentiometer down selected
- 8 PID Reference 2 Select – selects between **PID Reference** and PID Setpoint 2 from keypad
- 9 PM Setback – contact closed: PM Setback enabled
- 10 Fault reset – contact closed: All faults reset
- 11 Acceleration/Deceleration prohibited –  
Contact closed: No acceleration or deceleration possible until the contact is opened
- 12 HOA On/Off – contact closed: HOA Off
- 13 Speed Select 3
- 14 Fire Mode – contact closed: Fire Mode selected. See **Page 8-47**.
- 15 Fire Mode Preset Reference Select  
Contact open or closed based on **FMRefSelFunction**. If this input is "ON" then **FireModeFreqRef1** or **FireModeFreqRef2** is selected as a "Preset Speed."

April 2005

**P1.2.5**  
**DIN3 Function**

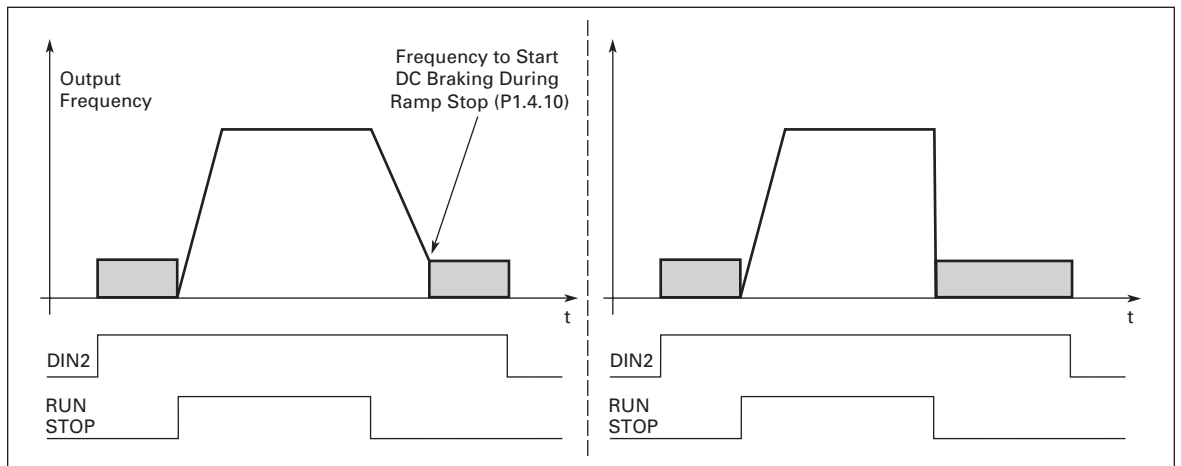
Range: 0 – 15

Default: 10 (Fault Reset)

*DIN3 FUNCTION*

This parameter determines the function of digital input DIN3. If DIN3 is not being used, set this parameter to 0.

- 0 Not Used
- 1 External fault – contact closed: Fault is displayed and motor stopped
- 2 External fault – contact open: Fault is displayed and motor stopped
- 3 Run enable/External interlock –  
Contact open: HVX9000 start disabled  
Contact closed: HVX9000 start enabled
- 4 Acceleration or deceleration time selection –  
Contact open: Acceleration/Deceleration time 1 selected  
Contact closed: Acceleration/Deceleration time 2 selected
- 5 Hand/Auto Select – contact closed: Auto control selected
- 6 Motor potentiometer up – contact closed: Motor potentiometer up selected
- 7 PID Control – contact closed: PID control selected
- 8 PID Reference 2 Select
- 9 Speed Select 1 – contact closed
- 10 Fault reset – contact closed: All faults reset
- 11 Acceleration/Deceleration prohibited –  
Contact closed: No acceleration or deceleration possible until the contact is opened
- 12 DC braking command –  
Contact closed: In Stop mode, the DC braking operates until the contact is opened. See **Figure 8-1**.
- 13 Reserved
- 14 Fire Mode – contact closed: Fire Mode selected. See **Page 8-47**.
- 15 Fire Mode Preset Reference Select  
Contact open or closed based on *FMRefSelFunction*. If this input is "ON" then *FireModeFreqRef1* or *FireModeFreqRef2* is selected as a "Preset Speed."



**Figure 8-1: DC Braking Command**

- P1.2.6** Range: 0 – 15 Default: 4 (Accel/decel time sel)  
**DIN4 Function** *DIN4 FUNCTION*
- This parameter determines the function of digital input DIN4. If DIN4 is not being used, set this parameter to 0.
- 0 Not Used
  - 1 External fault – contact closed: Fault is displayed and motor stopped
  - 2 External fault – contact open: Fault is displayed and motor stopped
  - 3 Run enable/External interlock –  
Contact open: HVX9000 start disabled  
Contact closed: HVX9000 start enabled
  - 4 Acceleration or deceleration time selection –  
Contact open: Acceleration/Deceleration time 1 selected  
Contact closed: Acceleration/Deceleration time 2 selected
  - 5 Hand/Auto Select – contact closed: Auto control selected
  - 6 PID Control – contact closed: PID control selected
  - 7 Motor potentiometer down – contact closed: Motor potentiometer down selected
  - 8 PID Reference 2 Select
  - 9 PM Setback
  - 10 Fault reset – contact closed: All faults reset
  - 11 Speed Select 2
  - 12 DC braking command –  
Contact closed: In Stop mode, the DC braking operates until the contact is opened. See **Figure 8-1**.
  - 13 HOA ON/OFF
  - 14 Fire Mode – contact closed: Fire Mode selected. See **Page 8-47**.
  - 15 Fire Mode Preset Reference Select 1 / 2  
Contact opened: Fire Mode Reference 1 selected  
Contact closed: Fire Mode Reference 2 selected

April 2005

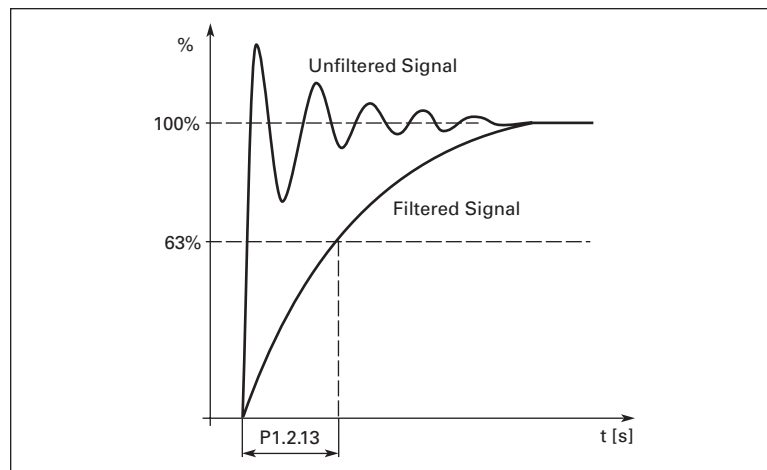
<b>P1.2.7</b>	Range: 0 – 15	Default: 13 (PM Setback)
<b>DIN5 Function</b>	<i>DIN5 FUNCTION</i>	
	This parameter determines the function of digital input DIN5. If DIN5 is not being used, set this parameter to 0.	
	0 Not Used	
	1 External fault – contact closed: Fault is displayed and motor stopped	
	2 External fault – contact open: Fault is displayed and motor stopped	
	3 Run enable/External interlock – Contact open: HVX9000 start disabled Contact closed: HVX9000 start enabled	
	4 Acceleration or deceleration time selection – Contact open: Acceleration/Deceleration time 1 selected Contact closed: Acceleration/Deceleration time 2 selected	
	5 Hand/Auto Select – contact closed: Auto control selected	
	6 Motor potentiometer up – contact closed: Motor potentiometer up selected	
	7 PID Control – contact closed: PID control selected	
	8 Reverse – contact closed: Reverses motor direction	
	9 DC Brake Command – contact closed: DC Brake is enabled	
	10 Fault reset – contact closed: All faults reset	
	11 Acceleration/Deceleration prohibited – Contact closed: No acceleration or deceleration possible until the contact is opened	
	12 HOA On/Off – contact closed: HOA Off	
	13 PM Setback – contact closed: PM Setback enabled	
	14 Fire Mode – contact closed: Fire Mode selected. See <b>Page 8-47</b> .	
	15 Fire Mode Preset Reference Select 1 / 2 Contact opened: Fire Mode Reference 1 selected Contact closed: Fire Mode Reference 2 selected	

- P1.2.8** Range: 0 – 15 Default: 11 (Speed Select 3)  
**DIN6 Function** *DIN6 FUNCTION*  
 This parameter determines the function of digital input DIN6. If DIN6 is not being used, set this parameter to 0. On IntelliPass DIN6 is automatically set to "Bypass Overload Fault"; selection 13. However if DIN2 is already programmed for "Bypass Overload Fault", selection 2, this will not occur.
- 0 Not Used
  - 1 External fault – contact closed: Fault is displayed and motor stopped
  - 2 External fault – contact open: Fault is displayed and motor stopped
  - 3 Run enable/External interlock –  
 Contact open: Drive start disabled  
 Contact closed: Drive start enabled
  - 4 Acceleration or deceleration time selection –  
 Contact open: Acceleration/Deceleration time 1 selected  
 Contact closed: Acceleration/Deceleration time 2 selected
  - 5 Hand/Auto Select – contact closed: Auto control selected
  - 6 Motor potentiometer up – contact closed: Motor potentiometer up selected
  - 7 Motor potentiometer down – contact closed: Motor potentiometer down selected
  - 8 PID Reference 2 Select
  - 9 PM Setback – contact closed: PM Setback enabled
  - 10 Fault reset – contact closed: All faults reset
  - 11 Speed Select 3 – contact closed
  - 12 HOA On/Off – contact closed: HOA Off
  - 13 Bypass Overload Fault
  - 14 Fire Mode – contact closed: Fire Mode selected
  - 15 Fire Mode Preset Reference Select 1 / 2  
 Contact opened: Fire Mode Reference 1 selected  
 Contact closed: Fire Mode Reference 2 selected  
 This selection is automatically set to 13 (Bypass Overload Fault) if P1.10.1 (IntelliPass) has Bypass enabled or if P1.10.3 (Auto Bypass) is enabled.
- Note:** If P1.2.4 DIN2 Function Selection 2, Bypass Ovld Fault is already programmed DIN6 will NOT change!
- P1.2.9** Range: 0 – 2 Default: 0 (0 – 20 mA / 0 – 100%)  
**AI1 Signal Range** Units: Percent  
*AI1 SIGNAL RANGE*  
 With this parameter you can select the analog input 1 signal range.
- 0 Signal range 0 – 20 mA / 0 – 100%
  - 1 Signal range 4 – 20 mA / 20 – 100%
  - 2 Customized signal range defined with **AI1 Custom Minimum** and **AI1 Custom Maximum**
- P1.2.10** Range: 0.00 – AI1 Custom Minimum Default: 0.00%  
**AI1 Custom Minimum** Units: Percent  
*AI1 CUSTOM MIN*  
 This parameter allows the setting of minimum level for the customized analog input 1 as a percentage of 10V.
- P1.2.11** Range: AI1 Custom Maximum – Default: 100.00%  
**AI1 Custom Maximum** Units: Percent  
*AI1 CUSTOM MAX*  
 This parameter allows the setting of the maximum level for the customized analog input 1 as a percentage of 10V.

April 2005

**P1.2.12** Range: 0 – 1 Default: 0 (No Inversion)  
**AI1 Signal Inversion** *AI1 SIGNAL INV*  
 Setting this parameter to 1 causes the maximum set output to occur with the minimum reference input and the minimum set output to occur with the maximum reference input.  
 0 No Inversion  
 1 AI1 signal inverted

**P1.2.13** Range: 0.00 – 10.00 Default: 0.10  
**AI1 Filter Time** Units: Seconds *AI1 FILTER TIME*  
 This parameter, given a value greater than 0, activates the function that filters out disturbances from the incoming analog input 1 ( $V_{in}$ ) signal. Long filtering time makes the signal change slower. See **Figure 8-2**.



**Figure 8-2: AI1 Signal Filtering**

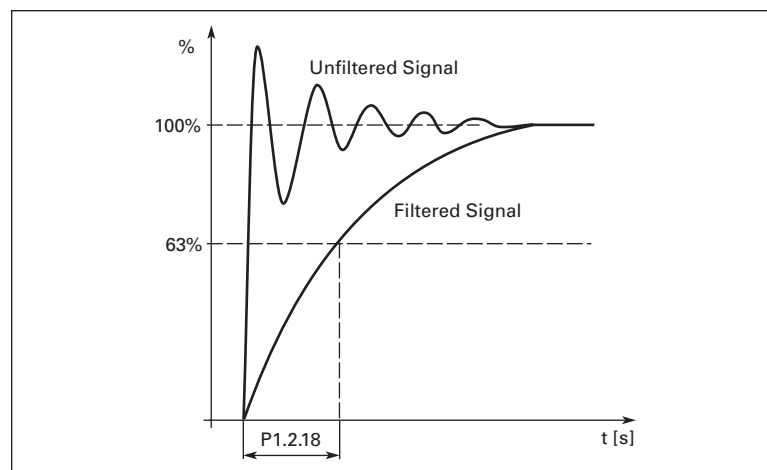
**P1.2.14** Range: 0 – 2 Default: 1 (4 – 20 mA / 20 – 100%)  
**AI2 Signal Range** Units: Percent *AI2 SIGNAL RANGE*  
 0 Signal range 0 – 20 mA / 0 – 100%  
 1 Signal range 4 – 20 mA / 20 – 100%  
 2 Custom signal range (see **AI2 Custom Minimum** and **AI2 Custom Maximum**)

**P1.2.15** Range: 0.00 – AI2 Custom Max Default: 0.00%  
**AI2 Custom Minimum** Units: Percent *AI2 CUSTOM MIN*  
 This parameter allows the setting of the minimum level of analog input 2 as a percentage of 20 mA.  
 See also **AI1 Custom Minimum**.

**P1.2.16** Range: AI2 Custom Min – 100.00% Default: 100.00%  
**AI2 Custom Maximum** Units: Percent *AI2 CUSTOM MAX*  
 This parameter allows the setting of the maximum level of analog input 2 as a percentage of 20 mA.  
 See also **AI1 Custom Maximum**.

**P1.2.17** Range: 0 – 1 Default: 0 (No Inversion)  
**AI2 Signal Inversion** *AI2 SIGNAL INV*  
 Setting this parameter to 1 causes the maximum set output to occur with the minimum reference input and the minimum set output to occur with the maximum reference input. See also **AI1 Signal Inversion**.  
 0 No Inversion  
 1 AI2 signal inverted

**P1.2.18** Range: 0.00 – 10.00 Default: 0.10  
**AI2 Filter Time** Units: Seconds *AI2 FILTER TIME*  
 This parameter, given a value greater than 0, activates the function that filters out disturbances from the analog input 2 ( $I_{in}$ ) signal. A long filtering time makes the signal change slower. See **Figure 8-3**.



**Figure 8-3: AI2 Signal Filtering**

**P1.2.19** Range: 0.1 – 2000.0 Default: 10.0  
**Motor Potentiometer Ramp Time** Units: Seconds *MOTORPOT RAMP TIME*  
 Defines the rate of change of the reference from the motor potentiometer.

**P1.2.20** Range: 0 – 2 Default: 1  
**Motor Potentiometer Memory Reset (Frequency Reference)** *MOTORPOTMEMFREQREF*  
 This parameter sets whether the memory of the motor potentiometer, when used as a frequency reference, is maintained or reset at stop or power down.  
 0 No reset  
 1 Memory reset at stop and power down  
 2 Memory reset at power down

**P1.2.21** Range: 0 – 2 Default: 0 (No Reset)  
**Motor Potentiometer Memory Reset (PID Reference)** *MOTORPOTMEMPIDREF*  
 This parameter sets whether the memory of the motor potentiometer, when used as a PID reference, is maintained or reset at stop or power down.  
 0 No reset  
 1 Memory reset at stop and power down  
 2 Memory reset at power down

April 2005

**P1.2.22  
Reference Scale  
Minimum**

Range: 0.00 – Ref Scale Max  
Units: Hertz  
*REF SCALE MIN*

Default: 0.00

This parameter allows the scaling of the minimum frequency reference from its preset value to a value less than that set by the **Reference Scale Maximum** parameter. If no scaling is desired, set this parameter to 0.

An example is shown in **Figure 8-4**. Voltage input AI1, with a signal range of 0 – 10V, is selected for the Place B reference, and its minimum and maximum output values are scaled from their preset values by using the **Reference Scale Minimum** and **Reference Scale Maximum** parameters.

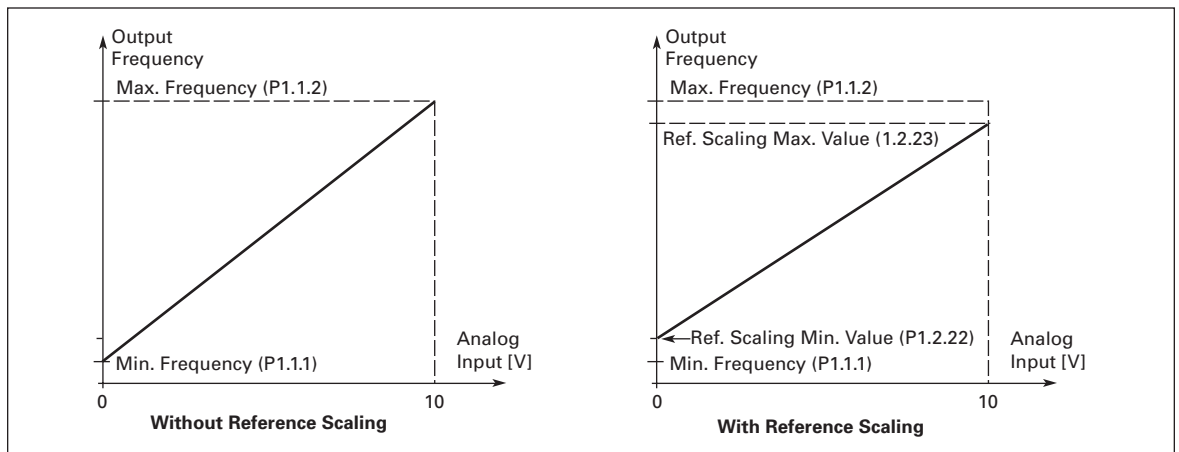
**P1.2.23  
Reference Scale  
Maximum**

Range: Ref Scale Min – 320.00  
Units: Hertz  
*REF SCALE MAX*

Default: 0.00

This parameter allows the scaling of the maximum frequency reference from its preset value to a value greater than that set by the **Reference Scale Minimum** parameter. If no scaling is desired, set this parameter to 0.

An example is shown in **Figure 8-4**. Voltage input AI1, with a signal range of 0 – 10V, is selected for the Place B reference, and its minimum and maximum output values are scaled from their preset values by using the **Reference Scale Minimum** and **Reference Scale Maximum** parameters.



**Figure 8-4: Control Place B with and without Reference Scaling**

**P1.2.24  
AI3 Signal  
Selection**

Range: AnIN:0.1 – AnIN:E.10  
*AI3 SIGNAL SEL*

Default: AnIN:0.1

Connect the AI3 signal to the analog input of your choice with this parameter.

**P1.2.25  
AI3 Signal Range**

Range: 0 – 1  
*AI3 SIGNAL RANGE*

Default: 1 (4 – 20 mA/20 – 100%)

This parameter sets the signal range of analog input 3.

0 Signal range 0 – 20 mA / 0 – 100%

1 Signal range 4 – 20 mA / 20 – 100%

This parameter allows the setting of the maximum level of analog input 2 as a percentage of 20 mA. See also **AI1 Custom Maximum**.

<b>P1.2.26</b> <b>AI3 Signal Inversion</b>	Range: 0 – 1 <i>AI3 SIGNAL INV</i> Setting this parameter to 1 causes the maximum set output to occur with the minimum reference input and the minimum set output to occur with the maximum reference input. 0 No inversion 1 AI3 signal inverted	Default: 0 (No Inversion)
<b>P1.2.27</b> <b>AI3 Filter Time</b>	Range: 0.00 – 10.00 Units: Seconds <i>AI3 FILTER TIME</i> When this parameter is given a value greater than 0, it activates the function that filters out disturbances from the incoming analog input 3 signal. A long filtering time makes the signal change slower. See <b>Figure 8-3</b> .	Default: 0.10
<b>P1.2.28</b> <b>AI4 Signal Selection</b>	Range: AnIN:0.1 – AnIN:E.10 <i>AI4 SIGNAL SEL</i> Connect the AI4 signal to the analog input of your choice with this parameter.	Default: AnIN:0.1
<b>P1.2.29</b> <b>AI4 Signal Range</b>	Range: 0 – 1 <i>AI4 SIGNAL RANGE</i> This parameter sets the signal range of analog input 4. 0 Signal range 0 – 20 mA / 0 – 100% 1 Signal range 4 – 20 mA / 20 – 100%	Default: 1 (4 – 20 mA/20 – 100%)
<b>P1.2.30</b> <b>AI4 Signal Inversion</b>	Range: 0 – 1 <i>AI4 SIGNAL INV</i> Setting this parameter to 1 causes the maximum set output to occur with the minimum reference input and the minimum set output to occur with the maximum reference input.	Default: 0 (No Inversion)
<b>P1.2.31</b> <b>AI4 Filter Time</b>	Range: 0.00 – 10.00 Units: Seconds <i>AI4 FILTER TIME</i> When this parameter is given a value greater than 0, it activates the function that filters out disturbances from the analog input 4 signal. A long filtering time makes the signal change slower. See <b>Figure 8-3</b> .	Default: 0.10

April 2005

**P1.2.32  
Interlock/Run  
Enable Display Text  
Parameters**

Range: 0 – 9

*INTLK TEXT DIN2*

**1.2.32.1**

Interlock/Run Enable Text for DIN2      Default: 0

*INTLK TEXT DIN3*

**1.2.32.2**

Interlock/Run Enable Text for DIN3      Default: 0

**1.2.32.3**

Interlock/Run Enable Text for DIN4      Default: 0

*INTLK TEXT DIN5*

**1.2.32.4**

Interlock/Run Enable Text for DIN5      Default: 0

*INTLK TEXT DIN6*

**1.2.32.5**

Interlock/Run Enable Text for DIN6      Default: 0

When a Digital Input is selected for External Interlock/Run Enable, the user has a choice of the following text displays when the contact is open.

- 0 Ext Interlock
- 1 Run Enable
- 2 Vibration Cutout
- 3 High Motor Temperature
- 4 Freeze Stat Trip
- 5 Low Pressure
- 6 High Pressure
- 7 Low Water
- 8 Smoke Detect
- 9 3-Wire Off
- 10 Damper Interlock
- 11 Open Safety

**Note:** When "Open Safety" is used along with "Damper Output" the operation of the start sequence is "restarted" when the contact opens. This varies only in "BAS" control whereas if any other of the 0 – 10 selections above are used, the damper output relay will remain ON when this contact is opened and the motor will automatically restart when contact is closed. If selection 11 (Open Safety) is selected, the damper output will turn OFF when the input is open. Once the "Open Safety" input is "closed", the damper output will turn ON and the motor will restart automatically as long as the BAS Start (DIN1) is "maintained" closed.

**Parameter Group G1.3: Output Signals**

**P1.3.1  
Analog Output  
(A<sub>out</sub>) Content**

Range: 0 – 13

Default: 1 (Output Frequency)

*ANALOG OUT FUNCTION*

This parameter selects the desired function for the analog output signal.

- 0 Not used
- 1 Output frequency (0 –  $f_{max}$ )
- 2 Frequency reference (0 –  $f_{max}$ )
- 3 Motor speed (0 – Motor nominal speed)
- 4 Output current (0 –  $I_{nMotor}$ )
- 5 Motor torque (0 –  $T_{nMotor}$ )
- 6 Motor power (0 –  $P_{nMotor}$ )
- 7 Motor voltage (0 –  $V_{nMotor}$ )
- 8 DC-link voltage (0 – 1000V)
- 9 PID controller reference value
- 10 PID controller actual value 1
- 11 PID controller actual value 2
- 12 PID controller error value
- 13 PID controller output

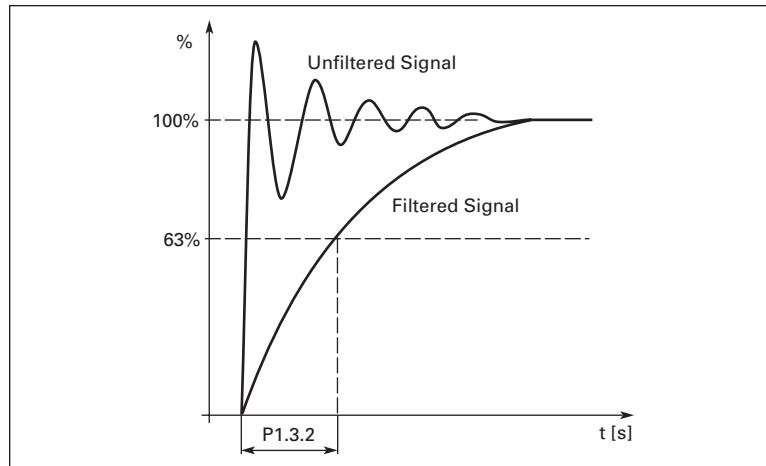
**P1.3.2**  
**Analog Output**  
**(A<sub>out</sub>) Filter Time**

Range: 0.00 – 10.00  
Units: Seconds

Default: 1.00

*A<sub>OUT</sub> FILTER TIME*

When this parameter is given a value greater than 0, it activates the function that filters out disturbances from the analog output signal. A long filtering time makes the output signal change slower. If you set a value of 0, no filtering takes place. See **Figure 8-5**.



**Figure 8-5: Analog Output Filtering**

**P1.3.3**  
**A<sub>out</sub> Invert**

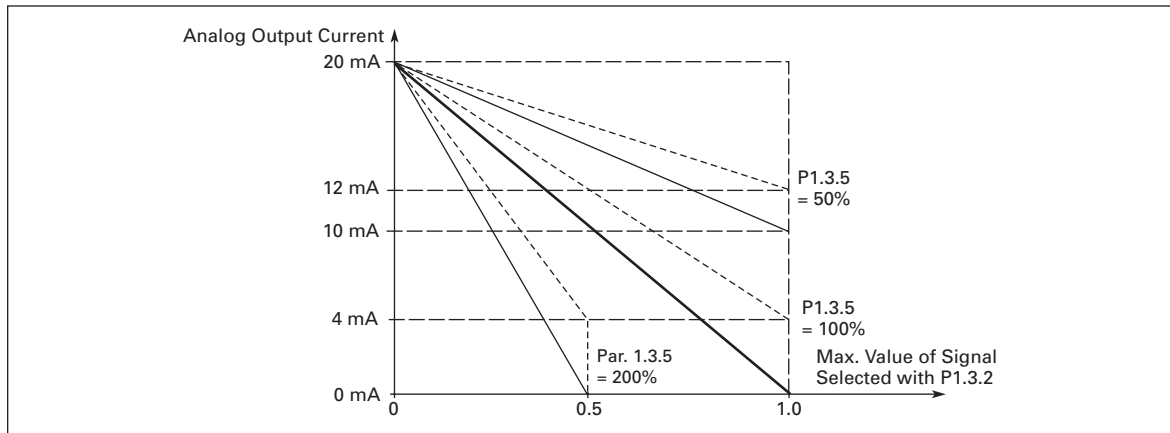
Range: 0 – 1

Default: 0 (Not Inverted)

*A<sub>OUT</sub> INVERT*

Setting this parameter to 1 inverts the analog output signal so that the maximum output occurs at the minimum value of the **Analog Output (A<sub>out</sub>) Content** parameter and the minimum output occurs at the maximum value of the **Analog Output (A<sub>out</sub>) Content** parameter. See **Figure 8-6**.

- 0 Not inverted
- 1 Inverted



**Figure 8-6: Analog Output Inversion**

**P1.3.4**  
**Analog Output**  
**(A<sub>out</sub>) Minimum**

Range: 0 – 1

Default: 0 (0 mA)

*A<sub>OUT</sub> MINIMUM*

Sets the signal minimum to either 0 mA or 4 mA.

- 0 0 mA minimum
- 1 4 mA minimum

April 2005

**P1.3.5**  
**Analog Output**  
**(Aout) Scale**

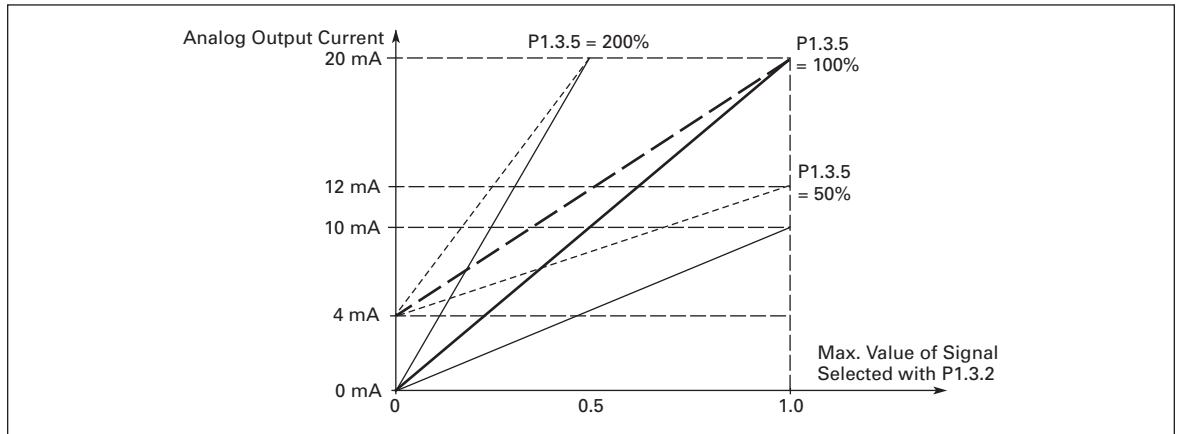
Range: 10 – 1000  
 Units: Percent  
*A<sub>OUT</sub> SCALE*

Default: 100

See **Figures 8-6** and **8-7** and **Table 8-1** for scaling information and examples.

**Table 8-1: Scaling Factor for the Analog Output**

Signal	Maximum Value of the Signal
Output frequency	100 x f <sub>max</sub>
Motor speed	100% x Motor nominal speed
Output current	100% x I <sub>nMotor</sub>
Motor torque	100% x T <sub>nMotor</sub>
Motor power	100% x P <sub>nMotor</sub>
Motor voltage	100% x V <sub>nmotor</sub>
DC-link voltage	1000 V
PI-ref. value	100% x ref. value max.
PI act. value 1	100% x actual value max.
PI act. value 2	100% x actual value max.
PI error value	100% x error value max.
PI output	100% x output max



**Figure 8-7: Analog Output Scale**

**P1.3.6**  
**Digital Output 1**  
**(DO1) Function**

Range: 1 – 26

Default: 1 (Ready)

*DO1 FUNCTION*

Digital output DO1 sinks current when the selected setting is true. See **Table 8-2** for setting information.

**Table 8-2: DO1 Function Settings**

Setting		Signal Content
1	Ready	The HVX9000 is ready to operate
2	Run	The HVX9000 is operating (motor is running)
3	Fault	A fault trip has occurred
4	Fault inverted	A fault trip has not occurred
5	Drive overheat warning	The heat-sink temperature exceeds +70C
6	External fault or warning	Fault or warning depending on <b>External Fault</b>
7	Reference fault or warning	Fault or warning depending on <b>4 mA (Reference) Fault Response</b> — if analogue reference is 4 – 20 mA and signal is <4 mA
8	Warning	Always if a warning exists
9	Reversed	The reverse command has been selected
10	Bypass Run	Bypass has been selected
11	At speed	The output frequency has reached the set reference
12	Motor regulator activated	Overvoltage or overcurrent regulator was activated
13	Output frequency limit 1 supervision	The output frequency is outside the set supervision low limit/high limit (see <b>Frequency Supervision Function 1</b> and <b>Speed Supervision Value 1</b> )
14	Output frequency limit 2 supervision	The output frequency is outside the set supervision low limit/high limit (see <b>Frequency Supervision Function 2</b> and <b>Speed Supervision Value 2</b> )
15	Torque limit supervision	The motor torque is beyond the set supervision low limit/high limit (see <b>Torque Supervision Function</b> and <b>Torque Supervision Value</b> )
16	Reference limit supervision	Active reference is beyond the set supervision low limit/high limit (see <b>Reference Supervision Limit</b> and <b>Reference Supervision Value</b> )
17	External brake control	External brake ON/OFF control with programmable delay (see <b>External Brake Off Delay</b> and <b>External Brake On Delay</b> )
18	Control from I/O terminals	In external control mode
19	Drive temperature limit supervision	Frequency converter heatsink temperature goes beyond the set supervision limits (see <b>Temperature Function Supervision</b> and <b>Temperature Supervision Value</b> )
20	Unrequested rotation direction	Motor rotation direction is different from the requested one.

April 2005

**Table 8-2: DO1 Function Settings, continued**

Signal		Signal Content
21	External brake control inverted	External brake ON/OFF control (see <b>External Brake Off Delay</b> and <b>External Brake On Delay</b> ); Output active when brake control is OFF
22	Thermistor fault or warning	The thermistor input of option board indicates overtemperature. Fault or warning depending on <b>Thermistor Fault Response</b>
23	Pass Through Communications	Output can be "forced" on via FLEdbus
24	Fire Mode	Fire Mode is active
25	Auto Control	In Auto Control mode
26	Hand Control	In Hand Control mode

**P1.3.7  
Relay Output 1  
(RO1) Function**

Range: 1 – 28

Default: 2 (Run)

*RO1 FUNCTION*

Relay output RO1 is activated when the selected setting is true. See **Table 8-3** for setting information.

**Table 8-3: RO1 Function Settings**

Setting		Signal Content
0	Not used	—
1	Ready	The HVX9000 is ready to operate
2	Run	The HVX9000 is operating (motor is running)
3	Fault	A fault trip has occurred
4	Fault inverted	A fault trip has not occurred
5	Drive overheat warning	The heat-sink temperature exceeds +70C
6	External fault or warning	Fault or warning depending on <b>External Fault</b>
7	Reference fault or warning	Fault or warning depending on <b>4 mA (Reference) Fault Response</b> — if analogue reference is 4 – 20 mA and signal is <4 mA
8	Warning	Always if a warning exists
9	Reversed	The reverse command has been selected
10	Bypass Run	Bypass has been selected
11	At speed	The output frequency has reached the set reference
12	Motor regulator activated	Overvoltage or overcurrent regulator was activated
13	Output frequency limit 1 supervision	The output frequency is outside the set supervision low limit/high limit (see <b>Frequency Supervision Function 1</b> and <b>Speed Supervision Value 1</b> )
14	Output frequency limit 2 supervision	The output frequency is outside the set supervision low limit/high limit (see <b>Frequency Supervision Function 2</b> and <b>Speed Supervision Value 2</b> )
15	Torque limit supervision	The motor torque is beyond the set supervision low limit/high limit (see <b>Torque Supervision Function</b> and <b>Torque Supervision Value</b> )

**Table 8-3: RO1 Function Settings, continued**

Setting	Signal Content
16	Reference limit supervision Active reference is beyond the set supervision low limit/high limit (see <b>Reference Supervision Limit</b> and <b>Reference Supervision Value</b> )
17	External brake control External brake ON/OFF control with programmable delay (see <b>External Brake Off Delay</b> and <b>External Brake On Delay</b> )
18	Control from I/O terminals In external control mode
19	Drive temperature limit supervision Frequency converter heatsink temperature goes beyond the set supervision limits (see <b>Temperature Function Supervision</b> and <b>Temperature Supervision Value</b> )
20	Unrequested rotation direction Motor rotation direction is different from the requested one
21	External brake control inverted External brake ON/OFF control (see <b>External Brake Off Delay</b> and <b>External Brake On Delay</b> ); Output active when brake control is OFF
22	Thermistor fault or warning The thermistor input of option board indicates overtemperature. Fault or warning depending on <b>Thermistor Fault Response</b>
23	Pass Through Communications Output can be "forced" on via Fieldbus
24	Fire Mode Fire Mode is active
25	Auto Control In Auto Control mode
26	Hand Control In Hand Control mode
27	Open Damper Opens damper previous to starting motor
28	Run Bypass or Drive Running in Bypass or Drive

**P1.3.8**  
**Relay Output 2**  
**(RO2) Function**

Range: 1 – 28

Default: 3 (Fault)

*RO2 FUNCTION*

Relay output RO2 is activated when the selected setting is true. See **Table 8-4** for setting information.

**Table 8-4: RO2 Function Settings**

Setting	Signal Content
0	Not used —
1	Ready The HVX9000 is ready to operate
2	Run The HVX9000 is operating (motor is running)
3	Fault A fault trip has occurred
4	Fault inverted A fault trip has not occurred
5	Drive overheat warning The heat-sink temperature exceeds +70C
6	External fault or warning Fault or warning depending on <b>External Fault</b>
7	Reference fault or warning Fault or warning depending on <b>4 mA (Reference) Fault Response</b> — if analogue reference is 4 – 20 mA and signal is <4 mA
8	Warning Always if a warning exists

April 2005

**Table 8-4: RO2 Function Settings, continued**

Setting		Signal Content
9	Reversed	The reverse command has been selected
10	Bypass Run	Bypass has been selected
11	At speed	The output frequency has reached the set reference
12	Motor regulator activated	Overvoltage or overcurrent regulator was activated
13	Output frequency limit 1 supervision	The output frequency is outside the set supervision low limit/high limit (see <b>Frequency Supervision Function 1</b> and <b>Speed Supervision Value 1</b> )
14	Output frequency limit 2 supervision	The output frequency is outside the set supervision low limit/high limit (see <b>Frequency Supervision Function 2</b> and <b>Speed Supervision Value 2</b> )
15	Torque limit supervision	The motor torque is beyond the set supervision low limit/high limit (see <b>Torque Supervision Function</b> and <b>Torque Supervision Value</b> )
16	Reference limit supervision	Active reference is beyond the set supervision low limit/high limit (see <b>Reference Supervision Limit</b> and <b>Reference Supervision Value</b> )
17	External brake control	External brake ON/OFF control with programmable delay (see <b>External Brake Off Delay</b> and <b>External Brake On Delay</b> )
18	Control from I/O terminals	External control mode
19	Drive temperature limit supervision	Frequency converter heatsink temperature goes beyond the set supervision limits (see <b>Temperature Function Supervision</b> and <b>Temperature Supervision Value</b> )
20	Unrequested rotation direction	Motor rotation direction is different from the requested one.
21	External brake control inverted	External brake ON/OFF control (see <b>External Brake Off Delay</b> and <b>External Brake On Delay</b> ); Output active when brake control is OFF
22	Thermistor fault or warning	The thermistor input of option board indicates overtemperature. Fault or warning depending on <b>Thermistor Fault Response</b>
23	Pass Through Communications	Output can be "forced" on via Fieldbus
24	Fire Mode	Fire Mode is active
25	Auto Control	In Auto Control mode
26	Hand Control	In Hand Control mode
27	Open Damper	Opens damper previous to starting motor
28	Run Bypass or Drive	Running in Bypass or Drive

**P1.3.9**  
**Relay Output 3**  
**(RO3) Content**

Range: 1 – 28

Default: 28 (Run Bypass or Drive)

*RO3 CONTENT*

Relay output RO3 is activated when the selected setting is true. See **Table 8-5** for setting information.

**Table 8-5: RO3 Content Settings**

Setting	Signal Content	
0	Not used	—
1	Ready	The HVX9000 is ready to operate
2	Run	The HVX9000 is operating (motor is running)
3	Fault	A fault trip has occurred
4	Fault inverted	A fault trip has not occurred
5	Drive overheat warning	The heat-sink temperature exceeds +70C
6	External fault or warning	Fault or warning depending on <b>External Fault</b>
7	Reference fault or warning	Fault or warning depending on <b>4 mA (Reference) Fault Response</b> — if analogue reference is 4 – 20 mA and signal is <4 mA
8	Warning	Always if a warning exists
9	Reversed	The reverse command has been selected
10	Bypass Run	Bypass has been selected
11	At speed	The output frequency has reached the set reference
12	Motor regulator activated	Overvoltage or overcurrent regulator was activated
13	Output frequency limit 1 supervision	The output frequency is outside the set supervision low limit/high limit (see <b>Frequency Supervision Function 1</b> and <b>Speed Supervision Value 1</b> )
14	Output frequency limit 2 supervision	The output frequency is outside the set supervision low limit/high limit (see <b>Frequency Supervision Function 2</b> and <b>Speed Supervision Value 2</b> )
15	Torque limit supervision	The motor torque is beyond the set supervision low limit/high limit (see <b>Torque Supervision Function</b> and <b>Torque Supervision Value</b> )
16	Reference limit supervision	Active reference is beyond the set supervision low limit/high limit (see <b>Reference Supervision Limit</b> and <b>Reference Supervision Value</b> )
17	External brake control	External brake ON/OFF control with programmable delay (see <b>External Brake Off Delay</b> and <b>External Brake On Delay</b> )
18	Control from I/O terminals	External control mode
19	Drive temperature limit supervision	Frequency converter heatsink temperature goes beyond the set supervision limits (see <b>Temperature Function Supervision</b> and <b>Temperature Supervision Value</b> )
20	Unrequested rotation direction	Motor rotation direction is different from the requested one.

April 2005

**Table 8-4: RO3 Content Settings, continued**

Setting		Signal Content
21	External brake control inverted	External brake ON/OFF control (see <b>External Brake Off Delay</b> and <b>External Brake On Delay</b> ); Output active when brake control is OFF
22	Thermistor fault or warning	The thermistor input of option board indicates overtemperature. Fault or warning depending on <b>Thermistor Fault Response</b>
23	Fault Reset	This output is activated when faults are reset
24	Fire Mode	Fire Mode is active
25	Auto Control	In Auto Control mode
26	Hand Control	In Hand Control mode
27	Open Damper	Opens damper previous to starting motor
28	Run Bypass or Drive	Running in Bypass or Drive

**P1.3.10 Relay Output 4 (RO4) Content**      Range: 1 – 28      Default: 10 (Bypass Run)  
*RO4 CONTENT*  
 Relay output RO4 is activated when the selected setting is true. See **Table 8-5** for setting information which is the same as RO3.

**P1.3.11 Relay Output 5 (RO5) Content**      Range: 1 – 28      Default: 23 (Fault Reset)  
*RO5 CONTENT*  
 Relay output RO5 is activated when the selected setting is true. See **Table 8-5** for setting information which is the same as RO3.

**P1.3.12 Relay Output 6 (RO6) Content**      Range: 1 – 28      Default: 0 (Not Used)  
*RO6 CONTENT*  
 Relay output RO6 is activated when the selected setting is true. See **Table 8-5** for setting information which is the same as RO3. This parameter is only available if optional relay board is added to slot D.

**P1.3.13 Relay Output 7 (RO7) Content**      Range: 1 – 28      Default: 0 (Not Used)  
*RO7 CONTENT*  
 Relay output RO7 is activated when the selected setting is true. See **Table 8-5** for setting information which is the same as RO3. This parameter is only available if optional relay board is added to slot D.

**P1.3.14 Relay Output 8 (RO8) Content**      Range: 1 – 28      Default: 0 (Not Used)  
*RO8 CONTENT*  
 Relay output RO8 is activated when the selected setting is true. See **Table 8-5** for setting information which is the same as RO3. This parameter is only available if optional relay board is added to slot D.

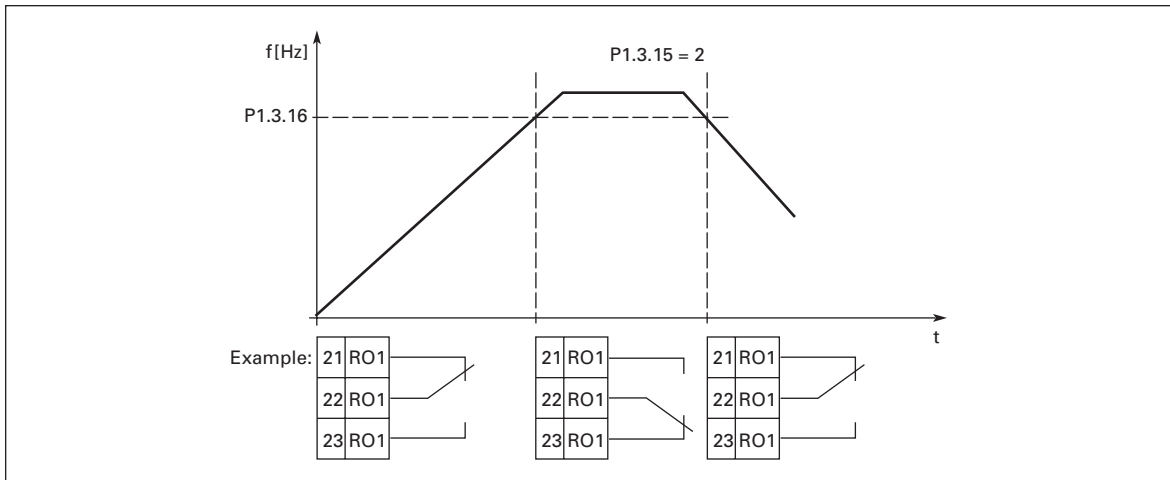
**Note:** P1.3.12 – P1.3.14 will be invisible unless there is an OPTB5 option board installed in slot D on drive.

**P1.3.15** Range: 0 – 2 Default: 0 (No Supervision)  
**Frequency Supervision Function 1**  
*FREQ SUPV FUNCTION 1*  
 If this parameter is set for 1 or 2, and the output frequency goes under/over **Frequency Supervision Function 1**, this function generates a warning message via digital output DO1 or via one of the relay outputs RO1 or RO2, dependent upon their settings.  
 0 No supervision  
 1 Low limit supervision  
 2 High limit supervision

**P1.3.16** Range: 0.0 – 200.0 Default: 0.0  
**Speed Supervision Value 1**  
*SPEEDSUPRVAL1*  
 Selects the frequency value supervised by **Frequency Supervision Function 1** parameter.

**P1.3.17** Range: 0 – 2 Default: 0 (No Supervision)  
**Frequency Supervision Function 2**  
*FREQ SUPV FUNCTION 2*  
 If this parameter is set for 1 or 2, and the output frequency goes under/over **Frequency Supervision Function 2**, this function generates a warning message via digital output DO1 or via one of the relay outputs RO1 or RO2, dependent upon their settings.  
 0 No supervision  
 1 Low limit supervision  
 2 High limit supervision

**P1.3.18** Range: 0.0 – 200.0 Default: 0.0  
**Speed Supervision Value 2**  
*SPEEDSUPRVAL 2*  
 Selects the frequency value supervised by **Frequency Supervision Function 2** parameter.



**Figure 8-8: Output Frequency Supervision**

April 2005

<b>P1.3.19</b> <b>Torque Supervision Function</b>	<p>Range: 0 – 2 <i>TORQUE SUPV FUNC</i></p> <p>If this parameter is set for 1 or 2 and the calculated torque value goes under/over the set limit (<b>Torque Supervision Value</b>) this function generates a warning message via digital output DO1 or via one of the relay outputs depending on the settings of <b>Digital Output 1 (DO1) Function</b>, <b>Relay Output 1 (RO1) Function</b> or <b>Relay Output 2 (RO2) Function</b>.</p> <p>0 No supervision 1 Low limit supervision 2 High limit supervision</p>	Default: 0 (No Supervision)
<b>P1.3.20</b> <b>Torque Supervision Value</b>	<p>Range: 0.0 – 300.0 Units: Percent <i>TORQUE SUPV VAL</i></p> <p>This parameter sets the torque value to be supervised by <b>Torque Supervision Function</b> parameter.</p>	Default: 100.0%
<b>P1.3.21</b> <b>Reference Supervision Limit</b>	<p>Range: 0 – 2 <i>REF SUPERV LIM</i></p> <p>If this parameter is set for 1 or 2 and the reference value goes under/over the set limit (<b>Reference Supervision Value</b>) this function generates a warning message via digital output DO1 or via one of the relay outputs depending on the settings of <b>Digital Output 1 (DO1) Function</b>, <b>Relay Output 1 (RO1) Function</b> or <b>Relay Output 2 (RO2) Function</b>. The current active reference is supervised. It may come from place A or B depending on the DIN6 input, from the keypad if keypad is the active control or from the communication bus if the communication bus is the active control.</p> <p>0 No supervision 1 Low limit supervision 2 High limit supervision</p>	Default: 0 (No Supervision)
<b>P1.3.22</b> <b>Reference Supervision Value</b>	<p>Range: 0.0 – 100.0 Units: Percent <i>REF SUPERV VAL</i></p> <p>This parameter sets the reference value to be supervised by <b>Reference Supervision Limit</b> parameter.</p>	Default: 0.0
<b>P1.3.23</b> <b>External Brake Off Delay</b>	<p>Range: 0.0 – 100.0 Units: Seconds <i>EXT BRAKE OFFDEL</i></p> <p>The activation of the external brake can be linked to the Start and Stop control signals with the <b>External Brake Off Delay</b> and <b>External Brake On Delay</b> parameters, which define the time for which the external brake remains in its previous position before reacting to the START/STOP signal. See <b>Figure 8-9</b>. To program the brake control signal, you can use either the digital output DO1 or the relay outputs RO1 and RO2, see <b>Digital Output 1 (DO1) Function</b>, <b>Relay Output 1 (RO1) Function</b> or <b>Relay Output 2 (RO2) Function</b>.</p>	Default: 0.5

**P1.3.24**  
**External Brake On Delay**

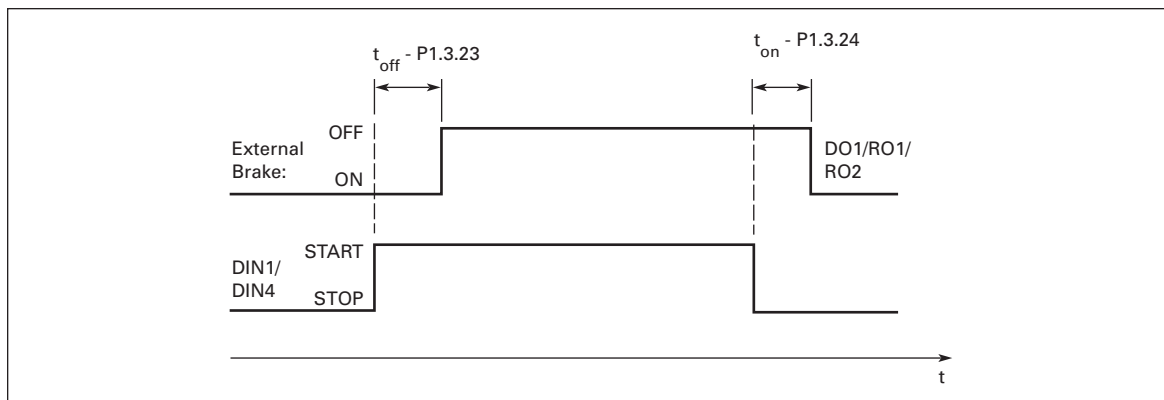
Range: 0.0 – 100.0

Units: Seconds

*EXT BRAKE ONDEL*

Default: 0.5

The activation of the external brake can be linked to the Start and Stop control signals with the **External Brake Off Delay** and **External Brake On Delay** parameters, which define the time for which the external brake remains in its previous position before reacting to the START/STOP signal. See **Figure 8-9**. To program the brake control signal, you can use either the digital output DO1 or the relay outputs RO1 and RO2, see **Digital Output 1 (DO1) Function**, **Relay Output 1 (RO1) Function** or **Relay Output 2 (RO2) Function**.



**Figure 8-9: External Brake Control**

**P1.3.25**  
**Temperature Function Supervision**

Range: 0 – 2

*TEMP FUNC SUPV*

Default: 0 (No Supervision)

If this parameter is set for 1 or 2 and the HVX9000 temperature goes under/over the set limit (**Temperature Supervision Value**), this function generates a warning message via digital output DO1 or the relay outputs depending on the settings of **Digital Output 1 (DO1) Function**, **Relay Output 1 (RO1) Function** or **Relay Output 2 (RO2) Function**.

- 0 No temperature limit supervision
- 1 Low limit supervision
- 2 High limit supervision

**P1.3.26**  
**Temperature Supervision Value**

Range: -10 – 75°C

Units: degrees Celsius

*TEMP SUPV VALUE*

Default: 40°C

This parameter sets the temperature that is supervised by **Temperature Function Supervision** parameter.

**P1.3.27**  
**Analog Output 2 (A2<sub>out</sub>) Signal**

Range: AnOUT:0.1 – AnOUT:E.10

*A2<sub>OUT</sub> SIGNAL*

Default: AnOUT:0.1

Connect the AO2 signal to the analog output of choice with this parameter.

April 2005

<p><b>P1.3.28</b> <b>Analog Output 2</b> <b>(A2<sub>out</sub>) Content</b></p>	<p>Range: 0 – 13 <i>A2<sub>OUT</sub> FUNCTION</i> This parameter selects the desired function for the analog output 2 signal.</p> <ul style="list-style-type: none"> <li>0 Not used</li> <li>1 Output frequency (0 – <math>f_{max}</math>)</li> <li>2 Frequency reference (0 – <math>f_{max}</math>)</li> <li>3 Motor speed (0 – Motor nominal speed)</li> <li>4 Output current (0 – <math>I_{nMotor}</math>)</li> <li>5 Motor torque (0 – <math>T_{nMotor}</math>)</li> <li>6 Motor power (0 – <math>P_{nMotor}</math>)</li> <li>7 Motor voltage (0 – <math>V_{nMotor}</math>)</li> <li>8 DC-link voltage (0 – 1000V)</li> <li>9 PID controller reference value</li> <li>10 PID controller actual value 1</li> <li>11 PID controller actual value 2</li> <li>12 PID controller error value</li> <li>13 PID controller output</li> </ul>	<p>Default: 4 (Output Current)</p>
<p><b>P1.3.29</b> <b>Analog Output 2</b> <b>(A2<sub>out</sub>) Filter Time</b></p>	<p>Range: 0.00 – 10.00 Units: Seconds <i>A2<sub>OUT</sub> FILTER TIME</i> When this parameter is given a value greater than 0, it activates the function that filters out disturbances from the analog output 2 signal. A long filtering time makes the output signal change slower. If you set a value of 0, no filtering takes place. See <b>Figure 8-5</b>.</p>	<p>Default: 1.00</p>
<p><b>P1.3.30</b> <b>Analog Output 2</b> <b>(A2<sub>out</sub>) Inversion</b></p>	<p>Range: 0 – 1 <i>A2<sub>OUT</sub> INVERT</i> Setting this parameter to 1, inverts the analog output 2 signal so that the maximum output occurs at the minimum value of the parameter selected in <b>Analog Output 2 (A2<sub>out</sub>) Content</b> and the minimum output occurs at the maximum value of the parameter selected in <b>Analog Output 2 (A2<sub>out</sub>) Content</b>. See <b>Figure 8-6</b>.</p> <ul style="list-style-type: none"> <li>0 Not inverted</li> <li>1 Inverted</li> </ul>	<p>Default: 0 (No Inversion)</p>
<p><b>P1.3.31</b> <b>Analog Output 2</b> <b>(A2<sub>out</sub>) Minimum</b></p>	<p>Range: 0 – 1 <i>A2<sub>OUT</sub> MINIMUM</i> Sets the signal minimum to either 0 mA or 4 mA.</p> <ul style="list-style-type: none"> <li>0 0 mA minimum</li> <li>1 4 mA minimum</li> </ul>	<p>Default: 1 (4 mA)</p>

**P1.3.32**  
**Analog Output 2**  
**(A2<sub>out</sub>) Scale**

Range: 0 – 1000  
Units: Percent  
*A2<sub>OUT</sub> SCALE*

Default: 100%

See **Figures 8-6** and **8-7** and **Table 8-6** for scaling information and examples.

**Table 8-6: Scaling Factor for the Analog Output**

Signal	Maximum Value of the Signal
Output Frequency	100 × f <sub>max</sub>
Motor speed	100% × Motor nominal speed
Output current	100% × I <sub>nMotor</sub>
Motor torque	100% × T <sub>nMotor</sub>
Motor power	100% × P <sub>nMotor</sub>
Motor voltage	100% × V <sub>nmotor</sub>
DC-link voltage	1000 V
PI-ref. value	100% × ref. value max.
PI act. value 1	100% × actual value max.
PI act. value 2	100% × actual value max.
PI error value	100% × error value max.
PI output	100% × output max
See <b>Analog Output (A<sub>out</sub>) Scale</b> .	

**P1.3.33**  
**Analog Output 3**  
**(A3<sub>out</sub>) Signal**

Range: AnOUT:0.1 – AnOUT:E.10  
*A3<sub>OUT</sub> SIGNAL*

Default: AnOUT:0.1

Connect the AO3 signal to the analog output of choice with this parameter.

**P1.3.34**  
**Analog Output 3**  
**(A3<sub>out</sub>) Content**

Range: 0 – 13  
*A3<sub>OUT</sub> FUNCTION*

Default: 0 (Not used)

This parameter selects the desired function for the analog output 3 signal.

- 0 Not used
- 1 Output frequency (0 – f<sub>max</sub>)
- 2 Frequency reference (0 – f<sub>max</sub>)
- 3 Motor speed (0 – Motor nominal speed)
- 4 Output current (0 – I<sub>nMotor</sub>)
- 5 Motor torque (0 – T<sub>nMotor</sub>)
- 6 Motor power (0 – P<sub>nMotor</sub>)
- 7 Motor voltage (0 – V<sub>nMotor</sub>)
- 8 DC-link voltage (0 – 1000V)
- 9 PID controller reference value
- 10 PID controller actual value 1
- 11 PID controller actual value 2
- 12 PID controller error value
- 13 PID controller output

**P1.3.35**  
**Analog Output 3**  
**(A3<sub>out</sub>) Filter Time**

Range: 0.00 – 10.00  
Units: Seconds  
*A3<sub>OUT</sub> FILTER TIME*

Default: 1.00

When this parameter is given a value greater than 0, it activates the function that filters out disturbances from the analog output 3 signal. A long filtering time makes the output signal change slower. If you set a value of 0, no filtering takes place. See **Figure 8-5**.

April 2005

**P1.3.36** Range: 0 – 1 Default: 0 (No Inversion)  
**Analog Output 3 (A3<sub>out</sub>) Inversion**  
*A3OUT INVERT*  
 Setting this parameter to 1, inverts the analog output 3 signal so that the maximum output occurs at the minimum value of the parameter selected in **Analog Output 3 (A3<sub>out</sub>) Content** and the minimum output occurs at the maximum value of the parameter selected in **Analog Output 3 (A3<sub>out</sub>) Content**. See **Figure 8-6**.  
 0 Not inverted  
 1 Inverted

**P1.3.37** Range: 0 – 1 Default: 0 (0 mA)  
**Analog Output 3 (A3<sub>out</sub>) Minimum**  
*A3OUT MINIMUM*  
 Sets the signal minimum to either 0 mA or 4 mA.  
 0 0 mA minimum  
 1 4 mA minimum

**P1.3.38** Range: 0 – 1000 Default: 100%  
**Analog Output 3 (A3<sub>out</sub>) Scale**  
*A3OUT SCALE*  
 See **Figures 8-6** and **8-7** and **Table 8-7** for scaling information and examples.

**Table 8-7: Scaling Factor for the Analog Output**

Signal	Maximum Value of the Signal
Output Frequency	100 x f <sub>max</sub>
Motor speed	100% x Motor nominal speed
Output current	100% x I <sub>nMotor</sub>
Motor torque	100% x T <sub>nMotor</sub>
Motor power	100% x P <sub>nMotor</sub>
Motor voltage	100% x V <sub>nmotor</sub>
DC-link voltage	1000 V
PI-ref. value	100% x ref. value max.
PI act. value 1	100% x actual value max.
PI act. value 2	100% x actual value max.
PI error value	100% x error value max.
PI output	100% x output max
See <b>Analog Output (A<sub>out</sub>) Scale</b> .	

**Parameter Group G1.4: Drive Control**

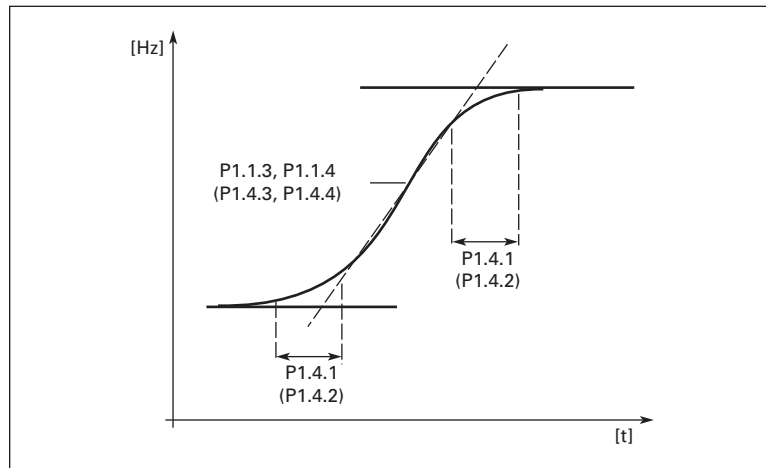
**P1.4.1** Range: 0.0 – 10.0 Default: 0.0  
**Ramp 1 Shape**  
*RAMP 1 SHAPE*  
 The start and end of the acceleration and deceleration ramps can be smoothed with this parameter. Setting the value to 0 gives a linear ramp shape, which causes acceleration and deceleration to act immediately to the changes in the reference signal. Setting a value of 0.1 to 10 seconds produces an S-shaped acceleration/deceleration curve. The ramp times are determined by **Acceleration Time 1** and **Deceleration Time 1**. See **Figure 8-10**.  
 0 Linear  
 >0 S-curve acceleration/deceleration ratio

**P1.4.2 Ramp 2 Shape** Range: 0.0 – 10.0 Units: Seconds Default: 0.0

*RAMP 2 SHAPE*

The start and end of acceleration and deceleration ramps can be smoothed with these parameters. Setting value 0 gives a linear ramp shape, which causes acceleration and deceleration to act immediately to the changes in the reference signal. Setting value 0.1 to 10 seconds for this parameter produces an S-shaped acceleration/deceleration. The acceleration time is determined with **Acceleration Time 1/Deceleration Time 1 (Acceleration Time 2/Deceleration Time 2)**. See **Figure 8-10**.

- 0 Linear
- >0 S-curve acceleration/deceleration ratio



**Figure 8-10: Acceleration/Deceleration Curve (S-Shaped)**

**P1.4.3 Acceleration Time 2** Range: 0.1 – 3000.0 Units: Seconds Default: 10.0

*ACCEL TIME 2*

Time required for output frequency to change from the minimum frequency to the maximum frequency set by **Minimum Frequency** and **Maximum Frequency**. With the use of **Acceleration Time 1** and **Acceleration Time 2**, two different acceleration times can be used for an application. The active set can be selected with one of the programmable digital inputs DIN2, DIN3, DIN4, DIN5 or DIN6 (**DIN2 Function**, **DIN3 Function**, **DIN4 Function**, **DIN5 Function**, and **DIN6 Function**).

**Note:** If the PID-controller is used, the acceleration/deceleration time set 2 is automatically selected as the active set.

**P1.4.4 Deceleration Time 2** Range: 0.1 – 3000.0 Units: Seconds Default: 10.0

*DECEL TIME 2*

Time required for output frequency to change from the maximum frequency to the minimum frequency set by **Minimum Frequency** and **Maximum Frequency**. With the use of **Deceleration Time 1** and **Deceleration Time 2**, two different deceleration times can be used for an application. The active set can be selected with one of the programmable digital inputs DIN2, DIN3, DIN4, DIN5 or DIN6 (**DIN2 Function**, **DIN3 Function**, **DIN4 Function**, **DIN5 Function**, and **DIN6 Function**).

**Note:** If the PID-controller is used, the acceleration/deceleration time set 2 is automatically selected as the active set.

April 2005

<b>P1.4.5</b> <b>Brake Chopper</b>	Range: 0 – 3 <i>BRAKE CHOPPER</i> When the HVX9000 is decelerating the motor, the energy stored in the inertia of the motor and the load are fed into an external brake resistor. This enables the HVX9000 to decelerate the load with a torque equal to that of acceleration (provided that the correct brake resistor has been selected). See separate brake resistor installation manual. 0 Brake chopper not used 1 Brake chopper in use 2 External brake chopper 3 In Ready state	Default: 0 (Not Used)
<b>P1.4.6</b> <b>Start Mode</b>	Range: 0 – 1 <i>START MODE</i> 0 Ramp: The HVX9000 starts from 0 Hz and accelerates to the set reference frequency within the set acceleration time. (Load inertia or starting friction may cause prolonged acceleration times.) 1 Flying start: The HVX9000 is able to start into a spinning motor by applying a small torque to motor and searching for the frequency corresponding to the speed the motor is spinning at. The searching starts from the maximum frequency towards the spinning equivalent frequency until the correct value is detected. Thereafter, the output frequency will be increased/ decreased to the set reference value following the set acceleration/ deceleration parameters. Use this mode if the motor may be spinning when the start command is given. With the flying start, it is possible to ride through short utility voltage interruptions.	Default: 0 (Ramping)
<b>P1.4.7</b> <b>Stop Mode</b>	Range: 0 – 3 <i>STOP MODE</i> 0 Coasting: The motor coasts to a halt without control from the HVX9000 after the Stop command. 1 Ramp: After the Stop command, the speed of the motor is reduced according to the set deceleration parameters. If the regenerated energy is high it may be necessary to use an external braking resistor for faster deceleration. 2 Normal = Ramp/Run Enable: coasting After the Stop command, the speed of the motor is decelerated according to the set deceleration parameters. However, when the Run Enable signal is de-energized using one of the digital inputs (e.g. DIN3), the motor coasts to a halt without control from the drive. 3 Normal stop = Coasting/Run Enable: ramping The motor coasts to a halt without any control from the drive. However, when Run Enable signal is de-energized using one of the digital inputs (e.g. DIN3), the speed of the motor is decelerated according to the set deceleration parameters. If the regenerated energy is high it may be necessary to use an external braking resistor for faster deceleration.	Default: 1 (Ramp)
<b>P1.4.8</b> <b>DC Brake Current</b>	Range: $0.15 \times I_{nHVX} - 1.5 \times I_{nHVX}$ Units: Amperes <i>DC-BRAKE CURRENT</i> This parameter's range and default value are determined by the HVX9000 nameplate current rating. It defines the current injected into the motor during DC-braking.	Default: $0.5 \times I_{nHVX}$

**P1.4.9**  
**DC Brake Time at Stop**

Range: 0.000 – 60.000

Default: 0.000

Units: Seconds

*STOP DC-BRAKETIME*

Determines if braking is ON or OFF and the on time of the DC-brake when the motor is stopping. The function of the DC-brake depends on the **Stop Mode**.

0 DC-brake is not used

>0 DC-brake is in use and its function depends on **Stop Mode**.

The DC-braking time is determined with this parameter.

**Stop Mode = 0 (Coasting):**

After the stop command, the motor coasts to a stop without control from the drive.

With the DC injection, the motor can be electrically stopped in the shortest possible time, without using an optional external braking resistor.

The braking time is scaled by the frequency when the DC-braking starts. If the frequency is greater than the nominal frequency of the motor, this set value determines the braking time. When the frequency is  $\leq 10\%$  of the nominal, the braking time is 10% of this set value. See **Figure 8-11**.

**Stop Mode = 1 (Ramp):**

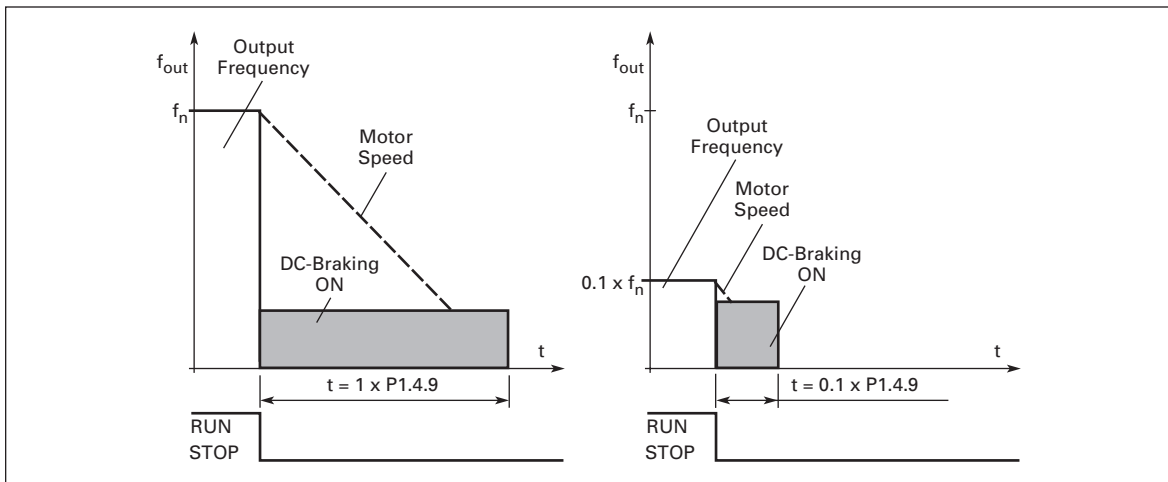
After the Stop command, the speed of the motor is reduced according to the set deceleration parameters, as fast as possible, to the speed defined with **DC Brake Frequency In Ramp Stop**, where the DC-braking starts. The braking time is defined with this parameter. If high inertia exists, it is recommended to use an external braking resistor for faster deceleration. See **Figure 8-12**.

**Stop Mode = 2 (Normal = Ramping/Run Enable = Coasting):**

Follows the Coasting or Stopping action described above, dependent upon the status of the Run Enable input.

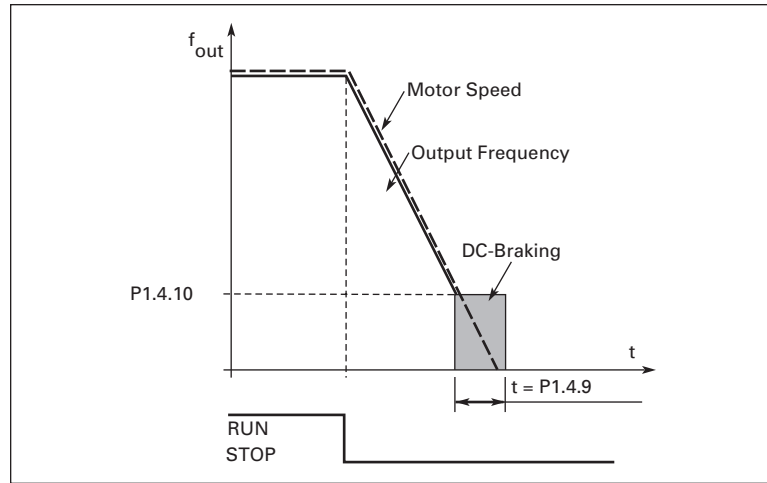
**Stop Mode = 3 (Normal = Coasting/Run Enable = Ramping):**

Follows the Coasting or Stopping action described above, dependent upon the status of the Run Enable input.



**Figure 8-11: DC Braking Time When Stop Mode = Coasting**

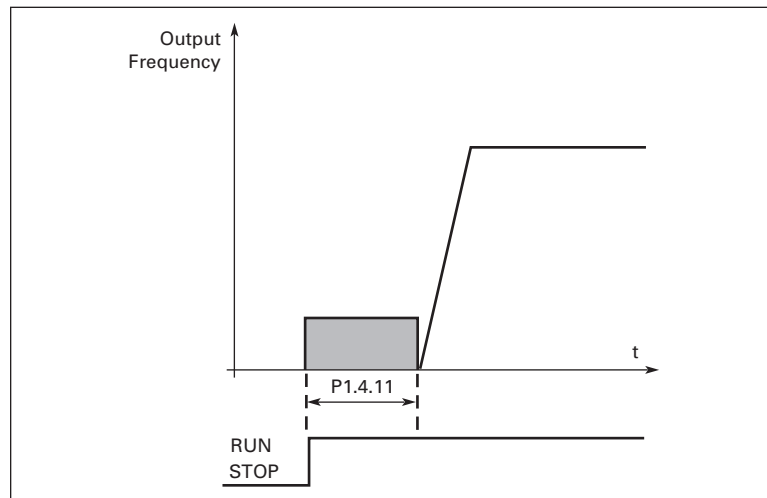
April 2005



**Figure 8-12: DC Braking Time When Stop Mode = Ramp**

**P1.4.10 DC Brake Frequency In Ramp Stop** Range: 0.10 – 10.00 Default: 1.50  
 Units: Hertz  
*STOP DC-BRAKEFR*  
 The output frequency at which the DC-braking is applied. See **Figure 8-13**.

**P1.4.11 Start DC Brake Time** Range: 0.000 – 60.000 Default: 0.000  
 Units: Seconds  
*START DC-BRAKETM*  
 DC-brake is activated when the start command is given. This parameter defines the time before the brake is de-energized. After the brake is de-energized, the output frequency increases according to the set start function by **Start Mode** parameter. See **Figure 8-13**.



**Figure 8-13: DC Braking Time at Start**

**P1.4.12 Flux Brake** Range: 0 – 1 Default: 0 (Off)  
*FLUX BRAKE*  
 Braking torque is created by controlling the motor flux.  
 0 Flux braking OFF  
 1 Flux braking ON

<b>P1.4.13</b> <b>Flux Brake Current</b>	Range: $0.1 \times I_{nMotor}$ – <b>Current Limit</b> Units: Amperes <i>FLUXBRAKECURRENT</i> Defines the flux braking current value. It can be set between $0.1 \times I_{nMot}$ <b>Motor Power Factor</b> and the <b>Current Limit</b> setting.	Default: $0.5 \times I_{nMotor}$
---	---	----------------------------------

### Parameter Group G1.5: Skip Frequencies

<b>P1.5.1</b> <b>Skip Frequency 1 Low Limit</b>	Range: $0.00$ – <b>Skip Frequency 1 High Limit</b> Units: Hertz <i>SKIPF 1 LOW LIM</i> In some systems it may be necessary to avoid certain frequencies because of mechanical resonances. Using <b>Skip Frequency 1 Low Limit</b> to <b>Skip Frequency 3 High Limit</b> parameters, it is possible to set limits for the “skip frequency” region. See <b>Figure 8-14</b> .	Default: $0.00$
<b>P1.5.2</b> <b>Skip Frequency 1 High Limit</b>	Range: <b>Skip Frequency 1 Low Limit</b> – Max Frequency Units: Hertz <i>SKIPF 1 HIGH LIM</i> In some systems it may be necessary to avoid certain frequencies because of mechanical resonances. Using <b>Skip Frequency 1 Low Limit</b> to <b>Skip Frequency 3 High Limit</b> parameters, it is possible to set limits for the “skip frequency” region. See <b>Figure 8-14</b> . 0 No skip frequency range 1	Default: $0.00$
<b>P1.5.3</b> <b>Skip Frequency 2 Low Limit</b>	Range: $0.00$ – <b>Skip Frequency 2 High Limit</b> Units: Hertz <i>SKIPF 2 LOW LIM</i> In some systems it may be necessary to avoid certain frequencies because of mechanical resonances. Using <b>Skip Frequency 1 Low Limit</b> to <b>Skip Frequency 3 High Limit</b> parameters, it is possible to set limits for the “skip frequency” region. See <b>Figure 8-14</b> .	Default: $0.00$
<b>P1.5.4</b> <b>Skip Frequency 2 High Limit</b>	Range: <b>Skip Frequency 2 Low Limit</b> – Max Frequency Units: Hertz <i>SKIPF 2 HIGH LIM</i> In some systems it may be necessary to avoid certain frequencies because of mechanical resonances. Using <b>Skip Frequency 1 Low Limit</b> to <b>Skip Frequency 3 High Limit</b> parameters, it is possible to set limits for the “skip frequency” region. See <b>Figure 8-14</b> . 0 No skip frequency range 2	Default: $0.00$
<b>P1.5.5</b> <b>Skip Frequency 3 Low Limit</b>	Range: $0$ – <b>Skip Frequency 3 High Limit</b> Units: Hertz <i>SKIPF 3 LOW LIM</i> In some systems it may be necessary to avoid certain frequencies because of mechanical resonances. Using <b>Skip Frequency 1 Low Limit</b> to <b>Skip Frequency 3 High Limit</b> parameters, it is possible to set limits for the “skip frequency” region. See <b>Figure 8-14</b> .	Default: $0.00$

April 2005

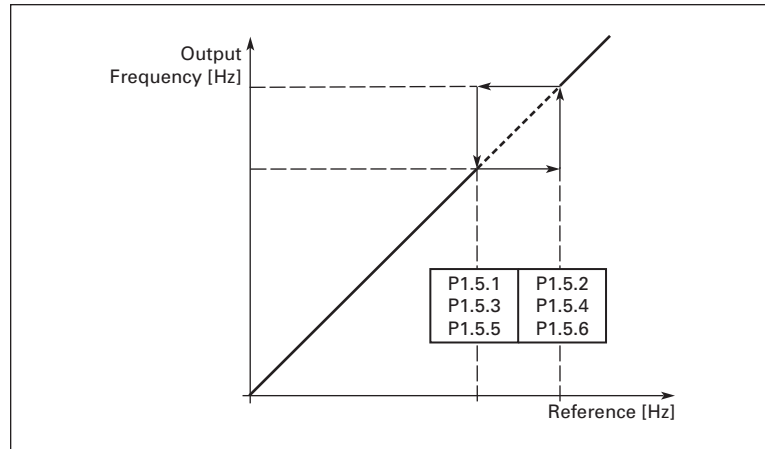
**P1.5.6**  
**Skip Frequency 3**  
**High Limit**

Range: **Skip Frequency 3 Low Limit** – Default: 0.00  
Max Frequency  
Units: Hertz

*SKIPF 3 HIGH LIM*

In some systems it may be necessary to avoid certain frequencies because of mechanical resonances. Using **Skip Frequency 1 Low Limit** to **Skip Frequency 3 High Limit** parameters, it is possible to set limits for the “skip frequency” region. See **Figure 8-14**.

0 No skip frequency range 3



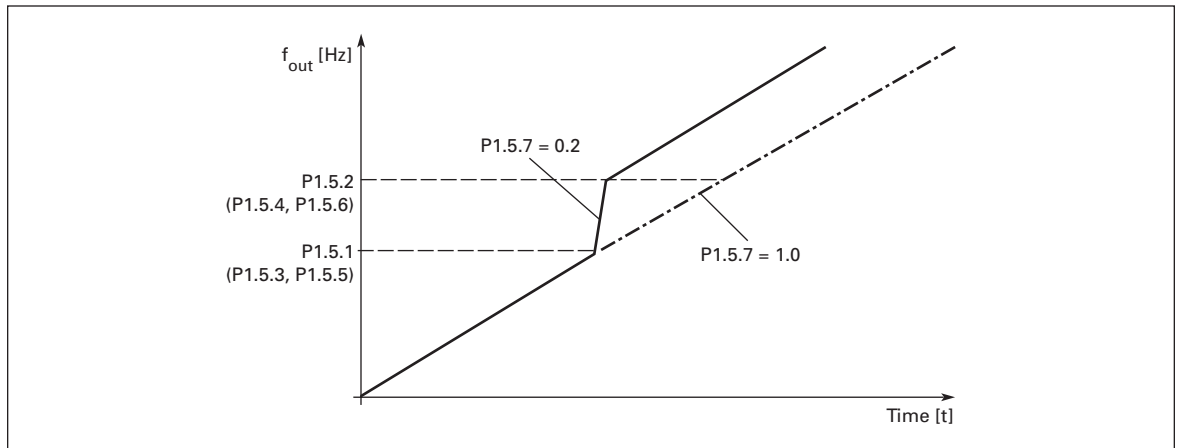
**Figure 8-14: Skip Frequency Area Setting**

**P1.5.7**  
**PH Acceleration/**  
**Deceleration Ramp**

Range: 0.1 – 10.0 Default: 1.0

*PH ACC/DEC RAMP*

Defines the acceleration/deceleration time when the output frequency is between the selected skip frequency range limits. The ramping speed (selected acceleration/deceleration time 1 or 2) is multiplied with this factor. E.g. value 0.1 makes the acceleration time 10 times shorter than outside the skip frequency range limits.



**Figure 8-15: Ramp Speed Scaling Between Skip Frequencies**

**Parameter Group G1.6: Motor Control**

<b>P1.6.1</b> <b>Motor Control Mode</b>	Range: 0 – 1 <i>MOTOR CTRL MODE</i>	Default: 0 (Frequency control)
	This parameter determines the mode the drive is using to control the motor. The reference may be from the I/O terminals, keypad or the communication bus.	
	0 Frequency control: The HVX9000 is controlling the output frequency (output frequency resolution = 0.01 Hz).	
	1 Speed control: The HVX9000 is controlling the motor speed compensating for the motor slip (accuracy $\pm 0.5\%$ ).	
<b>P1.6.2</b> <b>Voltage/Frequency Optimization</b>	Range: 0 – 1 <i>V/Hz OPTIMIZATION</i>	Default: 0 (None)
	0 None	
	1 Automatic torque boost	
	This parameter determines if automatic torque boost is used. With automatic torque boost the voltage to the motor changes automatically which allows the motor produce sufficient torque to start and run at low frequencies. The voltage increase depends on the motor type and power. Automatic torque boost can be used in applications where the starting torque required due to high starting friction is large, e.g. in conveyors.	
	EXAMPLE: What is required to start the load from 0 Hz?	
	- First set the motor nominal values ( <b>Motor Nominal Current</b> to <b>Current Limit</b> ).	
	- Second choose the <b>Motor Control Mode</b> .	
	- Third choose the Voltage Control Mode.	
	<b>Option 1:</b> Activate the automatic torque boost ( <b>Voltage/Frequency Optimization</b> value 1)	
	<b>Option 2:</b> Programmable V/f curve	
	To get torque you need to set the zero point voltage and midpoint voltage/frequency so the motor has enough current at low frequencies. First select the programmable V/F-curve ( <b>Voltage/Frequency Ratio Selection</b> value 2). Increase <b>Zero Frequency Voltage</b> to get enough current at zero speed. Then set the <b>V/f Mid-Point Voltage</b> to $1.4142 \times \text{Zero Frequency Voltage}$ and the <b>V/f Mid-Point Frequency</b> to a value of $\text{V/f Mid-Point Voltage} / 100\% \times \text{Motor Nominal Frequency}$ .	
	<b>Note:</b> In high torque — low speed applications — it is likely that the motor will overheat.	
	If the motor has to run a prolonged time under these conditions, special attention must be paid to cooling the motor. Use external cooling for the motor if the temperature tends to rise too high.	

April 2005

**P1.6.3  
Voltage/Frequency  
Ratio Selection**

Range: 0 – 3

Default: 0 (Linear)

*V/Hz RATIO SELECT*

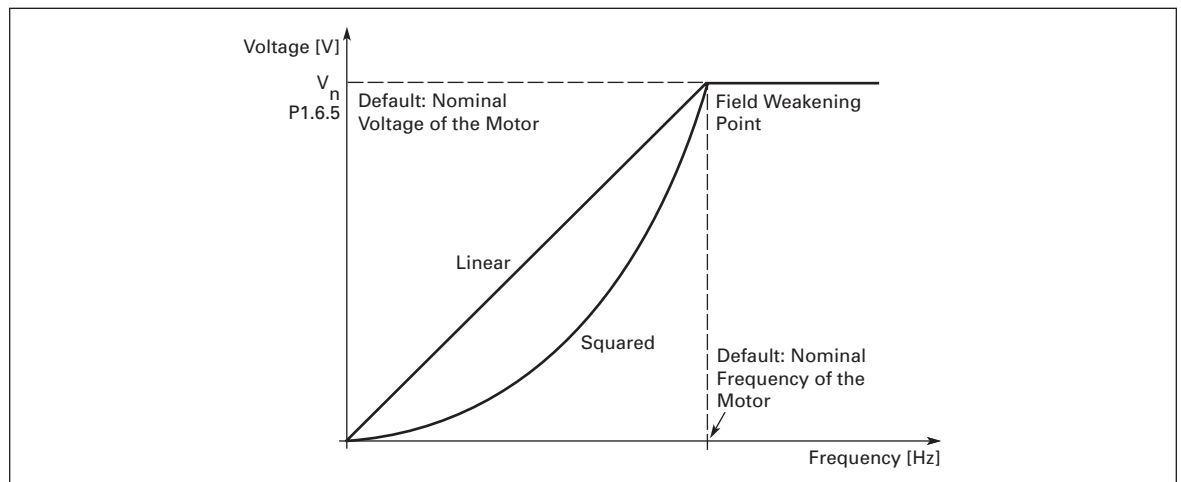
0 Linear: The voltage of the motor changes linearly with the frequency in the constant flux area from 0 Hz to the field weakening point where the nominal voltage is supplied to the motor. Linear V/f ratio should be used in constant torque applications. See **Figure 8-16**.

**This default setting should be used if there is no special need for another setting.**

1 Squared: The voltage of the motor changes following a squared curve waveform with the frequency in the area from 0 Hz to the field weakening point where the nominal voltage is supplied to the motor. The motor runs under-magnetized below the field weakening point and produces less torque and electromechanical noise. Squared V/f ratio can be used in applications where torque demand of the load is proportional to the square of the speed, e.g in centrifugal fans and pumps.

2 Programmable V/f curve: The V/f curve can be programmed with three different points. Programmable V/f curve can be used if the other settings do not satisfy the needs of the application. See **Figure 8-17**.

3 Linear with flux optimization: The HVX9000 searches for the minimum motor current in order to save energy, and to lower the audible motor noise. This can be used in applications with stable, low peak level motor load, such as fans, pumps, etc.



**Figure 8-16: Linear and Squared Change of Motor Voltage**

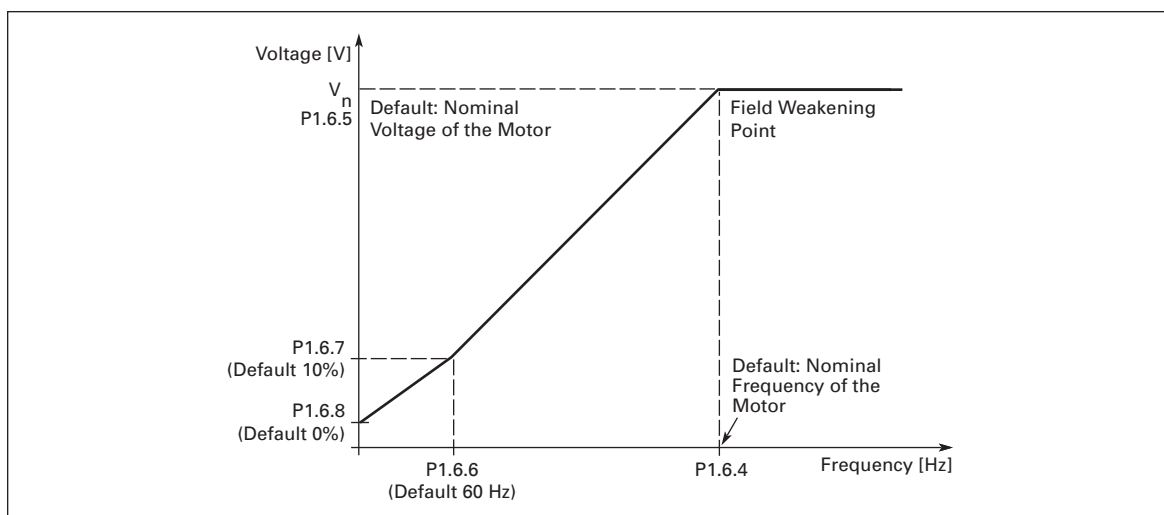


Figure 8-17: Programmable V/f Ratio

- |   |  |                 |
|---|--|-----------------|
| <b>P1.6.4</b><br><b>Field Weakening Point</b>   | Range: 30.00 – 320.00<br>Units: Hertz<br><i>FIELD WEAKNINGPNT</i>                  | Default: 60.00  |
| The field weakening point is the output frequency at which the output voltage reaches the set maximum value. This usually corresponds to the motor nameplate frequency.   |  |                 |
| <b>P1.6.5</b><br><b>Voltage at Field Weakening Point</b>  | Range: 10.00 – 200.00<br>Units: Percent<br><i>VOLTAGE AT FWP</i>                   | Default: 100.00 |
| Above the frequency at the field weakening point, the output voltage remains at the set maximum value. Below the frequency at the field weakening point, the output voltage depends on the setting of the V/f curve parameters. See <b>Voltage/Frequency Optimization, Voltage/Frequency Ratio Selection, V/f Mid-Point Frequency</b> and <b>V/f Mid-Point Voltage</b> and <b>Figure 8-17</b> .                         |  |                 |
| When the <b>Motor Nominal Voltage</b> and <b>Motor Nominal Frequency</b> are set, the <b>Field Weakening Point</b> and <b>Voltage at Field Weakening Point</b> are automatically given the corresponding values. If you need different values for the field weakening point and the maximum output voltage, change these parameters after setting the <b>Motor Nominal Voltage</b> and <b>Motor Nominal Frequency</b> . |  |                 |
| <b>P1.6.6</b><br><b>V/f Mid-Point Frequency</b>   | Range: 0.00 – <b>Field Weakening Point</b><br>Units: Hertz<br><i>V/Hz MID FREQ</i> | Default: 60.00  |
| If the programmable V/f curve has been selected with <b>Voltage/Frequency Ratio Selection</b> this parameter defines the middle point frequency of the curve. See <b>Figure 8-17</b> .  |  |                 |
| <b>P1.6.7</b><br><b>V/f Mid-Point Voltage</b>   | Range: 0.00 – 100.00<br>Units: Percent<br><i>V/Hz MID VOLTG</i>                    | Default: 100.00 |
| If the programmable V/f curve has been selected with the <b>Voltage/Frequency Ratio Selection</b> this parameter defines the middle point voltage of the curve. See <b>Figure 8-17</b> .  |  |                 |

April 2005

<b>P1.6.8</b> <b>Zero Frequency Voltage</b>	Range: 0.00 – 40.00 Units: Percent <i>ZERO FREQ VOLTG</i> If the programmable V/f curve has been selected with the <b>Voltage/Frequency Ratio Selection</b> this parameter defines the zero frequency voltage of the curve. See <b>Figure 8-17</b> .	Default: 1.50
<b>P1.6.9</b> <b>Switching Frequency</b>	Range: 1.0 – 16.0 Units: kiloHertz <i>SWITCHING FREQ</i> Motor noise can be minimized using a high switching frequency. Increasing the switching frequency reduces the capacity of the HVX9000.	Default: Model dependent
<b>P1.6.10</b> <b>Overvoltage Controller</b>	Range: 0 – 1 <i>OVERVOLT CONTR</i> 0 Overvoltage control switched off 1 Overvoltage control switched on With the overvoltage control switched on, if the utility supply voltage rises, the output frequency will increase to maintain a constant motor V/f relation. This may be useful, for example, if the utility supply voltage varies more than +10% and the motor cannot tolerate this overvoltage. In some applications the motor is required to operate at the desired set speed, regardless of supply line voltage variations. In this situation, the overvoltage control is switched off, the frequency will not increase as the utility supply voltage increases. This could lead to overexciting the motor, resulting in a large increase in motor current during overvoltage conditions. <b>Note:</b> Overvoltage trips may occur when the control is switched out of operation.	Default: 1 (Switched On)
<b>P1.6.11</b> <b>Undervoltage Controller</b>	Range: 0 – 1 <i>UNDERVOLT CONTR</i> 0 Disabled 1 Enabled With the undervoltage control switched on, if the utility supply voltage declines, the output frequency will decrease to maintain a constant motor V/f relation. This may be useful, for example, if the utility supply voltage varies more than -15% and the motor cannot tolerate this undervoltage. In some applications the motor is required to operate at the desired set speed, regardless of supply line voltage variations. In this situation, the undervoltage control is switched off, the frequency will not decrease as the utility supply voltage decreases. This could lead to under exciting the motor, resulting in a large increase in motor current during undervoltage conditions. <b>Note:</b> Undervoltage trips may occur when controllers are switched out of operation.	Default: 1 (Enabled)

**Parameter Group G1.7: Protections**

<b>P1.7.1</b> <b>4 mA (Reference) Fault Response</b>	Range: 0 – 5 <i>4MA FAULT RESP</i>	Default: 0 (No Response)
	A warning or a fault action and message is generated if the reference signal (P1.2.9, P1.2.14 or P1.2.25) is set to "1" (4 – 20 mA) and the signal falls below 3.5 mA for 5 seconds or below 0.5 mA for 0.5 seconds. The information can also be programmed into digital output DO1 or relay outputs RO1, RO2 or RO3.	
	0 No response 1 Warning 2 Warning, frequency applied 10s earlier is set as reference 3 Warning, the <b>4 mA Fault Frequency</b> is set as reference 4 Fault, stop mode after fault according to <b>Stop Mode</b> 5 Fault, stop mode after fault always by coasting	
<b>P1.7.2</b> <b>4 mA Fault Frequency</b>	Range: 0.00 – <b>Maximum Frequency</b> Units: Hertz <i>4MA FAULT FREQ</i>	Default: 0.00
	If the value of <b>4 mA (Reference) Fault Response</b> (above) is set to 3 and the 4 mA fault occurs, then the frequency reference to the motor is the value of this parameter.	
<b>P1.7.3</b> <b>External Fault</b>	Range: 0 – 3 <i>EXTERNAL FAULT</i>	Default: 2 (Fault)
	A warning or a fault action and message is generated from the external fault signal in the programmable digital inputs DIN2, DIN3, DIN4, DIN5 or DIN6. The information can also be programmed into digital output DO1 or programmed into digital output DO1, and RO2 or RO3.	
	0 No response 1 Warning 2 Fault, stop mode after fault according to <b>Stop Mode</b> 3 Fault, stop mode after fault always by coasting	
<b>P1.7.4</b> <b>Input Phase Supervision</b>	Range: 0 – 3 <i>INPUT PHASE SUPV</i>	Default: 0 (No Response)
	The input phase supervision monitors that the input phases of the HVX9000 have approximately equal currents. If not, the response programmed by this parameter occurs.	
	0 No response 1 Warning 2 Fault, stop mode after fault according to <b>Stop Mode</b> 3 Fault, stop mode after fault always by coasting	
<b>P1.7.5</b> <b>Undervoltage Fault Response</b>	Range: 0 – 1 <i>UVOLT FAULT RESP</i>	Default: 0 (Fault Stored)
	0 Fault Stored 1 No History	
	<b>Note:</b> This protection can not be inactivated.	

April 2005

<b>P1.7.6</b>	Range: 0 – 3	Default: 2 (Fault)
<b>Output Phase Supervision</b>	<i>OUTPUTPH SUPERV</i>	
	Output phase supervision monitors that the motor phases have approximately equal currents. If not, the response programmed by this parameter occurs.	
	0 No response	
	1 Warning	
	2 Fault, stop mode after fault according to <b>Stop Mode</b>	
	3 Fault, stop mode after fault always by coasting	

<b>P1.7.7</b>	Range: 0 – 3	Default: 2 (Fault)
<b>Earth (Ground) Fault</b>	<i>GROUND FAULT</i>	
	Ground fault protection monitors the sum of the motor phase currents which is zero if there is no ground fault. In addition, the overcurrent protection function is always operational to protect the HVX9000 from ground faults with high current levels.	
	0 No response	
	1 Warning	
	2 Fault, stop mode after fault according to <b>Stop Mode</b>	
	3 Fault, stop mode after fault always by coasting	

### Motor Thermal Protection General Information

The motor thermal protection is to protect the motor from overheating. The HVX9000 is capable of supplying higher than nominal current to the motor. If the load requires this high current there is a risk that the motor will be thermally overloaded. In addition, at low frequencies the cooling effect of the integral motor fan is reduced as well as is the motor's torque capacity. If the motor is equipped with an external fan the load reduction at low speeds is small.

The motor thermal protection is based on a calculated model and it uses the output frequency and current of the HVX9000 to determine the load on the motor.

The motor thermal protection can be adjusted with parameters **Motor Ambient Temperature Factor**, **Motor Thermal Protection Zero Speed** and **MTP Time Constant**.

---

### CAUTION

---

The calculated model does not protect the motor if the airflow to the motor is reduced by blocked air intake grill or if the external cooling device is off or fails.

<b>P1.7.8</b>	Range: 0 – 3	Default: 2 (Fault)
<b>Motor Thermal Protection</b>	<i>MOTOR THERM PROT</i>	
	0 No response	
	1 Warning	
	2 Fault, stop mode after fault according to <b>Stop Mode</b>	
	3 Fault, stop mode after fault always by coasting	
	Deactivating the protection, by setting this parameter to 0, will reset the thermal stage of the motor to 0%.	
<b>P1.7.9</b>	Range: -100.0 – 100.00	Default: 0.0
<b>Motor Ambient Temperature Factor</b>	Units: Percent <i>NOTAMBTEMPFACTOR</i>	
	When the motor ambient temperature must be taken into consideration, it is recommended to set a value for this parameter. The value of the factor can be set between -100.0% and 100.0% where -100.0% corresponds to °C and 100.0% to the maximum running temperature of the motor. Setting this parameter value to 0% assumes that the motor's ambient temperature is the same as the temperature of the HVX9000's heatsink at power-on.	

**P1.7.10**  
**Motor Thermal**  
**Protection Zero**  
**Speed**

Range: 0.0 – 150.0

Default: 40.0

Units: Percent

*MTP FO CURRENT*

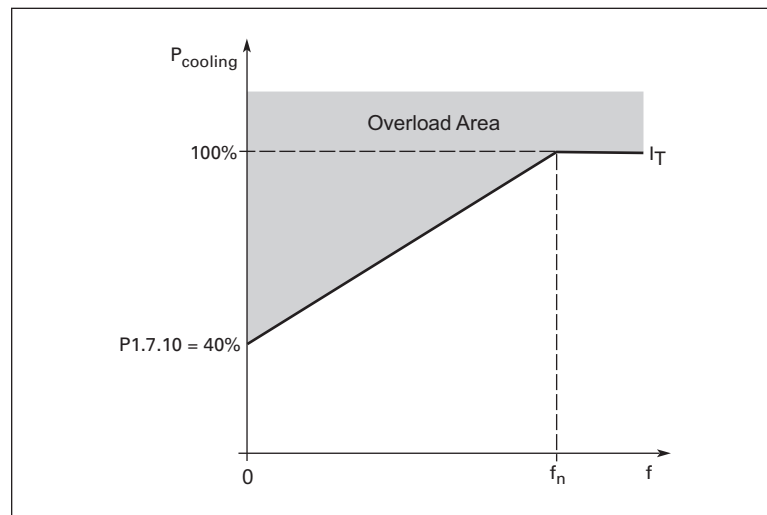
This parameter sets the value of the current allowed at zero frequency. It can be set between 0 – 150.0% of the cooling available at the nominal motor nameplate frequency **Motor Nominal Frequency**. See **Figure 8-18**.

The default value is set assuming that there is no external fan cooling the motor. If an external fan is used this parameter can be set to 90% (or even higher).

**Note:** The value is set as a percentage of the motor nameplate data, **Motor Nominal Current**, not the drive's nominal output current. The motor's nominal current is the current that the motor can withstand in direct on-line use without being overheated.

If you change the **Motor Nominal Current**, this parameter is automatically restored to the default value.

Setting this parameter does not affect the maximum output current of the HVX9000, which is determined by **Current Limit** alone.



**Figure 8-18: Motor Cooling Power**

April 2005

**P1.7.11**  
**MTP Time Constant**

Range: 1 – 200  
Units: Minutes

Default: 24 min.

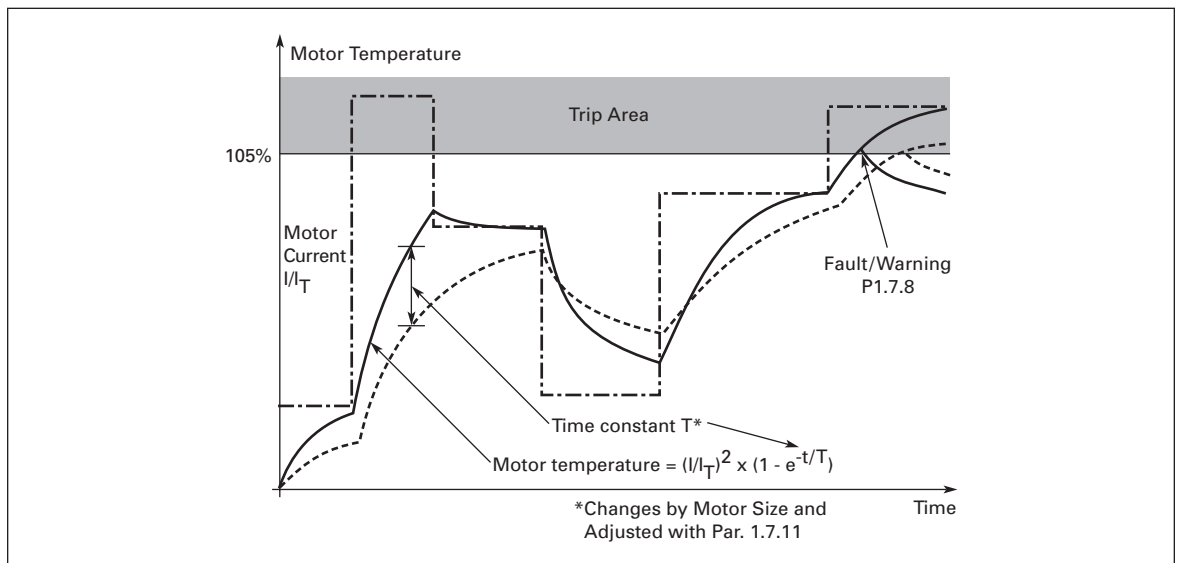
*MTP MOTOR T*

This is the thermal time constant of the motor. The larger the motor, the longer the time constant. The time constant is the time within which the calculated thermal stage has reached 63% of its final value.

The motor thermal time is specific to the motor design and it varies between different motor manufacturers.

If the motor's  $t_6$ -time ( $t_6$  is the time in seconds the motor can safely operate at six times the rated current) is known (given by the motor manufacturer) the time constant parameter can be set basing on it. As a rule of thumb, the motor thermal time constant in minutes equals to  $2 \times t_6$ . If the HVX9000 is stopped, the time constant is internally increased to three times the set parameter value. The cooling at stop is based on convection with an increased time constant. See **Figure 8-19**.

**Note:** If the **Motor Nominal Speed** or the **Motor Nominal Current** are changed this parameter is automatically set to the default value.



**Figure 8-19: Motor Temperature Calculation**

**P1.7.12**  
**Motor Duty Cycle**

Range: 0 – 100  
Units: Percent

Default: 100

*MOTOR DUTY CYCLE*

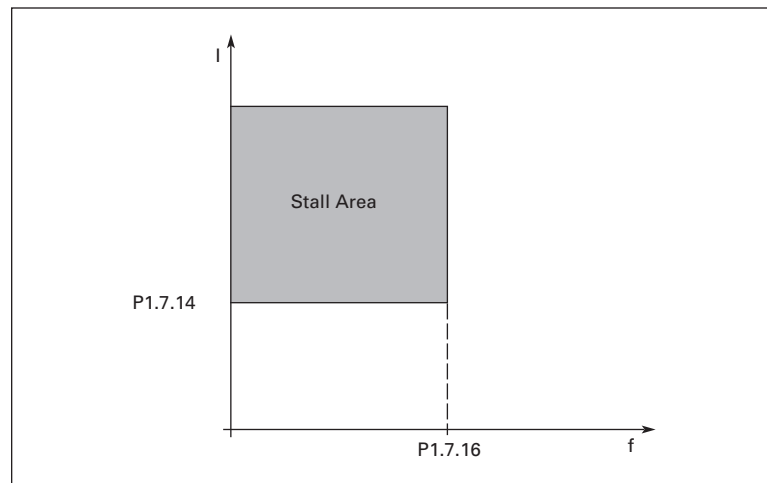
Defines how much of the nominal motor nameplate load is normally applied.

**Stall Protection General Information**

The motor stall protection protects the motor from short time overload situations such as one caused by a stalled shaft. The reaction time of the stall protection can be set shorter than that of the motor thermal protection. The stall state is defined with two parameters, **Stall Protection** and **Stall Current Limit**. If the current is higher than the set limit and output frequency is lower than the set limit, the stall state is true. There is actually no direct physical indication of the shaft rotation. Stall protection is a type of overcurrent protection.

**P1.7.13** Range: 0 – 3 Default: 1 (Warning)  
**Stall Protection**  
*STALL PROTECTION*  
 0 No response  
 1 Warning  
 2 Fault, stop mode after fault according to **Stop Mode**  
 3 Fault, stop mode after fault always by coasting  
 Setting the parameter to 0 will deactivate the protection and reset the stall time counter.

**P1.7.14** Range: 0.01 – **Motor Nominal Current** Default: **Motor Nominal Current** x 1.3  
**Stall Current Limit**  
 Units: Amperes  
*STALL CURRENT*  
 The current can be set between 0.01 and  $I_{nMotor} \times 2$ . For a stall stage to occur, the current must have exceeded this limit. See **Figure 8-20**. The software does not allow entering a greater value than  $I_{nMotor} \times 2$ . If **Motor Nominal Current** is changed, this parameter is automatically restored to the default value,  $I_{nMotor} \times 1.3$ .



**Figure 8-20: Stall Characteristics Settings**

**P1.7.15** Range: 1.00 – 120.00 Default: 15.00  
**Stall Time Limit**  
 Units: Seconds  
*STALL TIME LIM*  
 This is the maximum time allowed for a stall stage. The stall time is counted by an internal up/down counter. If the stall time counter value goes above this limit the protection will cause a trip (see **Stall Protection**).

**P1.7.16** Range: 1.00 – **Maximum Frequency** Default: 25.00  
**Stall Frequency Limit**  
*STALL FREQ LIM*  
 For a stall state to occur, the output frequency must be below this limit.

April 2005

**Underload Protection General Information**

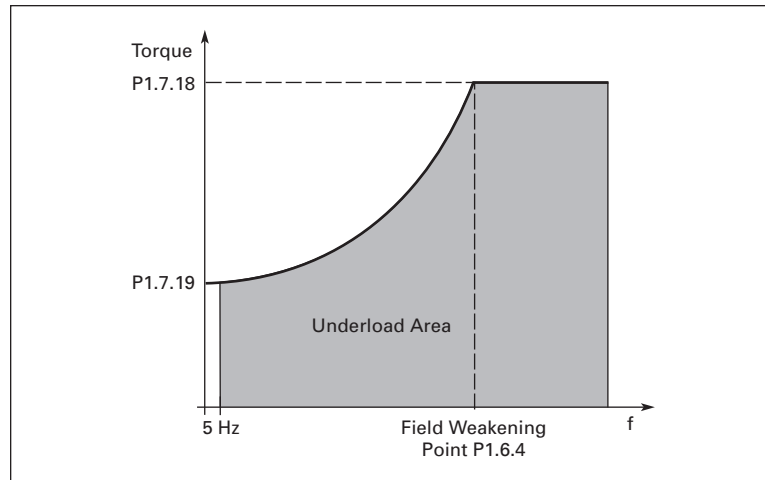
The purpose of the motor underload protection is to ensure that there is load on the motor when the HVX9000 is running. If the motor loses its load there might be a problem in the process, e.g. a broken belt or a dry pump.

Motor underload protection can be adjusted by setting the underload curve with **Underload Protection  $f_{nom}$  Torque** (Field weakening area load) and **Underload Protection  $f_0$  Torque** (Zero frequency load), see below. The underload curve is a squared curve set between the zero frequency and the field weakening point. The protection is not active below 5 Hz (the underload time counter is stopped).

The torque values for setting the underload curve are set in percentage of the nominal nameplate torque of the motor. The motor's nameplate data, the **Motor Nominal Current** and the HVX9000 drive's nominal nameplate current rating are used to find the scaling ratio for the internal torque value. If other than a standard motor of the same rating as the HVX9000 is used, the accuracy of the torque calculation decreases.

**P1.7.17 Underload Protection** Range: 0 – 3 Default: 0 (No Response)  
*UNDERLOAD PROTEC*  
 0 No response  
 1 Warning  
 2 Fault, stop mode after fault according to **Stop Mode**  
 3 Fault, stop mode after fault always by coasting  
 Deactivating the protection by setting the parameter to 0 will reset the underload time counter.

**P1.7.18 Underload Protection  $f_{nom}$  Torque** Range: 10.0 – 150.0 Default: 50.0  
 Units: Percent  
*UP  $f_{nom}$  TORQUE*  
 This parameter is based on a percentage of the nominal nameplate motor torque,  $T_{nMotor}$ , and sets the value for the minimum torque allowed when the output frequency is above the field weakening point. See **Figure 8-21**.  
 If you change the **Motor Nominal Current**, this parameter is automatically restored to the default value.



**Figure 8-21: Minimum Load Setting**

**P1.7.19**  
**Underload**  
**Protection f0**  
**Torque**

Range: 5.0 – 150.0  
Units: Percent  
*UP F0 TORQUE*

Default: 10.0

This parameter is based on a percentage of the nominal nameplate motor torque,  $T_{nMotor}$ , and sets the value for the minimum torque allowed with zero frequency. See **Figure 8-21**.

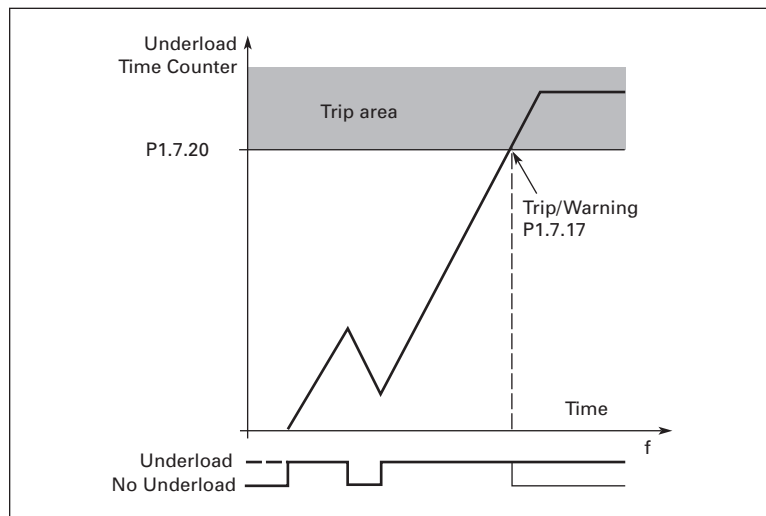
If you change the value of **Motor Nominal Current**, this parameter is automatically restored to the default value.

**P1.7.20**  
**Underload**  
**Protection Time**  
**Limit**

Range: 2.00 – 600.00  
Units: Seconds  
*UP TIME LIMIT*

Default: 20.00

This is the maximum time allowed for an underload state to exist. An internal up/down counter counts the accumulated underload time. If the underload counter value goes above this limit the protection will cause a trip according to **Underload Protection**. If the HVX9000 is stopped, the underload counter is reset to zero. See **Figure 8-22**.



**Figure 8-22: Underload Time Counter Function**

**P1.7.21**  
**Thermistor Fault**  
**Response**

Range: 0 – 3  
*THERMISTORF RESP*

Default: 0 (No Response)

A high temperature has been detected by an option board connected thermistor.

- 0 No response
- 1 Warning
- 2 Fault, stop mode after fault according to **Stop Mode**
- 3 Fault, stop mode after fault always by coasting

**P1.7.22**  
**Communications**  
**Fault Response**

Range: 0 – 3  
*COMM FAULT RESP*

Default: 2 (Fault)

The response mode for a communication fault is set with this parameter if a communication board is being used. For more information, see the appropriate Communication Board Manual.

- 0 No response
- 1 Warning
- 2 Fault, stop mode after fault according to **Stop Mode**
- 3 Fault, stop mode after fault always by coasting

April 2005

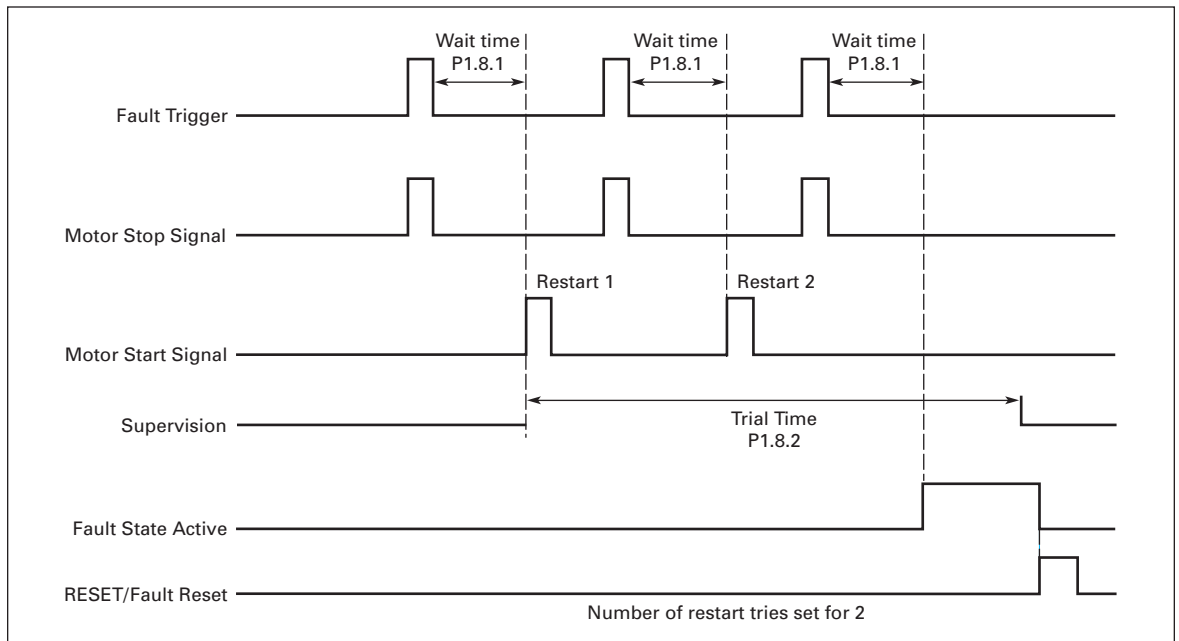
<b>P1.7.23</b>	Range: 0 – 3	Default: 2 (Fault)
<b>Slot Communication Fault Response</b>	<i>SLOTCOMMFAULTRESP</i>	
	The response mode for a board slot fault due to missing or failed board.	
	0 No response	
	1 Warning	
	2 Fault, stop mode after fault according to <b>Stop Mode</b>	
	3 Fault, stop mode after fault always by coasting	

**Parameter Group G1.8: Auto-Restart**

The automatic restart function restarts the drive when the cause of the fault, selected with **Undervoltage Restart Tries** to **External Fault Tries** parameters, has disappeared and the waiting time, **Wait Time**, has elapsed. **Undervoltage Restart Tries** to **External Fault Tries** parameters determine the maximum number of automatic restarts during the trial time set by **Trial Time**. See **Figure 8-23**.

<b>P1.8.1</b>	Range: 0.10 – 10.00	Default: 0.50
<b>Wait Time</b>	Units: Seconds	
	<i>WAIT TIME</i>	
	Defines the time before the HVX9000 tries to automatically restart the motor after the cause of the fault trip has disappeared.	

<b>P1.8.2</b>	Range: 0.00 – 60.00	Default: 30.00
<b>Trial Time</b>	Units: Seconds	
	<i>TRIAL TIME</i>	
	This parameter sets the trial time for the auto-restart function. The time count starts from the first auto-restart. If the number of faults occurring during the trial time exceeds the values of <b>Undervoltage Restart Tries</b> to <b>External Fault Tries</b> parameters, the fault trip is maintained. If the HVX9000 successfully restarts and no other fault occurs, the fault is cleared after the trial time has elapsed. The next fault starts the trial time count again.	



**Figure 8-23: Example of Automatic Restart with Two Restarts**

<b>P1.8.3</b> <b>Start Mode</b>	Range: 0 – 2 <i>START MODE</i> The Start function for automatic restart is selected with this parameter. 0 Ramp start 1 Flying start 2 Start according to <b>Start Mode</b>	Default: 0 (Ramping)
<b>P1.8.4</b> <b>Undervoltage Restart Tries</b>	Range: 0 – 10 <i>UNDERVOLT TRIES</i> This parameter determines how many automatic restarts are allowed during the <b>Trial Time</b> after an undervoltage trip. 0 No automatic restart after undervoltage fault trip >0 Number of automatic restarts after undervoltage fault. The fault is reset and the HVX9000 is started automatically after the DC-link voltage has returned to the normal level.	Default: 0
<b>P1.8.5</b> <b>Overvoltage Restart Tries</b>	Range: 0 – 10 <i>OVERVOLT TRIES</i> This parameter determines how many automatic restarts are allowed during the <b>Trial Time</b> after an overvoltage trip. 0 No automatic restart after overvoltage fault trip >0 Number of automatic restarts after overvoltage fault. The fault is reset and the HVX9000 is started automatically after the DC-link voltage has returned to the normal level.	Default: 0
<b>P1.8.6</b> <b>Overcurrent Restart Tries</b>	Range: 0 – 3 <i>OVERCURRE TRIES</i> This parameter determines how many automatic restarts are allowed during the <b>Trial Time</b> . <b>Note:</b> IGBT temperature faults are included in this function. 0 No automatic restart after overcurrent fault trip >0 Number of automatic restarts after an overcurrent fault trip, saturation trip or IGBT temperature fault.	Default: 0
<b>P1.8.7</b> <b>4 mA (Reference) Fault Tries</b>	Range: 0 – 10 <i>4 MA FAULT TRIES</i> This parameter determines how many automatic restarts are allowed during the <b>Trial Time</b> . 0 No automatic restart after reference fault trip >0 Number of automatic restarts after the analogue current signal (4 – 20 mA) has returned to the normal level (>4 mA)	Default: 0
<b>P1.8.8</b> <b>Motor Temperature Fault Tries</b>	Range: 0 – 10 <i>MOTTEMPF TRIES</i> This parameter determines how many automatic restarts are allowed during the <b>Trial Time</b> . 0 No automatic restart after a motor temperature fault trip >0 Number of automatic restarts after the motor temperature has returned to its normal level.	Default: 0
<b>P1.8.9</b> <b>External Fault Tries</b>	Range: 0 – 10 <i>EXTFAULT TRIES</i> This parameter determines how many automatic restarts are allowed during the <b>Trial Time</b> . 0 No automatic restart after external fault trip >0 Number of automatic restarts after an external fault trip	Default: 0

April 2005

**Parameter Group G1.9: Fire Mode PID****Fire Mode or Smoke Purge**

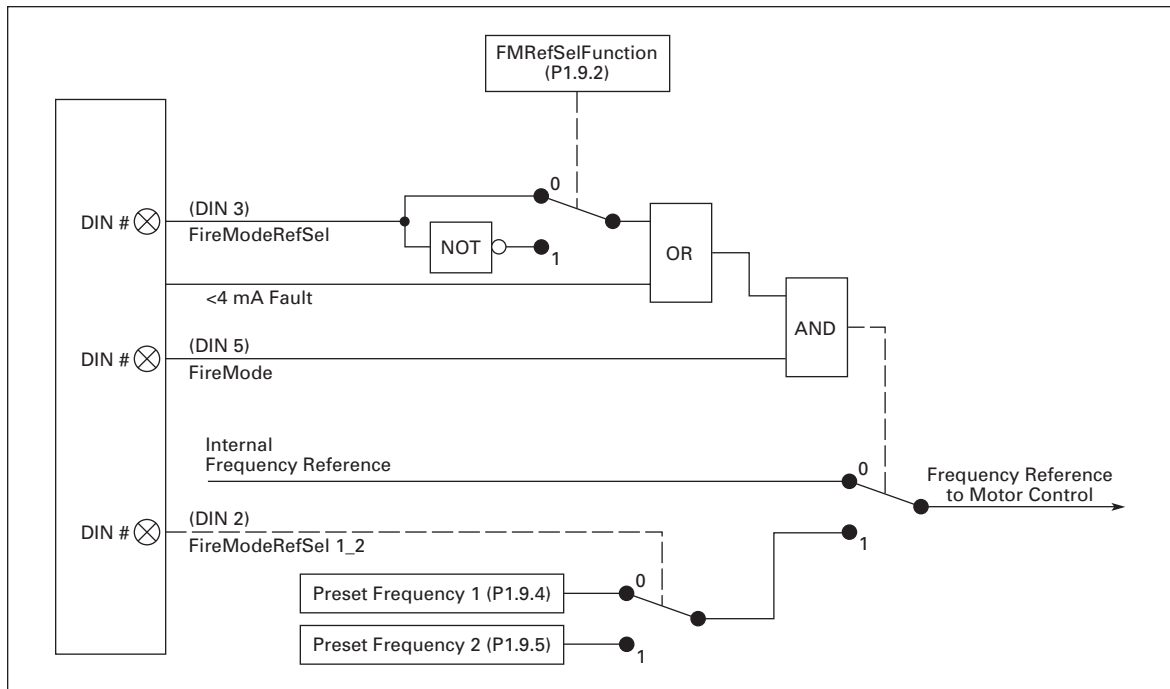
Fire Mode is used to start motor and continue to operate due to emergency conditions. Faults will be changed to warnings to prevent shutdown. The overload should be selected to AUTO to prevent overload trip during "Fire Mode" operation. This is only required if unit is an IntelliPass which uses an electronic overload with contactor to run motor. If set to AUTO on the overload, the overload fault will be ignored and motor will continue to run.

<b>P1.9.1</b> <b>Fire Mode Function</b>	Range: 0 – 1 <i>FIREMODEFUNCTION</i> This parameter determines whether the fire mode function is determined by a contact closure or contact opening on digital input. 0 Closing contact initiates fire mode function 1 Opening contact initiates fire mode function	Default: 0 (Closed Contact)
<b>P1.9.2</b> <b>Fire Mode Reference Selection Function</b>	Range: 0 – 1 <i>FIREMODESELECTIONFUNCTION</i> Setting this parameter to 1 causes the maximum frequency to occur with the minimum reference ( <b>Fire Mode Frequency Reference 1</b> or <b>Fire Mode Frequency Reference 2</b> ) input and the minimum frequency to occur with the maximum reference input. 0 Not inverted 1 Inverted	Default: 0 (Not Inverted)
<b>P1.9.3</b> <b>Fire Mode Minimum Frequency</b>	Range: <b>Minimum Frequency</b> – <b>Maximum Frequency</b> Units: Hertz <i>FIREMODEMINIFREQ</i> This parameter sets the minimum output frequency for fire mode.	Default: 15.00
<b>P1.9.4</b> <b>Fire Mode Frequency Reference 1</b>	Range: 0.0 – 100.0% Units: Percent <i>FIREMODEFREQREF1</i> This parameter sets the drive operating frequency for fire mode reference 1.	Default: 75.0
<b>P1.9.5</b> <b>Fire Mode Frequency Reference 2</b>	Range: 0.0 – 100% Units: Percent <i>FIREMODEFREQREF2</i> This parameter sets the drive operating frequency for fire mode reference 2.	Default: 100.0

**IMPORTANT**

The electronic overload on the contactor must be set to AUTO, otherwise the overload will function normally.

- Note:** (1) Fire Mode has no effect on Bypass operation.  
(2) Only pushing the STOP button on the drive keypad or removing the "Fire Mode" digital input will stop the drive operation.



**Figure 8-24: Frequency Reference Logic of the Fire Mode PID Application When Running in Fire Mode**

**P1.9.6** Range: 0.50 – 10.00 Default: 5.00  
**Fire Mode Auto Reset Delay**  
*FMAUTORESETDELAY*  
 Time delay before forced reset after a hardware generated fault while in the fire mode.

**Parameter Group G1.10: IntelliPass**

**P1.10.1** Range: 0 – 1 Default: 0 (IntelliPass Disabled)  
**IntelliPass**  
*INTELLIPASS*  
 This parameter identifies whether the IntelliPass bypass option is installed and enabled.  
 0 IntelliPass Disabled – Not used  
 1 IntelliPass enabled – Used

**P1.10.2** Range: 1 – 32,765 Default: 5  
**Bypass Start Delay**  
*BYPASS START DELAY*  
 This parameter specifies the time delay between when the Start Signal is applied in I/O or Fieldbus, to when the motor starts. There is no “Bypass Delay” when starting in BYPASS from the keypad.  
 The keypad will display “BYPASS Starting! WARNING!!!” until the motor starts in BYPASS. This display is also active when “Auto Bypass” is active and motor is about to start in BYPASS.

April 2005

<b>P1.10.3</b> <b>Auto Bypass</b>	Range: 0 – 1 <i>AUTO BYPASS</i> This parameter specifies whether an automatic switch to bypass will occur based on <b>Overvoltage Fault Auto Bypass</b> P1.10.5 through <b>Undervoltage Fault Auto Bypass</b> P1.10.9 parameters below. 0 Auto Bypass disabled 1 Auto Bypass enabled	Default: 0 (Auto Bypass Disabled)
<b>P1.10.4</b> <b>Auto Bypass Delay</b>	Range: 0 – 32,765 Units: Seconds <i>AUTO BYPASSDELAY</i> This parameter specifies the time delay before an automatic switch to bypass, as determined by <b>Overvoltage Fault Auto Bypass</b> P1.10.5 through <b>Undervoltage Fault Auto Bypass</b> P1.10.9 parameters, will occur.	Default: 10
<b>P1.10.5</b> <b>Overcurrent Fault Auto Bypass</b>	Range: 0 – 1 <i>OVER 1 BYPASSENAB</i> This parameter specifies whether an automatic switch to bypass will occur after the overcurrent fault auto-restart tries have been exceeded. 0 Auto bypass on overcurrent fault tries exceeded disabled 1 Auto bypass on overcurrent fault tries exceeded enabled	Default: 0
<b>P1.10.6</b> <b>IGBT Fault Auto Bypass</b>	Range: 0 – 1 <i>IGBT FLT BYPASSEM</i> This parameter specifies whether an automatic switch to bypass will occur after the IGBT fault auto-restart tries have been exceeded. 0 Auto bypass on IGBT fault tries exceeded disabled 1 Auto bypass on IGBT fault tries exceeded enabled	Default: 0
<b>P1.10.7</b> <b>4 mA (Reference) Fault Auto Bypass</b>	Range: 0 – 1 <i>NO REF BYPASSENAB</i> This parameter specifies whether an automatic switch to bypass will occur after the loss of reference fault auto-restart tries have been exceeded. 0 Auto bypass on loss of reference fault tries exceeded disabled 1 Auto bypass on loss of reference fault tries exceeded enabled <b>Note:</b> P1.7.1 ( <b>4 mA (Reference) Fault Auto Bypass</b> ) must be set to 4 or 5 (Fault).	Default: 0
<b>P1.10.8</b> <b>Undervoltage Fault Auto Bypass</b>	Range: 0 – 1 <i>UV BYPASSENAB</i> This parameter specifies whether an automatic switch to bypass will occur after the undervoltage fault auto-restart tries have been exceeded. 0 Auto bypass on undervoltage fault tries exceeded disabled 1 Auto bypass on undervoltage fault tries exceeded enabled	Default: 0
<b>P1.10.9</b> <b>Overvoltage Fault Auto Bypass</b>	Range: 0 – 1 <i>OVDLT BYPASSENAB</i> This parameter specifies whether an automatic switch to bypass will occur after the overvoltage fault auto-restart tries have been exceeded. 0 Auto bypass on overvoltage fault tries exceeded disabled 1 Auto bypass on overvoltage fault tries exceeded enabled	Default: 0

**Parameter Group G1.11: PID Control****P1.11.1  
PID Reference**

Range: 0 – 4

Default: 0 (AI1)

*PID REFERENCE*

Defines which frequency reference source is selected for the PID controller.

- 0 Analog voltage reference from terminals 2 – 3, e.g. potentiometer or voltage source
- 1 Analog current reference from terminals 4 – 5, e.g. transducer
- 2 PID reference from the Keypad
- 3 Reference from the communication bus (FB Process Data IN 1 [ID#2004])
- 4 Motor potentiometer

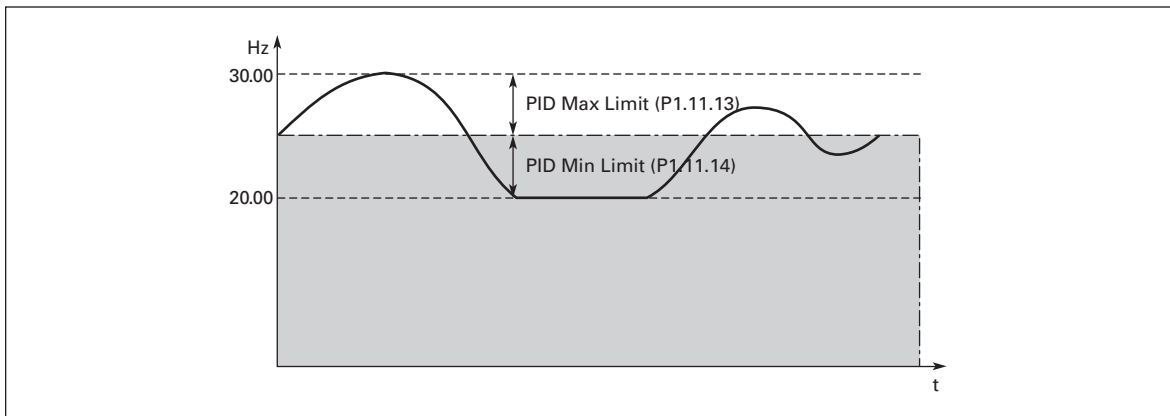
**P1.11.2  
PID Sum Point  
Reference Selection**

Range: 0 – 7

Default: 0 (No additional reference)

*PID SUMPOINT REF*Defines which reference source is added to PID controller output if PID controller is used. See **Figure 8-25**.

- 0 No additional reference (Direct PID output value)
- 1 PID output + AI1 reference from terminals 2 and 3 (e.g. potentiometer)
- 2 PID output + AI2 reference from terminals 4 and 5 (e.g. transducer)
- 3 PID output + AI3 reference (Not available at this time)
- 4 PID output + AI4 reference (Not available at this time)
- 5 PID output + PID keypad reference
- 6 PID output + Communication bus
- 7 PID output + Motor potentiometer

**Figure 8-25: PID Output + Motor Potentiometer Reference**

**Note:** The maximum and minimum limits illustrated in the picture limit only the PID output, no other outputs.

**P1.11.3  
Actual Value  
Selection**

Range: 0 – 7

Default: 0 (Actual Value 1)

*ACT VALUE SELECT*

This parameter selects the PID controller actual value input signal source.

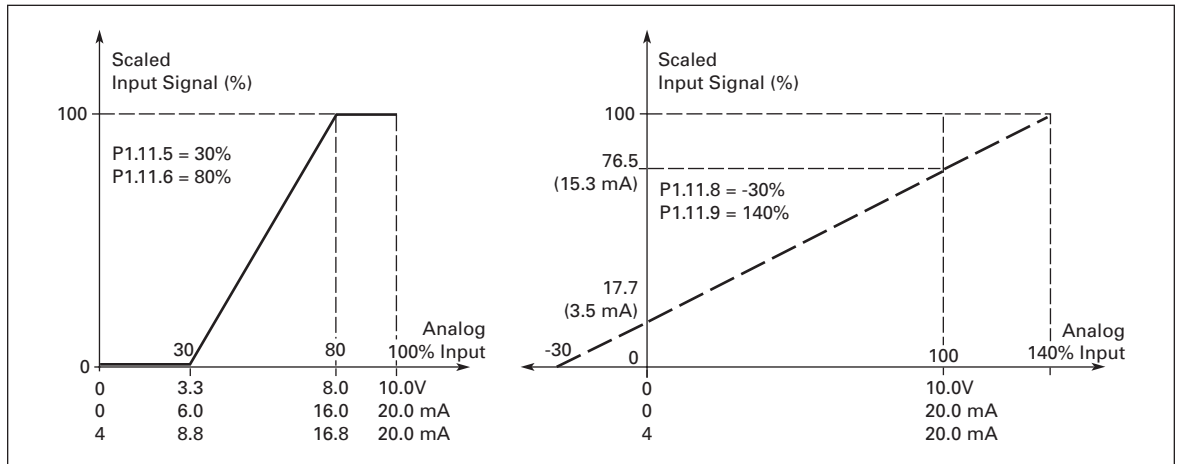
- 0 Actual value 1
- 1 Actual value 1 + Actual value 2
- 2 Actual value 1 - Actual value 2
- 3 Actual value 1 \* Actual value 2
- 4 Smaller of Actual value 1 and Actual value 2
- 5 Greater of Actual value 1 and Actual value 2
- 6 Mean value of Actual value 1 and Actual value 2
- 7 Square root of Actual value 1 + Square root of Actual value 2

April 2005

**P1.11.4 Actual Value 1 Input** Range: 0 – 9 Default: 2 (AI2)  
*ACTUAL 1 INPUT*  
 This parameter selects the PID controller actual value 1 input signal source.  
 0 Not used  
 1 Analog Input AI1 (control board terminals 2 and 3)  
 2 Analog Input AI2 (control board terminals 4 and 5)  
 3 Analog input AI3  
 4 Analog input AI4 (Not available at this time)  
 5 Communication bus (FB Process Data IN 2 [ID#2005])  
 6 Motor torque  
 7 Motor speed  
 8 Motor current  
 9 Motor power

**P1.11.5 Actual 1 Maximum Scale** Range: -1000.0 – 1000.0 Default: 100.0%  
 Units: Percent  
*ACT 1 MAX SCALE*  
 This parameter sets the maximum scaling point for actual value 1. 100% is equivalent to no maximum scaling. See **Figure 8-26**.

**P1.11.6 Actual 1 Minimum Scale** Range: -1000.0 – 1000.0 Default: 0.0  
 Units: Percent  
*ACT 1 MIN SCALE*  
 This parameter sets the minimum scaling point for actual value 1. 0% is equivalent to no minimum scaling. See **Figure 8-26**.



**Figure 8-26: Examples of Actual Value Signal Scaling**

<b>P1.11.7</b> <b>Actual Value 2 Input</b>	<p>Range: 0 – 9 <i>ACTUAL 2 INPUT</i></p> <p>This parameter selects the PID controller actual value 2 input signal source.</p> <ul style="list-style-type: none"> <li>0 Not used</li> <li>1 Analog Input AI1 (control board terminals 2 and 3)</li> <li>2 Analog Input AI2 (control board terminals 4 and 5)</li> <li>3 Analog input AI3</li> <li>4 Analog input AI4 (Not available at this time)</li> <li>5 Communication bus (FB Process Data IN 3 [ID#2006])</li> <li>6 Motor torque</li> <li>7 Motor speed</li> <li>8 Motor current</li> <li>9 Motor power</li> </ul>	Default: 0 (Not used)
<b>P1.11.8</b> <b>Actual 2 Maximum Scale</b>	<p>Range: -1000.0 – 1000.0 Units: Percent <i>ACTUAL 2 MAX SCALE</i></p> <p>This parameter sets the maximum scaling point for actual value 2. 100% is equivalent to no maximum scaling. See <b>Figure 8-26</b>.</p>	Default: 100.0
<b>P1.11.9</b> <b>Actual 2 Minimum Scale</b>	<p>Range: -1000.0 – 1000.0 Units: Percent <i>ACTUAL 2 MIN SCALE</i></p> <p>This parameter sets the minimum scaling point for actual value 2. 0% is equivalent to no minimum scaling. See <b>Figure 8-26</b>.</p>	Default: 0.0
<b>P1.11.10</b> <b>PID Control Gain</b>	<p>Range: 0.0 – 1000.0 Units: Percent <i>PID-CONTR GAIN</i></p> <p>This parameter defines the gain of the PID controller. If the value of the parameter is set to 100%, a change of 10% in the error value causes the controller output to change by 10%. If the parameter value is set to 0, the PID controller operates as an ID-controller. See examples 1, 2 and 3 below.</p>	Default: 100.0%
<b>P1.11.11</b> <b>PID Control I Time</b>	<p>Range: 0.00 – 320.00 Units: Seconds <i>PID-CONTR I TIME</i></p> <p>This parameter defines the integration time of the PID controller. If this parameter is set to 1.00 second, a change of 10% in the error value causes the controller output to change by 10.00%/s. If the parameter value is set to 0.00 s, the PID controller will operate as a PD controller. See examples 1, 2 and 3 below.</p>	Default: 1.00
<b>P1.11.12</b> <b>PID Control D Time</b>	<p>Range: 0.00 – 10.00 Units: Seconds <i>PID-CONTR D TIME</i></p> <p>This parameter defines the derivation time of the PID controller. If this parameter is set to 1.00 seconds, a change of 10% in the error value during 1.00 s causes the controller output to change by 10.00%. If the parameter value is set to 0.00 s the PID controller will operate as a PI controller. See examples 1, 2 and 3 below.</p>	Default: 0.00

April 2005

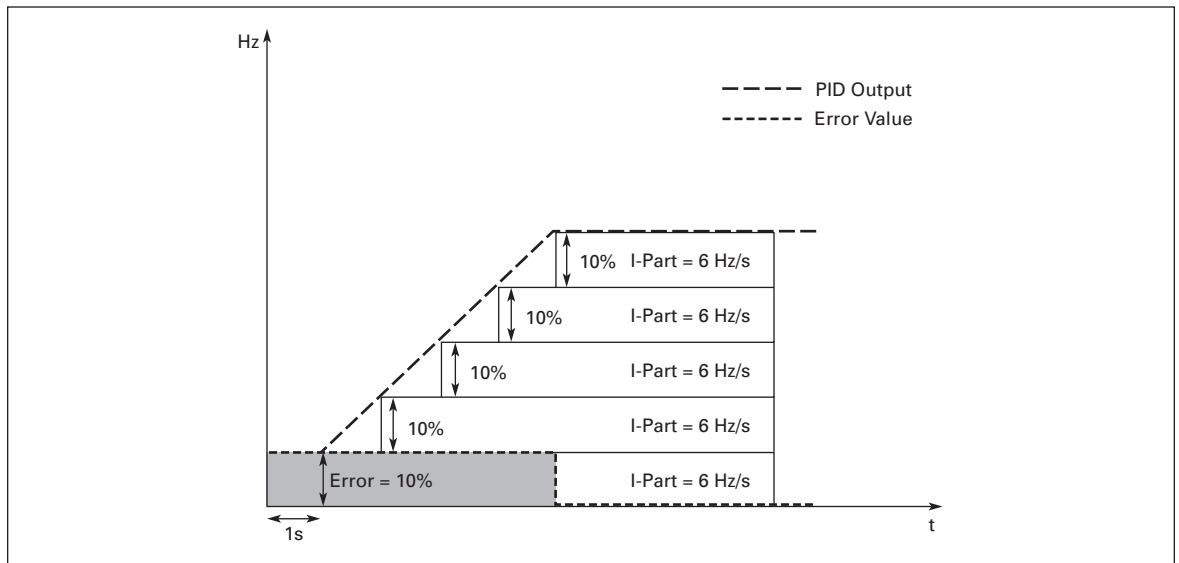
**Example 1:**

In order to reduce the error value to zero, with the given values, the drive output behaves as follows:

Given values:

**PID Control Gain**, P = 0% **PID Max Limit** = 100.0%  
**PID Control I Time**, I-time = 1.00 s **PID Min Limit** = 0.0%  
**PID Control D Time**, D-time = 0.00 s **Min Frequency** = 0 Hz  
 Error value (setpoint – process value) = 10.00% **Max Frequency** = 60 Hz

In this example, the PID controller operates practically as I-controller only. According to the given value of parameter **PID Control I Time** (I-time), the PID output increases by 5 Hz (10% of the difference between the maximum and minimum frequency) every second until the error value is 0.



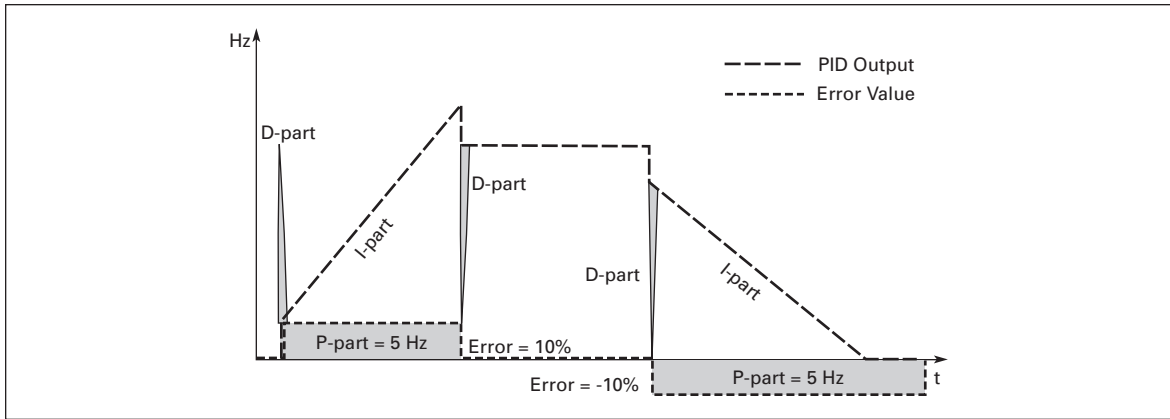
**Figure 8-27: PID Controller D-Time, Example 1**

**Example 2:**

Given values:

**PID Control Gain**, P = 0% **PID Max Limit** = 100.0%  
**PID Control I Time**, I-time = 1.00 s **PID Min Limit** = 0.0%  
**PID Control D Time**, D-time = 1.00 s **Min Frequency** = 0 Hz  
 Error value (setpoint – process value) = ±10% **Max Frequency** = 60 Hz

As the power is switched on, the system detects the difference between the setpoint and the actual process value and starts to either raise or decrease (in case the error value is negative) the PID output according to the I-time. Once the difference between the setpoint and the process value has been reduced to 0, the output is reduced by the amount corresponding to the value of **PID Control I Time**. In case the error value is negative, the HVX9000 reacts reducing the output correspondingly. See below.



**Figure 8-28: PID Controller D-Time, Example 2**

**Example 3:**

Given values:

**PID Control Gain, P** = 0%

**PID Control I Time, I-time** = 0.00 s

**PID Control D Time, D-time** = 1.00 s

Error value (setpoint – process value) = ±10%/s

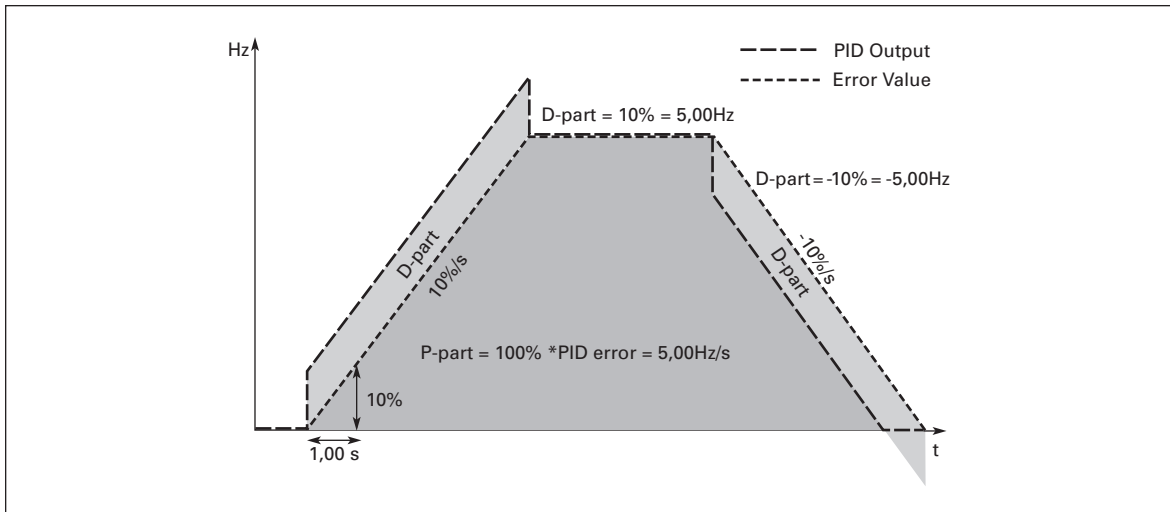
As the error value increases, also the PID output increases according to the set values (D-time = 1.00s)

**PID Max Limit** = 100.0%

**PID Min Limit** = 0.0%

**Min Frequency** = 0 Hz

**Max Frequency** = 60 Hz



**Figure 8-29: PID Controller D-Time, Example 3**

**P1.11.13  
PID Controller  
Maximum Limit**

Range: **PID Min Limit** – 1000.0

Default: 100.0%

Units: Percent

*PID MAX LIMIT*

With this parameter you can set the maximum limit for the PID controller output.

Limit setting: -100.0% (of  $f_{max}$ ) < **PID Controller Minimum Limit** < **PID Controller Maximum Limit** < 100.0% (of  $f_{max}$ ).

These limits are of importance for example when you define the gain, I-time and D-time for the PID controller.

April 2005

<b>P1.11.14</b> <b>PID Controller Minimum Limit</b>	<p>Range: 1000.0 – <b>PID Max Limit</b>                      Default: 0.0%</p> <p>Units: Percent</p> <p><i>PID MIN LIMIT</i></p> <p>With this parameter you can set the minimum limit for the PID controller output.</p> <p>Limit setting: <math>-100.0\%</math> (of <math>f_{max}</math>) &lt; <b>PID Controller Maximum Limit</b> &lt; <b>PID Controller Minimum Limit</b> &lt; <math>100.0\%</math> (of <math>f_{max}</math>).</p> <p>These limits are of importance for example when you define the gain, I-time and D-time for the PID controller.</p>
<b>P1.11.15</b> <b>PID Reference Rise Time</b>	<p>Range: 0.0 – 100.0    Default: 5.0</p> <p>Units: Seconds</p> <p><i>PID REF RISE TIM</i></p> <p>Defines the time during which the PID controller reference rises from 0% to 100%.</p>
<b>P1.11.16</b> <b>PID Reference Fall Time</b>	<p>Range: 0.0 – 100.0    Default: 5.0</p> <p>Units: Seconds</p> <p><i>PID REF FALL TIM</i></p> <p>Defines the time during which the PID controller reference falls from 100% to 0%.</p>
<b>P1.11.17</b> <b>PID Error Value Inversion</b>	<p>Range: 0 – 1    Default: 0 (No Inversion)</p> <p><i>ERROR INVERSION</i></p> <p>This parameter allows you to invert the error value of the PID controller (and thus the operation of the PID controller).</p> <p>0 No inversion 1 Inverted</p>
<b>P1.11.18</b> <b>Sleep Function Enabled</b>	<p>Range: 0 – 1    Default: 0</p> <p><i>SLEEP FUNC ENABL</i></p> <p>0 Disabled 1 Enabled</p> <p>This parameter sets whether the sleep function is enabled or disabled. If the sleep function is enabled, the HVX9000 is stopped automatically if its operating frequency falls below the Sleep level defined by <b>Sleep Frequency</b> for a time greater than that determined by <b>Sleep Delay</b>. During the Stop state, the PID controller is operating. The HVX9000 will switch to the Run state when the actual value signal either falls below or exceeds (see <b>Wake Up Action</b>) the Wake-Up level determined by <b>Wake Up Limit</b>. See <b>Figure 8-30</b>.</p>
<b>P1.11.19</b> <b>Sleep Frequency</b>	<p>Range: <b>Min Frequency</b> – <b>Max Frequency</b>                      Default: 10.00</p> <p>Units: Hertz</p> <p><i>SLEEP FREQUENCY</i></p> <p>The frequency converter is stopped automatically if the frequency of the HVX9000 falls below the Sleep level defined with this parameter for a time greater than that determined by <b>Sleep Delay</b>. During the Stop state, the PID controller is operating. The HVX9000 will switch to the Run state when the actual value signal either falls below or exceeds (see <b>Wake Up Action</b>) the <b>Wake Up Limit</b>. See <b>Figure 8-30</b>.</p>
<b>P1.11.20</b> <b>Sleep Delay</b>	<p>Range: 0 – 32,500    Default: 30</p> <p>Units: Seconds</p> <p><i>SLEEP DELAY</i></p> <p>The minimum amount of time the frequency has to remain below the Sleep level before the HVX9000 is stopped. See <b>Figure 8-30</b>.</p>

**P1.11.21**      Range: 0.00 – 100.00      Default: 25.00  
**Wake Up Limit**      Units: Percent

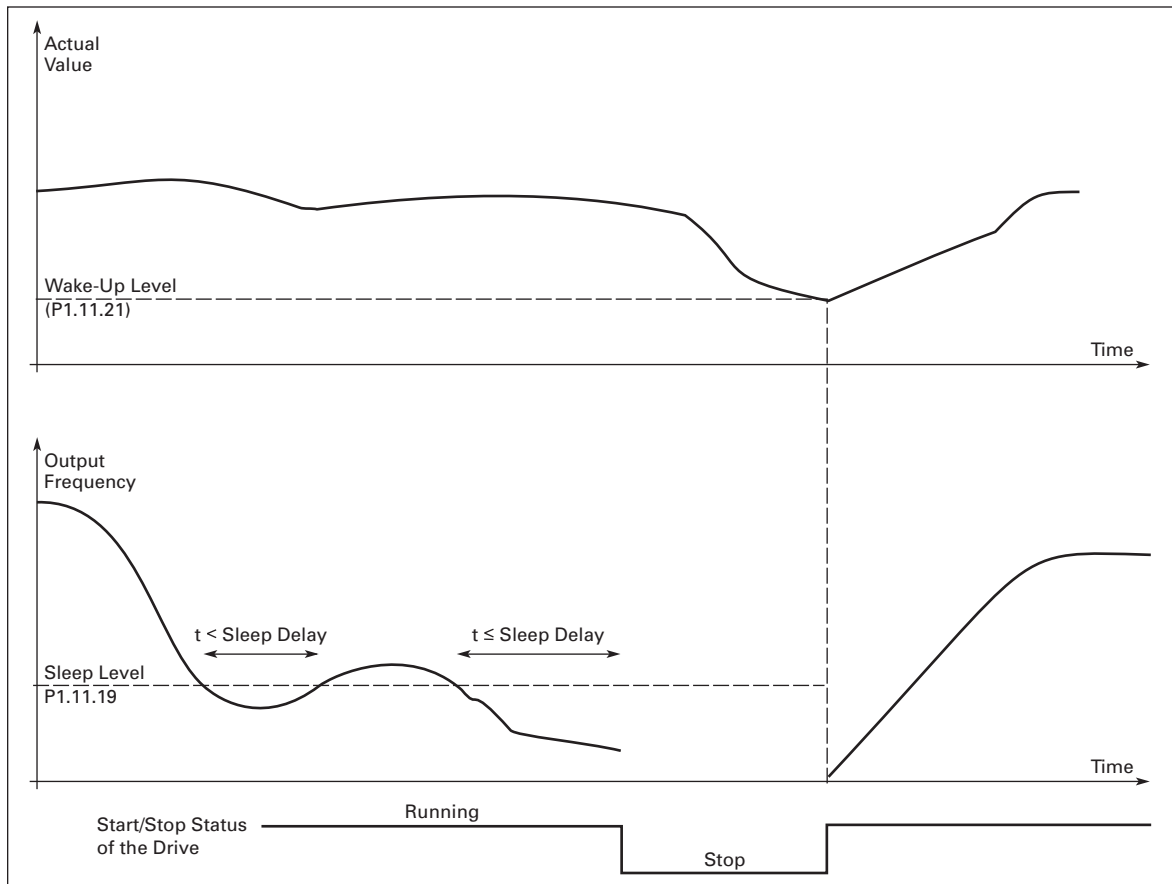
*WAKE UP LIMIT*

The wake up limit defines the frequency below which the actual value must fall or which has to be exceeded before the Run state of the HVX9000 is restored. See **Figure 8-30**.

**P1.11.22**      Range: 0 – 1      Default: 0 (Below Level)  
**Wake Up Action**      *WAKE UP ACTION*

This parameter defines if the restoration of the Run state occurs when the actual value signal falls below or exceeds the **Wake Up Limit**. See **Figure 8-30**.

- 0    Wake up falling below limit
- 1    Wake up exceeding limit



**Figure 8-30: Frequency Converter Sleep Function**

April 2005

**Parameter Group G1.12: Preset Speeds**

- P1.12.1**      Range: 0.0 – 100.0      Default: 10.0  
**#1 Preset Speed**      Units: Percent  
*#1 PRESET SPEED*  
 This parameter defines the #1 preset speed.
- P1.12.2**      Range: 0.0 – 100.0      Default: 20.0  
**#2 Preset Speed**      Units: Percent  
*#2 PRESET SPEED*  
 This parameter defines the #2 preset speed.
- P1.12.3**      Range: 0.0 – 100.0      Default: 30.0  
**#3 Preset Speed**      Units: Percent  
*#3 PRESET SPEED*  
 This parameter defines the #3 preset speed.
- P1.12.4**      Range: 0.0 – 100.0      Default: 40.0  
**#4 Preset Speed**      Units: Percent  
*#4 PRESET SPEED*  
 This parameter defines the #4 preset speed.
- P1.12.5**      Range: 0.0 – 100.0      Default: 50.0  
**#5 Preset Speed**      Units: Percent  
*#5 PRESET SPEED*  
 This parameter defines the #5 preset speed.
- P1.12.6**      Range: 0.0 – 100.0      Default: 75.0  
**#6 Preset Speed**      Units: Percent  
*#6 PRESET SPEED*  
 This parameter defines the #6 preset speed.
- P1.12.7**      Range: 0.0 – 100.0      Default: 100.0  
**#7 Preset Speed**      Units: Percent  
*#7 PRESET SPEED*  
 This parameter defines the #7 preset speed.

**Note:** Speeds are selected based on “Speed Select 1” through “Speed Select 3” digital input selections. The “Speed Selects” are based on Binary inputs converted to the “7 Preset Speeds”. See **Table 8-8** and Multistep Manual.

**Table 8-8: Binary Inputs for Seven Preset Speeds**

Preset Speed #	Speed Select 1	Speed Select 2	Speed Select 3
1	1	0	0
2	0	1	0
3	1	1	0
4	0	0	1
5	1	0	1
6	0	1	1
7	1	1	1

**Parameter Group G1.13: Fieldbus**

<b>P1.13.1</b> <b>Fieldbus Data</b> <b>Out 1 Select</b>	Range: 0 – 10000 <i>FBDATROUT1SEL</i> Allows a parameter or monitored value to be viewed from the communication bus. No decimal point is available, so scaling must be done by the viewing device. See <b>Table 8-9</b> .	Default: 1590 (Motor speed – %)
<b>P1.13.2</b> <b>Fieldbus Data</b> <b>Out 2 Select</b>	Range: 0 – 10000 <i>FBDATROUT2SEL</i> Allows a parameter or monitored value to be viewed from the communication bus. No decimal point is available, so scaling must be done by the viewing device. See <b>Table 8-9</b> .	Default: 1 (Output frequency – Hz)
<b>P1.13.3</b> <b>Fieldbus Data</b> <b>Out 3 Select</b>	Range: 0 – 10000 <i>FBDATROUT3SEL</i> Allows a parameter or monitored value to be viewed from the communication bus. No decimal point is available, so scaling must be done by the viewing device. See <b>Table 8-9</b> .	Default: 25 (Frequency reference – Hz)
<b>P1.13.4</b> <b>Fieldbus Data</b> <b>Out 4 Select</b>	Range: 0 – 10000 <i>FBDATROUT4SEL</i> Allows a parameter or monitored value to be viewed from the communication bus. No decimal point is available, so scaling must be done by the viewing device. See <b>Table 8-9</b> .	Default: 2 (Motor speed – rpm)
<b>P1.13.5</b> <b>Fieldbus Data</b> <b>Out 5 Select</b>	Range: 0 – 10000 <i>FBDATROUT5SEL</i> Allows a parameter or monitored value to be viewed from the communication bus. No decimal point is available, so scaling must be done by the viewing device. See <b>Table 8-9</b> .	Default: 1780 (Motor current)
<b>P1.13.6</b> <b>Fieldbus Data</b> <b>Out 6 Select</b>	Range: 0 – 10000 <i>FBDATROUT6SEL</i> Allows a parameter or monitored value to be viewed from the communication bus. No decimal point is available, so scaling must be done by the viewing device. See <b>Table 8-9</b> .	Default: 5 (Motor power)
<b>P1.13.7</b> <b>Fieldbus Data</b> <b>Out 7 Select</b>	Range: 0 – 10000 <i>FBDATROUT7SEL</i> Allows a parameter or monitored value to be viewed from the communication bus. No decimal point is available, so scaling must be done by the viewing device. See <b>Table 8-9</b> .	Default: 1701 (Motor run time – minutes)
<b>P1.13.8</b> <b>Fieldbus Data</b> <b>Out 8 Select</b>	Range: 0 – 10000 <i>FBDATROUT8SEL</i> Allows a parameter or monitored value to be viewed from the communication bus. No decimal point is available, so scaling must be done by the viewing device. See <b>Table 8-9</b> .	Default: 1666 (Energy meter – kW)

April 2005

**Table 8-9: Fieldbus Output Selection Examples**

Code	ID#	Description
V5.1	2	Calculated motor speed
V5.2	1590	Motor Nominal Speed %
V5.3	25	Frequency reference setting
V5.4	1	Frequency to the motor
V5.5	1780	Measured motor current
V5.6	4	Calculated torque based on nominal motor torque
V5.7	5	Calculated power based on nominal motor power
V5.8	1888	Calculated power based on output to motor
V5.9	1666	Kilowatt hours total usage
V5.10	6	Calculated motor voltage
V5.11	7	Measured DC-bus voltage
V5.12	1701	Motor run time total
V5.13	1565	Changes motor run time between seconds, minutes, hours and days
V5.14	8	Heatsink temperature
V5.15	1917	Calculated motor temperature based on the motor nameplate information and the calculated motor load
V5.16	13	Voltage Input at Terminal AI1+ and GND
V5.17	14	Current Input at Terminals AI2+ and AI2-
V5.18	1680	Current Input at Terminals AI3+ and AI3-
V5.19	1710	Current Input at Terminals AI4+ and AI4-
V5.20	15	Digital input status DIN-1 – DIN-3 (Binary converted to decimal)
V5.21	16	Digital input status DIN-4 – DIN-6 (Binary converted to decimal)
V5.22	17	Digital and relay output status D01, R01, R02 (Binary converted to decimal)
V5.23	1678	Relay output status R03 – R05 status (Binary converted to decimal)
V5.24	1773	Status of all relay outputs D01 – R08 status (Binary converted to decimal)
V5.25	26	Current Output at Terminals AO1+ and AO1-
V5.26	1874	Current Output at Terminals AO2+ and AO2-
V5.27	1875	Current Output at Terminals AO3+ and AO3-
R5.28	—	PID Setpoint 1 Level
V5.29	20	PID Reference Level
V5.30	21	PID Actual Level
V5.31	22	PID Error Value
V5.32	23	PID Output



April 2005

## Appendix A — Technical Data

### Specifications

**Table A-1: HVX9000 Drive Specifications**

Description	Specification
<b>Power Connections</b>	
Input Voltage ( $V_{in}$ )	230V +10%/-15% 480V +10%/-15% 575V +10%/-15%
Input Frequency ( $f_{in}$ )	50/60 Hz (variation up to 45 – 66 Hz)
Connection to Utility Power	Once per minute or less (typical operation)
High Interrupt Rating	The current withstand rating of the drive is 100,000 Amperes When Freedom Starters and an HMCP, the current interrupting rating is 100,000 Amperes When used with <i>IT</i> . style starters, the current interrupting rating is 36,000 Amperes
<b>Motor Connections</b>	
Output Voltage	0 to $V_{in}$
Continuous Output Current	Ambient temperature max. +104°F (+40°C), overload 1.1 x $I_L$ (1 min./10 min.)
Starting Torque	110%
Output Frequency	0 to 320 Hz
Frequency Resolution	0.01 Hz
<b>Control Characteristics</b>	
Control Method	Frequency Control (V/f) Open Loop Sensorless Vector Control
Switching Frequency	Adjustable with <b>Switching Frequency</b> 230V: 1 – 20 hp: 1 to 16 kHz; default 10 kHz 25 – 40 hp: 1 to 10 kHz; default 3.6 kHz 480V: 1 – 40 hp: 1 to 16 kHz; default 10 kHz 50 – 250 hp: 1 to 10 kHz; default 3.6 kHz 575V: All hp: 1 to 6 kHz; default 1.5 kHz
Frequency Reference	Analog Input: Resolution 0.1% (10-bit), accuracy ±1% Panel Reference: Resolution 0.01 Hz
Field Weakening Point	30 to 320 Hz
Acceleration Time	0.1 to 3000 sec.
Deceleration Time	0.1 to 3000 sec.
Braking Torque	DC brake: 15% to 150% x $T_n$ (without brake option)
<b>Environment</b>	
Ambient Operating Temperature	14°F (-10°C), no frost to 104°F (+40°C)
Storage Temperature	-40°F (-40°C) to 158°F (70°C)
Relative Humidity	0 to 95% RH, noncondensing, non-corrosive, no dripping water
Air Quality	Chemical vapors: IEC 60721-3-3, unit in operation, class 3C2 Mechanical particles: IEC 60721-3-3, unit in operation, class 3S2
Altitude	100% load capacity (no derating) up to 3300 ft. (1000m); 1% derating for each 330 ft. (100m) above 3300 ft. (1000m); max. 10000 ft. (3000m)

**Table A-1: HVX9000 Drive Specifications, continued**

Description	Specification
<b>Environment, continued</b>	
Vibration	EN 50178, EN 60068-2-6 5 to 50 Hz, displacement amplitude 1 mm (peak) at 3 to 15.8 Hz, Max. acceleration amplitude 1 G at 15.8 to 150 Hz
Shock	EN 50178, EN 60068-2-27 UPS Drop test (for applicable UPS weights) Storage and shipping: max. 15 G, 11 ms (in package)
Enclosure Class	NEMA 1/IP21 standard 250 hp and below Open chassis standard 300 hp and above
<b>Standards</b>	
EMC (at default settings)	Immunity: Fulfills all EMC immunity requirements Emissions: EN 61800-3
Safety	UL 508C
Product	IEC 61800-2
<b>Control Connections</b>	
Analog Input Voltage	0 to 10V, R - 200 $\Omega$ differential (-10 to 10V joystick control) Resolution 0.1%; accuracy $\pm$ 1%
Analog Input Current	0(4) to 20 mA; R <sub>i</sub> - 250 $\Omega$ differential
Digital Inputs (6)	Positive or negative logic; 18 to 24V DC
Auxiliary Voltage	+24V $\pm$ 15%, max. 250 mA
Output Reference Voltage	+10V +3%, max. load 10 mA
Analog Output	0(4) to 20 mA; R <sub>L</sub> max. 500 $\Omega$ ; Resolution 10 bit; Accuracy $\pm$ 2% or 0 to 10V, R <sub>L</sub> 1 k $\Omega$ , select with jumper
Digital Outputs	Open collector output, 50 mA/48V
Relay Outputs	2 programmable Form C relay outputs Switching capacity: 24V DC / 8A, 250V AC / 8A, 125V DC / 0.4A Minimum switching load: 5V/10 mA Continuous capacity: <2 A <sub>rms</sub>
<b>Protections</b>	
Overcurrent Protection	Yes
Undervoltage Protection	Yes
Ground (Earth) Fault	In case of a ground fault in motor or motor cables, only the HVX9000 is protected
Input Phase Supervision	Trips if any of the input phases are missing
Motor Phase Supervision	Trips if any of the output phases are missing
Overtemperature Protection	Yes
Motor Overload Protection	Yes
Motor Stall Protection	Yes
Motor Underload Protection	Yes
Short Circuit Protection of the +24V and +10V Reference Voltages	Yes

April 2005

## Power Ratings

**Table A-2: 230V VT Output Power Ratings**

Catalog Number ①	Frame Size	Three-Phase Input	
		Horsepower	Current
HVX001Ax-2A_1	FR4	1	4.8
HVXF15Ax-2A_1		1-1/2	6.6
HVX002Ax-2A_1		2	7.8
HVX003Ax-2A_1		3	11
HVX005Ax-2A_1	FR5	5	17.5
HVX007Ax-2A_1		7-1/2	25
HVX010Ax-2A_1		10	31
HVX015Ax-2A_1	FR6	15	48
HVX020Ax-2A_1		20	61
HVX025Ax-2A_1	FR7	25	75
HVX030Ax-2A_1		30	88
HVX040Ax-2A_1		40	114

① Insert a "1" for NEMA Type 1 or a "2" for NEMA Type 12 in place of the "x" in the Catalog Number.

**Table A-3: 480V VT Output Power Ratings**

Catalog Number ①	Frame Size	Three-Phase Input	
		Horsepower	Current
HVXF15Ax-4A_1	FR4	1-1/2	3.3
HVX002Ax-4A_1		2	4.3
HVX003Ax-4A_1		3	5.6
HVX005Ax-4A_1		4	7.6
HVX007Ax-4A_1		7-1/2	12
HVX010Ax-4A_1	FR5	10	16
HVX015Ax-4A_1		15	23
HVX020Ax-4A_1		20	31
HVX025Ax-4A_1	FR6	25	38
HVX030Ax-4A_1		30	46
HVX040Ax-4A_1		40	61
HVX050Ax-4A_1	FR7	50	72
HVX060Ax-4A_1		60	87
HVX075Ax-4A_1		75	105
HVX100Ax-4A_1	FR8	100	140
HVX125Ax-4A_1		125	170
HVX150Ax-4A_1		150	205
HVX200Ax-4A_1	FR9	200	261
HVX250Ax-4A_1		250	300
HVX300A0-4A_1	FR10	300	385
HVX400A0-4A_1		400	520

① Insert a "1" for NEMA Type 1 or a "2" for NEMA Type 12 in place of the "x" in the Catalog Number.

**Table A-4: 575V VT Output Power Ratings**

Catalog Number	Frame Size	Three-Phase Input	
		Horsepower	Current
HVX003A1-5A4N1	FR6	3	4.5
HVX005A1-5A4N1		5	7.5
HVX007A1-5A4N1		7-1/2	10
HVX010A1-5A4N1		10	13.5
HVX015A1-5A4N1	FR6	15	18
HVX020A1-5A4N1		20	22
HVX025A1-5A4N1		25	27
HVX030A1-5A4N1		30	34
HVX040A1-5A4N1	FR7	40	41
HVX050A1-5A4N1		50	52
HVX060A1-5A4N1	FR8	60	62
HVX075A1-5A4N1		75	80
HVX100A1-5A4N1		100	100
HVX125A1-5A4N1	FR9	125	125
HVX150A1-5A4N1		150	144
HVX200A1-5A4N1		200	208

## Power Loss and Switching Frequency

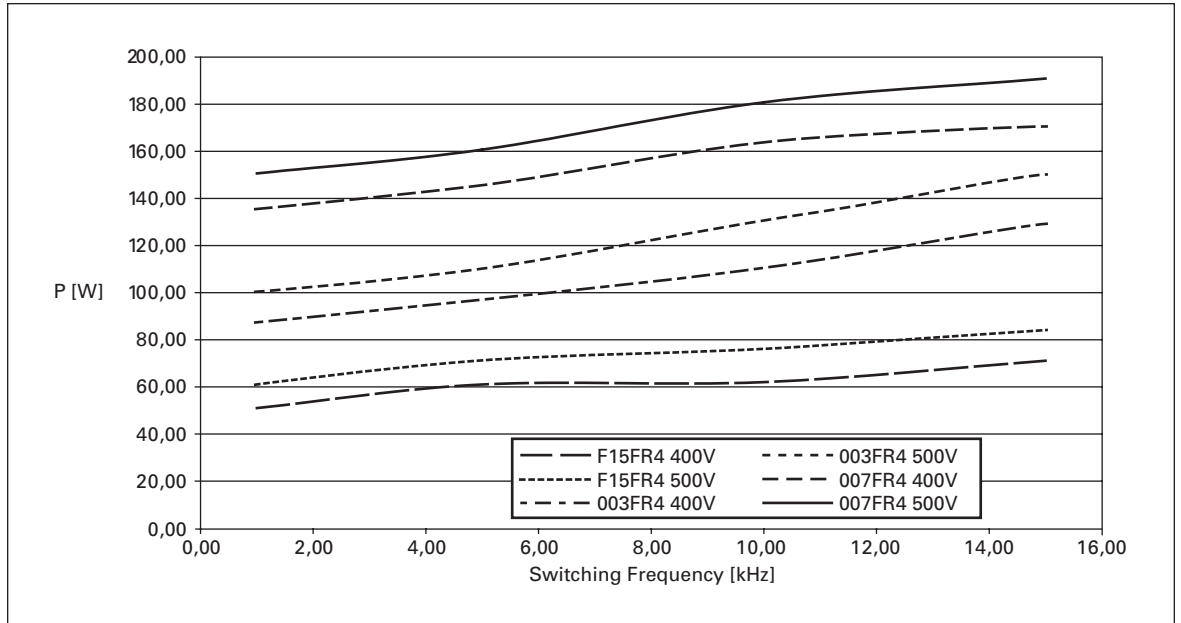
In some situations it may be desirable to change the switching frequency of the HVX9000 for some reason (typically e.g. to reduce the motor noise). Raising the switching frequency above the factory default level increases the drive power loss and increases the cooling requirements. **Figures A-1** through **A-6** illustrate the power loss increase for the different HVX9000 models. When operating above the default switching frequency, the HVX9000 output current rating should be derated by the ratio of the increased power loss to the nominal power loss.

*Example:* The user of a 40 hp, 61A, 480V HVX9000 wishes to increase the switching frequency from the factory default value of 10 kHz to 15 kHz to reduce motor noise. From **Figure A-3** the loss at the factory default switching frequency of 10 kHz is 1240 watts. The loss at 15 kHz from **Figure A-3** is 1340 watts.

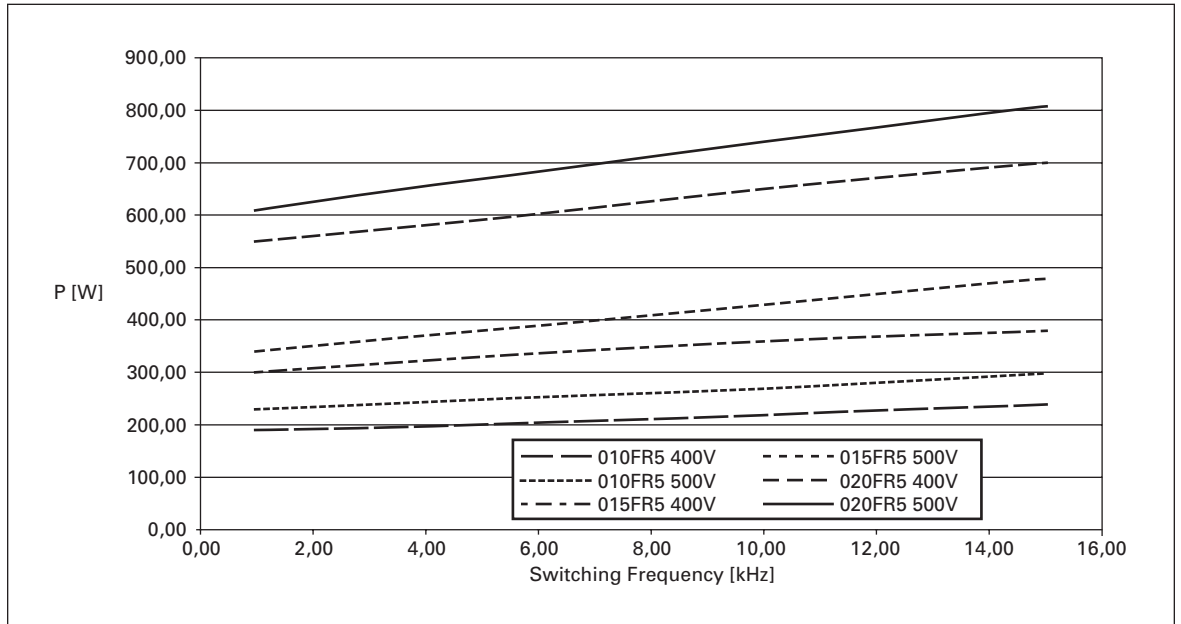
$$\text{Re rate} = 61 \times \frac{1240}{1340} = 56\text{A}$$

Thus at the increased switching frequency, the maximum load allowed is 56A to avoid overheating the HVX9000.

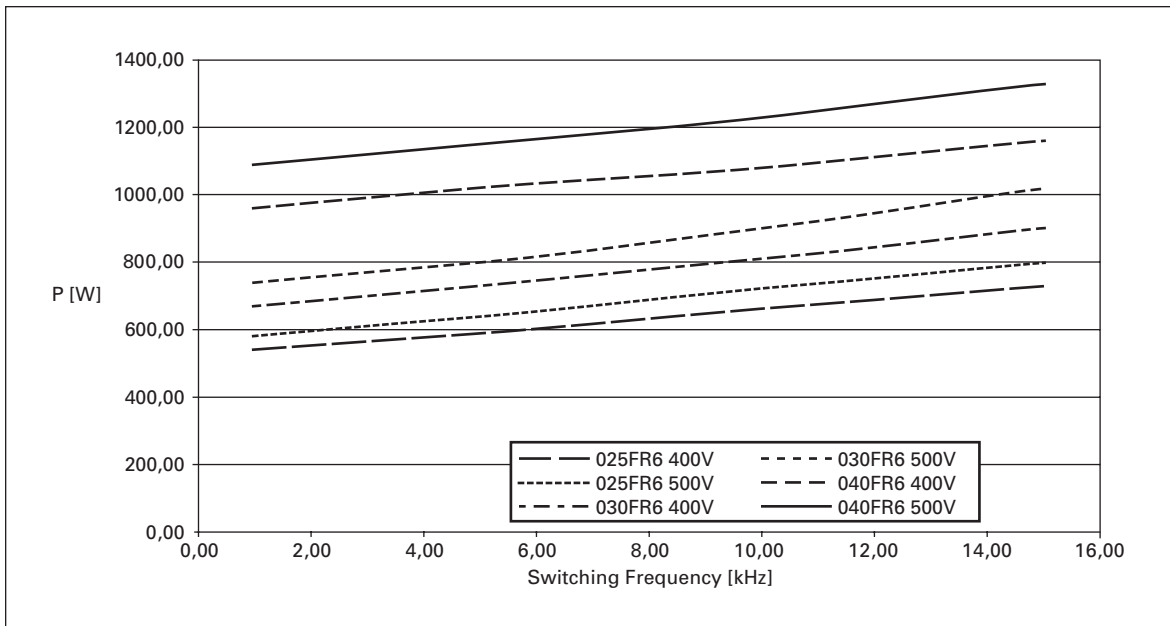
April 2005



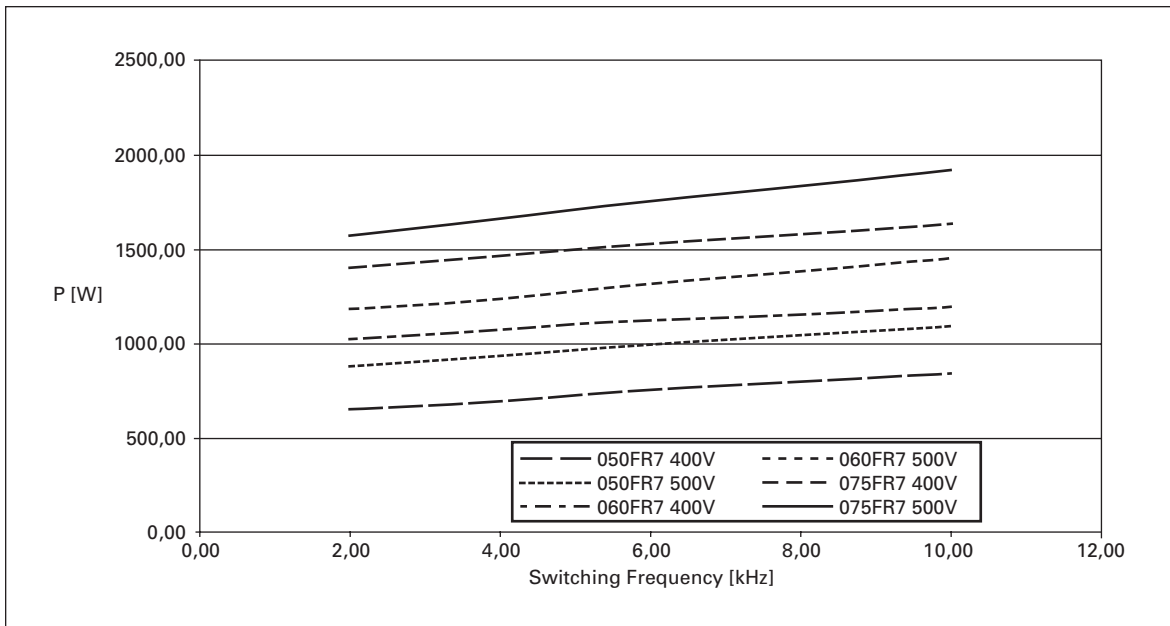
**Figure A-1: Power Loss as Function of Switching Frequency:  
1 – 3 hp 230V, 1-1/2 – 7-1/2 hp 480V**



**Figure A-2: Power Loss as Function of Switching Frequency:  
5 – 10 hp 230V, 10 – 20 hp 480V**

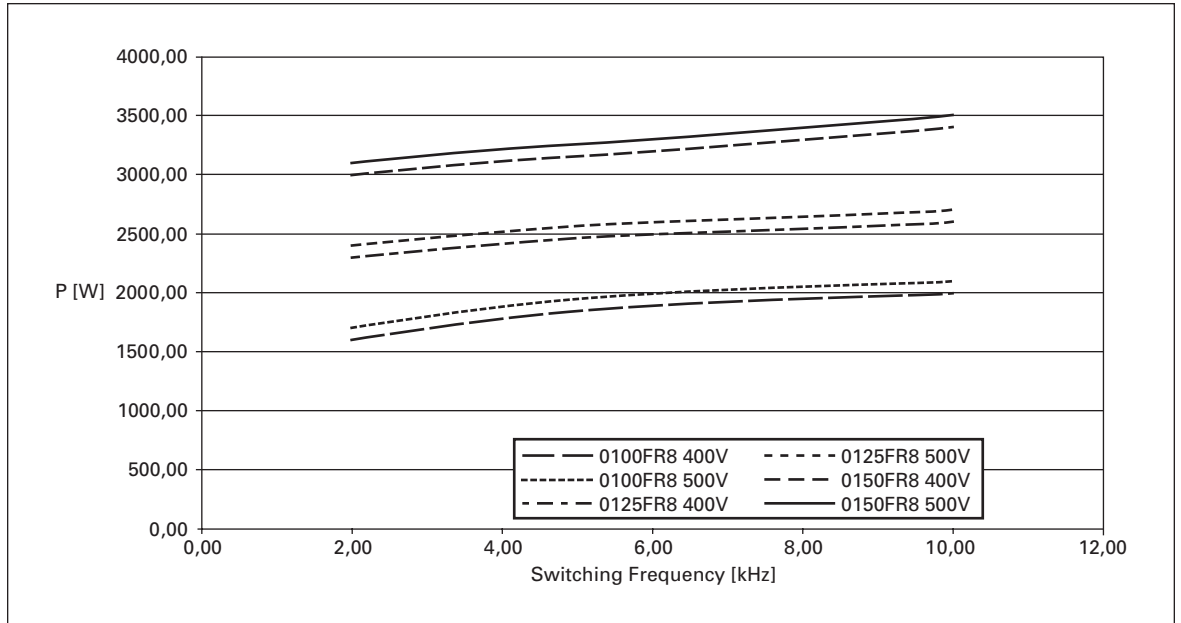


**Figure A-3: Power Loss as Function of Switching Frequency:  
15 – 20 hp 230V, 25 – 40 hp 480V**

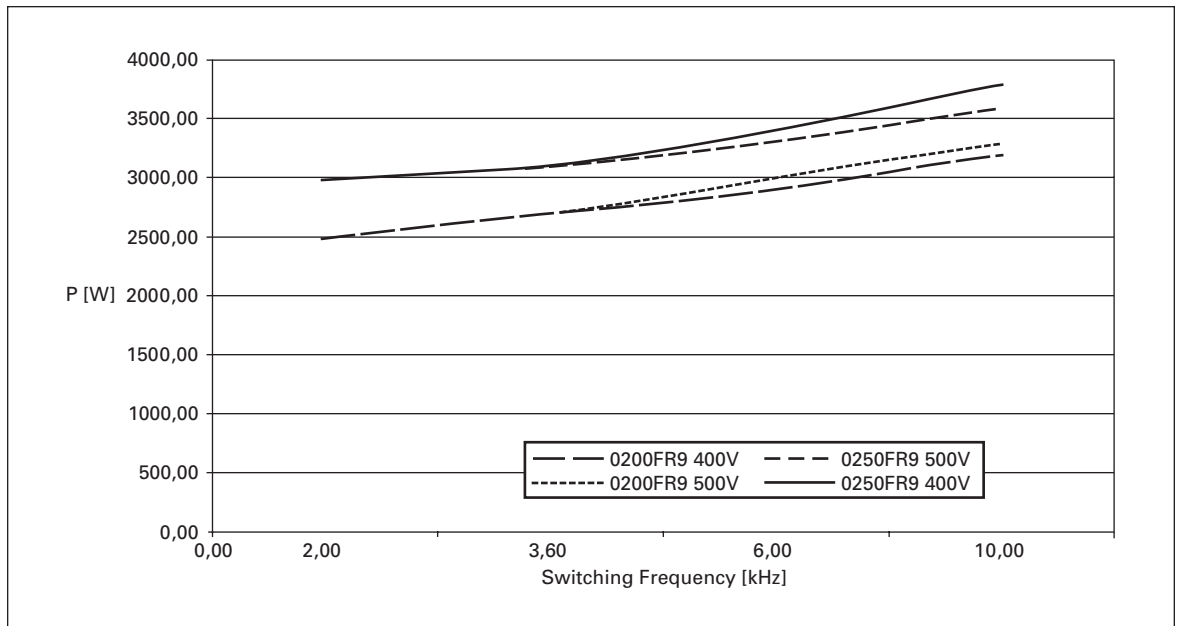


**Figure A-4: Power Loss as Function of Switching Frequency:  
50 – 75 hp 480V**

April 2005



**Figure A-5: Power Loss as Function of Switching Frequency:  
100 – 150 hp 480V**



**Figure A-6: Power Loss as Function of Switching Frequency:  
200 – 250 hp 480V**

## Dimensions

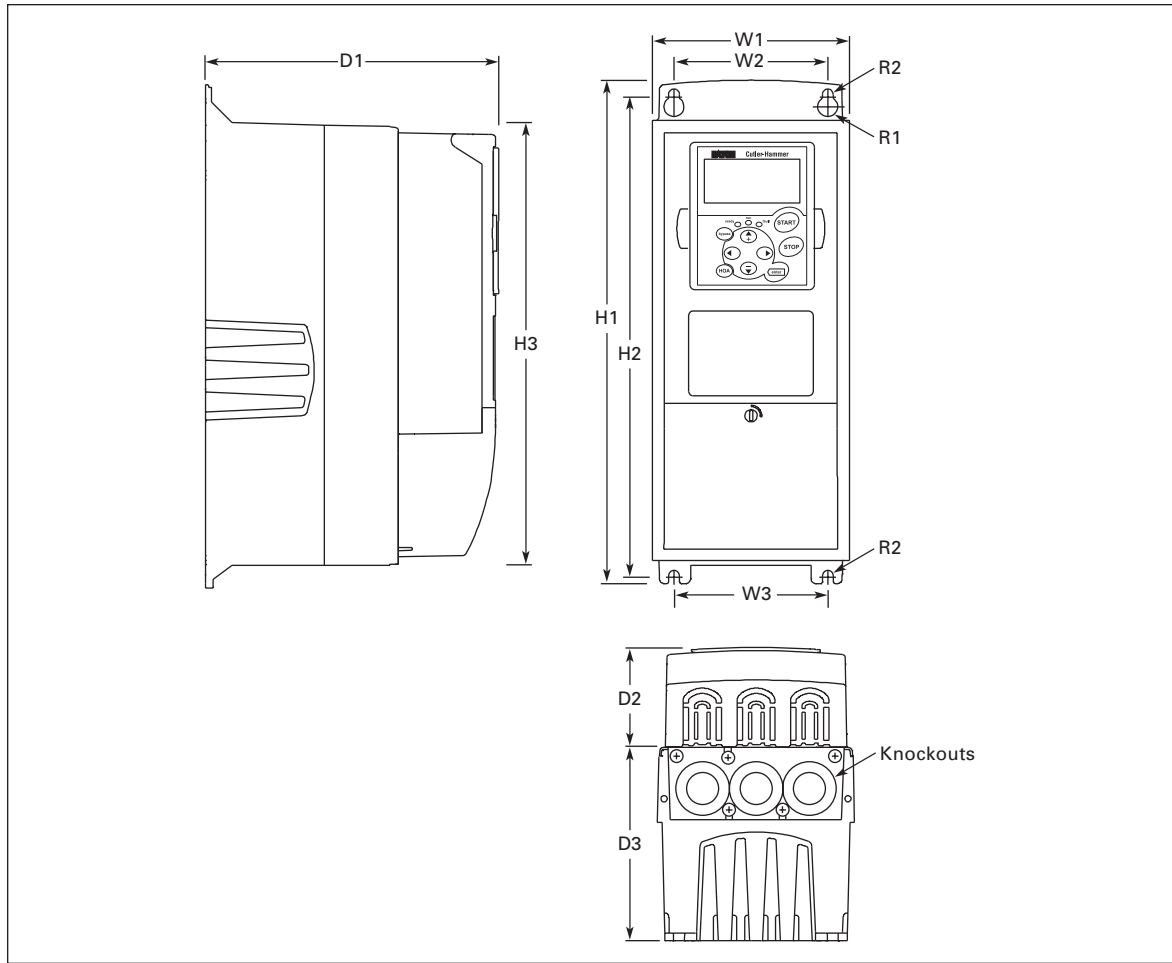


Figure A-7: NEMA Type 1 and NEMA Type 12 HVX9000 Drive Dimensions, FR4, FR5 and FR6

Table A-5: HVX9000 Drive Dimensions

Frame Size	Voltage	hp (VT)	Approximate Dimensions in Inches (mm)										Weight Lbs. (kg)	Knockouts @ Inches (mm) N1 (O.D.)	
			H1	H2	H3	D1	D2	D3	W1	W2	W3	R1 dia.			R2 dia.
FR4	230V	1 – 3	12.9 (327)	12.3 (313)	11.5 (292)	7.5 (190)	2.5 (64)	5.0 (126)	5.0 (128)	3.9 (100)	—	.5 (13)	.3 (7)	11.0 (5)	3 @ 1.1 (28)
	480V	1-1/2 – 7-1/2													
FR5	230V	5 – 10	16.5 (419)	16.0 (406)	15.4 (391)	8.4 (214)	2.7 (68)	5.7 (148)	5.7 (144)	3.9 (100)	—	.5 (13)	.3 (7)	17.9 (8)	2 @ 1.5 (37) 1 @ 1.1 (28)
	480V	10 – 20													
FR6	230V	15 – 20	22.0 (558)	21.3 (541)	20.4 (519)	9.3 (237)	2.7 (68)	6.7 (171)	7.6 (195)	5.8 (148)	—	.7 (18)	.4 (9)	40.8 (19)	3 @ 1.5 (37)
	480V	25 – 40													

April 2005

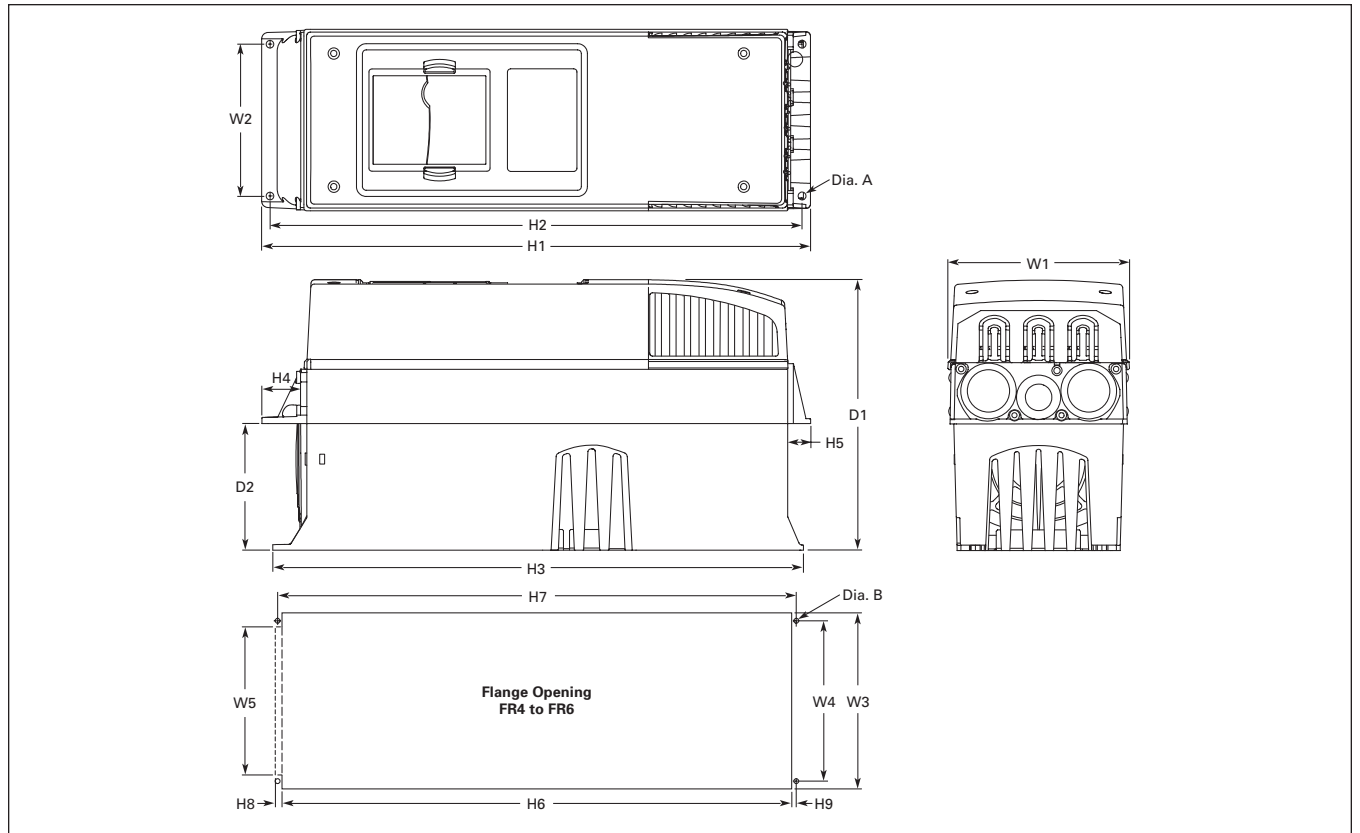


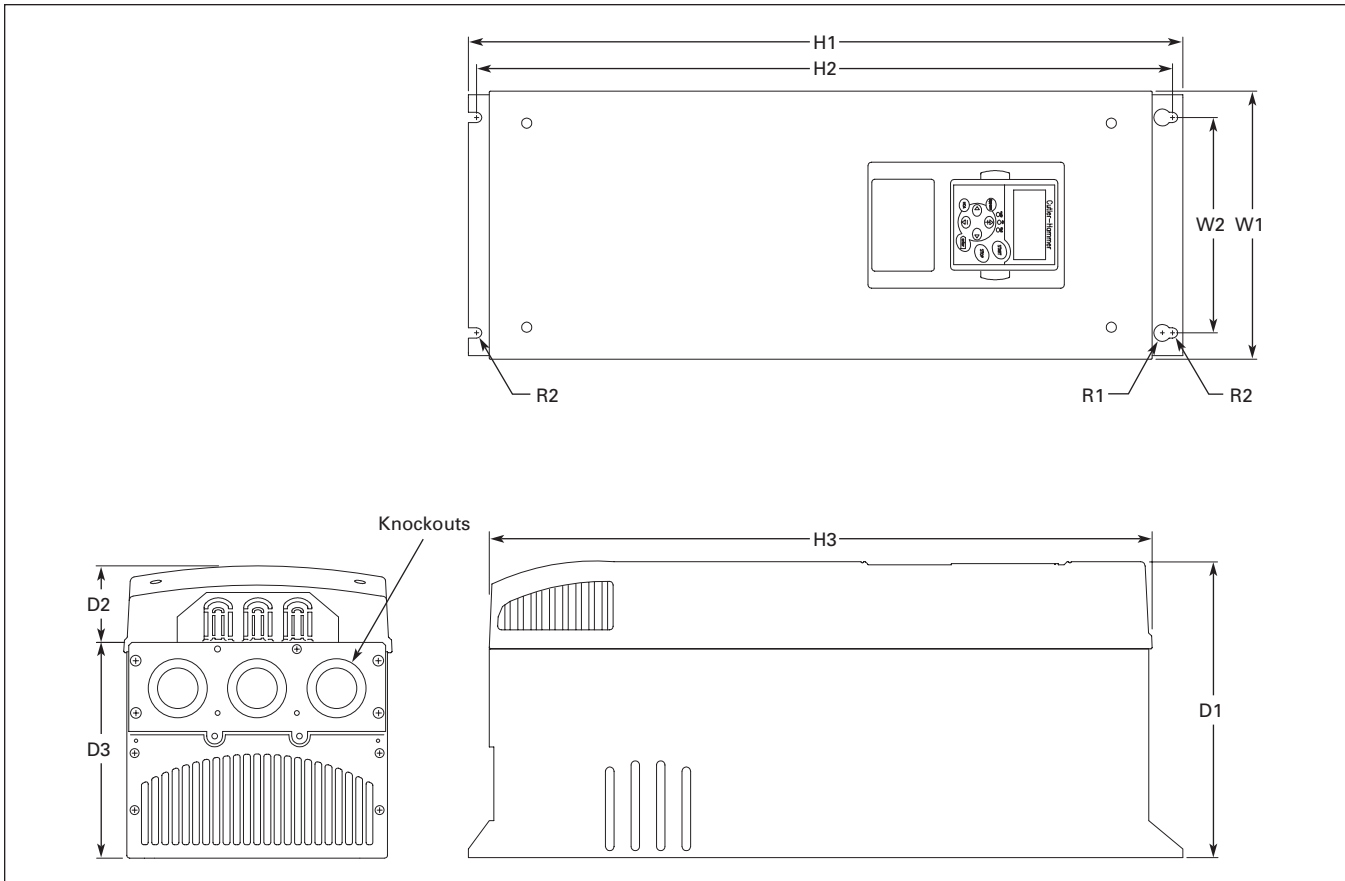
Figure A-8: HVX9000 Dimensions, NEMA Type 1 and NEMA Type 12 with Flange Kit, FR4, FR5 and FR6

Table A-6: Dimensions for HVX9000, FR4, FR5 and FR6 with Flange Kit

Frame Size	Voltage	Approximate Dimensions in Inches (mm)									
		W1	W2	H1	H2	H3	H4	H5	D1	D2	Dia. A
FR4	230V	5.0	4.5	13.3	12.8	12.9	1.2	.9	7.5	3.0	.3
	480V	(128)	(113)	(337)	(325)	(327)	(30)	(22)	(190)	(77)	(7)
FR5	230V	5.7	4.7	17.0	16.5	16.5	1.4	.7	8.4	3.9	.3
	480V	(144)	(120)	(434)	(420)	(419)	(36)	(18)	(214)	(100)	(7)
FR6	230V	7.7	6.7	22.0	21.6	22.0	1.2	.8	9.3	4.2	.3
	480V	(195)	(170)	(560)	(549)	(558)	(30)	(20)	(237)	(106)	(7)
	575V										

Table A-7: Dimensions for the Flange Opening, FR4 to FR6

Frame Size	Voltage	Approximate Dimensions in Inches (mm)							
		W3	W4	W5	H6	H7	H8	H9	Dia. B
FR4	230V	4.8	4.5	—	12.4	12.8	—	.2	.3
	480V	(123)	(113)		(315)	(325)		(5)	(7)
FR5	230V	5.3	4.7	—	16.2	16.5	—	.2	.3
	480V	(135)	(120)		(410)	(420)		(5)	(7)
FR6	230V	7.3	6.7	6.2	21.2	21.6	.3	.2	.3
	480V	(185)	(170)	(157)	(539)	(549)	(7)	(5)	(7)
	575V								

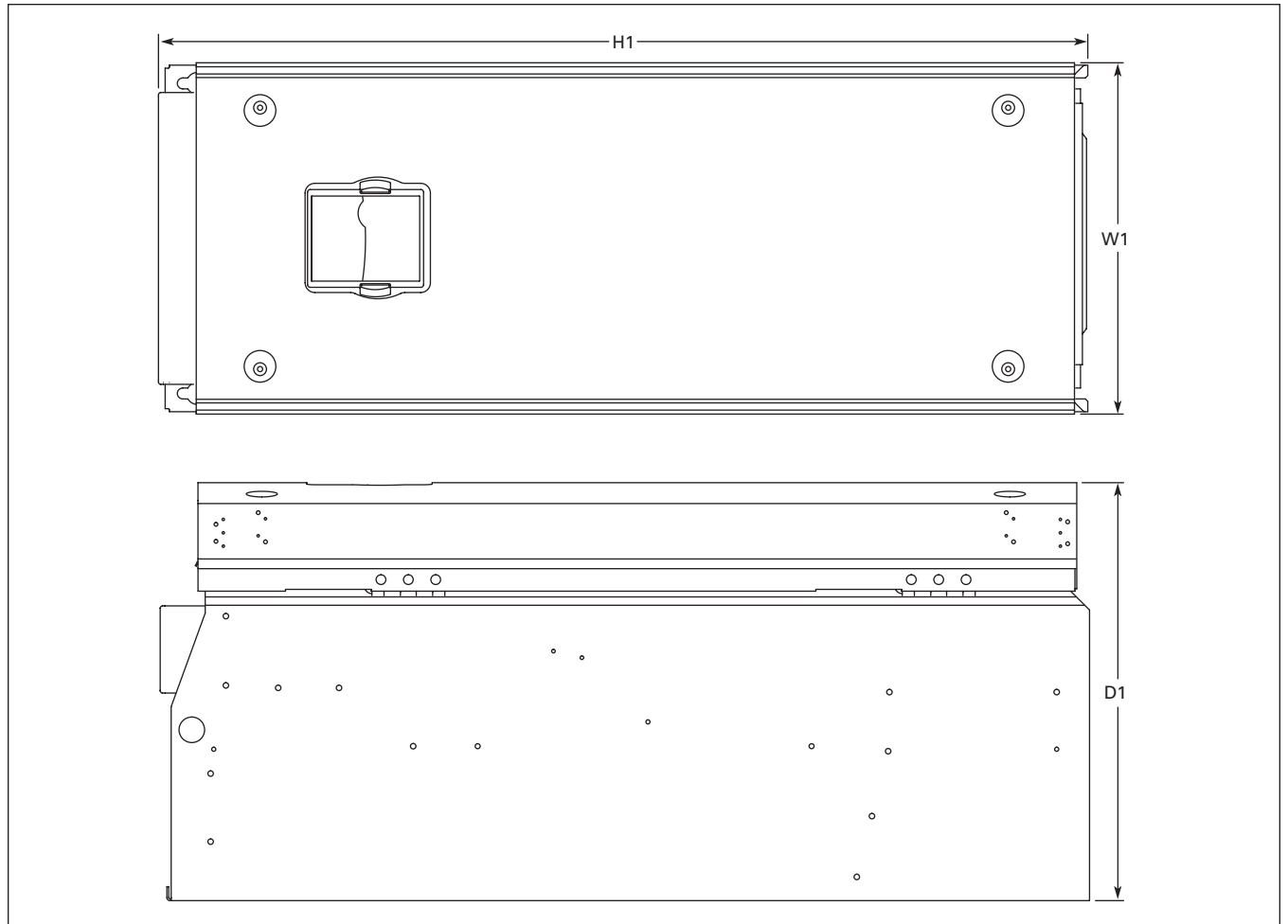


**Figure A-9: HVX9000 Dimensions, NEMA Type 1 and NEMA Type 12, FR7**

**Table A-8: HVX9000 Drive Dimensions, FR7**

Frame Size	Voltage	hp (VT)	Approximate Dimensions in Inches (mm)										Weight Lbs. (kg)	Knockouts @ Inches (mm)
			H1	H2	H3	D1	D2	D3	W1	W2	R1 dia.	R2 dia.		N1 (O.D.)
FR7	230V	25 – 40	24.8 (630)	24.2 (614)	23.3 (591)	10.1 (257)	2.7 (68)	7.5 (190)	9.3 (237)	7.5 (190)	.7 (18)	.4 (9)	77.2 (35)	3 @ 1.5 (37)
	480V	50 – 75												
	575V	40 – 50												

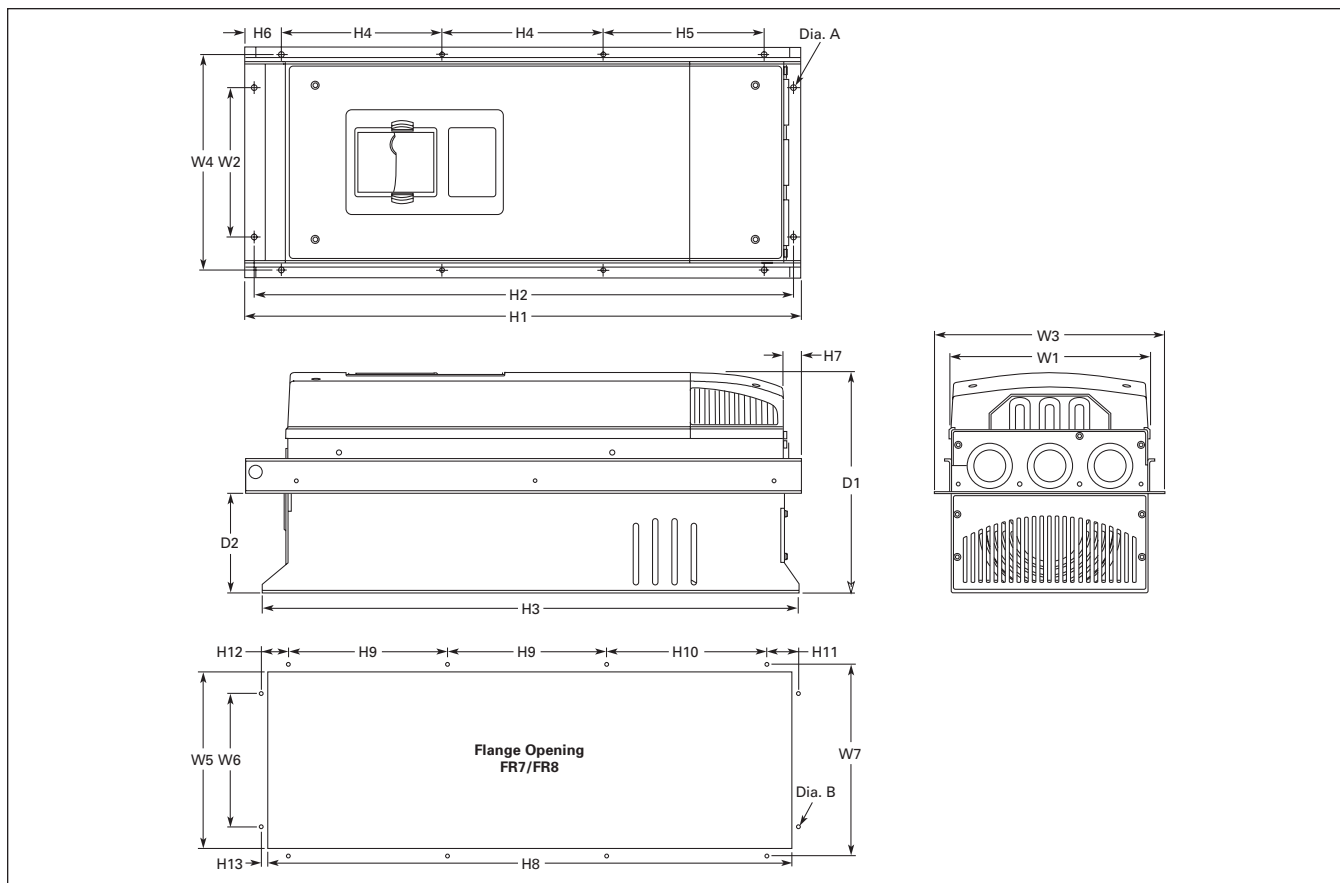
April 2005



**Figure A-10: HVX9000 Dimensions, NEMA Type 1 and NEMA Type 12, FR8**

**Table A-9: HVX9000 Drive Dimensions, FR8**

Frame Size	Voltage	hp (VT)	Approximate Dimensions in Inches (mm)		
			D1	H1	W1
FR8	480V	100 – 150	13.5 (344)	30.1 (764)	11.4 (289)
	575V	60 – 100			



**Figure A-11: HVX9000 Dimensions, NEMA Type 1 and NEMA Type 12, with Flange Kit, FR7 and FR8**

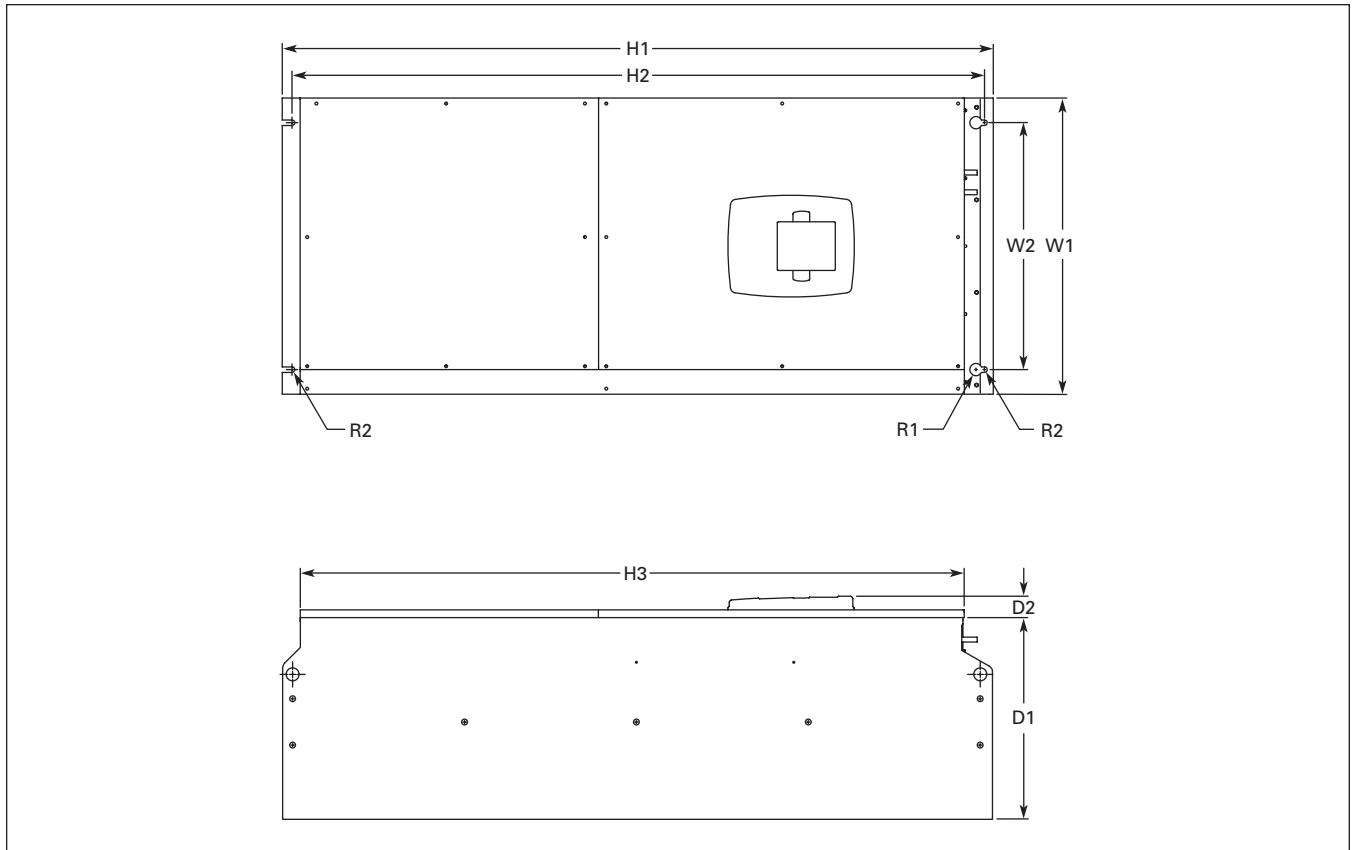
**Table A-10: Dimensions for HVX9000, FR7 and FR8 with Flange Kit**

Frame Size	Voltage	Approximate Dimensions in Inches (mm)													
		W1	W2	W3	W4	H1	H2	H3	H4	H5	H6	H7	D1	D2	Dia. A
FR7	230V	9.3	6.8	10.6	10.0	25.6	24.8	24.8	7.4	7.4	.9	.8	10.1	4.6	.3
	480V	(237)	(175)	(270)	(253)	(652)	(632)	(630)	(189)	(189)	(23)	(20)	(257)	(117)	(6)
	575V														
FR8	480V	11.2	—	14.0	13.0	32.8	—	29.3	10.2	10.4	1.7	2.2	13.5	4.3	.4
	575V	(285)		(355)	(330)	(832)		(745)	(258)	(265)	(43)	(57)	(344)	(110)	(9)

**Table A-11: Dimensions for the Flange Opening, FR7/FR8**

Frame Size	Voltage	Approximate Dimensions in Inches (mm)										
		W5	W6	W7	H8	H9	H10	H11	H12	H13	Dia. B	
FR7	230V	9.2	6.9	10.0	24.4	7.4	7.4	1.4	1.3	.3	.3	
	480V	(233)	(175)	(253)	(619)	(189)	(189)	(35)	(32)	(7)	(6)	
	575V											
FR8	480V	11.9	—	13.0	31.9	10.2	10.4	—	—	—	.4	
	575V	(301)		(330)	(810)	(258)	(265)				(9)	

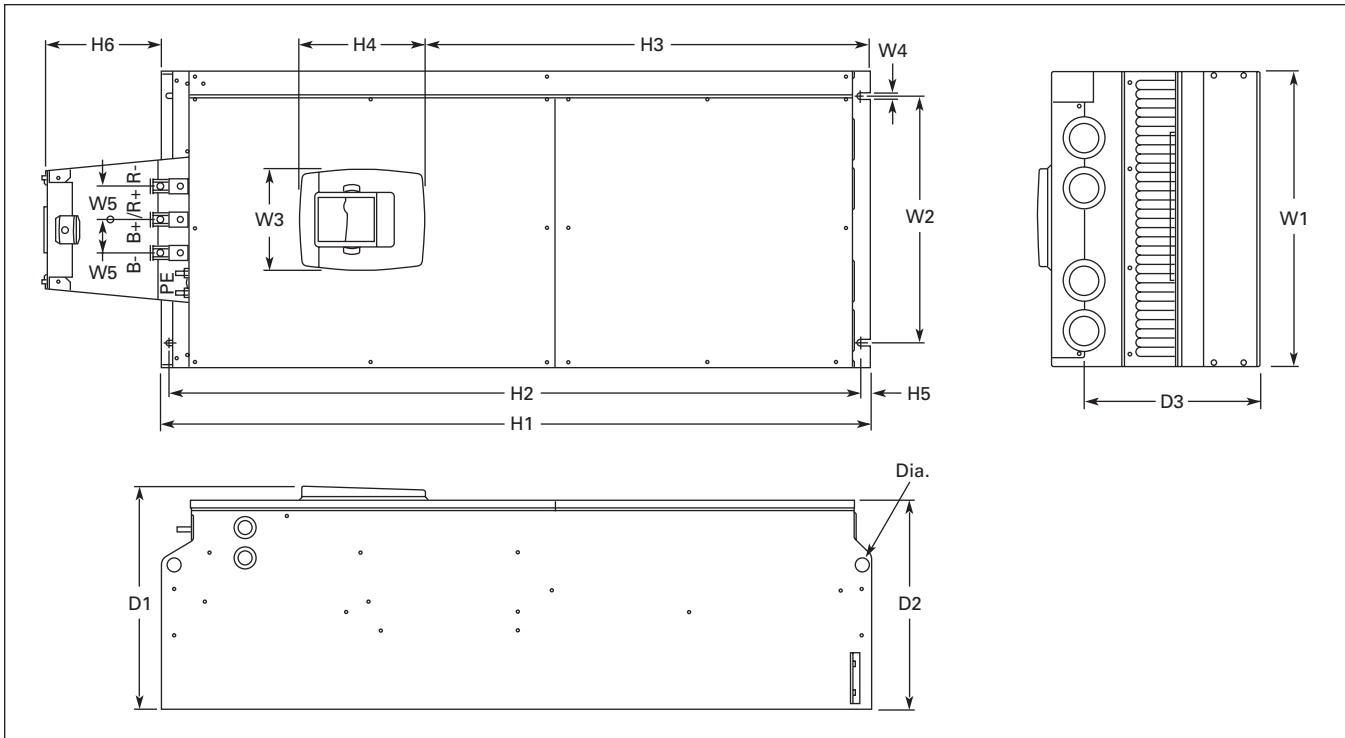
April 2005



**Figure A-12: HVX9000 Dimensions, NEMA Type 1 and NEMA Type 12, FR9**

**Table A-12: HVX9000 Drive Dimensions, FR9**

Frame Size	Voltage	hp (VT)	Approximate Dimensions in Inches (mm)								
			H1	H2	H3	D1	D2	W1	W2	R1 dia.	R2 dia.
FR9	480	200 – 250	45.3 (1152)	44.2 (1122)	42.4 (1076)	12.9 (327)	1.4 (35)	18.9 (480)	15.7 (400)	.8 (20)	.4 (9)
	575	125 – 200									



**Figure A-13: HVX9000 Dimensions, NEMA Type 1 and NEMA Type 12 FR9**

**Table A-13: Dimensions for HVX9000, FR9**

Frame Size	Voltage	Approximate Dimensions in Inches (mm)														
		W1	W2	W3	W4	W5	H1	H2	H3	H4	H5	H6 ①	D1	D2	D3	Dia.
FR9	480V	18.9	15.7	6.5	.4	2.1	45.3	44.2	28.3	8.0	.6	7.4	14.3	12.9	11.2	.8
	575V	(480)	(400)	(165)	(9)	(54)	(1152)	(1122)	(721)	(205)	(16)	(188)	(362)	(327)	(285)	(21)

① Brake resistor terminal box (H6) included when brake chopper ordered.

April 2005

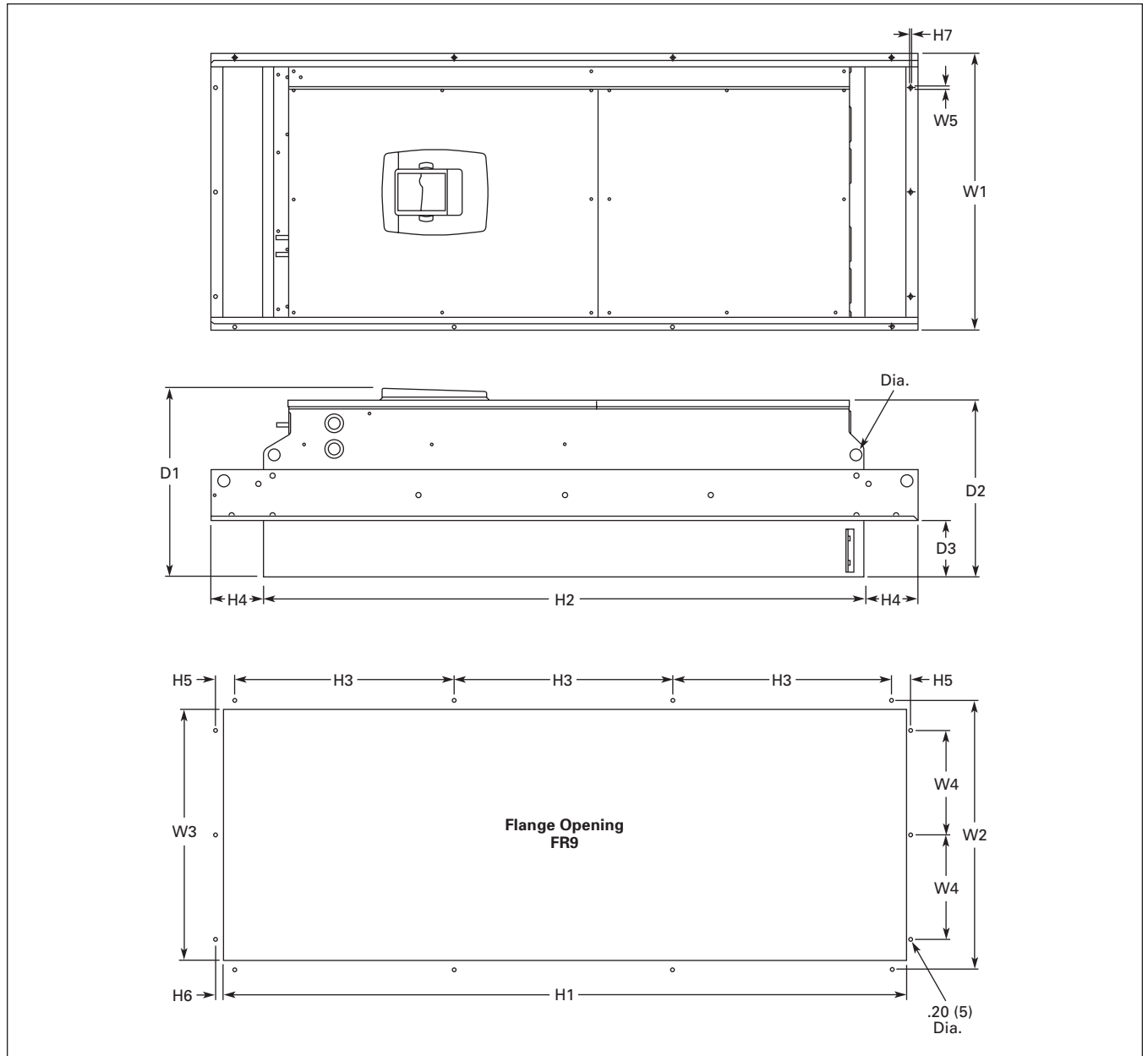
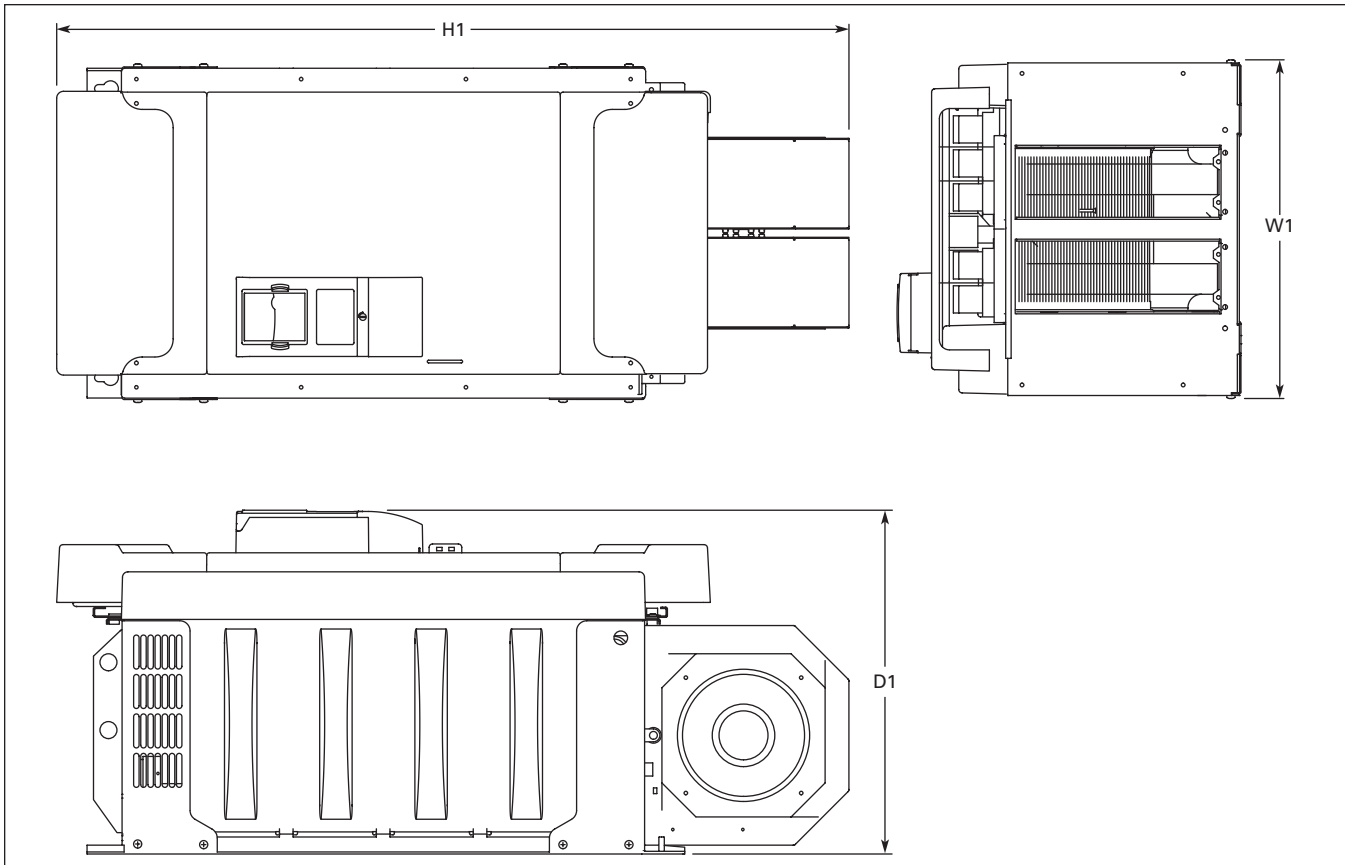


Figure A-14: HVX9000 Dimensions, NEMA Type 1 and NEMA Type 12 FR9 with Flange Kit

Table A-14: Dimensions for HVX9000, FR9 with Flange Kit

Frame Size	Voltage	Approximate Dimensions in Inches (mm)															
		W1	W2	W3	W4	W5	H1	H2	H3	H4	H5	H6	H7	D1	D2	D3	Dia.
FR9	480V	20.9	20.0	19.1	7.9	.2	51.7	45.3	16.5	3.9	1.4	.4	.1	24.9	13.4	4.3	.8
	575V	(530)	(510)	(485)	(200)	(6)	(1312)	(1150)	(420)	(100)	(35)	(9)	(2)	(362)	(340)	(109)	(21)



**Figure A-15: HVX9000 Dimensions, FR10 Open Chassis**

**Table A-15: Dimensions for HVX9000, FR10 Open Chassis**

Frame Size	Voltage	hp (VT)	Approximate Dimensions in Inches (mm)		
			W1	H1	D1
FR10	480V	300 – 400	19.7 (500)	45.9	19.9 (506)
	575V	250 – 400		(1165)	

April 2005

## EMC Capability

### *General*

For products used within the European Community (EC), the Electro Magnetic Compatibility (EMC) directive states that the electrical equipment must not disturb the environment and must be immune to other Electro Magnetic Disturbances in the environment.

The design intent was to develop a family of drives, which is user friendly and cost effective, while fulfilling the user's needs. EMC compliance was a major consideration from the outset of the design.

The HVX9000 derive series is targeted at the world market. To ensure maximum flexibility, yet meet the EMC needs of different regions, all drives meet the highest immunity levels, while emission levels meet the requirements noted in the following section.

### *EMC Classification*

The HVX9000 drive series are EMC classification H capable.

#### **Class H:**

HVX9000 drives have been designed to fulfill the requirements of the product standard EN 61800-3\_A11 for the 1st environment restricted distribution and the 2nd environment.

The emission levels correspond to the requirements of EN 61000-6-4.

HVX9000 series drives fulfill all applicable EMC immunity requirements (standards EN 61000-6-1, EN 61000-6-2 and EN 61800-3+A11).

## Declaration of Conformity

The Manufacturer's Declarations of Conformity assuring the compliance of the HVX9000 drives with the European Community (EC) EMC-directives is available upon request.

## Warranty and Liability Information

Eaton Electrical Inc. warrants the product delivered in the Cutler-Hammer shipping package to be free from defects in material and workmanship, under normal use and service, for twenty four (24) months from date of manufacturing. Products that fail during this period will be repaired or replaced at Eaton's discretion, with the same or a functionally equivalent product, provided the original purchaser (A) returns the failed product, and (B) provides proof of original date of purchase. This warranty does not apply, in the judgment of Eaton, to damage caused during shipment, handling, storage, or accidental misuse. The original purchaser of the product must obtain a Cutler-Hammer Return Material Authorization (RMA) number prior to returning any defective product. (When purchased through an Authorized Distributor, the Distributor should supply an RMA number to their customer.)

The maximum liability of this warranty is limited to the purchase price of the product. In no event, regardless of cause, shall Eaton Electrical Inc. be liable (a) for penalties or penalty clauses of any description, or (b) for certification not otherwise specifically provided herein and/or indemnification of purchaser or others for costs, damages or expenses, each arising out of or related to the product or services of any order or (c) for any damages resulting from loss of profits, use of products or for any incidental indirect or consequential damages, even if advised of the possibility of such damages.

April 2005

## Appendix B — Parameter Tables

**Table B-1: Parameter Group G1.1: Basic**

Code	Parameter	Range	Step	Default	ID #	Description	Page
P1.1.1	Min Frequency	0.00 – Max Frequency	0.01 Hz	12.00	101	Minimum frequency setting	8-1
P1.1.2	Max Frequency	Min Frequency – 320.00	0.01 Hz	60.00	102	Maximum frequency setting	8-1
P1.1.3	Accel Time 1	0.1 – 3000.0	0.1 s	60.0	103	Time from $f_{min}$ ( <b>Minimum Frequency</b> ) to $f_{max}$ ( <b>Maximum Frequency</b> )	8-1
P1.1.4	Decel Time 1	0.1 – 3000.0	0.1 s	60.0	104	Time from $f_{max}$ ( <b>Maximum Frequency</b> ) to $f_{min}$ ( <b>Minimum Frequency</b> )	8-1
P1.1.5	Motor Nom Currnt <sup>①</sup>	0.3 x InHVXL – 2.0 x InHVXL	0.1 A	InHVXL	113	Motor nominal nameplate full load current	8-1
P1.1.6	Motor Nom Voltg <sup>①</sup>	180 – 690	1 V	230 or 460 (Drive Rating)	110	Motor nominal nameplate base voltage	8-1
P1.1.7	Motor Nom Freq <sup>①</sup>	30.00 – 320.00	1 Hz	60.00	111	Motor nominal nameplate base frequency	8-1
P1.1.8	Motor Nom Speed <sup>①</sup>	300 – 20,000	1 rpm	1760	112	Motor nominal nameplate base speed	8-2
P1.1.9	MotorPowerFactor <sup>①</sup>	0.30 – 1.00	0.1 A	0.85	120	Motor nominal nameplate full load power factor	8-2
P1.1.10	Current Limit	0.1 x IL – 2.5 x InHVX Units: Amperes	0.01	InHVX	107	Output current limit level of the HVX9000	8-2
P1.1.11	HOA Control Src	0 – 2	1	0	1530	Hand-Off-Auto control source 0 Control from keypad 1 Control from I/O terminals 2 Control from communication bus	8-2
P1.1.12	Start Src Hand	0 – 3	1	0	1531	Start source for Hand operation 0 Control from keypad 1 BAS 2 3-wire Start/Stop 3 Panel Damper	8-2
P1.1.13	Ref Source Hand	0 – 7	1	4	201	Speed reference source for Hand operation 0 Analog input AI1 1 Analog input AI2 2 Analog input AI3 <sup>②</sup> 3 Analog input AI4 <sup>②</sup> 4 Keypad 5 Communication Bus 6 Motor potentiometer 7 PID-Controller	8-2
P1.1.14	Start Srce Auto	0 – 3	1	1	1532	Start source for Auto operation 0 Control from keypad 1 BAS 2 3-wire Start/Stop 3 Communication Bus	8-3
P1.1.15	Ref Source Auto	0 – 7	1	0	202	Speed reference source for Hand operation 0 Analog input AI1 1 Analog input AI2 2 Analog input AI3 <sup>②</sup> 3 Analog input AI4 <sup>②</sup> 4 Keypad 5 Communication Bus 6 Motor potentiometer 7 PID-Controller	8-3
P1.1.16	PM Setback Pct	0.0 – 100.0	0.1%	30.0	1640	Frequency setting for PM setback operation	8-3

<sup>①</sup> Drive must be stopped to edit these parameters.

<sup>②</sup> Not operational at this time.

**Table B-2: Parameter Group G1.2: Input Signals**

Code	Parameter	Range	Step	Default	ID #	Description	Page
P1.2.1	DIN1 Function	0 – 3	1	0 (Start)	1535	0 Start – standard start 1 Interlocked Start 2 Interlock Time Start 3 Delay Start	8-3
P1.2.2	Intlk Timeout	1 – 32,500	1 s	5 s	1561	Used when DIN1 function = 2	8-3
P1.2.3	Delay Time	1 – 32,500	1 s	5 s	1580	Used when DIN1 function = 3	8-4
P1.2.4	DIN2 Function <sup>①</sup>	0 – 15	1	1 (Ext fault close)	1700	0 Not Used 1 Ext Fault Close 2 Bypass Overload Fault 3 Run enable/External interlock 4 Accel/decel time selection 5 Hand/Auto Select 6 PID Control 7 Motor potentiometer down 8 PID Reference 2 Select 9 PM Setback 10 Fault reset 11 Accel/decel prohibited 12 HOA On/Off 13 Speed Select 3 14 Fire Mode 15 Fire Mode Reference Select 1/2	8-4
P1.2.5	DIN3 Function <sup>①</sup>	0 – 15	1	10 (Fault Reset)	301	0 Not Used 1 External fault, contact closed 2 External fault, contact open 3 Run enable/External interlock 4 Accel/decel time selection 5 Hand/Auto Select 6 Motor potentiometer up 7 PID Control 8 PID Reference 2 Select 9 Speed Select 1 10 Fault reset 11 Accel/decel prohibited 12 DC braking command 13 Reserved 14 Fire Mode 15 Fire Mode Reference Select 1/2	8-5
P1.2.6	DIN4 Function <sup>①</sup>	0 – 15	1	4 (Accel/decel time sel)	1536	0 Not Used 1 External fault, contact closed 2 External fault, contact open 3 Run enable/External interlock 4 Accel/decel time selection 5 Hand/Auto Select 6 PID Control 7 Motor potentiometer down 8 PID Reference 2 Select 9 PM Setback 10 Fault reset 11 Speed Select 2 12 DC braking command 13 HOA ON/OFF 14 Fire Mode 15 Fire Mode Reference Select 1/2	8-6

<sup>①</sup> Drive must be stopped to edit these parameters.

April 2005

**Table B-2: Parameter Group G1.2: Input Signals, continued**

Code	Parameter	Range	Step	Default	ID #	Description	Page
P1.2.7	DIN5 Function <sup>①</sup>	0 – 15	1	13 (PM Setback)	330	0 Not Used 1 External fault, contact closed 2 External fault, contact open 3 Run enable/External interlock 4 Accel/decel time selection 5 Hand/Auto Select 6 Motor potentiometer up 7 PID Control 8 Reverse 9 DC Brake Comm 10 Fault reset 11 Accel/decel prohibited 12 HOA On/Off 13 PM Setback 14 Fire Mode 15 Fire Mode Reference Select 1 / 2	8-7
P1.2.8	DIN6 Function <sup>①</sup>	0 – 15	1	11 (Speed Select 3)	1537	0 Not Used 1 External fault, contact closed 2 External fault, contact open 3 Run enable/External interlock 4 Accel/decel time selection 5 Hand/Auto Select 6 Motor potentiometer up 7 Motor potentiometer down 8 PID Reference 2 Select 9 PM Setback 10 Fault reset 11 Speed Select 3 12 HOA On/Off 13 Bypass Overload Fault 14 Fire Mode 15 Fire Mode Reference Select 1 / 2	8-8
P1.2.9	AI1 Signal Range	0 – 2	1	0 (0 – 20 mA / 0 – 100%)	320	0 0 – 20 mA 1 4 – 20 mA 2 ID #ized signal range	8-8
P1.2.10	AI1 Custom Min	0.00 – AI1 Custom Minimum	0.01 %	0.00%	321	Used when setting of <b>AI1 Signal Range</b> = 2	8-8
P1.2.11	AI1 Custom Max	AI1 Custom Maximum – 100.00%	0.01 %	100.00%	322	Used when setting of <b>AI1 Signal Range</b> = 2	8-8
P1.2.12	AI1 Signal Inv	0 – 1	1	0 (No Inversion)	323	0 No inversion 1 Signal inverted	8-9
P1.2.13	AI1 Filter Time	0.00 – 10.00	0.01 s	0.10 s	324	0 No filtering	8-9
P1.2.14	AI2 Signal Range	0 – 2	1	1 (4 – 20 mA / 20 – 100%)	325	0 0 – 20 mA 1 4 – 20 mA 2 ID #ized signal range	8-9
P1.2.15	AI2 Custom Min	0.00 – AI2 Custom Max	0.01 %	0.00%	326	Used when setting of <b>AI2 Signal Range</b> = 2	8-9
P1.2.16	AI2 Custom Max	AI2 Custom Min – 100.00%	0.01 %	100.00%	327	Used when setting of <b>AI2 Signal Range</b> = 2	8-9
P1.2.17	AI2 Signal Inv	0 – 1	1	0 (No Inversion)	328	0 No inversion 1 Signal inverted	8-10
P1.2.18	AI2 Filter Time	0.00 – 10.00	0.01 s	0.10 s	329	0.00 No filtering	8-10
P1.2.19	MotorPot Ramp Time	0.1 – 2000.0	0.1 s	10.0 s	331	Ramp rate of motor pot	8-10
P1.2.20	MotorPotMemFreqRef	0 – 2	1	1	367	0 No reset 1 Reset at stop and power down 2 Reset at power down	8-10
P1.2.21	MotorPotMemPIDRef	0 – 2	1	0 (No Reset)	368	0 No reset 1 Reset at stop and power down 2 Reset at power down	8-10
P1.2.22	Ref Scale Min	0.00 – Ref Scale Max	0.01 Hz	0.00	344	Sets the frequency corresponding to the minimum reference signal	8-11

<sup>①</sup> Drive must be stopped to edit these parameters.

**Table B-2: Parameter Group G1.2: Input Signals, continued**

Code	Parameter	Range	Step	Default	ID #	Description	Page
P1.2.23	Ref Scale Max	Ref Scale Min – 320.00	0.01 Hz	0.00	345	Sets the frequency corresponding to the maximum reference signal	8-11
P1.2.24	AI3 Signal Sel	AnIN:0.1 – AnIN:E.10	—	AnIN:0.1	141	Connect the AI3 signal to the analog input	8-11
P1.2.25	AI3 Signal Range	0 – 1	1	1 (4 – 20 mA/20 – 100%)	143	0 0 – 20 mA 1 4 – 20 mA	8-11
P1.2.26	AI3 Signal Inv	0 – 1	1	0 (No Inversion)	151	0 No inversion 1 Signal inverted	8-12
P1.2.27	AI3 Filter Time	0.00 – 10.00	0.01 s	0.10	142	0.00 No filtering	8-12
P1.2.28	AI4 Signal Sel	AnIN:0.1 – AnIN:E.10	—	AnIN:0.1	152	Connect the AI4 signal to the analog input of your choice	8-12
P1.2.29	AI4 Signal Range	0 – 1	1	1 (4 – 20 mA/20 – 100%)	154	0 0 – 20 mA 1 4 – 20 mA	8-12
P1.2.30	AI4 Signal Inv	0 – 1	1	0 (No Inversion)	162	0 No inversion 1 Signal inverted	8-12
P1.2.31	AI4 Filter Time	0.00 – 10.00	0.01 s	0.10	153	0 No filtering	8-12
P1.2.32	INTLK Text DIN2 – INTLK Text DIN6	0 – 9	1	0	1610 – 1614	0 Ext Interlock 1 Run Enable 2 Vibration Cutout 3 High Motor Temperature 4 Freeze Stat Trip 5 Low Pressure 6 High Pressure 7 Low Water 8 Smoke Detect 9 3-Wire Off 10 Damper Interlock 11 Open Safety	8-13

**Table B-3: Parameter Group G1.3: Output Signals**

Code	Parameter	Range	Step	Default	ID #	Description	Page
P1.3.1	Analog Out Function	0 – 13	1	1 (Output Frequency)	307	0 Not used 1 Output frequency (0 – $f_{max}$ ) 2 Frequency reference (0 – $f_{max}$ ) 3 Motor speed (0 – nominal speed) 4 Output current (0 – $I_{nMotor}$ ) 5 Motor torque (0 – $T_{nMotor}$ ) 6 Motor power (0 – $P_{nMotor}$ ) 7 Motor voltage (0 – $V_{nMotor}$ ) 8 DC-link voltage (0 – 1000V) 9 PID controller reference value 10 PID controller actual value 1 11 PID controller actual value 2 12 PID controller error value 13 PID controller output	8-13
P1.3.2	Aout Filter Time	0.00 – 10.00	0.01 s	1.00	308	0 No filtering	8-14
P1.3.3	Aout Invert	0 – 1	1	0 (Not Inverted)	309	0 No inversion 1 Signal inverted	8-14
P1.3.4	Aout Minimum	0 – 1	1	0 (0 mA)	310	0 0 mA 1 4 mA	8-14
P1.3.5	Aout Scale	10 – 1000	10.0 %	100	311	100 % No scaling	8-15

April 2005

**Table B-3: Parameter Group G1.3: Output Signals, continued**

Code	Parameter	Range	Step	Default	ID #	Description	Page
P1.3.6	DO1 Function	1 – 26	1	1 (Ready)	312	1 Ready 2 Run 3 Fault 4 Fault inverted 5 HVX9000 overheat warning 6 External fault or warning 7 Reference fault or warning 8 Warning 9 Reversed 10 Bypass Run 11 At speed 12 Motor regulator activated 13 Output frequency limit 1 supervision 14 Output frequency limit 2 supervision 15 Torque limit supervision 16 Reference limit supervision 17 External brake control 18 Control from I/O terminals 19 Drive temp. limit supervision 20 Unrequested rotation direction 21 External brake control inverted 22 Thermistor fault or warning 23 Pass Through Communication 24 Fire mode is active 25 In Auto Control mode 26 In Hand Control mode	8-16
P1.3.7	RO1 Function	1 – 28	1	2 (Run)	313	Same as <b>Digital Output 1 (DO1) Function</b> except 0 Not used 27 Open Damper 28 Run Bypass or Drive	8-17
P1.3.8	R02 Function	1 – 28	1	3 (Fault)	314	Same as <b>Digital Output 1 (DO1) Function</b> except 0 Not used 27 Start delay relay 28 Run Bypass or Drive	8-18
P1.3.9	R03 Content	1 – 28	1	28 (Run Bypass or Drive)	1520	Same as <b>Digital Output 1 (DO1) Function</b> except 0 Not used 23 Fault Reset 27 Start delay relay 28 Run Bypass or Drive	8-20
P1.3.10	R04 Content	1 – 28	1	10 (Bypass Run)	1522	Same as <b>Digital Output 1 (DO1) Function</b> except 0 Not used 23 Fault Reset 27 Start delay relay 28 Run Bypass or Drive	8-21
P1.3.11	R05 Content	1 – 28	1	23 (Fault Reset)	1523	Same as <b>Digital Output 1 (DO1) Function</b> except 0 Not used 23 Fault Reset 27 Start delay relay 28 Run Bypass or Drive	8-21
P1.3.12	R06 Content	1 – 28	1	0 (Not Used)	1626	With optional relay board only. Same as <b>Digital Output 1 (DO1) Function</b> except 0 Not used 23 Fault Reset 27 Start delay relay 28 Run Bypass or Drive	8-21
P1.3.13	R07 Content	1 – 28	1	0 (Not Used)	1633	With optional relay board only. Same as <b>Digital Output 1 (DO1) Function</b> except 0 Not used 23 Fault Reset 27 Start delay relay 28 Run Bypass or Drive	8-21

Table B-3: Parameter Group G1.3: Output Signals, continued

Code	Parameter	Range	Step	Default	ID #	Description	Page
P1.3.14	R08 Content	1 – 28	1	0 (Not Used)	1645	With optional relay board only. Same as <b>Digital Output 1 (DO1) Function</b> except 0 Not used 23 Fault Reset 27 Start delay relay 28 Run Bypass or Drive	8-21
P1.3.15	Freq Supv Function 1	0 – 2	1	0 (No Supervision)	315	0 No supervision 1 Low limit supervision 2 High limit supervision	8-22
P1.3.16	SpeedSuprValue1	0.0 – 200.0	0.1%	0.0	1591	Speed value supervised by <b>Frequency Supervision Function 1</b>	8-22
P1.3.17	Freq Supv Function 2	0 – 2	1	0 (No Supervision)	346	0 No supervision 1 Low limit supervision 2 High limit supervision	8-22
P1.3.18	SpeedSuprVal 2	0.0 – 200.0	0.1%	0.0	1592	Speed value supervised by <b>Frequency Supervision Function 2</b>	8-22
P1.3.19	Torque Supv Func	0 – 2	1	0 (No Supervision)	348	0 No supervision 1 Low limit supervision 2 High limit supervision	8-23
P1.3.20	Torque Supv Val	0.0 – 300.0	0.1 %	100.0%	349	Torque value supervised by <b>Torque Supervision Function</b>	8-23
P1.3.21	Ref SupERv Lim	0 – 2	1	0 (No Supervision)	350	0 No supervision 1 Low limit supervision 2 High limit supervision	8-23
P1.3.22	Ref SupERv Val	0.0 – 100.0	0.1 %	0.0	351	Torque value supervised by <b>Reference Supervision Limit</b>	8-23
P1.3.23	Ext Brake OffDel	0.0 – 100.0	0.1 s	0.5	352	Off delay after Start/Stop toggle	8-23
P1.3.24	Ext Brake OnDel	0.0 – 100.0	0.1 s	0.5	353	On delay after Start/Stop toggle	8-24
P1.3.25	Temp Func Supv	0 – 2	1	0 (No Supervision)	354	0 No supervision 1 Low limit supervision 2 High limit supervision	8-24
P1.3.26	Temp Supv Value	-10 – 75°C	1°C	40°C	455	Temperature value supervised by <b>Temperature Function Supervision</b>	8-24
P1.3.27	A2out Signal	AnOUT:0.1 – AnOUT:E.10	1	AnOUT:0.1	471	Connect the AO2 signal to the analog output of choice	8-24
P1.3.28	A2out Function	0 – 13	1	4 (Output Current)	472	0 Not used 1 Output frequency (0 – $f_{max}$ ) 2 Frequency reference (0 – $f_{max}$ ) 3 Motor speed (0 – nominal speed) 4 Output current (0 – $I_{nMotor}$ ) 5 Motor torque (0 – $T_{nMotor}$ ) 6 Motor power (0 – $P_{nMotor}$ ) 7 Motor voltage (0 – $V_{nMotor}$ ) 8 DC-link voltage (0 – 1000V) 9 PID controller reference value 10 PID controller actual value 1 11 PID controller actual value 2 12 PID controller error value 13 PID controller output	8-25
P1.3.29	A2out Filter Time	0.00 – 10.00	0.01 s	1.00	473	0.00 No filtering	8-25
P1.3.30	A2out InVert	0 – 1	1	0 (No Inversion)	474	0 No inversion 1 Signal inverted	8-25
P1.3.31	A2out Minimum	0 – 1	1	1 (4 mA)	475	0 0 mA 1 4 mA	8-25
P1.3.32	A2out Scale	0 – 1000	1 %	100%	476	—	8-26
P1.3.33	A3out Signal	AnOUT:0.1 – AnOUT:E.10	1	AnOUT:0.1	478	Connect the AO3 signal to the analog output of choice	8-26

April 2005

**Table B-3: Parameter Group G1.3: Output Signals, continued**

Code	Parameter	Range	Step	Default	ID #	Description	Page
P1.3.34	A3out Function	0 – 13	1	0 (Not used)	479	0 Not used 1 Output frequency (0 – $f_{max}$ ) 2 Frequency reference (0 – $f_{max}$ ) 3 Motor speed (0 – nominal speed) 4 Output current (0 – $I_{nMotor}$ ) 5 Motor torque (0 – $T_{nMotor}$ ) 6 Motor power (0 – $P_{nMotor}$ ) 7 Motor voltage (0 – $V_{nMotor}$ ) 8 DC-link voltage (0 – 1000V) 9 PID controller reference value 10 PID controller actual value 1 11 PID controller actual value 2 12 PID controller error value 13 PID controller output	8-26
P1.3.35	A3out Filter Time	0.00 – 10.00	0.01 s	1.00	480	0.00 No filtering	8-26
P1.3.36	A3out InVert	0 – 1	1	0 (No Inversion)	481	0 No inversion 1 Signal inverted	8-27
P1.3.37	A3out Minimum	0 – 1	1	0 (0 mA)	482	0 0 mA 1 4 mA	8-27
P1.3.38	A3out Scale	0 – 1000	1 %	100%	483	—	8-27

**Table B-4: Parameter Group G1.4: Drive Control**

Code	Parameter	Range	Step	Default	ID #	Description	Page
P1.4.1	Ramp 1 Shape	0.0 – 10.0	0.1	0.0	500	0 Linear >0 S-curve accel/decel	8-27
P1.4.2	Ramp 2 Shape	0.0 – 10.0	0.1	0.0	501	0 Linear >0 S-curve accel/decel	8-28
P1.4.3	Accel Time 2	0.1 – 3000.0	0.1 s	10.0	502	Time from $f_{min}$ ( <b>Minimum Frequency</b> ) to $f_{max}$ ( <b>Maximum Frequency</b> )	8-28
P1.4.4	Decel Time 2	0.1 – 3000.0	0.1 s	10.0	503	Time from $f_{max}$ ( <b>Maximum Frequency</b> ) to $f_{min}$ ( <b>Minimum Frequency</b> )	8-28
P1.4.5	Brake Chopper <sup>Ⓢ</sup>	0 – 3	1	0 (Not Used)	504	0 Brake chopper not used 1 Brake chopper in use (no testing) 2 External brake chopper (no testing) 3 In Ready state (no testing)	8-29
P1.4.6	Start Mode	0 – 1	1	0 (Ramping)	505	0 Ramp 1 Flying start	8-29
P1.4.7	Stop Mode	0 – 3	1	1 (Ramp)	506	0 Coasting 1 Ramp 2 Normal-ramp, Run enable-coasting 3 Normal-coasting, Run enable-ramp	8-29
P1.4.8	DC-Brake Current	0.15 x $I_{nHVX}$ – 1.5 x $I_{nHVX}$	0.01	0.5 x $I_{nHVX}$	507	DC-brake current in amperes	8-29
P1.4.9	Stop DC-BrakeTm	0.000 – 60.000	0.001 s	0.000	508	0 DC-brake not used at stop >0 DC-brake in use at stop for set time	8-30
P1.4.10	Stop DC-BrakeFr	0.10 – 10.00	0.01 Hz	1.50	515	Output frequency DC-brake applied	8-31
P1.4.11	Start DC-BrakeTm	0.000 – 60.000	0.001 s	0.000	516	0 DC-brake not used at start >0 DC-brake in use at start for set time	8-31
P1.4.12	Flux Brake	0 – 1	1	0 (Off)	520	0 Flu braking off 1 Flux braking on	8-31
P1.4.13	FluxBrakeCurrent	0.1 x $I_{nMotor}$ – Current Limit	0.1 x $I_{nMotor}$	0.5 x $I_{nMotor}$	519	Flux brake current in amperes	8-32

<sup>Ⓢ</sup> Drive must be stopped to edit these parameters.

**Table B-5: Parameter Group G1.5: Skip Frequencies**

Code	Parameter	Range	Step	Default	ID #	Description	Page
P1.5.1	SkipF 1 Low Lim	0.00 – Skip Frequency 1 High Limit	0.01 Hz	0.00	509	Skip frequency range 1 low limit	8-32
P1.5.2	Skipf 1 High Lim	Skip Frequency 1 Low Limit – Max Frequency	0.01 Hz	0.00	510	Skip frequency range 1 high limit	8-32
P1.5.3	Skipf 2 Low Lim	0.00 – Skip Frequency 2 High Limit	0.01 Hz	0.00	511	Skip frequency range 2 low limit	8-32
P1.5.4	Skipf 2 High Lim	Skip Frequency 2 Low Limit – Max Frequency	0.01 Hz	0.00	512	Skip frequency range 2 high limit	8-32
P1.5.5	Skipf 3 Low Lim	0 – Skip Frequency 3 High Limit	0.01 Hz	0.00	513	Skip frequency range 3 low limit	8-32
P1.5.6	Skipf 3 High Lim	Skip Frequency 3 Low Limit – Max Frequency	0.01 Hz	0.00	514	Skip frequency range 3 high limit	8-33
P1.5.7	PH Acc/Dec Ramp	0.1 – 10.0	0.1	1.0	518	Ramp time multiplier in skip range	8-33

**Table B-6: Parameter Group G1.6: Motor Control**

Code	Parameter	Range	Step	Default	ID #	Description	Page
P1.6.1	Motor Ctrl Mode <sup>①</sup>	0 – 1	1	0 (Frequency control)	600	0 Frequency control 1 Speed control	8-34
P1.6.2	V/Hz Optimization <sup>①</sup>	0 – 1	1	0 (None)	109	0 None 1 Automatic torque boost	8-34
P1.6.3	V/Hz Ratio Select <sup>①</sup>	0 – 3	1	0 (Linear)	108	0 Linear 1 Squared 2 Programmable V/f curve 3 Linear with flux optimization	8-35
P1.6.4	Field WeakngPnt <sup>①</sup>	30.00 – 320.00	0.01 Hz	60.00	602	Usually corresponds to <b>Motor Nominal Frequency</b>	8-36
P1.6.5	Voltage at FWP <sup>①</sup>	10.00 – 200.00	0.01 %	100.00	603	Usually corresponds to <b>Motor Nominal Voltage</b>	8-36
P1.6.6	V/Hz Mid Freq <sup>①</sup>	0.00 – Field Weakening Point	0.01 Hz	60.00	604	Midpoint frequency of the curve	8-36
P1.6.7	V/Hz Mid Voltg <sup>①</sup>	0.00 – 100.00	0.01 %	100.00	605	Maximum value is <b>Voltage at Field Weakening Point</b>	8-36
P1.6.8	Zero Freq Voltg <sup>①</sup>	0.00 – 40.00	0.01 %	1.50	606	Voltage at zero frequency	8-37
P1.6.9	Switching Freq <sup>①</sup>	1.0 – 16.0	0.1 kHz	—	601	HVX9000 model dependent	8-37
P1.6.10	Overvolt Contr <sup>①</sup>	0 – 1	1	1 (Switched On)	607	0 Overvoltage control switched off 1 Overvoltage control switched on	8-37
P1.6.11	Undervolt Contr <sup>①</sup>	0 – 1	1	1 (Enabled)	608	0 Disabled 1 Enabled	8-37

<sup>①</sup> Drive must be stopped to edit these parameters.

April 2005

**Table B-7: Parameter Group G1.7: Protections**

Code	Parameter	Range	Step	Default	ID #	Description	Page
P1.7.1	4mA Fault Resp	0 – 5	1	0 (No Response)	700	0 No response 1 Warning 2 Warning, 10 s earlier set frequency used as reference 3 Warning, preset frequency <b>4 mA Fault Frequency</b> used as reference 4 Fault, stop as set by <b>Stop Mode</b> 5 Fault, stop by coasting	8-38
P1.7.2	4mA Fault Freq	0.00 – Maximum Frequency	0.01 Hz	0.00	728	Used for 4 mA fault when <b>4 mA (Reference) Fault Response = 3</b>	8-38
P1.7.3	External Fault	0 – 3	1	2 (Fault)	701	0 No response 1 Warning 2 Fault, stop as set by <b>Stop Mode</b> 3 Fault, stop by coasting	8-38
P1.7.4	Input Phase Supv	0 – 3	1	0 (No Response)	730	0 No response 1 Warning 2 Fault, stop as set by <b>Stop Mode</b> 3 Fault, stop by coasting	8-38
P1.7.5	UVolt Fault Resp	0 – 1	1	0 (Fault Stored)	727	0 Fault Stored 1 No History	8-38
P1.7.6	OutputPh Superv	0 – 3	1	2 (Fault)	702	0 No response 1 Warning 2 Fault, stop as set by <b>Stop Mode</b> 3 Fault, stop by coasting	8-39
P1.7.7	Ground Fault	0 – 3	1	2 (Fault)	703	0 No response 1 Warning 2 Fault, stop as set by <b>Stop Mode</b> 3 Fault, stop by coasting	8-39
P1.7.8	Motor Therm Prot	0 – 3	1	2 (Fault)	704	0 No response 1 Warning 2 Fault, stop as set by <b>Stop Mode</b> 3 Fault, stop by coasting	8-39
P1.7.9	MotAmbTempFactor	-100.0 – 100.00	0.1 %	0.0	705	0 Motor at same ambient as HVX9000 heatsink <>0 Motor at different ambient than HVX9000 heatsink	8-39
P1.7.10	MTP f0 Current	0.0 – 150.0	0.1 %	40.0	706	Current allowed at zero frequency based on a percentage of <b>Motor Nominal Frequency</b>	8-40
P1.7.11	MTP Motor T	1 – 200	1 m	24 min.	707	Motor thermal time constant - $t_g$ time	8-41
P1.7.12	Motor Duty Cycle	0 – 100	1 %	100	708	Defines how much of the nominal motor nameplate load is normally applied	8-41
P1.7.13	Stall Protection	0 – 3	1	1 (Warning)	709	0 No response 1 Warning 2 Fault, stop as set by <b>Stop Mode</b> 3 Fault, stop by coasting	8-42
P1.7.14	Stall Current	0.01 – Motor Nominal Current x 2	0.1 A	Motor Nominal Current x 1.3	710	Stall current	8-42
P1.7.15	Stall Time Lim	1.00 – 120.00	0.01 s	15.00	711	Maximum stall time	8-42
P1.7.16	Stall Freq Lim	1.00 – Maximum Frequency	0.01 Hz	25.00	712	Maximum stall frequency	8-42
P1.7.17	Underload Protec	0 – 3	1	0 (No Response)	713	0 No response 1 Warning 2 Fault, stop as set by <b>Stop Mode</b> 3 Fault, stop by coasting	8-43

**Table B-7: Parameter Group G1.7: Protections, continued**

Code	Parameter	Range	Step	Default	ID #	Description	Page
P1.7.18	UP fnom Torque	10.0 – 150.0	0.1 %	50.0	714	Minimum torque setting as percentage of the nominal motor nameplate torque at <b>Motor Nominal Frequency</b>	8-43
P1.7.19	UP f0 Torque	5.0 – 150.0	0.1 %	10.0	715	Minimum torque setting as percentage of the nominal motor nameplate torque at f0	8-44
P1.7.20	UP Time Limit	2.00 – 600.00	0.01 s	20.00	716	Maximum time allowed for underload	8-44
P1.7.21	ThermistorF Resp	0 – 3	1	0 (No Response)	732	0 No response 1 Warning 2 Fault, stop as set by <b>Stop Mode</b> 3 Fault, stop by coasting	8-44
P1.7.22	Comm Fault Resp	0 – 3	1	2 (Fault)	733	0 No response 1 Warning 2 Fault, stop as set by <b>Stop Mode</b> 3 Fault, stop by coasting	8-44
P1.7.23	SlotComFaultResp	0 – 3	1	2 (Fault)	734	0 No response 1 Warning 2 Fault, stop as set by <b>Stop Mode</b> 3 Fault, stop by coasting	8-45

**Table B-8: Parameter Group G1.8: Auto-Restart Parameters**

Code	Parameter	Range	Step	Default	ID #	Description	Page
P1.8.1	Wait Time	0.10 – 10.00	0.01 s	0.50	717	Auto restart delay after fault cause clears	8-45
P1.8.2	Trial Time	0.00 – 60.00	0.01 s	30.00	718	Time limit for max set number of faults before fault is maintained	8-45
P1.8.3	Start Mode	0 – 2	1	0 (Ramping)	719	0 Ramp start 1 Flying start 2 Start per <b>Start Mode</b>	8-46
P1.8.4	Undervolt Tries	0 – 10	1	0	720	0 No auto restart >0 Number of auto restarts allowed during trial time	8-46
P1.8.5	Overvolt Tries	0 – 10	1	0	721	0 No auto restart >0 Number of auto restarts allowed during trial time	8-46
P1.8.6	Overcurr Tries	0 – 3	1	0	722	0 No auto restart >0 Number of auto restarts allowed during trial time	8-46
P1.8.7	4 mA Fault Tries	0 – 10	1	0	723	0 No auto restart >0 Number of auto restarts allowed during trial time	8-46
P1.8.8	MotTempF Tries	0 – 10	1	0	726	0 No auto restart >0 Number of auto restarts allowed during trial time	8-46
P1.8.9	ExtFault Tries	0 – 10	1	0	725	0 No auto restart >0 Number of auto restarts allowed during trial time	8-46

April 2005

**Table B-9: Parameter Group G1.9: Fire Mode**

Code	Parameter	Range	Step	Default	ID #	Description	Page
P1.9.1	FireModeFunction	0 – 1	1	0 (Closed Contact)	1501	0 Closed contact initiates fire mode 1 Open contact initiates fire mode	8-47
P1.9.2	FMRefSelFunction	0 – 1	1	0 (Not Inverted)	1502	0 No inversion 1 Signal inverted	8-47
P1.9.3	FireModeMiniFreq	Minimum Frequency – Maximum Frequency	0.01 Hz	15.00	1503	Minimum HVX9000 frequency in fire mode	8-47
P1.9.4	FireModeFreqRef1	0.0 – 100.0%	0.1%	75.0	1712	HVX9000 reference 1 frequency in fire mode	8-47
P1.9.5	FireModeFreqRef2	0.0 – 100%	0.1%	100.0	1711	HVX9000 reference 2 frequency in fire mode	8-47
P1.9.6	FMAutoResetDelay	0.50 – 10.00	0.01 s	5.00	1506	Auto restart delay in fire mode after fault cause clears	8-48

**Table B-10: Parameter Group G1.10: IntelliPass Parameters**

Code	Parameter	Range	Step	Default	ID #	Description	Page
P1.10.1	IntelliPass	0 – 1	1	0 (IntelliPass Disabled)	1521	0 Disabled – Not used 1 IntelliPass enabled	8-48
P1.10.2	Bypass Start Delay	1 – 32,765	1 s	5	1545	Time delay before motor is switched from HVX9000 to bypass after digital input closed	8-48
P1.10.3	Auto Bypass	0 – 1	1	0 (Auto Bypass Disabled)	1525	0 Auto bypass disabled 1 Auto bypass enabled	8-49
P1.10.4	Auto BypassDelay	0 – 32,765	1 s	10	1526	Time delay before auto bypass occurs	8-49
P1.10.5	Over 1 BypasEnab	0 – 1	1	0	1553	0 Auto bypass on overcurrent disabled 1 Auto bypass on overcurrent after restart tries exceeded enabled	8-49
P1.10.6	IGBT FLT BypasEn	0 – 1	1	0	1552	0 Auto bypass on IGBT fault disabled 1 Auto bypass on IGBT fault after restart tries exceeded enabled	8-49
P1.10.7	No Ref BypasEnab	0 – 1	1	0	1554	0 Auto bypass on 4 mA loss disabled 1 Auto bypass on 4 mA loss after restart tries exceeded enabled	8-49
P1.10.8	UV BypassEnab	0 – 1	1	0	1550	0 Auto bypass on undervoltage disabled 1 Auto bypass on undervoltage after restart tries exceeded enabled	8-49
P1.10.9	Ovolt BypassEnab	0 – 1	1	0	1555	0 Auto bypass on overvoltage disabled 1 Auto bypass on overvoltage after restart tries exceeded enabled	8-49

**Table B-11: Parameter Group G1.11: PID Control**

Code	Parameter	Range	Step	Default	ID #	Description	Page
P1.11.1	PID Reference <sup>①</sup>	0 – 4	1	0 (AI1)	332	0 Analog voltage AI1, terminals 2-3 1 Analog current AI2, terminals 4-5 2 Reference from keypad 3 Reference from communication bus 4 Reference from motor potentiometer	8-50
P1.11.2	PID SumPoint Ref <sup>①</sup>	0 – 7	1	0 (No additional reference)	376	0 No additional reference (direct output) 1 PID output + AI1, terminals 2-3 2 PID output + AI2, terminals 4-5 3 PID output + AI3 reference <sup>②</sup> 4 PID output + AI4 reference <sup>②</sup> 5 PID output + PID keypad reference 6 PID output + Communication bus 7 PID output + Motor potentiometer	8-50
P1.11.3	Act Value Select <sup>①</sup>	0 – 7	1	0 (Actual Value 1)	333	0 Actual value 1 1 Actual value 1 + actual value 2 2 Actual value 1 – actual value 2 3 Actual value 1 x actual value 2 4 Greater of actual value 1 and actual value 2 5 Smaller of actual value 1 and actual value 2 6 Mean value of actual value 1 and actual value 2 7 Square root of actual value 1 + square root of actual value 2	8-50
P1.11.4	Actual 1 Input <sup>①</sup>	0 – 9	1	2 (AI2)	334	0 Not used 1 Analog voltage AI1, terminals 2-3 2 Analog current AI2, terminals 4-5 3 Analog current AI3 <sup>②</sup> 4 Analog current AI4 <sup>②</sup> 5 Communication bus 6 Motor torque 7 Motor speed 8 Motor current 9 Motor power	8-51
P1.11.5	Act 1 Max Scale <sup>①</sup>	-1000.0 – 1000.0	0.1 %	100.0%	337	100 % = no maximum scaling	8-51
P1.11.6	Act 1 Min Scale <sup>①</sup>	-1000.0 – 1000.0	0.1 %	0.0	336	0 % = no minimum scaling	8-51
P1.11.7	Actual 2 Input <sup>①</sup>	0 – 9	1	0 (Not used)	335	0 Not used 1 Analog voltage AI1, terminals 2-3 2 Analog current AI2, terminals 4-5 3 Analog current AI3 <sup>②</sup> 4 Analog current AI4 <sup>②</sup> 5 Communication bus 6 Motor torque 7 Motor speed 8 Motor current 9 Motor power	8-52
P1.11.8	Actual 2 Max Scale	-1000.0 – 1000.0	0.1 %	100.0	339	100 % no maximum scaling	8-52
P1.11.9	Actual 2 Min Scale	-1000.0 – 1000.0	0.1 %	0.0	338	0 % no minimum scaling	8-52
P1.11.10	PID-Contr Gain	0.0 – 1000.0	0.1 %	100.0%	118	0 % PID controller acts as ID controller	8-52
P1.11.11	PID-Contr I Time	0.00 – 320.00	0.01 s	1.00	119	0.00 s PID controller acts as PD controller	8-52
P1.11.12	PID-Contr D Time	0.00 – 10.00	0.01 s	0.00	132	0.00 s PID controller acts as PI controller	8-52
P1.11.13	PID Max Limit	PID Min Limit – 1000.0	0.1 %	100.0%	360	Sets the maximum limit for PID controller output	8-54
P1.11.14	PID Min Limit	1000.0 – PID Max Limit	0.1 %	0.0%	359	Sets the minimum limit for PID controller output	8-55

<sup>①</sup> Drive must be stopped to edit these parameters.

<sup>②</sup> Not available at this time.

April 2005

**Table B-11: Parameter Group G1.11: PID Control, continued**

Code	Parameter	Range	Step	Default	ID #	Description	Page
P1.11.15	PID Ref Rise Tim	0.0 – 100.0	0.1 s	5.0	341	Time for reference to rise from 0 % to 100 %	8-55
P1.11.16	PID Ref Fall Tim	0.0 – 100.0	0.1 s	5.0	342	Time for reference to fall from 100 % to 0 %	8-55
P1.11.17	Error Inversion	0 – 1	1	0 (No Inversion)	340	0 No inversion 1 Signal inverted	8-55
P1.11.18	Sleep Func Enabl	0 – 1	1	0	1560	0 Disabled 1 Enabled	8-55
P1.11.19	Sleep Frequency	Min Frequency – Max Frequency	0.01 Hz	10.00	1016	Level below which a sleep stop will occur	8-55
P1.11.20	Sleep Delay	0 – 32,500	1 s	30	1017	Delay before which a sleep stop will occur	8-55
P1.11.21	Wake Up Limit	0.00 – 100.00	0.01 %	25.00	1018	Actual value to cause run after sleep stop	8-56
P1.11.22	Wake Up Action	0 – 1	1	0 (Below Level)	1019	0 Wake up after falling below limit 1 Wake up after exceeding limit	8-56

**Table B-12: Parameter Group G1.12: Preset Speeds**

Code	Parameter	Range	Step	Default	ID #	Description	Page
P1.12.1	#1 Preset Speed	0.0 – 100.0	0.1%	10.0	1600	Defines #1 preset speed as a percentage of Max Frequency.	8-57
P1.12.2	#2 Preset Speed	0.0 – 100.0	0.1%	20.0	1601	Defines #2 preset speed as a percentage of Max Frequency.	8-57
P1.12.3	#3 Preset Speed	0.0 – 100.0	0.1%	30.0	1602	Defines #3 preset speed as a percentage of Max Frequency.	8-57
P1.12.4	#4 Preset Speed	0.0 – 100.0	0.1%	40.0	1603	Defines #4 preset speed as a percentage of Max Frequency.	8-57
P1.12.5	#5 Preset Speed	0.0 – 100.0	0.1%	50.0	1604	Defines #5 preset speed as a percentage of Max Frequency.	8-57
P1.12.6	#6 Preset Speed	0.0 – 100.0	0.1%	75.0	1605	Defines #6 preset speed as a percentage of Max Frequency.	8-57
P1.12.7	#7 Preset Speed	0.0 – 100.0	0.1%	100.0	1606	Defines #7 preset speed as a percentage of Max Frequency.	8-57

**Table B-13: Parameter Group G1.13: Communication Bus**

Code	Parameter	Range	Step	Default	ID #	Description	Page
P1.13.1	FBDataOut1Sel	0 – 10000	1	1590 (Motor speed – %)	852	Motor Speed (Percent)	8-58
P1.13.2	FBDataOut2Sel	0 – 10000	1	1 (Output frequency – Hz)	853	Output Frequency (Hz)	8-58
P1.13.3	FBDataOut3Sel	0 – 10000	1	25 (Frequency reference – Hz)	854	Frequency Reference (Hz)	8-58
P1.13.4	FBDataOut4Sel	0 – 10000	1	2 (Motor speed – rpm)	855	Motor Speed (rpm)	8-58
P1.13.5	FBDataOut5Sel	0 – 10000	1	1780 (Motor current)	856	Motor Current	8-58
P1.13.6	FBDataOut6Sel	0 – 10000	1	5 (Motor power)	857	Motor Power	8-58

**Table B-13: Parameter Group G1.13: Communication Bus, continued**

Code	Parameter	Range	Step	Default	ID #	Description	Page
P1.13.7	FBDataOut7Sel	0 – 10000	1	1701 (Motor run time – minutes)	858	Motor Run Time (Minutes)	8-58
P1.13.8	FBDataOut8Sel	0 – 10000	1	1666 (Energy meter – kW)	859	Energy Meter (Kilowatts)	8-58

**Table B-14: Monitoring Menu Items**

Code	Signal Name	Unit	ID #	Description
V5.1	Motor speed	rpm	2	Calculated motor speed
V5.2	Motor speed %	%	1590	Motor Nominal Speed %
V5.3	Frequency reference	Hz	25	Frequency reference setting
V5.4	Output frequency	Hz	1	Frequency to the motor
V5.5	Motor current	A	1780	Measured motor current
V5.6	Motor torque	%	4	Calculated torque based on nominal motor torque
V5.7	Motor power	%	5	Calculated power based on nominal motor power
V5.8	Instantaneous	kW	1888	Calculated power based on output to motor
V5.9	Energy meter	KwH	1666	Kilowatt hours total usage <sup>①</sup>
V5.10	Motor voltage	V	6	Calculated motor voltage
V5.11	DC-bus voltage	V	7	Measured DC-bus voltage
V5.12	Motor run time	Hrs	1701	Motor run time total <sup>①</sup>
P5.13	Run Display Format	—	1565	Changes motor run time between seconds, minutes, hours and days <sup>③</sup>
V5.14	Unit temperature	°C	8	Heatsink temperature
V5.15	Calculated motor temperature	°C	1917	Calculated motor temperature based on the motor nameplate information and the calculated motor load
V5.16	Analog Input 1	V	13	Voltage Input at Terminal AI1+ and GND
V5.17	Analog Input 2	mA	14	Current Input at Terminals AI2+ and AI2-
V5.18	Analog Input 3	mA	1680	Current Input at Terminals AI3+ and AI3-
V5.19	Analog Input 4	mA	1710	Current Input at Terminals AI4+ and AI4-
V5.20	DIN1, DIN2, DIN3	—	15	Digital input status ( <b>Figure 6-8</b> )
V5.21	DIN4, DIN5, DIN6	—	16	Digital input status ( <b>Figure 6-9</b> )
V5.22	DO1, RO1, RO2	—	17	Digital and relay output status ( <b>Figure 6-10</b> )
V5.23	RO3, RO4, RO5	—	1678	Relay output status
V5.24	Relay out status	—	1773	Status of all relay outputs <sup>②</sup>
V5.25	Analog lout	mA	26	Current Output at Terminals AO1+ and AO1-
V5.26	Analog Output 2	mA	1874	Current Output at Terminals AO2+ and AO2-
V5.27	Analog Output 3	mA	1875	Current Output at Terminals AO3+ and AO3-
R5.28	PID Setpoint 1	%	—	PID Setpoint 1 Level
V5.29	PID Reference	%	20	PID Reference Level
V5.30	PID Actual Level	%	21	PID Actual Level
V5.31	PID Error Value	%	22	PID Error Value
V5.32	PID Output	%	23	PID Output
G5.33	Active Faults	—		See <b>Page 6-17</b>
G5.34	Fault History	—		See <b>Page 6-19</b>
G5.35	Multimonitor	—		See <b>Page 6-19</b>

<sup>①</sup> Resettable via S.3.8.2 trip counters.

<sup>②</sup> Includes BIN — Binary to decimal converted value for all digital and relay outputs.

<sup>③</sup> See description on **Page 6-17**.

April 2005

## Appendix C — Fault and Warning Codes

Table C-1: Fault Codes

Fault Code	Fault	Possible Cause	Solution
1	Overcurrent	HVX9000 has detected a high current ( $>4xI_n$ ) in its output due to: <ul style="list-style-type: none"> <li>sudden heavy load increase</li> <li>short in the motor</li> <li>short in the cables to the motor</li> <li>unsuitable motor</li> </ul>	Check loading. Check motor. Check cables.
2	Overvoltage	The DC-link voltage has exceeded its high limit due to: <ul style="list-style-type: none"> <li>too short a deceleration time</li> <li>high voltage levels or surges in the utility supply</li> </ul>	Make the deceleration time longer. Use brake chopper and brake resistor (standard on some models, available as options on others). Correct utility supply voltage (level is too high). Add input impedance to limit surges.
3	Ground (Earth) Fault	Current sensing indicates that the sum of motor phase currents is not zero. <ul style="list-style-type: none"> <li>insulation failure in motor or motor cables</li> </ul>	Check motor and motor cables.
5	Charging Switch	The charging switch was open, when the START command was given due to: <ul style="list-style-type: none"> <li>faulty operation</li> <li>component failure</li> </ul>	Reset the fault and restart. Should the fault re-occur, contact your Cutler-Hammer distributor.
6	Emergency stop	An Emergency stop signal was received from one of the digital inputs	Determine reason for the Emergency stop and remedy it.
7	Saturation trip	<ul style="list-style-type: none"> <li>defective component</li> <li>motor or motor cable short</li> </ul>	Cannot be reset from the keypad. Switch off power. <b>IF THE PROBLEM IS NOT IN THE MOTOR OR ITS CABLES, DO NOT RE-CONNECT POWER!</b> Contact your Cutler-Hammer distributor. If this fault appears simultaneously with Fault 1, check the motor and motor cables.
8	System fault	<ul style="list-style-type: none"> <li>component failure</li> <li>faulty operation</li> </ul> <b>Note:</b> exceptional fault data record, see Active Fault Menu for more information	Reset the fault and restart. Should the fault re-occur, contact your Cutler-Hammer distributor.

**Table C-1: Fault Codes, continued**

<b>Fault Code</b>	<b>Fault</b>	<b>Possible Cause</b>	<b>Solution</b>
9	Undervoltage	DC-link voltage is less than the minimum safe operating voltage limit <ul style="list-style-type: none"> <li>• most probable cause: too low a utility supply voltage</li> <li>• HVX9000 internal fault</li> </ul>	If there was a supply voltage loss or dip, reset the fault and restart the HVX9000. Check the supply voltage. If it was within specification at the time of the fault, an internal failure has occurred. Contact your Cutler-Hammer distributor.
10	Input line supervision	Input line phase is low or missing.	Check the utility supply voltage, cables and connections.
11	Output phase supervision	Current sensing indicates that there is no current in one motor phase	Check the motor cables, connections and motor.
12	Brake chopper supervision	<ul style="list-style-type: none"> <li>• no brake resistor installed</li> <li>• brake resistor is broken</li> <li>• brake chopper failure</li> </ul>	Check the brake resistor. If the resistor is ok, the chopper is faulty. Contact your Cutler-Hammer distributor.
13	HVX9000 undertemperature	Heatsink temperature is under -10°C	Provide supplemental heating or relocate the HVX9000 to a warmer location.
14	HVX9000 overtemperature	Heatsink temperature is over 90°C.	<p>An overtemperature warning is issued when the heatsink temperature exceeds 85°C, a fault occurs at 90°C. Check for the correct amount and unrestricted flow of cooling air. Check the heatsink for dust or dirt buildup.</p> <p>Check the highest ambient temperature level.</p> <p>Make sure that the switching frequency is not set too high in relation to the ambient temperature and motor load.</p>
15	Motor stalled	<ul style="list-style-type: none"> <li>• motor or load mechanical failure</li> <li>• load too high</li> <li>• stall parameter settings incorrect</li> </ul>	Check the motor, mechanical system and load level. Confirm the stall parameter settings.
16	Motor overtemperature	<ul style="list-style-type: none"> <li>• motor is overloaded</li> <li>• motor overheating has been detected by HVX9000 motor temperature model</li> </ul>	Decrease the motor load. If no motor overload exists, check the temperature model parameters.
17	Motor underload	<ul style="list-style-type: none"> <li>• mechanical or load problem</li> <li>• underload parameter settings incorrect</li> </ul>	Check the motor, check for a loose belt, broken coupling or load problems. Confirm underload parameter settings.

April 2005

**Table C-1: Fault Codes, continued**

<b>Fault Code</b>	<b>Fault</b>	<b>Possible Cause</b>	<b>Solution</b>
22 23	EEPROM checksum fault	Parameter save fault <ul style="list-style-type: none"> <li>• faulty operation</li> <li>• component failure</li> </ul>	Upon reset of this fault, the HVX9000 will automatically reload the parameter default settings. Check all parameter settings after reset. If the fault reoccurs, contact your Cutler-Hammer distributor.
25	Microprocessor watchdog fault	<ul style="list-style-type: none"> <li>• faulty operation</li> <li>• component failure</li> </ul>	Reset the fault and restart. If the fault reoccurs, contact your Cutler-Hammer distributor.
26	Start-up prevented	Start-up of the drive has been prevented.	Check Start Enable/Interlock settings.
29	Thermistor fault	The thermistor input of an option board has detected a high motor temperature	Check the motor cooling and the motor loading. Check the thermistor connection. (If the thermistor input of an option board is not being used, it must be short-circuited.)
32	Fan cooling	The HVX9000 cooling fan did not start when commanded	Contact your Cutler-Hammer distributor.
34	CAN bus communication	Sent message not acknowledged	Ensure that there is another device on the bus with the appropriate configuration.
36	Control unit	Control unit cannot control the power unit and vice-versa	Change control unit.
37	Device change	<ul style="list-style-type: none"> <li>• option board changed</li> <li>• different power rating of drive</li> </ul>	Reset. <b>Note:</b> No fault time data record!
38	Device added	<ul style="list-style-type: none"> <li>• option board added</li> <li>• drive of different power rating added</li> </ul>	Reset. <b>Note:</b> No fault time data record!
39	Device removed	<ul style="list-style-type: none"> <li>• option board removed</li> <li>• drive removed</li> </ul>	Reset. <b>Note:</b> No fault time data record!
40	Device unknown	Unknown option board or drive	Contact your Cutler-Hammer distributor.
41	IGBT temperature	IGBT Inverter Bridge overtemperature protection has detected high short term overload current	Check loading. Check motor size.
42	Brake resistor overtemperature	Brake resistor overtemperature protection has detected excessive braking	Set the deceleration time longer. Use an external brake resistor.

Table C-1: Fault Codes, continued

Fault Code	Fault	Possible Cause	Solution
43	Encoder fault	<p><b>Note:</b> the exceptional Fault data record. See Active Fault Menu for more information. Additional codes:</p> <ol style="list-style-type: none"> <li>1 Encoder 1 channel A is missing</li> <li>2 Encoder 1 channel B is missing</li> <li>3 Both encoder 1 channels are missing</li> <li>4 Encoder reversed</li> </ol>	<p>Check encoder channel connections.</p> <p>Check the encoder board.</p>
50	Analog input $I_{in} < 4 \text{ mA}$ (for signal range 4 to 20 mA)	<p>Current at the analog input is <math>&lt; 4 \text{ mA}</math></p> <ul style="list-style-type: none"> <li>• control cable is broken or loose</li> <li>• signal source has failed</li> </ul>	Check the current loop, signal source and wiring.
51	External fault	Digital input set as an external fault input has been triggered.	Check source of trigger.
52	Keypad communication fault	The connection between the control keypad and the HVX9000 has been lost.	Check keypad connection and keypad cable.
53	Communication bus fault	The data connection between the communication bus master and the communication bus board has failed	<p>Check installation.</p> <p>If installation is correct, contact your Cutler-Hammer distributor.</p>
54	Slot fault	Defective option board or slot	Check that the board is properly installed and seated in slot. If installation is correct, contact your Cutler-Hammer distributor.
82	BypassOverLoad	The motor has been overloaded while connected to the bypass	<p>Decrease the motor load.</p> <p>Disable the Current Imbalance feature – see the <i>IT</i> manual.</p>

April 2005

## Appendix D — Figures and Tables by Topics

### List of Figures

Acceleration/Deceleration Curve (S-Shaped) (Figure 8-10) .....	8-28
Active Fault Display Example (Figure 6-11) .....	6-17
AI1 Signal Filtering (Figure 8-2) .....	8-9
AI2 Signal Filtering (Figure 8-3) .....	8-10
Analog Output Filtering (Figure 8-5) .....	8-14
Analog Output Inversion (Figure 8-6) .....	8-14
Analog Output Scale (Figure 8-7) .....	8-15
Cable Protection Plate (Figure 3-4) .....	3-6
Control Place B with and without Reference Scaling (Figure 8-4) .....	8-11
DC Braking Command (Figure 8-1) .....	8-5
DC Braking Time at Start (Figure 8-13) .....	8-31
DC Braking Time When Stop Mode = Coasting (Figure 8-11) .....	8-30
DC Braking Time When Stop Mode = Ramp (Figure 8-12) .....	8-31
Digital Inputs DIN1, DIN2, DIN3 Status (Figure 6-8) .....	6-17
Digital Inputs DIN4, DIN5, DIN6 Status (Figure 6-9) .....	6-17
Digital Inputs DO1, RO1, RO2 Status (Figure 6-10) .....	6-17
Enable Bypass (Figure 5-8) .....	5-12
Example of Automatic Restart with Two Restarts (Figure 8-23) .....	8-45
Examples of Actual Value Signal Scaling (Figure 8-26) .....	8-51
Expander Board Menu Structure (Figure 6-7) .....	6-15
External Brake Control (Figure 8-9) .....	8-24
FR4 Power and Motor Wiring Terminals (Figure 3-8) .....	3-10
FR5 Power and Motor Wiring Terminals (Figure 3-9) .....	3-11
FR6 Power and Motor Wiring Terminals (Figure 3-10) .....	3-12
FR7 Power and Motor Wiring Terminals (Figure 3-11) .....	3-13
FR8 Power and Motor Wiring Terminals (Figure 3-12) .....	3-14
FR9 Power and Motor Wiring Terminals (Figure 3-13) .....	3-15
Frequency Converter Sleep Function (Figure 8-30) .....	8-56
Frequency Reference Logic of the Fire Mode PID Application When Running in Fire Mode (Figure 8-24) .....	8-48
Ground Terminal Locations (Figure 3-3) .....	3-5
HVX IntelliPass Dimensions (Figure 5-1) .....	5-2
HVX Series Enclosed Drive Dimensions (Figure 5-2) .....	5-3
HVX Series Enclosed Drive Dimensions (Figure 5-3) .....	5-4
HVX9000 Dimensions, FR10 Open Chassis (Figure A-15) .....	A-16
HVX9000 Dimensions, NEMA Type 1 and NEMA Type 12 FR9 (Figure A-13) .....	A-14
HVX9000 Dimensions, NEMA Type 1 and NEMA Type 12 FR9 with Flange Kit (Figure A-14) .....	A-15
HVX9000 Dimensions, NEMA Type 1 and NEMA Type 12 with Flange Kit, FR4, FR5 and FR6 (Figure A-8) .....	A-9
HVX9000 Dimensions, NEMA Type 1 and NEMA Type 12, FR7 (Figure A-9) .....	A-10
HVX9000 Dimensions, NEMA Type 1 and NEMA Type 12, FR8 (Figure A-10) .....	A-11
HVX9000 Dimensions, NEMA Type 1 and NEMA Type 12, FR9 (Figure A-12) .....	A-13
HVX9000 Dimensions, NEMA Type 1 and NEMA Type 12, with Flange Kit, FR7 and FR8 (Figure A-11) .....	A-12
Input Power and Motor Cable Stripping and Wire Lengths (Figure 3-1) .....	3-4
IntelliPass Power and Motor Terminal Wiring Example (Figure 5-4) .....	5-8
Keypad and Display (Figure 6-1) .....	6-1
Keypad Control Menu (Figure 6-5) .....	6-6

## List of Figures, continued

Linear and Squared Change of Motor Voltage (Figure 8-16) .....	8-35
Main Menu Navigation — 1 of 2 (Figure 6-2) .....	6-4
Main Menu Navigation — 2 of 2 (Figure 6-3) .....	6-5
Minimum Load Setting (Figure 8-21) .....	8-43
Motor Cooling Power (Figure 8-18) .....	8-40
Motor Temperature Calculation (Figure 8-19) .....	8-41
Mounting Space Requirements (Figure 2-1) .....	2-1
NEMA Type 1 and NEMA Type 12 HVX9000 Drive Dimensions, FR4, FR5 and FR6 (Figure A-7) .....	A-8
Operate Menu Navigation (Figure 5-7) .....	5-11
Operate Menu Navigation (Figure 6-13) .....	6-20
Option Board A2 Terminal Locations (Figure 4-5) .....	4-6
Option Board A2 Wiring Diagram (Slot B) (Figure 4-4) .....	4-5
Option Board A9 Jumper Location and Settings (Slot A) (Figure 4-3) .....	4-5
Option Board A9 Wiring Diagram (Figure 4-2) .....	4-3
Option Board B5 Terminal Location (Figure 5-6) .....	5-10
Option Board B5 Wiring Diagram (Figure 5-5) .....	5-9
Option Board Slots (Figure 4-1) .....	4-1
Output Frequency Supervision (Figure 8-8) .....	8-22
Parameter Menu Structure (Figure 6-4) .....	6-6
PID Controller D-Time, Example 1 (Figure 8-27) .....	8-53
PID Controller D-Time, Example 2 (Figure 8-28) .....	8-54
PID Controller D-Time, Example 3 (Figure 8-29) .....	8-54
PID Output + Motor Potentiometer Reference (Figure 8-25) .....	8-50
Positive/Negative Logic (Figure 4-6) .....	4-6
Power Loss as Function of Switching Frequency: 1 – 3 hp 230V, 1-1/2 – 7-1/2 hp 480V (Figure A-1) .....	A-5
Power Loss as Function of Switching Frequency: 100 – 150 hp 480V (Figure A-5) .....	A-7
Power Loss as Function of Switching Frequency: 15 – 20 hp 230V, 25 – 40 hp 480V (Figure A-3) .....	A-6
Power Loss as Function of Switching Frequency: 200 – 250 hp 480V (Figure A-6) .....	A-7
Power Loss as Function of Switching Frequency: 5 – 10 hp 230V, 10 – 20 hp 480V (Figure A-2) .....	A-5
Power Loss as Function of Switching Frequency: 50 – 75 hp 480V (Figure A-4) .....	A-6
Principle Wiring Diagram of HVX Power Unit, FR4, FR5 and FR6 (Figure 3-5) .....	3-7
Principle Wiring Diagram of HVX Power Unit, FR6, FR7 and FR8 (Figure 3-6) .....	3-8
Principle Wiring Diagram of HVX Power Unit, FR9 and FR10 (Figure 3-7) .....	3-9
Programmable V/f Ratio (Figure 8-17) .....	8-36
Ramp Speed Scaling Between Skip Frequencies (Figure 8-15) .....	8-33
Sample Fault History Display (Figure 6-12) .....	6-19
Skip Frequency Area Setting (Figure 8-14) .....	8-33
Stall Characteristics Settings (Figure 8-20) .....	8-42
System Menu Structure (Figure 6-6) .....	6-8
Underload Time Counter Function (Figure 8-22) .....	8-44
Wiring Plate (Figure 3-2) .....	3-5

April 2005

## List of Tables

230V VT Output Power Ratings (Table A-2) .....	A-3
480V VT Output Power Ratings (Table A-3) .....	A-3
575V VT Output Power Ratings (Table A-4) .....	A-4
Application Information (Table 6-7) .....	6-14
Binary Inputs for Seven Preset Speeds (Table 8-8) .....	8-57
Cable and Fuse Sizes — 208 – 240V Ratings (Table 3-2) .....	3-2
Cable and Fuse Sizes — 380 – 500V Ratings (Table 3-3) .....	3-2
Cable and Fuse Sizes — 575 – 690V Ratings (Table 3-4) .....	3-3
Cable Spacings (Table 3-1) .....	3-1
Control Wiring Instructions (Table 4-2) .....	4-2
Cooling Airflow Requirements (Table 2-2) .....	2-2
Dimensions for HVX9000, FR10 Open Chassis (Table A-15) .....	A-16
Dimensions for HVX9000, FR4, FR5 and FR6 with Flange Kit (Table A-6) .....	A-9
Dimensions for HVX9000, FR7 and FR8 with Flange Kit (Table A-10) .....	A-12
Dimensions for HVX9000, FR9 (Table A-13) .....	A-14
Dimensions for HVX9000, FR9 with Flange Kit (Table A-14) .....	A-15
Dimensions for the Flange Opening, FR4 to FR6 (Table A-7) .....	A-9
Dimensions for the Flange Opening, FR7/FR8 (Table A-11) .....	A-12
DO1 Function Settings (Table 8-2) .....	8-16
Fault Codes (Table C-1) .....	C-1
Fault Time Data (Table 6-12) .....	6-19
Fault Types (Table 6-11) .....	6-18
Fieldbus Output Selection Examples (Table 8-9) .....	8-59
Hardware Information (Table 6-8) .....	6-14
HVX IntelliPass Drive Catalog Numbering System (Table 5-1) .....	5-1
HVX Series TYPE 12 Enclosed IntelliPass Drive Dimensions (Table 5-3) .....	5-3
HVX Series TYPE 3R Enclosed IntelliPass Drive Dimensions (Table 5-4) .....	5-4
HVX9000 Drive Catalog Numbering System (Table 1-1) .....	1-2
HVX9000 Drive Dimensions (Table A-5) .....	A-8
HVX9000 Drive Dimensions, FR7 (Table A-8) .....	A-10
HVX9000 Drive Dimensions, FR8 (Table A-9) .....	A-11
HVX9000 Drive Dimensions, FR9 (Table A-12) .....	A-13
HVX9000 Drive Specifications (Table A-1) .....	A-1
IntelliPass Power Wiring Instructions (Table 5-5) .....	5-5
LCD Status Indicators (Table 6-1) .....	6-2
LED Status Indicators (Table 6-2) .....	6-2
Maximum Symmetrical Supply Current (Table 3-5) .....	3-3
Monitoring Menu Items (Table 6-10) .....	6-16
Monitoring Menu Items (Table B-14) .....	B-14
Navigation Buttons (Table 6-3) .....	6-3
NEMA TYPE 1 IntelliPass Drive Dimensions (Table 5-2) .....	5-2
Operate Menu Items — IntelliPass Application Example (Table 5-7) .....	5-11
Operate Menu Items — IntelliPass Application Example (Table 6-13) .....	6-20
Option Board A2 Terminal Descriptions (Table 4-4) .....	4-6
Option Board A9 Terminal Descriptions (Table 4-3) .....	4-4
Option Board B5 Terminal Descriptions (Table 5-6) .....	5-9

## List of Tables, continued

Parameter Group G1.1: Basic (Table B-1) . . . . .	B-1
Parameter Group G1.10: IntelliPass Parameters (Table B-10) . . . . .	B-11
Parameter Group G1.11: PID Control (Table B-11) . . . . .	B-12
Parameter Group G1.12: Preset Speeds (Table B-12) . . . . .	B-13
Parameter Group G1.13: Communication Bus (Table B-13) . . . . .	B-13
Parameter Group G1.2: Input Signals (Table B-2) . . . . .	B-2
Parameter Group G1.3: Output Signals (Table B-3) . . . . .	B-4
Parameter Group G1.4: Drive Control (Table B-4) . . . . .	B-7
Parameter Group G1.5: Skip Frequencies (Table B-5) . . . . .	B-8
Parameter Group G1.6: Motor Control (Table B-6) . . . . .	B-8
Parameter Group G1.7: Protections (Table B-7) . . . . .	B-9
Parameter Group G1.8: Auto-Restart Parameters (Table B-8) . . . . .	B-10
Parameter Group G1.9: Fire Mode (Table B-9) . . . . .	B-11
Power and Motor Cable Stripping Lengths (Table 3-7) . . . . .	3-4
Power Connection Tightening Torque (Table 3-6) . . . . .	3-3
RO1 Function Settings (Table 8-3) . . . . .	8-17
RO2 Function Settings (Table 8-4) . . . . .	8-18
RO3 Content Settings (Table 8-5) . . . . .	8-20
Scaling Factor for the Analog Output (Table 8-1) . . . . .	8-15
Scaling Factor for the Analog Output (Table 8-6) . . . . .	8-26
Scaling Factor for the Analog Output (Table 8-7) . . . . .	8-27
Slot A Expander Board Information (Table 6-9) . . . . .	6-14
Software Information (Table 6-6) . . . . .	6-14
Space Requirements for Mounting an HVX9000 Drive (Table 2-1) . . . . .	2-1
Tightening Torques of Terminals (Table 4-1) . . . . .	4-2
Total Counters (Table 6-4) . . . . .	6-13
Trip Counters (Table 6-5) . . . . .	6-13

April 2005





## Company Information

Eaton's electrical business is a global leader in electrical control, power distribution, and industrial automation products and services. Through advanced product development, world-class manufacturing methods, and global engineering services and support, Eaton's electrical business provides customer-driven solutions under brand names such as Cutler-Hammer®, Powerware®, Durant®, Heinemann®, Holec® and MEM®, which globally serve the changing needs of the industrial, utility, light commercial, residential, and OEM markets. For more information, visit [www.EatonElectrical.com](http://www.EatonElectrical.com).

Eaton Corporation is a diversified industrial manufacturer with 2004 sales of \$9.8 billion. Eaton is a global leader in fluid power systems and services for industrial, mobile and aircraft equipment; electrical systems and components for power quality, distribution and control; automotive engine air management systems, powertrain solutions and specialty controls for performance, fuel economy and safety; and intelligent truck drivetrain systems for safety and fuel economy. Eaton has 55,000 employees and sells products to customers in more than 125 countries. For more information, visit [www.eaton.com](http://www.eaton.com).

Eaton Electrical Inc.  
1000 Cherrington Parkway  
Moon Township, PA 15108-4312  
USA  
tel: 1-800-525-2000  
[www.EatonElectrical.com](http://www.EatonElectrical.com)

**EAT•N**

**Cutler-Hammer**

© 2005 Eaton Corporation  
All Rights Reserved  
Printed in USA  
Publication No. TD04008003E/CPG  
April 2005