

# FRENIC

## 5000VG7S Series

### INSTRUCTION MANUAL

High-Performance, Vector Control Inverter

#### CT Use (150%)

200V Series 0.75kW/FRN0.75VG7S-2 ~90kW/FRN90VG7S-2	400V Series 3.7kW/FRN3.7VG7S-4 ~400kW/FRN400VG7S-4
--	--

#### VT Use (110%)

200V Series 1.5kW/FRN0.75VG7S-2 ~110kW/FRN90VG7S-2	400V Series 5.5kW/FRN3.7VG7S-4 ~500kW/FRN400VG7S-4
--	--

#### HT Use (200%/170%)

200V Series 3.7kW/FRN3.7VG7S-2 ~55kW/FRN55VG7S-2	400V Series 3.7kW/FRN3.7VG7S-4 ~55kW/FRN55VG7S-4
--	--

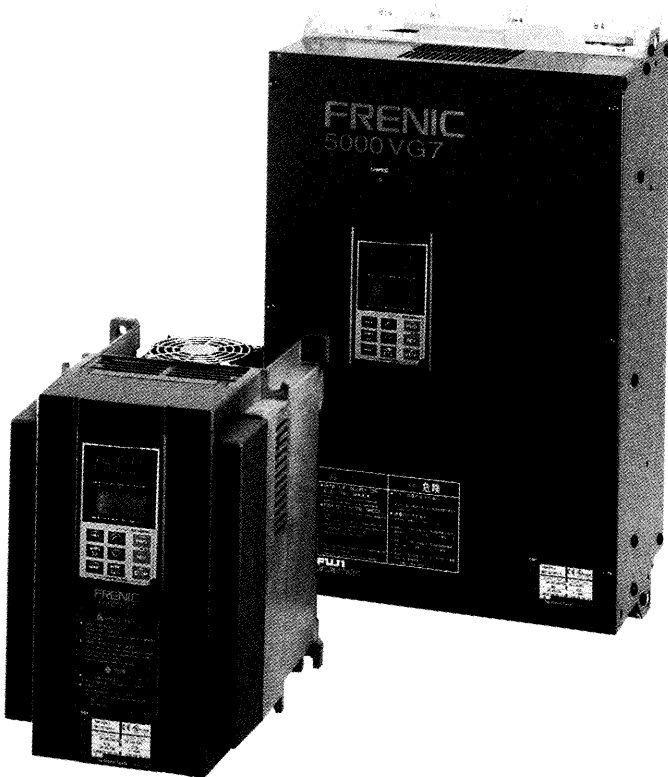

### ⚠ CAUTION

- Read all operating instructions before installing, connecting (wiring), operating, servicing, or inspecting the inverter.
- Ensure that this instruction manual is made available to the final user of the inverter.
- Store this manual in a safe, convenient location.
- The product is subject to change without prior notice.



## Instructions

Thank you for purchasing our FRENIC5000VG7S series inverter. This product is used to drive a 3-phase induction motor at variable speed. As incorrect use of this product may result in personal injury and/or property damage, read all operating instructions before using.

As this manual does not cover the use of function cords and option cards, etc., refer to FRENIC5000VG7S Users Manual.

### Safety Instructions

Read this manual carefully before installing, connecting (wiring), operating, servicing, or inspecting the inverter. Familiarize yourself with all safety features before using the inverter.

In this manual, safety messages are classified as follows:

 <b>WARNING</b>	Improper operation may result in serious personal injury or death.
--	--

 <b>CAUTION</b>	Improper operation may result in slight to medium personal injury or property damage.
--	---

Situations more serious than those covered by CAUTION will depend on prevailing circumstances.

Always follow instructions.

### Instructions on use

 <b>WARNING</b>	<ul style="list-style-type: none"><li>• This inverter is designed to drive a 3-phase induction motor and is not suitable for a single-phase motor or others, <b>as fire may result.</b></li><li>• This inverter may not be used (as is) as a component of a life-support system or other medical device directly affecting the personal welfare of the user.</li><li>• This inverter is manufactured under strict quality control standards. However, safety equipment must be installed if the failure of this device may result in personal injury and/or property damage.</li></ul> <p><b>There is a risk of accident.</b></p>
--	---

### Instructions on installation

 <b>CAUTION</b>	<ul style="list-style-type: none"><li>• Mount this inverter on an incombustible material such as metal.</li></ul> <p><b>There is a risk of fire.</b></p> <ul style="list-style-type: none"><li>• Do not place combustible or flammable material near this inverter, <b>as fire may result.</b></li><li>• The inverter housed in IP00 (18.5kW or over) should be installed in a place where no one can touch it easily.</li></ul> <p><b>Electric shock or injury may result.</b></p>
--	---

## CAUTION

- Do not hold or carry this inverter by the surface cover. Inverter may be dropped **causing injury**.
- Ensure that the inverter and heat sink surfaces are kept free from foreign matter (lint, paper dust, small chips of wood or metal chips), **as fire or accident may result**.
- Do not install or operate a damaged inverter or an inverter with missing parts, **as injury may result**.
- When changing installation bracket position, use the attached screws, **as injury may result**.

## Instructions on wiring

## CAUTION

- Confirm that the phases and rated voltage of this product match those of the AC power supply, **as injury may result**.
- Do not connect the AC power supply to the output terminals (U, V, and W), **as injury may result**.
- Do not connect a braking resistor directly to the DC terminals (P(+) and N(-)), **as fire may result**.
- When using DC power input, ensure that the fan power switching connector (CN RXTX) is correctly engaged in the inverter **as a trouble may occur**.
- When using DC power input of 18.5kW or larger inverter, be sure to connect AC power to terminals R0 and T0 for a power supply of fan **as a trouble may occur**.
- Ensure that the noise generated by the inverter, motor, or wiring does not adversely affect peripheral sensors and equipment, **as accident may result**.

## Instructions on operation

### **WARNING**

- Be sure to install the surface cover before turning on the power (closed). Do not remove the cover while power to the inverter is turned on.

#### **Electric shock may occur.**

- Do not operate switches with wet hands, **as electric shock may result.**
- When the retry function is selected, the inverter may restart automatically after tripping. (Design the machine to ensure personal safety in the event of restart)

#### **Accident may result.**

- When the torque limiting function is selected, operating conditions may differ from preset conditions (acceleration/deceleration time or speed). In this case, personal safety must be assured.

#### **Accident may result.**

- As the STOP key is effective only when a function setting has been established, install an emergency switch independently, and when an operation via the external signal terminal is selected, the STOP key on the KEYPAD panel will be disabled.

#### **Accident may result.**

- As operations start suddenly if alarm is reset with a running signal input, confirm that no running signal is input before resetting alarm.

#### **Accident may result.**

- When an alarm is activated, the motor coasts. If the motor needs to be stopped in such a case, install a brake to the machine with the motor.

#### **Accident may result.**

- If AUTO RESTART is selected in the restart mode after momentary power failure (function code F14), the inverter restarts automatically starting the motor rotation when the power is recovered.

#### **Accident may result.**

- When the tuning (function code H01) is started, the motor, machine or equipment starts and stops repeatedly. Ensure safety before performing tuning.

#### **Accident may result.**

- If the user set the function codes wrongly or without completely understanding this user's manual, the motor may rotate with a torque or at a speed not permitted for the machine.

#### **Accident or injury may result.**

- Do not touch inverter terminals when energized even if inverter has stopped.

#### **Electric shock may result.**

### **CAUTION**

- Do not start or stop the inverter using the main circuit power.

#### **Failure may result.**

- Do not touch the heat sink or braking resistor because they become very hot.

#### **Burns may result.**

- As the inverter can set high speed operation easily, carefully check the performance of motor or machine before changing speed settings.

#### **Injury may result.**

- Do not use the inverter braking function for mechanical holding.

#### **Injury may result.**

- During pre-excitation, the speed adjuster does not function and the motor may be rotated by load disturbance. When using pre-excitation, therefore, also use the mechanical brake.

#### **Injury may result.**

- If improper data is set at the function code related with speed adjuster as in the case of setting high gain abruptly, the motor may hunt.

#### **Injury may result.**

## Instructions on maintenance, inspection, and replacement

### **WARNING**

- Wait a minimum of five minutes (15kW or less) or ten minutes (18.5kW or more) after power has been turned off (open) before starting inspection. (Also confirm that the charge lamp is off and that DC voltage between terminals P(+) and N(-) does not exceed 25V.)

#### **Electric shock may result.**

- Only authorized personnel should perform maintenance, inspection, and replacement operations. (Take off metal jewelry, such as watches and rings. Use insulated tools.)

#### **Electric shock or injury may result.**

## Instructions on disposal

### **CAUTION**

- Treat as industrial waste when disposing it.

#### **Injury may result.**

## Other instructions

### **WARNING**

- Never modify the product.

#### **Electric shock or injury may result.**



### **General Instructions**

Although figures in this manual may show the inverter with covers and safety screens removed for explanation purposes, do not operate the device until all such covers and screens have been replaced.

## Warning Label Position



### Inverter with a small capacity (15kW or lower)

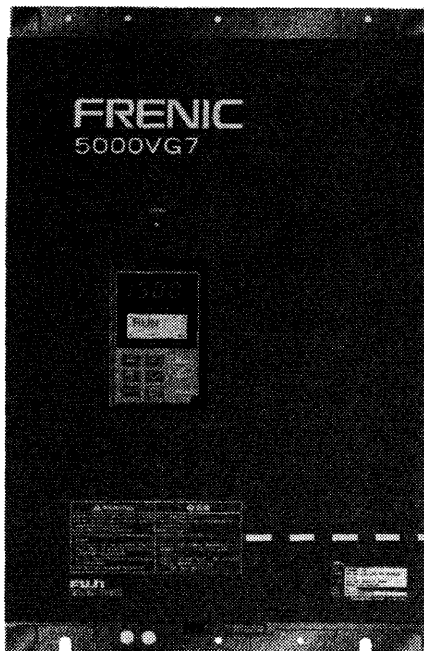

 <b>WARNING</b>	
<ul style="list-style-type: none"> <li>■ RISK OF INJURY OR ELECTRIC SHOCK                             <ul style="list-style-type: none"> <li>• Refer to the instruction manual before installation and operation.</li> </ul> </li> <li>■ RISK OF ELECTRIC SHOCK                             <ul style="list-style-type: none"> <li>• Do not remove this cover while applying power and at least 5min. after disconnecting power.</li> <li>• More than one live circuit.</li> <li>• Securely ground (earth) the inverter.</li> </ul> </li> </ul>	
 <b>危険</b>	
<ul style="list-style-type: none"> <li>■ けが、感電のおそれあり                             <ul style="list-style-type: none"> <li>• 据え付け及び運転の前に必ず取扱説明書を読んで、その指示に従うこと。</li> </ul> </li> <li>■ 感電のおそれあり                             <ul style="list-style-type: none"> <li>• 通電中及び電源遮断後5分以内は、表面カバーを開けないこと。</li> <li>• 表面カバーを開ける場合は、制御回路補助電源 (R0、T0端子) も遮断していることを確認してから行うこと。</li> <li>• アース線は、確実に接地すること。</li> </ul> </li> </ul>	

### Inverter with a middle capacity (18.5kW or higher)



 <b>WARNING</b>	 <b>危険</b>
<ul style="list-style-type: none"> <li>■ RISK OF INJURY OR ELECTRIC SHOCK                             <ul style="list-style-type: none"> <li>• Refer to the instruction manual before installation and operation.</li> </ul> </li> <li>■ RISK OF ELECTRIC SHOCK                             <ul style="list-style-type: none"> <li>• Do not remove this cover while applying power.</li> <li>• This cover can be removed after at least 10min of power off and after the "CHARGE" lamp turns off.</li> <li>• More than one live circuit.</li> </ul> </li> </ul> <p>• Do not insert fingers or anything else into the inverter.</p> <p>• Securely ground (earth) the inverter.</p>	<ul style="list-style-type: none"> <li>■ けが、感電のおそれあり                             <ul style="list-style-type: none"> <li>• 据え付け及び運転の前に必ず取扱説明書を読んで、その指示に従うこと。</li> </ul> </li> <li>■ 感電のおそれあり                             <ul style="list-style-type: none"> <li>• 通電中は、表面カバーを開けないこと。</li> <li>• 表面カバーを開ける場合は、電源遮断後10分以上経過後チャージランプが消灯したのを確認してから行うこと。</li> <li>• 表面カバーを開ける場合は、制御回路補助電源 (R0、T0端子) も遮断していることを確認してから行うこと。</li> <li>• 表面カバー取付状態であっても、開口部より装置内部に指・異物等挿入しないこと。</li> <li>• アース線は、確実に接地すること。</li> </ul> </li> </ul>
	

# Warning Label Position for Inside the Inverter

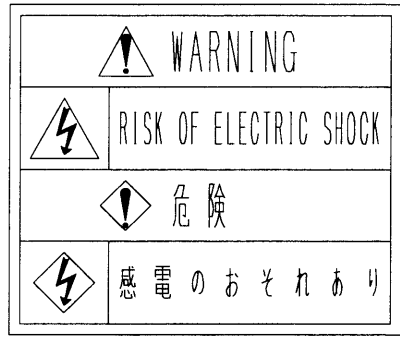
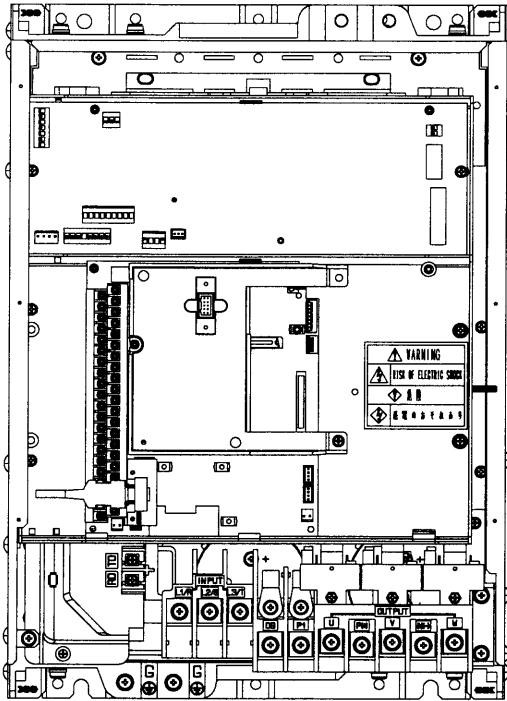

## Compliance with UL/cUL Standards

### 1. Overview

The UL standard is an abbreviation for Underwriters Laboratories Inc. and is a safety standard for preventing fires and other accidents, and protecting users, servicemen, and general people in the United States.

The cUL standard is a standard which the UL constituted to meet the CSA standard. Products approved by the cUL standard are as valid as products approved by the CSA standard.

### 2. Notes

See the following notes when you use your inverters as UL/cUL approved products.

## CAUTION for UL/cUL requirements



- Hazard of electrical shock. Disconnect incoming power before working on this control.
- Dangerous voltage exists until charge lights is off.
- More than one live circuit.
- Use 60/75°C or 90°C copper wire only.
- A Class 2 circuit wired with class 1 wire.
- Field wiring connection must be made by a UL Listed and CSA Certified closed-loop terminal connector sized for the wire gauge involved. connector must be fixed using the crimp tool specified by the connector manufacturer.
- Connect the power supply to main power supply terminals via the Molded-case circuit breaker (MCCB) or the earth leakage circuit breaker (ELCB) to apply the UL Listing Mark. (See Instruction Manual basic connection diagram Fig.2-3-1).
- In case of using auxiliary control-power input (R0, T0), connect it referring to Instruction Manual Basic connection diagram Fig.2-3-1.
- Solid state motor overload protection is provided in each model.  
See Users Manual : MHT263□ for details.



Tightening torque and wire range

1. 60°C/75°C copper wire

CT/HT Use

Voltage	Inverter type FRN □ VG7S-2/4	Required torque [lb-inch](N·m)				Wire range [AWG] (mm <sup>2</sup> )					
		Main terminal	Ground	Auxiliary control-power	Control	L1/R,L2/S, L3/T	U,V,W	P1,P(+)	P(+),DB, N(-)	Auxiliary control-power	Control
3-Phase 200V	0.75	31.0 (3.5)	31.0 (3.5)	10.6 (1.2)	6.2 (0.7)	14 (2.1)	14 (2.1)	14 (2.1)	14 (2.1)	16 (1.3)	24 (0.2)
	1.5					12 (3.3)					
	2.2					8 (8.4)	10 (5.3)	10 (5.3)			
	3.7					6 (13.3)	8 (8.4)	6 (13.3)			
	5.5					8X2 (8.4X2)	6 (13.3)	6 (13.3)			
	7.5					6X2 (13.3X2)	4 (21.2)	4 (21.2)			
	11	51.3 (5.8)	51.3 (5.8)			4X2 (21.2X2)	3 (26.7)	3 (26.7)	12 (3.3)		
	15					3X2 (26.7X2)	6X2 (13.3X2)	4X2 (21.2X2)	4X2 (21.2X2)		
	18.5	119 (13.5)	119 (13.5)			2X2 (33.6X2)	1/0 (53.5)	3X2 (26.7X2)	8 (8.4)		
	22					1X2 (42.4X2)	3/0 (85)	4/0 (107.2)	6 (13.3)		
	30					2/0X2 (67.4X2)	4/0 (107.2)	1X2 (42.4X2)	4 (21.2)		
	37					3/0X2 (85X2)	1/0X2 (53.5X2)	2/0X2 (67.4X2)	2 (33.6)		
	45	239 (27)	239 (27)			2/0X2 (67.4X2)	3/0X2 (85X2)	4/0X2 (107.2X2)	1 (13.3)		
	55					600 (304)	4/0X2 (107.2X2)	250X2 (127X2)	1 (42.4)		
	75	425 (48)	239 (27)			2/0X2 (67.4X2)	3/0X2 (85X2)	4/0X2 (107.2X2)	2 (33.6)		
	90					600 (304)	4/0X2 (107.2X2)	250X2 (127X2)	1 (42.4)		
3-Phase 400V	3.7	31.0 (3.5)	31.0 (3.5)	10.6 (1.2)	6.2 (0.7)	12 (3.3)	14 (2.1)	14 (2.1)	14 (2.1)	16 (1.3)	24 (0.2)
	5.5					10 (5.3)					
	7.5					8 (8.4)	10 (5.3)	10 (5.3)			
	11	6 (13.3)	8 (8.4)			6 (13.3)					
	15	4 (21.2)	8 (8.4)			6 (13.3)					
	18.5	3 (26.7)	6 (13.3)			4 (21.2)					
	22	51.3 (5.8)	51.3 (5.8)			6X2 (13.3X2)	4 (21.2)	4 (21.2)	12 (3.3)		
	30					2 (33.6)	3 (26.7)	3 (26.7)	10 (5.3)		
	37	119 (13.5)	119 (13.5)			1 (42.4)	2 (33.6)	2 (33.6)	8 (8.4)		
	45					3X2 (26.7X2)	2 (33.6)	1 (42.4)	6 (13.3)		
	55	239 (27)	239 (27)			2X2 (33.6X2)	1/0 (53.5)	3X2 (26.7X2)	4 (21.2)		
	75					2/0 (67.4)	3/0 (85)	4/0 (107.2)	2 (33.6)		
	90	425 (48)	239 (27)			3/0 (85)	4/0 (107.2)	1X2 (42.4X2)	1/0 (53.5)		
	110					1X2 (42.4X2)	1/0X2 (53.5X2)	1/0X2 (53.5X2)	3 (26.7)		
	132	425 (48)	239 (27)			350 (177)	400 (203)	3/0X2 (85X2)	2 (33.6)		
	160					3/0X2 (85X2)	3/0X2 (85X2)	4/0X2 (107.2X2)	1 (13.3)		
	200					4/0X2 (107.2X2)	250X2 (127X2)	300X2 (152X2)	2 (33.6)		
	220					250X2 (127X2)	300X2 (152X2)	350X2 (177X2)	1/0 (53.5)		
	280					400X2 (203X2)	400X2 (203X2)	250X3 (127X3)	2/0 (67.4)		
	315					250X3 (127X3)	250X3 (127X3)	300X3 (152X3)	3 (26.7)		
355	600X2 (304X2)			600X2 (304X2)	400X3 (203X3)	4 (21.2)					
400	350X3 (177X3)			350X3 (177X3)	500X3 (253X3)	3/0 (85)					
						250 (127)					

VT Use

Voltage	Inverter type FRN □ VG7S-2/4	Required torque [lb-inch](N·m)				Wire range [AWG] (mm <sup>2</sup> )					
		Main terminal	Ground	Auxiliary control-power	Control	L1/R,L2/S, L3/T	U,V,W	P1,P(+)	P(+),DB, N(-)	Auxiliary control-power	Control
3-Phase 200V	0.75	31.0 (3.5)	31.0 (3.5)	10.6 (1.2)	6.2 (0.7)	14 (2.1)	14 (2.1)	14 (2.1)	14 (2.1)	16 (1.3)	24 (0.2)
	1.5					12 (3.3)	10 (5.3)	10 (5.3)			
	2.2					8 (8.4)	8 (8.4)	6 (13.3)			
	3.7					6 (13.3)	8 (8.4)	6 (13.3)			
	5.5					8X2 (8.4X2)	6 (13.3)	6 (13.3)			
	7.5					6X2 (13.3X2)	8X2 (8.4X2)	10X2 (5.3X2)			
	11	51.3 (5.8)	51.3 (5.8)			4X2 (21.2X2)	3 (26.7)	3 (26.7)	12 (3.3)		
	15					3X2 (26.7X2)	6X2 (13.3X2)	6X2 (13.3X2)	10 (5.3)		
	18.5					4X2 (21.2X2)	4X2 (21.2X2)	4X2 (21.2X2)	8 (8.4)		
	22					3X2 (26.7X2)	3X2 (26.7X2)	3X2 (26.7X2)	6 (13.3)		
	30					1X2 (42.4X2)	2X2 (33.6X2)	2X2 (33.6X2)	4 (21.2)		
	37					2/0X2 (67.4X2)	4/0 (107.2)	1X2 (42.4X2)	2 (33.6)		
	45	425 (48)	239 (27)			3/0X2 (85X2)	1/0X2 (53.5X2)	2/0X2 (67.4X2)	4 (21.2)		
	55					2/0X2 (67.4X2)	3/0X2 (85X2)	4/0X2 (107.2X2)	1 (42.4)		
	75					4/0 (107.2X2)	4/0X2 (107.2X2)	250X2 (127X2)	1 (42.4)		
90	250X2 (127X2)			300X2 (152X2)	350X2 (177X2)						
3-Phase 400V	3.7	31.0 (3.5)	31.0 (3.5)	10.6 (1.2)	6.2 (0.7)	10 (5.3)	12 (3.3)	14 (2.1)	14 (2.1)	16 (1.3)	24 (0.2)
	5.5					8 (8.4)	10 (5.3)	10 (5.3)			
	7.5					6 (13.3)	8 (8.4)	6 (13.3)			
	11					4 (21.2)	8 (8.4)	6 (13.3)			
	15	51.3 (5.8)	51.3 (5.8)			3 (26.7)	6 (13.3)	3 (26.7)	12 (3.3)		
	18.5					6X2 (13.3X2)	4 (21.2)	4 (21.2)	10 (5.3)		
	22					1 (42.4)	2 (33.6)	2 (33.6)	8 (8.4)		
	30					3X2(26.7X2)	(33.6)	1 (42.4)	6 (13.3)		
	37	119 (13.5)	119 (13.5)			2X2 (33.6X2)	1/0 (53.5)	3X2 (26.7X2)	4 (21.2)		
	45					3X2 (26.7X2)	2X2 (33.6X2)	2X2 (33.6X2)	3 (26.7)		
	55					3/0 (85)	4/0 (107.2)	1X2 (42.4X2)	2 (33.6)		
	75					1X2 (42.4X2)	1/0X2 (53.5X2)	1/0X2 (53.5X2)	1 (42.4)		
	90	239 (27)	239 (27)			1/0X2 (53.5X2)	2/0X2 (67.4X2)	3/0X2 (85X2)	3 (26.7)		
	110					3/0X2 (85X2)	3/0X2 (85X2)	4/0X2 (107.2X2)	2 (33.6)		
	132					4/0X2 (107.2X2)	250X2 (127X2)	300X2 (152X2)	1/0 (53.5)		
	160					250X2 (127X2)	300X2 (152X2)	350X2 (177X2)	2/0 (67.4)		
	200	425 (48)	239 (27)			350X2 (177X2)	400X2 (203X2)	500X2 (253X2)	3/0 (85)		
	220					4/0X3 (107.2X3)	250X3 (127X3)	300X3 (152X3)	250 (127)		
	280					300X3 (152X3)	300X3 (152X3)	400X3 (203X3)			
	315					350X3 (177X3)	350X3 (177X3)	500X3 (253X3)			
	355					500X3 (253X3)	600X3 (304X3)	600X3 (304X3)			
400											

\* "Suitable for use on a circuit capable or delivering not more than 42,000 rms symmetrical amperes, 230V maximum" rated for 200V class input.

\* "Suitable for use on a circuit capable or delivering not more than 42,000 rms symmetrical amperes, 480V maximum" rated for 400V class input.

Connect power supplies described in the following table as the input power supply for your inverters. (short circuit standard)

Inverter model	Maximum input voltage	Input power supply current
FRN0.75VG7S-2 - FRN90VG7S-2	AC230V	42,000A or less
FRN3.7VG7S-4 - FRN400VG7S-4	AC480V	

2. 90°C copper wire  
CT/HT Use

Voltage	Inverter type FRN □ VG7S-2/4	Required torque [lb-inch](N·m)				Wire range [AWG] (mm <sup>2</sup> )										
		Main terminal	Ground	Auxiliary control-power	Control	L1/R,L2/S, L3/T	U,V,W	P1,P(+)	P(+),DB, N(-)	Auxiliary control-power	Control					
3-Phase 200V	0.75	31.0 (3.5)	31.0 (3.5)	10.6 (1.2)	6.2 (0.7)	14 (2.1)	14 (2.1)	14 (2.1)	14 (2.1)	16 (1.3)	24 (0.2)					
	1.5															
	2.2															
	3.7															
	5.5															
	7.5															
	11	51.3 (5.8)	51.3 (5.8)			8 (8.4)	10 (5.3)	12 (3.3)								
	15					6 (13.3)	8 (8.4)	8 (8.4)								
	18.5					3 (26.7)	6 (13.3)	6 (13.3)								
	22					6X2 (13.3X2)	4 (21.2)	4 (21.2)								
	30					4X2 (21.2X2)	6X2 (13.3X2)	6X2 (13.3X2)								
	37					3X2 (26.7X2)	1 (42.4)	1/0 (53.5)								
	45	239 (27)	119 (13.5)			4/0 (107.2)	2/0 (67.4)	3/0 (85)								
	55					1/0X2 (53.5X2)	3/0 (85)	4/0 (107.2)								
75	2/0X2 (67.4X2)			1X2 (42.4X2)	1/0X2 (53.5X2)											
90	350 (177)			400 (203)	3/0X2 (85X2)											
	500 (253)			600 (304)	4/0X2 (107.2X2)											
					2 (33.6)											
3-Phase 400V	3.7	31.0 (3.5)	31.0 (3.5)	10.6 (1.2)	6.2 (0.7)	14 (2.1)	14 (2.1)	14 (2.1)	14 (2.1)	16 (1.3)	24 (0.2)					
	5.5															
	7.5															
	11											51.3 (5.8)	51.3 (5.8)	8 (8.4)	10 (5.3)	12 (3.3)
	15													6 (13.3)	8 (8.4)	8 (8.4)
	18.5													4 (21.2)	6 (13.3)	6 (13.3)
	22	3 (26.7)	4 (21.2)			4 (21.2)										
	30	2 (33.6)	4 (21.2)			3 (26.7)										
	37	1/0 (53.5)	2 (33.6)			2 (33.6)										
	45	119 (13.5)	119 (13.5)			4X2 (21.2X2)	1 (42.4)	1/0 (53.5)								
	55					1/0 (53.5)	2/0 (67.4)	3/0 (85)								
	75					3/0 (85)	3/0 (85)	4/0 (107.2)								
	90					4/0 (107.2)	1X2 (42.4X2)	1X2 (42.4X2)								
	110					250 (127)	300 (152)	400(203)								
	132					400 (203)	400 (203)	3/0X2 (85X2)								
	160	239 (27)	239 (27)			600 (304)	600 (304)	250X2 (127X2)								
	200					4/0X2 (107.2X2)	4/0X2 (107.2X2)	300X2 (152X2)								
	220					300X2 (152X2)	350X2 (177X2)	400X2 (203X2)								
	280					350X2 (177X2)	400X2 (203X2)	500X2 (253X2)								
	315					500X2 (253X2)	500X2 (253X2)	300X3 (152X3)								
	355					600X2 (304X2)	600X2 (304X2)	400X3 (203X3)								
	400							4 (21.2)								
					1 (42.4)											
					1/0 (53.5)											
					2/0 (67.4)											

VT Use

Voltage	Inverter type FRN□ VG7S-2/4	Required torque [lb-inch](N·m)				Wire range [AWG] (mm <sup>2</sup> )						
		Main terminal	Ground	Auxiliary control-power	Control	L1/R, L2/S, L3/T	U, V, W	P1, P(+)	P(+), DB, N(-)	Auxiliary control-power	Control	
3-Phase 200V	0.75	31.0 (3.5)	31.0 (3.5)	10.6 (1.2)	6.2 (0.7)	14 (2.1)	14 (2.1)	14 (2.1)	14 (2.1)	16 (1.3)	24 (0.2)	
	1.5					10 (5.3)	10 (5.3)	12 (3.3)				
	2.2					8 (8.4)	8 (8.4)	8 (8.4)				
	3.7					6 (13.3)	8 (8.4)	6 (13.3)				
	5.5					8X2 (8.4X2)	6 (13.3)	6 (13.3)				
	7.5	6X2 (13.3X2)	4 (21.2)			4 (21.2)						
	11	51.3 (5.8)	51.3 (5.8)			4X2 (21.2X2)	6X2 (13.3X2)	6X2 (13.3X2)				
	15					3X2 (26.7X2)	4X2 (21.2X2)	10 (5.3)				
	18.5					2X2 (33.6X2)	4x2 (21.2x2)	3X2 (26.7X2)				8 (8.4)
	22					1/0X2 (53.5X2)	3/0 (85)	4/0 (107.2)				6 (13.3)
	30					2/0X2 (67.4X2)	1x2 (42.4x2)	1/0X2 (53.5X2)				4 (21.2)
	37	239 (27)	119 (13.5)			1/0X2 (53.5X2)	2/0X2 (67.4X2)	3/0X2 (85X2)				
	45					3/0X2 (85X2)	3/0X2 (85X2)	4/0X2 (107.2)				2 (33.6)
	55					4/0X2 (107.2X2)	4/0X2 (107.2X2)	300X2 (152X2)				
	75											
90												
3-Phase 400V	3.7	31.0 (3.5)	31.0 (3.5)	10.6 (1.2)	6.2 (0.7)	12 (3.3)	14 (2.1)	14 (2.1)	14 (2.1)	16 (1.3)	24 (0.2)	
	5.5					10 (5.3)	10 (5.3)	12 (3.3)				
	7.5					8 (8.4)	10 (5.3)	8 (8.4)				
	11					6 (13.3)	8 (8.4)	6 (13.3)				
	15					4 (21.2)	6 (13.3)	4 (21.2)				
	18.5	3 (26.7)	4 (21.2)			3 (26.7)						
	22	2 (33.6)	4 (21.2)			2 (33.6)	12 (3.3)					
	30	1/0 (53.5)	2 (33.6)			2 (33.6)	10 (5.3)					
	37	4X2 (21.2X2)	1 (42.4)			1/0 (53.5)	8 (8.4)					
	45	1/0 (53.5)	4X2 (21.2X2)			3X2 (26.7X2)	6 (13.3)					
	55	3/0 (85)	3/0 (85)			4/0 (107.2)	4 (21.2)					
	75	4/0 (107.2)	1X2 (42.4X2)			1X2 (42.4X2)	2 (33.6)					
	90	1X2 (42.4X2)	1/0X2 (53.5X2)			2/0X2 (67.4X2)	1 (42.4)					
	110	400 (203)	400 (203)			3/0X2 (85X2)	1/0 (53.5)					
	132	3/0X2 (85X2)	4/0X2 (107.2X2)			250X2 (127X2)	2/0 (67.4)					
	160	4/0X2 (107.2X2)	350X2 (177X2)			400X2 (203X2)						
	200	300X2 (152X2)	400X2 (203X2)			250X3 (127X3)						
	220	350X2 (177X2)	400X2 (203X2)			400X3 (203X3)						
	280	4/0X3 (107.2X3)	250X3 (127X3)			300X3 (152X3)						
	315	600X2 (304X2)	600X2 (304X2)			400X3 (203X3)						
355	400X3 (203X3)	500X3 (253X3)	600X3 (304X3)									

\* "Suitable for use on a circuit capable of delivering not more than 42,000 rms symmetrical amperes, 230V maximum" rated for 200V class input.

\* "Suitable for use on a circuit capable of delivering not more than 42,000 rms symmetrical amperes, 480V maximum" rated for 400V class input.

Connect power supplies described in the following table as the input power supply for your inverters. (short circuit standard)

Inverter model	Maximum input voltage	Input power supply current
FRN0.75VG7S-2 - FRN90VG7S-2	AC230V	42,000A or less
FRN3.7VG7S-4 - FRN400VG7S-4	AC480V	

## Compliance with European Standard

The CE marking presented on Fuji products is related to the Council Directive 89/336/EEC and the Low Voltage Directive 73/23/EEC for the Electromagnetic Compatibility (EMC) in Europe.

**Compliant standards**   · EN 61800-3: 1997  
                                  · EN 50178: 1997

Only the models in the 400V series comply with the standards above among the "FRENIC5000 VG7S" series. The 200V series do not conform to the standards. Please note that products of the CT/HT use 18.5 kW and the VT use 22 kW do not comply with the standards, and if you need to use compliant products, you should use the products of the CT/HT use 22 kW and the VT use 30 kW which are models with larger capacities by one grade.

### 1. Compliance with Low Voltage Directive

#### 1-1 Overview

Inverters are subject to the Low Voltage Directive in Europe. Fuji has obtained an approval for the compliance from a European inspection organization, and voluntarily declares the compliance with the Low Voltage Directive.

#### 1-2 Notes

See the notes below when you use the inverters in your products compliant with the Low Voltage Directive in Europe.

## CAUTION

- The contact capacity for the alarm relay output (30A, B, C) and the relay signal output (Y5A, Y5C) is DC 48V, 0.5A.
- Connect your inverter to the ground securely.
- Connect a ring terminal to a wire when you attach it to the main circuit and inverter ground terminals.
- Use an independent wiring for the inverter ground terminal  G. (Do not connect two or more wires)
- When you use an earth leakage breaker (RCD), you can use only the Type B for protection for the power supply.  
Also you should use a transformer for double insulation or reinforced insulation to insulate your inverter from the power supply.
- Use a molded case circuit breaker (MCCB) and a magnetic contactor (MC) compliant with the EN or IEC standard.
- For a power supply system (I-T NET) where a neutral point is not grounded, the control terminals are provided as basic insulation in respect to the main circuit. When a person may touch them directly, you should add an external insulation circuit for double insulation.
- Use your inverter under a condition corresponding to the overvoltage category III and the pollution degree 2 or more prescribed in the IEC664. Install your inverter in a control panel (IP54 or more) with a structure preventing water, oil, carbon and dusts from entering for meeting the pollution degree 2 or more.
- Use a wire with the diameter and the type prescribed in the Appendix C of the EN 60204 for the input/output wiring for your inverter.
- When you install an external heatsink which is a heatsink for inverter external to the control panel, you should install a protection cover preventing a capacitor and a braking resistor installed on the heatsink from being touched.
- When you install an optional AC reactor, a DC reactor, and an external braking resistor, follow the description below to prevent an electric shock due to touching the terminals and active electrical parts.
  - 1) Install them in a casing or wall of the IP4X when a person may have an easy access to them.
  - 2) Install them in a casing or wall of the IP2X when a person does not have an easy access to them.





## Contents

### Instructions

#### Safety Instructions

<b>1. Before Use</b> .....	<b>1-1</b>	<b>8. Maintenance and Inspection</b> .....	<b>8-1</b>
1-1 Inspection After Receipt .....	1-1	8-1 Daily Inspection .....	8-1
1-2 External View of the Product .....	1-1	8-2 Periodical Inspection .....	8-1
1-3 Handling of the Product .....	1-2	8-3 Measurement of Main Circuit Electrical Quantity .....	8-4
1-4 Transportation .....	1-3	8-4 Insulation Test .....	8-5
1-5 Storage .....	1-3	8-5 Parts Replacement .....	8-5
<b>2. Installation and Connection</b> .....	<b>2-1</b>	8-6 Inquiries about Products and Product Guarantee .....	8-5
2-1 Operating Conditions .....	2-1	<b>9. Compliance with Standards</b> .....	<b>9-1</b>
2-2 Installation Procedure .....	2-2	9-1 Compliance with UL/cUL Standards .....	9-1
2-3 Electric Connections .....	2-4	9-1-1 Overview .....	9-1
2-3-1 Basic Connections .....	2-4	9-1-2 Notes .....	9-1
2-3-2 Wiring of Main Circuit and Grounding Terminals .....	2-6	9-2 Compliance with European Standard .....	9-1
2-3-3 Wiring of Control Terminals .....	2-13	9-3 Compliance with Low Voltage Directive .....	9-1
2-3-4 Terminal Arrangement Chart ..	2-17	9-3-1 Overview .....	9-1
<b>3. Test Run</b> .....	<b>3-1</b>	9-3-2 Notes .....	9-1
3-1 Preliminary Check and Preparation ..	3-1	9-4 Compliance with EMC standard .....	9-1
3-2 Operating Methods .....	3-1	9-4-1 Overview .....	9-1
3-3 Test Run .....	3-1	9-4-2 RFI Filter .....	9-1
<b>4. KEYPAD Panel</b> .....	<b>4-1</b>	9-4-3 Recommended Installation .....	9-1
4-1 Appearance of KEYPAD Panel .....	4-1		
4-2 Alarm Mode .....	4-3		
4-3 KEYPAD Operation System (Hierarchical Structure of LCD Screens) .....	4-4		
4-3-1 During Normal Operation .....	4-4		
4-3-2 When an Alarm Raised Occurs .....	4-4		
4-3-3 Program Mode .....	4-6		
<b>5. Function Selection</b> .....	<b>5-1</b>		
<b>6. List of Inverter Protective Functions</b> .....	<b>6-1</b>		
<b>7. Function Description (Arranged by Function)</b> .....	<b>7-1</b>		
7-1 If You Think Defective .....	7-1		
7-1-1 If You Think Defective .....	7-1		
7-1-2 What You Should Check First ..	7-1		
7-2 Checks Using Flowchart .....	7-3		
7-2-1 Malfunctions not Followed by Alarms .....	7-3		
7-2-2 Malfunctions Followed Alarms .....	7-11		

# 1. Before Use

## 1-1 Inspection After Receipt

Unpackage the product and perform the following checks.

If the product is found to have a fault, please contact the dealer from which you purchased the product or the nearest sales office of Fuji Electric.

(1) Read the nameplate to check that the product is the same thing as ordered.

TYPE : Inverter type

FRN 30 VG7S - 4

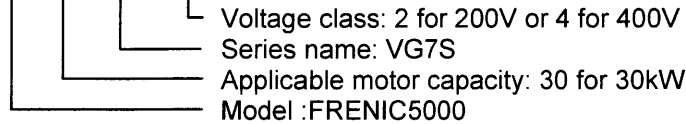

SOURCE : Power ratings

OUTPUT : Rated output

MASS : Mass

SER.No. : Serial No. 0 1 HY12345R001 - 1H

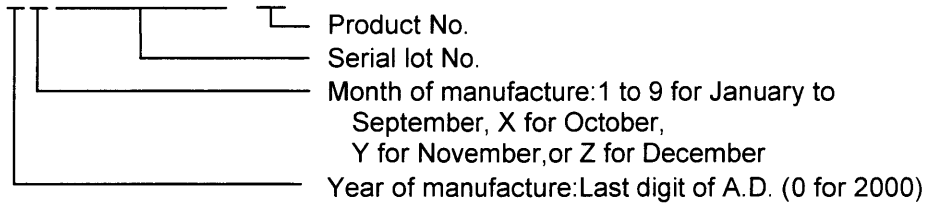

FUJI ELECTRIC		
TYPE	FRN30U67S-4	CE LISTED E40476 IND.CONT.EU 8844
SER.No.	01HY12345R001-1H	
SOURCE	Constant Torque	Variable Torque
	3PH 380-440V/50Hz	380-480V/60Hz
	86A	104A
OUTPUT	3PH 380-480V	
	45kVA 60A	57kVA 75A
		44kVA 58A
WEIGHT	30 kg	
Fuji Electric Co.,Ltd. Made in Japan		
TYPE	FRN30U67S-4	
SER.No.	01HY12345R001-1H	

Nameplate

(2) Check for broken or missing parts and damage caused to the cover/body during transportation.



**WARNING**  
 • Do not energize a product with broken or missing parts or damaged during transportation.  
 Doing so may lead to electric shock or fire.

## 1-2 External View of the Product

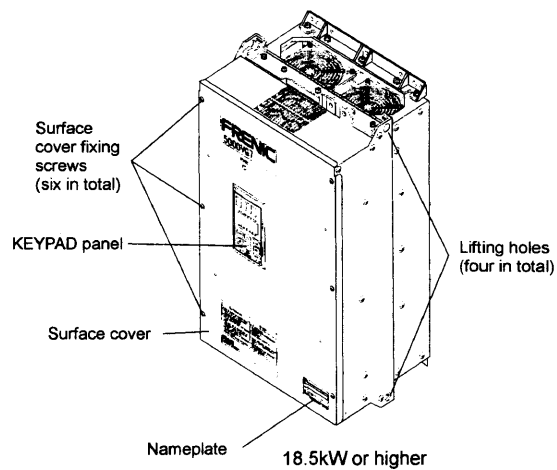
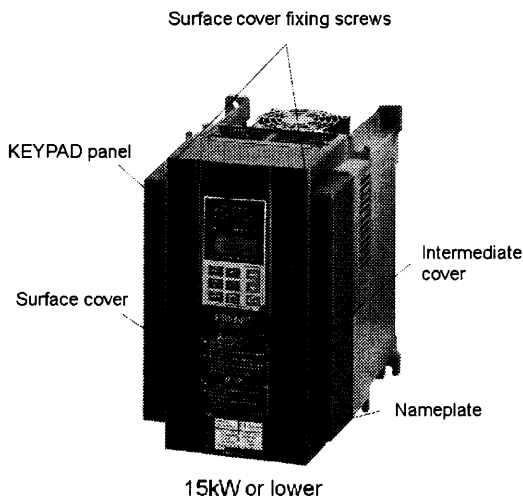

### 1-3 Handling of the Product

#### (1) Removal of Surface Cover

Loosen the surface cover fixing screws. Remove the cover by pulling the top of the cover as shown in Figure 1-3-1.

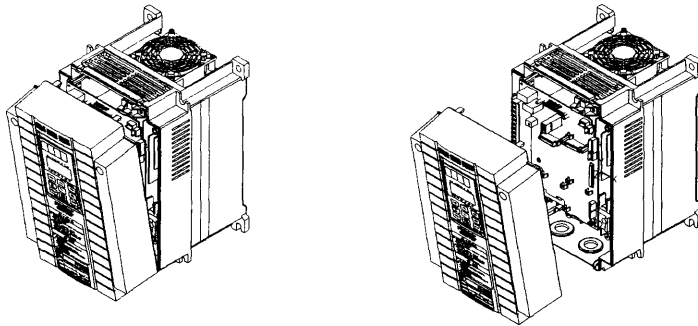

Figure 1-3-1 Removal of Surface Cover (15kW or lower)

Remove the six surface cover fixing screws. Remove the surface cover.

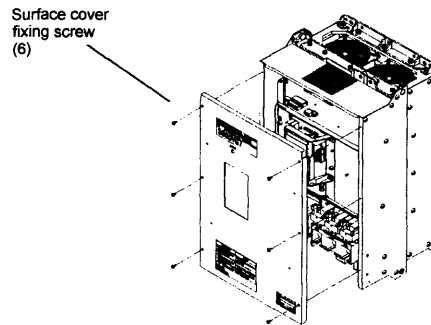

Figure 1-3-2 Removal of Surface Cover (18.5kW or higher)

#### (2) Removal of KEYPAD Panel

After removing the face cover in step (1), loosen the KEYPAD panel fixing screws. Remove the KEYPAD panel as shown in Figure 1-3-3.

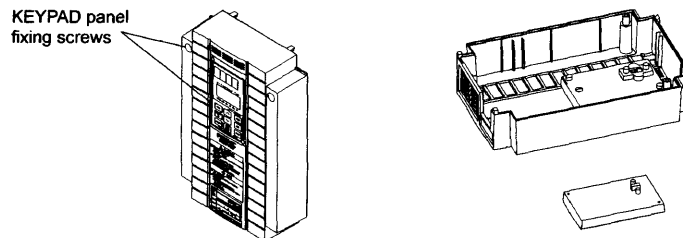

Figure 1-3-3 Removal of KEYPAD Panel (15kW or lower)

Loosen the KEYPAD panel fixing screws. Carefully remove the KEYPAD panel with your fingers inserted to the cutouts at the side of the KEYPAD panel. Careless handling may break connectors.

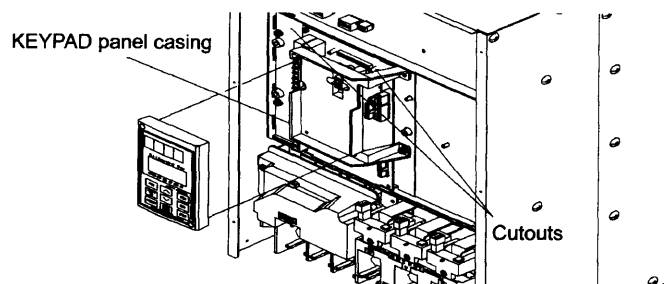

Figure 1-3-4 Removal of KEYPAD Panel (18.5kW or higher)

## 1-4 Transportation

Always hold the body during transportation.

Do not hold the cover or any other part. Doing so may break or fall the product.

When using a hoist or crane to transport a product with lifting holes, hang hooks and ropes to the holes.

## 1-5 Storage

### Temporary Storage

Store the product under the conditions specified on Table 1-5-1.

Table 1-5-1 Storage Conditions

Item	Requirement	
Ambient temperature	-10 to +50°C	No condensation or freezing should occur due to sudden temperature changes.
Storage temperature <small>See Note 1</small>	-25 to +65°C	
Relative humidity	5% to 95% <small>See Note 2</small>	
Atmosphere	The product should not be exposed to dust, direct sunlight, corrosive or combustible gas, oil mist, vapor, waterdrops, vibration, or air containing much salt.	

Note 1: The storage temperature applies to the temporary storage during transportation, for example.

Note 2: Do not store the product in a place where the temperature significantly changes as this may cause condensation or freezing even if the humidity requirement is satisfied.

- (1) Do not place the product directly on the floor.
- (2) Pack the product with a plastic sheet or such if stored under undesirable conditions.
- (3) Seal in a desiccative such as silica gel when packing the product if it may be affected by moisture.

### Extended Storage

The requirements to be satisfied when storing the product for an extended period after purchased greatly depend on the environment. General requirements are listed below.

- (1) Satisfy the requirements for temporary storage.  
If the storage period exceeds three months, the ambient temperature should be kept below 30 °C to protect the dead electrolytic capacitor from deterioration.
- (2) Carefully pack the product to prevent the intrusion of moisture, etc. Seal in a desiccant to keep the relative humidity inside the pack below 70%, as a guide.
- (3) The product will be often exposed to moisture or dust if left mounted on a unit or console, especially in a building under construction. In such a case, remove the product and relocate in a well-conditioned place. The electrolytic capacitor will be deteriorated if left dead for an extended period. Do not leave it dead for a period exceeding a year.

## 2. Installation and Connection

### 2-1 Operating Conditions

Install the product under the conditions specified in Table 2-1-1.

Table 2-1-1 Operating Conditions

Item	Requirement
Place	Indoor
Ambient temperature	-10 to +50°C
Relative humidity	5% to 95% (no condensation allowed)
Atmosphere	The product should not be exposed to dust, direct sunlight, corrosive gas, oil mist, vapor, waterdrops, or air containing much salt. No condensation should occur due to sudden temperature changes.
Altitude	1,000m or less (if more than 1,000m, see Table 2-1-2)
Vibration	2 to 9Hz: 3mm amplitude 9 to 20Hz: 9.8m/s <sup>2</sup> (or 2m/s <sup>2</sup> for 200V, 75kW or higher and 400V, 90kW or higher inverters) 20 to 55Hz: 2m/s <sup>2</sup> 55 to 200Hz: 1m/s <sup>2</sup>

Table 2-1-2 Output Reduction Rates at Higher Altitudes

Altitude	Output Current Reduction Rate
1,000m or less	1.00
1,000-1,500m	0.97
1,500-2,000m	0.95
2,000-2,500m	0.91
2,500-3,000m	0.88

## 2-2 Installation Procedure

- (1) Install the product onto a rigid structure in the vertical direction with the letters, FRENIC5000 VG7S, seen from the front and fix with specified bolts. Do not install upside down or in the horizontal direction.

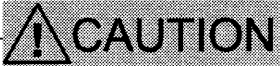

**Failure to do so may lead to injury.**

- (2) The inverter generates heat during operation. Reserve a space as shown in Figure 2-2-1 to ensure a sufficient flow of cooling air. The heat is radiated from the top. Do not install the inverter under any unit susceptible to heat.

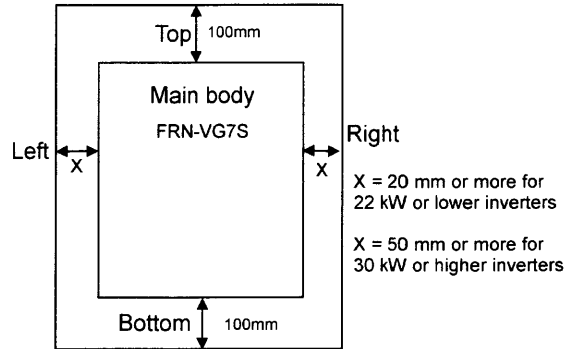
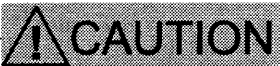

Figure 2-2-1

- (3) The cooling fins (heat sink) are heated to almost 90°C during operation of the inverter. The inverter mounting surface should be made of a material capable of withstanding this temperature rise.



**The fins may burn your skin.**



- Install the inverter onto an incombustible material such as metal.

**Failure to do so may lead to fire.**

- (4) When storing the inverter in a control panel, for example, sufficiently ventilate the inverter so that its ambient temperature will not exceed the specified limit. Do not store the inverter in a small closed box that does not radiate heat well.

- (5) When storing two or more inverters in a unit or control panel, they are desirably arranged side by side to minimize the thermal effect on each other. If they are inevitably arranged with one above another, separating plate should be provided to prevent the heat transfer from the bottom side inverter to the above.

- (6) The inverter is prepared to be mounted in a control panel when delivered. It may be externally cooled using the optional adapter if 15kW or lower or with the mounting legs relocated if 18.5kW or higher. With the inverter externally cooled, the heat generated inside the unit or control panel is dissipated because the cooling fins, which radiate 70% of the generated heat, are excluded from the unit or control panel. Do not exclude the cooling fins where they may be clogged with lint or damp dust.

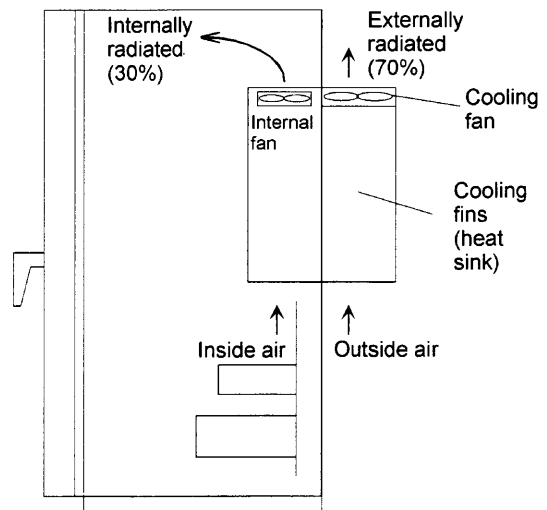

Figure 2-2-2 External Cooling System



- Do not admit lint, paper, wooden chips, dust, metallic pieces, and any other foreign matters into the inverter or allow them to stick to the cooling fins.

**Doing so may lead to fire or accident.**

To externally cool a 18.5kW or higher inverter, relocate the upper and lower mounting legs as shown in Figure 2-2-3. Remove the mounting leg fixing screws, relocate the legs, and fix with casing fixing screws. (The casing fixing screws cannot be directly used for some models. See the following table.) The mounting leg fixing screws become unnecessary after the legs are relocated.

Number and Size of Fixing Screws

Voltage class	Inverter model	Mounting leg fixing screws	Casing fixing screws
200V	FRN18.5VG7S-2~FRN55VG7S-2	5 (M6 × 20)	5 (M5 × 16)
	FRN75VG7S-2	7 (M6 × 20)	5 (M5 × 16)
	FRN90VG7S-2	6 (M6 × 20)	6 (M5 × 16)
400V	FRN18.5VG7S-4~FRN75VG7S-4	5 (M6 × 20)	5 (M5 × 16)
	FRN90VG7S-4~FRN110VG7S-4	7 (M6 × 20)	5 (M5 × 16) Note 1
	FRN132VG7S-4~FRN160VG7S-4	7 (M6 × 20)	7 (M5 × 16)
	FRN200VG7S-4~FRN220VG7S-4	6 (M6 × 20)	6 (M5 × 16) Note 1
	FRN280VG7S-4~FRN315VG7S-4 Note 3	6 (M8 × 20)	– Note 2
FRN355VG7S-4~FRN400VG7S-4 Note 3	8 (M8 × 20)		

**CAUTION**

- Do not use any screws other than specified.  
**Doing so may lead to fire or accident.**

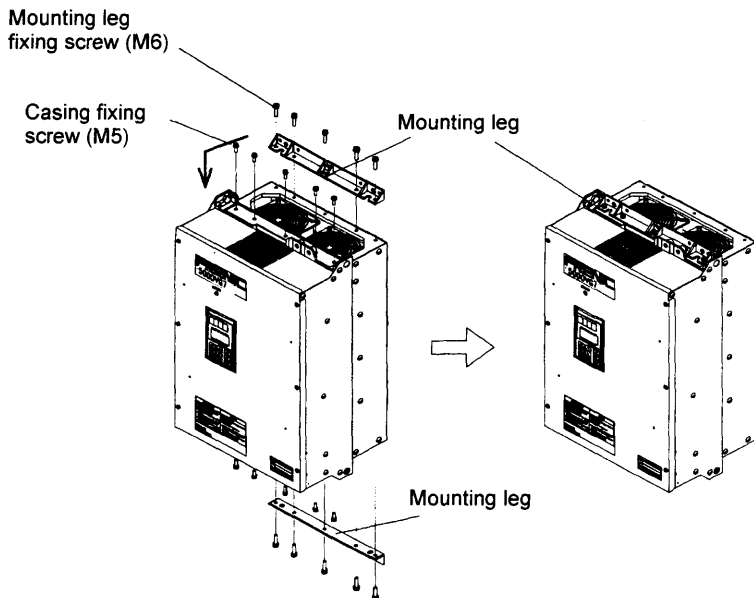

- Note 1: Fix the legs with M5 × 20 screws.
- Note 2: Fix the legs with leg fixing screws.
- Note 3: The lower leg becomes unnecessary when the inverter is installed on its bottom.

Figure 2-2-3

**CAUTION**

- Use the screws provided with the inverter when relocating the mounting legs.  
**Failure to do so may lead to injury.**

## 2-3 Electric Connections

Removing the surface cover exposes the terminal blocks. Correctly wire them after reading the following instructions.

### 2-3-1 Basic Connections

- (1) Connect power supply leads to the main circuit power terminals, L1/R, L2/S, and L3/T. Connecting any power supply lead to another terminal may fail the inverter. Check that the supply voltage does not exceed the permissible limit indicated on the nameplate, etc.
- (2) The grounding terminal must be grounded to prevent disasters such as electric shock and fire and reduce the noise.
- (3) Use a reliable crimp terminal to connect each lead.
- (4) After making connections (wiring), check that:
  - 1) leads are correctly connected,
  - 2) all necessary connections are made, and
  - 3) no terminal or wire is short-circuited or grounded.
- (5) When any connection is changed after the inverter is energized:

It takes a long time for the smoothing capacitor in the DC link circuit of the main circuit to be discharged after the power supply is shut off. After the CHARGE lamp goes off, check with a multimeter or such that the DC voltage has been reduced to a safe level (25V DC or less). Short-circuiting a circuit in which a voltage (potential) still remains may generate sparks. Wait until the voltage goes away.

### WARNING

- Always connect the grounding lead.
- Failure to do so may lead to electric shock or fire.**
- The wiring work should be performed by qualified persons.
  - Before working, check that the power supply is shut off (open).
- Failure to do so may lead to electric shock.**
- Do not use any lead size other than specified.
- Doing so may lead to fire.**

# Basic Wiring Diagram

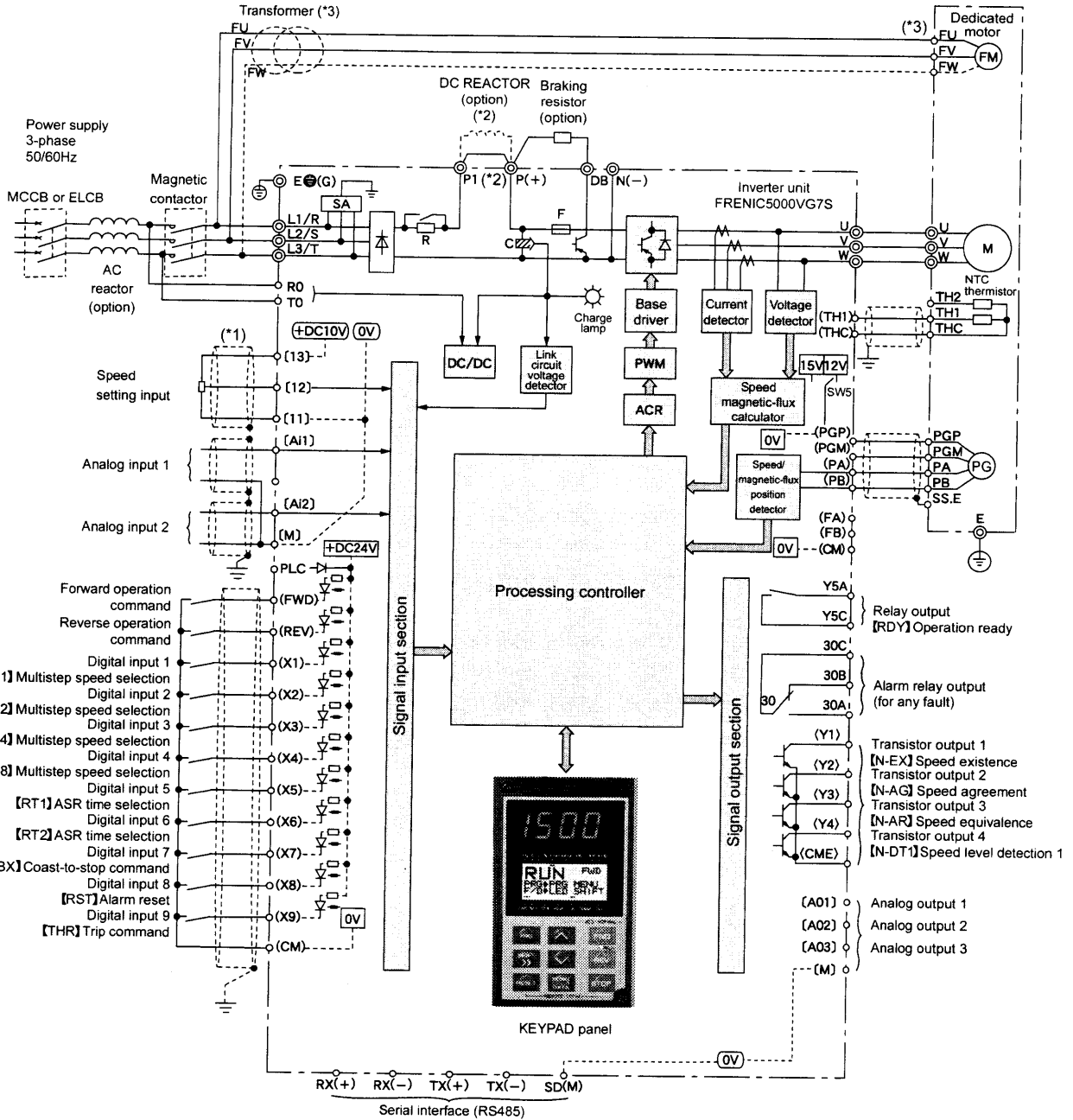

- (\*1) Use twisted cables or shielded cables for the wire indicated with . The shielded wires should be basically grounded. However, when the wires are influenced by induction noise from external devices, they may be connected to (0V) ([M], [11], [THC]), or (0V) ([CM]) to reduce such influence.
- (\*2) When connecting a DC REACTOR, remove the jumper wire between the P1 and P (+) terminals. The DC REACTOR comes with 75kW or larger inverters as a standard accessory (supplied separately from the unit). Be sure to connect the REACTOR to the inverter.
- (\*3) The power supply for cooling fan for motors of 7.5kW or less is single-phase. Connect to the FU and the FV terminals.  
The cooling fan for models of 7.5kW or less for the 400V series is 200V/50Hz or 200 to 230V/60Hz.  
The cooling fan for models of 11kW or more for the 400V series is 400 to 420V/50Hz or 400 to 440/60Hz.  
Obtain a transformer when using the fan for the power supply voltage that is not mentioned above.
- (\*4) The 24V power system and the 15V power system are insulated inside the inverter unit.

Figure 2-3-1 Basic Wiring Diagram

## 2-3-2 Wiring of Main Circuit and Grounding Terminals

Table 2-3-1 Functions of Main Circuit and Grounding Terminals

Terminal symbol	Terminal name	Description
L1/R, L2/S, L3/T	Main circuit power input terminals	Connected with three-phase power source.
U, V, W	Inverter output terminals	Connected with three-phase motor.
R0, T0	Auxiliary control power input terminals	Connected with the same AC power source as used for main circuit, as back-up power source for control circuit.
P1, P(+)	DC reactor connecting terminals	Connected with (optional) input power-factor correcting DC reactor.
P(+), DB	Braking resistor connecting terminals	Connected with (optional) braking resistor.
P(+), N(-)	DC link circuit terminals	Supplies DC link circuit voltage. Connected with (optional) external braking unit or (optional) power regenerative unit.
 G	Inverter grounding terminals	Grounds inverter chassis (casing). Connected with earth.

### (1) Main circuit power input terminals (L1/R, L2/S, and L3/T)

- 1) The main circuit power input terminals, L1/R, L2/S, and L3/T should be connected with the power source via earth-leakage circuit breaker for line protection. Any phase may be connected to any lead. If the zero-phase current is detectable by the upstream system, however, ordinary circuit breakers may be used.
- 2) Connect a magnetic contactor so that the inverter can be disconnected from the power source to minimize the influence of any failure when the inverter protective function is activated.
- 3) Do not start or stop the inverter by turning the main power switch on or off. Use the control circuit terminals, FWD and REV, or the FWD, REV, and STOP keys on the KEYPAD panel to start or stop the inverter. When the inverter is inevitably started or stopped using the main power switch, do not turn it on or off more than once per hour.
- 4) Do not connect any terminal to a single-phase power source.

(2) Inverter output terminals (U, V, and W)

- 1) Connect three-phase motor leads to the inverter output terminals, U, V, and W with care not to connect a wrong phase.
- 2) Do not connect a phase advancing capacitor or surge absorber (suppressor) to the inverter output terminals.
- 3) If the wiring between the inverter and the motor is too long, a high-frequency current will run through the wiring due to floating capacity to trip the inverter because of overcurrent, increase the leakage current, and/or deteriorate the current indication accuracy. Therefore, the motor wiring length should not exceed 50m for 3.7kW or lower inverters or 100m for others, as a guide.

Connect the optional output circuit filter (OFL filter) if the wiring is too long.

- 4) When you use a motor with an encoder, limit the wiring distance between your inverter and motor to 100 m or less.

This limit is due to encoder characteristic. When the distance exceeds 100 m, you need an arrangement such as inserting an isolation converter.

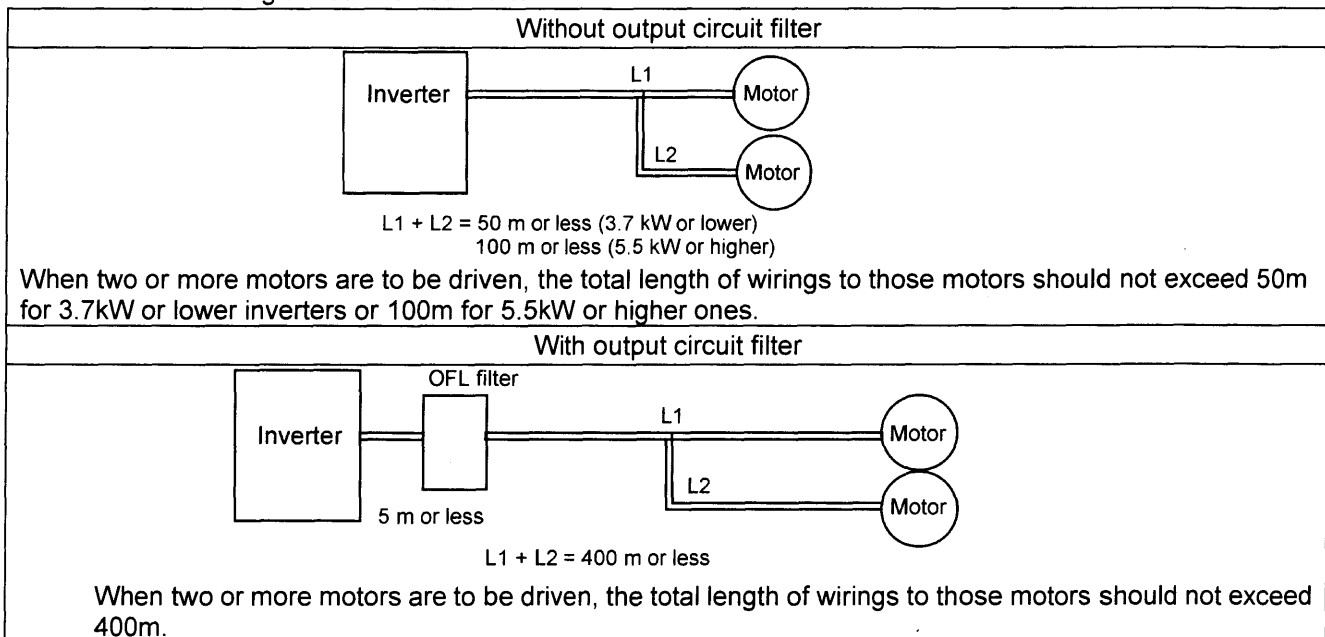

Note: When a thermal relay is used between the inverter and the motor, especially for 400V series, the thermal relay may malfunction even with a wiring length less than 50m. In this case, connect an OFL filter or reduce the inverter operation noise (carrier frequency) using function code F26 (motor sound (carrier frequency)).

• **Driving a 400V motor with an inverter**

If a motor is driven with a PWM inverter, the surge voltage generated by switching inverter elements is overlapped as applied to the motor terminals. Especially for 400V motors, the motor insulation may be deteriorated by the surge voltage if the motor wiring is too long. Therefore, any of the following measures should be taken when a 400V motor is to be driven with an inverter.

- 1) Use a motor with reinforced insulation (all the Fuji Electric's general-purpose motors have reinforced insulation).
- 2) Connect the optional output circuit filter (OFL filter) to the inverter output terminals.
- 3) Shorten the wiring between the inverter and the motor as short as possible (to 10 to 20m or less).

(3) Auxiliary control power input terminals (R0 and T0)

If the magnetic contactor in the power supply circuit to the inverter is turned off (open) when the protection circuit is activated, the inverter control power supply is shut off. As a result, alarm outputs (30A, B, and C) are no longer retained and indications on the KEYPAD panel go away. To prevent this, the same AC voltage as used for the main circuit is applied to the auxiliary control power input terminals, R0 and T0. Although the inverter functions with no voltage applied to these terminals, it is strongly recommended to connect the voltage to R0 and T0 to ensure safe operation.

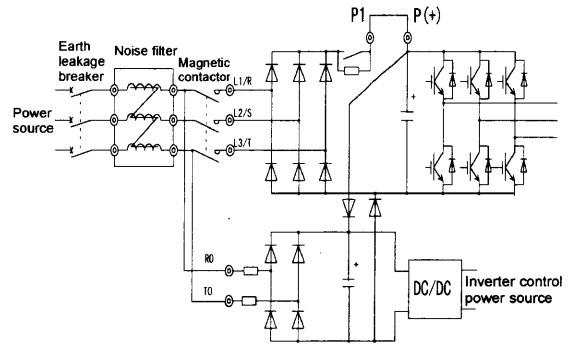

Figure 2-3-2 Wiring of Auxiliary Control Power Input Terminals

1) When a radio noise filter is used, the power to be connected to the auxiliary control power input terminals, R0 and T0, should be taken from a point downstream the filter.

If it is taken from a point upstream the filter, the noise reduction effect is impaired.

(4) DC reactor connecting terminals (P1 and P(+))

1) These terminals are provided to connect the optional input power-factor correcting DC reactor. A jumper is connected between the terminals before delivery from the factory. **Remove the jumper before connecting the DC reactor.**

2) Do not remove the jumper when the DC reactor is not used.

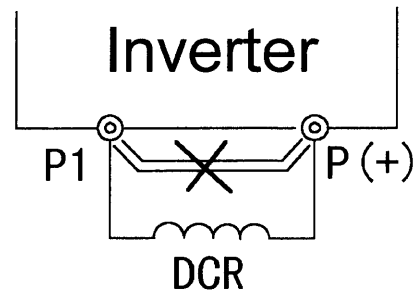

Figure 2-3-3

Note: The DC reactors are (externally) provided as standard equipment for 75kW or higher inverters. Always use the DC reactor for those inverters.

3) Connect a DC reactor for an inverter meeting the following conditions and having a rated motor output of 55 kW or less.

- The capacity ratio between the power transformer and the inverter follows the Figure 2-3-4.
- You connect a thyristor load to the same power supply, or you control to turn ON/OFF a capacitor adjusting power factor.
- Imbalance of 2% or more exists in power supply.

$$\text{Power supply voltage imbalance rate [\%]} = \frac{\text{Maximum voltage [V]} - \text{Minimum voltage [V]}}{\text{Three-phase average voltage [V]}} \times 67$$

- Improving input power factor is intended.

Power factor will be improved up to about 0.94.

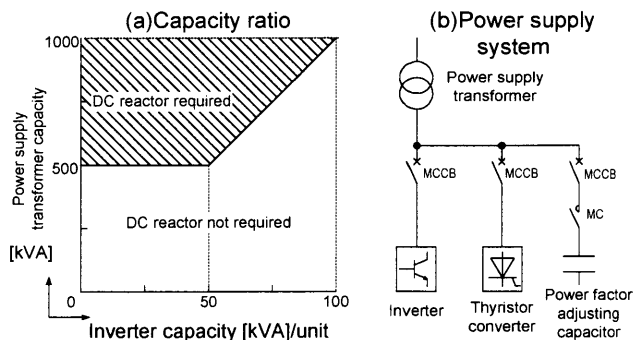

Figure 2-3-4

(5) Braking resistor connecting terminals (P(+)) and DB)

The optional braking resistor may be externally mounted. It is required when the inverter is operated frequently or under heavy inertia.

- 1) Connect the braking resistor terminals, P(+) and DB, to the inverter terminals, P(+) and DB.
- 2) Lay out so that the wiring length will not exceed 5m. The two leads should be twisted or in close contact (parallel).

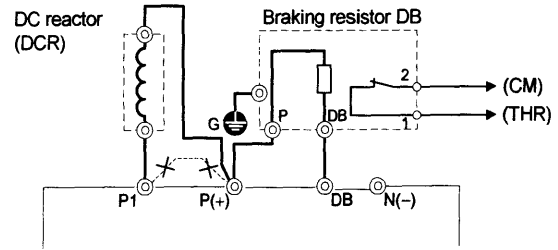
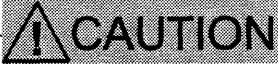

Figure 2-3-5 Connection Diagram  
(For 200V, 55kW or Lower and 400V, 110kW or Lower Inverters)



• Do not directly connect the braking resistor to the DC terminals, P(+) and N(-).  
**Doing so may lead to fire.**

(6) DC link circuit terminals (P(+)) and N(-))

The 200V series, 75kW or higher and 400V series, 132kW or higher inverters contain no braking resistor drive circuit. When the braking resistor is required, a braking unit should be used.

- 1) Connect the braking unit terminals, P(+) and N(-), to the inverter terminals, P(+) and N(-). Lay out so that the wiring length will not exceed 5m. The two leads should be twisted or in close contact (parallel).

- 2) Connect the braking resistor terminals, P(+) and DB, to the braking unit terminals, P(+) and DB. Lay out so that the wiring length will not exceed 10m.

The two leads should be twisted or in close contact (parallel).

When the inverter terminals, P(+) and N(-), are not used, they should be left open. Never short these terminals or directly connect the braking resistor. Doing so may break the inverter.

- 3) Auxiliary contacts 1 and 2 of the braking unit have polarity. When connecting a PWM Converter, see the instruction manual for the unit.

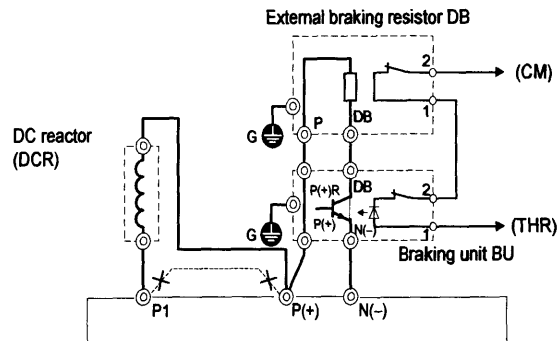

Figure 2-3-6 Connection Diagram  
(200V, 75kW or Higher and 400V, 132kW or Higher Inverters)

(7) Inverter grounding terminals (⚡G)

The inverter grounding terminals, ⚡G, must be grounded to ensure your safety and for noise measures. The Technical Standards for Electric Equipment requires metallic frames of electric equipment be grounded to prevent disasters such as electric shock and fire. Connect the terminals as described below.

- 1) Connect to type D grounded poles for 200V series or type C grounded poles for 400V series according to the Technical Standards for Electric Equipment.
- 2) Connect the earth terminal to the dedicated grounding pole of the inverter system using a thick, short lead.

Table 2-3-2

Voltage class	Grounding work class	Grounding resistance
200V	Type D	100Ω or less
400V	Type C	10Ω or less

(8) Auxiliary power switching connector (CN UX) (18.5kW or higher)

For 18.5kW or higher inverters, if the supply voltage to the main circuit is within the range shown in Table 2-3-3, reconnect the auxiliary power switching connector, CN UX, to **U2**. For other inverters, leave the connector connected to **U1**. For details, see Figure 2-3-9.

Table 2-3-3 Voltage Ranges Requiring Reconnection of Auxiliary Power Switching Connector

Frequency [Hz]	Supply voltage range [ V ]
50	380 to 398
60	380 to 430

**CAUTION**

- Check that the number of phases and rated voltage of the product agree with those of the AC power source.
  - Do not connect any AC power source to the output terminals, U, V, and W.
- Doing so may lead to injury.**

(9) Fan power switching connector (CN RXTX) (18.5kW or higher)

The VG7S accepts DC power inputs through a common DC terminal without using any optional equipment when combined with a PWM converter as shown in Figure 2-3-8.

However, 18.5kW or higher inverters contain AC power operated parts such as AC cooling fan. When such DC power inputs are used, reconnect the fan power switching connector, CN RXTX, inside the inverter to **R0-T0** as shown in Figure 2-3-6 and apply an AC power to the terminals, R0 and T0.

For details, see Figure 2-3-9.

Note: The fan power switching connector, CN RXTX, is normally connected to **L1/R-L3/T**. Do not reconnect the connector when no DC power inputs are used.

Always connect the same AC voltage as used for the main circuit to the auxiliary control power input terminals, R0 and T0. Failure to do so deactivates the fan, which may overheat (OH1) and then fail the inverter.

**CAUTION**

- Do not connect the fan power switching connector, CN RXTX, inside the inverter to a wrong terminal.
- Doing so may fail the inverter.**
- When DC power inputs are used, apply an AC power to R0 and T0 to drive the fan.
- Failure to do so may fail the inverter.**

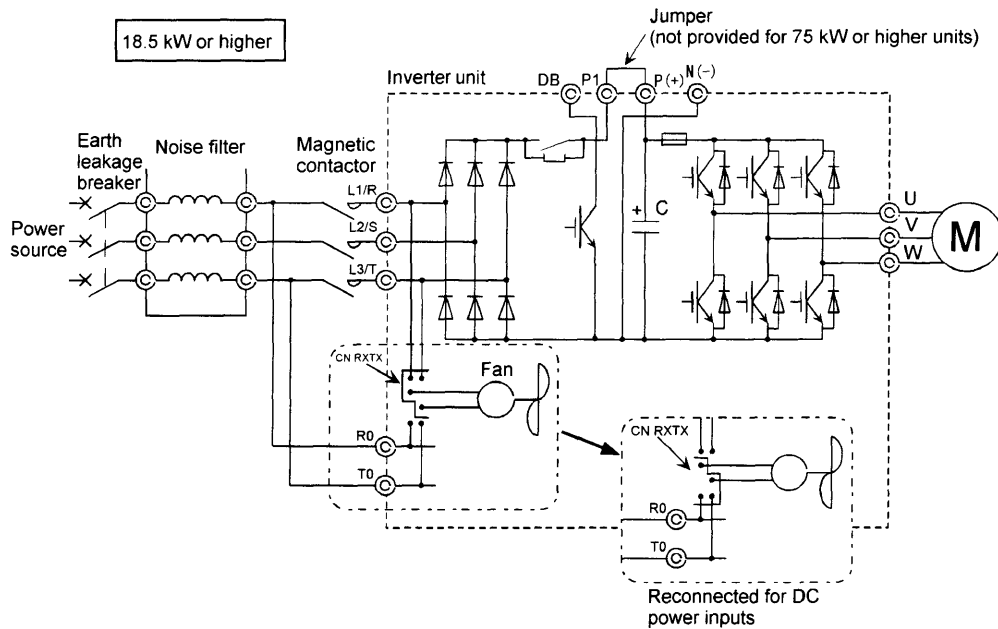

Figure 2-3-7 Reconnection of Fan Power Switching Connector

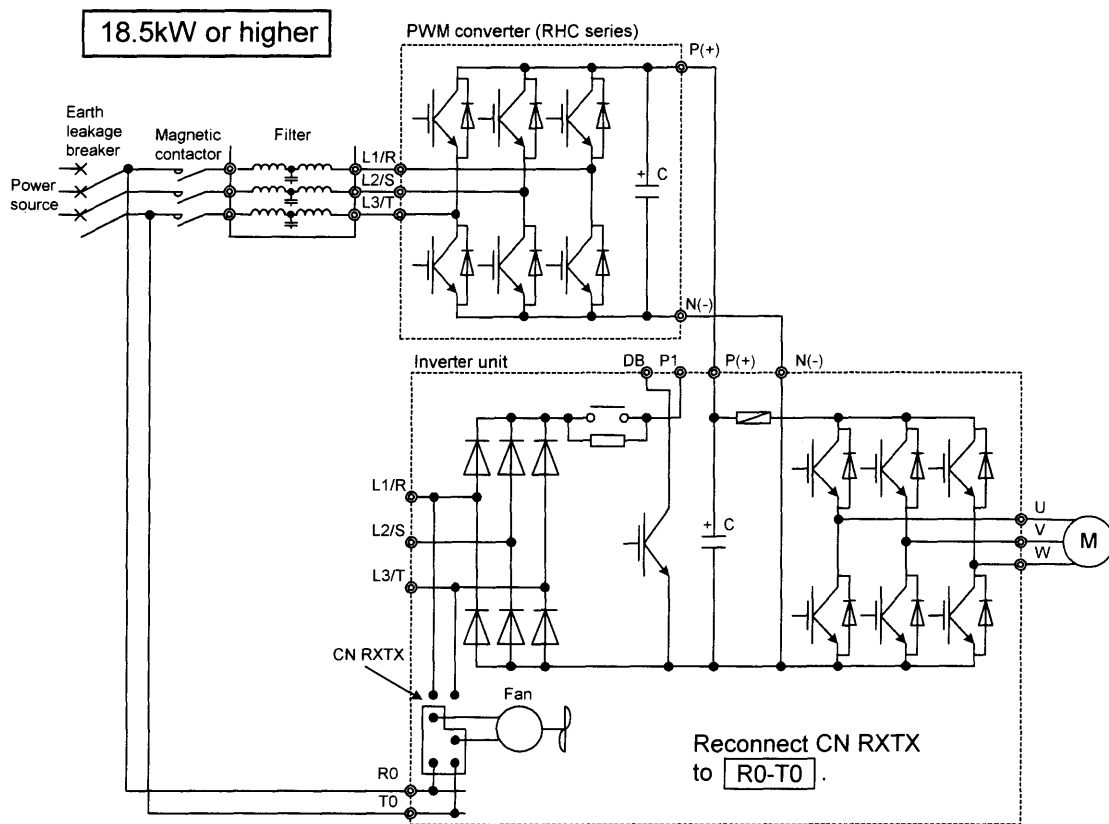

Figure 2-3-8 An Example of Wiring of Inverter Combined with PWM Converter

Note 1: When a 15kW or lower inverter is combined with a PWM converter, do not directly connect any power source to the auxiliary control power input terminals, R0 and T0. If connected to these terminals, the power source should be insulated from the main power supply to the PWM converter with insulating transformer.

Examples of wiring of the PWM converter are given in the instruction manual for PWM converter.

Note 2: 200V, 75kW or higher and 400V, 132kW or higher inverters contain no braking transistor.

The switching connectors are mounted in the power PC board at the top of the control circuit PC board.

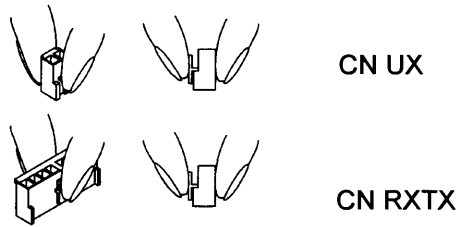

Note: When removing either connector, hold the top of the jaw between fingers to release the latch and remove by pulling upward.  
When mounting, fully insert the connector and apply the latch until it clicks.

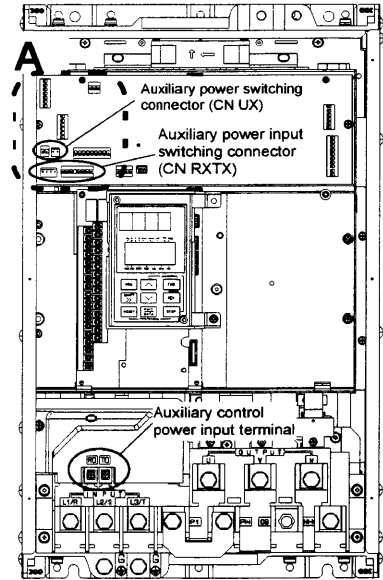

FRN18.5VG7S-2 to FRN55VG7S-2  
FRN18.5VG7S-4 to FRN110VG7S-4

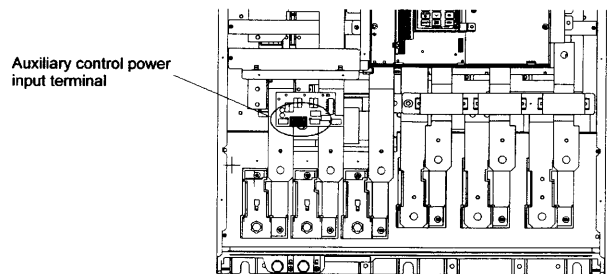

FRN75VG7S-2 to FRN90VG7S-2  
FRN132VG7S-4 to FRN220VG7S-4

< Enlarged View of Part A >

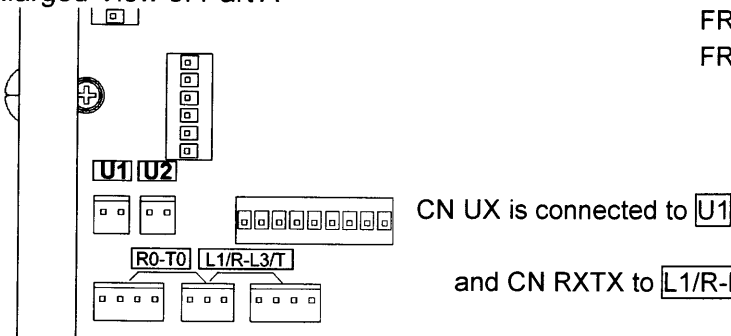

< Oblique Detail of Part A >

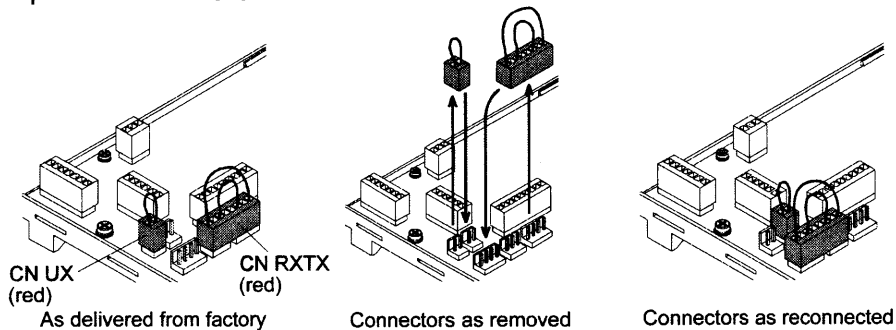

CN UX : **U1**  
CN RXTX : **L1/R-L3/T**

The Figure applies when the inverter is used with DC power inputs at a supply voltage of 380-398V, 50Hz or 380-430V, 60Hz.

Figure 2-3-9 Power Switching Connectors (18.5kW or Higher Inverters Only)



Transistor output	Y1	Transistor output 1	<p>Outputs signals such as Running, Speed equivalence, Overload early warning, ... and <math>\ominus</math> as transistor outputs from inverter to specified ports. For details, see 2.3.2 'Functions of Terminals'.          &lt;Transistor Output Circuit Specifications&gt;</p> <table border="1"> <thead> <tr> <th colspan="2">Item</th> <th>min.</th> <th>typ.</th> <th>max.</th> </tr> </thead> <tbody> <tr> <td rowspan="2">Operating voltage</td> <td>ON level</td> <td>-</td> <td>1V</td> <td>2V</td> </tr> <tr> <td>OFF level</td> <td>-</td> <td>24V</td> <td>27V</td> </tr> <tr> <td colspan="2">On-time max. load current</td> <td>-</td> <td>-</td> <td>50mA</td> </tr> <tr> <td colspan="2">Off-time permissible leak current</td> <td>-</td> <td>-</td> <td>0.1mA</td> </tr> </tbody> </table>	Item		min.	typ.	max.	Operating voltage	ON level	-	1V	2V	OFF level	-	24V	27V	On-time max. load current		-	-	50mA	Off-time permissible leak current		-	-	0.1mA
	Item			min.	typ.	max.																					
	Operating voltage	ON level		-	1V	2V																					
		OFF level		-	24V	27V																					
	On-time max. load current			-	-	50mA																					
Off-time permissible leak current		-	-	0.1mA																							
Y2	Transistor output 2																										
Y3	Transistor output 3																										
Y4	Transistor output 4																										
CME	Transistor output common	A common terminal for transistor output terminals. Insulated from terminals CM and 11.																									
Relay output terminals	30A,30B,30C	Alarm relay output (for any fault)	<p>Outputs alarm signal as relay contact output (1SPDT) when inverter stops due to alarm.          Contact capacity: 250V AC, 0.3A, <math>\cos \phi = 0.3</math> (or 48V DC, 0.5A when conformed with Low Voltage Directive)          You may choose to close contacts under unusual or normal conditions.</p>																								
	Y5A,Y5C	Relay output	You may select a signal as you may with Y1 to Y4 terminals. Contact capacity is the same as with alarm relay output terminals.																								
Communication	RX(+), RX(-), TX(+), TX(-)	RS485 communication input/output	<p>Input/output terminals for RS485 communication          Up to 31 inverters may be connected through multi-drop connections. Terminating resistor (100<math>\Omega</math>) can be connected via switch (SW3).</p>																								
	SD(M)	Communication shield cable connection	Connected with shielded wires.																								
Speed detection	PA,PB	Pulse generator 2-phase signal input	Connected with 2-phase signals from pulse generator																								
	PGP,PGM	Pulse generator power supply	Supplies power (+15V DC (switchable to +12V DC)) to PG.																								
	FA,FB	Pulse generator output	Output pulse generator signal with frequency divided to 1/n. (n is programmable with function code E29.)																								
	CM	Pulse generator output common	A common terminal for FA and FB.																								
Temperature detection	TH1,THC	NTC/PTC thermistor connection terminals	Monitors motor temperature with NTC and PTC thermistors. For PTC thermistor, motor overheat protection level can be set with function code E32.																								

(1) Input terminals (13, 12, and 11)

- 1) Shielded wires as short as possible (20m or less) should be used for cables because these terminals handle weak analog signals that are very susceptible to external noise. The shields should be grounded to the earth, as a rule. If the signals are greatly affected by external induction noise, however, connecting the shields to terminal 11 may be advantageous.
- 2) When relay contacts are required in this circuit, use twin contacts handling weak signals. Do not use contacts at terminal 11.
- 3) If any of these terminal is connected with an external analog signal output unit, it may malfunction due to the noise generated by the inverter, depending on the analog signal output circuit. In this case, connect a ferrite core or capacitor to the external analog signal output unit.

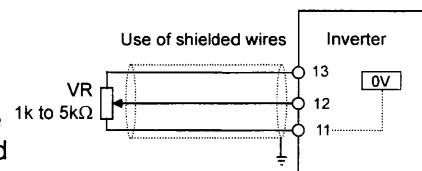

Figure 2-3-10

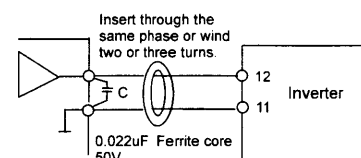

Figure 2-3-11

Protection against Noise (Example)

(2) Digital input terminals (FWD, REV, X1-X9, PLC, and CM)

1) The digital input terminals such as FWD, REV, and X1-X9 are generally turned on/off between the CM terminal. If turned on/off using an external power source and open collector outputs from the programmable logic controller, the terminals may malfunction due to current leak from the external power source. In this case, connect the external power source using the PLC terminal as shown in Figure 2-3-12.

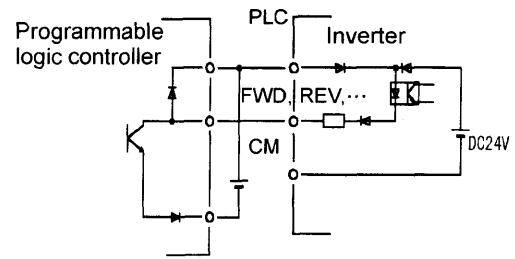

Figure 2-3-12  
Protection against Current Leak  
from External Power Source

2) When inputs are made through relay contacts, use a highly reliable relay contacts (Fuji Electric's HH54PW control relays, for example).

(3) Transistor output terminals (Y1-Y4 and CME)

1) A circuit configuration as shown in the 'Transistor Output Terminals' column of Table 2-3-4 is used. Take care not to connect external power leads with reversed polarity.

2) When control relays are used, connect a surge suppression diode to each end of the exciting coil.

(4) Miscellaneous

1) The control terminal leads should be kept as apart from the main circuit leads as possible to prevent malfunction due to noise.

2) The control leads inside the inverter should be secured to prevent direct contact with the live part of the main circuit (the main circuit terminal blocks, for example).

### WARNING

- The shield of each control cable does not serve as a reinforced insulator. If the shield is broken for some reason, a high voltage in the main circuit may invade the control signal circuit. The Low Voltage Directive in Europe also prohibits the users to wire the inverter with a main circuit lead in contact with a control lead.

**Doing so may lead to electric shock.**

### CAUTION

- Noise may be generated from the inverter, motor, and leads.
- Protect sensors and devices around the inverter from malfunction.

**Failure to do so may lead to accident.**

(5) Wiring of Control Circuits

1) FRN18.5VG7S-2 to FRN55VG7S-2  
FRN18.5VG7S-4 to FRN110VG7S-4

(a) Pull the wiring out along the left side panel of the inverter as shown in Figure 2-3-13.

(b) Tie leads with bands (Insulock, for example) and secure to the hole (tie mounting hole A) on the left side wall of the main circuit terminal block on the way outward. The bands should be 3.5mm or less in width and 1.5 mm or less in thickness as they are to be passed through the holes (4mm dia.).

(c) If an optional printed circuit board is mounted, secure signal leads to the tie mounting hole B.

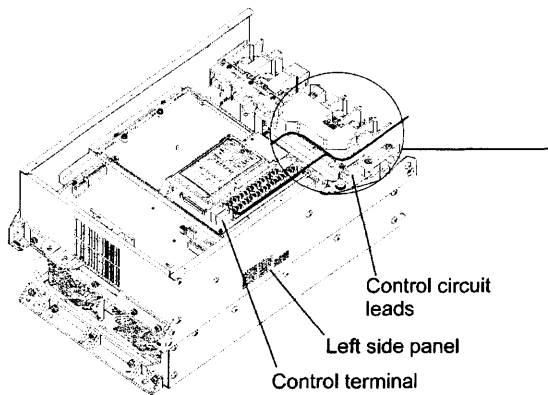

Figure 2-3-13  
Routing Inverter (18.5 kW or  
Higher) Control Circuit Leads

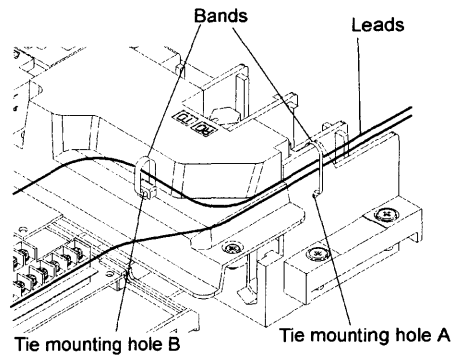

Figure 2-3-14  
Securing Inverter (18.5 kW or  
Higher) Control Circuit Leads

2) FRN132VG7S-4 to FRN160VG7S-4

- (a) Pull the wiring out along the left side panel as shown in Figure 2-3-15.
- (b) Tie leads with bands (Insulock, for example) and secure with cable tie holders on the beams on the way outward. The bands should be 3.8 mm or less in width and 1.5 mm or less in thickness as they are to be passed through square holes (3.8 × 1.5).

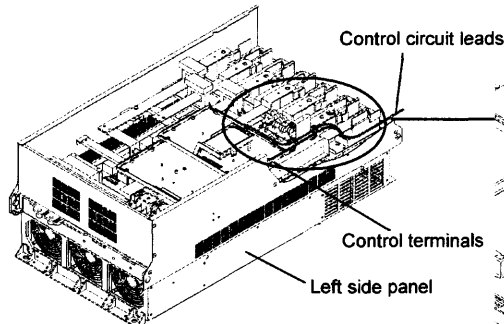

Figure 2-3-15  
Routing Inverter Control Circuit Leads

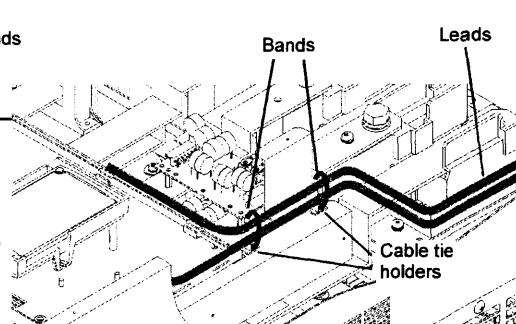

Figure 2-3-16  
Securing Inverter Control Circuit Leads

3) FRN75VG7S-2 to FRN90VG7S-2  
FRN200VG7S-4 to FRN220VG7S-4

- (a) Pull the wiring out along the left side panel as shown in Figure 2-3-17.
- (b) Tie leads with bands (Insulock, for example) and secure with cable tie holders on the beams on the way outward. The bands should be 3.8 mm or less in width and 1.5 mm or less in thickness as they are to be passed through holes (3.8 × 1.5).

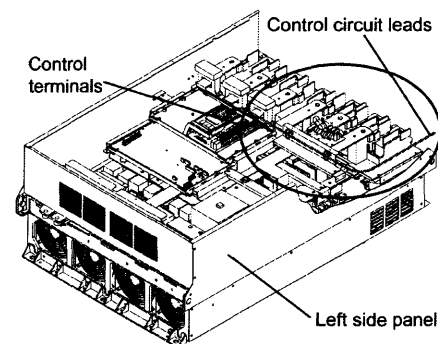

Figure 2-3-17  
Routing Inverter Control Circuit Leads

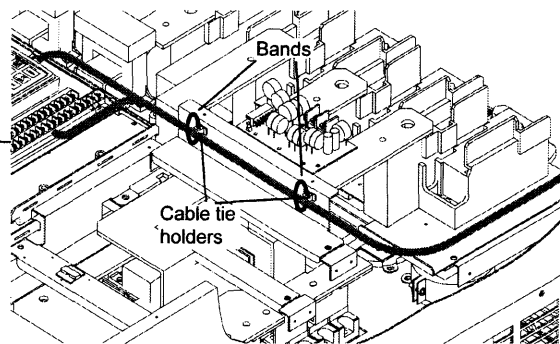

Figure 2-3-18  
Securing Inverter Control Circuit Leads

4) For FRN280VG7S-4 to FRN400VG7S-4

- (a) Draw out along the left side panel of your inverter as in the Figure 2-3-17.
- (b) Use an insulating clip above the main circuit terminal board L1/R to fix the wiring.

## 2-3-4 Terminal Arrangement Chart

### ● Main circuit terminals

FRN 0.75~7.5VG7S-2

FRN 3.7~7.5VG7S-4

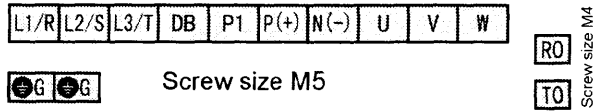

FRN 37~55VG7S-2

FRN 75~110VG7S-4

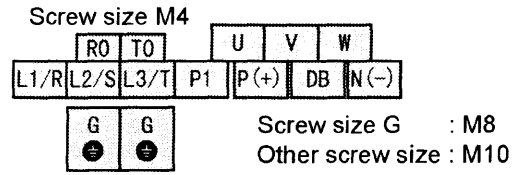

FRN 11~15VG7S-2

FRN 11~15VG7S-4

Screw size M4

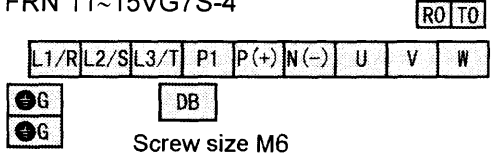

FRN 75VG7S-2

Screw size M4

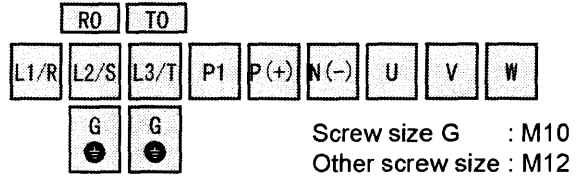

FRN 18.5~22VG7S-2

FRN 18.5~22VG7S-4

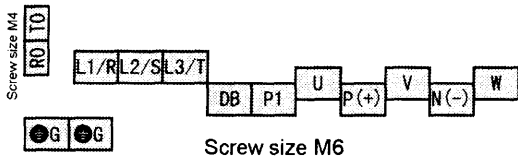

FRN 90VG7S-2

FRN 132~220VG7S-4

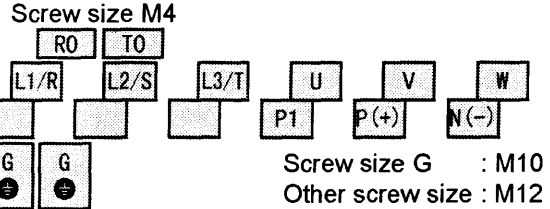

FRN 30VG7S-2

FRN 30~55VG7S-4

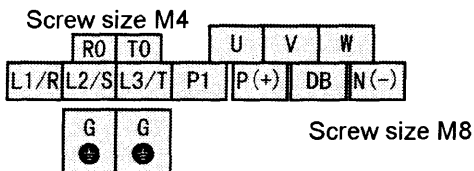

FRN 280, 315VG7S-4

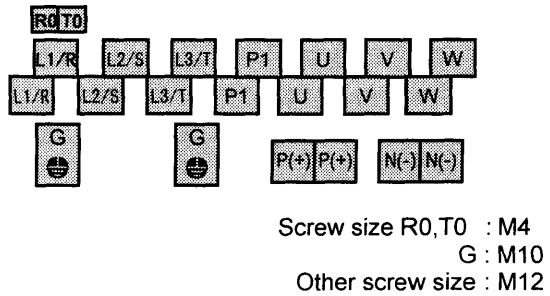

Main circuit terminals

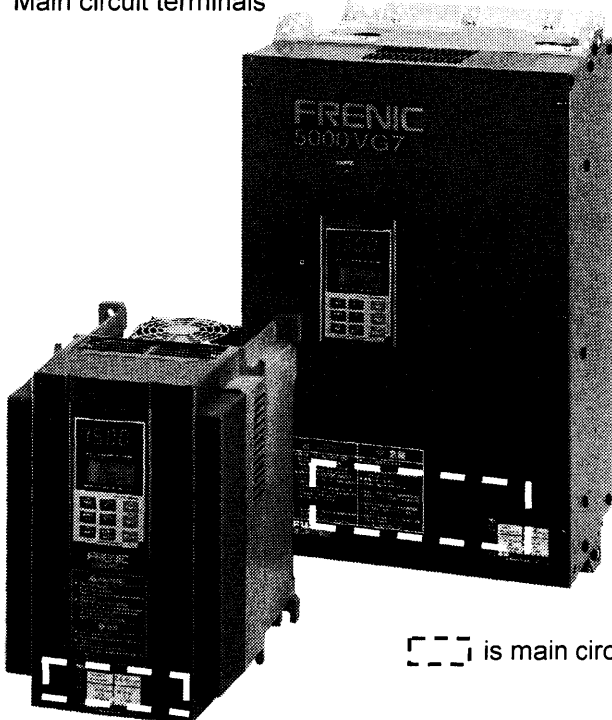

is main circuit terminals position.

FRN 355,400VG7S-4

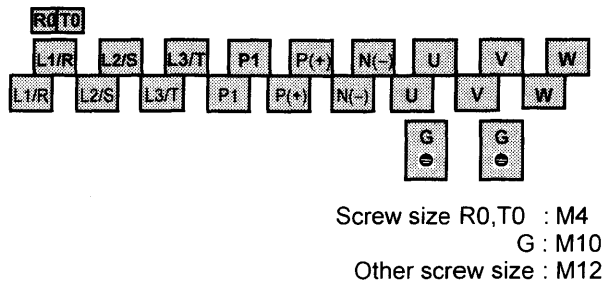

● Control circuit terminals



Control circuit terminals

30C	30A
Y5C	30B
Y4	Y5A
Y2	Y3
CME	Y1
11	Ai1
12	Ai2
13	M
Ao3	Ao1
CM	Ao2
FWD	PLC
REV	X1
CM	X2
X6	X3
X7	X4
X8	X5
X9	PGP
FA	PGM
FB	PA
CM	PB
TH1	THC

Screw size : M3

### 3. Test Run

#### 3-1 Preliminary Check and Preparation

Perform the following checks before starting operation.

- (1) Check that the inverter is correctly wired.  
Most importantly, the inverter output terminals, U, V, and W should not be connected to a power source and the earth terminal should be correctly grounded.
- (2) No terminal or exposed live part should be short-circuited or grounded.
- (3) Check for loose terminals, connectors, and screws.
- (4) Check that the motor is disconnected from mechanical devices.
- (5) Turn all switches off so that the inverter will not start or malfunction when powered on.
- (6) After power-up of the inverter, check that:
  - 1) the KEYPAD panel gives indications as shown in Figure 3-1-2 (no alarm message), and
  - 2) the inverter contained fan is rotating.  
(However, when the function code H06 "Cooling fan ON-OFF control" is used, there may be a case where the built-in fan is stopped.)

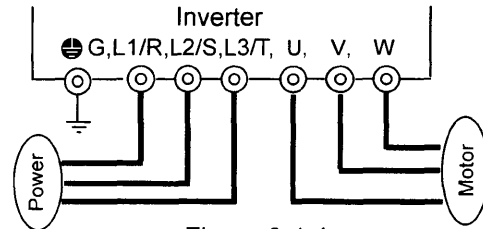

Figure 3-1-1  
Inverter Connection Diagram



Figure 3-1-2  
KEYPAD Panel Display with the Power ON

### WARNING

- Never turn the power switch on (closed) before mounting the face cover. Do not remove the cover while the inverter is energized.
- Do not handle the inverter with wet hand.

**Doing so may lead to electric shock.**

### 3-2 Operating Methods

There are many operating methods. Read this manual and select the one most suitable to the intended use and operating conditions. General operating methods are described in Table 3-2-1.

#### 3-3 Test Run

After checking that no abnormal condition exists in 3.1, perform a test run.

Before delivery, the inverter is programmed to be operated from the KEYPAD panel (with function code F01 set to 0 and F02 to 0).

- (1) Turn the power on. Check that the speed indicated by blinking LEDs is 0r/min.
- (2) Set the speed to a lower level around 100r/min using the key.
- (3) Press the key to run the motor in the forward direction or the key to run in the reverse direction. Press the key to stop the motor.
- (4) Check that:
  - 1) the motor runs in the selected direction (see Figure 3-3-1),
  - 2) it revolves without any problem (motor roars and excessive vibration), and
  - 3) it smoothly accelerates or decelerates.
 If no abnormal condition is observed, raise the operating speed and check again. If the inverter is found to normally function in the test run, start regular operation.

Table 3-2-1 General Operating Methods

Operating method	Speed controls	Operation commands
From KEYPAD panel	KEYPAD panel keys 	 
Through external signal input	 Variable resistor (POT) or analog voltages	Contact inputs (switches) Terminals: FWD - CM REV - CM

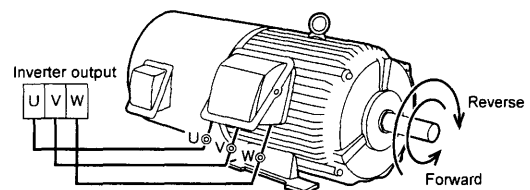

Figure 3-3-1 Motor Rotating Directions

If the inverter is found to normally function in the test run, start regular operation.

### CAUTION

- If any abnormal condition is observed with the inverter or motor, immediately stop and locate the cause (see 'Troubleshooting').
- Even after the inverter stops outputting, touching any of the inverter output terminals, U, V, and W may lead to electric shock if a voltage is continuously applied to the main circuit power terminals, L1/R, L2/S, and L3/T, and auxiliary control power terminals, R0 and T0. The smoothing capacitor remains live after the power switch is turned off and requires some time until completely discharged.  
When touching an electric circuit after the shut-down, check that the charge lamp is off or check with a multimeter that the voltage has been reduced to a safe level (24V or less).

### WARNING

- Setting a function code in a wrong manner or without fully understanding this manual may cause the motor to revolve at an unacceptable torque or speed, possibly resulting in accident or injury.

**Accident on injury may result.**

## 4. KEYPAD Panel

### **! WARNING**

- If the user set the function codes wrongly or without completely understanding this user's manual, the motor may rotate with a torque or at a speed not permitted for the machine.

#### **Accident or injury may result.**

- The STOP key is effective only when its function has been set. Install an emergency stop switch separately.

#### **Accident may result.**

### 4-1 Appearance of KEYPAD Panel

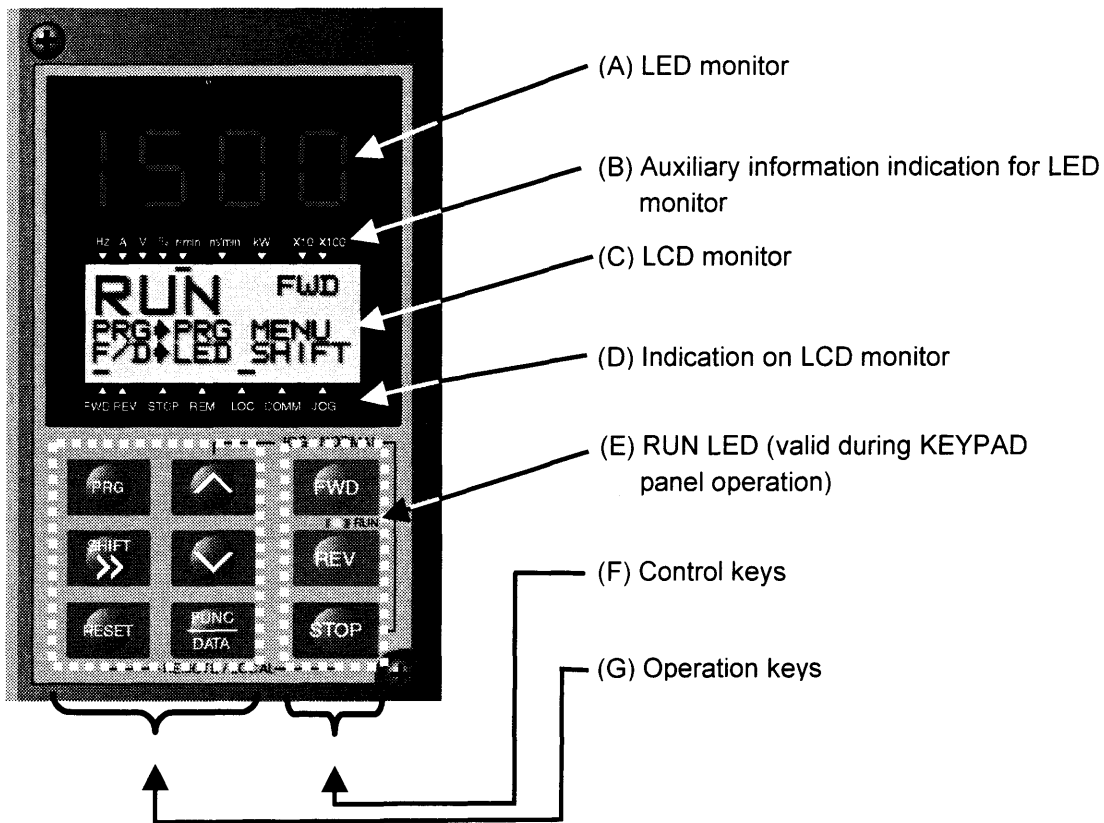

- (A) LED monitor:  
Four-digit 7-segment display  
Used to display various items of monitored data such as setting frequency, output frequency and alarm code.
- (B) Auxiliary information indication for LED monitor:  
Selected units or multiple of the monitored data (on the LED monitor) are displayed on the top line of the LCD monitor. The **■** symbol indicates selected units or multiple number. The symbol **▲** indicates there is an upper screen not currently displayed.
- (C) LCD monitor:  
Used to display such various items of information as operation status and function data. An operation guide message, which can be scrolled, is displayed at the bottom of the LCD monitor.
- (D) Indication on LCD monitor:  
Displays one of the following operation status with **■** .  
FWD: Forward operation REV: Reverse operation STOP: Stop  
Displays the selected operation method:  
REM: External signal LOC: KEYPAD panel COMM: Communication terminal JOG: Jogging mode  
The symbol **▼** indicates there is a lower screen not currently displayed.
- (E) RUN LED (valid during KEYPAD panel operation):  
Indicates that an operation command is being input by pressing the **FWD** or **REV** key.
- (F) Control keys:  
Used for inverter run and stop  
**FWD** : Forward operation command **REV** : Reverse operation command **STOP** : Stop command
- (G) Operation keys:  
Used for screen switching, data change, frequency setting, etc.  
The Table 4-1-1 shows the main function of the operation keys.

Table 4-1-1 Functions of Operation Keys

Operation key	Main function
<b>PRG</b>	Used to switch the current screen to the menu screen or switch to the initial screen in the operation/alarm mode.
<b>FUNC DATA</b>	Used to switch the LED monitor or to determine the entered frequency, function code, or data.
<b>▲</b> , <b>▼</b>	Used to change data, move the cursor up or down, or scroll the screen
<b>SHIFT</b> <b>&gt;</b>	Used to move the cursor horizontally at data change. When this key is pressed with the up or down key, the cursor moves to the next function block.
<b>RESET</b>	Used to cancel current input data and switch the displayed screen. If an alarm occurs, this key is used to reset the trip status (valid only when the alarm mode initial screen is displayed).
<b>STOP</b> + <b>▲</b>	Used to switch normal operation mode to jogging operation mode or vice versa. The selected mode is displayed on the LCD monitor.
<b>STOP</b> + <b>RESET</b>	Switches operation method (from KEYPAD panel operation to external signal operation or vice versa). When these keys are pressed, function F02 data is also switched from 0 to 1 or from 1 to 0. The selected mode is displayed on the LCD indicator. (REM, LOC)

## 4-2 Alarm Mode

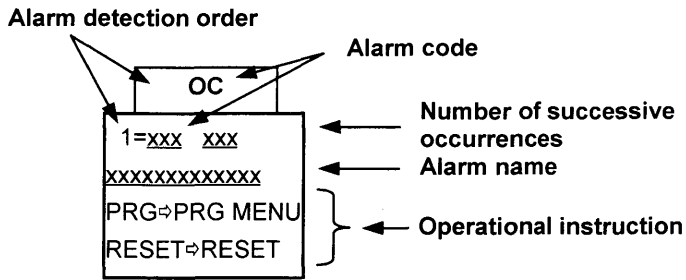

When a single alarm occurs, the alarm mode screen appears where the content of the alarm is indicated.

When multiple alarms occur at the same time, the contents of the alarms can be checked using the **▲** and **▼** keys.

Alarm Detection Order		LED display	LCD display	Content
<div style="display: flex; align-items: center; gap: 10px;"> <div style="text-align: center;"> <b>▲</b> ↑                 </div> <div style="text-align: center;"> <b>▼</b> ↓                 </div> </div>		5.	5	Alarm No. 5
		4.	4	Alarm No. 4
		3.	3	Alarm No. 3
		2.	2	Alarm No. 2
		1.	1	Alarm No. 1 (multiple alarms)
		Blank	0	Latest alarm (single alarm/already has been reset)
		Blank	-1	1st latest alarm
		Blank	-2	2nd latest alarm
		Blank	-3	3rd latest alarm
		Blank	-4	4th latest alarm
	Blank	-5	5th latest alarm	
	Blank	-6	6th latest alarm	
	Blank	-7	7th latest alarm	
	Blank	-8	8th latest alarm	
	Blank	-9	9th latest alarm	
	Blank	-10	10th latest alarm	

## 4-3 KEYPAD Operation System (Hierarchical Structure of LCD Screens)

### 4-3-1 During Normal Operation

The basic KEYPAD operation system (hierarchical structure of screens) is illustrated below.

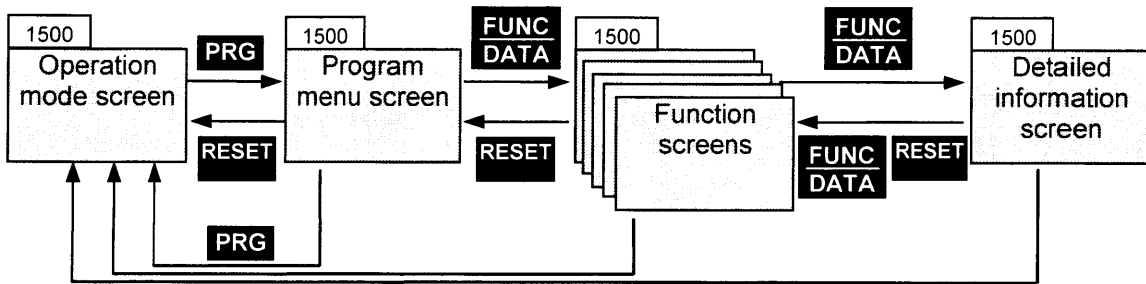
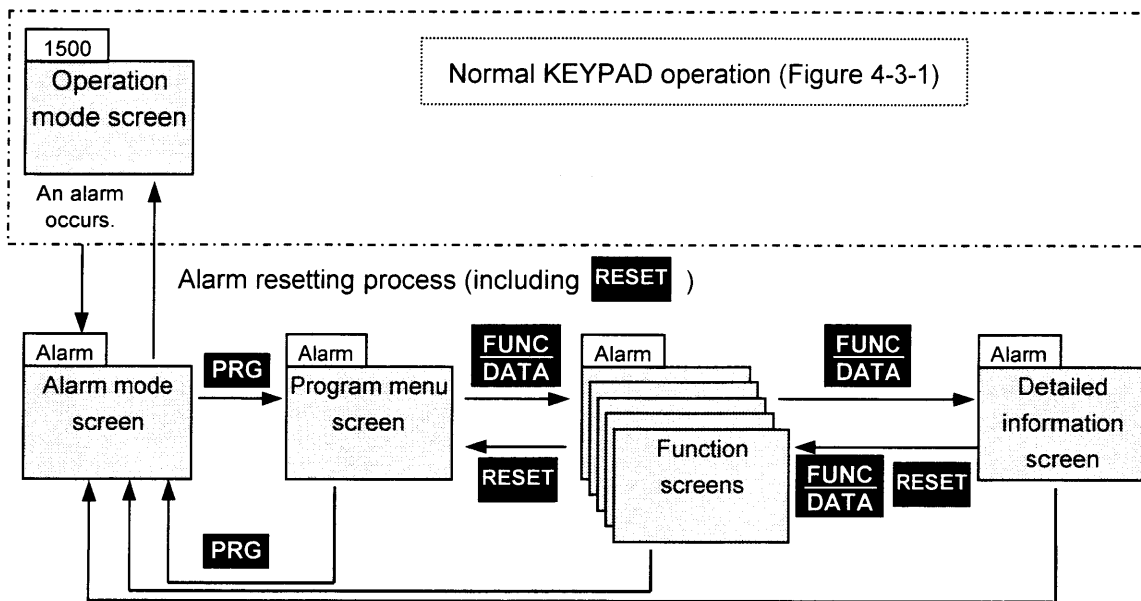

Figure 4-3-1 KEYPAD Operation in Operation Mode

### 4-3-2 When an Alarm Raised Occurs

When an alarm occurs, the KEYPAD screen system is switched from the normal operation mode to the alarm mode. The alarm mode screen appears where the alarm information is indicated.

The program menu, function, and detailed information screens are similar to those of normal operation. The program menu screen can be switched to the alarm mode screen using **PRG** only.



Outline of Indications on Different Screens

No.	Screen name	Description																														
1	Operation mode	You can change motor speed or switch LED monitor when this screen is shown on KEYPAD during normal operation.																														
2	Program menu (Program mode)	<p>Function menu is shown on this screen for your selection. Select a desired function from menu and press <b>FUNC DATA</b> to call screen for selected function. Menu contains the following options as KEYPAD functions.</p> <table border="1"> <thead> <tr> <th>No.</th> <th>Menu item</th> <th>Outline</th> </tr> </thead> <tbody> <tr> <td>1</td> <td>Function menu</td> <td>If this is selected, a name list of function codes appears. Select a desired code to call data setting screen for that code where its setting can be checked or changed.</td> </tr> <tr> <td>2</td> <td>CHECK DATA</td> <td>If this is selected, a data list of function codes appears. Select a desired code to check its setting. Similar to the SET DATA above, data setting screen can be selected where its setting can be changed.</td> </tr> <tr> <td>3</td> <td>MONITOR</td> <td>This screen is used as operation status monitor to check various data.</td> </tr> <tr> <td>4</td> <td>I/O CHECK</td> <td>This screen is used to check status of inverter and optional analog input/output and digital input/output signals.</td> </tr> <tr> <td>5</td> <td>MAINTENANCE INFO</td> <td>This screen is used to check maintenance information including inverter status, life expectancy, communication errors, and ROM version.</td> </tr> <tr> <td>6</td> <td>MEASURE LOAD FACTOR</td> <td>Maximum and average currents and average braking power can be measured to determine load factor.</td> </tr> <tr> <td>7</td> <td>ALARM INFO</td> <td>This screen is used to check operation status and I/O status at the time of the latest alarm.</td> </tr> <tr> <td>8</td> <td>ALARM HISTORY</td> <td>This screen is used to check the latest alarm, multiple alarms that occurred at the same time, and alarm history. Select an alarm and press <b>FUNC DATA</b> to check cause of that alarm and troubleshooting information.</td> </tr> <tr> <td>9</td> <td>COPY DATA</td> <td>Function code settings for an inverter can be stored and copied to another inverter.</td> </tr> </tbody> </table>	No.	Menu item	Outline	1	Function menu	If this is selected, a name list of function codes appears. Select a desired code to call data setting screen for that code where its setting can be checked or changed.	2	CHECK DATA	If this is selected, a data list of function codes appears. Select a desired code to check its setting. Similar to the SET DATA above, data setting screen can be selected where its setting can be changed.	3	MONITOR	This screen is used as operation status monitor to check various data.	4	I/O CHECK	This screen is used to check status of inverter and optional analog input/output and digital input/output signals.	5	MAINTENANCE INFO	This screen is used to check maintenance information including inverter status, life expectancy, communication errors, and ROM version.	6	MEASURE LOAD FACTOR	Maximum and average currents and average braking power can be measured to determine load factor.	7	ALARM INFO	This screen is used to check operation status and I/O status at the time of the latest alarm.	8	ALARM HISTORY	This screen is used to check the latest alarm, multiple alarms that occurred at the same time, and alarm history. Select an alarm and press <b>FUNC DATA</b> to check cause of that alarm and troubleshooting information.	9	COPY DATA	Function code settings for an inverter can be stored and copied to another inverter.
No.	Menu item	Outline																														
1	Function menu	If this is selected, a name list of function codes appears. Select a desired code to call data setting screen for that code where its setting can be checked or changed.																														
2	CHECK DATA	If this is selected, a data list of function codes appears. Select a desired code to check its setting. Similar to the SET DATA above, data setting screen can be selected where its setting can be changed.																														
3	MONITOR	This screen is used as operation status monitor to check various data.																														
4	I/O CHECK	This screen is used to check status of inverter and optional analog input/output and digital input/output signals.																														
5	MAINTENANCE INFO	This screen is used to check maintenance information including inverter status, life expectancy, communication errors, and ROM version.																														
6	MEASURE LOAD FACTOR	Maximum and average currents and average braking power can be measured to determine load factor.																														
7	ALARM INFO	This screen is used to check operation status and I/O status at the time of the latest alarm.																														
8	ALARM HISTORY	This screen is used to check the latest alarm, multiple alarms that occurred at the same time, and alarm history. Select an alarm and press <b>FUNC DATA</b> to check cause of that alarm and troubleshooting information.																														
9	COPY DATA	Function code settings for an inverter can be stored and copied to another inverter.																														
3	Function screens	When a function is selected from program menu, the corresponding function screen appears for execution of that function.																														
4	Detailed information screen	Functions that cannot be executed by function screens (change of function code settings and indication of causes of alarms) are displayed by detailed information screen.																														

### 4-3-3 Program Mode

The KEYPAD operation (hierarchical structure of screens) in the program mode is illustrated below.

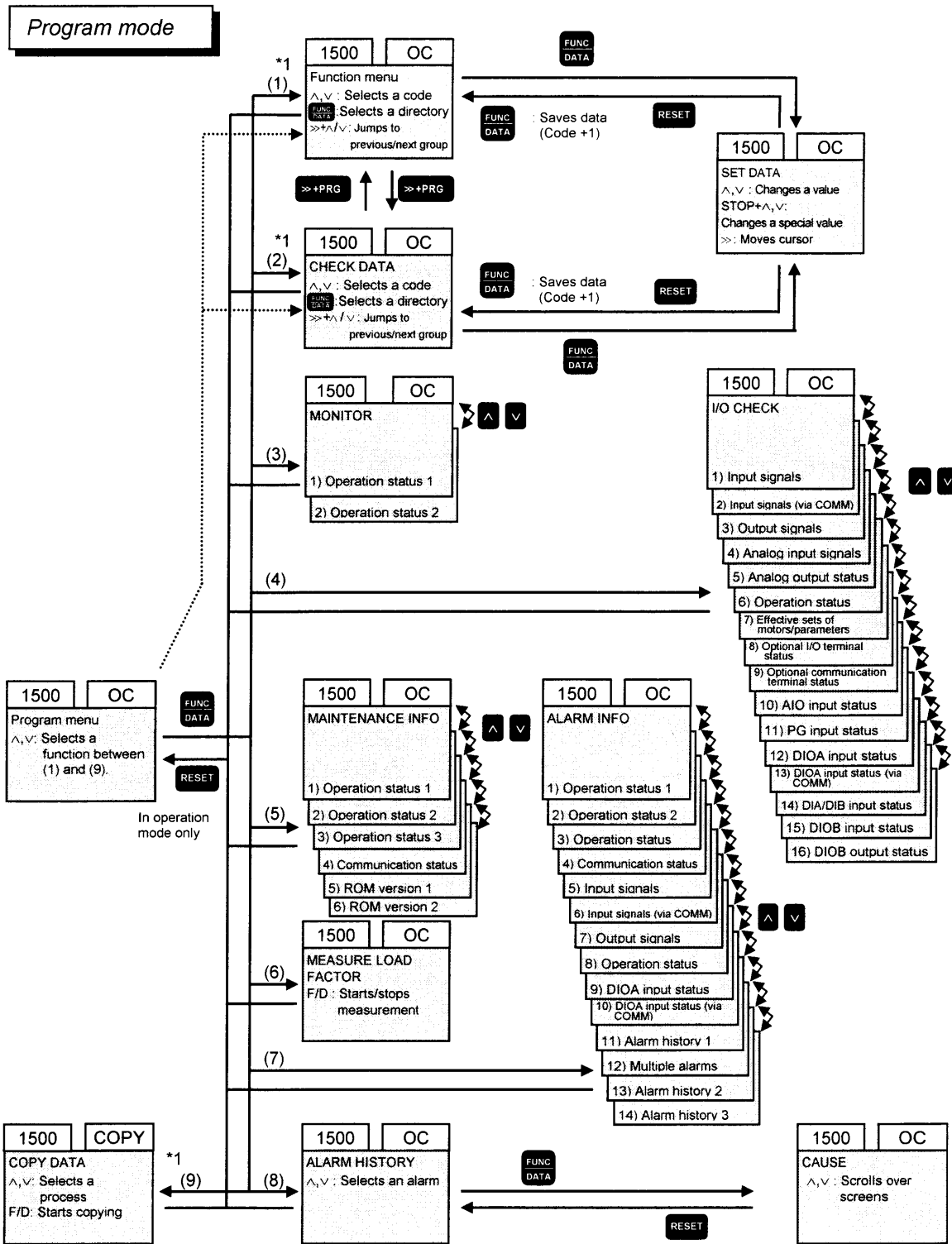

\*1: When the limiting function by the password (function code L01, L02) is active, you cannot select until the password setting is completed. Usually you can select, though.

## 5. Function Selection

### WARNING

- When the retry function is selected, the inverter may restart automatically after tripping.  
(Design the machine to ensure personal safety in the event of restart)

#### **Accident may result.**

- When the torque limiting function is selected, operating conditions may differ from preset conditions (acceleration/deceleration time or speed). In this case, personal safety must be assured.

#### **Accident may result.**

- If AUTO RESTART is selected in the restart mode after momentary power failure (function code F14), the inverter restarts automatically starting the motor rotation when the power is re-supplied.

#### **Accident may result.**

- When auto tuning (function code H01) is started, the motor, machine or equipment starts and stops repeatedly. Ensure safety before performing auto tuning.

#### **Accident may result.**

- If the user set the function codes wrongly or without completely understanding this user's manual, the motor may rotate with a torque or at a speed not permitted for the machine.

#### **Accident or injury may result.**

### CAUTION

- During pre-excitation, the speed adjuster does not function and the motor may be rotated by load disturbance. When using pre-excitation, therefore, also use the machine brake.

#### **Injury may result.**

- If improper data is set at the function code related with speed adjuster as in the case of setting high gain abruptly, the motor may hunt.

#### **Injury may result.**

## F: Fundamental Functions

Fcode	Communication address		Function name	Setting range
	485 number	Link number		
F00	0h	80( 50 h)	Data protection	0 to 1 0 : Data change enable 1 : Data protection This is a function to protect writing from the Keypad panel. The protection of writing from the link (T-Link, RS485, etc.) is defined with H29 "Link function protection".
F01	1h	( ) h)	Speed setting N1	0 to 7 0 : KEYPAD operation ( $\wedge$ and $\vee$ key) 1 : Analog input (0 to $\pm 10$ VDC) 2 : Analog input (0 to +10VDC) 3 : UP/DOWN control 1 (initial speed = 0 r/min) 4 : UP/DOWN control 2 (initial speed = last value) 5 : UP/DOWN control 3 (initial speed = Creep speed 1 or 2) 6 : DIA card input 7 : DIB card input
F02	2h	( ) h)	Operation method	0 to 1 The method of operation is set. 0 : KEYPAD operation (FWD or REV or STOP key) (LOCAL) 1 : FWD or REV signal input (REMOTE) The change of REMOTE/LOCAL is possible also by RST+STOP key to the keypad panel. This operation corresponds to writing data of F02.
F03	3h	81( 51 h)	M1 Maximum speed	50 to <u>1500</u> to 12000 r/min
F04	4h	82( 52 h)	M1-Rated speed	50 to 12000 r/min
F05	5h	83( 53 h)	M1-Rated voltage	80 to 999 V
F07	7h	84( 54 h)	Acceleration time 1	0.01 to <u>5.00</u> to 99.99s 100.0 to 999.9s 1000 to 3600s
F08	8h	85( 55 h)	Deceleration time 1	0.01 to <u>5.00</u> to 99.99s 100.0 to 999.9s 1000 to 3600s
F10	Ah	86( 56 h)	M1 Electronic thermal overload relay (Select)	0 to 2 The motor overheating protection operates by using NTC thermistor with the motor only for VG. In this case, please make setting F10 Electronic thermal "Inactive". 0 : Inactive (When you use the motor only for VG) 1 : Active (for 4-pole standard motor, with self-cooling fan) 2 : Active (for Inverter motor, with separate cooling fan)
F11	Bh	87( 57 h)	M1 Electronic thermal overload relay (Level)	0.01 to 99.99A 100.0 to 999.9A 1000 to 2000A
F12	Ch	88( 58 h)	M1 Electronic thermal overload relay (Thermal time constant)	0.5 to 75.0 min
F14	Eh	( ) h)	Restart mode after momentary power failure	0 to 5 0 : Inactive (Trip and alarm when power failure occurs.) 1 : Inactive (Trip, and alarm when power recovers.) 2 : Inactive (Deceleration to stop, and trip and alarm.) 3 : Active (Smooth recovery by continuous operation mode) 4 : Active (Momentarily stops and restarts at speed on power failure) 5 : Active (Momentarily stops and restarts at starting speed)
F17	11h	( ) h)	Gain (terminal 12 input)	0.0 to <u>100</u> to 200.0 %
F18	12h	( ) h)	Bias (terminal 12 input)	-24000 to 0 to 24000 r/min
F20	14h	89( 59 h)	DC brake (Starting speed)	0 to 3600 r/min
F21	15h	90( 5A h)	DC brake (Braking level)	0 to 100 %
F22	16h	91( 5B h)	DC brake (Braking time)	0.0 to 30.0 s 0.0 : (Inactive) 0.1 to 30.0 s
F23	17h	92( 5C h)	Starting speed (Speed)	0.0 to 150.0 r/min (The frequency is limited so as not to become 0.1Hz or less. (When using sensless or V/F control))
F24	18h	93( 5D h)	Starting speed (Holding time)	0.00 to 10.00 s
F26	1Ah	94( 5E h)	Motor sound (Carrier Freq.)	0.75 to <u>1</u> to 15 kHz A factory setting value of 75kW or more is 10kHz.

You can change the setting of a function indicated by  during operation.  
You should stop operation to change the setting of other functions.

Underline indicates a factory setting.  
Items without underline have different factory settings according to capacity.

Fcode	Communication address		Function name	Setting range
	485 number	Link number		
F27	1Bh	95( 5F h)	Motor sound (Sound tone)	0 to 3 0 : level 0 1 : level 1 2 : level 2 3 : level 3
F36	24h	( ) h)	30RY operation mode	0 to 1 0 : The relay(30) exits on trip mode. 1 : The relay(30) exits on normal mode.
F37	25h	96( 60 h)	Stop speed (Level)	0.0 to <u>10.0</u> to 150.0 r/min (The frequency is limited so as not to become 0.1Hz or less. (When using sensless or V/F control))
F38	26h	97( 61 h)	Stop speed (Detection method)	0 to 1 0 : Reference value 1 : Detected value It is fixed 0 to use the V/F control.
F39	27h	98( 62 h)	Stop speed (Zerospeed holding time)	0.00 to <u>0.50</u> to 10.00 s
F40	28h	99( 63 h)	Torque limiting mode 1	0 to 3 0 : Torque limiting invalid 1 : Torque limiting 2 : Power limiting 3 : Torque current limiting
F41	29h	100( 64 h)	Torque limiting mode 2	0 to 3 0 : Same limiting level (level 1) for 4 quadrants 1 : Drive torque limiting (level 1), and Brake torque limiting (level 2) 2 : Upper torque limiting (level 1), and Lower torque limiting (level 2) 3 : Same limiting level for 4 quadrants (level 1 and level 2 changeover) Level 1 and 2 is the data setting of the definition by F42, 43 ahead.
F42	2Ah	101( 65 h)	Torque limiter value (level 1) selection	0 to 5 0 : Internal preset value by F44 1 : Ai terminal input value [TL-REF1] 2 : DIA card input 3 : DIB card input 4 : Link enabled 5 : PID output
F43	2Bh	102( 66 h)	Torque limiter value (level 2) selection	0 to 5 0 : Internal preset value by F45 1 : Ai terminal input value [TL-REF2] 2 : DIA card input 3 : DIB card input 4 : Link enabled 5 : PID output
F44	2Ch	103( 67 h)	Torque limiter value (level 1)	-300 to <u>150</u> to 300 %
F45	2Dh	104( 68 h)	Torque limiter value (level 2)	-300 to <u>10</u> to 300 %
F46	2Eh	105( 69 h)	Mechanical loss compensation	-300.00 to <u>0.00</u> to 300.00 % This is used when mechanical loss of the load makes amends.
F47	2Fh	106( 6A h)	Torque bias set 1	-300.00 to <u>0.00</u> to 300.00 % This set value can be added to the torque reference value. TB1, 2 and 3 are switched by DI and are used.
F48	30h	( ) h)	Torque bias set 2	-300.00 to <u>0.00</u> to 300.00 % This set value can be added to the torque reference value. TB1, 2 and 3 are switched by DI and are used.
F49	31h	( ) h)	Torque bias set 3	-300.00 to <u>0.00</u> to 300.00 % This set value can be added to the torque reference value. TB1, 2 and 3 are switched by DI and are used.
F50	32h	( ) h)	Torque bias activation timer	<u>0.00</u> to 1.00 s ( 300% / 1.00s ) Time up to 300% is set.
F51	33h	251( 6B h)	Torque reference monitor (polarity)	0 to 1 Polarity selection of the data output related to torque (AO, Keypad panel, code M) 0 : Display with torque polarity 1 : (+) for driving mode, and (-) for braking mode
F52	34h	( ) h)	LED monitor coefficient (Display coefficient A)	-999.00 to <u>1.00</u> to 999.00 The conversion coefficient to decide load axis rotation speed and the display value at the line speed displayed in LED are set. Display value = Motor speed $\times$ (0.01 to 200.00) The set data is effective only by 0.01 to 200.00 and outside the range is invalid.

Underline indicates a factory setting.

Items without underline have different factory settings according to capacity.

Fcode	Communication address		Function name	Setting range
	485 number	Link number		
F53	35h	( h)	LED monitor coefficient (Display coefficient B)	-999.00 to <u>1.00</u> to 999.00 The conversion coefficient to decide the reference value of the PID adjustment machine and the display value (amount of the process) of the amount of feedback is set by using display coefficient A and B. Display coefficient A : Maximum value Display coefficient B : Minimum value Display value = (Reference value or feedback value) * (Display coefficient A - B) + B
F54	36h	( h)	LED display filter	0.0 to <u>0.2</u> to 5.0 s Filter to prevent LED from flickering by change of the display data. The filter is effective in all the data selected with F55
F55	37h	( h)	LED (Selection)	0 to 28 0 : Detected speed 1 or reference speed (r/min) (depending on F56 while motor is stopped) 1 : Speed reference value 4 (ASR input) (r/min) 2 : Output frequency after slip compensation (Hz) 3 : Torque current reference (%) 4 : Torque reference value (%) 5 : Torque (calculated value) (%) 6 : Inverter input power (kW or HP) (depending on F60) 7 : Output current (A) 8 : Output voltage (V) 9 : DC link circuit voltage (V) 10 : Magnetic flux reference (%) 11 : Magnetic flux (calculated value) (%) 12 : Motor temperature (°C) ("—" is displayed when NTC thermistor unused.) 13 : Load shaft speed (r/min) (depending on F56) 14 : Line speed (m/min) (depending on F56) 15 : Ai adjusted value (I2) (%) 16 : Ai adjusted value (Ai1) (%) 17 : Ai adjusted value (Ai2) (%) 18 : Ai adjusted value (Ai3) (%) 19 : Ai adjusted value (Ai4) (%) The following data becomes non-display by the mode on the option. 20 : PID reference (%) (Display at the PID mode) 21 : PID feedback value (%) (Display at the PID mode) 22 : PID output value (%) (Display at the PID mode) 23 : Option monitor 1 (HEX) (Displayed with use of option) 24 : Option monitor 2 (HEX) (Displayed with use of option) 25 : Option monitor 3 (DEC) (Displayed with use of option) 26 : Option monitor 4 (DEC) (Displayed with use of option) 27 : Option monitor 5 (DEC) (Displayed with use of option) 28 : Option monitor 6 (DEC) (Displayed with use of option)
F56	38h	( h)	LED (Display at stop mode)	0 to 1 Change of the display on F55 when the motor is stopping. The corresponding data is speed (0), load shaft rotation speed (13), and line speed (14). 0 : Speed reference (r/min) 1 : Speed feedback (r/min)
F57	39h	( h)	LCD (Selection)	0 to 1 Change of operation mode display on Keypad panel 0 : Operation guide (State of operation, Direction of rotation) 1 : Bar graph monitor (Speed, Current, Torque)
F58	3Ah	( h)	LCD (Language)	0 to 7 0 : Japanese 1 : English 2 : German 3 : French 4 : Spanish 5 : Italian 6 : Chinese 7 : Korean
F59	3Bh	( h)	LCD (Contrast)	0 to 5 to 10 0 (Soft) to 10 (Hard)
F60	3Ch	( h)	Output unit selection (kW or HP)	0 to 1 The unit of inverter power consumption and motor (M1,2,3) of the function setting is defined. 0 : kW 1 : HP
F51	3Dh	107( 6B h)	ASR1 (P-gain)	0.1 to <u>10.0</u> to 200.0 (times)

Fcode	Communication address		Function name	Setting range
	485 number	Link number		
F62	3Eh	108( 6C h)	ASR1 (I-gain)	0.010 to <u>0.200</u> to 1.000 s P control when setting 1.000
F63	3Fh	109( 6D h)	ASR1 (Feed forward gain)	<u>1.000</u> to 9.999 s
F64	40h	110( 6E h)	ASR1 (Input filter)	0.000 to <u>0.040</u> to 5.000 s
F65	41h	111( 6F h)	ASR1 (Detection filter)	0.000 to <u>0.005</u> to 0.100 s
F65	42h	112( 70 h)	ASR1 (Output filter)	0.000 to <u>0.002</u> to 0.100 s
F67	43h	113( 71 h)	S-curve (Acc start side)	0 to 50 %
F68	44h	114( 72 h)	S-curve (Acc end side)	0 to 50 %
F69	45h	115( 73 h)	S-curve (Dec start side)	0 to 50 %
F70	46h	116( 74 h)	S-curve (Dec end side)	0 to 50 %
F73	49h	( h)	Magnetic flux at light load	10 to <u>100</u> %
F74	4Ah	117( 75 h)	Pre-exiting time	<u>0.0</u> to 10.0 s
F75	4Bh	118( 76 h)	Pre-excitation initial level	<u>100</u> to 400 %
F75	4Ch	( h)	Speed limiter (Mode select)	0 to 3 0 : Limiting level 1 for forward rotation, and limiting level 2 for reverse rotation 1 : Limiting level 1 for both side rotation 2 : Limiting level 1 for upper limit, and limiting level 2 for lower limit 3 : Forward (Level 1) and reverse (Level 2). Add the [12] input as a bias
F77	4Dh	( h)	Speed limiting (Level 1)	-110.0 to <u>100.0</u> to 110.0 %
F78	4Eh	( h)	Speed limiting (Level 2)	-110.0 to <u>100.0</u> to 110.0 %
F79	4Fh	119( 77 h)	Motor selection (M1, M2, M3)	0 to 2 An effective motor (M1, 2 or 3) is selected by the function or terminal. 0 : M1 select The signal input by the terminal is given to priority. M1 select : (MCH2,MCH3)=(OFF,OFF) (If there is no allocation) M2 select : (MCH2,MCH3)=(ON,OFF)(ON,ON) 1 : M2 select (x function inactive) 2 : M3 select (x function inactive)
F80	50h	( h)	Current rating switching	0 to 2 0 : CT (Overload current 150%) 1 : VT (Overload current 110%) 2 : HT (Overload torque 200/170%)

You can change the setting of a function indicated by  during operation.  
You should stop operation to change the setting of other functions.

## E: Extension Terminal Functions

Fcode	Communication address		Function name	Setting range
	485 number	Link number		
E 0 1	101h	120( 78 h)	X1 terminal function	<u>0</u> to 63 0 to 3 : Multistep speed selection (1 to 15 steps) (0 : SS1, 1 : SS2, 2 : SS4, 3 : SS8) 4, 5 : ASR and ACC/DEC time selection (4 steps) (4 : RT1, 5 : RT2) 6 : 3 wire operation stop command (HLD) 7 : Coast-to-stop command (BX) 8 : Alarm reset (RST) 9 : External Alarm (THR) 10 : Jogging operation (JOG) 11 : Speed setting 2 / Speed setting 1 (N2/N1) 12 : Motor M2 selection (M-CH2) 13 : Motor M3 selection (M-CH3) 14 : DC brake command (DCBRK) 15 : ACC/DEC cleared to zero (CLR) 16 : Creep speed switching in UP/DOWN control (CRP-N2/N1) 17 : UP command (UP) 18 : DOWN command (DOWN) 19 : Write enable for KEYPAD (WE-KP) 20 : PID control cancel (N/PID) 21 : Inverse mode changeover (IVS) 22 : Interlock signal for 52-2 (IL) 23 : Write enable through link (WE-LK) 24 : Operation selection through link (LE) 25 : Universal DI (U-DI) 26 : Pick up start mode (STM) 27 : Synchronization command (PG (PR) optional function) (SYC) 28 : Zero speed locking command (LOCK) 29 : Pre-exiting command (EXITE) 30 : Speed reference limiter cancel (N-LIM) (Related function : F76, F77, F78) 31 : H41 [torque reference] cancel (H41-CCL) 32 : H42 [torque current reference] cancel (H42-CCL) 33 : H43 [magnetic flux reference] cancel (H43-CCL) 34 : F40 [torque limiter mode 1] cancel (F40-CCL) 35 : Torque limiter 2 / Torque limiter 1 (TL2/TL1) 36 : Bypass from ramp function generator (BPS) 37, 38 : Torque bias reference 1/2 (37 : TB1, 38 : TB2) 39 : DROOP selection (DROOP) 40 : Zero hold command for Ai1 (ZH-A11) 41 : Zero hold command for Ai2 (ZH-A12) 42 : Zero hold command for Ai3 (option) (ZH-A13) 43 : Zero hold command for Ai4 (option) (ZH-A14) 44 : Ai1 polarity change (REV-A11) 45 : Ai2 polarity change (REV-A12) 46 : Ai3 polarity change (option) (REV-A13) 47 : Ai4 polarity change (option) (REV-A14) 48 : Inverse mode of PID output (PID-INV) 49 : PG alarm cancel (PG-CCL) 50 : Undervoltage cancel (LU-CCL) 51 : Ai torque bias hold [H-TB] 52 : STOP1 (The motor stops with normal deceleration time.) (STOP1) 53 : STOP2 (The motor stops with deceleration 4) (STOP2) 54 : STOP3 (The motor stops with max. torque.) (STOP3) 55 : DIA data latch (DIA option) (DIA) 56 : DIB data latch (DIB option) (DIB) 57 : Multitwinding motor cancel (SI (MWS) option) (MT-CCL) 58 to 63 : Option Di 1/2/3/4/5/6 (O-DI1 to 6)
E 0 2	102h	121( 79 h)	X2 terminal function	0 to <u>1</u> to 63
E 0 3	103h	122( 7A h)	X3 terminal function	0 to <u>2</u> to 63
E 0 4	104h	123( 7B h)	X4 terminal function	0 to <u>3</u> to 63
E 0 5	105h	124( 7C h)	X5 terminal function	0 to <u>4</u> to 63
E 0 6	106h	125( 7D h)	X6 terminal function	0 to <u>5</u> to 63
E 0 7	107h	126( 7E h)	X7 terminal function	0 to <u>7</u> to 63
E 0 8	108h	127( 7F h)	X8 terminal function	0 to <u>8</u> to 63
E 0 9	109h	128( 80 h)	X9 terminal function	0 to <u>9</u> to 63
E 1 0	10Ah	129( 81 h)	X11 terminal function	0 to <u>25</u> to 63
E 1 1	10Bh	130( 82 h)	X12 terminal function	0 to <u>25</u> to 63

You can change the setting of a function indicated by  during operation. You should stop operation to change the setting of other functions.

Underline indicates a factory setting.  
Items without underline have different factory settings according to capacity.

Fcode	Communication address		Function name	Setting range
	485 number	Link number		
E 1 2	10Ch	131( 83 h)	X13 terminal function	0 to <u>25</u> to 63
E 1 3	10Dh	132( 84 h)	X14 terminal function	0 to <u>25</u> to 63
E 1 4	10Eh	( ) h)	X terminal function normal open/closed	<u>0000</u> to 01FF Setting of normal state of X1-X9 0 : Normally open 1 : Normally closed
E 1 5	10Fh	133( 85 h)	Y1 terminal function	0 to <u>1</u> to 47 0 : Inverter running (RUN) 1 : Speed existence signal (N-EX) 2 : Speed agreement signal (N-AG) 3 : Speed egilvarent signal (N-AR) 4 : Speed level detection 1 (N-DT1) 5 : Speed level detection 2 (N-DT2) 6 : Speed level detection 3 (N-DT3) 7 : Stopping on undervoltage (LU) 8 : Detected torque polarity (Braking/Driving) (B/D) 9 : Torque limiting (TL) 10 : Torque detection 1 (T-DT1) 11 : Torque detection 2 (T-DT2) 12 : KEYPAD operation mode (KP) 13 : Inverter stopping (STP) 14 : Operation ready output (RDY) 15 : Magnetic flux detection signal (MF-DT) 16 : Motor M2 selection status (SW-M2) 17 : Motor M3 selection status (SW-M3) 18 : Mechanical brake release signal (BRK) 19 : Alarm indication signal 1 (AL1) 20 : Alarm indication signal 2 (AL2) 21 : Alarm indication signal 4 (AL4) 22 : Alarm indication signal 8 (AL8) 23 : Fan operation signal (FAN) 24 : Auto-resetting (TRY) 25 : Universal DO (U-DO) 26 : Heat sink overheat early warning (INV-OH) 27 : Synchronization completion signal (SY-C) 28 : Lifetime alarm (LIFE) 29 : Under acceleration (U-ACC) 30 : Under deceleration (U-DEC) 31 : Inverter overload early warning (INV-OL) 32 : Motor overheat early warning (M-OH) 33 : Motor overload early warning (M-OL) 34 : DB overload early warning (DB-OL) 35 : Link transmission error (LK-ERR) 36 : Load adaptive control under limiting (ANL) 37 : Load adaptive control under calculation (ANC) 38 : Analog torque bias hold (TBH) 39 to 47 : Option DO1 to 9 (O-DO1 to O-DO9)
E 1 6	110h	134( 86 h)	Y2 terminal function	0 to <u>2</u> to 47
E 1 7	111h	135( 87 h)	Y3 terminal function	0 to <u>3</u> to 47
E 1 8	112h	136( 88 h)	Y4 terminal function	0 to <u>4</u> to 47
E 1 9	113h	137( 89 h)	Y5 terminal function	0 to <u>14</u> to 47
E 2 0	114h	138( 8A h)	Y11 terminal function	0 to <u>26</u> to 47
E 2 1	115h	139( 8B h)	Y12 terminal function	0 to <u>26</u> to 47
E 2 2	116h	140( 8C h)	Y13 terminal function	0 to <u>26</u> to 47
E 2 3	117h	141( 8D h)	Y14 terminal function	0 to <u>26</u> to 47
E 2 4	118h	142( 8E h)	Y15 terminal function	0 to <u>26</u> to 47
E 2 5	119h	143( 8F h)	Y16 terminal function	0 to <u>26</u> to 47
E 2 6	11Ah	144( 90 h)	Y17 terminal function	0 to <u>26</u> to 47
E 2 7	11Bh	145( 91 h)	Y18 terminal function	0 to <u>26</u> to 47
E 2 8	11Ch	( ) h)	Y terminal function normally open/closed	<u>0000</u> to 001F Setting of normal state of Y1to Y4,RY. 0 : Normally open 1 : Normally close

Underline indicates a factory setting.

Items without underline have different factory settings according to capacity.

Fcode	Communication address		Function name	Setting range
	485 number	Link number		
E 2 8	11Dh	146( 92 h)	PG pulse output selection	0 to 9 0 : No dividing 1 : 1/2 2 : 1/4 3 : 1/8 4 : 1/16 5 : 1/32 6 : 1/64 0 to 6 : Internal PG inputs are output after being divided. 7 : Pulse oscillation mode (A/B 90° phase difference signal) Internal speed reference is output after pulse conversion. 8 : PG (PD) Pulse inputs for position encoder are directly output. 9 : PG (PR) Pulse inputs for position command are directly output.
E 3 0	11Eh	( h)	Motor OH protection (temperature)	100 to <u>150</u> to 200°C It is effective when NTC thermistor is used with selected motor (M1.M2).
E 3 1	11Fh	( h)	M-OH early warning (temperature)	50 to <u>75</u> to 200 °C It is effective when NTC thermistor is used with selected motor (M1.M2).
E 3 2	120h	205( CD h)	M1-M3 (operation level PTC)	0.00 to <u>1.60</u> to 5.00 V
E 3 3	121h	( h)	INV-OL early warning	25 to <u>90</u> to 100 %
E 3 4	122h	( h)	M-OL early warning	25 to <u>90</u> to 100 %
E 3 5	123h	( h)	DB overload protection	0 to 100 %
E 3 6	124h	( h)	DB-OL early warning	0 to <u>80</u> to 100 %
E 3 7	125h	( h)	DB thermal time constant	0 to <u>300</u> to 1000 s
E 3 8	126h	147( 93 h)	Speed detection method	<u>000</u> to 111 (N-DT1) (N-DT2) (N-DT3) 0 : Detected speed 1 : Speed reference Only reference values are effective under VF control.
E 3 9	127h	148( 94 h)	N-DT1 Level	0 to <u>1500</u> to 24000 r/min
E 4 0	128h	149( 95 h)	N-DT2 Level	-24000 to <u>1500</u> to 24000 r/min
E 4 1	129h	150( 96 h)	N-DT3 Level	-24000 to <u>1500</u> to 24000 r/min
E 4 2	12Ah	151( 97 h)	N-AR detection width	1.0 to <u>3.0</u> to 20.0 %
E 4 3	12Bh	152( 98 h)	N-AG detection width	1.0 to <u>3.0</u> to 20.0 %
E 4 4	12Ch	153( 99 h)	N-AG off-delay timer	0.000 to <u>0.100</u> to 1.000 s
E 4 5	12Dh	154( 9A h)	Speed disagreement alarm	<u>00</u> to 21
E 4 6	12Eh	155( 9B h)	Torque detection level 1	0 to <u>30</u> to 300 % When the V/F control is used, the calculation value is set.
E 4 7	12Fh	156( 9C h)	Torque detection level 2	0 to <u>30</u> to 300 % When the V/F control is used, the calculation value is set.
E 4 8	130h	157( 9D h)	Magnetic flux detection level	10 to <u>100</u> %
E 4 9	131h	( h)	Ai1 function selection	0 to 18 0 : Input signal off (OFF) 1 : Auxiliary speed setting 1 (before ramp function) (±10 V / ±Nmax) (AUX-N1) 2 : Auxiliary speed setting 2 (after ramp function) (±10 V / ±Nmax) (AUX-N2) 3 : Torque limiter level 1 (±10 V / ±150 %) (TL-REF1) 4 : Torque limiter level 2 (±10 V / ±150 %) (TL-REF2) 5 : Torque bias reference (±10 V / ±150 %) (TB-REF) 6 : Torque reference (before limit function) (±10 V / ±150 %) (T-REF) 7 : Torque current reference (±10 V / ±150 %) (IT-REF) 8 : Creep speed 1 for UP/DOWN control (±10 V / ±Nmax) (CRP-N1) 9 : Creep speed 2 for UP/DOWN control (±10 V / ±Nmax) (CRP-N2) 10 : Magnetic flux reference (+10 V / +100 %) (MF-REF) 11 : Detected line speed (±10 V / ±Nmax) (LINE-N) 12 : Motor temperature (+10 V / 200 °C) (M-TMP) 13 : Speed override (±10 V / ±50 %) (N-OR) 14 : Universal Ai (±10 V / ±4000 (h)) (U-Ai) 15 : PID feedback (±10 V / ±20000 (d)) (PID-FB) 16 : PID reference (±10 V / ±20000 (d)) (PID-REF) 17 : PID correction gain (±10 V / ±4000 (h)) (PID-G) 18 : Option Ai (±10 V / ±7FFF (h)) (O-Ai)
E 5 0	132h	( h)	Ai2 function selection	0 to 18

You can change the setting of a function indicated by  during operation.  
You should stop operation to change the setting of other functions.

Fcode	Communication address		Function name	Setting range
	485 number	Link number		
E 5 1	133h	( h)	Ai3 function selection	0 to 18 (When the AIO option is installed, this is displayed.)
E 5 2	134h	( h)	Ai4 function selection	0 to 18 (When the AIO option is installed, this is displayed.)
E 5 3	135h	( h)	Gain adjustment for analog input (Ai1)	-10.000 to <u>1.000</u> to 10.000 (times) Use $\Delta$ or $\nabla$ key to write data onto RAM during editing with KEYPAD panel. Using F/D key causes data writing onto nonvolatile memory.
E 5 4	136h	( h)	Gain adjustment for analog input (Ai2)	-10.000 to <u>1.000</u> to 10.000 (times) Use $\Delta$ or $\nabla$ key to write data onto RAM during editing with KEYPAD panel. Using F/D key causes data writing onto nonvolatile memory.
E 5 5	137h	( h)	Gain adjustment for analog input (Ai3)	-10.000 to <u>1.000</u> to 10.000 (times) Use $\Delta$ or $\nabla$ key to write data onto RAM during editing with KEYPAD panel. Using F/D key causes data writing onto nonvolatile memory. (When the AIO option is installed, this is displayed.)
E 5 6	138h	( h)	Gain adjustment for analog input (Ai4)	-10.000 to <u>1.000</u> to 10.000 (times) Use $\Delta$ or $\nabla$ key to write data onto RAM during editing with KEYPAD panel. Using F/D key causes data writing onto nonvolatile memory. (When the AIO option is installed, this is displayed.)
E 5 7	139h	( h)	Bias adjustment for analog input (Ai1)	-100.0 to <u>0.0</u> to 100.0 % Use $\Delta$ or $\nabla$ key to write data onto RAM during editing with KEYPAD panel. Using F/D key causes data writing onto nonvolatile memory.
E 5 8	13Ah	( h)	Bias adjustment for analog input (Ai2)	-100.0 to <u>0.0</u> to 100.0 % Use $\Delta$ or $\nabla$ key to write data onto RAM during editing with KEYPAD panel. Using F/D key causes data writing onto nonvolatile memory.
E 5 9	13Bh	( h)	Bias adjustment for analog input (Ai3)	-100.0 to <u>0.0</u> to 100.0 % Use $\Delta$ or $\nabla$ key to write data onto RAM during editing with KEYPAD panel. Using F/D key causes data writing onto nonvolatile memory. (When the AIO option is installed, this is displayed.)
E 6 0	13Ch	( h)	Bias adjustment for analog input (Ai4)	-100.0 to <u>0.0</u> to 100.0 % Use $\Delta$ or $\nabla$ key to write data onto RAM during editing with KEYPAD panel. Using F/D key causes data writing onto nonvolatile memory. (When the AIO option is installed, this is displayed.)
E 6 1	13Dh	( h)	Filter adjustment for analog input (Ai1)	0.000 to <u>0.010</u> to 0.500 s
E 6 2	13Eh	( h)	Filter adjustment for analog input (Ai2)	0.000 to <u>0.010</u> to 0.500 s
E 6 3	13Fh	( h)	Filter adjustment for analog input (Ai3)	0.000 to <u>0.010</u> to 0.500 s (When the AIO option is installed, this is displayed.)
E 6 4	140h	( h)	Filter adjustment for analog input (Ai4)	0.000 to <u>0.010</u> to 0.500 s (When the AIO option is installed, this is displayed.)
E 6 5	141h	( h)	Increment/decrement limiter (Ai1)	<u>0.00</u> to 60.00 s
E 6 6	142h	( h)	Increment/decrement limiter (Ai2)	<u>0.00</u> to 60.00 s
E 6 7	143h	( h)	Increment/decrement limiter (Ai3)	<u>0.00</u> to 60.00 s (When the AIO option is installed, this is displayed.)
E 6 8	144h	( h)	Increment/decrement limiter (Ai4)	<u>0.00</u> to 60.00 s (When the AIO option is installed, this is displayed.)

Underline indicates a factory setting.  
Items without underline have different factory settings according to capacity.

Fcode	Communication address		Function name	Setting range
	485 number	Link number		
<u>E69</u>	145h	( h)	AO1 function selection	0 to 1 to 31 0: Detected speed 1 (0 to 10 Vdc / 0 to ±Nmax speed) (N-FB1+) 1: Detected speed 1 (0 to ±10 Vdc / 0 to ±Nmax speed) (N-FB1±) 2: Speed setting 2 (before ACC/DEC calculating) (0 to ±10 Vdc / 0 to ±Nmax) (N-REF2) 3: Speed setting 4 (ASR input) (0 to ±10 Vdc / 0 to ±Nmax) (N-REF4) 4: Detected speed 2 (ASR input) (0 to ±10 Vdc / 0 to ±Nmax) (N-FB2±) 5: Detected line speed (0 to ±10 Vdc / 0 to ±Nmax) (LINE-N±) 6: Torque current reference (0 to ±10 Vdc / 0 to ±150 %) (IT-REF±) 7: Torque current reference (0 to 10 Vdc / 0 to ±150 %) (IT-REF+) 8: Torque reference (0 to ±10 Vdc / 0 to ±150 %) (T-REF±) 9: Torque reference (0 to 10 Vdc / 0 to ±150 %) (T-REF+) 10: Motor current (0 to 10 Vdc / 0 to 200 %) (I-AC) 11: Motor voltage (0 to 10 Vdc / 0 to 200 %) (V-AC) 12: Input power (0 to 10 Vdc / 0 to 200 %) (PWR) 13: DC link circuit voltage (0 to 10 Vdc / 0 to 800 V) (V-DC) 14: Test voltage output (+10 Vdc) (P10) 15: Test voltage output (-10 Vdc) (N10) 30: Universal analog output (U-AO) 31: Option AO (O-AO)
<u>E70</u>	146h	( h)	AO2 function selection	0 to <u>9</u> to 31
<u>E71</u>	147h	( h)	AO3 function selection	0 to 3 to 31
<u>E72</u>	148h	( h)	AO4 function selection	0 to 31 (When the AIO option is installed, this is displayed.)
<u>E73</u>	149h	( h)	AO5 function selection	0 to 31 (When the AIO option is installed, this is displayed.)
<u>E74</u>	14Ah	( h)	Gain adjustment for analog output (AO1)	-100.00 to <u>1.00</u> to 100.00 (times)
<u>E75</u>	14Bh	( h)	Gain adjustment for analog output (AO2)	-100.00 to <u>1.00</u> to 100.00 (times)
<u>E76</u>	14Ch	( h)	Gain adjustment for analog output (AO3)	-100.00 to <u>1.00</u> to 100.00 (times)
<u>E77</u>	14Dh	( h)	Gain adjustment for analog output (AO4)	-100.00 to <u>1.00</u> to 100.00 (times) (When the AIO option is installed, this is displayed.)
<u>E78</u>	14Eh	( h)	Gain adjustment for analog output (AO5)	-100.00 to <u>1.00</u> to 100.00 (times) (When the AIO option is installed, this is displayed.)
<u>E79</u>	14Fh	( h)	Bias adjustment for analog output (AO1)	-100.0 to <u>0.0</u> to 100.0 %
<u>E80</u>	150h	( h)	Bias adjustment for analog output (AO2)	-100.0 to <u>0.0</u> to 100.0 %
<u>E81</u>	151h	( h)	Bias adjustment for analog output (AO3)	-100.0 to <u>0.0</u> to 100.0 %
<u>E82</u>	152h	( h)	Bias adjustment for analog output (AO4)	-100.0 to <u>0.0</u> to 100.0 % (When the AIO option is installed, this is displayed.)
<u>E83</u>	153h	( h)	Bias adjustment for analog output (AO5)	-100.0 to <u>0.0</u> to 100.0 % (When the AIO option is installed, this is displayed.)
<u>E84</u>	154h	( h)	Filter adjustment for analog output (AO1-5)	0.000 to <u>0.010</u> to 0.500 s

You can change the setting of a function indicated by  during operation.  
You should stop operation to change the setting of other functions.

### C: Control Functions of Frequency

Fcode	Communication address		Function name	Setting range
	485 number	Link number		
<u>C01</u>	201h	( h)	Jump speed (Speed 1)	0 to 24000 r/min
<u>C02</u>	202h	( h)	Jump speed (Speed 2)	0 to 24000 r/min
<u>C03</u>	203h	( h)	Jump speed (Speed 3)	0 to 24000 r/min
<u>C04</u>	204h	( h)	Jump speed (Hysteresis)	0 to 1000 r/min
<u>C05</u>	205h	158( 9E h)	Multistep speed 1	0 to 24000 r/min / <u>0.00</u> to 100.00 % / <u>0.0</u> to 999.9 m/m (Change by C21)
<u>C06</u>	206h	159( 9F h)	Multistep speed 2	0 to 24000 r/min / <u>0.00</u> to 100.00 % / <u>0.0</u> to 999.9 m/m (Change by C21)
<u>C07</u>	207h	160( A0 h)	Multistep speed 3	0 to 24000 r/min / <u>0.00</u> to 100.00 % / <u>0.0</u> to 999.9 m/m (Change by C21)
<u>C08</u>	208h	161( A1 h)	Multistep speed 4	0 to 24000 r/min / <u>0.00</u> to 100.00 % / <u>0.0</u> to 999.9 m/m (Change by C21)
<u>C09</u>	209h	162( A2 h)	Multistep speed 5	0 to 24000 r/min / <u>0.00</u> to 100.00 % / <u>0.0</u> to 999.9 m/m (Change by C21)
<u>C10</u>	20Ah	163( A3 h)	Multistep speed 6	0 to 24000 r/min / <u>0.00</u> to 100.00 % / <u>0.0</u> to 999.9 m/m (Change by C21)
<u>C11</u>	20Bh	164( A4 h)	Multistep speed 7	0 to 24000 r/min / <u>0.00</u> to 100.00 % / <u>0.0</u> to 999.9 m/m (Change by C21)
<u>C12</u>	20Ch	( h)	Multistep speed 8	0 to 24000 r/min / <u>0.00</u> to 100.00 % / <u>0.0</u> to 999.9 m/m (Change by C21)
<u>C13</u>	20Dh	( h)	Multistep speed 9	0 to 24000 r/min / <u>0.00</u> to 100.00 % / <u>0.0</u> to 999.9 m/m (Change by C21)
<u>C14</u>	20Eh	( h)	Multistep speed 10	0 to 24000 r/min / <u>0.00</u> to 100.00 % / <u>0.0</u> to 999.9 m/m (Change by C21)
<u>C15</u>	20Fh	( h)	Multistep speed 11	0 to 24000 r/min / <u>0.00</u> to 100.00 % / <u>0.0</u> to 999.9 m/m (Change by C21)
<u>C16</u>	210h	( h)	Multistep speed 12	0 to 24000 r/min / <u>0.00</u> to 100.00 % / <u>0.0</u> to 999.9 m/m (Change by C21)
<u>C17</u>	211h	( h)	Multistep speed 13	0 to 24000 r/min / <u>0.00</u> to 100.00 % / <u>0.0</u> to 999.9 m/m (Change by C21)
<u>C18</u>	212h	( h)	Multistep speed 14 / Creep speed 1	0 to 24000 r/min / <u>0.00</u> to 100.00 % / <u>0.0</u> to 999.9 m/m (Change by C21)
<u>C19</u>	213h	( h)	Multistep speed 15 / Creep speed 2	0 to 24000 r/min / <u>0.00</u> to 100.00 % / <u>0.0</u> to 999.9 m/m (Change by C21)
<u>C20</u>	214h	( h)	Multistep speed agreement timer	<u>0.000</u> to 0.100 s
<u>C21</u>	215h	( h)	Multistep speed setting definition	0 to 2 0: 0 to 24000 r/min 1: 0.00 to 100.00% 2: 0.0 to 999.9 m/m Defines setting methods of C05 to C19. With selection of "1", the setting range applies to the max speeds (F03, A06, A40) of selected motor. Refer to F79 for motor selection.
<u>C25</u>	219h	( h)	Speed setting N2	0 to 7 * Same as ( F01 )
<u>C29</u>	21Dh	( h)	Jogging speed	0 to <u>50</u> to 24000 r/min
<u>C30</u>	21Eh	( h)	ASR-JOG (P-gain)	0.1 to <u>10.0</u> to 200.0 (times)
<u>C31</u>	21Fh	( h)	ASR-JOG (I-gain)	0.010 to <u>0.200</u> to 1.000 s P control when setting 1.000
<u>C32</u>	220h	( h)	ASR-JOG (Input filter)	0.000 to <u>0.040</u> to 5.000 s
<u>C33</u>	221h	( h)	ASR-JOG (Detection filter)	0.000 to <u>0.005</u> to 0.100 s
<u>C34</u>	222h	( h)	ASR-JOG (Output filter)	0.000 to <u>0.002</u> to 0.100 s
<u>C35</u>	223h	( h)	Acceleration time JOG	0.01 to <u>5.00</u> to 99.99s 100.0 to 999.9s 1000 to 3600s
<u>C36</u>	224h	( h)	Deceleration time JOG	0.01 to <u>5.00</u> to 99.99s 100.0 to 999.9s 1000 to 3600s
<u>C37</u>	225h	( h)	S-curve JOG (Start side)	0 to 50 %
<u>C38</u>	226h	( h)	S-curve JOG (End side)	0 to 50 %
<u>C40</u>	228h	( h)	ASR2 (P-gain)	0.1 to <u>10.0</u> to 200.0 (times)
<u>C41</u>	229h	( h)	ASR2 (I-gain)	0.010 to <u>0.200</u> to 1.000 s P control when setting 1.000
<u>C42</u>	22Ah	( h)	ASR2 (F/F-gain)	<u>0.000</u> to 9.999 s
<u>C43</u>	22Bh	( h)	ASR2 (Input filter)	0.000 to <u>0.040</u> to 5.000 s
<u>C44</u>	22Ch	( h)	ASR2 (Detection filter)	0.000 to <u>0.005</u> to 0.100 s
<u>C45</u>	22Dh	( h)	ASR2 (Output filter)	0.000 to <u>0.002</u> to 0.100 s

Underline indicates a factory setting.

Items without underline have different factory settings according to capacity.

Fcode	Communication address		Function name	Setting range
	485 number	Link number		
C46	22Eh	( h)	Acceleration time 2	0.01 to <u>5.00</u> to 99.99s 100.0 to 999.9s 1000 to 3600s
C47	22Fh	( h)	Deceleration time 2	0.01 to <u>5.00</u> to 99.99s 100.0 to 999.9s 1000 to 3600s
C48	230h	( h)	S-curve 2 (Start side)	0 to 50 %
C49	231h	( h)	S-curve 2 (End side)	0 to 50 %
C50	232h	( h)	ASR3 (P-gain)	0.1 to <u>10.0</u> to 200.0 (times)
C51	233h	( h)	ASR3 (I-gain)	0.010 to <u>0.200</u> to 1.000 s P control when setting 1.000
C52	234h	( h)	ASR3 (F/F-gain)	<u>0.000</u> to 9.999 s
C53	235h	( h)	ASR3 (Input filter)	0.000 to <u>0.040</u> to 5.000 s
C54	236h	( h)	ASR3 (Detection filter)	0.000 to <u>0.005</u> to 0.100 s
C55	237h	( h)	ASR3 (Output filter)	0.000 to <u>0.002</u> to 0.100 s
C56	238h	( h)	Acceleration time 3	0.01 to <u>5.00</u> to 99.99s 100.0 to 999.9s 1000 to 3600s
C57	239h	( h)	Deceleration time 3	0.01 to <u>5.00</u> to 99.99s 100.0 to 999.9s 1000 to 3600s
C58	23Ah	( h)	S-curve 3 (Start side)	0 to 50 %
C59	23Bh	( h)	S-curve 3 (End side)	0 to 50 %
C60	23Ch	( h)	ASR4 (P-gain)	0.1 to <u>10.0</u> to 200.0 (times)
C61	23Dh	( h)	ASR4 (I-gain)	0.010 to <u>0.200</u> to 1.000 s P control when setting 1.000
C62	23Eh	( h)	ASR4 (F/F-gain)	<u>0.000</u> to 9.999 s
C63	23Fh	( h)	ASR4 (Input filter)	0.000 to <u>0.040</u> to 5.000 s
C64	240h	( h)	ASR4 (Detection filter)	0.000 to <u>0.005</u> to 0.100 s
C65	241h	( h)	ASR4 (Output filter)	0.000 to <u>0.002</u> to 0.100 s
C66	242h	( h)	Acceleration time 4	0.01 to <u>5.00</u> to 99.99s 100.0 to 999.9s 1000 to 3600s
C67	243h	( h)	Deceleration time 4	0.01 to <u>5.00</u> to 99.99s 100.0 to 999.9s 1000 to 3600s
C68	244h	( h)	S-curve 4 (Start side)	0 to 50 %
C69	245h	( h)	S-curve 4 (End side)	0 to 50 %
C70	246h	( h)	ASR switching time	0.00 to <u>1.00</u> to 2.55 s
C71	247h	165( A5 h)	ACC/DEC switching speed	<u>0.00</u> to 100.00 %
C72	248h	166( A6 h)	ASR switching time	<u>0.00</u> to 100.00 %
C73	249h	( h)	Creep speed select (at UP/DOWN mode)	<u>00</u> to 11 (Creep Speed 1)(Creep Speed 2) 0:Function setting (C18,19) 1:Analog input (CRP-N1, CRP-N2)

You can change the setting of a function indicated by  during operation.  
You should stop operation to change the setting of other functions.

P: Motor Parameters				
Fcode	Communication address		Function name	Setting range
	485 number	Link number		
P01	301h	( h)	M1 Control method	0 to 3 0 : Vector control 1 : Sensorless vector control 2 : Simulation operation mode 3 : Vector control (Synchronous motors)
P02	302h	( h)	M1 selection (for Motor parameter setting)	0 to 37 Display (kW,HP) changes by setting F60. 0 to 35: Settings for motors dedicated for VG7 Data at F04, F05, and P03 to P27 are automatically set and write-protected. 36: P-OTHER Data at F04, F05, and P03 to P27 are write-protected and cannot be overwritten. 37: OTHER Data at F04, F05, and P03 to P27 are write-protected and cannot be overwritten.
P03	303h	167( A7 h)	M1-Rated capacity	0.00 to 500.00kW at F60=0 0.00 to 600.00HP at F60=1
P04	304h	168( A8 h)	M1-Rated current	0.01 to 99.99A 100.0 to 999.9A 1000 to 2000A
P05	305h	169( A9 h)	M1-Poles	2 to <u>4</u> to 30 (poles)
P06	306h	170( AA h)	M1-%R1	0.00 to 30.00 %
P07	307h	171( AB h)	M1-%X	0.00 to 50.00 %
P08	308h	172( AC h)	M1-Exciting current	0.01 to 99.99A 100.0 to 999.9A 1000 to 2000A
P09	309h	173( AD h)	M1-Torque current	0.01 to 99.99A 100.0 to 999.9A 1000 to 2000A
P10	30Ah	174( AE h)	M1-Slip (Driving)	0.001 to 10.000 Hz
P11	30Bh	175( AF h)	M1-Slip (Braking)	0.001 to 10.000 Hz
P12	30Ch	176( B0 h)	M1-Iron loss coefficient 1	0.00 to 10.00 %
P13	30Dh	177( B1 h)	M1-Iron loss coefficient 2	0.00 to 10.00 %
P14	30Eh	178( B2 h)	M1-Iron loss coefficient 3	0.00 to 10.00 %
P15	30Fh	179( B3 h)	M1-Magnetic saturation coefficient 1	0.0 to 100.0 %
P16	310h	180( B4 h)	M1-Magnetic saturation coefficient 2	0.0 to 100.0 %
P17	311h	181( B5 h)	M1-Magnetic saturation coefficient 3	0.0 to 100.0 %
P18	312h	182( B6 h)	M1-Magnetic saturation coefficient 4	0.0 to 100.0 %
P19	313h	183( B7 h)	M1-Magnetic saturation coefficient 5	0.0 to 100.0 %
P20	314h	184( B8 h)	M1-Secondary time constant	0.0001 to 9.999 s
P21	315h	185( B9 h)	M1-Induced voltage coefficient	0 to 999 V
P22	316h	186( BA h)	M1-R2 correction coefficient 1	0.500 to 5.000
P23	317h	187( BB h)	M1-R2 correction coefficient 2	0.500 to 5.000
P24	318h	188( BC h)	M1-R2 correction coefficient 3	0.010 to 5.000
P25	319h	189( BD h)	M1-Exciting current correction coefficient.	0.000 to 5.000
P26	31Ah	190( BE h)	M1-ACR-P gain	0.1 to 20.0
P27	31Bh	191( BF h)	M1-ACR-I gain	0.5 to 100.0 ms
P28	31Ch	192( C0 h)	M1-PG pulses	100 to <u>1024</u> to 60000
P29	31Dh	214( D6 h)	M1-External PG correction coefficient	0000 to <u>4000</u> to 4FFF
P30	31Eh	193( C1 h)	M1-thermistor selection	0 to <u>1</u> to 3 0 : No use thermistor 1 : NTC thermistor 2 : PTC thermistor 3 : Ai (M-TMP) Please do the protection level setting of the motor at E30-E32.

Underline indicates a factory setting.

Items without underline have different factory settings according to capacity.

## H: High Performance Functions

Fcode	Communication address		Function name	Setting range
	485 number	Link number		
H01	401h	( h)	Tuning operation selection	0 to 4 After writing the data, this function's data code automatically returns to 0. 0 : Inactive 1 : ASR system tuning 2 : R1.L tuning 3 : Motor parameters tuning at stopping mode 4 : Motor parameters tuning at running mode The data after the tuning goes out when the power supply is turned off. H02 "All save function" must operate when the maintenance (preservation) of the data is necessary.
H02	402h	14( E h)	All Save Function	0 to 1 When tuning is executed at H01 and the internal data is written, or when the data is written by way of the link system (T-Link, field bus, and RS485, etc.), the data goes out when the power supply of the inverter is turned off. This function must operate when preservation is necessary. After writing the data, this function's data code automatically returns to 0.
H03	403h	( h)	Data initializing (Data reset)	0 to 1 The data which the customer rewrote is returned to the state of the factory setting value. Target functions for initialization are all fields of F, E, C, H, o, L, and U except motor parameter field (PA). After writing the data, this function's data code automatically returns to 0.
H04	404h	( h)	Auto-reset (Times)	0 to 10 0 : (Inactive) 1 to 10 times The auto-resetting signal can be output to the output terminal.
H05	405h	( h)	Auto-reset (Reset interval)	0.01 to <u>5.00</u> to 20.00 s
H06	406h	( h)	Fan stop operation	0 to 1 The temperature of the cooling fan in the inverter is detected and it is a function to control the cooling fan automatically ON/OFF. It always rotates when inactive is selected. 0 : Inactive 1 : Active The signal indicating the cooling fan operation can be output by synchronizing with this function.
H08	408h	( h)	Rev phase sequence lock	0 to 1 0 : Inactive 1 : Active
H09	409h	194( C2 h)	Start mode (rotating motor pick up)	0 to 2 0 : Inactive 1 : Active (at after momentary power failure) 2 : Active (at all start mode)
H10	40Ah	195( C3 h)	Energy-saving operation	0 to 1 0 : Inactive 1 : Active
H11	40Bh	( h)	Automatic operation OFF function	0 to 2 It is a function when becoming following the stop speed setting to turn off the inverter automatically. 0 : Deceleration stop with FWD or REV shorted to CM between FWD-CM and REV-CM. 1 : The inverter is turned off below the stop speed even for ON between FWD-CM and REV-CM. 2 : Coast-to-stop with FWD or REV shorted to CM.
H13	40Dh	196( C4 h)	Restart after momentary power failure (Restart waiting time)	0.1 to <u>0.5</u> to 5.0 s
H14	40Eh	( h)	Restart after momentary power failure (Fall rate)	1 to <u>500</u> to 3600 ( r/min/s)
H15	40Fh	( h)	Restart after momentary power failure (Holding voltage on continuous operation)	3ph 200V : 200 to <u>235</u> to 300V 3ph 400V : 400 to <u>470</u> to 600V
H16	410h	( h)	Operation command selfhold setting	0 to 1 0 : Set at H17 1 : Maximum time (The inverter judges that it is a power failure momentarily and self-maintains the operation command while the control power supply in the inverter establishes or until the main circuit DC voltage becomes almost 0.)

You can change the setting of a function indicated by  during operation.  
You should stop operation to change the setting of other functions.

Fcode	Communication address		Function name	Setting range
	485 number	Link number		
H17	411h	( h)	Operation command selfhold time	0.0 to <u>30.0</u> s
H19	413h	197( C5 h)	Active Drive	0 to 1 0 : Inactive 1 : Active
H20	414h	198( C6 h)	PID control (Mode select)	0 to 3 0 : Inactive 1 : Active (normal mode output) 2 : Active (inverse mode output 1) 3 : Active (inverse mode output 2)
H21	415h	199( C7 h)	Command select	0 to 1 0 : Keypad panel or 12 input 1 : Analog input (PIDS)
H22	416h	201( C9 h)	P-gain	0.000 to <u>1.000</u> to 10.000 (times)
H23	417h	202( CA h)	I-gain	0.00 to <u>1.00</u> to 100.00 s
H24	418h	203( CB h)	D-gain	<u>0.000</u> to 10.000 s
H25	419h	200( C8 h)	PID control (Upper limit)	-300 to <u>100</u> to 300 %
H26	41Ah	204( CC h)	PID control (Lower limit)	-300 to <u>100</u> to 300 %
H27	41Bh	206( CE h)	PID control (Speed reference)	0 to 2 0 : Inactive 1 : PID select 2 : Auxiliary speed
H28	41Ch	207( CF h)	Droop control	<u>0.0</u> to 25.0 %
H29	41Dh	( h)	Data protect via serial link	0 to 1 Function not to write data from link (T-Link, RS485, etc.) by mistake. 0 : Non-protect 1 : Protect via serial link There are two writing from the link about usual function field and serial data field. This S field is defined at H30.
H30	41Eh	208( D0 h)	Serial link (Function select)	0 to 3 (Monitor) (Speed reference) (Operation command) 0 : o x x 1 : o o x 2 : o x o 3 : o o o
H31	41Fh	( h)	RS485 (Address)	0 to 1 to 255 Setting of the station address of RS485 broadcast : (0 : RTU), (99 : Fujii) address : 1 to 255
H32	420h	( h)	RS485 (Mode select on no response error)	0 to 3 0 : Trip and alarm (Er5) 1 : Operation for H33 timer, and alarm (Er5) 2 : Operation for H33 timer, and retry to communicate. * If the retry fails, then the inverter trips. ("Er5") 3 : Continuous operation
H33	421h	( h)	RS485 (Timer)	0.01 to <u>2.00</u> to 20.00 s
H34	422h	( h)	RS485 (Baud rate)	0 to 4 0 : 38400 bps 1 : 19200 bps 2 : 9600 bps 3 : 4800 bps 4 : 2400 bps
H35	423h	( h)	RS485 (Data length)	0 to 1 0 : 8 bits 1 : 7 bits
H36	424h	( h)	RS485 (Parity check)	0 to 1 to 2 0 : No checking 1 : Even parity 2 : Odd parity
H37	425h	( h)	RS485 (Stop bits)	0 to 1 0 : 2 bits 1 : 1 bit
H38	426h	( h)	RS485 (No response error detection time)	0.0 to <u>60.0</u> s 0.0 : Detection of communication break invalid 0.1 to 60.0s : Detection of communication break valid It is a function to do Er5 trip detecting the access disappearing for each station which includes an own station in the set time due to some abnormality (no response etc.) from operation via RS485.
H39	427h	( h)	RS485 (Response interval)	0.00 to <u>0.01</u> to 1.00 s The time to return the response is set to the demand by a host device.

Underline indicates a factory setting.

Items without underline have different factory settings according to capacity.

Fcode	Communication address		Function name	Setting range
	485 number	Link number		
H 4 0	428h	( h)	RS485 (Protocol)	0 to 1 to 2 0 : FUJI inverter protocol 1 : SX bus (FUJI private link) protocol 2 : Modbus RTU protocol Please set 1 (SX bus protocol) when you use the PC loader of the VG7 exclusive use.
H 4 1	429h	209( D1 h)	Torque reference selection	0 to 5 0 : Internal ASR output 1 : AI terminal input (T-REF) 2 : DIA card input 3 : DIB card input 4 : Link input 5 : PID
H 4 2	42Ah	210( D2 h)	Torque current reference selection	0 to 4 0 : Internal ASR output 1 : AI terminal input (IT-REF) 2 : DIA card input 3 : DIB card input 4 : Link input
H 4 3	42Bh	211( D3 h)	Magnetic flux reference selection	0 to 3 0 : Internal calculation value 1 : AI terminal input (MF-REF) 2 : Function setting value (H44) 3 : Link input
H 4 4	42Ch	212( D4 h)	Magnetic flux reference value	10 to <u>100</u> %
H 4 6	42Eh	215( D7 h)	Observer (Mode select)	0 to 2 0 : Inactive 1 : Active (load disturbance observer) 2 : Active (oscillation suppressing observer)
H 4 7	42Fh	216( D8 h)	(P-gain 1)(M1)	<u>0.00</u> to 1.00 (times)
H 4 8	430h	( h)	(P-gain 2)(M2)	<u>0.00</u> to 1.00 (times)
H 4 9	431h	217( D9 h)	(I-gain 1)(M1)	0.005 to <u>0.100</u> to 1.000 s
H 5 0	432h	( h)	(I-gain 2)(M2)	0.005 to <u>0.100</u> to 1.000 s
H 5 1	433h	218( DA h)	Load inertia M1	0.001 to 50.000 (kg.m <sup>2</sup> )
H 5 2	434h	( h)	Load inertia M2	<u>0.001</u> to 50.000 (kg.m <sup>2</sup> )
H 5 3	435h	213( D5 h)	Line speed feedback selection	0 to 3 0 : Line speed disabled 1 : Line speed (analog input) (AI-LINE) 2 : Line speed (digital input) (PG(LD)) 3 : High level selected signal
H 5 5	437h	( h)	Zero speed control (Gain)	0 to <u>5</u> to 100 (times)
H 5 6	438h	( h)	Completion range	0 to <u>100</u> (pulse)
H 5 7	439h	( h)	OU alarm prevention	0 to 1 0 : Inactive 1 : Active
H 5 8	43Ah	( h)	OC alarm prevention	0 to 1 0 : Inactive 1 : Active
H 6 0	43Ch	( h)	Load adaptive control function 1	0 to 3 0 : Inactive 1 : Method 1 2 : Method 2 3 : Method 3
H 6 1	43Dh	( h)	Load adaptive control function 2	0 to 1 0 : Winding up on forward rotation 1 : Winding down on forward rotation
H 6 2	43Eh	( h)	Winding up speed	<u>0.0</u> to 999.9 m/min
H 6 3	43Fh	( h)	Counter weight	<u>0.00</u> to 600.00 (t)
H 6 4	440h	( h)	Safety coefficient (for rated torque)	0.50 to <u>1.00</u> to 1.20
H 6 5	441h	( h)	Machine efficiency	<u>0.500</u> to 1.000
H 6 6	442h	( h)	Rated loading	<u>0.00</u> to 600.00 (t)
H 6 8	444h	( h)	Alarm data delete	0 to 1 If these tuning are finished, this data code returns to 0.
H 7 0	446h	( h)	Reserved 1	0 to 9999 0 : Standard 1 : Lift 2 to 9999 : Undecided

You can change the setting of a function indicated by  during operation.  
You should stop operation to change the setting of other functions.

Fcode	Communication address		Function name	Setting range
	485 number	Link number		
H 7 1	447h	( h)	Reserved 2	0 to 6 It is not necessary to set usually. If these tuning are finished, this data code returns to 0. 0 : Inactive 1 : ACR system tuning 2 : Voltage gain tuning (execution without connecting motor) 3 : Voltage sensor offset tuning 4 : Current sensor balance tuning 5 : Magnet pole position tuning (for SM driving) 6 : Shunt resistor gain tuning
H 7 2	448h	( h)	Reserved 3	0 to 9999 0 : standard 1 to 9999 : Undecided
H 7 3	449h	( h)	Reserved 4	0 to 9999 0 : standard 1 to 9999 : Undecided

### A: Alternative Motor Parameters

Fcode	Communication address		Function name	Setting range
	485 number	Link number		
R 0 1	501h	( h)	M2-Control method	0 to 1 M2 is an induction motor only for the vector control. 0 : Vector control with PG 1 : Vector control without PG
R 0 2	502h	( h)	M2-Rated capacity	<u>0.00</u> to 500.00kW at F60=0 <u>0.00</u> to 600.00HP at F60=1
R 0 3	503h	( h)	M2-Rated current	<u>0.01</u> to 99.99A 100.0 to 999.9A 1000 to 2000A
R 0 4	504h	( h)	M2-Rated voltage	<u>80</u> to 999 V
R 0 5	505h	( h)	M2-Rated speed	50 to <u>1500</u> to 24000 r/min
R 0 6	506h	( h)	M2-Maximum speed	50 to <u>1500</u> to 24000 r/min
R 0 7	507h	( h)	M2-Poles	2 to 4 to 12 (poles)
R 0 8	508h	( h)	M2-%R1	<u>0.00</u> to 30.00 %
R 0 9	509h	( h)	M2-%X	<u>0.00</u> to 50.00 %
R 1 0	50Ah	( h)	M2-Exciting current	<u>0.01</u> to 99.99A 100.0 to 999.9A 1000 to 2000A
R 1 1	50Bh	( h)	M2-Torque current	<u>0.01</u> to 99.99A 100.0 to 999.9A 1000 to 2000A
R 1 2	50Ch	( h)	M2-Slip (Driving)	<u>0.001</u> to 10.000 Hz
R 1 3	50Dh	( h)	M2-Slip (Braking)	<u>0.001</u> to 10.000 Hz
R 1 4	50Eh	( h)	M2-Iron loss coefficient 1	<u>0.00</u> to 10.00 %
R 1 5	50Fh	( h)	M2-Iron loss coefficient 2	<u>0.00</u> to 10.00 %
R 1 6	510h	( h)	M2-Iron loss coefficient 3	<u>0.00</u> to 10.00 %
R 1 7	511h	( h)	M2-Magnetic saturation coefficient 1	<u>0.0</u> to 100.0 %
R 1 8	512h	( h)	M2-Magnetic saturation coefficient 2	<u>0.0</u> to 100.0 %
R 1 9	513h	( h)	M2-Magnetic saturation coefficient 3	<u>0.0</u> to 100.0 %
R 2 0	514h	( h)	M2-Magnetic saturation coefficient 4	<u>0.0</u> to 100.0 %
R 2 1	515h	( h)	M2-Magnetic saturation coefficient 5	<u>0.0</u> to 100.0 %
R 2 2	516h	( h)	M2-Secondary time constant	<u>0.001</u> to 9.999 s
R 2 3	517h	( h)	M2-Induced voltage coefficient	0 to 999 V
R 2 4	518h	( h)	M2-R2 correction coefficient 1	<u>0.000</u> to 5.000
R 2 5	519h	( h)	M2-R2 correction coefficient 2	<u>0.000</u> to 5.000

Underline indicates a factory setting  
Items without underline have different factory settings according to capacity.

Fcode	Communication address		Function name	Setting range
	485 number	Link number		
R 2 6	51Ah	( h )	M2-R2 correction coefficient 3	<u>0.010</u> to 5.000
R 2 7	51Bh	( h )	M2-Exciting current correction coefficient	<u>0.000</u> to 5.000
R 2 8	51Ch	( h )	M2-ACR-P gain	0.1 to <u>1.0</u> to 20.0
R 2 9	51Dh	( h )	M2-ACR-I gain	0.5 to <u>1.0</u> to 100.0 ms
R 3 0	51Eh	( h )	M2-PG pulses	100 to <u>1024</u> to 60000
R 3 1	51Fh	( h )	M2-thermistor selection	0 to <u>1</u> to 3 0 : No use thermistor 1 : NTC thermistor 2 : PTC thermistor 3 : AI (M-TMP) Please do the protection level setting of the motor at E30-E32
R 3 2	520h	( h )	M2-Electronic thermal overload relay (Selection)	0 to 2 The motor overheating protection operates by using NTC thermistor with the motor only for VG. In this case, please make setting a Electronic thermal "Inactive". 0 : Inactive 1 : Active (for standard motor, self-cooling fan) 2 : Active (for inverter motor, separate cooling fan)
R 3 3	521h	( h )	M2-Electronic thermal overload relay (Level)	<u>0.01</u> to 99.99A 100.0 to 999.9A 1000 to 2000A
R 3 4	522h	( h )	M2-Electronic thermal overload relay (Thermal time constant)	<u>0.5</u> to 75.0 min
R 3 5	523h	229( E5 h )	M3-Rated capacity	<u>0.00</u> to 500.00kW at F60=0 <u>0.00</u> to 600.00HP at F60=1
R 3 6	524h	230( E6 h )	M3-Rated current	<u>0.01</u> to 99.99A 100.0 to 999.9A 1000 to 2000A
R 3 7	525h	231( E7 h )	M3-Rated voltage	<u>80</u> to 999 V
R 3 8	526h	232( E8 h )	M3-Maximum voltage	<u>80</u> to 999 V
R 3 9	527h	233( E9 h )	M3-Rated speed	50 to <u>1500</u> to 24000 r/min
R 4 0	528h	234( EA h )	M3-Maximum speed	50 to <u>1500</u> to 24000 r/min
R 4 1	529h	235( EB h )	M3-Poles	<u>2</u> to 4 to 12 (poles)
R 4 2	52Ah	236( EC h )	M3-%R1	<u>0.00</u> to 30.00 %
R 4 3	52Bh	237( ED h )	M3-%X	<u>0.00</u> to 50.00 %
R 4 4	52Ch	238( EE h )	M3-Exciting current	<u>0.01</u> to 99.99A 100.0 to 999.9A 1000 to 2000A
R 4 5	52Dh	239( EF h )	M3-Slip compensation control	-20.000 to <u>0.000</u> to 5.000 Hz
R 4 6	52Eh	240( F0 h )	M3-Torque boost	<u>0.0</u> to 20.0 0.0 : Automatic torque boost (for CT load) 0.1 to 0.9 : Manual torque boost (for Square torque load) 1.0 to 1.9 : Manual torque boost (for VT load) 2.0 to 20.0 : Manual torque boost (for CT load)
R 4 7	52Fh	241( F1 h )	M3-Thermistor selection	0 to <u>1</u> to 3 0 : No use thermistor 1 : NTC thermistor 2 : PTC thermistor 3 : AI (M-TMP) Please do the protection level setting of the motor at E30-E32
R 4 8	530h	242( F2 h )	M3-Electronic thermal overload relay (Selection)	0 to 2 0 : Inactive (when using PTC thermistor) 1 : Active (for standard motor, self-cooling fan) 2 : Active (for inverter motor, separate-cooling fan)
R 4 9	531h	243( F3 h )	M3-Electronic thermal overload relay (Level)	<u>0.01</u> to 99.99A 100.0 to 999.9A 1000 to 2000A
R 5 0	532h	244( F4 h )	M3-Electronic thermal overload relay (Thermal time constant)	<u>0.5</u> to 75.0 min

You can change the setting of a function indicated by  during operation.  
You should stop operation to change the setting of other functions.

## O: Optional Functions

Fcode	Communication address		Function name	Setting range
	485 number	Link number		
O 0 1	601h	245( F5 h )	DIA function select	0 to 1 0 : Binary 1 : BCD
O 0 2	602h	246( F6 h )	DIB function select	0 to 1 0 : Binary 1 : BCD
O 0 3	603h	( h )	DIA BCD input speed setting	99 to <u>1000</u> to 7999
O 0 4	604h	( h )	DIB BCD input speed setting	99 to <u>1000</u> to 7999
O 0 5	605h	( h )	Pulse feedback select	0 to 1 0 : Build-in PG 1 : PG(PD) option
O 0 6	606h	( h )	Line speed detection (digital) (PG pulses)	100 to <u>1024</u> to 60000 (P/R)
O 0 7	607h	( h )	Line speed detection (digital) (Pulse correction function 1)	0 to <u>1000</u> to 9999
O 0 8	608h	( h )	Line speed detection (digital) (Pulse correction function 2)	0 to <u>1000</u> to 9999
O 0 9	609h	( h )	Definition of absolute PG signal input	0 to 16
O 1 0	60Ah	( h )	Magnetic pole position offset	<u>0000</u> to FFFF
O 1 1	60Bh	( h )	Salient pole ratio	1.000 to 3.000
O 1 2	60Ch	( h )	Pulse reference select	0 to 1 0 : PG(PR) option 1 : Internal input
O 1 3	60Dh	( h )	Pulse train input form selection	0 to 2 0 : Phase difference 90° between A-phase and B-phase 1 : A-phase : Reference pulse, B-phase : Reference sign 2 : A-phase : Forward pulse, B-phase : Reverse pulse
O 1 4	60Eh	247( F7 h )	Reference pulse correction 1	0 to <u>1000</u> to 9999
O 1 5	60Fh	248( F8 h )	Reference pulse correction 2	0 to <u>1000</u> to 9999
O 1 6	610h	249( F9 h )	APR P-gain	0.0 to <u>1.0</u> to 999.9 (times)
O 1 7	611h	250( FA h )	Feed forward gain	<u>0.0</u> to 1.5 (times)
O 1 8	612h	( h )	Deviation over width	0 to <u>65535</u> (pulse)
O 1 9	613h	( h )	Deviation zero width	0 to <u>20</u> to 1000 (pulse)
O 3 0	61Eh	( h )	Action on communication error	0 to 3 0 : Forced stop 1 : Stops after preset operation time. 2 : Stops if transmission error continues longer than the operation time. 3 : Continuous operation.
O 3 1	61Fh	( h )	LINK error (Timer)	0.01 to <u>0.10</u> to 20.00 s
O 3 2	620h	( h )	LINK format select	0 to 1 0 : 4W + 4W 1 : 8W + 8W
O 3 3	621h	253( FD h )	Multi-winding motor system (mode)	0 to 1 0 : Inactive 1 : Active
O 3 4	622h	( h )	Multi-winding motor system (Slave station number)	1 to 5 The numbers of slave units except master unit are set when multi-winding motor system is effective.
O 3 5	623h	( h )	Link station address	0 to 255
O 3 6	624h	( h )	Link system slave station	1 to 155
O 3 7	625h	( h )	Communication definition setting	00 to <u>10</u> to 24
O 3 8	626h	( h )	UPAC (Start/stop)	0 to 2 0 : Stop UPAC 1 : Start UPAC 2 : Start UPAC (Initialized start) Definition whether the instruction data from UPAC option is made active or inactive.

Underline indicates a factory setting.

Items without underline have different factory settings according to capacity.

Fcode	Communication address		Function name	Setting range
	485 number	Link number		
030	627h	( h)	UPAC memory	00 to 1F When the UPAC stop is changed, a pertinent field is set. 0 : Hold 1 : zero clear 1bit : IQ field 2bit : M field 3bit : RM field 4bit : FM field 5bit : SFM field
040	628h	( h)	UPAC address	100 to 255 Setting of UPAC address number in which RS485 communication is used when personal-computer accesses UPAC application.

Fcode	Communication address		Function name	Data setting range
	485 number	Link number		
U28	B1Ch	( h)	USER P28	-32768 to 32767
U29	B1Dh	( h)	USER P29	-32768 to 32767
U30	B1Eh	( h)	USER P30	-32768 to 32767
U31	B1Fh	( h)	USER P31	-32768 to 32767
U32	B20h	( h)	USER P32	-32768 to 32767
U33	B21h	( h)	USER P33	-32768 to 32767
U34	B22h	( h)	USER P34	-32768 to 32767
U35	B23h	( h)	USER P35	-32768 to 32767
U36	B24h	( h)	USER P36	-32768 to 32767
U37	B25h	( h)	USER P37	-32768 to 32767
U38	B26h	( h)	USER P38	-32768 to 32767
U39	B27h	( h)	USER P39	-32768 to 32767
U40	B28h	( h)	USER P40	-32768 to 32767
U41	B29h	( h)	USER P41	-32768 to 32767
U42	B2Ah	( h)	USER P42	-32768 to 32767
U43	B2Bh	( h)	USER P43	-32768 to 32767
U44	B2Ch	( h)	USER P44	-32768 to 32767
U45	B2Dh	( h)	USER P45	-32768 to 32767
U46	B2Eh	( h)	USER P46	-32768 to 32767
U47	B2Fh	( h)	USER P47	-32768 to 32767
U48	B30h	( h)	USER P48	-32768 to 32767
U49	B31h	( h)	USER P49	-32768 to 32767
U50	B32h	( h)	USER P50	-32768 to 32767
U51	B33h	( h)	USER P51	-32768 to 32767
U52	B34h	( h)	USER P52	-32768 to 32767
U53	B35h	( h)	USER P53	-32768 to 32767
U54	B36h	( h)	USER P54	-32768 to 32767
U55	B37h	( h)	USER P55	-32768 to 32767
U56	B38h	( h)	USER P56	-32768 to 32767
U57	B39h	( h)	USER P57	-32768 to 32767
U58	B3Ah	( h)	USER P58	-32768 to 32767
U59	B3Bh	( h)	USER P59	-32768 to 32767
U60	B3Ch	( h)	USER P60	-32768 to 32767
U61	B3Dh	( h)	USER P61	-32768 to 32767
U62	B3Eh	( h)	USER P62	-32768 to 32767
U63	B3Fh	( h)	USER P63	-32768 to 32767
U64	B40h	( h)	USER P64	-32768 to 32767

### L: Lift Function

Fcode	Communication address		Function name	Setting range
	485 number	Link number		
L01	901h	( h)	Password data 1	0 to 9999
L02	902h	( h)	Password data 2	0 to 9999
L03	903h	( h)	Lift rated speed	0.0 to <u>100.0</u> to 999.9 m/m
L04	904h	( h)	Preset S-curve (selection)	0 to 2 0 : Inactive <Normal accel/decel, S-curve (15 steps, S-curve 5)> 1 : Method 1 For VG3/VG5, accel/decel can be controlled via terminal 12 with SS1, SS2, and SS4 all OFF. 2 : Method 2 For VG7, zero speed is selected with SS1, SS2, and SS4 all OFF.
L05	905h	( h)	S-curve 1	0 to 50 %
L06	906h	( h)	S-curve 2	0 to 50 %
L07	907h	( h)	S-curve 3	0 to 50 %
L08	908h	( h)	S-curve 4	0 to 50 %
L09	909h	( h)	S-curve 5	0 to 50 %
L10	90Ah	( h)	S-curve 6	0 to 50 %
L11	90Bh	( h)	S-curve 7	0 to 50 %
L12	90Ch	( h)	S-curve 8	0 to 50 %
L13	90Dh	( h)	S-curve 9	0 to 50 %
L14	90Eh	( h)	S-curve 10	0 to 50 %
L15	90Fh	( h)	Maker	0 to 1

### U: User Functions

Fcode	Communication address		Function name	Setting range
	485 number	Link number		
U01	B01h	219( DB h)	USER P1	-32768 to 32767
U02	B02h	220( DC h)	USER P2	-32768 to 32767
U03	B03h	221( DD h)	USER P3	-32768 to 32767
U04	B04h	222( DE h)	USER P4	-32768 to 32767
U05	B05h	223( DF h)	USER P5	-32768 to 32767
U06	B06h	224( E0 h)	USER P6	-32768 to 32767
U07	B07h	225( E1 h)	USER P7	-32768 to 32767
U08	B08h	226( E2 h)	USER P8	-32768 to 32767
U09	B09h	227( E3 h)	USER P9	-32768 to 32767
U10	B0Ah	228( E4 h)	USER P10	-32768 to 32767
U11	B0Bh	( h)	USER P11	-32768 to 32767
U12	B0Ch	( h)	USER P12	-32768 to 32767
U13	B0Dh	( h)	USER P13	-32768 to 32767
U14	B0Eh	( h)	USER P14	-32768 to 32767
U15	B0Fh	( h)	USER P15	-32768 to 32767
U16	B10h	( h)	USER P16	-32768 to 32767
U17	B11h	( h)	USER P17	-32768 to 32767
U18	B12h	( h)	USER P18	-32768 to 32767
U19	B13h	( h)	USER P19	-32768 to 32767
U20	B14h	( h)	USER P20	-32768 to 32767
U21	B15h	( h)	USER P21	-32768 to 32767
U22	B16h	( h)	USER P22	-32768 to 32767
U23	B17h	( h)	USER P23	-32768 to 32767
U24	B18h	( h)	USER P24	-32768 to 32767
U25	B19h	( h)	USER P25	-32768 to 32767
U26	B1Ah	( h)	USER P26	-32768 to 32767
U27	B1Bh	( h)	USER P27	-32768 to 32767

You can change the setting of a function indicated by  during operation.  
You should stop operation to change the setting of other functions.

Function codes "S" and "M" are codes to access the inverter through links (RS485, T-Link, SX communication, field bus, etc). You cannot use them with the KEYPAD panel. Though you can access the codes "F" to "U" codes through these links, these links are specifically designed to access the code "S" for operation and control and the "M" for data monitoring.

Underline indicates a factory setting.  
Items without underline have different factory settings according to capacity.

Fcode	Communication address		Function name	Data setting range
	485 number	Link number		
M48	830h	62( 3E h)	Cooling fan life	0 to 65535 h
M49	831h	63( 3F h)	Speed setting 1 (before multistep speed command)	-24000 to 24000 r/min :(data)*Nmax/20000
M50	832h	64( 40 h)	Speed setting 2 (before calculation of accel/decel )	-24000 to 24000 r/min :(data)*Nmax/20000
M51	833h	65( 41 h)	Speed setting 3 (after speed limit)	-24000 to 24000 r/min :(data)*Nmax/20000
M52	834h	66( 42 h)	Control output 1	0000 to FFFF
M53	835h	67( 43 h)	Control output 2	0000 to FFFF
M54	836h	68( 44 h)	Control output 3	0000 to FFFF
M55	837h	69( 45 h)	Option monitor 1	0000 to FFFF
M56	838h	70( 46 h)	Option monitor 2	0000 to FFFF
M57	839h	71( 47 h)	Option monitor 3	0 to 65535
M58	83Ah	72( 48 h)	Option monitor 4	0 to 65535
M59	83Bh	73( 49 h)	Option monitor 5	-32768 to 32767
M60	83Ch	74( 4A h)	Option monitor 6	-32768 to 32767

### S: Serial Communication Functions

Fcode	Communication address		Function name	Data setting range
	485 number	Link number		
S01	701h	1( 1 h)	Frequency / speed reference (Setting 1)	-24000 to 24000 r/min :(data)*Nmax/20000
S02	702h	2( 2 h)	Torque reference	0.01% / 1d
S03	703h	3( 3 h)	Torque current reference	0.01% / 1d
S04	704h	4( 4 h)	Magnetic-flux reference	0.01% / 1d
S05	705h	5( 5 h)	Orientation position reference	0000 to FFFF
S06	706h	6( 6 h)	Operation method 1	0000 to FFFF
S07	707h	7( 7 h)	Universal Do	0000 to FFFF
S08	708h	8( 8 h)	Acceleration time	0.0 to 3600.0 s
S09	709h	9( 9 h)	Deceleration time	0.0 to 3600.0 s
S10	70Ah	10( A h)	Torque limiter level 1	0.01% / 1d
S11	70Bh	11( B h)	Torque limiter level 2	0.01% / 1d
S12	70Ch	12( C h)	Operation method 2	0000 to FFFF

### M: Monitoring Functions

Fcode	Communication address		Function name	Data setting range
	485 number	Link number		
M01	801h	15( F h)	Speed setting 4 (ASR input)	-24000 to 24000 r/min :(data)*Nmax/20000
M02	802h	16( 10 h)	Torque reference	0.01% / 1d
M03	803h	17( 11 h)	Torque current reference	0.01% / 1d
M04	804h	18( 12 h)	Magnetic-flux reference	0.01% / 1d
M05	805h	19( 13 h)	Output frequency reference	0.1Hz / 1d
M06	806h	20( 14 h)	Detected speed value	-24000 to 24000 r/min :(data)*Nmax/20000
M07	807h	21( 15 h)	Calculated torque value	0.01% / 1d
M08	808h	22( 16 h)	Calculated torque current value	0.01% / 1d
M09	809h	23( 17 h)	Output frequency	0.1Hz / 1d
M10	80Ah	24( 18 h)	Motor output	0.1kW / 1d
M11	80Bh	25( 19 h)	Output current rms value	0.1A / 1d
M12	80Ch	26( 1A h)	Output voltage rms value	0.1V / 1d
M13	80Dh	27( 1B h)	Operation method (final command)	0000 to FFFF
M14	80Eh	28( 1C h)	Operation status	0000 to FFFF
M15	80Fh	29( 1D h)	Output terminals Y1 - Y18	0000 to FFFF
M16	810h	30( 1E h)	Latest alarm data	0 to 48
M17	811h	31( 1F h)	Last alarm data	0 to 48
M18	812h	32( 20 h)	Second last alarm data	0 to 48
M19	813h	33( 21 h)	Third last alarm data	0 to 48
M20	814h	34( 22 h)	Accumulated operation time	0 to 65535 h
M21	815h	35( 23 h)	DC link circuit voltage	1V / 1d
M22	816h	36( 24 h)	Motor temperature	1 °C / 1d
M23	817h	37( 25 h)	Type code	0000 to FFFF
M24	818h	38( 26 h)	Capacity code	0 to 29
M25	819h	39( 27 h)	Inverter ROM (main control) version	0000 to FFFF
M26	81Ah	40( 28 h)	Communication error code	0 to 65535
M27	81Bh	41( 29 h)	Speed setting on alarm	-24000 to 24000 r/min :(data)*Nmax/20000
M28	81Ch	42( 2A h)	Torque reference on alarm	0.01% / 1d
M29	81Dh	43( 2B h)	Torque current reference on alarm	0.01% / 1d
M30	81Eh	44( 2C h)	Magnetic-flux reference on alarm	0.01% / 1d
M31	81Fh	45( 2D h)	Output frequency reference on alarm	0.1Hz / 1d
M32	820h	46( 2E h)	Detected speed on alarm	-24000 to 24000 r/min :(data)*Nmax/20000
M33	821h	47( 2F h)	Calculated torque on alarm	0.01% / 1d
M34	822h	48( 30 h)	Calculated torque current on alarm	0.01% / 1d
M35	823h	49( 31 h)	Output frequency on alarm	0.1Hz / 1d
M36	824h	50( 32 h)	Motor output on alarm	0.1kW / 1d
M37	825h	51( 33 h)	Output current rms value on alarm	0.1A / 1d
M38	826h	52( 34 h)	Output voltage rms value on alarm	0.1V / 1d
M39	827h	53( 35 h)	Operation method on alarm	0000 to FFFF
M40	828h	54( 36 h)	Operation status on alarm	0000 to FFFF
M41	829h	55( 37 h)	Output terminal on alarm	0000 to FFFF
M42	82Ah	56( 38 h)	Accumulated operation time on alarm	0 to 65535 h
M43	82Bh	57( 39 h)	DC link circuit voltage on alarm	0.1V / 1d
M44	82Ch	58( 3A h)	Inverter internal temperature on alarm	1 °C / 1d
M45	82Dh	59( 3B h)	Heat sink temperature on alarm	1 °C / 1d
M46	82Eh	60( 3C h)	Main circuit capacitor capacity	0 to 100 %
M47	82Fh	61( 3D h)	PC board capacitor life on alarm	0 to 65535 h

You can change the setting of a function indicated by  during operation. You should stop operation to change the setting of other functions.

## 6. List of Inverter Protective Functions

### WARNING

- The motor coasts when an alarm is issued. Install a brake on the driven machine side if you need to stop the motor.

#### An accident may occur.

- When you reset the inverter while applying the operation command, the motor restarts suddenly. Make sure the operation command is turned off before you restart.

Function	Description	Display	Related function code
DB resistor overheating	When the built-in braking resistor overheats, the inverter stops discharging and running. You must set the function codes E35 to 37 corresponding to the resistor (built-in/external).	d b H	E35 - 37
DC fuse blown	When a fuse at the main DC circuit blows due to a short-circuit in the IGBT circuit, the inverter stops operation. This function prevents secondary disaster. A damage to the inverter is suspected and contact FUJI immediately.	d C F	
Ground fault	Activated by a ground fault in the inverter output circuit. If a large current flows due to ground fault, the overcurrent protective function may operate to protect the inverter. Connect a separate earth-leakage protection relay or an earth-leakage circuit breaker for accident prevention such as human damage and fire.	E F	
Excessive position deviation	Activated when the position deviation between the reference and the detected values exceeds the function code o18 "Excessive deviation value" in synchronized operation. The option code "o" becomes valid and is displayed on the KEYPAD panel after installing options.	d 0	o18
Memory error	Activated when a fault such as "write error" occurs in the memory.	E r 1	
KEYPAD panel communication error	Activated if a communication error is detected between the inverter control circuit and the KEYPAD panel when the start/stop command from the KEYPAD is valid (function code F02=0). Note: KEYPAD panel communication errors do not indicate the alarm display and issue the alarm relay output when the inverter is operated by external signal input or the link function. The inverter continues operating.	E r 2	F02
CPU error	Activated when a CPU error occurs due to noise.	E r 3	
Network error	Activated if a communication error occurs due to noise when the inverter is operated through T- Link, SX bus or field bus.	E r 4	o30,31
RS485 communication error	Activated if: - RS485 communication error occurs while the function code H32 is set to 0 to 2. - A disconnection continues for more than the specified period of 0.1 to 60.0 with the function code H38.	E r 5	H32,H33 H38
Operation procedure error	Activated if multiple network options (T- Link, SX bus, and field bus) are installed. Though you can install multiple SI, DI and PG options, this error is issued if the two SW settings are identical. Activated when you use H01 and H71 to start auto-tuning while either [BX], [STOP1], [STOP2], or [STOP3] is ON. Activated when you do not turn ON the FWD key on the KEYPAD panel for more than 20 sec after you selected the auto-tuning operation of H01 and H71.	E r 6	
Output wiring error	Activated when the measured data are out of the motor characteristic data range during executing tuning or the wires are not connected in the inverter output circuit.	E r 7	H01,H71
A/D converter error	Activated when an error occurs in the A/D converter circuit.	E r 8	
Speed disagreement	Activated when the deviation between the speed reference (speed setting) and the motor speed (detected speed, predicted speed) becomes excessive.	E r 9	
UPAC error	Activated when a hardware failure in the UPAC option, a communication error with the controller part of the inverter or a backup battery exhaustion occurs.	E r R	

Function	Description	Display	Related function code
Inter-inverter communication error	Activated when a communication error occurs in an inter-inverter communication using the high-speed serial cards (optional).	Er b	
IPM error	Activated when the self cut-off function of the IPM operates due to an overcurrent or overheat.	IP E	
Input phase loss	The inverter is protected from being damaged due to input phase loss.	Li n	
Undervoltage	Activated if the DC link circuit voltage decreases to the undervoltage level due to a reduction in the supply voltage. The alarm output is not issued when the DC link circuit voltage decreases and the function code F14 is set to "3 to 5". ■ Undervoltage detection level: 200V series: 186Vdc, 400V series: 371Vdc.	LU	F14
NTC thermistor disconnection	Activated if the thermistor circuit is disconnected when the application of NTC thermistors to corresponding motors (M1, 2, 3) is specified with the function codes P30, A31 and A47.	n r b	P30,A31 A47
Overcurrent	Activated if the momentary value of the inverter output current exceeds the overcurrent detection level due to a short-circuit or ground fault. Inverters with a capacity of 15 kW use an IPM (Intelligent Power Module). This protection function is activated when an alarm (such as overcurrent) is detected on the IPM.	OC	
Overheating at heat sink	Activated if the temperature of the heat sink to cool the rectifier diodes and the IGBTs increases due to cooling fan stoppage.	OH 1	
External alarm	The inverter stops on receiving the external alarm signal (THR). It is activated by a terminal signal when the control circuit terminals (THR assignment) are connected to alarm terminals of external devices such as a braking unit or a braking resistor.	OH 2	E01 - E04
Inverter internal overheat	Activated if the ambient temperature of the control PC board increases due to poor ventilation of the inverter.	OH 3	
Motor overheat	Activated if the temperature detected by the NTC thermistor built in the VG7 dedicated motor exceeds the data of the function code E30 "Motor overheat protection".	OH 4	E30,E31
Motor 1 overload	Activated when the motor 1 current (inverter output current) exceeds the operation level set by function code F11.	OL 1	F11
Motor 2 overload	Activated when the motor 2 current (inverter output current) exceeds the operation level set by function code A33.	OL 2	A33
Motor 3 overload	Activated when the motor 3 current (inverter output current) exceeds the operation level set by function code A49.	OL 3	A49
Inverter unit overload	Activated if the output current exceeds the overload characteristic of the inverse time characteristic.	OLU	
Overspeed	Activated if the motor speed (detected speed value/predicted speed value) exceeds 120% of the specified value by the function code "maximum speed".	OS	F03,A06 A40
Overvoltage	Activated if the DC link circuit voltage exceeds the overvoltage level due to an increase of supply voltage or regenerative braking current from the motor. However, the inverter cannot be protected from excessive voltage (high voltage, for example) supplied by mistake. ■ Overvoltage detection level 200V series: 400Vdc, 400V series: 800Vdc	OU	
PG error	Activated when the pulse generator terminal PA/PB circuits are disconnected. It is not activated when the sensorless control or the V/f control is selected.	P g	
Charging circuit error	Activated if the bypass circuit of the DC link circuit is not formed (the magnetic contactor for the charging circuit bypass is not closed) two minutes after power is supplied.	P b F	

Note 1: All protective functions are reset automatically if the control power voltage decreases to where maintaining the operation of the inverter control circuit is impossible.

Note 2: Fault history data is stored for the last ten trips.

Note 3: Stoppage due to a protective function can be reset by the RST key of the KEYPAD or turning OFF and then ON between the X terminal (RST assigning) and the CM. Note that this action is invalid if the cause of an alarm is not found and resolved.

Note 4: In addition to these protective functions, there can be further protective from surge voltage by connecting surge suppressors to the main circuit power terminals (L1/R, L2/S, L3/T) and the auxiliary control power terminals (R0, T0).

## 7. Function Description (Arranged by Function)

### 7-1 If You Think Defective

#### WARNING

- After the inverter protective function was activated and you removed the cause, if you reset the alarm while the operation command has been set to ON, the inverter restarts. Reset the alarm after you confirm the operation command has been set to OFF.

**You may be injured.**

#### 7-1-1 If You Think Defective

An inverter may not operate as instructed while you think you specified the operation command and the speed reference properly or you may not reset the alarm to restart operation. Also an alarm may occur frequently to obstruct the operation of a facility.

If this is the case, use the KEYPAD panel to identify the cause of the malfunction or the alarm. If you still cannot identify the cause or you suspect an inverter fault or damaged parts, contact the shop you purchased the inverter or the FUJI's sales representative.

#### 7-1-2 What You Should Check First

This section describes how to use the KEYPAD panel to investigate causes though the protective function is not activated, but an inverter does not operate as instructed. Then the flowcharts illustrate the procedures.

##### (1) Is the inverter ready for operation?

It takes about one minute before an inverter becomes ready for operation after you turn on the main circuit. You can view the "CHARGE" lamp on the front of an inverter with 18.5kW or more capacity to confirm this state. Also you should use the "I/O check" screen of the KEYPAD panel to check if "■NUV" is displayed as shown in the right figure. This status indicates that the inverter is ready for operation.

If "□NUV" is displayed, the power may not be supplied to the inverter. Check the input power line to the main circuit.

When you do not use a DCR, you should connect a jumper wire between P1 and P(+ ) terminals. Check if the jumper wire is not disconnected.

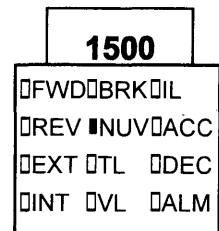

##### (2) Have you instructed an operation command?

Following the procedure described above to confirm that the inverter is ready.

When you direct the operation command (FWD), "RUN" must be displayed as in the right figure.

If the display remains "STOP", the inverter has not received your operation command.

When you enter the operation command from the KEYPAD panel, a green indicator RUN LED turns on.

You can see the indicator on the LCD monitor to check the available source of the operation command (LOC: KEYPAD panel, REM: External signal, and COMM: link).

You should change the function code F02 "Operation method" and H30 "Serial link" to change the source of the operation command.

If you have installed an option, you cannot use RS485 to enter the operation command (the option has higher priority). When you have several options, the priority may be fixed. See the description of applicable options.

When you use the UPAC, you should enter the operation command as well. See the description of the UPAC for more details.

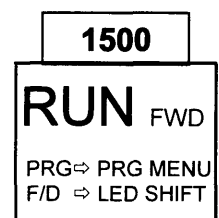

(3) Have you entered the speed reference?

Confirm the speed reference (N\*) on the "Operation monitor" when you have directed the speed reference by the KEYPAD panel, external analog input, or through the link (T-Link or RS485) or the UPAC. If the "N\*" is blank, the inverter has not received the speed reference.

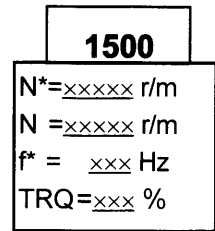

When you use the analog input [12] to provide the speed reference, you can check the voltage on the "I/O check" screen of the KEYPAD panel. Since the displayed voltage is the one the inverter recognizes, you can check the [12] input on this screen.

When you use the [12] and the value fluctuates, you can check if the analog reference itself fluctuates.

In the same manner, check the auxiliary speed reference supplied to the analog input Ai1 and Ai2.

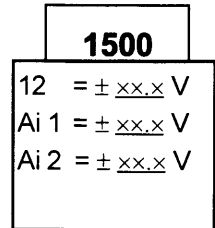

## 7-2 Checks Using Flowchart

### 7-2-1 Malfunctions not Followed by Alarms

(1) Vector control and sensorless vector control

1) Motor does not run.

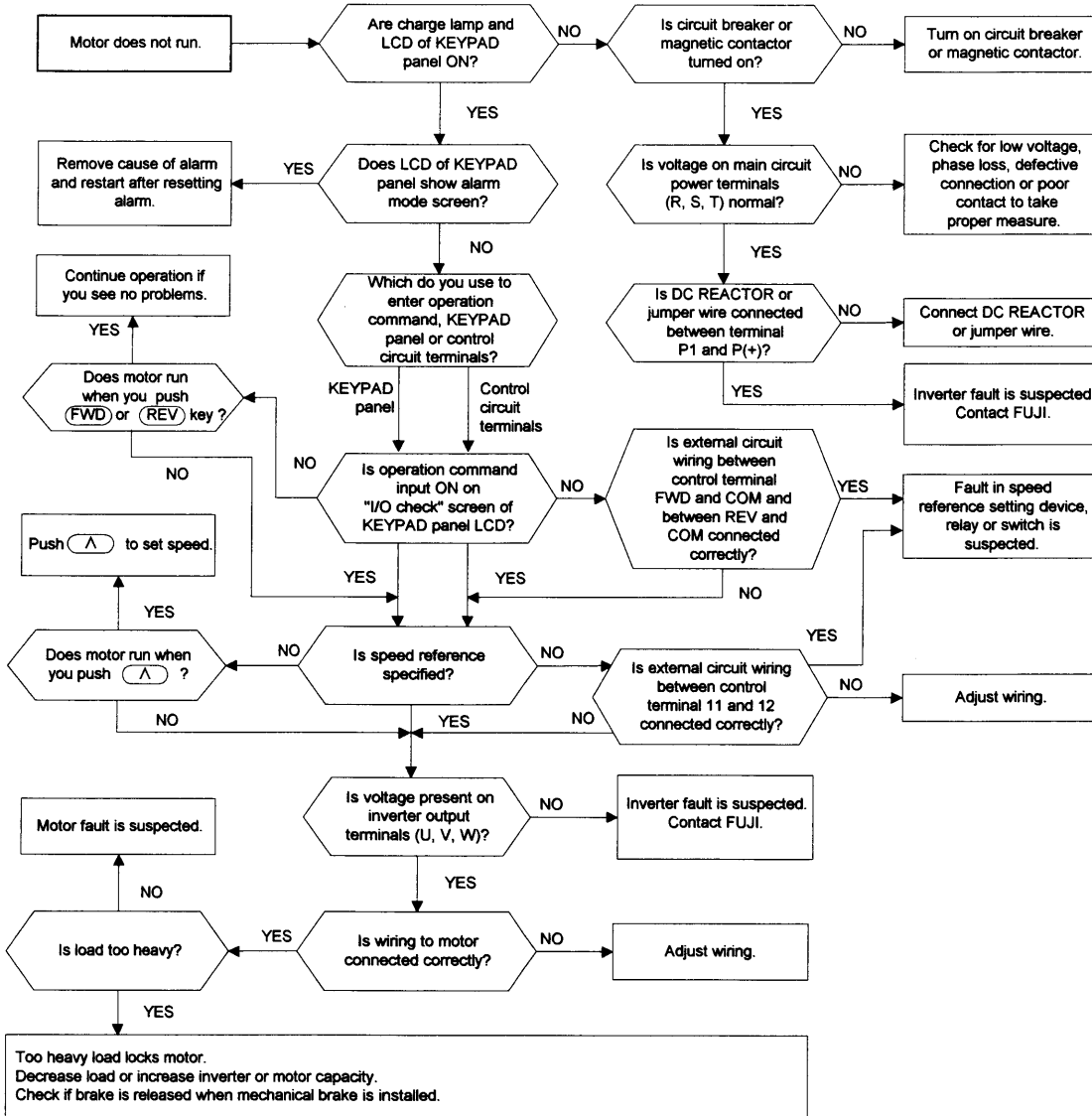

2) Motor runs but does not change speed

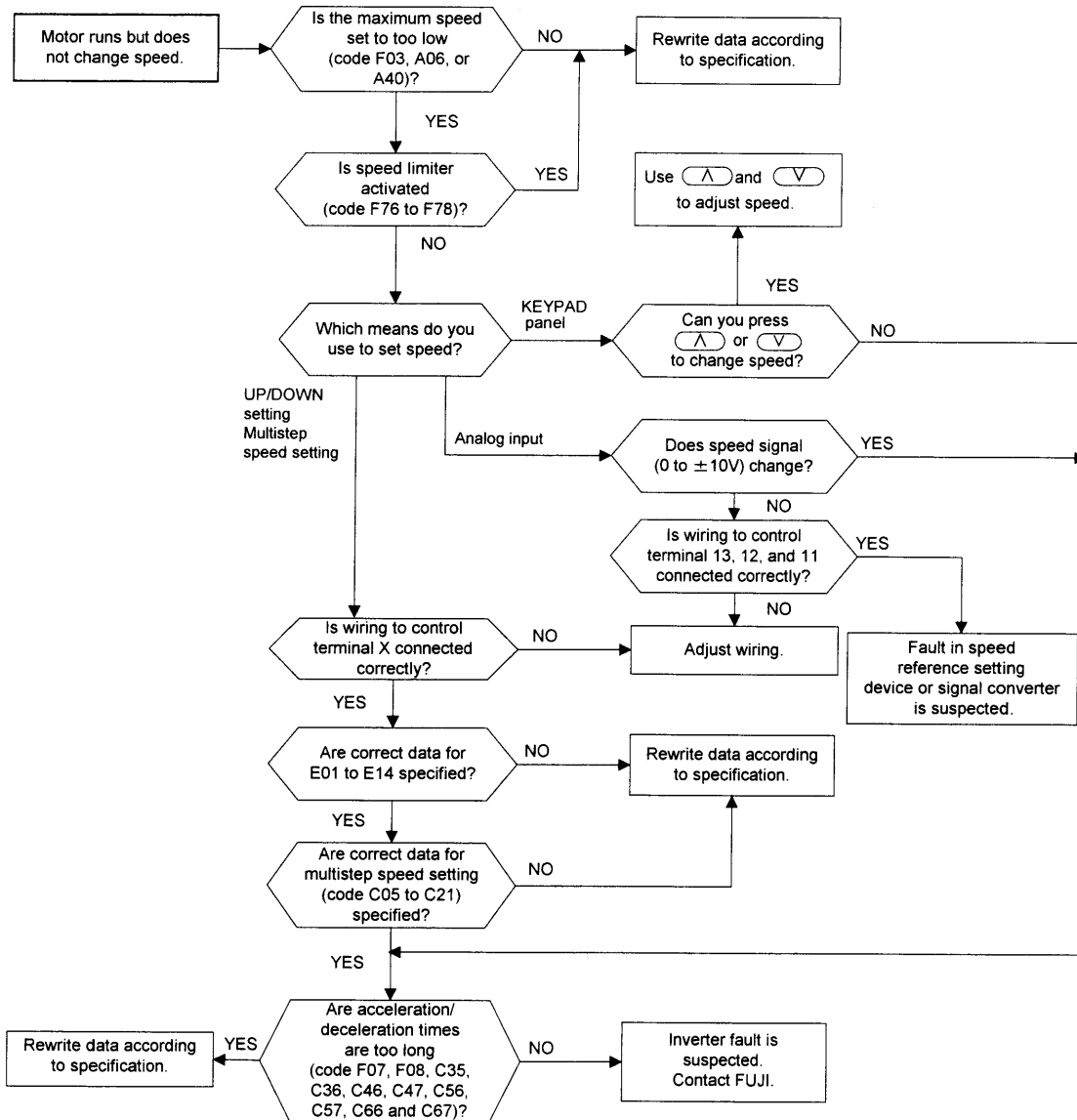

### 3) Motor runs only at low speed

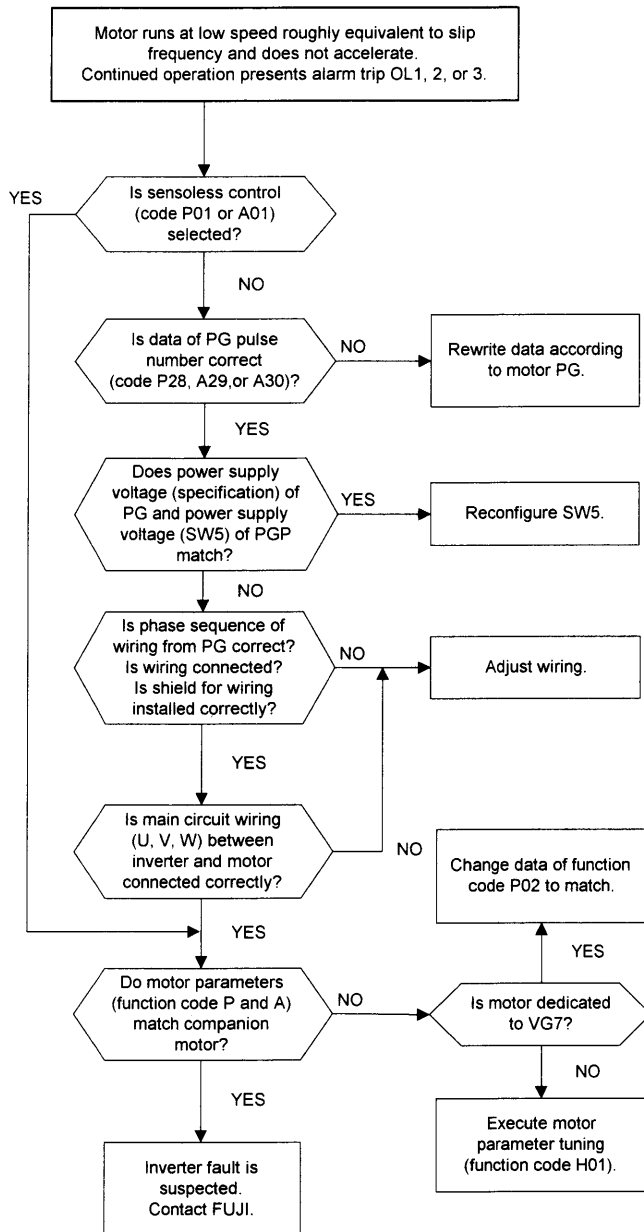

#### 4) Motor presents hunting

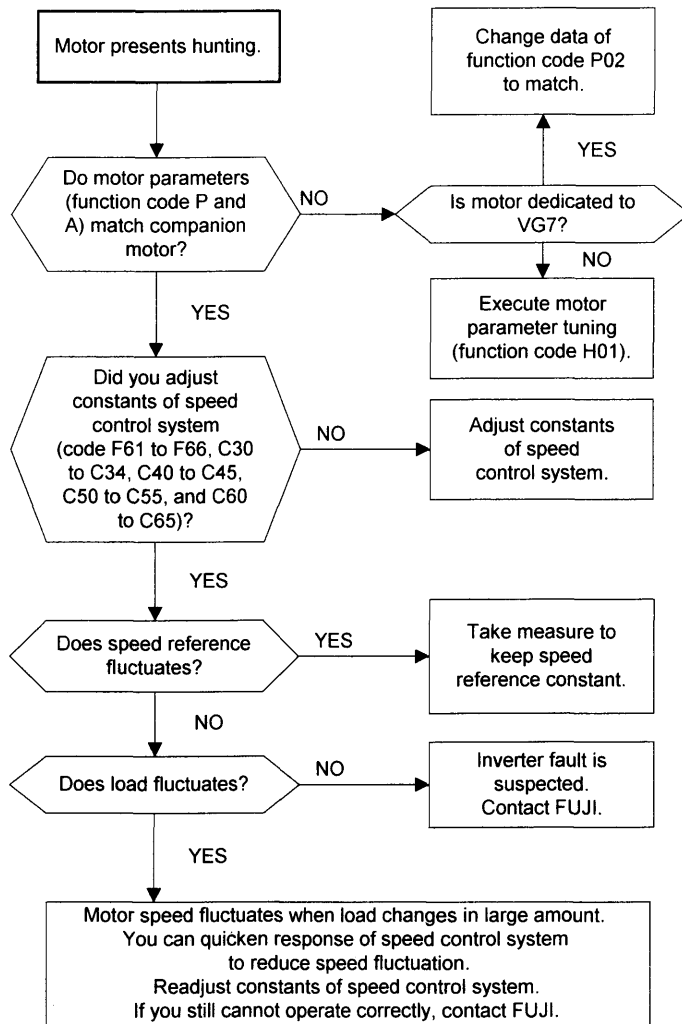

#### 5) Motor is unstable on acceleration/deceleration

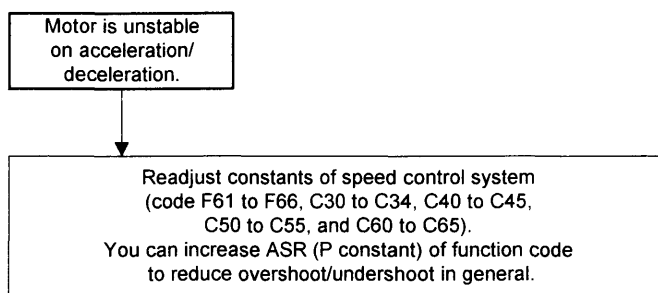

6) Motor generates abnormal heat

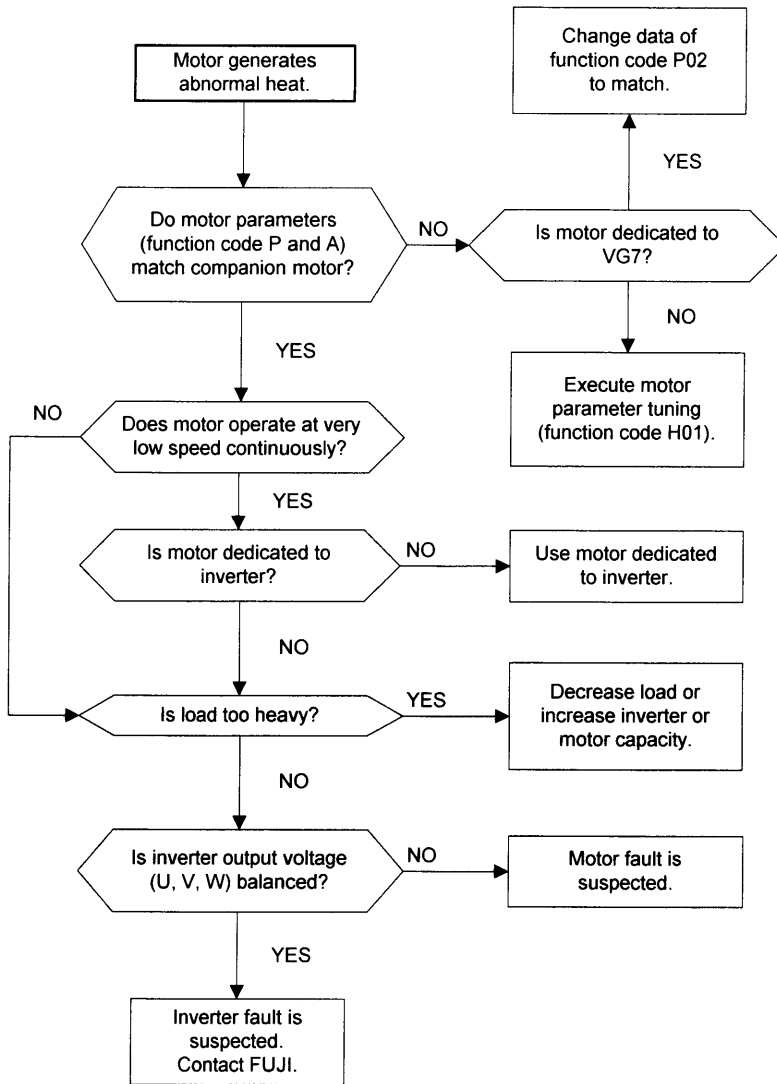

7) Motor runs inversely against direction reference

Phase sequence of main circuit wiring (U, V, W) between inverter and motor does not match in sensorless control.

Or, function data for speed reference are incorrect.

(2) V/f control  
 1) Motor does not run.

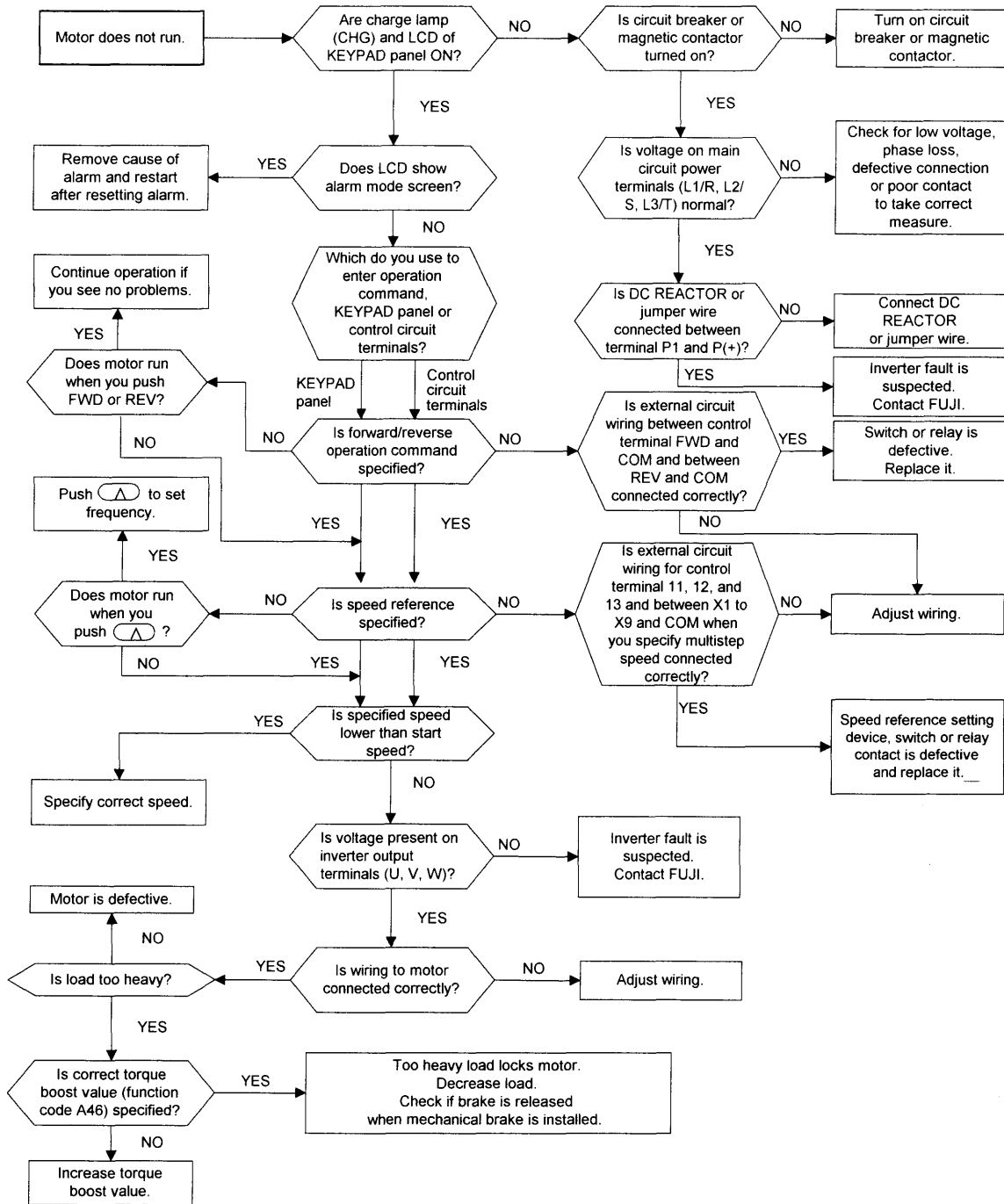

2) Motor runs but does not change speed

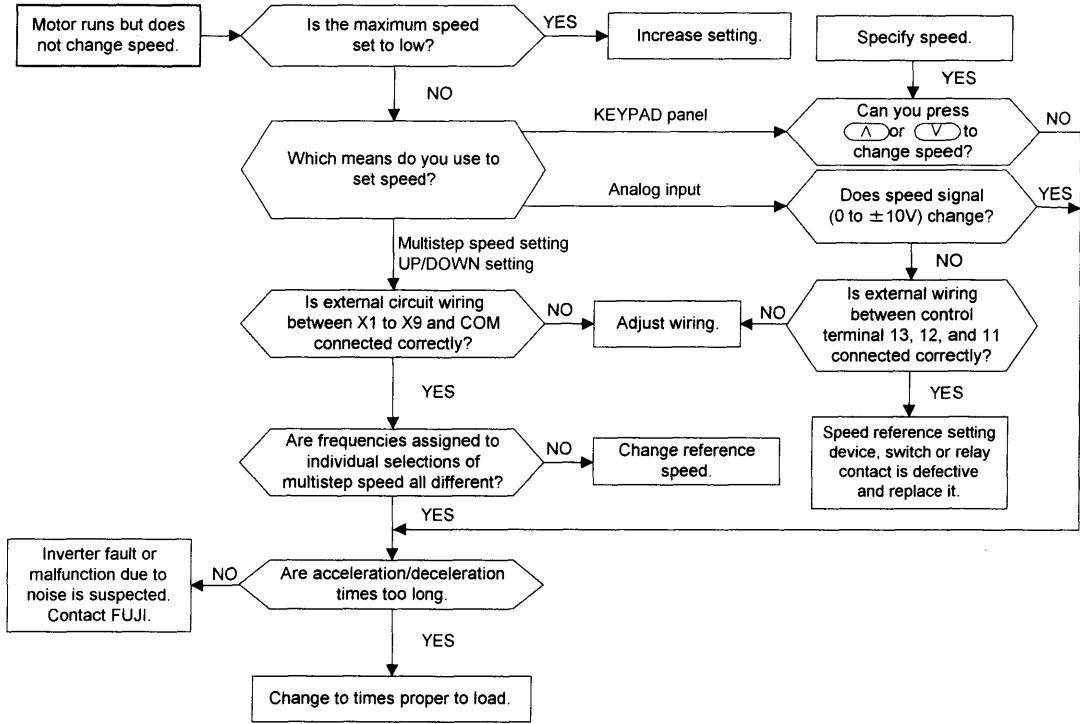

### 3) Motor stalls during acceleration

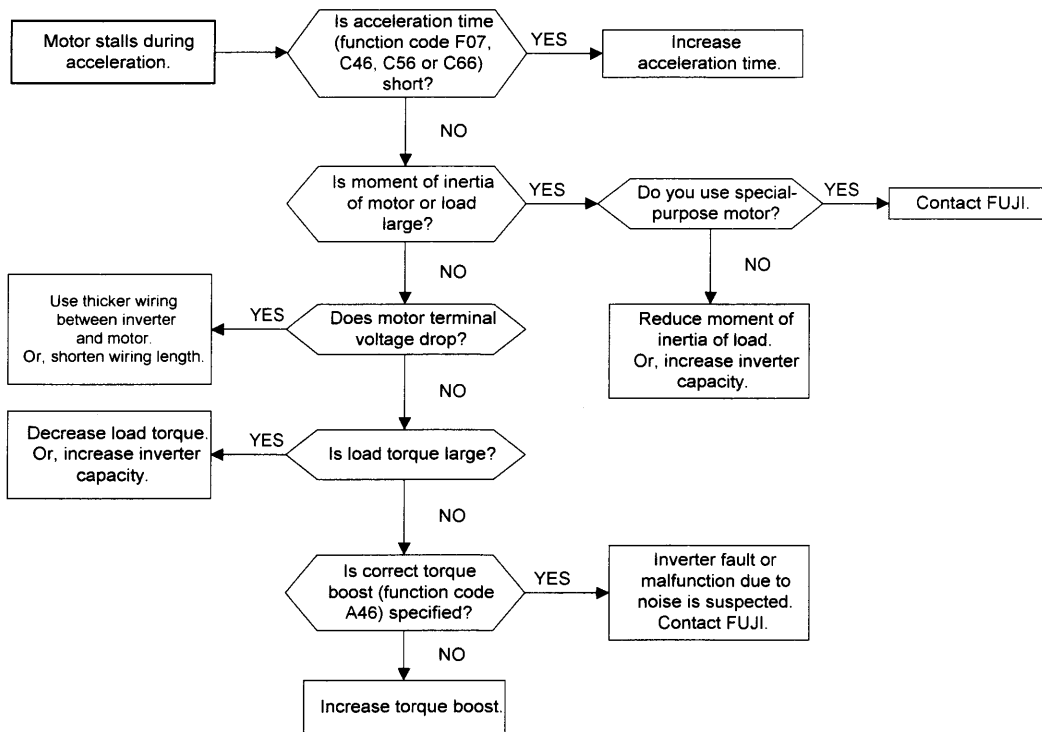

### 4) Motor generates abnormal heat

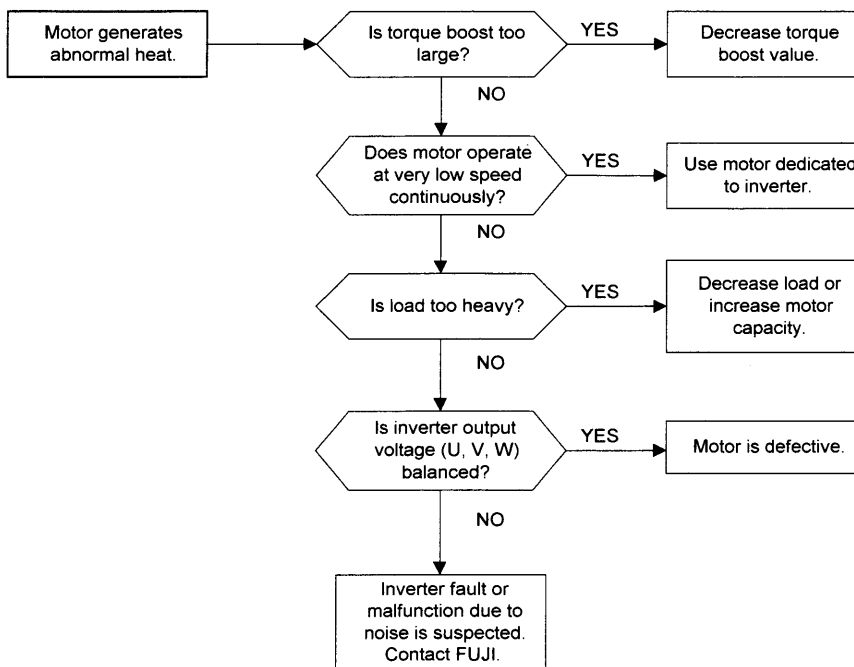

## 7-2-2 Malfunctions Followed by Alarms

### (1) Overcurrent

#### 1) Vector control and sensorless vector control

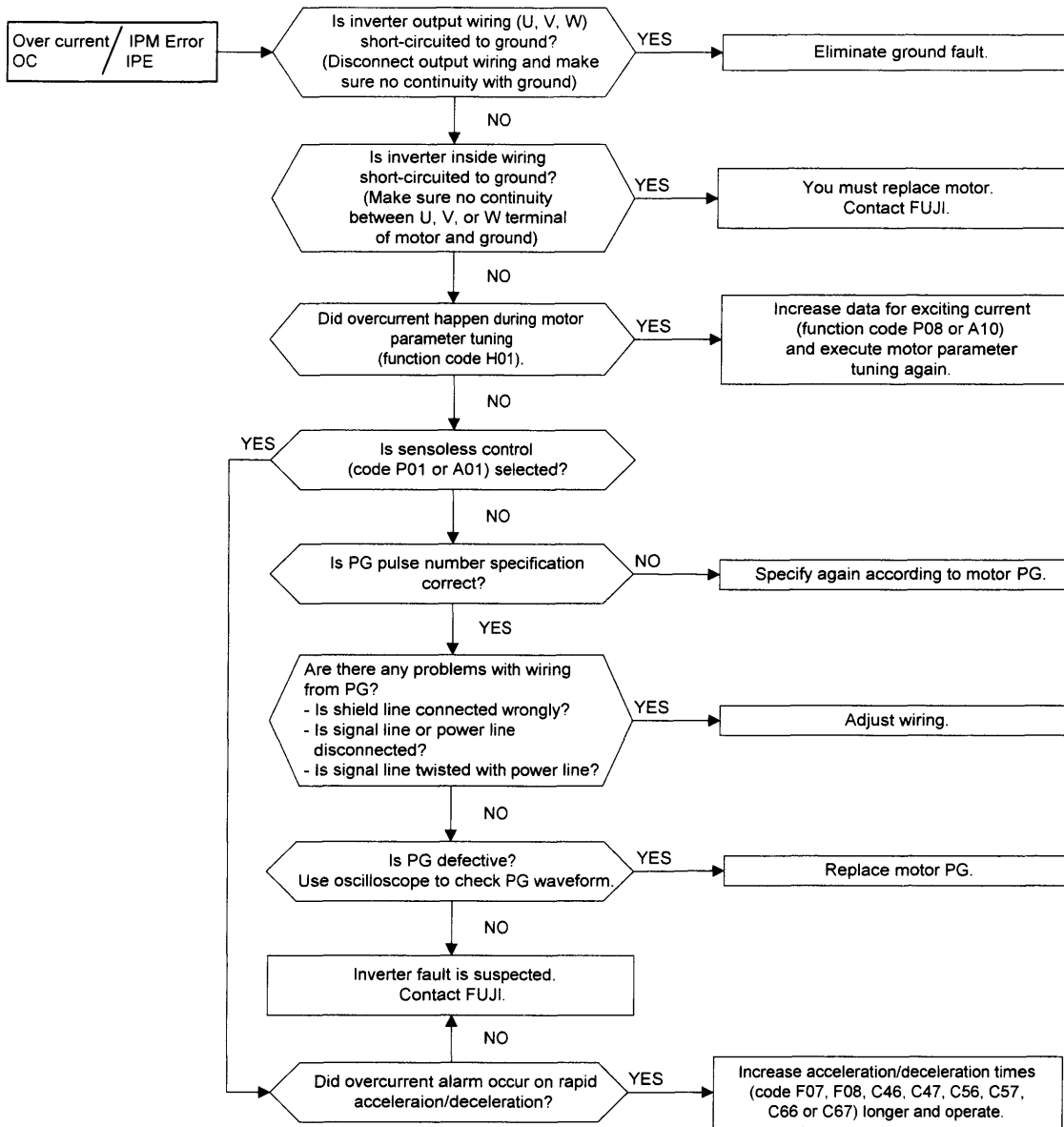

2) V/f control

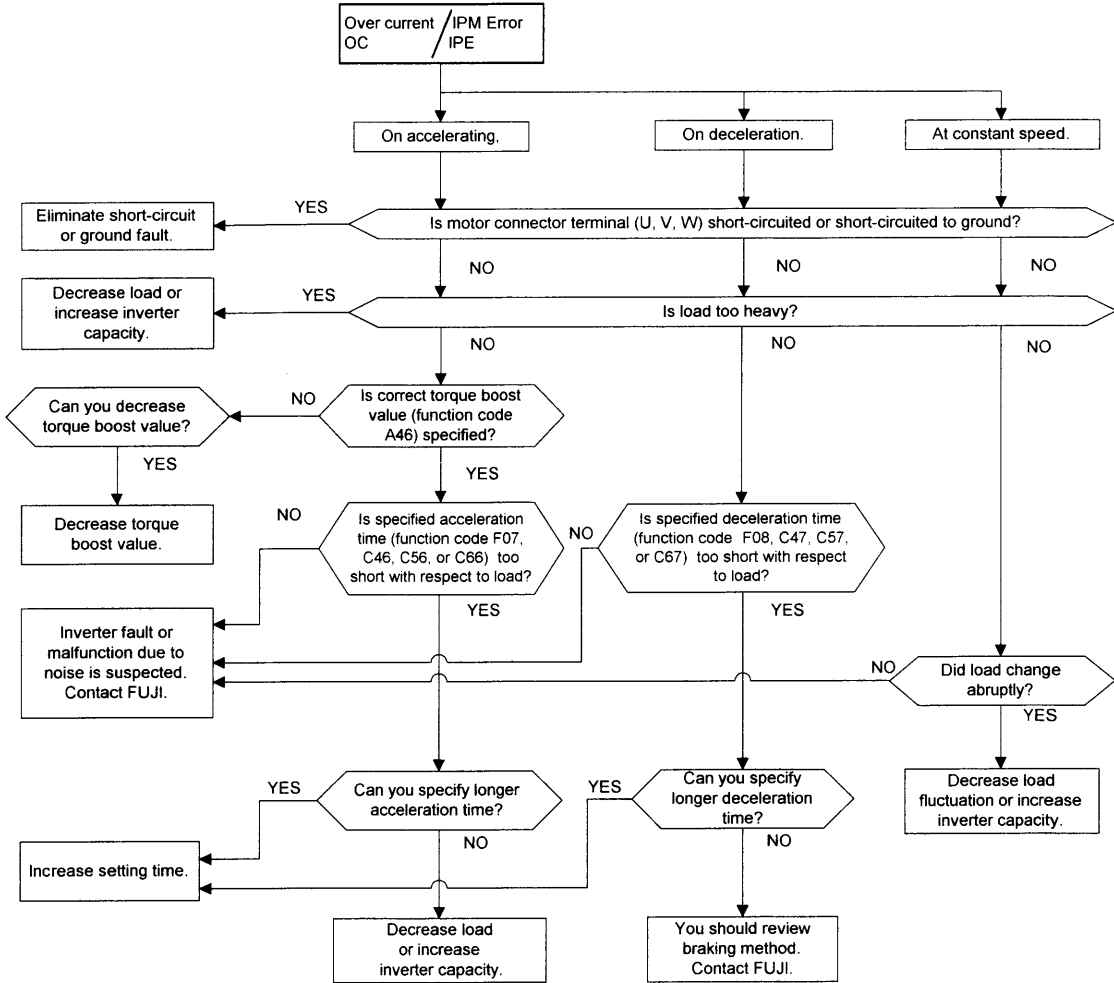

(2) Ground fault



**WARNING**

- Eliminate the cause before turn on the power.  
**You may start fire.**

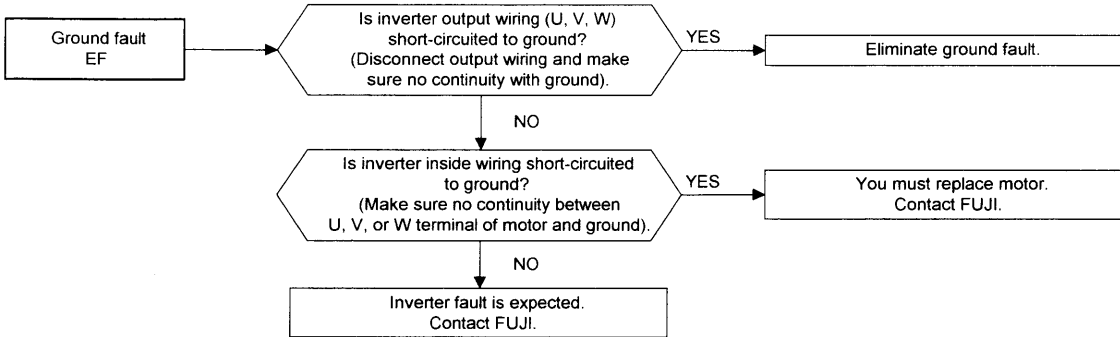

Note: The protective function from ground fault is installed on models of 18.5kW or more.

(3) Fuse blown



**WARNING**

- Replace inverter before turn on the power.  
**You may start fire.**

The fuse is provided to prevent a secondary disaster such as a fire. You cannot operate inverter with the fuse blown. When this alarm is issued, turn off the power immediately, identify the cause following the description below, and replace the inverter.

When this alarm is issued, do not turn on the power and contact us.

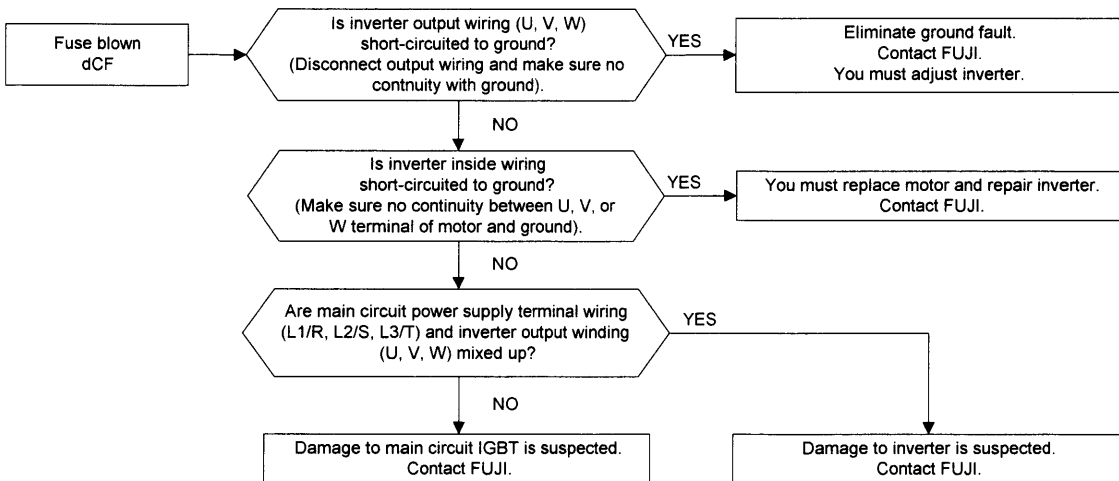

(4) Overvoltage

1) Vector control and sensorless vector control

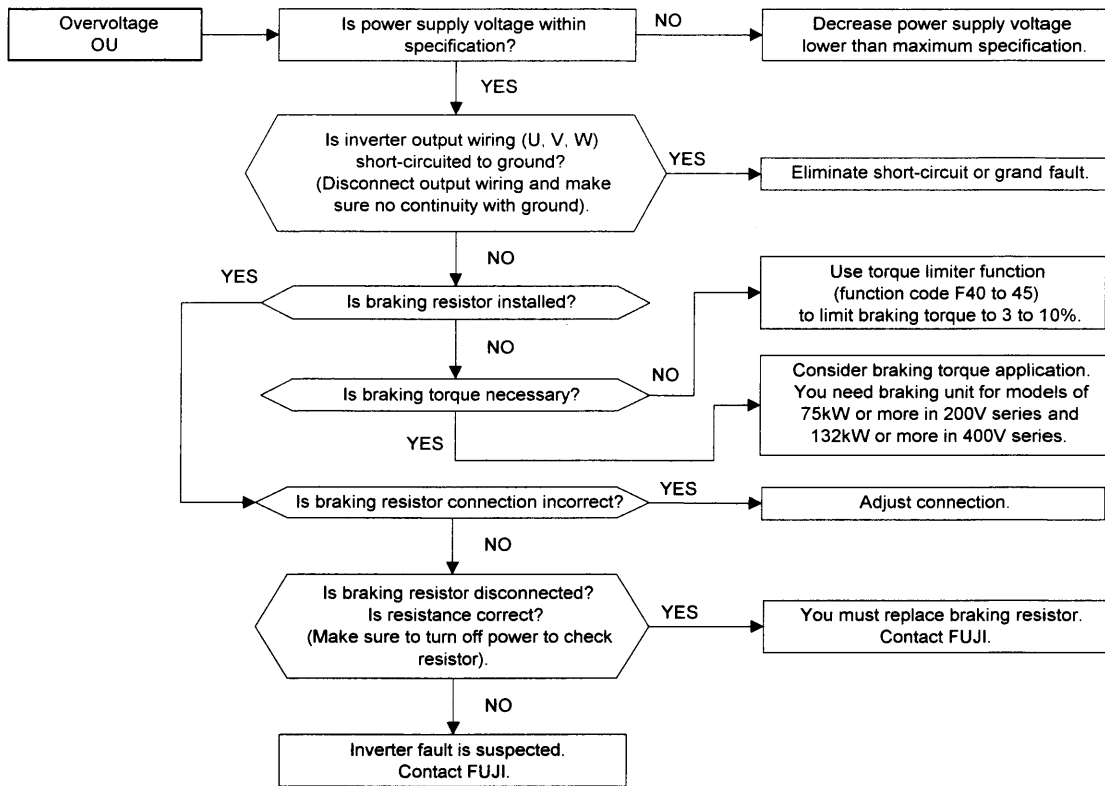

2) V/f control

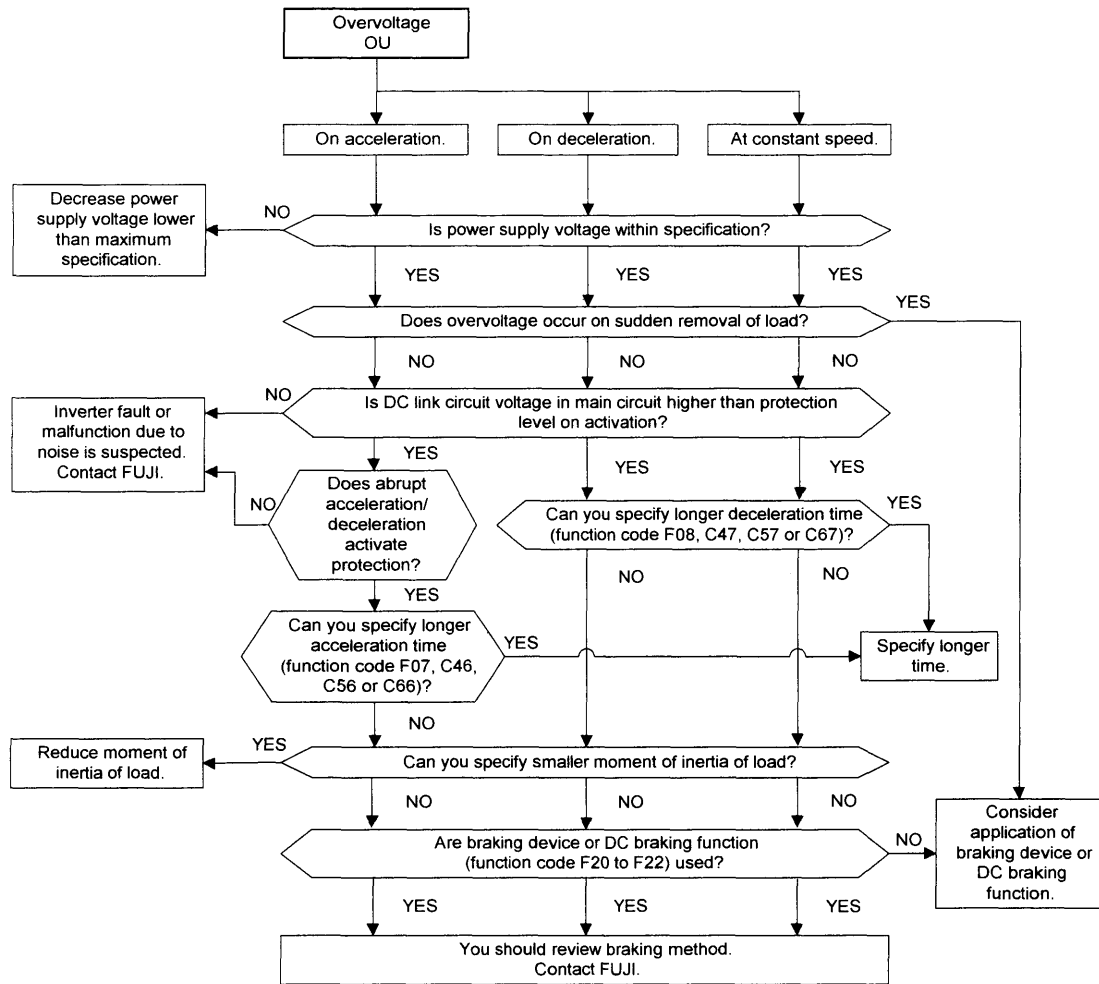

(5) Undervoltage

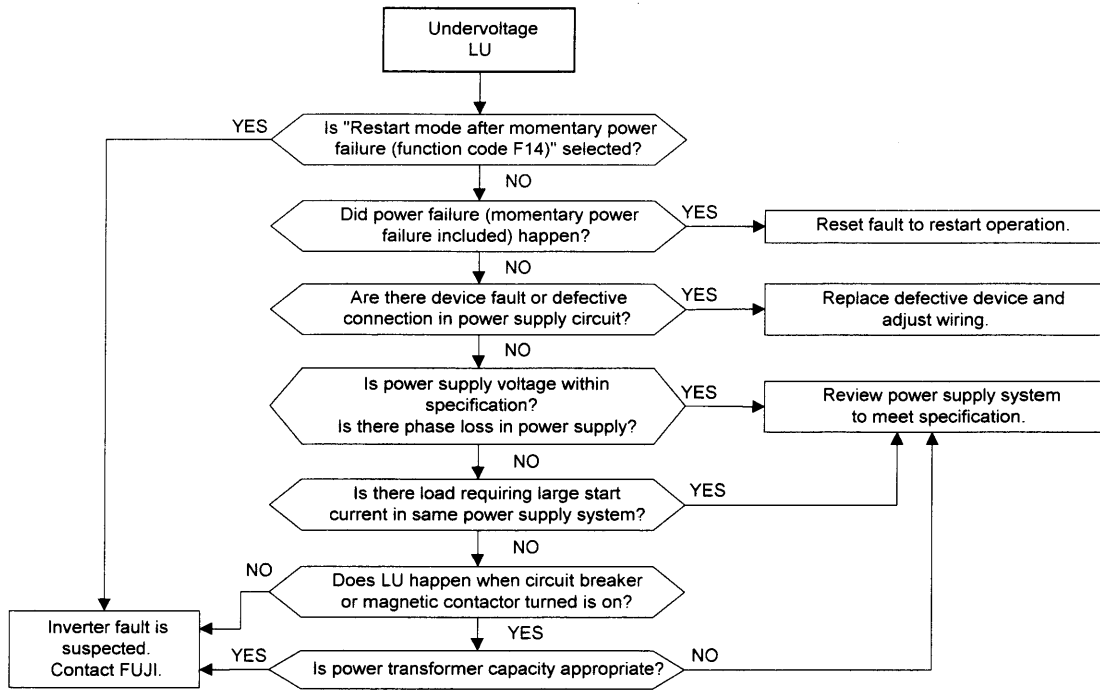

(6) Inverter internal overheat and overheating at heat sink



- Heatsink becomes very hot and do not touch it.  
**You may get burnt.**

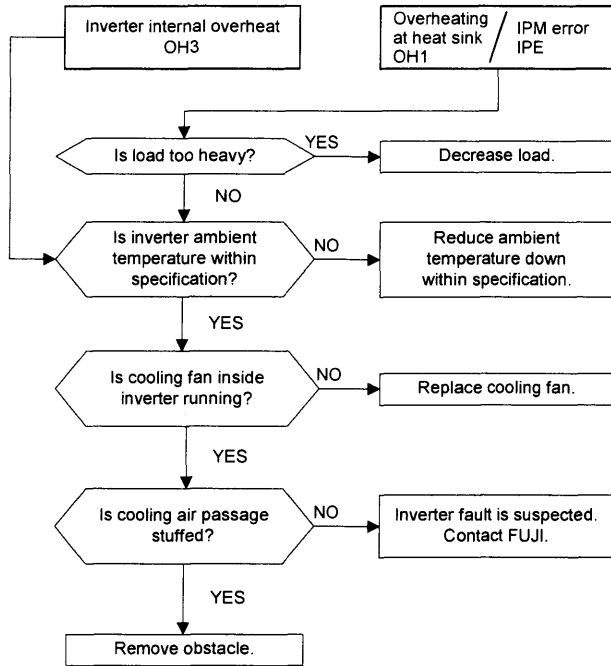

## (7) External alarm

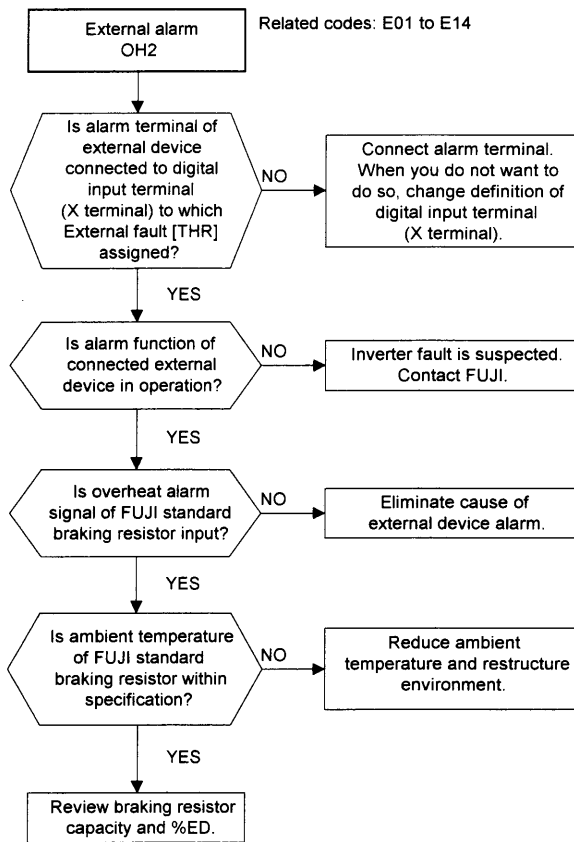

(8) Motor overheat

Related codes:  
E30, E31, E32, and P30

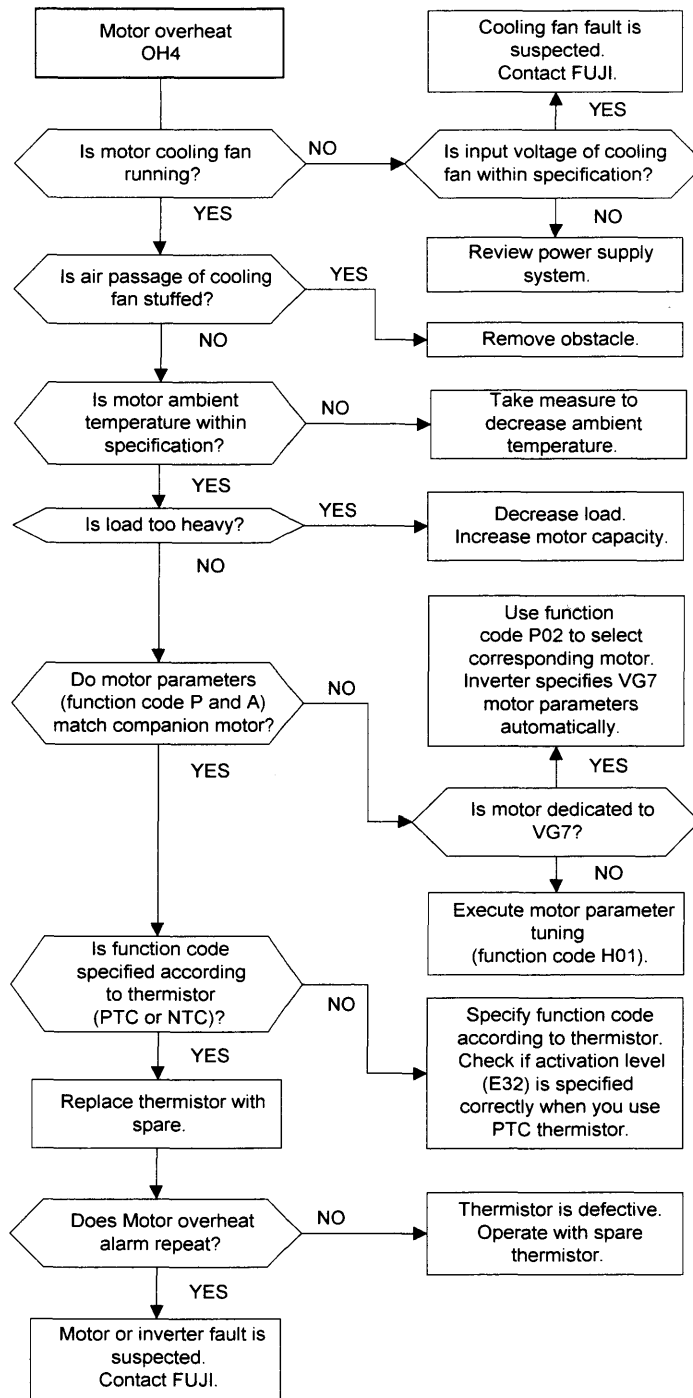

(9) Inverter overload and motor overload

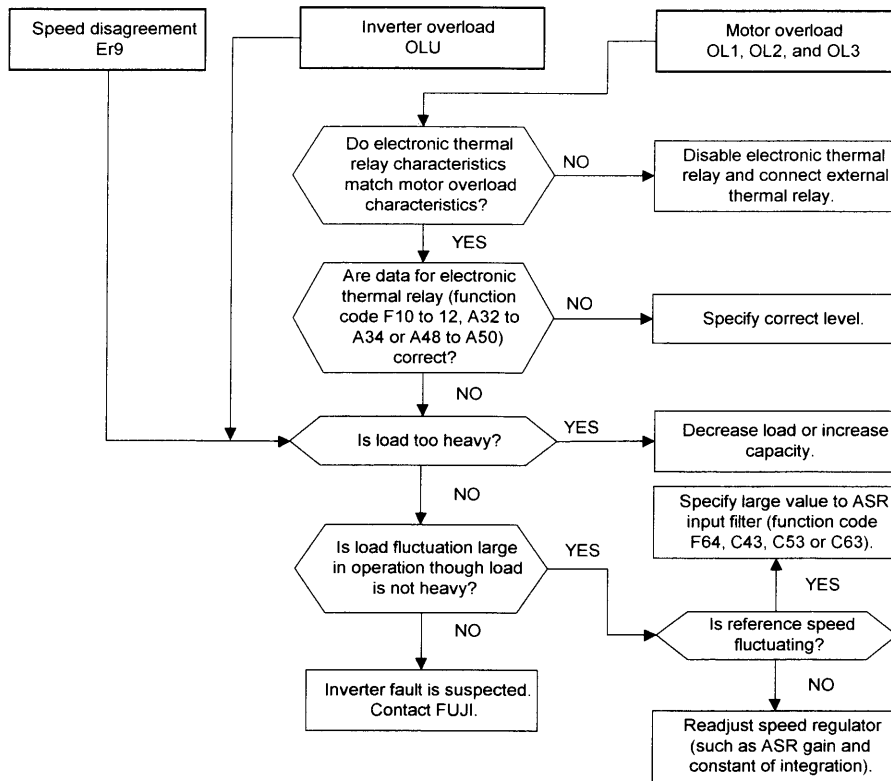

(10) PG error

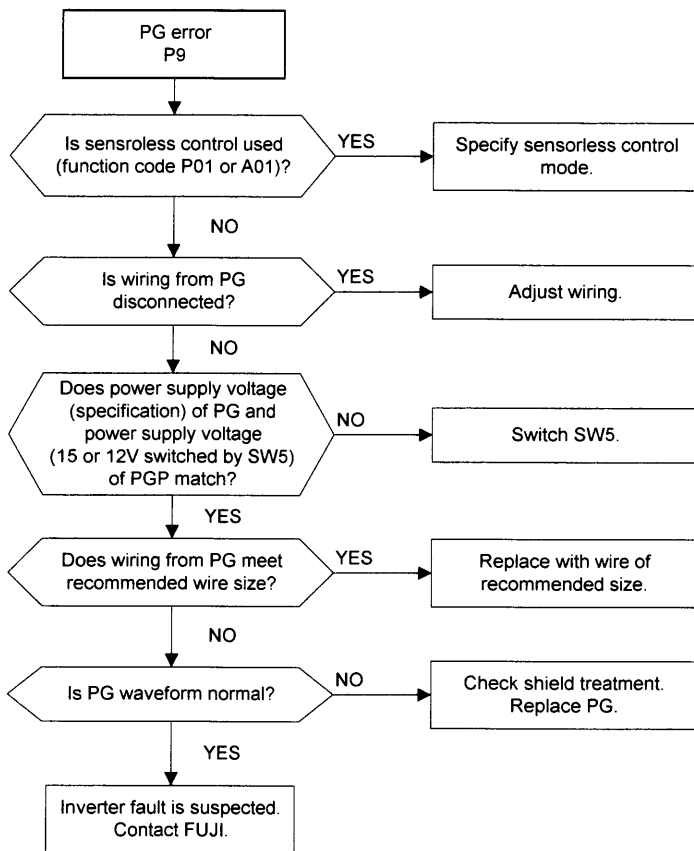

(11) Overspeed

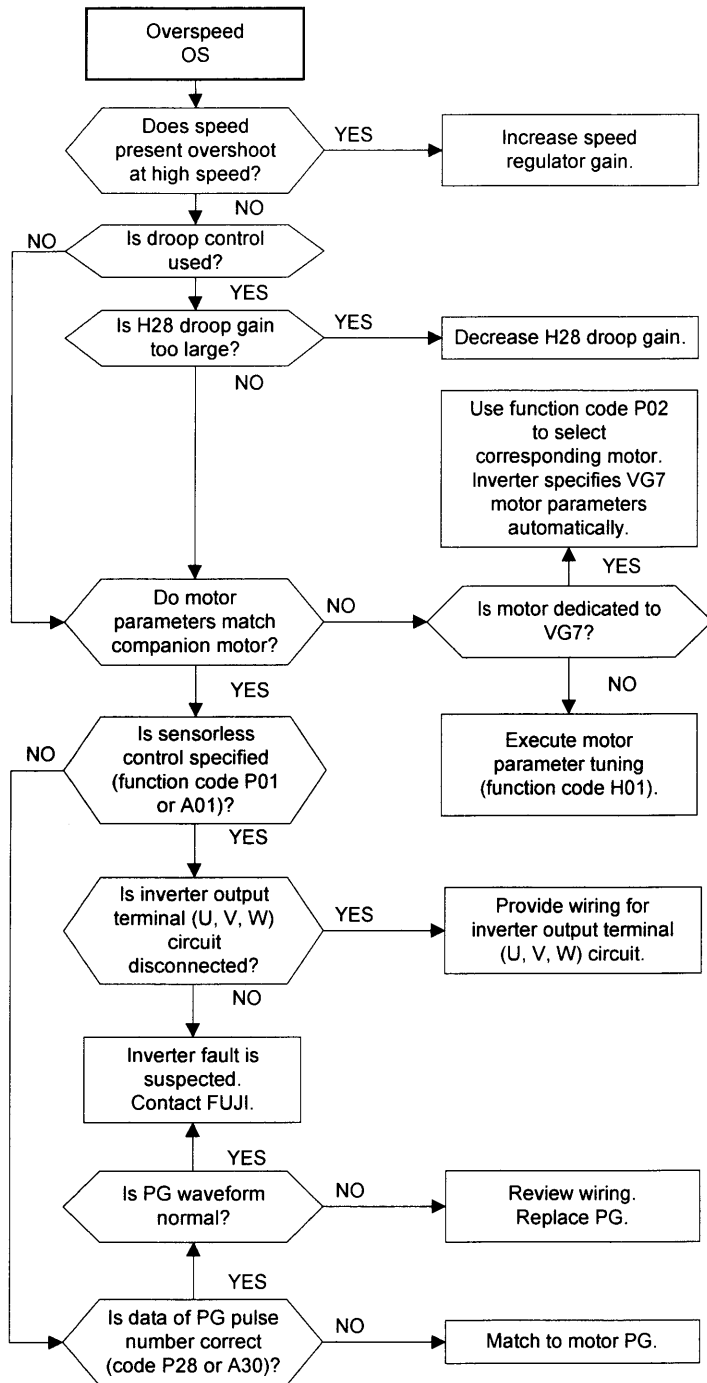

(12) NTC thermistor disconnection

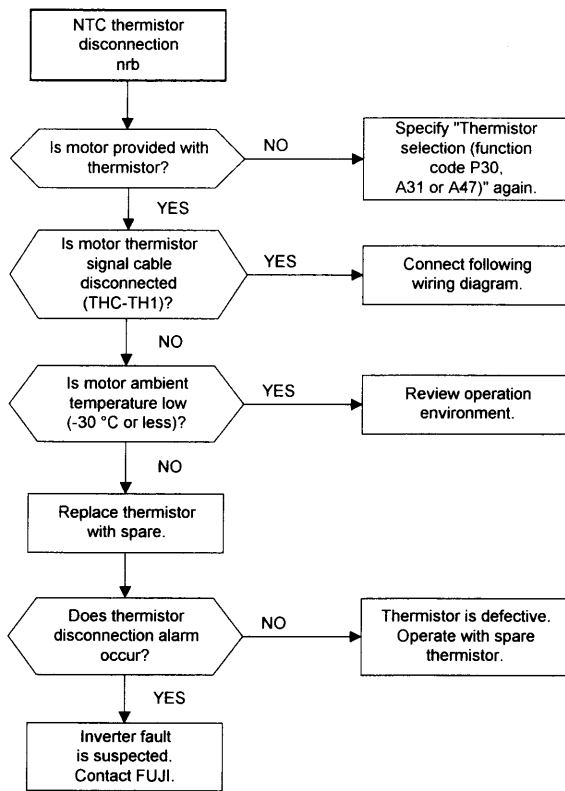

(13) Charging circuit error

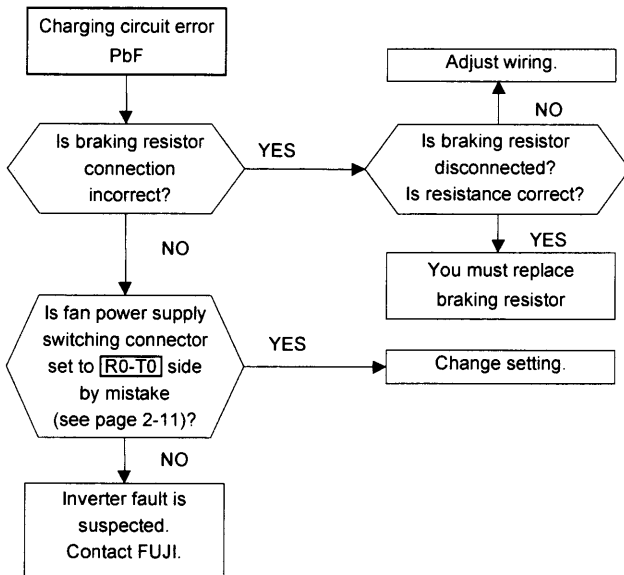

(14) Memory error (Er1)

Review the function data before you turn off the power when the memory error occurs. When the data are correct, the error is limited to data in the back up memory. Only if you can use "All save" to save data without reoccurrence of Memory error, you can operate the inverter. Check the printed circuit board visually for dusts.

When the function data are abnormal, or memory error occurs frequently while function data are normal, an inverter fault is suspected. Contact FUJI.

(15) KEYPAD panel communication error

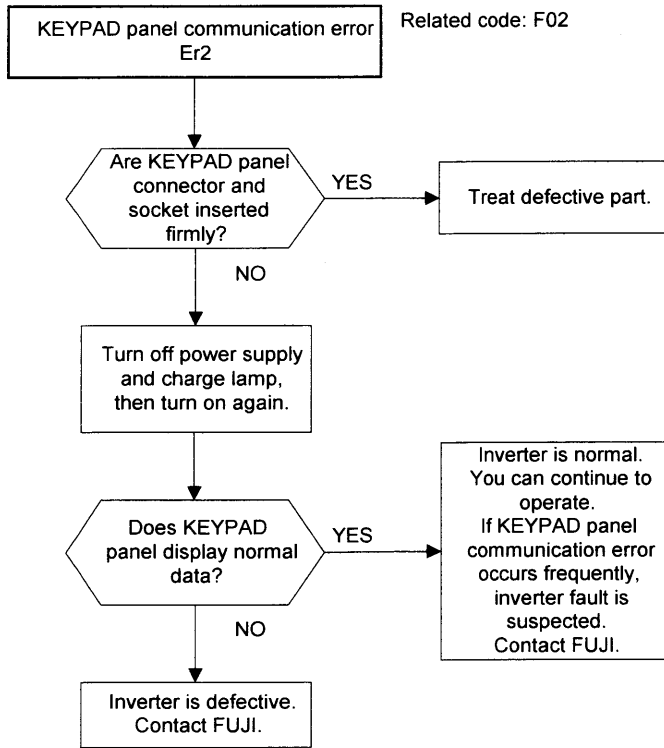

(16) CPU error and A/D converter error

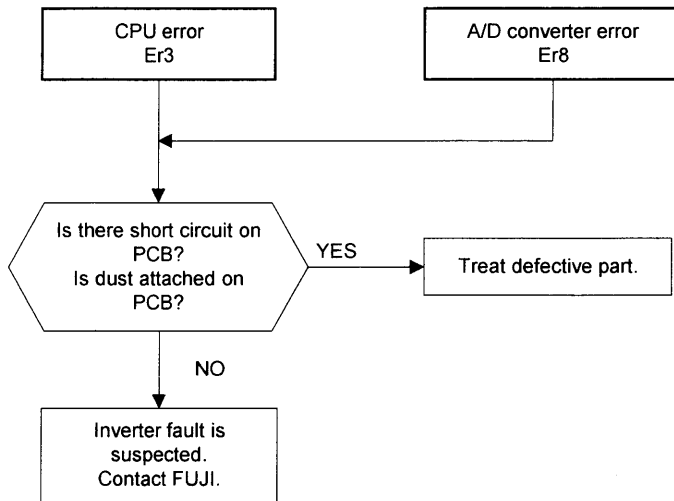

(17) Output wiring error

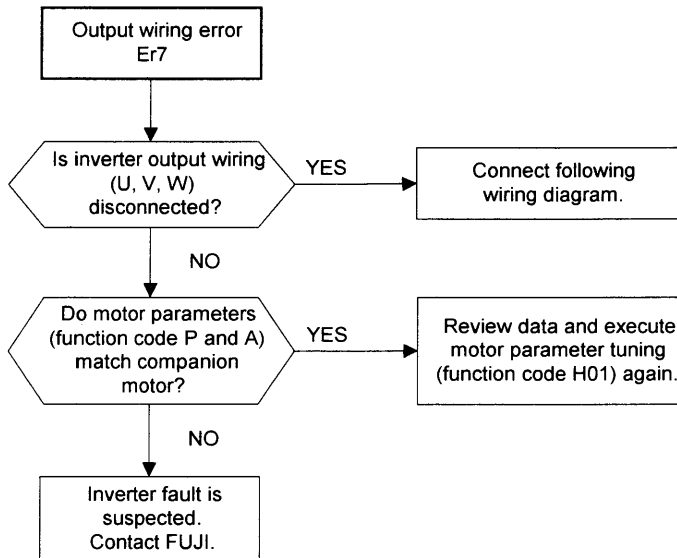

(18) RS485 communication error

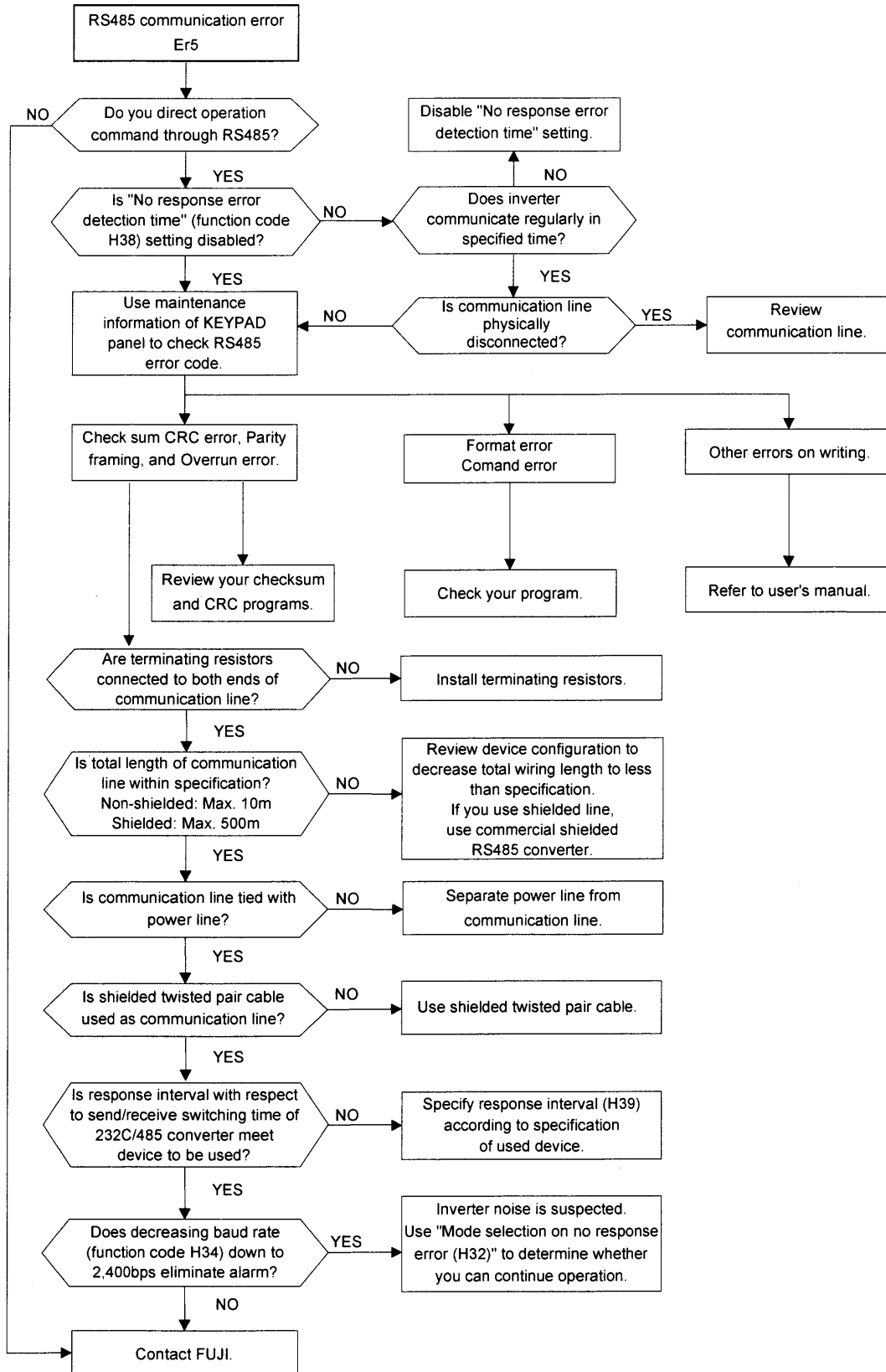

(19) Input phase loss



- Turn on the power after you eliminate faults.

**You may start fire.**

- You can change the setting for the function code E45 to 1\* to change the detection sensitivity of the input phase loss alarm. Change the parameter along with the application of the DC reactor (optional, standard for 75 kW or more models).

**You may damage your inverter if you set a wrong parameter.**

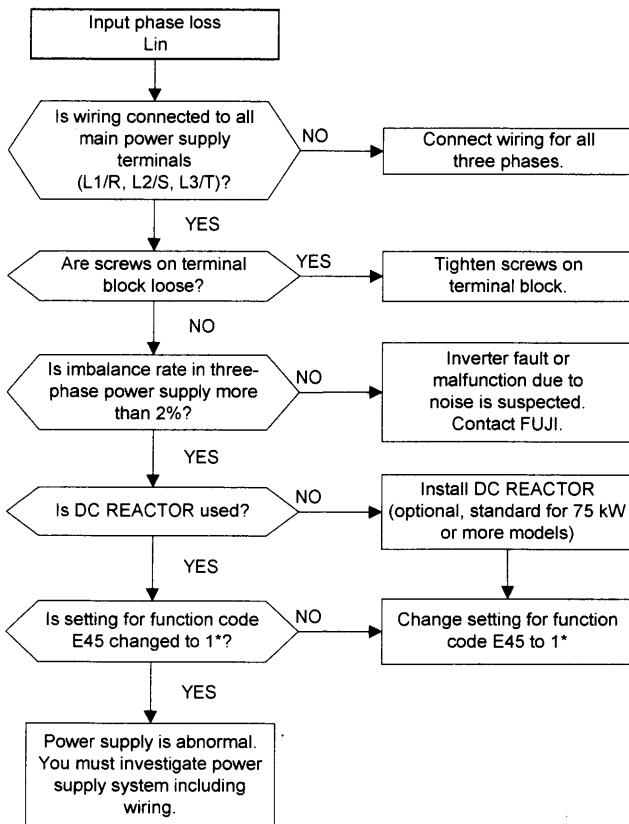

Note: Power supply voltage imbalance rate [%] =  $\frac{\text{Maximum voltage [V]} - \text{Minimum voltage [V]}}{\text{Three-phase average voltage [V]}} \times 67$

(20) DB resistor overheating

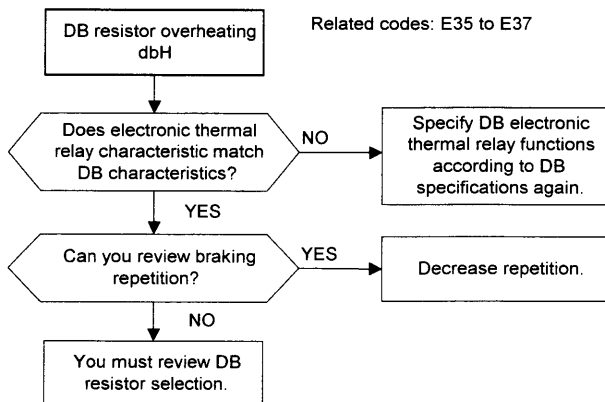

(21) Operation procedure error

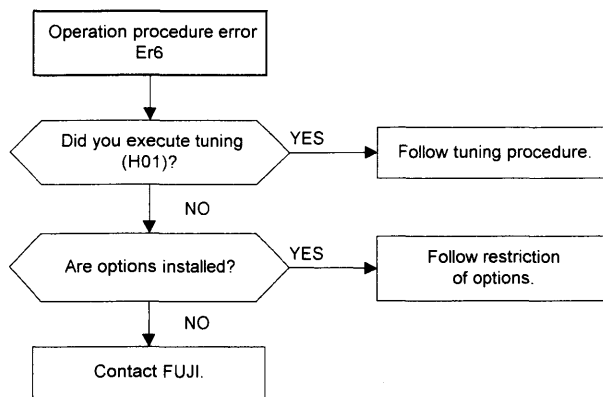

(22) Others

The following alarms are related to options. See User's Manual for details.

Er4 : Network error. When T-Link, SX bus or field bus option is installed.

ErA : UPAC error. When UPAC option is installed.

Erb : Inter-inverter communication error. When SI option is installed.

## 8. Maintenance and Inspection

Proceed with daily inspection and periodic inspection to prevent malfunction and ensure long-term reliability.  
Note the following:

### 8-1 Daily Inspection

During operation, a visual inspection for abnormal operation is completed externally without removing the covers

The inspections usually cover the following:

- (1) The performance (satisfying the standard specification) is as expected.
- (2) The environment satisfies standard specifications.
- (3) The KEYPAD panel display is normal.
- (4) There are no abnormal sounds, vibrations, or odors.
- (5) There are no indications of overheating or no discoloration.

### 8-2 Periodical Inspection

Periodic inspections must be completed after stopping operations, cutting off the power source, and removing the surface cover.

Note that after turning off the power, the smoothing capacitors in the DC section in the main circuit take time to discharge. To prevent electric shock, confirm using a multimeter that the voltage has dropped below the safety value (25V DC or below) after the charge lamp (CRG) goes off.

#### **WARNING**

- Start the inspection at least five minutes after turning off the power supply for inverter rated at 22kW or less, and ten minutes for inverter rated at 30kW or more. (Check that the charge lamp (CRG) goes off, and that the voltage is 25V DC or less between terminals P(+) and N(-).

#### **Electric shock may result.**

- Only authorized personnel should perform maintenance and component replacement operations.  
(Remove metal jewelry such as watches and rings.)  
(Use insulated tools.)  
Never modify the inverter.

#### **Electric shock or injury may result.**

For the replacement parts, contact your nearest service center.

Table 8-2-1 Periodical inspection list

Check parts	Check items	How to inspect	Evaluation Criteria
Environment	1) Check the ambient temperature, humidity, vibration, atmosphere (dust, gas, oil mist, water drops). 2) Is the area surrounding the equipment clear of foreign objects.	1) Conduct visual inspection and use the meter. 2) Visual inspection	1) The specified standard value must be satisfied. 2) The area is clear.
KEYPAD panel	1) Is the display hard to read? 2) Are the characters complete?	1),2) Visual inspection	1),2) The display can be read and is not abnormal.
Structure such as a frame or cover	1) Is there abnormal sound or vibration? 2) Are nuts or bolts loose? 3) Is there deformation or damage? 4) Is there discoloration as a result of overheating? 5) Are there stains or dust?	1) Visual and aural inspection 2) Tighten. 3),4),5) Visual inspection	1),2),3),4),5) Not abnormal
Main circuit	Common	1) Tighten. 2),3) Visual inspection	1),2),3) Not abnormal Note: Discoloration of the bus bar does not indicate a problem.
	Conductor and wire	1),2) Visual inspection	1),2) Not abnormal
	Terminal block	Visual inspection	Not abnormal
	Smoothing capacitor	1),2) Visual inspection 3) * Estimate life expectancy from maintenance information and from measurements using capacitance measuring equipment.	1),2) Not abnormal 3) Capacitance $\geq$ initial value x 0.85
	Resistor	1) Visual and olfactory inspection 2) Conduct a visual inspection or use a multimeter by removing the connection on one side.	1) Not abnormal 2) Less than about $\pm 10\%$ of the indicated resistance value
	Transformer and reactor	Aural, olfactory, and visual inspection	Not abnormal
	Magnetic conductor and relay	1) Aural inspection 2) Visual inspection	1),2) Not abnormal
Control circuit	Control PC board and connector	1) Tighten. 2) Visual and olfactory inspection 3) Visual inspection 4) * Estimate life expectancy by visual inspection and maintenance information	1),2),3),4) Not abnormal
Cooling system	Cooling fan	1) Aural and visual inspection. Turn manually (confirm the power is off). 2) Tighten. 3) Visual inspection 4) * Estimate life expectancy by maintenance information	1) The fan must rotate smoothly. 2),3) Not abnormal
	Ventilation	Visual inspection	Not abnormal

Note: If equipment is stained, wipe with a clean cloth. Vacuum the dust.

\* Estimation of life expectancy based on maintenance information

The maintenance information is stored in the inverter KEYPAD panel and indicates the electrostatic capacitance of the main circuit capacitors and the life expectancy of the electrolytic capacitors on the control PC board and of the cooling fans. Use this data as the basis to estimate the life expectancy of parts.

1) Determination of the capacitance of the main circuit capacitors

This inverter is equipped with a function to automatically indicate the capacitance of the capacitors installed in the main circuit when powering up the inverter again after disconnecting the power according to the prescribed conditions.

The initial capacitance values are set in the inverter when shipped from the factory, and the decrease ratio (%) to those values can be displayed.

Use this function as follows:

- (1) Remove any optional cards from the inverter. Also disconnect the DC bus connections to the main circuit P(+) and N(-) terminals from the braking unit or other inverters if connected. The existing power-factor correcting reactor (DC reactor) need not be disconnected. A power supply introduced to the auxiliary input terminals (R0, T0) that provides control power should be isolated.
- (2) Disable all the digital inputs (FWD, REV, X1-X9) on the control terminals. Also disconnect RS485 communication if used. Turn on the main power supply. Confirm that the cooling fan is rotating and that the inverter is not operating. (There is no problem if the "OH2 External thermal relay tripped" trip function is activated due to the digital input terminal setting off.)
- (3) Turn the main power off.
- (4) Turn on the main power again after verifying that the charge lamp is completely off.
- (5) Open the maintenance information on the KEYPAD panel and confirm the capacitance values of the built-in capacitors.

2) Life expectancy of the control PC board

The actual capacitance of a capacitor is not measured in this case. However, the integrated operating hours of the control power supply multiplied by the life expectancy coefficient defined by the temperature inside the inverter will be displayed. Hence, the hours displayed may not agree with the actual operating hours depending on the operational environment.

Since the integrated hours are counted by unit hours, power input for less than one hour will be disregarded.

3) Life expectancy of cooling fan

The integrated operating hours of the cooling fan are displayed. Since the integrated hours are counted by unit hours, power input for less than one hour will be disregarded.

The displayed value should be considered as a rough estimate because the actual life of a cooling fan is influenced significantly by the temperature.

Table 8-2-2 Rough estimate of life expectancy using maintenance information

Parts	Level of judgment
Capacitor in main circuit	85% or less of the initial value
Electrolytic capacitor on control PC board	61,000hours
Cooling fan	25,000hours (*1)

\*1 Estimated life expectancy of a ventilation-fan at inverter ambient temperature of 40°C







### 8-3 Measurement of Main Circuit Electrical Quantity

The indicated values depend on the type of meter because the harmonic component is included in the voltage and current of the main circuit power (input) and the output (motor) side of the inverter. When measuring with a meter for commercial power frequency use, use the meters shown in Table 8.3.1.

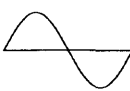
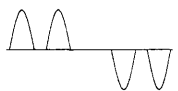
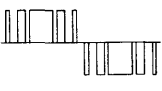
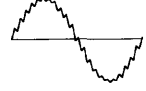
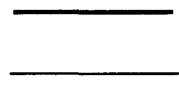
The power-factor cannot be measured using power-factor meters currently available on the market, which measure the phase difference between voltage and current. When power-factors must be measured, measure the power, voltage, and current on the input side and output side, then calculate the power-factor using the following formula:

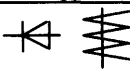
$$\text{Power - factor} = \frac{\text{Power}[W]}{\sqrt{3} \times \text{Voltage}[V] \times \text{Current}[A]} \times 100[\%]$$

Table 8-3-1 Meters for measuring main circuit

Item	Input (power supply) side			Output (motor) side			DC link circuit voltage (P(+) - N(-))
	Voltage	Current	Powermeter	Voltage	Current	Powermeter	
							
Meter name	Ammeter A <sub>R,S,T</sub>	Voltmeter V <sub>R,S,T</sub>	Powermeter W <sub>R,S,T</sub>	Ammeter A <sub>U,V,W</sub>	Voltmeter V <sub>U,V,W</sub>	Powermeter W <sub>U,V,W</sub>	DC voltmeter V
Meter type	Moving-iron type	Rectifier or moving-iron type	Digital power meter	Moving-iron type	Rectifier type	Digital power meter	Moving-coil type
Symbol							

Note: When measuring the output voltage using a rectifier type meter, an error may occur. Use a digital AC power meter to ensure accuracy.

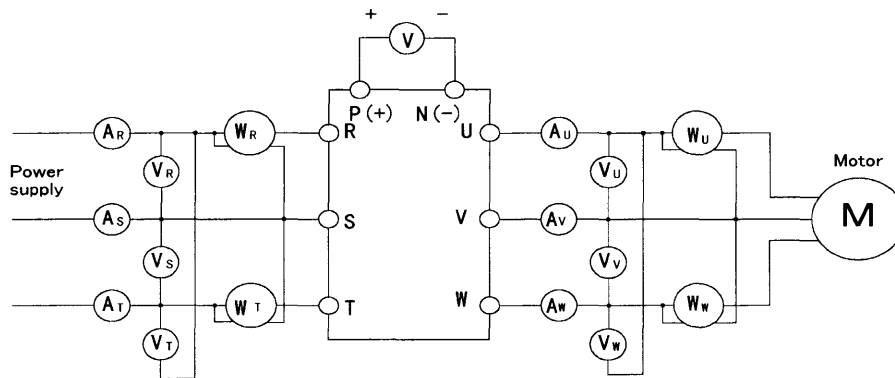

Figure 8-3-1 Connection of the meters

## 8-4 Insulation Test

Avoid testing an inverter with a megger because an insulation test is completed at the factory. If a megger test must be completed, proceed as described below. Use of an incorrect testing method may result in product damage.

If the specifications for the dielectric strength test are not followed, the inverter may be damaged. If a dielectric strength test must be completed, contact your local distributor or nearest Fuji Electric sales office.

### (1) Megger test for the main circuit

- 1) Use a 500V DC type megger and isolate the main power before commencing measurement.
- 2) If the test voltage is connected to the control circuit, remove all connection cables to the control circuit.
- 3) Connect the main circuit terminals using common cables as shown in Fig. 8-4-1.
- 4) Execute the megger test only between the common cables connected to the main circuit and the ground (terminal  $\ominus$ G).
- 5) A megger indicating 5M $\Omega$  or more is normal. (This is the value measured with an inverter only.)

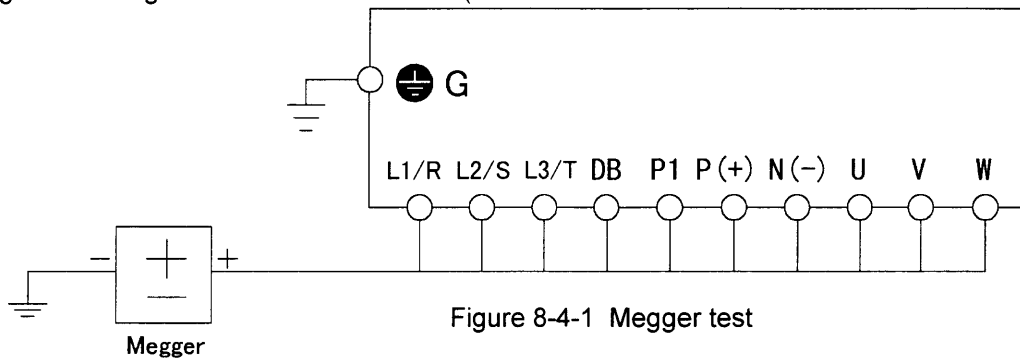

Figure 8-4-1 Megger test

### (2) Insulation test in the control circuit

A megger test and a dielectric strength test must not be performed in the control circuit. Prepare a high resistance range multimeter for the control circuit.

- 1) Remove all external cables from the control circuit terminals.
- 2) Conduct a continuity test between grounds. A result of 1M $\Omega$  or more is normal.

### (3) Exterior main circuit and sequence control circuit

Remove all cables from inverter terminals to ensure the test voltage is not applied to the inverter.

Table 8-5-1 Part replacement

Part name	Standard period for replacement	Comments
Cooling fan	3years	Exchange for a new part.
Smoothing capacitor	7years	Exchange for a new part (determine after checking).
Electrolytic capacitor on the PC board	7years	Exchange for a new PC board (determine after checking).
Fuse	10years	Exchange for a new part.
Other parts	—	Determine after checking.

## 8-5 Parts Replacement

The life expectancy of a part depends on the type of part, the environment, and usage conditions. Parts should be replaced as shown in Table 8-5-1.

## 8-6 Inquiries about Products and Product Guarantee

### (1) Inquiries

If there is damage, a fault in the product, or questions concerning the product, contact your local distributor or nearest Fuji Electric sales office:

- 1) Inverter type
- 2) Serial No. (equipment serial number)
- 3) Purchase date
- 4) Inquiry details (e.g., damaged part, extent of damage, questions, status of fault)

### (2) Product guarantee

The product guarantee term is one year after purchase or 18months from the year and month of manufacture on the nameplate, whichever expires first. However, the guarantee will not apply in the following cases, even if the guarantee term has not expired:

- 1) Damage was caused by incorrect use or inappropriate repair and modification.
- 2) The product was used outside the standard specified range.
- 3) Damage was caused by dropping the product after purchasing or damage during transportation.
- 4) Damage was caused by an earthquake, fire, flooding, lightning, abnormal voltage or other natural calamities and secondary disasters.

## 9. Compliance with Standards

### 9-1 Compliance with UL/cUL Standards

#### 9-1-1 Overview

The UL standard is an abbreviation for Underwriters Laboratories Inc. and is a safety standard for preventing fires and other accidents, and protecting users, servicemen, and general people in the United States.

The cUL standard is a standard which the UL constituted to meet the CSA standard. Products approved by the cUL standard are as valid as produces approved by the CSA standard.

#### 9-1-2 Notes

See the notes on page 0-7 when you use inverters as UL/cUL approved products.

### 9-2 Compliance with European Standard

The CE marking presented on Fuji products is related to the Council Directive 89/336/EEC and the Low Voltage Directive 73/23/EEC for the Electromagnetic Compatibility (EMC) in Europe.

Compliant standards           - EN 61800 - 3: 1997  
  - EN 50178: 1997

Only the models in the 400V series comply with the standards above among the "FRENIC5000 VG7S" series. The 200V series do not conform to the standards. Please note that products of the CT/HT use 18.5 kW and the VT use 22 kW do not comply with the standards, and if you need to use compliant products, you should use the products of the CT/HT use 22 kW and the VT use 30 kW which are models with larger capacities by one grade.

### 9-3 Compliance with Low Voltage Directive

#### 9-3-1 Overview

Inverters are subject to the Low Voltage Directive in Europe. Fuji has obtained an approval for the compliance from a European inspection organization, and voluntarily declares the compliance with the Low Voltage Directive.

#### 9-3-2 Notes

See the notes on page 0-12 when you use inverters as products compliant to the Low Voltage Directive in Europe.

### 9-4 Compliance with EMC Standard

#### 9-4-1 Overview

This CE marking does not certify that the entire machine to which you apply Fuji product complies with the EMC Directive. Thus presenting the CE marking for the entire machine will be up to the responsibility of a machine manufacturer. The reason is that the CE marking of Fuji product assumes the product is used under a certain condition. Using the product under the condition is up to the machine manufacturer.

In general, various products in addition to Fuji product are used in a machine. Thus the machine manufacturer should take care of the entire machine.

As the certain condition described above, you should combine the RFI filter recommended in this appendix with Fuji "FRENIC5000VG7S" series, store them in a metal control panel, and install them following this appendix.

#### 9-4-2 RFI Filter

The Table 9-1 shows RFI filter types recommended by Fuji and applicable inverters. These filters have been developed for the Fuji inverters, and are structured such that an inverter is installed on the side of the filter.

#### 9-4-3 Recommended Installation

Let your electrical engineer follow the steps below to wire your inverter, filter and motor. To comply with the EMC directive, you must follow as close to these steps as possible.

- 1) First, check if your filter's rated current, voltage, and type are correct.
- 2) Make holes according to the installation position of the filter on the control panel. To reduce the contact resistance between the filter and the control panel, remove paint around the installation holes to make the metal surface in contact with the installation surface of the filter sufficiently.
- 3) Connect the input power supply to the input terminal (LINE) and the earth line to the earth stud of the filter. Then, use a wire as short as possible to connect the output terminal (LOAD) of the filter to the power supply input terminal of your inverter.

- 4) Use shield wires to connect the output lines to the motor. Use as short wires as possible. Connect the earth to the earth terminals on both the motor and the inverter. Electrically connect the shield wires such that the shield of the shield wires completely fills the periphery of the holes at the entrance to the control panel.
- 5) If a ferrite ring is provided, make sure the wire pass through the ferrite ring. Wiring depends on the type of your inverter, and follow the Figure 9-8, 9-9, or 9-10 to wire.
- 6) Use a shield wire to wire to the control terminals on your inverter. Make sure that the shield of the shield wire is connected to earth. Use as short wires as possible for all places. Separate the wiring from the power supply to the filter and that from the inverter to the motor as far as possible.

**Table 9-1 RFI Filter Dimension List**

Filter type	Applicable inverter type	Rated current	Maximum rating	External dimension L,W,H[mm]	Installation dimension Y,X[mm]	Filter installation	Ferrite ring (number)			Figure
							Main circuit cable	Control terminal cable	Communication cable	
FS5941-40-47	FRN3.7VG7S-4(CT/HT/VT) FRN5.5VG7S-4(CT/HT/VT) FRN7.5VG7S-4(CT/HT/VT)	40A	Three-phase 480VAC	290x70 x185	275x45	M6(4)	-	-	-	9-1
FS5941-60-52	FRN11VG7S-4(CT/HT/VT) FRN15VG7S-4(CT/HT/VT)	60A		329x80 x185	314x55	M6(4)	ACL-74B (1)	ZCAT203 2-0930 (2)	ZCAT203 2-0930 (2)	9-2 9-3
FS5941-86-52	FRN22VG7S-4(CT/HT/VT)	86A					-	-	-	9-2
RF3100-F11	FRN30VG7S-4(CT/HT)	100A		435x200 x130	408x166	M6(4)	-	-	-	9-4
RF3180-F11	FRN30VG7S-4(VT) FRN37VG7S-4(CT/HT/VT) FRN45VG7S-4(CT/HT/VT) FRN55VG7S-4(CT/HT/VT) FRN75VG7S-4(CT/VT) FRN90VG7S-4(CT)	180A		495x200 x160	468x166	M6(4)	-	-	-	
RF3280-F11	FRN90VG7S-4(VT) FRN110VG7S-4(CT/VT) FRN132VG7S-4(CT)	280A		250x587 x205	560x85	M6(6)	-	-	-	
RF3400-F11	FRN132VG7S-4(VT) FRN160VG7S-4(CT/VT) FRN200VG7S-4(CT/VT) FRN220VG7S-4(CT)	400A		250x587 x205	560x85	M6(6)	-	-	-	9-5
RF3880-F11	FRN220VG7S-4(VT) FRN280VG7S-4(CT/VT) FRN315VG7S-4(CT/VT) FRN355VG7S-4(CT/VT) FRN400VG7S-4(CT/VT)	880A						-	-	-
			688x364 x180	648x150	M6(6)	F200160 (3)	-	-	9-6 9-7	

STRIP TERMINAL BLOCK FOR:

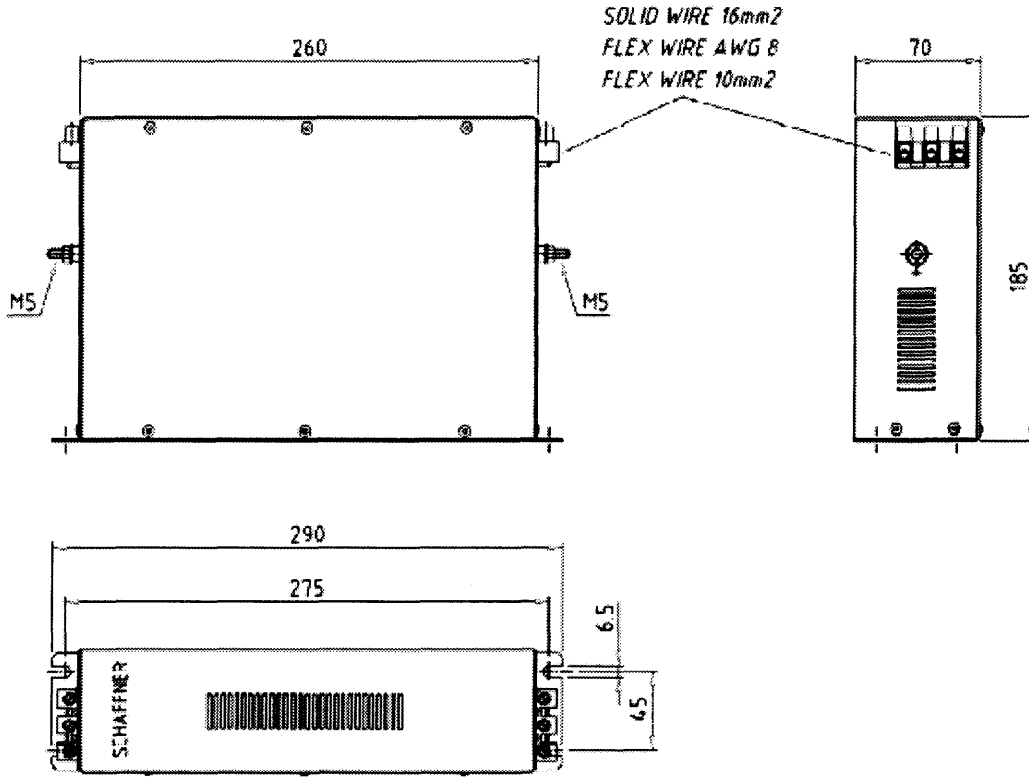

(FS5941-40-47)  
Figure 9-1

STRIP TERMINAL BLOCK FOR:

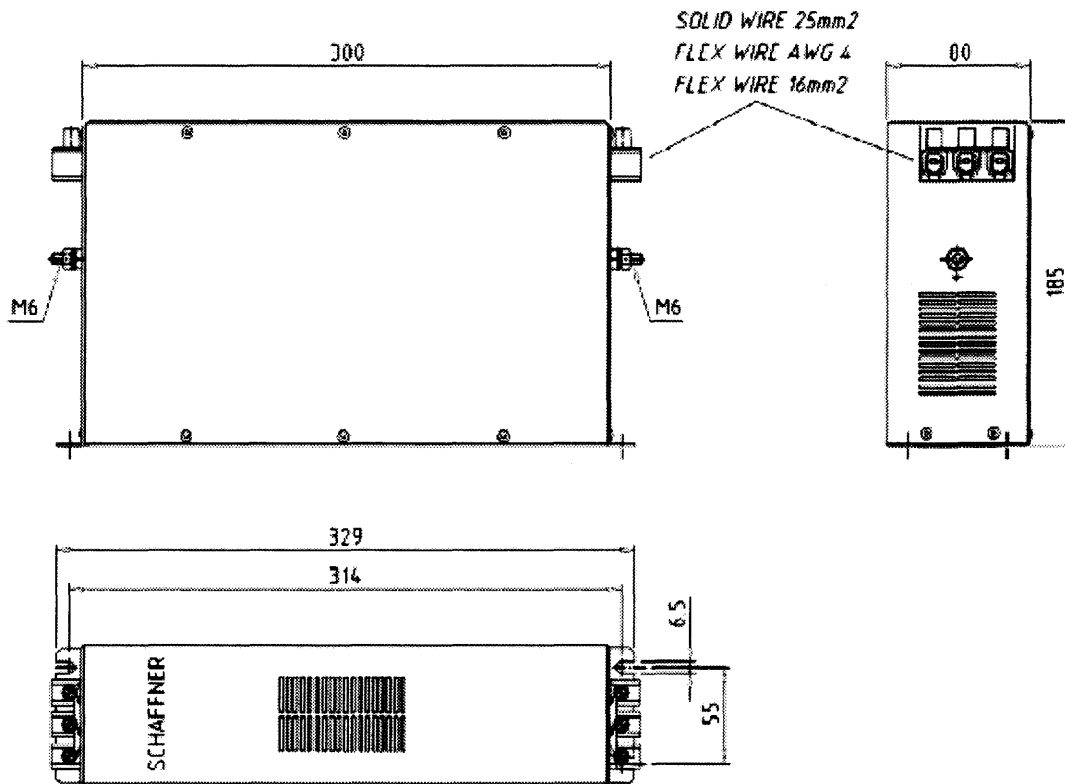

(FS5941-60-52, FS5941-86-52)  
Figure 9-2

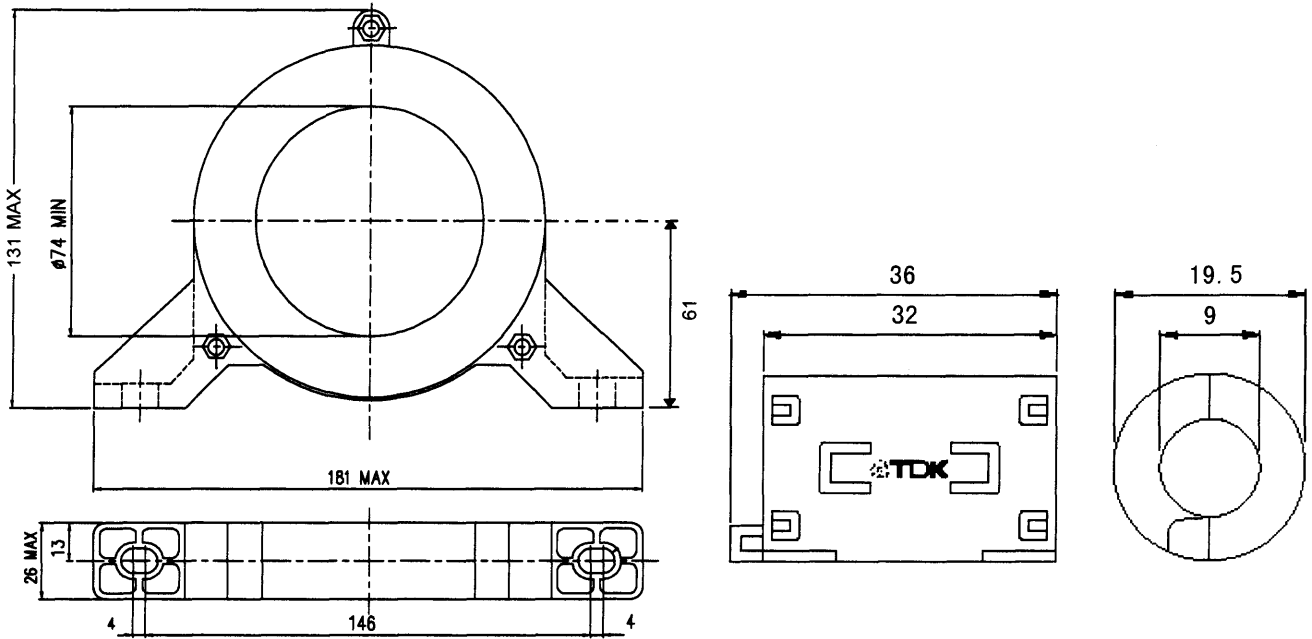

(ACL-74B)

(ZCAT2032-0930)

Figure 9-3

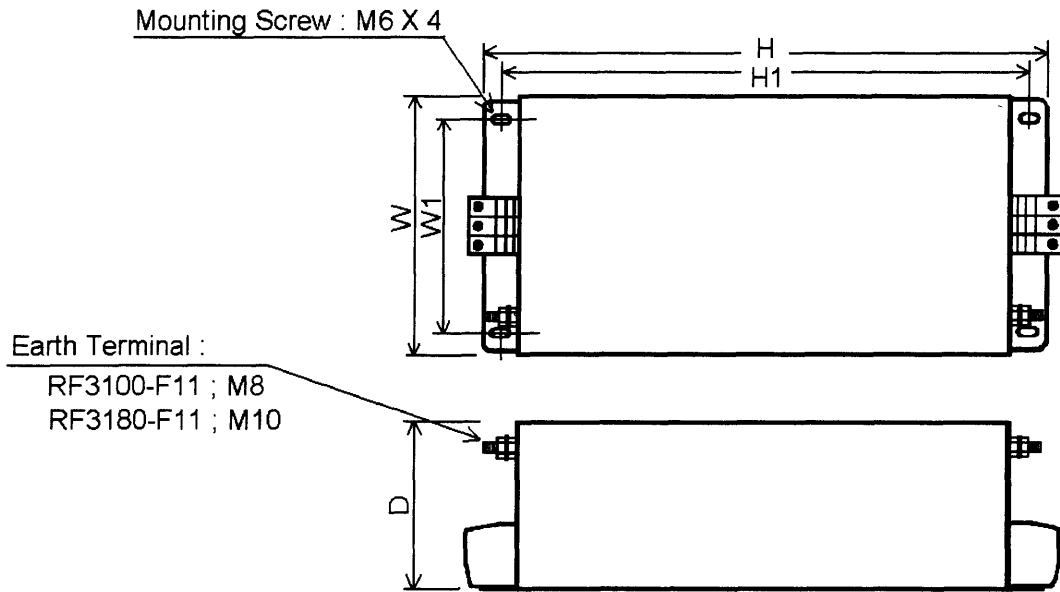

Earth Terminal :  
 RF3100-F11 ; M8  
 RF3180-F11 ; M10

Filter type	Dimension [mm]				
	W	W1	H	H1	D
RF3100-F11	200	166	435	408	130
RF3180-F11	200	166	495	468	160

(RF3100-F11, RF3180-F11)

Figure 9-4

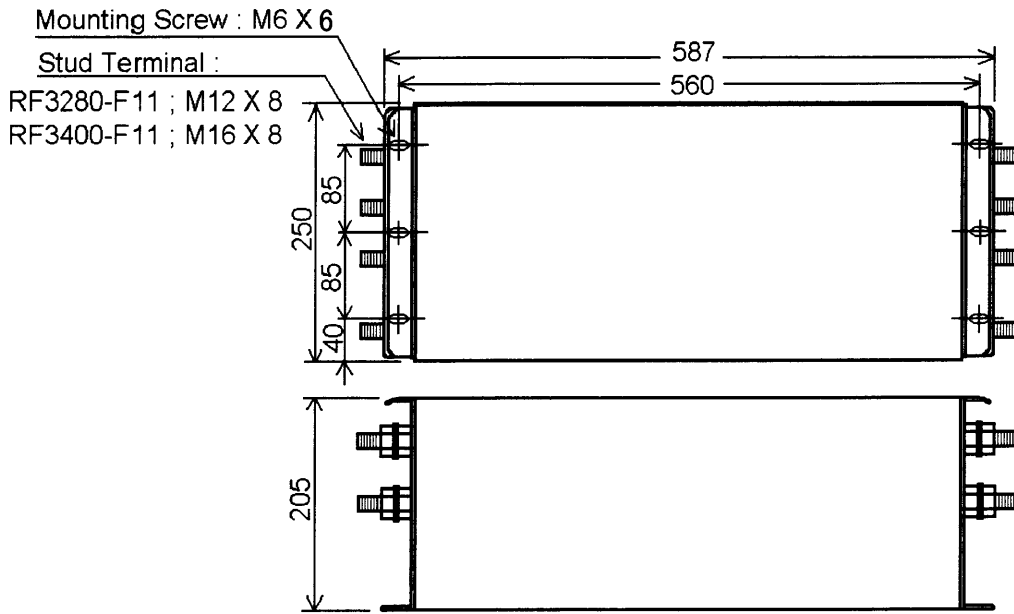

(RF3280-F11, RF3400-F11)

Figure 9-5

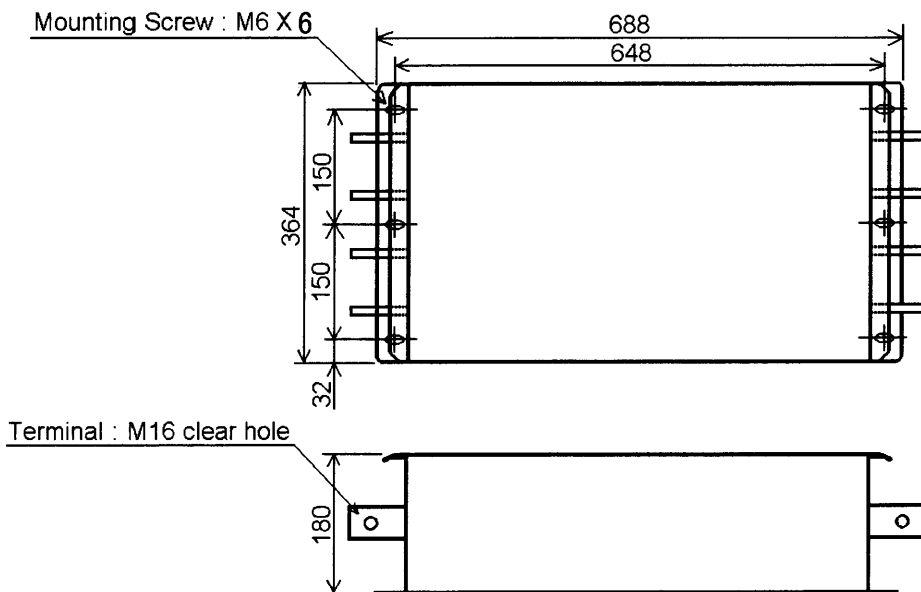

(RF3880-F11)

Figure 9-6

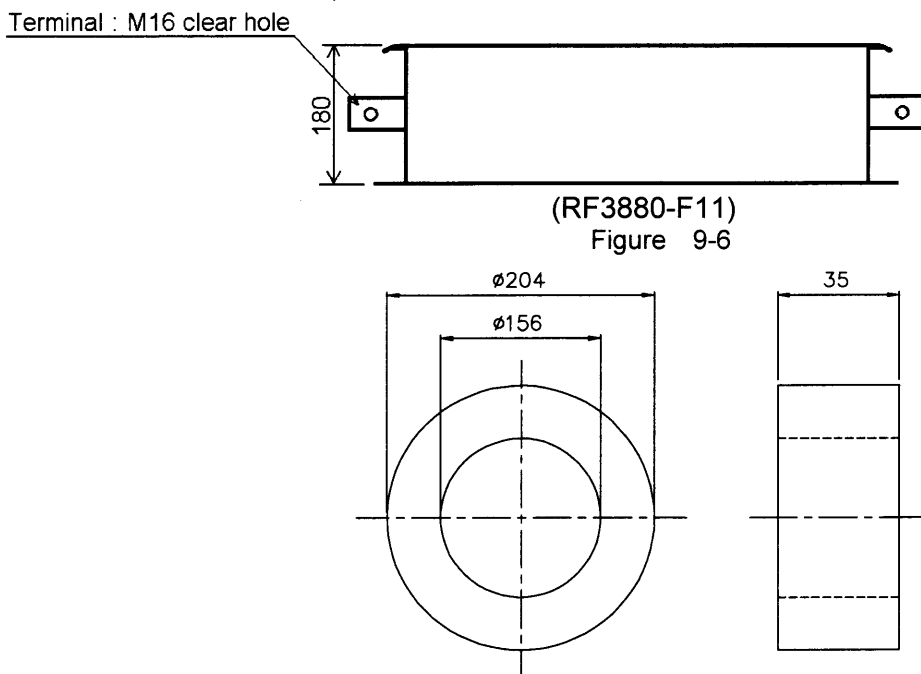

(F200160)

Figure 9-7

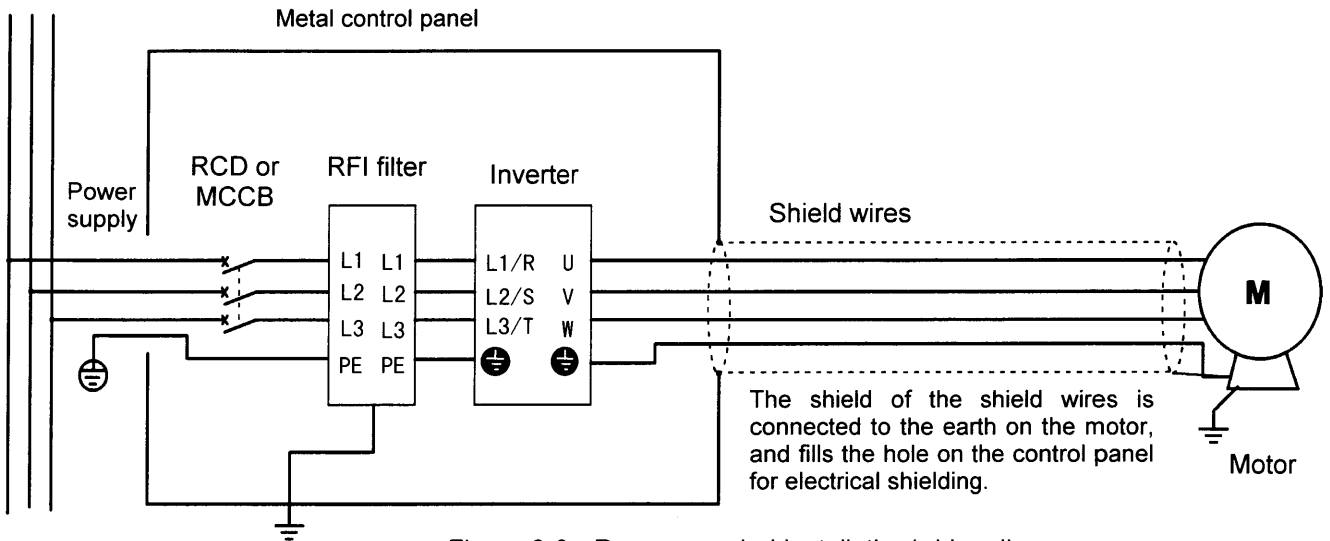

Figure 9-8 Recommended installation/wiring diagram  
 - For FRN3.7VG7S-4 to FRN7.5VG7S-4,  
 FRN22VG7S-4 to FRN220VG7S-4

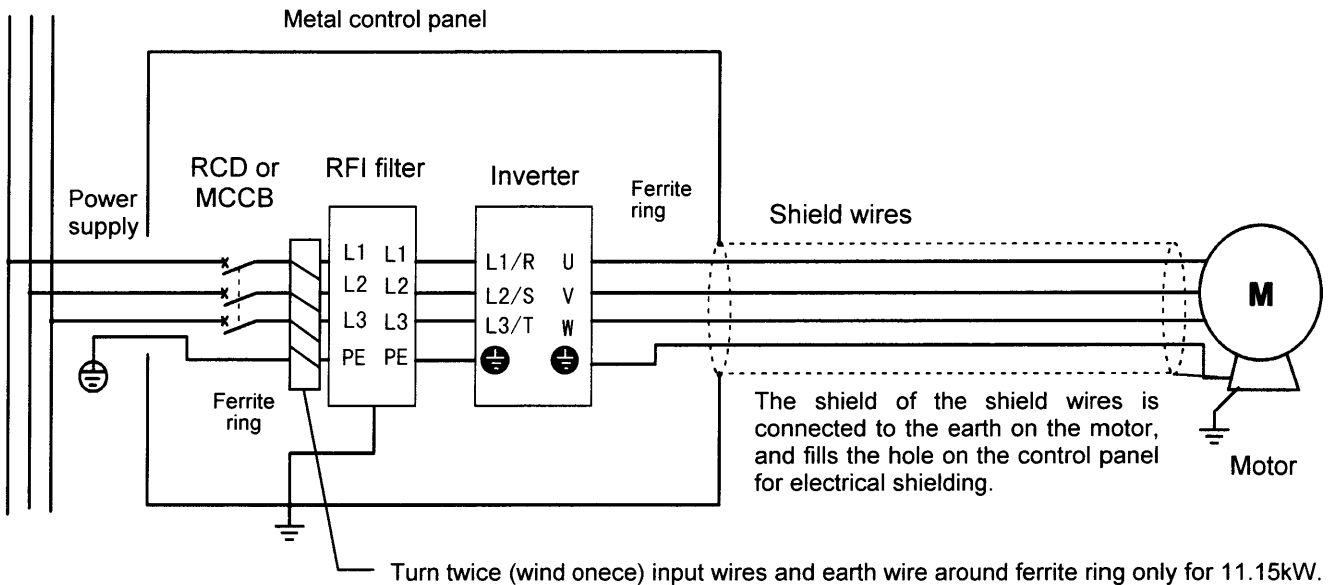

Figure 9-9 Recommended installation/wiring diagram  
 - For FRN11VG7S-4 to FRN15VG7S-4

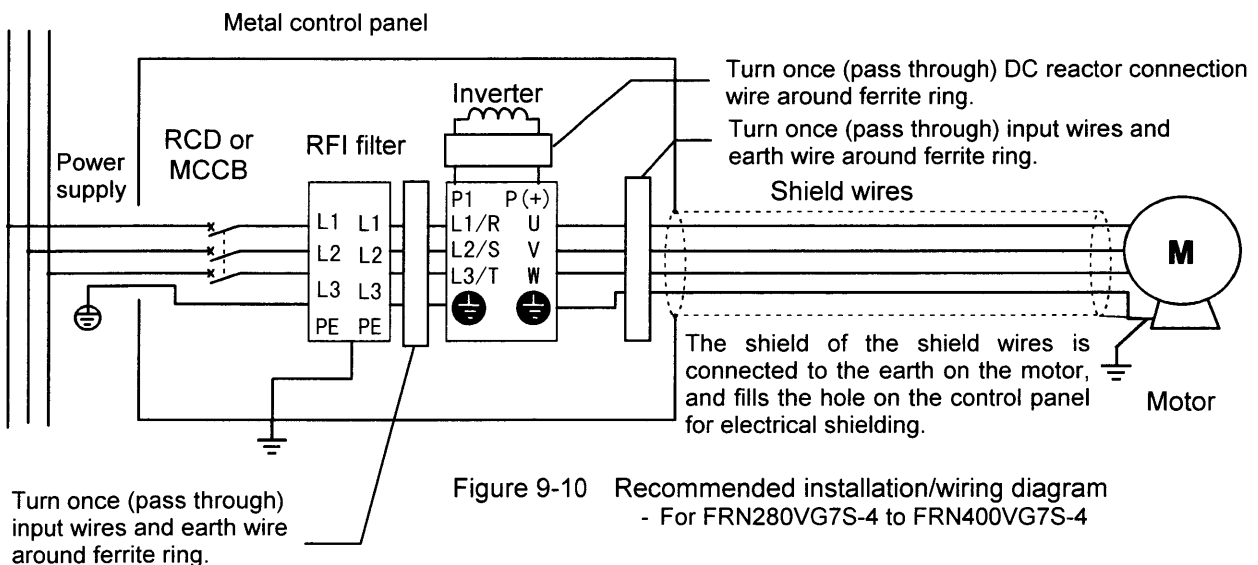

Figure 9-10 Recommended installation/wiring diagram  
 - For FRN280VG7S-4 to FRN400VG7S-4

- MEMO -

- MEMO -

- MEMO -