

GPD 305 Technical Manual

*This Manual
also available on
www.drives.com*



QUICK REFERENCE – – GPD 305 PARAMETERS

PARA-METERS	FACTORY SETTING	USER SETTING
n01	1	
n02	1	
n03	2	
n04	0	
n05	0	
n06	0	
n07	0	
n08	0	
n09	60.0	
n10	230/460	
n11	60.0	
n12	1.5	
n13	12/24	
n14	1.5	
n15	12/24	
n16	10.0	
n17	10.0	
n18	10.0	
n19	10.0	
n20	0	
n21	6.0	
n22	0.0	
n23	0.0	
n24	0.0	
n25	0.0	
n26	0.0	
n27	0.0	
n28	0.0	
n29	6.0	
n30	100	
n31	0	
n32	Note 1	
n33	0	
n34	8	
n35	0	
n36	2 (2)	
n37	5 (0)	
n38	3 (3)	
n39	6 (6)	
n40	1	

PARA-METERS	FACTORY SETTING	USER SETTING
n41	100	
n42	0	
n43	0.10	
n44	0	
n45	1.00	
n46	3	
n47	0	
n48	0	
n49	0.00	
n50	0.00	
n51	0.0	
n52	50	
n53	0.0	
n54	0.0	
n55	0	
n56	170	
n57	160	
n58	0.0	
n59	0	
n60	160	
n61	0.1	
n62	0	
n63	1.0	
n64	Note 1	
n65	Note 1	
n66	0.0	
n67	2.0	
n68	0	
n69	0	
n70	0	
n71	2	
n72	2	
n73	10	
n74	0	
n75	0	
n76	rdy	
n77	0	
n78	N/A	
n79	012	N/A

Note 1: Factory setting differs depending on GPD 305 capacity. See Appendix 3-1.



This procedure is a simplified step by step guide to installing, programming, and using the GPD305 drive. It highlights several common installation configurations. Detailed information on all features of this drive can be found in the GPD305 Technical Manual TM4305.

INSTALLATION

1. Be certain your input voltage source, motor and drive nameplates are all marked either 230V or 460V. Other voltages can be used, but require additional programming, see technical manual TM4305. **CAUTION: Verify that the input voltage matches the drive's nameplate BEFORE applying power or severe damage will result.**
2. Mount drive on a vertical surface with adequate space for air circulation (4.7" above and below, 1.2" on each side).
3. Remove front cover using the screw in the lower left corner, then connect power and ground wires as shown.

CAUTION: BE CERTAIN YOU CONNECT INPUT POWER TO TERMINALS L1, L2, AND L3 ONLY, OR SERIOUS DAMAGE WILL RESULT. CONNECT MOTOR TO TERMINALS T1, T2, AND T3 ONLY.

4. **Replace cover and apply input power** – digital operator shows "0.0"; The FREF LED is on and the RUN LED is flashing. Press the **DSPL** key until the LO/RE LED is on. Press the **UP ARROW** button until the display shows "Lo", then press the **DSPL** button until the FREF LED is on. Rotate the potentiometer on the front of the digital operator until the display shows "6.0". Press the **RUN** button and note the direction of motor rotation. If rotation is incorrect, remove power, wait for the display lights to go out, then switch wires between terminals T1 and T2. Replace the front cover and apply input power.

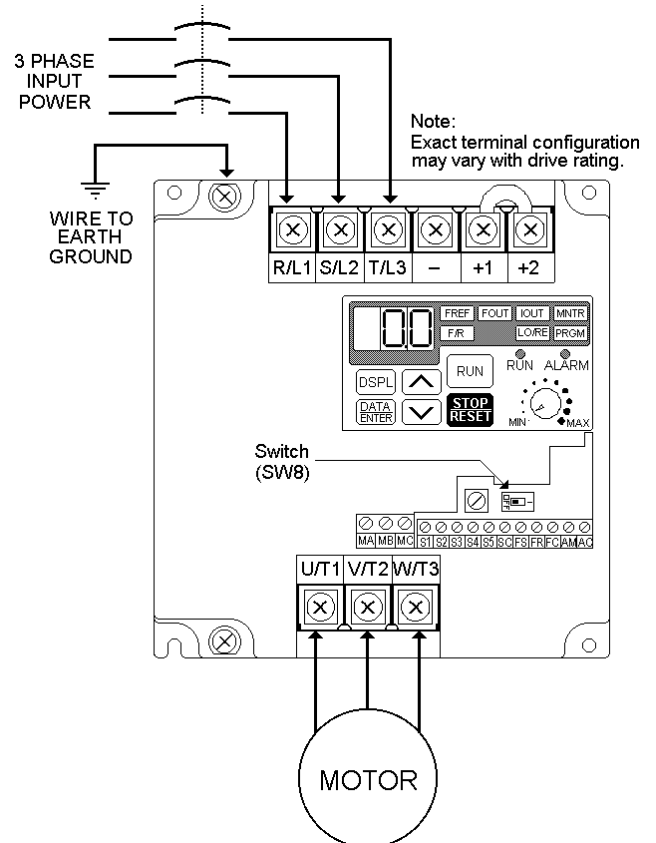

5. Digital Operator

The **DSPL** button cycles through all of the quick start LEDs.

To access a parameter, press the **DSPL** button until the PRGM LED is on. Use the **UP** and **DOWN** keys until the desired parameter number is displayed, then press **ENTER**. Use the **UP** and **DOWN** keys to adjust the value then press **ENTER** then **DSPL**.

Before the drive will accept a RUN command, one of the following LEDs must be on: FREF, FOUT, IOUT, MNTR, or F/R. For more specific information on the digital operator, see the GPD305 Tech. Manual TM4305, Section 4.

6. **Choose a configuration from Table 1 below.** Each example listed below contains a control wiring diagram, operation explanation, and all necessary programming. The GPD305 can be controlled in many more ways than is described in these examples. See Technical Manual TM4305 for details.

Table 1: Drive Configuration Examples

Sequence* Source (Run / Stop)	Reference* Source (Motor Speed)	Description	Example Page
Digital Operator	Digital Operator	This method requires no control wiring connections to the drive. It is most often used during startup of the drive.	Example 1 (Page 3)
2-wire	4-20 mA	With this method the drive can be started and stopped from a remote source, and the reference comes from a remote 4 – 20 mA source such as a PLC.	Example 2 (Page 4)
3-wire	Speed Potentiometer	With this method, remote pushbuttons start and stop the drive and the reference comes from a speed control (potentiometer).	Example 3 (Page 5)

* For a more detailed explanation of sequence and reference, consult Page 6 of this document.

7. **Control Terminal Wiring** – Remove power and wait for all LEDs to go out before making control terminal connections.

Control wiring should be sized 16 to 20 AWG. Control wiring should be shielded, with the shield wire connected to the ground terminal⊕, which is located towards the left side of the aluminum heat sink.

GPD305 Control Terminals

⊕	⊕	⊕	⊕	⊕	⊕	⊕	⊕	⊕	⊕	⊕	⊕	⊕	⊕	⊕	⊕	⊕	⊕	⊕	⊕	
M	A	M	B	M	C	S1	S2	S3	S4	S5	SC	FS	FR	FC	AM	AC				

Example 1: Sequence & Reference From The Digital Operator

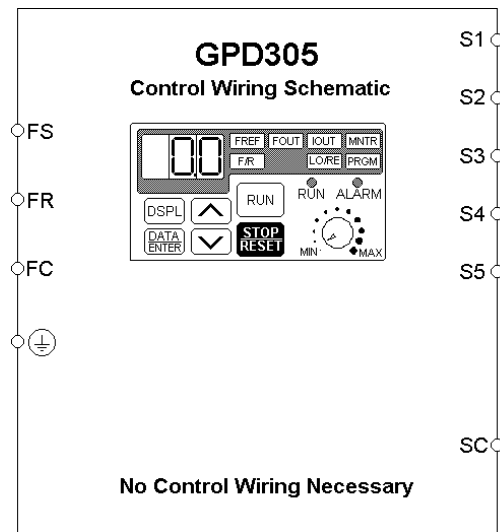

When the drive is set up with the sequence and the reference coming from the digital operator, it is in “Local” control. Local control is often used during startup to verify motor operation, rotation, etc. The drive can be temporarily placed in “Local” control simply by using the LO/RE quick start LED. If power is removed and then restored, the drive will come up in the “Remote” mode.

The drive can be programmed so that even if power is lost, the drive will come up in the local mode (see Table 2 below).

OPERATION:

- The frequency reference comes from the digital operator pot.
- The drive can be started by pressing the **RUN** key on the digital operator.
- The drive can be stopped by pressing the **STOP** key on the digital operator.
- The direction of the motor can be changed regardless of motor speed by using F/R quick start LED.

Table 2: Programming required for “Local” mode

Parameter	Display	Description
n02	0	This parameter sets the sequence (start/stop) to “Local” mode.
n03	0	This parameter sets the reference (motor speed) to come from the digital operator potentiometer (local).
n32	Set Motor F.L.A.	Enter the motor’s full load amps (as shown on the motor nameplate).
Quick Start LED	F/R	The motor direction can be changed regardless of motor speed using this quick start LED.

Example 2: Remote Sequence (2-Wire) & Remote Reference (4 – 20 mA)

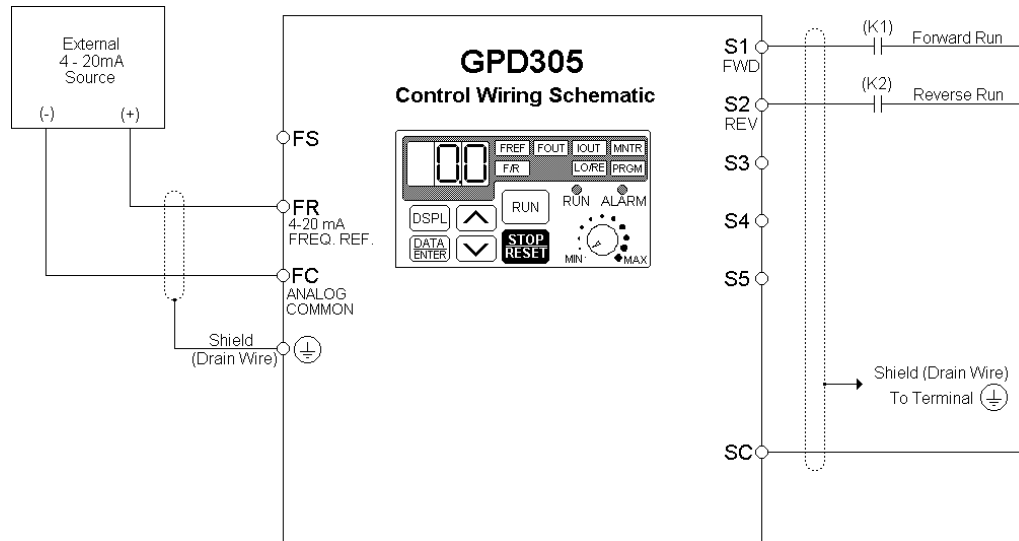

This configuration is used when the start & stop signals and the frequency reference come from a remote source, such as a PLC. It can also be used with a maintained switch when it is desirable to have the drive restart on restoration of power. It should not be used where safety of attending personnel might be threatened by a restart.

OPERATION:

- Close (K1) to Run Forward.
- Close (K2) to Run Reverse.
- If both (K1) & (K2) are closed, the drive stops and displays the error message: “EF”.
- Frequency reference is proportional to the signal level at Terminal FI. 4mA = 0 Hz, 12mA = 30 Hz, & 20mA = 60 Hz.
- If the drive is put in the “Local” mode using the LO/RE quick start LED, the drive will behave the same as illustrated in Example 1.

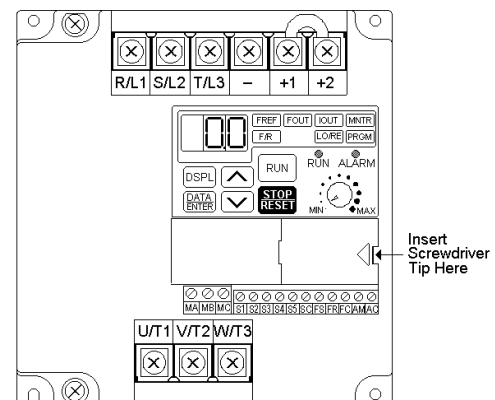
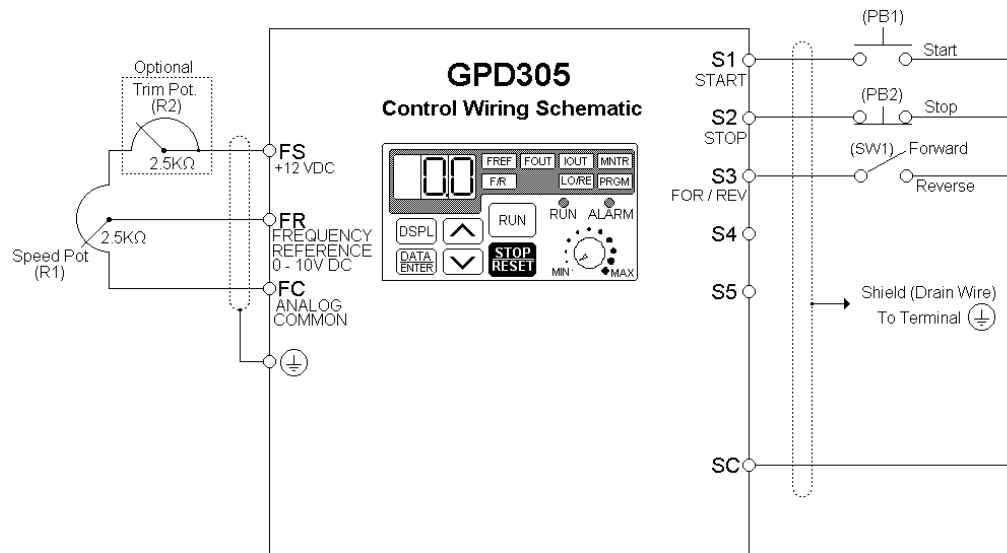

Table 3: Programming Required For Remote 2-wire Sequence & Remote (4-20 mA) Reference

Parameter	Display	Description
n01	Password 10	The drive will perform a 2-wire reset. CAUTION: Setting this value will reset all parameters to their original factory settings (all previous adjustments will be lost) <i>When the drive completes the reset, this parameter returns to a value of 1.</i>
n03	3	This parameter sets terminal FR to be a 4-20mA input. NOTE: Switch (SW8) must be closed (“on”). Prying off the cover using a small screwdriver as shown in the diagram above allows access to switch (SW8).
n32	Set Motor FLA	Enter the motor’s full load amps (as shown on the motor nameplate).

Example 3: Remote Sequence (3-Wire) & Speed Potentiometer



This configuration is best when a person rather than an external controller (PLC, relay, etc.) controls the drive. Both potentiometers ((R1) & (R2)) should have a resistance value between 2000Ω and 3000Ω and be rated for at least 1 Watt. The trim pot is optional, but without it the manual speed pot will output 10V (60 Hz) at just three-quarters of its rotation.

OPERATION:

- Close pushbutton (PB1) momentarily while pushbutton (PB2) is closed and the drive will start. Pushbutton (PB1) does *NOT* need to be maintained.
- Open pushbutton (PB2) at any time and the drive will stop.
- If switch (SW1) is open the drive will run in the forward direction. If switch (SW1) is closed, the drive will run in the reverse direction. Switch (SW1) can be operated with the drive running at any speed.
- Frequency reference is proportional to the signal level at Terminal FV.
0V = 0 Hz, 5V = 30 Hz, & 10V = 60 Hz.
- If the drive is put in the “Local” mode using the LO/RE quick start LED, the drive will behave the same as illustrated in Example 1.

Table 4: Programming Required For Remote 3-wire Sequence & Speed Pot Reference

Parameter	Display	Description
n01	11	The drive will perform a 3-wire reset. CAUTION: Setting this value will reset all parameters to their original factory settings (all previous adjustments will be lost) <i>When the drive completes the reset, this parameter returns to a value of 1.</i>
n32	Set Motor FLA	Enter the motor’s full load amps (as shown on the motor nameplate).

After the programming is complete, the trim pot needs to be calibrated. Press **DSPL** until the FREF quick start LED is illuminated. Turn the Speed Pot (R1) all the way up. Adjust the trim pot (R2) so that the “FREF” display is just flickering between 59.9 Hz and 60.0 Hz. This completes the trim pot calibration.

Sequence and Reference Explained

Sequence – refers to how the drive is started, stopped, and told which direction to run. When the sequence comes from the digital operator (local), the drive is started and stopped using the “RUN” and “STOP” keys on the digital operator, and direction is given via the “FWD/REV” key. Sequence can also come from the drive’s control terminals (remote) using either two-wire or three-wire control. **The sequence inputs to the drive do NOT require any outside voltages to activate them.** Instead, contact closures (either from switches, relay contacts or open collector circuits) activate the sequence inputs. Other sequence sources are available, consult the GPD305 Technical Manual TM4305 for details.

Two-wire sequence – utilizes a “maintained” switch or relay contact. It is used on applications where it is desirable to have the drive restart on restoration of power. It should not be used where safety of attending personnel might be threatened by a restart. This method is generally restricted to unattended fans & pumps, or where another controller is entrusted with the decision to restart. Direction is controlled by maintaining either a forward run or a reverse run command.

Three-wire sequence – utilizes “momentary” buttons or switches. This control scheme emulates the traditional 3-wire motor starter control. A momentary closure of a normally open run switch latches the drive in the RUN mode (STOP switch must be closed or the drive will not accept the momentary RUN command). A momentary opening of the normally closed STOP switch unlatches RUN mode bringing the drive to a stop. The three-wire sequence is used where it would be dangerous for the drive to restart after a power outage. This method requires an intentional restart, as the RUN command is unlatched immediately on loss of power. Direction is determined by another maintained contact closure (closed = reverse).

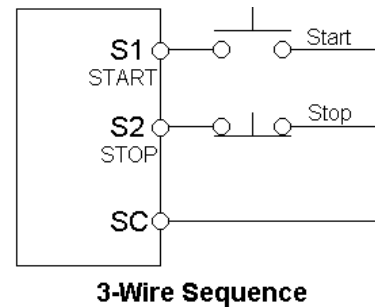

Reference - The frequency reference tells the drive how fast to run the motor. There are several source options for the frequency reference. First, the frequency reference can come from the digital operator (local). Simply put, the motor speed can be entered into the keypad. Second, the frequency reference can come from an analog signal (remote), such as 0 to 10 Volts DC. When 0 Volts is applied to the drive, the drive will run at zero speed. When 10V is applied to the drive, it will run at full speed. Apply anything in between and the drive will run at that corresponding frequency (2.5VDC = 25% speed = 15 Hz). Other reference sources are available, consult the GPD305 Technical Manual TM4305 for details.

Local Control – is when the sequence and/or reference comes from the digital operator

Remote Control – is when the sequence and/or reference comes from the control terminals.

CURRENT RATINGS & HORSEPOWER RANGE

RATED INPUT	CURRENT RATING (AMPS)	NOMINAL HORSEPOWER	MODEL NO.
2 3 0 V	0.8	1/8	JDA001
	1.6	1/4	JDA002
	3.0	1/2	JDA003
	5.0	3/4 & 1	JDA005
	8.0	2	JDA008
	11.0	3	JDA011
	17.5	5	JDA017
4 6 0 V	1.2	1/2	JDB001
	1.8	3/4	JDB002
	3.4	1 & 2	JDB003
	4.8	3	JDB005
	8.6	5	JDB009



Do not touch circuit components until main input power has been turned OFF. Status indicator LEDs and Digital Operator display will be extinguished when the DC bus voltage is below 50 VDC. Wait at least one additional minute.

Do not connect or disconnect wires and connectors while the main input power is turned on.



The GPD 305 leaves the factory with parameters initialized for 2-Wire control (when using external Run/Stop signals). Before using the initialization function of constant n01, know your control wiring configuration:

10 = Factory 2-Wire Control Initialization (Maintained RUN Contact)

11 = Factory 3-Wire Control Initialization (Momentary START/STOP Contact)

Entering either Initialization code resets all parameters to factory settings, and automatically returns parameter n001 setting to “ 1 ”. If the GPD 305 is connected for 3-Wire control and this parameter is set to “ 10 ” (2-Wire Control Initialization), the motor may run in reverse direction WITHOUT A RUN COMMAND APPLIED. Equipment damage or personal injury may result.



Parameter n10 must be set to proper motor voltage.



Always ground the GPD 305 using its ground terminal (⊕) (near the main circuit output terminals). See paragraph 1.4A, "Grounding".

Never connect main circuit output terminals T1 (U), T2 (V) & T3 (W) to AC main circuit power supply.



When drive is programmed for auto-restart (n48 = " 1 " thru " 10 "), the motor may restart unexpectedly — personal injury may result.



Wiring should be performed only by qualified personnel.

Always ground the GPD 305 using ground terminal (⊕). See paragraph 1.4C, "Grounding".

Verify that the rated voltage of the drive matches the voltage of the incoming power.

Never connect main circuit output terminals T1, T2, and T3 to AC main circuit power supply.

All parameters have been factory set. Do not change their settings unnecessarily.

Do not perform a "HIPOT" or withstand voltage test on any part of the GPD 305. Equipment uses semi-conductors and is vulnerable to high voltage.

The Control PCB employs CMOS ICs which are easily damaged by static electricity. Use proper electrostatic discharge (ESD) procedures when handling the Control PCB. Never touch the printed control board (PCB) while the main input power is turned on.

Any modification of the product by the user is not the responsibility of MagneTek, and will void the warranty.

Do not remove the Digital Operator or change dipswitch SW8 or rotary switch SW7 unless the main input power is turned OFF.

CONTENTS

PARAGRAPH	SUBJECT	PAGE
	QUICK REFERENCE FOR GPD 305 PARAMETERS	Inside Cover
	CURRENT RATINGS AND HORSEPOWER RANGE	vii
	WARNINGS & CAUTIONS	vii
1	RECEIVING / INSTALLATION	1-1
1.1	General	1-1
1.2	Receiving	1-1
1.3	Physical Installation	1-1
1.4	Electrical Installation	1-4
2	INITIAL START-UP	2-1
2.1	Pre-Power Checks	2-1
2.2	Startup Procedure	2-2
3	OPERATION AT LOAD	3-1
4	DIGITAL OPERATOR	4-1
4.1	General	4-1
4.2	Digital Operator	4-1
4.3	Status Indicator LEDs	4-3
4.4	Monitor Displays	4-3
5	PROGRAMMABLE FEATURES	5-1
5.1	General	5-1
5.2	Accel/Decel Time	5-2
5.3	Accel/Decel: S-Curve Characteristics	5-3
5.4	Auto-Restart	5-4
5.5	Carrier Frequency	5-5
5.6	Critical Frequency Rejection	5-6
5.7	DC Injection Braking	5-7
5.8	Frequency Reference Bias/Gain (Analog)	5-8
5.9	Frequency Reference Upper and Lower Limits	5-9
5.10	Frequency Reference Retention	5-9
5.11	Frequency Reference Selection	5-10
5.12	Jog Reference	5-12
5.13	Local/Remote Reference and Sequence Selection	5-13
5.14	Modbus Control (Optional).....	5-15
5.15	Momentary Power Loss Ride-Thru	5-19
5.16	Multi-Function Analog Monitor Output (Term. AM and AC)	5-19
5.17	Multi-Function Input Terminals (Term. S1-S5)	5-20
5.18	Multi-Function Output Terminals (Term. MA, MB, MC)	5-26
5.19	Overtorque Detection	5-28

CONTENTS – Continued

PARAGRAPH	SUBJECT	PAGE
5.20	Reset Codes: 2-Wire, 3-Wire Initialization	5-30
5.21	Slip Compensation	5-31
5.22	Stall Prevention	5-32
5.23	Stopping Method	5-33
5.24	Thermal Overload Protection	5-34
5.25	Torque Compensation	5-35
5.26	V/f Pattern	5-36
5.27	Copy Function.....	5-38
6	FAULT DIAGNOSIS AND CORRECTIVE ACTIONS	6-1
6.1	General	6-1
Appendix 1	LISTING OF PARAMETERS	A1-1
Appendix 2	SPECIFICATIONS	A2-1
Appendix 3	CAPACITY RELATED PARAMETERS	A3-1
Appendix 4	PERIPHERAL DEVICES	A4-1
Appendix 5	GPD 305 DIMENSIONS	A5-1
Index	I-1

Section 1. RECEIVING AND INSTALLATION

1.1 GENERAL

The GPD 305 is a high performance sine-coded pulse width modulated special purpose AC motor drive which generates an adjustable voltage/frequency three phase output for complete speed control of most conventional squirrel cage induction motors. Automatic stall prevention and voltage boost prevents nuisance tripping during load or line side transient conditions. The GPD 305 will not induce any voltage line notching distortion back to the utility line and maintains a displacement power factor of not less than 0.98 throughout its speed range.

When properly installed, operated and maintained, the GPD 305 will provide a lifetime of service. It is mandatory that the person who operates, inspects, or maintains this equipment thoroughly read and understand this manual before proceeding.

This manual primarily describes the GPD 305, but contains basic information for the operator control station as well. For detailed operation of other units in the drive system, refer to their respective manuals.

1.2 RECEIVING

The GPD 305 is thoroughly tested at the factory. After unpacking, verify the part numbers with the purchase order (invoice). Any damages or shortages evident when the equipment is received must be reported immediately to the commercial carrier who transported the equipment. Assistance, if required, is available from your sales representative.

If the drive will be stored after receiving, keep it in its original packaging and store according to storage temperature specifications in Appendix 2.

1.3 PHYSICAL INSTALLATION

Location of the GPD 305 is important to achieve proper performance and normal operating life. The unit should be installed in an area where it will be protected from:

- Direct sunlight, rain or moisture.
- Corrosive gases or liquids.
- Vibration, airborne dust or metallic particles.

When preparing to mount the GPD 305, lift it by its base, **never** by the front cover. For effective cooling, as well as proper maintenance, the GPD 305 must be installed on a flat, non-flammable vertical surface (wall or panel) using four mounting screws. There **MUST** be a **MINIMUM** 3.9 in. clearance above and below the GPD 305 to allow air flow over the heat sink fins. A minimum 1.2 in. clearance is required on each side on the GPD 305.

Make sure air entering the drive is below 122°F (50°C) by adding a fan or other cooling device, if needed. See environmental specifications in Appendix 2.

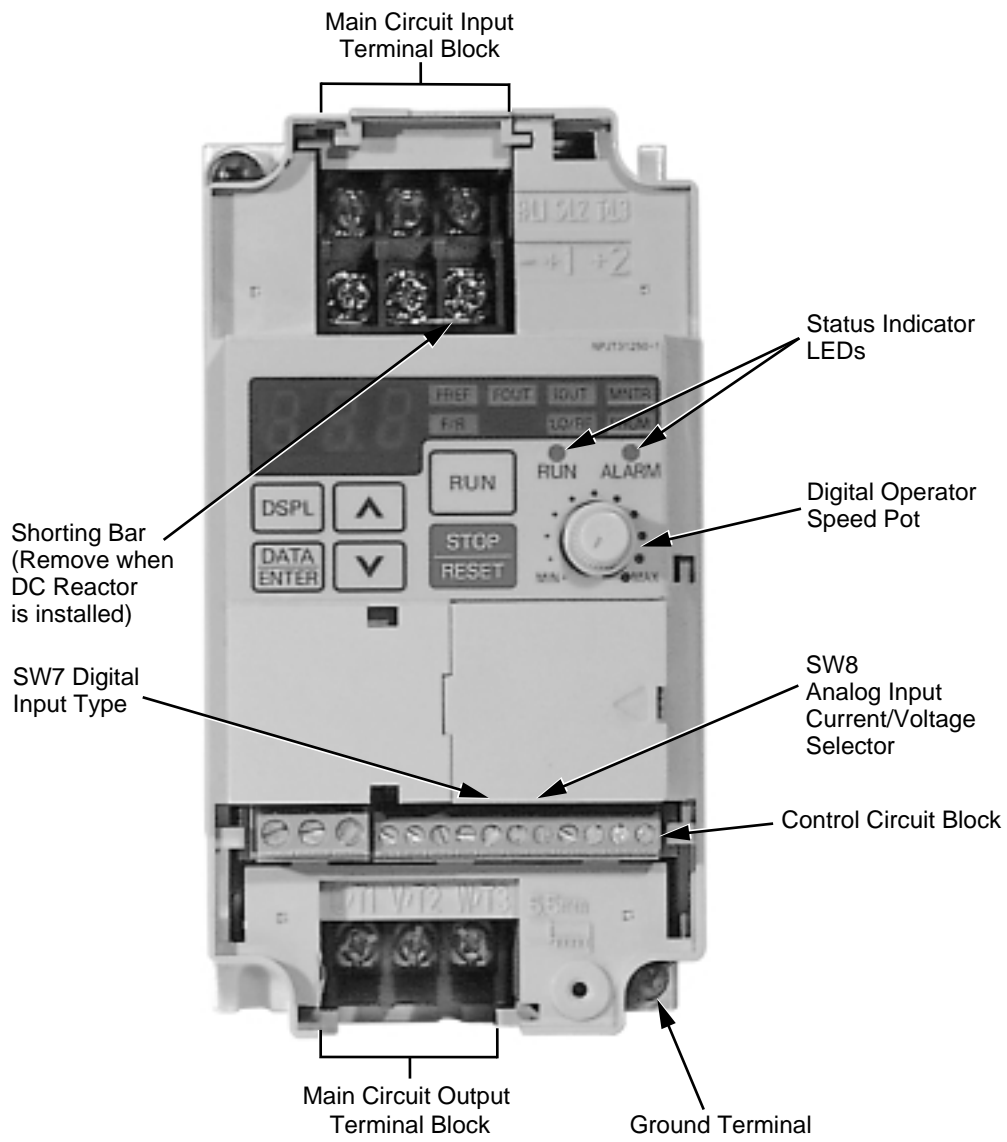

Figure 1-1. Component Identification (Sheet 1 of 2)

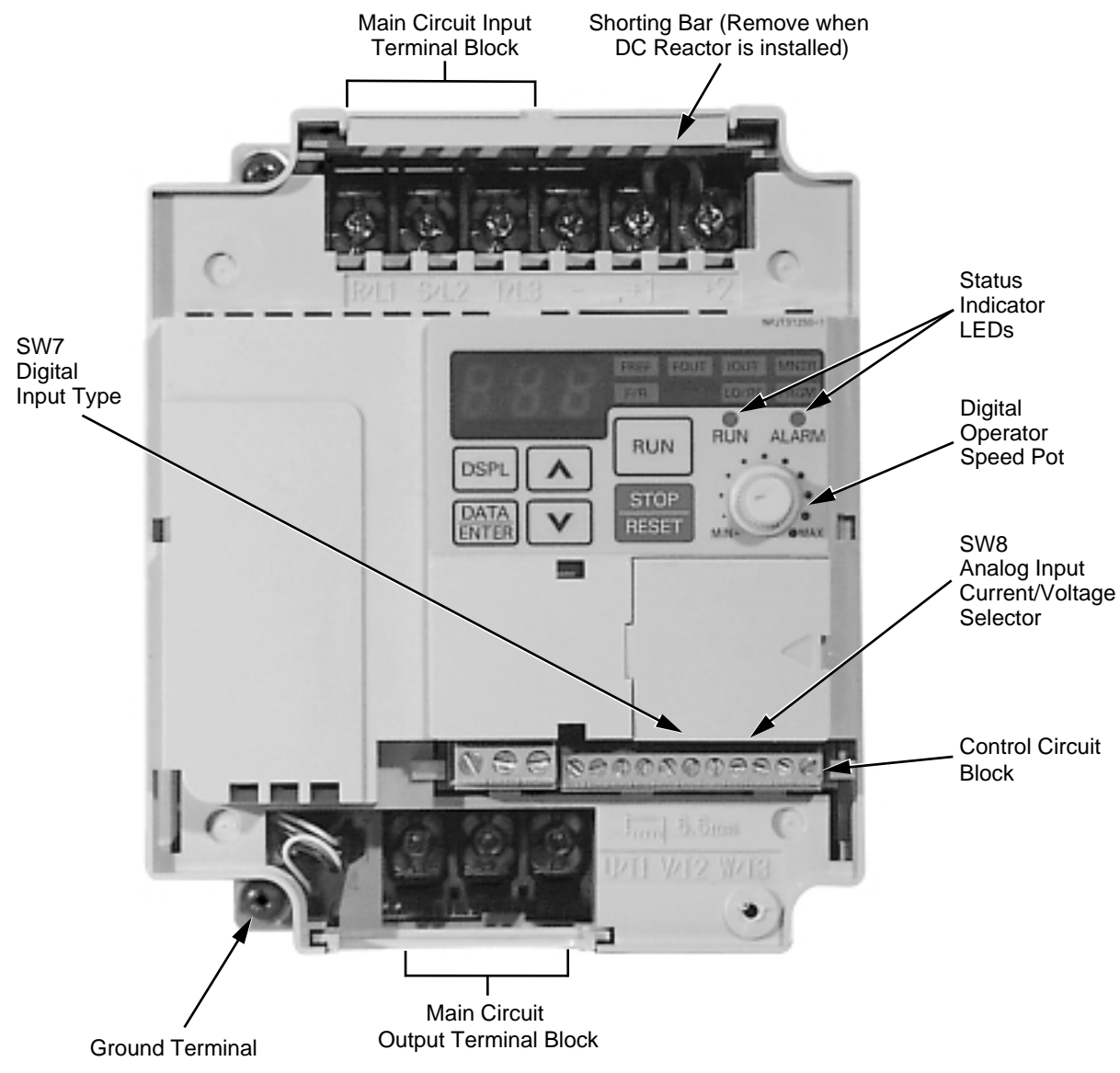

Figure 1-1. Component Identification (Sheet 2 of 2)

1.4 ELECTRICAL INSTALLATION

The GPD 305 leaves the factory with all parameters set for 2-Wire external reference control. Figure 1-5 must be used for all external connections.

To use the GPD 305 in a 3-Wire application, drive parameters **n01**, **n02**, and **n03** must be reprogrammed, using the Digital Operator. Figure 1-6 must then be used for all external connections.

A. Main Circuit Input/Output

Complete wire interconnections according to Tables 1-1 and 1-2; observe the following:

- Use 600 V vinyl-sheathed wire (75°C copper) or equivalent. Wire size should be determined considering voltage drop of leads.
- NEVER connect AC main power to output terminals T1 (U), T2 (V), and T3 (W).
- NEVER allow wire leads to contact metal surfaces. Short-circuit may result.
- NEVER connect power factor correction capacitors or noise filters to GPD 305 output.
- SIZE OF WIRE MUST BE SUITABLE FOR CLASS I CIRCUITS.
- Use only factory supplied installation instructions to install optional dynamic braking resistors. Failure to do so may cause equipment damage or personal injury.
- Motor lead length should NOT EXCEED 164 feet (50 meters), and motor wiring should be run in a separate conduit from the power wiring. If lead length must exceed this distance, reduce carrier frequency and consult factory for proper installation procedures.
- Use UL listed closed loop connectors or CSA certified ring connectors sized for the selected wire gauge. Install using the correct crimp tool recommended by the connector manufacturer.

Table 1-1. Wire and Terminal Screw Sizes for GPD 305



	Drive Model	Terminal Symbol	Screw	Max. Torque lb-ft	Wire	
					Size AWG	Type
Main Circuit	JDA001-JDA005	L1, L2, L3, B1, B2, -, +1, +2 T1, T2, T3, 	M3.5	0.7	18 to 14	600V
	JDA008-JDA017; JDB001-JDB009		M4	1.1	14 to 10	
Control Circuit (All)		S1-S5, SC, FS, FR, FC, AM, AC,	M2	0.2	20 to 16	Shielded wire with Class 1 wiring
		MA, MB, MC	M3	0.4	20 to 16	

Table 1-2. Main Circuit Terminal Functions and Voltages

TERMINAL	FUNCTION	VOLTAGE / SIGNAL LEVEL
L1 (R) L2 (S) L3 (T)	Main circuit input power supply	230V Drive: 200 / 208 / 220 / 230V at 50/60 Hz 460V Drive: 420 / 440 / 460 / 480V at 50/60 Hz
T1 (U) T2 (V) T3 (W)	Main circuit output	230V Drive: 0 - 200 / 208 / 220 / 230V 460V Drive: 0 - 400 / 440 / 460 / 480V
+1 +2	DC Reactor terminals	
-	DC Bus terminals (+1 & -)	
	Ground terminal (100 ohms or less)	-----

B. Control Circuit

All basic control circuit (signal) interconnections are shown in the appropriate diagram:

- Interconnections for external two-wire control in combination with the Digital Operator are shown in Figure 1-5 (for 230V or 460V rated drives).
- Interconnections for external three-wire control in combination with the Digital Operator are shown in Figure 1-6 (for 230V or 460V rated drives).

Make wiring connections according to Figures 1-1 thru 1-6 and Table 1-3, observing the following :

- Signal Leads : Terminals S1-S5 & SC; FS, FR, & FC; and AM & AC.
- Control Leads : Terminals MA, MB & MC.
- Power Leads : Input Terminals L1 (R), L2 (S), and L3 (T), and Output Terminals T1 (U), T2 (V), and T3 (W).
- Use twisted shielded or twisted-pair shielded wire (20-16 AWG (0.5-1.25mm²)) for control and signal circuit leads. Use twisted shielded or twisted-pair shielded wire (20-14 AWG (0.5-2mm²)) for shield sheath terminal (terminal \oplus). When using shielded wire, the shield sheath MUST be connected at the GPD 305 ONLY (terminal \oplus). The other end should be dressed neatly and left unconnected (floating). See Figure 1-2.
- Signal leads (see above) must be separated from control leads, main circuit leads L1 (R), L2 (S), L3 (T), T1 (U), T2 (V), T3 (W), and any other power cables, to prevent erroneous operation caused by noise interference.
- Lead length should NOT EXCEED 164 feet (50 meters). Wire sizes should be determined considering the voltage drop.

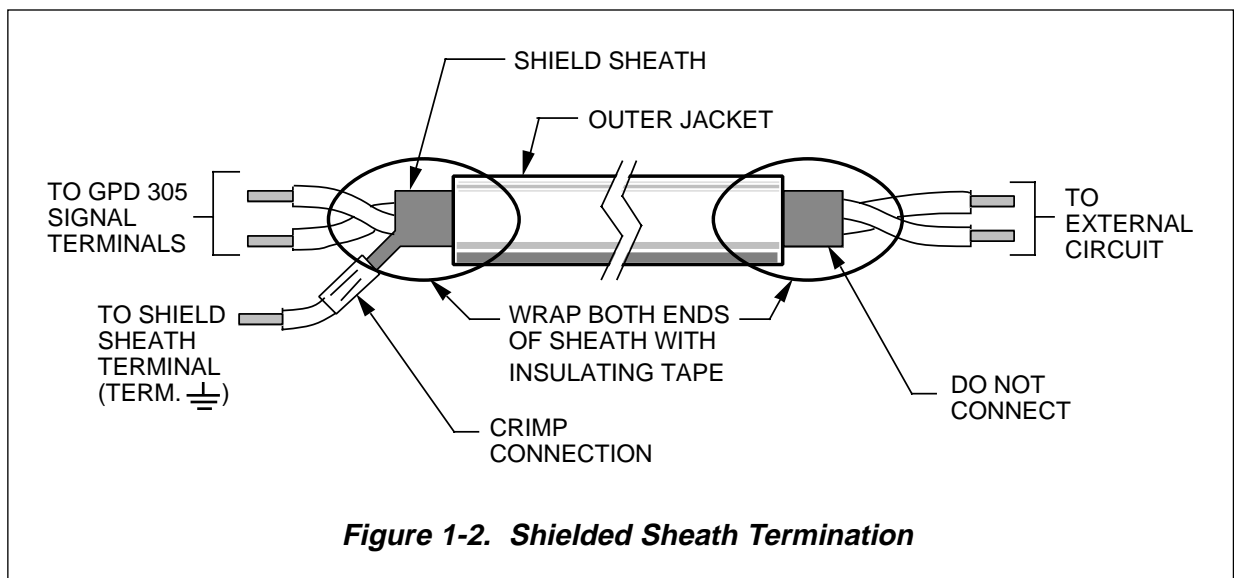

Figure 1-2. Shielded Sheath Termination

C. Grounding

- The GPD 305 must be solidly grounded using main circuit ground terminal \oplus . Ground resistance should be 100 ohms or less. Select lead size suitable for size of terminal screw. Make the length as short as possible.
- NEVER ground the GPD 305 in common with welding machines, motors, or other large-current electrical equipment.
- Where several GPD 305s are used, ground each directly or daisy-chain to the ground pole(s). DO NOT FORM A LOOP WITH THE GROUND LEADS.

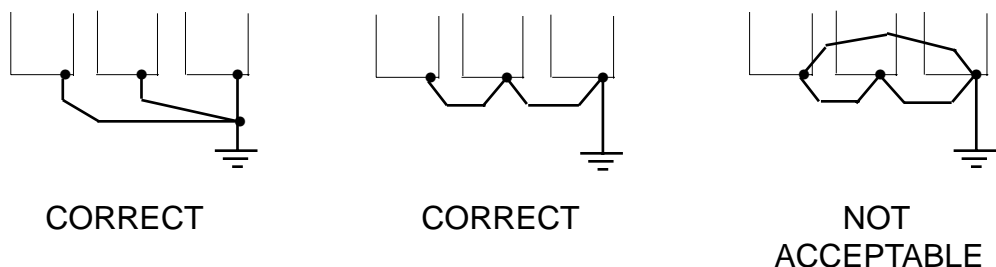

Table 1-3. Terminal Functions and Signals of Control Circuit

DATA	FUNCTION		DESCRIPTION*
S1	Input 1		Factory setting is " Forward Run/Stop " (1). (Forward run when closed, stop when open)
S2	Multi-Function-Input 2		Factory setting is " Reverse Run/Stop " (1). (Reverse Run when closed, stop when open)
S3	Multi-Function-Input 3		Factory setting is " Fault Reset " (1)
S4	Multi-Function-Input 4		Factory setting is " External Fault (NO contact) " (1)
S5	Multi-Function-Input 5		Factory setting is " Multi-step Speed Reference 1 " (1)
SC	Sequence common for terminals S1-S7.		Common terminal for sequence inputs
FS	Frequency reference power supply		+12 VDC
FR	Frequency reference input		0 to +10V/100% (20K ohms) or 4-20 mA (250 Ω)
FC	Frequency reference input common		0 V
MA	Multi-function contact output – NO contact	Factory Setting is " Drive Running "	Contact capacity: 250 Vac at 1A or below 30 Vdc at 1A or below
MB	Multi-function contact output – NC contact		
MC	Multi-function contact output – Common		
AM	Multi-function analog monitor (+)	Factory setting is " Output frequency " 0-10V = 0-100%	Monitor output: 0 to +10V; 2 mA maximum.
AC	Analog monitor common	0 V	

NOTES:

1. These inputs have factory settings based on 2-wire reset. For 3-wire reset definitions, see Figure 1-6.

D. Auxiliary Input and Output Power Option Devices

Figure 1-3 is a factory guideline for proper wiring practices and relative locations within the electrical path from the line to the load. It does not imply what devices are needed for a particular application, nor does it show what devices were shipped with a particular order. Therefore, disregard those items in the diagram which are not being used in your installation. However, it is recommended that an input or DC reactor be used with all ratings when wired to a source of 600 KVA or greater. Mount all power option devices as close to the drive, and keep electrical connections as short as possible.

DO NOT run input and output wiring in the same conduit.

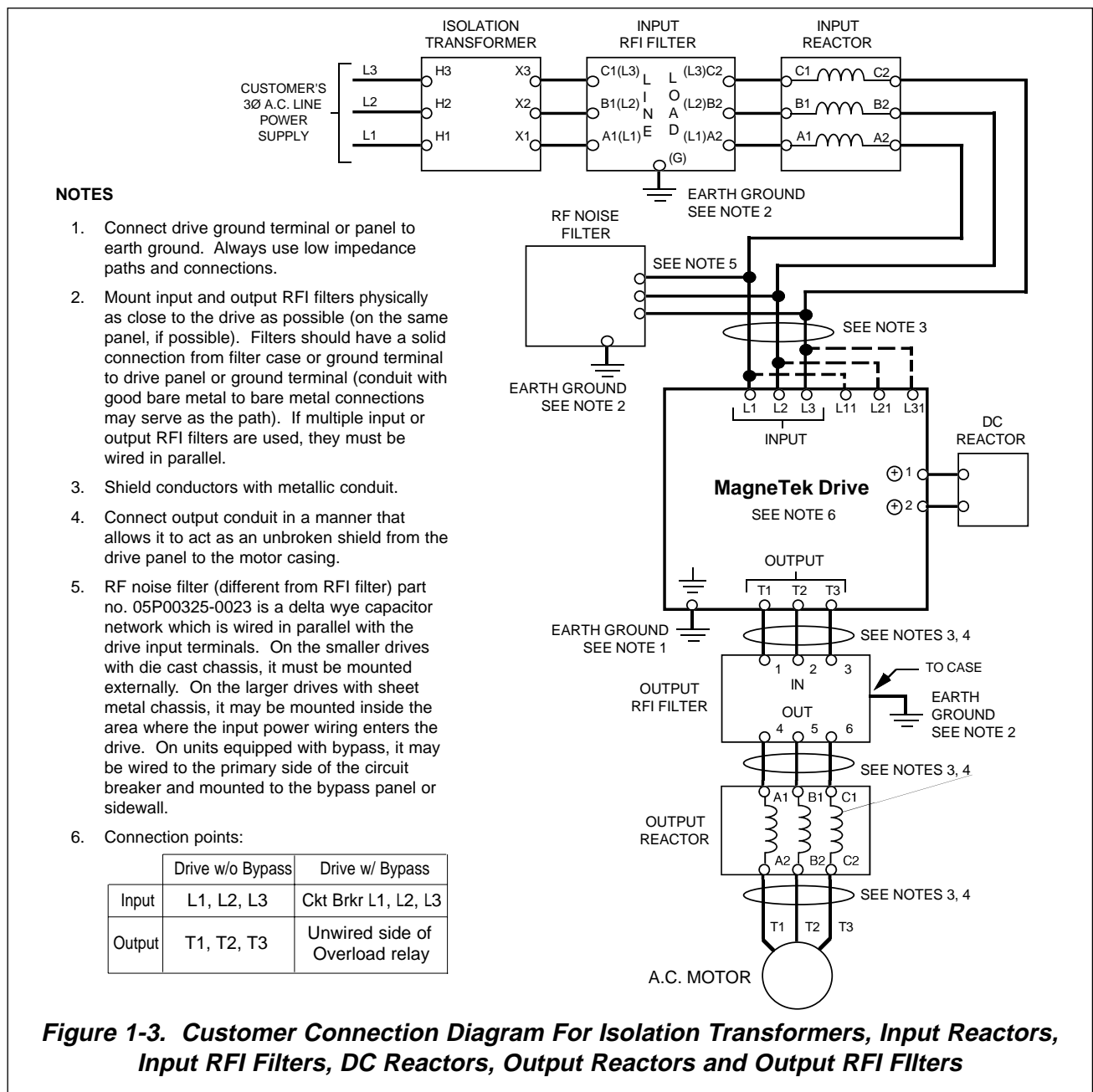

E. Conformance to European EMC Directive

In order to conform to EMC standards, the following methods are required for line filter application, cable shielding and drive installation.

The line filter and GPD 305 drive must be mounted on the same metal plate. The filter should be mounted as close to the drive as practical. The cable must be kept as short as possible and the metal plate should be securely grounded. The ground of the line filter and the drive must be bonded to the metal plate with as much bare-metal contact as possible.

For main circuit input cables, a screened cable is recommended within the panel and is also suggested for external connections. The screen of the cable should be connected to a solid ground. For the motor cables, a screened cable (max. 20 m) must be used and the screen of the motor cable should be connected to ground at both ends by a short connection, again using as much bare-metal contact as practical.

For a more detailed explanation, refer to MagneTek document TD 4077, "Installation Guidelines For EMC Directive using MagneTek AC Drive Products."

Table 1-4 and Figure 1-4 show the line filter list for EMC standards and the installation/wiring of the GPD 305 drive and line filter.

Table 1-4. Line Filters for EMC Standards

Drive Model Number	Line Filter			
	Part Number 5P616-	Rated Current (A)	Mass lbs. (kg)	Dimensions in in. (mm) L x W x D ⁽¹⁾
JDA001	0007	10	1.8 (0.8)	7.64 (194) x 3.23 (82) x 1.97 (50)
JDA002				
JDA003				
JDA005				
JDA008	0008	16	2.2 (1.0)	6.65 (169) x 4.37 (111) x 1.97 (50)
JDA011				
JDA017	0009	26	2.4 (1.1)	6.85 (174) x 5.67 (144) x 1.97 (50)
JDB001	0010	5	2.2 (1.0)	6.65 (169) x 4.37 (111) x 1.77 (45)
JDB002				
JDB003	0011	10	2.2 (1.0)	6.65 (169) x 4.37 (111) x 1.77 (45)
JDB005				
JDB009	0012	20	2.4 (1.1)	6.85 (174) x 5.67 (144) x 1.97 (50)

⁽¹⁾ D is the distance the filter will extend outward from the surface of the metal plate.

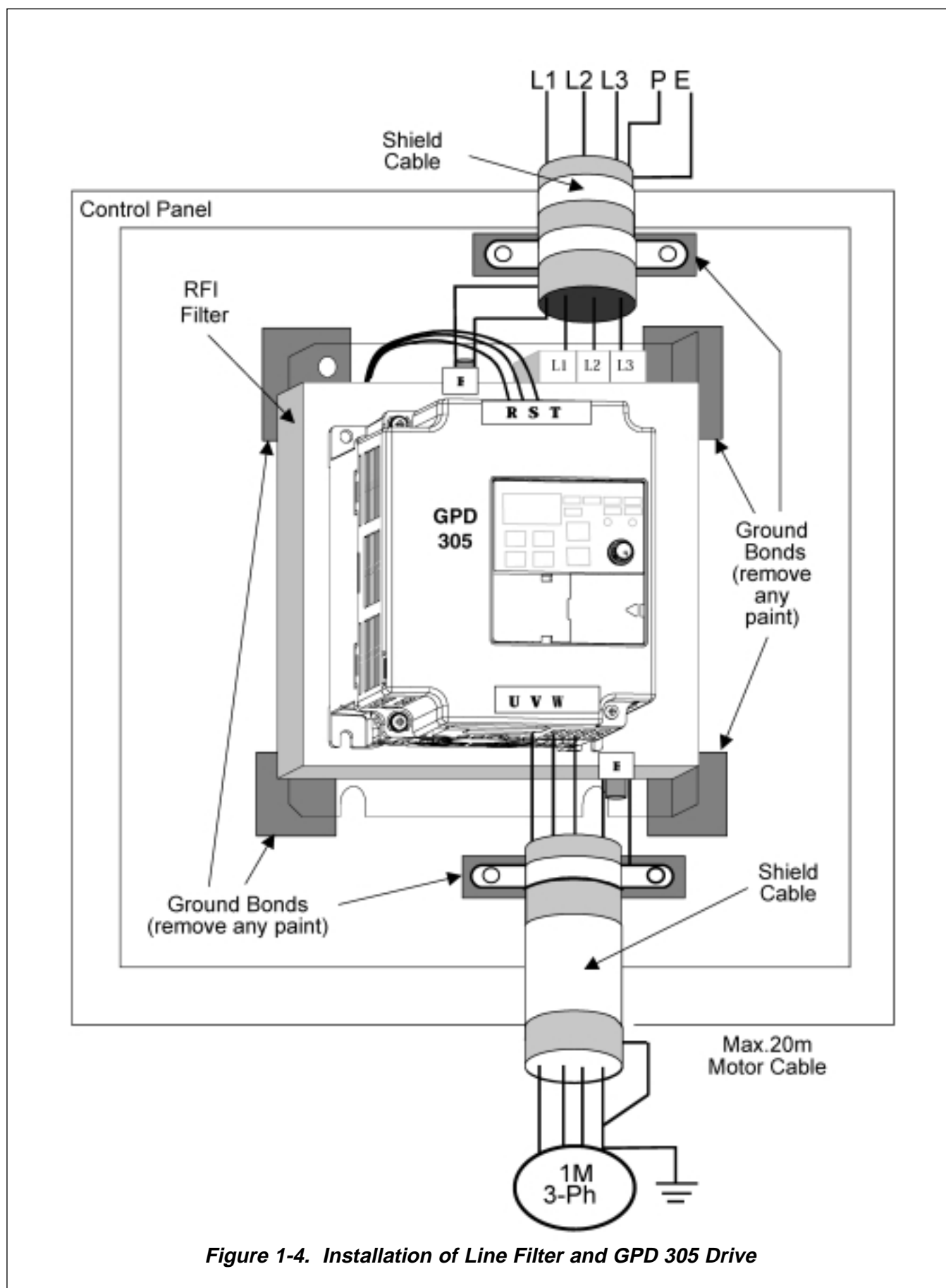



Figure 1-4. Installation of Line Filter and GPD 305 Drive

F. Interconnection - 2 Wire

NOTES FOR FIGURE 1-5

- ★ – Indicates components not supplied.
 - ⊙ – Main circuit terminal.
 - – Indicates control circuit terminal.
 - () – Indicates alternate terminal marking, i.e., (R) and L1.
 - ▲ – Function labels shown for these terminals are determined by factory settings of **n36** through **n39** (see paragraph 5.17).
 - – Function labels shown for these terminals are determined by factory setting of **n40** (see paragraph 5.18).
 - ◆ – Function label shown for this terminal is determined by factory setting of **n03** (see paragraph 5.11A).
 - – Function labels shown for these terminals are determined by factory setting of **n44** (see paragraph 5.16).
1. Insulated twisted shielded wire is required.
 - 2-conductor #18 GA. (Belden #8760 or equivalent).
 - 3-conductor #18 GA. (Belden #8770 or equivalent).
 Connect shield ONLY AT GPD 305 END (ground terminal ). Stub and isolate other end.
 2. +12V voltage output current capacity of control terminal FS is 20mA max.
 3. The GPD 305 does not include overload 1OL; it is a separate item. If local code requires separate mechanical overload protection, an overload relay should be installed, interlocked with the GPD 305 as shown. It should be the manual reset type to prevent automatic restart following a motor fault and subsequent contact reclosure after cool down. For Canadian installations, overload 1OL is to be provided in accordance with the Canadian Electrical Code, part 1 and NEC.
 4. Customer to connect terminal  to earth ground.
 5. If the Digital Operator is used, remote operators, which duplicate functions of its command keys may not be required. See Figure 4-1.
 6. An optional DC reactor may be added for harmonic attenuation, if needed. See separate instruction sheet for wiring.
 7. If application does not allow reverse operation, parameter **n05**, Reverse Run Prohibit Selection, should be set to " 1 " (Reverse Run Disabled), and the Reverse Run/Stop input can be eliminated.

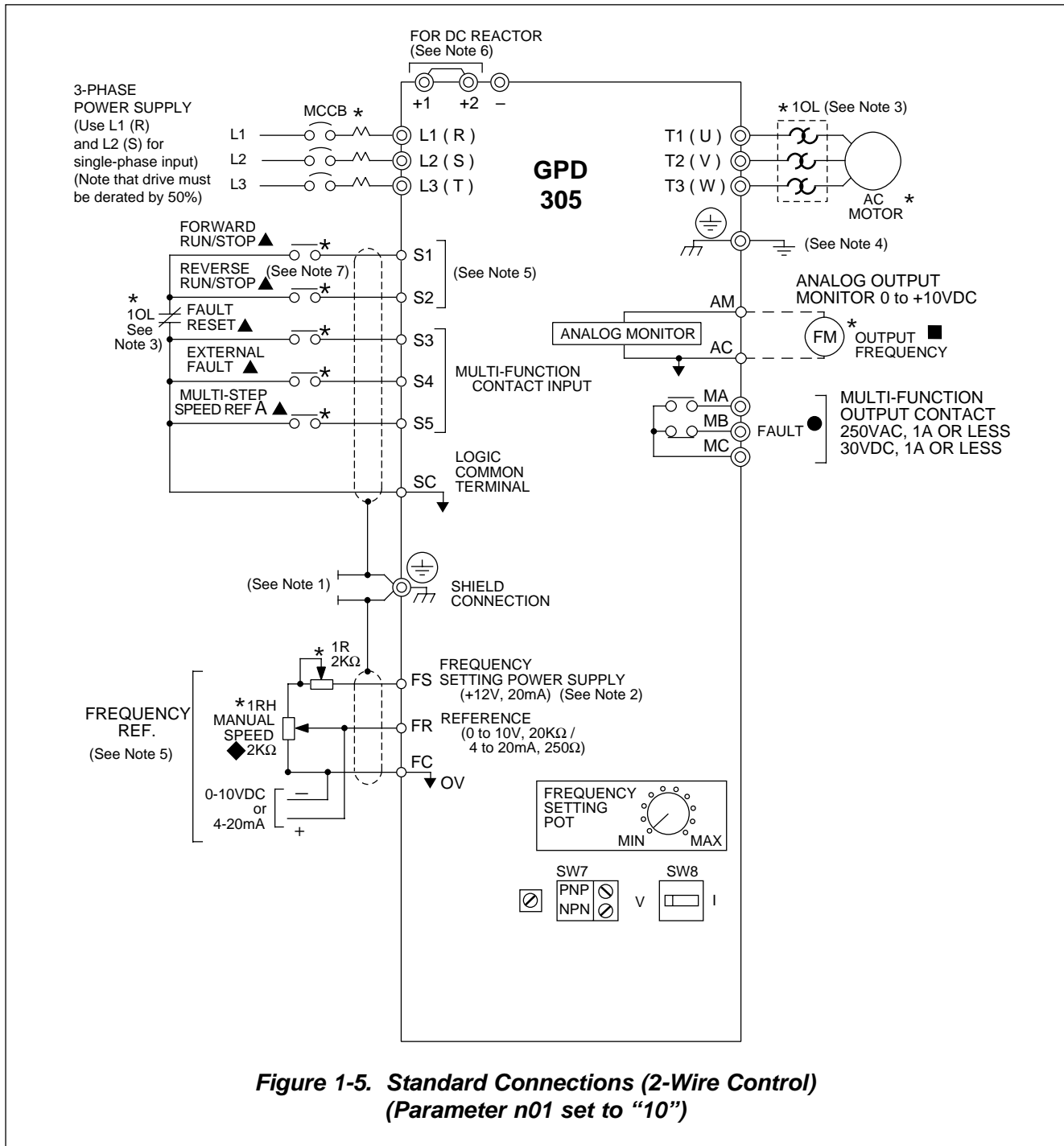

Figure 1-5. Standard Connections (2-Wire Control) (Parameter n01 set to "10")

H. Inspection. After wiring is complete, verify that:



- All wiring is correctly installed.
- Excess screws and wire clippings are removed from inside of unit.
- Screws are securely tightened.
- Exposed wire does not contact other wiring or terminals.



If a FWD or REV run command is given from the control circuit terminal when the operation method selection function (n02) is set to " 1 " and the "LO/RE" selection is set to "RE", the motor will start automatically as soon as power is applied to the main circuit.

G. Interconnection - 3 Wire

NOTES FOR FIGURE 1-6

- ★ – Indicates components not supplied.
 - ⊙ – Main circuit terminal.
 - – Indicates control circuit terminal.
 - () – Indicates alternate terminal marking, i.e., (R) and L1.
 - ▲ – Function labels shown for these terminals are determined by factory settings of **n36** through **n39** (see paragraph 5.17).
 - – Function labels shown for these terminals are determined by factory setting of **n40** (see paragraph 5.18).
 - ◆ – Function label shown for this terminal is determined by factory setting of **n03** (see paragraph 5.11A).
 - – Function labels shown for these terminals are determined by factory setting of **n44** (see paragraph 5.16).
1. Insulated twisted shielded wire is required.
 - 2-conductor #18 GA. (Belden #8760 or equivalent)
 - 3-conductor #18 GA. (Belden #8770 or equivalent)
 Connect shield only at GPD 305 end (ground terminal ()). Stub and isolate other end.
 2. +12V voltage output current capacity of control terminal FS is 20mA max.
 3. The GPD 305 does not include overload 1OL; it is a separate item. It may not be required; see page 5.34. The contact from the separately supplied overload relay should be interlocked with the GPD 305 as shown. It should be the manual reset type to prevent automatic restart following a motor fault and subsequent contact reclosure after cool down. *For Canadian installations, overload 1OL is to be provided in accordance with the Canadian Electrical Code, Part 1 and NEC.*
 4. Customer to connect ground terminal () to earth ground.
 5. If Digital Operator is used, remote operators which duplicate functions of its command keys (see Figure 4-1) may not be required.
 6. An optional DC reactor may be added for harmonic attenuation, if needed; see separate instruction sheet for wiring.
 7. If application does not allow reverse operation, parameter **n05**, Reverse Run Prohibit Selection, should be set to “ 1 ” (Reverse Run Disabled) and Fwd/Rev input can be eliminated.

CAUTION

Parameter *n37* must be set to “ 0 ”, AND parameter *n01* must be set to “ 11 ”. Resetting drive parameter *n01* to “ 10 ” may cause the motor to run in reverse direction WITHOUT A RUN COMMAND, and possibly result in equipment damage or personal injury.

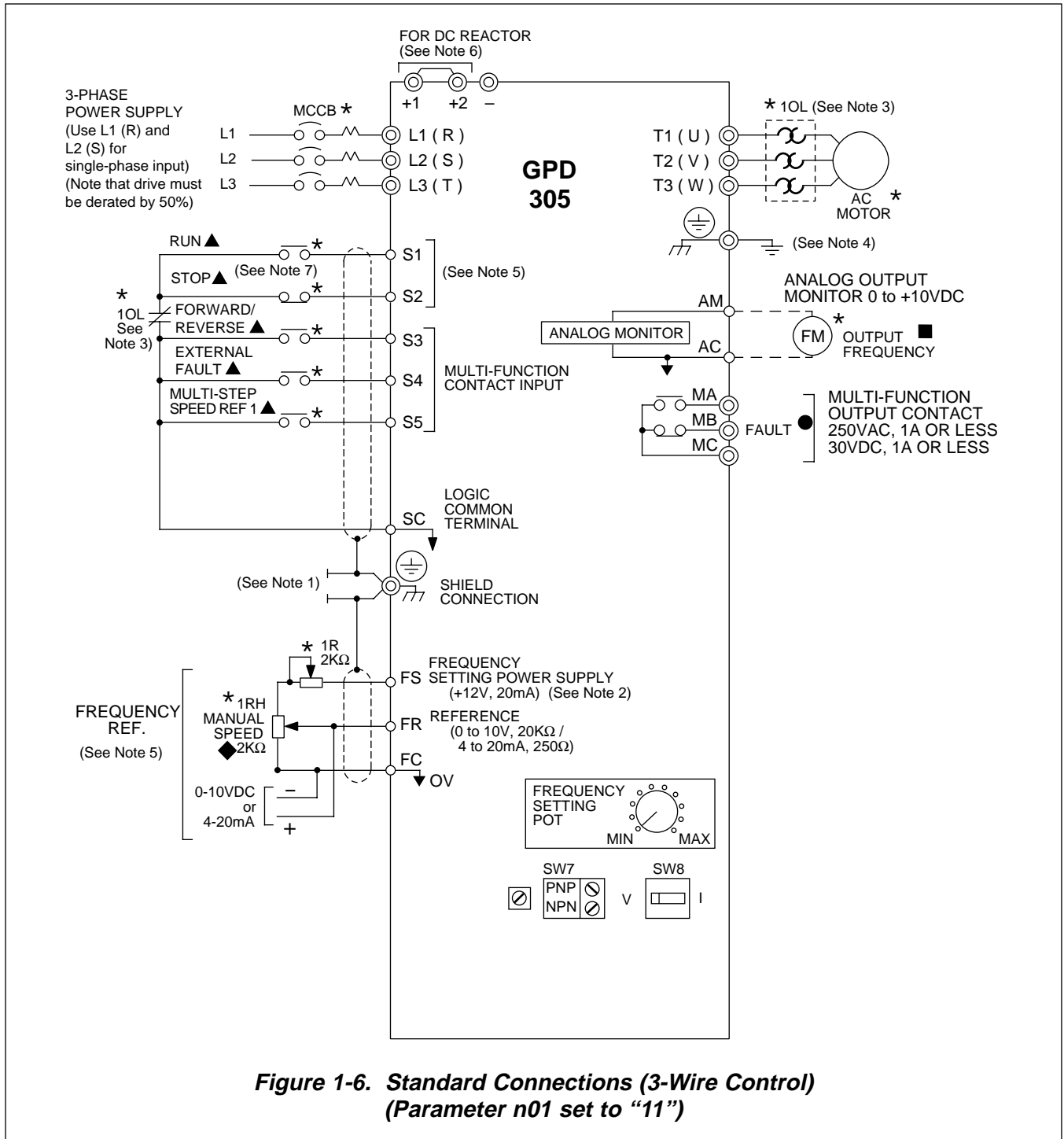

Figure 1-6. Standard Connections (3-Wire Control)
(Parameter n01 set to "11")

H. Inspection. After wiring is complete, verify that:

- All wiring is correctly installed.
- Excess screws and wire clippings are removed from inside of unit.
- Screws are securely tightened.
- Exposed wire does not contact other wiring or terminals.



If a FWD or REV run command is given from the control circuit terminal when the operation method selection function (n02) is set to " 1 " and the "LO/RE" selection is set to "RE", the motor will start automatically as soon as power is applied to the main circuit.

Section 2. INITIAL START-UP

2.1 PRE-POWER CHECKS

- Verify wires are properly connected and no erroneous grounds exist.
- Remove all debris from the GPD enclosure, such as loose wire clippings, metal shavings, etc.
- Verify all mechanical connections inside the GPD 305 are tight.
- Verify motor is not connected to load.
- Apply input power only after the front cover is in place. DO NOT remove the front cover or Digital Operator while input power is on.

2.2 STARTUP PROCEDURE

IMPORTANT: 2-wire or 3-wire sequence selection must be made prior to any other adjustments (Parameter n01).

Table 2-1. Startup Procedure

























DESCRIPTION	KEY SEQUENCE	DIGITAL OPERATOR DISPLAY
<p>Set motor rated current. (This can be obtained from the nameplate of the motor.)</p>	<p>Press  key until the  LED is lit on the digital operator.</p> <p>Press and hold  until n32 is displayed on the digital operator.</p> <p>Then press .</p> <p>Use the  &  keys until the number in the display matches the motor rated current.</p> <p>Then press .</p>	    ⁽¹⁾  
<p>Set the V/f pattern. Parameters n09 through n15 set the V/f pattern. Table 5-4 in section 5.26 lists recommended V/f patterns. The numbers in parentheses shown in the example below are for a 460V / 60 Hz variable torque application (fan or pump).</p>		
<p>Set Parameter n09- Maximum output frequency. (60.0 Hz)</p>	<p>Press and hold  until n09 is displayed on the digital operator.</p> <p>Then press .</p> <p>Use the  &  keys until the desired number is in the display.</p> <p>Then press .</p>	  ⁽¹⁾   ⁽¹⁾  

Table 2-1. Startup Procedure - Continued

































DESCRIPTION	KEY SEQUENCE	DIGITAL OPERATOR DISPLAY
<p>Set Parameter n10- Voltage Max. (460 V)</p>	<p>Press  then .</p> <p>Use the  &  keys until the desired number is in the display.</p> <p>Then press .</p>	  ⁽¹⁾   ⁽¹⁾  
<p>Set Parameter n11- Frequency at max. voltage point (motor rated frequency) (60.0 Hz)</p>	<p>Press  then .</p> <p>Use the  &  keys until the desired number is in the display.</p> <p>Then press .</p>	  ⁽¹⁾   ⁽¹⁾  
<p>Set Parameter n12- Frequency - Midpoint (30.0 Hz)</p>	<p>Press  then .</p> <p>Use the  &  keys until the desired number is in the display.</p> <p>Then press .</p>	  ⁽¹⁾   ⁽¹⁾  

Table 2-1. Startup Procedure - Continued

















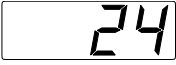

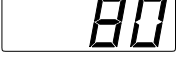

















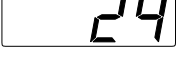

DESCRIPTION	KEY SEQUENCE	DIGITAL OPERATOR DISPLAY
<p>Set Parameter n13- Voltage - Midpoint (80 V)</p>	<p>Press  then .</p> <p>Use the  &  keys until the desired number is in the display.</p> <p>Then press .</p>	<p> ⁽¹⁾</p> <p> ⁽¹⁾</p> <p> </p>
<p>Set Parameter n14- Frequency - Minimum (1.5 Hz)</p>	<p>Press  then .</p> <p>Use the  &  keys until the desired number is in the display.</p> <p>Then press .</p>	<p> ⁽¹⁾</p> <p> ⁽¹⁾</p> <p> </p>
<p>Set Parameter n15- Voltage - Minimum (18 V)</p>	<p>Press  then .</p> <p>Use the  &  keys until the desired number is in the display.</p> <p>Then press .</p>	<p> ⁽¹⁾</p> <p> ⁽¹⁾</p> <p> </p>

Table 2-1. Startup Procedure - Continued

DESCRIPTION	KEY SEQUENCE	DIGITAL OPERATOR DISPLAY
<p>Prepare to test run the drive from the Digital Operator. Motor should be disconnected from the load.</p> <p>This will set the drive into the "Local" mode, and bring up the motor current display.</p>	<p>Press  several times until the "LO/RE" LED is lit.</p> <p>Press the  key once.</p> <p>Display the drive's output current by pressing  four times. Turn the Digital Operator Pot all the way to the left (counter-clockwise).</p>	  
<p>Test run the drive from the Digital Operator</p>	<p>WARNING: The next key press will cause the motor to turn! Take appropriate safety precautions!</p> <p>Press the  key then slowly turn the Digital Operator Pot to the right about 1/4 of a turn. The display on the drive will show the actual motor amps.</p> <p>Operation checkpoints:</p> <ul style="list-style-type: none"> • Motor rotates smoothly • Motor rotates in correct direction. (If motor does not rotate in the proper direction, stop the motor and remove power from the GPD 305. Switch motor connections T1 (U) and T2 (V) at the GPD 305 to change direction). • Motor has no abnormal vibration or noise. • Acceleration and deceleration are smooth. • Unit is not overloaded. (Displayed current does not exceed drive rated current). <p>Press the  key.</p>	
<p>This completes the startup. Make further programming changes as required.</p>		

(1) The number in the display may be different than shown.

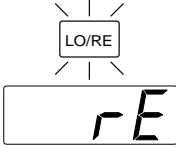
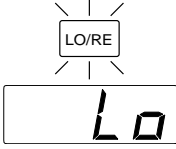
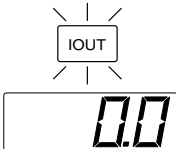
Section 3. OPERATION AT LOAD

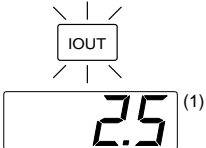
After completing the start-up, and programming of constants, turn off the AC main circuit power. Make additional wiring connections required for the external control functions selected by the constant programming. Connect the driven machine to the motor. Verify that the driven machine is in running condition, and that no dangerous conditions exist around the drive system.

OPERATING PRECAUTIONS

- Before applying a RUN command to the GPD 305, verify that the motor is stopped.
- **NEVER** use a motor whose full-load amps exceeds the GPD 305 rating.
- When starting and stopping the motor, use the operation signals (RUN/STOP, FWD/REV), NOT a magnetic contactor on the power supply side.

Run the motor under load with control by the Digital Operator using the same procedure as for the Initial Start-up. If the Digital Operator is used in combination with external commands or external commands only are used, the procedure must be altered accordingly.

Section 4. DIGITAL OPERATOR

4.1 GENERAL

All functions of the GPD 305 are accessed using the Digital Operator. In addition to controlling motor operation, the operator can enter information into the GPD 305 memory to configure the GPD 305 to the application, by using the Function LEDs.

4.2 DIGITAL OPERATOR

A. Digital Operator Description

The Digital Operator has a 3-digit LED display. Both numeric and alpha-numeric data can appear on the display.

Indicators and keys on the Digital Operator are described in Figure 4-1.

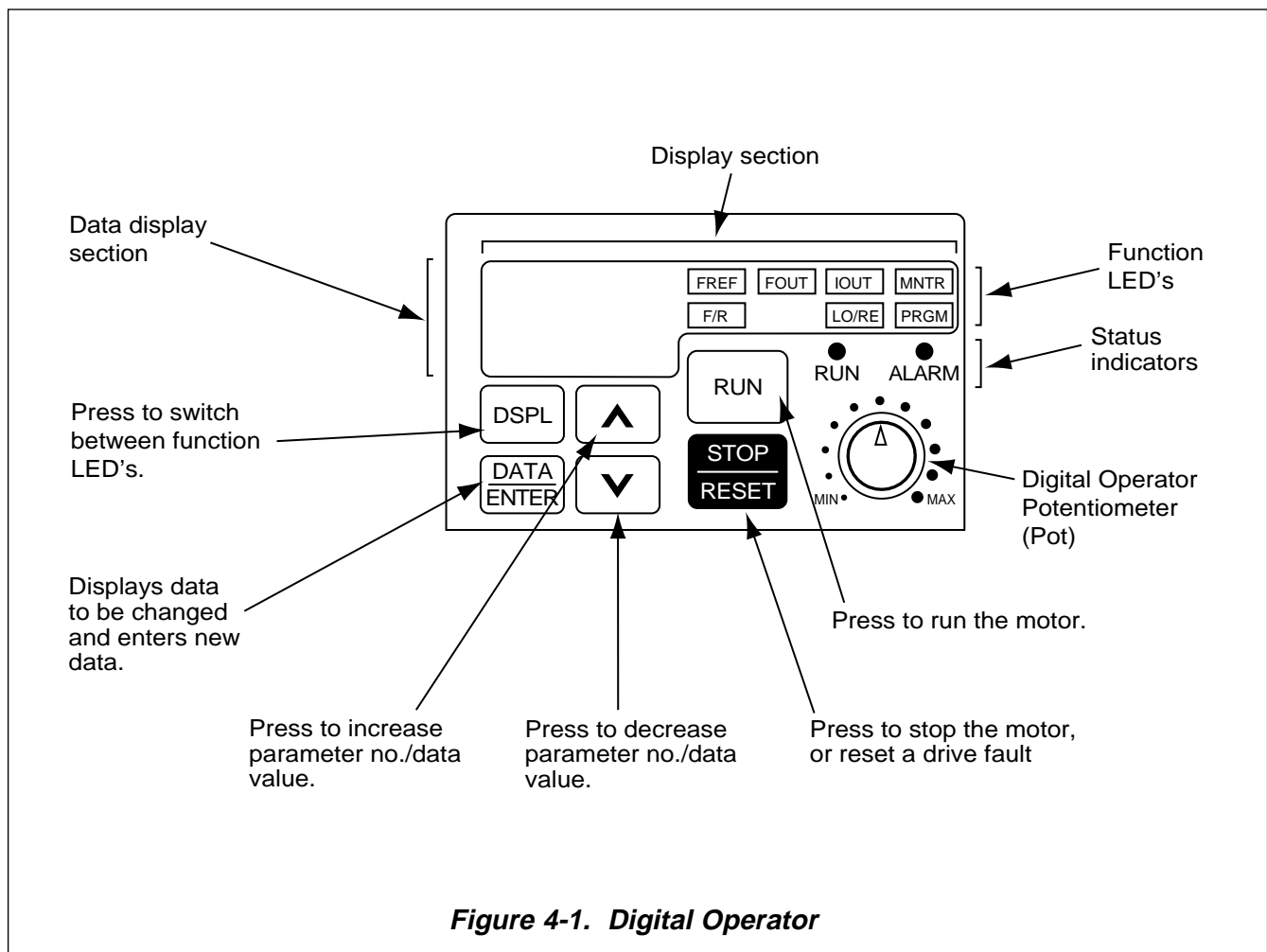

B. Description of Function LEDs

By pressing the **DSPL** key on the Digital Operator, the operator can step to each of the seven Function LEDs and its associated display/setting function:

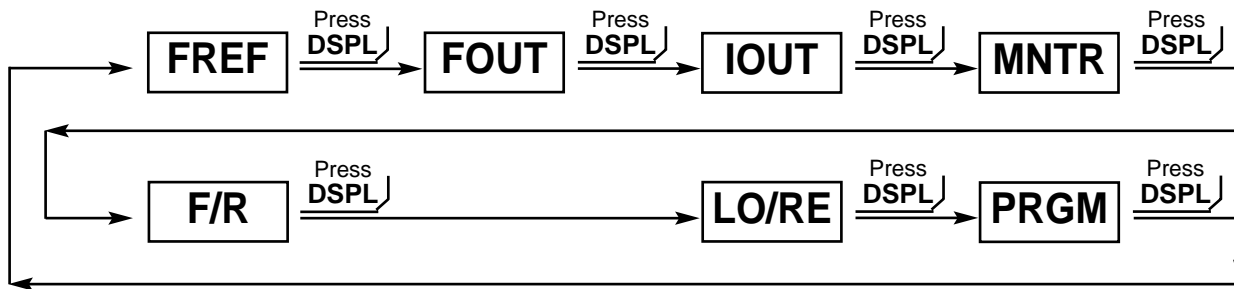

- FREF** — **Frequency Reference Setting**
Sets/Displays the GPD 305 operation speed (Hz).

- FOUT** — **Output Frequency Monitor**
Displays the output frequency (Hz) at which the GPD 305 is currently operating. This is a **monitor only** function; the operator cannot change the displayed value by use of the keypad.

- IOUT** — **Output Current Monitor**
Displays the level of output current (Amps) that the GPD 305 is currently producing. This is a **monitor only** function; the operator cannot change the displayed value by use of the keypad.

- MNTR** — **Monitor Selection**
Pressing **ENTER** allows access to the various Monitor parameters, **U-01** through **U-10** and **U-15**. These are monitor only functions; the operator cannot change the displayed value. Accessible during run command. See section 4.4. for complete listing of all monitor parameters.

- F/R** — **FWD/REV Run Selection**
Sets the rotation direction of the motor when a Run command is given by the Digital Operator keypad. Display of **For** = forward run, **rEu** = reverse run.

- LO/RE** — **Local / Remote Selection**
This toggles between the Local (Digital Operator) and Remote (set by parameters n02 & n03) modes of operation. This affects both the start/stop functions, as well as the frequency reference. Local / Remote status cannot be changed using this LED when a multi-function input terminal is set for Local/Remote (n36 through n39 set for "17").

- PRGM** — **Parameter Programming**
Selects or reads data using parameter number (**nXX**). Data is displayed by pressing the **ENTER** key, and can be changed by pressing the "up arrow" or "down arrow" keys. Any changes can be saved by again pressing the **ENTER** key. Pressing the **DSPL** key exits the Programming mode.

4.3 STATUS INDICATOR LEDs

There are two indicator LEDs on the front of the GPD 305. The drive status is indicated by various combinations of ON, Blinking, and OFF conditions of these two LEDs:

CONDITION	(Green) ○ RUN	(Red) ○ ALARM
Operation Ready (during stop) Ramp to Stop (during decel)	Blinking Long Blinking	Off Off
Normal Operation (running) Alarm	On Blinking or ON	Off Blinking
Fault	Off	On

For details of how the status indicator LEDs function during a drive fault, refer to the “TROUBLESHOOTING” section.

4.4 MONITOR DISPLAYS

When using the **Monitor** Function, a variety of information will appear on the Digital Operator display when each of the U-XX (display only) parameters is selected.

PARAMETER U -	MONITORED ITEM	DISPLAY EXAMPLE
01	Frequency reference (Hz)	60.0
02	Output frequency (Hz)	60.0
03	Output current (A)	12.5
04	AC output voltage (V)	230
05	DC Bus voltage (VPN)	325
06	Input terminal status	 ⁽¹⁾
07	Output terminal status	 ⁽²⁾
09	Fault record (last record faults) ⁽³⁾	oC
10	Software number <u>XXXX</u>	013
15	Data reception error	0

(1) Actual display appearance:

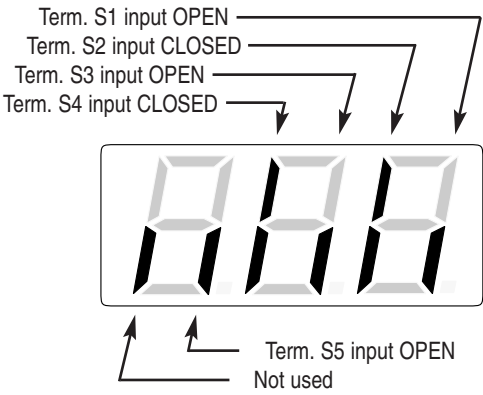

(2) Actual display appearance:

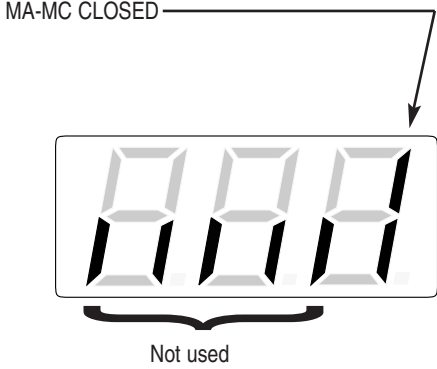

(3) See section 6 for viewing of fault log contents.

Fault record display

When U-09 is selected, a three-digit box is displayed.

- Example

- 3-digit numbers

- : Fault description

- “---” is displayed if there is no fault.

- (Refer to section 6 for details of fault.)

- Viewing fault record

- Press the or key to examine the complete fault record.

- Clearing fault record

- Set parameter n01 to “6” to clear the fault record. Display returns to “n01” after completion of 6 setting.

NOTE: Parameter initializing (n01=10 or 11) also clears the fault record.

Section 5. PROGRAMMABLE FEATURES

5.1 GENERAL

This section describes features of the GPD 305 which are defined by programmed settings in the various parameters in memory. Since most features use more than one parameter, the descriptions appear in alphabetical order by the function name. In Table 5-1, the functions are grouped into operational categories. To cross reference a particular parameter to the features to which it applies, see the listings in Appendix 1.

Table 5-1. List of Features Defined By Parameters

FUNCTION	PARAGRAPH REFERENCE	PARAMETER(S)
SET-UP		
Initialization (Reset), 2-Wire or 3-Wire	5.20	<i>n01</i>
Volts/Hertz Patterns	5.26	<i>n09 - n15</i>
Thermal Motor Overload Protection	5.24	<i>n32, n33</i>
Copy Function	5.27	<i>n76, n77</i>
STARTING		
Accel Time	5.2	<i>n16, n18</i>
S-Curve Characteristics	5.3	<i>n20</i>
DC Injection Braking at Start	5.7	<i>n52, n54</i>
STOPPING		
Stopping Method	5.23	<i>n04</i>
Decel Time	5.2	<i>n17, n19</i>
DC Injection Braking at Stop	5.7	<i>n52, n53</i>
SPEED CONTROL		
Frequency Reference, Upper & Lower Limits	5.9	<i>n30, n31</i>
Jog Reference	5.12	<i>n29, n36 - n39</i>
Frequency Reference Selection	5.11	<i>n03, n07, n08</i>
Multi-step Speed Setting	5.11	<i>n03, n21 - n28, n36 - n39</i>
Up/Down Frequency Setting	5.17E	<i>n39</i>
Modbus Control	5.14	<i>n02, n03, n68 - n74</i>
REVERSE		
Reverse Run Disabled	Table A1-1	<i>n05</i>
Critical Frequency Rejection	5.6	<i>n49 - n51</i>
Carrier Frequency	5.5	<i>n46</i>
Speed Search	5.17D	<i>n36 - n39</i>
Speed Coincidence	5.18	<i>n40, n58</i>
Slip Compensation	5.21	<i>n32, n64- n67</i>
RUNNING IMPROVEMENTS		
Torque Compensation	5.25	<i>n63</i>
Stall Prevention	5.22	<i>n55 - n57</i>
PROTECTIVE FEATURES		
Momentary Power Loss Ride-thru	5.15	<i>n47</i>
Auto Restart	5.4	<i>n48</i>
Overtorque/Undertorque Detection	5.19	<i>n40, n59 - n61</i>
DRIVE CONTROLS, INPUT		
Analog Frequency Reference Bias and Gain	5.8	<i>n41, n42</i>
Multi-function Analog Inputs	5.11	<i>n068 - n079, n149</i>
Multi-function Input Terminals	5.17	<i>n36 - n39</i>
External Fault Terminals	5.17	<i>n36 - n39</i>
DRIVE OUTPUT		
Multi-function Output Terminals	5.18	<i>n40</i>
Analog Monitor Output (Multi-function)	5.16	<i>n44, n45</i>

5.2 ACCEL/DECEL TIME

- A. **n16** : Accel Time 1
n17 : Decel Time 1

Factory setting (each): **10.0** seconds

Range (each): 0.0 to 999 seconds

- n18** : Accel Time 2
n19 : Decel Time 2

Factory setting (each): **10.0** seconds

Range (each): 0.0 to 999 seconds

The GPD Drive incorporates two sets of individually programmable acceleration and deceleration times. Setting resolution is 0.1 seconds when set to less than 100 seconds; resolution is 1 second when set to 100 seconds or more.

- B. **n36 thru n39** : Multi-function Inputs (Term. S1 thru S7)

Data **11** : Accel/Decel Time Selection

By programming data " 11 " into one of the multi-function parameters (**n36** thru **n39**), one of the multi-function input terminals (S2 thru S5) becomes a time selection input. When the input terminal (i.e. external contact) is open, Time 1 (**n16** / **n17**) is selected. When the input terminal is closed, Time 2 (**n18** / **n19**) is selected.

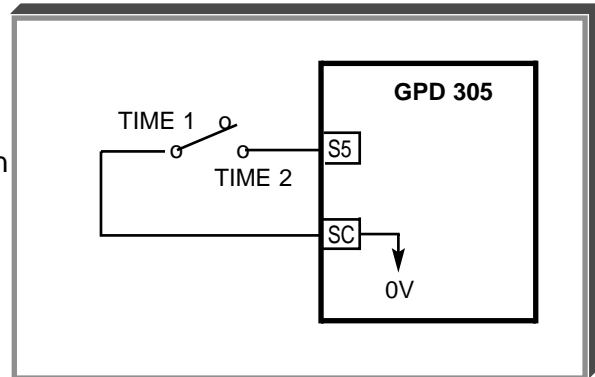

5.3 ACCEL/DECEL: S-CURVE CHARACTERISTICS

n020 : S-Curve Selection

Factory setting: **0**

Range: 0 to 3

Setting of this parameter determines the S-curve (starting) characteristics of the acceleration ramp.

- 0** = S-curve disabled
- 1** = S-curve of 0.2 seconds
- 2** = S-curve time of 0.5 seconds
- 3** = S-curve time of 1.0 seconds

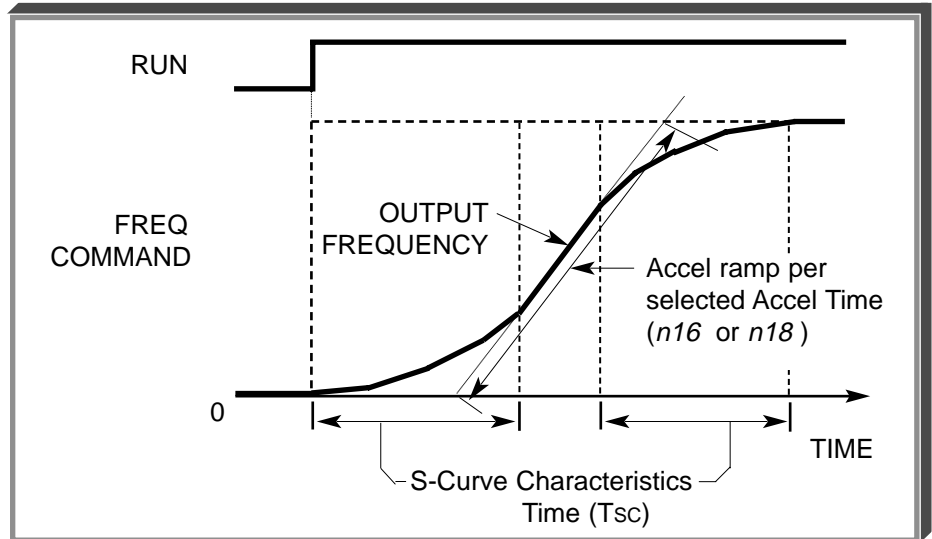

The following figure shows FWD/REV switching and acceleration & deceleration to a stop with S-curve active.

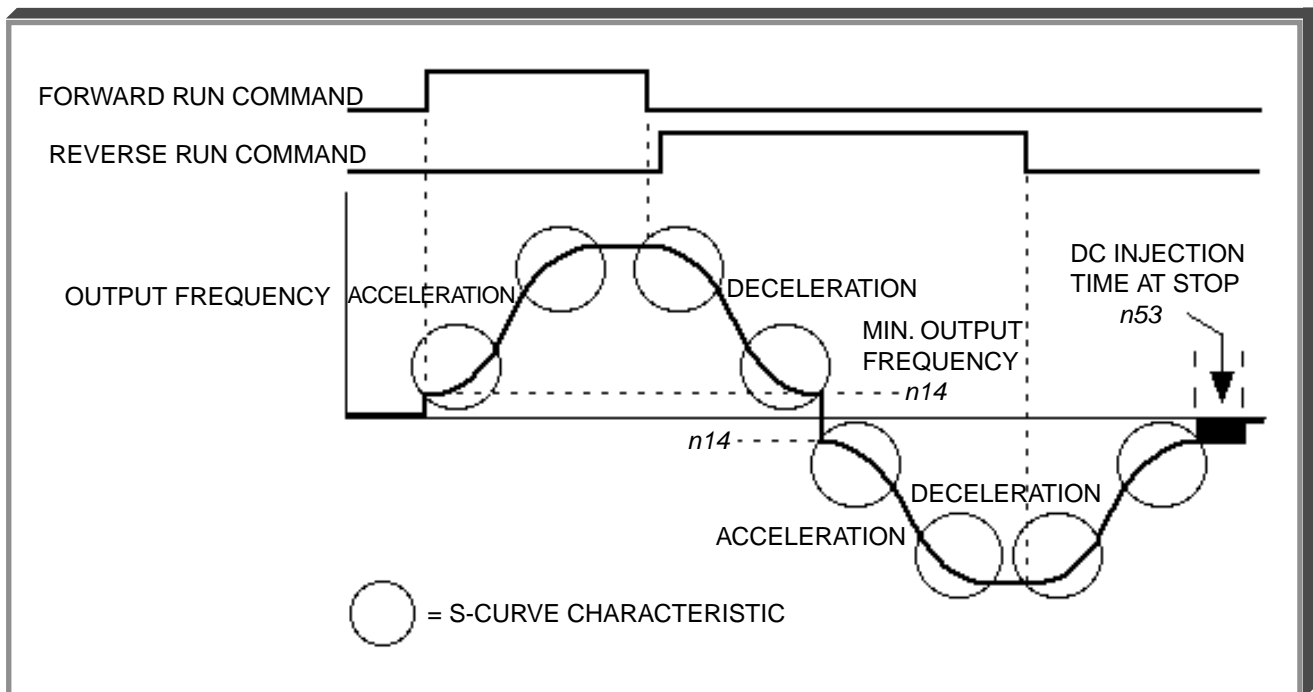

5.4 AUTO-RESTART

A. **n48** : Number of Auto-Restart Attempts

Factory setting: 0

Range: 0 to 10

When a fault occurs during operation, the GPD Drive can be programmed for an auto-restart operation to automatically reset the fault. Auto-restart operation will use the number of reset attempts set in this parameter, up to the maximum of 10. When set to " 0 ", no auto-restarts will be attempted.

- The following faults can be automatically reset:
 - oC: Overcurrent
 - ou: Overvoltage (OV)
 - GF: Ground Fault
- The number of restart attempts available will be reset to the **n48** setting when:
 1. 10 minutes has elapsed without a fault occurring.
 2. The **RESET** key, or external Fault Reset push button, is pressed.
 3. Power is removed from the Drive.

5.5 CARRIER FREQUENCY

n46 : Carrier Frequency Upper Limit

Factory Setting: 3
Range: 1 to 4; 7 to 9

The relationship between output frequency and carrier frequency is determined from the set value of **n46**.

- (a) For constant carrier frequency, set to " 1 ", " 2 ", " 3 ", " 4 " .
- (b) For synchronous mode, set **n46** to " 7 ", " 8 ", or " 9 ". These setting values establish carrier frequencies of 12f, 24f, or 36f, respectively.

n46 SETTING	CARRIER FREQUENCY(kHz)		SLOPE (= $\frac{F_c}{F_o}$)	OUTPUT FREQUENCY(Hz)		MODE
	Maximum(FcMAX)	Minimum(FcMIN)		F1	F2	
1	2.5	2.5	0	NA	NA	CONSTANT
2	5.0	5.0	0	NA	NA	
3	7.5	7.5	0	NA	NA	
4	10.0	10.0	0	NA	NA	
7	2.5	1.0	12	83.3	208.3	SYNCHRONOUS
8	2.5	1.0	24	41.6	104.1	
9	2.5	1.0	36	27.7	69.4	

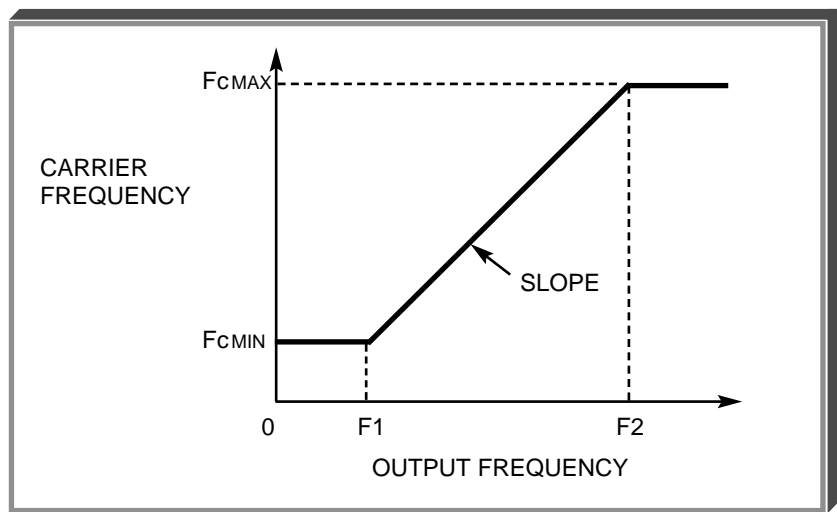

Carrier frequency should be decreased as the distance between the drive and the motor increases, to reduce capacitive coupling in the motor leads.

- For wiring distances greater than 100m (328 ft.), **n46** should be set to 5 kHz (data " 2 ") or less.

5.6 CRITICAL FREQUENCY REJECTION

- A. **n49** : Prohibited Frequency 1
n50 : Prohibited Frequency 2

Factory setting (each): **0.0**

Range (each): 0.0 to 400 Hz

These parameters allow programming of up to three prohibited frequency points for eliminating problems with resonant vibration of the motor/machine. This feature does not actually eliminate the selected frequency values, but will accelerate and decelerate the motor through the prohibited bandwidth.

- B. **n51** : Prohibited Frequency Deadband

Factory setting: **0.0**

Range: 0.0 to 25.5 Hz

This parameter determines the width of the deadband around each selected prohibited frequency point. The factory setting is " 1.0 ", which establishes a deadband of ± 1.0 Hz.

EXAMPLE:

Vibration encountered between 30.0 and 36.0 Hz.

SOLUTION: Set **n49** to " 33.0 ". This is the center of the problem frequency band.

Set **n51** to " 3.0 ". This will cause the GPD Drive to reject all frequency command values between 30.0 and 36.0 Hz.

A frequency command in the deadband will be converted to the bottom value of the deadband, e.g. a command of 33 Hz would result in a run frequency of 30 Hz.

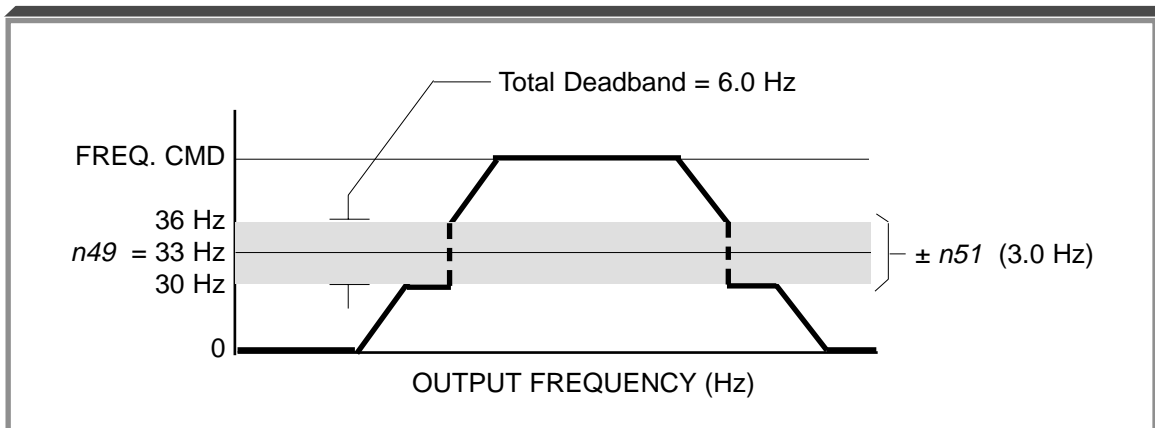

NOTE: **n49** > **n50** - The highest prohibit frequency required needs to be in **n49** and the lowest prohibit frequency needs to be in **n50**.

5.7 DC INJECTION BRAKING

n14 : Minimum Frequency

Range: 0.1 to 10.0 Hz

n52 : DC Injection Braking Current
(% of Drive Rated Current)

Factory setting: **50** %

Range: 0 to 100 %

n53 : DC Injection Time at Stop

Factory setting: **0.5** sec

Range: 0.0 to 25.5 sec

n54 : DC Injection Time at Start

Factory setting: **0.0** sec

Range: 0.0 to 25.5 sec

DC injection can be used to stop a motor whose rotational direction is uncertain at start-up, or to help stop a coasting motor.

With ramp to stop enabled (**n04** = " 0 "), after a STOP command is received the GPD 305 controls motor deceleration according to the Decel Time setting, until output frequency reaches the DC injection braking start frequency (or Minimum Frequency, **n14**). Then the GPD Drive output is turned off and DC injection current is applied to the motor. The effective DC injection time and current should be set to provide adequate stopping without excessive motor heating. The DC injection voltage is determined by the DC injection braking current and motor impedance.

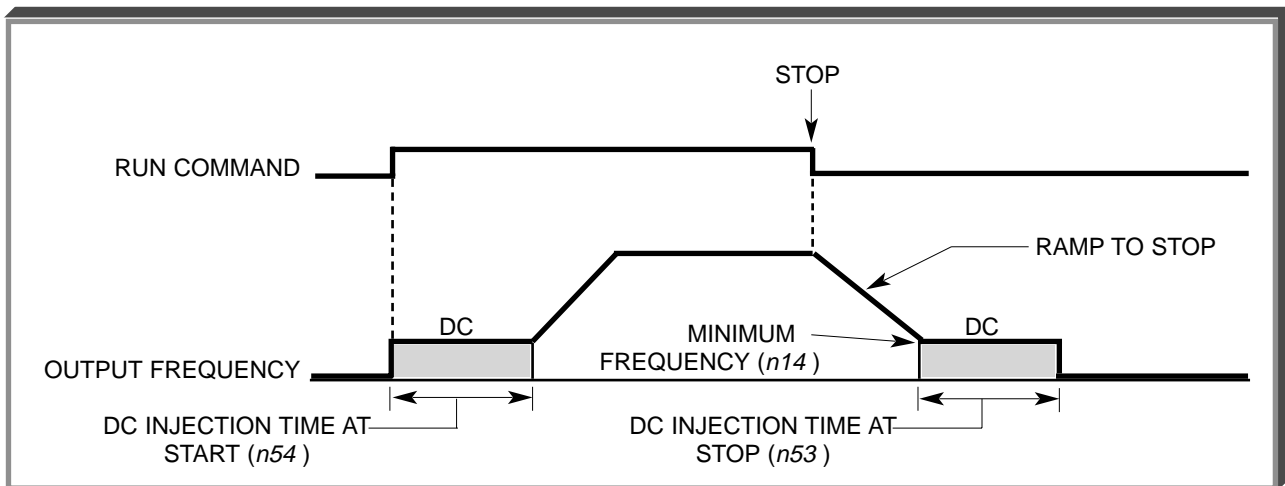

DC Braking Sequence

5.8 FREQUENCY REFERENCE BIAS/GAIN (ANALOG)

n41 : Analog Frequency Reference Gain

Factory setting: **100** %

Range: 0 to 255 %

Sets the auto-speed frequency command gain, in increments of 1%.

n42 : Analog Frequency Reference Bias

Factory setting: **0** %

Range: -99 to 99 %

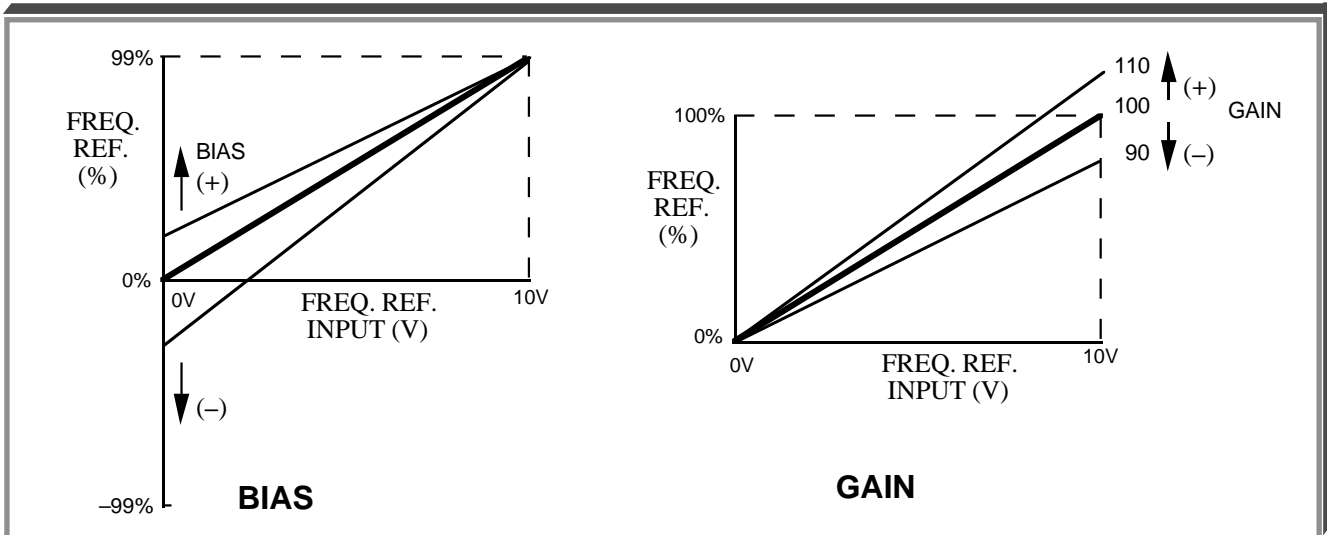

ADJUSTMENT PROCEDURE:

1. With no input, adjust Bias (**n42** setting) until an output of 0.0 Hz is obtained.
2. With full scale input, adjust Gain (**n41** setting) until an output of 60.0 Hz (or other desired max. output frequency) is obtained.

NOTE: Follow the same adjustment procedure for other desired frequency setpoints.

For inverse-acting frequency reference

1. Begin with **n41** & **n42** settings as shown below.
2. Fine tune as indicated above.

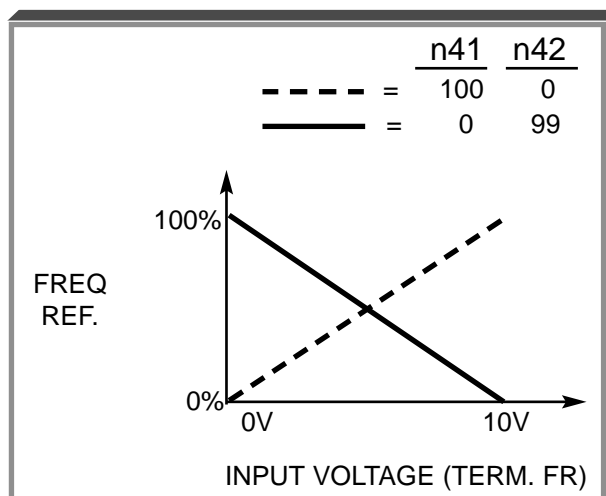

5.9 FREQUENCY REFERENCE UPPER AND LOWER LIMITS

n30 : Frequency Reference Upper Limit

Factory setting: 100 %
Range: 0 to 110 %

n31 : Frequency Reference Lower Limit

Factory setting: 0 %
Range: 0 to 110 %

These two parameters set the range for the frequency command signal. Each is set, in increments of 1%, as a percentage of maximum frequency (Fmax; **n09**) as established by either the selected standard V/f pattern or custom V/f pattern.

NOTE: All references are affected by the upper and lower limit points.

EXAMPLE:

n09 = " 60 " Hz (100%)
n30 = " 80 " % = 48Hz – Max. speed
n31 = " 10 " % = 6Hz – Min. speed

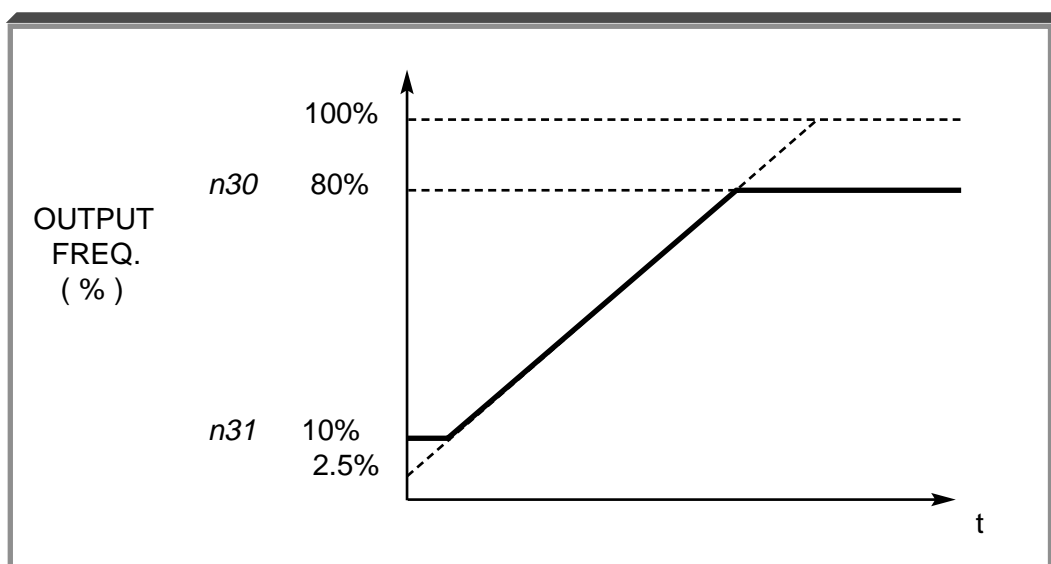

NOTE: **n30** must be set to a higher value than **n31**.

5.10 FREQUENCY REFERENCE RETENTION

n62 : Up/Down Hold Memory

Factory setting: 0
Range: 0 or 1

Used with the Up/Down command. To retain the held frequency reference when a stop command is issued or when power is removed, set **n62** to " 1 ".

SETTING	DESCRIPTION
0	Not retained
1	Held reference retained

Note: Frequency reference value must remain unchanged for a minimum of 5 seconds to be retained.

5.11 FREQUENCY REFERENCE SELECTION

The GPD Drive allows selection of up to eleven frequency references. One is an analog input (terminal FR), eight are digital presets (selected with multi-function inputs), one is a jog input, and one is via serial communications (MODBUS).

A. Frequency Reference via Analog Input

In order to set the GPD Drive so the frequency reference comes from the analog input, set parameter **n03** as shown in the table below:

PARAMETER	SETTING	DESCRIPTION
n03	2	Sets terminal FR for a voltage input (0 to 10V) Set SW8 to Off ⁽¹⁾
	3	Sets terminal FR for a current input (4 to 20mA) Set SW8 to 1 ⁽¹⁾
	4	Sets terminal FR for a current input (0 to 20mA) Set SW8 to 1 ⁽¹⁾

⁽¹⁾ SW8 can be found just above the upper row of control circuit terminals.

NOTE: All power must be removed from the GPD 305 before SW8 can be set.

B. Frequency Reference via Digital Presets

In order to set the GPD Drive so the frequency reference comes from the digital presets, the following parameters need to be set:

PARAMETER	SETTING	DESCRIPTION
n21 thru n29	User Set	Eight Frequency References, plus jog Frequency
n36 thru n39	6, 7, and/or 8	Sets the multi-function inputs so selection of the various references is possible with contact closures.

Depending upon how many preset references are required determines the actual settings of **n36** thru **n39**. Several examples are listed below.

5.11 FREQUENCY REFERENCE SELECTION

Continued

Example 1 - Four preset referencesProgramming: **n38 = 6** and **n39 = 7**

DIGITAL PRESET	S5	S4
Selectable Reference ⁽²⁾	Open	Open
n22	Open	Closed
n23	Closed	Open
n24	Closed	Closed

Example 2 - Eight preset referencesProgramming: **n37 = 6**, **n38 = 7** and **n39 = 8**

DIGITAL PRESET	S5	S4	S3
Selectable Reference ⁽²⁾	Open	Open	Open
n22	Open	Open	Closed
n23	Open	Closed	Open
n24	Open	Closed	Closed
n25	Closed	Open	Open
n26	Closed	Open	Closed
n27	Closed	Closed	Open
n28	Closed	Closed	Closed

⁽²⁾ The Selectable Reference is chosen from the following list:

REFERENCE SOURCE	PROGRAMMING
Digital Operator Speed Pot	n03 = 0
Digital Preset Reference parameter n21	n03 = 1
Analog Input Terminal FR	n03 = 2, 3, or 4
Serial Communications	n03 = 6

- C. Jog Reference** - See paragraph 5.12
- D. Frequency Reference via Serial Communications** - See paragraph 5.14

5.12 JOG REFERENCE

n29 : Jog Reference

Factory setting: **6.0** Hz

Range: 0.0 to 400 Hz

n36 thru **n39** : Multi-function Inputs
(Term. S1 - S5)

Data **10** : Jog Selection

When jog operation is selected (by external Jog and Run signals), the GPD Drive output will ramp to the output level set by this parameter.

When an external Jog signal is present, it will override the existing operation mode and the GPD Drive will ramp to the level set by this parameter.

EXAMPLE:

OPERATION BY REMOTE SIGNAL INPUT (RUN & JOG)

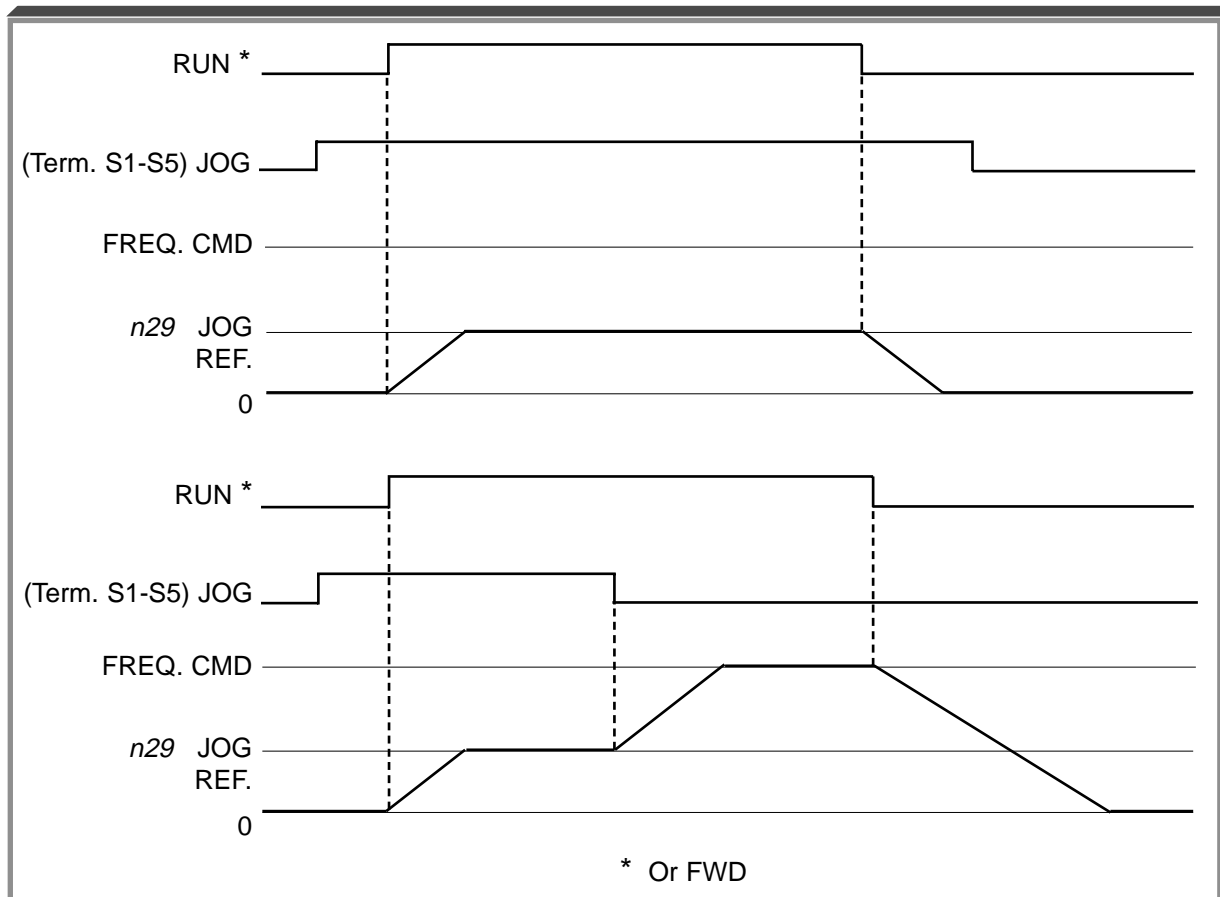

Also see descriptions of **MULTI-FUNCTION INPUT TERMINALS**, paragraph 5.17.

5.13 LOCAL/REMOTE REFERENCE AND SEQUENCE SELECTION

The GPD Drive has the ability to have either a local or a remote reference and sequence selection.



Local - Run and stop functions are controlled by the buttons on the digital operator (**n06**). The frequency reference can come from a digital preset reference (**n21** & **n08**) or the digital operator pot (**n07**).

Remote - Run and stop functions are determined by parameter **n02**. The frequency reference is determined by parameter **n03**.

Switching between local and remote is accomplished either by the LO/RE LED on the digital operator or by the use of a multi-function input terminal programmed to data "17" (see paragraph 5.17A).

n02 : Operation Method Selection

Factory setting: **1**

SETTING	DESCRIPTION
0	Run and stop is controlled by the  and  buttons on the digital operator.
1	Run and stop is controlled by the multi-function input terminals 2-Wire control - Run Forward (n36 thru n39 is set to a data of "1") Run Reverse (n36 thru n39 is set to a data of "2") 3-Wire control - Parameter n37 needs to be set to a data of "0" Run is controlled by a momentary closure on terminal S1 Stop is controlled by a momentary open on terminal S2 Forward/Reverse is controlled by terminal S3
2	Run and stop is controlled by serial communications

n03 : Reference Selection



Factory setting: **2**

SETTING	DESCRIPTION
0	Frequency reference is controlled by the digital operator potentiometer.
1	Frequency reference is controlled by a digital preset speed (n21) and is affected by n08 .
2	Frequency reference is controlled by the analog input terminal FR and is 0 - 10V DC
3	Frequency reference is controlled by the analog input terminals FR and is 4 - 20mA
4	Frequency reference is controlled by the analog input terminal FR and is 0 - 20mA
6	Frequency reference is controlled by serial communications.

n06 : Stop Key Function

Factory setting: **0**

Range: 0 or 1

SETTING	DESCRIPTION
0	 key is effective at all times, regardless of programming of n02
1	 key is effective only when the run/stop command is from the digital operator (n02 = 0)

5.13 LOCAL/REMOTE REFERENCE AND SEQUENCE SELECTION

Continued

n07 : Reference Selection - Digital OperatorFactory setting: **0**

Range: 0 or 1





This parameter is only effective when the GPD Drive is in the local mode.

SETTING	DESCRIPTION
0	Frequency reference is controlled by the digital operator potentiometer
1	Frequency reference is controlled by a digital preset speed (n21) and is affected by n08.

n08 : Frequency Reference Setting Method From Digital OperatorFactory setting: **0**

Range: 0 or 1

This parameter is only effective when the frequency reference is controlled by a digital preset (n21).

SETTING	DESCRIPTION
0	 key must be pressed in order for the drive to accept the frequency reference.
1	 key does not have to be pressed. The GPD 305 drive responds immediately to the  and  keys.

5.14 MODBUS CONTROL (OPTIONAL)

The GPD Drive can perform serial communication by using a programmable controller (PLC), MODBUS™ protocol, and by installing an optional RS-232 or RS-485/422 interface card. MODBUS is composed of one master PLC and 1 to 31 (maximum) slave units (GPD Drives). In serial communication between the master and slaves, the master always starts transmission and the slaves respond to it.

The master communicates with one slave at a time. Address numbers are assigned to each slave in advance, and the master specifies an address to communicate with. The slave which receives the command from the master executes the function, and then responds to the master.

A. Communication Specifications

- Interface : RS-485 & RS-422, or RS-232
- Synchronization : Asynchronous
- Transmission parameters :
 - Baud rate* — Selectable from 2400, 4800, 9600, 19,200 BPS (**n71**)
 - Data length* — Fixed to 8 bits
 - Parity* — Parity / no parity, even / odd selectable (**n72**)
 - Stop bit* — Fixed to 1 bit
- Protocol : MODBUS RTU
- Maximum number to units to be connected : 31 units

B.1. Connecting MODBUS - RS-485/422 Interface

Terminals S+, S-, R+, and R- are used for modbus communications. A terminating resistor can be enabled between R+ and R- by setting SW1 on the RS-422/485 Interface PCB (DS095) to "ON." SW1 is located directly below the connector on the DS095 PCB.

The terminating resistor should only be enabled on the drive farthest away from the master.

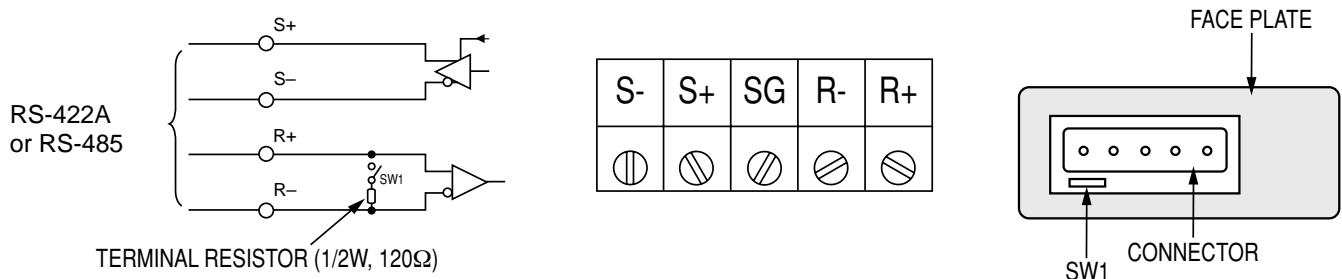

B.2. Connecting MODBUS - RS-232 Interface

Cable must be assembled per pin-out diagram shown below.

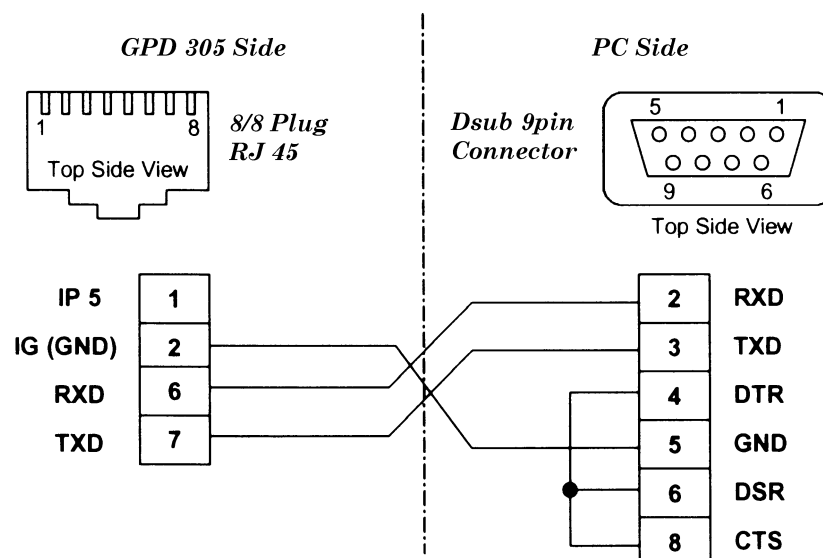

C. Sending/Receiving Data

Data that can be sent and received are run/stop commands, frequency reference, fault reset, drive status, and setting and reading of parameters.

n02 : Operation Method Selection

Factory setting: 0

Range: 0 to 2

Parameter **n02** selects where the run/stop commands (sequence) will come from. To be able to provide a run command over the Modbus serial communications link, set this to a data of "2."

n03 : Reference Selection

Factory setting: 0

Range: 0 to 6

Parameter **n03** selects where the frequency reference will come from. To be able to provide a frequency reference over the Modbus serial communications link, set this to a data of "6."

n36 thru **n39** : Multi-function Inputs
(Term. S2-S5)

Data 18 : Serial communication/ Digital Operator
--

Selects operation by serial communication or by external terminal. If the status of this command input is changed while the drive is running, the selection is ignored until the next time the drive is stopped.

Open : Run according to the setting of Operation Method Selection (**n02**) and Reference Selection (**n03**).

Closed : Run by frequency reference and run command from serial communication.

EXAMPLE: **n02** setting is " 1 ", and **n03** setting is " 2 ".
n39 = 18.

TERMINAL S5 Open: Frequency reference from control circuit terminal FR and run command from control circuit terminals S1, S2.

TERMINAL S5 Closed: Frequency reference and run command from serial communication.

5.14 MODBUS CONTROL

Continued

n69 : Modbus Frequency ResolutionFactory setting: **0**

Range: 0 to 3

The frequency resolution from the PLC and in the frequency reference and output frequency monitor (by communication) are selected with this parameter. The output frequency resolution of the GPD Drive is 0.1 Hz. Even if the Modbus resolution is changed to 0.01 Hz in **n69**, the value in the hundredths digit of 0.01 Hz of the received frequency reference is rounded off internally. When 30,000/100% in units of 0.1% is selected, the value is also rounded off.

n70 : Modbus Slave AddressFactory setting: **0**

Range: 0 to 31

Each slave GPD Drive on the same transmission line must be given a unique address.

n71 : Modbus Baud RateFactory setting: **2**

Range: 0 to 3

Selects the baud rate, as indicated by the following table:

Setting	Baud Rate (BPS)
0	2400
1	4800
2	9600
3	19,200

n72 : Modbus Parity SelectionFactory setting: **1**

Range: 0 to 2

Selects the parity, as indicated by the following table:

Setting	Parity
0	None
1	Even
2	Odd

NOTE: To change the values set in **n70** thru **n72** and enable the new settings, it is necessary to turn OFF power to the Drive, then turn it ON again.

n68 : Modbus Time Out Detection

Factory setting: 1

Range: 0 to 4

If time between Modbus messages exceeds 2.0 seconds, the drive will respond according to the table below. A setting of " 4 " disables this fault condition.

If communications error exists, drive will respond according to the following table:

Setting	Description
0	Coast to Stop (fault)
1	Ramp to Stop using n17 (fault)
2	Ramp to Stop using n19 (fault)
3	Continue Operation (Alarm)
4	Disabled

D. Loop Test

The GPD 305 has the ability to perform a serial communications self-check, in the form of a loop test. Use the following steps to perform a loop test.

1. With power applied to the GPD Drive set parameter **n39 = 35**.
2. Remove power from the GPD Drive and wait for the charge light to go off.
3. Disconnect all wiring terminals R+, R-, S+, S- & S7.
4. Install the following wires:
 connect S+ to R+
 connect S- to R-
 connect S7 to SC
5. Apply power to the GPD Drive.

If the GPD Drive displays a normal frequency reference, the loop test was successful.

If the GPD Drive displays "CE" on the digital operator, the loop test failed and the serial communications hardware is not functioning correctly. Remove power and recheck all of the above connections. Re-apply power. If the GPD 305 still displays "CE", the unit will need to be replaced.

6. Remove power from the GPD Drive.
7. Disconnect the wires installed in step 4.
8. Re-apply power and program **n39** to its previous setting. NOTE: the factory setting of **n39 = 6**.

5.15 MOMENTARY POWER LOSS RIDE-THRU

n47 : Momentary Power Loss Ride-thru Protection

- 0** = Disabled (Factory setting)
- 1** = Enabled – 2 sec. power loss ride-thru
- 2** = Enabled – indefinite power loss ride-thru, provided control power is maintained

The setting of this parameter either enables or disables the ride-thru feature of the GPD 305. If disabled, the unit will stop immediately whenever a power loss occurs. If enabled, the GPD 305 will continue to operate during a momentary power loss of up to 80%, but if the loss exceeds the identified time period, the GPD 305 will stop.

5.16 MULTI-FUNCTION ANALOG MONITOR OUTPUT (Term. AM and AC)

n44 : Multi-function Analog Output

Factory setting: **0**

The monitor output provides a 0-10 Vdc signal proportional to either output frequency or output current between terminals AM & AC:

- 0** = 0-10 Vdc proportional to output frequency
- 1** = 0-10 Vdc proportional to output current

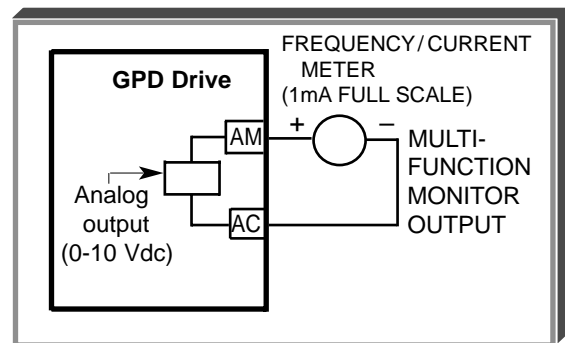

n45 : Analog Monitor Gain

Factory Setting: **1.00**

Range: 0.01 to 2.00

This constant is used to calibrate the meter connected to terminals AM & AC.

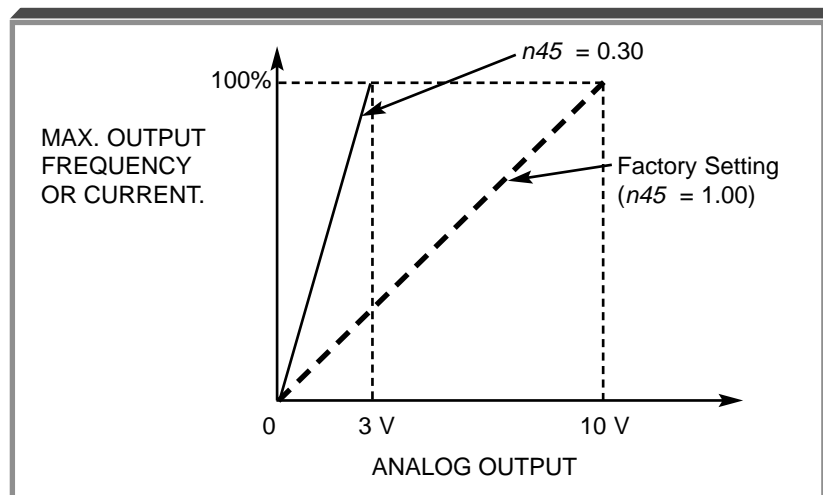

5.17 MULTI-FUNCTION INPUT TERMINALS (Term. S1-S5)

The multi-function input terminals can be activated in one of two ways:

Type of input	Description
NPN (Factory Setting)	A contact closure must be made between a multi-function terminal (S1 to S5) and SC in order to activate that input.
PNP	A DC voltage (+24) must be present on a multi-function input terminal (S1 to S5) in order to activate that input. NOTE: The minus (-) side of the 24 VDC supply must be connected to SC.

The multi-function inputs are configured using rotary switch SW7, which is located above the upper row of control circuit terminals and can be set with a small screwdriver.

NOTE: All power must be removed from the GPD Drive before SW7 can be set.

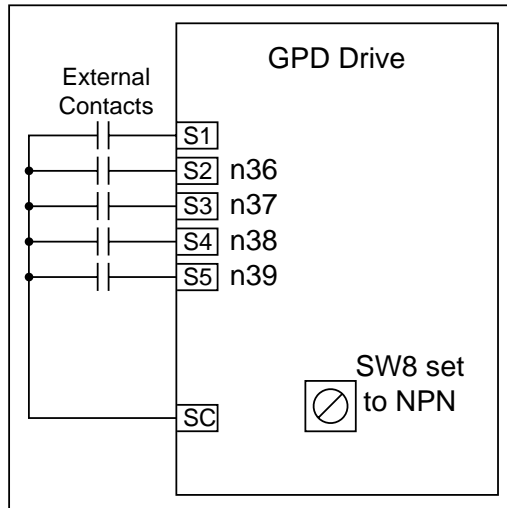

External wiring for NPN inputs

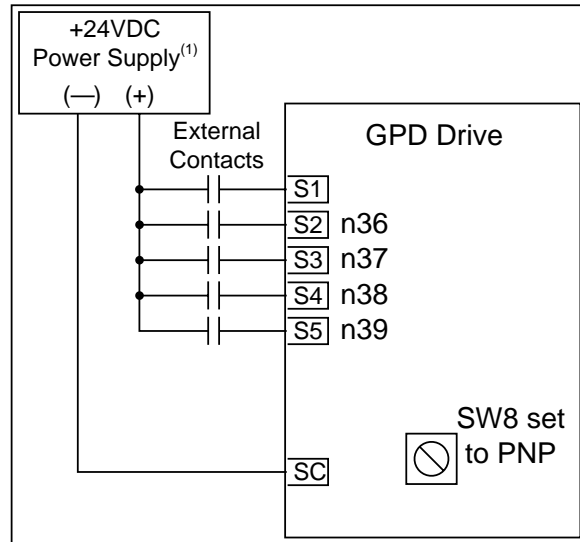

External wiring for PNP inputs

(1) Customer supplied component

n36 : Terminal S2 Function
n37 : Terminal S3 Function
n38 : Terminal S4 Function
n39 : Terminal S5 Function

Factory settings:	2-Wire control	3-Wire control
<i>n36</i>	2	2
<i>n37</i>	5	0
<i>n38</i>	3	3
<i>n39</i>	6	6

These seven parameters select the input signal function for terminals S1 thru S5, and can be independently set.

Parameter settings are checked whenever the enter key is pressed. A parameter set failure (**Err**) will occur if any of the following conditions are detected:

- Two parameters contain the same value (**n36** thru **n39**).
- Both the Accel/Decel Hold (data **16**) and the Up/Down (data **34**) functions have been selected.

Table 5-2 lists the possible data setting values and their descriptions for these parameters.

Table 5-2. n36 thru n39 Data Settings

DATA	FUNCTION	DESCRIPTION*
0	FWD/REV selection (for 3-wire control)	MUST BE SET ONLY IN n37 . Redefines terminals: S1 = Run; S2 = Stop; S3 = FWD/REV select
2	Reverse Run/Stop command (for 2-wire control)	Closed = Run Reverse (2-wire control) Open = Stop
3	External fault (N.O. contact input)	Drive trips; Digital Operator displays " EFX ", where X is 2-5, corresponding to the terminal, S2-S5, which is receiving the fault input signal
4	External fault (N.C. contact input)	
5	Fault Reset	Resets fault, only if RUN command is not present
6	Multi-step frequency ref. select A	See paragraph 5.11B
7	Multi-step frequency ref. select B	
8	Multi-step frequency ref. select C	
10	Jog selection	Closed = Jog selected See paragraph 5.12
11	Accel/decel time selection	Open = Accel/decel by n16 / n17 Closed = Accel/decel by n18 / n19 See paragraph 5.2
12	External base block (N.O. contact input)	Closed = Shuts off GPD Drive output (frequency command is held) See paragraphs 5.17B, 5.17C
13	External base block (N.C. contact input)	
14	Speed Search 1	Closed * = Speed Search operation from maximum frequency See paragraph 5.17D
15	Speed Search 2	Closed * = Speed Search operation from set frequency See paragraph 5.17D
16	Accel/Decel Hold	See paragraph 5.17F
17	Remote/Local selection	See paragraph 5.17A
18	GPD Drive operation & reference/serial communication selection	Open = Operates according to setting of n003 & n004 Closed = Operates from serial communication See paragraph 5.13
19	Fast Stop - Fault (Normally Open Contact)	Open = No effect Closed = If n04 = 0, ramp to stop using n19 If n04 = 1, coast to stop
20	Fast Stop - Alarm (Normally Open Contact)	Open = No effect Closed = If n04 = 0, ramp to stop using n19 If n04 = 1, coast to stop
21	Fast Stop - Fault (Normally Closed Contact)	Open = If n04 = 0, ramp to stop using n19 If n04 = 1, coast to stop Closed = No effect
22	Fast Stop - Alarm (Normally Closed Contact)	Open = If n04 = 0, ramp to stop using n19 If n04 = 1, coast to stop Closed = No effect
34	Up/Down function	See paragraph 5.17E (can only be set in n39)
35	Loop Test (Serial Communications)	See paragraph 5.14D Can only be set in n39

* All contact closures must be maintained, except for speed search, which may be momentary (see paragraph 5.17D).

A. Data 17: Remote/Local

The use of a Remote/Local command input allows switching between the Digital Operator control and the external terminal input signals or serial communications, without the need to re-program **n02** or **n03**. If the status of the Remote/Local command input is changed while the drive is running, the Remote/Local operation selection is not completed until the next time the GPD Drive is stopped.

Closed = Controlled locally (Digital Operator)

NOTE: Parameter **n07** determines if the frequency reference will come from the digital operator potentiometer or parameter **n21**.

Open = Controlled remotely (external terminal inputs, for Start/Stop and frequency reference, or serial communications).

NOTE: When a multi-function input terminal is programmed for Local/Remote, the LO/RE LED will only display local or remote status. Local/Remote cannot be adjusted from the digital operator.

B. Data 12: External Base Block by N.O. Contact

- When either the Forward Run command or Reverse Run command is present, and the external Base Block command is applied (i.e. contact closed), coast stop is accomplished (after a 20 msec delay), while the frequency command is maintained. When the Base Block command is removed, the drive will recover in a manner similar to that of Speed Search operation.
- When both the Forward Run command and Reverse Run command are open, and the external Base Block command is applied (i.e. contact closed), coast stop is accomplished and after a 20 msec delay the frequency command is changed to 0Hz. When the Base Block command is removed, the drive will remain in stopped condition until Forward Run command or Reverse Run command is again applied.
- When external Base Block command is active, a blinking “**bb**” will be displayed on the Digital Operator.

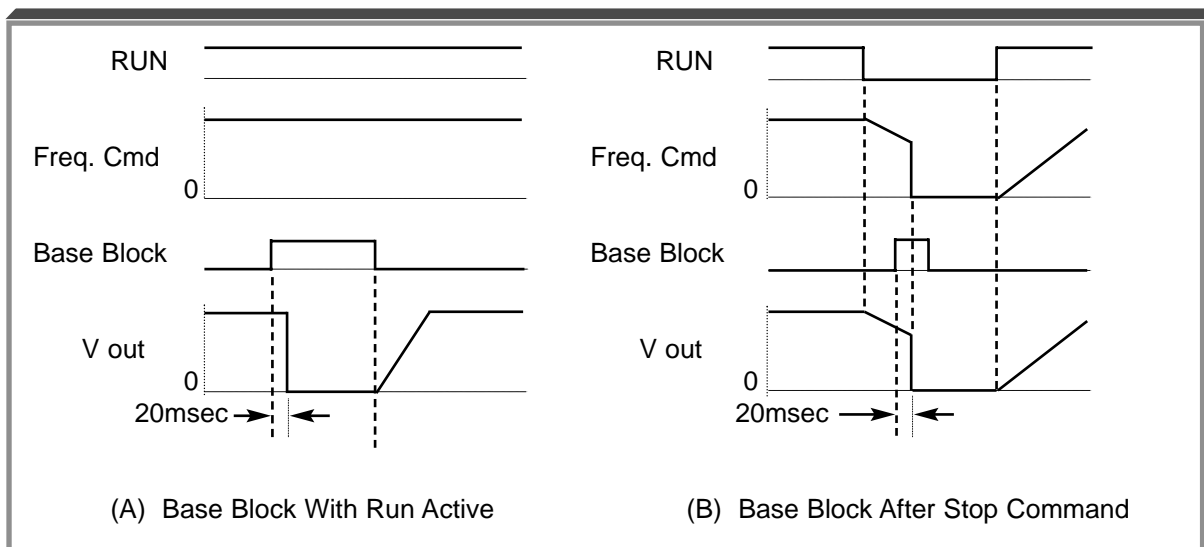
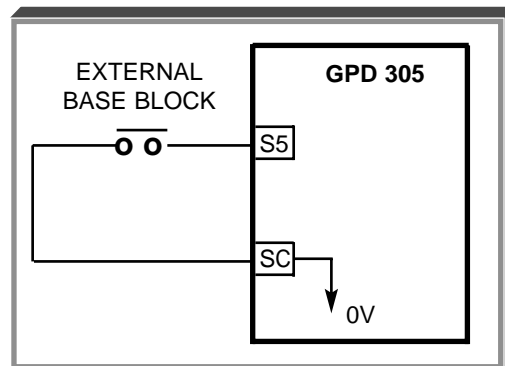

C. Data 13 : External Base Block by N.C. Contact

Base block operation is the same as described above, except that the Base Block contact must be *open* to be recognized.

**D. Data 14 : Speed Search From Max Frequency
Data 15 : Speed Search From Set Frequency**

A multi-function input terminal is utilized to activate speed search. When the external speed search command is closed, the base is blocked for the min. base block time, then the speed search is made. The operation depends on the set value.



Set values **14** and **15** CANNOT be selected in combination.

- When **14** is set, the speed search begins with the maximum frequency.
- When **15** is set, the speed search begins with the frequency command command that has been set after the search command was received.

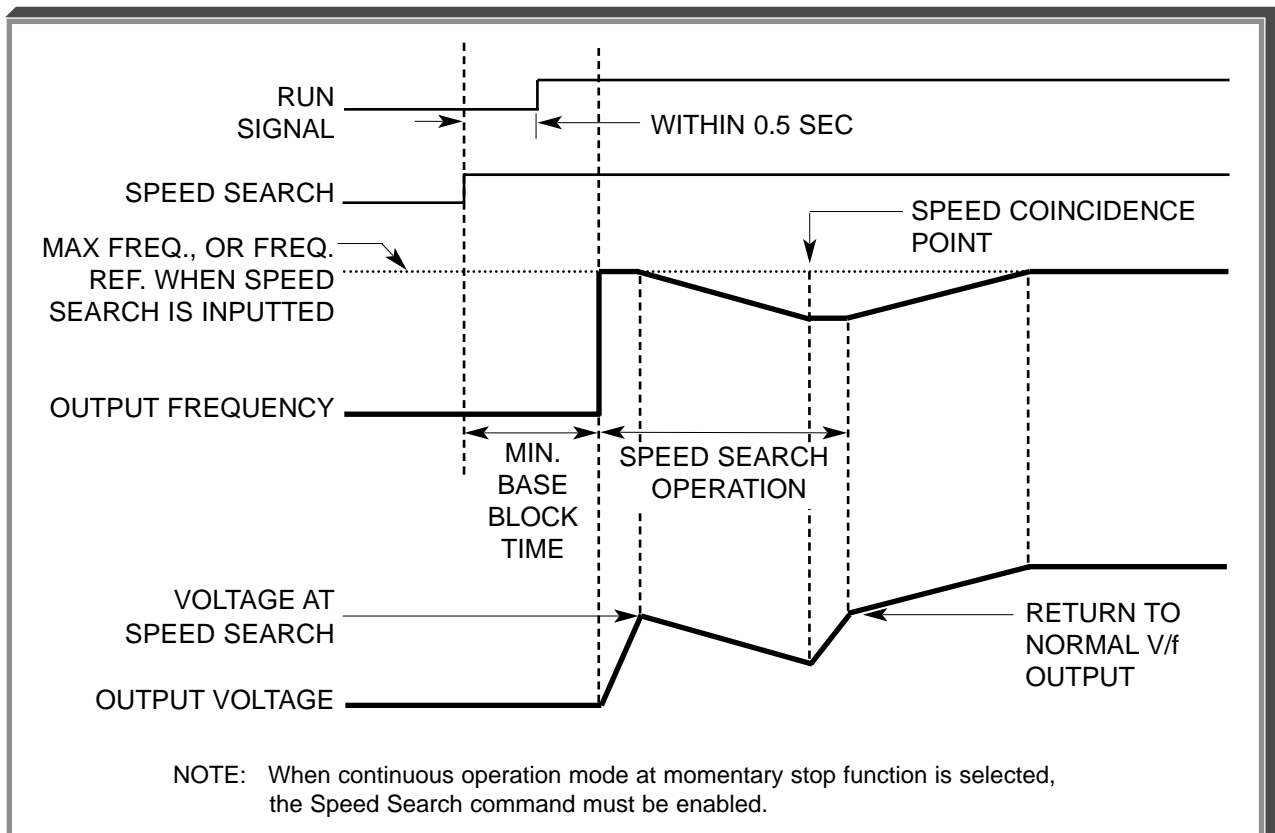

Speed Search Operation Timing

E. Data 34 : Up/Down Function

Programming data " 34 " for **n39** (multi-function input terminal) allows the S4 / S5 inputs to be used for Up/Down frequency setting.

NOTES:

1. Parameter **n38** will not be valid when **n39** is set to " 34 ".
2. Jog has priority over Up/Down.
3. Up/Down has priority over Multi-step Frequency inputs.
4. Upper limit speed is set by the formula:

$$n09 (F_{max}) \times \frac{n30 (Freq. Ref. Upper Limit)}{100}$$
5. Lower limit speed is from **n31** , Frequency Reference Lower Limit.
6. See section 5.10 for information on the Up/Down hold memory.

EXAMPLE:

n39 Data **34**: Up/Down function

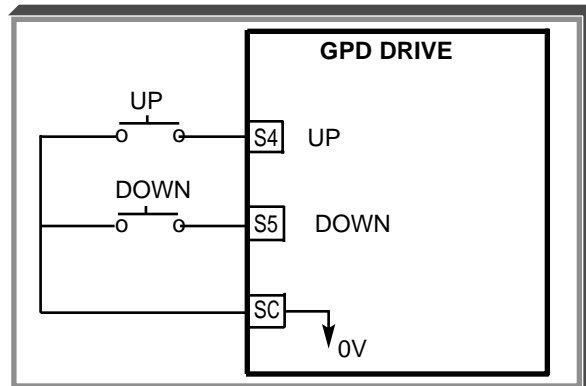

INPUT SIGNAL		FUNCTION
Term. S4 UP	Term. S5 DOWN	
Open	Open	HOLD
Closed	Open	UP (Frequency command approaches frequency command upper limit)
Open	Closed	DOWN (Frequency command approaches minimum output frequency or frequency command lower limit, whichever is larger)
Closed	Closed	HOLD

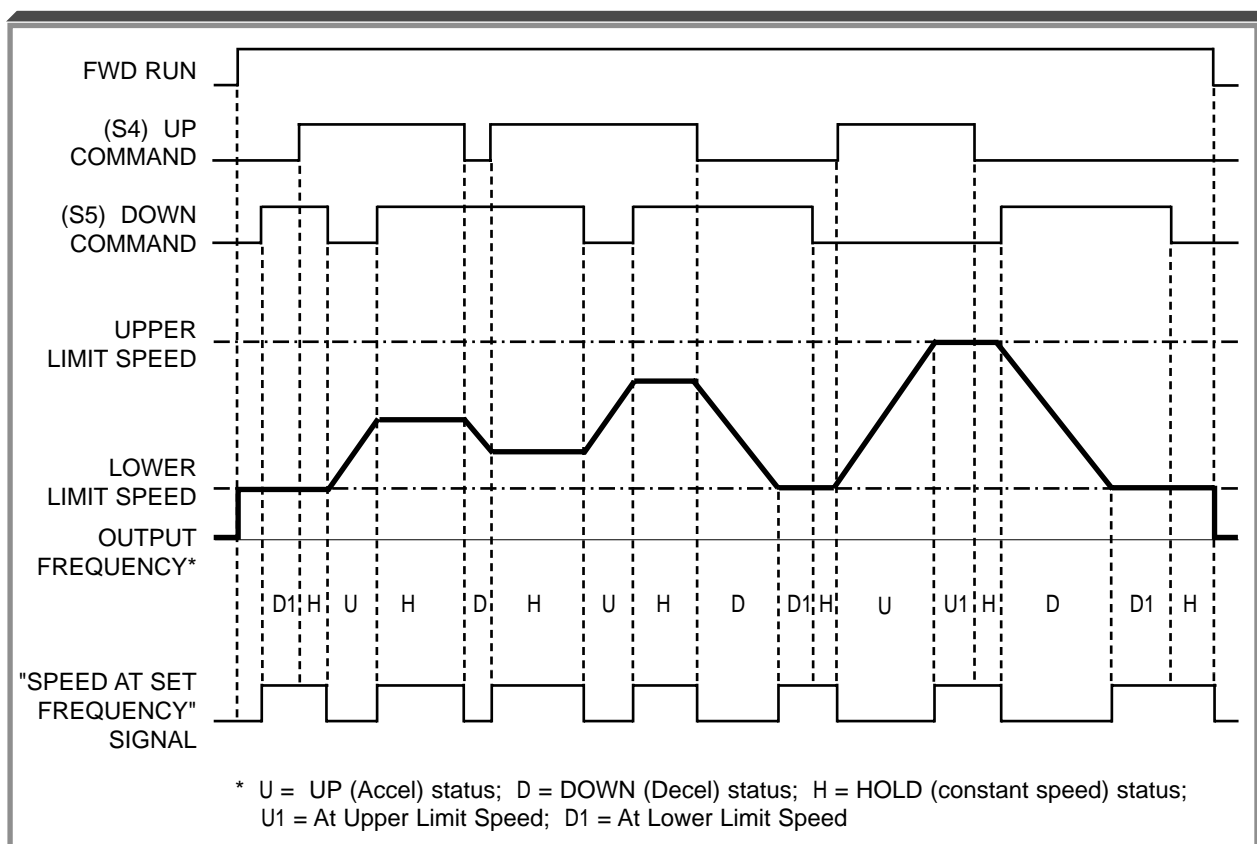

Up/Down Frequency Setting Timing

F. Data 16 : Accel/Decel Hold

By programming data " 16 " into one of the multifunction input parameters (*n36* thru *n39*), one of the multi-function input terminals (S1 thru S5) becomes a HOLD command input. As long as the HOLD command is present, accel and decel are in a prohibit state, and the output speed is held at the level it was at the time the HOLD command was input. When the HOLD command is removed while the system is still in Run condition, accel or decel will again become active to allow output to reach set speed. If Stop is initiated while the HOLD command is present, the prohibit state is cancelled and the system enters stop operation.

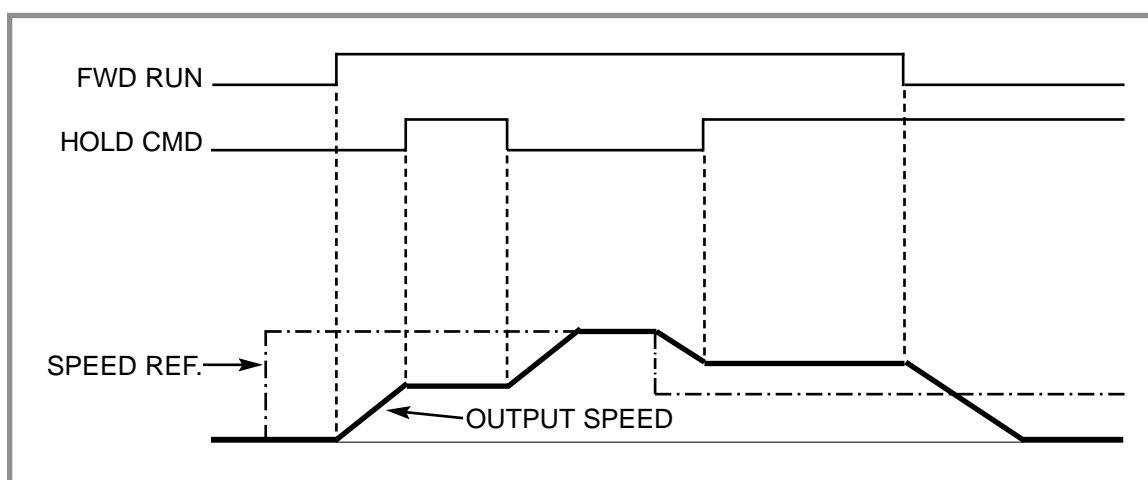

HOLD Function Timing

5.18 MULTI-FUNCTION OUTPUT TERMINALS (Term. MA, MB, MC)

n40 : Contact Output (external terminals MA, MB, & MC)

A contact can be programmed to change states during any of the conditions indicated in Table 5-3.

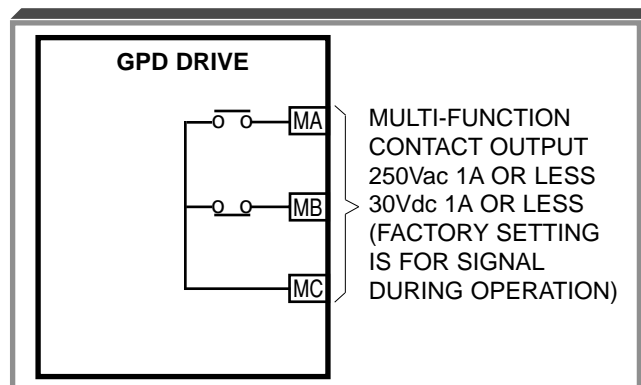

Table 5-3. Multi-function Output Terminals

Set Value	Description	
	Condition	Signal Level
0	Fault	Closed = GPD Drive fault has occurred (except CPF0, CPF1)
1	During operation	Closed = GPD Drive is operating
2	Speed at set frequency	Closed = Frequency Reference = output frequency See paragraph 5.18A
3	Zero Speed	Closed = GPD Drive is at zero Hz.
4	Frequency detection - low	Closed = Output frequency \leq n58 . See paragraph 5.18B
5	Frequency detection - high	Closed = Output frequency \geq n58 . See paragraph 5.18C
6	Overtorque detection (N.O. contact)	Closed = Overtorque detected See paragraph 5.19
7	Overtorque detection (N.C. contact)	Open = Overtorque detected See paragraph 5.19
10	Alarm (minor fault)	Closed = Alarm condition is present
11	During coast to stop	Closed = GPD Drive output base block is active; motor is coasting
12	Local/Remote	Open = Frequency and Run Command by ext. input; Closed = Frequency and Run Command by Digital Operator
13	Operation ready	Closed = GPD Drive is ready for operation (not faulted)
14	Auto-restart	Closed = During auto-restart operation
15	During Undervoltage	Closed = GPD Drive has an undervoltage fault or warning
16	During Reverse run	Closed = GPD Drive operation in reverse
17	During Speed Search	Closed = GPD Drive performing a speed search
18	Serial communication	Closed = Command from serial communication

5.18 MULTI-FUNCTION OUTPUT TERMINALS

Continued

n58 : Speed Coincidence Frequency / Frequency Detection Level

Factory setting: **0.0** Hz

Range: 0.0 to 400 Hz

Speed coincidence is used to control an output contact at terminals MA or MB (with respect to terminal MC), or terminals P1, P2 & PC, when selected by **n40**.

n40 : Multi-function Output Selection

Data **2, 4 or 5**

The output contact will close, dependent upon the data programmed into **n40**. See the appropriate figure below for operation.

A. Speed at Set Frequency (setting: n40 = " 2 ")

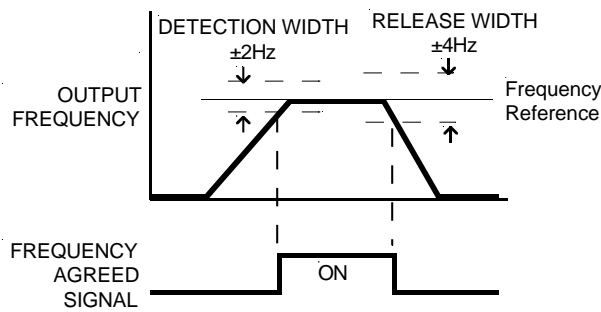

B. Frequency Detection – Low (setting: n40 = " 4 ")

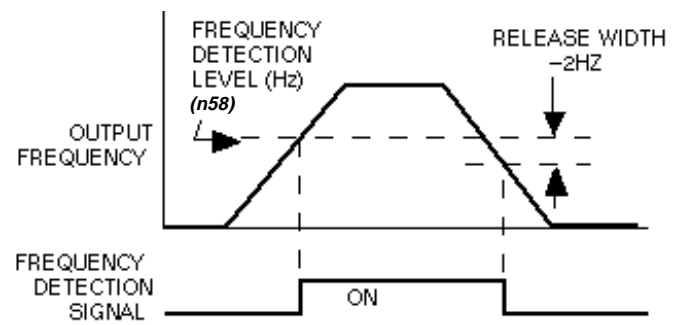

C. Frequency Detection – High (setting: n40 = " 5 ")

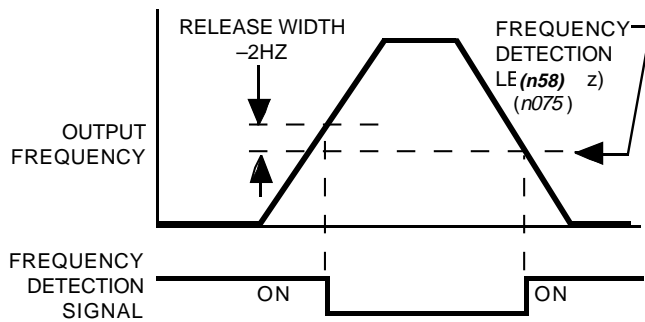

5.19 OVERTORQUE DETECTION

Overtorque detection is used to compare GPD Drive rated output current/torque with the overtorque detection level. When the output current is equal to or greater than the defined level, an overtorque condition exists. This will be indicated as an **oL3** fault on the Digital Operator. This feature can be selected to operate over a wide range of conditions.

A. **n59** : Overtorque Detection

Factory setting: 0

Range: 0 to 4

This constant determines whether the overtorque detection function of the GPD Drive is enabled, under what conditions it will detect for overtorque, and what operation it will perform after detecting an overtorque.

Setting	Overtorque / Undertorque Disabled	Operation After Detection	Detection Condition
0	Disabled	---	---
1	Overtorque	Continues	Only at set frequency
2	Overtorque	Coast to stop	Only at set frequency
3	Overtorque	Continues	At all times except during stopping or DC injection braking
4	Overtorque	Coast to stop	At all times except during stopping or DC injection braking

- For overtorque detection during accel or decel, set to " 3 " or " 4 ".
- For continuous operation after overtorque detection, set to " 1 " or " 3 ". During detection, the Digital Operator displays and " **oL3** " alarm (blinking).
- To stop the drive at an overtorque detection fault, set to " 2 " or " 4 ". At detection, the Digital Operator displays an " **oL3** " fault.
- To output an overtorque detection signal, set output terminal function selection (**n40**) to " 6 " or " 7 ".

B. **n60** : Overtorque Detection Level

Factory setting: 160 %

Range: 30 to 200 %

This is the reference point for determining that an overtorque condition exists. Set as a percent of GPD Drive rated current or as a percent of motor rated torque.

C. **n61** : Overtorque / Undertorque Detection Time

Factory setting: 0.1 sec.

Range: 0.1 to 10.0 seconds

Determines how long an overtorque condition must exist before another event will occur, e.g. coast to stop, multi-function output change of state, or **oL3** warning or fault display.

5.19 OVERTORQUE DETECTION

Continued

E. **n40**: Multi-function Output 1
(terminals MA, MB & MC)

Data **6** or **7**: Overtorque
Detection

The Form-C contact, or an open collector output, can be programmed to change states during an overtorque detection condition.

EXAMPLE OF OVERTORQUE DETECTION

- n59** setting: **2** — Overtorque enabled, only at set frequency, coast to stop
n40 setting: **6** — Output contact programmed for overtorque detection
n60 setting: **110%** — Level at which overtorque is sensed
n61 setting: **1.0 s** — Time delay before overtorque event occurs

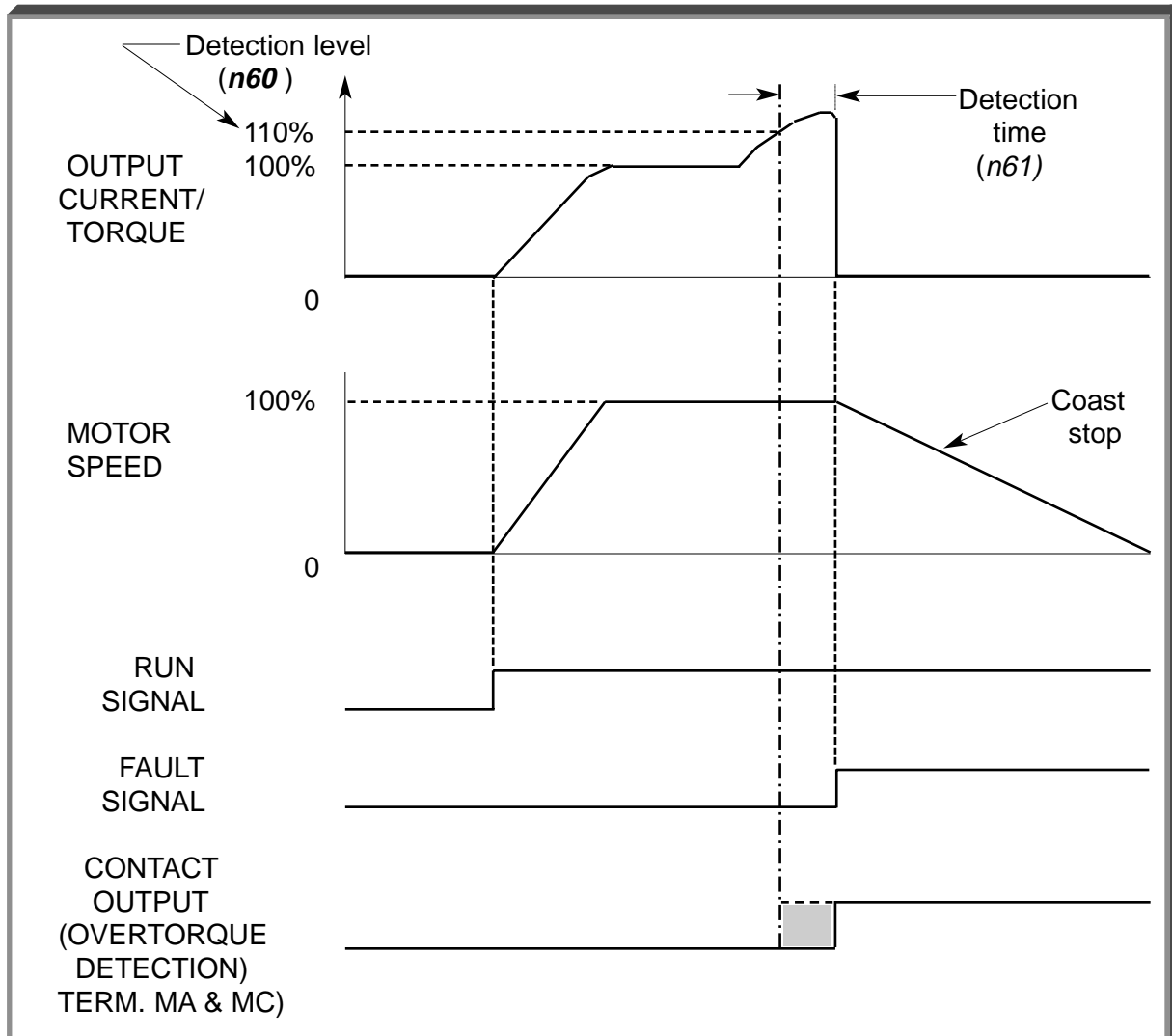

Overtorque Detection Timing Diagram

5.20 RESET CODES: 2-WIRE, 3-WIRE INITIALIZATION

n01 : Parameter Selection / Initialization

Factory setting: **1**

Range: 0 to 9

The following table shows which parameters can be programmed (displayed & changed) or only displayed when **n001** is selected.

Setting	Function
0	n01 can be read and set; n02 - n79 read only
1	n01 - n79 can be read and set
2-5	Not Used
6	Clear Fault Record Only
7-9	Not Used
10	Initialization: 2-Wire control
11	Initialization: 3-Wire control

WARNING

By entering an "10" or a "11" into **n01**, all parameters in the GPD Drive will return to their factory settings.

Parameter	Terminal	Factory Configuration for	
		2-Wire Control	3-Wire Control
—	S1	Forward Run	Start
n36	S2	2 = Reverse Run	2 = Stop
n37	S3	5 = Fault Reset	0 = Fwd/Rev Command
n38	S4	3 = External Fault (N.O.)	3 = External Fault (N.O.)
n39	S5	6 = Multi Step Ref. Cmd. A	6 = Multi Step Ref. Cmd. A

CAUTION

Know your application before using either Initialization function of **n01** .

This parameter must be set to " 0 " or " 1 " for operation.

" 10 " = Factory 2-Wire Control Initialization (Maintained RUN Contact)

" 11 " = Factory 3-Wire Control Initialization (Momentary START/STOP Contact)

Entering either Initialization code resets all parameters to factory settings, and automatically returns **n01** setting to " 1 ". If the GPD Drive is connected for 3-Wire control and this parameter is set to " 10 " (2-Wire Control Initialization), the motor may run in reverse direction WITHOUT A RUN COMMAND APPLIED. Equipment damage or personal injury may result.

IMPORTANT

After " 10 " or " 11 " has been entered in **n01** , the Motor Rated Current (**n32**) MUST BE REPROGRAMMED to the correct setting for the application.

5.21 SLIP COMPENSATION

n66 : Slip Compensation Gain

Factory setting: **0.0**

Range: 0.0 to 2.5

Slip compensation is used to increase motor speed to account for slip; the drive accomplishes this by automatically boosting output frequency, with a corresponding boost in output voltage.

The slip compensation gain (**n66**) determines how much compensation frequency is added. If using the GPD Drive in Open Loop Vector, typically no adjustment is necessary. The equation below illustrates how the compensation frequency is generated.

NOTE: A slip compensation gain setting of 0.0 disables slip compensation.

$$\text{Compensation Frequency} = \frac{\text{Output Current} - \frac{(n65 * n32)}{100}}{n32 - \frac{(n65 * n32)}{100}} * n64 * n66$$

Slip Compensation Equation

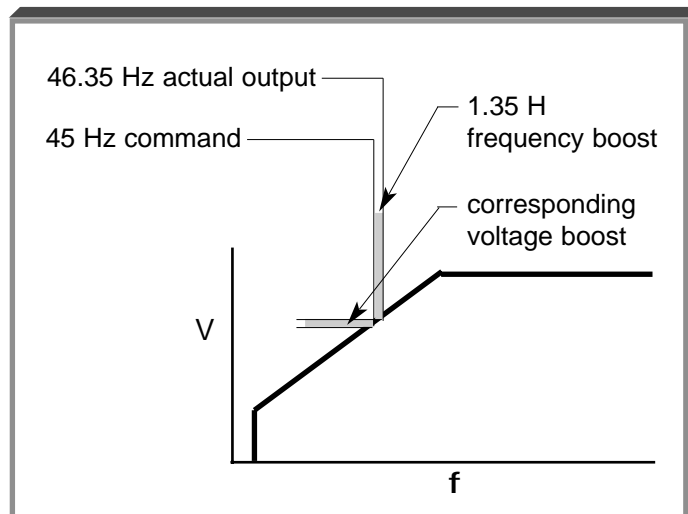

n65 : Motor No-Load Current

Factory setting: See Table A3-1

Range: 0 to 99%

Motor no-load current (**n65**) is set as a percentage of motor full-load current (**n32**). It is used as shown in the slip compensation equation.

n67 : Slip Compensation Primary Delay
Time Constant

Factory setting: **2.0** sec.

Range: 0.0 to 25.5 sec.

Parameter **n67** can be increased to improve stability or decreased to improve response to load changes.

5.22 STALL PREVENTION

A. *n55* : Stall Prevention During Deceleration

Factory setting: **0**

Range: 0 to 1

Setting	Function
0	Stall prevention during deceleration enabled
1	Stall prevention during deceleration disabled

Stall prevention during deceleration automatically adjusts the deceleration rate while monitoring the DC bus voltage to prevent overvoltage during deceleration.

When the motor load is large or decel time is short, actual decel time may be longer than the set value because of stall prevention.

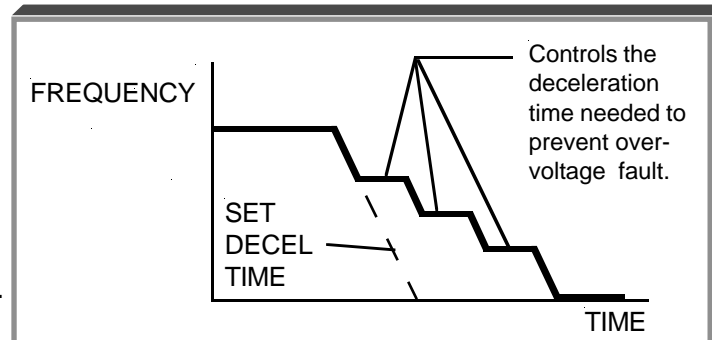

B. *n56* : Stall Prevention Level During Acceleration

Factory setting: 170%

Range: 30 - 200 %

This parameter determines the actual GPD 305 output current level during an acceleration condition. Set in percent of GPD 305 rated output current.

A setting of " 200 " disables stall prevention during acceleration. During acceleration, if the output current exceeds the value in *n56* , acceleration stops and frequency is maintained. When the output current goes below the value set in *n56* , acceleration resumes.

In the constant horsepower region [actual output frequency \geq max. voltage frequency (*n11*)], the stall prevention level during acceleration is changed by the following formula:

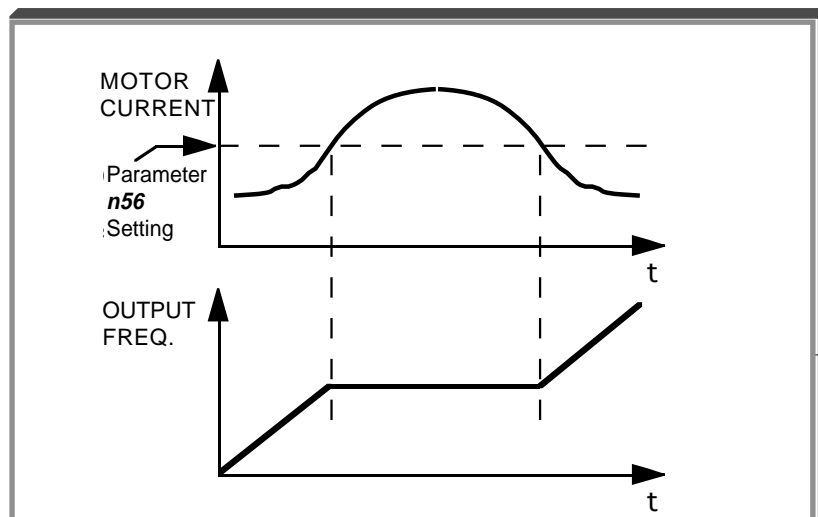

$$\text{Stall prevention level during accel (constant horsepower)} = \text{Stall prevention level during accel} \times \frac{\text{Max. voltage frequency}}{\text{Actual output frequency}}$$

C. *n57* : Stall Prevention Level At Set Speed

Factory setting: **160%**

Range: 30 - 200 %

This parameter determines the actual GPD Drive output current level while operating at set speed (frequency). Set in percent of GPD Drive rated output current (see Appendix 2).

A setting of " 200 " disables stall prevention at set speed. During running at set speed, if the output current exceeds the value set in *n57* , the drive will begin to decelerate. When the output current goes below the value set in *n57* , acceleration begins, up to the set frequency.

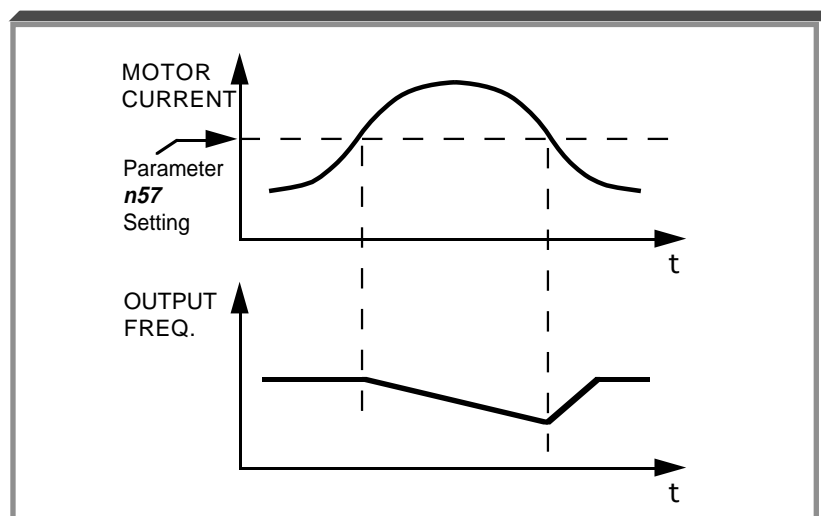

5.23 STOPPING METHOD

n04 : Stopping Method

Factory setting: 0
Range: 0 to 1

Selects the stopping method suitable for the application.

Setting	Description
0	Deceleration (ramp) to stop
1	Coast to stop

A. Data 0 : Deceleration to Stop

Upon removal of the FWD (REV) Run command, the motor decelerates at the deceleration rate determined by the time set in Decel Time 1 (**n17**), and DC injection braking is applied immediately before stop. If the decel time is too short or the load inertia is too large, an overvoltage (OV) fault may occur on a stop command — the decel time must be increased.

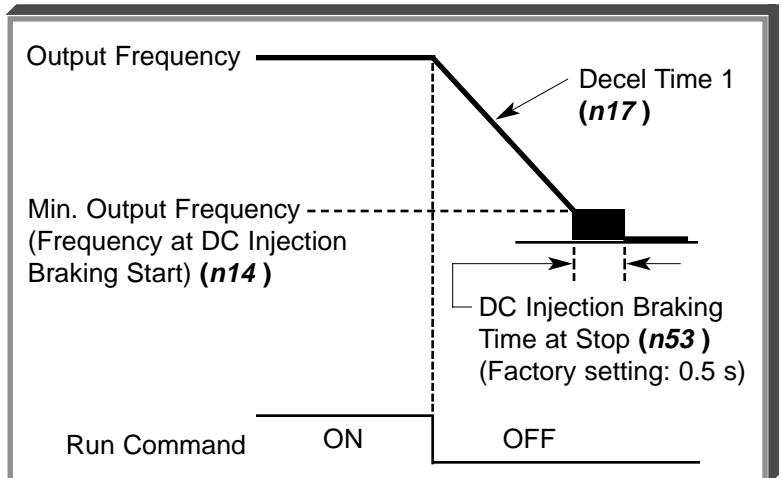

B. Data 1 : Coast to Stop

Upon removal of the FWD (REV) Run command, the motor coasts to rest.

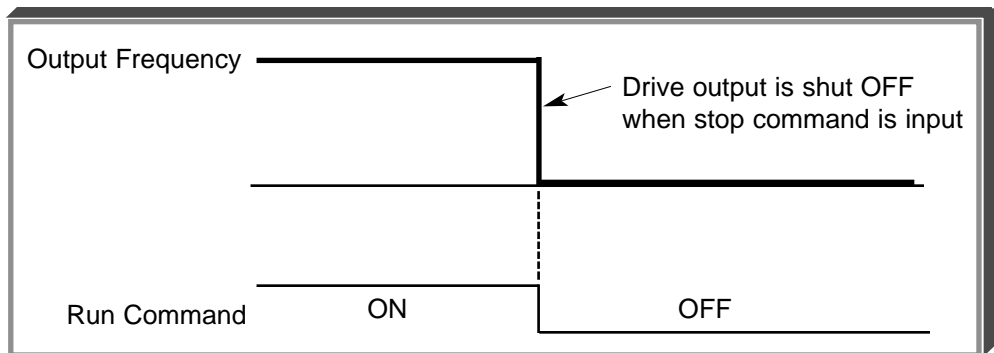

5.24 THERMAL OVERLOAD PROTECTION

n32 : Motor Rated Current

Factory setting: See Table A3-1

Range: see description

This parameter should be set, in increments of 0.1 A, to the rated current (FLA) value shown on the motor nameplate; this value **MUST BE** between 0% and 120% of the *drive rated current*. If the motor FLA does not fall within this range, a different Model No. drive must be used.

NOTE: Setting **n32** to " 0.0 " disables the motor overload protection function, regardless of the setting of **n33** or **n34**.

n33 : Electronic Thermal Motor Protection

Factory setting: **1**

Range: 0 to 2

Setting	Electronic Thermal Characteristics
0	General Purpose Motor, short-term rating
1	Inverter Duty Motor, standard rating
2	Electronic thermal overload protection disabled

n34 : Electronic Thermal Overload Protection Time Constant

Factory setting: **8**

Range: 1 to 60 min.

This parameter sets the electronic thermal overload relay protection time when when 150% of overload is applied after the motor is operated continuously at rated current.

The GPD Drive protects against motor overload with a UL-recognized, built-in electronic thermal overload relay.

The electronic thermal overload function monitors motor temperature, based on drive output current and time, to protect the motor from overheating. When the electronic thermal overload trips, an " **oL1** " error occurs, shutting OFF the drive output and preventing excessive overheating of the motor.

When operating with one drive connected to only one motor, an external thermal relay is not needed. When operating several motors with one drive, install a thermal overload relay on each motor.

	Cooling Effect	Current Characteristics	Electronic Thermal Overload
Short Term Rating	Effective when operated at 60Hz from a commercial power supply	<p>Base Frequency 60Hz (V/f for 60Hz, 230V Input Voltage)</p>	" oL1 " error (motor overload protection) occurs when continuously operated at less than 60Hz at 100% load.
Standard Rating	Effective when operated at low speed (approx. 6Hz)	<p>Base Frequency 60Hz (V/f for 60Hz, 230V Input Voltage)</p>	Electronic thermal overload protection not activated even when continuously operated at less than 60Hz at 100% load.

5.25 TORQUE COMPENSATION

n63 : Torque Compensation Gain (K τ)

Factory setting: **1.0**

Range: 0.0 to 2.5

Torque Compensation Gain (**n63**) adjusts how much the output voltage is boosted when motor load increases. It is used to compensate for resistive losses in the motor and the wiring between the drive and the motor. Torque compensation is only active when the GPD Drive is in the V/f control mode.

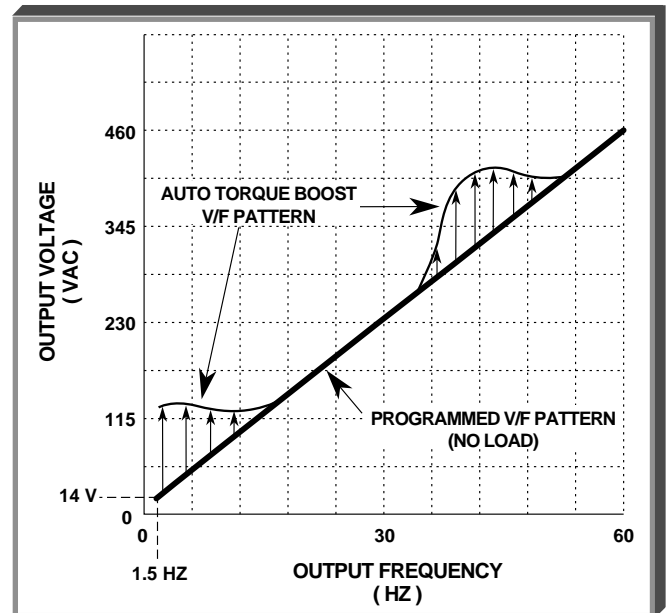

Example of Torque Compensation Operation

5.26 V/f PATTERN

The V/f pattern can be tailored to suit your specific application and load characteristics by adjusting parameters **n09** to **n15** (see the V/f characteristics figure on the following page).

Table 5-4. Recommended V/f Patterns

Max. Freq.	Starting Torque	Load Type ¹	n09 (Hz)	n10 (V) ³	n11 (Hz)	n12 (Hz)	n13 (V) ³	n14 (Hz)	n15 (V) ³
50	Normal	VT	50.0	230	50.0	25.0	40	1.3	9
50	High ²	VT	50.0	230	50.0	25.0	57	1.3	12
60	Normal	VT	60.0	230	60.0	30.0	40	1.5	9
60	High ²	VT	60.0	230	60.0	30.0	57	1.5	12
50	Normal	CT	50.0	230	50.0	3.0	17	1.5	12
50	Medium	CT	50.0	230	50.0	2.5	23	1.3	13
50	High ²	CT	50.0	230	50.0	2.5	28	1.3	16
60	Normal	CT	60.0	230	60.0	1.5	12	1.5	12
60	Medium	CT	60.0	230	60.0	3.0	20	1.5	13
60	High ²	CT	60.0	230	60.0	3.0	28	1.5	23
72	Normal	CT	72.0	230	60.0	3.0	17	1.5	12
90	Normal	CT	90.0	230	60.0	3.0	17	1.5	12
120	Normal	CT	120	230	60.0	3.0	17	1.5	12
180	Normal	CT	180	230	60.0	3.0	17	1.5	12

NOTES:

- ¹ VT = Variable Torque, typically used for blowers, centrifugal pumps, and fans.
 CT = Constant Torque, most other applications. Consult MagneTek for further assistance.

The following conditions must be considered when selecting a V/f pattern:

- Pattern matches the voltage-frequency characteristics of the motor.
 - Maximum motor speed.
- ² V/f pattern for high starting torque should be selected for:
- Long wiring distance.
 - Large voltage drop at start
 - AC reactor connected to GPD Drive input or output.
 - Use of motor rated below GPD Drive max. output.
- ³ Voltages shown are for 230V motors; for other motor voltages, multiply all voltage (V) values by (Vmtr/230).
 i.e., for a 460V motor, multiply by 460/230 = 2.

5.26 V/f PATTERN

Continued

- n09** : Frequency – Max. (Fmax)
- n10** : Voltage – Max. (Vmax)
- n11** : Frequency – Max. Voltage point (FA)
- n12** : Frequency – Midpoint (FB)
- n13** : Voltage – Midpoint (Vc)
- n14** : Frequency – Min. (Fmin)
- n15** : Voltage – Min. (Vmin)

These seven parameters define the V/f pattern. The illustration below shows how these constants relate to each other in establishing the custom V/f pattern.

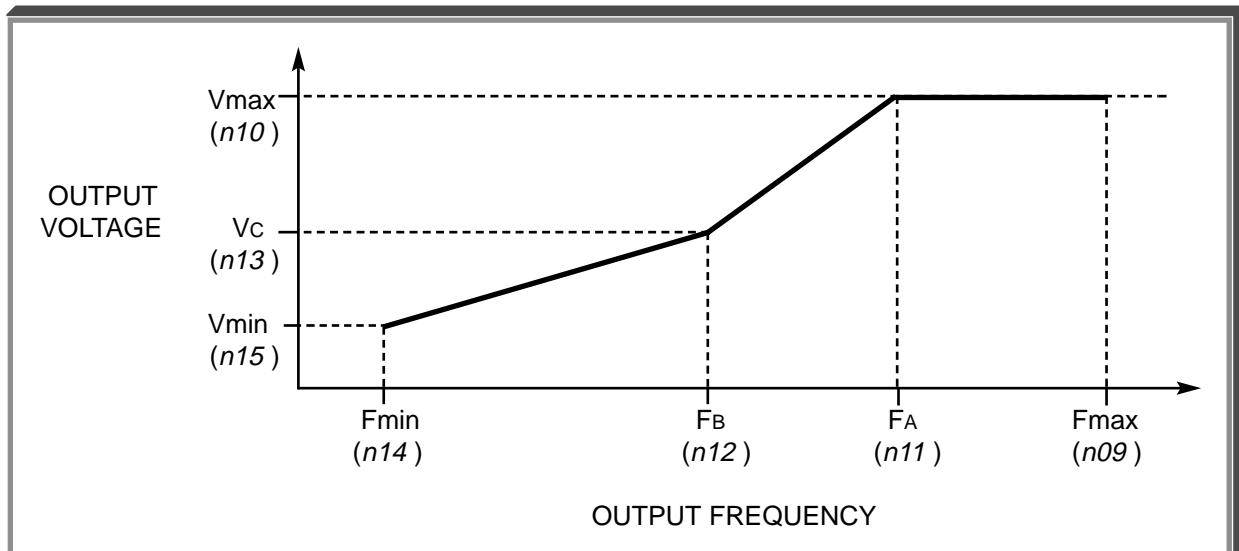

V/f Characteristics Set by n09 thru n15

NOTE: To establish a V/f pattern with a straight line from Fmin to FA, set FB = Fmin. The setting of Vc is then disregarded and does not affect the V/f pattern.

IMPORTANT

The V/f parameter settings are checked each time the **ENTER** key is pressed while programming the V/f parameters. A parameter set value failure (**Err**) will occur if any part of the following relationships among **n09** thru **n15** is not TRUE:

- (a) $F_{max} \geq F_A \geq F_B \geq F_{min}$
- (b) $V_{max} \geq V_c \geq V_{min}$

5.27 COPY FUNCTION

The GPD305 optional Remote Digital Operator can be used to store (upload) parameters from a drive, which can then be copied (downloaded) to another drive. These parameters are stored in EEPROM in the Digital Operator. The Copy Function is possible only for drives of the same type (i.e. from one GPD305 to another, but not from a GPD305 to a GPD315 or vice versa), and voltage rating (230V drive or 460V drive). In addition, the following parameters cannot be copied:

Parameter No.	Parameter Name
n09 to n15	V/f Settings
n32	Motor Rated Current
n46	Carrier Frequency
n64	Motor Rated Slip
n65	Motor No-load Current

n76 : Parameter Copy Function Selection

Ex : Factory Setting: **rdy**

Setting	Description
rdy	Drive is ready to use Copy Function
rEd	Read (or upload) all parameters from the drive and store them in the Digital Operator
Cpy	Copy (or download) all parameters stored in the Digital Operator to the drive
vFy	Verify that parameters stored in the Digital Operator and the drive are the same
vA	Displays the voltage and kW rating of the drive whose parameters are stored in the Digital Operator
Sno	Displays the software number of the drive whose parameters are stored in the Digital Operator

n77 : Parameter Copy Access Selection

Factory Setting: **0**

Range: 0 or 1

Setting	Description
0	Copying Disabled
1	Copying Allowed

The Copy Function can be enabled or disabled using parameter **n77** – parameters cannot be uploaded or downloaded when this parameter is disabled (**n77** = 0), preventing the accidental overwriting of parameters stored in either the Digital Operator or the drive.

If **n77** = 0 and an upload or download is attempted (**n76** = rEd or Cpy), a “PrE” error message will blink on the Digital Operator display – press **DSPL** or **DATA/ENTER** to clear the message.

For more detailed information on the use of the Copy Function, please visit our website at www.drives.com.

Section 6. FAULT DIAGNOSIS AND CORRECTIVE ACTIONS

6.1 GENERAL

This section describes the alarm and fault displays, explanations for fault conditions and corrective actions to be taken if the GPD 305 malfunctions.

A failure in the GPD 305 can fall into one of two categories, Alarm or Fault.

A blinking “Alarm” indication is a warning that a GPD 305 trouble condition will soon occur, or that a programming error has been made. The GPD 305 will continue to operate during an “Alarm” indication.

A blinking “Minor Fault” indication is displayed during less serious faults, or when a problem exists in the external circuitry. The GPD 305 will continue to operate, and a “Minor Fault” contact will be closed if a multi-function output is programmed for the condition.

A steady “Major Fault” indication is displayed when the GPD 305’s Fault relay has tripped. The motor coasts to a stop, and a fault signal output is present at control circuit terminals MA, MB and MC.

 : ON  : BLINKING ● : OFF

Table 6-1. Alarm Displays and Corrective Actions







Alarm Display		Drive Status	Explanation	Causes and Corrective Actions
Digital Operator	RUN (Green) ALARM (Red)			
 Blinking		Warning only. Fault contacts do not change state.	UV (Main circuit low voltage) Main circuit DC voltage drops below the low-voltage detection level while the drive output is OFF. 230V: Stops at main circuit DC voltage below approx. 200V (160V for single-phase) 460V: Stops at main circuit DC voltage below approx. 400 V	Check the following: <ul style="list-style-type: none"> • Power supply voltage • Main circuit power supply wiring is connected. • Terminal screws are securely tightened.
 Blinking	 		OV (Main circuit overvoltage) Main circuit DC voltage exceeds the over voltage detection level while the drive output is OFF. Detection level: approx. 410V or more (approx. 820V for 460V class).	Check the power supply voltage.
 Blinking			OH (Cooling fin overheat) Intake air temperature rises while the drive output is OFF.	Check the intake air temperature.
 Blinking			CAL (MODBUS communications waiting) Correct data has not been received from the PLC when the parameter n02 (operation command selection) is 2 or n03 (frequency reference selection) is 6, and power is turned ON.	Check communication devices, and transmission signals.

Table 6-1. Alarm Displays and Corrective Actions - Continued









Alarm Display		Drive Status	Explanation	Causes and Corrective Actions
Digital Operator	RUN (Green) ALARM (Red)			
 Blinking	  	Warning only. Fault contacts do not change state.	OP□ (Parameter setting error when the parameter setting is performed through the MODBUS communications) OP1: Two or more values are set for multi-function input selection. (parameters n36 to n39) OP2: Relationship among V / f parameters is not correct. (parameters n09 , n11 , n12 , n14) OP3: Setting value of electronic thermal standard current exceeds 150% of drive rated current. (parameter n32) OP4: Upper / lower limit of frequency reference is reversed. (parameters n32 , n33) OP5: (parameters n49 and n50) OP9: Carrier frequency setting is incorrect. (parameter n46)	Check the setting values.
 Blinking	 		OL 3 (Overtorque detection) Motor current exceeded the preset value in parameter n60 .	Reduce the load, and increase the accel / decel time.
 Blinking			SEr (Sequence error) Drive receives LOCAL / REMOTE select command or communication / control circuit terminal changing signals from the multi-function terminal while the drive output is ON.	Check the external circuit (sequence).

Table 6-1. Alarm Displays and Corrective Actions - Continued



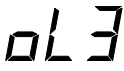

Alarm Display		Drive Status	Explanation	Causes and Corrective Actions
Digital Operator	RUN (Green) ALARM (Red)			
<i>bb</i> Blinking		Warning only. Fault contacts do not change state.	BB (External baseblock) Baseblock command at multi-function terminal is active, the drive output is shut OFF (motor coasting). Temporary condition is cleared when input command is removed.	Check the external circuit (sequence).
<i>EF</i> Blinking	  or  		EF (Simultaneous FWD/REV run commands) When FWD and REV run commands are simultaneously input for over 500ms, the drive stops according to parameter n04.	Check the external circuit (sequence).
<i>STP</i> Blinking			STP (Operator function stop) is pressed during running by the control circuit terminals FWD / REV command. The drive stops according to parameter n04. STP (Emergency stop) Drive receives emergency stop alarm signal. Drive stops according to parameter n04.	Open FWD/REV command of control circuit terminals. Check the external circuit (sequence).
<i>FAn</i> Blinking			FAN (Cooling fan fault) Cooling fan is locked.	Check the following: <ul style="list-style-type: none"> • Cooling fan • Cooling fan wiring is not connected.

Table 6-2. Fault Displays and Corrective Actions

Fault Display		Drive Status	Explanation	Causes and Corrective Actions
Digital Operator	RUN (Green) ALARM (Red)			
OL		Protective Operation. Output is shut OFF and motor coasts to a stop.	OC (Overcurrent) Drive output current momentarily exceeds approx. 200% of rated current.	<ul style="list-style-type: none"> • Short circuit or grounding at drive output side • Excessive load inertia • Extremely rapid accel/ decel time (parameters n16 to n19) • Special motor used • Starting motor during coasting • Motor of a capacity greater than the drive rating has been started. • Magnetic contactor open/closed at the drive output side
OU	● ☀		OV (Main circuit over-voltage) Main circuit DC voltage exceeds the overvoltage detection level because of excessive regenerative energy from the motor. Detection level: 230V: Stops at main circuit DC voltage below approx. 410V 460V: Stops at main circuit DC voltage approx. 820V or more	<ul style="list-style-type: none"> • Insufficient decel time parameters n17 and n19) • Lowering of minus load (elevator, etc.) <p style="text-align: center;">↩</p> <ul style="list-style-type: none"> • Increase decel time. • Connect optional dynamic braking resistor.
UV1			UV1 (Main circuit low voltage) Main circuit DC voltage drops below the low-voltage detection level while the drive output is ON. 230V: Stops at main circuit DC voltage below approx. 200V 460V: Stops at main circuit DC voltage approx. 400V or more	<ul style="list-style-type: none"> • Reduction of input power supply voltage • Open phase of input supply • Occurrence of momentary power loss <p style="text-align: center;">↩</p> <p>Check the following:</p> <ul style="list-style-type: none"> • Power supply voltage • Main circuit power supply wiring is connected. • Terminal screws are securely tightened.
GF			GF (Ground Fault) Ground current exceeded drive rated current.	Check motor insulation and wiring between drive and motor for damage.









Table 6-2. Fault Displays and Corrective Actions - Continued

Fault Display		Drive Status	Explanation	Causes and Corrective Actions
Digital Operator	RUN (Green) ALARM (Red)			
UV2		Protective Operation. Output is shut OFF and motor coasts to a stop.	UV2 (Control power supply fault) Voltage fault of control power supply is detected.	Cycle power. If the fault remains, replace the drive.
OH	●		OH (Cooling fin overheat) Temperature rise because of drive overload operation or intake air temperature rise.	<ul style="list-style-type: none"> Excessive load Improper V/f pattern setting Insufficient accel time if the fault occurs during acceleration Intake air temperature exceeding 122°F (50°C) <p style="text-align: center;">⇐</p> Check the following: <ul style="list-style-type: none"> Load size V/f pattern setting (parameters n09 to n15) Intake air temperature.
OL1	☀		OL1 (Motor overload) Motor overload protection operates by built-in electronic thermal overload relay.	<ul style="list-style-type: none"> Check the load size or V/f pattern setting (parameters n09 to n15) Set the motor rated current shown on the nameplate in parameter n32.
OL2			OL2 (Drive overload) Drive overload protection operates by built-in electronic thermal overload relay.	<ul style="list-style-type: none"> Check the load size or V/f pattern setting (parameters n09 to n15) Check the drive capacity.
OL3			OL3 (Overtorque detection) Drive output current exceeded the preset value in parameter n60. When overtorque is detected, drive performs operation according to the preset setting of parameter n59.	Check the driven machine and correct the cause of the fault, or increase the value of parameter n60 up to the highest value allowed for the machine.

Table 6-2. Fault Displays and Corrective Actions - Continued

Fault Display		Drive Status	Explanation	Causes and Corrective Actions
Digital Operator	RUN (Green) ALARM (Red)			
EF□	●	Protective Operation. Output is shut OFF and motor coasts to a stop.	EF□ (External fault) Drive receives an external fault input from control circuit terminal. EF0: External fault reference through MODBUS communications EF2: External fault input command from control circuit terminal S2 EF3: External fault input command from control circuit terminal S3 EF4: External fault input command from control circuit terminal S4 EF5: External fault input command from control circuit terminal S5	Check the external circuit (sequence).
F00	☀		CPF-00 Drive cannot communicate with the digital operator for 5 sec. or more when power is turned ON.	Cycle power after checking the digital operator is securely mounted. If the fault remains, replace the digital operator or drive.
F01			CPF-01 Transmission fault occurred for 5 sec or more when transmission starts with the digital operator.	Cycle power after checking the digital operator is securely mounted. If the fault remains, replace the digital operator or drive.
F04			CPF-04 EEPROM fault of drive control circuit is detected.	<ul style="list-style-type: none"> Record all parameter data and initialize the constants. (Refer to paragraph 5.____ for constant initialization.) Cycle power. If the fault remains, replace the drive.

Table 6-2. Fault Displays and Corrective Actions - Continued

Fault Display		Drive Status	Explanation	Causes and Corrective Actions
Digital Operator	RUN (Green) ALARM (Red)			
F05	 	Protective Operation. Output is shut OFF and motor coasts to a stop.	CPF-05 A/D converter fault is detected.	Cycle power. If the fault remains, replace the drive.
F06			CPF-06 Option card connecting fault	Remove power to the drive. Check the connection of the digital operator.
F07			CPF-07 Operator control circuit (EEPROM or A/D converter) fault	Cycle power after checking the digital operator is securely mounted. If the fault remains, replace the digital operator or drive.
OPR			OPR (Operator connecting fault)	Cycle power. If the fault remains, replace the drive.
CE			CE (MODBUS communications fault)	Check the communication devices or communication signals.
STP	  or  	Stops according to parameter	STP (Emergency stop) The drive stops according to parameter n04 after receiving the emergency stop fault signal.	Check the external circuit (sequence).
— (OFF)	 		<ul style="list-style-type: none"> • Insufficient power supply voltage • Control power supply fault • Hardware fault 	Check the following: <ul style="list-style-type: none"> • Power supply voltage • Main circuit power supply wiring is connected. • Terminal screws are securely tightened. • Control sequence. Replace the drive.

For display/clear of fault history, refer to page 4-4.

- Monitoring

Following items can be monitored by U-constants

Constant No.	Name		Description
U-01	Frequency reference	Hz	Frequency reference can be monitored.
	(FREF)		(Same as FREF)
U-02	Output frequency (FOUT)	Hz	Output frequency can be monitored. (Same as FOUT)
U-03	Output current (IOUT)	Hz	Output current can be monitored. (Same as IOUT)
U-04	Output voltage	V	Output voltage can be monitored.
U-05	DC voltage	V	Main circuit DC voltage can be monitored.
U-06	Input terminal status	—	Input terminal status can be monitored. (see paragraph 4.4)
U-07	Output terminal status	—	Output terminal status can be monitored. (see paragraph 4.4)
U-09	Fault history (last 4 faults)	—	Last four fault history is displayed. (see paragraph 4.4)
U-10	Software No.	—	Software No. can be checked.
U-15	Data reception error	—	See Table below

U-15 Data	Description
0	CRC Error
1	Data Length Error
2	Not Used
3	Parity Error
4	Overrun Error
5	Framing Error
6	Time out Error

Appendix 1. LISTING OF PARAMETERS

The GPD 305 control circuits use various parameters to select functions and characteristics of the GPD 305. Changing of parameter settings must be done in the Program mode, or by use of the Function LEDs, if available (see Section 4).

The following table lists all parameters in numerical order. For each parameter, reference paragraph(s) in Section 5 are listed (if applicable) where the features of the GPD 305 affected by that parameter are described.

Table A1-1. GPD 305 Parameters

PARAM-ETER	NAME	SETTING RANGE (AND UNITS)	SETTING INCREMENT	FACTORY SETTING	USER SETTING	PARA. REF.
n01	Parameter Selection / Initialization	0: n01 can be read and set; n02 - n79 read only 1: n01 - n79 can be read and set 2-5: Not Used 6: Clear Fault History Only 7: Not Used 10: 2 wire initialization (USA Spec) 11: 3 wire initialization (USA Spec.)	1	1		5.20
n02	Operation Method Selection	0: Digital Operator 1: Terminal 2: Serial Communication (Modbus)	1	1		5.13
n03	Reference Selection	0: Digital Operator Pot 1: Digital Operator 2: Voltage Reference (0 to 10V) 3: Current Reference (4 to 20 mA) 4: Current Reference (0 to 20 mA) 5: Pulse Train Reference 6: Serial Communications (Modbus)	1	2		5.13
n04	Stop Method	0: Ramp to stop 1: Coast to stop	1	0		5.23
n05	Reverse Prohibit	0: Reverse Run enabled 1: Reverse Run disabled	1	0		
n06	STOP Key Function	0: STOP key is effective regardless of programming of n02 1: STOP key is effective only when sequence command (per n02) is from Digital Operator	1	0		5.13
n07	Reference Selection - Digital Operator	0: Frequency Reference from digital operator pot 1: Frequency Reference from n21	1	0		5.13
n08	Frequency Reference Setting Method From Digital Operator	0: ENTER key must be pressed to write-in new value 1: ENTER key does not have to be pressed to write-in new value	1	0		5.13
n09	Frequency - Max.	50.0 to 400.0	0.1 (Hz)	60.0		5.26
n10	Voltage - Max.	0.1 to 255.0 (230V drive) 0.2 to 510.0 (460V drive)	0.1 (V)	230 460		
n11	Frequency - Max. Voltage Point	0.2 to 400.0	0.1 (Hz)	60.0		
n12	Frequency - Midpoint	0.1 to 399.9	0.1 (Hz)	1.5		
n13	Voltage - Midpoint	0.1 to 255.0 (230V drive) 0.2 to 510.0 (460V drive)	0.1 (V)	12		
n14	Frequency - Min.	0.1 to 10.0	0.1 (Hz)	1.5		
n15	Voltage - Min.	0.1 to 50.0 (230V drive) 0.2 to 100.0 (460V drive)	0.1 (V)	12		
n16	Acceleration Time 1	0.0 to 999	0.1 (sec) (<100 sec.)	10.0		
n17	Deceleration Time 1					
n18	Acceleration Time 2		1 (sec) (≥100 sec.)			
n19	Deceleration Time 2					
n20	S-curve Selection	0: No S-curve 1: 0.2 second 2: 0.5 second 3: 1.0 second	1	0		5.3

Table A1-1. GPD 305 Parameters - Continued

PARAM-ETER	NAME	SETTING RANGE (AND UNITS)	SETTING INCREMENT	FACTORY SETTING	USER SETTING	PARA. REF.
n21	Frequency Reference 1	0.0 to 400	0.1 (Hz) (< 100 Hz) or 1 (Hz) (≥ 100 Hz)	6.0		5.11
n22	Frequency Reference 2			0.0		
n23	Frequency Reference 3			0.0		
n24	Frequency Reference 4			0.0		
n25	Frequency Reference 5			0.0		
n26	Frequency Reference 6			0.0		
n27	Frequency Reference 7			0.0		
n28	Frequency Reference 8			0.0		
n29	Jog Frequency Reference				6.0	
n30	Frequency Reference Upper Limit	0 to 110	1 (%)	100		5.9
n31	Frequency Reference Lower Limit	0 to 110	1 (%)	0		
n32	Motor Rated Current	0.0 to 49.5 (Up to 120% of inverter rated current)	0.1 (A)	Note 1		5.24
n33	Electronic Thermal Overload Protection (for OL1 fault)	0: Standard Motor - Short Term 1: Inverter Motor - Standard Rating 2: Disabled	1	0		5.24
n34	Electronic Thermal Overload Protection Time Constant	1 to 60	1 (min)	8		
n35	Cooling Fan Operation Selection	0: Operates only when drive is running (continues operation for 1 minute after drive is stopped) 1: Operates with power applied to drive	1	0		
n36	Multi-function Input Selection 2 (Terminal S2)	0: Fwd / Rev command (3 wire control) [can only be set in n37] 2: Reverse run (2 wire control)	1	2 (2)		5.17
n37	Multi-function Input Selection 3 (Terminal S3)	3: External Fault (N.O.) 4: External Fault (N.C.) 5: Fault Reset	1	5 (0)		
n38	Multi-function Input Selection 4 (Terminal S4)	6: Multi-step speed ref. cmd. A 7: Multi-step speed ref. cmd. B 8: Multi-step speed ref. cmd. C	1	3 (3)		
n39	Multi-function Input Selection 5 (Terminal S5)	10: JOG Selection 11: Accel/Decel time change cmd. 12: External Base Block (N.O.) 13: External Base Block (N.C.) 14: Speed search from max. freq. 15: Speed search from set freq. 16: Accel/Decel hold command 17: Remote/Local selection 18: Serial Communication / control ckt. selection 19: Fast Stop - Fault (N.O.) 20: Fast Stop - Alarm (N.O.) 21: Fast Stop - Fault (N.C.) 22: Fast Stop - Alarm (N.C.) 23: Not used 24: I value reset (PID) 25: I value hold (PID) 34: Up / Down command 35: Loop Test [can only be set in n39]	1	6 (6)		
n40	Multi-Function Output Selection (Terminals MA, MB & MC)	0: Fault 1: During running 2: Speed Agree 3: Zero Speed 4: Frequency detection 1 5: Frequency detection 2 6: Overtorque detection (N.O.) 7: Overtorque detection (N.C.) 10: Minor Fault 11: During Base Block 12: Local / Remote 13: Ready 14: During auto restart 15: During undervoltage 16: During reverse run 17: During speed search 18: Serial Comm. Controlled	1	1		5.18

Table A1-1. GPD 305 Parameters - Continued

PARAM-ETER	NAME	SETTING RANGE (AND UNITS)	SETTING INCREMENT	FACTORY SETTING	USER SETTING	PARA. REF.
n41	Analog Frequency Reference Gain	0 to 255	1 (%)	100		5.8
n42	Analog Frequency Reference Bias	-100 to 100	1 (%)	0		
n43	Analog frequency reference filter time constant	0.00 to 2.00	0.01 (sec)	0.10		
n44	Multi-function Analog Output (Terminals AM & AC)	0: Output frequency 1: Output Current 2: DC Bus Voltage (10V / 400 VDC [800 VDC]) 3: Motor Torque (10V / Motor rated torque) 4: Output Power (10V / Drive Capacity kW)	1	0		5.16
n45	Analog Monitor Gain	0.00 to 2.00	0.01	1.00		
n46	Carrier Frequency	1 to 4 (x 2.5 kHz) 7 to 9 (synchronous)	1	4		5.5
n47	Momentary Power Loss Ride-through Method	0: Not Provided 1: Continuous operation after power recovery within 2 sec. 2: Continuous operation after power recovery within control logic time (no fault output)	1	0		5.15
n48	Number of auto restarts attempts	0 to 10	1	0		
n49	Prohibit Frequency 1	0.00 to 400.0	0.01 (Hz) or 0.1 (Hz)	0.00		5.6
n50	Prohibit Frequency 2	0.00 to 400.0	0.01 (Hz) or 0.1 (Hz)	0.00		
n51	Prohibit Frequency Deadband	0.0 to 25.5	0.01 (Hz)	0.00		
n52	DC Injection Current	0 to 100	1 (%)	50		5.7
n53	DC Injection Time at stop	0.0 to 25.5	0.1 (sec)	0.0		
n54	DC Injection Time at start	0.0 to 25.5	0.1 (sec)	0.0		
n55	Stall Prevention During Deceleration	0: Enabled 1: Disabled	1	0		5.22
n56	Stall Prevention During Acceleration	30 to 200	1 (%)	170		
n57	Stall Prevention Level During Running	30 to 200	1 (%)	160		
n58	Frequency Detection Level	0.00 to 400.0	0.01 (Hz) or 0.1 (Hz)	0.0		5.18
n59	Overtorque Detection (OL3)	0: Detection Disabled 1: Detect only at set frequency; operation continues 2: Detect only at set frequency; coast to stop 3: Detect during all frequency conditions; operation continues 4: Detect during all frequency conditions; coast to stop	1	0		5.19
n60	Overtorque Detection Level (OL3)	30 to 200	1 (%)	160		
n61	Overtorque Detection Delay Time (OL3)	0.1 to 10.0	0.1 (sec)	0.1		
n62	Up/Down Hold Memory	0: Disabled 1: Enabled	1	0		5.10
n63	Torque Compensation Gain	0.0 to 2.5	0.1	1.0		5.25
n64	Motor Rated Slip	0.0 to 20.0	0.1 (Hz)	Note 1		5.21
n65	Motor No-load Current	0 to 99	1 (%)	Note 1		2.4A
n66	Slip Compensation Gain	0.0 to 2.5	0.1	0.0		5.21
n67	Slip Compensation Primary Delay Time	0.0 to 25.5	0.1 (sec)	2.0		
n68	Modbus Time Out Detection	0: Fault - Coast to stop 1: Fault - Ramp to stop (n17) 2: Fault - Ramp to stop (n19) 3: Alarm - operation continues 4: Disabled	1	0		5.14
n69	Modbus Frequency Reference Unit	0: 0.1 Hz 1: 0.01 Hz 2: 100% / 30000 3: 0.1 %	1	0		
n70	Modbus Slave Address	0 to 32	1	0		

Table A1-1. GPD 305 Parameters - Continued

PARAM-ETER	NAME	SETTING RANGE (AND UNITS)	SETTING INCREMENT	FACTORY SETTING	USER SETTING	PARA. REF.
n71	Modbus Baud Rate	0: 2400 bps 1: 4800 bps 2: 9600 bps 3: 19200 bps	1	2		5.14
n72	Modbus Parity Selection	0: even parity 1: odd parity 2: no parity	1	2		
n73	Modbus Send Waiting Time	10 to 65	1 (msec)	10		
n74	Modbus RTS control	0: RTS control enabled 1: RTS control disabled (RS-422A 1 to 1 communication)	1	0		
n75	Reduce Carrier at low speed selection	0: Disabled 1: Carrier Frequency reduced to 2.5kHz when Fout <= 5Hz & Iout >= 110%	1	0		
n76	Digital Operator Parameter Copy Function Selection	rdy : READY status rEd: READ executes Cpy: COPY executes vFy: VERIFY executes vA: Inverter capacity display Sno: Software No. display	rdy rEd Cpy vFy vA Sno	rdy		
n77	Digital Operator Parameter Copy Access Selection	0: Copying disabled 1: Copying allowed	1	0		
n78	Fault History	Note 2	N/A	N/A		
n79	Software Number	Note 2		013		

Note 1: Factory setting differs depending on GPD 305 capacity. See Appendix 3-1.

Note 2: n78 and n79 are display only parameters, which are not settable.

Appendix 2. SPECIFICATIONS

Table A2-1. Standard Specifications

SECTION A. Model No. Related Specifications								
Output Characteristics	230 VAC Model Number	JDA001	JDA002	JDA003	JDA005	JDA008	JDA011	JDA017
	Max. applicable motor output HP (kW) (1)	1/8 (0.1)	1/4 (0.2)	1/2 (0.4)	1 (0.7)	2 (1.5)	3 (2.2)	5 (3.7)
	Drive capacity (kVA)	0.3	0.6	1.1	1.9	3.0	4.2	6.7
	Rated Output Current (A)	0.8	1.6	3.0	5.0	8.0	11.0	17.5
	Max. Output Voltage (V)	200V to 230V (proportional to input voltage)						
	Max. Output Frequency (Hz)	400 Hz (programmable)						
Power Supply	Rated Input Voltage and Frequency	three-phase. 200 to 230 V, 50/60 Hz						
	Allowable voltage fluctuation	-15% to +10%						
	Allowable frequency fluctuation	±5%						
Output Characteristics	460 VAC Model Number	--	--	JDB001	JDB002	JDB003	JDB005	JDB009
	Max. applicable motor output HP (kW) (1)	--	--	1/2 (0.2)	3/4 (0.4)	2 (0.7)	3 (1.5)	5 (3.7)
	Drive capacity (kVA)	--	--	0.9	1.4	2.6	3.7	7
	Rated Output Current (A)	--	--	1.2	1.8	3.4	4.8	8.6
	Max. Output Voltage (V)	380 to 460V (proportional to input voltage)						
	Max. Output Frequency (Hz)	400 Hz (programmable)						
Power Supply	Rated Input Voltage and Frequency	three-phase. 380 to 460 V, 50/60 Hz						
	Allowable voltage fluctuation	-15% to +10%						
	Allowable frequency fluctuation	±5%						
SECTION B. All GPD 305s								
Control Characteristics	Control method	Sine wave PWM (V/f Control or Open Loop Vector)						
	Frequency control range	0.1 to 400 Hz						
	Frequency accuracy (temperature change)	Digital command: ±0.01% (14 to 122°F, -10 to +50°C) Analog command: ±0.5% (77°F ± 18°F, 25°C ± 10°C)						
	Frequency setting resolution	Digital Operator reference: 0.1 Hz (< 100Hz) 1.0 Hz (100Hz or more) Analog reference: 0.06Hz/60Hz (1/1000)						
	Output frequency resolution	0.01 Hz						
	Overload capacity	150% of rated output current for 1 minute						
	Frequency Reference Signal	0 to 10VDC (20kΩ), 4 to 20mA (250Ω), 0 to 20mA (250Ω) pulse train input, Digital Operator Pot						
	Accel/Decel Time	0.01 to 6000 sec. (accel/decel time are independently programmed)						
	Braking Torque	Short-term average deceleration torque (2) 0.2kW: 150% 0.75kW: 100% 1.5kW: 50% 2.2kW or more: 20% Continuous regenerative torque: Approx. 20%						
	V/f characteristics	Custom V/f pattern						

See notes at end of table.

(table continued on next page)

Table A2-1. Standard Specifications (Continued)

SECTION B. All GPD 305s (Continued)			
Protective Functions	Motor overload protection	Electronic thermal overload relay	
	Instantaneous overcurrent	Motor coasts to stop at approx. 200% of drive current	
	Overload	Motor coasts to stop after 1 min. at 150% of drive rated current	
	Overvoltage	Motor coasts to stop if DC bus voltage exceeds 410VDC (230V), 820VDC (460V)	
	Undervoltage	Motor coasts to stop when DC bus voltage is 210VDC or less (230V), 400VDC or less (460V)	
	Momentary Power Loss	The following operations are selectable: <ul style="list-style-type: none"> • Not provided (stops if power loss is 15 ms or longer) • Automatic restart at recovery from 0.5 sec. power loss <ul style="list-style-type: none"> • Automatic restart 	
	Heatsink overheat	Protected by electronic circuit	
	Stall prevention level	Independently programmable during accel and constant-speed running. Selectable during decel.	
	Ground fault	Protected by electronic circuit (overcurrent level)	
	Power charge indication	ON until the DC bus voltage becomes 50V or less. RUN lamp says ON or digital operator LED stays ON. (Charge LED is Provided for 400V)	
	Cooling Fan Fault	Protected by electronic circuit	
Other Functions	Input signals	Run/stop input	2-Wire or 3-Wire
		Multi-function input	Seven of the following input signals are selectable: Forward/reverse run (3-Wire sequence), fault reset, external fault (NO/NC contact input), multi-step speed operation, Jog command, accel/decel time select, external baseblock (NO/NC contact input, speed search command, accel/decel hold command, LOCAL/REMOTE selection, communication/control circuit terminal selection, emergency stop fault emergency stop alarm
	Output signals	Multi-function output	Following output signals are selectable (1 NO/NC contact output, 2 photo-coupler outputs): Fault, running, zero speed, at frequency, frequency detection (output frequency \leq or \geq set value), during overtorque detection, during undervoltage detection, minor error, during baseblock, operation mode, inverter run ready, during fault retry, during UV, during speed search, data output through communication
		Analog monitor	0 to +10VDC output, programmable for output frequency or output current
	Standard functions		Full-range automatic torque boost, auto restart, upper/lower frequency limit, DC injection braking current/time at start/stop, frequency reference gain/bias, prohibited frequencies, analog meter calibrating gain, S-curve accel/decel, slip compensation, MODBUS communications optional (RS232 or RS485/422, Max. 19.2K bps), frequency reference from digital operator pot
	Display	Status indicator LEDs	RUN and ALARM LEDs provided as standard
		Digital Operator	Monitors frequency reference, output frequency, output current, FWD/REF selection
	Terminals		Screw terminals for both main circuit and control circuit
	Wiring distance between drive and motor		328 ft (100 m) or less (3)
	Enclosure		Protected chassis (IP 20)
	Cooling method		Self-cooling/cooling fan
Environmental conditions	Ambient temperature		14 to 122°F (-10 to 50°C)
	Humidity		95% RH or less (non-condensing)
	Storage temperature (4)		-4 to 140°F (-20 to 60°C)
	Location		Indoor (free from corrosive gases or dust)
	Elevation		3,280 feet (1,000 m) or less
	Vibration		Up to 1G, at less than 20 Hz; up to 0.2G, at 20 to 50 Hz

NOTES:

- (1) Based on an N.E.C. standard 4-pole motor for max. applicable motor output.
- (2) Shows deceleration torque for an uncoupled motor decelerating from 60 Hz in 0.1 seconds.
- (3) Contact your MagneTek representative for wiring distances greater than 328 ft. (100 m).
- (4) Temperature during shipping (for short periods of time).

Appendix 3. CAPACITY RELATED PARAMETERS

The factory setting of certain parameters change with drive rating and control method selected. The following two tables list the parameters and how they change.

Table A3-1. Parameters Related to GPD 305 Capacity

GPD 305 Model	n32	n64	n65
JDA001	0.6	2.5	72
JDA002	1.1	2.6	73
JDA003	1.9	2.9	62
JDA005	3.3	2.5	55
JDA008	6.2	2.6	45
JDA011	8.5	2.9	35
JDA017	14.1	3.3	32
JDB001	0.6	2.5	73
JDB002	1.0	2.7	63
JDB003	1.6	2.6	52
JDB005	3.1	2.5	45
JDB006	4.2	3.0	35
JDB009	7.0	3.2	33

Appendix 4. PERIPHERAL DEVICES

The following peripheral devices may be required to be mounted between the AC main circuit power supply and the GPD 305 input terminals L1 (R), L2 (S) and L3 (T).

CAUTION

Never connect a general LC/RC noise filter to the drive output circuit.

Never connect a phase-advancing capacitor to the input/output sides or a surge suppressor to the output side of the drive.

When a magnetic contactor is installed between the drive and the motor, never turn it on or off during operation.

For more details on peripheral devices, contact your MagneTek representative.

• Molded-case circuit breaker (MCCB)

230 V	Model	JDA001	JDA002	JDA003	JDA005	JDA008	JDA011	JDA017
Capacity (kVA)		0.3	0.6	1.1	1.9	3	4.2	6.7
Rated output current (A)		0.8	1.6	3.0	5.0	8.0	11.0	17.5
Rated input current (A)		1.1	1.8	3.9	6.4	11.0	15.1	24.0
MCCB rating (A)		5	5	5	10	20	20	30

460 V	Model	JDB001	JDB002	JDB003	JDB005	JDB009
Capacity (kVA)		0.9	1.4	2.6	3.7	7.0
Rated output current (A)		1.2	1.8	3.4	4.8	8.6
Rated input current (A)		1.6	2.4	4.7	7.0	13.5
MCCB rating		5	5	5	10	20

• Magnetic contactor

Mount a surge protector on the coil. When using a magnetic contactor to start and stop the drive, do not exceed one start per hour.

• Ground fault interrupter

Select a ground fault interrupter not affected by high frequencies. To prevent malfunctions, the current should be 200mA or more and the operating time 0.1 second or more.

• AC and DC reactor

Install a reactor to connect to a power supply transformer of large capacity (600 kVA or more) or to improve the power factor on the power supply side.

• Noise filter

Use a noise filter exclusively for the drive if radio noise generated from the drive causes other control devices to malfunction.

Appendix 5. GPD 305 DIMENSIONS

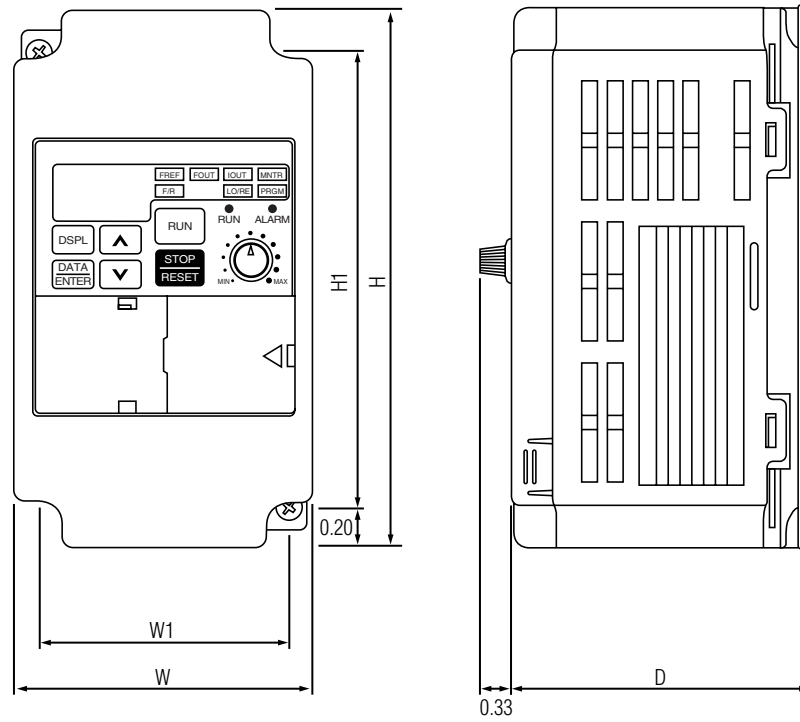

Rated Input	Drive Model No.	Horse-Power	Dimensions in Inches					Weight Lbs.	Heat loss (Watts)
			H	H1	W	D	W1		
230V	JDA001	1/8	5.04	4.65	2.68	2.76	2.20	1.1	13.0
	JDA002	1/4				2.76	2.20	1.1	18.0
	JDA003	1/2				4.02	2.20	1.8	28.1
	JDA005	3/4 & 1				4.80	2.20	2.0	45.1
460V	JDB001	1/2	5.04	4.65	4.25	3.19	3.78	2.2	23.1
	JDB002	3/4				3.90	3.78	2.4	30.1
	JDB003	1 & 2				5.08	3.78	3.3	54.9
	JDB005	3				6.06	3.78	3.3	75.7

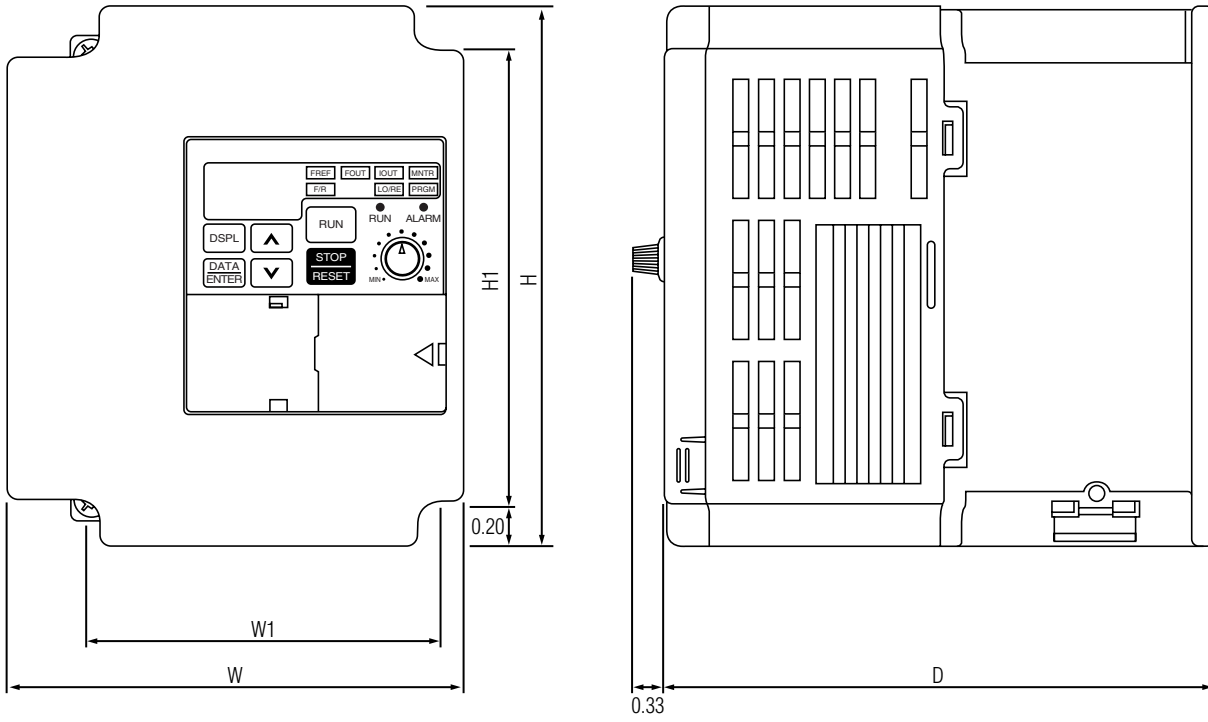

Rated Input	Drive Model No.	Horse-Power	Dimensions in Inches					Weight Lbs.	Heat loss (Watts)
			H	H1	W	D	W1		
230V	JDA008	2	5.04	4.65	4.25	5.08	3.78	2.9	72.8
	JDA011	3			4.25	6.06	3.78	3.3	94.8
	JDA017	5			5.51	6.34	5.04	4.6	149.1
460V	JDB009	5			5.51	6.34	5.04	4.6	117.9

INDEX

- A -

Acceleration :	
Accel time 1	5-2
Accel time 2	5-2
Hold	5-25
S-curve	5-3
Time setting unit	5-2
Analog monitor output,	
multi-function	5-19
Auto restart	5-4

- B -

Braking :	
DC injection	5-7

- C -

Carrier frequency	5-5
Conformance to European	
EMC Directive	1-8
Contactors — see	
Peripheral Devices	
Control circuit :	
Terminals	1-6
Wiring	1-5
Critical frequency	
rejection	5-6
Current :	
Limit — see Stall Prevention	
Motor	2-7
Output (IOUT).....	4-2
Output (monitor)	4-4

- D -

DATA/ENTER key	4-1
DC injection :	
Time at start	5-7
Time at stop	5-7
Deadband, prohibited	
frequency	5-6
Deceleration :	
Decel time 1	5-2
Decel time 2	5-2
S-curve	5-3
Time setting unit	5-2
Decrease (v) key	4-1
Diagnostics — see	
Troubleshooting	
Digital operator	4-1
Dimensions	A5-1, A5-2
DSPL key	4-1

- E -

EMC Directive, European,	
Conformance to	1-9
Enclosure	A2-2
Environment	1-1, A2-2
External base block	5-23

- F -

F/R LED	4-2
Fault displays	6-4
Fault history	5-31, A1-5
Faults :	
Restart attempts	5-4
FOUT LED	4-2
FREF LED	4-2
Frequency :	
Detection	5-28
Max. output	A2-1
Output (FOUT)	4-2
Output (monitor)	4-4
Frequency reference :	
Bias (analog)	5-8
Gain (analog)	5-8
Jog	5-12
Limits	5-9
Retention (Up/Down)	5-9
Selection	5-10

- G -

Gain :	
Analog monitor	5-19
Frequency reference (analog)	5-8
Torque compensation	5-35
Grounding	1-5

- H -

Heat loss (watts)	A5-1, A5-2
Hold :	
Accel/decel	5-21, 5-25
Frequency ref. (retention)	5-9

- I -

Increase (^) key	4-1
Initialize parameters	5-30
Inputs, multi-function	5-20
Inspection (receiving)	1-1
Installation:	
Electrical	1-4
Physical	1-1
IOUT LED	4-2

INDEX (Continued)

- J -

Jog reference 5-12

- K -

Keypad — *see Digital Operator*

- L -

LEDs :

 Function 4-2

 Status Indicator 4-3

Local/Remote reference and

 sequence selection 5-13

LO/RE LED 4-2

- M -

Main circuit :

 Terminals 1-4

 Wiring 1-4

Mechanical resonance —

see Critical Frequency Rejection

MNTR LED 4-2

MODBUS control 5-15

Model Number, GPD 305 A2-1

Momentary power loss ride-through 5-19

Monitor displays 4-4

Motor :

 No-load current 5-31

 Protection 5-34

 Rated current 5-32

 Switching — *see Speed Search*

 Wiring 1-4

Mounting :

 Clearances 1-1

 Dimensions A5-1, A5-2

 European EMC

 conformance 1-8

 Location 1-1, A2-2

Multi-function analog

 monitor output 5-19

Multi-function input

 terminals 5-20

Multi-function output

 terminals 5-26

- N -

Nameplate, motor 2-7

- O -

Operation at load 3-1

Operation mode 5-13

Operator display 4-1

Options — *see Peripheral*

Devices

Outputs :

 Analog 5-19

 Contact 5-26

 Multi-function 5-26

 Open collector 5-26

Overtorque detection 5-29

- P -

Parameters :

 Capacity and control

 method related A3-1

 Listing of A1-1

 Reset (initialize) 5-30

Peripheral devices :

 AC and DC reactor A4-1

 Ground fault interrupter A4-1

 Magnetic contactor A4-1

 Molded-case circuit

 breaker (MCCB) A4-1

 Noise filter A4-1

Potentiometer 4-1

Power loss ride-through 5-28

Power supply A2-1

Pre-power checks 2-1

Preset speeds — *see*

Multi-step speeds

PRGM LED 4-2

Prohibited frequency

 deadband 5-6

Protection :

 Overcurrent 5-32

 Overheat (drive) A2-1

 Overtorque 5-29

 Overvoltage (decel) 5-32

 Thermal overload (mtr) 5-34

 Undervoltage A2-2

Protective functions,

 miscellaneous 5-19

- R -

Rated current, motor 5-34

Ratings i, A2-1

Receiving 1-1

Remote reference — *see*

Local/Remote

Reset codes 5-22

Reverse prohibit 1-10, 1-12

Ride-through 5-19

RUN key 4-1

- S -

S-curve 5-3

Shock resistance — *see*

S-curve

Product Training



It is important to MagneTek that users of our products have a totally satisfying ownership experience.

Training is one of the most effective ways to ensure that satisfaction. Because of this conviction, MagneTek has operated a full-time professional training department since 1965.



MagneTek trainers are full-time instructors, with a wealth of “real-life” product experience gained through field service at customer facilities. This experience, combined with

backgrounds in engineering and education, has earned national recognition for MagneTek’s technical training programs.

Courses are conducted at the headquarters training facility, in selected cities, and at customer sites. Courses are available to cover all the issues of concern to product users: application, theory of operation, troubleshooting and repair, adjustment and startup, operation, programming, network communication, and optimizing the functions of MagneTek drives.

We work hard to make all of our products user-friendly, and our owner manuals easy to use. In spite of that, the simple fact is that you will learn better and faster in a class environment combined with hands-on practice, than by self-teaching when under the stress of a maintenance or operations problem.

On-Site Training and Customized Courses

Training courses are also provided at the user’s site. Course content can be customized to the specific installation and application if requested. For further information about on-site training and courses specific to your installation and application, contact the Training Manager at 1-800-541-0939.

Please send training information on:

Name _____

Position/Title _____

Company _____

Address _____

City _____ State _____ Zip _____

Phone _____

Fax _____

MagneTek Representative (if known): _____

Fax this form to (262) 782-3418

If you would prefer a larger (8-1/2 in. x 11 in.) version of this manual, please complete and submit the following:

NAME: _____

TITLE: _____

COMPANY: _____

ADDRESS: _____

CITY: _____

STATE: _____ ZIP: _____

PHONE: _____ FAX: _____

Manual #: **TM 4305 FS**

TO: MagneTek Drives & Systems
Attn: Marketing Communications
16555 W. Ryerson Road
New Berlin, WI 53151

FAX #: (262) 782-3418

GPD 305

MagneTek Technical Support is available to provide telephone assistance for **installation, programming, & troubleshooting** of MagneTek Drives. All support is available during normal business hours. Emergency breakdown support is available on a 24 hour / 7 day basis.

Review the Technical Manual provided with each MagneTek Product. This manual provides valuable information for proper installation & programming of MagneTek AC Drives. Most answers can be found in the Simplified Startup Procedures bound in the front of most manuals. Troubleshooting information can also be found within the manual. If you cannot find what you need, call for technical support.

Help us help you. When you call, please have the following information available.

- Have Technical Manual at hand. The Support Associate will refer to it.
- Drive model and all nameplate data.
- Motor type, brand, and all nameplate data.

For Troubleshooting, additional information may be required.

- Power distribution information (type – delta, wye; power factor correction; other major switching devices used; voltage fluctuations)
- Installation Wiring (separation of power & control wire; wire type/class used; distance between drive and motor, grounding).
- Use of any devices between the Drive & motor (output chokes, etc.).

Please phone us at 1-800-541-0939 for technical support.

Additional technical information is available at www.drives.com

Data subject to change without notice. GPD is a trademark of MagneTek, Inc. Modbus Plus and ModConnect are trademarks of Modicon, Inc.



MagneTek Drive Products
16555 W. Ryerson Road
New Berlin, WI 53151
(800) 541-0939, (262) 782-0200, Fax (262) 782-3418
www.drives.com