



VECTOR INVERTER

FR-V500

INSTRUCTION MANUAL (Detailed)

HIGH PRECISION & HIGH
RESPONSE VECTOR INVERTER

FR-V520-1.5K to 55K(-NA)

FR-V540-1.5K to 55K(-NA)

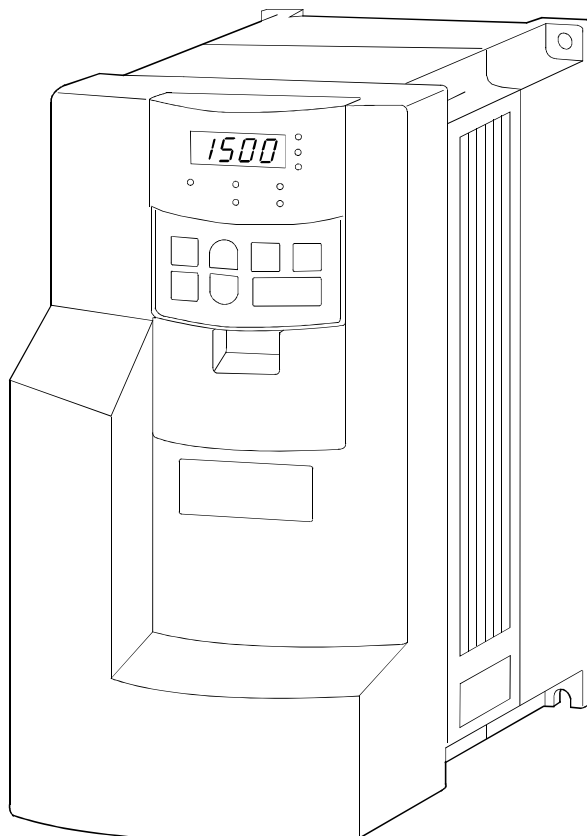

WIRING

1

VECTOR
CONTROL

2

PARAMETERS

3

SPECIFICATIONS

4

Thank you for choosing this Mitsubishi vector inverter. This Instruction Manual (detailed) provides instructions for advanced use of the FR-V500 series inverters. Incorrect handling might cause an unexpected fault. Before using the inverter, always read this Instruction Manual and the Instruction Manual (basic) [IB-0600064] packed with the product carefully to use the equipment to its optimum performance.

This instruction manual uses the International System of Units (SI). The measuring units in the yard and pound system are indicated in parentheses as reference values.

This section is specifically about safety matters

Do not attempt to install, operate, maintain or inspect the inverter until you have read through the Instruction Manual (basic) and appended documents carefully and can use the equipment correctly. Do not use the inverter until you have a full knowledge of the equipment, safety information and instructions. In this Instruction Manual, the safety instruction levels are classified into "WARNING" and "CAUTION".



WARNING

Assumes that incorrect handling may cause hazardous conditions, resulting in death or severe injury.



CAUTION

Assumes that incorrect handling may cause hazardous conditions, resulting in medium or slight injury, or may cause physical damage only.

Note that even the CAUTION level may lead to a serious consequence according to conditions. Please follow the instructions of both levels because they are important to personnel safety.

1. Electric Shock Prevention



WARNING

- While power is on or when the inverter is running, do not open the front cover. You may get an electric shock.
- Do not run the inverter with the front cover removed. Otherwise, you may access the exposed high-voltage terminals or the charging part of the circuitry and get an electric shock.
- Even if power is off, do not remove the front cover except for wiring or periodic inspection. You may access the charged inverter circuits and get an electric shock.
- Before starting wiring or inspection, check that power lamp display is turned off and check for residual voltages with a meter etc. more than 10 minutes after power-off.
- Earth (Ground) the inverter.
- Any person who is involved in wiring or inspection of this equipment should be fully competent to do the work.
- Always install the inverter before wiring. Otherwise, you may get an electric shock or be injured.
- Perform setting dial and key operations with dry hands to prevent an electric shock.
- Do not subject the cables to scratches, excessive stress, heavy loads or pinching. Otherwise, you may get an electric shock.
- Do not change the cooling fan while power is on. It is dangerous to change the cooling fan while power is on.

2. Fire Prevention



CAUTION

- Mount the inverter to incombustible material. Mounting it to or near combustible material can cause a fire.
- If the inverter has become faulty, switch off the inverter power. A continuous flow of large current could cause a fire.
- Do not connect a resistor directly to the DC terminals P, N. This could cause a fire.

3. Injury Prevention



CAUTION

- Apply only the voltage specified in the instruction manual to each terminal to prevent damage etc.
- Ensure that the cables are connected to the correct terminals. Otherwise damage etc. may occur.
- Always make sure that polarity is correct to prevent damage etc.
- While power is on and for some time after power-off, do not touch the inverter or brake resistor as they are hot and you may get burnt.

4. Additional Instructions

Also note the following points to prevent an accidental failure, injury, electric shock, etc.

1) Transportation and installation



CAUTION

- When carrying products, use correct lifting gear to prevent injury.
- Do not stack the inverter boxes higher than the number recommended.
- Ensure that installation position and material can withstand the weight of the inverter.
- Do not operate if the inverter is damaged or has parts missing.
- When carrying the inverter, do not hold it by the front cover or setting dial; it may fall off or fail.
- Do not stand or rest heavy objects on the inverter.
- Check the inverter mounting orientation is correct.
- Prevent screws, wire fragments, other conductive bodies, oil or other flammable substances from entering the inverter.
- Do not drop the inverter, or subject it to impact
- Use the inverter under the following environmental conditions:

Environment	Ambient temperature	-10°C to +50°C (14°F to 122°F) (non-freezing)
	Ambient humidity	90%RH or less (non-condensing)
	Storage temperature	-20°C to +65°C* (-4°F to 149°F)
	Ambience	Indoors (free from corrosive gas, flammable gas, oil mist, dust and dirt)
	Altitude, vibration	Maximum 1000m (3280.80feet) above sea level for standard operation. After that derate by 3% for every extra 500m (1640.40feet) up to 2500m (8202.00feet) (91%). 5.9m/s 2 or less (conforming to JIS C 0040)

*Temperature applicable for a short time, e.g. in transit.

2) Wiring

CAUTION

- Do not fit capacitive equipment such as power factor correction capacitor, surge suppressor or radio noise filter (option FR-BIF) to the inverter output side.
- The connection orientation of the output cables (terminals U, V, W) to the motor will affect the direction of rotation of the motor.

3) Trial run

CAUTION

- Check all parameters, and ensure that the machine will not be damaged by a sudden start-up.

4) Operation

WARNING

- When you have chosen the retry function, stay away from the equipment as it will restart suddenly after an alarm stop.
- The [STOP] key is valid only when the appropriate function setting has been made. Prepare an emergency stop switch separately.
- Make sure that the start signal is off before resetting the inverter alarm. A failure to do so may restart the motor suddenly.
- The load used should be a three-phase induction motor only. Connection of any other electrical equipment to the inverter output may damage the equipment.
- Do not modify the equipment.

CAUTION

- The electronic thermal relay does not guarantee protection of the motor from overheating.
- Do not use a magnetic contactor on the inverter input for frequent starting/stopping of the inverter.
- Use a noise filter to reduce the effect of electromagnetic interference. Otherwise nearby electronic equipment may be affected.
- Take measures to suppress harmonics. Otherwise power from the inverter may heat/damage the power capacitor and generator.
- When a 400V class motor is inverter-driven, it should be insulation-enhanced or surge voltages suppressed. Surge voltages attributable to the wiring constants may occur at the motor terminals, deteriorating the insulation of the motor.
- When parameter clear or all clear is performed, each parameter returns to the factory setting. Re-set the required parameters before starting operation.
- The inverter can be easily set for high-speed operation. Before changing its setting, fully examine the performances of the motor and machine.
- In addition to the inverter's holding function, install a holding device to ensure safety.
- Before running an inverter which had been stored for a long period, always perform inspection and test operation. In addition to the inverter's holding function, install a holding device to ensure safety.

5) Emergency stop

CAUTION

- Provide a safety backup such as an emergency brake which will prevent the machine and equipment from hazardous conditions if the inverter fails.

6) Maintenance, inspection and parts replacement

CAUTION

- Do not carry out a megger (insulation resistance) test on the control circuit of the inverter.

7) Disposing of the inverter

CAUTION

- Treat as industrial waste

8) General instructions

Many of the diagrams and drawings in this Instruction Manual show the inverter without a cover, or partially open. Never operate the inverter in this manner. Always replace the cover and follow this Instruction Manual when operating the inverter.

CONTENTS

1	WIRING	1
1.1	Internal block diagram	2
1.2	Main circuit terminal specifications	3
1.3	Connection of stand-alone option units	3
1.3.1	Connection of the dedicated external brake resistor (FR-ABR)	3
1.3.2	Connection of the brake unit (FR-BU)	5
1.3.3	Connection of the brake unit (BU type)	5
1.3.4	Connection of the high power factor converter (FR-HC)	6
1.3.5	Connection of the power regeneration common converter (FR-CV)	6
1.3.6	Connection of the power factor improving DC reactor (FR-BEL)	7
1.4	Control circuit terminal specifications	8
1.5	Precautions for use of the vector inverter	10
1.6	Others	11
1.6.1	Leakage currents and countermeasures	11
1.6.2	Power off and magnetic contactor (MC)	13
1.6.3	Installation of power factor improving reactor	13
1.6.4	Notes on earthing (grounding)	14
1.6.5	Inverter-generated noises and their reduction techniques	15
1.6.6	Power harmonics	17
1.6.7	Japanese harmonic suppression guidelines	18
1.6.8	Inverter-driven 400V class motor	20
1.6.9	Using the PU connector for Computer link	21
1.7	Input terminals	24
1.7.1	Run (start) and stop (STF, STR, STOP)	24
1.7.2	External thermal relay input (OH)	25
1.7.3	Speed setting potentiometer connection (10E, 2 (1), 5)	25
1.7.4	Torque setting input signal and motor-generated torque (terminals 3, 5)	26
1.7.5	Meter connection method and adjustment (DA1, DA2)	26
1.7.6	Common terminals (SD, 5, SE)	27
1.7.7	Signal inputs by contact-less switches	27
1.8	How to use the input signals (assigned terminals DI1 to DI4, STR) (Pr. 180 to Pr. 183, Pr. 187)	28
1.8.1	Multi-speed setting (RL, RM, RH, REX signals): Pr. 180 to Pr. 183, Pr. 187 setting "0, 1, 2, 8" Remote setting (RL, RM, RH signals): Pr. 180 to Pr. 183, Pr. 187 setting "0, 1, 2"	28
1.8.2	Second function selection/second motor switchover (RT signal) : Pr. 180 to Pr. 183, Pr. 187 setting "3"	28
1.8.3	Jog operation (jog signal): Pr. 180 to Pr. 183, Pr. 187 setting "5"	28
1.8.4	Third function selection (X9 signal): Pr. 180 to Pr. 183, Pr. 187 setting "9"	29
1.8.5	FR-HC, FR-CV connection (X10 signal): Pr. 180 to Pr. 183, Pr. 187 setting "10"	29
1.8.6	PU operation external interlock signal (X12 signal): Pr. 180 to Pr. 183, Pr. 187 setting "12"	29
1.8.7	PID control enable terminal: Pr. 180 to Pr. 183, Pr. 187 setting "14"	29
1.8.8	Brake sequence opening signal (BRI signal): Pr. 180 to Pr. 183, Pr. 187 setting "15"	29
1.8.9	PU operation/external operation switchover: Pr. 180 to Pr. 183, Pr. 187 setting "16"	29
1.8.10	S-pattern acceleration/deceleration C switchover terminal (X20 signal) : Pr. 180 to Pr. 183, Pr. 187 setting "20"	29
1.8.11	Orientation command (X22 signal): Pr. 180 to Pr. 183, Pr. 187 setting "22"	30
1.8.12	Pre-excitation/servo on (LX signal): Pr. 180 to Pr. 183, Pr. 187 setting "23"	30
1.8.13	Output stop (MRS signal): Pr. 180 to Pr. 183, Pr. 187 setting "24"	30
1.8.14	Start self-holding selection (STOP signal): Pr. 180 to Pr. 183, Pr. 187 setting "25"	30
1.8.15	Control mode changing (MC signal): Pr. 180 to Pr. 183, Pr. 187 setting "26"	31
1.8.16	Torque restriction selection (TL signal): Pr. 180 to Pr. 183, Pr. 187 setting "27"	31
1.8.17	Torque bias selection 1 (X42 signal): Pr. 180 to Pr. 183, Pr. 187 setting "42" Torque bias selection 2 (X43 signal): Pr. 180 to Pr. 183, Pr. 187 setting "43"	31
1.8.18	P control selection (P/PI control switchover) (X44 signal):	

Pr. 180 to Pr. 183, Pr. 187 setting "44"	31
1.9 How to use the output signals (assigned terminals DO1 to DO3, ABC) (Pr. 190 to Pr. 192, Pr. 195).....	32
1.10 Design information to be checked	34
1.11 Using the second motor	35
1.11.1 Wiring diagram (second motor)	35
1.11.2 Second motor setting parameters	35
1.12 Using the conventional Mitsubishi motor and other motors	36
1.12.1 Conventional Mitsubishi motor (SF-VR, SF-JR with PLG)	36
1.12.2 Precautions for and wiring of the motor with PLG (SF-JR with PLG)	37
2 VECTOR CONTROL	39
<hr/>	
2.1 What is vector control?	40
2.2 Speed control	42
2.2.1 Outline of speed control	42
2.2.2 Easy gain tuning function block diagram	42
2.3 Fine adjustment of gains for speed control	43
2.3.1 Control block diagram	43
2.3.2 Concept of adjustment of manual input speed control gains	44
2.3.3 Speed control gain adjustment procedure (Pr. 820, Pr. 821)	44
2.3.4 Troubleshooting	45
2.3.5 Speed feed forward control, model adaptive speed control (Pr. 828, Pr. 877 to Pr. 881)	47
2.4 Torque control.....	49
2.4.1 Outline of torque control	49
2.5 Fine adjustment for torque control	50
2.5.1 Control block diagram	50
2.6 Gain adjustment for torque control.....	51
2.6.1 Concept of torque control gains	51
2.6.2 Gain adjustment procedure	51
2.6.3 Troubleshooting	52
2.7 Conditional position control (Pr. 419 to Pr. 430, Pr. 464 to Pr. 494).....	53
2.7.1 Connection diagram	53
2.7.2 Control block diagram	54
2.7.3 Parameter	54
2.7.4 Conditional position feed function by contact input (Pr. 419=0)	56
2.7.5 Setting the electronic gear	57
2.7.6 In-position width (Pr. 426)	59
2.7.7 Excessive level error (Pr. 427)	59
2.7.8 Pulse monitor selection (Pr. 430)	59
2.7.9 Concept of position control gains	59
2.7.10 Troubleshooting	61
2.7.11 Position control is not exercised normally	62
3 PARAMETERS	63
<hr/>	
3.1 Parameter lists (Japanese version).....	64
3.2 Parameter lists (NA version).....	71
3.3 At-a-glance guide to functions	78
3.4 Basic functions (Pr. 0 to Pr. 9).....	81
3.4.1 Torque boost (Pr. 0)	81

3.4.2	Maximum and minimum speed settings (Pr. 1, Pr. 2).....	81
3.4.3	Base frequency, base frequency voltage (Pr. 3, Pr. 19).....	82
3.4.4	Multi-speed operation (Pr. 4 to Pr. 6, Pr. 24 to Pr. 27, Pr. 232 to Pr. 239)	82
3.4.5	Acceleration and deceleration times (Pr. 7, Pr. 8, Pr. 20, Pr. 21, Pr. 44, Pr. 45, Pr. 110, Pr. 111)	83
3.4.6	Motor overheat protection (Pr. 9, Pr. 452, Pr. 876)	85
3.5	Standard operation functions (Pr. 10 to Pr. 16)	87
3.5.1	DC injection brake (Pr. 10, Pr.11, Pr. 12, Pr.802)	87
3.5.2	Starting speed (Pr. 13)	88
3.5.3	Jog operation (Pr. 15, Pr. 16).....	89
3.6	Operation selection functions 1 (Pr. 17 to Pr. 37).....	90
3.6.1	Inverter output stop (MRS) (Pr. 17)	90
3.6.2	Torque restriction (Pr. 22, Pr. 803, Pr. 810, Pr. 812 to Pr. 817)	91
3.6.3	RH, RM, RL signal input compensation (Pr. 28)	92
3.6.4	S-pattern acceleration/deceleration curve (Pr. 29, Pr. 140 to Pr. 143, Pr. 380 to Pr. 383)	93
3.6.5	Regenerative brake duty (Pr. 30, Pr. 70).....	96
3.6.6	Speed jump (Pr. 31 to Pr. 36).....	97
3.6.7	Speed display (Pr. 37, Pr. 144)	97
3.7	Output terminal functions (Pr. 41 to Pr. 50).....	99
3.7.1	Up-to-speed sensitivity (Pr. 41)	99
3.7.2	Speed detection (Pr. 42, Pr. 43, Pr. 50, Pr. 116).....	99
3.8	Display functions 1 (Pr. 52 to Pr. 56).....	101
3.8.1	Monitor display/DA1, DA2 terminal function selection (Pr. 52 to Pr. 54, Pr. 158)	101
3.8.2	Monitoring reference (Pr. 55, Pr. 56, Pr. 866)	104
3.9	Automatic restart (Pr. 57, Pr. 58)	105
3.9.1	Automatic restart after instantaneous power failure (Pr. 57, Pr. 58, Pr. 162 to Pr. 165)	105
3.10	Additional functions (Pr. 59)	107
3.10.1	Remote setting function selection (Pr. 59)	107
3.11	Brake sequence (Pr. 60, Pr. 278 to Pr. 285)	109
3.11.1	Brake sequence function (Pr. 60, Pr. 278 to Pr. 285).....	109
3.12	Operation selection function 2 (Pr. 65 to Pr. 79).....	112
3.12.1	Retry function (Pr. 65, Pr. 67 to Pr. 69).....	112
3.12.2	Applied motor (Pr. 71, Pr. 450).....	114
3.12.3	PWM carrier frequency selection (Pr. 72, Pr. 240).....	115
3.12.4	Speed setting signal on/off selection (Pr. 73).....	116
3.12.5	Reset selection/disconnected PU detection/PU stop selection (Pr. 75)	118
3.12.6	Parameter write disable selection (Pr. 77)	119
3.12.7	Reverse rotation prevention selection (Pr. 78)	120
3.12.8	Operation mode selection (Pr. 79)	120
3.13	Offline auto tuning (Pr. 80 to Pr. 96).....	123
3.13.1	Offline auto tuning function (Pr. 9, Pr. 80, Pr. 81, Pr. 83, Pr. 84, Pr. 71, Pr. 96, Pr. 450, Pr. 452).....	123
3.13.2	Parameters.....	123
3.13.3	Execution of offline auto tuning	124
3.13.4	Utilizing or changing offline auto tuning data for use.....	126
3.13.5	Setting the motor constants directly	127
3.13.6	Direct input + offline auto tuning.....	128
3.14	Online auto tuning (Pr. 95)	128
3.14.1	Online auto tuning selection (Pr. 95, Pr. 9, Pr. 71, Pr. 80, Pr. 81).....	128
3.15	Communication functions (Pr. 117 to Pr. 124)	130
3.15.1	Computer link operation (RS-485 communication) (Pr. 117 to Pr. 124, Pr. 342)	130

3.16	PID control (Pr. 128 to Pr. 134)	141
3.16.1	PID control (Pr. 128 to Pr. 134)	141
3.17	Current detection (Pr. 150 to Pr. 153)	147
3.17.1	Output current detection function (Pr. 150, Pr. 151)	147
3.17.2	Zero current detection (Pr. 152, Pr. 153)	148
3.18	Auxiliary functions (Pr. 156, Pr. 157)	149
3.18.1	Stall prevention operation selection (Pr. 156)	149
3.18.2	OL signal output timer (Pr. 157)	150
3.19	Display function 3 (Pr. 160)	151
3.19.1	Extended function display selection (Pr. 160)	151
3.20	Initial monitor (Pr. 171)	151
3.20.1	Actual operation hour meter clear (Pr. 171)	151
3.21	Terminal assignment functions (Pr. 180 to Pr. 195)	151
3.21.1	Input terminal function selection (Pr. 180 to Pr. 183, Pr. 187)	151
3.21.2	Output terminal function selection (Pr. 190 to Pr. 192, Pr. 195)	153
3.22	Auxiliary function (Pr. 244)	155
3.22.1	Cooling fan operation selection (Pr. 244)	155
3.23	Stop selection function (Pr. 250)	155
3.23.1	Stop selection (Pr. 250)	155
3.24	Operation selection function (Pr. 251)	156
3.24.1	Output phase failure protection selection (Pr. 251)	156
3.25	Additional function 2 (Pr. 252, Pr. 253)	157
3.25.1	Override bias, gain (Pr. 252, Pr. 253)	157
3.26	Power failure stop functions (Pr. 261 to Pr. 266)	157
3.26.1	Power-failure deceleration stop function (Pr. 261 to Pr. 266)	157
3.27	Droop (Pr. 286 to Pr. 288)	159
3.27.1	Droop control (Pr. 286 to Pr. 288)	159
3.28	Orientation (Pr. 350 to Pr. 362, Pr. 393 to Pr. 399)	160
3.28.1	Orientation control (Pr. 350, Pr. 351, Pr. 356, Pr. 357, Pr. 360 to Pr. 362, Pr. 393, Pr. 396 to Pr. 399) 160	
3.29	Control system function (Pr. 374)	167
3.29.1	Overspeed detection (Pr. 374)	167
3.30	Position control (Pr. 419 to Pr. 430, Pr. 464 to Pr. 494)	168
3.30.1	Position control (Pr. 419 to Pr. 430, Pr. 464 to Pr. 494)	168
3.31	Remote Output (Pr. 495 to Pr. 497)	169
3.31.1	Remote output function (Pr. 495 to Pr. 497)	169
3.32	Operation selection functions 4 (Pr. 800 to Pr. 809)	170
3.32.1	Control selection (Pr. 800, Pr. 451)	170
3.32.2	Torque characteristic selection (Pr. 801)	170
3.32.3	Torque command right selection (Pr. 804 to Pr. 806)	172
3.32.4	Speed restriction (Pr. 807 to Pr. 809)	173
3.33	Control system functions (Pr. 818 to Pr. 837)	175
3.33.1	Easy gain tuning selection (Pr. 818, Pr. 819)	175
3.33.2	Speed loop proportional gain setting (Pr. 820, Pr. 830)	175
3.33.3	Speed control integral time setting (Pr. 821, Pr. 831)	175
3.33.4	Speed setting circuit filter function (Pr. 822, Pr. 832)	175
3.33.5	Speed detection filter function (Pr. 823, Pr. 833)	176
3.33.6	Current loop proportional gain setting for vector control (Pr. 824, Pr. 834)	176
3.33.7	Current control integral time setting for vector control	

(Pr. 825, Pr. 835).....	176
3.33.8 Torque setting filter function (Pr. 826, Pr. 836)	176
3.33.9 Torque detection filter function (Pr. 827, Pr. 837)	177
3.33.10 Model speed control gain (Pr. 828)	177
3.34 Torque biases (Pr. 840 to Pr. 848)	177
3.34.1 Torque bias function (Pr. 840 to Pr. 848)	177
3.35 Additional functions (Pr. 851 to Pr. 865).....	180
3.35.1 Selection of number of PLG pulses (Pr. 851).....	180
3.35.2 Selection of PLG rotation direction (Pr. 852).....	180
3.35.3 Excitation ratio (Pr. 854).....	181
3.35.4 Notch filter (Pr. 862, Pr. 863).....	181
3.35.5 Torque detection (Pr. 864)	182
3.35.6 Low speed detection (Pr. 865)	182
3.36 Display function (Pr. 867).....	183
3.36.1 DA1 output response level adjustment (Pr. 867).....	183
3.37 Terminal function assignment (Pr. 868).....	183
3.37.1 No. 1 terminal function assignment (Pr. 868).....	183
3.38 Protective functions (Pr. 870 to Pr. 874)	184
3.38.1 Speed deviation excessive (Pr. 870, Pr. 871)	184
3.38.2 Speed restriction (Pr. 873)	185
3.38.3 Stop by OLT level prevention (Pr. 874).....	185
3.39 Operation selection functions 5 (Pr. 875)	186
3.39.1 Fault definition (Pr. 875).....	186
3.40 Control system function 2 (Pr. 877 to Pr. 881)	186
3.40.1 Speed feed forward control, model adaptive speed control (Pr. 877 to Pr. 881).....	186
3.41 Maintenance function (Pr. 890 to Pr. 892).....	187
3.41.1 Maintenance output function (Pr. 890 to Pr. 892).....	187
3.42 Calibration functions (Pr. 900 to Pr. 920).....	188
3.42.1 DA1/DA2 terminal calibration (Pr. 900, Pr. 901).....	188
3.42.2 Biases and gains of speed setting terminals (speed setting No. 2, torque command No.3, multi function No. 1 terminal) (Pr. 902 to Pr. 905, Pr. 917 to Pr. 920).....	190
3.43 Additional function (Pr. 990)	193
3.43.1 Buzzer control (Pr. 990)	193

4 SPECIFICATIONS 195

4.1 Model specifications.....	196
4.2 Common specifications	198
4.3 Outline dimension drawings.....	199
4.3.1 Inverter outline dimension drawings.....	199
4.3.2 Operation panel (FR-DU04-1) outline dimension drawings.....	202
4.3.3 Parameter unit (FR-PU04V) outline dimension drawings.....	202
4.3.4 PLG connection cable outline dimension drawings.....	202
4.3.5 Mitsubishi dedicated motor outline dimension drawings (1500r/min series)	204

APPENDICES 207

Appendix	Parameter Data Code Lists.....	208
----------	--------------------------------	-----



1 WIRING

This chapter describes the basic "wiring" for use of this product.

Always read the instructions and other information before using the equipment.

1.1	Internal block diagram	2
1.2	Main circuit terminal specifications	3
1.3	Connection of stand-alone option units	3
1.4	Control circuit terminal specifications.....	8
1.5	Precautions for use of the vector inverter	10
1.6	Others.....	11
1.7	Input terminals	24
1.8	How to use the input signals (assigned terminals DI1 to DI4, STR) (Pr. 180 to Pr. 183, Pr. 187).....	28
1.9	How to use the output signals (assigned terminals DO1 to DO3, ABC) (Pr. 190 to Pr. 192, Pr. 195)	32
1.10	Design information to be checked	34
1.11	Using the second motor	35
1.12	Using the conventional Mitsubishi motor and other motors.....	36

<Abbreviations>

- DU : Operation panel (FR-DU04-1)
- PU : Operation panel (FR-DU04-1) and parameter unit (FR-PU04V)
- Inverter : Mitsubishi vector inverter FR-V500 series
- Pr. : Parameter number
- PU operation : Operation using the PU (FR-DU04-1/FR-PU04V)
- External operation : Operation using the control circuit signals
- Combined operation : Operation using both the PU (FR-DU04-1/FR-PU04V) and external operation
- Mitsubishi dedicated motor : SF-V5R
- Mitsubishi motor with PLG : SF-JR
- Mitsubishi constant-torque motor : SF-HRCA

1

2

3

4

1.1 Internal block diagram

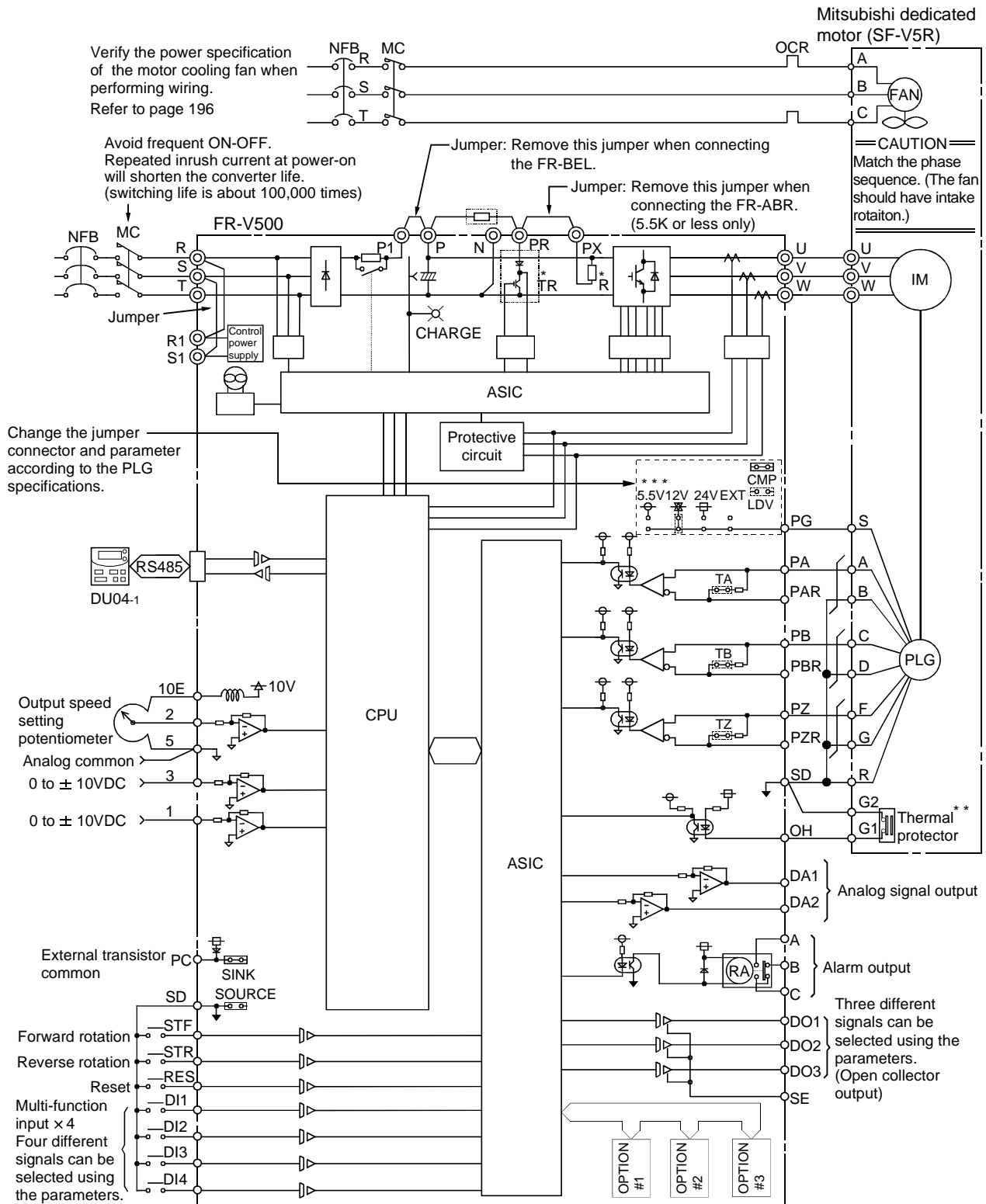

CAUTION

1. The 18.5K or more is not equipped with the built-in brake resistor and brake transistor marked *. The brake transistor is provided for the 15K or less and the built-in brake resistor for the 5.5K or less.
2. Always earth (ground) the inverter and motor.
3. **: When using an external thermal relay protection, set "1" (external thermal relay valid) in Pr. 876. (factory setting) (Refer to page 85.)
4. ***: The setting of the PLG power supply jumper connector and output circuit connector when shipped from the factory.

	Japanese Version	NA Version
PLG power supply jumper connector	12V	5V
Output circuit jumper connector	Complimentary (CMP)	Differential line driver (LDV)

1.2 Main circuit terminal specifications

Terminal Symbol	Terminal Name	Description
R, S, T	AC power input	Connect to the commercial power supply. Keep these terminals open when using the high power factor converter (FR-HC) or power regeneration common converter (FR-CV).
U, V, W	Inverter output	Connect a three-phase squirrel-cage motor or the Mitsubishi dedicated motor.
R1, S1	Power supply for control circuit	Connected to the AC power supply terminals R and S. To retain the alarm display and alarm output or when using the high power factor converter (FR-HC) or power regeneration common converter (FR-CV), remove the jumpers from terminals R-R1 and S-S1 and apply external power to these terminals. Do not turn off the power supply for control circuit (R1, S1) with the main circuit power (R, S, T) on. Doing so may damage the inverter. The circuit should be configured so that the main circuit power (R, S, T) is also turned off when the power supply for control circuit (R1, S1) is off. 15K or less : 60VA, 18.5K to 55K : 80VA
P, PR	Brake resistor connection	Disconnect the jumper from terminals PR-PX (5.5K or less) and connect the optional brake resistor (FR-ABR) across terminals P-PR. For the 15K or less, connecting the resistor further provides regenerative braking power.
P, N	Brake unit connection	Connect the optional FR-BU type brake unit, BU type brake unit, power regeneration common converter (FR-CV) or high power factor converter (FR-HC).
P, P1	Power factor improving DC reactor connection	Disconnect the jumper from terminals P-P1 and connect the optional power factor improving reactor (FR-BEL).
PR, PX	Built-in brake circuit connection	When the jumper is connected across terminals PX-PR (factory setting), the built-in brake circuit is valid. (Provided for the 5.5K or less.)
	Earth (Ground)	For earthing (grounding) the inverter chassis. Must be earthed (grounded).

CAUTION

- The inverter will be damaged if power is applied to the inverter output terminals (U, V, W). Never perform such wiring.
- When connecting the dedicated external brake resistor (FR-ABR), remove jumpers across terminals PR-PX (5.5K or less). Set "1" in Pr. 30 "regenerative function selection" and "10%" in Pr. 70 "special regenerative brake duty". Refer to the Instruction Manual (detailed) for details.
- When connecting the brake unit (FR-BU, BU type), remove jumpers across terminals PR-PX (5.5K or less). Refer to the Instruction Manual (detailed) for details.

1.3 Connection of stand-alone option units

The inverter accepts a variety of stand-alone option units as required.

Incorrect connection will cause inverter damage or accident. Connect and operate the option unit carefully in accordance with the corresponding option unit manual.

1.3.1 Connection of the dedicated external brake resistor (FR-ABR)

The built-in brake resistor is connected across terminals P and PR. Fit the external dedicated brake resistor (FR-ABR) when the built-in brake resistor does not have enough thermal capability for high-duty operation. At this time, remove the jumper from across terminals PR-PX and connect the dedicated brake resistor (FR-ABR) across terminals P-PR.

Set "1" in Pr. 30 "regenerative function selection" and "10%" in Pr. 70 "special regenerative brake duty". (Refer to page 96.)

CAUTION

1. The brake resistor connected should only be the dedicated brake resistor.
2. The jumper across terminals PR-PX (5.5K or less) must be disconnected before connecting the dedicated brake resistor. A failure to do so may damage the inverter.

Connection of stand-alone option units

● Model FR-V520-1.5K, 2.2K, FR-V540-1.5K, 2.2K

- 1) Remove the screws in terminals PR and PX and remove the jumper.
- 2) Connect the brake resistor across terminals P and PR. (The jumper should remain disconnected.)

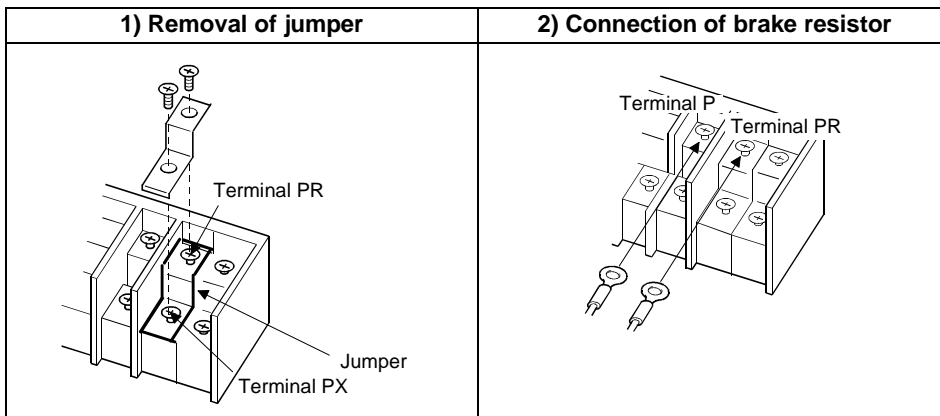

● Model FR-V520-3.7K to 7.5K, FR-V540-3.7K, 5.5K

- 1) Remove the screws in terminals PR and PX and remove the jumper
- 2) Connect the brake resistor across terminals P and PR. (The jumper should remain disconnected.)

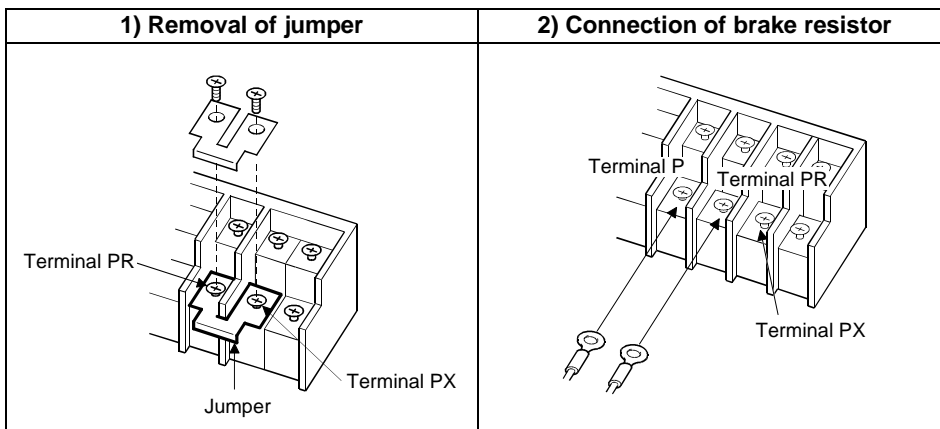

CAUTION

The FR-V520-7.5K does not have the PX terminal. Since it is a free terminal, keep it open.

● Model FR-V520-11K to 15K, FR-V540-7.5K to 15K

- 1) Connect the brake resistor across terminals P and PR.

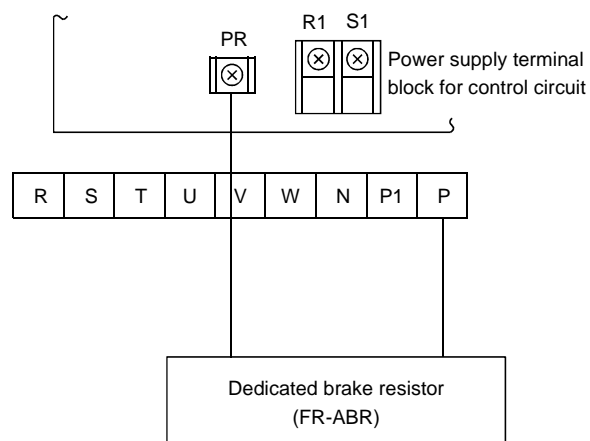

1.3.2 Connection of the brake unit (FR-BU)

Connect the optional FR-BU brake unit as shown below to improve the braking capability during deceleration.

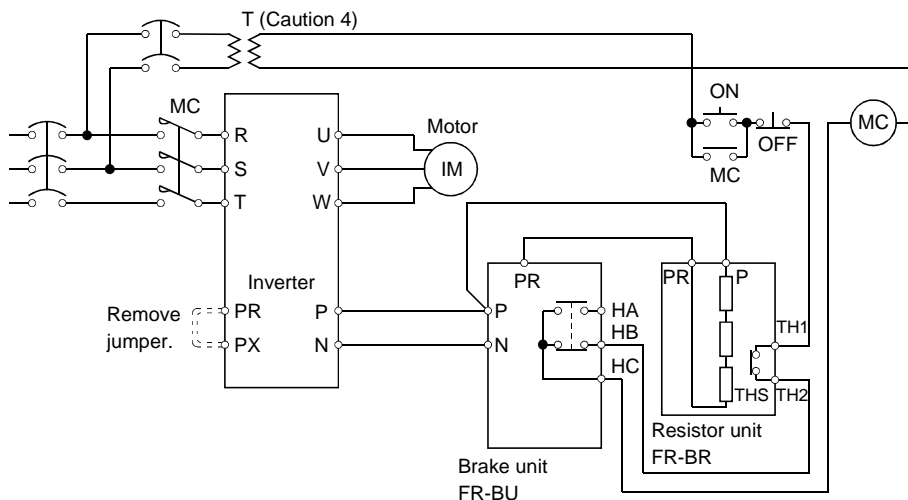

CAUTION

1. Connect the inverter terminals (P, N) and FR-BU type brake unit terminals so that their terminal signals match with each other. (Incorrect connection will damage the inverter.) For the 5.5K or less model, the jumper across terminals PR-PX must be removed.
2. The wiring distance between the inverter, brake unit and resistor unit should be within 5m (16.40 feet). If twisted wires are used, the distance should be within 10m (32.80 feet).
3. If a transistor in the brake unit should become faulty, the resistor can be unusually hot, causing a fire. Therefore, install a magnetic contactor on the inverter's power supply side to shut off a current in case of fault.
4. For the power supply of 400V class, install a voltage-reducing transformer.

1.3.3 Connection of the brake unit (BU type)

Connect the BU type brake unit correctly as shown on the right. Incorrect connection will damage the inverter.

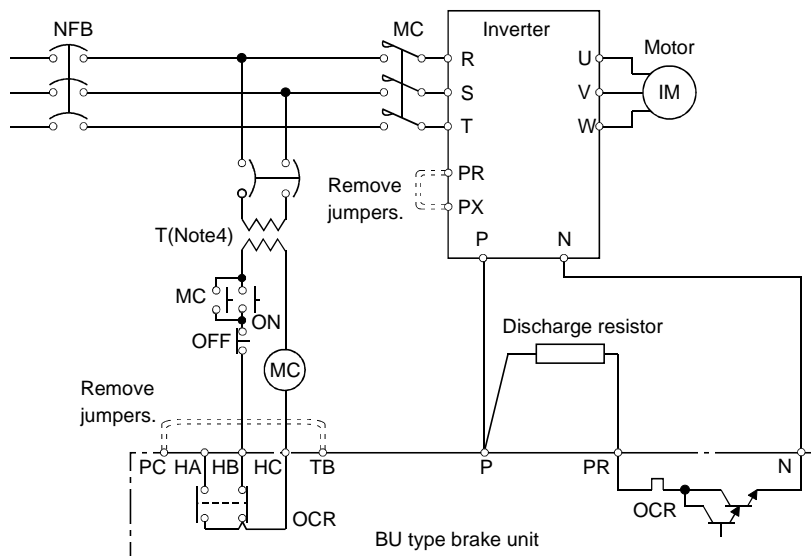

CAUTION

1. For the 5.5K or less capacity, remove the jumper across terminals PR-PX.
2. The wiring distance between the inverter, brake unit and discharge resistor should be within 2m (6.56 feet). If twisted wires are used, the distance should be within 5m (16.40 feet).
3. If the transistors in the brake unit should become faulty, the resistor can be unusually hot, causing a fire. Therefore, install a magnetic contactor on the inverter's power supply side to shut off a current in case of fault.
4. For the power supply of 400V class, install a voltage-reducing transformer.

Connection of stand-alone option units

1.3.4 Connection of the high power factor converter (FR-HC)

When connecting the high power factor converter (FR-HC) to suppress power harmonics, perform wiring securely as shown below. Incorrect connection will damage the high power factor converter and inverter. After making sure that the wiring is correct, set "2" in Pr. 30 "regenerative function selection".

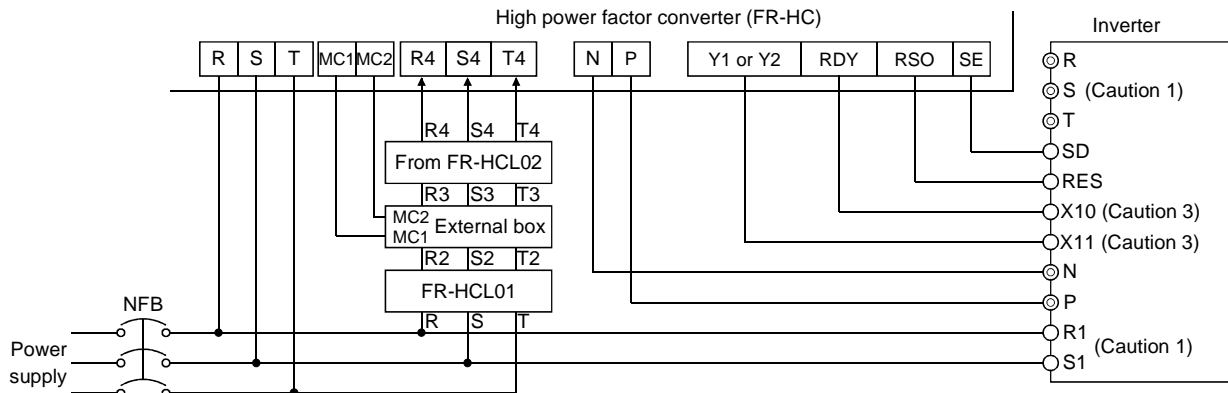

CAUTION

1. Remove the jumpers across the R-R1 and S-S1 terminals of the inverter, and connect the control circuit power supply across the R1-S1 terminals. The power input terminals R, S, T must be open. Accidental connection will damage the inverter. Opposite polarity of terminals N, P will damage the inverter.
2. The voltage phases of terminals R, S, T and terminals R4, S4, T4 must be matched before connection.
3. Use Pr. 180 to Pr. 183 and Pr. 187 (input terminal function selection) to assign the terminals used for the X10 (X11) signal.
The X11 signal is used when the computer link built-in option (FR-A5NR) is used. (Refer to page 151.)
4. Use sink logic (factory setting) when the FR-HC is connected. The FR-HC cannot be connected when source logic is selected.

1.3.5 Connection of the power regeneration common converter (FR-CV)

When connecting the FR-CV type power regeneration common converter, connect the inverter terminals (P, N) and FR-CV type power regeneration common converter terminals as shown below so that their signals match with each other. After making sure that the wiring is correct, set "2" in Pr. 30 "regenerative function selection". Use the FR-CV with capacity one rank greater than the inverter.

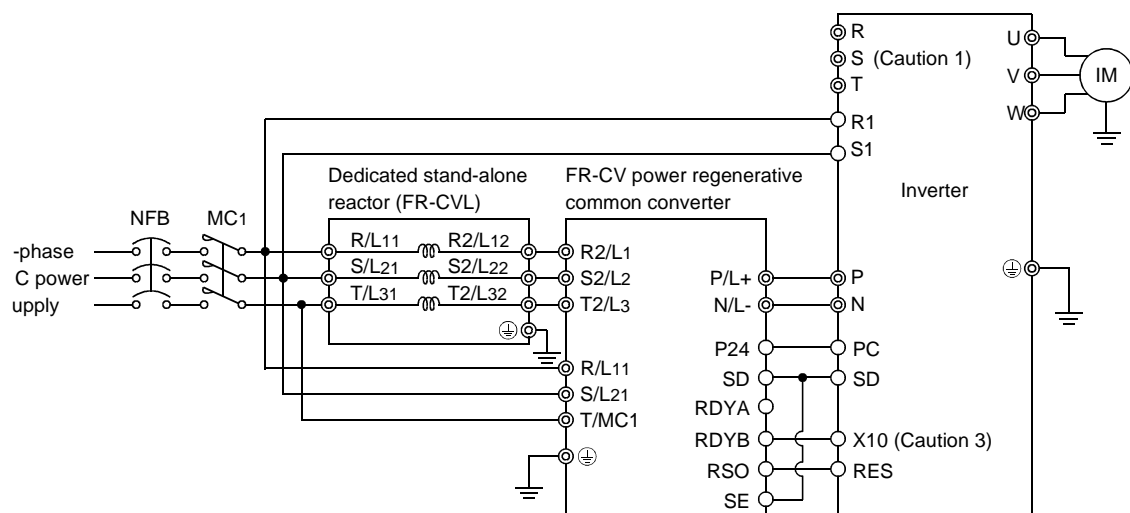

CAUTION

1. Remove the jumpers across the R-R1 and S-S1 terminals of the inverter, and connect the control circuit power supply across the R1-S1 terminals. The power input terminals R, S, T must be open. Accidental connection will damage the inverter. Opposite polarity of terminals N, P will damage the inverter.
2. The voltage phases of terminals R/L11, S/L21, T/MC1 and terminals R2/L1, S2/L2, T2/L3 must be matched before connection.
3. Use Pr. 180 to Pr. 183 and Pr. 187 (input terminal function selection) to assign the terminals used for the X10 signal. (Refer to page 151.)

1.3.6 Connection of the power factor improving DC reactor (FR-BEL)

When using the FR-BEL power factor improving DC reactor, connect it between terminals P1-P. In this case, the jumper connected across terminals P1-P must be removed. Otherwise, the reactor will not exhibit its function.

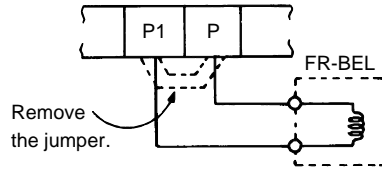

-
- CAUTION**
1. The wiring distance should be within 5m (16.40 feet).
 2. The size of the cables used should be equal to or larger than that of the power supply cables (R, S, T).
-

1.4 Control circuit terminal specifications

Type	Terminal Symbol	Terminal Name	Description		Rated Specifications
Input signals	Contact input	STF	Forward rotation start	Turn on the STF signal to start forward rotation and turn it off to stop.	Input resistance 4.7kΩ Voltage at opening 21 to 27VDC Current at short-circuited 4 to 6mADC Control by open collector output or 0V contact signal
		STR	Reverse rotation start	Turn on the STR signal to start reverse rotation and turn it off to stop. The terminal function varies with the input terminal function selection (Pr. 187) setting. Refer to page 151 for details.	
		DI1 to DI4	Digital input terminals 1 to 4	The terminal functions vary with the input terminal function selection (Pr. 180 to Pr. 183) settings. Refer to page 151 for details.	
		OH	Thermal protector input	Temperature sensor terminal input for motor overheat protection. OHT error occurs when terminals OH and SD are open.	Input resistance 150kΩ Voltage at opening 21 to 27VDC Current at short-circuited 140 to 180mADC Isolate by photocoupler
		RES	Reset	Used to reset the protective circuit activated. Turn on the RES signal for more than 0.1s, then turn it off. It takes about 1s for reset.	Input resistance 4.7kΩ Voltage at opening 21 to 27VDC Current at short-circuited 4 to 6mADC Control by open collector output or 0V contact signal.
		SD	Contact input common (sink)	Contact input common terminal. Common output terminal for 24VDC 0.1A power supply (PC terminal). Isolated from terminals 5 and SE.	—
		PC	24VDC power supply and external transistor common, contact input common (source)	When connecting a transistor output (open collector output) such as a programmable controller, connect the external power supply common for transistor output to this terminal to prevent a malfunction caused by a sneak current. PC-SD can be used as a 24VDC and 0.1A power supply. Note that a sneak current may not be prevented in this case. When source logic has been selected, this terminal serves as a contact input common.	Voltage range 18 to 26 VDC Permissible load current 0.1A
	Speed setting	10E	Speed setting power supply	Used as power supply when connecting volume for speed setting (torque setting) from outside of the inverter. (terminal 5 is a common terminal)	10VDC±0.4V Permissible load current 10mA
		2	Speed setting (voltage)	By entering 0 to 10VDC, the maximum output speed is reached at 10V and I/O are proportional.	Input resistance 10kΩ±1kΩ Permissible maximum voltage 20VDC
		3	Torque setting terminal	Acts as a torque setting signal for torque control or as a torque restriction signal for speed control or position control. Acts as an input terminal for the external analog-based torque bias function. 0 to ±10VDC input	
		1	Multi-function setting terminal	Since this is a multi-function selection terminal, its function varies with the Pr.868 "No. 1 terminal function assignment" setting. Refer to page 183 for details. 0 to ±10VDC input	
		5	Speed setting common, Analog signal output common	Common terminal for speed setting signal (terminal 2, 1 or 3) or DA1 and DA2. Isolated from terminals SD and SE. Do not earth (ground).	—

Type	Terminal Symbol	Terminal Name	Description	Rated Specifications	
Input signals	PLG signal	PA	A-phase signal input terminal	Differential line receiver input (AM26LS32 equivalent) or complimentary input	
		PAR	A-phase inverted signal input terminal	Differential line receiver input (AM26LS32 equivalent)	
		PB	B-phase signal input terminal	A-, B- and Z-phase signals are input from the PLG. For the Japanese version, the jumper connector is factory-set to complimentary. Thus, the PLG need not be connected to PAR, PBR, and PZR.	Differential line receiver input (AM26LS32 equivalent) or complimentary input
		PBR	B-phase inverted signal input terminal	For the NA version, the jumper connector is factory-set to differential line driver. Check the phase sequence before connecting.	Differential line receiver input (AM26LS32 equivalent)
		PZ	Z-phase signal input terminal		Differential line receiver input (AM26LS32 equivalent) or complimentary input
		PZR	Z-phase inverted signal input terminal		Differential line receiver input (AM26LS32 equivalent)
		PG	PLG power supply terminal (Positive side)	Power supply for PLG. You can switch the power supply between 5, 12 and 24VDC. Can be switched to the external power supply. For the Japanese version, the jumper connector is factory-set to 12VDC. For the NA version, the jumper connector is factory-set to 5VDC.  Refer to the Instruction Manual (basic) for the switchover method.)	5.5VDC 350mA 12VDC 150mA 24VDC 80mA
		SD	Contact input common (sink) , Power supply earth (ground) terminal	Common terminal for contact input or PLG power supply. Isolated from terminals 5 and SE. Do not earth (ground).	Power supply common
Output signals	Contact	A, B, C	Alarm output	Switch-over contact output indicating that the output has been stopped by the inverter protective function. 230VAC 0.3A, 30VDC 0.3A. Alarm: discontinuity across B-C (continuity across A-C), normal: continuity across B-C (discontinuity across A-C). The terminal function varies with the output terminal function selection (Pr. 195) setting. Refer to page 153 for details.	Contact output Permissible contact 230VAC 0.3A 30VDC 0.3A
	Open collector	DO1 to DO3	Digital output terminals 1 to 3	The terminal functions vary with the output terminal function selection (Pr. 190 to Pr. 192) settings. Refer to page 153 for details.	Open collector output Permissible load 24VDC 0.1A
		SE	Open collector output common	Common terminal for terminals DO1, DO2 and DO3. Isolated from terminals SD and 5.	—
	Analog	DA1, DA2	Analog signal output	One selected from monitoring items, such as the speed, is output.* The output signal is proportional to the magnitude of the corresponding monitoring item.	0 to ±10VDC Permissible load current 1mA Resolution 12 bit load impedance 10kΩ or more
		5	Analog signal output common	Common terminal for DA1 and DA2. Isolated from terminals SD and SE. Do not earth (ground).	
Communication	RS-485	—	PU connector	With the PU connector, communication can be made through RS-485. <ul style="list-style-type: none"> • Conforming standard : EIA Standard RS-485 • Transmission format : Multidrop link system • Communication speed : Maximum. 19200bps • Overall length : 500m (1640.42 feet) 	

* Not output during inverter reset.

1.5 Precautions for use of the vector inverter

The FR-V500 series is a highly reliable product, but incorrect peripheral circuit making or operation/handling method may shorten the product life or damage the product.

Before starting operation, always recheck the following items.

- (1) Use insulation-sleeved crimping terminals for the power supply and motor cables.
- (2) Power must not be applied to the output terminals (U, V, W) of the inverter. Otherwise the inverter will be damaged.
- (3) After wiring, wire off-cuts must not be left in the inverter.
Wire off-cuts can cause an alarm, fault or malfunction. Always keep the inverter clean.
When drilling mounting holes in a control box or the like, use care not to allow chips etc. to enter the inverter.
- (4) Wire the cables of the recommended size to make a voltage drop 2% or less.
If the wiring distance is long between the inverter and motor, a main circuit cable voltage drop will cause the motor torque to decrease especially at the output of a high frequency.
 Refer to Instruction Manual (basic) for the recommended wire sizes.
- (5) The overall wiring length should be 100m (328.08 feet) maximum.
Especially for long distance wiring, the fast-response current restriction function may be reduced or the equipment connected to the secondary side may malfunction or become faulty under the influence of a charging current due to the stray capacity of the wiring. Therefore, note the overall wiring length.
- (6) Electromagnetic wave interference
The input/output (main circuit) of the inverter includes harmonic components, which may interfere with the communication devices (such as AM radios) used near the inverter. In this case, install the optional FR-BIF radio noise filter (for use in the input side only) or FR-BSF01 or FR-BLF line noise filter to minimize interference.
- (7) Do not install a power factor correction capacitor, surge suppressor or radio noise filter (FR-BIF option) in the output side of the inverter.
This will cause the inverter to trip or the capacitor and surge suppressor to be damaged. If any of the above devices is installed, immediately remove it. (When the FR-BIF radio noise filter is connected, switching power off during motor operation may result in E. UVT. In this case, connect the radio noise filter in the primary side of the magnetic contactor.)
- (8) When rewiring after operation, switch power off, wait for more than 10 minutes, and then make sure that the voltage is zero using a tester, etc. For some time after power-off, there is a dangerous voltage in the capacitor.
- (9) A short circuit or earth (ground) fault in the inverter output side may damage the inverter modules.
 - Fully check the insulation resistance of the circuit prior to inverter operation since repeated short circuits caused by peripheral circuit inadequacy or an earth (ground) fault caused by wiring inadequacy or reduced motor insulation resistance may damage the inverter modules.
 - Fully check the to-earth (ground) insulation and inter-phase insulation of the inverter secondary side before power-on. Especially for an old motor or use in hostile atmosphere, securely check the motor insulation resistance etc.
- (10) Do not use the inverter power supply side magnetic contactor to start/stop the inverter.
Always use the start signal (turn on/off terminals STF, STR-SD) to start/stop the inverter. (Refer to page 13.)
- (11) Across the P and PR terminals, connect only an external regenerative brake discharge resistor.
Do not connect a mechanical brake.
- (12) Do not apply a voltage higher than the permissible voltage to the inverter I/O signal circuits.
Application (contact) of a voltage higher than the permissible voltage to the inverter I/O signal circuits or opposite polarity may damage the I/O devices. Especially check the wiring to prevent the speed setting potentiometer from being connected incorrectly to short terminals 10E-5.
- (13) Use of single-phase power supply
Do not use single-phase power input.
- (14) Precautions for use of any motor other than the vector control dedicated motor (SF-V5R, SF-VR) and standard motor with PLG (SF-JR with PLG)
 - a) Vector control cannot be exercised without PLG.
 - b) Connect the PLG directly to the backlash-free motor shaft.
- (15) Since the rated voltage differs from the commercial power supply voltage, the SF-V5R cannot perform commercial power supply-inverter switchover operation.

Motor		Rated Voltage
SF-V5R	3.7kW (5HP) or less	170V
	5.5kW (7.5HP) or more	160V
SF-V5RH	3.7kW (5HP) or less	340V
	5.5kW (7.5HP) or more	320V

● Capacity (VA) of separate power supply

The capacity is 60VA or more for 15kW(20HP) or less and 80 VA for 18.5kW(25HP) to 55kW(75HP) when separate power is supplied from R1, S1.

1.6 Others

1.6.1 Leakage currents and countermeasures

Leakage currents flow through static capacitances existing in the inverter I/O wiring and motor. Since their values depend on the static capacitances, carrier frequency, etc., take the following measures.

(1) To-earth (ground) leakage currents

Leakage currents may flow not only into the inverter's own line but also into the other lines through the earth (ground) cable, etc.

These leakage currents may operate earth (ground) leakage breakers and earth (ground) leakage relays unnecessarily.

● Countermeasures

- When the carrier frequency setting is high, decrease the carrier frequency (Pr. 72) of the inverter. Note that motor noise increases. Selection of Soft-PWM (Pr. 240) will make it unoffending.
- Earth (Ground) leakage breakers designed for harmonics and surges can be used in the inverter's own line and other lines to perform operation with the carrier frequency high (with low noise).

(2) Line-to-line leakage currents

Harmonics of leakage currents flowing in static capacitances between the inverter output cables may operate the external thermal relay unnecessarily. When the wiring length is long (50m (164.04 feet) or more) for the 400V class small-capacity model (7.5kW(10HP) or less), the external thermal relay is likely to operate unnecessarily because the ratio of the leakage current to the rated motor current increases.

● Line-to-line leakage current data example (200V class)

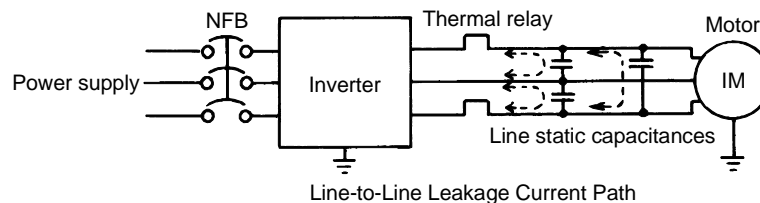

*The leakage currents of the 400V class are about twice as large.

● Measures

- Use the electronic thermal relay (Pr. 9) of the inverter.
- Decrease the carrier frequency. Note that motor noise increases. Selection of Soft-PWM (Pr. 240) will make it unoffending.
For other than the Mitsubishi dedicated motor (SF-V5R), using a temperature sensor to directly detect the motor temperature is recommended to ensure that the motor is protected against line-to-line leakage currents.

● Installation and selection of no-fuse breaker

Install a no-fuse breaker (NFB) on the power receiving side to protect the wiring of the inverter primary side. Select the NFB according to the power supply side power factor (which depends on the power supply voltage, output frequency and load). Especially for a completely electromagnetic NFB, one of a slightly large capacity must be selected since its operation characteristic varies with harmonic currents. (Check it in the data of the corresponding breaker.) As an earth (ground) leakage breaker, use the Mitsubishi earth (ground) leakage breaker designed for harmonics and surges (Progressive Super Series).

(3) Selection of rated sensitivity current of earth (ground) leakage breaker

When using the earth (ground) leakage breaker with the inverter circuit, select its rated sensitivity current as follows, independently of the PWM carrier frequency.

- Breaker for harmonic surge
Rated sensitivity current
 $I_{\Delta n} \geq 10 \times (I_{g1} + I_{gn} + I_{g2} + I_{gm})$
- Standard breaker
Rated sensitivity current
 $I_{\Delta n} \geq 10 \times \{I_{g1} + I_{gn} + 3 \times (I_{g2} + I_{gm})\}$
 I_{g1} , I_{g2} : Leakage currents of cable path during commercial power supply operation
 I_{gn} : Leakage current of noise filter on inverter input side
 I_{gm} : Leakage current of motor during commercial power supply operation

Leakage Current Example of Cable Path per 1km during Commercial Power Supply Operation When CV Cable Is Routed in Metal Conduit (200V 60Hz)

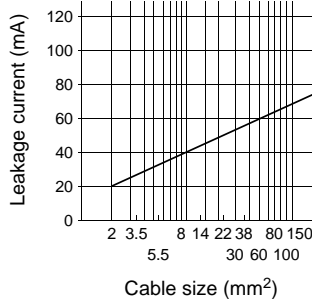

Leakage Current Example of 3-Phase Induction Motor during Commercial Power Supply Operation (200V 60Hz)

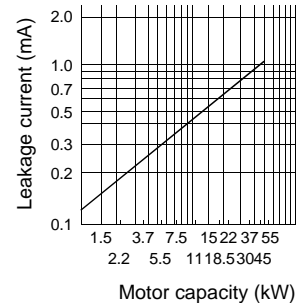

<Example>

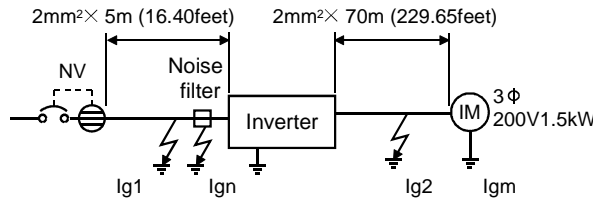

CAUTION

- Install the NV on the primary (power supply) side of the inverter.
- In the Δ connection neutral point earthing (grounding) system, the sensitivity current is purified against an earth (ground) fault in the inverter secondary side. Hence, the protective earthing (grounding) of the load equipment should be 10Ω class or less.
- When the breaker is installed on the secondary side of the inverter, it may be unnecessarily operated by harmonics if the effective value is less than the rating. In this case, do not install the breaker since the eddy current and hysteresis loss will increase, leading to temperature rise.
- The following models are standard breakers..... BV-C1, BC-V, NVB, NV-L, NV-G2N, NV-G3NA, and NV-2F type leakage current relays (except for NV-ZH), AA neutral wire, NV with open phase protection

The following models are breakers for harmonic surge .. NV-C/NV-S/MN series, NV30-FA, NV50-FA, BV-C2, leakage current alarm breaker, NV-ZH

* Note the leakage current value of the noise filter installed on the inverter input side.

	Breaker for Harmonic Surge	Standard Breaker
Leakage current I_{g1} (mA)	$20 \times \frac{5m(16.40feet)}{1000m(3280feet)} = 0.10$	
Leakage current I_{gn} (mA)	0 (without noise filter)	
Leakage current I_{g2} (mA)	$20 \times \frac{70m(229.65feet)}{1000m(3280feet)} = 1.40$	
Motor leakage current I_{gm} (mA)	0.14	
Total leakage current (mA)	1.66	4.78
Rated sensitivity current (mA) ($\geq I_g \times 10$)	30	100

1.6.2 Power off and magnetic contactor (MC)

CAUTION

- Do not use the inverter power supply side magnetic contactor to start/stop the inverter.
- Do not provide a magnetic contactor on the inverter output side and turn it on-off during operation. Turning it on during inverter operation can cause a large starting current to flow, resulting in a fault.

As shown on the right, always use the start signal (turn on/off terminals STF, STR-SD) to start/stop the inverter. (Refer to page 24.)

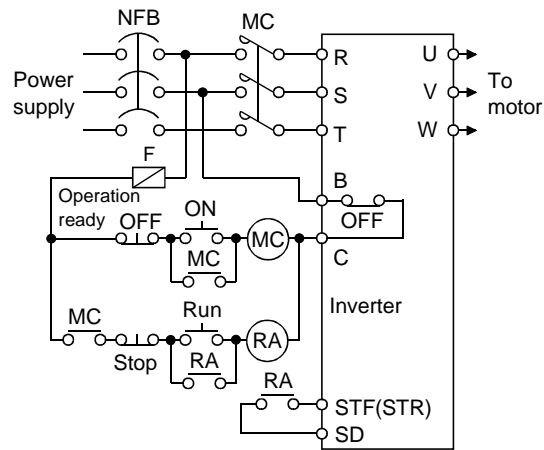

Inverter Start/Stop Circuit Example

(1) Inverter primary side magnetic contactor (MC)

On the inverter primary side, it is recommended to provide an MC for the following purposes.

(Refer to the Instruction Manual (basic) for selection.)

- 1) To release the inverter from the power supply when the inverter protective function is activated or the drive becomes faulty (e.g. emergency stop operation)
When cycle operation or heavy-duty operation is performed with an optional brake resistor connected, over-heat and burnout of the electrical-discharge resistor can be prevented if a regenerative brake transistor is damaged due to insufficient heat capacity of the electrical-discharge resistor and excess regenerative brake duty.
- 2) To prevent any accident due to an automatic restart at restoration of power after an inverter stop made by a power failure
- 3) To rest the inverter for an extended period of time
The control power supply for inverter is always running and consumes a little power. When stopping the inverter for an extended period of time, powering off the inverter will save power slightly.
- 4) To separate the inverter from the power supply to ensure safe maintenance and inspection work
Since the MC on the inverter primary side is used for the above purposes, they correspond to the standard duties. Therefore, when making an emergency stop during running, select a JEM1038 class AC3 MC for the inverter input side currents.

REMARKS

The MC may be switched on/off to start/stop the inverter. However, since repeated inrush currents at power-on will shorten the life of the converter circuit (switching life is about 100,000 times), frequent starts and stops must be avoided. Turn on/off the inverter start controlling terminals (STF, STR) to run/stop the inverter.

1.6.3 Installation of power factor improving reactor

When the inverter is connected near a large-capacity power transformer (1000kVA or more and wiring length 10m (32.80 feet) max.) or when a power capacitor is to be switched over, an excessive peak current may flow in the power input circuit, damaging the converter circuit. To prevent this, always install the power factor improving reactor (FR-BEL or FR-BAL).

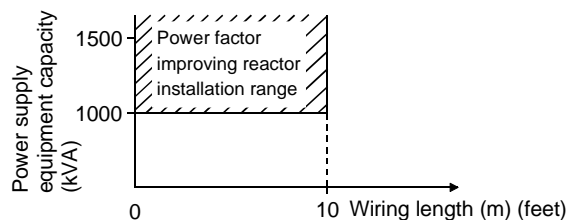
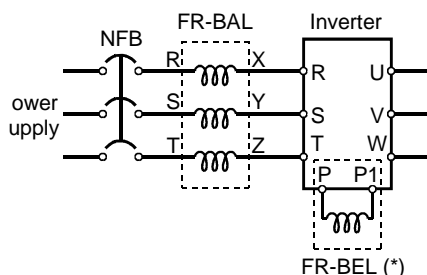

REMARKS

- * When connecting the FR-BEL, remove the jumper across terminals P-P1. The wiring length between the FR-BEL and inverter should be 5m(16.4feet) maximum and minimized. Use the same wire size as that of the power supply wire (R, S, T). (Refer to the Instruction Manual (basic).)

1.6.4 Notes on earthing (grounding)

- Leakage currents flow in the inverter. To prevent an electric shock, the inverter and motor must be earthed (grounded).
- Use the dedicated earth (ground) terminal to earth (ground) the inverter. (Do not use the screw in the case, chassis, etc.)

Connect the earth (ground) cable using a tin-plated* crimping terminal. Tighten the screw, taking care not to break its threads.

*Plating should not include zinc.

- Use the largest possible gauge for the earth (ground) cable. The gauge should be equal to or larger than those indicated in the following table. The earthing (grounding) point should be as near as possible to the inverter to minimize the earth (ground) cable length.

(Unit: mm²)

Motor Capacity	Earth (Ground) Cable Gauge	
	200V	400V
2.2kW (3HP) or less	2 (2.5)	2 (2.5)
3.7kW (5HP)	3.5 (4)	2 (2.5)
5.5kW, 7.5kW (7.5HP, 10HP)	5.5 (6)	3.5 (4)
11kW, 15kW (15HP, 20HP)	14 (16)	8 (10)
18.5kW to 37kW (25HP to 50HP)	22 (25)	14 (16)
45kW, 55kW (60HP, 75HP)	38 (35)	22 (25)

For use as a Low Voltage Directive-compliant product, use the PVC cables indicated in the parentheses for earthing (grounding).

- Earth (ground) the motor on the inverter side using one wire of the 4-core cable.
- Always earth (ground) the motor and inverter.

(1) Purpose of earthing (grounding)

Generally, an electrical apparatus has an earth (ground) terminal, which must be connected to the ground before use.

An electrical circuit is usually insulated by an insulating material and encased. However, it is impossible to manufacture an insulating material that can shut off a leakage current completely, and actually, a slight current flow into the case. The purpose of earthing (grounding) the case of an electrical apparatus is to prevent operator from getting an electric shock from this leakage current when touching it.

To avoid the influence of external noises, this earthing (grounding) is important to audio equipment, sensors, computers and other apparatuses that handle low-level signals or operate very fast.

(2) Earthing (grounding) methods and earthing (grounding) work

As described previously, earthing (grounding) is roughly classified into an electrical shock prevention type and a noise-affected malfunction prevention type. Therefore, these two types should be discriminated clearly, and the following work must be done to prevent the leakage current having the inverter's high frequency components from entering the malfunction prevention type earthing (grounding):

(a) Where possible, use independent earthing (grounding) for the inverter.

If independent earthing (grounding) (I) is impossible, use joint earthing (grounding) (II) where the inverter is connected with the other equipment at an earthing (grounding) point. Joint earthing (grounding) as in (III) must be avoided as the inverter is connected with the other equipment by a common earth (ground) cable. Also a leakage current including many high frequency components flows in the earth (ground) cables of the inverter and inverter-driven motor. Therefore, they must use the independent earthing (grounding) method and be separated from the earthing (grounding) of equipment sensitive to the aforementioned noises.

In a tall building, it will be a good policy to use the noise malfunction prevention type earthing (grounding) with steel frames and carry out electric shock prevention type earthing (grounding) in the independent earthing (grounding) method.

(b) Perform earthing (grounding) work with the earth resistance of less than 100Ω for the 200V class inverter and less than 10Ω for the 400V class inverter.

(c) Use the thickest possible earth (ground) cable. The earth (ground) cable should be of not less than the size indicated in the above table.

(d) The earthing (grounding) point should be as near as possible to the inverter to minimize the earth (ground) cable length.

(e) Run the earth (ground) cable as far away as possible from the I/O wiring of equipment sensitive to noises and run them in parallel in the minimum distance.

(f) Use one wire in a 4-core cable with the earth (ground) terminal of the motor and earth (ground) it on the inverter side.

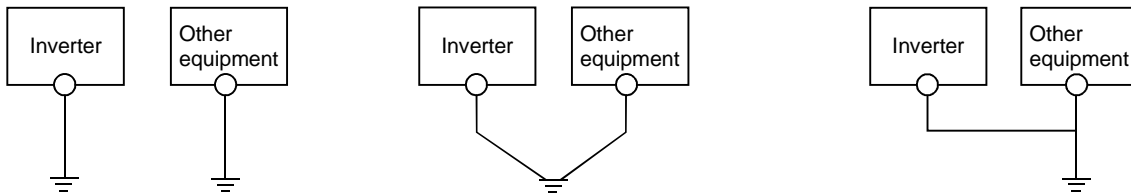

(I) Independent earthing (grounding) ... Best (II) Joint earthing (grounding) ... Good (III) Joint earthing (grounding) ... Not allowed

1.6.5 Inverter-generated noises and their reduction techniques

Some noises enter the inverter to malfunction it and others are radiated by the inverter to malfunction peripheral devices. Though the inverter is designed to be insusceptible to noises, it handles low-level signals, so it requires the following basic techniques. Also, since the inverter chops outputs at high carrier frequency, that could generate noises. If these noises cause peripheral devices to malfunction, measures should be taken to suppress noises. These techniques differ slightly depending on noise propagation paths.

1) Basic techniques

- Do not run the power cables (I/O cables) and signal cables of the inverter in parallel with each other and do not bundle them.
- Use twisted pair shielded cables for the detector connection and control signal cables, and connect the sheathes of the shield cables to terminal SD.
- Earth (Ground) the inverter, motor, etc. at one point.

2) Techniques to reduce noises that enter and malfunction the inverter

When devices that generate many noises (which use magnetic contactors, magnetic brakes, many relays, for example) are installed near the inverter and the inverter may be malfunctioned by noises, the following measures must be taken:

- Provide surge suppressors for devices that generate many noises to suppress noises.
- Fit data line filters (page 16) to signal cables.
- Earth (Ground) the shields of the detector connection and control signal cables with cable clamp metal.

3) Techniques to reduce noises that are radiated by the inverter to malfunction peripheral devices

Inverter-generated noises are largely classified into those radiated by the cables connected to the inverter and inverter main circuits (I/O), those electromagnetically and electrostatically induced to the signal cables of the peripheral devices close to the main circuit power supply, and those transmitted through the power supply cables.

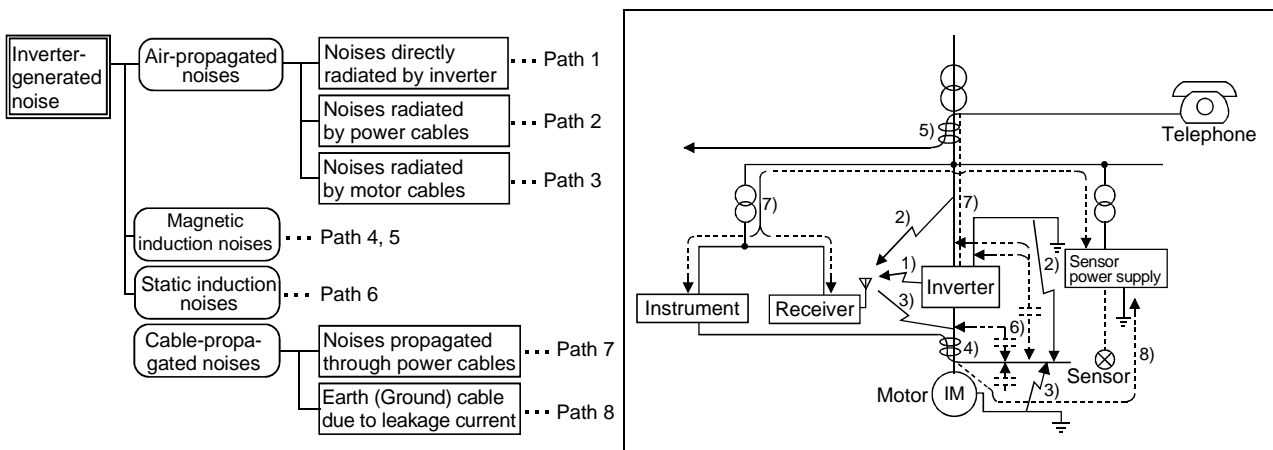

- By decreasing the carrier frequency, the mains terminal interface voltage* can be reduced. When motor noise does not pose a problem, set the carrier frequency to a low value using Pr. 72. (*Mains terminal interface voltage represents the magnitude of noise propagated from the inverter to the power supply side.)
- Using shield cables as signal cables, induction noise can be reduced greatly (to 1/10 - 1/100). Induction noise can also be reduced by separating the signal cables from the inverter output cables. (Separation of 30cm (11.8 inches) reduces noise to 1/2-1/3.)
By fitting the FR-BSF01 or BLF on the inverter output side, induction noise to the signal cables can be reduced.

Noise Propagation Path	Measures
1), 2), 3)	When devices that handle low-level signals and are liable to malfunction due to noises, e.g. instruments, receivers and sensors, are contained in the enclosure that contains the inverter or when their signal cables are run near the inverter, the devices may be malfunctioned by air-propagated noises. The following measures must be taken: (1) Install easily affected devices as far away as possible from the inverter. (2) Run easily affected signal cables as far away as possible from the inverter and its I/O cables. (3) Do not run the signal cables and power cables (inverter I/O cables) in parallel with each other and do not bundle them. (4) Insert line noise filters into I/O and radio noise filters into input to suppress cable-radiated noises. (5) Use shield cables as signal cables and power cables and run them in individual metal conduits to produce further effects.
4), 5), 6)	When the signal cables are run in parallel with or bundled with the power cables, magnetic and static induction noises may be propagated to the signal cables to malfunction the devices and the following measures must be taken: (1) Install easily affected devices as far away as possible from the inverter. (2) Run easily affected signal cables as far away as possible from the I/O cables of the inverter. (3) Do not run the signal cables and power cables (inverter I/O cables) in parallel with each other and do not bundle them. (4) Use shield cables as signal cables and power cables and run them in individual metal conduits to produce further effects.
7)	When the power supplies of the peripheral devices are connected to the power supply of the inverter in the same line, inverter-generated noises may flow back through the power supply cables to malfunction the devices and the following measures must be taken: (1) Install the radio noise filter (FR-BIF) to the power cables (input cables) of the inverter. (2) Install the line noise filter (FR-BLF, FR-BSF01) to the power cables (I/O cables) of the inverter.
8)	When a closed loop circuit is formed by connecting the peripheral device wiring to the inverter, leakage currents may flow through the earth (ground) cable of the inverter to malfunction the device. In such a case, disconnection of the earth (ground) cable of the device may cause the device to operate properly.

● Data line filters

Noise entry can be prevented by providing a data line filter for the detector cable etc.

● Example of noise reduction techniques

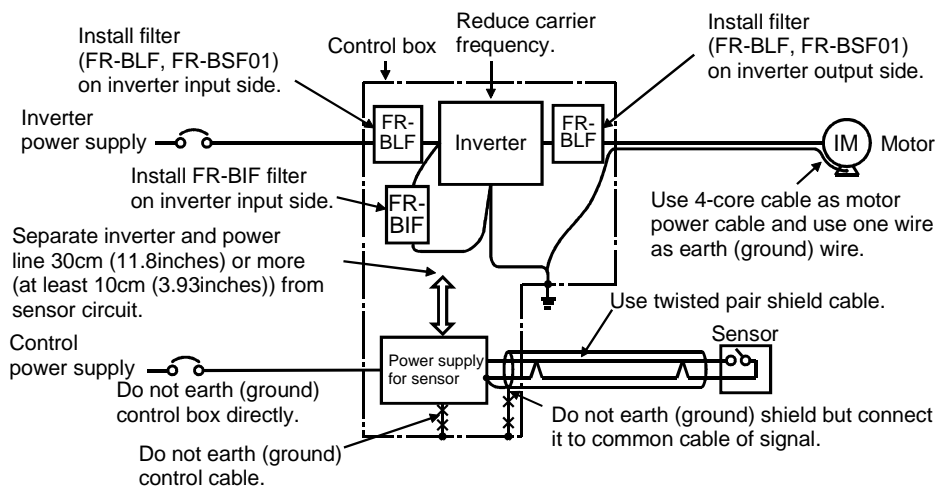

1.6.6 Power harmonics

Power harmonics may be generated from the converter section of the inverter, affecting the power supply equipment, power capacitors, etc. Power harmonics are different in generation source, frequency and transmission path from radio frequency (RF) noise and leakage currents. Take the following measures.

● **The differences between harmonics and RF noises are indicated below:**

Item	Harmonics	RF Noise
Frequency	Normally 40 to 50th degrees (3kHz or less)	High frequency (several 10kHz to 1GHz order)
Environment	To wire paths, power impedance	Across spaces, distance, laying paths
Quantitative understanding	Logical computation is possible	Occurs randomly, quantitative understanding is difficult.
Generated amount	Approximately proportional to load capacity	According to current fluctuation rate (larger with faster switching)
Immunity of affected device	Specified in standards for each device.	Differs according to maker's device specifications.
Examples of safeguard	Install a reactor.	Increase the distance.

● **Safeguard**

The harmonic current generated from the inverter to the power supply differs according to various conditions such as the wiring impedance, whether a power factor improving reactor is used or not, and output frequency and output current on the load side.

For the output frequency and output current, the adequate method is to obtain them under rated load at the maximum operating frequency.

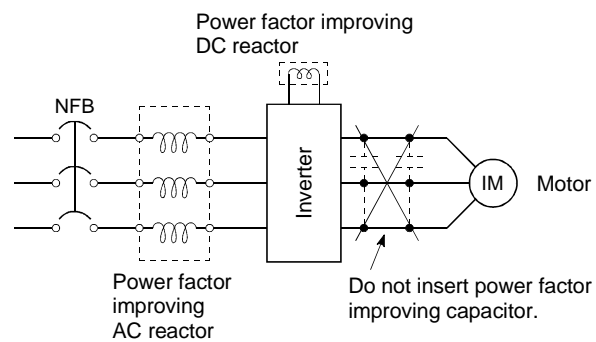

CAUTION

A power factor improving capacitor or surge suppressor on the inverter's output side may overheat or be damaged due to the harmonics of the inverter output. Also, when an overcurrent flows in the inverter, the overcurrent protection is activated. Hence, when the motor is driven by the inverter, do not install a capacitor or surge suppressor on the inverter's output side. To improve the power factor, insert a power factor improving reactor on the inverter's primary side or in the DC circuit.

1.6.7 Japanese harmonic suppression guidelines

Harmonic currents flow from the inverter to a power receiving point via a power transformer. The harmonic suppression guidelines were established to protect other consumers from these outgoing harmonic currents.

- 1) "Harmonic suppression guideline for household appliances and general-purpose products"
 This guideline was issued by the Ministry of Economy, Trade and Industry (formerly Ministry of International Trade and Industry) in September, 1994 and applies to three-phase 200V class inverters of 3.7kW(5HP) and less. By installing the FR-BEL or FR-BAL power factor improving reactor, inverters comply with the "harmonic suppression techniques for transistorized inverters (input current 20A or less)" established by the Japan Electrical Manufacturers' Association. Therefore install the optional reactor for the 200V class, 3.7kW(5HP) or less inverter.
- 2) "Harmonic suppression guideline for specific consumers"
 This guideline sets forth the maximum values of harmonic currents outgoing from a high-voltage or especially high-voltage consumer who will install, add or renew harmonic generating equipment. If any of the maximum values is exceeded, this guideline requires that consumer to take certain suppression measures.

Table 1 Maximum Values of Outgoing Harmonic Currents per 1kW(1.3HP) Contract Power

Received Power Voltage	5th	7th	11th	13th	17th	19th	23rd	Over 23rd
6.6kV	3.5	2.5	1.6	1.3	1.0	0.9	0.76	0.70
22kV	1.8	1.3	0.82	0.69	0.53	0.47	0.39	0.36
33kV	1.2	0.86	0.55	0.46	0.35	0.32	0.26	0.24

(1) Application of the harmonic suppression guideline for specific consumers

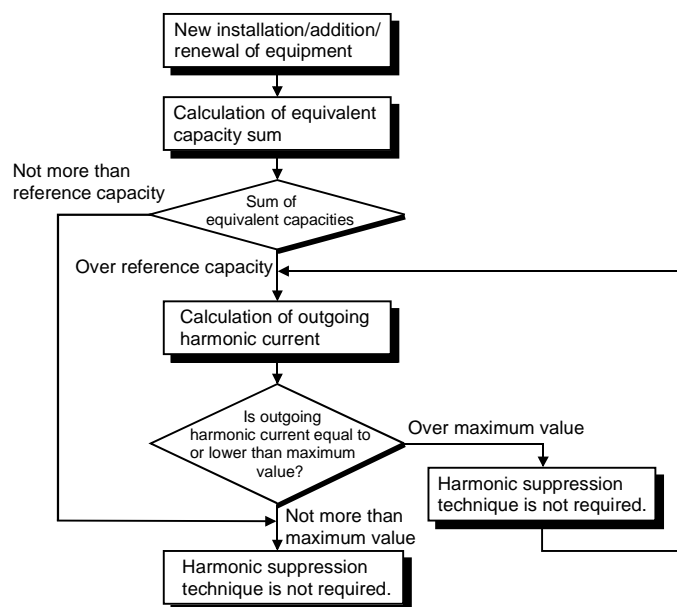

Table 2 Conversion Factors for FR-V500 Series

Class	Circuit Type		Conversion Factor Ki
3	3-phase bridge (Capacitor-smoothed)	Without reactor	K31 = 3.4
		With reactor (AC side)	K32 = 1.8
		With reactor (DC side)	K33 = 1.8
		With reactors (AC, DC sides)	K34 = 1.4
5	Self-exciting 3-phase bridge	When high power factor converter is used	K5 = 0

Table 3 Equivalent Capacity Limits

Received Power Voltage	Reference Capacity
6.6kV	50kVA
22/33kV	300kVA
66kV or more	2000kVA

Table 4 Harmonic Content (Assuming that the fundamental current is 100%.)

Reactor	5th	7th	11th	13th	17th	19th	23rd	25th
Not used	65	41	8.5	7.7	4.3	3.1	2.6	1.8
Used (AC side)	38	14.5	7.4	3.4	3.2	1.9	1.7	1.3
Used (DC side)	30	13	8.4	5.0	4.7	3.2	3.0	2.2
Used (AC, DC sides)	28	9.1	7.2	4.1	3.2	2.4	1.6	1.4

1) Calculation of equivalent capacity P0 of harmonic generating equipment

The "equivalent capacity" is the capacity of a 6-pulse converter converted from the capacity of consumer's harmonic generating equipment and is calculated with the following equation. If the sum of equivalent capacities is higher than the limit in Table 3, harmonics must be calculated with the following procedure:

$$P0 = \sum Ki \times Pi \text{ [kVA]}$$

Ki: Conversion factor (refer to Table 2)

Pi: Rated capacity of harmonic generating equipment* [kVA]

i : Number indicating the conversion circuit type

* Rated capacity: Determined by the capacity of the applied motor and found in Table 5. It should be noted that the rated capacity used here is used to calculate generated harmonic amount and is different from the power supply capacity required for actual inverter drive.

2) Calculation of outgoing harmonic current

Outgoing harmonic current = fundamental wave current (value converted from received power voltage)
× operation ratio × harmonic content

- Operation ratio: Operation ratio = actual load factor × operation time ratio during 30 minutes
- Harmonic contents: Found in Table 4

Table 5 Rated Capacities and Outgoing Harmonic Currents for Inverter Drive

Applied Motor kW (HP)	Rated Current [A]		Fundamental Wave Current Converted from 6.6kV (mA)	Rated Capacity (kVA)	Outgoing Harmonic Current Converted from 6.6kV (mA) (No reactor, 100% operation ratio)							
	200V	400V			5th	7th	11th	13th	17th	19th	23rd	25th
1.5(2)	5.50 (Caution)	2.75	167	1.95	108.6	68.47	14.20	12.86	7.181	5.177	4.342	3.006
2.2(3)	7.93 (Caution)	3.96	240	2.81	156.0	98.40	20.40	18.48	10.32	7.440	6.240	4.320
3.7(5)	13.0 (Caution)	6.50	394	4.61	257.1	161.5	33.49	30.34	16.94	12.21	10.24	7.092
5.5(7.5)	19.1	9.55	579	6.77	376.1	237.4	49.22	44.58	24.90	17.95	15.05	10.42
7.5(10)	25.6	12.8	776	9.07	504.4	318.2	65.96	59.75	33.37	24.06	20.18	13.97
11(15)	36.9	18.5	1121	13.1	728.7	459.6	95.29	86.32	48.20	34.75	29.15	20.18
15(20)	49.8	24.9	1509	17.6	980.9	618.7	128.3	116.2	64.89	46.78	39.24	27.16
18.5(25)	61.4	30.7	1860	21.8	1209	762.6	158.1	143.2	79.98	57.66	48.36	33.48
22(30)	73.1	36.6	2220	25.9	1443	910.2	188.7	170.9	95.46	68.82	57.72	39.96
30(40)	98.0	49.0	2970	34.7	1931	1218	252.5	228.7	127.7	92.07	77.22	53.46
37(50)	121	60.4	3660	42.8	2379	1501	311.1	281.8	157.4	113.5	95.16	65.88
45(60)	147	73.5	4450	52.1	2893	1825	378.3	342.7	191.4	138.0	115.7	80.10
55(75)	180	89.9	5450	63.7	3543	2235	463.3	419.7	234.4	169.0	141.7	98.10

CAUTION

The fundamental wave input currents are indicated because when a motor whose capacity is 3.7kW(5HP) or less is driven by a more than 3.7kW(5HP) inverter, e.g. when a 3.7kW(5HP) motor is driven by a 5.5kW(7.5HP) inverter, the transistorized inverter is not covered by the harmonic suppression guideline for household appliances and general-purpose products and must be included in the calculation of harmonic currents for the guideline.

3) Harmonic suppression technique requirement

If the outgoing harmonic current is higher than the maximum value per 1kW(1.3HP) contract power × contract power, a harmonic suppression technique is required.

4) Harmonic suppression techniques

No.	Item	Description
1	Reactor installation (ACL, DCL)	Install a reactor (ACL) on the AC side of the inverter or a reactor (DCL) on its DC side or both to suppress outgoing harmonic currents.
2	High power factor converter (FR-HC)	The converter circuit is switched on-off to convert an input current waveform into a sine wave, suppressing harmonic currents substantially. The high power factor converter (FR-HC) is used with the standard accessory.
3	Installation of power factor improving capacitor	When used with a series reactor, the power factor improving capacitor has an effect of absorbing harmonic currents.
4	Transformer multi-phase operation	Use two transformers with a phase angle difference of 30° as in λ -delta, delta-delta combination to provide an effect corresponding to 12 pulses, reducing low-degree harmonic currents.
5	Passive filter (AC filter)	A capacitor and a reactor are used together to reduce impedance at specific frequencies, producing a great effect of absorbing harmonic currents.
6	Active filter	This filter detects the current of a circuit generating a harmonic current and generates a harmonic current equivalent to a difference between that current and a fundamental wave current to suppress a harmonic current at a detection point, providing a great effect of absorbing harmonic currents.

1.6.8 Inverter-driven 400V class motor

In the PWM type inverter, a surge voltage attributable to wiring constants is generated at the motor terminals. Especially for a 400V class motor, the surge voltage may deteriorate the insulation. When the 400V class motor is driven by the inverter, consider the following measures:

● Measures

It is recommended to take either of the following measures.

(1) Rectifying the motor insulation

For the 400V class motor, use an inverter duty motor. Specifically,

1) Specify the "400V class inverter-driven, inverter duty motor".

2) For the dedicated motor such as the constant-torque motor or low-vibration motor, use the "inverter-driven, dedicated motor".

CAUTION

- If the wiring length between the motor and inverter is 40m(131.23feet) or longer, set Pr. 240 to long wiring mode in addition to the above measures to operate the inverter. (Refer to page 115 for Pr. 240 "soft-PWM selection".)

1.6.9 Using the PU connector for Computer link

(1) When connecting the operation panel or parameter unit using a connection cable

 Refer to the Instruction Manual (basic).

(2) For RS-485 communication

The PU connector can be used to perform communication operation from a personal computer etc. By connecting the PU connector to computers such as a personal computer and Factory Automation computer with a communication cable, you can monitor the inverter operation and read and write parameters using a user program.

<PU connector pin-outs>

Viewed from the inverter (receptacle side) front

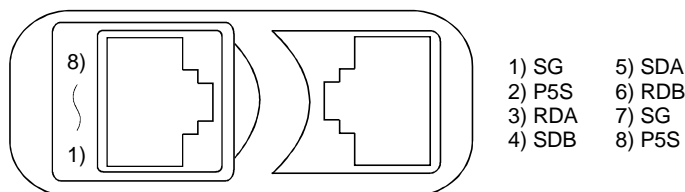

CAUTION

1. Do not connect the PU connector to the computer's LAN board, FAX modem socket or telephone modular connector. Otherwise, the product may be damaged due to electrical specification differences.
2. Pins No. 2 and 8 (P5S) provide power to the operation unit or parameter unit. Do not use these pins for RS-485 communication.

<System configuration example>

- 1) Using a computer having RS-485 interface with multiple inverters

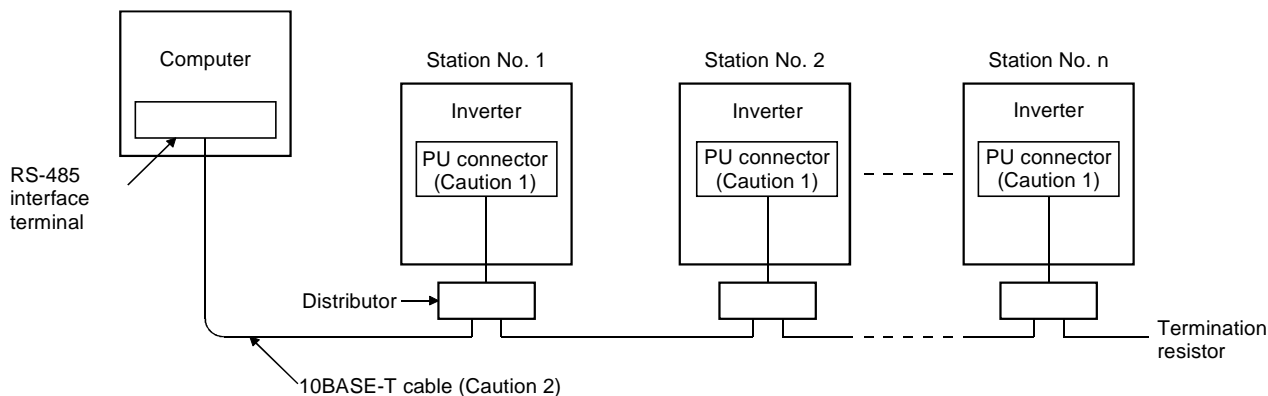

CAUTION

1. Connector: RJ45 connector
Example: Tyco Electronics Corporation, 5-554720-3
2. Cable : Cable conforming to EIA568 (e.g. 10BASE-T cable)
Example: Mitsubishi Cable Industries, LTD. SGLPEV 0.5mm (0.01 inch) × 4P (twisted pair cable, 4 pairs)
(Do not use pins No. 2 and 8 (P5S).)

Others

- 2) Using a computer having RS-232C interface with multiple inverters

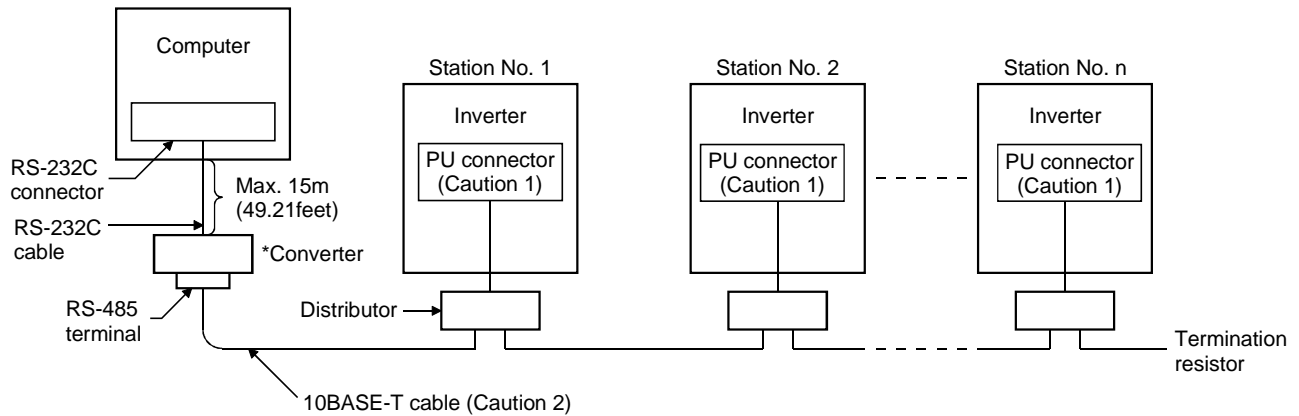

*Commercially available converter is required. (Caution 3)

CAUTION

Use the connector, cables and converter that are available on the market.

1. **Connector** : RJ45 connector
Example: Tyco Electronics Corporation, 5-554720-3
 2. **Cable** : Cable conforming to EIA568 (e.g. 10BASE-T cable)
Example: Mitsubishi Cable Industries, LTD SGLPEV 0.5mm (0.01 inch) × 4P (twisted pair cable, 4 pairs)
(Do not use pins No. 2 and 8 (P5S).)
 3. **Commercially available converter examples:**
 - 1) Model: FA-T-RS40
Converter
Mitsubishi Electric Engineering Co., Ltd.
-

<Wiring method>

1) Wiring of one RS-485 computer and one inverter

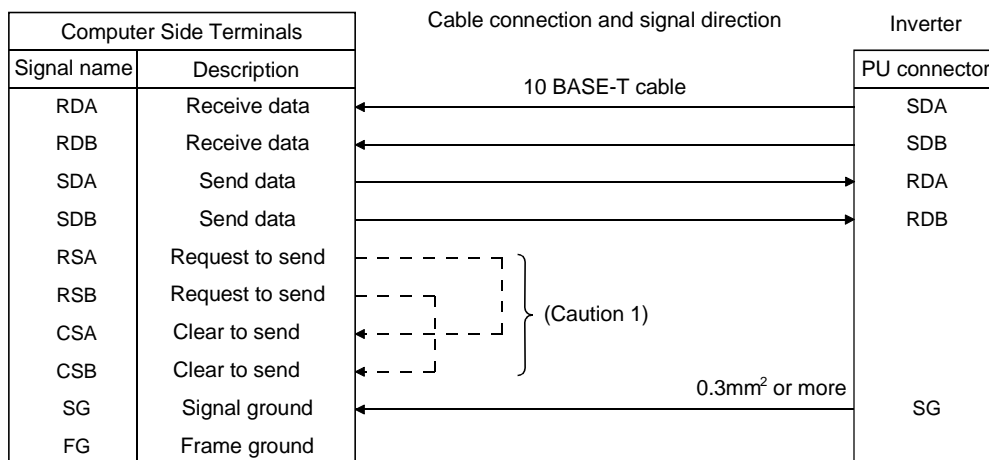

2) Wiring of one RS-485 computer and "n" (multiple) inverters

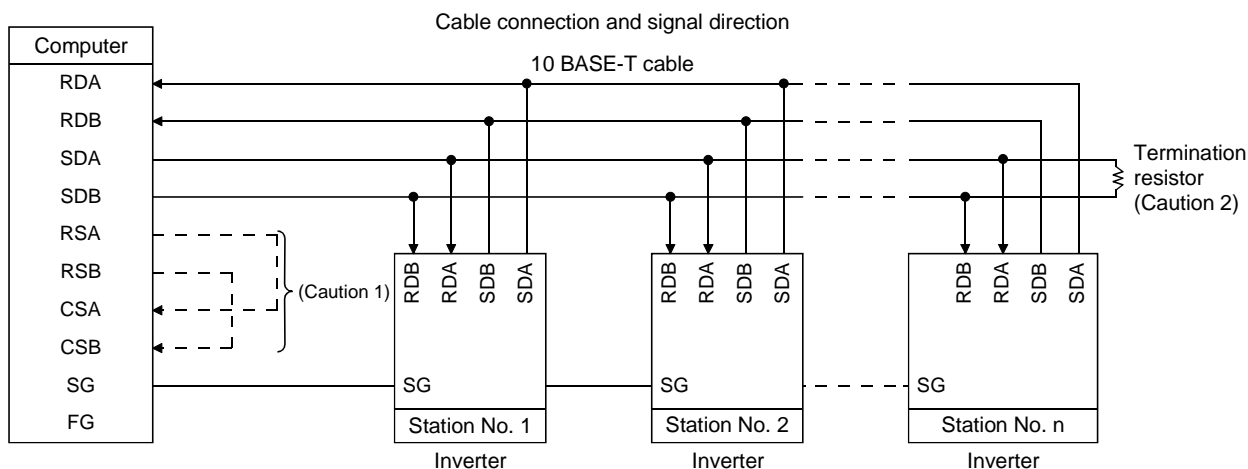

CAUTION

1. Make connections in accordance with the manual of the computer used.
Fully check the terminal numbers of the computer since they vary with the model.
2. There may be the influence of reflection depending on the transmission speed and/or transmission distance. If this reflection hinders communication, provide a termination resistor. If the PU connector is used to make a connection, use a distributor since a terminal resistor cannot be fitted.
Connect the termination resistor to only the inverter remotest from the computer.
(Termination resistor: 100Ω)

1.7 Input terminals

1.7.1 Run (start) and stop (STF, STR, STOP)

To start and stop the motor, first switch on the input power of the inverter (when there is a magnetic contactor on the input side, use the operation-ready switch to turn on the magnetic contactor), then start the motor with the forward or reverse rotation start signal.

(1) Two-wire type (STF, STR)

A two-wire type connection is shown on the right.

- 1) The forward/reverse rotation signal is used as both the start and stop signals. Turn on either of the forward and reverse rotation signals to start the motor in the corresponding direction. Turn on both or turn off the start signal during operation to decelerate the inverter to a stop.
- 2) The speed setting signal may either be given by entering 0 to 10VDC across the speed setting input terminal 2-5 or by setting the required values in Pr. 4 to Pr. 6 "three-speed setting" (high, middle, low speeds). (Refer to page 83 for three-speed operation.)

Two-Wire Type Connection Example

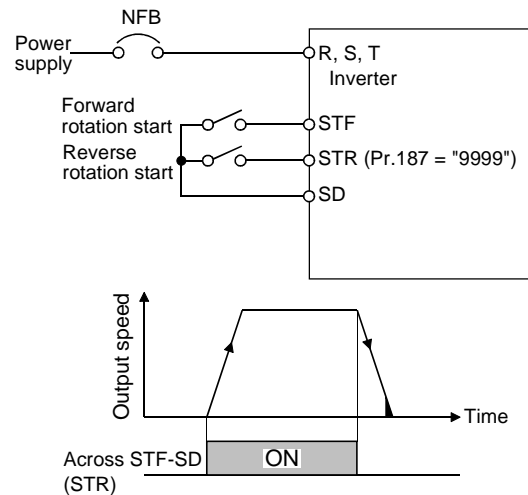

(2) Three-wire type (STF, STR, STOP)

A three-wire type connection is shown on the right. Assign the start self-holding signal (STOP) to any of the input terminals.

- 1) Short signals STOP-SD to enable the start self-holding function. In this case, the forward/reverse rotation signal functions only as a start signal.

REMARKS

Assign the STOP signal to any of Pr. 180 to Pr. 183 and Pr. 187 (input terminal function selection).

- 2) If the start signal terminals STF (STR)-SD are once shorted, then opened, the start signal is kept on and starts the inverter. To change the rotation direction, short the start signal STR (STF)-SD once, then open it.
- 3) The inverter is decelerated to a stop by opening terminals STOP-SD once. The three-wire connection is shown on the right.
- 4) When terminals JOG-SD are shorted, the STOP signal is invalid and jog signal has precedence.
- 5) If the output stop terminals MRS-SD are shorted, the self-holding function is not deactivated.

Three-Wire Type Connection Example

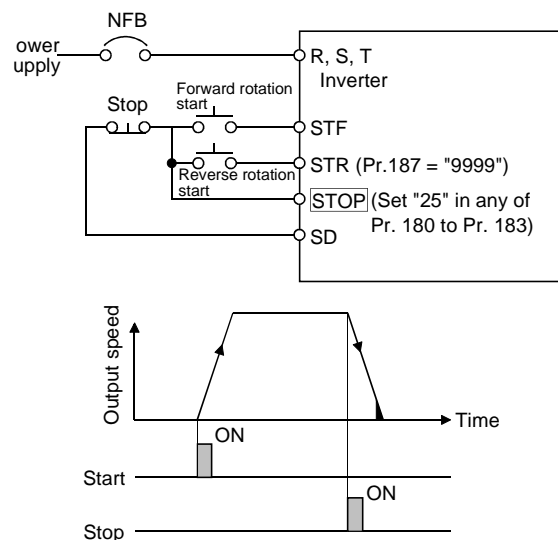

1.7.2 External thermal relay input (OH)

When the external thermal relay or the built-in thermal relay of the motor (thermal protector) is actuated to protect the motor from overheat, the inverter output can be shut off and the corresponding alarm signal can be provided to hold a stop status. If the thermal relay contact resets, the motor cannot be restarted unless the reset terminal RES-SD are shorted for more than 0.1 seconds and then opened or a power-on reset is made.

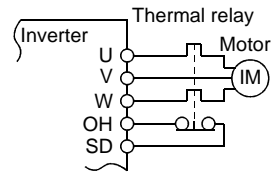

Therefore, this function can be used as an external emergency stop signal input.

1.7.3 Speed setting potentiometer connection (10E, 2 (1), 5)

As an analog speed setting input signal, a voltage signal can be input.

The relationships between the speed setting input voltages and output speeds are as shown below. The speed setting input signals are proportional to the output speeds. Note that when the input signal is less than the starting speed, the output speed of the inverter is 0r/min.

If the input signal of 10VDC or higher is entered, it cannot exceed Pr. 1 "maximum speed".

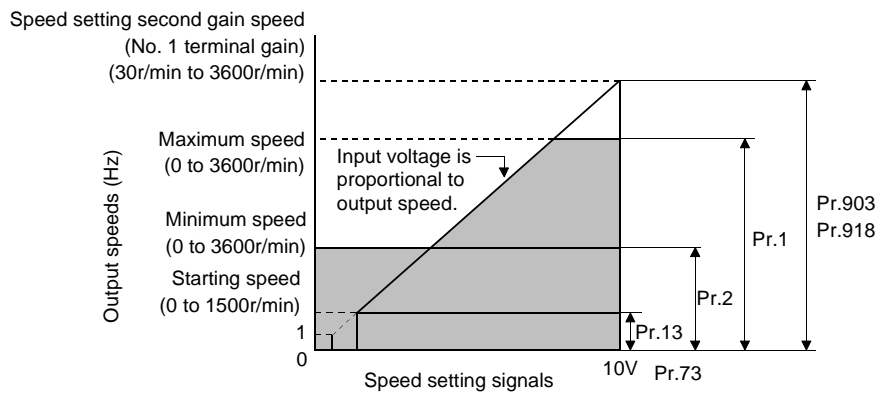

Relationships between Speed Setting Inputs and Output Speeds

Related parameters

Maximum speed setting Pr. 1 "maximum speed" (Refer to page 81.)

(1) Voltage input (10E, 2, 5)

Enter the speed setting input signal of 0 to 10VDC across the speed setting input terminals 2-5. The maximum output speed is reached when 10V is input across terminals 2-5.

The power supply used may either be the inverter's built-in power supply or an external power supply. For the built-in power supply, terminals 10E-5 provide 10VDC output.

- Use terminal 10E for the built-in power supply.

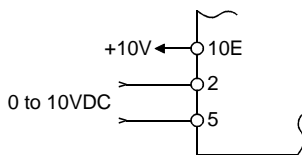

(2) Multi-function input (1, 5)

The analog input function can be multi-functioned, e.g. compensation signal may be entered across the main speed setting terminals 2-5 for synchronous operation.

Across auxiliary input terminals 1-5 ... 0 to ±10VDC

The function of terminal 1 depends on the setting of Pr. 868 "No. 1 terminal function assignment". Refer to page 183 for details of Pr 868.

Input terminals

1.7.4 Torque setting input signal and motor-generated torque (terminals 3, 5)

Refer to the diagrams shown at below right for the relationship between the torque setting input signal and output voltage. The torque setting input signal is in proportion to the output torque. However, motor-generated torque varies with the motor temperature. The guideline of the output torque accuracy relative to the torque setting input is torque accuracy $\pm 3\%$ (under condition of 75°C (167°F)) when the SF-V5R Mitsubishi inverter motor is used.

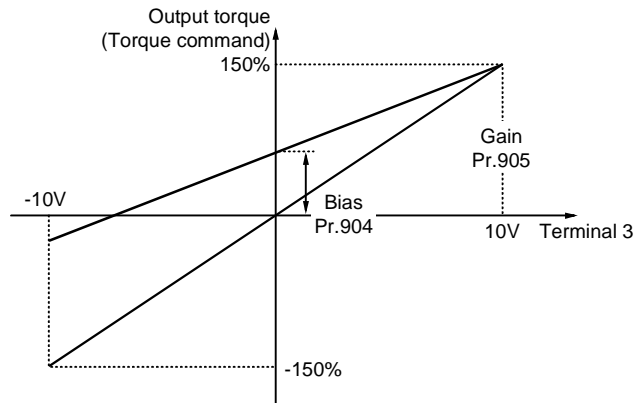
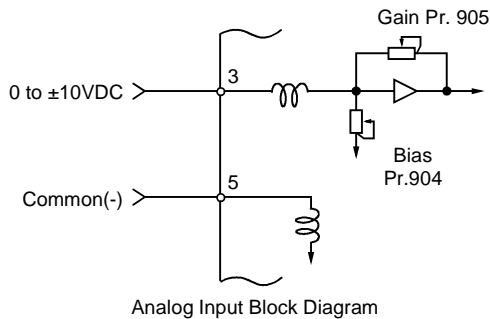

1.7.5 Meter connection method and adjustment (DA1, DA2)

The output speed etc. of the inverter can be displayed by connecting a meter (speed meter) across terminals DA1 (DA2)-5.

The meter can be calibrated from the operation panel or parameter unit. However, if the meter is away from the inverter, the display value will vary with the wiring distance.

The terminals DA1, DA2 are non-isolated from the control circuit of the inverter. Using a shield cable of within 30m (98.42feet) for wiring.

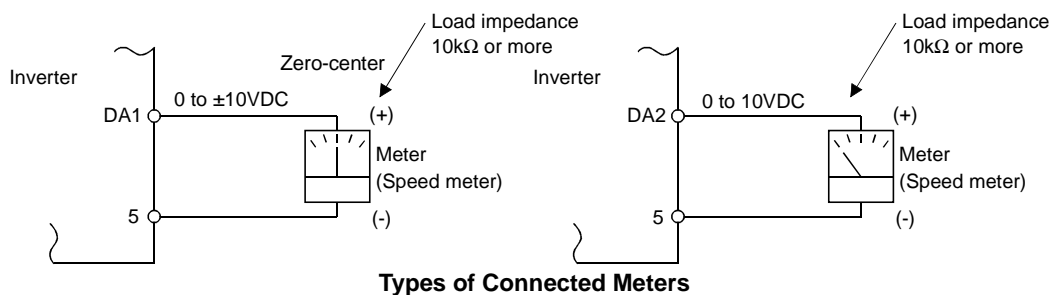

REMARKS

Using Pr. 867 "DA1 output filter", you can function the primary delay filter. (Refer to page 183.)

CAUTION



Refer to page 188 for the meter adjustment procedure.

[Example] To provide a 10V DA1-5 (DA2-5) output of 10V at the inverter output speed of 3000r/min, set "3000" (r/min) in Pr. 55.(factory setting : 1500r/min)

Parameter No.	Name	Factory Setting	Setting Range
55	Speed monitoring reference	Japanese version: 1500r/min	0 to 3600r/min
		NA version: 1800r/min	

CAUTION

Note that when wiring is long, a voltage type meter is susceptible to a voltage drop, induction noise, etc. and may not read correctly.

1.7.6 Common terminals (SD, 5, SE)

Terminals SD, 5 and SE are all common terminals (0V) for I/O terminals and the other common terminals are isolated from each other.

Terminal SD is a common terminal for the contact input terminals (STF, STR, OH, RES, DI1, DI2, DI3 and DI4) and the PLG output signals. When using the terminal SD as a common terminal for the PLG output signals, use a shielded or twisted cable to protect it from external noise.

Terminal 5 is a common terminal for the speed setting analog input signals and analog output signals. Use a shielded or twisted cable to protect it from external noise.

Terminal SE is a common terminal for the open collector output terminals (DO1, DO2, DO3).

1.7.7 Signal inputs by contact-less switches

If a transistor is used instead of a contacted switch as shown on the right, the input signals of the inverter can control the STF, STR, OH, RES, DI1, DI2, DI3 and DI4 terminals.

Input resistance : 4.7kΩ

Voltage when contacts are open : 21 to 27VDC

When contacts are short-circuited : 4 to 6mADC

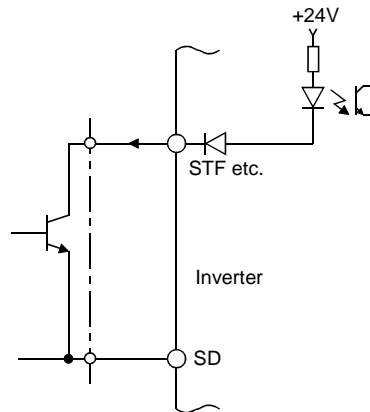

External Signal Input by Transistor

REMARKS

- When using an external transistor connected to the external power supply, use terminal PC to prevent a malfunction due to a sneak current.

(Refer to the Instruction Manual (basic) for details.)

- Note that when off, an SSR (solid-state relay) has a relatively large leakage current and it may be accidentally input to the inverter.

**How to use the input signals
(assigned terminals DI1 to DI4, STR)**

**1.8 How to use the input signals (assigned terminals DI1 to DI4, STR)
(Pr. 180 to Pr. 183, Pr. 187)**

These terminals vary in functions with the settings of Pr. 180 to Pr. 183 and Pr. 187.

Parameter	Factory-Set Value	Factory-Set Signal	Setting Range	
Pr. 180 "DI1 terminal function selection"	0	RL	0 to 3, 5, 8 to 16, 20, 22 to 27, 42 to 44, 9999 (9999 is valid for Pr. 187 only)	Page 151
Pr. 181 "DI2 terminal function selection"	1	RM		
Pr. 182 "DI3 terminal function selection"	2	RH		
Pr. 183 "DI4 terminal function selection"	3	RT		
Pr. 187 "STR terminal function selection"	9999	STR		

The priorities of the speed commands are in order of jog, multi-speed setting (RH, RM, RL, REX) and PID (X14).

**1.8.1 Multi-speed setting (RL, RM, RH, REX signals): Pr. 180 to Pr. 183, Pr. 187 setting "0, 1, 2, 8"
Remote setting (RL, RM, RH signals): Pr. 180 to Pr. 183, Pr. 187 setting "0, 1, 2"**

- When Pr. 59 = 0, turning on/off the RL, RM, RH and REX signals input as the speed commands enables multi-speed operation (15 speeds). (Refer to page 82 for details. Pr. 59 = 0)
- When Pr. 59 ≠ "0", you can use contact signals to perform continuous variable-speed operation without using analog signals even if the operation panel is away from the control box. (Refer to page 107 for details.)

**1.8.2 Second function selection/second motor switchover (RT signal)
: Pr. 180 to Pr. 183, Pr. 187 setting "3"**

- | | |
|---|--|
| Pr. 44 "second acceleration/deceleration time" | Pr. 830 "speed control P gain 2" |
| Pr. 45 "second deceleration time" | Pr. 831 "speed control integral time 2" |
| Pr. 450 "second applied motor" | Pr. 832 "speed setting filter 2" |
| Pr. 451 "second motor control method selection" | Pr. 833 "speed detection filter 2" |
| Pr. 452 "second electronic thermal O/L relay" | Pr. 834 "torque control P gain 2" |
| Pr. 453 "second motor capacity" | Pr. 835 "torque control integral time 2" |
| Pr. 454 "number of second motor poles" | Pr. 836 "torque setting filter 2" |
| | Pr. 837 "torque detection filter 2" |

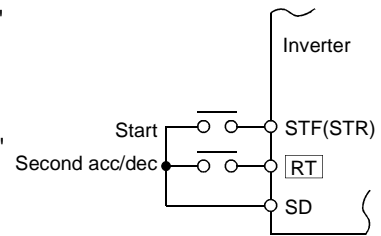

Entering the RT signal enables the second functions (above parameters). However, when Pr. 450 = 9999, it is judged that the second motor functions are not selected, and parameters Pr. 451 and Pr. 453, Pr. 454 are invalid. The second functions other than the above are enabled with the first moter.

1.8.3 Jog operation (jog signal): Pr. 180 to Pr. 183, Pr. 187 setting "5"

(1) Jog operation using external signals

Jog operation can be started/stopped by shorting the jog mode select terminal JOG-SD and shorting/opening the start signal terminal STF or STR-SD. The jog speed and jog acceleration/deceleration time are set in Pr. 15 (factory setting 150r/min, variable between 0 and 1500r/min) and Pr. 16 (factory setting 0.5s, variable between 0 and 3600s (when Pr. 21 = 0)/0 to 360s (when Pr. 21 = 1)), respectively, and their settings can be changed from the operation panel or parameter unit.

The jog signal has higher priority than the multi-speed signals. (external)

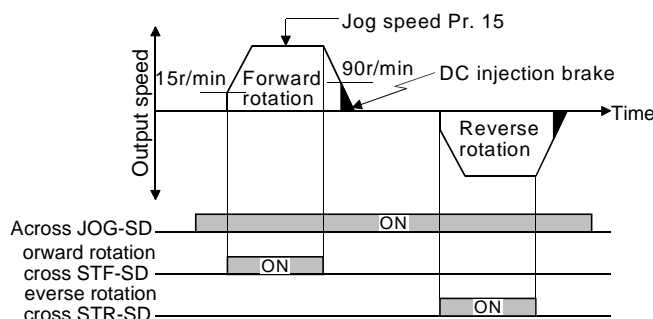

1.8.4 Third function selection (X9 signal): Pr. 180 to Pr. 183, Pr. 187 setting "9"

Turn on this "X9 signal" to set:
Pr. 110 "third acceleration/deceleration time"
Pr. 111 "third deceleration time"
Select either the first motor or the second motor according to the RT signal input.

X9 signal	RT signal	Applied Motor	Other Function
OFF	OFF	First motor	First function
OFF	ON	Second motor	Second function
ON	OFF	First motor	Third function
ON	ON	Second motor	Third function

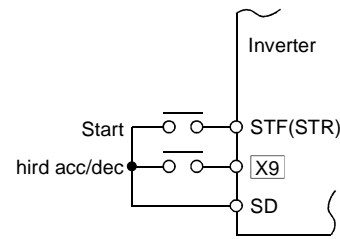

1.8.5 FR-HC, FR-CV connection (X10 signal): Pr. 180 to Pr. 183, Pr. 187 setting "10"

- FR-HC, FR-CV connection (inverter operation enable signal)
To provide protective coordination with the high power factor converter (FR-HC) or power regeneration common converter (FR-CV), use the inverter operation enable signal to shut off the inverter output. Enter the RDY signal of the high power factor converter or power regeneration common converter.

1.8.6 PU operation external interlock signal (X12 signal): Pr. 180 to Pr. 183, Pr. 187 setting "12"

This function prevents the inverter from being inoperative during operation using an external command if the mode is accidentally left unswitched from the PU operation mode. (Refer to page 118.)

- X12 signal on Shift to PU operation mode enabled (output stop during external operation)
- X12 signal off Shift to PU operation mode disabled (output stop during external operation)

1.8.7 PID control enable terminal: Pr. 180 to Pr. 183, Pr. 187 setting "14"

Turn the X14 signal on to exercise PID control. When this signal is off, normal inverter operation is performed. Refer to page 141 for details.

Related parameters

Pr. 128 "PID action selection", Pr. 129 "PID proportional band", Pr. 130 "PID integral time", Pr. 131 "upper limit", Pr. 132 "lower limit", Pr. 133 "PID action set point for PU operation", Pr. 134 "PID differential time" (Refer to page 141.)

1.8.8 Brake sequence opening signal (BRI signal): Pr. 180 to Pr. 183, Pr. 187 setting "15"

Used when the method of inputting the mechanical brake opening completion signal to the inverter is used for the brake sequence functions. (Refer to page 109.)

Related parameters

Pr. 60 "intelligent mode selection", Pr. 278 "brake opening speed", Pr. 279 "brake opening current", Pr. 280 "brake opening current detection time", Pr. 281 "brake operation time at start", Pr. 282 "brake operation speed", Pr. 283 "brake operation time at stop", Pr. 284 "deceleration detection function selection", Pr. 285 "overspeed detection speed" (Refer to page 109.)

1.8.9 PU operation/external operation switchover: Pr. 180 to Pr. 183, Pr. 187 setting "16"

You can change the operation mode.

When Pr. 79 "operation mode selection" = "8", turning the X16 signal on shifts the current operation mode to the external operation mode and turning that signal off shifts to the PU operation mode. Refer to page 120 for details.

Related parameters

Pr. 79 "operation mode selection" (Refer to page 120)

1.8.10 S-pattern acceleration/deceleration C switchover terminal (X20 signal)

: Pr. 180 to Pr. 183, Pr. 187 setting "20"

When Pr. 29 = "4", you can use the S-pattern acceleration/deceleration C switchover terminal to set the acceleration of S-pattern acceleration/deceleration in the parameter. (Refer to page 93.)

Related parameters

Pr. 29 "acceleration/deceleration pattern", Pr. 380 "acceleration S pattern 1", Pr. 381 "deceleration S pattern 1", Pr. 382 "acceleration S pattern 2", Pr. 383 "deceleration S pattern 2" (Refer to page 93.)

How to use the input signals (assigned terminals DI1 to DI4, STR)

1.8.11 Orientation command (X22 signal): Pr. 180 to Pr. 183, Pr. 187 setting "22"

With the position detector (PLG) fitted to the motor end, you can perform position stop (orientation) control of the rotation shaft. Refer to page 160 for details.

Related parameters

Pr. 350 "stop position command selection", Pr. 351 "orientation switchover speed", Pr. 356 "Internal stop position command", Pr. 357 "orientation in-position zone", Pr. 360 "external position command selection", Pr. 361 "position shift", Pr. 362 "orientation position loop gain", Pr. 393 "orientation selection", Pr. 396 "orientation speed gain (P term)", Pr. 397 "orientation speed integral time", Pr. 398 "orientation speed gain (D term)", Pr. 399 "orientation deceleration ratio" (Refer to page 160.)

1.8.12 Pre-excitation/servo on (LX signal): Pr. 180 to Pr. 183, Pr. 187 setting "23"

● Pre-excitation

When the start signal (STF, STR) is not input to the inverter (during a stop), turning on the pre-excitation terminal LX enables 0 speed control or servo lock. (Refer to page 87 for details.)

● Servo on

Use the LX signal to exercise position control.

Turning on the LX signal switches the servo on and cancels the base circuit shut-off, resulting in a servo lock status. (Refer to page 53 for details.)

Related parameters

Pre-excitation ⇒ Pr. 802 "pre-excitation selection" (Refer to page 87.)

Servo-on ⇒ Pr. 419 "position command right selection", Pr. 420 "command pulse scaling factor numerator", Pr. 421 "command pulse scaling factor denominator", Pr. 422 "position loop gain", Pr. 423 "position feed forward gain", Pr. 424 "position command acceleration/deceleration time constant", Pr. 425 "position feed forward command filter", Pr. 426 "in-position width", Pr. 427 "excessive level error", Pr. 430 "pulse monitor selection", Pr. 464 "digital position control sudden stop deceleration time", Pr. 465 to Pr. 494 (position feed amount) (Refer to page 53.)

1.8.13 Output stop (MRS signal): Pr. 180 to Pr. 183, Pr. 187 setting "24"

Short the output stop terminals MRS-SD during inverter output to cause the inverter to stop the output immediately.

This function is valid in any mode independently of the control mode.

Open terminals MRS-SD to resume operation in about 20ms.

Terminal MRS may be used as described below.

- (1) To stop the motor by mechanical brake (e.g. electromagnetic brake)
Terminals MRS-SD must be shorted when the mechanical brake is operated and be opened before the motor that has stopped restarts.
- (2) To provide interlock to disable operation by the inverter
After terminals MRS-SD have been shorted, the inverter cannot be operated if the start signal is given to the inverter.
- (3) To coast the motor to stop
The motor is decelerated according to the preset deceleration time and is stopped by operating the DC injection brake at the DC injection brake operation speed or less. Using terminal MRS, the motor is coasted to a stop.

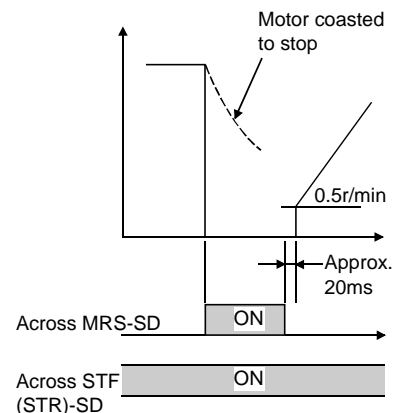

1.8.14 Start self-holding selection (STOP signal): Pr. 180 to Pr. 183, Pr. 187 setting "25"

The connection example given here is used to self-hold the start signal (forward rotation, reverse rotation).

* Connected to the STOP signal to disable forward or reverse rotation if forward or reverse rotation and stop are turned on at the same time.

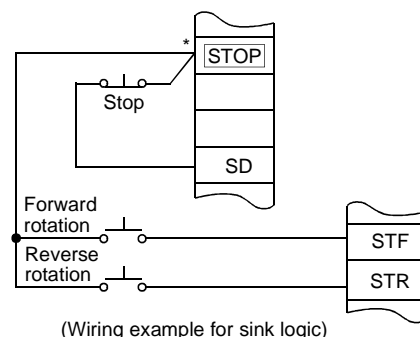

1.8.15 Control mode changing (MC signal): Pr. 180 to Pr. 183, Pr. 187 setting "26"

By setting Pr. 800 "control system selection", change the control mode between speed, torque and position. Refer to page 170 for details.

1.8.16 Torque restriction selection (TL signal): Pr. 180 to Pr. 183, Pr. 187 setting "27"

By setting Pr. 815 "torque restriction level 2", you can change the torque restriction value. Refer to the Instruction Manual (basic) for details.

1.8.17 Torque bias selection 1 (X42 signal): Pr. 180 to Pr. 183, Pr. 187 setting "42"
Torque bias selection 2 (X43 signal): Pr. 180 to Pr. 183, Pr. 187 setting "43"

When using the torque bias function, you can combine the on/off of the X42 and X43 signals to select the torque bias amount. Refer to page 177 for details.

Related parameters

Pr. 840 "torque bias selection", Pr. 841 "torque bias 1", Pr. 842 "torque bias 2", Pr. 843 "torque bias 3", Pr. 844 "torque bias filter", Pr. 845 "torque bias operation time", Pr. 846 "torque bias balance compensation", Pr. 847 "fall-time torque bias No. 3 bias", Pr. 848 "fall-time torque bias No. 3 gain" (Refer to page 177.)

1.8.18 P control selection (P/PI control switchover) (X44 signal):
Pr. 180 to Pr. 183, Pr. 187 setting "44"

By turning the X44 signal on/off during operation of the inverter under speed control, you can change between speed P control and speed PI control.

When X44 signal is off: PI control

When X44 signal is on: P control

Since speed deviation occurs according to the load, you can use the machine-coupled device to suppress the hunting of the control system.

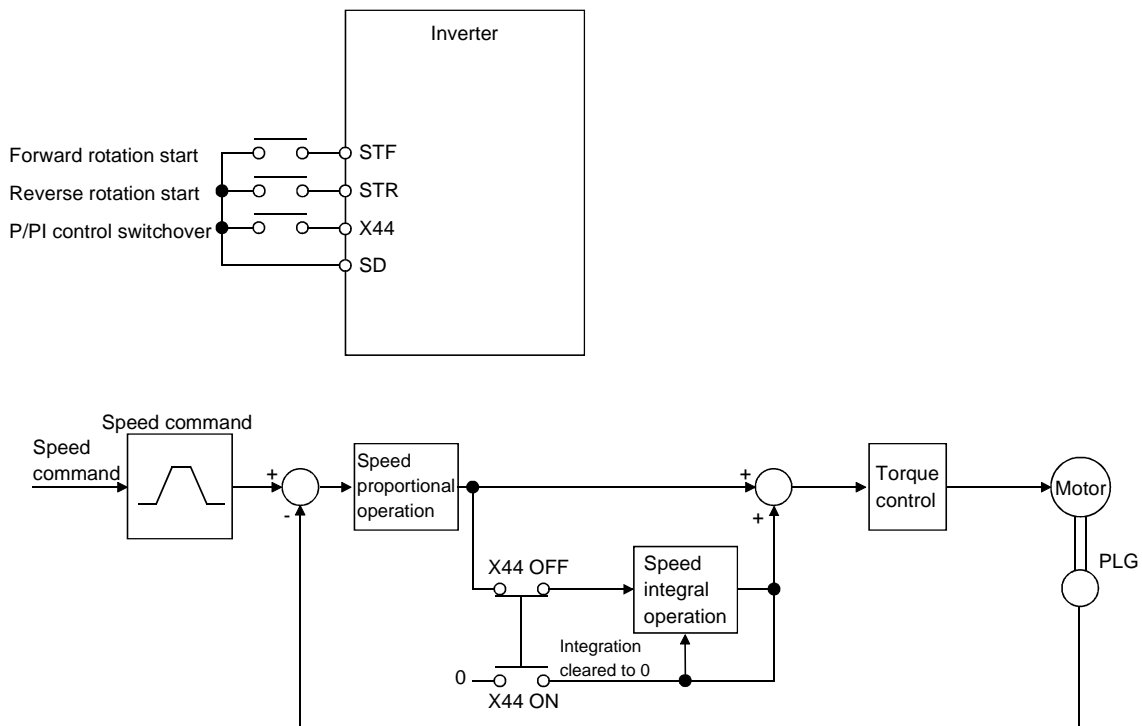

1.9 How to use the output signals (assigned terminals DO1 to DO3, ABC) (Pr. 190 to Pr. 192, Pr. 195)

The output terminals DO1, DO2, DO3, ABC vary in functions with the Pr. 190 to Pr. 192 and Pr. 195 settings.

Parameter	Name	Terminal Symbol	Factory Setting	Factory-Set Terminal Function	Setting Range	Remarks
190	DO1 terminal function selection	RUN	0	Inverter running	0 to 199, 9999	Extended mode
191	DO2 terminal function selection	SU	1	Up to speed	0 to 199, 9999	
192	DO3 terminal function selection	IPF	2	Instantaneous power failure, undervoltage	0 to 199, 9999	
195	ABC terminal function selection	A, B, C	99	Alarm output	0 to 199, 9999	

<Setting>

Refer to the following table for the settings of Pr. 190 to Pr. 192 and Pr. 195.

Setting		Signal Name	Function	Operation
Positive logic	Negative logic			
0	100	RUN	Inverter running	Output when the start command is input. For V/F control, this signal is output during operation when the inverter output speed rises to or above the starting speed. During DC injection brake, 0 speed control or servo lock, this signal is not output.
1	101	SU	Up to speed	Refer to Pr. 41 "up-to-speed sensitivity" (page 99).
2	102	IPF	Instantaneous power failure or undervoltage	Output at occurrence of an instantaneous power failure or undervoltage.
3	103	OL	Overload alarm	Output when torque or speed restriction is activated. For V/F control, this signal is output while the stall prevention function is activated.
4	104	FU	Output speed detection	Refer to Pr. 42, Pr. 43 (speed detection) (page 99).
5	105	FU2	Second output speed detection	Refer to Pr. 50 "second speed detection" (page 99).
6	106	FU3	Third output speed detection	Refer to Pr. 116 "third speed detection" (page 99).
7	107	RBP	Regenerative brake prealarm	Output when 85% of the regenerative brake duty set in Pr. 70 is reached.
8	108	THP	Electronic thermal relay prealarm	Output when the electronic thermal relay cumulative value reaches 85% of the preset level.
10	110	PU	PU operation mode	Output when the PU operation mode is selected.
11	111	RY	Inverter operation ready	Output when the inverter can be started by switching the start signal on or while it is running.
12	112	Y12	Output current detection	Refer to Pr. 150 and 151 (output current detection) (page 147).
13	113	Y13	Zero current detection	Refer to Pr. 152 and 153 (zero current detection) (page 148).
14	114	FDN	PID lower limit	Refer to Pr. 128 to 134 (PID control) (page 141).
15	115	FUP	PID upper limit	
16	116	RL	PID forward-reverse rotation output	
20	120	BOF	Brake opening request	Refer to Pr. 278 to Pr. 285 (brake sequence function) (page 109).
25	125	FAN	Fan fault output	Output at the time of a fan fault.
26	126	FIN	Fin overheat prealarm	Output when the heatsink temperature reaches about 85% of the fin overheat protection activating temperature.
27	127	ORA	Orientation in-position	When orientation is valid
30	130	Y30	Forward rotation output	For vector control
31	131	Y31	Reverse rotation output	

Setting		Signal Name	Function	Operation
Positive logic	Negative logic			
32	132	Y32	Regenerative status output	For vector control
33	133	RY2	Operation ready 2	Output on completion of pre-excitation. Turned on at an output start when pre-excitation is not made.
34	134	LS	Low speed output	Output when the speed falls to or below any preset low speed.
35	135	TU	Torque detection	Output when the motor torque rises above the predetermined value (Pr.864). (Refer to page 182.)
36	136	Y36	In-position	Acts as an in-position signal.
37	137	MT	Maintenance timer output	Refer to Pr. 890 to Pr. 892 (maintenance output function) (page 187).
40	140	Y40	Trace status	Acts as a trace completion signal.
41	141	FB	Speed detection	Output when the motor output speed (feed back value) exceeds the preset speed. Perform in the same way as FU, FU2 and FU3 under V/F control.
42	142	FB2	Second speed detection	
43	143	FB3	Third speed detection	
44	144	RUN2	Inverter running 2	<ul style="list-style-type: none"> • Output during forward operation or the reverse signal is ON. • Output at deceleration even during forward rotation or the reverse signal is OFF. (Does not output during pre-excitation LX is ON.) • Output during the orientation command signal (X22) is ON. • Switched ON when the servo is ON (LX-ON) under position control. (Switched OFF when the servo is OFF. (LX-OFF)
96	196	REM	Remote output	Refer to Pr. 495 to Pr.497 (page 169).
97	197	ER	Minor fault output 2	At occurrence of a major fault, the base circuit is shut off immediately. At occurrence of a minor fault, the base circuit is shut off after deceleration to a stop.
98	198	LF	Minor fault output	Output when a minor fault (fan fault or communication error alarm) occurs.
99	199	ABC	Alarm output	Output when the inverter's protective function is activated to stop the output (major fault).
9999	—	—	No function	—

0 to 99: Positive logic, 100 to 199: Negative logic

1.10 Design information to be checked

- 1) When performing commercial power supply-inverter switchover operation for the motor other than the Mitsubishi dedicated motor, securely provide electrical and mechanical interlocks for the MC1 and MC2 used for commercial power supply-inverter switchover.
When the wiring is wrong or there is a commercial power supply-inverter switchover circuit as shown below, the inverter will be damaged by a sneak current from the power supply due to arcs generated at the time of switchover or chattering caused by a sequence error.
- 2) If the machine must not be restarted when power is restored after a power failure, provide a magnetic contactor in the inverter's primary circuit and also make up a sequence that will not turn on the start signal.
If the start signal (start switch) remains on after a power failure, the inverter will automatically restart as soon as the power is restored.
- 3) When the power supply used with the control circuit is different from the one used with the main circuit, make up a circuit which will switch off the main circuit power supply terminals R, S, T when the control circuit power supply terminals R1, S1 are switched off.
- 4) Since the input signals to the control circuit are on a low level, use two parallel low-level signal contacts or a twin contact for contact inputs to prevent poor contact.
- 5) Do not apply a voltage to the contact input terminals (e.g. STF) of the control circuit.
- 6) Do not apply a voltage directly to the alarm output terminals (A, B, C). Always apply a voltage to these terminals via a relay coil, lamp, etc.
- 7) Fully make sure that the specifications and rating match the system requirements.

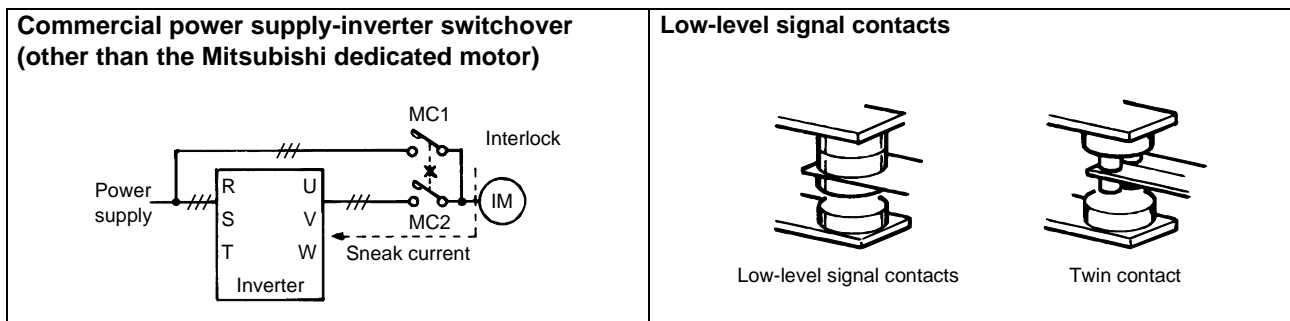

1.11 Using the second motor

1.11.1 Wiring diagram (second motor)

CAUTION

1. Provide interlocks to prevent the MC1 and MC2 from being turned on simultaneously.
2. For the second motor (motor without PLG), use Pr. 452 "second electronic thermal O/L relay" or provide an external thermal relay.
3. *: Give one external thermal relay signal to across OH-SD.

Related parameters

Second electronic thermal relay setting ⇒ (Pr. 452 "second electronic thermal O/L relay" (Refer to page 85.))

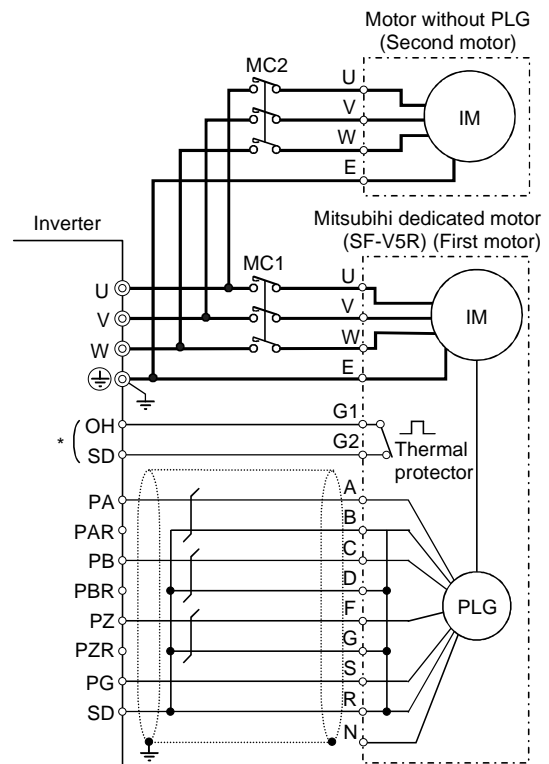

1.11.2 Second motor setting parameters

Parameter	Name	Factory Setting	Setting Range	
			Setting	Description
450	Second applied motor	9999	0	Mitsubishi standard motor (SF-JR)
			10	Mitsubishi constant torque motor (SF-HRCA)
			30	Mitsubishi dedicated motor (SF-V5R, SF-VR)
			9999	The second applied motor is made invalid and Pr. 71 "applied motor" is made valid.
451	Second motor control method selection	9999	20	V/F control
			9999	The setting is the same as that of control system of Pr. 800 "control system selection". (Caution 1)
452	Second electronic thermal O/L relay	9999	Set the rated motor current. 0 to 500A (Refer to page 85.)	
			9999	Function invalid
453	Second motor capacity	Inverter capacity	Set the motor capacity. 0.4 to 55kW (0.5 to 75HP)	
454	Number of second motor poles	4	Set the number of motor poles. 2, 4, 6P	
				Setting can be made when Pr. 450 ≠ "9999"

- Turn on/off the RT signal to switch between the first and second motors using contacts information of the magnetic contactor (MC).
(Use the RT signal after setting it to any of the DI1 to DI4 signals using Pr. 180 to Pr. 183, Pr. 187 (input terminal function selection).)
- Select V/F control for the Pr. 451 setting, vector control with PLG can not be selected.
- By setting values other than "9999" in Pr. 451 when Pr. 450="9999" (factory setting), the control system of the first motor can be changed by switching the RT terminal on and off.
(In this case, turning the RT signal on makes the second function of Pr. 44, Pr. 45, Pr. 452 and Pr. 830 to Pr. 837 valid.)

CAUTION

1. Even when the first motor is under vector control, the second motor is V/F controlled while the RT signal is on independently of the Pr. 451 setting when Pr. 450 ≠ "9999".
2. When switching the second motor (V/F control) to the first motor (position control), switch to the first motor when about 5 seconds elapsed after stopping the second motor.

1.12 Using the conventional Mitsubishi motor and other motors

1.12.1 Conventional Mitsubishi motor (SF-VR, SF-JR with PLG)

CAUTION

- When using the PLG cable (FR-VCBL/FR-JCBL) of the conventional Mitsubishi motor for the FR-V500 series, change the size of crimping terminals of the PLG cable from M3 to M3.5.

(1) PLG cable

● SF-VR motor	● SF-JR motor with PLG																
<table border="1" style="width: 100%; border-collapse: collapse;"> <thead> <tr> <th>Type</th> <th>Length L</th> </tr> </thead> <tbody> <tr> <td>FR-VCBL5</td> <td>5m (16.40 feet)</td> </tr> <tr> <td>FR-VCBL15</td> <td>15m (49.21 feet)</td> </tr> <tr> <td>FR-VCBL30</td> <td>30m (98.42 feet)</td> </tr> </tbody> </table>	Type	Length L	FR-VCBL5	5m (16.40 feet)	FR-VCBL15	15m (49.21 feet)	FR-VCBL30	30m (98.42 feet)	<table border="1" style="width: 100%; border-collapse: collapse;"> <thead> <tr> <th>Type</th> <th>Length L</th> </tr> </thead> <tbody> <tr> <td>FR-JCBL5</td> <td>5m (16.40 feet)</td> </tr> <tr> <td>FR-JCBL15</td> <td>15m (49.21 feet)</td> </tr> <tr> <td>FR-JCBL30</td> <td>30m (98.42 feet)</td> </tr> </tbody> </table>	Type	Length L	FR-JCBL5	5m (16.40 feet)	FR-JCBL15	15m (49.21 feet)	FR-JCBL30	30m (98.42 feet)
Type	Length L																
FR-VCBL5	5m (16.40 feet)																
FR-VCBL15	15m (49.21 feet)																
FR-VCBL30	30m (98.42 feet)																
Type	Length L																
FR-JCBL5	5m (16.40 feet)																
FR-JCBL15	15m (49.21 feet)																
FR-JCBL30	30m (98.42 feet)																

(2) PLG jumper connector setting

Make PLG setting according to the PLG. (Refer to the Instruction Manual (basic).)

Item	PLG for SF-VR	PLG for SF-JR	PLG for SF-V5R (for reference)
Resolution	1000 pulse/rev	1024 pulse/rev	2048 Pulse/Rev
Power supply voltage	5VDC±10%	5VDC±10%	12VDC±10%
Current consumption	150mA	150mA	150mA
Output signal form	A, B phases (90° phase shift) Z phase: 1 pulse/rev	A, B phases (90° phase shift) Z phase: 1 pulse/rev	A, B phases (90° phase shift) Z phase: 1 pulse/rev
Output circuit	Differential line driver AM26LS31 equivalent	Differential line driver 74LS113 equivalent	Complimentary (Constant voltage output matched by emitter follow)
Output voltage	"H" level 2.4V or more "L" level 0.4V or less	"H" level 2.4V or more "L" level 0.5V or less	"H" level -3V or more "L" level 3V or less

CAUTION

PLG with resolution of 1000 to 4096 pulse/rev is recommended.

⚠ CAUTION

- Perform the PLG setting correctly. Incorrect setting results in a motor failure.
- The power supply voltage and output circuit are factory set as follows:

	Japanese Version	NA Version
PLG power supply jumper connector	12V	5V
Output circuit jumper connector	Complimentary (CMP)	Differential line driver (LDV)

(3) Parameter setting

Parameters below are extended parameters. Set "1" in Pr. 160 "extended function selection" to read and make setting.

Parameter	Name	Factory Setting	Setting Range	Refer to
9	Electronic thermal O/L relay	0A	0 to 500A	85
71	Applied motor	30	0, 3 to 8, 10, 13 to 18, 20, 23, 24, 30, 33, 34	114
80	Motor capacity	Inverter capacity	0.4 to 55kW (0.5 to 75HP)	123
81	Number of motor poles	4	2, 4, 6	
851	Number of PLG pulses	Japanese version: 2048 NA version: 1024	0 to 4096 (Number of pulses before multiplied by 4)	Refer to the Instruction Manual (basic)
852	PLG rotation direction	1	0, 1	

CAUTION

- **Pr. 71 setting**
 - SF-VR: "30"
 - SF-JR (2, 4, 6P)- 2.2 to 55kW(3 to 75HP): "0"
 - SF-JR (4P)- 1.5kW(2HP) or less: "20"
 - SF-HRCA (4P): "10"
- When using motors other than the Mitsubishi dedicated motor (SF-V5R) or above motors, perform offline auto tuning. (Refer to page 123.)

1.12.2 Precautions for and wiring of the motor with PLG (SF-JR with PLG)

- When the motor used is other than the Mitsubishi dedicated motor, use the offline auto tuning function. (Refer to page 123 for details of offline auto tuning.)
- Set Pr. 800 to select the control method. (Refer to page170.)
- To protect the motor from overheat, set electronic thermal relay or provide an external thermal relay. (Refer to page 25.)

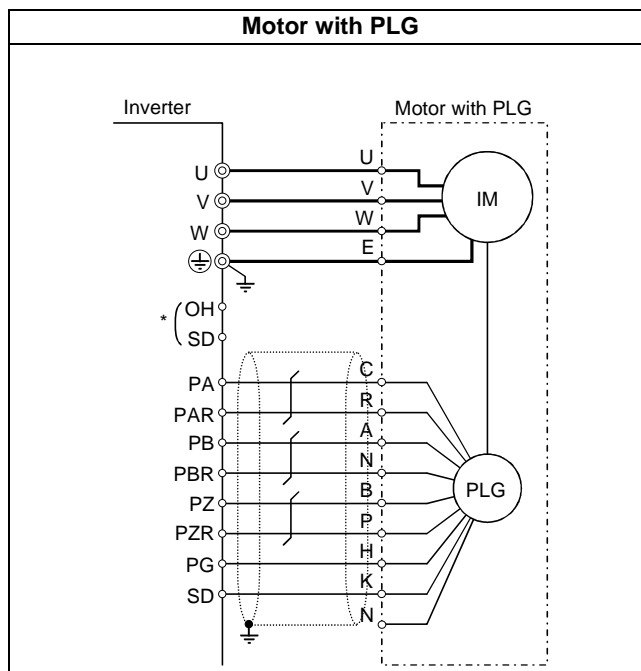

CAUTION

- *Leave the unused terminals open.
- When not using an external thermal relay, set "0" in Pr. 876 "thermal protector input". Set Pr. 9 "electronic thermal O/L relay".
- Check the power supply specification of PLG and change a jumper connector. (Refer to the Instruction Manual (basic).)

MEMO

2

VECTOR CONTROL

This chapter explains the basic "adjustment for vector control" for use of this product.

Always read the instructions and other information before using the equipment.

2.1	What is vector control?	40
2.2	Speed control	42
2.3	Fine adjustment of gains for speed control.....	43
2.4	Torque control	49
2.5	Fine adjustment for torque control.....	50
2.6	Gain adjustment for torque control.....	51
2.7	Conditional position control (Pr. 419 to Pr. 430, Pr. 464 to Pr. 494)	53

1

2

3

4

2.1 What is vector control?

Vector control is one of the control techniques for driving an induction motor. To help explain vector control, the fundamental equivalent circuit of an induction motor is shown below:

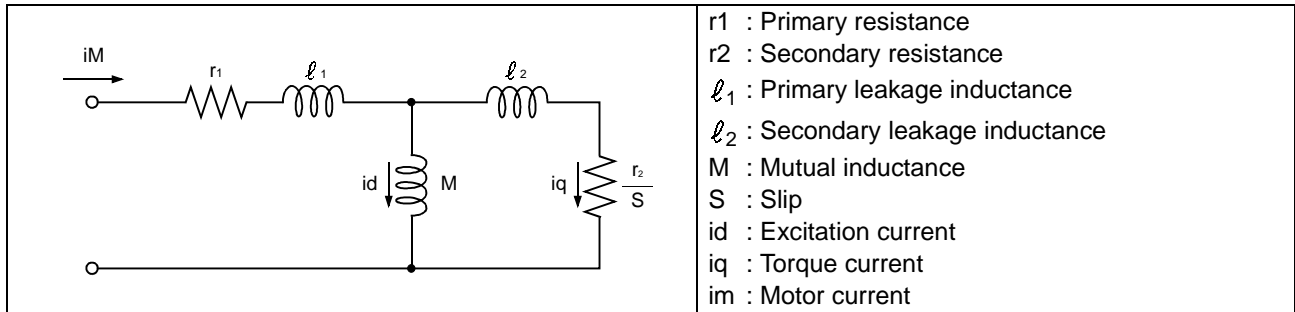

In the above diagram, currents flowing in the induction motor can be classified into a current i_d (excitation current) for making a magnetic flux in the motor and a current i_q (torque current) for causing the motor to develop a torque.

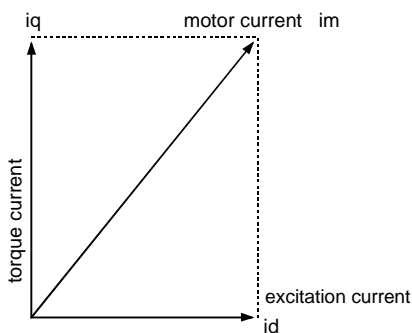

In vector control, the voltage and output frequency are calculated to control the motor so that the excitation current and torque current (as shown in the left figure) flow to the optimum as described below:

- (1) The excitation current is controlled to place the internal magnetic flux of the motor in the optimum status.
- (2) Derive the torque command value so that the difference between the motor speed command and the actual speed obtained from the PLG connected to the motor shaft is zero.

Motor-generated torque (T_M), slip angular velocity (ω_s) and the motor's secondary magnetic flux (ϕ_2) can be found by the following calculation:

$$T_M \propto \phi_2 \cdot i_q$$

$$\phi_2 = M \cdot i_d$$

$$\omega_s = \frac{r_2}{L_2} \cdot \frac{i_q}{i_d}$$

where, L_2 = secondary inductance

$$L_2 = l_2 + M$$

Vector control provides the following advantages:

- (1) Excellent control characteristics when compared to V/F control and other control techniques, achieving the control characteristics equal to those of DC machines.
- (2) Applicable to fast-response applications with which induction motors were previously regarded as difficult to use. Applications requiring a wide variable-speed range from extremely low speed to high speed, frequent acceleration/deceleration operations, continuous four-quadrant operations etc.
- (3) Allows torque control.
- (4) Allows servo-lock torque control which generates a torque at zero speed (i.e. status of motor shaft = stopped).

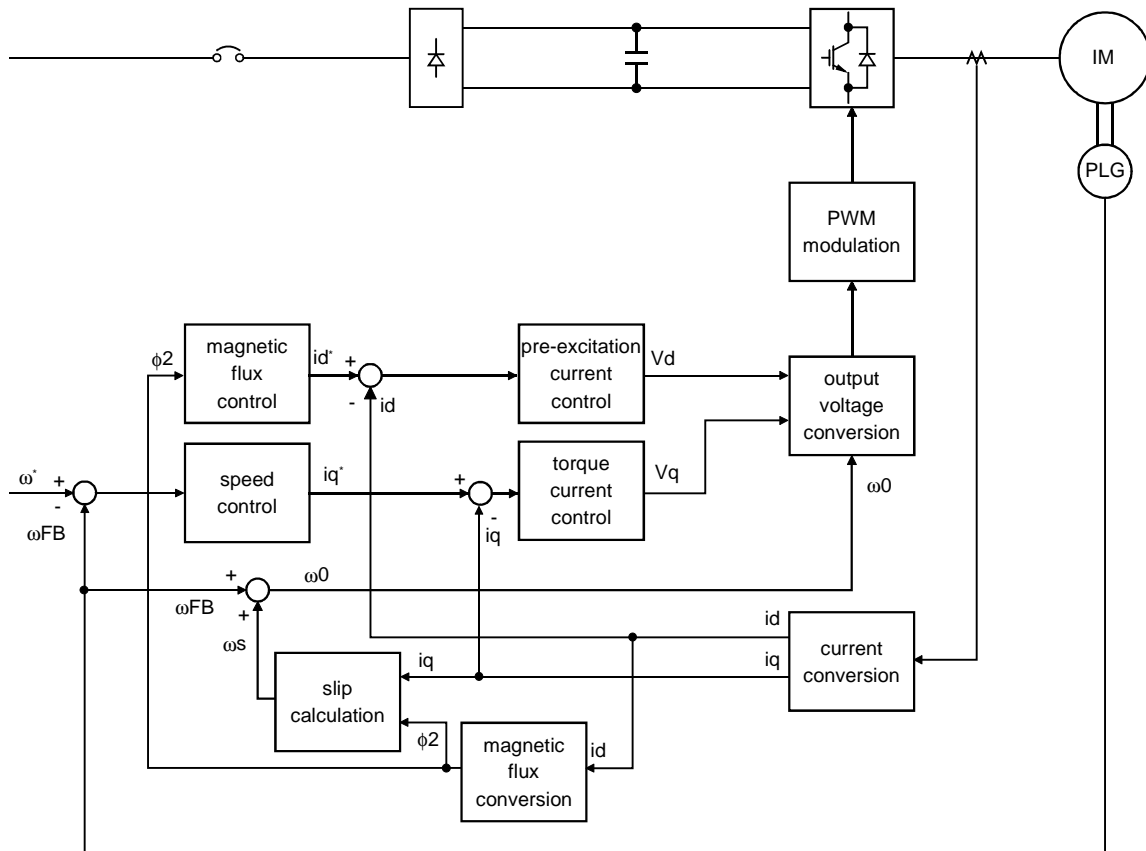

- (1) Speed control
Speed control operation is performed to zero the difference between the speed command (ω^*) and actual rotation detection value (ω_{FB}). At this time, the motor load is found and its result is transferred to the torque current controller as a torque current command (i_q^*).
- (2) Torque current control
A voltage (V_q) is calculated to start a current (i_q^*) which is identical to the torque current command (i_q) found by the speed controller.
- (3) Magnetic flux control
The magnetic flux (ϕ_2) of the motor is derived from the excitation current (i_d). The excitation current command (i_d^*) is calculated to use that motor magnetic flux (ϕ_2) as a predetermined magnetic flux.
- (4) Excitation current control
A voltage (V_d) is calculated to start a current (i_d) which is identical to the excitation current command (i_d^*) found by magnetic flux control.
- (5) Output frequency calculation
Motor slip (ω_s) is calculated on the basis of the torque current value (i_q) and magnetic flux (ϕ_2). The output frequency (ω_0) is found by adding that slip (ω_s) to the feedback (ω_{FB}) found by a feedback from the PLG.

The above results are used to make PWM modulation and run the motor.

Speed control

This inverter can control a motor under speed, torque or position control. (As required, set "1" (extended function parameters valid) in Pr. 160 "extended function selection".)

Refer to page 151 for details of Pr. 160 "extended function selection". (Since the factory setting of Pr. 77 is "0", perform parameter write in the PU mode or during a stop.)

2.2 Speed control

2.2.1 Outline of speed control

The basics of speed control are explained in the Instruction Manual (basic).

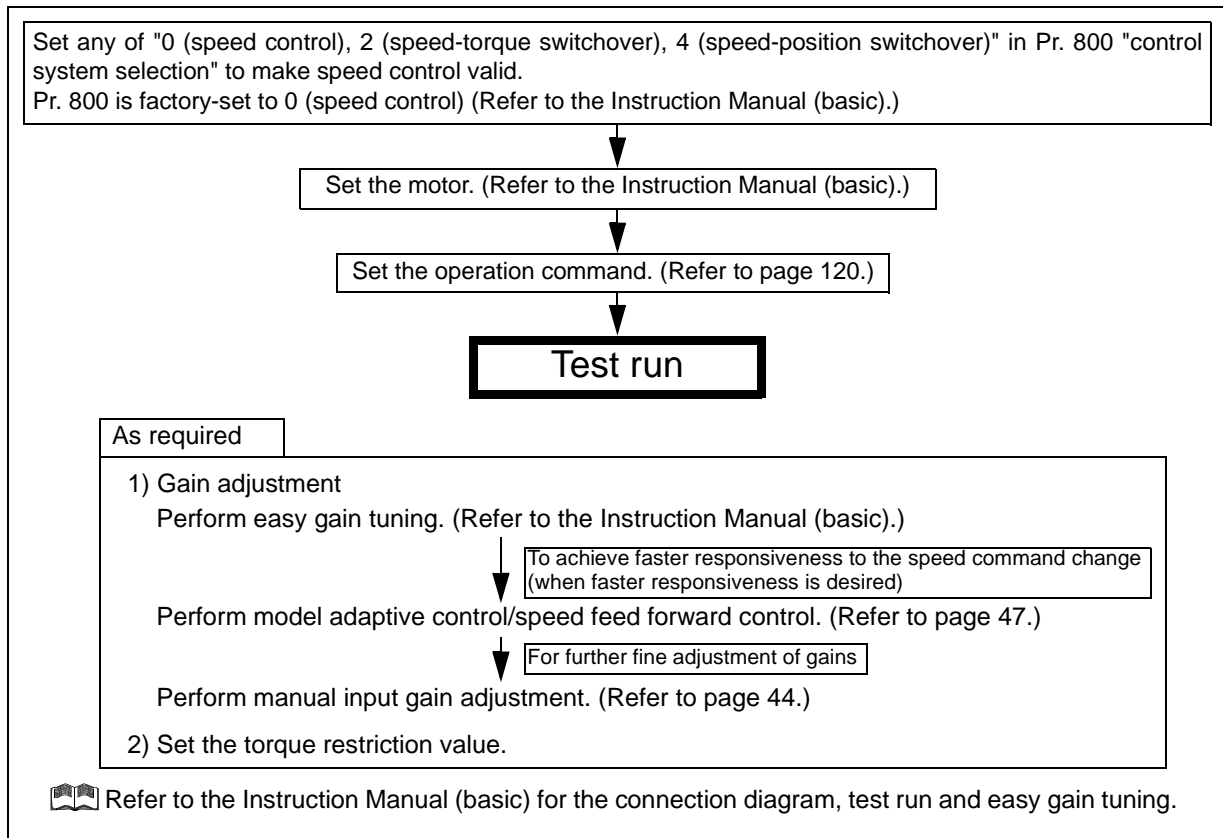

2.2.2 Easy gain tuning function block diagram

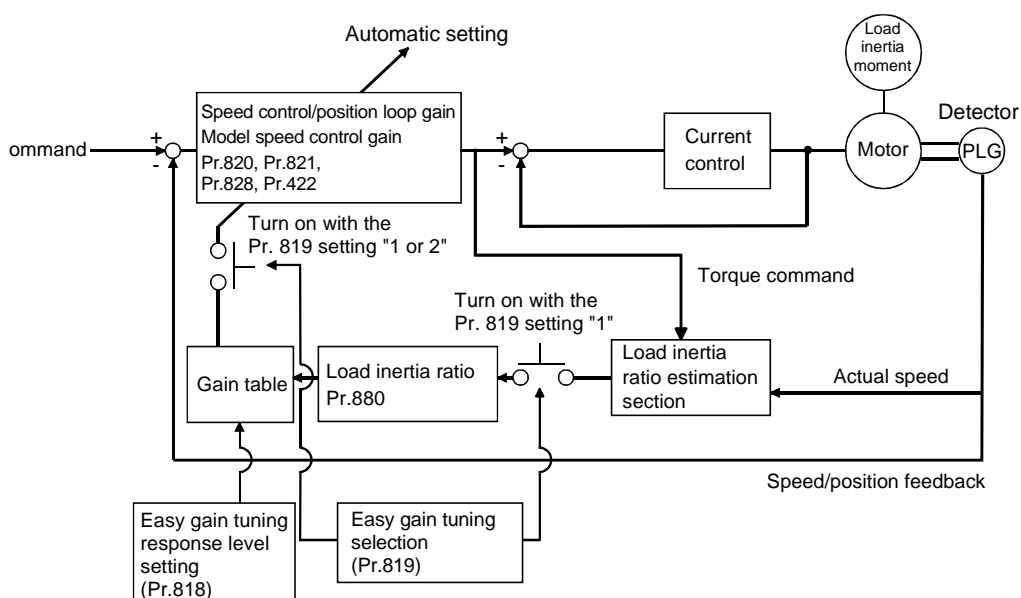

2.3 Fine adjustment of gains for speed control

If easy gain tuning does not provide high accuracy, refer to the next page and make adjustment. Make adjustment when vibration, noise or any other unfavorable phenomenon occurs due to large load inertia or gear backlash, for example, or when you want to exhibit the best performance that matches the machine.

2.3.1 Control block diagram

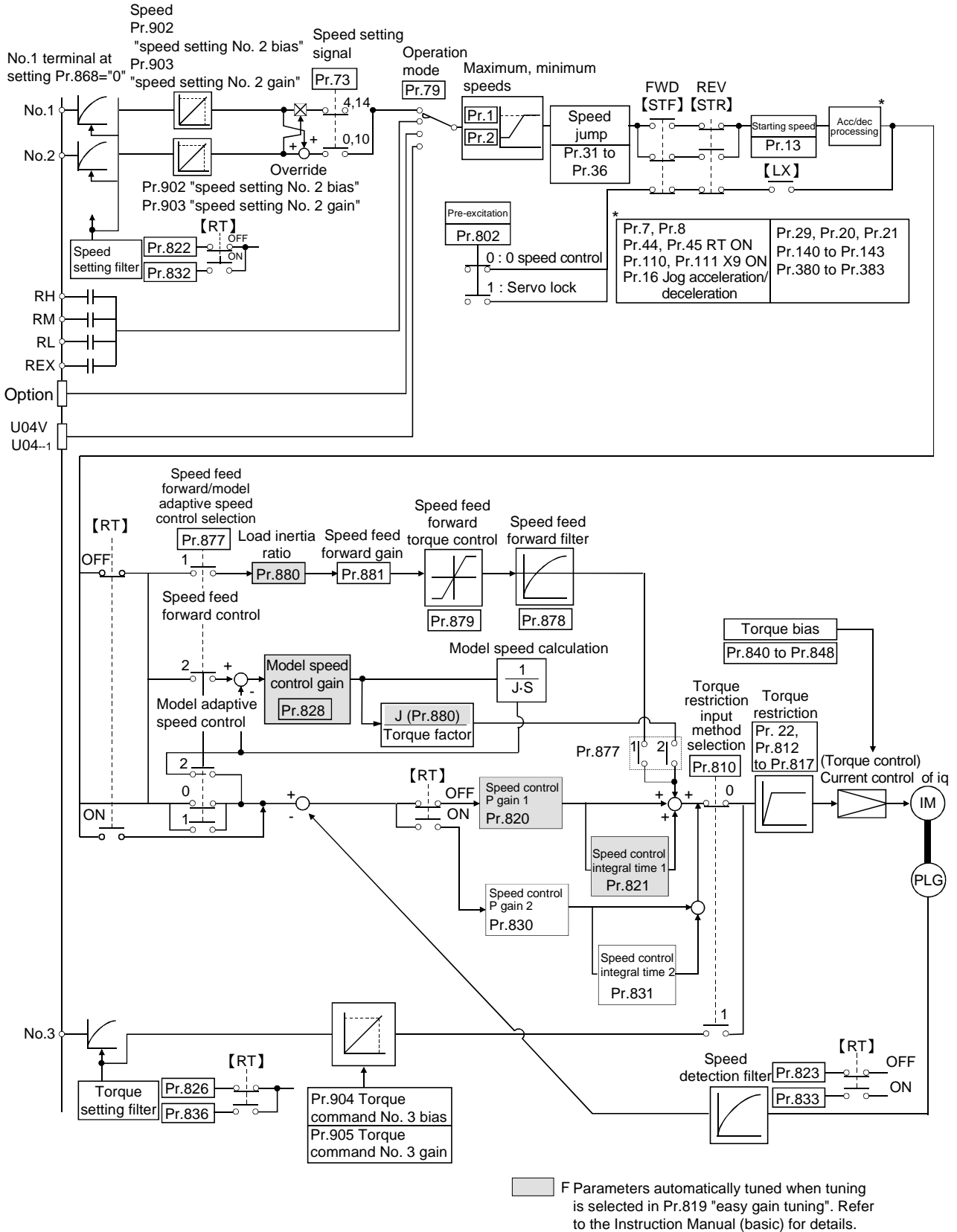

2.3.2 Concept of adjustment of manual input speed control gains

- 1) Speed control P gain 1
 - Pr. 820 = 60% is equivalent to 120rad/s (speed response of the motor alone). (factory setting)
 - Increasing the proportional gain increases the response level. However, a too high gain will produce vibration and/or unusual noise.
- 2) Speed control integral time
 - Pr. 821 = 0.333s (factory setting)
 - Decreasing the integral time shortens the return time taken at a speed change. However, a too short time will generate an overshoot.

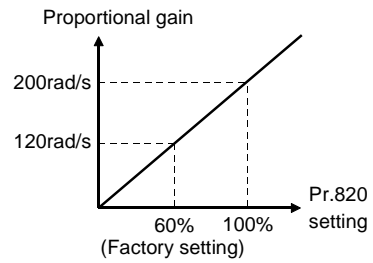

When there is load inertia, the actual speed gain is as given below.

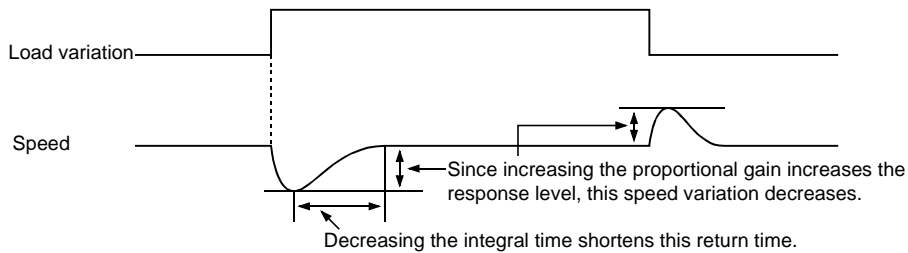

Also, when there is load inertia, the actual speed gain decreases as indicated below.

$$\text{Actual speed gain} = \text{speed gain of motor without load} \times \frac{J_M}{J_M + J_L}$$

J_M : Inertia of motor
 J_L : Motor shaft-equivalent load inertia

2.3.3 Speed control gain adjustment procedure (Pr. 820, Pr. 821)

- Set "0" in Pr. 819 "easy gain tuning". (Easy gain tuning is not performed.)
- Refer to the Instruction Manual (basic) for easy gain tuning.
- Refer to the following for manually input gain adjustment.

● Manuall input gain adjustment

- Pr. 820 "speed control P (proportional) gain 1", Pr. 830 "speed control P (proportional) gain 2"
- Pr. 821 "speed control integral time 1", Pr. 831 "speed control integral time 2"

Make adjustment when any of such phenomena as unusual machine vibration/noise, low response level and overshoot has occurred.

- 1) First check the conditions and simultaneously change Pr. 820 "speed control P gain 1" value.
- 2) If you cannot make proper adjustment, change Pr. 821 "speed control integral time 1" value and repeat step (1).







CAUTION

Pr. 830 "speed control P(proportional) gain 2" and Pr. 831 "speed control integral time 2" are made valid when the RT terminal is switched on. Make adjustments in the same way as Pr. 820 and Pr. 821.

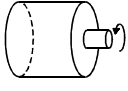
No.	Phenomenon/Condition	Adjustment Method	
1	Large load inertia	Set the Pr. 820 and Pr. 821 values a little higher.	
		Pr. 820	When a speed rise is slow, increase the value 10% by 10% until just before vibration/noise is produced, and set about 0.8 to 0.9 of that value.
		Pr. 821	If an overshoot occurs, double the value until an overshoot does not occur, and set about 0.8 to 0.9 of that value.
2	Vibration/noise generated from mechanical system	Set the Pr. 820 value a little lower and the Pr. 821 value a little higher.	
		Pr. 820	Decrease the value 10% by 10% until just before vibration/noise is not produced, and set about 0.8 to 0.9 of that value.
		Pr. 821	If an overshoot occurs, double the value until an overshoot does not occur, and set about 0.8 to 0.9 of that value.
3	Slow response	Set the Pr. 820 value a little higher.	
		Pr. 820	When a speed rise is slow, increase the value 5% by 5% until just before vibration/noise is produced, and set about 0.8 to 0.9 of that value.

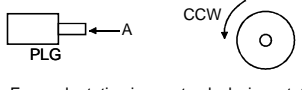
No.	Phenomenon/Condition	Adjustment Method
4	Long return time (response time)	Set the Pr. 821 value a little lower.
		Decrease the value by half until just before an overshoot or the unstable phenomenon does not occur, and set about 0.8 to 0.9 of that value.
5	Overshoot or unstable phenomenon occurs.	Set the Pr. 821 value a little higher.
		Double the value until just before an overshoot or the unstable phenomenon does not occur, and set about 0.8 to 0.9 of that value.

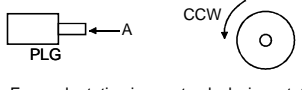
2.3.4 Troubleshooting

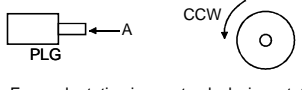
	Phenomenon	Cause	Corrective Action						
1	Motor does not rotate.	(1) The motor or PLG wiring is wrong.	<p>(1) Check the wiring. * Choose V/F control (Pr. 800 = 20) and check the rotation direction of the motor and the speed monitor output from the DA1 output terminal. For the FR-V5R, set "170V" for 3.7kW (5HP) or less and "160V" for more in Pr. 19 "base frequency voltage", and set "50Hz" in Pr. 3 "base frequency".</p> <p>When the forward rotation signal is input, the motor running in the counterclockwise direction as viewed from the motor shaft is normal. (If it runs in the clockwise direction, the phase sequence of the inverter secondary side wiring is incorrect.)</p>  <p>(2) Check the PLG specifications. Check the positions of the 5V/12V/24V/External and differential/complimentary jumper connectors.</p> <p>(3) Check that FWD is displayed when running the motor in the counter-clockwise direction from outside during a stop of the inverter. If REV is displayed, the PLG phase sequence is wrong. Perform the correct wiring or match the Pr. 852 "PLG rotation direction" setting.</p> <table border="1" style="width: 100%; border-collapse: collapse;"> <thead> <tr> <th style="width: 15%;">Pr. 852 Setting</th> <th style="width: 85%;">Relationship between the motor and PLG</th> </tr> </thead> <tbody> <tr> <td style="text-align: center;">0</td> <td>  <p>Forward rotation is clockwise rotation when viewed from A.</p> </td> </tr> <tr> <td style="text-align: center;">1 (factory setting)</td> <td>  <p>Forward rotation is counterclockwise rotation when viewed from A.</p> </td> </tr> </tbody> </table>	Pr. 852 Setting	Relationship between the motor and PLG	0	 <p>Forward rotation is clockwise rotation when viewed from A.</p>	1 (factory setting)	 <p>Forward rotation is counterclockwise rotation when viewed from A.</p>
		Pr. 852 Setting	Relationship between the motor and PLG						
0	 <p>Forward rotation is clockwise rotation when viewed from A.</p>								
1 (factory setting)	 <p>Forward rotation is counterclockwise rotation when viewed from A.</p>								
		(2) The PLG specifications (jumper connector setting) are wrong.							
		(3) The PLG wiring is wrong.							
		(4) The Pr. 851 "number of PLG pulses" setting and the number of PLG used are different.	(4) The motor will not run if the parameter setting is smaller than the number of PLG pulses used. Set Pr. 851 "number of PLG pulses" correctly.						
2	Motor does not run at correct speed. (Speed command does not match actual speed)	<p>(1) The speed command from the command device is incorrect. The speed command is compounded with noise.</p> <p>(2) The speed command value does not match the inverter-recognized value.</p> <p>(3) The number of PLG pulses setting is incorrect.</p>	<p>(1) Check that a correct speed command comes from the command device. Decrease the PWM carrier frequency in Pr. 72.</p> <p>(2) Readjust the speed command bias and gain in Pr. 902, Pr. 903, Pr. 917, and Pr. 918.</p> <p>(3) Check the setting of the number of PLG pulses in Pr. 851.</p>						

Fine adjustment of gains for speed control

	Phenomenon	Cause	Corrective Action
3	Speed does not rise to the speed command.	(1) Insufficient torque. Torque restriction is actuated. (2) Only P (proportional) control is selected.	(1)-1 Increase the torque restriction value. (Refer to the torque restriction of speed control in the Instruction Manual (basic).) (1)-2 Insufficient capacity (2) When the load is heavy, speed deviation will occur under P (proportional) control. Select PI control.
4	Motor speed is unstable.	(1) The speed command varies. (2) Insufficient torque. (3) The speed control gains do not match the machine. (machine resonance)	(1)-1 Check that a correct speed command comes from the command device. (Take measures against noises.) (1)-2 Decrease the PWM carrier frequency in Pr. 72. (1)-3 Increase the speed setting filter in Pr. 822. (2)-1 Increase the torque restriction value. (Refer to the torque restriction of speed control in the Instruction Manual (basic).) (2)-2 Return the excitation ratio in Pr. 854 to the factory setting (100%). (3)-1 Perform easy gain tuning. (3)-2 Adjust Pr. 820 and Pr. 821. (Refer to gain adjustment.) (3)-3 Perform speed feed forward control and model adaptive speed control.
5	Motor or machine hunts (vibration/noise is produced).	(1) The speed control gain is high. (2) High torque control gain.	(1)-1 Perform easy gain tuning. (1)-2 Decrease Pr. 820 and increase Pr. 821. (1)-3 Perform speed feed forward control and model adaptive speed control. (2) Decrease Pr. 824. (Refer to page 51.)
6	Acceleration/ deceleration time does not match the setting.	(1) Insufficient torque. (2) Large load inertia.	(1)-1 Increase the torque restriction value. (Refer to the torque restriction of speed control in the Instruction Manual (basic).) (1)-2 Return the excitation ratio in Pr. 854 to the factory setting. (1)-3 Perform speed feed forward control. (2) Set the acceleration/deceleration time that meets the load.
7	Machine operation is unstable	(1) The speed control gains do not match the machine. (2) Slow response because of improper acceleration/ deceleration time of the inverter.	(1)-1 Perform easy gain tuning. (1)-2 Adjust Pr. 820 and Pr. 821. (Refer to page 44.) (1)-3 Perform speed feed forward control and model adaptive speed control. (2) Change the acceleration/deceleration time to an optimum value.
8	Speed fluctuates at low speed.	(1) Adverse effect of high carrier frequency. (2) Adverse effect of weak excitation. (3) Low speed control gain.	(1) Decrease the PWM carrier frequency in Pr. 72. (2) Return the excitation ratio in Pr. 854 to the factory setting. (3) Increase Pr. 820 "speed control P gain".

Related parameter reference pages

- Pr. 71 "applied motor" (Refer to page 114.)
- Pr. 72 "PWM frequency selection" (Refer to page 115.)
- Pr. 800 "control system selection" (Refer to page 170.)
- Pr. 820 "speed control P gain 1" (Refer to page 175.)
- Pr. 821 "speed control integral time 1" (Refer to page 175.)
- Pr. 822 "speed setting filter 1" (Refer to page 175.)
- Pr. 851 "number of PLG pulses" (Refer to the Instruction Manual (basic).)
- Pr. 854 "excitation ratio" (Refer to page 181.)
- Pr. 902 "speed setting No. 2 bias" (Refer to page 190.)
- Pr. 903 "speed setting No. 2 gain" (Refer to page 190.)
- Pr. 917 "No.1 terminal bias (speed)" (Refer to page 190.)
- Pr. 918 "No.1 terminal gain (speed)" (Refer to page 190.)

2.3.5 Speed feed forward control, model adaptive speed control (Pr. 828, Pr. 877 to Pr. 881)

By making parameter setting, select the speed feed forward control or model adaptive speed control. The speed feed forward control enhances the trackability of the motor in response to a speed command change. The model adaptive speed control enables individual adjustment of speed trackability and motor disturbance torque response.

Parameter	Name	Factory Setting	Setting Range
828	Model speed control gain	60%	0 to 1000%
877	Speed feed forward control/model adaptive speed control selection	0	0,1,2
878	Speed feed forward filter	0s	0 to 1s
879	Speed feed forward torque restriction	150%	0 to 400%
880	Load inertia ratio	7	0,1 to 200 times
881	Speed feed forward gain	0%	0 to 1000%

POINT

When model adaptive speed gain is selected, the data obtained from easy gain tuning is used for Pr. 828 "model speed control proportional gain". Perform easy gain tuning also (simultaneously). (Refer to the Instruction Manual (basic).)

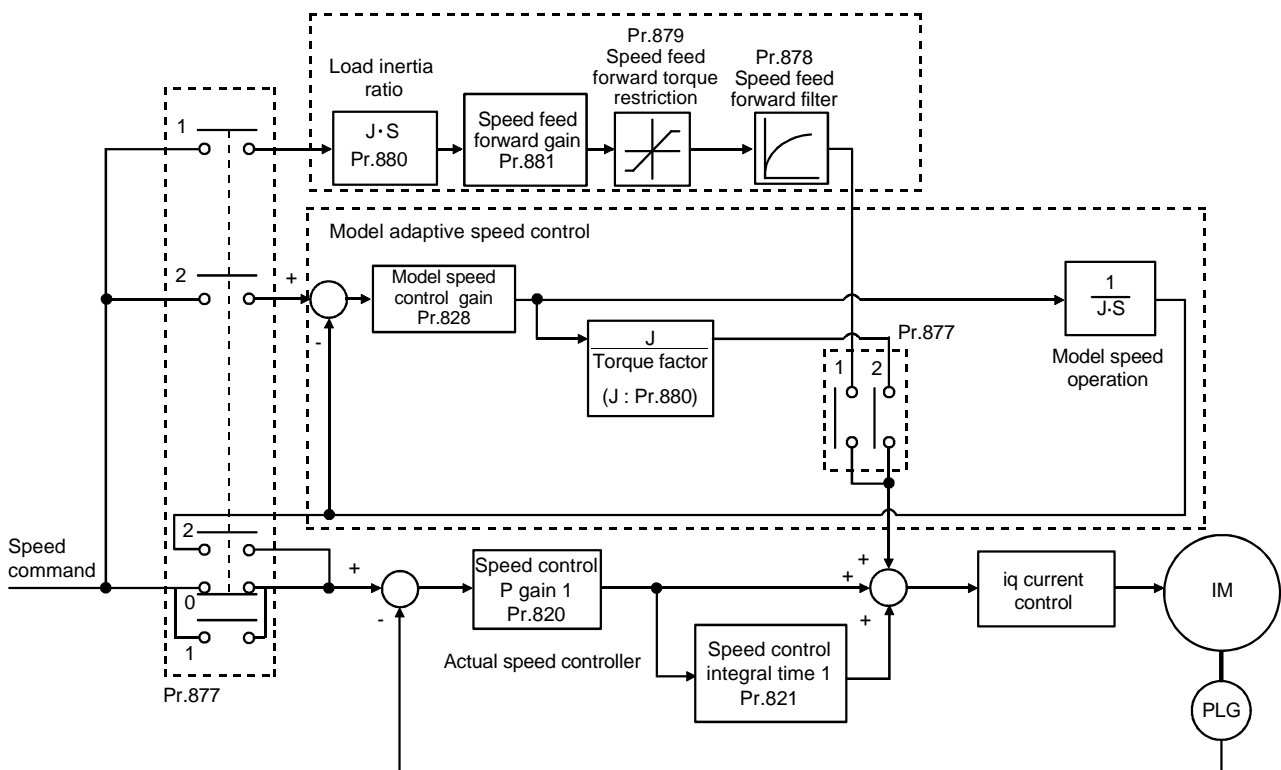

Fine adjustment of gains for speed control

Pr. 877 Setting	Description
0	Normal speed control is exercised.
1	Speed feed forward control is exercised. ① Calculate required torque in response to the acceleration/deceleration command for the inertia ratio set in Pr. 880 and generate torque immediately. ② When inertia ratio estimation has been made by easy gain tuning, the inertia ratio estimation result is used as the Pr. 880 setting, from which the speed feed forward is calculated. ③ When the speed feed forward gain is 100%, the calculation result of the speed feed forward in 1) is reflected as-is. ④ If the speed command changes suddenly, large torque is generated due to the speed feed forward calculation. The maximum value of the speed feed forward is restricted using Pr. 879. ⑤ Using Pr. 878, the speed feed forward result can be dulled by the primary delay filter.
2	Model adaptive speed control is enabled. • At this time, the motor's model speed is calculated to feed back the model side speed controller. This model speed is also used as the actual speed controller command. • The inertia ratio in Pr. 880 is used for calculation of the torque current command value given by the model side speed controller. When inertia ratio estimation has been made by easy gain tuning, Pr. 880 is overwritten by the inertia ratio estimation result, and that value is used to calculate the torque current command value. • The torque current command value of the model side speed controller is added to the output of the actual speed controller, and the result is used as the iq current control input. Pr. 828 is used for model side speed control (P control), and the first gain in Pr. 820 is used for the actual speed controller. The model adaptive speed control is valid for the first motor only. • When Pr. 877 = 2, switching to the second motor handles the second motor as Pr. 877 = 0.

CAUTION

The adequate gain value for the model and actual loop parts are set according to the response setting of easy gain tuning under model adaptive speed control. To increase the response level, Pr. 818 "response setting" needs to be changed (increased).

The following table indicates the relationships between the speed feed forward/model adaptive speed control and easy gain tuning function.

	Easy Gain Tuning Selection (Pr. 819) Setting		
	0	1	2
Load inertia ratio (Pr. 880)	Manual input	Inertia ratio estimation value found by easy gain tuning is displayed. Manual input enabled only during a stop.	Manual input
Model speed control gain (Pr. 828)	Manual input	Tuning results are displayed. Write disabled.	Tuning results are displayed. Write disabled.
Speed feed forward gain (Pr. 881)	Manual input	Manual input	Manual input

REMARKS

Calculate the inertia reference of the SF-V5R (H) using the inertia moment J on page 196.

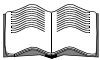

For details of easy gain tuning, refer to the Instruction Manual (basic) for details.

Related parameters

- Pr. 820 "speed control P gain 1" (Refer to page 175.)
- Pr. 821 "speed control integral time 1" (Refer to page 175.)
- Pr. 830 "speed control P gain 2" (Refer to page 175.)
- Pr. 831 "speed control integral time 2" (Refer to page 175.)

2.4 Torque control

2.4.1 Outline of torque control

The basics of torque control are explained in the Instruction Manual (basic).

Set any of "1 (torque control), 2 (speed-torque switchover), 5 (position-torque switchover)" in Pr. 800 "control system selection" to make torque control valid.
(The parameter is factory-set to enable speed control. Set "1" in Pr. 800 to make torque control valid.) (Refer to page 170.)

Set the motor. (Refer to the Instruction Manual (basic).)

Set the torque command. (No. 3 terminal)
When using the parameter or communication to input the torque command, refer to Pr. 804 "torque command right" (page 172).
When giving the torque command from the option (FR-A5NC, FR-V5AH, FR-A5AX, FR-V5AP), refer to the instruction manual of the corresponding option.

Set the speed restriction value. (Refer to the Instruction Manual (basic))

Test run

Set online auto tuning (adaptive magnetic flux observer) as required.

 Refer to the Instruction Manual (basic) for the details of connection diagram, test run, and online auto tuning.

2.5 Fine adjustment for torque control

Current loop gain parameter for adjusting torque control operation state is available with the FR-V500 series. Stable operation is possible with the factory-set parameter.

Refer to the next page and adjust the parameters when torque pulsation or any other unfavorable phenomenon occurs depending on the machine and operating conditions or when you want to exhibit the best performance that matches the machine.

2.5.1 Control block diagram

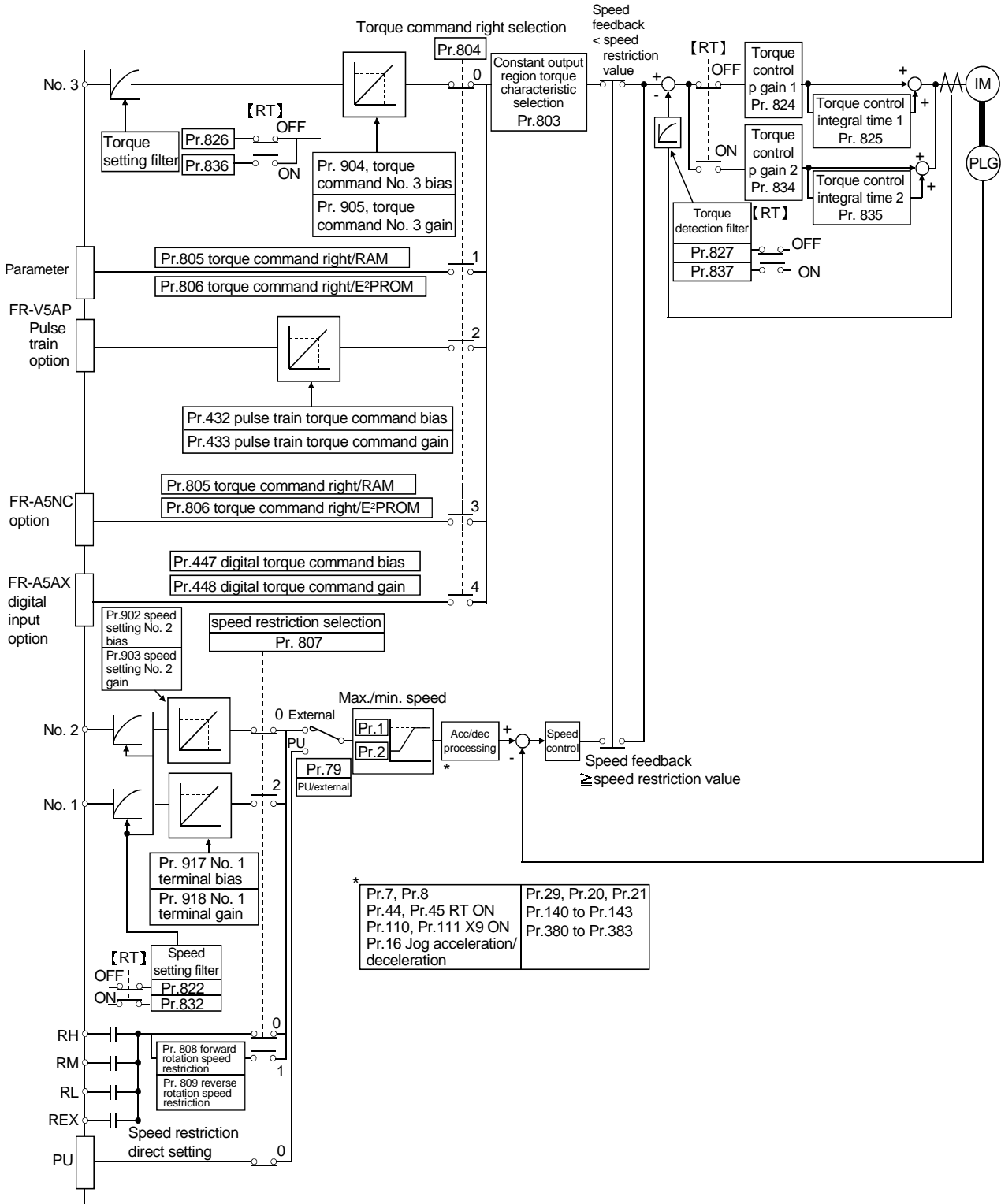

2.6 Gain adjustment for torque control

When exercising torque control, do not perform easy gain tuning. Easy gain tuning produces no effects. If torque accuracy is necessary, perform online auto tuning. (Refer to the Instruction Manual (basic).)

2.6.1 Concept of torque control gains

- (1) Torque control P gain 1
2000rad/s when Pr. 824 = 100% (factory setting).
- (2) Torque control integral time 1
Pr. 825 = 5ms (factory setting)

2.6.2 Gain adjustment procedure

Refer to the following table for manual input gain adjustment.

CAUTION

Normally, the current loop gains in Pr. 824 and Pr. 825 need not be changed. Fully note that unnecessarily changing the settings of the current loop gains will result in unstable phenomena and/or reduced response level.

● Manual input gain adjustment

Pr. 824 "torque control P gain 1", Pr. 834 "torque control P gain 2"
Pr. 825 "torque control integral time 1", Pr. 835 "torque control integral time 2"

Make adjustment when any of such phenomena as unusual machine vibration/noise and overcurrent has occurred.

- (1) First check the conditions and simultaneously change Pr. 824 "torque control P gain 1" value.
- (2) If you cannot make proper adjustment, change Pr. 825 "torque control integral time 1" value and repeat step (1).

CAUTION

Pr. 834 "torque control P gain 2" and Pr. 835 "torque control integral time 2" are made valid when the RT terminal is switched on. Make adjustments in the same way as Pr. 824 and Pr. 825.

No.	Phenomenon/Condition	Adjustment Method	
1	<ul style="list-style-type: none"> • Unusual noise generated from motor • Unusual current flowing 	Set Pr. 824 a little lower and Pr. 825 a little higher. First lower Pr. 824 and check the motor for unusual vibration/noise and overcurrent. If the problem still persists, increase Pr. 825.	
		Pr. 824	Decrease the value 10% by 10% until just before the phenomenon on the left is improved, and set about 0.8 to 0.9 of that value. Note that a too low value will produce current ripples, causing the motor to generate synchronous sound.
		Pr. 825	Double the value until just before the phenomenon on the left is improved, and set about 0.8 to 0.9 of that value. Note that a too high value will produce current ripples, causing the motor to generate synchronous sound.
2	Overcurrent occurs.	Set Pr. 824 a little lower and Pr. 825 a little higher. First lower Pr. 824 and check the motor for unusual vibration/noise and overcurrent. If the problem still persists, increase Pr. 825.	
		Pr. 824	Decrease the value 10% by 10% until just before an overcurrent does not occur, and set about 0.8 to 0.9 of that value.
		Pr. 825	Double the value until just before the phenomenon on the left is improved, and set about 0.8 to 0.9 of that value.

2.6.3 Troubleshooting

	Phenomenon	Cause	Corrective Action
1	Torque control is not exercised normally.	(1) The phase sequence of the motor or PLG wiring is wrong. (2) The control mode selection, Pr. 800, setting is improper. (3) The speed restriction value is not input. (4) The torque command varies. (5) Torque variation due to the change in the motor temperature. (6) The torque command does not match the inverter-recognized value.	(1) Check the wiring. (Refer to the Instruction Manual (basic).) (2) Check the Pr. 800 setting. (The factory setting is speed control) (3) Set the speed restriction value. (If the speed restriction value is not input, the motor will not rotate since the speed restriction value is regarded as 0r/min.) (4) Check that the command device gives a correct torque command. • Decrease the PWM carrier frequency in Pr. 72. • Increase the torque setting filter in Pr. 826. (5) Set the adaptive magnetic flux observer in Pr. 95. (6) Recalibrate the torque command bias and gain in Pr. 904 and Pr. 905.
2	When the torque command is small, the motor rotates in the direction opposite to the start signal.	The offset calibration of the torque command does not match.	Recalibrate the torque command bias in Pr. 904.
3	Normal torque control cannot be exercised during acceleration/deceleration. The motor vibrates.	Since the speed restriction value changes with the setting of the acceleration/deceleration time in Pr. 7, Pr. 8, the speed restriction may be activated. (When the speed restriction is activated, torque control cannot be exercised.)	Reduce the acceleration/deceleration time. Alternatively, set the acceleration/deceleration time to 0. (Speed restriction during acceleration/deceleration is speed restriction during constant speed)
4	Output torque is not linear in response to the torque command.	Insufficient torque.	Return the excitation ratio to the factory setting.

Related parameter reference pages

- Pr. 7 "acceleration time" (Refer to page 83.)
- Pr. 8 "deceleration time" (Refer to page 83.)
- Pr. 800 "control system selection" (Refer to page 170.)
- Pr. 802 "pre-excitation selection" (Refer to page 87.)
- Pr. 810 "torque restriction input method selection" (Refer to page 91.)
- Pr. 826 "torque setting filter 1" (Refer to page 176.)
- Pr. 904 "torque command No. 3 bias" (Refer to page 190.)
- Pr. 905 "torque command No. 3 gain" (Refer to page 190.)

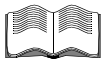

For online auto tuning, refer to the Instruction Manual (basic)

2.7 Conditional position control (Pr. 419 to Pr. 430, Pr. 464 to Pr. 494)

2.7.1 Connection diagram

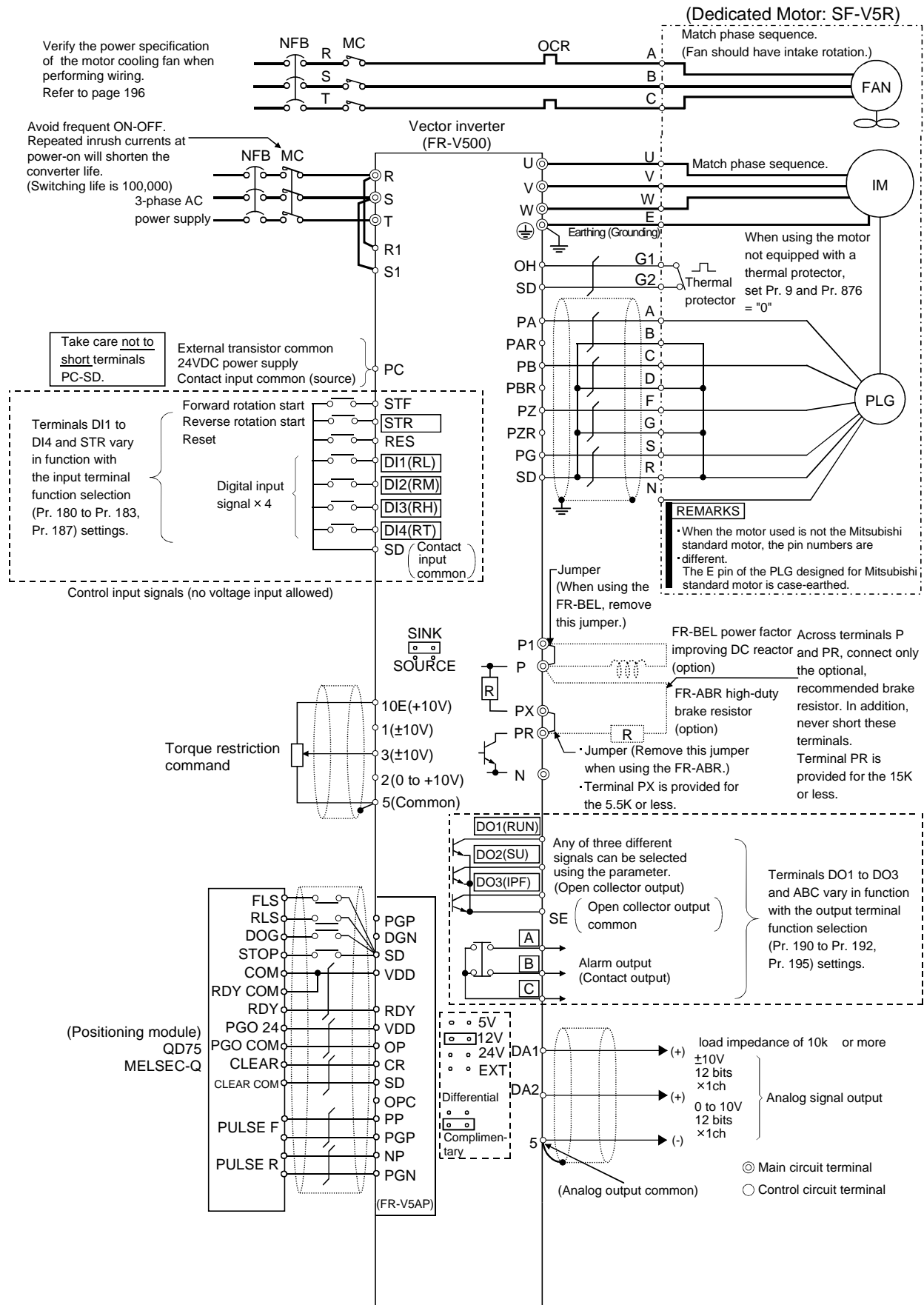

Conditional position control (Pr. 419 to Pr. 430, Pr. 464 to Pr. 494)

CAUTION

1. *: The setting of the PLG power supply jumper connector and output circuit connector when shipped from the factory.

	Japanese Version	NA Version
PLG power supply jumper connector	12V	5V
Output circuit jumper connector	Complimentary (CMP)	Differential line driver (LDV)

This inverter is allowed to perform position control by setting conditional position feed by contact input or the position control option (FR-V5AP). And the position loop gain that adjusts this position control status is provided for the inverter. It is not used independently but is used with the speed loop parameter to determine the value. Therefore, first adjust the speed loop gain and then adjust the position loop gain parameter.

2.7.2 Control block diagram

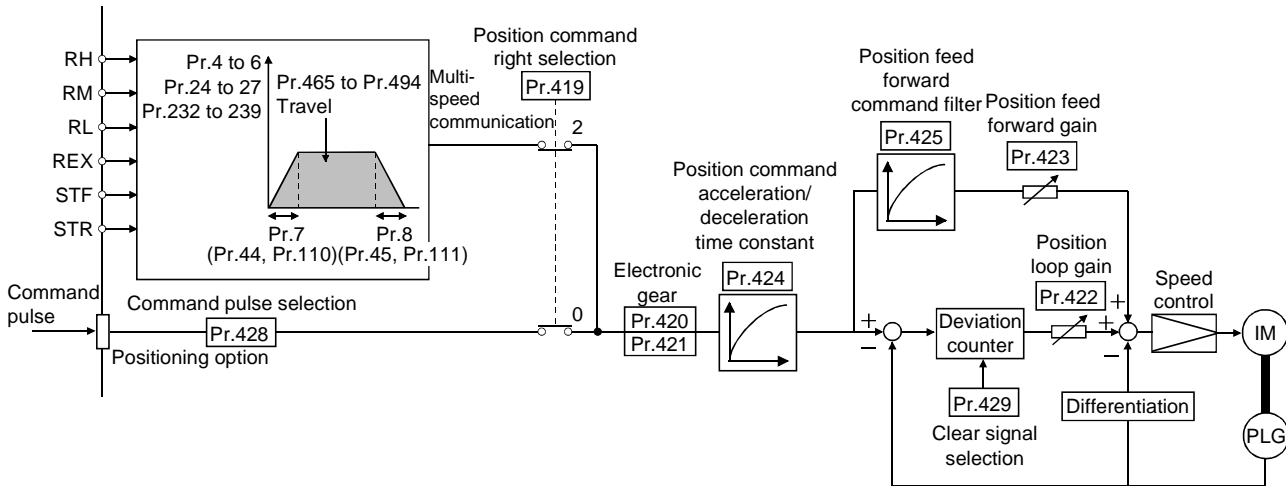

2.7.3 Parameter

Set the following parameters when exercising position control with the inverter.

Parameter	Name	Factory Setting	Setting Range	Description
419	Position command right selection	0	0, 1	Set position command input.
420	Command pulse scaling factor numerator	1	0 to 32767	Set the electronic gear.
421	Command pulse scaling factor denominator	1	0 to 32767	
422	Position loop gain	25	0 to 150s ⁻¹	Set the gain of the position loop.
423	Position feed forward gain	0%	0 to 100%	Function to cancel a delay caused by the droop pulses of the deviation counter.
424	Position command acceleration/ deceleration time constant	0s	0 to 50s	
425	Position feed forward command filter	0s	0 to 5s	Enter the primary delay filter in response to the feed forward command.
426	In-position width	100 pulses	0 to 32767 pulses	The in-position signal turns on when the droop pulses become less than the setting.
427	Excessive level error	40K	0 to 400K, 9999	An error becomes excessive when the droop pulses exceed the setting.
430	Pulse monitor selection	9999	0 to 5, 9999	Display the number of pulses.
464	Digital position control sudden stop deceleration time	0	0 to 360.0s	

1) Position command right selection (Pr. 419)

Pr. 419 Setting	Description
0 (factory setting)	Conditional position control function by contact input. (using parameters)
1	Position command by pulse train input (when the FR-V5AP is fitted). (Refer to the instruction manual of the option for details.)

2) Operation

The speed command given to rotate the motor is calculated to zero the difference between the number of internal command pulse train pulses (when Pr. 419=0, the number of pulses set by parameter (Pr. 465 to Pr. 494) is changed to the command pulses in the inverter) and the number of pulses fed back from the motor end PLG.

- 1) When a pulse train is input, pulses are accumulated in the deviation counter and these droop pulses act as position control pulses to give the speed command.
- 2) As soon as the motor starts running under the speed command of the inverter, the encoder generates feed back pulses and the droop of the deviation counter is counted down. The deviation counter maintains a given droop pulse value to keep the motor running.
- 3) When the command pulse input stops, the droop pulses of the deviation counter decrease, reducing the speed. The motor stops when there are no droop pulses.
- 4) When the number of droop pulses has fallen below the value set in Pr.426 (in-position width), it is regarded as completion of positioning and the in-position signal (Y36) turns on.

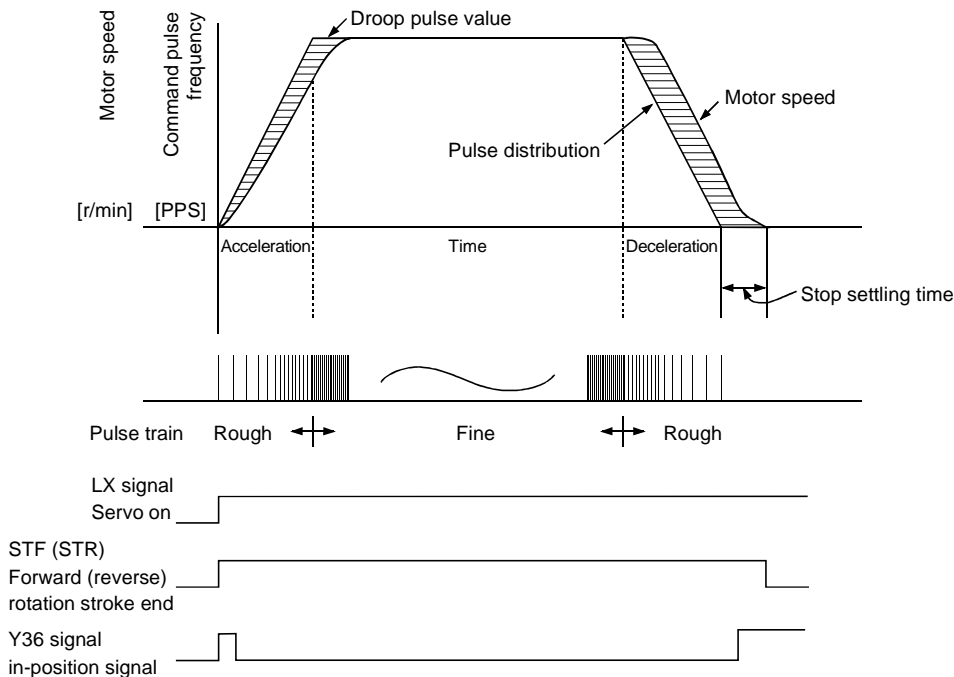

- For conditional position control function by contact input, the STF and STR terminals provide the forward (reverse) command signal. The motor can run only in the direction where the forward (reverse) signal is on.
- Opening STF-SD disables the forward rotation, and opening STR-SD disables the reverse rotation.
- The pulse train is rough during acceleration and fine at the maximum speed. During deceleration the pulse train is rough and at last there are no pulses. The motor stops shortly after the command pulses stop. This time lag is necessary for maintaining the stop accuracy and called stop setting time.

Related parameters

- Servo on (LX) signal ⇒ Set "23" in any of Pr. 180 to Pr. 183 and Pr. 187 (input terminal function selection). (Refer to page 151.)
- In-position signal (Y36) ⇒ Set "36" in any of Pr.190 to Pr.192 and Pr.195 (output terminal function selection). (Refer to page 153.)

Conditional position control (Pr. 419 to Pr. 430, Pr. 464 to Pr. 494)

2.7.4 Conditional position feed function by contact input (Pr. 419=0)

Inputting the number of pulses (positions) in the parameters and setting multi-speed and forward (reverse) commands enable position control during servo operation. This position feed function does not return to the home position.

1) Setting position command using parameters

Set position command using any two of Pr. 465 to Pr. 494 (position feed amount).
Resolution of encoder × speed × 4



(When stopping the motor after 100 rotations using the FR-V5R)
2048 (pulse/rev) × 100 (speed) × 4 = 819200 (feed amount)

Setting the first amount 819200

Pr. 466 (upper digits)= Pr. 465 (lower digits)= (decimal numeration)

<Position feed data setting parameters>

- Factory setting : 0
- Setting range : 0 to 9999
- Minimum setting range : 1

Parameter	Name	Selection Method				Position Feed Speed	
		REX	RH	RM	RL		
465	First position feed amount	(lower digits)	OFF	ON	OFF	OFF	High speed, Pr. 4
466		(upper digits)					
467	Second position feed amount	(lower digits)	OFF	OFF	ON	OFF	Middle speed, Pr. 5
468		(upper digits)					
469	Third position feed amount	(lower digits)	OFF	OFF	OFF	ON	Low speed, Pr. 6
470		(upper digits)					
471	Fourth position feed amount	(lower digits)	OFF	OFF	ON	ON	Speed 4, Pr. 24
472		(upper digits)					
473	Fifth position feed amount	(lower digits)	OFF	ON	OFF	ON	Speed 5, Pr. 25
474		(upper digits)					
475	Sixth position feed amount	(lower digits)	OFF	ON	ON	OFF	Speed 6, Pr. 26
476		(upper digits)					
477	Seventh position feed amount	(lower digits)	OFF	ON	ON	ON	Speed 7, Pr. 27
478		(upper digits)					
479	Eighth position feed amount	(lower digits)	ON	OFF	OFF	OFF	Speed 8, Pr. 232
480		(upper digits)					
481	Ninth position feed amount	(lower digits)	ON	OFF	OFF	ON	Speed 9, Pr. 233
482		(upper digits)					
483	Tenth position feed amount	(lower digits)	ON	OFF	ON	OFF	Speed 10, Pr. 234
484		(upper digits)					
485	Eleventh position feed amount	(lower digits)	ON	OFF	ON	ON	Speed 11, Pr. 235
486		(upper digits)					
487	Twelfth position feed amount	(lower digits)	ON	ON	OFF	OFF	Speed 12, Pr. 236
488		(upper digits)					
489	Thirteenth position feed amount	(lower digits)	ON	ON	OFF	ON	Speed 13, Pr. 237
490		(upper digits)					
491	Fourteenth position feed amount	(lower digits)	ON	ON	ON	OFF	Speed 14, Pr. 238
492		(upper digits)					
493	Fifteenth position feed amount	(lower digits)	ON	ON	ON	ON	Speed 15, Pr. 239
494		(upper digits)					

2) Operation by position command using parameters

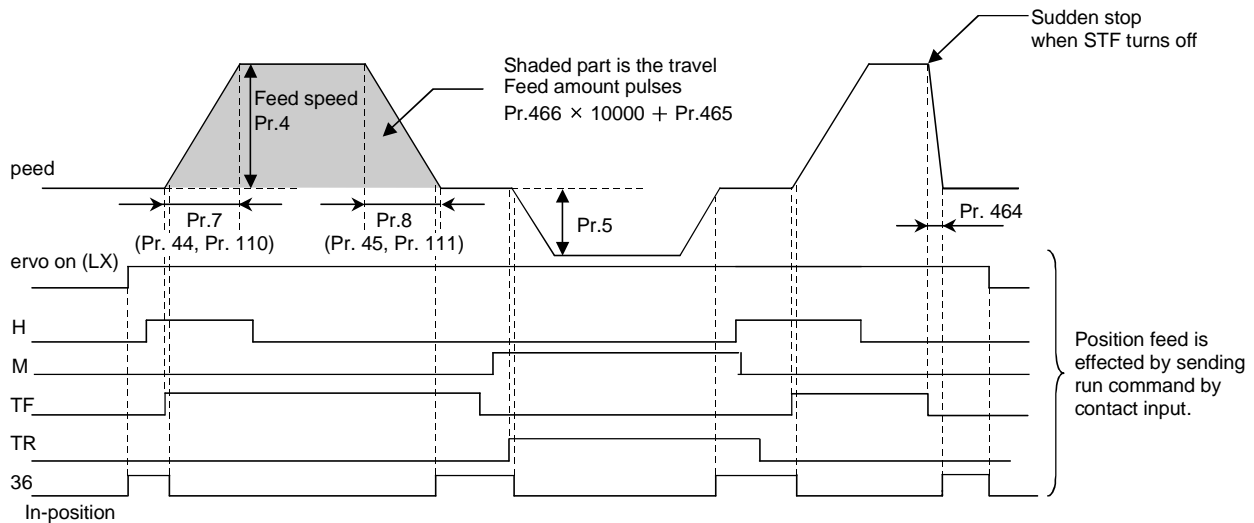

- Acceleration/deceleration time is 0.1s minimum and 360s maximum.
- Acceleration/deceleration reference speed (Pr. 20) is clamped at a minimum of 500r/min.
- Deceleration time can be set in Pr. 464 "digital position control sudden stop deceleration time".
- At this time, the acceleration/deceleration patterns are all linear acceleration and the setting of Pr. 29 "acceleration/deceleration pattern" is invalid. (Refer to page 93 for Pr. 29.)

CAUTION

Information on multi-speed command (position command) is determined at rising of the forward (reverse) command to perform position control. Therefore, set forward (reverse) command after multi-speed command (position command). Position feed is invalid if the multi-speed command is given after forward (reverse) command.

2.7.5 Setting the electronic gear

Adjust the ratio of the machine side gear and the motor side gear.

The position resolution (travel per pulse Δl [mm]) is determined by the travel per motor revolution Δs [mm] and the feedback pulses Pf [pulse/rev] of the detector, and is represented by the following expression.

$$\Delta l = \frac{\Delta s}{Pf}$$

Δl : Travel per pulse [mm]
 Δs : Travel per motor revolution [mm]
 Pf: Number of feedback pulses [pulse/rev]
 (the number of pulses after multiplying the number of PLG pulses by 4)

Using the parameters, the travel per command pulse can be set separately to set the travel per command pulse without a fraction.

$$\Delta l = \frac{\Delta s}{Pf} \times \frac{Pr. 420}{Pr. 421}$$

The relationship between the motor speed and internal command pulse frequency is as follows.

$$fo \times \frac{Pr. 420}{Pr. 421} = Pf \times \frac{No}{60}$$

fo : Internal command pulse frequency [pps]
 No : Motor speed [r/min]

CAUTION

Set the electronic gear in the range of 1/50 to 20.

"Setting example 1"

The travel per pulse is $\Delta \ell = 0.01$ (mm) in a drive system where the ballscrew pitch $PB = 10$ (mm) and the reduction ratio $1/n = 1$ and the electronic gear ratio is $\Delta s = 10$ (mm) when the number of feedback pulses $Pf = 4000$ (pulse/rev). According to the following expression,

$$\begin{aligned} \Delta \ell &= \frac{\Delta s}{Pf} \times \frac{\text{Pr. 420}}{\text{Pr. 421}} \\ \frac{\text{Pr. 420}}{\text{Pr. 421}} &= \Delta \ell \times \frac{Pf}{\Delta s} \\ &= 0.01 \times \frac{4000}{10} = \frac{4}{1} \end{aligned}$$

Therefore, set "4" in Pr. 420 and "1" in Pr. 421.

"Setting example 2"

Find the internal command pulse frequency of the Mitsubishi dedicated motor rated speed. Note that the command pulse scaling factor $\text{Pr. 420}/\text{Pr. 421} = 1$.

Assuming that the number of PLG pulses is 2048 (pulses/rev) (feedback pulse $Pf = 2048 \times 4$),

$$\begin{aligned} f_o &= 2048 \times \frac{N_o}{60} \times \frac{\text{Pr. 421}}{\text{Pr. 420}} \times 4 \\ &= 204800 \end{aligned}$$

Therefore, the internal command pulse frequency is 204800 (pps).

<Relationship between position resolution $\Delta \ell$ and overall accuracy>

Since overall accuracy (positioning accuracy of machine) is the sum of electrical error and mechanical error, normally take measures to prevent the electrical system error from affecting the overall error. As a guideline, refer to the following relationship.

$$\Delta \ell < \left(\frac{1}{5} \text{ to } \frac{1}{10} \right) \times \Delta \varepsilon \quad \Delta \varepsilon : \text{Positioning accuracy}$$

<Stopping characteristic of motor>

When parameters are used to run the motor, the command pulse frequency and motor speed have the relationship as shown in the chart on page 55, and as the motor speed decreases, pulses are accumulated in the deviation counter of the inverter. These pulses are called droop pulses (ε) and the relationship between command frequency (f_o) and position loop gain (K_p : Pr. 422) is as represented by the following expression.

$$\varepsilon = \frac{f_o}{K_p} \text{ [pulse]} \quad \varepsilon = \frac{204800}{25} \text{ [pulse]} \quad (\text{motor rated speed})$$

When the factory setting of K_p is $25s^{-1}$, the droop pulses (ε) are 8192 pulses.

Since the inverter has droop pulses during running, a stop settling time (t_s) is needed from when the command has zeroed until the motor stops. Set the operation pattern in consideration of the stop settling time.

$$t_s = 3 \times \frac{1}{K_p} \text{ [s]}$$

When the factory setting of K_p is $25s^{-1}$, the stop settling time (t_s) is 0.12s.

The positioning accuracy $\Delta \varepsilon$ is $(5 \text{ to } 10) \times \Delta \ell = \Delta \varepsilon$ [mm]

● Position command acceleration/deceleration time constant (Pr. 424)

- 1) When the electronic gear ratio is large (about 10 or more times) and the speed is low, rotation will not be smooth, resulting in pulse-wise rotation. At such a time, set this parameter to smooth the rotation.
- 2) When acceleration/deceleration time cannot be provided for the command pulses, a sudden change in command pulse frequency may cause an overshoot or error excess alarm. At such a time, set this parameter to provide acceleration/deceleration time. Normally set 0.

2.7.6 In-position width (Pr. 426)

The Y36 terminal signal acts as an in-position signal. The in-position signal turns on when the number of droop pulses becomes less than the setting.

2.7.7 Excessive level error (Pr. 427)

An error becomes excessive when the droop pulses exceed the setting.
When you decreased the position loop gain (Pr. 422) setting, increase the error excessive level setting.
Also decrease the setting when you want to detect an error slightly earlier under large load.
When Pr. 472="9999", an excessive position error (E.OD) is not output regardless of the droop pulses.

2.7.8 Pulse monitor selection (Pr. 430)

The states of various pulses during operation are displayed in terms of the number of pulses instead of the speed monitor output.

Pr. 430	Description	Display Range (FR-DU04-1)	Display Range (FR-PU04V)
0	The cumulative command pulse value is displayed.	Lower 4 digits	Lower 5 digits
1		Upper 4 digits	Upper 5 digits
2	The cumulative feedback pulse value is displayed.	Lower 4 digits	Lower 5 digits
3		Upper 4 digits	Upper 5 digits
4	The droop pulses are monitored.	Lower 4 digits	Lower 5 digits
5		Upper 4 digits	Upper 5 digits
9999	The frequency monitor is displayed. (factory setting)		

REMARKS

- Count the number of pulses when the servo is on.
- The cumulative pulse value is cleared when the base is shut off or the clear signal is turned on.

2.7.9 Concept of position control gains

Easy gain tuning is available as an easy tuning method. For easy gain tuning, refer to the Instruction Manual (basic). If it does not produce any effect, make fine adjustment by using the following parameters. Set "0" in Pr. 819 "easy gain tuning" before setting the parameters below.

- Pr. 422 "position loop gain" (factory setting $25s^{-1}$)
Make adjustment when any of such phenomena as unusual vibration, noise and overcurrent of the motor/machine occurs.
Increasing the setting improves trackability for the position command and also improves servo rigidity at a stop, but oppositely makes an overshoot and vibration more liable to occur. Normally set this parameter within the range about 5 to 50.

No.	Phenomenon/Condition	Adjustment Method	
1	Slow response	Increase the Pr. 422 value.	
		Pr. 422	Increase the value $3s^{-1}$ by $3s^{-1}$ until just before an overshoot, stop-time vibration or other instable phenomenon occurs, and set about 0.8 to 0.9 of that value.
2	Overshoot, stop-time vibration or other instable phenomenon occurs.	Decrease the Pr. 422 value.	
		Pr. 824	Decrease the value $3s^{-1}$ by $3s^{-1}$ until just before an overshoot, stop-time vibration or other instable phenomenon occurs, and set about 0.8 to 0.9 of that value.

- Pr. 423 "position feed forward gain" (factory setting 0)
This function is designed to cancel a delay caused by the droop pulses of the deviation counter.
When a tracking delay for command pulses poses a problem, increase the setting gradually and use this parameter within the range where an overshoot or vibration will not occur.
This function has no effects on servo rigidity at a stop.
Normally set this parameter to 0.

Conditional position control (Pr. 419 to Pr. 430, Pr. 464 to Pr. 494)

3) Changes in terminal functions by control mode switchover of terminals

The table below lists terminal functions according to control mode

Classification	Terminal Name	Description		
		Position Control	Speed Control/Position Control Switchover (MC:ON/OFF)	Position Control/Torque Control Switchover (MC:ON/OFF)
Contact input signal	STF	Forward rotation command *	Forward rotation command	Forward rotation command
	STR	Reverse rotation command *	Reverse rotation command	Reverse rotation command
	DI1	←	←	←
	DI2	←	←	←
	DI3	←	←	←
	DI4	←	←	←
Contact output	ABC	←	←	←
Open collector output	DO1	←	←	←
	DO2	←	←	←
	DO3	←	←	←
Analog input	2	Invalid	Speed command/invalid	Invalid/speed command
	1	Invalid	Speed command/invalid	Invalid/speed command
	3	Torque restriction input	←	Torque restriction/torque command
Analog output	DA1	←	←	←
	DA2	←	←	←

REMARKS

* When exercising position control by pulse train (Pr. 419 = 1, using the FR-V5AP), the STF acts as forward rotation stroke end signal and the STR acts as the reverse rotation stroke end signal. (Refer to the instruction manual of the FR-V5AP for details.)

Related parameters

- DI1 to DI4, STF terminal function selection⇒Pr.180 to Pr.183, Pr.187 (input terminal function selection) (Refer to page 151.)
- DO1 to DO3, ABC terminal function selection⇒Pr.190 to Pr.192, Pr.195 (output terminal function selection) (Refer to page 153.)
- No.1 terminal function selection⇒Pr.868 "No. 1 terminal function assignment". (Refer to page 183.)
- Bias/gain adjustment of No.1, 2, 3 terminals⇒Pr.902 to Pr.905, Pr.917, Pr.918 (bias/gain adjustment) (Refer to page 190.)
- DA1, DA2 terminal function selection⇒Pr.54, Pr.158 (DA1, DA2 function selection) (Refer to page 101.)
- DA1, DA2 terminal calibration⇒Pr.900, Pr.901 (DA1, DA2 terminal calibration) (Refer to page 188.)
- MC signal terminal assignment⇒Set "26" in any two of terminals DI1 to DI4 or STF using Pr.180 to Pr. 183 or Pr.187 (input terminal function selection) (Refer to page 151.)

2.7.10 Troubleshooting

	Phenomenon	Cause	Corrective Action
1	Motor does not rotate.	(1) The phase sequence of the motor or PLG wiring is wrong. (2) The control mode selection, Pr. 800, setting is improper. (3) The servo on signal or start signal (STF, STR) is not input. (4) The command pulses are not input correctly. (FR-V5AP) (5) The position command right selection, Pr. 419, setting is not correct. (6) When the position command right selection, Pr. 419, setting is 0, the position feed amount, Pr. 465 to Pr. 494, settings are not correct.	(1) Check the wiring. (Refer to page 53) (2) Check the Pr. 800 setting. (Factory setting is speed control) (3) Check that the signals are input normally. (4)-1 Check that the command pulses are input normally. (Check the cumulative command pulse value in Pr. 430.) (4)-2 Check the command pulse form and command pulse selection, Pr. 428, setting. (5) Check the position command right selection in Pr. 419. (6) Check the position feed amounts in Pr. 465 to Pr. 494.
2	Position shift occurs.	(1) The command pulses are not input correctly. (2) The command is affected by noise or the PLG feedback is compounded with noise.	(1)-1 Check the command pulse form and command pulse selection, Pr. 428, setting. (1)-2 Check that the command pulses are input normally. (Check the cumulative command pulse value in Pr. 430.) (2)-1 Decrease the PWM carrier frequency in Pr. 72. (2)-2 Change the shielded cable earthing (grounding) place or raise the cable.
3	Motor or machine hunts.	(1) The position loop gain is high. (2) The speed loop gain is high.	(1) Decrease Pr. 422. (2)-1 Perform easy gain tuning. (2)-2 Decrease Pr. 820 and increase Pr. 821.
4	Machine operation is unstable.	(1) The acceleration/deceleration time setting has adverse effect.	(1) Decrease Pr. 7 and Pr. 8.

Related parameter reference pages

- Pr. 800 "control system selection" (Refer to page 170.)
- Pr. 802 "pre-excitation selection" (Refer to page 87.)
- Pr. 820 "speed control P gain 1" (Refer to page 175.)
- Pr. 7 "acceleration time" (Refer to page 83.)
- Pr. 8 "deceleration time" (Refer to page 83.)
- Pr. 72 "PWM frequency selection" (Refer to page 115.)
- Pr. 821 "speed control integral time 1" (Refer to page 175.)

2.7.11 Position control is not exercised normally

(1) Position control

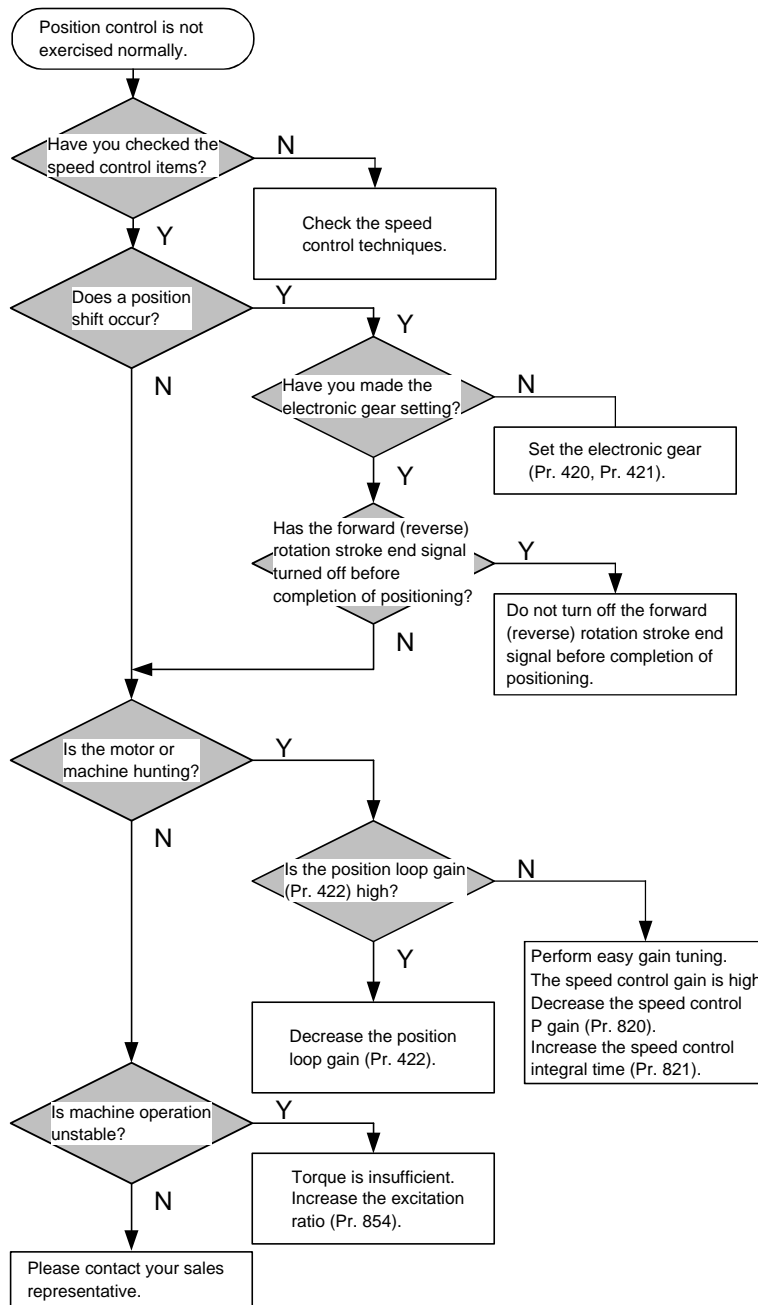

REMARKS

The speed command of position control relates to speed control. Refer to the Instruction Manual (basic) for details.

3

PARAMETERS

This chapter explains the "parameters" for use of this product.

Always read the instructions and other information before using the equipment.

The following marks indicate availability of parameters under each control.

speed : Available under speed control

torque : Available under torque control

position : Available under position control

position : Available under position control by parameter settings

1

2

3

4

3.1 Parameter lists (Japanese version)

The inverter is factory-set to display only the simple mode parameters.
Set Pr. 160 "extended function selection" as required.

Parameter	Name	Factory Setting	Setting Range	Remarks
160	Extended function selection	0	0	Accessible to only the simple mode parameters.
			1	Accessible to all parameters.

CAUTION

- The blacked out parameters in the table below indicate simple mode parameters.
- The shaded parameters in the table allow its setting to be changed during operation even if "0" (factory setting) is set in Pr. 77 (parameter write disable selection).
- *: Accessible when Pr. 77 = 801.

Function	Parameter No.	Name	Setting Range	Minimum Setting Increments	Factory Setting	Refer To	Customer Setting
Basic functions	0	Torque boost (manual)	0 to 30%	0.1%	4%/3%/2% (3.7K or less/ 5.5K, 7.5K/ 11K or more)	81	
	1	Maximum speed	0 to 3600r/min	1r/min	1500r/min	81	
	2	Minimum speed	0 to 3600r/min	1r/min	0r/min	81	
	3	Base frequency	20 to 200Hz	0.01Hz	60Hz	82	
	4	Multi-speed setting (high speed)	0 to 3600r/min	1r/min	1500r/min	82	
	5	Multi-speed setting (middle speed)	0 to 3600r/min	1r/min	750r/min	82	
	6	Multi-speed setting (low speed)	0 to 3600r/min	1r/min	150r/min	82	
	7	Acceleration time	0 to 3600s/0 to 360s	0.1s/0.01s	5s/15s (1.5K to 5.5K /7.5K to 55K)	83	
	8	Deceleration time	0 to 3600s/0 to 360s	0.1s/0.01s	5s/15s (1.5K to 5.5K /7.5K to 55K)	83	
Standard operation functions	9	Electronic thermal O/L relay	0 to 500A	0.01A	0A	85	
	10	DC injection brake operation speed	0 to 1500r/min, 9999	0.1r/min	15r/min	87	
	11	DC injection brake operation time	0 to 0.5s	0.1s	0.5s	87	
	12	DC injection brake voltage	0 to 30%	0.1%	4%/2% (7.5K or less/ 11K or more)	87	
	13	Starting speed	0 to 1500r/min	0.1r/min	15r/min	88	
	15	Jog speed setting	0 to 1500r/min	0.1r/min	150r/min	89	
Operation selection functions	16	Jog acceleration/deceleration time	0 to 3600s/0 to 360s	0.1s/0.01s	0.5s	89	
	17	MRS input selection	0, 2	1	0	90	
	19	Base frequency voltage	0 to 1000V, 8888, 9999	0.1V	9999	82	
	20	Acceleration/deceleration reference speed	1 to 3600r/min	1r/min	1500r/min	83	
	21	Acceleration/deceleration time increments	0, 1	1	0	83	
	22	Torque restriction level	0 to 400%	0.1%	150%	91	
	24	Multi-speed setting (speed 4)	0 to 3600r/min, 9999	1r/min	9999	82	
	25	Multi-speed setting (speed 5)	0 to 3600r/min, 9999	1r/min	9999	82	
	26	Multi-speed setting (speed 6)	0 to 3600r/min, 9999	1r/min	9999	82	
	27	Multi-speed setting (speed 7)	0 to 3600r/min, 9999	1r/min	9999	82	
	28	Multi-speed input compensation	0, 1	1	0	92	
	29	Acceleration/deceleration pattern	0, 1, 2, 3, 4	1	0	93	
	30	Regenerative function selection	0, 1, 2	1	0	96	
	31	Speed jump 1A	0 to 3600r/min, 9999	1r/min	9999	97	
32	Speed jump 1B	0 to 3600r/min, 9999	1r/min	9999	97		

Function	Parameter No.	Name	Setting Range	Minimum Setting Increments	Factory Setting	Refer To	Customer Setting
Operation selection functions	33	Speed jump 2A	0 to 3600r/min, 9999	1r/min	9999	97	
	34	Speed jump 2B	0 to 3600r/min, 9999	1r/min	9999	97	
	35	Speed jump 3A	0 to 3600r/min, 9999	1r/min	9999	97	
	36	Speed jump 3B	0 to 3600r/min, 9999	1r/min	9999	97	
	37	Speed display	0, 1 to 9998	1	0	97	
Output terminal functions	41	Up-to-speed sensitivity	0 to 100%	0.1%	10%	99	
	42	Speed detection	0 to 3600r/min	1r/min	300r/min	99	
	43	Speed detection for reverse rotation	0 to 3600r/min, 9999	1r/min	9999	99	
Second functions	44	Second acceleration/deceleration time	0 to 3600s/0 to 360s	0.1s/0.01s	5s	83	
	45	Second deceleration time	0 to 3600s/0 to 360s, 9999	0.1s/0.01s	9999	83	
Output terminal function	50	Second speed detection	0 to 3600r/min	1r/min	750r/min	99	
Display functions	52	DU/PU main display data selection	0, 5 to 12, 17 to 20, 23, 24, 32 to 35, 38, 100	1	0	101	
	53	PU level display data selection	0 to 3, 5 to 12, 17, 18	1	1	101	
	54	DA1 terminal function selection	1 to 3, 5 to 12, 17, 18, 21, 32 to 34, 36	1	1	101	
	55	Speed monitoring reference	0 to 3600r/min	1r/min		104	
	56	Current monitoring reference	0 to 500A	0.01A	Inverter rated output current	104	
Automatic restart	57	Restart coasting time	0, 0.1 to 5s, 9999	0.1s	9999	105	
	58	Restart cushion time	0 to 60s	0.1s	1.0s	105	
Additional function	59	Remote setting function selection	0, 1, 2, 3	1	0	107	
Operation selection functions	60	Intelligent mode selection	0, 7, 8	1	0	109	
	65	Retry selection	0 to 5	1	0	112	
	67	Number of retries at alarm occurrence	0 to 10, 101 to 110	1	0	112	
	68	Retry waiting time	0 to 10s	0.1s	1s	112	
	69	Retry count display erasure	0	1	0	112	
	70	Special regenerative brake duty	0 to 15%/0 to 30%	0.1%	0%	96	
	71	Applied motor	0, 3 to 8, 10, 13 to 18, 20, 23, 24, 30, 33, 34	1	30	114	
	72	PWM frequency selection	1 to 6	1	1	115	
	73	Speed setting signal	0, 4, 10, 14	1	0	116	
	75	Reset selection/disconnected PU detection/PU stop selection	0 to 3, 14 to 17	1	14	118	
	77	Parameter write disable selection	0, 1, 2	1	0	119	
	78	Reverse rotation prevention selection	0, 1, 2	1	0	120	
79	Operation mode selection	0 to 4, 6 to 8	1	0	120		
Motor constants	80	Motor capacity	0.4 to 55kW	0.01kW	Inverter capacity	123	
	81	Number of motor poles	2, 4, 6	1	4	123	
	82	Motor excitation current (no load current) *	0 to , 9999		9999	127	
	83	Rated motor voltage	0 to 1000V	0.1V	200V (200V class) / 400V (400V class)	123	
	84	Rated motor frequency	20 to 200Hz	0.01Hz	60Hz	123	
	90	Motor constant R1 *	0 to , 9999		9999	127	
	91	Motor constant R2 *	0 to , 9999		9999	127	
	92	Motor constant L1 *	0 to , 9999		9999	127	
	93	Motor constant L2 *	0 to , 9999		9999	127	
	94	Motor constant X *	0 to , 9999		9999	127	
Third functions	95	Online auto tuning selection	0, 1, 2	1	0	128	
	96	Auto tuning setting/status	0, 1, 101	1	0	123	
Third functions	110	Third acceleration/deceleration time	0 to 3600/0 to 360s	0.1s/0.01s	5s	83	
	111	Third deceleration time	0 to 3600/0 to 360s, 9999	0.1s/0.01s	9999	83	

Parameter lists (Japanese version)

Function	Parameter No.	Name	Setting Range	Minimum Setting Increments	Factory Setting	Refer To	Customer Setting	
Output terminal function	116	Third speed detection	0 to 3600r/min	1r/min	1500r/min	99		
Communication functions	117	Station number	0 to 31	1	0	130		
	118	Communication speed	48, 96, 192	1	192	130		
	119	Stop bit length/data length	0, 1, 10, 11	1	1	130		
	120	Parity check presence/absence	0, 1, 2	1	2	130		
	121	Number of communication retries	0 to 10, 9999	1	1	130		
	122	Communication check time interval	0 to 999.8s, 9999	0.1s	9999	130		
	123	Waiting time setting	0 to 150ms, 9999	1ms	9999	130		
PID control	124	CR, LF presence/absence selection	0, 1, 2	1	1	130		
	128	PID action selection	10, 11, 30, 31	1	10	141		
	129	PID proportional band	0.1 to 1000%, 9999	0.1%	100%	141		
	130	PID integral time	0.1 to 3600s, 9999	0.1s	1s	141		
	131	Upper limit	0 to 100%, 9999	0.1%	9999	141		
	132	Lower limit	0 to 100%, 9999	0.1%	9999	141		
Backlash	133	PID action set point for PU operation	0 to 100%	0.01%	0%	141		
	134	PID differential time	0.01 to 10s, 9999	0.01s	9999	141		
	140	Backlash acceleration stopping speed	0 to 3600r/min	1r/min	30r/min	93		
	141	Backlash acceleration stopping time	0 to 360s	0.1s	0.5s	93		
Display functions	142	Backlash deceleration stopping speed	0 to 3600r/min	1r/min	30r/min	93		
	143	Backlash deceleration stopping time	0 to 360s	0.1s	0.5s	93		
	144	Speed setting switchover	0, 2, 4, 6, 8, 10	1	0	97		
Current detection	145	Parameter for the option (FR-PU04V).						
	150	Output current detection level	0 to 200%	0.1%	150%	147		
	151	Output current detection time	0 to 10s	0.1s	0	147		
	152	Zero current detection level	0 to 200.0%	0.1%	5.0%	148		
Sub functions	153	Zero current detection time	0 to 1s	0.01s	0.5s	148		
	156	Stall prevention operation selection	0 to 31, 100, 101	1	1	149		
Display functions	157	OL signal output timer	0 to 25s, 9999	0s	0	150		
	158	DA2 terminal function selection	1 to 3, 5 to 12, 17, 18, 21, 32 to 34, 36	1	1	101		
Automatic restart after instantaneous power failure	160	Extended function selection	0, 1	1	0	151		
	162	Automatic restart after instantaneous power failure selection	0, 1, 10	1	0	105		
	163	First cushion time for restart	0 to 20s	0.1s	0s	105		
	164	First cushion voltage for restart	0 to 100%	0.1%	0%	105		
Maintenance functions	165	Restart current restriction level	0 to 200%	0.1%	150%	105		
	168	Maker setting parameters. Do not make setting.						
Initial monitor	169	Maker setting parameters. Do not make setting.						
Terminal assignment functions	171	Actual operation hour meter clear	0	1	0	151		
	180	DI1 terminal function selection	0 to 3, 5, 8 to 16, 20, 22 to 27, 42 to 44, 9999	1	0	151		
	181	DI2 terminal function selection		1	1			
	182	DI3 terminal function selection		1	2			
	183	DI4 terminal function selection		1	3			
	187	STR terminal function selection		1	9999			
	190	DO1 terminal function selection	0 to 8, 10 to 16, 20, 25 to 27, 30 to 37, 40 to 44, 96 to 99, 100 to 108, 110 to 116, 120, 125 to 127, 130 to 137, 140 to 144, 196 to 199, 9999	1	0	153		
	191	DO2 terminal function selection	1	1				
192	DO3 terminal function selection	1	2					
195	A,B,C terminal function selection	1	99					
Multi-speed operation	232	Multi-speed setting (speed 8)	0 to 3600r/min, 9999	1r/min	9999	82		
	233	Multi-speed setting (speed 9)	0 to 3600r/min, 9999	1r/min	9999	82		
	234	Multi-speed setting (speed 10)	0 to 3600r/min, 9999	1r/min	9999	82		
	235	Multi-speed setting (speed 11)	0 to 3600r/min, 9999	1r/min	9999	82		
	236	Multi-speed setting (speed 12)	0 to 3600r/min, 9999	1r/min	9999	82		

Function	Parameter No.	Name	Setting Range	Minimum Setting Increments	Factory Setting	Refer To	Customer Setting
Multi-speed operation	237	Multi-speed setting (speed 13)	0 to 3600r/min, 9999	1r/min	9999	82	
	238	Multi-speed setting (speed 14)	0 to 3600r/min, 9999	1r/min	9999	82	
	239	Multi-speed setting (speed 15)	0 to 3600r/min, 9999	1r/min	9999	82	
Sub functions	240	Soft-PWM setting	0, 1, 10, 11	1	10	115	
	244	Cooling fan operation selection	0, 1	1	0	155	
Stop selection function	250	Stop selection	0 to 100s, 9999	0.1s	9999	155	
Operation selection function	251	Output phase failure protection selection	0, 1	1	1	156	
Additional functions	252	Override bias	0 to 200%	0.1%	50%	157	
	253	Override gain	0 to 200%	0.1%	150%	157	
Power failure stop functions	261	Power failure stop selection	0, 1	1	0	157	
	262	Subtracted speed at deceleration start	0 to 600r/min	1r/min	90r/min	157	
	263	Subtraction starting speed	0 to 3600r/min, 9999	1r/min	1500r/min	157	
	264	Power-failure deceleration time 1	0 to 3600/0 to 360s	0.1s/0.01s	5s	157	
	265	Power-failure deceleration time 2	0 to 3600/0 to 360s, 9999	0.1s/0.01s	9999	157	
	266	Power-failure deceleration time switchover speed	0 to 3600r/min	1r/min	1500r/min	157	
Brake sequence	278	Brake opening speed	0 to 900r/min	1r/min	20r/min	109	
	279	Brake opening current	0 to 200%	0.1%	130%	109	
	280	Brake opening current detection time	0 to 2s	0.1s	0.3s	109	
	281	Brake operation time at start	0 to 5s	0.1s	0.3s	109	
	282	Brake operation speed	0 to 900r/min	1r/min	25r/min	109	
	283	Brake operation time at stop	0 to 5s	0.1s	0.3s	109	
	284	Deceleration detection function selection	0, 1	1	0	109	
Droop	285	Overspeed detection speed	0 to 900r/min, 9999	1r/min	9999	109	
	286	Droop gain	0 to 100.0%	0.01%	0%	159	
	287	Droop filter constant	0.00 to 1.00s	0.01s	0.3s	159	
Additional function	288	Droop function activation selection	0, 1, 2	1	0	159	
Additional function	342	E ² PROM write presence/absence	0, 1	1	0	130	
Orientation	350	Stop position command selection	0, 1, 2, 3, 9999	1	9999	160	
	351	Orientation switchover speed	0 to 1000r/min	1r/min	200r/min	160	
	356	Internal stop position command	0 to 16383	1	0	160	
	357	In-position zone	0 to 8192	1	11	160	
	360	External position command selection	0, 1, 2 to 127	1	0	160	
	361	Position shift	0 to 16383	1	0	160	
	362	Orientation position loop gain	0.1 to 100	0.1	10	160	
Control system function	374	Overspeed detection level	0 to 4200r/min	1r/min	3450r/min	167	
S-pattern C	380	Acceleration S pattern 1	0 to 50%	1%	0%	93	
	381	Deceleration S pattern 1	0 to 50%	1%	0%	93	
	382	Acceleration S pattern 2	0 to 50%	1%	0%	93	
	383	Deceleration S pattern 2	0 to 50%	1%	0%	93	
Orientation	393	Orientation selection	1, 2, 10, 11, 12	1	0	160	
	396	Orientation speed gain (P term)	0 to 1000	1	60	160	
	397	Orientation speed integral time	0 to 20.0s	0.001	0.333	160	
	398	Orientation speed gain (D term)	0 to 100.0%	0.1	1	160	
	399	Orientation deceleration ratio	0 to 1000	1	20	160	
Position control	419	Position command right selection	0, 1	1	0	54	
	420	Command pulse scaling factor numerator	0 to 32767	1	1	54	
	421	Command pulse scaling factor denominator	0 to 32767	1	1	54	
	422	Position loop gain	0 to 150s ⁻¹	1s ⁻¹	25s ⁻¹	54	
	423	Position feed forward gain	0 to 100%	1%	0%	54	
	424	Position command acceleration/ deceleration time constant	0 to 50s	0.001s	0s	54	
	425	Position feed forward command filter	0 to 5s	0.001s	0s	54	

Parameter lists (Japanese version)

PARAMETERS
(Japanese version)

Function	Parameter No.	Name	Setting Range	Minimum Setting Increments	Factory Setting	Refer To	Customer Setting
Position control	426	In-position width	0 to 32767 pulses	1 pulse	100 pulses	168	
	427	Excessive level error	0 to 400K, 9999	1K	40K	168	
	430	Pulse monitor selection	0 to 5, 9999	1	9999	168	
Motor constants	450	Second applied motor	0, 10, 30, 9999	1	9999	114	
	451	Second motor control method selection	20, 9999	1	9999	170	
	452	Second electronic thermal O/L relay	0 to 500A, 9999	0.01A	9999	85	
	453	Second motor capacity	0.4 to 55kW	0.01kW	Inverter capacity	35	
	454	Number of second motor poles	2, 4, 6	1	4	35	
Position control	464	Digital position control sudden stop deceleration time	0 to 360.0s	0.1s	0	168	
	465	First position feed amount lower 4 digits	0 to 9999	1	0	168	
	466	First position feed amount upper 4 digits	0 to 9999	1	0	168	
	467	Second position feed amount lower 4 digits	0 to 9999	1	0	168	
	468	Second position feed amount upper 4 digits	0 to 9999	1	0	168	
	469	Third position feed amount lower 4 digits	0 to 9999	1	0	168	
	470	Third position feed amount upper 4 digits	0 to 9999	1	0	168	
	471	Fourth position feed amount lower 4 digits	0 to 9999	1	0	168	
	472	Fourth position feed amount upper 4 digits	0 to 9999	1	0	168	
	473	Fifth position feed amount lower 4 digits	0 to 9999	1	0	168	
	474	Fifth position feed amount upper 4 digits	0 to 9999	1	0	168	
	475	Sixth position feed amount lower 4 digits	0 to 9999	1	0	168	
	476	Sixth position feed amount upper 4 digits	0 to 9999	1	0	168	
	477	Seventh position feed amount lower 4 digits	0 to 9999	1	0	168	
	478	Seventh position feed amount upper 4 digits	0 to 9999	1	0	168	
	479	Eighth position feed amount lower 4 digits	0 to 9999	1	0	168	
	480	Eighth position feed amount upper 4 digits	0 to 9999	1	0	168	
	481	Ninth position feed amount lower 4 digits	0 to 9999	1	0	168	
	482	Ninth position feed amount upper 4 digits	0 to 9999	1	0	168	
	483	Tenth position feed amount lower 4 digits	0 to 9999	1	0	168	
	484	Tenth position feed amount upper 4 digits	0 to 9999	1	0	168	
	485	Eleventh position feed amount lower 4 digits	0 to 9999	1	0	168	
	486	Eleventh position feed amount upper 4 digits	0 to 9999	1	0	168	
	487	Twelfth position feed amount lower 4 digits	0 to 9999	1	0	168	
	488	Twelfth position feed amount upper 4 digits	0 to 9999	1	0	168	
	489	Thirteenth position feed amount lower 4 digits	0 to 9999	1	0	168	
490	Thirteenth position feed amount upper 4 digits	0 to 9999	1	0	168		
491	Fourteenth position feed amount lower 4 digits	0 to 9999	1	0	168		
492	Fourteenth position feed amount upper 4 digits	0 to 9999	1	0	168		
493	Fifteenth position feed amount lower 4 digits	0 to 9999	1	0	168		
494	Fifteenth position feed amount upper 4 digits	0 to 9999	1	0	168		
Remote output	495	Remote output selection	0, 1	1	0	168	
	496	Remote output data 1	0 to 4095	1	0	168	
	497	Remote output data 2	0 to 4095	1	0	168	
Operation selection functions	800	Control system selection	0 to 5, 20	1	0	170	
	801	Torque characteristic selection	0, 1	1	1	170	
	802	Pre-excitation selection	0, 1	1	0	87	

Function	Parameter No.	Name	Setting Range	Minimum Setting Increments	Factory Setting	Refer To	Customer Setting
Operation selection functions	803	Constant output region torque characteristic selection	0, 1	1	0	91	
	804	Torque command right selection	0, 1, 2	1	0	172	
	805	Torque command value (RAM)	600 to 1400%	1%	1000%	172	
	806	Torque command value (RAM, E ² PROM)	600 to 1400%	1%	1000%	172	
	807	Speed restriction selection	0, 1, 2	1	0	173	
	808	Forward rotation speed restriction	0 to 3600r/min	1r/min	1500r/min	173	
	809	Reverse rotation speed restriction	0 to 3600r/min, 9999	1r/min	9999	173	
Control system functions	810	Torque restriction input method selection	0, 1	1	0	91	
	812	Torque restriction level (regeneration)	0 to 400%, 9999	0.1%	9999	91	
	813	Torque restriction level (3 quadrant)	0 to 400%, 9999	0.1%	9999	91	
	814	Torque restriction level (4 quadrant)	0 to 400%, 9999	0.1%	9999	91	
	815	Torque restriction level 2	0 to 400%, 9999	0.1%	9999	91	
	816	Acceleration torque restriction	0 to 400%, 9999	0.1%	9999	91	
	817	Deceleration torque restriction	0 to 400%, 9999	0.1%	9999	91	
	818	Easy gain tuning response level setting	1 to 15	1	2	175	
	819	Easy gain tuning selection	0, 1, 2	1	0	175	
	820	Speed control P gain 1	0 to 1000%	1%	60%	175	
	821	Speed control integral time 1	0 to 20s	0.001s	0.333s	175	
	822	Speed setting filter 1	0 to 5s	0.001s	0s	175	
	823	Speed detection filter 1	0 to 5s	0.001s	0.001s	176	
	824	Torque control P gain 1	0 to 200%	1%	100%	176	
	825	Torque control integral time 1	0 to 500ms	0.1ms	5ms	176	
	826	Torque setting filter 1	0 to 5s	0.001s	0s	176	
	827	Torque detection filter 1	0 to 5s	0.001s	0s	176	
	828	Model speed control gain	0 to 1000%	1%	60%	47	
	830	Speed control P gain 2	0 to 1000%, 9999	1%	9999	175	
	831	Speed control integral time 2	0 to 20s, 9999	0.001s	9999	175	
832	Speed setting filter 2	0 to 5s, 9999	0.001s	9999	175		
833	Speed detection filter 2	0 to 5s, 9999	0.001s	9999	176		
834	Torque control P gain 2	0 to 200%, 9999	1%	9999	176		
835	Torque control integral time 2	0 to 500ms, 9999	0.1ms	9999	176		
836	Torque setting filter 2	0 to 5s, 9999	0.001s	9999	176		
837	Torque detection filter 2	0 to 5s, 9999	0.001s	9999	176		
Torque biases	840	Torque bias selection	0 to 3, 9999	1	9999	177	
	841	Torque bias 1	600 to 1400%, 9999	1%	9999	177	
	842	Torque bias 2	600 to 1400%, 9999	1%	9999	177	
	843	Torque bias 3	600 to 1400%, 9999	1%	9999	177	
	844	Torque bias filter	0 to 5s, 9999	0.001s	9999	177	
	845	Torque bias operation time	0 to 5s, 9999	0.01s	9999	177	
	846	Torque bias balance compensation	0 to 10V, 9999	0.1V	9999	177	
	847	Fall-time torque bias No. 3 bias	0 to 400%, 9999	1%	9999	177	
848	Fall-time torque bias No. 3 gain	0 to 400%, 9999	1%	9999	177		
Additional functions	849	Analog input offset adjustment *	0 to 200%	0.1%	100%	193	
	851	Number of PLG pulses	0 to 4096	1	2048	180	
	852	PLG rotation direction	0, 1	1	1	180	
	854	Excitation ratio	0 to 100%	1%	100%	181	
	859	Torque current	0 to , 9999	1	9999	126	
	862	Notch filter frequency	0 to 31	1	0	181	
	863	Notch filter depth	0 to 3	1	0	181	
	864	Torque detection	0 to 400%	0.1%	150%	182	
865	Low speed detection	0 to 3600r/min	1r/min	45r/min	182		
Display functions	866	Torque monitoring reference	0 to 400%	0.1%	150%	104	
	867	DA1 output filter	0 to 5s	0.001s	0.05s	183	
Terminal assignment function	868	No. 1 terminal function assignment	0, 1, 2, 5, 9999	1	0	183	

Parameter lists (Japanese version)

Function	Parameter No.	Name	Setting Range	Minimum Setting Increments	Factory Setting	Refer To	Customer Setting
Protective functions	870	Speed deviation level	0 to 1500r/min, 9999	1r/min	9999	184	
	871	Speed deviation time	0 to 100s	0.1s	12s	184	
	873	Speed restriction	0 to 3600r/min	1r/min	600r/min	185	
	874	OLT level setting	0 to 200%	0.1%	150%	185	
Operation selection functions	875	Fault definition	0, 1	1	0	186	
	876	Thermal relay protector input	0, 1	1	1	85	
Control system functions	877	Speed feed forward control/model adaptive speed control selection	0, 1, 2	1	0	47	
	878	Speed feed forward filter	0 to 1s	0.01s	0s	47	
	879	Speed feed forward torque restriction	0 to 400%	0.1%	150%	47	
	880	Load inertia ratio	0, 1 to 200 times	0.1	7	47	
	881	Speed feed forward gain	0 to 1000%	1%	0%	47	
Maintenance functions	890	Maintenance output setting time	0 to 9998, 9999	10hr	9999	187	
	891	Maintenance output timer	0 to 9998	10hr	0	187	
	892	Maintenance output signal clear	0	1	0	187	
Calibration functions	900	DA1 terminal calibration				188	
	901	DA2 terminal calibration				188	
	902	Speed setting No.2 bias	0 to 10V, 0 to 3600r/min	0.1r/min	0V, 0r/min	190	
	903	Speed setting No.2 gain	0 to 10V, 0 to 3600r/min	1r/min	10V, 1500r/min	190	
	904	Torque command No.3 bias	0 to 10V, 0 to 400%	0.1%	0V, 0%	190	
	905	Torque command No.3 gain	0 to 10V, 0 to 400%	0.1%	10V, 150%	190	
	917	No. 1 terminal bias (speed)	0 to 10V, 0 to 3600r/min	0.1r/min	0V, 0r/min	190	
	918	No. 1 terminal gain (speed)	0 to 10V, 0 to 3600r/min	1r/min	10V, 1500r/min	190	
	919	No. 1 terminal bias (torque/magnetic flux)	0 to 10V, 0 to 400%	0.1%	0V, 0%	190	
Additional functions	990	Buzzer control	0, 1	1	1	193	
	991	Parameter for the option (FR-PU04V)					

3.2 Parameter lists (NA version)

The inverter is factory-set to display only the simple mode parameters.
Set Pr. 160 "extended function selection" as required.

Parameter	Name	Factory Setting	Setting Range	Remarks
160	Extended function selection	0	0	Accessible to only the simple mode parameters.
			1	Accessible to all parameters.

CAUTION

- The blacked out parameters in the table below indicate simple mode parameters.
- The shaded parameters in the table allow its setting to be changed during operation even if "0" (factory setting) is set in Pr. 77 (parameter write disable selection).
- *: Accessible when Pr. 77 = 801.

Function	Parameter No.	Name	Setting Range	Minimum Setting Increments	Factory Setting	Refer To	Customer Setting
Basic functions	0	Torque boost (manual)	0 to 30%	0.1%	4%/3%/2% (3.7K or less/ 5.5K, 7.5K/ 11K or more)	81	
	1	Maximum speed	0 to 3600r/min	1r/min	1800r/min	81	
	2	Minimum speed	0 to 3600r/min	1r/min	0r/min	81	
	3	Base frequency	20 to 200Hz	0.01Hz	60Hz	82	
	4	Multi-speed setting (high speed)	0 to 3600r/min	1r/min	1800r/min	82	
	5	Multi-speed setting (middle speed)	0 to 3600r/min	1r/min	750r/min	82	
	6	Multi-speed setting (low speed)	0 to 3600r/min	1r/min	150r/min	82	
	7	Acceleration time	0 to 3600s/0 to 360s	0.1s/0.01s	5s/15s (1.5K to 5.5K /7.5K to 55K)	83	
	8	Deceleration time	0 to 3600s/0 to 360s	0.1s/0.01s	5s/15s (1.5K to 5.5K /7.5K to 55K)	83	
	9	Electronic thermal O/L relay	0 to 500A	0.01A	Rated inverter output current	85	
Standard operation functions	10	DC injection brake operation speed	0 to 1500r/min, 9999	0.1r/min	15r/min	87	
	11	DC injection brake operation time	0 to 0.5s	0.1s	0.5s	87	
	12	DC injection brake voltage	0 to 30%	0.1%	4%/2% (7.5K or less/ 11K or more)	87	
	13	Starting speed	0 to 1500r/min	0.1r/min	15r/min	88	
	15	Jog speed setting	0 to 1500r/min	0.1r/min	150r/min	89	
	16	Jog acceleration/deceleration time	0 to 3600s/0 to 360s	0.1s/0.01s	0.5s	89	
Operation selection functions	17	MRS input selection	0, 2	1	0	90	
	19	Base frequency voltage	0 to 1000V, 8888, 9999	0.1V	9999	82	
	20	Acceleration/deceleration reference speed	1 to 3600r/min	1r/min	1800r/min	83	
	21	Acceleration/deceleration time increments	0, 1	1	0	83	
	22	Torque restriction level	0 to 400%	0.1%	150%	91	
	24	Multi-speed setting (speed 4)	0 to 3600r/min, 9999	1r/min	9999	82	
	25	Multi-speed setting (speed 5)	0 to 3600r/min, 9999	1r/min	9999	82	
	26	Multi-speed setting (speed 6)	0 to 3600r/min, 9999	1r/min	9999	82	
	27	Multi-speed setting (speed 7)	0 to 3600r/min, 9999	1r/min	9999	82	
	28	Multi-speed input compensation	0, 1	1	0	92	

Parameter lists (NA version)

Function	Parameter No.	Name	Setting Range	Minimum Setting Increments	Factory Setting	Refer To	Customer Setting
Operation selection functions	29	Acceleration/deceleration pattern	0, 1, 2, 3, 4	1	0	93	
	30	Regenerative function selection	0, 1, 2	1	0	96	
	31	Speed jump 1A	0 to 3600r/min, 9999	1r/min	9999	97	
	32	Speed jump 1B	0 to 3600r/min, 9999	1r/min	9999	97	
	33	Speed jump 2A	0 to 3600r/min, 9999	1r/min	9999	97	
	34	Speed jump 2B	0 to 3600r/min, 9999	1r/min	9999	97	
	35	Speed jump 3A	0 to 3600r/min, 9999	1r/min	9999	97	
	36	Speed jump 3B	0 to 3600r/min, 9999	1r/min	9999	97	
	37	Speed display	0, 1 to 9998	1	0	97	
Output terminal functions	41	Up-to-speed sensitivity	0 to 100%	0.1%	10%	99	
	42	Speed detection	0 to 3600r/min	1r/min	300r/min	99	
	43	Speed detection for reverse rotation	0 to 3600r/min, 9999	1r/min	9999	99	
Second functions	44	Second acceleration/deceleration time	0 to 3600s/0 to 360s	0.1s/0.01s	5s	92	
	45	Second deceleration time	0 to 3600s/0 to 360s, 9999	0.1s/0.01s	9999	92	
Output terminal function	50	Second speed detection	0 to 3600r/min	1r/min	750r/min	99	
Display functions	52	DU/PU main display data selection	0, 5 to 12, 17 to 20, 23, 24, 32 to 35, 38, 100	1	0	101	
	53	PU level display data selection	0 to 3, 5 to 12, 17, 18	1	1	101	
	54	DA1 terminal function selection	1 to 3, 5 to 12, 17, 18, 21, 32 to 34, 36	1	1	101	
	55	Speed monitoring reference	0 to 3600r/min	1r/min	1800r/min	104	
	56	Current monitoring reference	0 to 500A	0.01A	Inverter rated output current	104	
Automatic restart	57	Restart coasting time	0, 0.1 to 5s, 9999	0.1s	9999	105	
	58	Restart cushion time	0 to 60s	0.1s	1.0s	105	
Additional function	59	Remote setting function selection	0, 1, 2, 3	1	0	107	
Operation selection functions	60	Intelligent mode selection	0, 7, 8	1	0	109	
	65	Retry selection	0 to 5	1	0	112	
	67	Number of retries at alarm occurrence	0 to 10, 101 to 110	1	0	112	
	68	Retry waiting time	0 to 10s	0.1s	1s	112	
	69	Retry count display erasure	0	1	0	112	
	70	Special regenerative brake duty	0 to 15%/0 to 30%/0%	0.1%	0%	96	
	71	Applied motor	0, 3 to 8, 10, 13 to 18, 30, 33, 34	1	0	114	
	72	PWM frequency selection	1 to 6	1	1	115	
	73	Speed setting signal	0, 4, 10, 14	1	0	116	
	75	Reset selection/disconnected PU detection/PU stop selection	0 to 3, 14 to 17	1	14	118	
	77	Parameter write disable selection	0, 1, 2	1	0	119	
Motor constants	78	Reverse rotation prevention selection	0, 1, 2	1	0	120	
	79	Operation mode selection	0 to 4, 6 to 8	1	0	120	
	80	Motor capacity	0.4 to 55kW	0.01kW	Motor capacity	123	
	81	Number of motor poles	2, 4, 6	1	4	123	
	82	Motor excitation current (no load current) *	0 to , 9999		9999	126	
	83	Rated motor voltage	0 to 1000V	0.1V	200V (200V class) / 400V (400V class)	123	
	84	Rated motor frequency	20 to 200Hz	0.01Hz	60Hz	123	
	90	Motor constant R1 *	0 to , 9999		9999	126	
	91	Motor constant R2 *	0 to , 9999		9999	126	
	92	Motor constant L1 *	0 to , 9999		9999	126	
Motor constants	93	Motor constant L2 *	0 to , 9999		9999	126	
	94	Motor constant X *	0 to , 9999		9999	126	
	95	Online auto tuning selection	0, 1, 2	1	0	128	
	96	Auto tuning setting/status	0, 1, 101	1	0	123	

PARAMETERS (NA version)

Function	Parameter No.	Name	Setting Range	Minimum Setting Increments	Factory Setting	Refer To	Customer Setting
Third functions	110	Third acceleration/deceleration time	0 to 3600/0 to 360s	0.1s/0.01s	5s	83	
	111	Third deceleration time	0 to 3600/0 to 360s, 9999	0.1s/0.01s	9999	83	
Output terminal function	116	Third speed detection	0 to 3600r/min	1r/min	1800r/min	99	
Communication functions	117	Station number	0 to 31	1	0	130	
	118	Communication speed	48, 96, 192	1	192	130	
	119	Stop bit length/data length	0, 1, 10, 11	1	1	130	
	120	Parity check presence/absence	0, 1, 2	1	2	130	
	121	Number of communication retries	0 to 10, 9999	1	1	130	
	122	Communication check time interval	0 to 999.8s, 9999	0.1s	9999	130	
	123	Waiting time setting	0 to 150ms, 9999	1ms	9999	130	
PID control	124	CR, LF presence/absence selection	0, 1, 2	1	1	130	
	128	PID action selection	10, 11, 30, 31	1	10	141	
	129	PID proportional band	0.1 to 1000%, 9999	0.1%	100%	141	
	130	PID integral time	0.1 to 3600s, 9999	0.1s	1s	141	
	131	Upper limit	0 to 100%, 9999	0.1%	9999	141	
	132	Lower limit	0 to 100%, 9999	0.1%	9999	141	
	133	PID action set point for PU operation	0 to 100%	0.01%	0%	141	
Backlash	134	PID differential time	0.01 to 10s, 9999	0.01s	9999	141	
	140	Backlash acceleration stopping speed	0 to 3600r/min	1r/min	30r/min	93	
	141	Backlash acceleration stopping time	0 to 360s	0.1s	0.5s	93	
	142	Backlash deceleration stopping speed	0 to 3600r/min	1r/min	30r/min	93	
Display functions	143	Backlash deceleration stopping time	0 to 360s	0.1s	0.5s	93	
	144	Speed setting switchover	0, 2, 4, 6, 8, 10	1	0	97	
Current detection	145	Parameter for the option (FR-PU04V).					
	150	Output current detection level	0 to 200%	0.1%	150%	147	
	151	Output current detection time	0 to 10s	0.1s	0	147	
	152	Zero current detection level	0 to 200.0%	0.1%	5.0%	148	
Sub functions	153	Zero current detection time	0 to 1s	0.01s	0.5s	148	
	156	Stall prevention operation selection	0 to 31, 100, 101	1	1	149	
Display functions	157	OL signal output timer	0 to 25s, 9999	0s	0.1s	150	
	158	DA2 terminal function selection	1 to 3, 5 to 12, 17, 18, 21, 32 to 34, 36	1	1	101	
Automatic restart after instantaneous power failure	160	Extended function selection	0, 1	1	0	151	
	162	Automatic restart after instantaneous power failure selection	0, 1, 10	1	0	105	
	163	First cushion time for restart	0 to 20s	0.1s	0s	105	
	164	First cushion voltage for restart	0 to 100%	0.1%	0%	105	
Maintenance functions	165	Restart current restriction level	0 to 200%	0.1%	150%	105	
	168	Maker setting parameters. Do not make setting.					
Initial monitor	169						
Terminal assignment functions	171	Actual operation hour meter clear	0	1	0	151	
	180	DI1 terminal function selection	0 to 3, 5, 8 to 12, 14 to 16, 20, 22 to 27, 42 to 44, 9999	1	0	151	
	181	DI2 terminal function selection		1	1		
	182	DI3 terminal function selection		1	2		
	183	DI4 terminal function selection		1	3		
	187	STR terminal function selection		1	9999		
	190	DO1 terminal function selection	0 to 8, 10 to 16, 20, 25 to 27, 30 to 37, 40 to 44, 96 to 99, 100 to 108, 110 to 116, 120, 125 to 127, 130 to 137, 140 to 144, 196 to 199, 9999	1	0	153	
	191	DO2 terminal function selection	1	1			
192	DO3 terminal function selection	1	2				
195	ABC terminal function selection	1	99				
Multi-speed operation	232	Multi-speed setting (speed 8)	0 to 3600r/min, 9999	1r/min	9999	82	
	233	Multi-speed setting (speed 9)	0 to 3600r/min, 9999	1r/min	9999	82	

PARAMETERS (NA version)

PARAMETERS

3

Parameter lists (NA version)

Function	Parameter No.	Name	Setting Range	Minimum Setting Increments	Factory Setting	Refer To	Customer Setting
Multi-speed operation	234	Multi-speed setting (speed 10)	0 to 3600r/min, 9999	1r/min	9999	82	
	235	Multi-speed setting (speed 11)	0 to 3600r/min, 9999	1r/min	9999	82	
	236	Multi-speed setting (speed 12)	0 to 3600r/min, 9999	1r/min	9999	82	
	237	Multi-speed setting (speed 13)	0 to 3600r/min, 9999	1r/min	9999	82	
	238	Multi-speed setting (speed 14)	0 to 3600r/min, 9999	1r/min	9999	82	
	239	Multi-speed setting (speed 15)	0 to 3600r/min, 9999	1r/min	9999	82	
Sub functions	240	Soft-PWM setting	0, 1, 10, 11	1	10	115	
	244	Cooling fan operation selection	0, 1	1	0	155	
Stop selection function	250	Stop selection	0 to 100s, 9999	0.1s	9999	155	
Operation selection function	251	Output phase failure protection selection	0, 1	1	1	156	
Additional functions	252	Override bias	0 to 200%	0.1%	50%	157	
	253	Override gain	0 to 200%	0.1%	150%	157	
Power failure stop functions	261	Power failure stop selection	0, 1	1	0	157	
	262	Subtracted speed at deceleration start	0 to 600r/min	1r/min	90r/min	157	
	263	Subtraction starting speed	0 to 3600r/min, 9999	1r/min	1800r/min	157	
	264	Power-failure deceleration time 1	0 to 3600/0 to 360s	0.1s/0.01s	5s	157	
	265	Power-failure deceleration time 2	0 to 3600/0 to 360s, 9999	0.1s/0.01s	9999	157	
	266	Power-failure deceleration time switchover speed	0 to 3600r/min	1r/min	1800r/min	157	
Brake sequence	278	Brake opening speed	0 to 900r/min	1r/min	20r/min	109	
	279	Brake opening current	0 to 200%	0.1%	130%	109	
	280	Brake opening current detection time	0 to 2s	0.1s	0.3s	109	
	281	Brake operation time at start	0 to 5s	0.1s	0.3s	109	
	282	Brake operation speed	0 to 900r/min	1r/min	25r/min	109	
	283	Brake operation time at stop	0 to 5s	0.1s	0.3s	109	
	284	Deceleration detection function selection	0, 1	1	0	109	
Droop	285	Overspeed detection speed	0 to 900r/min, 9999	1r/min	9999	109	
	286	Droop gain	0 to 100.0%	0.01%	0%	159	
	287	Droop filter constant	0.00 to 1.00s	0.01s	0.3s	159	
Additional function	288	Droop function activation selection	0, 1, 2	1	0	159	
	342	E ² PROM write presence/absence	0, 1	1	0	130	
Orientation	350	Stop position command selection	0, 1, 2, 9999	1	9999	160	
	351	Orientation switchover speed	0 to 1000r/min	1r/min	200r/min	160	
	356	Internal stop position command	0 to 16383	1	0	160	
	357	Orientation in-position zone	0 to 8192	1	11	160	
	360	External position command selection	0, 1, 2 to 127	1	0	160	
	361	Position shift	0 to 16383	1	0	160	
Control system function	362	Orientation position loop gain	0.1 to 100	0.1	10	160	
	374	Overspeed detection level	0 to 4200r/min	1r/min	4200r/min	167	
S-pattern C	380	Acceleration S pattern 1	0 to 50%	1%	0%	93	
	381	Deceleration S pattern 1	0 to 50%	1%	0%	93	
	382	Acceleration S pattern 2	0 to 50%	1%	0%	93	
	383	Deceleration S pattern 2	0 to 50%	1%	0%	93	
Orientation	393	Orientation selection	1, 2, 10, 11, 12	1	0	160	
	396	Orientation speed gain (P term)	0 to 1000	1	60	160	
	397	Orientation speed integral time	0 to 20.0s	0.001	0.333	160	
	398	Orientation speed gain (D term)	0 to 100.0%	0.1	1	160	
	399	Orientation deceleration ratio	0 to 1000	1	20	160	
Position control	419	Position command right selection	0, 1	1	0	54	
	420	Command pulse scaling factor numerator	0 to 32767	1	1	54	

Function	Parameter No.	Name	Setting Range	Minimum Setting Increments	Factory Setting	Refer To	Customer Setting
Position control	421	Command pulse scaling factor denominator	0 to 32767	1	1	54	
	422	Position loop gain	0 to 150s ⁻¹	1s ⁻¹	25s ⁻¹	54	
	423	Position feed forward gain	0 to 100%	1%	0%	54	
	424	Position command acceleration/ deceleration time constant	0 to 50s	0.001s	0s	54	
	425	Position feed forward command filter	0 to 5s	0.001s	0s	54	
	426	In-position width	0 to 32767 pulses	1 pulse	100 pulses	54	
	427	Excessive level error	0 to 400K, 9999	1K	40K	54	
	430	Pulse monitor selection	0 to 5, 9999	1	9999	54	
Motor constants	450	Second applied motor	0, 10, 30, 9999	1	9999	114	
	451	Second motor control method selection	20, 9999	1	9999	170	
	452	Second electronic thermal O/L relay	0 to 500A, 9999	0.01A	9999	85	
	453	Second motor capacity	0.4 to 55kW (0.5 to 75HP)	0.01kW (0.01HP)	Inverter capacity	35	
	454	Number of second motor poles	2, 4, 6	1	4	35	
Position control	464	Digital position control sudden stop deceleration time	0 to 360.0s	0.1s	0	54	
	465	First position feed amount lower 4 digits	0 to 9999	1	0	56	
	466	First position feed amount upper 4 digits	0 to 9999	1	0	56	
	467	Second position feed amount lower 4 digits	0 to 9999	1	0	56	
	468	Second position feed amount upper 4 digits	0 to 9999	1	0	56	
	469	Third position feed amount lower 4 digits	0 to 9999	1	0	56	
	470	Third position feed amount upper 4 digits	0 to 9999	1	0	56	
	471	Fourth position feed amount lower 4 digits	0 to 9999	1	0	56	
	472	Fourth position feed amount upper 4 digits	0 to 9999	1	0	56	
	473	Fifth position feed amount lower 4 digits	0 to 9999	1	0	56	
	474	Fifth position feed amount upper 4 digits	0 to 9999	1	0	56	
	475	Sixth position feed amount lower 4 digits	0 to 9999	1	0	56	
	476	Sixth position feed amount upper 4 digits	0 to 9999	1	0	56	
	477	Seventh position feed amount lower 4 digits	0 to 9999	1	0	56	
	478	Seventh position feed amount upper 4 digits	0 to 9999	1	0	56	
	479	Eighth position feed amount lower 4 digits	0 to 9999	1	0	56	
	480	Eighth position feed amount upper 4 digits	0 to 9999	1	0	56	
	481	Ninth position feed amount lower 4 digits	0 to 9999	1	0	56	
	482	Ninth position feed amount upper 4 digits	0 to 9999	1	0	56	
	483	Tenth position feed amount lower 4 digits	0 to 9999	1	0	56	
	484	Tenth position feed amount upper 4 digits	0 to 9999	1	0	56	
	485	Eleventh position feed amount lower 4 digits	0 to 9999	1	0	56	
486	Eleventh position feed amount upper 4 digits	0 to 9999	1	0	56		
487	Twelfth position feed amount lower 4 digits	0 to 9999	1	0	56		
488	Twelfth position feed amount upper 4 digits	0 to 9999	1	0	56		
489	Thirteenth position feed amount lower 4 digits	0 to 9999	1	0	56		
490	Thirteenth position feed amount upper 4 digits	0 to 9999	1	0	56		
491	Fourteenth position feed amount lower 4 digits	0 to 9999	1	0	56		
492	Fourteenth position feed amount upper 4 digits	0 to 9999	1	0	56		
493	Fifteenth position feed amount lower 4 digits	0 to 9999	1	0	56		
494	Fifteenth position feed amount upper 4 digits	0 to 9999	1	0	56		

Parameter lists (NA version)

Function	Parameter No.	Name	Setting Range	Minimum Setting Increments	Factory Setting	Refer To	Customer Setting
Remote output	495	Remote output selection	0, 1	1	0	168	
	496	Remote output data 1	0 to 4095	1	0	168	
	497	Remote output data 2	0 to 4095	1	0	168	
Operation selection functions	800	Control system selection	0 to 5, 20	1	0	170	
	801	Torque characteristic selection	0, 1	1	1	170	
	802	Pre-excitation selection	0, 1	1	0	87	
	803	Constant output region torque characteristic selection	0, 1	1	0	91	
	804	Torque command right selection	0, 1, 2	1	0	172	
	805	Torque command value (RAM)	600 to 1400%	1%	1000%	172	
	806	Torque command value (RAM, E ² PROM)	600 to 1400%	1%	1000%	172	
	807	Speed restriction selection	0, 1, 2	1	0	173	
	808	Forward rotation speed restriction	0 to 3600r/min	1r/min	1800r/min	173	
Control system functions	809	Reverse rotation speed restriction	0 to 3600r/min, 9999	1r/min	9999	173	
	810	Torque restriction input method selection	0, 1	1	0	91	
	812	Torque restriction level (regeneration)	0 to 400%, 9999	0.1%	9999	91	
	813	Torque restriction level (3rd quadrant)	0 to 400%, 9999	0.1%	9999	91	
	814	Torque restriction level (4th quadrant)	0 to 400%, 9999	0.1%	9999	91	
	815	Torque restriction level 2	0 to 400%, 9999	0.1%	9999	91	
	816	Acceleration torque restriction	0 to 400%, 9999	0.1%	9999	91	
	817	Deceleration torque restriction	0 to 400%, 9999	0.1%	9999	91	
	818	Easy gain tuning response level setting	1 to 15	1	2	175	
	819	Easy gain tuning selection	0, 1, 2	1	0	175	
	820	Speed control P gain 1	0 to 1000%	1%	60%	175	
	821	Speed control integral time 1	0 to 20s	0.001s	0.333s	175	
	822	Speed setting filter 1	0 to 5s	0.001s	0s	175	
	823	Speed detection filter 1	0 to 5s	0.001s	0.001s	176	
	824	Torque control P gain 1	0 to 200%	1%	100%	176	
	825	Torque control integral time 1	0 to 500ms	0.1ms	5ms	176	
	826	Torque setting filter 1	0 to 5s	0.001s	0s	176	
	827	Torque detection filter 1	0 to 5s	0.001s	0s	176	
	828	Model speed control gain	0 to 1000%	1%	60%	177	
	Torque biases	830	Speed control P gain 2	0 to 1000%, 9999	1%	9999	175
831		Speed control integral time 2	0 to 20s, 9999	0.001s	9999	175	
832		Speed setting filter 2	0 to 5s, 9999	0.001s	9999	175	
833		Speed detection filter 2	0 to 5s, 9999	0.001s	9999	176	
834		Torque control P gain 2	0 to 200%, 9999	1%	9999	176	
835		Torque control integral time 2	0 to 500ms, 9999	0.1ms	9999	176	
836		Torque setting filter 2	0 to 5s, 9999	0.001s	9999	176	
837		Torque detection filter 2	0 to 5s, 9999	0.001s	9999	176	
840		Torque bias selection	0 to 3, 9999	1	9999	177	
Additional functions	841	Torque bias 1	600 to 1400%, 9999	1%	9999	177	
	842	Torque bias 2	600 to 1400%, 9999	1%	9999	177	
	843	Torque bias 3	600 to 1400%, 9999	1%	9999	177	
	844	Torque bias filter	0 to 5s, 9999	0.001s	9999	177	
	845	Torque bias operation time	0 to 5s, 9999	0.01s	9999	177	
	846	Torque bias balance compensation	0 to 10V, 9999	0.1V	9999	177	
	847	Fall-time torque bias No. 3 bias	0 to 400%, 9999	1%	9999	177	
	848	Fall-time torque bias No. 3 gain	0 to 400%, 9999	1%	9999	177	
Additional functions	849	Analog input offset adjustment *	0 to 200%	0.1%	100%	193	
	851	Number of PLG pulses	0 to 4096	1	1024	180	
	852	PLG rotation direction	0, 1	1	1	180	
	854	Excitation ratio	0 to 100%	1%	100%	181	
	859	Torque current	0 to , 9999	1	9999	123	
	862	Notch filter frequency	0 to 31	1	0	181	
	863	Notch filter depth	0 to 3	1	0	181	
Additional functions	864	Torque detection	0 to 400%	0.1%	150%	182	
	865	Low speed detection	0 to 3600r/min	1r/min	45r/min	182	

PARAMETERS (NA version)

Function	Parameter No.	Name	Setting Range	Minimum Setting Increments	Factory Setting	Refer To	Customer Setting
Display functions	866	Torque monitoring reference	0 to 400%	0.1%	150%	104	
	867	DA1 output filter	0 to 5s	0.001s	0.05s	183	
Terminal assignment function	868	No. 1 terminal function assignment	0, 1, 2, 5, 9999	1	0	183	
Protective functions	870	Speed deviation level	0 to 1500r/min, 9999	1r/min	9999	184	
	871	Speed deviation time	0 to 100s	0.1s	12s	184	
	873	Speed restriction	0 to 3600r/min	1r/min	600r/min	185	
	874	OLT level setting	0 to 200%	0.1%	150%	185	
Operation selection functions	875	Fault definition	0, 1	1	0	186	
	876	Thermal relay protector input	0, 1	1	0	85	
Control system functions	877	Speed feed forward control/model adaptive speed control selection	0, 1, 2	1	0	186	
	878	Speed feed forward filter	0 to 1s	0.01s	0s	186	
	879	Speed feed forward torque restriction	0 to 400%	0.1%	150%	186	
	880	Load inertia ratio	0, 1 to 200 times	0.1	7	47	
	881	Speed feed forward gain	0 to 1000%	1%	0%	47	
Maintenance functions	890	Maintenance output setting time	0 to 9998, 9999	10hr	9999	187	
	891	Maintenance output timer	0 to 9998	10hr	0	187	
	892	Maintenance output signal clear	0	1	0	187	
Calibration functions	900	DA1 terminal calibration				188	
	901	DA2 terminal calibration				188	
	902	Speed setting No.2 bias	0 to 10V, 0 to 3600r/min	0.1r/min	0V, 0r/min	190	
	903	Speed setting No.2 gain	0 to 10V, 0 to 3600r/min	1r/min	10V, 1800r/min	190	
	904	Torque command No.3 bias	0 to 10V, 0 to 400%	0.1%	0V, 0%	190	
	905	Torque command No.3 gain	0 to 10V, 0 to 400%	0.1%	10V, 150%	190	
	917	No. 1 terminal bias (speed)	0 to 10V, 0 to 3600r/min	0.1r/min	0V, 0r/min	190	
	918	No. 1 terminal gain (speed)	0 to 10V, 0 to 3600r/min	1r/min	10V, 1800r/min	190	
	919	No. 1 terminal bias (torque/magnetic flux)	0 to 10V, 0 to 400%	0.1%	0V, 0%	190	
	920	No. 1 terminal gain (torque/magnetic flux)	0 to 10V, 0 to 400%	0.1%	10V, 150%	190	
Additional functions	990	Buzzer control	0, 1	1	1	193	
	991	Parameter for the option (FR-PU04V).					

**PARAMETERS
(NA version)**

PARAMETERS

3.3 At-a-glance guide to functions

○....Usable function, ×..... Unusable function

Category	Function	Pr. number	Terminal	PLG Vector		
				Speed	Torque	Position
				SF-V5R "Motor with PLG (standard, constant torque)" *: This function can be usable under position control by parameter setting.		
Control	Speed restriction	Pr. 807 to Pr. 809, Pr. 902, Pr. 903, Pr. 917, Pr. 918	No. 2(1) terminal, multi-speed	×	○	×
	Torque restriction	Pr. 22, Pr. 803, Pr. 810 to Pr. 817, Pr. 904, Pr. 905, Pr.919, Pr.920	No. 3(1) terminal	○	×	○
	Offline auto tuning	Pr. 9, Pr. 71, Pr. 80 to Pr. 84, Pr. 90 to Pr. 94, Pr. 96, Pr. 859		○	○	×
	Online auto tuning (start-time) Pr.95=1	Pr. 95		○	○	×
	Online auto tuning (adaptive magnetic flux observer) Pr.95=2	Pr. 95		○	○	○
	Easy gain tuning	Pr. 818, Pr. 819		○	×	○
	Gain adjustment	Pr. 820 to Pr. 827, Pr. 830 to Pr. 837		○	○	○
	Machine analyzer (notch filter)	Pr. 862, Pr. 863		○	×	○
	0 speed control	Pr. 802		○	×	○
	Servo lock	Pr. 802		○	×	○
	Variable excitation	Pr. 854		○	○	○
	Speed feed-forward, model adaptive speed control	Pr. 877 to Pr. 881, Pr. 820, Pr. 821, Pr. 828		○	×	○
	P/PI switchover	Pr. 180 to Pr. 183, Pr. 187	X44 signal	○	○	○
Speed feedback filter	Pr. 823, Pr. 833		○	○	○	
Basic functions	Extended function display	Pr. 160		○	○	○
	Maximum speed	Pr. 1		○	○	○
	Minimum speed	Pr. 2		○	○	×
	Acceleration time	Pr. 7, Pr. 8, Pr. 20, Pr. 21, Pr. 44, Pr. 45, Pr. 110, Pr. 111		○	○	×
	Acceleration/deceleration pattern	Pr. 29, Pr. 140 to Pr. 143, Pr. 380 to Pr. 383		○	○	×
	Jog operation mode	Pr. 15, Pr. 16		○	○	×
	PWM frequency selection	Pr. 72, Pr. 240		○	○	○
	Operation mode (PU/external/combined)	Pr. 79		○	○	×
	Switchover mode	Pr. 79		○	○	×
	PU operation interlock mode	Pr. 79, Pr. 180 to Pr. 183, Pr. 187	X12	○	○	○
	Operation mode external signal switchover mode	Pr. 79, Pr. 180 to Pr.183, Pr. 187	X16	○	○	○
	Start command (2-wire, 3-wire)	Pr. 180 to Pr. 183, Pr. 187	STOP	○	○	○
	Parameter write disable selection	Pr. 77		○	○	○
Application functions	Starting speed	Pr. 13		○	○	×
	DC injection brake	Pr. 10, Pr. 11, Pr. 12		○	○	×
	Second, third functions	Pr. 180 to Pr. 183, Pr. 187	RT, X9	○	○	○
	Multi-speed setting	Pr. 4 to Pr. 6, Pr. 24 to Pr. 27, Pr. 28, Pr. 232 to Pr. 239		○	○	×
	Remote setting	Pr. 59		○	○	×
	Speed jump	Pr. 31 to Pr. 36		○	○	×
	PID control	Pr. 128 to Pr. 134, Pr. 180 to Pr. 183, Pr. 187	X14	○	×	×
	Stop selection	Pr. 250		○	○	×
	Power failure stop	Pr. 261 to Pr. 266		○	○	×
	PU stop	Pr. 75		○	○	○
	Reset selection	Pr. 75		○	○	○
	Forward/reverse rotation prevention	Pr. 78		○	○	○
	Automatic restart after instantaneous power failure	Pr. 57, Pr. 58		○	○	×
	Cooling fan on/off control	Pr. 244		○	○	○
	Retry function	Pr. 65, Pr. 67, Pr. 68, Pr. 69		○	○	×
	Inverter RS485 communication	Pr. 117 to Pr. 124		○	○	○
	Droop control	Pr. 286 to Pr. 288		○	×	×
Brake sequence	Pr. 60, Pr. 278 to Pr. 285		○	×	×	
Torque bias	Pr. 180 to Pr. 183, Pr. 187, Pr. 840 to Pr. 848, Pr. 904, Pr. 905	X42, X43	○	×	×	
Regenerative function selection	Pr. 30, Pr. 70		○	○	○	

Category	Function	Pr. number	Terminal	Control Applicable Motor	PLG Vector			
					Speed	Torque	Position	
					SF-V5R "Motor with PLG (standard, constant torque)" *: This function can be usable under position control by parameter setting.			
Application functions	Soft-PWM	Pr. 240			○	○	○	
	Torque characteristic selection	Pr. 801			○	○	○	
	PLG rotation direction	Pr. 852			○	○	○	
	Number of PLG pulses	Pr. 851			○	○	○	
	Conditional position control by contact input	Pr. 465 to Pr. 494			×	×	○	
	Direct display and direct setting of motor constants	Pr. 71, Pr. 82, Pr. 90 to Pr. 94, Pr. 859			○	○	○	
	Speed setting/display unit switchover	Pr. 37, Pr. 144, Pr. 81, Pr. 454			○	○	○	
Input functions	Electronic gear	Pr. 420, Pr. 421			×	×	○	
	Multi-function input terminal assignment	Pr. 180 to Pr. 183, Pr. 187			○	○	○	
	Analog input assignment/calibration	Pr. 868 / Pr. 902 to Pr. 920	No. 1, 2, 3 terminals		○	○	○	
	Analog command filter time constant	Pr. 822, Pr. 826, Pr. 832, Pr. 836			○	○	○	
	Override, polarity reversible	Pr. 73, Pr. 252, Pr. 253			○	○	×	
Output functions	Output stop	Pr. 17, Pr. 180 to Pr. 183, Pr. 187	MRS		○	○	○	
	Multi-function output terminal assignment	Pr. 190 to Pr. 192, Pr. 195			○	○	○	
	Speed restriction output	Pr. 190 to Pr. 192, Pr. 195	SL		×	○	×	
	Inverter running signal	Pr. 13, Pr.190 to Pr. 192, Pr. 195	RUN		○	○	○	
	Up-to-speed signal	Pr. 41, Pr. 190 to Pr. 192, Pr. 195	SU		○	×	×	
	Overload alarm signal	Pr. 190 to Pr. 192, Pr. 195	OL					
	Speed detection signal	Pr. 42, Pr. 43, Pr. 50, Pr. 116, Pr. 190 to Pr. 192, Pr. 195	FU, FU2, FU3 FB, FB2, FB3		○	×	×	
	Regenerative brake prealarm signal	Pr. 190 to Pr. 192, Pr. 195	RBP		○	○	○	
	Electronic thermal relay prealarm signal	Pr. 190 to Pr. 192, Pr. 195	THP		○	○	○	
	PU operation mode signal	Pr. 190 to Pr. 192, Pr. 195	PU		○	○	○	
	Operation ready signal	Pr. 190 to Pr. 192, Pr. 195	RY		○	○	○	
	Output current detection signal, zero current detection signal	Pr. 150, Pr. 151, Pr. 152, Pr. 153, Pr. 190 to Pr. 192, Pr. 195	Y12, Y13		○	○	○	
	Fan fault output signal	Pr. 190 to Pr. 192, Pr. 195	FAN		○	○	○	
	Fin overheat prealarm signal	Pr. 190 to Pr. 192, Pr. 195	FIN		○	○	○	
	Forward, reverse rotation output signal	Pr. 190 to Pr. 192, Pr. 195	Y30, Y31		○	○	○	
	Regenerative status output signal	Pr. 190 to Pr. 192, Pr. 195	Y32		○	○	○	
	Operation ready 2 signal	Pr. 190 to Pr. 192, Pr. 195	RY2		○	○	○	
	Low speed detection signal	Pr. 190 to Pr. 192, Pr. 195, Pr. 865	LS		○	○	○	
	Torque detection signal	Pr. 190 to Pr. 192, Pr. 195, Pr. 864	TU		○	○	○	
	Maintenance output	Pr. 190 to Pr. 192, Pr. 195, Pr. 890 to Pr. 892	MT		○	○	○	
	Remote output	Pr. 190 to Pr.192, Pr. 195, Pr. 495 to Pr. 497	REM		○	○	○	
	Instantaneous power failure (undervoltage) signal	Pr. 190 to Pr. 192, Pr. 195	IPF		○	○	○	
	Fault definition	Pr. 190 to Pr. 192, Pr. 195, Pr. 875	ER		○	○	×	
	Minor fault output signal	Pr. 190 to Pr. 192, Pr. 195	LF		○	○	○	
	Alarm output signal	Pr. 190 to Pr. 192, Pr. 195	ABC		○	○	○	
	Monitor functions	DU/PU display data selection	Pr. 52, Pr. 53			○	○	○
		DA1, DA2 output/calibration	Pr. 54 to Pr. 56, Pr. 866, Pr. 158, Pr. 900, Pr. 901	DA1, DA2		○	○	○
DA1 output filter		Pr. 867	DA1		○	○	○	
Speed monitor		Pr. 52 to Pr. 55, Pr.158			○	○	○	
Output current monitor/output current peak value monitor		Pr. 52 to Pr. 54, Pr. 56, Pr. 158			○	○	○	
Output voltage monitor		Pr. 52 to Pr. 54, Pr. 158			○	○	○	
Preset speed monitor		Pr. 52 to Pr. 55, Pr. 158			○	○	○	
Output frequency monitor		Pr. 52 to Pr. 55, Pr. 158			○	○	○	
Motor torque monitor		Pr. 52 to Pr. 54, Pr. 158, Pr. 866			○	○	○	
Converter output voltage monitor, converter output voltage peak value monitor		Pr. 52 to Pr. 54, Pr. 158			○	○	○	
Input terminal monitor, output terminal monitor		—			○	○	○	
Load meter monitor		Pr. 52 to Pr. 54, Pr. 158, Pr. 866			○	○	○	
Motor excitation current monitor		Pr. 52 to Pr. 54, Pr. 158, Pr. 56			○	○	○	
Cumulative operation time monitor		Pr. 52			○	○	○	
Actual operation time monitor		Pr. 52, Pr. 171			○	○	○	
Motor load factor		Pr. 52			○	○	○	
Orientation status		Pr. 52			○	×	×	
Option fitting status monitor		—			○	○	○	
Terminal assignment status monitor		—			○	○	○	
Motor output monitor		Pr. 52			○	○	○	
Feedback pulse monitor	Pr. 52			○	○	○		
Torque command/torque current command	Pr. 52, Pr. 54, Pr. 158 , Pr. 866			○	○	○		

At-a-glance guide to functions

Category	Function	Pr. number	Terminal	Control Applicable Motor	PLG Vector		
					Speed	Torque	Position
					SF-V5R "Motor with PLG (standard, constant torque)" *: This function can be usable under position control by parameter setting.		
Protective functions	Overcurrent protection	—			○	○	○
	Overvoltage protection	—			○	○	○
	Electronic thermal O/L relay	Pr. 9			○	○	○
	Fin overheat	—			○	○	○
	Brake transistor alarm	Pr. 30, Pr. 70			○	○	○
	Earth (Ground) fault overcurrent protection	—			○	○	○
	External thermal relay <OHT>	Pr. 876	OH		○	○	○
	Motor overload (OLT)	Pr. 865, Pr. 874			○	○	○
	Option alarm	—			○	○	○
	Parameter error	—			○	○	○
	Disconnected PU detection	Pr. 75			○	○	○
	Output phase failure protection	Pr. 251			○	○	○
	CPU error	—			○	○	○
	12/24VDC power supply short circuit protection	—			○	○	○
	Operation panel power supply short circuit protection	—			○	○	○
	Overspeed occurrence	Pr. 374			○	○	○
	Speed deviation large	Pr. 870, Pr. 871			○	○	○
	Encoder no-signal	—			○	○	○
	Encoder A no-signal	—			○	×	×
	Position error large	Pr. 427			×	×	○
Output short circuit protection	—			○	○	○	
Encoder phase error (E. EP)	—			○	○	○	
PU	PU language changing	Pr. 145			○	○	○
	Buzzer control	Pr. 990			○	○	○
	PU contrast adjustment	Pr. 991			○	○	○
Options	12-bit digital input "A5AX"	Pr. 300 to Pr. 305, Pr. 329			○	○	×
	Digital setting of torque command "A5AX"	Pr. 447, Pr. 448, Pr. 804			×	○	×
	Machine end orientation "V5AM"	Pr. 350 to Pr. 369, Pr. 390 to Pr. 396			○	×	×
	Pulse position control "V5AP"	Pr. 419 to Pr. 431			×	×	○
	PLG output "V5AY"	Pr. 410 to Pr. 413			○	○	○
	Thermistor secondary resistance compensation "V5AX"	Pr. 407, Pr. 925			○	○	○
	Extension analog input "V5AX"	Pr. 406			○	○	○
	Extension contact input "V5AX"	Pr. 400 to Pr. 405			○	○	○
	Digital output "A5AY, V5AY"	Pr. 313 to Pr. 319 / Pr. 410 to Pr. 413			○	○	○
	Extension analog output "A5AY"	Pr. 306 to Pr. 312			○	○	○
	Relay output "A5AR"	Pr. 320 to Pr. 322, Pr. 330			○	○	○
	Pulse train input "A5AP"	Pr. 384 to Pr. 386			○	○	×
	RS485 communication "A5NR"	Pr. 331 to Pr. 342			○	○	○
	CC-Link "A5NC"	Pr. 338 to Pr. 342			○	○	○
	Profibus-DP "A5NPA"	Pr. 338 to Pr. 342			○	○	○
	Device-Net "A5ND"	Pr. 338 to Pr. 342, Pr. 345 to Pr. 348			○	○	○
	Modbus Plus "A5NM"	Pr. 338 to Pr. 342			○	○	○
Trace (plug-in option)	Pr. 520 to Pr. 536			○	○	○	

3.4 Basic functions (Pr. 0 to Pr. 9)

3.4.1 Torque boost (Pr. 0)

Use this parameter for V/F control only.

- Motor torque in the low speed region can be adjusted according to the load to increase the starting motor torque.

Parameter	Name	Factory Setting	Setting Range	Remarks
0	Torque boost (manual)	4%/3%/2% (3.7K or less/5.5K, 7.5K/11K or more)	0 to 30%	Extended mode

<Setting>

- Increase the setting when the distance between the inverter and motor is long or when the motor torque in the low speed region is insufficient (when the stall prevention protective function is activated), for example.
- Assuming that the base frequency voltage is 100%, set the 0Hz voltage in %.

CAUTION

If the setting is too large, the motor may result in overheat or overcurrent trip. The guideline for maximum value is about 10%.

3.4.2 Maximum and minimum speed settings

(Pr. 1 speed torque position, Pr. 2 speed torque)

You can limit the maximum (minimum) speed.

- Speed control
The maximum setting is placed on the running speed.
The minimum setting is placed on the preset speed.
- Torque control
The maximum and minimum settings are made on the speed restriction commands. (Restriction is not placed on the running speed.)
- Position control
The maximum setting is valid for the speed command obtained from the droop pulses. The minimum setting is invalid.

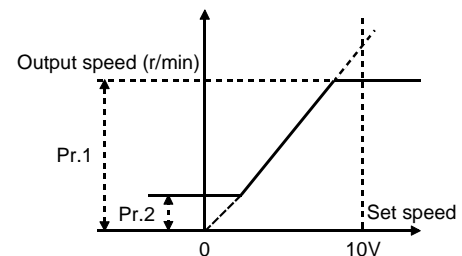

Parameter	Name	Factory Setting	Setting Range	Remarks
1	Maximum speed	Japanese version: 1500r/min	0 to 3600r/min	Simple mode
		NA version :1800r/min		
2	Minimum speed	0r/min	0 to 3600r/min	Simple mode

<Setting>

● Speed control

- When the upper limit of the output speed is set in Pr. 1, the output speed is clamped at the maximum speed even if the speed command entered is higher than the speed set in Pr.1. (This also applies to the minimum speed setting.)

⚠ CAUTION

⚠ When the Pr. 2 setting is higher than Pr. 13 "starting speed" value, note that the motor will run at the pre-set speed by merely turning the start signal on, even if the command speed has not been entered.

Related parameters

- Starting speed setting ⇒ Pr. 13 "starting speed" (Refer to page 88.)
- Speed restriction command selection for torque control ⇒ Pr. 807 "speed restriction selection" (Refer to page 173.)
- External (example: terminal 2-5 connection) speed setting potentiometer adjustment ⇒ Pr. 902 "speed setting No. 2 bias" (Refer to page 190.), Pr. 903 "speed setting No. 2 gain" (Refer to page 190.)

3.4.3 Base frequency, base frequency voltage (Pr. 3, Pr. 19)

Use this parameter for V/F control only.
This parameter matches the inverter outputs (voltage, frequency) to the motor rating.

Parameter	Name	Factory Setting	Setting Range	Remarks
3	Base frequency	Japanese version :60Hz	20 to 200Hz	Extended mode
		NA version :60Hz		
19	Base frequency voltage	9999	0 to 1000V, 8888, 9999	Extended mode 8888: 95% of power supply voltage 9999: Same as power supply voltage

<Setting>

- Use Pr. 3 to set the base frequency (rated motor frequency).
- If only "50Hz" is given on the motor rating plate as the frequency, always set the "base frequency" to "50Hz". If it remains at "60Hz", the voltage may become too low and torque shortage occurs, resulting in an overload trip.
- Use Pr. 19 to set the base voltage (e.g. rated motor voltage).
The motor whose rated voltage is lower than the power supply voltage of the inverter can be used optimally. This function is useful when a motor rated at 200V is used with a 230V power supply.
- For the SF-V5R motor, set "170V" for 3.7kW (5HP) or less and "160V" for 5.5kW (7.5HP) or more in Pr. 19 "base frequency voltage". For the SF-VR motor, set "160V". Set "50 Hz" in Pr. 3 "base frequency".

REMARKS

If vector control is disabled due to an encoder fault, setting "20" in Pr. 800 "control system selection" enables operation under V/F control. (Refer to page 170.)

Related parameters

Motor setting ⇒ Pr. 71 "applied motor", Pr. 450 "second applied motor" (Refer to page 114.)

3.4.4 Multi-speed operation

(Pr. 4 to Pr. 6, Pr. 24 to Pr. 27, Pr. 232 to Pr. 239 **speed** **torque** **position**)

Can be used to change between the predetermined running speeds by switching from one terminal to another.

- Any speed can be selected by merely turning on-off the contact signals (RH, RM, RL, REX signals).
- Using these parameters with Pr. 1 "maximum speed" and Pr. 2 "minimum speed" allows the setting of up to 17 speeds.

POINT

- Valid in the external operation mode or in the combined operation mode that is made available by setting "3 or 4" in Pr. 79.
- Valid when "0" is set in Pr. 59.

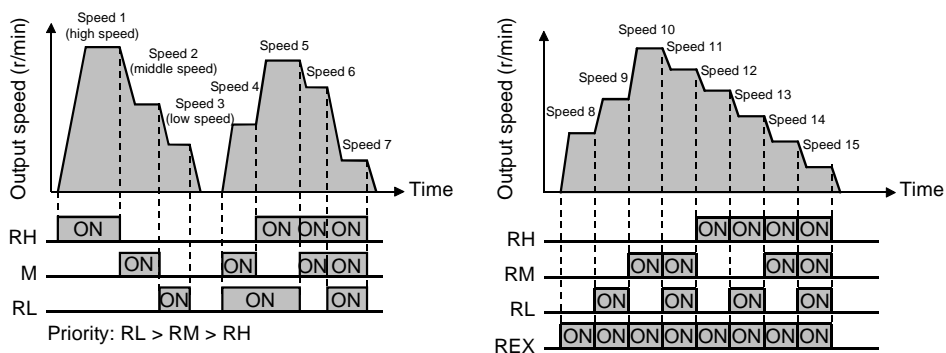

Parameter	Name	Factory Setting	Setting Range	Remarks
4	Multi-speed setting (high speed)	Japanese version: 1500r/min	0 to 3600r/min	Simple mode
		NA version: 1800r/min		
5	Multi-speed setting (middle speed)	750r/min	0 to 3600r/min	Simple mode
6	Multi-speed setting (low speed)	150r/min	0 to 3600r/min	Simple mode
24 to 27	Multi-speed setting (speeds 4 to 7)	9999	0 to 3600r/min, 9999	"9999" No setting
232 to 239	Multi-speed setting (speeds 8 to 15)	9999	0 to 3600r/min, 9999	"9999" No setting

<Setting>

- Set the running speeds in the corresponding parameters. Each speed can be set as desired in the range 0 to 3600r/min during inverter operation. With any multi-speed setting parameter being read, press / to change the setting. In this case, press to store the preset speed. (This is also enabled in the external mode.) Pressing reflects the preset speed.

REMARKS

- Press when the FR-PU04V (option) is used.
- Use Pr. 180 to Pr. 183 and Pr. 187 to assign the terminals used for signals RH, RM, RL, and REX. (*)
*Changing terminal assignment using Pr. 180 to Pr. 183, Pr. 187 may affect the other functions. Check the functions of the corresponding terminals before making setting.
- The priorities of the external terminals for speed commands are as follows.
Jog > pulse train input (option FR-A5AP) > digital setting (option FR-A5AX) > multi-speed operation > PID > No. 2 terminal

CAUTION

- The multi-speed settings override the main speed (across terminals 2-5).
- The multi-speeds can also be set in the PU or external operation mode.
- For 3-speed setting, if two or more speeds are simultaneously selected, priority is given to the preset speed of the lower signal. (RL > RM > RH)
- Pr. 24 to Pr. 27 and Pr. 232 to Pr. 239 settings have no priority between them.
- The settings can also be changed during operation.
- When the jog signal is used with multi-speed signals, the jog signal has priority.

Related parameters

- Maximum, minimum speed setting⇒ Pr. 1 "maximum speed", Pr. 2 "minimum speed" (Refer to page 81.)
- Signal RH, RM, RL, REX terminal assignment⇒ Pr. 180 to Pr. 183, Pr. 187 (input terminal function selection) (Refer to page 151.)
- External operation mode setting⇒ Pr. 79 "operation mode selection" (Refer to page 120.)
- Extended mode/simple mode setting⇒ Pr. 160 "extended function selection" (Refer to page 151.)

3.4.5 Acceleration and deceleration times

(Pr. 7, Pr. 8, Pr. 20, Pr. 21, Pr. 44, Pr. 45, Pr. 110, Pr. 111)

Set the acceleration/deceleration time of the motor during speed control and position control by parameter setting. Set a larger value for a slower speed increase/decrease or a smaller value for a faster speed increase/decrease. Under torque control, the speed restriction value varies with the acceleration/deceleration time.

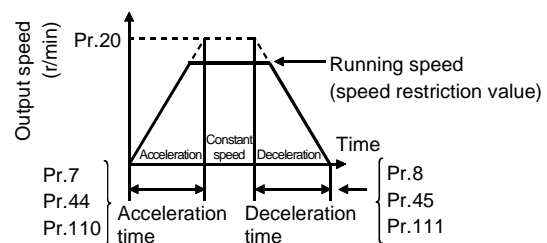

Parameter	Name	Factory Setting	Setting Range	Remarks	
7	Acceleration time	5s/15s (5.5K or less/7.5K or more)	0 to 3600s	Simple mode	
			0 to 360s		
8	Deceleration time	5s/15s (5.5K or less/7.5K or more)	0 to 3600s	Simple mode	
			0 to 360s		
20	Acceleration/ deceleration reference speed	Japanese version: 1500r/min	1 to 3600 r/min	Extended mode	
		NA version: 1800r/min			
21	Acceleration/ deceleration time increments	0	0, 1	0: 0 to 3600s 1: 0 to 360s	Extended mode
44	Second acceleration/ deceleration time	5s	0 to 3600s	Pr. 21 = 0	Extended mode
			0 to 360s	Pr. 21 = 1	
45	Second deceleration time	9999	0 to 3600s	Pr. 21 = 0	Extended mode
			0 to 360s	Pr. 21 = 1	
			9999	Acceleration time = deceleration time	
110	Third acceleration/ deceleration time	5s	0 to 3600s	Pr. 21 = 0	Extended mode
			0 to 360s	Pr. 21 = 1	
111	Third deceleration time	9999	0 to 3600s	Pr. 21 = 0	Extended mode
			0 to 360s	Pr. 21 = 1	
			9999	Acceleration time = deceleration time	

<Setting>

- Use Pr. 21 to set the acceleration/deceleration time and minimum setting range.
Value "0" (factory setting) 0 to 3600s (minimum setting increments: 0.1s)
Value "1" 0 to 360s (minimum setting increments: 0.01s)
Changing the Pr. 21 value changes the setting of Pr. 7, Pr. 8, Pr. 44, Pr. 45, Pr. 110 and Pr. 111.

CAUTION

Changing the Pr. 21 setting changes the acceleration/deceleration setting (Pr. 7, Pr. 8, Pr. 16, Pr. 44, Pr. 45, Pr. 110, Pr. 111)

<Example>

When Pr. 21 = "0", setting "5.0" s in Pr. 7 and "1" in Pr. 21 changes the Pr. 7 setting to "0.5" s.

- Use Pr. 7, Pr. 44 and Pr. 110 to set the acceleration time taken to reach the speed set in Pr. 20 from 0r/min.
- Use Pr. 8, Pr. 45 and Pr. 111 to set the deceleration time taken to reach 0r/min from the speed set in Pr. 20.
- Use Pr. 180 to Pr. 183 and Pr. 187 to assign the terminals used to input the RT and X9 signals.

CAUTION

- **Pr. 44 and Pr. 45 are valid when the RT signal is on.**
When the RT signal is on, the other second functions (Pr. 450 to Pr. 463, Pr. 815, Pr. 830 to Pr. 837) are also valid.
- **Pr. 110 and Pr. 111 are valid when the X9 signal is on.**
When the X9 signal is on, Pr. 820 to Pr. 827 are also valid.
- **When both RT and X9 are on, Pr. 110 and Pr. 111 are valid.**
- **Switching the RT and X9 signals during operation does not change the acceleration/deceleration time immediately when position control is exercised with the conditional position control function (Pr. 419 = "0") by the contact input.**

REMARKS

- Changing the Pr. 20 "acceleration/deceleration reference speed" setting does not adjust the speed gain setting signal. To adjust the gain, adjust the calibration function (Pr. 903).
- When the setting of Pr. 7, Pr. 8, Pr. 44, Pr. 45, Pr. 110 or Pr. 111 is "0" under V/F control, the acceleration/deceleration time is 0.04s.
- However short the acceleration/deceleration time setting is, the actual motor acceleration/deceleration time cannot be made shorter than the shortest acceleration/deceleration time that is determined by the mechanical system J (inertia moment) and the motor torque.

Related parameters

- Jog acceleration/deceleration time ⇒ Pr. 16 "jog acceleration/deceleration time" (Refer to page 89.)
- RT signal, X9 signal setting ⇒ Pr. 180 to Pr. 183, Pr. 187 (input terminal function selection) (Refer to page 151.)

3.4.6 Motor overheat protection (Pr. 9, Pr. 452, Pr. 876 speed torque position)

When an external thermal relay is not used, protect the motor from overheat by integration processing of the inverter output current. This feature provides the optimum protective characteristics, including reduced motor cooling capability, at low speed.

Parameter	Name	Factory Setting	Setting Range	Remarks
9	Electronic thermal O/L relay	Japanese version: 0	0 to 500A	Extended mode (NA version: simple mode)
		NA version: Rated inverter output current		
452	Second electronic thermal O/L relay	9999	0 to 500A, 9999	Extended mode 9999: Without second electronic thermal relay
876	Thermal relay protector input	1 (0)	0, 1	Extended mode

<Setting>

- When not using an external thermal relay, set the rated current value [A] of the motor in Pr. 9 (Pr. 452) to make the electronic thermal relay valid.
(Normally set the rated current value at 50Hz. When the rated current value of 50Hz is not indicated on the name plate, set the value obtained from multiplying the rated current value of 60Hz by 1.1.)
- Setting "0" in Pr. 9 (Pr. 452) deactivates the electronic thermal relay (motor protective function). (The inverter's output transistor protective function is activated).
When using the Mitsubishi dedicated motor, set "0" since the thermal protector is onboard (outside).
- When using the Mitsubishi constant-torque motor
Set "10" in Pr. 71 "applied motor" to select the 100% continuous torque characteristic in the low speed range.
Set the rated current of the motor in Pr. 9 "electronic thermal O/L relay".
- The electronic thermal relay of the second motor (Pr. 452 "second electronic thermal O/L relay" is made valid by: Turning on the RT signal; and Setting other than 9999 in Pr. 450.
(The value set in Pr. 9 is valid when Pr. 452 = 9999.)

● Selection for whether to use an external thermal relay or not (Pr. 876 "thermal relay protector input")

Pr. 876 Setting	Motor with PLG (e.g. SF-JR)
0	When thermal relay etc. is not used (thermal relay protector input invalid)
1	When thermal relay etc. is used (thermal relay protector input valid)

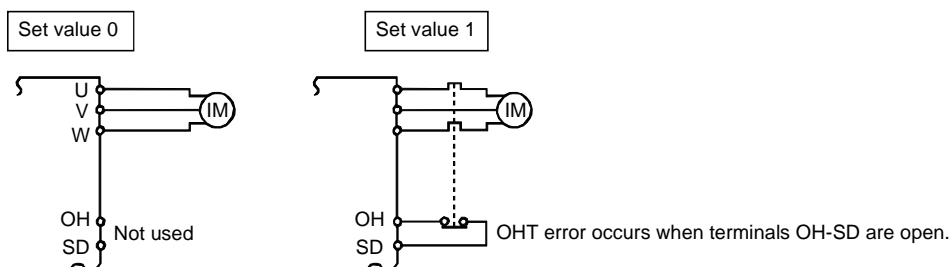

CAUTION

- When two or more motors are connected to the inverter under V/F control, they cannot be protected by the electronic thermal relay. Install an external thermal relay to each motor.
- When a difference between the inverter and motor capacities is large and the setting is small, the protective characteristics of the electronic thermal relay will be deteriorated. In this case, use an external thermal relay.
- A special motor cannot be protected by the electronic thermal relay. Use an external thermal relay.

REMARKS

- When running two motors with one inverter, you can set the electronic thermal relay of each inverter.

Pr. 450 "second applied motor"	Pr. 9 "electronic thermal O/L relay"	Pr. 452 "second electronic thermal O/L relay"	First Motor Electronic Thermal Relay		Second Motor Electronic Thermal Relay	
			RT = OFF	RT = ON	RT = OFF	RT = ON
9999	0	9999	×	×	×	×
		0	×	×	×	×
		0.01 to 500	×	×	△	○
9999	Other than 0	9999	○	○	×	×
		0	○	△	×	×
		0.01 to 500	○	△	△	○
Other than 9999	0	9999	×	×	×	×
		0	×	×	×	×
		0.01 to 500	×	×	△	○
Other than 9999	Other than 0	9999	○	△	△	○
		0	○	△	×	×
		0.01 to 500	○	△	△	○

○... Output current value is used to perform integration processing.

△... Output current is assumed as 0A to perform integration processing. (cooling processing)

×... Electronic thermal relay is not activated.

- It is valid for controlling one motor with one inverter in two different control systems.
- It is valid for controlling the first motor with an external thermal relay and the second motor with an electronic thermal relay.

Related parameters

- When constant-torque motor is used ⇒ Pr. 71 "applied motor", Pr. 450 "second applied motor" (Refer to page 114.)
- Use of second motor ⇒ Pr. 450 "second applied motor" (Refer to page 114.)
- RT signal setting ⇒ Set "3" in any of Pr. 180 to Pr. 183 and Pr. 187 (input terminal function selection). (Refer to page 151.)

3.5 Standard operation functions (Pr. 10 to Pr. 16)

3.5.1 DC injection brake (Pr. 10, Pr.11 speed torque , Pr. 12, Pr.802 speed position)

By setting the DC injection brake voltage (torque) at a stop, operation time and operation starting speed, the stopping accuracy of positioning operation, etc. or the timing of applying the DC injection brake to stop the motor is adjusted according to the load.

Parameter	Name	Factory Setting	Setting Range	Remarks	
10	DC injection brake operation speed	15r/min	0 to 1500 r/min, 9999	9999: Operated at or below Pr. 13 value.	
11	DC injection brake operation time	0.5s	0 to 0.5s	Extended mode	
12	DC injection brake voltage	4%/2% (7.5K or less/11K or more)	0 to 30%		Use only during V/F control.
802	Pre-excitation selection	0	0, 1		Use only during speed control.

<Setting>

- Use Pr. 10 to set the speed at which the DC injection brake application is started.
By setting "9999", the brake is operated at or below the speed set in Pr. 13.
- When stopping the motor by using a STOP key or turning the STF/STR off, the DC injection brake application is started at the speed set in Pr.10. When stopping the motor by setting speed to 0r/min (with PU or Volume), the DC injection brake application is started at the speed set in Pr.13.
- Use Pr. 11 to set the duration period the brake is applied. During this period, DC injection brake operation is exercised.
When this period has elapsed, the motor is coasted to a stop.
- Use Pr. 12 to set the percentage to the power supply voltage. (Use this parameter only during V/F control.)
When using the inverter dedicated motor (Mitsubishi constant-torque motor SF-JRCA and Mitsubishi energy saving motor SF-HR, SF-HRCA), change the Pr. 12 setting as follows:
 - SF-JRCA: 3.7K or less ... 4%, 5.5K or more ... 2%
 - SF-HR, SF-HRCA: 3.7K or less ... 4%, 5.5K, 7.5K ... 3%, 11K or more ... 2%

REMARKS

- For the 5.5K and 7.5K, the Pr. 12 setting is automatically changed to 2% if Pr. 71 "applied motor" value is set to the Mitsubishi constant motor. To the contrary, the Pr. 12 setting is changed to 4% if the Pr. 71 value is set to the general purpose motor.
- When pre-excitation is performed with the LX signal, select zero speed control or servo lock using Pr. 802.
Turning on the LX signal enables the pre-excitation function. (valid only during speed control)

Parameter	Name	Description
802	Pre-excitation selection	0: Zero speed control (factory setting) Even under load, an attempt is made to maintain 0r/min to keep the motor shaft stopped. Note that if the shaft is overcome and turned by external force, it does not return to the original position. Position control is not exercised and only speed control is carried out to perform operation.
		1: Servo lock Even under load, an attempt is made to maintain the motor shaft position. Note that if the shaft is turned by external force, it returns to the original position after the external force has gone away. Since position control is exercised, you can adjust this position loop gain using Pr. 422 "position loop gain".

- The relationship between the DC injection brake operation and pre-excitation operation under each control

Control Mode	Operation			
	LX terminal OFF (Deceleration to stop)		LX terminal ON	
	Pre-excitation selection Pr. 802 = 0	Pre-excitation selection Pr. 802 = 1	Pre-excitation selection Pr. 802 = 0	Pre-excitation selection Pr. 802 = 1
V/F control	DC injection brake	DC injection brake	No operation	No operation
Speed control (vector control)	Zero speed control	Servo lock	Zero speed control	Servo lock
Position control (vector control)	No operation	No operation	Servo lock	Servo lock

Standard operation functions (Pr. 10 to Pr. 16)

● The control block diagram during pre-excitation

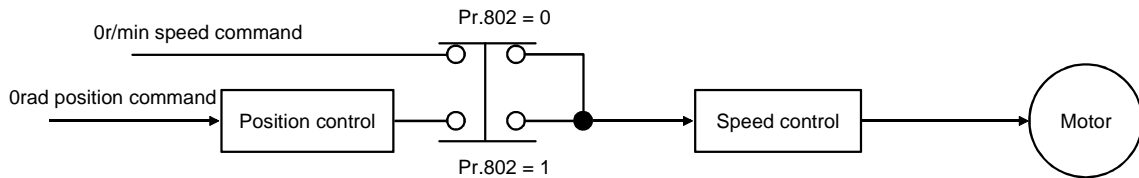

● Timing chart

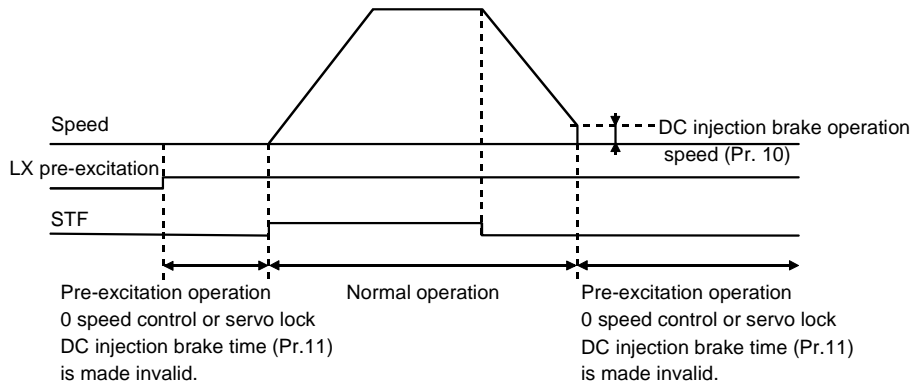

* When the LX (pre-excitation) terminal is off, the pre-excitation operation functions for the time set in the DC injection brake time (Pr. 11).

⚠ CAUTION

⚠ **Install a mechanical brake.**
After the machine stops fully and the mechanical brake is applied, switch the LX signal (pre-excitation) off.

CAUTION

The DC injection brake functions during speed restriction under speed control or torque control, but does not function under position control.

Related parameters

- DC injection brake operation speed when Pr. 10 = 9999 ⇒ Pr. 13 "starting speed"(Refer to page 88.)
- When using constant-torque motor ⇒ Pr. 71 "applied motor", Pr. 450 "second applied motor"(Refer to page 114.)
- Setting control mode ⇒ Pr. 800 "control system selection" (Refer to page 114.)
- LX signal terminal assignment ⇒ Set "23" in any of Pr. 180 to Pr. 183 and Pr. 187 (input terminal function selection). (Refer to page 151.)

3.5.2 Starting speed (Pr. 13 speed torque)

You can set the starting speed at which the start signal is turned on.

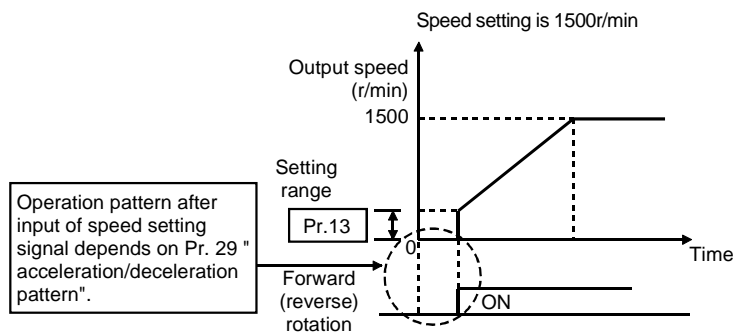

Parameter	Name	Factory Setting	Setting Range	Remarks
13	Starting speed	15r/min	0 to 1500r/min	Extended mode

CAUTION

- If the speed setting signal is less than the value set in Pr. 13 "starting speed", the operation is either 0 speed or servo lock.
For example, when 150r/min is set in Pr. 13, the motor will start running when the speed setting signal reaches 150r/min.
- When the analog voltage command (example: across 2-5) is used as speed for operation, too low of a setting of the rotation speed at a start may start the motor running by merely entering the start signal although the voltage command is zero. In this case, adjustment can be made using the calibration function, Pr. 902.

⚠ CAUTION

⚠ When the Pr. 13 setting is lower than Pr. 2 "minimum speed" value, note that the motor will start running at the preset speed by merely turning the start signal on, even if the command speed has not been entered.

Related parameters

- Minimum speed setting ⇒ Pr. 2 "minimum speed" (Refer to page 81.)
- Acceleration/deceleration pattern setting ⇒ Pr. 29 "acceleration/deceleration pattern" (Refer to page 93.)
- Adjustment for analog voltage command ⇒ Pr. 902 "speed setting No. 2 bias" (Refer to page 190.)

3.5.3 Jog operation (Pr. 15, Pr. 16 speed torque)

To start/stop jog operation in the external operation mode, choose the jog operation function in input terminal function selection, turn on the jog signal, and turn on/off the start signal (STF, STR). When using the parameter unit (FR-PU04V), choose the jog operation mode and use **[FWD]** or **[REV]** to perform jog operation.
(When the FR-PU04V is connected, these parameters can be read as the basic parameters.)
Perform PU JOG operation using PU (FR-DU04-1, FR-PU04V) in the PU-JOG operation mode. Refer to the Instruction Manual (basic) for details.

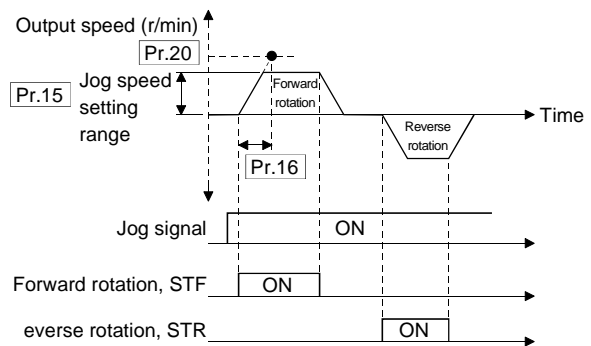

- Set the speed and acceleration/deceleration time for jog operation.

Parameter	Name	Factory Setting	Setting Range	Remarks
15	Jog speed setting	150r/min	0 to 1500r/min	Extended mode
16	Jog acceleration/ deceleration time	0.5s	0 to 3600s	
			0 to 360s	When Pr. 21=1

REMARKS

For the operation method from the operation panel (FR-DU04-1), refer to the Instruction Manual (basic).

CAUTION

- The acceleration time and deceleration time cannot be set separately for jog operation.
- Pr. 15 "jog speed setting" value should be equal to or higher than Pr. 13 "starting speed" setting.
- Assign the jog signal to any of Pr. 180 to Pr. 183 and Pr. 187 (input terminal function selection).
- The priorities of the external terminals for speed commands are:
Jog > multi-speed operation > No. 2 terminal
- During jog operation, the RT and X9 signals cannot be used to switch to the second and third acceleration/deceleration time.
- Under torque control, the jog speed acts as the speed restriction value by turning on the jog signal.
- Jog operation is invalid under position control.

Related parameters

- Jog signal terminal assignment ⇒ Set "5" in any of Pr. 180 to Pr. 183, Pr. 187 (input terminal function selection) (Refer to page 151.)
- S-shaped acceleration/deceleration pattern A ⇒ Pr. 29 "acceleration/deceleration pattern" (Refer to page 93.)
- Pr. 16 setting range, minimum setting increments condition setting ⇒ Pr. 21 "acceleration/deceleration time increments" (Refer to page 83.)

3.6 Operation selection functions 1 (Pr. 17 to Pr. 37)

3.6.1 Inverter output stop (MRS) (Pr. 17 speed torque position)

The setting of this parameter needs to be changed to:

- Stop the motor with a mechanical brake (e.g. electromagnetic brake);
- Provide interlocks to prevent the inverter from running if the start signal is input to the inverter; or
- Coast the motor to a stop.

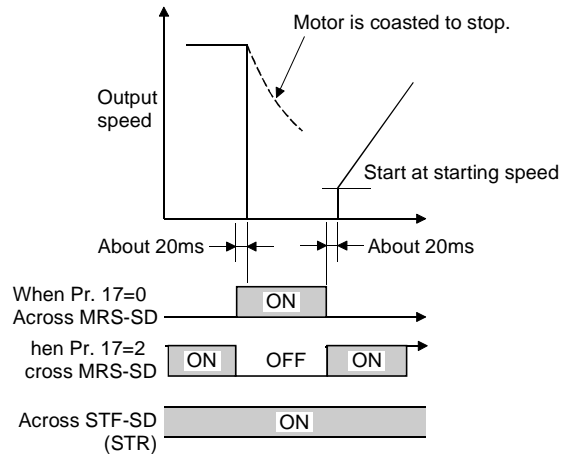

Parameter	Name	Factory Setting	Setting Range	MRS Signal Specifications	Remarks
17	MRS input selection	0	0	Output stops when MRS signal turns on.	Extended mode
			2	Output stops when MRS signal turns off. (b contact input specifications)	

<Wiring example> For sink logic

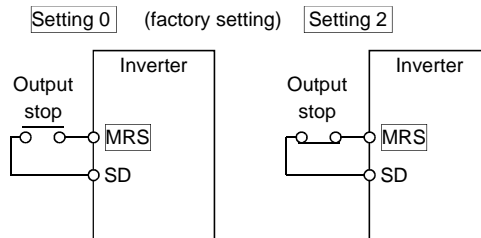

REMARKS

- Set the MRS signal using the input terminal function selection (Pr. 180 to Pr. 183, Pr. 187).
- The setting cannot be changed during operation.
- Refer to the Instruction Manual (basic) for inverter reset.

CAUTION

- When Pr. 30 = 2 (FR-HC connection), use the X10 signal.
- When the operation mode is the NET mode and Pr. 338 = 0, the MRS signal is used as both the external terminal and communication-based signals, and the output stops when either signal turns on. At the Pr. 17 setting of 2, the output stops when either signal turns off. (Oppositely, at the Pr. 17 setting of 2, both the external terminal and communication-based signals should turn on to make a start.)

Related parameters

- Starting speed setting ⇒ Pr. 13 "starting speed" (Refer to page 88.)
- MRS signal terminal assignment ⇒ Pr. 180 to Pr. 183, Pr. 187 (input terminal function selection) (Refer to page 151.)

Pr. 19 Refer to Pr. 3 (page 82)

Pr. 20, Pr. 21 Refer to Pr. 7, Pr. 8 (page 83)

3.6.2 Torque restriction (Pr. 22 speed position , Pr. 803 speed torque position , Pr. 810 speed position , Pr. 812 to Pr. 817 speed position)

Used to restrict the output torque to the predetermined value during speed control.
For details of the setting method, refer to the torque restriction of the Instruction Manual (basic).

Parameter	Name	Factory Setting	Setting Range	Remarks	
22	Torque restriction level (*1)	150%	0 to 400%	When Pr. 810 = 0, 1 quadrant Pr. 22 2 quadrant Pr. 812 3 quadrant Pr. 813 4 quadrant Pr. 814	Extended mode
803	Constant output region torque characteristic selection	0	0	Constant output restriction	
			1	Constant torque restriction	
810	Torque restriction input method selection	0	0	Internal torque restriction Parameter-set torque restriction operation is performed.	
			1	External torque restriction Speed restriction based on the analog voltage from the No. 3 terminal	
812	Torque restriction level (regeneration)	9999	0 to 400%, 9999	Valid in the regeneration mode when Pr. 810 = 0. 9999: Pr. 22 value is used for restriction.	
813	Torque restriction level (3rd quadrant)	9999	0 to 400%, 9999	Valid in the reverse rotation driving mode when Pr. 810 = 0. 9999: Pr. 22 value is used for restriction.	
814	Torque restriction level (4th quadrant)	9999	0 to 400%, 9999	Valid in the regeneration mode when Pr. 810 = 0. 9999: Pr. 22 value is used for restriction.	
815	Torque restriction level 2	9999	0 to 400%, 9999	When the torque restriction selection (TL) signal is on, Pr. 815 is used as the torque restriction value regardless of Pr. 810. Valid when torque restriction selection (TL) terminal input is provided. 9999: Depending on Pr. 22 setting	
816	Acceleration torque restriction(*2)	9999	0 to 400%, 9999	Set the torque restriction value during acceleration. 9999: Same torque restriction as at constant speed	
817	Deceleration torque restriction(*2)	9999	0 to 400%, 9999	Set the torque restriction value during deceleration. 9999: Same torque restriction as at constant speed	

CAUTION

- *1.Output current level (stall prevention function) is activated to prevent the inverter from alarm stop due to overcurrent etc. during V/F control. When "0" is set in Pr. 22, stall prevention function is invalid.
- *2.Pr. 816 "acceleration torque restriction" and Pr. 817 "deceleration torque restriction" are invalid during position control.

<Details>

Torque restriction is activated so that the output torque does not exceed the predetermined value during speed control. The block diagram is shown below. The output of speed control is suppressed within the torque restriction value.

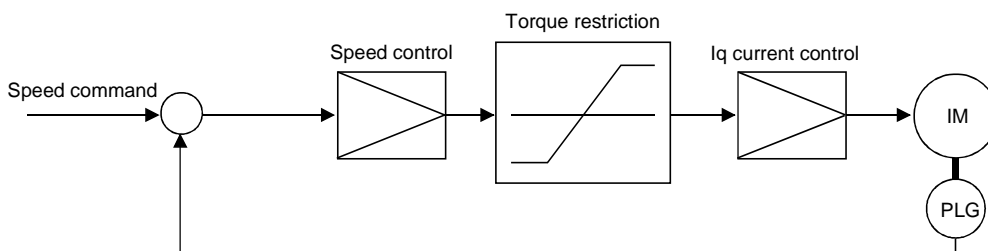

At this time, set Pr. 810 to select the way to make torque restriction.

<Setting>

Pr. 810 Setting	Torque Restriction Input Method	Operation
0	Internal torque restriction	Parameter-set torque restriction operation is performed. Changing the torque restriction parameter value by communication enables torque restriction to be adjusted by communication.
1	External torque restriction	Torque restriction using the analog voltage from the No. 3 terminal is made valid.

REMARKS



Refer to the Instruction Manual (basic) for details of the other parameters.

CAUTION

Whether the torque restriction in the constant output range is set to constant torque restriction or constant output restriction in the torque restriction setting depends on the setting of Pr. 803 "constant output range torque characteristic selection".

Related parameters

- Torque command bias adjustment ⇒ Pr. 904 "torque command No. 3 bias" (Refer to page 190.)
- Torque command gain adjustment ⇒ Pr. 905 "torque command No. 3 gain" (Refer to page 190.)

Pr. 24 to Pr. 27 ➡ Refer to Pr. 4 to Pr. 6 (page 82)

3.6.3 RH, RM, RL signal input compensation (Pr. 28 speed torque)

By entering 0 to ±10V into terminal 1 (speed setting auxiliary terminal), the speeds of the RH, RM and RL signals (command speeds for multi-speed operation) can be compensated for.

Parameter	Name	Factory Setting	Setting Range	Description	Remarks
28	Multi-speed input compensation	0	0	Without compensation	Extended mode
			1	With compensation	

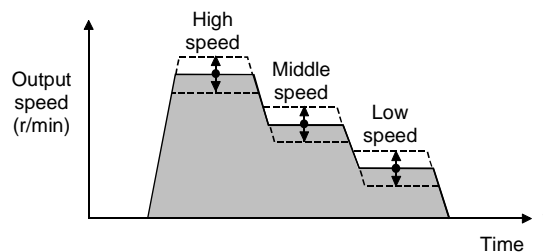

CAUTION

- When "4 or 14" is set in Pr. 73, the compensation signal is input from terminal 2, not from terminal 1. (Override function)
- Since terminal 1 is a multi-function selection terminal, its function varies with the Pr. 868 setting. Set "0" in Pr. 868. Refer to Pr. 902 and Pr. 903 for calibration of the terminal 1.

Related parameters

- Multi-speed setting ⇒ Pr. 4 to Pr. 6, Pr. 24 to Pr. 27, Pr. 232 to Pr. 239 (multi-speed setting) (Refer to page 82.)
- RH, RM, RL signals ⇒ Pr. 180 to Pr. 183, Pr. 187 (input terminal function selection) (Refer to page 151.)
- Speed compensation using terminal 2 ⇒ Pr. 73 "speed setting signal" (Refer to page 116.)
- Function assignment to terminal 1 ⇒ Set "0" in Pr. 868 "No. 1 terminal function assignment" (Refer to page 183.)
- Pr. 59 "remote setting function selection" ⇒ Refer to page 107.
- Calibration of terminal 1 ⇒ Pr. 902 "speed setting No. 2 bias", Pr. 903 "speed setting No. 2 gain" (Refer to page 190)

3.6.4 S-pattern acceleration/deceleration curve (Pr. 29, Pr. 140 to Pr. 143, Pr. 380 to Pr. 383 (speed torque)

When you have changed the preset speed during start, acceleration, deceleration, stop, or operation, you can change the running speed by acceleration/deceleration to make adjustment to reach the preset speed. Set the acceleration/deceleration pattern in Pr. 29 "acceleration/deceleration pattern".

Parameter	Name	Factory Setting	Setting Range	Remarks
29	Acceleration/ deceleration pattern	0	0	Linear acceleration/deceleration
			1	S-pattern acceleration/deceleration A
			2	S-pattern acceleration/deceleration B
			3	Backlash compensation acceleration/ deceleration
			4	S-pattern acceleration/deceleration C
140	Backlash acceleration stopping speed	30r/min	0 to 3600r/min	Accessible when Pr. 29 = 3
141	Backlash acceleration stopping time	0.5s	0 to 360s	
142	Backlash deceleration stopping speed	30r/min	0 to 3600r/min	
143	Backlash deceleration stopping time	0.5s	0 to 360s	
380	Acceleration S pattern 1	0%	0 to 50%	Accessible when Pr. 29 = 4
381	Deceleration S pattern 1	0%	0 to 50%	
382	Acceleration S pattern 2	0%	0 to 50%	
383	Deceleration S pattern 2	0%	0 to 50%	

Extended mode

<Setting>

Pr. 29 Setting	Function	Description	Operation
0	Linear acceleration/ deceleration (factory setting)	Acceleration/deceleration is made linearly up/down to the preset speed .	
1	S-pattern acceleration/ deceleration A (torque variation technique)	<p>The motor torque is utilized effectively to make fast acceleration/deceleration in a large motor-generated torque area and smooth acceleration/deceleration in a small motor-generated torque area.</p> <p>In this acceleration/deceleration pattern, the base frequency is the inflection point of an S shape, and you can set the acceleration/deceleration time according to the reduction in motor torque in the constant-output operation range at higher than the rated speed.</p> <p>This function is valid for V/F control only. For other than V/F control, linear acceleration/deceleration is made.</p> <p style="text-align: center;">CAUTION</p> <p>As the acceleration/deceleration time, set the time taken to reach Pr. 3 "base frequency", not Pr. 20 "acceleration/deceleration reference speed". Refer to page 80 for details of Pr. 3.</p>	
2	S-pattern acceleration/ deceleration B (shock absorption)	<p>Prevention of cargo collapse on conveyor, etc.</p> <p>This setting always provides S-pattern acceleration/ deceleration from s2 (current speed) to s1 (preset speed), easing an acceleration/deceleration shock and producing an effect on the prevention of cargo collapse, etc.</p>	
3	Backlash compensation acceleration/ deceleration	<p>Backlash compensation for reduction gear, etc.</p> <p>This function stops a speed change temporarily during acceleration/deceleration, reducing a shock generated when a reduction gear backlash is eliminated suddenly. Use Pr. 140 to Pr. 143 to set the stopping times and stopping speed in accordance with the chart on the right. The acceleration/deceleration time is increased by the stopping time.</p> <p>REMARKS</p> <p>Output speed is retained for the time for the starting speed (Pr. 13) and $\Delta s1$ (Pr. 140) time at a start and accelerate again after $\Delta t1$ time has elapsed. Speed reaches or below $-\Delta n$ (Pr. 142) is retained for $\Delta t2$ (Pr. 143) time at a start of deceleration and decelerate again after $\Delta t2$ time has elapsed.</p>	
4	S-pattern acceleration/ deceleration C	See next page.	See next page.

REMARKS

For the acceleration/deceleration time, turning on the RT signal makes Pr. 44 "second acceleration/deceleration time" and Pr. 45 "second deceleration time" valid (turning on the X9 signal makes Pr. 110 and Pr. 111 valid). Refer to page 83.

Pr. 29 = 4 (S-pattern acceleration/deceleration C)

The S-pattern acceleration/deceleration C switch signal (X20) changes an acceleration/deceleration curve.

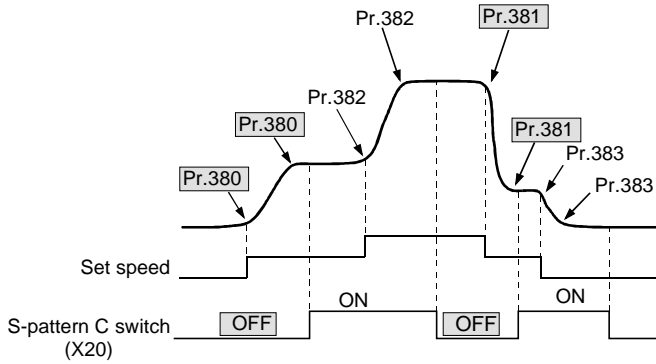

CAUTION

Change the S pattern acceleration/deceleration C switch (X20) after the speed becomes constant. S pattern operation before switching continues even if the X20 is changed during acceleration or deceleration.

X20 Signal \ Operation	During Acceleration	During Deceleration
	OFF	Pr. 380 "acceleration S pattern 1"
ON	Pr. 382 "acceleration S pattern 2"	Pr. 383 "deceleration S pattern 2"

As the acceleration/deceleration time during acceleration/deceleration, set the percentage to the acceleration/deceleration time T in Pr. 380 to Pr. 383.

Parameter setting (%) = $T_s / T \times 100\%$

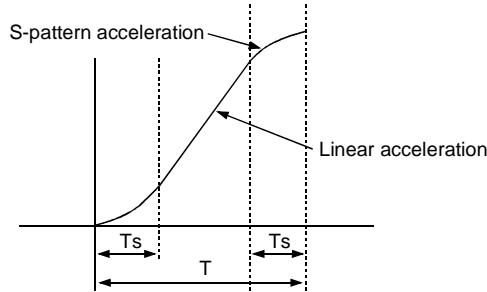

REMARKS

- At a start, the motor starts at Pr. 13 "starting speed" when the start signal turns on.
- If there is a difference between the speed command and speed at a start of deceleration due to torque restriction operation etc., the speed command is matched with the speed to make deceleration.

Related parameters

- Base frequency setting (acceleration/deceleration time setting) ⇒ Pr. 3 "base frequency" (Refer to page 82.)
- X20 signal setting when Pr. 29 = 4 (S-pattern acceleration/deceleration switch) ⇒ Pr. 180 to Pr. 187 (input terminal function selection) (Refer to page 151.)
- Starting speed setting ⇒ Pr. 13 "starting speed" (Refer to page 88.)

3.6.5 Regenerative brake duty (Pr. 30, Pr. 70 speed torque position)

- When making frequent starts/stops in a 15K or less inverter, use the optional "high-duty brake resistor (FR-ABR)" to increase the regenerative brake duty.
- Use the optional "high power factor converter (FR-HC) or power regeneration common converter (FR-CV)" to reduce harmonics, improve the power factor, or continuously use the regenerative mode.

Parameter	Name	Factory Setting	Setting Range	Remarks
30	Regenerative function selection	0	0	When using built-in brake resistor or brake unit (Type FR-BU, BU)
			1	When using the high-duty brake resistor (FR-ABR)
			2	When using the high power factor converter (FR-HC) or power regeneration common converter (FR-CV)
70	Special regenerative brake duty	0%	0 to 15%	1.5K
			0 to 30%	2.2K or more

<Setting>

- When using the built-in brake resistor, brake unit or power regeneration converter
Set "0" in Pr. 30. The Pr. 70 setting is made invalid.
At this time, the regenerative brake duty is as follows.
 - FR-V520-1.5K to 3.7K..... 3%
 - FR-V520-5.5K..... 2%
 - FR-V520-7.5K or more..... 0% (without a built-in brake resistor)
 - FR-V540-1.5K to 5.5K..... 2%
 - FR-V540-7.5K or more..... 0% (without a built-in brake resistor)
- When using the high-duty brake resistor (FR-ABR)
 - Set "1" in Pr. 30.
 - Set "10%" in Pr. 70.
- When using the high power factor converter (FR-HC) or power regeneration common converter (FR-CV)
 - Set "2" in Pr. 30.
 - Use any of Pr. 180 to Pr. 183 and Pr. 187 to assign the following signals to the contact input terminals.
 - X10: FR-HC connection, FR-CV connection (inverter operation enable signal)
To make protective coordination with the high power factor converter (FR-HC) or power regeneration common converter (FR-CV), use the inverter operation enable signal to shut off the inverter output. Enter the RDY signal of the high power factor converter or power regeneration common converter.
 - X11: FR-HC connection (instantaneous power failure detection signal)
When the computer link plug-in option (FR-A5NR) is used and the setting is made to hold the pre-instantaneous power failure mode, use this signal to hold that mode. Enter the instantaneous power failure detection signal of the high power factor converter.
 - The Pr. 70 setting is made invalid.

CAUTION

Set "10" and "11" in any of Pr. 180 to Pr. 183 and Pr. 187 to assign the terminals used to input the X10 and X11 signals.

⚠ WARNING

⚠ The value set in Pr. 70 must not exceed the setting of the brake resistor used. Otherwise, the resistor can overheat.

REMARKS

- The Pr. 70 setting is invalid for the inverter of 18.5K or more.
- Pr. 70 "regenerative brake duty" indicates the %ED of the built-in brake transistor operation.

Related parameters

- X10, X11 signal terminal assignment ⇒ Pr. 180 to Pr. 183, Pr. 187 (input terminal function selection) (Refer to page 151.)

CAUTION

Changing the terminal assignment with any of Pr. 180 to 183 and Pr. 187 may affect the other functions. Check the functions of the corresponding terminals before making setting.

3.6.6 Speed jump (Pr. 31 to Pr. 36 speed torque)

When it is desired to avoid resonance attributable to the natural frequency of a mechanical system, these parameters allow resonance occurrence speeds to be jumped. Up to three areas may be set, with the jump speeds set to either the top or bottom point of each area.

The value set to 1A, 2A or 3A is a jump point and operation is performed at this speed.

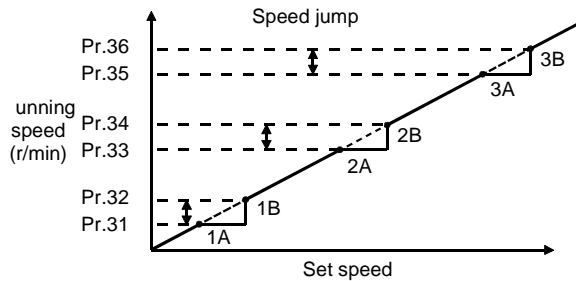

Parameter	Name	Factory Setting	Setting Range	Remarks
31	Speed jump 1A	9999	0 to 3600r/min, 9999	<ul style="list-style-type: none"> • 9999: Function invalid • Extended mode
32	Speed jump 1B	9999	0 to 3600r/min, 9999	
33	Speed jump 2A	9999	0 to 3600r/min, 9999	
34	Speed jump 2B	9999	0 to 3600r/min, 9999	
35	Speed jump 3A	9999	0 to 3600r/min, 9999	
36	Speed jump 3B	9999	0 to 3600r/min, 9999	

<Setting>

- To fix the speed at 600r/min between Pr. 33 and Pr. 34 (600r/min and 700r/min), set 600r/min in Pr. 33 and 700r/min in Pr. 34.
- To jump to 700r/min between 600r/min and 700r/min, set 700r/min in Pr. 33 and 600r/min in Pr. 34.

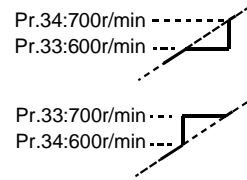

CAUTION

During acceleration/deceleration, the running speed within the set area is valid.

REMARKS

If the speed jump setting ranges overlap, a write disable error "Err" appears.

3.6.7 Speed display (Pr. 37, Pr. 144 speed torque position)

The units of the running speed monitor display of the PU (FR-DU04-1/FR-PU04V), the running speed/frequency setting in the PU operation mode, and the parameter setting unit used for frequency setting can be changed from the frequency to the motor speed or machine speed.

Parameter	Name	Factory Setting	Setting Range	Remarks
37	Speed display	0	0	Output speed
			1 to 9998	Extended mode
144	Speed setting switchover	0	0, 2, 4, 6, 8, 10	Number of motor poles

Operation selection functions 1 (Pr. 17 to Pr. 37)

<Setting>

- To display the machine speed, set in Pr. 37 the machine speed for 1500r/min operation.
- To display the motor frequency, set the number of motor poles (2, 4, 6, 8, 10) in Pr. 144.
- When the running speed monitoring has been selected, the parameter setting unit and the running speed setting in the PU operation mode depend on the combination of the Pr. 37 and Pr. 144 settings as indicated below:

Pr. 37	Pr. 144	Running Speed Monitor	Preset Speed Monitor	Output Frequency Monitor	Running Speed Setting/Pr. Setting
0	0	r/min	r/min	Hz Pr. 81, Pr. 454	r/min
	2 to 10	Hz Pr. 144	Hz Pr. 144	Hz Pr. 144	Hz Pr. 144
1 to 9998	0	Machine speed Pr. 37	Machine speed Pr. 37	Hz Pr. 81, Pr. 454	r/min
	2 to 10	Machine speed Pr. 37	Machine speed Pr. 37	Hz Pr. 81, Pr. 454	Machine speed Pr. 37

CAUTION

1. When Pr. 37 and Pr. 144 are combined to select the Hz setting, the number of poles set in Pr. 144 is used to calculate the frequency, independently of the number of motor poles (Pr. 81, Pr. 454) used for control.
Note this when the number of motor poles (Pr. 81, Pr. 454) differs from Pr. 144.
2. When the speed setting has been selected, operation is performed at the synchronous speed.
When 4 poles and 60Hz are set, operation is performed at 1800r/min. For V/F control, the output frequency is 60Hz.
3. To change the PU main monitor (PU main display) or PU level meter (PU level display), refer to Pr. 52 and Pr. 53.
4. As the operation panel display is 4 digits, "-- --" is displayed when the monitored value exceeds "9999".

CAUTION

-  **Make sure that the settings of the running speed and number of motor poles are correct. Otherwise, the motor might run at extremely high speed, damaging the machine.**

Related parameters

- PU main monitor changing ⇒ Pr. 52 "DU/PU main display data selection" (Refer to page 101.)
- PU level meter changing ⇒ Pr. 53 "PU level display data selection" (Refer to page 101.)
- Setting of number of motor poles ⇒ Pr. 81 "number of motor poles", Pr. 454 "number of second motor poles" (Refer to page 123.)

3.7 Output terminal functions (Pr. 41 to Pr. 50)

3.7.1 Up-to-speed sensitivity (Pr. 41 speed)

You can adjust the ON range of the up-to-speed signal (SU) output when the output speed reaches the running speed. This parameter can be used to confirm that the running speed has been reached and used as the operation start signal etc. for related equipment.

- Under PLG vector control: Actual motor speed (feedback value) is adjusted.

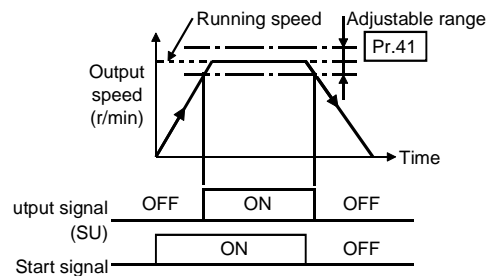

Parameter	Name	Factory Setting	Setting Range	Remarks
41	Up-to-speed sensitivity	10%	0 to 100%	Extended parameter

REMARKS

- Assign functions to the terminals DO1 to DO3 and ABC to use the SU signal. The SU signal is assigned to the terminal DO2 when shipped from the factory. Use any of Pr. 190 to Pr. 192 and Pr. 195 to change the terminal functions. Changing the terminal assignment with any of Pr. 190 to Pr. 192 and Pr. 195 may affect the other functions. Check the functions of the corresponding terminals before making setting. (Refer to page 153.)
- For V/F control, operation is performed at the speed converted from the output frequency.

Related parameters

- SU signal terminal assignment ⇒ Set "1" in any of Pr. 190 to Pr. 192 and Pr. 195 (output terminal function selection) (Refer to page 153.)

3.7.2 Speed detection (Pr. 42, Pr. 43, Pr. 50, Pr. 116 speed torque position)

When the speed reaches or exceeds the setting, the output speed detection signal (FU, FU2, FU3 signal) or speed detection signal (FB, FB2, FB3 signal) is output.

- This function can be used for electromagnetic brake operation, open signal, etc.
- You can also set speed detection used exclusively for reverse rotation.
- This function is effective for changing the timing of electromagnetic brake operation between forward rotation (rise) and reverse rotation (fall) during vertical lift operation, etc.
 - Under PLG vector control: FB signal is the detected speed of the actual motor speed (feedback value)

Parameter	Name	Factory Setting	Setting Range	Remarks	
42	Speed detection	300r/min	0 to 3600r/min	Extended parameters	
43	Speed detection for reverse rotation	9999	0 to 3600r/min, 9999		9999: Same as Pr. 42 setting
50	Second speed detection	750r/min	0 to 3600r/min		
116	Third speed detection	Japanese version: 1500r/min NA version: 1800r/min	0 to 3600r/min		

(1) Signal operation

The FU, FU2 and FU3 signals function under speed/V/F control. They do not function under torque/position control.

	FU	FB
Compared signals	Speed command value	Actual motor speed
FU/FB signal	Forward rotation: On when speed is equal to or higher than in Pr. 42 Reverse rotation: On when speed is equal to or higher than in Pr. 43	
FU2/FB2 signal	On when speed is equal to or higher than in Pr. 50 (both forward and reverse) Off when speed is lower than in Pr. 50 (both forward and reverse)	
FU3/FB3 signal	On when speed is equal to or higher than in Pr. 116 (both forward and reverse) Off when speed is lower than in Pr. 116 (both forward and reverse)	

Output terminal functions (Pr. 41 to Pr. 50)

REMARKS

For V/F control, on/off control is exercised at the speed converted from the output frequency. (The detection actions of the FU and FB signals are the same.)

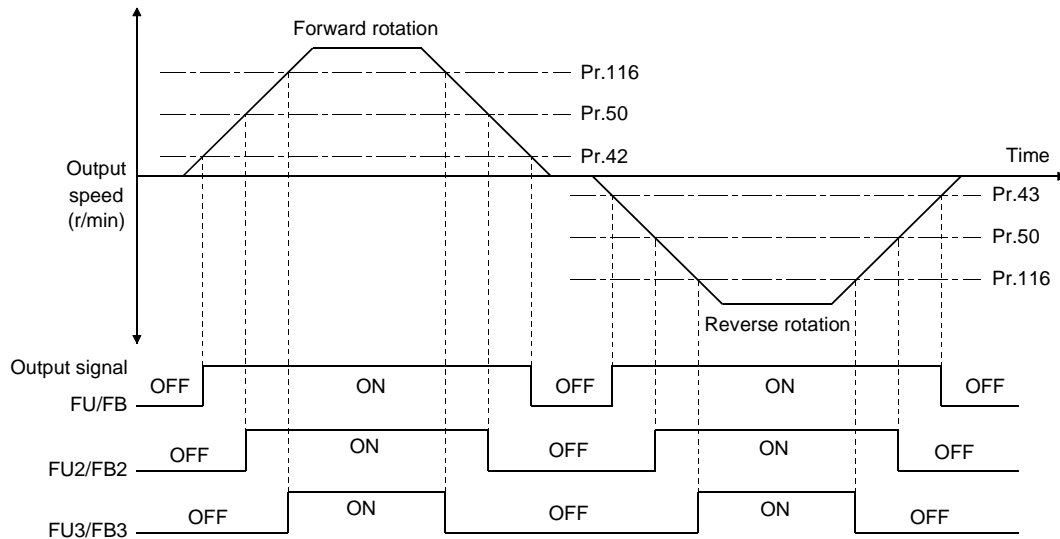

REMARKS

The speed command value indicates the last speed command value given after acceleration/deceleration processing.

CAUTION

- Assign functions to the terminals DO1 to DO3 and ABC to use the FU, FU2, FU3 and FB, FB2, FB3 signals. Use any of Pr. 190 to Pr. 192 and Pr. 195 to change the terminal functions. Changing the terminal assignment with Pr. 190 to Pr. 192 and Pr. 195 may affect the other functions. Check the functions of the corresponding terminals before making setting.
- The speed detection signal turns off when an inverter alarm occurs or when the reset terminal (MRS, RES signal) turns on.
- When any parameter setting is "0", the corresponding signal turns on as soon as the start signal turns on.

Related parameters

- FB, FB2, FB3, FU, FU2, FU3 signal terminal assignment ⇒ Pr. 190 to Pr. 192, Pr. 195 (output terminal function selection) (Refer to page 153.)

Pr. 44, Pr. 45 ➡ Refer to Pr. 7, Pr. 8 (page 83)

Pr. 50 ➡ Refer to Pr. 42, Pr. 43 (page 99)

3.8 Display functions 1 (Pr. 52 to Pr. 56)

3.8.1 Monitor display/DA1, DA2 terminal function selection (Pr. 52 to Pr. 54, Pr. 158 speed torque position)

During operation, you can select the signals shown on the operation panel (FR-DU04-1)/parameter unit (FR-PU04V) main display screen and on the parameter unit (FR-PU04V) level meter and the signals output to the DA1 and DA2 terminals.

- There are two analog output DA1 and DA2 terminals.
Select the signals using Pr. 54 and Pr. 158.

Parameter	Name	Factory Setting	Setting Range	Remarks
52	DU/PU main display data selection	0	0, 5 to 12, 17 to 20, 23, 24, 32 to 35, 38, 100 (5 to 12 are invalid for FR-PU04V)	Extended mode
53	PU level display data selection	1	0 to 3, 5 to 12, 17, 18	
54	DA1 terminal function selection	1	1 to 3, 5 to 12, 17, 18, 21, 32 to 34, 36	
158	DA2 terminal function selection	1	1 to 3, 5 to 12, 17, 18, 21, 32 to 34, 36	

<Setting>

Any of the following signals can be monitored by parameter setting.
The signals marked × cannot be selected for monitoring.

Signal Type	Display Unit	Parameter Settings					± Output	Full-Scale Value of the Level Meter Connected to DA1 and DA2	Description
		Pr. 52		Pr. 53	Pr. 54	Pr. 158			
		DU LED	PU main monitor	PU level meter	DA1 terminal 12 bits (±10V)	DA2 terminal 12 bits (+10V)			
No display	—	×	×	0	×		—	When "0" is set in Pr. 53, the level meter of the parameter unit is not displayed.	
Speed	0.1 r/min	0/100	0/100	1	1	○	Pr. 55	Vector control	Speed feedback value from PLG
								V/F control	Speed calculated from output frequency
Output current	0.01A	0/100	0/100	2	2	×	Pr. 56	The output current is displayed as effective value.	
Output voltage	0.1V	0/100	0/100	3	3	×	400V/800V	The output voltage is displayed as effective value.	
Alarm display	—	0/100	0/100	×	×	×	—	—	
Set speed	0.1 r/min	5	*2	5	5	×	Pr. 55	Under speed control, the current speed setting is displayed. 0r/min under position control.	
Output frequency	0.01 Hz	6	*2	6	6	○	The frequency converted from Pr. 55	The output frequency is displayed.	
Motor torque	0.1%	7	*2	7	7	○	Pr. 866	The output torque is displayed. The ratio to the rated torque is displayed. When the DA1 output monitor is used, a positive voltage is output during forward driving and reverse regeneration and a negative voltage is output during reverse driving and forward regeneration.	
Converter output voltage	0.1V	8	*2	8	8	×	400V/800V	DC bus voltage is displayed.	

Display functions 1 (Pr. 52 to Pr. 56)

Signal Type	Display Unit	Parameter Settings					± Output	Full-Scale Value of the Level Meter Connected to DA1 and DA2	Description
		Pr. 52		Pr. 53	Pr. 54	Pr. 158			
		DU LED	PU main monitor	PU level meter	DA1 terminal 12 bits (±10V)	DA2 terminal 12 bits (+10V)			
Regenerative brake duty	0.1%	9	*2	9	9	×	Pr. 70	The brake resistor duty is displayed.	
Electronic overcurrent protection load factor	0.1%	10	*2	10	10	×	Thermal relay operation level	The thermal relay load factor is displayed.	
Output current peak value	0.01A	11	*2	11	11	×	Pr. 56	The peak value of the output voltage is displayed as effective value.	
Converter output voltage peak value	0.1V	12	*2	12	12	×	400V/800V	The peak value of DC bus voltage is displayed.	
Input terminal status	—	×	*2	×	×	×	—	—	
Output terminal status	—	×	*2	×	×	×	—	—	
Load meter *1	0.1%	17	17	17	17	○	Pr. 866	The load meter is output.	
Motor excitation current	0.01A	18	18	18	18	×	Pr. 56	Pre-excitation current is displayed.	
Position pulse	—	19	19	×	×	×	—	The position of the motor output shaft is monitored.	
Cumulative operation time	1h	20	20	×	×	×	—	Cumulative operation time since the inverter shipment (power on time) is displayed. (Minimum increment is Hr)	
Reference voltage output	—	×	×	×	21	×	—	The voltage of DA1 and DA2 at full-scale is output	
Actual operation time	1h	23	23	×	×	×	—	The inverter running time is accumulated. (The time during a stop is not accumulated.) It is cleared using Pr. 171 "actual operation hour meter clear".	
Motor load factor	0.1%	24	24	×	×	×	—	The load factor to the rated motor capacity is displayed.	
Torque command*1	0.1%	32	32	×	32	○	Pr. 866	The torque command value is displayed.	
Torque current command*1	0.1%	33	33	×	33	○	Pr. 866	The torque current command value is displayed.	
Motor output *1	0.01 kW (0.01 HP)	34	34	×	34	○	Rated motor current	The machine output of the motor shaft end is displayed.	
Feedback pulse	—	35	35	×	×	×	—	The number of pulses fed back during 1 sampling is displayed. Display range is 0 to 99999 pulses. Sampling time for the following number of PLG pulses are: 1.0s for 1500 pls/rev or less; 0.5s for 1501 to 3200 pls/rev; and 0.25s for 3201 to 4096 pls/rev.	

Signal Type	Display Unit	Parameter Settings					± Output	Full-Scale Value of the Level Meter Connected to DA1 and DA2	Description
		Pr. 52		Pr. 53	Pr. 54	Pr. 158			
		DU LED	PU main monitor	PU level meter	DA1 terminal 12 bits (±10V)	DA2 terminal 12 bits (+10V)			
Torque monitor (driving/regenerative polarity switchover) *1	—	×	×	×	36	○	Pr. 866	The output torque is monitored. When the DA1 output monitor is used, a positive voltage is output during forward and reverse driving and a negative voltage is output during forward and reverse regeneration.	
Trace status	—	38	38	×	×	×	—	The trace status is displayed. 0: Stop 1: During pre-trigger 2: Waiting for trigger 3: During trace 4: Trace completion 101: During data output 102: Data output completion	

CAUTION

- *1 When DA1 (Pr. 54) is selected, high response output is available. When DA2 (Pr. 158) is selected, average value is output.
- *2 Select this monitor in "Others" of the FR-PU04V (option).

When "100" is set in Pr. 52, the monitored values during stop and during operation differ as indicated below. (The LED on the left of r/min flickers during stop, and is lit during operation.)

	Pr.52		
	0	100	
	During operation/ during stop	During stop	During operation
Speed	Speed	Set speed	Speed
Output current	Output current		
Output voltage	Output voltage		
Alarm display	Alarm display		

REMARKS

- During a reset, the values are the same as at a stop. During offline auto tuning, the tuning status monitor has priority.
- By setting "0" in Pr. 52, the monitoring of output speed to alarm display can be selected in sequence by the SHIFT key.
- *Speed setting to output terminal status on the PU main monitor are selected by "other monitor selection" of the parameter unit (FR-PU04V).
- When Pr. 52 = any of "17, 18 and 24", the output current monitor changes to the set monitored data.
When Pr. 52 = any of "19, 20, 23 and 32 to 35, 38", the output voltage monitor changes to the set monitored data.

CAUTION

1. The cumulative operation time and actual operation time are accumulated from 0 to 65535 hours, then cleared, and accumulated again from 0.
When the operation panel (FR-DU04-1) is used, more than 9999h is displayed as "----".
Use the parameter unit (FR-PU04V) to confirm more than 9999h.
2. The cumulative operation time and actual operation time is not accumulated unless the inverter is run continuously for more than one hour.
3. When the operation panel (FR-DU04-1) is used, the display unit is r/min, V or A only.

REMARKS

Where to monitor the data set in Pr. 52 varies with the setting.

Factory setting

* The monitor displayed at powering on is the first monitor. To set the first monitor, press **SET** for more than 1.5s.

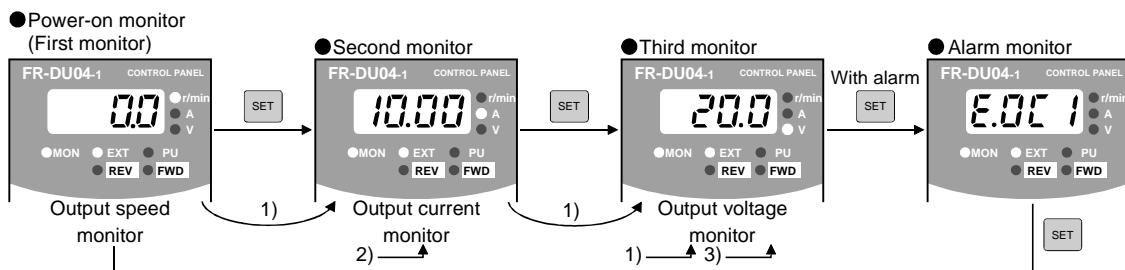

1) Setting is any of "5 to 12" (Displayed in the third monitor position)

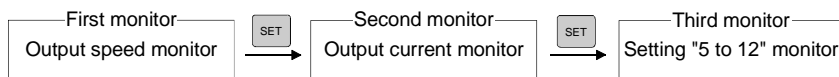

2) Setting is any of "17, 18 and 24" (Displayed instead of output current monitor)

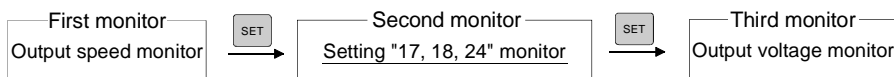

3) Setting is any of "19, 20, 23, 25" (Displayed instead of output voltage monitor)

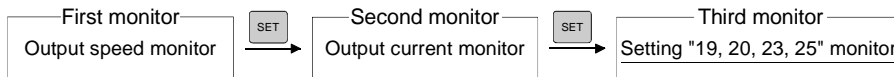

Related parameters

- Speed monitoring reference setting ⇒ Pr. 55 (Refer to page 104.)
- Current monitoring reference setting ⇒ Pr. 56 (Refer to page 104.)
- Torque monitoring reference setting ⇒ Pr. 866 (Refer to page 104.)
- Output filter of terminal DA1 ⇒ Pr. 867 (Refer to page 183.)

3.8.2 Monitoring reference (Pr. 55, Pr. 56, Pr. 866 speed torque position)

Set the value that is referenced when the output speed or output current is selected for the DA1 and DA2 terminals and PU level meter display.

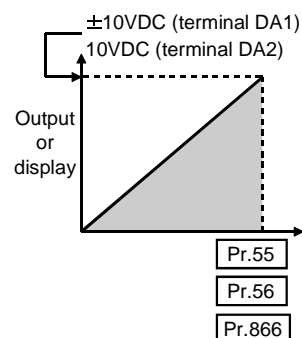

Parameter	Name	Factory Setting	Setting Range	Remarks
55	Speed monitoring reference	Japanese version: 1500r/min	0 to 3600r/min	Extended mode
		NA version: 1800r/min		
56	Current monitoring reference	Inverter rated output current	0 to 500A	
866	Torque monitoring reference	150%	0 to 400%	

3.9 Automatic restart (Pr. 57, Pr. 58)

3.9.1 Automatic restart after instantaneous power failure (Pr. 57 speed torque, Pr. 58, Pr. 162 to Pr. 165)

You can restart the inverter without stopping the motor (with the motor coasting) when power is restored after an instantaneous power failure.

Parameter	Name	Factory Setting	Setting Range	Remarks
57	Restart coasting time	9999	0	Set to 0.1s.
			0.1 to 5s	
			9999	9999: No restart
58	Restart cushion time	1.0s	0 to 60s	
162	Automatic restart after instantaneous power failure selection	0	0	0: With speed search
			1	1: Without speed search
			10	10: Speed search initiated per start
163	First cushion time for restart	0s	0 to 20s	Valid for V/F control
164	First cushion voltage for restart	0%	0 to 100%	
165	Restart current restriction level	150%	0 to 200%	

When vector control is exercised
(The Pr. 162 setting "0,1" is invalid under vector control.)

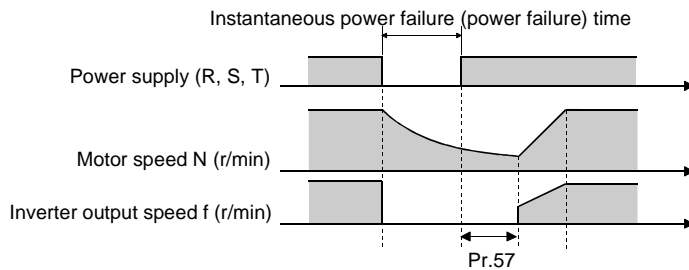

* 0r/min when search speed is 15r/min or less.
Pr.58 is invalid under vector control

Pr. 162 = 0 (with speed search) (V/F)

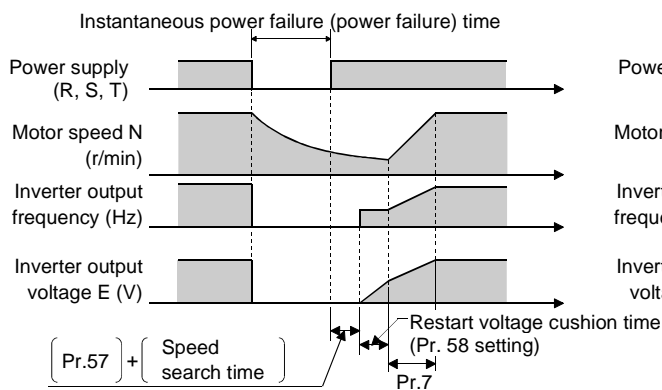

Pr. 162 = 1 (without speed search) (V/F)

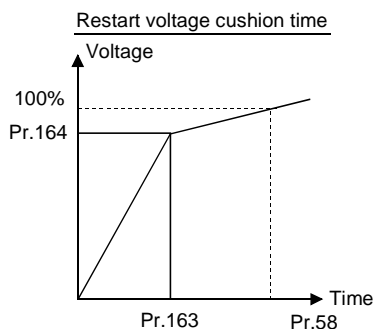
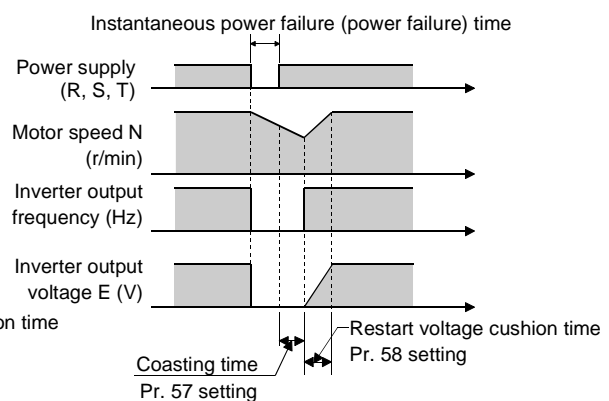

<Setting>

Refer to the above figures and following table to set the corresponding parameters.

Parameter Number	Setting	Description	
162	0	With speed search Speed search is made after detection of an instantaneous power failure.	
	1	Without speed search Independently of the motor coasting speed, the output voltage is gradually increased with the speed kept as preset, i.e. a reduced voltage starting system.	
	10	Speed search is made on startup. The motor starts running at the speed detected by the PLG under vector control.	
57	0	0.1s coasting time	Generally this setting may be used without problem. (Coasting times are 0.5s for 1.5K, 10s for 2.2K to 7.5K, and 3.0s for 11K or more under V/F control.)
	0.1 to 5s	Waiting time for inverter-triggered restart after power is restored from an instantaneous power failure. (Set this time between 0.1s and 5s according to the inertia moment (J) and torque magnitude.)	
	9999	Without restart	
58	0 to 60s	Normally the motor may be run with the factory settings, but restart or voltage cushion time are adjustable according to the load (inertia moment, torque) magnitude using Pr. 58, Pr. 163, or Pr. 164. Also the output frequency is reduced when the current flow exceeds the Pr. 165 setting. Invalid for vector control.	
163	0 to 20s		
164	0 to 100%		
165	0 to 200%		

CAUTION

1. When restart operation is selected, UVT and IPF among the alarm output signals are not output at occurrence of an instantaneous power failure.
2. When "0" is set in Pr. 162 under V/F control, the DC injection brake is operated instantly on detection of restarting speed. Therefore, if the inertia moment (J) of the load is small, the speed may reduce.
3. When Pr. 162 = "1", the output speed before an instantaneous power failure is stored and output at the time of restart. If the power of the inverter control circuit is lost, the output speed before an instantaneous power failure cannot be stored and the inverter will start at 0r/min.
4. The SU and FU signals are not output during restart but are output after the restart cushion time has elapsed.
5. The restart coasting time in Pr. 57 does not include the speed search time (300ms maximum). There is no delay time due to speed search when speed search is not made or vector control is exercised. (excluding the inverter starting time)
6. V/F control
 - When the inverter capacity is two rank or more larger than the motor capacity when Pr. 162="0" (with speed search), the inverter may not start due to overcurrent (OCT) alarm.
 - If two or more motors are connected to one inverter, the inverter functions abnormally. (The inverter does not start smoothly.)
 - Recommended settings for Pr. 57 are 0.5s for 1.5K, 1.0s for 2.2 to 7.5K, and 3.0s for 11K or more.

⚠ CAUTION

- When automatic restart after instantaneous power failure has been selected, the motor and machine will start suddenly (after the restart coasting time has elapsed) after occurrence of an instantaneous power failure. Stay away from the motor and machine.
When you have selected automatic restart after instantaneous power failure, apply the supplied CAUTION seals, provided for the Instruction Manual (basic), in easily visible places.
- The motor coasts to a stop as soon as the start signal is turned off or  is pressed during automatic restart cushion time.

Related parameters

- Setting of alarm output signal for executing automatic restart after instantaneous power failure ⇒ Pr. 65 "retry selection" (Refer to page 112.)

3.10 Additional functions (Pr. 59)

3.10.1 Remote setting function selection (Pr. 59 speed torque)

Even if the operation panel is located away from the control box, you can use contact signals to perform continuous variable-speed operation, without using analog signals.

Parameter	Name	Factory Setting	Setting Range	Remarks
59	Remote setting function selection	0	0	Remote function not activated.
			1	Remote function activated: Stored into E ² PROM.
			2	Remote function activated: Not stored into E ² PROM.
			3	Remote function activated: Not stored into E ² PROM. (Turn on STF (STR) to clear remote setting)

(1) Pr. 59 = "1" or "2"

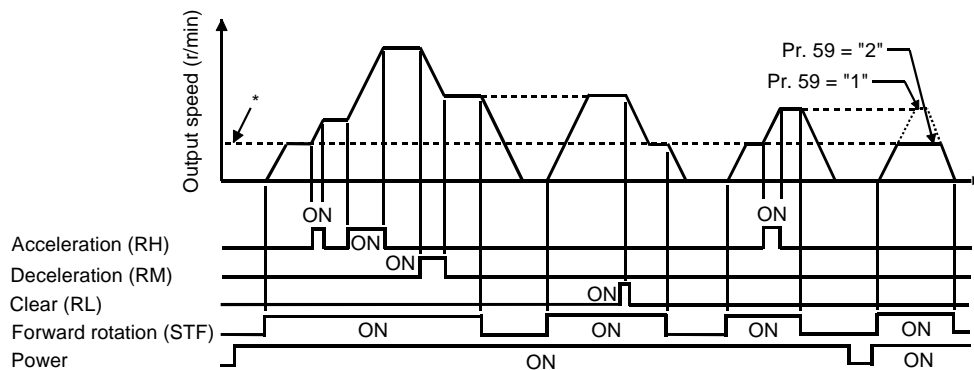

*External operation speed or PU operation speed other than multi-speed

(2) Pr. 59 = "3"

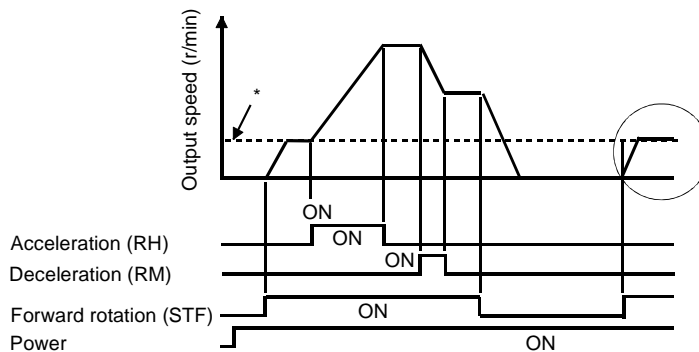

*External operation speed or PU operation speed other than multi-speed

REMARKS

- By merely setting this parameter, you can use the acceleration, deceleration and setting clear functions of the motorized speed setter (FR-FK).
- When the remote function is used, the output speed of the inverter can be compensated for as follows:
For external operation, speed set by RH/RM operation plus external analog speed command
For PU operation mode, speed set by RH/RM operation plus DU/PU digital setting speed
- When any value other than 0 is set in Pr. 59, multi-speed operation is invalid. (Refer to page 92.)
- Speed compensation by terminal 1 is made invalid when speed command by terminal 2 is selected.
Set "1" in Pr. 28 "multi-speed input compensation" to enable speed compensation of terminal 1 (Pr. 28 = "0").

<Setting>

Use Pr. 59 to select whether the remote setting function is used or not and whether the speed setting storage function* in the remote setting mode is used or not. When "1" or "2" is set in Pr. 59, the functions of signals RH, RM and RL are changed to acceleration (RH), deceleration (RM) and clear (RL), respectively. Use Pr. 180 to Pr. 183 and Pr. 187 (input terminal function selection) to set signals RH, RM and RL.

* Speed setting storage function (Pr. 59 = "1")

This function stores the remotely-set speed (speed set by RH/RM operation) into memory. When power is switched off once, then on, operation is resumed with that output speed value.

<Speed setting storage conditions>

- Speed at which the start signal (STF or STR) turns off
- The remotely-set speed is stored every one minute after one minute has elapsed since turn off (on) of both the RH (acceleration) and RM (deceleration) signals. (The speed is written if the present speed value compared with the past speed value every one minute is different.) (The state of the RL signal does not affect writing.)

REMARKS

This function is invalid under jog operation and PID control operation.

Setting speed is "0"

Even when the remotely-set speed is cleared by turning on the RL (clear) signal after turn off (on) of both the RH and RM signals, the inverter operates at the remotely-set speed stored in the last operation if power is reapplied before one minute has elapsed since turn off (on) of both the RH and RM signals.

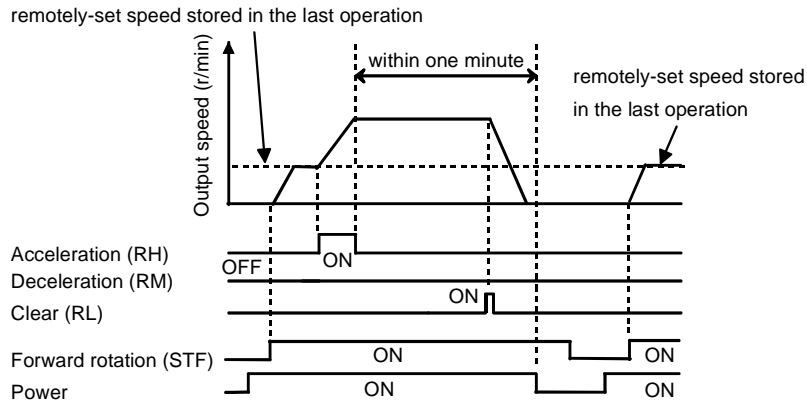

When the remotely-set speed is cleared by turning on the RL (clear) signal after turn off (on) of both the RH and RM signals, the inverter operates at the speed in the remotely-set speed cleared state if power is reapplied after one minute has elapsed since turn off (on) of both the RH and RM signals.

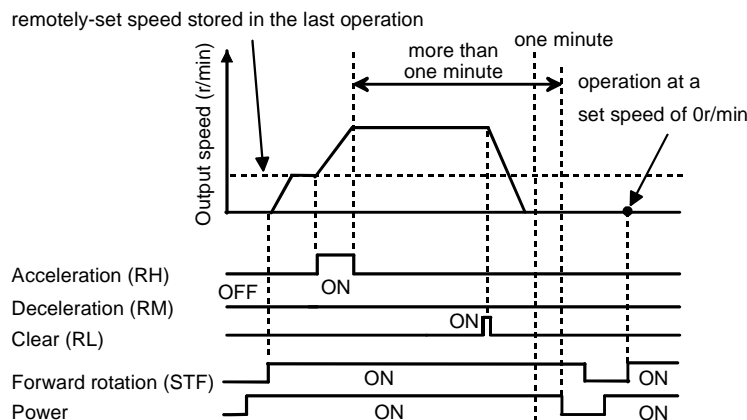

CAUTION

- The speed can be varied by RH (acceleration) and RM (deceleration) between 0 and the maximum speed (Pr. 1 setting).
- When the acceleration or deceleration signal turns on, the set speed varies according to the slope set in Pr. 44 "second acceleration/deceleration time" or Pr. 45 "second deceleration time". The output speed acceleration/deceleration times are as set in Pr. 7 "acceleration time" and Pr. 8 "deceleration time", respectively. Therefore, the longer preset times are used to vary the actual output speed. (Refer to page 25 for the set speed and output speed.)
- If the start signal (STF or STR) is off, turning on the RH (acceleration) or RM (deceleration) signal varies the set speed.

⚠ CAUTION

⚠ When selecting this function, re-set Pr. 1 "maximum speed" according to the machine.

Related parameters

- RH, RM, RL signal terminal assignment ⇒ Pr. 180 to Pr. 183, Pr. 187 (input terminal function selection) (Refer to page 151.)
- Maximum speed setting ⇒ Pr. 1 "maximum speed" (Refer to page 81.)
- Output speed acceleration/deceleration time ⇒ Pr. 7 "acceleration time", Pr. 8 "deceleration time" (Refer to page 83.)
- Time setting for acceleration/deceleration ⇒ Pr. 44 "second acceleration/deceleration time", Pr. 45 "second deceleration time" (Refer to page 83.)
- RH, RM, RL signal compensation ⇒ Pr. 28 "multi-speed input compensation" (Refer to page 92.)

3.11 Brake sequence (Pr. 60, Pr. 278 to Pr. 285)

3.11.1 Brake sequence function (Pr. 60, Pr. 278 to Pr. 285 speed)

The inverter automatically sets appropriate parameters for operation.

This function is used to output from the inverter the mechanical brake opening completion signal timing signal in vertical lift and other applications.

This function prevents the load from dropping with gravity at a start due to the operation timing error of the mechanical brake or an overcurrent alarm from occurring at a stop, ensuring secure operation.

POINT

Set "7" or "8" in Pr. 60.

Set any of "0, 2 or 4" in Pr. 800 "control system selection" under external operation and set speed control. (Refer to page 170)

Parameter	Name	Factory Setting	Setting Range	Remarks
60	Intelligent mode selection	0	0, 7, 8	Extended mode
278	Brake opening speed	20r/min	0 to 900r/min	
279	Brake opening current	130%	0 to 200%	
280	Brake opening current detection time	0.3s	0 to 2s	
281	Brake operation time at start	0.3s	0 to 5s	
282	Brake operation speed	25r/min	0 to 900r/min	
283	Brake operation time at stop	0.3s	0 to 5s	
284	Deceleration detection function selection	0	0, 1	
285	Overspeed detection speed	9999	0 to 900r/min, 9999	

CAUTION

When brake sequence mode is selected, automatic restart after instantaneous power failure is invalid.

(1) Wiring example

- Sink logic
- Pr.183=15
- Pr.190=20

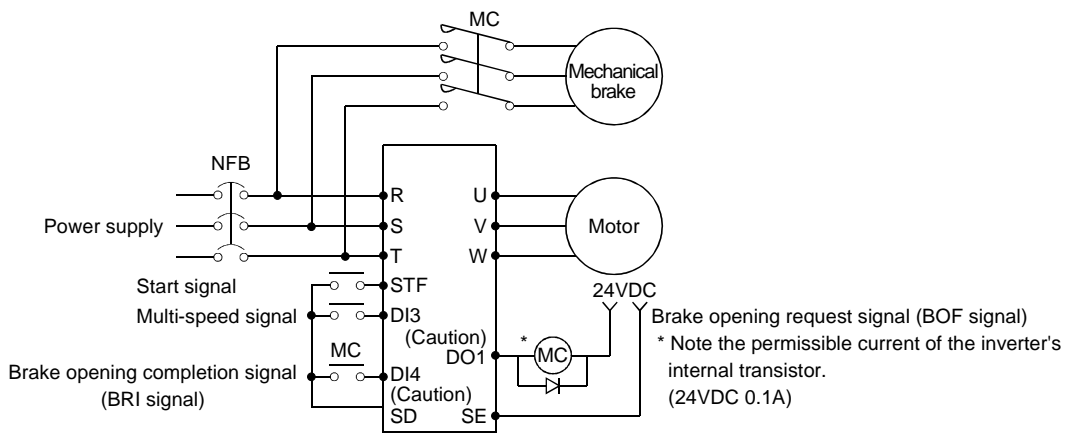

CAUTION

The input signal terminal used differs according to the parameter settings. (Refer to page 111.)

(2) Operation example

- At start: When the start signal is input to the inverter, the inverter starts running. When the internal speed command reaches the value set in Pr. 278 and the output current is not less than the value set in Pr. 279, the inverter outputs the brake opening request signal (BOF) after the time set in Pr. 280 has elapsed. When the time set in Pr. 281 has elapsed after the brake opening completion signal (BRI) was input, the inverter increases the internal speed command to the set speed.
- At stop: When the speed has decreased to the speed set in Pr. 282, the brake opening request signal (BOF) is turned off. When the time set in Pr. 283 has elapsed after the brake operation confirmation signal (BRI) was input, the inverter output is switched off.
 *If Pr. 60 = "8" (mechanical brake opening completion signal not input), this time is the time after the brake opening request signal is output.

1. Pr. 60 = "7" (brake opening completion signal input)

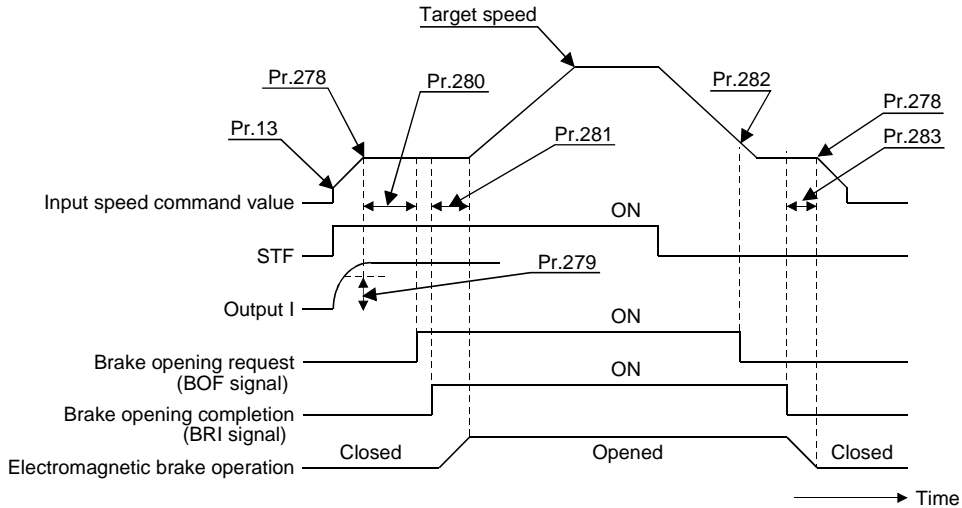

2. Pr. 60 = "8" (mechanical brake opening completion signal not input)

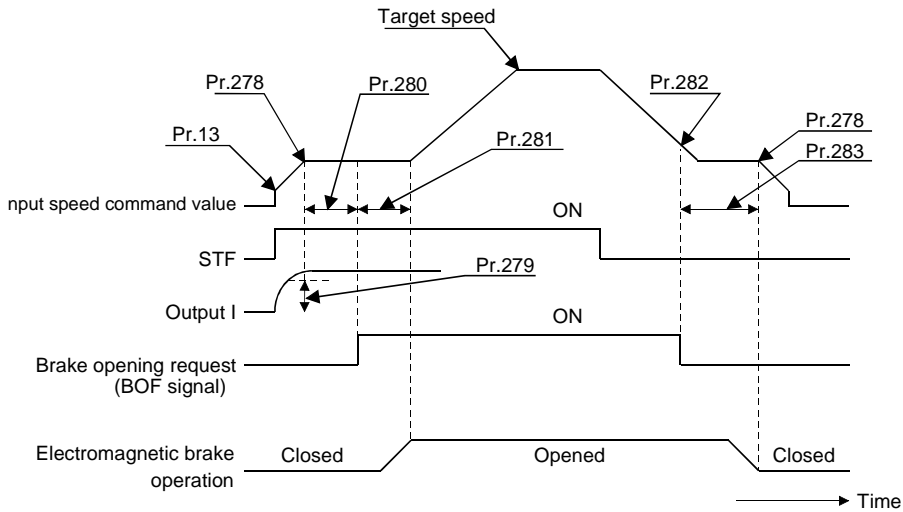

(3) Parameter setting

1. Set speed control in Pr.800 "control system selection". (Refer to page 170.)
2. Set "7 or 8" (brake sequence mode) in Pr. 60.
To ensure more complete sequence control, it is recommended to set "7" (brake opening completion signal input) in Pr. 60.

Pr. 60 Setting	Operation Mode	Description	
0	Normal operation mode	—	
7	Brake sequence mode	With mechanical brake opening completion signal input	This function causes the inverter to output the mechanical brake operation timing signal for elevating application. For the function details and setting method, refer to Pr. 278 to Pr. 285 (brake sequence function).
8		Without mechanical brake opening completion signal input	

REMARKS

Even if the intelligent operation function has been selected, inputting the jog or RT (second function selection) signal during an inverter stop will switch to the normal operation and give priority to jog operation or second function selection.
After intelligent operation has been started, neither the jog signal nor the RT signal is accepted.

3. Refer to the following table and set the parameters.

Parameter	Name	Setting Range	Description
278	Brake opening speed	0 to 900r/min	Set the value higher than the Pr. 13 "starting speed". Setting is enabled only when Pr. 278 ≤ Pr. 282.
279	Brake opening current	0 to 200%	Generally, set this parameter to about 50 to 90%. If the setting is too low, the load is liable to drop with gravity at start. Suppose that the rated inverter current is 100%.
280	Brake opening current detection time	0 to 2s	Generally, set this parameter to about 0.1 to 0.3s.
281	Brake operation time at start	0 to 5s	Pr. 60 = 7: Set the mechanical delay time until the brake is loosened. Pr. 60 = 8: Set the mechanical delay time until the brake is loosened + about 0.1 to 0.2s.
282	Brake operation speed	0 to 900r/min	Generally, set the Pr. 278 setting + 1 to 2r/min to this parameter. Setting is enabled only when Pr. 282 ≥ Pr. 278.
283	Brake operation time at stop	0 to 5s	Pr. 60 = 7: Set the mechanical delay time until the brake is closed + 0.1s. Pr. 60 = 8: Set the mechanical delay time until the brake is closed + about 0.2 to 0.3s.
284	Deceleration detection function selection	0	Deceleration is not detected.
		1	If deceleration is not normal during deceleration operation, the inverter alarm (E.MB2) is provided to shut off the output and turn off the brake opening request signal (BOF).
285	Overspeed detection speed*	0 to 900r/min	If (detected speed) - (output speed) > Pr. 285, the inverter alarm (E.MB1) is provided to shut off the output and turn off the brake opening request signal (BOF).
		9999	Overspeed is not detected.

* This function is valid during vector control.

CAUTION

When using this function, set the acceleration/deceleration time to 1s or longer.

(4) Setting terminals

The terminals must be assigned using Pr. 180 to Pr. 183 and Pr. 187 and Pr. 190 to Pr. 192 and Pr. 195.

Signal	Brake Sequence Mode	
	Pr. 60 = 7 (with mechanical brake opening completion signal)	Pr. 60 = 8 (without mechanical brake opening completion signal)
BOF	Brake opening request	Brake opening request
BRI	Brake opening completion signal	—

CAUTION

1. The brake opening completion signal (BRI) is a parameter valid when Pr. 60 = 7.
2. Changing the terminal function using any of Pr. 180 to Pr. 183, Pr. 187, Pr. 190 to Pr. 192, and Pr. 195 may affect the other functions. Confirm the functions of the corresponding terminals before making setting. (Refer to page 151.)

(5) Protective functions

If any of the following errors occurs in the brake sequence mode, the inverter results in an alarm, shuts off the output, and turns off the brake opening request signal (BOF terminal).

On the operation panel (FR-DU04-1) LED or parameter unit (FR-PU04V) screen, the following errors are displayed:

Error Display	Description
E.MB1	(Detected speed) - (output speed) > Pr. 285 during vector control. (Overspeed detection function)
E.MB2	Deceleration is not normal during deceleration operation (Use Pr. 284 to select this function.) (Except stall prevention operation)
E.MB3	Brake opening request signal (BOF) turned on though the motor is at a stop. (Gravity drop prevention function)
E.MB4	More than 2s after the run command (forward or reverse rotation) is input, the brake opening request signal (BOF) does not turn on.
E.MB5	More than 2s after the brake opening request signal turned on, the brake opening completion signal (BRI) does not turn on.
E.MB6	Though the inverter had turned on the brake opening request signal (BOF), the brake opening completion signal (BRI) turned off midway.
E.MB7	More than 2s after the brake opening request signal (BOF) turned off at a stop, the brake opening completion signal (BRI) does not turn off.

3.12 Operation selection function 2 (Pr. 65 to Pr. 79)

3.12.1 Retry function (Pr. 65, Pr. 67 to Pr. 69) speed torque

When the inverter output is stopped by the protective function (major fault), this function causes the inverter to automatically reset itself to make a retry. You can select whether retry operation is to be performed or not, alarms reset for retry, number of retries made, and waiting time.

Parameter	Name	Factory Setting	Setting Range	Remarks
65	Retry selection	0	0 to 5	Extended mode
67	Number of retries at alarm occurrence	0	0, 1 to 10, 101 to 110	
68	Retry waiting time	1s	0 to 10s	
69	Retry count display erasure	0	0	

<Setting>

- Use Pr. 65 to select the protective functions (major faults) to be activated for retries.

Errors Reset for Retry		Pr. 65						Remarks
Error definition	Abbreviation	0	1	2	3	4	5	
Acceleration overcurrent	E.OC1	●	●		●	●	●	
Constant-speed overcurrent	E.OC2	●	●		●	●		
Deceleration overcurrent	E.OC3	●	●		●	●	●	
Acceleration overvoltage	E.OV1	●		●	●	●		
Constant-speed overvoltage	E.OV2	●		●	●	●		
Deceleration overvoltage	E.OV3	●		●	●	●		
Motor thermal relay	E.THM	●						
Transistor thermal relay	E.THT	●						
Instantaneous power failure	E.IPF	●				●		
Undervoltage	E.UVT	●				●		
Brake transistor	E.BE	●				●		
Earth (Ground) fault protection	E.GF	●				●		
Output phase failure	E.LF							
External thermal relay	E.OHT	●						
Stall prevention-triggered stop	E.OLT	●				●		

Errors Reset for Retry		Pr. 65						Remarks
Error definition	Abbreviation	0	1	2	3	4	5	
Option alarm	E.OPT	●				●		
Option 1 alarm	E.OP1	●				●		
Option 2 alarm	E.OP2	●				●		
Option 3 alarm	E.OP3	●				●		
Storage device alarm	E.PE	●				●		
PU disconnection	E.PUE							
Retry count excess	E.RET							
CPU error	E.CPU							
Fan stop	E.FAN							
Fin overheat	E.FIN							
Overspeed occurrence	E.OS	●				●		Under vector control
Speed deviation large	E.OSD	●				●		Under vector control
Encoder no-signal	E.ECT							Under vector control
Position error large	E.OD	●				●		Under vector control
Encoder A no-signal	E.ECA							Under vector control
MB1	E.MB1	●				●		Brake sequence
MB2	E.MB2	●				●		Brake sequence
MB3	E.MB3	●				●		Brake sequence
MB4	E.MB4	●				●		Brake sequence
MB5	E.MB5	●				●		Brake sequence
MB6	E.MB6	●				●		Brake sequence
MB7	E.MB7	●				●		Brake sequence
P24 short circuit	E.P24							
P12 short circuit	E.P12							
Circuit alarm (P5S short circuit)	E.CTE							

* ● indicates the errors selected for retry.

- Use Pr. 67 to set the number of retries at alarm occurrence.

Pr. 67 Setting	Number of Retries	Alarm Signal Output
0	Retry is not made.	—
1 to 10	1 to 10 times	Not output every time.*
101 to 110	1 to 10 times	Output every time.

* If the number of retries to be made is exceeded, "E_r E_T" (retry count excess) is displayed.

- Use Pr. 68 to set the waiting time from when an inverter alarm occurs until a retry is made in the range 0 to 10s.
- Reading the Pr. 69 value provides the cumulative number of successful restarts made by retries. Writing "0" erases the cumulative number of times.

CAUTION

- The cumulative number in Pr. 69 is incremented by "1" when retry operation is regarded as successful, i.e. when normal operation is continued without the protective function (major fault) being activated during a period four times longer than the time set in Pr. 68.
- If the protective function (major fault) is activated consecutively within a period four times longer than the above waiting time, the operation panel may show data different from the latest data or the parameter unit (FR-PU04V) may show data different from the first retry data. The data stored as the error reset for retry is only that of the protective function (major fault) activated the first time.
- When an inverter alarm is reset by the retry function at the retry time, the accumulated data of the electronic thermal relay, etc. are not cleared. (Different from the power-on reset.)

⚠ CAUTION

⚠ When you have selected the retry function, stay away from the motor and machine unless required. They will start suddenly (after the predetermined time has elapsed) after occurrence of an alarm. When you have selected the retry function, apply the CAUTION seals provided for the Instruction Manual (basic) in easily visible places.

Pr. 70 ➡ Refer to Pr. 30 (page 96)

3.12.2 Applied motor (Pr. 71, Pr. 450 **speed** **torque** **position**)

Set the motor used.

When using an other manufacturer's motor, set "3" or "13" in Pr.71 and perform offline auto tuning. Refer to the Instruction Manual (basic) for the motor setting, etc.

Parameter	Name	Factory Setting	Setting Range	Remarks
71	Applied motor	Japanese version: 30	0, 3 to 8, 10, 13 to 18, 20, 23, 24, 30, 33, 34	
		NA version: 0		
450	Second applied motor	9999	0, 10, 30, 9999	9999 : Second applied motor invalid

<Setting>

- Refer to the following table and set this parameter according to the motor used.

Setting	Motor	Control Constants
0	Mitsubishi standard motor (SF-JR)	Inverter internal constants
3	Other manufacturer's motor	Offline auto tuning
4		Offline auto tuning data utilization
5		Star connection direct input
6		Delta connection direct input
7		Star connection direct input + offline auto tuning
8		Delta connection direct input + offline auto tuning
10	Mitsubishi constant-torque motor (SF-HRCA)	Inverter internal constants
13	Other manufacturer's motor	Offline auto tuning
14		Offline auto tuning data utilization
15		Star connection direct input
16		Delta connection direct input
17		Star connection direct input + offline auto tuning
18	Delta connection direct input + offline auto tuning	
20	SF-JR (4P)-1.5kW (2HP) or less (during vector control)	Inverter internal constants
23		Offline auto tuning
24		Offline auto tuning data utilization
30	Mitsubishi SF-V5R dedicated motor (including SF-VR type motor)	Inverter internal constants
33		Offline auto tuning
34		Offline auto tuning data utilization

CAUTION

- Refer to page 123 for offline auto tuning.
- Refer to page 36 for details of setting conventional Mitsubishi motors and other manufacturer's motors.

⚠ CAUTION

⚠ Set this parameter correctly according to the motor used.

REMARKS

- For online auto tuning, refer to the Instruction Manual (basic).

3.12.3 PWM carrier frequency selection (Pr. 72, Pr. 240 speed torque position)

By parameter setting, you can set whether to exercise the Soft-PWM control that changes the motor tone or select with or without long wiring mode.

- Soft-PWM control is a control system that changes the motor noise from a metallic tone into an unoffending tone.
- Surge voltage is suppressed regardless of wiring length in the long wiring mode. (When operating the 400V motor with wiring length of 40m(131.23feet) or longer, select long wiring mode.)

Parameter	Name	Factory Setting	Setting Range	Remarks
72	PWM frequency selection	1	1 to 6	Simple mode
240	Soft-PWM setting	10	0, 1, 10, 11	Extended mode

<Setting>

Pr. 72 Setting	Description
1	2.25kHz
2	4.5kHz
3	6.75kHz
4	9kHz
5	11.25kHz
6	13.5kHz

CAUTION

1. An increased PWM carrier frequency will decrease the motor sound but increase noise and leakage currents. Therefore, perform the reduction techniques. (Refer to page 11.)
2. Since Pr. 240 is factory-set to "10", PWM carrier frequency is 2.25 kHz constant even if "2" or larger value is set in Pr. 72. Set "0 or 1" in Pr. 240 to decrease the motor noise.

Pr. 240 Setting	Description		Remarks
	Soft-PWM	long wiring mode	
0	Invalid	Invalid	
1	Valid (when Pr. 72 = "1 or 2")	Invalid	
10	Invalid	Valid	Carrier frequency is 2.25kHz. (The Pr.72 "PWM frequency selection" setting is made invalid.)
11	Valid	Valid	

CAUTION

1. When long wiring mode is made valid, torque reduces about 5% in the constant output region.
2. The output voltage at rated frequency decreases by about 1.5V maximum (200V class)/about 3.0V maximum (400V class) during V/F control.
3. Use an inveter duty motor for the 400V class. Refer to page 20 for inverter driving of the 400V class motor.

3.12.4 Speed setting signal on/off selection (Pr. 73 speed torque)

You can select the override function to make main speed setting with the speed setting auxiliary terminal 1. Using Pr. 73, set the input specifications of terminals 1 and 2 and whether to use the override function or not.

POINT

- Set "0" in Pr. 807 "speed restriction selection". (Refer to page 173.)
- Set "0" in Pr. 868 "No.1 terminal function selection". (Refer to page 183.)
- Refer to Pr. 902 "speed setting No. 2 bias", Pr. 903 "speed setting No. 2 gain" for calibration. (Refer to page 190.)

Parameter	Name	Factory Setting	Setting Range	Remarks
73	Speed setting signal	0	0	Extended mode
			4	
			10	
			14	

Pr. 73 Setting	Control Mode	Function		Terminal 1 (0 to ±10V)	Terminal 2 (0 to 10V) ^{*3}
		Override	Polarity reversible		
0	Speed control	×	×	Addition auxiliary ^{*1} Speed command	Main speed setting
4		○ ^{*2}	×	Main speed setting	Override signal
10		×	○	Addition auxiliary ^{*1} Speed command	Main speed setting
14		○ ^{*2}	○	Main speed setting	Override signal
0	Torque control	×	×	Addition auxiliary Speed restriction	Speed restriction
4		○ ^{*4}	×	Speed restriction	Override signal
10		×	×	Addition auxiliary Speed restriction	Speed restriction
14		○ ^{*4}	×	Speed restriction	Override signal
0, 4, 10, 14	Position control	No function		No function	No function

*1:The value of terminal 1 (speed setting auxiliary input) is added to the main speed setting signal of terminal 2.

*2:When override has been selected, terminal 1 is for the main speed setting and terminal 2 for the override signal (50 to 150% at 0 to 10V). (Refer to page 157 for bias/gain adjustment.)

*3:When "30" or "31" is set in Pr. 128, terminal 2 acts as the PID set point function.

*4:When override has been selected, terminal 1 is for speed restriction and terminal 2 is for the override signal.

CAUTION

To change the maximum output speed at the input of the maximum speed command voltage, use the speed setting voltage gain, Pr. 903 (Pr. 905).

At this time, the command voltage need not be input.

Also, the acceleration/deceleration time, which is a slope up/down to the acceleration/deceleration reference speed, is not affected by the change in Pr. 73 setting.

- (a) When Pr. 73 "speed setting signal" value is "0"
 The voltage across terminals 1-5 is added to the voltage signal (positive) across terminals 2-5. If the result of addition is negative, it is regarded as 0 and the motor comes to a stop.
- (b) When Pr. 73 "speed setting signal" value is "10"
 The polarity reversible operation function is selected.
 The voltage signal across terminals 1-5 is added to the voltage signal (positive) across terminals 2-5. A positive addition result turns the motor in the forward rotation direction (when the STF terminal turns on), or a negative result turns it in the reverse rotation direction (when the STF terminal turns on). The compensation signal of terminal 1 can also be added to the multi-speed setting.

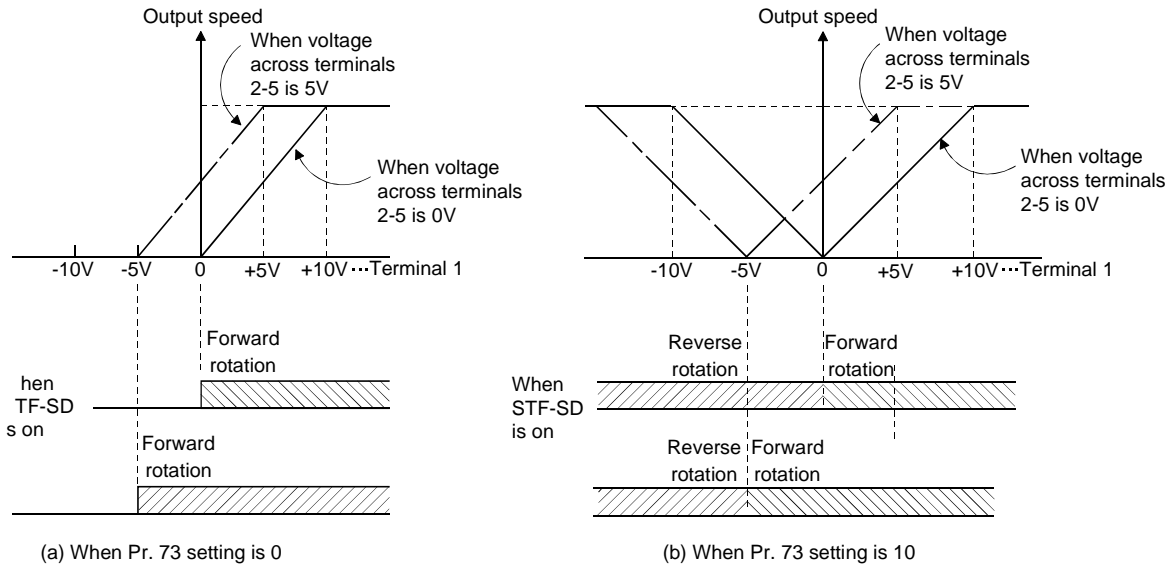

Auxiliary Input Characteristics

- 1) Multi-speed input compensation
 By setting 1 in Pr. 28 "multi-speed input compensation selection" (factory setting 0), the speed from the auxiliary input terminal 1 is added when multi-speed operation is performed. (Refer to page 82.)

Inverter Output According to Start Signal and Auxiliary Input Terminal Polarity

Pr. 73 Setting	Added Command Voltage	Start Signal Input	
		STF-SD	STR-SD
0	+	Forward rotation	Reverse rotation
	-	Stop	Stop
10	+	Forward rotation	Reverse rotation
	-	Reverse rotation	Forward rotation

- 2) Override
 For the above compensation input, the fixed compensation amount is applied to each speed.
 Using the override function easily varies each speed equally.
 By setting either "4 or 14" in Pr. 73, override allows the parameter-set multiple speeds and analog input across terminals 1-5 to be varied equally within the range 50% to 150% (The range can be increased with Pr. 252 and Pr. 253) by the analog signal input across terminals 2-5.

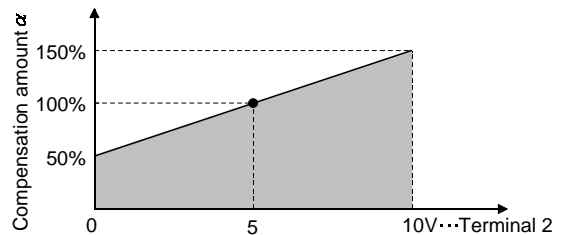

Override Setting Signal vs. Compensation Amount

How to find each speed (N)

$$N = N_{pr.} \times \frac{\alpha}{100} \text{ [r/min]}$$

Npr.: Speed setting [r/min]

[Multiple speeds
 [Analog input across terminals 1-5]

α : Override compensation amount [%]
 (Analog input across terminals 2-5)

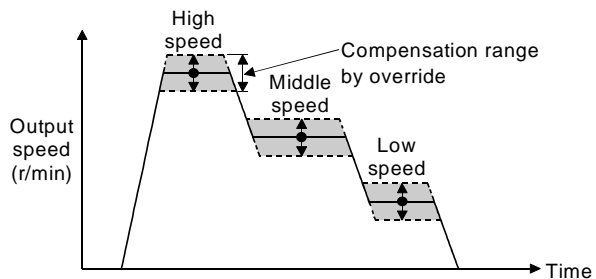

Multi-speed Override Operation

3.12.5 Reset selection/disconnected PU detection/PU stop selection

(Pr. 75)

You can select the reset input acceptance, PU (FR-DU04-1/FR-PU04V) connector disconnection detection function and PU stop function.

- Reset selection: You can select the reset function input (RES signal) timing.
- Disconnected PU detection: When the disconnection of the PU (FR-DU04-1/FR-PU04V) from the inverter for more than 1s is detected, the inverter outputs an alarm code (E.PUE) and comes to an alarm stop.
- PU stop selection: When an alarm etc. occurs in any operation mode, you can stop the motor from the operation panel by pressing .

Parameter	Name	Factory Setting	Setting Range	Remarks
75	Reset selection/disconnected PU detection/PU stop selection	14	0 to 3, 14 to 17	Extended mode

<Setting>

Pr. 75 Setting	Reset Selection	Disconnected PU Detection	PU Stop Selection
0	Reset input is always enabled.	If the PU is disconnected, operation will be continued as-is.	The PU stop key is invalid.
1	Reset input is enabled only when the protective function is activated.		
2	Reset input is always enabled.	When the PU is disconnected, the inverter output is shut off.	input is valid only in the PU or combined operation mode (Pr. 79 = "4").
3	Reset input is enabled only when the protective function is activated.		
14	Reset input is always enabled.	If the PU is disconnected, operation will be continued as-is.	input decelerates the motor to a stop in any of the PU, external and communication operation modes.
15	Reset input is enabled only when the protective function is activated.		
16	Reset input is always enabled.	When the PU is disconnected, the inverter output is shut off.	
17	Reset input is enabled only when the protective function is activated.		

(1) Restarting method when stop was made by inputting from the operation panel (Method of restarting from indication)

- 1) After the motor has decelerated to a stop, turn off the STF or STR signal.
- 2) Press twice* to display .

CAUTION

When Pr. 79 = "3", press three times to display . Then press and proceed to 3).

(*For monitor screen)..... Refer to the Instruction Manual (basic) for details of the monitor display provided by pressing .

- 3) Press .
- 4) Turn on the STF or STR signal.

REMARKS

- When you provide a reset input (RES) during operation, the inverter that is being reset shuts off the output and resets the internal heat integrating value of the electronic thermal relay and the number of retries, and the motor coasts.
- The Pr. 75 value can be set any time. This value does not return to the initial value even if parameter (all) clear is executed.
- When the motor is stopped from the PU, and are displayed alternately. An alarm output is not provided.

**(2) Restarting method when stop was made by inputting STOP
RESET from PU**

- 1) After the motor has decelerated to a stop, turn off the STF or STR signal.
- 2) Press EXT.
- (Recovery from PS)
- 3) Turn on the STF or STR signal.

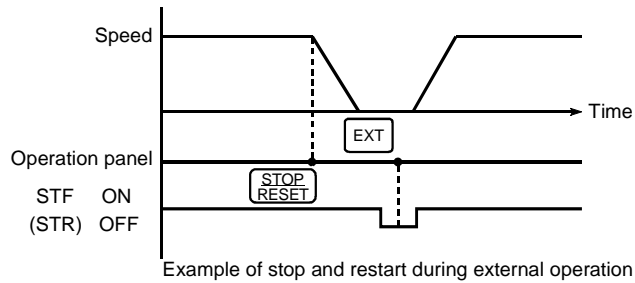

Alternatively, you can make a restart by making a power-on reset or resetting the inverter using the reset terminal of the inverter.

REMARKS

- When you provide a reset input (RES) during operation, the inverter that is being reset shuts off the output and resets the data of the electronic thermal relay, and the motor coasts.
- To make a restart, confirm that the PU is connected and then reset the inverter.
- The Pr. 75 value can be set any time. This value does not return to the initial value even if parameter (all) clear is executed.
- When the motor is stopped from the PU, PS is displayed. An alarm output is not provided.
- Pr. 250 is made invalid.

⚠ CAUTION

⚠ Do not reset the inverter with the start signal input. Doing so will start the inverter immediately after it has recovered from the error, causing hazard.

3.12.6 Parameter write disable selection (Pr. 77 speed torque position)

You can select between enable and disable for parameter write. This function is used to prevent parameter values from being rewritten by misoperation.

Parameter	Name	Factory Setting	Setting Range	Remarks
77	Parameter write disable selection	0	0, 1, 2	Simple mode

<Setting>

Pr. 77 Setting	Function
0	Write is enabled only during a stop in the PU operation mode.*
1	Parameter write is disabled.**
2	Write is enabled even during operation. Write is enabled independently of the operation mode.

CAUTION

- * The shaded parameters in the parameter list (refer to page 64) always allow setting.
- Even when "2" is set in Pr. 77, the following parameters do not allow writing during operation. Pr. 60, Pr. 71, Pr. 72, Pr. 79, Pr. 80 to Pr. 84, Pr. 90 to Pr. 96, Pr. 180 to Pr. 183, Pr. 187, Pr. 190 to Pr. 192, Pr. 195, Pr. 450, Pr. 451, Pr. 453, Pr. 454, Pr. 800, Pr. 819, Pr. 851, Pr. 852, Pr. 859 and Pr. 868
Stop operation when changing the values of the above parameters.
- By setting "1" in Pr. 77, the following clear operations can be inhibited:
 - Parameter clear
 - Parameter all clear
- Even when "1" is set in Pr. 77, write is allowed for Pr. 22, Pr. 75, Pr. 77 and Pr. 79.

3.12.7 Reverse rotation prevention selection (Pr. 78 speed torque position)

This function can prevent any reverse rotation fault resulting from the mis-input of the start signal.

POINT

Used for a machine that runs only in one direction, e.g. fan, pump.
(The setting of this parameter is valid for combined operation, PU operation, external operation and communication operation.)

Parameter	Name	Factory Setting	Setting Range	Remarks
78	Reverse rotation prevention selection	0	0, 1, 2	Extended mode

<Setting>

Control Method	Pr. 78 Setting	Start Signal		Restriction on Analog Reversible					
		STF	STR						
Speed control V/F control	0	Valid	Valid	Negative input starts rotation in the direction opposite to that of start signal					
	1 (reverse rotation lock)	Valid	Invalid	Negative input does not start rotation.					
	2 (forward rotation lock)	Invalid	Valid						
Torque control	0	Valid	Valid	Negative input starts rotation in the direction opposite to that of start signal					
	1 (reverse rotation lock)	Valid	Invalid	Negative analog input results as follows.					
	2 (forward rotation lock)	Invalid	Valid	<table border="1"> <thead> <tr> <th>Speed</th> <th>Operation</th> </tr> </thead> <tbody> <tr> <td>Start speed or less</td> <td>No rotation</td> </tr> <tr> <td>When rotation is in the same direction as that of start signal and speed is higher than starting speed.</td> <td>Torque in the direction opposite to that of start signal is generated.</td> </tr> </tbody> </table>	Speed	Operation	Start speed or less	No rotation	When rotation is in the same direction as that of start signal and speed is higher than starting speed.
Speed	Operation								
Start speed or less	No rotation								
When rotation is in the same direction as that of start signal and speed is higher than starting speed.	Torque in the direction opposite to that of start signal is generated.								
Position control	0	Functions as a stroke signal and motor does not rotate in the direction where the STF or STR signal does not exist.		Under position control, analog command is irrelevant to the forward/reverse rotation lock function as it does not function in other than torque restriction setting (absolute value used for operation).					
	1 (reverse rotation lock)	Motor does not rotate in the reverse rotation direction.							
	2 (forward rotation lock)	Motor does not rotate in the forward rotation direction.							

3.12.8 Operation mode selection (Pr. 79 speed torque position)

Used to select the operation mode of the inverter.







The inverter can be run from the operation panel or parameter unit (PU operation), with external signals (external operation), or by combination of PU operation and external operation (external/PU combined operation).

The external operation mode is selected at power-on (factory setting).

Parameter	Name	Factory Setting	Setting Range
79	Operation mode selection	0	0 to 4, 6 to 8

<Setting>

In the following table, operation from the operation panel or parameter unit is abbreviated to PU operation.

Pr. 79 Setting	Function		
0	At power-on, the external operation mode is selected. You can change between the PU operation mode and external operation mode from the operation panel () or parameter unit ( / ). Refer to the fields of settings 1 and 2 for the corresponding modes.		
1	Operation mode	Speed command	Start signal
	PU operation mode	Setting from the operation panel or FR-PU04V	 , 
2	External operation mode	External signal input (across terminals 2(1)-5, multi-speed selection, jog)	External signal input (terminal STF, STR)
3	External/PU combined operation mode 1	Digital setting by PU key operation or external signal input (multi-speed setting)	External signal input (terminal STF, STR)
4	External/PU combined operation mode 2	External signal input (across terminals 2(1)-5, multi-speed selection, jog)	 , 
6	Switchover mode Switchover between PU operation, external operation and computer link operation (when a communication option is used) can be done while running.		
7	External operation mode (PU operation interlock) X12 signal ON..... Can be switched to PU operation mode (output stop during external operation) X12 signal OFF Switching to PU operation mode inhibited		
	Operation mode switchover using external signal (disallowed during operation) X16 signal ON..... Switched to external operation mode X16 signal OFF Switched to PU operation mode		

REMARKS

- A stop function (PU stop selection) by  of the PU (FR-DU04-1/FR-PU04V) is made valid during the operation other than the PU operation mode. (Refer to page 118)
- Either "3" or "4" may be set to select the PU/external combined operation, and these settings differ in starting method. Refer to page 130 for the computer link operation mode.

(1) Switchover mode

PU operation, external operation and computer link operation (when communication option is used) can be used by switching between them.

Operation Mode Switching	Switching Operation/Operating Status
External operation to PU operation	1) Change the operation mode to the PU operation mode. •Rotation direction is the same as that of external operation. •Set speed is as set by the potentiometer (speed setting potentiometer). (Note that the setting will disappear when power is switched off or the inverter is reset.)
External operation to computer link operation	1) Mode change command to computer link mode is transmitted from the computer. •Rotation direction is the same as that of external operation. •Set speed is as set by the potentiometer (speed setting potentiometer). (Note that the setting will disappear when power is switched off or the inverter is reset.)
PU operation to external operation	1) Press the external operation key of the parameter unit. •Rotation direction is determined by the external operation input signal. •Set speed is determined by the external speed setting signal.
PU operation to computer link operation	1) Mode change command to computer link mode is transmitted from the computer. •Rotation direction and set speed are the same as those of PU operation.
Computer link operation to external operation	1) Command to change to external mode is transmitted from the computer. •Rotation direction is determined by the external operation input signal. •Set speed is determined by the external speed setting signal.
Computer link operation to PU operation	1) Select the PU operation mode with the operation panel or parameter unit. •Rotation direction and set speed are the same as those of computer link operation.

(2) PU operation interlock

The PU operation interlock function is designed to forcibly change the operation mode to the external operation mode when the X12 signal input turns off. This function prevents the inverter from being inoperative by the external command if the mode is accidentally left unswitched from the PU operation mode.

1) Preparation

- Set "7" (PU operation interlock) in Pr. 79.
- Using any of Pr. 180 to Pr. 183 and Pr. 187 (input terminal function selection), allocate the terminal used to input the X12 signal. (Refer to page 151)

REMARKS

Changing the terminal assignment with any of Pr. 180 to 183 and Pr. 187 may affect the other functions. Check the functions of the corresponding terminals before making setting.

2) Function

X12 Signal	Function/Operation
ON	Output stop during external operation. Operation mode can be switched to the PU operation mode. PU operation allowed.
OFF	Forcibly switched to the external operation mode. External operation allowed. Switching to the PU operation mode inhibited.

<Function/operation changed by switching on-off the X12 signal>

Operating Condition		X12 Signal	Operation Mode	Operating Status
Operation mode	Status			
PU	During stop	ON→OFF (*)	PU → External	During stop
	During operation	ON→OFF (*)		If external operation speed setting and start signal are entered, operation is performed in that status.
External	During stop	OFF→ON	External	During stop
		ON→OFF		During operation → output stop
	During operation	OFF→ON		Output stop → operation
		ON→OFF		

REMARKS

- If the X12 signal is on, the operation mode cannot be switched to the PU operation mode when the start signal (STF, STR) is on.
- * The operation mode switches to the external operation mode independently of whether the start signal (STF, STR) is on or off. Therefore, the motor is run in the external operation mode when the X12 signal is turned off with either of STF and STR on.
- When the X12 signal is off during external operation mode, the operation mode cannot be changed to the PU operation mode. (Change to the PU operation mode after switching the X12 signal on)

(3) Operation mode external signal switching function

1) Preparation

Set "8" (operation mode with signal) in Pr. 79.

Using any of Pr. 180 to Pr. 183 and Pr. 187 (input terminal function selection), allocate the terminal used to input the X16 signal.

REMARKS

Changing the terminal assignment with any of Pr. 180 to 183 and Pr. 187 may affect the other functions. Check the functions of the corresponding terminals before making setting. Refer to page 151 for details.

2) Function

This switching is enabled only during an inverter stop and cannot be achieved during operation.

X16 Signal	Operation Mode
ON	External operation mode (cannot be changed to the PU operation mode)
OFF	PU operation mode (cannot be changed to the external operation mode)

Related parameters

Pr. 75 "PU stop selection" (Refer to page 118.)

3.13 Offline auto tuning (Pr. 80 to Pr. 96)

3.13.1 Offline auto tuning function

(Pr. 9, Pr. 80, Pr. 81, Pr. 83, Pr. 84, Pr. 71, Pr. 96, Pr. 450, Pr. 452 speed torque position)

If any other manufacturer's motor is used, using the offline auto tuning function runs the motor with the optimum operating characteristics.

- By performing offline auto tuning, the inverter measures the necessary motor constants.
- Offline auto tuning can be performed with an inertia load, e.g. coupling, connected. (As the load is lighter, tuning accuracy is higher. Tuning accuracy does not change if the inertia is large.)
- For the offline auto tuning, you can select either the motor non-rotation mode or rotation mode. The rotation mode has higher tuning accuracy than the non-rotation mode. The rotation mode should be selected for the online auto tuning.
- If any other manufacturer's motor is used, perform offline auto tuning (Pr. 96="101") with motor alone to run the motor before performing online auto tuning. (The motor with inertia load can be connected.)
- Note that it is necessary to perform offline auto tuning (non-rotation mode (Pr. 96="1")) in order for the wiring length resistance to be reflected on the control when the wiring length of the Mitsubishi motor used (SF-V5R, SF-JR, SF-HRCA) is long (30m (98.42 feet) or longer as a reference).
(For online auto tuning, refer to the Instruction Manual (basic). For other settings, refer to 36)

CAUTION

1. The motor capacity is equal to or one rank lower than the inverter capacity.
2. Special motors such as high-slip motor and high-speed motor cannot be tuned.
3. Motor runs at up to about the rated speed of the motor.
4. Make sure that the motor is connected. (At a tuning start, the motor should be at a stop.)
5. Tune the motor alone without connecting a load (e.g. frictional stationary load) to the motor. (An inertia load such as a coupling may remain connected.)
6. Use the PLG that is coupled directly to the motor shaft without looseness.
7. Offline auto tuning will not be performed properly if it is performed with a reactor connected between the inverter and motor. Remove it before starting tuning.

REMARKS

- When using the Mitsubishi dedicated motor (SF-V5R, SF-VR), Mitsubishi standard motor (SF-JR with PLG), or Mitsubishi constant-torque motor, offline auto tuning is not necessary.
- You can copy the online tuning data (motor constants) to another inverter with the PU (FR-DU04-1/FR-PU04V).
- The offline auto tuning status can be monitored with the PU (FR-DU04-1/FR-PU04V).

3.13.2 Parameters

Set the following parameters.

Parameter	Name	Setting Range	Factory Setting	Remarks
71	Applied motor	Refer to page 114 and set "3 (standard motor)", "13 (constant-torque motor)" or "33 (SF-V5R or SF-VR)". Electronic thermal characteristics are also changed in accordance with the motor.		
9	Electronic thermal O/L relay	0 to 500A (Set 0 for use of an external thermal relay.)	Japanese version: 0A	Refer to the motor rating plate and set the rated value. (If two or more rated values are given in the motor rating plate, set the values for 200V/60Hz(400/60Hz)
			NA version: Rated inverter output current)	
80	Motor capacity	0.4 to 55kW	Inverter capacity	
81	Number of motor poles	2, 4, 6	4	
83	Rated motor voltage	0 to 1000V	200V/400V	
84	Rated motor frequency	20 to 200Hz	Japanese version: 60Hz	
			NA version: 60Hz	
96	Auto tuning setting/status	0, 1, 101	0	0 : Auto tuning not performed 1 : Tuning performed without motor running 101 : Tuning performed with motor running
851	Number of PLG pulses	0 to 4096	Japanese version: 2048	
			NA version: 1024	
852	PLG rotation direction	0,1	1	
876	Thermal relay protector input	0,1	Japanese version: 1	
			NA version: 0	

3.13.3 Execution of offline auto tuning

The following applies to the first motor.

CAUTION

- Note the following when "101" (offline auto tuning performed with motor running) is set in Pr. 96.
 - Ensure safety when the motor starts running.
 - Torque is not enough during tuning.
 - The motor may be run at nearly its rated frequency (Pr. 84 setting) without any problem.
 - The brake is open.
 - When over current alarm (E.OC1, OC2, OC3)occurs, set acceleration time longer using Pr. 7.
 - No external force is applied to rotate the motor.
- If "1" (tuning performed without motor running) is set in Pr. 96, the motor may run slightly (However, torque is not enough). Therefore, fix the motor securely with a mechanical brake, or before tuning, make sure that there will be no problem in safety if the motor runs.
 - *This instruction must be followed especially in vertical lift applications.*
 - Note that if the motor runs slightly, tuning performance is unaffected.
- During offline auto tuning, only the following I/O signals are valid:
 - Input signals (STOP, OH, MRS, RT, RES, STF, STR)
 - Output signals (RUN, OL, IPF, DA1, DA2, A, B, C)
 - Take extra precaution when designing a sequence where a mechanical brake is opened by the RUN signal.

<Setting>

(1) Parameter setting

- Select Pr. 851 "number of PLG pulses" and Pr. 852 "PLG rotation direction" (Refer to the Instruction Manual (basic).)
- Select Pr. 80 "motor capacity" and Pr. 81 "number of motor poles".
- Refer to the parameter details to set the parameters below.
 - 1) Set "1" or "101" in Pr. 96
 - When the setting is "1"tuning performed without motor running
 - When the setting is "101"tuning performed with motor running
 - 2) Set Pr. 9 "electronic thermal O/L relay".
 - When using the external thermal, change the Pr. 9 setting back to "0" after offline auto tuning. The electronic thermal function is made invalid. Set "0" in Pr. 876 if the external thermal relay is not used.
 - 3) Set the rated motor voltage (V) in Pr. 83.
 - 4) Set the rated motor frequency (Hz) in Pr. 84.
 - 5) Select the motor in Pr. 71.
 - Example
 - Mitsubishi standard motor. Pr. 71 = "3"
 - Mitsubishi constant torque motor Pr. 71 = "13"
 - Mitsubishi standard motor SF-JR 4 poles (1.5kW(2HP) or less)Pr. 71 = "23"
 - SF-V5R, SF-VR Pr. 71 = "33"

CAUTION

For the setting value, set the motor rating plate value. When using a motor having several rated values, e.g. a standard motor, set a value for 200V/60Hz or 400V/60Hz.

(2) Tuning command

After setting the above parameters, press **FWD** or **REV**.
(For external operation, turn on the run command (STF, STR).)

REMARKS

- To force tuning to end, use the MRS or RES signal or press **STOP/RESET**. (The start signal may also be turned off to end.)
- Excitation noise is produced during tuning.
- When executing offline auto tuning, input the run command after switching on the main circuit power (R, S, T) of the inverter.

(3) Monitoring during execution

When the parameter unit (FR-PU04V) is used, the Pr. 96 value is displayed during tuning on the main monitor as shown on the next page. When the operation panel (FR-DU04-1) is used, the same value as on the PU is only displayed.

When Pr.96=1

- Parameter unit (FR-PU04V) main monitor

	1. Setting	2. Tuning in progress	3. Completion	4. Error-activated end (for inverter trip)
Display				

- Operation panel (FR-DU04-1) display

	1. Setting	2. Tuning in progress	3. Completion	4. Error-activated end (for inverter trip)
Displayed value				

REMARKS

- Offline auto tuning time (factory setting)
 - 1: No-rotation mode: Approx. 25s
 - 2: Rotation mode: Approx. 40s

(Offline auto tuning time varies with the acceleration and deceleration time settings as indicated below.
Offline auto tuning time = acceleration time + deceleration time + approx. 30s)

(4) Ending the offline auto tuning

- Confirm the Pr. 96 value.
 - Normal end: "3" or "103" is displayed.
 - Error end: "9", "91", "92" or "93" is displayed.
 - Forced end: "8" is displayed.
- When tuning ended normally

For PU operation, press . For external operation, turn off the start signal (STF or STR) once. This operation resets the offline auto tuning and the PU's monitor display returns to the normal indication. (Without this operation, next operation cannot be started.) (Refer to the Instruction Manual (basic) for inverter reset.)
- When tuning was ended due to an error

Offline auto tuning did not end normally. (The motor constants have not been set.) Reset the inverter and start tuning all over again.
- Error display definitions

Error Display	Error Cause	Remedy
9	Inverter trip	Make setting again.
91	Current limit (stall prevention) function was activated.	Increase acceleration/deceleration time. Set "1" in Pr. 156.
92	Converter output voltage reached 75% of rated value.	Check for fluctuation of power supply voltage.
93	Calculation error	Check the motor wiring and make setting again.

No connection with motor will also result in "93" error.

- When tuning was ended forcibly

Tuning is ended forcibly by pressing or turning off the start signal (STF or STR) during tuning. In this case, offline auto tuning has not ended properly. (The motor constants have not been set.) Perform an inverter reset and restart tuning.

REMARKS

1. The motor constants measured once in the offline auto tuning are stored as parameters and their data are held until the offline auto tuning is performed again.
2. An instantaneous power failure occurring during tuning will result in a tuning error. After power is restored, the inverter goes into the ordinary operation mode. Therefore, when STF (STR) is on, the motor runs in the forward (reverse) rotation.
3. Any alarm occurring during tuning is handled as in the ordinary mode. Note that if an error retry has been set, retry is ignored.
4. The set speed monitor displayed during the offline auto tuning is 0r/min.

⚠ CAUTION

- ⚠ **Note that the motor may start running suddenly.**
- ⚠ **When the offline auto tuning in the rotation mode is used in vertical lift application, e.g. a lifter, it may drop due to insufficient torque.**

3.13.4 Utilizing or changing offline auto tuning data for use

<Setting the motor constants as desired>

The motor constants (Pr. 90 to Pr. 94) may be set as desired in either of two ways; the data measured in the offline auto tuning are read and utilized or changed, or the motor constants are set without the offline auto tuning data being used.

<Operating procedure>

1. Set the following value in Pr. 71 (Pr. 450):
 - Mitsubishi standard motor Pr. 71 = "4"
 - Mitsubishi constant-torque motor..... Pr. 71 = "14"
 - Mitsubishi standard motor SF-JR (4P) (1.5kW(2HP) or less) . Pr. 71 = "24"
 - SF-V5R, SF-VR Pr. 71 = "34"
2. Set "801" in Pr. 77.
 (The parameter values of Pr. 82 "motor excitation current" and Pr. 90 to Pr. 94 (motor constants) can be displayed. Though the parameter values of other than Pr. 82 and Pr. 90 to Pr. 94 can also be displayed, they are parameters for manufacturer setting and their values should not be changed.)
3. In the parameter setting mode, read the following parameters and set desired values.

Parameter Number	Name	Setting Range	Setting Increments	Factory Setting
82	Motor excitation current (no load current)	0 to ****, 9999	1	9999
90	Motor constant R1	0 to ****, 9999	1	9999
91	Motor constant R2	0 to ****, 9999	1	9999
92	Motor constant L1	0 to ****, 9999	1	9999
93	Motor constant L2	0 to ****, 9999	1	9999
94	Motor constant x	0 to ****, 9999	1	9999
859	Torque current	0 to ****, 9999	1	9999

REMARKS

When "0" (factory setting) is set in Pr. 684 "tuning data increment switchover", the motor constants are set in "internal variable increment". When "1" is set in Pr. 684, the motor constants are set in "mH, Ω, A". (can be set when Pr.77 = "801")

4. Return the Pr. 77 setting to the original value.

REMARKS

1. Set "9999" in Pr. 90 to Pr. 94 to use the standard motor constants (including those for the constant-torque motor).
2. Set "3 (standard motor), "13" (constant-torque motor) or "23" (Mitsubishi standard SF-JR(4P) 1.5kW(2HP) or less) in Pr. 71 to use the constants measured in the offline auto tuning. Set "4, 14 or 24" in Pr. 71 and change the motor constants to change the values measured in the offline auto tuning.
3. As the motor constants measured in the offline auto tuning have been converted into internal data (****), refer to the following setting example when making setting:
 Setting example: To slightly increase Pr. 90 value (5%)
 When Pr. 90 is displayed "2516", set 2642, i.e. 2516 × 1.05=2641.8, in Pr. 90. (The value displayed has been converted into a value for internal use. Hence, simple addition of a given value to the displayed value has no significance.)
4. When "1" is set in Pr. 96, the last values of Pr. 82, Pr. 92, and Pr. 93 remain unchanged.

3.13.5 Setting the motor constants directly

Offline auto tuning is not used.

The Pr. 92 and Pr. 93 motor constants may either be entered in [Ω] or in [mH]. Before starting operation, confirm which motor constant unit is used. (Refer to page 123.)

● To enter the Pr. 92 and Pr. 93 motor constants in [Ω]

<Operating procedure>

1. After checking that the input motor constants are those for star connection or delta connection, set the Pr. 71 value as indicated below (When direct input is selected and offline auto tuning is performed, set "7, 8, 17 or 18") in Pr. 71. (Refer to page 128.)

		Star Connection Motor	Delta Connection Motor
Pr. 71	Standard motor	5	6
Setting	Constant-torque motor	15	16

2. Set "801" in Pr. 77.

(The parameter values of the motor constants (Pr. 90 to Pr. 94) can be displayed. Though the parameter values of other than Pr. 90 to Pr. 94 can also be displayed, they are parameters for manufacturer setting and their values should not be changed.)

3. In the parameter setting mode, read the following parameters and set desired values.

I_q =Torque, I_{100} =Rated current, I_0 =No load current

$$I_q = \sqrt{I_{100}^2 - I_0^2}$$

Parameter Number	Name	Setting Range	Setting Increments	Factory Setting
82	Motor excitation current (no load current)	0 to 500A	0.01A	9999
90	Motor constant r1	0 to 50 Ω , 9999	0.001 Ω	9999
91	Motor constant r2	0 to 50 Ω , 9999	0.001 Ω	9999
92	Motor constant x1	0 to 50 Ω , 9999	0.001 Ω	9999
93	Motor constant x2	0 to 50 Ω , 9999	0.001 Ω	9999
94	Motor constant xm	0 to 500 Ω , 9999	0.01 Ω	9999
859	Torque current	0 to 500A	0.01A	9999

4. Return the Pr. 77 setting to the original value.

5. Set Pr. 83 and Pr. 84.

Parameter Number	Name	Setting Range	Setting Increments	Factory Setting
83	Rated motor voltage	0 to 1000V	0.1V	200V/400V
84	Rated motor frequency	20 to 200Hz	0.01Hz	60Hz

CAUTION

1. Set "9999" in Pr. 90 to Pr. 94 to use the standard motor constants (including those for the constant-torque motor).
2. If "star connection" is mistaken for "delta connection" or vice versa during setting of Pr. 71, control cannot be exercised properly.

● To enter the Pr. 92 and Pr. 93 motor constants in [mH]

<Operating procedure>

1. After checking that the input motor constants are those for star connection or delta connection, set the Pr. 71 value as indicated below.

Pr. 71 Setting	Standard motor	0
	Constant-torque motor	10
	SF-V5R	30

2. Set "801" in Pr. 77.

(The parameter values of the motor constants (Pr. 90 to Pr. 94) can be displayed. Though the parameter values of other than Pr. 90 to Pr. 94 can also be displayed, they are parameters for manufacturer setting and their values should not be changed.)

Online auto tuning (Pr. 95)

3. In the parameter setting mode, read the following parameters and set desired values.

Parameter Number	Name	Setting Range	Setting Increments	Factory Setting
82	Motor excitation current (no load current)	0 to 500A	0.01A	9999
90	Motor constant R1	0 to 50Ω, 9999	0.001Ω	9999
91	Motor constant R2	0 to 50Ω, 9999	0.001Ω	9999
92	Motor constant L1	0 to 1000mH, 9999	0.1mH	9999
93	Motor constant L2	0 to 1000mH, 9999	0.1mH	9999
94	Motor constant x	0 to 100%, 9999	0.1%	9999
859	Torque current	0 to 500A	0.01A	9999

4. Return the Pr. 77 setting to the original value.

5. Refer to the following table and set Pr. 83 and Pr. 84.

Parameter Number	Name	Setting Range	Setting Increments	Factory Setting
83	Rated motor voltage	0 to 1000V	0.1V	200V/400V
84	Rated motor frequency	20 to 200Hz	0.01Hz	60Hz

CAUTION

Set "9999" in Pr. 90 to Pr. 94 to use the standard motor constants (including those for the constant-torque motor).

3.13.6 Direct input + offline auto tuning

Perform offline auto tuning after directly inputting the motor constants.

1. Set Pr. 71.

Pr. 71 Setting	Description	
7	Star connection direct input + offline auto tuning	General-purpose motor
8	Delta connection direct input + offline auto tuning	
17	Star connection direct input + offline auto tuning	Constant-torque motor
18	Delta connection direct input + offline auto tuning	

2. Set the motor constants (Refer to page 127).

3. Set Pr. 96 to perform offline auto tuning (Refer to page 124).

3.14 Online auto tuning (Pr. 95)

- Excellent torque accuracy is provided by temperature compensation even if the secondary resistance value of the motor varies with the rise in the motor temperature.

3.14.1 Online auto tuning selection (Pr. 95, Pr. 9, Pr. 71, Pr. 80, Pr.

81 speed torque position)

Parameter	Name	Factory Setting	Setting Range	Remarks
95	Online auto tuning selection	0	0, 1, 2	0: Online auto tuning not performed 1: Start-time tuning (at start-up) 2: Adaptive magnetic flux observer (normal)
9	Electronic thermal O/L relay	Japanese version: 0A	0 to 500A	Used as rated motor current and electronic thermal relay parameters. (Refer to page 85)
		NA version: Rated inverter output current		
71	Applied motor	Japanese version: 30	Refer to page 114 and make setting.	
		NA version: 0		
80	Motor capacity	Inverter capacity	0.4 to 55kW	(Down to one rank lower of the inverter capacity)
81	Number of motor poles	4	2, 4, 6	

(1) Pr. 95="1" (start-time tuning)

The current at a start is detected to compensate for the secondary resistance of the motor so that excellent characteristics are provided regardless of the change in value of the secondary resistance of the motor with the rise of the motor temperature.

CAUTION

1. Perform offline auto tuning in the mode with rotation before performing online auto tuning of the start-time tuning.
For offline auto tuning, refer to page 123.
2. For using start-time tuning in vertical lift applications, examine the utilization of a brake sequence for the brake opening timing at a start. Though the tuning ends in about a maximum of 500ms after a start, torque is not provided fully during that period. Therefore, note that there may be a possibility of gravity drop.

(2) Pr. 95 = "2" (normal tuning)/adaptive magnetic flux observer

This function is effective for torque accuracy improvement when using the motor with PLG.

The current flowing in the motor and the inverter output voltage are used to estimate/observe the magnetic flux in the motor.

The magnetic flux of the motor is always detected with high accuracy so that excellent characteristics are provided regardless of the change in the temperature of the secondary resistance.

Set "2" when exercising PLG vector control.

CAUTION

1. For the SF-V5R, SF-JR (with PLG) or SF-HRCA (with PLG), it is not necessary to perform offline auto tuning to select adaptive magnetic flux observer. (Note that it is necessary to perform offline auto tuning (non-rotation mode) for the wiring length resistance to be reflected on the control when the wiring length is long (30m (98.43feet) or longer as reference).)
For offline auto tuning, refer to page 123.

REMARKS

1. Online auto tuning of the start-time tuning is not enabled when the starting conditions of the inverter are not satisfied, e.g. the MRS is input, the preset speed is less than the starting speed (Pr. 13), during inverter error, etc.
2. Online auto tuning of the start-time tuning does not operate during deceleration or at a restart during DC brake operation.
3. Invalid for jog operation.
4. The RUN signal is not output during online auto tuning of the start-time tuning. The RUN signal turns on at a start.
5. If the period from an inverter stop to a restart is within 4s, online auto tuning of the start-time tuning is performed but the tuning results are not reflected.
6. Automatic restart after instantaneous power failure overrides when automatic restart after instantaneous power failure is selected.
7. Zero current detection and output current detection are valid during online auto tuning.

CAUTION

Refer to the Instruction Manual (basic) for details.

Pr. 96 ➡ Refer to page 123.

Pr. 110, Pr. 111 ➡ Refer to Pr. 7 (page 83).

Pr. 116 ➡ Refer to Pr. 42 (page 99).

3.15 Communication functions (Pr. 117 to Pr. 124)

3.15.1 Computer link operation (RS-485 communication)

(Pr. 117 to Pr. 124, Pr. 342 **speed** **torque** **position**)

Used to perform required settings for communication between the inverter and personal computer. Using the inverter setup software (FR-SW1-SETUP-WE) enables efficient parameter setting, monitoring, etc.

- Communication operation can be performed from the PU connector of the inverter by RS-485 communication.

<Communication specifications>

Conforming standard		RS-485 Standard	
Number of inverters connected		1: N (max. 32 inverters)	
Communication speed		Selected among 19200, 9600 and 4800bps	
Control protocol		Asynchronous system	
Communication method		Half-duplex system	
Communication specifications	Character system	ASCII (7 bits/8 bits) selectable	
	Stop bit length	Selectable between 1 bit and 2 bits.	
	Terminator	CR/LF (presence/absence selectable)	
	Check system	Parity check	Selectable between presence (even/odd) and absence
		Sum check	Presence
Waiting time setting		Selectable between presence and absence	

- For the data codes of the parameters, refer to the data code list in Appendices (page 208).

REMARKS

For computer link operation, set 65520 (HFFF0) as "8888" and 65535 (HFFFF) as "9999".

<Setting>

To make communication between the personal computer and inverter, the initial settings of the communication specifications must be made to the inverter. Data communication cannot be made if the initial settings are not made or there is any setting error.

CAUTION

Always reset the inverter after making the initial settings of the parameters. Communication is disabled unless the inverter is reset after the communication-related parameter values have been changed.

Parameter Number	Name	Factory Setting	Setting	Description	
117	Station number	0	0 to 31	Station number specified for communication from the PU connector. Set the inverter station numbers when two or more inverters are connected to one personal computer.	
118	Communication speed	192	48	4800bps	
			96	9600bps	
			192	19200bps	
119	Stop bit length/ data length	1	8 bits	0	Stop bit length 1 bit
				1	Stop bit length 2 bits
			7 bits	10	Stop bit length 1 bit
				11	Stop bit length 2 bits
120	Parity check presence/ absence	2	0	Absent	
			1	Odd parity present	
			2	Even parity present	
121	Number of communication retries	1	0 to 10	Set the permissible number of retries at occurrence of data receive error. If the number of consecutive errors exceeds the permissible value, the inverter will come to an alarm stop (E. PUE).	
			9999 (65535)	If a communication error occurs, the inverter will not come to an alarm stop. At this time, the inverter can be coasted to a stop by MRS or RESET input. During a communication error (H0 to H5), the minor fault signal (LF) is given to the open collector output. Allocate the used terminal with any of Pr. 190 to Pr. 192 and Pr. 195 (output terminal function selection).	
122*	Communication check time interval	Japanese version: 0	0	No communication	
		NA version: 9999	0.1 to 999.8s	Set the communication check time [s] interval. If a no-communication state persists for longer than the permissible time, the inverter will come to an alarm stop (E. PUE).	
123	Waiting time setting	9999	0 to 150ms	Set the waiting time between data transmission to the inverter and response.	
			9999	Set with communication data.	
124	CR/LF instruction presence/ absence	1	0	Without CR/LF	
			1	With CR	
			2	With CR/LF	
342**	E ² PROM write presence/ absence	0	0	Parameter values written from the computer are written to the E ² PROM.	
			1	Parameter values written from the computer are written to the RAM.	

* When making communication, set any value other than 0 in Pr. 122 "communication check time interval".

** When write to RAM has been set, powering off the inverter will erase the changed parameter values. Therefore, the parameter values available when power is switched on again are the values stored in E²PROM previously.

When changing the parameter values frequently, set "1" in Pr. 342 to write them to the RAM.

The setting of Pr. 342 "E²PROM write presence/absence" is valid for computer link communication operation only.

<Computer programming>

(1) Communication procedure

Data communication between the computer and inverter is made in the following procedure.

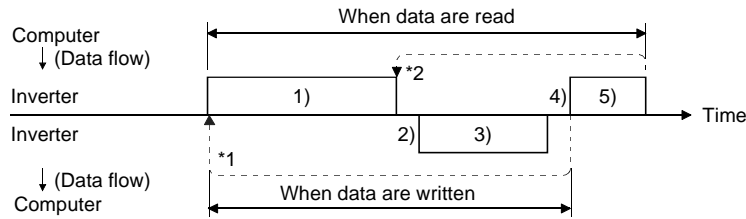

- *1 If a retry must be made at occurrence of a data error, execute retry operation with the user program. The inverter comes to an alarm stop if the number of consecutive retries exceeds the parameter setting.
- *2 On receipt of a data error occurrence, the inverter returns retry data 3 to the computer again. The inverter comes to an alarm stop if the number of consecutive data errors reaches or exceeds the parameter setting.

(2) Communication operation presence/absence and data format types

Communication operation presence/absence and data format types are as follows.

No.	Operation	Run Command	Running Speed	Parameter Write	Inverter Reset	Monitoring	Parameter Read	
1)	Communication request is sent to the inverter in accordance with the user program of the computer.	A'	A	A	A	B	B	
2)	Inverter data processing time	Present	Present	Present	Absent	Present	Present	
3)	Reply data from the inverter (Data 1 is checked for error)	No error* (Request accepted)	C	C	C	Absent	E E'	E
		With error (Request rejected)	D	D	D	Absent	F	F
4)	Computer processing delay time	Absent	Absent	Absent	Absent	Absent	Absent	
5)	Answer from computer in response to reply data 3 (Data 3 is checked for error)	No error* (Inverter performs no processing)	Absent	Absent	Absent	Absent	G	G
		With error (Inverter re-outputs 3)	Absent	Absent	Absent	Absent	H	H

* In the communication request data from the computer to the inverter, 10ms or more is also required after "no data error (ACK)". (Refer to page 134.)

(3) Data format

Data are used in hexadecimal.

Data are automatically converted into ASCII for communication between the computer and inverter.

Data format types

1) Communication request data from the computer to the inverter

[Data write]

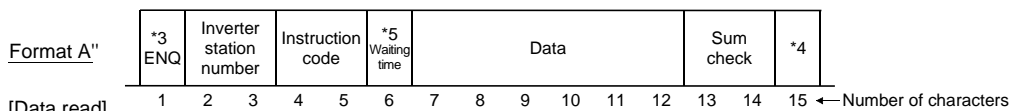
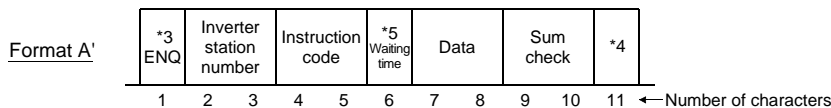

[Data read]

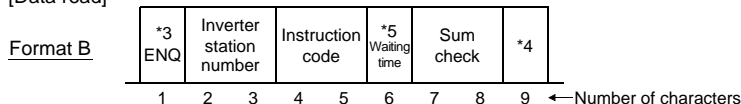

CAUTION

1. Specify the inverter station numbers between H00 and H1F (stations 0 and 31) in hexadecimal.
2. *3 indicates the control code.
3. *4 indicates the CR or LF code.
When data is transmitted from the computer to the inverter, codes CR (carriage return) and LF (line feed) are automatically set at the end of a data group on some computers. In this case, setting must also be made from the inverter according to the computer.
Also, the presence and absence of the CR and LF codes can be selected using Pr. 124.
4. *5: When the Pr. 123 "waiting time setting" setting is other than 9999, create the communication request data without "waiting time" in the data format. (The number of characters decreases by 1.)

2) Reply data from the inverter to the computer during data write

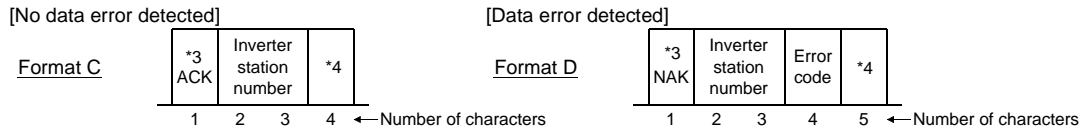

3) Reply data from the inverter to the computer during data read

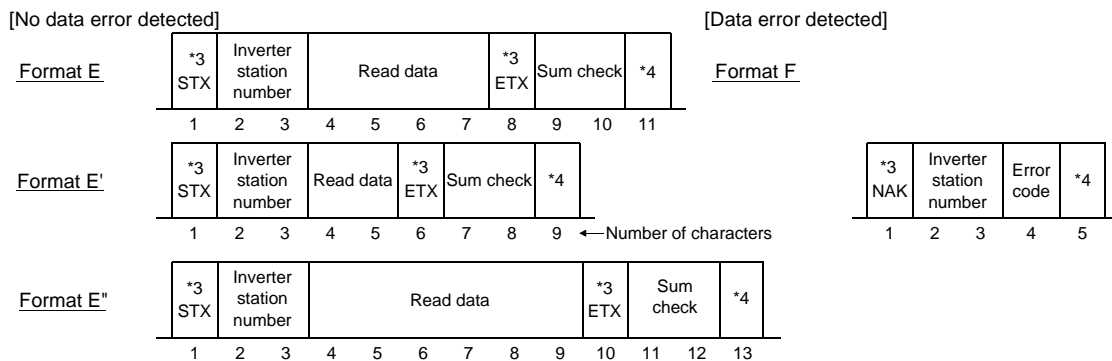

4) Send data from the computer to the inverter during data read

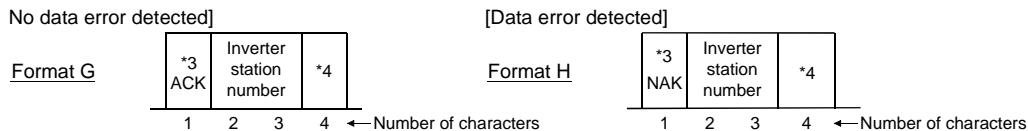

(4) Data definitions

1) Control codes

Signal Name	ASCII Code	Description
STX	H02	Start of Text (Start of data)
ETX	H03	End of Text (End of data)
ENQ	H05	Enquiry (Communication request)
ACK	H06	Acknowledge (No data error detected)
LF	H0A	Line Feed
CR	H0D	Carriage Return
NAK	H15	Negative Acknowledge (Data error detected)

2) Inverter station number

Specify the station number of the inverter which communicates with the computer.

3) Instruction code

Specify the processing request, e.g. operation or monitoring, given by the computer to the inverter. Hence, the inverter can be run and monitored in various ways by specifying the instruction codes as appropriate. (Refer to page 208.)

4) Data

Indicates the data such as speed and parameters transferred to and from the inverter. The definitions and ranges of set data are determined in accordance with the instruction codes. (Refer to page 208.)

5) Waiting time

Specify the waiting time between the receipt of data by the inverter from the computer and the transmission of reply data from the inverter. Set the waiting time in accordance with the response time of the computer between 0 and 150ms in 10ms increments. (Example: 1 = 10ms, 2 = 20ms)

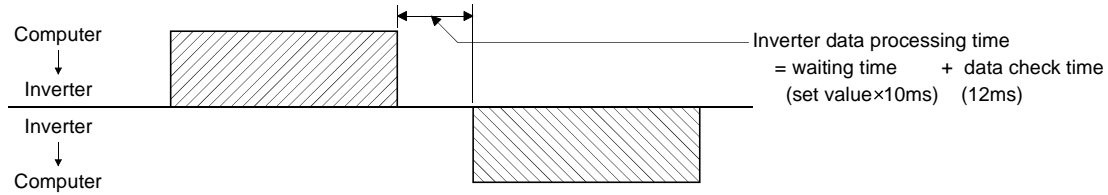

CAUTION

When the Pr. 123 "waiting time setting" setting is other than 9999, create the communication request data without "waiting time" in the data format. (The number of characters decreases by 1.)

6) Response time

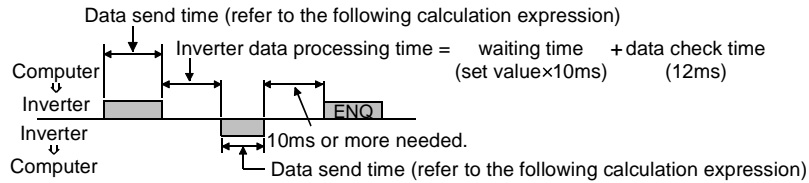
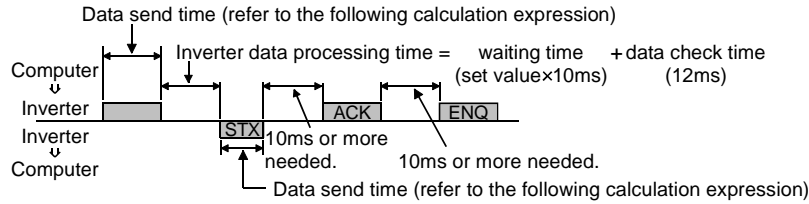

[Data send time calculation expression]

$$\frac{1}{\text{Communication speed (bps)}} \times \text{Number of data characters} \times \text{Communication specifications} = \text{Data send time (s)}$$

(Refer to page 132) (Total number of bits) (See below)

• Communication specifications

Name	Number of Bits
Stop bit length	1 bit 2 bits
Data length	7 bits 8 bits
Parity check	Yes 1bit No 0

1 start bit is needed in addition to the bits in the left table.
Minimum total number of bits.....9 bits
Maximum total number of bits.....12 bits

7) Sum check code

The sum check code is 2-digit ASCII (hexadecimal) representing the lower 1 byte (8 bits) of the sum (binary) derived from the checked ASCII data.

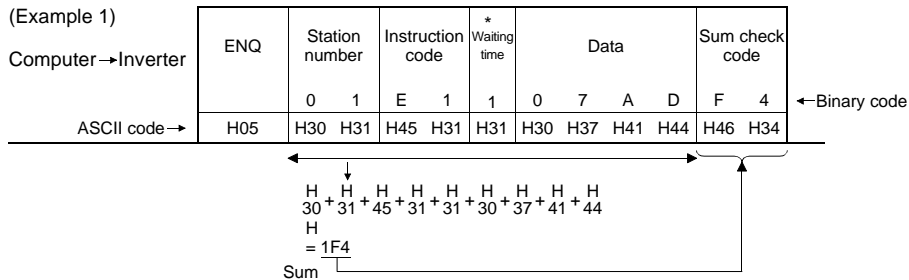

*: When the Pr. 123 "waiting time setting" setting is other than 9999, create the communication request data without "waiting time" in the data format. (The number of characters decreases by 1.)

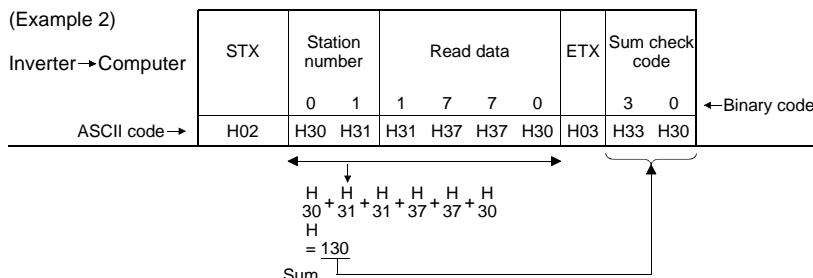

8) Error code

If any error is found in the data received by the inverter, its definition is sent back to the computer together with the NAK code. (Refer to page 139.)

CAUTION

1. When the data from the computer has an error, the inverter does not accept that data.
2. Any data communication, e.g. run command or monitoring, is started when the computer gives a communication request. Without the computer's command, the inverter does not return any data. For monitoring, etc. therefore, design the program to cause the computer to provide a data read request as required.
3. Data for link parameter expansion setting differs as indicated below between access to Pr. 0 to Pr. 99 values and access to Pr. 100 to Pr. 905.

		Instruction Code	Data
Link parameter expansion setting	Read	H7F	H00: Pr. 0 to Pr. 96 values are accessible. H01: Pr. 110 to Pr. 158, Pr.900 to Pr.905 values are accessible. H02: Pr. 160 to Pr. 195 and Pr. 232 to Pr. 288 values are accessible. H03: Pr. 300 to Pr. 399 values are accessible. H04: Pr. 400 to Pr. 496 values are accessible. H05: Pr. 500 to Pr. 538 values are accessible.
	Write	HFF	H06: Pr. 684 to Pr. 690 values are accessible. H08: Pr. 800 to Pr. 892 values are accessible. H09: Pr. 917 to Pr. 991 values are accessible.

(5) Instructions for the program

- 1) When data from the computer has any error, the inverter does not accept that error. Hence, in the user program, always insert a retry program for data error.
- 2) Since any data communication, such as operation command or monitoring, is always requested by the computer, the inverter will not return data without the computer's request. Hence, design the program so that the computer gives a data read request for monitoring, etc. as required.
- 3) Program example
When the operation mode is switched to communication operation

10 OPEN "COM1:9600,E,8,2,HD" AS #1	: Initial setting of I/O file
20 COMST1,1,1:COMST1,2,1	: Communication file opening
30 ON COM(1)GOSUB REC	: Circuit control signal (RS, ER) ON/OFF setting
40 COM(1)ON	: Interrupt definition at data receive
50 D\$= "01FB10002"	: Interrupt enable
60 S=0	: Transmission data setting
70 FOR I=1 TO LEN(D\$)	
80 A\$=MID\$(D\$,I,1)	
90 A=ASC(A\$)	: Sum code calculation
100 S=S+A	
110 NEXTI	
120 D\$=CHR\$(&H5)+D\$+RIGHT\$(HEX\$(S),2)	: Addition of control and sum codes
130 PRINT#1,D\$: Data transmission
140 GOTO 50	
000 REC	: Interrupt data receive
010 IF LOC(1)=0 THEN RETURN	: Interrupt occurrence at data receive
020 PRINT "RECEIVE DATA"	
030 PRINT INPUT\$(LOC(1),#1)	
040 RETURN	

General flowchart

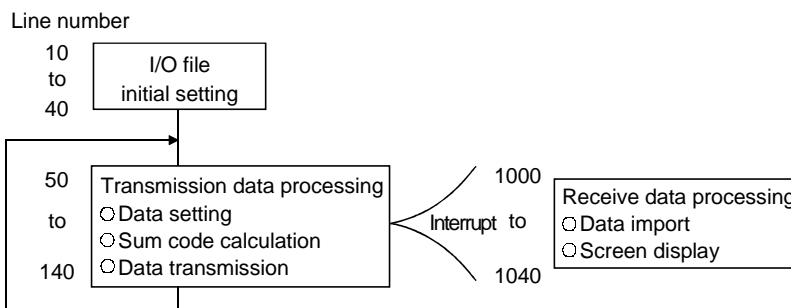

⚠ CAUTION

- ⚠ When the inverter's communication time interval is not set, interlocks are provided to disable operation to prevent hazard. Always set the communication check time interval before starting operation.
- ⚠ Data communication is not started automatically but is made only once when the computer provides a communication request. If communication is disabled during operation due to signal cable breakage etc., the inverter cannot be stopped. When the communication check time interval has elapsed, the inverter will come to an alarm stop (E.PUE).
The inverter can be coasted to a stop by turning on its RES signal or by switching power off.
- ⚠ If communication is broken due to signal cable breakage, computer fault, etc. the inverter does not detect such a fault. This should be fully noted.

<Setting items and set data>

After completion of parameter setting, set the instruction codes and data and start communication from the computer to allow various types of operation control and monitoring.

No.	Item	Instruction Code	Description	Number of Data Digits
1	Operation mode	Read H7B	H0000: Communication option operation H0001: External operation H0002: Communication operation (PU connector)	4 digits
		Write HFB	H0000: Communication option operation H0001: External operation H0002: Communication operation (PU connector)	

Communication functions (Pr. 117 to Pr. 124)

No.	Item	Instruction Code	Description	Number of Data Digits																									
4	Run command	HFA	<table style="margin-left: auto; margin-right: auto;"> <tr> <td style="text-align: center;">b7</td> <td style="text-align: center;">b0</td> </tr> <tr> <td style="text-align: center;">0</td><td style="text-align: center;">0</td><td style="text-align: center;">0</td><td style="text-align: center;">0</td><td style="text-align: center;">0</td><td style="text-align: center;">0</td><td style="text-align: center;">1</td><td style="text-align: center;">0</td> </tr> </table> <p>(For example 1) [Example 1] H02...Forward rotation [Example 2] H00...Stop</p> <p>b0: — b1: Forward rotation (STF) b2: Reverse rotation (STR) b3: — b4: — b5: — b6: — b7: —</p>	b7	b0	0	0	0	0	0	0	1	0	2 digits															
b7	b0																												
0	0	0	0	0	0	1	0																						
5	Inverter status monitor	H7A	<table style="margin-left: auto; margin-right: auto;"> <tr> <td style="text-align: center;">b7</td> <td style="text-align: center;">b0</td> </tr> <tr> <td style="text-align: center;">0</td><td style="text-align: center;">0</td><td style="text-align: center;">0</td><td style="text-align: center;">0</td><td style="text-align: center;">0</td><td style="text-align: center;">0</td><td style="text-align: center;">1</td><td style="text-align: center;">0</td> </tr> </table> <p>(For example 1) [Example 1] H02.....During forward rotation [Example 2] H80.....Stop due to alarm occurrence</p> <p>b0: Inverter running (RUN) b1: Forward rotation b2: Reverse rotation b3: DO1* b4: DO2* b5: DO3* b6: Speed detection (FB) b7: Alarm occurrence*</p> <p>* Output data varies with the settings of Pr. 190 to Pr. 192 and Pr. 195.</p>	b7	b0	0	0	0	0	0	0	1	0	2 digits															
b7	b0																												
0	0	0	0	0	0	1	0																						
6	Set speed write (E ² PROM)	HEE	HFF=0 H0000 to H1C20: 1r/min increments (hexadecimal) (4 digits)	4 digits (6 digits)																									
	Set speed write (RAM)	HED	HFF=1 H0000 to H11940: 0.1r/min increments (hexadecimal) (6 digits) To change the running speed consecutively, write data to the inverter RAM. (Instruction code: HED)																										
7	Set speed (E ² PROM) read	H6E	HFF = 0 H0000 to H1C20: 1r/min increments (hexadecimal) (4 digits)	4 digits (6 digits)																									
	Set speed (RAM) read	H6D	HFF = 1 H0000 to 11940: 0.1r/min increments (hexadecimal) (6 digits)																										
8	Inverter reset	HFD	H9696: Resets the inverter. As the inverter is reset at start of communication by the computer, the inverter cannot send reply data back to the computer.	4 digits																									
9	Parameter all clear	HFC	<p>All parameters return to the factory settings. Any of four different clear operations is performed according to the data.</p> <table border="1" style="margin-left: auto; margin-right: auto;"> <thead> <tr> <th style="text-align: center;">Pr. Data</th> <th style="text-align: center;">Communi- cation Pr.</th> <th style="text-align: center;">Calibra- tion Pr.</th> <th style="text-align: center;">Other Pr. *</th> <th style="text-align: center;">HEC HF3 HFF</th> </tr> </thead> <tbody> <tr> <td style="text-align: center;">H9696</td> <td style="text-align: center;">○</td> <td style="text-align: center;">×</td> <td style="text-align: center;">○</td> <td style="text-align: center;">○</td> </tr> <tr> <td style="text-align: center;">H9966</td> <td style="text-align: center;">○</td> <td style="text-align: center;">○</td> <td style="text-align: center;">○</td> <td style="text-align: center;">○</td> </tr> <tr> <td style="text-align: center;">H5A5A</td> <td style="text-align: center;">×</td> <td style="text-align: center;">×</td> <td style="text-align: center;">○</td> <td style="text-align: center;">○</td> </tr> <tr> <td style="text-align: center;">H55AA</td> <td style="text-align: center;">×</td> <td style="text-align: center;">○</td> <td style="text-align: center;">○</td> <td style="text-align: center;">○</td> </tr> </tbody> </table> <p>When parameter all clear is executed for H9696 or H9966, communication-related parameter settings also return to the factory settings. When resuming operation, set the parameters again. *Pr. 75 is not cleared.</p>	Pr. Data	Communi- cation Pr.	Calibra- tion Pr.	Other Pr. *	HEC HF3 HFF	H9696	○	×	○	○	H9966	○	○	○	○	H5A5A	×	×	○	○	H55AA	×	○	○	○	4 digits
Pr. Data	Communi- cation Pr.	Calibra- tion Pr.	Other Pr. *	HEC HF3 HFF																									
H9696	○	×	○	○																									
H9966	○	○	○	○																									
H5A5A	×	×	○	○																									
H55AA	×	○	○	○																									
10	Parameter write	H80 to HFD	Refer to the data list (page 208) and write and/or read parameter values as required.	4 digits																									
11	Parameter read	H00 to H7B																											

No.	Item	Instruction Code	Description	Number of Data Digits
12	Link parameter expansion setting	Read H7F	H00: Pr. 0 to Pr. 96 values are accessible. H01: Pr. 110 to Pr. 158, Pr.900 to Pr.905 values are accessible. H02: Pr. 160 to Pr. 195 and Pr. 232 to Pr. 288 values are accessible. H03: Pr. 300 to Pr. 399 values are accessible. H04: Pr. 400 to Pr. 496 values are accessible. H05: Pr. 500 to Pr. 538 values are accessible. H06: Pr. 684 to Pr. 690 values are accessible. H08: Pr. 800 to Pr. 892 values are accessible. H09: Pr. 917 to Pr. 991 values are accessible. <hr/> CAUTION <hr/> When the instruction code "HFF" was rewritten, increments of the speed monitor , write and read is changed. HFF = "0"1r/min increments HFF = "1"0.1r/min increments HFF = more than "2" ...1r/min increments <hr/>	2 digits
		Write HFF		
13	Second parameter changing (Code FF=1)	Read H6C	When reading/setting the bias/gain (data code H5E to H61, HDE to HE1) parameters H00: Speed/torque H01: Analog H02: Analog value of terminal (When written, the data value is any 4-digit value.)	2 digits
		Write HEC		

REMARKS

For the instruction codes HFF, HEC and HF3, their values are held once written but cleared to zero when an inverter reset or all clear is performed.

<Error code list>

The corresponding error code in the following list is displayed if an error is detected in any communication request data from the computer.

Error Code	Error Item	Error Definition	Inverter Side Operation
H0	Computer NAK error	The number of errors consecutively detected in communication request data from the computer is greater than the allowed number of retry times.	Brought to an alarm stop (E. PUE) if error occurs continuously more than the allowable number of retry times.
H1	Parity error	The parity check result does not match the specified parity.	
H2	Sum check error	The sum check code in the computer does not match that of the data received by the inverter.	
H3	Protocol error	Data received by the inverter is in the wrong protocol, data receive is not completed within the given time, or CR and LF are not as set in the parameter.	
H4	Framing error	The stop bit length differs from the initial setting.	
H5	Overrun	New data has been set by the computer before the inverter completes receiving the preceding data.	
H6	—	—	—
H7	Character error	The character received is invalid (other than 0 to 9, A to F, control code).	Does not accept receive data but is not brought to alarm stop.
H8	—	—	—
H9	—	—	—
HA	Mode error	Parameter write was attempted in other than the computer link operation mode or during inverter operation.	Does not accept or receive data but is not brought to alarm stop.
HB	Instruction code error	The specified command does not exist.	
HC	Data range error	Invalid data has been specified for parameter, running frequency write, etc.	
HD	—	—	—
HE	—	—	—
HF	—	—	—

(6) Communication specifications for RS-485 communication

Operation Location	Item	Operation Mode		
		Communication operation from PU connector	External operation	Computer link operation (When plug-in option is used)
On-computer user program from PU connector	Run command (start)	Enable	Disable	Disable
	Running speed setting	Enable	Enable (Combined operation mode)	Disable
	Monitoring	Enable	Enable	Enable
	Parameter write	Enable (*4)	Disable (*4)	Disable (*4)
	Parameter read	Enable	Enable	Enable
	Inverter reset	Enable (*2)	Enable (*2)	Enable (*2)
	Stop command (*3)	Enable	Enable	Enable
On-computer user program from plug-in option	Run command	Disable	Disable	Enable (*1)
	Running speed setting	Disable	Disable	Enable (*1)
	Monitoring	Enable	Enable	Enable
	Parameter write	Disable (*4)	Disable (*4)	Enable (*4)
	Parameter read	Enable	Enable	Enable
	Inverter reset	Disable	Disable	Enable (*2)
	Stop command (*3)	Disable	Disable	Enable
Control circuit terminal	Inverter reset	Enable	Enable	Enable
	Run command	Disable	Enable	Enable (*1)
	Speed setting	Disable	Enable	Enable (*1)

(*1) As set in the Pr.79 external/PU combined mode.

(*2) At occurrence of RS-485 communication error, the inverter cannot be reset from the computer.

(*3) As set in Pr. 75.

(*4) As set in Pr. 77.

(7) Operation at alarm occurrence

Alarm Location	State	Operation Mode			
		Communication operation (PU connector)	External operation	Computer link operation (When plug-in option is used)	
Inverter fault	Inverter operation	Stop	Stop	Stop	
	Communication	PU connector	Continued	Continued	Continued
		Plug-in option	Continued	Continued	Continued
Communication error (Communication from PU connector)	Inverter operation	Stop/continued (*5)	Continued	Continued	
	Communication	PU connector	Stop	Stop	Stop
		Plug-in option	Continued	Continued	Continued

*5: Can be selected using the parameter (factory-set to Continued).

(8) Communication error

Alarm Location	Error Message
Communication error (Error in communication from PU connector)	E.PUE

3.16 PID control (Pr. 128 to Pr. 134)

3.16.1 PID control (Pr. 128 to Pr. 134 speed)

The inverter can be used to exercise process control, e.g. flow rate, air volume or pressure.

- The voltage input signal (0 to ±10V) is used as a feedback value to constitute a feedback system for PID control.

Parameter Number	Name	Factory Setting	Setting Range	Remarks
128	PID action selection	10	10, 11, 30, 31	
129	PID proportional band	100%	0.1 to 1000%, 9999	9999: No proportional control
130	PID integral time	1s	0.1 to 3600s, 9999	9999: No integral control
131	Upper limit	9999	0 to 100%, 9999	9999: Function invalid
132	Lower limit	9999	0 to 100%, 9999	9999: Function invalid
133	PID action set point for PU operation	0%	0 to 100%	
134	PID differential time	9999	0.01 to 10.00s, 9999	9999: No differential control

<Setting>

(1) Basic PID control configuration

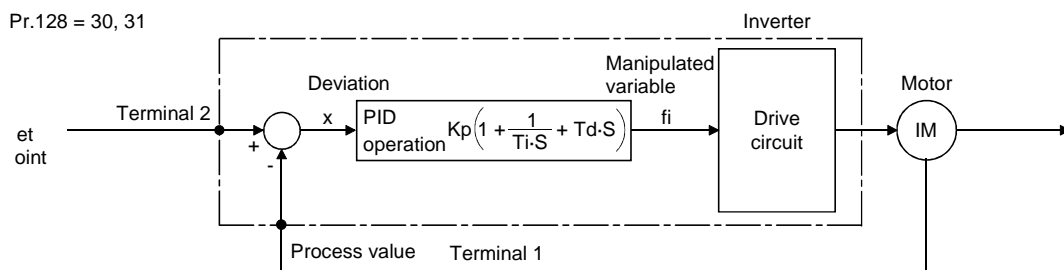
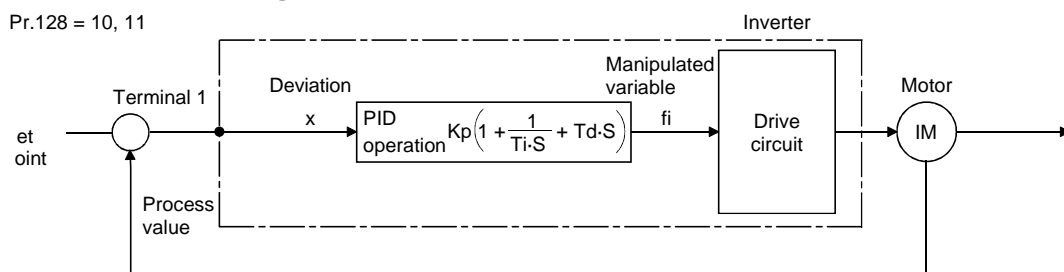

Kp: Proportional constant Ti: Integral time S: Operator Td: Differential time

(2) PID action overview

1) PI action

A combination of proportional control action (P) and integral control action (I) for providing a manipulated variable in response to deviation and changes with time.

[Operation example for stepped changes of process value]

CAUTION
PI action is the sum of P and I actions.

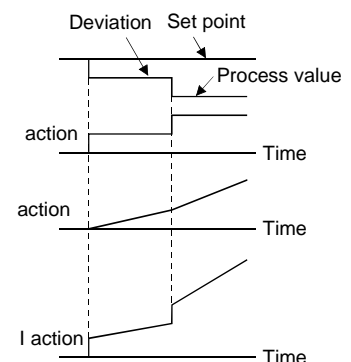

2) PD action

A combination of proportional control action (P) and differential control action (D) for providing a manipulated variable in response to deviation speed to improve the transient characteristic.

[Operation example for proportional changes of process value]

CAUTION
PD action is the sum of P and D actions.

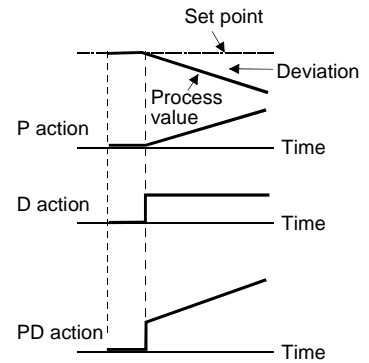

3) PID action

The PI action and PD action are combined to utilize the advantages of both actions for control.

CAUTION
The PID action is the sum of P and I and D actions.

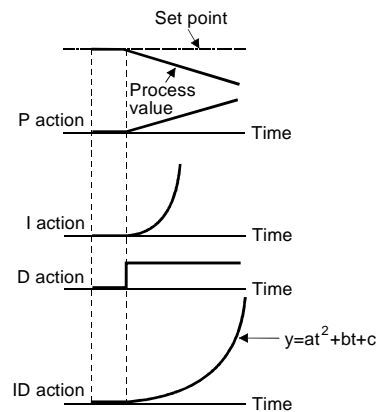

4) Reverse action

Increases the manipulated variable (output speed) if deviation X (set point - process value) is positive, and decreases the manipulated variable if deviation is negative.

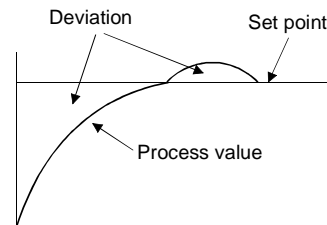
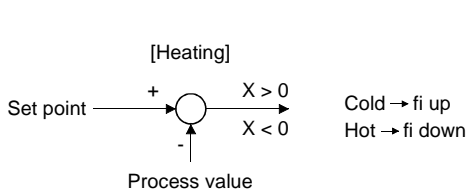

5) Forward action

Increases the manipulated variable (output speed) if deviation X (set point - process value) is negative, and decreases the manipulated variable if deviation is positive.

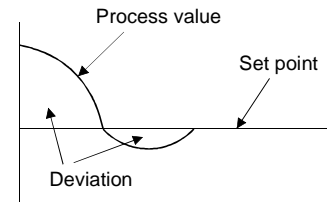
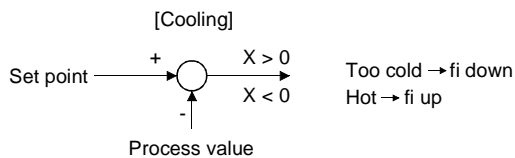

Relationships between deviation and manipulated variable (output speed)

	Deviation	
	Positive	Negative
Reverse Action	↗	↘
Forward Action	↘	↗

(3) Wiring example

Pr.128 = 10, 11

Pr.128 = 30, 31

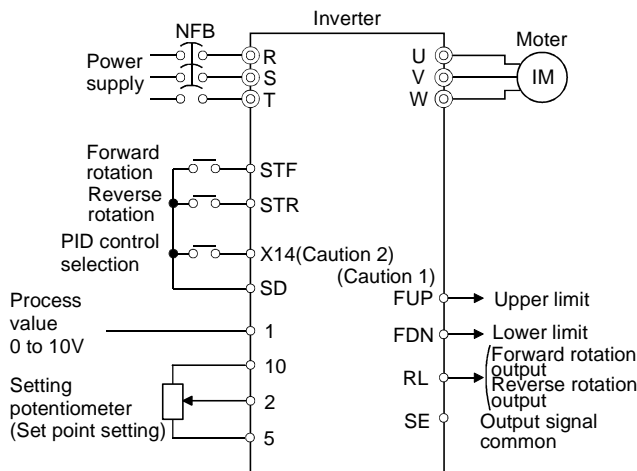
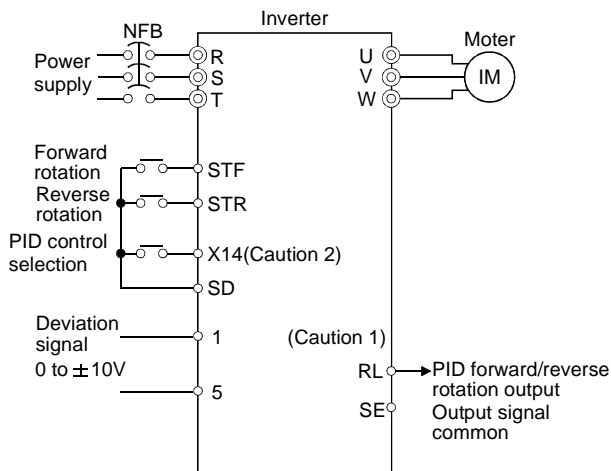

CAUTION

1. Set "16" to the output signal terminal used (Pr. 190 to Pr. 192, Pr. 195). (Refer to page 153.)
2. Set "14" to the input signal terminal used (Pr. 180 to Pr. 183, Pr. 187). (Refer to page 151.)

(4) I/O signals

Signal	Terminal Used	Function	Description	Remarks		
Input	X14	Depending on Pr. 180 to 183, Pr. 187	PID control selection	Turn on X14 to select PID control.	Set any of 10, 11, 30 and 31 in Pr. 128.	
	1	1	Deviation signal input	Enter the deviation signal of the 0 to ±10V signal calculated externally.	When Pr. 128 = 10, 11	Refer to Pr. 917 and Pr. 918 (page 190) for calibration.
			Process value input	Enter the 0 to 10V process value signal from the detector.	When Pr. 128 = 30, 31	
	2	2	Set point input	Enter the set point for PID control.	When Pr. 128 = 30, 31	Refer to Pr. 902 and Pr. 903 (page 190) for calibration.
5	5	Common terminal to the PID control setting signal (terminal 2, 1)	Isolated from terminals SD and SE. Do not earth (ground).			
Out-put	RL		PID forward/reverse rotation output	"Hi" is output to indicate that the output indication of the parameter unit is forward rotation (FWD) or "Low" to indicate that it is reverse rotation (REV) or stop (STOP).	(When Pr. 128 = 10, 11, 30, 31)	Open collector output
	FUP	Depending on Pr. 190 to 192, Pr. 195	Upper limit output	Output to indicate that the process value signal exceeded the upper limit value.	When Pr. 128 = 30, 31	
	FDN		Lower limit output	Output to indicate that the process value signal exceeded the lower limit value.		
	SE	SE	Output terminal common	Common terminal for terminal RL		

- To start PID control, turn on the X14 signal. When this signal is off, normal inverter operation is performed without the PID action being done.
- When entering the externally calculated deviation signal, enter it across terminals 1-5. At this time, set "10" or "11" in Pr. 128.
- Enter the set point across inverter terminals 2-5 or into Pr. 133 and enter the process value signal across inverter terminals 1-5. At this time, set "30" or "31" in Pr. 128.

Item	Entry Method	Description	
Deviation signal	Across terminals 1-5	Set -10V as -100% Set 0V as 0% and +10V as +100%.*	When 10 or 11 is set in Pr. 128, terminal 1 gives the deviation input signal independently of the Pr. 868 setting.
Set point	Across terminals 2-5	Set 0V as 0% and 10V as +100%.*	When 30 or 31 is set in Pr. 128, terminal 1 gives the process value input signal independently of the Pr. 868 setting.
	Pr.133	Set the set point (%) in Pr. 133.	
Process value	Across terminals 1-5	Set 0V as 0% and +10V as +100%.*	

*: The value changes by calibration

(5) Parameter setting

Parameter Number	Setting	Name	Description		
128	10	PID action selection	For heating, pressure control, etc.	Deviation value signal input (No. 1 terminal)	PID reverse action
	11		For cooling, etc.		PID forward action
	30		For heating, pressure control, etc.	Process value input (No. 1 terminal)	PID reverse action
	31		For cooling, etc.		PID forward action
129	0.1 to 1000%	PID proportional band	If the proportional band is narrow (parameter setting is small), the manipulated variable varies greatly with a slight change of the process value. Hence, as the proportional band narrows, the response sensitivity (gain) improves but the stability deteriorates, e.g. hunting occurs. Gain $K_p = 1/\text{proportional band}$		
	9999		No proportional control		
130	0.1 to 3600s	PID integral time	Time required for only the integral (I) action to provide the same manipulated variable as that for the proportional (P) action. As the integral time decreases, the set point is reached earlier but hunting occurs more easily.		
	9999		No integral control.		
131	0 to 100%	Upper limit	Set the upper limit value. If the feedback value exceeds the setting, the FUP signal is output. (Process value of 0V is equivalent to 0% and 10V to 100%.)*		
	9999		No function		
132	0 to 100%	Lower limit	Set the lower limit value. (If the process value goes out of the setting range, an alarm can be output. In this case, the process value of 0V is equivalent to 0% and 10V to 100%.)*		
	9999		No function		
133	0 to 100%	PID action set point for PU operation	Only valid for the PU command in the PU operation or PU/external combined mode. For external operation, the voltage across terminals 2-5 is the set point. (Pr. 902 value is equivalent to 0% and Pr. 903 value to 100%.)		
134	0.01 to 10.00s	PID differential time	Time required for only the differential (D) action to provide the same manipulated variable as that for the proportional (P) action. As the differential time increases, greater response is made to a deviation change.		
	9999		No differential control.		

*: The value changes by calibration

(6) Adjustment procedure

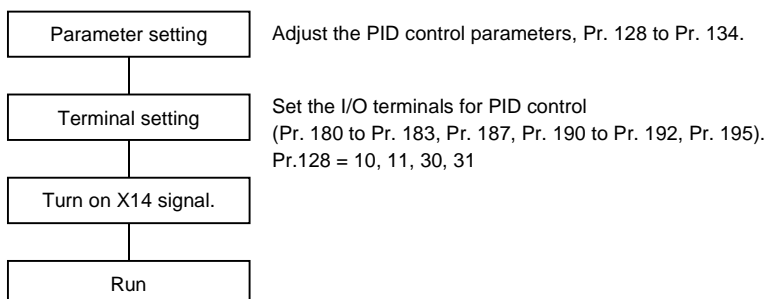

(7) Adjustment example

(A detector of 0V at 0°C (32°F) and 10V at 50°C (122°F) is used to adjust the room temperature to 25°C (77°F) under PID control.
The set point is given to across inverter terminals 2-5 (0 to 10V).)

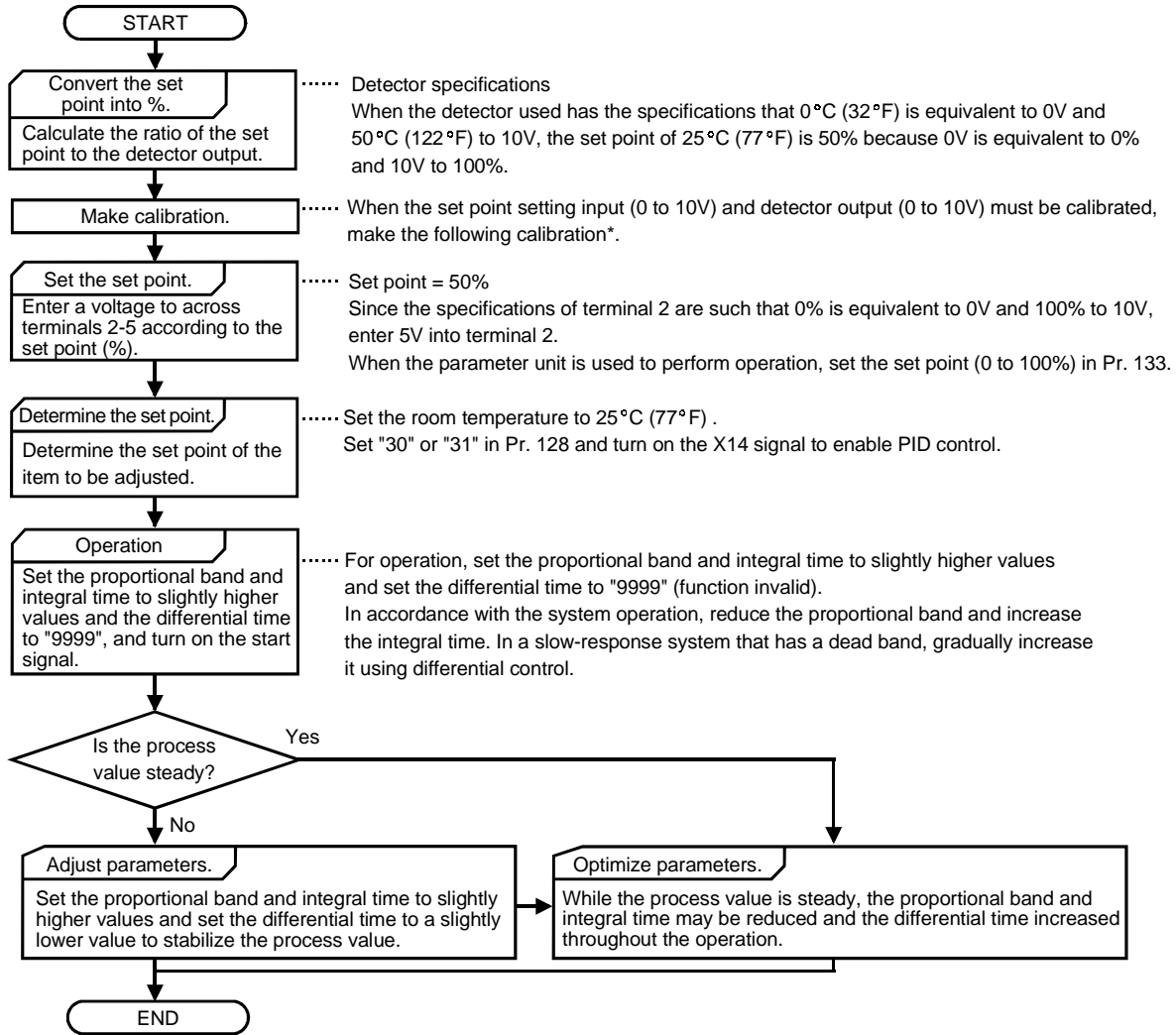

* Calibration is required → Calibrate the set point setting input and detector output using Pr. 902, Pr. 903, Pr. 917 and Pr. 918. Make calibration in the PU mode during inverter stop.

(8) Calibration example

<Set point input calibration>

1. Apply the input voltage of 0% set point setting (e.g. 0V) to across terminals 2-5.
2. Make calibration using Pr. 902. At this time, enter the speed output by the inverter at the deviation of 0% (e.g. 0r/min).
3. Apply the voltage of 100% set point setting (e.g. 10V) to across terminals 2-5.
4. Make calibration using Pr. 903. At this time, enter the speed output by the inverter at the deviation of 100% (e.g. 1500r/min).

<Detector output calibration>

1. Apply the output current of 0% detector setting (e.g. 0V) to across terminals 1-5.
2. Make calibration using Pr. 917.
3. Apply the output current of 100% detector setting (e.g. 5V) to across terminals 1-5.
4. Make calibration using Pr. 918.

CAUTION

The frequencies set in Pr. 917 and Pr. 918 should be the same as set in Pr. 902 and Pr. 903.

The results of the above calibration are as shown below:

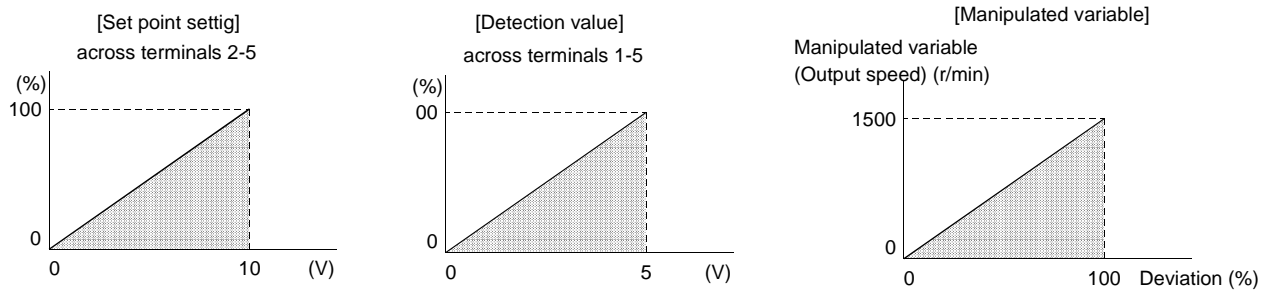

CAUTION

1. If the multi-speed (RH, RM, RL) signal or jog operation (jog) signal is entered with the X14 signal on, PID control is stopped and multi-speed or jog operation is started.
2. When "6" (switchover mode) is selected for Pr. 79, PID is made invalid.
3. When "1" (online auto tuning) is selected for Pr. 95, PID control is made invalid.
4. Changing the terminal function using any of Pr. 180 to 183 and Pr. 187 and Pr. 190 to 192 and Pr. 195 may affect the other functions. Confirm the functions of the corresponding terminals before making setting.
5. When PID control is selected, the minimum speed is as set in Pr. 902 and the maximum speed is as set in Pr. 903.
(Pr. 1 "maximum speed" and Pr. 2 "minimum speed" settings are also valid.)

Related parameters

- Pr. 73 "speed setting signal" (Refer to page 116.)
- Pr. 79 "operation mode selection" (Refer to page 120.)
- Pr. 180 to Pr. 183, Pr. 187 (input terminal function selection) (Refer to page 151.)
- Pr. 191 to Pr. 192, Pr. 195 (output terminal function selection) (Refer to page 153.)
- Pr. 902, Pr. 903, Pr. 917, Pr. 918 (Speed setting terminal bias/gain) (Refer to page 183.)

Pr. 140 to Pr. 143 ➡ Refer to Pr. 29 (page 93)

Pr. 144 ➡ Refer to Pr. 37 (page 97)

3.17 Current detection (Pr. 150 to Pr. 153)

3.17.1 Output current detection function (Pr. 150, Pr. 151 speed torque position)

- If the output current remains higher than the Pr. 150 setting during inverter operation for longer than the time set in Pr. 151, the output current detection signal (Y12) is output from the inverter's open collector output terminal.

(Use any of Pr. 190 to Pr. 192 and Pr. 195 to assign the terminal used for Y12 signal output.)

Parameter	Name	Factory Setting	Setting Range
150	Output current detection level	150%	0 to 200.0%
151	Output current detection time	0	0 to 10s

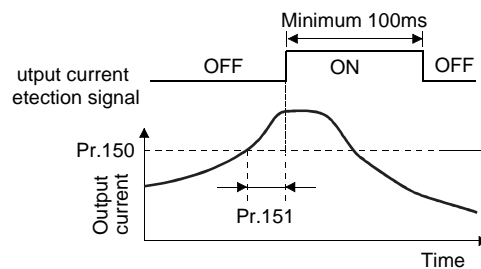

<Setting>

Refer to the following table and set the parameters.

Parameter	Description
150	Set the output current detection level. 100% is the rated inverter current.
151	Set the output current detection time. Set the time from when the output current has risen above the setting until the output current detection signal (Y12) is output.

CAUTION

1. Once turned on, the output current detection signal is held on for at least 100ms.
2. This function is also valid during execution of the online or offline auto tuning.
3. Changing the terminal function using any of Pr. 190 to 192 and Pr. 195 may affect the other functions. Confirm the functions of the corresponding terminals before making setting.
4. When "0" is set in Pr. 151, the output current detection time is about 50ms.

Related parameters

- Y12 signal terminal assignment ⇒ Pr. 190 to Pr. 192, Pr. 195 (output terminal function selection) (Refer to page 153.)

3.17.2 Zero current detection (Pr. 152, Pr. 153) speed torque position

When the inverter's output current falls to "0", torque will not be generated. This may cause a gravity drop to occur when the inverter is used in vertical lift application.

To prevent this, the output current "zero" signal can be output from the inverter to close the mechanical brake when the output current has fallen to "zero".

- If the output current remains lower than the Pr. 152 setting during inverter operation for longer than the time set in Pr. 153, the zero current detection (Y13) signal is output from the inverter's open collector output terminal.

(Use any of Pr. 190 to Pr. 192 and Pr. 195 to assign the terminal used for Y13 signal output.)

Parameter	Name	Factory Setting	Setting Range
152	Zero current detection level	5.0%	0 to 200.0%
153	Zero current detection time	0.5s	0 to 1s

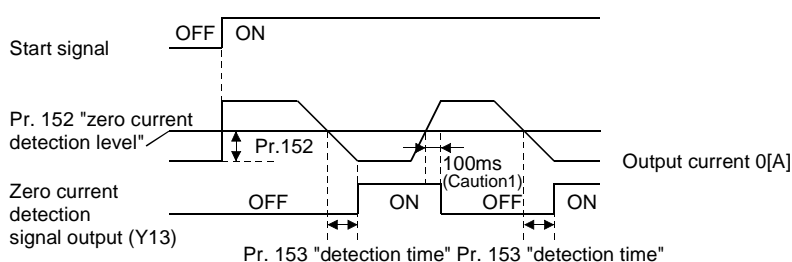

<Setting>

Refer to the following table and set the parameters.

Parameter	Description
152	Set the zero current detection level. Set this parameter to define the percentage of the rated current at which the zero current will be detected.
153	Set the current detection time. Set this parameter to define the period from when the output current drops below the Pr. 152 value until the zero current detection signal (Y13) is output.

CAUTION

1. If the current rises above the preset detection level and the condition is not satisfied, the zero current detection signal is held on for about 100ms.
2. This function is also valid during execution of the online auto tuning.
3. Changing the terminal function using any of Pr. 190 to 192 and Pr. 195 may affect the other functions. Confirm the functions of the corresponding terminals before making setting.
4. When "0 to 0.04" is set in Pr. 153, the zero current detection time is about 50ms.

⚠ CAUTION

- ⚠ The zero current detection level setting should not be too high, and the zero current detection time setting not too long. Otherwise, the detection signal may not be output when torque is not generated at a low output current.
- ⚠ To prevent the machine and equipment from resulting in hazardous conditions by use of the zero current detection signal, install a safety backup such as an emergency brake.

Related parameters

- Y13 signal terminal assignment ⇒ Pr. 190 to Pr. 192, Pr. 195 (output terminal function selection) (Refer to page 153.)

3.18 Auxiliary functions (Pr. 156, Pr. 157)

3.18.1 Stall prevention operation selection (Pr. 156 speed torque position)

Make setting to disable stall prevention activated by overcurrent and/or to prevent the inverter from resulting in an overcurrent trip if an excessive current flows due to sudden load fluctuation or running inverter output side ON-OFF (to disable fast-response current restriction that limits the current). An OL signal output delay can be set in Pr. 157.

- Stall prevention (only during V/F control)
Automatically change the output speed of the inverter to reduce the amount of current when the current flow exceeds the current restriction value.
- High response current restriction
Shut off the output of the inverter to prevent overcurrent when the current flows exceeds the current restriction value.

Parameter	Name	Factory Setting	Setting Range	Remarks
156	Stall prevention operation selection	1	0 to 31, 100, 101	Extended mode

Setting	Fast-Response Current Restriction ○ : Activated ● : Not activated	Stall Prevention ○ : Activated			OL Signal Output ○ : Operation continued ● : Operation not continued (Caution1)
		Acceleration	Constant speed	Deceleration	
0	○	○	○	○	○
1	●	○	○	○	○
2	○	●	○	○	○
3	●	●	○	○	○
4	○	○	●	○	○
5	●	○	●	○	○
6	○	●	●	○	○
7	●	●	●	○	○
8	○	○	○	●	○
9	●	○	○	●	○
10	○	●	○	●	○
11	●	●	○	●	○
12	○	○	●	●	○
13	●	○	●	●	○
14	○	●	●	●	○
15	●	●	●	●	○
16	○	○	○	○	●
17	●	○	○	○	●
18	○	●	○	○	●
19	●	●	○	○	●
20	○	○	●	○	●
21	●	○	●	○	●
22	○	●	●	○	●
23	●	●	●	○	●

Setting	Fast-Response Current Restriction ○ : Activated ● : Not activated	Stall Prevention ○ : Activated			OL Signal Output ○ : Operation continued ● : Operation not continued (Caution1)
		Acceleration	Constant speed	Deceleration	
24	○	○	○	●	●
25	●	○	○	●	●
26	○	●	○	●	●
27	●	●	○	●	●
28	○	○	●	●	●
29	●	○	●	●	●
30	○	●	●	●	●
31	●	●	●	●	●
100	Driving	○	○	○	○
	Regenerative	●	●	●	○
101 (Caution 3)	Driving	●	○	○	○
	Regenerative	●	●	●	○

CAUTION

1. When "Operation not continued for OL signal output" is selected, the "E. OLT" alarm code (stopped by stall prevention) is displayed and operation stopped.
(Alarm stop display "E. OLT")
2. For the lift application, make setting to disable fast-response current restriction.
Otherwise the torque may not be generated, resulting in the lift drop with gravity.
3. When the setting value is "101", fast-response current restriction at driving is well disabled compared to when "100" is set.

⚠ CAUTION

⚠ Always perform test operation.
 Stall prevention operation performed during acceleration may increase the acceleration time.
 Stall prevention operation performed during constant speed may cause sudden speed changes.
 Stall prevention operation performed during deceleration may increase the deceleration time, increasing the deceleration distance.

3.18.2 OL signal output timer (Pr. 157 speed torque position)

Use this parameter to set whether the overload alarm signal (OL signal) is output immediately or a preset period of time after occurrence of an overload status.

Parameter	Name	Factory Setting	Setting Range	Remarks
157	OL signal output timer	0.1s	0 to 25s, 9999	9999: No signal output

V/F control On when stall prevention operation level is exceeded.
 Speed control On when torque restriction is activated.
 Torque control On when speed restriction is activated.
 Position control ... On when torque restriction is activated.

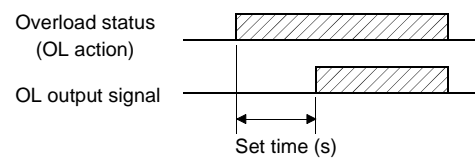

<Setting>

Refer to the following table and set the parameter.

Pr. 157 Setting	Description
0	Output immediately.
0.1 to 25	Output after the set time (s) has elapsed.
9999	Overload alarm signal is not output.

Related parameters

- OL signal terminal assignment ⇒ Set 3 in any of Pr. 190 to Pr. 192, Pr. 195 (output terminal function selection). (Refer to page 153.)

Pr.158 ➔ Refer to Pr. 54 (page 153).

3.19 Display function 3 (Pr. 160)

3.19.1 Extended function display selection (Pr. 160 speed torque position)

Used to display the extended function parameters.

- Refer to page 64 for the extended function parameter list.

Parameter	Name	Factory Setting	Setting Range	Remarks
160	Extended function selection	0	0	Only the simple mode parameters are accessible.
			1	All parameters are accessible.

Pr. 162 to Pr. 165 ➔ Refer to Pr. 57 (page 105).

3.20 Initial monitor (Pr. 171)

3.20.1 Actual operation hour meter clear (Pr. 171 speed torque position)

You can clear the actual operation hour of the monitoring function.

Parameter	Name	Factory Setting	Setting Range
171	Actual operation hour meter clear	0	0

<Setting>

Write "0" in the corresponding parameter to clear the actual operation hour.

REMARKS

The actual operation time is the value monitored by setting "23" in Pr. 52.

Related parameters

- Pr. 52 "DU/PU main display data selection" (Refer to page 101.)

3.21 Terminal assignment functions (Pr. 180 to Pr. 195)

3.21.1 Input terminal function selection

(Pr. 180 to Pr. 183, Pr. 187 speed torque position)

Use these parameters to select/change the input terminal functions.

Parameter	Name	Terminal Symbol	Factory-Set Value	Factory-Set Terminal Function	Setting Range	Remarks
180	DI1 terminal function selection	DI1	0	Low speed operation command (RL)	0 to 3, 5, 8 to 12, 14 to 16, 20, 22 to 27, 42 to 44, 9999	9999: No function Extended mode
181	DI2 terminal function selection	DI2	1	Middle speed operation command (RM)		
182	DI3 terminal function selection	DI3	2	High speed operation command (RH)		
183	DI4 terminal function selection	DI4	3	Second function/ second motor switchover (RT)		
187	STR terminal function selection	STR	9999	Reverse rotation command (STR)		9999: STR

<Setting>

Refer to the following table and set the parameters.

Setting	Signal Name	Functions		Related Parameters	Response Time
0	RL	Pr. 59 = 0	Low speed operation command	Pr. 4 to Pr. 6, Pr. 24 to Pr. 27, Pr. 232 to Pr. 239	Within 20ms
		Pr. 59 = 1, 2 *	Remote setting (setting clear)		
1	RM	Pr. 59 = 0	Middle speed operation command	Pr. 4 to Pr. 6, Pr. 24 to Pr. 27, Pr. 232 to Pr. 239	
		Pr. 59 = 1, 2, 3 *	Remote setting (deceleration)		
2	RH	Pr. 59 = 0	High speed operation command	Pr. 4 to Pr. 6, Pr. 24 to Pr. 27, Pr. 232 to Pr. 239	
		Pr. 59 = 1, 2, 3*	Remote setting (acceleration)		
3	RT	Second function selection		Pr. 44 to Pr. 50, Pr. 450 to Pr. 457, Pr. 463	
5	JOG	Jog operation selection		Pr. 15, Pr. 16	
8	REX	15-speed selection (combination with three speeds RL, RM, RH)		Pr. 4 to Pr. 6, Pr. 24 to Pr. 27, Pr. 232 to Pr. 239	
9	X9	Third function		Pr. 110, Pr. 111, Pr. 116	
10	X10	FR-HC connection, FR-CV connection (inverter operation enable)		Pr. 30, Pr. 70	Within 2ms
11	X11	FR-HC connection (instantaneous power failure detection) (only when FR-A5NR option is fitted)		Pr. 30, Pr. 70	Within 20ms
12	X12	PU operation external interlock signal		Pr. 79	
14	X14	PID control enable terminal		Pr. 128 to Pr. 134	
15	BRI	Brake sequence opening completion signal		Pr. 278 to Pr. 285	
16	X16	PU/external operation switchover		Pr. 79	
20	X20	S-pattern acceleration/deceleration C switchover		Pr. 29, Pr. 380 to Pr. 383	
22	X22	Orientation command (Caution 4)		Pr. 350 to Pr. 369	
23	LX	Pre-excitation/servo on (Caution 5)		Pr. 802	
24	MRS	Output stop		Pr. 17	
25	STOP	Start self-holding selection		—	
26	MC	Control mode changing		—	
27	TL	Torque restriction selection		Pr. 815	
42	X42	Torque bias selection 1		—	
43	X43	Torque bias selection 2		—	
44	X44	P control selection (P/PI control switchover)		—	
9999	STR	Reverse rotation start		STR terminal (Pr. 187) only (Note) DI1 to DI4 functions are made invalid.	—

* When Pr. 59 = "1, 2, or 3", the functions of the RL, RM, RH and RT signals change as listed above.

CAUTION

- One signal can be assigned to two or more terminals. In this case, the terminal inputs are ORed.
- The speed command priorities are higher in order of jog, multi-speed setting (RH, RM, RL, REX) and PID (X14).
- Use common terminals to assign multi-speeds (7 speeds) and remote setting. They cannot be set individually.
(Common terminals are used since these functions are designed for speed setting and need not be set at the same time.)
- The FR-A5AX (12-bit digital input) is needed to externally input a stop position under orientation control.
- Made valid under vector control.

3.21.2 Output terminal function selection

(Pr. 190 to Pr. 192, Pr. 195 speed torque position)

You can change the functions of the open collector output terminal and contact output terminal.

Parameter	Name	Factory-Set Value	Factory-Set Signal Function	Setting Range	Remarks
190	DO1 terminal function selection	0	RUN (Inverter running)	0 to 8, 10 to 16, 20, 25 to 27, 30 to 37, 40 to 44, 96 to 99, 100 to 108, 110 to 116, 120, 125 to 127, 130 to 137, 140 to 144, 196 to 199, 9999	Extended mode
191	DO2 terminal function selection	1	SU (Up to speed)		
192	DO3 terminal function selection	2	IPF (Instantaneous power failure/ undervoltage)		
195	ABC terminal function selection	99	A, B, C (Alarm output)		

<Setting>

Refer to the following table and set the parameters.

Setting		Signal Name	Function	Operation	Related Parameters	Response Time
Positive logic	Negative logic					
0	100	RUN	Inverter running	This signal is output during operation when the inverter output speed rises to or above the starting speed. During DC injection brake, 0 speed control or servo lock, this signal is not output. However, LX is output as ON under position control.	—	Within 20ms
1	101	SU	Up to speed	Refer to Pr. 41 "up-to-speed sensitivity" (page 99). (Caution 1)	—	
2	102	IPF	Instantaneous power failure or undervoltage	Output at occurrence of an instantaneous power failure or undervoltage.	—	—
3	103	OL	Overload alarm	Output when torque or speed restriction is activated. For V/F control, this signal is output while the stall prevention function is activated.	Pr. 22, Pr. 806, Pr. 807, Pr. 812 to Pr. 817	—
4	104	FU	Output speed detection	Refer to Pr. 42, Pr. 43, Pr. 50 and Pr. 116 (speed detection) (page 99).	—	Within 20ms
5	105	FU2	Second output speed detection			
6	106	FU3	Third output speed detection			
7	107	RBP	Regenerative brake prealarm	Output when 85% of the regenerative brake duty set in Pr. 70 is reached.	Pr. 70	—
8	108	THP	Electronic thermal relay prealarm	Output when the electronic thermal relay cumulative value reaches 85% of the preset level.	Pr. 9	—
10	110	PU	PU operation mode	Output when the PU operation mode is selected.	—	Within 20ms
11	111	RY	Inverter operation ready	Output when the inverter can be started by switching the start signal on or while it is running.		
12	112	Y12	Output current detection	Refer to Pr. 150 and Pr. 151 (output current detection).	Pr. 150, Pr. 151	—
13	113	Y13	Zero current detection	Refer to Pr. 152 and Pr. 153 (zero current detection).	Pr. 152, Pr. 153	
14	114	FDN	PID lower limit	Refer to Pr. 128 to Pr. 134 (PID control).	Pr. 128 to Pr. 134	Within 20ms
15	115	FUP	PID upper limit			
16	116	RL	PID forward-reverse rotation output			
20	120	BOF	Brake opening request	Refer to Pr. 278 to Pr. 285 (brake sequence function).	Pr. 278 to Pr. 285	—



Terminal assignment functions (Pr. 180 to Pr. 195)

Setting		Signal Name	Function	Operation	Related Parameters	Response Time
Positive logic	Negative logic					
25	125	FAN	Fan fault output	Output at the time of a fan fault.	Pr. 244	—
26	126	FIN	Fin overheat prealarm	Output when the heatsink temperature reaches about 85% of the fin overheat protection activating temperature.	—	
27	127	ORA	Orientation in-position	When orientation is valid (Refer to page 160)		
30	130	Y30	Forward rotation output	On: Forward rotation under vector control Off: Other controls		—
31	131	Y31	Reverse rotation output	On: Reverse rotation under vector control Off: Other controls		
32	132	Y32	Regenerative status output	On: Regeneration under vector control Off: Other controls (include stop, pre-excitation)		
33	133	RY2	Operation ready 2	Output on completion of pre-excitation. Turned on at an output start when pre-excitation is not made.	Pr. 802	—
34	134	LS	Low speed output	Output when the speed falls to or below any preset low speed.	Pr. 865	
35	135	TU	Torque detection	Output when the motor torque rises above the predetermined value.	Pr. 864	
36	136	Y36	In-position	Output when positioning is completed under position control.	—	Within 20ms
37	137	MT	Maintenance timer output	When Pr. 891 ≥ Pr. 890, the MT output signal turns on and the warning indication MT appears.	Pr. 890, Pr. 891	—
40	140	Y40	Trace status	Refer to the instruction manual of the trace option.	—	
41	141	FB	Speed detection	Output when the inverter output speed rises to or above the preset speed. Refer to Pr. 42, Pr.43, Pr. 50, and Pr. 116 (speed detection) (page 99).	—	Within 20ms
42	142	FB2	Second speed detection			
43	143	FB3	Third speed detection			
44	144	RUN2	Inverter running 2	<ul style="list-style-type: none"> Output during forward operation or the reverse signal is ON. Output at deceleration even during forward rotation or the reverse signal is OFF. (Does not output during pre-excitation LX is ON.) Output during the orientation command signal (X22) is ON. Switched ON when the servo is ON (LX-ON) under position control. (Switched OFF when the servo is OFF. (LX-OFF)) 	—	—
96	196	REM	Remote output	You can use the on/off of signals instead of the remote output function of the PLC.	Pr. 495, Pr. 496, Pr. 497	Within 20ms
97	197	ER	Minor fault output 2	At occurrence of a major fault, the base circuit is shut off immediately. At occurrence of a minor fault, the base circuit is shut off after deceleration to a stop.	Pr. 875	
98	198	LF	Minor fault output	Output when a minor fault (fan fault or communication error alarm) occurs.	Pr. 121, Pr. 244	
99	199	ABC	Alarm output	Output when the inverter's protective function is activated to stop the output (major fault).	—	
9999	—	—	No function	—	—	—

0 to 99: Positive logic

100 to 199: Negative logic

CAUTION

- Note that when the speed setting is varied using an analog signal or / of the operation panel, the output of the SU (up to speed) signal may alternate on and off depending on that varying speed and the timing of the varying speed due to acceleration/deceleration time setting. (The output will not alternate on and off when the acceleration/deceleration time setting is "0s".)
- The same function may be set to more than one terminal.
- Pr. 190 to Pr. 192 and Pr. 195 do not function if the values set are other than the above.

Pr.232 to Pr.239 ➡ Refer to Pr. 4 (page 82).

Pr.240 ➡ Refer to Pr. 72 (page 115).

3.22 Auxiliary function (Pr. 244)

3.22.1 Cooling fan operation selection (Pr. 244 speed torque position)

You can control the operation of the cooling fan built in the inverter.

Parameter	Name	Factory Setting	Setting Range	Remarks
244	Cooling fan operation selection	0	0, 1	Extended mode

<Setting>

Setting	Description
0	Operated with power on (independently of whether the inverter is running or at a stop).
1	Cooling fan on-off control valid (The cooling fan is always on while the inverter is running. During a stop, the inverter status is monitored and the fan switches on-off according to temperature.)

REMARKS

In either of the following cases, fan operation is regarded as faulty, [FN] is shown on the operation panel, and the fan fault (FAN) and minor fault (LF) signals are output. Use Pr. 190 to Pr. 192, Pr. 195 (output terminal function selection) to allocate the terminals used to output the FAN and LF signals.

- Pr. 244 = "0"
When the fan comes to a stop with power on.
- Pr. 244 = "1"
When the fan comes to a stop during the fan ON command while the inverter is running, or the fan starts during the fan OFF command.

CAUTION

Changing the terminal function using any of Pr. 190 to 192 and Pr. 195 may affect the other functions. Confirm the functions of the corresponding terminals before making setting.

3.23 Stop selection function (Pr. 250)

3.23.1 Stop selection (Pr. 250 speed torque)

Used to select the stopping method (deceleration to a stop or coasting) when the start signal (STF/STR) turns off.

This function is valid for V/F control, speed control, and torque control only.

Parameter	Name	Factory Setting	Setting Range	Remarks
250	Stop selection	9999	0 to 100s, 9999	Extended mode

Operation selection function (Pr. 251)

(1) Pr. 250 = "9999"

When the start signal turns off, the motor is decelerated to a stop.

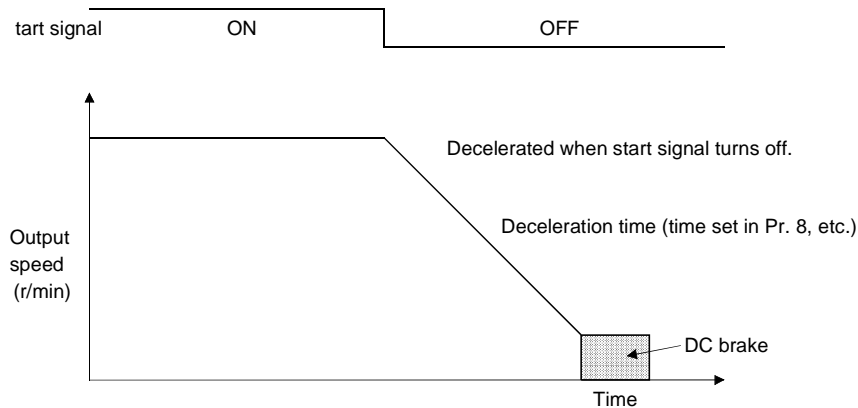

(2) Pr. 250 = other than "9999" (Output is shut off after preset time)

The output is shut off when the time set in Pr. 250 has elapsed after the start signal had turned off. The motor coasts to a stop.

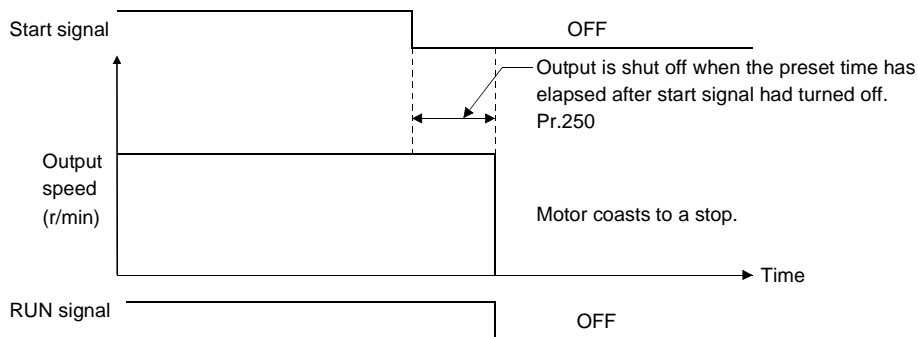

CAUTION

1. The RUN signal turns off when the output stops.
2. When the start signal is turned on again during motor coasting, the motor starts at 0Hz.
3. The output speed becomes the speed restriction value during torque control.

3.24 Operation selection function (Pr. 251)

3.24.1 Output phase failure protection selection (Pr. 251 speed torque position)

You can disable the output phase failure protection (E.LF) function that will stop the inverter output if any of the three phases (U, V, W) on the inverter output side (load side) opens.

Parameter	Name	Setting Range	Minimum Setting Increments	Factory Setting	Description	Remarks
251	Output phase failure protection selection	0, 1	1	1	0: Without output phase failure protection 1: With output phase failure protection	Extended mode

3.25 Additional function 2 (Pr. 252, Pr. 253)

3.25.1 Override bias, gain (Pr. 252, Pr. 253 speed torque)

When override is selected in Pr. 73 "speed setting signal", the override range of 50% to 150% can be increased (to between 0% and 200%) as desired.

Parameter	Name	Setting Range	Minimum Setting Increments	Factory Setting	Remarks
252	Override bias	0 to 200%	0.1%	50%	Extended mode
253	Override gain	0 to 200%	0.1%	150%	

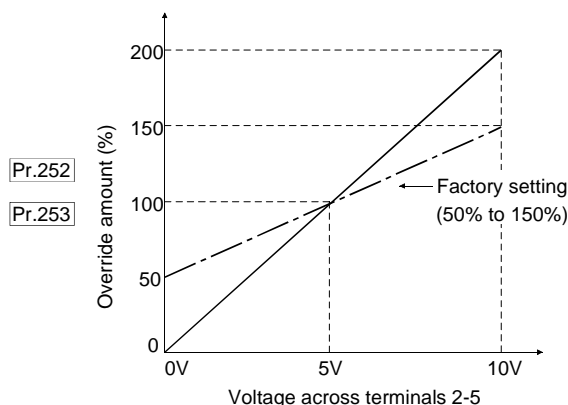

Related parameters

- ⇒ Pr. 73 "speed setting signal" (Refer to page 116.)

3.26 Power failure stop functions (Pr. 261 to Pr. 266)

3.26.1 Power-failure deceleration stop function (Pr. 261 to Pr. 266 speed torque)

When a power failure or undervoltage occurs, the inverter can be decelerated to a stop.

- Remove the jumpers from across terminals R-R1 and S-S1, and connect terminal R1 to terminal P and terminal S1 to terminal N.

Parameter	Name	Factory Setting	Setting Range	Remarks
261	Power failure stop selection	0	0, 1	Extended mode
262	Subtracted speed at deceleration start	90r/min	0 to 600r/min	
263	Subtraction starting speed	Japanese version: 1500r/min	0 to 3600r/min, 9999	
		NA version:1800r/min		
264	Power-failure deceleration time 1	5s	0 to 3600/0 to 360s	
265	Power-failure deceleration time 2	9999	0 to 3600/0 to 360s, 9999	
266	Power-failure deceleration time switchover speed	Japanese version: 1500r/min	0 to 3600r/min	
		NA version:1800r/min		

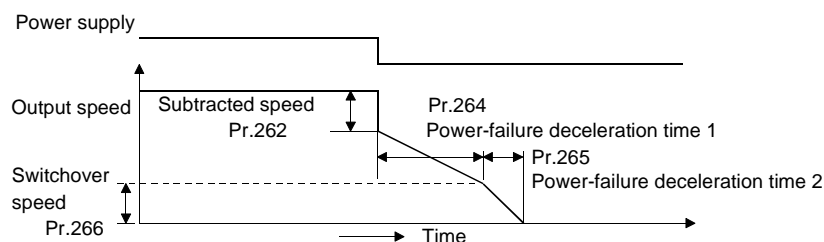

<Setting>

Parameter	Setting	Description	
261	0	Coasting to stop When undervoltage or power failure occurs, the inverter output is shut off.	
	1	When undervoltage or power failure occurs, the inverter is decelerated to a stop.	
262	0 to 600r/min	Normally, operation can be performed with the factory setting unchanged, but the speed can be adjusted within the range 0 to 600r/min according to the load specifications (inertia moment, torque).	
263	0 to 3600r/min	If the output speed at occurrence of undervoltage or power failure is equal to or greater than the speed set in Pr. 263, deceleration starts at the value found by subtracting the speed set in Pr. 262 from the output speed at that time. If the output speed at occurrence of undervoltage or power failure is less than the speed set in Pr. 263, the inverter is decelerated to a stop, starting at the output speed at that time.	
	9999	The inverter is decelerated to a stop, starting at the value found by subtracting the speed set in Pr. 262 from the output speed at occurrence of undervoltage or power failure.	
264	Pr. 21 = 0	0 to 3600s	Set a deceleration slope down to the speed set in Pr. 266. Set the slope in terms of time required for deceleration from the speed set in Pr. 20 to 0r/min.
	Pr. 21 = 1	0 to 360s	
265	Pr. 21 = 0	0 to 3600s	Set a deceleration slope below the speed set in Pr. 266. Set the slope in terms of time required for deceleration from the speed set in Pr. 20 to 0r/min.
	Pr. 21 = 1	0 to 360s	
		9999	Same slope as in Pr. 264.
266	0 to 3600r/min	Set the speed at which the deceleration slope is switched from the Pr. 264 setting to the Pr. 265 setting.	

CAUTION

1. This function is invalid when the automatic restart after instantaneous power failure function is activated.
2. For the output speed at occurrence of undervoltage or power failure, the calculation result is regarded as 0r/min if the speed set in Pr. 262 is negative.
3. The power failure stop function is not activated if a power failure occurs during a stop or error.
4. If power is restored during deceleration, the inverter is kept decelerated to a stop.
To restart, turn off the start signal once, then turn it on again.
5. This function is not activated when the high power factor converter or power regeneration common converter is used (Pr. 30 = 2).

⚠ CAUTION

**⚠ If power-failure deceleration operation is set, some loads may cause the inverter to trip and the motor to coast.
The motor will coast if enough regenerative energy is given from the motor.**

Related parameters

- ⇒ Pr. 12 "DC injection brake voltage" (Refer to page 87.)
- ⇒ Pr. 20 "acceleration/deceleration reference speed", Pr. 21 "acceleration/deceleration time increments" (Refer to page 83.)

Pr.278 to Pr.285 ➡ Refer to Pr.60 (page 109).

3.27 Droop (Pr. 286 to Pr. 288)

3.27.1 Droop control (Pr. 286 to Pr. 288 speed)

This function is designed to balance the load in proportion to the load torque to provide the speed drooping characteristic.

This function is effective for balancing the load when using multiple inverters

- The speed command is varied according to the magnitude of the motor load (load meter of the inverter). The drooping amount at the rated torque is set by the droop gain as a percentage using the rated speed as a reference.

$$\text{Droop compensation speed} = \frac{\text{Amount of torque current after filtering}}{100\% \text{ torque amount current}} \times \frac{\text{Rated speed} \times \text{droop gain}}{100}$$

- Droop control is made valid when Pr. 286 is other than "0".

Parameter	Name	Factory Setting	Setting Range	Remarks
286	Droop gain	0%	0 to 100%	The drooping amount at the rated torque is set by the droop gain as a percentage using the rated speed as a reference. When the setting value is "0", the function will be invalid.
287	Droop filter constant	0.3s	0.00 to 1.00s	Set the time constant of the primary delay filter applied to the torque current.
288	Droop function activation selection	0	0	Droop control is not exercised during acceleration/deceleration.
			1	Droop control is always exercised during operation. (speed command after droop is zero limited)
			2	Droop control is always exercised during operation (speed command after droop is not zero limited)

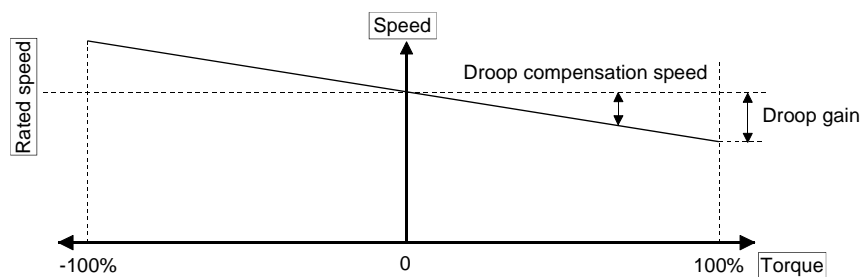

Pr. 342 ➡ Refer to Pr. 117 (page 130).

3.28 Orientation (Pr. 350 to Pr. 362, Pr. 393 to Pr. 399)

3.28.1 Orientation control (Pr. 350, Pr. 351, Pr. 356, Pr. 357, Pr. 360 to Pr. 362, Pr. 393, Pr. 396 to Pr. 399 speed)

Orientation is a function that stops a motor shaft at a preset position using the motor built-in position detector (PLG). Install the option (FR-V5AM or FR-A5AP) on the inverter to perform stop position command control with a position detector (PLG) fitted to the machine. Refer to the instruction manual of the option for details. Pr. 350 "stop position command selection" is factory-set to "9999" to make the orientation control function invalid.

Parameter No.	Name	Setting Range	Factory Setting	Remarks
350	Stop position command selection	0, 1, 2, 9999	9999	Extended mode
351	Orientation switchover speed	0 to 1000r/min	200r/min	
356	Internal stop position command	0 to 16383	0	
357	Orientation in-position zone	0 to 8192	11	
360	External position command selection	0, 1, 2 to 127	0	
361	Position shift	0 to 16383	0	
362	Orientation position loop gain	0.1 to 100	10	
393	Orientation selection	1, 2, 10, 11, 12	0	
396	Orientation speed gain (P term)	0 to 1000	60	
397	Orientation speed integral time	0 to 20.0s	0.333	
398	Orientation speed gain (D term)	0 to 100.0%	1	
399	Orientation deceleration ratio	0 to 1000	20	

REMARKS

Check the Pr. 851 and Pr. 852 settings. (Refer to the Instruction Manual (basic).)

<Settings>

If the orientation command signal (X22) is turned on during operation after the various parameters have been set, the speed will decelerate to the "orientation switchover speed". After the "orientation stop distance" is calculated, the speed will further decelerate, and the "orientation state" (servo lock) will be entered. The "orientation complete signal" (ORA) will be output when the "orientation complete width" is entered.

(1) Setting I/O signals

Input	Orientation command	X22 signal	Orientation control is valid with the signal on. Set "22" in any of Pr. 180 to Pr.183 or Pr. 187 (input terminal function selection). (Refer to page 151.)
Output	Orientation complete signal	ORA signal	Switched low if the orientation has stopped within the in-position zone while the start and orientation signals are input. Open collector output Permissible load 24VDC, 0.1A Set 27 in any of Pr.190 to Pr. 192 or Pr. 195 (output terminal function selection). (Refer to page 153.)

(2) Selecting stop position command (Pr. 350 "stop position command selection")

Select either the internal stop position command (Pr. 356) or the external stop position command (6/12/16-bit data).

Pr. 350 Setting	Type of Command
0	Internal stop position command (Pr. 356:0 to 16383)
1	External stop position command (FR-V5AX) 6-bit data
2	External stop position command (FR-A5AX) 12-bit data
3	External stop position command (FR-V5AH) 16-bit data
9999 (factory setting)	Orientation control invalid

(1) Internal stop position command (Pr. 350="0")

The value set in Pr. 356 is the stop position.

When the number of PLG pulses is 1024p/r, one revolution of the PLG (360°) is divided into 4096 positions, i.e. $360^\circ/4096$ pulses = 0.0879° /pulses per address, as shown on the right.

The stop positions (addresses) are indicated in parentheses.

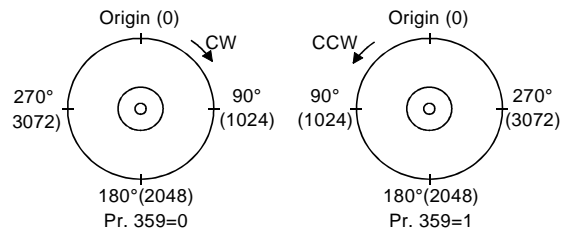

(2)-1 External stop position command (Pr. 350="1")

(Pr. 360 "external position command selection" (factory setting: 0))

Mount the option FR-V5AX and set a stop position using 6-bit data (binary input).

- The value set in Pr. 360 "external position command selection" should be the number of stop positions less 1.

Pr. 360 Setting	Description
0	External position command is made invalid (multi-function input with the FR-V5AX)
1	Set 64 stop positions at regular intervals
2 to 127	Set the stop position command dividing up to 128 stop positions at regular intervals. If the external stop command entered is greater than the setting, the stop positions are the same as those in the maximum external stop command value. Note that the stop command greater than the 64 stop positions can not be entered if the number of stop positions are 65 to 128. <Example> When the number of stop positions is 20 (divided at intervals of 18°), $20 - 1 = 19$. Hence, set "19".

<p>[Example 1] 4 stop positions</p>	<p>[Example 2] 8 stop positions</p>	<p>[Example 3] 120 stop positions</p> <p>The external stop command can not be entered.</p>
---	---	--

(2)-2 External stop position command (Pr. 350="2")

Mount the option FR-A5AX and set a stop position using 12-bit data (binary input).

- The value set in Pr. 360 "external position command selection" should be the number of stop positions less 1.

Pr. 360 Setting	Description
0	External position command is made invalid (speed command with the FR-A5AX)
1	Set 4096 stop positions at regular intervals
2 to 127	Set the stop position command dividing up to 128 stop positions at regular intervals. If the external stop command entered is greater than the setting, the stop positions are the same as those in the maximum external stop command value. <Example> When the number of stop positions is 90 (divided at intervals of 4°), $90 - 1 = 89$. Hence, set "89".

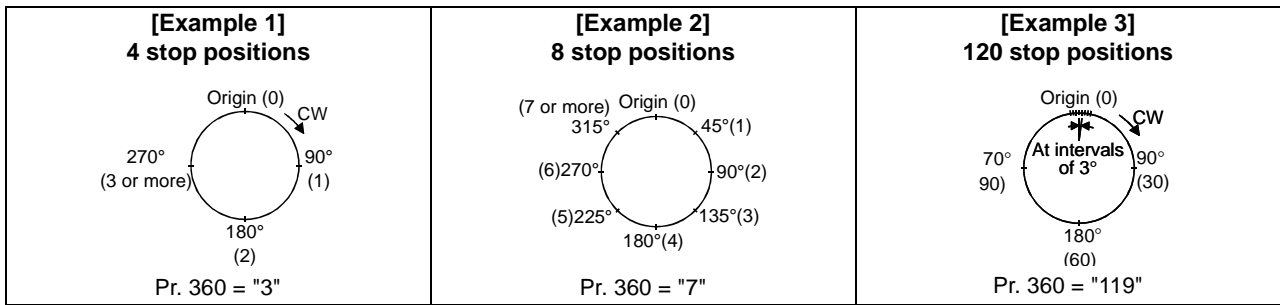

CAUTION

- Values in parentheses indicate binary data entered from the terminals. If the position pulse monitoring (Pr. 52 "DU/PU main display screen data selection" = 19) is selected, the data monitored is not the number of stop positions but is 0 to 4095 pulses.
- When any of "1 to 127" is set in Pr. 360, parameters (Pr. 300 to Pr. 305) of the FR-A5AX are made invalid. (Parameters are valid when Pr. 360="0".)
- Terminal DY (Data read timing input signal) is made invalid. (The position data is downloaded at the start of orientation.)
- When the option is not fitted or Pr. 360="0", the stop position is 0 even if the external stop position command is selected with the Pr. 350 setting.

(2)-3 External stop position command (Pr. 350="3")

Mount the option FR-V5AH and set a stop position using 16-bit data (binary input).

- The value set in Pr. 360 "external position command selection" should be the number of stop positions less 1.

Pr. 360 Setting	Description
0	External position command is made invalid (speed command or torque command with the FR-V5AH)
1	Set 65536 stop positions at regular intervals
2 to 127	Set the stop position command dividing up to 128 stop positions at regular intervals. If the external stop command entered is greater than the setting, the stop positions are the same as those in the maximum external stop command value. <Example> When the number of stop positions is 90 (divided at intervals of 4°), 90 - 1 = 89. Hence, set "89".

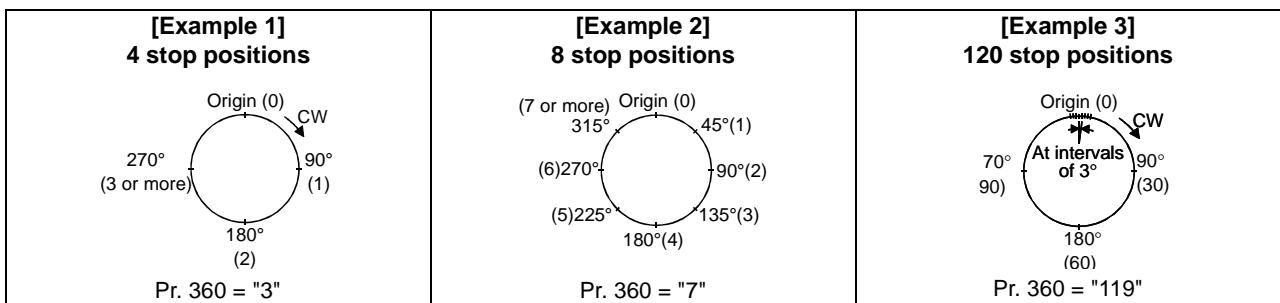

CAUTION

- Values in parentheses indicate binary data entered from the input terminals. If the position pulse monitoring (Pr. 52 "DU/PU main display screen data selection" = 19) is selected, the data monitored is not the number of stop positions but is 0 to 65535 pulses.
- When any of "1 to 127" is set in Pr. 360, parameters (Pr. 300 to Pr. 305) of the FR-V5AH are made invalid. (Parameters are valid when Pr. 360="0".)
- Terminal DY (Data read timing input signal) is made invalid. (The position data is downloaded at the start of orientation.)
- When the option is not fitted or Pr. 360="0", the stop position is 0 even if the external stop position command is selected with the Pr. 350 setting.

(3) Setting the rotation direction (Pr. 393 "orientation selection")

Pr. 393 setting	Rotation Direction	Type	Remarks
0 (factory setting)	Pre-orientation	Motor end orientation	Orientation is executed from the current rotation direction.
1	Forward rotation orientation		Orientation is executed from the forward rotation direction. (If the motor is running in reverse, orientation is executed from the forward rotation direction after deceleration.)
2	Reverse rotation orientation		Orientation is executed from the reverse rotation direction. (If the motor is running in forward, orientation is executed from the reverse rotation direction after deceleration.)
10	Pre-orientation	Machine end orientation (when the FR-V5AM or FR-A5AP is used)	Refer to the instruction manual of the option for details.
11	Forward rotation orientation		
12	Reverse rotation orientation		

(1) Orientation from the current rotation direction

- When the orientation command (terminal X22) is input, the motor speed will decelerate from the running speed to Pr. 351 "orientation switchover speed". At the same time, the orientation stop position command will be read in. (The stop position command is determined by the settings of Pr.350 and Pr.360. Refer to the diagram on the right.)
- When the orientation switchover speed is reached, the PLG Z phase pulse will be confirmed, and the mode will change from speed control to position control (orientation position loop gain parameter (Pr. 362)).
- When the control is changed, the distance to the orientation stop position will be calculated. The motor will decelerate and stop with a set deceleration pattern (Pr. 399), and the orientation (servo lock) state will be entered.
- When entered in the Pr. 357 in-position zone is entered, the orientation complete signal (terminal ORA) will be output.
- The zero point position (origin) can be moved using position shift (Pr. 361).

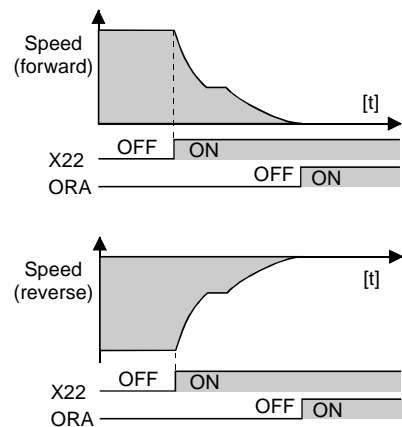

⚠ WARNING

⚠ **If the orientation command (terminal X22) is turned off while the start signal is input, the motor will accelerate toward the speed of the current speed command. Thus, to stop, turn the forward rotation (reverse rotation) signal off.**

(2) Orientation from the forward rotation direction

This method is used to improve the stopping precision and maintain the mechanical precision when the backlash is large.

If the motor is running in the forward rotation direction, it will orientation stop with the same method as "orientation from the current rotation direction". If the motor is running in reverse, it will decelerate, the rotation direction will be changed to forward run, and then orientation stop will be executed.

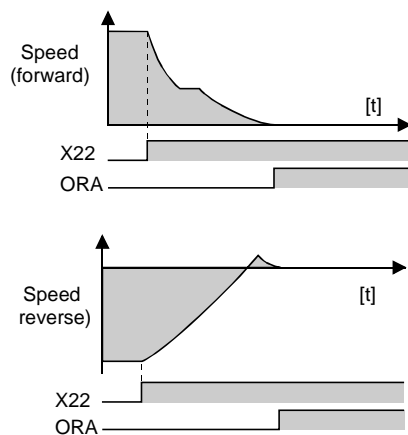

Orientation (Pr. 350 to Pr. 362, Pr. 393 to Pr. 399)

(3) Orientation from the reverse rotation direction

If the motor is running in the reverse rotation direction, it will orientation stop with the same method as "orientation from the current rotation direction".

If the motor is running in forward, it will decelerate, the rotation direction will be changed to reverse run, and then orientation stop will be executed.

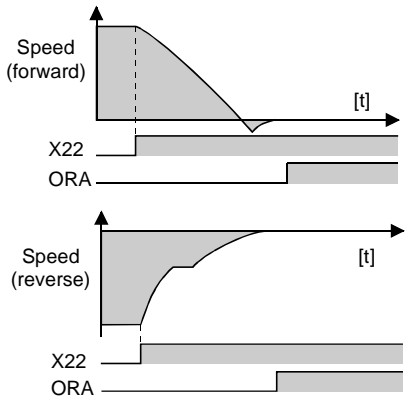

CAUTION

1. The PLG should be coupled with the motor shaft or the spindle oriented with a speed ratio of 1 to 1 without any mechanical looseness.
2. To ensure correct positioning, the PLG must be set in the proper rotation direction and the A and B phases connected correctly.
3. The orientation may not be completed if the pulse signal is not given from the PLG during orientation due to an open cable, etc.
4. To terminate orientation, the start signal (STF or STR) must be first switched off and the orientation signal (X22) must be switched off. As soon as this orientation signal is switched off, orientation control ends.
5. For orientation control, set correct values in Pr. 350 "stop position command selection" and Pr. 360 "external position command selection"
If the values set are incorrect, proper orientation control will not be performed.
6. When orientation control is exercised, PID control is invalid.

REMARKS

If "E.ECT" (no encoder signal) is displayed causing the inverter to trip when the orient signal (X22) is ON, check for an open cable of the Z phase of the encoder.

- Pr. 357 "orientation in-position zone" (factory setting:11)
- The positioning width for orientation stop can be set. The factory setting of Pr. 357 is "11". To change the $\Delta\theta$ value, finely adjust with ± 10 increments, and make fine adjustment.
- If the position detection value from the PLG enters $\pm\Delta\theta$ during orientation stop, the orientation complete signal (ORA) will be output.

Example of operation

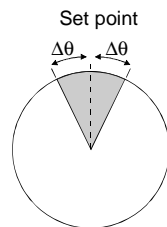

$$\Delta\theta = \frac{360^\circ}{\text{Pr.851 number of PLG pulses} \times 4} \times \text{Pr.357}$$

CAUTION

This setting is used to judge the ON/OFF of the orientation complete signal, and does not determine the orientation stop precision.

(4) Fine adjustment of the orientation stop position (Pr. 361 "position shift" (factory setting: 0))

The orientation stop position will deviate by the value set x 360° / Pr. 851 "number of PLG pulses" x4.
 Finely adjust the position by changing this setting value in 10 increments.
 The orientation stop position will differ according to the direction that the PLG is installed in.
 (Refer to the drawings below.)

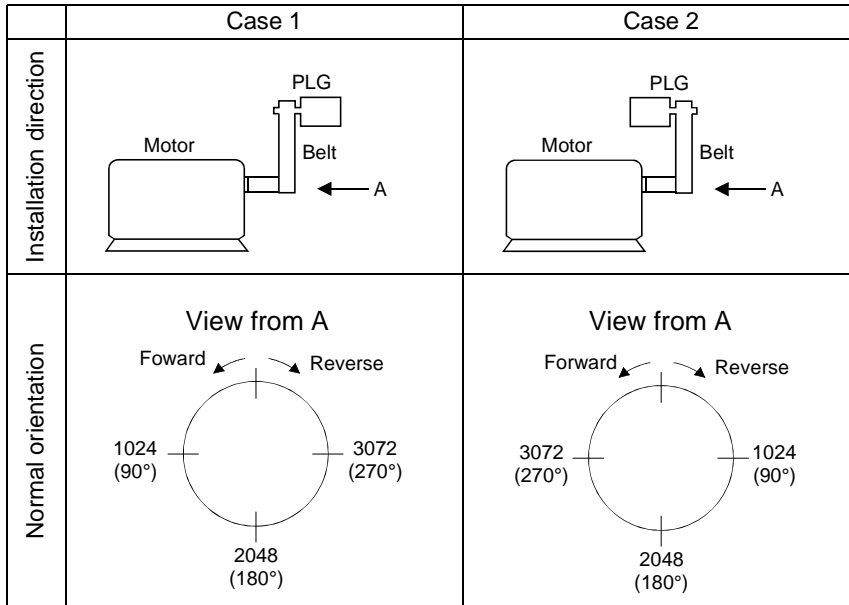

(5) Adjustment of the servo rigidity

- Pr. 396 "orientation speed gain (P term)" (factory setting: 60)
 - Pr. 397 "orientation speed integral time" (factory setting: 0.333)
 - Pr. 398 "orientation speed gain (D term)" (factory setting: 1)
 - Pr. 362 "orientation position loop gain" (factory setting: 10)
- To increase the servo rigidity*1 during orientation stop in Pr. 396 or Pr. 397, adjust with the following procedures.
- 1) Increase the Pr. 362 "orientation position loop gain" value to the extent that rocking does not occur during orientation stop.
 - 2) Increase Pr. 396 and Pr. 397 at the same rate.
 Generally adjust Pr. 396 in the range from 10 to 100, and Pr. 397 from 0.1 to 1.0s.
 (Note that these do not need to be set to the same rate.)
 <Example>
 When the Pr. 396 value is multiplied by 1.2, divide the Pr. 397 value by 1.2.
 If vibration occurs during orientation stop, the scale cannot be raised any higher.
 - 3) Pr. 398 is the lag/advance compensation gain.*2
 The limit cycle can be provided by increasing the value, and the running can be stopped stably. However, the torque in regard to the position deviation will drop, and the motor will stop with deviation.

POINT

Application of lag/advance control and PI control
 PI control can be applied by setting Pr. 398 to 0. Normally, the lag/advance control is selected. Use PI control in the following cases.
 When using a machine with a high spindle stationary friction torque and requires a stopping position precision.

REMARKS

- *1. Servo rigidity: This is the response when a position control loop is configured.
 When the servo rigidity is raised, the holding force will increase, the running will stabilize, but vibration will occur easily.
 When the servo rigidity is lowered, the holding force will drop, and the setting time will increase.
- *2. Limit cycle*: This is a phenomenon that generates ± continuous vibration centering on the target position.
- *3. Rocking: Movement in which return occurs if the stopping position is exceeded.

Orientation (Pr. 350 to Pr. 362, Pr. 393 to Pr. 399)

- Pr. 399 "orientation deceleration ratio" (factory setting: 20)
- Make adjustments as shown below according to the orientation status.
(Refer to the Pr. 396 and Pr. 397 details also.)
Generally adjust Pr. 362 in the range from 5 to 20 and Pr. 399 from 5 to 50.

Phenomenon	Adjustment Procedure			
	Pr. 396	Pr. 397	Pr. 362	Pr. 399
Rocking occurs during stopping	3) ↗	3) ↗	2) ↘	1) ↘
The orientation time is long	→	→	2) ↗	1) ↗
Hunting occurs when stopping	2) ↘	2) ↗	1) ↘	→
The servo rigidity during stopping is low	1) ↗	1) ↘	2) ↗	→

REMARKS

- ↗ :Increase the parameter setting value.
 - :Do not change the parameter setting value.
 - ↘ :Decrease the parameter setting value.
- The numbers 1) 2) and 3) in the table show the order of priority for changing the parameters setting value.

CAUTION

If orientation stop is not possible and the excessive position error alarm occurs, or if the motor does forward/reverse reciprocation operation , the parameter setting value for the orientation detector installation direction may be incorrect. Review Pr. 393 "orientation selection" (Refer to page 163.) and Pr. 852 "PLG rotation direction" (Refer to the Instruction Manual (basic)).

- Pr. 351 "orientation switchover speed" (factory setting: 200)
Set the speed when switching between the speed control mode and the position control mode under orientation operation. Decreasing the set speed enables stable orientation stop. Note that the orientation time will increase.

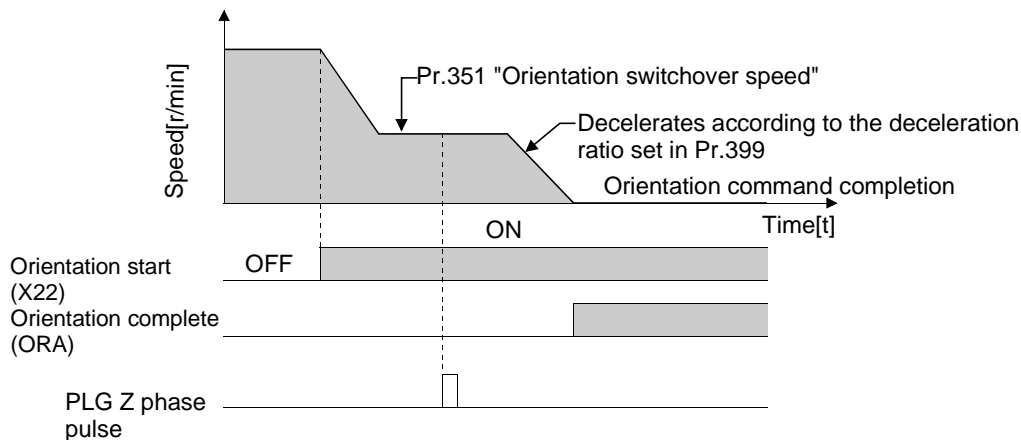

REMARKS

When "19" is set in Pr. 52 "DU/PU main display data selection", position pulse monitor is displayed instead of PU output voltage monitor.

3.29 Control system function (Pr. 374)

3.29.1 Overspeed detection (Pr. 374 speed torque position)

- Excess of the motor speed over the overspeed detection level results in E.OS, stopping the output. This function is enabled only under speed control, torque control or position control.

Parameter	Name	Setting Range	Factory Setting	Remarks
374	Overspeed detection level	0 to 4200r/min	Japanese version: 3450r/min	Extended mode
			NA version: 4200r/min	

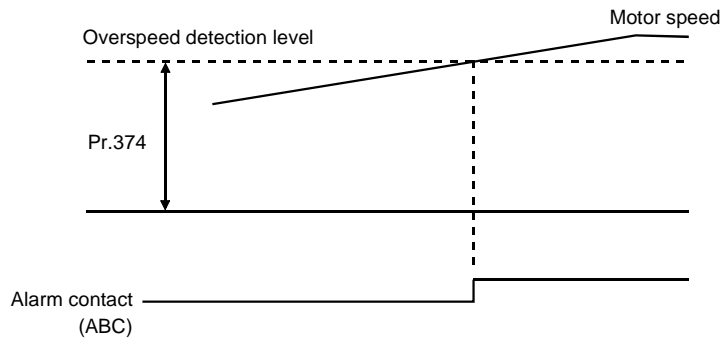

REMARKS

This function is enabled under speed control, torque control or position control.

Pr. 380 to Pr. 383 ➡ Refer to Pr. 29 (page 93).

3.30 Position control (Pr. 419 to Pr. 430, Pr. 464 to Pr. 494)

3.30.1 Position control (Pr. 419 to Pr. 430, Pr. 464 to Pr. 494 position)

Parameter	Name	Setting Range	Factory Setting
419	Position command right selection	0, 1	0
420	Command pulse scaling factor numerator	0 to 32767	1
421	Command pulse scaling factor denominator	0 to 32767	1
422	Position loop gain	0 to 150s ⁻¹	25s ⁻¹
423	Position feed forward gain	0 to 100%	0%
424	Position command acceleration/deceleration time constant	0 to 50s	0s
425	Position feed forward command filter	0 to 5s	0s
426	In-position width	0 to 32767 pulses	100 pulses
427	Excessive level error	0 to 400K, 9999	40K
430	Pulse monitor selection	0 to 5, 9999	9999
464	Digital position control sudden stop deceleration time	0 to 360.0s	0

Parameter	Name	Setting Range	Factory Setting	Selection Method				Positioning Speed
				REX	RH	RM	RL	
465	First position feed amount lower 4 digits	0 to 9999	0	OFF	ON	OFF	OFF	High speed, Pr. 4
466	First position feed amount upper 4 digits			OFF	OFF	ON	OFF	Middle speed, Pr. 5
467	Second position feed amount lower 4 digits			OFF	OFF	OFF	ON	Low speed, Pr. 6
468	Second position feed amount upper 4 digits			OFF	OFF	ON	ON	Speed 4, Pr. 24
469	Third position feed amount lower 4 digits			OFF	ON	OFF	ON	Speed 5, Pr. 25
470	Third position feed amount upper 4 digits			OFF	ON	ON	OFF	Speed 6, Pr. 26
471	Fourth position feed amount lower 4 digits			OFF	ON	ON	ON	Speed 7, Pr. 27
472	Fourth position feed amount upper 4 digits			ON	OFF	OFF	OFF	Speed 8, Pr. 232
473	Fifth position feed amount lower 4 digits			ON	OFF	OFF	ON	Speed 9, Pr. 233
474	Fifth position feed amount upper 4 digits			ON	OFF	ON	OFF	Speed 10, Pr. 234
475	Sixth position feed amount lower 4 digits			ON	OFF	ON	ON	Speed 11, Pr. 235
476	Sixth position feed amount upper 4 digits			ON	ON	OFF	OFF	Speed 12, Pr. 236
477	Seventh position feed amount lower 4 digits			ON	ON	OFF	ON	Speed 13, Pr. 237
478	Seventh position feed amount upper 4 digits			ON	ON	ON	OFF	Speed 14, Pr. 238
479	Eighth position feed amount lower 4 digits			ON	ON	ON	ON	Speed 15, Pr. 239
480	Eighth position feed amount upper 4 digits							
481	Ninth position feed amount lower 4 digits							
482	Ninth position feed amount upper 4 digits							
483	Tenth position feed amount lower 4 digits							
484	Tenth position feed amount upper 4 digits							
485	Eleventh position feed amount lower 4 digits							
486	Eleventh position feed amount upper 4 digits							
487	Twelfth position feed amount lower 4 digits							
488	Twelfth position feed amount upper 4 digits							
489	Thirteenth position feed amount lower 4 digits							
490	Thirteenth position feed amount upper 4 digits							
491	Fourteenth position feed amount lower 4 digits							
492	Fourteenth position feed amount upper 4 digits							
493	Fifteenth position feed amount lower 4 digits							
494	Fifteenth position feed amount upper 4 digits							

Refer to page 53 for details of position control.

Pr. 450 ➡ Refer to Pr. 71 (page 114).

Pr. 451 ➡ Refer to Pr. 800 (page 170).

Pr. 452 ➡ Refer to Pr. 9 (page 85).

Pr. 453, Pr. 454 ➡ Refer to page 35.

Pr. 464 to Pr. 494 ➡ Refer to page 53.

3.32 Operation selection functions 4 (Pr. 800 to Pr. 809)

3.32.1 Control selection (Pr. 800, Pr. 451 speed torque position)

Used to select the control method.

- Setting Pr. 800 (Pr. 451) control system selection enables the following combination using the MC signal (mode changing). Use terminal RT to switch to the second motor, control method selection.

Parameter	Name	Factory Setting	Setting Range
800	Control system selection	0	0 to 5, 20
451	Second motor control method selection	9999	20, 9999

- Select the inverter control system such as speed control, torque control or position control.

Pr. 800 Setting	Control System	Control Method	Remarks
0 (factory setting)	PLG vector control	Speed control	Factory setting
1		Torque control	—
2		Speed control-torque control switchover	MC ON: Torque control MC OFF: Speed control
3		Position control	—
4		Speed control-position control switchover	MC ON: Position control MC OFF: Speed control
5		Position control-torque control switchover	MC ON: Torque control MC OFF: Position control
20	V/F control	Speed control	—

Related parameters

MC signal terminal assignment ⇒ Set "26" in any of Pr. 180 to Pr. 183 and Pr. 187 (input terminal function selection). (Refer to page 151.)

3.32.2 Torque characteristic selection (Pr. 801 speed torque position)

When using the motor with PLG, you can select the torque characteristic.

Parameter	Name	Factory Setting	Setting Range	
			Dedicated motor (SF-V5R)	Motor with PLG (e.g. SF-JR)
801	Torque characteristic selection	1	0	Cyclic operation mode
			1	Continuous operation mode

CAUTION

- Whether the motor used is a Mitsubishi dedicated motor or motor with PLG is judged by the setting of Pr. 71 "applied motor". Refer to page 114.
- Usually, operate in the continuous operation mode (setting value : 1)
Torque at a low speed is not sufficient in the cyclic operation mode (setting value : 0).
Note this when changing the setting.

● Mitsubishi dedicated motor torque characteristic

Torque characteristic available when the inverter and motor of the same capacity are used and the rated voltage is input

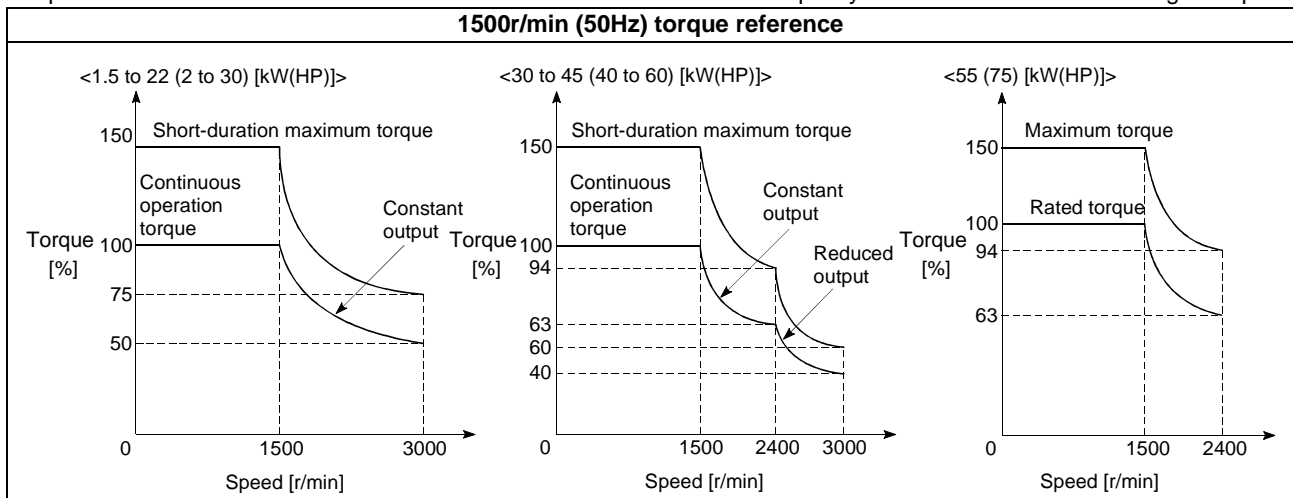

● **Torque characteristic of motor with PLG (Example: SF-JR with PLG (4 poles))**

Torque characteristic available when the inverter and motor of the same capacity are used and the rated voltage is input

1800r/min (60Hz) torque reference	
Cyclic operation mode setting	Continuous operation mode setting
<p>● Short-duration maximum torque <1.5 to 55 (2 to 75)[kW (HP)]></p>	<p>● Short-duration maximum torque <1.5 to 55 (2 to 75) [kW (HP)]></p>
<p>● 50%ED torque <1.5, 2.2 to 55 (2, 3 to 75) [kW (HP)]></p>	<p>● Continuous operation torque <1.5, 2.2 to 55 (2, 3 to 75) [kW (HP)]></p>

CAUTION

1. The maximum speeds are 1) 1.5kW to 7.5kW (2HP to 10HP): 3600r/min, 2) 11kW to 30kW (15HP to 40HP): 3000r/min, and 3) 37kW to 55kW (50HP to 75HP): 1950r/min.
2. 50%ED continuously repeated operation can be performed at the cycle time of 10 minutes. Note that continuous operation can be performed for a maximum of 5 minutes.

Pr. 802 ➡ Refer to Pr. 10 to Pr. 12 (page 87).

Pr. 803 ➡ Refer to Pr. 22 (page 91).

3.32.3 Torque command right selection (Pr. 804 to Pr. 806 torque)

When you selected torque control, you can choose the torque command.

Parameter	Name	Factory Setting	Setting Range	
804	Torque command right selection	0	0	No. 3 terminal analog input
			1	Digital input from parameter Pr. 805 or Pr. 806 setting (-400% to 400%)
			2	Torque command using pulse train command (FR-V5AP) Refer to the instruction manual of the option "FR-V5AP" for details.
			3	Torque command by using CC-Link (FR-A5NC) Refer to the instruction manual of the option "FR-A5NC" for details.
			4	Torque command from the option (digital) (FR-V5AH, FR-A5AX) Refer to the instruction manual of the option "FR-V5AH, FR-A5AX" for details.
805	Torque command value (RAM)	1000%	600 to 1400%	
806	Torque command value (RAM, E ² PROM)	1000%	600 to 1400%	

- (1) No. 3 terminal calibration (Pr. 804 = 0)
The torque command value for the analog input of the No. 3 terminal varies with Pr. 904 and Pr. 905 as shown on the right.

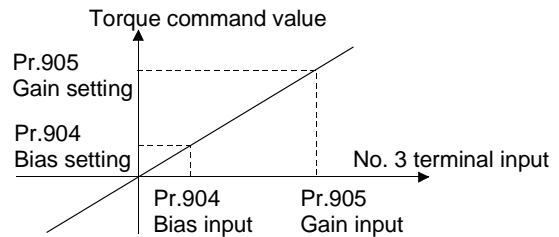

- (2) Digital input from parameter (Pr. 804 = 1)
Digital setting of the torque command can be made by writing the torque command value to Pr. 805 or Pr. 806 by communication. The torque command can also be specified by parameter direct setting. In this case, set the speed restriction value to an appropriate value to prevent acceleration. The relationship between the Pr. 805 or Pr. 806 setting and actual torque command value at this time is shown on the right. On the assumption that 1000% is 0%, the torque command is indicated by an offset from 1000%.

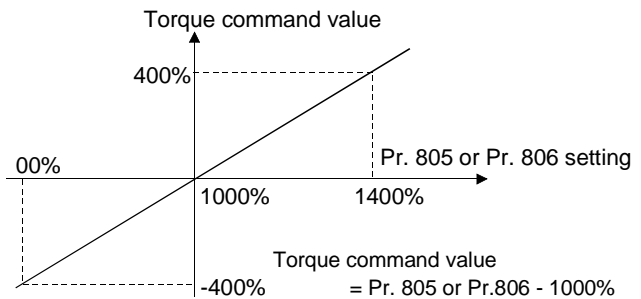

CAUTION

- For the command given by the torque setting command E²PROM (RYE), the set torque (RWW1) is reflected on the torque command value of the inverter when the torque setting command E²PROM (RYE) changes from off to on.
For the command given by the torque setting command RAM (RYD), the set torque (RWW1) is reflected on the inverter while the torque setting command RAM (RYD) is on.
- When writing the torque command value by communication (Pr. 804 = 1, Pr. 804 = 3), there is a restriction on the number of write times to E²PROM. When the value is changed often, write it to RAM. (When Pr. 804 = 1, set "1" in Pr. 342 "E²PROM write presence/absence" to select write to RAM.)

3.32.4 Speed restriction (Pr. 807 to Pr. 809 torque)

When you selected torque control, set the speed restriction value to prevent the load torque from becoming less than the torque command value, resulting in motor overspeed.

Parameter	Name	Factory Setting	Setting Range
807	Speed restriction selection	0	0, 1, 2
808	Forward rotation speed restriction	Japanese version: 1500r/min	0 to 3600r/min
		NA version: 1800r/min	
809	Reverse rotation speed restriction	9999	0 to 3600r/min, 9999

<Settings>

Set the speed restriction value to prevent the load torque from becoming less than the torque command value, resulting in motor overspeed. Select the speed restriction input method using Pr. 807.

Pr. 807 Setting	Speed Restriction Input Method	Operation
0 (factory setting)	Same method as in speed setting for speed control	<ul style="list-style-type: none"> Speed setting from the operation panel External analog command (terminal 1, 2) Multi-speed command Option (FR-V5AX etc.) For both PU and external operations, speed restriction changes according to the acceleration/deceleration time.
1	Pr. 808 Forward rotation speed restriction Pr. 809 Reverse rotation speed restriction	According to the rotation direction, set the speed restrictions in forward and reverse rotation directions individually. When the reverse rotation speed restriction is 9999, the setting is the same as that of the torque restriction in the forward rotation direction.
2	Forward/reverse rotation speed restriction (analog polarity switchover speed restriction) (No. 1 terminal analog input)	The analog voltage of the No. 1 terminal input is used to make speed restriction. For 0 to 10V input, set the forward rotation speed restriction. (The reverse rotation speed restriction is Pr. 1 "maximum speed" .) For -10 to 0V input, set the reverse rotation speed restriction. (The forward rotation speed restriction is Pr. 1 "maximum speed".) The maximum speed of both the forward and reverse rotation is Pr. 1 "maximum speed". When No. 1 terminal input is selected, set "5" in Pr. 868 "No. 1 terminal function assignment". (Refer to page 183.)

(1) When Pr. 807 = 0

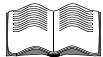

Refer to the Instruction Manual (basic).

(2) When Pr. 807 = 1

Parameter	Name	Factory Setting	Setting Range
808	Forward rotation speed restriction	Japanese version: 1500r/min	0 to 3600r/min
		NA version: 1800r/min	
809	Reverse rotation speed restriction	9999	0 to 3600r/min, 9999

Using the parameters, set the forward rotation and reverse rotation speed restriction levels individually.

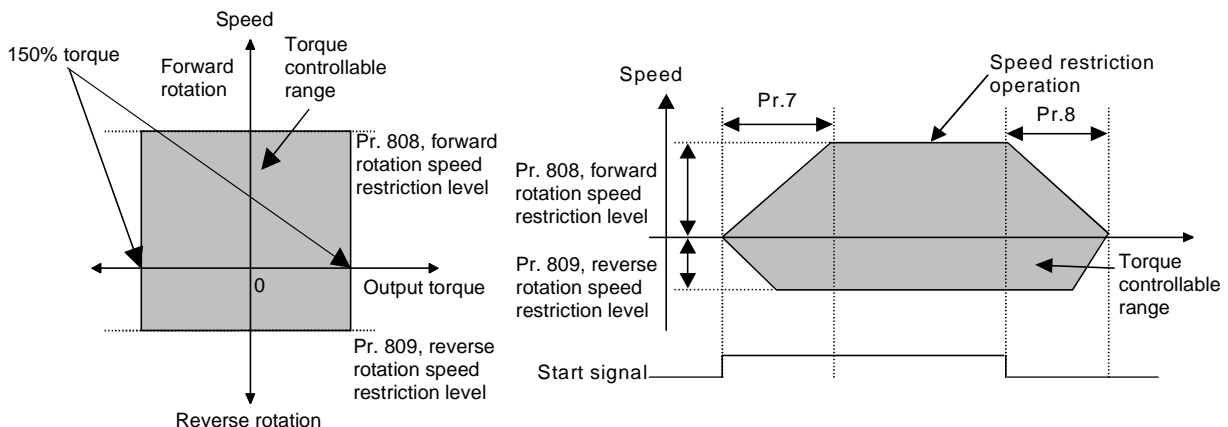

(3) When Pr. 807 = 2

Using the analog input of the No. 1 terminal, set the forward rotation and reverse rotation speed restriction levels.

At this time, the speed restriction made on the analog input is as shown below.

1) When No. 1 terminal input is -10 to 0V
Reverse rotation speed restriction

2) When No. 1 terminal input is 0V to 10V
Forward rotation speed restriction

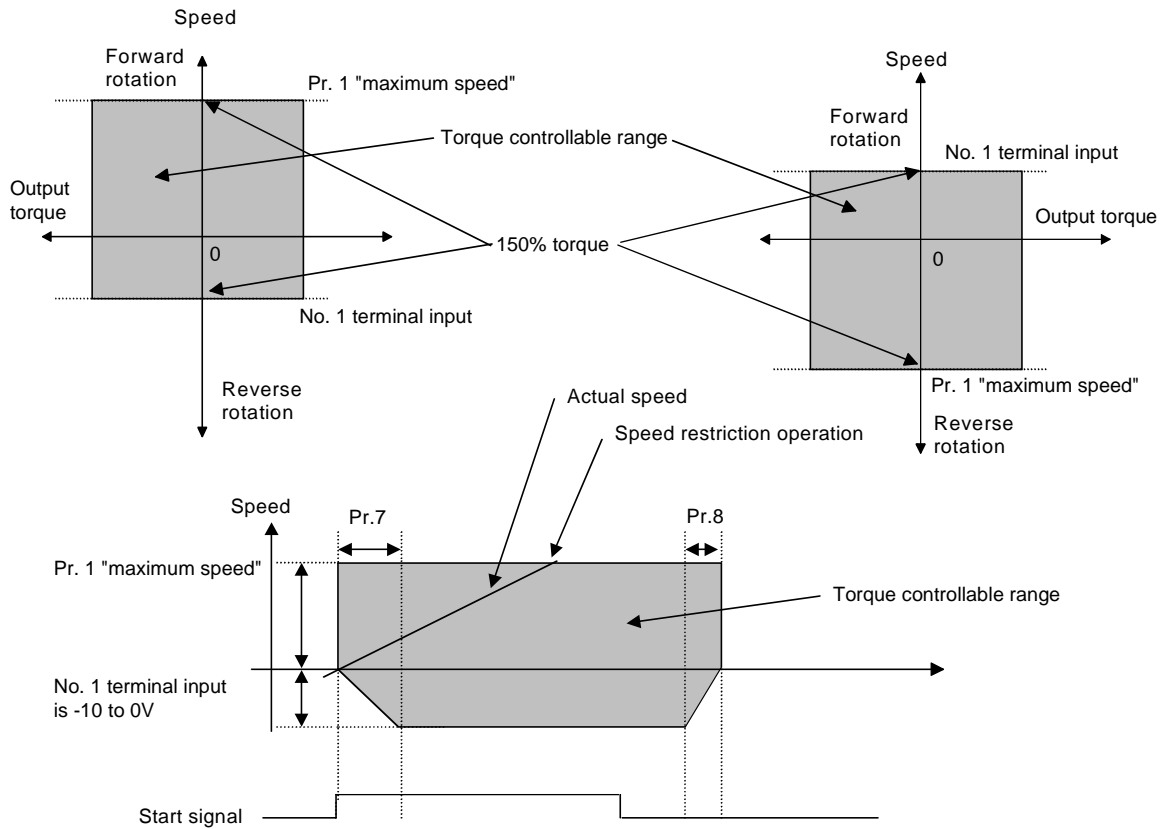

Related parameters

- Selection of No.1 terminal function ⇒ Pr. 868 "No. 1 terminal function assignment" (Refer to page 183.)
- Speed restriction during acceleration/deceleration ⇒ Pr. 7 "acceleration time", Pr. 8 "deceleration time" (Refer to page 83.)
- DC injection brake operation level ⇒ Pr. 10 "DC injection brake operation speed" (Refer to page 87.)
- Speed restriction level maximum setting ⇒ Pr. 1 "maximum speed" (Refer to page 81.)

CAUTION

When speed ≥ speed restriction, torque control is switched to speed control.

Pr. 810, Pr. 812 to Pr. 817 ➡ Refer to Pr. 22 (page 91)

3.33 Control system functions (Pr. 818 to Pr. 837)

3.33.1 Easy gain tuning selection (Pr. 818, Pr. 819 speed position)

The ratio of load inertia to motor inertia (load inertia moment ratio) is estimated in real time from the torque command and speed during motor operation, and this value is used to automatically set the optimum gain for speed/position control, reducing the time and effort of making gain adjustment.

Parameter	Name	Factory Setting	Setting Range	
818	Easy gain tuning response level setting	2	1 to 15	
819	Easy gain tuning selection	0	0	No tuning
			1	With load estimation
			2	Manual load input

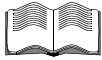

Refer to the Instruction Manual (basic) for details.

Related parameters

- Adjusted gains ⇒ Pr. 820 "speed control P gain 1", Pr. 821 "speed control integral time 1", Pr. 828 "model speed control gain", Pr. 422 "position loop gain"
- Adjusted load inertia ratio ⇒ Pr. 880 "load inertia ratio"

3.33.2 Speed loop proportional gain setting (Pr. 820, Pr. 830 speed position)

Parameter	Name	Factory Setting	Setting Range	Remarks
820	Speed control P gain 1 (when RT signal is off)	60%	0 to 1000%	Extended mode
830	Speed control P gain 2 (when RT signal is on)	9999	0 to 1000%, 9999	

- Set the proportional gain of the speed loop.
Increasing the gain enhances the speed response level and decreases the speed fluctuation relative to disturbance, but a too large gain will produce vibration and/or sound.
- Pr. 820 "speed control P gain 1" and Pr. 830 "speed control P gain 2" are 0 to 1000% in the setting range and 60% in the factory setting. For general adjustment, set them within the range of 20 to 200%.

REMARKS

- The response level will be worse when the coupling is loose.
- When performing positioning, increase the setting to enhance accuracy.
- Decrease the setting when there is gear backlash, etc.

3.33.3 Speed control integral time setting (Pr. 821, Pr. 831 speed position)

Parameter	Name	Factory Setting	Setting Range	Remarks
821	Speed control integral time 1 (when RT signal is off)	0.333s	0 to 20s	Extended mode
831	Speed control integral time 2 (when RT signal is on)	9999	0 to 20s, 9999	

- Set the integral compensation time of the speed loop.
If speed fluctuation occurs relative to disturbance, decreasing the value shortens the recovery time, but a too small value will cause a speed overshoot.
A large value improves stability but increases the recovery time (response time) and may cause an undershoot.

3.33.4 Speed setting circuit filter function (Pr. 822, Pr. 832 speed position)

Set the time constant of the primary delay filter relative to the external speed command (analog input command).

Set a large time constant when you want to delay the tracking of the speed command or when the analog input voltage is unstable.

Parameter	Name	Factory Setting	Setting Range	Remarks
822	Speed setting filter 1 (when RT signal is off)	0s (without filter)	0 to 5s	Extended mode
832	Speed setting filter 2 (when RT signal is on)	9999	0 to 5s, 9999	

3.33.5 Speed detection filter function (Pr. 823, Pr. 833 speed torque position)

- Set the time constant of the primary delay filter relative to the speed feedback signal. Since this function reduces the speed loop response, use it with the factory setting. Set the time constant when speed ripples occur due to harmonic disturbance. Note that a too large value will run the motor unstably.

Parameter	Name	Factory Setting	Setting Range	Remarks
823	Speed detection filter 1 (when RT signal is off)	0.001s	0 to 0.1s	0: without filter
833	Speed detection filter 2 (when RT signal is on)	9999	0 to 0.1s, 9999	9999: same as the Pr. 823 setting Extended mode

REMARKS

When speed ripples are large, setting this parameter Pr. 823 or Pr. 833 ensures stability.

3.33.6 Current loop proportional gain setting for vector control

(Pr. 824, Pr. 834 speed torque position)

- Set the current loop proportional gain for vector control. Increasing the gain enhances the torque response level, but a too large gain will cause instability, generating harmonic torque pulsation.
- Pr. 824 "torque control P gain 1" and Pr. 834 "torque control P gain 2" are 0 to 200% in the setting range and 100% in the factory setting. For general adjustment, set them within the range 50 to 200%.

Parameter	Name	Factory Setting	Setting Range	Remarks
824	Torque control P gain 1 (when RT signal is off)	100%	0 to 200%	Extended mode
834	Torque control P gain 2 (when RT signal is on)	9999	0 to 200%, 9999	

REMARKS

The factory setting ensures fully stable operation.

For general adjustment, make setting within the range 50 to 200% as a guideline.

3.33.7 Current control integral time setting for vector control

(Pr. 825, Pr. 835 speed torque position)

- Set the current loop integral compensation time for vector control.
- A small value enhances the torque response level, but a too small value will cause current fluctuation.

Parameter	Name	Factory Setting	Setting Range	Remarks
825	Torque control integral time 1 (when RT signal is off)	5ms	0 to 500ms	Extended mode
835	Torque control integral time 2 (when RT signal is on)	9999	0 to 500ms, 9999	

REMARKS

The factory setting ensures fully stable operation.

3.33.8 Torque setting filter function (Pr. 826, Pr. 836 speed torque position)

- Set the time constant of the primary delay filter relative to the external torque command (analog input command). Set a large time constant value when you want to delay the tracking of the torque command, the analog input voltage fluctuates, etc.

Parameter	Name	Factory Setting	Setting Range	Remarks
826	Torque setting filter 1 (when RT signal is off)	0s (without filter)	0 to 5s	Extended mode
836	Torque setting filter 2 (when RT signal is on)	9999	0 to 5s, 9999	

(1) Parameter details

1) Pr. 840 "torque bias selection"

Select the setting method of the torque bias amount.

Pr. 840 Setting	Description
0	Set the torque bias amount based on the contact signals (DI1 to DI4) in Pr. 841 to Pr. 843.
1	To raise the cage when the motor runs in forward rotation direction. Set the No. 3 terminal-based torque bias amount as desired in Pr. 904 and Pr. 905.
2	To raise the cage when the motor runs in reverse rotation direction. Set the No. 3 terminal-based torque bias amount as desired in Pr. 904 and Pr. 905.
3	The No. 3 terminal-based torque bias amount can be set automatically in Pr. 904, Pr. 905 and Pr. 846 according to the load.
9999	No torque bias

<Operation diagrams>

- When Pr. 840 = 0

Set the torque bias values (Pr. 841 to Pr. 843) in the following table according to the combination of the contact signals (DI1 to DI4).

Torque Bias Selection 1 (X42 Terminal)	Torque Bias Selection 2 (X43 Terminal)	Torque Bias (Pr. 841 to Pr. 843)
OFF	OFF	No selection
ON	OFF	Pr.841 1000 to 1400%: Positive value 600 to 999%: Negative value
OFF	ON	Pr.842 1000 to 1400%: Positive value 600 to 999%: Negative value
ON	ON	Pr.843 1000 to 1400%: Positive value 600 to 999%: Negative value

(Example) 25% when Pr. 841 = 1025, -25% when Pr. 842 = 975, -75% when Pr. 843 = 925

- When Pr. 840 = 1

Calculate the torque bias from the analog input value of the No. 3 terminal as shown below and set the gain and bias (Pr. 904, Pr. 905) of the torque command.

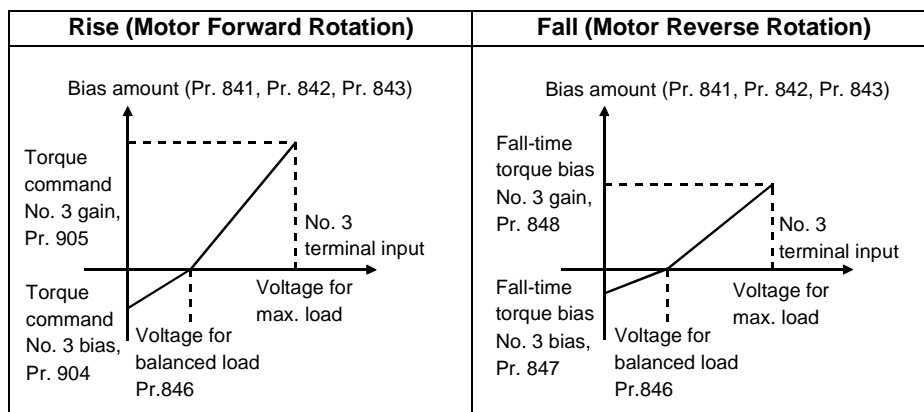

- When Pr. 840 = 2

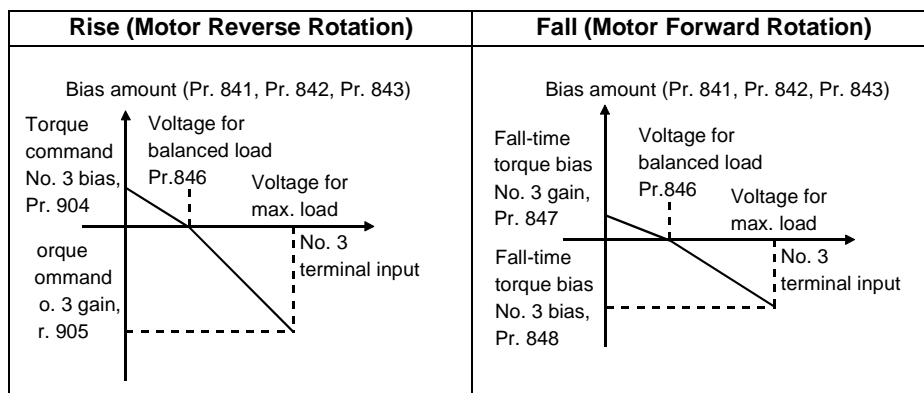

- When Pr. 840 = 3

Pr. 904 "torque command No. 3 bias", Pr. 905 "torque command No. 3 gain" and Pr. 846 "torque bias balance compensation" can be set automatically according to the load.

Pr. 904, Pr. 905 settings

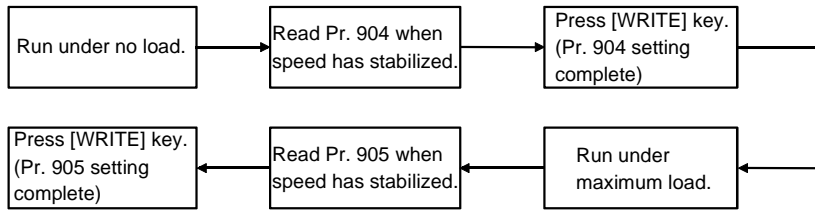

Pr. 846 setting

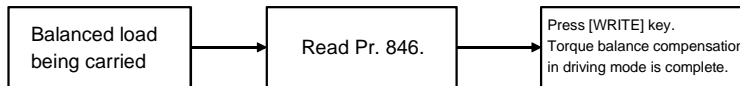

CAUTION

When starting torque bias operation after completion of automatic setting, set "1 or 2" in Pr. 840.

- 2) Pr. 841 "torque bias 1", Pr. 842 "torque bias 2", Pr. 843 "torque bias 3"

On the assumption that the rated torque is 100%, the torque bias setting of 1000% is the center value of torque and the bias value is "0".

Setting	Description
600 to 999%	Negative torque bias amount (-400% to -1%)
1000 to 1400%	Positive torque bias amount (0% to 400%)
9999	Without torque bias setting

- 3) Pr. 844 "torque bias filter"

You can make a torque rise gentler. At this time, the torque rises according to the time constant of the primary delay filter.

Setting	Description
0 to 5s	Time until torque rises.
9999	Same operation as when 0s is set.

- 4) Pr. 845 "torque bias operation time"

Set the time for output torque be maintained with the torque bias command value alone.

Setting	Description
0 to 5s	Time for maintaining torque equivalent to the torque bias amount.
9999	Same operation as when 0s is set.

- 5) Pr. 846 "torque bias balance compensation"

Set the voltage of the torque bias analog input value input to the No. 3 terminal to compensate for the balance of the torque bias amount.

Setting	Description
0 to 10V	Set the voltage under balanced load.
9999	Same operation as when 0V is set.

- 6) Pr. 847 "fall-time torque bias No. 3 bias"

Set the torque bias amount at a fall time (when the motor runs in the reverse rotation direction).

Setting	Description
0 to 400%	Set the bias value of the torque command.
9999	Same as at a rise time (Pr. 904).

- 7) Pr. 848 "fall-time torque bias No. 3 gain"

Set the torque bias amount at a fall time.

Setting	Description
0 to 400%	Set the gain value of the torque command.
9999	Same as at a rise time (Pr. 905).

(2) Torque bias operation

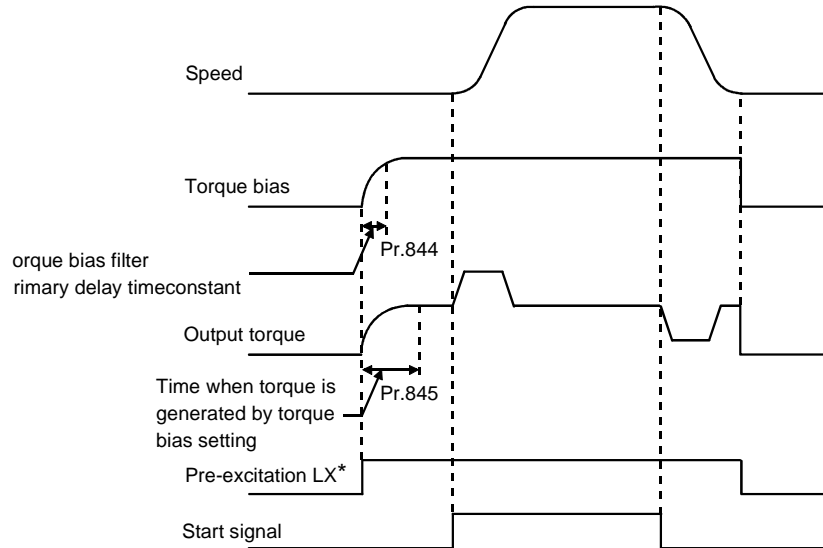

*When pre-excitation is not made, the torque bias functions simultaneously with the start signal.

Pr. 849 Refer to Pr. 902, Pr.903 (page 190)

3.35 Additional functions (Pr. 851 to Pr. 865)

3.35.1 Selection of number of PLG pulses (Pr. 851 speed torque position)

Set the number of pulses of the PLG fitted to the motor. (number of pulses before multiplied by 4)

Parameter	Name	Factory Setting	Setting Range
851	Number of PLG pulses	Japanese version: 2048	0 to 4096
		NA version: 1024	

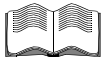

Refer to the Instruction Manual (basic) for details.

3.35.2 Selection of PLG rotation direction (Pr. 852 speed torque position)

You can set the rotation direction of the PLG.

Parameter	Name	Factory Setting	Setting Range	Remarks
852	PLG rotation direction	1	0, 1	Extended mode

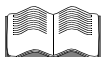

Refer to the Instruction Manual (basic) for details.

3.35.3 Excitation ratio (Pr. 854 speed torque position)

- Decrease the excitation ratio when you want to improve efficiency under light load. (motor magnetic noise decreases) Note that the rise of output torque becomes slow if excitation ratio is decreased. This function is appropriate for applications as machine tools which repeat rapid acceleration/deceleration up to high speed.

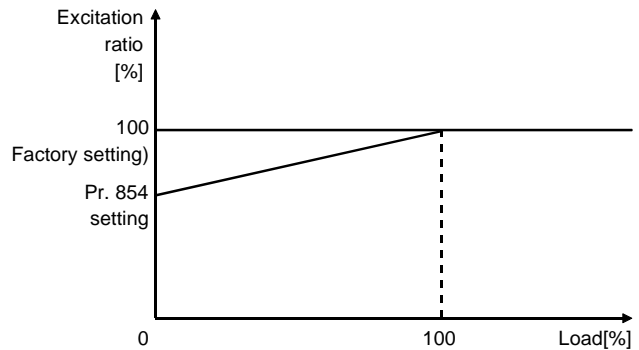

Parameter	Name	Factory Setting	Setting Range	Remarks
854	Excitation ratio	100%	0 to 100%	Extended mode

Pr. 859 ➡ Refer to page 123

3.35.4 Notch filter (Pr. 862, Pr. 863 speed position)

You can reduce the response level of speed control in the resonance frequency band of the mechanical system to avoid mechanical resonance.

Parameter	Name	Setting Range	Increments	Factory Setting	Remarks
862	Notch filter frequency	0 to 31	1	0	0: Function invalid Extended mode
863	Notch filter depth	0 to 3	1	0	

●Pr. 862 "notch filter frequency"

Pr. 862 Setting	Frequency	Pr. 862 Setting	Frequency	Pr. 862 Setting	Frequency	Pr. 862 Setting	Frequency
0	invalid	8	140.6	16	70.3	24	46.9
1	1125.0	9	125.0	17	66.2	25	45.0
2	562.5	10	112.5	18	62.5	26	43.3
3	375.0	11	102.3	19	59.2	27	41.7
4	281.3	12	93.8	20	56.3	28	40.2
5	225.0	13	86.5	21	53.6	29	38.8
6	187.5	14	80.4	22	51.1	30	37.5
7	160.7	15	75.0	23	48.9	31	36.3

●Pr. 863 "notch filter depth"

Pr. 863 Setting	Depth (Gain)
0	deep (-40dB)
1	↑ (-14dB)
2	↓ (-8dB)
3	sharow (-4dB)

CAUTION

- If you do not know the machine resonance frequency, decrease notch frequency gradually from the highest value. The point at which the smallest vibration is generated is the notch frequency setting.
- The notch filter with deeper depth has an effect on minimizing mechanical resonance. However, large vibration may be generated adversely due to substantial phase delay.
- Machine characteristic can be obtained beforehand with machine analyzer by setup software. Necessary notch frequency can be determined from this.

3.35.5 Torque detection (Pr. 864 speed torque position)

This function outputs a signal if the motor torque rises to or above the Pr. 864 setting. The signal is used as operation and open signal for an electromagnetic brake.

Parameter	Name	Factory Setting	Setting Range	Remarks
864	Torque detection	150%	0 to 400%	Extended mode

The signal turns on when the output torque rises to or above the detection torque value set in Pr. 864. It turns off when the torque falls below the detection torque value.

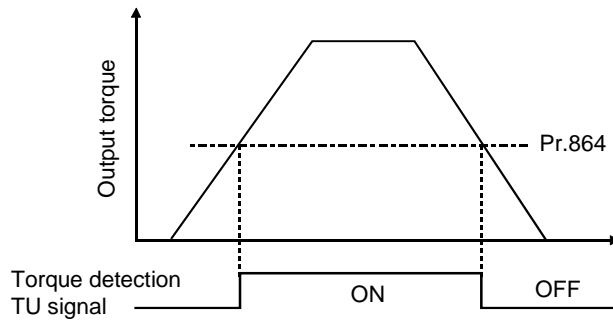

Related parameters

TU signal terminal assignment ⇒ Set "35" in any of Pr. 190 to Pr. 192 and Pr. 195 (output terminal function selection). (Refer to page 153.)

3.35.6 Low speed detection (Pr. 865 speed torque position)

This function outputs a signal if the speed falls to or below the Pr. 865 setting.

Parameter	Name	Factory Setting	Setting Range	Remarks
865	Low speed detection	45r/min	0 to 3600r/min	Extended mode

<Operation>

The signal is output during inverter operation under the following conditions.

- (1) Vector control
 - Motor speed ≤ Pr. 865 ... ON
 - Motor speed > Pr. 865 ... OFF
- (2) V/F control
 - Output speed ≤ Pr. 865 speed equivalent ... ON
 - Output speed > Pr. 865 speed equivalent ... OFF

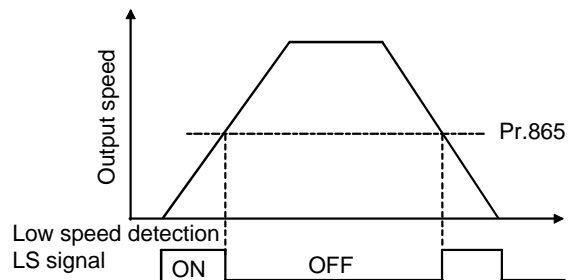

REMARKS

When "0" is set, low speed detection (LS signal) is output under position control only.

Related parameters

LS signal terminal assignment ⇒ Set "34" in any of Pr. 190 to Pr. 192 and Pr. 195 (output terminal function selection). (Refer to page 153.)

Pr. 866 ➡ Refer to Pr. 55 (page 104)

3.36 Display function (Pr. 867)

3.36.1 DA1 output response level adjustment (Pr. 867 speed torque position)

You can adjust the response level of the output voltage of the output signal DA1.

Parameter	Name	Factory Setting	Setting Range	Remarks
867	DA1 output filter	0.05s	0 to 5s	Extended mode

3.37 Terminal function assignment (Pr. 868)

3.37.1 No. 1 terminal function assignment (Pr. 868 speed torque position)

The No. 1 terminal can be multi-functioned.

Parameter	Name	Factory Setting	Setting Range	Remarks
868	No. 1 terminal function assignment	0	0, 1, 2, 5, 9999	Extended mode

<No1. terminal function according to control>

Pr. 868 Setting	No. 1 Terminal Function under Speed Control	No. 1 Terminal Function under Torque Control	No. 1 Terminal Function under Position Control	Bias/Gain Setting	Remarks
0 (factory setting)	Speed setting auxiliary *	Speed restriction auxiliary	No function	Pr. 902 "speed setting No. 2 bias" Pr. 903 "speed setting No. 2 gain"	
1	Magnetic flux command	Magnetic flux command	Magnetic flux command	Pr. 919 "No.1 terminal bias (torque/magnetic flux)" Pr. 920 "No.1 terminal gain (torque/magnetic flux)"	
2	Regenerative torque restriction	No function	Regenerative torque restriction	Pr. 919 "No.1 terminal bias (torque/magnetic flux)" Pr. 920 "No.1 terminal gain (torque/magnetic flux)"	Setting can be made when Pr. 810 = 1.
5	No function	Forward/reverse rotation speed restriction (analog polarity switchover speed restriction)	No function	Pr. 917 "No.1 terminal bias (speed)" Pr. 918 "No1. terminal gain (speed)"	
9999	No function	No function	No function	No function	No function

* The function is changed to main speed according to the Pr.73 setting with which override, polarity reversible function, etc. can be selected. (Refer to page 116.)

REMARKS

Refer to page 190 for bias/gain settings.

<Detailed operation>

The following table indicates the functional combinations of the No. 1, No. 2 and No. 3 terminals. Basically, the analog multiple functions are assigned to the No. 1 terminal alone and only one function may be selected for the multi-function analog input.

Control Method	No. 2 Terminal Speed Command/ Speed Restriction/ PID Set Point	No. 3 Terminal Torque Restriction/ Torque Command/ Torque Bias	No. 1 Terminal Multi-function	Remarks
Speed control	Speed command	No function (Pr. 810 = 0, Pr. 840=9999)	Speed auxiliary setting (Reversible operation also possible)	Factory-set status
		Torque restriction (Pr. 810 = 1)	Magnetic flux command	
			Speed auxiliary setting (Reversible operation also possible)	
		Torque bias (Pr. 810=0, Pr. 840=1,2,3)	Magnetic flux command	
Torque control	Speed restriction	Torque command	Speed restriction auxiliary input	
	No function		Forward/reverse rotation speed restriction (analog polarity switchover speed restriction)	Setting can be made when Pr. 807=2.
Position control	No function	No function (Pr. 810 = 0)	No function	
		Torque restriction (Pr. 810 = 1)	Magnetic flux command	
			No function	
			Magnetic flux command	
		Regenerative torque restriction	Setting can be made when Pr. 810=1.	

When the PID control function is selected, the No. 2 terminal is used for the PID set point. For PID control, refer to page 141.

When the torque bias function is selected, the No. 3 terminal is used for the torque bias input.

REMARKS

Magnetic flux command is a function used to command magnetic flux (strength of magnetic flux) from the external analog (No.1) terminal. In addition to torque command "No.3 terminal", the inverter can control torque using magnetic flux as a command. For example, the characteristic of motor torque is that output torque is constant independently of the output speed when exercising line feed/tension constant control on a winder, unwinder, etc. Constant output control by variable magnetic flux, equivalent to field excitation control of the DC shunt motor, can be exercised.

3.38 Protective functions (Pr. 870 to Pr. 874)

3.38.1 Speed deviation excessive (Pr. 870, Pr. 871 speed)

- If the difference (absolute value) between the speed command value and actual speed exceeds the Pr. 870 "speed deviation level" setting for longer than the time set in Pr. 871 "speed deviation time", speed deviation excessive occurs and error "E. OSD" appears, resulting in a stop.

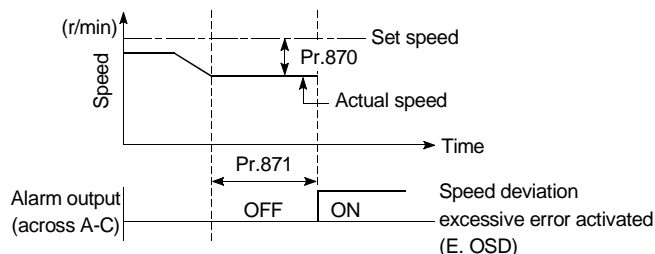

Parameter	Name	Factory Setting	Setting Range	Remarks
870	Speed deviation level	9999	0 to 1500r/min, 9999	9999:Invalid
871	Speed deviation time	12s	0 to 100s	-

REMARKS

1. Set these parameters when a speed difference will pose a problem.
2. This function is activated only under vector control.
3. When the motor with PLG is driven, setting the Pr. 851 "number of PLG pulses" value that is different from the actual number of PLG pulses may make control unstable, resulting in "E. OSD" (even if Pr. 870 = 9999).

3.38.2 Speed restriction (Pr. 873 speed)

This function prevents the motor from overrunning when the setting of number of PLG pulses and the actual number differ. When the setting of number of PLG pulses is smaller than the actual number, the motor may increase its speed. To prevent this, restrict the output speed with the synchronous speed obtained by adding the set speed and Pr.873 setting. (*)

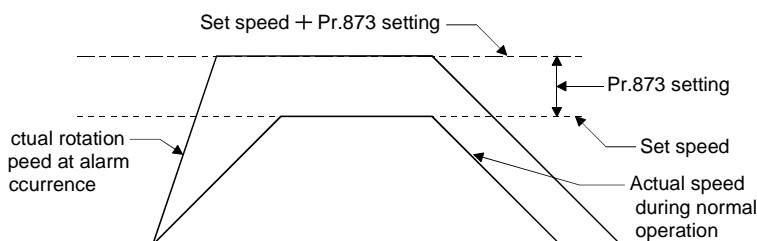

Parameter	Name	Factory Setting	Setting Range	Remarks
873	Speed restriction	600r/min	0 to 3600r/min	Extended mode

CAUTION

* When the setting of number of the PLG pulses is smaller than the actual number, selecting automatic restart after instantaneous power failure function (set a value other than "9999" in Pr. 57) restrict the output speed with the synchronous speed obtained by adding the maximum speed (Pr. 1) and Pr. 873 setting.

3.38.3 Stop by OLT level prevention (Pr. 874 speed position)

This function can make an alarm stop if the torque restriction is activated to stall the motor.

Parameter	Name	Factory Setting	Setting Range	Remarks
874	OLT level setting	150%	0 to 200%	Extended mode

(1) Speed control, position control

The motor stalls if the torque restriction is activated under a high load applied during speed control or position control. At this time, if the motor speed is lower than the speed set in Pr. 865 (low speed detection) and also the output torque exceeds the level set in Pr. 874 for 3s, it is regarded as a stop effected by stall prevention and E. OLT is output, resulting in an alarm stop.

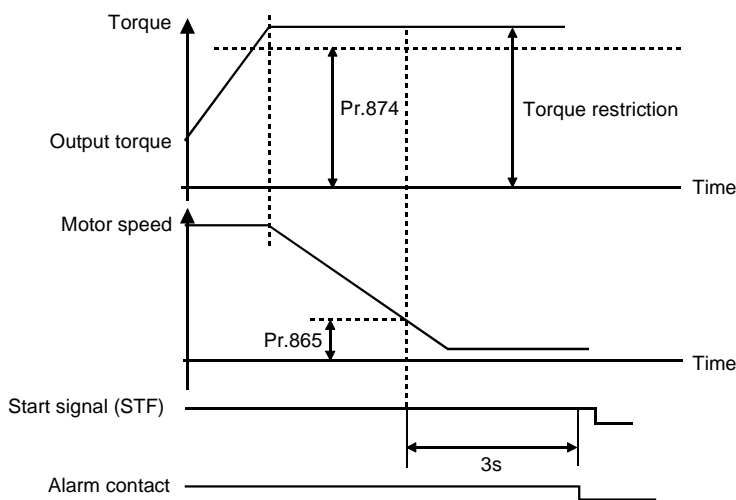

If torque restriction is activated and speed falls below Pr. 865 setting, OLT alarm does not occur when output torque at this time is lower than Pr. 874.

(2) V/F control

If the stall prevention function is activated and the output frequency is kept reduced to 0Hz for 3s, OLT will cause an alarm stop.

In this case, this function is activated regardless of Pr. 874.

(3) Torque control

This alarm is not activated.

Related parameters

- Low speed detection ⇒ Pr. 865 "low speed detection" (Refer to page 182.)

3.39 Operation selection functions 5 (Pr. 875)

3.39.1 Fault definition (Pr. 875 **speed** **torque**)

With the alarm definitions classified into major and minor faults, the base circuit is shut off immediately at occurrence of a major fault, or after deceleration to a stop at occurrence of a minor fault.

Parameter	Name	Factory Setting	Setting Range	Remarks
875	Fault definition	0	0, 1	Extended mode

1) Pr. 875 = 0: Normal operation

At occurrence of any alarm, the base circuit is shut off immediately. At this time, the alarm output also turns on.

2) Pr. 875 = 1: Fault definition

At occurrence of OHT or THM alarm, the motor is decelerated to a stop. At this time, minor fault output 2 (ER) signal turns on and the base circuit is shut off when the DC brake operation starts after deceleration.

When the ER signal turns on, the electronic thermal relay is activated and the inverter decelerates to a stop. Decrease load, etc. to allow the inverter to decelerate.

At occurrence of an alarm other than OHT or THM, the base circuit is shut off immediately.

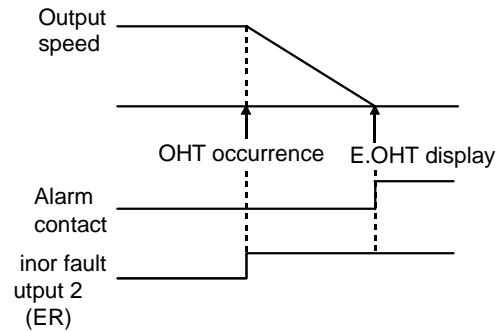

CAUTION

This function is invalid during position control.
The value "0" is recommended for the system in which the motor continues running without deceleration due to a large torque on the load side.

Pr.876 ➡ Refer to Pr.9 (page 85).

3.40 Control system function 2 (Pr. 877 to Pr. 881)

3.40.1 Speed feed forward control, model adaptive speed control

(Pr. 877 to Pr. 881 **speed** **position**)

By making parameter setting, select the speed feed forward control or model adaptive speed control.

The speed feed forward control enhances the trackability of the motor in response to a speed command change.

The model adaptive speed control enables individual adjustment of speed trackability and motor disturbance torque response.

Parameter	Name	Factory Setting	Setting Range
877	Speed feed forward control/model adaptive speed control selection	0	0, 1, 2
878	Speed feed forward filter	0s	0 to 1s
879	Speed feed forward torque restriction	150%	0 to 400%
880	Load inertia ratio	7	0, 1 to 200 times
881	Speed feed forward gain	0%	0 to 1000%

Refer to page 45 for details.

3.41 Maintenance function (Pr. 890 to Pr. 892)

3.41.1 Maintenance output function (Pr. 890 to Pr. 892 speed torque position)

When the cumulative operation time (Pr. 891 "maintenance output timer") of the inverter has elapsed the time set in Pr. 890 "maintenance output setting time", the maintenance output (MT) signal is output and an alarm is displayed on the PU (FR-DU04-1/FR-PU04V). A repetition signal output and alarm display at specified intervals can be set using Pr. 890 "maintenance output setting time". (usable for a capacitor life alarm, etc.)

Parameter	Name	Factory Setting	Setting Range	Remarks
890	Maintenance output setting time	9999	0 to 9998, 9999	9999: Function invalid
891	Maintenance output timer	0	0 to 9998	Extended mode
892	Maintenance output signal clear	0	0	

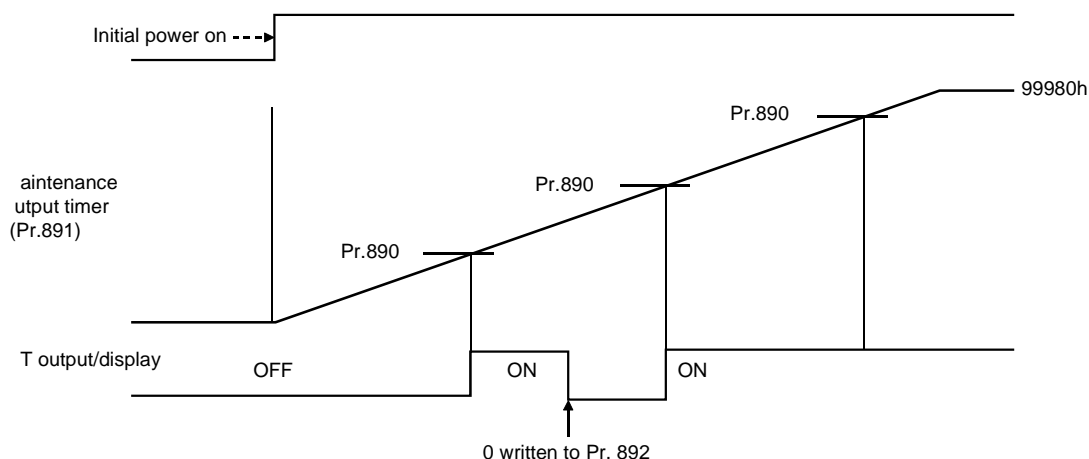

- The maintenance output timer count displayed on the FR-DU04-1 is clamped at 9998 (99980h).
- Writing 0 to Pr. 892 enables the maintenance (MT) output/display to be turned off. (This is designed to turn it off only when the user intends to turn it off.)
- When the Pr. 891 setting is less than the Pr. 890 value, the maintenance output turns off.

1) Pr. 891 "Maintenance output timer"

The cumulative operation time of the inverter is counted every 1hr and the stored time in E²PROM is output in 10hrs increment.

REMARKS

- The time is counted regardless of the Pr. 890 "maintenance output setting time" value.
- The timer can be cleared by setting "0" in Pr. 891 when Pr. 77="801". Make sure that the Pr. 77 value is reset to the original value.

2) Setting the MT signal

Set "37" (maintenance output signal) in Pr. 190 to Pr. 192 or Pr. 195 (output terminal function selection) to set the MT signal. (Refer to page 153)

3.42 Calibration functions (Pr. 900 to Pr. 920)

3.42.1 DA1/DA2 terminal calibration (Pr. 900, Pr. 901 speed torque position)

Pr. 900 "DA1 terminal calibration"

Pr. 901 "DA2 terminal calibration"

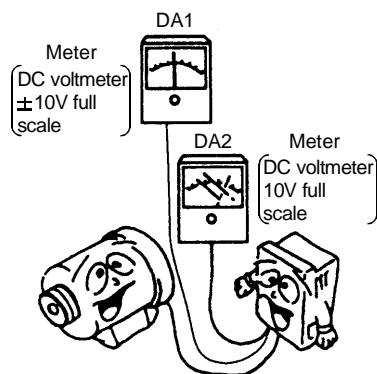

- When the item to be monitored is selected and set in Pr. 54 "DA1 terminal function selection" or Pr. 158 "DA2 terminal function selection", the inverter is factory-set to provide a 10VDC output in the full-scale status of the corresponding monitor item as described in the section of Pr. 54 and Pr. 158. These parameters allow the output voltage ratios (gains) to be adjusted according to the meter scale. Note that the maximum output voltage is 10VDC. (Terminal DA1 can also provide a -10VDC output.) (Refer to page 101 for Pr. 54 and Pr. 158.)

CAUTION
DA1 and DA2 output voltage even at an alarm stop.

(1) Calibration of DA1 terminal

- 1) Connect a meter (speed meter) across inverter terminals DA1-5. (Note the polarity. DA1 is positive.)
- 2) When a calibration resistor has already been connected, adjust the resistance to "0" or remove the resistor.
- 3) Set any of "1 to 3, 5 to 12, 17, 18, 21, 32 to 34 and 36" in Pr. 54.
When the speed, inverter output current etc. has been selected as the output signal, preset in Pr. 55, Pr. 56 or Pr. 866 the speed, current value or torque at which the output signal is 1500r/min.
At this 1500r/min or rated current, the meter is normally deflected to full scale.
- 4) When outputting the item that cannot achieve a 100% value easily by operation, e.g. output current, set "21" (reference voltage output) in Pr. 158 and perform the following operation. After that, set "2" (output current, for example) in Pr. 158.

(2) Calibration of terminal DA2

- 1) Connect a 0-10VDC meter (speed meter) to across inverter terminals DA2-5. (Note the polarity. DA2 is positive.)
- 2) Set any of "1 to 3, 5 to 12, 17, 18, 21, 32 to 34, 36" in Pr. 158.
When the speed, inverter output current or the like has been selected as the output signal, preset in Pr. 55, Pr. 56 or Pr. 866 the speed, current value or torque at which the output signal is 10V.
- 3) When outputting the item that cannot achieve a 100% value easily by operation, e.g. output current, set "21" (reference voltage output) in Pr. 158 and perform the following operation. After that, set "2" (output current, for example) in Pr. 158.

<Operation procedure>

- When operation panel (FR-DU04-1) is used

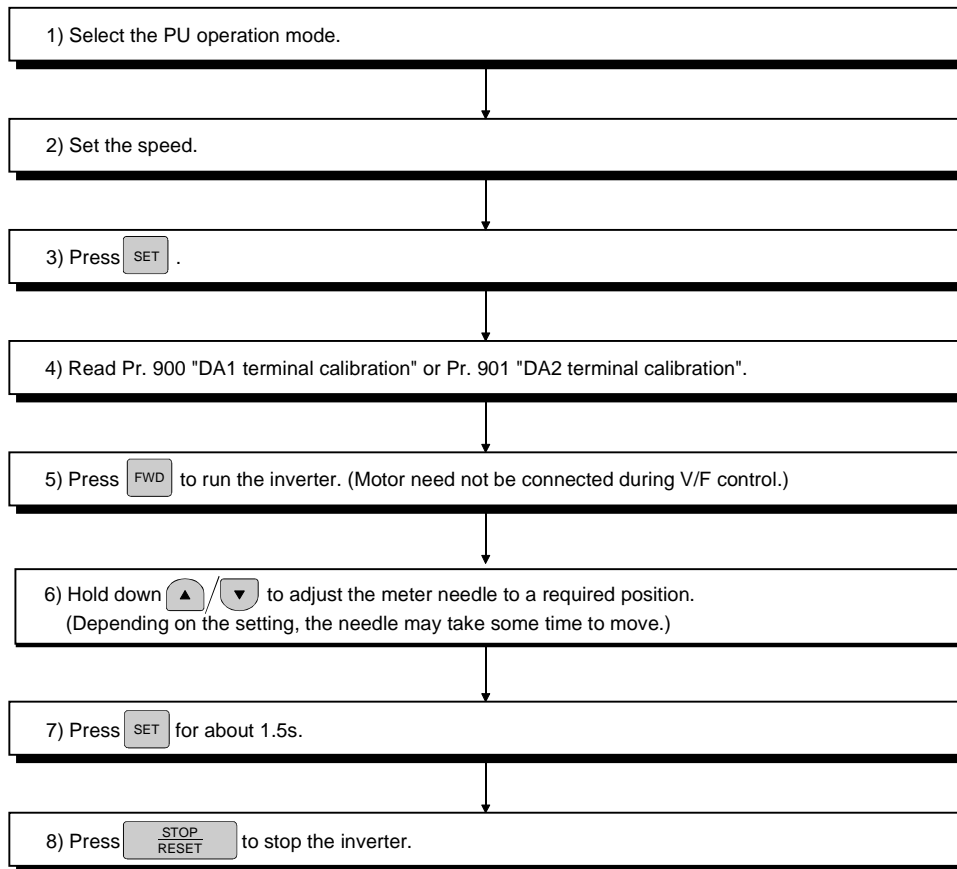

REMARKS

Calibration can also be made for external operation. Set the speed in the external operation mode and make calibration as in steps 4) to 8).

CAUTION

1. Calibration can be made even during operation.
2. Refer to the FR-PU04V instruction manual for the operation procedure using the parameter unit (FR-PU04V).

Related parameters

- Pr. 54 "DA1 terminal function selection" (Refer to page 101.)
- Pr. 55 "speed monitoring reference" (Refer to page 104.)
- Pr. 56 "current monitoring reference" (Refer to page 104.)
- Pr. 158 "DA2 terminal function selection" (Refer to page 101.)

3.42.2 Biases and gains of speed setting terminals
(speed setting No. 2, torque command No.3, multi function No. 1 terminal)

(Pr. 902 to Pr. 905, Pr. 917 to Pr. 920 speed torque position)

The "bias" and "gain" functions are designed to adjust the relationships between the externally input 0-10V setting input signal and output speed to set the output speed.

- Using Pr. 902, set the bias speed at 0V.

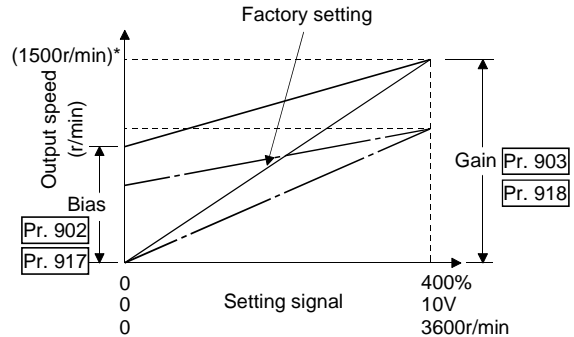
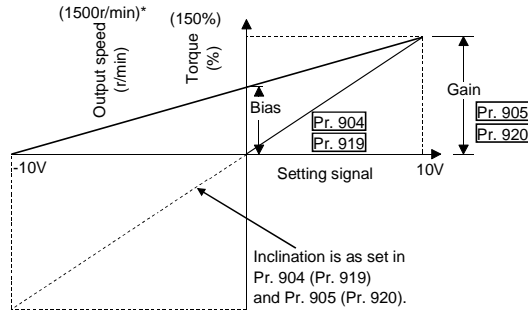

*: The output speed is 1800r/min for the NA version.

Parameter	Name	Factory Setting	Setting Range	Remarks
902	Speed setting No. 2 bias	0V	0r/min	Extended mode
903	Speed setting No. 2 gain	10V	Japanese version: 1500r/min NA version: 1800r/min	
904	Torque command No. 3 bias	0V	0%	
905	Torque command No. 3 gain	10V	150%	
917	No. 1 terminal bias (speed)	0V	0r/min	
918	No. 1 terminal gain (speed)	10V	Japanese version: 1500r/min NA version: 1800r/min	
919	No. 1 terminal bias (torque/magnetic flux)	0V	0%	
920	No. 1 terminal gain (torque/magnetic flux)	10V	150%	

Parameter	Calibration Terminal	Speed Command/Speed Restriction (Pr. 807, Pr. 868, Pr. 73)			Forward/Reverse Rotation-Speed Restriction	Torque			Magnetic Flux	PID Control		
		Speed (main speed+auxiliary)	Compensation input	Override		Magnetic flux command	Torque restriction (Pr. 810)	Torque command (Pr. 804)		Torque bias (Pr. 840)	Deviation	Set point
902	No. 2 terminal (+No. 1 terminal)	●	●	● (No. 1 terminal)								
903												
904	No. 3 terminal					●	●	●				
905												
917	No. 1 terminal				● (Pr. 868)					●		●
918												
919												
920						● (regenerative torque restriction (Pr. 868))				● (Pr. 868)		

<Setting>

There are three methods to adjust the speed setting voltage bias and gain.

- 1) Method to adjust any point by application of voltage to across terminals 2-5
- 2) Method to adjust any point without application of voltage to across terminals 2-5
- 3) Method that does not adjust the bias voltage

Pr. 903 "speed setting No. 2 gain"

(You can also adjust Pr. 902 to Pr. 905 and Pr. 917 to Pr. 920 in the similar manner.)

<Adjustment procedure> Using the speed setting signal from the operation panel (FR-DU04-1) to make speed setting

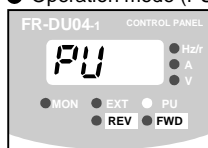
<p>(1) Power on (Monitoring mode)</p> 	<p>(2) Choose the PU operation mode.</p> <p>1. Press MODE to make sure that the inverter is in the PU operation mode. (For monitoring displays, refer to the Instruction Manual (basic).)</p> <p>● Operation mode (PU operation mode)</p> 
---	---

2. Set "1" (PU operation mode) in Pr. 79 "operation mode selection".
 Example: To change the external operation mode (Pr. 79 = 2) to the PU operation mode (Pr. 79 = 1)

As in the procedure in 1), press **MODE** to choose the "parameter setting mode".

● Parameter setting mode

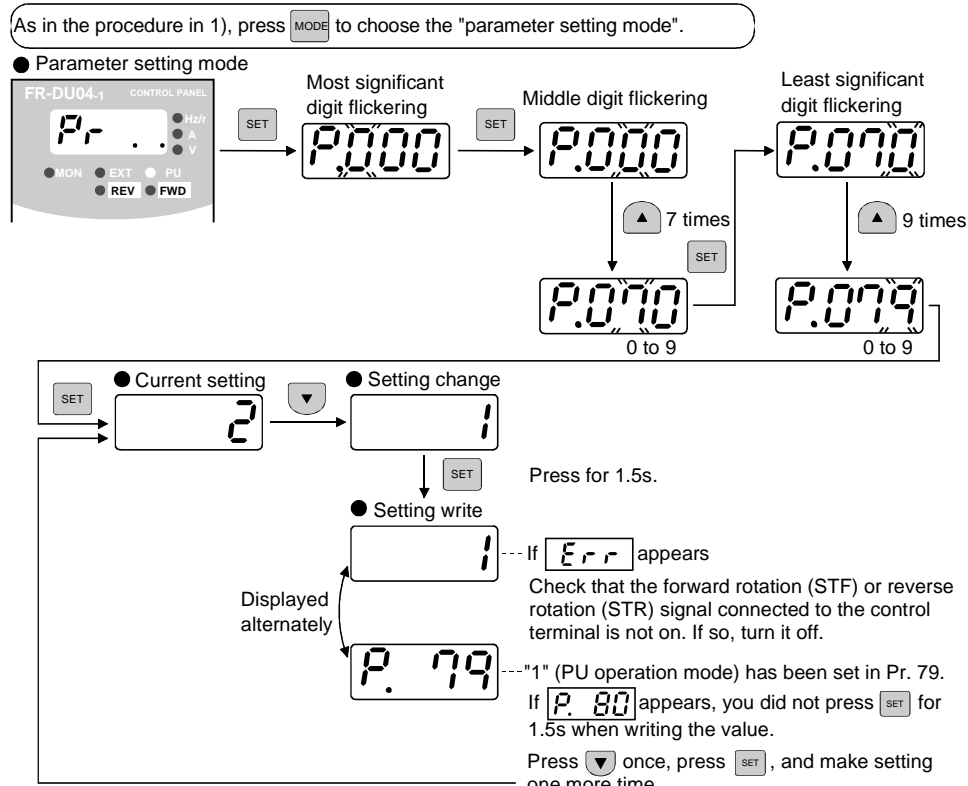

● Current setting

● Setting change

● Setting write

Displayed alternately

If **Err** appears
 Check that the forward rotation (STF) or reverse rotation (STR) signal connected to the control terminal is not on. If so, turn it off.

If "1" (PU operation mode) has been set in Pr. 79.
 If **P. 80** appears, you did not press **SET** for 1.5s when writing the value.
 Press **▼** once, press **SET**, and make setting one more time.

(3) Read Pr. 903 to display the currently set gain speed. (You can also adjust Pr. 902, Pr. 904 and Pr. 905 in a similar manner.)

● Parameter setting mode

As in the procedure in (2)-1), press **MODE** to choose the "parameter setting mode".

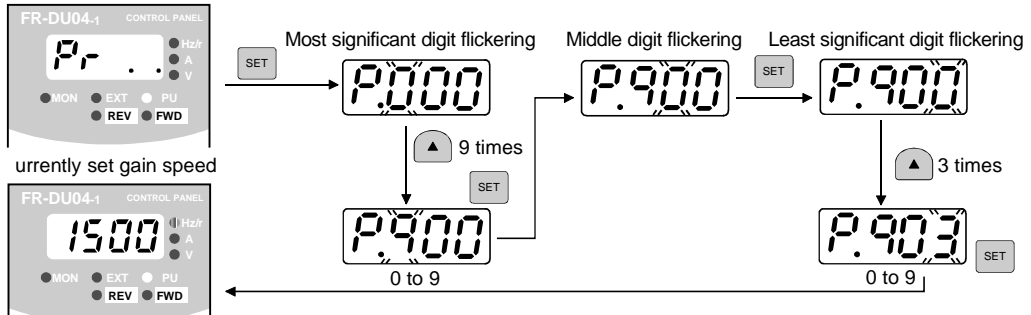

currently set gain speed

(4) Set the gain speed in Pr. 903 and display the analog voltage A/D value across terminals 2-5 in %.
(To change to 1000r/min)

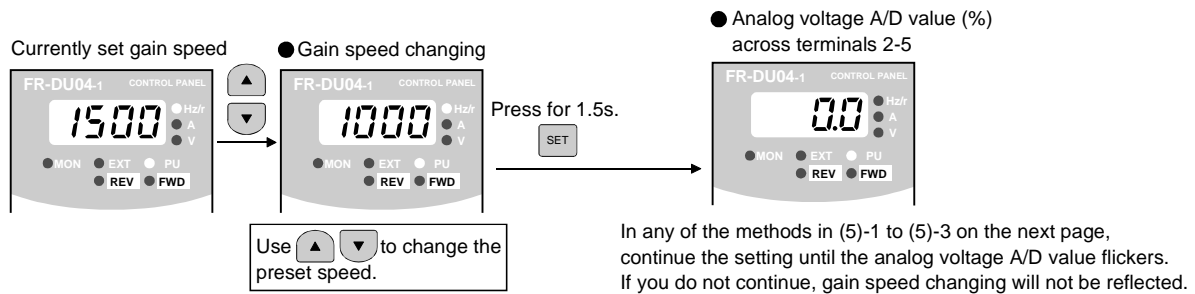

- (1) When not adjusting the gain voltage To (5)-1
- (2) When adjusting any point by application of voltage To (5)-2
- (3) When adjusting any point without application of voltage To (5)-3

(5)-1 Method to adjust only the gain speed and not to adjust the voltage

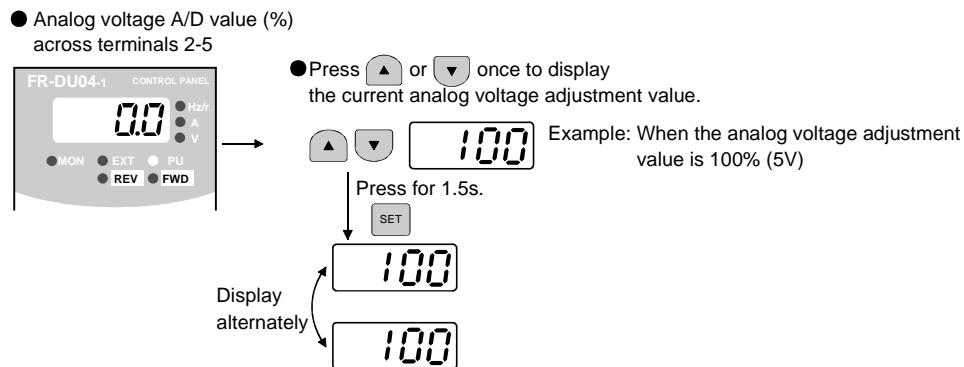

(5)-2 Method to adjust any point by application of voltage to across terminals 2-5 (e.g. from external potentiometer)(Current: across terminals 4-5) (when 5V is applied)

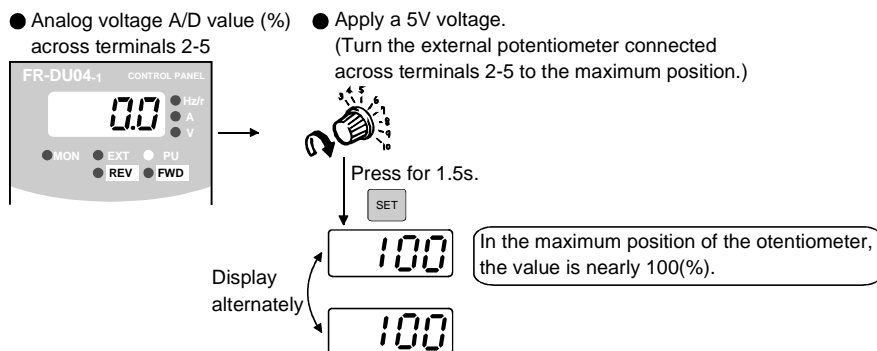

(5)-3 Method to adjust any point without application of voltage to across terminals 2-5
(To change from 4V (80%) to 5V (100%))

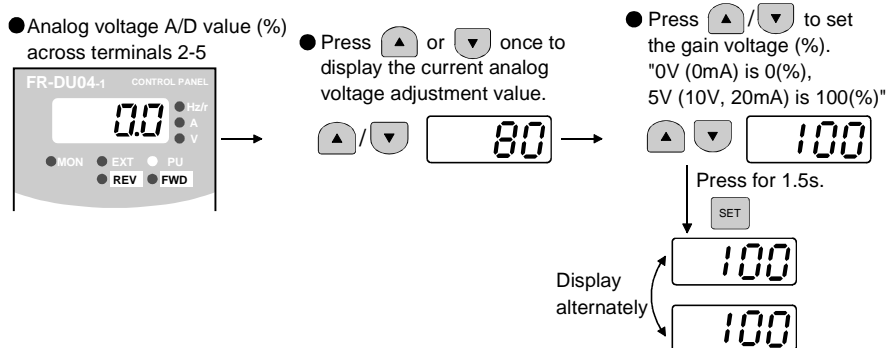

(6) Pressing the **SET** key shifts to the next parameter.

(7) Re-set the Pr. 79 "operation mode selection" value according to the operation mode being used.

CAUTION

1. Changing the Pr. 903 or Pr. 905 (gain adjustment) value will not change the Pr. 20 value. The input of terminal 1 (speed setting auxiliary input) is added to the speed setting signal.
2. For the operation procedure using the parameter unit (FR-PU04V), refer to the FR-PU04V instruction manual.

⚠ CAUTION

⚠ Take care when setting any value other than "0" as the bias speed at 0V. If a speed command is not given, merely turning on the start signal will start the motor at the preset speed.

Related parameters

- Pr. 20 "acceleration/deceleration reference speed" (Refer to page 83.)
- Pr. 79 "operation mode selection" (Refer to page 120.)

● **Analog input offset adjustment**

When speed command by analog input is set, the range where the motor remains stop is created to prevent malfunction at very slow speed.

Parameter	Name	Factory setting	Setting Range	Remarks
849	Analog input offset adjustment	100%	0 to 200%	Pr. 77=801

Setting Pr. 849 provides speed command by analog input (No. 2 terminal or No. 6 terminal (FR-V5AX)) with offset and avoids speed command to be given due to noise under 0 speed command.

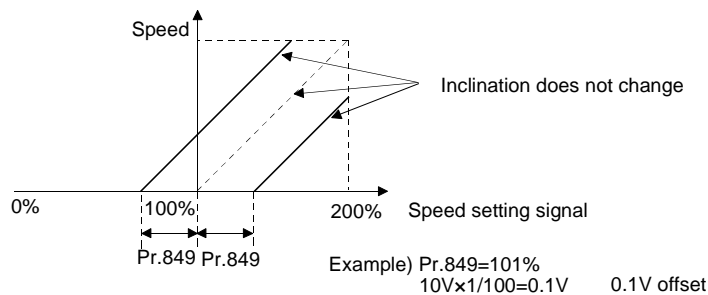

3.43 Additional function (Pr. 990)

3.43.1 Buzzer control (Pr. 990 speed torque position)

You can make the buzzer "beep" when you press any key of the operation panel or parameter unit.

Parameter	Name	Factory Setting	Setting Range	Remarks
990	Buzzer control	1	0, 1	0: Without beep, 1: With beep Extended mode

MEMO

4

SPECIFICATIONS

This chapter explains the "specifications" for use of this product. Always read this instructions before use.

4.1	Model specifications	196
4.2	Common specifications.....	198
4.3	Outline dimension drawings	199

4.1 Model specifications

● 200V class (for use with the Mitsubishi dedicated motor [SF-V5R (1500r/min series)])

Type	FR-V520-□□□K-NA	1.5	2.2	3.7	5.5	7.5	11	15	18.5	22	30	37	45	55		
Inverter	Applied motor capacity (kW (HP))	1.5 (2)	2.2 (3)	3.7 (5)	5.5 (7.5)	7.5 (10)	11 (15)	15 (20)	18.5 (25)	22 (30)	30 (40)	37 (50)	45 (60)	55 (75)		
	Rated capacity (kVA) (Caution 1)	3.1	4.5	6.9	9.8	13.0	18.7	25.2	30.4	35.8	43.8	58.1	68.5	91.0		
	Rated current (A)	9.0	13.0	20.0	28.5	37.5	54	72.8	88	103.5	126.5	168	198	264		
	Overload current rating (Caution 2)	150% 60s, 200% 0.5s (inverse-time characteristics)														
	Output	Voltage Three-phase, 200V to 220V 50Hz, 200 to 240V 60Hz Three-phase, 200 to 220V 50Hz, 200 to 230V 60Hz														
	Regenerative braking torque	Maximum value/permissible duty	100% torque/3%ED (Caution 3) (Caution 7)				100% torque/2%ED (Caution 3) (Caution 7)		20% torque/continuous (Caution 7)							
	Power supply	Rated input AC voltage, frequency	Three-phase, 200V to 220V 50Hz, 200 to 240V 60Hz							Three-phase, 200 to 220V 50Hz, 200 to 230V 60Hz						
		Permissible AC voltage fluctuation	170 to 242V 50Hz, 170 to 264V 60Hz							170 to 242V 50Hz, 170 to 253V 60Hz						
		Permissible frequency fluctuation	±5%													
		Instantaneous voltage drop immunity	Operation continues at 165V or higher voltage. If the rated voltage drops to lower than 165V, 15ms operation continues.													
Power supply capacity (kVA) (Caution 4)		5.0	6.5	10	14	19	23	33	39	48	57	77	90	123		
Protective structure (JEM 1030)	Enclosed type (IP20 NEMA1) (Caution 5)							Open type (IP00)								
Cooling system	Forced air cooling															
Approx. weight (kg (lbs))	3.5 (7.7)	3.5 (7.7)	6.0 (13.2)	6.0 (13.2)	6.0 (13.2)	14.0 (30.9)	14.0 (30.9)	21.0 (46.3)	30.0 (66.1)	40.0 (88.2)	40.0 (88.2)	55.0 (121.3)	58.0 (128.9)			
Mitsubishi dedicated motor	Motor type	SF-V5R1K	SF-V5R2K	SF-V5R3K	SF-V5R5K	SF-V5R7K	SF-V5R11K	SF-V5R15K	SF-V5R18K	SF-V5R22K	SF-V5R30K	SF-V5R37K	SF-V5R45K	SF-V5R55K		
	Rated output (kW (HP))	1.5 (2)	2.2 (3)	3.7 (5)	5.5 (7.5)	7.5 (10)	11 (15)	15 (20)	18.5 (25)	22 (30)	30 (40)	37 (50)	45 (60)	55 (75)		
	Rated torque (N·m)	9.55	14.1	23.6	35.0	47.7	70.0	95.5	118	140	191	235	286	350		
	Maximum torque 150% 60s (N·m)	14.3	21.1	35.4	52.4	71.6	105	143	176	211	287	353	429	525		
	Rated speed (r/min)	1500														
	Maximum speed (r/min)	3000 (Caution 6)													2400	
	Frame No.	90L	100L	112M	132S	132M	160M	160L	180M	180M	200L	200L	200L	225S		
	Inertia moment J (X10 ⁻⁴ kg·m ²)	67.5	105	175	275	400	750	875	1725	1875	3250	3625	3625	6850		
	Cooling fan	Voltage	Single-phase 200V/50Hz Single-phase 200V/60Hz (Caution 9)			Single-phase 200V/50Hz Single-phase 200 to 230V/60Hz		Three-phase 200V/50Hz Three-phase 200 to 230V/60Hz						Three-phase 200V/50Hz Three-phase 200V/60Hz		
		Input (50Hz/ 60Hz)	36/31W (0.26/0.22A)			34/28W (0.17/0.13A)		55/71W (0.39/0.39A)			100/156W (0.47/0.53A)			85/ 130W (0.46/ 0.52A)		
	Ambient temperature, humidity	-10 to +40°C (14°F to 104°F) (non-freezing), 90%RH or less (non-condensing)														
	Structure	Totally enclosed forced draft system														
	Detector	PLG 2048P/R, A phase, B phase, Z phase +12VDC power supply														
	Equipment	PLG, thermal protector, fan														
	Insulation	Class F														
Vibration rank	V10															
Approx. weight (kg (lbs))	24 (52.8)	33 (72.6)	41 (90.2)	52 (114.4)	62 (136.4)	99 (217.8)	113 (248.6)	138 (303.6)	160 (352)	238 (523.6)	255 (561)	255 (561)	320 (704)			
Mitsubishi dedicated PLG cable	Resolution	2048 pulse/rev														
	Power supply voltage	12VDC±10%														
	Current consumption	90mA														
	Output signal form	A, B phases (90° phase shift) Z phase: 1 pulse/rev														
	Output circuit	Complimentary (constant voltage output matched by emitter follow)														
Output voltage	"H" level: Power supply voltage 9V or more (Ioh: -20mA), "L" level: Power supply voltage 3V or less (Iol: 20mA)															

CAUTION

- The rated output capacity indicated assumes that the output voltage is 200V.
- The overload current rating indicated in % is the ratio of the overload current to the rated output current of the inverter. For repeated duty, allow time for the inverter and motor to return to or below the temperatures under 100% load.
- The short-time rating is 5s.
- The power supply capacity varies with the value of the power supply side inverter impedance (including those of the input reactor and cables).
- Open type (IP00) when the plug-in option is fitted after removal of the option wiring port cover.
- You can run the 3.7kW (5HP) or less Mitsubishi dedicated motor at the maximum speed of 3600r/min, consult us when you want to run the motor at higher than 3000r/min.
- For the 1.5K to 15K capacities, using the optional high-duty brake resistor (FR-ABR) will achieve the performance of 100% torque/10%ED.
- If the motor is one rank lower in capacity than the inverter, it can be used by setting Pr. 80 "motor capacity" and Pr. 81 "number of motor poles". Other manufacturers' motors and special motors can be used by performing online auto tuning.
- The power supply fluctuation range is 200V ±10%.

● 400V class (for use with the Mitsubishi dedicated motor [SF-V5RH (1500r/min series)])

Type FR-V540-□□□K-NA		1.5	2.2	3.7	5.5	7.5	11	15	18.5	22	30	37	45	55		
Inverter	Applied motor capacity (kW (HP))	1.5 (2)	2.2 (3)	3.7 (5)	5.5 (7.5)	7.5 (10)	11 (15)	15 (20)	18.5 (25)	22 (30)	30 (40)	37 (50)	45 (60)	55 (75)		
	Output	Rated capacity (kVA) (Caution 1)	3.1	4.5	6.9	10.0	12.8	19.0	24.6	30.4	35.8	46.3	59.5	68.5	91.0	
		Rated current (A)	4.5	6.5	10.0	14.5	18.5	27.5	35.5	44	51.8	67	86	99	132	
		Overload current rating (Caution 2)	150% 60s, 200% 0.5s (inverse-time characteristics)													
	Voltage		Three-phase, 380 to 480V 50Hz/60Hz													
	Regenerative braking torque	Max. value/permissible duty	100% torque/2%ED (Caution 3) (Caution 7)							20% torque/continuous (Caution 7)						
	Rated input AC voltage, frequency		Three-phase, 380V to 480V 50Hz/60Hz													
	Permissible AC voltage fluctuation		323 to 528V 50Hz/60Hz													
	Permissible frequency fluctuation		±5%													
Instantaneous voltage drop immunity		Operation continues at 330V or higher voltage. If the rated voltage drops to lower than 330V, 15ms operation continues.														
Power supply capacity (kVA) (Caution 4)		5.0	6.5	10	14	19	23	33	39	48	57	77	90	123		
Protective structure (JEM 1030)		Enclosed type (IP20 NEMA1) (Caution 5)							Open type (IP00)							
Cooling system		Forced air cooling														
Approx. weight (kg (lbs))		3.5 (7.7)	3.5 (7.7)	6.0 (13.2)	6.0 (13.2)	14.0 (30.9)	14.0 (30.9)	14.0 (30.9)	14.0 (30.9)	24.0 (52.8)	35.0 (77.0)	35.0 (77.0)	50.0 (110)	52.0 (114)		
Mitsubishi dedicated motor	Motor type	SF-V5RH1K	SF-V5RH2K	SF-V5RH3K	SF-V5RH5K	SF-V5RH7K	SF-V5RH11K	SF-V5RH15K	SF-V5RH18K	SF-V5RH22K	SF-V5RH30K	SF-V5RH37K	SF-V5RH45K	SF-V5RH55K		
	Rated output (kW (HP))	1.5 (2)	2.2 (3)	3.7 (5)	5.5 (7.5)	7.5 (10)	11 (15)	15 (20)	18.5 (25)	22 (30)	30 (40)	37 (50)	45 (60)	55 (75)		
	Rated torque (N·m)	9.55	14.1	23.6	35.0	47.7	70.0	95.5	118	140	191	235	286	350		
	Maximum torque 150% 60s (N·m)	14.3	21.1	35.4	52.4	71.6	105	143	176	211	287	353	429	525		
	Rated speed (r/min)	1500														
	Maximum speed (r/min)	3000 (Caution 6)													2400	
	Frame No.	90L	100L	112M	132S	132M	160M	160L	180M	180M	200L	200L	200L	200L	225S	
	Inertia moment J (X10 ⁻⁴ kg·m ²)	67.5	105	175	275	400	750	875	1725	1875	3250	3625	3625	6850		
	Cooling fan	Voltage	Single-phase 200V/50Hz Single-phase 200V/60Hz (Caution 9)			Single-phase 200V/50Hz Single-phase 200 to 230V/60Hz			Three-phase 400V/50Hz Three-phase 400 to 460V/60Hz							
		Input (50Hz/60Hz)	36/31W(0.26/0.22A)			34/28W (0.17/0.13A)			55/73W (0.19/0.19A)			100/156W (0.27/0.3A)			85/130W (0.23/0.26A)	
	Ambient temperature, humidity	-10 to +40°C (14°F to 104°F) (non-freezing), 90%RH or less (non-condensing)														
	Structure	Totally enclosed forced draft system														
	Detector	PLG 2048P/R, A phase, B phase, Z phase +12VDC power supply														
	Equipment	PLG, thermal protector, fan														
	Insulation	Class F														
Vibration rank	V10															
Approx. weight (kg (lbs))	24 (52.8)	33 (72.6)	41 (90.2)	52 (114.4)	62 (136.4)	99 (217.8)	113 (248.6)	138 (303.6)	160 (352)	238 (523.6)	255 (561)	255 (561)	320 (704)			
Mitsubishi dedicated PLC cable	Resolution	2048 pulse/rev														
	Power supply voltage	12VDC±10%														
	Current consumption	90mA														
	Output signal form	A, B phases (90° phase shift) Z phase: 1 pulse/rev														
	Output circuit	Complimentary (constant voltage output matched by emitter follow)														
Output voltage	"H" level: Power supply voltage 9V or more (Ioh: -20mA), "L" level: Power supply voltage 3V or less (Iol: 20mA)															

CAUTION

1. The rated output capacity indicated assumes that the output voltage is 400V.
2. The overload current rating indicated in % is the ratio of the overload current to the rated output current of the inverter. For repeated duty, allow time for the inverter and motor to return to or below the temperatures under 100% load.
3. The short-time rating is 5s.
4. The power supply capacity varies with the value of the power supply side inverter impedance (including those of the input reactor and cables).
5. Open type (IP00) when the plug-in option is fitted after removal of the option wiring port cover.
6. You can run the 3.7kW (5HP) or less Mitsubishi dedicated motor at the maximum speed of 3600r/min, consult us when you want to run the motor at higher than 3000r/min.
7. For the 1.5K to 15K capacities, using the optional high-duty brake resistor (FR-ABR-H) will achieve the performance of 100% torque/10%ED.
8. If the motor is one rank lower in capacity than the inverter, it can be used by setting Pr. 80 "motor capacity" and Pr. 81 "number of motor poles". Other manufacturers' motors and special motors can be used by performing online auto tuning.
9. The power supply fluctuation range is 200V ±10%.

4.2 Common specifications

Inverter	Control system		Soft-PWM control or high carrier frequency sine-wave PWM control can be selected. Vector control, or V/F control can be selected.			
	Control mode		Speed control, torque control, position control			
	Speed setting resolution	Analog input	0.03% of the maximum set speed			
		Digital input	0.003% to the maximum setting (minimum setting 0.1r/min)			
	Acceleration/deceleration time		0 to 3600 s (0.1 s increments)			
	Acceleration/deceleration pattern		Linear, S pattern (3 types) or backlash compensation acceleration/deceleration can be selected.			
	Torque restriction level		Torque restriction value can be set (0 to 400% variable)			
	Input signals	Analog setting signal	Terminal No.	Setting Range	Speed Control	Torque Control
			2	0 to 10V (resolution 0.03%)	Main speed setting	Speed restriction
			1	0 to ±10V (resolution 0.05%)	Auxiliary speed setting/magnetic flux command/regenerative torque restriction	Speed restriction compensation/magnetic flux command/forward/reverse rotation speed restriction (analog polarity switchover speed restriction)
		3	0 to ±10V (resolution 0.05%)	Torque restriction/Torque bias	Torque command	
		Option (FR-V5AX)	6	0 to ±10V (resolution 0.003%)	Main speed setting (at this time, terminal 2 is invalid)/torque restriction	Speed restriction (at this time, terminal 2 is invalid)/Torque command (at this time, terminal 3 is invalid)
	Contact signal	3 fixed function terminals		Forward rotation command, alarm reset, external thermal relay		
		5 function terminals		Selection can be made from reverse rotation command, multi-speed setting (max. 15 speeds), remote setting, jog operation (Caution 1), second function selection, third function selection, output stop, start signal self-holding, pre-excitation, control mode switchover, torque restriction selection, S pattern switchover, PID control terminal, orientation command, break opening completion signal, PU operation/external operation switchover, torque bias selection 1, torque bias selection 2, P control selection, servo on, HC connection, and PU/external interlock.		
	Option (FR-V5AX)	6 multi-function terminals				
		1 changeover contact (230VAC 0.3A, 30VDC 0.3A)		Selection can be made from inverter running, inverter running 2, up to speed, instantaneous power failure (undervoltage), speed detection, second speed detection, third speed detection, PU operation mode, overload alarm, regenerative brake prealarm, electronic thermal relay prealarm, output current detection, zero current detection, PID lower limit, PID upper limit, PID forward/reverse rotation output, operation ready, operation ready 2, brake opening request, fan fault output, heatsink overheat prealarm, orientation in-position, forward rotation output, reverse rotation output, low speed output, torque detection, regenerative status output, minor fault output, minor fault output 2, alarm output, maintenance timer output, remote output, output speed detection, second (third) output speed detection, in-position and trace status.		
	Output signals	Open collector signal		3 multi-function terminals		
		Option (FR-V5AY)		3 multi-function terminals		
		Option (FR-V5AM)		1 multi-function terminal		
		Option (FR-A5AY)		7 multi-function terminals		
Analog output		0 to ±10V 12 bits x1CH 0 to 10V 12 bits x1CH		Selection can be made from speed, output current, output voltage, preset speed, output frequency, motor torque, converter output voltage, regenerative brake duty, electronic overcurrent protection load factor, output current peak value, converter output voltage peak value, input terminal status (Caution 4), load meter, motor exciting current, position pulse, cumulative operation time, actual operation time, motor load factor, torque command, torque current command, feedback pulse, motor output, trace status.		
Option (FR-A5AY)		0 to 10V 10 bits x 1CH 0 to 20mA 10 bits x 1CH		Selection can be made from speed, output current, output voltage, preset speed, output frequency, motor torque, converter output voltage, regenerative brake duty, electronic overcurrent protection load factor, output current peak value, converter output voltage peak value, input terminal status (Caution 4), load meter, motor exciting current, position pulse, cumulative operation time, actual operation time, motor load factor, torque command, torque current command, feedback pulse, motor output, trace status.		
PLG pulse output option (FR-V5AY)		A phase, B phase, Z phase (A and B phases can be divided) Open collector/differential line driver.				
Operational functions		Maximum/minimum speed setting, speed jump, external thermal relay input selection, polarity reversible operation, override function, automatic restart operation after instantaneous power failure, forward/reverse rotation prevention, operation mode selection, offline auto tuning function, online auto tuning function, easy gain tuning, computer link operation, remote setting, brake sequence, second function, third function, multi-speed operation, coasting to stop, power failure stop, PID control, speed feed forward, model adaptive speed control, master/slave, torque bias, 12-bit digital command (FR-A5AX option), 16-bit digital command (FR-A5AH option), pulse train input (FR-A5AP option), motor thermistor interface (FR-V5AX option)				
Display	Parameter unit (FR-DU04-1/FR-PU04V)		Selection can be made from speed, output current, output voltage, preset speed, output frequency, motor torque, converter output voltage, regenerative brake duty, electronic overcurrent protection load factor, output current peak value, converter output voltage peak value, input terminal status (Caution 4), output terminal status (Caution 4), load meter, motor exciting current, position pulse, cumulative operation time, actual operation time, motor load factor, torque command, torque current command, feedback pulse, motor output, trace status.			
	Alarm definition		Alarm definition is displayed when protective function is activated. 8 past alarm definitions are stored. (Only 4 alarm definitions are displayed on the operation panel.)			
Protective functions		Overcurrent shut-off (acceleration, deceleration, constant speed), regenerative overvoltage shut-off (acceleration, deceleration, constant speed), undervoltage, instantaneous power failure, overload shut-off (electronic thermal relay), brake transistor alarm (Caution 2), earth (ground) fault current, power output short circuit (12/24VDC/operation panel), stall prevention, external thermal relay, heatsink overheat, fan fault, option alarm, parameter error, PU disconnection, encoder no-signal, speed deviation large, overspeed, position error large, CPU error, encoder phase error, output phase failure, retry count excess, brake sequence error				
Environment	Ambient temperature		-10C to +50°C (14°F to 122°F) (non-freezing)			
	Ambient humidity		90%RH or less (non-condensing)			
	Storage temperature (Caution 3)		-20 to +65°C (-4°F to 149°F)			
	Atmosphere		Indoor use. (No corrosive gas, flammable gas, oil mist, dust and dirt)			
Altitude, vibration		Maximum 1,000m (3280.80feet) above sea level, 5.9m/s ² or less (compliant with JIS C 0040)				

CAUTION

- Jog operation may also be performed from the operation panel (FR-DU04-1) or the parameter unit (FR-PU04V).
- Not provided for the FR-V520-18.5K to 55K, FR-V540-18.5K to 55K that do not have a built-in brake circuit.
- Temperature applicable for a short period in transit, etc.
- Not provided for the operation panel (FR-DU04-1).

4.3 Outline dimension drawings

4.3.1 Inverter outline dimension drawings

- FR-V520-1.5K, 2.2K
- FR-V540-1.5K, 2.2K

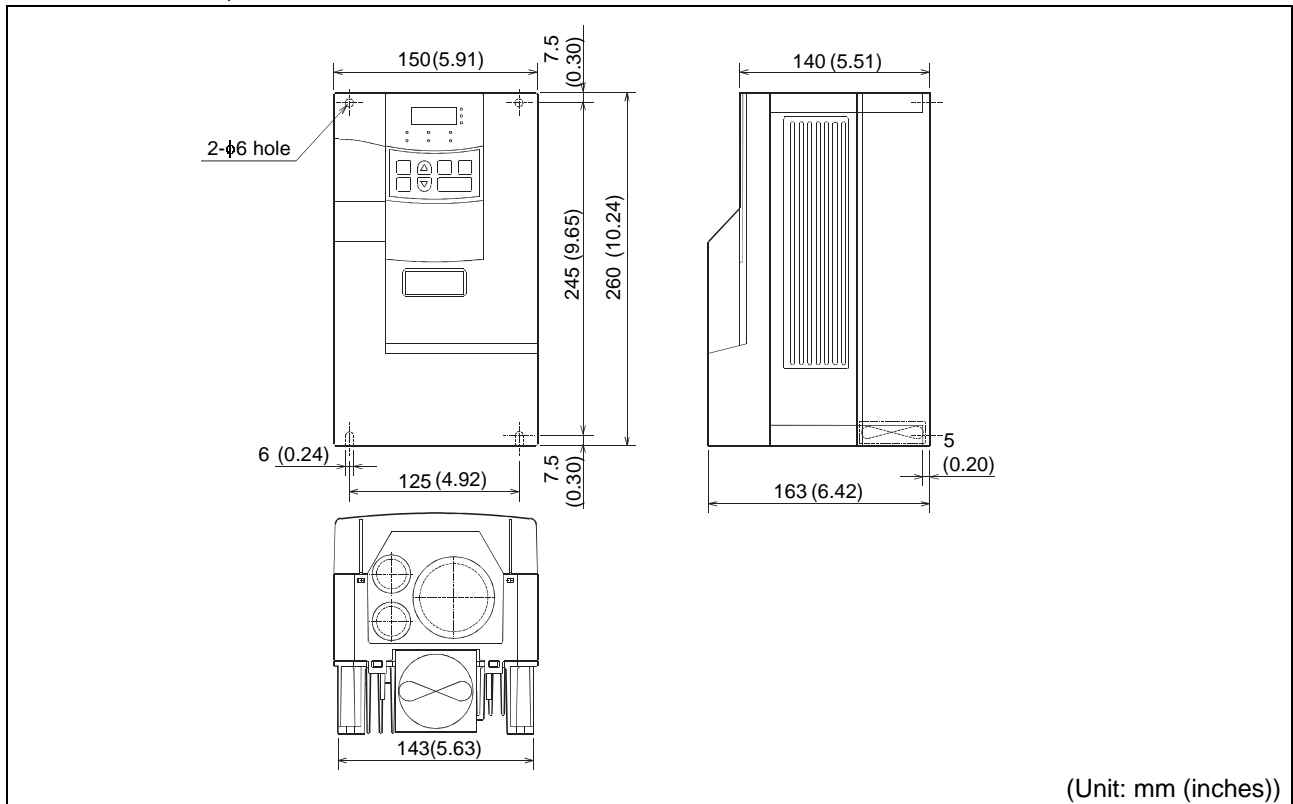

- FR-V520-3.7K, 5.5K, 7.5K
- FR-V540-3.7K, 5.5K

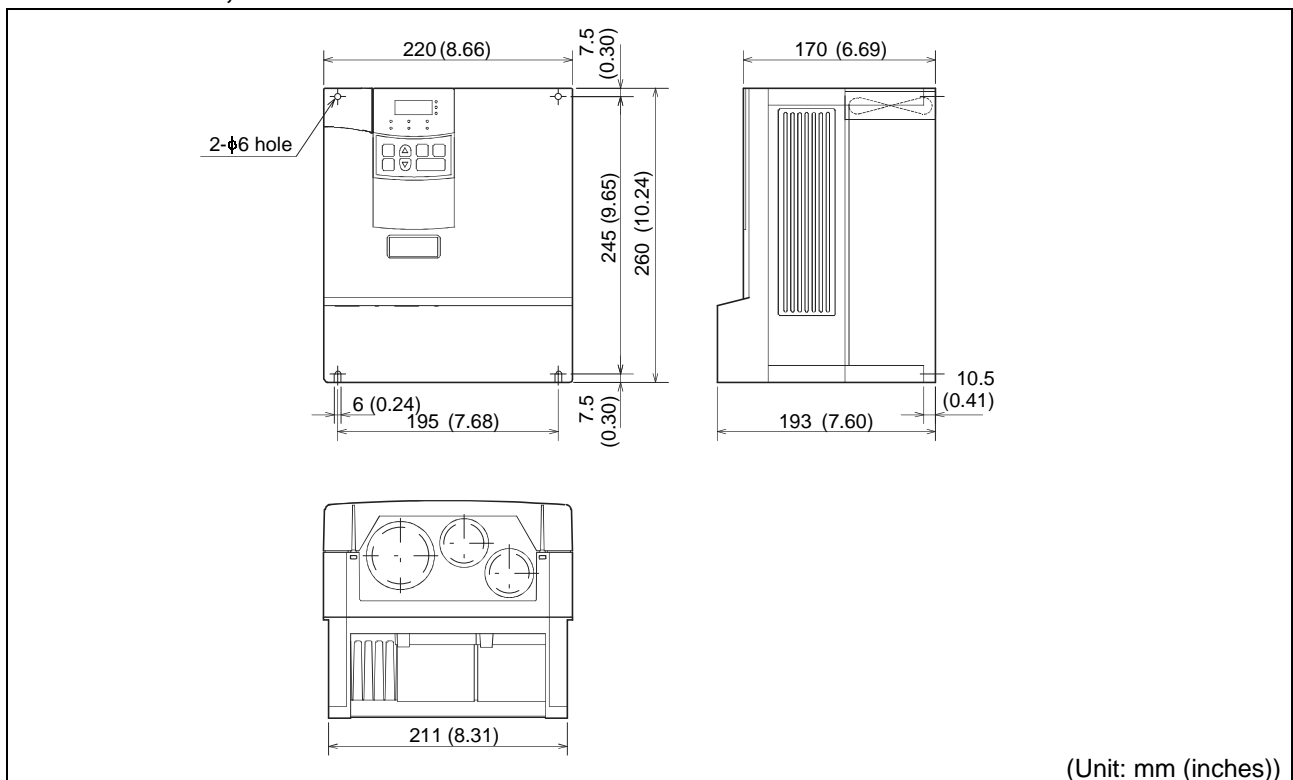

Outline dimension drawings

●FR-V520-11K, 15K

●FR-V540-7.5K, 11K, 15K, 18.5K

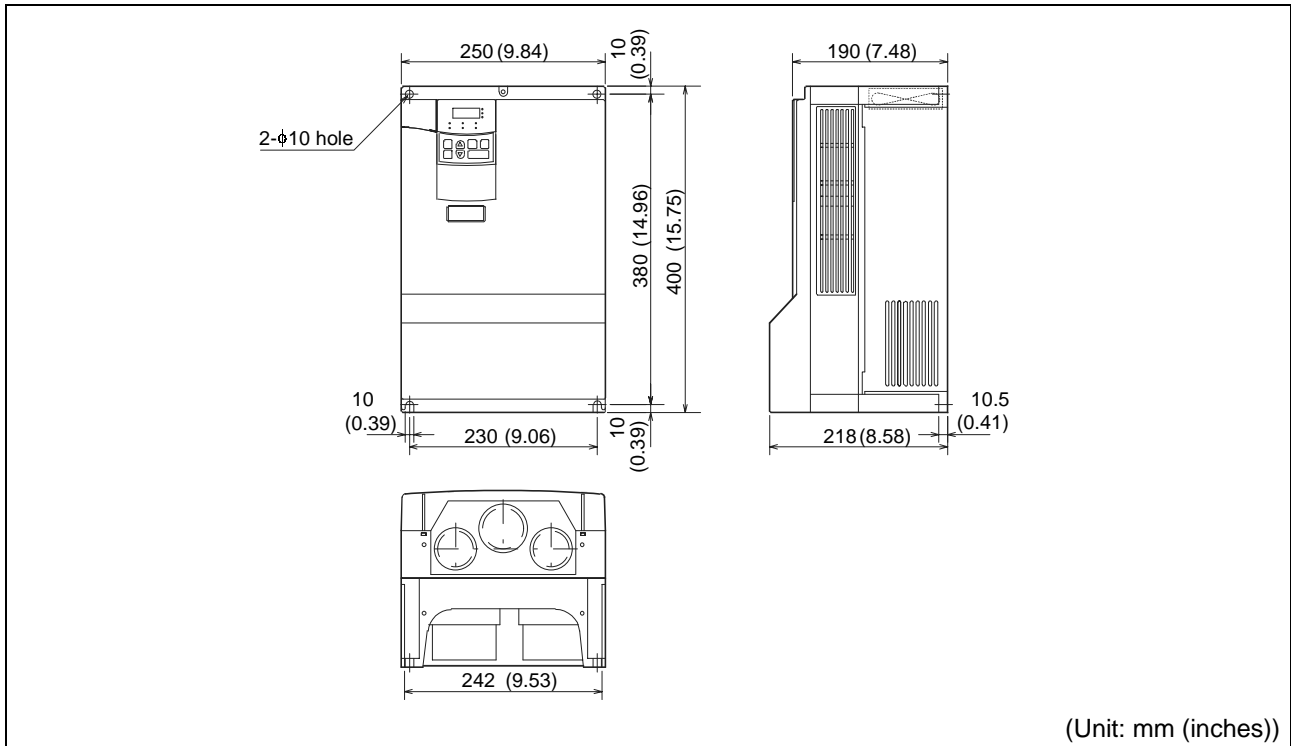

●FR-V520-18.5K

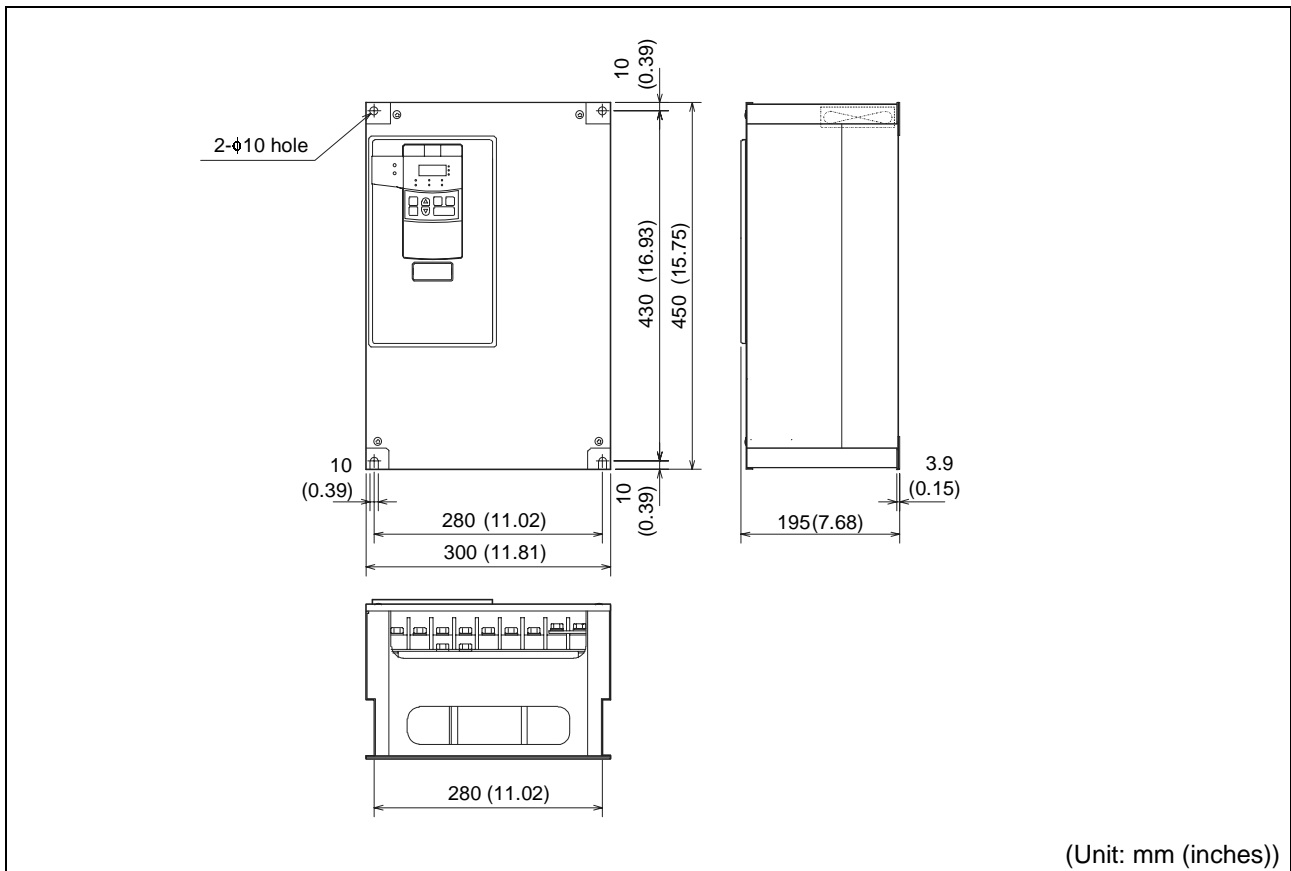

- FR-V520-22K, 30K, 37K
- FR-V540-22K, 30K, 37K

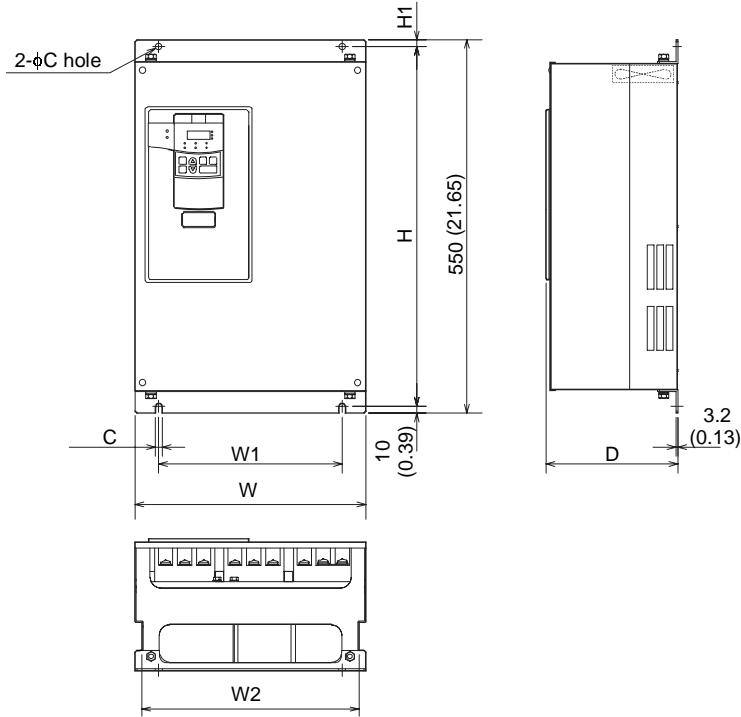

●200V class

Inverter Type	W	W1	W2	H	H1	D	C
FR-V520-22K	340 (13.39)	270 (10.63)	320 (12.60)	530 (20.87)	10 (0.39)	195 (7.68)	10 (0.39)
FR-V520-30K,37K	450 (17.72)	380 (14.96)	430 (16.93)	525 (20.67)	15 (0.59)	250 (9.84)	12 (0.47)

●400V class

Inverter Type	W	W1	W2	H	H1	D	C
FR-V540-22K	340 (13.39)	270 (10.63)	320 (12.60)	530 (20.87)	10 (0.39)	195 (7.68)	10 (0.39)
FR-V540-30K,37K	450 (17.72)	380 (14.96)	430 (16.93)	525 (20.67)	15 (0.59)	250 (9.84)	12 (0.47)

(Unit: mm (inches))

- FR-V520-45K, 55K
- FR-V540-45K, 55K

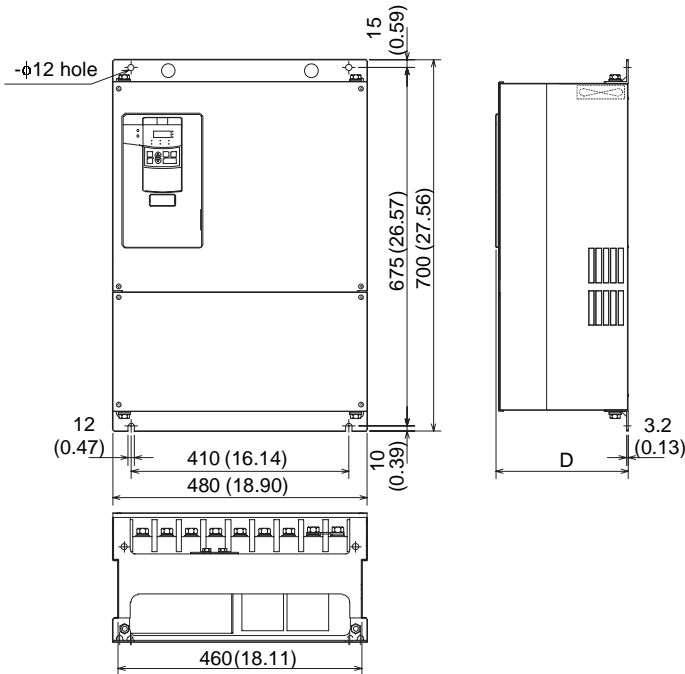

●200V class

Inverter Type	D
FR-V520-45K	250 (9.84)
FR-V520-55K	270 (10.63)

●400V class

Inverter Type	D
FR-V540-45K	250 (9.84)
FR-V540-55K	270 (10.63)

(Unit: mm (inches))

Outline dimension drawings

4.3.2 Operation panel (FR-DU04-1) outline dimension drawings

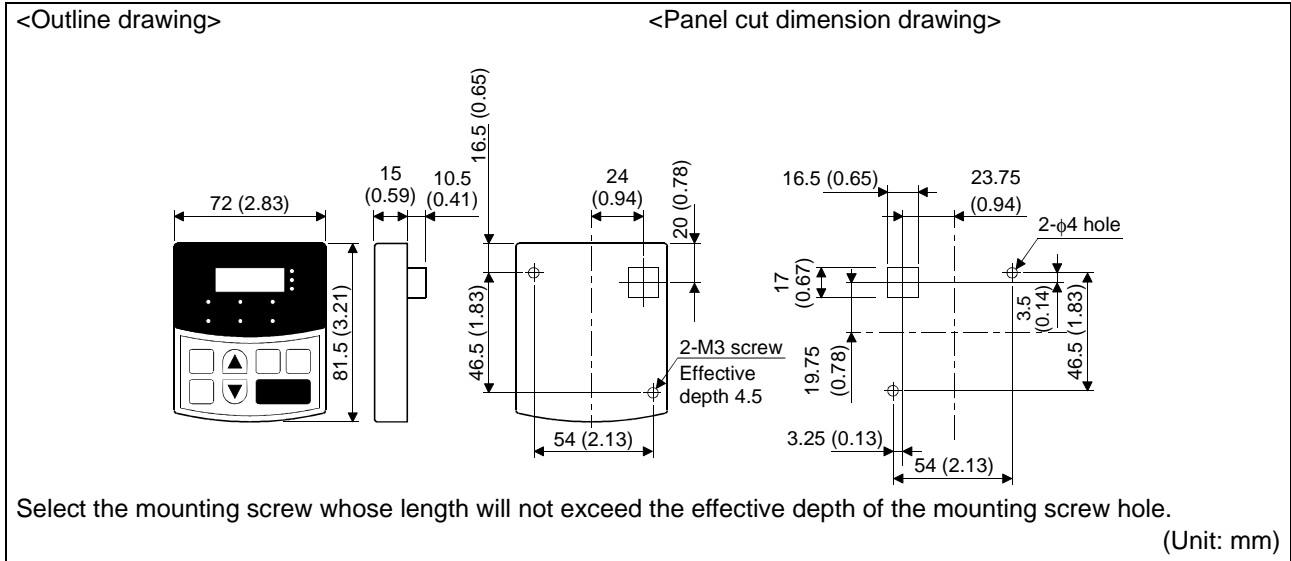

4.3.3 Parameter unit (FR-PU04V) outline dimension drawings

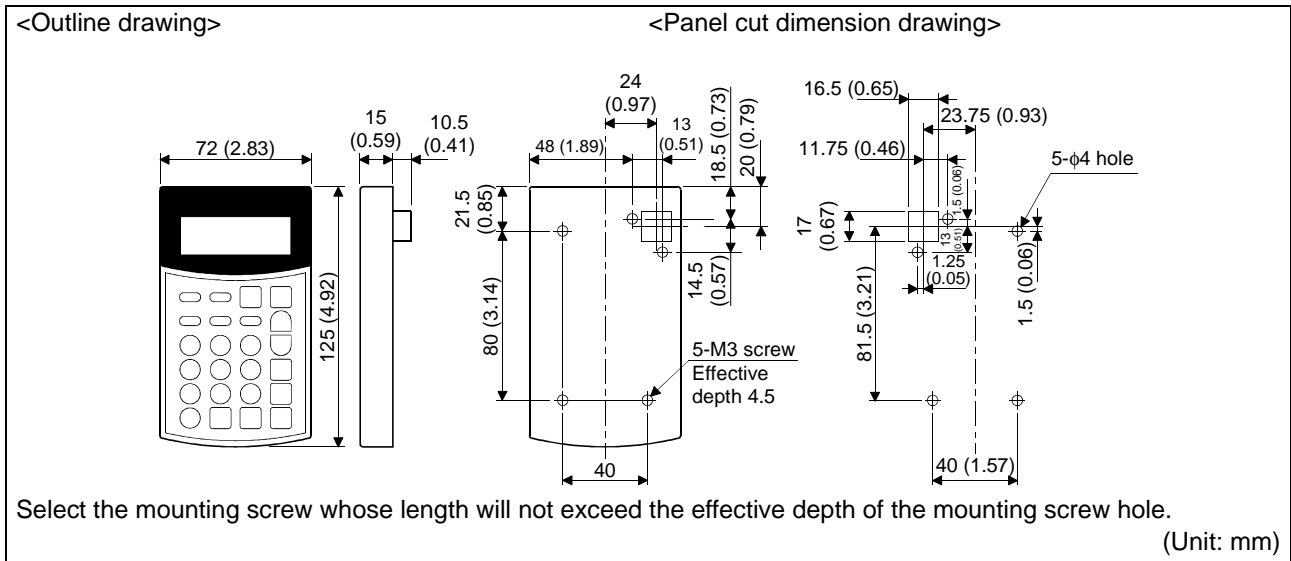

4.3.4 PLG connection cable outline dimension drawings (FR-V5CBL)

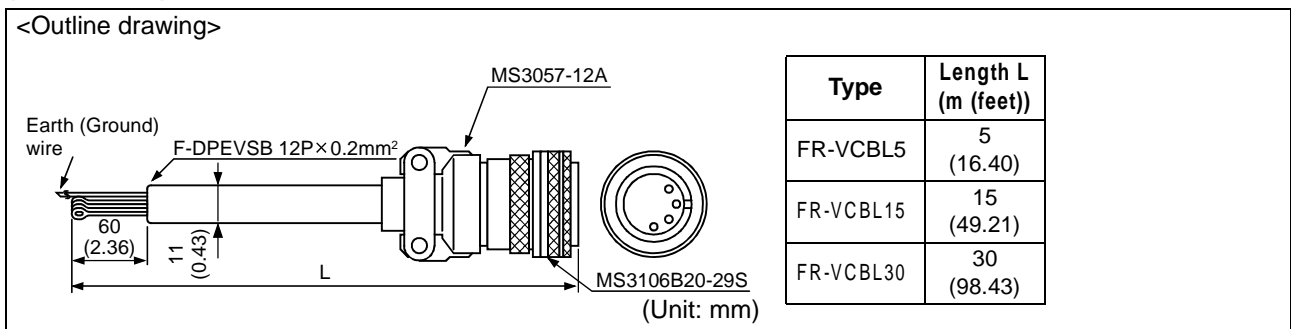

(FR-VCBL,FR-JCBL)

<Outline drawing>

Type	Length L (m (feet))	Type	Length L (m (feet))
FR-VCBL5	5 (16.40)	FR-JCBL5	5 (16.40)
FR-VCBL15	15 (49.21)	FR-JCBL15	15 (49.21)
FR-VCBL30	30 (98.43)	FR-JCBL30	30 (98.43)

(Unit: mm) For the FR-VCBL/FR-JCBL, change the crimping terminal size from M3 to M3.5.

(1) Cable selection specifications

Wiring Distance	PLG Cable for Options	Cable Specification	
		Wiring 0.2mm ² Cables	Using larger gauge cable
5m (16.4feet) or less	FR-V5CBL5	2 parallels or more	0.4mm ² or more
10m (32.8feet) or less	FR-V5CBL15	2 parallels or more	
15m (49.21feet) or less		4 parallels or more	0.75mm ² or more
20m (65.62feet) or less	FR-V5CBL30	4 parallels or more	
30m (98.43feet) or less		6 parallels or more	
50m (164.04feet) or less	Available on request, please consult us.	6 parallels or more	1.25mm ² or more
100m (328.08feet) or less			

If connection cables are not available, make cables according to the table above.
For the pin arrangement for the FR-VCBL/FR-JCBL, refer to page 36.

(2) PLG connector (Manufactured by Japan Aviation Electronics Industries) for reference

Straight Plug MS3106B20-29S	Angle Plug MS3108B20-29S
	<p>Note This angle type connector is not optional. Please obtain it separately.</p>

Cable Clamp MS3057-12A

Outline dimension drawings

(3) Cable stresses

- (1) The way of clamping the cable must be fully considered so that flexing stress and cable's own weight stress are not applied to the cable connection.
- (2) In any application where the motor moves, do not subject the cable to excessive stress.
- (3) Avoid any probability that the cable sheath might be cut by sharp chips, rubbed by a machine corner or trampled over by workers or vehicles.
- (4) The reference value of PLG cable flexing life is shown on the right.
When mounting the PLG on a machine where the motor will move, the flexing radius should be as large as possible.

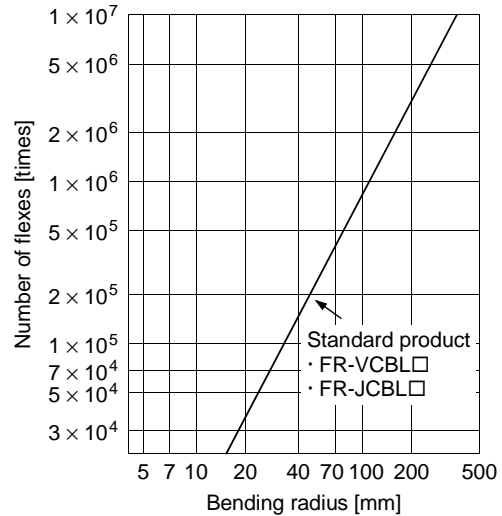

CAUTION

This graph shows calculated values and not guaranteed values.

4.3.5 Mitsubishi dedicated motor outline dimension drawings (1500r/min series)

Install the motor on the floor and use it with the shaft horizontal.

Leave an enough clearance between the fan suction port and wall to ensure adequate cooling.

For the flange type and brake motors, refer to the separately available outline dimension drawings.

The 400V class motor has H at the end of its type name.

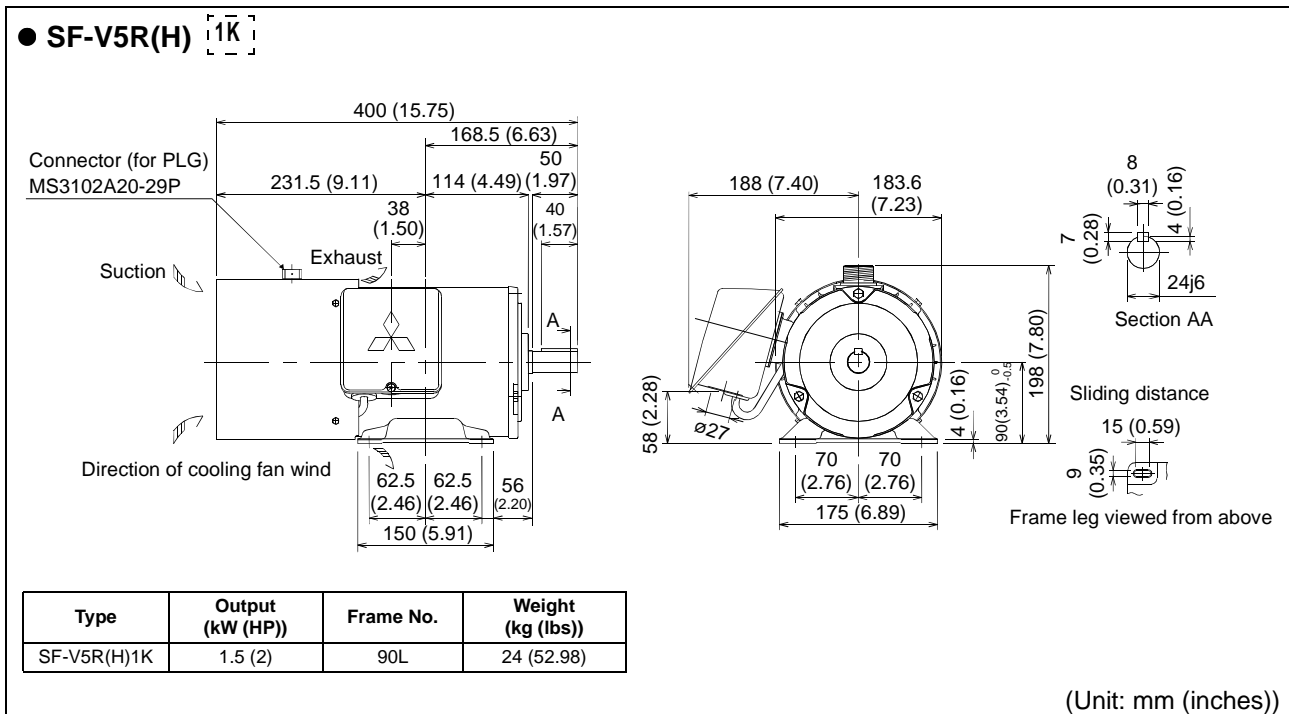

● SF-V5R(H) [2K] [3K]

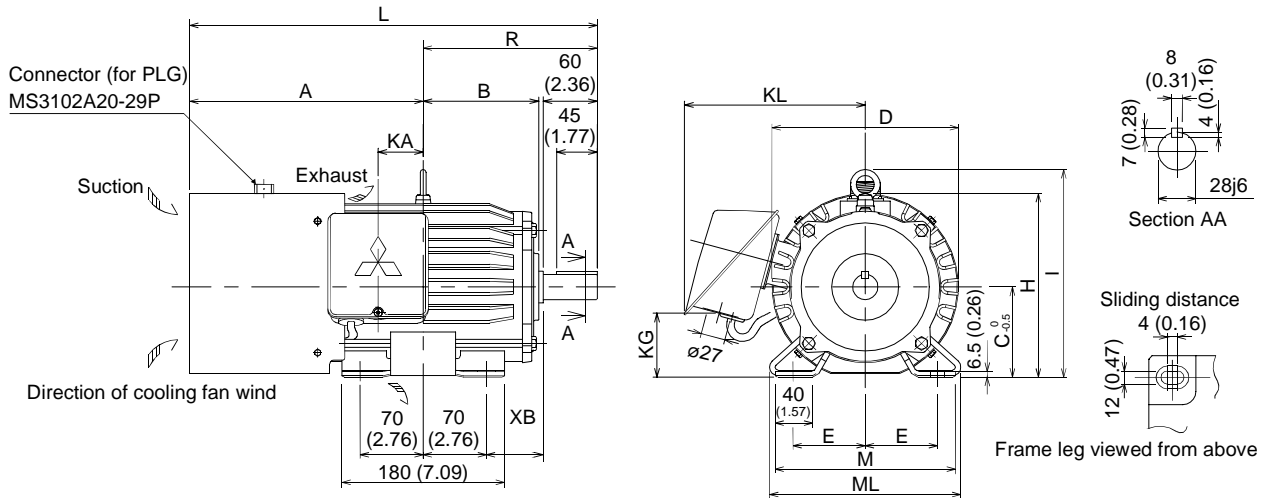

Type	Output (kW (HP))	Frame No.	Dimensions(mm(inches))														Weight (kg(lbs))		
			A	B	C	D	E	H	I	KA	KG	KL	L	M	ML	R		XB	
SFV5R(H)2K	2.2 (3)	100L	259 (10.20)	128 (5.04)	100 (3.94)	207 (8.15)	80 (3.15)	203.5 (8.01)	230 (9.06)	50 (1.97)	71 (2.80)	200 (7.87)	452 (17.80)	200 (7.87)	212 (8.35)	193 (7.60)	63 (2.48)	33 (1.30)	72.85
SFV5R(H)3K	3.7 (5)	112M	253 (9.96)	135 (5.31)	112 (4.41)	228 (8.98)	95 (3.74)	226 (8.90)	253 (9.96)	54 (2.13)	86 (3.39)	211 (8.31)	453 (17.83)	230 (9.06)	242 (9.53)	200 (7.87)	70 (2.76)	41 (1.61)	90.2

(Unit: mm (inches))

● SF-V5R(H) [5K] [7K]

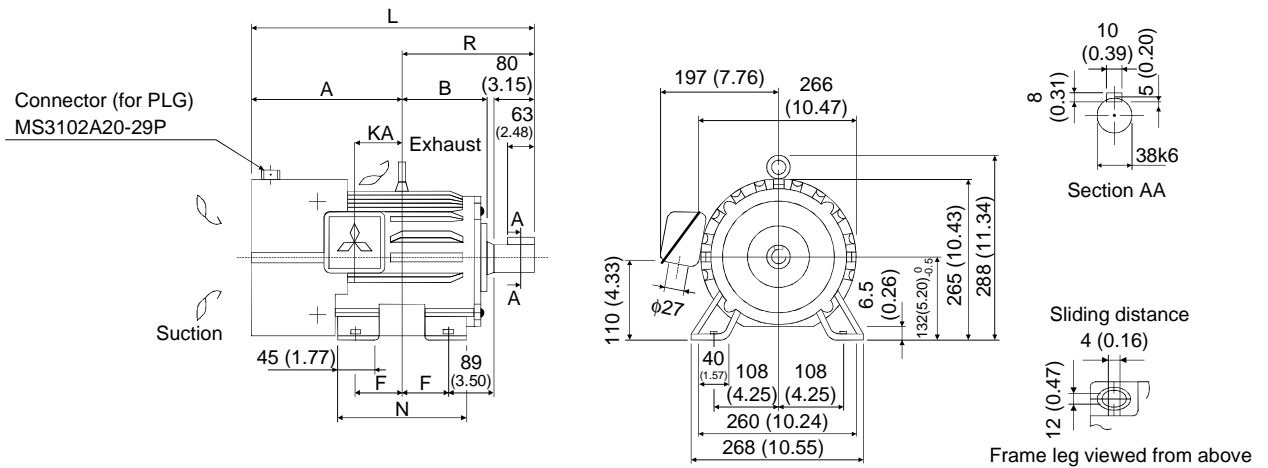

Type	Output (kW (HP))	Frame No.	Dimensions(mm(inches))							Weight (kg (lbs))
			A	B	F	KA	L	N	R	
SF-V5R(H)5K	5.5 (7.5)	132S	278 (10.94)	152 (5.98)	70 (2.76)	60 (2.36)	517 (20.35)	180 (7.09)	239 (9.41)	52 (114.79)
SF-V5R(H)7K	7.5 (10)	132M	297 (11.69)	171 (6.73)	89 (3.50)	79 (3.11)	555 (21.85)	218 (8.58)	258 (10.16)	62 (136.87)

(Unit: mm (inches))

Outline dimension drawings

● SF-V5R(H) [11K] [15K] [18K] [22K]

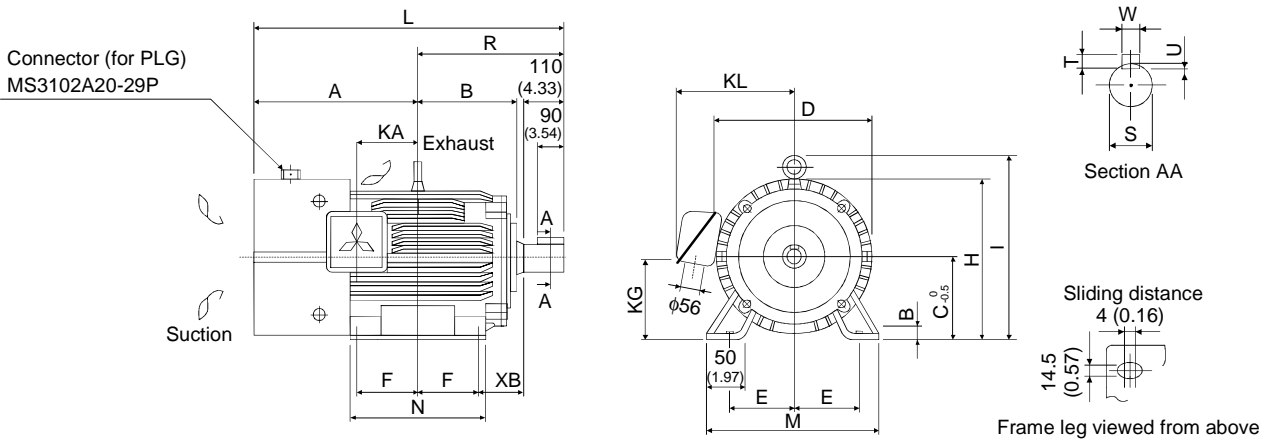

Type	Output (kW (HP))	Frame No	Dimensions(mm(inches))																	Weight (kg (lbs))			
			A	B	C	D	E	F	H	I	KA	KG	KL	L	M	N	XB	R	S		T	U	W
SF-V5R(H)11K	11 (15)	160M	362 (14.25)	198 (7.80)	160 (6.30)	318 (12.52)	127 (5.00)	105 (4.13)	316 (12.44)	367 (14.45)	105 (4.13)	142 (5.59)	266 (10.47)	685 (26.97)	310 (12.20)	254 (10.00)	108 (4.25)	323 (12.72)	42k6	8 (0.31)	5 (0.20)	12 (0.47)	99 (218.54)
SF-V5R(H)15K	15 (20)	160L	384 (15.12)	220 (8.66)	160 (6.30)	318 (12.52)	127 (5.00)	316 (12.44)	367 (14.45)	127 (5.00)	142 (5.59)	266 (10.47)	729 (28.70)	310 (12.20)	298 (11.73)	108 (4.25)	345 (13.58)	42k6	8 (0.31)	5 (0.20)	12 (0.47)	113 (249.45)	
SF-V5R(H)18K	18.5 (25)	180M	388.5 (15.30)	225.5 (8.88)	180 (7.09)	363 (14.29)	139.5 (5.49)	359 (14.13)	410 (16.14)	127 (5.00)	168 (6.61)	289 (11.38)	740 (29.13)	335 (13.19)	285 (11.22)	121 (4.76)	351.5 (13.84)	48k6	9 (0.35)	5.5 (0.22)	14 (0.55)	138 (300.22)	
SF-V5R(H)22K	22 (30)	180M	388.5 (15.30)	225.5 (8.88)	180 (7.09)	363 (14.29)	139.5 (5.49)	359 (14.13)	410 (16.14)	127 (5.00)	168 (6.61)	289 (11.38)	740 (29.13)	335 (13.19)	285 (11.22)	121 (4.76)	351.5 (13.84)	48k6	9 (0.35)	5.5 (0.22)	14 (0.55)	160 (353.20)	

(Unit: mm (inches))

● SF-V5R(H) [30K] [37K] [45K] [55K]

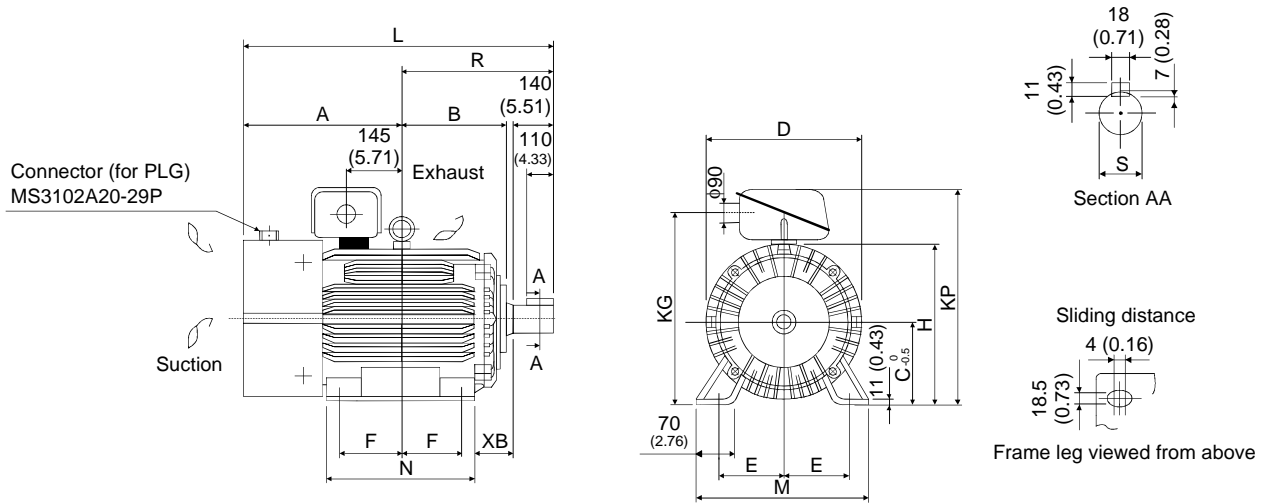

Type	Output (kW (HP))	Frame No	Dimensions(mm(inches))														Weight (kg (lbs))	
			A	B	C	D	E	F	H	KG	KP	L	M	N	R	S		XB
SF-V5R(H)30K	30 (40)	200L	433.5 (17.07)	267.5 (10.53)	200 (7.87)	406 (15.98)	159 (6.26)	152.5 (6.00)	401 (15.79)	472 (18.58)	548 (21.57)	859 (33.82)	390 (15.35)	361 (14.21)	425.5 (16.75)	60m6	133 (5.24)	238 (525.39)
SF-V5R(H)37K	37 (50)																	255 (562.91)
SF-V5R(H)45K	45 (60)																	255 (562.91)
SF-V5R55K	55 (75)	225S	450 (17.72)	277 (10.91)	225 (8.89)	446 (17.56)	178 (7.01)	143 (5.63)	406 (15.98)	517 (20.35)	593 (23.35)	882 (34.72)	428 (16.85)	342 (13.46)	432 (17.01)	65m6	149 (5.87)	320 (706.40)

(Unit: mm (inches))

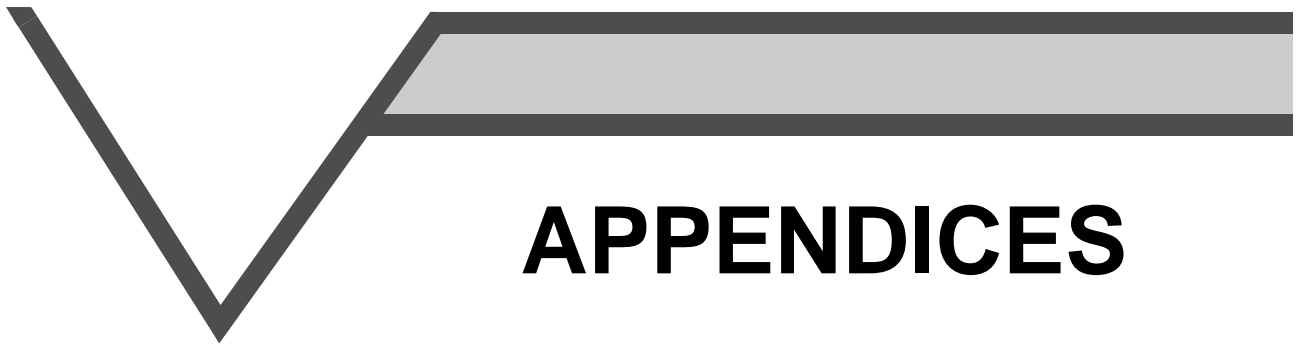

APPENDICES

This chapter provides the "appendices" for use of this product. Always read this instructions before use.

Appendix	Parameter Data Code Lists.....	208
-----------------	---------------------------------------	------------

Appendix Parameter Data Code Lists

Function	Parameter No.	Name (*: Simple mode for NA version)	Data Codes		Link Parameter Expansion Setting (Data code 7F/FF)
			Read	Write	
Basic functions	0	Torque boost (manual)	00	80	0
	1	Maximum speed (simple mode)	01	81	0
	2	Minimum speed (simple mode)	02	82	0
	3	Base frequency	03	83	0
	4	Multi-speed setting (high speed) (simple mode)	04	84	0
	5	Multi-speed setting (middle speed) (simple mode)	05	85	0
	6	Multi-speed setting (low speed) (simple mode)	06	86	0
	7	Acceleration time (simple mode)	07	87	0
	8	Deceleration time (simple mode)	08	88	0
Standard operation functions	9	Electronic thermal O/L relay (*)	09	89	0
	10	DC injection brake operation speed	0A	8A	0
	11	DC injection brake operation time	0B	8B	0
	12	DC injection brake voltage	0C	8C	0
	13	Starting speed	0D	8D	0
	15	Jog speed setting	0F	8F	0
Operation selection functions	16	Jog acceleration/deceleration time	10	90	0
	17	MRS input selection	11	91	0
	19	Base frequency voltage	13	93	0
	20	Acceleration/deceleration reference speed	14	94	0
	21	Acceleration/deceleration time increments	15	95	0
	22	Torque restriction level	16	96	0
	24	Multi-speed setting (speed 4)	18	98	0
	25	Multi-speed setting (speed 5)	19	99	0
	26	Multi-speed setting (speed 6)	1A	9A	0
	27	Multi-speed setting (speed 7)	1B	9B	0
	28	Multi-speed input compensation	1C	9C	0
	29	Acceleration/deceleration pattern	1D	9D	0
	30	Regenerative function selection	1E	9E	0
	31	Speed jump 1A	1F	9F	0
	32	Speed jump 1B	20	A0	0
	33	Speed jump 2A	21	A1	0
	Output terminal functions	34	Speed jump 2B	22	A2
35		Speed jump 3A	23	A3	0
36		Speed jump 3B	24	A4	0
Second functions	37	Speed display	25	A5	0
	41	Up-to-speed sensitivity	29	A9	0
Terminal assignment functions	42	Speed detection	2A	AA	0
	43	Speed detection for reverse rotation	2B	AB	0
Display functions	44	Second acceleration/deceleration time	2C	AC	0
	45	Second deceleration time	2D	AD	0
Automatic restart	50	Second speed detection	32	B2	0
	52	DU/PU main display data selection	34	B4	0
	53	PU level display data selection	35	B5	0
	54	DA1 terminal function selection	36	B6	0
Additional function	55	Speed monitoring reference	37	B7	0
	56	Current monitoring reference	38	B8	0
Operation selection functions	57	Restart coasting time	39	B9	0
	58	Restart cushion time	3A	BA	0
	59	Remote setting function selection	3B	BB	0
	60	Intelligent mode selection	3C	BC	0
	65	Retry selection	41	C1	0
	67	Number of retries at alarm occurrence	43	C3	0
	68	Retry waiting time	44	C4	0
	69	Retry count display erasure	45	C5	0
	70	Special regenerative brake duty	46	C6	0
	71	Applied motor (*)	47	C7	0
	72	PWM frequency selection (simple mode)	48	C8	0
	73	Speed setting signal	49	C9	0
	75	Reset selection/disconnected PU detection/PU stop selection	4B	CB	0
77	Parameter write disable selection (simple mode)	4D	CD (Caution)	0	
78	Reverse rotation prevention selection	4E	CE	0	
79	Operation mode selection (simple mode)	4F	CF (Caution)	0	

Function	Parameter No.	Name (*: Simple mode for NA version)	Data Codes		Link Parameter Expansion Setting (Data code 7F/FF)
			Read	Write	
Motor constants	80	Motor capacity (*)	50	D0	0
	81	Number of motor poles (*)	51	D1	0
	82	Motor excitation current (no load current)	52	D2	0
	83	Rated motor voltage (*)	53	D3	0
	84	Rated motor frequency (*)	54	D4	0
	90	Motor constant R1	5A	DA	0
	91	Motor constant R2	5B	DB	0
	92	Motor constant L1	5C	DC	0
	93	Motor constant L2	5D	DD	0
	94	Motor constant X	5E	DE	0
Third functions	95	Online auto tuning selection (simple mode)	5F	DF	0
	96	Auto tuning setting/status (*)	60	E0	0
Third functions	110	Third acceleration/deceleration time	0A	8A	1
	111	Third deceleration time	0B	8B	1
Terminal assignment functions	116	Third speed detection	10	90	1
Communication functions	117	Station number	11	91	1
	118	Communication speed	12	92	1
	119	Stop bit length/data length	13	93	1
	120	Parity check presence/absence	14	94	1
	121	Number of communication retries	15	95	1
	122	Communication check time interval	16	96	1
	123	Waiting time setting	17	97	1
PID control	124	CR, LF presence/absence selection	18	98	1
	128	PID action selection	1C	9C	1
	129	PID proportional band	1D	9D	1
	130	PID integral time	1E	9E	1
	131	Upper limit	1F	9F	1
	132	Lower limit	20	A0	1
Backlash	133	PID action set point for PU operation	21	A1	1
	134	PID differential time	22	A2	1
	140	Backlash acceleration stopping speed	28	A8	1
	141	Backlash acceleration stopping time	29	A9	1
Display functions	142	Backlash deceleration stopping speed	2A	AA	1
	143	Backlash deceleration stopping time	2B	AB	1
	144	Speed setting switchover	2C	AC	1
Current detection	145	Parameter unit language changing	2D	AD	1
	150	Output current detection level	32	B2	1
	151	Output current detection time	33	B3	1
	152	Zero current detection level	34	B4	1
Sub functions	153	Zero current detection time	35	B5	1
	156	Stall prevention operation selection	38	B8	1
Display functions	157	OL signal output timer	39	B9	1
	158	DA2 terminal function selection	3A	BA	1
	160	Extended function selection (simple mode)	00	80	2
Automatic restart after instantaneous power failure	162	Automatic restart after instantaneous power failure selection	02	82	2
	163	First cushion time for restart	03	83	2
	164	First cushion voltage for restart	04	84	2
	165	Restart current restriction level	05	85	2
Initial monitor	171	Actual operation hour meter clear	0B	8B	2
Terminal assignment functions	180	DI1 terminal function selection	14	94	2
	181	DI2 terminal function selection	15	95	2
	182	DI3 terminal function selection	16	96	2
	183	DI4 terminal function selection	17	97	2
	187	STR terminal function selection	1B	9B	2
	190	DO1 terminal function selection	1E	9E	2
	191	DO2 terminal function selection	1F	9F	2
	192	DO3 terminal function selection	20	A0	2
Multi-speed operation	195	A, B, C terminal function selection	23	A3	2
	232	Multi-speed setting (speed 8)	28	A8	2
	233	Multi-speed setting (speed 9)	29	A9	2
	234	Multi-speed setting (speed 10)	2A	AA	2
	235	Multi-speed setting (speed 11)	2B	AB	2
	236	Multi-speed setting (speed 12)	2C	AC	2
	237	Multi-speed setting (speed 13)	2D	AD	2
Sub functions	238	Multi-speed setting (speed 14)	2E	AE	2
	239	Multi-speed setting (speed 15)	2F	AF	2
Sub functions	240	Soft-PWM setting	30	B0	2
	244	Cooling fan operation selection	34	B4	2

Parameter Data Code Lists

Function	Parameter No.	Name (*: Simple mode for NA version)	Data Codes		Link Parameter Expansion Setting (Data code 7F/FF)
			Read	Write	
Stop selection function	250	Stop selection	3A	BA	2
Operation selection function	251	Output phase failure protection selection	3B	BB	2
Additional functions	252	Override bias	3C	BC	2
	253	Override gain	3D	BD	2
Power failure stop functions	261	Power failure stop selection	45	C5	2
	262	Subtracted speed at deceleration start	46	C6	2
	263	Subtraction starting speed	47	C7	2
	264	Power-failure deceleration time 1	48	C8	2
	265	Power-failure deceleration time 2	49	C9	2
	266	Power-failure deceleration time switchover speed	4A	CA	2
Brake sequence	278	Brake opening speed	56	D6	2
	279	Brake opening current	57	D7	2
	280	Brake opening current detection time	58	D8	2
	281	Brake operation time at start	59	D9	2
	282	Brake operation speed	5A	DA	2
	283	Brake operation time at stop	5B	DB	2
	284	Deceleration detection function selection	5C	DC	2
Droop	285	Overspeed detection speed	5D	DD	2
	286	Droop gain	5E	DE	2
	287	Droop filter constant	5F	DF	2
Digital input	288	Droop function activation selection	60	E0	2
	300	BCD input bias	00	80	3
	301	BCD input gain	01	81	3
	302	Binary input bias	02	82	3
	303	Binary input gain	03	83	3
	304	Digital input and analog compensation input enable/disable selection	04	84	3
Analog output	305	Read timing operation selection	05	85	3
	306	Analog output signal selection	06	86	3
	307	Setting for zero analog output	07	87	3
	308	Setting for maximum analog output	08	88	3
	309	Analog output signal voltage/current switchover	09	89	3
	310	Analog meter voltage output selection	0A	8A	3
	311	Setting for zero analog meter voltage output	0B	8B	3
Digital output	312	Setting for maximum analog meter voltage output	0C	8C	3
	313	Y0 output selection	0D	8D	3
	314	Y1 output selection	0E	8E	3
	315	Y2 output selection	0F	8F	3
	316	Y3 output selection	10	90	3
	317	Y4 output selection	11	91	3
	318	Y5 output selection	12	92	3
Relay output	319	Y6 output selection	13	93	3
	320	RA1 output selection	14	94	3
	321	RA2 output selection	15	95	3
Digital input	322	RA3 output selection	16	96	3
	329	Digital input unit selection	1D	9D	3
Relay output	330	RA0 output selection	1E	9E	3
Communication	331	Station number	1F	9F	3
	332	Communication speed	20	A0	3
	333	Stop bit length	21	A1	3
	334	Parity check presence/absence	22	A2	3
	335	Number of communication retries	23	A3	3
	336	Communication check time interval	24	A4	3
	337	Waiting time setting	25	A5	3
	338	Operation control command source	26	A6	3
	339	Speed command source	27	A7	3
	340	Link startup mode selection	28	A8	3
	341	CR/LF presence/absence selection	29	A9	3
	342	E ² PROM write presence/absence	2A	AA	3
	345	DeviceNet address (lower)	2D	AD	3
	346	DeviceNet baud rate (lower)	2E	AE	3
	347	DeviceNet address (higher)	2F	AF	3
	348	DeviceNet baud rate (higher)	30	B0	3

Function	Parameter No.	Name (*: Simple mode for NA version)	Data Codes		Link Parameter Expansion Setting (Data code 7F/FF)
			Read	Write	
Orientation	350	Stop position command selection	32	B2	3
	351	Orientation switchover speed	33	B3	3
	356	Internal stop position command	38	B8	3
	357	In-position zone	39	B9	3
	359	Orientation PLG rotation direction	3B	BB	3
	360	External position command selection	3C	BC	3
	361	Position shift	3D	BD	3
	362	Orientation position loop gain	3E	BE	3
	369	Number of orientation PLG pulses	45	C5	3
Control system function	374	Overspeed detection level	4A	CA	3
S-pattern C	380	Acceleration S pattern 1	50	D0	3
	381	Deceleration S pattern 1	51	D1	3
	382	Acceleration S pattern 2	52	D2	3
	383	Deceleration S pattern 2	53	D3	3
Pulse train input	384	Input pulse division scaling factor	54	D4	3
	385	Speed for zero input pulse	55	D5	3
	386	Speed for maximum input pulse	56	D6	3
Orientation	393	Orientation selection	5D	DD	3
	394	Number of machine side gear teeth	5E	DE	3
	395	Number of motor side gear teeth	5F	DF	3
	396	Orientation speed gain (P term)	60	E0	3
	397	Orientation speed integral time	61	E1	3
	398	Orientation speed gain (D term)	62	E2	3
	399	Orientation deceleration ratio	63	E3	3
Extension inputs	400	DI11 terminal function selection	00	80	4
	401	DI12 terminal function selection	01	81	4
	402	DI13 terminal function selection	02	82	4
	403	DI14 terminal function selection	03	83	4
	404	DI15 terminal function selection	04	84	4
	405	DI16 terminal function selection	05	85	4
	406	High resolution analog input selection	06	86	4
	407	Motor temperature detection filter	07	87	4
Extension outputs	410	DO11 terminal function selection	0A	8A	4
	411	DO12 terminal function selection	0B	8V	4
	412	DO13 terminal function selection	0C	8C	4
	413	PLG pulse output division ratio	0D	8D	4
Position control	419	Position command right selection	13	93	4
	420	Command pulse scaling factor numerator	14	94	4
	421	Command pulse scaling factor denominator	15	95	4
	422	Position loop gain	16	96	4
	423	Position feed forward gain	17	97	4
	424	Position command acceleration/deceleration time constant	18	98	4
	425	Position feed forward command filter	19	99	4
	426	In-position width	1A	9A	4
	427	Excessive level error	1B	9B	4
	428	Command pulse selection	1C	9C	4
429	Clear signal selection	1D	9D	4	
	430	Pulse monitor selection	1E	9E	4
Torque command	432	Pulse train torque command bias	20	A0	4
	433	Pulse train torque command gain	21	A1	4
Position control	434	IP address 1	22	A2	4
	435	IP address 2	23	A3	4
	436	IP address 3	24	A4	4
	437	IP address 4	25	A5	4
	438	Sub-net mask 1	26	A6	4
	439	Sub-net mask 2	27	A7	4
	440	Sub-net mask 3	28	A8	4
	441	Sub-net mask 4	29	A9	4
	442	Gateway address 1	2A	AA	4
	443	Gateway address 2	2B	AB	4
	444	Gateway address 3	2C	AC	4
	445	Gateway address 4	2D	AD	4
	446	Password	2E	AE	4
Torque command	447	Digital torque command bias	2F	AF	4
	448	Digital torque command gain	30	B0	4

Parameter Data Code Lists

Function	Parameter No.	Name (*: Simple mode for NA version)	Data Codes		Link Parameter Expansion Setting (Data code 7F/FF)
			Read	Write	
Motor constants	450	Second applied motor	32	B2	4
	451	Second motor control method selection	33	B3	4
	452	Second electronic thermal O/L relay	34	B4	4
	453	Second motor capacity	35	B5	4
	454	Number of second motor poles	36	B6	4
	464	Digital position control sudden stop deceleration time	40	C0	4
	465	First position feed amount lower 4 digits	41	C1	4
	466	First position feed amount upper 4 digits	42	C2	4
	467	Second position feed amount lower 4 digits	43	C3	4
	468	Second position feed amount upper 4 digits	44	C4	4
	469	Third position feed amount lower 4 digits	45	C5	4
	470	Third position feed amount upper 4 digits	46	C6	4
	471	Fourth position feed amount lower 4 digits	47	C7	4
	472	Fourth position feed amount upper 4 digits	48	C8	4
	473	Fifth position feed amount lower 4 digits	49	C9	4
	474	Fifth position feed amount upper 4 digits	4A	CA	4
	475	Sixth position feed amount lower 4 digits	4B	CB	4
	476	Sixth position feed amount upper 4 digits	4C	CC	4
	477	Seventh position feed amount lower 4 digits	4D	CD	4
	478	Seventh position feed amount upper 4 digits	4E	CE	4
	479	Eighth position feed amount lower 4 digits	4F	CF	4
	480	Eighth position feed amount upper 4 digits	50	D0	4
	481	Ninth position feed amount lower 4 digits	51	D1	4
	482	Ninth position feed amount upper 4 digits	52	D2	4
	483	Tenth position feed amount lower 4 digits	53	D3	4
	484	Tenth position feed amount upper 4 digits	54	D4	4
	485	Eleventh position feed amount lower 4 digits	55	D5	4
	486	Eleventh position feed amount upper 4 digits	56	D6	4
	487	Twelfth position feed amount lower 4 digits	57	D7	4
	488	Twelfth position feed amount upper 4 digits	58	D8	4
489	Thirteenth position feed amount lower 4 digits	59	D9	4	
490	Thirteenth position feed amount upper 4 digits	5A	DA	4	
491	Fourteenth position feed amount lower 4 digits	5B	DB	4	
492	Fourteenth position feed amount upper 4 digits	5C	DC	4	
493	Fifteenth position feed amount lower 4 digits	5D	DD	4	
494	Fifteenth position feed amount upper 4 digits	5E	DE	4	
495	Remote output selection	5F	DF	4	
496	Remote output data 1	60	E0	4	
497	Remote output data 2	61	E1	4	
Communication	499	Action selection at SSCNET communication interruption	63	E3	4
	500	Communication error recognition waiting time	00	80	5
	501	Communication error occurrence count display	01	81	5
	502	Communication error-time stop mode selection	02	82	5
Trace	520	Trace data CH1	14	94	5
	521	Trace data CH2	15	95	5
	522	Trace data CH3	16	96	5
	523	Trace data CH4	17	97	5
	524	Trace data CH5	18	98	5
	525	Trace data CH6	19	99	5
	526	Trace data CH7	1A	9A	5
	527	Trace data CH8	1B	9B	5
	528	Trace data CH9	1C	9C	5
	529	Trace data CH10	1D	9D	5
	530	Sampling period	1E	9E	5
	531	Sampling count selection	1F	9F	5
	532	Trigger source selection 1	20	A0	5
	533	Trigger source selection 2	21	A1	5
	534	Trigger level	22	A2	5
	535	Trigger slope selection	23	A3	5
	536	Pre-trigger	24	A4	5
537	Trace data D/A output selection	25	A5	5	
538	Trace start/stop selection	26	A6	5	

Function	Parameter No.	Name (*: Simple mode for NA version)	Data Codes		Link Parameter Expansion Setting (Data code 7F/FF)
			Read	Write	
Operation selection functions	800	Control system selection (simple mode)	00	80	8
	801	Torque characteristic selection	01	81	8
	802	Pre-excitation selection	02	82	8
	803	Constant output region torque characteristic selection	03	83	8
	804	Torque command right selection	04	84	8
	805	Torque command value (RAM)	05	85	8
	806	Torque command value (RAM, E ² PROM)	06	86	8
	807	Speed restriction selection	07	87	8
	808	Forward rotation speed restriction	08	88	8
	809	Reverse rotation speed restriction	09	89	8
Control system functions	810	Torque restriction input method selection	0A	8A	8
	812	Torque restriction level (regeneration)	0C	8C	8
	813	Torque restriction level (3 quadrant)	0D	8D	8
	814	Torque restriction level (4 quadrant)	0E	8E	8
	815	Torque restriction level 2	0F	8F	8
	816	Acceleration torque restriction	10	90	8
	817	Deceleration torque restriction	11	91	8
	818	Easy gain tuning response level setting (simple mode)	12	92	8
	819	Easy gain tuning selection (simple mode)	13	93	8
	820	Speed control P gain 1	14	94	8
	821	Speed control integral time 1	15	95	8
	822	Speed setting filter 1	16	96	8
	823	Speed detection filter 1	17	97	8
	824	Torque control P gain 1	18	98	8
	825	Torque control integral time 1	19	99	8
	826	Torque setting filter 1	1A	9A	8
	827	Torque detection filter 1	1B	9B	8
	828	Model speed control gain	1C	9C	8
	830	Speed control P gain 2	1E	9E	8
	831	Speed control integral time 2	1F	9F	8
	832	Speed setting filter 2	20	A0	8
	833	Speed detection filter 2	21	A1	8
	834	Torque control P gain 2	22	A2	8
	835	Torque control integral time 2	23	A3	8
	836	Torque setting filter 2	24	A4	8
837	Torque detection filter 2	25	A5	8	
Torque biases	840	Torque bias selection	28	A8	8
	841	Torque bias 1	29	A9	8
	842	Torque bias 2	2A	AA	8
	843	Torque bias 3	2B	AB	8
	844	Torque bias filter	2C	AC	8
	845	Torque bias operation time	2D	AD	8
	846	Torque bias balance compensation	2E	AE	8
	847	Fall-time torque bias No. 3 bias	2F	AF	8
	848	Fall-time torque bias No. 3 gain	30	B0	8
	849	Analog input offset adjustment	31	B1	8
Additional functions	851	Number of PLG pulses	33	B3	8
	852	PLG rotation direction	34	B4	8
	854	Excitation ratio	36	B6	8
	859	Torque current	3B	BB	8
	862	Notch filter frequency	3E	BE	8
	863	Notch filter depth	3F	BF	8
	864	Torque detection	40	C0	8
Display functions	865	Low speed detection	41	C1	8
	866	Torque monitoring reference	42	C2	8
Terminal assignment function	867	DA1 output filter	43	C3	8
	868	No. 1 terminal function assignment	44	C4	8
Protective functions	870	Speed deviation level	46	C6	8
	871	Speed deviation time	47	C7	8
	873	Speed restriction	49	C9	8
	874	OLT level setting	4A	CA	8
Operation selection functions	875	Fault definition	4B	CB	8
	876	Thermal relay protector input	4C	CC	8

Parameter Data Code Lists

Function	Parameter No.	Name (*: Simple mode for NA version)	Data Codes		Link Parameter Expansion Setting (Data code 7F/FF)
			Read	Write	
Control system functions	877	Speed feed forward/model adaptive speed control selection	4D	CD	8
	878	Speed feed forward filter	4E	CE	8
	879	Speed feed forward torque restriction	4F	CF	8
	880	Load inertia ratio	50	D0	8
	881	Speed feed forward gain	51	D1	8
Maintenance functions	890	Maintenance output setting time	5A	DA	8
	891	Maintenance output timer	5B	DB	8
	892	Maintenance output signal clear	5C	DC	8
Calibration functions	900	DA1 terminal calibration	5C	DC	1
	901	DA2 terminal calibration	5D	DD	1
	902	Speed setting No. 2 bias	5E	DE	1
	903	Speed setting No. 2 gain	5F	DF	1
	904	Torque command No. 3 bias	60	E0	1
	905	Torque command No. 3 gain	61	E1	1
	917	No. 1 terminal bias (speed)	11	91	9
	918	No. 1 terminal gain (speed)	12	92	9
	919	No. 1 terminal bias (torque/magnetic flux)	13	93	9
	920	No. 1 terminal gain (torque/magnetic flux)	13	94	9
	925	Motor temperature detection calibration	19	99	9
	926	No. 6 terminal bias (speed)	1A	9A	9
	927	No. 6 terminal gain (speed)	1B	9B	9
928	No. 6 terminal bias (torque)	1C	9C	9	
929	No. 6 terminal gain (torque)	1D	9D	9	
Additional functions	990	Buzzer control	5A	DA	9
	991	Parameter for the option (FR-PU04V)	5B	DB	9

CAUTION

Note that read and write of the Pr. 77 and Pr. 79 values are enabled for computer link operation that uses the PU connector, but write is disabled for computer link operation that uses the option (FR-A5NR).

MEMO

REVISIONS

*The manual number is given on the bottom left of the back cover.

Print Date	*Manual Number	Revision
Oct., 2001	IB(NA)-0600065-A	First edition
Mar., 2002	IB(NA)-0600065-B	<div data-bbox="544 306 655 340" style="border: 1px solid black; padding: 2px;">Addition</div> <ul style="list-style-type: none"> • Three-phase 400V power input specifications
May, 2002	IB(NA)-0600065-C	<div data-bbox="544 392 735 425" style="border: 1px solid black; padding: 2px;">Partial change</div> <ul style="list-style-type: none"> • Addition of "2" to the setting range of Pr. 288 "droop function activation selection". • Addition of "9999" to the setting range of Pr. 427 "excessive level error". <div data-bbox="544 510 655 544" style="border: 1px solid black; padding: 2px;">Addition</div> <ul style="list-style-type: none"> • In accordance with NA