

Installing, Operating  
and Maintaining  
Three-Phase Input  
Three-Phase Output  
General Purpose GP-1200  
A-C V★S Drives

460 VAC

2 HP, 3 HP, 5 HP, 7½ HP, 10 HP



Instruction Manual D2-3103-2

July 1988

**RELIANCE**  
**ELECTRIC** 



# Table of Contents

Chapter/Topic	Page
<b>1: Receive and Accept the Controller</b>	
Identify the Controller . . . . .	1:1
Receive and Accept the Shipment . . . . .	1:1
Store the Controller until Installation . . . . .	1:1
File a Return Request . . . . .	1:1
<b>2: Know the Controller</b>	
Terminology Used in This Manual . . . . .	2:1
Definitions and Abbreviations . . . . .	2:1
Dangers, Warnings, and Cautions . . . . .	2:1
Related Publications . . . . .	2:1
Drive Components . . . . .	2:1
Controller Features . . . . .	2:2
Available Controller Options . . . . .	2:2
Local Operator's Control Station . . . . .	2:2
Remote Operator's Control Station . . . . .	2:3
Customer Interface Module . . . . .	2:3
Dynamic Braking . . . . .	2:3
Digital Meter . . . . .	2:3
Extended Line Dip Module . . . . .	2:3
Cabinet Conversion . . . . .	2:3
Voltmeter . . . . .	2:3
Ammeter . . . . .	2:3
Frequency Meter (Analog) . . . . .	2:3
Controller Specifications . . . . .	2:3
Controller Ratings . . . . .	2:3
Service Conditions . . . . .	2:4
Controller Application Data . . . . .	2:4
<b>3: Install the Drive</b>	
Plan and Complete the Installation . . . . .	3:1
Select the Controller Enclosure Location . . . . .	3:1
Install the Controller . . . . .	3:1
Install a Transformer (if needed) . . . . .	3:3
Install an Input Disconnect . . . . .	3:3
Install the Motor . . . . .	3:4
Ground the Controller and Enclosure, Motor, Remote Operator's Control Station, and Regulator Transformer . . . . .	3:4
Suppress Electrical Noise . . . . .	3:4
Wire the Drive . . . . .	3:4
Power Wiring . . . . .	3:7
Control and Signal Wiring . . . . .	3:7
Controller Regulator Modifications . . . . .	3:10
Extended Speed Range . . . . .	3:11
Variable Torque Curve . . . . .	3:11
Variable Carrier Frequency . . . . .	3:11
24 VDC Grounding . . . . .	3:11
Output Contactor Turn-off Delay . . . . .	3:11
Process Control . . . . .	3:11
Extended Line Dip Ride Thru . . . . .	3:11
Regenerative Voltage Limit . . . . .	3:11
D-C Offset at Zero Hertz . . . . .	3:12
Ramp-to-Rest . . . . .	3:12
Extended Acceleration and Deceleration Times . . . . .	3:12

**4: Start and Adjust the Drive**

Test Equipment Needed . . . . .	4:1
Check the Installation . . . . .	4:1
Check the Motor . . . . .	4:1
Check the Transformer (if used) . . . . .	4:2
Check the Controller and Enclosure . . . . .	4:2
Check the Grounding . . . . .	4:2
Start the Controller Purchased as Drive Package . . . . .	4:4
Start the Controller Purchased Separately . . . . .	4:4

**5: How the Controller Operates**

Fundamentals of Variable Voltage, Variable Frequency Controllers . . . . .	5:1
Power Circuit Operation . . . . .	5:1
Controller Regulator Operation . . . . .	5:2
Fundamentals of Controller Operator's Controls . . . . .	5:4
Start/Stop Control . . . . .	5:4
Speed Control . . . . .	5:4
Run/Jog Switch . . . . .	5:5
Automatic/Manual Switch (Option) . . . . .	5:5
Forward/Reverse Switch (Option) . . . . .	5:5

**6: Troubleshoot the Controller**

Controller LEDs . . . . .	6:1
Test Equipment Needed . . . . .	6:1
General Troubleshooting Procedure . . . . .	6:2
Fault Symptom Troubleshooting Flow Charts . . . . .	6:2

# List of Figures

Figure/Description	Page
Figure 3-1. Physical Dimensions and Weights for NEMA 1 Enclosed and Chassis Controllers . . . . .	3:2
Figure 3-2. Wiring Locations in NEMA 1 Controller with Basic Local Operation Control Station . . . . .	3:5
Figure 3-3. Wiring Locations in Chassis Controller with Customer Interface Module . . . . .	3:6
Figure 3-4. Interconnection Diagram of Controller with Local Operator's Control Station Functions . . . . .	3:8
Figure 3-5. Interconnection Diagram Using Customer Interface Module . . . . .	3:9
Figure 3-6. Location of Modification Jumpers and Switches on the Regulator . . . . .	3:10
Figure 4-1. Regulator Pots, LED and Checkpins . . . . .	4:3
Figure 4-2. Volts/Hertz Pot Adjustable Region for 460V Input . . . . .	4:6
Figure 4-3. Relationship of Min Hz and Max Hz . . . . .	4:6
Figure 5-1. Power Circuit Schematic . . . . .	5:2
Figure 5-2. Controller Regulator Block Diagram . . . . .	5:3
Figure 5-3. Theory of Generating PWM . . . . .	5:4
Figure 6-1. Motor Will not Run . . . . .	6:3
Figure 6-2. Motor Will not Reach Maximum Speed . . . . .	6:4
Figure 6-3. Controller IET Occurs during Controlled Deceleration . . . . .	6:5
Figure 6-4. Controller IET Occurs Occasionally while Running but Can Be Restarted . . . . .	6:6
Figure 6-5. Motor Overheats above Allowable Temperature . . . . .	6:7
Figure 6-6. Typical Component Identification (2 to 5 HP) . . . . .	6:9
Figure 6-7. Typical Component Identification (7½ to 10 HP) . . . . .	6:10
Figure 6-8. Typical Wiring Diagram of Standard NEMA 1 Enclosed Controller . . . . .	6:11
Figure 6-9. Typical Wiring Diagram of Chassis Controller . . . . .	6:12
Figure 6-10. Typical Regulator PC Board Schematic . . . . .	6:13
Figure 6-11. Typical Customer Interface PC Board Schematic . . . . .	6:14
Figure 6-12. Typical Component Layout of Regulator PC Board . . . . .	6:15

# List of Tables

Table/Description	Page
Table 2-1. Standard Kit Options . . . . .	2:2
Table 2-2. Local Operator's Control Station Kits . . . . .	2:2
Table 2-3. Controller Current Ratings . . . . .	2:3
Table 3-1. Sizing the Metal Enclosure That Will House the Chassis . . . . .	3:3
Table 3-2. Motor Derating Data for Centrifugal Loads . . . . .	3:4
Table 3-3. Regulator Modifications . . . . .	3:10
Table 3-4. Possible Speed Ranges . . . . .	3:11
Table 3-5. Extended Acceleration and Deceleration Time Selection . . . . .	3:12
Table 4-1. Controller Pot Settings . . . . .	4:3
Table 6-1. Possible Causes of IET Trips . . . . .	6:1
Table 6-2. Replacement Parts List . . . . .	6:8
Table 6-3. Recommended Spare Parts for Every 6 Controllers . . . . .	6:8

# 1: Receive and Accept the Controller

## Identify the Controller

Each Reliance Electric GP-1200 A-C V★S® Controller can be positively identified by its model number (standard controller) or sales order number (customer specified controller). This number appears on the shipping label and is stamped on the controller nameplate. Refer to this number whenever discussing the equipment with Reliance Electric personnel.

The standard model number describes the controller as follows:

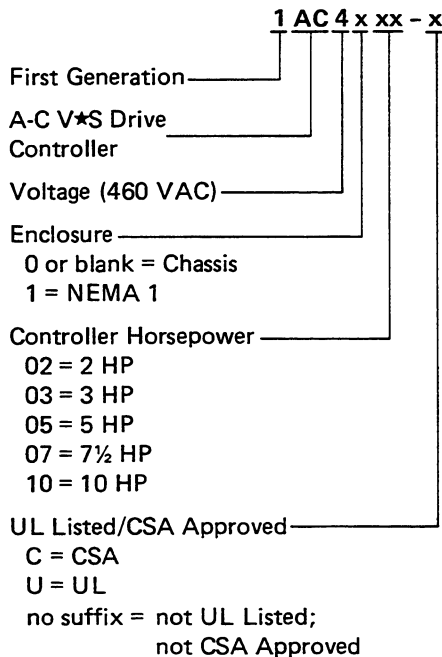

The sales order number is a six-digit number following a plant code that uniquely describes a controller manufactured to customer specifications.

## Receive and Accept the Shipment

Reliance Electric's terms of sales, in all instances, are F.O.B. point of origin. The user is responsible for thoroughly inspecting the equipment before accepting shipment from the transportation company.

If all the items called for on the bill of lading or on the express receipt are not included or if any items are obviously damaged, **do not** accept the shipment until the freight or express agent makes an appropriate notation on your freight bill or express receipt.

If any concealed loss or damage is discovered later, notify your freight or express agent within 15 days of receipt and request that he make an inspection of the shipment. Keep the entire shipment intact in its original shipping container.

The Consignee is responsible for making claim against the Carrier for any shortage or damage occurring in transit. Claims for loss or damage in shipment must not be deducted from the Reliance Electric invoice, nor should payment of the Reliance® invoice be withheld while awaiting adjustment of such claims since the Carrier guarantees safe delivery.

If considerable damage has been incurred and the situation is urgent, contact the nearest Reliance Electric Sales Office for assistance.

## Store the Controller until Installation

After receipt inspection, repack the GP-1200 A-C V★S Controller in its shipping container until installation. If a period of storage is expected, store in the original shipping container with its internal packing.

To ensure satisfactory drive operation at startup and to maintain warranty coverage, store the equipment:

- in its original shipping container in a clean, dry, safe place.
- within an ambient temperature range of  $-40^{\circ}$  to  $65^{\circ}$  C ( $-40^{\circ}$  to  $149^{\circ}$  F).
- within a relative humidity range of 5 to 95% without condensation.
- away from a highly corrosive atmosphere. In harsh environments, cover the shipping/storage container.
- away from construction areas.

## File a Return Request

1. To return equipment, send a written request to Reliance Electric within ten days of receipt.
2. Do not return equipment without a numbered authorization form (ERA form) from Reliance Electric.
3. Reliance Electric reserves the right to inspect the equipment on site.

# 2: Know the Controller

## Terminology Used in This Manual

### Definitions and Abbreviations

**CCW:** The abbreviation for counter-clockwise.

**CEC:** The abbreviation for the Canadian Electrical Code.

**CIF:** The abbreviation for the Customer Interface Module, which is an option.

**Controller:** The term substituted throughout this manual for "GP-1200 A-C V\*S Drive Controller" to make the manual easier to read and understand.

**CW:** The abbreviation for clockwise.

**Drive:** The reference to the controller and the motor combined as one system.

**GP-1200 A-C V\*S Drive Controller:** See "controller."

**IET:** The abbreviation for instantaneous electronic trip.

**NEC:** The abbreviation for the National Electrical Code.

**Pot:** The shortened reference for potentiometer.

**PWM:** The abbreviation for Pulse Width Modulation.

### Dangers, Warnings, and Cautions

Dangers, warnings, and cautions point out potential trouble areas. All three of these forms are enclosed in a box to call attention to them.

- A **danger** alerts a person that high voltage is present which could result in severe bodily injury or loss of life.
- A **warning** alerts a person of potential bodily injury if procedures are not followed.
- A **caution** alerts a person that, if procedures are not followed, damage to, or destruction of, equipment could result.

## Related Publications

For more information about the application and operation of this controller and related equipment and service, refer to these publications:

- "Long Term Storage for Control Cabinets" (D-8079)
- "GP-1200 Data Sheet" (D-2769)
- "Selection and Application of A-C V\*S Drives" (D-9084)
- "A-C Motor Efficiency" (B-7087)
- "Duty Master Energy Efficient XE A-C Motors" (B-2639)
- "Installation, Operation and Care of Reliance Standard Integral Horsepower Induction Motors" (B-3620)

These publications are available through your Reliance Electric Sales Office.

## Drive Components

The Reliance Electric drive consists of a controller with local operator controls and a three-phase A-C motor. When purchased as a drive system, the GP-1200 Controller is performance-matched with a Reliance Duty Master® XE Motor. The controller and/or motor can be purchased separately.

**Operator Control Devices.** The enclosed controller is equipped with a Basic Local Operator's Control Station mounted on the front of the enclosure. This station provides a Speed pot, a Start/Stop switch and a Run/Jog switch. The chassis controller option is provided with a Blank Local Operator's Control Station. Both of these stations include two LEDs: RUN and IET.

Duty Master is a registered trademark of Reliance Electric Company.

## Controller Features

- Two LEDs, located on the Local Operator's Control Station, indicate the drive status (RUN) and a fault condition (IET).
- Line transient protection prevents power line transients from harming the controller.
- Line-to-line and line-to-ground output short circuit protection.
- Standard fuses for easy replacement.
- IET on high D-C bus voltage, high motor current, high or low input A-C line, phase loss, low regulator power supply voltage, or function loss input.
- Isolated start/stop and function loss circuitry.
- Local devices (standard) for speed, start/stop and run/jog control.
- Coast-to-rest on Stop as standard or ramp-to-rest with a switch change.
- Torque boost for increased starting torque.
- Automatic correction of output voltage for input voltage fluctuations.
- Variable torque V/Hz curve selection.
- Motoring current limit and regenerative voltage limit.
- Adjustment pots:
  - acceleration rate (1P)
  - deceleration rate (2P)
  - maximum hertz (3P)
  - minimum hertz (4P)
  - torque boost (5P)
  - current limit (6P)
  - volts per hertz (7P)
- Hybrid-based regulator.
- NEMA 1 enclosure (standard); chassis available as an option.
- Operates with standard off-the-shelf NEMA B and synchronous motors.
- Other features available; contact your Reliance Electric Sales Office for information.

## Available Controller Options

This controller is designed to accept the pre-engineered options listed in Table 2-1. The options can be added either at the factory or in the field. Each option is packaged separately and has its own model number identification. Installation instructions are provided with each option.

## Local Operator's Control Station

The controller has a Local Operator's Control Station on the front of the cabinet. Ten Local Operator's Control Stations are available. See Table 2-2.

**Table 2-1. Standard Kit Options.**

Description	Model Number	Instruction Sheet
Local Operator's Control Station Kit (1)	See Table 2-2	D2-3105
Remote Operator's Control Station NEMA 1 with Start/Stop, Run/Jog, Forward/Reverse, Automatic/Manual, Speed Pot, Analog Frequency Meter	1RS2000	D2-3065
Customer Interface Module Kit (1)	1CI2001	D2-3104
Dynamic Braking Kit 460 V, 2 thru 5 HP (UL) 460 V, 2 thru 5 HP (CSA) 460 V, 7½ thru 10 HP (UL) 460 V, 7½ thru 10 HP (CSA)	1DB4005U 1DB4005C 1DB4010U 1DB4010C	D2-3106 D2-3106 D2-3106 D2-3106
Digital Meter with First Fault Indication	1DM2000	D2-3113
Extended Line Dip Module Kit	1LD4000	D2-3107
Output Frequency Meter	2FM4000	D2-3108
Output Ammeter 2 HP 3 thru 5 HP 7½ thru 10 HP	2AM4002 2AM4005 2SM4010	D2-3109 D2-3109 D2-3109
Output Voltmeter	2VM4000	D2-3110
Cabinet Conversion (NEMA 1 to Chassis ) Kit (1) 2 thru 5 HP 7½ thru 10 HP	1CK4005 1CK4010	D2-3112 D2-3112

(1) Mounts to or has components that mount to the controller.

**Table 2-2. Local Operator's Control Station Kits.**

Description	Function			Run/IET LEDs	Digital Meter Cutout (1)	Model Number
	Start/Stop Run/Jog Speed Pot	FWD/REV	AUTO/MAN			
Blank	NO	NO	NO	YES	NO	1LS2000A
	NO	NO	NO	NO	YES	1LS2004
Basic	YES	NO	NO	YES	NO	1LS2010
	YES	NO	NO	NO	YES	1LS2011
Reversing	YES	YES	NO	YES	NO	1LS2012
	YES	YES	NO	NO	YES	1LS2013
Automatic	YES	NO	YES	YES	NO	1LS2014
	YES	NO	YES	NO	YES	1LS2015
All Function	YES	YES	YES	YES	NO	1LS2002A
	YES	YES	YES	NO	YES	1LS2016

(1), Operator's Control Stations with a cutout for the Digital Meter are not supplied with the meter. The Digital Meter with First Fault Indication (Model 1DM2000) must be ordered along with the station.

## Remote Operator's Control Station

The Remote Operator's Control Station includes the Start/Stop, Run/Jog, Forward/Reverse, and Automatic/Manual function switches; a Speed pot; and an Analog Frequency Meter. Use of the remote station requires the Customer Interface Module and a Blank Local Operator's Station options. The frequency meter on the Remote Operator's Control Station connects to the Customer Interface Module in the controller.

## Customer Interface Module

The Customer Interface Module is required when using the Remote Operator's Control Station or user-supplied operator's devices and/or a separately mounted Analog Frequency Meter. It provides isolation for operator's devices and for a process control input signal of 4 to 20 mA, 0 to 20 mA or 0 to 10 VDC.

Normally open and normally closed IET contacts and a normally open RUN contact are provided for customer use. The contacts are rated 1 amp at 250 VAC and 2 amps at 30 VDC. The kit can be used with an operator's station: 1LS2000A or 1LS2004. The chassis controller is supplied with a Blank Local Operator's Control Station and a Customer Interface Module.

## Dynamic Braking

The Dynamic Braking Kit provides rapid deceleration of the drive motor by providing 150% intermittent braking of the motor. The kit dissipates the power regenerated by the motor during deceleration through a resistor.

Model 1DB4005 for 2 to 5 HP controllers is rated for 2.6 lb-ft<sup>2</sup>; Model 1DB4010 for 7.5 to 10 HP controllers is rated for 6.6 lb-ft<sup>2</sup>. Each is designed for six starts/stops per minute. The kits are provided in a separate enclosure for field wiring.

## Digital Meter

The Digital Meter displays not only the controller output frequency but also the first fault causing an IET. Local Operator's Control Station with cutout for the meter is required.

## Extended Line Dip Module

The kit consists of capacitors to backup control power supply. If provided controller is capable to extend to 330 milliseconds from 10 milliseconds of line dip ride-thru without IET.

## Cabinet Conversion

This option provides the necessary hardware to allow converting the NEMA 1 enclosure to the chassis configuration. It consists of a Blank Local Operator's Control Station, a Customer Interface Module, and the chassis enclosure's top and bottom plates.

## Voltmeter

The voltmeter connects directly to the output of the controller. It measures 0 to 500 VAC.

## Ammeter

The ammeter, using a current transformer as its input, measures current in one of the output lines of the controller. The ampere scale depends on the controller rating.

## Frequency Meter (Analog)

The frequency meter monitors the controller output terminals. It indicates the actual output frequency of the controller.

## Controller Specifications

### Controller Ratings

The controller operates on three-phase, 460 VAC and can be set to operate on 50 or 60 Hz line frequency. The controller provides three-phase variable voltage (0 to 460 VAC), variable frequency (3 to 60 Hz). Current ratings are listed in Table 2-3.

Table 2-3. Controller Current Ratings.

Nominal Horsepower Range	Controller Input KVA	Max Input Amps	Max Motor Sine Wave Amps (1)	Max Controller Output Amps
1/4 to 2	3.3	4.2	3.2	3.4
3	7.0	8.8	5.0	5.3
5	9.8	12.3	7.8	8.2
7½	10.7	13.4	10.5	11.1
10	13.6	17.2	13.5	14.2

- (1) To obtain motor nameplate horsepower, the controller's sine wave output ampere rating should be equal to or greater than the motor nameplate current. If the motor nameplate amperes are higher than the controller sine wave rating, the motor horsepower should be derated by the ratio of the controller sine wave ampere rating to the motor nameplate current. Refer to "Single-Motor Applications" and "Multi-Motor Applications" for more details.

## Service Conditions

- Ambient temperature: 0° to 40°C (32° to 104°F) for enclosed controllers and 0° to 55°C (32° to 131°F) for chassis controllers.
- Storage temperature: -40° to 65°C (-40° to 149°F)
- Atmosphere: 5 to 95% non-condensing relative humidity
- Elevation: To 3300 feet (1000 meters) above sea level without derating. For every 300 feet (91.4 meters) above 3300 feet, derate the current rating by 1%. Consult your Reliance Electric Sales Office for operation above 10,000 feet.
- Line frequency: 50/60 Hz ±2 Hz
- Line voltage variation: -10% to +10%
- A-C line distribution system capacity (maximum): 1,000 KVA, three-phase with 25,000 amps symmetrical fault current capacity.

## Controller Application Data

Pulse Width Modulation (PWM): sine wave  
Service Factor: 1.0  
Displacement Power Factor: 0.96  
Maximum Load: 150% for one minute  
Volts/Hz (60 Hz base): 6.8 to 16.0 V/Hz  
IET: 200% load  
Current Limit Adjustment: 50 to 150%  
Speed reference to output frequency (linearity): ±1%  
Minimum Frequency: 0 to 40 Hz <sup>(1)</sup>  
Maximum Frequency: 15 to 90 Hz <sup>(2)</sup>  
Acceleration Adjustment: 1.5 to 20 seconds <sup>(3)</sup>  
Deceleration Adjustment: 1.5 to 20 seconds <sup>(3)</sup>  
Torque Boost: 0 to 80 volts

- (1) Minimum frequency adjustment is additive to Maximum frequency adjustment up to 90 Hz.
- (2) Higher output frequency ranges are available. Contact your Reliance Electric Sales Office for assistance when operation above 60 Hz is required.
- (3) 4.5 to 60 seconds selectable by switch.

## Single-Motor Applications

The controller and motor must be sized for the specific application load and speed requirements. Refer to "Selection and Application of A-C V\***S** Drives" (D-9084) for assistance.

If the motor is overframed, the motor operating current must not exceed the controller's rated output current and the motor horsepower must not be more than one size larger than the controller's horsepower rating. A motor overload relay, sized to be equal to or less than the controller output current rating, must be connected between the motor and the controller output.

If the motor will be operated at speeds below one half the motor's rated speed, the motor overload relay may not protect the motor because of the reduction in motor cooling action due to the reduced speed. A motor thermostat built into or connected to the motor windings should be installed because it monitors the actual temperature of the motor windings.

### **Multi-motor Applications**

One controller can run two or more motors. Adhere to the following requirements to assure correct drive operation:

**When all the motors connected to the output of the controller are to start and stop at the same time**, the sum of the sine wave currents of all the motors must be less than or equal to the maximum motor sine wave current rating of the controller.

**When one or more of the motors connected to the output of the controller are to start and stop independently,**

- Any motor that starts or stops while the controller is running must have a current rating less than 10% of the maximum motor sine wave current rating of the controller.
- The sum of the sine wave currents of all the motors connected continuously on the output of the controller and the locked rotor sine wave current of any motor which is to start and stop independently must be less than or equal to the maximum motor sine wave current rating of the controller.

# 3: Install the Drive

## DANGER

ONLY QUALIFIED ELECTRICAL PERSONNEL FAMILIAR WITH THE CONSTRUCTION AND OPERATION OF THIS EQUIPMENT AND THE HAZARDS INVOLVED SHOULD INSTALL THIS EQUIPMENT. FAILURE TO OBSERVE THIS PRECAUTION COULD RESULT IN SEVERE BODILY INJURY OR LOSS OF LIFE.

## DANGER

THE USER IS RESPONSIBLE FOR CONFORMING TO THE NEC AND ALL OTHER APPLICABLE LOCAL CODES WITH RESPECT TO WIRING, GROUNDING, DISCONNECTS, AND OVERCURRENT PROTECTION. FAILURE TO OBSERVE THIS PRECAUTION COULD RESULT IN SEVERE BODILY INJURY OR LOSS OF LIFE.

## Plan and Complete the Installation

Read and understand this chapter in its entirety before beginning the actual installation. Follow these guidelines and procedures to minimize both installation and operating problems.

The controller is shipped standard as an enclosed unit, fully assembled in its own NEMA 1 enclosure. The chassis controller is shipped fully assembled for mounting in a NEMA 1 enclosure.

## Select the Controller Enclosure Location

1. Verify that the controller can be kept clean, cool, and dry.
2. Check that the enclosure is away from oil, coolant, and other airborne contaminants.
3. Check that temperatures in the controller vicinity are between 0° to 40°C (32° to 104°F) for enclosed controllers and 0° to 55°C (32° to 131°F) for chassis controllers.
4. Check that relative humidity is between 5 and 95% (non-condensing).
5. Do not install above 3300 feet (1000 meters) without derating. For every 300 feet (91.4 meters) above 3300 feet, derate the current rating 1%. Consult your Reliance Electric Sales Office for operation above 10,000 feet.

## Install the Controller

### Enclosed Controller

1. In the location selected, mount the enclosed controller vertically with the input/output terminals at the bottom.
2. Make sure the door or other components do not hinder service access. See Figure 3-1 for mounting dimensions.
3. Provide adequate clearance for air ventilation:
  - At least 2 inches from the sides and 4 inches from the top and bottom of the controller to adjacent non-heat producing equipment, such as a cabinet wall.
  - At least 2 inches from the sides and 10 inches from the top and bottom of adjacent controllers. For the best air movement with three or more controllers, do not mount the controllers in a vertical stack; offset the controllers.

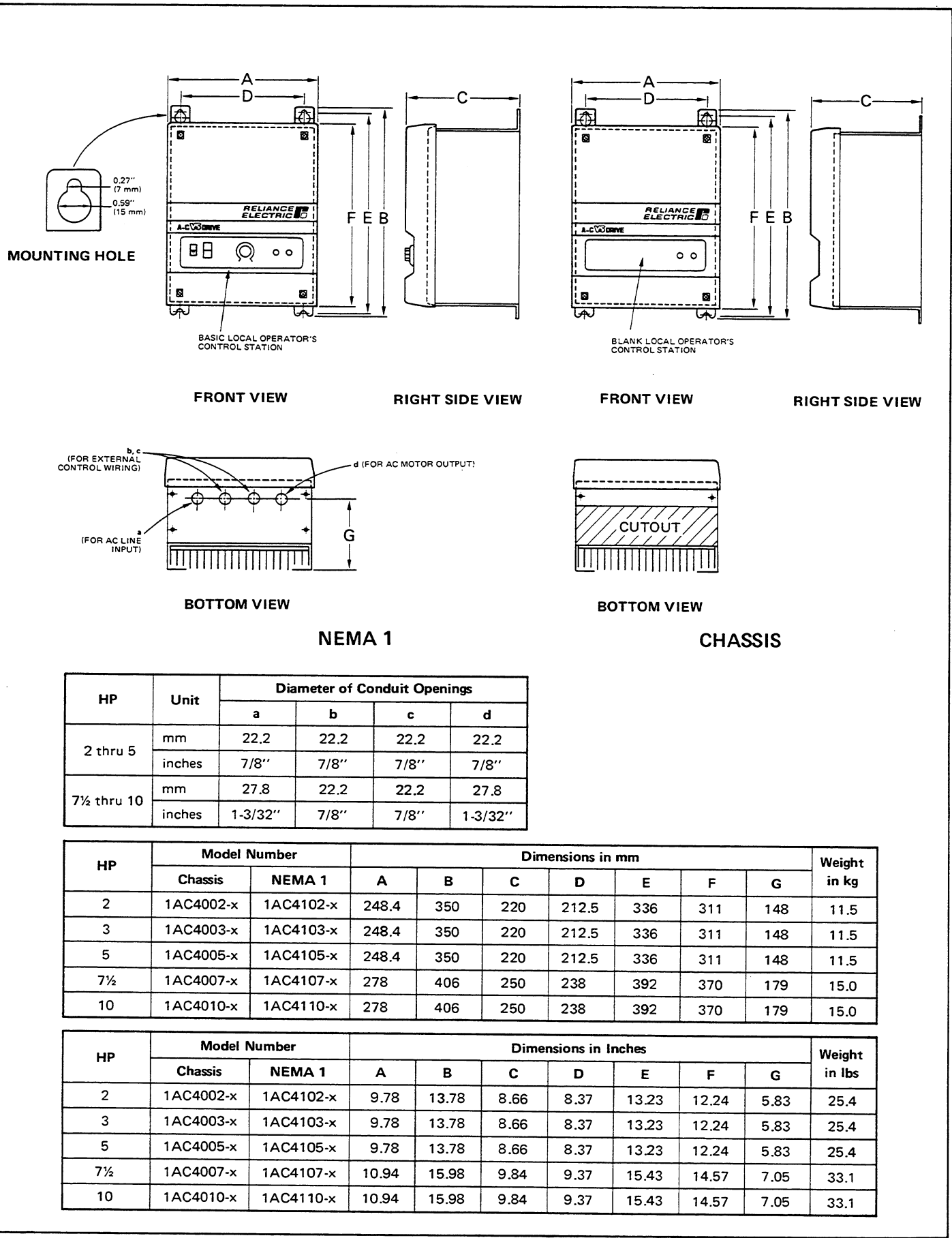

Figure 3-1. Physical Dimensions and Weights for NEMA 1 Enclosed and Chassis Controllers.

## Chassis Controller

**CAUTION:** Complete all drilling, cutting, welding, etc., before mounting the chassis in the metal enclosure. During installation protect the chassis from metal chips, weld splatters and other debris. Failure to observe these precautions could result in damage to, or destruction of, the equipment.

1. In the location selected, mount the metal enclosure in which the chassis will be mounted. If the enclosure is totally enclosed, size the metal enclosure using the following equation along with Table 3-1:

$$S = S_s + \frac{4}{3}S_t + \frac{2}{3}S_b \quad (1)$$

where:

$S_s$  = Area of enclosure's four side surfaces

$S_t$  = Area of enclosure's ceiling surface

$S_b$  = Area of enclosure's bottom surface

- (1) If a surface does not have at least a 1/2" layer of air beside it, it does not have any cooling effect. Use a zero area in the equation for any such surface.

For example, if you want to enclose a 2 HP chassis in an enclosure that is 30" high by 20" wide by 16" deep and the back side is 1/2" off the mounting wall, solve the equation and verify the answer with the Table 3-1 specifications.

$$\begin{aligned} S &= 2(30 \times 20) + 2(30 \times 16) + \\ &\frac{4}{3}(320) + \frac{2}{3}(320) \\ &= 2800 \text{ sq. in.} \end{aligned}$$

Referring to Table 3-1, note that a 2 HP controller requires 2.8 times  $10^3$  or 2800 sq. in. of surface area. The example enclosure meets the size requirements.

2. Mount the chassis directly to the enclosure mounting panel. Stand-off hardware is not necessary. See Figure 3-1 for mounting dimensions.

3. Provide adequate clearance for air ventilation within the enclosure:

- At least 2 inches from the sides and 4 inches from the top and bottom of the controller to adjacent non-heat producing equipment, such as a cabinet wall.
- At least 2 inches from the sides and 10 inches from the top and bottom of adjacent controllers. For the best air movement with three or more controllers, do not mount the controllers in a vertical stack; offset the controllers.

**Table 3-1. Sizing the Metal Enclosure That Will House the Chassis.**

HP	Power Loss (watts)	Effective Surface (S) Area	
		sq cm	sq in.
2	100	$1.8 \times 10^4$	$2.8 \times 10^3$
3	150	$2.7 \times 10^4$	$4.2 \times 10^3$
5	200	$3.6 \times 10^4$	$5.6 \times 10^3$
7½	250	$4.5 \times 10^4$	$7.0 \times 10^3$
10	300	$5.4 \times 10^4$	$8.4 \times 10^3$

### Install a Transformer (if needed)

In all applications requiring the use of an **output transformer**, contact your Reliance Electric Sales Office for assistance.

**Input transformers** step up or step down input voltage and can be either auto-transformers or isolation transformers. Isolation transformers help eliminate

- Damaging A-C line voltage transients from reaching the controller.
- Damaging currents, which could develop if a point inside the controller becomes grounded.

**CAUTION:** If an input transformer is installed ahead of the controller, a power disconnecting device must be installed between the power line and the primary of the transformer. If this power disconnecting device is a circuit breaker, the circuit breaker trip rating must be coordinated with the inrush current (10 to 12 times full-load current) of the input transformer. Do not connect an input transformer rated at more than 1000 KVA to the controller. Distribution system capacity above the 1000 KVA requires using an isolation transformer, a line reactor, or other means of adding similar impedance. Failure to observe these precautions could result in damage to, or destruction of, the equipment.

### Install an Input Disconnect

**DANGER**

**THE NEC REQUIRES THAT AN INPUT DISCONNECT BE PROVIDED IN THE INCOMING POWER LINE AND EITHER BE LOCATED WITHIN SIGHT OF THE CONTROLLER OR BE LOCKABLE. FAILURE TO OBSERVE THIS PRECAUTION COULD RESULT IN SEVERE BODILY INJURY OR LOSS OF LIFE.**

1. Install an input disconnect in the incoming power line according to the NEC. It must either be located within sight of the controller or be lockable.
2. Size the disconnect to handle the transformer primary as well as any additional loads the disconnect may supply.
3. Wire this disconnect in the primary circuit of the controller isolation transformer (if used).

## Install the Motor

1. Verify the motor is the appropriate size to use with the controller.

Derate the A-C motor to compensate for additional heating in the motor caused by harmonics. Refer to D-9084 "Selection and Application of A-C V\*S Drives" for application guidelines for constant torque loads. Refer to Table 3-2 for motor derating values for centrifugal loads.

2. Install the A-C motor according to its instruction manual.
3. According to NEC requirements, install an overload protection device responsive to motor current in each power line of the motor (motor overload relay) or verify that a thermal protection device responsive to motor heat is built into or connected to the motor windings.

If the motor is overframed, verify that the motor operating current does not exceed the controller's output current and the motor horsepower is not more than one size larger than the controller's horsepower rating. Then connect a motor overload relay, sized to be equal to or less than the controller output current rating.

If the motor will be operated at speeds below one half the motor's rated speed, use the thermal responsive type of protection device because it monitors the actual temperature of the motor windings. The motor overload relay may not protect the motor because of the reduction in motor cooling action due to the reduced speed.

4. Make sure the motor is properly aligned with the driven machine to minimize unnecessary motor loading from shaft misalignment.
5. If the motor is accessible while it is running, install a protective guard around all exposed rotating parts.

## Ground the Controller and Enclosure, Motor, Remote Operator's Control Station, and Regulator Transformer

**DANGER**  
**THE USER IS RESPONSIBLE TO MEET ALL CODE REQUIREMENTS WITH RESPECT TO GROUNDING ALL EQUIPMENT. FAILURE TO OBSERVE THIS PRECAUTION COULD RESULT IN SEVERE BODILY INJURY OR LOSS OF LIFE.**

1. Open the enclosure door by loosening the two screws.
2. Run a suitable equipment grounding conductor or bonding jumper **unbroken** from the chassis GND terminal (Figure 3-2 or 3-3) to the grounding electrode conductor (earth ground).
3. Connect a suitable equipment grounding conductor or bonding jumper to the motor frame, the remote operator's control station (if used), the regulator transformer, and the controller enclosure. Run this conductor or jumper **unbroken** to the grounding electrode conductor (earth ground).
4. If code requires the 24 VDC Start/Stop circuit be grounded, connect a green wire between 2TB-5 and chassis ground and move jumper J9 to J8.

## Suppress Electrical Noise

Electrical noise from nearby relays, solenoids, or brake coils can cause erratic drive behavior. To keep this from happening, add an R-C suppressor, such as Reliance part 600686-33A, across the coils of these devices. If the circuit is 115 to 230 VAC, a 220-ohm, 0.5 watt resistor in series with a 0.5 microfarad, 600-volt capacitor can be used as the suppressor.

## Wire the Drive

1. Verify that the input power to the controller corresponds to the controller nameplate voltage and frequency and that the plant supply is of sufficient ampacity to support the input current requirements of the controller.

**CAUTION:** If the incorrect voltage is applied to the controller, an IET could result from a variation in line voltage within the  $\pm 10\%$  range. Failure to observe this precaution could result in damage to, or destruction of, the controller.

2. Provide a transformer between the plant power supply and the controller if the correct input line voltage is not available. Refer to "Provide a Transformer" in this chapter.
3. Use a tightening torque of 20 in-lbs for wire connections to input terminals and output terminals in the controller.
4. Refer to the wiring locations (Figure 3-2 or 3-3).

**Table 3-2. Motor Derating Data for Centrifugal Loads.**

Motor Insulation Class	Motor Service Factor	Motor Derating Percentage of Nameplate HP
B	1.0	15%
B	1.15	10%
F	1.0	5%
F	1.15	0%

- 1> **TERMINAL 1TB**
- 1 } Process Control Input
  - 2 } 4 to 20 mA, 0 to 20 mA or 0 to 10 VDC (Non-isolated)
  - 3 } Function Loss Input
  - 4 } (Isolated)
  - 5 } DB Signal to DB Kit (Option)
  - 6 } (Isolated)

- 1> **TERMINAL 2TB**
- 1 } Output Contactor Sequencing Contact
  - 2 } Auxiliary Contact Input (Isolated)
  - 3 } Output Contactor Output
  - 4 } (Isolated)
  - 5 } Ground for Start/Stop circuitry if required. Refer to "24 VDC Grounding" in Chapter 3.

CHASSIS GROUND

INPUT  
TERMINALS  
(181, 182, 183)

TERMINALS  
FOR DB (OPTION)  
(13, 14, 147, 45)

OUTPUT  
TERMINALS  
(601, 602, 603)

- 1> Any wiring connected to this terminal board must be rated at 600 volts or greater because this wiring may make contact with un-insulated (460 VAC) components.

Figure 3-2. Wiring Locations in NEMA 1 Controller with Basic Local Operation Control Station.

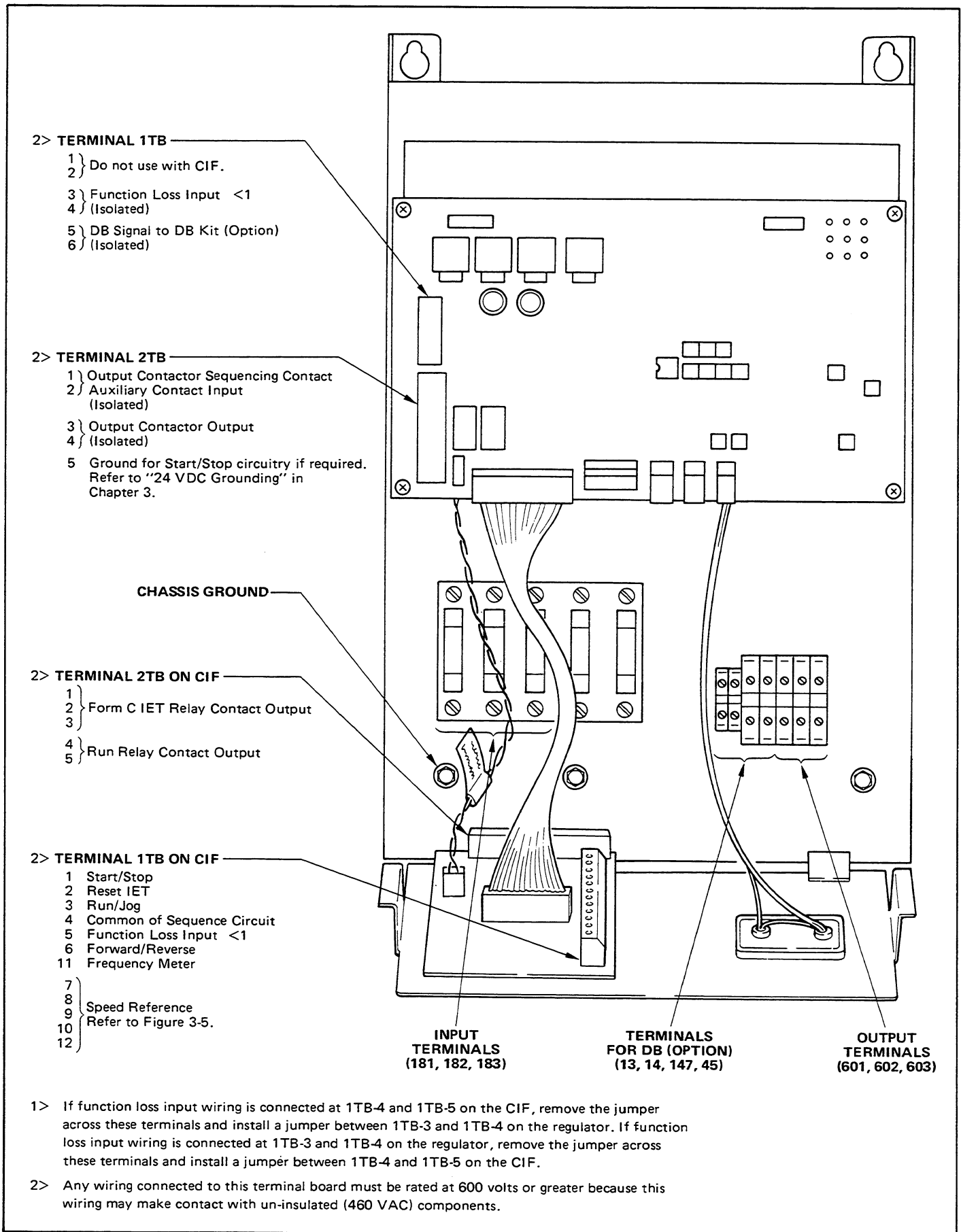

Figure 3-3. Wiring Locations in Chassis Controller with Customer Interface Module.

## Power Wiring

Size and install all wiring in conformance with the NEC and all other applicable local codes.

1. Use only copper wire rated 60/75°C.
2. Size input and output power wiring, according to applicable codes, to handle the maximum controller current as listed under "Controller Current Information" in Chapter 2.
3. Install the power wiring according to the interconnection diagram (Figure 3-4 or 3-5).
4. Route A-C input leads through the bottom left opening of the controller (Figure 3-1) to terminals 181, 182 and 183.
5. Route motor leads through the bottom right opening of the controller (Figure 3-1) to terminals 601, 602, and 603.

## Control and Signal Wiring

Size and install all wiring in conformance with the NEC and all other applicable local codes.

1. Use twisted wire having two to three twists per inch. If you use shielded wire rather than twisted wire, the shields should not attach to any ground point; they should "float."
2. For distances of less than 150 feet, use a minimum of #22 AWG. For distances of more than 150 feet and less than 300 feet, use a minimum of #16 AWG. For distances of more than 300 feet, contact your Reliance Electric Sales Office.
3. If a separately mounted operator's control station or a Remote Operator's Control Station is required, disconnect the control devices from the Basic Local Operator's Control Station. Remove this control station panel and replace it with a Blank Local Operator's Control Station and a Customer Interface Module (CIF).
4. Wire control and signal wiring, rated at 600 volts or greater, according to the interconnection diagram. Use Figure 3-4 (controller with Local Operator's Control Station) or Figure 3-5 (controller with CIF).

**CAUTION:** It is important to use wire rated at 600 volts or greater because this wiring may make contact with uninsulated (460 VAC) components. Failure to observe this precaution could result in damage to, or destruction of, the equipment.

5. Route user-supplied interlock and function loss input wiring (if any) through either of the center openings in the bottom of the controller. See Figure 3-1.

**WARNING**  
**IF THE FACTORY-INSTALLED JUMPER IS NOT REMOVED WHEN FUNCTION LOSS INPUT OR INTERLOCKS ARE USED, THESE CONTACTS WILL NOT OPEN TO STOP THE CONTROLLER ON AN IET. FAILURE TO OBSERVE THIS PRECAUTION COULD RESULT IN BODILY INJURY.**

Connection can be made at 1TB-3 and 1TB-4 on the regulator or, if the CIF is installed, at 1TB-4 and 1TB-5 on the CIF. Both of these terminal sets have a factory-installed jumper between the two terminals. Remove only the jumper between the two terminals where the interlock and function loss input wiring will be made. Connect the wiring. See Figure 3-4 or 3-5.

6. Route external control wiring, rated at 600 volts or greater, on the CIF (isolated from the logic circuit) through the remaining center opening in the bottom of the controller in separate steel conduit to eliminate electrical noise pick-up. The conduit can be rigid steel or flexible armored steel. See Figure 3-1. Terminal 1TB-4 on the CIF is common for the wiring of start/stop, run/jog, forward/reverse, function loss and analog frequency. Terminal 1TB-10 on the CIF is common for the wiring of the Speed pot, Auto/Man and process control. Note that the Speed pot must be 5K ohms and 0.5 watt minimum.

**CAUTION:** It is important to use wire rated at 600 volts or greater because this wiring may make contact with uninsulated (460 VAC) components. Failure to observe this precaution could result in damage to, or destruction of, the equipment.

**DANGER**  
**EXTERNAL POWER WIRING MAY REMAIN ENERGIZED WHEN THE MAIN A-C POWER IS DISCONNECTED. IDENTIFY ALL SUCH EXTERNAL WIRING. FAILURE TO OBSERVE THIS PRECAUTION COULD RESULT IN SEVERE BODILY INJURY OR LOSS OF LIFE.**

7. If required, connect user-supplied RUN and IET contacts to 2TB on the CIF. Identify this as external power wiring (Reliance normally uses yellow wire.). Provide a means to disconnect this external wiring.
8. Do not route signal wire through junction or terminal boxes that contain power or control wire.
9. Do not route signal wire in close proximity to devices producing external magnetic fields.

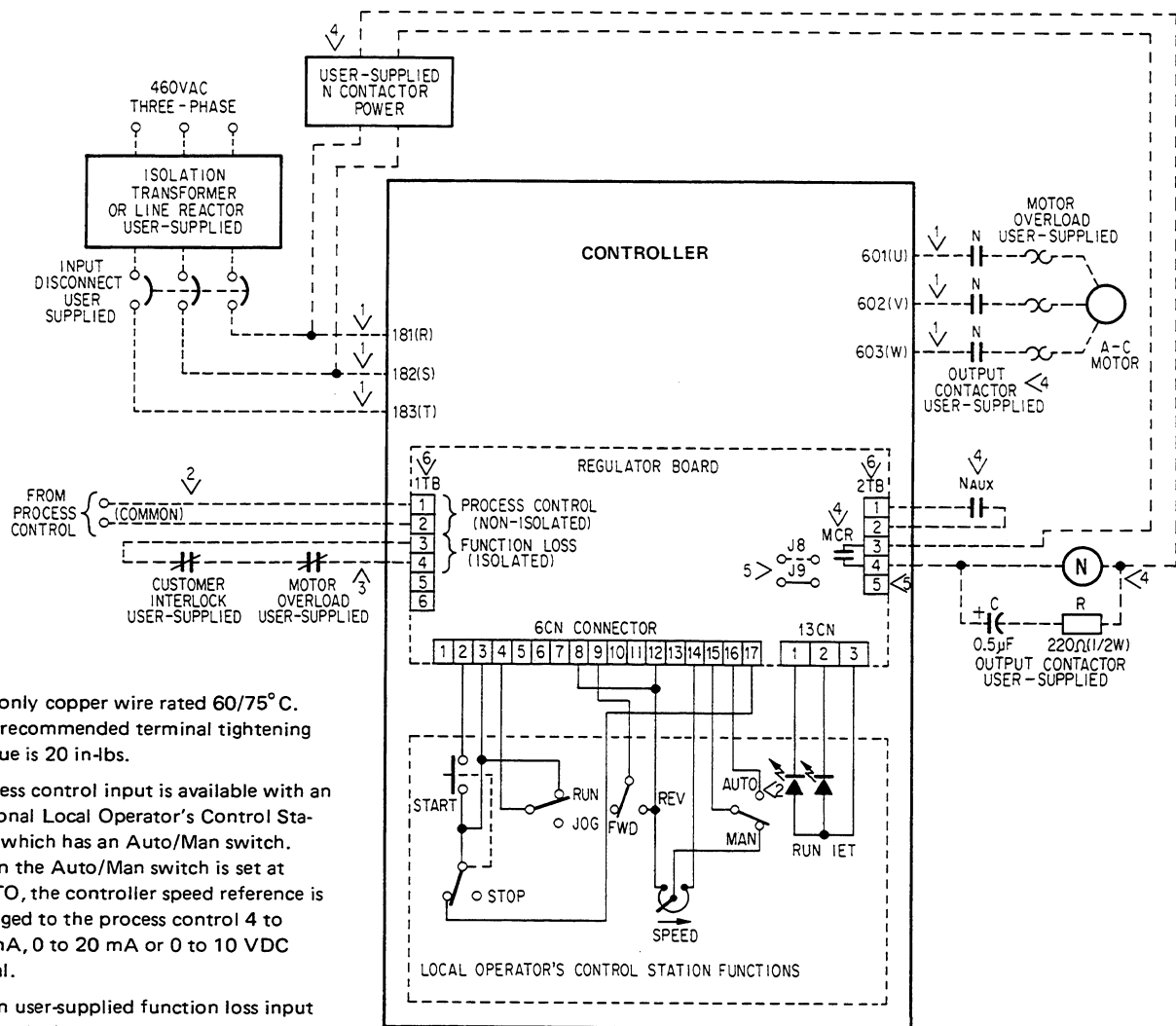

1. Use only copper wire rated 60/75° C. The recommended terminal tightening torque is 20 in-lbs.
2. Process control input is available with an optional Local Operator's Control Station which has an Auto/Man switch. When the Auto/Man switch is set at AUTO, the controller speed reference is changed to the process control 4 to 20 mA, 0 to 20 mA or 0 to 10 VDC signal.
3. When user-supplied function loss input or interlocks are connected, remove the factory-installed jumper between 1TB-3 and 1TB-4 in order for these contacts to be operational. When these contacts open, the controller stops on an IET and the motor coasts to rest.

**WARNING**

IF THE FACTORY-INSTALLED JUMPER IS NOT REMOVED BETWEEN 1TB-3 AND 1TB-4 WHEN FUNCTION LOSS INPUT OR INTERLOCKS ARE USED, THESE CONTACTS WILL NOT OPEN TO STOP THE CONTROLLER ON AN IET. FAILURE TO OBSERVE THIS PRECAUTION COULD RESULT IN BODILY INJURY.

4. When a user-supplied output "N" contactor is installed, the following conditions must be met:  
Provide power (having the capacity required for the coil) to the N contactor coil from the input disconnect used for the controller. This power should be fused according to NEC and all codes.

**CAUTION:** Only the MCR relay should control the N contactor. Do not add any external switches or contacts in series with the N contactor or coil. Failure to observe this precaution could result in damage to, or destruction of, this equipment.

Remove the factory-installed jumper between 2TB-1 and 2TB-2 and connect the contactor's NAUX contact. After the START command is given, the NAUX contact closes and the controller output follows the input speed reference.

The MCR contact [rated for 1 amp at a maximum of 250 VAC (PF = 0.4, L/R = 7 ms) or 2 amps at 30 VDC] provides sequencing control for the N contactor. The MCR contact makes sure the controller output transistors are OFF.

5. This is an optional grounding connection. Refer to Section 3 "24 VDC Grounding."
6. Any wiring connected to this terminal board must be rated at 600 volts or greater because this wiring may make contact with uninsulated (460 VAC) components.

Figure 3-4. Interconnection Diagram of Controller with Local Operator's Control Station Functions.

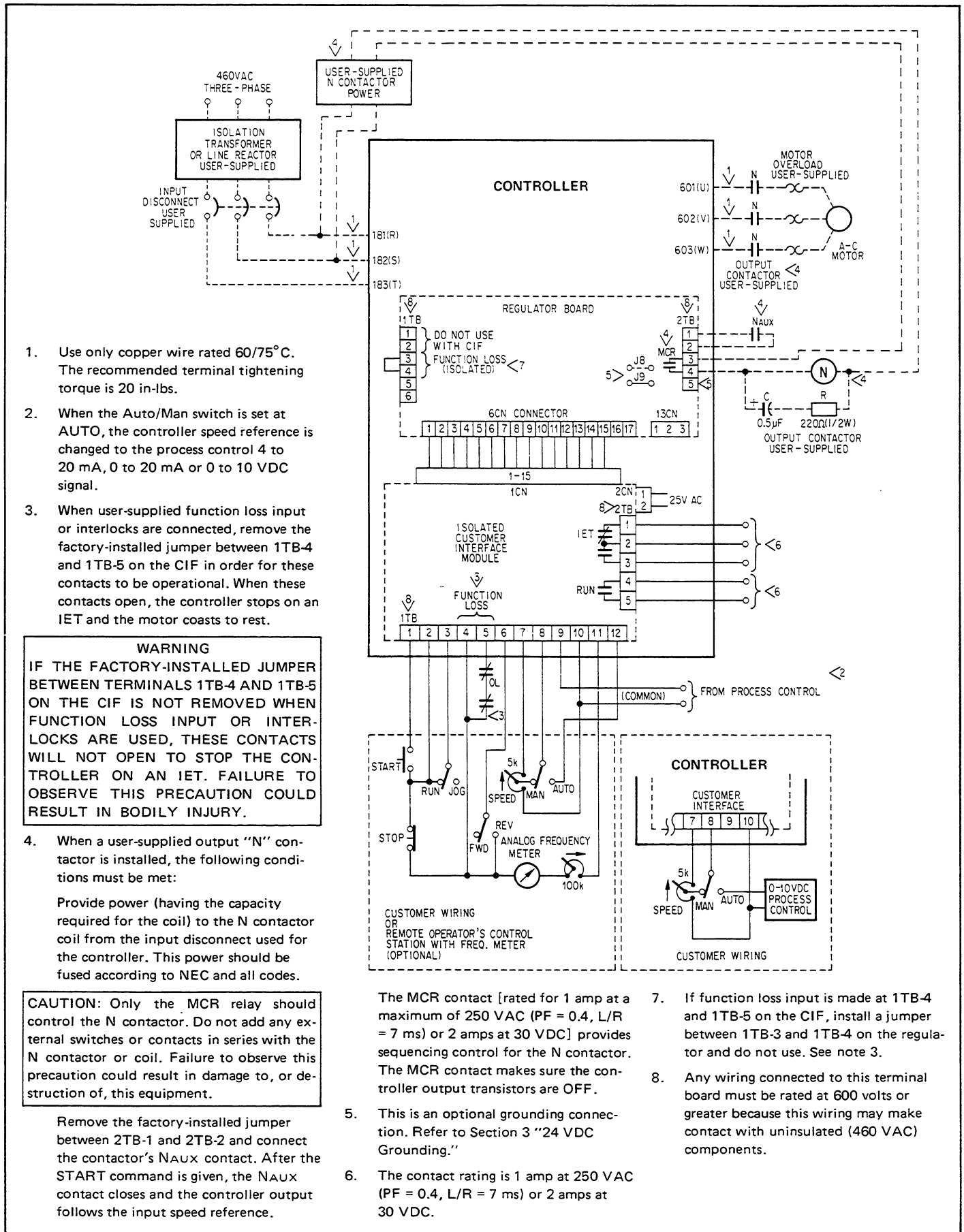

1. Use only copper wire rated 60/75°C. The recommended terminal tightening torque is 20 in-lbs.
2. When the Auto/Man switch is set at AUTO, the controller speed reference is changed to the process control 4 to 20 mA, 0 to 20 mA or 0 to 10 VDC signal.
3. When user-supplied function loss input or interlocks are connected, remove the factory-installed jumper between 1TB-4 and 1TB-5 on the CIF in order for these contacts to be operational. When these contacts open, the controller stops on an IET and the motor coasts to rest.

**WARNING**  
 IF THE FACTORY-INSTALLED JUMPER BETWEEN TERMINALS 1TB-4 AND 1TB-5 ON THE CIF IS NOT REMOVED WHEN FUNCTION LOSS INPUT OR INTERLOCKS ARE USED, THESE CONTACTS WILL NOT OPEN TO STOP THE CONTROLLER ON AN IET. FAILURE TO OBSERVE THIS PRECAUTION COULD RESULT IN BODILY INJURY.

4. When a user-supplied output "N" contactor is installed, the following conditions must be met:  
 Provide power (having the capacity required for the coil) to the N contactor coil from the input disconnect used for the controller. This power should be fused according to NEC and all codes.

**CAUTION:** Only the MCR relay should control the N contactor. Do not add any external switches or contacts in series with the N contactor or coil. Failure to observe this precaution could result in damage to, or destruction of, this equipment.

Remove the factory-installed jumper between 2TB-1 and 2TB-2 and connect the contactor's NAUX contact. After the START command is given, the NAUX contact closes and the controller output follows the input speed reference.

5. This is an optional grounding connection. Refer to Section 3 "24 VDC Grounding."
6. The contact rating is 1 amp at 250 VAC (PF = 0.4, L/R = 7 ms) or 2 amps at 30 VDC.

7. If function loss input is made at 1TB-4 and 1TB-5 on the CIF, install a jumper between 1TB-3 and 1TB-4 on the regulator and do not use. See note 3.
8. Any wiring connected to this terminal board must be rated at 600 volts or greater because this wiring may make contact with uninsulated (460 VAC) components.

Figure 3-5. Interconnection Diagram Using Customer Interface Module.

# Controller Regulator Modifications

The controller regulator has several built-in modifications which can be made by connecting a jumper or setting a DIP switch on the regulator PC board. The modifications are listed in Table 3-3 and are located in Figure 3-6.

Table 3-3. Regulator Modifications.

Modification	Jumper	Switch
Extended Speed Range	*	—
Variable Torque Curve	J4, J5	—
Variable Carrier Frequency	J6, J7	—
24 VDC Grounding	J8, J9	—
Output Contactor Turn-off Delay	J10, J11	—
Process Control	J12, J13	—
Extended Line Dip Ride Thru	J14, J15	—
Regenerative Voltage Limit	—	1SW (1)
D-C Offset at Zero Hertz	—	1SW (2)
Ramp-to-Rest	—	1SW (3)
Extended Acceleration and Deceleration Times	—	1SW (4)

\* Factory set at 60 Hz with wirewrap jumpered at J1. Extended speed requires application assistance; contact Reliance Electric.

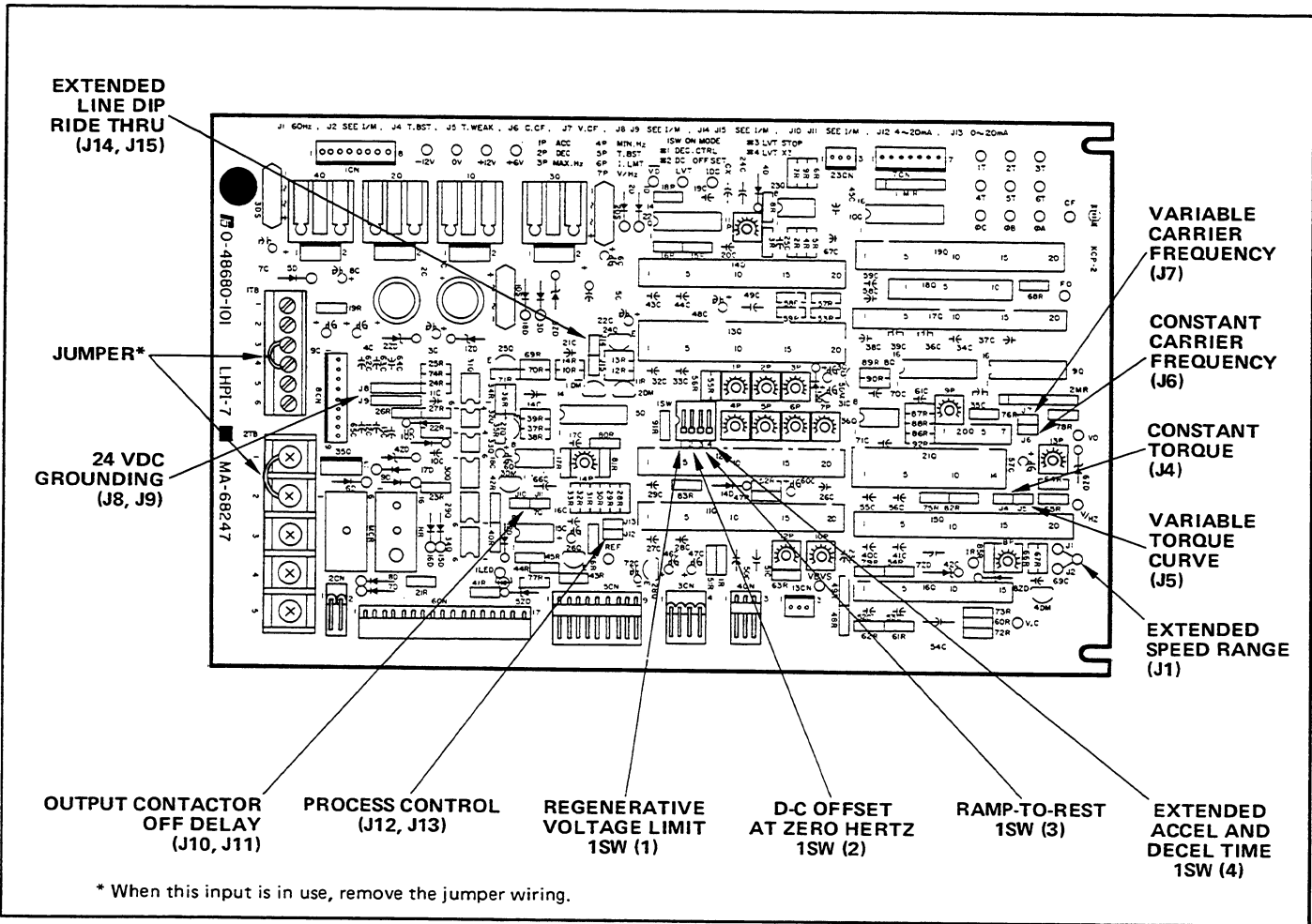

\* When this input is in use, remove the jumper wiring.

Figure 3-6. Location of Modification Jumpers and Switches on the Regulator.

## Extended Speed Range

The controller is factory set to provide a 60 Hz base frequency with a 90 Hz (150%) maximum. An 80 Hz base frequency with a 120 Hz (150%) maximum is available (Table 3-4); however, contact Reliance Electric for application assistance with and instructions for this modification.

**WARNING**  
**THE USER IS RESPONSIBLE FOR ENSURING THAT DRIVEN MACHINERY, ALL DRIVE-TRAIN MECHANISMS, AND PROCESS LINE MATERIAL ARE CAPABLE OF SAFE OPERATION AT AN APPLIED FREQUENCY OF 150% OF THE MAXIMUM SELECTED BASE FREQUENCY TO THE A-C MOTOR. FAILURE TO OBSERVE THIS PRECAUTION COULD RESULT IN BODILY INJURY.**

If a fault occurs, the controller is designed so that, regardless of the base frequency selected (60 Hz or 80 Hz), the maximum output frequency to the motor will be limited to 150% (90 Hz or 120 Hz, respectively) of the selected base frequency.

**Table 3-4. Possible Speed Ranges.**

Base Frequency	Frequency Range
60 (standard)	0 to 90
80*	0 to 120*

\* Requires application assistance; contact Reliance Electric.

## Variable Torque Curve

The controller has been designed for general purpose applications. For variable torque applications with energy savings at speeds below base speed, move jumper J4 to J5. A variable torque curve for 460-volt input is shown in Figure 4-2.

## Variable Carrier Frequency

The controller is factory set to provide a constant carrier frequency of 1.0 kHz above a preset speed range. This high value lessens acoustic noise but produces a rather small fundamental output voltage in a low speed range. Adjusting the Torque Boost pot can provide more starting or breakaway torque. If the Torque Boost pot cannot provide enough voltage boost, move jumper J6 to J7 for the variable carrier frequency modification.

With this modification, the carrier frequency automatically decreases in proportion to the decrease in speed, providing enough starting torque in a low speed range (but with higher acoustic noise) to have smooth operation. See Figure 5-3.

## 24 VDC Grounding

The secondary winding for the 24 VDC start/stop circuit is isolated from other logic circuits. If code requires that the 24 VDC power supply for the start/stop circuit be grounded to earth, move jumper J9 to J8. Connect a green wire between 2TB-5 and the chassis ground terminal (green).

**CAUTION:** Do not use this ground unless code requires it. If grounding is required, make sure a green wire is connected between 2TB-5 and the chassis GND terminal and the jumper is at J8. Failure to observe these precautions could result in damage to, or destruction of, this equipment.

## Output Contactor Turn-off Delay

The controller includes output contactor sequencing. As shipped, the contactor opens when the Stop switch is pressed and closes when the Start switch is pressed. There is a slight time delay before closing and opening to ensure the output is at zero when the contactor is opened. To hold the contactor closed for up to 1.5 seconds after pressing the Stop switch, move jumper J10 to J11.

## Process Control

To provide a speed reference from a user-supplied process control signal (4 to 20 mA, 0 to 20 mA or 0 to 10 VDC), the controller must have a Local Operator's Control Station with an Auto/Man switch. The switch changes the speed reference from the Speed pot (MAN) to the process control signal (AUTO). The standard controller provides only non-isolated input; isolated input with Bias and Gain pots is available with the CIF option.

Connect the process control signal at 1TB-1 and 1TB-2 (non-isolated). See Figure 3-4. Verify the jumper is at J12 with a 4 to 20 mA signal or at J13 with a 0 to 20 mA or 0 to 10 VDC signal. If the 0 to 10 VDC signal cannot handle a 500-ohm load, do not have a jumper at J12 or J13.

When the controller includes the optional CIF (includes isolated input), 1TB-1 and 1TB-2 are inoperable. Refer to the Customer Interface Module Kit Instruction Sheet D2-3104 for wiring details.

## Extended Line Dip Ride Thru

If the line power supply is interrupted or dipped for more than 10 milliseconds, an IET (low line) will occur. If an Extended Line Dip Module Kit (option) is additionally installed outside the controller to back up capacitor, it is possible to extend the line-dip-rise-thru from 10 milliseconds to 330 milliseconds.

There are two jumpers, J14 and J15, on the controller's regulator PC board. The jumper is usually located at J14, when an IET will occur at a typical line dip of 10 milliseconds or more. Be sure relocate the jumper from J14 to J15, when the Extended Line Dip Module Kit is employed.

## Regenerative Voltage Limit

The controller is factory set to provide regenerative voltage limit by extending the deceleration time when the D-C bus voltage exceeds a nominal preset value. This feature prevents an IET during deceleration. If the Dynamic Braking Kit is installed, this circuit must be turned off. Move Dip Switch 1SW (1) to the OFF position.

### D-C Offset at Zero Hertz

For the controller to operate a permanent magnet synchronous motor, move the Dip Switch 1SW (2) to the ON position. This mode will provide D-C offset voltage at 0 Hz, which is required to synchronize the motor rotor at starting to avoid high current demand. Adjusting the Torque Boost pot provides 0 to 80 VAC at 0 Hz.

Controllers are shipped with Dip Switch 1SW (2) in the OFF position for operation of standard induction motors.

**CAUTION:** Operating induction motors with Dip Switch 1SW (2) in the ON position could result in excessive motor heating at low speeds. Failure to observe this precaution could result in damage to, or destruction of, this equipment.

### Ramp-to-Rest

The controller is factory set to provide a coast-to-rest stop. Move Dip Switch 1SW (3) to the ON position to provide a ramp-to-rest stop.

**WARNING**  
**THE RAMP-TO-REST FUNCTION REQUIRES PROPER OPERATION OF REGULATOR ELECTRONICS AND IS NOT FAIL-SAFE. WHEN THE RAMP-TO-REST STOP FUNCTION IS REQUIRED, A COAST-STOP PUSHBUTTON IS REQUIRED. THE COAST-STOP PUSHBUTTON DISABLES THE REGULATOR AND ALLOWS THE MOTOR TO COAST-TO-REST. FAILURE TO OBSERVE THIS PRECAUTION COULD RESULT IN BODILY INJURY.**

When ramp-to-rest is selected, a coast-stop pushbutton must be wired to the function loss input terminals.

### Extended Acceleration and Deceleration Times

The controller is factory set to provide an acceleration and deceleration time from 1.5 to 20 seconds. To extend the minimum time from 1.5 to 4.5 seconds and the maximum time from 20 to 60 seconds, move Dip Switch 1SW (4) to ON. See Table 3-5.

Table 3-5. Extended Acceleration and Deceleration Time Selection.

Switch 1SW (4)	Min. Time (Seconds)	Max. Time (Seconds)
OFF	1.5	20
ON	4.5	60

# 4: Start and Adjust the Drive

**DANGER**  
**ONLY QUALIFIED ELECTRICAL PERSONNEL FAMILIAR WITH THE CONSTRUCTION AND OPERATION OF THIS EQUIPMENT AND THE HAZARDS INVOLVED SHOULD START AND ADJUST THIS EQUIPMENT. FAILURE TO OBSERVE THIS PRECAUTION COULD RESULT IN SEVERE BODILY INJURY OR LOSS OF LIFE.**

## Test Equipment Needed

**CAUTION:** Do not use a megger to perform continuity checks in the drive equipment. Failure to observe this precaution could result in damage to, or destruction of, the equipment.

1. Two volt-ohmmeters each having a sensitivity of 20,000 ohms-per-volt, such as a Triplet Model 630.
2. A volt-ohmmeter with a 10 meg-ohm input impedance on all ranges, such as a Fluke 8022B. (This unit provides an accuracy of  $\pm 15\%$  when measuring controller output voltage at terminals 601, 602, and 603.)

The most common voltmeters in use are digital and analog voltmeters. However, these two voltmeters use several different methods of measuring the RMS voltage of a waveform, thus producing a wide range of RMS readings for a particular PWM waveform.

A fundamental voltmeter is best suited for measuring output voltage of PWM waveforms because it filters out unwanted harmonics. An accurate measurement is important since the fundamental waveform is the main contributor to the power conducted to the motor. Therefore, in this manual, voltages given are fundamental voltages.

In comparison testing, the Fluke 8022B provides an RMS measurement nearly equivalent to that of the fundamental voltmeter; the Triplet 630 provides an RMS measurement that is 20 volts higher than that of the fundamental voltmeter.

Follow these guidelines when measuring the output voltage of this PWM controller:

- Keep voltmeter lead lengths as short as possible.
- When using an analog voltmeter, use the 500-750 VAC scale.
- When using a digital voltmeter, use the 200 VAC scale for measuring output voltages up to 200 VAC and the 750 VAC scale for measuring output voltages above 200 VAC.
- When using a Triplet 630 voltmeter, subtract 20 volts from the reading to determine the fundamental output voltage.
- When using a Fluke 8022B voltmeter, the meter reading can be used as an approximate fundamental voltage.

## Check the Installation

**DANGER**  
**THIS EQUIPMENT IS AT LINE VOLTAGE WHEN A-C POWER IS CONNECTED TO THE CONTROLLER. DISCONNECT ALL UN-GROUNDED CONDUCTORS OF THE A-C POWER LINE FROM THE CONTROLLER. AFTER POWER IS REMOVED, VERIFY WITH A VOLTMETER AT TERMINALS 147(+) AND 45(-) THAT THE D-C BUS CAPACITORS ARE DISCHARGED BEFORE TOUCHING ANY INTERNAL PARTS OF THE CONTROLLER. FAILURE TO OBSERVE THESE PRECAUTIONS COULD RESULT IN SEVERE BODILY INJURY OR LOSS OF LIFE.**

1. Make sure the input disconnect is in the OFF position (power OFF).
2. Make sure the drive shutdown interlocks, such as safety switches installed around the driven machine, are operational. When activated, they should shut down the drive.

**CAUTION:** Make sure electrical commons are not intermixed when monitoring voltage and current points in the controller. Failure to observe this precaution could result in damage to, or destruction of, the equipment.

## Check the Motor

1. Verify that motor nameplate data corresponds to the controller output ratings:
  - Voltage: 460 VAC; three-phase. If the motor has dual voltage capability, verify that it is connected for the voltage corresponding to the input voltage.
  - Current: Verify that full-load current does not exceed the controller's motor sine wave current rating. If the motor is over-framed, verify that the motor operating current does not exceed the controller's rated current and the motor horsepower rating is not more than one size larger than the controller's horsepower rating.
  - Frequency: 60 or 50 hertz or other frequency consistent with the controller output frequency.

For synchronous motor applications, consult your Reliance Electric Sales Office.

2. Check that the motor is installed according to the motor instruction manual.
3. Disconnect any power factor correction capacitors connected to the motor.
4. If possible, uncouple the motor from the driven machinery.
5. Rotate the motor shaft by hand to check that the motor is free from any binding or mechanical load problem.
6. Check that no loose items, such as shaft keys, couplings, etc., are present.
7. Check all connections for tightness and proper insulation.
8. Check that any motor thermal switch or overload device is wired according to the interconnection diagram (Figure 3-4 or 3-5).

## Motor Overspeed

### WARNING

THE USER IS RESPONSIBLE FOR ENSURING THAT DRIVEN MACHINERY, ALL DRIVE-TRAIN MECHANISMS, AND PROCESS LINE MATERIAL ARE CAPABLE OF SAFE OPERATION AT AN APPLIED FREQUENCY OF 150% OF THE MAXIMUM SELECTED BASE FREQUENCY TO THE A-C MOTOR. FAILURE TO OBSERVE THIS PRECAUTION COULD RESULT IN BODILY INJURY.

## Check the Transformer (if used)

1. Check that the rating of the transformer (if used) matches the controller requirements. Refer to "Install a Transformer" in Chapter 3.
2. Check that the transformer is connected for the proper voltages.

## Check the Controller and Enclosure

1. Remove the controller enclosure cover, if not already open.
2. Look for physical damage, remaining installation debris, wire strands, etc.
3. Use clean, dry, low pressure air (below 25 PSI) for removing debris from the controller.
4. Check that there is adequate clearance around the controller for air flow.
5. Check that the controller is wired according to the interconnection diagram (Figure 3-4 or 3-5).
6. If a user-supplied output contactor and/or user-supplied interlocks or function loss devices are installed, make sure the respective factory-installed jumpers are removed.
7. Using a voltmeter, check that 460 VAC power is available on the incoming line side of the input disconnect.
8. Check that all control and power terminal connections are tight (20 in-lbs torque for input and output power terminal connections).
9. Check that all fuses are in place and properly seated in the fuseholders.
10. Check the continuity of all fuses. If any fuse reads open, replace the defective fuse. Refer to Table 6-2 for fuse data.

## Check Settings of Adjustment Pots

1. Make sure power is OFF.
2. Verify that the adjustment pots on the regulator are as listed in Table 4-1. The location of these pots are shown in Figure 4-1.
3. Do not adjust pots 8P, 9P, 10P, 11P, 12P, 13P and 14P. They are factory set and sealed; any readjustment could degrade the performance of the controller.

## Check the Grounding

### DANGER

THE USER IS RESPONSIBLE TO MEET ALL CODE REQUIREMENTS WITH RESPECT TO GROUNDING ALL EQUIPMENT. FAILURE TO OBSERVE THIS PRECAUTION COULD RESULT IN SEVERE BODILY INJURY OR LOSS OF LIFE.

1. Verify that a properly sized ground wire is installed between the chassis ground terminal, the controller enclosure, and a suitable earth ground and that the connections are tight.
2. With an ohmmeter, check for and eliminate any grounds between the input power leads to the chassis ground and between the output power leads to the chassis ground.
3. Verify that a properly sized ground wire is installed between the motor frame and a suitable earth ground and that the connections are tight.
4. With an ohmmeter, check for and eliminate any grounds between the motor frame and the motor power leads.
5. Verify that a properly sized ground wire is installed between the transformer (if used) and a suitable earth ground and that the connections are tight.
6. Verify the above ground wires are run **unbroken**.

**Table 4-1. Controller Pot Settings.**

Adjustment			Functional Description	Control Range	Initial Factory Setting
Name	Abbreviation	Pot			
Acceleration Rate	ACC	1P	Sets rate to accelerate from zero to maximum hertz. (Current limit overrides this function.)	1SW(4) OFF: 1.5 to 20 seconds from 0 to 60 hertz 1SW(4) ON: 4.5 to 60 seconds from 0 to 60 hertz	1SW(4) OFF 20 sec.
Deceleration Rate	DEC	2P	Sets rate to decelerate from maximum to zero hertz. (Voltage limit overrides this function.)	1SW(4) OFF: 1.5 to 20 seconds from 60 to 0 hertz 1SW(4) ON: 4.5 to 60 seconds from 60 to 0 hertz	1SW(4) OFF 20 sec.
Maximum Hertz	MAX HZ	3P	Sets motor frequency when Speed pot is fully clockwise.	J1: 15 to 90 hertz (1)	60 Hz
Minimum Hertz	MIN HZ	4P	Sets motor frequency when Speed pot is fully counterclockwise.	J1: 0 to 40 hertz (1)	6 Hz
Torque Boost	T.BST	5P	Increases voltage in order to increase motor starting torque. (3)	0 to 80 VAC	20 VAC
Current Limit	I.LMT	6P	Limits controller output frequency dependent upon D-C bus current.	50 to 150% of controller current rating	100% (2)
Volts per Hertz	V/HZ	7P	Sets output frequency for a given output voltage.	6.8 to 16.0 V/Hz (1)	7.6 V/Hz

- (1) This is the V/Hz with the base frequency set at 60 Hz (J1). If a base frequency above 60 Hz is required, contact your Reliance Electric Sales Office for assistance. The V/Hz will change inversely as the base frequency increases.
- (2) This is 100% of the controller's maximum output amps (RMS) and is equal to 110% of the controller's maximum motor sine wave current rating.
- (3) In most cases, adjustment is not necessary. Should the application require adjustment, turn the 5P pot slightly and check the performance of the controller over the entire normal load range. Remember that motor current cannot exceed 150% of controller current rating for more than one minute.

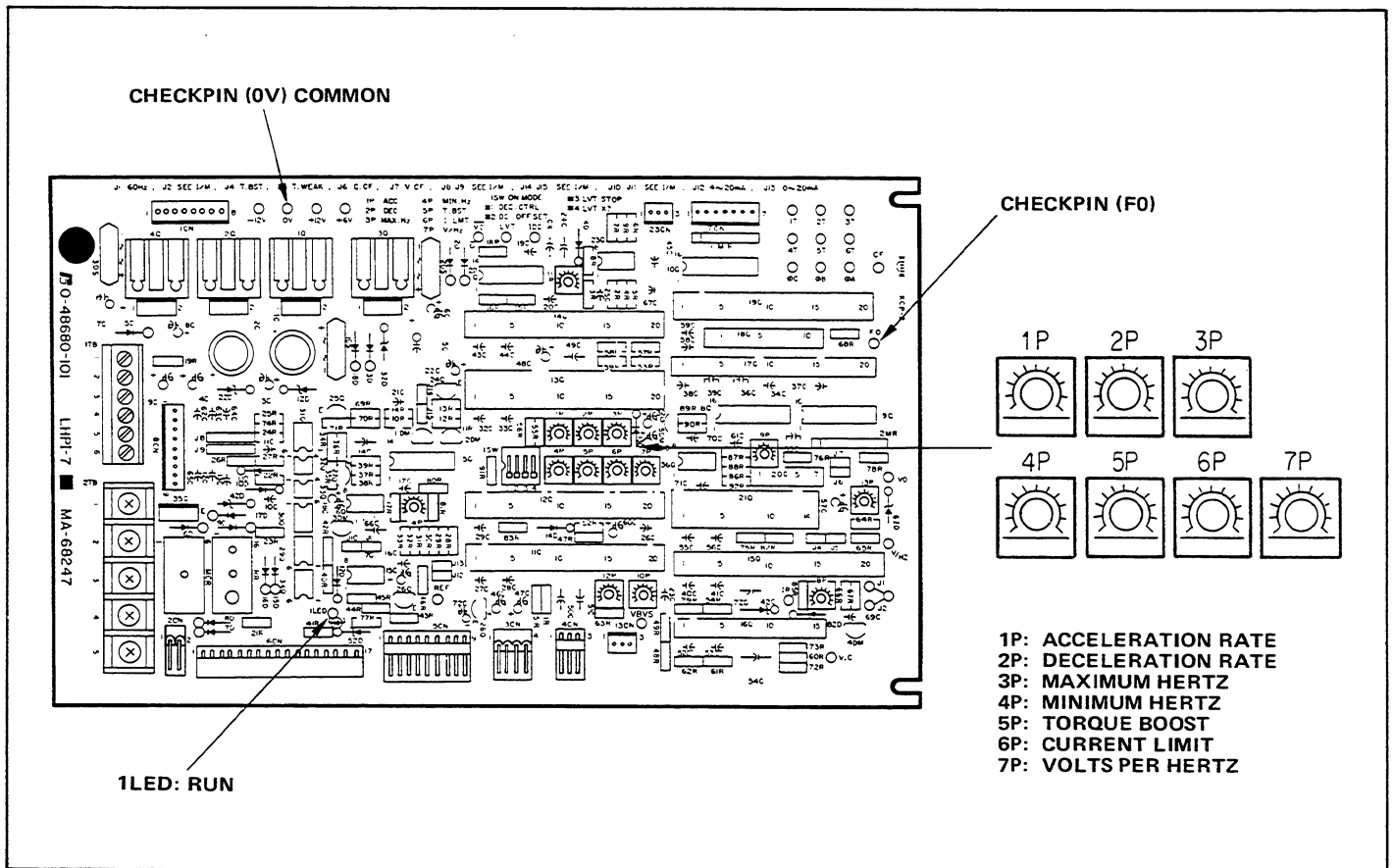

**Figure 4-1. Regulator Pots, LED and Checkpins.**

## Start the Controller Purchased as Drive Package

Use this simplified procedure **only** when the controller and motor are purchased together as a drive package; otherwise, proceed to "Start the Controller Purchased Separately."

The controller is shipped with a NEMA B induction motor sized to the controller's horsepower rating and is pre-adjusted to operate this motor. In most cases, this startup procedure will locate any shipping damage, verify proper installation and field wiring, provide a second check of adjustments, and successfully start the controller.

### DANGER

**ALTHOUGH ZERO SET ADJUSTMENT ON THIS CONTROLLER ALLOWS FOR ADJUSTMENT DOWN TO ZERO SPEED, THIS ZERO SPEED SETTING MUST NOT BE USED WHERE THE OPERATOR MAY RELY ON A MAINTAINED ZERO SPEED. ELECTRICAL NOISE, IMPROPER WIRING, POWER LINE, OR MALFUNCTIONING COMPONENTS COULD CAUSE THE CONTROLLER TO TURN ON WHILE AT THE ZERO SPEED SETTING. FAILURE TO OBSERVE THIS PRECAUTION COULD RESULT IN SEVERE BODILY INJURY OR LOSS OF LIFE.**

1. Follow all of the "Check the Installation" procedures if not already performed.
2. Make sure all power is OFF.
3. Set a voltmeter on the 1000 VDC scale or a similar high voltage scale. Connect the voltmeter to terminals 147(+) and 45(-).

Read this voltmeter every time you turn power OFF to verify the D-C bus capacitor is fully discharged. Within one minute after power is turned OFF, the bus voltage should measure about 50 VDC.

4. If the controller has been stored for less than six months, proceed to Step 5. If the controller has been stored for over six months, form the capacitor as follows:

### DANGER

**THE REMAINING STEPS TO FORM THE CAPACITOR ARE MADE WITH POWER ON. EXERCISE EXTREME CAUTION BECAUSE HAZARDOUS VOLTAGE EXISTS. FAILURE TO OBSERVE THIS PRECAUTION COULD RESULT IN SEVERE BODILY INJURY OR LOSS OF LIFE.**

- Turn the Speed pot fully CCW. Turn the power ON.
  - Observe that the voltmeter reading is 621 VDC with respect to 460 VAC input.
  - Let the controller sit undisturbed for fifteen minutes while the capacitor charges. **Put a tag on the controller that power is ON and hazardous voltage exists.**
  - Turn the power OFF. Verify the D-C bus voltage is zero (read the voltmeter).
5. With power OFF, connect the motor power leads, if not already connected, to the controller. Couple the driven equipment to the motor, if not already coupled.

### DANGER

**THE REMAINING STEPS ARE MADE WITH POWER ON. EXERCISE EXTREME CAUTION BECAUSE HAZARDOUS VOLTAGE EXISTS. FAILURE TO OBSERVE THIS PRECAUTION COULD RESULT IN SEVERE BODILY INJURY OR LOSS OF LIFE.**

6. Turn the Speed pot fully CCW. Turn the power ON.
7. Press the Start switch. Note: Do not press the Start switch while the motor is rotating. An IET trip will occur (The IET LED will light and the drive will stop.). Always wait for the motor to completely stop. To reset the controller after an IET, press the Stop switch and wait for the motor to completely stop.

8. Turn the Speed pot slowly CW to check the motor shaft rotation. If shaft rotation is correct, go to Step 9. If shaft rotation is incorrect, change the motor shaft rotation direction as follows:

- Press the Stop switch and wait until the motor has completely stopped.
- Turn the power OFF.
- After verifying the D-C bus voltage is zero, reverse any two of the three motor power leads.
- Turn power ON and press the Start switch.

9. Run the drive across the speed range under load. If the drive operates satisfactorily, startup is complete.

If the motor draws unnecessarily high current, operation is unstable, or the motor does not break away when starting; proceed to "Start the Controller Purchased Separately" for more detailed startup instructions.

Minor user adjustments may be necessary for satisfactory operation. Refer to Steps 23 through 33 in "Start the Controller Purchased Separately" and Table 4-1.

10. Press the Stop switch.
11. Turn the input power OFF. After verifying the D-C bus voltage is zero, remove the voltmeter and any other instrumentation connected during startup.
12. Close and secure the controller enclosure cover.

## Start the Controller Purchased Separately

Use this startup procedure when you purchase the controller separately to use with an existing motor or a separately ordered motor. If any of the following steps cannot be made because of a controller problem, go to "Section 6, Troubleshooting," in this manual.

1. Follow all of the "Check the Installation" procedures if not already performed.
2. Make sure all power is OFF.

- Set a voltmeter on the 1000 VDC scale or a similar high voltage scale. Connect the voltmeter to terminals 147(+) and 45(—).

Read this voltmeter every time you turn power OFF to verify the D-C bus capacitor is fully discharged. Within one minute after power is turned OFF, the bus voltage should measure about 50 VDC.

- Disconnect the motor power leads from the controller, if connected.
- If the controller has been stored for less than six months, proceed to Step 6. If the controller has been stored for over six months, form the capacitor as follows:

**DANGER**

**THE REMAINING STEPS TO FORM THE CAPACITOR ARE MADE WITH POWER ON. EXERCISE EXTREME CAUTION BECAUSE HAZARDOUS VOLTAGE EXISTS. FAILURE TO OBSERVE THIS PRECAUTION COULD RESULT IN SEVERE BODILY INJURY OR LOSS OF LIFE.**

- Put the Run/Jog switch in the RUN position.
- Turn the Speed pot fully CCW. Turn the power ON.
- Observe that the voltmeter reading is 621 VDC with respect to 460 VAC input.
- Let the controller sit undisturbed for fifteen minutes while the capacitor charges. **Put a tag on the controller that power is ON and hazardous voltage exists.**
- Turn the power OFF. Verify the D-C bus voltage is zero (read the voltmeter).

- With power OFF, set a second voltmeter on the 500 VAC scale. Connect this voltmeter to any two of the three output power terminals (601, 602, and 603).
- With the Speed pot fully CCW, turn the power ON.
- Press the Start switch. The green RUN LED (Figure 4-1) should light. The controller output frequency is 6 Hz (minimum hertz preset with 4P). The second voltmeter should read about 66 VAC (fundamental output voltage preset with 5P).

- Gradually turn the Speed pot CW while reading the voltmeter. As the speed increases, the voltage increases. When the Speed pot reaches fully CW, the output voltage should about equal the input voltage. Output frequency should be 60 Hz. Note: The output voltage of the PWM controller equals the fundamental voltage plus the harmonics.
- Quickly turn the Speed pot fully CCW. The voltage and frequency will decrease to 66 VAC (fundamental voltage) and 6 Hz in about 20 seconds.
- Quickly turn the Speed pot fully CW. The voltage and frequency will increase to the rated voltage and 60 Hz in about 20 seconds.
- Note that the V/Hz (volts per hertz) pot is factory adjusted to produce 460 fundamental output voltage at 60 Hz output frequency for 460 volts input using fundamental reading voltmeters. Do not adjust the V/Hz unless your application requires a different voltage at 60 Hz. The factory adjustment will maintain the required 7.6 V/Hz characteristic over the speed range (the voltage will be slightly higher than this below 40 Hz due to the torque boost adjustment which is set to provide up to 150% torque capability for starting).

Note: The output voltage of the PWM controller equals the fundamental voltage plus the harmonics.

If a different volts/hertz ratio is required (See Figure 4-2), adjust the V/Hz (7P) pot as follows:

- Make sure the motor is disconnected.
- Turn the T.BST (5P) pot fully CCW.
- Turn the MIN Hz (4P) pot fully CW.
- With the Speed pot fully CCW, push the Start switch. The controller will ramp to approximately 40 Hz (Min Hz pot fully CW). Allow the controller to reach steady-state speed.

- While reading the second voltmeter, adjust the V/Hz pot until the voltage determined by the following equation is obtained:

$$\text{Fundamental Voltage} = \frac{\text{Motor's Rated Voltage} \times 40 \text{ Hz}}{\text{Motor's Rated Frequency}}$$

Note: The output voltage of the PWM controller equals the fundamental voltage plus the harmonics.

**DANGER**

**ALTHOUGH ZERO SET ADJUSTMENT ON THIS CONTROLLER ALLOWS FOR ADJUSTMENT DOWN TO ZERO SPEED, THIS ZERO SPEED SETTING MUST NOT BE USED WHERE THE OPERATOR MAY RELY ON A MAINTAINED ZERO SPEED. ELECTRICAL NOISE, IMPROPER WIRING, POWER LINE, OR MALFUNCTIONING COMPONENTS COULD CAUSE THE CONTROLLER TO TURN ON WHILE AT THE ZERO SPEED SETTING. FAILURE TO OBSERVE THIS PRECAUTION COULD RESULT IN SEVERE BODILY INJURY OR LOSS OF LIFE.**

- If a minimum frequency other than 6 Hz is required, adjust the Min Hz (4P) pot as follows (See Figure 4-3):
  - Turn the Min Hz pot fully CCW.
  - Turn the Speed pot fully CCW.
  - While observing the frequency meter, if supplied, adjust the Min Hz pot until the desired frequency is obtained. If the controller is not equipped with a frequency meter, determine the required pot position with the following equation and turn the Min Hz pot to that position:

$$4P \text{ Position} = \frac{\text{Desired Min Hz}}{40 \text{ Hz}} \times 8 + 1$$

Note that the pot has 10 divisions with 0 equal to 0 Hz and 10 equal to approximately 40 Hz. Therefore, each division equals 4 Hz.

14. If a maximum frequency other than 60 Hz is required or if minimum frequency was changed in Step 13, adjust the Max Hz (3P) pot as follows (See Figure 4-3): Note that the Min Hz pot must always be adjusted before adjusting the Max Hz pot.

- Turn the Max Hz pot fully CCW.
- Turn the Speed pot fully CW.
- While observing the frequency meter, if supplied, adjust the Max Hz pot until the desired frequency is obtained. If the controller is not equipped with a frequency meter, determine the required pot position with the following equation and turn the Max Hz pot to that position:

$$\left(1.2 - \frac{18}{\text{Desired Max Hz} - \text{Desired Min Hz}}\right) \times 8 + 1$$

For example, if the desired minimum Hz is 30 Hz and the desired maximum Hz is 60 Hz, the required pot position is 5.8:

$$\left(1.2 - \frac{18}{60 - 30}\right) \times 8 + 1$$

Note that the application may require further adjustment.

Note: You can obtain a precise reading of the output frequency by connecting a frequency counter having an input impedance of more than 1 megohm between checkpins F0 and 0 V (common) on the regulator. See Figure 4-1. It should measure 256 times the controller output frequency.

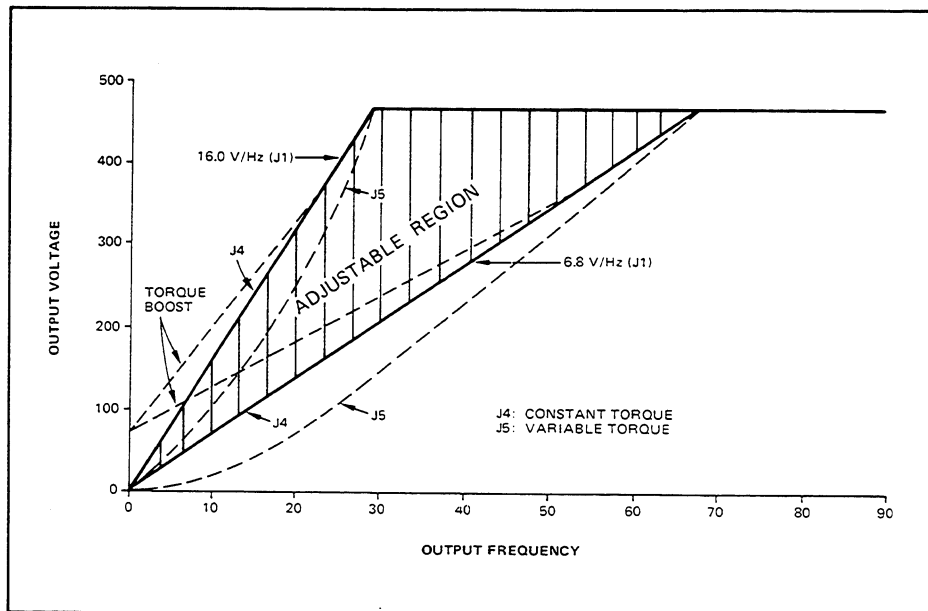

Figure 4-2. Volts/Hz Pot Adjustable Region for 460 V Input.

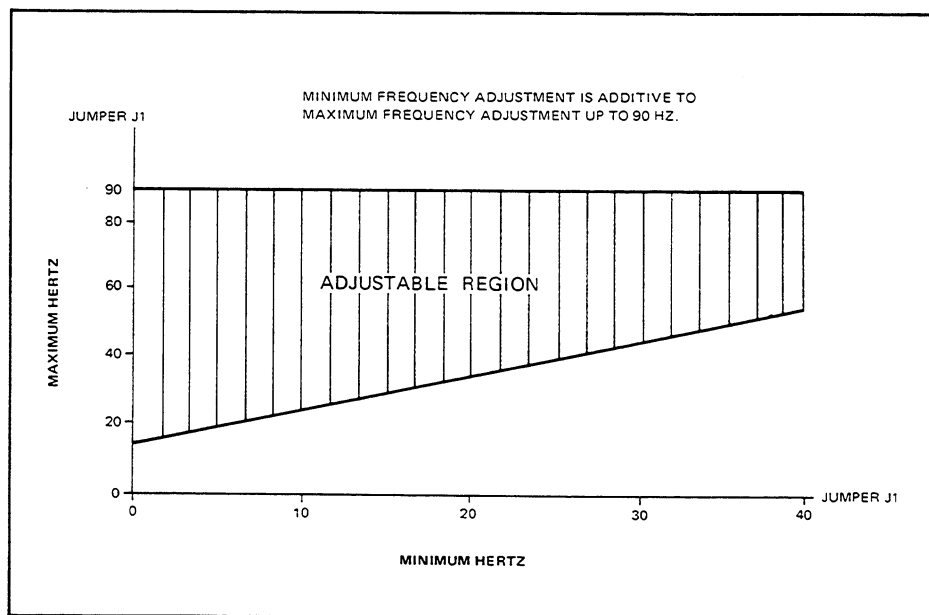

Figure 4-3. Relationship of Min Hz and Max Hz.

15. Note the reading on the second voltmeter. Put the Forward/Reverse switch, if applicable, in the REV position. The reading should decrease to zero and then return to the original reading. Return the Forward/Reverse switch to the FWD position.
16. Put the Auto/Man switch, if applicable, in the AUTO position. The Speed pot is now ineffective; speed is controlled by a process control reference signal of 4 to 20 mA, 0 to 20 mA, or 0 to 10 VDC. Return the Auto/Man switch to the MAN position.
17. Turn the Speed pot fully CCW and press the Stop switch.
18. Turn the power OFF. Verify the D-C bus voltage is zero (read the first voltmeter).
19. With power OFF, connect the motor power leads to the controller and couple the driven machinery to the motor, if not already coupled.

**DANGER**  
**THE REMAINING STEPS ARE MADE WITH POWER ON. HAZARDOUS VOLTAGE EXISTS. FAILURE TO OBSERVE THIS PRECAUTION COULD RESULT IN SEVERE BODILY INJURY OR LOSS OF LIFE.**

20. With the Speed pot fully CCW, turn the power ON.
21. Press the Start switch.
22. Turn the Speed pot slowly CW to check the motor shaft rotation. If shaft rotation is correct, go to Step 23. If shaft rotation is incorrect, change the motor shaft rotation direction as follows:

Note: Do not press the Start switch while the motor is rotating. An IET trip will occur (The IET LED will light and the drive will stop.). Always wait for the motor to completely stop. To reset the controller after an IET, press the Stop switch and wait for the motor to completely stop.

- Press the Stop switch and wait until the motor has completely stopped.
- Turn the power OFF.
- After verifying the D-C bus voltage is zero, reverse any two of the three motor power leads.

- Turn power ON and press the Start switch.
23. Note that T.BST (5P) pot is factory adjusted to produce the required voltage to produce up to 150% starting torque for Reliance Electric standard and energy efficient motors. This setting should, in most cases, produce 150% starting torque for other motors too. Adjust the Torque Boost pot for the following applications.

- With the drive coupled to the machine, the torque boost may not be high enough to break away or accelerate the load within the current limit of the drive. The torque boost should be increased until either the motor performs properly or current limit is reached.
- If the V/Hz was adjusted in Step 12, the torque boost may not be high enough to break away or accelerate the load within the current limit of the drive.
- If the motor does not run smoothly in a low speed range, turn power OFF and wait until the D-C bus capacitors are fully discharged. Relocate jumper J6 to J7. Set the Torque Boost pot at zero. Turn power ON and restart the drive. Using the Torque Boost pot, gradually increase the voltage until the motor runs smoothly.

Note: Acoustic noise may become high as the carrier frequency becomes low in a low speed range at jumper J7. Consult Reliance Electric if satisfactory performance cannot be obtained.

24. Current limit is preadjusted for 110% of the motor sine wave current rating. To adjust current limit between the range of 50% (fully CCW) and 150% (fully CW), turn the Current Limit (6P) pot as necessary.
25. Turn the Speed pot to the maximum CW position and the motor will accelerate slowly to maximum speed (60 hertz). Maximum speed may not be reached due to current limit. The controller is not designed to supply 150% of the current rating for more than one minute. If satisfactory adjustment cannot be reached, contact your Reliance Electric Sales Office.

26. Turn the Speed pot fully CCW and the motor will decelerate to the minimum speed set with the Min Hz pot.
  27. With the Speed pot fully CCW, quickly turn the Speed pot fully CW. If the acceleration time is too long, turn the Acceleration Rate (1P) pot a quarter turn CW and accelerate the motor again. Repeat the motor acceleration process until the desired acceleration time is achieved.
- Note: The shortest acceleration time is limited by the current limit circuit. When the Acceleration Rate pot no longer has any effect, the acceleration rate is at its maximum for the application. When the motor is in acceleration while the current is limited, the acceleration will not be smooth. To smooth the acceleration, turn the Acceleration Rate pot slightly CCW.

28. Turn the Speed pot fully CW and wait until the motor reaches top speed. Quickly turn the Speed pot fully CCW. If the deceleration time is too long, turn the Deceleration Rate (2P) pot a quarter turn CW and decelerate the motor again. Repeat the motor deceleration process until the desired deceleration time is achieved.

Note: The shortest deceleration time is limited by the voltage limit circuit. When the Deceleration Rate pot no longer has any effect, the deceleration rate is at its maximum for the application. When the motor is in deceleration while the D-C bus voltage is limited, the deceleration will not be smooth. To smooth the deceleration, turn the Deceleration Rate pot slightly CCW.

29. Turn the Speed pot CCW and wait until the motor completely stops. Then put the Run/Jog switch in the JOG position.
30. Turn the Speed pot a quarter turn CW and press the Start switch. The motor will rotate while the Start switch is held in the START position. The speed depends on the Speed pot setting.
31. Turn the Speed pot CCW, and put the Run/Jog switch in the RUN position. Press the Stop switch.

32. Turn the power OFF. After verifying the D-C bus voltage is zero, remove the two voltmeters and any other instrumentation connected during startup.
33. Close and secure the controller enclosure cover.

# 5: How the Controller Operates

## Fundamentals of Variable Voltage, Variable Frequency Controllers

An A-C motor is a fixed-speed machine operating from a constant voltage, constant frequency source, such as 460 VAC and 60 Hz. To vary the speed of the motor, the voltage and frequency of the source to the motor must be variable. A controller provides this source. The controller transforms its input (three-phase, constant A-C voltage, constant frequency) into an output compatible with the A-C adjustable speed requirement of the A-C motor (three-phase, variable voltage, variable frequency).

The operating frequency of the controller, along with the basic design of the motor, determines the operating speed (rpm) of the motor. The output voltage of the controller establishes the magnetic flux level within the motor to meet the torque demands of the load over the entire speed range. The basic equation to determine motor synchronous speed is:

$$\text{Synchronous RPM} = \frac{\text{Controller Output Frequency} \times 120}{\text{Number of A-C Motor Poles}}$$

The relationship between output voltage and operating frequency is the "Volts per Hertz" ratio (V/Hz). Except at low speed, this ratio is usually a constant determined by this equation:

$$\text{V/Hz} = \frac{\text{Motor Nameplate Voltage}}{\text{Motor Nameplate Frequency}}$$

The two major sections of a controller are the power circuit and the regulator. The power circuit consists of a diode bridge that converts A-C to D-C voltage and a solid state transistor module that transforms the constant voltage, constant frequency input power into variable voltage, variable frequency output power. The regulator controls when the solid state transistor module switches in the power circuit turn ON or OFF.

## Power Circuit Operation

Figure 5-1 shows the power circuit schematic divided into three sections.

The first section is the **input rectifier**. A-C power is applied to terminals 181, 182 and 183 and is full-wave rectified by the diode cube to constant D-C voltage. This voltage is approximately 621 VDC. Three input fuses (1FU, 2FU, 3FU) protect the power circuit from any ground faults. A suppressor (MOV) limits voltage transients within the maximum voltage rating of the diodes.

The rectified voltage is then filtered by the **D-C bus filter**. The capacitors are charged through a precharge resistor to limit the charging current. Relay DCR is energized and shorts out the precharge resistor when the bus filter capacitor voltage reaches approximately 90% of the rated bus voltage. Two discharge resistors discharge the bus voltage when the input power is removed.

The positive and negative D-C bus voltage lines run through the Hall Effect Current Sensor to detect D-C bus current. The D-C bus current feedback protects against an overload or a short circuit in the output inverter section.

The filtered D-C bus voltage is fed into the **output inverter** section. This section transforms D-C bus voltage into three-phase A-C variable voltage, variable frequency by switching transistors in the transistor module. The transistor module, consisting of six transistors with anti-parallel diodes around them, provides a path for reactive motor current.

In summary, constant D-C voltage is produced by rectifying and filtering the incoming A-C power line. Variable voltage, variable frequency is produced by six output transistors inverting the constant D-C voltage to a PWM voltage waveform.

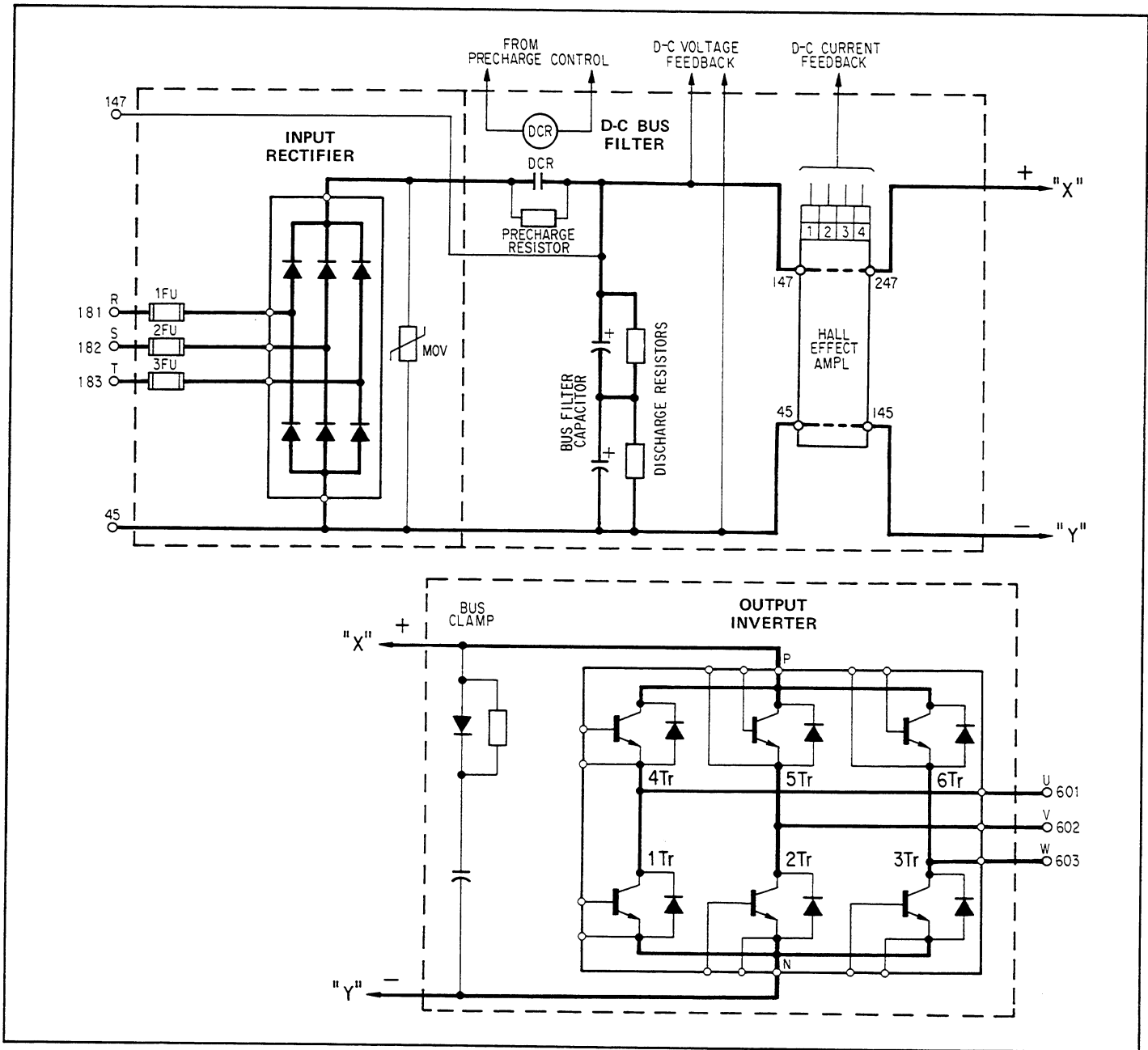

Figure 5-1. Power Circuit Schematic.

### Controller Regulator Operation

Figure 5-2 shows the regulator block diagram. It is divided into nine sections as described below.

The first section is the **input signal conditioner**. The input to this section is the speed reference signal (This section is not isolated; use the Customer Interface Module when isolation is required.) The first conditioning that is done on the input is to set minimum and maximum hertz using the Min and Max Hz pots. These adjustments limit the reference between minimum hertz and maximum hertz.

The reference signal goes into the ramp control, which controls the length of time the motor takes to accelerate to full speed and decelerate to zero speed. The length of time can be adjusted from 1.5 to 20 seconds using the Acceleration and Deceleration Rate pots, respectively. Typical voltage output of the ramp control is 6 volts equals 60 hertz. Acceleration and deceleration times can be extended to three times the maximum time of 20 seconds.

The **current limiter** sets the required limit value using the Current Limit pot. The current limit circuit compares the

current limit value with the D-C bus current feedback. If the D-C bus current exceeds the limit value, the current limit circuit modifies the ramp control to limit the D-C bus current and extend acceleration or deceleration time.

The **voltage limiter** has a fixed limit reference. When in the regenerative mode, the D-C bus voltage will rise as the motor decelerates. If the D-C bus voltage exceeds the limit reference, the signal conditioner generates a limit signal. This signal goes to the ramp control to limit the D-C voltage and extend the deceleration time. This

limit function operates if the D-C bus voltage exceeds 750 VDC.

This function may be selected by switching Dip Switch 1SW(1) to the ON position. If the dynamic braking option is used, the Dip Switch should be in the OFF position to remove this function from the circuit.

The timed reference provides the reference for the **inverter control** section. The reference signal goes to the signal conditioner, which defines the Volts/Hertz ratio, dependent upon the Volts/Hertz pot and the Torque Boost pot settings. It also goes to the voltage-to-frequency converter and the frequency divider. These blocks determine the output frequency of the controller. The torque boost is required to offset the IR drop of the A-C motor at a low speed to produce a constant torque capability.

D-C offset at zero hertz may be selected by Dip Switch 1SW(2). In the standard OFF position, A-C torque boost is

provided for operation of standard induction motors. In the ON position, D-C offset at zero hertz is provided for operation of permanent magnet synchronous motors to provide synchronous operation from starting. This limits the current demand during acceleration.

The **additional function** section provides automatic output voltage correction for A-C line power voltage fluctuations and either automatic torque boost for constant torque loads or an energy saver function generator for centrifugal torque loads.

The automatic torque correction circuit (J4) compares the timed reference to the D-C bus voltage feedback and automatically corrects output voltage for A-C line voltage fluctuations up to 95% output voltage. The automatic torque boost circuit monitors D-C current feedback and adjusts the output voltage with the D-C bus current.

The function generator block is provided for saving energy and reducing acoustic noise on centrifugal pump and fan applications. This is done by means of a V/Hz curve which is approximately reduced with the square of the speed reduction since torque is proportional to speed squared on a centrifugal load. See Figure 4-2. This function should not be used for constant torque applications because the controller would not be able to produce full load torque at low speeds. Jumper J5 should be used for centrifugal torque applications.

The PWM generates the sine wave pulse-width modulation signal corresponding to the V/Hz and frequency signals. Figure 5-3 illustrates the principle of generating the PWM sine wave. Jumper J6 selects "constant" carrier frequency of the PWM while J7 selects "variable" carrier frequency of the PWM. With the "variable" selection, the carrier frequency is automatically decreased in

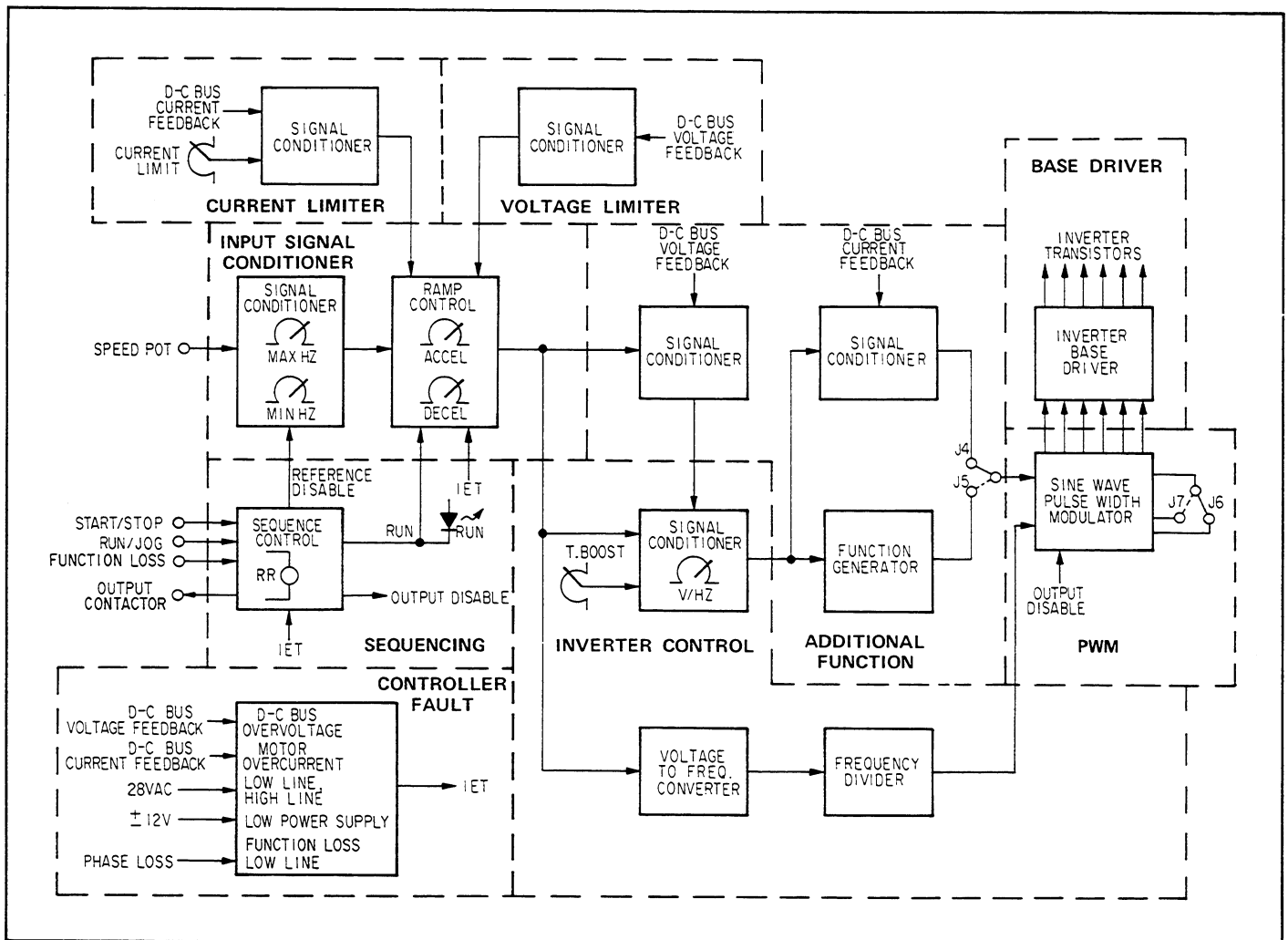

Figure 5-2. Controller Regulator Block Diagram.

proportion to a decrease in speed. It is possible to have torque increase in a low speed range though the acoustic noise may also increase.

The **base driver** section is an amplifier for switching the six inverter transistors to produce the required pulse widths. The signal from the regulator is isolated by an optical coupler. The output of the optical coupler is current amplified by a drive transistor which supplies the required base driver to the power transistor. These base drivers require an isolated power supply that is supplied by additional secondaries of the driver transformer.

The **controller fault** section monitors selected signals within the controller and generates an IET fault signal whenever the following signals exceed preset limits:

- D-C bus voltage (621 VDC nominal) exceeds 800 volts.
- D-C bus current exceeds 200% of full load current.
- Regulator A-C input voltage (28 VAC nominal) is not within +15%, -15%.
- Regulator D-C power supply ( $\pm 12$  VDC nominal) is 9.6 volts or less.
- Function Loss input is open.
- Input phase loss occurs.

The output of the IET circuit turns OFF the regulator in a controlled manner by turning off the sequencing control, the ramp control and the PWM modulator. This redundancy assures the controller turns OFF when a fault occurs. The controller can only be reset by pressing the Stop switch or turning power OFF and then ON again. If an external IET contact is required, an external IET contact (form C) is available by adding the Customer Interface Module Kit.

The **sequencing** section is the interface between the regulator and the Start/Stop inputs from the operator's control devices. Input circuits for Start/Stop, Run/Jog and Function Loss are isolated by an RR relay and an isolated secondary winding. The Start/Stop switch picks up the RR relay if the function loss input is closed. Contacts from the RR relay are connected to the sequence logic as a start/stop input.

There are two Stop modes: coast-to-rest and ramp-to-rest. The normal Stop mode is coast-to-rest set with Dip Switch 1SW(3) in the OFF position. This stop mode instantly turns OFF the controller and the motor coasts to rest. If the controller is restarted while the motor is still in motion, an IET may occur.

The ramp-to-rest Stop mode is set with Dip Switch 1SW(3) in the ON position. With this setting the Stop switch will cause a ramp-to-rest. With this method the controller can be restarted while the motor is still in motion without causing an IET because the motor voltage and frequency are kept under control until the motor stops rotating. A Coast-Stop pushbutton must be provided to the function loss input.

Opening the function loss input causes an IET, which instantly turns OFF the controller causing the motor to coast to a rest. To restart, the Stop switch must be pressed to reset the IET, and the motor must be completely stopped. Then the Start switch is pressed to start the controller.

Normally, the Run/Jog switch is in RUN. In the Jog mode, the run relay (RR) will not latch by pressing the Start switch. Therefore, the controller operates only while the Start switch is held in.

## Fundamentals of Controller Operator's Controls

### Start/Stop Control

With power ON, pressing the Start switch causes the motor to accelerate to the speed determined by the speed reference. The length of time for the motor to accelerate to this speed depends on the time set with the Acceleration 1P pot.

Pressing the Stop switch causes the motor to coast to a rest. The standard Stop mode is coast-to-rest, but ramp-to-rest is available.

If the controller is stopped because of an IET, restart by pressing the Stop switch, waiting for the motor to completely stop, and pressing the Start switch.

### Speed Control

**WARNING**

**THIS CONTROLLER CAN BE ADJUSTED DOWN TO ZERO SPEED. DO NOT USE THIS ZERO SPEED SETTING TO STOP DRIVEN EQUIPMENT. CHANGING CONDITIONS COULD RESULT IN UNEXPECTED ROTATION. FAILURE TO OBSERVE THIS PRECAUTION COULD RESULT IN BODILY INJURY.**

The speed of the motor is controlled by the speed reference set with the Speed pot. When the controller is ON and the Start switch is pressed, the motor will accelerate to the speed set with the Speed pot. While the motor is running, the speed can be increased or decreased by turning the Speed pot CW or CCW, respectively. (If speed control is provided by a 4 to 20 mA, 0 to 20 mA, or 0 to 10 VDC process control signal, the speed is increased or decreased by increasing or decreasing the process signal.) The length of time for the motor to accelerate or decelerate to the set speed depends on the time set with the Acceleration 1P pot or Deceleration 2P pot.

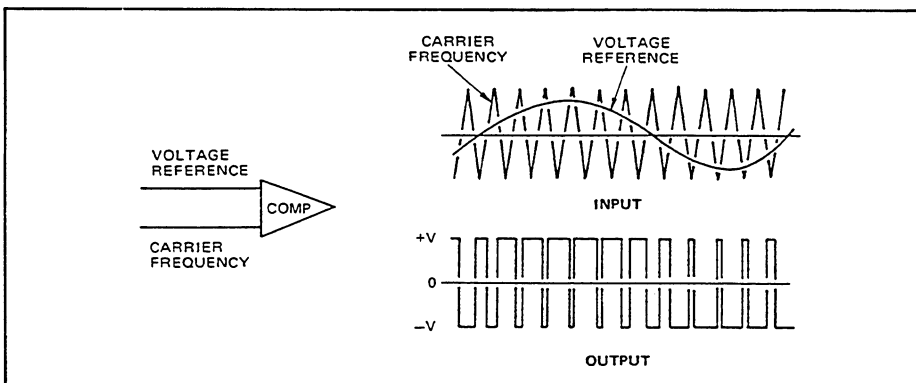

Figure 5-3. Theory of Generating PWM.

### **Run/Jog Switch**

When this switch is in the RUN position, the controller controls motor speed until the Stop switch is pressed. When this switch is in the JOG position, the motor runs only while the Start switch is pressed and held in. Releasing the Start switch stops the controller. The motor will stop in a coast-to-rest or ramp-to-rest mode depending on the mode selected.

### **Automatic/Manual Switch (Option)**

The Auto/Man switch option changes the speed reference from the Speed pot (MAN) to an external reference from a process control (AUTO). The standard controller includes the means to convert a 4 to 20 mA or 0 to 20 mA signal to 0 to 10 VDC.

### **Forward/Reverse Switch (Option)**

This option is provided for changing motor phase rotation direction electronically. To operate the controller in the REVERSE mode, put the Forward/Reverse switch in the REVERSE position. This can be done while the motor is at full speed in the forward direction. The motor will decelerate to zero speed and then accelerate in the opposite direction to the set speed. Note that the forward/reverse input circuit is not isolated on the controller regulator; if isolation is required, use the CIF option.

# 6: Troubleshoot the Controller

**DANGER**

**ONLY QUALIFIED ELECTRICAL PERSONNEL FAMILIAR WITH THE CONSTRUCTION AND OPERATION OF THIS EQUIPMENT AND THE HAZARDS INVOLVED SHOULD SERVICE THIS EQUIPMENT. FAILURE TO OBSERVE THIS PRECAUTION COULD RESULT IN SEVERE BODILY INJURY OR LOSS OF LIFE.**

## Controller LEDs

- The controller has 2 LED indicators:
  - RUN (green) – normally ON
  - IET (red) – OFF; ON when fault occurs

The RUN and IET LEDs are located on the Local Operator's Control Station. The Digital Meter with First Fault Indication (option), when used, is mounted where the RUN and IET LEDs normally are located. A RUN LED also is provided on the regulator board.

- A lit IET LED indicates a fault has occurred. If a Digital Meter with First Fault Indication (option) is used, the display will indicate the first fault causing the IET. If an IET has occurred, refer to Table 6-1 for possible cause.
  - Clear the fault.
  - Reset the controller by pressing the Stop switch, waiting for the motor to completely stop, and pressing the Start switch. Note that the controller cannot start until the fault is cleared and the controller is reset.

**Table 6-1. Possible Causes of IET Trips.**

Type of IET	Possible Cause
Overcurrent	Output line-to-ground or line-to-line short
	Motor current higher than 200% of the controller sine wave current rating
	Acceleration time too short
	Hall effect amplifier card is faulty
Overvoltage	Input voltage too high
	Deceleration time too short
Low Line	Input voltage too low
	Momentary power drop
	Input phase loss
Power Supply	±12 VDC on regulator board too low
Function Loss	Function loss input (1TB 3-4) is open

## Test Equipment Needed

**CAUTION:** Do not use a megger to perform continuity checks in the drive equipment. Failure to observe this precaution could result in damage to, or destruction of, the equipment.

- Two volt-ohmmeters each having a sensitivity of 20,000 ohms-per-volt, such as a Triplet Model 630.
- A volt-ohmmeter with a 10 meg-ohm input impedance on all ranges, such as a Fluke 8022B. (This unit provides an accuracy of ±15% when measuring controller output voltage at terminals 601, 602, and 603.)

The most common voltmeters in use are digital and analog voltmeters. However, these two voltmeters use several different methods of measuring the RMS voltage of a waveform, thus producing a wide range of RMS readings for a particular PWM waveform.

A fundamental voltmeter is best suited for measuring output voltage of PWM waveforms because it filters out unwanted harmonics. An accurate measurement is important since the fundamental waveform is the main contributor to the power conducted to the motor. Therefore, in this manual, voltages given are fundamental voltages.

In comparison testing, the Fluke 8022B provides an RMS measurement nearly equivalent to that of the fundamental voltmeter; the Triplet 630 provides an RMS measurement that is 20 volts higher than that of the fundamental voltmeter.

Follow these guidelines when measuring the output voltage of this PWM controller:

- Keep voltmeter lead lengths as short as possible.
- When using an analog voltmeter, use the 500-750 VAC scale.
- When using a digital voltmeter, use the 200 VAC scale for measuring output voltages up to 200 VAC and the 750 VAC scale for measuring output voltages above 200 VAC.
- When using a Triplet 630 voltmeter, subtract 20 volts from the reading to determine the fundamental output voltage.
- When using a Fluke 8022B voltmeter, the meter reading can be used as an approximate fundamental voltage.

**DANGER**

**THIS EQUIPMENT IS AT LINE VOLTAGE WHEN A-C POWER IS CONNECTED TO THE CONTROLLER. DISCONNECT ALL UN-GROUNDED CONDUCTORS OF THE A-C POWER LINE FROM THE CONTROLLER. AFTER POWER IS REMOVED, VERIFY WITH A VOLT-METER AT TERMINALS 147(+) AND 45(-) THAT THE D-C BUS CAPACITORS ARE DISCHARGED BEFORE TOUCHING ANY INTERNAL PARTS OF THE CONTROLLER. FAILURE TO OBSERVE THESE PRECAUTIONS COULD RESULT IN SEVERE BODILY INJURY OR LOSS OF LIFE.**

### General Troubleshooting Procedure

1. Verify that an IET has not occurred; the IET LED will be lit and the drive shut down. If an IET has occurred, refer to Table 6-1 for possible causes of the IET
  - Clear the fault.
  - Reset the controller by pressing the Stop switch, waiting for the motor to completely stop, and pressing the Start switch. Note that the controller cannot start until the fault is cleared and the controller is reset.
  - If the controller does not restart, proceed to Step 2.
2. Turn power off.
3. Open the enclosure cover.
4. With power OFF, make a complete physical inspection of all control and motor wiring for correct and tight connections. Be sure that connectors on the regulator are correctly positioned and tight.
5. Verify that the input power voltage is in the  $\pm 10\%$  tolerance range. If not, add a transformer between the plant power supply and the controller.

6. Check for and correct poor wiring conditions:
  - Input and output leads routed through the same conduit.
  - Input or output leads running parallel or in the same conduit with control signal wiring.
  - Control signal wire that is not twisted.
7. Make sure that all nearby relays, solenoids, or brake coils are suppressed.
8. Check that the ambient temperature does not exceed  $40^{\circ}\text{C}$  ( $104^{\circ}\text{F}$ ) for enclosed controllers or  $55^{\circ}\text{C}$  ( $131^{\circ}\text{F}$ ) for chassis controllers.
9. The Torque Boost 5P pot may need adjustment if the following conditions are true:
  - Too much torque boost caused high no-load and full-load motor current, causing excessive heating in the motor and overloading of the controller.
  - Not enough torque boost resulted in abnormally high current during hard starting, fast acceleration, and/or transient load operations.

Readjust the 5P pot as needed. Note that the controller is designed to supply 150% of the current rating for not more than one minute; an IET will occur should current reach 200%.

10. If satisfactory operation still cannot be obtained, proceed to "Fault Symptom Troubleshooting Flow Charts."

### Fault Symptom Troubleshooting Flow Charts

Identify the fault symptom from the following list. Then turn to the flow chart having the figure number corresponding to the symptom. If a part needs to be replaced, refer to Table 6-2 and Figures 6-6 and 6-7. Figures 6-8 through 6-11 provide detailed wiring diagrams, and Figure 6-12 locates components of the regulator board.

1. Motor will not run, which includes the following symptoms:
  - Controller will not start.
  - Input fuses are blown.
  - IET trip occurs when the controller is started.
  - Controller starts, but with a loud humming noise, and then stops.
2. Motor will not reach maximum speed, which includes the following symptoms:
  - Controller starts but motor stays at low speed.
  - Controller IET occurs during acceleration.
3. Controller IET occurs during controlled deceleration.
4. Controller IET occurs occasionally while running but can be restarted.
5. Motor overheats above allowable temperature.

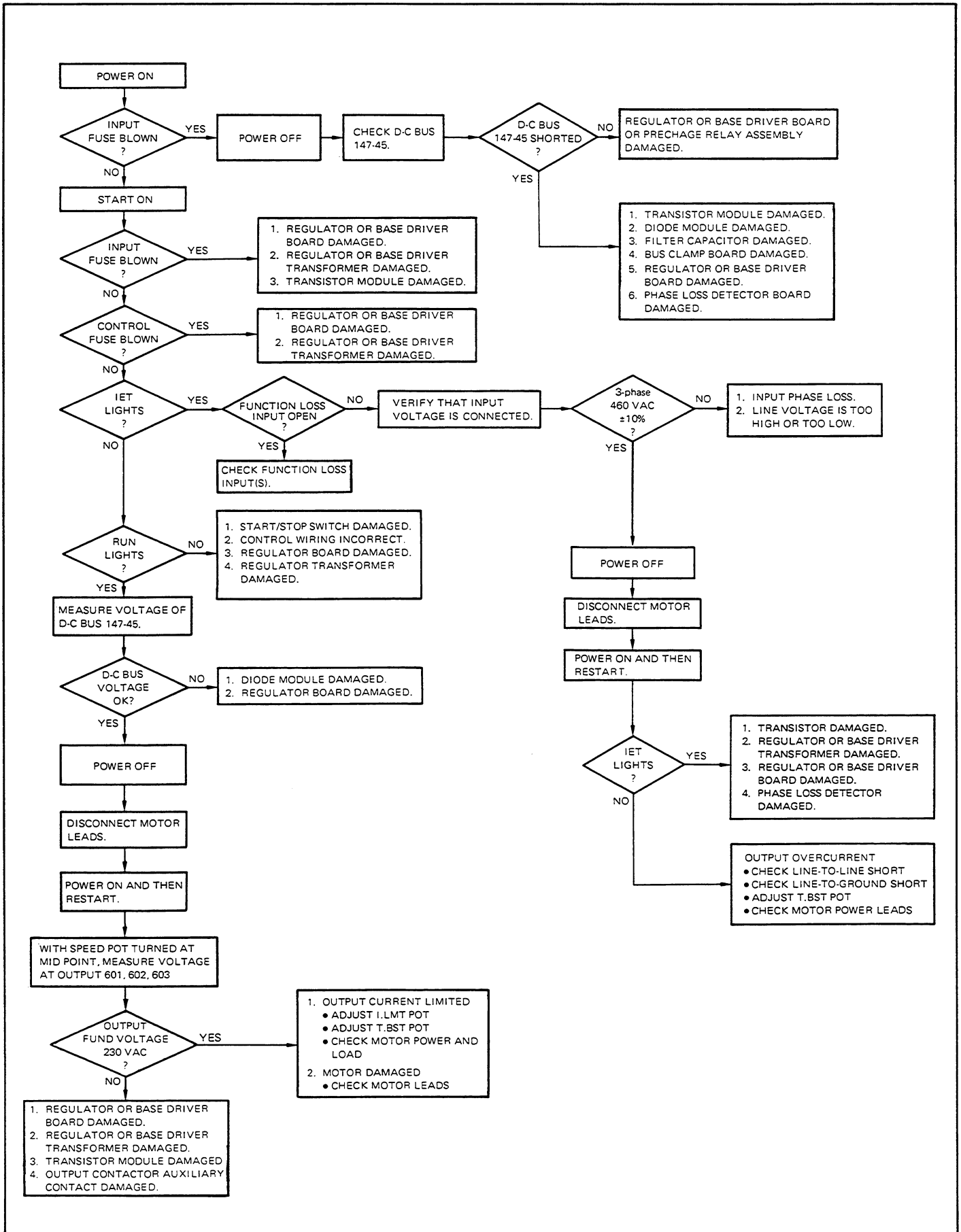

Figure 6-1. Motor Will not Run.

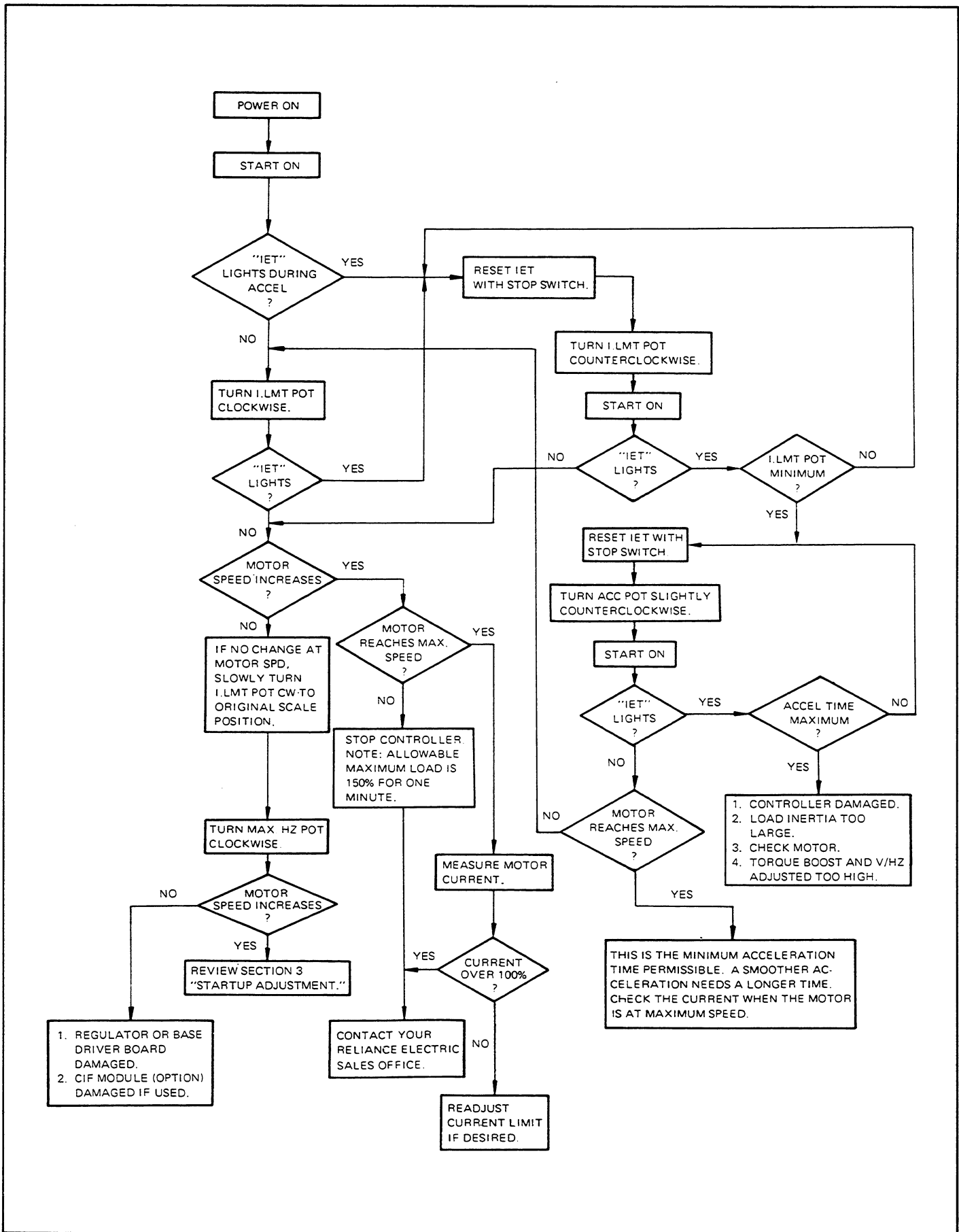

Figure 6-2. Motor Will not Reach Maximum Speed.

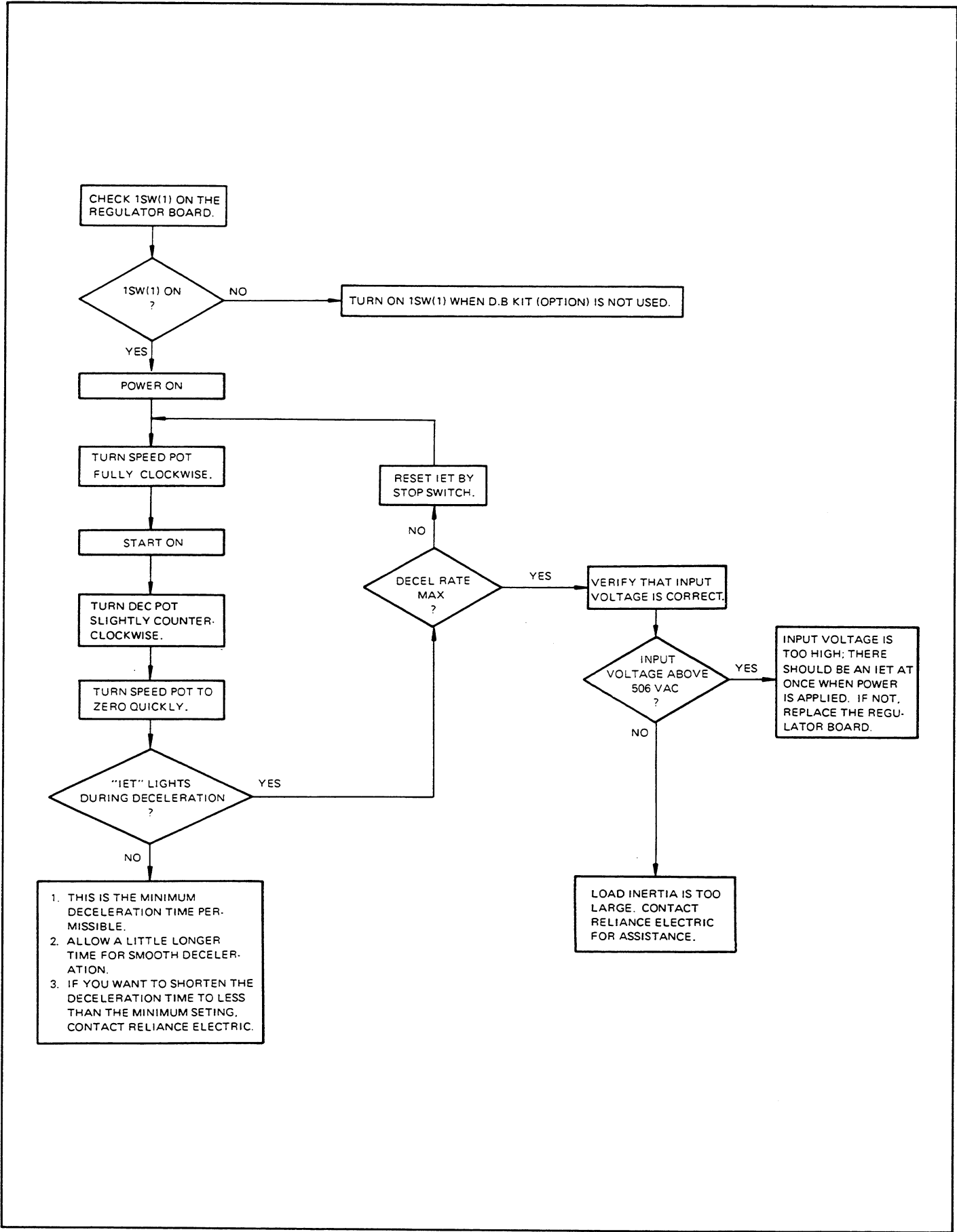

Figure 6-3. Controller IET Occurs during Controlled Deceleration.

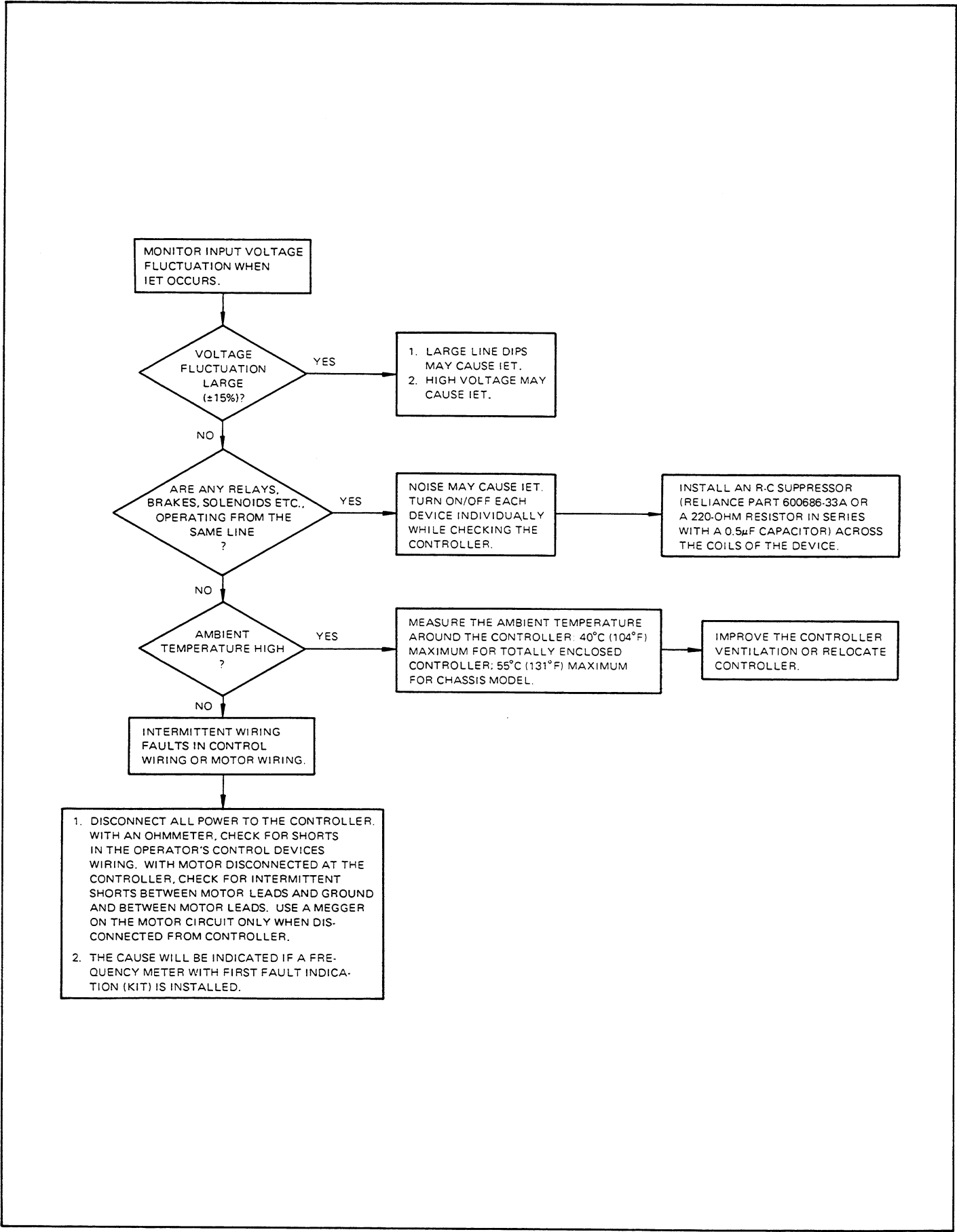

Figure 6-4. Controller IET Occurs Occasionally while Running but Can Be Restarted.

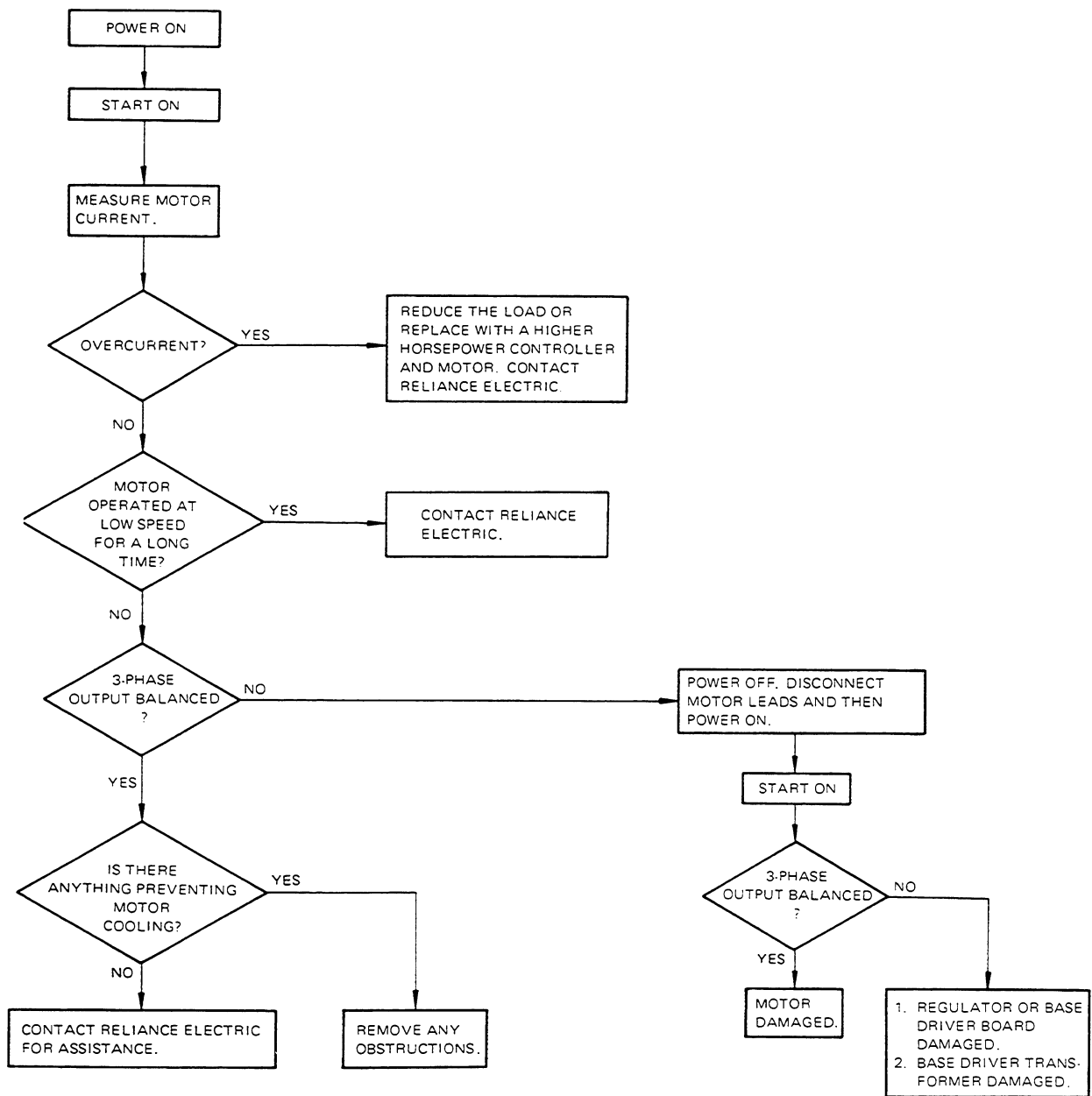

Figure 6-5. Motor Overheats above Allowable Temperature.

**Table 6-2. Replacement Parts List.**

Description	Qty. Per Drive	Reliance Part Number
Diode Cube 2 to 5HP 7½ to 10HP	1 1	402410-100BA 402410-101BA
Transistor Module 2HP 3 to 5HP 7½ to 10HP	1 1 3	402410-200AS 402410-201AS 402410-202AS
Capacitor 2HP 3HP 5HP 7½HP 10HP	2 2 2 2 2	402410-400AA 402410-401AA 402410-402AA 402410-403AA 402410-404AA
Precharge Relay Assembly 2HP 3 to 5HP 7½HP 10HP	1 1 1 1	612180-100R 612180-100S 612180-100T 612180-100V
Input Suppressor 2 to 10HP	1	612180-500R
Bus Clamp PC Board 2 to 10HP	1	0-48680-500
Discharge Resistor Assembly 2HP 3 to 5HP 7½ to 10HP	1 1 1	612180-200R 612180-200S 612180-200T
Regulator PC Board 2 to 10HP	1	0-48680-101
Base Driver PC Board 2HP 3 to 10HP	1 1	0-48680-200 0-48680-201
Regulator Transformer 2 to 10HP	1	612180-600R
Base Driver Transformer 2 to 10HP	1	612180-601R
Hall Effect Amplifier 2HP 3HP 5HP 7½HP 10HP	1 1 1 1 1	0-48680-501 0-48680-502 0-48680-503 0-48680-504 0-48680-505
Phase Loss Detector PC Board 2 to 10HP	1	0-48680-506

Description	Qty. Per Drive	Reliance Part Number
Input Fuse A060URL030T13 600V, 30A Ferraz 2 to 10HP	3	402410-500AC
Control Fuse 6JX 600V, 1.5A Ferraz 2 to 10HP ( or ATQ 2/10A ) ( Gould )	2	402410-503AC (402410-501AC)

**Table 6-3. Recommended Spare Parts for Every 6 Controllers.**

Description	Qty.	Reliance Part Number
Diode Cube 2 to 5HP 7½ to 10HP	1 1	402410-100BA 402410-101BA
Transistor Module 2HP 3 to 5HP 7½ to 10HP	1 1 3	402410-200AS 402410-201AS 402410-202AS
Precharge Relay Assembly 2HP 3 to 5HP 7½HP 10HP	1 1 1 1	612180-100R 612180-100S 612180-100T 612180-100V
Bus Clamp PC Board 2 to 10HP	1	0-48680-500
Regulator PC Board 2 to 10HP	1	0-48680-100
Base Driver PC Board 2HP 3 to 10HP	1 1	0-48680-200 0-48680-201
Regulator Transformer 2 to 10HP	1	612180-600R
Base Driver Transformer 2 to 10HP	1	612180-601R
Input Fuse A060URL030T13 600V, 30A Ferraz 2 to 10HP	12	402410-500AC
Control Fuse 6JX 600V, 1.5A Ferraz 2 to 10HP ( or ATQ 2/10A ) ( Gould )	12	402410-503AC (402410-501AC)

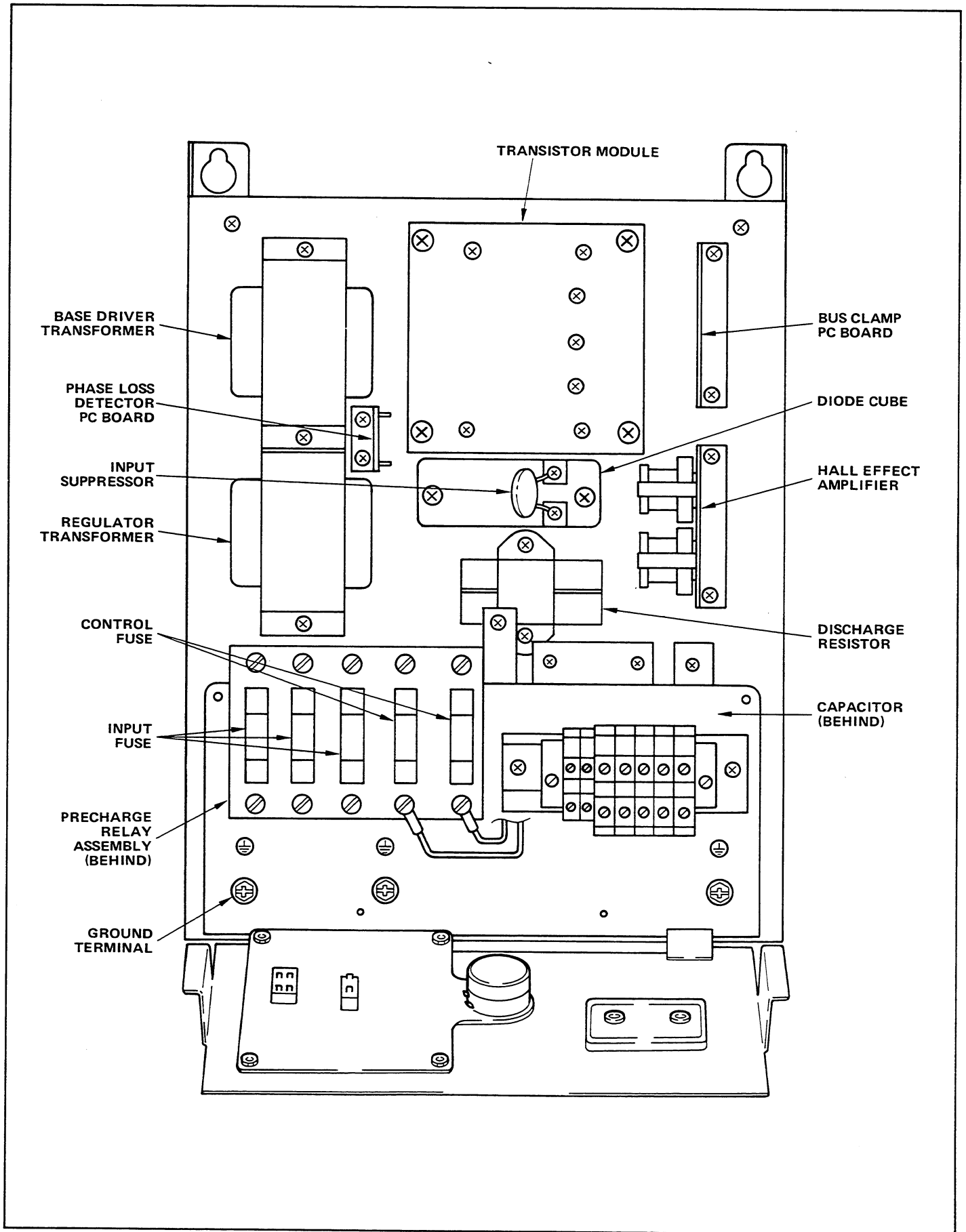

Figure 6-6. Typical Component Identification (2 to 5 HP).

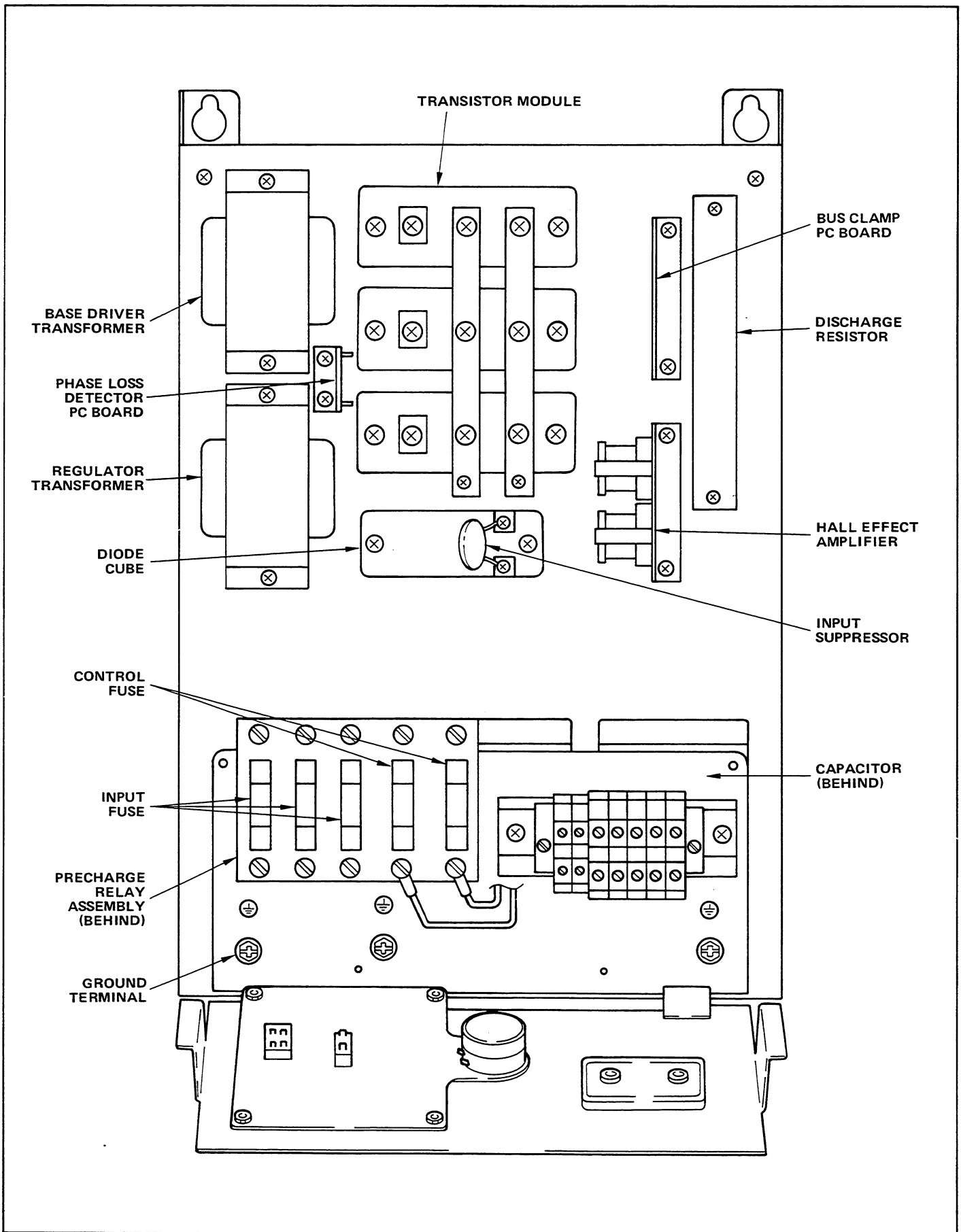
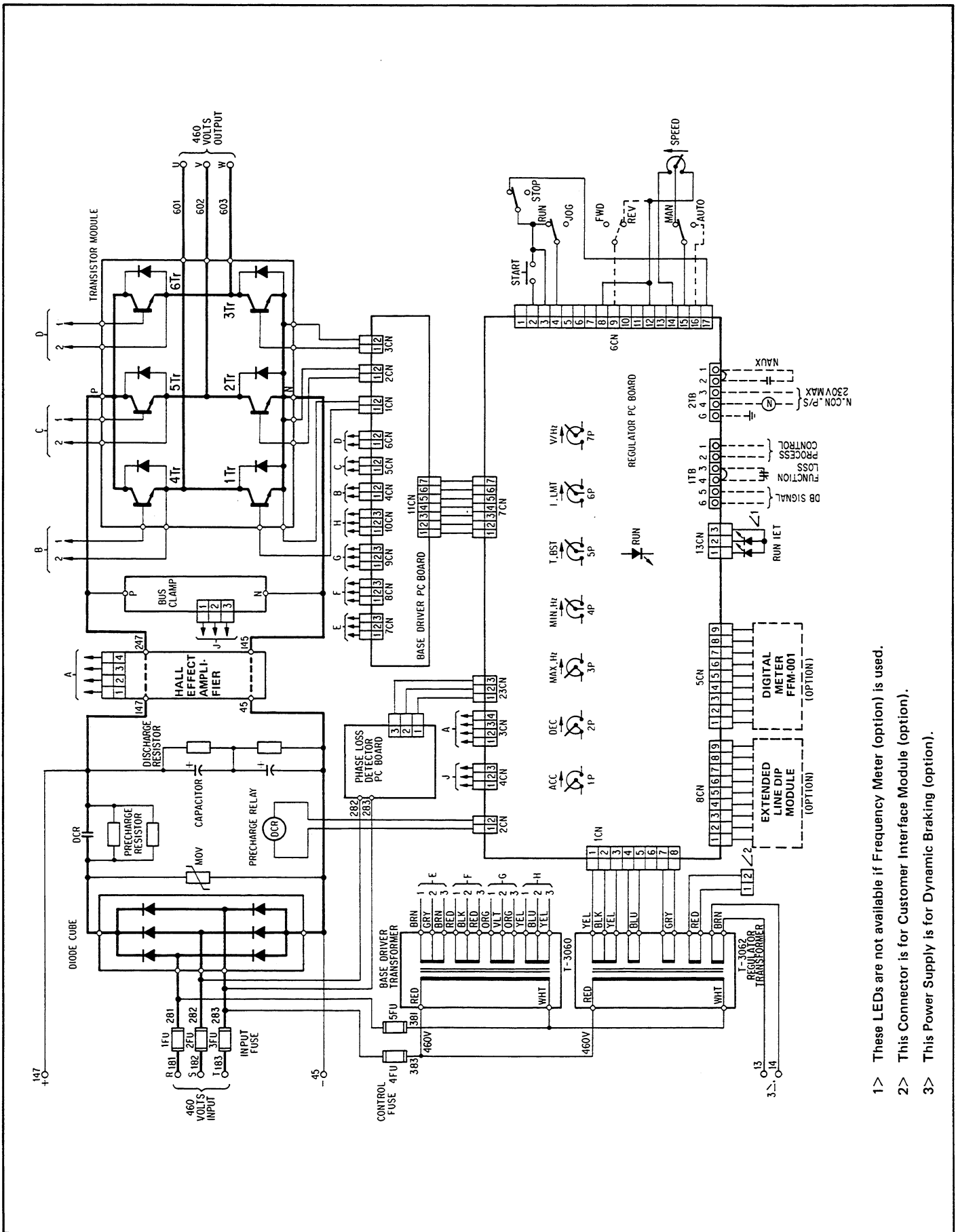

Figure 6-7. Typical Component Identification (7½ to 10 HP).



- 1> These LEDs are not available if Frequency Meter (option) is used.
- 2> This Connector is for Customer Interface Module (option).
- 3> This Power Supply is for Dynamic Braking (option).

Figure 6-8. Typical Wiring Diagram of Standard NEMA 1 Enclosed Controller.

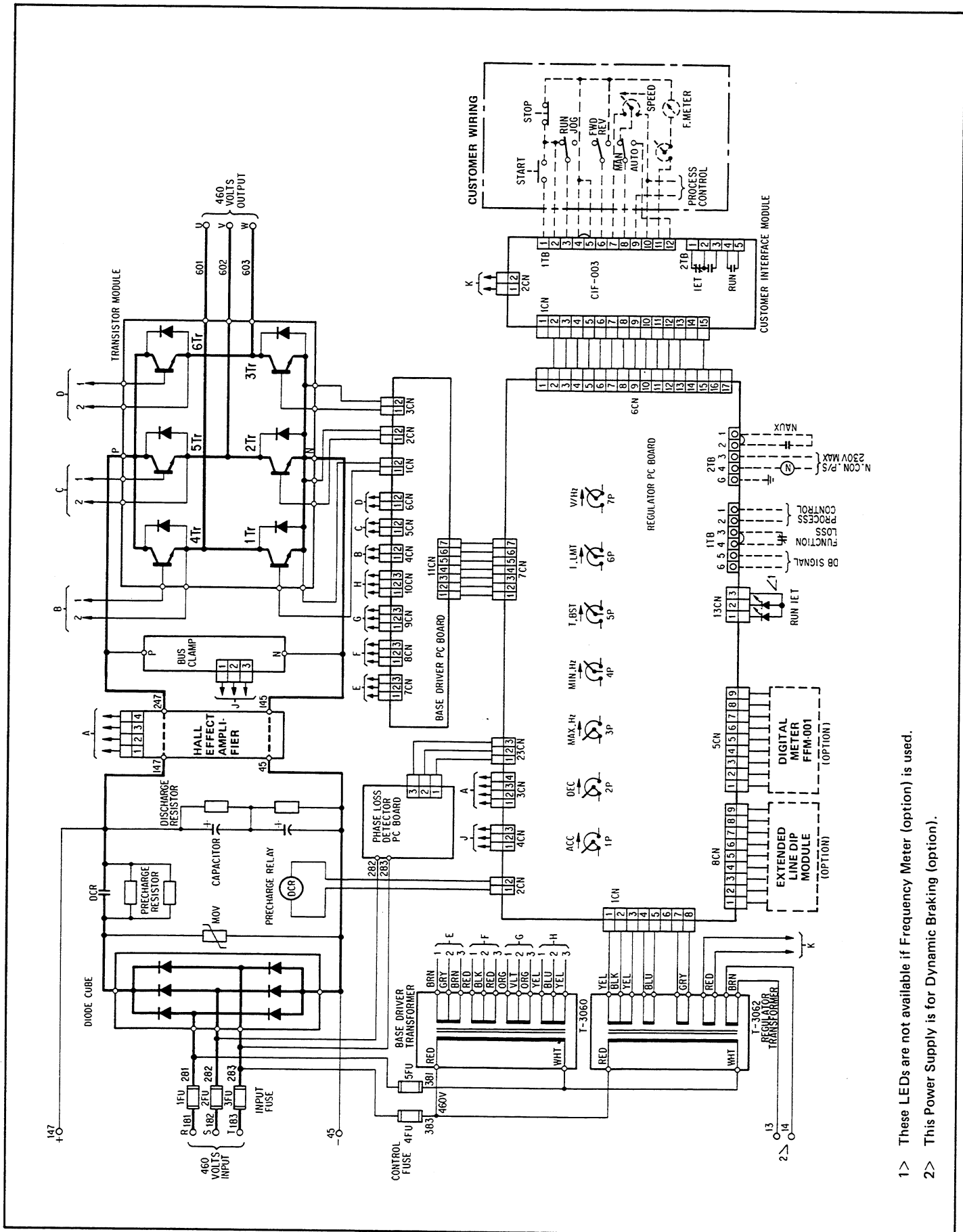
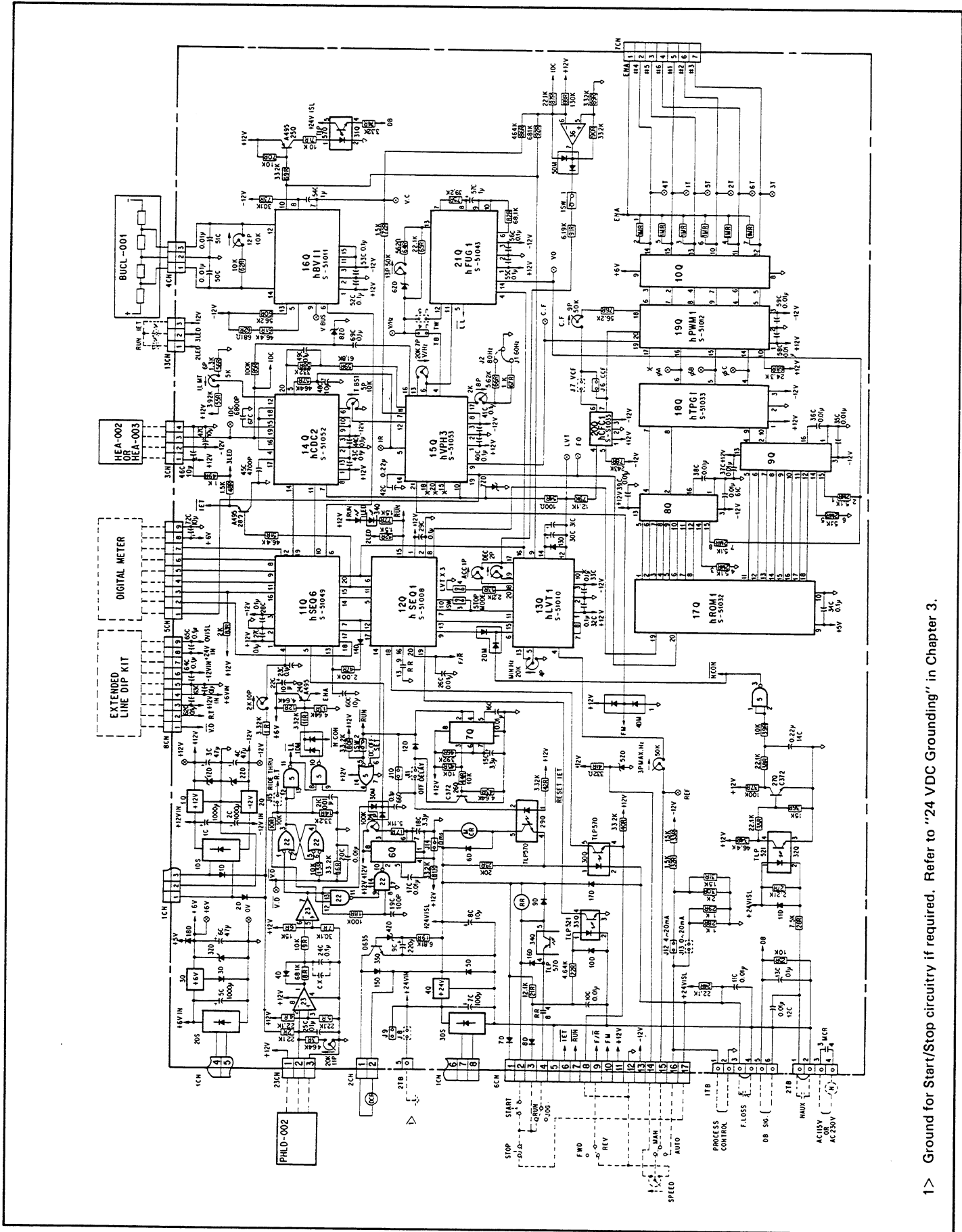

Figure 6-9. Typical Wiring Diagram of Chassis Controller.

1> These LEDs are not available if Frequency Meter (option) is used.

2> This Power Supply is for Dynamic Braking (option).



1 > Ground for Start/Stop circuitry if required. Refer to "24 VDC Grounding" in Chapter 3.

Figure 6-10. Typical Regulator PC Board Schematic.



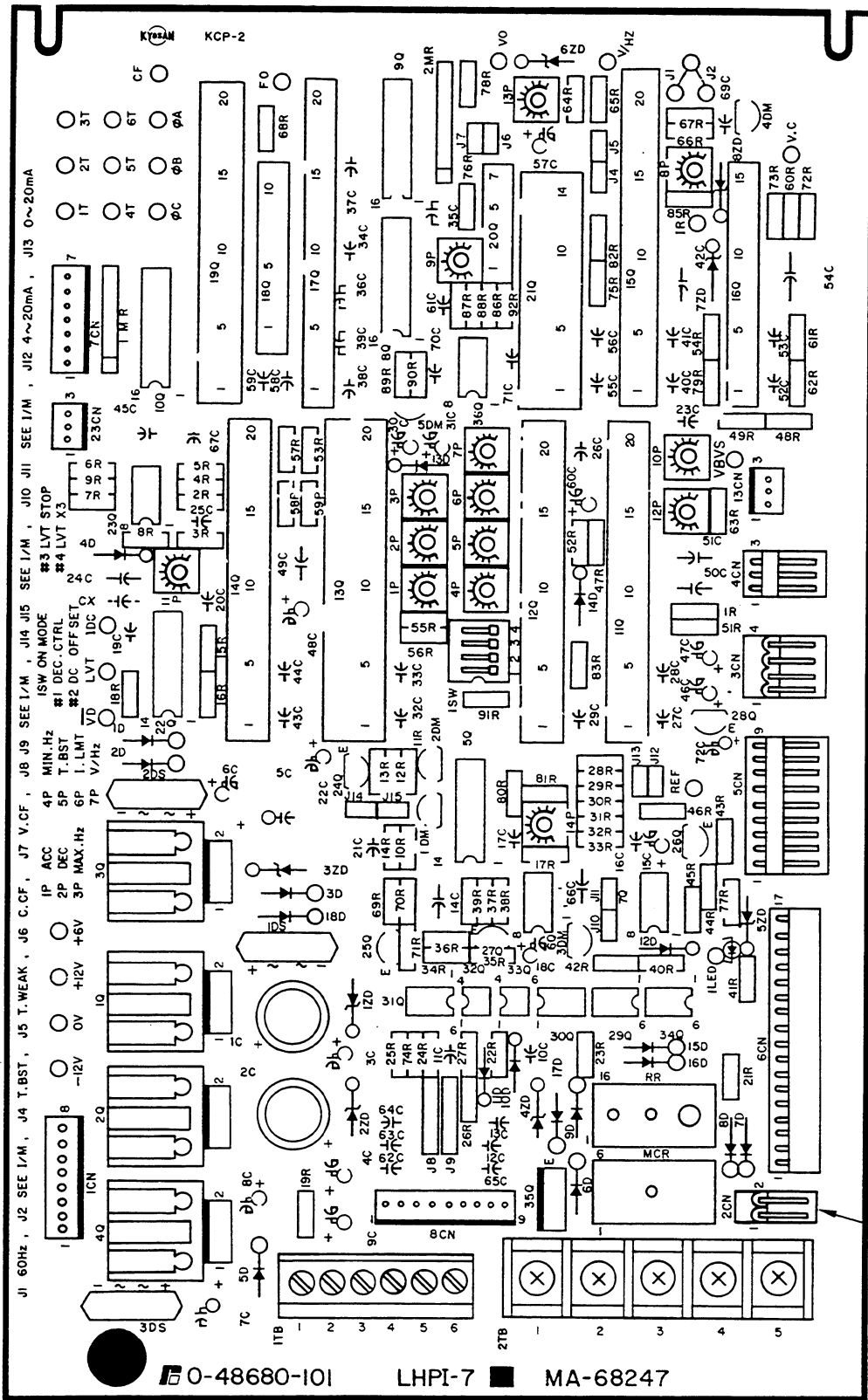

Figure 6-12. Typical Component Layout of Regulator PC Board.

Reliance Electric / 24703 Euclid Avenue / Cleveland, Ohio 44117 / (216) 266-7000

---

