

**GV3000/SE 230 VAC 1-20 HP
General Purpose (Volts/Hertz)
and Vector Duty Drive
Software Start-Up and Reference Manual
Version 6.06**

Instruction Manual D2-3387-5

**Rockwell
Automation**

The information in this manual is subject to change without notice.

Throughout this manual, the following notes are used to alert you to safety considerations:



ATTENTION: Identifies information about practices or circumstances that can lead to personal injury or death, property damage, or economic loss.

Important: Identifies information that is critical for successful application and understanding of the product.



ATTENTION: Only qualified electrical personnel familiar with the construction and operation of this equipment and the hazards involved should install, adjust, operate, or service this equipment. Read and understand this manual and other applicable manuals in their entirety before proceeding. Failure to observe this precaution could result in severe bodily injury or loss of life.

ATTENTION: DC bus capacitors retain hazardous voltages after input power has been disconnected. After disconnecting input power, wait five (5) minutes for the DC bus capacitors to discharge and then check the voltage with a voltmeter to ensure the DC bus capacitors are discharged before touching any internal components. Failure to observe this precaution could result in severe bodily injury or loss of life.

ATTENTION: The drive can operate at and maintain zero speed. The user is responsible for assuring safe conditions for operating personnel by providing suitable guards, audible or visual alarms, or other devices to indicate that the drive is operating or may operate at or near zero speed. Failure to observe this precaution could result in severe bodily injury or loss of life.

ATTENTION: Do not install modification kits with power applied to the drive. Disconnect and lock out incoming power before attempting such installation or removal. Failure to observe this precaution could result in severe bodily injury or loss of life.

ATTENTION: The user must provide an external, hardwired emergency stop circuit outside of the drive circuitry. This circuit must disable the system in case of improper operation. Uncontrolled machine operation may result if this procedure is not followed. Failure to observe this precaution could result in bodily injury.

ATTENTION: The drive contains ESD- (Electrostatic Discharge) sensitive parts and assemblies. Static control precautions are required when installing, testing, servicing, or repairing the drive. Erratic machine operation and damage to, or destruction of, equipment can result if this procedure is not followed. Failure to observe this precaution can result in bodily injury.

ATTENTION: The user is responsible for conforming with all applicable local, national, and international codes. Failure to observe this precaution could result in damage to, or destruction of, the equipment.

DeviceNet is a trademark of the Open DeviceNet Vendor Association.

ControlNet is a trademark of ControlNet International, Ltd.

PROFIBUS is a trademark of PROFIBUS International.

GV3000/SE, AutoMax, RPM, and Reliance are trademarks of Rockwell International.

© 2001 Rockwell International Corporation.

CONTENTS

| | | |
|--|---|------------|
| Preface | | VII |
| Chapter 1 Starting Up the Drive for Volts/Hertz Regulation | | |
| 1.1 | Preparing for Start Up (Volts/Hertz) | 1-2 |
| 1.2 | Start-Up Procedure (Volts/Hertz) | 1-3 |
| Chapter 2 Starting Up the Drive for Vector Regulation | | |
| 2.1 | Preparing for Start Up (Vector) | 2-2 |
| 2.2 | Start-Up Procedure (Vector) | 2-3 |
| Chapter 3 Using the Keypad/Display to Program, Monitor, and Control the Drive | | |
| 3.1 | Monitor Mode | 3-2 |
| 3.1.1 | Displaying the Selected Reference | 3-2 |
| 3.1.2 | Entering the Manual Speed Reference | 3-3 |
| 3.2 | Program Mode | 3-3 |
| 3.3 | Drive Control | 3-4 |
| 3.4 | The Display | 3-4 |
| 3.4.1 | Display Range | 3-4 |
| 3.4.2 | Scaling the Manual Reference, Speed Display, and Reference Display Using P.028 | 3-5 |
| 3.5 | The Keypad | 3-6 |
| 3.6 | Drive Status LEDs | 3-8 |
| 3.7 | Monitor Mode LEDs | 3-9 |
| Chapter 4 Programming Reference | | |
| 4.1 | Parameter Menus | 4-1 |
| 4.2 | Parameter Types | 4-2 |
| 4.3 | Displaying or Changing Parameter Values | 4-3 |
| 4.4 | Ensuring Program Security | 4-5 |
| 4.5 | First Menu Parameters | 4-6 |
| 4.5.1 | First Menu General Parameter Descriptions (P.000 to P.006) .. | 4-6 |
| 4.6 | Second Menu Parameters | 4-11 |
| 4.6.1 | Entering the Second Menu Password | 4-11 |
| 4.6.2 | Second Menu General Parameter Descriptions (P.007 to P.099) | 4-14 |
| 4.6.3 | Second Menu V/Hz Parameter Descriptions (H.000 to H.022) | 4-55 |
| 4.6.4 | Second Menu Vector Parameter Descriptions (U.000 to U.048) | 4-68 |
| Chapter 5 Troubleshooting the Drive Using Error Codes | | |
| 5.1 | Identifying Alarm Codes and Recovering | 5-2 |
| 5.2 | Identifying Fault Codes and Recovering | 5-3 |
| 5.3 | Accessing, Reading, and Clearing the Faults in the Error Log | 5-6 |
| 5.4 | Identifying Fatal Fault Codes and Recovering | 5-9 |

| | |
|---|------------|
| Appendix A Alphabetical Listing of Parameters | A-1 |
| Appendix B Record of User Parameter Settings | B-1 |
| Appendix C Power Module-Dependent Parameter Default Values (230 V Series)..... | C-1 |
| Appendix D Default Parameter Settings | D-1 |
| Appendix E Configuring the Digital Inputs When the RMI Board is Installed in the Drive | E-1 |
| Appendix F Using the Terminal Strip Analog Input | F-1 |
| Appendix G Drive Regulation Overview | G-1 |

List of Figures

| | |
|--|------|
| Figure 3.1 – Keypad/Display | 3-1 |
| Figure 3.2 – Example of a Monitor Mode Display | 3-2 |
| Figure 3.3 – Example of a Program Mode Display | 3-4 |
| Figure 4.1 – Parameter Menu Structure | 4-2 |
| Figure 4.2 – Analog Output Selection and Setting | 4-21 |
| Figure 4.3 – Trim Reference Source Selection | 4-23 |
| Figure 4.4 – Draw and Trim Gain | 4-24 |
| Figure 4.5 – S-Curves | 4-26 |
| Figure 4.6 – Typical Preset Operation | 4-35 |
| Figure 4.7 – Drive Start, Stop, and Running Status when Configured for Edge Control vs. Level Control | 4-45 |
| Figure 4.8 – Sample Alarm Circuit for 1-20 HP Drives Using the Level Sense Enable Feature | 4-46 |
| Figure 4.9 – Signal Selection for Network Output Registers | 4-52 |
| Figure 4.10 – Volts/Hertz Ratio | 4-55 |
| Figure 4.11 – Torque Boost Voltage | 4-57 |
| Figure 4.12 – Avoidance Frequency Band | 4-61 |
| Figure 4.13 – Volts/Hertz Curve Selection | 4-65 |
| Figure 4.14 – Motor Equivalent Circuit Diagram for Calculating Rotor Time Constant | 4-80 |
| Figure 4.15 – Outer Control Loop Proportional Trim | 4-90 |
| Figure F.1 – Terminal Strip Analog Input | F-1 |
| Figure F.2 – Analog Input Conversion Scaling (Speed and Trim Reference) .. | F-3 |
| Figure F.3 – Hysteresis Band Created by the Start and Stop Thresholds (Default Configuration) | F-6 |
| Figure G.1 – Volts/Hertz Regulator Block Diagram | G-3 |
| Figure G.2 – Flux Vector Control Block Diagram | G-4 |
| Figure G.3 – Sensorless Vector Control Block Diagram | G-4 |
| Figure G.4 – Vector Regulator: Reference Detail | G-5 |
| Figure G.5 – Vector Regulator: Speed Loop Detail | G-6 |
| Figure G.6 – Vector Speed PI and Iq Reference Limit Selection | G-7 |
| Figure G.7 – Outer Control Loop Block Diagram | G-8 |

List of Tables

| | |
|--|------|
| Table 3.1 – Display Range Examples | 3-5 |
| Table 3.2 – Drive Status LEDs | 3-8 |
| Table 3.2 – Monitor Mode LEDs | 3-9 |
| Table 4.1 – Speed Reference Source Based on P.000 and AUTO/MAN Key Status | 4-7 |
| Table 4.2 – Function Selection for Digital Inputs 6, 7, and 8 | 4-14 |
| Table 4.3 – Acceptable P.007 and P.008 Selection Combinations | 4-18 |
| Table 4.4 – Preset Speed Digital Inputs | 4-34 |
| Table 4.5 – Faults That Can Be Auto Reset | 4-38 |
| Table 4.6 – AUTO/MAN Key Status Based on P.000 and P.052 | 4-42 |
| Table 4.7 – STOP/RESET Key Status Based on P.000 and P.055 | 4-47 |
| Table 5.1 – List of Alarm Codes | 5-2 |
| Table 5.2 – List of Fault Codes | 5-3 |
| Table 5.3 – Fatal Fault Codes That Can Be Reset | 5-9 |
| Table F.1 – Analog Input Conversion Scaling for Speed or Trim Reference .. | F-2 |
| Table F.2 - Analog Input Conversion Scaling for Torque Reference | F-4 |

PREFACE

This manual is a start-up and programming reference guide for the version 6.06 GV3000/SE (Sensorless Enhanced) drive. The drive can be set up for either volts per hertz (V/Hz) or vector regulation. This manual provides a start-up procedure for both.

The start-up procedures are followed by reference information. This information includes a complete list of all parameters and a description of the keypad/display.

- You will need to know how to use the **keypad** to perform the start-up procedures described in chapters 1 and 2. If you do not, refer to chapter 3 first.
- For drives that will be set up for **V/Hz regulation**, go to chapter 1 for the start-up procedure.
- For drives that will be set up for **vector regulation**, go to chapter 2 for the start-up procedure.
- For a description of all the **parameters**, go to chapter 4.
- For **troubleshooting guidelines**, go to chapter 5.
- For a description of the **drive hardware**, refer to the GV3000/SE 230 VAC 1-20 HP Drive Hardware Reference, Installation, and Troubleshooting instruction manual (D2-3388).

Getting assistance from Reliance Electric

If you have any questions or problems with the products described in this instruction manual, contact your local Reliance Electric sales office. For technical assistance, call 1-800-726-8112.

CHAPTER 1

Starting Up the Drive for Volts/Hertz Regulation

This chapter describes the basic start-up procedure for drives which utilize open-loop V/Hz regulation. V/Hz regulation is the default method of regulation. You do not need to select it.

If you are starting up a drive which will perform vector regulation, refer to the vector start-up procedure in chapter 2.0 instead. Do not perform the start-up procedure in this chapter.

The start-up procedure below provides step-by-step instructions for:

- powering up
- checking monitor mode displays
- accessing program mode
- configuring General parameters (designated with a "P")
- configuring specific V/Hz parameters (designated with an "H")
- checking motor rotation direction
- running the drive

This start-up procedure describes how to program the minimum set of parameters that usually need to be programmed for applications using V/Hz regulation. Once you program these parameters, their values are retained even if power is lost. You only need to re-program them if you want to change how the drive operates.

Your application may require programming other parameters in addition to the ones described in this start-up procedure. Refer to chapter 4 for a description of all the parameters to verify whether you need to program any additional parameters as well. Appendix A provides a list of parameters listed alphabetically.

Throughout this manual, you will see references to parameter names and the numbers that identify them for the drive. This manual uses the same format that will be shown on the keypad/display to refer to parameters:

P.nnn
U.nnn
H.nnn
r.nnn

where: nnn is a number

P designates General parameters

U designates Vector parameters

H designates Volts/Hertz parameters

r designates optional RMI parameters

1.1 Preparing for Start Up (Volts/Hertz)

Read through the following sections to prepare for the start-up procedure.

What You Need To Know:

- You must be qualified to perform the procedure and be familiar with V/Hz regulation.
- You should be familiar with the keypad/display. If you are not familiar with the keypad/display, refer to chapter 3, which describes it.

What You Need To Do:

- Complete all hardware installation as described in the hardware reference manual. This includes connecting input power, input transformers (if required), disconnects, fuses, and the terminal strip on the drive.
- Record the following motor data from each motor nameplate for use during the procedure. Space is provided for recording information from three motors:

| | |
|-----------------------|--|
| Motor rated amps: | |
| Motor rated volts: | |
| Motor base frequency: | |

| | |
|-----------------------|--|
| Motor rated amps: | |
| Motor rated volts: | |
| Motor base frequency: | |

| | |
|-----------------------|--|
| Motor rated amps: | |
| Motor rated volts: | |
| Motor base frequency: | |

- Connect the drive to the motor.
- Check that you have not been prevented from programming the drive. If the PASSWORD LED on the keypad is on, programming has been prevented in parameter P.051, Programming Disable. Refer to section 4.4 in this manual for the procedure to enable programming.

If You Have a Problem:

To Exit:

During most of the start-up procedure, you will be in program mode, which is used to program parameters. If you want to stop programming parameters, you can exit program mode. You can do this by pressing the PROGRAM key until the PROGRAM LED turns off. This will place the keypad/display in monitor mode, the default. You can read more about these modes in chapter 3.

To Restore a Default Parameter Value after Writing over It:

If you enter the wrong value while programming parameters, you can restore the default if you have not yet pressed the ENTER key. To do so:

1. Press the PROGRAM key.
2. Press the ENTER key. The default value of the parameter will be displayed again. You can select it with ENTER or enter a new one and press ENTER.

To Restore All the Default Values to General (P) Parameters:

If you need to restore all the default values for General (P) parameters after programming them, you can do so using the Restore Defaults parameter (P.050).

1.2 Start-Up Procedure (Volts/Hertz)

This section describes the start-up procedure for drives set up for V/Hz regulation. Before using this procedure, you should have read section 1.1 for information you need to know before working with the drive.

Step 1. Power Up the Drive

This step verifies that the drive powers up and passes the power-up diagnostics. After the drive passes the diagnostics, the keypad/display automatically enters monitor mode, with speed displayed.

Turn power on.

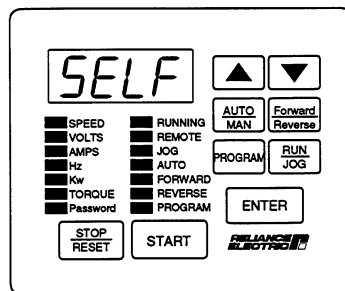

The initial display shows SELF, with all monitor mode and status LEDs on, indicating the drive is performing power-up diagnostics.

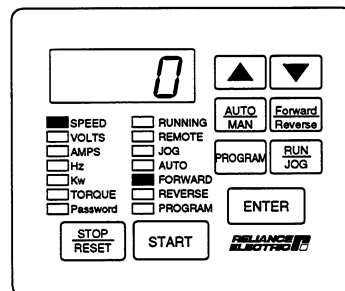

After diagnostics are complete (5-6 seconds), the SPEED LED is on and the keypad/display is in monitor mode. The displayed value is zero. You can move through the five items accessible in monitor mode - Speed, Volts, Amps, Hz, and Kw - by pressing the ENTER key.

Step 2. Select Program Mode

In this step, you will select program mode, which will give you access to the First Menu General (P) parameters.

Press the PROGRAM key.

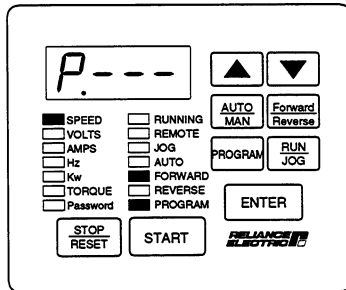

The PROGRAM LED is on and the First Menu General (P) parameters can be accessed.

Step 3. Program First Menu General Parameters P.000 - P.005

This step describes how to change First Menu General (P) parameters P.000 through P.005. P.000 selects where the drive is controlled from. This procedure assumes local control from the keypad (P.000 = LOCL), which is the default setting for the parameter.

Step 3.1 Press the ENTER key to display the first parameter, P.000, Control Source.

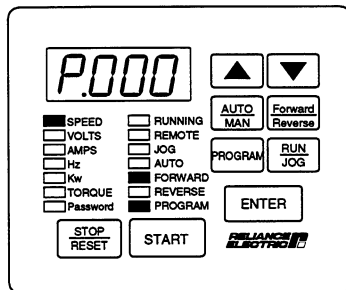

The default setting for P.000 is LOCL, or local control.

Step 3.2 Press the ▲ key to display P.001, Accel Time 1 (RAMP 1).

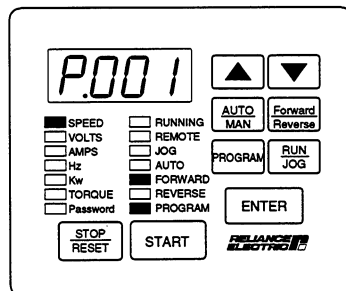

This parameter sets the acceleration time in seconds.

Step 3.3 Press the ENTER key to display the default setting of P.001.

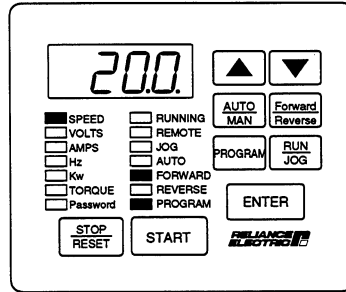

This displays the default setting for acceleration time (20.0 seconds).

Step 3.4 Press the ▲ key to increase acceleration time, or the ▼ key to decrease acceleration time.

The adjustment range is:

1.0 to 999.9 seconds.

VALUE ENTERED:

Step 3.5 Press the ENTER key to save the changed value.

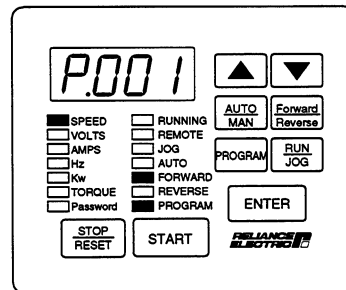

After pressing ENTER, the same parameter number is displayed. You can now go to the next parameter.

Step 3.6 Press the ▲ key to display P.002, Decel Time 1 (RAMP 1).

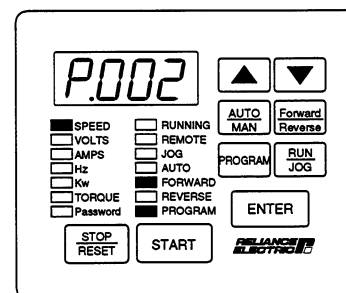

This parameter sets the deceleration time in seconds. The default stop method is coast-to-stop, set in P.025.

Step 3.7 Press the ENTER key to display the default setting of P.002.

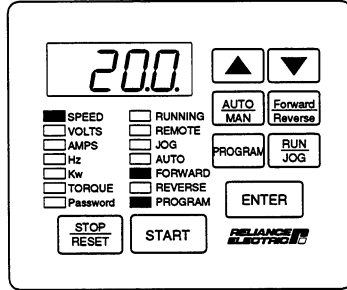

This displays the default setting for deceleration time (20.0 seconds).

Step 3.8 Press the ▲ key to increase deceleration time, or the ▼ key to decrease deceleration time.

The adjustment range is:

1.0 to 999.9 seconds.

VALUE ENTERED:

Step 3.9 Press the ENTER key to save the changed value.

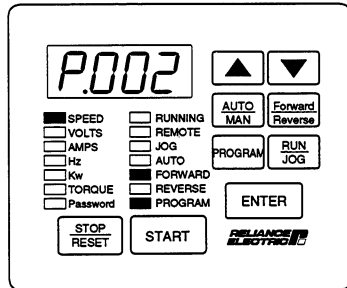

After pressing ENTER, the same parameter number is displayed. You can now go to the next parameter.

Step 3.10 Press the ▲ key to display P.003, Minimum Speed.



ATTENTION: The drive can operate near zero speed. The user is responsible for ensuring safe conditions for operating personnel by providing suitable guards, audible or visual alarms, or other devices to indicate that the drive is operating near zero speed. Failure to observe this precaution could result in severe bodily injury or loss of life.

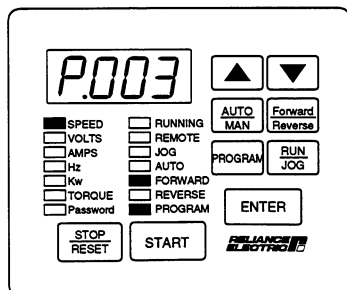

This parameter sets the minimum speed in Hz.

Step 3.11 Press the ENTER key to display the default setting of P.003.

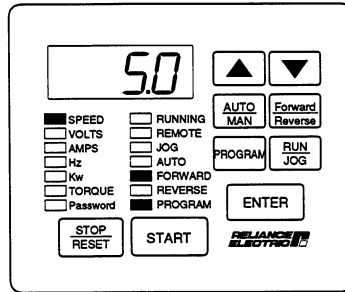

This shows that the default setting for Minimum Speed is 5.0 Hz.

Step 3.12 Press the ▲ key to increase minimum speed or the ▼ key to decrease minimum speed.

The adjustment range is:

0.5 Hz to the value set for P.004 (Maximum Speed).

VALUE ENTERED:

Step 3.13 Press the ENTER key to save the changed value.

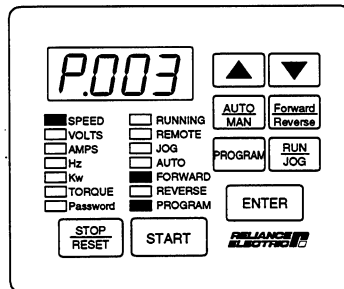

After pressing ENTER, the same parameter number is displayed. You can now go to the next parameter.

Step 3.14 Press the ▲ key to display P.004, Maximum Speed.

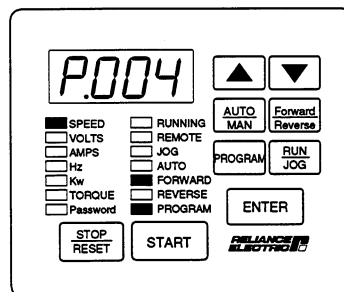

This parameter sets the maximum speed in Hz.

In addition, the drive has overfrequency protection by means of H.022. Refer to the description of this parameter and be sure to set it appropriate to your application.

Step 3.15 Press the ENTER key to display the default setting of P.004.



ATTENTION: The user is responsible for ensuring that driven machinery, all drive-train mechanisms, and application material are capable of safe operation at the maximum operating speed of the drive. In V/Hz regulation, overfrequency protection in the drive is provided by means of H.022. Failure to observe this precaution could result in bodily injury.

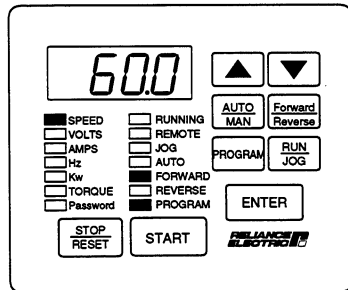

This shows that the default setting for Maximum Speed is 60.0 Hz.

Step 3.16 Press the ▲ key to increase maximum speed or the ▼ key to decrease maximum speed.

The adjustment range is:

15.0 Hz to the value set for H.022 (Overfrequency Limit).

The maximum value is 210 Hz.

VALUE ENTERED:

Step 3.17 Press the ENTER key to save the changed value.

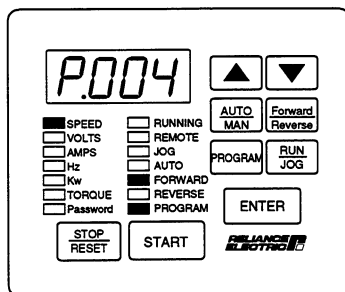

After pressing ENTER, the same parameter number is displayed. You can now go to the next parameter.

Step 3.18 Press the ▲ key to display P.005, Current Limit.

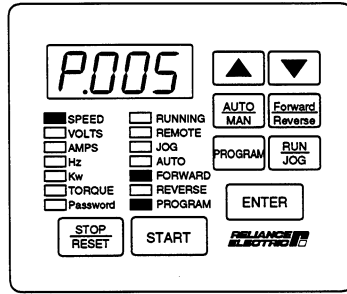

This parameter sets Current Limit, which corresponds to the value in parameter P.095, Power Module Output Amps.

Step 3.19 Press the ENTER key to display the default setting of P.005.

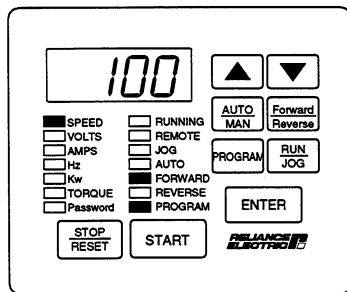

This shows that the default setting for Current Limit is 100.

Step 3.20 Press the ▼ key to decrease current limit. Decrease current limit only if the motor nominal current rating is less than the drive nominal current rating.

Use the following equation to calculate current limit:

$$\frac{\text{Motor Rated Amps}^{(1)}}{\text{Rated Drive Output Amps}^{(2)}} \times 100$$

(1) From motor nameplate

(2) See the hardware reference manual for ratings.

Adjustment Range: 50 to 110

VALUE ENTERED:

Step 3.21 Press the ENTER key to save the entered value.

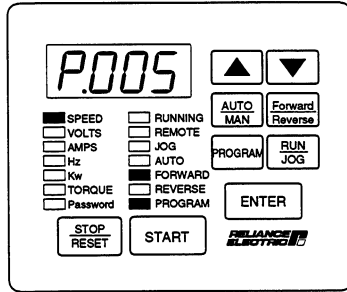

After pressing ENTER, the same parameter number is displayed. You can now move to the next parameter.

Step 4. Enter the Second Menu Password

This step is required in order to access the Second Menu General (P) parameters and the Volts/Hertz (H) parameters.

Step 4.1 Press the ▲ key to display parameter P.006, Second Menu Password.

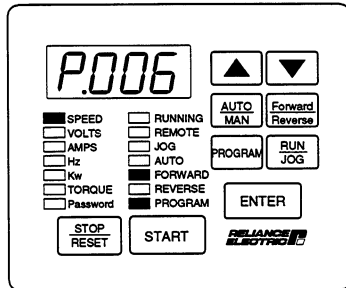

This parameter allows you to enter the factory preset password that allows access to the Second Menu.

The Second Menu provides access to all parameters and the error log.

Step 4.2 Press the ENTER key.

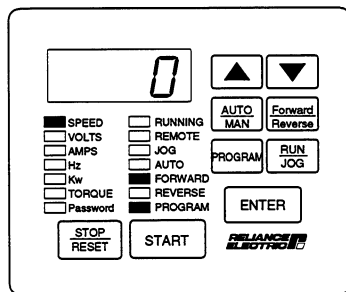

Zero is displayed.

Step 4.3 Press the ▲ key until the password number 107 is displayed.

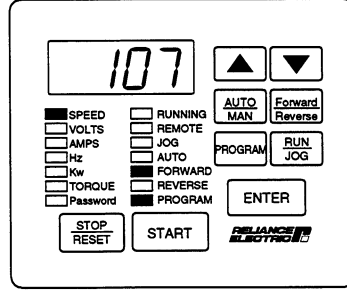

Note that the password, and access to the Second Menu, will be retained if the drive loses and regains power.

Step 4.4 Press the ENTER key to save the password number.

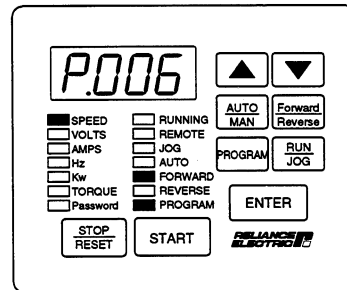

After pressing ENTER, P.006 is displayed. You now have access to all parameters and the error log.

After the password is entered, the parameter value is reset to 0.

Step 5. Program the Second Menu Volts/Hertz (H) Parameters

This step describes how to program the parameters that apply to V/Hz regulation only.

Step 5.1 Press the PROGRAM key to return to the First Menu.

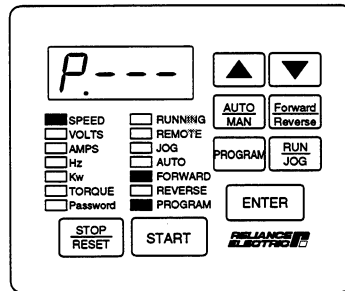

The display returns to the General (P) parameters in the First Menu.

Step 5.2 Press the ▲ key twice.

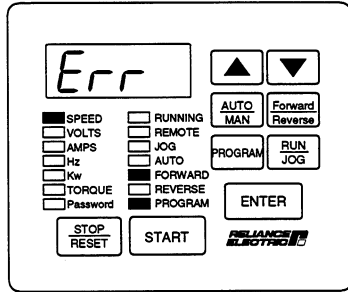

The error log (Err) is bypassed, then

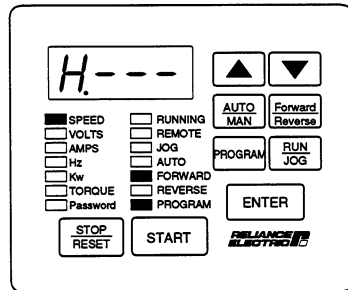

.... the Volts/Hertz (H) parameter main menu is displayed.

Step 5.3 Press the ENTER key to access the first Volts/Hertz parameter: H.000, Motor Nameplate Volts.

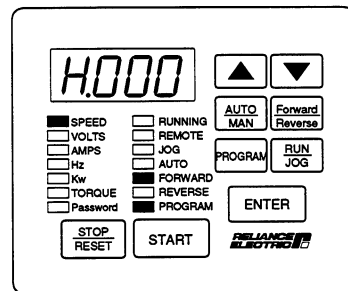

This parameter sets the Motor Nameplate Volts and is taken directly from the motor nameplate.

Step 5.4 Press the ENTER key.

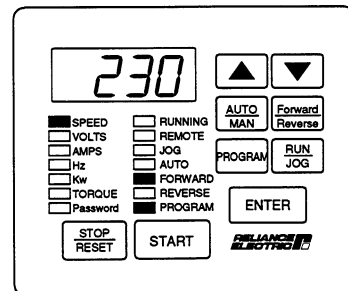

The default setting for H.000 is displayed. The factory-set default value is 230.

Default value varies.

Step 5.5 If no change was made, press the ENTER key to return to the parameter. If you changed the value, press ENTER to accept the change and return to the parameter.

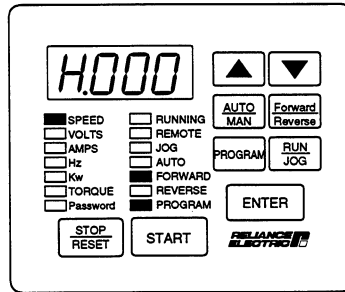

After pressing ENTER, the same parameter is displayed. You can now move to the next parameter.

Step 5.6 Press the ▲ key to display H.001, Motor Nameplate Base Frequency.

Note that if Motor Nameplate Base Frequency is not set correctly, the monitor mode SPEED display will also not be scaled correctly.

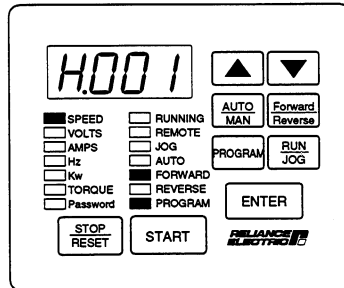

This parameter adjusts the volts/hertz ratio. Base frequency is the set frequency at which the output voltage reaches the Motor Nameplate Voltage.

See figure 4.10 in chapter 4 for more information.

Step 5.7 Press the ENTER key.

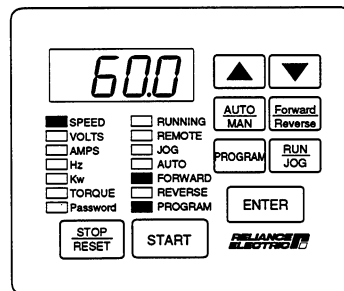

The default setting of 60.0 Hz is displayed.

Step 5.8 Press the ▼ key to decrease base frequency, if necessary.

This value will typically not need to be changed from 60 Hz.

Step 5.9 Press the ENTER key.

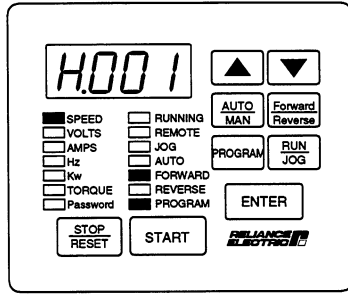

After pressing ENTER, the same parameter is displayed. You can now move to the next parameter.

Step 5.10 Press the ▲ key to display H.002, Motor Nameplate Amps.

ATTENTION: This parameter setting must not exceed the rated amps found on the motor nameplate. Excess heating of the motor could result if this is not the case. Failure to observe this precaution could result in damage to, or destruction of, the equipment.

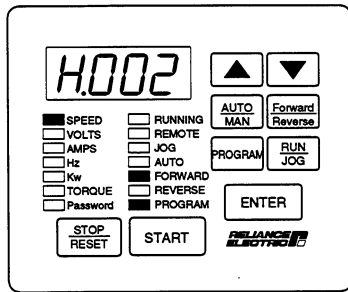

This parameter specifies the Motor Nameplate Amps and is taken directly from the motor nameplate.

Step 5.11 Press the ENTER key.

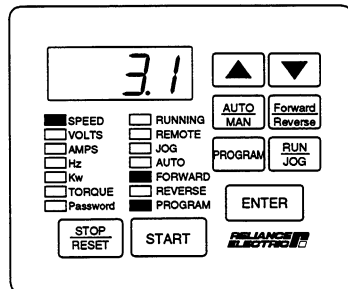

The default setting depends on the drive rating. The display shown here is only an example.

Step 5.12 Press the ▲ key to increase the motor nameplate amps, or the ▼ key to decrease motor nameplate amps.

The adjustment range depends on the drive rating. See Appendix C.

VALUE ENTERED:

Step 5.13 Press the ENTER key to save the changed value.

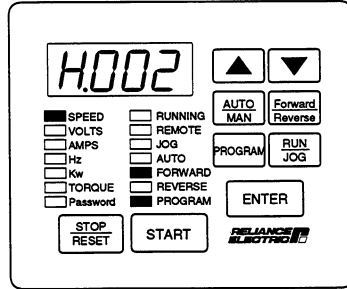

After pressing ENTER, the same parameter is displayed. You can now move to the next parameter.

Step 5.14 Press the ▲ key to display H.003, Torque Boost Voltage.

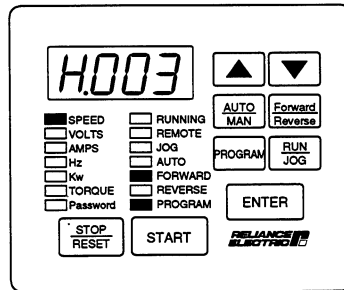

This parameter is required to offset the voltage drop of the motor at low speeds and produce constant torque. For example, high friction loads may require high starting torque.

Refer to figure 4.11 in chapter 4 for more information.

Step 5.15 Press the ENTER key.

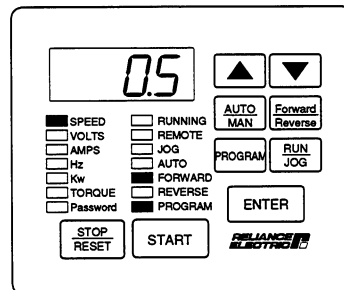

The default setting is 0.5.

Step 5.16 Press the ▲ key to increase the torque boost voltage, or the ▼ key to decrease torque boost voltage.

Important: If you set H.003 = 0, you must perform the identification test, controlled by H.020, prior to running. Refer to the H.020 parameter description for more information.

The adjustment range is:

0.0% to 20.0%

VALUE ENTERED:

Step 5.17 Press the ENTER key to save the changed value.

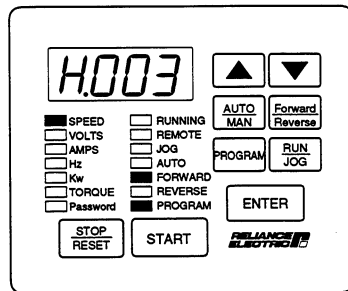

After pressing ENTER, the same parameter is displayed. You can now move to the next parameter.

Step 5.18 Press the ▲ key until H.017, Input Power/Snubber Configuration, is displayed.

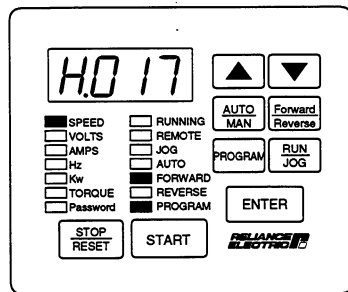

This parameter selects the input power supply type/snubber resistor kit configuration. See chapter 4 for more information.

Step 5.19 Press the ENTER key.

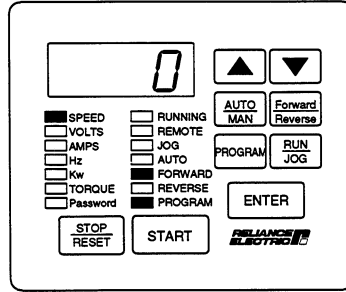

The default setting is 0.

Step 5.20 Press the ▲ key to increase the selection value, or leave it at 0.

If you do not have AC input or you are using a snubber resistor, see the H.017 parameter description for more information.

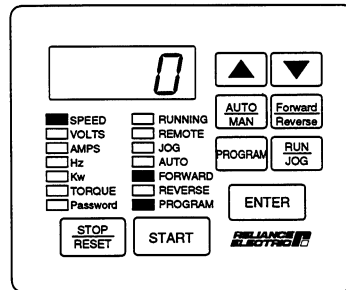

The adjustment range is:

- 0 = AC input; snubber resistor not used; ride-through enabled.
- 1 = AC input; snubber resistor used; ride-through enabled.
- 2 = DC input; snubber resistor not used; ride-through disabled.
- 3 = DC input; snubber resistor used; ride-through disabled.
- 4 = DC input, snubber resistor not used; ride-through enabled.
- 5 = DC input; snubber resistor used; ride-through enabled.

VALUE ENTERED:

Step 5.21 Press the ENTER key to save the changed value.

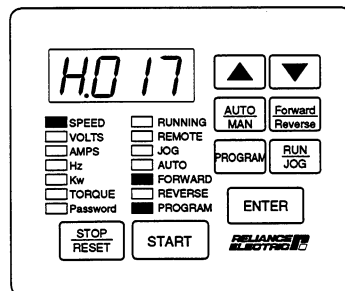

After pressing ENTER, the same parameter is displayed. You can now move to the next parameter.

Step 5.22 Press the ▲ key until H.018, Volts/Hertz Curve Type, is displayed.

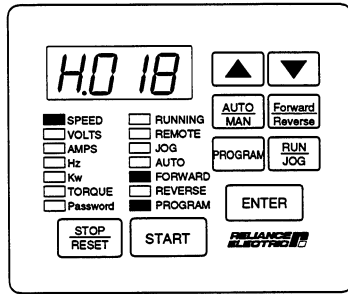

This parameter selects the type of curve for volt/hertz regulation. See chapter 4 and step 5.24 for more information.

Step 5.23 Press the ENTER key.

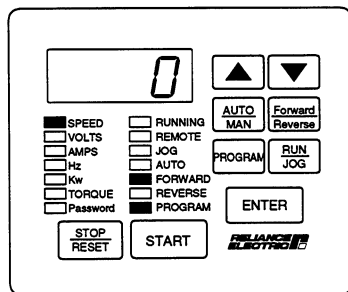

The default setting is 0 for linear curve.

Step 5.24 Press the ▲ key to increase the selection value to 1 or 2, or leave it at 0.

The adjustment range is:

- 0 = Linear curve
- 1 = Optimized curve for Reliance Electric RPM AC motors
- 2 = For centrifugal pump and fan motor applications

VALUE ENTERED:

Step 5.25 Press the ENTER key to save the changed value.

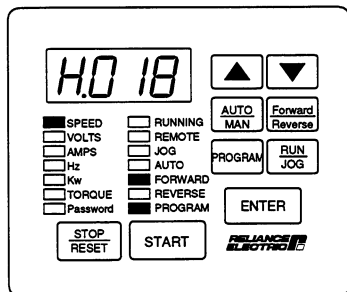

After pressing ENTER, the same parameter is displayed. You can now move to the next parameter.

Step 6. Return to Monitor Mode

This step describes how to exit program mode and return to monitor mode.

Step 6.1 The display should now show the last parameter adjusted in Step 5, H.018.

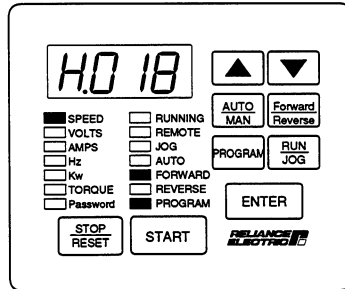

Step 6.2 Press the PROGRAM key twice to exit program mode.

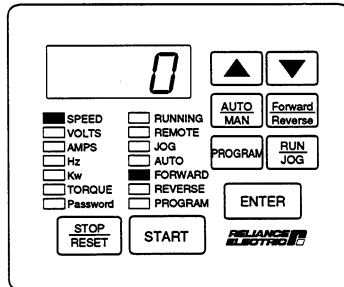

The display returns to monitor mode with speed displayed. The SPEED LED is on and the PROGRAM LED is off.



ATTENTION: The subsequent steps require rotating parts and/or electrical circuits to be exposed. Stay clear if unit must be running, or disconnect and lock out or tag power source if contact must be made. Failure to observe this precaution could result in severe bodily injury or loss of life.

Important: The stop input on the terminal strip is not active when the Control Source parameter (P.000) is set to LOCL, as it is during this start-up procedure. Use the STOP/RESET key if you need to stop the drive.

Step 7. Check Motor Rotation Direction

This step involves verifying the speed reference is set to minimum speed, starting the drive, and checking that the motor rotates in the correct direction. It is performed with the motor disconnected from the load.

Step 7.1 Press the PROGRAM key until the PROGRAM LED turns off.

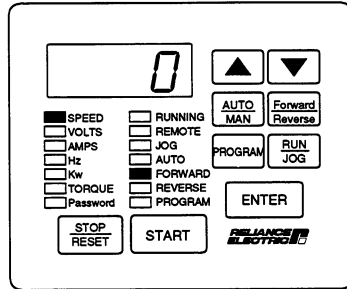

The keypad/display will enter monitor mode.

Step 7.2 Verify that the AUTO LED is off (press the AUTO/MAN key until the AUTO LED turns off).

This selects the local keypad as the speed reference source.

Step 7.3 Press the ▲ key or the ▼ key once.

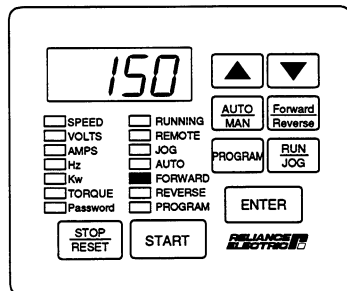

The monitor mode LEDs will all turn off and the manual speed reference value will be displayed. The speed reference value is in the units defined in P.028. The display shown here is only an example.

Step 7.4 If the speed reference is at minimum speed, then proceed to Step 7.6.

If the speed reference is not at minimum speed, proceed to Step 7.5.

Step 7.5 Press the ▼ key to decrease the speed reference value.

Step 7.6 Press the ENTER key to return to monitor mode.

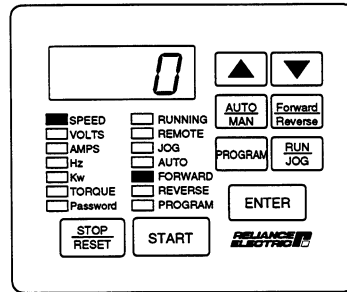

Step 7.7 Verify that you have selected RUN and FORWARD. Press the START key.

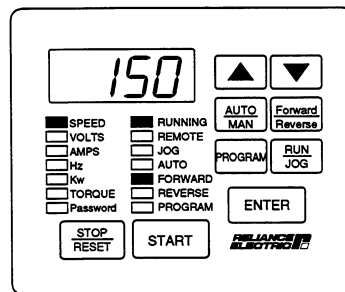

The drive is now running. The keypad/display is in monitor mode and the SPEED, RUNNING, and FORWARD LEDs are on. The drive should be running at minimum speed. The sample display shows 150 RPM.

Step 7.8 Visually check that the motor rotates counter-clockwise (CCW) when viewed from the driven motor shaft end.

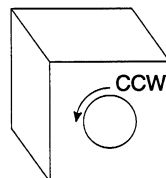

Step 7.9

- If the rotation direction is NOT correct, press the STOP/RESET key and continue with Step 7.10.
- If the rotation direction is correct, continue with Step 7.14.

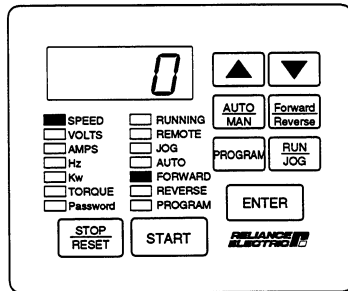

When the STOP/RESET key is pressed, the RUNNING LED turns out.

Step 7.10 Turn off and lock out or tag power to the drive.

Step 7.11 Verify that the DC bus capacitors are discharged. Refer to the hardware reference manual for this procedure.



ATTENTION: DC bus capacitors retain hazardous voltages after input power has been disconnected. After disconnecting input power, wait five (5) minutes for the DC capacitors to discharge and then check the voltage with a voltmeter to ensure the DC capacitors are discharged before touching any internal components. Failure to observe this precaution could result in severe bodily injury or loss of life.

Step 7.12 Switch any two of the motor leads (U, V, or W).

Step 7.13 Turn power on, and press the START key. Repeat Step 7.8.

Step 7.14 To make sure that the drive is not inadvertently started, turn off and lock out or tag power to the drive. Verify that the motor direction is appropriate for the required machine direction, and then connect the motor to the load.

Step 8. Run the Drive

This step describes how to adjust the speed reference from the keypad and run the motor up to maximum speed in Hz. At maximum Hz, you must check values in monitor mode. This step assumes you have connected motor to the load.



ATTENTION: The user is responsible for ensuring that driven machinery, all drive-train mechanisms, and application material are capable of safe operation at the maximum operating speed of the drive. In V/Hz regulation, overfrequency protection in the drive is provided by means of H.022. Failure to observe this precaution could result in bodily injury.

Step 8.1 Press the ENTER key until the Hz LED turns on. (If the drive is not running, press the START key.)

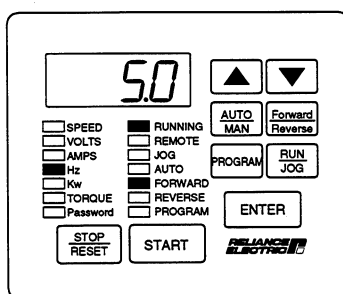

This example shows the minimum hertz setting of parameter P.003.

Step 8.2 Press the ▲ or ▼ key once. All of the monitor mode LEDs turn off. Increase the speed reference to the maximum value by using the ▲ key.

Wait five seconds or press the ENTER key to return to monitor mode.

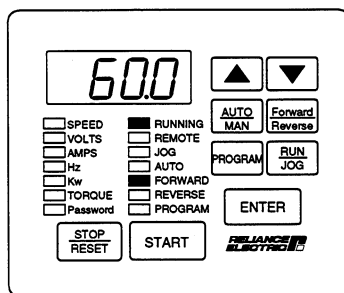

This increases the drive speed reference and the motor will rotate up to maximum speed.

The monitor mode LEDs turn off when the reference is changed.

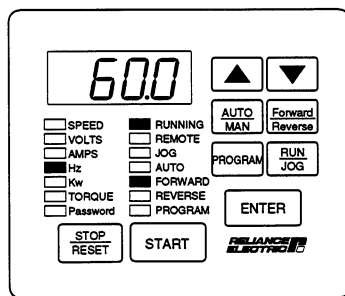

The display now shows the drive speed. Your speed display may be different.

Step 8.3 Press the ENTER key to move to the VOLTS display.

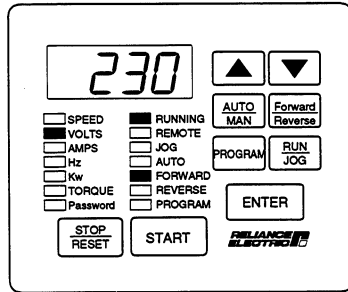

This example shows the output volts at Maximum Speed (P.004). Your actual reading may be different.

VALUE READ:

Step 8.4 Press the ENTER key to move to the AMPS display.

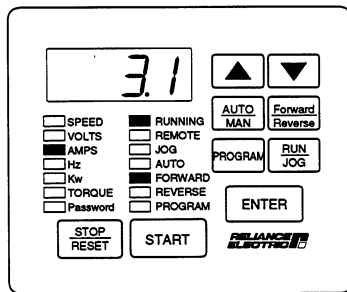

This example shows the output amps at Maximum Speed (P.004). Your actual reading may be different.

VALUE READ:

Step 8.5 Press the ENTER key to move to the Hz display.

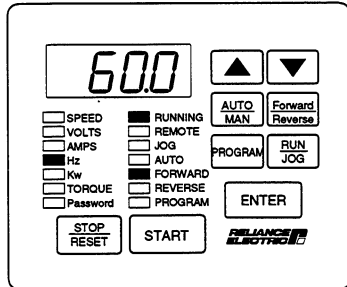

This example shows the Hz value corresponding to the value set in parameter P.004, Maximum Speed. Your actual reading may be different.

VALUE READ:

Step 8.6 Press the STOP/RESET key. The driven motor should stop as programmed in P.025, Stop Type.

End of V/Hz Start-Up Procedure

This is the end of the basic V/Hz start-up procedure. When the start-up values are final, Appendix B can be used to record final settings.

To configure remaining parameters according to the specific application, refer to Chapter 4, Programming Reference. If you have purchased the Control and Configuration Software (CS3000), save your configuration to a personal computer. Refer to the CS3000 software instruction manual (D2-3348) for this procedure.

Recall that the Control Source parameter (P.000) was set to LOCL in this start-up procedure. If you need to operate the drive from a different control source, you will need to change the setting in parameter P.000.

CHAPTER 2

Starting Up the Drive for Vector Regulation

This chapter describes the basic start-up procedure for drives which utilize flux vector control (FVC) or sensorless vector control (SVC). Part of this procedure describes how to select vector regulation.

If you are starting up a drive which will perform V/Hz regulation, refer to the V/Hz start-up procedure in chapter 1.0 instead. Do not perform the start-up procedure in this chapter.

The start-up procedure below provides step-by-step instructions for:

- powering up
- checking monitor mode displays
- accessing program mode
- configuring General parameters (designated with a "P")
- configuring specific vector parameters (designated with a "U")
- checking motor rotation direction
- running the drive

This start-up procedure describes how to program the minimum set of parameters that usually need to be programmed for applications using vector regulation. Once you program these parameters, their values are retained even if power is lost. You only need to re-program them if you want to change how the drive operates.

Your application may require programming other parameters in addition to the ones described in this start-up procedure. Refer to chapter 4 for a description of all parameters to verify whether you need to program any additional parameters as well. Appendix A provides a list of parameters listed alphabetically.

Throughout this manual, you will see references to parameter names and the numbers that identify them for the drive. This manual uses the same format that will be shown on the keypad/display to refer to parameters:

P.nnn
U.nnn
H.nnn
r.nnn

where: nnn is a number
P designates General parameters
U designates Vector parameters
H designates Volts/Hertz parameters
r designates optional RMI parameters

2.1 Preparing for Start Up (Vector)

Read through the following sections to prepare for the start-up procedure.

What You Need To Know:

- You must be qualified to perform the procedure and be familiar with vector regulation.
- You should be familiar with the keypad/display. If you are not familiar with the keypad/display, refer to chapter 3, which describes it.

What You Need To Do:

- Complete all hardware installation as described in the hardware reference manual. This includes connecting input power, input transformers (if required), disconnects, fuses, the encoder (if used), and the terminal strip on the drive.
- Record the following motor data from motor nameplate for use during the procedure:

| | |
|--------------------------------------|--|
| Motor rated horsepower: | |
| Motor rated amps: | |
| Motor rated volts: | |
| Motor base frequency: | |
| Motor rated RPM: | |
| Number of motor poles ¹ : | |

¹ Reliance RPMTH AC motors are 4-pole regardless of base RPM. Standard NEMA motors are as follows:

| | | |
|----------|---|---------|
| 3600 RPM | = | 2 poles |
| 1800 RPM | = | 4 poles |
| 1200 RPM | = | 6 poles |
| 900 RPM | = | 8 poles |

Consult your motor supplier if you are unsure of the motor design you are using.

- If an encoder is used, record the following encoder data. Make sure the encoder is mounted to the motor and connected to the drive.

| | |
|--------------|--|
| Encoder PPR: | |
|--------------|--|

- Connect the drive to the motor and disconnect the motor from the load.
- Check that you have not been prevented from programming the drive. If the PASSWORD LED on the keypad is on, programming has been prevented in parameter P.051, Programming Disable. Refer to section 4.4 in this manual for the procedure to enable programming.

If You Have a Problem:

To Exit:

During most of the start-up procedure, you will be in program mode, which is used to program parameters. If you want to stop programming parameters, you can exit program mode. You can do this by pressing the PROGRAM key until the PROGRAM LED has turned off. This will place the keypad/display in monitor mode, the default. You can read more about these modes in chapter 3.

To Restore a Default Parameter Value after Writing over It:

If you enter the wrong value while programming parameters, you can restore the default if you have not yet pressed the ENTER key. To do so:

1. Press the PROGRAM key.
2. Press the ENTER key. The default value of the parameter will be displayed again. You can select it with ENTER or enter a new one and press ENTER.

To Restore All the Default Values to General (P) Parameters:

If you need to restore all the default values for General (P) parameters after programming them, you can do so using the Restore Defaults parameter (P.050).

2.2 Start-Up Procedure (Vector)

This section describes the start-up procedure for drives set up for vector regulation. Before using this procedure, you should have read section 2.1 for information you need to know before working with the drive.

Step 1. Power Up the Drive

This step verifies that the drive powers up and passes the power-up diagnostics. After the drive passes the diagnostics, the keypad/display automatically enters monitor mode with speed displayed.

Turn power on.

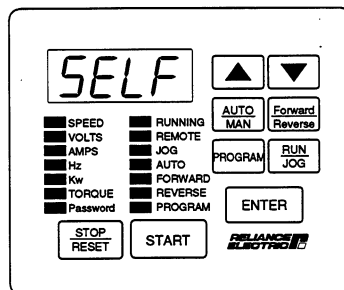

The initial display will show SELF, with all monitor mode and status LEDs on, indicating the drive is performing power-up diagnostics.

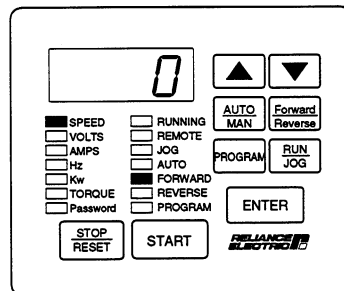

After diagnostics are complete (5-6 seconds), the SPEED LED is on and the keypad/display is in monitor mode. The displayed value is zero. You can move through the six items that can be accessed in monitor mode – Speed, Volts, Amps, Hz, Kw, and Torque – by pressing the ENTER key.

Step 2. Select Program Mode

In this step, you will select program mode, which gives you access to the First Menu General (P) parameters.

Step 2.1 Press the PROGRAM key.

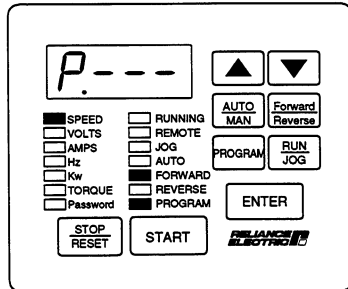

The PROGRAM LED is on and the First Menu General (P) parameters can be accessed.

Step 2.2 Press the ENTER key.

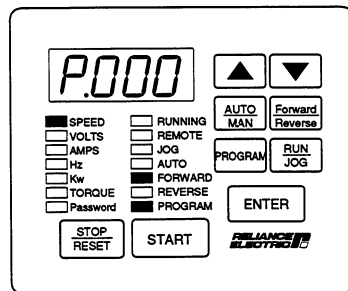

The first General (P) parameter in the First Menu, P.000, is displayed.

Step 3. Enter the Second Menu Password

This step is required to access the Second Menu General (P) parameters and Vector (U) parameters.

Step 3.1 Press the ▲ key until P.006, Second Menu Password, is displayed.

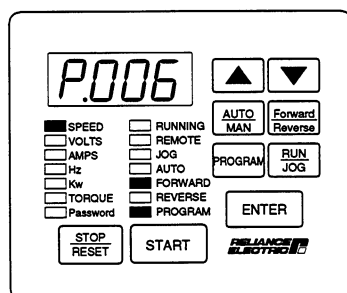

This parameter allows you to enter the password that allows access to the Second Menu.

The Second Menu provides access to all the parameters and the error log.

Step 3.2 Press the ENTER key.

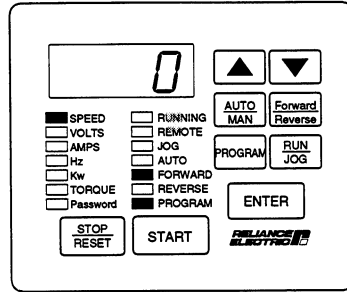

Zero is displayed.

Step 3.3 Press the ▲ key until the password 107 is displayed.

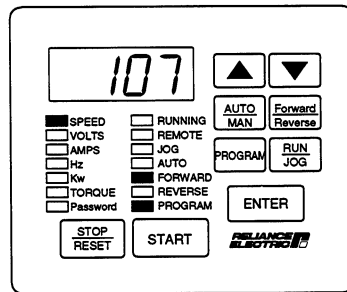

Note that the password, and access to the Second Menu, will be retained if the drive loses and then regains power.

Step 3.4 Press the ENTER key to save the password number.

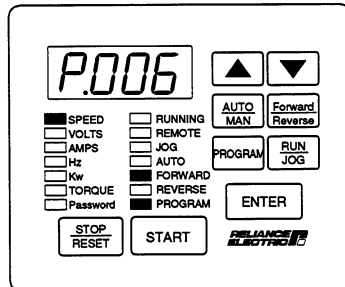

After pressing ENTER, P.006 is displayed. You now have access to all parameters and the error log.

Step 4. Program the Drive for Vector Regulation

This step describes how to change parameter P.048 (Volts/Hertz or Vector Regulation) to vector.

Within vector regulation, you can program the drive for flux vector control (FVC) or sensorless vector control (SVC). FVC operation requires an encoder. SVC operation does not require an encoder. Both options require U.048 to be set to UEC. In a later step, you will select either the FVC option or the SVC option.

When you enter the value for vector regulation (P.048 = UEC), the drive performs a diagnostic check. After the diagnostics, the drive enters monitor mode with speed displayed.

Step 4.1 Press the ▲ key until P.048, Volts/Hertz or Vector Regulation, is displayed.

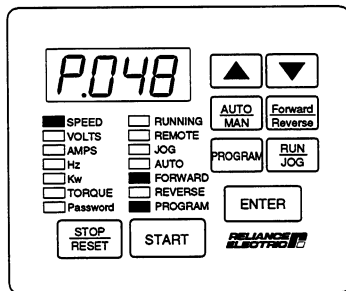

Step 4.2 Press the ENTER key.

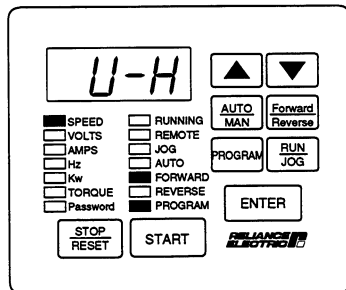

The default setting for P.048 is V/Hz regulation.

Step 4.3 Press the ▲ key to display UEC, vector regulation.

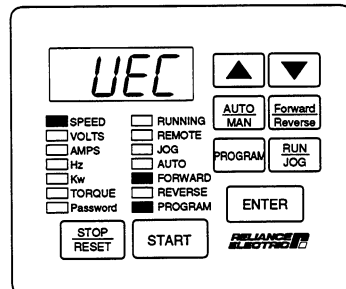

Step 4.4 Press the ENTER key to save the setting.

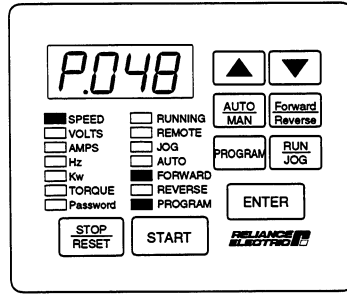

After pressing ENTER, the same parameter number is displayed. You can now go to the next step.

Step 4.5 Note the display.

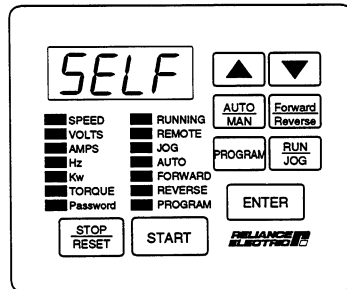

After the regulation selection is changed, the drive will perform diagnostics and displays SELF, with all monitor mode and status LEDs on.

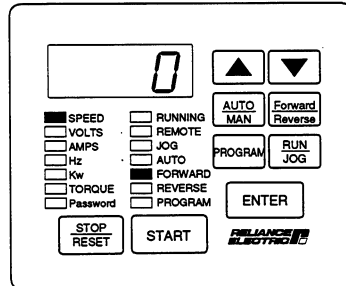

When the diagnostics are complete, the keypad/display will enter monitor mode with speed displayed.

Step 5. Program First Menu General Parameter P.000 - P.005

This step describes how to change First Menu General (P) parameters P.000 through P.005. P.000 selects where the drive is controlled from. This procedure assumes local control from the keypad (P.000 = LOCL), which is the default setting for the parameter.

Step 5.1 Press the PROGRAM key.

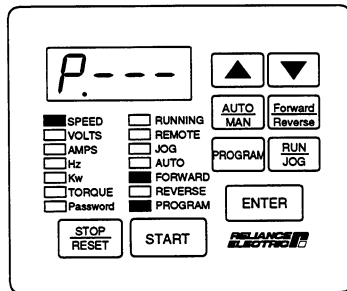

You are now in program mode. The PROGRAM LED is on and the First Menu General (P) parameters can be accessed.

Step 5.2 Press the ENTER key to display the first parameter, P.000, Control Source.

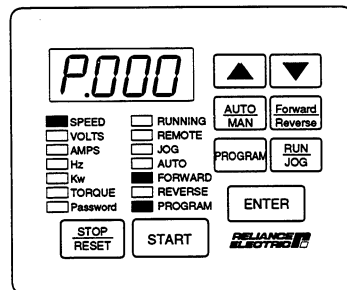

The default setting for P.000 is LOCL, or local control.

Step 5.3 Press the ▲ key to display P.001, Accel Time 1 (RAMP 1).

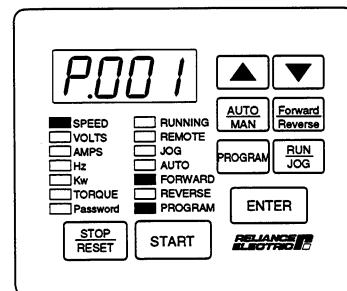

This parameter sets the acceleration time in seconds.

Step 5.4 Press the ENTER key to display the default setting of P.001.

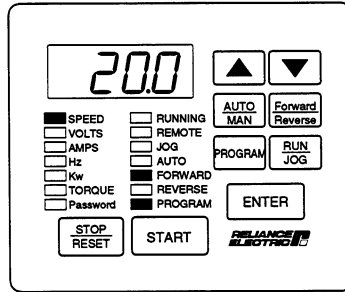

This displays the default setting for acceleration time (20.0 seconds).

Step 5.5 Press the ▲ key to increase acceleration time, or the ▼ key to decrease acceleration time.

The adjustment range is:

0.1 to 999.9 seconds.

VALUE ENTERED:

Step 5.6 Press the ENTER key to save the changed value.

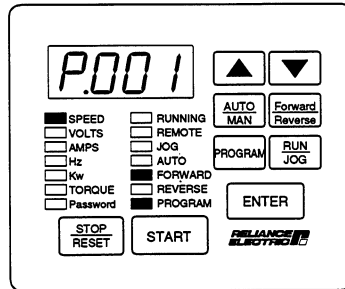

After pressing ENTER, the same parameter number is displayed. You can now go to the next parameter.

Step 5.7 Press the ▲ key to display P.002, Decel Time 1 (RAMP1).

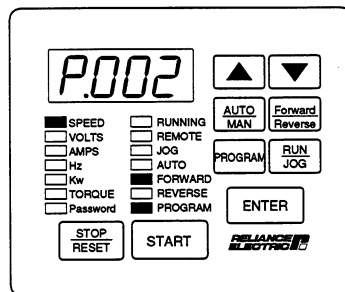

This parameter sets the deceleration time in seconds. The default stop method is coast-to-stop, set in P.025.

Step 5.8 Press the ENTER key to display the default setting of the P.002.

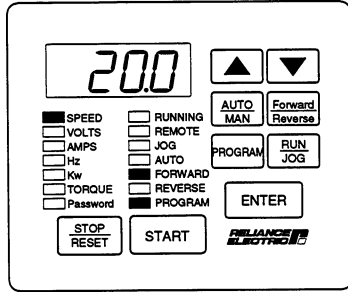

This displays the default setting for deceleration time (20.0 seconds).

Step 5.9 Press the ▲ key to increase deceleration time, or the ▼ key to decrease deceleration time.

The adjustment range is:

0.1 to 999.9 seconds.

VALUE ENTERED:

Step 5.10 Press the ENTER key to save the changed value.

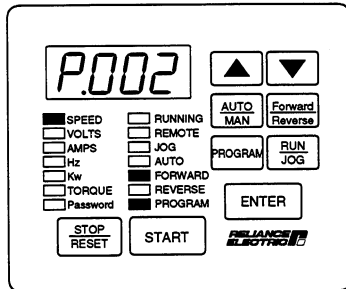

After pressing ENTER, the same parameter number is displayed. You can now go to the next parameter.

Step 5.11 Press the ▲ key to display P.003, Minimum Speed.



ATTENTION: The drive can operate at and maintain zero speed. The user is responsible for ensuring safe conditions for operating personnel by providing suitable guards, audible or visual alarms, or other devices to indicate that the drive is operating or may operate at or near zero speed. Failure to observe this precaution could result in severe bodily injury or loss of life.

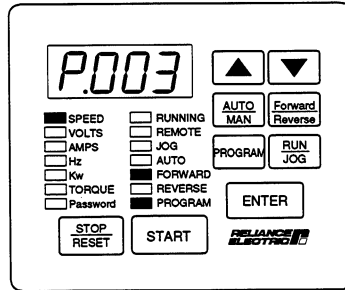

This parameter sets the minimum speed in RPM.

Step 5.12 Press the ENTER key to display the default setting of P.003.

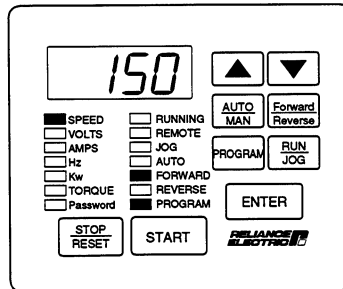

This displays the default setting for Minimum Speed, 150 RPM.

Step 5.13 Press the ▲ key to increase minimum speed or the ▼ key to decrease minimum speed.

The adjustment range is:

0 to the value set for P.004 (Maximum Speed).

VALUE ENTERED:

Step 5.14 Press the ENTER key to save the changed value.

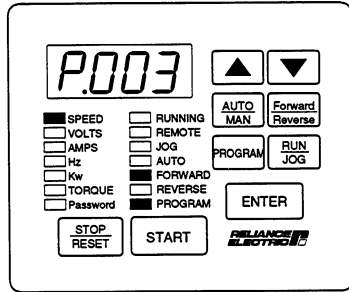

After pressing ENTER, the same parameter number is displayed. You can now go to the next parameter.

Step 5.15 Press the ▲ key to display P.004, Maximum Speed.

 **ATTENTION:** The user is responsible for ensuring that driven machinery, all drive-train mechanisms, and application material are capable of safe operation at the maximum operating speed of the drive. For vector regulation, overspeed detection in the drive determines when the drive shuts down and is factory set to 130% of maximum speed. Failure to observe this precaution could result in bodily injury.

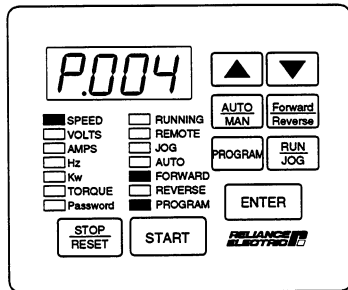

This parameter sets the maximum speed in RPM.

Step 5.16 Press the ENTER key to display the default setting of P.004.

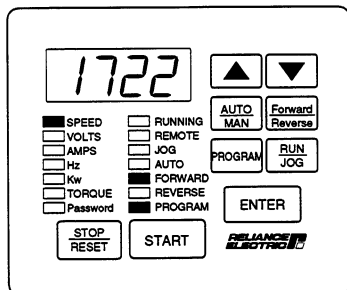

This displays the default setting for Maximum Speed.

The default setting is 1722.

Step 5.17 Press the ▲ key to increase maximum speed or the ▼ key to decrease maximum speed.

The adjustment range is:

10 to Motor Top Speed (set in parameter U.017). Refer to Step 7 for parameter U.017.

VALUE ENTERED:

Step 5.18 Press the ENTER key to save the changed value.

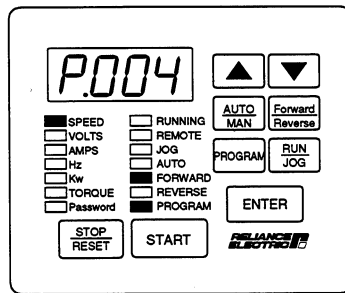

After pressing ENTER, the same parameter number is displayed. You can now go to the next step.

Step 5.19 Press the ▲ key until P.005, Current Limit, is displayed.

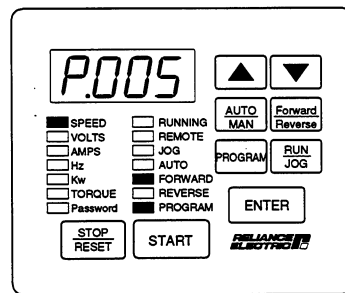

This parameter sets the stator current limit as a percentage of motor rated amps.

Step 5.20 Press the ENTER key to display the default setting of P.005.

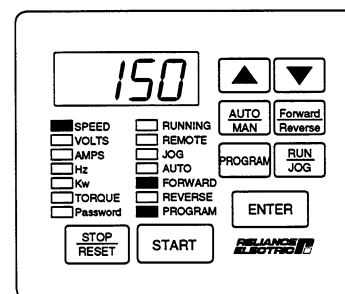

This display is the default setting for Current Limit, 150% of the value entered in U.004.

Step 5.21 Press the ▼ key to decrease current limit percent.

Note that changing current limit rating affects the maximum attainable torque the motor can produce.

The adjustment range for current limit is:

U.006 (Magnetizing Current) to 150%.

VALUE ENTERED:

Step 5.22 Press the ENTER key to save the entered value.

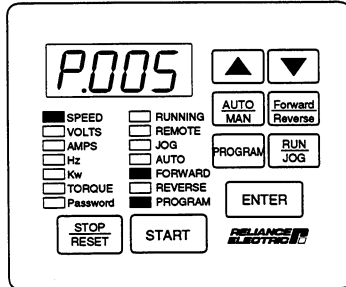

After pressing ENTER, the same parameter number is displayed. You can now move to the next parameter.

Step 6. Program the Second Menu Vector (U) Parameters

This step describes how to program the Vector (U) parameters that apply to vector regulation only. You will not be adjusting any parameters for V/Hz regulation (H parameters) in this procedure.

Step 6.1 Press the PROGRAM key to return to the main menu level.

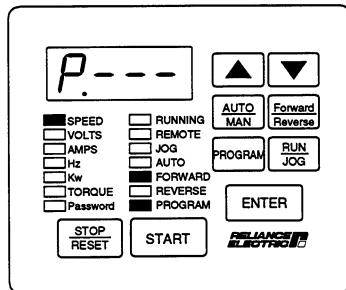

The display will return to the First Menu General (P) parameters.

Step 6.2 Press the ▲ key twice.

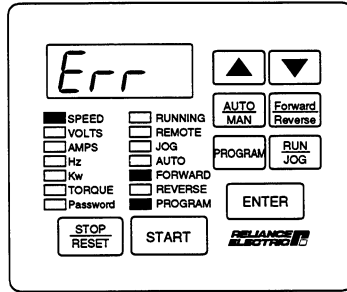

The error log (Err) is bypassed, then

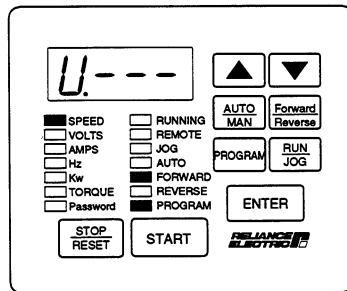

.... the Vector (U) parameter main menu is displayed.

Step 6.3 Press the ENTER key to access the first Vector parameter, which is U.000, Torque Reference Source.

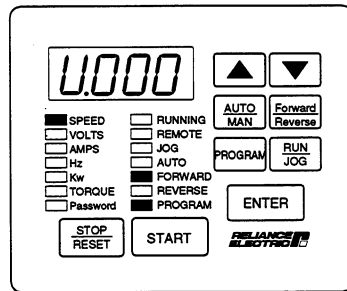

This parameter specifies the source for the torque reference. The source can be the output of the speed loop (the default), the analog input, the option port, or the selected speed reference. This procedure assumes that the torque reference is taken from the speed loop.

Step 6.4 Press the ENTER key to display the default setting of U.000.

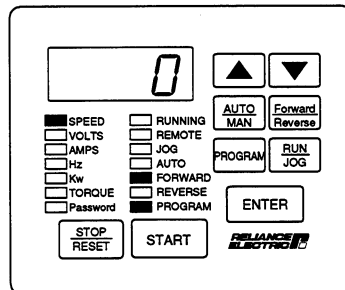

This displays the default setting for the Torque Reference Source, which is 0.

Step 6.5 Press the ▲ key to increase the value.

Important: If you are going to change the value for this parameter, see the description in chapter 4.

The adjustment options are:

- 0 = Speed loop output (default setting)
- 1 = Terminal strip analog input
- 2 = Option port (network torque reference register)
- 3 = Selected speed reference

VALUE ENTERED:

Step 6.6 Press the ENTER key to save the displayed value.

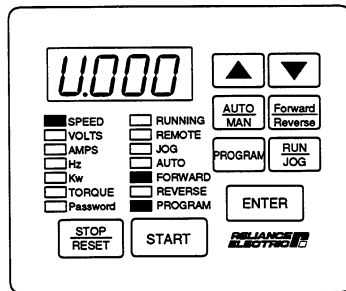

After pressing ENTER, the same parameter number is displayed. You can now go to the next parameter.

Step 6.7 Press the ▲ key to display U.001, Encoder PPR.



ATTENTION: The Setting of parameters U.001 (Encoder PPR), U.002 (Motor Poles), U.003 (Motor Nameplate Base Frequency), U.005 (Motor Nameplate RPM), and U.017 (Motor Top Speed) determines the motor maximum speed. These parameters must be set by a qualified person who understands the significance of setting them accurately. Failure to observe this precaution could result in bodily injury.

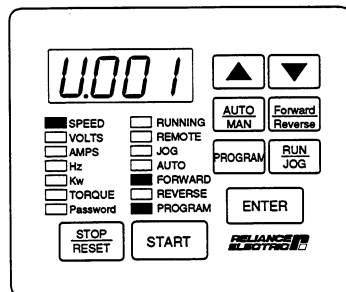

This parameter selects the number of pulses per revolution (PPR) of the encoder or selects sensorless vector control (SVC) if an encoder is not used.

For flux vector control (FVC), when the self-tuning procedure (Step 8) is performed, the value of this parameter is automatically set; however, if the encoder PPR is known, it should be entered now.

Step 6.8 Press the ENTER key to display the default setting of U.001.

 **ATTENTION:** Do not use a 4096 PPR encoder with a 2-pole motor. Overspeed and motor damage can result. Failure to observe this precaution could result in bodily injury.

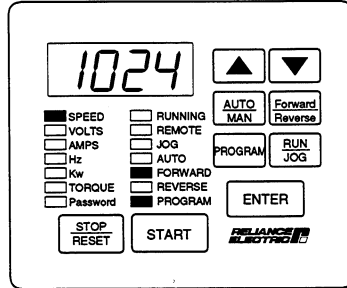

This displays the default setting for Encoder PPR, 1024 PPR.

Step 6.9 Press the ▲ key to increase the PPR, or the ▼ key to decrease the PPR.

Select one of the four PPR values if an encoder is used. Select SE if an encoder is not used. See the description of U.001 in Chapter 4 for more information.

VALUE ENTERED:

Step 6.10 Press the ENTER key to save the changed value.

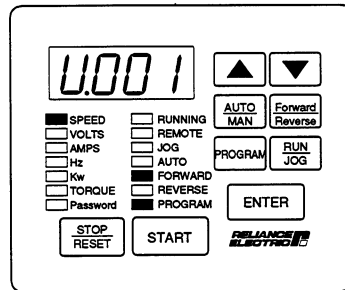

After pressing ENTER, the same parameter is displayed. You can now move to the next parameter.

Step 6.11 Press the ▲ key to display U.002, Motor Poles.



ATTENTION: The setting of parameters U.001 (Encoder PPR), U.002 (Motor Poles), U.003 (Motor Nameplate Base Frequency), U.005 (Motor Nameplate RPM), and U.017 (Motor Top Speed) determines the motor maximum speed. These parameters must be set by a qualified person who understands the significance of setting them accurately. Failure to observe this precaution could result in bodily injury.

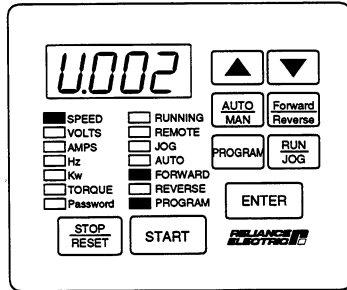

This parameter selects the number of poles in the motor. If the number of motor poles is not known, refer to chapter 4.

Step 6.12 Press the ENTER key to display the default setting of U.002.



ATTENTION: Do not use a 4096 PPR encoder with a 2-pole motor. Overspeed and motor damage can result. Failure to observe this precaution could result in bodily injury.

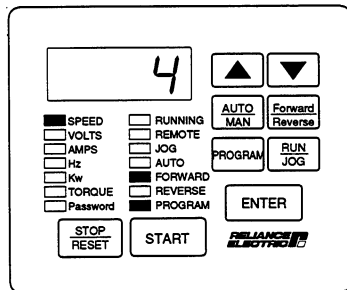

This shows that the default setting for Motor Poles is 4 (4 poles).

Step 6.13 Press the ▲ key to increase the selection, or the ▼ key to decrease the selection.

The adjustment options are:

- 2 = 2 poles
- 4 = 4 poles (default)
- 6 = 6 poles
- 8 = 8 poles

VALUE ENTERED:

Step 6.14 Press the ENTER key to save the changed value.

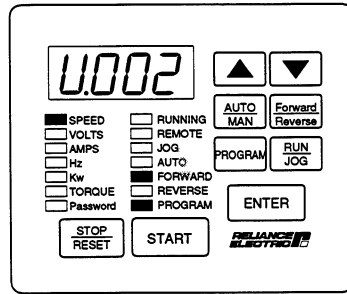

After pressing ENTER, the same parameter is displayed. You can now move to the next parameter.

Step 6.15 Press the ▲ key to display U.003, Motor Nameplate Base Frequency.

 **ATTENTION:** The setting of parameters U.001 (Encoder PPR), U.002 (Motor Poles), U.003 (Motor Nameplate Base Frequency), U.005 (Motor Nameplate RPM), and U.017 (Motor Top Speed) determines the motor maximum speed. These parameters must be set by a qualified person who understands the significance of setting them accurately. Failure to observe this precaution could result in bodily injury.

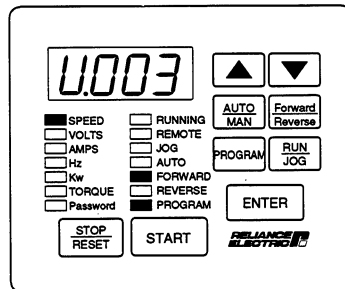

This parameter is the Motor Nameplate Base Frequency and is taken from the motor nameplate.

Step 6.16 Press the ENTER key to display the default setting of U.003.

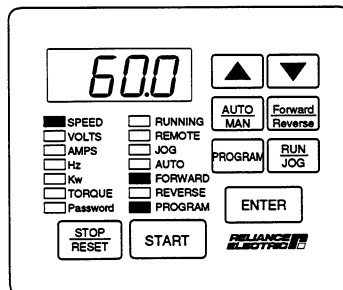

This shows that the default setting is 60.0 Hz.

Step 6.17 Press the ▲ key to increase the motor nameplate base frequency or the ▼ key to decrease the motor nameplate base frequency.

The adjustment range is:

15.0 Hz to 120.0 Hz

VALUE ENTERED:

Step 6.18 Press the ENTER key to save the changed value.

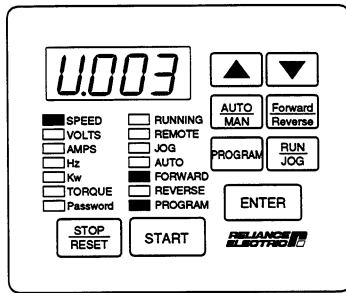

After pressing ENTER, the same parameter is displayed. You can now move to the next parameter.

Step 6.19 Press the ▲ key to display U.004, Motor Nameplate Amps.



ATTENTION: This parameter setting must not exceed the rated amps found on the motor nameplate. Overcurrent or excess heating of the motor could result if this is not the case. Failure to observe this precaution could result in damage to, or destruction of, the equipment.

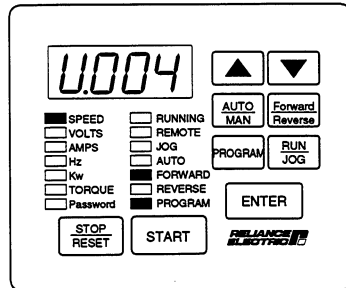

This parameter is the Motor Nameplate Rated Amps and is taken from the motor nameplate.

Step 6.20 Press the ENTER key to display the default setting of U.004.

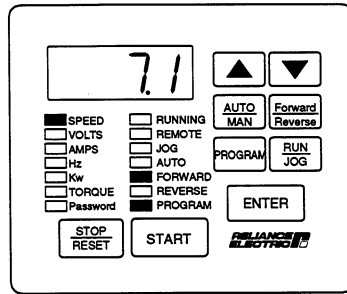

This displays the Motor Nameplate Amps setting. The default depends on the HP rating of the Power Module. The display shown here is only an example.

Step 6.21 Press the ▲ key to increase the motor nameplate amps or the ▼ key to decrease the motor nameplate amps.

The minimum and maximum allowed adjustment range for this value depends on the Power Module HP rating.

VALUE ENTERED:

Step 6.22 Press the ENTER key to save the changed value.

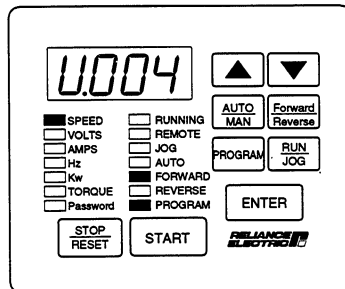

After pressing ENTER, the same parameter is displayed. You can now move to the next parameter.

Step 6.23 Press the ▲ key to display U.005, Motor Nameplate RPM.



ATTENTION: The setting of parameters U.001 (Encoder PPR), U.002 (Motor Poles), U.003 (Motor Nameplate Base Frequency), U.005 (Motor Nameplate RPM), and U.017 (Motor Top Speed) determines the motor maximum speed. These parameters must be set by a qualified person who understands the significance of setting them accurately. Failure to observe this precaution could result in bodily injury.

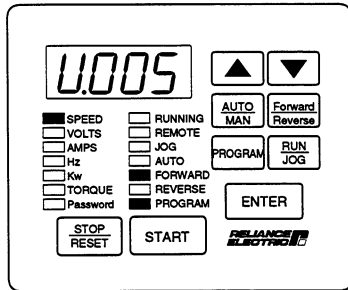

This parameter is the Motor Nameplate RPM and is taken from the motor nameplate.

Step 6.24 Press the ENTER key to display the default setting of U.005.

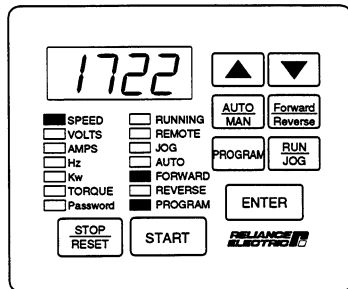

This displays the Motor Nameplate RPM setting. The default depends on the HP rating of the Power Module. The display shown here is only an example.

Step 6.25 Press the ▲ key to increase the motor nameplate RPM or the ▼ key to decrease the motor nameplate RPM.

The adjustment range for this value depends on the settings of U.002 (Motor Poles) and U.003 (Motor Nameplate Base Frequency).

VALUE ENTERED:

Step 6.26 Press the ENTER key to save the changed value.

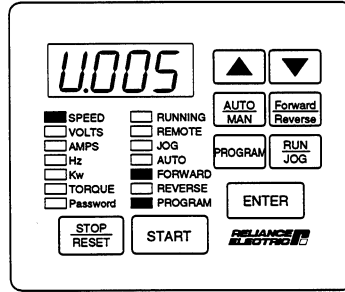

After pressing ENTER, the same parameter is displayed. You can now move to the next parameter.

Step 6.27 Press the ▲ key to display U.006, Motor Magnetizing Current.



ATTENTION: If this parameter is set incorrectly, overcurrent or excess heating of the motor could result. Failure to observe this precaution could result in damage to, or destruction of, the equipment.

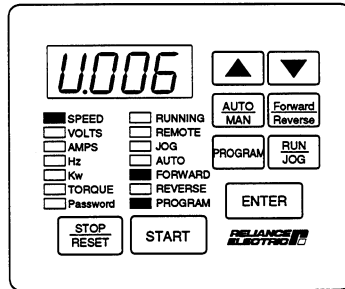

This parameter is the percent of magnetizing current with respect to motor rated amps.

Note that when the vector regulation self-tuning procedure is performed (Step 8), the value of this parameter is automatically calculated. You do not need to enter a value now.

Step 6.28 Press the ▲ key to display U.007, Motor Nameplate Volts.

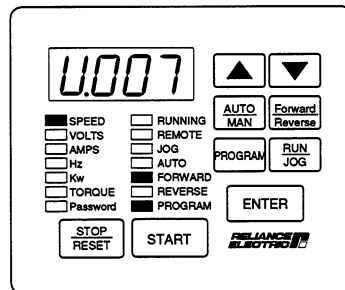

This parameter is the Motor Nameplate Volts and is taken from the motor nameplate.

Step 6.29 Press the ENTER key to display the default setting of U.007.

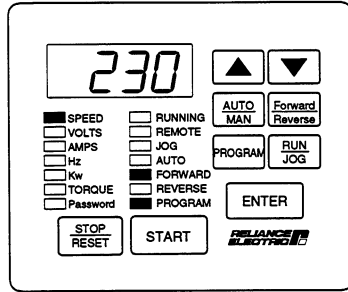

This displays the default setting for the Motor Nameplate Volts. The default setting is 230.

Step 6.30 Press the ▲ key or the ▼ key to increase or decrease the motor nameplate volts.

The adjustment range is:

180 to 690 Volts

VALUE ENTERED:

Step 6.31 Press the ENTER key to save the displayed value.

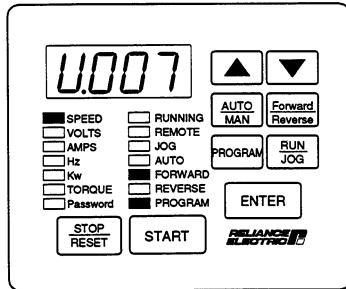

After pressing ENTER, the same parameter is displayed. You can now move to the next parameter.

Step 6.32 Press the ▲ key to display U.022, Motor Nameplate Horsepower.

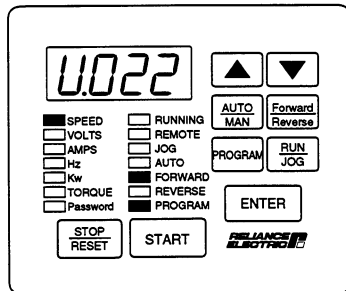

This parameter specifies the motor horsepower as it appears on the motor nameplate.

Step 6.33 Press the ENTER key to display the default setting of U.022.

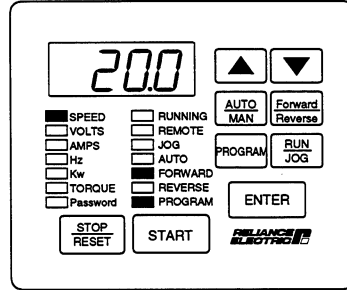

This display the default setting for Motor Nameplate Horsepower. The default setting depends on the Power Module rating and is factory-set. This display here is only an example.

Step 6.34 Press the ▲ key or the ▼ key to increase or decrease the value if it is different from the motor nameplate.

The adjustment range is 0.3 to 600.0 HP.

VALUE ENTERED:

Step 6.35 Press the ENTER key to save the displayed value.

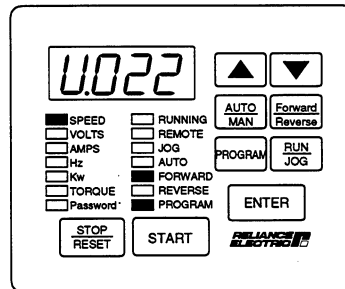

After pressing ENTER, the same parameter is displayed. You can now move to the next parameter.

Step 7. Set the Motor Top Speed

This step sets the Motor Top Speed (U.017) in RPM. For applications that do not support field weakening, Motor Top Speed must be equal to U.005 (Motor Nameplate RPM). For applications that do support field weakening, Motor Top Speed is the maximum field-weakened speed.

Step 7.1 Press the ▼ key until U.017 is displayed.

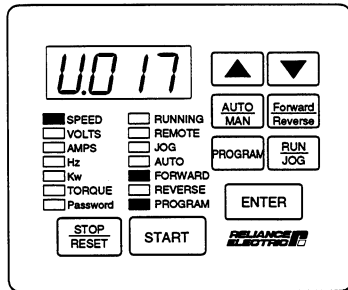

This parameter is the Motor Top Speed in RPM.

Step 7.2 Press the ENTER key to display the default setting of U.017.

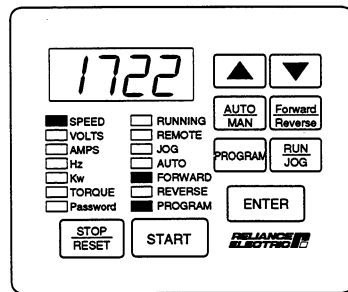

This displays the default setting for the Motor Top Speed. The actual setting depends on the Power Module HP type. The display shown here is only an example.

Step 7.3 Check the value entered for Step 6.25 (U.005, Motor Nameplate RPM). If the application does not support field weakening, U.005 and U.017 must be the same. If the application does support field weakening, the value can be set higher. Press the ▲ or ▼ key until the value is set appropriately.

The adjustment range is:

The value set for U.005 to (Maximum value depends on settings of U.002 and U.003)

VALUE ENTERED:

Step 7.4 Press the ENTER key to save the displayed value.

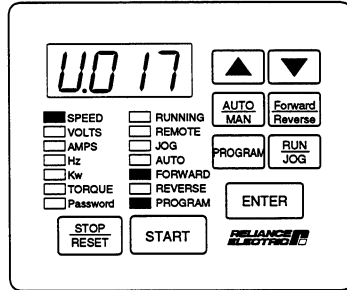

After pressing ENTER, the same parameter number is displayed. You can now go to the next step.

Step 8. Perform Vector Regulator Self-Tuning

Before performing the self-tuning procedure, you should have performed steps 1 through 7 above and adjusted all the parameters as described. Note that U.016 may also need to be set if your application requires field weakening.



ATTENTION: The motor will rotate during the self-tuning procedure. Stay clear of rotating machinery. Failure to observe this precaution could result in severe bodily injury or loss of life.

ATTENTION: The motor must be uncoupled from the driven load during the self-tuning operation or incorrect parameter values will result. This includes any shaft-coupled devices, such as reducers, belts, and brakes. Failure to observe this precaution could result in damage to, or destruction of, the equipment.

This step describes how to start the vector regulator self-tuning procedure. This procedure is enabled by setting parameter U.008, Torque Self-Tune Enable, to ON. Self-tuning is performed by the drive and determines the proper no load current value for parameter U.006 and, for flux vector control (U.001 \neq SE), the encoder PPR value for parameter U.001. These values must be accurate to ensure that rated motor torque, speed, and horsepower can be developed for drives set up for vector regulation. During the procedure, the drive will accelerate up to the value specified in U.017 (Motor Top Speed).

Verify the following before starting the self-tuning procedure:

- The motor is unloaded.
- The drive is not running. If the RUNNING LED is on, press the STOP/RESET key.
- There are no faults in the error log. If a fault is flashing on the display, refer to Chapter 5 for instructions on clearing the errors.

How to Interrupt the Self-Tuning Procedure:

If the procedure is enabled only but not active (S-En is displayed), set U.008 to OFF.

If the procedure is active (S-Ac is displayed), press the STOP/RESET key.

What Happens if a Fault Occurs During Self-Tuning?

1. If the drive stops due to a fault, the motor will coast to stop. A self-tuning fault code (SF) will be displayed and must be cleared. Refer to chapter 5 for more information.
2. Once the drive is stopped, parameter U.008 will be reset to OFF and the self-tuning procedure will be completed. The results are stored in U.009, Torque Self-Tune Result.

Step 8.1 Press the ▼ key to display U.008, Torque Self-Tune Enable.

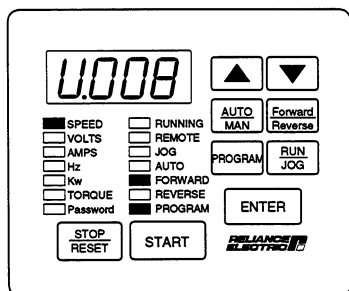

Parameter U.008 is displayed.

Step 8.2 Press the ENTER key.

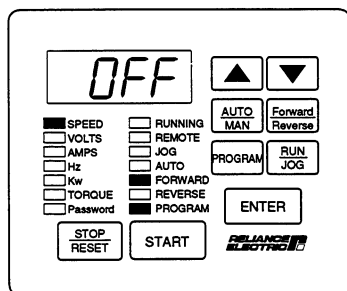

The default setting of OFF is displayed.

Step 8.3 Press the ▲ key to enable the self-tuning procedure.

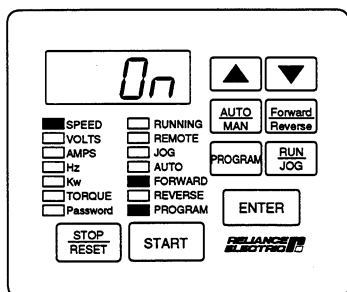

On is displayed.

Step 8.4 Press the ENTER key.

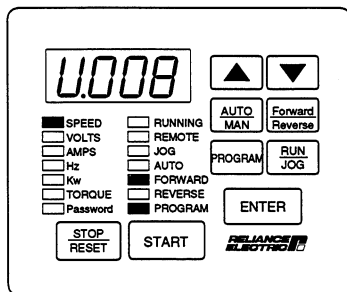

After pressing ENTER, the same parameter is displayed. You can now go to the next step.

Step 8.5 Press the PROGRAM key twice to exit program mode.

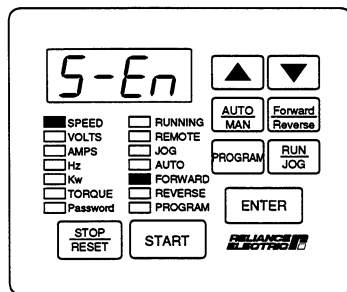

This display flashes S-En. This reminds you that the self-tuning procedure is enabled.

Step 8.6 Press the START key to begin the self-tuning procedure.



ATTENTION: The motor will rotate during the self-tuning procedure. Stay clear of rotating machinery. Failure to observe this precaution could result in severe bodily injury or loss of life.

ATTENTION: The motor must be uncoupled from the driven load during the self-tuning operation or incorrect parameter values will result. This includes any shaft-coupled devices, such as reducers, belts, and brakes. Failure to observe this precaution could result in damage to, or destruction of, the equipment.

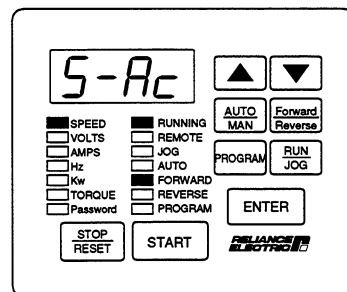

The display flashes S-Ac, indicating that the self-tuning procedure is active.

This procedure takes a few minutes. S-Ac flashes on the display until the procedure is complete.

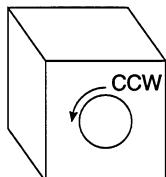

The motor should be rotating in the counter-clockwise (CCW) direction when viewed from the driven motor shaft end.

Step 8.7 Self-tuning is now completed. If a zero is displayed, the self-tuning procedure was completed successfully. Go to step 10.

If SF is displayed, the procedure was not successfully completed. Go to step 9 to view parameter U.009 for a specific fault code.

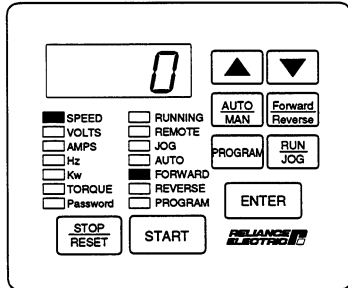

When self-tuning is complete, the motor will ramp to a stop.

The following parameters will be updated based on the self-tuning results:

- U.001 - Encoder PPR (if U.001 ≠ SE)
- U.006 - Magnetizing Current
- U.008 - Torque Self-Tune Enable (reset to OFF)
- U.009 - Torque Self-Tune Result

Step 9. Check Self-Tuning Results

The results of the self-tuning procedure is displayed in U.009. This step describes how to view the results if SF is displayed after the test is started.

Step 9.1 Press the PROGRAM key until the PROGRAM LED turns on to enter program mode.

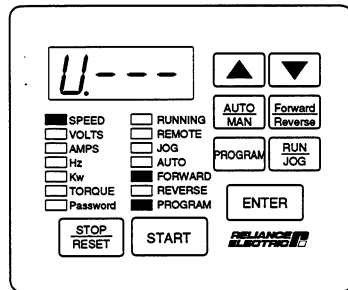

The display returns to the Vector (U) parameters.

Step 9.2 Press the ENTER key to access the Vector parameters.

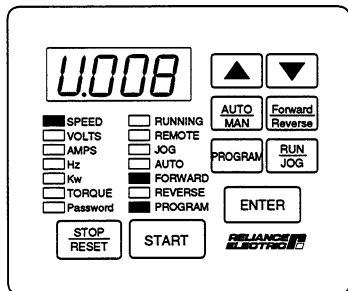

The display shows U.008, the last parameter accessed.

Step 9.3 Press the ▲ key until U.009 is displayed.

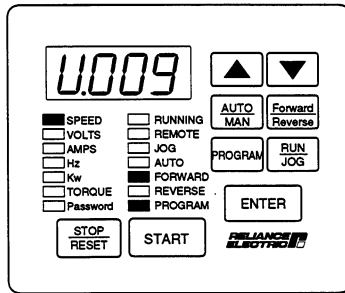

Step 9.4 Press the ENTER key to view the test result.

Step 9.5 Refer to the U.009 parameter description in chapter 4 for the corresponding cause and corrective action.

Step 9.6 Once the cause of the fault has been corrected, repeat the self-tuning procedure (Step 8).



ATTENTION: The subsequent steps require rotating parts and/or electrical circuits to be exposed. Stay clear if the drive must be running, or disconnect and lock out or tag power source if contact must be made. Failure to observe this precaution could result in severe bodily injury or loss of life.

Important: The stop input on the terminal strip is not active when the Control Source parameter (P.000) is set to LOCL, as it is during this start-up procedure. Use the STOP/RESET key if you need to stop the drive.

Step 10. Check Motor Rotation Direction

This step involves verifying the speed reference is set to minimum speed, starting the drive, and checking that the motor rotates in the correct direction. It is performed with the motor disconnected from the load.

Step 10.1 Press the PROGRAM key until the PROGRAM LED turns off.

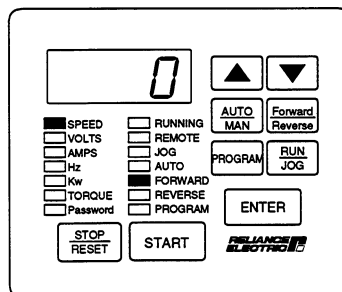

The keypad/display will enter monitor mode.

Step 10.2 Verify that the AUTO LED is off (press the AUTO/MAN key until the AUTO LED turns off).

This selects the local keypad as the speed reference source.

Step 10.3 Press the ▲ key or the ▼ key once.

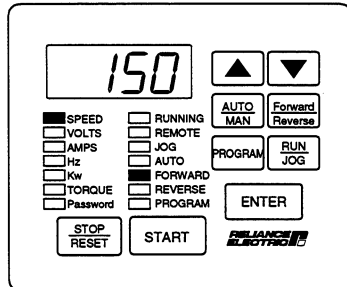

The monitor mode LEDs will all turn off and the manual speed reference value will be displayed. The speed reference value is in the units defined in P.028. The display shown here is only an example.

Step 10.4 If the speed reference is at minimum speed, then proceed to Step 10.6.
If the speed reference is not at minimum speed, proceed to Step 10.5.

Step 10.5 Press the ▼ key to decrease the speed reference value.

Step 10.6 Press the ENTER key to return to monitor mode.

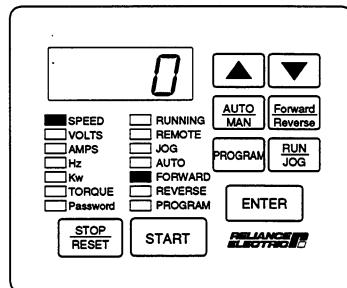

Step 10.7 Verify you have selected RUN and FORWARD. Press the START key.

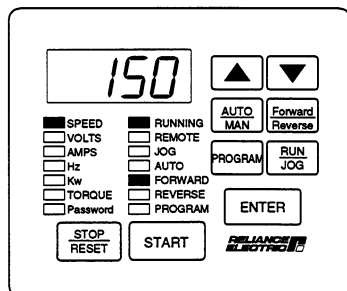

The drive is now running. The keypad/display is in monitor mode, and the SPEED, RUNNING, and FORWARD LEDs are on.

The drive should be running at minimum speed. The sample display shows 150 RPM.

Step 10.8 Visually check that the motor rotates counter-clockwise (CCW) when viewed from the driven motor shaft end.

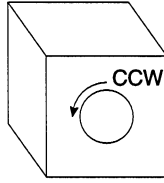

Step 10.9

- If the rotation direction is NOT correct, press the STOP/RESET key and continue with Step 10.10.
- If the rotation direction is correct, continue with Step 10.14.

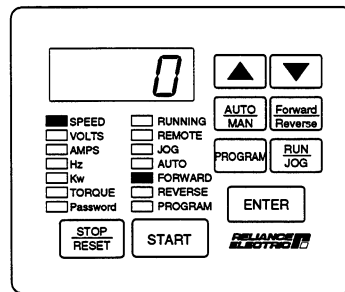

When the STOP/RESET key is pressed, the RUNNING LED turns off.

Step 10.10 Turn off and lock out or tag power to the drive.

Step 10.11 Verify that the DC bus capacitors are discharged. Refer to hardware reference manual for this procedure.



ATTENTION: DC bus capacitors retain hazardous voltages after input power has been disconnected. After disconnecting input power, wait five (5) minutes for the DC bus capacitors to discharge and then check the voltage with a voltmeter to ensure the DC bus capacitors are discharge before touching any internal components. Failure to observe this precaution could result in severe bodily injury or loss of life.

Step 10.12 Switch any two of the motor leads (U, V, or W) and A and A NOT on the encoder (if an encoder is used).

Step 10.13 Turn power on, and press the START key. Repeat Step 10.8.

Step 10.14 To make sure the drive is not inadvertently started, turn off and lock out or tag power to the drive. Verify that the motor direction is appropriate for the required machine direction, and then connect the motor to the load.

Step 11. Run the Drive

This step describes how to increase the speed reference across the speed range and check for proper motor operation. This step assumes that P.000 is set to LOCL (control is local) and the motor is connected to the load.

Step 11.1 Press the START key.

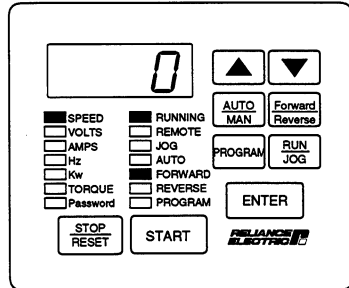

The drive is now running and the keypad/display is in monitor mode.

Step 11.2 Press the ▲ or ▼ key once. All monitor mode LEDs will turn off. Increase the speed reference to the maximum value by using the ▲ key.

Wait five seconds or press the ENTER key to return to monitor mode.

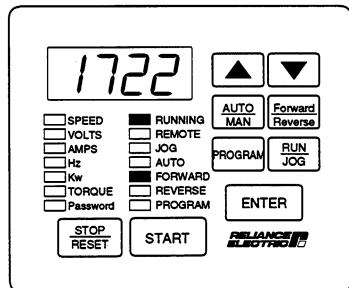

This increases the drive speed reference and the motor will rotate up to maximum speed.

The monitor mode LEDs turn off when the reference is changed.

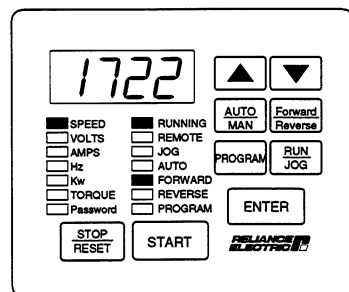

The display now shows the actual drive speed. Your speed display may be different.

Step 11.3 Press the ENTER key to move to the VOLTS display.

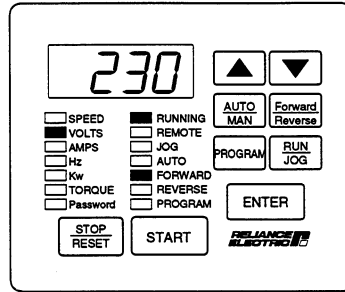

The sample display shows the output volts at maximum speed. Your actual reading may be different.

VALUE READ:

Step 11.4 Press the ENTER key to move to the AMPS display.

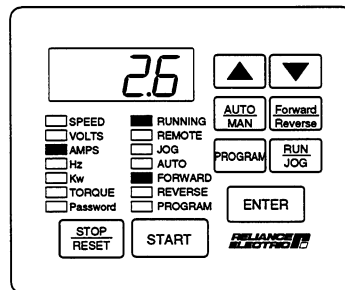

This sample display shows the output amps at maximum speed. Your actual reading may be different.

VALUE READ:

Step 11.5 Press the ENTER key to move to the Hz display.

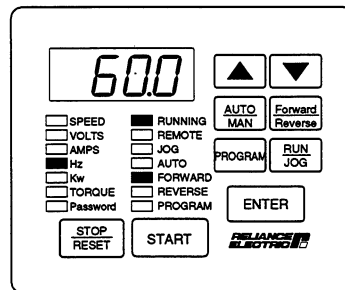

This sample display shows the hertz value corresponding to the value set into P.004, Maximum Speed. Your actual reading may be different.

VALUE READ:

Step 11.6 Press the STOP/RESET key.

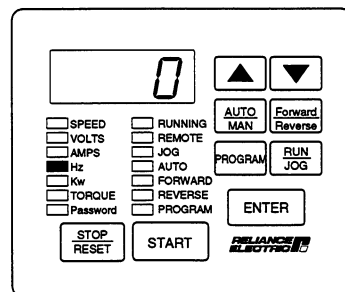

The driven motor should stop as programmed in P.025, Stop Type.

Step 12. Tune the Speed Regulator

Tuning the speed regulator consists of adjusting the speed regulator proportional and integral gain values according to the application. The speed regulator uses these values to calculate the drive's response to a change in speed reference and to changes in load or other factors in the driven system. This procedure may or may not be required. This step assumes you have connected the motor to the load.

Step 12.1 Press the START key.

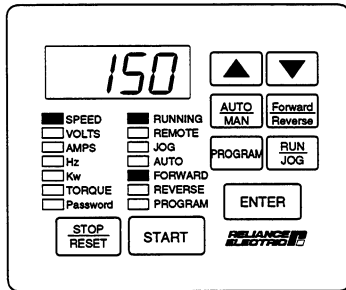

The drive is now running. The keypad/display is in monitor mode, and the RUNNING and FORWARD LEDs are on. Speed is displayed.

Step 12.2 Press the PROGRAM key to enter program mode.

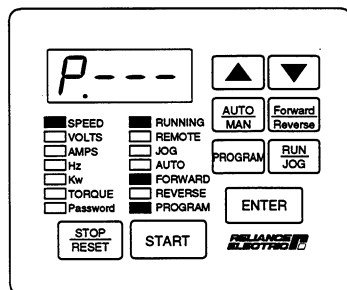

The PROGRAM LED is on and the First Menu General (P) parameter main menu is displayed.

Step 12.3 Press the ▲ key until U.--- is displayed.

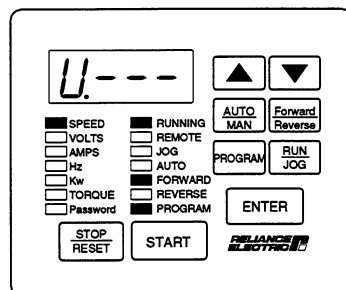

The error log (Err) is bypassed, then the Vector (U) parameter main menu is displayed.

Step 12.4 Press the ▲ key until U.012 is displayed. This parameter sets the speed regulator proportional gain.

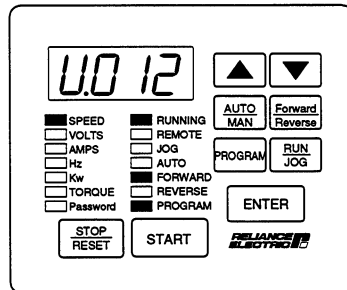

The speed loop gain is set for typical speed loop response and should be adjusted only when faster speed loop response is required.

Larger proportional gain values result in faster response, but may result in less stability. If the drive overshoots the speed reference when changes to the reference are made, or if the drive is unstable, reduce the value.

Step 12.5 Press the ENTER key when the value is acceptable.

Step 12.6 Press the ▲ key until U.013, Speed Regulator Integral Gain, is displayed.

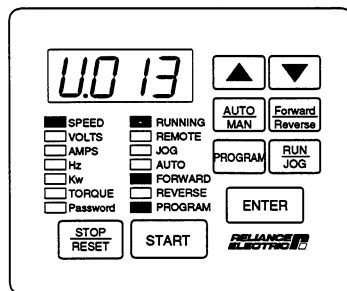

This parameter should not normally need adjusting. High inertia loads may require adjusting this parameter.

Larger integral gain values may result in faster response, but may result in less stability. If the drive overshoots the speed reference when changes to the reference are made, or if the drive is unstable, reduce the value.

Step 12.7 Press the ENTER key when the value is acceptable.

Step 12.8 Continue adjusting until the proper operation is achieved.

End of Vector Start-Up Procedure

This is the end of the basic vector start-up procedure. When the start-up values are final, Appendix B can be used to record final settings.

To configure the remaining parameters according to the specific application, refer to chapter 4. If you have purchased the Control and Configuration Software (CS3000), save your configuration to a personal computer. Refer to the CS3000 software instruction manual (D2-3348) for this procedure.

Recall that the Control Source parameter (P.000) was set to LOCL in this start-up procedure. If you need to operate the drive from a different control source, you will need to change the setting in parameter P.000.

CHAPTER 3

Using the Keypad/Display To Program, Monitor, and Control the Drive

The front-panel keypad/display is used to program, monitor, and control the drive. It operates in two modes, monitor mode and program mode. The functions available at the keypad depend on what mode the keypad/display is in and what is selected as the drive control source.

In monitor mode (the default mode), you can monitor specific drive outputs as well as enter the speed or frequency reference for the drive.

In program mode, you can view and adjust drive parameter values, and examine the error log.

In addition to the functions listed above, if the control source is local (the REMOTE LED is off), the keypad is also used to select run or jog, select motor direction, and start the drive.

Regardless of the control source selection, the keypad/display can be used to stop the drive, reset drive faults, and switch between a manual speed reference or the selected control source auto reference.

Important: The STOP/RESET key can be disabled by parameter P.055. Refer to the P.055 parameter description for more information.

The following sections describe monitor mode and program mode in more detail. The keypad, display, and LEDs are described later in this chapter.

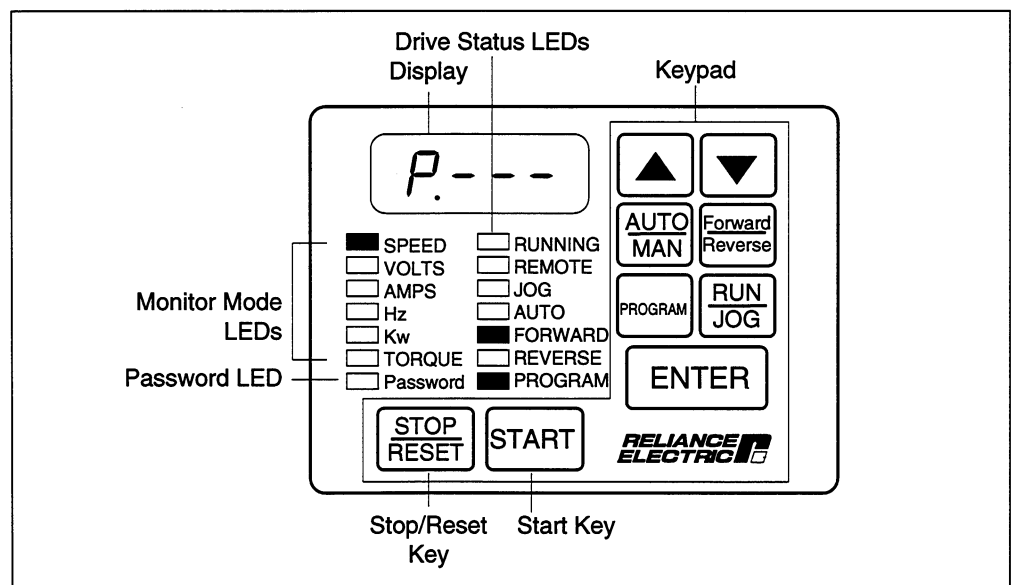

Figure 3.1 – Keypad/Display

3.1 Monitor Mode

Monitor mode is the keypad/display's default mode during drive operation or it is entered by pressing the PROGRAM key until the PROGRAM LED turns off. The following output data can be displayed in monitor mode:

- Speed
- Volts
- Amps
- Hz
- Kw
- Torque (vector regulation only)
- Selected reference (speed or torque)

To select a value to monitor, press the ENTER key until the LED turns on next to the desired display item. Pressing the ENTER key advances you through each of the displays. (Note that all of the LEDs will turn on to indicate the selected reference display. Refer to section 3.1.1.)

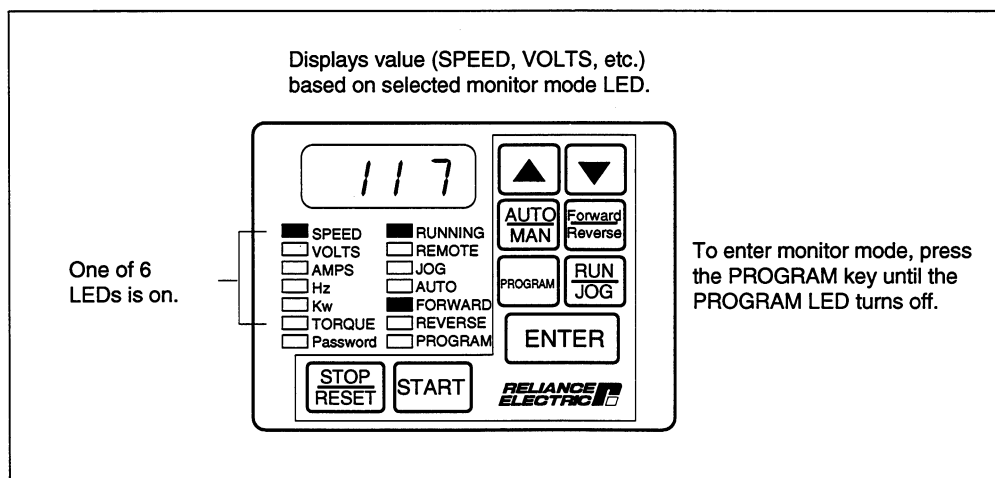

Figure 3.2 – Example of a Monitor Mode Display

3.1.1 Displaying the Selected Reference

In monitor mode, you can display the speed reference (speed or frequency) or the torque reference the drive is using while it is running (RUNNING LED is on, JOG LED is off). Follow these steps to display the selected reference:

- Step 1. If you are not already in monitor mode, access it by pressing the PROGRAM key until the PROGRAM LED turns off.
- Step 2. Press the ENTER key repeatedly to advance through each of the monitor mode LEDs. All of the monitor mode LEDs will then turn on at once and the reference will be displayed. Note that the displayed speed reference value is scaled based on P.028. The torque reference value is displayed in percent.

If the selected reference is negative and its value is greater than 999, the SPEED LED will flash (refer to section 3.4.1, Display Range).

Pressing the ENTER key again will advance you to the SPEED monitor display.

3.1.2 Entering the Manual Speed Reference

You can change the manual speed reference at any time while in monitor mode regardless of the control source. Follow these steps to enter the manual speed reference:

- Step 1. From monitor mode, press the ▲ key or the ▼ key once. The monitor mode LEDs all turn off, and the current manual speed reference value is displayed.
- Step 2. Press the ▲ key or the ▼ key to change the displayed value to the desired manual speed reference. Note that the speed reference is in the units defined in P.028.

Important: The drive accepts the value as it is changed. You do not have to press the ENTER key to save the value as you do with parameter entry.

- Step 3. Press the ENTER key or wait approximately 5 seconds without pressing the ▲ or ▼ key to return to monitor mode. (If the drive is not running, you must press the ENTER key to return to monitor mode.)

3.2 Program Mode

Program mode allows you to display and modify drive parameter values. To enter program mode, press the PROGRAM key until the PROGRAM LED turns on. The following can be displayed in program mode:

- Parameter numbers
- Parameter values
- Error log information

If the Programming Disable parameter (P.051) has been set to prevent parameter modification from the keypad, the PASSWORD LED will also be on. In this case, before any parameter values can be modified, the operator will have to access parameter P.051 and enter the password (a factory-set value) to re-enable programming. When programming has been enabled, the PASSWORD LED will turn off.

Note that some of the parameters can be changed only when the drive is stopped. Refer to chapter 4 for programming instructions and parameter descriptions.

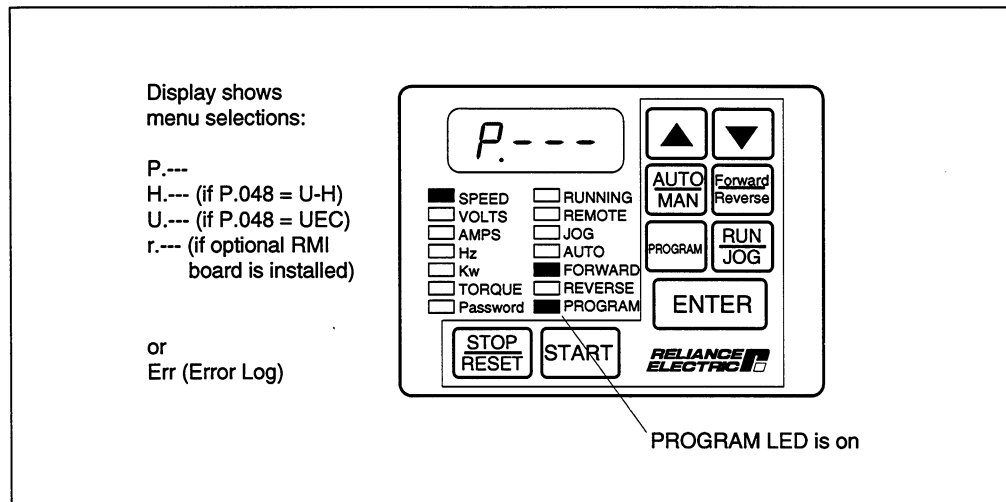

Figure 3.3 – Example of a Program Mode Display

3.3 Drive Control

When the control source is the local keypad/display (REMOTE LED is off), the keypad is used to control the drive. This means that the drive will respond to START, RUN/JOG, and FORWARD/REVERSE commands only from the keypad.

The functions of the keypad keys are described in section 3.5. Refer to the Control Source parameter description (P.000) in chapter 4 for more information on selecting a drive control source.

3.4 The Display

The display portion of the keypad/display is a four-character, seven-segment LED. At drive power-up, SELF is displayed as the drive performs power-up diagnostics. During drive operation, the display indicates parameter numbers, parameter values, fault or alarm codes, and the drive output values. Figures 3.2 and 3.3 show sample displays.

3.4.1 Display Range

Normally, a minus (–) sign is used as one of the four characters in the display to indicate a negative value. If a value (including the minus sign) exceeds four characters, the display will drop the minus sign and display four digits. In this case, the SPEED LED will flash to indicate that the displayed value is a negative number. Refer to the examples in table 3.1.

A decimal point to the right of the last digit in the display indicates there is further resolution (examples A and E) unless decimal point already appears as part of the number displayed (example G). In either case, the system uses the full resolution of the number for drive control, not the displayed value.

Table 3.1 – Display Range Examples

| Example | If the actual number is... | It will appear on the display as... | And the SPEED LED will... |
|---------|----------------------------|-------------------------------------|---------------------------|
| A | 1000.5 | 1000. | Not flash |
| B | -999 | -999 | Not flash |
| C | -1000 | 1000 | Flash |
| D | -99.9 | -99.9 | Not flash |
| E | -1000.5 | 1000. | Flash |
| F | -9.99 | -9.99 | Not flash |
| G | -100.25 | 100.2 | Flash |
| H | -9.999 | 9.999 | Flash |

This does not apply for the speed display. For the speed display, the FORWARD or REVERSE LEDs indicate actual speed reference polarity.

3.4.2 Scaling the Manual Reference, Speed Display, and Reference Display Using P.028

In versions 5.0 and later, the values displayed for the manual reference, the output speed, and the selected speed reference represent relative speed as opposed to always being displayed in RPM. These values are scaled using P.028 (Speed Display Scaling). Refer to the Speed Display Scaling parameter description in chapter 4 for more information.

3.5 The Keypad

The drive's keypad has nine membrane keys that are used to monitor, program, and control the drive.



Use the AUTO/MAN key to switch between the auto speed reference and the manual speed reference as shown below.

| AUTO/MAN Status | Control Source (P.000) | Speed Reference Source |
|-----------------|---|------------------------------------|
| AUTO selected | Local keypad/display (P.000=LOCL) | Terminal strip |
| | Terminal strip remote inputs (P.000=rE) | Terminal strip |
| | Option port (P.000=OP) | Network |
| | Serial port (P.000=SErL) | Terminal strip |
| MAN selected | Local keypad/display (P.000=LOCL) | Local keypad/display or OIM/CS3000 |
| | Terminal strip remote inputs (P.000=rE) | Local keypad/display or OIM/CS3000 |
| | Option port (P.000=OP) | Local keypad/display or OIM/CS3000 |
| | Serial port (P.000=SErL) | Local keypad/display or OIM/CS3000 |



ATTENTION: When switching from auto to manual, or manual to auto, the drive will ramp to the reference level provided by the new source at the rate specified in P.001 (Accel Time 1), P.002 (Decel Time 1), P.017 (Accel Time 2), or P.018 (Decel Time 2). Be aware that an abrupt speed change may occur depending upon the new reference level and the rate specified in these parameters. Failure to observe this precaution could result in bodily injury.

If the control source is changed, the AUTO/MAN selection may be changed as well. When the control source is changed to OP or rE, the AUTO/MAN selection is forced to AUTO. If the control source is changed to LOCL or SErL, the AUTO/MAN selection is forced to MANUAL. However, if the control source is changed from LOCL to SErL or vice versa, the AUTO/MAN selection is not changed.

Note that this key is not active if the control source is SErL. Refer to the P.000 parameter description for more information on control source selection.

Refer to the following parameters for more information on the AUTO/MAN key:

- P.052 AUTO/MAN Key Disable
- P.053 Manual Reference Preset Enable

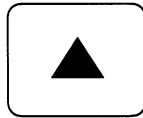

Use the ▲ and ▼ arrow keys to:

- Step through the drive parameter menus and error log when the keypad/display is in program mode.
- Increase (or decrease) a numeric value (such as the reference or a parameter value).

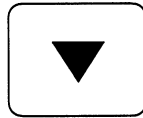

Holding down these keys will increase the scroll speed.



Use the ENTER key to:

- Display a parameter (or a selection) value in program mode
 - Save a value
 - Move through each monitor display item when in monitor mode
-

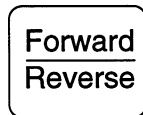

Use the FORWARD/REVERSE key to select the direction of motor rotation when the control source is local (REMOTE LED is off). This key is ignored if the control source is not local (REMOTE LED is on). See the FORWARD and REVERSE LED descriptions for more information.

Refer to the P.027 (Forward/Reverse Configuration) parameter description.



Use the PROGRAM key to move between program and monitor modes. The PROGRAM LED turns on when the keypad/display is in program mode and turns off when the keypad/display is in monitor mode.



Use the RUN/JOG key to toggle between run and jog when in local control (REMOTE LED is off). When run is selected, pressing the START key results in continuous drive operation. When jog is selected, pressing the START key results in drive operation only until the START key is released.

This key is ignored if the control source is not local (REMOTE LED is on). See the RUN and JOG LED descriptions for more information.



Use the START key to apply power to the motor in local control (REMOTE LED is off). See the RUNNING LED description for more information.



If the drive is running (RUNNING LED is on), the STOP/RESET key stops the drive. If the drive is not running (RUNNING LED is off), pressing this key resets drive faults. Refer also the STOP/RESET Disable Parameter (P.055).

Important: The STOP/RESET key can be disabled by P.055. See the P.055 parameter description for more information.

3.6 Drive Status LEDs

The keypad contains eight LEDs that show the present drive status. Table 3.2 describes what each drive status LED means.

Table 3.2 – Drive Status LEDs

| LED | Status | Meaning |
|----------------------|----------|---|
| RUNNING | On | Output power is being applied to the motor. |
| | Off | Output power is not being applied to the motor. |
| REMOTE | On | The drive is being controlled (START, RUN/JOG, FORWARD/REVERSE, speed reference) from a source other than the keypad. |
| | Off | The drive is being controlled from the keypad. |
| | Flashing | The network connection is lost. |
| JOG | On | Jog is selected. |
| | Off | Run is selected. |
| AUTO | On | The drive is receiving its speed reference from the terminal strip input or network option. |
| | Off | The drive is receiving its speed reference from the local keypad or serial port (OIM or CS3000), i.e., using a manual reference. |
| FORWARD ¹ | Flashing | The requested motor direction is forward; the actual motor direction is reverse (REVERSE LED is on). |
| | On | The motor is running in the forward direction. |
| | Off | The motor direction is not forward. |
| REVERSE ¹ | Flashing | The requested motor direction is reverse; the actual motor direction is forward (FORWARD LED is on). |
| | On | The motor is running in the reverse direction. |
| | Off | The motor direction is not reverse. |
| PROGRAM | On | The keypad/display is in program mode. |
| | Off | The keypad/display is in monitor mode. |
| PASSWORD | On | Parameters cannot be modified from the keypad without entering the correct password into P.051 (Programming Disable). See section 4.4, Ensuring Program Security, for more information. Note that disabling program changes by means of P.051 does not prevent parameter changes being made from the serial port or the network. |
| | Off | Parameters can be modified from the keypad. |

¹ If the speed reference is zero (0), pressing the FORWARD/REVERSE key (or toggling the FWD/REV input) will not alter the state of the FORWARD or REVERSE LEDs.

3.7 Monitor Mode LEDs

Table 3.3 describes the values that will be displayed when the corresponding monitor mode LED is on.

Table 3.3 - Monitor Mode LEDs

| Monitor Mode LED | Corresponding Display When LED is ON (Actual Values) |
|------------------|--|
| SPEED | Motor speed is displayed. This value is scaled in parameter P.028. |
| VOLTS | Drive output volts are displayed. This value is not DC bus volts. |
| AMPS | Drive output amps are displayed. |
| HZ | Drive output frequency in hertz is displayed. |
| Kw | Output power of the drive in kilowatts is displayed. Note that this is intended for display purposes as a general indication of kilowatt output and should not be used for control or exact metering purposes. |
| TORQUE | Motor output torque is displayed in percent. (Valid only for vector regulation). |
| ALL LEDs | Selected speed reference (in P.028 units) or torque reference (in %) is displayed. |

CHAPTER 4

Programming Reference

To program the drive for a specific application, you display the appropriate parameter and adjust it as required. The parameters are used to define characteristics of the drive. This chapter provides an overview of the parameter menus as well as detailed descriptions of each parameter. This chapter also describes how to access, display, and modify parameters.

4.1 Parameter Menus

To simplify the configuration process, the GV3000/SE drive software parameter list is divided into two menus: the First Menu and the Second Menu. These are shown in figure 4.1 and described below.

The First Menu contains General parameters (P.000 through P.006) which are commonly used for simple applications.

The Second Menu contains parameters that allow drive adjustment for more complex applications. These functions can be safety related and should be used only with a thorough understanding of how they may affect motor operation.

Within the Second Menu are:

- General parameters (P.007 through P.099). These parameters apply to both vector and V/Hz applications.
- Volts/Hertz parameters (H.000 through H.022). These parameters are used only for V/Hz applications and are displayed if U-H is selected in parameter P.048 (Volts/Hertz or Vector Regulation).
- Vector parameters (U.000 through U.048). These parameters are used only for vector applications and are displayed if UEC is selected in parameter P.048. Unless specified, all vector parameters are used for both flux vector control (FVC) and sensorless vector control (SVC) operation.
- RMI parameters (r.001 through r.066). These parameters are displayed only if an optional Remote Meter Interface board (M/N 2SI3000) is installed in the drive.
- The error log. The error log is shown as Err on the display. For more information on accessing the error log or clearing errors, refer to chapter 5 of this manual.

Access to the Second Menu parameters is enabled/disabled using the Second Menu Password parameter (P.006). Refer to section 4.6.1 for more information.



ATTENTION: It is the user's responsibility to determine how to distribute the Second Menu password. Reliance Electric is not responsible for unauthorized access violations within the user's organization. Failure to observe this precaution could result in bodily injury.

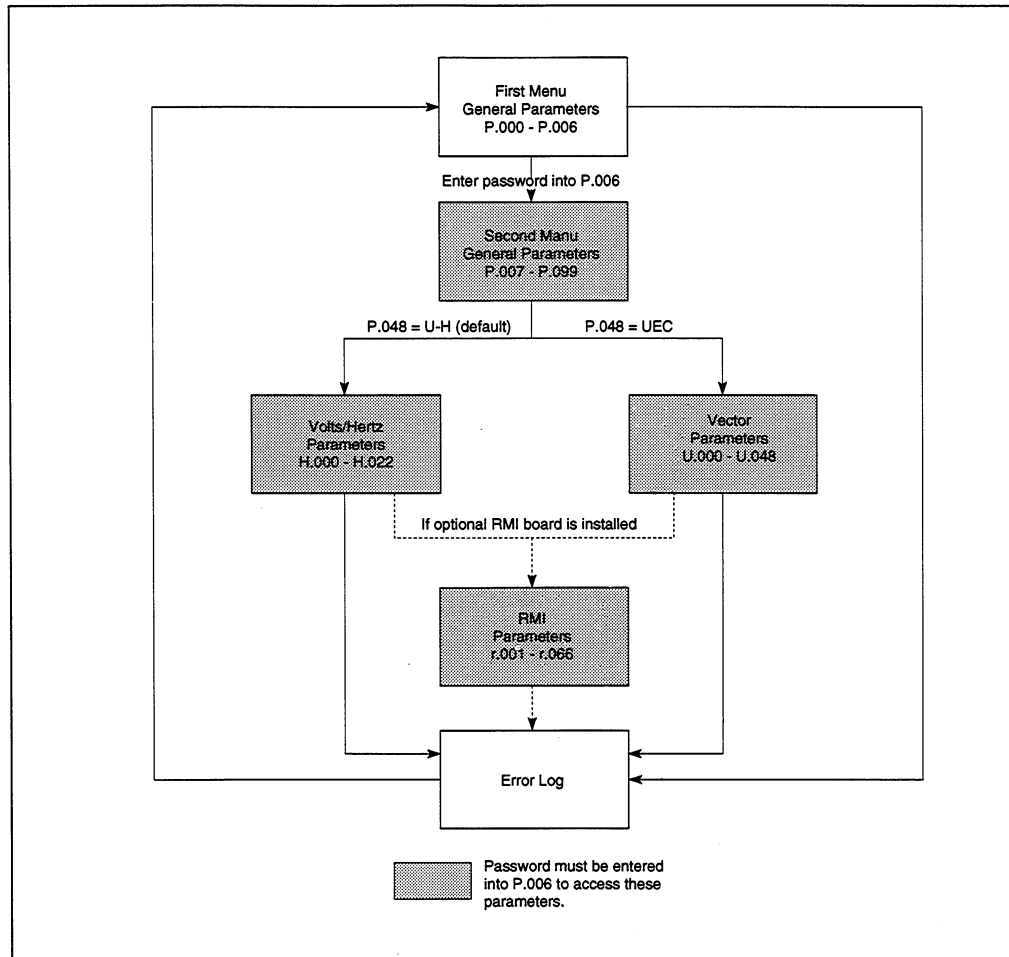

Figure 4:1 – Parameter Menu Structure

4.2 Parameter Types

There are three types of parameters:

Configurable: These parameters can be adjusted or changed only while the drive is stopped.

Tunable: These parameters can be adjusted or changed while the drive is running or stopped.

Read only: These parameters cannot be adjusted.

Each parameter is described in detail in this chapter. The following information is provided for each parameter:

Parameter Number: the unique number assigned to a specific parameter. The number is preceded by either P, H, U, or r to identify it as a General, Volts/Hertz, Vector, or optional RMI parameter, respectively. The parameter number is displayed on the drive's keypad/display.

Parameter Name: the name assigned to a parameter number. The parameter name is not displayed when programming the drive using the keypad/display. The parameter name is only visible when using the CS3000 software or Operator Interface Module (OIM).

Parameter Description: a description of the parameter's function.

Parameter Range: the pre-defined parameter value limits or selections.

Default Setting: the factory default setting for USA is mentioned. Refer to APPENDIX D for Europe and Japan.

Parameter Type: identifies whether the parameter is tunable, configurable, or read only.

Refer also to parameters: a list of associated parameters that may provide additional or related information.

4.3 Displaying or Changing Parameter Values

Use the following procedure to display or change parameter values:

Step 1. Press the PROGRAM key until the PROGRAM LED turns on to enter program mode.

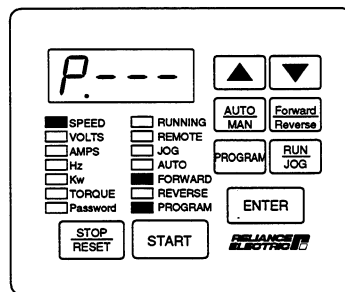

One of the main parameter menus (P.---, H.---, U.---, Err, etc.) will be displayed.

Step 2. Use the ▲ key or the ▼ key to move through the menus.

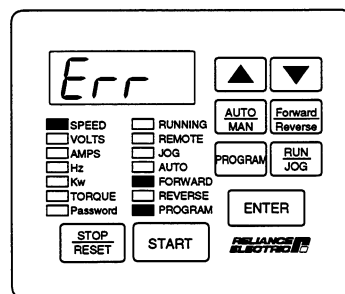

Note that if P.--- and Err are the only two menu selections displayed, access to the Second Menu parameters has been restricted. A password must be entered into parameter P.006 in order to access the Second Menu parameters. Refer to section 4.6 for this procedure.

Step 3. Once the desired menu is displayed, press the ENTER key to select it.

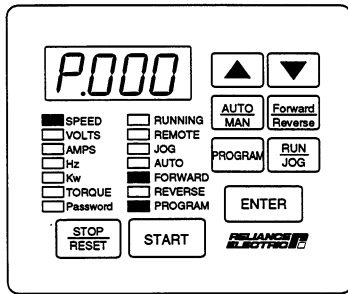

The first parameter number in the menu or the last parameter number previously accessed from that menu will be displayed.

Step 4. Press the ▲ key or the ▼ key to move through the parameters.

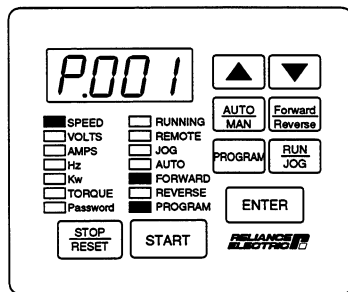

Each parameter number will be displayed as you move through the parameters.

Step 5. Once the desired parameter is displayed, press the ENTER key to access it.

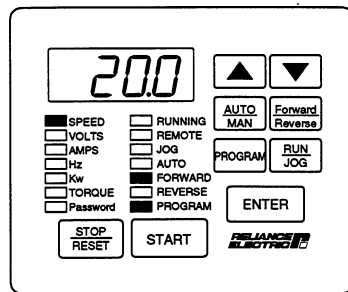

The parameter value will be displayed.

Step 6. Press the ▲ key or the ▼ key to change the value.

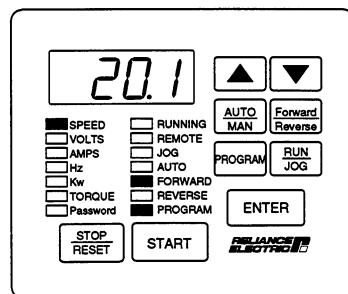

Note that if programming is disabled in parameter P.051 (Programming Disable), or if the parameter is configurable and the drive is running, the value will not change.

Step 7. Press the ENTER key to save the changed value.

- OR -

Press the PROGRAM key to exit the parameter without changing the value.

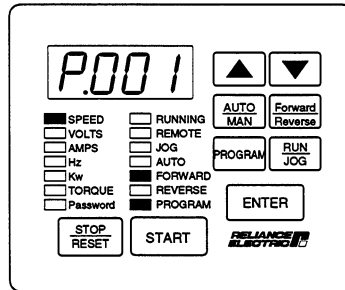

The parameter number will be displayed again.

Important: The value will not be written into memory unless the ENTER key is pressed.

To display or change additional parameters within this menu, repeat steps 4 through 7.

To display or change parameters in a different menu, press the PROGRAM key to return to the main menu selections. Then repeat steps 2 through 7.

To exit program mode, press the PROGRAM key until the PROGRAM LED turns off.

Note that parameter values and the local keypad status are retained through a line dip or power shutdown.

4.4 Ensuring Program Security

Parameter values can be password-protected using parameter P.051 (Programming Disable). When programming is disabled, parameter values can be displayed but cannot be modified from the keypad unless the correct password is entered in P.051. Note that disabling program changes by means of P.051 will not prevent parameter changes being made from the serial port on the network.



ATTENTION: It is the user's responsibility to determine how to distribute the password. Reliance Electric is not responsible for unauthorized access violations within the user's organization. Failure to observe this precaution could result in bodily injury.

Use the following procedure to disable/enable parameter programming. (See section 4.3, Displaying or Changing Parameter Values, if you are unfamiliar with modifying parameters using the keypad/display.)

Step 1. Select parameter P.051 from the Second Menu General parameters. P.051 will appear on the display.

Step 2. Press the ENTER key to access the parameter. A zero will be displayed.

Step 3. Use the ▲ key to increment the value to 26. This is the password number.

Step 4. Press the ENTER key to save the value. P.051 will be displayed.

Parameter programming is disabled when the PASSWORD LED is on and enabled when the PASSWORD LED is off.

To prevent unauthorized password use, a zero value (not the saved password value) is displayed whenever this parameter is accessed.

Note that parameter values and the local keypad status are retained through a line dip or power shutdown.

4.5 First Menu Parameters

The First Menu contains General parameters that are most commonly used for simple applications. No password is required to access them. These parameters apply to both vector and V/Hz programming and are described in detail in section 4.5.1.

4.5.1 First Menu General Parameter Descriptions (P.000 to P.006)

P.000 Control Source

This parameter selects the drive control source.

The drive responds to the reference, forward/reverse, run/jog, and start commands (inputs) only from the source selected in this parameter.

| | |
|----------------------------------|---|
| Parameter Range: | LOCL = Local keypad/display rE = Terminal strip remote inputs OP = Option port* SErL = Serial port (CS3000 or OIM)** |
| Default Setting: | LOCL |
| Parameter Type: | Configurable |
| Refer also to parameters: | P.007 Terminal Strip Digital Inputs Configure P.008 Terminal Strip Speed Reference Source P.063 Option Port: Network Reference Source |

* OP selection is not available if a network option board is not used.

** For more information about the Control and Configuration Software (CS3000), refer to instruction manual D2-3348. For more information about the GV3000/SE OIM (Operator Interface Module, M/N 2RK3000), refer to instruction manual D2-3342.



ATTENTION: In V/Hz regulation, if P.000 (Control Source) is set to OP (Option Port), and P.062 is set to 1 (Hold Last Reference), and the drive loses communication with the network, the drive will maintain the last frequency command sent to it. Ensure that driven machinery, all drive-train mechanisms, and application material are capable of safe operation at the maximum operating speed of the drive. Failure to observe this precaution could result in bodily injury.

The selected drive control source is determined primarily by the value in P.000. However, if P.000 = rE, then the REM/LOC input may toggle the control source between the local keypad and the terminal strip. See P.007 (Terminal Strip Digital Inputs Configure).

Depending on the control source selected, the AUTO/MAN key can be used to switch between speed reference sources as shown in table 4.1.

P.000 Control Source *(continued)*

Table 4.1 – Speed Reference Source Based on P.000 and AUTO/MAN Key Status

| Control Source (P.000) | AUTO/MAN Status | Speed Reference Source |
|--|-----------------|-----------------------------|
| Local keypad/display (P.000 = LOCL) | AUTO selected | Terminal strip |
| | MAN selected | Local keypad/display or OIM |
| Terminal strip remote inputs (P.000 = rE) | AUTO selected | Terminal strip |
| | MAN selected | Local keypad/display or OIM |
| Option port (P.000 = OP) | AUTO selected | Network |
| | MAN selected | Local keypad/display or OIM |
| Serial port (P.000 = SErL) | AUTO selected | Terminal strip |
| | MAN selected | Local keypad/display or OIM |

Refer to chapter 3 and the description of parameter P.052 (AUTO/MAN Key Disable) in chapter 4 for more information on the AUTO/MAN key.

Set P.000 = OP to select the DeviceNet™ Network option board, the AutoMax™ Network option board, the PROFIBUS™ Interface board, or the ControlNet™ Network option board as the drive control source.

Note that the REMOTE LED will turn on if any control source other than the local keypad is selected.

P.001 Accel Time 1 (RAMP 1)

For V/Hz regulation, this parameter specifies the amount of time in which the motor ramps from zero speed to Maximum Speed (P.004).

For vector regulation, this parameter specifies the amount of time in which the motor ramps from zero speed to Motor Top Speed (U.017).

| | |
|----------------------------------|---|
| Parameter Range: | 1.0 to 999.9 seconds (V/Hz) 0.1 to 999.9 seconds (vector) |
| Default Setting: | 20.0 |
| Parameter Type: | Tunable |
| Refer also to parameters: | P.004 Maximum Speed P.005 Current Limit U.017 Motor Top Speed |

The time the motor takes to make any speed increase is directly proportional to the value in this parameter. This parameter does not apply if JOG is selected. See P.021 (Jog Ramp Accel Time).

If the motor load inertia is high, or the Current Limit (P.005) setting is too low, actual motor acceleration time will be longer than the time set in P.001. If Accel Time 1 is set too short, an overcurrent fault may occur.

P.002 Decel Time 1 (RAMP 1)

For V/Hz regulation, this parameter specifies the amount of time in which the motor ramps from Maximum Speed (P.004) to zero speed.

For vector regulation, this parameter specifies the amount of time in which the motor ramps from Motor Top Speed (U.017) to zero speed.

| | |
|----------------------------------|---|
| Parameter Range: | 1.0 to 999.9 seconds (V/Hz) 0.1 to 999.9 seconds (vector) |
| Default Setting: | 20.0 |
| Parameter Type: | Tunable |
| Refer also to parameters: | P.004 Maximum Speed P.005 Current Limit U.017 Motor Top Speed U.024 High DC Bus Fault Avoidance Enable |

The time the motor takes to make any speed decrease (except a coast-to-rest stop) is directly proportional to the value in this parameter. This parameter does not apply if JOG is selected. See P.022 (Jog Ramp Decel Time).

Note that motor load inertia and input line conditions can extend the deceleration time to a value greater than the preset time. With very fast deceleration times, regenerative motor voltage may charge up the DC bus voltage, causing a high bus voltage (HU) fault. To avoid a fault condition, extend the deceleration time for a longer period. If a deceleration time faster than the acceptable range is required, installing an optional Snubber Resistor Kit or Regenerative Braking Module Kit may prevent the fault.

For V/Hz regulation with dynamic braking (snubber resistor) disabled (H.017 = 0, 2, or 4), the deceleration time may be extended to prevent a high bus voltage (HU) fault from occurring.

P.003 Minimum Speed

This parameter limits the speed reference to the drive. Regardless of what speed reference is supplied, the regulator will not command a speed less than the value in P.003.

Parameter Range: 0.5 to P.004 Maximum Speed (V/Hz)
0 to P.004 Maximum Speed (vector)

Default Setting: 5.0 Hz (V/Hz)
150 RPM (vector)

Parameter Type: Tunable

Refer also to parameters: P.004 Maximum Speed



ATTENTION: The drive can operate at and maintain zero speed. The user is responsible for ensuring safe conditions for operating personnel by providing suitable guards, audible or visual alarms, or other devices to indicate that the drive is operating or may operate at or near zero speed. Failure to observe this precaution could result in severe bodily injury or loss of life.

Note that in V/Hz regulation, the drive may decrease the output frequency below P.003 (but not below 0.5 Hz) to avoid an overcurrent fault.

P.004 Maximum Speed

This parameter limits the speed reference to the drive. Regardless of what speed reference is supplied, the regulator will not command a speed greater than the value in P.004.

Parameter Range: 15.0 to H.022 Overfrequency Limit (V/Hz)
10 RPM to U.017 Motor Top Speed (vector)

Default Setting: 60.0 Hz (V/Hz)
1722 RPM (vector)

Parameter Type: Tunable

Refer also to parameters: P.028 Speed Display Scaling
H.022 Overfrequency Limit
U.017 Motor Top Speed



ATTENTION: The user is responsible for ensuring that driven machinery, all drive-train mechanisms, and application material are capable of safe operation at the maximum operating speed of the drive. Overspeed detection in the drive determines when the drive shuts down. For vector regulation, this is factory-set to 130% of maximum speed. For volts/hertz regulation, this is fixed at the frequency level set in parameter H.022 (Overfrequency Limit). Failure to observe this precaution could result in bodily injury.

For V/Hz regulation, this parameter specifies the maximum allowed speed in hertz. The drive is equipped with configurable overspeed protection at the frequency level set in H.022 (Overfrequency Limit).

For vector regulation, this parameter specifies the maximum allowed speed in RPM. This drive is equipped with fixed overspeed protection at 130% of Maximum Speed.

P.005 Current Limit

This parameter provides the means to limit motor stator current while running at constant speed or during acceleration.

| | |
|----------------------------------|---|
| Parameter Range: | 50 to 110% (V/Hz) U.006 to 150% (vector) |
| Default Setting: | 100% (V/Hz) 150% (vector) |
| Parameter Type: | Tunable |
| Refer also to parameters: | P.095 Power Module Output Amps H.002 Motor Nameplate Amps U.004 Motor Nameplate Amps U.006 Magnetizing Current Percent |

For V/Hz regulation: Current limit is set as a percentage of the Power Module rated amps with a maximum value of 110%. 110% current limit equals the current value in parameter P.095 (Power Module Output Amps).

When the output current attempts to exceed the preset current limit, the output voltage and frequency will be lowered as the GV3000/SE drive reduces output current.

For vector regulation: Current limit is a percentage of the value entered in U.004.

The output current will be limited to the current limit value, which may result in motor speed decreasing or the acceleration/deceleration time being extended.

P.006 Second Menu Password

This parameter is used to enable/disable access to Second Menu General (P), Vector (U), Volts/Hertz (H), and RMI (r) parameters. Refer to section 4.6.1 of this manual for more information about this password.

| | |
|----------------------------------|---------------------------|
| Parameter Range: | 0 to 9999; 107 = password |
| Default Setting: | N/A |
| Parameter Type: | Tunable |
| Refer also to parameters: | N/A |



ATTENTION: It is the user's responsibility to determine how to distribute the second menu password. Reliance Electric is not responsible for unauthorized access violations within the user's organization. Failure to observe this precaution could result in bodily injury.

Note that if the password is entered to enable access to the Second Menu parameters, the password must then be re-entered to disable access.

4.6 Second Menu Parameters

The Second Menu contains parameters used for more complex applications. Within the Second Menu are General (P.---) parameters that apply to both vector and V/Hz programming, and Vector (U.---) or Volts/Hertz (H.---) parameters. If an optional RMI board is installed in the drive, RMI (r.---) parameters are also contained in the Second Menu.

| For a detailed description of: | Refer to: |
|------------------------------------|--------------------------------|
| Second Menu General parameters | Section 4.6.2 |
| Second Menu Vector parameters | Section 4.6.3 |
| Second Menu Volts/Hertz parameters | Section 4.6.4 |
| Second Menu RMI parameters | RMI instruction manual D2-3341 |

Access to the Second Menu parameters is enabled/disabled using the Second Menu Password parameter (P.006). Refer to section 4.6.1 for more information.

4.6.1 Entering the Second Menu Password



ATTENTION: It is the user's responsibility to determine how to distribute the second menu password. Reliance Electric is not responsible for unauthorized access violations within the user's organization. Failure to observe this precaution could result in bodily injury.

The Second Menu Password parameter (P.006) is used to enable/disable access to the Second Menu parameters. When access is disabled, the Second Menu parameters cannot be displayed or changed (refer to figure 4.1). To enable access, a factory-set password is entered into P.006. Access to the Second Menu parameters will then remain enabled until the password is entered into P.006 again.

Step 1. Press the PROGRAM key until the PROGRAM LED turns on to enter program mode.

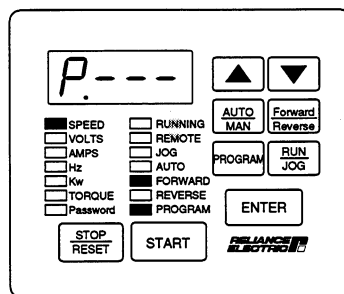

If P.--- is not displayed, press the ▲ key or the ▼ key until it is.

Step 2. Press the ENTER key.

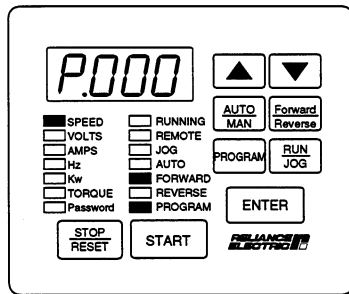

The first parameter number in the First Menu General parameters (P.000) or the last parameter number accessed will be displayed.

Step 3. Press the ▲ key to increment the parameter numbers until P.006 is displayed.

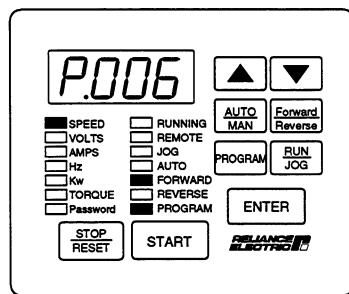

Important: If you are able to display parameter P.007, access to the Second Menu is enabled. Continue with this procedure only if you wish to disable access to the Second Menu.

Step 4. Press the ENTER key to access the parameter.

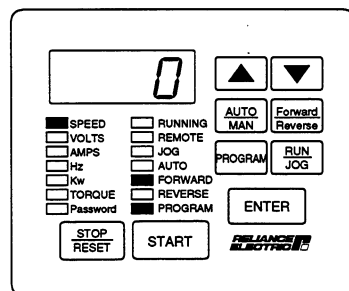

Zero will be displayed.

To prevent unauthorized password use, a zero value (not the saved password number) is displayed whenever this parameter is accessed.

Step 5. Press the ▲ key to increment the value until 107 is displayed. This is the password. (Holding down the ▲ key will increase the scroll speed.)

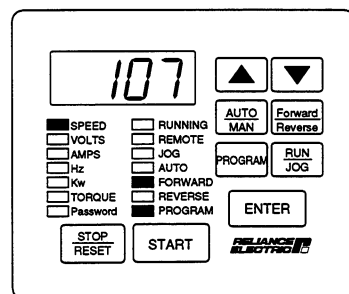

Step 6. Press the ENTER key to select the password.

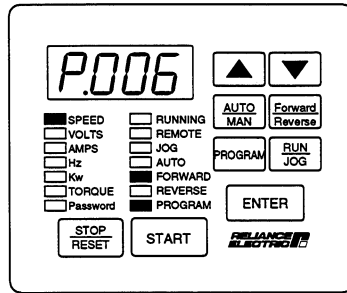

P.006 is displayed.

Step 7. Press the ▲ key to verify the access status.

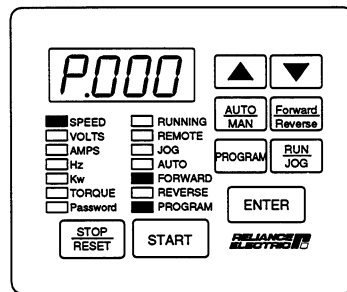

Access Disabled

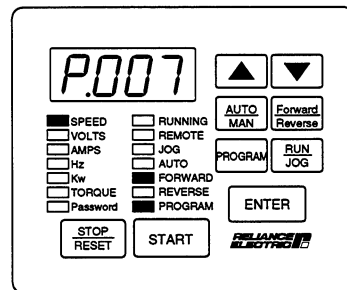

Access Enabled

4.6.2 Second Menu General Parameter Descriptions (P.007 to P.099)

P.007 Terminal Strip Digital Inputs Configure

The GV3000/SE drive provides multiple configurations of digital inputs 6, 7, and 8 on the terminal strip. This parameter determines how these inputs are used.

The P.008 (Terminal Strip Speed Reference Source) selection will limit the selection of P.007 because the P.008 selection may use one or more of digital inputs 6 through 8.

| Parameter Range: | Preset Configurations of Inputs 6, 7, and 8 | | |
|----------------------------------|---|----------------------------------|----------------------------------|
| | Digital Input 6 (Terminal 19) | Digital Input 7 (Terminal 18) | Digital Input 8 (Terminal 17) |
| 0 = | FWD/REV | RAMP 1/2 | REM/LOC |
| 1 = | Not used | FWD/REV | RAMP 1/2 |
| 2 = | Not used | FWD/REV | REM/LOC |
| 3 = | Not used | RAMP 1/2 | REM/LOC |
| 4 = | Not used | Not used | FWD/REV |
| 5 = | Not used | Not used | RAMP 1/2 |
| 6 = | Not used | Not used | REM/LOC |
| 7 = | Not used | Not used | Not used |
| 8* = | FWD/REV | TRQ/SPD | REM/LOC |
| 9* = | Not used | TRQ/SPD | REM/LOC |
| 10* = | Not used | TRQ/SPD | FWD/REV |
| 11* = | Not used | TRQ/SPD | RAMP 1/2 |
| 12* = | Not used | Not used | TRQ/SPD |
| Default Setting: | 0 | | |
| Parameter Type: | Configurable | | |
| Refer also to parameters: | P.008 Terminal Strip Speed Reference Source | | |

*Vector regulation only.



ATTENTION: If a maintained start contact is used when the control source = rE, switching from local to remote from the terminal strip will cause power to be applied to the motor if the remote start contact is closed. Stay clear of rotating machinery in this case. Failure to observe this precaution could result in bodily injury.

An unasserted (open) or asserted (closed) input will select the input functions as shown in table 4.2. If a function is not configured, the unasserted (open) state will be applied.

Table 4.2 – Function Selection for Digital Inputs 6, 7, and 8

| Input | Open (Unasserted) | Closed (Asserted) |
|----------|-------------------|-------------------|
| FWD/REV | Forward | Reverse |
| RAMP 1/2 | Ramp 1 | Ramp 2 |
| REM/LOC | Remote | Local |
| TRQ/SPD | Torque | Speed |

P.007 Terminal Strip Digital Inputs Configure *(continued)*

FWD/REV

FWD/REV allows you to select between forward or reverse operation. If the input is closed, this function will invert the selected speed reference. For example, if the selected speed reference value is negative (<0) and the FWD/REV input is closed, the resulting speed reference will be positive.

The digital input for FWD/REV is active only if the control source is remote.

RAMP 1/2

RAMP 1/2 allows you to select one of two paired acceleration/deceleration rates. RAMP 1 uses acceleration or deceleration rates based on P.001/P.002 (Accel Time 1/Decel Time 1). RAMP 2 uses acceleration or deceleration rates based on P.017/P.018 (Accel Time 2/Decel Time 2).

The digital input for RAMP 1/2 is always active regardless of the control source.

REM/LOC

REM/LOC allows you to switch from terminal strip control to local keypad control. The drive must be stopped in order to do this. (Note that if an OIM is connected, REM/LOC will switch control from the terminal strip to the OIM, not to the local keypad.)

The digital input for REM/LOC is active only if the control source is remote.

The following example shows how this input can be used.

REM/LOC Input Example

Assume the drive is stopped and started using an external two-wire control signal. The drive's control source is the terminal strip (P.000 = rE), and a START command is given. The REM/LOC option (P.007 = 2) is selected so that an external REM/LOC switch switches the drive from REMOTE to LOCAL or from LOCAL to REMOTE. The external switch is in the REMOTE position.

The following happens:

1. The STOP/RESET key is pressed, and the motor stops.
2. LOCAL is selected using the externally-wired REM/LOC switch.
3. Control of the drive is done locally through the keypad (or through the OIM, if connected). (This could be for troubleshooting purposes, or for viewing/adjusting parameter values).
4. The REM/LOC switch is switched back to the REMOTE position. The drive runs immediately because there is already an asserted remote START signal.
5. The drive is now being controlled by the remote control source.

P.007 Terminal Strip Digital Inputs Configure *(continued)*

TRQ/SPD

TRQ/SPD allows you to switch between torque regulation and speed regulation while the drive is running or stopped. This feature only applies when the drive has been configured as a vector regulator (P.048 = UEC), and U.000 (Torque Reference Source) > 0.

To provide smooth transitioning when switching from torque to speed, the speed regulator is preset with the last torque reference. When switching from speed to torque, the torque regulator will switch to the new torque reference.

The digital input for TRQ/SPD is active if the control source is local, remote, or serial.

Interaction with P.008

The default value of 0 for P.007 will limit P.008 (Terminal Strip Speed Reference Source) to a selection of 0. You must change P.007 to some value other than 0 in order to change P.008 to some value other than 0. See table 4.3 and the selection example in the P.008 parameter description.

Refer to the GV3000/SE hardware reference manual for terminal strip wiring.

P.008 Terminal Strip Speed Reference Source

This parameter selects the source of the terminal strip speed reference.

The terminal strip speed reference is used when:

- the terminal strip is the selected control source (P.000 = rE)

or

- the local keypad or serial port is the selected control source (P.000 = LOCL or SErL) and AUTO is selected (AUTO LED is on).

| | |
|----------------------------------|--|
| Parameter Range: | 0 = Analog reference. (Digital inputs 6, 7, and 8 are not used. See P.007.) 1 = MOP selection. (Uses terminal strip digital input 6 for the MOP increment and digital input 7 for the MOP decrement function. Digital input 8 is not used.) 2 = Two (2) preset speeds. (Uses terminal strip digital input 6. Digital inputs 7 and 8 are not used.) 3 = Four (4) preset speeds. (Uses terminal strip digital inputs 6 and 7. Digital input 8 is not used.) 4 = Eight (8) preset speeds. (Uses all terminal strip digital inputs.) 5 = Analog reference and one (1) preset speed. (Uses terminal strip digital input 6. Digital inputs 7 and 8 are not used.) 6 = Analog reference and three (3) preset speeds. (Uses terminal strip digital inputs 6 and 7. Digital input 8 is not used.) 7 = Analog reference and seven (7) preset speeds. (Uses terminal strip digital inputs 6, 7 and 8.) |
| Default Setting: | 0 |
| Parameter Type: | Configurable |
| Refer also to parameters: | P.007 Terminal Strip Digital Inputs Configure P.031 Preset Speed 1 r.030 Digital Input Configuration |

In selections 5, 6, and 7, a digital input will initiate the selected preset speed which will override the analog speed reference. Refer to table 4.4 in the P.031 parameter description.

The selection is dependent upon what is selected for parameter P.007 (Terminal Strip Digital Inputs Configure). The selection made in P.007 determines what the remaining free digital inputs are used for. See table 4.3 for acceptable combinations.

P.008 Terminal Strip Speed Reference Source *(continued)*

Table 4.3 – Acceptable P.007 and P.008 Selection Combinations

| P.007 Selections | P.008 Selections | | | | | | | |
|------------------|------------------|---|---|---|---|---|---|---|
| | 0 | 1 | 2 | 3 | 4 | 5 | 6 | 7 |
| 0 | ✓ | | | | | | | |
| 1 | ✓ | | ✓ | | | ✓ | | |
| 2 | ✓ | | ✓ | | | ✓ | | |
| 3 | ✓ | | ✓ | | | ✓ | | |
| 4 | ✓ | ✓ | ✓ | ✓ | | ✓ | ✓ | |
| 5 | ✓ | ✓ | ✓ | ✓ | | ✓ | ✓ | |
| 6 | ✓ | ✓ | ✓ | ✓ | | ✓ | ✓ | |
| 7 | ✓ | ✓ | ✓ | ✓ | ✓ | ✓ | ✓ | ✓ |
| 8 | ✓ | | | | | | | |
| 9 | ✓ | | ✓ | | | ✓ | | |
| 10 | ✓ | | ✓ | | | ✓ | | |
| 11 | ✓ | | ✓ | | | ✓ | | |
| 12 | ✓ | ✓ | ✓ | ✓ | | ✓ | ✓ | |

✓ = Selection combination is acceptable.

P.007/P.008 Selection Example

If you want to select the MOP as the speed reference source, P.008 must be set to 1. Next, select the value for P.007 using table 4.3. Following the 1 column down under P.008 Selections, the acceptable selections for P.007 are 4, 5, 6, 7, or 12.

If an optional RMI board is installed in the drive, refer to Appendix E for more information regarding digital input configuration.

P.009 Terminal Strip Analog Input Offset

This parameter allows for correcting any offset in the terminal strip analog input prior to the signal reaching the drive.

This parameter is not used if the terminal strip analog input is used as vector torque reference (U.000 = 1).

Parameter Range: -900 to +900*
Default Setting: 0
Parameter Type: Tunable
Refer also to parameters: P.000 Control Source

*For 0 to 10 V (or -10 V to +10 V input), a value of +1 equals an offset of approximately 10 mV.
 For 0 to 20 mA input, a value of +1 equals an offset of approximately 20 μ A.

For more information about the analog input, refer to Appendix F.

P.010 Terminal Strip Analog Input Gain

This parameter is used to compensate for component tolerance errors or insufficient voltage from the input reference source at the terminal strip.

This parameter is not used if the terminal strip analog input is used as vector torque reference (U.000 = 1).

Parameter Range: 0.100 to 5.000
Default Setting: 1.000
Parameter Type: Tunable
Refer also to parameters: P.000 Control Source

For more information about the analog input, refer to Appendix F.

P.011 Terminal Strip Analog Input Configure

This parameter selects the type of analog input signal being used and whether to invert it (negate it) after it has been converted from analog to digital by the drive.

If the terminal strip analog input is used as vector torque reference (U.000 = 1), this parameter is used only to enable the analog input signal loss detection feature.

Parameter Range:

| | |
|---------------------------|--|
| Jumper J4 on pins 2 and 3 | 0 = +/- 10 VDC 1 = +/- 10 VDC inverted 2 = 0 to 10 VDC 3 = 0 to 10 VDC inverted |
| Jumper J4 on pins 1 and 2 | 4 = 4 to 20 mA. Generate fault on signal loss. 5 = 4 to 20 mA inverted. Generate fault on signal loss. 6 = 0 to 20 mA 7 = 0 to 20 mA inverted 8 = 4 to 20 mA. Display alarm and use previous reference on signal loss. 9 = 4 to 20 mA inverted. Display alarm and use previous reference on signal loss. 10 = 4 to 20 mA. Display alarm and use Preset Speed 1 (P.031) as reference on signal loss. 11 = 4 to 20 mA inverted. Display alarm and use Preset Speed 1 (P.031) as reference on signal loss. 12 = 0 to 10 VDC. <i>Start and stop</i> the drive based on analog input value. (P.000 must be set to rE.) See section F.4 if you select this option. |

Default Setting: 2
Parameter Type: Configurable
Refer also to parameters: P.009 Terminal Strip Analog Input Offset
P.010 Terminal Strip Analog Input Gain

Important: Verify that the hardware (jumper J4) and software configurations match each other and the external signal.

P.011 Terminal Strip Analog Input Configure *(continued)*



ATTENTION: The drive may inadvertently start due to the effects of temperature or electrical noise on the analog input when the analog input is configured to start and stop the drive (P.011 = 12), and the following conditions are true:

- P.000 = rE
- The function loss, stop, and start inputs on the terminal strip are all closed.

The user is responsible for;

- providing suitable notification to operating personnel that this feature is being used and the drive could start any time.
- ensuring that the inadvertent starting of the driven equipment will not cause injury to operating personnel or damage to the driven equipment.
- ensuring that the input wiring has been installed according to IEEE Standard 518 to minimize electrical noise.

Failure to observe this precaution could result in severe bodily injury or loss of life.

ATTENTION: Due to the effect of temperature on the analog input, the possibility exists that the stop threshold cannot be reached. The application must rely on the terminal strip stop and function loss inputs as the alternate methods of stopping the drive. Failure to observe this precaution could result in severe bodily injury or loss of life.

If P.011 = 2 or 12, the input + offset (P.009) will be low limited at 0 and then multiplied by P.010.

If P.011 = 3, the input + offset (P.009) will be low limited at 0, multiplied by P.010, and then negated.

If P.011 = 4, 8, or 10, the input will be offset by -4 mA + offset parameter (P.009), low limited at 0, and then multiplied by P.010.

If P.011 = 5, 9, or 11, the input will be offset by -4 mA + offset parameter (P.009), low limited at 0, multiplied by P.010, and then negated.

If P.011 = 6, the input + offset (P.009) will be low limited at 0 and multiplied by P.010.

If P.011 = 7, the input + offset (P.009) will be low limited at 0, multiplied by P.010, and then negated.

For the 4 to 20 mA input selections, the drive can be configured to generate a fault (selections 4 and 5) or an alarm (selections 8 through 11) if the input falls below 2 mA. If P.011 = 8 or 9, the drive continues to run using the value of the analog input 4 to 5 seconds prior to the loss detection. If P.011 = 10 or 11, the drive continues to run using Preset Speed 1 (P.031) as the analog input value. In both cases, once the input returns (≥ 4 mA), the alarm clears, and the drive uses the converted input.

For more information about the analog input, refer to Appendix F. For more information about alarms and faults, refer to chapter 5.

P.012 Terminal Strip Analog Output Source

This parameter selects the source of the analog output signal.

| | |
|----------------------------------|---|
| Parameter Range: | 0 = Speed (bipolar) |
| | 1 = Torque (bipolar) |
| | 2 = Speed (unipolar) |
| | 3 = Current (unipolar) (V/Hz) Torque (unipolar) (vector) |
| Default Setting: | 0 |
| Parameter Type: | Tunable |
| Refer also to parameters: | N/A |

Selections 2 and 3 select the same signals as selections 0 and 1, but instead of providing a 5V (1/2 scale) offset to allow for a bipolar signal, no 5V offset is used. Instead, the signal is presented in a unipolar manner. The absolute value of the selected signal is used to drive the analog output over its full range of 0 to 10 VDC. This provides greater resolution of the selected signal at the expense of indicating polarity. Refer to figure 4.2.

Note that in V/Hz control, signals are updated every 500 ms. In Vector control, all signals are updated every 5.0 ms.

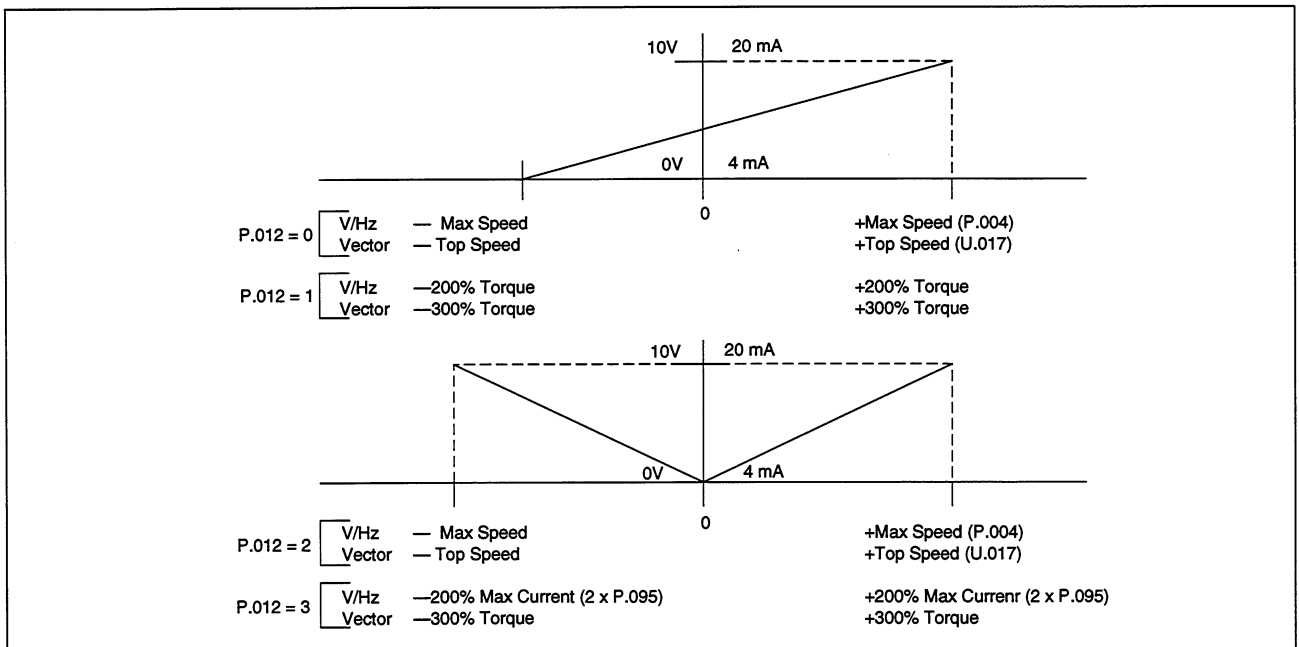

Figure 4.2 – Analog Output Selection and Scaling

P.013 Output Relay Configuration

This parameter specifies the type of status indication provided by the output relay contacts (terminal 28, 29, 30, and 31 on the drive's terminal strip).

| | |
|----------------------------------|---|
| Parameter Range: | 0 = Output relay is energized when one or more faults (IET) are active. 1 = Output relay is energized to show state of drive running with 0.5 second delay added between a start assertion and generation of motor voltage. 2 = Output relay is energized to show state of drive running but without 0.5 second start delay. 3 = Output relay is energized when network communication is active. 4 = Output relay is energized when all start permissive conditions are met. 5 = Output relay is energized when one or more alarms are active. 6 = Output relay is energized when no faults are active. |
| Default Setting: | 0 |
| Parameter Type: | Configurable |
| Refer also to parameters: | N/A |

For example, for an application using an output contactor, you can obtain a 0.5 second delay between a start assertion and the generation of motor voltage by setting P.013 to 1. The delay will provide time for the contactor to close before motor voltage is generated.

P.014 Trim Reference Source

This parameter specifies the source for the trim reference. Trim reference is added to the speed reference.

Refer to figure 4.3.

| | |
|----------------------------------|---|
| Parameter Range: | 0 = No trim reference used 1 = Terminal strip analog input 2 = Option port trim reference register 3 = Maximum speed 4 = Torque current feedback (vector only) 5 = RMI board analog input 6 = RMI board frequency input 7 = Switched RMI board analog input or frequency input 8 = RMI outer loop PI block (Mode 1) 9 = RMI outer loop PI block (Mode 2) |
| Default Setting: | 0 |
| Parameter Type: | Configurable |
| Refer also to parameters: | P.015 Trim Gain Percentage |

Selections 5 through 9 are available only if an optional RMI board is installed in the drive. Refer to instruction manual D2-3341 for more information about the RMI board.

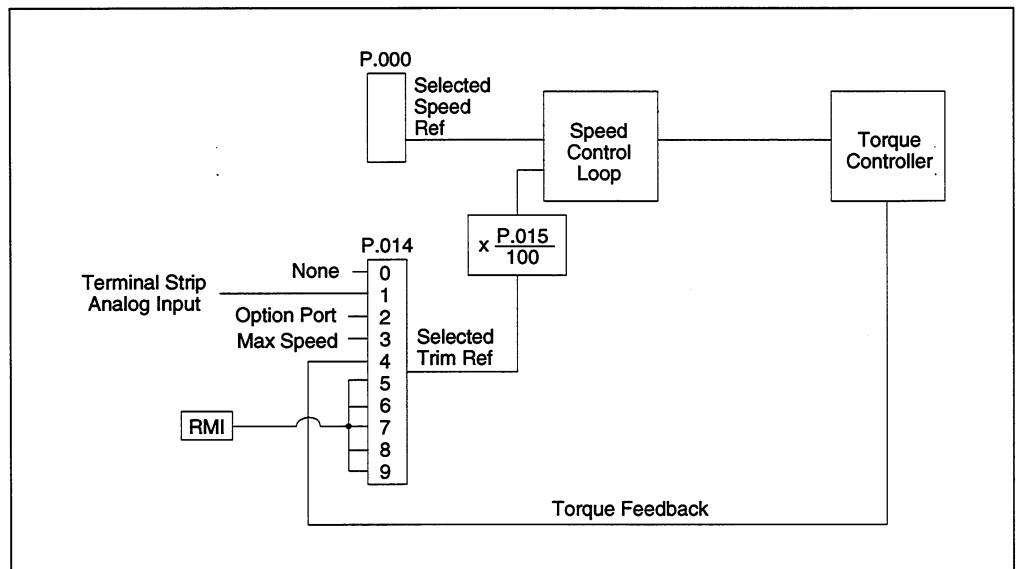

Figure 4.3 – Trim Reference Source Selection

P.015 Trim Gain Percentage

This parameter specifies a percentage of the selected trim reference entering the speed regulator.

See figure 4.4.

Parameter Range: -100.0 to +100.0% (1.0 = 1%)
Default Setting: 0.0
Parameter Type: Tunable
Refer also to parameters: P.014 Trim Reference Source

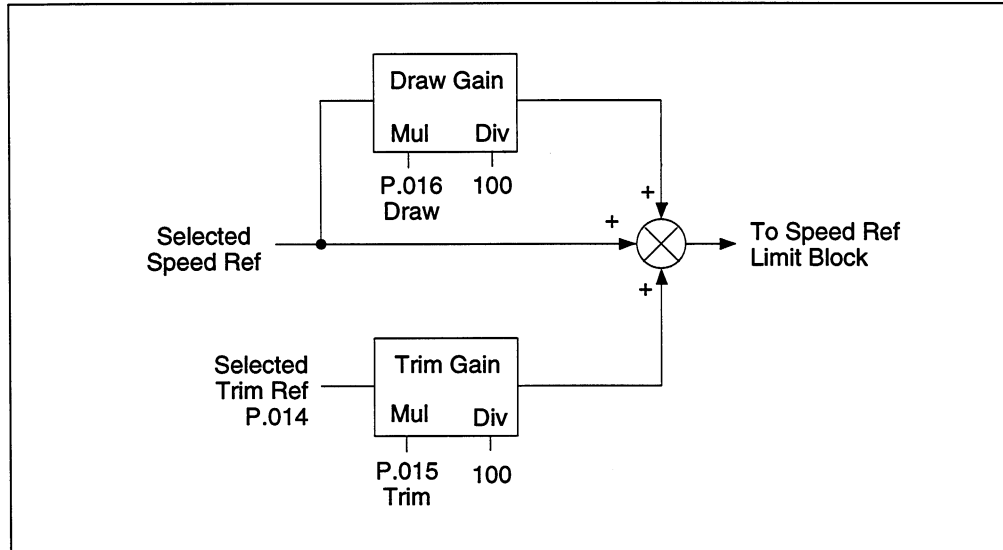

Figure 4.4 – Draw and Trim Gain

See Appendix G for the complete block diagram.

P.016 Draw Gain Percentage

This parameter is used to increase or decrease the selected speed reference to the speed regulator.

Parameter Range: -100.0 to +100.0% (1.0 = 1%)
Default Setting: 0.0
Parameter Type: Tunable
Refer also to parameters: N/A

This parameter allows multiple drive sections with a common line reference, but with different values for draw gain, to run at different speeds depending on the percent draw.

Note that P.016 affects the accel/decel times. As draw gain increases positive, the accel/decel time decreases proportionately. As draw gain increases negative, the accel/decel increases proportionately. This is based on the following formula:

$$\text{Modified Accel/Decel} = \text{Accel/Decel} \times [1 / (1.00 + (\text{Draw}\% / 100))]$$

P.017 Accel Time 2 (RAMP 2)

This parameter sets the acceleration time when a second ramp selection is configured as a digital input.

When the RAMP 2 acceleration time digital input is asserted, the RAMP 2 deceleration time also takes effect.

| | |
|----------------------------------|---|
| Parameter Range: | 1.0 to 999.9 seconds (V/Hz) 0.1 to 999.9 seconds (vector) |
| Default Setting: | 20.0 |
| Parameter Type: | Tunable |
| Refer also to parameters: | P.001 Accel Time 1 P.007 Terminal Strip Digital Inputs Configure |

In V/Hz regulation, this parameter specifies the time in which the motor ramps from zero speed to Maximum Speed (P.004).

In vector regulation, this parameter specifies the time in which the motor ramps from zero speed to Motor Top Speed (U.017).

The time it takes the motor to make any speed increase is directly proportional to the value in this parameter. This parameter does not apply if JOG is selected.

P.018 Decel Time 2 (RAMP 2)

This parameter specifies the deceleration time when a second ramp selection is configured as a digital input.

When the RAMP 2 deceleration time digital input is asserted, the RAMP 2 acceleration time also takes effect.

| | |
|----------------------------------|---|
| Parameter Range: | 1.0 to 999.9 seconds (V/Hz) 0.1 to 999.9 seconds (vector) |
| Default Setting: | 20.0 |
| Parameter Type: | Tunable |
| Refer also to parameters: | P.002 Decel Time 1 P.007 Terminal Strip Digital Inputs Configure |

In V/Hz regulation, this parameter specifies the time in which motor speed ramps from Maximum Speed (P.004) to zero speed.

In vector regulation, this parameter specifies the time in which motor speed ramps from Motor Top Speed (U.017) to zero speed.

The time it takes the motor to make any speed decrease (except a coast-to-rest stop) is directly proportional to the value in this parameter.

This parameter does not apply if JOG is selected.

P.019 S-Curve Enable

When S-Curve accel/decel is selected, the accel or decel ramp time begins and ends slowly, creating an S-Curve function. Refer to figure 4.5.

For V/Hz regulation, this parameter is always set = ON.

| | |
|----------------------------------|--|
| Parameter Range: | OFF = Use linear accel/decel function ON = Use S-Curve accel/decel function |
| Default Setting: | ON (V/Hz) OFF (vector) |
| Parameter Type: | Configurable |
| Refer also to parameters: | P.001 Accel Time 1 P.002 Decel Time 1 P.017 Accel Time 2 P.018 Decel Time 2 |

Important: This parameter does not apply to the Jog Ramp Accel Time (P.021) or Jog Ramp Decel Time (P.022) parameters.

The acceleration and deceleration times must be set the same for the S-Curve ramp to function the same for acceleration as for deceleration. If the deceleration time is set lower than the acceleration time, the deceleration time specified may not be met.

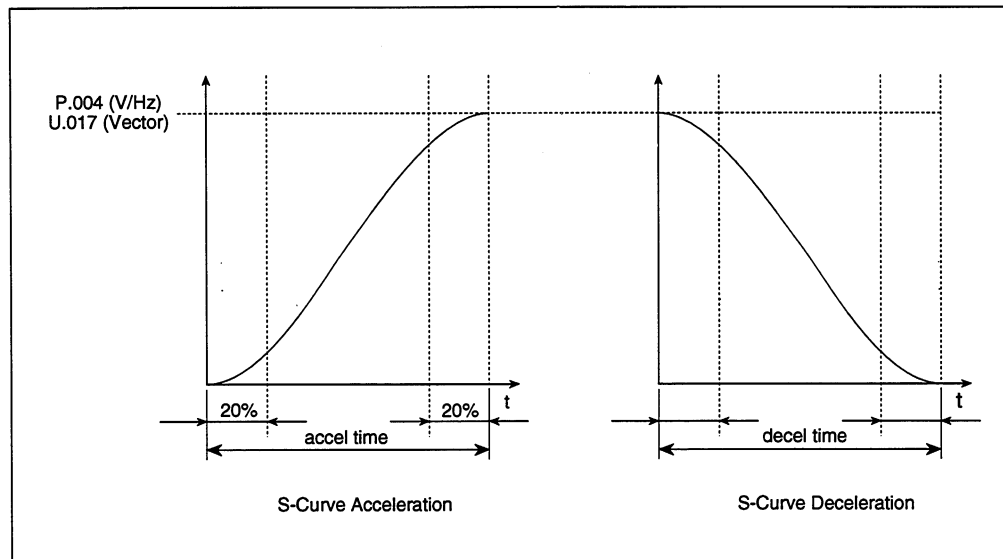

Figure 4.5 – S-Curves

P.020 Jog Speed Reference

This parameter is the speed reference for the drive when JOG is selected.

| | |
|----------------------------------|--|
| Parameter Range: | Minimum Speed (P.003) to Maximum Speed (P.004) |
| Default Setting: | 5.0 Hz (V/Hz) 150 RPM (vector) |
| Parameter Type: | Tunable |
| Refer also to parameters: | P.003 Minimum Speed P.004 Maximum Speed |

Jog reference is independent of any other speed reference. Unlike the run speed reference, the jog speed reference cannot be adjusted using the ▲ or ▼ keys.

P.021 Jog Ramp Accel Time

For V/Hz regulation, this parameter specifies the amount of time it takes the motor to ramp from zero speed to Maximum Speed (P.004) when JOG is selected.

For vector regulation, this parameter specifies the amount of time it takes the motor to ramp from zero speed to Motor Top Speed (U.017) when JOG is selected.

| | |
|----------------------------------|--|
| Parameter Range: | 1.0 to 999.9 seconds (V/Hz) 0.1 to 999.9 seconds (vector) |
| Default Setting: | 20.0 |
| Parameter Type: | Tunable |
| Refer also to parameters: | P.004 Maximum Speed U.017 Motor Top Speed |

The time the motor takes to make any speed increase is directly proportional to the value in this parameter.

P.022 Jog Ramp Decel Time

For V/Hz regulation, this parameter specifies the amount of time it takes the motor to ramp from Maximum Speed (P.004) to zero speed when JOG is selected.

For vector regulation, this parameter specifies the amount of time it takes the motor to ramp from Motor Top Speed (U.017) to zero speed when JOG is selected.

| | |
|----------------------------------|---|
| Parameter Range: | 1.0 to 999.9 seconds (V/Hz) 0.1 to 999.9 seconds (vector) |
| Default Setting: | 20.0 |
| Parameter Type: | Tunable |
| Refer also to parameters: | P.004 Maximum Speed P.025 Stop Type U.017 Motor Top Speed |

The time the motor takes to make any speed decrease (except a coast-to-rest stop) is directly proportional to the value in this parameter.

P.023 MOP Accel/Decel Time

For V/Hz regulation, this parameter specifies the amount of time it takes the MOP to ramp from Maximum Speed (P.004) to zero speed and from zero speed to Maximum Speed (P.004).

For vector regulation, this parameter specifies the amount of time it takes the MOP to ramp from Motor Top Speed (U.017) to zero speed and from zero speed to Motor Top Speed (U.017).

| | |
|----------------------------------|--|
| Parameter Range: | 0.1 to 999.9 seconds |
| Default Setting: | 20.0 |
| Parameter Type: | Tunable |
| Refer also to parameters: | P.004 Maximum Speed P.007 Terminal Strip Digital Inputs Configure P.008 Terminal Strip Speed Reference Source U.017 Motor Top Speed |

The MOP (Motor Operated Potentiometer) is a digital reference controlled by the increment/decrement inputs.

P.024 MOP Reset Configuration

This parameter determines when and if the MOP (Motor Operated Potentiometer) reference is reset to Minimum Speed (P.003).

| | |
|----------------------------------|---|
| Parameter Range: | 0 = Reset MOP reference after IET 1 = Reset MOP reference during each stop 2 = Do not reset MOP reference |
| Default Setting: | 0 |
| Parameter Type: | Tunable |
| Refer also to parameters: | P.003 Minimum Speed P.008 Terminal Strip Speed Reference Source |

Important: If the drive is powered down and powered back up, the MOP function reference will always be reset to equal Minimum Speed (P.003).

The MOP provides a digital speed reference that can be increased and decreased using terminal strip digital inputs.

When the MOP function is set and then disabled by using parameter P.008 (Terminal Strip Speed Reference Source), the last value in effect prior to the MOP being disabled will be retained.

P.025 Stop Type

This parameter selects how the motor will stop when a stop command is given.

| | |
|----------------------------------|--|
| Parameter Range: | 0 = Coast-to-rest stop 1 = Ramp stop |
| Default Setting: | 0 |
| Parameter Type: | Tunable |
| Refer also to parameters: | P.002 Decel Time 1 P.018 Decel Time 2 P.022 Jog Ramp Decel Time U.000 Torque Reference Source |



ATTENTION: The user must provide an external, hardwired emergency stop circuit outside the drive circuitry. This circuit must disable the system in case of improper operation. Uncontrolled machine operation may result if this procedure is not followed. Failure to observe this precaution could result in bodily injury.

A function loss or a fault will always cause a coast-to-rest stop.

If the drive is configured as a torque regulator (U.000 > 0 and TRQ/SPD digital input = TRQ), then the stop type will always be coast-to-rest regardless of the value in parameter P.025.

P.025 Stop Type *(continued)*

If RUN is selected:

If P.025 = 0, pressing the STOP/RESET key or giving an external stop command will cause the motor to coast to rest.

If P.025 = 1, pressing the STOP/RESET key or giving an external stop command will cause the motor to ramp to rest within a time equal to or greater than the preset deceleration time (P.002/P.018).

If JOG is selected:

When the START input from the selected control source is released (unasserted), the motor will ramp down in speed regardless of the value in P.025.

Pressing the STOP/RESET key or giving an external stop command when JOG is selected will stop the motor differently depending on whether the drive is configured for V/Hz or vector regulation:

For V/Hz regulation, the motor will always perform a ramp stop regardless of the value in P.025.

For vector regulation, the motor will stop based on the value of P.025:

- If P.025 = 0, pressing the STOP/RESET key or giving an external stop command will cause the motor to coast to rest.
- If P.025 = 1, pressing the STOP/RESET key or giving an external stop command will cause the motor to ramp to rest within a time equal to or greater than the preset deceleration time (P.022).

P.026 Function Loss Response

This parameter specifies how the drive will respond to an open circuit between terminal strip inputs 16 and 20.

| | |
|----------------------------------|--|
| Parameter Range: | 0 = Generate a fault (IET), and coast to rest 1 = Coast to rest without a fault |
| Default Setting: | 0 |
| Parameter Type: | Tunable |
| Refer also to parameters: | P.013 Output Relay Configuration |

If a function loss occurs, the motor will coast to rest. If P.026 = 0, a function loss fault will be generated, and FL will be displayed.

P.027 Forward/Reverse Configuration

This parameter specifies how the motor responds to forward or reverse inputs from any control source.

| | |
|----------------------------------|--|
| Parameter Range: | 0 = Forward or reverse enabled from the selected control source. 1 = Reverse disabled from the selected control source. 2 = The state of the forward/reverse input is latched when the motor is started. |
| Default Setting: | 0 |
| Parameter Type: | Tunable |
| Refer also to parameters: | N/A |

When P.027 is set to 0, the forward/reverse input allows forward or reverse rotation of the motor.

When P.027 is set to 1, reverse rotation of the motor is prohibited and the forward/reverse selection from the front panel or serial port is set to forward. Note that reverse rotation is prohibited regardless of the polarity of the speed reference input.

When P.027 is set to 2, the state of the forward/reverse input is latched when the motor is started (RUNNING LED is on). Direction changes requested from any control source after the motor is started are ignored. Note, however, that this selection will not inhibit a motor direction change due to a change in the polarity of the speed reference input.

In V/Hz or SVC regulation, setting H.016 (Sync Mode Direction) or U.031 (SVC Sync Direction) to any value but F or OFF may cause the motor to operate in the reverse direction briefly regardless of the setting in P.027.

P.028 Speed Display Scaling

This parameter defines the scaling value applied to the manual reference, the selected speed reference, and the output speed displays.

| | |
|----------------------------------|---|
| Parameter Range: | 10 to 9999 |
| Default Setting: | Synchronous speed based on H.001 (assuming a 4-pole motor) (V/Hz) U.017 (Vector) |
| Parameter Type: | Tunable |
| Refer also to parameters: | U.017 Motor Top Speed H.001 Motor Nameplate Base Frequency |

For **vector regulation**, P.028 will correspond to U.017:

$$\frac{\text{Actual Speed in RPM} \times \text{P.028}}{\text{U.017}} = \text{value displayed when SPEED monitor mode or selected reference is selected.}$$

P.028 Speed Display Scaling *(continued)*

For **V/Hz regulation**, P.028 will correspond to H.001:

$$\frac{\text{Actual Speed in Hz} \times \text{P.028}}{\text{H.001}} = \text{value displayed when SPEED monitor mode or selected reference is selected.}$$

Note that the values entered for P.003 and P.004 are automatically converted to P.028 units by the system. Therefore, the adjustment range for the manual reference is limited as follows:

For **vector regulation**:

$$\text{Minimum reference} = \frac{\text{P.003} \times \text{P.028}}{\text{U.017}} \quad \text{Maximum reference} = \frac{\text{P.004} \times \text{P.028}}{\text{U.017}}$$

For **V/Hz regulation**:

$$\text{Minimum reference} = \frac{\text{P.003} \times \text{P.028}}{\text{H.001}} \quad \text{Maximum reference} = \frac{\text{P.004} \times \text{P.028}}{\text{H.001}}$$

V/Hz Speed Display Scaling Example

Your application requires the display to be scaled to show the speed reference or the output speed as 800 gallons/minute when operating at maximum speed.

H.001 (Motor Nameplate Base Frequency) = 60

Step 1. Set parameter P.028 = 800

Step 2. Enter SPEED monitor mode by pressing the PROGRAM key until the PROGRAM LED turns off and the SPEED LED turns on.

Step 3. Start the drive (press the START key).

Step 4. When the drive is running at half of rated speed, the display shows that speed is 400 (gallons/minute).

Using the equation for V/Hz regulation: $\frac{30 \times 800}{60} = 400$

Important: This parameter does not change the speed. It changes only the scaling value applied to the display.

P.029 Elapsed Time Meter

This parameter displays the number of days (24-hour periods) that the drive has been under power or the time elapsed since the Elapsed Time Meter Reset (P.030) parameter was last reset.

Parameter Range: 0 to 9999 days
Default Setting: N/A
Parameter Type: Read only
Refer also to parameters: P.030 Elapsed Time Meter Reset

P.030 Elapsed Time Meter Reset

This parameter sets parameter P.029 (Elapsed Time Meter) and the error log clock to zero. This parameter is set to OFF after the reset operation is carried out.

Parameter Range: OFF = No action
ON = Reset the Elapsed Time Meter (P.029) and the error log clock to zero (0).
Default Setting: OFF
Parameter Type: Tunable
Refer also to parameters: P.029 Elapsed Time Meter

P.031 to P.038 Preset Speed 1 Through Preset Speed 8

This parameter allows the setting of up to eight different preset speeds.

Parameter Range: Minimum Speed (P.003) to Maximum Speed (P.004)
Default Setting: 5.0 Hz (V/Hz)
150 RPM (vector)
Parameter Type: Tunable
Refer also to parameters: P.007 Terminal Strip Digital Inputs Configure
P.008 Terminal Strip Speed Reference Source

The presets are configured using parameters P.007 and P.008. P.008 must be set to values of 2 through 7 for preset speeds. See table 4.4 and figure 4.6.

P.031 to P.038 Preset Speed 1 Through Preset Speed 8 *(continued)*

Each speed is selected using external switches connected to terminals 17, 18, and 19 on the Regulator board.

The presets may also be selected using the Remote Meter Interface (RMI) board. If you have installed an optional RMI board in your drive, refer to Appendix E and the RMI board instruction manual (D2-3341) for more information.

Table 4.4 – Preset Speed Digital Inputs

| Digital Inputs (Terminals) | | | Selected Speed Reference |
|----------------------------|------------|------------|---|
| 8 (17) | 7 (18) | 6 (19) | |
| 0 (open) | 0 (open) | 0 (open) | P.031 or analog input (see P.008, selections 5, 6, and 7) |
| 0 (open) | 0 (open) | 1 (closed) | P.032 |
| 0 (open) | 1 (closed) | 0 (open) | P.033 |
| 0 (open) | 1 (closed) | 1 (closed) | P.034 |
| 1 (closed) | 0 (open) | 0 (open) | P.035 |
| 1 (closed) | 0 (open) | 1 (closed) | P.036 |
| 1 (closed) | 1 (closed) | 0 (open) | P.037 |
| 1 (closed) | 1 (closed) | 1 (closed) | P.038 |

The presets can also be selected as the OCL reference using P.064 (Option Port: Network Trim Reference Source). See Appendix G for more information about the OCL.

P.031 to P.038 Preset Speed 1 Through Preset Speed 8 (continued)

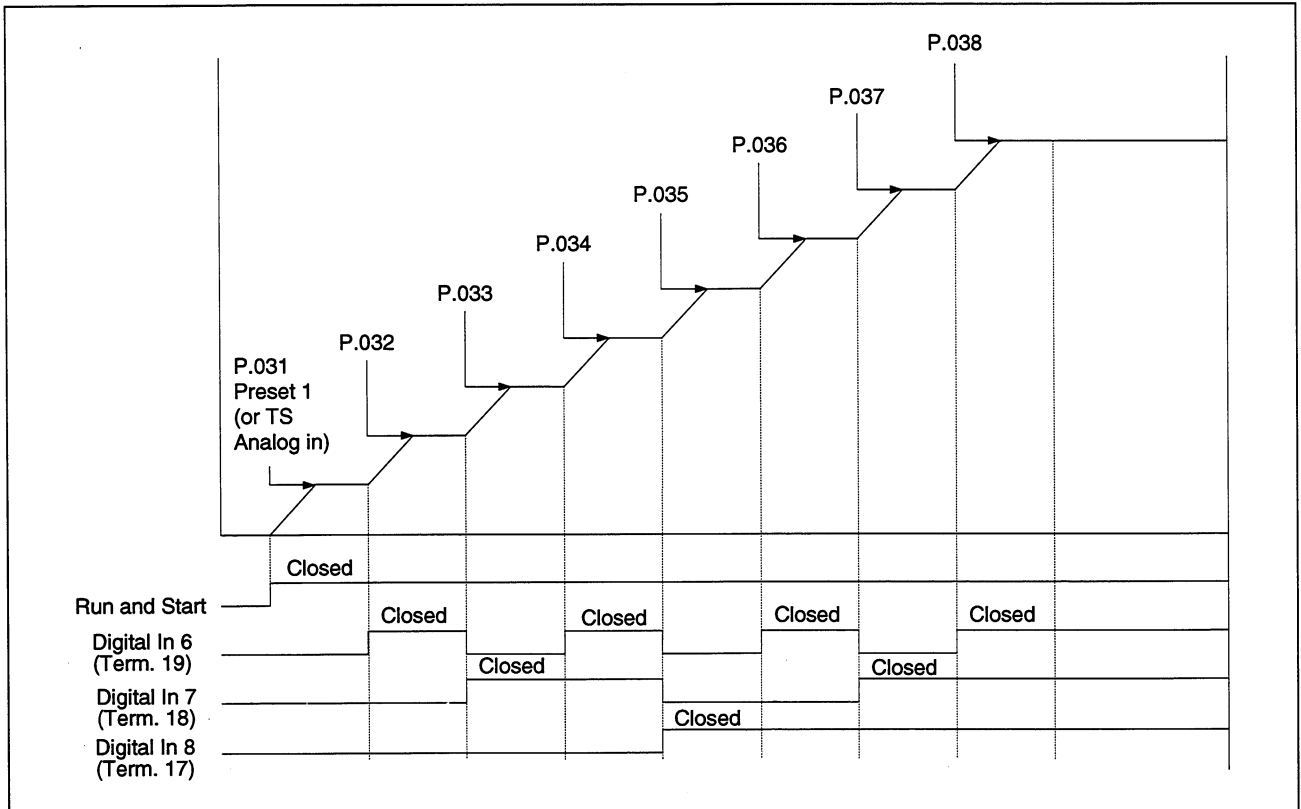

Figure 4.6 – Typical Preset Operation

P.039 Encoder Loss Enable

This parameter enables the encoder loss detection diagnostic.

This diagnostic is available for flux vector control (FVC) only.

| | |
|----------------------------------|--|
| Parameter Range: | OFF = Disable encoder loss diagnostic ON = Enable encoder loss diagnostic |
| Default Setting: | OFF |
| Parameter Type: | Tunable |
| Refer also to parameters: | N/A |

The encoder loss detection diagnostic is functional only when the drive is operating as a speed regulator (not as a torque regulator).

When the diagnostic is enabled and feedback from the encoder is not detected, a drive fault will be logged (EL will be displayed).

If the encoder fails, loss will be detected down to 1 RPM. If only one of the quadrature feedback wires is disconnected, loss may not be detected below 15 RPM.

P.040 Motor Overload Enable

This parameter enables the electronic motor thermal overload function. This function operates similarly to a motor overload relay to protect the motor from overheating.

P.040 applies to single-motor applications only.

| | |
|----------------------------------|---|
| Parameter Range: | OFF = Disable electronic motor thermal overload function ON = Enable motor thermal overload function |
| Default Setting: | ON |
| Parameter Type: | Configurable |
| Refer also to parameters: | P.041 Motor Overload Type H.002 Motor Nameplate Amps U.004 Motor Nameplate Amps |



ATTENTION: For single-motor applications with no external thermal overload relay, this parameter should always be set to ON. Failure to observe this precaution could result in damage to, or destruction of, the equipment.

For V/Hz regulation, the drive trips after 60 seconds at 150% of Motor Nameplate Amps (H.002) and will display fault code OL. Lower currents above 100% will take longer to trip (for example, 25 minutes at 110%). The motor overload protection fault level depends on the settings of the Motor Overload Type selection (P.041) and Motor Nameplate Amps (H.002).

For vector regulation, the drive trips after 60 seconds at 150% of Motor Nameplate Amps (U.004) and will display fault code OL. The overload current amount is automatically calculated by the GV3000/SE software based on the Motor Nameplate Amps (U.004).

Important: While the electronic thermal overload relay is similar to a motor overload relay, neither measures actual motor temperature. Temperature-measuring devices integral to the motor are the best way to thermally protect AC motors under all conditions.

P.041 Motor Overload Type

This parameter specifies the type of motor being used to determine the electronic motor thermal overload function characteristics.

| | |
|----------------------------------|---|
| Parameter Range: | nC = Standard motor without forced cooling FC = Force-cooled motor |
| Default Setting: | FC |
| Parameter Type: | Configurable |
| Refer also to parameters: | P.040 Motor Overload Enable |

P.042 Line Dip Ride-Through Time

For V/Hz regulation, this parameter sets the maximum time allowed for the drive to stay active during low line voltage or line voltage loss.

For vector regulation, this value is fixed at 500 ms.

| | |
|----------------------------------|---|
| Parameter Range: | 0.1 to 999.9 seconds (V/Hz) 500 ms (vector) |
| Default Setting: | 5.0 |
| Parameter Type: | Configurable |
| Refer also to parameters: | H.017 Input Power/Snubber Configuration H.021 AC Line Voltage U.018 AC Line Voltage |

If DC bus voltage drops below the low DC bus voltage threshold for more than the time set in P.042, fault code LU is logged. After line voltage has been restored, the fault must be reset, and then the drive may be restarted.

If line voltage is restored before the specified time is exceeded, the drive will accelerate to operating speed at the rate specified in P.001 (Accel Time 1).

For V/Hz regulation, alarm code LIL will flash on the display during a line dip ride-through. The levels for LIL and LU depend on the parameter setting for AC Line Voltage (H.021).

P.043 Fault Auto Reset Attempts

This parameter selects the number of times the drive will attempt to reset drive faults.

| | |
|----------------------------------|-----------------------------|
| Parameter Range: | 0 to 10 |
| Default Setting: | 0 |
| Parameter Type: | Configurable |
| Refer also to parameters: | P.044 Fault Auto Reset Time |

Important: The drive will restart after a reset if the start input is still asserted.

If the auto reset feature is enabled (P.043 \neq 0), faults detected while the drive is running are logged and reset. The drive will then wait the amount of time specified in P.044 (Fault Auto Reset Time) and, if the start input is asserted from the selected control source, start the drive automatically. Note that the drive must run for at least five minutes in order to reset the number of fault reset attempts to the value in P.043.

If the fault occurs again, the drive will wait and try to restart up to the programmed number of attempts. If the drive faults on all of these attempts, it will remain in the faulted state and will display the fault code on the keypad/display.

P.043 Fault Auto Reset Attempts *(continued)*

Table 4.5 lists the faults that can be auto reset:

Table 4.5 – Faults That Can Be Auto Reset

| Fault Code | Description |
|------------|--------------------------------------|
| AIn | 4 to 20 mA analog input signal loss |
| bYc | DC bus charging bypass contactor |
| EC | Earth current failure (ground fault) |
| HIL | High line voltage |
| HU | High DC bus voltage |
| LU | Low DC bus voltage |
| nCL | Network communications loss |
| OC | Overcurrent steady state |
| OCA | Overcurrent while accelerating |
| OCb | Overcurrent during DC braking |
| OH | Drive overtemperature |
| OL | Electronic motor overload |
| UbS | Asymmetrical bus charge |

All other faults cannot be auto reset.

Note that the auto reset feature will be disabled during the vector self-tuning operation and the V/Hz identification procedure.

P.044 Fault Auto Reset Time

This parameter specifies the amount of time the drive will wait to attempt to reset drive faults.

| | |
|----------------------------------|---------------------------------|
| Parameter Range: | 1 to 60 seconds |
| Default Setting: | 8 |
| Parameter Type: | Configurable |
| Refer also to parameters: | P.043 Fault Auto Reset Attempts |

After the drive has detected the fault and is counting down the auto-reset time period, the display will flash the countdown period in seconds in the following format:

"Ar30...Ar29...Ar28.....Ar01...Ar00"

If during this countdown, the operator presses the keypad STOP/RESET key, or asserts the fault reset from the selected control source, the auto-reset countdown will stop, and all faults will be reset.

P.045 Output Phase Loss Enable

This parameter is used to enable the output phase loss detection diagnostic.

| | |
|----------------------------------|--|
| Parameter Range: | OFF = Disable output phase loss diagnostic ON = Enable output phase loss diagnostic |
| Default Setting: | ON |
| Parameter Type: | Tunable |
| Refer also to parameters: | N/A |

This diagnostic detects phase loss between the drive and the motor. When the diagnostic is enabled and output phase loss is detected, a drive fault is logged (OPL is displayed).

The output phase loss diagnostic can be disabled to avoid nuisance faults which may occur, for example, when a small motor is used with a large Power Module.

P.047 Carrier Frequency (kHz)

This parameter selects the drive's carrier frequency.

| | |
|----------------------------------|---|
| Parameter Range: | 2 = 2 kHz Carrier frequency 4 = 4 kHz Carrier frequency 8 = 8 kHz Carrier frequency |
| Default Setting: | Power Module-dependent, see Appendix C |
| Parameter Type: | Configurable |
| Refer also to parameters: | N/A |

This parameter can compensate for acoustic noise by allowing adjustment of the switching frequency of the transistors in the inverter bridge.

Keeping the carrier frequency at 8 kHz will ordinarily provide the quietest motor operation.

P.048 Volts/Hertz or Vector Regulation

This parameter selects the drive regulator type: volts/hertz (V/Hz) or vector.

| | |
|----------------------------------|--|
| Parameter Range: | U-H = V/Hz control UEC = vector control |
| Default Setting: | U-H |
| Parameter Type: | Configurable |
| Refer also to parameters: | U.001 Encoder PPR |

For V/Hz control, the drive provides open-loop volts per hertz regulation which is appropriate for general purpose applications.

For vector control, you may select either flux vector control (FVC) or sensorless vector control (SVC).

Flux vector control uses the actual encoder value for speed feedback and, therefore, requires an encoder mounted to the motor and connected to the drive. You program the drive for FVC by first selecting UEC in parameter P.048, and the selecting the PPR value of the encoder in parameter U.001.

Sensorless vector control (SVC) is an extension of the FVC regulator. It provides performance close to FVC without using an encoder. Control is based on estimated speed feedback. You program the drive for SVC by first selecting UEC in parameter P.048 and then selecting SE in parameter U.001 (Encoder PPR).

Switching from one regulator type to the other (V/Hz to vector or vice versa) takes approximately 5 seconds. The drive reinitiates power-up diagnostics (SELF appears on the display and all LEDs turn on for approximately 4 seconds).

Changing this parameter will also restore default values for all First and Second Menu General parameters (P.---) as if a Restore Defaults command (P.050 = ON) was given. However, this will NOT change the value of P.048 or P.049 (Country Defaults).

Important: All other parameter values must be verified if this parameter is changed after initial programming, regardless of whether they are restored to their default values.

P.049 Country Defaults

This parameter selects the factory default settings for the First and Second Menu General parameters. USA default settings are listed throughout this chapter. Refer to Appendix D for the European and Japanese default settings.

| | |
|----------------------------------|--|
| Parameter Range: | USA = USA default settings EUr = European default settings JPn = Japanese default settings |
| Default Setting: | USA |
| Parameter Type: | Configurable |
| Refer also to parameters: | N/A |

P.050 Restore Defaults

This parameter resets all First and Second Menu General parameters (P.---) to factory default settings.

| | |
|----------------------------------|--|
| Parameter Range: | OFF = No action ON = Reset parameters to default settings |
| Default Setting: | OFF |
| Parameter Type: | Configurable |
| Refer also to parameters: | P.049 Country Defaults |

Note that P.048 (Volts/Hertz or Vector Regulation) is not restored to its factory default setting when P.050 is set to ON.

P.051 Programming Disable

When the password is entered into this parameter, parameter values cannot be modified from the keypad unless the correct password (26) is entered again. Refer to section 4.4, Ensuring Program Security, for more information.

| | |
|----------------------------------|-------------------------|
| Parameter Range: | 0 to 9999 |
| Default Setting: | 0 (Programming enabled) |
| Parameter Type: | Tunable |
| Refer also to parameters: | N/A |



ATTENTION: It is user's responsibility to determine how to distribute the password. Reliance Electric is not responsible for unauthorized access violations within the user's organization. Failure to observe this precaution could result in bodily injury.

The PASSWORD LED will be on to indicate parameters cannot be modified from the keypad.

Note that disabling program changes by means of P.051 will not prevent parameter changes being made from the serial port on the network.

P.052 AUTO/MAN Key Disable

This parameter disables the AUTO/MAN key except from the selected control source.

| | |
|----------------------------------|---|
| Parameter Range: | OFF = Enable the AUTO/MAN key regardless of control source ON = Disable the AUTO/MAN key except from the selected control source |
| Default Setting: | OFF |
| Parameter Type: | Tunable |
| Refer also to parameters: | P.000 Control Source P.053 Manual Reference Preset Enable |

When this parameter is set to ON, the AUTO/MAN key is functional only from the selected control source. This parameter can be used to protect against inadvertent reference change when the drive is controlled from the terminal strip (P.000 = rE) or the option port (P.000 = OP).

Table 4.6 details whether the AUTO/MAN key is active based on the selected control source and P.052.

Table 4.6 – AUTO/MAN Key Status Based on P.000 and P.052

| Control Source (P.000 =) | P.052 | Front Panel AUTO/MAN Key | OIM/CS3000 AUTO/MAN Key |
|---------------------------|-------|--------------------------|-------------------------|
| Front panel (LOCL) | OFF | Active | Inactive |
| Terminal strip (rE) | OFF | Active | Active |
| Network/option board (OP) | OFF | Active | Active |
| OIM/CS3000 (SErL) | OFF | Inactive | Active |
| Front panel (LOCL) | ON | Active | Inactive |
| Terminal strip (rE) | ON | Inactive | Inactive |
| Network/option board (OP) | ON | Inactive | Inactive |
| OIM/CS3000 (SErL) | ON | Inactive | Active |

Note that if P.000 = rE, but the REMOTE/LOCAL switch at terminal 17 is set for LOCAL (closed), the AUTO/MAN key is active even if P.052 is set to ON.

P.053 Manual Reference Preset Enable

When ON is selected, the manual reference will be preset with the auto reference value when the transition is made from AUTO to MANUAL.

| | |
|----------------------------------|--|
| Parameter Range: | OFF = Do not preset the manual reference ON = Preset the manual reference with the auto reference at the transition from AUTO to MANUAL |
| Default Setting: | OFF |
| Parameter Type: | Tunable |
| Refer also to parameters: | P.027 Forward/Reverse Configuration P.028 Speed Display Scaling |



ATTENTION: The absolute value of the auto reference is used to preset the manual reference. When this feature is enabled (P.053 = ON), and the auto reference is a negative value, a direction change will occur when the transition is made from AUTO to MANUAL. Verify that the auto reference is a positive value and the FORWARD/REVERSE command is appropriate to the application before making the transition from AUTO to MANUAL. Failure to observe this precaution may result in damage to, or destruction of, the equipment.

The absolute value of the auto reference is limited between Minimum Speed (P.003) and Maximum Speed (P.004) before it is used to preset the manual reference. Therefore, when this feature is enabled (P.053 = ON), and the auto reference is negative value, a direction change will occur when the transition is made from AUTO to MANUAL. Verify that the auto reference is a positive value and the FORWARD/REVERSE command is appropriate to the application before making the transition from AUTO to MANUAL.

Important: If the manual reference is being modified using the front-panel keypad/display when the transition from AUTO to MANUAL is made, the manual reference may not be preset with the auto reference.

Refer to chapter 3 for more information on the AUTO/MAN key and the AUTO LED.

P.054 Level Sense Start Enable

This parameter selects whether the start input is edge-sensitive or level-sensitive for remote (P.000 = rE) and option port (P.000 = OP) control sources.

| | |
|----------------------------------|--|
| Parameter Range: | OFF = Start input is edge-sensitive ON = Start input is level-sensitive |
| Default Setting: | OFF |
| Parameter Type: | Configurable |
| Refer also to parameters: | P.000 Control Source |



ATTENTION: Be aware of the following before enabling this function:

- Setting this parameter to ON immediately applies output power to the motor when all start conditions are met.
- If the drive is running from the terminal strip, both start and stop inputs are closed. If P.054 = ON and a fault occurs, the drive coasts to rest and generates a fault. In this case, resetting and clearing the fault immediately restarts the drive without any change to the start or stop input states.
- If P.026 (Function Loss Response) = 1, the control source is the terminal strip (start and stop inputs are closed), and P.054 = ON, the drive coasts to rest if the function loss input is opened and does not generate a fault. In this case, closing the function loss input immediately starts the drive without any change to the start or stop input.

When this function is enabled, the user must ensure that automatic start up of the driven equipment will not cause injury to operating personnel or damage to the driven equipment. In addition, the user is responsible for providing suitable audible or visual alarms or other devices to indicate that this function is enabled and the drive may start at any moment. Failure to observe this precaution could result in severe bodily injury or loss of life.

This parameter applies to remote (P.000 = rE) and option port (P.000 = OP) control sources only. Local keypad (P.000 = LOCL) and serial port (P.000 = SErL) control sources always require an off-to-on edge on the start input to start the drive.

Regardless of the status of P.054, the following conditions must be met in order for the drive to start.

- The terminal strip function loss input must be closed.
- No fault can be active.
- The DC bus must be valid.
- No active stop input can be asserted.

When P.054 is set to OFF, and the above requirements are met, the drive requires an off-to-on edge at the start input in order to start.

When P.054 is set to ON, and the above requirements are met, the drive applies output power to the motor when the start input is asserted.

Note that in V6.06, the analog input can be configured to start and stop the drive. Refer to section F.4.2 if you are using this feature and have configured the drive to use the analog input to start and stop the drive.

P.054 Level Sense Start Enable *(continued)*

Figure 4.7 shows the start, stop, and running status of the drive when configured for edge control versus level control.

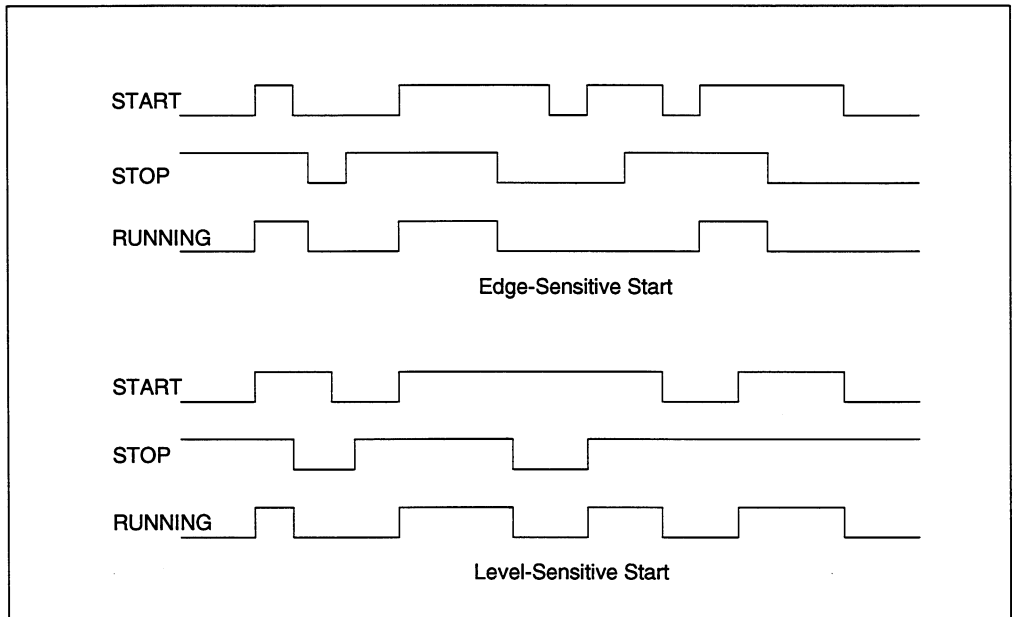

Figure 4.7 – Drive Start, Stop, and Running Status when Configured for Edge Control vs. Level Control

Note that when operating from the terminal strip (rE) or a network option, an edge is required at the start input for the following two conditions, even if P.054 = ON:

- The front panel keypad/display or OIM/CS3000 STOP key is pressed.
- After a vector self-tuning procedure.

These forced edge requirements do not apply if the control source is changed to any other value and then back again as shown in the following example.

Example

Assume the selected control source is the terminal strip (P.000 = rE), level sense start is enabled (P.054 = ON), no faults are active, and both the start and stop inputs are closed. The drive, therefore, is running.

The drive is stopped using the front-panel STOP key. The drive now waits for an open-to-close edge on the terminal strip start input to restart.

The control source is changed to any value other than rE. This is done by changing P.000 to any value but rE or toggling the REM/LOC switch.

The control source is then changed back to the terminal strip (rE).

Since the start input is still closed, the drive starts. A start edge is no longer required because switching from the terminal strip and back again effectively acts as an edge.

P.054 Level Sense Start Enable *(continued)*



ATTENTION: As a safety precaution, Reliance Electric recommends that the user provide an audible or visible alarm to indicate that this feature is enabled and the motor may start when power is applied to the drive. The user should also post warnings on the motor, the drive, and any other applicable equipment to alert personnel that the application uses an automatic start-up feature. Failure to observe this precaution could result in severe bodily injury or loss of life.

Figure 4.8 shows an example of a typical circuit that can be used on 1 to 20 HP drives. This circuit will energize an alarm device prior to motor start up.

Note that if P.000 =rE, the terminal strip LOC/REM switch determines the control source (local or remote) at power up.

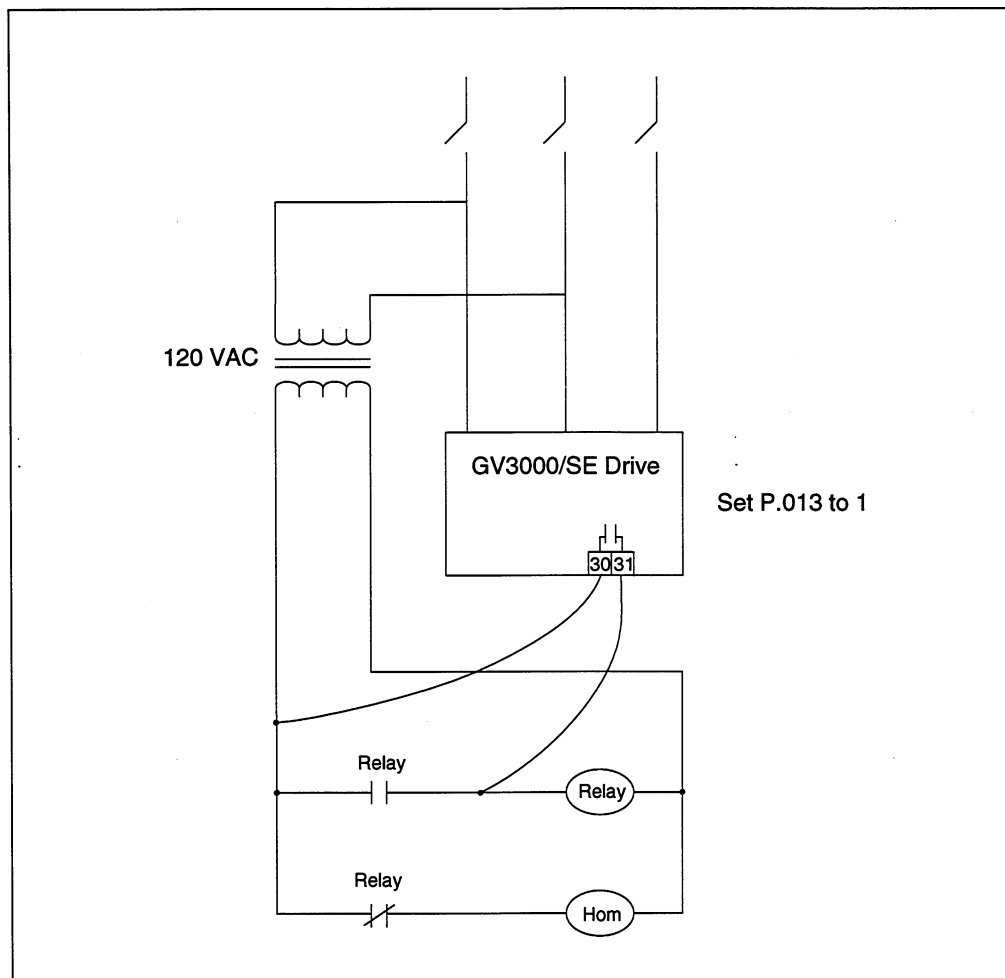

Figure 4.8 – Sample Alarm Circuit for 1-20 HP Drives Using the Level Sense Enable Feature

P.055 STOP/RESET Key Disable

This parameter disables the STOP/RESET key except from the selected control source.

| | |
|----------------------------------|---|
| Parameter Range: | OFF = Enable the STOP/RESET key regardless of the control source ON = Disable the STOP/RESET key except from the selected control source |
| Default Setting: | OFF |
| Parameter Type: | Tunable |
| Refer also to parameters: | P.000 Control Source |

 **ATTENTION:** When P.055 is set to ON, the STOP/RESET key is functional only from the selected control source. As a safety precaution, Reliance Electric recommends that an emergency stop push button be located near the drive in an easily accessible location. As a further safety precaution, the user should post a warning on the drive to alert personnel that the STOP/RESET key is not functional. Failure to observe this precaution could result in severe bodily injury or loss of life.

Table 4.7 details whether the STOP/RESET key is active based on the selected control source (P.000) and P.055.

Table 4.7 – STOP/RESET Key Status Based on P.000 and P.055

| Control Source (P.000 =) | P.055 | Front Panel STOP/RESET Key | OIM/CS3000 STOP/RESET Key |
|-----------------------------|-------|-------------------------------|------------------------------|
| Front panel (LOCL) | OFF | Active | Active |
| Terminal strip (rE) | OFF | Active | Active |
| Network/option board (OP) | OFF | Active | Active |
| OIM/CS3000 (SErL) | OFF | Active | Active |
| Front panel (LOCL) | ON | Active | Inactive |
| Terminal strip (rE) | ON | Inactive | Inactive |
| Network/option board (OP) | ON | Inactive | Inactive |
| OIM/CS3000 (SErL) | ON | Inactive | Active |

Note that if P.000 = rE, but the REMOTE/LOCAL switch at terminal 17 is set for LOCAL (closed), the STOP key is active even if P.055 is set to ON.

P.060 Network Drop Number

This parameter assigns the base drop number or node number to the drive.

| | |
|----------------------------------|-------------------------------|
| Parameter Range: | Network-dependent |
| Default Setting: | 1 |
| Parameter Type: | Configurable |
| Refer also to parameters: | P.061 Network Connection Type |

This parameter must be set at the drive via the keypad/display or via a personal computer serial interface. This parameter cannot be written to the drive by the network master.

For AutoMax applications, refer to the AutoMax Network Communication Option Board manual (D2-3308).

For DeviceNet applications, refer to the DeviceNet Network Communication Option Board manual (MAN0096-03).

For ControlNet applications, refer to the ControlNet Network Communication Option Board manual (D2-3390).

For PROFIBUS application, refer to the PROFIBUS Interface Board manual (49'1355).

P.061 Network Connection Type Run/Program Response)

This parameter is network-dependent. Refer to the appropriate network manual for the parameter description.

| | |
|----------------------------------|-------------------|
| Parameter Range: | Network-dependent |
| Default Setting: | 0 |
| Parameter Type: | Configurable |
| Refer also to parameters: | N/A |

For AutoMax applications, refer to the AutoMax Network Communication Option Board manual (D2-3308).

For DeviceNet applications, refer to the DeviceNet Network Communication Option Board manual (MAN0096-03).

For ControlNet applications, refer to the ControlNet Network Communication Option Board manual (D2-3390).

For PROFIBUS application, refer to the PROFIBUS Interface Board manual (49'1355).

P.062 Option Port: Communication Loss Response

This parameter specifies how the drive will respond to a network communication failure if the option port has been selected as the drive control source (P.000 = OP).

| | |
|----------------------------------|----------------------|
| Parameter Range: | Network-dependent |
| Default Setting: | 0 |
| Parameter Type: | Tunable |
| Refer also to parameters: | P.000 Control Source |

For AutoMax applications, refer to the AutoMax Network Communication Option Board manual (D2-3308).

For DeviceNet applications, refer to the DeviceNet Network Communication Option Board manual (MAN0096-03).

For ControlNet applications, refer to the ControlNet Network Communication Option Board manual (D2-3390).

For PROFIBUS application, refer to the PROFIBUS Interface Board manual (49'1355).

P.063 Option Port: Network Reference Source

This parameter specifies where the drive will get its speed or torque reference when the option port is selected as the control source (P.000 = OP).

| | |
|----------------------------------|-------------------------------|
| Parameter Range: | Network-dependent |
| Default Setting: | 0 |
| Parameter Type: | Configurable |
| Refer also to parameters: | U.000 Torque Reference Source |

For AutoMax applications, refer to the AutoMax Network Communication Option Board manual (D2-3308).

For DeviceNet applications, refer to the DeviceNet Network Communication Option Board manual (MAN0096-03).

For ControlNet applications, refer to the ControlNet Network Communication Option Board manual (D2-3390).

For PROFIBUS application, refer to the PROFIBUS Interface Board manual (49'1355).

P.064 Option Port: Network Trim Reference Source

This parameter specifies where the drive gets its trim reference when the option port is selected as the control source (P.000 = OP).

| | |
|----------------------------------|--|
| Parameter Range: | Option board-dependent. See option board instruction manual. |
| Default Setting: | 0 |
| Parameter Type: | Configurable |
| Refer also to parameters: | P.063 Option Port: Network Reference Source U.000 Torque Reference Source |

The option port trim reference is used as the outer control loop reference and/or the speed trim reference (see the P.014 (Trim Reference Source) parameter description).

In V/Hz regulation, the trim reference represents speed in hertz scaled 0 to 4095 for 0 to Maximum Speed (P.004).

In vector regulation, the trim reference represents speed scaled 0 to 4095 for 0 to Top Speed (U.017). When used for the outer control loop, the value should be scaled based on the scaling of the selected feedback.

Refer to the following option board manuals:

- AutoMax Network Communication Option Board (D2-3308)
- ControlNet Network Communication Option Board (D2-3390)
- DeviceNet Network Communication Option Board (MAN0096-03)
- PROFIBUS Interface Board manual (49'1355)
- Super Remote Meter Interface Board (D2-3341)

OCL Reference Selection (FVC/SVC Only)

The parameter is also used to select the OCL reference. Refer to Appendix G for more information.

P.065 Option Port: Type and Version

This parameter displays the option type and the software version number of the option board.

| | |
|----------------------------------|-----------|
| Parameter Range: | N/A |
| Default Setting: | N/A |
| Parameter Type: | Read only |
| Refer also to parameters: | N/A |

The display format is N.vvv, where N represents the option type (1 = RMI, 2 = AutoMax network or PROFIBUS network, 4 = DeviceNet network, and 5 = ControlNet network) and vvv represents the software version number.

For example, if 2.103 is displayed, it means the drive is using the AutoMax network option and is running version 1.03 software.

P.066 to P.069 Network Output Register 1 Source through Network Output Register 4 Source

These parameters select the signal written to the option port network output registers 1 through 4.

See figure 4.9.

| | |
|----------------------------------|---|
| Parameter Range: | 0 = (P.066) Motor Kw display value (P.067) Motor torque display value* (P.068) Output power factor (P.069) Encoder counter (x4)* 1 = Speed reference rate limit output* 2 = Speed reference at the ref/fdbk summing junction (includes OCL output and current compounding)* 3 = Speed loop feedback* 4 = Speed loop error* 5 = Speed PI output* 6 = Outer control loop feedback* 7 = Outer control loop error* 8 = Outer control loop output* 9 = Terminal strip analog input normalized to speed (see Appendix F) 10 = Terminal strip analog input scaled (see Appendix F) 11 = Torque reference* 12 = Torque feedback* |
| Default Setting: | 0 |
| Parameter Type: | Tunable |
| Refer also to parameters: | N/A |

*These signals are valid only in vector control (P.048 = UEC).

Refer to the AutoMax Network Communication Option Board instruction manual (D2-3308) for the AutoMax network register map.

Refer to the ControlNet Network Communication Option Board instruction manual (D2-3390) for the ControlNet network register map.

P.066 to P.069 Network Output Register 1 Source through Network Output Register 4 Source *(continued)*

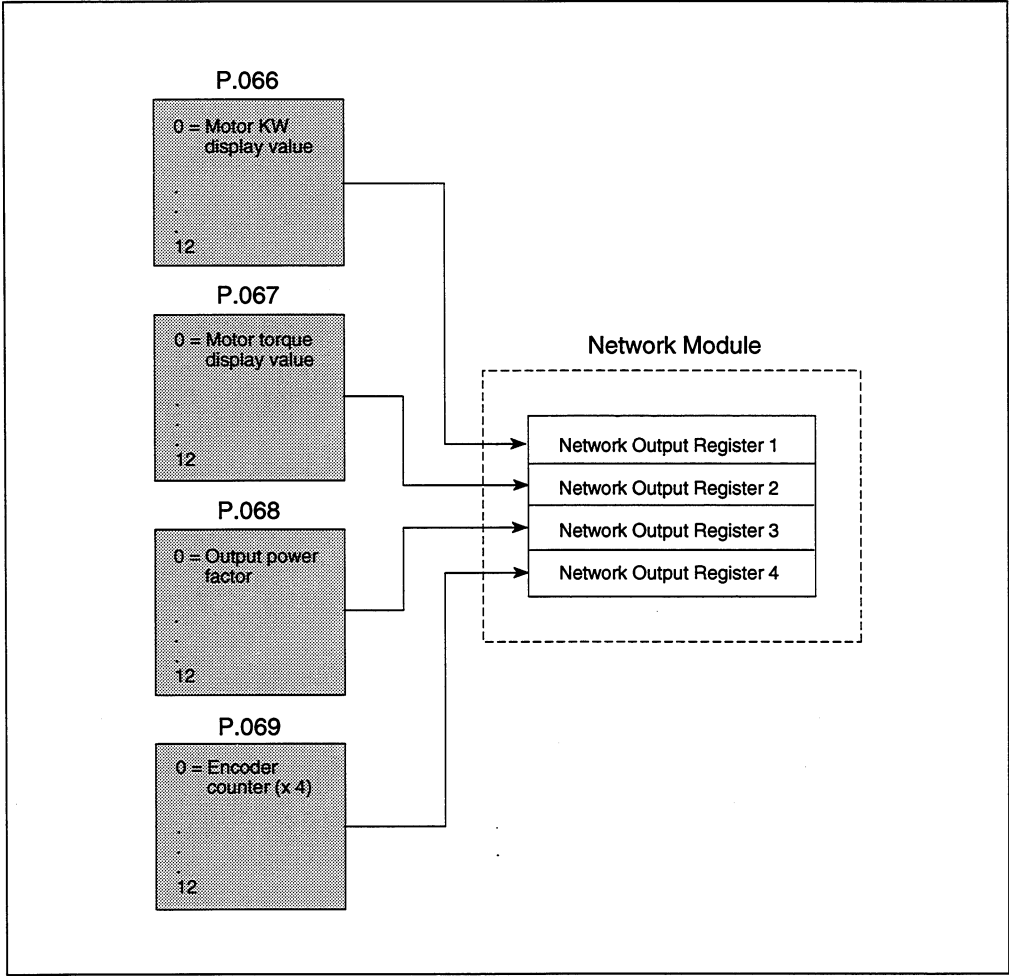

Figure 4.9 – Signal Selection for Network Output Registers

P.090 Diagnostics Source

This parameter is used to select internal information such as I/O data, network statistics, etc., for display in parameter P.091.

| | |
|----------------------------------|--|
| Parameter Range: | 0 = Diagnostic not used 1 = Terminal strip digital inputs 4, 3, 2, 1 2 = Terminal strip digital inputs 8, 7, 6, 5 3 = Terminal strip analog input normalized to speed (see Appendix F) 4 = RMI digital inputs 4, 3, 2, 1 5 = RMI analog input (see Appendix F) 6 = RMI frequency input (see Appendix F) 7 = Encoder data 8 = DC bus voltage 9 = Terminal strip analog input scaled (see Appendix F) 10 = Terminal strip analog input with P.009 (Terminal Strip Analog Input Offset) applied (see Appendix F) 11 = Analog input stop threshold (see Appendix F) 12 = Analog input start threshold (see Appendix F) 14 = Network interface: number of messages received from the network 15 = Network interface: number of message receive time-out errors 16 = Network interface: number of message CRC errors 17 = Network interface: number of message overrun errors 18 = Network interface: number of messages aborted 19 = Network interface: number of messages transmitted to the network |
| Default Setting: | 0 |
| Parameter Type: | Tunable |
| Refer also to parameters: | P.091 Diagnostics Display |

P.091 Diagnostics Display

This parameter displays the data selected in P.090.

| | |
|----------------------------------|--------------------------|
| Parameter Range: | N/A |
| Default Setting: | N/A |
| Parameter Type: | Read only |
| Refer also to parameters: | P.090 Diagnostics Source |

The status of the digital inputs (selected by entering a value of 1, 2, or 4 in P.090) is

P.091 Diagnostics Display (continued)

displayed as a four-digit combination of 1s and 0s (1 = on, 0 = off) in the following manner:

Four-Character Display

| | | | | |
|--|---|---|---|---|
| | | | | |
| | ↑ | ↑ | ↑ | ↑ |

| | | | | |
|--|---|---|---|---|
| P.090 = 1, terminal strip digital inputs | 4 | 3 | 2 | 1 |
| P.090 = 2, terminal strip digital inputs | 8 | 7 | 6 | 5 |
| P.090 = 4, RMI digital inputs | 4 | 3 | 2 | 1 |

P.095 Power Module Output Amps

This parameter displays the maximum output current rating of the drive. The maximum value of Current Limit (P.005) corresponds to P.095.

| | |
|----------------------------------|---------------------|
| Parameter Range: | N/A |
| Default Setting: | N/A |
| Parameter Type: | Read only |
| Refer also to parameters: | P.005 Current Limit |

For example, if P.095 = 11.0 and P.005 = 110% of maximum, then the maximum output current rating with no overload rating (100% rating) = 10.0 amps.

P.098 Software Version Number

The parameter displays the software version number.

| | |
|----------------------------------|-----------|
| Parameter Range: | N/A |
| Default Setting: | N/A |
| Parameter Type: | Read only |
| Refer also to parameters: | N/A |

P.099 Power Module Type

This parameter displays the type of Power Module the drive is configured for.

| | |
|----------------------------------|-----------|
| Parameter Range: | N/A |
| Default Setting: | N/A |
| Parameter Type: | Read only |
| Refer also to parameters: | N/A |

The Power Module type is displayed in the format V.nnn where V represents the drive's voltage rating (2 = 230V, 4 = 460V, 5 = 575V), and nnn represents horsepower. For example, the display 2.010 represents 230V, 10 HP.

4.6.3 Second Menu V/Hz Parameter Descriptions (H.000 to H.022)

H.000 Motor Nameplate Base Volts

This parameter identifies the motor nominal voltage as it appears on the motor nameplate.

| | |
|----------------------------------|--------------------|
| Parameter Range: | 100 VAC to 345 VAC |
| Default Setting: | 230 VAC |
| Parameter Type: | Configurable |
| Refer also to parameters: | N/A |

H.001 Motor Nameplate Base Frequency

This parameter configures the V/Hz ratio.

| | |
|----------------------------------|--|
| Parameter Range: | 30.0 Hz to 200.0 Hz |
| Default Setting: | 60.0 Hz |
| Parameter Type: | Configurable |
| Refer also to parameters: | H.003 Torque Boost Voltage H.018 Volts/Hertz Curve Type |

Base frequency is the frequency at which the output voltage reaches Motor Nameplate Voltage (H.000). Below base frequency, the output voltage varies with output frequency according to the V/Hz adjustment in parameter H.018 (Volts/Hertz Curve Type). Above base frequency, output voltage is held constant as frequency increases (constant horsepower range).

The V/Hz ratio is affected by the selection of Volts/Hertz Curve Type in H.018 and the setting of Torque Boost Voltage in H.003. See figure 4.10.

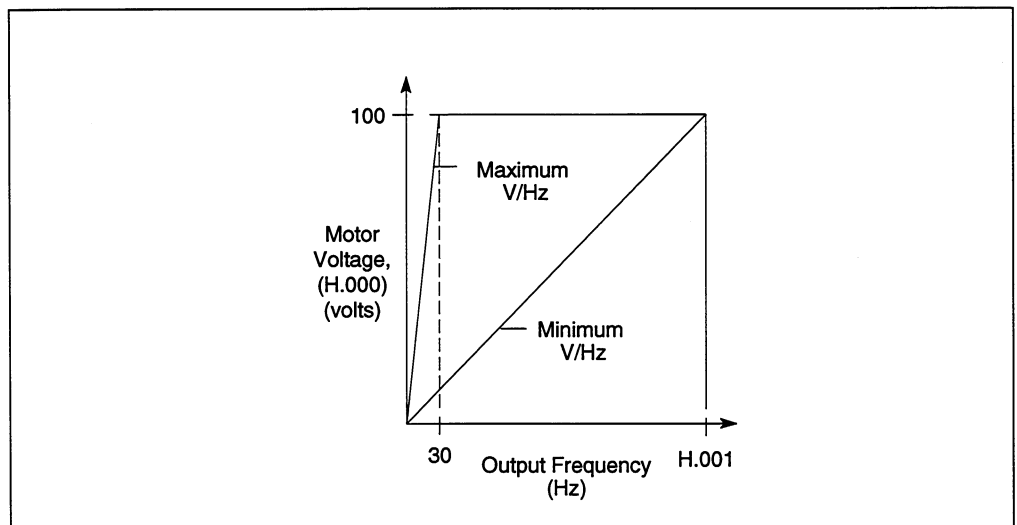

Figure 4.10 – Volts/Hertz Ratio

H.002 Motor Nameplate Amps

This parameter is the motor amp rating as it appears on the motor nameplate.

| | |
|----------------------------------|--|
| Parameter Range: | Power Module-dependent |
| Default Setting: | Power Module-dependent, see Appendix C |
| Parameter Type: | Configurable |
| Refer also to parameters: | P.005 Current Limit |



ATTENTION: This parameter must not exceed the rated amps found on the motor nameplate. Excess heating of the motor could result if this is not done. Failure to observe this precaution could result in damage to, or destruction of, the equipment.

H.003 Torque Boost Voltage

This parameter sets the percentage of output voltage boost at zero frequency. It is set as a percentage of Motor Nameplate Volts (H.000).

| | |
|----------------------------------|---|
| Parameter Range: | 0.0% to 20.0% of nominal inverter voltage |
| Default Setting: | 0.5% |
| Parameter Type: | Configurable |
| Refer also to parameters: | H.000 Motor Nameplate Volts |

Important: If you set H.003 = 0, you must perform the identification test (using H.020) prior to running.

Torque boost is required to offset the voltage drop of the AC motor at low speeds. For high friction loads and high inertia loads, high starting torque may be needed. Increasing Torque Boost Voltage will increase motor starting torque. See figure 4.11.

If the torque boost voltage setting (H.003) is too high, the motor may draw excessive starting current, resulting in an OL or PUo fault, or the drive may go into current limit and not accelerate. When H.003 = 0, the drive automatically provides torque boost voltage that is a function of motor load. If the motor does not accelerate or a fault occurs, set parameter H.003 equal to 0.

H.003 Torque Boost Voltage *(continued)*

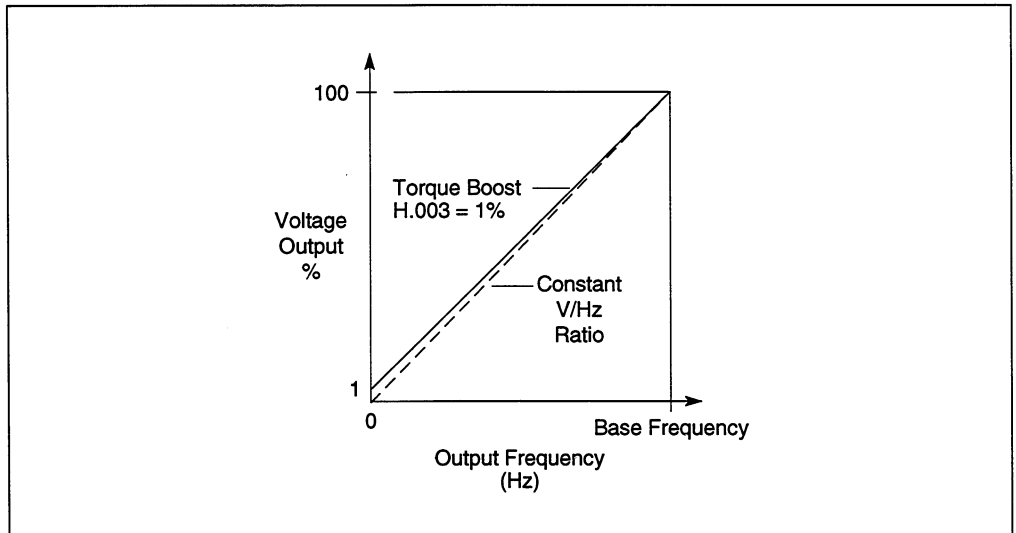

Figure 4.11 – Torque Boost Voltage

H.004 Slip Compensation

This parameter is used to improve motor speed regulation by increasing the output frequency applied to the motor (the percentage of frequency rise at Power Module Output Amps (P.095)).

| | |
|----------------------------------|--|
| Parameter Range: | 0.0% to 10.0% of base frequency (H.001) |
| Default Setting: | 0.0% (no slip compensation) |
| Parameter Type: | Tunable |
| Refer also to parameters: | P.095 Power Module Output Amps H.001 Motor Nameplate Base Frequency |

The level of increased output frequency is a function of the value entered in H.004 and the motor current.

Actual motor shaft speed is determined by two factors: inverter output frequency and the slip of the motor. The speed reference is converted into output frequency. Motor slip varies with load and is determined by the type of induction motor.

At rated load, slip compensation measures inverter output current and increases the output frequency by the percentage entered in H.004. Below rated load, slip compensation will increase inverter output frequency by the percentage in H.004 multiplied by the percent of rated load.

Because of load changes, the long-term speed behavior of the motor is greatly improved through the use of this parameter.

To calculate the value entered for H.004, use the following equation:

$$H.004 = 100 \times \frac{\text{Synchronous RPM} - \text{Nameplate RPM}}{\text{Synchronous RPM}} \times \frac{\text{Max Power Module Amps}}{\text{Motor Nominal Current}}$$

H.004 Slip Compensation *(continued)*

$$\text{Synchronous RPM} = \frac{120 \times F}{\text{No. of Motor Poles}}$$

Example: 1722 RPM

Motor Nominal Current = 78% of Maximum Power Module Amps (P.095)

V/Hz regulation

2 kHz

$$H.004 = 100 \times \frac{1800 - 1722}{1800} \times \frac{100\%}{78\%} = 5.56\%$$

If the parameter is set to zero, motor speed will not be proportional to reference, but will vary depending on load.

H.005 DC Braking Enable

This parameter enables or disables DC braking.

| | |
|----------------------------------|---|
| Parameter Range: | ON = Enable DC braking OFF = Disable DC braking |
| Default Setting: | OFF |
| Parameter Type: | Tunable |
| Refer also to parameters: | P.025 Stop Type H.006 DC Braking Start Frequency H.007 DC Braking Current H.008 DC Braking Time H.017 Input Power/Snubber Configuration |

Important: This function will not provide holding torque as a mechanical brake. DC braking is only operative when Stop Type (P.025) is set to 1 (ramp stop).

DC braking is used to provide additional motor braking (by DC current flow through motor windings) at speeds below DC Braking Start Frequency (H.006). If DC braking is required, DC braking functions (H.008, H.007) must be greater than zero (0).

When the motor decelerates to the preset DC Braking Start Frequency (H.006), the DC Braking current (H.007) is applied to the motor after a Power Module-dependent delay time.

H.006 DC Braking Start Frequency

This parameter sets the frequency at which DC braking begins.

| | |
|----------------------------------|--|
| Parameter Range: | 0.5 to P.004 (Maximum Speed) |
| Default Setting: | 1.0 |
| Parameter Type: | Tunable |
| Refer also to parameters: | H.005 DC Braking Enable H.007 DC Braking Current H.008 DC Braking Time |

With DC braking enabled (H.005 = ON), braking will be activated after a stop command when the motor speed is less than or equal to DC Braking Start Frequency (H.006).

Note that if H.005 is set to ON, and this value is set too high, faults may occur (OC, OCb, or PUo will be displayed).

H.007 DC Braking Current

This parameter sets the DC current level applied to the motor during DC braking.

| | |
|----------------------------------|--|
| Parameter Range: | 0 to 100% of motor nameplate amps |
| Default Setting: | 10 |
| Parameter Type: | Tunable |
| Refer also to parameters: | H.005 DC Braking Enable H.006 DC Braking Start Frequency H.008 DC Braking Time |

With DC braking enabled (H.005 = ON), the braking torque by the motor is defined by a percentage of motor rated amps (100% is motor rated amps).

Important: If H.007 is set too high, faults may occur (OC, OCA, OCb, or PUo will be displayed.)

Note that this parameter was modified in version 6.0. Prior releases scaled voltage instead of current for braking.

H.008 DC Braking Time

This parameter sets the time period for which DC braking will be applied.

| | |
|----------------------------------|---|
| Parameter Range: | 0.1 to 20.0 seconds |
| Default Setting: | 3.0 |
| Parameter Type: | Tunable |
| Refer also to parameters: | H.005 DC Braking Enable H.006 DC Braking Start Frequency H.007 DC Braking Current |

With DC braking enabled (H.005 = ON), braking will be activated after a stop command when the decelerating drive reaches a speed corresponding to DC Braking Start Frequency (H.006). The braking period ends after the programmed time regardless of the actual motor speed. The value should be set to a level that avoids activation at rest.

H.009 Avoidance Frequency Enable

This parameter enables the avoidance frequency bands selected in H.011, H.013, and H.015.

| | |
|----------------------------------|--|
| Parameter Range: | OFF = Disable avoidance frequency processing ON = Enable avoidance frequency processing |
| Default Setting: | OFF |
| Parameter Type: | Tunable |
| Refer also to parameters: | P.003 Minimum Speed P.004 Maximum Speed H.010 to H.015 Avoidance Frequency Midpoint and Band 1, 2, and 3 |

Operating a motor continuously at a particular frequency may cause vibrational resonance within some machines. Three independent parameter pairs can be configured for avoidance frequency and frequency band to prevent motor vibration by preventing the drive output frequency from operating within the selected band(s). Refer to figure 4.12.

The actual avoidance frequency selection is limited by Minimum Speed (P.003) and Maximum Speed (P.004). Normal acceleration and deceleration is not affected by this function.

H.009 Avoidance Frequency Enable *(continued)*

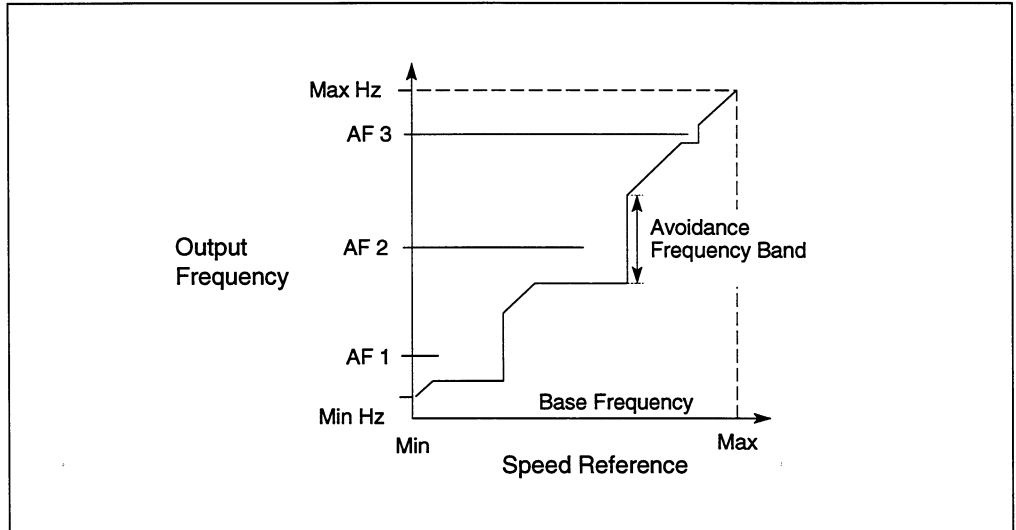

Figure 4.12 – Avoidance Frequency Band

H.010, H.012, H.014 Avoidance Frequency Midpoint 1, 2, and 3

This parameter specifies the midpoint of each avoidance frequency band selected in H.011, H.013, and H.015.

| | |
|----------------------------------|--|
| Parameter Range: | 0.0 to 200.0 Hz |
| Default Setting: | 0.0 |
| Parameter Type: | Tunable |
| Refer also to parameters: | H.009 Avoidance Frequency Enable H.011, H.013, H.015 Avoidance Frequency Band 1, 2, and 3 |

The adjusted values may be in any order. The frequency will not be affected at normal acceleration or deceleration but will be avoided at continuous output frequency.

H.011, H.013, H.015 Avoidance Frequency Band 1, 2, and 3

This parameter specifies the avoidance frequency band that will be applied to each avoidance frequency midpoint selected in H.010, H.012, and H.014.

| | |
|----------------------------------|---|
| Parameter Range: | 0.2 to 10 Hz |
| Default Setting: | 2.0 |
| Parameter Type: | Tunable |
| Refer also to parameters: | H.009 Avoidance Frequency Enable H.010, H.012, H.014 Avoidance Frequency Midpoints 1, 2, and 3 |

The avoided frequency range is:

$(\text{Avoidance freq. midpoint 'n'} - \text{freq. band 'n'}/2) < \text{range} < (\text{avoidance freq. midpoint 'n'} + \text{freq. band 'n'}/2)$

where $n = 1, 2, \text{ or } 3$.

H.016 Sync Direction

When starting into a rotating load is required, this parameter selects the direction in which the drive will search in order to synchronize to motor speed.

| | |
|----------------------------------|---|
| Parameter Range: | OFF = Disable synchronization F = Search starts in motor forward direction r = Search starts in motor reverse direction Fr = Search starts in motor forward then reverse direction rF = Search starts in motor reverse then forward direction |
| Default Setting: | OFF |
| Parameter Type: | Configurable |
| Refer also to parameters: | N/A |

Note that when Forward/Reverse Configuration (P.027) is set to 1, setting this parameter to r, Fr, or rF may cause the motor to operate in the reverse direction.



ATTENTION: When starting with search enabled, there will be a several second delay, and motor may drift in the forward and reverse direction, before the motor begins operating in the desired direction even if reverse has been disabled in P.027. Stay clear of rotating machinery. Failure to observe this precaution could result in bodily injury.

H.017 Input Power/Snubber Configuration

This parameter is used to identify the input power supply type/snubber resistor/line dip ride-through configuration being used.

| | |
|----------------------------------|---|
| Parameter Range: | 0 = AC input, snubber resistor not used, ride-through enabled. 1 = AC input, snubber resistor is used, ride-through enabled. 2 = DC input, snubber resistor not used, ride-through disabled. 3 = DC input, snubber resistor used, ride-through disabled. 4 = DC input, snubber resistor not used, ride-through enabled. 5 = DC input, snubber resistor used, ride-through enabled. |
| Default Setting: | 0 |
| Parameter Type: | Configurable |
| Refer also to parameters: | P.042 Line Dip Ride-Through Time P.002 Decel Time 1 (RAMP 1) |



ATTENTION: When connected to a non-regenerative common DC bus, regeneration may cause a rise in DC bus voltage. Be aware that other drives on the bus may experience an unexpected speed increase due to the high bus voltage. Failure to observe this precaution may result in bodily injury.

For AC input Power Modules (200-230V, 3-phase, 50/60Hz or 380-460V, 3-phase, 50/60Hz), set H.017 = 0 or 1.

For DC input Power Modules, set H.017 = 2 or 3 if multiple motors are connected to the inverter. Set H.017 = 4 or 5 if a single motor is connected to the inverter.

Snubber Resistor

If a snubber resistor is not used, set H.017 = 0, 2, or 4. If the DC bus voltage rises above a certain threshold (14% above the rectified nominal AC line), the drive will increase the commanded frequency in an effort to reduce bus voltage. The drive will increase the commanded frequency a maximum of 10 Hz but will not exceed the value specified in P.004 (Maximum Speed). The deceleration time (P.002) may be automatically extended to prevent a high bus voltage fault from occurring. If the bus voltage continues to rise, a high bus voltage fault (HU) will be generated.

If a snubber resistor is used, set H.017 = 1, 3, or 5. If the DC bus voltage rises above a certain threshold (14% above the rectified nominal AC line), the drive will not attempt to increase the commanded frequency, but will rely on the hardware snubber resistor to decrease voltage. Note that you may need to extend the deceleration time specified in P.002 (Decel Time) to prevent a high bus voltage fault (HU) from occurring.

H.017 Input Power/Snubber Configuration *(continued)*

Line Dip Ride-Through

Line dip ride-through allows the drive to remain active during low line voltage or line voltage loss for the time period specified in P.042 (Line Dip Ride-Through Time).

To enable line dip ride-through, set H.017 = 0, 1, 4, or 5. If the DC bus drops below the low DC bus voltage threshold, or the AC line voltage drops out, the drive will reduce the commanded frequency and regenerate to hold up the bus. Note that the drive will decelerate at a rate required to hold up the bus, and may not use the value specified in P.002 (Decel Time 1).

To disable line dip ride-through, set H.017 = 2 or 3. If the bus voltage drops below the low DC bus voltage threshold or the AC line drops out, a low bus voltage fault (LU) will be generated, and the drive will stop.

Refer to P.042 for more information regarding line dip ride-through.

H.018 Volts/Hertz Curve Type

This parameter provides an application-dependent selection of nominal motor voltage versus frequency. This selection is effective from any control source.

| | |
|----------------------------------|---|
| Parameter Range: | 0 = Linear V/Hz curve 1 = Optimized V/Hz curve 2 = Squared V/Hz curve |
| Default Setting: | 0 |
| Parameter Type: | Configurable |
| Refer also to parameters: | H.003 Torque Boost Voltage |

Set H.018 = 0 for constant torque applications (such as extruders and conveyors).

Set H.018 = 1 for use with Reliance Electric RPM and XE AC motors. A special V/Hz curve (with two different slopes) will provide wider constant torque capability and best efficiency.

Set H.018 = 2 for centrifugal fan and pump motor applications.

Refer to figure 4.13.

H.018 Volts/Hertz Curve Type (continued)

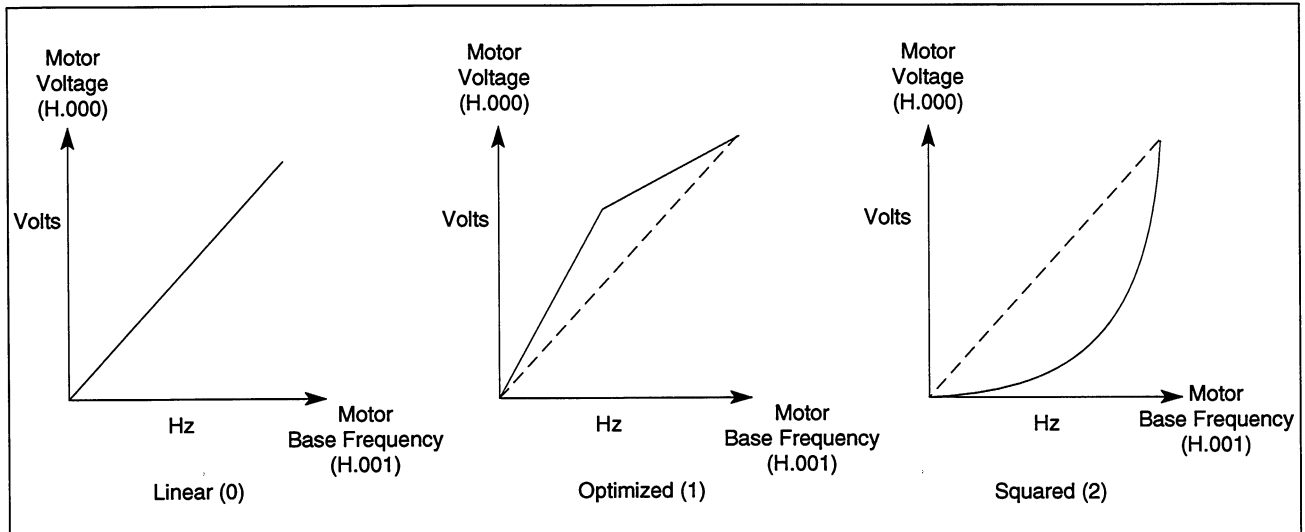

Figure 4.13 – Volts/Hertz Curve Selection

H.019 Identification Result

This parameter displays the result of the identification procedure. Normally, the identification procedure will be successful, and the value in H.019 will be = 0.

Parameter Range:

- 0 = Identification procedure successful. No fault.
- 1 = A logged error aborted the identification procedure. Refer to section 5.3 for how to determine the cause of the fault. Remove the cause and repeat the procedure.
- 2 = A function loss aborted the identification procedure. Depending on Function Loss Response (P.026), this is or is not logged. Remove the cause and repeat the procedure.
- 3 = A stop command aborted the identification procedure. Repeat the procedure without stopping.
- 4 = The identification procedure aborted because the measured current feedback signal is too low. Feedback signal elements or wiring is defective. Check motor connections, inverter wiring, and feedback devices (current sensors). Repeat procedure.
- 6 = Calculation result based on identification procedure measurements is out of range. Check causes of incorrect measurements, such as motor connections. Repeat procedure.

Default Setting:

0

Parameter Type:

Read only

Refer also to parameters: H.020 Identification Request

H.020 Identification Request

This parameter enables the procedure that identifies Power Module and motor characteristics.

| | |
|----------------------------------|---|
| Parameter Range: | OFF = Disable identification procedure ON = Enable identification procedure |
| Default Setting: | OFF |
| Parameter Type: | Configurable |
| Refer also to parameters: | P.005 Current Limit P.047 Carrier Frequency (kHz) P.095 Power Module Output Amps H.002 Motor Nameplate Amps H.019 Identification Result |



ATTENTION: The motor shaft can rotate in either direction by up to one (1) revolution, providing minimum torque immediately after the identification procedure has been started. Stay clear of rotating machinery. Failure to observe this precaution could result in bodily injury.

ATTENTION: Carrier Frequency (P.047) and Current Limit (P.005) must be set correctly before activating the identification procedure to avoid motor overloading and/or overheating. Failure to observe this precaution could result in damage to, or destruction of, the equipment.

ATTENTION: The motor can rotate in the reverse direction even if reverse disable has been selected in P.027. Uncouple the motor from any driven machinery that could be damaged by reverse rotation. Failure to observe this precaution could result in damage to, or destruction of, the equipment.

Before starting this procedure, verify that the motor is at rest and connected to the drive. The motor can be connected to the driven machinery. Verify that Motor Nameplate Volts (H.000), Carrier Frequency (P.047), and Current Limit (P.005) are set correctly.

The identification procedure should be run only in the following cases:

- after the initial assembly of the inverter (performed at Reliance Electric)
- if H.003 (Torque Boost Voltage) = 0

The ratio of maximum Power Module Output Amps (P.095) to Motor Nameplate Amps (H.002) should not be greater than 3:1. (Maximum Power Module Output Amps is dependent on Power Module size and the selected Carrier Frequency (P.047)). Compare the value of P.095 to H.002 to decide on the adjustment of Current Limit (P.005) to avoid motor damage.

Do not connect a motor that cannot withstand maximum Power Module Output Amps reduced by selected Current Limit (P.005).

Note that the identification procedure must not be performed when more than one motor is being driven by the inverter.

H.020 Identification Request *(continued)*

To activate the identification procedure after it has been enabled (H.020 = ON), the program mode must be exited. I-En will flash on the display to indicate the procedure has been enabled. The keypad START key must be pressed to start the procedure. I-Ac will flash on the display to indicate the procedure is being performed (active). The results of this procedure are written to parameter H.019.

If the fault code nld is displayed after a start command is asserted, it indicates that the identification procedure has not been performed. Reset the fault, and then perform the procedure.

If a fault or a stop command is detected, the procedure will abort. Hld will be displayed if the procedure is aborted. Refer to Identification Result (H.019).

H.021 AC Line Volts

This parameter is the phase-to-phase line voltage provided to the drive input power terminals.

| | |
|----------------------------------|--------------------|
| Parameter Range: | 180 VAC to 300 VAC |
| Default Setting: | 230 |
| Parameter Type: | Configurable |
| Refer also to parameters: | N/A |

The value entered should be within 10% of actual line voltage. If this parameter is set too low, it may cause a drive fault on overvoltage.

H.022 Overfrequency Limit

This parameter provides overspeed protection by setting the fault level for maximum frequency output.

| | |
|----------------------------------|--|
| Parameter Range: | 30.0 to $4 \times \text{H.001} + 5\%$ or 210 Hz* |
| Default Setting: | 90.0 |
| Parameter Type: | Configurable |
| Refer also to parameters: | P.004 Maximum Speed |

* Drive will use the lesser value.



ATTENTION: The user is responsible for ensuring that driven machinery, all drive-train mechanisms, and application material are capable of safe operation at the overfrequency limit. Failure to observe this precaution could result in bodily injury.

If actual frequency exceeds the set value, the inverter will fault (OF will be displayed on the keypad/display) and the drive will stop.

The overfrequency limit should be set approximately 15 Hz above Maximum Speed (P.004).

4.6.4 Second Menu Vector Parameter Descriptions (U.000 to U.048)

U.000 Torque Reference Source

This parameter specifies the source for the torque reference when torque regulation is selected.

| | |
|----------------------------------|--|
| Parameter Range: | 0 = Speed loop output 1 = Terminal strip analog input 2 = Option port (network torque reference register)* 3 = Selected speed reference |
| Default Setting: | 0 |
| Parameter Type: | Configurable |
| Refer also to parameters: | P.007 Terminal Strip Digital Inputs Configure |

* If the AutoMax Network option is used, see P.063.

If U.000 = 0, the drive will always regulate speed.

If U.000 > 0, the drive will regulate torque or speed. Torque or speed regulation is selected by a terminal strip digital input (see the P.007 configuration) or the network option board (depending on the control source).

If torque regulation is selected:

- the Current Limit parameter (P.005) is not applied.
- asserting the START input when JOG is selected will enable the torque regulator, not the speed regulator (i.e., P.020, P.021, and P.022 are not used).
- the stop type will always be coast-to-rest regardless of the value in P.025 (Stop Type).

If U.000 = 1, the analog input conditioning (P.009 through P.011) does not apply. The analog input in this case is converted every torque regulator scan (0.5ms) for external closed-loop control (e.g., positioning applications using the QUIQ module).

If U.000 = 3:

- The FWD/REV input can be used to invert the selected speed reference when it is used as the torque reference.
- If the speed reference is used as the torque reference, the %torque is computed as

$$\frac{\text{Speed value} \times 150}{\text{U.017 (Top Speed)}} = \% \text{torque reference}$$

This assumes that P.028 = U.017.

U.001 Encoder PPR

This parameter selects the number of pulses per revolution (PPR) of the encoder being used or selects sensorless vector control (SVC) if no encoder is used.

If SE is not selected, the value of this parameter is automatically set when self-tuning (U.008) is successful.

| | |
|----------------------------------|--|
| Parameter Range: | 512 = 512 PPR 1024 = 1024 PPR 2048 = 2048 PPR 4096 = 4096 PPR SE = No encoder connected. Operate in sensorless vector control (SVC). |
| Default Setting: | 1024 |
| Parameter Type: | Configurable |
| Refer also to parameters: | U.008 Torque Self-Tune Enable |



ATTENTION: The setting of parameters U.001 (Encoder PPR), U.002 (Motor Poles), U.003 (Motor Nameplate Base Frequency), U.005 (Motor Nameplate RPM), and U.017 (Motor Top Speed) determines the motor maximum speed. These parameters must be set by a qualified person who understands the significance of setting them accurately. Failure to observe this precaution could result in bodily injury.

ATTENTION: Do not use a 4096 PPR encoder with a 2-pole motor. Overspeed and motor damage can result. Failure to observe this precaution could result in bodily injury.

If an encoder is used, select the PPR based on a 125 kHz maximum input frequency limitation. The encoder PPR selection affects the minimum and the maximum operation speed in RPM and also affects the speed range.

The maximum input frequency can be calculated by the formula:

$$F_{\max} = \frac{U.017 \times U.001}{60}$$

where F_{\max} is the maximum frequency in pulses per second.

If U.001 = SE, the drive operates using sensorless vector control (SVC). Unless specified, all vector parameters apply to SVC. Refer also to the following parameters which specifically support SVC:

- U.022 Motor Nameplate Horsepower
- U.023 Low DC Bus Fault Avoidance Enable
- U.030 SVC Slip Adjust
- U.031 SVC Sync Direction
- U.032 SVC Flux Current Regulator Gain

U.002 Motor Poles

This parameter identifies the number of poles in the motor.

This parameter must be entered before parameter U.005 (Motor Nameplate RPM). Parameter U.005 is limited by the number of motor poles entered into parameter U.002.

| | |
|----------------------------------|---|
| Parameter Range: | 2 = 2 poles 4 = 4 poles 6 = 6 poles 8 = 8 poles |
| Default Setting: | 4 |
| Parameter Type: | Configurable |
| Refer also to parameters: | U.003 Motor Nameplate Base Frequency U.005 Motor Nameplate RPM |



ATTENTION: The setting of parameters U.001 (Encoder PPR), U.002 (Motor Poles), U.003 (Motor Nameplate Base Frequency), U.005 (Motor Nameplate RPM), and U.017 (Motor Top Speed) determines the motor maximum speed. These parameters must be set by a qualified person who understands the significance of setting them accurately. Failure to observe this precaution could result in bodily injury.

ATTENTION: Do not use a 4096 PPR encoder with a 2-pole motor. Overspeed and motor damage can result. Failure to observe this precaution could result in bodily injury.

Important: Verify that the value in U.017 (Motor Top Speed) is correct if U.002 is changed.

If the number of poles is unknown, this value can be calculated using data on the motor nameplate as follows:

Step 1. Calculated the RPM value at 60 Hz as follows:

$$\text{RPM @ 60 Hz} = \frac{60}{\text{Motor Nameplate Base Freq. (Hz) (U.003)}} \times \text{Nameplate RPM (U.005)}$$

Step 2. Determine the number of motor poles by looking up the value computed for RPM @ 60 Hz:

| <u>Range of RPM @ 60 Hz*</u> | <u>Number of Poles</u> |
|------------------------------|------------------------|
| 3240 to 3600 | 2 |
| 1620 to 1800 | 4 |
| 1080 to 1200 | 6 |
| 810 to 900 | 8 |

If you change this parameter after performing self-tuning using parameter U.008, you must repeat the self-tuning procedure.

* RPM AC motors are 4-pole regardless of motor base RPM.

U.003 Motor Nameplate Base Frequency

This parameter identifies the motor base frequency as it appears on the motor nameplate.

This parameter must be entered before parameter U.005 (Motor Nameplate RPM). Parameter U.005 is limited by the motor base frequency.

| | |
|----------------------------------|--|
| Parameter Range: | 15.0 to 240.0 Hz |
| Default Setting: | 60.0 |
| Parameter Type: | Configurable |
| Refer also to parameters: | U.002 Motor Poles U.005 Motor Nameplate RPM |



ATTENTION: The setting of parameters U.001 (Encoder PPR), U.002 (Motor Poles), U.003 (Motor Nameplate Base Frequency), U.005 (Motor Nameplate RPM), and U.017 (Motor Top Speed) determines the motor maximum speed. These parameters must be set by a qualified person who understands the significance of setting them accurately. Failure to observe this precaution could result in bodily injury.

Important: Verify that the value in U.017 is correct if U.003 is changed.

U.004 Motor Nameplate Amps

This parameter identifies the motor rated amps as it appears on the motor nameplate.

| | |
|----------------------------------|--|
| Parameter Range: | Power Module-dependent |
| Default Setting: | Power Module-dependent, see Appendix C |
| Parameter Type: | Configurable |
| Refer also to parameters: | N/A |



ATTENTION: This parameter must not exceed the rated amps found on the motor nameplate. Overcurrent or excess heating of the motor could result if rated amps are exceeded. Failure to observe this precaution could result in damage to, or destruction of, the equipment.

If you change this parameter after performing self-tuning using parameter U.008, you must repeat the self-tuning procedure.

Note that the Power Module's Current Limit value (P.005) scales to the value entered in U.004 to assure drive and motor coordination.

U.005 Motor Nameplate RPM

This parameter identifies the motor rated RPM as it appears on the motor nameplate.

This parameter must be set prior to activating the torque control self-tuning operation (U.008).

| | |
|----------------------------------|--|
| Parameter Range: | * |
| Default Setting: | Power Module-dependent, see Appendix C |
| Parameter Type: | Configurable |
| Refer also to parameters: | U.002 Motor Poles U.003 Motor Nameplate Base Frequency U.008 Torque Self-Tune Enable |

* The actual adjustment range changes based on the values in U.002 (Motor Poles) and U.003 (Motor Nameplate Base Frequency):

| Motor Poles (U.002) | Base Frequency 60 Hz (U.003) | Base Frequency 50 Hz (U.003) |
|---------------------|------------------------------|------------------------------|
| 2 | 3240-3596 | 2700-2997 |
| 4 | 1620-1798 | 1350-1498 |
| 6 | 1080-1198 | 900-999 |
| 8 | 810-899 | 675-749 |

In general, the value range for U.005 is:

$$\frac{U.003 \times 120 \times .900}{U.002} \quad \text{to} \quad \frac{U.003 \times 120 \times .999}{U.002}$$

If the value is too close to the synchronous RPM, the drive may exhibit instability. This value directly affects torque linearity and the maximum attainable horsepower.

If you change this parameter after performing self-tuning using parameter U.008, you must repeat the self-tuning procedure.



ATTENTION: The setting of parameters U.001 (Encoder PPR), U.002 (Motor Poles), U.003 (Motor Nameplate Base Frequency), U.005 (Motor Nameplate RPM), and U.017 (Motor Top Speed) determines the motor maximum speed. These parameters must be set by a qualified person who understands the significance of setting them accurately. Failure to observe this precaution could result in bodily injury.

U.006 Magnetizing Current

This parameter identifies the percentage of magnetizing current (no load amps) with respect to motor rated amps.

A value is automatically generated for this parameter when self-tuning is performed (U.008).

| | |
|----------------------------------|--|
| Parameter Range: | 10.00 to 80.00% |
| Default Setting: | Power Module-dependent, see Appendix C |
| Parameter Type: | Configurable |
| Refer also to parameters: | U.008 Torque Self-Tune Enable |



ATTENTION: If this parameter is set incorrectly, overcurrent or excess heating of the motor could result. Failure to observe this precaution could result in damage to, or destruction of, the equipment.

If the motor nameplate shows the no load current data, then this parameter value can be calculated using the following formula. If this data does not appear on the motor nameplate, perform the self-tuning procedure (U.008) to automatically calculate the result.

$$\text{Magnetizing Current} = \frac{\text{No Load Amps}}{\text{Motor Rated Amps}} \times 100$$

U.007 Motor Nameplate Volts

This parameter identifies motor rated voltage as it appears on the motor nameplate.

| | |
|----------------------------------|-------------------------------|
| Parameter Range: | 100 to 345 volts |
| Default Setting: | 230 |
| Parameter Type: | Configurable |
| Refer also to parameters: | U.008 Torque Self-Tune Enable |

Important: This parameter must be set prior to activating the torque control self-tuning operation (U.008).

If you change this parameter after performing self-tuning using parameter U.008, you must repeat the self-tuning procedure.

U.008 Torque Self-Tune Enable

This parameter enables the self-tuning procedure.

| | |
|----------------------------------|--|
| Parameter Range: | ON = Enable self-tuning OFF = Disable self-tuning |
| Default Setting: | OFF |
| Parameter Type: | Configurable |
| Refer also to parameters: | U.001 Encoder PPR U.006 Magnetizing Current |



ATTENTION: The motor must be uncoupled from the driven load during the self-tuning operation or incorrect parameter values will result. This includes any shaft-coupled devices such as reducers, belts, or brakes. Failure to observe this precaution could result in damage to, or destruction of, the equipment.

For FVC operation (U.001 \neq SE), this procedure determines the encoder PPR selection for parameter U.001 (Encoder PPR). Determining the encoder PPR may be necessary since the PPR is not always listed on the motor or encoder nameplate. Determining the magnetizing current ratio is necessary in vector regulation so that the proper no-load current, or magnetizing current, is set. The proper magnetizing current is required to develop rated motor torque, speed, and horsepower in vector regulation.

For FVC and SVC operation, this procedure also determines the value for parameter U.006 (Magnetizing Current).

This parameter will be set to OFF when self-tuning is completed or aborted. This parameter only enables self-tuning. It does not start the procedure. Parameters U.002, U.003, U.004, U.005, and U.007 must be programmed before enabling self-tuning in U.008. Then the START key can be pressed to start the procedure. During the test, the motor will accelerate up to 90% of U.005 (Motor Nameplate RPM) even if this value is greater than the value set in P.004 (Maximum Speed).

U.009 Torque Self-Tune Result

This parameter displays the results of the self-tuning operation requested by parameter U.008.

SF will be displayed with a fault entry in the error log showing the cause(s) of the fault(s) for any values of 1 through 7.

| | |
|----------------------------------|--|
| Parameter Range: | 0 = Self tuning successful 1 = User initiated a normal stop. Self-tuning aborted. 2 = Emergency stop or fault stop occurred during self-tuning. Self-tuning aborted. 3 = Motor or encoder direction in reverse. Motor must rotate in clockwise direction facing the motor/encoder end. The encoder leads might also be reversed if the motor direction is correct. 4 = Encoder PPR out of range. The result of the determination of the encoder PPR was not one of the four selections of U.001. The encoder leads might also be reversed. 5 = Magnetizing current percent out of range. The measured no load current was not within 10% to 80% of rated current. Check to see that nothing is connected to the shaft and check the value in U.004. 6 = Bus voltage error. Bus voltage out of range. Check that the AC input line is +/-10% of U.018. 7 = Current limit exceeded. Self-tuning should be run with the motor unloaded, and without being connected to any inertia load. |
| Default Setting: | N/A |
| Parameter Type: | Read only |
| Refer also to parameters: | U.001 Encoder PPR U.008 Torque Self-Tune Enable |

U.012 Speed Regulator Proportional Gain

This parameter selects the proportional gain of the PI amplifier in the speed loop. This value affects the dynamic performance of the speed regulation of the motor.

| | |
|----------------------------------|--|
| Parameter Range: | 0.01 to 99.99 |
| Default Setting: | Power Module-dependent, see Appendix C |
| Parameter Type: | Tunable |
| Refer also to parameters: | N/A |

Larger gain values result in faster response, but may result in less stability. If the drive overshoots the speed reference when changes to the reference are made, or if the drive is unstable, reduce the value.

With the default value, the drive should perform satisfactorily. However, with increased inertia loads, this parameter may need to be adjusted.

U.013 Speed Regulator Integral Gain

This parameter selects the lead frequency of the PI amplifier in the speed loop. This value affects the dynamic performance of the speed regulation of the motor.

For most applications, it is recommended that this parameter not be adjusted.

| | |
|----------------------------------|--|
| Parameter Range: | 0.02 to 327.67 radians/second |
| Default Setting: | Power Module-dependent, see Appendix C |
| Parameter Type: | Tunable |
| Refer also to parameters: | N/A |

Larger gain values result in faster response, but may result in less stability. If the drive overshoots the speed reference when changes to the reference are made, or if the drive is unstable, reduce the value.

With the default value, the drive should perform satisfactorily. However, with increased inertia loads, this parameter may need to be adjusted.

U.014 Torque Regulator Proportional Gain

This parameter determines the performance of the torque response.

For most applications, it is recommended that this value not be changed.

| | |
|----------------------------------|--|
| Parameter Range: | 0.10 to 31.99 |
| Default Setting: | Power Module-dependent, see Appendix C |
| Parameter Type: | Tunable |
| Refer also to parameters: | U.015 Torque Regulator Integral Gain |

The higher the gain is set in this parameter, the higher the performance of the torque loop. If the gain is set too high, the drive will become more susceptible to overcurrent trips and/or instability. Decreasing the gain will help to increase stability.

This parameter is not used when the drive is programmed for SVC operation.

U.015 Torque Regulator Integral Gain

This parameter determines the performance of the torque regulator.

For most applications, it is recommended that this value not be changed.

Parameter Range: 10.0 to 628.0 radians/second
Default Setting: Power Module-dependent, see Appendix C
Parameter Type: Tunable
Refer also to parameters: U.014 Torque Regulator Proportional Gain

The higher the gain, the higher the performance of the torque loop. However, if the gain is set too high, the drive will become more susceptible to overcurrent trips and/or instability. Decreasing the gain will help increase stability.

This parameter is not used when the drive is programmed for SVC operation.

U.016 Field Weakening Start RPM

This parameter sets the speed at which field weakening begins.

Parameter Range: * to U.005
Default Setting: Power Module-dependent, see Appendix C
Parameter Type: Configurable
Refer also to parameters: U.002 Motor Poles
U.003 Motor Nameplate Base Frequency
U.005 Motor Nameplate RPM
U.017 Motor Top Speed

* The low limit is calculated as 80% of synchronous speed where:

$$\text{Synchro. Speed} = \frac{120 \times \text{Base Frequency (U.003)}}{\text{No. of Motor Poles (U.002)}}$$

Using a 60 Hz motor as an example:

| 60 Hz Motor | |
|-----------------------|-----------------------|
| Number of Motor Poles | U.016 Parameter Range |
| 2 | 2880 to U.005 |
| 4 | 1440 to U.005 |
| 6 | 960 to U.005 |
| 8 | 720 to U.005 |

Beyond the speed specified in this parameter, torque will be inversely proportional to speed. Increasing this number will maximize the output voltage and, therefore, maximize the horsepower. Lowering the number may improve dynamic performance near base speed.

U.017 Motor Top Speed

This parameter selects the top speed that the motor can reach.

| | |
|----------------------------------|--|
| Parameter Range: | U.005 to 7200 RPM * |
| Default Setting: | Power Module-dependent, see Appendix C |
| Parameter Type: | Configurable |
| Refer also to parameters: | P.004 Maximum Speed P.005 Current Limit U.002 Motor Poles U.005 Motor Nameplate RPM |

* To determine the upper limit of U.017, the drive compares the results of two formulas and uses the lower value:

For FVC operation (U.001 ≠ SE):

$$4 \times \text{sync speed} \text{ or } \frac{120 \times 240}{U.002} \text{ (drive uses lower value)}$$

For SVC operation (U.001 = SE):

$$2 \times \text{sync speed} \text{ or } \frac{120 \times 240}{U.002} \text{ (drive uses lower value)}$$

$$\text{where sync speed} = \frac{120 \times U.003}{U.002}$$



ATTENTION: The setting of parameters U.001 (Encoder PPR), U.002 (Motor Poles), U.003 (Motor Nameplate Base Frequency), U.005 (Motor Nameplate RPM), and U.017 (Motor Top Speed) determines the motor maximum speed. These parameters must be set by a qualified person who understands the significance of setting them accurately. Failure to observe this precaution could result in bodily injury.

Note that the drive limits the output frequency to the motor to 240 Hz.

Note the following about U.017:

- Increasing this number above Motor Nameplate RPM (U.005) will increase the field weakening range.
- The range of the tunable parameter P.004 (Maximum Speed) is limited by the value in U.017.
- For applications not requiring constant horsepower operation, U.017 should be set equal to U.005 (Motor Nameplate RPM).

U.018 AC Line Volts

The phase-to-phase line voltage provided to the drive input power terminals.

The value entered should be within 10% of actual line voltage.

Parameter Range: 180 to 300 VAC
Default Setting: 230
Parameter Type: Configurable
Refer also to parameters: N/A

U.019 Flux Current Regulator Proportional Gain

This parameter determines the performance of the magnetizing current regulator.

For most applications, it is recommended that this parameter not be changed.

Parameter Range: 0.10 to 31.99
Default Setting: Power Module-dependent, see Appendix C
Parameter Type: Tunable
Refer also to parameters: U.020 Flux Current Regulator Integral Gain

U.020 Flux Current Regulator Integral Gain

This parameter determines the performance of the magnetizing current regulator.

For most applications, it is recommended that this parameter not be changed.

Parameter Range: 10.0 to 628.0 radians/second
Default Setting: Power Module-dependent, see Appendix C
Parameter Type: Tunable
Refer also to parameters: U.019 Flux Current Regulator Proportional Gain

U.021 Rotor Time Constant / Fast Flux Up

This parameter determines the performance of the magnetizing current regulator.

For most applications, it is recommended that this parameter not be changed.

For SVC operation, this parameter is used to enable the fast flux-up feature.

| | |
|----------------------------------|--|
| Parameter Range: | 0 to 9999 ms |
| Default Setting: | Power Module-dependent, see Appendix C |
| Parameter Type: | Tunable |
| Refer also to parameters: | N/A |

For special motors or for motors with base speeds < 1150 RPM, the rotor time constant must be calculated by evaluating equivalent motor circuit data as shown in figure 4.14.

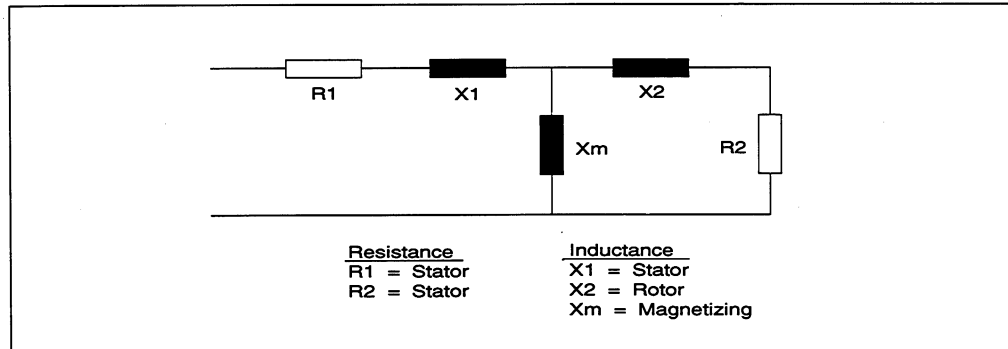

Figure 4.14 – Motor Equivalent Circuit Diagram for Calculating Rotor Time Constant

To calculate the rotor time constant, use the following formula:

$$\text{Rotor time constant} = L / R2$$

Where:

$$L = Lm + L2$$

$$Lm = Xm / 2 \times 3.14 \times 60$$

$$L2 = X2 / 2 \times 3.14 \times 60$$

Fast Flux-Up Feature (SVC Only)

The fast flux-up feature, available for drives configured for SVC operation only, significantly reduces the delay between the initiation of a run command and the actual motor shaft turning.

Setting U.021 to 0 enables the fast flux-up feature. Parameter U.031 (SVC Sync Direction) must be set to OFF to use this feature.

Note that this parameter is not functional in version 6.0 through 6.05.

U.022 Motor Nameplate Horsepower

This parameter identifies the motor horsepower as it appears on the motor nameplate.

| | |
|----------------------------------|--|
| Parameter Range: | 0.3 to 600.0 HP |
| Default Setting: | Power Module-dependent, see Appendix C |
| Parameter Type: | Configurable |
| Refer also to parameters: | U.002 Motor Poles U.003 Motor Nameplate Base Frequency U.004 Motor Nameplate Amps U.005 Motor Nameplate RPM U.006 Magnetizing Current U.007 Motor Nameplate Volts |

U.023 Low DC Bus Fault Avoidance Enable

This parameter selects how the drive responds to power loss (line dip condition).

This feature applies to SVC applications only and is not available if the drive is configured as a torque regulator.

| | |
|----------------------------------|---|
| Parameter Range: | OFF = Drive will not regulate the DC bus on a line dip condition ON = Drive will decelerate the motor to attempt to hold up the DC bus on a line dip condition |
| Default Setting: | OFF |
| Parameter Type: | Tunable |
| Refer also to parameters: | N/A |

If this feature is enabled and DC bus voltage drops below 80% of normal, the drive decelerates the motor enough to maintain bus voltage. Alarm code LIL appears on the display while the drive is regulating the DC bus. Note that the lighter the load, the longer the power dip ride-through time can be. When input power is restored, the drive ramps to the reference speed.

If this feature is enabled, and the DC bus voltage drops while the drive is stopped, LIL will be displayed.

This parameter is not related to P.042 (Line Dip Ride-Through Time).

U.024 High DC Bus Avoidance Enable

This parameter selects how the drive responds to high bus voltage.

This feature is not available if the drive is configured as a torque regulator.

| | |
|----------------------------------|---|
| Parameter Range: | OFF = Drive will not attempt to regulate the DC bus on a high bus condition ON = Drive will attempt to regulate the DC bus on a high bus condition |
| Default Setting: | OFF |
| Parameter Type: | Tunable |
| Refer also to parameters: | P.002 Decel Time 1 P.018 Decel Time 2 |

If DC bus voltage exceeds a predetermined threshold, the drive generates a high bus alarm (HIdc). If U.024 = ON, the drive attempts to regulate the bus to avoid a high bus fault (HU). Note that this may extend the programmed deceleration time (P.002, P.018). See table 5.1 in chapter 5 for the alarm thresholds.

Set this parameter to OFF if a dynamic braking unit is connected to the drive.

For SVC operation, drive speed may increase as much as 5% above the speed reference in an attempt to decrease the DC bus voltage level.

U.025 Zero Speed Hold Time

This parameter selects the amount of time for which zero speed is held at the end of ramp stop sequence.

| | |
|----------------------------------|----------------------|
| Parameter Range: | 0.0 to 655.0 seconds |
| Default Setting: | 0.0 |
| Parameter Type: | Tunable |
| Refer also to parameters: | N/A |



ATTENTION: The motor is energized when the drive is operating at zero speed. The user is responsible for ensuring safe conditions for operating personnel by providing suitable guards, audible or visual alarms, or other devices to indicate that the drive is operating at zero speed. Failure to observe this precaution could result in severe bodily injury or loss of life.

This feature provides the capability to hold the motor at zero speed at the end of a ramp stop for a user-specified amount of time (U.025). During the zero speed hold time period, the running indicator remains on.

For FVC operation, a zero speed reference is applied for the time specified in U.025, regulating torque based on load. Note that this will override the Minimum Speed setting (P.003).

For SVC operation, magnetizing current is applied for the time specified in U.025.

U.026 Current Compounding Gain

This parameter specifies the gain applied to the speed PI output. This is used to generate the current compounding signal that is subtracted from the speed loop reference.

| | |
|----------------------------------|---|
| Parameter Range: | 0.0 to 1.000 |
| Default Setting: | 0.0 (Current compounding disabled) |
| Parameter Type: | Tunable |
| Refer also to parameters: | U.027 Inertia Compensation Gain U.028 Losses Compensation Gain |

Refer to the speed loop block diagram in Appendix G.

U.027 Inertia Compensation Gain

This parameter specifies the gain applied to the selected inertia compensation source signal to produce the inertia compensation signal. The result is added to the speed PI output to produce the torque reference signal.

| | |
|----------------------------------|--|
| Parameter Range: | 0.0 to 5.000 |
| Default Setting: | 0.0 (Disable inertia compensation) |
| Parameter Type: | Tunable |
| Refer also to parameters: | U.026 Current Compounding Gain U.028 Losses Compensation Gain |

The inertia compensation signal can be either the S/Ramp (ramp) block rate output (dv/dt), used for standalone applications, or a value provided directly from the network option. Signal selection is controlled by a network register. No corresponding parameter local to the drive is provided.

Inertia compensation can be used with or without an option board installed in the drive. If a network option is not installed, network inertia compensation is not enabled, the network is not active or is not the control source (P.000 ≠ OP), inertia compensation is supplied from the S/Ramp block rate output. The signal provided from the network for inertia compensation is typically used to compensate for inertia as well as all system losses.

Note that if the selected torque reference is not the speed loop output, then the inertia compensation circuit does not apply. Refer to the speed loop block diagram in Appendix G.

U.028 Losses Compensation Gain

This parameter specifies the gain applied to the speed loop reference signal to generate the losses compensation signal. The result is added to the speed PI output to produce the torque reference signal.

| | |
|----------------------------------|---|
| Parameter Range: | 0.0 to 1.000 |
| Default Setting: | 0.0 (Disable losses compensation) |
| Parameter Type: | Tunable |
| Refer also to parameters: | U.026 Current Compounding Gain U.027 Inertia Compensation Gain |

Losses compensation is the scaled output of the speed loop S/Ramp block (speed reference). It is added to the speed loop output and the inertia compensation signal to produce the final torque reference.

Refer to the speed loop block diagram in Appendix G.

U.030 SVC Slip Adjust

This parameter adjusts the slip compensation to match the operating temperature of the motor.

| | |
|----------------------------------|--------------|
| Parameter Range: | 0.50 to 1.50 |
| Default Setting: | 1.00 |
| Parameter Type: | Tunable |
| Refer also to parameters: | N/A |

This feature applies to SVC operation only.

For SVC operation, in the absence of a speed feedback device, operation of the speed loop is based on an estimated speed feedback. Estimated speed feedback is based on knowing the slip of the motor, which changes with motor temperature. This parameter is provided to accommodate various operating conditions.

For a cold motor, the typical value should be 0.80. For a hot motor, the value should be 1.0.

U.031 SVC Sync Direction

When starting into a rotating load is required, this parameter selects the direction in which the drive will search in order to synchronize to motor speed.

| | |
|----------------------------------|---|
| Parameter Range: | OFF = Disable synchronization F = Search starts in motor forward direction r = Search starts in motor reserve direction Fr = Search starts in motor forward then reverse direction rF = Search starts in motor reverse then forward direction |
| Default Setting: | OFF |
| Parameter Type: | Configurable |
| Refer also to parameters: | N/A |



ATTENTION: When starting with search enabled, there will be a several second delay, and the motor may drift in the forward and reverse direction, before the motor begins operating in the desired direction even if reverse has been disabled in P.027. Stay clear of rotating machinery. Failure to observe this precaution could result in bodily injury.

Note that when Forward/Reverse Configuration (P.027) is set to 1, setting this parameter to r, Fr, or rF may still cause the motor to operate in the reverse direction.

U.032 SVC Flux Current Regulator Gain

This parameter specifies the gain of the flux current regulator.

For most applications, it is recommended that this parameter not be adjusted.

This parameter applies to SVC operation only.

| | |
|----------------------------------|---|
| Parameter Range: | 100 to 1500 radians/sec |
| Default Setting: | Power Module-dependent, see Appendix C |
| Parameter Type: | Tunable |
| Refer also to parameters: | U.012 Speed Regulator Proportional Gain U.013 Speed Regulator Integral Gain U.030 SVC Slip Adjust |

On lower horsepower motors, the value can be increased to allow faster acceleration and deceleration.

U.040 Outer Control Loop Feedback Source

This parameter specifies what is used as the outer loop feedback signal.

| | |
|----------------------------------|--|
| Parameter Range: | 0 = Terminal strip analog input scaled (see Appendix F) 1 = Speed loop PI output (torque reference, 4095 = 150% torque) |
| Default Setting: | 0 |
| Parameter Type: | Configurable |
| Refer also to parameters: | U.041 Outer Control Loop Lead/Lag Select U.042 Outer Control Loop Lead/Lag Low Frequency U.043 Outer Control Loop Lead/Lag Ratio U.044 Outer Control Loop Reference Gain U.045 Outer Control Loop Proportional Gain U.046 Outer Control Loop Integral Gain U.047 Outer Control Loop Trim Range Percentage U.048 Outer Control Loop Proportional Trim Enable |

The feedback signal is fed through a lead/lag block which can be configured as a lead/lag, lag/lead, or null (bypassed) function using parameter U.041 (Outer Control Loop Lead/Lag Select). See Appendix G for the outer control loop block diagram.

U.041 Outer Control Loop Lead/Lag Select

This parameter selects whether the outer control loop feedback lead/lag block will operate as a lead/lag, a lag/lead, or a null function (bypassed).

| | |
|----------------------------------|--|
| Parameter Range: | 0 = Bypass 1 = Lead/lag 2 = Lag/lead |
| Default Setting: | 0 |
| Parameter Type: | Tunable |
| Refer also to parameters: | U.040 Outer Control Loop Feedback Source U.042 Outer Control Loop Lead/Lag Low Frequency U.043 Outer Control Loop Lead/Lag Ratio U.044 Outer Control Loop Reference Gain U.045 Outer Control Loop Proportional Gain U.046 Outer Control Loop Integral Gain U.047 Outer Control Loop Trim Range Percentage U.048 Outer Control Loop Proportional Trim Enable |

See Appendix G for the outer control loop block diagram.

U.042 Outer Control Loop Lead/Lag Low Frequency

This parameter specifies the lead/lag low break frequency of the outer control loop feedback.

| | |
|----------------------------------|---|
| Parameter Range: | 0.01 to 34.90 radians/second |
| Default Setting: | 1.0 |
| Parameter Type: | Tunable |
| Refer also to parameters: | U.040 Outer Control Loop Feedback Source U.041 Outer Control Loop Lead/Lag Select U.043 Outer Control Loop Lead/Lag Ratio U.044 Outer Control Loop Reference Gain U.045 Outer Control Loop Proportional Gain U.046 Outer Control Loop Integral Gain U.047 Outer Control Loop Trim Range Percentage U.048 Outer Control Loop Proportional Trim Enable |

This parameter sets the lead break frequency if U.041 (Outer Control Loop Lead/Lag Select) = 1 (lead/lag) or the lag break frequency if U.041 = 2 (lag/lead). The upper limit may be restricted by the lead/lag ratio setting (U.043).

See Appendix G for the outer control loop block diagram.

U.043 Outer Control Loop Lead/Lag Ratio

This parameter specifies the ratio between the lead/lag low break frequency and high break frequency of the outer control loop feedback lead/lag block.

| | |
|----------------------------------|---|
| Parameter Range: | 2 to 20 |
| Default Setting: | 10 |
| Parameter Type: | Tunable |
| Refer also to parameters: | U.040 Outer Control Loop Feedback Source U.041 Outer Control Loop Lead/Lag Select U.042 Outer Control Loop Lead/Lag Low Frequency U.044 Outer Control Loop Reference Gain U.045 Outer Control Loop Proportional Gain U.046 Outer Control Loop Integral Gain U.047 Outer Control Loop Trim Range Percentage U.048 Outer Control Loop Proportional Trim Enable |

The high break frequency is determined by the value in parameters U.042 (Outer Control Loop Lead/Lag Low Frequency) and U.043 as shown:

$$\text{High break frequency} = \text{Low frequency} \times \text{ratio} = \text{U.042} \times \text{U.043}$$

See Appendix G for the outer control loop block diagram.

U.044 Outer Control Loop Reference Gain

This parameter specifies the gain to be applied to the reference entering the outer control loop.

| | |
|----------------------------------|---|
| Parameter Range: | -5.000 to +5.000 |
| Default Setting: | 1.000 |
| Parameter Type: | Tunable |
| Refer also to parameters: | U.040 Outer Control Loop Feedback Source U.041 Outer Control Loop Lead/Lag Select U.042 Outer Control Loop Lead/Lag Low Frequency U.043 Outer Control Loop Lead/Lag Ratio U.045 Outer Control Loop Proportional Gain U.046 Outer Control Loop Integral Gain U.047 Outer Control Loop Trim Range Percentage U.048 Outer Control Loop Proportional Trim Enable |

See Appendix G for the outer control loop block diagram.

U.045 Outer Control Loop Proportional Gain

This parameter selects the proportional gain of the outer control loop PI amplifier.

| | |
|----------------------------------|--|
| Parameter Range: | 0.10 to 128.0 |
| Default Setting: | 2.00 |
| Parameter Type: | Tunable |
| Refer also to parameters: | U.040 Outer Control Loop Feedback Source U.041 Outer Control Loop Lead/Lag Select U.042 Outer Control Loop Lead/Lag Low Frequency U.043 Outer Control Loop Lead/Lag Ratio U.044 Outer Control Loop Reference Gain U.046 Outer Control Loop Integral Gain U.047 Outer Control Loop Trim Range Percentage U.048 Outer Control Loop Proportional Trim Enable |

See Appendix G for the outer control loop block diagram.

U.046 Outer Control Loop Integral Gain

This parameter selects the integral gain of the outer control loop PI amplifier.

| | |
|----------------------------------|--|
| Parameter Range: | 0.01 to 141.37 radians/second |
| Default Setting: | 2.00 |
| Parameter Type: | Tunable |
| Refer also to parameters: | U.040 Outer Control Loop Feedback Source U.041 Outer Control Loop Lead/Lag Select U.042 Outer Control Loop Lead/Lag Low Frequency U.043 Outer Control Loop Lead/Lag Ratio U.044 Outer Control Loop Reference Gain U.045 Outer Control Loop Proportional Gain U.047 Outer Control Loop Trim Range Percentage U.048 Outer Control Loop Proportional Trim Enable |

See Appendix G for the outer control loop block diagram.

U.047 Outer Control Loop Trim Range Percentage

This parameter specifies the amount of control the outer control loop output signal has on the speed loop reference. It represents a percentage of Top Speed (U.017).

| | |
|----------------------------------|--|
| Parameter Range: | 0.0 to 100.0% |
| Default Setting: | 0.0 (OCL output signal has no effect on speed loop reference) |
| Parameter Type: | Tunable |
| Refer also to parameters: | U.040 Outer Control Loop Feedback Source U.041 Outer Control Loop Lead/Lag Select U.042 Outer Control Loop Lead/Lag Low Frequency U.043 Outer Control Loop Lead/Lag Ratio U.044 Outer Control Loop Reference Gain U.045 Outer Control Loop Proportional Gain U.046 Outer Control Loop Integral Gain U.048 Outer Control Loop Proportional Trim Enable |

See Appendix G for the outer control loop block diagram.

U.048 Outer Control Loop Proportional Trim Enable

This parameter enables the gain block on the output of the outer control loop PI block.

| | |
|----------------------------------|---|
| Parameter Range: | OFF = Disable proportional trim ON = Enable proportional trim |
| Default Setting: | OFF |
| Parameter Type: | Configurable |
| Refer also to parameters: | U.040 Outer Control Loop Feedback Source U.041 Outer Control Loop Lead/Lag Select U.042 Outer Control Loop Lead/Lag Low Frequency U.043 Outer Control Loop Lead/Lag Ratio U.044 Outer Control Loop Reference Gain U.045 Outer Control Loop Proportional Gain U.046 Outer Control Loop Integral Gain U.047 Outer Control Loop Trim Range Percentage |

If U.048 = ON, a gain block scales the outer control loop output proportional to the speed reference signal at the output of the S/Ramp block (normalized to top speed). See figure 4.15. See Appendix G for the complete outer control loop block diagram.

This parameter limits the control the outer control loop has on the speed reference during line start.

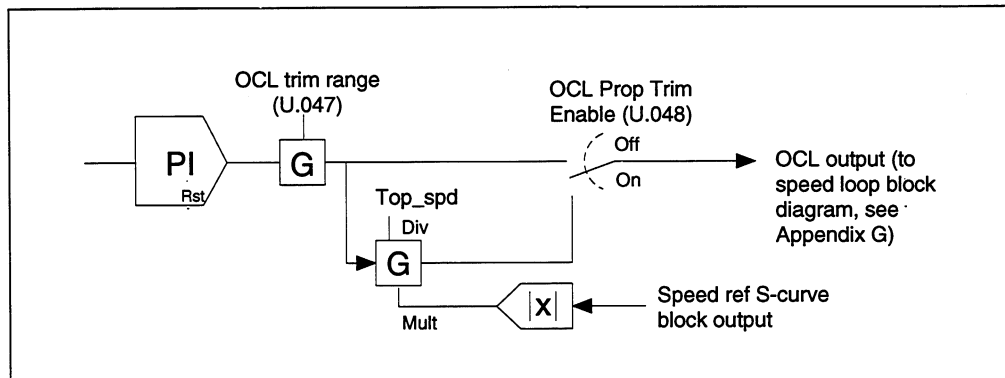

Figure 4.15 – Outer Control Loop Proportional Trim

CHAPTER 5

Troubleshooting the Drive Using Error Codes

The drive can display two kinds of error codes, called alarm and fault codes, to signal a problem detected during self tuning or drive operation. Fault and alarm codes are shown in tables 5.1 and 5.2. A special type of fault code, which occurs rarely, is the fatal fault code. If the code you see is not in tables 5.1 or 5.2, refer to section 5.4.

Alarm Codes

An alarm condition is signified by a two- or three-letter code flashing on the display. The drive will continue to operate during the alarm condition. You should investigate the cause of the alarm to ensure that it does not lead to a fault condition. The alarm code remains on the display as long as the alarm condition exists. The drive automatically clears the alarm code when the condition causing it is removed.

Fault Codes

A fault condition is also signified by a two-or three-letter code flashing on the display. If a fault occurs, the drive coasts to stop and the RUNNING LED turns off. The first fault detected is maintained flashing on the display, regardless of whether other faults occur after it. The fault code remains on the display until it is cleared by the operator using the STOP/RESET key or using the fault reset input from the selected control source (P.000).

Error Log

The drive automatically stores all fault codes for faults that have occurred in the system error log. The error log is accessible through the keypad, the OIM, or the CS3000 software. There is no visual indication that there are faults in the log. You must access the error log to view the faults.

The error log holds the 10 most recent faults that have occurred. The last fault to occur is the first one to appear on the display when you access the error log. The faults in the log are numbered sequentially. The most recent fault is identified with the highest number (up to 9). Once the log is full, older faults are discarded from the log as new faults occur.

For each entry in the error log, the system also displays the day and time that the fault occurred. The day data is based on a relative 248-day counter (rolls over after 248.55). The time is based on a 24-hour clock. The first two digits of the clock data represent hours. The last two digits represent minutes. The clock can be reset using P.030 (Elapsed Time Meter Reset).

All entries in the error log and the day and time data are retained, even if power is lost. Refer to section 5.3 for the procedure for accessing and clearing the error log using the keypad.

5.1. Identifying Alarm Codes and Recovering

GV3000/SE drive alarm codes are shown in table 5.1. Note that the alarm code will only be displayed for as long as the problem exists. Once the problem has been corrected, the alarm code will disappear from the display.

Table 5.1 – List of Alarm Codes

| Code | Alarm Description | Alarm Cause | Corrective Action |
|------|---------------------------------------|--|--|
| Aln | Analog input signal loss | P.011 = 8, 9, 10, or 11 and the 4 to 20 mA input is below 2 mA. | Verify that P.011 is set correctly. Check that the analog input source supply is ≥ 4 mA. |
| Hldc | High DC bus voltage | The DC bus is charged above the trip threshold. (DC bus is above 371 VDC.) | Increase the deceleration time in P.002, P.018. Install optional snubber resistor braking kit. Verify that the AC input is within specification. Install an isolation transformer if required. Check the actual line voltage against U.018. |
| I-Ac | V/Hz identification procedure active | V/Hz identification procedure is enabled and in progress. | Allow identification procedure to finish. Press keypad STOP/RESET to cancel identification procedure if desired. |
| I-En | V/Hz identification procedure enabled | H.020 = On; V/Hz identification procedure has been enabled but not started. | Proceed with V/Hz identification procedure, start drive and allow procedure to begin. Display will change to I-Ac when drive is started. Change H.020 to OFF to cancel identification and clear I-En if desired. |
| LIL | Low AC input line | AC input line is low. For SVC, indicates DC bus is being regulated. No corrective action is required. | Adjust line voltage parameter (H.021 or U.018) to match actual AC line voltage. |
| S-Ac | Vector self-tuning active | Vector self-tuning is enabled and in progress. | Allow vector self-tuning procedure to finish. Press keypad STOP/RESET to cancel vector self-tuning procedure if desired. |
| S-En | Vector self-tuning enabled | U.008 = On; vector self-tuning has been enabled but not started. | Proceed with vector self-tuning, start drive and allow self-tuning procedure to begin. Display will change to S-Ac when drive is started. Change U.008 to OFF to cancel self-tuning and clear S-En if desired. |

5.2 Identifying Fault Codes and Recovering



ATTENTION: DC bus capacitors retain hazardous voltages after input power has been disconnected. After disconnecting input power, wait five (5) minutes for the DC bus capacitors to discharge and then check the voltage with a voltmeter to ensure the DC bus capacitors are discharged before touching any internal components. Failure to observe this precaution could result in severe bodily injury or loss of life.

GV3000/SE drive fault codes are shown in table 5.2. To clear a single fault that has occurred so that the drive can be started again, correct any problems indicated by the fault code and press the STOP/RESET key on the keypad, or assert the fault reset from the selected control source (P.000). Because multiple faults can occur and only the first will be displayed, you must access the error log in order to view all of the faults that have occurred. See section 5.3 for instructions on how to view the error log.

Table 5.2 – List of Fault Codes

| Code | Fault Description | Fault Cause | Corrective Action |
|------|--|---|---|
| AIn | Analog input signal loss | P.011 = 4 or 5 and 4 to 20 mA analog input is below 2 mA. | Verify that P.011 is set correctly. Check that analog input source supply ≥ 4 mA. |
| bYC | Incorrect precharge status | Precharge initiated and incorrect precharge status is returned. | Check the operation of the precharge. |
| CHS | Default parameter restore (checksum error) | During drive operation: Regulator board failure. | Contact Reliance or replace Regulator board. |
| | | After Regulator board replacement: | Contact Reliance. |
| EC | Earth current failure (ground fault) | Unintentional grounding of the output. | Check isolation between ground and output terminals. Possible leakage, current sensor defects; replace sensor. |
| EEr | Non-volatile memory write failure | Failure on write to non-volatile memory. | Connect CS3000 software to upload parameters or record by hand. Then replace Regulator board. Parameter values will be lost when power is cycled. |
| EL | Encoder loss | Drive is not detecting feedback from the encoder. | Check the connection between the encoder and the drive. Check the encoder/motor coupling. |
| | | For SVC operation, conditions exist for more than 5 seconds that may result in an inability to complete a ramp-to-rest stop. | For SVC operation, check motor data parameters. Check U.006. Incorrect magnetizing current may be generated by performing self-tuning with a load connected to the motor. |
| FL | Function loss | Function loss input on control terminal is opened. | Check external interlocks at terminals 16, 20. |
| HId | High time identification aborted | Identification process for V/Hz has been aborted. | See H.019 for identification result. |
| HIL | High line voltage | Input voltage more than 15% above nominal. (Note that this is not tested for in 1-20 HP Power Modules configured for vector control.) | Check actual line voltage against U.018 or H.021. |

Table 5.2 – List of Fault Codes (Continued)

| Code | Fault Description | Fault Cause | Corrective Action |
|------|--|---|--|
| HU | High DC bus voltage | DC bus voltage too high (capacitor protection). | Check input line voltage; if necessary, add transformer. |
| | | Deceleration time too short. | Increase deceleration time P.002/P.018/P.023 versus Maximum Speed/Hz (P.004). Install DB option with resistors. |
| IPL | Input phase loss | Voltage ripple on DC bus due to missing input phase or an imbalance between phases. | Verify that proper voltage is being applied to the drive. Check all phases. |
| LU | Low DC bus voltage | DC bus voltage too low. Line dip too long (P.042). | Check input voltage, line fuses. If necessary, add transformer. Check value of Ride-Through Time (P.042), Line Voltage (H.021, U.018). |
| | | Input rectifier diodes defective. | Check DC Bus voltage. If incorrect, replace diode set. |
| nCL | Network comm loss | Communications with the AutoMax network have been lost. | Check network cabling from network master to network option board. Check that network master is operating properly. |
| nId | Identification Request not yet performed (V/Hz only) | Drive started but Identification Result = Zero. | Reset fault. Perform Identification Request. Restart drive. |
| OC | Overcurrent (steady state). Trips at 200% rated current. | Output phase-to-phase short. | Check isolation between each output line. |
| | | Bus voltage line-to-line. | Check transistor modules for correct output. If incorrect, possible board defect; replace. Possible Hall effect current sensor defective; replace. |
| | | Ground fault. | Check isolation between ground and output terminals. Possible leakage current sensor defect; replace sensor. |
| | | Momentary overload. | Check for motor overload; reduce load on motor. |
| | | Bad motor. | Check motor for correct operation. |
| | | Torque boost/ V/Hz too high (V/Hz). | Check parameters H.001, H.002, and/or H.003. Enable Identification Request (H.020) |
| | | Motor unknown to regulator (V/Hz). | Check that regulator was updated with actual motor characteristics via Identification Request (H.020). |
| | | Parameter settings (Vector). | Check Encoder PPR (U.001), Motor Poles (U.002), Base Frequency (U.003), Motor Nameplate Amps (U.004), Magnetizing Current (U.006), Speed Regulator Prop. Gain (U.012). |
| | | Encoder wired incorrectly, wrong PPR. | Check encoder wiring. Perform vector self-tuning. |

Table 5.2 – List of Fault Codes (Continued)

| Code | Fault Description | Fault Cause | Corrective Action |
|------|-----------------------------------|--|--|
| OCA | Overcurrent (at acceleration) | Overcurrent condition occurred while accelerating. Acceleration time too short. | See OC fault corrective actions. Increase acceleration time (P.001, P.017, P.021). |
| OCb | Overcurrent (at DC Braking) | DC voltage too high. | Check parameters H.006, H.007. |
| OCd | Overcurrent (at deceleration) | Overcurrent condition occurred while decelerating. Deceleration time too short. | See OC fault corrective actions. Increase deceleration time (P.002, P.018, P.022). |
| OF | Overfrequency | Drive has exceeded maximum allowable output frequency. Regenerating energy is too high. Stability or slip compensation circuit adds frequency reference. If H.016 ON, searching current is too high. Motor is too small. | Vector: check parameters Encoder PPR (U.001), Motor Poles (U.002), Base Frequency (U.003). |
| | | | V/Hz: check DC bus voltage; increase deceleration time. Check values Maximum Speed (P.004)/Overfreq. (H.022). Check slip compensation (H.004). If H.016 ON, check motor size versus Power Module size, recheck setting of P.005 (too high). |
| OH | Drive overtemperature | Cooling fan failure. | Check ambient temperature, cooling fan, minimum clearances around drive. |
| OL | Motor overload | Excess motor current. V/Hz: Torque boost too high, therm. overload level too low. | Vector: Check actual/Motor Rated Nameplate Amps (U.004) V/Hz: Check actual current/Torque Boost (H.003). Check that Power Module is sized correctly. Reduce load on motor (for example, at low frequency). |
| | | Excess load on motor, for example, at too low speeds. | Check that Power Module is sized correctly. Reduce load on motor (e.g., at low frequency). |
| | | Loss of phase connection. | Check output lines to the motor. |
| OPL | Motor output phase loss | Phase lost between drive and motor. | Check connections and cable of all 3 phases and motor windings. Replace any damaged cable. |
| OSP | Overspeed (Vector only) | RPM above 130% Maximum Speed (P.004), speed regulator response not optimized. | Check Encoder PPR (U.001), Motor Poles (U.002), Base Frequency (U.003), Motor Nameplate RPM Speed (U.005). Check Reg. Proportional (U.012), Integral Gain (U.013). |
| PUC | Missing Power Module ID connector | Bad or disconnected cable between Regulator and Power Module. | Check cables between Regulator board and Power Module. |
| PUn | Power Module not identified | Drive parameters have been restored to power-up defaults. Regulator has not been configured to match Power Module. | Power Module must be configured by Reliance service personnel. |

Table 5.2 – List of Fault Codes (Continued)

| Code | Fault Description | Fault Cause | Corrective Action |
|------|---|--|--|
| PUo | Drive power electronic overload | Power Module overload. Too high DC Braking Current (H.007) or Torque Boost (H.003). | Check load to Power Module. Check Power Module sizing versus application. Check DC Braking Current value (H.007). Check Torque Boost (H.003). |
| SF | Self-tuning status (Vector only) | | See parameter U.009. |
| SrL | Communication loss between Regulator/PC/OIM | Serial port communication cable, PC or OIM communication port setup. | Check connection cable and communication port setup. |
| UAr | Spurious host PC comm interrupt | Regulator board failure. | Replace Regulator board. |
| UbS | Asymmetrical bus charge | Bad Power Module. | Contact Reliance. |

5.3 Accessing, Reading, and Clearing the Faults in the Error Log

The following procedure shows how to access and clear the error log. Note that you cannot clear a single entry from the error log. The entire log, including all the fault codes and the day and time stamp of each fault, will be cleared simultaneously using this procedure.

Step 1. Press the PROGRAM key.

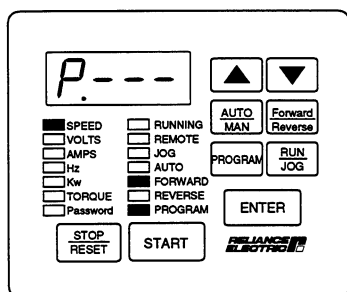

The First Menu General parameters are displayed. The PROGRAM LED will turn on.

Step 2. Press the ▼ key until Err is displayed.

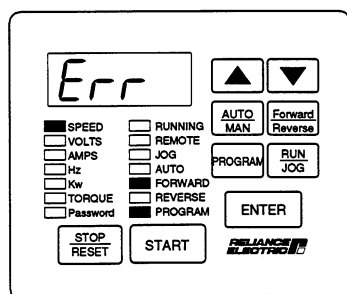

Step 3. Press the ENTER key.

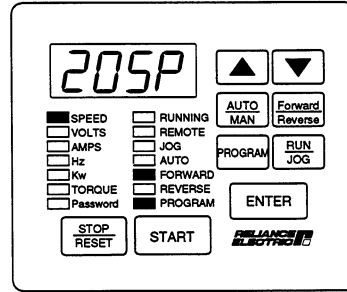

If no faults have occurred, Err will be displayed again. If only one fault has occurred, the fault code will be displayed as the first entry in the log. If more than one fault has occurred, the first entry is the latest fault that occurred.

Step 4. Press the ▲ key or the ▼ key. The display steps through the error log entries, which are numbered 0 through 9 (maximum).

Step 5. Press the ENTER key.

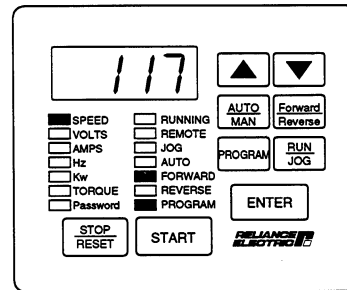

The display shows the day stamp, which can range from 0-248 days.

Step 6. Press the ▼ key.

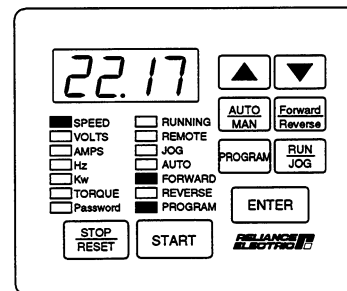

The display shows the time stamp, which is based on a 24-hour clock. Use the arrow keys to move between the day and time data.

Step 7. Press the PROGRAM key, which displays the error log entries again. The display shows the error log entry viewed prior to or associated with the time stamp.

Step 8. Repeat steps 4 through 7 for each additional error log entry to view the time and date for each error log entry.

Step 9. When you have viewed all the entries, you should clear the error log. Press the ▼ key while you are viewing any entry in the log until the display shows CLr. Press ENTER to clear the error log. All entries will be cleared.

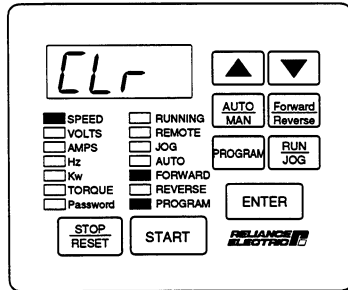

Step 10. Err will be displayed again to indicate that the log is empty.

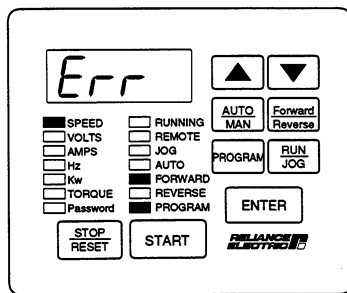

Step 11. Press the PROGRAM key to access program mode.

5.4 Identifying Fatal Fault Codes and Recovering

Fatal fault codes are distinguished by the letter F preceding the code. They normally indicate a malfunction of the microprocessor on the Regulator board. In some cases, fatal fault codes can be reset and the drive can be re-started. Table 5.3 lists the fatal fault codes which can be reset. If any other fault code appears on the display, you will need to replace the Regulator board.

If the fault code FUE appears in error log entry 0, it indicates a fatal fault occurred before power was lost. Contact Reliance Electric or observe the drive for subsequent fatal errors before turning off power. Fatal fault codes are lost after power loss.

Table 5.3 – Fatal Fault Codes Than Can Be Reset

| Code | Fault Description | Fault Cause | Corrective Action |
|--------------------|---|--|---|
| F 3 | Encoder power-up diagnostic error. | Encoder voltage is less than 10 V. | Turn off power to the drive. Disconnect the encoder wiring from the terminal strip. Turn power to the drive back on. If the F 3 error does not occur again, the problem is in the wiring between the drive and the encoder. If the F 3 error does occur again, the problem is in the Regulator board, which should be replaced. |
| F 60 | Option port identification error. | The option board could not be identified by the regulator. | Check the ribbon cable between the Regulator board and the option board. Refer to the appropriate option board instruction manual for more information about the option board. |
| F 61 | Option board power-up diagnostic failure. | Option board has failed one or more power-up diagnostics. | Check the ribbon cable between the Regulator board and the network option board. Replace the option board if necessary. Refer to the appropriate option board instruction manual for more information about the option board. |
| F 62 or F 26 | Option board runtime error. | During operation, the option board watchdog failed or handshaking with the drive failed. | If intermittent, check for causes of noise, for proper grounding, and that outputs are not exceeding rated current capacities. Replace the option board if necessary. Refer to the appropriate option board instruction manual for more information about the option board. |

APPENDIX A

Alphabetical Listing of Parameters

First Menu General Parameters

| | |
|-----------------------------|-------|
| Accel Time (RAMP 1) | P.001 |
| Control Source | P.000 |
| Current Limit | P.005 |
| Decel Time 1 (RAMP 1) | P.002 |
| Maximum Speed | P.004 |
| Minimum Speed | P.003 |
| Second Menu Password | P.006 |

Second Menu General Parameters

| | |
|--|-------|
| Accel Time 2 (RAMP 2) | P.017 |
| AUTO/MAN Key Disable | P.052 |
| Carrier Frequency (kHz) | P.047 |
| Country Defaults | P.049 |
| Decel Time 2 (RAMP 2) | P.018 |
| Diagnostics Display | P.091 |
| Diagnostics Source | P.090 |
| Draw Gain Percentage | P.016 |
| Elapsed Time Meter | P.029 |
| Elapsed Time Meter Reset | P.030 |
| Encoder Loss Enable | P.039 |
| Fault Auto Reset Attempts | P.043 |
| Fault Auto Reset Time | P.044 |
| Forward/Reverse Configuration | P.027 |
| Function Loss Response | P.026 |
| Jog Ramp Accel Time | P.021 |
| Jog Ramp Decel Time | P.022 |
| Jog Speed Reference | P.020 |
| Level Sense Start Enable | P.054 |
| Line Dip Ride-Through Time | P.042 |
| Manual Reference Preset Enable | P.053 |
| MOP Accel/Decel Time | P.023 |
| MOP Reset Configuration | P.024 |
| Motor Overload Enable | P.040 |
| Motor Overload Type | P.041 |
| Network Connection Type | P.061 |
| Network Drop Number | P.060 |
| Network Output Register 1 Source | P.066 |
| Network Output Register 2 Source | P.067 |
| Network Output Register 3 Source | P.068 |
| Network Output Register 4 Source | P.069 |
| Option Port: Communication Loss Response | P.062 |
| Option Port: Network Reference Source | P.063 |
| Option Port: Network Trim Reference Source | P.064 |
| Option Port: Type and Version | P.065 |
| Output Phase Loss Enable | P.045 |
| Output Relay Configuration | P.013 |

**Second Menu General Parameters
(continued)**

| | |
|---|-------|
| Power Module Output Amps | P.095 |
| Power Module Type | P.099 |
| Preset Speed 1 | P.031 |
| Preset Speed 2 | P.032 |
| Preset Speed 3 | P.033 |
| Preset Speed 4 | P.034 |
| Preset Speed 5 | P.035 |
| Preset Speed 6 | P.036 |
| Preset Speed 7 | P.037 |
| Preset Speed 8 | P.038 |
| Programming Disable | P.051 |
| Restore Defaults | P.050 |
| S-Curve Enable | P.019 |
| Software Version Number | P.098 |
| Speed Display Scaling | P.028 |
| STOP/RESET Key Disable | P.055 |
| Stop Type | P.025 |
| Terminal Strip Analog Input Gain | P.010 |
| Terminal Strip Analog Input Configure | P.011 |
| Terminal Strip Analog Input Offset | P.009 |
| Terminal Strip Analog Output Source | P.012 |
| Terminal Strip Digital Inputs Configure | P.007 |
| Terminal Strip Speed Reference Source | P.008 |
| Trim Gain Percentage | P.015 |
| Trim Reference Source | P.014 |
| Volts/Hertz or Vector Regulation | P.048 |

Second Menu Volts/Hertz Parameters

| | |
|---|-------|
| AC Line Volts | H.021 |
| Avoidance Frequency Band 1 | H.011 |
| Avoidance Frequency Band 2 | H.013 |
| Avoidance Frequency Band 3 | H.015 |
| Avoidance Frequency Enable | H.009 |
| Avoidance Frequency Midpoint 1 | H.010 |
| Avoidance Frequency Midpoint 2 | H.012 |
| Avoidance Frequency Midpoint 3 | H.014 |
| DC Braking Current | H.007 |
| DC Braking Enable | H.005 |
| DC Braking Start Frequency | H.006 |
| DC Braking Time | H.008 |
| Identification Request | H.020 |
| Identification Result | H.019 |
| Input Power/Snubber Configuration | H.017 |
| Motor Nameplate Amps | H.002 |
| Motor Nameplate Base Frequency | H.001 |
| Motor Nameplate Volts | H.000 |
| Overfrequency Limit | H.022 |
| Slip Compensation | H.004 |
| Sync Direction | H.016 |
| Torque Boost Voltage | H.003 |
| Volts/Hertz Curve Type | H.018 |

Second Menu Vector Parameters

| | |
|---|-------|
| AC Line Volts | U.018 |
| Current Compounding Gain | U.026 |
| Encoder PPR | U.001 |
| Field Weakening Start RPM | U.016 |
| Flux Current Regulator Integral Gain | U.020 |
| Flux Current Regulator Proportional Gain | U.019 |
| High DC Bus Fault Avoidance Enable | U.024 |
| Inertia Compensation Gain | U.027 |
| Losses Compensation Gain | U.028 |
| Low DC Bus Fault Avoidance Enable | U.023 |
| Magnetizing Current | U.006 |
| Motor Nameplate Amps | U.004 |
| Motor Nameplate Base Frequency | U.003 |
| Motor Nameplate Horsepower | U.022 |
| Motor Nameplate RPM | U.005 |
| Motor Nameplate Volts | U.007 |
| Motor Poles | U.002 |
| Motor Top Speed | U.017 |
| Outer Control Loop Feedback Select | U.040 |
| Outer Control Loop Integral Gain | U.046 |
| Outer Control Loop Lead/Lag Low Frequency | U.042 |
| Outer Control Loop Lead/Lag Ratio | U.043 |
| Outer Control Loop Lead/Lag Select | U.041 |
| Outer Control Loop Proportional Gain | U.045 |
| Outer Control Loop Proportional Trim Enable | U.048 |
| Outer Control Loop Reference Gain | U.044 |
| Outer Control Loop Trim Range Percentage | U.047 |
| Rotor Time Constant / Fast Flux Up | U.021 |
| Speed Regulator Integral Gain | U.013 |
| Speed Regulator Proportional Gain | U.012 |
| SVC Slip Adjust | U.030 |
| SVC Sync Direction | U.031 |
| SVC Flux Current Regulator Gain | U.032 |
| Torque Reference Source | U.000 |
| Torque Regulator Integral Gain | U.015 |
| Torque Regulator Proportional Gain | U.014 |
| Torque Self-Tune Enable | U.008 |
| Torque Self-Tune Result | U.009 |
| Zero Speed Hold Time | U.025 |

Second Menu RMI Parameters

| | |
|------------------------------------|-------|
| Analog Input Gain | r.011 |
| Analog Input Offset | r.010 |
| Analog Output 1 Gain | r.003 |
| Analog Output 1 Offset | r.002 |
| Analog Output 1 Source | r.001 |
| Analog Output 2 Gain | r.006 |
| Analog Output 2 Offset | r.005 |
| Analog Output 2 Source | r.004 |
| Analog Output 3 Gain | r.009 |
| Analog Output 3 Offset | r.008 |
| Analog Output 3 Source | r.007 |
| Current Detection Hysteresis | r.060 |
| Current Detection Level 1 | r.057 |
| Current Detection Level 2 | r.058 |
| Current Detection Level 3 | r.059 |
| Digital Input Configuration | r.030 |

**Second Menu RMI Parameters
(continued)**

| | |
|--|-------|
| Digital Output 1 Configuration | r.031 |
| Digital Output 1 Delay Time | r.040 |
| Digital Output 2 Configuration | r.032 |
| Digital Output 2 Delay Time | r.041 |
| Digital Output 3 Configuration | r.033 |
| Digital Output 3 Delay Time | r.042 |
| Digital Output 4 Configuration | r.034 |
| Digital Output 4 Delay Time | r.043 |
| Frequency Input Gain | r.016 |
| Frequency Input Offset | r.015 |
| Frequency Input Sample Period | r.014 |
| Low Speed Detection Level | r.056 |
| PI Regulator Integral Gain | r.022 |
| PI Regulator Offset | r.020 |
| PI Regulator Proportional Gain | r.021 |
| Relay Output 1 (NO) Configuration | r.035 |
| Relay Output 1 Delay Time | r.044 |
| Relay Output 2 (NO/NC) Configuration | r.036 |
| Relay Output 2 Delay Time | r.045 |
| Relay Output 3 (NO/NC) Configuration | r.037 |
| Relay Output 3 Delay Time | r.046 |
| Speed Detection Hysteresis Band | r.053 |
| Speed Detection Level 1 | r.050 |
| Speed Detection Level 2 | r.051 |
| Speed Detection Level 3 | r.052 |
| Torque Detection Hysteresis | r.066 |
| Torque Detection Level 1 | r.063 |
| Torque Detection Level 2 | r.064 |
| Torque Detection Level 3 | r.065 |
| Torque/Current Limit Source | r.025 |

Refer to the Remote Meter Interface board manual (D2-3341) for the RMI parameter descriptions.

APPENDIX B

Record of User Parameter Settings

| Parameter No. | Parameter Name | Setting | Date |
|--------------------|----------------|-----------------------|------|
| First Menu General | P.000 | Control Source | |
| | P.001 | Accel Time 1 (RAMP 1) | |
| | P.002 | Decel Time 1 (RAMP 1) | |
| | P.003 | Minimum Speed | |
| | P.004 | Maximum Speed | |
| | P.005 | Current Limit | |
| | P.006 | Second Menu Password | |

| | | | |
|---------------------|-------|---|--|
| Second Menu General | P.007 | Terminal Strip Digital Inputs Configure | |
| | P.008 | Terminal Strip Speed Reference Source | |
| | P.009 | Terminal Strip Analog Input Offset | |
| | P.010 | Terminal Strip Analog Input Gain | |
| | P.011 | Terminal Strip Analog Input Configure | |
| | P.012 | Terminal Strip Analog Output Source | |
| | P.013 | Output Relay Configuration | |
| | P.014 | Trim Reference Source | |
| | P.015 | Trim Gain Percentage | |
| | P.016 | Draw Gain Percentage | |
| | P.017 | Accel Time 2 (RAMP 2) | |
| | P.018 | Decel Time 2 (RAMP 2) | |
| | P.019 | S-Curve Enable | |
| | P.020 | Jog Speed Reference | |
| | P.021 | Jog Ramp Accel Time | |
| | P.022 | Jog Ramp Decel Time | |
| | P.023 | MOP Accel/Decel Time | |
| | P.024 | MOP Reset Configuration | |
| | P.025 | Stop Type | |
| | P.026 | Function Loss Response | |
| | P.027 | Forward/Reverse Configuration | |
| | P.028 | Speed Display Scaling | |
| | P.029 | Elapsed Time Meter | |
| | P.030 | Elapsed Time Meter Reset | |
| | P.031 | Preset Speed 1 | |
| | P.032 | Preset Speed 2 | |
| | P.033 | Preset Speed 3 | |
| | P.034 | Preset Speed 4 | |
| | P.035 | Preset Speed 5 | |
| | P.036 | Preset Speed 6 | |
| | P.037 | Preset Speed 7 | |
| | P.038 | Preset Speed 8 | |
| | P.039 | Encoder Loss Enable | |

| | Parameter No. | Parameter Name | Setting | Date |
|---------------------------------------|----------------------|--|----------------|-------------|
| Second Menu General (cont'd) | P.040 | Motor Overload Enable | | |
| | P.041 | Motor Overload Type | | |
| | P.042 | Line Dip Ride Through Time | | |
| | P.043 | Fault Auto Reset Attempts | | |
| | P.044 | Fault Auto Reset Time | | |
| | P.045 | Output Phase Loss Enable | | |
| | P.047 | Carrier Frequency (kHz) | | |
| | P.048 | Volts/Hertz or Vector Regulation | | |
| | P.049 | Country Defaults | | |
| | P.050 | Restore Defaults | | |
| | P.051 | Programming Disable | | |
| | P.052 | AUTO/MAN Key Disable | | |
| | P.053 | Manual Reference Preset Enable | | |
| | P.054 | Level Sense Start Enable | | |
| | P.055 | STOP/RESET Key Disable | | |
| | P.060 | Network Drop Number | | |
| | P.061 | Network Connection Type | | |
| | P.062 | Option Port: Communication Loss Response | | |
| | P.063 | Option Port: Network Reference Source | | |
| | P.064 | Option Port: Network Trim Reference Source | | |
| | P.065 | Option Port: Type and Version | | |
| | P.066 | Network Output Register 1 Source | | |
| | P.067 | Network Output Register 2 Source | | |
| | P.068 | Network Output Register 3 Source | | |
| | P.069 | Network Output Register 4 Source | | |
| | P.090 | Diagnostics Source | | |
| | P.091 | Diagnostics Display | | |
| | P.095 | Power Module Output Amps | | |
| | P.098 | Software Version Number | | |
| | P.099 | Power Module Type | | |

| Parameter No. | Parameter Name | Setting | Date |
|-----------------------------------|-----------------------|-----------------------------------|-------------|
| Second Menu Volts/ Hertz | H.000 | Motor Nameplate Volts | |
| | H.001 | Motor Nameplate Base Frequency | |
| | H.002 | Motor Nameplate Amps | |
| | H.003 | Torque Boost Voltage | |
| | H.004 | Slip Compensation | |
| | H.005 | DC Braking Enable | |
| | H.006 | DC Braking Start Frequency | |
| | H.007 | DC Braking Voltage | |
| | H.008 | DC Braking time | |
| | H.009 | Avoidance Frequency Enable | |
| | H.010 | Avoidance Frequency Midpoint 1 | |
| | H.011 | Avoidance Frequency Band 1 | |
| | H.012 | Avoidance Frequency Midpoint 2 | |
| | H.013 | Avoidance Frequency Band 2 | |
| | H.014 | Avoidance Frequency Midpoint 3 | |
| | H.015 | Avoidance Frequency Band 3 | |
| | H.016 | Sync Direction | |
| | H.017 | Input Power/Snubber Configuration | |
| | H.018 | Volts/Hertz Curve Type | |
| | H.019 | Identification Result | |
| | H.020 | Identification Request | |
| | H.021 | AC Line Volts | |
| H.022 | Overfrequency Limit | | |

| Parameter No. | Parameter Name | Setting | Date |
|--------------------------|----------------|---|------|
| Second Menu Vector | U.000 | Torque Reference Source | |
| | U.001 | Encoder PPR | |
| | U.002 | Motor Poles | |
| | U.003 | Motor Nameplate Base Frequency | |
| | U.004 | Motor Nameplate Amps | |
| | U.005 | Motor Nameplate RPM | |
| | U.006 | Magnetizing Current | |
| | U.007 | Motor Nameplate Volts | |
| | U.008 | Torque Self-Tune Enable | |
| | U.009 | Torque Self-Tune Result | |
| | U.012 | Speed Regulator Proportional Gain | |
| | U.013 | Speed Regulator Integral Gain | |
| | U.014 | Torque Regulator Proportional Gain | |
| | U.015 | Torque Regulator Integral Gain | |
| | U.016 | Field Weakening Start RPM | |
| | U.017 | Motor Top Speed | |
| | U.018 | AC Line Volts | |
| | U.019 | Flux Current Regulator Proportional Gain | |
| | U.020 | Flux Current Regulator Integral Gain | |
| | U.021 | Rotor Time Constant / Fast Flux Up | |
| | U.022 | Motor Nameplate Horsepower | |
| | U.023 | Low DC Bus Fault Avoidance Enable | |
| | U.024 | High DC Bus Fault Avoidance Enable | |
| | U.025 | Zero Speed Hold Time | |
| | U.026 | Current Compounding Gain | |
| | U.027 | Inertia Compensation Gain | |
| | U.028 | Losses Compensation Gain | |
| | U.030 | SVC Slip Adjust | |
| | U.031 | SVC Sync Direction | |
| | U.032 | SVC Flux Current Regulator Gain | |
| | U.040 | Outer Control Loop Feedback Source | |
| | U.041 | Outer Control Loop Lead/Lag Select | |
| | U.042 | Outer Control Loop Lead/Lag Low Frequency | |
| | U.043 | Outer Control Loop Lead/Lag Ratio | |
| | U.044 | Outer Control Loop Reference Gain | |
| | U.045 | Outer Control Loop Proportional Gain | |
| | U.046 | Outer Control Loop Integral Gain | |
| | U.047 | Outer Control Loop Trim Range Percentage | |
| | U.048 | Outer Control Loop Proportional Trim Enable | |

| Parameter No. | Parameter Name | Setting | Date |
|-----------------------|----------------|--------------------------------------|------|
| Second Menu RMI | r.001 | Analog Output 1 Source | |
| | r.002 | Analog Output 1 Offset | |
| | r.003 | Analog Output 1 Gain | |
| | r.004 | Analog Output 2 Source | |
| | r.005 | Analog Output 2 Offset | |
| | r.006 | Analog Output 2 Gain | |
| | r.007 | Analog Output 3 Source | |
| | r.008 | Analog Output 3 Offset | |
| | r.009 | Analog Output 3 Gain | |
| | r.010 | Analog Input Offset | |
| | r.011 | Analog Input Gain | |
| | r.014 | Frequency Input Sample Period | |
| | r.015 | Frequency Input Offset | |
| | r.016 | Frequency Input Gain | |
| | r.020 | PI Regulator Offset | |
| | r.021 | PI Regulator Proportion Gain | |
| | r.022 | PI Regulator Integral Gain | |
| | r.025 | Torque/Current Limit Source | |
| | r.030 | Digital Input Configuration | |
| | r.031 | Digital Output 1 Configuration | |
| | r.032 | Digital Output 2 Configuration | |
| | r.033 | Digital Output 3 Configuration | |
| | r.034 | Digital Output 4 Configuration | |
| | r.035 | Relay Output 1 (NO) Configuration | |
| | r.036 | Relay Output 2 (NO/NC) Configuration | |
| | r.037 | Relay Output 3 (NO/NC) Configuration | |
| | r.040 | Digital Output 1 Delay Time | |
| | r.041 | Digital Output 2 Delay Time | |
| | r.042 | Digital Output 3 Delay Time | |
| | r.043 | Digital Output 4 Delay Time | |
| | r.044 | Relay Output 1 Delay Time | |
| | r.045 | Relay Output 2 Delay Time | |
| | r.046 | Relay Output 3 Delay Time | |
| | r.050 | Speed Detection Level 1 | |
| | r.051 | Speed Detection Level 2 | |
| | r.052 | Speed Detection Level 3 | |
| | r.053 | Speed Detection Hysteresis Band | |
| | r.056 | Low Speed Detection Level | |
| | r.057 | Current Detection Level 1 | |
| | r.058 | Current Detection Level 2 | |
| | r.059 | Current Detection Level 3 | |
| | r.060 | Current Detection Hysteresis | |
| | r.063 | Torque Detection Level 1 | |
| | r.064 | Torque Detection Level 2 | |
| | r.065 | Torque Detection Level 3 | |
| | r.066 | Torque Detection Hysteresis | |

APPENDIX C

Power Module-Dependent Parameter Default Values (230 V Series)

Second Menu General Parameters (USA Defaults)

| Parameter No. | Parameter Name | Power Module | | | | | | | |
|---------------|-------------------------|------------------|------------------|------------------|------------------|------------------|--------------------|--------------------|--------------------|
| | | 1V2160 1V2460 | 2V2160 2V2460 | 3V2160 3V2460 | 5V2160 5V2460 | 7V2160 7V2260 | 10V2160 10V2260 | 15V2160 15V2260 | 20V2160 20V2260 |
| P.047 | Carrier Frequency (kHz) | 8 | 8 | 8 | 8 | 8 | 8 | 8 | 8 |

Note: The drives can use any carrier frequency of 2, 4 or 8 kHz. But when 8 kHz of carrier frequency is used, the drive's rated output current is automatically limited to 80%.

Second Menu Volts/Hertz Parameters (USA Defaults)

| Parameter No. | Parameter Name | Power Module | | | | | | | |
|---------------|----------------------|------------------|------------------|------------------|------------------|------------------|--------------------|--------------------|--------------------|
| | | 1V2160 1V2460 | 2V2160 2V2460 | 3V2160 3V2460 | 5V2160 5V2460 | 7V2160 7V2260 | 10V2160 10V2260 | 15V2160 15V2260 | 20V2160 20V2260 |
| H.002 | Motor Nameplate Amps | 2.6 | 5.4 | 7.6 | 12.2 | 18.0 | 23.8 | 35.6 | 48.0 |

Second Menu Vector Parameters (USA Defaults)

| Parameter No. | Parameter Name | Power Module | | | | | | | |
|---------------|------------------------------|------------------|------------------|------------------|------------------|------------------|--------------------|--------------------|--------------------|
| | | 1V2160 1V2460 | 2V2160 2V2460 | 3V2160 3V2460 | 5V2160 5V2460 | 7V2160 7V2260 | 10V2160 10V2260 | 15V2160 15V2260 | 20V2160 20V2260 |
| U.004 | Motor Nameplate Amps | 3.2 | 6.0 | 8.8 | 14.2 | 22.2 | 25.2 | 42.0 | 54.0 |
| U.005 | Motor Nameplate RPM | 1736 | 1744 | 1726 | 1722 | 1778 | 1780 | 1780 | 1777 |
| U.006 | Magnetizing Current | 51.2 | 59.4 | 56.7 | 54.5 | 60.3 | 52.8 | 52.1 | 52.0 |
| U.012 | Speed Reg. Prop. Gain | 5.00 | 5.00 | 5.00 | 5.00 | 5.00 | 5.00 | 5.00 | 5.00 |
| U.013 | Speed Reg. Int. Gain | 5.00 | 5.00 | 5.00 | 5.00 | 5.00 | 5.00 | 5.00 | 5.00 |
| U.014 | Torque Reg. Prop. Gain | 0.40 | 0.40 | 0.40 | 0.40 | 0.40 | 0.40 | 0.40 | 0.40 |
| U.015 | Torque Reg. Int. Gain | 200.0 | 200.0 | 200.0 | 200.0 | 200.0 | 200.0 | 200.0 | 200.0 |
| U.016 | Field Weakening Start RPM | 1736 | 1744 | 1726 | 1722 | 1778 | 1780 | 1780 | 1777 |
| U.017 | Motor Top Speed | 1736 | 1744 | 1726 | 1722 | 1778 | 1780 | 1780 | 1777 |
| U.019 | Flux Current Reg. Prop. Gain | 0.30 | 0.30 | 0.30 | 0.30 | 0.30 | 0.30 | 0.30 | 0.30 |
| U.020 | Flux Current Reg. Int. Gain | 50.0 | 50.0 | 50.0 | 50.0 | 50.0 | 50.0 | 50.0 | 50.0 |
| U.021 | Rotor Time Constant | 250 | 250 | 250 | 250 | 250 | 250 | 250 | 250 |
| U.022 | Motor Nameplate HP | 1.0 | 2.0 | 3.0 | 5.0 | 7.5 | 10.0 | 15.0 | 20.0 |
| U.032 | SVC Flux Current Reg. Gain | 1000 | 1000 | 1000 | 1000 | 1000 | 1000 | 950 | 900 |

APPENDIX D

Default Parameter Settings

First and Second Menu General Parameters

| Parameter No. | Parameter Name | USA (P.049 = USA) | EUROPE (P.049 = EUR) | JAPAN (P.049 = JPN) |
|---------------|--|----------------------|-------------------------|------------------------|
| P.000 | Control Source | LOCL | LOCL | LOCL |
| P.001 | Accel Time 1 | 20.0 | 20.0 | 20.0 |
| P.002 | Decel Time 1 | 20.0 | 20.0 | 20.0 |
| P.003 | Minimum Speed P.048 = U-H P.048 = UEC | 5.0 Hz 150 RPM | 5.0 Hz 150 RPM | 5.0 Hz 150 RPM |
| P.004 | Maximum Speed P.048 = U-H P.048 = UEC | 60.0 Hz 1722 RPM | 50.0 Hz 1400 RPM | 52.7 Hz 1500 RPM |
| P.005 | Current Limit P.048 = U-H P.048 = UEC | 100 150 | 100 150 | 100 150 |
| P.006 | Second Menu Password | Read only | Read only | Read only |
| P.007 | Terminal Strip Digital Inputs Configure | 0 | 0 | 0 |
| P.008 | Terminal Strip Speed Reference Source | 0 | 0 | 0 |
| P.009 | Terminal Strip Analog Input Offset | 0 | 0 | 0 |
| P.010 | Terminal Strip Analog Input Gain | 1.000 | 1.000 | 1.000 |
| P.011 | Terminal Strip Analog Input Configure | 2 | 2 | 2 |
| P.012 | Terminal Strip Analog Output Source | 0 | 0 | 0 |
| P.013 | Output Relay Configuration | 0 | 0 | 0 |
| P.014 | Trim Reference Source | 0 | 0 | 0 |
| P.015 | Trim Gain Percentage | 0.0 | 0.0 | 0.0 |
| P.016 | Draw Gain Percentage | 0.0 | 0.0 | 0.0 |
| P.017 | Accel Time 2 | 20.0 | 20.0 | 20.0 |
| P.018 | Decel Time 2 | 20.0 | 20.0 | 20.0 |
| P.019 | S-Curve Enable P.048 = U-H P.048 =UEC | ON OFF | ON ON | ON OFF |
| P.020 | Jog Speed Reference P.048 = U-H P.048 =UEC | 5.0 Hz 150 RPM | 5.0 Hz 150 RPM | 5.0 Hz 150 RPM |
| P.021 | Jog Ramp Accel Time | 20.0 | 20.0 | 20.0 |
| P.022 | Jog Ramp Decel Time | 20.0 | 20.0 | 20.0 |
| P.023 | MOP Accel/Decel | 20.0 | 20.0 | 20.0 |
| P.024 | MOP Reset Configuration | 0 | 0 | 0 |
| P.025 | Stop Type | 0 | 0 | 0 |
| P.026 | Function Loss Response | 0 | 0 | 1 |
| P.027 | Forward/Reverse Configuration | 0 | 0 | 0 |

Second Menu General Parameters (Continued)

| Parameter No. | Parameter Name | | USA (P.049 = USA) | EUROPE (P.049 = EUR) | JAPAN (P.049 = JPN) |
|---------------|---------------------------------|----------------------------|----------------------|-------------------------|------------------------|
| P.028 | Speed Display Scaling | P.048 = U-H P.048 = UEC | 1800 ① | 1500 ① | ① 1500 |
| P.029 | Elapsed Time Meter | | Read only | Read only | Read only |
| P.030 | Elapsed Time Meter Reset | | OFF | OFF | OFF |
| P.031 | Preset Speed 1 | P.048 = U-H P.048 = UEC | 5.0 Hz 150 RPM | 5.0 Hz 150 RPM | 5.0 Hz 150 RPM |
| P.032 | Preset Speed 2 | P.048 = U-H P.048 = UEC | 5.0 Hz 150 RPM | 5.0 Hz 150 RPM | 5.0 Hz 150 RPM |
| P.033 | Preset Speed 3 | P.048 = U-H P.048 = UEC | 5.0 Hz 150 RPM | 5.0 Hz 150 RPM | 5.0 Hz 150 RPM |
| P.034 | Preset Speed 4 | P.048 = U-H P.048 = UEC | 5.0 Hz 150 RPM | 5.0 Hz 150 RPM | 5.0 Hz 150 RPM |
| P.035 | Preset Speed 5 | P.048 = U-H P.048 = UEC | 5.0 Hz 150 RPM | 5.0 Hz 150 RPM | 5.0 Hz 150 RPM |
| P.036 | Preset Speed 6 | P.048 = U-H P.048 = UEC | 5.0 Hz 150 RPM | 5.0 Hz 150 RPM | 5.0 Hz 150 RPM |
| P.037 | Preset Speed 7 | P.048 = U-H P.048 = UEC | 5.0 Hz 150 RPM | 5.0 Hz 150 RPM | 5.0 Hz 150 RPM |
| P.038 | Preset Speed 8 | P.048 = U-H P.048 = UEC | 5.0 Hz 150 RPM | 5.0 Hz 150 RPM | 5.0 Hz 150 RPM |
| P.039 | Encoder Loss Enable | | OFF | OFF | OFF |
| P.040 | Motor Overload Enable | | ON | ON | ON |
| P.041 | Motor Overload Type | | FC | FC | FC |
| P.042 | Line Dip Ride-Through Time | | 5.0 | 5.0 | 5.0 |
| P.043 | Fault Auto Reset Attempts | | 0 | 0 | 0 |
| P.044 | Fault Auto Reset Time | | 8 | 8 | 8 |
| P.045 | Output Phase Loss Enable | | ON | ON | ON |
| P.047 | Carrier Frequency (kHz) | | 8 | 8 | 8 |
| P.048 | V/Hz or Vector Regulation | | U-H | U-H | UEC |
| P.049 | Country Defaults | | USA | EUR | JPN |
| P.050 | Restore Defaults | | OFF | OFF | OFF |
| P.051 | Programming Disable | | 0 | 0 | 0 |
| P.052 | AUTO/MAN Key Disable | | OFF | ON | OFF |
| P.053 | Manual Reference Preset Enable | | OFF | OFF | OFF |
| P.054 | Level Sense Start Enable | | OFF | OFF | OFF |
| P.055 | STOP/RESET Key Disable | | OFF | OFF | OFF |
| P.060 | Network Drop Number | | 1 | 1 | 1 |
| P.061 | Network Connection Type | | 0 | 1 | 0 |
| P.062 | Option Port: Communication Loss | | 0 | 0 | 0 |

① : Parameter default is Power Module-dependent.

Second Menu General Parameters (Continued)

| Parameter No. | Parameter Name | USA (P.049 = USA) | EUROPE (P.049 = EUR) | JAPAN (P.049 = JPN) |
|---------------|--|----------------------|-------------------------|------------------------|
| P.063 | Option Port: Network Reference Source | 0 | 0 | 0 |
| P.064 | Option Port: Network Trim Reference Source | 0 | 0 | 0 |
| P.065 | Option Port: Type and Version | Read only | Read only | Read only |
| P.066 | Network Output Register 1 Source | 0 | 0 | 0 |
| P.067 | Network Output Register 2 Source | 0 | 0 | 0 |
| P.068 | Network Output Register 3 Source | 0 | 0 | 0 |
| P.069 | Network Output Register 4 Source | 0 | 0 | 0 |
| P.090 | Diagnostics Source | 0 | 0 | 0 |
| P.091 | Diagnostics Display | Read only | Read only | Read only |
| P.095 | Power Module Output Amps | Read only | Read only | Read only |
| P.098 | Software Version Number | Read only | Read only | Read only |
| P.099 | Power Module Type | Read only | Read only | Read only |

Second Menu Volts/Hertz Parameters

| Parameter No. | Parameter Name | USA (P.049 = USA) | EUROPE (P.049 = EUR) | JAPAN (P.049 = JPN) |
|---------------|-----------------------------------|----------------------|-------------------------|------------------------|
| H.000 | Motor Nameplate Volts | 230 | 220 | 180 |
| H.001 | Motor Nameplate Base Frequency | 60.0 | 50.0 | ① |
| H.002 | Motor Nameplate Amps | ① | ① | ① |
| H.003 | Torque Boost Voltage | 0.5 | 0.5 | 0.5 |
| H.004 | Slip Compensation | 0.0 | 0.0 | 0.0 |
| H.005 | DC Braking Enable | OFF | OFF | OFF |
| H.006 | DC Braking Start Frequency | 1.0 | 1.0 | 1.0 |
| H.007 | DC Braking Current | 10 | 10 | 10 |
| H.008 | DC Braking Time | 3.0 | 3.0 | 3.0 |
| H.009 | Avoidance Frequency Enable | OFF | OFF | OFF |
| H.010 | Avoidance Frequency Midpoint 1 | 0.0 | 0.0 | 0.0 |
| H.011 | Avoidance Frequency Band 1 | 2.0 | 2.0 | 2.0 |
| H.012 | Avoidance Frequency Midpoint 2 | 0.0 | 0.0 | 0.0 |
| H.013 | Avoidance Frequency Band 2 | 2.0 | 2.0 | 2.0 |
| H.014 | Avoidance Frequency Midpoint 3 | 0.0 | 0.0 | 0.0 |
| H.015 | Avoidance Frequency Band 3 | 2.0 | 2.0 | 2.0 |
| H.016 | Sync Direction | OFF | OFF | OFF |
| H.017 | Input Power/Snubber Configuration | 0 | 0 | 0 |
| H.018 | Volts/Hertz Curve Type | 0 | 0 | 0 |
| H.019 | Identification Result | 0 | 0 | 0 |
| H.020 | Identification Request | OFF | OFF | OFF |
| H.021 | AC Line Volts | 230 | 220 | 200 |
| H.022 | Overfrequency Limit | 90.0 | 65.0 | 75.0 |

① : Parameter default is Power Module-dependent.

Second Menu Vector Parameters

| Parameter No. | Parameter Name | USA (P.049 = USA) | EUROPE (P.049 = EUR) | JAPAN (P.049 = JPN) |
|---------------|---|----------------------|-------------------------|------------------------|
| U.000 | Torque Reference Source | 0 | 0 | 0 |
| U.001 | Encoder PPR | 1024 | 2048 | 2048 |
| U.002 | Motor Poles | 4 | 4 | 4 |
| U.003 | Motor Nameplate Base Frequency | 60.0 | 50.0 | ① |
| U.004 | Motor Nameplate Amps | ① | ① | ① |
| U.005 | Motor Nameplate RPM | ① | 1450 | 1500 |
| U.006 | Magnetizing Current | ① | ① | ① |
| U.007 | Motor Nameplate Volts | 230 | 220 | 180 |
| U.008 | Torque Self-Tune Enable | OFF | OFF | OFF |
| U.009 | Torque Self-Tune Result | Read only | Read only | Read only |
| U.012 | Speed Regulator Proportional Gain | 5.00 | 5.00 | 5.00 |
| U.013 | Speed Regulator Integral Gain | 5.00 | 5.00 | 5.00 |
| U.014 | Torque Regulator Prportional Gain | 0.40 | 0.40 | 0.40 |
| U.015 | Torque Regulator Integral Gain | 200.0 | 200.0 | 200.0 |
| U.016 | Field Weakening Start RPM | ① | 1450 | 1500 |
| U.017 | Motor Top Speed | ① | 1450 | 1500 |
| U.018 | AC Line Volts | 230 | 220 | 200 |
| U.019 | Flux Current Regulator Proportional Gain | 0.30 | 0.30 | 0.30 |
| U.020 | Flux Current Regulator Integral Gain | 50.0 | 50.0 | 50.0 |
| U.021 | Rotor Time Constant | 250 | 250 | 250 |
| U.022 | Motor Nameplate Horsepower | ① | ① | ① |
| U.023 | Low DC Bus Fault Avoidance Enable | OFF | OFF | OFF |
| U.024 | High DC Bus Fault Avoidance Enable | OFF | OFF | OFF |
| U.025 | Zero Speed Hold Time | 0.0 | 0.0 | 0.0 |
| U.026 | Current Compounding Gain | 0.000 | 0.000 | 0.000 |
| U.027 | Inertia Compensation Gain | 0.000 | 0.000 | 0.000 |
| U.028 | Losses Compensation Gain | 0.000 | 0.000 | 0.000 |
| U.030 | SVC Slip Adjust | 1.00 | 1.00 | 1.00 |
| U.031 | SVC Sync Direction | OFF | OFF | OFF |
| U.032 | SVC Flux Current Regulator Gain | ① | ① | ① |
| U.040 | Outer Control Loop Feedabck Source | 0 | 0 | 0 |
| U.041 | Outer Control Loop Lead/Lag Select | 0 | 0 | 0 |
| U.042 | Outer Control Loop Lead/Lag Low Frequency | 1.00 | 1.00 | 1.00 |
| U.043 | Outer Control Loop Lead/Lag Ratio | 10 | 10 | 10 |
| U.044 | Outer Control Loop Reference Gain | 1.000 | 1.000 | 1.000 |
| U.045 | Outer Control Loop Proportional Gain | 2.00 | 2.00 | 2.00 |
| U.046 | Outer Control Loop Integral Gain | 2.00 | 2.00 | 2.00 |
| U.047 | Outer Control Loop Trim Range Percentage | 0.0 | 0.0 | 0.0 |
| U.048 | Outer Control Loop Proportional Trom Gain | OFF | OFF | OFF |

① : Parameter default is Power Module-dependent.

APPENDIX E

Configuring the Digital Inputs When the RMI Board Is Installed in the Drive

The GV3000/SE Regulator board contains three user-configurable digital inputs. Parameter P.007 (Terminal Strip Digital Inputs Configure) and P.008 (Terminal Strip Speed Reference Source) are used to specify how these digital inputs are used.

If an optional Remote Meter Interface (RMI) board is installed in the drive, four additional digital inputs are available. RMI parameter r.030 is used to specify how the RMI digital inputs are used.

The Regulator board digital inputs and the RMI digital inputs are not permitted to be used for the same functions. One parameter cannot be set to a value which requires resources (digital inputs) or a duplication of function which is used or defined by the value of another parameter.

The acceptable values for P.008 are based on the value selected for P.007 and by the value selected for r.030:

- P.008 is limited by P.007 and r.030
- P.007 is limited by P.008
- r.030 is limited by P.008

First determine what functions are to be assigned to the three digital inputs on the Regulator board. Once you have determined this, select the appropriate settings for P.007 and P.008. As shown in the following tables, **the desired value for P.008 must be permissible by both the P.007 and r.030 values.** If either column indicates the value is not acceptable, then P.008 cannot be set to that value. Use the following tables to help determine the appropriate settings for your application.

Refer to chapter 4 in this manual for a complete description of parameters P.007 and P.008 and their corresponding options. Refer to the RMI board instruction manual (D2-3341) for a complete description of parameter r.030 and its options.

Summary of Options for P.007, P.008, and r.030

| P.007 Options | | | |
|---------------|----------|----------|----------|
| | DIGIN 6 | DIGIN 7 | DIGIN 8 |
| 0 = | FWD/REV | RAMP 1/2 | REM/LOC |
| 1 = | Not used | FWD/REV | RAMP 1/2 |
| 2 = | Not used | FWD/REV | REM/LOC |
| 3 = | Not used | RAMP 1/2 | REM/LOC |
| 4 = | Not used | Not used | FWD/REV |
| 5 = | Not used | Not used | RAMP 1/2 |
| 6 = | Not used | Not used | REM/LOC |
| 7 = | Not used | Not used | Not used |
| 8 = | FWD/REV | TRQ/SPD | REM/LOC |
| 9 = | Not used | TRQ/SPD | REM/LOC |
| 10 = | Not used | TRQ/SPD | FWD/REV |
| 11 = | Not used | TRQ/SPD | RAMP 1/2 |
| 12 = | Not used | Not used | TRQ/SPD |

| P.008 Options | | | |
|---------------|--------------------------|----------|----------|
| | DIGIN 6 | DIGIN 7 | DIGIN 8 |
| 0 = | Not used | Not used | Not used |
| 1 = | MOP ↑ | MOP ↓ | Not used |
| 2 = | 2 Presets | Not used | Not used |
| 3 = | 4 Presets | | Not used |
| 4 = | 8 Presets | | |
| 5 = | Analog ref and 1 preset | Not used | Not used |
| 6 = | Analog ref and 3 presets | | Not used |
| 7 = | Analog ref and 7 presets | | |

| r.030 Options | | | | |
|---------------|-------------|-------------|-------------|-------------|
| | RMI DIGIN 1 | RMI DIGIN 2 | RMI DIGIN 3 | RMI DIGIN 4 |
| 0 = | Ref 1/2 | A/F | Aux 2 | Aux 1 |
| 1 = | Ref 1/2 | A/F | Aux 2 | PI Enable |
| 2 = | Ref 1/2 | MOP ↑ | MOP ↓ | Aux 1 |
| 3 = | Ref 1/2 | MOP ↑ | MOP ↓ | PI Enable |
| 4 = | Ref 1/2 | 2 Presets | Aux 2 | Aux 1 |
| 5 = | Ref 1/2 | 2 Presets | Aux 2 | PI Enable |
| 6 = | Ref 1/2 | 4 Presets | 4 Presets | Aux 1 |
| 7 = | Ref 1/2 | 4 Presets | 4 Presets | PI Enable |
| 8 = | Ref 1/2 | 8 Presets | 8 Presets | 8 Presets |

Option Comparison Tables

| If P.007 = | Acceptable P.008 Values |
|------------|-------------------------|
| 0 | 0 |
| 1 | 0, 2, 5 |
| 2 | 0, 2, 5 |
| 3 | 0, 2, 5 |
| 4 | 0-3, 5, 6 |
| 5 | 0-3, 5, 6 |
| 6 | 0-3, 5, 6 |
| 7 | 0-7 (all) |
| 8 | 0 |
| 9 | 0, 2, 5 |
| 10 | 0, 2, 5 |
| 11 | 0, 2, 5 |
| 12 | 0-3, 5, 6 |

| If r.030 = | Acceptable P.008 Values |
|------------|-------------------------|
| 0 | 0-6 (all) |
| 1 | 0-6 (all) |
| 2 | 0, 2-6 |
| 3 | 0, 2-6 |
| 4 | 0, 1 |
| 5 | 0, 1 |
| 6 | 0, 1 |
| 7 | 0, 1 |
| 8 | 0, 1 |

| If P.008 = | Acceptable P.007 Values |
|------------|-------------------------|
| 0 | 0-12 (all) |
| 1 | 4-7, 12 |
| 2 | 1-7, 9-12 |
| 3 | 4-7, 12 |
| 4 | 7 |
| 5 | 1-7, 9-12 |
| 6 | 4-7, 12 |
| 7 | 7 |

| If P.008 = | Acceptable r.030 Values |
|------------|-------------------------|
| 0 | 0-8 (all) |
| 1 | 0, 1, 4-8 |
| 2 | 0-3 |
| 3 | 0-3 |
| 4 | 0-3 |
| 5 | 0-3 |
| 6 | 0-3 |
| 7 | 0-3 |

Example 1

Functions to be assigned to Regulator board terminal strip:

- 2 preset speeds
- TRQ/SPD
- FWD/REV

Function to be assigned to RMI terminal strip:

- MOP

To configure the Regulator board digital inputs for the above functions, P.007 should be set to 10, and P.008 should be set to 2. Using the Option Comparison Tables, a setting in P.007 of 10 allows P.008 to be set to 2.

To configure the RMI terminal strip for the MOP function, r.030 should be set to 2. Using the Option Comparison Tables, this setting is acceptable if P.008 is set to 2.

Therefore, these functions can be easily accommodated by the four digital inputs by setting P.007 = 10, P.008 = 2, and r.030 = 2.

Example 2

Functions to be assigned to the Regulator board terminal strip:

- 4 preset speeds
- TRQ/SPD
- FWD/REV

Function to be assigned to the RMI terminal strip:

- MOP

To configure the Regulator board digital inputs for the above functions, P.007 should be set to 10, and P.008 should be set to 3. Using the Option Comparison Tables, a setting of 10 in P.007 does not allow a setting of 3 for P.008. This is because the parameter settings both require the use of digital inputs 7 (the TRQ/SPD and FWD/REV functions use digital inputs 7 and 8; the four presets use digital inputs 6 and 7).

In this case, the function to be assigned to the Regulator board terminal strip need to be re-assessed (for example, reduce the number of preset speeds to 2).

APPENDIX F

Using the Terminal Strip Analog Input

An analog reference input is provided at terminals 12 through 15 on the drive's Regulator board. This input accepts either a ± 10 VDC or 0 to 20 mA signal. The analog-to-digital conversion provides 10-bit plus sign resolution and a digital range of ± 1023 .

The analog input can be used as a reference for:

- Speed reference (P.000, P.007/P.008)
- Trim reference (P.014)
- Torque reference (vector control only) (U.000)
- Outer control loop feedback (U.040)

Parameters P.009 (Terminal Strip Analog Input Offset) and P.010 (Terminal Strip Analog Input Gain) are used to adjust the converted value for any external signal errors. Parameter P.011 (Terminal Strip Analog Input Configure) is used to specify the type of signal used and to invert the converted value, if required.

Three quantities are calculated from the analog input value: scaled, speed normalized, and torque reference. The scaled value is used for the outer control loop (OCL) feedback. The speed normalized value is used for either speed or trim reference. The torque reference value is used for torque reference for vector control. Figure F.1 shows the relationship between the input and the calculated values.

In addition, the input, with only the offset applied (P.009), is used for 4-20 mA loss detection and 0-10 V start/stop control.

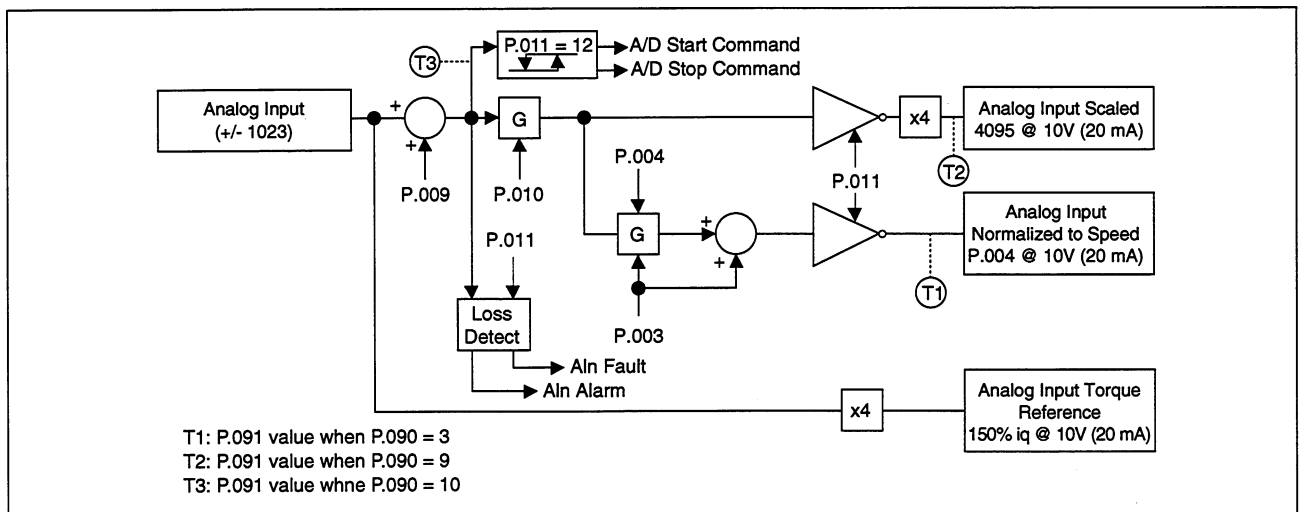

Figure F.1 – Terminal Strip Analog Input

F.1 Configuring the Analog Input

Parameter P.011 is used to specify the type of input and whether it is to be inverted after it is converted by the drive. The parameter setting should coincide with the position of jumper J4 on the Regulator board. For example, if a voltage input is applied, J4 should be set to +/- 10 VDC and P.011 should be between 0 and 3. If a current input is applied, J4 should be set to 0 to 20 mA and P.011 should be between 4 and 11.

If P.011 is odd, the digital value of the input is inverted resulting in a positive input inverted to a negative reference value, and a negative input converted to a positive reference value. Note that the Forward/Reverse Configuration parameter (P.027) is applied after the analog input.

The 4 to 20 mA input can be configured to generate a drive fault or a drive alarm if the input falls below 2 mA. Refer to the P.011 parameter description for more information.

F.2 Using the Analog Input as Speed or Trim Reference

When the analog input is used as speed or trim reference, the analog input value will be interpreted internally as shown in table F.1 and described below:

Table F.1 – Analog Input Conversion Scaling for Speed or Trim Reference

| Analog Input Value | Corresponding Internal Value |
|--------------------|--|
| +10 VDC (20 mA) | P.004 (Maximum Speed) |
| 0 VDC (0 mA) | P.003 (Minimum Speed) |
| -10 VDC | -P.004 (Negative Maximum Speed; reverse or 0, see P.027) |

- The maximum positive analog input value (+10 VDC or 20 mA) corresponds to the value specified as the maximum speed of the drive (P.004).
- The maximum negative analog input value (-10 VDC) corresponds to -P.004 (reverse or 0, see P.027).
- The minimum analog input value (0 VDC or 0 mA; 4 mA if P.011 = 4, 5, or 8-11) corresponds to the value specified as the minimum speed of the drive (P.003).
- When P.011 = 0 or 1, there is no hysteresis provided around zero on the input. Therefore, if the input fluctuates around zero, the reference will toggle between positive minimum speed (+P.003) and negative minimum speed (-P.003).

Note that the analog input is scaled based on the values entered in P.003 and P.004. If these parameters are changed while the drive is running, and the analog input is used as the speed or trim reference, the speed reference will change even though the input value has not.

Figure F.2 illustrates how the analog signal is scaled internally by the drive when it is used as the speed or trim reference. The solid line indicates the conversion when the non-inverted state is selected (P.011 is even). The dashed line indicates the conversion when the inverted state is selected (P.011 is odd).

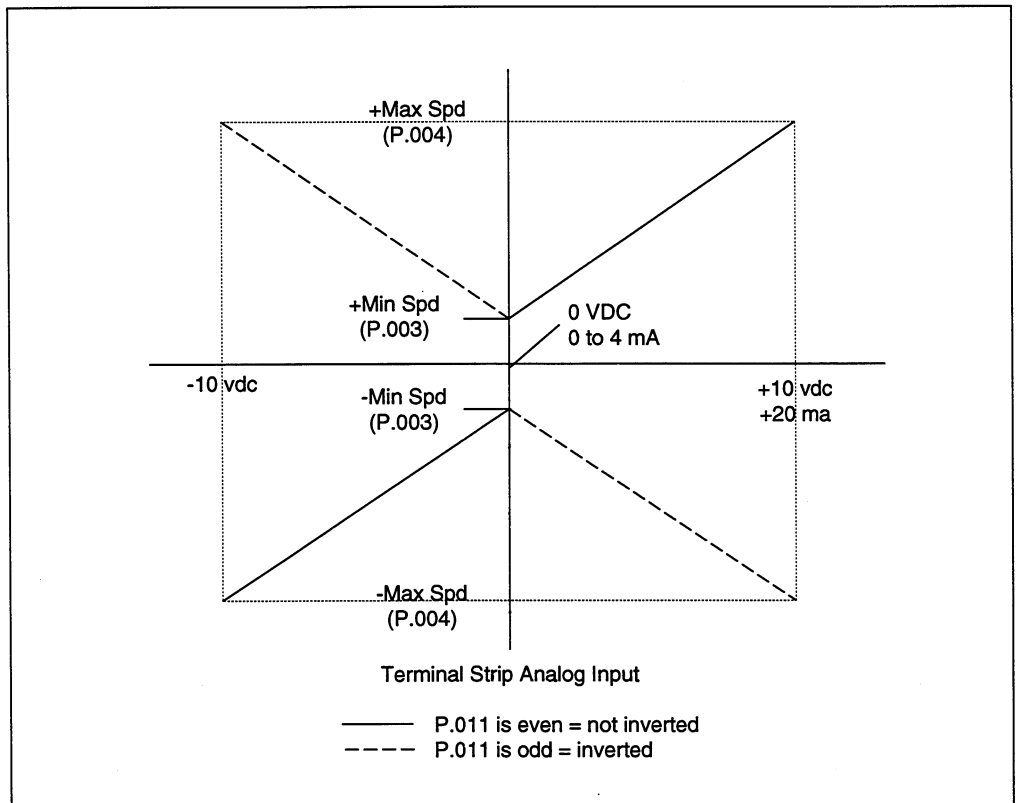

Figure F.2 – Analog Input Conversion Scaling (Speed or Trim Reference)

F.2.1 Adjusting for External Signal Errors Using the Offset and Gain Parameters

When the analog input is used for speed or trim reference, parameters P.009 (Terminal Strip Analog Input Offset) and P.010 (Terminal Strip Analog Input Gain) can be used to compensate for any offset or gain errors in the external circuitry.

The value in P.009 is first added to the converted 10-bit value and then the gain is applied. If an offset or gain adjustment is needed, the offset should be adjusted first, with the minimum input applied, and the gain adjusted last, with the maximum input applied.

To remove a positive external offset, enter a negative value into P.009. In most cases, the offset is left at the default value of zero and is only adjusted to counteract external circuitry errors.

The adjustment range for P.009 is -900 to +900. For 0 to 10 V (or -10 V to +10 V) input, a value of +1 equals an offset of approximately 10 mV. For 0 to 20 mA input, a value of +1 equals an offset of approximately 20 μ A.

To adjust the offset (P.009):

- Step 1. Verify that the analog input is configured as the speed reference control source (P.000 = rE or LOCL and AUTO is selected), P.008 = 0, and U.000 = 0).
- Step 2. Display the converted value of the analog input using the selected speed reference display mode. (Refer to chapter 3 for the procedure for displaying the selected speed reference.)
- Step 3. Adjust P.009 to achieve the value of minimum speed when the analog input is set to the position where minimum speed is desired.

The gain parameter is typically used to compensate for saturation or insufficient voltage from the input source.

Unless the input is a 4 to 20 mA signal, before adjusting the gain, set P.011 to 0 to avoid clamping the reference at 0. After adjusting P.009 and P.010, change P.011 to reflect the intended input.

To adjust the gain (P.010):

- Step 1. Verify that the analog input is configured as the speed reference control source (P.000 = rE or LOCL and AUTO is selected), P.008 = 0, and U.000 = 0).
- Step 2. Display the converted value of the analog input using the selected speed reference display mode. (Refer to chapter 3 for the procedure for displaying the selected speed reference.)
- Step 3. Adjust P.010 to achieve the value of maximum speed when the analog input is set to the position where maximum speed is desired. For example, if a speed pot is used, rotate the pot to its maximum position.

The adjustment range for P.010 is 0.100 to 5.000.

F.3 Using the Analog Input for Vector Torque Reference (U.000 = 1)

When the analog input is used as the vector control torque reference (U.000 = 1), the analog input value will be interpreted internally as shown in table F.2 and described below. Note that P.009 and P.010 are not used when U.001=1. Parameter P.011 is used only to enable the analog input signal loss detection feature.

Table F.2 – Analog Input Conversion Scaling for Torque Reference

| Analog Input Value | Corresponding Internal Value |
|--------------------|--|
| +10 VDC (20 mA) | Positive torque limit of the drive. (+150% of the rated motor torque.) |
| 0 VDC (0 mA) | Zero torque reference. |
| -10 VDC | Negative torque limit of the drive. (-150% of the rated motor torque.) |

- The maximum positive analog input value (+10 VDC or 20 mA) corresponds to the positive torque limit of the drive (+150% of the rated motor torque).

- The maximum negative analog input value (-10 VDC) corresponds to the negative torque limit of the drive (-150% of the rated motor torque).
- The minimum analog input value (0 VDC or 0 mA) corresponds to zero torque reference.

Refer to the GV3000/SE drive hardware reference manual for terminal location, wiring guidelines, and jumper settings.

F.4 Using the Analog Input to Start and Stop the Drive



ATTENTION: The drive may inadvertently start due to the effects of temperature or electrical noise on the analog input when the analog input is configured to start and stop the drive (P.011 = 12), and the following conditions are true:

- P.000 = rE
- The function loss, stop, and start inputs on the terminal strip are all closed.

The user is responsible for:

- providing suitable notification to operating personnel that this feature is being used and the drive could start at any time.
- ensuring that the inadvertent starting of the drive equipment will not cause injury to operating personnel or damage to the driven equipment.
- ensuring that the input wiring has been installed according to IEEE Standard 518 to minimize electrical noise.

Failure to observe this precaution could result in severe bodily injury or loss of life.

ATTENTION: Due to the effect of temperature on the analog input, the possibility exists that the stop threshold cannot be reached. The application must rely on the terminal strip stop and function loss inputs as the alternate methods of stopping the drive. Failure to observe this precaution could result in severe bodily injury or loss of life.

Important: To reduce the effects of electrical noise on the analog input, maintain physical separation between the analog input signal wiring and any noise source including power and/or control wiring. The use of a shielded twisted-pair cable with the shield terminated at one point only is recommended for the analog input.

Setting P.011 (Terminal Strip Analog Input Configure) = 12 configures the analog input as a 0-10 VDC input and to start and stop the drive based on the analog input value:

- The drive will start when the input becomes greater than the start threshold and all other permissible conditions are met.
- The drive will stop when the input becomes less than or equal to the stop threshold.

Refer to figure F.3

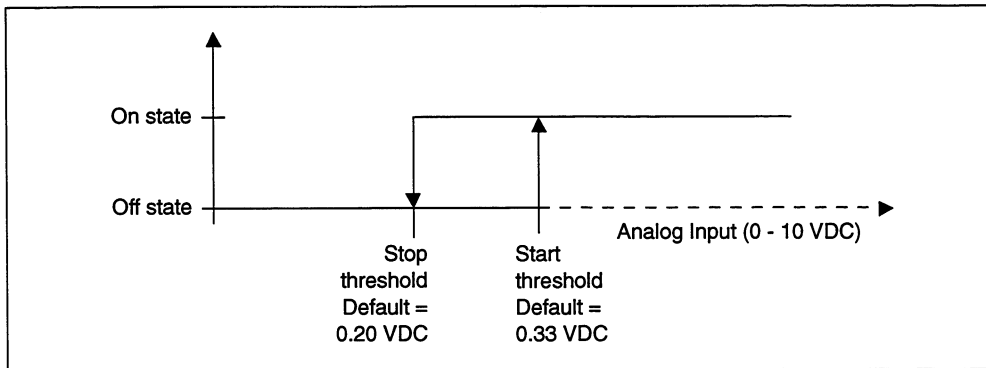

Figure F.3 – Hysteresis Band Created by the Start and Stop Thresholds (Default Configuration)

Important: The terminal strip start input then becomes another stop function and start permissive condition:

- When the start input is open, the drive will stop and remain stopped.
- The start input must be closed to allow the drive to start.

The control source must be the terminal strip (P.000 = rE) to use this feature.

The converted analog input value, after the offset parameter (P.009) has been applied, can be viewed in P.091 (Diagnostics Display) when P.090 (Diagnostics Source) is set to 10. This is the value against which the stop and start threshold values are compared to determine the appropriate input start/stop action.

F.4.1 Adjusting the Stop and Start Thresholds

The start threshold default to 0.33 VDC (nominally) and the stop threshold defaults to 0.20 VDC (nominally) when the Power Module is identified (P.098/P.099). These thresholds can be viewed and adjusted using parameters P.090 (Diagnostics Source) and P.091 (diagnostics Display).

Setting P.090 to 11 selects the analog input stop threshold for viewing and modifying in parameter P.091.

Setting P.090 to 12 selects the analog input start threshold for viewing and modifying in parameter P.091.

Note that the default threshold values are not restored when P.050 (Restore Defaults) is set to ON.

F.4.1.1 Stop Threshold Range

The default value of the stop threshold is 20 A/D counts, which corresponds to 0.20 VDC (nominal).

The stop threshold minimum value is 5 counts. The stop threshold maximum value is 1023 counts.

If the stop threshold is greater than the start threshold, the stop will take precedence. In other words, if the analog input is less than or equal to the stop threshold, the drive will stop regardless of the start threshold.

F.4.1.2 Start Threshold Range

The default value of the start threshold is 33 A/D counts, which corresponds to 0.33 VDC (nominal).

The start threshold minimum value is 0 counts. The start threshold maximum value is 2000 counts.

F.4.2 Using the Level Sense Start Enable Feature and the Analog Input Start/Stop Feature

The level sense start enable feature, configured with parameter P.054 (Level Sense Start Enable), can be used with the analog input start/stop feature.

If the drive is configured for edge sense start (P.054 = 0), then the analog input must transition from the off state to the on state while all permissive conditions are met to start the drive.

If the drive is configured for level sense start (P.054 = 1), the drive will start whenever the analog input is in the on state and all permissive conditions are met. Note, however, that pressing the STOP key on the keypad/display will require a subsequent off-state to on-state transition on the analog input to restart the drive.

Regardless of the value in P.054 (Level Sense Start Enable), if the analog input is in the off state, the drive will stop and remain stopped.

APPENDIX G

Drive Regulation Overview

The GV3000/SE digital drive provides vector or volts/hertz regulation of AC motors. Parameter P.048 (Volts/Hertz or Vector Regulation) is used to select the type of regulation for the application.

Volts/Hertz Regulation (P.048 = U-H)

Volts/hertz regulation provides general purpose open loop AC drive control. It does not use an encoder feedback device. In this type of control, the regulator maintains a programmed ratio of voltage to an output frequency, which provides constant or variable motor torque across a wide speed range. An internal function generator calculates the output motor voltage based on requested frequency and user-specified motor characteristics. The control loop output switches the power device gates, generating a pulse-width-modulated (PWM) waveform to the motor.

Figure G.1 shows a block diagram of the V/Hz regulator.

Vector Regulation (P.048 = UEC)

Vector regulation allows dynamic open- or closed-loop performance in an AC drive similar to that achieved with a DC drive. Torque is constant across the motor's base speed range in both forward and reverse directions. The drive uses two digital control loops, speed and torque, to obtain vector performance. An outer control loop is also available. The speed loop executes every 5 ms. The outer control loop executes every 20 ms.

The **speed loop** reference can be an internal or an external source. For flux vector control (FVC), speed loop feedback is provided by an encoder attached to the motor's shaft. For sensorless vector control (SVC), speed feedback is estimated based on motor parameters. The speed loop provides inertia compensation, losses compensation, and current compounding.

The torque will vary to maintain the motor at the requested speed. The torque control loop output controls the switching on and off of the power devices, generating a pulse-width-modulated (PWM) waveform to the motor.

Figure G.2 shows a block diagram of the flux vector regulator. Figure G.3 shows a block diagram of the sensorless vector regulator. Figures G.4 and G.5 shows detail of the reference and speed loop portions of the vector regulator.

The optional **outer control loop** (OCL) acts as a trim to the speed loop reference signal. Figure G.7 shows a block diagram of the outer control loop portion of the vector regulator.

If a network board is installed, the OCL reference comes from the network trim reference register based on P.064 (Option Port: Network Trim Reference Source) as defined for each network type. (Refer to the specific network board instruction manual for more information on P.064.)

If a Remote Meter Interface (RMI) board is installed, P.064 is used to select the OCL reference as follows for FVC/SVC applications only:

- 0 = RMI analog input
- 1 to 8 = Preset speed 1 to 8 (P.031 to P.038), respectively

If no option board is installed, P.064 is used to select the OCL reference for FVC/SVC applications only:

- 0 = Preset speed 8 (P.038)
- 1 to 8 = Preset speed 1 to 8 (P.031 to P.038), respectively

The OCL feedback is either the drive's scaled terminal strip analog input (default) or the speed loop PI output (user option). The feedback is fed through a lead/lag block which can be configured as a lead/lag, lag/lead, or null (bypass) function.

If a network option board is installed in the drive, the OCL enable signal is controlled by a bit in the drive control word.

If an RMI board is installed, the OCL enable signal is controlled by the RMI digital input (configured for RMI PI regulator enable) or by the same internal signal used to control the speed loop enable signal. (Refer to the r.030 parameter description in the RMI instruction manual, D2-3341, for more information.)

If there is no option board installed, the OCL is enabled when the drive is running (that is, the speed and torque controllers are active) and is disabled if the drive is stopped.

If the drive is running and the OCL enable signal is on (closed), the outer loop will operate. If the enable signal is off (open) or the drive is not running, the outer loop is held in reset.

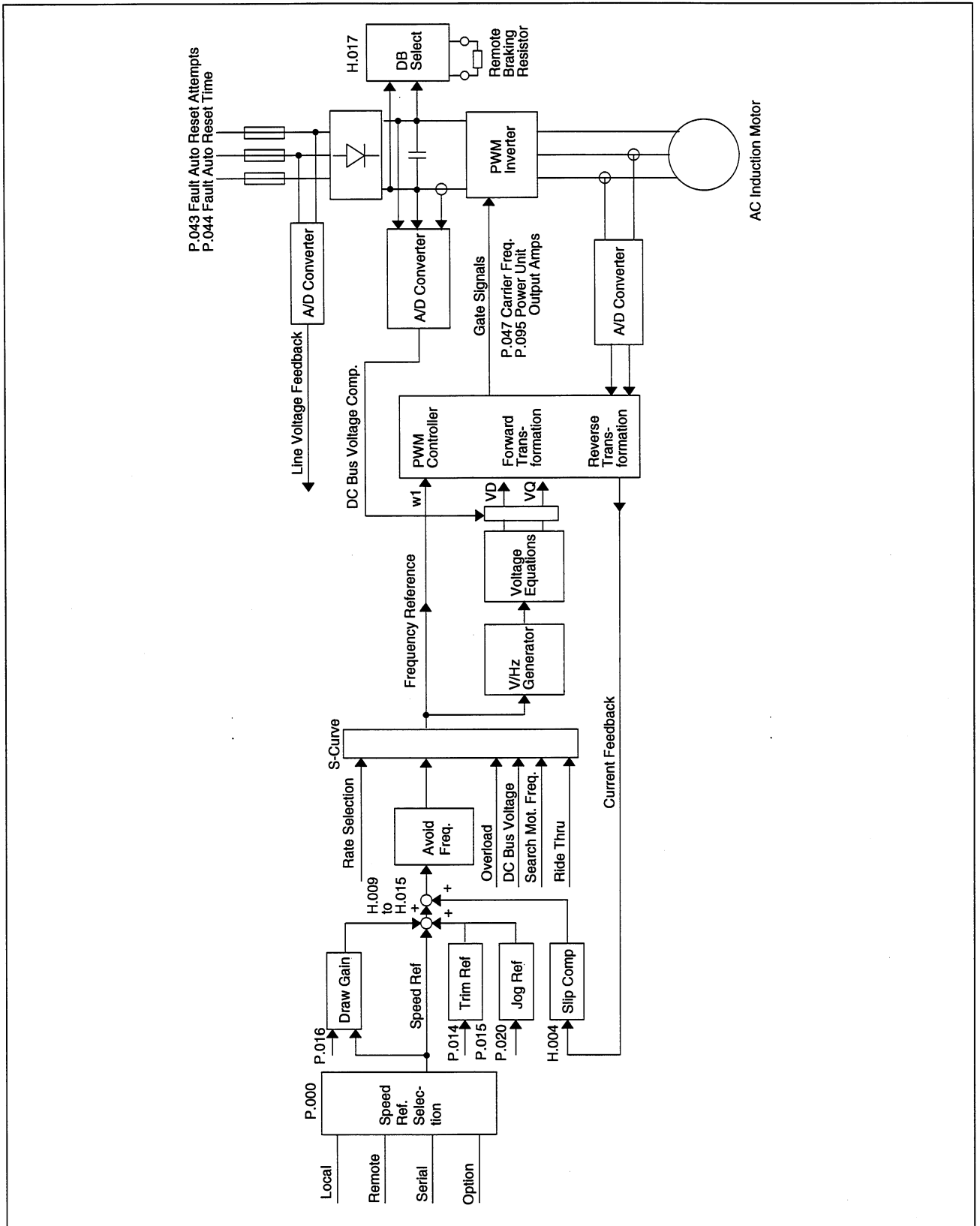

Figure G.1 – Volts/Hertz Regulator Block Diagram

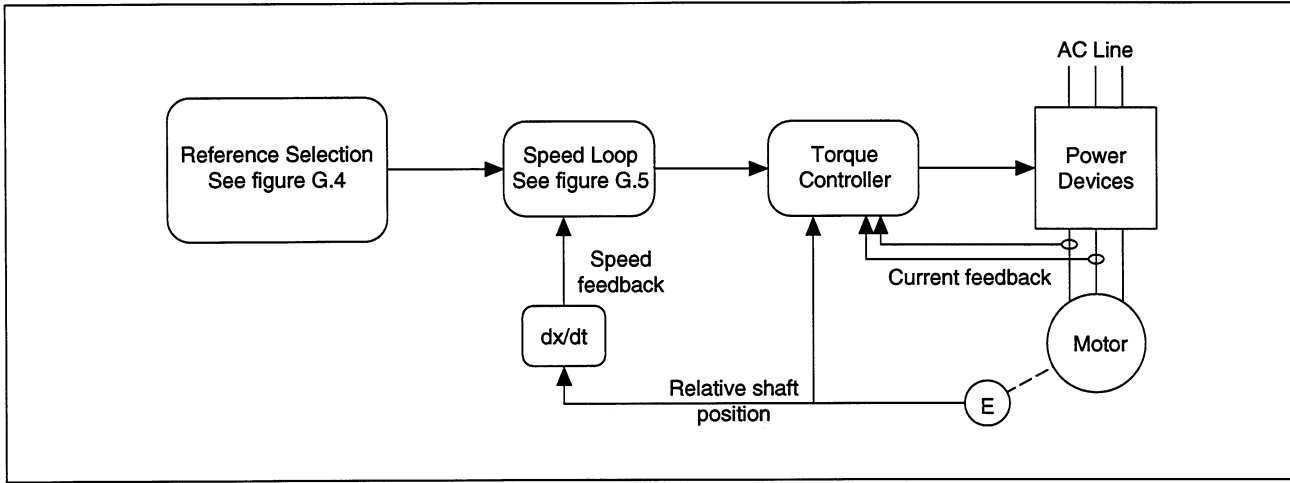

Figure G.2 – Flux Vector Control Block Diagram

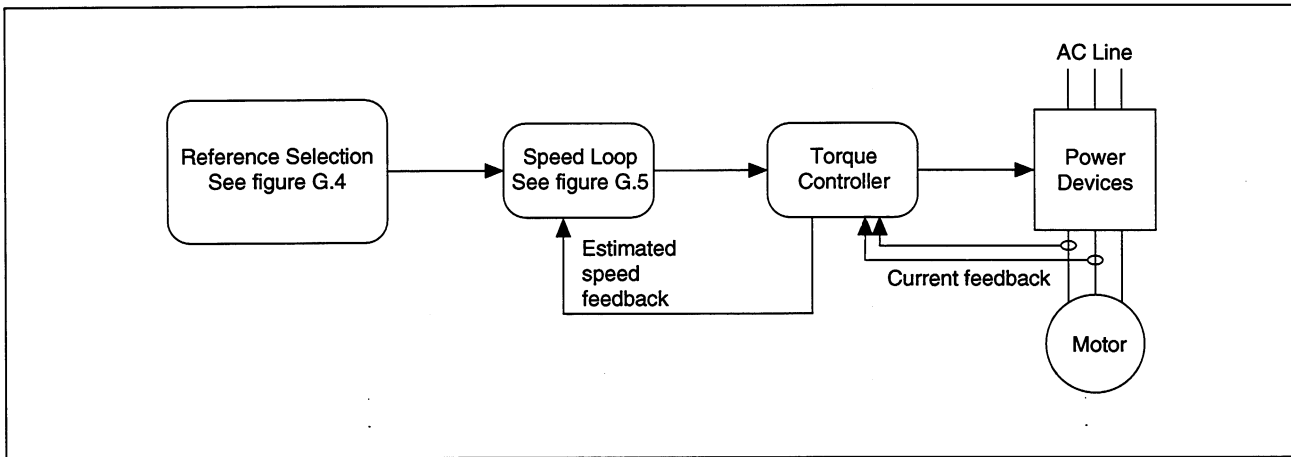

Figure G.3 – Sensorless Vector Control Block Diagram

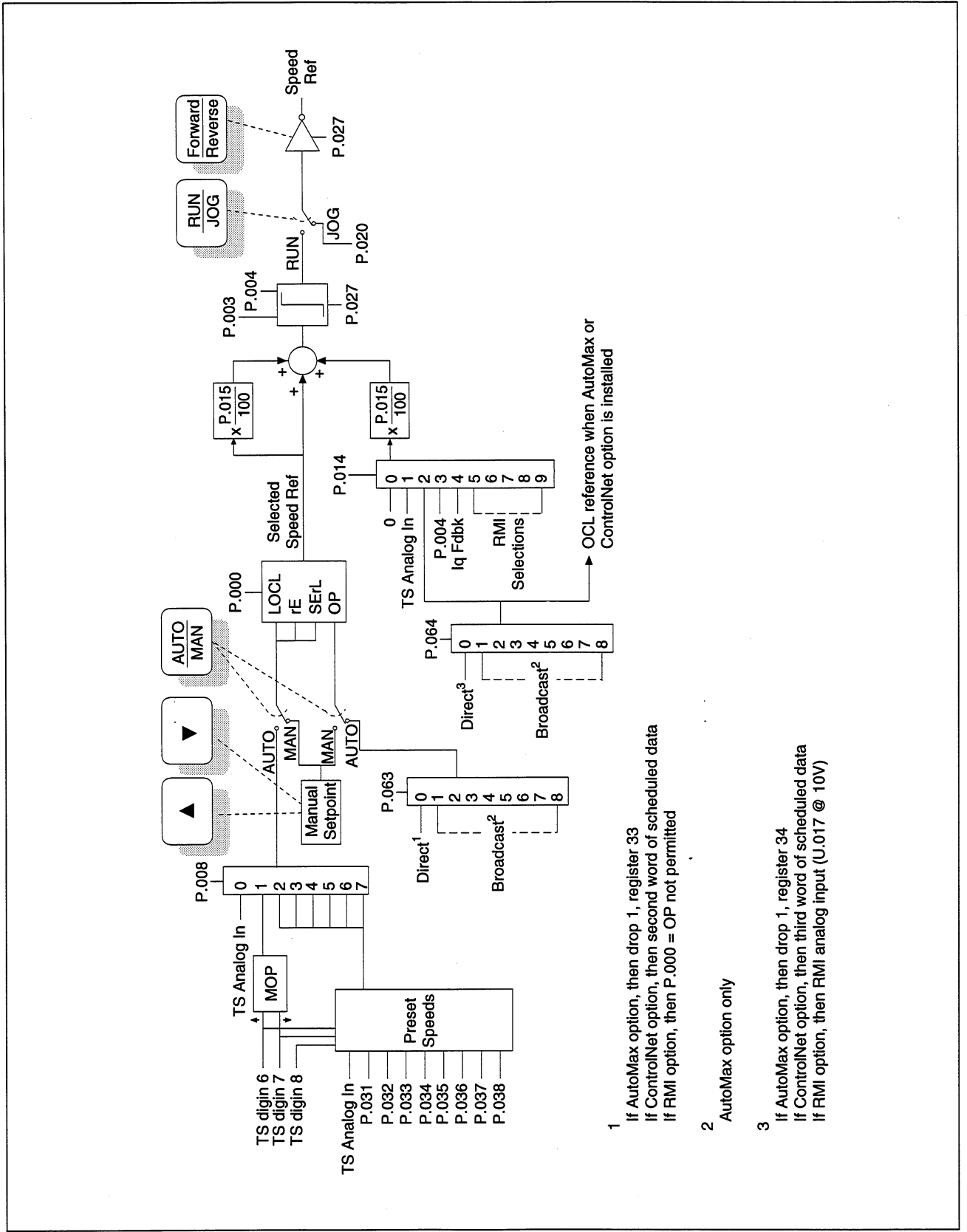

Figure G.4 – Vector Regulator: Reference Detail

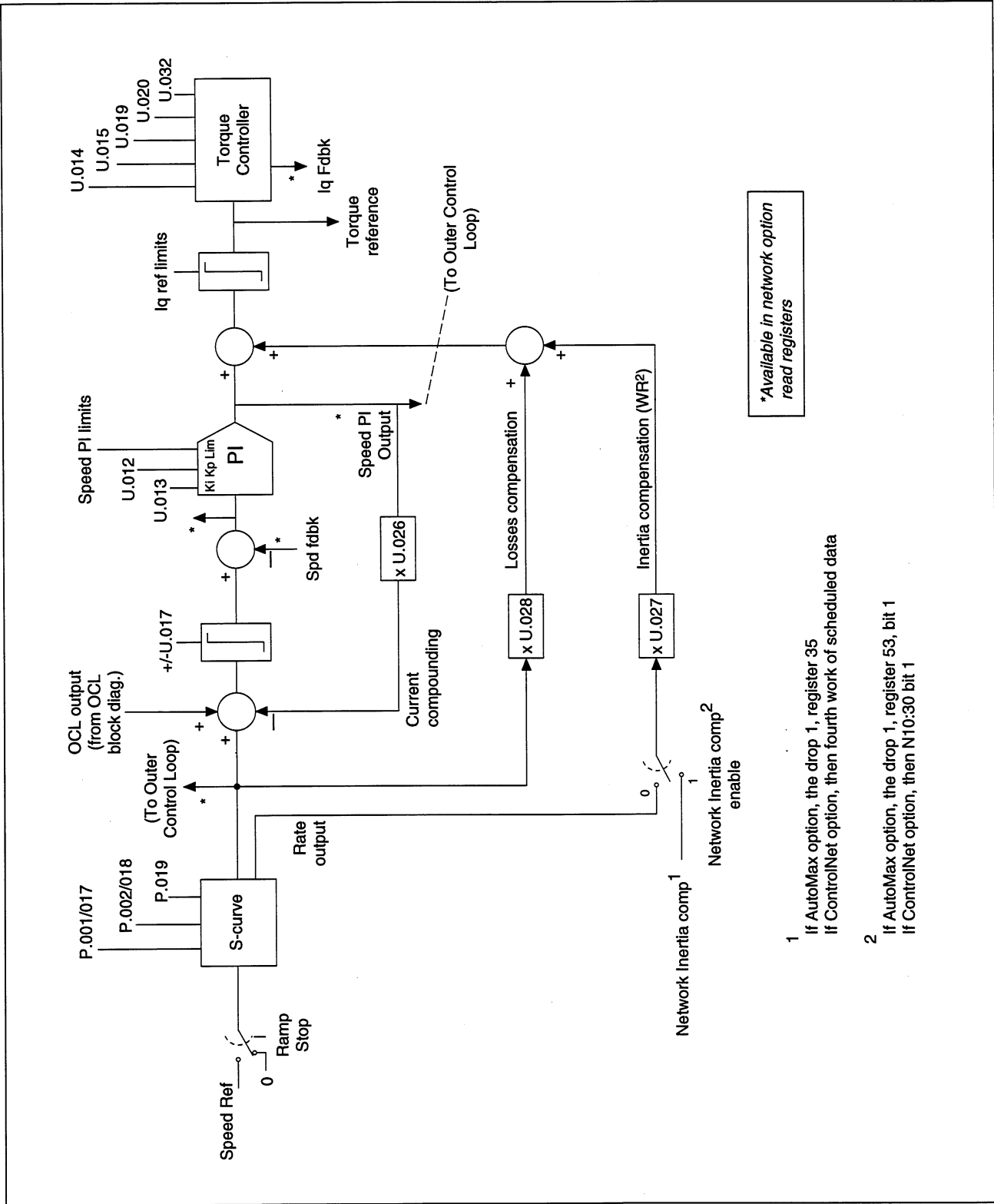

Figure G.5 – Vector Regulator: Speed Loop Detail

- 1 If AutoMax option, the drop 1, register 35
If ControlNet option, then fourth work of scheduled data
- 2 If AutoMax option, the drop 1, register 53, bit 1
If ControlNet option, then N10:30 bit 1

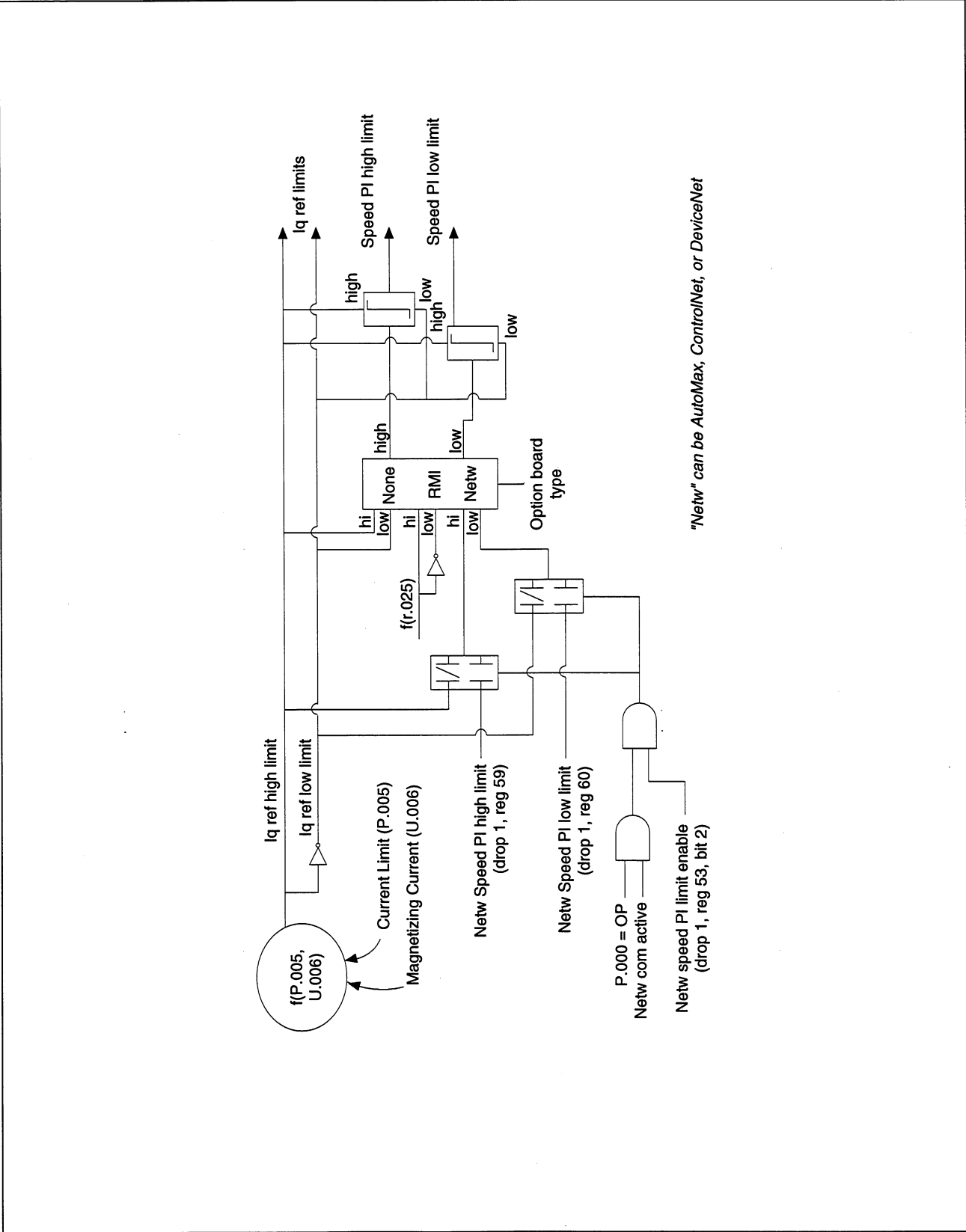

Figure G.6 – Vector Speed PI and Iq Reference Limit Selection

Reach us now at www.rockwellautomation.com

Wherever you need us, Rockwell Automation brings together leading brands in industrial automation including Allen-Bradley controls, Reliance Electric power transmission products, Dodge mechanical power transmission components, and Rockwell Software. Rockwell Automation's unique, flexible approach to helping customers achieve a competitive advantage is supported by thousands of authorized partners, distributors and system integrators around the world.

Americas Headquarters, 1201 South Second Street, Milwaukee, WI 53204, USA, Tel: (1) 414 382-2000, Fax: (1) 414 382-4444
European Headquarters SA/NV, Boulevard du Souverain 36, 1170 Brussels, Belgium, Tel: (32) 2 663 06 00, Fax (32) 2 663 06 40
Asia Pacific Headquarters, 27/F Citicorp Centre, 18 Whitfield Road, Causeway Bay, Hong Kong, Tel: (852) 2887 4788, Fax: (852) 2508 1846
Reliance Electric Standard Drives Business, 24800 Tungsten Road, Cleveland, OH 44117, USA, Tel: (1) 888 374 8370, Fax (216) 266 7095



**Rockwell
Automation**