



**SAF DRIVE SYSTEMS**

*Complete Drive Solutions*

**ONYX**

**VARIABLE FREQUENCY DRIVE**

Instruction Manual D2-3310-1

**INSTALLATION & OPERATING INSTRUCTIONS**

The information

**ONLY QUALIFIED  
CONSTRUCTION  
INVOLVED SHOULD  
EQUIPMENT. R  
BEFORE PROCEED  
RESULT IN SEVERE**

# Table of Contents

<b>1.0</b>	<b>Receive and Accept Shipment</b>	<b>1-1</b>
1.1	About this Instruction Manual	1-1
1.2	Identify the Controller	1-1
1.3	Controller Description	1-2
1.4	Controller Nameplate	1-5
1.5	Receive and Accept the Shipment	1-5
1.6	File a Return Request	1-6
1.7	Storage until Installation	1-6
1.8	ONYX Demo Packages - Model ONYX-DEMO-N4 Only	1-6
<b>2.0</b>	<b>Specifications</b>	<b>2-1</b>
2.1	Controller Specifications	2-1
2.2	Service Conditions	2-3
2.3	Controller Input/Output Specifications	2-4
2.3.1	Controller Inputs	2-4
2.3.2	Controller Outputs	2-5
2.4	Controller Application Data	2-5
2.5	Motor Applications	2-6
2.5.1	Single-Motor Applications	2-6
2.5.2	Multi-Motor Applications	2-6
2.5.3	Motor Lead Lengths	2-7
2.6	Controller Power Loss	2-8
<b>3.0</b>	<b>Installation and Wiring</b>	<b>3-1</b>
3.1	Planning and Location	3-1
3.2	Controller Mounting	3-2
3.3	Size A Controller Mounting (115 VAC & 230 VAC 1 HP)	3-2
3.4	Size B Controller Mounting (460 VAC 1-5 HP & 575 VAC 1-5 HP)	3-4
3.5	Size C Controller Mounting (230 VAC 2, 3 and 5 HP, 460 VAC 7.5 and 10 HP, and 575 VAC 7.5 and 10 HP)	3-5
3.6	Install an External Input Disconnect	3-6
3.7	Install A-C Branch Circuit Protection	3-7
3.8	Transformer Installation (If Needed)	3-9
3.8.1	Input Transformers	3-9
3.8.2	Output Transformers	3-9
3.9	Grounding	3-10
3.10	Motor Preparation	3-11
3.11	Controller Wiring	3-11
3.11.1	Power Wiring	3-16
3.11.2	Control and Signal Wiring	3-18
3.11.3	Remote Analog Input Reference Jumper Setting	3-24
3.12	Optional Dynamic Braking Wiring	3-26
<b>4.0</b>	<b>Keypad and Display Operation</b>	<b>4-1</b>
4.1	Keypad and Display Description	4-1
4.2	Indicator Lights	4-1
4.2.1	Display Mode LEDs	4-2

4.2.2	Operation Mode LEDs	4-2
4.3	Key Descriptions	4-3
4.4	Power Up	4-5
4.5	Modes of Controller Operation	4-6
4.5.1	Display Modes	4-6
4.5.2	Program Mode	4-7
4.6	Error Log	4-8
<b>5.0</b>	<b>Adjusting the Values of Drive Functions</b>	<b>5-1</b>
5.1	F-00 - Control Source Select	5-3
5.2	F-01 - Acceleration Rate	5-4
5.3	F-02 - Deceleration Rate	5-4
5.4	F-03 - Minimum Speed	5-5
5.5	F-04 - Maximum Speed	5-5
5.6	F-05 - Current Limit	5-6
5.7	F-06 - Manual Torque Boost	5-6
5.8	F-07 - V/Hz (Base Speed)	5-7
5.9	F-08 - RPM At Base Speed	5-7
5.10	F-09 - Configurable Output Relay Select	5-8
5.11	F-10 - Carrier Frequency	5-9
5.12	F-11 - Remote Reference Gain	5-9
5.13	F-12 - Remote Reference Offset	5-10
5.14	F-13 - Percent Selected Speed, Reference Display Enable (4th Display Mode)	5-11
5.15	F-14 - Electronic Thermal Overload	5-11
5.16	F-15 - Electronic Thermal Overload Enable	5-12
5.17	F-16 - Coast Stop Enable	5-12
5.18	F-17 - Reverse Disable	5-13
5.19	F-18 - RPM Setpoint Enable	5-13
5.20	F-19 - Power-up Start Enable	5-14
5.21	F-20 - Password Lockout Enable	5-15
5.22	F-21 - Avoidance Frequency	5-15
5.23	F-22 - Avoidance Bandwidth	5-16
5.24	F-23, F-24, and F-25 - Multi-speed Presets #1, #2, and #3	5-17
5.25	F-26 - Auto-Restart Number of Attempts	5-18
5.26	F-27 - Auto-Restart Retry Wait Time	5-19
5.27	F-28 - Controller Voltage Selection	5-19
5.28	F-49 - Version Information	5-19
5.29	ERR - Error Log	5-19
<b>6.0</b>	<b>Start the Controller</b>	<b>6-1</b>
6.1	Check the Installation	6-1
6.2	Start the Controller	6-2
6.3	Cover Installation, NEMA 4X (Indoor Only)/12	6-4
<b>7.0</b>	<b>Troubleshooting, Fault Codes, and Replacement Parts</b>	<b>7-1</b>
7.1	System Operation	7-1
7.2	Fault Codes	7-3
7.3	How to Access and Read the Error Log	7-4
7.4	Verify D-C Bus Voltage	7-7

<b>8.0</b>	<b>Glossary of Common Terms .....</b>	<b>8-1</b>
<b>9.0</b>	<b>Index .....</b>	<b>9-1</b>

# List of Figures

Figure 1.1 - Controller Functional Block Diagram .....	1-4
Figure 1.2 - Nameplate Information. ....	1-5
Figure 2.1 - Motor Lead Length Connections. ....	2-7
Figure 3.1 - Size A Physical Dimensions. ....	3-3
Figure 3.2 - Size B Physical Dimensions. ....	3-4
Figure 3.3 - Size C Physical Dimensions. ....	3-5
Figure 3.4 - Size A Wiring Locations. ....	3-12
Figure 3.5 - Size B Wiring Locations. ....	3-13
Figure 3.6 - Size C Wiring Locations. ....	3-14
Figure 3.6a - Controller Diagram .....	3-15
Figure 3.7 - Power Terminal Strip For 115 VAC and 230 VAC Controllers. ...	3-16
Figure 3.8 - Power Terminal Strip For 460 VAC and 575 VAC Controllers. ...	3-16
Figure 3.9 - Control Terminal Strip. ....	3-19
Figure 3.10 - Speed Reference Input Wiring .....	3-21
Figure 3.11 - Analog Meter Output Wiring. ....	3-22
Figure 3.12 - IET/Controller Output Wiring. ....	3-22
Figure 3.13 - Start-Stop Control Wiring for Control Modes other than Multi-speed Inputs. ....	3-23
Figure 3.14 - IET Reset Control Wiring for Control Modes other than Multi-speed Inputs .....	3-23
Figure 3.15 - Forward/Reverse Control Wiring. ....	3-24
Figure 3.16 - Coast-Stop Pushbutton Control Wiring. ....	3-24
Figure 3.17 - J6 Jumper Settings. ....	3-25
Figure 3.18 - Dynamic Braking Output Wiring for 230 VAC Controllers. ...	3-27
Figure 3.19 - Dynamic Braking Output Wiring For 460 VAC and 575 VAC Controllers. ....	3-28
Figure 4.1 - ONYX Controller Keypad and Display. ....	4-1
Figure 5.1 - Manual Torque Boost Adjustable Range. ....	5-6
Figure 5.2 - Volts/Hertz Curve. ....	5-7
Figure 7.1 - System Block Diagram. ....	7-2
Figure 7.2 - System Block Diagram (cont'd.) .....	7-3
Figure 7.3 - D-C Bus Terminals on 230 VAC Controllers. ....	7-8
Figure 7.4 - D-C Bus Terminals on 460 VAC and 575 VAC Controllers. ....	7-8

# List of Tables

Table 2.1 - 115 VAC (Demo) Controller Ratings with Single-Phase Power(1) .....	2-1
Table 2.2 - 230 VAC Controller Ratings with Single-Phase Power(1) .....	2-1
Table 2.3 - 230 VAC Controller Ratings with Three-Phase Power .....	2-2
Table 2.4 - 460 VAC Controller Ratings with Three-Phase Power .....	2-2
Table 2.5 - 575 VAC Controller Ratings with Three-Phase Power .....	2-3
Table 2.6 - Controller Power Loss (Watts) .....	2-10

Table 3.1 - Controller Model Dimensional Size .....	3-2
Table 3.2 - Single-Phase A-C Input Line Branch Circuit Protection. ....	3-7
Table 3.3 - Three-Phase A-C Input Line Branch Circuit Protection for 230 VAC Controllers. ....	3-7
Table 3.4 - Three-Phase A-C Input Line Branch Circuit Protection for 460 VAC Controllers. ....	3-8
Table 3.5 - Three-Phase A-C Input Line Branch Circuit Protection for 575 VAC Controllers. ....	3-8
Table 3.6 - Recommended Power Wire Size (1,2) .....	3-17
Table 3.7 - Power Terminal Tightening Torques (in-lbs) .....	3-17
Table 3.8 - Recommended Control and Signal Wire Sizes .....	3-20
Table 3.9 - Control Terminal Strip Tightening Torques (in-lbs) .....	3-20
Table 5.1 - Factory Default Settings .....	5-1
Table 6.1 - D-C Bus Voltage Value. ....	6-3
Table 7.1 - Fault Code Action List. ....	7-5



# 1.0 Receive and Accept Shipment

## DANGER

**ONLY QUALIFIED ELECTRICAL PERSONNEL FAMILIAR WITH THE CONSTRUCTION AND OPERATION OF THIS EQUIPMENT AND THE HAZARDS INVOLVED SHOULD INSTALL, ADJUST, OPERATE, AND/OR SERVICE THIS EQUIPMENT. READ AND UNDERSTAND THIS MANUAL IN ITS ENTIRETY BEFORE PROCEEDING. FAILURE TO OBSERVE THIS PRECAUTION COULD RESULT IN SEVERE BODILY INJURY OR LOSS OF LIFE.**

## 1.1 About this Instruction Manual

This instruction manual provides the information necessary to install, start up, operate and troubleshoot the ONYX controller.

Section 2 provides the specifications required to ensure proper operation of the controllers.

Section 3 instructs on how to install the controller along with, necessary wiring, and precautions.

Keypad operation is described in Section 4. A thorough understanding of the keypad, display and indicators is necessary to adjust, start-up, operate or troubleshoot the ONYX controller.

Section 5 instructs on how to adjust the drive functions and the defaults as shipped from the factory.

Section 6 gives Controller Startup procedures.

Section 7 provides troubleshooting information and fault code conditions, replacement parts, and illustrates the drive functionality through a system functional block diagram.

Section 8 contains a Glossary of common terms used throughout this instruction manual.

Section 9 is an alphabetical index arranged by subject to be used to locate specific information quickly.

## 1.2 Identify the Controller

Each SAF Drive Systems Ltd., ONYX can be identified by its model number (for standard controllers) or by the sales order number (for customer-specified controllers). This number appears on the shipping label and is stamped on the controller nameplate. (Refer to controller nameplate for more information.) Verify that the model number shown on the nameplate matches the shipping label. Refer to this model number whenever discussing the equipment with SAF Drive Systems Ltd. personnel.

The standard model number describes the controller as follows:

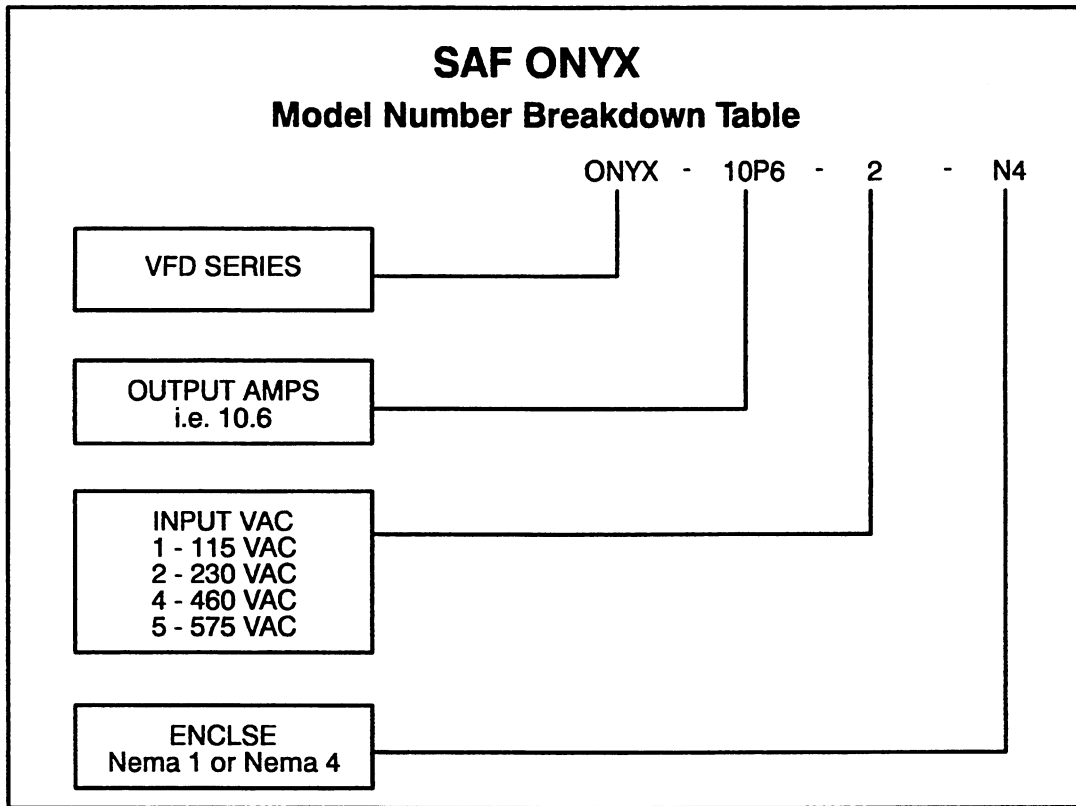

### 1.3 Controller Description

ONYX controllers operate on a three-phase (single-phase) A-C power source at the appropriate rated input voltage. As shown in Figure 1-1, the A-C power source is supplied to the controller's input terminals and passes through three suppressors (MOV). The suppressors are used to limit voltage transients within the maximum voltage rating of the diode module.

The diode module rectifies the incoming A-C source to a constant D-C voltage. This D-C voltage is then applied to an internal power supply and to a large D-C bus capacitor. The internal power supply is a D-C to D-C type to provide the necessary voltage and current source required within the controller. The large D-C bus capacitor filters the D-C voltage which then enters an IGBT (insulated-gate bipolar transistor) inverter bridge. Under software control from an internal microcontroller, the IGBT transforms the constant D-C voltage into a PWM (Pulse-width Modulated) voltage signal corresponding to the variable voltage and variable frequency source selected for the motor.

The IGBT inverter bridge is switched by the microcontroller using a 4, 6, or 8 kHz carrier frequency. A low carrier frequency will maximize the power rating of the controller but also increase acoustic noise. A higher carrier frequency selection reduces acoustic noise but results in a derating of the controller's efficiency. The microcontroller also provides for operational input data from the local operator interface and operates the controller.

The microcontroller directs the overall operation of the ONYX controller for adjustable-speed performance of A-C induction and synchronous motors. User programmable functions, configure the controller's performance to fit motor characteristics and the users end application. (Refer to Motor Applications in Section 2, and Adjusting Drive Functions, Section 5 for more information.) External control of the controller is provided by the local operator interface or user installed wiring.

The local operator interface contains a display, indicators, and control and programming keys. (Refer to Section 4, Keypad and Display Operation, for more information.) In addition to using the local operator interface, user wiring can be installed for operational control, motor speed adjustment, analog metering, dynamic braking (optional) and an emergency stop (customer supplied). (Refer to Installation and Wiring, Section 3).

The controller is intended to operate under trip free (fault) characteristics. The controller uses selected signals to extend the acceleration (starting) and deceleration (stopping) rates of the motor. When a fault does occur, however, the controller's microcontroller generates an instantaneous electronic trip (IET) signal to turn the controller off (coast-to-stop). An indication of the IET fault, which occurred, is stored in the controller and can be displayed on the local operator interface. After a fault, the STOP/RESET key or a wired IET RESET pushbutton switch must be pressed (resetting the IET signal) to clear the fault from the controller (Refer to Section 7, Troubleshooting, Fault Codes, and Replacement Parts).

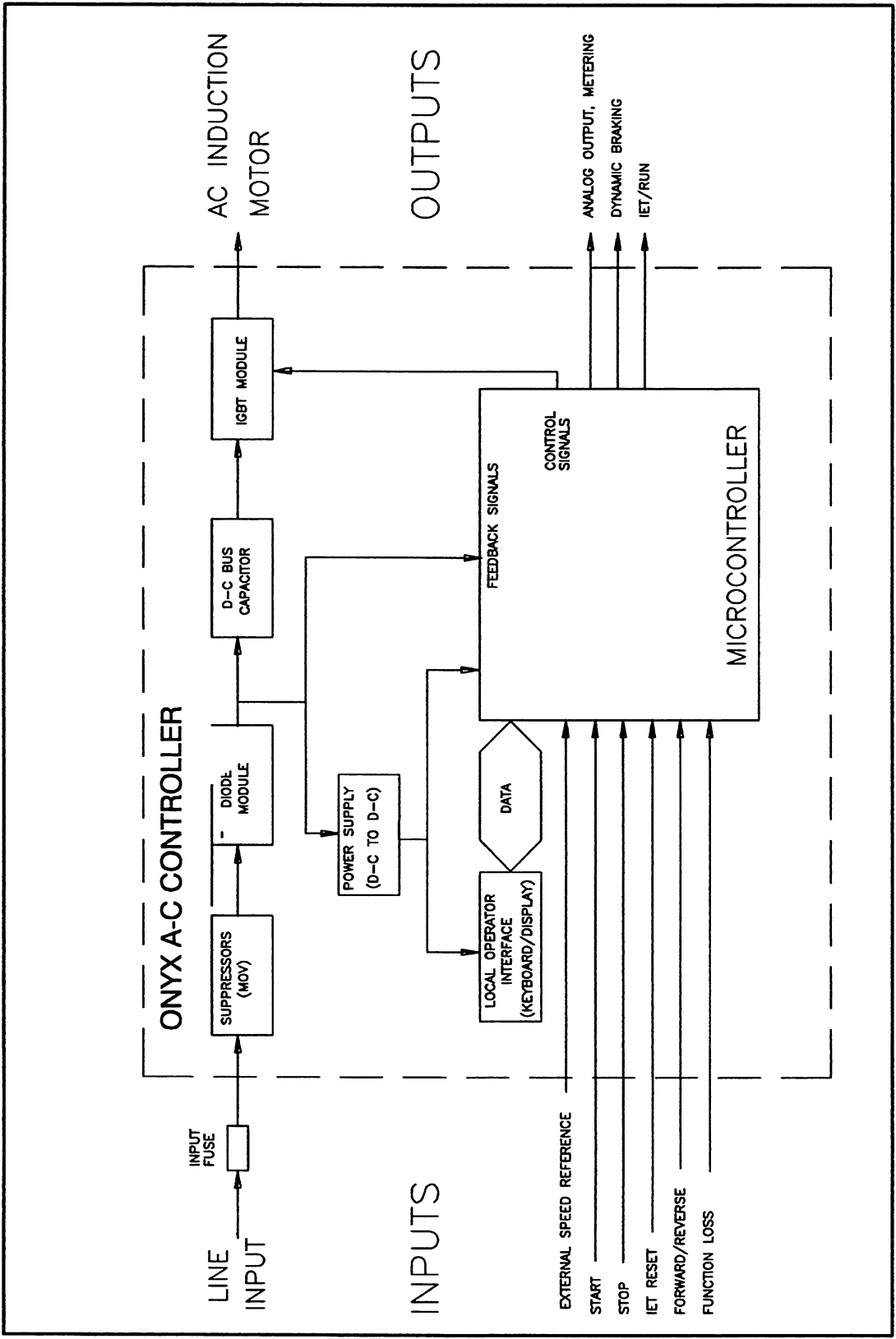

Figure 1.1 - Controller Functional Block Diagram

## 1.4 Controller Nameplate

The controller nameplate is located on the base in the upper right side of the controller. The nameplate gives information such as Model Number, Controller rated amps, etc. Refer to Figure 1-2.

<b>SAF Drive Systems</b> Complete Drive Solutions				
				M/N
SER NO				
	KVA	HP@0.8Pf	I/M	
AC INPUT	VOLTS	MAX AMPS	HZ	PH
AC OUT	VOLTS	MAX AMPS		
SHORT CIRCUIT SYM RMS RATING				
ENCLOSURE				

615154-5

Figure 1.2 - Nameplate Information.

*NOTE: Actual nameplate configuration is subject to change.*

## 1.5 Receive and Accept the Shipment

SAF Drive Systems Ltd. terms of sale, in all instances, are F.O.B. point of origin. The user is responsible for thoroughly inspecting the equipment before accepting shipment from the transportation company.

If all the items called for on the bill of lading or on the express receipt are not included or if any items are obviously damaged, do not accept the shipment until the freight or express agent makes an appropriate notation on your freight bill or express receipt. If any concealed loss or damage is discovered later, notify your freight or express agent within 15 days of receipt and request that he make an inspection of the shipment. Keep the entire shipment intact in its original shipping container.

The user is responsible for making a claim against the Carrier for any shortage or damage occurring in transit. Claims for loss or damage in shipment must not be deducted from the SAF Drive Systems Ltd. invoice, nor should payment of the invoice be withheld while awaiting adjustment of such claims since the Carrier guarantees safe delivery.

## 1.6 File a Return Request

1. To return equipment, send a written request to SAF within ten days of receipt.
2. Do not return equipment without a numbered Material Return Authorization (MRA) from SAF Drive Systems Ltd.
3. SAF Drive Systems Ltd. reserves the right to inspect the equipment on site.

## 1.7 Storage until Installation

After receipt inspections, repack the controller in its original shipping container until installation. If a period of storage is expected, store in the original shipping container with its internal packing.

To ensure satisfactory operation at startup and to maintain warranty coverage, store the equipment:

- in its original shipping container in a clean, dry, safe place.
- within an ambient temperature range of  $-40^{\circ}\text{C}$  to  $65^{\circ}\text{C}$  ( $-40^{\circ}\text{F}$  to  $149^{\circ}\text{F}$ )
- within a relative humidity range of 5 to 95% without condensation.
- away from a highly corrosive atmosphere. In harsh environments, cover the shipping/storage container.

## 1.8 ONYX Demo Packages - Model ONYX-DEMO-N4 Only

**CAUTION:** The ONYX-DEMO-N4 controller operates with a single-phase, 115 VAC input. Do not operate this controller with 230 VAC input. Failure to observe this precaution could result in damage to, or destruction of the equipment.

The controller model number, ONYX-DEMO-N4, supplied in the ONYX demo package is specially configured to operate on 1 phase, 115 volt power and is intended for demonstration purposes only. It will operate an unloaded motor. Refer to Table 2.1 for the controller's current and voltage data.

## 2.0 Specifications

### 2.1 Controller Specifications

ONYX 230 VAC, 460 VAC, and 575 VAC Controllers are intended to operate from a three phase, A-C power source at the rated voltage listed on the controller nameplate (See Figure 1.1). Each type of controller model can operate on either a 50 Hz or 60 Hz line frequency. The controllers provide three-phase variable voltage and variable frequency to the motor. Some 230 VAC Controllers can also operate from a single-phase voltage source. Three-phase and single-phase controller current ratings are listed in Tables 2.1 thru 2.5.

Table 2.1 - Model 115 VAC (Demo) Controller Ratings with Single-Phase Power<sup>(1)</sup>

Model Number	Type	Input voltage (VAC)	Output Amps (A)	Input Amps (A)	Input (KVA)
ONYX-6P8-N1	1 Hp NEMA 1	115	6.8	13.1	1.5
ONYX-DEMO-N4	Demo	115	2.0	5.2	0.6

Table 2.2 - 230 VAC Controller Ratings with Single-Phase Power<sup>(1)</sup>

Model Number	Type <sup>(2, 3)</sup>	Input voltage (VAC)	Output <sup>(2)</sup> Amps (A)	Input Amps (A)	Input (KVA)
ONYX-4P5-2-N4	1Hp NEMA 4X/12	200-230	1.7	5.0	1.3

(1) Single-phase input power applies only to models shown in Table 2.1 and Table 2.2.

(2) To size the controller for **Motor Nameplate Horsepower** and **Motor Nameplate Amperes**, refer to Motor Applications in this section.

(3) NEMA 4X is indoor only.

Table 2.3 - 230 VAC Controller Ratings with Three-Phase Power

Model Number	Type <sup>(1, 2)</sup>	Input voltage (VAC)	Output <sup>(1)</sup> Amps (A)	Input Amps (A)	Input KVA
ONYX-4P5-2-N4	1Hp NEMA 4X/12	200-230			
	4 kHz Carrier		4.5	6.4	2.6
	6 kHz Carrier		3.6	5.2	2.0
	8 kHz Carrier		3.6	5.2	2.0
ONYX-7P5-2-N4	2Hp NEMA 4X/12	200-230	7.5	9.9	4.0
ONYX-10P6-2-N4	3Hp NEMA 4X/12	200-230	10.6	12.5	5.0
ONYX-14P2-2-N4	5Hp NEMA 4X/12	200-230	14.2	17.2	6.9

(1) To size the controller for **Motor Nameplate Horsepower** and **Motor Nameplate Amperes**, refer to Motor Applications in this section.

(2) NEMA 4X is indoor only.

Table 2.4 - 460 VAC Controller Ratings with Three-Phase Power

Model Number	Type <sup>(1, 2)</sup>	Input voltage (VAC)	Output <sup>(1)</sup> Amps (A)	Input Amps (A)	Input (KVA)
ONYX-2P1-4-N4	1Hp NEMA 4X/12	380-460	2.1	2.5	2.0
ONYX-3P4-4-N4	2Hp NEMA 4X/12	380-460	3.4	4.2	3.3
ONYX-5P3-4-N4	3Hp NEMA 4X/12	380-460	5.3	6.4	5.1
ONYX-8P2-4-N4	5Hp NEMA 4X/12	400-460	8.2	9.9	8.0
ONYX-11P1-4-N4	7.5Hp NEMA 4X/12	380-460	11.1	13.4	10.7
ONYX-14P2-4-N4	10Hp NEMA 4X/12	380-460	14.2	17.2	13.7

(1) To size the controller for **Motor Nameplate Horsepower** and **Motor Nameplate Amperes**, refer to Motor Applications in this section.

(2) NEMA 4X is indoor only.

Table 2.5 - 575 VAC Controller Ratings with Three-Phase Power

Model Number	Type <sup>(1, 2)</sup>	Input voltage (VAC)	Output <sup>(1)</sup> Amps (A)	Input Amps (A)	Input (KVA)
ONYX-1P6-5-N4	1Hp NEMA 4X/12	575	1.6	2.0	2.0
ONYX-2P7-5-N4	2Hp NEMA 4X/12	575	2.7	3.4	3.3
ONYX-4P3-5-N4	3Hp NEMA 4X/12	575	4.3	5.2	5.1
ONYX-6P2-5-N4	5Hp NEMA 4X/12	575	6.2	7.5	7.5
ONYX-9-5-N4	7.5Hp NEMA 4X/12	575	9.0	10.9	10.9
ONYX-12-5-N4	10Hp NEMA 4X/12	575	12.0	14.5	14.4

(1) To size the controller for **Motor Nameplate Horsepower** and **Motor Nameplate Amperes**, refer to Motor Applications in this section.

(2) NEMA 4X is indoor only.

## 2.2 Service Conditions

- Ambient temperature: 0°C to 40°C (32°F to 104°F) for enclosed controllers  
0°C to 55°C for open chassis controller (cover removed)
- Storage temperature: -40°C to 65°C (-40°F to 149°F)
- Atmosphere: 5 to 95% non-condensing relative humidity
- Elevation: To 3300 feet (1000 meters) above sea level without derating.  
For every 300 feet (91.4 meters) from 3300 to 10,000 feet (1001 to 3033 meters), derate the current by 1%  
Above 10,000 feet (3033 meters) - Consult SAF Drive Systems Ltd.
- Line frequency: 50 ± 5% Hz and 60 ± 5% Hz
- Line voltage variation: ± 10%

- A-C Line distribution capacity (maximum):
  - 230 VAC and 115 VAC Controllers:  
100KVA 115 VAC, single-phase and  
and for 230 VAC, three-phase with a  
maximum of 5,000 symmetrical amp  
fault current capacity.
  - 460 VAC and 575 VAC Controllers:  
1000KVA for 460 and 575 VAC,  
three-phase with a maximum of 25,000  
symmetrical amp fault current  
capacity.

## 2.3 Controller Input/Output Specifications

The controller input/output specifications are subject to some of the 29 functions which can be adjusted for user specified applications. (Refer to Section 5, **Adjusting the Values of Drive Functions.**)

### 2.3.1 Controller Inputs

- Speed Reference input: 5K $\Omega$  Potentiometer (0-10 VDC) or 0-20 mA current-loop (**Jumper selectable**, Refer to Section 3)

*NOTE: The controller provides +15 VDC buffered through a 1.875 K $\Omega$  resistor, a 500 $\Omega$  current loop resistor and an associated reference.*

#### Control logic

The controller uses an internal 24 VDC power supply to provide the required voltage for control signals. Enabling or disabling a control signal requires that a contact (switch) be opened or closed.

- Stop: Open Contact  
(Contact must be closed when drive is running. An open contact turns the controller "off". The drive will remain and/or be held off as long as contact is open.)
- Start: Open to Closed Contact Transition - momentary or fixed contact closure  
(Edge-sensitive control input signal which must see an open to closed transition.)
- IET Reset: Open to Closed Contact Transition - momentary or fixed contact closure  
(Edge-sensitive control input signal which must see an open to closed transition.)
- Forward/  
Reverse: Open Contact - asserting the Forward Direction  
-or-  
Closed Contact - asserting the Reverse Direction

- **Function**  
Loss: Open Contact

(Contact must be closed when drive is running. An open contact turns the controller “off”. The drive will remain and/or be held off as long as contact is open.)

See Sections 5.1 and 5.24 for a description of multi-speed start/stop configuration.

## 2.3.2 Controller Outputs

- **Analog Output, metering:** 0 to 10 VDC scaled signal (The signal represents the same display mode currently shown on the local display of the controller.) The display mode can be **one** of the following:
  - Output Volts - (0 - 115 VAC for 115 VAC Controllers)  
(0 - 253 VAC, for 230 VAC Controllers)  
(0 - 506 VAC, for 460 VAC Controllers)  
(0 - 632 VAC, for 575 VAC Controllers)
  - % Load (AMPS) - 0 - 200% (Percentage of output amps based on controller nameplate)
  - RPM/  
Engineering Unit - Minimum to Maximum RPM  
-or-  
Minimum to Maximum of any Engineering unit  
(user application dependent - Refer to Function F-08 in Section 5)
  - % Selected Speed  
Reference - 0 - 100% (Percentage of the selected reference signal range)

**NOTE:** *Changing the mode displayed on the local operator interface will change the signal on the meter analog output. The selected mode displayed when the drive is powered down will be the same mode displayed when the controller is powered up.*

- **Dynamic Braking**  
Signal: Dynamic braking control signal used by the the controllers optional Dynamic Braking Kit
- **Configurable Output Relay:** 115 VAC/ 24 VDC, 1/2 Amp relay output (1 Form A and 1 Form B contact wired with a single common)

## 2.4 Controller Application Data

- Displacement Power Factor: 0.96
- Maximum Load: 150% for one minute (based on controller nameplate rating)
- Overcurrent Trip (IET): 200% rated drive current
- Linearity:  $\pm 0.05\%$  (Speed reference to output frequency)

## DANGER

**THE ONYX CONTROLLER IS INTENDED TO OPERATE THE MOTOR AT A PREDETERMINED MINIMUM SPEED UNLESS DISCONNECTED FROM THE POWER SOURCE. TO PREVENT INADVERTENT CONTACT WITH OPERATING EQUIPMENT, THE USER MUST VERIFY THAT THE MOTOR OUTPUT SHAFT WILL ROTATE AT ALL COMBINATIONS OF LOAD AND OUTPUT SPEED REQUIRED BY THE APPLICATION. FAILURE TO OBSERVE THIS PRECAUTION MAY RESULT IN SEVERE BODILY INJURY OR LOSS OF LIFE.**

- Minimum Frequency: 0.5 to 30 Hz
- Maximum Frequency: 30 to 240 Hz
- Long Term Frequency Stability: 0.01%
- Line Dip Ride Through Capacity: 500ms

## 2.5 Motor Applications

The ONYX is a current rated variable frequency controller. The horsepower ratings listed are for reference purposes only. To ensure proper sizing of controller, check the current rating of the variable frequency controller is equal or larger than the motor current.

### 2.5.1 Single-Motor Applications

The controller and motor must be sized for the load and speed requirements of the specific application.

If the motor is oversized the motor operating current must not exceed the drive's rated output current (at a selected carrier frequency). In addition, the motor horsepower must not be more than one size larger than the controller's horsepower rating.

If the motor will be operated BELOW one half of the motor's rated speed, the motor overload relay may not protect the motor because of reduced cooling action due to the reduced speed. A motor thermostat, internal to the motor, should be installed because it monitors the actual temperature of the windings.

### 2.5.2 Multi-Motor Applications

One controller can run two or more motors. Adhere to the following requirements to assure correct drive operation:

1. When starting and stopping all the motors at the same time (using the drive for starting and stopping), the sum of the full-load sine wave currents of all the motors must be equal to or less than the maximum sine wave output current, at the carrier frequency selected, for the drive.

For example:

$$\begin{matrix} I_{FLA} & + & I_{FLA} & + & I_{FLA} & = & I_{TLA} \\ \text{(MOTOR 1)} & & \text{(MOTOR 2)} & & \text{(MOTOR 3)} & & \text{(TOTAL LOAD)} \end{matrix}$$

Where:  $I_{TLA} \leq 100\%$  rated drive output at the carrier frequency selected

2. When one or more of the motors connected to the output of the controller are to start independently (using a secondary switching device to add or remove the motor from the drive):
  - Any motor that starts or stops, while the controller is running, must have a current rating less than 10% of the maximum sine wave current rating of the drive at the selected carrier frequency.
  - The sum of the maximum full load sine wave currents of all the motors connected continuously to the controller must be less than the maximum drive output current rating under any conditions.

**NOTE:** *Each motor requires separate overload protection (i.e. a motor relay or a motor thermostat).*

### 2.5.3 Motor Lead Lengths

For applications using one motor connected to the controller, individual motor lead lengths cannot exceed 250 feet per phase.

For applications where multiple motors are used, total lead lengths on each phase cannot exceed 250 feet, and each motor connection cannot exceed 250 feet. For example, Figure 2.1 illustrates correct application connections.

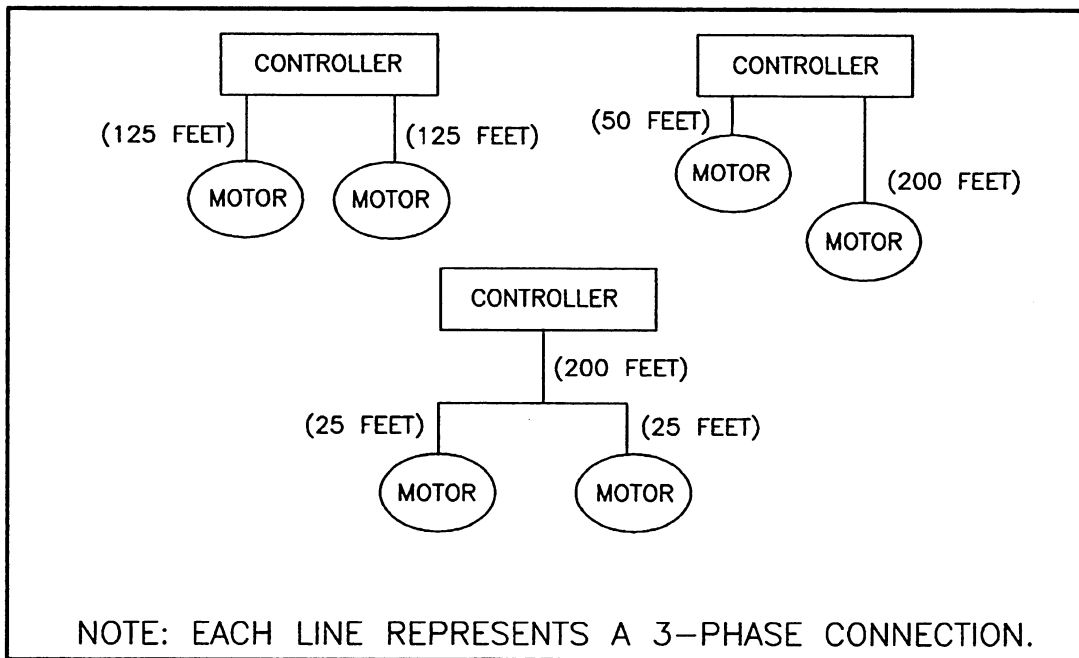

Figure 2.1 - Motor Lead Length Connections.

If total lead length exceeds 250 feet, nuisance tripping may occur. These trips are caused by capacitive current flow to ground and are not an indication of any problem with the controller. If the lead length must be exceeded, output line reactors or other steps must be taken to correct the problem.

## 2.6 Controller Power Loss

The typical full load power loss watts under all operating carrier frequencies is shown in Table 2.6.

Table 2.6 - Controller Power Loss (Watts)

Horsepower (Hp)	Input Voltage (VAC)	Typical Full Load Power Loss (WATTS)
<b>115 VAC Controllers</b>		
1/4-1	115	80
<b>230 VAC Controllers</b>		
1/4-1	200-230	70
2		120
3		210
5		250
<b>460 VAC Controllers</b>		
1/4-1	380-460	60
2		100
3		140
5		180
7.5		210
10		250
<b>575 VAC Controllers</b>		
1/4-1	575	50
2		90
3		120
5		150
7.5		180
10		220

## 3.0 Installation and Wiring

### DANGER

ONLY QUALIFIED ELECTRICAL PERSONAL FAMILIAR WITH THE CONSTRUCTION AND OPERATION OF THIS EQUIPMENT AND THE HAZARDS INVOLVED SHOULD INSTALL, ADJUST, OPERATE, AND/OR SERVICE THIS EQUIPMENT. READ AND UNDERSTAND THIS MANUAL IN ITS ENTIRETY BEFORE PROCEEDING .FAILURE TO OBSERVE THIS PRECAUTION COULD RESULT IN SEVERE BODILY INJURY OR LOSS OF LIFE.

### DANGER

THE USER IS RESPONSIBLE FOR CONFORMING TO THE NATIONAL ELECTRICAL CODE (NEC) AND ALL OTHER APPLICABLE LOCAL CODES. WIRING, GROUNDING, DISCONNECTS, AND OVERCURRENT PROTECTION ARE OF PARTICULAR IMPORTANCE. FAILURE TO OBSERVE THIS PRECAUTION COULD RESULT IN SEVERE BODILY INJURY OR LOSS OF LIFE.

**CAUTION:** Use of power correction capacitors on the output of the controller can result in erratic operation of the motor, nuisance tripping, and/or permanent damage to the controller. Remove power factor capacitors before proceeding. Failure to observe this precaution could result in damage to, or destruction of the equipment.

## 3.1 Planning and Location

Planning before installation is necessary to ensure that the controller environment and operation conditions are satisfactory. Read and follow the recommendations advised in this section before proceeding with the installation.

1. Verify that the controller can be kept clean and cool.
2. Check that the controller will be away from oil, coolants, or other airborne contaminants.
3. Check that the temperatures within the vicinity of the controller are between 0° to 40°C (32° to 104°F).
4. Check that the relative humidity is between 5 and 95% noncondensing.
5. Do not install above 3300 feet (1000 meters) without derating. For every 300 feet (91.4 meters) above 3300 feet, derate the current rating by 1%. Consult SAF Drive Systems Ltd. for operation above 10,000 feet.
6. Check that the area chosen will allow the space required for air flow around the controller.

**NOTE:** *In applications with multiple controllers, power wiring between each controller and motor should be routed in separate conduits to avoid nuisance tripping.*

## 3.2 Controller Mounting

The dimensional size of ONYX Controller models will vary depending on horsepower (HP) rating. Refer to Table 3.1 to determine the appropriate dimensional size, (given in type A,B, or C) for 115 VAC, 230 VAC, 460 VAC and 575 VAC controllers. When mounting a controller, adhere to the guidelines and physical diagrams for the specific size type (A,B, or C).

Table 3.1 - Controller Model Dimensional Size

Horsepower (HP)	Dimensional Size (Type)	Controller Model Number(s)
<b>115 VAC Controllers</b>		
1+ DEMO	A	ONYX-6P8-1-N1, ONYX-DEMO-N4
<b>230 VAC Controllers</b>		
1 2	A	ONYX-4P5-2-N4
2 3 5	C	ONYX-7P5-2-N4 ONYX-10P6-2-N4 ONYX-14P5-2-N4
<b>460 VAC Controllers</b>		
1 2 3 5	B	ONYX-2P1-4-N4 ONYX-3P4-4-N4 ONYX-5P3-4-N4 ONYX-8P2-4-N4
7.5 10	C	ONYX-11P1-4-N4 ONYX-14P2-4-N4
<b>575 VAC Controllers</b>		
1 2 3 5	B	ONYX-1P6-5-N4 ONYX-2P7-5-N4 ONYX-4P3-5-N4 ONYX-6P2-5-N4
7.5 10	C	ONYX-9-5-N4 ONYX-12-5-N4

### 3.3 Size A Controller Mounting (115 VAC & 230 VAC HP)

1. Loosen the four (4) cover screws and then remove the cover from the controller. See Figure 3.1 for locations of the cover mounting holes.
2. Mount the controller vertically using the two (2) mounting holes provided in the controller base. See Figure 3.1.
3. Use the following as reference to provide adequate clearances for air ventilation:
  - At least 2 inches from the sides and 4 inches from the top and bottom of the controller to adjacent non-heat producing equipment, such as a cabinet wall.
  - At least 2 inches from the sides and 10 inches from the top and bottom of adjacent controllers. For best air movement with three or more controllers, do not mount the controllers in a vertical stack (i.e. offset (stagger) the controllers).

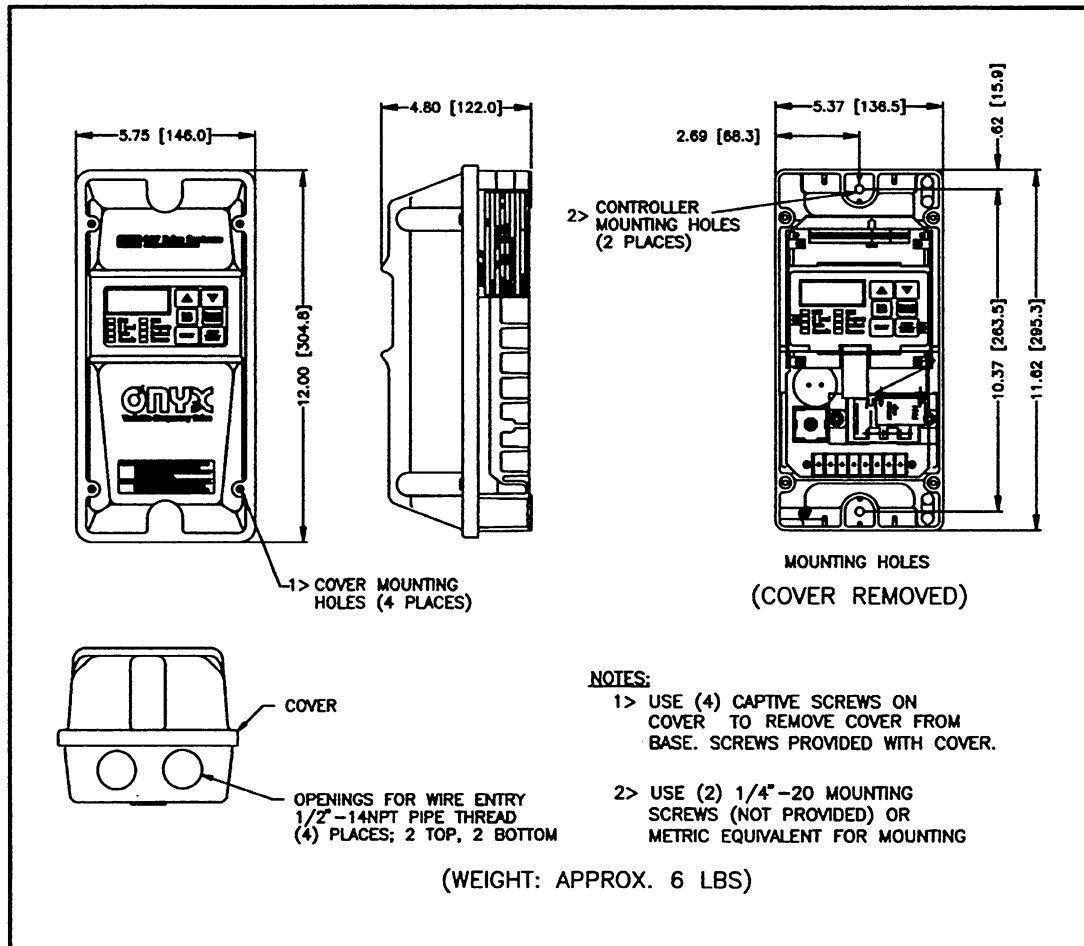

Figure 3.1 - Size A Physical Dimensions.

### 3.4 Size B Controller Mounting (460 VAC 1-5 HP & 575 VAC 1-5 HP)

1. In the location selected, mount the controller vertically using the four (4) mounting holes provided on the controller base. See Figure 3-2.
2. Use the following as reference to provide adequate clearances for air ventilation:
  - At least 4 inches from the sides and 4 inches from the top and bottom of the controller to adjacent non-heat producing equipment, such as a cabinet wall.
  - At least 4 inches from the sides and 10 inches from the top and bottom of adjacent controllers. For best air movement with three or more controllers, do not mount the controllers in a vertical stack (i.e. offset (stagger) the controllers).

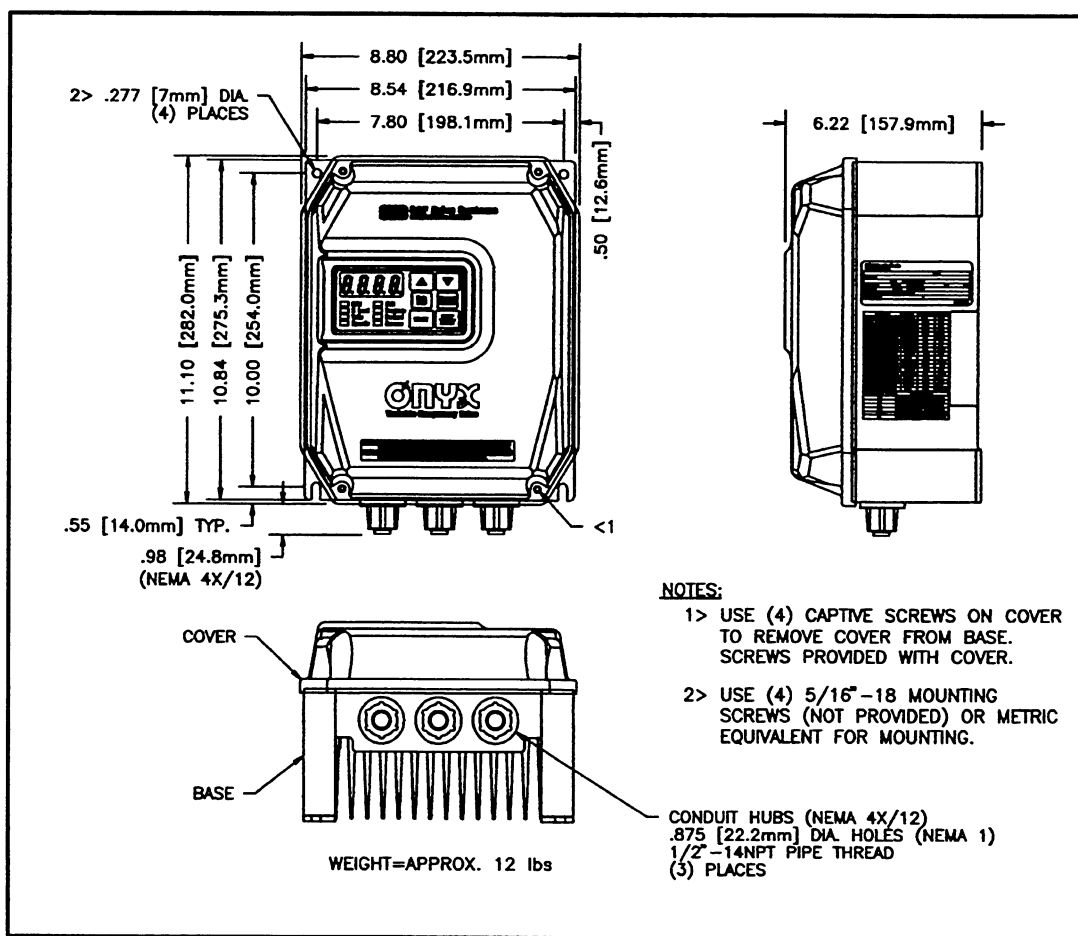

Figure 3.2 - Size B Physical Dimensions.

### 3.5 Size C Controller Mounting (230 VAC 2, 3 and 5 HP, 460 VAC 7.5 and 10 HP, and 575 VAC 7.5 and 10 HP)

1. In the location selected, mount the controller vertically using the four (4) mounting holes provided in the controller base. See Figure 3.3.
2. Use the following as reference to provide adequate clearances for air ventilation:
  - At least 4 inches from the sides and 4 inches from the top and bottom of the controller to adjacent non-heat producing equipment, such as a cabinet wall.
  - At least 4 inches from the sides and 10 inches from the top and bottom of adjacent controllers. For best air movement with three or more controllers, do not mount the controllers in a vertical stack (i.e. offset (stagger) the controllers).

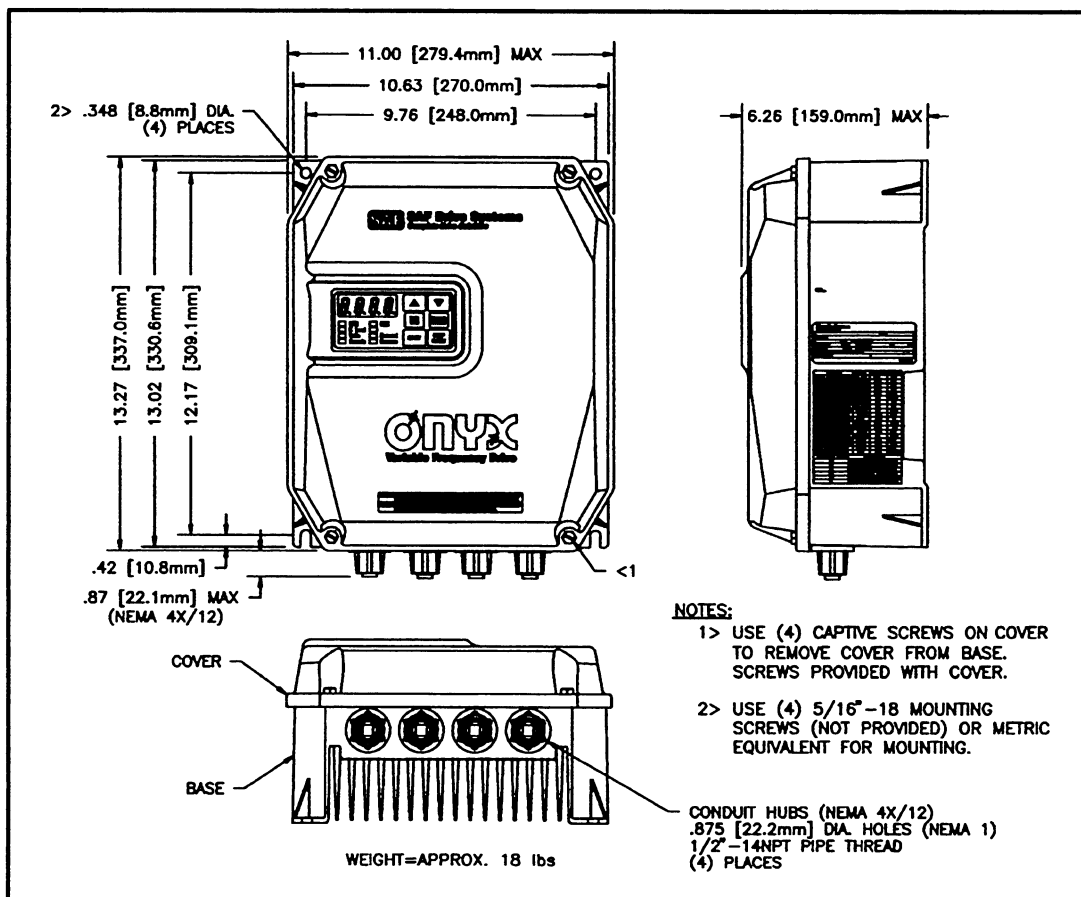

Figure 3.3 - Size C Physical Dimensions

## 3.6 Install an External Input Disconnect

### DANGER

**THE NEC/CEC REQUIRES THAT UPSTREAM BRANCH PROTECTION BE PROVIDED TO PROTECT INPUT POWER WIRING. INSTALL AND DO NOT EXCEED THE RECOMMENDED BRANCH PROTECTION RATING. FAILURE TO OBSERVE THIS PRECAUTION COULD RESULT IN SEVERE BODILY INJURY OR LOSS OF LIFE.**

1. Install an input disconnect in the incoming power line according to the NEC/CEC guidelines.
2. Size the disconnect according to the inrush current as well as any additional loads the disconnect may supply.

**Application Note:** The inrush current for 1-5 HP drives can exceed 400 amps. If a contactor is used as the input disconnect to the drive, a lighting contactor designed for this high inrush current should be used.

**NOTE:** *Coordinate the trip rating for the in-rush current (10-12 times full load current) with that of a transformer (if used). See **Transformer Installation (If needed)**, later in this section.*

### 3.7 Install A-C Branch Circuit Protection

**DANGER**

**THE NEC/CEC REQUIRES THAT UPSTREAM BRANCH PROTECTION BE PROVIDED TO PROTECT INPUT POWER WIRING. INSTALL AND DO NOT EXCEED RECOMMENDED THE BRANCH PROTECTION RATING. FAILURE TO OBSERVE THIS PRECAUTION COULD RESULT IN SEVERE BODILY INJURY OR LOSS OF LIFE.**

**CAUTION:** The input fuse ratings listed in tables 3.2 through 3.5 are applicable for one driver per branch circuit. No other load can be applied to that fused branch circuit. Failure to observe this precaution could result in damage to, or destruction of the equipment.

1. Install user-supplied branch circuit protection.
2. According to the values given in Tables 3.2 through 3.5, size the branch circuit protection for the specific controller model.

Table 3.2 - Single-Phase A-C Input Line Branch Circuit Protection.

Model Number	Horsepower (Hp)	Single-phase Input Voltage (VAC)	Input A-C Fuse Rating <sup>(1)</sup> (Amps)
ONYX-DEMO-N4	Demo	115	12
ONYX-6P8-1-N1	1	115	20
ONYX-4P5-2-N4	1	200-230	10

(1) The recommended fuse type is UL Class J, 600V, time-delay.

Table 3.3- Three-Phase A-C Input Line Branch Circuit Protection for 230 VAC Controllers.

Model Number	Horsepower (Hp)	Three-phase Input Voltage (VAC)	Input A-C Fuse Rating <sup>(1)</sup> (Amps)
ONYX-4P5-2-N4	1	200-230	12
ONYX-7P5-2-N4	2		20
ONYX-10P6-2-N4	3		25
ONYX-14P2-2-N4	5		35

(1) The recommended fuse type is UL Class J, 600V, time-delay.

Table 3.4 - Three-Phase A-C Input Line Branch Circuit Protection for 460 VAC Controllers.

Model Number	Horsepower (Hp)	Three-phase Input Voltage (VAC)	Input A-C Fuse Rating <sup>(1)</sup> (Amps)
ONYX-2P1-4-N4	1	380-460	6
ONYX-3P4-4-N4	2		8
ONYX-5P3-4-N4	3		12
ONYX-8P2-4-N4	5		25
ONYX-11P1-4-N4	7.5	380-460	25
ONYX-14P2-4-N4	10		35

(1) The recommended fuse type is UL Class J, 600V, time-delay.

Table 3.5 - Three-Phase A-C Input Line Branch Circuit Protection for 575 VAC Controllers.

Model Number	Horsepower (Hp)	Three-phase Input Voltage (VAC)	Input A-C Fuse Rating <sup>(1)</sup> (Amps)
ONYX-1P6-5-N4	1	575	4
ONYX-2P7-5-N4	2		7
ONYX-4P3-5-N4	3		10
ONYX-6P2-5-N4	5		15
ONYX-9-5-N4	7.5		20
ONYX-12-5-N4	10		25

(1) The recommended fuse type is UL Class J, 600V, time-delay.

## 3.8 Transformer Installation (If Needed)

Transformers step up or step down the voltage and can be either autotransformers or isolation transformers. Isolation transformers help eliminate:

- Damaging A-C line voltage transients from reaching the controller.
- Line noise from the controller back to the incoming power.
- Damaging currents, which could develop if a point inside the controller becomes grounded.

### 3.8.1 Input Transformers

If an input transformer is installed ahead of the controller, adhere to the following:

1. A power disconnecting device must be installed between the power line and the primary of the transformer.
2. If the power disconnecting device is a circuit breaker, the circuit breaker trip rating must be coordinated with the inrush of current (10 to 12 times full load current) of the transformer.
3. An input transformer rated more than 100 KVA for 230VAC (1000 KVA for 460 and 575 VAC) with less than 5% impedance should **NOT** be used directly ahead of the controller without additional impedance between the controller and the transformer.

**CAUTION:** Distribution system capacity above the maximum recommended system KVA (100KVA for 230 VAC; 1000KVA for 460 and 575 VAC) requires using an isolation transformer, a line reactor, or other means of adding similar impedance. Failure to observe these precautions could result in damage to, or destruction of, the equipment.

**CAUTION:** When the A-C line is shared directly with other SCR rectified drives, a line reactor or optional DB kit may be required to alleviate excess D-C bus voltage. Failure to observe these precautions could result in damage to, or destruction of, the equipment.

### 3.8.2 Output Transformers

In applications requiring the use of an output transformer on the controller, contact SAF Drive Systems Ltd. for assistance.

## 3.9 Grounding

### DANGER

**THE USER IS RESPONSIBLE FOR CONFORMING TO THE NEC/CEC AND ALL OTHER APPLICABLE CODES. WIRING, GROUNDING, DISCONNECTS, AND OVERCURRENT PROTECTION ARE OF PARTICULAR IMPORTANCE. FAILURE TO OBSERVE THIS PRECAUTION COULD RESULT IN SEVERE BODILY INJURY OR LOSS OF LIFE.**

1. Remove the four (4) captive screws and remove the cover. (When installing the cover on the controller, refer to **Cover Installation for NEMA 4X (Indoor only)/12 Controllers**, Section 6.)

*NOTE: To conform to CSA requirements, when adding more than one grounding conductor wire to a single chassis ground, twist the conductors together.*

2. Run a suitable equipment grounding conductor unbroken from the controller ground terminal (See Figures 3.4, 3.5, and 3.6) to an earth ground conductor. See Table 3.6 for recommended wire sizes.
3. Connect a suitable equipment grounding conductor to the motor frame, the remote control station (if used), and the transformer. Run each conductor **unbroken** to the earth ground.

### 3.10 Motor Preparation

1. Install the motor according to the motor instruction manual.
2. Verify that the motor is the appropriate size to use with the controller. (Refer to **Motor Applications**, Section 2).
3. In single motor applications, verify that the total lead length on each phase does not exceed 250 feet per phase.

-or-

In multi-motor applications, verify that the total lead length on each phase does not exceed 250 feet, and each motor connection cannot exceed 250 feet.

Refer to **Motor Applications**, Section 2, for more information.

4. Verify that the motor is properly aligned with the driven machine to minimize unnecessary motor loading from shaft misalignment.
5. If the motor is accessible while running, install a protective guard around all exposed rotating parts.

In applications requiring the use of an output transformer on the controller, contact your SAF Drive Systems Ltd. for assistance.

### 3.11 Controller Wiring

**Size and install all wiring in conformance with the NEC/CEC and all other applicable local codes.** If not already done, loosen the four (4) captive screws on the cover and remove the cover from the controller base. Refer to Figures 3.4, 3.5, and 3.6 for jumper and wiring locations. Follow recommended wires and tightening torques.

**CAUTION:** Do not route signal and control wiring with power wiring in the same conduit. This may cause interference with controller operation. Failure to observe this precaution could result in damage to, or destruction of the equipment.

#### WARNING

**THE CONTROLLER IS NOT EQUIPPED WITH A COAST-STOP PUSHBUTTON. THE USER MUST INSTALL A HARDWIRED, OPERATOR-ACCESSIBLE PUSHBUTTON THAT PROVIDES A POSITIVE INTERRUPT AND SHUTS DOWN THE DRIVE. (USE TERMINALS 10 AND 11. SEE FIGURE 3.4, 3.5, 3.6 AND 3.16.) FAILURE TO OBSERVE THIS PRECAUTION COULD RESULT IN BODILY INJURY.**

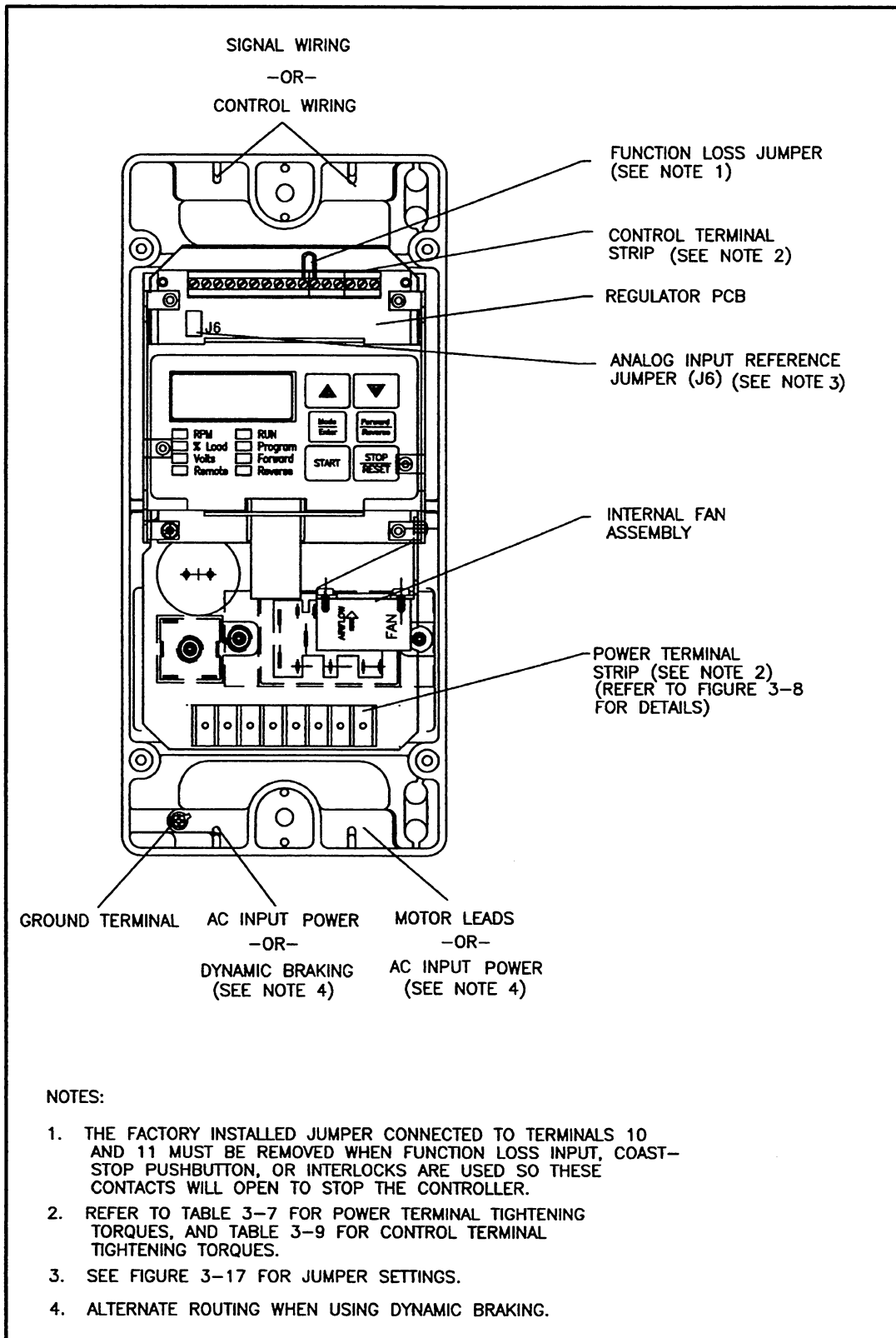

Figure 3.4 - Size A Wiring Locations.

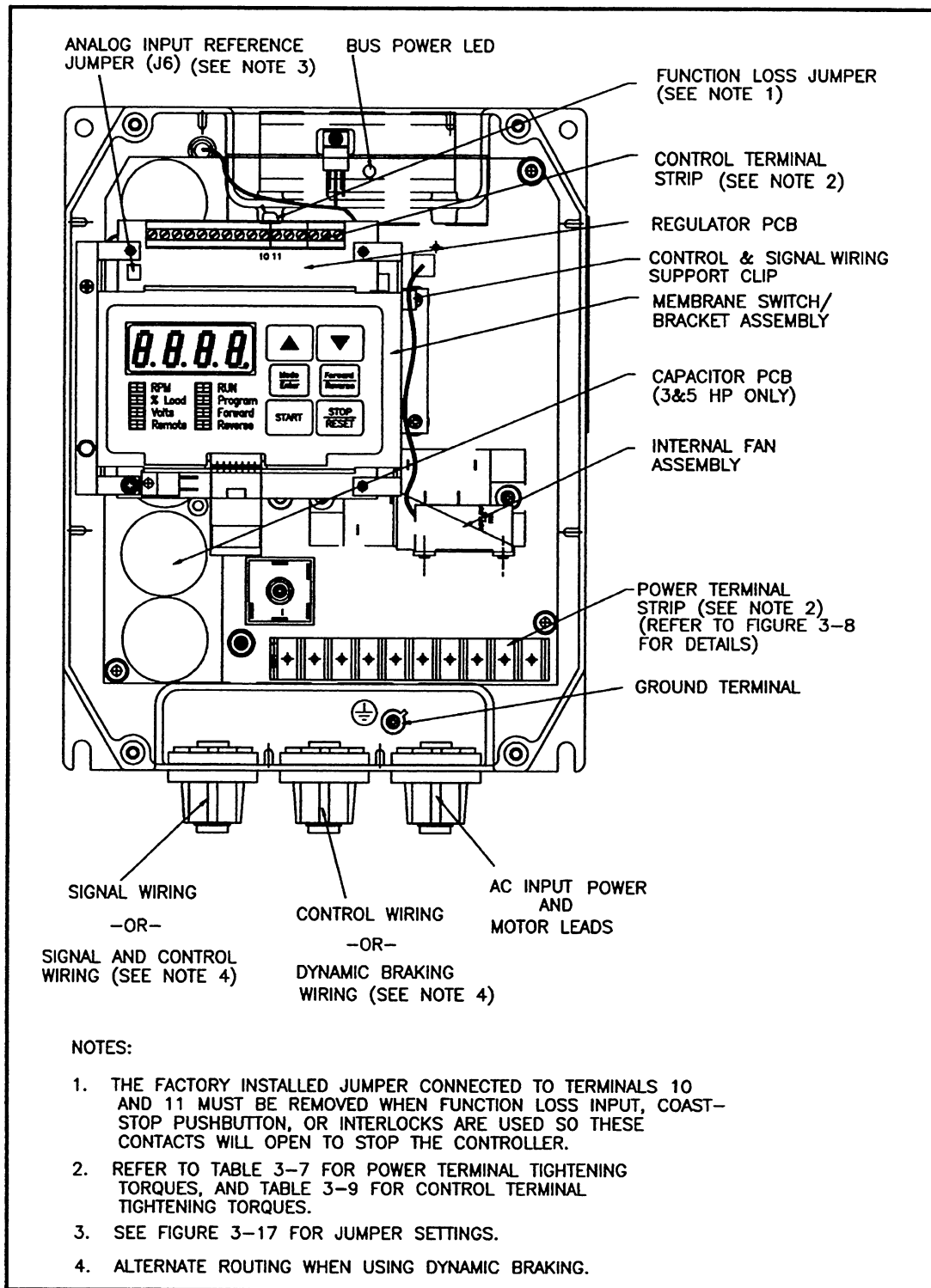
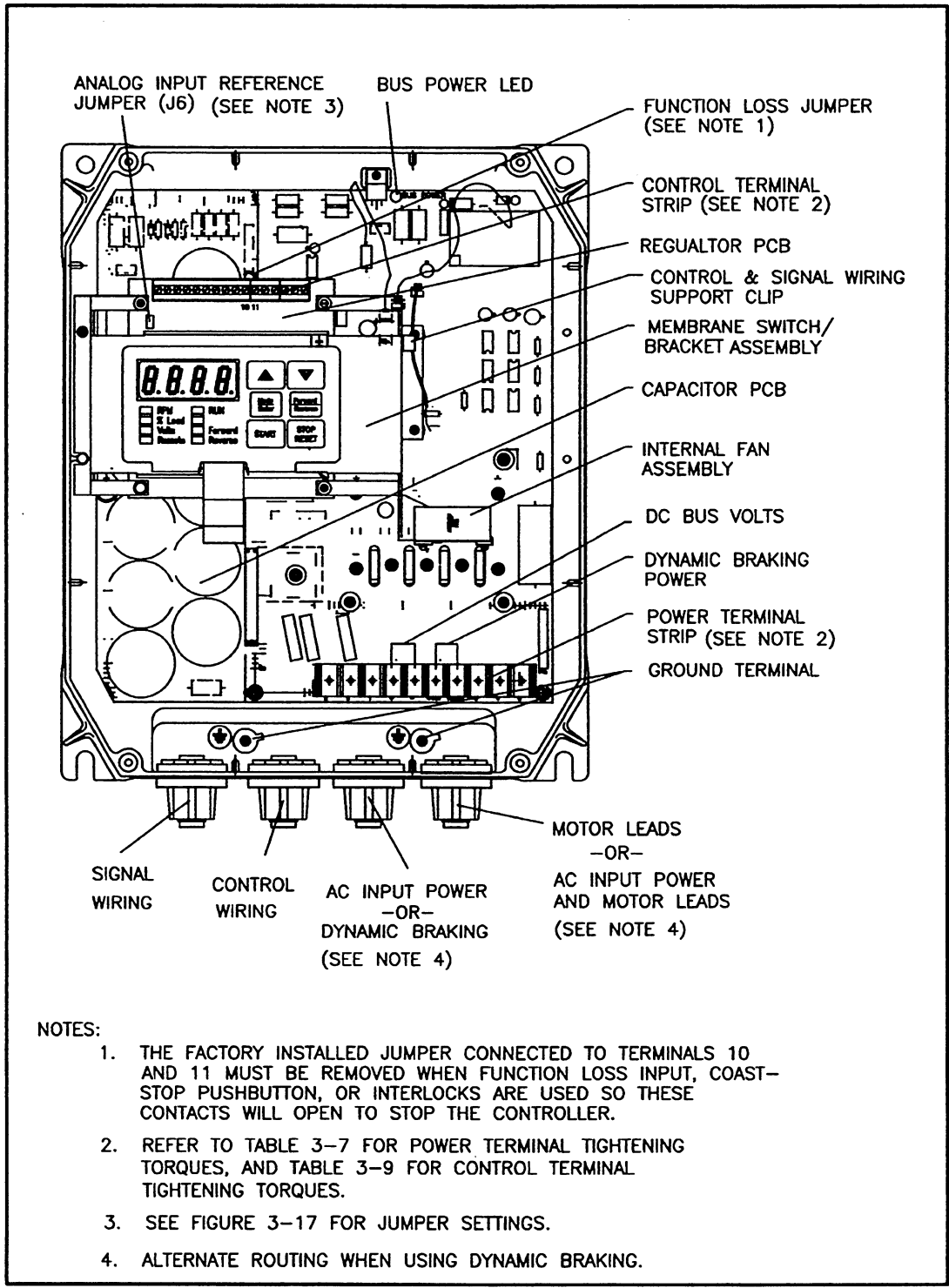

Figure 3.5 - Size B Wiring Locations.



NOTES:

1. THE FACTORY INSTALLED JUMPER CONNECTED TO TERMINALS 10 AND 11 MUST BE REMOVED WHEN FUNCTION LOSS INPUT, COAST-STOP PUSHBUTTON, OR INTERLOCKS ARE USED SO THESE CONTACTS WILL OPEN TO STOP THE CONTROLLER.
2. REFER TO TABLE 3-7 FOR POWER TERMINAL TIGHTENING TORQUES, AND TABLE 3-9 FOR CONTROL TERMINAL TIGHTENING TORQUES.
3. SEE FIGURE 3-17 FOR JUMPER SETTINGS.
4. ALTERNATE ROUTING WHEN USING DYNAMIC BRAKING.

Figure 3.6 - Size C Wiring Locations.

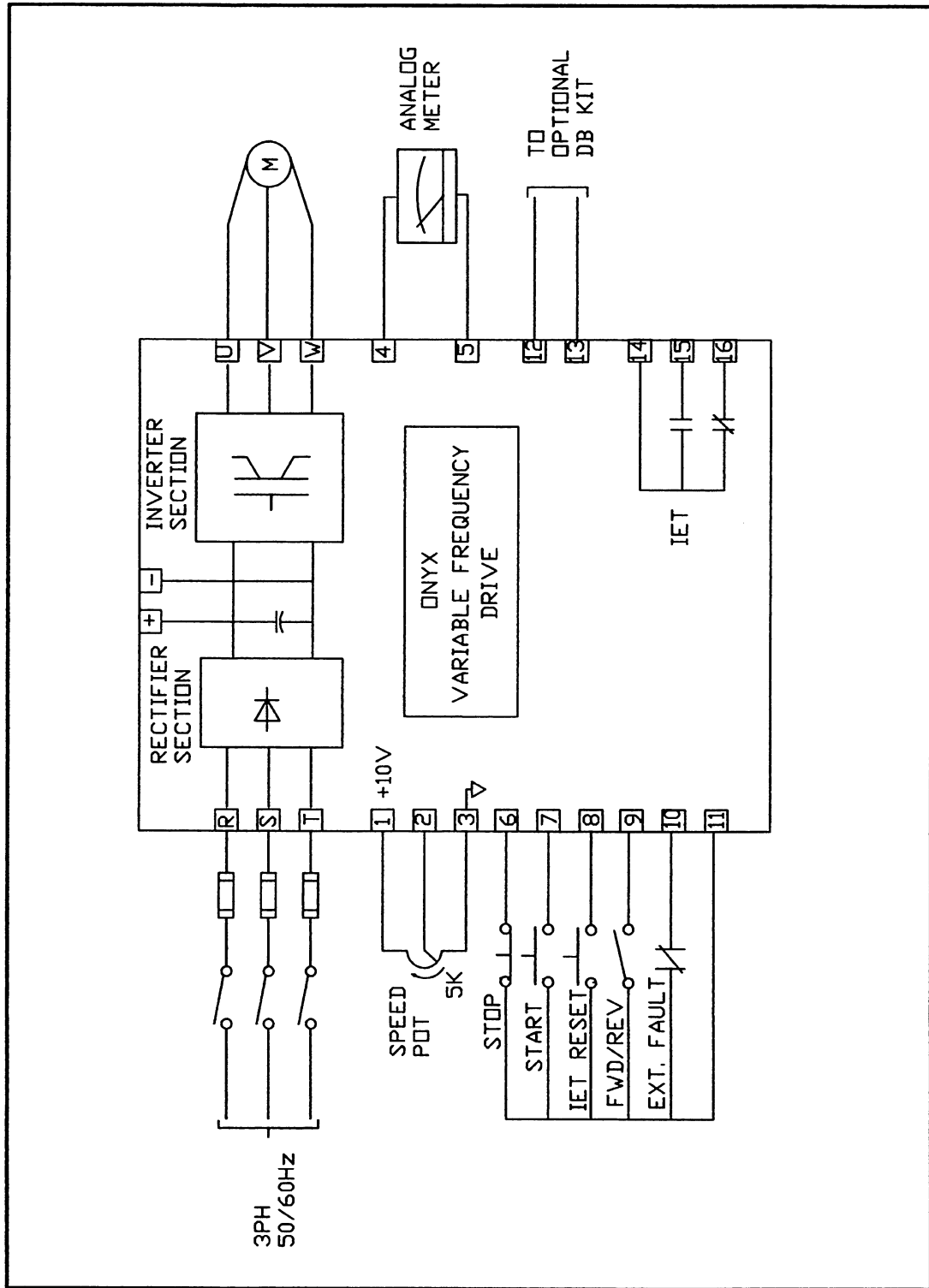

Figure 3.6a - Controller Diagram

### 3.11.1 Power Wiring

Size and install all wiring in conformance with the NEC/CEC and all other applicable local codes. Refer to Figures 3.7 and 3.8 when making wire connections to the power terminal strip. See Table 3.6 for recommended wires sizes and Table 3.7 for power terminal tightening torque.

1. Verify that the input power to the controller corresponds to the controller nameplate voltage and frequency and that the plant supply is of sufficient capacity to support the input current requirements. (Refer to Specifications, Section 2.)
2. Provide a transformer between the plant power supply and the controller if the correct input line voltage is not available. (Refer to Transformer Installation in this section.)
3. Size upstream branch circuit protection (fuses) according to Tables 3.2 through 3.5.

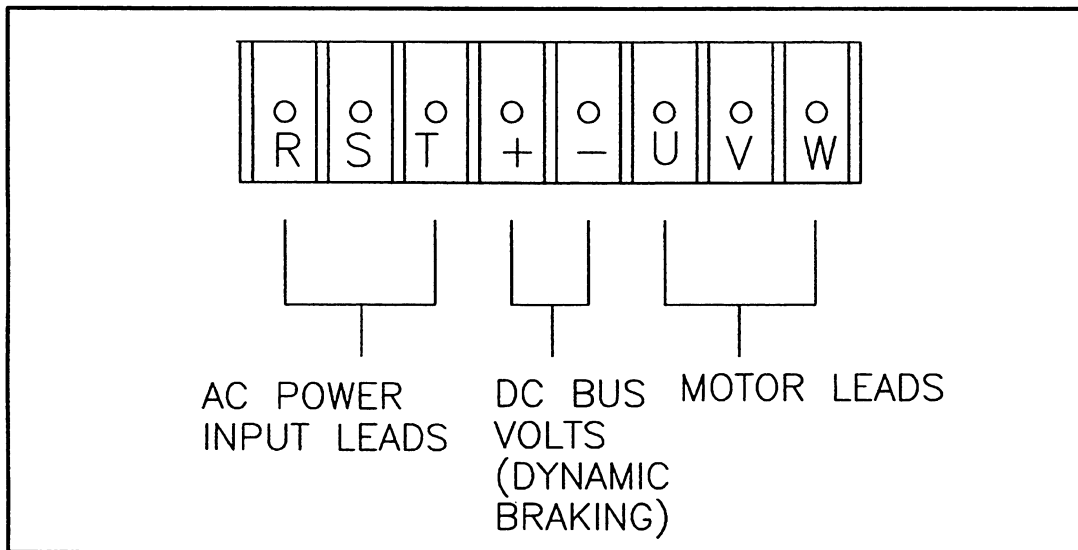

Figure 3.7 - Power Terminal Strip For 115 VAC and 230 VAC Controllers.

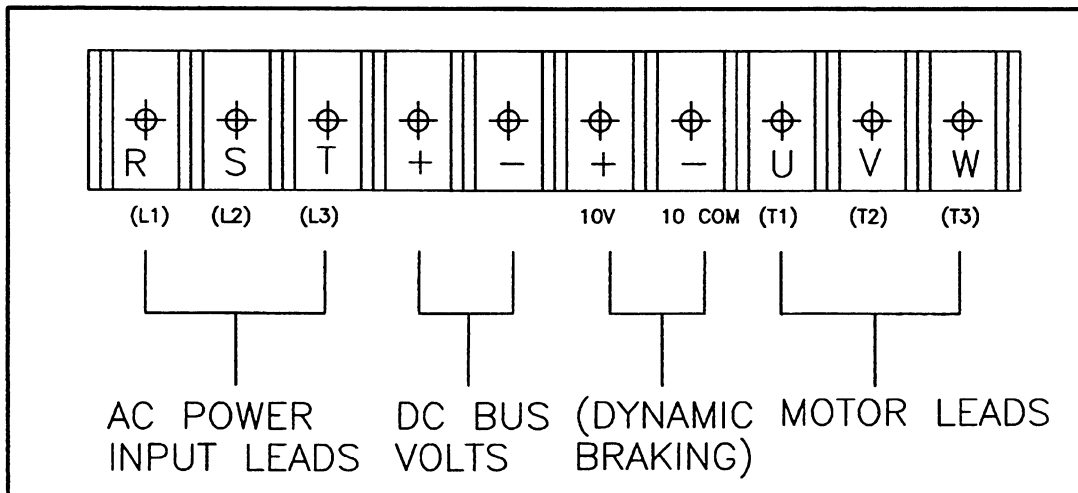

Figure 3.8 - Power Terminal Strip For Model 460 VAC and 575 VAC Controllers.

4. Refer to Table 3.6 and size the input and output power wiring to handle the rated maximum controller current. (Refer to Tables 2.1 through 2.5 for maximum controller currents.)

Table 3.6 - Recommended Power Wire Size (1,2)

Wiring	Terminal(3)	Terminal(4)	Wire Size(5)
Input power	R, S, T	R(L <sub>1</sub> ), S(L <sub>2</sub> ), T(L <sub>3</sub> )	14 AWG -or- 12 AWG (See Note 5)
Output power	U, V, W	U(T <sub>1</sub> ), V(T <sub>2</sub> ), W(T <sub>3</sub> )	
D-C Bus	-, +	-, +	
DB Power		+10 VDC, 10 COM	
GND Terminal	GND Stud	GND Stud	

- 1) The user is responsible for the following NEC/CEC and all applicable local codes with respect to wire sizes used with the controllers. Acceptable wire sizes are shown in the Table.
- 2) Use only copper wire with a minimum temperature rating of 60/75°C.
- 3) Terminals on 115 VAC and 230 VAC Controllers.
- 4) Terminals on 460 VAC and 575 VAC Controllers.
- 5) The following is a list of the controller models where 12 AWG wire is recommended, all other models can use 14 AWG wire:

ONYX-14P2-2-N4  
ONYX-14P2-4-N4

5. Use the appropriate terminal torque as listed in Table 3.7 for wire connections to the power terminal.

Table 3.7 - Power Terminal Tightening Torques (in-lbs)

115 VAC and 230 VAC Terminals	460 VAC and 575 VAC Terminals	Torque
R, S, T, U, V, W -, +, GND Stud	R(L <sub>1</sub> ), S(L <sub>2</sub> ), T(L <sub>3</sub> ), U(T <sub>1</sub> ), V(T <sub>2</sub> ), W(T <sub>3</sub> ) -, +, +10 VDC, 10 COM, GND Stud	9 min. - 12 max. in-lbs

6. The recommended routing for power wiring through the controller base is as follows:  
(Refer to Figures 3.4, 3.5, and 3.6.)

Without the Dynamic Braking Option -

- Size A - Route only AC input leads through the bottom left opening of the controller base.
- Size B - Route A-C input leads through the bottom center (or right) opening of the controller base.
- Size C - Route A-C input leads through the third opening (from the left) of the controller base.

With the Dynamic Braking option -

Route A-C input power and motor leads through the bottom right (far right) opening of the controller base as indicated in Figures 3.4, 3.5, and 3.6.

7. Wire the A-C input power leads as follows: (Refer to Figures 3.7 and 3.8.)

For 115 VAC and 230 VAC Single-phase Controllers - To terminals R and S.

For 230 VAC, 460 VAC and 575 VAC Three-phase Controllers- To terminals R, S and T (L1, L2, L3).

8. Wire the motor leads as follows: (Refer to Figures 3.7 and 3.8.)

For 115 VAC and 230 VAC Controllers - To terminals U,V, and W.

For 460 VAC and 575 VAC Controllers - To terminals U(T<sub>1</sub>), V(T<sub>2</sub>), and W(T<sub>3</sub>).

*NOTE: In applications with multiple controllers, power wiring between each controller and motor should be routed in separate conduits to avoid nuisance tripping.*

### 3.11.2 Control and Signal Wiring

**Size and install all wiring in conformance with the NEC and all other applicable local codes.** Refer to Figure 3.9 when making wire connections to the control terminal strip. See Table 3.8 for recommended wires sizes. Refer to Table 3.9 for terminal tightening torque.

**CAUTION:** Do not route signal wiring with power wiring in the same conduit. This may cause interference with controller operation. Failure to observe this precaution could result in damage to, or destruction of the equipment.

## REGULATOR BOARD

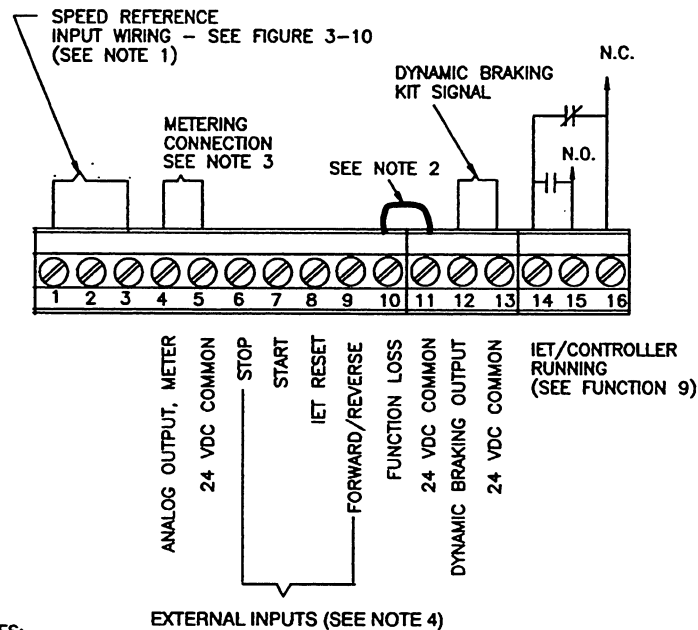

### NOTES:

1. SPEED REFERENCE INPUT IS JUMPER SELECTABLE BY SETTING OF JUMPER J6 ON THE REGULATOR BOARD. SEE FIGURE 3-17.
2. A FACTORY INSTALLED JUMPER CONNECTED TO TERMINALS 10 AND 11 MUST BE REMOVED WHEN FUNCTION LOSS INPUT, A COAST-STOP PUSHBUTTON, OR OTHER INTERLOCK IS INSTALLED SO THAT THE CONTACT WILL OPEN TO STOP THE CONTROLLER.  
A MOTOR THERMOSTAT CAN BE WIRED TO TERMINALS 10 AND 11 THAT WILL OPEN WHEN THE MOTOR OVERHEATS. IF A THERMOSTAT IS INSTALLED, FUNCTION F-15 SHOULD BE DISABLED (OFF).
3. 0-10VDC OUTPUT PROPORTIONAL TO EITHER OUTPUT HERTZ, VOLTAGE, AMPS, OR SELECTED SPEED REFERENCE, DEPENDING ON WHICH OUTPUT IS CURRENTLY SELECTED ON THE KEYPAD/DISPLAY.
4. FOR MULTI-SPEED PRESET CONFIGURATION, TB6 IS 2 WIRE START/STOP. TB8 PROVIDES 3 MULTI-SPEED PRESETS. SEE SECTION 5.24 FOR HOW TO CONFIGURE MULTI-SPEED PRESETS.

ALL CUSTOMER WIRING COMES IN AT THE TOP OF THE CONTROL TERMINAL STRIP

Figure 3.9 - Control Terminal Strip.

1. For all signal wiring use twisted pair wire.
2. For distances of up to 1000 feet, use a minimum of #22 AWG wire.
3. Refer to Table 3.8 and size control and signal wiring.

Table 3.8 - Recommended Control and Signal Wire Sizes

Wiring	Terminal	Wire Size
Speed Reference	1, 2, 3	22-14 AWG
Analog output	4, 5	
Stop	6, 11	
Start	7, 11	
IET Reset	8, 11	
Forward/ Reverse	9, 11	
Function Loss	10, 11	
DB Control	12, 13	
IET/ Controller Running <sup>(1)</sup>	14, 15	
	-or- 14, 16	

1) Terminals 14 and 15 provide a N.O. relay contact while, terminals 14 and 16 provide a N.C. relay contact. (Function of contacts controlled by setting of Function F-09. Refer to Adjusting the Drive Functions, Section 5.)

4. Use the appropriate terminal torque as listed in Table 3.9 for control and signal wire connections to the control Terminal Strip.

Table 3.9 - Control Terminal Strip Tightening Torques (in-lbs)

Terminal	Torque
1 - 16	7 in-lbs max.

5. Route the signal wiring (External Speed Reference, Analog Output, and IET/ Controller Running) and the control wiring (Stop, Start, IET Reset, Forward/Reverse, Function Loss) to the controller as follows:

Refer to Figures 3.4, 3.5, and 3.6.

Size **A** - Route the wiring as follows:

- All signal wiring through the top left opening in the controller.
- All control wiring through the top right opening in the controller.

Size **B** - Route the wiring as follows:

Without the Dynamic Braking Option -

- Route all signal wiring through the bottom left opening of the controller, around the bracket assembly and through the wiring support clip.
- Route all control wiring through the bottom center opening of the controller, around the bracket assembly and through the wiring support clip.

With the Dynamic Braking Option -

- Route all signal and control wiring through the bottom left opening of the controller, around the bracket assembly and through the wiring support clip.

Size **C** - Route the wiring as follows:

- Route all signal wiring through the bottom left opening of the controller, around the bracket assembly and through the wiring support clip.
  - Route all control wiring through the second opening (from the left) on the controller, around the bracket assembly and through the wiring support clip.
6. Wire the signal leads. Refer to Figures 3.10, 3.11, and 3.12 for External Speed Reference, Analog Output, and IET/ Controller Running connections.

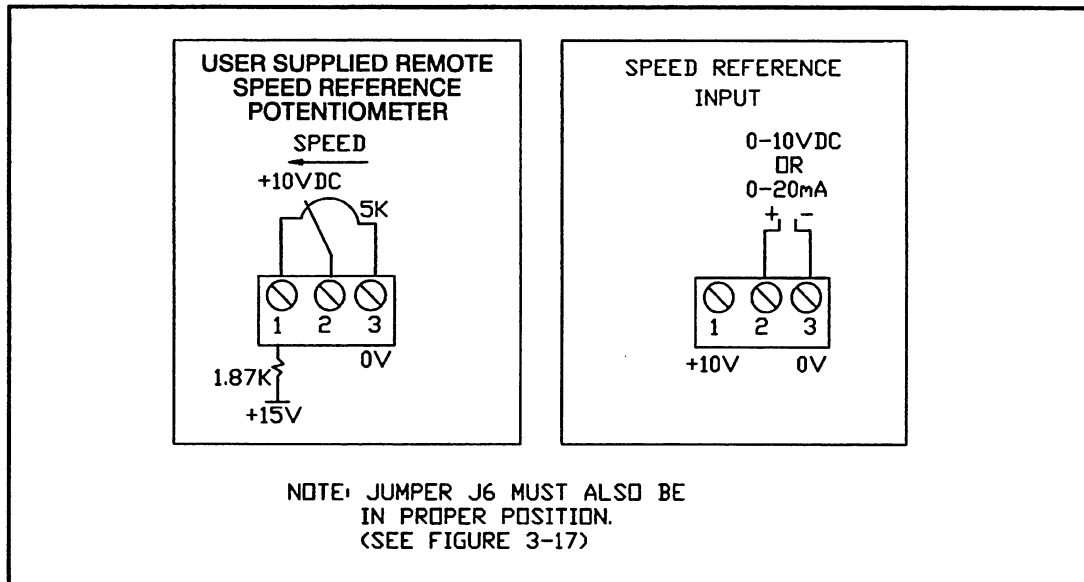

Figure 3.10 - Speed Reference Input Wiring

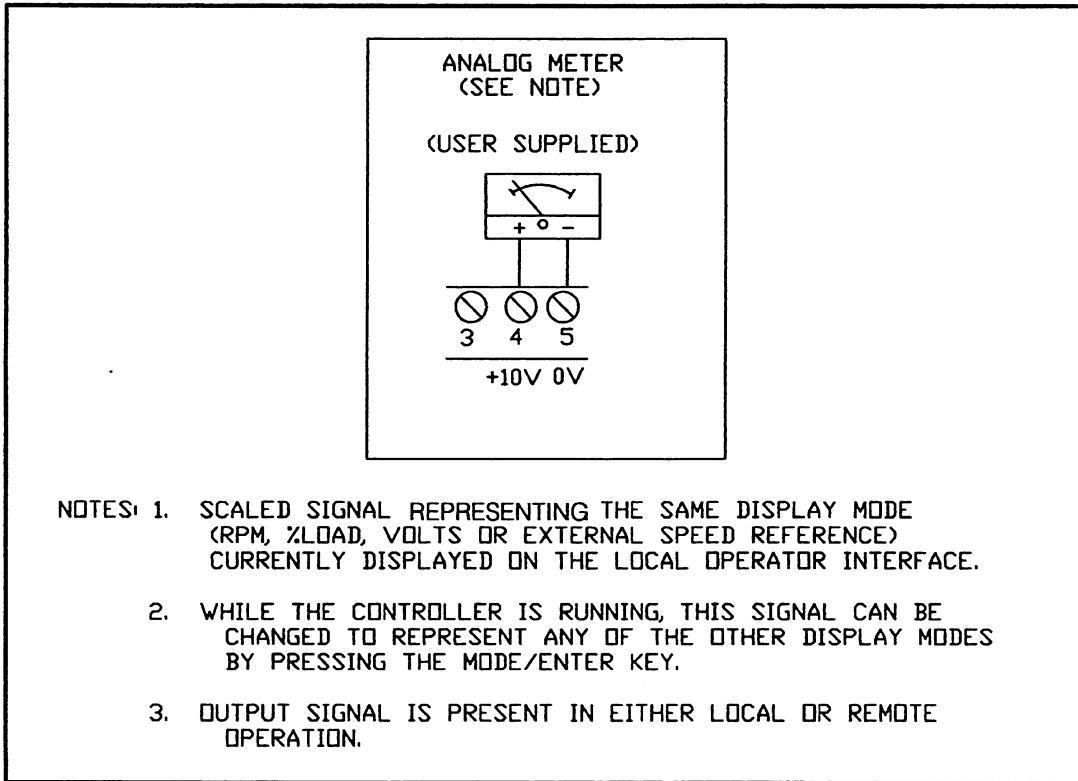

Figure 3.11 - Analog Meter Output Wiring.

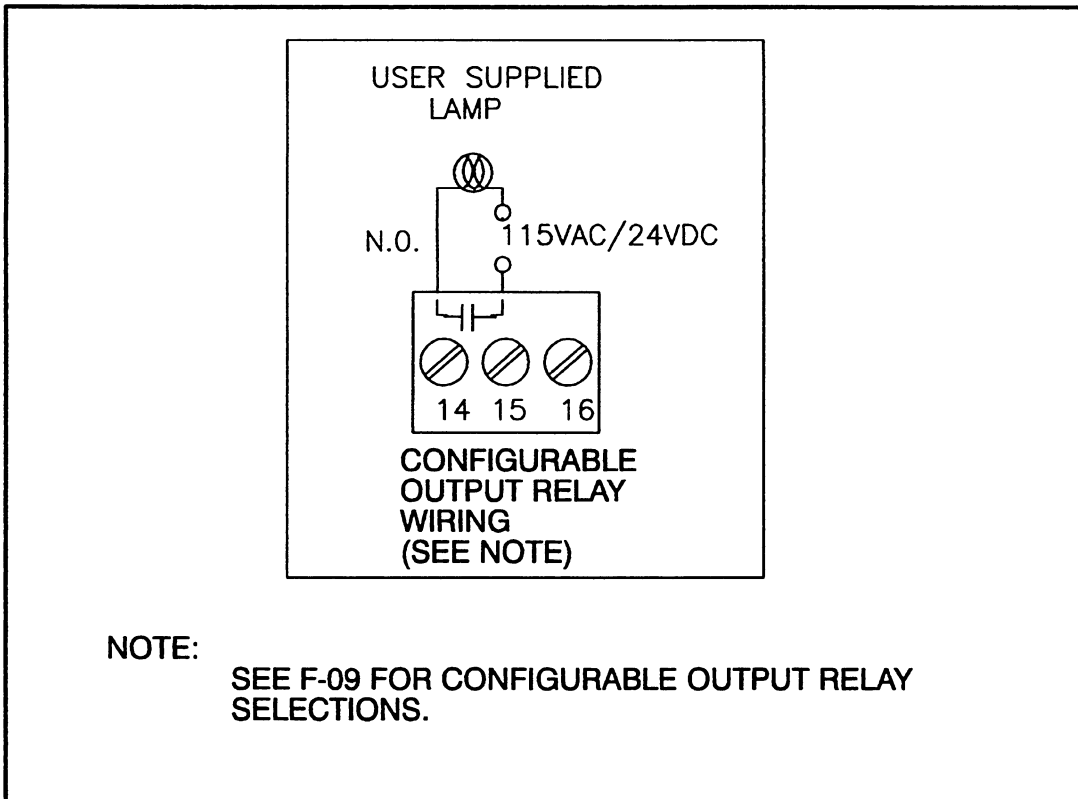

Figure 3.12 - IET/Controller Output Wiring.

7. Wire the control leads. Refer to Figures 3.13, 3.14, 3.15, and 3.16 for Stop, Start, IET Reset, Forward/Reverse, and Function Loss connections.

**NOTE:** Remove the factory-installed jumper at terminals 10 and 11 (Refer to Figure 3.18) to install a normally closed, maintained emergency stop pushbutton as shown in Figure 3.6.

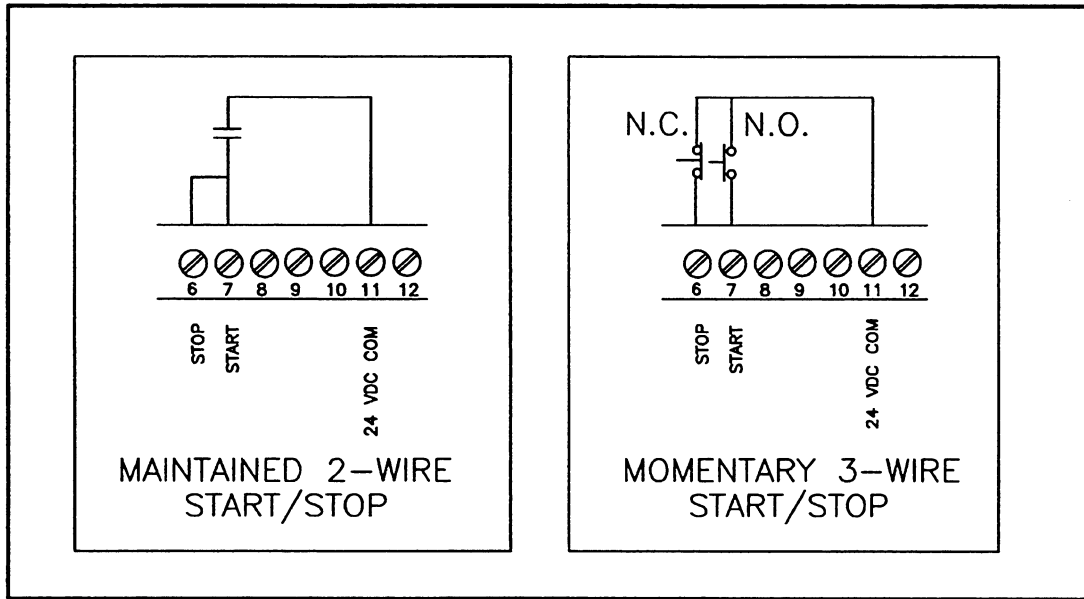

Figure 3.13 -Start-Stop Control Wiring for Control Modes other than Multi-speed Inputs.

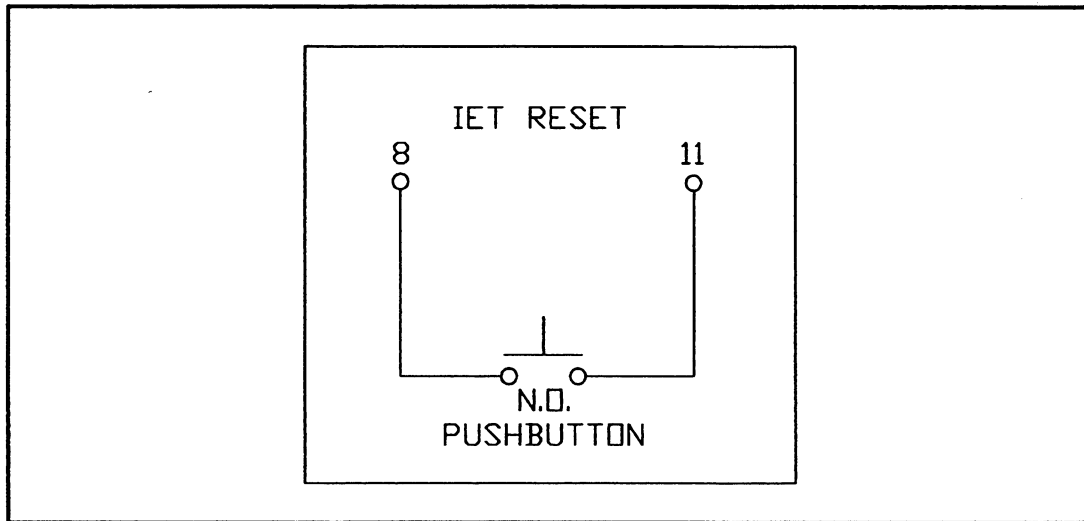

Figure 3.14-IET Reset Control Wiring for Control Modes other than Multi-speed Inputs

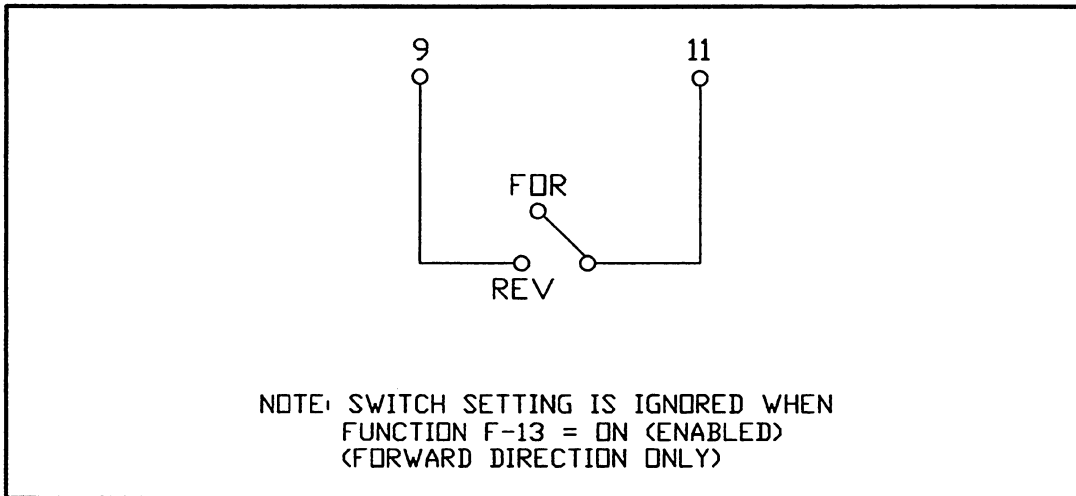

Figure 3.15 - Forward/Reverse Control Wiring.

**WARNING**

**THE CONTROLLER IS NOT EQUIPPED WITH A COAST-STOP PUSHBUTTON. THE USER MUST INSTALL A HARDWIRED, OPERATOR-ACCESSIBLE PUSHBUTTON THAT PROVIDES A POSITIVE INTERRUPT AND SHUTS DOWN THE DRIVE. (USE TERMINALS 10 AND 11. SEE FIGURE 3.16.) FAILURE TO OBSERVE THIS PRECAUTION COULD RESULT IN BODILY INJURY.**

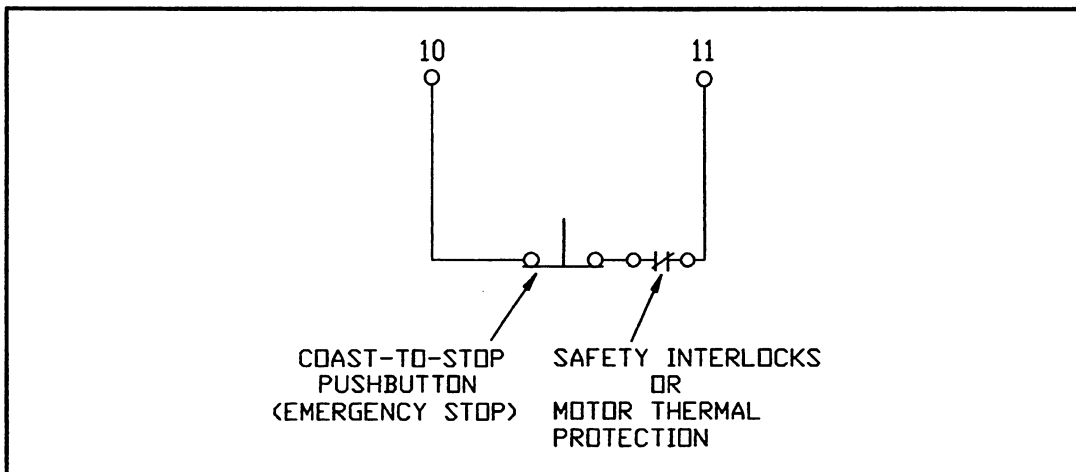

Figure 3.16 - Coast-Stop Pushbutton Control Wiring.

### 3.11.3 Remote Analog Input Reference Jumper Setting

Located on the regulator board (Refer to Figures 3.4, 3.5 and 3.6) is a remote speed reference input jumper (J6) that provides a jumper-selectable 0-10 VDC or 0-20 mA input with a software programmable gain and offset adjustment (See Functions F-11 and F-12 in section 5).

**NOTE:** *If the position of the reference jumper is changed, the software does not recognize that the input signal has been changed from 0-10 VDC to 0-20 mA, or vice versa. Verify that calculations for functions F-11 (remote reference gain) and F-12 (remote reference offset) are correct before starting the drive.*

● **To change the remote speed reference jumper J6:**

**DANGER**

**AFTER DISCONNECTING INPUT POWER WAIT FIVE MINUTES AND CHECK WITH A VOLTMETER TO INSURE THAT D-C BUS CAPACITORS ARE DISCHARGED. VOLTMETER SHOULD READ ZERO VOLTS D-C. FAILURE TO OBSERVE THESE PRECAUTIONS COULD RESULT IN SEVERE BODILY INJURY OR LOSS OF LIFE.**

1. Turn off power supplied to the controller.
2. If not already done, loosen the four (4) attaching screws and remove the cover from the controller.
3. Verify at the + and - terminals that the D-C Bus voltage is zero (0) VDC. Refer to Figures 3.7 and 3.8.
4. Locate jumper J6 on the Controller's Regulator Board. Refer to Figure 3.4, 3.5 and 3.6.
5. Locate Pin 1 of jumper J6 on the Regulator Board.
6. Move the jumper to the desired setting as shown in Figure 3.17.

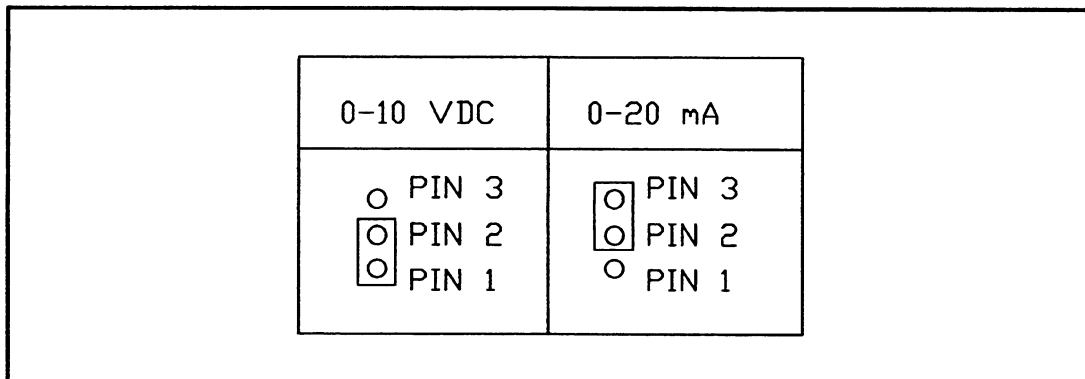

Figure 3.17 - J6 Jumper Settings.

7. After moving jumper (J6), verify (with each move) that Function F-11 (reference gain) and F-12 (reference offset) are correctly set.
8. Make a written note of the jumper settings in the table labeled "Settings Table" on the back cover of this manual.

## 3.12 Optional Dynamic Braking Wiring

1. Route the dynamic braking power and signal wiring through the opening at the bottom of the controller as follows:

Refer to Figures 3.4, 3.5, and 3.6.

**Size A -** Route dynamic power and signal leads through the bottom left opening of the controller base.

Continue routing the signal leads up and around the bracket assembly.

**Size B -** Route dynamic power and signal leads through the bottom center opening of the controller.

**Size C -** Route dynamic power and signal leads through the third opening (from the left) of the controller.

**NOTE:** *On size B and C controllers, continue routing the signal leads up, around the bracket assembly, and through the support clip.*

2. Wire the Dynamic Braking (DB) Power leads to the controllers as follows. Refer to Figures 3.18 and 3.19.

For 230 VAC controllers -

DB terminals 147 and 45 to controller power terminals +, - (DC Bus Volts).

For 460 VAC and 575 VAC controllers -

DB terminals 147 and 45 to controller power terminals +, - (DC BUS Volts)

DB terminals 13 and 14 to controller power terminals + (10V), - (10V com)

3. Wire the Dynamic Braking (DB) signal leads to the controllers as follows. Refer to Figures 3.18 and 3.19.

For all models: DB terminals 1 and 2 to controller control terminals 12 and 13.

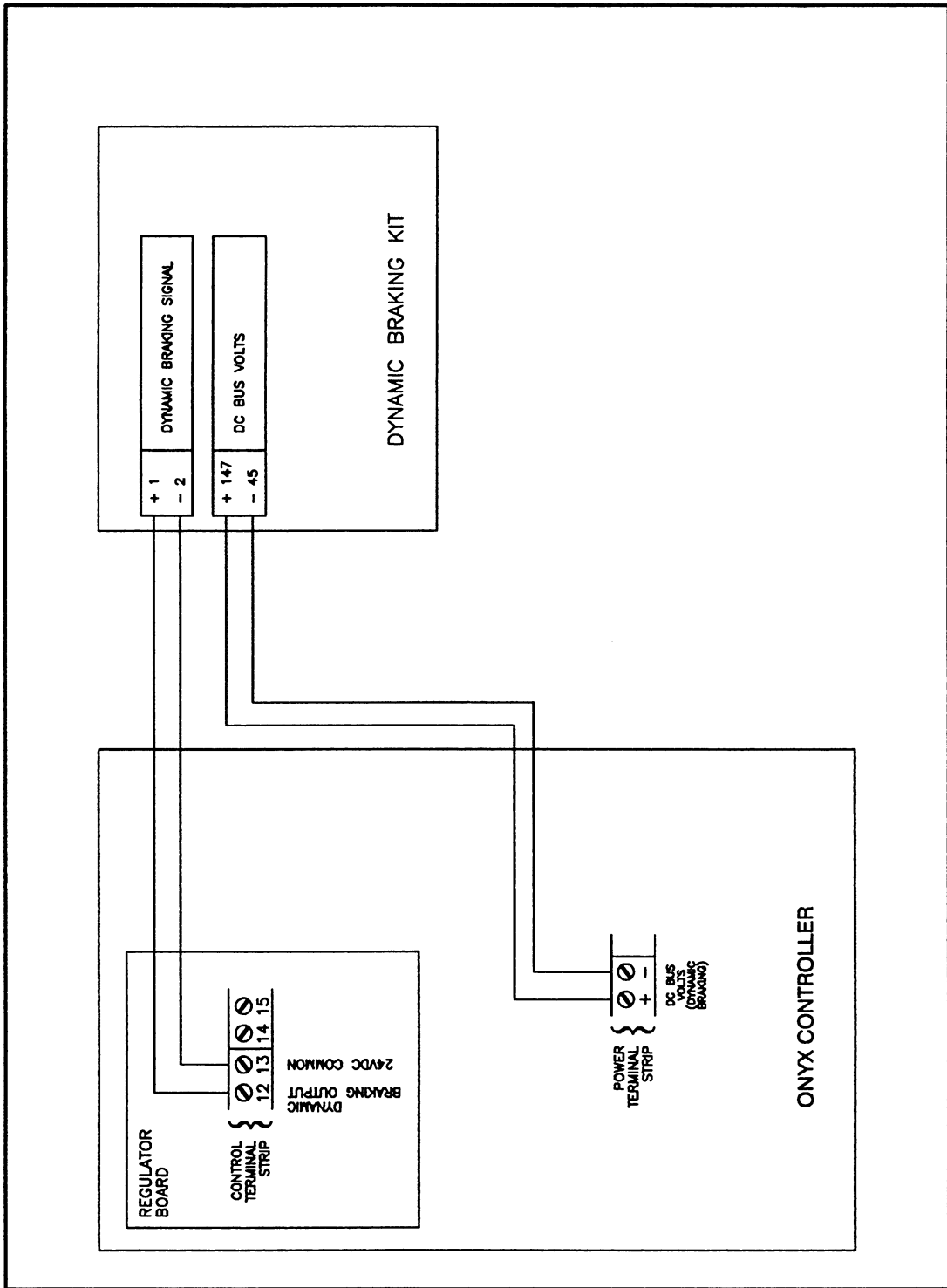

Figure 3.18 - Dynamic Braking Output Wiring for 230 VAC Controllers.

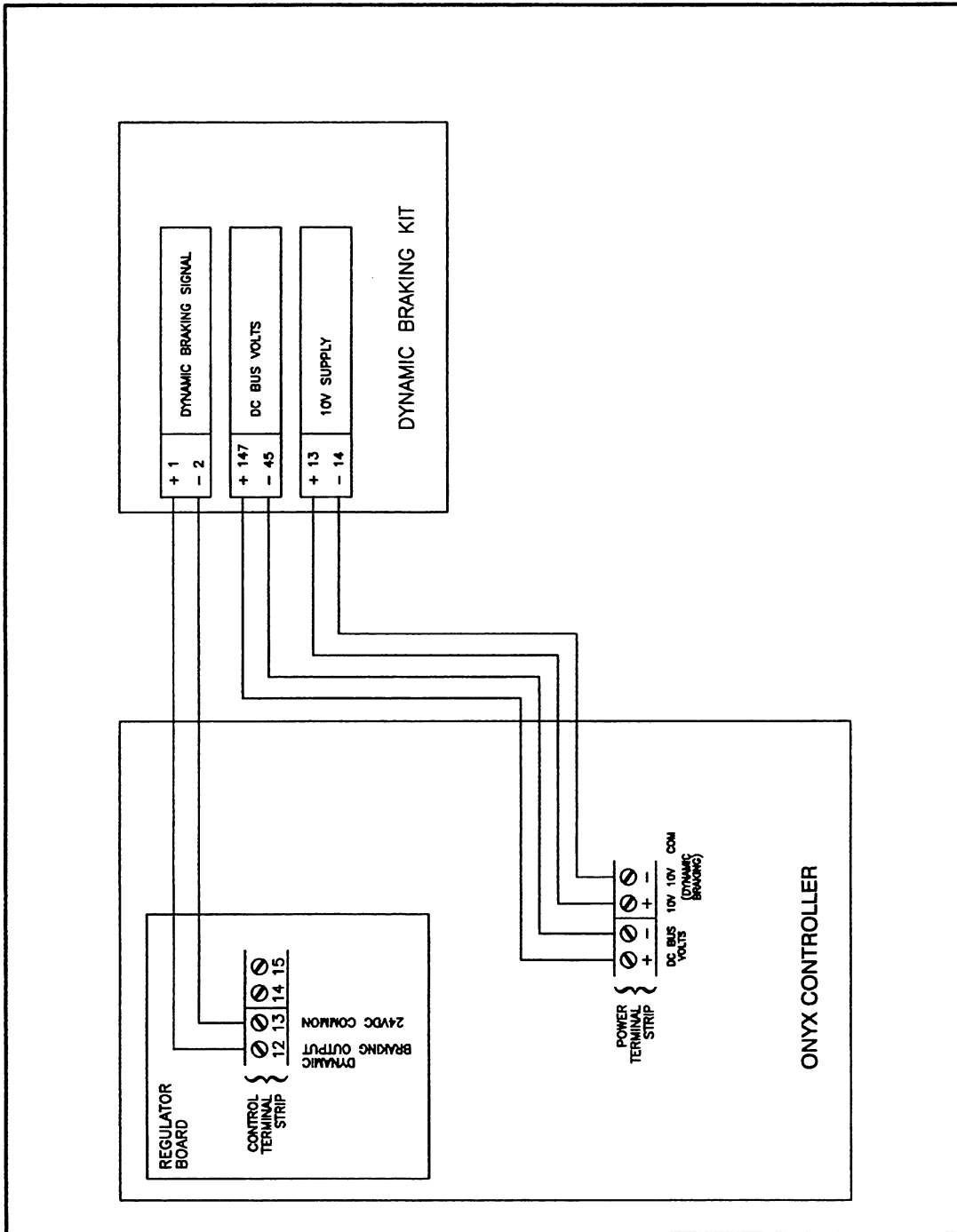

Figure 3.19 - Dynamic Braking Output Wiring For 460 VAC and 575 VAC Controllers.

# 4.0 Keypad and Display Operation

**DANGER**

**ONLY QUALIFIED ELECTRICAL PERSONNEL FAMILIAR WITH THE CONSTRUCTION AND OPERATION OF THIS EQUIPMENT AND THE HAZARDS INVOLVED SHOULD INSTALL, ADJUST, OPERATE AND/OR SERVICE IT. READ AND UNDERSTAND THIS MANUAL IN ITS ENTIRETY BEFORE PROCEEDING. FAILURE TO OBSERVE THIS PRECAUTION COULD RESULT IN SEVERE BODILY INJURY OR LOSS OF LIFE.**

## 4.1 Keypad and Display Description

The controller contains a four-character display, eight indicator lights, and six keys as shown in Figure 4.1. The display is used to indicate power up self test, one of four display modes, program functions, program function values, and fault codes. The indicator lights (LEDs) give controller status on display modes, and mode of controller operation. Finally, the keys provide for the control and programming of the controller.

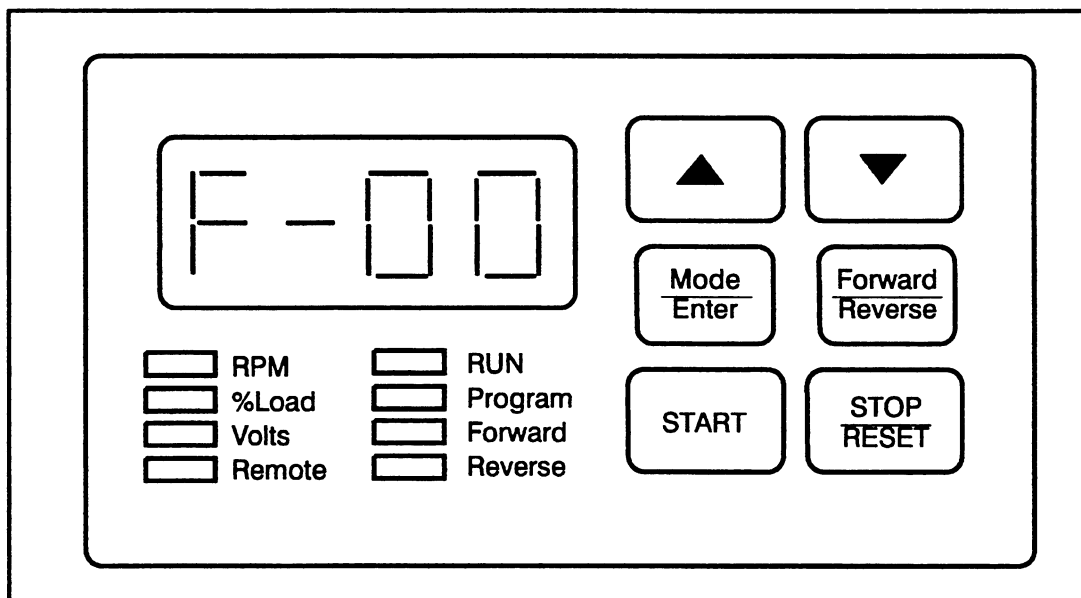

Figure 4.1 - ONYX Controller Keypad and Display.

## 4.2 Indicator Lights

In general, the group of LEDs on the left indicate display modes while, the group on the right indicate operation modes. However, the fourth LED on the left indicates whether the controller is under LOCAL or REMOTE control.

## 4.2.1 Display Mode LEDs

The four (4) LEDs on the left of the controller's keypad indicate the current display mode of either RPM, %Load, Volts, or (when enabled) Percent selected speed reference. While the controller is running, the mode displayed and LED indication can be changed by using the MODE/ENTER key. (Refer to **Modes of Controller Operation**, later in this section for more information on changing display modes.) These LEDs are described further below.

- RPM LED  
-or-  
("Engineering Unit")  
The RPM/Engineering Unit LED indicates that the values being displayed, while the controller is running, are in units of RPM or some user-specified engineering units to match an application. (See Section 5, **Adjusting the Controller Functions**, for more information.)  
  
The "RPM" mode is the drives default display mode and this LED will illuminate upon the initial power up of the controller. However, once the display mode unit is changed (programmed), the controller will power up in the display mode active at the time it was turned off.
- %LOAD LED:  
The "%LOAD" LED indicates, while the drive is running, that the values being displayed are in a percentage of full load amps. When the drive is stopped, the value displayed will be zero.
- VOLTS LED:  
The "VOLTS" LED indicates, while the drive is running, that the value being displayed is that of the drive output voltage to the motor. When the drive is stopped, the value displayed will be zero.
- PERCENT  
SELECTED  
SPEED  
REFERENCE  
If the "RPM", "%LOAD", "VOLTS" and "REMOTE" LEDs are lit, the value displayed is the percentage of selected speed reference. This display mode is only active when Function F-13 is enabled (ON). (See Section 5, **Adjusting the Controller Functions**)

*NOTE: The last display mode chosen when the drive is powered down will then be the same one active when the drive is powered up again. Example: The display mode RPM is changed to %LOAD. The drive is powered down, and powered back up again. The display mode will remain as %LOAD.*

## 4.2.2 Operation Mode LEDs

The group of four (4) LEDs on the right side of the controller's keypad, indicate that the controller is running (RUN LED), whether the Program Mode (PROGRAM LED) is active, or indicates the speed direction (either FORWARD or REVERSE). The fourth LED on the left indicates whether the controller is under REMOTE or LOCAL control operation. These LEDs are described below.

- **RUN LED:** This LED is illuminated when the drive is running (the controller is generating an output voltage and frequency).

### **DANGER**

**THE RUN LED MUST NOT BE USED AS AN INDICATION THAT THERE IS NO LINE VOLTAGE PRESENT IN THE CONTROLLER. VERIFY THERE IS NO VOLTAGE PRESENT AT THE D-C BUS TERMINALS (+) AND (–) BEFORE SERVICING THE CONTROLLER. FAILURE TO OBSERVE THIS PRECAUTION COULD RESULT IN SEVERE BODILY INJURY OR LOSS OF LIFE.**

- **PROGRAM LED:** This LED is illuminated when the controller is in Program Mode. Program Mode is entered by pressing the MODE/ENTER key when the drive is stopped.
- **FORWARD LED:** This LED is illuminated, when the drive is running, to indicate that the requested rotation of the motor is in the Forward Direction.
- **REVERSE LED:** This LED is illuminated, when the controller is running, to indicate that the requested rotation of the motor is in the Reversed Direction. However, when Function 17 is enabled (=ON), the LED is not be illuminated because the requested rotation of the motor is forced in the Forward direction. See Section 5, **Adjusting the controller functions**, for more information.
- **REMOTE LED:** The “REMOTE” LED indicates, when illuminated, that the drive is in remote operation and is following signals from the terminal strip. When the REMOTE LED is not lit, the drive is in LOCAL mode. Enabling Function F-00 (=ON) will illuminate the LED. (See Section 5, **Adjusting the Controller Functions**, for more information on F-00.)

## **4.3 Key Descriptions**

Drive operation is controlled by six keys. These keys are described below.

- **START key:** The START key will start the controller when:
  - Power is applied to the controller
  - No faults are active
  - Drive is in the LOCAL control mode.

When this key is pressed, the controller will accelerate to the last programmed frequency set point (speed). The frequency set point is the last displayed RPM (speed) or engineering unit value set from the up/down arrow keys before the drive was turned off

and/or powered down. The drive will also display its last mode selection along with illuminating the appropriate display, rotation, and run indicating LEDs. The controller remembers and uses all the functional settings and values that were enabled and selected prior to turning it off and/or powering down.

## DANGER

**AFTER DISCONNECTING INPUT POWER WAIT FIVE MINUTES AND CHECK WITH VOLTMETER TO INSURE D-C BUS CAPACITORS ARE DISCHARGED. FAILURE TO OBSERVE THESE PRECAUTIONS COULD RESULT IN SEVERE BODILY INJURY OR LOSS OF LIFE.**

- **STOP/RESET key:** The STOP/RESET key provides three functions for the controller. If the controller is running, this key will turn off the controller output to the motor. If the controller is stopped due to a fault, this key will clear the fault from the controller providing the cause of the fault has been removed from the controller. When the controller is in the program mode, this key will terminate the program operation.

THE STOP/RESET KEY WILL ALWAYS STOP THE CONTROLLER REGARDLESS OF THE SELECTED CONTROL MODE. (REMOTE OR LOCAL).

*NOTE: The drive will perform a ramp to a rest stop (ramp down based on the set deceleration rate) or coast-to-rest stop, depending on the value of Function F-16, when stopped under normal conditions.*

- **MODE/ENTER key:** The MODE/ENTER key provides three functions for the drive. If the drive is running, this key will change (or “toggle through”) the active display mode (RPM, %LOAD, VOLTS, or PERCENT SELECTED SPEED REFERENCE). If the controller is stopped, this key will select the program mode. Once in the program mode, this key will display and save a function value. The MODE/ENTER key functions in either REMOTE or LOCAL control modes.

- **FORWARD/REVERSE KEY:** The FORWARD/REVERSE key is used to select (“toggle between”) the direction for motor rotation. The FORWARD or REVERSE LED will also illuminate to indicate the requested rotation direction for the motor. However, when Function F-17 is enabled (ON), this key will not change the motor rotation because the controller is forced (programmed) only in the Forward direction. See Section 5, **Adjusting the Controller Functions**, for more information. This Key is only active in the LOCAL control mode.

**NOTE:** *The LED may illuminate before the motor turns in the new direction.*

- **UP/DOWN ARROW KEYS:** The UP and DOWN ARROW keys provide three functions for the controller. When the controller is running in the LOCAL mode, they are used to increase or decrease the (internal) speed reference of the controller. When the controller is stopped and placed in the program operation mode, these keys will step through the controller functions (F-00 to ERR). The UP ARROW will increase the Controller Function number while the DOWN ARROW will decrease the controller function number. After the selection of a controller function, these keys are used to change function status (ON/OFF) or value (step incrementing/decrementing).

**NOTE:** *While in Remote operation mode, the changing of the drives internal speed reference, using the UP and DOWN ARROW keys, will NOT have any operational effect on the controller. The controller’s display will show the internal speed reference in Hertz (Hz) while using the keys. A slight delay will be noticed before the controller’s display returns to the display mode active prior to changing the internal speed reference.*

*Holding the UP/DOWN ARROW keys for more than a few seconds will increase the scroll speed.*

## 4.4 Power Up

When the power is applied to the drive, the display will show “SELF” and during this display period, the microcontroller will perform a series of self-test diagnostic routines. This is normal and the display should “change” to the RPM display mode, or whatever mode the controller was in when it was powered down last.

## 4.5 Modes of Controller Operation

### 4.5.1 Display Modes

There are three display modes (or four, if Percent Selected Speed Reference Display mode is active) available when the drive is powered up. These are: RPM, %Load, and Volts. The current display mode (while the drive is running) is indicated by an illuminated LED. The factory default display mode is RPM.

- **To select a display mode (RPM, %LOAD, or VOLTS):**

1. While the drive is running, press the MODE/ENTER key. The display will show %LOAD, and the %LOAD LED will be lit. Each time the MODE/ENTER key is pressed, the next mode is displayed and the appropriate LED will light. The value displayed is in the units of the display mode chosen.
2. To change the display mode again, press the MODE/ENTER key.

A fourth display mode, "PERCENT SELECTED SPEED REFERENCE DISPLAY", can be activated by Function F-13. The value displayed in this mode is the value of the active speed reference signal as 0-100% of the total scaled reference range. (Functions F-11 and F-12 are functions that "scale" the reference.)

If Function F-13 is enabled (or turned "ON") a fourth display mode choice can be activated by pressing the MODE/ENTER key once after the "VOLTS" display mode. All three LED's (RPM, %LOAD, and VOLTS) will be illuminated at the same time, indicating the fourth display mode is active. Refer to Function F-13 for more information and examples for the PERCENT SELECTED SPEED REFERENCE DISPLAY ENABLE Function.

- **To select the PERCENT SELECTED SPEED REFERENCE DISPLAY mode:**

1. Stop the drive (if running) by pressing the STOP/RESET key.
2. Press the MODE/ENTER key to select the PROGRAM mode. (The PROGRAM LED will be illuminated and the display will show "F-00".)
3. Press the up arrow key until "F-13" is displayed. (The down arrow key can also be used to decrement through the program function list.)
4. Press the MODE/ENTER key.
5. Move the up arrow key until the display shows "ON".
6. Press the MODE/ENTER key to "lock in" the value.
7. Press the STOP/RESET key to exit the PROGRAM Mode.
8. Start the drive by pressing the START key.
9. Press the MODE/ENTER key until all three display mode LEDs are lit.
10. The display should now be in the PERCENT SELECTED SPEED REFERENCE DISPLAY mode and percentage of full speed reference is displayed.

#### 4.5.2 Program Mode

The Program Mode allows function values to be viewed or adjusted. All functions (F-00 thru F-49), including the error log ('ERR') are accessible in the Program Mode.

*NOTE: The PROGRAM mode can only be entered if the drive is stopped.*

- **To enter the Program Mode and access the functions:**

1. Stop the drive (if running) by pressing the STOP/RESET key.
2. Press the MODE/ENTER key. The PROGRAM LED should be illuminated.
3. Use the Up/down arrow keys to move through the function list.
4. Press the MODE/ENTER key to display the value of the current function displayed.
5. Use the Up/down arrow keys to change the value of a function. (NOTE: Holding down the up or down arrow key for more than one second will increase the scroll speed.)
6. Press the MODE/ENTER key again to "lock in" the new value. (The display will return to displaying the function number.)

- **To exit the Program mode:**

Press the STOP/RESET key. Note that if the error log is being examined, the STOP/RESET key will reset the error log (and clear all errors). The errors will only clear if the external cause of the problem has been eliminated. The error log function can be exited by pressing the STOP/RESET key while the 'ERR' display is active.

## 4.6 Error Log

Located after Function F-49, is an error log ("Err" is displayed) that stores the first three faults that have occurred. The Program mode must first be entered to access the error log. Refer to **Section 7, Troubleshooting Fault Codes, and Replacement Parts** for more information on the Error Log and clearing the faults.

- **To access the Error Log:**

1. Stop the drive (if running) by pressing the STOP/RESET key.
2. Press the Mode/Enter key. The Program LED should be illuminated.
3. Enter the Program Mode.
4. If the display shows "F-00", use the down arrow key to move directly to 'Err'. Either the up or down arrow key can be used to move through the function list. 'Err' follows "F-49".
5. Press the MODE/ENTER key.
6. Press the up arrow key to move through the error codes.
7. Press the STOP/RESET key to clear the faults. (Refer to **Section 7, Troubleshooting Fault Codes, and Replacement Parts** for more information on error codes.)

# 5.0 Adjusting the Values of Drive Functions

**DANGER**

**ONLY QUALIFIED ELECTRICAL PERSONNEL FAMILIAR WITH THE CONSTRUCTION AND OPERATION OF THIS EQUIPMENT AND THE HAZARDS INVOLVED SHOULD INSTALL, ADJUST, OPERATE, AND/OR SERVICE THIS EQUIPMENT. READ AND UNDERSTAND THIS MANUAL IN ITS ENTIRETY BEFORE PROCEEDING. FAILURE TO OBSERVE THIS PRECAUTION COULD RESULT IN SEVERE BODILY INJURY OR LOSS OF LIFE.**

The controller offers users 29 software functions that are either selectable or adjustable by using the program keys on the keypad. The factory preset values for these functions suit a wide range of standard applications. To configure the controller for a specific application, activate and adjust the values of these functions as necessary.

This section describes how to configure the controller using the keypad and displays. It also gives a complete description of each function by its assigned function number. The functions appear in numerical order by the assigned function numbers. A quick reference summary of these functions, in numerical order by the function number, is given in Table 5.1.

Table 5.1 - Factory Default Settings

Function	Range	Step Size	Default
F-00 Control Source Select	0, 1, 2, 3	N/A	0
F-01 Accel rate (seconds)	0.5-90.0	0.10	5.0
F-02 Decel rate (seconds)	0.5-90.0	0.10	5.0
F-03 Minimum speed (Hz)	0.5-30.0	0.10 / 0.25	5.0
F-04 Maximum speed (Hz)	30.0-240.0	0.10 / 0.25	60.0
F-05 Current Limit (%)	10-150	1.0	150
F-06 Manual Torque boost (%)	2-10	1.0	2
F-07 Volts/Hertz (Base speed (Hz)	3-240	1.0	60
F-08 RPM scaling at base speed	10-9999	1.0	1750
F-09 Configurable Output Relay Select	0, 1, 2	N/A	0
F-10 Carrier frequency (KHz)	4, 6, 8	N/A	4
F-11 Remote reference gain (%)	60-100	0.10	100
F-12 Remote reference off-set (%)	0-40	0.10	0

Table 5.1 - Factory Default Settings (continued)

F-13	Percent Selected Speed Reference display enable	On, OFF	N/A	OFF
F-14	Electronic thermal overload (%)	20-100	1.0	100
F-15	Electronic thermal overload enable	On, OFF	N/A	On
F-16	Coast stop enable	On, OFF	N/A	On
F-17	Reverse disable	On, OFF	N/A	OFF
F-18	RPM setpoint enable	On, OFF	N/A	OFF
F-19	Power-up start enable	On, OFF	N/A	OFF
F-20	Password lockout enable	On, OFF	N/A	OFF
F-21	Avoidance frequency (Hz)	Min_speed- Max_speed	0.10	5
F-22	Avoidance bandwidth (Hz)	0.0-10.0	0.10	0
F-23	Multi-speed preset #1 (Hz)	Min_speed- Max_speed	0.10	20
F-24	Multi-speed preset #2 (Hz)	Min_speed- Max_speed	0.10	20
F-25	Multi-speed preset #3 (Hz)	Min_speed- Max-Speed	0.10	20
F-26	Auto-restart number of attempts	0-10 (0 = Disabled)	N/A	0
F-27	Auto-restart retry wait time (seconds)	1-30	1.0	1
F-28	Controller Voltage Select	This parameter is set at the factory. It should <u>never</u> be changed by the user.		
F-49	Version number	x.xx	N/A	Read Only
ERR	IET Fault Codes	<b>Displayed Code</b>	<b>Description</b>	
		HU	D-C bus high voltage condition	
		LU	D-C bus low voltage condition	
		OL	Electronic Thermal Overload	
		OH	Controller High Temperature	
		OC	Overcurrent, short circuit, or ground fault	
		FL	External function loss asserted	

**DANGER**

**ONLY QUALIFIED ELECTRICAL PERSONNEL FAMILIAR WITH THE CONSTRUCTION AND OPERATION OF THIS EQUIPMENT AND THE HAZARDS INVOLVED SHOULD INSTALL, ADJUST, OPERATE, AND/OR SERVICE THIS EQUIPMENT. READ AND UNDERSTAND THIS MANUAL IN ITS ENTIRETY BEFORE PROCEEDING. FAILURE TO OBSERVE THIS PRECAUTION COULD RESULT IN SEVERE BODILY INJURY OR LOSS OF LIFE.**

Use the procedure that follows to change the value of a function:

1. Power up the drive.
2. Press the MODE/ENTER key to select the PROGRAM mode. (The PROGRAM LED will be illuminated and the display will show "F-00"; the first function number.)
3. Move the up/down arrow keys until the desired function number is displayed.
4. Press the MODE/ENTER key.
5. Press the up/down arrow keys to change the value.
7. Proceed to the next function to be changed using the up/down arrow keys.
8. Press the STOP/RESET key to exit the PROGRAM mode.

## 5.1 F-00 - Control Source Select

### Settings

- 0 = LOCAL keypad control (DEFAULT)
- 1 = REMOTE TB (terminal block) control with all control signals from terminal block and speed reference from analog input
- 2 = REMOTE TB control with LOCAL keypad setpoint and all control signals from the terminal block
- 3 = REMOTE TB control with TB multi-speed presets and all control signals from the terminal block

### Step Size

Not Applicable

### Description

This function is used to select the control mode for the drive.

When under LOCAL control (0), the drive takes input from the keypad.

When under REMOTE TB control (1, 2, or 3), the drive takes all sequencing commands (START, STOP, etc.) from signals on the terminal strip.

When F-00 = 1, all control signals will come from the terminal board. Speed reference will come from analog input.

When F-00 = 2, all control signals will come from the terminal board. Speed reference will come from the local keypad setpoint.

When F-00 = 3, all control signals will come from the terminal board. Multi-speed presets will also come from the terminal board (see section 5.24 which describes multi-speed presets ).

## 5.2 F-01 - Acceleration Rate

### Settings

Range of 0.5 - 90 seconds; 5.0 = DEFAULT

### Step Size

0.10 seconds

### Description

The acceleration rate is the amount of time to ramp from stop to the programmed maximum speed setting (Function F-04).

If the setpoint frequency (last requested local speed from the up/down arrow key) is less than the maximum speed setting, the time to ramp to that setpoint will be proportionally less than the actual acceleration rate setting. If maximum speed equals 60 Hz and accel time equals 4 seconds, it will take 2 seconds to ramp to a frequency setpoint of 30 Hz (and 1 second to ramp to 15 Hz).

If the acceleration rate is set too fast, the controller may trip out on an overcurrent condition. (See Section 7 if this condition exists.)

## 5.3 F-02 - Deceleration Rate

### Settings

Range of 0.5 to 90 seconds; 5.0 = DEFAULT

### Step Size

0.10 seconds

### Description

The deceleration rate is the amount of time to ramp from the programmed maximum speed setting (Function F-04) to a stop.

The deceleration time is also proportional to the last set frequency. (See Function F-01, acceleration.)

If the deceleration rate is set too fast, the drive may trip out on a high bus fault. (See Section 7 if this condition exists.)

## 5.4 F-03 - Minimum Speed

### DANGER

THE ONYX CONTROLLER IS INTENDED TO OPERATE THE MOTOR AT A PREDETERMINED MINIMUM SPEED UNLESS DISCONNECTED FROM THE POWER SOURCE. TO PREVENT INADVERTENT CONTACT WITH OPERATING EQUIPMENT, THE USER MUST VERIFY THAT THE MOTOR OUTPUT SHAFT WILL ROTATE AT ALL COMBINATIONS OF LOAD AND OUTPUT SPEED REQUIRED BY THE APPLICATION. FAILURE TO OBSERVE THIS PRECAUTION MAY RESULT IN SEVERE BODILY INJURY OR LOSS OF LIFE

#### Settings

Range of 0.5 - 30 Hz; 5.0 = DEFAULT

#### Step Size

0.10 Hz if maximum speed is less than 100 Hz

0.25 Hz if maximum speed is greater than or equal to 100 Hz

#### Description

Minimum speed is the user requested minimum output frequency value of the controller. This speed (Hz) reference must always be lower than the maximum (Hz) setting (Function F-04) of the controller. The base or running speed setting (base speed, Function F-07) will always be a value between this minimum and the maximum speed (Hz) reference.

## 5.5 F-04 - Maximum Speed

### WARNING

THE USER IS RESPONSIBLE FOR ENSURING THAT DRIVEN MACHINERY, ALL DRIVE-TRAIN MECHANISMS, AND PROCESS LINE MATERIAL ARE CAPABLE OF SAFE OPERATION AT AN APPLIED FREQUENCY OF 100% OF THE MAXIMUM FREQUENCY (UP TO THE FREQUENCY OF F-04). FAILURE TO OBSERVE THIS PRECAUTION COULD RESULT IN BODILY INJURY.

#### Settings

Range of 30 - 240 Hz; 60.0 = DEFAULT

#### Step Size

0.10 Hz if max speed is less than 100 Hz

0.25 Hz if max speed is greater than or equal to 100 Hz

#### Description

The maximum speed is the user requested maximum output frequency value of the controller. The base or running speed setting (base speed Function F-07) will always be a value between the minimum reference and this maximum.

## 5.6 F-05 - Current Limit

### Settings

Range of 10% to 150% of rated controller current; 150 = DEFAULT

### Step Size

1.0%

### Description

This function provides the means to limit motor output torque during run or acceleration. When output current attempts to exceed the preset current limit, motor current is maintained or reduced, or acceleration/deceleration time is extended. If current limit is set too low or too high relative to the required load, an "OC" (Overcurrent) fault may occur.

## 5.7 F-06 - Manual Torque Boost

### Settings

Range of 0 - 10%; 2 = DEFAULT

### Step Size

1.0%

### Description

Torque boost is required to offset the voltage drop of the ac motor at low speeds. For friction loads, or high inertia loads, a high starting torque level may be needed. Manual torque boost is only effective at speeds lower than one-half of base frequency. See Figure 5.2.

When adjusting this function, start with the default setting of 2%, and gradually increase the adjustment until satisfactory motor operation is reached.

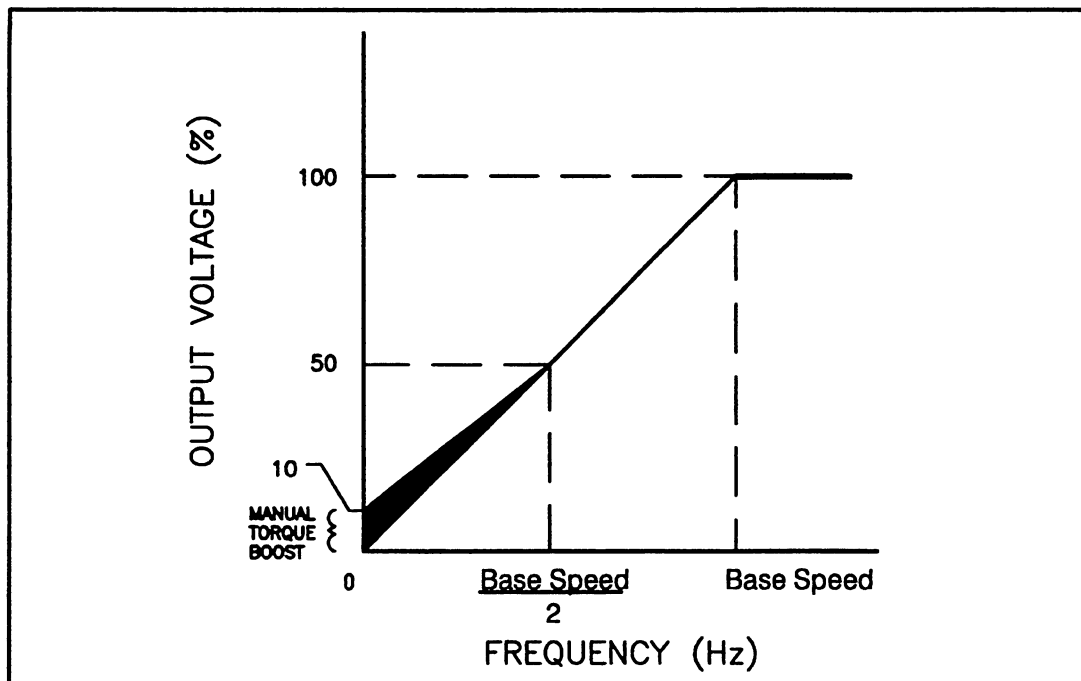

Figure 5.1 - Manual Torque Boost Adjustable Range.

## 5.8 F-07 - V/Hz (Base Speed)

### Settings

Range of 30 - 240 Hz; 60 = DEFAULT

### Step Size

1.0 Hz

### Description

The volts/hertz feature allows the drive to maintain a constant volts/hz ratio, thus providing constant torque at any frequency. The frequency value entered to establish the volts/hertz curve is the base speed at maximum output voltage. See Figure 5.3.

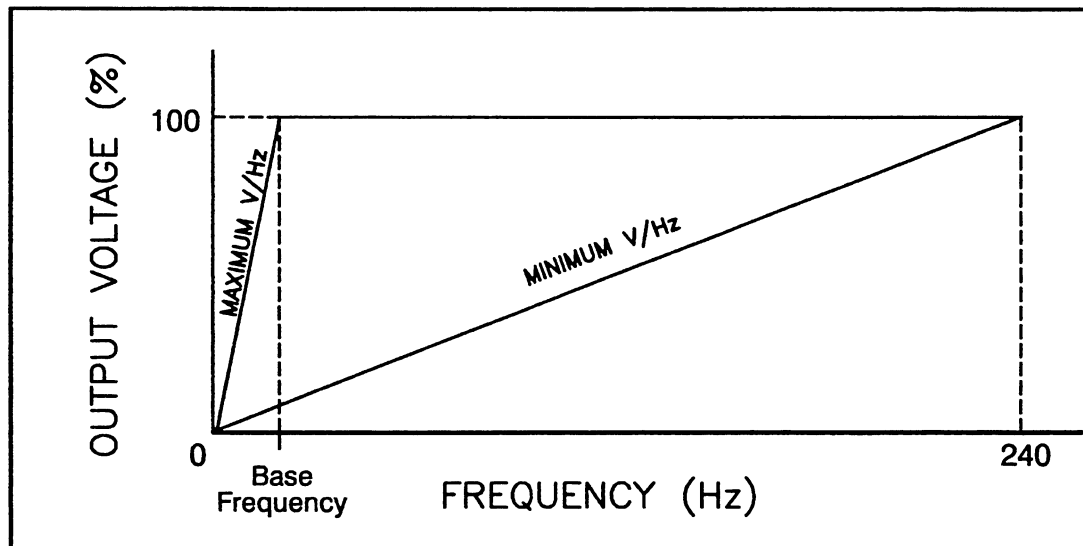

Figure 5.2 - Volts/Hertz Curve.

## 5.9 F-08 - RPM At Base Speed

### Settings

Range of 10 - 9999; 1750 = DEFAULT

### Step Size

1.0 unit

### Description

This feature provides the ability to scale the display and setpoint to an engineering unit to match your specific application. Although Function F-08 is called "RPM at Base Speed", it can be set up as Hertz, Feet/Min, or any other unit needed. The value scaled in this function is what is displayed when looking at the Display Mode, "RPM", and is used for the local control setpoint range.

The value entered into Function F-08 is the maximum value (RPM, or any other engineering unit) to be displayed in the RPM display mode, when the controller is running at base speed (Function F-07).

**Example 1:** You want 1750 RPM to be the displayed value when the controller is running at a base speed of 60 Hz. You enter 1750 into Function F-08.

The actual displayed value for the RPM display mode, is a scaled value of what is entered for Function F-08:

Example: You want 1750 RPM to be the displayed value when the controller is running at a base speed of 60 Hz. You are presently running at 30 Hz. The RPM display mode value is scaled as follows:

$$\begin{array}{rcl} \text{Present Operating} & \times & \text{F-08 (You entered 1750)} \\ \text{Speed (Hz)} & & \text{F-07 (Base speed of 60 Hz)} \\ 30\text{Hz} & \times & \frac{1750}{60} = 875 \end{array}$$

In this example, when you are running at 30Hz, the RPM display mode will show 875.

## 5.10 F-09 - Configurable Output Relay Select

### Settings

0 = Controller running (DEFAULT);  
1 = IET active;  
2 = Drive at speed

### Description

This function determines whether the remote output signal (at terminals 14-16) represents that the controller is currently running (0), the state of an active fault (1), or whether the drive is running at speed (2).

If the signal represents an active fault (1), the signal will remain asserted until the fault is cleared by pressing the STOP/RESET key (in LOCAL operation) or by using the remote IET reset signal (for REMOTE operation). Refer to figure 3-8.

If the signal represents controller running (0), the signal is asserted only when the RUN LED is lit.

If the signal represents drive at speed (2), the following will apply :

- When the drive is running and 'at speed' the output will be asserted.
- When the drive is stopped the output will not be asserted
- When the drive has an active fault the output will not be asserted.

The drive will be considered to be 'at speed' if the current frequency output is within 0.5% of the maximum speed range. In other words, if the maximum speed is 60.0 Hz, then, when the drive is within 0.5% x 60.0 = 0.3 Hz, the output will be asserted.

## 5.11 F-10 - Carrier Frequency

### Settings

Range of 4, 6, 8 KHz; 4 = DEFAULT

### Description

The carrier frequency can compensate for acoustic noise, heating, and other current problems by adjusting the switching frequency of the transistors in the inverter section.

The carrier frequency controls the width of the pulse and keeps the current smooth to the motor.

Keeping the carrier frequency at 4kHz will maximize the continuous power rating of the drive and generally still have an acceptable acoustic noise from the motor. Increasing the carrier frequency will alleviate the acoustic noise, but in some applications can result in derating of the controller output amps. (Refer to Tables 2.2 and 2.3 for the derated ratings at the various carrier frequencies.)

## 5.12 F-11 - Remote Reference Gain

### Settings

Range of 60% - 100% of full scale maximum reference; 100 = DEFAULT

### Step Size

0.10%

### Description

The remote reference gain scaling is used to scale the **maximum** remote speed reference to match external equipment. Normally, the maximum speed reference (amount of reference at maximum speed, F-04) is either 10 VDC or 20 mA. The reference gain is used to scale the speed reference to another value (for example 9.5 VDC or 19 mA). Enter this function in percent (%) of full scale reference. To calculate the scaled reference, use the following equations:

If using a 0-20 mA remote reference:

$$\frac{\text{Desired Maximum Reference (mA)}}{\text{Reference Range (20)}} \times 100 = \% \text{ gain (mA reference)}$$

Example 1. If the remote speed reference is 0-20 mA and the maximum reference required is 19.2 mA, scale as follows:

$$\frac{19.2}{20} \times 100 = 96\% \text{ gain}$$

If using a 0-10 VDC remote reference:

$$\frac{\text{Desired Maximum Reference (VDC)}}{\text{Reference Range (10)}} \times 100 = \% \text{ gain (VDC reference)}$$

Example 2. If the remote speed reference is 0-10 VDC and the maximum reference required is 9.5 VDC, scale as follows:

$$\frac{9.5}{10} \times 100 = 95\% \text{ gain}$$

## 5.13 F-12 - Remote Reference Offset

### Settings

Range of 0% - 40% of full scale minimum reference; 0 = DEFAULT

### Step Size

0.10%

### Description

The remote reference offset scales the remote speed reference (0-10 VDC or 0-20 mA) to a **minimum** value. Typically, the value of the minimum speed reference (the amount of reference at minimum speed, F-03) is either 0 VDC or 0 mA. Enter this value as a percent (%) of full scale reference to be offset from minimum speed. To calculate the scaled minimum reference, use the following equation:

$$\frac{\text{Desired Minimum Speed Offset}}{\text{Reference Range}} \times 100 = \% \text{ offset}$$

Example 1. If the remote speed reference is 0-20ma and the offset from minimum speed required is 4 ma, scale as follows:

$$\frac{4}{20} \times 100 = 20\% \text{ offset}$$

Example 2. If the remote speed reference is 0-10 VDC and the offset from minimum speed required is 0.4 VDC, scale as follows:

$$\frac{0.4}{10} \times 100 = 4\% \text{ offset}$$

## 5.14 F-13 - Percent Selected Speed Reference Display Enable (4th Display Mode)

### Settings

Displays the active speed reference as 0 - 100% of the scaled reference range.

ON = 4th display mode is enabled and will display the active speed reference when the REFERENCE display mode is chosen. (Function F-00 = ON)

OFF = 4th display mode is disabled. The active speed reference will not be displayed. (DEFAULT)

### Description

This function enables a 4th display mode which allows the display of the current value of the active speed reference in percent (%).

When enabled (Function F-13 = ON), the 4th display mode is activated by pressing the MODE/ENTER key (while the drive is running) and all three display LEDs are illuminated at the same time.

When the REFERENCE Display Mode is chosen, the display will show the active reference as 0 - 100% of the speed reference range.

## 5.15 F-14 - Electronic Thermal Overload

### Settings

20% - 100% rated current; 100 = DEFAULT

### Step Size

1%

### Description

This function should be adjusted if the motor amperage rating is less than the controller amperage rating. Using the formula below, calculate the setting level as a percentage of maximum continuous current:

$$F14 = \frac{\text{Motor Full Load Current}}{\text{Controller Output Rated Current}} \times 100$$

The motor full load current can be taken from the motor nameplate, and the controller rated output current can be taken from Table 2.1 through 2-5 as applicable (or the controller nameplate).

**CAUTION:** Function F-15 should be set equal to "ON" (ENABLED). Failure to observe this precaution could result in damage to, or destruction of the motor and controller.

## 5.16 F-15 - Electronic Thermal Overload Enable

### Settings

OFF = No electronic thermal overload protection.

ON = Electronic thermal overload protection is active. (DEFAULT)

The electronic thermal overload enable is used to simulate the functionality of a motor thermal switch, protecting the motor from overheating due to excessively high current in a short period of time.

If this function is ON, the controller will trip if the thermal overload time is exceeded (60 seconds at 150% of F-14). When an external thermal switch (an alarm, or warning light, etc.) is wired into the Function Loss circuit (terminals 10 and 11), this function should be set equal to "ON". Refer to Figure 3-9, Control Terminal Strip Wiring.

**CAUTION:** This function should be set equal to "ON" (ENABLED). Failure to observe this precaution could result in damage to, or destruction of the motor and controller.

## 5.17 F-16 - Coast Stop Enable

### WARNING

**THE CONTROLLER IS NOT EQUIPPED WITH A COAST-STOP PUSHBUTTON. THE USER MUST INSTALL A HARDWIRED, OPERATOR-ACCESSIBLE PUSHBUTTON THAT PROVIDES A POSITIVE INTERRUPT AND SHUTS DOWN THE DRIVE. (USE TERMINALS 10 AND 11. SEE FIGURES 3-4, 3-5, 3-6 AND 3-16.) FAILURE TO OBSERVE THIS PRECAUTION COULD RESULT IN BODILY INJURY.**

### Settings

ON = Enable Coast-Stop (Coast-to-rest) (DEFAULT)

OFF = Disable Coast Stop (Ramp-to-rest)

### Description

This function, when enabled, will permit a coast-to-rest stop, instead of the ramp-to-rest stop.

## 5.18 F-17 - Reverse Disable

### Settings

ON = Disable Reverse (from LOCAL and REMOTE control)

OFF = Enable Reverse (DEFAULT)

### Description

When this function is ON, the drive will not be able to turn in the reverse direction. Also, when the drive is in LOCAL mode, pressing the Forward or Reverse keys, will have no effect on drive operation. The Forward LED will always display ON, and the Reverse LED will always display OFF. When the drive is in REMOTE mode, any wiring to terminal 9 of the Control terminal strip (see Figure 3-9) is ignored, and the drive will only run in the forward direction.

Regardless of what is entered or changed, when this function is ON (reverse is disabled), the drive will be forced in the forward direction.

## 5.19 F-18 - RPM Setpoint Enable

### Settings

OFF = Setpoint based on frequency (DEFAULT)

On = Setpoint based on scaled RPM display (same as F-08)

### Description

This function is used to select the setpoint based on frequency (OFF) or the scaled RPM display parameter (F-08) (On).

If you have set F-08 = 1750 and F-18 = On, when you press  $\blacktriangle$  or  $\blacktriangledown$  to modify the local setpoint, the controller will display the current value (and subsequently change the value) in integral units based on the current speed. For example, the drive is currently running at 60 Hz = 1750 RPM and F-08 = 1750. When you press  $\blacktriangledown$ , the display reads 1750. You then push  $\blacktriangledown$  3 more times and see the display change from 1750 to 1749 to 1748 to 1747. The reference is then re-scaled based on this input:

$$\text{Input Reference} = \frac{\text{Setpoint (1747)}}{\text{F-08 (1750)}} \times \text{F-04 (60 Hz)} = 59.89 \text{ Hz}$$

If F-18 is On (1), the setpoint range will be from F-08 at the top end down to the equivalent RPM for the minimum frequency (absolute minimum = 0.5 Hz currently). This would be the smallest whole RPM value scaling F-08 to minimum frequency.

## Changes to the RPM display mode

The RPM display mode will now follow the rules:

1. If the RPM setpoint mode is selected (F-18 = 1 (On)), the display will always be an integral number.
2. If the frequency setpoint mode is selected (F-18 = 0 (OFF)), the display may have one of two forms :
  - A. If the value for RPM scaling is the same as the value for base speed, the presumption is the user would like to see his current speed displayed in Hz. In this case, the RPM monitor mode will display Hz with one decimal place all the time. This is the same level of resolution as he can enter his setpoint with (in Hz).
  - B. If the above case is not true (RPM scaling  $\neq$  Base speed) then the display will be in integral units.

## 5.20 F-19 - Power-up Start Enable

### **DANGER**

**ENABLING THIS FUNCTION CAUSES THE DRIVE TO START AUTOMATICALLY ON POWER UP. WHEN THIS FUNCTION IS ENABLED, THE USER MUST ENSURE THAT AUTOMATIC STARTUP OF THE DRIVEN EQUIPMENT WILL NOT CAUSE INJURY TO OPERATING PERSONNEL OR DAMAGE TO THE DRIVEN EQUIPMENT. FAILURE TO OBSERVE THIS PRECAUTION COULD RESULT IN SEVERE BODILY INJURY OR LOSS OF LIFE.**

### **Settings**

OFF = Drive does not start upon power-up (DEFAULT)

On = Drive automatically starts upon power-up

### **Description**

When this function is set On, the drive will automatically start upon power-up. This will be qualified as follows:

1. If any permissives are not qualified, the drive will not start. This might include any faults detected during power-up such as a checksum failure, or if the function loss was asserted upon power-up, or if the LOCAL STOP key is asserted.
2. If in LOCAL control mode, the drive will effectively simulate an edge on the START button which will cause the drive to start.
3. If the drive is in the REMOTE control mode, the drive will only force a START if the terminal block (TB) START is asserted.

## 5.21 F-20 - Password Lockout Enable

### WARNING

**IT IS THE USER MANAGEMENT'S RESPONSIBILITY TO DISTRIBUTE THE PASSWORD WITH DISCRETION WITHIN THEIR ORGANIZATIONAL LEVELS. RELIANCE IS NOT RESPONSIBLE FOR UNAUTHORIZED ACCESS VIOLATIONS WITHIN THE USER'S ORGANIZATION. FAILURE TO OBSERVE THIS PRECAUTION COULD RESULT IN BODILY INJURY.**

#### Settings

OFF = Password lockout disabled (DEFAULT)

On = Password lockout enabled

#### Description

Password protection can be used to lock out all programming modifications.

Pressing ENTER when 'F-20' is displayed will display 'ON' or 'OFF' depending on whether the password lockout feature is currently enabled or disabled. Then pressing either the ▲ or ▼ keys will result in the number zero being displayed. You then use ▲ or ▼ to adjust the number to the correct password (257). When you press ENTER, it will toggle the state of the password lockout. The appropriate text ('On', 'OFF') will be displayed dependent on the current state of the password lockout enable function. Pressing ENTER again will cause the display to return to F-20.

When program lockout is enabled, you will be able to examine the current values of all parameters, but you will not be able to change these values (except F-20).

*NOTE: There is no visual indication that the drive is in the program lockout mode without going to F-20 and checking its current value (On or OFF).*

## 5.22 F-21 - Avoidance Frequency

#### Settings

Min\_speed to Max\_speed (Hz)

#### Step Size

0.10 Hz

#### Description

This function is used to set the avoidance band center point, and is used in conjunction with F-22 (Avoidance Bandwidth). The avoidance band can help alleviate the problem with vibrations/harmonics at a specific operating frequency of the driven motor/machinery. Refer to 5.23 for additional information.

## 5.23 F-22 - Avoidance Bandwidth

### Settings

0 - 10 Hz (0 = Avoidance frequency disabled)

### Step Size

0.10 Hz

### Description

This function is used to set the avoidance bandwidth, and is used in conjunction with F-21 (Avoidance Frequency). Any frequency which falls within the avoidance band will result in a generated frequency below the bandwidth. For example,

Assume Min speed = 3 Hz

Max speed = 60.0 Hz

Programmed Avoidance frequency = 32.2 Hz

Programmed avoidance bandwidth = 4 Hz

Avoidance band 30.2 - 34.2 Hz

<b>Requested output frequency via setpoint or TB reference</b>	<b>Output frequency after avoidance band correction</b>
20.0 Hz	20.0 Hz
23.0 Hz	23.0 Hz
25.0 Hz	25.0 Hz
30.0 Hz	30.0 Hz
31.0 Hz	30.2 Hz
32.0 Hz	30.2 Hz
34.0 Hz	30.2 Hz
34.2 Hz	30.2 Hz
34.3 Hz	34.3 Hz
35.0 Hz	35.0 Hz

Note the drive is permitted to accel/decel through the avoidance band. However, it is not allowed to operate at a steady state at any of the avoidance band frequencies.

## 5.24 F-23, F-24, and F-25 - Multi-speed Presets #1, #2, and #3

### Settings

Min\_speed to Max\_speed (Hz); 20 = DEFAULT

### Step Size

0.10 Hz

### Description

Three (3) multi-speed presets can be used to add remote functionality to the existing drive configuration. When the control source for the drive (F-00) is selected to be mode 0, 1, or 2, the terminal board inputs will be assigned as follows:

TB 6 = STOP

TB 7 = START

TB 8 = IET RESET

TB 9 = Forward/Reverse

However, when F-00 = 3 (multi-speed configuration), the terminal board inputs will take on the following configuration:

TB 6 = START/STOP/IET RESET

TB 7 = Mspd 1

TB 8 = Mspd 0

TB 9 = Forward/Reverse

The START/STOP/IET RESET has been combined into one input.

The combined START/STOP/IET RESET has the sense OPEN = STOPPED, CLOSED = IET RESET/START.

The multi-speed inputs will be processed as follows :

Mspd 1	Mspd 0	Reference source
0	0	TB analog input
0	1	Multi-speed #1
1	0	Multi-speed #2
1	1	Multi-speed #3

## 5.25 F-26 - Auto-Restart Number of Attempts

### DANGER

**ENABLING THIS FUNCTION CAUSES THE DRIVE TO RESTART AUTOMATICALLY AFTER CERTAIN DRIVE FAULTS HAVE SHUT DOWN THE DRIVE. WHEN THIS FUNCTION IS ENABLED, THE USER MUST ENSURE THAT AUTOMATIC RESTART OF THE DRIVEN EQUIPMENT WILL NOT CAUSE INJURY TO OPERATING PERSONNEL OR DAMAGE TO THE DRIVEN EQUIPMENT. FAILURE TO OBSERVE THIS PRECAUTION COULD RESULT IN SEVERE BODILY INJURY OR LOSS OF LIFE.**

#### Settings

0 - 10; 0 = DEFAULT (0 = Auto-restart disabled)

#### Step Size

Not Applicable

#### Description

This function is used to set the number of auto-restart attempts. It is used in conjunction with F-27, Auto-restart Wait Time (see section 5.26).

When certain faults are detected ('auto-restartable' faults), the drive will log the fault as usual and then wait a specific amount of time (F-27) before attempting to restart the drive automatically. If the fault occurs again, the drive will wait and then try to start again, up to a programmed number of attempts (F-26). If the drive fails all these attempts, it will remain in the faulted state and will display the fault code for the fault it is trying to auto-restart.

After the drive has detected the fault and is counting down the auto-restart time period, the display will flash the count down period (in seconds) in the following format:

"Ar30 .. Ar29 .. Ar28 ..... Ar01 .. Ar00"

This will show you the amount of time remaining before the auto-restart is to take effect.

Once the drive is restarted from an auto-restart (after the time period has counted down), it must run for 5 minutes for the auto-restart to be considered successful. If the drive faults again before the 5 minutes has passed, the drive will decrement the number of auto-restart attempts, count down the auto-restart time again, and continue its auto-restart processing.

If a fault occurs which is auto-restartable and other faults are also active which are not auto-restartable, then the auto-restart function will be disabled until all faults are cleared.

When a fault is being 'auto-restarted', its first occurrence will be logged in the fault log. Any subsequent occurrence of that fault while attempting to restart the drive will not be logged. As described above, if the drive cannot be restarted (fails all attempts), it will then flash the fault code on the display (as it does with non-auto-restartable faults).

Auto-restartable faults are:

Overtemperature	OV
Overcurrent	OC
High Bus	HU
Low Bus	LU
Thermal Overload	OL

## 5.26 F-27 - Auto-Restart Retry Wait Time

### Settings

1- 30 seconds; DEFAULT = 1

### Step Size

1.0 second

### Description

This function is used to set the delay time between auto-restart attempts. It is used in conjunction with F-26, Auto-Restart Number of Attempts. Refer to section 5.25 for a description of how these functions work together.

## 5.27 F-28 - Controller Voltage Selection

**CAUTION:** The controller voltage is set at the factory. This parameter must not be changed by the user. Failure to observe this precaution could result in damage to or destruction of the equipment.

## 5.28 F-49 - Version Information

### Settings

X.XX = Version Number

### Description

When the display shows "F-18", press the MODE/ENTER key to show the current revision. This function cannot be changed.

## 5.29 ERR - Error Log

Refer to Section 7, "**Troubleshooting, Fault Codes, and Replacement Parts**" for information on the Error Log that follows Function F-49.



## 6.0 Start the Controller

### DANGER

**ONLY QUALIFIED ELECTRICAL PERSONNEL FAMILIAR WITH THE CONSTRUCTION AND OPERATION OF THIS EQUIPMENT AND THE HAZARDS INVOLVED SHOULD INSTALL, ADJUST, OPERATE, AND/OR SERVICE THIS EQUIPMENT. READ AND UNDERSTAND THIS MANUAL IN ITS ENTIRETY BEFORE PROCEEDING. FAILURE TO OBSERVE THIS PRECAUTION COULD RESULT IN SEVERE BODILY INJURY OR LOSS OF LIFE.**

### 6.1 Check the Installation

### DANGER

**AFTER DISCONNECTING INPUT POWER WAIT FIVE MINUTES AND CHECK WITH A VOLTMETER TO INSURE THAT D-C BUS CAPACITORS ARE DISCHARGED. THE VOLTMETER SHOULD READ ZERO UDC. FAILURE TO OBSERVE THESE PRECAUTIONS COULD RESULT IN SEVERE BODILY INJURY OR LOSS OF LIFE.**

1. If an input disconnect is installed, make sure it is in the OFF position.
2. Verify that D-C bus volts is zero. See Figures 3.7 and 3.8. Even if the bus LED is OFF, always verify that the D-C bus is discharged.
3. Make sure the controller interlocks installed around the driven machine are operational.

### WARNING

**THE ONYX CONTROLLER IS NOT EQUIPPED WITH A COAST-STOP PUSHBUTTON. THE USER MUST INSTALL A HARDWIRED, OPERATOR-ACCESSIBLE PUSHBUTTON THAT PROVIDES A POSITIVE INTERRUPT AND SHUTS DOWN THE DRIVE. (USE TERMINALS 10 AND 11, SEE FIGURES 3.4, 3.5, 3.6 AND 3.16.) FAILURE TO OBSERVE THIS PRECAUTION COULD RESULT IN BODILY INJURY.**

4. Verify that the user-installed stop pushbutton is operational. When pushed, it should shut down the controller. The factory-installed jumper should not be connected to terminals 10 and 11 for the stop pushbutton to work. Remove this jumper.

**CAUTION:** Make sure electrical commons are not intermixed in the controller. Failure to observe this precaution could result in damage to, or destruction of the equipment.

5. Remove any debris from around the controller.
6. Check that there is adequate clearance around the controller.

7. Check and verify that the wiring to the control terminal strip and power terminals is correct (Figures 3.4, 3.5 and 3.6).
8. Check that the terminals are tightened properly to the appropriate torque specifications given in Tables 3.6, 3.7 and 3.9.
9. Check that user-supplied branch circuit protection is installed and correctly rated.
10. Check that the incoming A-C power is rated correctly.
11. Check the motor installation and length of motor leads.
12. Disconnect any power correction capacitors connected to the motor.
13. Uncouple the motor from any driven machinery to initially start the controller.
14. Check that any motor thermal switch and the controller's electronic thermal overload (Function F-15) is set (enabled).
15. Check that the rating of the transformer (if used) matches the controller requirements, and is connected for the proper voltage.
16. Verify that a properly sized ground wire is installed and that a suitable earth ground is used. Check for and eliminate any grounds between the motor frame and the motor power leads. Verify that all ground leads are run unbroken.

## 6.2 Start the Controller

### **DANGER**

**THE SUBSEQUENT STEPS REQUIRE ROTATING PARTS AND/OR ELECTRICAL CIRCUITS TO BE EXPOSED. STAY CLEAR IF UNIT MUST BE RUNNING OR DISCONNECT AND LOCKOUT OR TAG POWER SOURCE IF CONTACT MUST BE MADE. FAILURE TO OBSERVE THESE PRECAUTIONS COULD RESULT IN SEVERE BODILY INJURY OR LOSS OF LIFE.**

### **DANGER**

**AFTER DISCONNECTING INPUT POWER WAIT FIVE MINUTES AND CHECK WITH A VOLTMETER TO INSURE THAT D-C BUS CAPACITORS ARE DISCHARGED. FAILURE TO OBSERVE THESE PRECATUIONS COULD RESULT IN SEVERE BODILY INJURY OR LOSS OF LIFE.**

1. Turn OFF, lock out and tag power to the controller.
2. Connect a voltmeter to terminals (+) and (–), and verify that the controller bus voltage is 0 VDC. See Figures 3.7 and 3.8.
3. Uncouple the driven equipment from the motor, if possible.
4. Turn the power ON. With a voltmeter at terminals (+) and (–), observe a voltmeter reading for an approximate no load D-C bus voltage value on the controller as listed in Table 6.1. (D-C bus voltage readings are effected by the incoming line

characteristics such as, amplitude, frequency, harmonic distortion, etc.)

Table 6.1 - D-C Bus Voltage Value.

A-C Input Line Voltage	D-C Bus Voltage (No Load) <sup>(1)</sup>
115 VAC Controllers	
115 VAC	160 VDC
230 VAC Controllers	
230 VAC	323 VDC
460 VAC Controllers	
380 VAC	535 VDC
400 VAC	563 VDC
415 VAC	585 VDC
440 VAC	620 VDC
460 VAC	648 VDC
575 VAC Controllers	
575 VAC	811 VDC

(1) D-C No Load Voltage readings are approximate values and will vary greatly depending on the characteristics of the incoming A-C voltage line.

5. Check all function settings (Section 5) and verify that they are set correctly.
6. Press the START key. The controller should ramp to the preset maximum speed (F-04). The motor should ramp up at the acceleration rate (F-01) until it reaches the preset Hz.

**DANGER**

**AFTER DISCONNECTING INPUT POWER, WAIT FIVE MINUTES AND CHECK WITH A VOLTMETER TO INSURE THAT D-C BUS CAPACITORS ARE DISCHARGED. THE VOLTMETER SHOULD READ ZERO UDC. FAILURE TO OBSERVE THESE PRECATUIONS COULD RESULT IN SEVERE BODILY INJURY OR LOSS OF LIFE.**

7. While the controller is in the RUN mode, check the display modes and verify that VOLTS and %LOAD are reading correctly.  
**For Remote:** If using a remote speed reference check that the speed reference (F-13 must be "ON") is correct (0-10VDC, or 0-20mA). All three display mode LEDs should be lit to indicate that the remote reference is currently being displayed. The fourth display LED (REMOTE LED) should also be lit.  
Take into account any values set into F-11 (Remote Reference Gain) and F-12 (Remote Reference Offset) that have scaled the speed reference.
8. RPM can also be monitored by using the RPM display mode.
9. Verify the direction of the motor shaft rotation. Press the STOP key to stop the controller.
10. If the direction of shaft rotation is incorrect, change as follows:
  - a. Wait until motor has completely stopped.

- b. Turn OFF, lock out and tag power to the controller.
  - c. Verify that the D-C Bus voltage (at terminals + and –) is 0 VDC. See Figures 3.7 and 3.8.
  - d. Reverse any of two of the three motor power leads (U,V, or W).
11. Turn the Power ON.
  12. Press the START key.
  13. Using the up or down arrow keys, change the maximum speed setting (F-04) and run the motor without any load across the speed range. If the motor is unloaded and does not operate satisfactory, check the function settings in Section 5. If it does operate satisfactory, go to Step 14.
  14. Turn OFF, lock out and tag power to the controller. Verify that the D-C bus has discharged to 0 VDC at terminals (+) and (–). See Figures 3.7 and 3.8.
  15. Couple the driven equipment to the motor.
  16. Turn Power ON.
  17. Press the controller START key.
  18. Run the controller across the required speed range under load. If the motor does not rotate at minimum speed, increase manual torque boost (F-06).
  19. If the controller operates the motor properly:
    - a. Turn OFF, lock out and tag power to the controller. Verify that the D-C bus has discharged to 0 VDC at terminals (+) and (–).
    - b. Replace the controller cover and secure.
    - c. Make a note of final function settings in the “Settings Table” in the back of this manual.
- If the controller does not operate the motor properly:
- a. Refer to **Section 7, Troubleshooting, Fault Codes and Replacement Parts** if any fault indications occurred during startup.
  - b. Verify function settings again.

### 6.3 Cover Installation, NEMA 4X (Indoor Only)/12

In order to maintain integrity of the NEMA 4X/12 enclosure, some care must be taken when re-installing the cover:

- 1) Verify that the perimeter gasket is positioned flat and straight on the cover channel.
- 2) Gradually tighten the (4) captive screws down, sequentially, to ensure even compression of the gaskets. Do not exceed 20 inch-pounds of torque on these screws.

# 7.0 Troubleshooting, Fault Codes, and Replacement Parts

## DANGER

**ONLY QUALIFIED ELECTRICAL PERSONNEL FAMILIAR WITH THE CONSTRUCTION AND OPERATION OF THIS EQUIPMENT AND THE HAZARDS INVOLVED SHOULD INSTALL, ADJUST, OPERATE, AND/OR SERVICE THIS EQUIPMENT. READ AND UNDERSTAND THIS MANUAL IN ITS ENTIRETY BEFORE PROCEEDING. FAILURE TO OBSERVE THIS PRECAUTION COULD RESULT IN SEVERE BODILY INJURY OR LOSS OF LIFE.**

## 7.1 System Operation

Refer to Figures 7.1 and 7.2, System Block Diagrams.

The ONYX uses the conventional inverter bridge to transfer energy from the A-C input line to the A-C motor. The A-C line voltage is rectified through the input diode module which in turn generates the constant D-C bus voltage.

A large bus capacitor across the D-C bus smooths the D-C bus voltage and buffers the current flow to the motor. The six IGBT's and the associated diodes convert the constant D-C voltage into PWM (pulse width modulated) waveforms.

The ONYX uses the Volts/Hz constant control scheme which generates constant primary flux over the variable speed range of the motor so that torque is linearly produced in proportion to the slip of the motor.

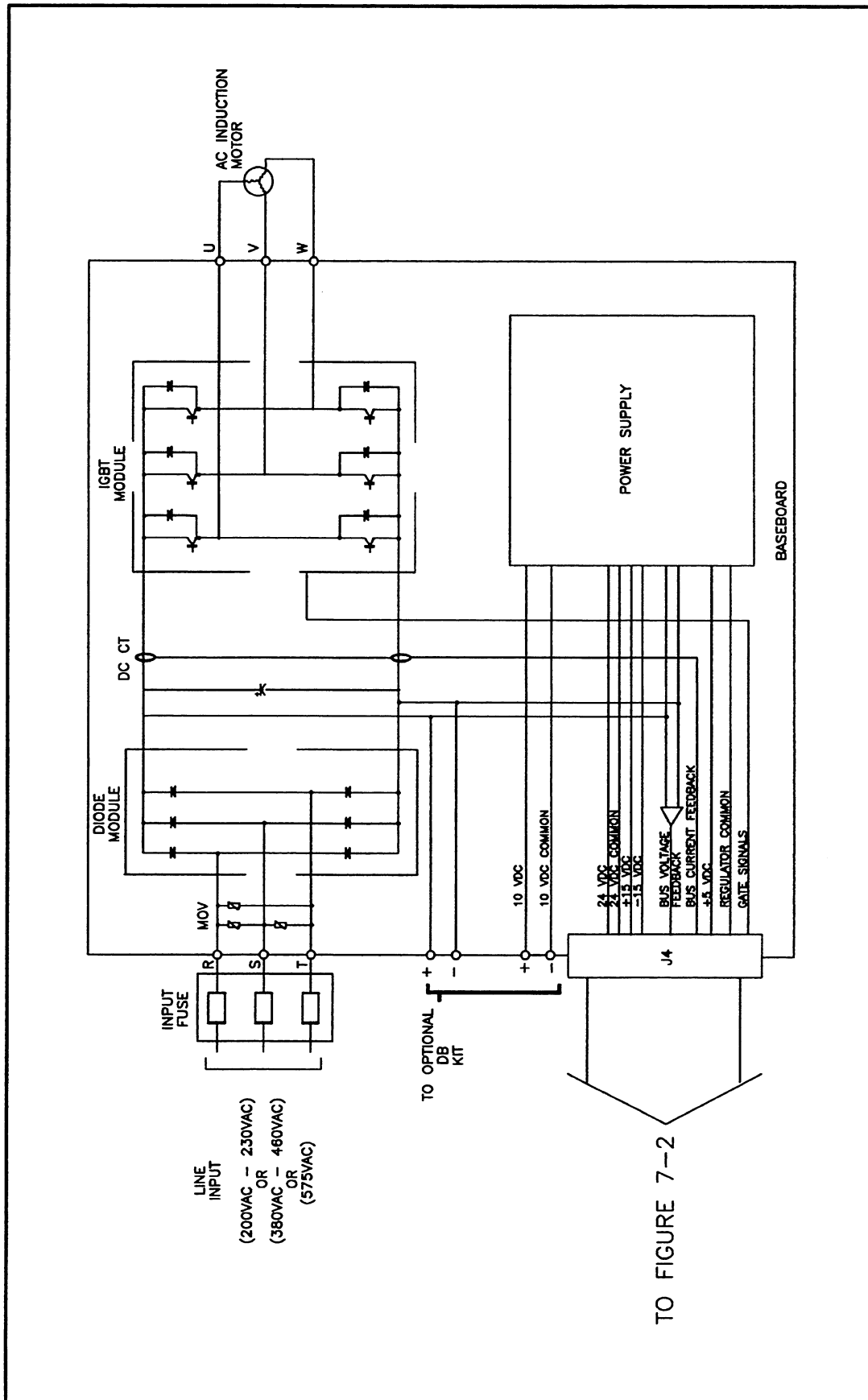

Figure 7.1 - System Block Diagram.

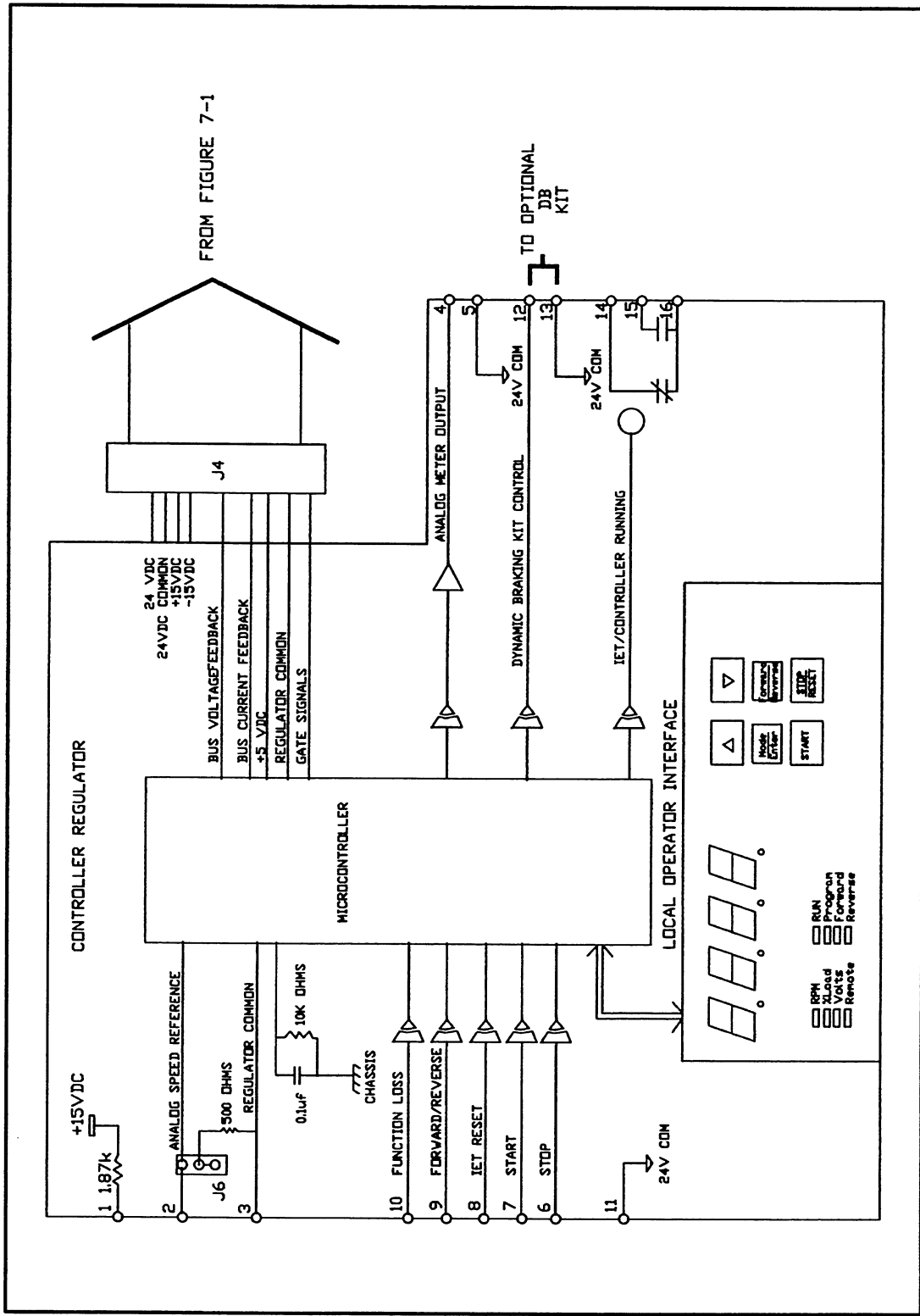

Figure 7.2 - System Block Diagram (cont'd.)

## 7.2 Fault Codes

The ONYX controller displays fault (ERR) codes which assist in troubleshooting if a fault should occur. If a fault condition occurs while the drive is running, the drive will coast-to-rest and a 2-digit fault code is flashed on the display.

The fault code is then entered into the error log. The error log is accessible after Function F-49, and is designated as "ERR" on the display.

## 7.3 How to Access and Read the Error Log

Fault codes are entered into the error log in sequential order if more than 1 fault should occur. The first error to occur will be flashed on the display, and two more errors will then be logged into the error log. (The error log must be accessed to see them). After three faults have occurred, no more subsequent faults will be entered into the error log.

The faults entered into the error log are numbered sequentially. If first an overcurrent fault were to occur, it would be in the error log as "1=OC". If next a thermal overload fault were to occur (and the first error was not yet cleared), it would be in the error log as "2=OL", and so on.

The last fault to occur will appear first when accessing the error log. For example, if the last fault was a low bus fault, and the error log has 3 entries, then the error log would display "3=LU" when the error log is first accessed.

The entire error log can be cleared by pressing the STOP/RESET button.

Faults are retentive to the error log if a power loss occurs.

Table 7.1 lists fault codes, descriptions, causes, and actions if a fault occurs.

### ● To access the Error Log:

1. Enter the Program Mode. (Press the MODE/ENTER key.)
2. If the display shows "F-00", use the down arrow key to move directly to 'Err'. Either the up or down arrow key can be used to move through the function list. 'Err' follows "F-49".
3. Press the MODE/ENTER key.
4. Press the up arrow key to move through the error codes.
5. Press the STOP/RESET key to clear all faults. Refer to Table 7.1.

Table 7.1 - Fault Code Action List.

<b>HU: High bus voltage condition.</b>	
<b><u>Cause</u></b>	<b><u>Action</u></b>
The D-C bus charged above the electronic trip threshold level.	Press the STOP/RESET button (or a REMOTE IET reset for remote operation). The error will not clear until the bus falls below the high bus level.
1. Decel rate too fast (Function 2).	1a. Lower the decel rate (Function F-02). Refer to Section 5. 1b. Install the optional DB kit.
2. Starting the drive into a forward running load that has a high inertia.	2. Install the optional DB Kit.
<hr/>	
<b>LU: Low bus voltage condition.</b>	
<b><u>Cause</u></b>	<b><u>Action</u></b>
The D-C bus has fallen below the electronic trip low threshold level.	Press the STOP/RESET button (or a REMOTE IET reset for remote operation). The error will not clear until the input line voltage is within the proper range. This may take a few seconds.
1. Loss of input power.	1. Check incoming power.
2. Low line voltage.	2. Check incoming power.
<b>Note:</b> If a line dip or momentary power loss occurs, and the bus level is able to rise back to the proper range within 500 ms, the drive will automatically restart (if the drive was already running when the fault occurred). If the drive does not restart, perform above steps, or press the STOP/RESET key.	
<hr/>	
<b>OL: Electronic thermal overload</b>	
<b><u>Cause</u></b>	<b><u>Action</u></b>
The electronic thermal overload trip level has been exceeded. This fault protects the drive and motor from overheating due to excessive current within a specified period.	Press the STOP/RESET button (or a REMOTE IET reset for remote operation). The error will not clear until the drive has integrated to the proper range. This may take a few seconds.
1. The Current Limit Setting (Function F-05) is not set correctly.	1. If current limit level is too low relative to load, increase the current limit level.
2. Function F-14, Electronic Thermal Overload is not set correctly to match the motor and controller combination.	2. Verify the value of Function F-14. Refer to Section 5.

Table 7.1 - Fault Code Action List (Continued)

<b>OH: Thermostat/Drive Overload</b>	
<b>Cause</b>	<b>Action</b>
The internal thermostat has caused a trip that indicates excessive temperatures in the controller.	Press the STOP/RESET button (or a IET RESET for remote operation). The error will not clear until the internal drive temperature is back within range. This may take a few seconds.
1. The drive derating specifications are exceeded. See Table 2-1.	1. Re-check the application and change the carrier frequency of Function F-10. Refer to Section 5.
2. The ambient temperature of the controller is exceeded.	2. Check the location site and move the controller to a cooler area.
<hr/>	
<b>OC: Overcurrent</b>	
<b>Cause</b>	<b>Action</b>
The current rating of the controller (>200% rated drive current) has been exceeded.	Press the STOP/RESET button (or IET RESET for remote operation).
This fault can be caused by any of the following conditions:	
1. Short in drive outputs	1. Verify that the input and output wiring to the drive are properly connected.
2. Ground fault condition	2a. Verify that the input and output wiring to the drive are properly connected. See Figures 3.4 and 3.5 or 3.6. 2b. Verify that the output wiring to the motor is not connected to Ground or any other voltage source. See Figures 3.4, 3.5, or 3.6.
3. Instantaneous overcurrent resulting in greater than 200% rated drive current.	3a. Increase acceleration or deceleration time (F-01 or F-02). 3b. Adjust the current limit level, if it is too low, or too high, relative to the load. (Change in 5% increments.)
<hr/>	
<b>FL: Function Loss</b>	
<b>Cause</b>	<b>Action</b>
The remote (external) function loss signal has been asserted. (Terminals 10 and 11.)	Press the STOP/RESET button (or IET RESET for remote operation). This fault will not clear until the function loss signal is unasserted.
1. The external equipment connected to the function loss terminals has failed, or is giving repeated stop requests.	1a. Check the external equipment wired to the remote function loss terminals (10 and 11). 1b. Check function loss connections.

Table 7.1 - Fault Code Action List (Continued)

<b>SELU: Invalid Drive Voltage Selected</b>	
<b>Cause</b> Invalid drive voltage was selected.	<b>Action</b> Select voltage to match input line voltage
<hr/>	
<b>CH: Checksum Failure</b>	
<b>Cause</b> Parameter checksum failure.	<b>Action</b> Press STOP/RESET to clear the fault. Set all parameters to desired values.
<hr/>	
<p>AdPF EErd diSc EEOU OLP2 EPCH rSF FSF rEF1 rEF2 noAd In00 In02 In04 In06 In08 In10 In15 7rAP UnOP</p>	
<b>Cause</b> Any of the above codes indicate a controller failure.	<b>Action</b> Replace the drive.

## 7.4 Verify D-C Bus Voltage

### DANGER

**AFTER DISCONNECTING INPUT POWER WAIT FIVE MINUTES AND CHECK WITH A VOLTMETER TO INSURE THAT D-C BUS CAPACITORS ARE DISCHARGED. THE VOLTMETER SHOULD READ ZERO UDC. FAILURE TO OBSERVE THESE PRECAUTIONS COULD RESULT IN SEVERE BODILY INJURY OR LOSS OF LIFE.**

Before servicing the controller:

1. Turn OFF, lock out and tag power to the controller.
2. Verify that there is no voltage entering the controller at terminals R(L1), S(L2), and T(L3).

- Verify at D-C Bus terminals (+) and (-) that the D-C Bus has fallen to zero VDC. This will take a few minutes to drop to a safe level. (Even if the bus LED is OFF, always verify that the D-C bus is discharged.) See Figure 7.3 and 7.4 for location of the D-C Bus.

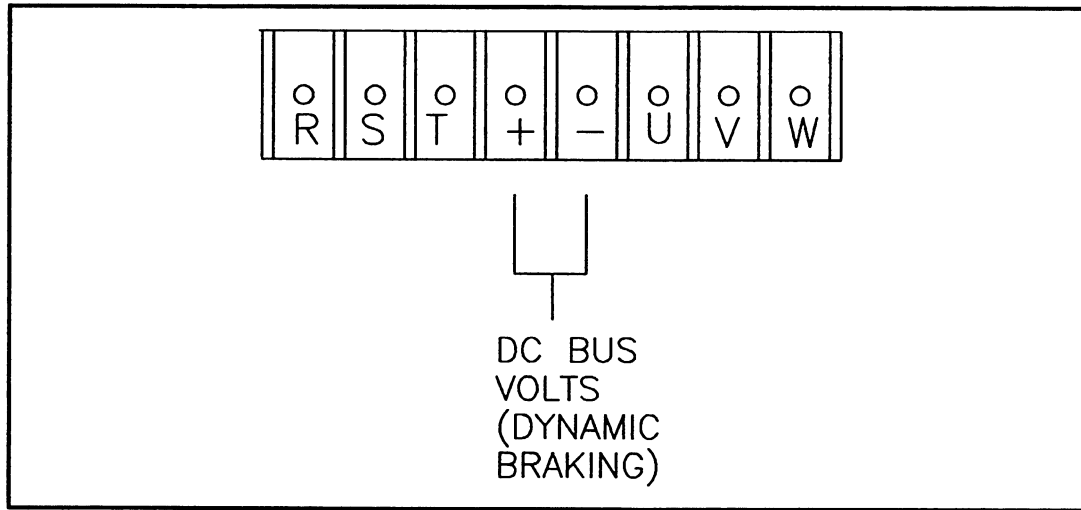

Figure 7.3 - D-C Bus Terminals on 230 VAC Controllers.

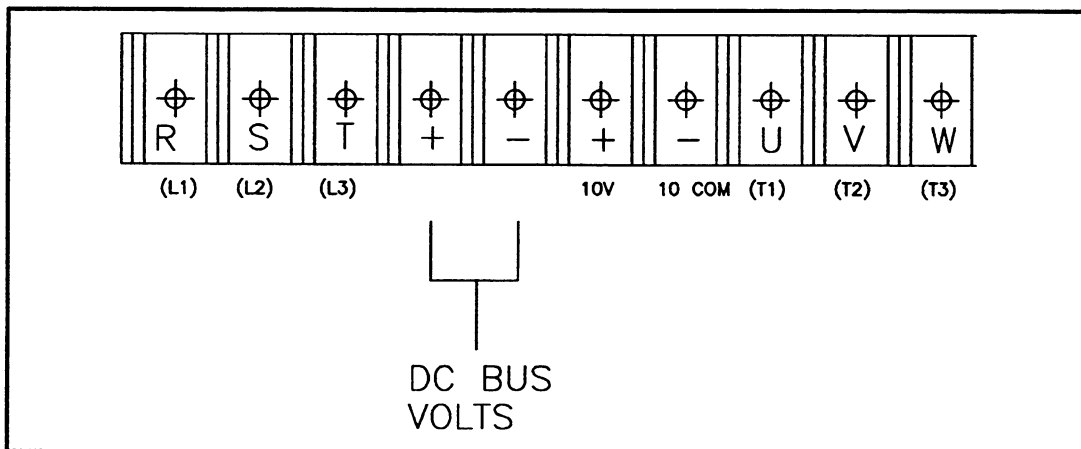

Figure 7.4 - D-C Bus Terminals on 460 VAC and 575 VAC Controllers.

## 8.0 Glossary of Common Terms

Accelerating Torque	An increase in torque (force) generated by a motor in order to achieve running speed.
Base Speed	Nominal motor speed rating in RPM on the motor's nameplate. Found by subtracting the slip speed from the synchronous speed at base frequency.
Base Frequency	Motor nameplate frequency rating
Carrier Frequency	The switching frequency at which an IGBT inverter bridge converts a D-C voltage into a PWM voltage.
Caution	Alerts a person that, if procedures are not followed, damage to or destruction of, equipment could result.
Constant Torque	A torque (force) characteristic independent of motor speed.
CSA	The abbreviation for the Canadian Standards Association.
Current Feedback	A current signal used by the microcontroller to control the operating current of the drive.
Danger	Alerts a person that high voltage is present which could result in severe bodily injury or loss of life.
Decelerating Torque	The torque (force) generated, by the decrease in motor and load kinetic energy, required by the motor and load to reach its final (slower) speed condition.
Drive	The reference to the controller and the motor combined as one system. The reference has also been used for another name for the controller.
Dynamic Braking	A braking technique in which the kinetic energy is converted into electrical energy and dissipated as heat energy via a resistor or other means.
Frequency Setpoint	The frequency value stored in memory (either by the local or remote means) within a given frequency range of the drives output voltage. Used to set the speed of the motor.
Hz	The Abbreviation for Hertz. The number of cycles per second.
IET	Instantaneous electronic trip. A fault condition that occurs while the drive is running resulting in a motor coast-to-stop. The drive senses a condition that could result in equipment damage and turns itself off.
Input Power Factor	The ratio of the input inverter A-C effective power to the input A-C apparent Power.

<b>Inverter</b>	A static power converter used to change D-C power to A-C power.
<b>Line Dip</b>	A short duration low input voltage condition.
<b>Load torque</b>	The motor torque required to keep the load rotating at nearly constant speed.
<b>NEMA</b>	The abbreviation for the National Electrical Manufacture's Association
<b>NEMA 1</b>	The Type 1 enclosure defined in NEMA standards that provides protection against accidental or inadvertent bodily contact with live parts and a limited amount of falling dirt.
<b>NEMA 4X</b>	The Type 4X enclosure defined in NEMA standards that provides a degree of protection from falling rain, splashing water, hose directed water and corrosion. The Type 4X described here is for indoor use only.
<b>NEMA 12</b>	The Type 12 enclosure defined in NEMA standards provides a degree of protection against dust, dirt, fiber, flying, dripping water and external condensation of non-corrosive liquids.
<b>Overcurrent</b>	A current greater than a specified maximum current value.
<b>Overload Capacity</b>	The overload current allowed by the drive in a specified time. Overload current is displayed as a percentage of the rated output current.
<b>Overtemperature</b>	A temperature greater than the specified (rated) temperature limit.
<b>Power Factor</b>	The ratio of true to apparent power.
<b>Pulse Width Modulation</b>	A method whereby a D-C voltage is converted to produce an A-C voltage whose magnitude and frequency can be varied.
<b>Rated Input Voltage</b>	Specified A-C line voltage, connected to a drive.
<b>Rated Output Current</b>	Total maximum current delivered out of a drive or to a motor under full load conditions.
<b>Rated Output Voltage</b>	Total maximum output voltage of a drive while delivering rated current under full load conditions.
<b>Rated Output Frequency</b>	Fundamental output wave frequency.
<b>Rectifier</b>	A static power converter used to change A-C power to D-C power.

<b>Stall</b>	A motor state where the motor remains motionless even though the motor is generating torque.
<b>Surge Suppressor</b>	Circuit protection which suppresses the peak value of any unusual input voltage to the drive. Its sometimes used to lighten the leading edge of voltage.
<b>Torque</b>	Tendency of a motor to produce rotation (Rotational force). It is a measure of the motor's ability to develop power.
<b>Torque Compensation</b>	The increase of the volts/frequency ratio of the drive, in the low frequency area, to compensate for the reduced torque of the motor at low speeds. Reduced torque at low speeds is due to the resistance of the motor stator windings.
<b>Voltage Feedback</b>	A voltage signal used by the microcontroller to control the operation of the drive.
<b>Voltage per Hertz</b>	The ratio to output voltage (in volts) to output frequency (in hertz) in the output frequency range of the drive to achieve constant torque in the motor.
<b>Warning</b>	Alerts a person to potential bodily injury if the procedure is not followed.



# 9.0 Index

<b>A</b>	<b>Page</b>
%LOAD .....	4-2, 4-4, 4-6
Acceleration function (F-01) .....	5-4
altitude .....	2-3, 3-1
ambient temperature .....	1-6, 2-3, 3-1
analog output, metering .....	2-5, 3-20, 3-21
arrow keys .....	4-5
atmosphere .....	2-3
Auto-restart attempts (F-26) .....	5-18
Auto-start wait time (F-27) .....	5-19
Avoidance frequency (F-21) .....	5-15
Avoidance bandwidth (F-22) .....	5-16
<b>B</b>	
base speed .....	5-7, 5-8
block diagram, functional .....	1-4
block diagram, system .....	7-2, 7-3
branch circuit protection .....	3-6, 3-7, 3-8, 6-2
<b>C</b>	
Carrier Frequency function (F-10) .....	5-9, 8-1
clearances .....	3-3, 3-4, 3-5
Coast Stop Enable function (F-16) .....	5-12
code, fault .....	7-4 through 7-7
Configurable output relay (F-09) .....	5-8
control logic .....	2-4
Control source select (F-00) .....	5-3
controller running, IET, (F-09) .....	2-5, 5-8
Current Limit function (F-05) .....	5-6
<b>D</b>	
Deceleration function (F-02) .....	5-4
default settings .....	5-1, 5-2
diagram, Control terminal strip .....	3-9 through 3-14, 3-18
diagram, Power terminal strip .....	3-9 through 3-15
diagram, system .....	7-2, 7-3
dimensions, physical size A .....	3-3
dimensions, physical size B .....	3-4
dimensions, physical size C .....	3-5
disconnect, input .....	3-5
display mode .....	4-1, 4-2, 4-6, 4-7, 4-8, 5-11
dynamic braking kit .....	3-17, 3-19, 3-20, 3-24 through 3-27

<b>E</b>	<b>Page</b>
Electronic Thermal Overload function (F-14) . . .	5-11
Electronic Thermal Overload Enable	
function (F-15) . . . . .	5-12
elevation . . . . .	2-3, 3-1
emergency stop . . . . .	3-23
error log . . . . .	4-8, 5-19, 7-4
 <b>F</b>	
factory settings . . . . .	5-1, 5-2
fault code . . . . .	4-8, 7-4
fault code action list . . . . .	7-5, 7-6, 7-7
forward direction . . . . .	3-23, 4-3, 4-5
fourth display mode . . . . .	4-2, 5-11
frequency, carrier . . . . .	1-3, 5-9
frequency minimum, maximum . . . . .	2-6, 5-5
function loss . . . . .	3-11 through 3-14, 3-18, 3-19, 3-21
fuses, branch circuit protection . . . . .	3-6, 3-7, 3-8
 <b>G</b>	
gain, remote reference . . . . .	5-9
grounding . . . . .	3-9
 <b>I</b>	
IET relay . . . . .	2-5, 3-18
indicators . . . . .	4-1, 4-2, 4-3
input Amps . . . . .	2-1 through 2-3
input KVA . . . . .	2-1 through 2-3
inputs, specifications . . . . .	2-1 through 2-5
 <b>J</b>	
jumper (J6) . . . . .	3-24
 <b>K</b>	
keypad and display, operation . . . . .	4-1
 <b>L</b>	
line frequency . . . . .	2-3
line voltage variation . . . . .	2-3
local control . . . . .	5-3
location, mounting . . . . .	3-1 through 3-5, 3-6
log, error . . . . .	4-8, 5-19, 7-4

<b>M</b>	<b>Page</b>
Manual Torque Boost function (F-06) .....	5-6
Minimum Speed function (F-03) .....	5-5
maximum load .....	2-5
Maximum Speed function (F-04) .....	5-5
MODE/ENTER key .....	4-2, 4-4 through 4-8, 5-3, 7-4
model numbers .....	1-2, 2-1 through 2-3, 3-2
modes, display .....	4-2, 4-6, 4-7, 4-8
monitor, RPM .....	4-2, 4-6
motor .....	2-6, 2-7, 3-9, 3-10
mounting, controller .....	3-2 through 3-8
Multi-speed presets (F-23, F-24, F-25) .....	5-17

## **N**

nameplate .....	1-5, 2-1
-----------------	----------

## **O**

offset, remote reference .....	5-10
output amps .....	2-1 through 2-3
output, specifications .....	2-4
overcurrent .....	5-6, 7-6
overload, electronic thermal .....	5-11, 7-5

## **P**

Password (F-20) .....	5-15
Percent selected speed reference enable (F-13) .....	5-11
planning, installation .....	3-1
power factor, displacement .....	2-5
Power-on start enable (F-19) .....	5-14
powerup .....	4-5, 6-2, 6-3
PROGRAM .....	4-3, 4-8

## **R**

ratings, controller .....	2-1 through 2-3
Remote Reference Gain function (F-11) .....	5-9, 5-10
Remote Reference Offset function (F-12) .....	5-10
Reverse Disable function (F-17) .....	5-13
REVERSE key .....	4-5
RPM at Base Speed function (F-08) .....	5-7, 5-8
RPM monitor .....	4-2
RUN .....	4-3

<b>S</b>	<b>Page</b>
scaling, offset, gain .....	3-23, 5-9, 5-10
shipment .....	1-1
specifications, controller .....	2-1
speed, maximum .....	5-5
speed, minimum .....	5-5
speed reference local remote .....	3-23
START .....	4-3, 4-4
stop pushbutton .....	3-21, 3-22, 4-4
STOP/RESET key .....	4-4, 4-7, 4-8
storage .....	1-6
system diagram .....	7-2, 7-3

<b>T</b>	
terminal strip, control .....	3-18
terminal strip, power .....	3-15
thermal overload .....	5-11
torque boost .....	5-6
torque ratings .....	3-16, 3-19, 6-4
transformer .....	3-8

<b>V</b>	
version, software .....	5-2, 5-19
Volts/hz Base Speed function (F-07) .....	5-7
VOLTS .....	4-2, 4-6

<b>W</b>	
watts, power loss .....	2-18
wiring, power .....	3-13 through 3-17
wiring, control .....	3-17 through 3-27

## Settings Table

Function	Description	Factory Initial Setting	Range of Setting	User Data	
				Date	Setting
F-00	Control source select	0	0, 1, 2, 3		
F-01	Accel Rate (seconds)	5.0	0.5-90.0		
F-02	Decel Rate (seconds)	5.0	0.5-90.0		
F-03	Minimum speed (Hz)	5.0	0.5-30.0		
F-04	Maximum speed (Hz)	60.0	30.0-240.0		
F-05	Current Limit (percent)	150	10-150		
F-06	Manual Torque Boost (%)	2	2-10		
F-07	Volts/Hertz (Base Speed) (Hz)	60	3-240		
F-08	RPM scaling at base speed	1750	10-9999		
F-09	Configurable output relay	0	0, 1, 2		
F-10	Carrier frequency (KHz)	4	4, 6, 8		
F-11	Remote reference gain (%)	100	60-100		
F-12	Remote reference offset (%)	0	0-40		
F-13	Percent selected speed reference enable	OFF	On, OFF		
F-14	Electronic thermal overload (%)	100	20-100		
F-15	Electronic thermal overload enable	On	On, OFF		
F-16	Coast stop enable	On	On, OFF		
F-17	Reverse disable	OFF	On, OFF		
F-18	RPM setpoint enable	OFF	On, OFF		
F-19	Power-up start enable	OFF	On, OFF		
F-20	Password lockout enable	OFF	On, OFF		
F-21	Avoidance frequency (Hz)	5	Min_speed- Max_speed		
F-22	Avoidance bandwidth (Hz)	0	0.0-10.0		
F-23	Multi-speed preset #1 (Hz)	20	Min_speed- Max_speed		
F-24	Multi-speed preset #2 (Hz)	20	Min_speed- Max_speed		

## Settings Table (cont'd)

F-25	Multi-speed preset #3 (Hz)	20	Min_speed- Max_speed		
F-26	Auto-restart number of attempts	0	0-10		
F-27	Auto-restart retry wait time (sec.)	1	1-30		
F-28	Controller Voltage Select	Factory set. Do not change this parameter.			
F-49	Version number	Read Only	x.xx		
ERR	IET Fault Codes	N/A	N/A		





# A-C DRIVES

## TRAINING AND AUDIO/VISUAL PRODUCTS

---

Reliance Electric offers a wide variety of Industrial Training courses for electricians, electronic technicians and engineers who are responsible for the installation, repair and maintenance of production equipment and systems.

Professional quality A/V Programs are also available. These programs have been designed to provide years of efficient in-house training. Available for playback at the user's convenience, these videotape programs allow individual or groups to learn or review subjects at any time.

Printed reference materials come with all diagnostic and troubleshooting programs.

### Training Courses

No.	Title
<b>A-C DRIVE COURSES</b>	
2-1	Maintenance and Troubleshooting of VVI Style Variable-Speed A-C Drives
2-5	Maintenance and Troubleshooting of PWM Style Variable-Speed A-C Drives
2-4	VVI/PWM A-C Drives Hands-On Troubleshooting Lab
2-7	Maintenance and Troubleshooting VCI A-C Inverters
2-8	Maintenance and Troubleshooting VGI A-C Inverters

### Audio/Visual Products

Order No.	Title	Format	Price
<b>A-C DRIVES PROGRAMS</b>			
TM2241	Introduction to the VVI	Videotape	<b>\$725</b>
TM2242	Troubleshooting the VVI Regulator	Videotape	<b>995</b>
TM2367	Troubleshooting the 6-Transistor Power Module	Videotape	<b>725</b>
<b>VIDEO TRAINING PROGRAMS</b>			
VMBA001	Fundamentals of A-C Motors	Videotape	<b>\$495</b>
VMBV001	Concepts of Digital Controls	Videotape	<b>495</b>
VWVS001	GP2000 Video Training	Videotape	<b>495</b>
VWVS002	HR2000 Video Training	Videotape	<b>495</b>
VWVS005	Basics of A-C Drives	Videotape	<b>495</b>

**For details and prices on these courses, audio/visual products and FREE Training Schedule Brochure, HD-405, contact:**

Industrial Training Department  
 Reliance Electric  
 35000 Curtis Boulevard  
 Eastlake, Ohio 44095

**Call Toll Free:**

**800-RELIANCE**  
**(800-735-4262)**







## **SAF Drive Systems Ltd.**

*Complete Drive Solutions*

88 Ardelt Ave.

Kitchener, Ontario N2C 2C9

Tel: 519-743-5491

Fax: 519-743-3610