

Installing and Operating the SP200 AC Drive

Model A - Single Channel Analog

Model B - Preset Speed

Model C - Dual Channel Analog

Instruction Manual D2-3408

 **Rockwell** Automation

Reliance Electric

The information in this manual is subject to change without notice.

Throughout this manual, the following notes are used to alert you to safety considerations:



ATTENTION: Identifies information about practices or circumstances that can lead to personal injury or death, property damage, or economic loss.

Important: Identifies information that is critical for successful application and understanding of the product.



ATTENTION: Only qualified personnel familiar with the construction and operation of this equipment and the hazards involved should install, adjust, operate, and/or service this equipment. Read and understand this instruction manual in its entirety before proceeding. Failure to observe this precaution could result in severe bodily injury or loss of life.

ATTENTION: After disconnecting input power, wait three minutes to insure that DC bus capacitors are discharged. Failure to observe this precaution could result in severe bodily injury or loss of life.

ATTENTION: The user is responsible for conforming with all applicable local and national codes. Failure to observe this precaution could result in severe bodily injury or loss of life.

SP200 and Reliance are trademarks of Rockwell Automation.

©1998 Rockwell International Corporation

CONTENTS AND INSTALLATION CHECKLIST

□ Chapter 1	Identify Your Drive.....	1-1
□ Chapter 2	Install the Drive.....	2-1
□ Chapter 3	Install External Components	3-1
	3.1 Install Branch Circuit Protection	3-1
	3.2 Install an AC Input Disconnect	3-2
	3.3 Install Motor Overload Protection	3-2
□ Chapter 4	Wire Input Power and Output Power	4-1
	4.1 Wire AC Power to the Drive and Motor	4-2
□ Chapter 5	Wire the Control Signal Terminal Block	5-1
	5.1 Install an Emergency Stop.....	5-3
Chapter 6	Using the Local Keypad.....	6-1
	6.1 Display Description.....	6-2
	6.2 Run and Program LED Descriptions	6-2
	6.3 Step-by-Step Keypad Operation.....	6-3
□ Chapter 7	Editing Drive Parameters	7-1
	7.1 Program Parameters	7-2
	7.1.1 Protection Parameters (Group 0)	7-2
	7.1.2 Digital Input/Output Control Parameters (Group 1).....	7-4
	7.1.3 Speed Reference Parameters (Group 2)	7-7
	7.1.3.1 Selecting the Speed Reference for Model A and Model B Drives.....	7-7
	7.1.3.2 Selecting the Speed Reference for Model C Drives	7-9
	7.1.3.3 Speed Selection Examples	7-9
	7.1.4 Dynamic Control Parameters (Group 3).....	7-13
	7.1.5 Fixed Speed Parameters (Group 4)	7-15
	7.1.6 V/Hz Curve Parameters (Group 5).....	7-17
	7.1.7 Utility Parameters (Group 6).....	7-19
	7.2 Display Parameters	7-21
□ Chapter 8	Check the Installation.....	8-1
	8.1 Check the Installation with the Power Off.....	8-1
	8.2 Check the Direction of Motor Rotation.....	8-2
	8.3 Test the Drive under Load	8-2
□ Chapter 9	Diagnostics and Troubleshooting.....	9-1
	9.1 Problems Not Reported by Fault Codes.....	9-1
	9.2 Problems Reported by Fault Codes	9-2

Appendix A	Technical Specifications.....	A-1
Appendix B	Alphabetical Listing of Parameters.....	B-1
Appendix C	Compliance with EU Requirements	C-1
Appendix D	Motor Cable Recommendations.....	D-1
Appendix E	User Quick Reference Table.....	E-1
Index	Index-1

List of Figures

Figure 1.1 – SP200 AC Drive	1-1
Figure 1.2 – Model Number Structure	1-1
Figure 2.1 – Access Clearances and Installation Guidelines.....	2-1
Figure 2.2 – SP200 Drive Mounting Dimensions.....	2-2
Figure 4.1 – AC Input Power Connections	4-2
Figure 4.2 – Three-Phase AC Output Power Connections.....	4-2
Figure 5.1 – Supply Methods for Digital (Switch) Input Connections.....	5-1
Figure 5.2 – Model A Control Signal Terminal Block Wiring.....	5-2
Figure 5.3 – Model B Control Signal Terminal Block Wiring.....	5-2
Figure 5.4 – Model C Control Signal Terminal Block Wiring.....	5-2
Figure 6.1 – Keypad Functions.....	6-1
Figure 7.1 – Speed Reference Source for Model A Drives.....	7-7
Figure 7.2 – Speed Reference Source for Model B Drives.....	7-8
Figure 7.3 – Speed Reference Source for Model C Drives	7-9
Figure C.1 - Grounding, Control, and Motor Connections	C-2

List of Tables

Table 3.1 – Required AC Branch Circuit Protection	3-1
Table 6.1 – Run LED.....	6-2
Table 6.2 – Program LED	6-2
Table 6.3 – Keypad Operation	6-3
Table 7.1 – Parameter Organization	7-1
Table 9.1 – Problems Not Reported by Fault Codes	9-1
Table 9.2 – Fault Codes and Corrective Actions.....	9-3

CHAPTER 1

Identify Your Drive

This user's manual describes the functionality of SP200 drives rated from 0.5 HP to 2 HP. Figure 1.1 shows the location of components.

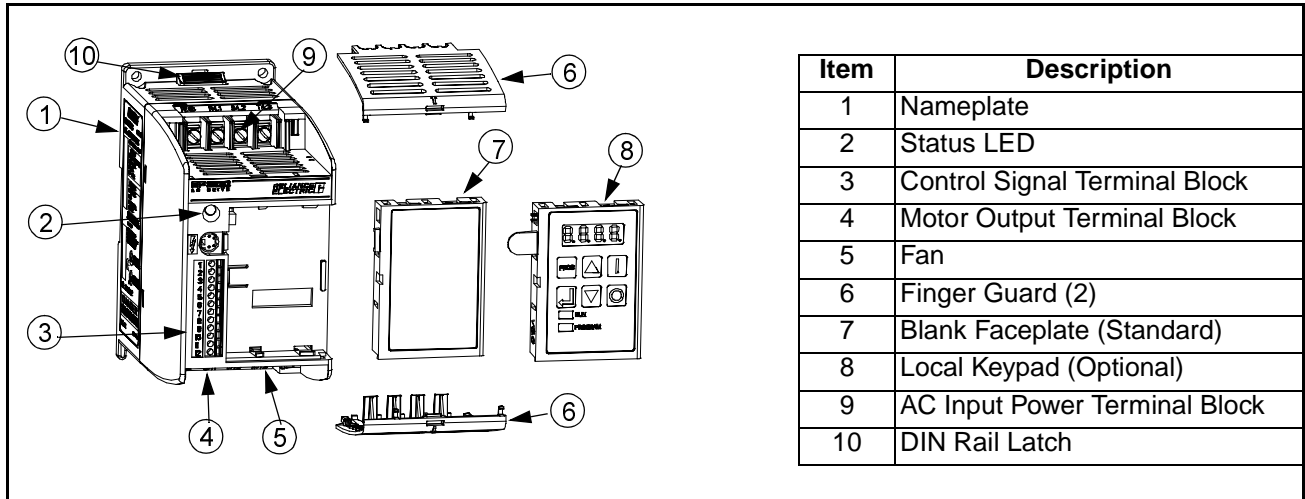

Figure 1.1 – SP200 AC Drive

SP200 drives are identified by model number. This number appears on the shipping label and on the unit's nameplate. Figure 1.2 shows the format of this number and what it indicates.

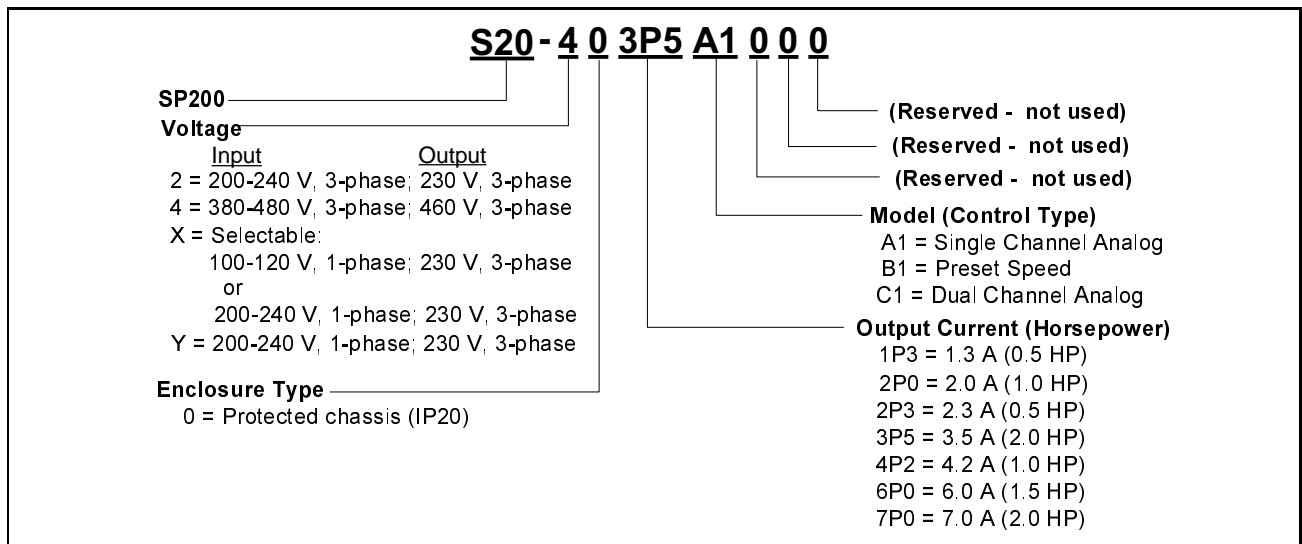

Figure 1.2 – Model Number Structure

CHAPTER 2

Install the Drive



ATTENTION: Only qualified electrical personnel, familiar with the construction and operation of this equipment and the hazards involved, should install, adjust, operate, and/or service this equipment. Read and understand this instruction manual in its entirety before proceeding. Failure to observe this precaution could result in severe bodily injury or loss of life.

ATTENTION: This equipment is at line voltage when AC power is connected. Disconnect and lockout all ungrounded conductors of the AC power line before working on the unit. Failure to observe this precaution could result in severe bodily injury or loss of life.

ATTENTION: The user is responsible for conforming with all applicable local and national codes. Failure to observe this precaution could result in severe bodily injury or loss of life.

Review all installation and wiring instructions thoroughly before proceeding. Throughout the installation procedures, use figure 1.1 to locate wiring termination points.

Plan the installation to ensure acceptable environmental and operating conditions for the drive. Read and follow the requirements given below before proceeding with the installation:

- Locate the drive where it will have unrestricted clearance as shown. Mount the drive on a flat surface.
- Locate the drive where it will be kept clean (away from oil, coolants, or airborne contaminants).
- Verify that the ambient temperature will remain between 0 °C to 50 °C (32 °F to 122 °F).
- Verify that the relative humidity will be between 0% and 95%, non-condensing.
- For installations above 1000 meters (3300 feet), refer to Appendix A for derating guidelines.
- Verify that there will be adequate clearance for fan intake.
- When using the optional local keypad, 25.4 mm (1.0 in) clearance is required on the right side only for installing/removing the keypad.

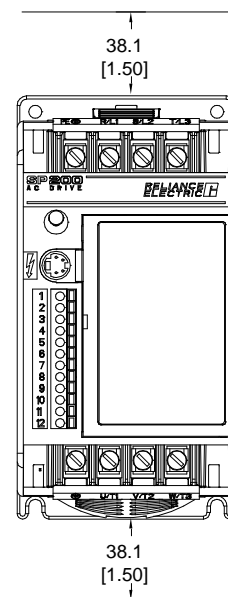

Figure 2.1 – Access Clearances and Installation Guidelines

The drive must be mounted vertically to a wall, a panel, or a DIN rail. Mounting dimensions are provided in figure 2.2.

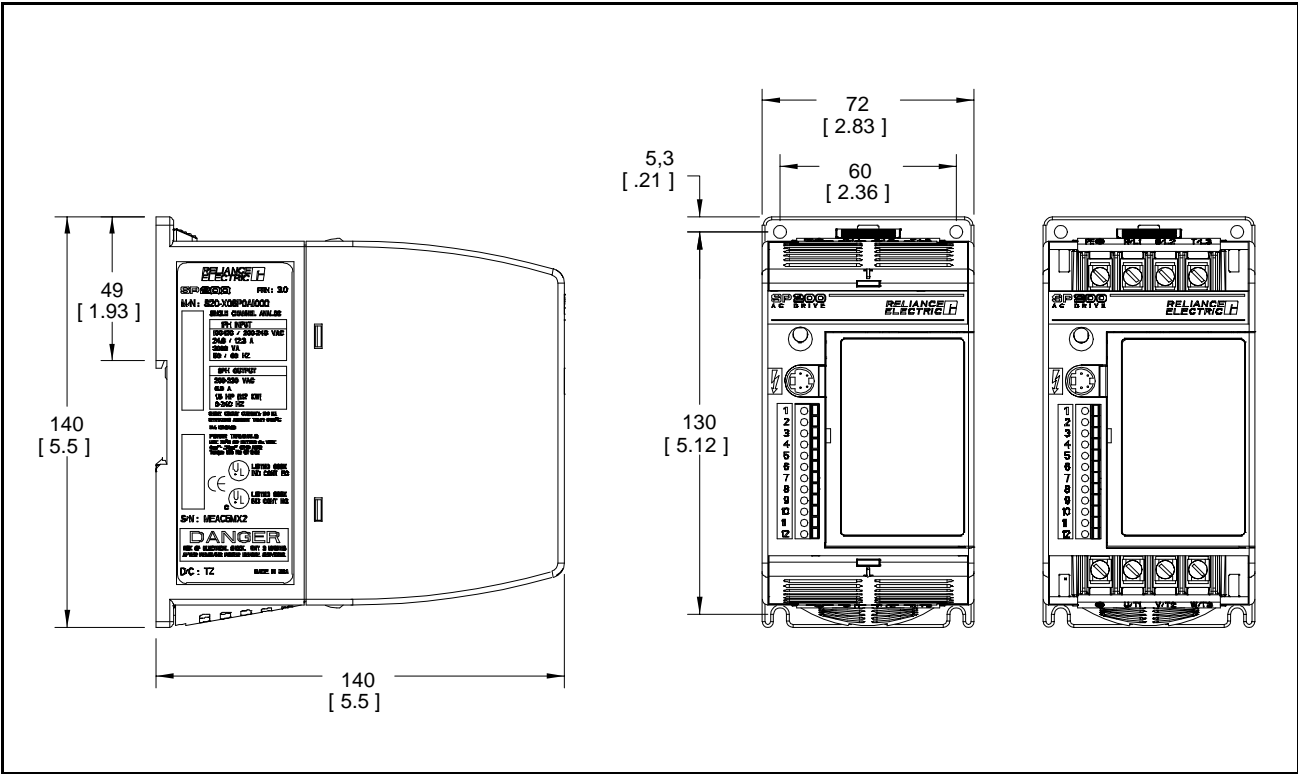

Figure 2.2 – SP200 Drive Mounting Dimensions

Install External Components

Install external components using the guidelines in the following sections. Each installation requires either:

- an AC input disconnect and input fusing, or
- a circuit breaker.

3.1 Install Branch Circuit Protection



ATTENTION: Many local and national electrical codes require that upstream branch protection be provided to protect input power wiring. The input fuse and circuit breaker ratings listed in table 3.1 are applicable for one SP200 AC drive per branch circuit. No other load can be applied to that protected branch circuit. Failure to observe this precaution could result in severe bodily injury or loss of life.

Install the required, user-supplied branch circuit protection fuses (or circuit breakers) according to local and national electrical code guidelines. Refer to table 3.1 for recommended ratings.

Table 3.1 – Required AC Branch Circuit Protection

AC Input Voltage ¹	Unit HP	Input Current (A)	Fuse Rating (A) ²	Circuit Breaker Rating (A) ³
100 - 120, 1-phase	0.5	9.4	15 or 16	15
	1.0	17.2	30	30
	1.5	24.6	40	40
200 - 240, 1-phase	0.5	4.7	10	10
	1.0	8.6	15 or 16	15
	1.5	12.3	20	20
	2.0	14.3	25	25
200 - 240, 3-phase	0.5	2.7	6	5
	1.0	5.0	10	7
	2.0	8.3	15 or 16	15
380 - 460, 3-phase	0.5	1.5	3 or 4	3
	1.0	2.4	6	4
	2.0	4.1	10	7

¹ The input supply has a voltage tolerance of $\pm 10\%$ and frequency range of 47 to 63 Hz.

² Recommended fuse type: UL Class J or CC, 600 V, time delay

³ Device must meet UL 489 for UL purposes

3.2 Install an AC Input Disconnect



ATTENTION: Many local and national electrical codes require that an input disconnect be provided in the incoming power lines. Failure to observe this precaution could result in severe bodily injury or loss of life.

A user-supplied AC input disconnect must be provided in the incoming power lines in accordance with local and national electrical code guidelines.

3.3 Install Motor Overload Protection

The SP200 AC drive contains electronic motor overload protection to protect a single motor that has a full load amp rating no less than 20% of the SP200 drive's amp rating.

If any of the following apply, you must install an external motor overload for each motor in accordance with local and national electrical code guidelines:

- using an unprotected motor with a full load amp rating less than 20% of the SP200 drive's amp rating.
- using more than one motor (any kind) per drive.

Wire Input Power and Output Power



ATTENTION: This equipment is at line voltage when AC power is connected. Disconnect and lockout all ungrounded conductors of the AC power line before working on the unit. Failure to observe this precaution could result in severe bodily injury or loss of life.

ATTENTION: The user is responsible for conforming with all local and national codes applicable to the grounding of this equipment. Failure to observe this precaution could result in severe bodily injury or loss of life.

ATTENTION: If the distribution system capacity exceeds the drive's maximum symmetrical fault short-circuit current of 100,000 amps, additional impedance must be added to the AC line supplying the drive to limit available current in the event of a fault. Failure to observe this precaution could result in damage to, or destruction of, the equipment.

Observe the following guidelines when wiring AC power:

- The recommended temperature rating for power wire is 75° C or greater.
- The terminal blocks accept up to 4 mm² (12 AWG) wire.
- The recommended tightening torque is 1.35 newton-meters (12 in-lb).

Verify that the input power to the drive corresponds to the drive voltage and frequency and that the input supply is of sufficient capacity to support the input current requirements. Refer to Appendix A, Technical Specifications.

Size the AC line conductors for the drive rating and in accordance with all applicable local and national codes.

Ensure that motor cables conform to the recommendations in Appendix D, Motor Cable Recommendations.

Procedures for wiring input power to the drive and output power to the motor are described in section 4.1.

4.1 Wire AC Power to the Drive and Motor

Use the following procedure to wire power to the drive and motor.

- Step 1. Remove the finger guards by inserting a screwdriver in the slot at the front of each guard and pushing gently.
- Step 2. **For 115 VAC input power only**, remove the protective label from the 115 VAC terminal.
- Step 3. Connect the incoming AC line to the appropriate input power terminals as shown in figure 4.1.
- Step 4. Connect a ground wire to the drive's input grounding screw (labeled PE \oplus). This grounding conductor must run unbroken from the drive to earth ground.

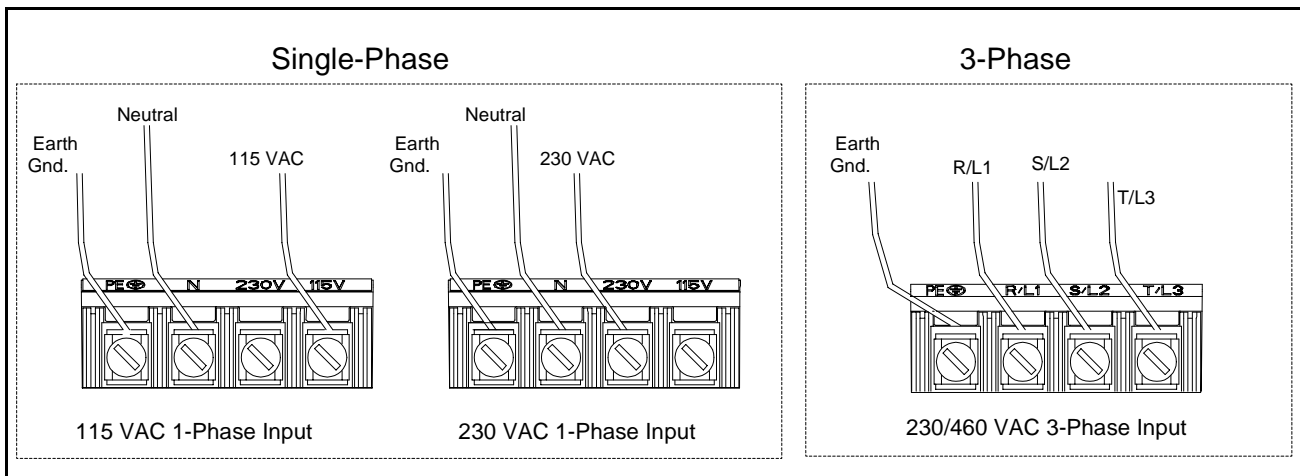

Figure 4.1 – AC Input Power Connections

- Step 5. Connect the output power terminals from the drive to the motor as shown in figure 4.2.
- Step 6. Replace the finger guards by locating the tabs in the slots adjacent to the power terminal block and pressing each guard into place.

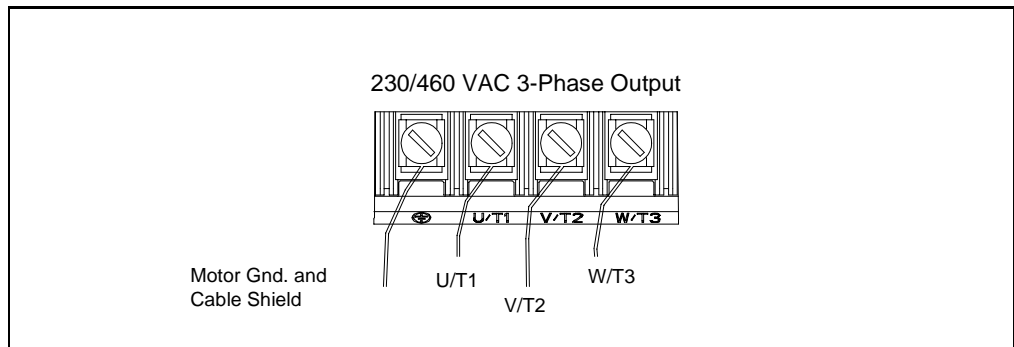

Figure 4.2 – Three-Phase AC Output Power Connections

Wire the Control Signal Terminal Block



ATTENTION: If 2-wire control is selected, the drive will immediately run when powered up in the presence of a forward or reverse run command. Failure to observe this precaution could result in severe bodily injury or loss of life.

The following sections describe how to wire the control signal terminal block. (Refer to figure 1.1 for the location of the terminal block).

Refer to figure 5.2 (Model A, Single Channel Analog), 5.3 (Model B, Preset Speed), or 5.4 (Model C, Dual Channel Analog) before you begin wiring. These figures show typical wiring connections.

Note the following when wiring the terminal block:

- The terminal block is isolated from the input power.
- Control wires should be routed separately from the power wires.
- The terminal block accepts 1.5 mm² (16 AWG) through 0.14 mm² (26 AWG) wire.
- The maximum control wire length is 30 meters (100 ft).

The SP200 drive's digital control inputs can be activated by either its own +10 VDC supply or an external supply rated between 10 and 24 VDC. Figures 5.2, 5.3, and 5.4 show connections using the drive's +10 V supply. If you are using an external supply, connect each digital input as shown in the external supply method shown in figure 5.1.

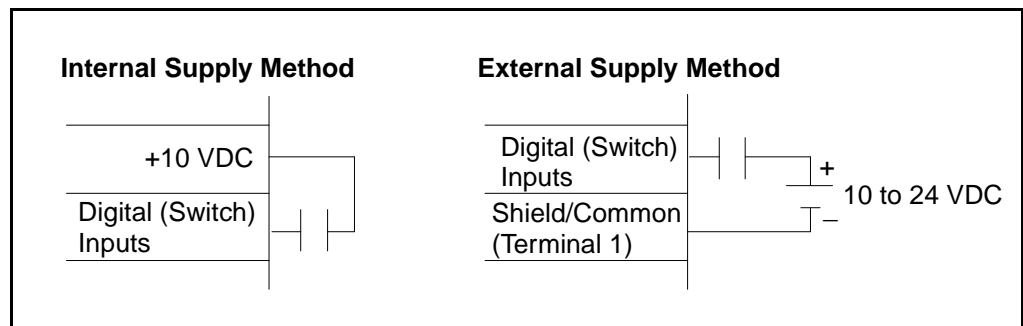

Figure 5.1 – Supply Methods for Digital (Switch) Input Connections

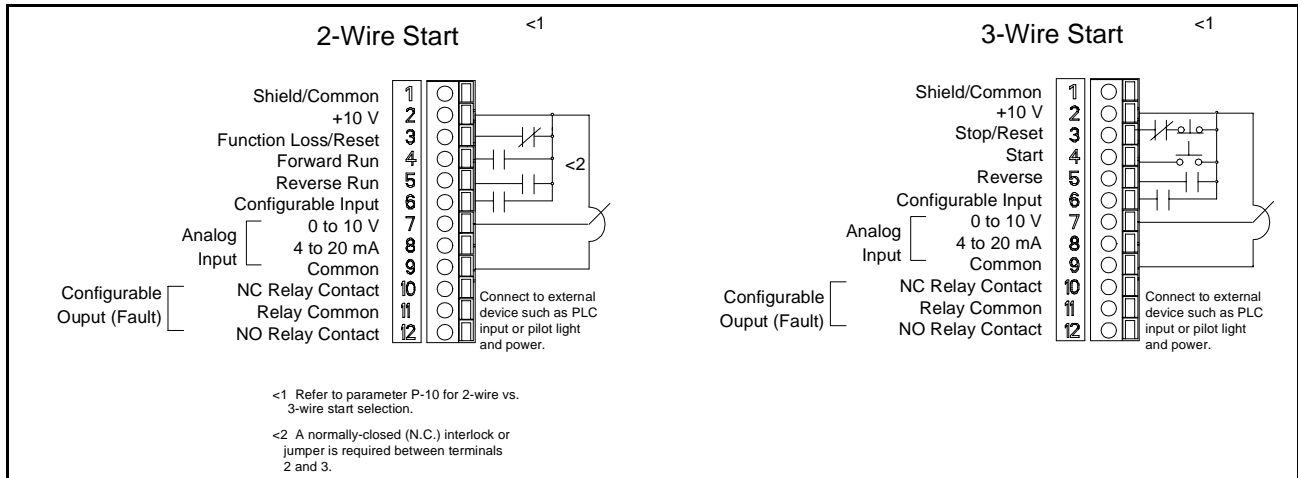

Figure 5.2 – Model A Control Signal Terminal Block Wiring

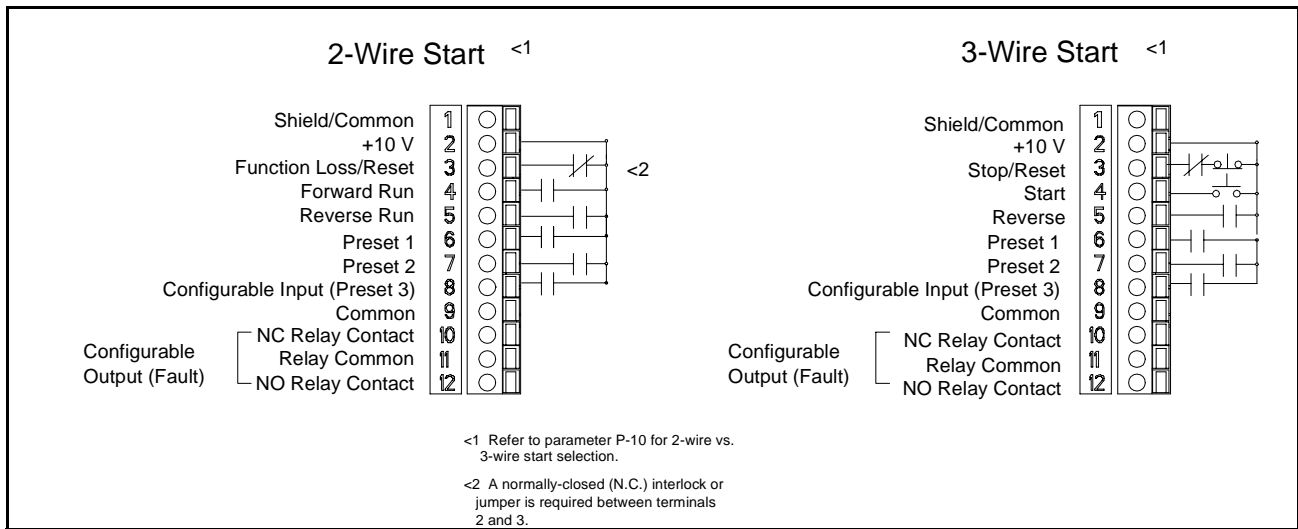

Figure 5.3 – Model B Control Signal Terminal Block Wiring

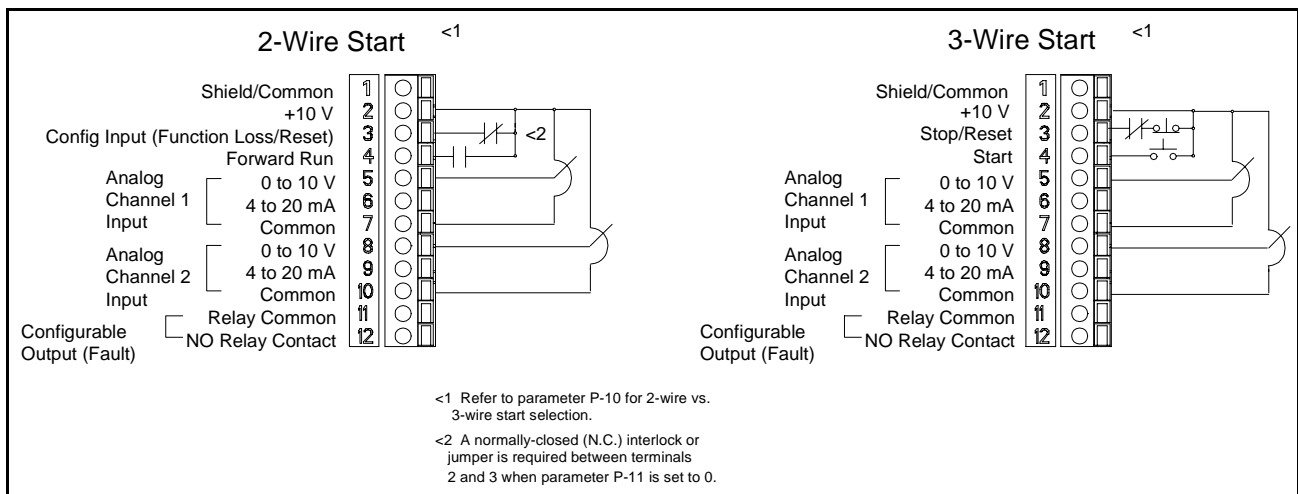

Figure 5.4 – Model C Control Signal Terminal Block Wiring

5.1 Install an Emergency Stop



ATTENTION: The user must provide an external, hardwired emergency stop circuit outside of the SP200 drive circuitry. This circuit must disable the system in case of improper operation. Uncontrolled machine operation may result if this procedure is not followed. Failure to observe this precaution could result in severe bodily injury or loss of life.

Depending upon the requirements of the application, the SP200 AC drive can be set up to provide either a coast-to-rest or a ramp-to-rest operational stop. In addition to the operational stop, the user must provide a hardwired emergency stop external to the unit. The emergency stop circuit must contain only hardwired electromechanical components. Operation of the emergency stop must not depend on electronic logic (hardware or software) or on the communication of commands over an electronic network or link.

CHAPTER 6

Using the Local Keypad

The optional keypad can be used to change parameter values, display operating conditions, and command drive operation. Figure 6.1 shows the SP200 drive keypad and identifies the keypad keys.

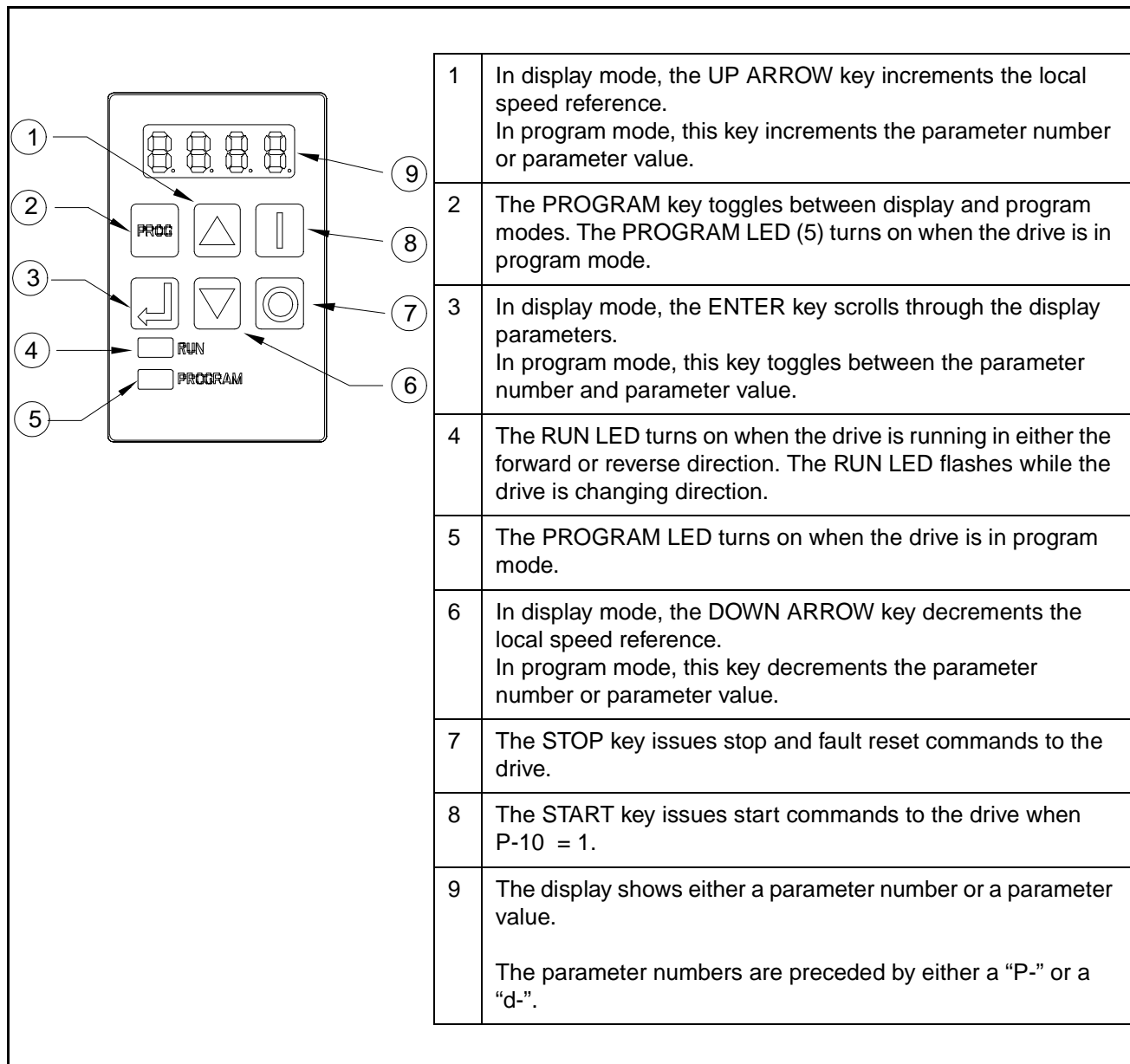

Figure 6.1 – Keypad Functions

The following sections describe the four-character display, the Run and Program LEDs, and step-by-step operation of the keypad.

6.1 Display Description

The keypad has a four-character display which is used to show parameter numbers and parameter values. The keypad monitors its connection to the drive and will display **- - - -** if this connection fails due to electrical noise or a hardware failure.

If the drive faults, the full display will flash to indicate the presence of the fault, and the fault code will be displayed. The ▲, ▼, and ↵ keys can still be pressed to change parameter number and value, but the display will continue to flash until the fault condition is reset. If the fault condition is reset without the operator changing the parameter number or value, the display will return to the parameter value that was selected prior to the occurrence of the fault.

6.2 Run and Program LED Descriptions

The keypad has two LEDs which indicate the drive status.

Table 6.1 – Run LED

Run Indicator Status	Description
Off	The drive is not running.
On	The drive is running.
Flashing	The drive is changing direction.













Table 6.2 – Program LED

Program Indicator Status	Description
Off	The drive is in monitor mode.
On	The drive is in program mode.

6.3 Step-by-Step Keypad Operation

The following table provides detailed steps for keypad operation.

Table 6.3 – Keypad Operation

Desired Action	User Steps
Start the unit ¹	Press the green  key to start the drive.
Stop the unit	Press the red  key to stop the drive.
Increment the local speed reference	While in display mode (PROG LED is off), press the  key to increase speed.
Decrement the local speed reference	While in display mode (PROG LED is off), press the  key to decrease speed.
View the value of the present display parameter	While in display mode (PROG LED is off), the value of the present display parameter is normally displayed.
View the number of the present display parameter	While in display mode, press and release the  key once. The present display parameter number will be displayed for 2 seconds. The display will then return to the present parameter value.
Increment the display parameter number	While in display mode, press the  key until the desired parameter is displayed. Following a 2 second delay, the parameter value will be displayed.
Increment the program parameter number	<ol style="list-style-type: none"> 1. Press the PROG key to enter program mode. 2. Press the  key until the desired number is displayed.
Decrement the program parameter number	<ol style="list-style-type: none"> 1. Press the PROG key to enter program mode. 2. Press the  key until the desired number is displayed.
Increment the current program parameter value	<ol style="list-style-type: none"> 1. Press the PROG key to enter program mode. 2. Press the  key while the desired program parameter number is displayed. 3. Press the  key until the desired value is displayed.
Decrement the current program parameter value	<ol style="list-style-type: none"> 1. Press the PROG key to enter program mode. 2. Press the  key while the desired program parameter number is displayed. 3. Press the  key until the desired value is displayed.
Clear faults	Press the red  key.

¹ For the  key to work, a connection must be present between terminals 2 and 3. In addition, parameter P-10 must be set to 1.

Editing Drive Parameters

The SP200 drive has two types of parameters: program parameters (P-xx), which configure the drive operation, and display parameters (d-xx), which display information regarding the drive status. Sections 7.1 and 7.2 provide descriptions of all drive parameters. The table below shows the parameter organization.

Table 7.1 – Parameter Organization

Range	Parameter Group	Parameter Type
P-00 to P-05 P-10 to P-13 P-20 to P-29 P-30 to P-38 P-40 to P-48 P-50 to P-55 P-60 to P-64	Protection Digital Input/Output Speed Reference Dynamic Control Fixed Speeds V/Hz Curve Utility	Program Parameters
d-00 to d-09	Display Parameters	Display Parameters

Important: The default value of most parameters is appropriate for most applications. The following parameters may need to be adjusted for some applications.

• P-00 Minimum Speed	• P-30 Acceleration Time 1
• P-01 Maximum Speed	• P-31 Deceleration Time 1
• P-02 Motor Overload Current	• P-34 Stop Control
• P-03 Reverse Disable	• P-40 Internal / Jog Frequency
• P-10 Start Control	• P-50 Base Voltage
• P-20 Main Speed Reference	• P-51 Base Frequency

7.1 Program Parameters

Program parameters are used to configure drive operation.

Important: Some parameters can be edited when the drive is running. Note the access code listed for each parameter (RO = read only; RW = read/write). The code listed indicates whether the parameter can be edited when the drive is running. All program parameters can be edited when the drive is not running.

7.1.1 Protection Parameters (Group 0)

P-00 Minimum Speed	Model		
	A	B	C
Use this parameter to set the lowest frequency the drive will output.	Parameter Range:	0 to Maximum Speed (Hz)	
	Default Setting:	0	
	Running Access:	RO	
		X	X

P-01 Maximum Speed	Model		
	A	B	C
Use this parameter to set the highest frequency the drive will output.	Parameter Range:	Minimum Speed to 240 (Hz)	
	Default Setting:	60	
	Running Access:	RO	
		X	X

P-02 Motor Overload Current	Model		
	A	B	C
Use this parameter to set the motor overload protection level (in amps) so that constant operation above this value will result in a motor overload fault, based on the magnitude and	Parameter Range:	20% to 200% of the rated drive current in amps (x.x A)	
	Default Setting:	100% of the rated drive current	
	Running Access:	RW	
		X	X

time of the condition. For example, a load condition equal to 150% of this setting will cause a fault in approximately one minute. Smaller overload conditions will require more time to fault. Larger overload conditions will require less time to fault. Set this parameter value to the full load amp rating of the motor (usually specified on the motor nameplate).

P-03 Reverse Disable

This parameter enables or disables output frequency in the reverse direction. If reverse is disabled, a reverse command will be ignored.

		Model		
		A	B	C
Parameter Range:	0 = Reverse enabled 1 = Reverse disabled	X	X	X
Default Setting:	0	X	X	X
Running Access:	RO			

P-04 Auto Restart Attempts

Use this parameter to select the number of times the drive will attempt to restart after the occurrence of an auto-resettable fault (listed in table 9.2).

If the value for this parameter is nonzero, the drive will wait for 1 second after an auto-resettable fault occurs and then clear the fault and attempt to restart the drive automatically.

Once the drive restarts, it must run for 5 minutes without faulting to restore the number of attempts specified by this parameter.

The auto restart sequence is terminated if the drive is intentionally stopped.



ATTENTION : If parameter P-04 \neq 0, the drive will attempt to restart automatically after the occurrence of an auto-resettable fault. When this feature is enabled, the user must ensure that automatic restart of the driven equipment will not cause injury to operating personnel or damage to the driven equipment.

P-05 Current Limit

Use this parameter to specify the drive current limit. When the drive is operating at commanded speed, and the current subsequently reaches this value, the drive output frequency and

voltage are reduced until the current limit is not exceeded. At this point, it will accelerate back to the reference speed. If the current limit is exceeded while accelerating, the acceleration time will be automatically increased until the current limit is not exceeded.

		Model		
		A	B	C
Parameter Range:	10 to 150 (%)	X	X	X
Default Setting:	150	X	X	X
Running Access:	RW			

7.1.2 Digital Input/Output Control Parameters (Group 1)

P-10 Start Control	Model			
	A	B	C	
Use this parameter to define the source of the run, stop, and direction commands.	Parameter Range: 1 = Keypad control	X	X	X
	2 = 2-Wire control	X	X	X
	3 = 3-Wire control	X	X	X
See section 9.2 for fault reset methods.	Default Setting: 2	X	X	X
	Running Access: RO			

P-11 Configurable Input	Model			
	A	B	C	
Use this parameter to define how the configurable input works.	Parameter Range:	0 = Function Loss (P-10 ≠ 3)		X
		1 = Disabled	X	
		1 = Preset Speed		X
		1 = Reverse Run (2-wire)		X
		2 = Jog (P-10 ≠ 1)	X	X
		2 = Jog (P-10 ≠ 1 or 3)		X
		3 = Alternate Speed.Reference	X	X
		3 = Alt. Spd. Reference (P-10 ≠ 3)		X
		4 = N.C. Coast to stop	X	X
		4 = N.C. Coast to stop (P-10 ≠ 3)		X
See section 9.2 for fault reset methods.	Default Setting:	2	X	
		1		X
		0		X
Running Access:	RO			

Model A:

When P-11 is set to:	Then the configurable input works as follows:
1 (Disabled)	The configurable input not used.
2 (Jog)	When the configurable input is ON, the drive will jog at the Internal / Jog Frequency (P-40) in the direction specified by the Reverse input.
3 (Alternate Speed Reference)	When the configurable input is ON, the drive will use the value of parameter P-21 (Alternate Speed Reference) as the source of the command frequency. See figure 7.1 or 7.2 for more information
4 (N.C. Coast to Stop)	When the configurable input is OFF, the drive will coast to stop.
5 (Secondary Accel/Decel)	When the configurable input is ON, the drive will use parameters P-32 (Acceleration Time 2) and P-33 (Deceleration Time 2) for the accel and decel times.

P-11 Configurable Input (continued)

Model B:

When P-11 is set to:	Then the configurable input works as follows:			
1 (Preset Speed)	The configurable input is combined with Preset 1 and Preset 2 to select the command frequency from a set of preset speeds as shown in the table below. If P-11 \neq 1, then only preset frequencies 1 through 4 can be selected.			
	Terminal 8 (Configurable Input)	Terminal 7 (Preset 2)	Terminal 6 (Preset 1)	Preset Frequency
	OFF	OFF	OFF	Preset Frequency 1
	OFF	OFF	ON	Preset Frequency 2
	OFF	ON	OFF	Preset Frequency 3
	OFF	ON	ON	Preset Frequency 4
	ON	OFF	OFF	Preset Frequency 5
	ON	OFF	ON	Preset Frequency 6
	ON	ON	OFF	Preset Frequency 7
ON	ON	ON	Preset Frequency 8	
2 (Jog)	When the configurable input is ON, the drive will jog at the Internal / Jog Frequency (P-40) in the direction specified by the Reverse input.			
3 (Alternate Speed Reference)	When the configurable input is ON, the drive will use the value of parameter P-21 (Alternate Speed Reference) as the source of the command frequency. See figure 7.1 or 7.2 for more information			
4 (N.C. Coast to Stop)	When the configurable input is OFF, the drive will coast to stop.			
5 (Secondary Accel/Decel)	When the configurable input is ON, the drive will use parameters P-32 (Acceleration Time 2) and P-33 (Deceleration Time 2) for the accel and decel times.			

P-11 Configurable Input (continued)

Model C:

For 3-wire control, the configurable input always operates as a stop input, regardless of the value of parameter P-11 (Configurable Input Select). The configurable input must be maintained on to enable the drive to run. If the configurable input is off, the drive will stop according to the specified stop mode. A falling edge of this input is used to reset a fault condition.

For 2-wire control, the following functions are supported:

When P-11 is set to:	Then the configurable input works as follows:
0 (Function Loss)	When the configurable input is OFF, the drive will stop and a Function Loss (FL) error will be displayed.
1 (Disabled)	When the configurable input is ON, the drive will run in the reverse direction.
2 (Jog)	When the configurable input is ON, the drive will jog at the Internal / Jog Frequency (P-40) in the forward direction.
3 (Alternate Speed Reference)	When the configurable input is ON, the drive will use the value of parameter P-21 (Alternate Speed Reference) as the source of the command frequency. See figure 7.1 or 7.2 for more information
4 (N.C. Coast to Stop)	When the configurable input is OFF, the drive will coast to stop.
5 (Secondary Accel/Decel)	When the configurable input is ON, the drive will use parameters P-32 (Acceleration Time 2) and P-33 (Deceleration Time 2) for the accel and decel times.

P-12 Configurable Output

Use this parameter to define the way the Configurable Output works.

		Model		
		A	B	C
Parameter Range:	0 = No Fault	X	X	X
	1 = No Fault or Auto-Restarting	X	X	X
	2 = Run	X	X	X
	3 = At Frequency	X	X	X
	4 = Above Frequency	X	X	X
	5 = Above Current Level	X	X	X
Default Setting:	0	X	X	X
Running Access:	RW			

Drive models A and B (Single Channel Analog and Preset Speed) have one normally open and one normally closed contact (Form C). Drive model C (Dual Channel Analog) has a single normally open contact (Form A). The condition that drives this relay to turn on or off is programmable, as summarized in the following table.

If P-12 is set to:	Then the normally open relay contact closes when...
0 (No Fault) (default)	the drive is not faulted.
1 (No Fault or Auto-Restarting)	the drive is not faulted or is auto-restarting.
2 (Running)	the drive is running.
3 (At Frequency)	the output frequency is equal to the commanded frequency.
4 (Above Frequency)	the output frequency is greater than a specified level.
5 (Above Current Level)	the output current is greater than a specified level.

P-13 Configurable Output Level	Model				
	A	B	C		
Use this parameter to define the turn on/off threshold for the configurable output. Its definition and units depend on P-12 (Configurable Output) .	Parameter Range:	0 to 999.9 (x.x decimal)	X	X	X
	Default Setting:	0	X	X	X
	Running Access:	RW			

- If **P-12** is set to 0, 1, 2, or 3, this parameter is not used.
- If **P-12** is set to 4, the user relay turns on when the commanded frequency exceeds this value in Hz.
- If **P-12** is set to 5, the user relay turns on when the output current exceeds this value in amps.

7.1.3 Speed Reference Parameters (Group 2)

The following sections (7.1.3.1 and 7.1.3.2) and parameter descriptions describe the method of selecting the speed reference for each of the drive models. The following items apply to all models:

- When using the jog function ($P-11 = 2$), the Internal/Jog Frequency ($P-40$) is used, thus overriding $P-20$ (Main Speed Reference) and $P-21$ (Alternate Speed Reference). See the description of $P-11$ (Configurable Input) for more information.
- If the keypad is the selected speed reference ($P-20 = 1$ or $P-21 = 1$) and the connection between the keypad and the drive is bad or not present, a Bad Keypad Connection fault (CL) will be generated.

7.1.3.1 Selecting the Speed Reference for Model A and Model B Drives

Figures 7.1 and 7.2 show the logic that is used to establish the source of the speed reference for model A and model B drives. See the parameter descriptions for additional configuration information.

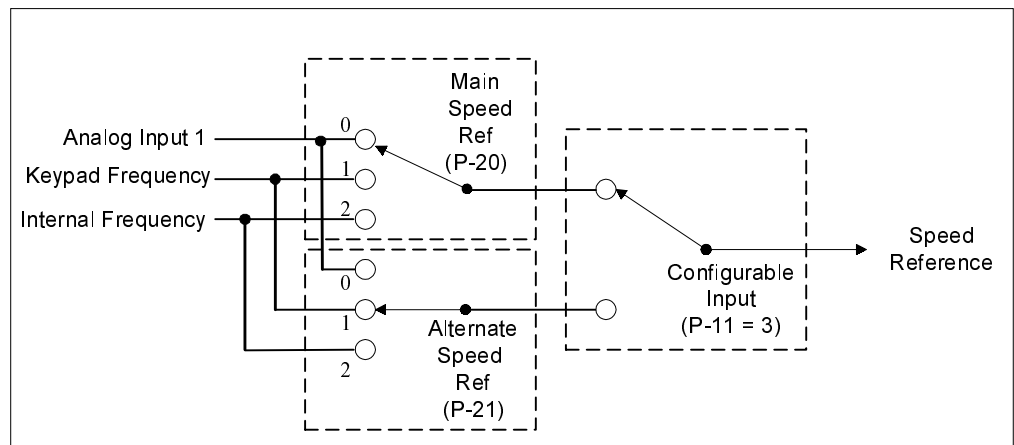

Figure 7.1 – Speed Reference Source for Model A Drives

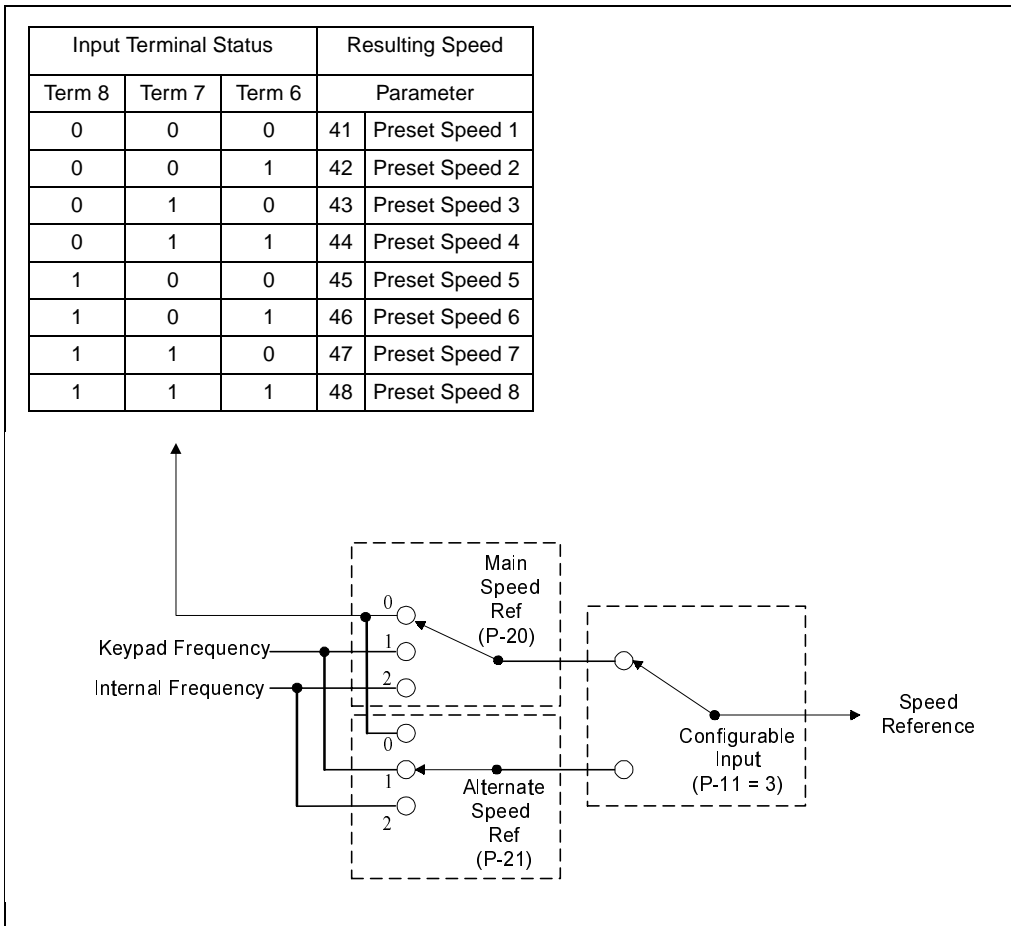

Figure 7.2 – Speed Reference Source for Model B Drives

7.1.3.2 Selecting the Speed Reference for Model C Drives

Figure 7.2 shows the logic that is used to establish the source of the speed reference for model C drives. See the parameter descriptions for additional configuration information.

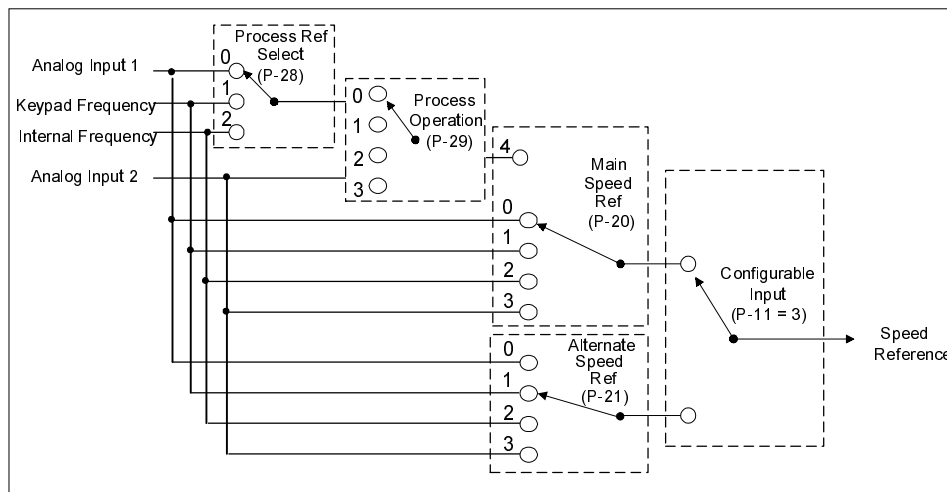

Figure 7.3 – Speed Reference Source for Model C Drives

7.1.3.3 Speed Selection Examples

Following are two examples of setting the speed reference for SP200 drives.

Example 1

Configure the drive to use two speed references : **P-40 (Internal/Jog Frequency)** and the keypad frequency. Use the Configurable Input to switch between these two speed references so that when it is turned on, **P-40 (Internal/Jog Frequency)** is selected.

This is accomplished as follows:

- Step 1. Set **P-20 (Main Speed Reference)** = 1 to select the keypad frequency as the main speed reference.
- Step 2. Set **P-21 (Alternate Speed Reference)** = 2 to select **P-40 (Internal/Jog Frequency)** as the alternate speed reference.
- Step 3. Set **P-11 (Configurable Input)** = 3 to select the alternate speed reference enable function. When the configurable input is turned on, **P-40 (Internal/Jog Frequency)** is selected as the active speed reference for the drive.

Example 2 (Model C only)

Configure the drive to use PI control. The reference for the process is Analog Input 2.

This is accomplished as follows :

- Step 1. Set **P-28 (Process Reference)** = 0 to select Analog Input 1 as the process reference.

- Step 2. Set **P-29 (Process Operation)** = 2 to select PI control as the process operation.
- Step 3. Set **P-20 (Main Speed Reference)** = 4 to select **P-29 (Process Operation)** as the main speed reference.
- Step 4. Set **P-26 (Process Proportional Gain)** and **P-27 (Process Integral Gain)** to nonzero values that are chosen to match the dynamics of the process being controlled and also the desired response.

P-20 Main Speed Reference		Model		
		A	B	C
Use this parameter to select the source for the main speed reference.	Parameter Range:	0 = Analog input 1	X	X
		0 = Preset Speeds		X
		1 = Keypad	X	X
		2 = Internal/Jog Frequency	X	X
		3 = Analog input 2		X
	4 = Process Operation output		X	
	Default Setting:	0	X	X
	Running Access:	RW		

P-21 Alternate Speed Reference		Model		
		A	B	C
Use this parameter to select the source for the alternate speed reference.	Parameter Range:	0 = Analog Input 1	X	X
		0 = Preset Speeds		X
		1 = Keypad	X	X
		2 = Internal/Jog Frequency	X	X
		3 = Analog Input 2		X
	Default Setting:	1	X	X
	Running Access:	RW		

P-22 Analog Input 1 Offset		Model		
		A	B	C
When using analog input 1 for a speed reference, use this parameter to set the level of the analog input used to command Minimum Speed (P-00) .	Parameter Range:	0.0 to 110.0 (x.x%)	X	X
	Default Setting:	0.0	X	X
	Running Access:	RW		

P-23 Analog Input 1 Gain	Model		
	A	B	C
When using analog input 1 for a speed reference, use this parameter to set the level of the analog input used to command Maximum Speed (P-01) .			
Parameter Range: 0.0 to 110.0 (x.x%)	X		X
Default Setting: 100.0	X		X
Running Access: RW			

P-24 Analog Input 2 Offset	Model		
	A	B	C
When using analog input 2 for a speed reference, use this parameter to set the level of the analog input used to command Minimum Speed (P-00) .			
Parameter Range: 0.0 to 110.0 (x.x%)			X
Default Setting: 0.0			X
Running Access: RW			

P-25 Analog Input 2 Gain	Model		
	A	B	C
When using analog input 2 for a speed reference, use this parameter to set the level of the analog input used to command Maximum Speed (P-01) .			
Parameter Range: 0.0 to 110.0 (x.x%)			X
Default Setting: 100.0			X
Running Access: RW			

P-26 Process Proportional Gain	Model		
	A	B	C
Use this parameter to specify the proportional gain (Ki) for the closed loop process PI controller. It is used only when P-29 (Process Operation) is set to 2 or 3 to select PI control or			
Parameter Range: 0 to 10.0 (x.x decimal)			X
Default Setting: 0			X
Running Access: RW			

inverted PI control. This parameter is scaled so that when it is set to 1.0, the process response is 1 Hz when the process error is 1 Hz. The correct value for this parameter depends on the dynamics of the process being controlled, as well as the desired response.

P-27 Process Integral Gain	Model		
	A	B	C
Use this parameter to specify the integral gain (Kp) for the closed loop process PI controller. It is used only when P-29 (Process Operation) is set to 2 or 3 to select PI control or inverted PI control. This parameter is scaled so that when it is set to 1.0, the process response is 10 Hz/sec when the process error is 1 Hz. The correct value for this parameter depends on the dynamics of the process being controlled, as well as the desired response.			X
Parameter Range: 0 to 10.00 (x.x decimal)			X
Default Setting: 0			X
Running Access: RW			

P-28 Process Reference	Model		
	A	B	C
Use this parameter to select the reference source for (P-29) Process Operation .			X
Parameter Range: 0 = Analog Input 1 1 = Keypad 2 = Internal/Jog Frequency			X
Default Setting: 0			X
Running Access: RW			

P-29 Process Operation	Model		
	A	B	C
Use this parameter to specify the type of operation performed by the process controller. It is used only when P-20 (Main Speed Reference) is set to the value 4 to select the process output as the main speed reference. The table below describes the different types of process operations.			X
Parameter Range: 0 = Add 1 = Multiply 2 = PI Control 3 = Inverted PI Control			X
Default Setting: 0			X
Running Access: RW			

Value	Process Operation	Description
0	Add	Add the process reference selected by P-28 and Analog Input 2. The resultant sum is the process output.
1	Multiply	Multiply the process reference selected by P-28 by Analog Input 2. The resultant product is the process output. In this case, Analog Input 2 is a gain that ranges from 0.0 when the input is equal to P-24 (Analog Input 2) Offset to 1.0 when the input is equal to P-25 (Analog Input 2 Gain) .
2	PI Control	Calculate the process error by subtracting Analog Input 2 from the process reference selected by P-28. This error along with P-26 (Process Proportional Gain) and P-27 (Process Integral Gain) are used to calculate the process output so that the process error is forced to zero. Use this setting to control a system variable that is directly proportional to motor speed.
3	Inverted PI Control	Calculate the process error by subtracting the process reference selected by P-28 from Analog Input 2. This error along with P-26 (Process Proportional Gain) and P-27 (Process Integral Gain) are used to calculate the process output so that the process error is forced to zero. Use this setting to control a system variable that is inversely proportional to motor speed.

7.1.4 Dynamic Control Parameters (Group 3)

P-30 Acceleration Time 1	Model				
	A	B	C		
Use this parameter to define the time it will take the drive to ramp up from 0 Hz to P-01 (Maximum Speed) .	Parameter Range:	0 to 600.0 (x.x seconds)	X	X	X
	Default Setting:	5.0	X	X	X
	Running Access:	RW			

P-31 Deceleration Time 1	Model				
	A	B	C		
Use this parameter to define the time it will take the drive to ramp down from P-01 (Maximum Speed) to 0 Hz.	Parameter Range:	0 to 600.0 (x.x seconds)	X	X	X
	Default Setting:	5.0	X	X	X
	Running Access:	RW			

P-32 Acceleration Time 2	Model				
	A	B	C		
When enabled by the Configurable input, this parameter determines the time it will take the drive to ramp up from 0 Hz to P-01 (Maximum Speed) .	Parameter Range:	0 to 600.0 (x.x seconds)	X	X	X
	Default Setting:	10.0	X	X	X
	Running Access:	RW			

P-33 Deceleration Time 2	Model				
	A	B	C		
When enabled by the Configurable input, this parameter determines the time it will take the drive to ramp down from P-01 (Maximum Speed) .	Parameter Range:	0 to 600.0 (x.x seconds)	X	X	X
	Default Setting:	10.0	X	X	X
	Running Access:	RW			

P-34 Stop Control	Model				
	A	B	C		
Use this parameter to define the stopping mode that is used when a stop command is received.	Parameter Range:	0 = Ramp-to-rest	X	X	X
		1 = Coast-to-rest	X	X	X
		2 = DC Injection	X	X	X
	Default Setting:	0	X	X	X
	Running Access:	RW			

P-35 DC Brake Current	Model		
	A	B	C
Use this parameter to specify the output current level that is applied to the motor during DC injection braking. Important: DC injection braking can cause motor thermal failure if used improperly or excessively.	Parameter Range:	10 to 150 (%)	X X X
	Default Setting:	50	X X X
	Running Access:	RW	

P-36 DC Brake Time at Stop	Model		
	A	B	C
Use this parameter to specify the time that DC injection braking at the level specified in P-35 (DC Brake Current) will be applied to the motor. If P-34 (Stop Control) is set to 0 to select ramp- to- stop, DC injection braking begins after the drive is stopped and the output frequency has ramped down to zero. If P-34 (Stop Mode) is set to 2 to select DC injection braking, it begins immediately when the drive is commanded to stop.	Parameter Range:	0 to 20.0 (x.x seconds)	X X X
	Default Setting:	0.5	X X X
	Running Access:	RW	

P-37 Avoidance Frequency	Model		
	A	B	C
Use this parameter, along with P-38 (Avoidance Frequency Band) , to prevent the drive from continuous operation within a range (band) of frequencies. This may be useful to prevent continuous operation at undesirable speeds. This parameter specifies the midpoint of the frequency avoidance band specified by P-38 (Avoidance Frequency Band) . A zero value disables this function.	Parameter Range:	0 to 240.0 (x.x Hz)	X X X
	Default Setting:	0 (disabled)	X X X
	Running Access:	RW	

P-38 Avoidance Frequency Band

This parameter specifies the width of the frequency avoidance band. If the speed reference is within the band defined by this parameter and **P-37**

(**Avoidance Frequency**), then the resultant speed reference is below the avoidance band as shown in the following illustration.

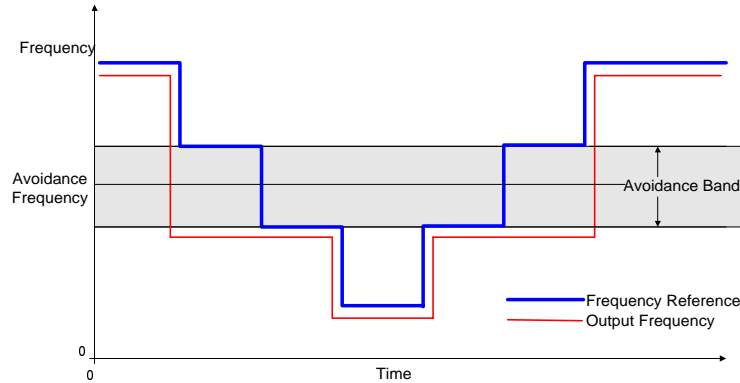

Note that the drive can accelerate and decelerate through the avoidance band. However, it cannot operate at a steady state within the avoidance band. Setting the value of this parameter to zero disables the avoidance frequency feature.

7.1.5 Fixed Speed Parameters (Group 4)

P040 Internal/Jog Frequency

Use this parameter to set the digital frequency setpoint used when jogging. When this parameter is selected as the frequency source, it is also used as the command frequency.

	Model		
	A	B	C
Parameter Range: 0 to 240.0 (x.x Hz)	X	X	X
Default Setting: 60.0	X	X	X
Running Access: RW			

P-41 Preset Speed 1

Use this parameter to define the commanded drive frequency when it is selected by the control inputs and the drive is operating in the preset mode.

	Model		
	A	B	C
Parameter Range: 0 to 240.0 (x.x Hz)		X	
Default Setting: 2.5		X	
Running Access: RW			

P-42 Preset Speed 2		Model		
		A	B	C
Use this parameter to define the commanded drive frequency when it is selected by the control inputs and the drive is operating in the preset mode.	Parameter Range: 0 to 240.0 (x.x Hz)		X	
	Default Setting: 5.0		X	
	Running Access: RW			

P-43 Preset Speed 3		Model		
		A	B	C
Use this parameter to define the commanded drive frequency when it is selected by the control inputs and the drive is operating in the preset mode.	Parameter Range: 0 to 240.0 (x.x Hz)		X	
	Default Setting: 10.0		X	
	Running Access: RW			

P-44 Preset Speed 4		Model		
		A	B	C
Use this parameter to define the commanded drive frequency when it is selected by the control inputs and the drive is operating in the preset mode.	Parameter Range: 0 to 240.0 (x.x Hz)		X	
	Default Setting: 20.0		X	
	Running Access: RW			

P-45 Preset Speed 5		Model		
		A	B	C
Use this parameter to define the commanded drive frequency when it is selected by the control inputs and the drive is operating in the preset mode.	Parameter Range: 0 to 240.0 (x.x Hz)		X	
	Default Setting: 30.0		X	
	Running Access: RW			

P-46 Preset Speed 6		Model		
		A	B	C
Use this parameter to define the commanded drive frequency when it is selected by the control inputs and the drive is operating in the preset mode.	Parameter Range: 0 to 240.0 (x.x Hz)		X	
	Default Setting: 40.0		X	
	Running Access: RW			

P-47 Preset Speed 7

Use this parameter to define the commanded drive frequency when it is selected by the control inputs and the drive is operating in the preset mode.

	Model		
	A	B	C
Parameter Range: 0 to 240.0 (x.x Hz)		X	
Default Setting: 50.0		X	
Running Access: RW			

P-48 Preset Speed 8

Use this parameter to define the commanded drive frequency when it is selected by the control inputs and the drive is operating in the preset mode.

	Model		
	A	B	C
Parameter Range: 0 to 240.0 (x.x Hz)		X	
Default Setting: 60.0		X	
Running Access: RW			

7.1.6 Volts/Hertz Curve Parameters (Group 5)

Following is a volts/hertz curve diagram and the volts/hertz parameter descriptions.

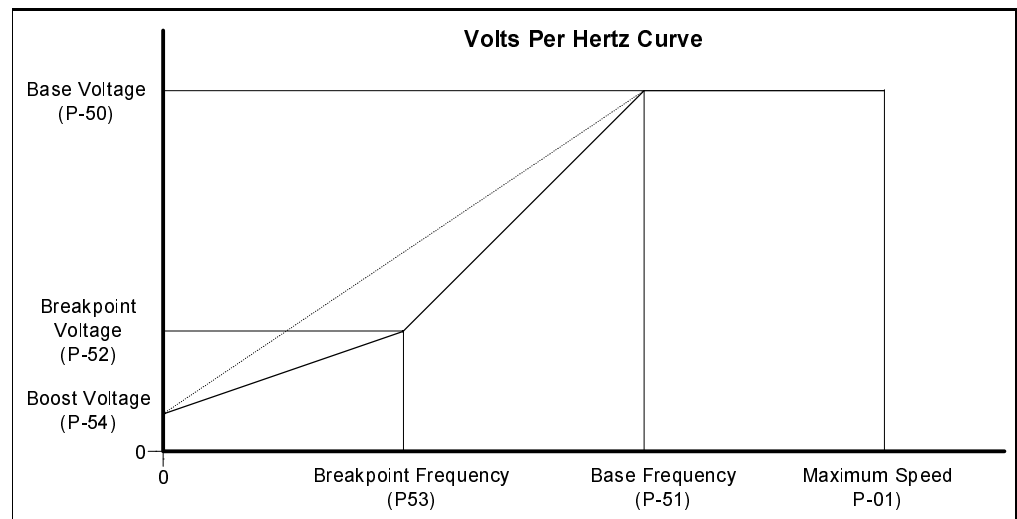

P-50 Base Voltage

Use this parameter to set the motor rated nameplate voltage.

	Model		
	A	B	C
Parameter Range: 0 to rated drive voltage (V)	X	X	X
Default Setting: 230 or 460	X	X	X
Running Access: RW			

P-51 Base Frequency		Model			
		A	B	C	
Use this parameter to set the motor rated nameplate frequency.	Parameter Range:	0 to 240 (Hz)	X	X	X
	Default Setting:	60	X	X	X
	Running Access:	RW			

P-52 Breakpoint Voltage		Model			
		A	B	C	
Use this parameter to define the voltage corresponding to P-53 (Breakpoint Frequency) for a breakpoint in the V/Hz curve.	Parameter Range:	0 to rated drive voltage (V)	X	X	X
	Default Setting:	0	X	X	X
	Running Access:	RW			

P-53 Breakpoint Frequency		Model			
		A	B	C	
Use this parameter to define the frequency corresponding to P-52 (Breakpoint Voltage) for a breakpoint in the V/Hz curve.	Parameter Range:	0 to 240 (Hz)	X	X	X
	Default Setting:	0 (breakpoint disabled)	X	X	X
	Running Access:	RW			

P-54 Boost Voltage		Model			
		A	B	C	
Use this parameter to define the amount of voltage applied to the motor when running at 0 Hz.	Parameter Range:	0 to 20% of rated drive voltage (V)	X	X	X
	Default Setting:	5% of rated drive voltage	X	X	X
	Running Access:	RW			

P-55 Auto Torque Boost	Model				
	A	B	C		
<p>Use this parameter to specify the additional voltage (derived from the torque producing component of the output current, Iq) that is added to the voltage command for improved low speed torque performance. The value represents the percent of rated drive voltage that is added to the voltage command when Iq is equal to the rated drive current. For example, if the rated drive voltage is 230V, P-55 = 3.0%, and Iq is equal to the rated drive current, then 6.9 volts is added to the voltage command. Setting the value of this parameter to zero disables the auto torque boost feature.</p>	Parameter Range:	0 to 150 (%)	X	X	X
	Default Setting:	50	X	X	X
	Running Access:	RW			

7.1.7 Utility Parameters (Group 6)

P-60 Reset to Defaults	Model				
	A	B	C		
<p>Use this parameter to set all parameters to the factory default values.</p> <p>The value of this parameter will be reset to 0 when the default process is completed.</p>	Parameter Range:	0 = (see description) 1 = Reset all values to factory defaults.	X	X	X
	Default Setting:	0	X	X	X
	Running Access:	RO			

P-61 Program Password	Model				
	A	B	C		
<p>Use this parameter to lock out any changes to parameter values.</p> <p>When this parameter is set to ON, editing of any parameter values (other than this parameter) is prohibited. If this parameter is set to OFF, the values of writable parameters can be changed. Enter the number 257 to toggle the setting of this parameter.</p>	Parameter Range:	OFF / ON Entering 257 toggles the setting.	X	X	X
	Default Setting:	OFF	X	X	X
	Running Access:	RW			

P-62 Speed Display Units	Model				
	A	B	C		
<p>Use this parameter to scale the d-00 (Command Frequency) and d-01 (Output Frequency) display parameters. Enter the number to be displayed at base frequency.</p>	Parameter Range:	0 - 9999	X	X	X
	Default Setting:	0	X	X	X
	Running Access:	RW			

P-63 Analog Input Display Units

Use this parameter to scale the units for **d-08 (Analog Input 1 Units)** and **d-09 (Analog Input 2 Units)** display parameters. Enter the number to be displayed at the maximum analog input level.

	Model		
	A	B	C
Parameter Range: 0 to 9999	X		X
Default Setting: 0	X		X
Running Access: RW			

P-64 Carrier Frequency

Use this parameter to set the carrier frequency for the PWM output waveform. Note that derating may be required above 2 kHz (see below).

	Model		
	A	B	C
Parameter Range: 2 to 8 (kHz)	X	X	X
Default Setting: 2	X	X	X
Running Access: RW			

Carrier Frequency Derating Curves

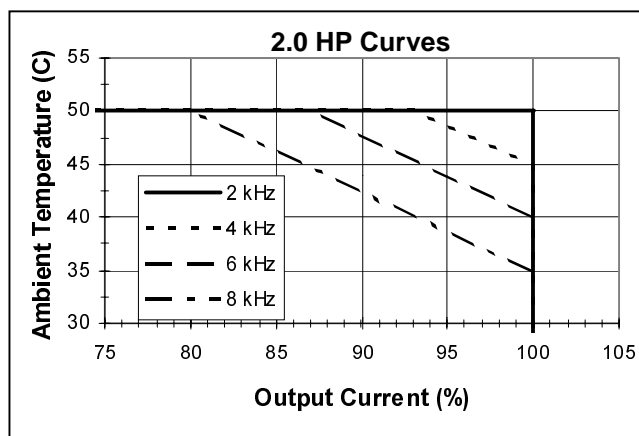
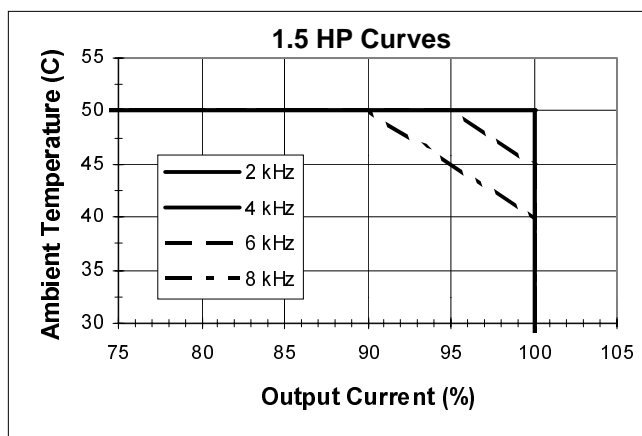

When using a carrier frequency greater than 2 kHz, the ambient temperature and/ or output current must be limited to values less than the standard ratings for 1.5 HP and 2 HP drives. Units 1 HP and smaller do not require derating. Use the graphs above to determine the maximum operating conditions when using a carrier frequency greater than 2 kHz. For example, consider a 1.5 HP drive rated at 230 V and 6 A output. When set to 8 kHz carrier frequency and used in a 45° C ambient, the maximum output current is limited to 95% (5.7A).

7.2 Display Parameters

Display parameters show information regarding the drive status. These parameters are always read only.

d-00 Command Frequency

This parameter represents the frequency that the drive is commanded to output. This

command may come from any of the frequency sources selected by **P-20 (Main Speed Reference)** or **P-21 (Alternate Speed Reference)**. The displayed value of this parameter can be scaled to other units by changing **P-62 (Speed Display Units)**.

Parameter Range:	0 to 240.0 (x.x Hz)
Running Access:	RO

d-01 Output Frequency

This parameter represents the output frequency at terminals U, V, and W. The displayed value of this parameter can be scaled to other units by changing **P-62 (Speed Display Units)**.

Parameter Range:	0 to 240.0 (x.x Hz)
Running Access:	RO

d-02 Output Current

This parameter represents the output current at terminals U, V, and W.

Parameter Range:	0 to 200% of rated current (x.x amps RMS)
Running Access:	RO

d-03 Bus Voltage

This parameter represents the DC bus voltage level.

Parameter Range:	0 to 500 for 230 V drives; 0 to 1000 for 460 V drives.
Running Access:	RO

d-04 Fault Code

This parameter represents the fault code for the last detected fault. Refer to chapter 9 for troubleshooting code definitions.

Parameter Range:	alphanumeric code
Running Access:	RO

d-05 Input Status

This parameter displays the status of the inputs that are connected to the control signal terminal block.

Parameter Range:	0000 to 7111
Running Access:	RO

For Model A (Single Channel Analog), the value is formatted as follows:

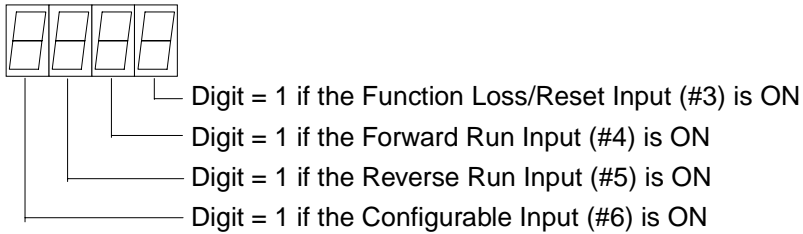

For Model B (Preset), the value is formatted as follows:

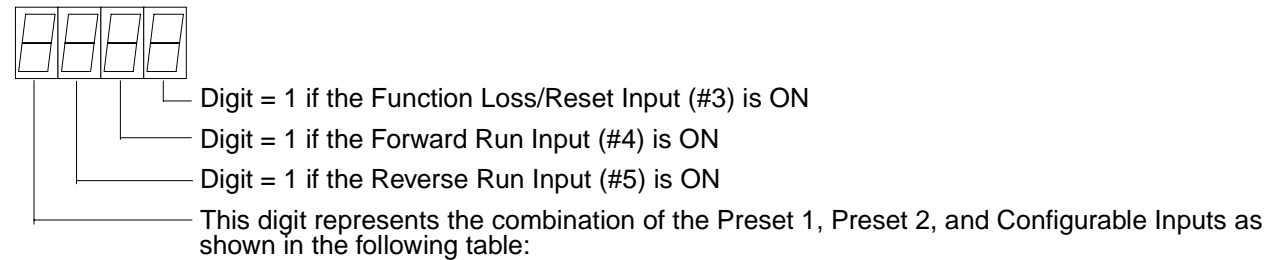

Left Digit Value	Terminal 8 (Configurable Input)	Terminal 7 (Preset 2)	Terminal 6 (Preset 1)
0	OFF	OFF	OFF
1	OFF	OFF	ON
2	OFF	ON	OFF
3	OFF	ON	ON
4	ON	OFF	OFF
5	ON	OFF	ON
6	ON	ON	OFF
7	ON	ON	ON

For Model C (Dual Channel Analog), the value is formatted as follows:

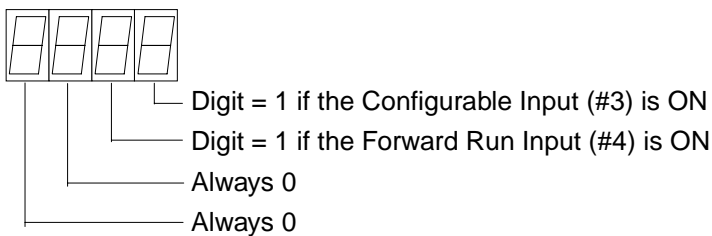

d-06 Drive Rating

This parameter defines the drive voltage and horsepower rating as shown in the table below.

Parameter Range:	0 to 255
Running Access:	RO

Drive HP	ID Code		
	230 V, 1 Phase	230 V, 3 Phase	460 V, 3 Phase
0.5	0205	0205	0405
1.0	0210	0210	0410
1.5	0215	None	None
2.0	0220	0220	0420

d-07 Firmware Version

This parameter represents the drive firmware version number.

Parameter Range:	alphanumeric code
Running Access:	RO

d-08 Analog Input 1 Units

This parameter displays the value of the signal that is connected to the Analog Channel 1 input on the

Parameter Range:	0 to 110.0 (%)
Running Access:	RO

control signal terminal block. It can be scaled by changing **P-63 (Analog Input Display Units)**. This parameter is used for models A and C only.

d-09 Analog Input 2 Units

This parameter displays the value of the signal that is connected to the Analog Channel 2 input on the

Parameter Range:	0 to 110.0 (%)
Running Access:	RO

control signal terminal block. It can be scaled by changing **P-63 (Analog Input Display Units)**. This parameter is used for model C only.

Check the Installation



ATTENTION: Only qualified electrical personnel, familiar with the construction and operation of this equipment and the hazards involved, should install, adjust, operate, and/or service this equipment. Read and understand this manual in its entirety before proceeding. Failure to observe this precaution could result in severe bodily injury or loss of life.

To ensure safe operation, check the installation with the power off before operating the unit. When power is first applied, the direction of rotation, operator speed reference, and operation under load should be tested.

8.1 Check the Installation with the Power Off

Perform the following installation checks of the unit with the power off:

- Step 1. Turn off, lockout, and tag AC input power to the unit.
- Step 2. If an input disconnect is installed, make sure it is in the OFF position.
- Step 3. Check that any interlocks installed around the driven machine are operational.
- Step 4. Check that there is adequate clearance around the unit. Refer to figure 2.1.
- Step 5. Check that the wiring to the power terminals and to the control signal terminal strip is correct (figures 4.1, 4.2, 5.1, 5.2, 5.3 and 5.4).
- Step 6. Check that user-supplied branch circuit protection is properly installed and correctly rated.
- Step 7. Check that incoming AC power is correctly rated.
- Step 8. Check that the rating of the transformer (if used) matches the unit requirements and that the transformer is connected for the proper voltage.
- Step 9. Check that a properly sized ground wire is installed and that a suitable earth ground is used. Verify that all ground leads are run unbroken.

8.2 Check the Direction of Motor Rotation



ATTENTION: The following procedures require rotating parts and/or electrical circuits to be exposed. Stay clear if the motor must be running. Disconnect, lockout, and tag the power source if contact must be made. Failure to observe this precaution could result in severe bodily injury or loss of life.

Important: If any problems occur while the drive is running, refer to chapter 9, Diagnostics and Troubleshooting.

After verifying that the drive installation is correct, check the direction of rotation of the motor using the following procedure:

- Step 1. Turn off, lockout, and tag AC input power to the unit.
- Step 2. Uncouple the driven equipment from the motor, if possible.
- Step 3. Set the speed reference signal to minimum speed.
- Step 4. Remove the lockout and tag, and turn power on to the unit.
- Step 5. Press the  key or supply a start signal.
- Step 6. Visually check the direction of shaft rotation. If shaft rotation is correct, proceed to the next section, Testing the Drive under Load. If shaft rotation is incorrect, continue to step 7.
- Step 7. Turn off, lockout, and tag AC input power to the unit.
- Step 8. Wait three minutes after disconnecting power to allow the DC bus to discharge.
- Step 9. Reverse any two of the three motor power leads (U/T1, V/T2, and W/T3).

8.3 Test the Drive under Load

Use the following procedure to test the drive under load:

- Step 1. Turn off, lockout, and tag power to the drive.
- Step 2. Couple the driven equipment to the motor.
- Step 3. Turn power on and start the drive.
- Step 4. Run the drive across the required speed range under load.
If the motor does not rotate properly at minimum speed, adjust the auto torque boost (see parameter P-55) until the desired operation is achieved.
- Step 5. If the drive operates the motor properly, record any changes made to parameter settings in Appendix D.
- Step 6. If the drive does not operate the motor properly:
 - a. Refer to chapter 9, Diagnostics and Troubleshooting.
 - b. Verify the parameter settings.

Diagnostics and Troubleshooting



ATTENTION: Only qualified personnel familiar with the construction and operation of this equipment and the hazards involved should install, adjust, operate, and/or service this equipment. Read and understand this instruction manual in its entirety before proceeding. Failure to observe this precaution could result in severe bodily injury or loss of life.

ATTENTION: After disconnecting input power, wait three minutes to allow the DC bus capacitors to discharge. Failure to observe this precaution could result in severe bodily injury or loss of life.

Observe the following precautions when troubleshooting the drive:

- Stop the drive.
- Disconnect, tag, and lockout AC power before working on the drive.
- Verify that there is no voltage present at the AC input power terminals. Refer to figure 4.1 for the location of the terminals.

9.1 Problems Not Reported by Fault Codes

If a problem exists in the absence of a fault code, it is most likely the result of wiring or programming. Refer to the table below to diagnose and correct some of these types of problems.

Table 9.1 – Problems Not Reported by Fault Codes

Problem	Parameter Values to Review	Possible Cause	Corrective Action
Drive does not run when commanded to run.	d-01 d-03 d-05 P-10	- Incorrect or faulty control wiring. - Start control (P-10) not set properly.	- Refer to control wiring diagrams for proper connections. Verify condition of signals which are intended to control drive. - Understand and set P-10 according to control requirements.
Drive runs, but not at commanded speed.	d-00 d-01 d-02 P-05 P-20 P-21 P-40 through P-48	- Speed reference (P-20 and/ or P-21) not set properly. - Speed reference not present. - Current limit (P-05) is set too low. - Load is excessive	- Understand and set P-20 and/or P-21 according to control requirements. - Determine which speed reference you have chosen and then provide it. - Increase P-05 to an operable but safe level - Reduce load

9.2 Problems Reported by Fault Codes

The SP200 AC drive will generate a fault in response to several different conditions. The presence of any fault will disable all PWM outputs and terminate the run state. The drive will coast to stop.

The drive has a bicolor (green/red) LED, located just above the mini-DIN connector, which indicates drive status. It functions as follows:

- If no fault condition exists, the green LED will be on.
- If a fault condition exists, and a local keypad is connected, the red LED will be on. The keypad will indicate the specific fault code.
- If a fault condition exists, and a local keypad is not present or has a bad connection, the red LED will flash. The flashing sequence will consist of a number of flashes to indicate the type of fault.

A fault may be reset by one of the following methods:

- Cycling the reset control input.
Exception: When a model C drive has P-10 = 2 and P-11 ≠ 0, cycle the forward run control input to reset faults.
- Cycling input power.
- Pressing the red  (stop) key on the keypad.

In all cases, a rising edge of the run or start signal is required to resume drive operation.

The following table lists all of the displayable faults.

Table 9.2 – Fault Codes and Corrective Actions

Display Code	No. of Fault LED Flashes	Fault Description	Fault Cause	Corrective Action
CF	2	Control Input	Illegal control input sequence.	- 3-wire: Verify Start and Jog inputs are not both ON. - 2-wire: Verify that only one input (Forward, Reverse, or Jog) is on.
FL	2	Function Loss	Start attempt while STOP (Function Loss) input is off.	Verify STOP (Function Loss) input is ON before attempting to start drive.
LU	3	Under Voltage ¹	- Low input line. - Temporary loss of input line.	Check input line to verify voltage is within operating specifications.
HU	4	Over Voltage ¹	- High input line. - Decel time too fast. - Overhauling load.	- Check input line to verify voltage is within operating specifications. - Increase decel time.
dO	5	Drive Overload ¹	Excessive driven load.	Reduce the load.
OL	5	Motor Overload ¹	Excessive driven load.	- Verify P-02 is set correctly. - Reduce the load.
OH	6	Over Temperature ¹	- Operating environment is too hot. - Fan is blocked or not operating. - Excessive driven load.	- Verify the ambient temperature is < 50°. - Verify clearance above/ below drive. - Check for fan obstruction. Replace fan if required. - Reduce the carrier frequency (P-64). - Reduce the load.
OC	7	Over Current ¹ (300%)	- Shaft rotation blocked. - Excessive driven load. - Output wiring is incorrect or shorted.	- Check for obstructions to shaft rotation or reduce excessive load. - Increase accel / decel time. - Verify output wiring is correct.
CL	8	Bad Keypad Connection	Bad connection from keypad to drive.	Verify keypad is properly connected to drive.
UF	9	Negative Slope	Conflicting parameter values.	Adjust values of parameters -P-50 through P-54.
J1	10	Ground Short	Phase U	- Verify output wiring is correct - Verify output phase is not grounded. - Verify motor is not damaged.
J2	10		Phase V	
J3	10		Phase W	
J4	10	Phase to Phase Short	Phase U - V	- Verify output wiring is correct.
J5	10		Phase U - W	- Verify motor is not damaged.
J6	10		Phase V - W	
CH	11	Checksum Failure	Parameter value out of range.	Load default parameter values (P-60 =1), then cycle power. If fault persists, replace drive.
UP	12	Microprocessor Fault	Internal processor error.	Cycle power. If fault persists, replace drive.

¹ Auto Resettable

Technical Specifications

Input/Output Ratings

- AC line voltage ($\pm 10\%$): 100 - 120 VAC, single phase
200 - 240 VAC, single-phase
200 - 240 VAC, 3-phase
380 - 460 VAC, 3-phase
- AC line frequency: 47 to 63 Hz
- Maximum symmetrical RMS fault current: 100,000 A
- Horsepower: 0.5 HP to 2 HP
- Output voltage: 0 to 230 VAC or 0 to 460 VAC
- Maximum output current: 150% for 60 sec; 200% for 10 sec
- Output frequency: 0 to 240 Hz
- Output carrier frequency: 2 kHz to 8 kHz; output current is derated above 2 kHz
- Input/output current:

Input Voltage	Unit HP	Input Amps	Output Amps
100 -120, 1-phase	0.5	9.4	2.3
	1.0	17.2	4.2
	1.5	24.6	6.0
200 - 240, 1-phase	0.5	4.7	2.3
	1.0	8.6	4.2
	1.5	12.3	6.0
	2.0	14.3	7.0
200 - 240, 3-phase	0.5	2.7	2.3
	1.0	5.0	4.2
	2.0	8.3	7.0
380 - 460, 3-phase	0.5	1.5	1.3
	1.0	2.4	2.0
	2.0	4.1	3.5

Control Inputs

- Rated voltage: 10 VDC to 24 VDC ($\pm 10\%$)
- Load (each): 10 mA minimum, 20 mA maximum
- Maximum allowable off-state leakage current: 1.5 V / 2.0 mA
- Analog input impedance: 0 to 10 V input: $\geq 100 \text{ k}\Omega$
4 to 20 mA input: $\sim 250 \Omega$

Relay Output

- Rated current and voltage(resistive): 0.5 A maximum at 125 VAC
1.0 A maximum at 30 VDC

Operating Performance

- Input frequency resolution: 0.4% analog; 0.1 Hz digital
- Output frequency resolution: 0.1%
- Output voltage regulation: 3%
- Power dip control ride through time: 100 msec minimum

Drive Power Loss

- Typical Full load power loss:

Input Voltage	Unit HP	Typical Power Dissipation (W)			
		2 kHz	4 kHz	6 kHz	8 kHz
100 -120, 1-phase	0.5	25	27	28	30
	1.0	45	48	50	52
	1.5	70	73	77	80
200 - 240, 1-phase	0.5	25	27	28	30
	1.0	45	48	50	52
	1.5	70	73	77	80
	2.0	75	80	85	90
200 - 240, 3-phase	0.5	25	27	28	30
	1.0	40	43	45	47
	2.0	70	75	80	85
380 - 460, 3-phase	0.5	25	30	35	40
	1.0	30	37	44	50
	2.0	50	60	72	85

Ambient Conditions

- Operating temperature: 0° C to 50° C (32° F to 122° F)
- Storage temperature: -40° C to 85° C (-40° F to 185° F)
- Humidity: 0 to 95% non-condensing
- Elevation: 1000 meters (3300 ft) maximum without derating. For every 91.4 meters (300 ft) above 1000 meters, derate the current by 1%. Above 3000 meters, (10,000 ft), consult your Reliance Electric Sales Office.

Dimensions

- Height: 139.8 mm (5.5 in)
- Width: 72.0 mm (2.835 in)
- Depth: 138.8 mm (5.47 in)

Standards and Approvals

- UL508C
- CSA22.2
- EN50178, EN60204-1 for Low Voltage Directive
- EN50081-1, EN50082-2, parts of EN61800-3 for EMC

Alphabetical Listing of Parameters

Program Parameters			
Acceleration Time 1	P-30	Deceleration Time 2	P-33
Acceleration Time 2	P-32	Internal/Jog Frequency	P-40
Alternate Speed Reference	P-21	Main Speed Reference	P-20
Analog Input Display Units	P-63	Maximum Speed	P-01
Analog Input 1 Gain	P-23	Minimum Speed	P-00
Analog Input 1 Offset	P-22	Motor Overload Current	P-02
Analog Input 2 Gain	P-25	Preset Speed 1	P-41
Analog Input 2 Offset	P-24	Preset Speed 2	P-42
Auto Restart Attempts	P-04	Preset Speed 3	P-43
Auto Torque Boost	P-55	Preset Speed 4	P-44
Avoidance Frequency	P-37	Preset Speed 5	P-45
Avoidance Frequency Band	P-38	Preset Speed 6	P-46
Base Frequency	P-51	Preset Speed 7	P-47
Base Voltage	P-50	Preset Speed 8	P-48
Boost Voltage	P-54	Process Integral Gain	P-27
Breakpoint Frequency	P-53	Process Operation	P-29
Breakpoint Voltage	P-52	Process Proportional Gain	P-26
Carrier Frequency	P-64	Process Reference	P-28
Configurable Input	P-11	Program Password	P-61
Configurable Output	P-12	Reset to Defaults	P-60
Configurable Output Level	P-13	Reverse Disable	P-03
Current Limit	P-05	Speed Display Units	P-62
DC Brake Current	P-35	Start Control	P-10
DC Brake Time at Stop	P-36	Stop Control	P-34
Deceleration Time 1	P-31		

Display Parameters			
Analog Input 1 Units	d-08	Fault Code	d-04
Analog Input 2 Units	d-09	Firmware Version	d-07
Bus Voltage	d-03	Input Status	d-05
Command Frequency	d-00	Output Current	d-02
Drive Rating	d-06	Output Frequency	d-01

Compliance with EU Requirements

The SP200 drive is CE-marked for Low Voltage (LV) Directive 73/23/EEC and all applicable standards when installed as described within the Low Voltage section that follows. It also has been tested to meet Electromagnetic Compatibility (EMC) Directive 89/336/EEC when installed as described within the Electromagnetic Compatibility section that follows. Contact the Rockwell AutoFax service in the United States at 216-646-7777 (or your local Rockwell Automation office if outside the U.S.) for copies of the Declaration of Conformity (DOC).

Conformity of the SP200 drive to EU directives does not guarantee that the entire system will conform. For EMC, many other factors can affect the total installation, and only direct measurements can verify total conformity. It is the responsibility of the machine manufacturer (or end user, if the machine is being modified or used beyond manufacturer's specifications) to comply.

Low Voltage Directive 72/23/EEC

- Follow all general precautions and ATTENTION statements throughout this manual.
- Provide an earth ground connection to the PE terminal.
- Install in a protective enclosure which restricts access to IP 20 rated devices as required by your national and local codes and regulatory agencies.

Electromagnetic Compatibility Directive 89/336/EEC

- Install the SP200 drive and Input Mains Filter (as specified in the table below) in a typical IEC or NEMA metal (shielded) enclosure as shown in the figure on the following page. Adhere to maximum motor cable lengths as specified in appendix D or 25 meters, whichever is shorter.

Drive Model Number	Filter Model Number	Drive Model Number	Filter Model Number
S20-X02P3.....	S20-MF1-Y014	S20-204P2.....	S20-MF1-45P0
S20-X04P2.....	S20-MF1-Y014	S20-207P0.....	S20-MF1-49P5
S20-X06P0.....	S20-MF1-Y014	S20-401P3.....	S20-MF1-45P0
S20-Y07P0.....	S20-MF1-Y014	S20-402P0.....	S20-MF1-45P0
S20-202P3.....	S20-MF1-45P0	S20-402P3.....	S20-MF1-45P0

Refer to *SP200 Mains Filters* (D2-3420) for filter dimensions and weights.

- Keep all input power, output power, and control signal wiring, both inside and outside enclosure, physically separate from one another.
- Connect the enclosure to the SP200 PE input (top) terminal.
- Connect the enclosure to earth ground.
- Use shielded cable with a ground conductor or individual conductors in grounded metal conduit for motor power wiring on the output side of the drive, both inside and outside the enclosure, all the way to the motor. Bring the shield as close to the output power terminals as possible. Connect the motor cable ground and shield to the ground terminal on the output (bottom) side of the SP200 drive. Connect the opposite end of the motor cable ground conductor and shield to the motor housing.

- Use shielded cable or grounded metal conduit for control wiring both inside and outside the enclosure, all the way to the control source. Bring the shield as close to the control terminals as possible. Connect the shield to the SP200 shield/common (terminal 1) and to the PE terminal on the input side (top) of the SP200 drive. Also connect the opposite end of the shield to the common of the device that is controlling the SP200 drive.
- Use EMC-tested 360 degree cable clamps to connect the motor and control shields to the enclosure cable exit point(s) and to the motor housing. Contact points must be clean and free of paint or nonconductive coating.
- Make certain all ground connections provide a low impedance path for high frequency signals.

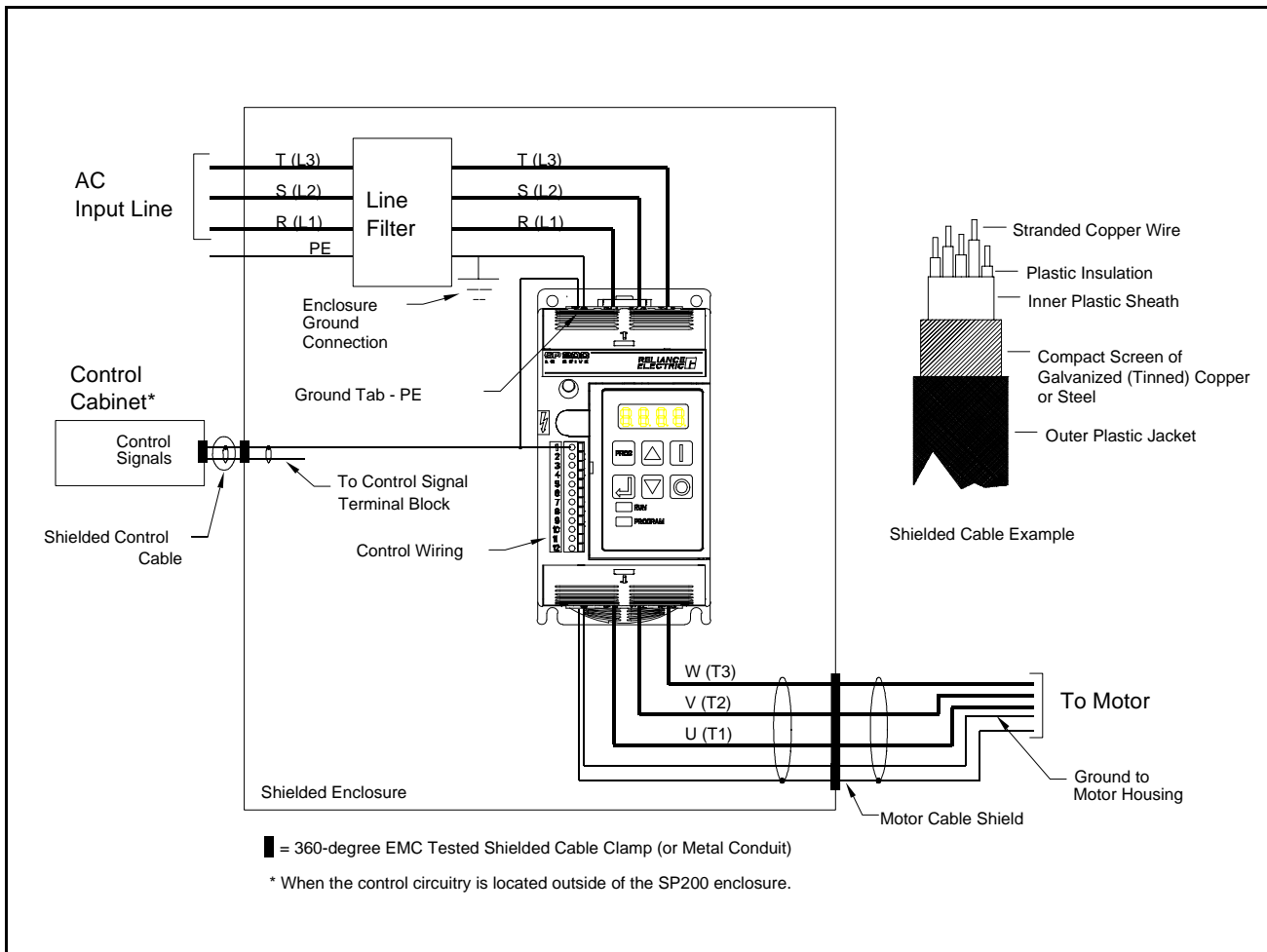

Figure C.1 – Grounding, Control, and Motor Connections

Motor Cable Recommendations

D.1 Drive-to-Motor Cable Distance

The cable distance between the drive and motor is limited for the following three reasons:

1. Long drive-to-motor cables can produce peak voltages that can damage motors having an electrical insulation system less than that of MG-1 (1600 V). The use of output line reactors can affect the limit. Use the table on the following page to determine the maximum distance that may be applied with a non MG-1 motor (for example, a motor with an insulation of 1000 V peak).
2. Long drive-to-motor cables also produce current that is capacitively coupled to ground. This can cause the drive to fault and misrepresent the cause. The use of output line reactors and cable shields or conduit can affect the limit. Use the table on the following page to determine the maximum distance under which the SP200 drive may be applied.
3. Long drive-to-motor cables produce electromagnetic noise which affects the system EMC compatibility. When compliance with EMC Directive 89/336/EEC is necessary (see appendix C), the maximum drive-to-motor cable distance for which a mains input filter may be used must be also be considered (25 m for S20-MF1-xxxx filters listed in appendix C.)

All of the limitations described above must be considered for your installation. The smallest of these numbers will dictate your final limit.

D.2 Drive-to-Motor Wire Type

The type of wire that is recommended to be used between the drive and motor is dependent on the environment in which it is used. The use of wire with PVC (PolyVinyl Chloride) insulation is restricted to certain conditions. A common example of this wire type is THHN. In these conditions where PVC is not recommended, XLPE (Cross Linked PolyEthylene) is recommended. An example of this wire type is XHHW-2. The action of pulling wire through 90° bends in conduit removes some of the wire's insulation. For this reason, extra care should be taken during this process and a wire with above average insulation thickness should be chosen.

Condition	Recommended Wire Type(s)	
	Insulation Type(s)	Example(s)
Dry	PVC ¹ XLPE	THHN XHHW-2
Wet	XLPE	XHHW-2

¹When using wire with PVC type insulation, standard 15mil thickness is adequate under normal conditions; however, when multiple motor's wires are run in the same conduit for more than 50 ft (15m), and the voltage is greater than 240V + 10%, 20 mil or greater thickness is recommended.

Reactor	Drive Rating		1000 V Motor Limit		SP200 Drive Limit															
	Input Volts	HP (kW)			Shielded Cable or Wires in Conduit								Unshielded Cable							
			2 kHz		4 kHz		6 kHz		8 kHz		2 kHz		4 kHz		6 kHz		8 kHz			
			ft	m	ft	m	ft	m	ft	m	ft	m	ft	m	ft	m	ft	m		
None	120 / 240	0.5 (0.37)	—	—	250	76	250	76	250	76	200	61	600	183	600	183	600	183	600	183
	120 / 240	1.0 (0.75)	—	—	500	152	500	152	400	122	300	91	600	183	600	183	600	183	600	183
	120 / 240	1.5 (1.1)	—	—	600	183	600	183	500	152	300	91	600	183	600	183	600	183	600	183
	240	2.0 (1.5)	—	—	600	183	600	183	500	152	300	91	600	183	600	183	600	183	600	183
	460	0.5 (0.37)	50	15	100	30	100	30	100	30	90	27	175	53	175	53	175	53	150	46
	460	1.0 (0.75)	25	8	120	37	100	30	100	30	100	30	300	91	300	91	300	91	300	91
	460	2.0 (1.5)	20	6	220	67	180	55	180	55	100	30	400	122	400	122	400	122	400	122
3 % at Drive	120 / 240	0.5 (0.37)	—	—	400	122	300	91	300	91	100	30	600	183	600	183	600	183	600	183
	120 / 240	1.0 (0.75)	—	—	500	152	300	91	300	91	200	61	600	183	600	183	600	183	600	183
	120 / 240	1.5 (1.1)	—	—	600	183	400	122	300	91	200	61	600	183	600	183	600	183	600	183
	240	2.0 (1.5)	—	—	600	183	400	122	300	91	200	61	600	183	600	183	600	183	600	183
	460	0.5 (0.37)	15	5	120	37	100	30	100	30	90	27	200	61	200	61	200	61	150	46
	460	1.0 (0.75)	40	12	180	55	140	43	100	30	100	30	600	183	600	183	600	183	400	122
	460	2.0 (1.5)	80	24	220	67	200	61	170	52	130	40	600	183	600	183	600	183	200	183
3 % at Motor	120 / 240	0.5 (0.37)	—	—	300	91	280	85	280	85	280	85	600	183	600	183	600	183	600	183
	120 / 240	1.0 (0.75)	—	—	600	183	600	183	500	152	400	122	600	183	600	183	600	183	600	183
	120 / 240	1.5 (1.1)	—	—	600	183	600	183	500	152	300	91	600	183	600	183	600	183	600	183
	240	2.0 (1.5)	—	—	600	183	600	183	500	152	300	91	600	183	600	183	600	183	600	183
	460	0.5 (0.37)	300	91	100	30	100	30	100	30	90	27	175	53	175	53	175	53	150	46
	460	1.0 (0.75)	300	91	120	37	100	30	100	30	100	30	300	91	300	91	300	91	300	91
	460	2.0 (1.5)	300	91	200	61	200	61	200	61	170	52	400	122	400	122	400	122	400	122

APPENDIX E

User Quick Reference Table

No.	Parameter Name	Default	User Value/Date				
P-00	Minimum Speed	0					
P-01	Maximum Speed	60					
P-02	Motor Overload Current	100% of rated drive amps					
P-03	Reverse Disable	0					
P-04	Auto Restart Attempts	0					
P-05	Current Limit	150					
P-10	Start Control	2					
P-11	Configurable Input	2 (A) / 1 (B) / 0 (C)					
P-12	Configurable Output	0					
P-13	Configurable Output Level	0					
P-20	Main Speed Reference	0					
P-21	Alternate Speed Reference	1					
P-22	Analog Input 1 Offset	0.0 (model A, C only)					
P-23	Analog Input 1 Gain	100.0 (model A, C only)					
P-24	Analog Input 2 Offset	0.0 (model C only)					
P-25	Analog Input 2 Gain	100.0 (model C only)					
P-26	Process Proportional Gain	0 (model C only)					
P-27	Process Integral Gain	0 (model C only)					
P-28	Process Reference	0 (model C only)					
P-29	Process Operation	0 (model C only)					
P-30	Acceleration Time 1	5.0					
P-31	Deceleration Time 1	5.0					
P-32	Acceleration Time 2	10.0					
P-33	Deceleration Time 2	10.0					
P-34	Stop Control	0					
P-35	DC Brake Current	50					
P-36	DC Brake Time at Stop	0.5					
P-37	Avoidance Frequency	0					
P-38	Avoidance Frequency Band	0					
P-40	Internal/Jog Frequency	60.0					
P-41	Preset Speed 1	2.5					
P-42	Preset Speed 2	5.0					
P-43	Preset Speed 3	10.0					
P-44	Preset Speed 4	20.0					
P-45	Preset Speed 5	30.0					
P-46	Preset Speed 6	40.0					
P-47	Preset Speed 7	50.0					
P-48	Preset Speed 8	60.0					
P-50	Base Voltage	230 / 460					
P-51	Base Frequency	60					
P-52	Breakpoint Voltage	0					
P-53	Breakpoint Frequency	0					
P-54	Boost Voltage	11 / 23					
P-55	Auto Torque Boost	3.0					
P-60	Reset to Defaults	0					
P-61	Program Password	OFF					
P-62	Speed Display Units	0					
P-63	Analog Input Display Units	0					
P-64	Carrier Frequency	2.0					

Numbers

0 to 10 V input, wiring, 5-1, 5-2
4 to 20 mA input, wiring, 5-1 , 5-2

A

AC input disconnect, installing, 3-2
AC input power, connecting, 4-1 to 4-2
AC input terminal block, 4-2
Acceleration Time 1(P-30), 7-13
Acceleration Time 2 (P-32), 7-13
Alternate Speed Reference (P-21), 7-10
Analog Input Display Units (P-63), 7-20
Analog Input 1 Gain (P-23), 7-11
Analog Input 1 Offset (P-22), 7-10
Analog Input 1 Units (d-08), 7-23
Analog Input 2 Gain (P-25), 7-11
Analog Input 2 Offset (P-24), 7-11
Analog Input 2 Units (d-09), 7-23
Auto Restart Attempts (P-04), 7-3
Auto Torque Boost (P-55), 7-19
Avoidance Frequency (P-37), 7-14
Avoidance Frequency Band (P-38), 7-15

B

Base Frequency (P-51), 7-18
Base Voltage (P-50), 7-17
Boost Voltage (P-54), 7-18
Branch circuit protection, installing, 3-1
Breakpoint Frequency (P-53), 7-18
Breakpoint Voltage (P-52), 7-18
Bus Voltage (d-03), 7-21

C

Cable distance, drive-to-motor, D-1
Carrier Frequency (P-64), 7-20
Carrier frequency derating curves, 7-20
Clearances, access, 2-1
Command Frequency (d-00), 7-21
Configurable Input (P-11), 7-4 to 7-6
Configurable Output (P-12), 7-6
Configurable Output Level (P-13), 7-7

Control signal terminal block
location, 1-1
wiring, 5-1 to 5-2
Current Limit (P-05), 7-3

D

DC Brake Current (P-35), 7-14
DC Brake Time at Stop (P-36), 7-14
Deceleration Time 1 (P-31), 7-13
Deceleration Time 2 (P-33), 7-13
Direction, checking motor rotation, 8-2
Disconnect, *see* AC input disconnect
Display, *see* Keypad
Display parameters, 7-21 to 7-23
Drive Rating (d-06), 7-23
Drive-to-motor cable distance, D-1
Drive-to-motor wire type, D-1

E

Editing parameters, 7-1
Emergency stop, installing, 5-3
EU requirements, compliance with, C-1

F

Fault Code (d-04), 7-21
Fault codes, 9-1 to 9-3
Faults, clearing, 9-2
Firmware Version (d-07), 7-23
Forward control, wiring, 5-2
Function loss, wiring, 5-2

G

Grounding, 4-2

I

- Input Status (d-05), 7-22
- Installation
 - AC input power, 4-1 to 4-2
 - AC input disconnect, 3-2
 - branch circuit protection, 3-1
 - emergency stop, 5-3
 - grounding, 4-2
 - motor overload protection, 3-2
 - mounting, 2-1 to 2-2
 - planning, 2-1
 - wire routing, 2-1
- Internal/Jog Frequency, (P-40), 7-15

K

- Keypad
 - key functions, 6-1
 - LEDs, 6-1
 - location, 1-1

L

- LED
 - program, 6-1
 - run, 6-1
 - status, 1-1
- Line frequency, A-1
- Local keypad, *see* Keypad

M

- Main Speed Reference (P-20), 7-10
- Maximum Speed (P-01), 7-2
- Minimum Speed (P-00), 7-2
- Model number structure, 1-1
- Motor Overload Current (P-02), 7-2
- Motor overload protection, installing, 3-2
- Motor rotation, checking, 8-2
- Mounting dimensions, 2-2

O

- Operating drive using keypad, 6-3
- Output Current (d-02), 7-21
- Output Frequency (d-00), 7-21
- Output power, wiring, 4-2

P

- Parameters
 - alphabetical listing, B-1
 - display, 7-21 to 7-23
 - editing, 6-3
 - program, 7-2 to 7-20
- Planning, installation, 2-1
- Power off checks, 8-1
- Preset Speed 1 (P-41), 7-15
- Preset Speed 2 (P-42), 7-16
- Preset Speed 3 (P-43), 7-16
- Preset Speed 4 (P-44), 7-16
- Preset Speed 5 (P-45), 7-16
- Preset Speed 6 (P-46), 7-16
- Preset Speed 7 (P-47), 7-17
- Preset Speed 8 (P-48), 7-17
- Process Integral Gain (P-27), 7-12
- Process Operation (P-29), 7-12
- Process Proportional Gain (P-26), 7-11
- Process Reference (P-28), 7-12
- Program parameters, 7-2 to 7-20
- Program Password (P-61), 7-19

Q

- Quick reference table, E-1

R

- Relay control output, 5-2
- Reset to Defaults (P-60), 7-19
- Reverse control, wiring, 5-2
- Reverse Disable (P-03), 7-3

S

- Speed Display Units (P-62), 7-19
- Speed reference
 - selecting for model A and B, 7-7 to 7-8
 - selecting for model C, 7-9
 - 4 to 20 mA input, wiring, 5-2
 - preset speed inputs, 5-2
 - signal potentiometer, 5-2
- Start Control (P-10), 7-4
- Start control, wiring, 5-2
- Starting the unit with local keypad, 6-3
- Stop Control (P-34), 7-13
- Stop control
 - switch location, 5-2
 - wiring, 5-2

Stopping the unit using local keypad, 6-3

T

Technical Specifications, A-1

Terminal block

 model A, 5-2

 model B, 5-2

 model C, 5-2

Testing drive under load, 8-2

Troubleshooting, 9-1 to 9-3

W

Wire routing, 2-1

Wire size, 4-1, D-1

Wire type, drive-to-motor, D-1

Wiring

 control signal terminal block, 5-1, 5-2

 input power, 4-1 to 4-2

 output power, 4-2

Documentation Improvement Form

Use this form to give us your comments concerning this publication or to report an error that you have found. For convenience, you may attach copies of the pages with your comments. After you have completed this form, please return it to:

Reliance Electric
 RGA (Technical Publications)
 25001 Tungsten Road
 Cleveland, Ohio 44117

Fax: 216.266.7120

Publication Name:	
Publication Number:	Publication Date:

Comments:

Your Name:	Date:
Company Name:	Phone: ()
Address:	

Thank you for your comments.

Technical Writing Internal Use	
Date:	DIF Number:
Follow-Up Action:	

Reliance Electric / 24703 Euclid Avenue / Cleveland, Ohio 44117 / (216) 266-7000

 **Rockwell** Automation

Reliance Electric