

# Class 8839 58M

## Adjustable Speed Drive Controllers

1–75 hp CT & 1–500 hp VT, 460Vac;  
1–40 hp CT & 1–50 hp VT, 208/230Vac

Instruction Bulletin  
Retain for future use.



## **⚠ DANGER**

### **HAZARD OF ELECTRIC SHOCK, EXPLOSION, OR ARC FLASH**

- Apply appropriate personal protective equipment (PPE) and follow safe electrical work practices. See NFPA 70E.
- This equipment must only be installed and serviced by qualified electrical personnel.
- Turn off all power supplying this equipment before working on or inside equipment.
- Always use a properly rated voltage sensing device to confirm power is off.
- Replace all devices, doors, and covers before turning on power to this equipment.

**Failure to follow these instructions will result in death or serious injury.**

## **⚠ DANGER**

### **HAZARDOUS VOLTAGE**

- Read and understand this bulletin in its entirety before installing or operating Class 8839 58M drive controllers. Installation, adjustment, repair, and maintenance of the drive controllers must be performed by qualified personnel.
- User is responsible for conforming to all applicable code requirements with respect to grounding all equipment.
- Many parts in this drive controller, including printed wiring boards, operate at line voltage. **DO NOT TOUCH.** Use only electrically insulated tools.
- **DO NOT** short across DC bus capacitors or touch unshielded components or terminal strip screw connections with voltage present.
- Before servicing the drive controller:
  - Disconnect all power including external control power that may be present before servicing the drive controller.
  - Place a "DO NOT TURN ON" label on the drive controller disconnect.
  - Lock the disconnect in open position.
  - **WAIT TEN MINUTES** for the DC bus capacitors to discharge. Then follow the DC bus voltage measurement procedure on page 42 to verify that the DC voltage is less than 45 V. The drive controller LEDs are not accurate indicators of the absence of DC bus voltage.
- Install and close all covers before applying power or starting and stopping the drive controller.

**Electrical shock will result in death or serious injury.**

# TABLE OF CONTENTS

<b>SECTION 1: INTRODUCTION AND TECHNICAL CHARACTERISTICS</b> .....	7
<b>Introduction</b> .....	7
<b>Related Documentation</b> .....	7
<b>Terminology</b> .....	8
<b>Precautions</b> .....	8
<b>Controller Nameplate Identification</b> .....	9
<b>Controller Catalog Numbers</b> .....	10
<b>Technical Characteristics</b> .....	12
Class 8839 58M Drive Controller Ratings .....	12
Input Current Ratings .....	15
Specifications .....	19
<b>Standard Features</b> .....	21
<b>Factory Modifications</b> .....	22
Power Options .....	22
Control Options .....	22
Light Options .....	24
Option Cards .....	26
Miscellaneous Options .....	27
<b>Total Dissipated Watts Loss</b> .....	29
<b>Mounting Dimensions and Weights</b> .....	31
<b>SECTION 2: RECEIVING, INSTALLATION, AND START-UP</b> .....	37
<b>Preliminary Inspection</b> .....	37
<b>Handling the Drive Controller</b> .....	38
<b>Installation</b> .....	39
Mechanical Installation .....	39
Electrical Installation .....	39
General Wiring Practices .....	39
Input Power .....	40
Branch Circuit Connections .....	40
Grounding .....	41
Output Wiring .....	41
Output Cable .....	42
DC Bus Voltage Measurement Procedure .....	42
Wire Routing and Interconnection .....	44
Wire Class .....	44
Noise Class .....	44
Voltage Class .....	45
Wiring Methods .....	45
Component Identification and Terminal Strip Locations .....	46
Power Wiring .....	52
Control Wiring .....	57
<b>Initial Start-Up Procedure</b> .....	60
Start-Up Procedure .....	61
Step 1: Checking the Enclosure Components and Connections .....	61
Step 2: Providing Motor Overload Protection and Thermal Protection .....	62
Step 3: Testing Motor Rotation .....	62

---

Correcting Motor Rotation .....	63
Step 4: Testing Motor Rotation in Bypass Mode .....	63
Correcting Motor Rotation in Bypass Mode .....	63
Step 5: Checking Keypad Display Settings .....	64
Circuit Breaker Trip Adjustment Procedure .....	64
<b>Start-Up Checklist</b> .....	67
Customer Readiness Acknowledgment .....	68
<b>SECTION 3: CIRCUIT DESCRIPTIONS AND OPTIONS</b> .....	69
<b>Introduction</b> .....	69
<b>Terminal Command Versus Keypad Command Operation</b> .....	69
<b>Keypad Operation</b> .....	70
<b>Forced Local Operation</b> .....	70
<b>Control Circuit Sequencing and Operation</b> .....	70
Run Command Relay (RCR) .....	70
Auxiliary Run Command Relay (ARCR) .....	71
Auxiliary Drive Run Relay (ADRR1) .....	71
Auxiliary Drive Run Relay (ADRR2) .....	71
Auxiliary Drive Fault Relay (ADFR1) .....	71
Auxiliary Drive Fault Relay (ADFR2) .....	71
Auxiliary Transfer Bypass Relay (ATB) .....	71
Communication Mode Relay (CMR) .....	71
Check Valve Sequence (CVS) Relay .....	72
Fault Reset .....	72
<b>Power Circuits—General</b> .....	73
Controller Operation .....	73
Interlocks .....	73
<b>Power Circuit W (Without Bypass)</b> .....	73
Operator Controls—General Arrangement and Operation .....	73
<b>Power Circuit Y (Bypass)</b> .....	73
Operator Controls—General Arrangement and Operation .....	74
Test-Normal Operation .....	74
Bypass Operation .....	74
<b>Modifications</b> .....	75
Control Function Descriptions (A07–F07) .....	75
Hand Mode .....	75
Off Mode .....	75
Auto Mode .....	75
Start Push Button .....	75
Stop Push Button .....	76
Manual Speed Potentiometer .....	76
Forward/Reverse .....	76
Local/Remote .....	76
Communication Mode .....	76
Pilot Light Option Clusters (A08–F08) .....	76
Power On (red) .....	76
AFC Run (green) .....	76
Auto (yellow) .....	77
Fault (yellow) .....	77
Bypass (yellow) .....	77
Forward (green) .....	77

Reverse (green) .....	77
Hand (blue) .....	77
Comm (yellow) .....	77
Option A09 Modbus Plus .....	77
Option B09 Modbus .....	77
Option C09 Metasys N2 .....	77
Option D09 Ethernet .....	77
Option E09 LonWorks .....	78
Option F09 DeviceNet .....	78
Option H09 Analog Card .....	78
Option A10 Line Reactor .....	78
Option B10 Line Contactor .....	78
Option C10 3–15 psi Transducer with Digital Display (TB2-G1/S2+ to TB2-J/S3) .....	78
Option D10 Omit Keypad Display .....	78
Option E10 Smoke Purge Relay (TB1-48 to TB1-49) .....	78
Option G10 cUL Listing .....	78
Option H10 Seismic Certification (Floor Mount Enclosures) .....	78
Option J10 0–10 V Auto Speed Reference (TB2-G1/S2+ to TB2-G2/S2-) .....	79
Option K10 Additional N.O. Auxiliary Drive Run Contact (TB1-57 to TB1-58) .....	79
Option L10 Additional N.C. Auxiliary Drive Fault Contact (TB1-59 to TB1-60) .....	79
Option M10 N.O. Auxiliary Bypass Run Contact (TB1-61 to TB1-62) .....	79
Option O10 N.O. Auxiliary Auto Mode Contact (TB1-63 to TB1-64) .....	79
Option P10 AFC Fault Reset (TB2-A to TB2-C) .....	79
Option Q10 Push-To-Test Pilot Lights .....	79
Option R10 Auto Transfer to Bypass (TB1-23 to TB1-27 and TB1-22 to TB1-23) .....	79
Option S10 Motor Elapsed Time Meter (TB1-44 to TB1-50) .....	79
Option T10 Emergency Stop (TB1-2 to TB1-3) .....	80
Option U10 Motor Space Heater Sequencing (TB1-45 to TB1-50) .....	80
Option V10 Seal Water Solenoid (TB1-43 to TB1-50) .....	80
Option W10 Check Valve Sequencing (TB1-46 to TB1-47) .....	80
Option Z10 24 Vdc Power Supply [TB2-O (+) to TB2-N (COM)] .....	80
Option 110 Additional Control Power VA (TB1-1 to TB1-50) .....	80
Option 410 RFI Suppressor .....	80
Option 510 Permanent Wire Marker Sleeves .....	80
Option 610 I.D. Engraved Nameplates .....	80
Option 710 Harmonic Filter Provisions .....	80
Option 910 Barriered Bypass Enclosure .....	81
<b>Notes</b> .....	82
<b>SECTION 4: MAINTENANCE AND SUPPORT</b> .....	83
<b>Introduction</b> .....	83
<b>External Signs of Damage</b> .....	83
<b>Preventive Maintenance</b> .....	83
<b>Field Replacement of CT and 1–100 hp VT Power Converters (Not Applicable on 125–500 hp, 460 V, VT Controllers)</b> .....	84
Removing the Power Converter Assembly .....	84
Installing the Power Converter Assembly .....	86
<b>Field Replacement of Heatsink Fan Assembly</b> .....	88

---

Removing the Heatsink Fan Assembly .....	88
Installing the Heatsink Fan Assembly .....	90
<b>Field Replacement of the Stirring Fans .....</b>	<b>90</b>
<b>Field Replacement of the Plenum Fans .....</b>	<b>91</b>
<b>Technical Support .....</b>	<b>91</b>
<b>APPENDIX A: SPARE PARTS .....</b>	<b>93</b>
<b>APPENDIX B: FIELD INSTALLATION OF INLET VENT FILTER ASSEMBLY .....</b>	<b>97</b>
<b>Overview .....</b>	<b>97</b>
<b>Installation .....</b>	<b>97</b>
<b>Maintenance .....</b>	<b>98</b>
<b>INDEX: .....</b>	<b>99</b>

# SECTION 1— INTRODUCTION AND TECHNICAL CHARACTERISTICS

## INTRODUCTION

The Class 8839 58M enclosed drive controller is targeted for industrial, municipal, and high end commercial applications. See Table 1 for available enclosures and short-circuit current ratings. All drive controllers are UL 508C Listed with selectable control and power configurations.

This instruction bulletin covers receiving, installation, start-up, configuration, and troubleshooting of the Class 8839 58M AC drive controllers listed in Table 1.

**Table 1: Class 8839 58M AC Drive Controller Enclosures and Short-Circuit Current Ratings**

Controllers	Enclosure Type(s)	Short-Circuit Current Ratings	
		65 kA	100 kA
1–75 hp constant torque, 460 V	1, 12	X	
1–40 hp constant torque, 208/230 V	1, 12	X	
1–100 hp variable torque, 460 V	1, 12	X	
125–500 hp variable torque, 460 V	1, 1G		X
1–50 hp variable torque, 208/230 V	1, 12	X	

## RELATED DOCUMENTATION

For further information, refer to the latest revision of the following bulletins, which ship with a drive controller when the corresponding option is selected.

- Instruction bulletin VVDED397047US, *ALTIVAR<sup>®</sup> 58 TRX Adjustable Speed Drive Controllers Keypad Display, VW3A58101*.
- Instruction bulletin 30072-200-50, *Handling, Installation, Operation, and Maintenance of Electrical Control Equipment*.
- Instruction bulletin VVDED397046US, *ALTIVAR 58 Adjustable Speed Drive Controllers Analog I/O Extension Card, VW3A58201U* (supplied with controller when analog card, option H09, is selected).
- Instruction bulletin VVDED300055US, *LonWorks<sup>®</sup> to MODBUS<sup>®</sup> Module VW3A58312PU* (supplied with controller when LONWORKS, option E09, is selected).
- Instruction bulletin VVDED397054US, *ALTIVAR 58 Adjustable Speed Drive Controllers MODBUS/JBUS/UNITELWAY<sup>™</sup> User's Guide, VW3A58303U* (supplied with controller when Modbus, option B09 or LONWORKS E09, is selected).
- Instruction bulletin VVDED300028US, *ALTIVAR 58 Adjustable Speed Drive Controllers METASYS<sup>®</sup> N2 Communication Option VW3A58354U* (supplied with controller when Metasys N2, option C09, is selected).
- Instruction bulletin VVDED397044US, *ALTIVAR 58 Adjustable Speed Drive Controllers MODBUS Plus Communication Option, VW3A58302U* (supplied when Modbus Plus, option A09, is selected).
- Instruction bulletin VVDED300053US, *ALTIVAR 58 Ethernet MODBUS TCP/IP Communication Option VW3A58310U* (supplied when Ethernet, option D09, is selected).
- Instruction bulletin VVDED300052US, *ALTIVAR 58 Adjustable Speed Drive Controllers DEVICENET<sup>™</sup> Communication Option, VW3A58309U* (supplied when DeviceNet, option F09, is selected).

All controllers include factory-supplied user drawings and are identified by a factory order number. The factory order number for the controller is referenced in Figure 1 on page 9. This same number appears as part of the number sequence in the title block of the factory supplied user drawings. The drawing set includes:

- an enclosure outline drawing
- a power elementary drawing
- a control elementary drawing
- an interconnection drawing
- a component layout drawing

## TERMINOLOGY

The following terminology is used throughout this instruction bulletin in reference to the Class 8839 58M drive controller family. This distinction is made to minimize confusion when discussing installation and adjustment practices.

- When used as a component of the Class 8839 58M drive controller, catalog numbers beginning with FLEX58 or ATV58H are referred to in this instruction bulletin as *power converters*.
- The combination of the power converter, the enclosure, and the power and control circuits that constitute the Class 8839 58M product is referred to as the *drive controller, the controller, or the adjustable frequency controller (AFC)*.

The following abbreviations are used throughout this instruction bulletin:

- CT for constant torque
- VT for variable torque

## PRECAUTIONS

### DANGER

#### HAZARDOUS VOLTAGE

Turn off all power supplying this equipment before working on it.

**Failure to follow this instruction will result in death or serious injury.**

Follow these precautions when installing Class 8839 58M drive controllers:

- The Type 1 and 1G controllers are suitable for installation in a Pollution Degree 2 environment as defined in NEMA ICS1 and IEC 60664-1. The Type 12 controller is suitable for installation in a Pollution Degree 3 environment as defined in NEMA ICS1 and IEC 60664-1. The expected environment must be compatible with this rating.
- When attaching wall-and floor mounted controllers to their mounting surfaces, use fasteners rated for the weight of the apparatus, the expected shock and vibration of the installation, and the expected environment.
- Provide sufficient cooling to maintain ambient temperature within the specified ratings in Tables 21–23 on pages 29–30.

## CONTROLLER NAMEPLATE IDENTIFICATION

The nameplate for the Class 8839 58M drive controller is located on the inside of the door. This nameplate, described in Figure 1, identifies the controller class, type, and modification (options) listing. When identifying or describing Class 8839 58M drive controllers, use the data from this nameplate.

Figure 1: Information Provided by the Drive Controller Nameplate

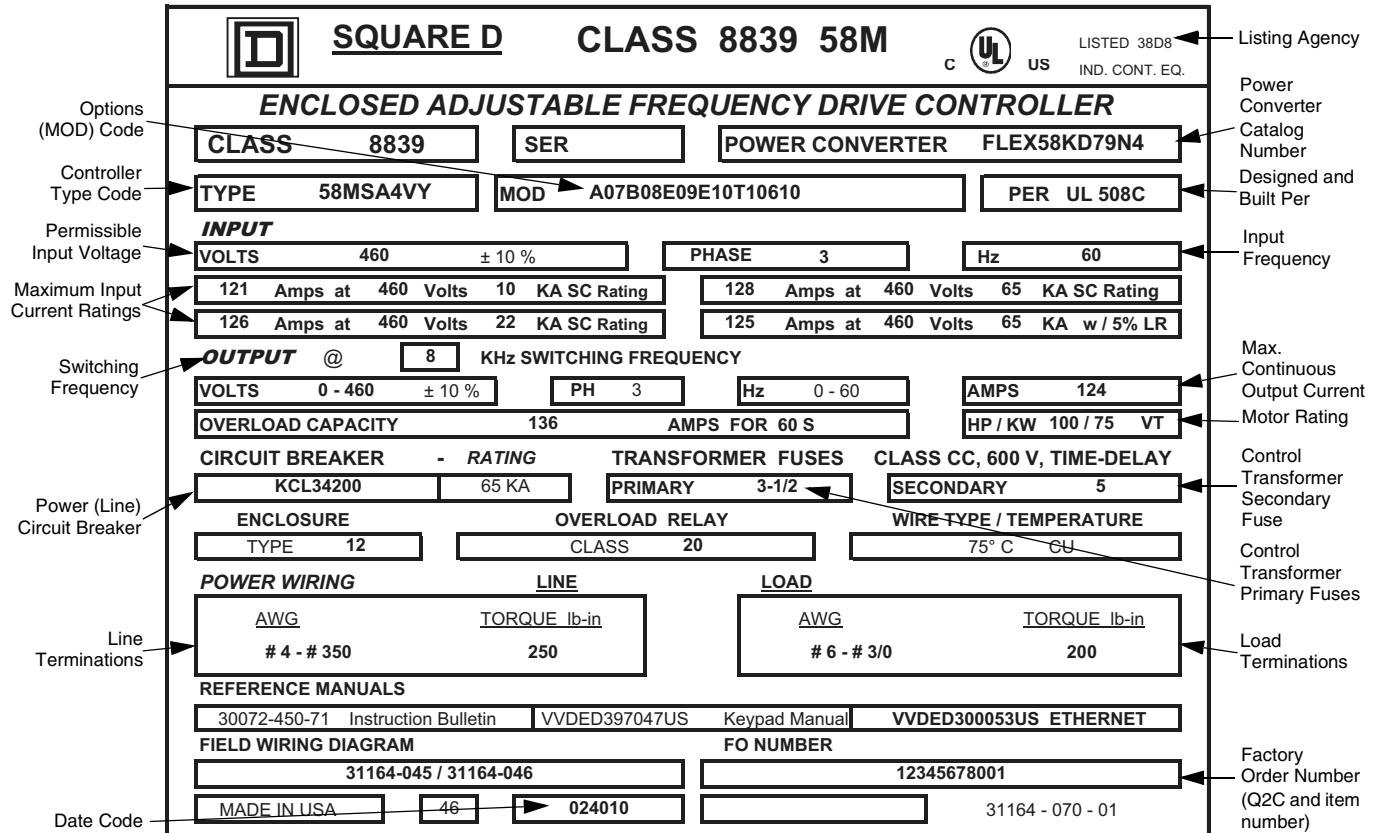

## CONTROLLER CATALOG NUMBERS

The controller catalog number, located on the nameplate on the inside of the door, is coded to describe the configuration and options present. Use the grid on pages 10–11 to translate the catalog number into a description of the drive controller.

### Class Type

8839	58M	.	.	.	.	.
		①	②	③	④	⑤

### Modifications

Control	Light	Card	Misc.
.	.	.	.
⑦	⑧	⑨	⑩

#### ① Product

Code	Drive Type
58M	ALTIVAR 58M Controller

#### ② Horsepower Code

Code	hp Rating	Code	hp Rating
C	1	Q	60 (460 V only)
D	2	R	75 (460 V only)
E	3	S	100 (460 V only, VT only)
F	5	T	125 (460 V only, VT only)
G	7.5	U	150 (460 V only, VT only)
H	10	W	200 (460 V only, VT only)
J	15	X	250 (460 V only, VT only)
K	20	Y	300 (460 V only, VT only)
L	25	Z	350 (460 V only, VT only)
M	30	4	400 (460 V only, VT only)
N	40	5	450 (460 V only, VT only)
P	50	6	500 (460 V only, VT only)

#### ③ Enclosure Type

Code	Environment Rating
A	Type 12
G	Type 1
B	Type 1G

#### ④ Voltage Rating

Code	Voltage
2	208 V
3	230 V
4	460 V

#### ⑤ Application Type

Code	Applied Rating
V	Variable Torque
C	Constant Torque

#### ⑥ Device Type

Code	Power Circuit
W <sup>[1]</sup>	Without Bypass
Y <sup>[2]</sup>	Bypass

- [1] Line contactor B10 is not compatible with this option.
- [2] Includes AFC/Off/Bypass switch and Test/Normal switch.
- [3] All controls are mutually exclusive. Select only one.
- [4] The Hand-Off-Auto switch can be set to the Off position for AFC fault reset.
- [5] Supplied as the default.
- [6] Control option C07 is not compatible with bypass or any light cluster except C08.
- [7] Only available without bypass.
- [8] Only available with a communication card. This option is the default control option supplied when a communication option is selected.
- [9] Light clusters are mutually exclusive. Select only one.
- [10] Not available with option C07 or D07.
- [11] Only available with bypass.
- [12] Light cluster B08 is not compatible without bypass.
- [13] Only available with option C07 and non-bypass.
- [14] Only available with option D07.
- [15] Only available with option A07, B07, or E07.
- [16] Only available with option F07.

- [17] Select only one option card.
- [18] Must use option F07 for control.
- [19] Provided with 24 V power supply. Mutually exclusive with option Z10.
- [20] Line contactor is not standard with bypass. It can be selected if bypass is also selected. Without bypass option B10, requires order engineering.
- [21] C10 is not compatible with C07, D07, or J10.
- [22] User must buy separate device to program the controller.
- [23] Smoke purge relay E10 permits the motor to run at full speed.
- [24] J10 is not compatible with C07, D07, or C10.
- [25] Available only when pilot lights are selected.
- [26] Not available on power on light.
- [27] Not available without bypass.
- [28] Not available with option B07, C07, or D07.
- [29] With options U10 and V10 you must select option 110.
- [30] Supplied with illuminated reset push button.
- [31] Not available with 1, 2, or 3 hp controllers. Not available with line reactor A10.

⑦ Control Option [3]

Code	AFC Controls	Code	AFC Controls
A07 [4], [5]	Hand/Off/Auto, Speed Potentiometer	D07 [7]	Stop/Start, Forward/Reverse, Speed Potentiometer
B07 [4]	Hand/Off/Auto, Start/Stop, Speed Potentiometer	E07 [4]	Hand/Off/Auto, Local/Remote, Speed Potentiometer
C07 [6], [7]	Start/Stop, Speed Potentiometer	F07 [8]	Communication/Auto/Off/Hand, Speed Potentiometer

⑧ Light Option [9]

Code	Light Cluster	Code	Light Cluster	Code	Light Cluster
A08 [10]	Red Power On	C08 [7], [13]	Red Power On	E08 [15]	Red Power On
	Green AFC Run		Green AFC Run		Green AFC Run
	Yellow AFC Fault		Yellow AFC Fault		Yellow AFC Fault
	Yellow Auto		Red Power On		Blue Hand
B08 [11], [12], [10]	Red Power On	D08 [7], [14]	Yellow AFC Fault	F08 [16]	Yellow Auto
	Green AFC Run		Green Run Forward		Red Power On
	Yellow AFC Fault		Green Run Reverse		Green AFC Run
	Yellow Bypass				Yellow AFC Fault
					Yellow Communication

⑨ Option Cards [17]

Code	Feature	Code	Feature
A09 [18]	Modbus Plus	E09 [18], [19]	LONWORKS Gateway
B09 [18]	Modbus / Unitelway	F09 [18]	DeviceNet
C09 [18]	Metasys N2	H09	Analog card: adds 1 additional analog output, 2 additional logic inputs, 1 additional logic output, and 1 differential analog input.
D09 [18]	Ethernet		

⑩ Miscellaneous Options

Code	Feature	Code	Feature
A10	Line Reactor nominal 5% impedance	R10 [27], [28]	Auto Transfer to Bypass
B10 [20]	Line Contactor	S10	Motor Elapsed Time Meter
C10 [21]	3–15 psi Transducer	T10 [10]	Emergency Stop
D10 [22]	Omit Keypad	U10 [29]	Motor Space Heater Sequencing
E10 [23]	Smoke Purge Relay	V10 [29]	Seal Water Solenoid
G10	cUL Listing	W10 [30]	Check Valve Sequencing
H10	Seismic Certification (Floor Mounted Enclosures)	Z10	24 Vdc Power Supply
J10 [24]	0–10 Vdc Auto Speed Reference	110 [29]	Additional Control Power VA
K10	Additional N.O. Auxiliary Drive Run Contact	310	Order engineered (internal use only)
L10	Additional N.C. Auxiliary Drive Fault Contact	410	RFI Suppressor
M10 [11]	1 N.O. Auxiliary Bypass Run Contact	510	Permanent Wire Marker Sleeves
O10 [10], [15]	1 N.O. Auxiliary Auto Mode Contact	610	I.D. Engraved Nameplates
P10 [13]	AFC Fault Reset	710 [31]	Harmonic Filter Provisions
Q10 [25], [26]	Push-To-Test Pilot Lights	910 [1], [11]	Barriered Bypass Enclosure

## TECHNICAL CHARACTERISTICS

### CLASS 8839 58M DRIVE CONTROLLER RATINGS

**Table 2: Constant Torque 460 V (4 kHz Switching Frequency)**

Drive Controller Catalog Number <sup>[1]</sup>	Motor Power <sup>[2]</sup> 460 V, 60 Hz (hp)	Max. Continuous <sup>[3]</sup> Output Current (A)	Max. Transient Output Current (60 s) (A)	Power Converter Catalog Number
58MC•4C_	1	2.1	2.3	FLEX58KU18N4
58MD•4C_	2	3.4	3.7	FLEX58KU29N4
58ME•4C_	3	4.8	5.3	FLEX58KU41N4
58MF•4C_	5	7.6	8.4	FLEX58KU72N4
58MG•4C_	7.5	11	12.1	FLEX58KU90N4
58MH•4C_	10	14	15.4	FLEX58KD12N4
58MJ•4C_	15	21	23.1	FLEX58KD16N4
58MK•4C_	20	27	29.7	FLEX58KD23N4
58ML•4C_	25	34	37.4	FLEX58KD28N4
58MM•4C_	30	40	44.0	FLEX58KD33N4
58MN•4C_	40	52	57.2	FLEX58KD46N4
58MP•4C_	50	65	71.5	FLEX58KD54N4
58MQ•4C_	60	77	84.7	FLEX58KD64N4
58MR•4C_	75	96	105.6	FLEX58KD79N4

*Notes to Tables 2 and 3:*

1. "•" can be "A" or "G". "A" denotes a Type 12 enclosure; "G" denotes a Type 1 enclosure.  
 "▼" can be "G" or "B". "G" denotes a Type 1 enclosure; "B" denotes a Type 1G enclosure.  
 "\_" indicates that the catalog number continues. See pages 10 and 11 for a detailed description of catalog numbers.
2. Power shown is for the carrier switching frequency shown. For a switching frequency above factory settings, select the next largest size drive controller. If the duty cycle does not exceed 60% (36 s maximum for a 60 s cycle) this is not necessary.
3. Continuous output current is based on NEC table 430-150. The Class 8839 58M controller nameplate rating is per the NEC table, **not** the current value listed in the ATV58 TRX instruction manual.

**Table 3: Variable Torque 460 V (1–100 hp @ 8 kHz; 125–500 hp @ 2 kHz Switching Frequency)**

Drive Controller Catalog Number <sup>[1]</sup>	Motor Power <sup>[2]</sup> 460 V, 60 Hz (hp)	Max. Continuous <sup>[3]</sup> Output Current (A)	Max. Transient Output Current (60 s) (A)	Power Converter Catalog Number
58MC•4V_	1	2.1	2.3	FLEX58KU18N4
58MD•4V_	2	3.4	3.7	FLEX58KU29N4
58ME•4V_	3	4.8	5.3	FLEX58KU41N4
58MF•4V_	5	7.6	8.4	FLEX58KU54N4
58MG•4V_	7.5	11	12.1	FLEX58KU72N4
58MH•4V_	10	14	15.4	FLEX58KU90N4
58MJ•4V_	15	21	23.1	FLEX58KD12N4
58MK•4V_	20	27	29.7	FLEX58KD16N4
58ML•4V_	25	34	37.4	FLEX58KD23N4
58MM•4V_	30	40	44.0	FLEX58KD28N4
58MN•4V_	40	52	57.2	FLEX58KD33N4
58MP•4V_	50	65	71.5	FLEX58KD46N4
58MQ•4V_	60	77	84.7	FLEX58KD54N4
58MR•4V_	75	96	105.6	FLEX58KD64N4
58MS•4V_	100	124	136.4	FLEX58KD79N4
58MT▼4V_	125	156	172	ATV58C10N4X
58MU▼4V_	150	180	198	ATV58C13N4X
58MW▼4V_	200	240	264	ATV58C15N4X
58MX▼4V_	250	302	332	ATV58C19N4X

**Table 3: Variable Torque 460 V (1–100 hp @ 8 kHz; 125–500 hp @ 2 kHz Switching Frequency) (continued)**

Drive Controller Catalog Number <sup>[1]</sup>	Motor Power <sup>[2]</sup> 460 V, 60 Hz (hp)	Max. Continuous <sup>[3]</sup> Output Current (A)	Max. Transient Output Current (60 s) (A)	Power Converter Catalog Number
58MY▼4V_	300	361	397	ATV58C23N4X
58MZ▼4V_	350	414	455	ATV58C25N4X
58M4▼4V_	400	477	525	ATV58C28N4X
58M5▼4V_	450	515	567	ATV58C31N4X
58M6▼4V_	500	590	649	ATV58C33N4X

**Table 4: Constant Torque 230 V (4 kHz Switching Frequency)**

Drive Controller Catalog Number <sup>[1]</sup>	Motor Power <sup>[2]</sup> 230 V, 60 Hz (hp)	Max. Continuous <sup>[3]</sup> Output Current (A)	Max. Transient Output Current (60 s) (A)	Power Converter Catalog Number
58MC•3C_	1	4.2	4.6	FLEX58U29M2
58MD•3C_	2	6.8	7.5	FLEX58U29M2
58ME•3C_	3	9.6	10.5	FLEX58U41M2
58MF•3C_	5	15.2	16.7	FLEX58U72M2
58MG•3C_	7.5	22	24.2	FLEX58U90M2
58MH•3C_	10	28	30.8	FLEX58D12M2
58MJ•3C_	15	42	46.2	FLEX58D16M2
58MK•3C_	20	54	59.4	FLEX58D23M2
58ML•3C_	25	68	74.8	FLEX58D28M2
58MM•3C_	30	80	88	FLEX58D33M2
58MN•3C_	40	104	114.4	FLEX58D46M2

*Notes to Tables 4 and 5:*

1. “\*” can be “A” or “G”. “A” denotes a Type 12 enclosure; “G” denotes a Type 1 enclosure. “\_” indicates that the catalog number continues. See pages 10 and 11 for a detailed description of catalog numbers.
2. Power shown is for the carrier switching frequency shown. For a switching frequency above factory settings, select the next largest size drive controller. If the duty cycle does not exceed 60% (36 s maximum for a 60 s cycle) this is not necessary.
3. Continuous output current is based on NEC table 430-150. The Class 8839 58M controller nameplate rating is per the NEC table, **not** the current value listed in the ATV58 TRX instruction manual.

**Table 5: Variable Torque 230 V (8 kHz Switching Frequency)**

Drive Controller Catalog Number <sup>[1]</sup>	Motor Power <sup>[2]</sup> 230 V, 60 Hz (hp)	Max. Continuous <sup>[3]</sup> Output Current (A)	Max. Transient Output Current (60 s) (A)	Power Converter Catalog Number
58MC•3V_	1	4.2	4.6	FLEX58U29M2
58MD•3V_	2	6.8	7.5	FLEX58U29M2
58ME•3V_	3	9.6	10.5	FLEX58U41M2
58MF•3V_	5	15.2	16.7	FLEX58U72M2
58MG•3V_	7.5	22	24.2	FLEX58U90M2
58MH•3V_	10	28	30.8	FLEX58D12M2
58MJ•3V_	15	42	46.2	FLEX58D16M2
58MK•3V_	20	54	59.4	FLEX58D16M2
58ML•3V_	25	68	74.8	FLEX58D23M2
58MM•3V_	30	80	88	FLEX58D28M2
58MN•3V_	40	104	114.4	FLEX58D33M2
58MP•3V_	50	130	143	FLEX58D46M2

**Table 6: Constant Torque 208 V (4 kHz Switching Frequency)**

Drive Controller Catalog Number <sup>[1]</sup>	Motor Power <sup>[2]</sup> 208 V, 60 Hz (hp)	Max. Continuous <sup>[3]</sup> Output Current (A)	Max. Transient Output Current (60 s) (A)	Power Converter Catalog Number
58MC•2C_	1	4.6	5.1	FLEX58U29M2
58MD•2C_	2	7.5	8.3	FLEX58U29M2
58ME•2C_	3	10.6	11.7	FLEX58U41M2
58MF•2C_	5	16.7	18.4	FLEX58U72M2
58MG•2C_	7.5	24.2	26.6	FLEX58U90M2
58MH•2C_	10	30.8	33.9	FLEX58D12M2
58MJ•2C_	15	46.2	50.8	FLEX58D16M2
58MK•2C_	20	59.4	65.3	FLEX58D23M2
58ML•2C_	25	74.8	82.3	FLEX58D28M2
58MM•2C_	30	88.0	96.8	FLEX58D33M2
58MN•2C_	40	114	125.4	FLEX58D46M2

*Notes to Tables 6 and 7:*

1. “•” can be “A” or “G”. “A” denotes a Type 12 enclosure; “G” denotes a Type 1 enclosure.  
 “\_” indicates that the catalog number continues. See pages 10 and 11 for a detailed description of catalog numbers.
2. Power shown is for the carrier switching frequency shown. For a switching frequency above factory settings, select the next largest size drive controller. If the duty cycle does not exceed 60% (36 s maximum for a 60 s cycle) this is not necessary.
3. Continuous output current is based on NEC table 430-150. The Class 8839 58M controller nameplate rating is per the NEC table, **not** the current value listed in the ATV58 TRX instruction manual.

**Table 7: Variable Torque 208 V (8 kHz Switching Frequency)**

Drive Controller Catalog Number <sup>[1]</sup>	Motor Power <sup>[2]</sup> 208 V, 60 Hz (hp)	Max. Continuous <sup>[3]</sup> Output Current (A)	Max. Transient Output Current (60 s) (A)	Power Converter Catalog Number
58MC•2V_	1	4.6	5.1	FLEX58U29M2
58MD•2V_	2	7.5	8.3	FLEX58U29M2
58ME•2V_	3	10.6	11.7	FLEX58U41M2
58MF•2V_	5	16.7	18.4	FLEX58U72M2
58MG•2V_	7.5	24.2	26.6	FLEX58U90M2
58MH•2V_	10	30.8	33.9	FLEX58D12M2
58MJ•2V_	15	46.2	50.8	FLEX58D16M2
58MK•2V_	20	59.4	65.3	FLEX58D16M2
58ML•2V_	25	74.8	82.3	FLEX58D23M2
58MM•2V_	30	88	96.8	FLEX58D28M2
58MN•2V_	40	114	125.4	FLEX58D33M2
58MP•2V_	50	143	157.3	FLEX58D46M2

## INPUT CURRENT RATINGS

All branch circuit components and equipment such as feeder cables, disconnect devices, and protective devices must be rated for the highest input current, usually the input current of the drive controller, not the motor full load current. The input current is printed on the nameplate (see Figure 1 on page 9). The branch circuit feeder protection must be sized according to NEC Article 430-2.

Line reactors can be used to add reactance to the branch circuit, minimize drive controller input line current, reduce controller nuisance tripping due to transient overvoltage, reduce harmonic distortion, and improve phase-to-phase voltage imbalance. If line reactors are used:

- In systems that use bypass contactors, the line reactor should only be connected between the breaker load terminals in the controller and the power converter. A line reactor in a bypass motor starting circuit will reduce the motor's ability to produce starting torque.
- The voltage tolerance at the input of the reactor will be different from that of the drive controller due to the voltage drop across the line reactor. Voltage tolerance measured at the input terminals of the drive controller will be as specified on pages 16–19.

The input line current ratings listed in Tables 8–14 are based upon short circuit UL-coordinated ratings. To calculate the necessary minimum line inductance, use the formula shown below to verify the selection of the minimum reactor impedance needed for installation.

$$L = \frac{V_{L-L} \times \%Z \times 10}{I_{fund} \times \sqrt{3} \times 2\pi \times f}$$

where:

L = inductance, in millihenries (mH)

$V_{L-L}$  = input voltage measured line-to-line (utilization voltage)

%Z = desired input impedance rating

$I_{fund}$  = desired output current rating

f = fundamental line frequency (50 or 60 Hz)

For example, for a 7.5 hp, 11 A at 460 V/60 Hz motor in combination with a Class 8839 Type 58MGG4VW (7.5 hp @ 460 V, 11 FLA) drive controller, calculate the minimum inductance of a nominal 3% reactor as follows:

$V_{L-L}$  = 460 V (utilization voltage)

%Z = 3 (3% rated line reactor)

$I_{fund}$  = 11 A (output current rating)

f = 60 Hz (fundamental line frequency)

$$L = \frac{460 \times 3 \times 10}{11 \times \sqrt{3} \times 2\pi \times 60} = 1.9213 \text{ mH}$$

Thus, select a line reactor that has a minimum inductance rating (per phase) greater than or equal to 1.9213 mH.

**Table 8: Input Line Currents for Selection of Branch Circuit Feeders for 460 V, CT <sup>[1]</sup>**

Drive Controller Catalog Number <sup>[2]</sup>	Motor Power 460 V 60 Hz (hp)	Rated Output Current	Short-Circuit Current Rating							
			5,000 A		10,000 A		22,000 A		65,000 A	
			without reactor option	with 5% reactor option	without reactor option	with 5% reactor option	without reactor option	with 5% reactor option	without reactor option	with 5% reactor option
58MC•4C_	1	2.1	2.8	1.9	2.9	1.9	3.1	1.9	3.1	1.9
58MD•4C_	2	3.4	4.8	3.3	5.0	3.3	5.3	3.3	5.3	3.3
58ME•4C_	3	4.8	6.5	4.4	6.9	4.4	7.7	4.4	7.7	4.4
58MF•4C_	5	7.6	9.9	6.5	10.4	6.5	11.7	6.5	12.1	6.5
58MG•4C_	7.5	11	14.0	9.6	15.2	9.6	16.6	9.6	17.3	9.6
58MH•4C_	10	14	18.0	12.9	20.1	12.9	21.8	13.0	23.3	13.0
58MJ•4C_	15	21	25.1	18.6	26.8	18.6	30.1	18.7	32.2	18.7
58MK•4C_	20	27	31.9	24.3	33.4	24.3	38	24.4	41.2	24.4
58ML•4C_	25	34	32.9	29.7	34.3	29.7	35.2	29.8	35.4	29.8
58MM•4C_	30	40	38.3	35.1	39.2	35.1	41.4	35.1	41.8	35.1
58MN•4C_	40	52	50.4	46.9	52.8	46.9	55.4	46.9	56.1	46.9
58MP•4C_	50	65	61	57.6	63.4	57.6	67.7	57.9	68.8	58.0
58MQ•4C_	60	77	—	—	79.2	68.8	82.6	68.8	84.4	68.8
58MR•4C_	75	96	—	—	96.7	86.1	102.8	86.3	105.6	86.5

1. Select a conductor based on the input line current. Input line currents are based on the source impedance capable of providing the listed amperage levels.
2. “•” can be “A” or “G”. “A” denotes a Type 12 enclosure; “G” denotes a Type 1 enclosure.  
 “\_” indicates that the catalog number continues. See pages 10 and 11 for a detailed description of catalog numbers.

**Table 9: Input Line Currents for Selection of Branch Circuit Feeders for 1–100 hp, 460 V, VT <sup>[1]</sup>**

Drive Controller Catalog Number <sup>[2]</sup>	Motor Power 460 V 60 Hz (hp)	Rated Output Current	Short-Circuit Current Rating							
			5,000 A		10,000 A		22,000 A		65,000 A	
			without reactor option	with 5% reactor option	without reactor option	with 5% reactor option	without reactor option	with 5% reactor option	without reactor option	with 5% reactor option
58MC•4V_	1	2.1	2.7	1.9	2.9	1.9	3.1	1.9	3.1	1.9
58MD•4V_	2	3.4	4.8	3.3	5.0	3.3	5.3	3.3	5.3	3.3
58ME•4V_	3	4.8	6.5	4.4	6.9	4.4	7.7	4.4	7.7	4.4
58MF•4V_	5	7.6	9.9	6.5	10.4	6.5	11.7	6.5	12.1	6.5
58MG•4V_	7.5	11	14.1	9.6	15.3	9.6	16.7	9.6	17	9.6
58MH•4V_	10	14	17.8	12.9	19.9	12.9	21.1	13.0	21.7	13.0
58MJ•4V_	15	21	25.5	18.7	27.1	18.7	31.2	18.7	32.5	18.7
58MK•4V_	20	27	32.2	24.3	33.7	24.3	38.6	24.4	40.6	24.4
58ML•4V_	25	34	38.6	30.4	39.3	30.5	46	30.6	49.3	30.7
58MM•4V_	30	40	38.1	35.2	39.0	35.2	40.8	35.3	41.5	35.3
58MN•4V_	40	52	49.4	46.9	51.2	46.9	52.4	46.9	53.5	46.9
58MP•4V_	50	65	60.6	57.7	62.3	57.8	65.9	57.9	67.8	58.0
58MQ•4V_	60	77	—	—	74.9	69.1	78.1	69.1	81	69.2
58MR•4V_	75	96	—	—	94.8	86.1	101.2	86.3	103.5	86.3
58MS•4V_	100	124	—	—	123	114.9	131.3	115.2	137.1	115.5

1. Select a conductor based on the input line current. Input line currents are based on the source impedance capable of providing the listed amperage levels.
2. “•” can be “A” or “G”. “A” denotes a Type 12 enclosure; “G” denotes a Type 1 enclosure.  
 “\_” indicates that the catalog number continues. See pages 10 and 11 for a detailed description of catalog numbers.

**Table 10: Input Line Currents for Selection of Branch Circuit Feeders for 125–500 hp, 460 V, VT [1]**

Drive Controller Catalog Number [2]	Motor Power 460 V 60 Hz (hp)	Rated Output Current	Short-Circuit Current Rating				
			UL Minimum 1.5% std. reactor [3]	65,000 A		100,000 A	
				with standard 1.5% reactor	with 5% reactor option	with standard 1.5% reactor	with 5% reactor option
58MT▼4V_	125	156	143^	155	137	157	138
58MU▼4V_	150	180	167^	186	160	189	160
58MW▼4V_	200	240	222^	245	220	249	220
58MX▼4V_	250	302	282+	300	274	305	273
58MY▼4V_	300	361	327+	339	317	344	318
58MZ▼4V_	350	414	390+	406	379	413	380
58M4▼4V_	400	477	437+	454	429	459	428
58M5▼4V_	450	515	500~	516	493	524	492
58M6▼4V_	500	590	553~	568	543	574	543

1. Select a conductor based on the input line current. Input line currents are based on the source impedance capable of providing the listed amperage levels.
2. "▼" can be "G" or "B". "G" denotes a Type 1 enclosure; "B" denotes a Type 1G enclosure.  
"\_" indicates that the catalog number continues. See pages 10 and 11 for a detailed description of catalog numbers.
3. "^" indicates 10,000 A available short-circuit current. "+" indicates 18,000 A available short-circuit current. "~" indicates 30,000 A available short-circuit current.

**Table 11: Input Line Currents for Selection of Branch Circuit Feeders for 230 V, CT [1]**

Drive Controller Catalog Number [2]	Motor Power 230 V 60 Hz (hp)	Rated Output Current	Short-Circuit Current Rating							
			5,000 A		10,000 A		22,000 A		65,000 A	
			without reactor option	with 5% reactor option	without reactor option	with 5% reactor option	without reactor option	with 5% reactor option	without reactor option	with 5% reactor option
58MC*3C_	1	4.2	4.9	3.2	5.1	3.2	5.7	3.2	5.9	3.2
58MD*3C_	2	6.8	8.5	5.6	8.9	5.6	9.8	5.6	10.0	5.6
58ME*3C_	3	9.6	11.8	8.0	12.3	8.0	13.5	8.0	13.8	8.0
58MF*3C_	5	15.2	18.0	13.2	19.4	13.2	20.6	13.3	21.0	13.3
58MG*3C_	7.5	22	25.2	19.1	26.8	19.1	28.7	19.2	29.1	19.2
58MH*3C_	10	28	32.0	25.5	34.2	25.6	36.1	25.8	36.7	25.8
58MJ*3C_	15	42	38.4	37.9	38.6	37.9	39	37.9	39.2	37.9
58MK*3C_	20	54	50.4	49.2	50.8	49.2	51.5	49.2	51.9	49.4
58ML*3C_	25	68	61.8	60.6	62.2	60.6	62.9	60.6	63.3	60.6
58MM*3C_	30	80	73.2	71.5	75.1	71.5	76.7	71.7	78.1	71.8
58MN*3C_	40	104	96.8	95.6	97.8	95.6	101.2	95.6	103.2	95.6

1. Select a conductor based on the input line current. Input line currents are based on the source impedance capable of providing the listed amperage levels.
2. "\*" can be "A" or "G". "A" denotes a Type 12 enclosure; "G" denotes a Type 1 enclosure.  
"\_" indicates that the catalog number continues. See pages 10 and 11 for a detailed description of catalog numbers.

**Table 12: Input Line Currents for Selection of Branch Circuit Feeders for 230 V, VT <sup>[1]</sup>**

Drive Controller Catalog Number <sup>[2]</sup>	Motor Power 230 V 60 Hz (hp)	Rated Output Current	Short-Circuit Current Rating							
			5,000 A		10,000 A		22,000 A		65,000 A	
			without reactor option	with 5% reactor option	without reactor option	with 5% reactor option	without reactor option	with 5% reactor option	without reactor option	with 5% reactor option
58MC•3V_	1	4.2	4.9	3.2	5.2	3.2	5.7	3.2	5.9	3.2
58MD•3V_	2	6.8	8.5	5.6	9.1	5.6	9.8	5.6	10.0	5.6
58ME•3V_	3	9.6	11.8	8.0	12.2	8.0	13.5	8.0	13.8	8.0
58MF•3V_	5	15.2	17.8	13.9	18.4	13.9	20.5	14.0	20.9	14.0
58MG•3V_	7.5	22	25.2	19.1	27.1	19.1	28.6	19.1	29.0	19.1
58MH•3V_	10	28	31.9	25.5	33.4	25.6	36.0	25.7	36.6	25.7
58MJ•3V_	15	42	37.9	37.3	38.2	37.3	38.5	37.3	38.7	37.3
58MK•3V_	20	54	49.3	48.9	49.4	48.9	49.8	48.9	50.0	48.9
58ML•3V_	25	68	61.2	60.6	61.7	60.6	62.2	60.6	62.4	60.6
58MM•3V_	30	80	71.8	71.3	72.3	71.3	73.1	71.3	73.5	71.3
58MN•3V_	40	104	95.7	94.9	96.8	94.9	98.5	94.9	99.8	94.9
58MP•3V_	50	130	117.6	117.0	119.2	117.0	121.3	117.0	123.2	117.0

1. Select a conductor based on the input line current. Input line currents are based on the source impedance capable of providing the listed amperage levels.
2. “\*” can be “A” or “G”. “A” denotes a Type 12 enclosure; “G” denotes a Type 1 enclosure.  
 “\_” indicates that the catalog number continues. See pages 10 and 11 for a detailed description of catalog numbers.

**Table 13: Input Line Currents for Selection of Branch Circuit Feeders for 208 V, CT <sup>[1]</sup>**

Drive Controller Catalog Number <sup>[2]</sup>	Motor Power 208 V 60 Hz (hp)	Rated Output Current	Short-Circuit Current Rating							
			5,000 A		10,000 A		22,000 A		65,000 A	
			without reactor option	with 5% reactor option	without reactor option	with 5% reactor option	without reactor option	with 5% reactor option	without reactor option	with 5% reactor option
58MC•2C_	1	4.6	5.6	3.5	6.0	3.5	6.4	3.6	6.5	3.6
58MD•2C_	2	7.5	9.7	6.4	10.3	6.4	11.0	6.4	11.0	6.4
58ME•2C_	3	10.6	13.4	9.3	13.8	9.3	15.1	9.3	15.2	9.3
58MF•2C_	5	16.7	20.4	15.0	21.2	15.0	23.1	15.0	23.1	15.0
58MG•2C_	7.5	24.2	28.6	21.9	29.4	21.9	32.0	21.9	32.1	21.9
58MH•2C_	10	30.8	36.3	29.1	37.8	29.2	40.2	29.3	40.5	29.3
58MJ•2C_	15	46.2	43.7	43.6	43.8	43.6	44.1	43.6	44.2	43.6
58MK•2C_	20	59.4	57.2	57.0	57.6	57.0	58.0	57.0	58.2	57.0
58ML•2C_	25	74.8	70.1	70.1	70.3	70.1	71.0	70.1	71.3	70.1
58MM•2C_	30	88	83.4	82.2	84.2	82.2	85.8	82.2	87.0	82.2
58MN•2C_	40	114	110.5	110.5	111.3	110.5	113.6	110.5	115.0	110.5

1. Select a conductor based on the input line current. Input line currents are based on the source impedance capable of providing the listed amperage levels.
2. “\*” can be “A” or “G”. “A” denotes a Type 12 enclosure; “G” denotes a Type 1 enclosure.  
 “\_” indicates that the catalog number continues. See pages 10 and 11 for a detailed description of catalog numbers.

**Table 14: Input Line Currents for Selection of Branch Circuit Feeders for 208 V, VT <sup>[1]</sup>**

Drive Controller Catalog Number <sup>[2]</sup>	Motor Power 208 V 60 Hz (hp)	Rated Output Current	Short-Circuit Current Rating							
			5,000 A		10,000 A		22,000 A		65,000 A	
			without reactor option	with 5% reactor option	without reactor option	with 5% reactor option	without reactor option	with 5% reactor option	without reactor option	with 5% reactor option
58MC•2V_	1	4.6	5.9	3.5	6.1	3.5	6.4	3.6	6.5	3.6
58MD•2V_	2	7.5	9.7	6.4	10.2	6.4	11.0	6.4	11.0	6.4
58ME•2V_	3	10.6	13.0	9.3	13.8	9.3	15.1	9.3	15.2	9.3
58MF•2V_	5	16.7	20.2	14.9	21.2	14.9	22.9	14.9	23.0	14.9
58MG•2V_	7.5	24.2	28.5	21.9	29.2	21.9	31.9	21.9	32.1	21.9
58MH•2V_	10	30.8	36.2	29.0	37.3	29.0	40.1	29.2	40.3	29.2
58MJ•2V_	15	46.2	43.1	43.0	43.2	43.0	43.5	43.0	43.6	43.0
58MK•2V_	20	59.4	56.4	56.6	56.5	56.6	56.7	56.6	56.8	56.6
58ML•2V_	25	74.8	69.9	70.2	70.1	70.2	70.5	70.2	70.8	70.2
58MM•2V_	30	88	82.1	82.5	82.4	82.5	82.9	82.5	83.2	82.5
58MN•2V_	40	114	109.4	109.8	110.5	109.8	111.3	109.8	112.2	109.8
58MP•2V_	50	143	134.0	136.2	136.1	136.2	137.3	136.2	138.5	136.2

1. Select a conductor based on the input line current. Input line currents are based on the source impedance capable of providing the listed amperage levels.
2. “•” can be “A” or “G”. “A” denotes a Type 12 enclosure; “G” denotes a Type 1 enclosure.  
“\_” indicates that the catalog number continues. See pages 10 and 11 for a detailed description of catalog numbers.

**SPECIFICATIONS**

**Table 15: Specifications for Drive Controllers**

Input voltage	460 V ±10%, 230 V ±10%, 208 V ±10%
Displacement power factor	98% through speed range
Input frequency	60 Hz ± 5%
Output voltage	Three-phase output Maximum voltage equal to input voltage
Galvanic isolation	Galvanic isolation between power and control (inputs, outputs, and power supplies)
Frequency range of power converter	0.1 to 500 Hz (factory setting of 60 Hz)
Torque/overtorque	110% of nominal motor torque for 60 s (VT) 150% of nominal motor torque for 60 s (CT)
Current	110% of controller rated current for 60 s
Switching frequency	Selectable from 0.5 to 16 kHz <sup>[1]</sup> Factory setting: 4 kHz CT, 8 kHz for 208 V, 230 V, and 1–100 hp @ 460 V VT 2 kHz for 125–500 hp @ 460 V VT
Speed reference	AI1: 0 to +10 V, Impedance = 30 kΩ Speed potentiometer to AI1, 1–10 kΩ AI2: factory setting: 4 to 20 mA, Impedance = 100 Ω (reassignable, X–Y range with keypad display). Factory modification J10 provides a controller interface 0–10 Vdc reference signal to the AI2 input using a 0–10 V / 4–20 mA converter with Z= 40 kΩ.
Frequency resolution in analog reference	0.1 for 100 Hz (10 bits)
Speed regulation	V/f: determined by motor slip, typically 3% Sensorless flux vector (SLFV): 1%

1. On 1–75 hp CT and 1–100 hp VT controllers, above 4 kHz CT/8 kHz VT, select the next largest size drive controller. If the duty cycle does not exceed 60% (36 s maximum for a 60 s cycle), this is not necessary.
2. Class 10 electromechanical for 1 hp @ 460 V.

**Table 15: Specifications for Drive Controllers** *(continued)*

Efficiency	97% at full load typical
Reference sample time	5 ms
Acceleration and deceleration ramps	0.1 to 999.9 s (definition in 0.1 s increments)
Drive controller protection	<ul style="list-style-type: none"> <li>• Thermal protection of transformer, rectifier, and power converter</li> <li>• Phase loss of AC mains</li> <li>• Circuit breaker rated at 65 kAIC</li> </ul>
Motor protection	Class 10 electronic overload protection Class 20 electromechanical overload protection with bypass <sup>[2]</sup>
Keypad display	Self diagnostics with fault messages in three languages; also refer to instruction bulletin VVDED397047US
Temperature	Storage for all enclosures: -13 to +149 °F (-25 to +65 °C) Operation: +14 to +104 °F (-10 to 40 °C)
Humidity	95% with no condensation or dripping water, conforming to IEC 60068-2-3.
Altitude	3,300 ft (1000 m) maximum without derating; derating of the current by 1% for each additional 330 ft (100 m)
Enclosure	Type 1: all controllers Type 1G: 125–500 hp @ 460 V VT only Type 12 : all except 125–500 hp @ 460 V VT
Pollution degree	Type 1, 1G: Pollution degree 2 per NEMA ICS-1 Annex A and IEC 60664-1 Type 12: Pollution degree 3 per NEMA ICS-1 and IEC 60664-1
Operational test vibration	Conforming to IEC 60721-3-3-3M3 amplitude 1.5 mm peak to peak from 3 to 13 Hz 1 g from 13 to 200 Hz
Transit test to shock	Conforming to National Safe Transit Association and International Safe Transit Association test for packages.
Operational shock	15 g, 11 ms
Codes and standards	UL Listed per UL 508C under category NMMS. Conforms to applicable NEMA ICS, NFPA, and IEC standards. Manufactured under ISO 9001 standards. Factory modification G10 provides Canadian cUL certification.

1. On 1–75 hp CT and 1–100 hp VT controllers, above 4 kHz CT/8 kHz VT, select the next largest size drive controller. If the duty cycle does not exceed 60% (36 s maximum for a 60 s cycle), this is not necessary.
2. Class 10 electromechanical for 1 hp @ 460 V.

## STANDARD FEATURES

The following are standard for controllers without bypass when no options are ordered:

- Circuit breaker disconnect
- Only controllers less than 125 hp are rated for constant torque (CT) applications
- UL Listed per UL 508C
- 65,000 A short-circuit current rating on 100 hp controllers and less, 100,000 A short-circuit current rating on controllers 125 hp and greater
- Heavy duty industrial disconnect handle with lockout/tag-out provisions
- Hand-Off-Auto selector switch and manual speed potentiometer
- Door mounted keypad display
- Auto start relay (115-volt control)
- One Form C AFC run mode contact
- One Form C AFC fault contact
- Remote fault condition reset in Auto mode with transition of auto start contact
- Manual fault condition reset in Off position of H-O-A selector switch
- Safety interlock/run permissive wired to user terminal block TB1
- Permanent wire markers
- White component mounting plate
- Conduit knockouts on wall mounted enclosures
- Removable conduit entry plates on floor mount enclosures
- ANSI 49 dark gray enclosure
- Class 10 electronic overload protection

The following are standard for controllers with bypass when no options are ordered:

- Circuit breaker disconnect
- Only controllers less than 125 hp are rated for constant torque (CT) applications
- UL Listed per UL 508C
- 65,000 A short-circuit current rating on 100 hp controllers and less, 100,000 A short-circuit current rating on controllers 125 hp and greater
- Heavy duty industrial disconnect handle with lockout/tag-out provisions
- Hand-Off-Auto selector switch and manual speed potentiometer
- Door mounted keypad display
- Auto start relay (115-volt control)
- One Form C AFC run mode contact
- One Form C AFC fault contact
- Remote fault condition reset in Auto mode with transition of auto start contact
- Manual fault condition reset in Off position of H-O-A selector switch
- Safety interlock/run permissive wired to user terminal block TB1
- Permanent wire markers
- White component mounting plate
- Conduit knockouts on wall mounted enclosures
- Removable conduit entry plates on floor mount enclosures
- ANSI 49 dark gray enclosure
- Class 20 overload protection with door mounted reset

- AFC-Off-Bypass selector switch
- Test-Normal selector switch
- Isolation and bypass contactors (with mechanical and electrical interlocking)
- Bypass and isolation contactor sequencing for true motor isolation
- Remote automatic bypass operation using Auto Start relay

## FACTORY MODIFICATIONS

### POWER OPTIONS

**Table 16: Parts List for Bypass Circuit Selector Switches**

Selector Switch	Part No.	Description
Test-Normal Selector Switch	ZB5AD2	Two-position selector switch
	ZB5AZ009	Mounting collar
	ZBE204	Additional contact block (2 N.C.)
	ZBE101	Additional contact block (1 N.O.)
	65170-166-72	Engraved legend plate, "Test-Normal"
	ZBZ32	Legend plate holder
AFC-Off-Bypass Selector Switch	ZB5AD3	Three-position selector switch
	ZB5AZ103	Mounting collar with contact block (2 N.O.)
	65170-166-43	Engraved legend plate "AFC-Off-Bypass"
	ZBZ32	Legend plate holder

### CONTROL OPTIONS

**Table 17: Control Options**

Control Option	Description	Parts List
A07	Hand-Off-Auto Selector Switch	ZB5AD3 Three-position selector switch ZB5AZ009 Mounting collar (2) ZBE205 Contact blocks (1 N.C. and 1 N.O.) 65170-166-17 Hand-Off-Auto legend plate ZBZ32 Legend plate holder
	Speed Potentiometer	31 158-050-50 Potentiometer ZB5AD922 Potentiometer operator 65170-166-44 Legend plate ZBZ32 Legend plate holder
B07	Hand-Off-Auto Selector Switch	ZB5AD3 Three-position selector switch ZB5AZ009 Mounting collar (2) ZBE205 Contact blocks (1 N.C. and 1 N.O.) 65170-166-17 Hand-Off-Auto legend plate ZBZ32 Legend plate holder
	Stop/Start Push Buttons	ZB5AA2 Black push button ZB5AA4 Red push button ZB5AZ101 Mounting collar w/ contact block (1 N.O.) ZB5AZ102 Mounting collar w/ contact block (1 N.C.) 65170-166-31 Start legend plate 65170-166-09 Stop legend plate (2) ZBZ32 Legend plate holders
	Speed Potentiometer	31 158-050-50 Potentiometer ZB5AD922 Potentiometer operator 65170-166-44 Legend plate ZBZ32 Legend plate holder

*NOTE: Refer to the notes on pages 10 and 11 for rules governing component selection.*

**Table 17: Control Options** *(continued)*

Control Option	Description	Parts List
C07	Stop/Start Push Buttons	ZB5AA2 Black push button ZB5AA4 Red push button ZB5AZ101 Mounting collar w/ contact block (1 N.O.) ZB5AZ102 Mounting collar w/ contact block (1 N.C.) 65170-166-31 Start legend plate 65170-166-09 Stop legend plate (2) ZBZ32 Legend plate holders
	Speed Potentiometer	31 158-050-50 Potentiometer ZB5AD922 Potentiometer operator 65170-166-44 Legend plate ZBZ32 Legend plate holder
D07	Stop/Start Push Buttons	ZB5AA2 Black push button ZB5AA4 Red push button ZB5AZ101 Mounting collar w/ contact block (1 N.O.) ZB5AZ102 Mounting collar w/ contact block (1 N.C.) 65170-166-31 Start legend plate 65170-166-09 Stop legend plate (2) ZBZ32 Legend plate holders
	Forward/Reverse Selector Switch	ZB5AD2 Two-position selector switch ZBE203 Contact block (2 N.O.) ZBE204 Contact block (2 N.C.) ZB5AZ009 Mounting collar 65170-166-45 Forward/Reverse legend plate ZBZ32 Legend plate holder
	Speed Potentiometer	31 158-050-50 Potentiometer ZB5AD922 Potentiometer operator 65170-166-44 Legend plate ZBZ32 Legend plate holder
E07	Hand-Off-Auto Selector Switch	ZB5AD3 Three-position selector switch ZB5AZ009 Mounting collar (2) ZBE205 Contact blocks (1 N.C. and 1 N.O.) 65170-166-17 Hand-Off-Auto legend plate ZBZ32 Legend plate holder
	Local/Remote Selector Switch	ZB5AD2 Two-position selector switch ZB5AZ101 Mounting collar w/ contact block (1 N.O.) 65170-166-80 Local/Remote legend plate ZBZ32 Legend plate holder
	Speed Potentiometer	31 158-050-50 Potentiometer ZB5AD922 Potentiometer operator 65170-166-44 Legend plate ZBZ32 Legend plate holder
F07	Communication-Auto-Off-Hand Selector Switch	KAXZ1M12 Operator handle 9003K2H0285USX Contact block assembly 65170-170-41 A-O-H legend plate 31164-098-01 Comms label ZA2BZ32 Legend plate holder
	Speed Potentiometer	31 158-050-50 Potentiometer ZB5AD922 Potentiometer operator 65170-166-44 Legend plate ZBZ32 Legend plate holder

**LIGHT OPTIONS**

**Table 18: Light Options**

*NOTE: Refer to the notes on pages 10 and 11 for rules governing component selection.*

*Notes for Table 18:*

- For the push-to-test feature, the following pilot light operators are used:  
ZB5AW35 replaces ZB5AV05  
ZB5AW33 replaces ZB5AV03  
ZB5AW36 replaces ZB5AV06
- For the push-to-test feature, ZB5AW065 (mounting collar w/ light module and 1 N.O. and 1 N.C. contact) replaces ZB5AV6 (mounting collar w/ light module).

Light Option	Description	Parts List
<b>A08</b> Pilot Light Cluster Option #1	Red Power On	ZB5AV04 Red pilot light head ZB5AV6 Mounting collar with light module 25501-00003 LED 65170-166-24 Power On legend plate ZBZ32 Legend plate holder
	Green AFC Run	ZB5AV03 Green pilot light head <sup>[1]</sup> ZB5AV6 Mounting collar with light module <sup>[2]</sup> 25501-00005 LED 65170-166-42 AFC Run legend plate ZBZ32 Legend plate holder
	Yellow Fault	ZB5AV05 Amber pilot light head <sup>[1]</sup> ZB5AV6 Mounting collar with light module <sup>[2]</sup> 25501-00004 LED 65170-166-39 Fault legend plate ZBZ32 Legend plate holder
	Yellow Auto	ZB5AV05 Amber pilot light head <sup>[1]</sup> ZB5AV6 Mounting collar with light module <sup>[2]</sup> 25501-00004 LED 65170-166-08 Auto legend plate ZBZ32 Legend plate holder
<b>B08</b> Pilot Light Cluster Option #2	Red Power On	ZB5AV04 Red pilot light head ZB5AV6 Mounting collar with light module 25501-00003 LED 65170-166-24 Power On legend plate ZBZ32 Legend plate holder
	Green AFC Run	ZB5AV03 Green pilot light head <sup>[1]</sup> ZB5AV6 Mounting collar with light module <sup>[2]</sup> 25501-00005 LED 65170-166-42 AFC Run legend plate ZBZ32 Legend plate holder
	Yellow Fault	ZB5AV05 Amber pilot light head <sup>[1]</sup> ZB5AV6 Mounting collar with light module <sup>[2]</sup> 25501-00004 LED 65170-166-39 Fault legend plate ZBZ32 Legend plate holder
	Yellow Bypass	ZB5AV05 Amber pilot light head <sup>[1]</sup> ZB5AV6 Mounting collar with light module <sup>[2]</sup> 25501-00004 LED 65170-166-37 Bypass legend plate ZBZ32 Legend plate holder
<b>C08</b> Pilot Light Cluster Option # 3	Red Power On	ZB5AV04 Red pilot light head ZB5AV6 Mounting collar with light module 25501-00003 LED 65170-166-24 Power On legend plate ZBZ32 Legend plate holder
	Green AFC Run	ZB5AV03 Green pilot light head <sup>[1]</sup> ZB5AV6 Mounting collar with light module <sup>[2]</sup> 25501-00005 LED 65170-166-42 AFC Run legend plate ZBZ32 Legend plate holder
	Yellow Fault	ZB5AV05 Amber pilot light head <sup>[1]</sup> ZB5AV6 Mounting collar with light module <sup>[2]</sup> 25501-00004 LED 65170-166-39 Fault legend plate ZBZ32 Legend plate holder

**Table 18: Light Options (continued)**

*NOTE: Refer to the notes on pages 10 and 11 for rules governing component selection.*

*Notes for Table 18:*

1. For the push-to-test feature, the following pilot light operators are used:  
ZB5AW35 replaces ZB5AV05  
ZB5AW33 replaces ZB5AV03  
ZB5AW36 replaces ZB5AV06
2. For the push-to-test feature, ZB5AW065 (mounting collar w/ light module and 1 N.O. and 1 N.C. contact) replaces ZB5AV6 (mounting collar w/ light module).

Light Option	Description	Parts List
<b>D08</b> Pilot Light Cluster Option #4	Red Power On	ZB5AV04 Red pilot light head ZB5AV6 Mounting collar with light module 25501-00003 LED 65170-166-24 Power On legend plate ZBZ32 Legend plate holder
	Yellow Fault	ZB5AV05 Amber pilot light head <sup>[1]</sup> ZB5AV6 Mounting collar with light module <sup>[2]</sup> 25501-00004 LED 65170-166-39 Fault legend plate ZBZ32 Legend plate holder
	Green AFC Forward	ZB5AV03 Green pilot light head <sup>[1]</sup> ZB5AV6 Mounting collar with light module <sup>[2]</sup> 25501-00005 LED 65170-166-15 Forward legend plate ZBZ32 Legend plate holder
	Green AFC Reverse	ZB5AV03 Green pilot light head <sup>[1]</sup> ZB5AV6 Mounting collar with light module <sup>[2]</sup> 25501-00005 LED 65170-166-27 Reverse legend plate ZBZ32 Legend plate holder
<b>E08</b> Pilot Light Cluster Option #5	Red Power On	ZB5AV04 Red pilot light head ZB5AV6 Mounting collar with light module 25501-00003 LED 65170-166-24 Power On legend plate ZBZ32 Legend plate holder
	Green AFC Run	ZB5AV03 Green pilot light head <sup>[1]</sup> ZB5AV6 Mounting collar with light module <sup>[2]</sup> 25501-00005 LED 65170-166-42 AFC legend plate ZBZ32 Legend plate holder
	Yellow Fault	ZB5AV05 Amber pilot light head <sup>[1]</sup> ZB5AV6 Mounting collar with light module <sup>[2]</sup> 25501-00004 LED 65170-166-39 Fault legend plate ZBZ32 Legend plate holder
	Blue Hand	ZB5AV06 blue pilot light head <sup>[1]</sup> ZB5AV6 Mounting collar with light module <sup>[2]</sup> 25501-00006 LED 65170-166-16 Hand legend plate ZBZ32 Legend plate holder
	Yellow Auto	ZB5AV05 Amber pilot light head <sup>[1]</sup> ZB5AV6 Mounting collar with light module <sup>[2]</sup> 25501-00004 LED 65170-166-08 Auto legend plate ZBZ32 Legend plate holder

**Table 18: Light Options (continued)**

Light Option	Description	Parts List
<b>F08</b> Pilot Light Cluster Option #6	Red Power On	ZB5AV04 Red pilot light head ZB5AV6 Mounting collar with light module 25501-00003 LED 65170-166-24 Power On legend plate ZBZ32 Legend plate holder
	Green AFC Run	ZB5AV03 Green pilot light head <sup>[1]</sup> ZB5AV6 Mounting collar with light module <sup>[2]</sup> 25501-00005 LED 65170-166-42 AFC Run legend plate ZBZ32 Legend plate holder
	Yellow Fault	ZB5AV05 Amber pilot light head ZB5AV6 Mounting collar with light module 25501-00004 LED 65170-166-39 Fault legend plate ZBZ32 Legend plate holder
	Yellow Communication	ZB5AV05 Amber pilot light head ZB5AV6 Mounting collar with light module 25501-00004 LED 65170-170-39 Communication legend plate ZBZ32 Legend plate holder

*NOTE: Refer to the notes on pages 10 and 11 for rules governing component selection.*

*Notes for Table 18:*

- For the push-to-test feature, the following pilot light operators are used:  
ZB5AW35 replaces ZB5AV05  
ZB5AW33 replaces ZB5AV03  
ZB5AW36 replaces ZB5AV06
- For the push-to-test feature, ZB5AW065 (mounting collar w/ light module and 1 N.O. and 1 N.C. contact) replaces ZB5AV6 (mounting collar w/ light module).

**OPTION CARDS**

**Table 19: Option Cards**

Misc. Option	Name	Description
<b>A09</b>	Modbus Plus	Provides factory installed plug-in Modbus Plus card VW3A58302U and 990NAD219XX Modbus Plus cable with connector.
<b>B09</b>	Modbus/Unitelway Serial Communication <sup>[1]</sup>	Provides factory installed plug-in Modbus card VW3A58303U and separate user termination to D-shell interface device, Square D part number 25410-00084. (Phoenix connector part #2761839.) Serial Communication is factory installed for register monitoring.
<b>C09</b>	Metasys <sup>®</sup> N2 Serial Communication <sup>[1]</sup>	Provides factory installed plug-in Metasys N2 card VW3A58354U and separate user termination to D-shell interface device, Square D part number 25410-00084. (Phoenix connector part #2761839.) Serial communication is factory installed for register monitoring.
<b>D09</b>	Ethernet	Provides factory installed plug-in Ethernet card VW3A58310U with RJ45 connector port.
<b>E09</b>	LONWORKS Serial Communication <sup>[2]</sup>	Provides factory installed LONWORKS to Modbus Module VW3A58312PU, 24 Vdc power supply ABL7CEM24003 and plug-in Modbus card VW3A58303U. Serial Communication is factory installed for register monitoring.
<b>F09</b>	DeviceNet	Provides factory installed plug-in DeviceNet card VW3A58309U and user terminal block TB5. <sup>[3]</sup>
<b>H09</b>	Analog Card	Provides factory installed analog card VW3A58201U wired to user terminal block TB3 <sup>[3]</sup> . Provides 1 additional analog output, 2 additional logic inputs, 1 additional logic output, and 1 differential analog input.

*NOTE: Refer to the notes on pages 10 and 11 for rules governing component selection.*

*Notes for Table 19:*

- Class 8839 58M controllers do not ship with the 9-pin to 15-pin connector cable that is usually supplied with the Modbus card. Instead, they ship with a Phoenix connector for user terminations.
- For the most recent \*.xif installation help files, refer to www.SquareD.com. Search for the LONWORKS to Modbus module instruction bulletin, VVDED300055US.
- See pages 46–48 for terminal block TB3 or TB5 location.

MISCELLANEOUS OPTIONS

NOTE: Refer to the notes on pages 10 and 11 for rules governing component selection.

Notes for Table 20:

1. One N.O. and one N.C. Form C Drive Run contact is provided as standard on the user terminal block.
2. One N.O. and one N.C. Form C Drive Fault contact is provided as standard on the user terminal block.
3. If the motor space heater (U10) and seal water solenoid (V10) are both required, you must also select an additional control power VA (110).
4. See pages 46–48 to locate terminal blocks TB1 and TB2.

Table 20: Miscellaneous Options

Misc. Option	Name	Description
A10	Line Reactor	Optional, 5% impedance, factory-mounted line reactor within the enclosure.
B10	Line Contactor	A line contactor can be added between the circuit breaker and the drive controller when bypass is also selected.
C10	3–15 psi Transducer	Allows the controller to follow a user-supplied 3–15 psi input.
D10	Omit Door-Mounted Keypad	The keypad is not supplied. The user must buy a keypad as a separate device to program the drive controller.
E10	Smoke Purge Relay	Provides a smoke purge operating mode controlled by a user-supplied 120 Vac signal wired to terminal block TB1 <sup>[4]</sup> , terminals 48 and 49.
G10	cUL Listing	Provides Canadian cUL certification when required by local code requirements.
H10	Seismic Certification (Floor Mounted Enclosures)	Provides a certification label and hardware certified to seismic rating AC156 harmonized with NFPA 5000 and IBC 2000 standards.
J10	0–10 Vdc Auto Speed Reference	Provides a controller interface with differential input, 31158-297-50, for a 0–10 Vdc user supplied auto speed reference signal to the AI2 input using a 0–10 V/4–20 mA converter with Z=40 kΩ.
K10	Additional N.O. Aux. Drive Run Contact <sup>[1]</sup>	Provides 1 additional N.O. controller run contact on terminal block TB1 <sup>[4]</sup> , terminals 57 and 58.
L10	Additional N.C. Aux. Drive Fault Contact <sup>[2]</sup>	Provides 1 additional N.C. controller fault contact on terminal block TB1 <sup>[4]</sup> , terminals 59 and 60.
M10	1 N.O. Aux. Bypass Run Contact	Provides 1 N.O. bypass run contact on terminal block TB1 <sup>[4]</sup> , terminals 61 and 62.
O10	1 N.O. Aux. Auto Mode Contact	Provides 1 N.O. auto mode contact on terminal block TB1 <sup>[4]</sup> , terminals 63 and 64.
P10	AFC Fault Reset	Factory-installed door mounted push button to reset the controller fault when hand-off-auto is not used.
Q10	Push-To-Test Pilot Lights	Provides push-to-test function on all pilot lights except Power On.
R10	Auto Transfer to Bypass	Provides an automatic transfer to the bypass in the event that the drive controller faults. A selector switch is provided to enable or disable this function.
S10	Motor Elapsed Time Meter	Provides elapsed time meter to record the motor run time. Runs whenever the motor is running.
T10	Emergency Stop	Provides door mounted maintained off emergency stop red mushroom push button with turn-to-reset feature.
U10 <sup>[3]</sup>	Motor Space Heater Sequencing	Provides 50 VA/120 V to terminal block TB1 <sup>[4]</sup> , terminals 45 to 50, for motor space heater whenever the motor is not running.
V10 <sup>[3]</sup>	Seal Water Solenoid	Provides 50 VA/120 V to terminal block TB1 <sup>[4]</sup> , terminals 43 to 50, whenever the motor is running.

**Table 20: Miscellaneous Options** *(continued)*

Misc. Option	Name	Description
<b>W10</b>	Check Valve Sequencing	Provides an automatic shutdown of the drive controller when the user supplied N.C. contact from the check valve limit switch does not open within 5 s after the motor starts. The user limit switch contact connects to terminal block TB1 <sup>[4]</sup> , terminals 46 and 47.
<b>Z10</b>	24 Vdc Power Supply	Provides 24 Vdc, 300 mA power supply at terminal block TB2 <sup>[4]</sup> , terminals 0 (+) to N (-).
<b>110</b> <sup>[3]</sup>	Additional Control Power VA	Provides a 50 VA larger control transformer for use with 120 Vac connected to terminal block TB1 <sup>[4]</sup> , terminals 1 to 50.
<b>310</b>	OE Specials	Order engineered special configurations. (for internal use only)
<b>410</b>	RFI Suppressor	Provides radio frequency interference suppression with ferrites on the power leads to the drive controller input.
<b>510</b>	Permanent Wire Marker Sleeves	Provides permanent wire-sleeve markers.
<b>610</b>	I.D. Engraved Nameplates	Provides an engraved lamacoid nameplate attached to the front door of the enclosure (engraved per user request at time of order).
<b>710</b>	Harmonic Filter Provisions	Provides fused output terminals with return terminals for connection of an externally mounted harmonic filter. Class J fuses are provided.
<b>910</b>	Barriered Bypass Enclosure	Provides a floor mounted, two door, two compartment enclosure with two disconnects (one for the drive controller and one for the bypass).

*NOTE: Refer to the notes on pages 10 and 11 for rules governing component selection.*

*Notes for Table 20:*

1. One N.O. and one N.C. Form C Drive Run contact is provided as standard on the user terminal block.
2. One N.O. and one N.C. Form C Drive Fault contact is provided as standard on the user terminal block.
3. If the motor space heater (U10) and seal water solenoid (V10) are both required, you must also select an additional control power VA (110).
4. See pages 46–48 to locate terminal blocks TB1 and TB2.

## TOTAL DISSIPATED WATTS LOSS

The total dissipated watts loss in Tables 21–23 is provided for sizing the environment HVAC cooling requirements based upon worst-case operating conditions for Type 1 and Type 12 enclosures.

**Table 21: Total Dissipated Watts Loss, 460 V**

Drive Controller Catalog No. <sup>[1]</sup>	Constant Torque		Variable Torque	
	hp	Total Dissipated Watts Loss	hp	Total Dissipated Watts Loss
58MC•4◊_	1	320	1	320
58MD•4◊_	2	370	2	370
58ME•4◊_	3	400	3	400
58MF•4◊_	5	516	5	515
58MG•4◊_	7.5	663	7.5	657
58MH•4◊_	10	684	10	672
58MJ•4◊_	15	868	15	861
58MK•4◊_	20	1025	20	1007
58ML•4◊_	25	895	25	1134
58MM•4◊_	30	961	30	1087
58MN•4◊_	40	1178	40	1228
58MP•4◊_	50	1254	50	1356
58MQ•4◊_	60	1525	60	1654
58MR•4◊_	75	1761	75	1737
58MS•4◊_	—	—	100	2255
58MT▼4V_	—	—	125	2950 <sup>[2]</sup>
58MU▼4V_	—	—	150	3450 <sup>[2]</sup>
58MW▼4V_	—	—	200	4000 <sup>[2]</sup>
58MX▼4V_	—	—	250	5524 <sup>[2]</sup>
58MY▼4V_	—	—	300	6524 <sup>[2]</sup>
58MZ▼4V_	—	—	350	7024 <sup>[2]</sup>
58M4▼4V_	—	—	400	7974 <sup>[2]</sup>
58M5▼4V_	—	—	450	8500 <sup>[2]</sup>
58M6▼4V_	—	—	500	9380 <sup>[2]</sup>

*Note for Table 21:*

1. “•” can be “A”, or “G”. “A” denotes a Type 12 enclosure; “G” denotes a Type 1 enclosure.  
“▼” can be “G” or “B”. “G” denotes a Type 1 enclosure; “B” denotes a Type 1G enclosure.  
“◊” can be “C” or “V”. “C” denotes a constant torque controller; “V” denotes a variable torque controller. “\_” indicates that the catalog number continues. See pages 10 and 11 for a detailed description of catalog numbers.
2. This watts loss data is for stand-alone controllers only. If you have integrated or barriered bypass controllers, contact Technical Support, see page 91.

**Table 22: Total Dissipated Watts Loss, 230 V**

Drive Controller Catalog No. <sup>[1]</sup>	Constant Torque		Variable Torque	
	hp	Total Dissipated Watts Loss	hp	Total Dissipated Watts Loss
58MC*30_	1	326	1	326
58MD*30_	2	392	2	392
58ME*30_	3	462	3	460
58MF*30_	5	552	5	510
58MG*30_	7.5	589	7.5	569
58MH*30_	10	729	10	701
58MJ*30_	15	1205	15	1008
58MK*30_	20	1388	20	1232
58ML*30_	25	1447	25	1461
58MM*30_	30	1553	30	1408
58MN*30_	40	1965	40	1665
58MP*30_	—	—	50	2080

*Note for Tables 22 and 23:*

1. "a" can be "A" or "G". "A" denotes a Type 12 enclosure; "G" denotes a Type 1 enclosure.  
 "0" can be "C" or "V". "C" denotes a constant torque controller; "V" denotes a variable torque controller.  
 "\_" indicates that the catalog number continues. See pages 10 and 11 for a detailed description of catalog numbers.

**Table 23: Total Dissipated Watts Loss, 208 V**

Drive Controller Catalog No. <sup>[1]</sup>	Constant Torque		Variable Torque	
	hp	Total Dissipated Watts Loss	hp	Total Dissipated Watts Loss
58MC*20_	1	330	1	330
58MD*20_	2	394	2	394
58ME*20_	3	467	3	465
58MF*20_	5	560	5	517
58MG*20_	7.5	602	7.5	582
58MH*20_	10	748	10	720
58MJ*20_	15	1231	15	1034
58MK*20_	20	1419	20	1264
58ML*20_	25	1498	25	1505
58MM*20_	30	1589	30	1445
58MN*20_	40	2030	40	1731
58MP*20_	—	—	50	2111

## MOUNTING DIMENSIONS AND WEIGHTS

Figure 2: 1–20 hp CT Controllers and 1–25 hp VT Controllers @ 460 V and 1–10 hp CT/VT Controllers @ 208/230 V

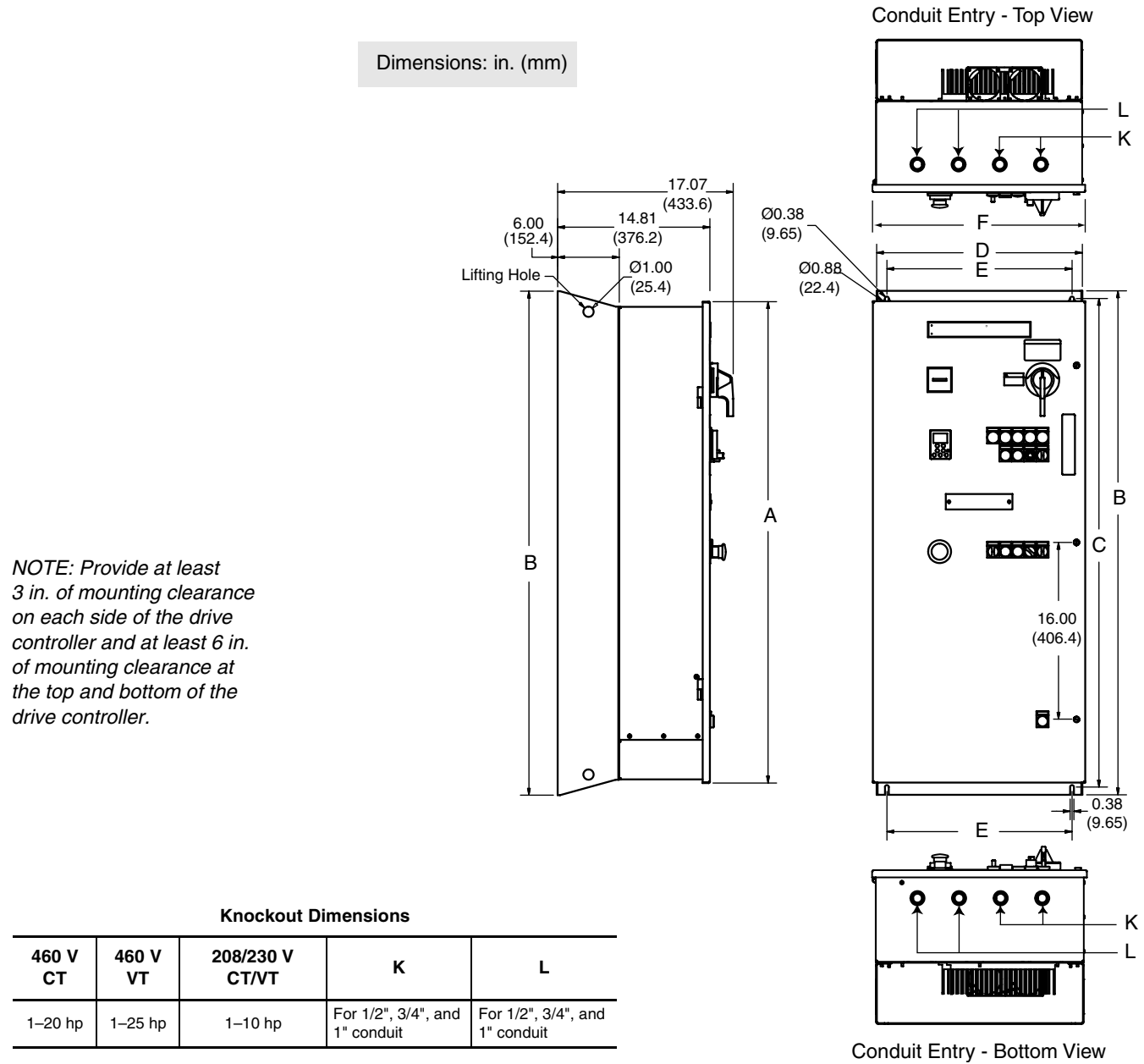

hp			Weight		Enclosure Dimensions												Enclosure Size
460 V		208/230 V	lb	kg	A		B		C		D		E		F		
CT	VT	CT/VT			in.	mm	in.	mm	in.	mm	in.	mm	in.	mm	in.	mm	
1–20	1–25	1–5	174	78	46.80	1188	49.00	1244.6	47.83	1214.9	20	508	18.04	458.2	20.65	524.5	C
—	—	7.5–10	242	109	60.80	1544	63.00	1600.2	61.83	1570.5	25	635	23.05	585.5	25.65	651.5	D

**Figure 3: 25–75 hp CT Controllers and 30–100 hp VT Controllers @ 460 V and 15–40 hp CT Controllers and 15–50 hp VT Controllers @ 208/230 V**

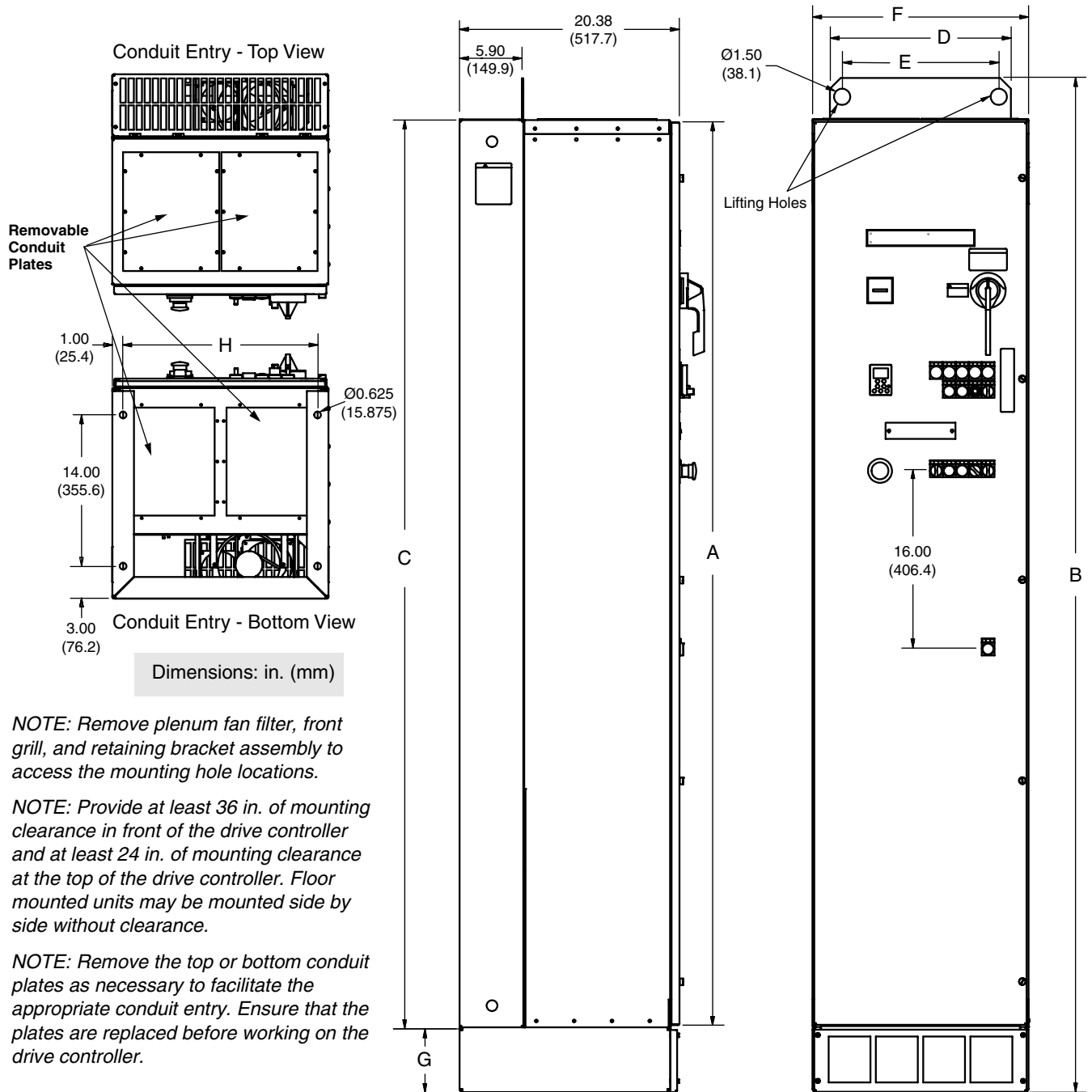

*NOTE: Remove plenum fan filter, front grill, and retaining bracket assembly to access the mounting hole locations.*

*NOTE: Provide at least 36 in. of mounting clearance in front of the drive controller and at least 24 in. of mounting clearance at the top of the drive controller. Floor mounted units may be mounted side by side without clearance.*

*NOTE: Remove the top or bottom conduit plates as necessary to facilitate the appropriate conduit entry. Ensure that the plates are replaced before working on the drive controller.*

hp				Weight		Enclosure Dimensions														Enclosure Size		
460 V		208/230 V		lb	kg	A		B		C		D		E		F		G			H	
CT	VT	CT	VT			in.	mm	in.	mm	in.	mm	in.	mm	in.	mm	in.	mm	in.	mm		in.	mm
25–40	30–50	15–20	15–25	378	171	83.38	2117.9	93.87	2384.3	84	2133.6	16.75	425.4	14.50	368.3	20	508	8.0	203.2	18	457.2	E
50–75	60–100	25–40	30–50	562	254	83.38	2117.9	93.87	2384.3	84	2133.6	23	584	19.00	482.6	25	635	8.0	203.2	23	584.2	F

**Figure 4: Barriered 1–20 hp CT Controllers and 1–25 hp VT Controllers @ 460 V and 1–10 hp CT/VT Controllers @ 208/230 V**

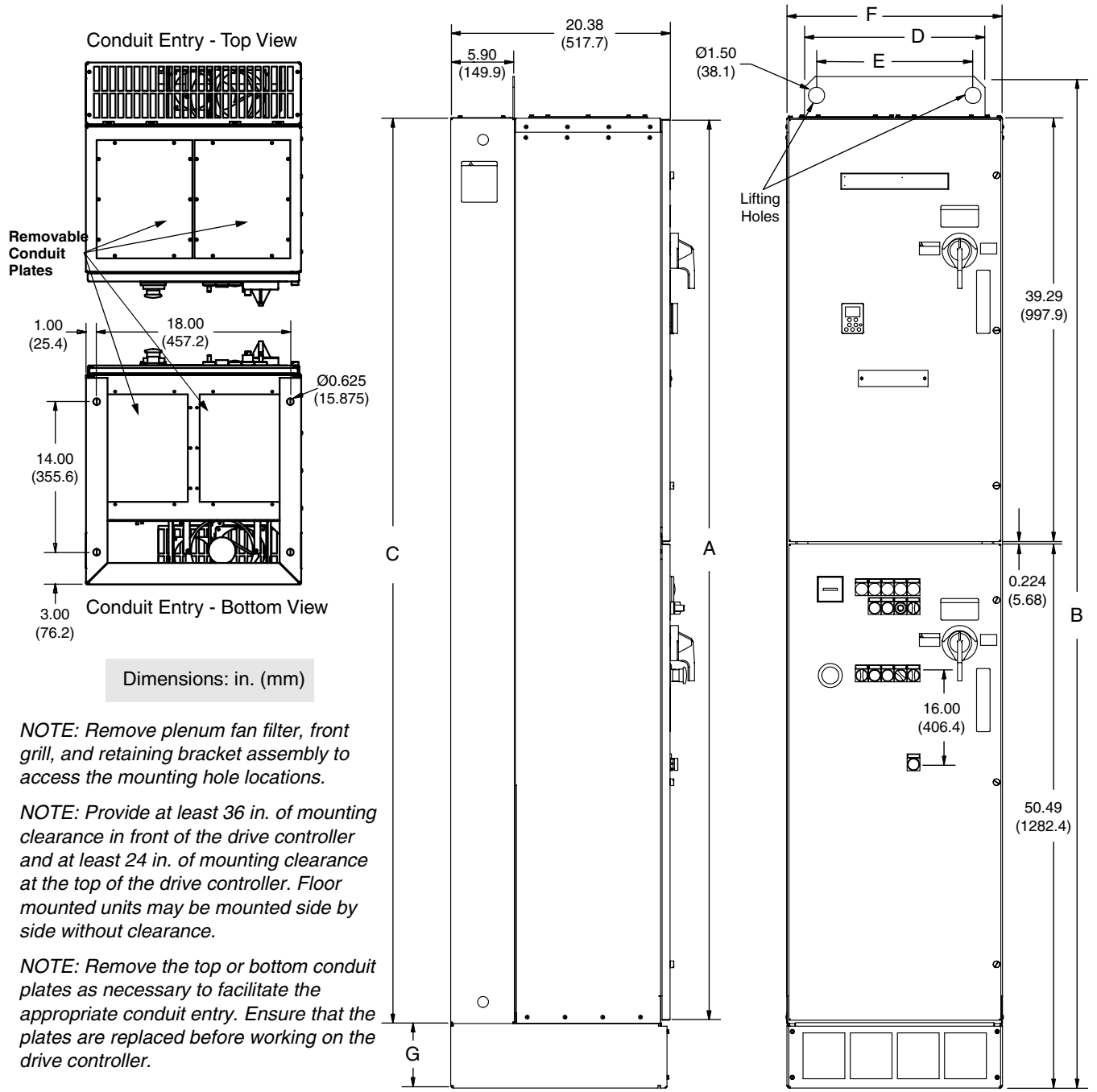

hp			Weight		Enclosure Dimensions														Enclosure Size
460 V		208/230 V	lb	kg	A		B		C		D		E		F		G		
CT	VT	CT/VT			in.	mm	in.	mm	in.	mm	in.	mm	in.	mm	in.	mm	in.	mm	
1–20	1–25	1–10	378	171	83.38	2117.9	93.87	2384.3	84	2133.6	16.75	425.4	14.50	368.3	20	508	8.0	203.2	C/D barriered

Figure 5: 125–500 hp VT Controllers @ 460 V

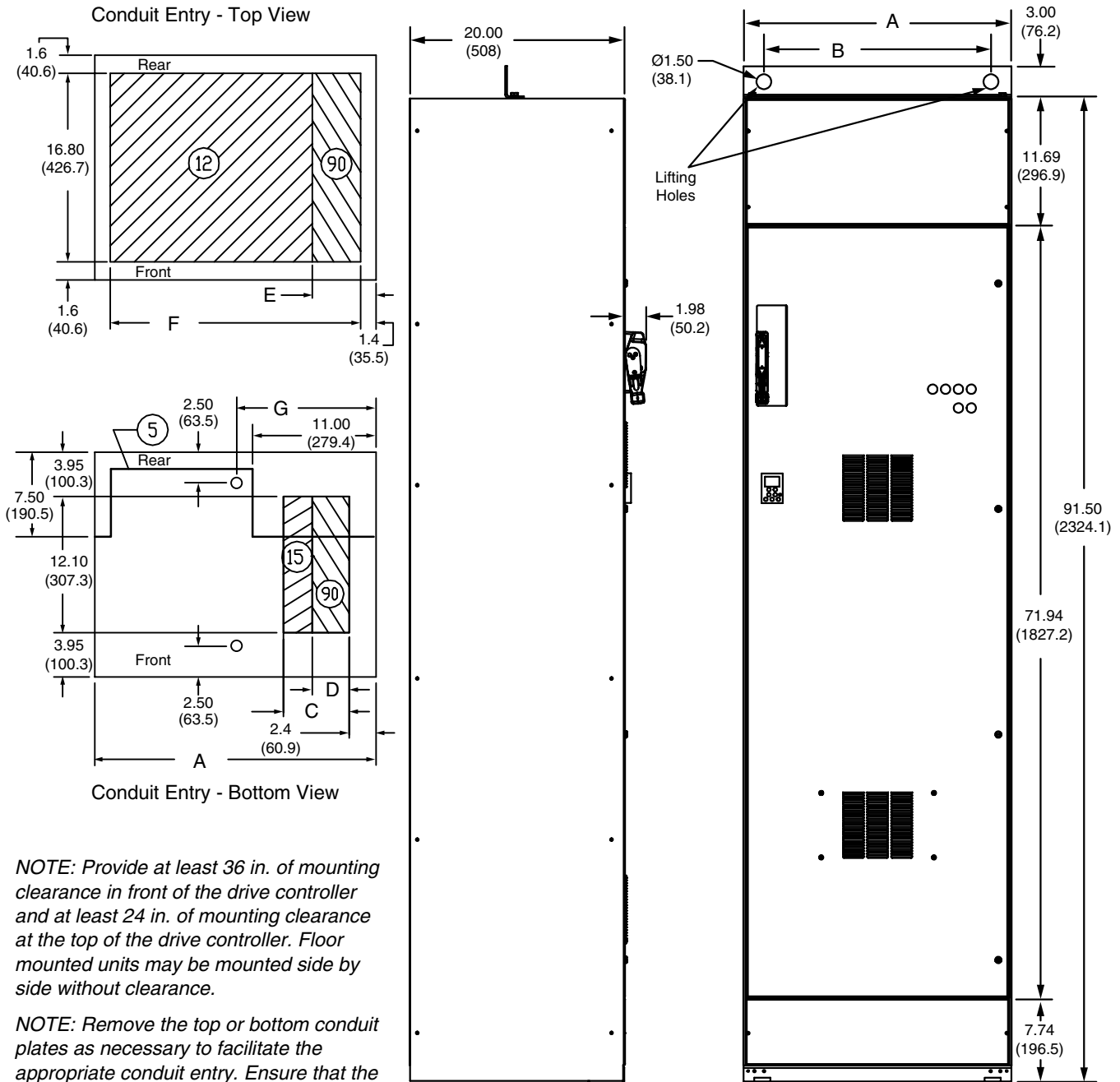

NOTE: Provide at least 36 in. of mounting clearance in front of the drive controller and at least 24 in. of mounting clearance at the top of the drive controller. Floor mounted units may be mounted side by side without clearance.

NOTE: Remove the top or bottom conduit plates as necessary to facilitate the appropriate conduit entry. Ensure that the plates are replaced before working on the drive controller.

Dimensions: in. (mm) NOTE: Circled numbers indicate depth in inches.

hp	Weight		Enclosure Dimensions														Enclosure Size
			A		B		C		D		E		F		G		
460 V	lb	kg	in.	mm	in.	mm	in.	mm	in.	mm	in.	mm	in.	mm	in.	mm	
VT																	
125	500	226.7	25	635	21.16	537.4	5.84	148.3	3.3	83.8	4.3	109.2	22.0	558.8	12.5	317.5	H
150–250	650	294.8	30	762	26.16	664.4	10.63	270.0	3.3	83.8	4.3	109.2	27.2	690.8	15.0	381.0	I
300–500	975	442.2	35	889	31.16	791.4	15.03	381.7	4.1	104.1	5.1	129.5	32.2	817.8	17.5	444.5	J

Figure 6: 125–500 hp VT Controllers @ 460 V with Integrated or Barriercd Bypass (Front and Side Views)

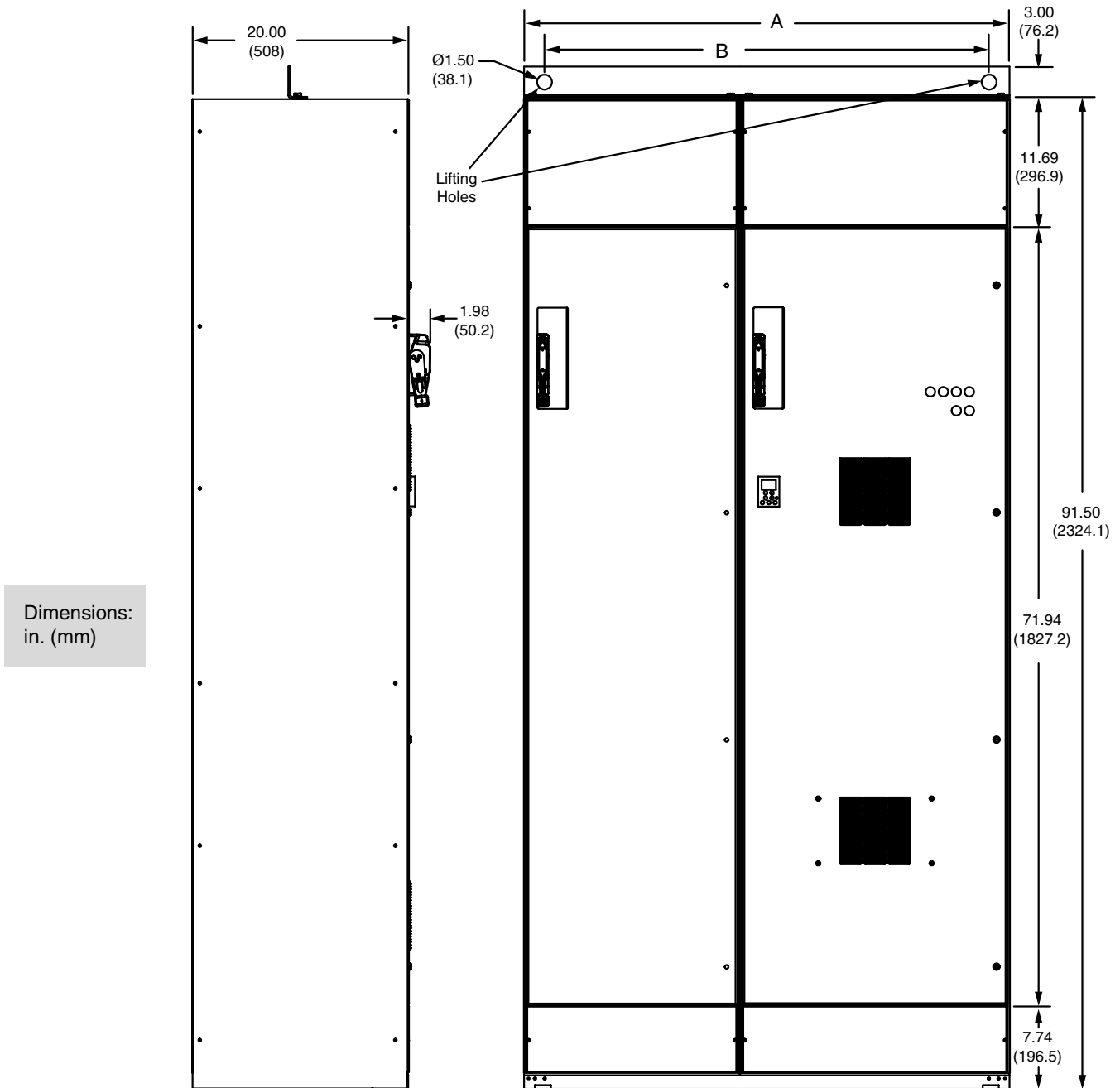

hp	Weight		Enclosure Dimensions				Enclosure Size
			A		B		
460 V	lb	kg	in.	mm	in.	mm	
VT							
125	1025	464.9	45	1143	41.16	1045.4	H-integrated
150–200	1175	532.9	50	1270	46.16	1172.4	I-integrated
125	1150	521.6	50	1270	46.16	1172.4	H-barriered
150–200	1300	589.6	55	1397	51.16	1299.4	I-barriered

NOTE: Provide at least 36 in. of mounting clearance in front of the drive controller. Floor mounted units may be mounted side by side without clearance.

Figure 7: 125–500 hp VT Controllers @ 460 V with Integrated or Barrired Bypass (Conduit Views)

hp	460 V	VT	125	150–200	125	150–200	
Weight	lb		1025	1175	1150	1300	
	kg		464.9	532.9	521.6	589.6	
Enclosure Dimensions	C	in.	5.84	10.63	5.84	10.63	
		mm	148.3	270.0	148.3	270.0	
	D	in.	25	30	25	30	
		mm	635	762	635	762	
	E	in.	22.2	27.2	22.2	27.2	
		mm	563.8	690.8	563.8	690.8	
	F	in.	22.5	25.0	25.0	27.5	
		mm	571.5	635	635	698.5	
	G	in.	12.5	15.0	12.5	12.5	
		mm	317.5	381.0	317.5	317.5	
	Enclosure Size			integrated		barrired	
				H	I	H	I

NOTE: Provide at least 24 in. of mounting clearance at the top of the drive controller.

NOTE: Remove the top or bottom conduit plates as necessary to facilitate the appropriate conduit entry. Ensure that the plates are replaced before working on the drive controller.

Dimensions: in. (mm)

NOTE: Circled numbers indicate depth in inches.

Anchor Mounting Holes

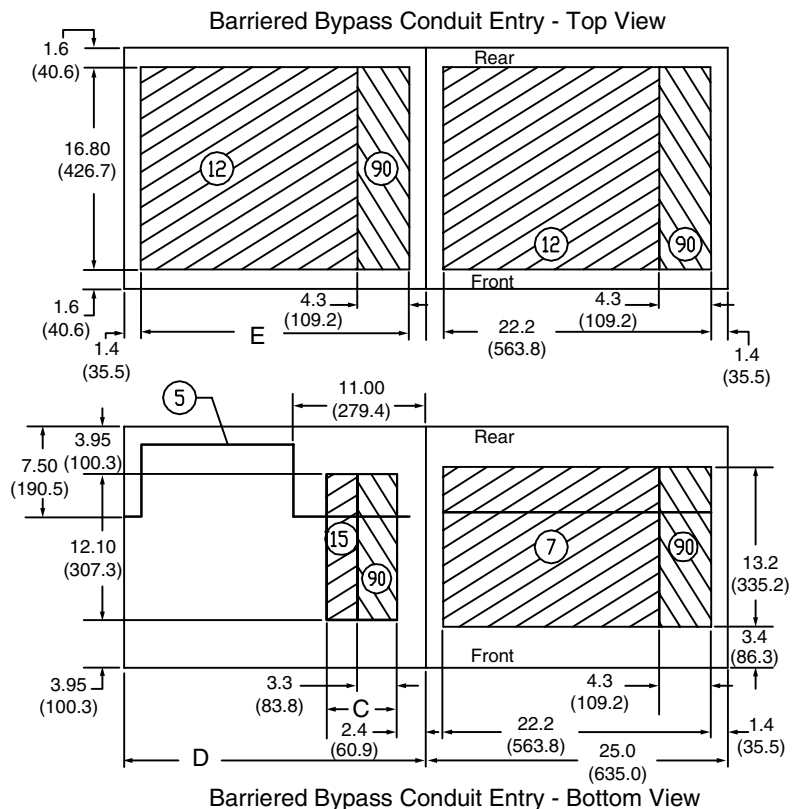
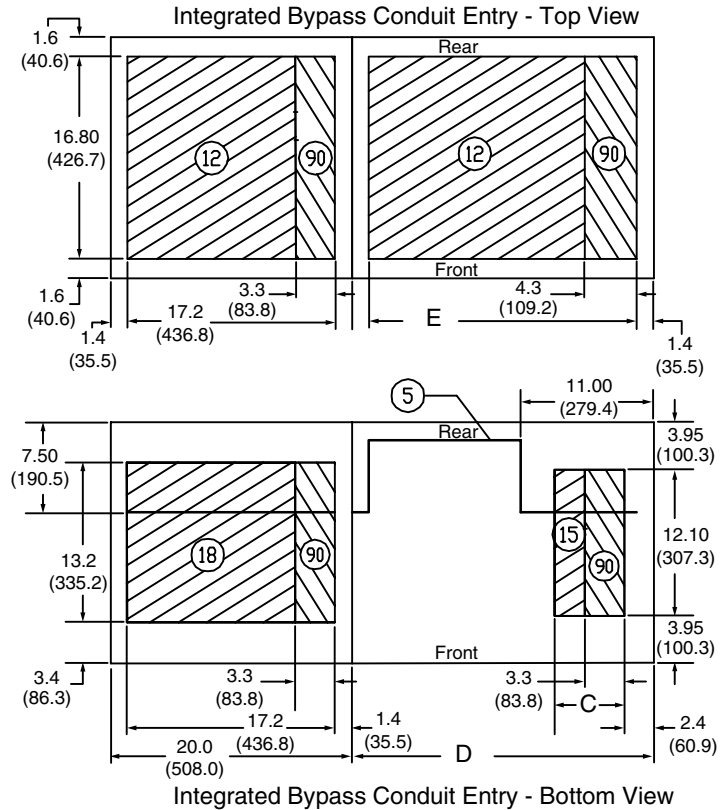
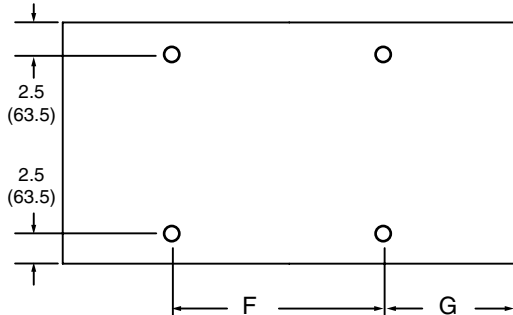

## SECTION 2— RECEIVING, INSTALLATION, AND START-UP

### PRELIMINARY INSPECTION

<b>⚠ CAUTION</b>
<b>DAMAGED EQUIPMENT</b> Do not operate any drive controller that appears damaged. <b>Failure to follow this instruction can result in injury or equipment damage.</b>

**Figure 8: Circuit Breaker Handle Assembly**

208 V, 230 V, and 1–100 hp @ 460 V controllers

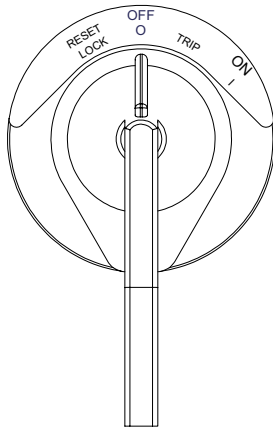

125–500 hp @ 460 V controllers

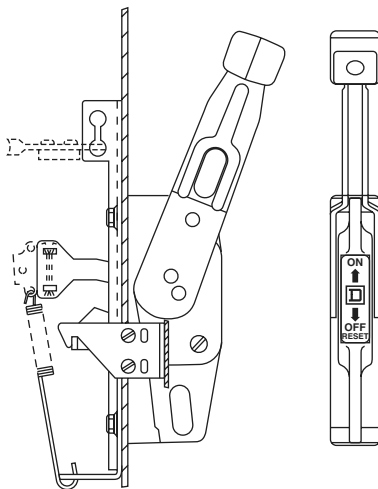

The drive controller must be thoroughly inspected before it is stored or installed. Upon receipt:

- A. Remove the drive controller from its packaging and visually inspect the exterior for shipping damage.
- B. Ensure that the Class, Type, and option specified on the drive controller nameplate (refer to page 9) agree with the packaging slip and corresponding purchase order.
- C. If you find any shipping damage, notify the carrier and your sales representative.
- D. If you plan to store the drive controller after receipt, replace it in its original packaging material and observe storage temperature specifications in Table 15 on page 19.

<b>⚠ CAUTION</b>
<b>DAMAGE TO INSULATED PARTS IN AIR DUCT</b> <ul style="list-style-type: none"><li>• Protect the air duct at the rear of the enclosure from entry of foreign material.</li><li>• Do not place loose objects on top of the enclosure.</li><li>• Do not block air flow from the duct.</li></ul> <b>Failure to follow this instruction can cause breaker trip, resulting in process shutdown or equipment damage.</b>

Before installation:

1. Open the drive controller door by moving the circuit breaker handle assembly to the Off position as shown in Figure 8.
2. Visually verify that all internal mounting and terminal connection hardware is properly seated, securely fastened, and undamaged.
3. Visually verify that the control board and any communication boards on the power converter are properly seated, securely fastened, and undamaged. Verify that the internal plugs and wiring connections are tight. Inspect all connections for damage.
4. Verify that all relays and fuses are installed and fully seated.
5. Close and secure the drive controller door, by fully tightening the thumb screws.

## HANDLING THE DRIVE CONTROLLER

**Figure 9: Hoisting Class 8839 58M Drive Controllers**

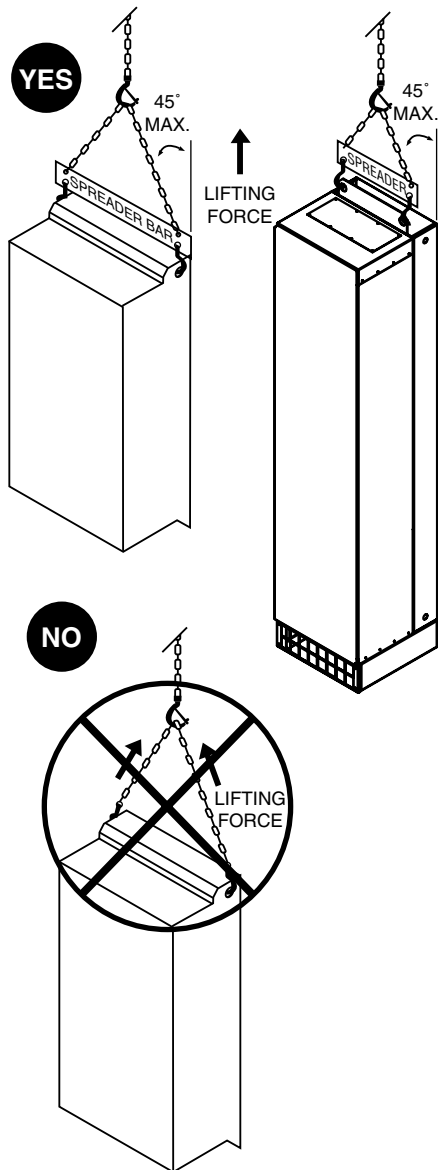

### ⚠ WARNING

#### LIFTING HEAVY EQUIPMENT

Keep the area below any equipment being lifted clear of all personnel and property. Use the lifting method shown in Figure 9.

**Failure to follow this instruction can result in death, serious injury, or equipment damage.**

Drive controllers are shipped on a pallet on their back. To avoid damage, do not stack drive controllers on top of each other. Store the drive controller in its original packaging until it is at the final installation site. The packaging protects the drive controller and prevents damage to its exterior.

Handle the drive controller carefully to avoid damage to the internal components, frame, or exterior. When handling a drive controller, balance it carefully to keep it from tipping. After removing packaging materials, drive controllers require some type of mechanical lifting.

When handling drive controllers:

- Always work with another person. The weight, size, and shape of the drive controller is such that two people are required to handle it.
- Use gloves.
- Attach a spreader bar to the two top lifting holes on the drive controller back panel or lifting bracket (see Figures 2–4 on pages 31–33 for location of lifting holes) and hoist the controller with chains or straps. See Figure 9 for the proper hoisting method.
- Raise the drive controller from a horizontal position (i.e., the back of the controller resting on a pallet).
- Place the drive controller in an upright position.

*NOTE: Wall mounted enclosures will not sit upright without support. The bottom of the wall mounting drive controller is on an angle.*

### ⚠ WARNING

#### IMPROPER MOUNTING

Before removing the lifting mechanism:

- Ensure that all hardware is of sufficient size and type for the controller weight.
- Secure and tighten all hardware.

**Failure to follow this instruction can result in death, serious injury, or equipment damage.**

## INSTALLATION

### MECHANICAL INSTALLATION

Refer to Table 15 beginning on page 19 for specifications.

- Secure all four appropriate corners of the controller with hardware of a sufficient size and type for the controller weight.
  - For floor mounted enclosures, these corners are on the base support of the enclosure. For locations see pages 32 and 33.
  - For wall mounted enclosures, these corners are at the back of the enclosure. For locations see page 31.
- Mount the wall mounted drive controller on a flat, noncombustible vertical surface.
- Mount the floor mounted drive controller on a flat, solid surface capable of supporting the controller weight.
- The floor mounted controller must be mounted in a location which provides air access into the lower front of the controller.
- If drilling for conduit entry, exercise care to prevent metal chips from falling on parts and electronic printed wiring boards.
- See Figures 2–4 on pages 31–33 for mounting dimensions, mounting clearances, conduit entry areas, and controller weights.
- Do not mount the drive controller on hot surfaces.
- Do not mount the drive controller in direct sunlight.

### ELECTRICAL INSTALLATION

#### General Wiring Practices

Before wiring, perform the bus voltage measurement procedure on page 42. Good wiring practice requires the separation of control circuit wiring from all power wiring. Power wiring to the motor must have the maximum possible separation from all other power wiring, whether from the same drive controller or other drive controllers. **Do not run power and/or control or multiple power wiring in the same conduit.** This separation reduces the possibility of coupling electrical transients from power circuits into control circuits or from motor power wiring into other power circuits.

### **⚠ DANGER**

#### **HAZARDOUS VOLTAGE**

- Turn off all power (main and remote) before installing the equipment.
- Read the hazard statements on page 2 of this manual.

**Failure to follow these instructions will result in death or serious injury.**

### **⚠ CAUTION**

#### **IMPROPER WIRING**

Follow the wiring practices described in this document in addition to those already required by the National Electrical Code and local codes.

**Failure to follow this instruction can result in injury or equipment damage.**

Follow the practices below when wiring the Class 8839 58M drive controller:

- Use metallic conduit for all drive controller wiring. Do not run control and power wiring in the same conduit.
- Separate metallic conduits carrying power wiring or low-level control wiring by at least 3 inches (76 mm).
- Separate existing, non-metallic conduits or cable trays used to carry power wiring from metallic conduit carrying low-level control wiring by at least 12 inches (305 mm).
- Whenever power and control wiring cross, the metallic conduits and non-metallic conduits or trays must cross at right angles.
- Equip all inductive circuits near the controller (relays, contactors, solenoid valves) with noise suppressors or connect them to a separate circuit.

## INPUT POWER

The Class 8839 58M drive controller operates from a three-phase, 460 Vac  $\pm$  10%, 230 Vac  $\pm$  10%, or 208 Vac  $\pm$  10% 60 Hz  $\pm$  5% supply connected to the input circuit breaker disconnect.

## BRANCH CIRCUIT CONNECTIONS

All branch circuit components and equipment (such as feeder cables, disconnect devices, and protective devices) must be rated for the maximum input current of the drive controller, as defined in Article 430 of the National Electrical Code. For controllers supplied with bypass, branch circuit feeder protection should be rated for the motor FLA. The drive controller input current and motor FLA is printed on the nameplate. Refer to Tables 8–14 on pages 16–19 for drive controller input currents.

Connect input power leads L1, L2, and L3 to the input of the circuit breaker. Refer to Figures 13–15 (pages 46–48) for location. Refer to Tables 27–31 (pages 52–56) for lug data and wire size range for drive controller input terminals L1, L2, and L3.

### **⚠ WARNING**

#### **IMPROPER OVERCURRENT COORDINATION**

- Protective devices must be properly coordinated.
- Do not connect the drive controller to a power feeder whose short circuit capacity exceeds the short circuit rating listed on the drive controller nameplate.

**Failure to follow these instructions can result in death or serious injury.**

### **⚠ CAUTION**

#### **IMPROPER WIRING**

##### **Can Cause Drive Controller Damage**

The drive controller will be damaged and the warranty voided if input line voltage is applied to the output terminals (T1, T2, T3). Check the power connections before energizing the drive controller.

**Failure to follow this instruction can result in injury or equipment damage.**

## GROUNDING

Ground the drive controller according to the National Electrical Code and all local codes. To ground the drive controller:

- Connect a copper wire from the ground bar terminal to the power system ground.
- Verify that the resistance to ground is 1  $\Omega$  or less. Improper grounding causes intermittent and unreliable operation.
- Do not remove any internal ground wires or connections.

**⚠ DANGER**

**HAZARDOUS VOLTAGE**

- Ground equipment using the provided ground connection point as shown in Figures 13–15 starting on page 46. The drive controller panel must be properly grounded before power is applied.
- Do not use metallic conduit as a ground conductor.

**Failure to follow this instruction will result in death or serious injury.**

Ground multiple drive controllers as shown in Figure 10. Use one grounding conductor per device. Do not loop ground conductors or install them in series.

**Figure 10: Grounding Multiple Drive Controllers**

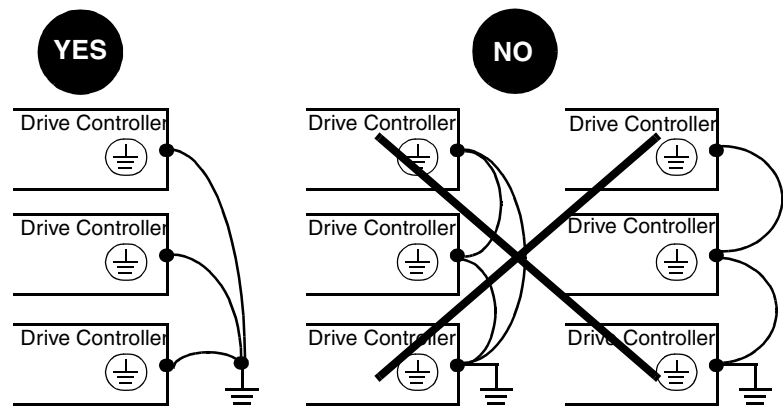

## OUTPUT WIRING

The ampacity of motor power conductors should be sized according to the motor full load current, National Electrical Code, and applicable local codes.

Connect motor conductors to the lugs provided, and connect the motor ground to the ground bar provided.

If the controller is supplied with a bypass circuit, connect the motor conductors to T1, T2, and T3 on the overload relay. If the controller is supplied without a bypass circuit, connect the motor conductors to T1, T2, and T3 on the power converter distribution block. See Figures 13–15 (pages 46–48) for location. See Tables 27–31 (pages 52–56) for lug data and wire size range. Refer to the nameplate for torque requirements.

The drive controller is sensitive to the amount of capacitance (either phase-to-phase or phase-to-ground) present on the output power conductors. If excessive capacitance is present, the drive controller may trip on overcurrent.

## Output Cable

Follow the guidelines below when selecting output cable:

- Cable type: the cable selected must have a low capacitance phase-to-phase and to ground. Do not use mineral-impregnated cable because it has a very high capacitance. Immersion of cables in water increases capacitance.
- Cable length: the longer the cable, the greater the capacitance. Cable lengths greater than 100 ft (30.5 m) may cause ground faults. For installation where cable capacitances may be a problem, a reactor can be installed between the drive controller and the motor.
- Proximity to other output cables: because of high frequency switching and increased capacitance, the drive controller may fault under some conditions.
- **Do not use lightning arrestors or power factor correction capacitors on the output of the drive controller.**

### **⚠ CAUTION**

#### **INSUFFICIENT OUTPUT INDUCTANCE**

For proper drive controller short circuit protection, certain values of inductance may be required in the output power wiring. Inductance can be supplied by the power wiring or auxiliary inductors.

**Failure to follow this instruction can result in injury or equipment damage.**

A minimum inductance is needed to protect the drive controller output from short circuits. Provide at least 20 in. (508 mm) of cable at the drive controller output (T1, T2, and T3).

## DC BUS VOLTAGE MEASUREMENT PROCEDURE

### **⚠ DANGER**

#### **HAZARDOUS VOLTAGE**

- Read and understand the bus voltage measurement procedure before performing the procedure. Measurement of bus capacitor voltage must be performed by qualified personnel.
- **DO NOT** short across DC bus capacitors or touch unshielded components or terminal strip screw connections with voltage present.
- Many parts in this drive controller, including printed wiring boards, operate at line voltage. **DO NOT TOUCH.** Use only electrically-insulated tools.

**Failure to follow this instruction will result in death or serious injury.**

To measure the DC bus capacitor voltage:

1. Observe the lockout/tagout procedures as identified in OSHA Standard 29 CFR, Subpart J covering:
  - 1910.147: The control of hazardous energy (lockout/tagout).
  - 1910.147: App A, Typical minimal lockout procedures.
2. Open the disconnect between the input line and the drive controller. Lock the disconnect in the open position and install a “Do Not Turn On” sign. Open the circuit breaker disconnect located on the front of the drive controller. Also, be sure to remove all external control power that may be present such as on the control board and the option board terminals.

3. Wait ten minutes for the DC bus capacitors to discharge.
4. Open the door of the drive controller.
5. Set the voltmeter to the 1000 Vdc scale. Measure the voltage between the (+) and (-) terminals. See Figures 11 and 12 for terminal locations.
6. Verify that the DC bus voltage has discharged below 45 V before servicing the drive controller. If the DC bus capacitors will not discharge below 45 V, contact your local Square D representative. **Do not operate the drive controller.**
7. After servicing the drive controller, close and secure the door.

**Figure 11: DC Bus Measurement Terminals on the Power Converter (1–75 hp CT and 1–100 hp VT @ 460 V, 1–40 hp CT and 1–50 hp VT @ 208/230 V controllers)**

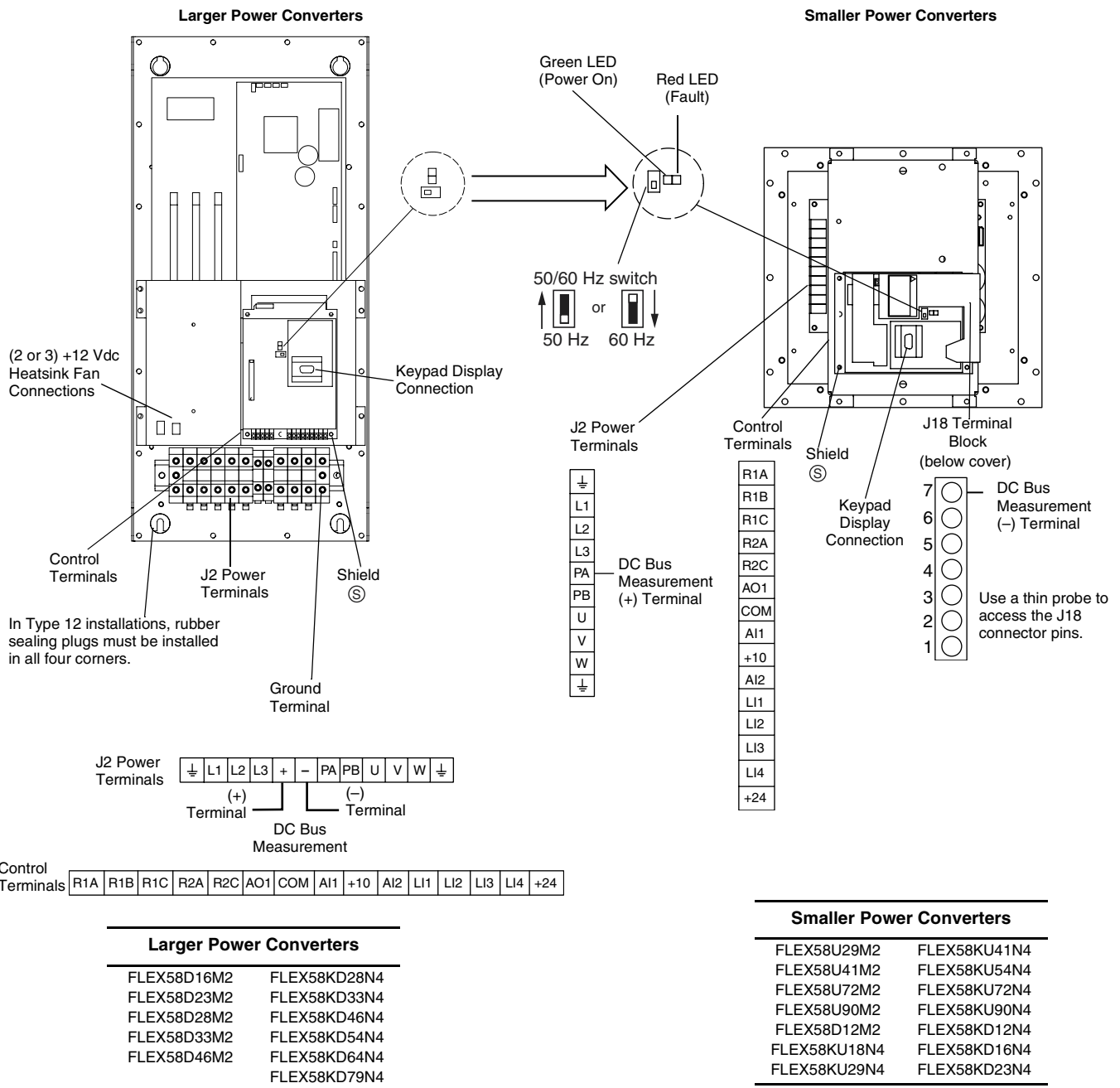
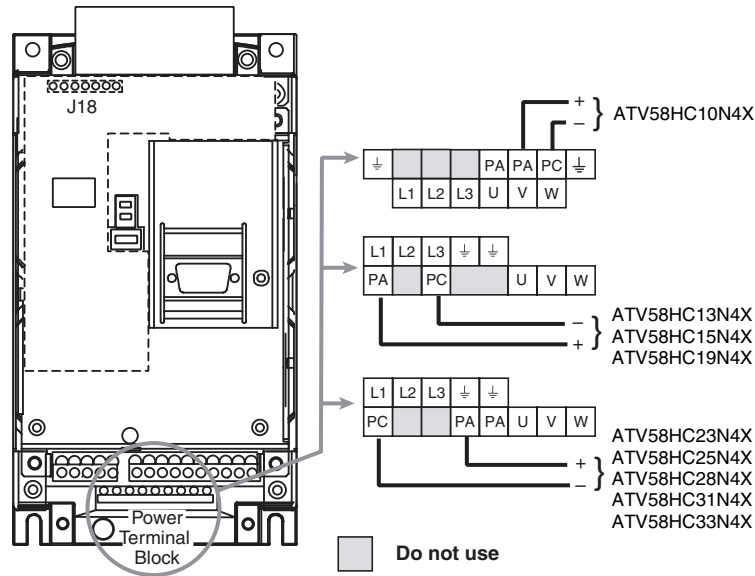

Figure 12: DC Bus Measurement Terminals on the Power Converter (125–500 hp VT @ 460 V controllers)



## WIRE ROUTING AND INTERCONNECTION

### Wire Class

The Wire Class describes the compatibility of the field wiring terminal with the conductor material and insulation system. When used in conjunction with the required conductor current rating and controller ambient temperature rating, the Wire Class forms the basis for selecting a conductor size that limits the temperature on the conductor insulation at the field wiring terminal to acceptable limits. Although it is permissible to use conductors with operating temperatures exceeding those given by the Wire Class, conductor **size** must fall within the Wire Class limits.

### Noise Class

The Noise Class categorizes the electromagnetic properties of the voltages and currents present. The Noise Class is comprised of the six categories shown in Table 24.

Table 24: Noise Class Categories

Noise Class	Definition
Quiet Wiring 1 (QW1)	High susceptibility to analog and digital control signals. Signals falling under this classification include digital communication/network circuits, controller analog I/O and analog process signals.
Quiet Wiring 2 (QW2)	Medium susceptibility to analog and digital control signals. Signals falling under this classification include 24 Vdc and Vac control circuits.
Standard Wiring 1 (SW1)	Low susceptibility to control or power circuits rated less than 600 Vac (250 Vdc) and less than 15 A (voltage and current spectra are generally contained within 0.05–9 kHz). Signals falling under this classification include 120 Vac control circuits.
Standard Wiring 2 (SW2)	Power circuits rated greater than 15 A (voltage and current spectra are generally contained within 0.05–9 kHz). Signals falling under this classification include line power to controllers.
Standard Wiring 3 (SW3)	Reserved.
Pulse Wiring 1 (PW1)	Control or power circuits whose voltage or current spectra significantly exceed 9 kHz. Signals falling under this classification include motor and dynamic braking circuits fed from pulse width modulation (PWM) power converters.

**Voltage Class**

The Voltage Class categorizes the voltages present into recognized conductor insulation categories (30, 150, 300, and 600 V) for selection of the conductor voltage rating and physical segregation purposes.

**Wiring Methods**

Based upon the Noise Class and Voltage Class of the conductors, apply the wiring methods in Table 25 to the drive controller system.

**Table 25: Wire Routing and Interconnection**

Wiring Methods and Considerations	Noise Class of Conductors				
	QW1	QW2	SW1	SW2	PW1
<b>Conductor Grouping in Wireways/Conduits</b>					
1. All conductors of 1 or 3 phase AC power circuits must be bundled to minimize stray magnetic fields.			X	X	X
2. All conductors of a DC power circuit must be bundled to minimize stray magnetic fields.			X	X	X
3. When paralleled conductors must be run in separate wireways or conduit, bundle conductors into groups that minimize stray magnetic fields.				X	X
4. Maintain conductor runs as short and direct as practical.	X	X	X	X	X
<b>Separation of Circuits</b>					
1. DO NOT run different Noise Class conductors in the same conduit.	X	X	X	X	X
2. DO NOT run different Voltage Class conductors in the same conduit unless all conductors are insulated for the maximum Voltage Class present.	X	X	X	X	X
3. All PW conductor groups must be individually segregated using metallic conduit.					X
4. Segregate all conductors by Noise Class. Use the following circuit separation when conductors can run parallel for more than 12 in. (305 mm)					
• Metallic conduit: 3 in. (76 mm) between QW to SW/PW	X	X	X	X	X
• Metallic tray: 3 in. (76 mm) between SW to PW			X	X	X
• Metallic tray: 6 in. (152 mm) between QW to SW/PW	X	X	X	X	X
• Against continuous metal surface: 3 in. (76 mm) between SW to PW			X	X	X
• Against continuous metal surface: 6 in. (152 mm) between QW to SW/PW	X	X	X	X	X
• Metallic conduit housing QW: 12 in. (305 mm) to non-metallic conduit SW/PW	X	X	X	X	X
• Non-metallic conduit: 3 in. (76 mm) between SW to PW			X	X	X
• Non-metallic conduit: 24 in. (610 mm) between QW to SW/PW	X	X	X	X	X
5. If QW and SW1 wiring must cross SW2 or PW1 wiring, the bundles must cross at right angles.	X	X	X	X	X
<b>Common Mode Noise Issues</b>					
1. Provide adjacent signal returns using twisted pair cable.	X	X			
2. Galvanically isolate signal and associated signal return path when possible.	X	X			
<b>Shielding</b>					
1. Use metallic conduit for all power and control circuits external to the controller enclosure.	X	X	X	X	X
2. Shields should be continuous and equipped with a drain wire.	X	X	X		
3. DO NOT group different Noise Class conductors within the same shield.	X	X	X	X	X
4. Minimize non-shielded portion of conductor at the ends of shielded cable.	X	X	X	X	X
5. When shielding AC or DC power conductors, group conductors to minimize magnetic field in shield.			X	X	X
<b>Grounding</b>					
1. Ground shields only at the controller end.	X	X	X	X	X
2. Use separate ground wire for each shield ground.	X	X	X	X	X
3. Provide a ground wire with all conductor groups whether in tray or conduit.			X	X	X
4. When multiple grounds must be made to a shielded power cable, the shield must have the same short circuit withstand capability as the ground conductor in the power cable.			X	X	X
5. Terminate all power grounds and power shield grounds to the controller grounding point or bar.			X	X	X
6. Terminate all signal shield grounds to the terminals provided.	X	X			
7. Always supply a separate equipment grounding conductor with the controller power feed. DO NOT depend upon metallic conduit for ground connection.			X	X	X

**COMPONENT IDENTIFICATION AND  
TERMINAL STRIP LOCATIONS**

Figures 13 and 14 show component identification and terminal strip locations for Class 8839 58M drive controllers 1–20 hp constant torque at 460 V, 1–25 hp variable torque at 460 V, and 1–10 hp constant torque and variable torque at 208/230 V. Tables 27–31 (pages 52–56) list wire size range and terminal torque requirements.

**Figure 13: Component Identification and Terminal Strip Locations for 1–20 hp CT @ 460 V, 1–25 hp VT @ 460 V, and 1–10 hp CT/VT @ 208/230 V**

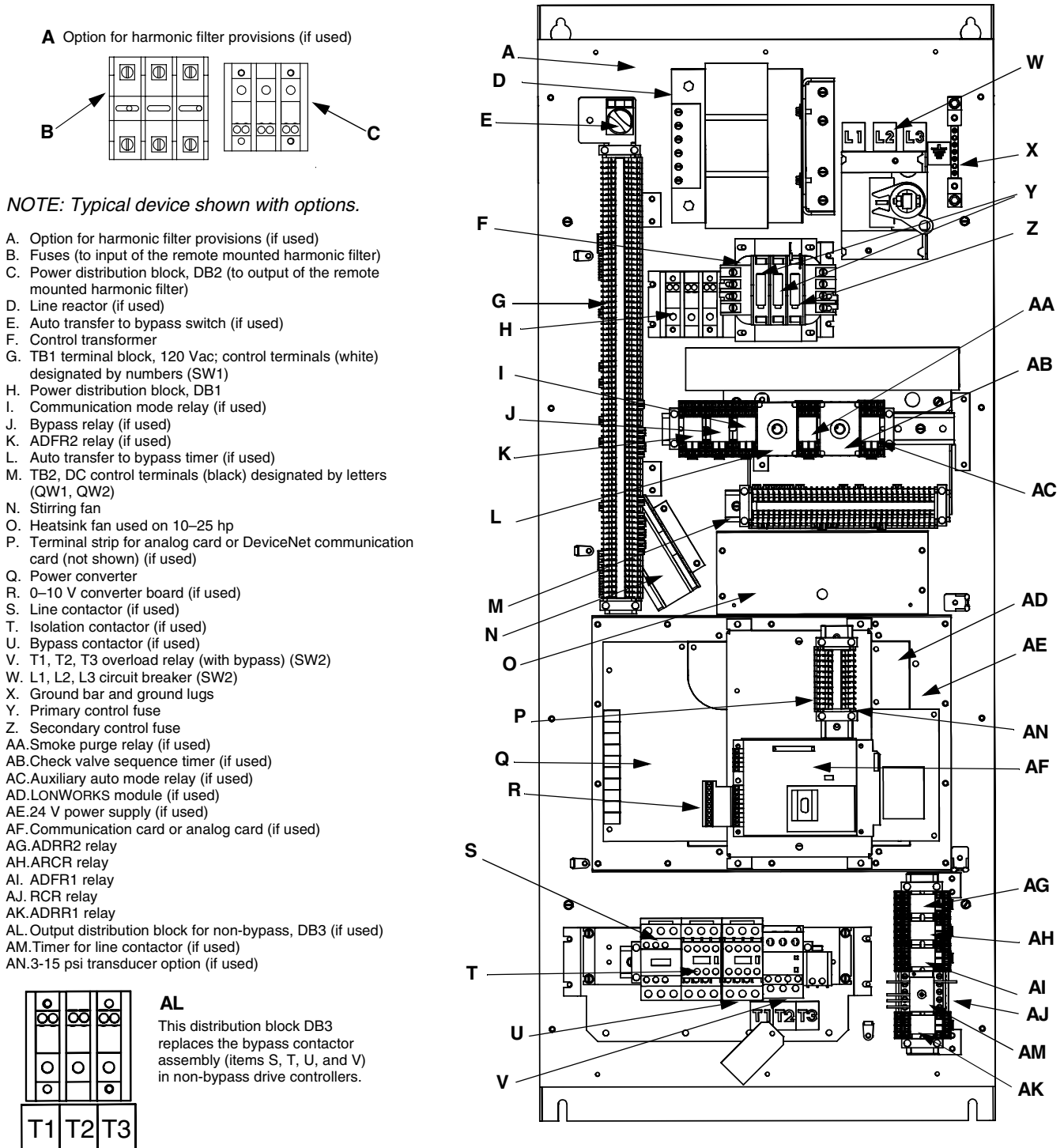

**Figure 14: Barriered Bypass Component Identification and Terminal Strip Locations for 1–20 hp CT @ 460 V, 1–25 hp VT @ 460 V, and 1–10 hp CT/VT @ 208/230 V**

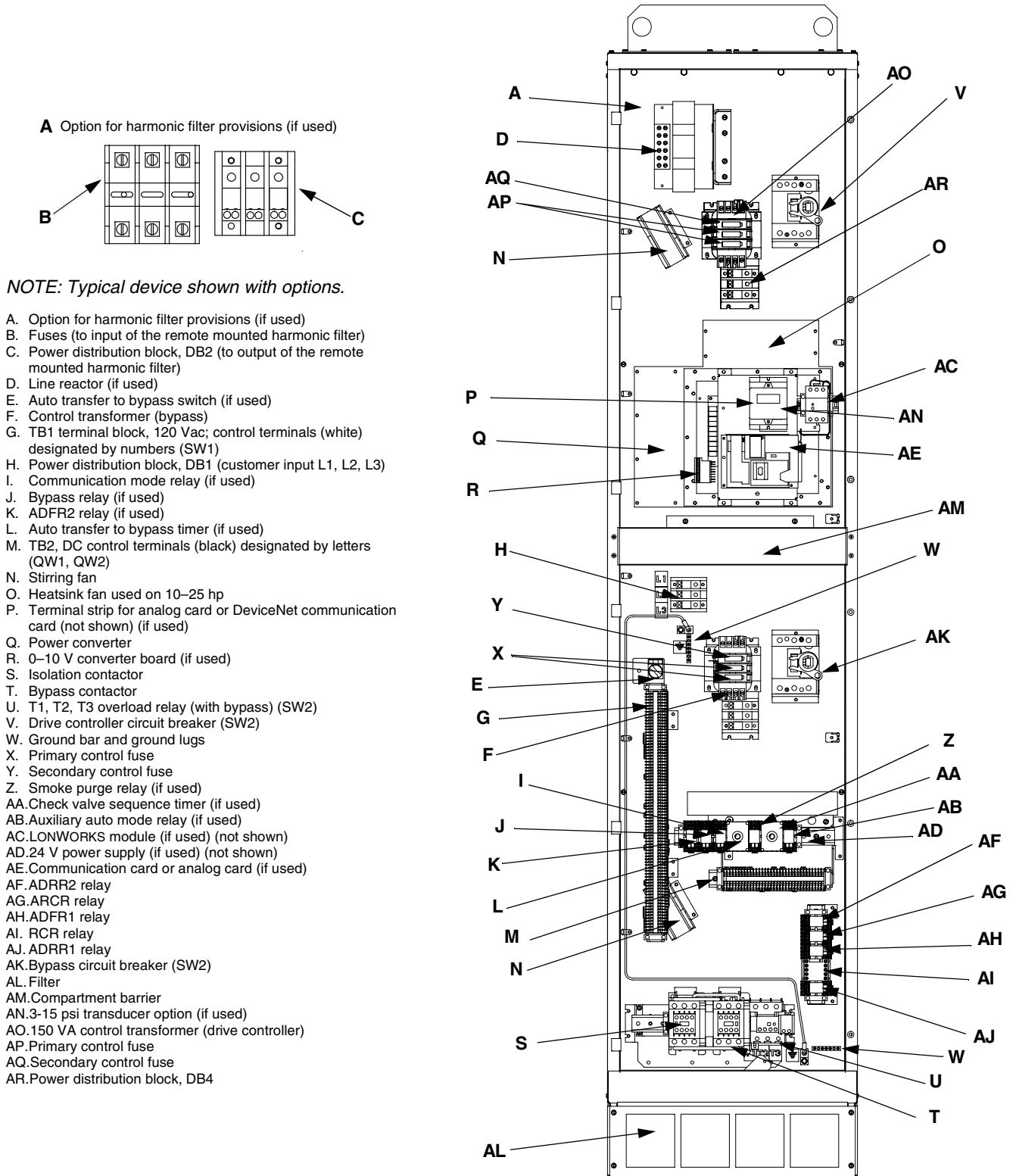
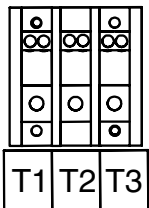
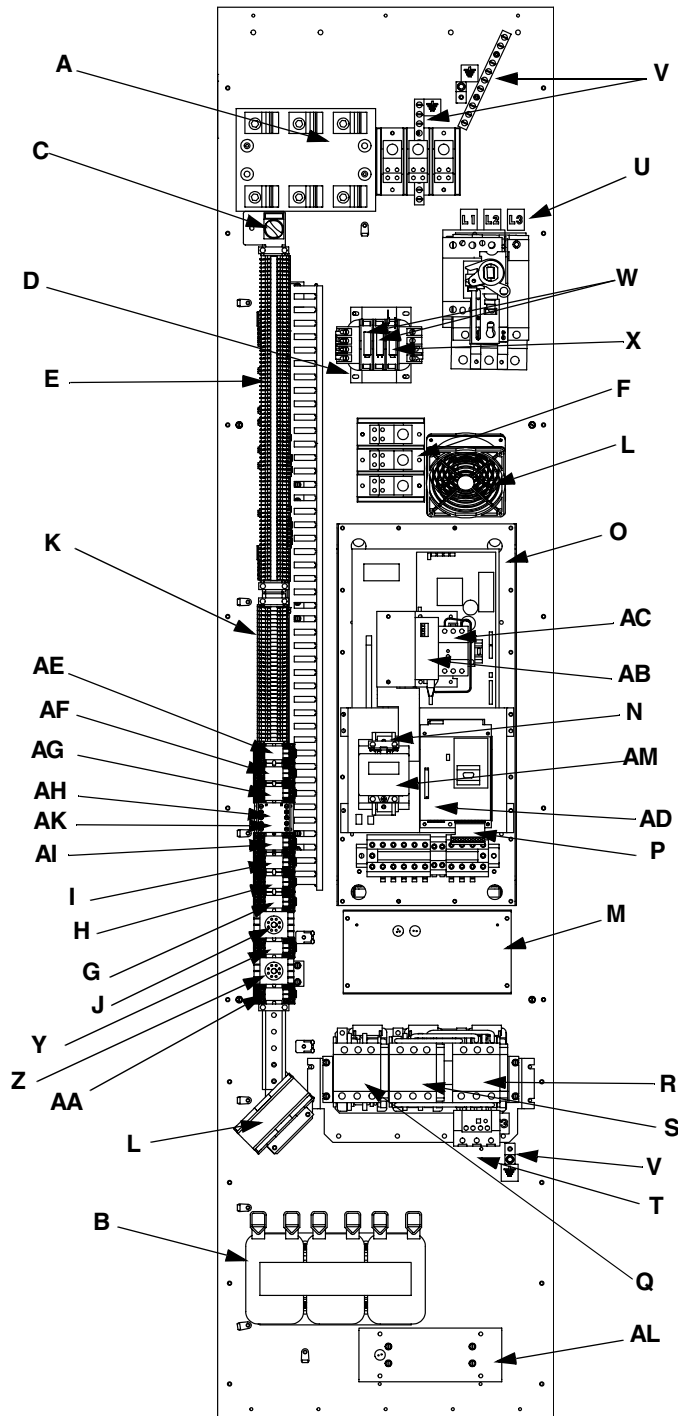

Figure 15 shows component identification and terminal strip locations for Class 8839 58M drive controllers 25–75 hp constant torque, 30–100 hp variable torque at 460 V and 15–40 hp constant torque, 15–50 hp variable torque at 208/230 V. Tables 27–31 (pages 52–56) list wire size range and terminal torque requirements.

**Figure 15: Component Identification and Terminal Strip Locations for 25–75 hp CT, 30–100 hp VT @ 460 V and 15–40 hp CT, 15–50 hp VT @ 208/230 V**

*NOTE: Typical device shown with options.*

- A. Option for harmonic filter provisions (if used):  
Fuses (to input of the remote mounted harmonic filter)  
Power distribution block, DB2 (to output of the remote mounted harmonic filter)
- B. Line reactor (if used)
- C. Auto transfer to bypass switch (if used)
- D. Control transformer
- E. TB1 terminal block, 120 Vac; control terminals (white) designated by numbers (SW1)
- F. Power distribution block DB1
- G. Communication mode relay (if used)
- H. Bypass relay (if used)
- I. ADFR2 relay (if used)
- J. Auto transfer to bypass timer (if used)
- K. TB2, DC control terminals (black) designated by letters (QW1, QW2)
- L. Stirring fan
- M. Heatsink fan
- N. Terminal strip for analog card or communication card (not shown) (if used)
- O. Power converter
- P. 0–10 V converter board (if used)
- Q. Line contactor (if used)
- R. Bypass contactor (if used)
- S. Isolation contactor (if used)
- T. T1, T2, T3 overload relay (with bypass) (SW2)
- U. L1, L2, L3 circuit breaker (SW2)
- V. Ground bar and ground lugs
- W. Primary control fuses
- X. Secondary control fuses
- Y. Smoke purge relay (if used)
- Z. Check valve sequence timer (if used)
- AA. Auxiliary auto mode relay (if used)
- AB. LONWORKS module (if used) (not shown)
- AC. 24 V power supply (if used)
- AD. Communication card or analog card (if used) (not shown)
- AE. ADRR2 relay
- AF. ARCR relay
- AG. ADFR1 relay
- AH. RCR relay
- AI. ADRR1 relay
- AJ. Output distribution block for non-bypass, DB3 (if used)
- AL. Plenum fan
- AM. 3-15 psi transducer option (if used)



**AJ**  
This distribution block DB3 replaces the bypass contactor assembly (items Q, R, S, and T) in non-bypass drive controllers.

Figure 16 shows component identification and terminal strip locations for Class 8839 58M drive controllers 125–500 hp variable torque at 460 V. Tables 27–31 (pages 52–56) list wire size range and terminal torque requirements.

**Figure 16: Typical Component Identification and Terminal Strip Locations for 125–500 hp @ 460 V without Bypass**

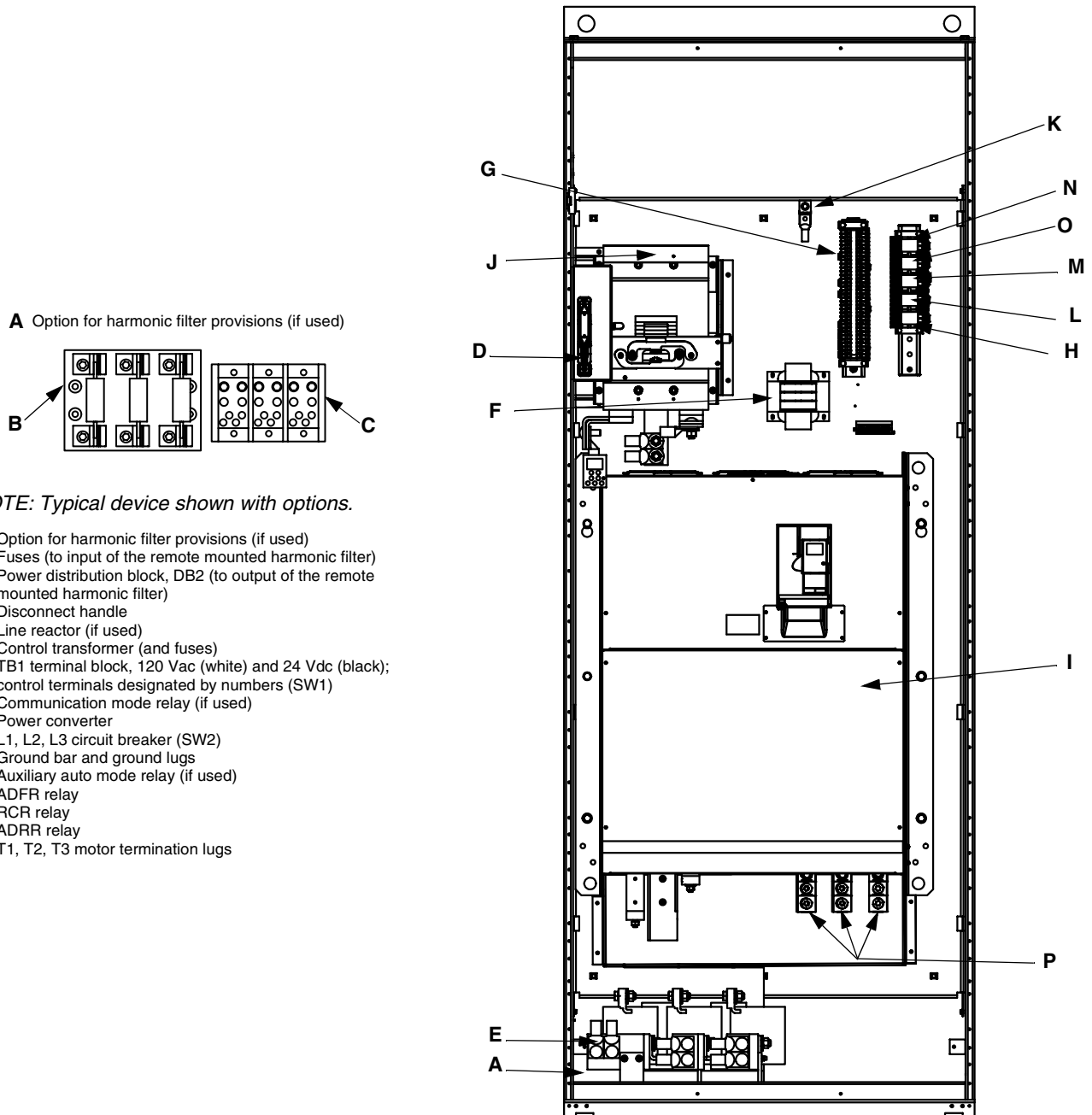

*NOTE: Typical device shown with options.*

- A. Option for harmonic filter provisions (if used)
- B. Fuses (to input of the remote mounted harmonic filter)
- C. Power distribution block, DB2 (to output of the remote mounted harmonic filter)
- D. Disconnect handle
- E. Line reactor (if used)
- F. Control transformer (and fuses)
- G. TB1 terminal block, 120 Vac (white) and 24 Vdc (black); control terminals designated by numbers (SW1)
- H. Communication mode relay (if used)
- I. Power converter
- J. L1, L2, L3 circuit breaker (SW2)
- K. Ground bar and ground lugs
- L. Auxiliary auto mode relay (if used)
- M. ADFR relay
- N. RCR relay
- O. ADRR relay
- P. T1, T2, T3 motor termination lugs

Figures 17 and 18 show component identification and terminal strip locations for Class 8839 58M bypass drive controllers 125–200 hp variable torque at 460 V. Tables 27–31 (pages 52–56) list wire size range and terminal torque requirements.

**Figure 17: Typical Component Identification and Terminal Strip Locations for 125–200 hp @ 460 V with Integrated Bypass**

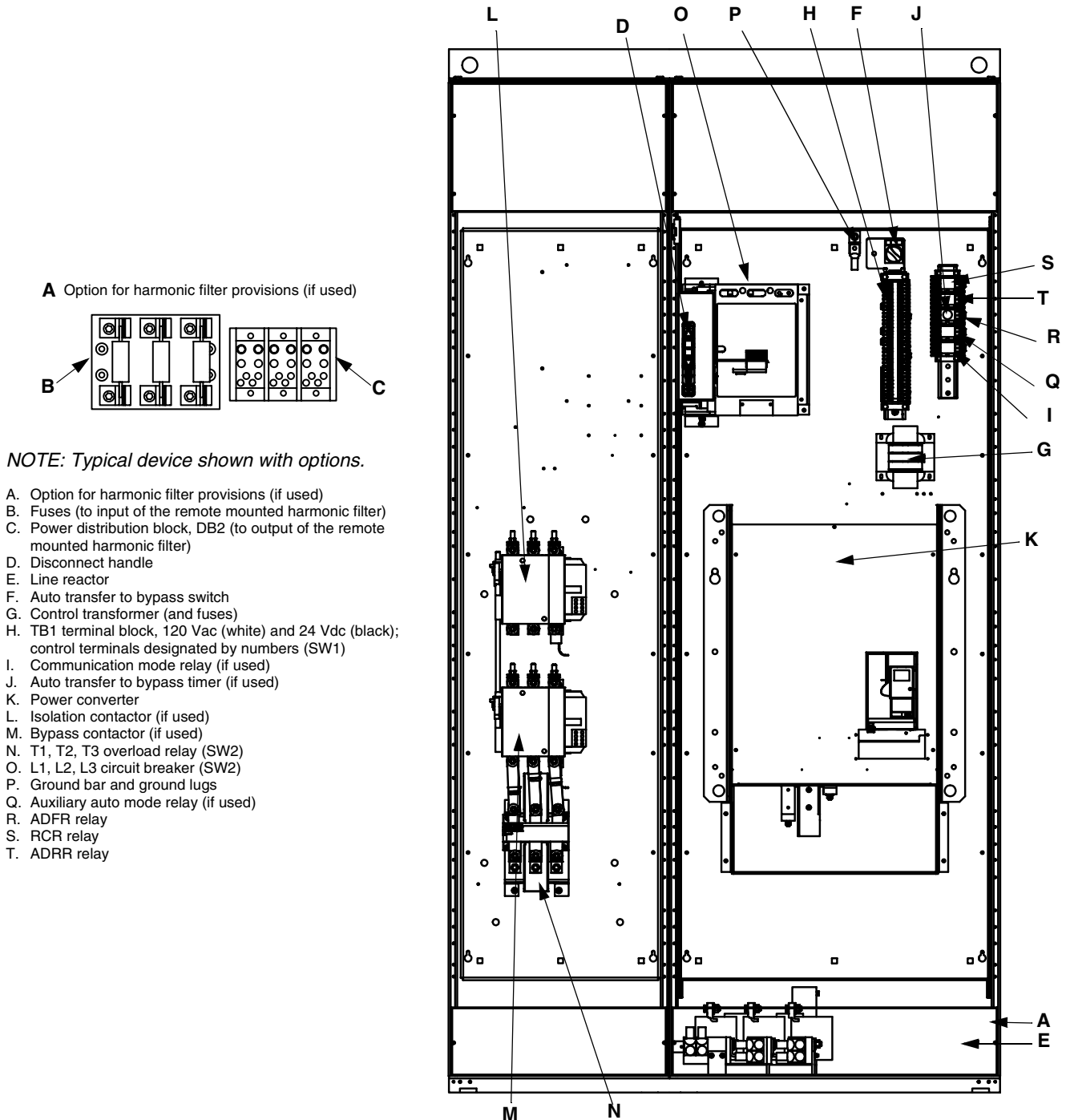

**Figure 18: Typical Component Identification and Terminal Strip Locations for 125–200 hp @ 460 V with Barriercd Bypass**

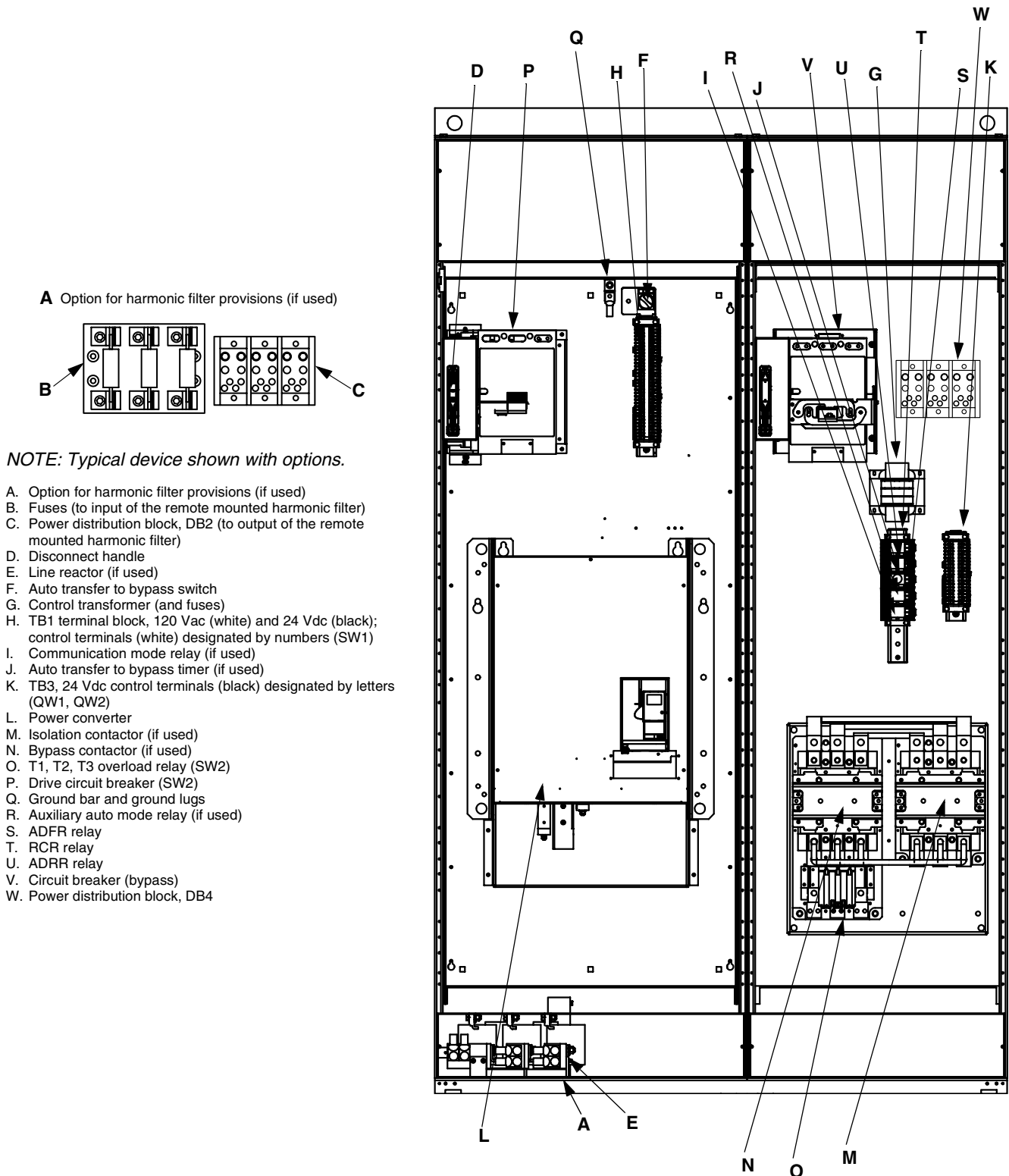

**POWER WIRING**

**Table 26: Power Terminal Functions [1]**

Terminal		Function
GND		Ground bar and ground lugs
L1, L2, L3	with and without integrated bypass	3-phase input power (at top of circuit breaker)
	with barriered bypass	3-phase input power (at distribution block DB1)
T1, T2, T3	with bypass	Output connections to motor (at bottom of overload relay)
	without bypass	Output connections to motor (power distribution block DB3), 1–100 hp
	without bypass	Output connections to motor (controller terminals), 125–500 hp
Output 1, Output 2, Output 3 [2]		Output from fuses to externally mounted harmonic filter.
Input 1, Input 2, Input 3 [2]		Input from externally mounted harmonic filter to drive controller.

1. For terminal locations refer to figures 13–15 on pages 46–48.
2. Only applicable with option 710, harmonic filter provision.

**Table 27: Power Terminal Wire Range, 460 V, Power Circuit W (Without Bypass)**

Drive Controller Catalog No. [1]	hp	Terminals							
		Maximum Wire Size AWG (mm <sup>2</sup> ) [2]	Terminal Torque lb-in (N•m)	Maximum Wire Size AWG (mm <sup>2</sup> ) [2]	Terminal Torque lb-in (N•m)	Maximum Wire Size AWG (mm <sup>2</sup> ) [2]	Terminal Torque lb-in (N•m)	Maximum Wire Size AWG (mm <sup>2</sup> ) [2]	Terminal Torque lb-in (N•m)
		L1, L2, L3 (Line) Circuit Breaker		T1, T2, T3 (Load) Distribution Block, DB3		GND Bar		GND Lugs	
58MC•4◊W_	1	1/0 (53.5)	50 (5.65)	2/0 (67.4)	35 (4.0)	4 (21.15)	15 (1.69)	4/0 (107)	110 (12.43)
58MD•4◊W_	2								
58ME•4◊W_	3								
58MF•4◊W_	5								
58MG•4◊W_	7.5								
58MH•4◊W_	10								
58MJ•4◊W_	15	1/0 (53.5)	50 (5.65)	2/0 (67.4)	40 (4.5)	4 (21.15)	15 (1.69)	4/0 (107)	110 (12.43)
58MK•4◊W_	20								
58ML•4VW_	25								
58ML•4CW_	25								
58MM•4◊W_	30								
58MN•4◊W_	40								
58MP•4VW_	50	1/0 (53.5)	80 (9.04)	400 (203)	250 (28.25)	1/0 (53.5)	45 (5.08)	4/0 (107)	110 (12.43)
58MP•4CW_	50								
58MQ•4◊W_	60								
58MR•4◊W_	75								
58MS•4VW_	100								
58MT▼4V_	125								
58MU▼4V_	150	1—600 (304) or 2—250 (127)	375 (42.36)	500 (253)	375 (42.36)	250 (127)	200 (22.59)	300 (152)	275 (31.07)
58MW▼4V_	200								
58MX▼4V_	250								
58MY▼4V_	300	3—500 (253)	300 (33.89)	2—600 (304)	375 (42.36)	250 (127)	200 (22.59)	300 (152)	275 (31.07)
58MZ▼4V_	350								
58M4▼4V_	400								
58M5▼4V_	450								
58M6▼4V_	500								

1. “◊” can be “A” or “G”. “A” denotes a Type 12 enclosure; “G” denotes a Type 1 enclosure.  
 “▼” can be “G” or “B”. “G” denotes a Type 1 enclosure; “B” denotes a Type 1G enclosure.  
 “◊” can be “C” or “V”. “C” denotes a constant torque controller; “V” denotes a variable torque controller.  
 “\_” indicates that the catalog number continues. See pages 10 and 11 for a detailed description of catalog numbers.
2. 75 °C copper.

**Table 28: Power Terminal Wire Range, 460 V, Power Circuit Y (With Integrated Bypass)**

Drive Controller Catalog No. [1]		Terminals							
		Maximum Wire Size AWG (mm <sup>2</sup> ) [2]	Terminal Torque lb-in (N•m)	Maximum Wire Size AWG (mm <sup>2</sup> ) [2]	Terminal Torque lb-in (N•m)	Maximum Wire Size AWG (mm <sup>2</sup> ) [2]	Terminal Torque lb-in (N•m)	Maximum Wire Size AWG (mm <sup>2</sup> ) [2]	Terminal Torque lb-in (N•m)
	hp	L1, L2, L3 (Line) Circuit Breaker		T1, T2, T3 (Load) Overload Relay		GND Bar		GND Lugs	
58MC•4◊Y_	1	1/0 (53.5)	50 (5.65)	8 (8.37)	15 (1.69)	4 (21.15)	15 (1.69)	4/0 (107)	110 (12.43)
58MD•4◊Y_	2								
58ME•4◊Y_	3								
58MF•4◊Y_	5								
58MG•4◊Y_	7.5								
58MH•4◊Y_	10								
58MJ•4◊Y_	15	1/0 (53.5)	50 (5.65)	1/0 (53.5)	15 (1.69)	4 (21.15)	15 (1.69)	4/0 (107)	110 (12.43)
58MK•4◊Y_	20								
58ML•4VY_	25								
58ML•4CY_	25								
58MM•4◊Y_	30								
58MN•4◊Y_	40								
58MP•4VY_	50	1/0 (53.5)	80 (9.04)	1/0 (53.5)	80 (9.04)	1/0 (53.5)	45 (5.08)	4/0 (107)	110 (12.43)
58MP•4CY_	50								
58MQ•4◊Y_	60								
58MR•4◊Y_	75								
58MS•4VY_	100								
58MT▼4V_	125								
58MU▼4V_	150	2—500 (253)	300 (33.89)	300 (152)	375 (31.25)	250 (127)	200 (22.59)	300 (152)	275 (31.07)
58MW▼4V_	200								

- “◊” can be “A” or “G”. “A” denotes a Type 12 enclosure; “G” denotes a Type 1 enclosure.
  - “▼” can be “G” or “B”. “G” denotes a Type 1 enclosure; “B” denotes a Type 1G enclosure.
  - “◊” can be “C” or “V”. “C” denotes a constant torque controller; “V” denotes a variable torque controller.
  - “\_” indicates that the catalog number continues. See pages 10 and 11 for a detailed description of catalog numbers.
- 75 °C copper.

**Table 29: Power Terminal Wire Range, 460 V, Power Circuit Y (With Barrired Bypass)**

Drive Controller Catalog No. [1]		Terminals							
		Maximum Wire Size AWG (mm <sup>2</sup> ) [2]	Terminal Torque lb-in (N•m)	Maximum Wire Size AWG (mm <sup>2</sup> ) [2]	Terminal Torque lb-in (N•m)	Maximum Wire Size AWG (mm <sup>2</sup> ) [2]	Terminal Torque lb-in (N•m)	Maximum Wire Size AWG (mm <sup>2</sup> ) [2]	Terminal Torque lb-in (N•m)
hp		L1, L2, L3 (Line) Distribution Block, DB3		T1, T2, T3 (Load) Overload Relay		GND Bar		GND Lugs	
58MC•4ϕY_	1	2/0 (67.4)	35 (4.0)	8 (8.37)	15 (1.69)	4 (21.15)	15 (1.69)	4/0 (107)	110 (12.43)
58MD•4ϕY_	2								
58ME•4ϕY_	3								
58MF•4ϕY_	5								
58MG•4ϕY_	7.5								
58MH•4ϕY_	10								
58MJ•4ϕY_	15	2/0 (67.4)	40 (4.5)	8 (8.37)	15 (1.69)	4 (21.15)	15 (1.69)	4/0 (107)	110 (12.43)
58MK•4ϕY_	20	2/0 (67.4)	40 (4.5)	1/0 (53.5)	15 (1.69)	4 (21.15)	15 (1.69)	4/0 (107)	110 (12.43)
58ML•4VY_	25	2/0 (67.4)	40 (4.5)	1/0 (53.5)	80 (9.04)	4 (21.15)	15 (1.69)	4/0 (107)	110 (12.43)
58ML•4CY_	25	2/0 (67.4)	120 (3.6)	1/0 (53.5)	80 (9.04)	1/0 (53.5)	45 (5.08)	4/0 (107)	110 (12.43)
58MM•4ϕY_	30								
58MN•4ϕY_	40								
58MP•4VY_	50	400 (203)	250 (28.25)	1/0 (53.5)	80 (9.04)	1/0 (53.5)	45 (5.08)	4/0 (107)	110 (12.43)
58MP•4CY_	50	350 (177)	250 (28.25)	3/0 (85.0)	200 (22.59)	1/0 (53.5)	45 (5.08)	350 (177)	250 (28.25)
58MQ•4ϕY_	60								
58MR•4ϕY_	75								
58MS•4VY_	100								
58MT▼4V_	125	drive side: 350 (177)	drive side: 250 (20.83)	500 (253)	375 (31.25)	250 (127)	200 (22.59)	300 (152)	275 (31.07)
58MU▼4V_	150	bypass side: 1—600 (304) or 2—250 (127)	bypass side: 375 (31.25)						
58MW▼4V_	200								

- “a” can be “A” or “G”. “A” denotes a Type 12 enclosure; “G” denotes a Type 1 enclosure.  
 “▼” can be “G” or “B”. “G” denotes a Type 1 enclosure; “B” denotes a Type 1G enclosure.  
 “ϕ” can be “C” or “V”. “C” denotes a constant torque controller; “V” denotes a variable torque controller.  
 “\_” indicates that the catalog number continues. See pages 10 and 11 for a detailed description of catalog numbers.
- 75 °C copper.

**Table 30: Power Terminal Wire Range, 230 V**

Drive Controller Catalog No. [1]		Terminals							
		Maximum Wire Size AWG (mm <sup>2</sup> ) [2]	Terminal Torque lb-in (N•m)	Maximum Wire Size AWG (mm <sup>2</sup> ) [2]	Terminal Torque lb-in (N•m)	Maximum Wire Size AWG (mm <sup>2</sup> ) [2]	Terminal Torque lb-in (N•m)	Maximum Wire Size AWG (mm <sup>2</sup> ) [2]	Terminal Torque lb-in (N•m)
Power Circuit W (Without Bypass) [1]	hp	L1, L2, L3 (Line) Circuit Breaker		T1, T2, T3 (Load) Distribution Block, DB3		GND Bar		GND Lugs	
58MC•3◊W_	1	1/0 (53.5)	50 (5.65)	2/0 (67.4)	35 (4.0)	4 (21.15)	15 (1.69)	4/0 (107)	110 (12.43)
58MD•3◊W_	2								
58ME•3◊W_	3								
58MF•3◊W_	5								
58MG•3◊W_	7.5	1/0 (53.5)	50 (5.65)	2/0 (67.4)	40 (4.5)	4 (21.15)	15 (1.69)	4/0 (107)	110 (12.43)
58MH•3◊W_	10								
58MJ•3◊W_	15	1/0 (53.5)	50 (5.65)	2/0 (67.4)	120 (3.6)	1/0 (53.5)	45 (5.08)	4/0 (107)	110 (12.43)
58MK•3VW_	20	1/0 (53.5)	50 (5.65)	400 (203)	250 (28.25)	1/0 (53.5)	45 (5.08)	4/0 (107)	110 (12.43)
58MK•3CW_	20								
58ML•3VW_	25	1/0 (53.5)	80 (9.04)	400 (203)	250 (28.25)	1/0 (53.5)	45 (5.08)	4/0 (107)	110 (12.43)
58ML•3CW_	25	1/0 (53.5)	80 (9.04)	350 (177)	250 (28.25)	1/0 (53.5)	45 (5.08)	350 (177)	250 (28.25)
58MM•3◊W_	30								
58MN•3◊W_	40	350 (177)	250 (28.25)	350 (177)	250 (28.25)	1/0 (53.5)	45 (5.08)	350 (177)	250 (28.25)
58MP•3VW_	50								

Power Circuit Y (With Bypass) [1]	hp	L1, L2, L3 (Line) [3]		T1, T2, T3 (Load) Overload Relay		GND Bar		GND Lugs	
58MC•3◊Y_	1	1/0 (53.5) † 2/0 (67.4) ‡	50 (5.65) † 35 (4.0) ‡	8 (8.37)	15 (1.69)	4 (21.15)	15 (1.69)	4/0 (107)	110 (12.43)
58MD•3◊Y_	2								
58ME•3◊Y_	3								
58MF•3◊Y_	5								
58MG•3◊Y_	7.5	1/0 (53.5) † 2/0 (67.4) ‡	50 (5.65) † 40 (4.5) ‡	8 (8.37)	15 (1.69)	4 (21.15)	15 (1.69)	4/0 (107)	110 (12.43)
58MH•3◊Y_	10	1/0 (53.5) † 2/0 (67.4) ‡	50 (5.65) † 40 (4.5) ‡	1/0 (53.5)	80 (9.04)	4 (21.15)	15 (1.69)	4/0 (107)	110 (12.43)
58MJ•3◊Y_	15	1/0 (53.5) † 2/0 (67.4) ‡	50 (5.65) † 120 (3.6) ‡	1/0 (53.5)	80 (9.04)	1/0 (53.5)	45 (5.08)	4/0 (107)	110 (12.43)
58MK•3VY_	20	1/0 (53.5) † 400 (203) ‡	50 (5.65) † 250 (28.25) ‡	1/0 (53.5)	80 (9.04)	1/0 (53.5)	45 (5.08)	4/0 (107)	110 (12.43)
58MK•3CY_	20								
58ML•3VY_	25	1/0 (53.5) † 400 (203) ‡	80 (9.04) † 250 (28.25) ‡	1/0 (53.5)	75 (8.47)	1/0 (53.5)	45 (5.08)	4/0 (107)	110 (12.43)
58ML•3CY_	25	1/0 (53.5) † 350 (177) ‡	80 (9.04) † 250 (28.25) ‡	3/0 (85.0)	200 (22.6)	1/0 (53.5)	45 (5.08)	350 (177)	250 (28.25)
58MM•3◊Y_	30								
58MN•3◊Y_	40	350 (177) †, ‡	250 (28.25) †, ‡	3/0 (85.0)	200 (22.6)	1/0 (53.5)	45 (5.08)	350 (177)	250 (28.25)
58MP•3VY_	50								

1. "◊" can be "A", "G". "A" denotes a Type 12 enclosure; "G" denotes a Type 1 enclosure.  
"◊" can be "C" or "V". "C" denotes a constant torque controller; "V" denotes a variable torque controller.  
"\_" indicates that the catalog number continues. See pages 10 and 11 for a detailed description of catalog numbers.
2. 75 °C copper.
3. "†" denotes the torque for an integrated bypass enclosure. L1, L2, and L3 in an integrated bypass enclosure are located on the circuit breaker.  
"‡" denotes the torque for a barriered bypass enclosure. L1, L2, and L3 in a barriered bypass enclosure are located on the distribution block, DB1.

**Table 31: Power Terminal Wire Range, 208 V**

Drive Controller Catalog No. [1]		Terminals							
		Maximum Wire Size AWG (mm <sup>2</sup> ) [2]	Terminal Torque lb-in (N•m)	Maximum Wire Size AWG (mm <sup>2</sup> ) [2]	Terminal Torque lb-in (N•m)	Maximum Wire Size AWG (mm <sup>2</sup> ) [2]	Terminal Torque lb-in (N•m)	Maximum Wire Size AWG (mm <sup>2</sup> ) [2]	Terminal Torque lb-in (N•m)
Power Circuit W (Without Bypass) [1]	hp	L1, L2, L3 (Line) Circuit Breaker		T1, T2, T3 (Load) Distribution Block, DB3		GND Bar		GND Lugs	
58MC•2∅W_	1	1/0 (53.5)	50 (5.65)	2/0 (67.4)	35 (4.0)	4 (21.15)	20 (2.26)	4/0 (107)	110 (12.43)
58MD•2∅W_	2								
58ME•2∅W_	3								
58MF•2∅W_	5								
58MG•2∅W_	7.5	1/0 (53.5)	50 (5.65)	2/0 (67.4)	40 (4.5)	4 (21.15)	20 (2.26)	4/0 (107)	110 (12.43)
58MH•2∅W_	10								
58MJ•2∅W_	15	1/0 (53.5)	50 (5.65)	2/0 (67.4)	120 (3.6)	1/0 (53.5)	45 (5.08)	4/0 (107)	110 (12.43)
58MK•2VW_	20	1/0 (53.5)	80 (9.04)	400 (203)	250 (28.25)	1/0 (53.5)	45 (5.08)	4/0 (107)	110 (12.43)
58MK•2CW_	20								
58ML•2VW_	25								
58ML•2CW_	25	1/0 (53.5)	80 (9.04)	350 (177)	250 (28.25)	1/0 (53.5)	45 (5.08)	350 (177)	250 (28.25)
58MM•2∅W_	30								
58MN•2∅W_	40	350 (177)	250 (28.25)	350 (177)	250 (28.25)	1/0 (53.5)	45 (5.08)	350 (177)	250 (28.25)
58MP•2VW_	50								

Power Circuit Y (With Bypass) [1]	hp	L1, L2, L3 (Line) [3]		T1, T2, T3 (Load) Overload Relay		GND Bar		GND Lugs	
58MC•2∅Y_	1	1/0 (53.5) † 2/0 (67.4) ‡	50 (5.65) † 35 (4.0) ‡	8 (8.37)	15 (1.69)	4 (21.15)	20 (2.26)	4/0 (107)	110 (12.43)
58MD•2∅Y_	2								
58ME•2∅Y_	3								
58MF•2∅Y_	5								
58MG•2∅Y_	7.5	1/0 (53.5) † 2/0 (67.4) ‡	50 (5.65) † 40 (4.5) ‡	1/0 (53.5)	80 (9.04)	4 (21.15)	20 (2.26)	4/0 (107)	110 (12.43)
58MH•2∅Y_	10								
58MJ•2∅Y_	15	1/0 (53.5) † 2/0 (67.4) ‡	50 (5.65) † 120 (3.6) ‡	1/0 (53.5)	80 (9.04)	1/0 (53.5)	45 (5.08)	4/0 (107)	110 (12.43)
58MK•2VY_	20	1/0 (53.5) † 400 (203) ‡	80 (9.04) † 250 (28.25) ‡	1/0 (53.5)	80 (9.04)	1/0 (53.5)	45 (5.08)	4/0 (107)	110 (12.43)
58MK•2CY_	20								
58ML•2VY_	25								
58ML•2CY_	25	1/0 (53.5) † 350 (177) ‡	80 (9.04) † 250 (28.25) ‡	3/0 (85)	200 (22.6)	1/0 (53.5)	45 (5.08)	350 (177)	250 (28.25)
58MM•2∅Y_	30								
58MN•2∅Y_	40	350 (177) †, ‡	250 (28.25) †, ‡	3/0 (85)	200 (22.6)	1/0 (53.5)	45 (5.08)	350 (177)	250 (28.25)
58MP•2VY_	50								

1. “∅” can be “A”, “G”. “A” denotes a Type 12 enclosure; “G” denotes a Type 1 enclosure.  
 “∅” can be “C” or “V”. “C” denotes a constant torque controller; “V” denotes a variable torque controller.  
 “\_” indicates that the catalog number continues. See pages 10 and 11 for a detailed description of catalog numbers.  
 2. 75 °C copper.  
 3. “†” denotes the torque for an integrated bypass enclosure. L1, L2, and L3 in an integrated bypass enclosure are located on the circuit breaker.  
 “‡” denotes the torque for a barriered bypass enclosure. L1, L2, and L3 in a barriered bypass enclosure are located on the distribution block, DB1.

**CONTROL WIRING**

Refer to figures 13–15 on pages 46–48 for terminal block location.

**Table 32: TB1 Terminal Block Characteristics, 120 Vac Control**

Terminal	Function	Characteristics
1	Control power <sup>[2]</sup>	115 Vac (line side) 60 Hz <sup>[1]</sup>
1 to 2	Fire/Freezestat interlocks	Provision for user supplied, N.C. fire/freezestat contact
2 to 3	User emergency stop	Provision for user supplied, N.C. emergency freewheel stop contact
3 to 4	Jumper for customer use	Provision for user supplied, N.C. safety interlock contact
4 to 5	Jumper for customer use	Provision for user supplied, N.C. safety interlock contact
5 to 6	Check valve sequence contact	N.C. timed open contact from check valve sequence relay
7 to 11	Stop push button <sup>[3]</sup>	
8 to 11	Start push button (and holding circuit) <sup>[3]</sup>	
9 to 8	User-supplied auto start contact	
10 to 50	Auto mode pilot light	
18 to 32	Test contact of Test-Normal switch <sup>[3]</sup>	
25 to 26	Normal contact of Test-Normal switch <sup>[3]</sup>	
26 to 31	Isolation contactor coil and bypass contactor N.C. interlock <sup>[3]</sup>	
30 to 31	Bypass pilot light and bypass contactor coil <sup>[3]</sup>	
31 to 32	Line contactor coil <sup>[3]</sup>	
33 to 1	Drive controller internal relay (AFC fault) N.O. contact	
35 to 50	AFC fault pilot light	
36 to 1	Drive controller internal relay (AFC run) N.O. contact	
36 to 50	AFC run pilot light and run relay coils (ADRR1, ADRR2)	
37 to 1	Drive controller internal relay (AFC fault) N.C. contact	
39 thru 42	Reserved	
43 to 50	User-connected seal water solenoid <sup>[3]</sup>	
44 to 50	Factory connection for elapsed time meter <sup>[3]</sup>	
45 to 50	User-connected motor space heater <sup>[3]</sup>	
46 to 47	User-supplied N.C contact from check valve limit switch <sup>[3]</sup>	
48 to 49	Smoke purge relay coil connection (user supplied 115 Vac control)	
50	Control power, ground side	
50 to 1	Power On pilot light	
50 to 10	Auto mode pilot light	
50 to 12	Hand mode pilot light	
50 to 36	AFC run pilot light	
50 to 35	Fault pilot light	
51 to 53	ADRR1 N.C. contact for customer use	Standard controller run
52 to 53	ADRR1 N.O. contact for customer use	Standard controller run
54 to 56	ADFR1 N.C. contact for customer use	Standard controller fault
55 to 56	ADFR1 N.O. contact for customer use	Standard controller fault
57 to 58	ADRR1 N.O. contact for customer use <sup>[3]</sup>	Optional controller run
59 to 60	ADFR2 N.C. contact for customer use <sup>[3]</sup>	Optional controller fault
61 to 62	Bypass relay N.O. contact for customer use <sup>[3]</sup>	Optional bypass run
63 to 64	Auto mode N.O. contact for customer use <sup>[3]</sup>	Optional auto mode

1. Wall mount with standard transformer has 50 VA available, (30 VA with option E09, LONWORKS module)  
460 V 1–25 hp VT, 1–20 hp CT  
208/230 V 1–10 hp VT/CT  
Whereas floor mount below 100 hp has 20 VA available, (0 VA with option E09, LONWORKS module)  
460 V 30–100 hp VT, 25–75 hp CT  
208/230 V 15–50 hp VT, 15–40 hp CT  
Floor mount for 125–500 hp has 20–50 VA for customer use
2. Approximately 50 VA additional to standard is available with option 110 (additional VA transformer).
3. Available only when this option is provided.

**Table 33: Terminal Block Characteristics, 24 Vdc Control  
1–100 hp: TB2  
125–500 hp: Black Terminals**

Terminal [1, 2]	Function	Characteristics
O	+24 V (+24 V control supply)	Minimum: 20 V; Maximum: 30 V; I = 140 mA maximum [3]
N	+24 V (common)	
B	LI3 (Logic Input 3) programmed for reference switching Auto/Manual	24 Vdc, 10 mA State 0: V<5 V; State 1: V>11 V; Z = 3.5 kΩ
C	LI4 (Logic Input 4) programmed for fault reset. Communication option programmed for forced local.	24 Vdc, 10 mA State 0: V<5 V; State 1: V>11 V; Z = 3.5 kΩ
D	LI2 (Logic Input 2) is programmed for Freewheel Stop on bypass. Without bypass it is not assigned.	24 Vdc, 10 mA State 0: V<5 V; State 1: V>11 V; Z = 3.5 kΩ
E	LI1 (Logic Input 1) Run Forward	24 Vdc, 10 mA State 0: V<5 V; State 1: V>11 V; Z = 3.5 kΩ
F	Line contactor auxiliary contact or jumper (if used)	24 Vdc, 10 mA State 0: V<5 V; State 1: V>11 V; Z = 3.5 kΩ
G1 (S2+)	AI2 (Analog Input 2: Speed Reference Current)	4–20 mA [4], Z = 100 Ω
G2 (S2–)	A jumper to the G1 (S2+) terminal is factory installed unless the 0–10 V Auto speed reference option is selected.	
H	+10 V Reference Supply	10 V, I = 10 mA maximum
I or W	AI1 (Analog Input 1: Speed Reference Voltage)	0–10 V, Z = 30 kΩ
J (S3)	COM (Speed Reference Common)	0 V
S1	Shield	

*Notes to Table 33:*

1. See the drawings provided separately.
2. All terminals are rated 600 V, 30 A (Class 9080 Type GM6). Max. wire size for all terminals: 10 AWG (5.26 mm<sup>2</sup>). Tightening Torque: 7–8 lb-in (0.8–0.9 N•m).
3. Total current of +24 V internal supply is 140 mA. If more current is required, an external supply must be used.
4. 0–20 mA, X–Y programmable with keypad display.

**Table 34: 58M User Terminal Connections**

TB1 *	Option	User Terminals	
120 Vac (for additional VA use)	110	1	50
Safety Interlocks	standard	1	2
Emergency Stop (door)	T10	2	3
Emergency Stop (user)	standard	3	4
Open	standard	4	5
AUTO Start Contacts	A07,B07,E07,F07	8	9
Seal Water Solenoid	V10	43	50
Motor Space Heater	U10	45	50
Check Valve N.C. Contact	W10	46	47
N.C. AFC Fault Contact	standard	54	55
N.O. AFC Fault Contact	standard	56	55
N.C. AFC Run Contact	standard	51	53
N.O. AFC Run Contact	standard	52	53
SPR Coil	E10	48	49
N.O. Bypass Run Contact	M10	61	62
N.O. Auto Mode Contact	O10	63	64
N.C. AFC Fault Contact	L10	59	60
N.O. AFC Run Contact	K10	57	58

TB2 *	Option	User Terminals		
24 Vdc	Z10	O (+)	N (-)	
Speed Potentiometer Input	standard	H (+10V)	I (IN)	J (S3) Com
4-20 mA Input	standard	G1 (S2+) IN	J (S3) Com	
0 - 10 V Input	J10	G1 (S2+) IN	G2 (S2-) IN	
Analog Output # 1	standard	AO1	J (S3) Com	

TB3 *	Option	User Terminals	
Analog Output # 2	H09	AO	Com

\* Terminal connections enabled only when option selected

## INITIAL START-UP PROCEDURE

<b>⚠ DANGER</b>
<p><b>HAZARDOUS VOLTAGE</b></p> <p>Before working on this equipment, turn off all power supplying it and perform the bus voltage measurement procedure on page 42.</p> <p><b>FAILURE TO FOLLOW THIS INSTRUCTION WILL RESULT IN DEATH OR SERIOUS INJURY.</b></p>

<b>⚠ DANGER</b>
<p><b>UNQUALIFIED USER</b></p> <ul style="list-style-type: none"> <li>This equipment must be installed and serviced only by qualified personnel.</li> <li>Qualified personnel performing diagnostics or troubleshooting that requires electrical conductors to be energized must comply with NFPA 70 E - Standard for Electrical Safety Requirements for Employee Workplaces and OSHA Standards – 29 CFR Part 1910 Subpart S Electrical.</li> </ul> <p><b>Electrical shock will cause death or serious injury.</b></p>

**Figure 19: Keypad Access Switch**

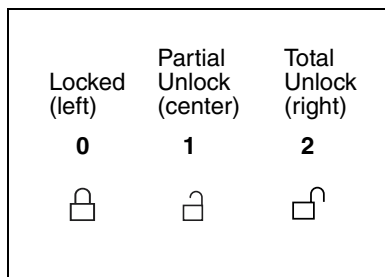

The Class 8839 58M drive controller has been configured for the installed options and tested at the factory. Minor adjustments to complete the field installation may be required based upon the application requirements. This initial start-up procedure should be followed step by step. In case of difficulty, refer to section 4, Maintenance and Support, beginning on page 83.

A door-mounted or remote-mounted keypad must be used to perform the initial start-up procedure. The keypad must be in the Total Unlock position to perform any drive controller programming. The keypad access switch is accessible through the back of the enclosure door. To set the keypad to Total Unlock, move the switch all the way to the right. To lock the keypad after programming, move the switch all the way to the left. Refer to Figure 19 for switch positions.

<b>⚠ DANGER</b>
<p><b>HAZARDOUS VOLTAGE</b></p> <ul style="list-style-type: none"> <li>Properly ground the controller panel before applying power.</li> <li>Close and secure the enclosure door before applying power.</li> <li>Certain adjustments and test procedures require that power be applied to this controller. Extreme caution must be exercised as hazardous voltages exist. The enclosure door must be closed and secured while turning on power or starting and stopping this controller.</li> </ul> <p><b>Failure to follow these instructions will result in death or serious injury.</b></p>

<b>⚠ WARNING</b>
<p><b>UNINTENDED CONFIGURATION CHANGES</b></p> <ul style="list-style-type: none"> <li>Changing the macro configurations or installing a new option card reconfigures the drive controller to factory settings.</li> <li>The controller configuration must be reinstalled.</li> </ul> <p><b>Failure to follow these instructions can result in death or serious injury.</b></p>

*After replacing the power converter or installing any plug-in option card, the programming parameters must be set as listed in the elementary diagram that corresponds to the options ordered. See the diagrams provided with the controller.*

*In addition, after installing any plug-in option card for the first time, previously-saved parameters downloaded from the keypad or PC software will not be correct because they do not include the additional parameters available with the card. The analog card parameters must be set as listed in the elementary diagram that corresponds to the options ordered. See the diagrams provided with the controller.*

## START-UP PROCEDURE

### STEP 1: CHECKING THE ENCLOSURE COMPONENTS AND CONNECTIONS

Figure 20: 50/60 Hz Switch

(See Figure 11 on page 43 for switch location)

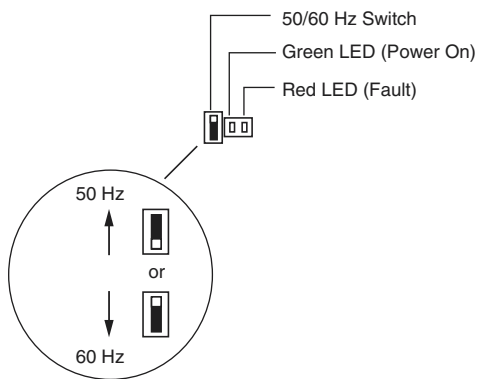

With all incoming power removed, make the following equipment checks:

- ❑ Step 1: Check the enclosure components and connections (page 61).
  - ❑ Step 2: Provide motor overload protection and thermal protection (page 62).
  - ❑ Step 3: Test motor rotation (page 62).
  - ❑ Step 4: If your controller has a bypass, test the motor rotation in bypass mode (page 63).
  - ❑ Step 5: Check the keypad display high speed, low speed, acceleration, and deceleration settings (page 64).
- A. Verify that all equipment disconnects are open.
  - B. Set the Hand-Off-Auto selector switch (controller mounted or remote mounted) to Off and the AFC-Off-Bypass switch (if used) to Off.
  - C. Set the speed potentiometer (controller mounted or remote mounted) to its minimum setting (full counterclockwise position).
  - D. Open the enclosure door. Turn the circuit breaker and handle assembly to the Off position as shown in Figure 8 on page 37, and unscrew the door thumbscrews or quarter-turn fasteners.
  - E. Check the wiring of the input power ground, motor ground, speed potentiometer (if remote mounted), and Hand-Off-Auto circuit connections (if remote mounted). See the control circuit elementary diagrams provided separately, and the power circuit descriptions starting on page 73, for wiring diagrams of the remote control operators.
  - F. When using the bypass circuit, check that the motor conductors are wired to the T1, T2, and T3 terminals of the overload relay. When using the power circuit *without* bypass, ensure that the motor conductors are wired to T1, T2, and T3 or the DB3 distribution block below the power converter.
  - G. Follow the “Circuit Breaker Trip Adjustment Procedure” on page 64.
  - H. Using a voltmeter set at the 1000 Vac scale, verify that the incoming line voltage at the line side of the disconnecting means is within  $\pm 10\%$  of the input voltage rating on the controller nameplate.
  - I. The 50/60 Hz switch, on the power converter control board, is factory set to 60 Hz. Check the switch before operating the drive controller to ensure that it is set to 60 Hz. See Figure 20.

## STEP 2: PROVIDING MOTOR OVERLOAD PROTECTION AND THERMAL PROTECTION

Figure 21: Overload Relay Dial

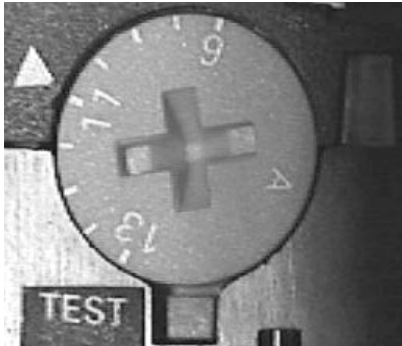

The LRD1516 overload relay is shown. Your dial setting range may be different.

- A. If the controller includes a bypass option for running the motor across the line, set the overload relay dial (on the load side of the bypass contactor) to the full load ampere rating on the nameplate of the connected motor. See Figure 21.
- B. Close and secure the enclosure door by tightening the thumbscrews. Close the equipment disconnect means. The Power On pilot light (if used) illuminates.
- C. Provide power by closing the disconnect.
- D. Press the ESC key on the keypad.
- E. Scroll with the down arrow key to Menu 2—Adjust (SEt), press the ENT key, then scroll with the down key to ThermCurrent—A (Ith) and press ENT.
- F. Use the up/down arrow keys to enter the motor nameplate full load amperes, then press ENT and ESC.

The controller is now calibrated to provide motor overload protection.

Refer to instruction bulletin VVDED397047US, *ALTIVAR 58 TRX Adjustable Speed Drive Controllers Keypad Display VW3A58101*.

### ▲ CAUTION

#### OVERHEATED MOTOR

- This drive controller does not provide direct thermal protection for the motor.
- Use of a thermal sensor in the motor may be required for protection at all speeds or load conditions.
- Consult the motor manufacturer for the thermal capability of the motor when it is operated over the desired speed range.

**Failure to follow these instructions can result in injury or equipment damage.**

## STEP 3: TESTING MOTOR ROTATION

### ▲ WARNING

#### HAZARDOUS MOVING PARTS

Before starting the drive controller, ensure that personnel are clear of the motor and its connected load and that the motor and load are ready to run.

**Failure to follow this instruction can result in death or serious injury.**

*NOTE: The settings listed in this procedure are suitable for most applications. If your application requires different operating characteristics, refer to instruction bulletin VVDED397047US, ALTIVAR 58 TRX Adjustable Speed Drive Controllers Keypad Display VW3A58101 for more information.*

- A. Set the AFC-Off-Bypass selector switch (if used) to AFC, the Normal-Test selector switch (if used) to Normal, and Hand-Off-Auto selector switch to Hand (push Start if the Start/Stop push buttons are used).
- B. Slowly turn the speed potentiometer clockwise to accelerate the motor. Check the direction of motor rotation.
  - If correct, proceed to “Step 4: Testing Motor Rotation in Bypass Mode” below.
  - If incorrect, stop the drive controller. **Remove all power!** Correct the motor rotation.

### Correcting Motor Rotation

**⚠ DANGER**

**HAZARDOUS VOLTAGE**

Turn off all power supplying this equipment and perform the bus voltage measurement procedure on page 42 before proceeding.

**Failure to follow this instruction will result in death or serious injury.**

To correct the direction of motor rotation:

- A. Reverse any two motor leads located on the device terminals marked T1, T2, or T3.
- B. Reset the speed potentiometer to minimum speed (fully counterclockwise). Close and secure the enclosure door, then reapply power and restart the controller.
- C. Slowly turn the speed potentiometer clockwise to accelerate the motor. Check the direction of motor rotation.
  - If correct, this completes the controller mode motor rotation check.
  - If incorrect, repeat Steps A–C until correct.

### STEP 4: TESTING MOTOR ROTATION IN BYPASS MODE

- A. Set the AFC-Off-Bypass selector switch (if used) to Off, leaving the Hand-Off-Auto selector switch in the Hand position.
- B. Momentarily set the AFC-Off-Bypass selector switch to Bypass to check the direction of motor rotation, then return it immediately to the Off position.
  - If the direction of motor rotation is correct, proceed to step “Step 5: Checking Keypad Display Settings” below.
  - If incorrect, stop the drive controller. **Remove all power!** Correct the motor rotation.

*NOTE: If the controller circuit breaker trips during this test, a higher trip setting may be required. Refer to “Circuit Breaker Trip Adjustment Procedure” on page 64.*

### Correcting Motor Rotation in Bypass Mode

**⚠ DANGER**

**HAZARDOUS VOLTAGE**

Turn off all power supplying this equipment and perform the bus voltage measurement procedure on page 42 before proceeding.

**Failure to follow this instruction will result in death or serious injury.**

To correct the direction of motor rotation:

- C. Reverse any two incoming leads to the circuit breaker disconnect means marked L1, L2, or L3.
- D. Momentarily set the AFC-Off-Bypass selector switch to Bypass to check the direction of motor rotation, then return it immediately to the Off position.
  - If correct, this completes the bypass mode, motor rotation check.
  - If incorrect, repeat Steps C and D until correct.

## STEP 5: CHECKING KEYPAD DISPLAY SETTINGS

- A. Check the High Speed (HSP) setting (maximum motor speed setting).
  - a. Press the ESC key on the keypad.
  - b. Scroll with the down arrow key to Menu 2—Adjust (SEt), press the ENT key, then scroll with the down key to parameter High Speed—Hz and press ENT.
  - c. Use the up/down arrow keys to enter the maximum output frequency required for the application (factory default is 60 Hz), then press ENT and ESC. The controller HSP setting is now complete.  
  
Refer to instruction bulletin VVDED397047US, *ALTIVAR 58 TRX Adjustable Speed Drive Controllers Keypad Display VW3A58101*.
- B. Check the Low Speed (LSP) setting (minimum motor speed setting).
  - a. Press the ESC key on the keypad.
  - b. Scroll with the down arrow key to Menu 2—Adjust (SEt), press the ENT key, then scroll with the down key to parameter Low Speed—Hz and press ENT.
  - c. Use the up/down arrow keys to enter the minimum output frequency required for the application (factory default is 3 Hz), then press ENT and ESC. The controller LSP setting is now complete.  
  
Refer to instruction bulletin VVDED397047US, *ALTIVAR 58 TRX Adjustable Speed Drive Controllers Keypad Display VW3A58101*.
- C. The application may require changing the setting of acceleration (ACC) and deceleration (dEC) times. Factory default is 10 seconds. To change the setting:
  - a. Press the ESC key.
  - b. Scroll with the down arrow to Menu 2—Adjust, press ENT, then scroll with the down key to parameter Acceleration-s and Deceleration-s.
  - c. Use the up/down arrows to enter in seconds the time required for the application, then press ENT and ESC. The controller acceleration and deceleration time setting is now complete.

## CIRCUIT BREAKER TRIP ADJUSTMENT PROCEDURE

For Type GJL breakers, use the following equation to calculate the circuit breaker dial setting. See Tables 36 and 37.

$$\text{Dial Setting} = \frac{\text{Motor FLA} \times \text{Multiplication Factor}}{\text{Breaker Rating}}$$

Read the motor FLA from the motor nameplate and read the breaker rating from Tables 36 or 37. The multiplication factor is derived from NEC Table 430-152. For example, to calculate the dial factory setting of a 7.5 hp, 460 V motor, with a GJL circuit breaker:

$$4 = \frac{11 \times 11}{30}$$

In this example, the arrow on the circuit breaker dial should be turned to 4X.

**Figure 22: Circuit Breaker Trip Adjustment Dial**

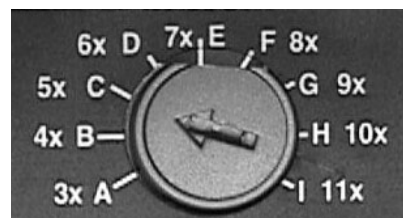

For Type KCL, FHL, and KHL circuit breakers, set the breaker dial to the magnetic trip setting shown in Tables 38–41 .

For circuit breakers used in 125–500 hp 460 V controllers see Table 35.

**Table 35: 460 V KAL, LAL, MAL, and LIL Circuit Breaker Trip Adjustment**  
*(Note: Controllers are shipped with the magnetic trip settings for the circuit breakers listed in this table at the minimum settings. At start-up, adjust trip settings per motor FLA, NEC, and local codes to avoid nuisance tripping on full voltage starting. Maximum trip setting is based upon 13 times the motor FLA; multiplication factor = 13.)*

hp VT	Rated Output Current	Circuit Breaker	Max. Input Current				Factory Setting (A)	Circuit Breaker FLA	Maximum Trip Setting			
			65,000 A		100,000 A				65,000 A		100,000 A	
			1.5%	5%	1.5%	5%			1.5%	5%	1.5%	5%
<b>Without Bypass</b>												
125	156	KAL36250-30M	156	156	157	156	1000	250	2000	2000	2000	2000
150	180	LAL36400-32M	186	186	189	186	1250	400	2418	2418	2457	2418
200	240	LAL36400-35M	245	240	249	240	1750	400	3185	3120	3237	3120
250	302	LAL36400-36M	302	302	305	302	2000	400	3926	3926	3965	3926
300	361	MAL36600-40M	361	361	361	361	2500	600	4693	4693	4693	4693
350	414	MAL36600-42M	414	414	414	414	3000	600	5382	5382	5382	5382
400	477	MAL36600-44M	477	477	477	477	3500	600	6201	6201	6201	6201
450	515	MAL36800-45M	516	515	524	515	4000	800	6708	6695	6812	6695
500	590	MAL36800-45M	590	590	590	590	4000	800	7670	7670	7670	7670
<b>With Integrated Bypass</b>												
125	156	LIL36300	156	156	157	156	1500	300	2028	2028	2041	2028
150	180	LIL36300	186	186	189	186	1500	300	2418	2418	2457	2418
200	240	LIL36400	245	240	249	240	2000	400	3185	3120	3237	3120
<b>With Barrired Bypass</b>												
125	156	LAL36400	156	156	157	156	2000	400	2028	2028	2041	2028
150	180	LAL36400	186	186	189	186	2000	400	2418	2418	2457	2418
200	240	LAL36400	245	240	249	240	2000	400	3185	3120	3237	3120

**Table 36: 460 V GJL Circuit Breaker Trip Adjustment**

hp		Circuit Breaker		Motor FLA	Circuit Breaker Rating	Circuit Breaker Dial Setting	
CT	VT	Thermal-Magnetic <sup>[1]</sup>	Mag-Gard® <sup>[2]</sup>			Factory <sup>[3]</sup>	Max. <sup>[4]</sup>
1	1	GJL36015	GJL36007M02	2.1	007	3.3	3.9
2	2	GJL36015	GJL36007M02	3.4	007	5.3	6.3
3	3	GJL36020	GJL36015M03	4.8	015	3.5	4.2
	5	GJL36030	GJL36015M03	7.6	015	5.6	6.6
5		GJL36030	GJL36030M04	7.6	030	2.8	3.3
7.5	7.5	GJL36040	GJL36030M04	11	030	4.0	4.8
	10	GJL36050	GJL36030M04	14	030	5.1	6.1
10		GJL36060	GJL36030M04	14	030	5.1	6.1
15	15	GJL36080	GJL36050M05	21	050	4.6	5.5
20	20	GJL360100	GJL36050M05	27	050	6.0	7.0
25	25	GJL360100	GJL36075M06	34	075	5.0	6.0
30	30	GJL360100	GJL36075M06	40	075	6.0	7.0
40	40	GJL360150	GJL36075M06	52	075	7.6	9.0

1. Thermal-Magnetic circuit breakers are approved factory substitutions and do not require dial setting adjustment.
2. Circuit breaker dial settings apply only to Mag-Gard circuit breakers.
3. Factory setting is 11 times the motor FLA (multiplication factor = 11).
4. Maximum trip setting is 13 times the motor FLA (multiplication factor = 13).

**Table 37: 230 and 208 V GJL Circuit Breaker Trip Adjustment**

hp		Circuit Breaker		Motor FLA		Circuit Breaker Rating	Circuit Breaker Dial Setting			
CT	VT	Thermal-Magnetic <sup>[1]</sup>	Mag-Gard® <sup>[2]</sup>	208 V	230 V		Factory <sup>[3]</sup>		Max. <sup>[4]</sup>	
						208 V	230 V	208 V	230 V	
1	1	GJL36015	GJL36007M02	4.6	4.2	007	7.2	6.6	8.5	7.8
2	2	GJL36030	GJL36015M03	7.5	6.8	015	5.5	5.0	6.5	6.0
3	3	GJL36040	GJL36030M04	10.6	9.6	030	3.9	3.5	4.6	4.2
5	5	GJL36050 <sup>[5]</sup>	GJL36030M04	16.7	15.2	030	6.1	5.6	7.2	6.6
5	5	GJL36060 <sup>[6]</sup>	GJL36030M04	16.7	15.2	030	6.1	5.6	7.2	6.6
7.5	7.5	GJL36070 <sup>[5]</sup>	GJL36050M05	24.2	22	050	5.3	4.8	6.3	5.7
7.5	7.5	GJL36080 <sup>[6]</sup>	GJL36050M05	24.2	22	050	5.3	4.8	6.3	5.7
10	10	GJL36080 <sup>[5]</sup>	GJL36075M06	30.8	—	075	4.5	—	5.3	—
10	10	GJL360100 <sup>[6]</sup>	GJL36050M05	—	28	050	—	6.2	—	7.3
15	15	GJL360100	GJL36075M06	46.2	42	075	6.8	6.2	8.0	7.3
20	20	GJL360100	GJL36075M06	—	54	075	—	7.9	—	9.4

1. Thermal-Magnetic circuit breakers are approved factory substitutions and do not require dial setting adjustment.
2. Circuit breaker dial settings apply only to Mag-Gard circuit breakers.
3. Factory setting is 11 times the motor FLA (multiplication factor = 11).
4. Maximum trip setting is 13 times the motor FLA (multiplication factor = 13).
5. Used on 230 V controllers.
6. Used on 208 V controllers.

**Table 38: 460 V KCL Circuit Breaker Trip Adjustment**

hp		Circuit Breaker	Max. Input Current					Circuit Breaker Dial Setting									
CT	VT		5 kA	10 kA	22 kA	65 kA	FLA	Factory <sup>[1]</sup>					Max. <sup>[2]</sup>				
								5 kA	10 kA	22 kA	65 kA	FLA	5 kA	10 kA	22 kA	65 kA	FLA
50		KCL34125	61	—	67.7	68.8	65	671	—	745	757	715	793	—	880	894	845
	50	KCL34125	60.6	—	65.9	67.8	65	667	—	725	746	715	788	—	857	881	845
60		KCL34150	—	79.2	82.6	84.4	77	—	871	909	928	847	—	1030	1074	1097	1001
	60	KCL34150	—	74.9	78.1	81	77	—	824	859	891	847	—	974	1015	1053	1001
75		KCL34175	—	96.7	102.8	105.6	96	—	1064	1131	1162	1056	—	1257	1336	1373	1248
	75	KCL34175	—	94.8	101.2	103.5	96	—	1043	1113	1139	1056	—	1232	1316	1346	1248
	100	KCL34200	—	123	131.3	137.1	124	—	1353	1444	1508	1364	—	1599	1707	1782	1612

1. Factory setting is 11 times the motor FLA (multiplication factor = 11).
2. Maximum trip setting is 13 times the motor FLA (multiplication factor = 13).

**Table 39: 208 V FHL and KHL Circuit Breaker Trip Adjustment**

hp		Circuit Breaker	Max. Input Current					Circuit Breaker Dial Setting									
CT	VT		5 kA	10 kA	22 kA	65 kA	FLA	Factory <sup>[1]</sup>					Max. <sup>[2]</sup>				
								5 kA	10 kA	22 kA	65 kA	FLA	5 kA	10 kA	22 kA	65 kA	FLA
20		FHL36100-18M	57.2	57.6	58	58.2	59.4	629	634	638	640	653	744	749	754	757	772
	20	FHL36100-18M	56.4	56.5	56.7	56.8	59.4	620	622	624	625	653	733	735	737	738	772
25		FHL36100-18M	70.1	70.8	71	71.3	74.8	771	779	781	784	823	911	920	923	927	972
	25	FHL36100-18M	69.9	70.1	70.5	70.8	74.8	769	771	776	779	823	909	911	917	920	972
30		FHL36150-24M	83.4	84.2	85.8	87	88	917	926	944	957	968	1084	1095	1115	1131	1144
	30	FHL36150-24M	82.1	82.4	82.9	83.2	88	903	906	912	915	968	1067	1071	1078	1082	1144
40		FHL36150-24M	110.5	111.3	113.6	115	114.4	1216	1224	1250	1265	1258	1437	1447	1477	1495	1487
	40	FHL36150-24M	109.4	110.5	111.3	112.2	114.4	1203	1216	1224	1234	1258	1422	1437	1447	1459	1487
	50	KHL36250-30M	134	136.1	137.3	138.5	143	1474	1497	1510	1524	1573	1742	1769	1785	1800	1859

1. Factory setting is 11 times the motor FLA (multiplication factor = 11).
2. Maximum trip setting is 13 times the motor FLA (multiplication factor = 13).

**Table 40: 230 V FHL and KHL Circuit Breaker Trip Adjustment**

hp		Circuit Breaker	Max. Input Current					Circuit Breaker Dial Setting									
CT	VT		5 kA	10 kA	22 kA	65 kA	FLA	Factory <sup>[1]</sup>					Max. <sup>[2]</sup>				
								5 kA	10 kA	22 kA	65 kA	FLA	5 kA	10 kA	22 kA	65 kA	FLA
25		FHL36100-18M	61.8	62.2	62.9	63.3	68	680	684	692	696	748	803	809	818	823	884
	25	FHL36100-18M	61.2	61.7	62.2	62.4	68	673	679	684	686	748	796	802	809	811	884
30		FHL36150-24M	73.2	75.1	76.7	78.1	80	805	826	844	859	880	952	976	997	1015	1040
	30	FHL36100-18M	71.8	72.3	73.1	73.5	80	790	795	804	809	880	933	940	950	955	1040
40		FHL36150-24M	96.8	97.8	101.2	103.2	104	1065	1076	1113	1135	1144	1258	1271	1316	1342	1352
	40	FHL36150-24M	95.7	96.8	98.5	99.8	104	1053	1065	1084	1298	1144	1244	1258	1280	1292	1352
	50	KHL36250-29M	117.6	119.2	121.3	123.2	130	1294	1311	1334	1355	1430	1529	1550	1577	1602	1690

1. Factory setting is 11 times the motor FLA (multiplication factor = 11).
2. Maximum trip setting is 13 times the motor FLA (multiplication factor = 13).

**START-UP CHECKLIST**

Table 41 on page 68 is an initial start-up checklist for customer use. It is recommended that you store this information with the drive controller.

**Table 41: Drive Controller Start-Up Checklist**

	Yes	No	N/A
<b>Equipment Location</b>			
1. Is (Are) the drive(s) mounted in its (their) permanent location(s)?			
2. Is the work area around the drive(s) accessible?			
3. Does the work facility have safety provisions such as first aid, fire extinguishers, etc.?			
<b>Power Connections (Line Side)</b>			
1. Is (Are) the proper sized incoming power connection(s) installed, completely terminated, and properly tightened?			
2. Are the incoming power leads in the standard (A-B-C) rotation pattern?			
3. Have proper grounding practices per NEC codes been followed?			
<b>Motor Connections (Load Side)</b>			
1. Is (Are) the proper motor(s) installed for each drive controller?			
2. Is (Are) the motor lead(s) completely terminated and properly tightened to the output of each drive controller?			
3. If an iso/bypass application is part of the installation, are the contactors mounted, wired, and properly tightened?			
4. Is each AFC output power cable in an independent conduit with respect to other AFC output cables?			
5. Can the motor be run at full speed in Bypass mode?			
<b>Motor Load Device</b>			
1. Is the proper load device installed and ready?			
2. Is the desired motor rotation known?			
3. Is the load properly coupled to the motor shaft?			
4. At time of start-up, can the application provide maximum motor loading?			
<b>Control Circuit Wiring</b>			
1. Is all local and remote control wiring properly identified, securely terminated, and properly tightened?			
2. Are the low level analog signals separated from control and power wiring?			
3. Was shielded cable used for all analog signals, and is the shield wire grounded at the AFC end <b>only</b> ?			
4. Is control wiring separated from the power wiring?			
<b>Other User Interfaces</b>			
1. Is (Are) any remote commissioning terminal(s) with any interconnect cable(s) operational and available?			
2. Are any of your serial communication links ready for AFC operational use?			
3. Are accurate control and power wiring diagrams available at the start-up location?			
4. Are specific drive settings known for each drive controller (e.g., Min/Max speed, Acc/Dec Time, etc.)?			
<b>Availability Of Equipment</b>			
1. Will the equipment be available to be energized and de-energized on the date of start-up?			
2. Will the <b>process/load</b> be available to be exercised?			
<b>Authorized Personnel</b>			
1. Will the person(s) responsible for the entire process be available to verify final operation?			
2. Will all necessary <b>union</b> trade personnel be ready and available if they need to be present when Square D Company personnel are working on the equipment?			
<b>Special Requirements:</b> Please list any <b>specific</b> concerns/comments			
For enclosed drive controllers with bypass, are the bypass fuses installed?			
For bypass drive controllers with NEMA contactors, are the the overload elements properly selected to the motor nameplate information and installed?			

**CUSTOMER READINESS  
ACKNOWLEDGMENT**

I/We have verified that all checklist questions have been answered. All questions with a Yes response indicate a ready state for the start-up to be efficient and successful. Explanation(s) for any question with a No response is listed in the Special Requirements section above.

CUSTOMER NAME: \_\_\_\_\_  
 COMPANY NAME: \_\_\_\_\_  
 PHONE: (\_\_\_\_\_) \_\_\_\_\_ FAX: (\_\_\_\_\_) \_\_\_\_\_  
 SIGNATURE: \_\_\_\_\_ DATE: \_\_\_\_\_

## SECTION 3— CIRCUIT DESCRIPTIONS AND OPTIONS

### INTRODUCTION

This section describes basic sequences of operation for the two types of pre-engineered power circuit configurations and available options. The options are:

- Power Circuit W: Without Bypass (see page 73)
- Power Circuit Y: Bypass (see page 73)

### TERMINAL COMMAND VERSUS KEYPAD COMMAND OPERATION

For factory and/or user-supplied pilot devices and controls to be recognized, the Class 8839 58M drive controller is factory-configured to operate from the terminal command mode. Enabling the Keypad Command (KeypadCom.) parameter (LCC in Menu 4) to YES disables certain power converter logic inputs. Factory and/or user-provided control devices are ignored. For this reason, do not operate the drive controller in the Keypad Command mode.

Before re-programming inputs, outputs, torque types, or control types:

- Consult the factory configuration listing on the applicable control circuit diagram in the diagrams provided separately.
- Refer to instruction bulletin VVDED397047US, *ALTIVAR<sup>®</sup> 58 Adjustable Speed Drive Controllers Keypad Display, VW3A58101*.
- Refer to instruction bulletin VVDED397046US, *ALTIVAR 58 Adjustable Speed Drive Controllers Analog I/O Extension Card, VW3A58201U* (supplied with controller when analog card, option H09, is selected).
- Refer to instruction bulletin VVDED300055US, *LONWORKS<sup>®</sup> to MODBUS<sup>®</sup> Module VW3A58312PU* (supplied with controller when LONWORKS, option E09, is selected).
- Refer to instruction bulletin VVDED397054US, *ALTIVAR 58 Adjustable Speed Drive Controllers MODBUS/JBUS/UNITELWAY Card, VW3A58303U* (supplied with controller when Modbus, option B09 or LONWORKS E09, is selected).
- Refer to instruction bulletin VVDED300028US, *ALTIVAR 58 Adjustable Speed Drive Controllers METASYS<sup>®</sup> N2 Communication Option VW3A58354U* (supplied with controller when Metasys N2, option C09, is selected).
- Refer to instruction bulletin VVDED397044US, *ALTIVAR 58 Adjustable Speed Drive Controllers MODBUS Plus Communication Option, VW3A58302U* (supplied when Modbus Plus, option A09, is selected).
- Refer to instruction bulletin VVDED300053US, *ALTIVAR 58 Ethernet MODBUS TCP/IP Communication Option VW3A58310U* (supplied when Ethernet, option D09, is selected).
- Refer to instruction bulletin VVDED300052US, *ALTIVAR 58 Adjustable Speed Drive Controllers DEVICENET Communication Option, VW3A58309U* (supplied when DeviceNet, option F09, is selected).

Changing certain factory settings will affect the performance of the Class 8839 58M drive controller.

## **⚠ WARNING**

### **UNINTENDED EQUIPMENT OPERATION**

- The controller has been factory-programmed. Alteration of factory programming may create incompatibilities with the supplied controller configuration.
- Read and understand instruction bulletin VVDED397047US as well as the programming information found in the applicable control circuit elementary diagrams provided with each controller.
- If the power converter unit is re-initialized using the **Total** or **Partial Factory Setting** function, the power converter must be re-programmed according to the programming instructions found in the applicable control circuit elementary diagrams provided with each controller.
- If the power converter unit or the main control board of the power converter is replaced, or if any option cards are field installed, the power converter must be re-programmed according to the programming instructions found in the applicable control circuit elementary diagrams provided with each controller.

**Failure to follow these instructions can result in death or serious injury.**

*NOTE: The factory program can be saved in the keypad. Refer to instruction bulletin VVDED397047US, ALTIVAR 58 TRX Adjustable Speed Drive Controllers Keypad Display VW3A58101, for saving and retrieving factory settings.*

## **KEYPAD OPERATION**

The keypad is for programming and display. The FWD/REV, Run, and Stop/Reset buttons are not for controller primary operation. Use the 22 mm operators located on the front of the controller door to command the AFC and Bypass modes of operation.

## **FORCED LOCAL OPERATION**

When a communication option is selected, the drive controller fault reset feature will be removed. Instead, a connection from terminals A to C is provided on terminal block TB2 and LI4 is programmed for forced local.

The user may choose to remove the forced local function if Start/Stop commands are not sent over a digital communication link. To activate the fault reset function:

- remove the factory provided connection to terminal C from CMR (1) on terminal block TB2
- program LI4 to fault reset

## **CONTROL CIRCUIT SEQUENCING AND OPERATION**

The following descriptions **do not** represent all possible combinations of standard control options. Order engineered (OE) options are available for other possible combinations.

### **RUN COMMAND RELAY (RCR)**

The RCR closes if all safety interlocks are closed and the controller has been commanded to run. A run command initiates when:

- The HOA selector switch is in the Hand position.
- The HOA selector switch is in the Hand position and the Start push button has been pressed.

- The H-O-A selector switch is in the Auto position and a user-supplied start contact is closed.
- The C-A-O-H selector switch is in the Communication position, allowing the communication relay to close, and a start command has been transmitted over a digital communication link.
- The start push button has been pushed.

#### **AUXILIARY RUN COMMAND RELAY (ARCR)**

ARCR is in parallel with the RCR and provides additional contacts to prevent transfer to bypass when the drive controller has power applied and is in a fault state, if not commanded to run. If a line contactor is used and the safety circuits are not closed, the ARCR disconnects line power from the drive controller via control of the line contactor and isolation contactor.

#### **AUXILIARY DRIVE RUN RELAY (ADRR1)**

If the power converter is running, ADRR1 provides run contacts, and when bypass is supplied, circuit operation of the power converter isolation contactor. This relay is controlled by a programmable relay (R2), internal to the drive controller, programmed for Drive Run. One N.O. and one N.C. run contact from ADRR1 are provided as standard for customer use. If option K10 is supplied, one additional N.O. contact is wired to the user terminal block TB1.

#### **AUXILIARY DRIVE RUN RELAY (ADRR2)**

ADRR2 is in parallel with ADRR1 and provides additional contacts for operation of the motor elapsed time meter (option S10) and seal water solenoid (option V10), when the controller is operating. ADRR2 contacts provide operation of the motor space heater relays (option U10) when the controller is not running but power to the controller is on. If the contact from the check valve limit switch is closed and the drive controller is running the motor, ADRR2 contacts also provide actuation of the check valve sequence timer (option W10).

#### **AUXILIARY DRIVE FAULT RELAY (ADFR1)**

ADFR1 provides fault contacts for initiating drive controller shutdown. If the drive controller detects a fault condition, it illuminates the drive fault pilot light. This relay is controlled by a non-programmable relay (R1), internal to the drive controller, when a line contactor is supplied. A timing head mounted on the RCR holds in the ADFR1 for five seconds. This provides time for the input line contactor (if used) to close and eliminates a momentary false power loss fault indication. ADFR1 provides one N.O. and one N.C. fault contacts as standard for customer use.

#### **AUXILIARY DRIVE FAULT RELAY (ADFR2)**

ADFR2 (option L10) supplies one additional N.C. contact wired to user terminal block TB1.

#### **AUXILIARY TRANSFER BYPASS RELAY (ATB)**

The ATB relay (option R10) is an adjustable timing relay, factory set for 5 seconds. If the automatic transfer to bypass is enabled (using the selector switch mounted inside the enclosure), the relay provides a time delay before automatically transferring to bypass after a drive controller fault condition. You must confirm that application ductwork and piping can handle the pressure resulting from a rapid transfer to full speed operation.

#### **COMMUNICATION MODE RELAY (CMR)**

The CMR is provided when control option F07 is supplied. The CMR provides contacts to control the RCR circuit. If the line contactor is used, contacts from the CMR keep power applied to the controller by keeping the line contactor closed when the motor is not running and removing control to LI1. CMR contacts are also used to remove the forced local from LI4. Forced local is a logic input assignment used to force start/stop and speed control command away from communication systems using local control operators such as Hand-Off-Auto.

**CHECK VALVE SEQUENCE (CVS)  
RELAY**

The CVS relay is a timing relay providing indication of a properly sequenced check valve. If the check valve does not open within the specified time, the CVS relay times out and shuts down the drive controller. If the valve does not open after the drive controller starts, the CVS relay circuit illuminates a blue pilot light. Pressing the blue push-to-reset pilot light resets this circuit.

**FAULT RESET**

The 58M drive controllers have remote fault reset capability when H-O-A or H-O-A with Local/Remote control is used. In Auto mode, faults can be remotely reset by cycling the user's auto start contact. If automatic fault reset is not desired, the user's auto start contacts must remain in the closed state. To manually reset fault conditions, select the Off position of the H-O-A selector switch. To disable automatic fault reset, remove the wire connected to terminal TB2-C shown in Figure 23.

**Figure 23: Disabling Fault Reset**

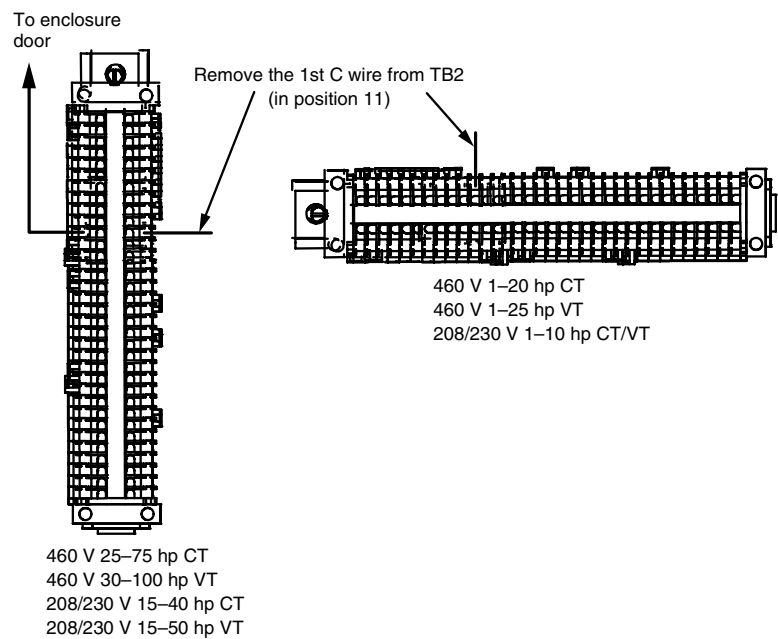

When a fault reset occurs, the display fault is cleared and stored in the drive controller. The last eight faults are stored in the drive controller and can be viewed using the keypad display.

When Start-Stop control option C07 or D07 is provided, a separate fault reset push button (option P10) must be used. When the fault reset push button is pressed the drive fault is reset.

When C-A-O-H control option F07 is provided, fault reset can be performed over the communication link or by cycling power using the disconnect handle at the drive controller.

## POWER CIRCUITS—GENERAL

### CONTROLLER OPERATION

To operate the controller, the circuit breaker disconnect located on the front of the drive controller must be in the closed position. There are several modes of operation depending upon the control method used.

- Two-wire control functionality: Hand-Off-Auto selector switch. The controller will automatically restart when power is restored after a power loss or upon resetting a fault condition (in Hand or Auto mode).
- Three-wire control functionality: Start/Stop push buttons. The controller will not restart when power is restored after a power loss or upon resetting an AFC fault. In Hand mode, the Start push button must be pressed to restart the controller. In Auto mode, restart is dependent on the auto start contact position.

### INTERLOCKS

The interlock terminals on terminal block TB1, noted below, are dedicated for accepting a user-supplied N.C. interlock. The power converter will stop operation if the connection between the two terminals is opened. Remove the factory jumper wire located on these terminals before installing the interlock.

- The fire/freezestat interlock connects to terminals TB1-1 to TB1-2.
- The external emergency stop interlock connects to terminals TB1-3 to TB1-4.
- Additional user interlocks connect at terminals TB1-3 to TB1-4 and TB1-5 to TB1-6.

### POWER CIRCUIT W (WITHOUT BYPASS)

This power circuit consists of:

- a fused control transformer
- circuit breaker disconnect with means for locking in the open position
- power converter
- optional equipment as specified

### OPERATOR CONTROLS—GENERAL ARRANGEMENT AND OPERATION

The operator controls are located on the front door of the drive controller unless no control options are specified. The drive controller is factory configured to operate in terminal command mode.

Option D10 omits the keypad display. If D10 is selected, a separate keypad must be ordered to program the drive controller.

### POWER CIRCUIT Y (BYPASS)

This power circuit operates the motor from the power converter or from full voltage line power (bypass mode). The motor can be run in the bypass mode in the unlikely event that the power converter becomes inoperative. The bypass package consists of:

- Isolation and bypass contactors with Class 20 overloads (Class 10 for 1 hp @ 460 V)
- Fused control transformer
- Circuit breaker disconnect with means for locking in the open position
- AFC-Off-Bypass switch
- Test-Normal switch
- Overload relay reset push button
- Power converter
- Optional equipment as specified

## OPERATOR CONTROLS—GENERAL ARRANGEMENT AND OPERATION

Operator controls are located on the front door of the drive controller unless no control options are specified. The drive controller is factory configured to operate in terminal command mode. Option D10 omits the keypad display. If D10 is selected, a separate keypad must be ordered to program the drive controller.

The AFC-Off-Bypass switch allows selection of either adjustable speed operation of the motor through the power converter (AFC position) or line power operation of the motor (Bypass position). Both AFC and Bypass operation may be started in the Hand mode for immediate start or in the Auto mode for remote start with an external contact, when an HOA switch is used.

## TEST-NORMAL OPERATION

The test-normal switch is used to test the power converter while operating the motor in bypass. To use this function and maintain motor operation, place the following switches in these positions:

- AFC-Off-Bypass: Set the switch to Bypass to run the motor at full speed across the line.
- Test-Normal: Set the switch to Test.
- Hand-Off-Auto: Set the switch to Hand. Use the manual speed potentiometer to change the speed reference and observe power converter operation. Refer to instruction bulletin VVDED397047US, *ALTIVAR 58 Adjustable Speed Drive Controller Keypad Display VW3A58101* for fault definitions.

## BYPASS OPERATION

To control the operation of the motor with line power, the circuit breaker disconnect located on the front of the drive controller must be in the closed position and the AFC-Off-Bypass switch must be in the Bypass position. When the AFC-Off-Bypass selector switch is set to Bypass, motor operation is transferred to line power.

- In Hand mode the motor will immediately start.
- In Hand mode with a stop/start push button, the motor will start when the Start push button is pressed.
- In Auto mode, the motor will start when the user-supplied contact is closed.
- When the selector switch is moved to the Off position, the bypass contactor opens and the motor stops.

## MODIFICATIONS

### CONTROL FUNCTION DESCRIPTIONS (A07–F07)

Table 42 shows the door-mounted power converter control functions supplied with the available control options. Selector switches are provided for Hand-Off-Auto (H-O-A), Communication-Auto-Off-Hand (C-A-O-H), Forward/Reverse, and Local/Remote control. Push buttons are provided for Start and Stop functions and reset functions. A dial is provided for the manual speed potentiometer.

**Table 42: Modification Control Circuits**

Control Option (Modifications)	Hand	Off	Auto	Speed Potentiometer	Start/Stop	Forward/Reverse	Local/Remote	Communication
A07	X	X	X	X				
B07	X	X	X	X	X			
C07 <sup>[1]</sup>				X	X			
D07 <sup>[1]</sup>				X	X	X		
E07	X	X	X	X			X	
F07	X	X	X	X				X

1. This option is only available for power circuit W (without bypass).

#### Hand Mode

Hand mode is for local control. As soon as Hand mode is selected, the power converter starts the motor. In Bypass operation, as soon as Hand mode is selected, a full-voltage across-the-line start occurs. In AFC operation, as soon as Hand mode is selected, the power converter starts the motor. When used in conjunction with a start/stop push button, the power converter will not start the motor until the Start push button is pressed.

#### Off Mode

Off mode commands the power converter to stop the motor by either following the programmed deceleration ramp (factory setting) or by a freewheel stop. Set the H-O-A switch to Off for fault reset.

#### Auto Mode

Auto mode is for remote control. In Bypass operation, a full-voltage across-the-line start will occur when the user-supplied run contact is closed between controller terminals 8 and 9 on terminal block TB1. In Auto mode and AFC operation, the power converter starts the motor when the user-supplied run contact is closed between controller terminals 8 and 9 on terminal block TB1. Motor speed is varied by adjusting the user-supplied auto speed reference signal (4–20 mA) supplied to terminals G1 (S2+) and J (S3) on terminal block TB2 in the drive controller. Refer to instruction bulletin VVDED397047US for scaling of this signal.

When option J10 is selected, the motor speed is varied by adjusting the user-supplied auto speed reference signal (0–10 V) supplied to terminals G1 (S2+) and G2 (S2–) on terminal block TB2. This input is differential to maximize noise immunity. Remove the jumper between G1 (S2+) and G2 (S2–).

#### Start Push Button

The Start push button commands the power converter to start the motor (in Hand mode) for local control. The manual speed potentiometer is used to control the speed of the controller.

### Stop Push Button

**⚠ WARNING**

**INABILITY TO INITIATE A STOP**

The Stop push button is only active in the Hand mode.

- To stop the drive controller, open the disconnect switch or set the Hand-Off-Auto switch to Off.
- Use appropriate guarding or interlocking.

**Failure to follow this instruction can result in death or serious injury.**

The Stop push button commands the power converter to stop the motor for local control by either following the programmed deceleration ramp (factory setting) or by freewheel stopping. If the Hand-Off-Auto switch is in the Auto mode, the switch must be set to Off to stop the power converter. The Stop push button is only active for local control (Hand), not for remote control (Auto).

### Manual Speed Potentiometer

The manual speed potentiometer is used to control the speed of the controller in Hand mode.

### Forward/Reverse

The Forward/Reverse switch selects the input to the power converter, which is programmed for LI1= forward and LI2= reverse.

### Local/Remote

The Local/Remote switch selects whether speed control is sent by signal into terminal AI1 (local) or AI2 (remote) on terminal block TB2, when the Hand-Off-Auto switch is in Auto mode.

### Communication Mode

Communication mode is for communication option card control of the drive controller. When Communication mode is selected the RCR is picked up, input to LI1 opens, and forced local releases. In Communication mode, the drive controller receives start, stop, and speed commands from a serial communication protocol.

### PILOT LIGHT OPTION CLUSTERS (A08–F08)

The pilot light options listed in Table 43 provide visual indication of protective functions and circuit status. All pilot light bulbs are LEDs, which can be removed from the front with the enclosure door closed.

**Table 43: Pilot Light Cluster Identification**

Cluster/Option	Power On	AFC Run	Auto	Fault	Bypass	Forward	Reverse	Hand	Comm
A08, #1 Cluster	X	X	X	X					
B08, #2 Cluster <sup>[1]</sup>	X	X		X	X				
C08, #3 Cluster <sup>[2]</sup>	X	X		X					
D08, #4 Cluster <sup>[2]</sup>	X			X		X	X		
E08, #5 Cluster	X	X	X	X				X	
F08, #6 Cluster	X	X		X					X

1. This option is only available for power circuit Y (bypass).  
2. This option is only available for power circuit W (without bypass).

### Power On (red)

This pilot light illuminates when mains power is applied to the controller. The pilot light device is rated for 120 Vac.

### AFC Run (green)

This pilot light illuminates to annunciate an AFC run condition. The pilot light device is rated for 120 Vac.

<b>Auto (yellow)</b>	This pilot light illuminates to annunciate that speed control is via the remote contact closure and 4–20 mA signal into AI2 with the Hand-Off-Auto switch set to Auto.
<b>Fault (yellow)</b>	<ul style="list-style-type: none"><li>• For power circuit W (without bypass): the pilot light illuminates to annunciate an AFC fault (trip) condition. The pilot light device is rated for 120 Vac.</li><li>• For power circuit Y (bypass): the pilot light illuminates to annunciate an AFC fault (trip) condition. When option B10 (line contactor) is selected, the light illuminates when the AFC-Off-Bypass selector switch is in the Off or Bypass position to indicate that the power converter is not running. The pilot light device is rated for 120 Vac.</li></ul>
<b>Bypass (yellow)</b>	This pilot light illuminates when the motor is started across the line. The pilot light device is sequenced by initiation of the bypass contactor and is rated for 120 Vac.
<b>Forward (green)</b>	This pilot light illuminates to annunciate that the power converter is set to run in the forward direction with input to LI1.
<b>Reverse (green)</b>	This pilot light illuminates to annunciate that the power converter is set to run in the reverse direction with input to LI2.
<b>Hand (blue)</b>	This pilot light illuminates to annunciate that speed control is by the speed potentiometer on AI1 and the Hand-Off-Auto switch is set to Hand.
<b>Comm (yellow)</b>	This pilot light illuminates to annunciate that the Communication-Auto-Off-Hand switch is set to Comm and control is via a communication card with LI4 set to forced local.
<b>OPTION A09 MODBUS PLUS</b>	This option card provides a factory installed plug-in Modbus Plus card, VW3A58302U, and separate Modbus cable and connector 990NAD219XX. Serial communication is factory installed for register monitoring. This interface device connects to a Modbus Plus tap.
<b>OPTION B09 MODBUS</b>	<p>This option card provides a factory installed plug-in Modbus card, VW3A58303U, and separate user termination to a D-shell interface device. Serial communication is factory installed for register monitoring.</p> <p>This interface device is suited for incoming and outgoing bus cable or end-of-the-line termination. The interface device contains two cable entries to two termination blocks for pins 2, 3, 4, 5, 7, and 9. Refer to page 70 for a description of forced local operation.</p>
<b>OPTION C09 METASYS N2</b>	<p>This option provides a factory installed plug-in. Metasys N2 card, VW3A58354U, and separate user termination to a D-shell interface device. Serial communication is factory installed for register monitoring.</p> <p>This interface device is suited for incoming and outgoing bus cable or end of the line termination. The interface device has two cable entries to two termination blocks for pins 2, 3, 4, 5, 7, and 9. Refer to page 70 for a description of forced local operation.</p>
<b>OPTION D09 ETHERNET</b>	This option provides a factory installed plug-in Ethernet card, VW3A58310U, with user termination to RJ45 plug-in interface connector. Serial communication is factory installed for register monitoring. Refer to page 70 for a description of forced local operation.

**OPTION E09  
LONWORKS**

This option provides a factory installed LONWORKS to Modbus Module, VW3A58312PU, plug-in Modbus card, VW3A58303U, and 24 Vdc power supply. Serial communication is factory installed for register monitoring. Refer to page 70 for a description of forced local operation.

**OPTION F09  
DEVICENET**

This option provides a factory installed plug-in DeviceNet card, VW3A58309U, with user termination to a 5-point terminal block TB5, located on the power converter. Serial communication is factory installed for register monitoring. Refer to page 70 for a description of forced local operation.

**OPTION H09  
ANALOG CARD**

This option provides a 0–20 mA analog output for customer use. It includes a plug-in analog card, VW3A58201U, with AO and COM wired to terminal block TB3. The output is factory-programmed for motor frequency. Refer to instruction bulletin VVDED397046US for other programming choices. Selectable x–y range with keypad display.

**OPTION A10  
LINE REACTOR**

This miscellaneous option includes an integrally-mounted AC line reactor factory-installed and wired between the circuit breaker disconnect means and the power converter for high true power factor and effective harmonic mitigation. It complies with IEEE 519 guidelines.

**OPTION B10  
LINE CONTACTOR**

This miscellaneous option is only available for power circuit Y (bypass). It provides a line contactor factory-wired between the circuit breaker disconnect (or line reactor or harmonic filter when provided) and the power converter.

*NOTE: With line contactor option B10, the AFC Fault light illuminates when the AFC-Off-Bypass selector switch is in the Off or Bypass position to indicate that the power converter is not running.*

**OPTION C10  
3–15 PSI TRANSDUCER WITH DIGITAL  
DISPLAY (TB2-G1/S2+ TO TB2-J/S3)**

This miscellaneous option provides the controller with the capability to follow a 3–15 psi follower signal with digital display. The module is calibrated to operate as a 4–20 mA DC follower for the power converter. User connection to the module is made at terminals G1 (S2+) and J (S3) on terminal block TB2. Not available with control options C07, start-stop, D07, forward-reverse, or if option J10, 0–10 V auto speed reference, is used.

**OPTION D10  
OMIT KEYPAD DISPLAY**

This miscellaneous option omits the keypad display. If option D10 is selected, a separate keypad must be ordered to program the drive controller.

**OPTION E10  
SMOKE PURGE RELAY (TB1-48 TO  
TB1-49)**

This miscellaneous option provides a smoke purge operating mode controlled by a user-supplied 120 Vac signal applied between terminals 48 and 49 on terminal block TB1.

- For power circuit W (without bypass): When 120 Vac power is supplied to 48 and 49, the drive controller runs the motor at 60 Hz.
- For power circuit Y (bypass): When 120 Vac power is supplied to 48 and 49, motor operation is transferred to bypass (if not operating in this mode already).

**OPTION G10  
CUL LISTING**

This miscellaneous option provides Canadian cUL certification when required by local code requirements.

**OPTION H10  
SEISMIC CERTIFICATION (FLOOR  
MOUNT ENCLOSURES)**

This miscellaneous option supplies a certification label and hardware certified to seismic operation AC156 harmonized with NFPA 5000 and IBC 2000 standards.

**OPTION J10  
0–10 V AUTO SPEED REFERENCE  
(TB2-G1/S2+ TO TB2-G2/S2–)**

This miscellaneous option provides a controller interface for a 0–10 V user-supplied auto speed reference signal into the AI2 input, terminals G1 (S2+) and G2 (S2–) on terminal block TB2, using a 0–10 V/4–20 mA converter with Z=40 k $\Omega$ . Not available with C07 or D07 controls, or with 3–15 psi transducer, C10.

**OPTION K10  
ADDITIONAL N.O. AUXILIARY DRIVE  
RUN CONTACT (TB1-57 TO TB1-58)**

This miscellaneous option provides one N.O. drive run contact at terminals 57 and 58 on terminal block TB1 in addition to the Form C drive run contacts provided as standard. This contact indicates when the power converter is running.

**OPTION L10  
ADDITIONAL N.C. AUXILIARY DRIVE  
FAULT CONTACT (TB1-59 TO TB1-60)**

This miscellaneous option supplies one N.C. drive fault contact at terminals 59 and 60 on terminal block TB1 in addition to the standard Form C drive fault contacts. This contact indicates a power converter fault.

**OPTION M10  
N.O. AUXILIARY BYPASS RUN  
CONTACT (TB1-61 TO TB1-62)**

This miscellaneous option is only available for power circuit Y (bypass). It supplies one N.O. bypass run contact at terminals 61 and 62 on terminal block TB1 to indicate that the controller is running in bypass mode.

**OPTION O10  
N.O. AUXILIARY AUTO MODE CONTACT  
(TB1-63 TO TB1-64)**

This miscellaneous option supplies one N.O. auto mode contact at terminals 63 and 64 on terminal block TB1 to indicate that the controller is set to run in Auto mode with a signal into AI2 and operation by remote operating contact. Not available with C07 or D07 controls.

**OPTION P10  
AFC FAULT RESET (TB2-A TO TB2-C)**

This miscellaneous option is only available with control options C07 and D07 and for power circuit W (without bypass). It provides fault reset to LI4 on the power converter at terminals A and C on terminal block TB2 when an H-O-A switch is not supplied.

**OPTION Q10  
PUSH-TO-TEST PILOT LIGHTS**

This miscellaneous option provides a push-to-test feature on all pilot lights except Power On. Not available on a fault light unless P10 is selected.

**OPTION R10  
AUTO TRANSFER TO BYPASS (TB1-23  
TO TB1-27 AND TB1-22 TO TB1-23)**

This miscellaneous option is only available for power circuit Y (bypass). It is not available with control options B07, C07, or D07. This option provides an automatic transfer to bypass at terminals 23 to 27 and 22 to 23 on terminal block TB1. Whenever the power converter faults, this function transfers to bypass within 5 seconds of the fault. An enable/disable (off) switch is provided internally at the top end of terminal block TB1.

**OPTION S10  
MOTOR ELAPSED TIME METER (TB1-44  
TO TB1-50)**

This miscellaneous option provides an elapsed time meter, connected at terminals 44 and 50 on terminal block TB1, which operates whenever the motor runs. The motor elapsed time meter is non-resettable

**OPTION T10  
EMERGENCY STOP (TB1-2 TO TB1-3)**

**⚠ WARNING**

**POWER IS MAINTAINED ON MOTOR AND CONTROLLER**

- Emergency Stop, option T10, does not remove all power for the motor or the drive controller.
- Automatic restart may occur when the mushroom head operator is rotated to reclose the contact.
- Emergency Stop is a normal ramp-to-stop function using power from the drive controller, and it will force a controlled ramp-to-stop in all control modes, including Communication mode.
- Always open the controller disconnect or remove power to the controller after an emergency stop is initiated.

**Failure to follow this instruction can result in death or serious injury.**

This miscellaneous option provides an emergency stop mushroom-operator push button mounted on the enclosure door. The push button is maintained in the open position until the operator is rotated to reclose the contact. This option is not available with control options C07 or D07.

**OPTION U10  
MOTOR SPACE HEATER SEQUENCING  
(TB1-45 TO TB1-50)**

This miscellaneous option provides contact closure and terminals on terminal block TB1 with 120 V/50 VA available. This voltage will be available at terminals 45 and 50 whenever the motor is not running.

**OPTION V10  
SEAL WATER SOLENOID (TB1-43 TO  
TB1-50)**

This miscellaneous option provides contact closure and terminals on terminal block TB1 with 120 V/50 VA available. This voltage will be available at terminals 43 and 50 whenever the motor is energized.

**OPTION W10  
CHECK VALVE SEQUENCING (TB1-46  
TO TB1-47)**

This miscellaneous option provides a timed safety contact at terminals 46 and 47 on terminal block TB1, available for an N.C. limit switch contact that shuts down the drive controller whenever the user-supplied limit switch contact does not open within a specified time. This option also supplies an illuminated blue reset push button on the enclosure door.

**OPTION Z10  
24 VDC POWER SUPPLY [TB2-O (+) TO  
TB2-N (COM)]**

This miscellaneous option provides a 24 Vdc/300 mA power supply to terminals O (+) and N (COM) on terminal block TB2.

**OPTION 110  
ADDITIONAL CONTROL POWER VA  
(TB1-1 TO TB1-50)**

This option provides an additional 50 VA increase in the transformer to 350 VA at terminals 1 and 50 on terminal block TB1. It must be selected if options U10 and V10 are both selected.

**OPTION 410  
RFI SUPPRESSOR**

This option provides RFI suppression with ferrite cores which are factory attached on the power wires ahead of the power converter.

**OPTION 510  
PERMANENT WIRE MARKER SLEEVES**

This option provides permanent wire marking on the control wires with marker sleeves.

**OPTION 610  
I.D. ENGRAVED NAMEPLATES**

This option provides a lamacoid nameplate which is engraved per user request and attached to the front door of the enclosure.

**OPTION 710  
HARMONIC FILTER PROVISIONS**

This option provides fuses in a fuseblock for connection to an externally mounted harmonic filter input, and a distribution block for return wires from

the harmonic filter to the drive controller. Not available for 1, 2, or 3 hp controllers.

### **OPTION 910 BARRIERED BYPASS ENCLOSURE**

This option consists of one floor mounted enclosure with two doors, two disconnects, and a barrier separating the power converter from the bypass circuit. Each section is supplied by its own circuit breaker disconnect. On controllers rated for:

- 1–25 hp, VT and 1–20 hp CT @ 460 V and 1–10 hp VT, CT @ 208/230 V: The power converter is above the bypass circuit and the enclosure is 20 in (508 mm) wide.
- 30–50 hp VT and 25–40 hp CT @ 460 V and 15–25 hp VT, 15–20 hp CT @ 208/230 V: The power converter is below the bypass circuit and the enclosure is 25 in (635 mm) wide.
- 60–100 hp VT and 50–75 hp CT @ 460 V and 30–50 hp VT, 25–40 hp CT @ 208/230 V: The power converter is below the bypass circuit and the enclosure is 30 in (762 mm) wide.
- 125–500 hp VT @ 460 V: The power converter is to the left of the bypass circuit and the bypass section of the enclosure is 25 in (635 mm) wide.

Barriered bypass provides two separate compartments, one for the drive controller and one for the bypass. This provides maximum maintenance flexibility if emergency full speed operation is required while servicing or replacing the drive controller. Each compartment is provided with its own circuit breaker disconnect with a door mounted operating handle to ensure the removal of power within the drive compartment when service is required. The circuit breaker disconnect for the bypass provides control power for the contactors and must remain on for drive operation. Line contactor option (B10) is not available as standard with a barriered bypass.

The bypass compartment door cannot be opened unless the power converter compartment door is open.

## NOTES

## SECTION 4— MAINTENANCE AND SUPPORT

### INTRODUCTION

A number of diagnostic and status codes are included on the power converter. The keypad display provides visual indication of controller operation and protective circuit functions and indicator lights to assist in maintenance and troubleshooting. If the controller trips while operating, the codes must be viewed before power is removed because removing power resets the fault code.

*NOTE: For controllers equipped with optional line contactor (option B10) the power is removed via the line contactor upon power converter fault trips.*

### EXTERNAL SIGNS OF DAMAGE

The following are examples of external signs of damage:

- Cracked, charred, or damaged covers or enclosure parts
- Damage to the keypad such as scratches, punctures, burn marks, chemical burns, or moisture in the screen
- Oil or electrolyte on the bottom of the drive controller which might have leaked from the capacitors inside
- Excessive surface temperatures of enclosures and conduits
- Damage to power or control conductors
- Unusual noise or odors from any of the equipment
- Abnormal temperature, humidity, or vibration

If any of the above signs are found while the equipment is powered up, immediately inform operating personnel and assess the risk of leaving the drive system powered up. Before removing power from the equipment, always consult with the operating personnel responsible for the machinery and process.

If troubleshooting indicates the necessity of component replacement, refer to “Field Replacement of CT and 1–100 hp VT Power Converters (Not Applicable on 125–500 hp, 460 V, VT Controllers)” on page 84.

### PREVENTIVE MAINTENANCE

Type 1 controllers in the 1–7.5 hp range at 460 V and 1–5 hp range at 208/230 V use convection cooling. All Type 12 controllers and Type 1 controllers for 10 hp and above (at 460 V) and 7.5 hp and above (at 208/230 V) use forced air cooling. Inspect the interior fans and exterior fans of the controller for blockage and impeded rotation. To prevent overheating and to allow proper air flow, maintain the clearances shown on the enclosure outline drawings on pages 31–32.

To maintain the environmental rating of Type 12 enclosures, periodically inspect the enclosure gaskets for damage.

The keypad display is an integral part of the enclosure and must be installed on the door to maintain the environmental integrity of a Type 12 enclosure. It can be omitted when option D10 is selected and in that case a closing plate must be installed to maintain the Type 12 environmental rating.

On 125–500 hp, 460 V controller with 1G enclosures, clean the filters once every 6 months. See Appendix B on page 97.

**FIELD REPLACEMENT OF CT AND 1–100 HP VT POWER CONVERTERS**  
 (Not Applicable on 125–500 hp, 460 V, VT Controllers)

If the power converter becomes inoperable in the Class 8839 58M controllers, it must be replaced. Refer to Table 44 for power converter weight before handling this component.

NOTE: For 125–500 hp, 460 V, VT controllers, contact:

Square D AC Drives Technical Support Group  
 8001 Highway 64 East  
 Knightdale, NC 27545-9023

Telephone: 919-266-8600  
 Fax Line: 919-217-6508  
 E-mail: drivepsg@squared.com

**Table 44: Power Converter Weights**

Constant Torque				Variable Torque			
hp		Weight		hp		Weight	
460 V	208/230 V	lb	kg	460 V	208/230 V	lb	kg
1–5	1–5	20	9.1	1–7.5	1–5	20	9.1
7.5–20	7.5–10	30	13.6	10–25	7.5–10	30	13.6
25–40	15–20	70	31.7	30–50	15–25	70	31.7
50–75	25–40	122	55.3	60–100	30–50	122	55.3
				125 <sup>1</sup>	—	108	49
				150–250 <sup>1</sup>	—	169	77
				300–500 <sup>1</sup>	—	370	168

1. Contact Square D AC Drives Technical Support for replacement of any 125–500 hp power converters.

Observe the lockout/tagout procedures as identified in OSHA Standard 29 CFR, Subpart J covering:

- 1910.147: The control of hazardous energy (lockout/tagout).
- 1910.147: App A, Typical minimal lockout procedures.

**REMOVING THE POWER CONVERTER ASSEMBLY**

**⚠ DANGER**

**HAZARDOUS VOLTAGE**

- Read and understand the bus voltage measurement procedure on page 42 before performing the procedure. Measurement of bus capacitor voltage must be performed by qualified personnel.
- Many parts in the drive controller, including printed wiring boards, operate at line voltage. DO NOT TOUCH. Use only electrically insulated tools.
- DO NOT short across DC bus capacitors or touch unshielded components or terminal strip screw connectors with voltage present.
- Disconnect all power.
- Place a “Do Not Turn On” label on the drive controller disconnect.
- Lock the disconnect in open position.

**Failure to follow these instructions will result in death or serious injury.**

**⚠ CAUTION**

**ELECTROSTATIC DISCHARGE**

Do not subject this device to electrostatic discharge. This controller contains electronic components that are very susceptible to damage from electrostatic discharge.

**Failure to follow this instruction can result in injury or equipment damage.**

To replace the power converter, follow these steps:

1. Open the door of the drive controller. Refer to step 1 on page 37.
2. Measure the DC bus voltage as described on page 42 of this instruction bulletin.
3. Disconnect all power and control wiring from the power converter assembly. Identify each wire for ease of re-assembling the new power converter. See Figure 24.

**Figure 24: Remove All Power and Control Wiring**

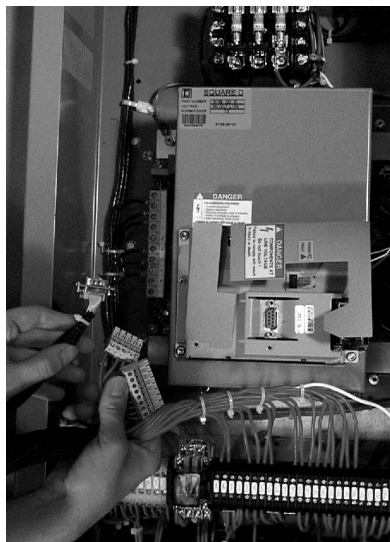

Disconnect:

- The keypad cable
- Two MAC board plugs
- Six power wires
- The ground
- The shield
- The heatsink fan connections on 25–75 hp CT, 30–100 hp VT (460 V) or 15–40 hp CT, 15–50 hp VT (208/230 V)
- The analog card (if used)
- The serial communication card (if used)
- The user terminal block on the power converter (if used)
- The 3–15 psi transducer (if used)
- The 0–10 V signal converter (if used)
- Analog card or DeviceNet terminal connection block

4. For the 60–100 hp VT, 50–75 hp CT 460 V and 30–50 hp VT, 25–40 hp CT 208/230 V, it is necessary to remove the heatsink fan assembly before removing the power converter. Refer to the “Field Replacement of Heatsink Fan Assembly” on page 88 for directions.
5. Remove the outside hex-slot picture frame screws that secure the power converter to the enclosure back pan. Refer to Figures 13–15 starting on page 46 for screw locations. Refer to Table 45 for the number of screws on your controller. Keep the screws for the new power converter. See Figure 25.

**Table 45: Number of Picture Frame Screws**

Constant Torque hp		Variable Torque hp		No. of Screws
460 V	208/230 V	460 V	208/230 V	
1–5	1–5	1–7.5	1–5	12
7.5–20	7.5–10	10–25	7.5–10	14

**Table 45: Number of Picture Frame Screws** (continued)

Constant Torque hp		Variable Torque hp		No. of Screws
460 V	208/230 V	460 V	208/230 V	
25–40	15–20	30–50	15–25	18
50–75	25–40	60–100	30–50	22

**Figure 25: Remove Picture Frame Screws**

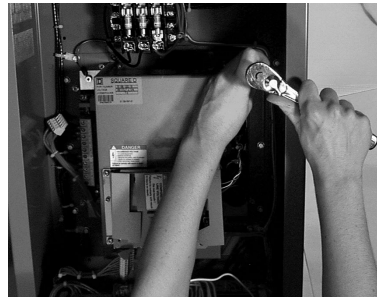

6. Remove the power converter assembly from the enclosure. See Figure 26.

**Figure 26: Remove Power Converter**

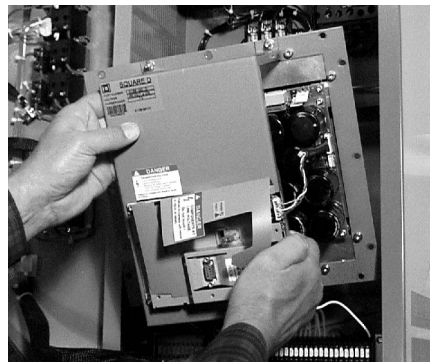

7. Remove four 0.5 in. (33 mm) rubber sealing plugs from the corners of the Type 12 power converters (25–75 hp CT, 30–100 hp VT at 460 V and 15–40 hp CT, 15–50 hp VT at 208/230 V). Keep the plugs for the new power converter.

## INSTALLING THE POWER CONVERTER ASSEMBLY

To install the new power converter, follow these steps:

1. Install the four 0.5 in. (13mm) rubber sealing plugs in the corners of the Type 12 power converters (25–75 hp CT, 30–100 hp VT at 460 V and 15–40 hp CT, 15–50 hp VT at 208/230 V). The plugs maintain the Type 12 enclosure rating.
2. Install the new power converter assembly in the enclosure. See Figures 26 and 27.

**Figure 27: Install New Power Converter**



1–25 hp VT @ 460 V and  
1–10 hp VT @ 208/230 V  
1–20 hp CT @ 460 V and  
1–10 hp CT @ 208/230 V  
Typical

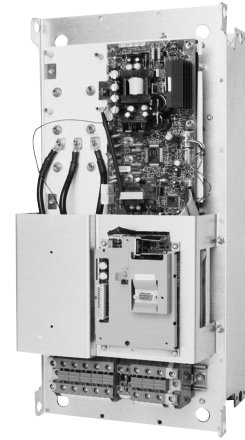

30–100 hp VT @ 460 V and  
15–50 hp VT @ 208/230 V  
25–75 hp CT @ 460 V and  
15–40 hp CT @ 208/230 V  
Typical

3. Secure the power converter picture frame to the enclosure back pan with the picture frame screws from the removed power converter. Torque the screws to 15 ± 2 lb-in. (1.7 ± 0.2 N•m) See Figure 25 on page 86.
4. Install all power and control wiring to the power converter assembly terminal blocks. Install all other removed equipment. See Figure 24 on page 85. Tighten the hardware to the torque values given in the table below. Check all wiring connections for correct terminations and check the power wiring for grounds with an ohmmeter.

Terminal	Torque		
	lb-in	N•m	
Ground (heatsink)	15	1.7	
J2 Power Terminal Strip:			
460 V	58MC•4V_ to 58MG•4V_ (1–7.5 hp)	7.5	0.85
	58MH•4V_ to 58ML•4V_ (10–25 hp)	20	2.3
	58MM•4V_ to 58MP•4V_ (30–50 hp)	88	9.9
	58MQ•4V_ to 58MS•4V_ (60–100 hp)	170	19.2
230 V	58MC•3V_ to 58MF•3V_ (1–5 hp)	7.5	0.85
	58MG•3V_ to 58MH•3V_ (7.5–10 hp)	20	2.3
	58MJ•3V_ to 58ML•3V_ (15–25 hp)	88	9.9
	58MM•3V_ to 58MP•3V_ (30–50 hp)	170	19.2
208 V	58MC•2V_ to 58MF•2V_ (1–5 hp)	7.5	0.85
	58MG•2V_ to 58MH•2V_ (7.5–10 hp)	20	2.3
	58MJ•2V_ to 58ML•2V_ (15–25 hp)	88	9.9
	58MM•2V_ to 58MP•2V_ (30–50 hp)	170	19.2
S Shield Connection (power converter)	3.5	0.34	
Analog output user terminal block DIN rail mounting screws (if used)	22	2.5	

5. Shut the enclosure door, secure the door with door fasteners, and close the circuit breaker disconnect.

## **⚠ DANGER**

### **UNQUALIFIED USER**

- This equipment must be installed and serviced only by qualified personnel.
- Qualified personnel performing diagnostics or troubleshooting requiring electrical conductors to be energized, must comply with NFPA 70 E - Standard for Electrical Safety Requirements for Employee Workplaces and OSHA Standards – 29 CFR Part 1910 Subpart S Electrical.

**Failure to follow this instruction will result in death or serious injury.**

6. Program the drive controller according to the control circuit elementary diagrams provided with each controller. Follow the initial start-up procedure on page 60.

The drive controller is now ready to operate.

## **FIELD REPLACEMENT OF HEATSINK FAN ASSEMBLY**

If a heatsink fan becomes inoperable in the 10–100 hp 460 V or 7.5–50 hp 208/230 V controllers, the fan assembly must be replaced. Observe the lockout/tagout procedures as identified in OSHA Standard 29 CFR, Subpart J covering:

- 1910.147: The control of hazardous energy (lockout/tagout).
- 1910.147: App A, Typical minimal lockout procedures.

## **REMOVING THE HEATSINK FAN ASSEMBLY**

*NOTE: For the equipment required for this procedure, refer to the recommended spare parts list for the heatsink fan assembly catalog number.*

## **⚠ DANGER**

### **HAZARDOUS VOLTAGE**

- Read and understand the bus voltage measurement procedure on page 42 before performing the procedure. Measurement of bus capacitor voltage must be performed by qualified personnel.
- Many parts in the drive controller, including printed wiring boards, operate at line voltage. **DO NOT TOUCH.** Use only electrically insulated tools.
- **DO NOT** short across DC bus capacitors or touch unshielded components or terminal strip screw connectors with voltage present.
- Disconnect all power.
- Place a “Do Not Turn On” label on the drive controller disconnect.
- Lock the disconnect in open position.

**Failure to follow these instructions will result in death or serious injury.**

**⚠ CAUTION**

**ELECTROSTATIC DISCHARGE**

Do not subject this device to electrostatic discharge. This controller contains electronic components that are very susceptible to damage from electrostatic discharge.

**Failure to follow this instruction can result in injury or equipment damage.**

To replace the heatsink fan assembly, follow these steps:

1. Open the door of the drive controller. Refer to Step 1 on page 37.
2. Measure the DC bus voltage as described on page 42.
3. Locate the heatsink fan assembly above or below the power converter.

**Figure 28: Heatsink Fan Assembly Location**

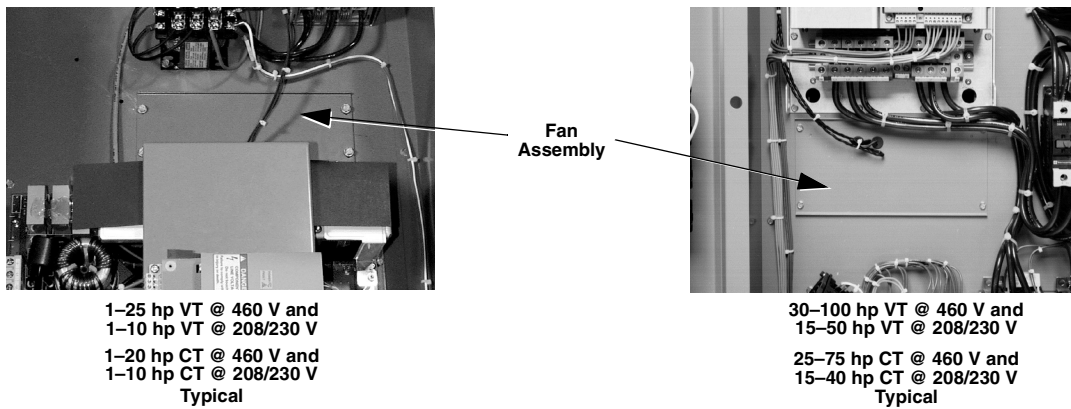

4. For 10–25 hp VT and 7.5–20 hp CT controllers, disconnect the four fan wires connected to the control transformer. The 0.25 in. (6.35 mm) fast-on is connected to XF on the transformer fuse. The spade lug is connected to the X2 terminal on the transformer. See Figure 29. For 25–75 hp CT, 30–100 hp VT 460 V controllers and 20–50 hp VT, 20–40 hp CT 208/230 V controllers, disconnect the heatsink fan wire connectors.

**Figure 29: Remove the Fan Wiring**

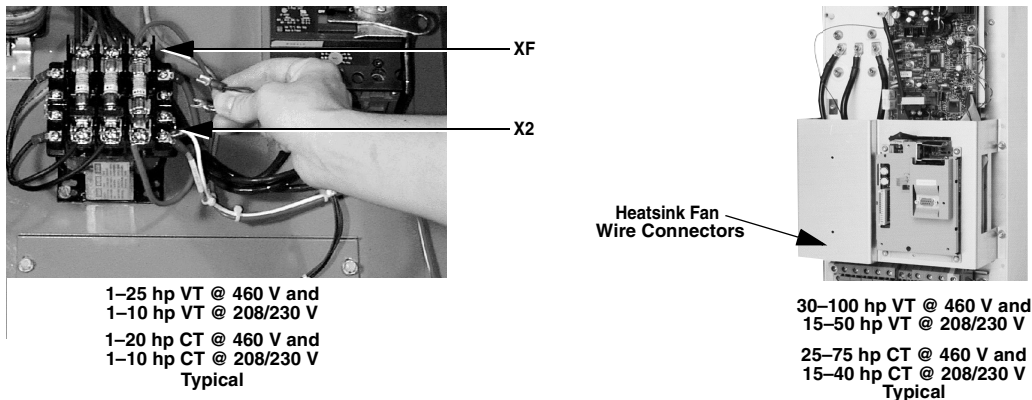

5. Remove the four screws securing the heatsink fan assembly. Keep the four screws. See Figure 28.
6. Remove the heatsink fan assembly from the enclosure. For the 10–25 hp VT and 7.5–20 hp CT 460 V controllers and 7.5–10 hp CT or VT 208/230 V controllers, lift the assembly up toward the top of the enclosure then pull it out. For 25–75 hp CT, 30–100 hp VT 460 V controllers and 15–50 hp VT, 15–40 hp CT 208/230 V controllers, pull the assembly down toward the bottom of the enclosure then pull it out. See Figure 30.

**Figure 30: Remove the Heatsink Fan Assembly**

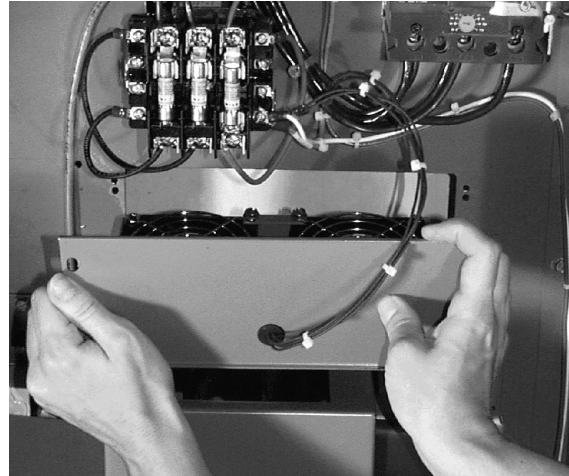

## INSTALLING THE HEATSINK FAN ASSEMBLY

To install the new heatsink fan assembly, follow these steps:

1. Install the heatsink fan assembly. Secure the assembly with the four screws saved from Step 5 above. Torque the screws to 15 lb-in (1.7 N•m). See Figure 28 and Figure 30.
2. For 10–25 hp VT and 7.5–20 hp CT 460 V controllers and 7.5–10 hp CT or VT 208/230 V controllers, terminate the wire with the spade lug to X2 on the transformer. Torque the screw to 20–25 lb-in (2.3–2.8 N•m). Terminate the fast-on to XF on the transformer fuse. See Figure 29. Check all wiring connections for correct terminations. For 25–75 hp CT, 30–100 hp VT controllers at 460 V and 15–50 hp VT, 15–40 hp CT controllers at 208/230 V, plug the DC fan connectors to the power converter.
3. Shut the enclosure door and secure it with door fasteners. Then close the circuit breaker disconnect.
4. The drive controller is now ready to operate.

*NOTE: For 25–75 hp CT, 30–100 hp VT controllers at 460 V and 15–50 hp VT, 15–40 hp CT controllers at 208/230 V, when the heatsink fan connectors are not properly attached to the power converter, the power converter may cycle on and off or not function. If either of these occurs, check the heatsink fan connections.*

## FIELD REPLACEMENT OF THE STIRRING FANS

If a stirring fan inside the enclosure becomes inoperable in the Class 8839 58M controllers, the fan must be replaced.

Before removing the inoperable stirring fan, mark airflow direction to ensure proper installation of the replacement fan.

## FIELD REPLACEMENT OF THE PLENUM FANS

Floor mount units (460 V, 30–100 hp VT / 25–75 hp CT and 208/230 V 15–50 hp VT / 15–40 hp CT) use a plenum fan to assist in air movement over the drive controller heatsink. If the plenum fan becomes inoperable in the Class 8839 58M controller, the fan must be replaced.

Before removing the inoperable plenum fan, mark airflow direction to ensure proper installation of the replacement fan.

**Figure 31: Plenum and Heatsink Fan Locations**

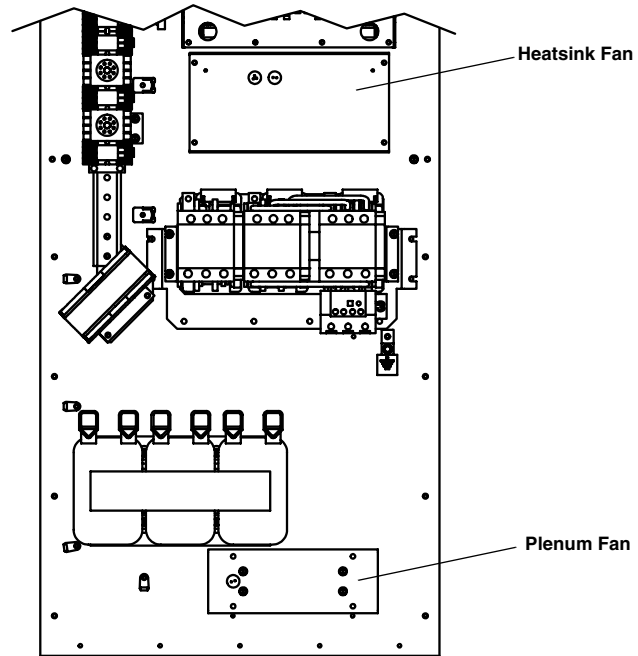

## TECHNICAL SUPPORT

When troubleshooting the Class 8839 58M drive controller, discuss with operating personnel the symptoms of the reported problems. Ask them to describe the problem, when they first observed the problem, and where the problem was seen. Observe directly the drive system and process.

For more information, call, fax, or write:

Square D AC Drives Technical Support Group  
8001 Highway 64 East  
Knightdale, NC 27545-9023

Telephone: 919-266-8600  
Fax Line: 919-217-6508  
E-mail: [drivepsg@squared.com](mailto:drivepsg@squared.com)



## APPENDIX A—SPARE PARTS

**Table 46: 460 V Spare Parts, 1–100 hp**

Description	Qty	1–7.5 hp	Qty	10–25 hp	Qty	30–50 hp	Qty	60–100 hp
Power Converter	1	FLEX58KU18N4 (1 hp) FLEX58KU29N4 (2 hp) FLEX58KU41N4 (3 hp) FLEX58KU54N4 (5 hp VT) FLEX58KU72N4 (7.5 hp VT, 5 hp CT)	1	FLEX58KU90N4 (7.5 hp CT, 10 hp VT) FLEX58KD12N4 (10 hp CT, 15 hp VT) FLEX58KD16N4 (15 hp CT, 20 hp VT) FLEX58KD23N4 (20 hp CT, 25 hp VT)	1	FLEX58KD28N4 (25 hp CT, 30 hp VT) FLEX58KD33N4 (30 hp CT, 40 hp VT) FLEX58KD46N4 (40 hp CT, 50 hp VT)	1	FLEX58KD54N4 (50 hp CT, 60 hp VT) FLEX58KD64N4 (60 hp CT, 75 hp VT) FLEX58KD79N4 (75 hp CT, 100 hp VT)
Keypad Display	1	VW3A58101U	1	VW3A58101U	1	VW3A58101U	1	VW3A58101U
Primary Control Fuses								
Standard 300 VA	2	25430-20320	2	25430-20320	2	25430-20320	2	25430-20320
Barriered bypass additional 150 VA	2	25430-20150	2	25430-20150	2	25430-20150	2	25430-20150
Option 110 350 VA	2	25430-20351	2	25430-20351	2	25430-20351	2	25430-20351
Secondary Control Fuses								
Standard 300 VA	1	25430-20400	1	25430-20400	1	25430-20400	1	25430-20400
Barriered bypass additional 150 VA	1	25430-20200	1	25430-20200	1	25430-20200	1	25430-20200
Option 110 350 VA	1	25430-20500	1	25430-20500	1	25430-20500	1	25430-20500
Pilot Light Red	1	LED 25501-00003 Head ZB5AV04	1	LED 25501-00003 Head ZB5AV04	1	LED 25501-00003 Head ZB5AV04	1	LED 25501-00003 Head ZB5AV04
Pilot Light Yellow	2	LED 25501-00004 Head ZB5AV05 w/o p-t-t <sup>[1]</sup> Head ZB5AW35 w/ p-t-t <sup>[1]</sup>	2	LED 25501-00004 Head ZB5AV05 w/o p-t-t <sup>[1]</sup> Head ZB5AW35 w/ p-t-t <sup>[1]</sup>	2	LED 25501-00004 Head ZB5AV05 w/o p-t-t <sup>[1]</sup> Head ZB5AW35 w/ p-t-t <sup>[1]</sup>	2	LED 25501-00004 Head ZB5AV05 w/o p-t-t <sup>[1]</sup> Head ZB5AW35 w/ p-t-t <sup>[1]</sup>
Pilot Light Green	1	LED 25501-00005 Head ZB5AV03 w/o p-t-t <sup>[1]</sup> Head ZB5AW33 w/ p-t-t <sup>[1]</sup>	1	LED 25501-00005 Head ZB5AV03 w/o p-t-t <sup>[1]</sup> Head ZB5AW33 w/ p-t-t <sup>[1]</sup>	1	LED 25501-00005 Head ZB5AV03 w/o p-t-t <sup>[1]</sup> Head ZB5AW33 w/ p-t-t <sup>[1]</sup>	1	LED 25501-00005 Head ZB5AV03 w/o p-t-t <sup>[1]</sup> Head ZB5AW33 w/ p-t-t <sup>[1]</sup>
Pilot Light Blue	1	LED 25501-00006 Head ZB5AV06 w/o p-t-t <sup>[1]</sup> Head ZB5AW36 w/ p-t-t <sup>[1]</sup>	1	LED 25501-00006 Head ZB5AV06 w/o p-t-t <sup>[1]</sup> Head ZB5AW36 w/ p-t-t <sup>[1]</sup>	1	LED 25501-00006 Head ZB5AV06 w/o p-t-t <sup>[1]</sup> Head ZB5AW36 w/ p-t-t <sup>[1]</sup>	1	LED 25501-00006 Head ZB5AV06 w/o p-t-t <sup>[1]</sup> Head ZB5AW36 w/ p-t-t <sup>[1]</sup>
Pilot Light Mounting Collar w/ Light Module	1	ZB5AV6	1	ZB5AV6	1	ZB5AV6	1	ZB5AV6
Pilot Light Mounting Collar w/ Light Module and 1 N.O. and 1 N.C. Contact for p-t-t <sup>[1]</sup>	1	ZB5AW065	1	ZB5AW065	1	ZB5AW065	1	ZB5AW065
Analog I/O Board <sup>[2]</sup>	1	VW3A58201U	1	VW3A58201U	1	VW3A58201U	1	VW3A58201U
LONWORKS to MODBUS Module <sup>[3]</sup>	1	VW3A58312PU	1	VW3A58312PU	1	VW3A58312PU	1	VW3A58312PU
Modbus <sup>[2] [3]</sup>	1	VW3A58303U	1	VW3A58303U	1	VW3A58303U	1	VW3A58303U

1. p-t-t: Push-to-test operator.
2. Field replacement of the option board will reset the power converter to the Material Handling macro. The user must configure the controller per the elementary diagram provided.
3. Refer to notes 1 and 2 on page 26.
4. 0–10 V converter kit is for use with ATV58 AC drive products only. Kit contains board part no. 31164-099-50.

**Table 46: 460 V Spare Parts, 1–100 hp (continued)**

Description	Qty	1–7.5 hp	Qty	10–25 hp	Qty	30–50 hp	Qty	60–100 hp
Metasys N2 [2]	1	VW3A58354U	1	VW3A58354U	1	VW3A58354U	1	VW3A58354U
24 Vdc Supply	1	ABL7CEM24003	1	ABL7CEM24003	1	ABL7CEM24003	1	ABL7CEM24003
User Termination to D-Shell Interface Device	1	25410-00084	1	25410-00084	1	25410-00084	1	25410-00084
0–10 V Converter Kit [4]	1	31158-297-50	1	31158-297-50	1	31158-297-50	1	31158-297-50
Stirring Fan Assembly	1	31158-065-50	1	31158-065-50	2	31158-065-50	2	31158-065-50
Heatsink Fan Assembly	—	N/A	1	31158-296-50	1	31158-296-51	1	31158-296-52
Plenum Fan Assembly	—	N/A	—	N/A	1	31164-215-50	1	31164-215-50
Filter for Input Plenum	—	N/A	—	N/A	1	31164-152-01	1	31164-153-01
Barriercd Enclosure	1	31164-152-01	1	31164-152-01	1	31164-153-01	1	31164-159-01
Circuit Breaker Handle	1	3 in. handle for wall mount and barriered floor mount enclosure: 9421LH3	1	3 in. handle for wall mount and barriered floor mount enclosure: 9421LH3	1	6 in. handle for floor mount enclosure: 9421LH6	1	6 in. handle for floor mount enclosure: 9421LH6

1. p-t-t: Push-to-test operator.
2. Field replacement of the option board will reset the power converter to the Material Handling macro. The user must configure the controller per the elementary diagram provided.
3. Refer to notes 1 and 2 on page 26.
4. 0–10 V converter kit is for use with ATV58 AC drive products only. Kit contains board part no. 31164-099-50.

**Table 47: 460 V, Spare Parts 125–500 hp**

Description	Qty	125–200 hp	Qty	250 hp	Qty	300–500 hp
Power Converter	1	ATV58HC10N4XZU (125 hp VT) ATV58HC13N4XZU (150 hp VT) ATV58HC15N4XZU (200 hp VT)	1	ATV58HC19N4XZU (250 hp VT)	1	ATV58HC23N4XZU (300 hp VT) ATV58HC25N4XZU (350 hp VT) ATV58HC28N4XZU (400 hp VT) ATV58HC31N4XZU (450 hp VT) ATV58HC33N4XZU (500 hp VT)
Keypad Display	1	VW3A58101U	1	VW3A58101U	1	VW3A58101U
Primary Control Fuses						
Standard 300 VA	2	25430-20161 (no bypass)	2	25430-20161 (no bypass)	2	25430-20281 (no bypass)
	2	25430-20281 (w/ bypass)				
Secondary Control Fuses						
Standard 300 VA	1	25430-20250 (no bypass) 25430-20400 (w/ bypass)	1	25430-20250 (no bypass)	1	25430-20400 (no bypass)
Pilot Light Red	1	LED 25501-00003 Head ZB5AV04	1	LED 25501-00003 Head ZB5AV04	1	LED 25501-00003 Head ZB5AV04
Pilot Light Yellow	2	LED 25501-00004 Head ZB5AV05 w/o p-t-t [1] Head ZB5AW35 w/ p-t-t [1]	2	LED 25501-00004 Head ZB5AV05 w/o p-t-t [1] Head ZB5AW35 w/ p-t-t [1]	2	LED 25501-00004 Head ZB5AV05 w/o p-t-t [1] Head ZB5AW35 w/ p-t-t [1]
Pilot Light Green	1	LED 25501-00005 Head ZB5AV03 w/o p-t-t [1] Head ZB5AW33 w/ p-t-t [1]	1	LED 25501-00005 Head ZB5AV03 w/o p-t-t [1] Head ZB5AW33 w/ p-t-t [1]	1	LED 25501-00005 Head ZB5AV03 w/o p-t-t [1] Head ZB5AW33 w/ p-t-t [1]
Pilot Light Blue	1	LED 25501-00006 Head ZB5AV06 w/o p-t-t [1] Head ZB5AW36 w/ p-t-t [1]	1	LED 25501-00006 Head ZB5AV06 w/o p-t-t [1] Head ZB5AW36 w/ p-t-t [1]	1	LED 25501-00006 Head ZB5AV06 w/o p-t-t [1] Head ZB5AW36 w/ p-t-t [1]

1. p-t-t: Push-to-test operator.
2. Field replacement of the option board will reset the power converter to the Material Handling macro. The user must configure the controller per the elementary diagram provided.
3. Refer to notes 1 and 2 on page 26.
4. 0–10 V converter kit is for use with ATV58 AC drive products only. Kit contains board part no. 31164-099-50.
5. See Appendix B on page 97 for maintenance instructions.

**Table 47: 460 V, Spare Parts 125–500 hp (continued)**

Description	Qty	125–200 hp	Qty	250 hp	Qty	300–500 hp
Pilot Light Mounting Collar w/ Light Module	1	ZB5AV6	1	ZB5AV6	1	ZB5AV6
Pilot Light Mounting Collar w/ Light Module and 1 N.O. and 1 N.C. Contact for p-t-t <sup>[1]</sup>	1	ZB5AW065	1	ZB5AW065	1	ZB5AW065
Analog I/O Board <sup>[2]</sup>	1	VW3A58201U	1	VW3A58201U	1	VW3A58201U
LONWORKS to MODBUS Module <sup>[3]</sup>	1	VW3A58312PU	1	VW3A58312PU	1	VW3A58312PU
Modbus <sup>[2] [3]</sup>	1	VW3A58303U	1	VW3A58303U	1	VW3A58303U
Metasys N2 <sup>[2]</sup>	1	VW3A58354U	1	VW3A58354U	1	VW3A58354U
24 Vdc Supply	1	ABL7CEM24003	1	ABL7CEM24003	1	ABL7CEM24003
User Termination to D-Shell Interface Device	1	25410-00084	1	25410-00084	1	25410-00084
0–10 V Converter Kit <sup>[4]</sup>	1	31158-297-50	1	31158-297-50	1	31158-297-50
Stirring Fan Kit	1	26016-31100	1	26016-31100	2	26016-31100
Heatsink Fan Assembly	1	VZ3V3808 (125 hp) VZ3V3809 (150–200 hp)	1	VZ3V3809	1	VZ3V3810
Internal Fan Kit	1	VZ3V3818	1	VZ3V3819	1	VZ3V3820
Foam Filter Element for 1G Enclosures <sup>[5]</sup>	1	80444-134-01	1	80444-134-01	1	80444-134-02
Circuit Breaker Operating Mechanism	1	80418-841-50 (125 hp, no bypass) 80439-801-51 (150–200 hp, no bypass) 80444-669-50 (w/ bypass)	1	80439-801-51 (no bypass)	1	80439-805-51 (no bypass)

1. p-t-t: Push-to-test operator.
2. Field replacement of the option board will reset the power converter to the Material Handling macro. The user must configure the controller per the elementary diagram provided.
3. Refer to notes 1 and 2 on page 26.
4. 0–10 V converter kit is for use with ATV58 AC drive products only. Kit contains board part no. 31164-099-50.
5. See Appendix B on page 97 for maintenance instructions.

**Table 48: 208/230 V Spare Parts**

Description	Qty	1–5 hp	Qty	7.5–10 hp	Qty	15–25 hp	Qty	30–50 hp
Power Converter	1	FLEX58U29M2 (1-2 hp CT/VT) FLEX58U41M2 (3 hp CT/VT) FLEX58U72M2 (5 hp CT/VT)	1	FLEX58U90M2 (7.5 hp CT/VT) FLEX58D12M2 (10 hp CT/VT)	1	FLEX58D16M2 (15hp CT/VT, 20 hp VT) FLEX58D23M2 (20 hp CT, 25 hp VT)	1	FLEX58D28M2 (25-30 hp CT, 30 hp VT) FLEX58D33M2 (40 hp CT/VT) FLEX58D46M2 (50 hp VT)
Keypad Display	1	VW3A58101U	1	VW3A58101U	1	VW3A58101U	1	VW3A58101U
Control Fuses Primary								
Standard	2	25430-20625	2	25430-20625	2	25430-20625	2	25430-20625
Barriered bypass additional 150 VA	2	25430-20350 (208 V) 25430-20300 (230 V)	2	25430-20350 (208 V) 25430-20300 (230 V)	2	25430-20350 (208 V) 25430-20300 (230 V)	2	25430-20350 (208 V) 25430-20300 (230 V)
Option 110	2	25430-20800 (208 V) 25430-20750 (230 V)	2	25430-20800 (208 V) 25430-20750 (230 V)	2	25430-20800 (208 V) 25430-20750 (230 V)	2	25430-20800 (208 V) 25430-20750 (230 V)

1. p-t-t: Push-to-test operator.
2. Field replacement of the option board will reset the power converter to the Material Handling macro. The user must configure the controller per the elementary diagram provided.
3. Refer to notes 1 and 2 on page 26.
4. 0–10 V converter kit is for use with ATV58 AC drive products only. Kit contains board part no. 31164-099-50.

Table 48: 208/230 V Spare Parts (continued)

Description	Qty	1–5 hp	Qty	7.5–10 hp	Qty	15–25 hp	Qty	30–50 hp
Control Fuses Secondary								
Standard	1	25430-20400	1	25430-20400	1	25430-20400	1	25430-20400
Barriered bypass additional 150 VA	1	25430-20200	1	25430-20200	1	25430-20200	1	25430-20200
Option 110	1	25430-20500	1	25430-20500	1	25430-20500	1	25430-20500
Pilot Light Red	1	LED 25501-00003 Head ZB5AV04	1	LED 25501-00003 Head ZB5AV04	1	LED 25501-00003 Head ZB5AV04	1	LED 25501-00003 Head ZB5AV04
Pilot Light Yellow	2	LED 25501-00004 Head ZB5AV05 w/o p-t-t <sup>[1]</sup> Head ZB5AW35 w/ p-t-t <sup>[1]</sup>	2	LED 25501-00004 Head ZB5AV05 w/o p-t-t <sup>[1]</sup> Head ZB5AW35 w/ p-t-t <sup>[1]</sup>	2	LED 25501-00004 Head ZB5AV05 w/o p-t-t <sup>[1]</sup> Head ZB5AW35 w/ p-t-t <sup>[1]</sup>	2	LED 25501-00004 Head ZB5AV05 w/o p-t-t <sup>[1]</sup> Head ZB5AW35 w/ p-t-t <sup>[1]</sup>
Pilot Light Green	1	LED 25501-00005 Head ZB5AV03 w/o p-t-t <sup>[1]</sup> Head ZB5AW33 w/ p-t-t <sup>[1]</sup>	1	LED 25501-00005 Head ZB5AV03 w/o p-t-t <sup>[1]</sup> Head ZB5AW33 w/ p-t-t <sup>[1]</sup>	1	LED 25501-00005 Head ZB5AV03 w/o p-t-t <sup>[1]</sup> Head ZB5AW33 w/ p-t-t <sup>[1]</sup>	1	LED 25501-00005 Head ZB5AV03 w/o p-t-t <sup>[1]</sup> Head ZB5AW33 w/ p-t-t <sup>[1]</sup>
Pilot Light Blue	1	LED 25501-00006 Head ZB5AV06 w/o p-t-t <sup>[1]</sup> Head ZB5AW36 w/ p-t-t <sup>[1]</sup>	1	LED 25501-00006 Head ZB5AV06 w/o p-t-t <sup>[1]</sup> Head ZB5AW36 w/ p-t-t <sup>[1]</sup>	1	LED 25501-00006 Head ZB5AV06 w/o p-t-t <sup>[1]</sup> Head ZB5AW36 w/ p-t-t <sup>[1]</sup>	1	LED 25501-00006 Head ZB5AV06 w/o p-t-t <sup>[1]</sup> Head ZB5AW36 w/ p-t-t <sup>[1]</sup>
Pilot Light Mounting Collar w/ Light Module	1	ZB5AV6	1	ZB5AV6	1	ZB5AV6	1	ZB5AV6
Pilot Light Mounting Collar w/ Light Module and 1 N.O. and 1 N.C. Contact for p-t-t <sup>[1]</sup>	1	ZB5AW065	1	ZB5AW065	1	ZB5AW065	1	ZB5AW065
Analog I/O Board <sup>[2]</sup>	1	VW3A58201U	1	VW3A58201U	1	VW3A58201U	1	VW3A58201U
LONWORKS to Modbus module <sup>[3]</sup>	1	VW3A58312PU	1	VW3A58312PU	1	VW3A58312PU	1	VW3A58312PU
Modbus <sup>[2][3]</sup>	1	VW3A58303U	1	VW3A58303U	1	VW3A58303U	1	VW3A58303U
Metasys N2 <sup>[2]</sup>	1	VW3A58354U	1	VW3A58354U	1	VW3A58354U	1	VW3A58354U
24 Vdc Supply	1	ABL7CEM24003	1	ABL7CEM24003	1	ABL7CEM24003	1	ABL7CEM24003
User Termination to D-Shell Interface Device	1	25410-00084	1	25410-00084	1	25410-00084	1	25410-00084
0–10 V Converter Kit <sup>[4]</sup>	1	31158-297-50	1	31158-297-50	1	31158-297-50	1	31158-297-50
Stirring Fan Assembly	1	31158-065-50	1	31158-065-50	2	31158-065-50	2	31158-065-50
Heatsink Fan Assembly	—	N/A	1	31158-296-50	1	31158-296-51	1	31158-296-52
Plenum Fan Assembly	—	N/A	—	N/A	1	31164-214-50	1	31164-214-50
Filter for Input Plenum	—	N/A	—	N/A	1	31164-152-01	1	31164-153-01
Barriered Enclosure	1	31164-152-01	1	31164-152-01	1	31164-153-01	1	31164-159-01
Circuit Breaker Handle	1	3 in. handle for wall mount and barriered floor mount enclosure: 9421LH3	1	3 in. handle for wall mount and barriered floor mount enclosure: 9421LH3	1	6 in. handle for floor mount enclosure: 9421LH6	1	6 in. handle for floor mount enclosure: 9421LH6

1. p-t-t: Push-to-test operator.
2. Field replacement of the option board will reset the power converter to the Material Handling macro. The user must configure the controller per the elementary diagram provided.
3. Refer to notes 1 and 2 on page 26.
4. 0–10 V converter kit is for use with ATV58 AC drive products only. Kit contains board part no. 31164-099-50.

## APPENDIX B—FIELD INSTALLATION OF INLET VENT FILTER ASSEMBLY

### OVERVIEW

**Figure 32: Altivar 58 TRX Drive Controller with Inlet Vent Filter Assembly Installed**

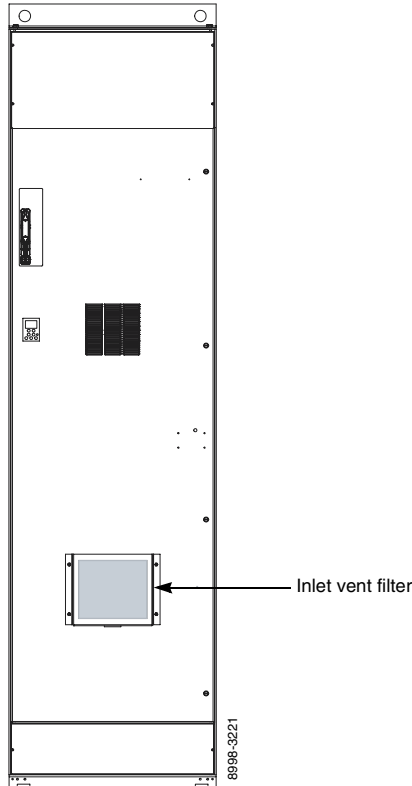

This appendix contains installation instructions for a foam filter assembly. The assembly is installed onto the enclosure door over the bottom inlet ventilation louvers of the Altivar 58 TRX adjustable speed drive controller unit. The assembly is available only for 125–500 hp, variable torque Altivar 58 TRX drives.

When installed correctly, the filter will capture some contaminants in a foam filter media rated at 30 pores per inch. The factory installs the foam filter assembly as standard for 1G gasketed enclosures. The foam filter assembly is available only as a field installed option on Type 1 enclosures.

This filter is offered for users who desire a reduction in the amount of contaminants pulled through the cooling vents of the drive controller unit. Filters are not required to maintain the UL Listing of the unit for Type 1 integrity.

The assembly requires the following parts (see Table 49):

- (1) Outer filter bracket
- (1) Inner filter bracket
- (1) Foam filter element

**Table 49: Inlet Vent Filter Assembly Parts**

Controller Rating (hp)	Part Description	Part Number
125–250	Outer filter bracket	80444-132-02
	Inner filter bracket	80444-133-02
	Foam filter element	80444-134-01
300–500	Outer filter bracket	80444-132-01
	Inner filter bracket	80444-133-01
	Foam filter element	80444-134-02

Each filter media is pre-cut to fit a particular drive horsepower size inlet vent.

### INSTALLATION

Follow these steps to install the inlet vent filter assembly:

1. With the door closed, install the filter brackets (outer and inner) over the louvers as shown in Figure 33 using the hardware provided in the pre-drilled holes around the louvers.
2. Insert the foam filter element into the opening at the top of the filter bracket. The element should be completely inside the filter brackets.

Figure 33: Inlet Vent Filter Assembly Hardware Locations

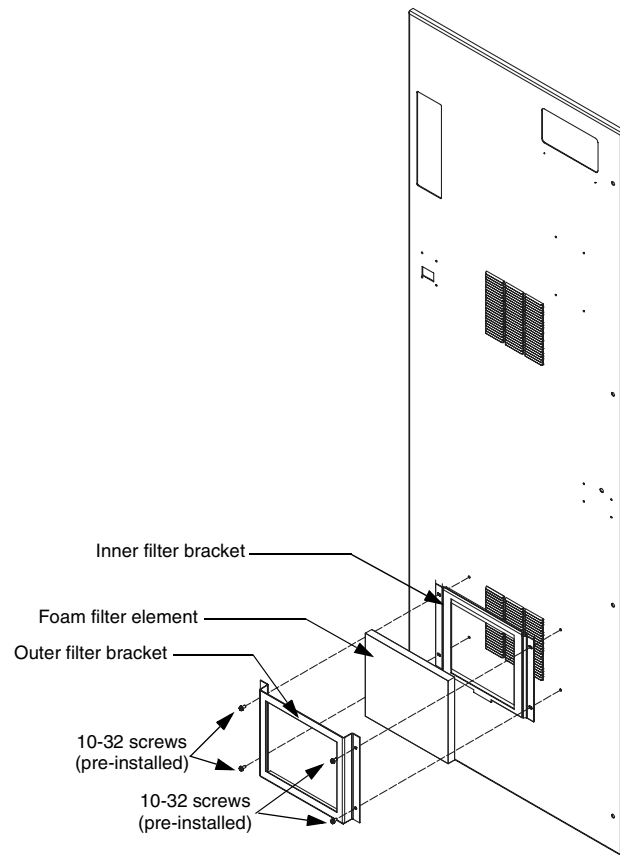

## MAINTENANCE

Enclosure sizes H–J drive controllers in 1G (gasketed) enclosures include a filter over the lower door vents. The maintenance procedures for the drive controller require that the filter element be inspected and cleaned every six months, or more frequently if indicated by service conditions and your established maintenance schedule.

To clean the filter element:

1. Remove the filter element from the front door bracket by pushing the filter element up from the bottom of the filter bracket, using the access slots in the bottom of the bracket. Once the filter element is partially above the bracket, remove it by pulling it out of the top of the bracket.
2. Vacuum and wash the filter thoroughly.
3. Dry the filter completely and re-install it.

*NOTE: If the filter element becomes damaged, or when it deteriorates, replace it. See Table 49 on page 97 for a list of replacement filter part numbers.*

## INDEX

### Numerics

110 11, 28, 80  
24 Vdc power supply 80  
310 11, 28  
410 11, 28, 80  
50/60 Hz switch 61  
510 11, 28, 80  
610 11, 28, 80  
710 11, 28, 80  
910 11, 28, 81

### A

A07 11, 22, 75  
A08 11, 24, 76  
A09 11, 26, 77  
A10 11, 27, 78  
acceleration ramp  
  range 20  
  setting 64  
additional interlocks 73  
adjustable frequency controller 8  
AFC 8  
AFC fault reset 79  
AFC-off-bypass selector switch 74  
altitude 20  
analog card 11, 26, 78  
auto speed ref. 11, 27, 79  
auto transfer to bypass 79

### B

B07 11, 22, 75  
B08 11, 24, 76  
B09 11, 26, 77  
B10 11, 27, 78  
barriered bypass enclosure 33, 47, 81  
branch circuit  
  components 15, 40  
  feeder protection 15–19  
bus voltage  
  measuring 42

### C

C07 11, 23, 75  
C08 11, 24, 76  
C09 11, 26, 77  
C10 11, 27, 78  
cable  
  input 16–19, 52–56  
  output 42, 52–56  
capacitance 41  
cards 11, 26  
catalog numbers 10  
check valve 80  
circuit breaker  
  disconnect  
    location 46–51  
  handle 94, 96  
  trip adjustment 65–67

codes and standards 20  
communication options 26, 77–78  
communication-auto-off-hand selector switch  
  75  
communication-hand-off-auto selector switch  
  23, 75–76  
component locations 46, 48–50  
conductor  
  choosing 44  
  grounding 41  
  grouping 45  
  motor power 41  
conduit  
  choosing 40–41  
  entry 39  
control  
  transformer 46–51  
  wiring 59  
control options 11, 22, 75–76  
controller 8  
cooling 8, 29  
cUL certification 27, 78  
current 15, 19  
  output 12–14

### D

D07 11, 23, 75  
D08 11, 25, 76  
D09 11, 26, 77  
D10 11, 27, 78  
deceleration ramp  
  range 20  
  setting 64  
DeviceNet serial communications 26, 78  
diagnostic tools 83  
dimensions 31–35  
displacement power factor 19  
door  
  opening 37  
drive controller 8

### E

E07 11, 23, 75  
E08 11, 25, 76  
E09 11, 26, 78  
E10 11, 27, 78  
efficiency 20  
emergency stop 80  
emergency stop interlock 73  
enclosure 10, 20  
engraved nameplates 80  
environment 8  
Ethernet serial communications 26, 77

### F

F07 11, 23, 75  
F08 11, 26, 76  
F09 11, 26, 78

factory modifications  
  card options 11, 26  
  control options 11, 22, 75–76  
  light options 11, 24–26, 76  
  miscellaneous options 11, 27–28, 78–  
    81  
factory settings  
  changing, saving, retrieving 70  
fasteners 8, 39  
fault  
  reset 10, 58, 70, 75  
features  
  standard 21  
fire/freezestat interlock 73  
forced local 58, 78  
forward/reverse selector switch 23, 75–76  
frequency  
  input 19  
  range 19  
  resolution 19

### G

G10 11, 27, 78  
galvanic isolation 19  
grounding 45

### H

H09 11, 26, 78  
H10 11, 27, 78  
handling 38  
hand-off-auto selector switch 22  
harmonic distortion 15, 78  
harmonic filter 46–47, 49–51, 80  
heatsink fan assembly  
  installing 90  
  removing 88  
high speed setting 64  
hoisting 38  
humidity 20

### I

input  
  cable 16–19, 40, 52–56  
  current 15  
  frequency 19  
  power 40  
  voltage 19  
  wiring 40  
installation  
  electrical 39  
  mechanical 39  
interlocks 73

### J

J10 11, 27, 79

### K

K10 11, 27, 79

keypad 20  
  option to omit 11, 27, 78  
keypad access switch 60  
keypad command operation 69

## L

L10 11, 27, 79  
light options 11, 24–26, 76  
lightning arrestors 42  
line  
  contactor 11, 27, 46, 48, 78, 83  
  inductance 15  
  reactor 11, 15, 27, 46–51, 78  
local/remote selector switch 23, 75–76  
LonWorks serial communications 11, 26, 78  
low speed setting 64

## M

M10 11, 27, 79  
Metasys N2 serial communications 11, 26,  
  77  
miscellaneous options 11, 27–28, 78–81  
MOD  
  B10 83  
  D10 83

Modbus Plus serial communications 26, 77  
Modbus serial communications 11, 26, 77

## motor

  power conductors 41  
  protection 20  
  rotation  
    correcting direction of 63  
    terminal connection 46, 48–50

motor space heater sequencing 80

## mounting

  clearance 31–35  
  dimensions and weights 31–35  
  environment 8  
  fasteners 8, 39  
  precautions 8  
  suitable surface 39

## N

N.O. aux. auto mode contact 79  
N.O. aux. bypass run contact 79  
N.O. aux. drive fault contact 79  
N.O. aux. drive run contact 79  
nameplate identification 9

## noise

  class 44  
  suppressors 40  
nuisance tripping 15, 41

## O

O10 11, 27, 79  
option cards 11, 26, 60  
options 11, 26, 75–81  
  control 11, 22, 75–76  
  light 11, 24–26, 76  
  miscellaneous 11, 27–28, 78–81  
  selection rules 10

output  
  cable 42, 52–56  
  inductance 42  
  current 12–14  
  voltage 19  
  wiring 39  
overcurrent protective devices 40  
overload  
  protection 20  
  relay dial 62

## P

P10 11, 27, 79  
permanent wire marker sleeves 80  
pilot lights  
  blue 25, 77  
  green 24–25, 76–77  
  red 24–25, 76  
  yellow 24–25, 77  
plenum fan 91  
pollution degree 8, 20  
power circuit w (without bypass) 73  
  operator controls 73  
  standard features 21  
power circuit y (bypass) 73–74  
  bypass operation 74  
  operator controls 74  
  standard features 21  
power converter 8  
  location 46–51  
  replacing 60, 84–88  
power factor correction capacitors 42  
precautions 38  
PSI transducer 11, 27, 78  
push-to-test pilot light 79

## Q

Q10 11, 27, 79

## R

R10 11, 27, 79  
ratings 12–14, 16–19  
RCR relay

  location 46–51  
reactor impedance  
  calculating 15

receiving 37  
RFI suppressor 80

## S

S10 11, 27, 79  
seal water solenoid 80  
seismic qualification 78  
selector switch  
  communication-auto-off-hand 75  
  communication-hand-off-auto 23, 75–76  
  forward/reverse 23, 75–76  
  local/remote 23, 75–76  
selector switches  
  AFC-off-bypass 74  
  hand-off-auto 22  
  parts 22  
  test-normal 74  
serial communication 26, 77–78

shielding 45  
shipping damage 37  
shock 20  
smoke purge 11, 27, 78  
space heater  
  sequencing 80  
spare parts 93  
specifications 19  
speed 19, 64  
speed potentiometer 22, 75–76  
start push button 22, 75  
start-up 60  
stirring fans  
  replacing 90  
stop push button 22, 75–76  
storage 37  
switching frequency 12–14, 19

## T

T10 11, 27, 80  
technical support 91  
temperature 20  
terminal command operation 69  
terminals  
  bus voltage measurement 43–44  
  control 58  
  locations 46–50  
  power 52  
terminology  
  adjustable frequency controller 8  
  AFC 8  
  controller 8  
  CT 8  
  drive controller 8  
  power converter 8  
  VT 8  
test-normal operation 74  
test-normal selector switch 10, 74  
three-wire control functionality 73  
time meter  
  motor elapsed 79  
transient overvoltage 15  
two-wire control functionality 73

## U

U10 11, 27, 80

## V

V10 11, 27, 80  
VA transf. capacity 80  
vibration 20  
voltage  
  imbalance 15  
  input 19  
  output 19

## W

W10 11, 28, 80  
weights 31–35  
wire class 44

wiring  
  control 59  
  general 39  
  general practices 45  
  grounding 45  
  methods 45  
  separation of circuits 45  
  shielding 45  
  terminal locations 46–50  
  wire class 44

**Z**

Z10 11, 28, 80





**Instruction Bulletin**  
**Class 8839 58M Drive Controllers**

**Schneider Electric**

8001 Highway 64 East  
Knightdale, NC 27545 USA  
1-888-SquareD  
(1-888-778-2733)  
[www.SquareD.com](http://www.SquareD.com)

Electrical equipment should be installed, operated, serviced, and maintained only by qualified personnel. No responsibility is assumed by Schneider Electric for any consequences arising out of the use of this material.

30072-450-71A © 2003 Schneider Electric All Rights Reserved  
Replaces bulletin 30072-450-71 dated 03/2003

08/2003