

ECONOFLEX™

**Adjustable Speed Drive Controllers for
HVAC and Pumping Applications
1–100 HP, 460 V and 1–50 HP, 208/230 V
Class 8839**

Instruction Bulletin

Retain for future use.



⚠ DANGER

HAZARD OF ELECTRIC SHOCK, BURN, OR EXPLOSION

- This equipment must be installed and serviced only by qualified electrical personnel.
- Turn off all power supplying this equipment before working on or inside the equipment.
- Always use a properly rated voltage sensing device to confirm that the power is off.
- Replace all devices, doors, and covers before turning on power to this equipment.

Failure to follow these instructions will result in death or serious injury.

⚠ DANGER

HAZARDOUS VOLTAGE

- Read and understand this bulletin in its entirety before installing or operating Class 8839 ECONOFLEX drive controllers. Installation, adjustment, repair, and maintenance of the drive controllers must be performed by qualified personnel.
- Disconnect all power including external control power that may be present before servicing the drive controller. WAIT THREE MINUTES for the DC bus capacitors to discharge. Then follow the DC bus voltage measurement procedure on page 40 to verify that the DC voltage is less than 45 V. The drive controller LEDs are not accurate indicators of the absence of DC bus voltage.
- DO NOT short across DC bus capacitors or touch unshielded components or terminal strip screw connections with voltage present.
- Install and close all covers before applying power or starting and stopping the drive controller.
- User is responsible for conforming to all applicable code requirements with respect to grounding all equipment.
- Many parts in this drive controller, including printed wiring boards, operate at line voltage. DO NOT TOUCH. Use only electrically insulated tools.

Before servicing the drive controller:

- Disconnect all power.
- Place a "DO NOT TURN ON" label on the drive controller disconnect.
- Lock disconnect in open position.

Electrical shock will result in death or serious injury.

PRODUCT SUPPORT

The Product Support Group is staffed from 8:00 am until 6:00 pm Eastern time for product selection, start-up assistance, or diagnosis of product problems. Emergency phone support is available 24 hours a day, 365 days a year.

Toll free: 888-SquareD (888-778-2733)

Phone: 919-217-8600

Fax: 919-217-6508

E-mail: drivepsg@squared.com

**CHAPTER 1
INTRODUCTION AND
TECHNICAL
CHARACTERISTICS**

INTRODUCTION 8
REVISION LEVEL 8
DOCUMENTATION REFERENCE 8
TERMINOLOGY 8
PRECAUTIONS 9
CONTROLLER CATALOG NUMBERS 10
CONTROLLER NAMEPLATE IDENTIFICATION 11
COMPONENT LOCATIONS 12
 Drive Controller Ratings 15
TECHNICAL CHARACTERISTICS 15
 Input Current Ratings 16
 Specifications 19
 Short Circuit Ratings 20
STANDARD FEATURES 21
FACTORY MODIFICATIONS 22
 Control Options 22
 Light Options 23
 Misc. Options 24
DIMENSIONS AND WEIGHTS FOR WALL MOUNTING 25
TOTAL DISSIPATED WATTS LOSS 28

**CHAPTER 2
RECEIVING, INSTALLATION,
AND START-UP**

PRELIMINARY INSPECTION 30
HANDLING THE DRIVE CONTROLLER 31
INSTALLATION 32
 Mechanical Installation 32
 Electrical Installation 32
 General Wiring Practices 32
 Input Power 33
 Branch Circuit Connections 33
 Grounding 34
 Output Wiring 35
 Output Cable 35
 DC Bus Voltage Measurement Terminal Locations 36
 DC Bus Voltage Measurement Procedure 40
 Wire Routing and Interconnection 42
 Wire Class 42
 Noise Class 42
 Voltage Class 42
 Wiring Methods 43
 Component Identification and Terminal Strip Locations 44
 Control Wiring 51
INITIAL START-UP PROCEDURE 53
 Circuit Breaker Trip Adjustment Procedure 57

**CHAPTER 3
 CIRCUIT DESCRIPTIONS
 AND OPTIONS**

INTRODUCTION 61

TERMINAL VERSUS KEYPAD COMMAND OPERATION 61

KEYPAD OPERATION 62

TYPE 3R OPERATION 62

FORCED LOCAL OPERATION 62

POWER CIRCUIT W (WITHOUT BYPASS) 62

 Operator Controls—General Arrangement and Operation 62

 Controller Operation 62

 Fire/Freezestat Interlocks 62

 MOD A07

 Hand-Off-Auto Selector and Manual Speed Potentiometer 62

 MOD B07 Hand-Off-Auto Selector,
 Start/Stop Push Buttons, and Manual Speed Potentiometer 63

 MOD C07

 Start/Stop Push Buttons and Manual Speed Potentiometer 64

 MOD N07 No Operators 64

 MOD A08 Pilot Light Option #1 Cluster 66

 MOD C08 Pilot Light Option #3 Cluster 66

 MOD A09 Line Reactor 66

 MOD C09 3–15 PSI Transducer with Digital Display Option 66

 MOD D09 Omit Keypad Display 66

 MOD E09 Smoke Purge Option 66

 MOD G09 22 KAIC UL Coordinated Rating 66

 MOD H09 Analog Card 66

 MOD J09 0–10 V Auto Speed Reference 66

 MOD K09 cUL Listing 67

 MOD L09 LONWORKS 67

 MOD M09 MODBUS 67

 MOD P09 METASYS N2 67

POWER CIRCUIT Y (BYPASS) 67

 Operator Controls—General Arrangement and Operation 67

 Test-Normal Operation 68

 Controller Operation 68

 Bypass Operation 68

 Fire/Freezestat Interlocks 68

 MOD AO7

 Hand-Off-Auto Selector and Manual Speed Potentiometer 68

 MOD BO7 Hand-Off-Auto Selector,
 Start/Stop Push Buttons, and Manual Speed Potentiometer 69

 MOD N07 No Operators 70

 MOD A08 Pilot Light Option #1 Cluster 71

 MOD B08 Pilot Light Option #2 Cluster 71

 MOD A09 Line Reactor 71

 MOD B09 Line Contactor 71

 MOD C09 3–15 PSI Transducer with Digital Display Option 71

 MOD D09 Omit Keypad Display 71

 MOD E09 Smoke Purge Option 72

 MOD G09 22 KAIC UL Coordinated Rating 72

	MOD H09 Analog Card	72
	MOD J09 0–10 V Auto Speed Reference	72
	MOD K09 cUL Listing	72
	MOD L09 LonWorks	72
	MOD M09 MODBUS	72
	MOD P09 METASYS N2	72
CHAPTER 4		
TROUBLESHOOTING AND		
MAINTENANCE		
	INTRODUCTION	74
	EXTERNAL SIGNS OF DAMAGE	74
	PREVENTIVE MAINTENANCE	74
	TROUBLESHOOTING FLOW DIAGRAMS	74
	Motor Will Not Start	75
	Will Not Accelerate The Load	76
	Accelerates The Load Too Slowly	77
	Excessive Motor Temperature	77
	FIELD REPLACEMENT OF THE POWER CONVERTER	78
	Removing the Power Converter Assembly	78
	Installing the Power Converter Assembly	81
	FIELD REPLACEMENT OF HEATSINK FAN ASSEMBLY	83
	Removing the Heatsink Fan Assembly	83
	Installing the Heatsink Fan Assembly	85
	FIELD REPLACEMENT OF THE STIRRING FANS	85
	FIELD REPLACEMENT OF THE VENTILATION FAN ON TYPE 3R	85
	FIELD REPLACEMENT OF THE SPACE HEATER ON TYPE 3R	85
	FIELD MAINTENANCE AND REPLACEMENT OF HOOD FILTERS ON TYPE 3R	85
	TECHNICAL SUPPORT	86
CHAPTER 5		
POWER AND CONTROL		
CIRCUIT ELEMENTARY		
DIAGRAMS		
	POWER CIRCUIT W (WITHOUT BYPASS)	90
	Hand-Off-Auto and Speed Potentiometer	90
	Hand-Off-Auto, Start-Stop, and Speed Potentiometer	91
	Start-Stop and Speed Potentiometer	92
	POWER CIRCUIT Y (WITHOUT BYPASS)	93
	Hand-Off-Auto and Speed Potentiometer	93
	Hand-Off-Auto, Start-Stop, and Speed Potentiometer	94
	APPENDIX	
	Recommended Spare Parts	95
	Field Installed Damper Control Circuit for Air Handler Ducts	98
	INDEX	101

**CHAPTER 1:
INTRODUCTION AND
TECHNICAL
CHARACTERISTICS**

INTRODUCTION	8
REVISION LEVEL	8
DOCUMENTATION REFERENCE	8
TERMINOLOGY	8
PRECAUTIONS	9
CONTROLLER CATALOG NUMBERS	10
CONTROLLER NAMEPLATE IDENTIFICATION	11
COMPONENT LOCATIONS	12
Drive Controller Ratings	15
TECHNICAL CHARACTERISTICS	15
Input Current Ratings	16
Specifications	19
Short Circuit Ratings	20
STANDARD FEATURES	21
FACTORY MODIFICATIONS	22
Control Options	22
Light Options	23
Misc. Options	24
DIMENSIONS AND WEIGHTS FOR WALL MOUNTING	25
TOTAL DISSIPATED WATTS LOSS	28

INTRODUCTION

The Class 8839 ECONOFLEX enclosed drive controllers are tailored for commercial market specifications in wall-mounted Type 1, Type 12K, or Type 3R enclosures. With a circuit breaker disconnect, these drive controllers may be configured with or without bypass.

This instruction bulletin covers receiving, installation, start-up, configuration, and troubleshooting of the 1 to 100 hp, 460 V and 1 to 50 hp, 208/230 V Class 8839 ECONOFLEX drive controllers.

REVISION LEVEL

This document replaces bulletin no. 30072-450-10G dated February 2002.

DOCUMENTATION REFERENCE

For further information, refer to the latest revision of the following instruction bulletins:

- Instruction bulletin VVDED397047US, *ALTIVAR® 58 Adjustable Speed Drive Controllers Keypad Display, VW3A58101*.
- Instruction bulletin 30072-200-50, *Handling, Installation, Operation, and Maintenance of Electrical Control Equipment*.
- Instruction bulletin VVDED397046US, *ALTIVAR 58 Adjustable Speed Drive Controllers Analog I/O Extension Card, VW3A58201U* (supplied with controller when analog card, MOD H09, is selected).
- Instruction bulletin VVDED300055US, *LONWORKS® to MODBUS® Module VW3A58312PU* (supplied with controller when LONWORKS, MOD L09, is selected).
- Instruction bulletin VVDED397054US, *ALTIVAR 58 Adjustable Speed Drive Controllers MODBUS/JBUS/UNITELWAY User's Guide, VW3A58303U* (supplied with controller when MODBUS, MOD M09 or LONWORKS L09, is selected).
- Instruction bulletin VVDED300028US, *ALTIVAR 58 Adjustable Speed Drive Controllers METASYS® N2 Communication Option VW3A58354U* (supplied with controller when METASYS N2, MOD P09, is selected).

TERMINOLOGY

The following terminology is used throughout this instruction bulletin in reference to the Class 8839 ECONOFLEX drive controller family. This distinction is made to minimize confusion when discussing installation and adjustment practices.

- When used as a component of the Class 8839 ECONOFLEX drive controller, part numbers beginning with FLEX58 are referred to in this instruction bulletin as *power converters*.
- The combination of the power converter, the enclosure, and the power and control circuits that constitute the Class 8839 ECONOFLEX product is referred to as the *drive controller, the controller, or the adjustable frequency controller (AFC)*.

PRECAUTIONS

DANGER

HAZARDOUS VOLTAGE

Turn off all power supplying this equipment before working on it.

Failure to follow this instruction will result in death or serious injury.

Follow these precautions unique to the Class 8839 ECONOFLEX drive controller:

- The Type 1 or Type 3R controller is suitable for installation in a Pollution Degree 2 environment as defined in NEMA ICS1 and IEC 90664-1. The Type 12K controller is suitable for installation in a Pollution Degree 3 environment as defined in NEMA ICS1 and IEC 90664-1. The expected environment must be compatible with this rating.
- When attaching wall-mountable controllers to their mounting surfaces, use fasteners rated for the weight of the apparatus, the expected shock and vibration of the installation, and the expected environment.
- Provide sufficient cooling for the expected heat load.

CONTROLLER CATALOG NUMBERS

The controller catalog number, located on the nameplate on the inside of the door, is coded to describe the configuration and options present. Use the following grid to translate the catalog number into a description of the drive controller.

Class		Type	Modifications					
			Control	Light	Misc.			
8839	58E	• • • V •	•	•	•			
		① ② ③ ④ ⑤ ⑥	⑦	⑧	⑨			

① Product

Code	Drive Type
58E	ECONOFLEX Controller

② Horsepower Code

Code	HP Rating	Code	HP Rating
C	1 hp	L	25
D	2 hp	M	30
E	3 hp	N	40
F	5 hp	P	50
G	7.5 hp	Q	60 (460 V only)
H	10 hp	R	75 (460 V only)
J	15 hp	S	100 (460 V only)
K	20 hp		

③ Enclosure Type

Code	Environment Rating
A	Type 12K
G	Type 1
H [5]	Type 3R

④ Voltage Rating

Code	Voltage
2	208 V
3	230 V
4	460 V

⑤ Application Type

Code	Applied Rating
V	Variable Torque

⑥ Device Type

Code	Power Circuit
W [5]	Without Bypass
Y [8]	Bypass

- [1] Control option C07 (Start/Stop, Speed Potentiometer) is not compatible with Power Circuit Y (Bypass) or light cluster A08 or B08.
- [2] Light cluster A08, B08, and C08 cannot be selected together. Select only one.
- [3] Light cluster B08 is not compatible with Power Circuit W (Without Bypass).
- [4] Light cluster C08 is not compatible with A07 (Hand/Off/Auto, Speed Potentiometer), or B07 (Hand/Off/Auto, Start/Stop, Speed Potentiometer).
- [5] Line contactor B09 is not compatible with this option.
- [6] Smoke purge E09 permits the motor to run at full speed.

⑦ Control Option

Code	AFC Controls
A07 [7]	Hand/Off/Auto, Speed Potentiometer
B07 [7]	Hand/Off/Auto, Start/Stop, Speed Potentiometer
C07 [1]	Start/Stop, Speed Potentiometer
N07	None

⑧ Light Option

Code	Light Cluster
A08 [2]	Red Power On
	Green AFC Run
	Yellow AFC Fault
B08 [2], [3]	Yellow Auto
	Red Power On
	Green AFC Run
C08 [2], [4]	Yellow AFC Fault
	Yellow Bypass
	Red Power On
C08 [2], [4]	Green AFC Run
	Yellow AFC Fault

⑨ Misc. Options

Code	Feature
A09 [9]	Line Reactor (included with 30–100 hp @ 460 V and 15–50 hp @ 208/230 V)
B09	Line Contactor
C09 [10]	3-15 PSI Transducer
D09 [13]	Omit Keypad
E09 [6]	Smoke Purge
G09	22 KAIC UL Coordinated Rating
H09 [11]	Analog Card, 0–20 mA, programmable for 4–20 mA output
J09 [12]	0–10 Vdc Auto Speed Reference
K09	cUL Listing
L09 [14]	LONWORKS
M09 [14]	MODBUS
P09 [14]	METASYS N2

- [7] Place the Hand-Off-Auto switch in the Off position for AFC fault reset.
- [8] Includes AFC/Off/Bypass switch and Test/Normal switch.
- [9] Line reactor A09 is an option for 1–25 hp @ 460 V and 1–10 hp @ 208/230 V.
- [10] 3–15 PSI Transducer C09 is not compatible with Start/Stop, Speed Potentiometer C07, 0–10 V Auto Speed Reference J09, or Analog Card H09.
- [11] Analog Card H09 is not compatible with 3–15 PSI Transducer C09 or serial communication L09, M09 or P09.
- [12] 0–10 V Auto Speed Reference J09 is not compatible with C07 Start/Stop Potentiometer or C09 3–15 PSI Transducer.
- [13] Omit the keypad D09. User must buy separate device to program the controller.
- [14] Serial communication L09, M09 and P09 cannot be selected together. Select only one. Serial communication cannot be selected with H09 analog card.

CONTROLLER NAMEPLATE IDENTIFICATION

The nameplate for the Class 8839 ECONOFLEX drive controller is located on the inside of the door. This nameplate, described in Figure 1, identifies the controller class, type, and modification (options) listing. When identifying or describing Class 8839 ALTIVAR ECONOFLEX drive controllers, use the data from this nameplate.

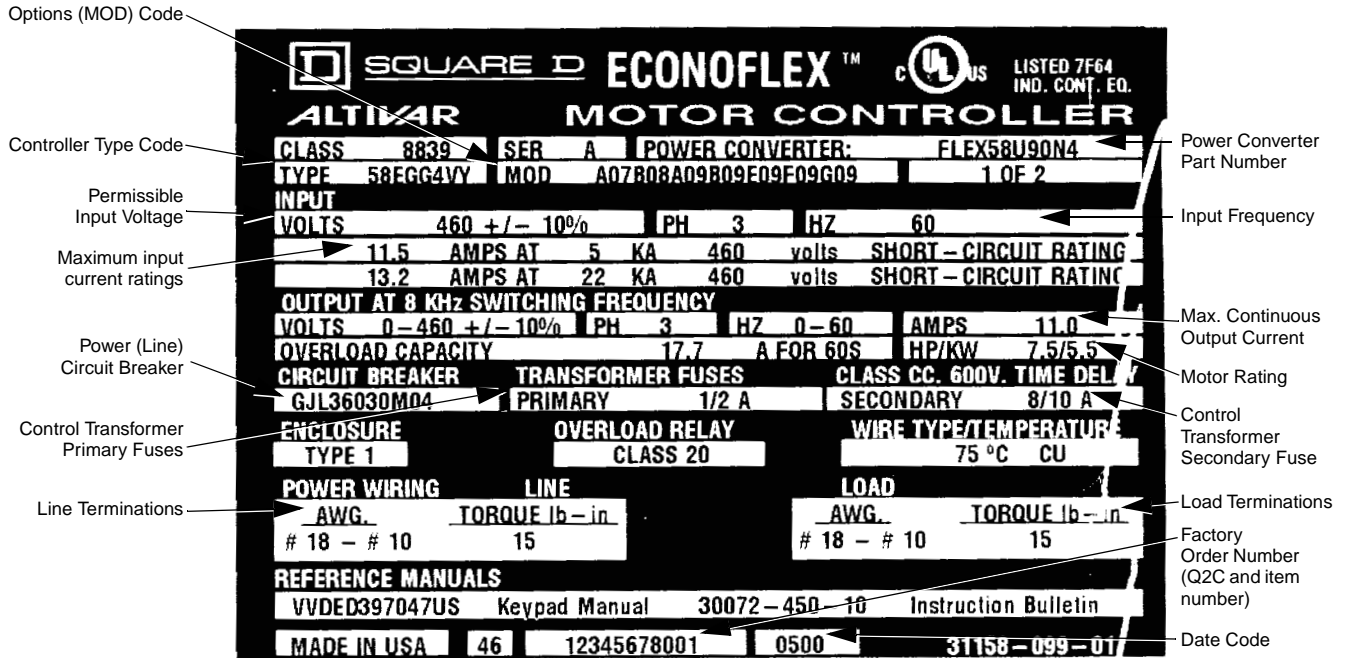

Figure 1: Information Provided by the Drive Controller Nameplate

COMPONENT LOCATIONS

NOTE: See pages 13 and 14 for components inside of the cabinet.

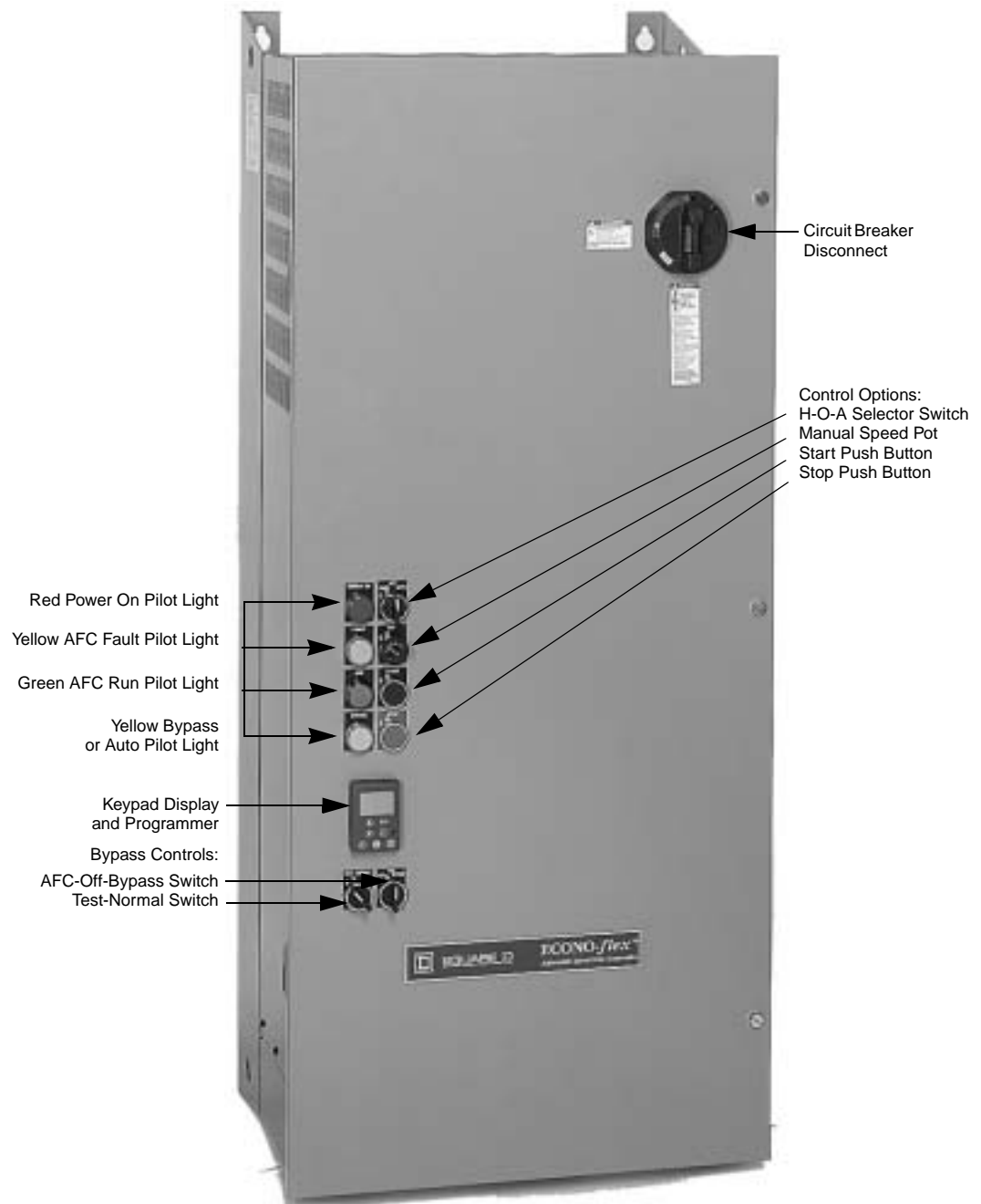

Figure 2: Front Component Locations for Controller: 1–100 HP @ 460 V and 1–50 HP @ 208/230 V (Class 8839, 58EPG4VY, MODS B07, B08, A09, B09, and E09 Shown)

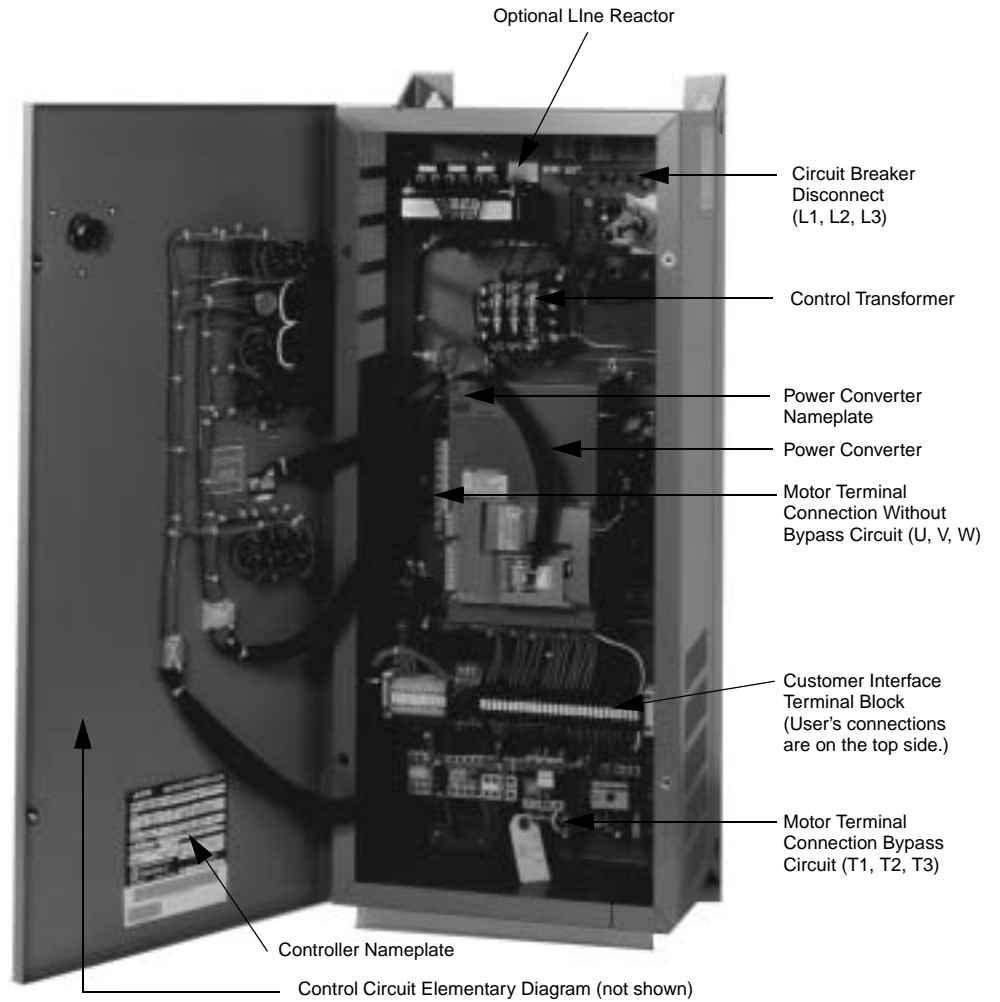

Figure 3: Inside Cabinet Component Locations for Controller: 1–25 HP @ 460 V and 1–10 HP @ 208/230 V (Class 8839, 58EGG4VY, MODS B07, B08, A09, B09, and E09 Shown)

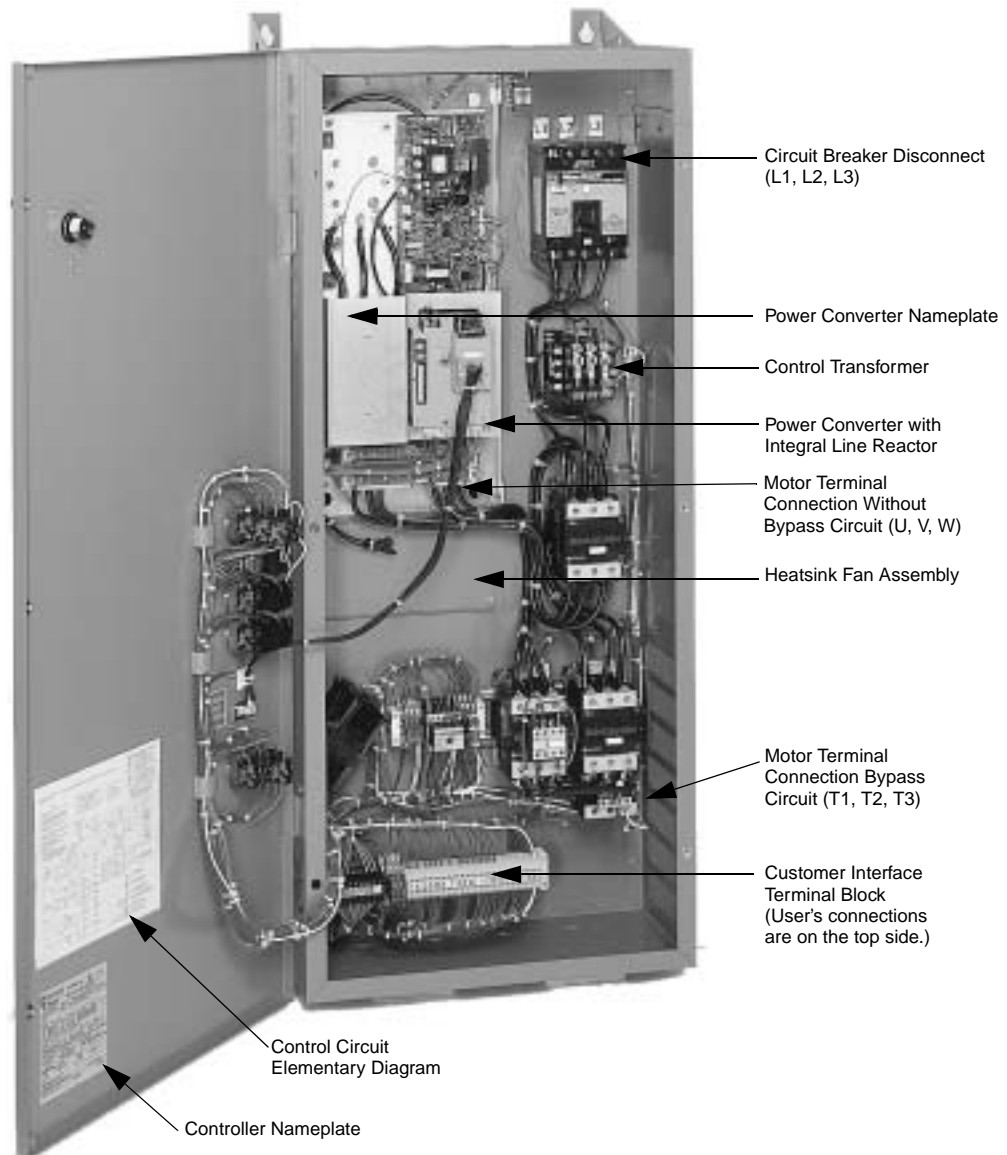

Figure 4: Inside Cabinet Component Locations for Controller: 30–100 HP @ 460 V and 15–50 HP @ 208/230 V (Class 8839, 58EPG4VY, MODS B07, B08, A09, B09, and E09 Shown)

**TECHNICAL
CHARACTERISTICS**

Drive Controller Ratings

Notes to Table 1:

- [1] “*” can be “A”, “G”, or “H”. “A” denotes a Type 12K enclosure; “G” denotes a Type 1 enclosure; “H” denotes Type 3R enclosure. “_” indicates that the catalog number continues. See page 10 for a detailed description of catalog numbers.
- [2] Power shown is for a carrier switching frequency of 8 kHz. For a switching frequency between 12 and 16 kHz, select the next largest size drive controller. If the duty cycle does not exceed 60% (36 s maximum for a 60 s cycle) this is not necessary.
- [3] Continuous output current is based on NEC table 430-150. The ECONOFLEX controller nameplate rating is per the NEC table, not the current value listed in the keypad lookup table.

Table 1: Class 8839 ECONOFLEX Drive Controller Ratings, 460 V

Drive Controller Catalog Number ^[1]	Motor Power ^[2] 460 V 60 Hz (HP)	Max. Continuous Output Current ^[3] (A)	Max. Transient Output Current (60 s) (A)	Power Converter Part Number
58EC*4V_	1	2.1	2.3	FLEX58KU18N4
58ED*4V_	2	3.4	3.7	FLEX58KU29N4
58EE*4V_	3	4.8	5.3	FLEX58KU41N4
58EF*4V_	5	7.6	8.4	FLEX58KU54N4
58EG*4V_	7.5	11	12.1	FLEX58KU72N4
58EH*4V_	10	14	15.4	FLEX58KU90N4
58EJ*4V_	15	21	23.1	FLEX58KD12N4
58EK*4V_	20	27	29.7	FLEX58KD16N4
58EL*4V_	25	34	37.4	FLEX58KD23N4
58EM*4V_	30	40	44.0	FLEX58KD28N4
58EN*4V_	40	52	57.2	FLEX58KD33N4
58EP*4V_	50	65	71.5	FLEX58KD46N4
58EQ*4V_	60	77	84.7	FLEX58KD54N4
58ER*4V_	75	96	105.6	FLEX58KD64N4
58ES*4V_	100	124	136.4	FLEX58KD79N4

Table 2: Class 8839 ECONOFLEX Drive Controller Ratings, 230 V

Notes to Table 2:

- [1] “*” can be “A”, “G”, or “H”. “A” denotes a Type 12K enclosure; “G” denotes a Type 1 enclosure; “H” denotes Type 3R enclosure. “_” indicates that the catalog number continues. See page 10 for a detailed description of catalog numbers.
- [2] Power shown is for a carrier switching frequency of 8 kHz. For a switching frequency between 12 and 16 kHz, select the next largest size drive controller. If the duty cycle does not exceed 60% (36 s maximum for a 60 s cycle) this is not necessary.
- [3] Continuous output current is based on NEC table 430-150. The ECONOFLEX controller nameplate rating is per the NEC table, not the current value listed in the keypad lookup table.

Drive Controller Catalog Number ^[1]	Motor Power ^[2] 230 V 60 Hz (HP)	Max. Continuous Output Current ^[3] (A)	Max. Transient Output Current (60 s) (A)	Power Converter Part Number
58EC*3V_	1	4.2	4.6	FLEX58U29M2
58ED*3V_	2	6.8	7.5	FLEX58U29M2
58EE*3V_	3	9.6	10.5	FLEX58U41M2
58EF*3V_	5	15.2	16.7	FLEX58U72M2
58EG*3V_	7.5	22	24.2	FLEX58U90M2
58EH*3V_	10	28	30.8	FLEX58D12M2
58EJ*3V_	15	42	46.2	FLEX58D16M2
58EK*3V_	20	54	59.4	FLEX58D16M2
58EL*3V_	25	68	74.8	FLEX58D23M2
58EM*3V_	30	80	88	FLEX58D28M2
58EN*3V_	40	104	114.4	FLEX58D33M2
58EP*3V_	50	130	143	FLEX58D46M2

Table 3: Class 8839 ECONOFLEX Drive Controller Ratings, 208 V

Drive Controller Catalog Number ^[1]	Motor Power ^[2] 208 V 60 Hz (HP)	Max. Continuous Output Current ^[3] (A)	Max. Transient Output Current (60 s) (A)	Power Converter Part Number
58EC•2V_	1	4.6	5.1	FLEX58U29M2
58ED•2V_	2	7.5	8.3	FLEX58U29M2
58EE•2V_	3	10.6	11.7	FLEX58U41M2
58EF•2V_	5	16.7	18.4	FLEX58U72M2
58EG•2V_	7.5	24.2	26.6	FLEX58U90M2
58EH•2V_	10	30.8	33.9	FLEX58D12M2
58EJ•2V_	15	46.2	50.8	FLEX58D16M2
58EK•2V_	20	59.4	65.3	FLEX58D16M2
58EL•2V_	25	74.8	82.3	FLEX58D23M2
58EM•2V_	30	88	96.8	FLEX58D28M2
58EN•2V_	40	114	125.4	FLEX58D33M2
58EP•2V_	50	143	157.3	FLEX58D46M2

Notes to Table 3:

- [1] “•” can be “A”, “G”, or “H”. “A” denotes a Type 12K enclosure; “G” denotes a Type 1 enclosure; “H” denotes Type 3R enclosure. “_” indicates that the catalog number continues. See page 10 for a detailed description of catalog numbers.
- [2] Power shown is for a carrier switching frequency of 8 kHz. For a switching frequency between 12 and 16 kHz, select the next largest size drive controller. If the duty cycle does not exceed 60% (36 s maximum for a 60 s cycle) this is not necessary.
- [3] Continuous output current is based on NEC table 430-150. The ECONOFLEX controller nameplate rating is per the NEC table, not the current value listed in the keypad lookup table.

Input Current Ratings

All branch circuit components and equipment such as feeder cables, disconnect devices, and protective devices must be rated for the input current of the drive controller, not the motor full load current. The input current is stamped on the nameplate (see Figure 1 on page 11). The branch circuit feeder protection must be sized according to NEC Article 430-2.

Line reactors can be used to add reactance to the branch circuit, minimize drive controller input line current, reduce controller nuisance tripping due to transient overvoltage, reduce harmonic distortion, and improve phase-to-phase voltage imbalance. If line reactors are used:

- In systems that use bypass contactors, the line reactor should only be connected between the breaker load terminals in the controller and the power converter. A line reactor in a bypass motor starting circuit will reduce the ability of the motor to produce starting torque.
- The voltage tolerance at the input of the reactor will be different from that of the drive controller due to the voltage drop across the line reactor. Voltage tolerance measured at the input terminals of the drive controller will be as specified in this manual.

The input line current ratings listed in Tables 4, 5, and 6 are based upon short circuit UL-coordinated ratings. To calculate the necessary minimum line inductance, use the formula shown below to verify the selection of the minimum reactor impedance needed for installation.

$$L = \frac{V_{L-L} \times \%Z \times 10}{I_{fund} \times \sqrt{3} \times 2\pi \times f}$$

where:

L = inductance, in millihenries (mH)

V_{L-L} = input voltage measured line-to-line (utilization voltage)

%Z = desired input impedance rating

I_{fund} = desired output current rating

f = fundamental line frequency (50 or 60 Hz)

For example, for a 7.5 hp, 11 A at 460 V/60 Hz motor in combination with a Class 8839 Type 58EGG4VW (7.5 hp @ 460 V, 11 FLA) drive controller, calculate the minimum inductance of a nominal 3% reactor as follows:

V_{L-L} = 460 V (utilization voltage)

%Z = 3 (3% rated line reactor)

I_{fund} = 11 A (output current rating)

f = 60 Hz (fundamental line frequency)

$$L = \frac{460 \times 3 \times 10}{11 \times \sqrt{3} \times 2\pi \times 60} = 1.9213 \text{ mH}$$

Thus, select a line reactor that has a minimum inductance rating (per phase) greater than or equal to 1.9213 mH.

**Table 4: Input Line Currents for Selection of Branch Circuit Feeders
460 V^[1]**

Notes to Table 4:

- [1] Select conductor based on the input line current.
- [2] “•” can be “A”, “G”, or “H”. “A” denotes a Type 12K enclosure; “G” denotes a Type 1 enclosure; “H” denotes Type 3R enclosure. “_” indicates that the catalog number continues. See page 10 for a detailed description of catalog numbers.
- [3] Factory modification A09 is optional for 1–25 hp, included in 30–100 hp.
- [4] 10 KAIC is denoted with an asterisk (*).

Drive Controller Catalog Number ^[2]	Motor Power 460 V 60Hz (HP)	5 KAIC (0.141 mH) 10 KAIC ^[4] (0.070 mH) (A)	22 KAIC (0.032 mH) (A)	Factory Mounted Line Reactor ^[3] MOD A09	
				5 KAIC (0.141 mH) 10 KAIC ^[4] (0.070 mH) (A)	22 KAIC 0.032 mH (A)
58EC•4V_	1	2.8	3.2	1.8	2
58ED•4V_	2	4.8	5.2	3.5	3.8
58EE•4V_	3	6.5	7.6	4.9	5.7
58EF•4V_	5	10.0	12.6	7.9	9.3
58EG•4V_	7.5	14.3	16.9	11.5	13.2
58EH•4V_	10	18.1	22	12.9	15.6
58EJ•4V_	15	25.8	31	22.9	22.9
58EK•4V_	20	32.4	38.9	25.2	30
58EL•4V_	25	38.9	40.6	30.7	31.3
58EM•4V_	30	38.1	39.8	38.1	39.8
58EN•4V_	40	49.3	51.6	49.3	51.6
58EP•4V_	50	61.8	65.4	61.8	65.4
58EQ•4V_	60	75.2*	77.7	75.2*	77.7
58ER•4V_	75	96.3*	100.8	96.3*	100.8
58ES•4V_	100	122.6*	129.3	122.6*	129.3

**Table 5: Input Line Currents for Selection of Branch Circuit Feeders
 230 V^[1]**

Notes to Table 5:

- [1] Select conductor based on the input line current.
- [2] "*" can be "A", "G", or "H". "A" denotes a Type 12K enclosure; "G" denotes a Type 1 enclosure; "H" denotes Type 3R enclosure. "_" indicates that the catalog number continues. See page 10 for a detailed description of catalog numbers.
- [3] Factory modification A09 is optional for 1–10 hp, included in 15–50 hp.

Drive Controller Catalog Number ^[2]	Motor Power 230 V 60Hz (HP)	5 KAIC (0.141 mH) (A)	22 KAIC (0.032 mH) (A)	Factory Mounted Line Reactor ^[3] MOD A09	
				5 KAIC (0.141 mH) (A)	22 KAIC (0.032 mH) (A)
58EC•3V_	1	4.9	5.6	3.3	3.5
58ED•3V_	2	8.6	9.7	5.6	5.9
58EE•3V_	3	11.8	13.4	8.1	8.5
58EF•3V_	5	19.5	22.1	14.1	14.7
58EG•3V_	7.5	26.4	30	19.9	20.6
58EH•3V_	10	35	38.2	27.5	28.6
58EJ•3V_	15	37.8	38	37.8	38
58EK•3V_	20	50.5	50.8	50.5	50.8
58EL•3V_	25	61.8	61.8	61.8	61.8
58EM•3V_	30	73.3	73.6	73.3	73.6
58EN•3V_	40	97.9	98.5	97.9	98.5
58EP•3V_	50	121.2	124	121.2	124

**Table 6: Input Line Currents for Selection of Branch Circuit Feeders
 208 V^[1]**

Notes to Table 6:

- [1] Select conductor based on the input line current.
- [2] "*" can be "A", "G", or "H". "A" denotes a Type 12K enclosure; "G" denotes a Type 1 enclosure; "H" denotes Type 3R enclosure. "_" indicates that the catalog number continues. See page 10 for a detailed description of catalog numbers.
- [3] Factory modification A09 is optional for 1–10 hp, included in 15–50 hp.

Drive Controller Catalog Number ^[2]	Motor Power 208 V 60Hz (HP)	5 KAIC (0.141 mH) (A)	22 KAIC (0.032 mH) (A)	Factory Mounted Line Reactor ^[3] MOD A09	
				5 KAIC (0.141 mH) (A)	22 KAIC (0.032 mH) (A)
58EC•2V_	1	5.3	6	3.7	3.8
58ED•2V_	2	9.4	10.6	6.5	6.6
58EE•2V_	3	13	14.5	9.2	9.5
58EF•2V_	5	21.4	24	16.2	17.1
58EG•2V_	7.5	29	34.7	22.9	23.3
58EH•2V_	10	38.3	44.4	31.7	32.3
58EJ•2V_	15	41.7	41.7	41.7	41.7
58EK•2V_	20	55.5	55.7	55.5	55.7
58EL•2V_	25	67	67.2	67	67.2
58EM•2V_	30	80.9	80.9	80.9	80.9
58EN•2V_	40	107.6	108.4	107.6	108.4
58EP•2V_	50	134.8	135.5	134.8	135.5

Specifications

Table 7: Specifications for Drive Controllers

Input voltage	460 V \pm 10%, 230 V \pm 10%, 208 V \pm 10%
Displacement power factor	98% through speed range
Input frequency	60 Hz \pm 5%
Output voltage	Three-phase output Maximum voltage equal to input voltage
Galvanic isolation	Galvanic isolation between power and control (inputs, outputs, and power supplies)
Frequency range of power converter	0.1 to 500 Hz (factory setting of 60 Hz maximum)
Current	110% of controller rated current for 60 s
Switching frequency	Selectable from 0.5 to 16 kHz ^[1] Factory setting: 8 kHz
Speed reference	AI1: 0 to +10 V, Impedance = 30 k Ω Speed potentiometer to AI1 AI2: FACTORY SETTING: 4 to 20 mA, Impedance = 100 Ω (reassignable, X–Y range with keypad display). FACTORY MODIFICATION J09 provides a controller interface 0–10 Vdc reference signal to the AI2 input using a 0–10 V / 4–20 mA converter with Z= 100 k Ω
Frequency resolution in analog reference	0.1 for 100 Hz (10 bits)
Speed regulation	V/f: determined by motor slip, typically 3% SLFV (sensorless flux vector): 1%
Efficiency	97% at full load typical
Reference sample time	5 ms
Acceleration and deceleration ramps	0.1 to 999.9 seconds (definition in 0.1 s increments)
Motor protection	Class 10 electronic overload protection Class 20 electromechanical overload protection with bypass ^[2]
Keypad display	Self diagnostics with fault messages in three languages; also refer to instruction bulletin VVDED397047US
Temperature	Storage for all enclosures: -13 to +149 °F (-25 to +65 °C) Operation for Type 1 and 12K: +14 to +104 °F (-10 to 40 °C) Operation for Type 3R: +14 to +122 °F (-10 to 50 °C)
Humidity	95% with no condensation or dripping water, conforming to IEC 60068-2-3.
Altitude	3,300 ft (1000 m) maximum without derating; derating of the current by 1% for each additional 330 ft (100 m)
Enclosure	Type 1, Type 12K (Type 12 with knockouts) or Type 3R
Pollution degree	Type 1 or Type 3R: Pollution degree 2 per NEMA ICS-1 Annex A and IEC 60664-1 Type 12K: Pollution degree 3 per NEMA ICS-1 and IEC 60664-1
Operational test vibration	Conforming to IEC 60721-3-3-3M3 amplitude 1.5 mm peak to peak from 3 to 13 Hz 1 g from 13 to 200 Hz
Transit test to shock	Conforming to National Safe Transit Association and International Safe Transit Association test for packages.
Operational shock	15 g, 11 ms
Codes and standards	UL Listed per UL508C under category NMMS. Conforms to applicable NEMA ICS, NFPA, and IEC Standards. Manufactured under ISO 9001 standards. Factory Modification K09 provides Canadian cUL Certification.

[1] Above 8 kHz, select the next largest size drive controller. If the duty cycle does not exceed 60% (36 s maximum for a 60 s cycle), this is not necessary.

[2] Class 10 electromechanical for 1 hp @ 460 V.

Short Circuit Ratings

Notes to Table 8:

- [1] “*” can be “A”, “G”, or “H”. “A” denotes a Type 12K enclosure; “G” denotes a Type 1 enclosure; “H” denotes Type 3R enclosure. “_” indicates that the catalog number continues. See page 10 for a detailed description of catalog numbers.

Table 8: Short Circuit Ratings, 460 V

8839 Controller [1]	Power Circuit	HP	MOD G09	Power Converter (AFC) Path Short-Circuit Rating (Symm.)	Bypass Path Short-Circuit Rating (Symm.)
58EC*4VW_ to 58EP*4VW_	W (Without Bypass)	1–50	Not selected	5,000 A	N/A
58EC*4VY_ to 58EP*4VY_	Y (Bypass)			5,000 A	5,000 A
58EQ*4VW_ to 58ES*4VW_	W (Without Bypass)	60–100	Not selected	10,000 A	N/A
58EQ*4VY_ to 58ES*4VY_	Y (Bypass)			10,000 A	10,000 A
58EC*4VWG09_ to 58EP*4VWG09_	W (Without Bypass)	1–50	Selected	22,000 A	N/A
58EC*4VYG09_ to 58EP*4VYG09_	Y (Bypass)			22,000 A	22,000 A
58EQ*4VWG09_ to 58ES*4VWG09_	W (Without Bypass)	60–100	Selected	22,000 A	N/A
58EQ*4VYG09_ to 58ES*4VYG09_	Y (Bypass)			22,000 A	22,000 A

Notes to Table 9:

- [1] “*” can be “A”, “G”, or “H”. “A” denotes a Type 12K enclosure; “G” denotes a Type 1 enclosure; “H” denotes Type 3R enclosure. “_” indicates that the catalog number continues. See page 10 for a detailed description of catalog numbers.

Table 9: Short Circuit Ratings, 230 V

8839 Controller [1]	Power Circuit	HP	MOD G09	Power Converter (AFC) Path Short-Circuit Rating (Symm.)	Bypass Path Short-Circuit Rating (Symm.)
58EC*3VW_ to 58EP*3VW_	W (Without Bypass)	1–50	Not selected	5,000 A	N/A
58EC*3VY_ to 58EP*3VY_	Y (Bypass)			5,000 A	5,000 A
58EC*3VWG09_ to 58EP*3VWG09_	W (Without Bypass)	1-50	Selected	22,000 A	N/A
58EC*3VYG09_ to 58EP*3VYG09_	Y (Bypass)			22,000 A	22,000 A

Notes to Table 10:

- [1] “*” can be “A”, “G”, or “H”. “A” denotes a Type 12K enclosure; “G” denotes a Type 1 enclosure; “H” denotes Type 3R enclosure. “_” indicates that the catalog number continues. See page 10 for a detailed description of catalog numbers.

Table 10: Short Circuit Ratings, 208 V

8839 Controller [1]	Power Circuit	HP	MOD G09	Power Converter (AFC) Path Short-Circuit Rating (Symm.)	Bypass Path Short-Circuit Rating (Symm.)
58EC*2VW_ to 58EP*2VW_	W (Without Bypass)	1–50	Not selected	5,000 A	N/A
58EC*2VY_ to 58EP*2VY_	Y (Bypass)			5,000 A	5,000 A
58EC*2VWG09_ to 58EP*2VWG09_	W (Without Bypass)	1-50	Selected	22,000 A	N/A
58EC*2VYG09_ to 58EP*2VYG09_	Y (Bypass)			22,000 A	22,000 A

STANDARD FEATURES

The Class 8839 ECONOFLEX drive controller includes the following standard features:

With or Without Bypass

- Circuit breaker disconnect
- Form C AFC fault contact wired to customer terminal block
- Form C AFC run contact wired to customer terminal block
- Fire/Freezestat interlock location provided to customer terminal block
- Keypad
- Factory-mounted line reactor (see Table 14 on page 24)

Bypass Only

- Isolation and bypass contactors
- AFC-Off-Bypass selector switch
- Test-Normal selector switch
- Class 20 overload protection (Class 10 for 1 hp @ 460 V)

Table 11: Parts List for Bypass Circuit Selector Switches and Circuit Breaker Handle

Selector Switch or Handle	Part No.	Description
Test-Normal Selector Switch	ZB5AD2	Two-position selector switch
	ZB5AZ009	Mounting collar with contact block (1 N.O.)
	ZBE204	Additional contact block (2 N.C.)
	ZBE101	Additional contact block (1 N.O.)
	65170-166-72	Engraved legend plate, "Test-Normal"
	ZBZ32	Legend plate holder
AFC-Off-Bypass Selector Switch	ZB5AD3	Three-position selector switch
	ZB5AZ103	Mounting collar with contact block (2 N.O.)
	65170-166-43	Engraved legend plate "AFC-Off-Bypass"
	ZBZ32	Legend plate holder
Circuit Breaker Handle	9421NW3B	Disconnect switch handle, black

FACTORY MODIFICATIONS

Control Options

NOTE: Refer to the notes on page 10 for rules governing component selection.

Table 12: Control Options (Required Selection)

Control Option	Description	Parts List
A07	Hand-Off-Auto Selector Switch	ZB5AD3 Three-position selector switch ZB5AZ009 mounting collar ZBE203 Additional contact block (2 N.O.) (2) ZBE102 Additional contact block (1 N.C.) ZBZ32 Legend plate holder
	Speed Potentiometer	ZB5AD922 Potentiometer operator ZBZ32 Legend plate holder
B07	Hand-Off-Auto Selector Switch	ZB5AD3 Three-position selector switch ZB5AZ009 mounting collar ZBE203 Additional contact block (2 N.O.) (2) ZBE102 Additional contact block (1 N.C.) ZBZ32 Legend plate holder
	Stop/Start Push Buttons	ZB5AA2 Black push button w/ mounting base ZB5AA4 Red push button w/ mounting base ZB5AZ101 Mounting collar w/ additional contact block (1 N.O.) ZB5AZ102 Mounting collar w/ additional contact block (1 N.C.) (2) ZBZ32 Legend plate holder
	Speed Potentiometer	ZB5AD922 Potentiometer operator ZBZ32 Legend plate holder
C07	Stop/Start Push Buttons	ZB5AA2 Black push button w/ mounting base ZB5AA4 Red push button w/ mounting base ZB5AZ101 Mounting collar w/ additional contact block (1 N.O.) ZB5AZ102 Mounting collar w/ additional contact block (1 N.C.) (2) ZBZ32 Legend plate holder
	Speed Potentiometer	ZB5AD922 Potentiometer operator ZBZ32 Legend plate holder
N07	None	No drive control options are supplied on the front door of the drive controller. For use in remote-mounted operator applications. Refer to chapter 3, Power Circuit Descriptions, for remote mounting information.

Light Options

NOTE: Refer to the notes on page 10 for rules governing component selection.

Table 13: Light Options (Optional Selection)

Light Option	Description	Parts List
A08 Pilot Light Option #1 Cluster	Red Power On	ZB5AV04 Red pilot light head ZB5AV6 Mounting collar with light module ZBZ32 Legend plate holder
	Green AFC Run	ZB5AV03 Green pilot light head ZB5AV6 Mounting collar with light module ZBZ32 Legend plate holder
	Yellow Fault	ZB5AV05 Amber pilot light head ZB5AV6 Mounting collar with light module ZBZ32 Legend plate holder
	Yellow Auto	ZB5AV05 Amber pilot light head ZB5AV6 Mounting collar with light module ZBZ32 Legend plate holder
B08 Pilot Light Option #2 Cluster	Red Power On	ZB5AV04 Red pilot light head ZB5AV6 Mounting collar with light module ZBZ32 Legend plate holder
	Green AFC Run	ZB5AV03 Green pilot light head ZB5AV6 Mounting collar with light module ZBZ32 Legend plate holder
	Yellow Fault	ZB5AV05 Amber pilot light head ZB5AV6 Mounting collar with light module ZBZ32 Legend plate holder
	Yellow Bypass	ZB5AV05 Amber pilot light head ZB5AV6 Mounting collar with light module ZBZ32 Legend plate holder
C08 Pilot Light Option # 3 Cluster	Red Power On	ZB5AV04 Red pilot light head ZB5AV6 Mounting collar with light module ZBZ32 Legend plate holder
	Green AFC Run	ZB5AV03 Green pilot light head ZB5AV6 Mounting collar with light module ZBZ32 Legend plate holder
	Yellow Fault	ZB5AV05 Amber pilot light head ZB5AV6 Mounting collar with light module ZBZ32 Legend plate holder

Misc. Options

NOTE: Refer to the notes on page 10 for rules governing component selection.

Table 14: Miscellaneous Options (Optional Selection)

Misc. Option	Name	Description
A09	Line Reactor	Factory-mounted line reactor within enclosure. Optional 1–25 hp, included 30–100 hp @ 460 V Optional 1–10 hp, included 15–50 hp @ 208/230 V
B09	Line Contactor	A line contactor can be added between the circuit breaker and the drive controller, (Type 1 and 12K only).
C09	3–15 PSI Transducer	Allows the controller to follow a user-supplied 3–15 PSI input.
D09	Omit Door-Mounted Keypad	The keypad is not supplied. The user must buy a keypad as a separate device to program the drive.
E09	Smoke Purge	Provides a smoke purge operating mode controlled by a user-supplied 120 Vac signal wired to customer's terminal block.
G09	22 KAIC UL Coordinated Rating	Provides a fully-coordinated 22 KAIC rating marked on enclosure nameplate (short circuit coordination to UL508C Power Conversion Equipment and NEMA ICS 7.1).
H09	Analog Card	0–20 mA analog output for customer use. Factory programmed for motor frequency. Includes analog card VW3A58201U and customer terminal block. Reassignable x–y range with keypad display.
J09	0–10 Vdc Auto Speed Reference	Provides a controller interface with differential input, 31158-297-50, for a 0–10 Vdc user-supplied auto speed reference signal to the AI2 input using a 0–10 V/4–20 mA converter with Z=40 kΩ.
K09	cUL Listing	Provides Canadian cUL certification when required by local code requirements.
L09	LONWORKS Serial Communication ^[1]	Provides factory installed LONWORKS to MODBUS Module VW3A58312PU, 24 Vdc power supply 8440PS24 and plug-in MODBUS card VW3A58303U. Serial Communication is factory installed for register monitoring.
M09	MODBUS Serial Communication ^[2]	Provides factory installed plug-in MODBUS card VW3A58303U and separate user termination to D-shell interface device, Square D part number 25410-00084. (Phoenix contact connector part #2761839.) Serial Communication is factory installed for register monitoring.
P09	METASYS® N2 Serial Communication	Provides factory installed plug-in METASYS N2 card VW3A58354U and separate user termination to D-shell interface device, Square D part number 25410-00084. (Phoenix contact connector part #2761839.) Serial Communication is factory installed for register monitoring.

^[1] For the most recent *.xif installation help files, refer to www.us.SquareD.com. The files are listed on the LONWORKS instruction bulletin page in the Product Technical Library. Refer to instruction bulletin VVDED300055US.

^[2] The 9-pin to 15-pin connector cable that ships with the MODBUS® card when ordered from the distributor does not ship with an ECONOFLEX unit. ECONOFLEX units ship with a Phoenix connector for user terminations.

DIMENSIONS AND WEIGHTS FOR WALL MOUNTING

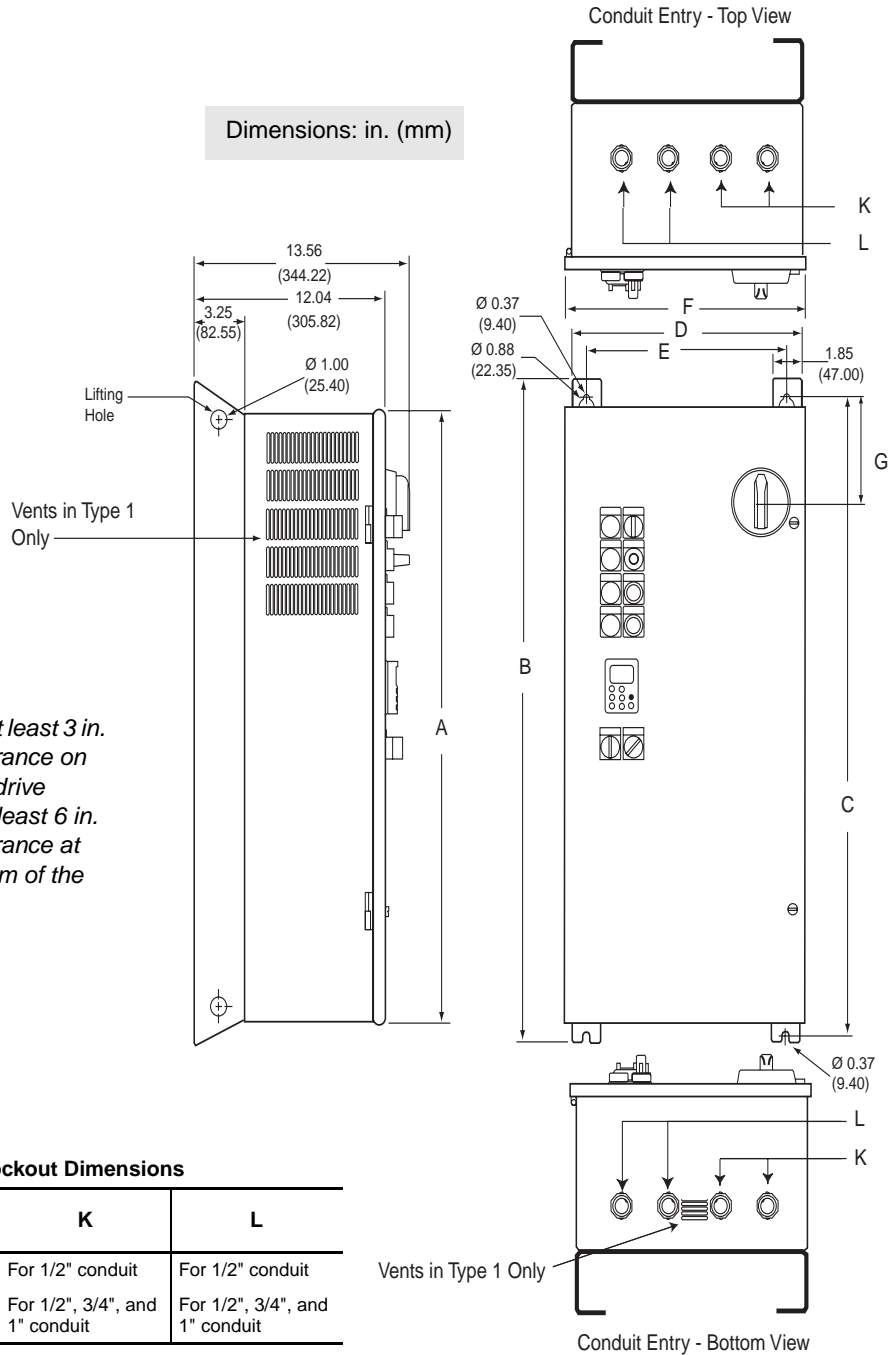

Knockout Dimensions

460 V	208/ 230 V	K	L
1-7.5 hp	1-5 hp	For 1/2" conduit	For 1/2" conduit
10-25 hp	7.5-10 hp	For 1/2", 3/4", and 1" conduit	For 1/2", 3/4", and 1" conduit

HP		Weight		Enclosure Dimensions													
				A		B		C		D		E		F		G	
460 V	208/ 230 V	lb	kg	in	mm	in	mm	in	mm	in	mm	in	mm	in	mm	in	mm
1-7.5	1-5	87	39.5	32.00	812.8	35.00	889.00	33.75	857.25	14.25	361.95	12.29	312.17	14.76	374.90	4.88	123.95
10-25	7.5-10	126	57.2	38.00	965.2	41.0	1041.40	39.75	1009.65	19.49	495.05	17.53	445.26	20.52	521.21	4.88	123.95

Figure 5: Mounting Information for Type 1 or Type 12K 1-25 HP Controllers @ 460 V and 1-10 HP Controllers @ 208/230 V

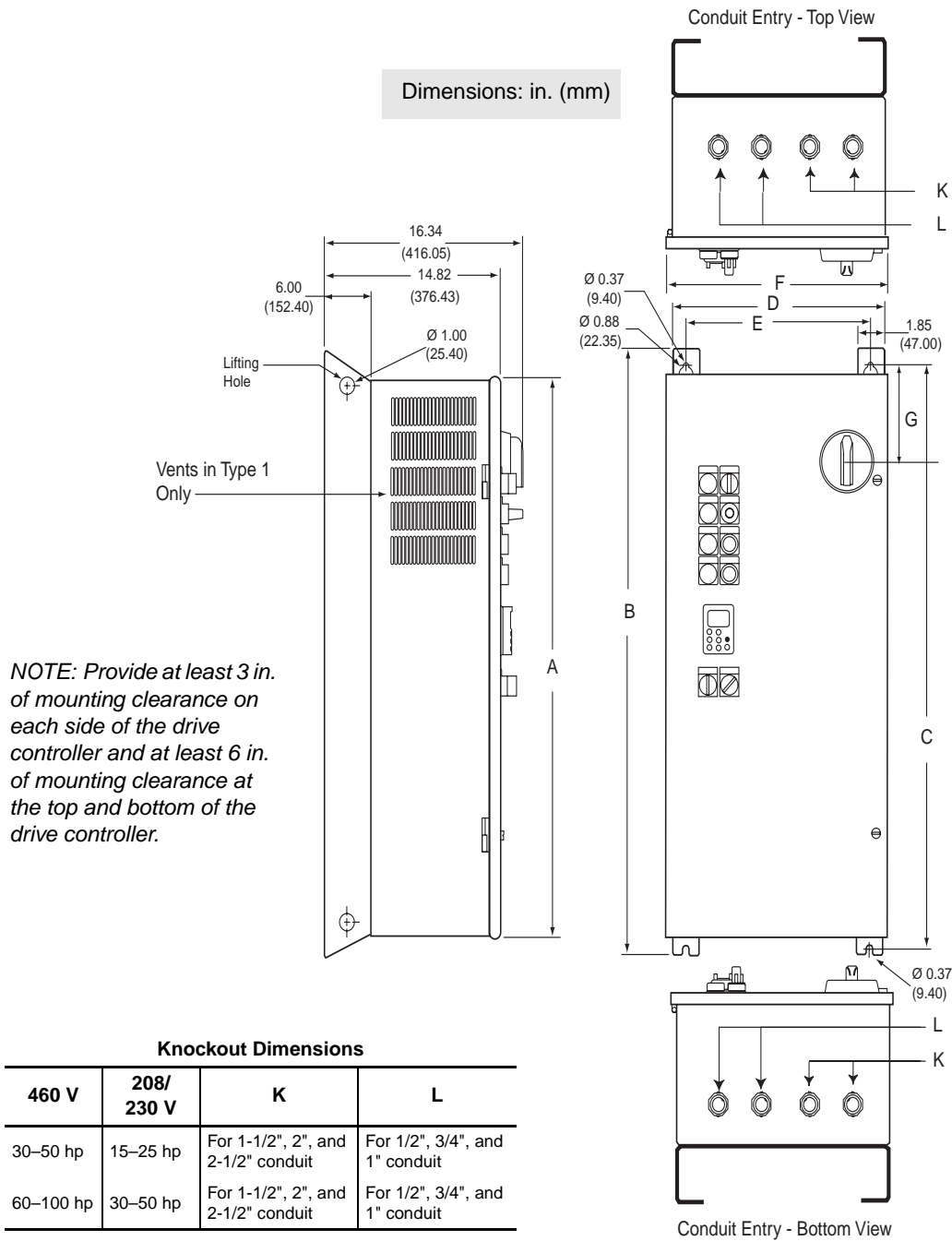

HP		Weight		Enclosure Dimensions													
				A		B		C		D		E		F		G	
460 V	208/ 230V	lb	kg	in	mm	in	mm	in	mm	in	mm	in	mm	in	mm	in	mm
30-50	15-25	180	81.60	46.00	1168.00	49.00	1244.60	47.83	1214.88	20.00	508.00	18.04	458.22	20.65	524.51	7.45	189.23
60-100	30-50	225	102.10	60.00	1524.00	63.00	1600.20	61.83	1570.48	25.00	635.00	23.05	585.47	25.65	651.51	13.75	349.25

Figure 6: Mounting Information for Type 1 or 12K 30-100 HP Controllers @ 460 V and 15-50 HP Controllers @ 208/230 V

Dimensions: in. (mm)

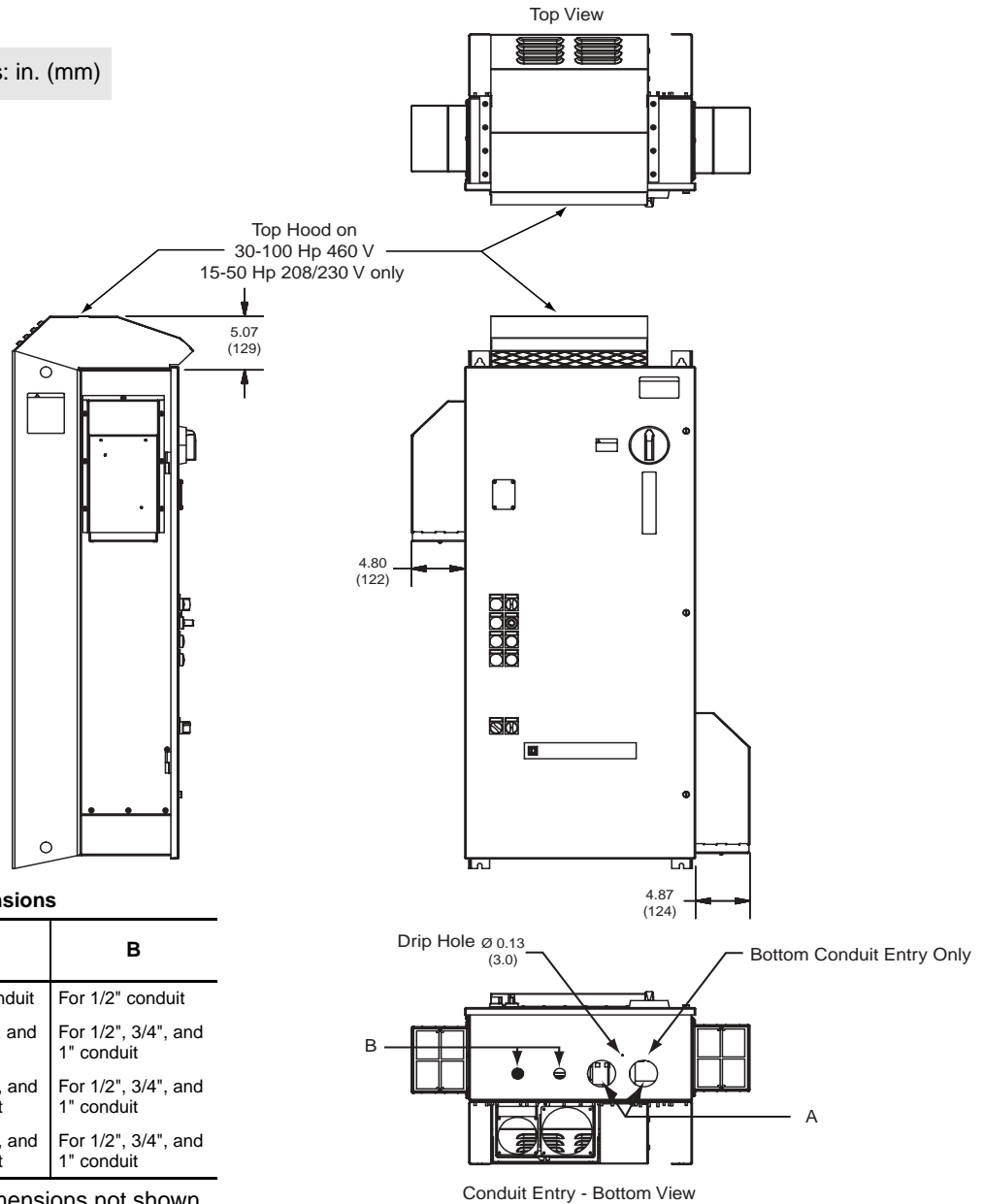

Knockout Dimensions

460 V	208/ 230 V	A	B
1-7.5 hp	1-5 hp	For 1-1/2" conduit	For 1/2" conduit
10-25 hp	7.5-10 hp	For 1/2", 3/4", and 1" conduit	For 1/2", 3/4", and 1" conduit
30-50 hp	15-25 hp	For 1-1/2", 2", and 2-1/2" conduit	For 1/2", 3/4", and 1" conduit
60-100 hp	30-50 hp	For 1-1/2", 2", and 2-1/2" conduit	For 1/2", 3/4", and 1" conduit

Refer to Figures 5 and 6 for dimensions not shown.

HP		Weight		Maximum Enclosure Dimensions					
460 V	208/ 230V	lb	kg	Height		Width		Depth	
				in	mm	in	mm	in	mm
1-7.5	1-5	119	54	35	889	24.43	620.52	13.69	347.73
10-25	7.5-10	163	74	41	1041.4	30.19	766.83	13.69	347.73
30-50	15-25	216	98	52.22	1326.39	30.32	770.13	16.34	415.04
60-100	30-50	261	118	66.22	1681.99	35.32	897.13	16.34	415.04

Figure 7: Mounting Information for Type 3R 1-100 HP Controllers @ 460 V and 1-50 HP Controllers @ 208/230 V

TOTAL DISSIPATED WATTS LOSS

Notes to Table 15:

[1] “•” can be “A” or “G”. “A” denotes a Type 12K enclosure; “G” denotes a Type 1 enclosure. “_” indicates that the catalog number continues. See page 10 for a detailed description of catalog numbers.

The total dissipated watts loss in Tables 15–17 is provided for sizing the environment HVAC cooling requirements based upon worst-case operating conditions for Type 1 and Type 12K enclosures.

Table 15: Total Dissipated Watts Loss, 460 V

Drive Controller Catalog No. [1]	HP	Total Dissipated Watts Loss
58EC•4V_	1	185
58ED•4V_	2	230
58EE•4V_	3	252
58EF•4V_	5	355
58EG•4V_	7.5	447
58EH•4V_	10	520
58EJ•4V_	15	656
58EK•4V_	20	785
58EL•4V_	25	1034
58EM•4V_	30	975
58EN•4V_	40	1133
58EP•4V_	50	1251
58EQ•4V_	60	1318
58ER•4V_	75	1692
58ES•4V_	100	1972

Notes to Table 16:

[1] “•” can be “A” or “G”. “A” denotes a Type 12K enclosure; “G” denotes a Type 1 enclosure. “_” indicates that the catalog number continues. See page 10 for a detailed description of catalog numbers.

Table 16: Total Dissipated Watts Loss, 230 V

Drive Controller Catalog No. [1]	HP	Total Dissipated Watts Loss
58EC•3V_	1	237
58ED•3V_	2	298
58EE•3V_	3	380
58EF•3V_	5	406
58EG•3V_	7.5	510
58EH•3V_	10	732
58EJ•3V_	15	934
58EK•3V_	20	1098
58EL•3V_	25	1210
58EM•3V_	30	1258
58EN•3V_	40	1569
58EP•3V_	50	1899

Notes to Table 17:

[1] “•” can be “A” or “G”. “A” denotes a Type 12K enclosure; “G” denotes a Type 1 enclosure. “_” indicates that the catalog number continues. See page 10 for a detailed description of catalog numbers.

Table 17: Total Dissipated Watts Loss, 208 V

Drive Controller Catalog No. [1]	HP	Total Dissipated Watts Loss
58EC•2V_	1	238
58ED•2V_	2	297
58EE•2V_	3	384
58EF•2V_	5	408
58EG•2V_	7.5	513
58EH•2V_	10	735
58EJ•2V_	15	939
58EK•2V_	20	1100
58EL•2V_	25	1213
58EM•2V_	30	1263
58EN•2V_	40	1580
58EP•2V_	50	1923

**CHAPTER 2:
RECEIVING, INSTALLATION,
AND START-UP**

PRELIMINARY INSPECTION	30
HANDLING THE DRIVE CONTROLLER	31
INSTALLATION	32
Mechanical Installation	32
Electrical Installation	32
General Wiring Practices	32
Input Power	33
Branch Circuit Connections	33
Grounding	34
Output Wiring	35
Output Cable	35
DC Bus Voltage Measurement Terminal Locations	36
DC Bus Voltage Measurement Procedure	40
Wire Routing and Interconnection	42
Wire Class	42
Noise Class	42
Voltage Class	42
Wiring Methods	43
Component Identification and Terminal Strip Locations	44
Control Wiring	51
INITIAL START-UP PROCEDURE	53
Circuit Breaker Trip Adjustment Procedure	57

PRELIMINARY INSPECTION

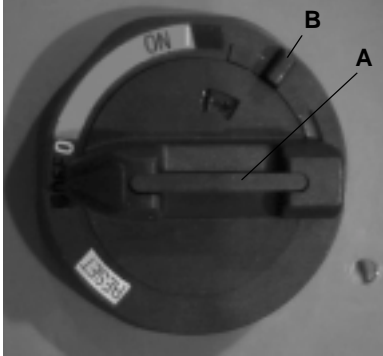

Circuit Breaker and Handle Assembly

⚠ CAUTION

DAMAGED EQUIPMENT

Do not operate any drive controller that appears damaged.

Failure to follow this instruction can result in injury or equipment damage.

The drive controller must be thoroughly inspected before it is stored or installed. Upon receipt:

- a. Remove the drive controller from its packaging and visually inspect the exterior for shipping damage.
- b. Ensure that the class, type, and MOD specified on the drive controller nameplate agree with the packaging slip and corresponding purchase order.
- c. If you find any shipping damage, notify the carrier and your sales representative.
- d. If you plan to store the drive controller after receipt, replace it in its original packaging material and observe storage temperature specifications in Table 7 on page 19.

⚠ CAUTION

DAMAGE TO INSULATED PARTS IN AIR DUCT

- Protect the air duct at the rear of the enclosure from entry of foreign material.
- Do not place loose objects on top of the enclosure.
- Do not block air flow from the duct.

Failure to follow these instructions can cause breaker trip, resulting in process shutdown or equipment damage.

Before installation:

1. Open the door of the drive controller. To open the door, turn the circuit breaker and handle assembly to the Off position as shown in the illustration at left. Pinch the handle (**A**) and handle latch (**B**) together and jiggle the assembly if necessary to open the door.
2. Visually verify that all internal mounting and terminal connection hardware is properly seated, securely fastened, and undamaged.
3. Visually verify that the control board on the power converter is properly seated, securely fastened, and undamaged. Verify that the internal wiring connections are tight. Inspect all connections for damage.
4. Close and secure the drive controller door.

HANDLING THE DRIVE CONTROLLER

⚠ WARNING

HANDLING AND LIFTING HAZARD

Keep the area below any equipment being lifted clear of all personnel and property. Use the lifting method shown in Figure 8.

Failure to follow this instruction can result in death, serious injury, or equipment damage.

Drive controllers are shipped on a pallet on their back. To avoid damage, do not stack drive controllers on top of each other. Store the drive controller in its original packaging until it is at the final installation site. The packaging protects the drive controller and prevents damage to its exterior.

Handle the drive controller carefully to avoid damage to the internal components, frame, or exterior. When handling a drive controller, balance it carefully to keep it from tipping. After removing packaging materials, drive controllers require some type of mechanical lifting.

When handling drive controllers:

- Always work with another person. The weight, size, and shape of the drive controller is such that two people are required to handle it.
- Use gloves.
- Attach a spreader bar to the two top lifting holes on the drive controller back panel (see Figure 5 on page 25 for location of lifting holes) and hoist the controller with chains or straps. See Figure 8 for the proper hoisting method.
- Raise the drive controller from a horizontal position (i.e., the back of the controller resting on a pallet).
- Place the drive controller in an upright position. Note: The bottom of the drive controller is on an angle.
- Mount the drive controller on a flat, solid, noncombustible vertical surface.
- Secure all four corners of the controller with hardware of a sufficient size and type for the controller weight.

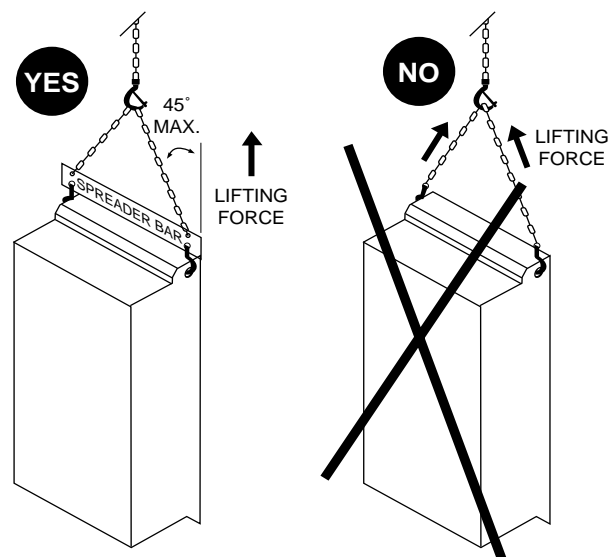

Figure 8: Hoisting Class 8839 ECONOFLEX Drive Controllers

INSTALLATION

Mechanical Installation

Refer to Table 7 on page 19 for Specifications.

- The Type 1 or 12K controller must be mounted vertically against a solid, flat surface to allow for proper ventilation.
- If drilling for conduit entry, exercise care to prevent metal chips from falling on parts and electronic printed wiring boards.
- See Figure 5 on page 25, Figure 6 on page 26, Figure 7 on page 27 for mounting dimensions, mounting clearances, conduit entry areas, and controller weights.
- Do not mount the drive controller on hot surfaces.
- Do not mount the Type 1 or 12K drive controllers in direct sunlight.

Electrical Installation

⚠ DANGER
HAZARDOUS VOLTAGE
Turn off all power (main and remote) before installing the equipment. Failure to follow this instruction will result in death or serious injury.

General Wiring Practices

Before wiring, perform the bus voltage measurement procedure on page 40. Good wiring practice requires the separation of control circuit wiring from all power wiring. Power wiring to the motor must have the maximum possible separation from all other power wiring, whether from the same drive controller or other drive controllers. **Do not run power and/or control or multiple power wiring in the same conduit.** This separation reduces the possibility of coupling electrical transients from power circuits into control circuits or from motor power wiring into other power circuits.

⚠ CAUTION
EQUIPMENT DAMAGE HAZARD
Follow the wiring practices described in this document in addition to those already required by the National Electrical Code and local codes. Failure to follow this instruction can result in injury or equipment damage.

Follow the practices below when wiring the Class 8839 ECONOFLEX drive controller:

- Use metallic conduit for all drive controller wiring. Do not run control and power wiring in the same conduit.
- Separate metallic conduits carrying power wiring or low-level control wiring by at least 3 inches (76 mm).
- Separate existing, non-metallic conduits or cable trays used to carry power wiring from metallic conduit carrying low-level control wiring by at least 12 inches (305 mm).
- Whenever power and control wiring cross, the metallic conduits and non-metallic conduits or trays must cross at right angles.
- Equip all inductive circuits near the controller (relays, contactors, solenoid valves) with noise suppressors or connect them to a separate circuit.

Input Power

The Class 8839 ECONOFLEX drive controller operates from a three-phase, 460 Vac \pm 10%, 230 Vac \pm 10%, or 208 Vac \pm 10% 60 Hz \pm 5% supply connected to the input circuit breaker disconnect. The circuit breaker disconnect is coordinated and tested with the controller power circuit for a short circuit rating of 5 KAIC for 1–50 hp and 10 KAIC for 60–100 hp. When modification G09 is selected, the circuit breaker disconnect is coordinated and tested with the controller power circuit for a short circuit rating of 22 KAIC.

Branch Circuit Connections

All branch circuit components and equipment (such as feeder cables, disconnect devices, and protective devices) must be rated for the maximum input current of the Class 8839 ECONOFLEX drive controller, not the FLA of the motor. The drive controller input current is stamped on the nameplate. Refer to Tables 4, 5, and 6 on pages 17–18 for drive controller input currents.

Connect input power leads L1, L2, and L3 to the input of the circuit breaker. Refer to Figure 3 (page 13) or Figure 4 (page 14) or Figures 14–17 (pages 44–47) for location. Refer to Tables 22, 23, and 24 (pages 48–50) for lug data and wire size range for drive controller input terminals L1, L2 and L3.

⚠ WARNING

IMPROPER OVERCURRENT COORDINATION

- Protective devices must be properly coordinated.
- Do not connect the drive controller to a power feeder whose short circuit capacity exceeds the short circuit rating listed on the drive controller nameplate.

Failure to follow this instruction can result in death or serious injury.

⚠ CAUTION

IMPROPER WIRING

- Do not connect input power leads to the drive controller output terminals (T1, T2, T3 or U, V, W). This damages the controller and voids the warranty.
- Check the power connections before energizing the controller.

Failure to follow this instruction can result in injury or equipment damage.

Grounding

Ground the drive controller according to the National Electrical Code and all local codes. To ground the drive controller:

- Connect a copper wire from the ground bar terminal to the power system ground.
- Verify that the resistance to ground is 1 Ω or less. Improper grounding causes intermittent and unreliable operation.

⚠ DANGER

HAZARDOUS VOLTAGE

- Ground equipment using the provided ground connection point as shown in Figures 14–17 starting on page 44. The drive controller panel must be properly grounded before power is applied.
- Do not use metallic conduit as a ground conductor.

Failure to follow this instruction will result in death or serious injury.

Ground multiple drive controllers as shown in Figure 9. Use one grounding conductor per device. Do not loop ground conductors or install them in series.

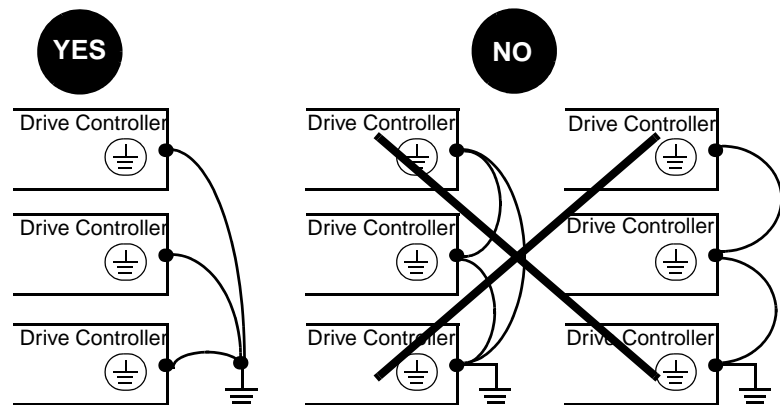

Figure 9: Grounding Multiple Drive Controllers

Output Wiring

The ampacity of motor power conductors should be sized according to the motor full load current, National Electrical Code, and applicable local codes.

Connect motor conductors to the lugs provided and connect the motor ground to the ground bar provided. Connect motor conductors to T1, T2, and T3 on the overload relay when the controller is supplied with a bypass circuit. Connect motor conductors to U, V, and W on the power converter when the controller is supplied without a bypass circuit. See Figure 3 (page 13) or Figure 4 (page 14) and Figures 14–17 starting on page 44 for location. See Tables 22, 23, and 24 (pages 48–50) for lug data and wire size range. Refer to the nameplate for torque requirements.

The drive controller is sensitive to the amount of capacitance (either phase-to-phase or phase-to-ground) present on the output power conductors. If excessive capacitance is present, the drive controller may trip on overcurrent.

Output Cable

Follow the guidelines below when selecting output cable:

- Cable type: the cable selected must have a low capacitance phase-to-phase and to ground. Do not use mineral-impregnated cable because it has a very high capacitance. Immersion of cables in water increases capacitance.
- Cable length: the longer the cable, the greater the capacitance. Cable lengths greater than 100 ft (30.5 m) may cause ground faults. For installation where cable capacitances may be a problem, a reactor can be installed between the drive controller and the motor.
- Proximity to other output cables: because of high frequency switching and increased capacitance, the drive controller may fault under some conditions.
- **Do not use lightning arrestors or power factor correction capacitors on the output of the drive controller.**

A minimum inductance is needed to protect the drive controller output from short circuits. Provide at least 20 in. (500 mm) of cable at the drive controller output (U, V, and W for a controller without bypass or T1, T2, and T3 for a controller with bypass).

⚠ CAUTION

INSUFFICIENT OUTPUT INDUCTANCE

For proper drive controller short circuit protection, certain values of inductance may be required in the output power wiring. Inductance can be supplied by the power wiring or auxiliary inductors.

Failure to follow this instruction can result in injury or equipment damage.

**DC Bus Voltage Measurement
Terminal Locations**

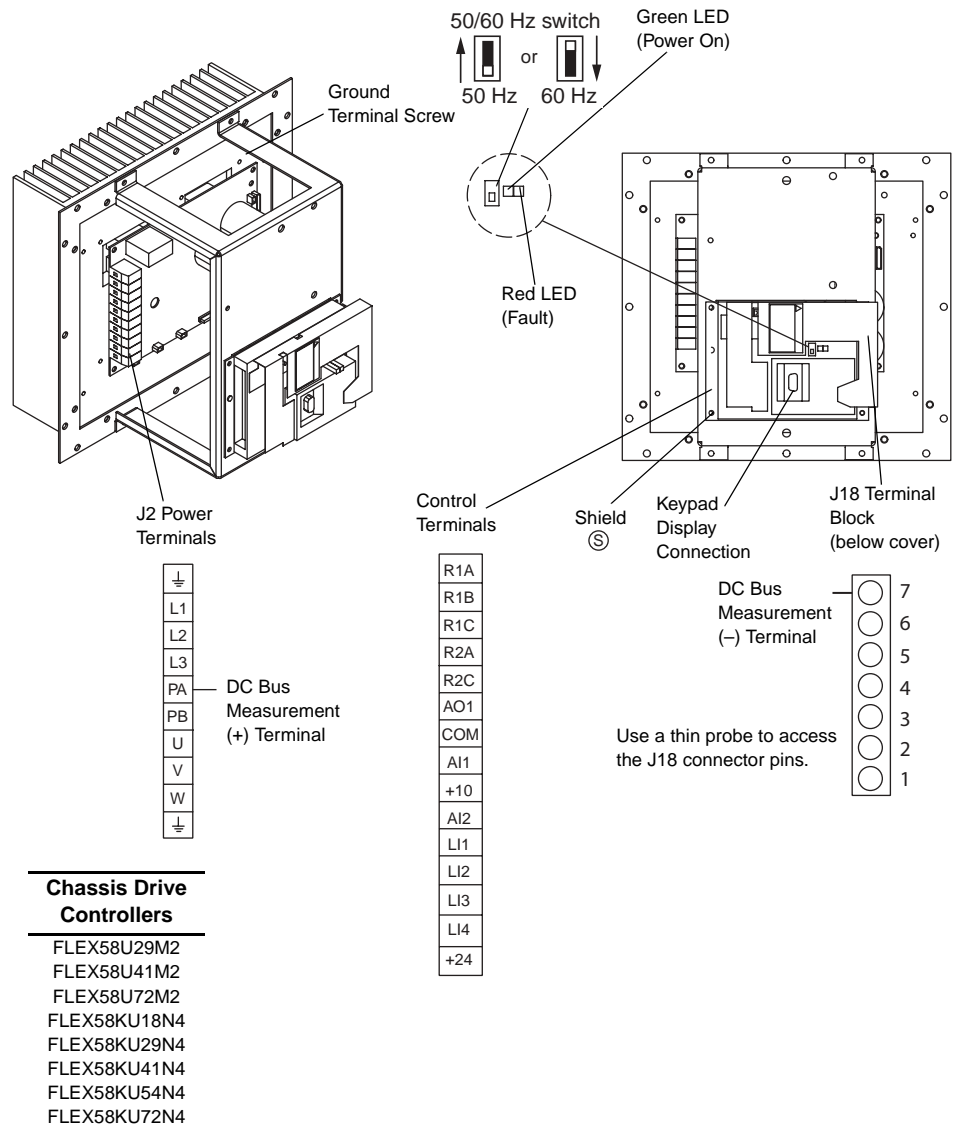

Figure 10: FLEX58U29M2-U72M2 and FLEX58KU18N4-KU72N4

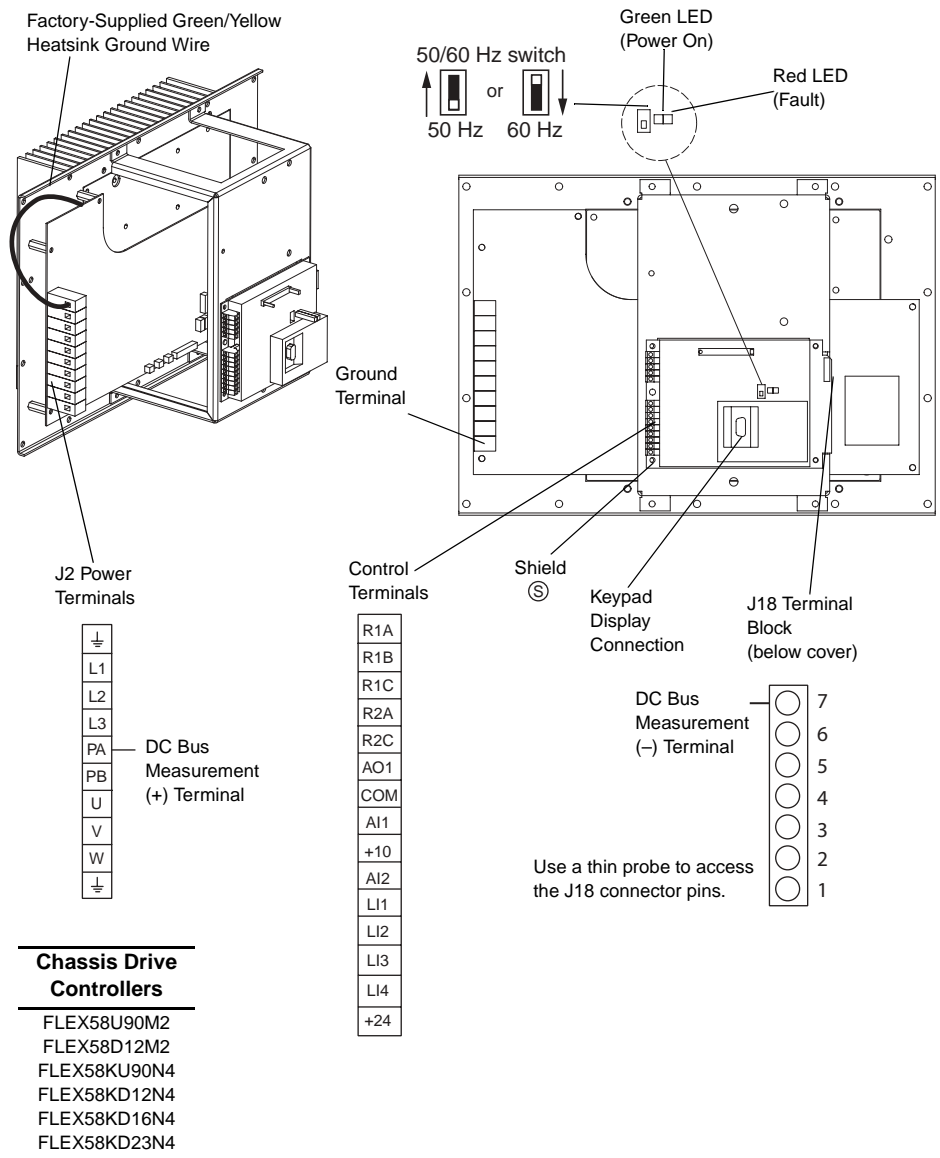
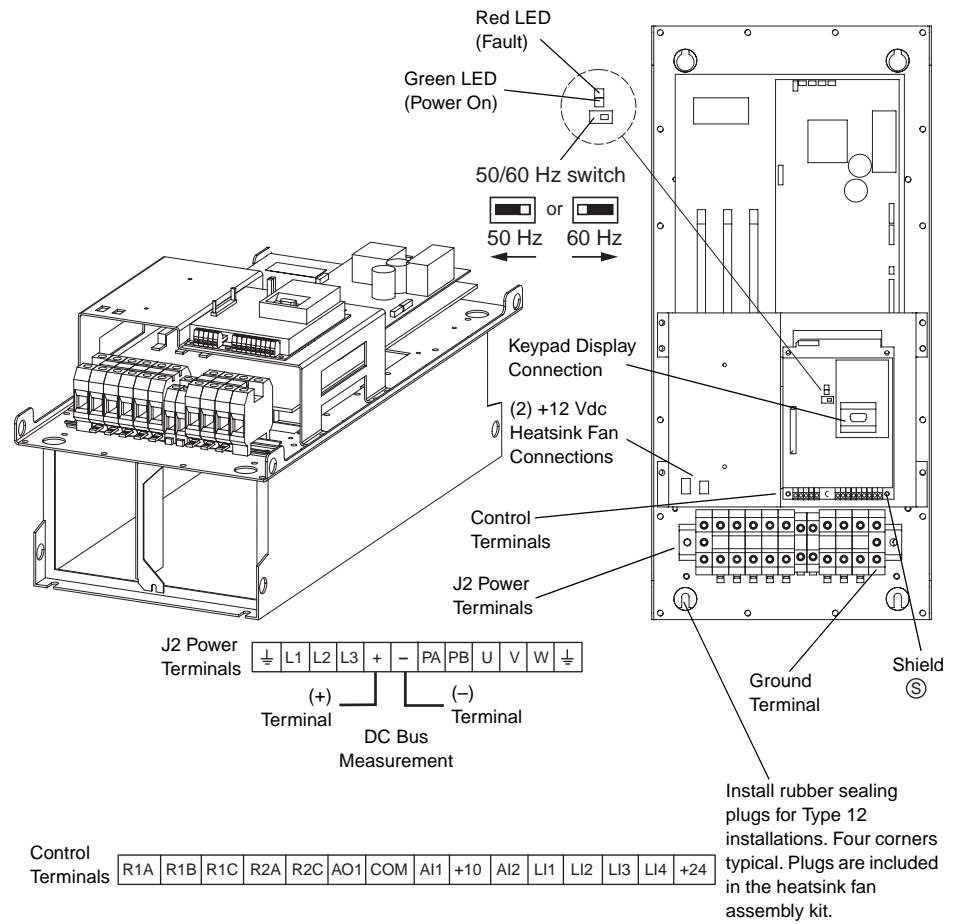

Figure 11: FLEX58U90M2, FLEX58D12M2, and FLEX58KU90N4–KD23N4



**Chassis Drive
Controllers**

- FLEX58D16M2
- FLEX58D23M2
- FLEX58KD28N4
- FLEX58KD33N4
- FLEX58KD46N4

Figure 12: FLEX58D16M2, FLEX58D23M2, and FLEX58KD28N4–KD46N4

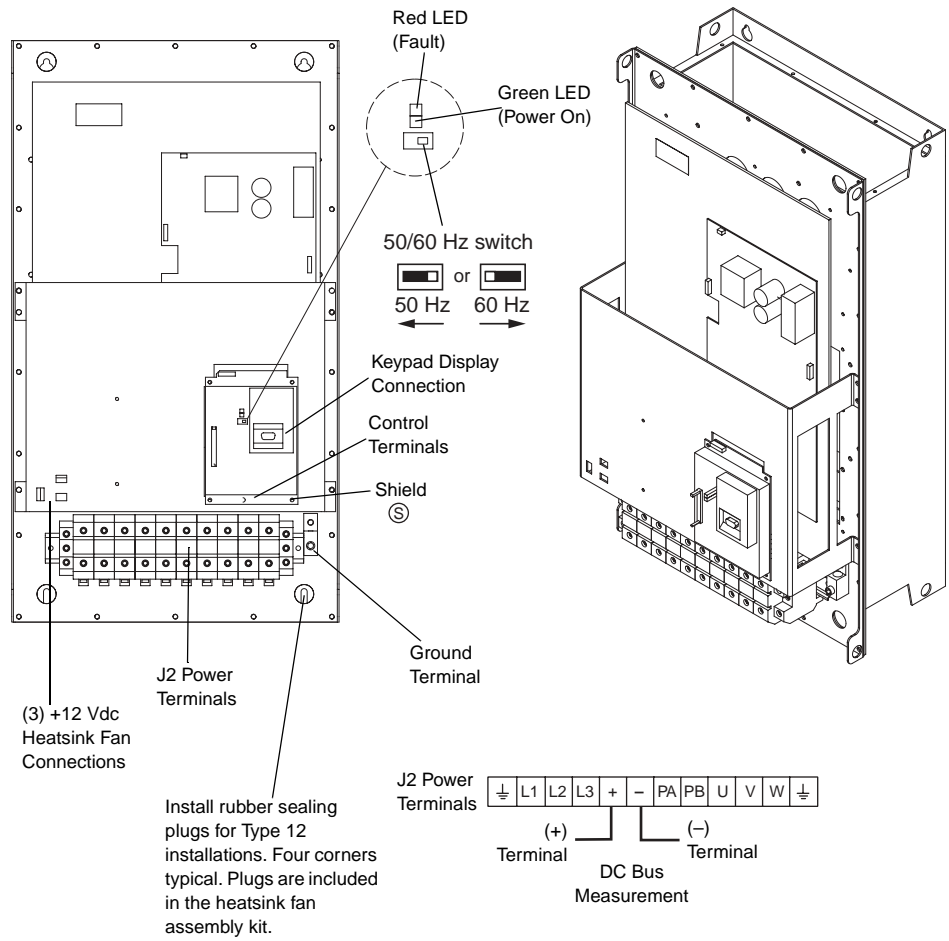

Chassis Drive Controllers

- FLEX58D28M2
- FLEX58D33M2
- FLEX58D46M2
- FLEX58KD54N4
- FLEX58KD64N4
- FLEX58KD79N4

Control Terminals

R1A	R1B	R1C	R2A	R2C	AO1	COM	AI1	+10	AI2	LI1	LI2	LI3	LI4	+24
-----	-----	-----	-----	-----	-----	-----	-----	-----	-----	-----	-----	-----	-----	-----

Figure 13: FLEX58D28M2–D46M2 and FLEX58KD54N4–KD79N4

DC Bus Voltage Measurement
Procedure

⚠ DANGER

HAZARDOUS VOLTAGE

- Read and understand the Bus Voltage Measurement Procedure before performing the procedure. Measurement of bus capacitor voltage must be performed by qualified personnel.
- DO NOT short across capacitors or touch unshielded components or terminal strip screw connections with voltage present.
- Many parts in this drive controller, including printed wiring boards, operate at line voltage. DO NOT TOUCH. Use only electrically insulated tools.

Failure to follow this instruction will result in death or serious injury.

The DC bus voltage level is determined by monitoring the (+) and (–) measurement points. Their location varies by power converter model number as listed in Table 18. The power converter model number is listed on its nameplate.

Table 18: (+) and (–) Measurement Points

FLEX58 Power Converter		Refer to Figure	(+) Measurement Point		(–) Measurement Point	
208/230 V	460 V		Terminal Block or Connector	Terminal Designation	Terminal Block or Connector	Terminal Designation
FLEX58U29M2 FLEX58U41M2 FLEX58U72M2	FLEX58KU18N4 FLEX58KU29N4 FLEX58KU41N4 FLEX58KU54N4 FLEX58KU72N4	10 on page 36	J2	PA	J18	7
FLEX58U90M2 FLEX58D12M2	FLEX58KU90N4 FLEX58KD12N4 FLEX58KD16N4 FLEX58KD23N4	11 on page 37				
FLEX58D16M2 FLEX58D23M2	FLEX58KD28N4 FLEX58KD33N4 FLEX58KD46N4	12 on page 38	J2	(+)	J2	(-)
FLEX58D28M2 FLEX58D33M2 FLEX58D46M2	FLEX58KD54N4 FLEX58KD64N4 FLEX58KD79N4	13 on page 39				

To measure the DC bus capacitor voltage:

1. Observe the lockout/tagout procedures as identified in OSHA Standard 29 CFR, Subpart J covering:
 - 1910.147: The control of hazardous energy (lockout/tagout).
 - 1910.147: App A, Typical minimal lockout procedures.
2. Open the disconnect between the input line and the drive controller. Lock the disconnect in the open position and install a “Do Not Turn On” sign. Open the circuit breaker disconnect located on the front of the drive controller. Also, be sure to remove all external control power that may be present such as on the control board and the option board terminals.
3. Wait three minutes for the DC bus capacitors to discharge.
4. Read the model number of the power converter from the nameplate, and identify the corresponding (+) and (–) measurement points from Table 18 and Figures 10 to 13 on pages 36 to 39.
5. Open the door of the power converter.

6. Set the voltmeter to the 1000 Vdc scale. Measure the voltage between the (+) and (-) measurement points identified in step 4.
7. Verify that the DC bus voltage has discharged below 45 V before servicing the drive controller. If the DC bus capacitors will not discharge below 45 V, contact your local Square D representative. **Do not operate the drive controller.**
8. After servicing the drive controller, close and secure door.

Wire Routing and Interconnection

Wire Class

The Wire Class describes the compatibility of the field wiring terminal with the conductor material and insulation system. When used in conjunction with the required conductor current rating and controller ambient temperature rating, the Wire Class forms the basis for selecting a conductor size that limits the temperature on the conductor insulation at the field wiring terminal to acceptable limits. Although it is permissible to use conductors with operating temperatures exceeding those given by the Wire Class, conductor **size** must fall within the Wire Class limits.

Noise Class

The Noise Class categorizes the electromagnetic properties of the voltages and currents present. The Noise Class is comprised of the six categories shown in Table 19.

Table 19: Noise Class Categories

Noise Class	Definition
Quiet Wiring 1 (QW1)	High susceptibility analog and digital control signals. Signals falling under this classification include digital communication/network circuits, controller analog I/O and analog process signals.
Quiet Wiring 2 (QW2)	Medium susceptibility, analog and digital control signals. Signals falling under this classification include 24 Vdc and Vac control circuits.
Standard Wiring 1 (SW1)	Low susceptibility control or power circuits rated less than 600 Vac (250 Vdc) and less than 15 A (voltage and current spectra are generally contained within 0.05–9 kHz). Signals falling under this classification include 120 Vac control circuits.
Standard Wiring 2 (SW2)	Power circuits rated greater than 15 A (voltage and current spectra are generally contained within 0.05–9 kHz). Signals falling under this classification include line power to controllers.
Standard Wiring 3 (SW3)	Reserved.
Pulse Wiring 1 (PW1)	Control or power circuits whose voltage or current spectra significantly exceed 9 kHz. Signals falling under this classification include motor and dynamic braking circuits fed from PWM power converters.

Voltage Class

The Voltage Class categorizes the voltages present into recognized conductor insulation categories (30, 150, 300, and 600 V) for selection of the conductor voltage rating and physical segregation purposes.

Wiring Methods

Based upon the Noise Class and Voltage Class of the conductors, apply the wiring methods in Table 20 to the drive system.

Table 20: Wire Routing and Interconnection

Wiring Methods and Considerations	Noise Class of Conductors				
	QW1	QW2	SW1	SW2	PW1
Conductor Grouping in Wireways/Conduits					
1. All conductors of 1 or 3 phase AC power circuits must be bundled to minimize stray magnetic fields.			X	X	X
2. All conductors of a DC power circuit must be bundled to minimize stray magnetic fields.			X	X	X
3. When paralleled conductors must be run in separate wireways or conduit, bundle conductors into groups that minimize stray magnetic fields.				X	X
4. Maintain conductor runs as short and direct as practical.	X	X	X	X	X
Separation of Circuits					
1. DO NOT run different Noise Class conductors in the same conduit.	X	X	X	X	X
2. DO NOT run different Voltage Class conductors in same conduit unless all conductors are insulated for the maximum Voltage Class present.	X	X	X	X	X
3. All PW conductor groups must be individually segregated using metallic conduit.					X
4. Segregate all conductors by Noise Class. Use the following circuit separation when conductors can run parallel for more than 12 in.					
• Metallic conduit: 3 in. between QW to SW/PW	X	X	X	X	X
• Metallic tray: 3 in. between SW to PW			X	X	X
• Metallic tray: 6 in. between QW to SW/PW	X	X	X	X	X
• Against continuous metal surface: 3 in. between SW to PW			X	X	X
• Against continuous metal surface: 6 in. between QW to SW/PW	X	X	X	X	X
• Metallic conduit housing QW: 12 in. to non-metallic conduit SW/PW	X	X	X	X	X
• Non-metallic conduit: 3 in. between SW to PW			X	X	X
• Non-metallic conduit: 24 in. between QW to SW/ PW	X	X	X	X	X
5. If QW and SW1 wiring must cross SW2 or PW1 wiring, the bundles must cross at right angles.	X	X	X	X	X
Common Mode Noise Issues					
1. Provide adjacent signal returns using twisted pair cable.	X	X			
2. Galvanically isolate signal and associated signal return path when possible.	X	X			
Shielding					
1. Use metallic conduit for all power and control circuits external to the controller enclosure.	X	X	X	X	X
2. Shields should be continuous and equipped with a drain wire.	X	X	X		
3. DO NOT group different Noise Class conductors within the same shield.	X	X	X	X	X
4. Minimize non-shielded portion of conductor at the ends of shielded cable.	X	X	X	X	X
5. When shielding AC or DC power conductors, group conductors to minimize magnetic field in shield.			X	X	X
Grounding					
1. Ground shields only at the controller end.	X	X	X	X	X
2. Use separate ground wire for each shield ground.	X	X	X	X	X
3. Provide a ground wire with all conductor groups whether in tray or conduit.			X	X	X
4. When multiple grounds must be made to a shielded power cable, the shield must have the same short circuit withstand capability as the ground conductor in the power cable.			X	X	X
5. Terminate all power grounds and power shield grounds to the controller grounding point or bar.			X	X	X
6. Terminate all signal shield grounds to the terminals provided.	X	X			
7. Always supply a separate equipment grounding conductor with the controller power feed. DO NOT depend upon metallic conduit for ground connection.			X	X	X

Component Identification and Terminal Strip Locations

NOTE: Typical device shown with options. Type 3R ventilation fan and space heater not shown.

Figure 14 shows component identification and terminal strip locations for Class 8839 ECONOFLEX drive controllers 1–7.5 hp at 460 V and 1–5 hp at 208/230 V. Tables 22, 23, and 24 (pages 48–50) list wire size range and terminal torque requirements.

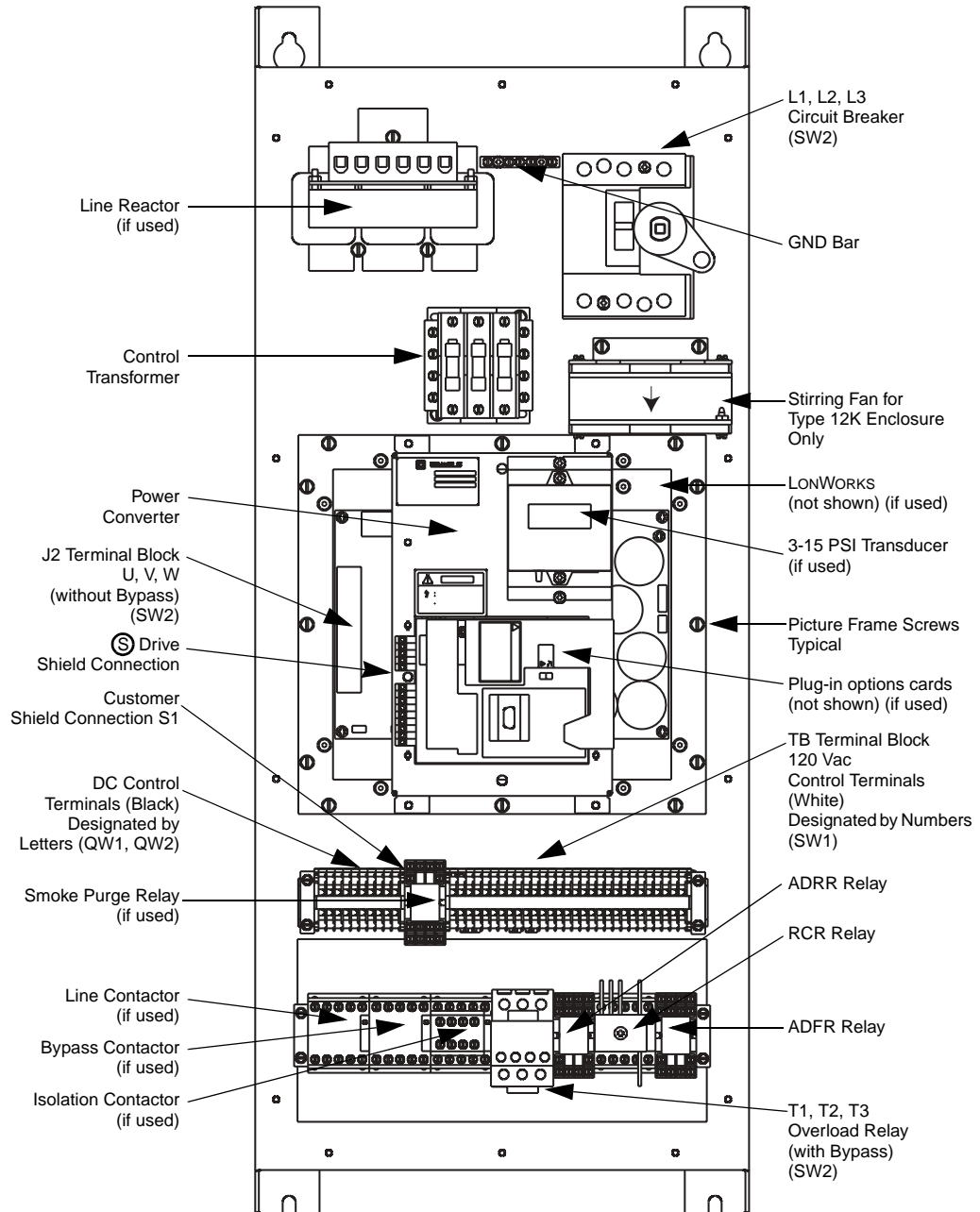

Figure 14: Component Identification and Terminal Strip Locations for 1–7.5 HP @ 460 V and 1–5 HP @ 208/230 V

Figure 15 shows component identification and terminal strip locations for Class 8839 ECONOFLEX drive controllers 10–25 hp at 460 V and 7.5–10 hp at 208/230 V. Tables 22, 23, and 24 (pages 48–50) list wire size range and terminal torque requirements.

NOTE: Typical device shown with options. Type 3R ventilation fan and space heater not shown.

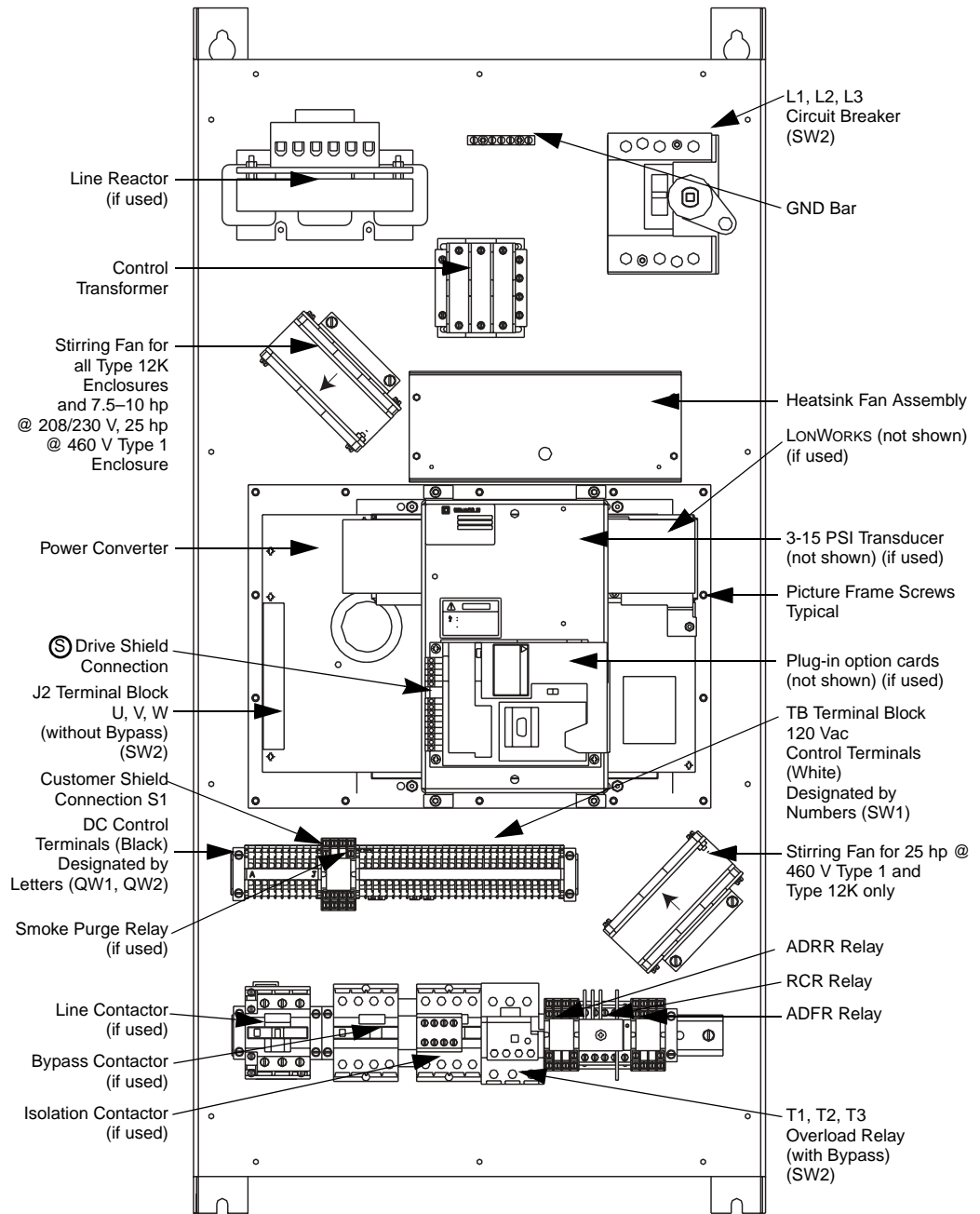

Figure 15: Component Identification and Terminal Strip Locations for 10–25 HP @ 460 V and 7.5–10 hp @ 208/230 V

Figure 16 shows component identification and terminal strip locations for Class 8839 ECONOFLEX drive controllers 30–50 hp at 460 V and 15–25 hp at 208/230 V. Tables 22, 23, and 24 (pages 48–50) list wire size range and terminal torque requirements.

NOTE: Typical device shown with options. Type 3R ventilation fan and space heater not shown.

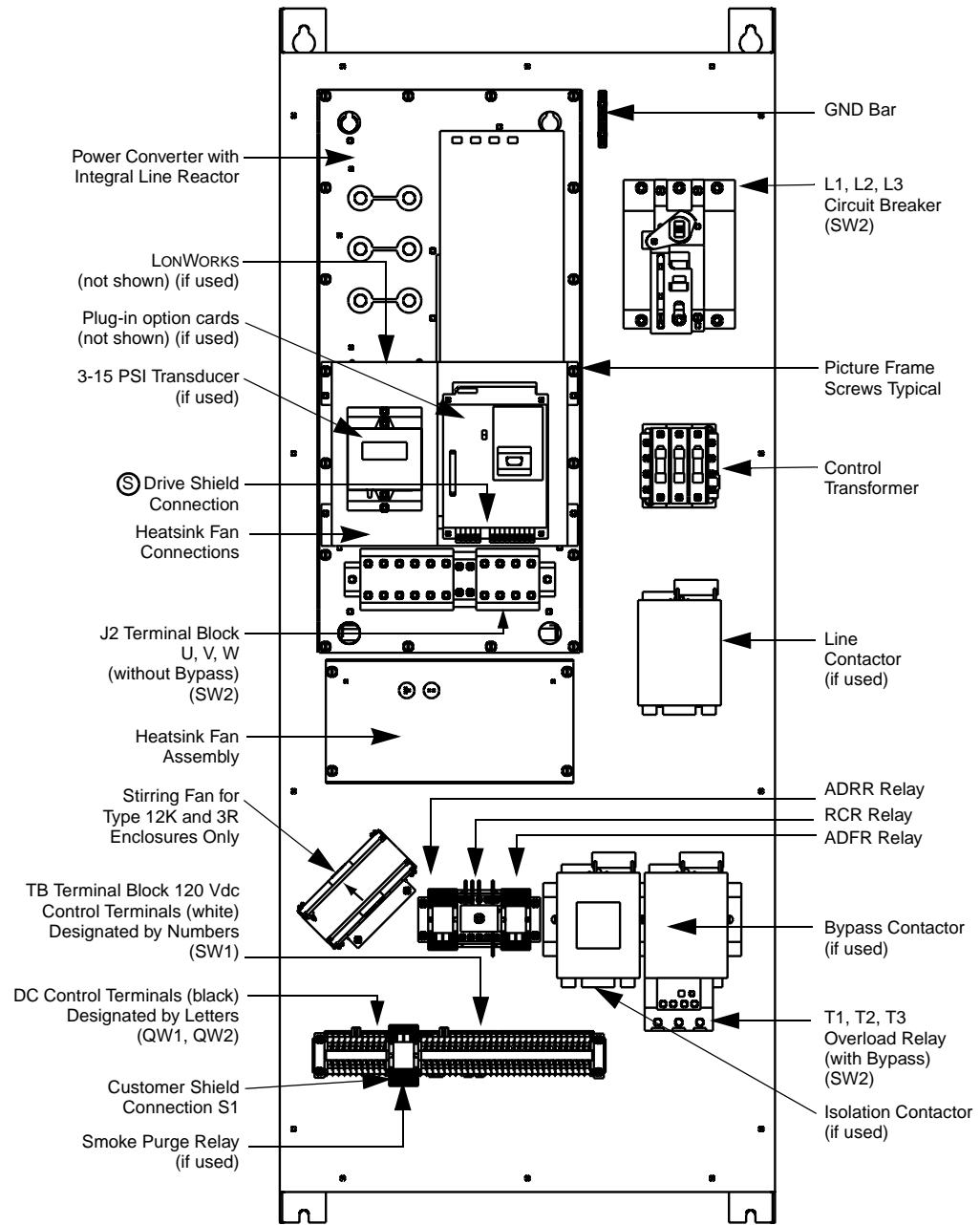

Figure 16: Component Identification and Terminal Strip Locations for 30–50 HP @ 460 V and 15–25 HP @ 208/230 V

Figure 17 shows component identification and terminal strip locations for Class 8839 ECONOFLEX drive controllers 60–100 hp at 460 V and 30–50 hp at 208/230 V. Tables 22, 23, and 24 (pages 48–50) list wire size range and terminal torque requirements.

NOTE: Typical device shown with options. Type 3R ventilation fan and space heater not shown.

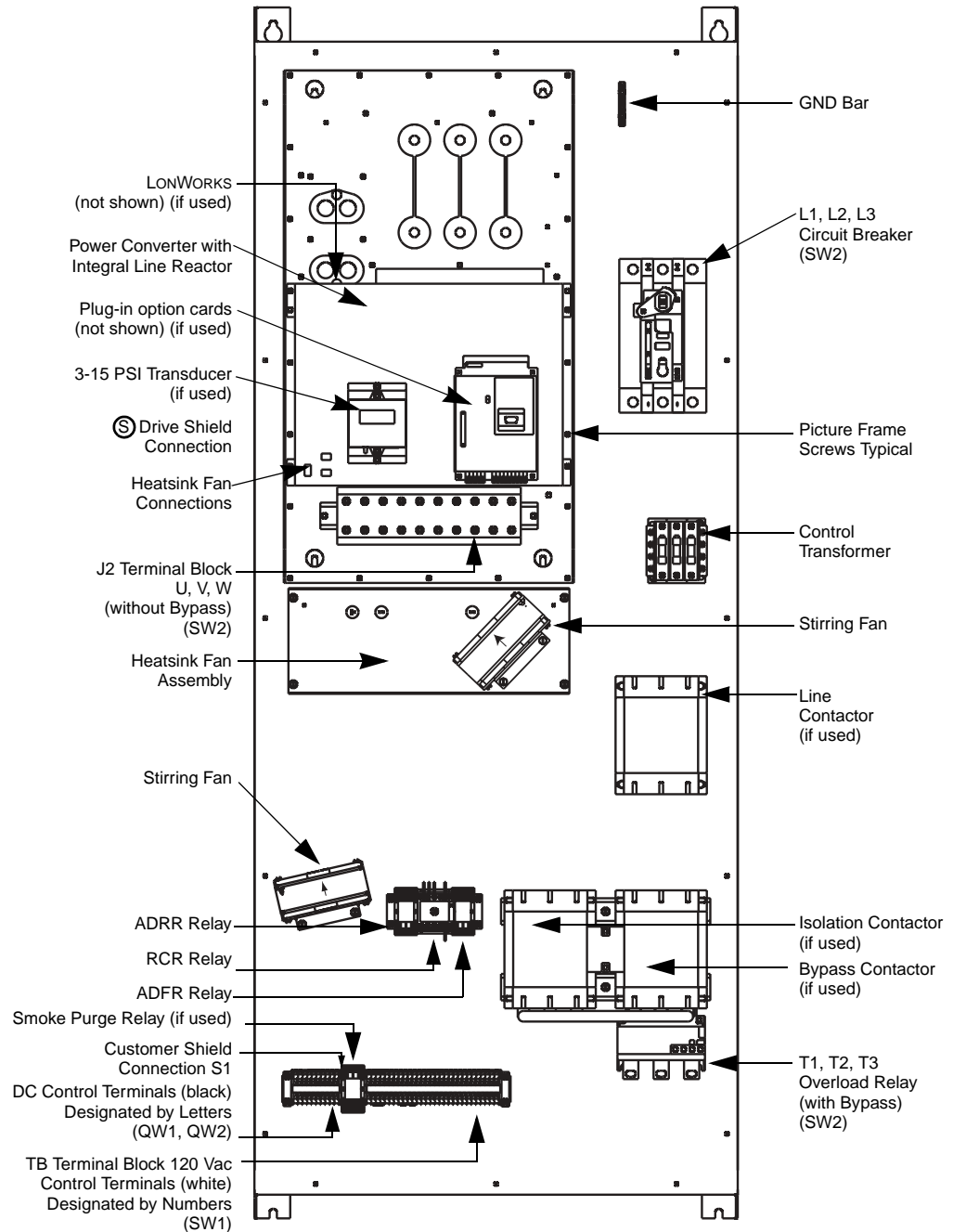

Figure 17: Component Identification and Terminal Strip Locations for 60–100 HP @ 460 V and 30–50 HP @ 208/230 V

Power Wiring

Table 21: Power Terminal Functions

Terminal	Function
GND	(Ground Bar)
L1 L2 L3	3-phase input power supply (at top of circuit breaker)
T1 T2 T3	Output connections to motor for controller with bypass (at bottom of overload relay)
U V W	Output connections to motor for controller without bypass (power converter output J2 terminal)

Table 22: Power Terminal Wire Range, 460 V

		Terminals					
		Maximum Wire Size AWG (mm ²) ^[2]	Terminal Torque lb-in (N•m)	Maximum Wire Size AWG (mm ²) ^[2]	Terminal Torque lb-in (N•m)	Maximum Wire Size AWG (mm ²) ^[2]	Terminal Torque lb-in (N•m)
Power Circuit W (Without Bypass) ^[1]	HP	L1, L2, L3 (Line)		U, V, W (Load)		GND Bar	
58EC•4VW_	1	1/0 (53.5)	50 (5.65)	8 (8.37)	7.5 (0.85)	4 (21.15)	20 (2.26)
58ED•4VW_	2	1/0 (53.5)	50 (5.65)	8 (8.37)	7.5 (0.85)	4 (21.15)	20 (2.26)
58EE•4VW_	3	1/0 (53.5)	50 (5.65)	8 (8.37)	7.5 (0.85)	4 (21.15)	20 (2.26)
58EF•4VW_	5	1/0 (53.5)	50 (5.65)	8 (8.37)	7.5 (0.85)	4 (21.15)	20 (2.26)
58EG•4VW_	7.5	1/0 (53.5)	50 (5.65)	8 (8.37)	7.5 (0.85)	4 (21.15)	20 (2.26)
58EH•4VW_	10	1/0 (53.5)	50 (5.65)	8 (8.37)	7.5 (0.85)	4 (21.15)	20 (2.26)
58EJ•4VW_	15	1/0 (53.5)	50 (5.65)	6 (13.3)	20 (2.26)	4 (21.15)	20 (2.26)
58EK•4VW_	20	1/0 (53.5)	50 (5.65)	6 (13.3)	20 (2.26)	4 (21.15)	20 (2.26)
58EL•4VW_	25	1/0 (53.5)	50 (5.65)	6 (13.3)	20 (2.26)	4 (21.15)	20 (2.26)
58EM•4VW_	30	1/0 (53.5)	50 (5.65)	2/0 (67.4)	88 (9.94)	4 (21.15)	20 (2.26)
58EN•4VW_	40	1/0 (53.5)	80 (9.04)	2/0 (67.4)	88 (9.94)	4 (21.15)	20 (2.26)
58EP•4VW_	50	1/0 (53.5)	80 (9.04)	2/0 (67.4)	88 (9.94)	4 (21.15)	20 (2.26)
58EQ•4VW_	60	1/0 (53.5)	80 (9.04)	4/0 (107.2)	170 (19.21)	4 (21.15)	20 (2.26)
58ER•4VW_	75	350 (177)	250 (28.25)	4/0 (107.2)	170 (19.21)	4 (21.15)	20 (2.26)
58ES•4VW_	100	350 (177)	250 (28.25)	4/0 (107.2)	170 (19.21)	4 (21.15)	20 (2.26)

		Terminals					
		Maximum Wire Size AWG (mm ²) ^[2]	Terminal Torque lb-in (N•m)	Maximum Wire Size AWG (mm ²) ^[2]	Terminal Torque lb-in (N•m)	Maximum Wire Size AWG (mm ²) ^[2]	Terminal Torque lb-in (N•m)
Power Circuit Y (Bypass) ^[1]	HP	L1, L2, L3 (Line)		T1, T2, T3 (Load)		GND Bar	
58EC•4VY_	1	1/0 (53.5)	50 (5.65)	10 (5.26)	15 (1.69)	4 (21.15)	20 (2.26)
58ED•4VY_	2	1/0 (53.5)	50 (5.65)	10 (5.26)	15 (1.69)	4 (21.15)	20 (2.26)
58EE•4VY_	3	1/0 (53.5)	50 (5.65)	10 (5.26)	15 (1.69)	4 (21.15)	20 (2.26)
58EF•4VY_	5	1/0 (53.5)	50 (5.65)	10 (5.26)	15 (1.69)	4 (21.15)	20 (2.26)
58EG•4VY_	7.5	1/0 (53.5)	50 (5.65)	10 (5.26)	15 (1.69)	4 (21.15)	20 (2.26)
58EH•4VY_	10	1/0 (53.5)	50 (5.65)	10 (5.26)	15 (1.69)	4 (21.15)	20 (2.26)
58EJ•4VY_	15	1/0 (53.5)	50 (5.65)	10 (5.26)	15 (1.69)	4 (21.15)	20 (2.26)
58EK•4VY_	20	1/0 (53.5)	50 (5.65)	6 (13.3)	15 (1.69)	4 (21.15)	20 (2.26)
58EL•4VY_	25	1/0 (53.5)	50 (5.65)	1/0 (53.5)	75 (8.47)	4 (21.15)	20 (2.26)
58EM•4VY_	30	1/0 (53.5)	50 (5.65)	1/0 (53.5)	75 (8.47)	4 (21.15)	20 (2.26)
58EN•4VY_	40	1/0 (53.5)	80 (9.04)	1/0 (53.5)	75 (8.47)	4 (21.15)	20 (2.26)
58EP•4VY_	50	1/0 (53.5)	80 (9.04)	1/0 (53.5)	75 (8.47)	4 (21.15)	20 (2.26)
58EQ•4VY_	60	1/0 (53.5)	80 (9.04)	1/0 (53.5)	75 (8.47)	4 (21.15)	20 (2.26)
58ER•4VY_	75	350 (177)	250 (28.25)	250 (127)	300 (33.9)	4 (21.15)	20 (2.26)
58ES•4VY_	100	350 (177)	250 (28.25)	250 (127)	300 (33.9)	4 (21.15)	20 (2.26)

[1] "*" can be "A", "G" or "H". "A" denotes a Type 12K enclosure; "G" denotes a Type 1 enclosure; "H" denotes a Type 3R enclosure. "_" indicates that the catalog number continues. See page 10 for a detailed description of catalog numbers.
[2] 75 °C copper.

Notes to Table 23:

- [1] "*" can be "A", "G" or "H". "A" denotes a Type 12K enclosure; "G" denotes a Type 1 enclosure; "H" denotes a Type 3R enclosure. "-" indicates that the catalog number continues. See page 10 for a detailed description of catalog numbers.
- [2] 75 °C copper.

Table 23: Power Terminal Wire Range, 230 V

Power Circuit W (Without Bypass) ^[1]	HP	Terminals					
		L1, L2, L3 (Line)		U, V, W (Load)		GND Bar	
		Maximum Wire Size AWG (mm ²) ^[2]	Terminal Torque lb-in (N•m)	Maximum Wire Size AWG (mm ²) ^[2]	Terminal Torque lb-in (N•m)	Maximum Wire Size AWG (mm ²) ^[2]	Terminal Torque lb-in (N•m)
58EC•3VW_	1	1/0 (53.5)	50 (5.65)	8 (8.37)	7.5 (0.85)	4 (21.15)	20 (2.26)
58ED•3VW_	2	1/0 (53.5)	50 (5.65)	8 (8.37)	7.5 (0.85)	4 (21.15)	20 (2.26)
58EE•3VW_	3	1/0 (53.5)	50 (5.65)	8 (8.37)	7.5 (0.85)	4 (21.15)	20 (2.26)
58EF•3VW_	5	1/0 (53.5)	50 (5.65)	8 (8.37)	7.5 (0.85)	4 (21.15)	20 (2.26)
58EG•3VW_	7.5	1/0 (53.5)	50 (5.65)	6 (13.3)	20 (2.26)	4 (21.15)	20 (2.26)
58EH•3VW_	10	1/0 (53.5)	50 (5.65)	6 (13.3)	20 (2.26)	4 (21.15)	20 (2.26)
58EJ•3VW_	15	1/0 (53.5)	50 (5.65)	2/0 (67.4)	88 (9.94)	4 (21.15)	20 (2.26)
58EK•3VW_	20	1/0 (53.5)	50 (5.65)	2/0 (67.4)	88 (9.94)	4 (21.15)	20 (2.26)
58EL•3VW_	25	1/0 (53.5)	80 (9.04)	2/0 (67.4)	88 (9.94)	4 (21.15)	20 (2.26)
58EM•3VW_	30	1/0 (53.5)	80 (9.04)	4/0 (107.2)	170 (19.21)	4 (21.15)	20 (2.26)
58EN•3VW_	40	350 (177)	250 (28.25)	4/0 (107.2)	170 (19.21)	4 (21.15)	20 (2.26)
58EP•3VW_	50	350 (177)	250 (28.25)	4/0 (107.2)	170 (19.21)	4 (21.15)	20 (2.26)

Power Circuit Y (Bypass) ^[1]	HP	Terminals					
		L1, L2, L3 (Line)		T1, T2, T3 (Load)		GND Bar	
		Maximum Wire Size AWG (mm ²) ^[2]	Terminal Torque lb-in (N•m)	Maximum Wire Size AWG (mm ²) ^[2]	Terminal Torque lb-in (N•m)	Maximum Wire Size AWG (mm ²) ^[2]	Terminal Torque lb-in (N•m)
58EC•3VY_	1	1/0 (53.5)	50 (5.65)	10 (5.26)	15 (1.69)	4 (21.15)	20 (2.26)
58ED•3VY_	2	1/0 (53.5)	50 (5.65)	10 (5.26)	15 (1.69)	4 (21.15)	20 (2.26)
58EE•3VY_	3	1/0 (53.5)	50 (5.65)	10 (5.26)	15 (1.69)	4 (21.15)	20 (2.26)
58EF•3VY_	5	1/0 (53.5)	50 (5.65)	10 (5.26)	15 (1.69)	4 (21.15)	20 (2.26)
58EG•3VY_	7.5	1/0 (53.5)	50 (5.65)	6 (13.3)	15 (1.69)	4 (21.15)	20 (2.26)
58EH•3VY_	10	1/0 (53.5)	50 (5.65)	6 (13.3)	15 (1.69)	4 (21.15)	20 (2.26)
58EJ•3VY_	15	1/0 (53.5)	50 (5.65)	6 (13.3)	75 (8.47)	4 (21.15)	20 (2.26)
58EK•3VY_	20	1/0 (53.5)	50 (5.65)	6 (13.3)	75 (8.47)	4 (21.15)	20 (2.26)
58EL•3VY_	25	1/0 (53.5)	80 (9.04)	6 (13.3)	75 (8.47)	4 (21.15)	20 (2.26)
58EM•3VY_	30	1/0 (53.5)	80 (9.04)	3/0 (85)	200 (22.6)	4 (21.15)	20 (2.26)
58EN•3VY_	40	350 (177)	250 (28.25)	3/0 (85)	200 (22.6)	4 (21.15)	20 (2.26)
58EP•3VY_	50	350 (177)	250 (28.25)	3/0 (85)	200 (22.6)	4 (21.15)	20 (2.26)

Table 24: Power Terminal Wire Range, 208 V

Notes to Table 24:

- [1] “•” can be “A,” “G” or “H”. “A” denotes a Type 12K enclosure; “G” denotes a Type 1 enclosure; “H” denotes a Type 3R enclosure. “_” indicates that the catalog number continues. See page 10 for a detailed description of catalog numbers.
- [2] 75 °C copper.

Power Circuit W (Without Bypass) ^[1]	HP	Terminals					
		L1, L2, L3 (Line)		U, V, W (Load)		GND Bar	
		Maximum Wire Size AWG (mm ²) ^[2]	Terminal Torque lb-in (N•m)	Maximum Wire Size AWG (mm ²) ^[2]	Terminal Torque lb-in (N•m)	Maximum Wire Size AWG (mm ²) ^[2]	Terminal Torque lb-in (N•m)
58EC•2VW_	1	1/0 (53.5)	50 (5.65)	8 (8.37)	7.5 (0.85)	4 (21.15)	20 (2.26)
58ED•2VW_	2	1/0 (53.5)	50 (5.65)	8 (8.37)	7.5 (0.85)	4 (21.15)	20 (2.26)
58EE•2VW_	3	1/0 (53.5)	50 (5.65)	8 (8.37)	7.5 (0.85)	4 (21.15)	20 (2.26)
58EF•2VW_	5	1/0 (53.5)	50 (5.65)	8 (8.37)	7.5 (0.85)	4 (21.15)	20 (2.26)
58EG•2VW_	7.5	1/0 (53.5)	50 (5.65)	6 (13.3)	20 (2.26)	4 (21.15)	20 (2.26)
58EH•2VW_	10	1/0 (53.5)	50 (5.65)	6 (13.3)	20 (2.26)	4 (21.15)	20 (2.26)
58EJ•2VW_	15	1/0 (53.5)	50 (5.65)	2/0 (67.4)	88 (9.94)	4 (21.15)	20 (2.26)
58EK•2VW_	20	1/0 (53.5)	80 (9.04)	2/0 (67.4)	88 (9.94)	4 (21.15)	20 (2.26)
58EL•2VW_	25	1/0 (53.5)	80 (9.04)	2/0 (67.4)	88 (9.94)	4 (21.15)	20 (2.26)
58EM•2VW_	30	1/0 (53.5)	80 (9.04)	4/0 (107.2)	170 (19.21)	4 (21.15)	20 (2.26)
58EN•2VW_	40	350 (177)	250 (28.25)	4/0 (107.2)	170 (19.21)	4 (21.15)	20 (2.26)
58EP•2VW_	50	350 (177)	250 (28.25)	4/0 (107.2)	170 (19.21)	4 (21.15)	20 (2.26)

Power Circuit Y (Bypass) ^[1]	HP	Terminals					
		L1, L2, L3 (Line)		T1, T2, T3 (Load)		GND Bar	
		Maximum Wire Size AWG (mm ²) ^[2]	Terminal Torque lb-in (N•m)	Maximum Wire Size AWG (mm ²) ^[2]	Terminal Torque lb-in (N•m)	Maximum Wire Size AWG (mm ²) ^[2]	Terminal Torque lb-in (N•m)
58EC•2VY_	1	1/0 (53.5)	50 (5.65)	10 (5.26)	15 (1.69)	4 (21.15)	20 (2.26)
58ED•2VY_	2	1/0 (53.5)	50 (5.65)	10 (5.26)	15 (1.69)	4 (21.15)	20 (2.26)
58EE•3VY_	3	1/0 (53.5)	50 (5.65)	10 (5.26)	15 (1.69)	4 (21.15)	20 (2.26)
58EF•2VY_	5	1/0 (53.5)	50 (5.65)	10 (5.26)	15 (1.69)	4 (21.15)	20 (2.26)
58EG•2VY_	7.5	1/0 (53.5)	50 (5.65)	6 (13.3)	15 (1.69)	4 (21.15)	20 (2.26)
58EH•2VY_	10	1/0 (53.5)	50 (5.65)	6 (13.3)	15 (1.69)	4 (21.15)	20 (2.26)
58EJ•2VY_	15	1/0 (53.5)	50 (5.65)	1/0 (53.5)	75 (8.47)	4 (21.15)	20 (2.26)
58EK•2VY_	20	1/0 (53.5)	80 (9.04)	1/0 (53.5)	75 (8.47)	4 (21.15)	20 (2.26)
58EL•2VY_	25	1/0 (53.5)	80 (9.04)	1/0 (53.5)	75 (8.47)	4 (21.15)	20 (2.26)
58EM•2VY_	30	1/0 (53.5)	80 (9.04)	3/0 (85)	200 (22.6)	4 (21.15)	20 (2.26)
58EN•2VY_	40	350 (177)	250 (28.25)	3/0 (85)	200 (22.6)	4 (21.15)	20 (2.26)
58EP•2VY_	50	350 (177)	250 (28.25)	3/0 (85)	200 (22.6)	4 (21.15)	20 (2.26)

Notes to Table 25 and Table 26:

- [1] See the Control Circuit Elementary Diagrams in chapter 5.
- [2] All terminals are rated 600 V, 30 A (Class 9080 Type GM6). Max. wire size for all terminals: 10 AWG (2.5 mm²). Tightening Torque: 7–8 lb-in (0.8–0.9 N•m).

Table 25: Analog Output (MOD H09)

Terminal ^{[1][2]}	Function	Characteristics
AO	Analog output programmed for motor frequency	0–20 mA Z=500 Ω Reassignable x–y range with keypad
COM	Common for analog output	0 V

Table 26: 0–10 V Auto Speed Reference (MOD J09), Signal Converter Board 31158-297-50

Terminal ^{[1][2]}	Function (Differential)	Characteristics
G1, S2+	AI2A+ Input	0–10 V, Z = 40 kΩ
G2, S2–	AI2B– Input	

Control Wiring

Table 27: Terminal Block Characteristics

NOTE: Refer to Table 25 for characteristics of the analog output available with MOD H09.

Terminal ^{[1][2]}	Function	Characteristics
A	+24 V (+24 V control supply)	Minimum: 20 V; Maximum: 30 V; I = 140 mA maximum ^[5]
B	LI3 (Logic Input 3) programmed for reference switching Auto/Manual	24 Vdc, 10 mA State 0: V<5 V; State 1: V>11 V; Z = 3.5 kΩ
C	LI4 (Logic Input 4) programmed for fault reset. Communication option programmed for forced local.	24 Vdc, 10 mA State 0: V<5 V; State 1: V>11 V; Z = 3.5 kΩ
D	LI2 (Logic Input 2) programmed for Freewheel Stop on bypass. Without bypass not assigned.	24 Vdc, 10 mA State 0: V<5 V; State 1: V>11 V; Z = 3.5 kΩ
E F	Line contactor auxiliary contact or jumper LI1 (Logic Input 1) Run Forward	24 Vdc, 10 mA State 0: V<5 V; State 1: V>11 V; Z = 3.5 kΩ
G1, S2+	AI2 (Analog Input 2: Speed Reference Current)	4-20 mA ^[6] , Z = 100 Ω
G2, S2–	Factory jumpered to G1, S2+ terminal unless 0–10 V Auto speed reference option selected. See Table 26 on page 51.	
H	+10 V Reference Supply	10 V, I = 10 mA maximum
I	AI1 (Analog Input 1: Speed Reference Voltage)	0–10 V, Z = 30 kΩ
J, S3	COM (Speed Reference Common)	0 V
S1	Shield	
1 2	Fire/Freezestat Interlocks	Provision for user-supplied, N.C. fire/freezestat contact.
2	Control Transformer (Ungrounded)	115 Vac, 60 Hz, [100 VA Type 1, 12k ^[8] 350 VA Type 3R ^[9]]
2 3	Smoke Purge Relay Contact ^[7]	Normally-jumpered or N.C. SPR contact when option is supplied.
3 4	AFC Select ^[7]	Supplied with bypass circuit
3 5	Bypass Select ^[7]	Supplied with bypass circuit
6 7	Auto Enabled	User-supplied auto start contact (run permissive)
6A 8	Stop push button ^[7]	
6 8	Start push button and Interlock ^[7]	
9	AFC Fault Pilot Light ^[7]	
10A	Auto Pilot Light ^[7]	
10	AFC Run Pilot Light ^[7]	
11	Line Contactor Coil ^[7]	
12 13	Normal Contact of Test-Normal Switch ^[7]	
14 -15	Bypass Pilot Light ^[7]	
16 17 18	AFC Run Contacts ^[4] Auxiliary N.C. Contact (AFC Run) COM Auxiliary N.O. Contact (AFC Run)	Minimum: 10 mA, 24 Vdc; Maximum: Inductive load of: <ul style="list-style-type: none"> • 2.0 A @ 120 Vac; maximum 0.10 J/operation, 80 operations/minute • 1.0 A @ 220 Vac; maximum 0.25 J/operation, 25 operations/minute • 2.0 A @ 24 Vac; maximum 0.10 J/operation, 80 operations/minute

Notes to Table 27:

- [1] See the Control Circuit Elementary Diagrams in chapter 5.
- [2] All terminals are rated 600 V, 30 A (Class 9080 Type GM6). Max. wire size for all terminals: 10 AWG (5.26 mm²). Tightening Torque: 7–8 lb-in (0.8–0.9 N•m).
- [3] Relay coil deenergizes on fault. Contacts are shown in fault mode.
- [4] Contact state with drive controller deenergized.
- [5] Total current of +24 V internal supply is 140 mA. If more current is required, an external supply must be used.
- [6] 0–20 mA, X–Y programmable with keypad display.
- [7] Available only when option is provided.
- [8] Approximately 45 VA available when all mods selected except L09 LONWORKS. 26 VA when LONWORKS selected.
- [9] Approximately 58 VA available when all mods selected except L09 LONWORKS. 38 VA when LONWORKS selected.

Table 27: Terminal Block Characteristics (Continued)

Notes to Table 27:

- [1] See the Control Circuit Elementary Diagrams in chapter 5.
- [2] All terminals are rated 600 V, 30 A (Class 9080 Type GM6). Max. wire size for all terminals: 10 AWG (5.26 mm²). Tightening Torque: 7–8 lb-in (0.8–0.9 N•m).
- [3] Relay coil deenergizes on fault. Contacts are shown in fault mode.
- [4] Contact state with drive controller deenergized.
- [5] Total current of +24 V internal supply is 140 mA. If more current is required, an external supply must be used.
- [6] 0–20 mA, X–Y programmable with keypad display.
- [7] Available only when option is provided.
- [8] Approximately 45 VA available when all mods selected except L09 LONWORKS. 26 VA when LONWORKS selected.
- [9] Approximately 58 VA available when all mods selected except L09 LONWORKS. 38 VA when LONWORKS selected.

Terminal ^{[1] [2]}	Function	Characteristics
19 20 21	AFC Fault Contacts ^[3] Auxiliary N.C. Contact (AFC Fault) COM Auxiliary N.O. Contact (AFC Fault)	Minimum: 10 mA, 24 Vdc; Maximum: Inductive load of: <ul style="list-style-type: none"> • 2.0 A @ 120 Vac; maximum 0.10 J/operation, 80 operations/minute • 1.0 A @ 220 Vac; maximum 0.25 J/operation, 25 operations/minute • 2.0 A @ 24 Vac; maximum 0.10 J/operation, 80 operations/minute
22 23	120 Vac Smoke Purge Relay coil ^[7]	115–120 Vac/60 Hz supply (user supplied)
24	Control Transformer (Grounded)	115 Vac, 60 Hz

INITIAL START-UP PROCEDURE

⚠ DANGER

HAZARDOUS VOLTAGE

Before working on this equipment, turn off all power supplying it and perform the bus voltage measurement procedure on page 40.

Failure to follow this instruction will result in death or serious injury.

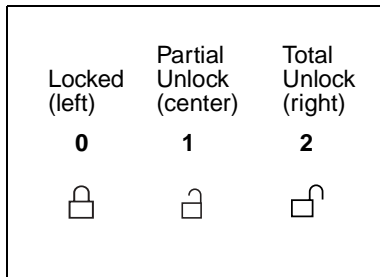

Keypad Access Switch

⚠ DANGER

HAZARDOUS VOLTAGE

- Properly ground the controller panel before applying power.
- Close and secure the enclosure door before applying power.
- Certain adjustments and test procedures require that power be applied to this controller. Extreme caution must be exercised as hazardous voltages exist. The enclosure door must be closed and secured while turning on power or starting and stopping this controller.

Failure to follow these instructions will result in death or serious injury.

⚠ DANGER

ELECTRIC SHOCK, BURN, OR EXPLOSION

- This equipment must be installed and serviced only by qualified personnel.
- Qualified personnel performing diagnostics or troubleshooting requiring electrical conductors to be energized, must comply with NFPA 70 E - Standard for Electrical Safety Requirements for Employee Workplaces and OSHA Standards – 29 CFR Part 1910 Subpart S Electrical.

Failure to follow this instruction will result in death or serious injury.

The Class 8839 ECONOFLEX drive controller has been configured for the installed options and tested at the factory. Minor adjustments to complete the field installation may be required based upon the application requirements. This initial start-up procedure should be followed step by step. In case of difficulty, refer to Chapter 4, Troubleshooting and Maintenance, on page 74.

A door-mounted or remote-mounted keypad must be used to perform the initial start-up procedure. The keypad must be in the Total Unlock position to perform any drive controller programming. On Type 1 and 12K enclosures, the keypad access switch is accessible through the back of the enclosure door. Type 3R enclosures include a keypad cable and keypad located inside the enclosure. To set the keypad to Total Unlock, move the switch all the way to the right. To lock the keypad after programming, move the switch all the way to the left. Refer to the diagram at left for switch positions.

To perform any programming on the Type 3R Enclosure:

1. **Remove all power.**
2. Open the door of the drive controller. Refer to step 1 on page 30.
3. Remove the keypad and cable from the cloth bag.
4. Connect the keypad cable to the power converter and keypad. The 9-pin male D-shell plugs into the power converter, the female D-shell plugs into the keypad.
5. Place the keypad cable outside the enclosure by positioning the cable in the bottom left corner between the hinge and bottom of the door.
6. Close and secure the enclosure door.
7. Close the equipment disconnect means.
8. Perform programming on keypad.
9. When programming is completed. **Remove all power.**
10. Open enclosure door.
11. Remove keypad cable from power converter.
12. Place keypad and cable inside cloth bag.
13. Close and secure the enclosure door.

After replacing the power converter or installing any plug-in option card, the programming parameters must be set as listed in the elementary diagram that corresponds to the options ordered. See pages 90–94.

In addition, after installing any plug-in option card for the first time, previously-saved parameters downloaded from the keypad or PC software will not be correct because they do not include the additional parameters available with

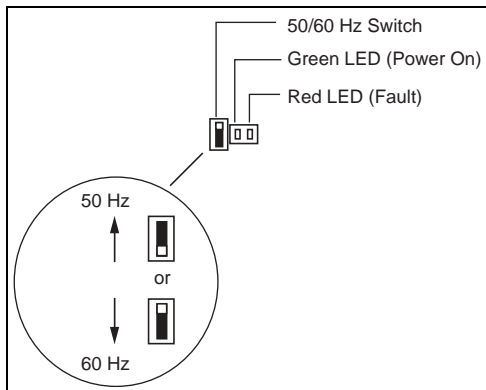

50/60 Hz Switch
(See Figs. 10–13
for switch location)

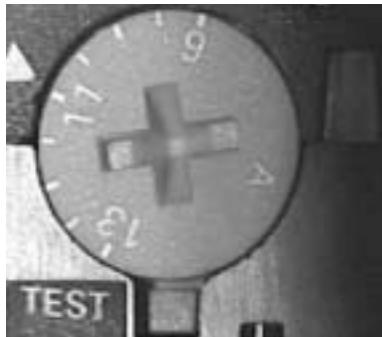

Overload Relay Dial

The LR2-D1516 overload relay is shown. Your dial setting range may be different.

the card. The analog card parameters must be set as listed in the elementary diagram that corresponds to the options ordered. See pages 90–94.

With all incoming power removed, make the following equipment checks:

- a. Verify that all equipment disconnects are open.
- b. Set the Hand-Off-Auto selector switch (controller mounted or remote mounted) to Off and the AFC-Off-Bypass switch (if used) to Off.
- c. Set the speed potentiometer (controller mounted or remote mounted) to its minimum setting (full counterclockwise position).
- d. Open the enclosure door. Refer to Step 1 on page 30.
- e. Check the wiring of the input power ground, motor ground, speed potentiometer (if remote mounted), and Hand-Off-Auto circuit connections (if remote mounted). See the control circuit elementary diagrams in chapter 5, and the power circuit descriptions starting on page 62, for wiring diagrams of the remote control operators.
- f. When using the bypass circuit, check that the motor conductors are wired to the T1, T2, and T3 terminals of the overload relay. When using the power circuit *without* bypass, check the motor conductors wired to U, V, and W on the J2 terminal block of the power converter.
- g. If the controller includes a bypass option for running the motor across the line, set the overload relay dial (on the load side of the bypass contactor) to the full load ampere rating on the nameplate of the connected motor. See example at left.
- h. Using a voltmeter set at the 1000 Vac scale, verify that the incoming line voltage at the line side of the disconnecting means is within $\pm 10\%$ of the input voltage rating on the controller nameplate.
- i. The 50/60 Hz switch, on the power converter control board, is factory set to 60 Hz. Check the switch before operating the drive controller to ensure that it is set to 60 Hz. See the diagram at left.
- j. Close and secure the enclosure door. Close the equipment disconnect means. The Power On pilot light (if used) illuminates.

⚠ CAUTION

MOTOR HEATING HAZARD

This drive controller does not provide direct thermal protection for the motor. Use of a thermal sensor in the motor may be required for protection at all speeds or load conditions. Consult the motor manufacturer for the thermal capability of motor when it is operated over desired speed range.

Failure to follow this instruction can result in injury or equipment damage.

- k. Press the ESC key on the keypad. Scroll with the down arrow key to Menu 2–Adjust (SEt), press the ENT key, then scroll with the down key to ThermCurrent–A (ItH) and press ENT. Use the up/down arrow keys to enter the motor nameplate full load amperes, then press ENT and ESC. The controller is now calibrated to provide motor overload protection. Refer to instruction bulletin VVDED397047US, *ALTIVAR 58 Adjustable Speed Drive Controllers Keypad Display VW3A58101*.

NOTE: The settings listed in this procedure are suitable for most applications. If your application requires different operating characteristics, refer to instruction bulletin VVDED397047US, ALTIVAR 58 Adjustable Speed Drive Controllers Keypad Display VW3A58101 for more information.

WARNING

HAZARD OF MACHINE ENTANGLEMENT

Before starting the drive controller, ensure that the motor and its connected load are clear from personnel and are ready to run.

Failure to follow this instruction can result in death or serious injury.

- i. Set the AFC-Off-Bypass selector switch (if used) to AFC, the Normal-Test selector switch (if used) to Normal, and Hand-Off-Auto selector switch to Hand (push Start if the Start/Stop push buttons are used). Slowly turn the speed potentiometer clockwise to accelerate the motor. Check the direction of motor rotation. If correct, proceed to step p. If incorrect, stop the drive. **Remove all power!**

DANGER

HAZARDOUS VOLTAGE

Turn off all power supplying this equipment and perform the bus voltage measurement procedure on page 40 before proceeding.

Failure to follow this instruction will result in death or serious injury.

- m. Correct the direction of motor rotation by reversing any two motor leads located on terminals T1, T2, or T3 for a drive controller with bypass; or U, V, or W for a drive controller without bypass.
- n. Reset the speed potentiometer to minimum speed (fully counterclockwise). Close and secure the enclosure door, then reapply power and restart the controller.
- o. Slowly turn the speed potentiometer clockwise to accelerate the motor. Check the direction of motor rotation. If correct, this completes the controller mode, motor rotation check.
- p. Set the AFC-Off-Bypass selector switch (if used) to Off, leaving the Hand-Off-Auto selector switch in the Hand position.
- q. Momentarily set the AFC-Off-Bypass selector switch to Bypass to check the direction of motor rotation, then return it immediately to the Off position. If the direction of motor rotation is correct, proceed to step t. If incorrect, stop the drive controller. **Remove all power!**

Note: If the controller circuit breaker trips during this test, a higher trip setting may be required. Refer to "Circuit Breaker Trip Adjustment Procedure" on page 57.

DANGER

HAZARDOUS VOLTAGE

Turn off all power supplying this equipment and perform the bus voltage measurement procedure on page 40 before proceeding.

Failure to follow this instruction will result in death or serious injury.

- r. Correct the direction of motor rotation by reversing any two incoming leads to the circuit breaker disconnect means marked L1, L2, or L3.
- s. Momentarily set the AFC-Off-Bypass selector switch to Bypass to check the direction of motor rotation, then return it immediately to the Off position. If correct, this completes the bypass mode, motor

rotation check.

- t. Check the High Speed (HSP) setting (maximum motor speed setting). Press the ESC key on the keypad. Scroll with the down arrow key to Menu 2–Adjust (SEt), press the ENT key, then scroll with the down key to parameter High Speed–Hz and press ENT. Use the up/down arrow keys to enter the maximum output frequency required for the application (factory default is 60 Hz), then press ENT and ESC. The controller HSP setting is now complete.

Refer to instruction bulletin VVDED397047US, *ALTIVAR 58 Adjustable Speed Drive Controllers Keypad Display VW3A58101*.

- u. Check the Low Speed (LSP) setting (minimum motor speed setting). Press the ESC key on the keypad. Scroll with the down arrow key to Menu 2–Adjust (SEt), press the ENT key, then scroll with the down key to parameter Low Speed–Hz and press ENT. Use the up/down arrow keys to enter the minimum output frequency required for the application (factory default is 3 Hz), then press ENT and ESC. The controller LSP setting is now complete.

Refer to instruction bulletin VVDED397047US, *ALTIVAR 58 Adjustable Speed Drive Controllers Keypad Display VW3A58101*.

- v. The application may require changing the setting of acceleration (ACC) and deceleration (dEC) times. Factory default is 10 seconds. To change the setting, press the ESC key. Scroll with the down arrow to Menu 2–Adjust, press ENT, then scroll with the down key to parameter Acceleration-s and Deceleration-s. Use the up/down arrows to enter in seconds the time required for the application, then press ENT and ESC. The controller acceleration and deceleration time setting is now complete.

Circuit Breaker Trip Adjustment Procedure

Use the following equation to calculate the circuit breaker dial setting. For the Type GJL breakers see Tables 28–30.

$$\text{Dial Setting} = \frac{\text{Motor FLA} \times \text{Multiplication Factor}}{\text{Breaker Rating}}$$

Read the motor FLA from the motor nameplate and read the breaker rating from Tables 28–30. The multiplication factor is derived from NEC Table 430-152. For Type FAL and KAL circuit breakers, set the breaker dial according to the magnetic trip setting shown on the breaker nameplate. See Tables 31–33. For example, to calculate the dial factory setting of a 7.5 hp, 460 V motor:

$$4 = \frac{11 \times 11}{30}$$

In this example, the arrow on the circuit breaker dial should be turned to 4X.



Figure 18: Circuit Breaker Trip Adjustment Dial

Notes to Tables:

- [1] Factory setting is 11 times the motor FLA (multiplication factor = 11).
- [2] Maximum trip setting is 13 times the motor FLA (multiplication factor = 13).

Table 28: 460 V GJL Circuit Breaker Trip Adjustment

HP	Circuit Breaker	Breaker Rating	Circuit Breaker Dial Setting	
			Factory ^[1]	Max. ^[2]
1	GJL36007M02	007	3.3X	3.9X
2	GJL36007M02	007	5.3X	6.3X
3	GJL36015M03	015	3.5X	4.2X
5	GJL36030M04	030	3X	3.3X
7.5	GJL36030M04	030	4X	4.8X
10	GJL36030M04	030	5.1X	6.1X
15	GJL36050M05	050	4.6X	5.5X
20	GJL36050M05	050	6X	7.0X
25	GJL36075M06	075	5X	5.9X
30	GJL36075M06	075	5.9X	6.9X

Table 29: 230 V GJL Circuit Breaker Trip Adjustment

HP	Circuit Breaker	Breaker Rating	Circuit Breaker Dial Setting	
			Factory ^[1]	Max. ^[2]
1	GJL36015M03	015	3.1X	3.7X
2	GJL36015M03	015	5X	5.9X
3	GJL36030M04	030	3.5X	4.2X
5	GJL36050M05	050	3.4X	4X
7.5	GJL36050M05	050	4.9X	5.7X
10	GJL36075M06	075	4.1X	4.9X
15	GJL36075M06	075	6.2X	7.3X
20	GJL36075M06	075	7.9X	9.4X

Notes to Tables:

- [1] Factory setting is 11 times the motor FLA (multiplication factor = 11).
- [2] Maximum trip setting is 13 times the motor FLA (multiplication factor = 13).

Table 30: 208 V GJL Circuit Breaker Trip Adjustment

HP	Circuit Breaker	Breaker Rating	Circuit Breaker Dial Setting	
			Factory ^[1]	Max. ^[2]
1	GJL36015M03	015	3.4X	4X
2	GJL36030M04	030	3X	3.3X
3	GJL36030M04	030	3.9X	4.6X
5	GJL36050M05	050	3.7X	4.4X
7.5	GJL36050M05	050	5.3X	6.3X
10	GJL36075M06	075	4.5X	5.4X
15	GJL36075M06	075	6.8X	8X

Table 31: 460 V FAL and KAL Circuit Breaker Trip Adjustment

HP	Circuit Breaker	Max. Input Current	Circuit Breaker Dial Setting	
			Factory ^[1]	Max. ^[2]
40	FAL36100-18M	54.5	600	709
50	FAL36100-18M	67	737	871
60	KAL36250-25M	82.8	911	1076
75	KAL36250-26M	100.5	1106	1307
100	KAL36250-29M	129.3	1422	1681

Table 32: 230 V FAL and KAL Circuit Breaker Trip Adjustment

HP	Circuit Breaker	Max. Input Current	Circuit Breaker Dial Setting	
			Factory ^[1]	Max. ^[2]
25	FAL36100-18M	68	748	884
30	KAL36250-25M	80	880	1040
40	KAL36250-26M	104	1144	1352
50	KAL36250-29M	130	1430	1690

Table 33: 208 V FAL and KAL Circuit Breaker Trip Adjustment

HP	Circuit Breaker	Max. Input Current	Circuit Breaker Dial Setting	
			Factory ^[1]	Max. ^[2]
20	FAL36100-18M	59.4	653	772
25	FAL36100-18M	74.8	823	972
30	KAL36250-25M	88	968	1144
40	KAL36250-26M	114	1254	1482
50	KAL36250-30M	143	1573	1859

**CHAPTER 3:
CIRCUIT DESCRIPTIONS
AND OPTIONS**

INTRODUCTION 61

TERMINAL VERSUS KEYPAD COMMAND OPERATION 61

KEYPAD OPERATION 62

TYPE 3R OPERATION 62

FORCED LOCAL OPERATION. 62

POWER CIRCUIT W (WITHOUT BYPASS) 62

 Operator Controls—General Arrangement and Operation 62

 Controller Operation 62

 Fire/Freezestat Interlocks 62

 MOD A07

 Hand-Off-Auto Selector and Manual Speed Potentiometer 62

 MOD B07 Hand-Off-Auto Selector,
 Start/Stop Push Buttons, and Manual Speed Potentiometer 63

 MOD C07

 Start/Stop Push Buttons and Manual Speed Potentiometer 64

 MOD N07 No Operators 64

 MOD A08 Pilot Light Option #1 Cluster 66

 MOD C08 Pilot Light Option #3 Cluster 66

 MOD A09 Line Reactor 66

 MOD C09 3–15 PSI Transducer with Digital Display Option 66

 MOD D09 Omit Keypad Display 66

 MOD E09 Smoke Purge Option 66

 MOD G09 22 KAIC UL Coordinated Rating 66

 MOD H09 Analog Card 66

 MOD J09 0–10 V Auto Speed Reference. 66

 MOD K09 cUL Listing 67

 MOD L09 LONWORKS 67

 MOD M09 MODBUS. 67

 MOD P09 METASYS N2 67

POWER CIRCUIT Y (BYPASS). 67

 Operator Controls—General Arrangement and Operation 67

 Test-Normal Operation 68

 Controller Operation 68

 Bypass Operation 68

 Fire/Freezestat Interlocks 68

 MOD AO7

 Hand-Off-Auto Selector and Manual Speed Potentiometer 68

 MOD BO7 Hand-Off-Auto Selector,
 Start/Stop Push Buttons, and Manual Speed Potentiometer 69

 MOD N07 No Operators 70

 MOD A08 Pilot Light Option #1 Cluster 71

 MOD B08 Pilot Light Option #2 Cluster 71

 MOD A09 Line Reactor. 71

 MOD B09 Line Contactor 71

 MOD C09 3–15 PSI Transducer with Digital Display Option 71

 MOD D09 Omit Keypad Display 71

 MOD E09 Smoke Purge Option 72

 MOD G09 22 KAIC UL Coordinated Rating 72

MOD H09 Analog Card	72
MOD J09 0–10 V Auto Speed Reference	72
MOD K09 cUL Listing	72
MOD L09 LONWORKS	72
MOD M09 MODBUS	72
MOD P09 METASYS N2	72

INTRODUCTION

This chapter describes basic sequences of operation for the two types of pre-engineered power circuit configurations and available options. The options are:

- Power Circuit W: Without Bypass (see page 62)
- Power Circuit Y: Bypass (see page 67)

TERMINAL VERSUS KEYPAD COMMAND OPERATION

For factory and/or user-supplied pilot devices and controls to be recognized, the Class 8839 ECONOFLEX drive controller is factory-configured to operate from the terminal strip. Enabling the Keypad Command (KeypadCom.) parameter (LCC in Menu 4) to YES disables certain power converter logic inputs. Factory and/or user-provided control devices are ignored. For this reason, do not operate the drive controller in the Keypad Command mode.

Before re-programming inputs, outputs, torque types, or control types:

- Consult the factory configuration listing on the applicable control circuit diagram in chapter 5.
- Refer to instruction bulletin VVDED397047US, *ALTIVAR® 58 Adjustable Speed Drive Controllers Keypad Display, VW3A58101*.
- Refer to instruction bulletin VVDED397046US, *ALTIVAR 58 Adjustable Speed Drive Controllers Analog I/O Extension Card, VW3A58201U* (supplied with controller when analog card, MOD H09, is selected).
- Refer to instruction bulletin VVDED300055US, *LONWORKS® to MODBUS® Module VW3A58312PU* (supplied with controller when LONWORKS, MOD L09, is selected).
- Refer to instruction bulletin VVDED397054US, *ALTIVAR 58 Adjustable Speed Drive Controllers MODBUS/JBUS/UNITELWAY Card, VW3A58303U* (supplied with controller when MODBUS, MOD M09 or LONWORKS L09, is selected).
- Refer to instruction bulletin VVDED300028US, *ALTIVAR 58 Adjustable Speed Drive Controllers METASYS® N2 Communication Option VW3A58354U* (supplied with controller when METASYS N2, MOD P09, is selected).

Changing certain factory settings will affect the performance of the Class 8839 ECONOFLEX drive controller.

▲ WARNING

UNINTENDED EQUIPMENT OPERATION

- Controller has been factory-programmed. Alteration of factory programming may create incompatibilities with supplied controller configuration.
- Read and understand instruction bulletin VVDED397047US as well as the programming information found in the applicable control circuit elementary diagrams in chapter 5.
- If the power converter unit is re-initialized using the TOTAL or PARTIAL FACTORY SETTING function, the power converter must be re-programmed according to the programming instructions found in the applicable control circuit elementary diagrams in chapter 5.
- If the power converter unit or the main control board of the power converter is replaced, or if any option cards are field installed, the power converter must be re-programmed according to the programming instructions found in the applicable control circuit elementary diagrams in chapter 5.

Failure to follow these instructions can result in death or serious injury.

NOTE: The factory program can be saved in the keypad. Refer to instruction bulletin VVDED397047US, ALTIVAR 58 Adjustable Speed Drive Controllers Keypad Display VW3A58101, for saving and retrieving factory settings.

KEYPAD OPERATION

The keypad is for programming and display. The FWD/REV, Run, and Stop/Reset buttons are not for controller primary operation. The 22 mm operators located on the front of the controller door are used to command the AFC and Bypass modes of operation.

TYPE 3R OPERATION

To prevent condensation on the inside of the cabinet, it is the manufacturer's recommendation to leave the mains energized when the motor is not running.

FORCED LOCAL OPERATION

When a communication option is selected, the drive controller fault reset feature will be removed. Instead:

- a factory jumper is provided on the terminal strip from A to C
- LI4 is programmed for forced local

The user may choose to remove the forced local function if start/stop commands are not commanded over the communication system network. To activate the fault reset function:

- remove the factory provided jumper from terminals A to C
- program LI4 to fault reset

POWER CIRCUIT W (WITHOUT BYPASS)

This power circuit consists of a fused control transformer, circuit breaker disconnect with means for locking in the open position, power converter, and optional equipment as specified.

Operator Controls—General Arrangement and Operation

The operator controls are located on the front door of the drive controller unless no control options are specified. The drive controller is factory configured to operate in terminal command mode.

MOD D09 omits the keypad display. If D09 is selected, a separate keypad must be ordered to program the drive controller.

Controller Operation

To operate the controller, the circuit breaker disconnect located on the front of the drive controller must be in the closed position. There are several modes of operation depending upon the control method used.

- Two-wire control functionality: Hand-Off-Auto selector switch. The controller will automatically restart when power is restored after a power loss or upon resetting a fault condition.
- Three-wire control functionality: Start/Stop push buttons. The controller will not restart when power is restored after a power loss or upon resetting a fault. The start push button must be pressed to restart the controller.

Fire/Freezestat Interlocks

Terminals TB1 and TB2 are dedicated terminals for accepting a user-supplied fire/freezestat interlock (normally closed). The power converter will stop operation if the connection between TB1 and TB2 is opened. Remove the factory jumper wire located on these terminals before installing the fire/freezestat interlock.

MOD A07 Hand-Off-Auto Selector and Manual Speed Potentiometer

This control option provides a door-mounted Hand-Off-Auto (H-O-A) selector switch and manual speed potentiometer to operate the power converter.

Hand mode is for local control. As soon as Hand mode is selected, the power converter starts the motor. In Hand mode, the speed potentiometer is used to control the speed of the drive controller.

Off mode commands the power converter to stop the motor by either following the programmed deceleration ramp (factory setting) or by a freewheel stop.

Set the H-O-A switch to Off for fault reset.

Auto mode is for remote control. In Auto mode, the power converter starts the motor when the user-supplied run contact is closed between controller terminals TB6 and TB7. Motor speed is varied by adjusting the user-supplied auto speed reference signal (4–20 mA) supplied to terminals TBS2+ (+) and TBS3 (–) in the drive controller. Refer to instruction bulletin VVDED397047US for signal scaling.

When MOD J09 is selected, the motor speed is varied by adjusting the user-supplied auto speed reference signal (0–10 V) supplied to terminals S2+ (+) and S2– (–). This input is differential to maximize noise immunity.

MOD B07
Hand-Off-Auto Selector,
Start/Stop Push Buttons, and
Manual Speed Potentiometer

This control option provides a door-mounted Hand-Off-Auto (H-O-A) selector switch, a Start push button, a Stop push button, and a manual speed potentiometer to operate the power converter.

Hand mode is for local control. The power converter will not start the motor until the Start push button is pushed. In Hand mode, the manual speed potentiometer is used to control the speed of the controller.

Off mode commands the power converter to stop the motor by either following the programmed deceleration ramp (factory setting) or by a freewheel stop.

Set the H-O-A switch to Off for fault reset.

▲ WARNING

INABILITY TO INITIATE A STOP

The Stop push button is only active in the Hand mode.

- To stop the drive controller, open the disconnect switch or set the Hand-Off-Auto switch to Off.
- Use appropriate guarding or interlocking.

Failure to follow this instruction can result in death or serious injury.

Auto mode is for remote control. In Auto mode, the power converter starts the motor when the user-supplied run contact is closed between controller terminals TB6 and TB7. Motor speed is varied by adjusting the user supplied auto speed reference signal (4–20 mA) supplied to terminals TBS2+ (+) and TBS3 (–) in the drive controller. Refer to instruction bulletin VVDED397047US for scaling of this signal.

When MOD J09 is selected, the motor speed is varied by adjusting the user-supplied auto speed reference signal (0–10 V) supplied to terminals S2+ (+) and S2– (–). This input is differential to maximize noise immunity.

The **Start** push button commands the power converter to start the motor for local control. The manual speed potentiometer is used to control the speed of the controller.

The **Stop** push button commands the power converter to stop the motor for local control by either following the programmed deceleration ramp (factory setting) or by freewheel stopping. If the Hand-Off-Auto switch is in the Auto mode, the switch must be set to Off to stop the power converter. The

Stop push button is only active for local control (Hand), not for remote control (Auto).

MOD C07
Start/Stop Push Buttons and
Manual Speed Potentiometer

This control option provides door-mounted Start and Stop push buttons and a manual speed potentiometer to operate the power converter locally.

The **Start** push button commands the power converter to start the motor. The manual speed potentiometer mounted on the drive controller is used to control the speed of the controller.

The **Stop** push button commands the power converter to stop the motor by either following the programmed deceleration ramp (factory setting) or by a freewheel stop.

MOD N07
No Operators

Control option N07 omits control operator functions. It is for use with customer-supplied external control devices.

There are a number of ways to sequence the power converter when door-mounted control devices are not present. Figures 19 through 21 on pages 64 and 65 show recommended sequencing diagrams for commonly-used control methods.

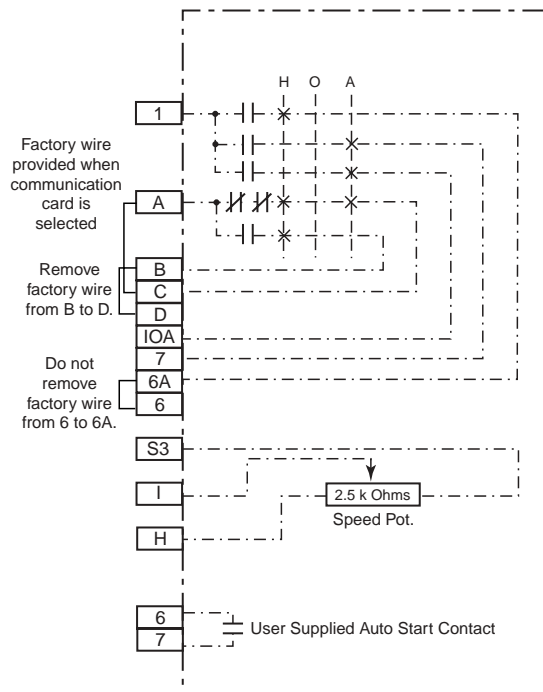

Configure Controller Functions as Follows:

MENU	CODE	ADJ.	DESCRIPTION
Sup	tFr		Display Parameter: Output Freq.
Macro	CFG	VT [1]	Variable Torque Application
CtL	tCC	2W	Two Wire Control
CtL	tCt	LEL	Two Wire Control, Maintained
I-O	NO	LI2	Not Assigned
I-O	RFC	LI3	Reference Switching, Auto/Manual
I-O	RST	LI4	Fault Reset
I-O	RUN	R2	Drive Running
SEt	ACC	10	Acceleration Time, In Seconds
SEt	dEC	10	Deceleration Time, In Seconds
SEt	LSP	3	Low Speed, In Hz
drC	SFt	HFI	High Switching Freq. W/Foldback
drC	SFr	8	8k Hz Switching Frequency
FLt	FLr	Yes	Catch on Fly

When MOD H09, Analog Card, is selected:

I-O	NO	LI5	Not assigned
I-O	NO	AI3	Not Assigned
I-O	OFR	AO	Motor Freq

When Communication Card is selected:

I-O	FLO	LI4	Forced Local
-----	-----	-----	--------------

[1] After programming is complete, Macro description will read "Customized".

Directions:

- Wire according to the diagram at left for Hand-Off-Auto and Speed Potentiometer.
- Program the power converter according to the chart above.
- DO NOT remove the factory wire on the terminal block from 6 to 6A.
- REMOVE the factory wire on the terminal block B to D.

Legend

2	Number: 115 VAC Terminal Block
A	Letter: VDC Terminal Block

Legend to Figure 19.

Figure 19: User-Supplied Wiring Equivalent to MOD A07

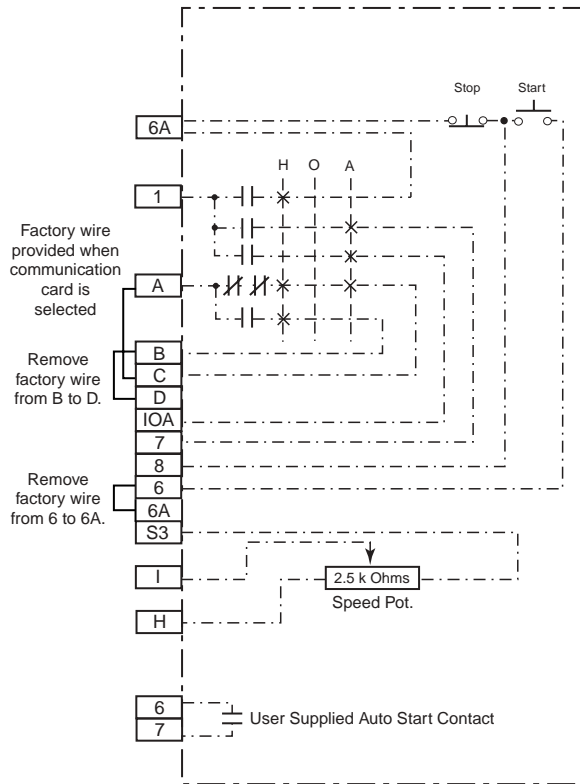

Configure Controller Functions as Follows:

MENU	CODE	ADJ.	DESCRIPTION
Sup	rFr		Display Parameter: Output Freq.
Macro	CFG	VT [1]	Variable Torque Application
CTL	tCC	2W	Two Wire Control
CTL	tCt	LEL	Two Wire Control, Maintained
I-O	NO	LI2	Not assigned.
I-O	RFC	LI3	Reference Switching, Auto/Manual
I-O	RST	LI4	Fault Reset
I-O	RUN	R2	Drive Running
SEt	ACC	10	Acceleration Time, In Seconds
SEt	dEC	10	Deceleration Time, In Seconds
SEt	LSP	3	Low Speed, In Hz
drC	SFt	HFI	High Switching Freq. W/Foldback
drC	SFr	8	8k Hz Switching Frequency
FLt	FLr	Yes	Catch on Fly

When MOD H09, Analog Card, is selected:

I-O	NO	LI5	Not assigned
I-O	NO	AI3	Not Assigned
I-O	OFr	AO	Motor Freq

When Communication Card is selected:

I-O	FLO	LI4	Forced Local
-----	-----	-----	--------------

[1] After programming is complete, Macro description will read "Customized".

Directions:

- Wire according to the diagram at left for Hand-Off-Auto, Stop-Start, and Speed Potentiometer
- Program the power converter according to the chart above.
- REMOVE the factory wire on the terminal block from 6 to 6A.
- REMOVE the factory wire on the terminal block from B to D.

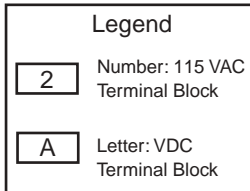

Legend to Figures 20 and 21.

Figure 20: User-Supplied Wiring Equivalent to MOD B07

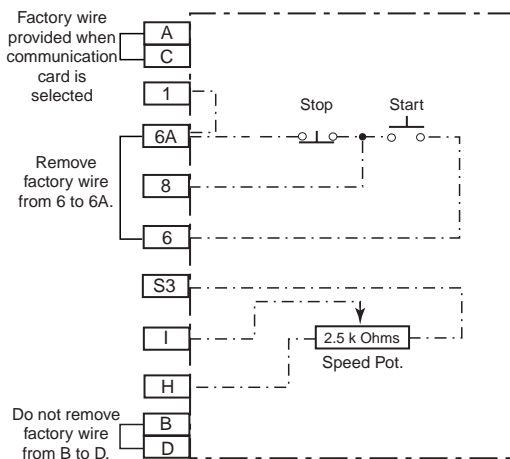

Configure Controller Functions as Follows:

MENU	CODE	ADJ.	DESCRIPTION
Sup	rFr		Display Parameter: Output Freq.
Macro	CFG	VT [1]	Variable Torque Application
CTL	tCC	2W	Two Wire Control
CTL	tCt	LEL	Two Wire Control, Maintained
I-O	NO	LI2	Not Assigned
I-O	NO	LI3	Not Assigned
I-O	NO	LI4	Not Assigned
I-O	RUN	R2	Drive Running
SEt	ACC	10	Acceleration Time, In Seconds
SEt	dEC	10	Deceleration Time, In Seconds
SEt	LSP	3	Low Speed, In Hz
drC	SFt	HFI	High Switching Freq. W/Foldback
drC	SFr	8	8k Hz Switching Frequency
FLt	FLr	Yes	Catch on Fly

When MOD H09, Analog Card, is selected:

I-O	NO	LI5	Not assigned
I-O	NO	AI3	Not Assigned
I-O	OFr	AO	Motor Freq

When Communication Card is selected:

I-O	FLO	LI4	Forced Local
-----	-----	-----	--------------

[1] After programming is complete, Macro description will read "Customized".

Directions:

- Wire according to the diagram at left for Stop-Start and Speed Potentiometer.
- Program the power converter according to the chart above.
- REMOVE the factory wire on the terminal block from 6 to 6A.
- DO NOT remove the factory wire on the terminal block from B to D. The speed reference will always read AI1.

Figure 21: User-Supplied Wiring Equivalent to C07

MOD A08
Pilot Light Option #1 Cluster

This pilot light option provides visual indication of protective functions and circuit status.

Power On (red): illuminates when mains power is applied to the controller. The pilot light device is rated 120 Vac.

AFC Run (green): illuminates to annunciate an AFC run condition. The pilot light device is rated 120 Vac.

Auto (yellow): illuminates when the Hand-Off-Auto selector switch is set to Auto. The pilot light device is rated 120 Vac.

Fault (yellow): illuminates to annunciate an AFC fault (trip) condition. The pilot light device is rated 120 Vac.

MOD C08
Pilot Light Option #3 Cluster

This pilot light option provides visual indication of protective functions and circuit status.

Power On (red): illuminates when mains power is applied to the controller. The pilot light device is rated 120 Vac.

AFC (green): illuminates to annunciate an AFC run condition. The pilot light device is rated 120 Vac.

Fault (yellow): illuminates to annunciate an AFC fault (trip) condition. The pilot light device is rated 120 Vac.

MOD A09
Line Reactor

This miscellaneous option includes an integrally-mounted AC line reactor factory-installed and wired between the circuit breaker disconnect means and the power converter for high true power factor and effective harmonic mitigation. It complies with IEEE 519 guidelines. For 460 V controllers, the line reactor is an option for 1–25 hp and standard for 30–100 hp. For 208/230 V controllers, the line reactor is an option for 1–10 hp and standard for 15–50 hp.

MOD C09
3–15 PSI Transducer with Digital Display Option

This miscellaneous option provides the controller with the capability to follow a user-supplied 3–15 PSI follower signal with digital display. The module is calibrated to operate as a 4–20 mA DC follower for the power converter.

MOD D09
Omit Keypad Display

This miscellaneous option omits the keypad display. If MOD D09 is selected, a separate keypad must be ordered to program the drive controller.

MOD E09
Smoke Purge Option

This miscellaneous option provides a smoke purge operating mode controlled by a user-supplied 120 Vac signal applied between terminals TB22 and TB23. When 120 Vac power is supplied to TB22 and TB23, the drive controller runs the motor at 60 Hz.

MOD G09
22 KAIC UL Coordinated Rating

This miscellaneous option provides a fully-coordinated 22 KAIC rating marked on enclosure nameplate (short-circuit coordination to UL508C Power Conversion Equipment and NEMA ICS 7.1).

MOD H09
Analog Card

This miscellaneous option provides a 0–20 mA analog output for customer use. It includes a plug-in analog card VW3A58201U with AO and COM wired to the customer terminal block located on the power converter. The output is factory-programmed for motor frequency. Refer to instruction bulletin VVDED397046US for other programming choices. Selectable x–y range with keypad display.

MOD J09
0–10 V Auto Speed Reference

This miscellaneous option provides a controller interface for a 0–10 V user-supplied auto speed reference signal into the AI2 input, terminals G1 (S2+) and G2 (S2–) on terminal block TB2, using a 0–10 V/4–20 mA converter with Z=40 kΩ. Not available with MOD C07 (page 64) or with MOD C09 (above).

MOD K09
cUL Listing

This miscellaneous option provides Canadian cUL certification when required by local code requirements.

MOD L09
LONWORKS

This miscellaneous option provides a factory installed LONWORKS to MODBUS Module VW3A58312PU, plug-in MODBUS card VW3A58303U. Serial communication is factory installed for register monitoring. Refer to page 62 for a description of forced local operation.

MOD M09
MODBUS

This miscellaneous option provides a factory installed plug-in MODBUS card VW3A58303U and separate user termination to D-shell interface device. Serial communication is factory installed for register monitoring.

Interface device suited for incoming and outgoing bus cable or end of the line termination. Two cable entries to two termination blocks for pins 2, 3, 4, 5, 7, and 9. Refer to page 62 for a description of forced local operation.

MOD P09
METASYS N2

This miscellaneous option provides a factory installed plug-in METASYS N2 card VW3A58354U and separate user termination to D-shell interface device. Serial communication is factory installed for register monitoring.

Interface device suited for incoming and outgoing bus cable or end of the line termination. Two cable entries to two termination blocks for pins 2, 3, 4, 5, 7, and 9. Refer to page 62 for a description of forced local operation.

POWER CIRCUIT Y
(BYPASS)

This power circuit operates the motor from the power converter or from full voltage line power (bypass mode). The motor can be run in the bypass mode in the unlikely event that the power converter becomes inoperative. The Bypass Package consists of:

- Isolation and bypass contactors with Class 20 overloads (Class 10 for 1 hp @ 460 V)
- Control transformer
- Circuit breaker disconnect with means for locking in the open position
- AFC-Off-Bypass switch
- Test-Normal switch
- Power Converter
- Optional equipment as specified

Operator Controls—General
Arrangement and Operation

Operator controls are located on the front door of the drive controller unless no control options are specified. The drive controller is factory configured to operate in terminal command mode. MOD D09 omits the keypad display. If D09 is selected, a separate keypad must be ordered to program the drive controller.

The AFC-Off-Bypass switch allows selection of either adjustable speed operation of the motor through the power converter (AFC position) or line power operation of the motor (Bypass position). Both AFC and Bypass operation can be started in the Hand mode for immediate start or in the Auto mode for remote contactor start.

Test-Normal Operation

The test-normal switch is used to test the power converter while operating the motor in bypass. To use this function and maintain motor operation, place the following switches in these positions:

- AFC-Off-Bypass: Set the switch to Bypass to run the motor at full speed across the line.
- Test-Normal: Set the switch to Test.
- Hand-Off-Auto: Set the switch to Hand. Use the manual speed potentiometer to change the speed reference and observe power converter operation. Refer to instruction bulletin VVDED397047US, *ALTIVAR 58 Adjustable Speed Drive Controller Keypad Display VW3A58101* for fault definitions.

Controller Operation

To operate the controller, the circuit breaker disconnect located on the front of the drive controller must be in the closed position. There are several modes of operation depending upon the control method used.

- Two-wire control functionality: Hand-Off-Auto selector switch. The controller will automatically restart when power is restored after a power loss or upon resetting an AFC fault condition.
- Three-wire control functionality: Start/Stop push buttons. The controller will not restart when power is restored after power loss or upon resetting an AFC fault. The start push button must be pressed to restart the controller.

Bypass Operation

To control the operation of the motor with line power, the circuit breaker disconnect located on the front of the drive controller must be in the closed position and the AFC-Off-Bypass switch must be in the Bypass position. When the AFC-Off-Bypass selector switch is set to Bypass, motor operation is transferred to line power. In hand mode the motor will immediately start. In hand mode with a start/start push button, the motor will start when the start push button is pressed. In auto mode, the motor will start when the user-supplied contact is closed. When the selector switch is moved to the Off position, the bypass contactor opens and the motor stops.

Fire/Freezestat Interlocks

Terminals TB1 and TB2 are dedicated terminals for accepting a user-supplied fire/freezestat interlock (normally-closed). The drive output isolation contactor and bypass contactor open if the connection between terminals TB1 and TB2 is opened. As a result, the motor will stop. Remove the factory-installed jumper from these terminals before installing the interlock.

MOD A07 Hand-Off-Auto Selector and Manual Speed Potentiometer

This control option provides a door-mounted Hand-Off-Auto (H-O-A) selector switch and manual speed potentiometer to operate the power converter.

Hand mode is for local control. In Bypass operation, as soon as Hand mode is selected, a full-voltage across-the-line start will occur. In AFC operation, as soon as Hand mode is selected, the power converter starts the motor. The manual speed potentiometer is used to control the speed of the controller.

Off mode commands the power converter to stop the motor by either following the programmed deceleration ramp (factory setting) or by a freewheel stop.

Set the H-O-A switch to Off for fault reset.

Auto mode is for remote control. In Bypass operation, a full-voltage across-the-line start will occur when the user-supplied run contact is closed between controller terminals TB6 and TB7. In AFC operation, the power converter starts the motor when the user-supplied run contact is closed between controller terminals TB6 and TB7. Motor speed is varied by adjusting the user-supplied auto speed reference signal (4-20 mA) supplied to terminals

MOD B07
Hand-Off-Auto Selector,
Start/Stop Push Buttons, and
Manual Speed Potentiometer

TBS2+ (+) and TBS3 (-) in the drive controller. Refer to instruction bulletin VVDED397047US for signal scaling.

When MOD J09 is selected, the motor speed is varied by adjusting the user-supplied auto speed reference signal (0–10 V) supplied to terminals S2+ (+) and S2- (-). This input is differential to maximize noise immunity.

This control option provides a door-mounted Hand-Off-Auto (H-O-A) selector switch, a Start push button, a Stop push button, and a manual speed potentiometer to operate the power converter.

▲ WARNING

INABILITY TO INITIATE A STOP

The Stop push button is only active in the Hand mode.

- To stop the drive controller, open the disconnect switch or set the Hand-Off-Auto switch to Off.
- Use appropriate guarding or interlocking.

Failure to follow this instruction can result in death or serious injury.

Hand mode is for local control. In Bypass operation, when Hand mode is selected, a full-voltage across-the-line start will occur when the start push button is pushed. In AFC operation, the power converter will not start the motor until the Start push button is pressed. The manual speed potentiometer is used to control the speed of the controller.

Off mode commands the power converter to stop the motor by either following the programmed deceleration ramp (factory setting) or by a freewheel stop.

Set the H-O-A switch to Off for fault reset.

Auto mode is for remote control. In Bypass operation, a full-voltage across-the-line start will occur when the user-supplied run contact is closed between controller terminals TB6 and TB7. In AFC operation, the power converter starts the motor when the user-supplied run contact is closed between controller terminals TB6 and TB7. Motor speed is varied by adjusting the user-supplied auto speed reference signal (4–20 mA) supplied to terminals TBS2+ (+) and TBS3 (-) in the drive controller. Refer to instruction bulletin VVDED397047US for signal scaling.

When MOD J09 is selected, the motor speed is varied by adjusting the user-supplied auto speed reference signal (0–10 V) supplied to terminals S2+ (+) and S2- (-). This input is differential to maximize noise immunity.

The **Start** push button commands the power converter to start the motor in Hand mode for local control. The manual speed potentiometer is used to control the speed of the controller.

The **Stop** push button commands the power converter to stop the motor for local control by either following the programmed deceleration ramp (factory setting) or by a freewheel stop. If the Hand-Off-Auto Switch is in Auto mode, it must be set to Off to stop the power converter. The Stop push button is only active for local control (Hand), not for remote control (Auto).

MOD N07
No Operators

Control option N07 omits control operator functions. It is for use with customer-supplied external control devices.

There are a number of ways to sequence the power converter when door mounted control devices are not present. Figures 22 and 23 show recommended sequencing diagrams for commonly used control methods.

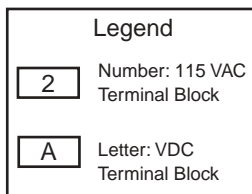

Legend to Figures 22 and 23.

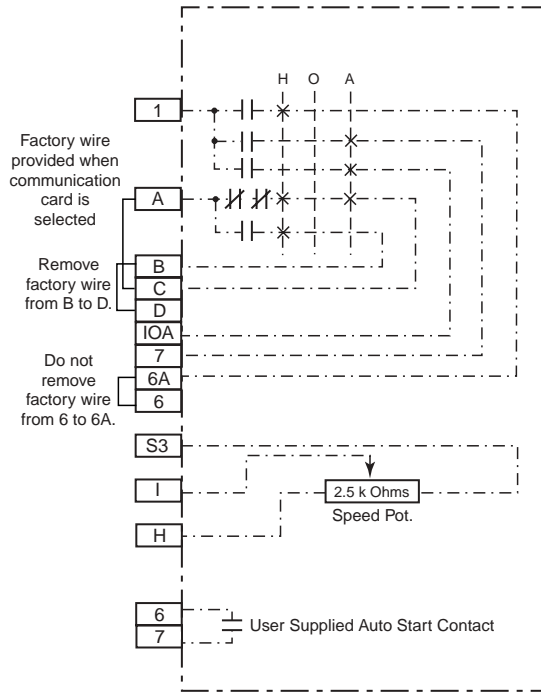

Figure 22: User-Supplied Wiring Equivalent to MOD A07

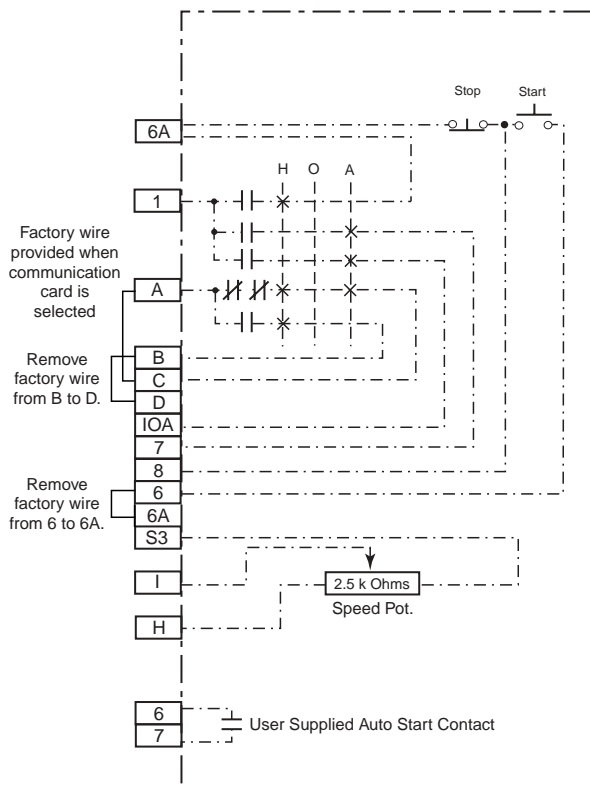

Figure 23: User-Supplied Wiring Equivalent to MOD B07

Configure Controller Functions as Follows:

MENU	CODE	ADJ.	DESCRIPTION
Sup	rFr		Display Parameter: Output Freq.
Macro	CFG	VT [1]	Variable Torque Application
CtL	tCC	2W	Two Wire Control
CtL	tC1	LEL	Two Wire Control, Maintained
I-O	NST	LI2	Freewheel Stop
I-O	RFC	LI3	Reference Switching, Auto/Manual
I-O	RST	LI4	Fault Reset
I-O	RUN	R2	Drive Running
SEt	ACC	10	Acceleration Time, In Seconds
SEt	dEC	10	Deceleration Time, In Seconds
SEt	LSP	3	Low Speed, In Hz
drC	SfT	HFI	High Switching Freq. W/Foldback
drC	SfF	8	8k Hz Switching Frequency
drC	SPC	PSM	Open circuit output testing
FLt	FLr	Yes	Catch on Fly
FLt	OPL	No	Output phase loss

When MOD H09, Analog Card, is selected:

I-O	NO	LI5	Not assigned
I-O	NO	AI3	Not Assigned
I-O	OFR	AO	Motor Freq

When Communication Card is selected:

I-O	FLO	LI4	Forced Local
-----	-----	-----	--------------

[1] After programming is complete, Macro description will read "Customized".

Directions:

- Wire according to the diagram at left for Hand-Off-Auto and Speed Potentiometer.
- Program the power converter according to the chart above.
- DO NOT remove the factory wire on the terminal block from 6 to 6A.
- REMOVE the factory wire on the terminal block from B to D.

Configure Controller Functions as Follows:

MENU	CODE	ADJ.	DESCRIPTION
Sup	rFr		Display Parameter: Output Freq.
Macro	CFG	VT [1]	Variable Torque Application
CtL	ICC	2W	Two Wire Control
CtL	IC1	LEL	Two Wire Control, Maintained
I-O	NST	LI2	Freewheel Stop
I-O	RFC	LI3	Reference Switching, Auto/Manual
I-O	RST	LI4	Fault Reset
I-O	RUN	R2	Drive Running
SEt	ACC	10	Acceleration Time, In Seconds
SEt	dEC	10	Deceleration Time, In Seconds
SEt	LSP	3	Low Speed, In Hz
drC	SfT	HFI	High Switching Freq. W/Foldback
drC	SfF	8	8k Hz Switching Frequency
drC	SPC	PSM	Open circuit output testing
FLt	FLr	Yes	Catch on Fly
FLt	OPL	No	Output phase loss

When MOD H09, Analog Card, is selected:

I-O	NO	LI5	Not assigned
I-O	NO	AI3	Not Assigned
I-O	OFR	AO	Motor Freq

When Communication Card is selected:

I-O	FLO	LI4	Forced Local
-----	-----	-----	--------------

[1] After programming is complete, Macro description will read "Customized".

Directions:

- Wire according to the diagram at left for Hand-Off-Auto, Stop-Start, and Speed Potentiometer.
- Program the power converter according to the chart above.
- REMOVE the factory wire on the terminal block from 6 to 6A.
- REMOVE the factory wire on the terminal block from B to D.

MOD A08
Pilot Light Option #1 Cluster

This pilot light option provides visual indication of protective functions and circuit status.

Power On (red): illuminates when mains power is applied to the controller. The pilot light device is rated 120 Vac.

AFC (green): illuminates to annunciate an AFC run condition. The pilot light device is rated 120 Vac.

Fault (yellow): illuminates to annunciate an AFC fault (trip) condition. When MOD B09 (line contactor) is selected, the light illuminates when the AFC-Off-Bypass selector switch is in the Off or Bypass position to indicate that the power converter is not running. The pilot light device is rated 120 Vac.

Auto (yellow): illuminates when the Hand-Off-Auto selector switch is set to Auto. The pilot light device is rated 120 Vac.

MOD B08
Pilot Light Option #2 Cluster

This pilot light option provides visual indication of protective functions and circuit status.

Power On (red): illuminates when mains power is applied to the controller. The pilot light device is rated 120 Vac.

AFC (green): illuminates to annunciate an AFC run condition. The pilot light device is rated 120 Vac.

Fault (yellow): illuminates to annunciate an AFC fault (trip) condition. When MOD B09 (line contactor) is selected, the light illuminates when the AFC-Off-Bypass selector switch is in the Off or Bypass position to indicate that the power converter is not running. The pilot light device is rated 120 Vac.

Bypass (yellow): illuminates when the motor is started across the line. The pilot light device is sequenced by the Hand-Off-Auto selector switch and is rated 120 Vac.

MOD A09
Line Reactor

This miscellaneous option includes an integrally-mounted AC line reactor factory-installed and wired between the circuit breaker disconnect means and the power converter for high true power factor and effective harmonic mitigation. It complies with IEEE 519 guidelines. For 460 Vac controllers, the line reactor is an option for 1–25 hp and standard for 30–100 hp. For 208/230 Vac controllers, the line reactor is an option for 1–10 hp and standard for 15–50 hp.

MOD B09
Line Contactor

This miscellaneous option provides a line contactor factory-wired between the circuit breaker disconnect (or line reactor when provided) and the power converter. Not available with Type 3R.

NOTE: With line contactor MOD B09, the AFC Fault light will illuminate when the AFC-Off-Bypass selector switch is in the off or Bypass position to indicate that the power converter is not running.

MOD C09
**3–15 PSI Transducer with
Digital Display Option**

This miscellaneous option provides the controller with the capability to follow a user-supplied 3–15 PSI follower signal with digital display. The module is calibrated to operate as a 4–20 mA DC follower for the power converter.

MOD D09
Omit Keypad Display

This miscellaneous option omits the keypad display. If MOD D09 is selected, a separate keypad must be ordered to program the drive controller.

MOD E09
Smoke Purge Option

This miscellaneous option provides a smoke purge operating mode controlled by a user-supplied 120 Vac signal applied between terminals TB22 and TB23. When 120 Vac power is supplied to TB22 and TB23, motor operation is transferred to bypass (if not operating in this mode already).

The jumper between terminals TB2 and TB3 must be removed before using this mode.

MOD G09
22 KAIC UL Coordinated Rating

This miscellaneous option provides a fully-coordinated 22 KAIC rating marked on enclosure nameplate (short-circuit coordination to UL508C power conversion equipment and NEMA ICS 7.1).

MOD H09
Analog Card

This miscellaneous option provides a 0-20 mA analog output for customer use. It includes a plug-in analog card VW3A58201U with AO and COM wired to the customer terminal block located on the power converter. The output is factory-programmed for motor frequency. Refer to instruction bulletin VVDED397046US for other programming choices. Selectable x-y range with keypad display.

MOD J09
0-10 V Auto Speed Reference

This miscellaneous option provides a controller interface for a 0-10 V user-supplied auto speed reference signal into the AI2 input, terminals G1 (S2+) and G2 (S2-) on terminal block TB2, using a 0-10 V/4-20 mA converter with Z=40 kΩ. Not available with MOD C09 (page 71).

MOD K09
cUL Listing

This miscellaneous option provides Canadian cUL certification when required by local code requirements.

MOD L09
LONWORKS

This miscellaneous option provides a factory installed LONWORKS to MODBUS Module VW3A58312PU, plug-in MODBUS card VW3A58303U. Serial communication is factory installed for register monitoring. Refer to page 62 for a description of forced local operation.

MOD M09
MODBUS

This miscellaneous option provides a factory installed plug-in MODBUS card VW3A58303U and separate user termination to D-shell interface device. Serial communication is factory installed for register monitoring.

Interface device suited for incoming and outgoing bus cable or end of the line termination. Two cable entries to two termination blocks for pins 2, 3, 4, 5, 7, and 9. Refer to page 62 for a description of forced local operation.

MOD P09
METASYS N2

This miscellaneous option provides a factory installed plug-in METASYS N2 card VW3A58354U and separate user termination to D-shell interface device. Serial communication is factory installed for register monitoring.

Interface device suited for incoming and outgoing bus cable or end of the line termination. Two cable entries to two termination blocks for pins 2, 3, 4, 5, 7, and 9. Refer to page 62 for a description of forced local operation.

**CHAPTER 4:
TROUBLESHOOTING AND
MAINTENANCE**

INTRODUCTION	74
EXTERNAL SIGNS OF DAMAGE	74
PREVENTIVE MAINTENANCE	74
TROUBLESHOOTING FLOW DIAGRAMS	74
Motor Will Not Start	75
Will Not Accelerate The Load	76
Accelerates The Load Too Slowly	77
Excessive Motor Temperature	77
FIELD REPLACEMENT OF THE POWER CONVERTER	78
Removing the Power Converter Assembly	78
Installing the Power Converter Assembly	81
FIELD REPLACEMENT OF HEATSINK FAN ASSEMBLY	83
Removing the Heatsink Fan Assembly	83
Installing the Heatsink Fan Assembly	85
FIELD REPLACEMENT OF THE STIRRING FANS	85
FIELD REPLACEMENT OF THE VENTILATION FAN ON TYPE 3R	85
FIELD REPLACEMENT OF THE SPACE HEATER ON TYPE 3R	85
FIELD MAINTENANCE AND REPLACEMENT OF HOOD FILTERS ON TYPE 3R	85
TECHNICAL SUPPORT	86

INTRODUCTION

A number of diagnostic and status codes are included on the power converter. The keypad display provides visual indication of controller operating and protective circuit functions and indicator lights to assist in maintenance and troubleshooting. If the controller trips while operating, the codes must be viewed before power is removed because removing power resets the fault code.

NOTE: For controllers equipped with optional line contactor (MOD B09) the power is removed via the line contactor upon power converter fault trips.

EXTERNAL SIGNS OF DAMAGE

The following are examples of external signs of damage:

- Cracked, charred, or damaged covers or enclosure parts
- Damage to the keypad such as scratches, punctures, burn marks, chemical burns, or moisture in the screen
- Oil or electrolyte on the bottom of the drive controller which might have leaked from the capacitors inside
- Excessive surface temperatures of enclosures and conduits
- Damage to power or control conductors
- Unusual noise or odors from any of the equipment
- Abnormal temperature, humidity, or vibration

If any of the above signs are found while the equipment is powered up, immediately inform operating personnel and assess the risk of leaving the drive system powered up. Before removing power from the equipment, always consult with the operating personnel responsible for the machinery and process.

If troubleshooting indicates the necessity of component replacement, refer to "Field Replacement of The Power Converter" on page 78.

PREVENTIVE MAINTENANCE

Type 1 controllers in the 1–7.5 hp range at 460 V and 1–5 hp range at 208/230 V use convection cooling. All Type 12K controllers and Type 1 controllers for 10 hp and above at 460 V and 7.5 hp and above at 208/230 V use forced air cooling. All Type 3R controllers use ventilation cooling. Inspect the interior fans (if used) and exterior fans of the controller for blockage and impeded rotation. To prevent overheating and to allow proper air flow, maintain clearances shown on the enclosure outline drawings in this instruction bulletin.

To maintain the environmental rating of Type 12K or 3R enclosures, periodically inspect the enclosure gaskets for damage.

The keypad display is an integral part of the enclosure and must be installed on the door to maintain the environmental integrity of a Type 12K enclosure. It can be omitted when MOD D09 is selected and in that case a closing plate must be installed to maintain the Type 12K environmental rating.

TROUBLESHOOTING FLOW DIAGRAMS

The flow charts on pages 75 to 77 contain troubleshooting procedures for the following conditions:

- Motor will not start (page 75)
- Will not accelerate the load (page 76)
- Accelerates the load too slowly (page 77)
- Excessive motor temperature (page 77)

Motor Will Not Start

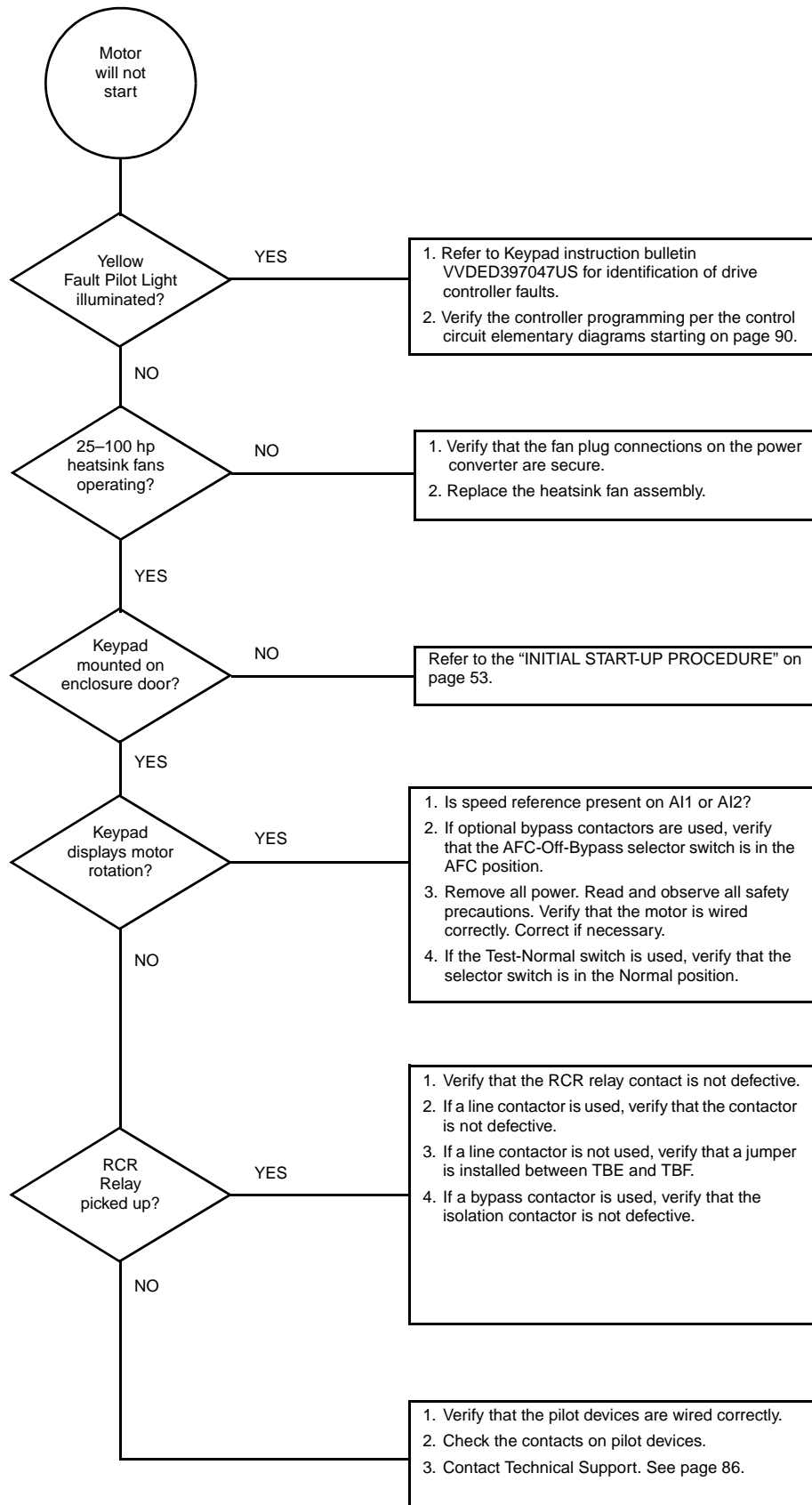

**Will Not Accelerate
The Load**

NOTE: You must have a keypad for this procedure and the keypad must be in "Var. State". To set the keypad, press the ESC key, scroll up with the arrow to 1—Display menu (SUP), and press the ENT key. Then scroll up to Var. State (RDY) and press ENT.

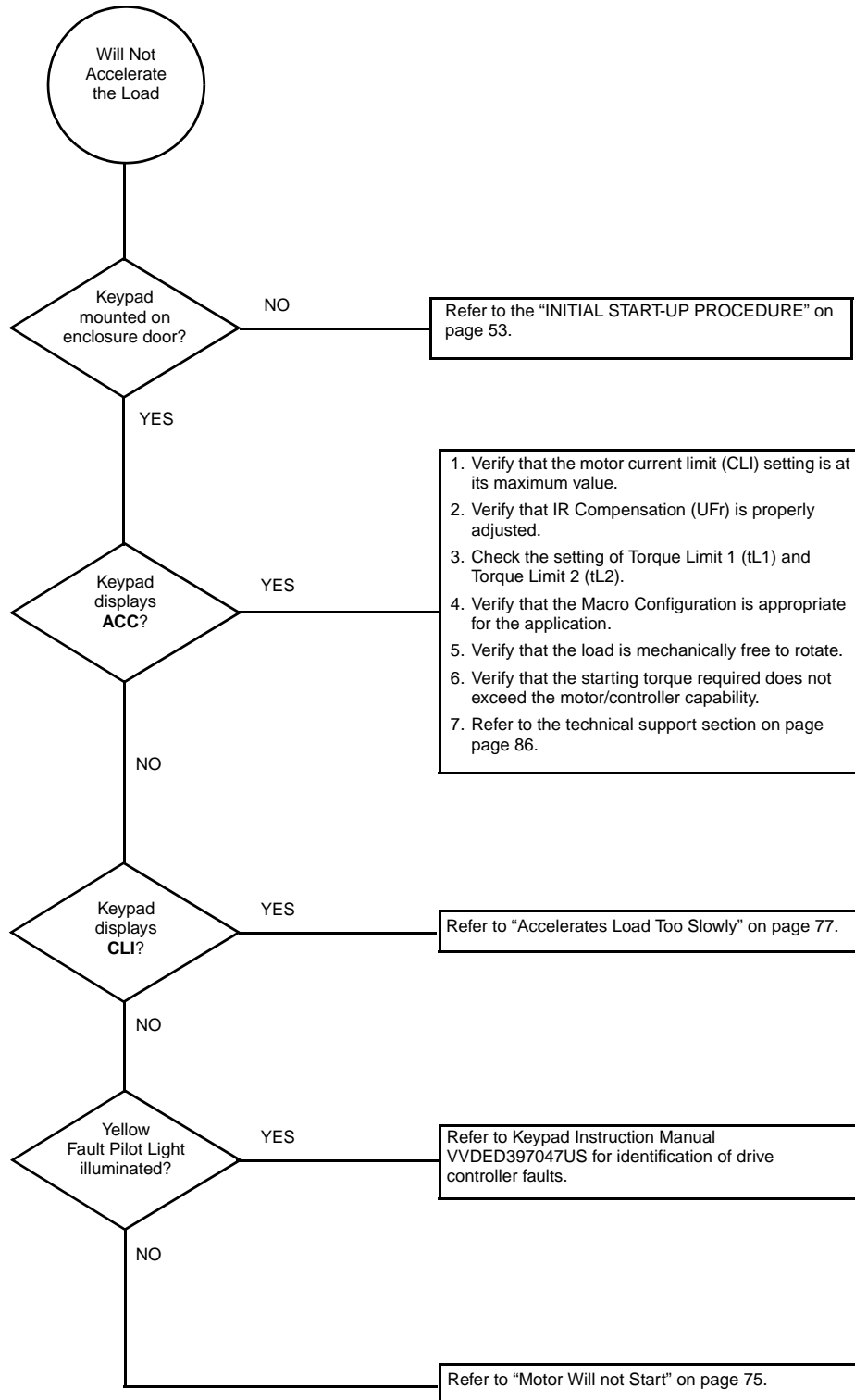

Accelerates The Load Too Slowly

NOTE: You must have a keypad for this procedure and the keypad must be in "Var. State". To set the keypad, press the ESC key, scroll up with the arrow to 1—Display menu (SUP), and press the ENT key. Then scroll up to Var. State (RDY) and press ENT.

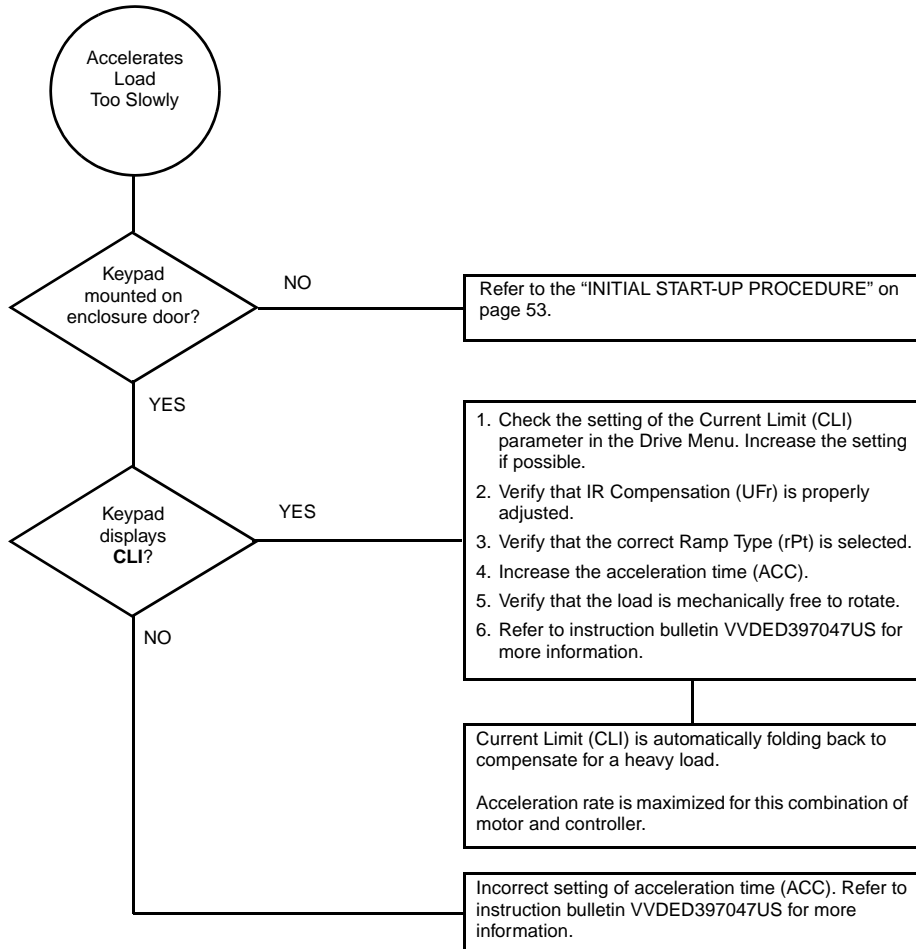

Excessive Motor Temperature

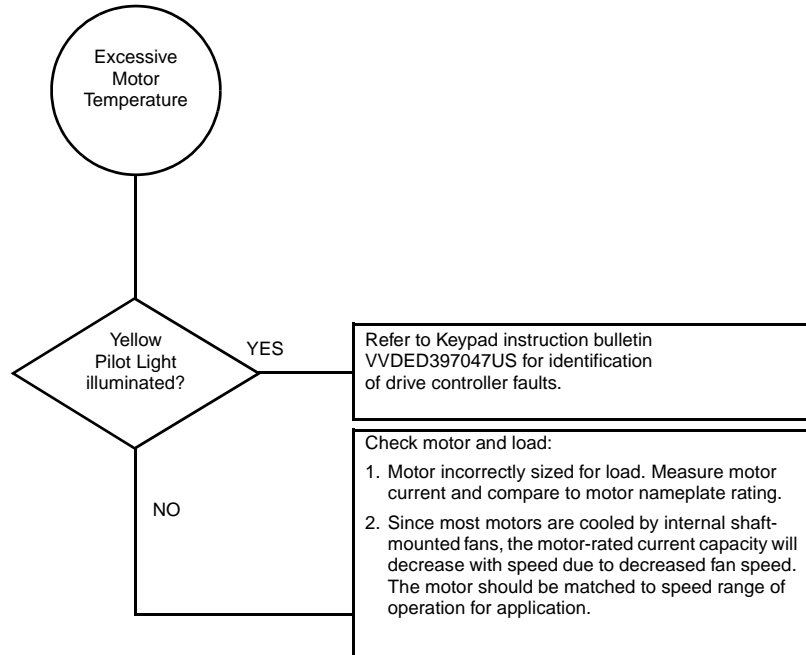

**FIELD REPLACEMENT OF
 THE POWER CONVERTER**

If the power converter becomes inoperable in the ECONOFLEX controllers, it must be replaced. Refer to Table 34 for power converter weights.

Table 34: Power Converter Weights

HP		Weight	
460 V	208/230 V	lb	kg
1–7.5	1–5	20	9.1
10–25	7.5–10	30	13.6
30–50	15–25	70	31.7
60–100	30–50	122	55.3

Observe the lockout/tagout procedures as identified in OSHA Standard 29 CFR, Subpart J covering:

- 1910.147: The control of hazardous energy (lockout/tagout).
- 1910.147: App A, Typical minimal lockout procedures.

**Removing the Power Converter
 Assembly**

⚠ DANGER
<p>HAZARDOUS VOLTAGE</p> <ul style="list-style-type: none"> • Disconnect all power. • Place a “Do Not Turn On” label on the drive controller disconnect. • Lock the disconnect in open position. • Read and understand the bus voltage measurement procedure on page 40 before performing procedure. Measurement of bus capacitor voltage must be performed by qualified personnel. • DO NOT short across DC bus capacitors or touch unshielded components or terminal strip screw connectors with voltage present. • Many parts in the drive controller, including printed wiring boards, operate at line voltage. DO NOT TOUCH. Use only electrically insulated tools. <p>Failure to follow these instructions will result in death or serious injury.</p>

⚠ CAUTION
<p>ELECTROSTATIC DISCHARGE</p> <p>Do not subject this device to electrostatic discharge. This controller contains electronic components that are very susceptible to damage from electrostatic discharge.</p> <p>Failure to follow this instruction can result in injury or equipment damage.</p>

To replace the power converter, follow these steps:

1. Open the door of the drive controller. Refer to step 1 on page 30.
2. Measure the DC bus voltage as described on page 40 of this instruction bulletin.
3. Disconnect all power and control wiring from the power converter assembly. Identify each wire for ease of re-assembling the new power converter. See Figure 24.



Disconnect:

- The keypad cable
- Two MAC board plugs
- Six power wires
- The ground
- The shield
- The heatsink fan connections on 30–100 hp (460 V) or 15–50 hp (208/230 V)
- The analog card (if used)
- The Serial communication card (if used)
- The customer terminal block on the power converter (if used)
- The 3–15 PSI transducer (if used)
- The 0–10 V signal converter (if used)

Figure 24: Remove All Power and Control Wiring

4. For the 60-100 hp 460 V and 30-50 hp 208/230 V, it may be easier to remove the heatsink fan assembly before removing the power converter. Refer to the “FIELD REPLACEMENT OF HEATSINK FAN ASSEMBLY” on page 83 for directions.
5. Remove the outside hex-slot picture frame screws that secure the power converter to the enclosure back pan. Refer to Figures 14–17 starting on page 44 for screw locations. Refer to Table 35 for the number of screws on your controller. Keep the screws for the new power converter. See Figure 25.

Table 35: Number of Picture Frame Screws

HP		No. of Screws
460 V	208/230 V	
1–7.5	1–5	12
10–25	7.5–10	14
30–50	15–25	18
60–100	30–50	22



Figure 25: Remove Picture Frame Screws

6. Remove the power converter assembly from the enclosure. See Figure 26.



Figure 26: Remove Power Converter

7. Remove four 1/2" (33 mm) rubber sealing plugs from the corners of the Type 12K and 3R power converters (30–100 hp at 460 V and 15–50 hp at 208/230 V). Keep the plugs for the new power converter.

Installing the Power Converter Assembly

To install the new power converter, follow these steps:

1. Install the four 1/2" (13mm) rubber sealing plugs in the corners of the Type 12K and 3R power converters (30–100 hp at 460 V and 15–50 hp at 208/230 V). The plugs maintain the Type 12K enclosure rating.
2. Install the new power converter assembly in the enclosure. See Figures 26 and 27.



1–25 hp @ 460 V and
 1–10 hp @ 208/230 V
 Typical



30–100 hp @ 460 V and
 15–50 hp @ 208/230 V
 Typical

Figure 27: Install New Power Converter

3. Secure the power converter picture frame to the enclosure back pan with the picture frame screws from the removed power converter. Torque the screws to 15 ± 2 lb-in. (1.7 ± 0.2 N•m) See Figure 25 on page 80.
4. Install all power and control wiring to the power converter assembly terminal blocks. Install all other removed equipment. See Figure 24 on page 79. Tighten the hardware to the torque values given in the table below. Check all wiring connections for correct terminations and check the power wiring for grounds with an ohmmeter.

Terminal	Torque		
	lb-in	N•m	
Ground (heatsink)	15	1.7	
J2 Power Terminal Strip:			
460 V	58EC•4V_ to 58EG•4V_ (1–7.5 hp)	7.5	0.85
	58EH•4V_ to 58EL•4V_ (10–25 hp)	20	2.3
	58EM•4V_ to 58EP•4V_ (30–50 hp)	88	9.9
	58EQ•4V_ to 58ES•4V_ (60–100 hp)	170	19.2
230 V	58EC•3V_ to 58EF•3V_ (1–5 hp)	7.5	0.85
	58EG•3V_ to 58EH•3V_ (7.5–10 hp)	20	2.3
	58EJ•3V_ to 58EL•3V_ (15–25 hp)	88	9.9
	58EM•3V_ to 58EP•3V_ (30–50 hp)	170	19.2
208 V	58EC•2V_ to 58EF•2V_ (1–5 hp)	7.5	0.85
	58EG•2V_ to 58EH•2V_ (7.5–10 hp)	20	2.3
	58EJ•2V_ to 58EL•2V_ (15–25 hp)	88	9.9
	58EM•2V_ to 58EP•2V_ (30–50 hp)	170	19.2
Ⓢ Shield Connection (power converter)	3.5	0.34	
Analog output customer terminal block	22	2.5	
Din rail mounting screws (if used)			

5. Shut the enclosure door, secure the door with door fasteners, and close the circuit breaker disconnect. See Figure 28.



Figure 28: Close and Secure the Door

⚠ DANGER

ELECTRIC SHOCK, BURN, OR EXPLOSION

- This equipment must be installed and serviced only by qualified personnel.
- Qualified personnel performing diagnostics or troubleshooting requiring electrical conductors to be energized, must comply with NFPA 70 E - Standard for Electrical Safety Requirements for Employee Workplaces and OSHA Standards – 29 CFR Part 1910 Subpart S Electrical.

Failure to follow this instruction will result in death or serious injury.

6. Program the drive controller according to the control circuit elementary diagrams in chapter 5. Follow the initial start-up procedure on page 53. The drive controller is now ready to operate.

FIELD REPLACEMENT OF HEATSINK FAN ASSEMBLY

Removing the Heatsink Fan Assembly

NOTE: For the equipment required for this procedure, refer to the recommended spare parts list for the heatsink fan assembly part number.

If a heatsink fan becomes inoperable in the 10–100 hp 460 V or 7.5–50 hp 208/230 V controllers, the fan assembly must be replaced. Observe the lockout / tagout procedures as identified in OSHA Standard 29 CFR, Subpart J covering:

- 1910.147: The control of hazardous energy (lockout/tagout).
- 1910.147: App A, Typical minimal lockout procedures.

⚠ DANGER

HAZARDOUS VOLTAGE

- Disconnect all power.
- Place a “Do Not Turn On” label on the drive controller disconnect.
- Lock the disconnect in the open position.
- Read and understand the bus voltage measurement procedure on page 40 before performing procedure. Measurement of bus capacitor voltage must be performed by qualified personnel.
- DO NOT short across DC bus capacitors or touch unshielded components or terminal strip screw connectors with voltage present.
- Many parts in the drive controller, including printed wiring boards, operate at line voltage. DO NOT TOUCH. Use only electrically insulated tools.

Failure to follow these instructions will result in death or serious injury.

⚠ CAUTION

ELECTROSTATIC DISCHARGE

Do not subject this device to electrostatic discharge. This controller contains electronic components that are very susceptible to damage from electrostatic discharge.

Failure to follow this instruction can result in injury or equipment damage.

To replace the heatsink fan assembly, follow these steps:

1. Open the door of the drive controller. Refer to Step 1 on page 30.
2. Measure the DC bus voltage as described on page 40.
3. Locate the heatsink fan assembly above or below the power converter.

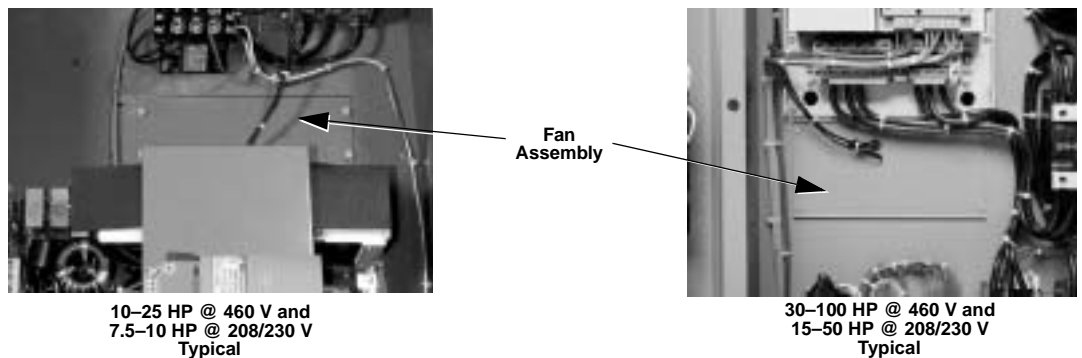

Figure 29: Heatsink Fan Assembly Location

- For 10–25 hp controllers, disconnect the four fan wires connected to the control transformer. The 1/4" (6.35 mm) fast-on is connected to XF on the transformer fuse. The spade lug is connected to the X2 terminal on the transformer. See Figure 30. For 30–100 hp 460 V controllers and 20–50 hp 208/230 V controllers, disconnect the heatsink fan wire connectors.

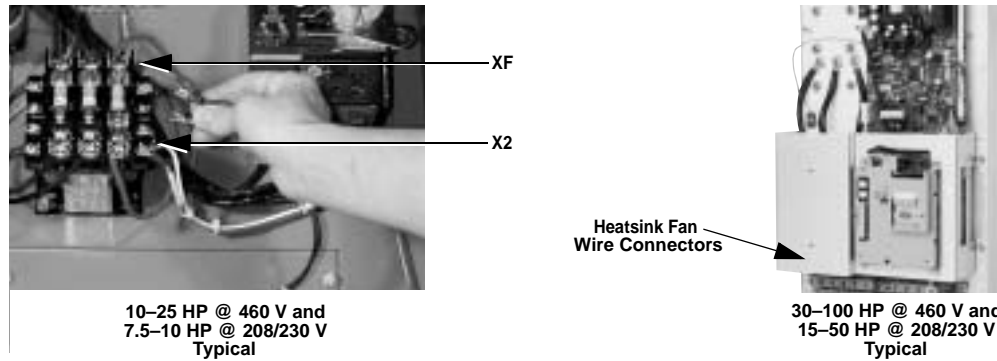

Figure 30: Remove the Fan Wiring

- Remove the four screws securing the heatsink fan assembly. Keep the four screws. See Figure 29.
- Remove the heatsink fan assembly from the enclosure. For the 10–25 hp 460 V controllers and 7.5–10 hp 208/230 V controllers, lift the assembly up toward the top of the enclosure then pull it out. For 30–100 hp 460 V controllers and 15–50 hp 208/230 V controllers, pull the assembly down toward the bottom of the enclosure then pull it out. See Figure 31.



Figure 31: Remove the Heatsink Fan Assembly

Installing the Heatsink Fan Assembly

To install the new heatsink fan assembly, follow these steps:

1. Install the heatsink fan assembly. Secure the assembly with the four screws saved from step 5 above. Torque the screws to 15 lb-in (1.7 N•m). See Figure 29 and Figure 31.
2. For 10–25 hp 460 V controllers and 7.5–10 hp 208/230 V controllers, terminate the wire with the spade lug to X2 on the transformer. Torque the screw to 20–25 lb-in (2.3–2.8 N•m). Terminate the fast-on to XF on the transformer fuse. See Figure 30. Check all wiring connections for correct terminations. For 30–100 hp controllers at 460 V and 15–50 hp controllers at 208/230 V, plug the DC fan connectors to the power converter.
3. Shut the enclosure door and secure it with door fasteners. Then close the circuit breaker disconnect.
4. The drive controller is now ready to operate.

NOTE: For 30–100 hp controllers at 460 V and 15–50 hp controllers at 208/230 V, when the heatsink fan connectors are not properly attached to the power converter, the power converter may cycle on and off or not function. If either of these occurs, check the heatsink fan connections.

FIELD REPLACEMENT OF THE STIRRING FANS

If a stirring fan inside the enclosure becomes inoperable in the ECONOFLEX controllers, the fan must be replaced.

Before removing the inoperable stirring fan, mark airflow direction to ensure proper installation of the replacement fan.

FIELD REPLACEMENT OF THE VENTILATION FAN ON TYPE 3R

If a Type 3R ventilation fan becomes inoperable in the ECONOFLEX controllers, the fan must be replaced.

Before removing the inoperable ventilation fan, mark airflow direction to ensure proper installation of the replacement fan.

FIELD REPLACEMENT OF THE SPACE HEATER ON TYPE 3R

If a Type 3R space heater becomes inoperable in the ECONOFLEX controllers, the space heater must be replaced. The thermostat is factory set at 60 °F (30 °C).

FIELD MAINTENANCE AND REPLACEMENT OF HOOD FILTERS ON TYPE 3R

The Type 3R ECONOFLEX filter material located on the bottom of the side hoods is washable. Remove, wash and install as required to maintain airflow.

The fan mounting bracket assembly must be removed first. This assembly is fastened to the hood by four screws. Then the fan can be removed from the bracket assembly by removing two mounting screws.

TECHNICAL SUPPORT

When troubleshooting the Class 8839 ECONOFLEX drive controller, discuss with operating personnel the symptoms of the reported problems. Ask them to describe the problem, when they first observed the problem, and where the problem was seen. Observe directly the drive system and process. Record the drive controller, motor and peripheral equipment nameplate data on the Class 8839 ECONOFLEX Trouble-shooting Sheet, a sample of which is shown on the next page. (You may copy this form as needed.)

For more information, call, fax, or write:

Square D AC Drives Technical Support Group
8001 Highway 64 East
Knightdale, NC 27545-9023

Telephone: 919-266-8600
Fax Line: 919-217-6508
E-mail: drivepsg@squared.com

Class 8839 ECONOFLEX Troubleshooting Sheet

WHEN REQUESTING AFTER-SALES SERVICE, IT IS IMPORTANT TO DISCLOSE ALL CONDITIONS UNDER WHICH THE SQUARE D EQUIPMENT CURRENTLY OPERATES. THIS WILL HELP IN DIAGNOSING THE SYSTEM QUICKLY. CALL SQUARE D AC DRIVES TECHNICAL SUPPORT AT 919-266-8600

DATE: _____
 CONTACT NAME: _____
 COMPANY: _____
 ADDRESS: _____
 CITY: _____
 STATE: _____
 PHONE: _____
 FAX: _____

DRIVE CONTROLLER CONFIGURATION

CATALOG NUMBER: CLASS **8839** TYPE **58E** _____ MODS: _____
 APPLICATION/EQUIPMENT DESIGNATION: _____

MOTOR NAMEPLATE DATA

HORSEPOWER: _____ VOLTAGE (3 PHASE): _____ FREQUENCY: _____ POLES: _____ FLA: _____
 SERVICE FACTOR: _____ MOTOR INSTALLATION: NEW OR EXISTING
 MOTOR CABLE TYPE: _____ LENGTH (IN FEET): _____
 IS MOTOR DESIGNED TO COMPLY NEMA MG-1 PART 31 GUIDELINES? YES NO

POWER SOURCE AND ENVIRONMENT

VOLTAGE BETWEEN L1 AND L2: _____ VOLTAGE BETWEEN L2 AND L3: _____ VOLTAGE BETWEEN L3 AND L1: _____
 SERVICE TRANSFORMER RATING: _____ KVA, _____ % Z FREQUENCY: 60HZ OR 50 HZ
 AMBIENT TEMPERATURES: _____ MIN °C (°F) _____ MAX °C (°F) HUMIDITY: _____
 ALTITUDE IF GREATER THAN 3300 FEET ABOVE SEA LEVEL, SPECIFY: _____ FT

DRIVE FAULT CODES

REFER TO BULLETIN NO. VVDED397047US, PAGES 58 THROUGH 60 FOR POSSIBLE CAUSES & CORRECTIVE ACTION

<input type="checkbox"/> PHF (INPUT PHASE LOSS)	<input type="checkbox"/> USF (UNDERVOLTAGE)	<input type="checkbox"/> OSF (OVERVOLTAGE)	<input type="checkbox"/> OHF (DRIVE OVERHEATING)
<input type="checkbox"/> OLF (MOTOR OVERLOAD)	<input type="checkbox"/> ObF (OVERBRAKING)	<input type="checkbox"/> OPF (MOTOR PHASE LOSS)	<input type="checkbox"/> LFF (LOSS OF 4-20 MA)
<input type="checkbox"/> OCF (OVERCURRENT)	<input type="checkbox"/> SCF (MOTOR SHORT CIRCUIT)	<input type="checkbox"/> CrF (PRECHARGE FAULT)	<input type="checkbox"/> SLF (LOSS OF RS485)
<input type="checkbox"/> OtF (MOTOR OVERHEATING)	<input type="checkbox"/> tSF (THERMAL SENSOR FAULT)	<input type="checkbox"/> EEF (EEPROM FAULT)	<input type="checkbox"/> INF (INTERNAL FAULT)
<input type="checkbox"/> EPF (EXTERNAL FAULT)	<input type="checkbox"/> SPF (SPEED FEEDBACK FAULT)	<input type="checkbox"/> ANF (RAMP NOT FOLLOWED)	<input type="checkbox"/> SOF (OVERSPEED)
<input type="checkbox"/> CNF (COMM NETWORK FAULT)	<input type="checkbox"/> ILF (INTERNAL COMM FAULT)	<input type="checkbox"/> CFF (PWR, OPTION, OPT REMOVED, EEP CKS, ETC.)	<input type="checkbox"/> SLF (CONFIGURATION FAULT)

DETAILED DESCRIPTION OF PROBLEM:

**CHAPTER 5:
POWER AND CONTROL
CIRCUIT ELEMENTARY
DIAGRAMS**

POWER CIRCUIT W (WITHOUT BYPASS)	90
Hand-Off-Auto and Speed Potentiometer	90
Hand-Off-Auto, Start-Stop, and Speed Potentiometer	91
Start-Stop and Speed Potentiometer	92
POWER CIRCUIT Y (WITHOUT BYPASS)	93
Hand-Off-Auto and Speed Potentiometer	93
Hand-Off-Auto, Start-Stop, and Speed Potentiometer	94

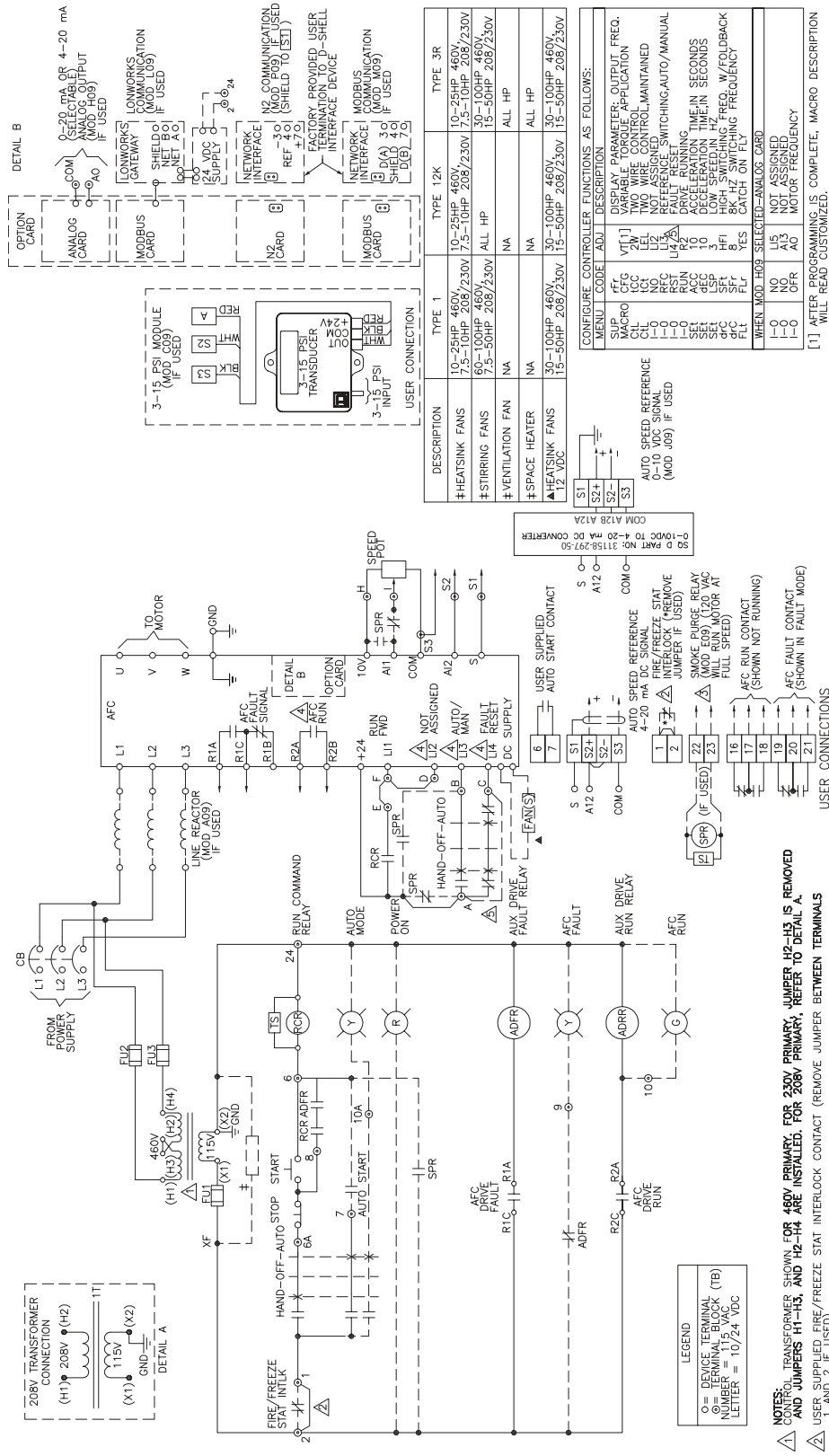

Figure 33: Power Circuit W (Without Bypass): Hand-Off-Auto, Start-Stop, and Speed Potentiometer (Drawing No. 8839-450-2, Feb. 2002)

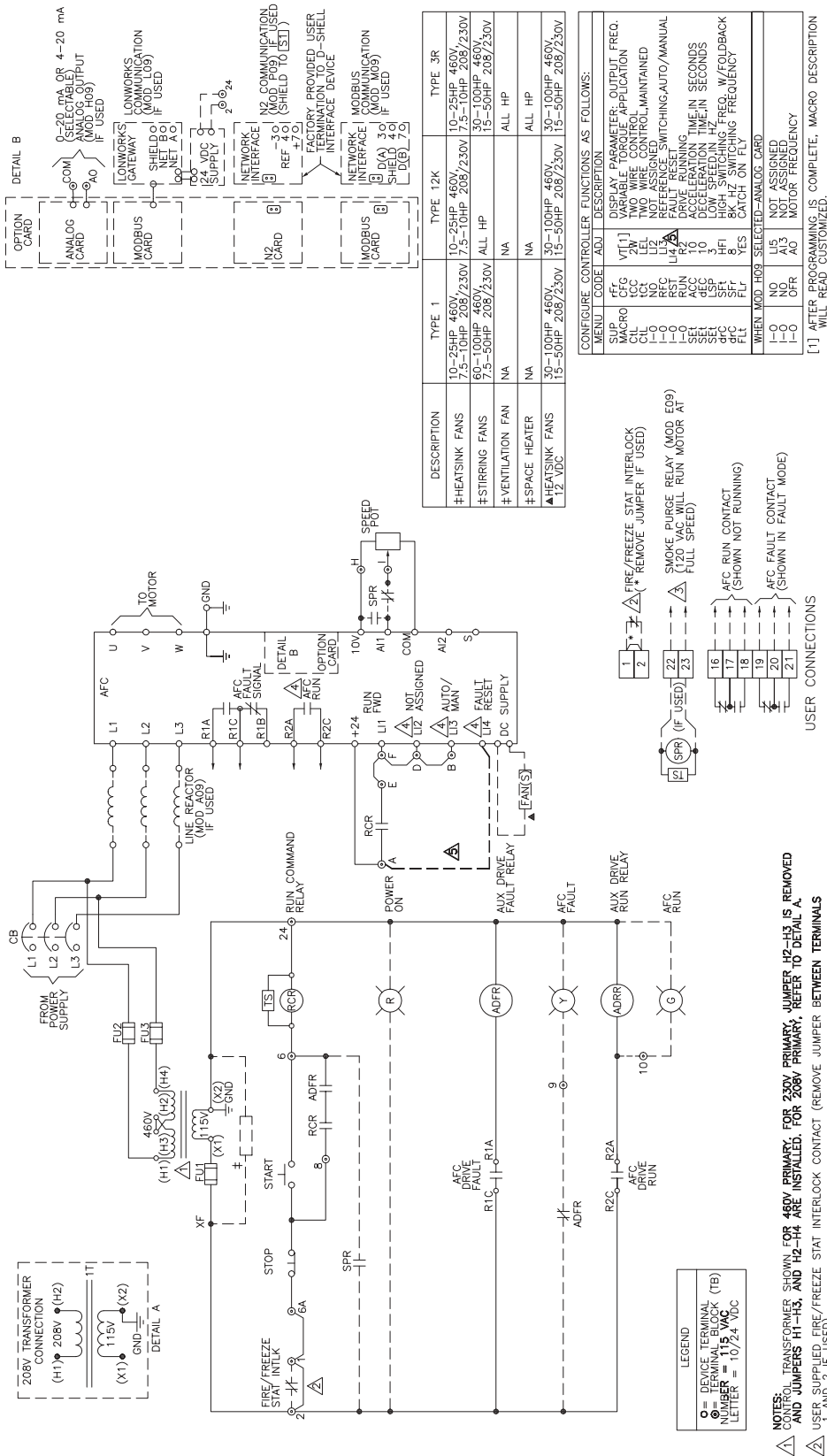

Figure 34: Power Circuit W (Without Bypass): Start-Stop and Speed Potentiometer (Drawing No. 8839-450-3, Feb. 2002)

APPENDIX: RECOMMENDED SPARE PARTS

Table 36: 460 V Recommended Spare Parts

Description	Qty	1-7.5 HP	Qty	10-25 HP	Qty	30-50 HP	Qty	60-100 HP
Power Converter	1	FLEX58KU18N4 (1 hp) FLEX58KU29N4 (2 hp) FLEX58KU41N4 (3 hp) FLEX58KU54N4 (5 hp) FLEX58KU72N4 (7.5 hp)	1	FLEX58KU90N4 (10 hp) FLEX58KD12N4 (15 hp) FLEX58KD16N4 (20 hp) FLEX58KD23N4 (25 hp)	1	FLEX58KD28N4 (30 hp) FLEX58KD33N4 (40 hp) FLEX58KD46N4 (50 hp)	1	FLEX58KD54N4 (60 hp) FLEX58KD64N4 (75 hp) FLEX58KD79N4 (100 hp)
Keypad Display	1	VW3A58101U	1	VW3A58101U	1	VW3A58101U	1	VW3A58101U
Control Fuses Primary	2	25430-20050 (Type 1 and 12K) 25430-20161 (Type 3R)	2	25430-20050 (Type 1 and 12K) 25430-20161 (Type 3R)	2	25430-20050 (Type 1 and 12K) 25430-20161 (Type 3R)	2	25430-20050 (Type 1 and 12K) 25430-20161 (Type 3R)
Control Fuses Secondary	1	25430-20080 (Type 1 and 12K) 25430-20281 (Type 3R)	1	25430-20080 (Type 1 and 12K) 25430-20281 (Type 3R)	1	25430-20080 (Type 1 and 12K) 25430-20281 (Type 3R)	1	25430-20080 (Type 1 and 12K) 25430-20281 (Type 3R)
Pilot Light Red	1	LED 25501-00003 Head ZB5AV04	1	LED 25501-00003 Head ZB5AV04	1	LED 25501-00003 Head ZB5AV04	1	LED 25501-00003 Head ZB5AV04
Pilot Light Yellow	1	LED 25501-00004 Head ZB5AV05	1	LED 25501-00004 Head ZB5AV05	1	LED 25501-00004 Head ZB5AV05	1	LED 25501-00004 Head ZB5AV05
Pilot Light Green	1	LED 25501-00005 Head ZB5AV03	1	LED 25501-00005 Head ZB5AV03	1	LED 25501-00005 Head ZB5AV03	1	LED 25501-00005 Head ZB5AV03
Pilot Light Mounting Collar w/ Light Module	1	ZB5AV6	1	ZB5AV6	1	ZB5AV6	1	ZB5AV6
Analog I/O Board [1]	1	VW3A58201U	1	VW3A58201U	1	VW3A58201U	1	VW3A58201U
LONWORKS TO MODBUS Module [2]	1	VW3A58312PU	1	VW3A58312PU	1	VW3A58312PU	1	VW3A58312PU
MODBUS [1] [2]	1	VW3A58303U	1	VW3A58303U	1	VW3A58303U	1	VW3A58303U
METASYS N2 [1]	1	VW3A58354U	1	VW3A58354U	1	VW3A58354U	1	VW3A58354U
24 Vdc supply	1	8440PS24	1	8440PS24	1	8440PS24	1	8440PS24
3R Hood Filter Material	2	31158-441-01	2	31158-441-01	2	31158-441-01	2	31158-441-01
3R Space Heater	1	29904-00027	1	29904-00027	1	29904-00027	1	29904-00027
3R Ventilation Fan	1	26016-00006	1	26016-00006	1	26016-00006	1	26016-00006
User termination to D-shell interface device	1	25410-00084	1	25410-00084	1	25410-00084	1	25410-00084
0–10 V Converter Kit [3]	1	31158-297-50	1	31158-297-50	1	31158-297-50	1	31158-297-50
Stirring Fan Assembly	1	N/A (Type 1 and 3R) 31158-065-50 (Type 12K)	1 2	31158-065-50: 10–20 hp Type 12K 25 hp Type 1 and 12K N/A (10–20 hp Type 1) N/A (Type 3R)	1	N/A (Type 1) 31158-065-50 (Type 12K and 3R)	2	31158-065-50 (Type 1, 12K, and 3R)
Heatsink Fan Assembly	1	N/A	1	31158-296-50 (Type 1, 12K, and 3R)	1	31158-296-51 (Type 1, 12K, and 3R)	1	31158-296-52 (Type 1, 12K, and 3R)

[1] Field replacement of the option board will reset the power converter to the Material Handling Macro. The user must configure the controller per the elementary diagram with or without bypass starting on page 90.

[2] Refer to notes 1 and 2 on page 24.

[3] 0–10 V converter kit is for use with ALTIVAR 58 products only. Kit contains board part no. 31164-099-50.

Table 37: 208/230 V Recommended Spare Parts

Description	Qty	1-5 HP	Qty	7.5-10 HP	Qty	15-25 HP	Qty	30-50 HP
Power Converter	1	FLEX58U29M2 (1-2 hp) FLEX58U41M2 (3 hp) FLEX58U72M2 (5 hp)	1	FLEX58U90M2 (7.5 hp) FLEX58D12M2 (10 hp)	1	FLEX58D16M2 (15-20 hp) FLEX58D23M2 (25 hp)	1	FLEX58D28M2 (30 hp) FLEX58D33M2 (40 hp) FLEX58D46M2 (50 hp)
Keypad Display	1	VW3A58101U	1	VW3A58101U	1	VW3A58101U	1	VW3A58101U
Control Fuses Primary	2	25430-20126 (Type 1 and 12K) 25430-20500 (Type 3R 208 V) 25430-20400 (Type 3R 230 V)	2	25430-20126 (Type 1 and 12K) 25430-20500 (Type 3R 208 V) 25430-20400 (Type 3R 230 V)	2	25430-20126 (Type 1 and 12K) 25430-20500 (Type 3R 208 V) 25430-20400 (Type 3R 230 V)	2	25430-20126 (Type 1 and 12K) 25430-20500 (Type 3R 208 V) 25430-20400 (Type 3R 230 V)
Control Fuses Secondary	1	25430-20080 (Type 1 and 12K) 25430-20281 (Type 3R)	1	25430-20080 (Type 1 and 12K) 25430-20281 (Type 3R)	1	25430-20080 (Type 1 and 12K) 25430-20281 (Type 3R)	1	25430-20080 (Type 1 and 12K) 25430-20281 (Type 3R)
Pilot Light Red	1	LED 25501-00003 Head ZB5AV04	1	LED 25501-00003 Head ZB5AV04	1	LED 25501-00003 Head ZB5AV04	1	LED 25501-00003 Head ZB5AV04
Pilot Light Yellow	1	LED 25501-00004 Head ZB5AV05	1	LED 25501-00004 Head ZB5AV05	1	LED 25501-00004 Head ZB5AV05	1	LED 25501-00004 Head ZB5AV05
Pilot Light Green	1	LED 25501-00005 Head ZB5AV03	1	LED 25501-00005 Head ZB5AV03	1	LED 25501-00005 Head ZB5AV03	1	LED 25501-00005 Head ZB5AV03
Pilot Light Mounting Collar w/ Light Module	1	ZB5AV6	1	ZB5AV6	1	ZB5AV6	1	ZB5AV6
Analog I/O Board [1]	1	VW3A58201U	1	VW3A58201U	1	VW3A58201U	1	VW3A58201U
LONWORKS TO MODBUS Module [2]	1	VW3A58312PU	1	VW3A58312PU	1	VW3A58312PU	1	VW3A58312PU
MODBUS [1] [2]	1	VW3A58303U	1	VW3A58303U	1	VW3A58303U	1	VW3A58303U
METASYS N2 [1]	1	VW3A58354U	1	VW3A58354U	1	VW3A58354U	1	VW3A58354U
24 Vdc supply	1	8440PS24	1	8440PS24	1	8440PS24	1	8440PS24
3R Hood Filter Material	2	31158-441-01	2	31158-441-01	2	31158-441-01	2	31158-441-01
3R Space Heater	1	29904-00027	1	29904-00027	1	29904-00027	1	29904-00027
3R Ventilation Fan	1	26016-00006	1	26016-00006	1	26016-00006	1	26016-00006
User termination to D-shell interface device	1	25410-00084	1	25410-00084	1	25410-00084	1	25410-00084
0-10 V Converter Kit [3]	1	31158-297-50	1	31158-297-50	1	31158-297-50	1	31158-297-50
Stirring Fan Assembly	1	N/A (Type 1 and 3R) 31158-065-50 (Type 12K)	1	31158-065-50 (Type 1 and 12K) N/A (Type 3R)	1	31158-065-50 (Type 1, 12K, and 3R) 31158-295-50 (Type 12K and 3R)	2	31158-065-50 (Type 1, 12K, and 3R)
Heatsink Fan Assembly	1	N/A	1	31158-296-50 (Type 1, 12K, and 3R)	1	31158-296-51 (Type 1, 12K, and 3R)	1	31158-296-52 (Type 1, 12K, and 3R)

[1] Field replacement of the option board will reset the power converter to the Material Handling Macro. The user must configure the controller per the elementary diagram with or without bypass starting on page 90.

[2] Refer to notes 1 and 2 on page 24.

[3] 0-10 V converter kit is for use with ALTIVAR 58 products only. Kit contains board part no. 31164-099-50.

Table 38: Circuit Breaker List

Notes to Table 38:

[1] “•” can be “A”, “G” or “H”. “A” denotes a Type 12K enclosure; “G” denotes a Type 1 enclosure. “H” denotes a Type 3R enclosure. “_” indicates that the catalog number continues. See page 10 for a detailed description of catalog numbers.

8839 Controller [1]	HP	Circuit Breaker
460 V		
58EC•4V_	1	GJL36007M02
58ED•4V_	2	GJL36007M02
58EE•4V_	3	GJL36015M03
58EF•4V_	5	GJL36030M04
58EG•4V_	7.5	GJL36030M04
58EH•4V_	10	GJL36030M04
58EJ•4V_	15	GJL36050M05
58EK•4V_	20	GJL36050M05
58EL•4V_	25	GJL36075M06
58EM•4V_	30	GJL36075M06
58EN•4V_	40	FAL36100-18M
58EP•4V_	50	FAL36100-18M
58EQ•4V_	60	KAL36250-25M
58ER•4V_	75	KAL36250-26M
58ES•4V_	100	FAL36250-29M
230 V		
58EC•3V_	1	GJL36015M03
58ED•3V_	2	GJL36015M03
58EE•3V_	3	GJL36030M04
58EF•3V_	5	GJL36050M05
58EG•3V_	7.5	GJL36050M05
58EH•3V_	10	GJL36075M06
58EJ•3V_	15	GJL36075M06
58EK•3V_	20	GJL36075M06
58EL•3V_	25	FAL36100-18M
58EM•3V_	30	KAL36250-25M
58EN•3V_	40	KAL36250-26M
58EP•3V_	50	FAL36250-29M
208 V		
58EC•2V_	1	GJL36015M03
58ED•2V_	2	GJL36030M04
58EE•2V_	3	GJL36030M04
58EF•2V_	5	GJL36050M05
58EG•2V_	7.5	GJL36050M05
58EH•2V_	10	GJL36075M06
58EJ•2V_	15	GJL36075M06
58EK•2V_	20	FAL36100-18M
58EL•2V_	25	FAL36100-18M
58EM•2V_	30	KAL36250-25M
58EN•2V_	40	KAL36250-26M
58EP•2V_	50	KAL36250-30M

**FIELD INSTALLED DAMPER CONTROL
CIRCUIT FOR AIR HANDLER DUCTS**

NOTE: Refer to Figure 35 on page 93 for complete diagram.

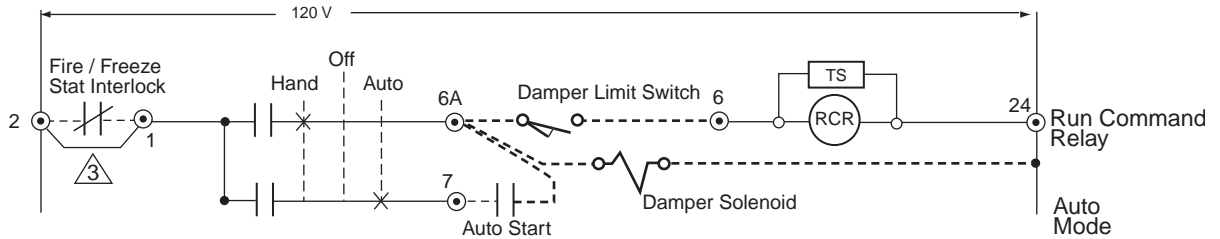

Figure 37: Identification of User Locations to Field Installed Damper Control Circuit

A damper control circuit is used to coordinate the position of a damper to open before the motor is started either in AFC or Bypass. This type of coordination is not required in the majority of applications, therefore it is not a standard factory option. When damper control coordination is required, refer to these instructions to install in the field.

Observe the lockout/tagout procedures as identified in OSHA Standard 29 CFR, Subpart J covering:

- 1910.147: The control of hazardous energy (lockout/tagout).
- 1910.147: App A, Typical minimal lockout procedures.

⚠ DANGER

HAZARDOUS VOLTAGE

- Disconnect all power.
- Place a “Do Not Turn On” label on the drive controller disconnect.
- Lock the disconnect in the open position.
- Read and understand the bus voltage measurement procedure on page 40 before performing procedure. Measurement of bus capacitor voltage must be performed by qualified personnel.
- DO NOT short across DC bus capacitors or touch unshielded components or terminal strip screw connectors with voltage present.
- Many parts in the drive controller, including printed wiring boards, operate at line voltage. DO NOT TOUCH. Use only electrically insulated tools.

Failure to follow these instructions will result in death or serious injury.

⚠ CAUTION

ELECTROSTATIC DISCHARGE

Do not subject this device to electrostatic discharge. This controller contains electronic components that are very susceptible to damage from electrostatic discharge.

Failure to follow this instruction can result in injury or equipment damage.

1. Open the door of the drive controller.
2. Measure the DC bus voltage as described on page 40 of this instruction bulletin.
3. The Control Circuit should consist of Hand-Off-Auto only, not Hand-Off-Auto, Stop-Start.
4. Install the damper control circuit by performing the following (reference the bold dashed lines in Figure 33).
 - a. Install the user-supplied auto start contact between customer terminals 7 and 6A. (This is a change from Figure 31 that shows the auto start contact between terminals 7 and 6.)
 - b. Install the user-supplied normally open (N.O.) damper limit switch (if used) between customer terminals 6A and 6. The limit switch will not allow the motor to start until the damper is open.
Switch Closed – Damper Open
Switch Open – Damper Closed
 - c. If the damper limit switch is installed in step b) remove the factory installed jumper between customer terminals 6A and 6.
 - d. Install the user supplied damper solenoid between customer terminals 6A and 24. Solenoid maximum power rating of 40 VA sealed and 100 VA inrush. The solenoid is used to control the opening and closing of a damper.

Numerics

22 KAIC UL coordinated rating 24, 66, 72
50/60 Hz switch 54

A

ACC 76
accelerates load too slowly 77
acceleration ramp
 range 19
 setting 56, 77
adjustable frequency controller 8
AFC 8
AFC-off-bypass selector switch 67, 75
 location 12
altitude 19
analog card 10, 24, 66, 72
auto speed ref. 10, 24, 66, 72

B

branch circuit
 components 16, 33
 feeder protection 16–18
bus voltage
 measuring 40
bypass contactor 75

C

cable
 input 17–18, 48–50
 output 35, 48–50
capacitance 35
catalog numbers 10
circuit breaker
 disconnect
 description 33
 location 12–14, 44–47
 handle 21
 trip adjustment 57–58
circuit diagrams
 power circuit w 90–92
 power circuit y 93
CLI 76–77
codes and standards 19
communication options 10, 24, 67, 72
component locations 12, 14, 44–46

conductor
 choosing 42
 grounding 34
 grouping 43
 motor power 35
conduit
 choosing 32, 34
 entry 32
control
 transformer 13–14, 44–47
 wiring 51
control options 10, 22, 62–64, 68, 70
controller 8
cooling 9, 28
cUL certification 24, 67
cUL listing 10, 24, 67, 72
current 17–19
 output 15–16
current limit 77
customer interface terminal block
 location 13–14, 44–47

D

damper control circuit 98
deceleration ramp
 range 19
 setting 56
diagnostic tools 74
dimensions 25–27
displacement power factor 19
documentation 8
door
 opening 30
drive controller 8

E

efficiency 19
enclosure 8, 10, 19
environment 9
excessive motor temperature 77

F

factory modifications
 control options 10, 22, 62–64, 68, 70
 light options 10, 23, 66, 71
 miscellaneous options 10, 24, 66,
 71–72

factory settings
 changing, saving, retrieving 61
fasteners 9, 31
fault
 reset 10, 51, 62–63, 68–69
features
 standard 21
fire/freezestat interlocks 21, 62, 68
forced local 51, 62, 67, 72
frequency
 input 19
 range 19
 resolution 19

G

galvanic isolation 19
grounding 34, 43

H

handling 31
hand-off-auto selector switch 22
 location 12
 operation in MOD A07 61–62, 68
 operation in MOD B07 63, 69
harmonic distortion 16, 66, 71
heatsink fan assembly 14, 45–47
 installing 85
 removing 83
heavy load 77
high speed setting 56
hoisting 31
hood filters 85
humidity 19

I

input
 cable 17–18, 33, 48–50
 current 17
 frequency 19
 power 33
 voltage 19
 wiring 33
installation
 electrical 32
 mechanical 32
IR compensation 76–77

K

- keypad 19, 21
 - location 12
 - option to omit 10, 24, 66, 71
- keypad access switch 53
- keypad command operation 61

L

- light options 10, 23, 66, 71
- lightning arrestors 35
- line
 - contactor 10, 24, 44–47, 71, 74–75
 - inductance 17
 - reactor 10, 13, 16–17, 24, 44–47, 66, 71
- LonWorks serial communications 10, 24, 67, 72
- low speed setting 56

M

- macro configuration 76
- METASYS N2 serial communications 10, 24, 67, 72
- misc. options 24
- miscellaneous options 10, 24, 66, 71–72
- MOD
 - A07 10, 22, 61–62, 68
 - user-supplied wiring equivalent 64, 70
 - A08 10, 23, 66, 71
 - A09 10, 24, 66, 71
 - B07 10, 22, 63, 69
 - user-supplied wiring equivalent 65, 70
 - B08 10, 23, 71
 - B09 10, 24, 71, 74
 - C07 10, 22, 64
 - user-supplied wiring equivalent 65
 - C08 10, 23, 66
 - C09 10, 24, 66, 71
 - D09 10, 24, 66, 71
 - E09 10, 24, 66, 72
 - G09 10, 24, 33, 66, 72
 - H09 10, 24, 66, 72
 - J09 10, 24, 66, 72
 - K09 10, 24, 67, 72

- L09 10, 24, 67, 72
- M09 10, 24, 67, 72
- N07 10, 22, 64, 70
- P09 10, 24, 67, 72

MODBUS serial communications 10, 24, 67, 72

- motor
 - current limit 76
 - excessive temperature 77
 - power conductors 35
 - protection 19
 - rotation
 - correcting direction of 55
 - displayed on keypad 75
 - terminal connection 13–14, 44–47
 - will not start 75
- mounting
 - clearance 25–27
 - dimensions and weights 25–27
 - environment 9
 - fasteners 9, 31
 - precautions 9
 - suitable surface 31–32

N

- nameplate identification 11
- noise
 - class 42
 - suppressors 32
- nuisance tripping 16, 35

O

- operators
 - option to omit 22, 64
- option card 53
- options
 - control 10, 22, 62–64, 68, 70
 - light 10, 23, 66, 71
 - misc. 24
 - miscellaneous 10, 24, 66, 71–72
 - selection rules 10
- output
 - cable 35, 48–50
 - inductance 35
 - current 15–16
 - voltage 19
 - wiring 32, 35
- overcurrent protective devices 33

- overload
 - protection 19, 21
 - relay dial 54

P

- pilot lights
 - green 23, 66, 71
 - locations 12
 - red 23, 66, 71
 - yellow 23, 66, 71, 75–77
- pollution degree 9, 19
- power circuit w (without bypass) 61–66
 - 2-wire control functionality 62
 - 3-wire control functionality 62
 - control options 62–64
 - controller operation 62
 - fire/freezestat interlocks 62
 - light options 66
 - misc. options 66–67
 - operator controls 62
- power circuit y (bypass) 67–72
 - 2-wire control functionality 68
 - 3-wire control functionality 68
 - bypass operation 68
 - control options 68–70
 - controller operation 68
 - fire/freezestat interlocks 68
 - light options 71
 - misc. options 71–72
 - operator controls 67
 - test-normal operation 68
- power converter 8
 - location 13–14, 44–47
 - nameplate location 13–14
 - replacing 53, 78–82
- power factor correction capacitors 35
- precautions 30–31
- PSI transducer 10, 24, 66, 71

R

- ramp type 77
- ratings 15–19
- RCR relay 75
 - function 90–92, 94
 - location 44–47
- reactor impedance
 - calculating 17
- receiving 30

S

selector switches
 AFC-off-bypass 67, 75
 hand-off-auto 22
 parts 21
 test-normal 68, 75
serial communication 24, 67, 72
shielding 43
shipping damage 30
shock 19
smoke purge 10, 24, 66, 72
space heater 85
spare parts 95
specifications 19
speed 19, 56, 75
speed potentiometer 22
 location 12
 operation in MOD A07 61–62, 68
 operation in MOD B07 63, 69
 operation in MOD C07 64
start pushbutton 22
 location 12
 operation in MOD B07 63, 69
 operation in MOD C07 64
start-up 53
stirring fans
 location 44–47
 replacing 85
stop pushbutton 22
 location 12
 operation in MOD B07 63, 69
 operation in MOD C07 64
storage 30
switching frequency 15–16, 19

T

technical support 86
temperature 19
terminal command operation 61
terminals
 bus voltage measurement 40
 control 51
 locations 13–14, 44–47
 power 48
terminology
 adjustable frequency controller 8

AFC 8
 controller 8
 drive controller 8
 power converter 8
test-normal selector switch 10, 21, 68, 75
 location 12
three-wire control functionality 62, 68
torque
 limit 1 76
 limit 2 76
transient overvoltage 16
troubleshooting 74–77
two-wire control functionality 62, 68
type 3R
 hood filters 85
 space heater 85
 ventilation fans 85

V

ventilation fans 85
vibration 19
voltage
 class 42
 imbalance 16
 input 19
 output 19

W

weights 25–27
will not accelerate load 76
wire class 42
wiring
 control 51
 general 32
 general practices 43
 grounding 34, 43
 methods 43
 noise class 42
 output 35
 pilot lights 75
 separation of circuits 43
 shielding 43
 terminal locations 44
 voltage class 42
 wire class 42

Instruction Bulletin
Class 8839 ECONOFLEX Adjustable Speed Drive Controllers

Schneider Electric USA

8001 Hwy 64 East
Knightdale, NC 27545 USA
1-888-SquareD
(1-888-778-2733)
www.us.SquareD.com

LONWORKS is a trademark of Echelon Corporation registered in the United States and other countries.

Electrical equipment should be installed, operated, serviced, and maintained only by qualified personnel. No responsibility is assumed by Schneider Electric for any consequences arising out of the use of this material.

Bulletin No. 30072-450-10H © 1999–2004 Schneider Electric All Rights Reserved
Replaces 30072-450-10G dated February 2002