

INSTRUCTION MANUAL

PHOENIX EX

3 TO 3500 HP

VECTOR AC DRIVE

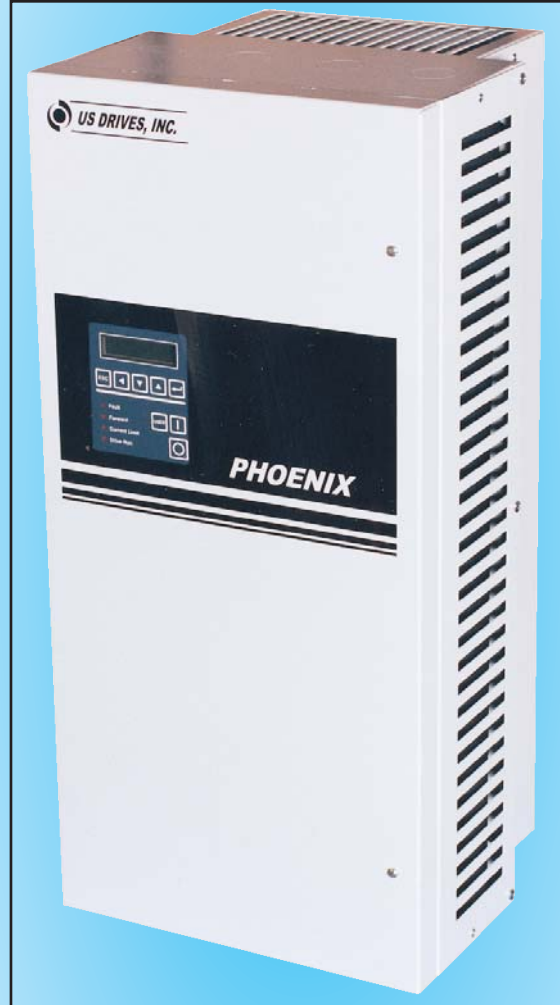

Thank You

We at US Drives would like to say thank you for purchasing our product. We believe the Phoenix AC Drive Series is the most problem free product in the market today. If you have any questions or comments please feel free to call us. On behalf of all of us here once again thank you.

Recording Drive Information

It is a good idea to record all drive nameplate information for future reference. The nameplate is usually mounted on the side of the drive. The following tables should be filled in during starting or prior to starting the drive.

Drive Part Number P/N	
Drive Serial Number S/N	
Software Revision Level SRL	

Free Software

Free software for setting and storing of parameters is available to all owners of the Phoenix AC Drive Series. Please fill out the owners registration card and mail it in and we will send one to you. You can also call us if you need it quicker.

Mounting Location Of The Drive

The drive should be installed in a well ventilated, moisture free area. If there are: fumes, vapors, dirt, lint, liquids or gases that can interact with the drive, then a clean air supply must be provided. The ambient temperature should not exceed the range of 14 F to 122 F (-10 C to 50 C). If the drive will be subject to vibration then the enclosure should be shock mounted.

Safety Warnings

AC drives, like all electrical equipment in industry, if not properly installed and operated can cause personal injury. Always use common sense when working around electrical equipment. Make sure you read this manual **before** any work on the drive begins. Never work on this drive if you are tired or under the influence of any drug. The drive must be grounded and installed in accordance with National Electrical Codes (NEC) and any local codes. Make sure that all power is disconnected, before working on the drive. **Always** measure the incoming voltage at the drive to make sure it is zero after disconnecting the power. Make sure all air passages are clear for proper cooling of the drive. After the drive is energized lethal voltages are present. **Wait at least 5 minutes after disconnecting power before working on the drive**, since high voltages will still be present. Call us if you have any questions.

Branch Circuit Protection

Branch circuit protection must be provided by the end user. In this manual you will find recommended fuse sizes and types for each Horsepower size.

Maintenance

If the enclosure is subject to foreign material, clean the enclosure and check any filters for build up of debris. If the inside of the enclosure needs cleaning, a low pressure vacuum cleaner is recommended. Do not use an air hose because of the possible oil vapor in the compressed air and its high pressure.

SECTION	TITLE	PAGE	SECTION	TITLE	PAGE
1.0	INTRODUCTION	1-1	3.6.3	Remove Power	3-6
1.1	Manual Objectives	1-1	3.6.4	Reconnect Motor	3-6
1.1.1	Who Should Use this Manual	1-1	3.6.5	Check for Correct Motor Rotation	3-6
1.2	Safety	1-1	3.6.6	Check for Proper Operation	3-7
1.2.1	General Safety Precautions	1-1	3.7	Typical Control Setups	3-8
1.3	Model Ratings	1-1	3.7.1	Keypad Mode	3-8
1.4	Specifications And Features	1-2	3.7.2	Keypad Start/Stop with Analog Speed Reference	3-8
2.0	INSTALLATION AND WIRING	2-1	3.7.2.a	"3-Wire" or Momentary Contact Control with Keypad Speed Reference	3-9
2.1	Safety Warning	2-1	3.7.2.b	"2-Wire" or Maintained Contact Control with Keypad Speed Reference	3-9
2.2	Initial Checks	2-1	3.7.3	"3-Wire" or Momentary Contact Control	3-10
2.3	Determining Control Location	2-1	3.7.4	"2-Wire" or Maintained Contact	3-10
2.4	Mounting	2-1	3.7.5	Hand-Auto with 2-Wire Control in Auto-Mode	3-11
2.5	AC Supply Source	2-10	3.7.6	Hand-Auto with 3-Wire Control in Auto-Mode	3-11
2.5.1	Unbalanced Distribution Systems	2-10	3.7.7	Hand-Off-Auto #1A Control	3-12
2.5.2	Ungrounded Distribution Systems	2-10	3.7.8	Hand-Off-Auto #2A Control	3-12
2.5.3	Input Power Conditioning	2-10	3.7.9	Hand-Off-Auto #3A Control	3-13
2.5.4	Input Fusing	2-10	3.7.10	Hand-Off-Auto #1B Control	3-13
2.6	Input Devices	2-11	3.7.11	Hand-Off-Auto #2B Control	3-14
2.7	Electrical Interference (EMI/RFI)	2-11	3.7.11.a	Hand-Off-Auto & Local Remote #28.a	3-14
2.7.1	Drive Immunity	2-11	3.7.12	Hand-Off-Auto #3B Control	3-15
2.7.2	Drive Emissions	2-11	3.7.13	Run Forward / Run Reverse "2-Wire" Control	3-15
2.8	Grounding	2-11	3.7.14	Run Forward / Run Reverse "3-Wire" Control	3-16
2.8.1	Grounding Sensitive Circuits	2-12	3.7.15	Hand-Off-Auto #4A Control	3-16
2.8.2	Motor Cable Grounding	2-12	3.7.16	Motorized Potentiometer with "2-Wire" Control	3-17
2.8.3	Control Logic and Signal Grounding	2-12	3.7.17	Motorized Potentiometer with "3-Wire" Control	3-17
2.9	Power Cabling	2-14	3.7.18	Motorized Potentiometer with Keypad Start/Stop	3-18
2.9.1	Motor Cables	2-14	3.7.19	Preset Speeds with "2-Wire" Control	3-18
2.9.1.1	Shielded Motor Cable	2-14	3.7.19.a	Preset Speeds with "2-Wire" Control and Speed Pot	3-19
2.9.1.2	Conduit for Routing Motor Cables	2-14	3.7.20	Preset Speeds with "3-Wire" Control	3-19
2.9.1.3	Motor Lead Lengths	2-14	3.7.21	Preset Speeds with Keypad Start/Stop	3-20
2.10	Control and Signal Wiring	2-14	3.7.21.a	Auto Preset Scan Timer with "3-Wire" Control	3-21
2.10.1	Signal Conduit Requirements	2-15	3.7.21.b	Auto Preset Scan Timer with Keypad Start/Stop	3-22
2.10.2	Signal Wire Requirements	2-15	3.7.22	Auto-Restart Typical Setup	3-23
3.0	REAL-TIME OPERATOR MODULE	3-1	3.7.23	PID with "2-Wire" Control	3-23
3.1	ROM Description	3-1	3.7.24	PID with "3-Wire" Control	3-24
3.2	Display Panel Key Descriptions	3-1	3.7.25	PID with Keypad Start/Stop	3-24
3.3	Control Panel Key and LED Descriptions	3-1	3.7.26	PID Additional Notes	3-25
3.4	List of Parameters	3-3	4.0	Menu and Parameter Description	4-1
3.4.1	Values and Character Strings	3-3	4.1	Menu Descriptions	4-1
3.4.2	List of Menus	3-3	4.2	Parameter Definitions	4-19
3.4.3	Quick Setup Menu List	3-3		Fault Description	4-75
3.4.4	Parameter Attribute	3-3			
3.4.5	Menu Structure	3-4			
3.4.6	Types of Parameters	3-4			
3.4.7	Restore All Parameters to Default Values	3-4			
3.4.8	Security Code	3-4			
3.5	Start Up and Quick Setup	3-5			
3.6	Start up Procedure for Running Drive with ROM "Keypad"	3-5			
3.6.1	Wiring Checks – Motor Disconnected	3-5			
3.6.2	Drive Programming	3-6			

ii TABLE OF CONTENTS

APPENDIX	Page		
Common Options and Interconnects	A-1	4-1	Basic Structure of the Control System 4-1
Standard Drive with Manual Bypass Setup and Diagram 1 of 2	A-2	4-2	Menu 1- Frequency Reference, Limits, Filters 4-2
Standard Drive with Manual Bypass Setup and Diagram 2 of 2	A-3	4-3	Menu 2 – Ramps 4-3
3-15 PSI Signal Board P/N: 3000-4045	A-4	4-4	Menu 3 – Encoder Input and Speed Loop 4-4
Process Signal Board	A-5	4-5	Menu 4 – Current Limits, Torque & Flux 4-5
P/N: 3000-4040 & 3000-4040-120	A-5	4-6	Menu 5 – Motor Control 4-6
Interconnect for Option Boards: 3000-4040, 3000-4040-120, 3000-4045, & 3000-4050-120	A-6	4-7	Menu 6 – Operational Modes 4-7
Isolated Communication Card 3000-4135-1 (1 of 2)	A-7	4-8	Menu 7 – Analog Inputs and Outputs 4-8
Isolated Communication Card 3000-4135-1 (2 of 2)	A-8	4-9	Menu 8 – Programmable Digital Inputs and Mode Selector 4-9
Digital Encoder Card 3000-4140-1 (1 of 3)	A-9	4-10	Menu 9 – Programmable Digital Outputs and Bit Selectors 4-10
Digital Encoder Card 3000-4140-1 (2 of 3)	A-10	4-11	Menu 10 – Status Logic and Diagnostic Information 4-11
Digital Encoder Card 3000-4140-1 (3 of 3)	A-11	4-12	Menu 11 – Miscellaneous 4-12
I/O Expansion Board 3000-4150 (1 of 2)	A-12	4-13	Menu 12 – Programmable Thresholds and Variable Selectors 4-13
I/O Expansion Board 3000-4150 (2 of 2)	A-13	4-14	Menu 13 – Timers Function & General Purpose Generator 4-14
Digital Encoder #2 - 3000-4160 (1 of 3)	A-14	4-15	Menu 14 – PID Control Loop 4-15
Digital Encoder #2 - 3000-4160 (2 of 3)	A-15	4-16	Menu 15 – Position Control (1 of 2) 4-16
Digital Encoder #2 - 3000-4160 (3 of 3)	A-16	4-17	Menu 15 – Position Control (2 of 2) 4-17
Power Circuit Test	B-1	4-18	Menu 17 – 2 nd Motor Parameters 4-18
Phoenix Power Circuit Test Table	B-2		

FIGURE		PAGE
2-1	Required Surrounding space	2-1
2-2	Phoenix Mounting Information: Size 0	2-2
2-2a	Phoenix Mounting Information: Size 1 and Size 2 (Nema Type 1)	2-3
2-2b	Phoenix Mounting Information: Size 3 (Nema Type 1)	2-4
2-2c	Phoenix Mounting Information: Size 0 with Disconnect Switch and Fuses (Nema Type 1)	2-5
2-2d	Phoenix Mounting Information: Size 1 and Size 2 with Disconnect Switch And Fuses (Nema Type 1)	2-6
2-2e	Phoenix Mounting Information: Size 3 with Disconnect Switch and Fuses (Nema Type 1)	2-7
2-2f	Phoenix Mounting Information: Size 0* with Bypass (Nema Type 1)	2-8
2-2g	Phoenix Mounting Information: Size 1 and Size 2 with Bypass (Nema Type 1)	2-9
2-3	Recommended Power Wiring	2-13
2-4	Terminal Block Location for Drive Control Board	2-16
2-5	Control Logic and Signal Wiring	2-17
3-1	ROM Front Panel	3-1
3-2	Control Wiring for Keypad Operation	3-5

1.0 INTRODUCTION

1.1 MANUAL OBJECTIVES

The purpose of this manual is to provide the user with the necessary information to install, program, start-up and maintain the PHOENIX Digital AC Drive. This manual should be read thoroughly before operating, servicing or setting up the PHOENIX Drive.

1.1.1 Who Should Use this Manual

This manual is intended for qualified service personnel responsible for setting up and servicing the PHOENIX AC Drive. You must have previous experience with and a basic understanding of electrical terminology, programming procedures, required equipment and safety precautions before attempting and service on the PHOENIX Drive.

1.2 SAFETY

1.2.1 General Safety Precautions

WARNING

Only personnel familiar with the PHOENIX Drive and the associated machinery should plan or implement the installation, start-up, and subsequent maintenance of the Drive. Failure to comply may result in personnel injury and/or equipment damage.

WARNING

An incorrectly applied or installed Drive can result in component damage or a reduction in product life. Wiring or application errors such as undersizing the motor, incorrect or inadequate AC supply or excessive ambient temperatures may result in damage to the Drive or motor.

WARNING

This Drive contains ESD (Electrostatic Discharge) sensitive parts and assemblies. Static control precautions are required when servicing or repairing this assembly. Component damage may result if ESD control procedures are not followed. If you are not familiar with static control procedures, please consult with the factory.

1.3 MODEL RATINGS

The following tables 1-1 through 1-3 show the PHOENIX model ratings for size 0 through size 4 for class 200, class 400 and class 500 units.

1-2 INTRODUCTION

1.4 SPECIFICATIONS AND FEATURES

Electrical Specifications:

Rated Input Voltage:	200-250Vac, 380-500Vac, 500-600Vac -10% of minimum, +10% of maximum.
Frequency Tolerance:	48-63 Hz
Number of Phases:	3
Displacement Power Factor:	.95 or greater
Efficiency:	97% or greater at rated current
Max. Short Circuit Current Rating:	200,000A rms symmetrical, 600 volts (when used with AC input line fuses specified in tables 1-1 to 1-3).

Control Specifications:

Control Method:	Sine coded PWM with programmable carrier. Space Vector control.
Output Voltage:	0 to rated voltage.
Output Frequency Range:	0 to 600 Hz.
Frequency accuracy:	Analog reference: 0.1% of max frequency. Digital reference: 0.01% of max frequency.
Frequency resolution:	Analog reference: 0.06Hz at 60Hz. Digital reference: 0.001Hz at 60Hz.
Accel/Decel:	0.1 to 3276 sec.
Drive overload:	At Constant Torque: 150% of drive rated output for 1 minute. At Variable Torque: 120% of drive rated output for 1 minute.
Inverse Time Overload:	Programmable motor overload protection to comply with N.E.C. Article 430.
Current limit:	Proactive current limit programmable in % of motor rated current.
Braking torque:	Approximately 20%.
Maximum connected motor:	2 times rated drive horsepower.
Control power ride-thru:	2 seconds or greater, depending on load.

Environmental Specifications:

Ambient Temperature:	-10°C to 50°C (14°F to 122°F) Nema type 1 enclosed.
Storage Temperature:	-40°C to 70°C (-40°F to 158°F) Nema type 1 enclosed.
Altitude:	Sea level to 3300 Feet [1000m] without derating.
Humidity:	95% relative humidity non-condensing.
Vibration:	9.8m/sec ² (1.0G) peak.
Immunity:	IEEE C62.41-1991 Category B (Formally known as IEEE 587) EN50082-2 (Generic Immunity Standard).
Input R.F.I. Filter:	Standard on all models.

Physical attributes:

Mounting:	Though hole or panel mount for size 0 to size 3 drives. Size 4 drives are free standing enclosure.
Nema Rating:	Type 1 (IP20) as standard, Type 12 (IP54) optional.
Construction:	Steel construction (reduces E.M.I.)

Protective Features:

- Programmable motor overload protection to comply with N.E.C. Article 430.
- Drive overload protection to protect inverter.
- Motor stall protection at acceleration /deceleration and constant speed operation.
- Peak output current monitoring to protect against line-to-line shorts and line-to-ground shorts.
- Ground fault monitoring.
- Heatsink over-temperature monitoring.
- AC line overvoltage protection.
- DC bus over-voltage protection.
- DC bus under-voltage protection.
- Programmable stall protection.
- Control power ride-thru 2 seconds or greater, depending on load.
- Internal power supply monitoring.

- AC power loss detection.
- Critical speed rejection with programmable 3 points with bandwidth to avoid mechanical resonance.
- Flycatcher “catch a spinning motor”.
- Password protection to prevent parameter changes by unauthorized personnel.
- 4 to 20ma reference loss detection.
- Programmable thresholds and more.

Control I/O:

- 8 Digital Inputs: 7 user programmable inputs and 1 dedicated input for “Stop”, rated for 24Vdc logic control.
- 2 Digital Outputs: 2 programmable dry contacts rated 115Vac @ 5A; 30Vdc @ 3.5A.
- 2 analog inputs: -10 to +10V (10 bits) with input impedance: 75K Ω , or 4-20 mA @ 500 Ω - Programmable.
- 2 analog outputs: -10 to +10V (10 bits) @ 2 mA max; output impedance = 100 Ω . - Programmable.
- 1 voltage reference: +15Vdc reference @ 10 mA max.
- 24Vdc source: Use to power operator pushbuttons and US Drives option boards: 24Vdc @ 80 mA max.

Standard Drives Features:

- New generation IGBT.
- Nema type 1 (IP20) as standard for all models.
- 50°C ambient with standard Nema type 1 (IP20) enclosure.
- High voltage ratings: 250Vac+10% , 500Vac+10% models, and 600Vac+10% models
- Built-in power factor correction DC reactor for all models above 20 Hp.
- Modbus RTU & Metasys N2 serial communications ready.
- Input line suppression: Metal oxide varistors for line-to-line and line-to-ground voltage surge protection.
- Built-in radio frequency filter.
- Nonvolatile parameter storage.
- All parameters are saved in EEPROM (nonvolatile).
- Autologging fault history: ten last faults recorded in order of occurrence.
- Internal control diagnostics.
- Simple programming through the Real-time Operator module (R.O.M.) with all data entries and monitoring in engineering units with English descriptions.
- Setpoint Control P.I.D.
- Injection DC Braking with braking time calculated automatically by the drive.
- Critical speed rejection.
- Programmable autorestart.
- Fixed or variable carrier (programmable).
- Programmable “Total Drive Run Time” accumulator.
- Parameter security code.
- User definable displays with programmable format and parameter scaling.
- 7 programmable digital inputs for custom setups.
- Metering: AC line voltage, motor current, motor voltage, DC Bus voltage, Kw, Kwh, running Kwh cost, and more...
- 8 programmable digital preset speeds with user selectable acceleration and deceleration rates.
- M.O.P. function.
- Programmable PWM carrier frequency, fixed or variable.
- Programmable thresholds.
- Programmable maintenance timers.
- Bi-directional auto-speed search (flycatcher) for starting into rotating loads.
- S-curve accel/decel control.
- Programmable time delay and logic functions (AND, OR, NOR) of bit parameters, digital inputs and outputs.
- Adding, subtracting, multiplying, dividing, ramping, limiting, and/or filtering functions of parameters and analog inputs and outputs.
- Parameters can be displayed, routed to an analog/digital output, or re-routed and used as an input parameter to control another function within the drive.
- User programmable functions and modes.
- Open Loop or closed-loop control operation easy setup.
- Precise control of motor speed and torque.
- Rigid and non-rigid position control including orientation.

1-4 INTRODUCTION

Option Kits:

Catalog Number:

Process Input Signal Conditioner / Isolator Card Availability: Factory Installed or Kit Form	3000-4040
Process Input Signal Conditioner / Isolator Card – 120 VAC Availability: Factory Installed or Kit Form	3000-4040-120
Non-Isolated 4 to 20 ma Process Signal Output Card Availability: Factory Installed or Kit Form	3000-4040
Isolated 4 to 20 ma Process Signal Output Card Availability: Factory Installed or Kit Form	3000-4040-120
0 to 15 PSI Pneumatic Signal Follower Card Availability: Factory Installed or Kit Form	3000-4045
115 Vac Operator (Digital Input) Interface Card Availability: Factory Installed or Kit Form	3000-4050
Isolated Communications Card (RS-232/422/485, Modbus RTU) Availability: Factory Installed or Kit Form	3000-4135-1
Isolated Communications Card (Metasys N2) Availability: Factory Installed or Kit Form	3000-4135-2
I/O Expansion Board Availability: Factory Installed or Kit Form (X = See Appendix A)	3000-4150-X
Encoder Feedback Card Availability: Factory Installed or Kit Form	3000-4140-1
Digital Encoder 2 Availability: Factory Installed or Kit Form	3000-4160
Removable RS-232 Isolated Communications Interface with Cable Availability: Kit form	3000-4225-D9
HOA Switch Availability: Factory Installed Only	PEX-HOA-SW
Local / Remote Switch Availability: Factory Installed Only	PEX-LR-SW
Auto / Manual Switch Availability: Factory Installed Only	PEX-AM-SW
Speed Potentiometer Availability: Factory Installed Only	PEX-POT
Automatic Bypass Adder For Size 0 Drive with Manual Bypass Availability: Factory Installed Only	PEX-ABP0
Automatic Bypass Adder For Size 1 Drive with Manual Bypass Availability: Factory Installed Only	PEX-ABP1
Automatic Bypass Adder For Size 2 Drive with Manual Bypass Availability: Factory Installed Only	PEX-ABP2
Bezel Assembly For Keypad Availability: Kit Form	PEX-BZL
Ribbon Cable Extender For Keypad – 6 Feet Availability: Kit Form	PEX-CBL-6
Remote Keypad Kit Availability: Kit Form	PEX-RMT
Floor Stand Kit For Nema 1 Enclosed Size 3 Drives Availability: Factory Installed or Kit Form	PEX-FS1
Nema 12 Sealing (Size 0, 1, 2) Availability: Factory Installed Only	PEX-N12SEAL
Nema 12 Sealing (Size 3) Availability: Factory Installed Only	PNX-N12SEAL3
Nema 4 Sealing and Fans (Size 0) Availability: Factory Installed Only	PEX-N4SEAL0
Nema 4 Sealing and Fans (Size 1) Availability: Factory Installed Only	PEX-N4SEAL1
Nema 4 Sealing and Fans (Size 2A) Availability: Factory Installed Only	PEX-N4SEAL2A
Nema 4 Sealing and Fans (Size 2B) Availability: Factory Installed Only	PEX-N4SEAL2B
Nema 4 Sealing and Fans (Size 3) Availability: Factory Installed Only	PEX-N4SEAL3
Size 0 Nema 1 Enclosure extension (Room to Mount Options) Availability: Factory Installed Only	PEX-SZ0-N1XL
Size 0 Nema 12 Enclosure Extension (Room to Mount Options) Availability: Factory Installed Only	PEX-SZ0-N12XL
Size 0 Nema 4 Oversized Enclosure (Room to Mount Options) Availability: Factory Installed Only	PEX-SZ0-N4XL

Table 1-1
Class 200 Drive Models (Typical Voltage 208/230/240 VAC)

200-250VAC (-10% to +10%)												
Frame Designation	NEMA 1 (IP20) Catalog Number	Motor HP ¹		Continuous ² Output Current (Amps)		Output KVA ³		Input Current (Amps)		Input KVA ³		Maximum Recommended AC Line Fuses ⁴ (Amps)
		HT	NT	HT	NT	HT	NT	HT	NT	HT	NT	
SIZE 0	E2-0005-N1	3	5	10	16	4	7	12	19	5	8	35
	E2-0007.5-N1	5	7.5	16	22	7	9	19	25	8	10	40
	E2-0010-N1	7.5	10	22	28	9	12	25	33	10	14	50
	E2-0015-N1	10	15	28	42	12	17	25	36	10	15	60
	E2-0020-N1	15	20	42	54	17	22	36	50	15	21	70
	E2-0020HT-N1	20	-	54	-	22	-	50	-	21	-	70
SIZE 1	E2-0025-N1	20	25	54	68	22	28	50	61	21	25	90
	E2-0030-N1	25	30	68	85	28	35	61	79	25	33	100
	E2-0030HT-N1	30	-	80	-	33	-	74	-	31	-	100
SIZE 2	E2-0040-N1	30	40	80	104	33	43	74	96	31	40	150
	E2-0050-N1	40	50	104	130	43	54	96	120	40	50	200
	E2-0060-N1	50	60	130	163	54	68	120	155	50	64	250
	E2-0075-N1	60	75	145	192	60	80	140	186	58	77	300
	E2-0100-N1	75	100	192	248	80	103	186	230	77	96	300
	E2-0100HT-N1	100	-	248	-	103	-	230	-	96	-	300
SIZE 3	E2-0125NT-N1	-	125	-	312	-	130	-	290	-	121	400
	E2-0125HT-N1	125	-	312	-	130	-	290	-	121	-	400
	E2-0150NT-N1	-	150	-	360	-	150	-	335	-	139	500
	E2-0150HT-N1	150	-	360	-	150	-	335	-	139	-	500
	E2-0200NT-N1	-	200	-	480	-	200	-	446	-	186	600
	E2-0200HT-N1	200	-	480	-	200	-	446	-	186	-	600
	E2-0250NT-N1	-	250	-	602	-	250	-	560	-	233	800
	E2-0250HT-N1	250	-	602	-	250	-	560	-	233	-	800

¹ Horsepower based on 220-240 Vac Motors.

² High Overload Torque (HT) rating is 150% for 1 minute; Normal Overload Torque (NT) rating is 120% for 1 minute.

³ Output and Input KVA at nominal 240Vac

⁴ UL Class T, J, and Semiconductor Fuses (preferred): Gould Shawmut A50Q, Bussmann FWH.

⁵ Built-in as standard

Table 1-2
Class 400 Drive Models (Typical Voltage 380/415/480 VAC)

380-500VAC (-10% to +10%)												
Frame Designation	NEMA 1 (IP20) Catalog Number	Motor HP ¹		Continuous ² Output Current (Amps)		Output KVA ³		Input Current (Amps)		Input KVA ³		Maximum Recommended AC Line Fuses ⁴ (Amps)
		HT	NT	HT	NT	HT	NT	HT	NT	HT	NT	
SIZE 0	E4-0007.5-N1	5	7.5	8	11	7	9	10	13	8	11	25
	E4-0010-N1	7.5	10	11	14	9	12	13	17	11	14	30
	E4-0015-N1	10	15	14	21	12	17	17	25	14	21	40
	E4-0020-N1	15	20	21	27	17	22	25	33	21	27	50
	E4-0025-N1	20	25	27	34	22	28	26	31	22	26	50
	E4-0030-N1	25	30	34	43	28	36	31	38	26	32	60
	E4-0040-N1	30	40	40	52	33	43	36	48	30	40	70
SIZE 1	E4-0040HT-N1	40	-	52	-	43	-	48	-	40	-	70
	E4-0050-N1	40	50	52	66	43	55	48	56	40	47	90
	E4-0060-N1	50	60	65	82	54	68	56	72	47	60	100
SIZE 2	E4-0060HT-N1	60	-	77	-	64	-	67	-	56	-	100
	E4-0075-N1	60	75	77	97	64	81	67	83	56	69	125
	E4-0100-N1	75	100	96	124	80	103	86	110	71	91	175
	E4-0125-N1	100	125	124	156	103	130	110	139	91	116	200
	E4-0150-N1	125	150	156	180	130	150	139	163	116	136	250
	E4-0200-N1	150	200	180	240	150	200	167	223	139	186	350
SIZE 3	E4-0200HT-N1	200	-	240	-	200	-	223	-	186	-	350
	E4-0250NT-N1	-	250	-	302	-	251	-	281	-	234	400
	E4-0250HT-N1	250	-	302	-	251	-	281	-	234	-	400
	E4-0300NT-N1	-	300	-	361	-	300	-	336	-	279	500
	E4-0300HT-N1	300	-	361	-	300	-	336	-	279	-	500
	E4-0350NT-N1	-	350	-	414	-	344	-	385	-	320	600
	E4-0350HT-N1	350	-	414	-	344	-	385	-	320	-	600
	E4-0400NT-N1	-	400	-	477	-	397	-	444	-	369	700
	E4-0400HT-N1	400	-	477	-	397	-	444	-	369	-	700
	E4-0450NT-N1	-	450	-	540	-	449	-	503	-	418	800
SIZE 4	E4-0450HT-N1	450	-	540	-	449	-	503	-	418	-	800
	E4-0500NT-N1	-	500	-	600	-	499	-	558	-	464	800
	E4-0500HT-N1	500	-	600	-	499	-	558	-	464	-	800
	E4-0600NT-N1	-	600	-	720	-	599	-	670	-	557	5
	E4-0600HT-N1	600	-	720	-	599	-	670	-	557	-	5
	E4-0700NT-N1	-	700	-	840	-	698	-	781	-	649	5
	E4-0700HT-N1	700	-	840	-	698	-	781	-	649	-	5
	E4-0800NT-N1	-	800	-	960	-	798	-	893	-	742	5
SIZE 4	E4-0800HT-N1	800	-	960	-	798	-	893	-	742	-	5
	E4-0900NT-N1	-	900	-	1080	-	898	-	1004	-	835	5
	E4-0900HT-N1	900	-	1080	-	898	-	1004	-	835	-	5
	E4-1000NT-N1	-	1000	-	1200	-	998	-	1116	-	928	5
	E4-1000HT-N1	1000	-	1200	-	998	-	1116	-	928	-	5
	E4-1250NT-N1	-	1250	-	1500	-	1247	-	1395	-	1160	5
	E4-1250HT-N1	1250	-	1500	-	1247	-	1395	-	1160	-	5
	E4-1500NT-N1	-	1500	-	1800	-	1496	-	1674	-	1392	5
	E4-1500HT-N1	1500	-	1800	-	1496	-	1674	-	1392	-	5
	E4-1750NT-N1	-	1750	-	2100	-	1746	-	1953	-	1624	5
	E4-1750HT-N1	1750	-	2100	-	1746	-	1953	-	1624	-	5
	E4-2000NT-N1	-	2000	-	2400	-	1995	-	2232	-	1856	5
E4-2000HT-N1	2000	-	2400	-	1995	-	2232	-	1856	-	5	
E4-2500NT-N1	-	2500	-	3000	-	2494	-	2790	-	2320	5	
E4-2500HT-N1	2500	-	3000	-	2494	-	2790	-	2320	-	5	

THIS VOLTAGE SERIES HAS A MAXIMUM HP RATING OF 3,000HP.

¹ Horsepower based on 440-480 Vac Motors.

² High Overload Torque (HT) rating is 150% for 1 minute; Normal Overload Torque (NT) rating is 120% for 1 minute.

³ Output and Input KVA at nominal voltage 480Vac

⁴ UL Class T, J, and Semiconductor Fuses (preferred): Gould Shawmut A50Q, Bussmann FWH.

⁵ Built-in as standard

Table 1-3
Class 500 Drive Models (Typical Voltage 525/575/600 VAC)

500-600VAC (-10% to +10%)												
Frame Designation	NEMA 1 (IP20) Catalog Number	Motor HP ¹		Continuous ² Output Current (Amps)		Output KVA ³		Input Current (Amps)		Input KVA ³		Maximum Recommended AC Line Fuses ⁴ (Amps)
		HT	NT	HT	NT	HT	NT	HT	NT	HT	NT	
SIZE 0	E5-0007.5-N1	5	7.5	7	9	7	9	9	11	9	11	20
	E5-0010-N1	7.5	10	9	12	9	12	11	13	11	13	25
	E5-0015-N1	10	15	11	17	11	17	13	20	13	20	35
	E5-0020-N1	15	20	17	22	17	22	20	25	20	25	40
	E5-0025-N1	20	25	22	28	22	28	22	28	22	28	40
	E5-0030-N1	25	30	27	34	27	34	27	34	27	34	50
	E5-0040-N1	30	40	32	41	32	41	32	40	32	40	60
	E5-0040HT-N1	40	-	41	-	41	-	40	-	40	-	60
SIZE 1	E5-0050-N1	40	50	41	52	41	52	40	48	40	48	80
	E5-0060-N1	50	60	52	65	52	65	54	61	54	61	90
	E5-0075-N1	60	75	62	78	62	78	58	72	58	72	100
	E5-0075HT-N1	75	-	77	-	77	-	75	-	75	-	150
SIZE 2	E5-0100-N1	75	100	77	99	77	99	75	96	75	96	150
	E5-0125-N1	100	125	99	125	99	124	96	124	96	123	175
	E5-0150-N1	125	150	125	157	124	156	124	154	123	153	200
	E5-0200-N1	150	200	144	192	143	191	142	191	141	190	300
	E5-0200HT-N1	200	-	192	-	191	-	191	-	190	-	300
SIZE 3	E5-0250NT-N1	-	250	-	242	-	241	-	240	-	239	350
	E5-0250HT-N1	250	-	242	-	241	-	240	-	239	-	350
	E5-0300NT-N1	-	300	-	289	-	288	-	286	-	285	400
	E5-0300HT-N1	300	-	289	-	288	-	286	-	285	-	400
	E5-0350NT-N1	-	350	-	336	-	335	-	333	-	331	500
	E5-0350HT-N1	350	-	336	-	335	-	333	-	331	-	500
	E5-0400NT-N1	-	400	-	382	-	380	-	378	-	377	600
	E5-0400HT-N1	400	-	382	-	380	-	378	-	377	-	600
	E5-0450NT-N1	-	450	-	432	-	430	-	428	-	426	700
	E5-0450HT-N1	450	-	432	-	430	-	428	-	426	-	700
	E5-0500NT-N1	-	500	-	472	-	470	-	467	-	465	700
	E5-0500HT-N1	500	-	472	-	470	-	467	-	465	-	700
	E5-0600NT-N1	-	600	-	576	-	574	-	570	-	568	800
	E5-0600HT-N1	600	-	576	-	574	-	570	-	568	-	800
SIZE 4	E5-0700NT-N1	-	700	-	672	-	669	-	665	-	663	5
	E5-0700HT-N1	700	-	672	-	669	-	665	-	663	-	5
	E5-0800NT-N1	-	800	-	768	-	765	-	760	-	757	5
	E5-0800HT-N1	800	-	768	-	765	-	760	-	757	-	5
	E5-0900NT-N1	-	900	-	864	-	860	-	855	-	852	5
	E5-0900HT-N1	900	-	864	-	860	-	855	-	852	-	5
	E5-1000NT-N1	-	1000	-	960	-	956	-	950	-	947	5
	E5-1000HT-N1	1000	-	960	-	956	-	950	-	947	-	5
	E5-1250NT-N1	-	1250	-	1200	-	1195	-	1188	-	1183	5
	E5-1250HT-N1	1250	-	1200	-	1195	-	1188	-	1183	-	5
	E5-1500NT-N1	-	1500	-	1440	-	1434	-	1426	-	1420	5
	E5-1500HT-N1	1500	-	1440	-	1434	-	1426	-	1420	-	5
	E5-1750NT-N1	-	1750	-	1680	-	1673	-	1663	-	1656	5
	E5-1750HT-N1	1750	-	1680	-	1673	-	1663	-	1656	-	5
	E5-2000NT-N1	-	2000	-	1920	-	1912	-	1901	-	1893	5
	E5-2000HT-N1	2000	-	1920	-	1912	-	1901	-	1893	-	5
	E5-2500NT-N1	-	2500	-	2400	-	2390	-	2376	-	2366	5
	E5-2500HT-N1	2500	-	2400	-	2390	-	2376	-	2366	-	5

THIS VOLTAGE SERIES HAS A MAXIMUM HP RATING OF 3,500HP.

¹ Horsepower based on 550-600 Vac Motors.

² High Overload Torque (HT) rating is 150% for 1 minute; Normal Overload Torque (NT) rating is 120% for 1 minute.

³ Output and Input KVA at nominal voltage 575Vac.

⁴ UL Class T, CC, J, and Semiconductor Fuses (preferred): Gould Shawmut A70Q, Bussmann FWP.

⁵ Built-in as standard

1-8 INTRODUCTION

END INTRODUCTION SECTION

2.0 INSTALLATION AND WIRING

Section 2.0 provides the information needed to properly mount and wire the PHOENIX Drive. Since most start-up difficulties are the result of incorrect wiring, it is essential that the wiring is done as instructed. Read and understand this section in its entirety before actual installation begins.

2.1 SAFETY WARNINGS

WARNING

Only qualified electrical personnel familiar with the construction and operation of this equipment and the hazards involved should install, adjust, operate or service this equipment.

WARNING

The control and its associated motors and operator control devices must be installed and grounded in accordance with all national and local codes (NEC, VDE 0160, BSI, etc.). To reduce the potential for electric shock, disconnect all power sources before initiating any maintenance or repairs. Keep fingers and foreign objects away from ventilation and other openings. Keep air passages clear. Potentially lethal voltages exist within the drive enclosure and connections. Use extreme caution during installation and start-up.

WARNING

The following information is only a guide for proper installation. US Drives cannot assume responsibility for the compliance or noncompliance to any code, national, local or otherwise for the proper installation of this drive or associated equipment. A hazard of personal injury and/or equipment damage exists if codes are ignored during the installation.

2.2 INITIAL CHECKS

Before installing the PHOENIX Drive, check the unit for physical damage sustained during shipment. If damaged, file a claim with the shipper and return for repair following the procedures outlined on the back cover. If no damage is observed, remove all shipping restraints and padding. Check drive nameplate data for conformance with the AC power source and motor.

2.3 DETERMINING CONTROL LOCATION

The PHOENIX Drive is suitable for most well-ventilated factory areas where industrial equipment is installed. Locations subject to steam vapors or excessive moisture, oil vapors, flammable or combustible vapors, chemical fumes, corrosive gases or liquids, or excessive dirt, dust or lint should be avoided unless an appropriate enclosure has been supplied or a source of clean air is supplied to the enclosure. The location should be dry and the ambient temperature should not exceed 122°F (50°C). If the mounting location is subject to vibration, the unit should be shock mounted.

2.4 MOUNTING

Figure 2-1 shows the minimum required surrounding air space for panel mounted PHOENIX Drives (size 0 through size 3 units). Note that the panel mounted units must be mounted in an upright position. Figure 2-2a shows dimensional information for size 1 through size 2 units. Figure 2-2 shows dimensional information for size 0. Figure 2-2b shows dimensional information for size 3. If through panel mounting is chosen (available on size 0 through size 3 Drives), a suitable sealant should be applied to the mounting faces of the drive and the panel to prevent leakage.

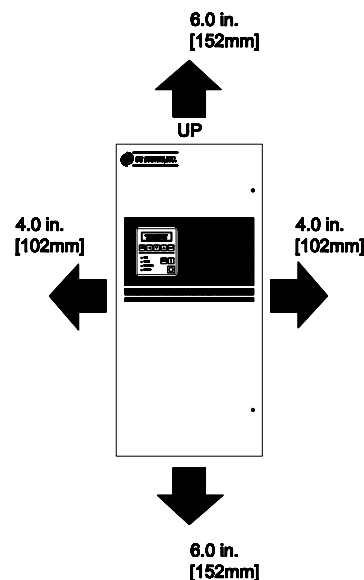
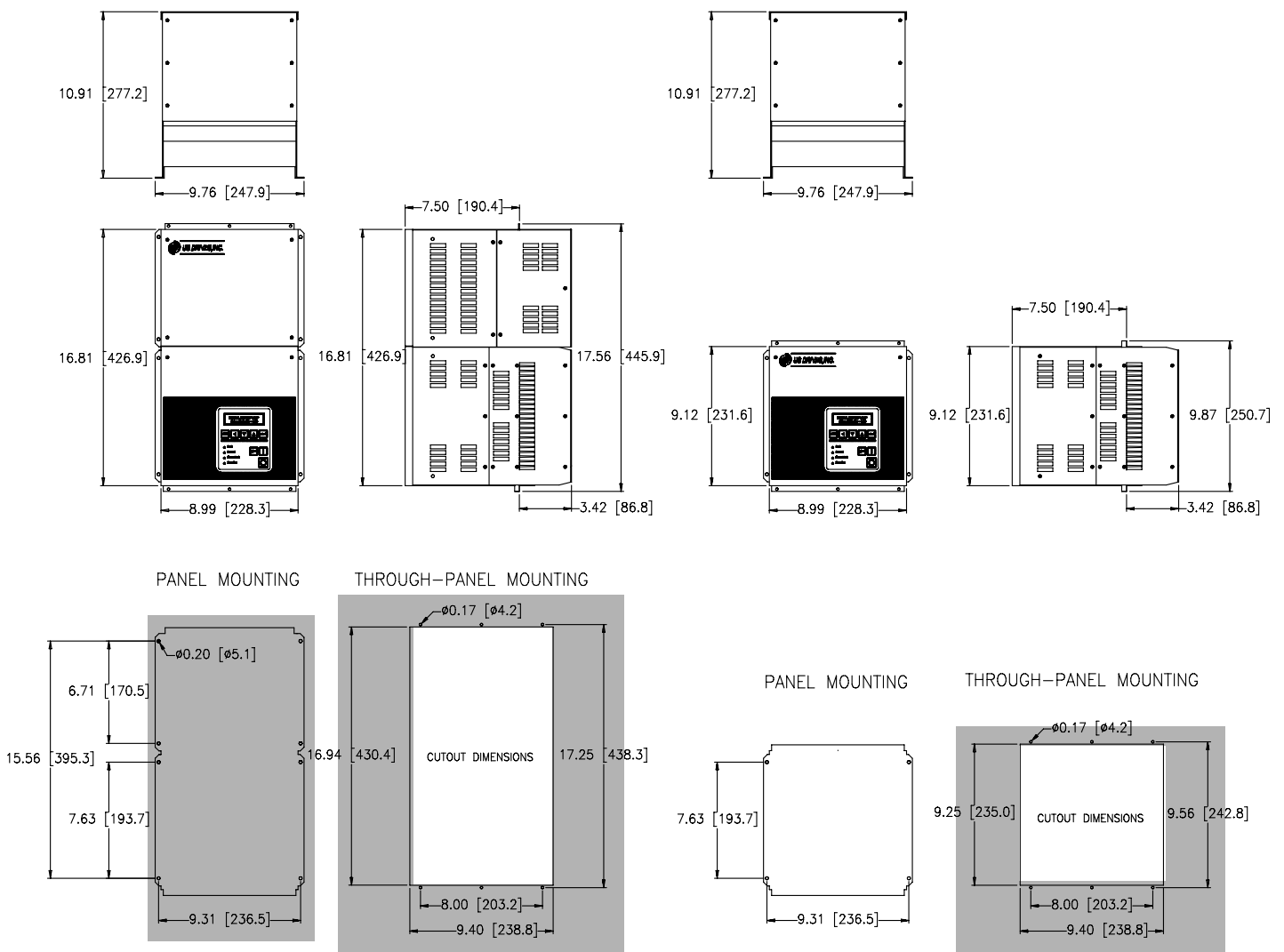

Figure 2-1

Minimum Required Surrounding Air Space for size 0 through size 3 PHOENIX Drives

2-2 INSTALLATION AND WIRING



Size 0-B Mounting Dimensions

Size 0-A Mounting Dimensions

*Note: Top endplates and front covers are removable to gain access inside drive for wiring. For through-panel mounting customer provides seal for gap on both sides of cutout.

	MODEL NUMBER	WEIGHT
SIZE 0-A	E2-0005-N1, E2-0007.5-N1, E2-0010-N1, E2-0015-N1, E2-0020-N1, E2-0020CT-N1 E4-0007.5-N1, E4-0010-N1, E4-0015-N1, E4-0020-N1 E5-0007.5-N1, E5-0010-N1, E5-0015-N1, E5-0020-N1	26 Lbs [12 Kg]
SIZE 0-B	E4-0025-N1, E4-0030-N1, E4-0040-N1, E4-0040CT-N1 E5-0025-N1, E5-0030-N1, E5-0040-N1, E5-0040CT-N1	40 Lbs [18 Kg]

Figure 2-2
PHOENIX Mounting Information:
Size 0 (Nema Type 1)

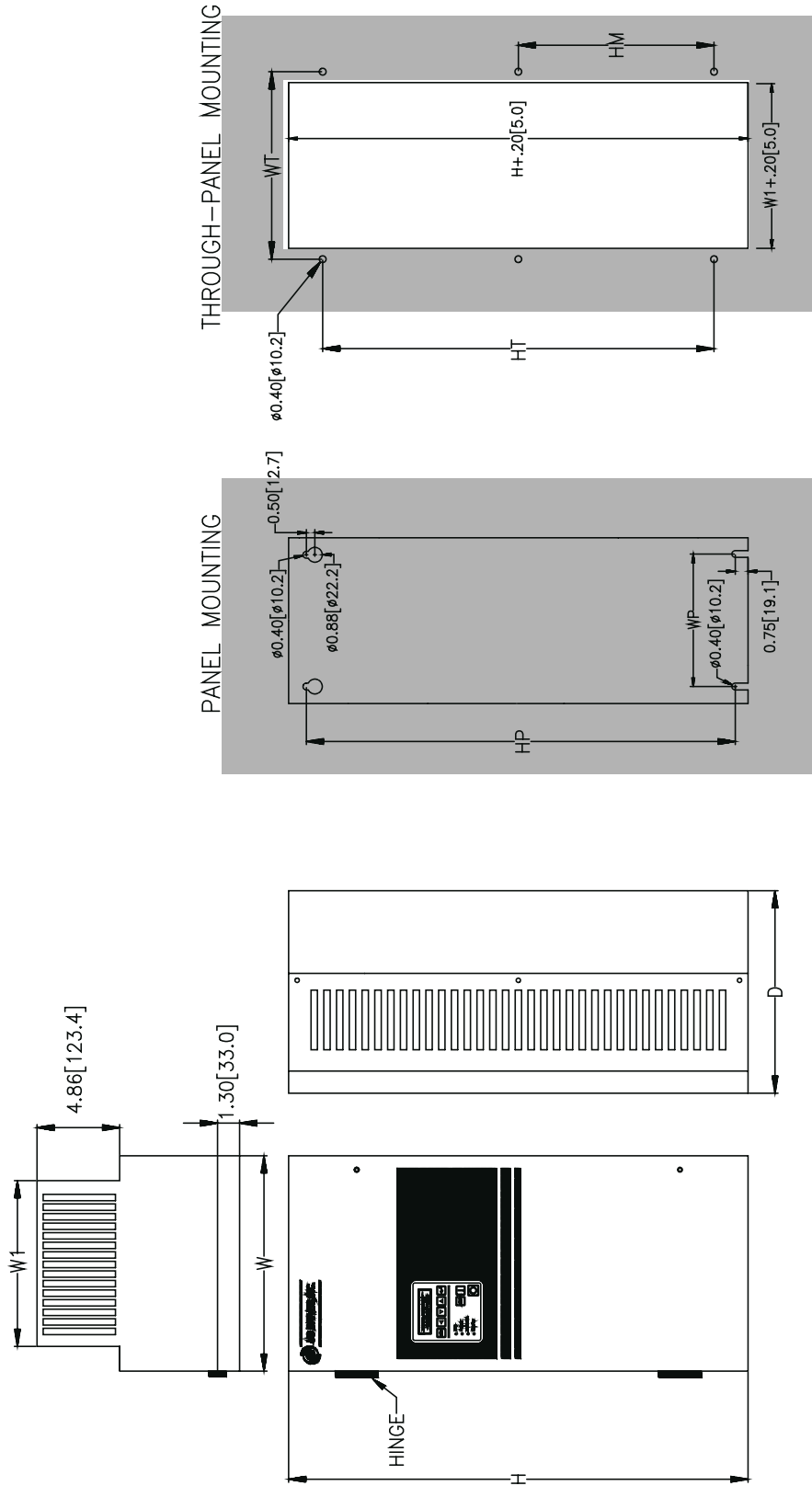

*Note: Top and bottom endplates are removable to gain access to mounting holes and to punch holes for conduits.

Frame Designation	H Inches [mm]	W Inches [mm]	D Inches [mm]	W1 Inches [mm]	HP Inches [mm]	WP Inches [mm]	HT Inches [mm]	HM Inches [mm]	Weights	
									WT Inches [mm]	Lbs [Kgs]
SIZE 1	27.00 [685.8]	12.67 [321.8]	11.91 [302.5]	9.75 [247.7]	25.21 [640.3]	7.75 [196.9]	23.00 [584.2]	12.5 [317.5]	11.03 [280.2]	75 [34]
SIZE 2	32.50 [825.5]	20.11 [510.8]	13.52 [343.4]	17.74 [450.6]	30.1 [764.5]	11.74 [298.2]	28.5 [723.9]	14.25 [362.0]	18.74 [476.0]	180 [82]

Figure 2-2a
**PHOENIX Mounting Information:
 Size 1 and Size 2 (Nema Type 1)**

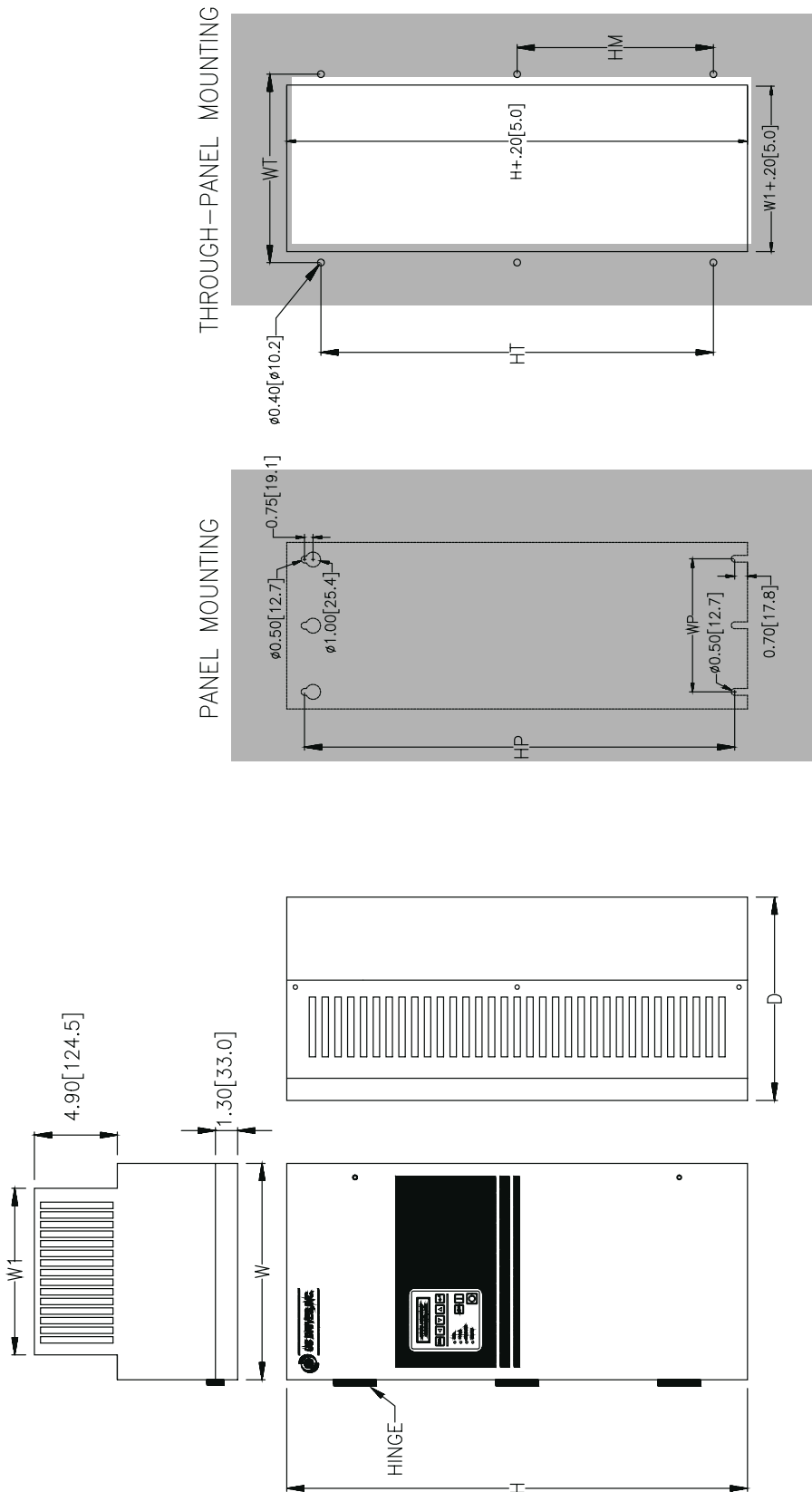
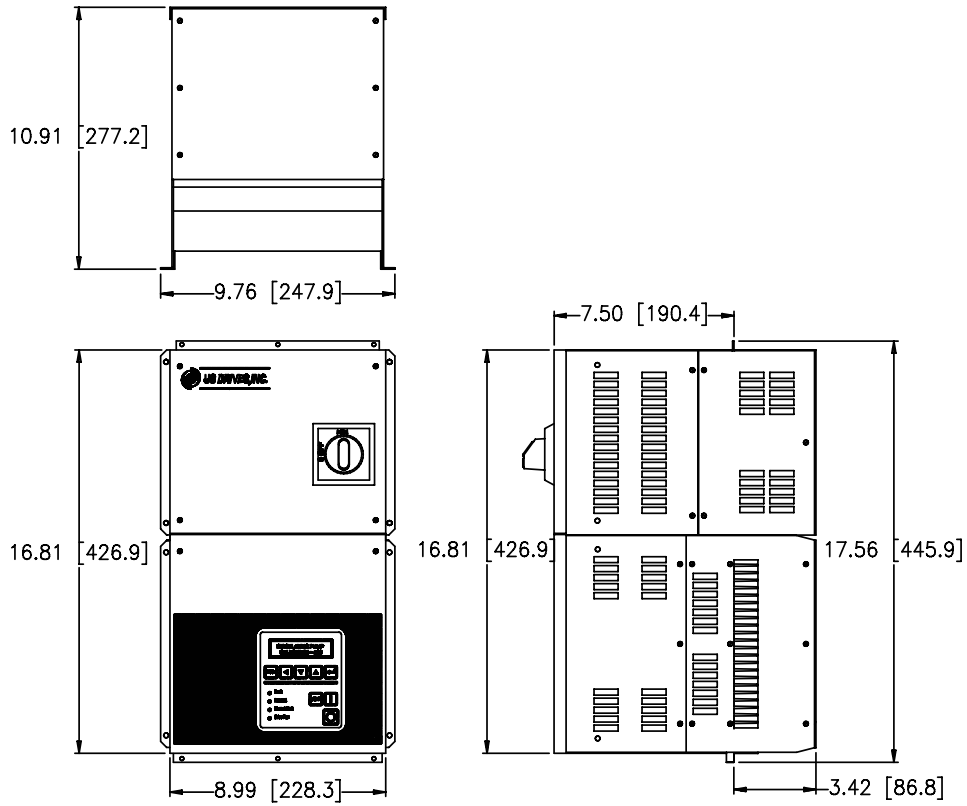

Figure 2-2b
PHOENIX Mounting Information
Size 3 (Nema Type 1)

*Note: Top and bottom endplates are removable to gain access to mounting holes and to punch holes for conduits.

Frame Designation	H Inches [mm]	W Inches [mm]	D Inches [mm]	W1 Inches [mm]	HP Inches [mm]	WP Inches [mm]	HT Inches [mm]	HM Inches [mm]	WT Inches [mm]	Weights Lbs [Kgs]
SIZE 3	44.16 [1121.7]	31.13 [790.7]	17.81 [452.4]	29.15 [740.4]	41.21 [1047]	25.31 [642.8]	40 [1016]	21 [533.4]	29.72 [754.9]	500 [227]

Size 3 can also be free-standing with optional floor stand kit from US Drives.
 All size 4 drives are free-standing enclosures. Consult factory for dimensions.



PANEL MOUNTING

THROUGH-PANEL MOUNTING

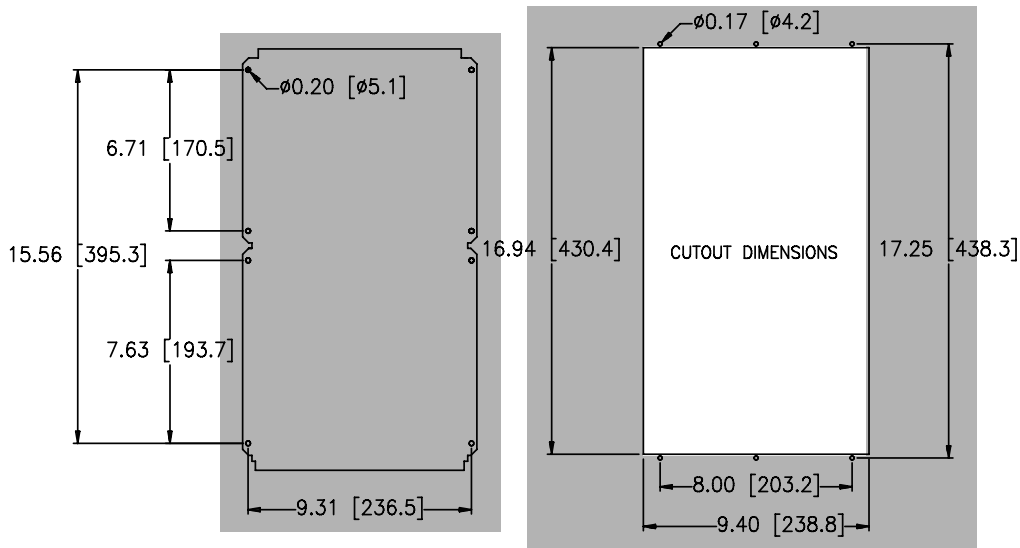

*Note: Top endplate and front covers are removable to gain access inside drive for wiring. For through-panel mounting customer provides seal for gap on both sides of cutout.

Approximate Weighth Lbs/[Kgs]: 42/[19]

Figure 2-2c
PHOENIX Mounting Information:
Size 0 with Disconnect Switch and Fuses (Nema Type 1)

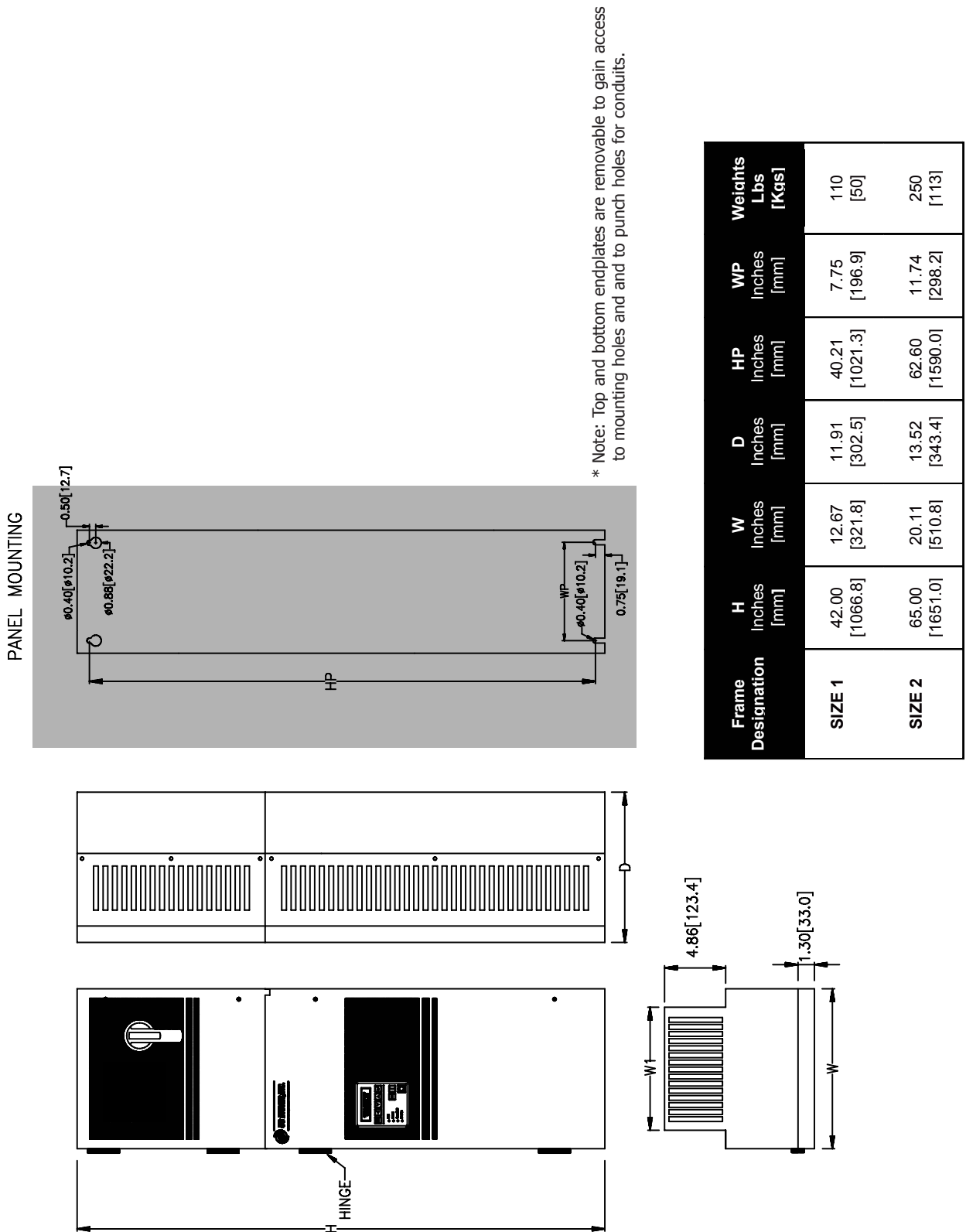
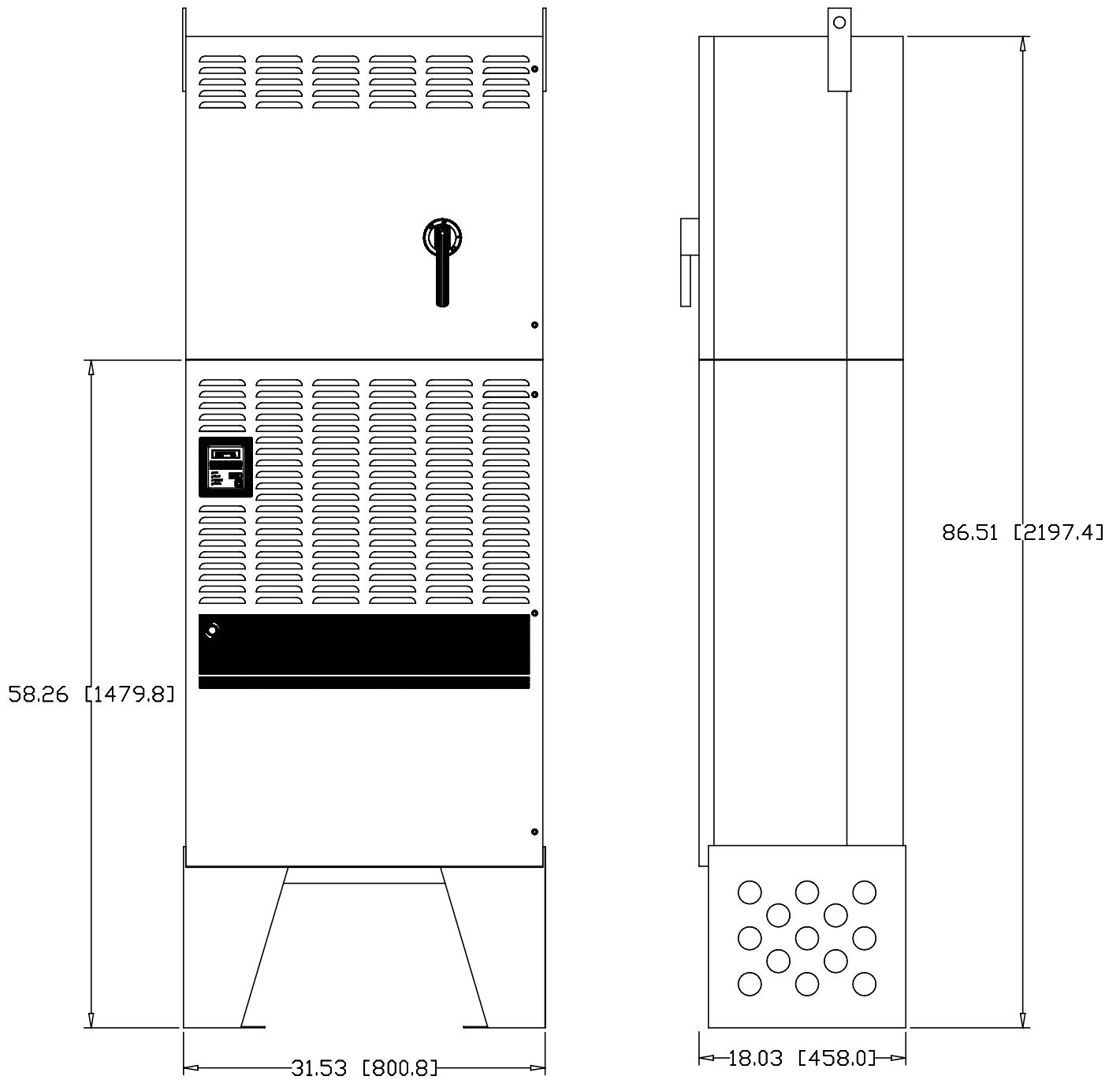

Figure 2-2d
PHOENIX Mounting Information:
 Size 1 and Size 2 with Disconnect Switch and Fuses (Nema Type 1)



*Note: Top endplate is removable to gain access to mounting holes and to punch holes for conduit.

Approximate Weight Lbs/[Kgs]: 700/[317]

Figure 2-2e
PHOENIX Mounting Information:
Size 3 with Disconnect Switch and Fuses (Nema Type 1)

2-8 INSTALLATION AND WIRING

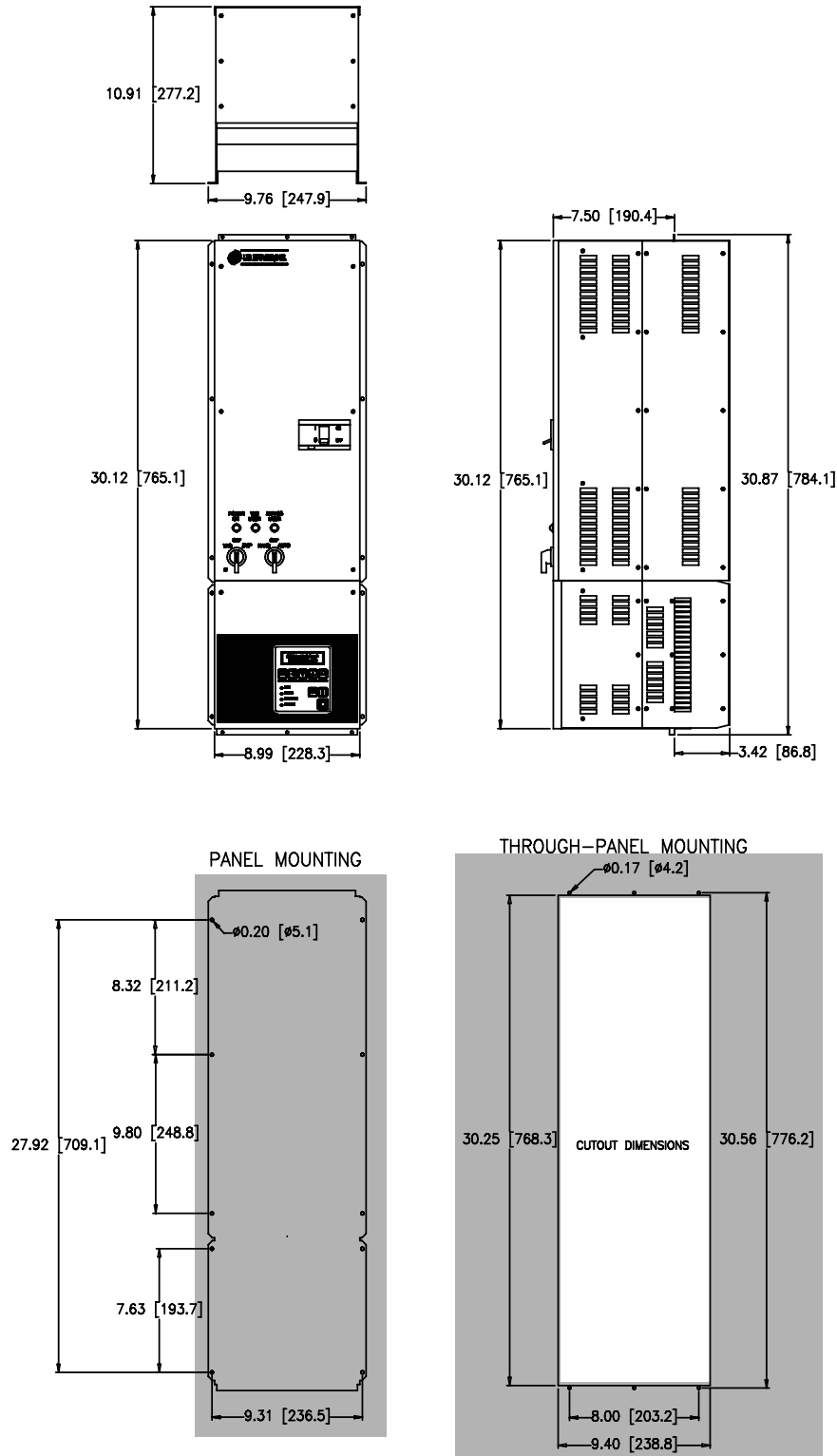

*Note: Top endplate and front covers are removable to gain access inside drive for wiring. For through-panel mounting customer provides seal for gap on both sides of cutout.

Approximate Weight Lbs/[Kgs]: 75/[34]

Figure 2-2f
PHOENIX Mounting Information:
Size 0* with Bypass (Nema 1 Type 1)

* 240VAC & 480VAC only (D2 & D4 models), for 600VAC (D5 models) consult factory for enclosure size.

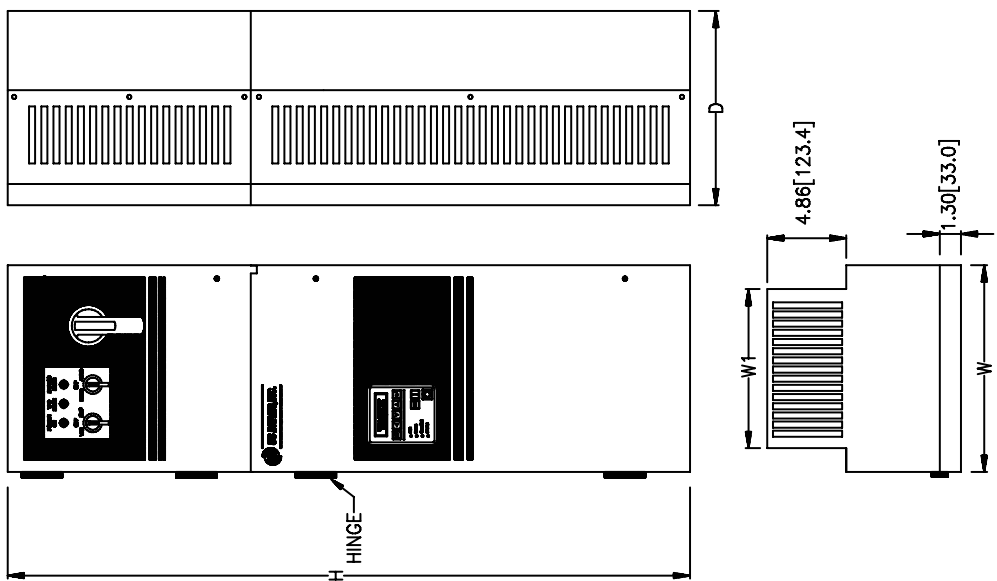
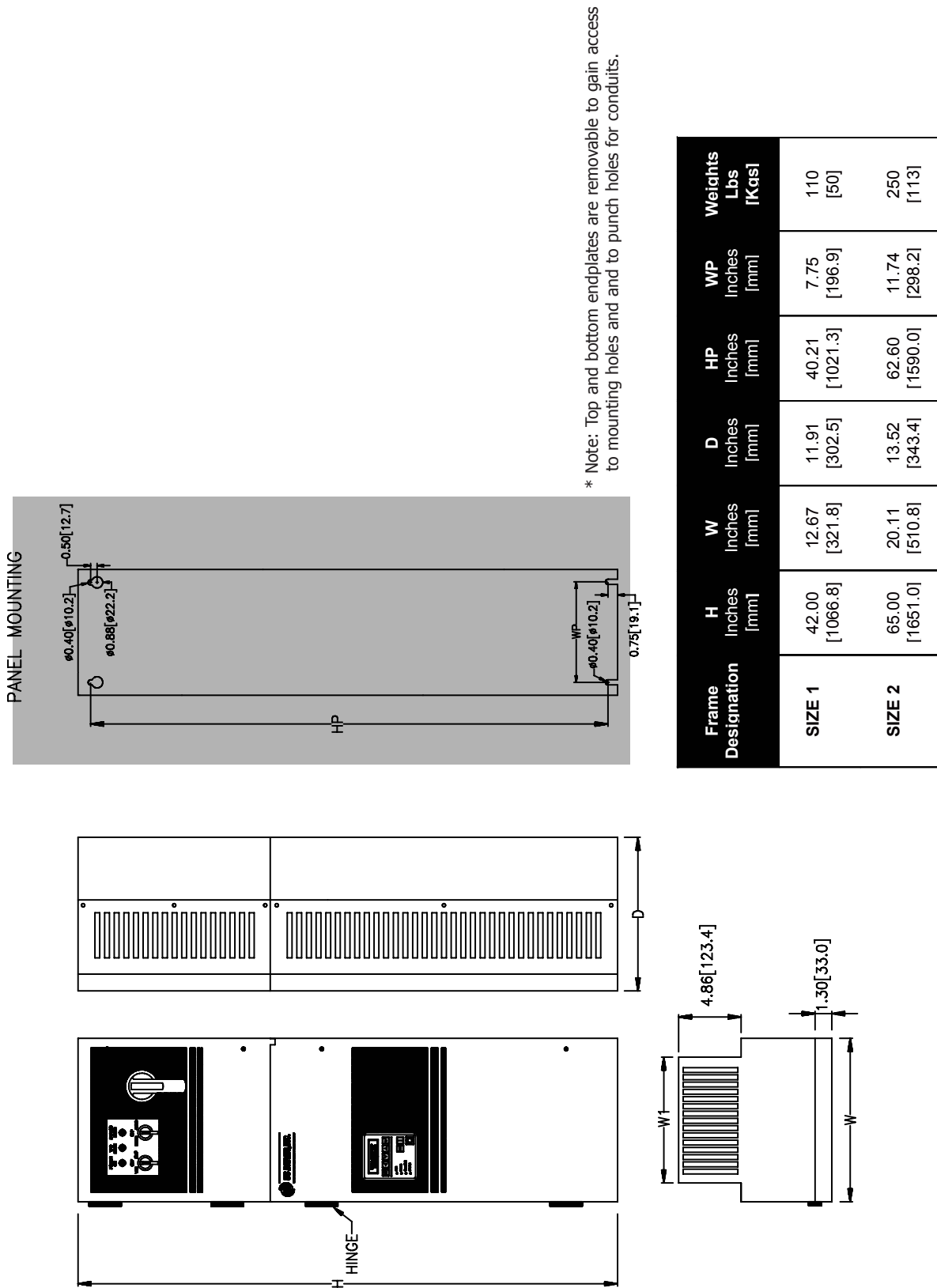

Figure 2-2g
PHOENIX Mounting Information:
Size 1 and Size 2 with Bypass (Nema Type 1)

*Note: For 100HP - 240VAC and 250HP - 480VAC: Enclosure is 72" x 30" x 23" floor mount.

2.5 AC SUPPLY SOURCE

PHOENIX Drives are suitable for use on a power system capable of delivering up to a maximum of 200,000 rms symmetrical amperes, 250/500/600 +10% volts maximum when used with AC input line fuses specified in tables 1-1, 1-2 and 1-3 respectively.

WARNING

To guard against personal injury and/or equipment damage caused by improper fusing, use only the recommended line fuses specified in tables 1-1, 1-2 and 1-3.

2.5.1 Unbalanced Distribution Systems

The PHOENIX Drive is designed to operate on three-phase supply systems whose line voltages are symmetrical. Surge suppression devices are included to protect the drive from lightning induced overvoltages between line and ground. Where the potential exists for abnormally high phase-to-ground voltages (in excess of one hundred twenty-five percent (125%) of nominal), or where the supply ground is tied to another system or equipment that could cause the ground potential to vary with operation, suitable isolation is required for the drive. Where this condition exists, an isolation transformer is **strongly recommended**.

2.5.2 Ungrounded Distribution Systems

All Phoenix drives are equipped with MOVs that provides voltage surge protection and phase-to-phase plus phase-to-ground protection which is designed to meet IEEE 587. Where the potential exists for abnormally high phase-to-ground voltages (in excess of 125% of nominal), an isolation transformer is strongly recommended. The MOV circuit is designed for surge suppression only (transient line protection), not continuous operation. With ungrounded distribution systems, the phase-to-ground MOV connection could become a continuous current path to ground.

If the AC source for the drive does not have a ground reference (neutral or phase ground), an isolation transformer with the neutral of the secondary grounded is highly recommended. These drives contain PE referenced MOV devices for input transient voltage limiting. Transients occurring on a non-ground referenced voltage source may generate excessive line to ground voltages which could exceed the limits of the insulation system of the drive. Under these conditions, it is highly recommended that a system level transient voltage suppression device be employed in order to limit the potential line to ground voltage. Contact factory If the drive must be operated on an ungrounded voltage source.

2.5.3 Input Power Conditioning

Since all PHOENIX Drives (E2-0025 and higher, E4-0025 and higher, E5-0025 and higher) have a built in three percent (3%) bus reactor, an external line reactor or isolation transformer is generally not required. Under extreme conditions, however, an external line reactor or isolation transformer may be required.

The basic guidelines for determining if a line reactor or isolation transformer is required are as follows:

1. If the AC input power system does not have a neutral or one phase referenced to ground (see section 2.5.2), an isolation transformer with the neutral of the secondary grounded is **highly recommended**. If the line-to-ground voltages on any phase can exceed one hundred twenty-five percent (125%) of the nominal line-to-line voltage, an isolation transformer with the neutral of the secondary grounded, is **always required**.
2. If the AC line supplying the drive has power factor correction capacitors that are switched in and out, an isolation transformer or three percent (3%) line reactors are recommended between the drive and the capacitors.
3. If the AC line frequently experiences transient power interruptions or significant voltage spikes, an isolation transformer or three percent (3%) reactor is recommended.

2.5.4 Input Fusing

WARNING

PHOENIX Drives sizes 0 through 3 do not provide input power short circuit fusing. Maximum Recommended AC Line Fuses are shown in tables 1-1, 1-2 and 1-3. Note that branch circuit breakers or disconnect switches can not respond fast enough to provide the level of protection that the drive components require.

2.6 Input Devices

WARNING

Hardwired Stop Circuit

The drive start/stop control circuitry includes solid-state components. If hazards due to accidental contact with moving machinery or unintentional flow of liquid, gas or solids exist, an additional hardwired stop circuit is required to remove AC line power to the drive. When AC power is removed, the motor will coast to a stop. Consequently, an auxiliary braking method may be required.

WARNING

Motor Starters

The PHOENIX Drive is intended to be controlled by control input signals that will start and stop the motor. A device that routinely disconnects then reapplies line power to the drive for the purpose of starting and stopping the motor is not recommended.

WARNING

Bypass Contactors

An incorrectly applied or installed bypass system can result in Drive damage or reduction in product life. The most common mistakes are:

- Wiring the AC line to the Drive output or control terminals.
- Incorrect bypass or output circuits.
- Output circuits that do not directly connect to the motor.

2.7 ELECTRICAL INTERFERENCE (EMI/RFI)

2.7.1 Drive Immunity

The immunity of the PHOENIX Drives to externally generated interference is outstanding. No special precautions other than following the procedures outlined in this manual are required.

It is recommended that the coils of AC and DC energized contactors interfaced with the drives be suppressed with RC networks and diodes respectively or with similar devices. This is because non-suppressed coils (inductors) can generate high electrical transients.

In areas prone to frequent lightning strikes, the standard MOV's (Metal Oxide Varistors) supplied with the drive may need to be supplemented with additional surge suppression MOV's on the AC line feeding the drive.

2.7.2 Drive Emissions

Care must be used in the routing of power and ground connections to the drive to avoid interference with sensitive equipment that may be nearby. The cable from the drive to the motor carries switched voltages and should be routed well clear of sensitive equipment. The ground conductor of the motor cable should be connected to the drive ground stud directly. Connecting this ground conductor to a cabinet ground point or ground bus bar may cause high frequency current to circulate in the ground system of the drive enclosure. The motor end of this ground conductor must be solidly connected to the motor case ground. See Figure 2-3.

Shielded or armored cable may be used to minimize radiated emissions from the motor cable. The shield or armor should be connected to the drive ground stud and to the motor ground as shown in Figure 2-3.

2.8 GROUNDING

Refer to the "Recommended Power Wiring" diagram in figure 2-3 for grounding instructions. The drive must be connected to AC system ground using the **power ground stud(s)** provided near the input and output power terminal blocks. All drives provide a separate power ground stud or terminal point for both the input AC power terminal blocks (L1, L2 and L3) and the output to motor terminal blocks (U, V, and W). Ground impedance must conform to requirements of national and local industrial codes (NEC, VDE 0160, BSI, etc.) and should be inspected and tested at regular intervals.

The outgoing motor cable ground wire connects directly to the power ground stud as well as incoming AC line system ground wire. **These ground wires must have a current rating in compliance with the above mentioned national and local codes.** This results in the motor frame ground to be solidly connected through the drive chassis to the AC system ground.

Note that the drive signal common (**COM**) should **not** be connected to the **power ground stud** directly. If desired, **one** of these commons may be connected to **earth ground** at a single point outside the drive enclosure – see section 2.8.3 for more details.

For multiple drive systems, if the signal common on each drive is to be grounded, they can be "daisy-chained" connected, using a single **COM** point on each drive. Note that this drive **COM** "bus" should only tie to **earth ground** at only one point.

2-12 INSTALLATION AND WIRING

2.8.1 Grounding Sensitive Circuits

It is critical to control the paths through which high frequency ground currents flow. Sensitive circuits should not share a path with such currents. Control and signal conductors should not be run near or parallel to power conductors.

2.8.2 Motor Cable Grounding

The ground conductor of the motor cable (drive end) must be connected to the **power ground stud** provided near the U, V and W output to motor terminals. Grounding directly to drive provides a direct path for high frequency current returning from the motor frame and ground conductor. At the motor end, the ground conductor should also be connected to the motor case ground. See Figure 2-3.

If armored or shielded cables are used, the armor/shield should be grounded at both ends per figure 2-3.

2.8.3 Control Logic and Signal Grounding

The control logic and signal wiring for the PHOENIX Drive is shown in Figure 2-4. If the control wires are short, and contained within a cabinet that has no sensitive circuits, the use of shielded control wiring is not necessary. For all configurations, it is strongly suggested that shielded wire be used for the signal wiring.

It is generally recommended that the drive control board signal common (COM) be connected to true earth ground at one point in a single or multi-drive system. For this case, a single #16AWG wire should be connected from **one COM** terminal on the control board to a single point outside of the drive enclosure. With this ground connection in place, shields from incoming signal cables may be grounded at the control board terminal block **COM** terminals. The remote end of the shielded signal cables should be taped off with no connection to earth ground.

CAUTION

Floating Signal Common

If the signal common (**COM**) on the drive control board is to be left floating (not connected to earth ground), the shields should be grounded only at the remote end. At the drive end, the shields should be taped off. For the case of a floating signal common on the drive control board, signal shields for external cables routed to the drive control board terminal blocks must not be connected to any of the **COM** terminals. This is so high frequency ground currents will not be injected into the control board signal common with no low impedance path to ground.

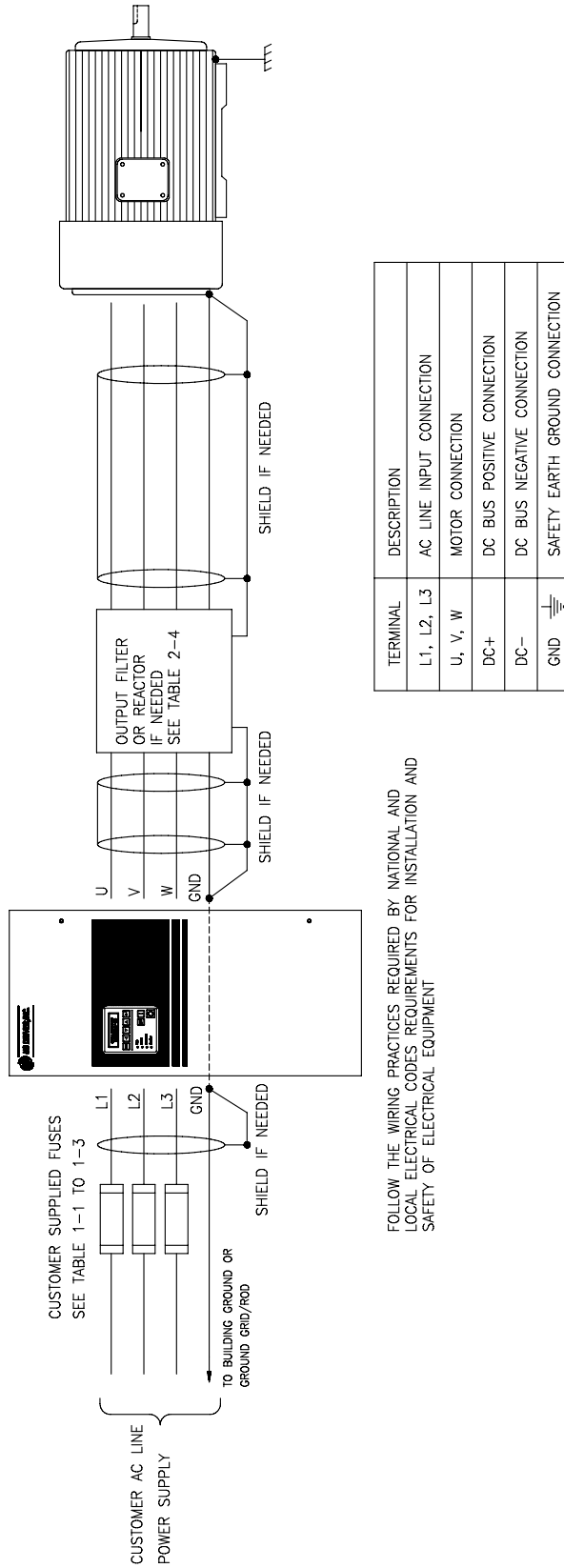

FOLLOW THE WIRING PRACTICES REQUIRED BY NATIONAL AND LOCAL ELECTRICAL CODES REQUIREMENTS FOR INSTALLATION AND SAFETY OF ELECTRICAL EQUIPMENT

Figure 2-3
Recommended Power Wiring

2.9 Power Cabling

Input and Output power connections are made through the power terminal block and power ground stud. The actual drive label markings are shown in Table 2-1. Maximum torque values for terminal connections are also indicated on labels next to the connection points.

**Table 2-1
Power Signal Description**

Terminal	Description
GND	Power Earth Ground Stud
L1 L2 L3 AC LINE INPUT	AC Line Input Terminals
DC- DC+	DC Bus Terminals
U V W OUTPUT TO MOTOR	Motor Connection

2.9.1 Motor Cables

There are a wide variety of cable types that are acceptable for drive installations. For many installations, unshielded motor cable is acceptable, providing that it can be separated from sensitive circuits. A good rule of thumb to use is to allow a spacing of one foot (0.3 meters) for every 33 feet (10 meters) of length. For all situations, long parallel runs must be avoided. Conform to requirements of national and local industrial codes (NEC, VDE 0160, BSI, etc.) when selecting the type and size of the motor cable.

The cable should be 4-conductor with the ground being connected directly to the drive power ground and the motor frame ground terminal.

2.9.1.1 Shielded Motor Cable

If the separation suggested in section 2.9.1 above cannot be maintained or if sensitive circuits or devices are mounted or connected to machinery driven by the motor, shielded motor cable is recommended. The shield must be connected to ground at both ends to minimize interference. At the motor end, the motor cable shield should be tied to the motor frame ground and the drive end, to the power ground stud or ground terminal.

Shielded cable is also recommended for multiple drive installations where cable trays or large conduits are to be used to route motor leads from more than one drive. The shielded cable reduces the emission and capture (cross coupling) of noise between the motor leads of different drives. The cable shield

connected to ground at both the drive end and the motor end.

Armored cable can also be used effectively to shield the motor leads. If possible, it should only be grounded at the drive end and to the motor frame at the motor end. With PVC coated armored cable, if the armored cable is grounded at a user supplied cabinet entrance, shielded cable should be used within the cabinet if the power leads will run to close to control or signal wiring.

2.9.1.2 Conduit for Routing Motor Cables

If metal conduit is to be used for motor cable distribution, the following procedures must be adhered to.

- When drives are mounted in user supplied cabinets, ground connections should be made to a common point in the cabinet. When conduit is used, it is normally grounded at the motor frame ground (junction box) and the cabinet ground.

This helps reduce noise emissions from the drive. Please note that this recommendation is strictly for noise reduction and does not concern safety grounding requirements which are dictated by national and local codes. See section 2.1 (SAFETY WARNINGS) for details.

- If possible, each conduit should contain only one set of motor leads to minimize "cross talk" between drives which degrades the noise suppression techniques described above. If this is not practical, under no conditions should more than three sets of motor leads be installed in a common conduit. If more than three sets of motor leads are to be run in a common conduit, shielded cable must be used as described above.

2.9.1.3 Motor Lead Lengths

Installations with long motor cables may require the addition of an output reactor, a dv/dt filter or a carrier suppression filter to limit voltage reflections that become additive at the motor. Refer to Table 2-4 for guidance in using various techniques to limit the voltage reflections.

2.10 Control and Signal Wiring

Terminal blocks TB1 through TB4 on the drive main control board are used for connecting control and signal wiring to the PHOENIX drive. See Figure 2-4

for terminal block physical location and Figure 2-5 for terminal point connections. A brief summary of the terminal block assignments are shown in Table 2-3.

**Table 2-3
Drive Main Control Board Terminal
Block Layout**

TERMINAL BLOCK	DESCRIPTION
TB1	Programmable Output Contacts
TB2	Control Logic Inputs (start, stop, jog, etc.)
TB3	Programmable Analog Outputs
TB4	Analog Reference Inputs (speed refs., PID setpoints, etc.)

CAUTION
User installed control and signal wiring must be routed inside the drive enclosure such that it is separated from any other wiring and uninsulated live parts. Failure to observe this precaution can result in equipment damage.

Before proceeding with any signal wiring, the following precautions for the signal conduit and wire must be followed:

2.10.1 Signal Conduit Requirements

- Use either rigid steel or flexible armored steel cable.
- The signal conduit must cross non-signal conduit at an angle of between 45° and 90°.
- Do not route the conduit through junction or terminal boxes that have non-signal wiring.

2.10.2 Signal Wire Requirements

- Size and install all wiring in conformance with the requirements of national and local industrial safety regulations (NEC, VDE 0160, BSI, etc.)
- Use shielded wire for reference and other signal wire connections.
- Route all signal wiring away from high current lines such as AC lines.
- Always run the signal wire in steel conduit. Never run the signal wire with non-signal wire.
- Route external wiring, rated at 600 volts or more, in separate steel conduit to eliminate electrical noise pickup.
- For distances less than 150 feet, use a minimum of #22AWG wire. For distances more than 150 feet and less than 1000 feet, use a minimum of #16AWG wire.

**Table 2-4
Maximum Recommended Motor Cable Lengths**

Type of Termination at Drive	Maximum Cable Length With General Purpose Motor Feet [Meters]	Maximum Cable Length With "Definite Purpose Inverter-Fed Motor" ¹ Feet [meters]
None	100 [30]	400 [120]
3 % Reactor at Drive ²	300 [90]	600[180]
<i>dv/dt</i> Filter at Drive ³	1000 [300]	3000 [915]]
Carrier Suppression Filter ⁴	10 Miles [16 Kilometers]	10 Miles [16 Kilometers]

¹ "Definite Purpose Inverter-Fed Motor" as defined in NEMA MG1- Part 31 section 31.40.4.2 "Voltage Spikes".

² Reactor designed for Inverter output installation.

³ *dv/dt* Filters available from *US Drives*.

⁴ Carrier Suppression Filters available from *US Drives*. A Step-up-Transformer and/or oversized motor cables must be used when long wire run is required.

**Figure 2-4
Terminal Block Locations for Drive Control Board**

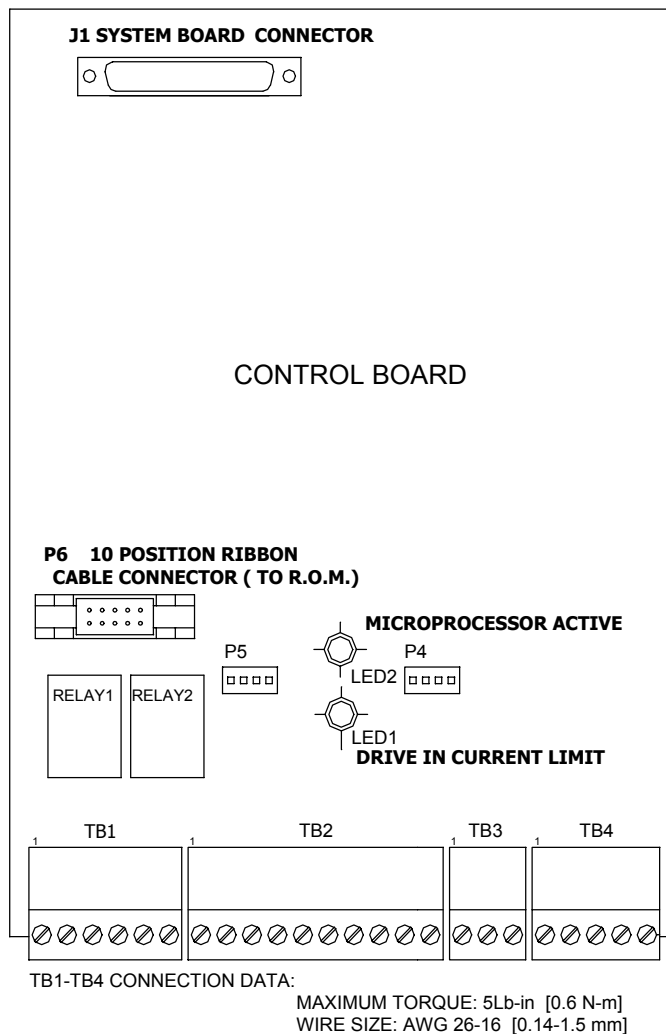

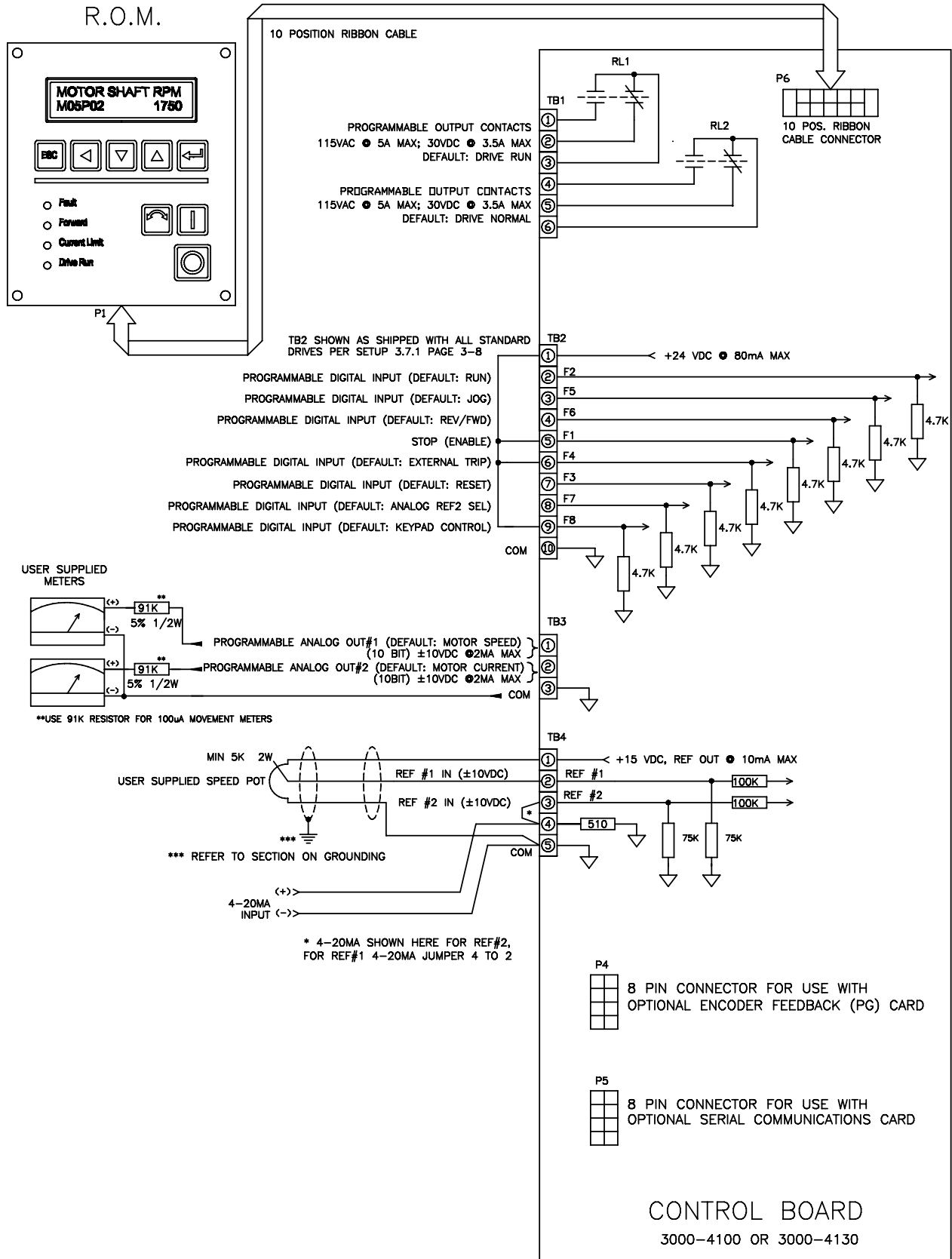

Figure 2-5
Control Logic and Signal Wiring

THIS PAGE INTENTIONALLY LEFT BLANK

3.0 REAL-TIME OPERATOR MODULE

3.1 ROM DESCRIPTION

This section gives a brief description of the various controls and indicators on the Real-time Operator Module (ROM). The material presented here must be understood before the user proceeds to the "Quick Setup" section.

The ROM, in its standard configuration, is mounted to the enclosure door. For applications where the drive is mounted in another enclosure (e.g. – NEMA 12), the ROM can be remotely mounted as far as forty feet from the control board.

The ROM can be viewed as having two sections; a Display Panel and a Control Panel. The Display Panel provides access to program and to view the various Drive parameters. The Control Panel allows various drive functions to be controlled such as starting and stopping as well as displaying the drive status.

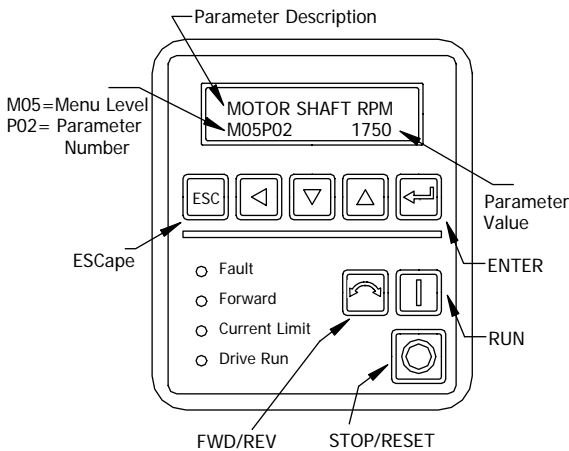

**Figure 3-1
ROM Front Panel**

3.2 DISPLAY PANEL KEY DESCRIPTIONS:

Escape

When pressed, the Escape key will abort the editing of a given parameter (restoring the original value if the parameter is R/W) if in the edit mode.

Enter

Pressing the enter key while on a menu item line, a flashing cursor will be displayed indicating a parameter value is ready for editing. After editing a parameter, pressing the enter key will cause the flashing cursor to go away and the value displayed is entered into memory.

Up/Down Arrow Keys

These keys are used to move up and down the menu level or to increment or decrement the parameter value.

Also simultaneous activation of both the Up and Down arrow keys quickly displays keypad reference parameter M01P04 (M00P10) for "Motor Operated Potentiometer" (MOP) mode. The MOP mode allows Keypad Reference to be increased or decreased by use of the Up and Down arrow keys. Pressing the enter key, the display will revert to the power-up display.

Left Arrow Key

Pressing the left arrow key when in the menu/parameter scrolling mode moves the flashing cursor from menu level to parameter number and vice versa, the up or down arrow keys can be used to change the menu level or the parameter number. Pressing the left arrow key when in edit mode moves the flashing cursor left to the next decade of the parameter value to be increased or decreased by the up or down arrow keys respectively. When reaching the extreme left travel, further pressing of the left arrow key "wraps" to extreme right decade position.

3.3 CONTROL PANEL KEY AND LED DESCRIPTIONS:

Run

The Run key will start the drive if no other Stop commands are present and the keypad is enabled.

Stop/Reset

If the drive is running, pressing the Stop/Reset key will cause the drive to stop if the keypad is enabled.

If the drive has stopped due to a fault, pressing the Stop/Reset key will clear the fault and reset the drive.

Fwd/Rev

This key has the function of Forward and Reverse command.

Fault LED

The Fault LED becomes lit upon generation any fault and remains lit until the drive is reset either by way of the Stop/Reset key or a terminal block reset button. Simultaneous with the illumination of the Fault LED the appropriate Fault message is put out on the display. A blinking fault LED indicates that motor current is greater than 105% of the programmed motor rated current. If the current is not reduced, the drive will trip on IxT overload after a period of time that depends on the extent of the overload. See Section 4-2 parameter M10B07 definition.

NOTE

Pressing any Display Panel key will clear the fault message allowing normal use of the display. However, until the drive is reset, the fault remains uncleared and the Fault LED will remain lit.

Forward LED

The Forward LED becomes lit upon command for the drive to run in the forward direction. This may be achieved by way of the programmable User key or from a terminal block input. When this LED is not lit, the drive is being commanded to run in the reverse direction.

Current Limit LED

This LED is lit whenever the drive is in current limit.

Drive Run LED

This LED indicates when the drive is running.

3.4 LIST OF PARAMETERS

3.4.1 Values and Character Strings

For parameters containing character strings, the following lists give the character strings as well as their numeric equivalents. When these parameters are accessed using serial communications, the numeric equivalents are used.

NOTE

Some parameters have alternative default values for certain versions of drive.

3.4.2 List of Menus

M00	Quick Setup & Quick Metering Menu
M01	Frequency reference selection, limits and filters
M02	Ramps
M03	Encoder
M04	Current limits and torque control
M05	Motor control
M06	Operational modes
M07	Analog inputs and outputs
M08	Digital inputs
M09	Digital outputs & bit selectors
M10	Status logic and diagnostic information
M11	Miscellaneous
M12	Programmable thresholds and variable selectors
M13	Timer functions
M14	PID control loop
M15	Position control
M17	2 nd Motor Parameters

Menu display names:

M00	QUICK SETUP MENU
M01	FREQ REFS MENU
M02	RAMPS MENU
M03	ENCODER MENU
M04	CURR-TORQUE CTRL
M05	MOTOR CONTROL
M06	OPERATION MODES
M07	ANALOG I/O MENU
M08	DIG INS-MODE SEL
M09	DIG OUTS-BIT SEL
M10	STATUS-DIAGNOSTIC
M11	MISCELLANEOUS
M12	THRESHOLDS-VARSEL
M13	TIMERS FUNCTIONS
M14	PID CONTROL LOOP
M15	POSITION CONTROL
M17	2 ND MOTOR PARAMS

3.4.3 Quick Setup menu List

The Quick Setup menu contains only the most commonly used parameters

Quick Setup Menu:
(Program Type parameters):

RATED MOTOR VOLT	- M00P01
BASE MOTOR FREQ	- M00P02
RATED MOTOR CURR	- M00P03
NUMBER OF POLES	- M00P04
SYM CURRENT LIM	- M00P05
ACCEL RAMP	- M00P06
DECEL RAMP	- M00P07
MAX FREQUENCY	- M00P08
MINIMUM FREQ	- M00P09
KEYPAD REFERENCE	- M00P10

Quick Setup Menu:
(Metering Type parameters)

SOFTWARE VERSION	- M00P11
DRIVE MODEL NO	- M00P12
MOTOR VOLTAGE	- M00P13
MOTOR POWER	- M00P14
DC BUS VOLTAGE	- M00P15
AC LINE VOLTAGE	- M00P16
LAST FAULT	- M00P17
MOT CURR-TOTAL	- M00P18
FINAL FREQ REF	- M00P19
MOTOR SHAFT RPM	- M00P20

3.4.4 Parameter Attribute

Parameter changing and saving

New values given to parameters become effective immediately and are saved into eeprom.

Read-write and read-only parameters

Read-write parameters are shown as R-W; read-only parameters are shown as RO.

Default values

Default values displayed on the drive are given in the Default column in Parameter Definitions 4.2.

3.4.5 Menu Structure

The drive is programmed by entering values into parameters. The parameters are held in menus that group the parameters according to their functions.

The first menu is Menu 0 which is the Quick Setup Menu. This contains the basic parameters that may be read or adjusted for simple applications

The remaining menus are the advanced Menus. These contain all the parameters that may be read or adjusted for advanced applications.

The parameters in Menu 0 (M00) are duplicates of certain parameters in the advanced menus; for example, parameter M00P10 is a duplicate of M01P04 (Keypad speed reference).

This menu is also user programmable. A user can define and create a menu using other parameters, for details refer to parameters M11P01 – M11P20.

3.4.6 Types of parameters

There are two types of parameter, as follows:

Bit parameters

Bit parameters can be set in either of two logic states and are used as on/off or change-over switches.

Bit parameters are prefixed with the letter B (e.g. – M01B11)

Variable Parameters

Variable parameters can be set at a value within a specified range. They are used to set numerical values, or to set the positions of switches having more than two options.

Variable parameters are prefixed with the letter P (e.g. –M01P25)

Certain parameters contain character strings instead of numerical values. The character strings are displayed on the Control Keypad in place of values. When these parameters are accessed and edited using serial communications, a numerical equivalent is displayed on the host computer. The numerical equivalent is used for programming these parameters.

3.4.7 Restore All Parameters to Factory Default Values

To restore all parameters to factory default value

1. Make sure the drive is disabled and that the motor is not being driven.
2. Select parameter M11P36 "FACTORY DEFAULTS".
3. Select "YES".
4. Press the enter key.
5. The default values are entered into all the parameters.

3.4.8 Security Code

A security code can be set to prevent unauthorized personnel from making changes to the drive parameters. There are two states, "locked state" and "unlocked state". In the "locked state" parameters can be viewed but cannot be changed, except of course entering the access code. In the "unlocked state", the user can edit any parameter.

The drive is shipped defaulted "unlocked" where all parameters are accessible and be can edited by the user. The user programmable security code (parameter M11P29 "SECURITY CODE") is shipped defaulted to 0, so that on every power-up, the drive is always "unlocked".

To change to "locked state" where no parameter editing is allowed, you must change security code parameter M11P29 "SECURITY CODE" from 0 to any number up to 4 digits (be sure to remember this number because your access code must match this number to "unlock" the drive). Right after you change the security code, you must go to parameter M11P37 "ACCESS CODE" and reenter 0 to "lock" the drive. To go back to the "unlocked state" you must enter your access code into parameter M11P37 "ACCESS CODE", the drive will stay in "unlocked state" until you power down the drive or change parameter M11P37 "ACCESS CODE".

3.5 START UP AND QUICK SETUP

The "Factory Default" settings for the drive have been purposely setup to make the "Start-Up and Quick Setup" as simple as possible. Even for advanced users, going through this procedure is a quick and simple way to verify proper drive operation and it provides a good starting platform for more advanced setups.

This Start-Up and Quick Setup procedure covers only the most commonly adjusted parameters, all of which appear in the quick setup menu 0.

WARNING

THE FOLLOWING PROCEDURES SHOULD ONLY BE PERFORMED AFTER A COMPLETE REVIEW OF THE INSTALLATION SECTION OF THIS MANUAL. THIS SECTION CONTAINS WARNINGS, INITIAL CHECKS, WIRING INSTRUCTIONS AND OTHER INFORMATION CRITICAL TO THE SUCCESSFUL STARTUP OF THE DRIVE. PAY PARTICULAR ATTENTION TO THE "WARNING" AND "CAUTION" NOTES.

Power must be applied to the drive to perform the following procedure. Some of the voltages present are at the incoming line potential. To avoid electric shock hazard or damage to equipment, only qualified service personnel should perform the following procedure. Thoroughly read and understand the procedure before beginning. If an event does not occur while performing this procedure, **Do Not Proceed. Remove Power** by opening the branch circuit disconnect device and correct the malfunction before continuing.

NOTE

Power must be applied to the drive when viewing or changing Phoenix parameters. Previous programming may affect the drive status when power is applied. If the state of the parameters is in question, load factory defaults as detailed in section 3.4.7, "Drive Programming" before proceeding. Remote start circuits may be connected to TB2 of the control board. Confirm that all circuits are in a de-energized state before applying power. User supplied voltages may exist at TB2, even when power is not applied to the drive. Refer to section 4.0, for fault message information

The following procedure describes starting and stopping the drive using the ROM Run and Stop keys. The drive frequency reference is from the ROM Keypad reference parameter M00P10.

3.6 START-UP PROCEDURE FOR RUNNING DRIVE WITH ROM "KEYPAD":

3.6.1 Wiring Checks – Motor Disconnected:

1. Verify that AC line power at the disconnect device is within the rated value of the drive. If a control interface option is installed, verify that the control power to this board matches the board rating.
2. Remove and lock-out all incoming power to the drive including incoming AC power to terminals L1, L2 and L3 plus any separate control power for remote interface devices. Open the drive door and disconnect the motor leads from terminals U, V and W.
3. Verify that the "Stop", "External Fault" and "keypad enable" interlocks are installed. If not, connect jumpers between TB2-1, TB2-5, TB2-6 and TB2-9 as shown in Figure 3-1 below

**Figure 3-2
Control Wiring for Keypad Operation**

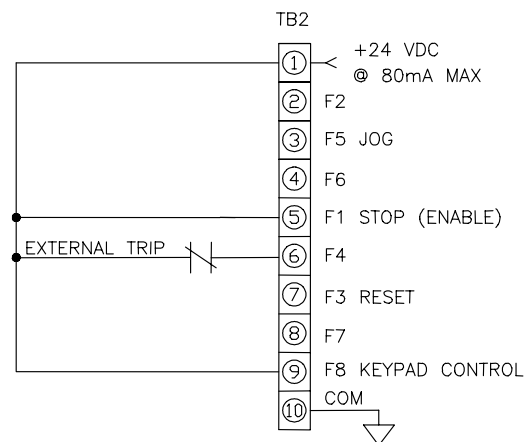

4. Check for earth ground faults with an ohmmeter. A very high resistance of over 1 mega-ohm should be measured from earth ground to all terminals. If there is a low reading, investigate before proceeding. If all readings are high, then power can be applied.
5. Apply AC power and control voltages to the drive.

3.6.2 Drive Programming:

1. On power-up, the LCD Display should light and show the default Powerup Display. Press the Escape key and then the Left arrow key and you see a flashing cursor on the menu level. Press the Up/Down Arrow keys until you see the M00PXX menu 0. Press Left arrow key until you see a flashing cursor on the parameter number. You are now ready to edit the following parameters if necessary.
2. Use the UP/Down Arrow key to view each parameter listed below and observe its value. If you like what you see, go on to the next parameter. If you want to change the value of a parameter, press the Enter key and using the Left and Up/Down Arrow keys to get the value you want. Accept the parameter value by hitting the Enter key, then proceed to the next parameter. The following parameters are found under the Quick Setup menu:

Quick Setup Menu (Program Type):

RATED MOTOR VOLT	- M00P01
BASE MOTOR FREQ	- M00P02
RATED MOTOR CURR	- M00P03
NUMBER OF POLES	- M00P04
SYM CURRENT LIM	- M00P05
ACCEL RAMP	- M00P06
DECEL RAMP	- M00P07
MAX FREQUENCY	- M00P08
MINIMUM FREQ	- M00P09
KEYPAD REFERENCE	- M00P10

3.6.3 Remove Power

Remove and lock-out the input and control power to the drive. When the ROM Display is no longer illuminated, open the drive door.

WARNING

TO AVOID A HAZARD OF ELECTRIC SHOCK, AFTER THE INPUT AND CONTROL POWER IS REMOVED FROM THE DRIVE AND THE ROM DISPLAY IS NO LONGER LIT, WAIT FIVE (5) MINUTES FOR BUS CAPACITORS TO FULLY DISCHARGE.

3.6.4 Reconnect Motor:

WARNING

In the following steps, rotation of the motor in an undesired direction can occur. To guard against possible equipment damage, it is recommended that the motor be disconnected from the load before proceeding.

1. Reconnect motor leads and close drive door.

3.6.5 Check for Correct Motor Rotation:

1. Reapply power to the drive
2. Verify that the drive reference frequency is at zero Hz.

For Keypad frequency reference control, press the Up arrow and Down arrow keypad keys simultaneously to quickly access the keypad reference parameter M01P04 (M00P10). Simply then use the Display Panel Left Arrow key to select the desired decade and the Down Arrow key to decrease the parameter value to zero. When finished adjusting speed, pressing the Enter.

3. Using the Forward LED on the ROM Display Panel verify that the forward direction is selected. (LED should be illuminated).
4. Start the drive using the ROM Run key. Slowly increase the drive speed until the motor begins to turn. Note the direction of motor rotation, then stop the drive using the ROM Stop key. If the direction of rotation is correct, proceed on to section 3.6.6, "Check for Proper Operation".

If the direction of motor rotation is incorrect, remove and lock-out input and control power to the drive. When the ROM is no longer illuminated, wait for five (5) minutes for the bus capacitors to fully discharge. Open drive door and interchange any two of the three motor leads, U, V, or W. Close drive door and repeat steps 2 through 5 to verify correct rotation.

3.6.6 Check for Proper Operation:

1. Start the drive and slowly increase the frequency reference. Check for proper motor operation throughout the speed range.
2. With the drive running at 10 Hz or greater, press the ROM Stop key and verify that the correct stopping mode has been programmed.
3. This completes the "Startup and Quick Setup" procedure. Depending on your application, further parameter programming may be required. Refer to the Programming section of this manual for more information.

That's all there is to it! Remember; use the Run and Stop Display Panel keys to control the drive.

Remember, you can use the following Quick Metering Menu to verify and view motor current, speed, and other display parameters.

SOFTWARE VERSION	- M00P11
DRIVE MODEL NO	- M00P12
MOTOR VOLTAGE	- M00P13
MOTOR POWER	- M00P14
DC BUS VOLTAGE	- M00P15
AC LINE VOLTAGE	- M00P16
LAST FAULT	- M00P17
MOT CURR-TOTAL	- M00P18
FINAL FREQ REF	- M00P19
MOTOR SHAFT RPM	- M00P20

3.7 TYPICAL CONTROL SETUPS

Starting point for all setups described below are from factory default setup shipped with all standard drives.

3.7.1 Keypad Mode (Keypad Start/Stop & Keypad Reference)

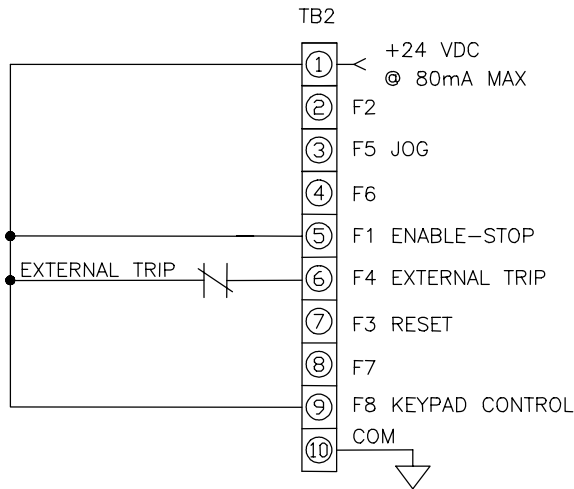

- Start command: Keypad RUN key.
- Stop command: Keypad STOP key.
- * FWD/REV command: Keypad FWD/REV key.
- Jog command: JOG contact at TB2-3-TB2-1.
- Reset command: keypad STOP/RESET key or pushbutton at TB2-7-TB2-1.
- Speed reference source: Keypad reference M00P10.

3.7.2 Keypad Start/Stop with Analog Speed Reference

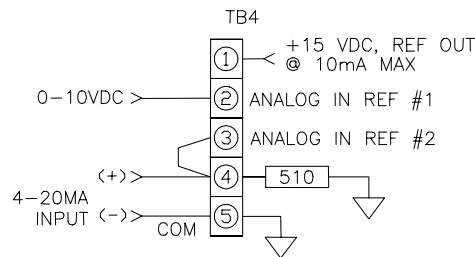
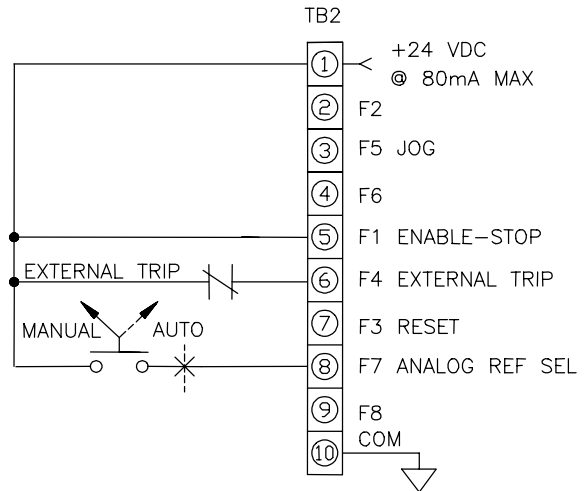

- Change the following parameters in the order shown:
- M06P18 (KEYPAD CONT MODE) ← NO KEYS
 - M06B15 (EN KEYPAD RUN) ← 1
 - M06B16 (KEYPAD STOP) ← 1
 - M06B17 (EN KEYPAD FWD/RV) ← 0

Manual Mode:

- Start command: Keypad RUN key.
- Stop command: Keypad STOP key.
- * FWD/REV command: Keypad FWD/REV key.
- Jog command: JOG contact at TB2-3-TB2-1.
- Reset command: keypad STOP/RESET key or pushbutton at TB2-7-TB2-1.
- Speed reference source: Analog reference 1, 0-10Vdc operation.

Auto Mode:

- Start command: Keypad RUN key.
- Stop command: Keypad STOP key.
- * FWD/REV command: Keypad FWD/REV key.
- Jog command: JOG contact at TB2-3-TB2-1.
- Reset command: keypad STOP/RESET key or pushbutton at TB2-7-TB2-1.
- Speed reference source: Analog reference 2, 4-20MA operation with min speed when loss of 4-20MA signal (refer to M07P13 for other choices).

*NOTE: Reverse function is disabled. If FWD/REV is needed set M06B23 (DISABLE REV ROT) to 0 and M06P18 (KEYPAD CONT MODE) to "ALL KEYS".

*NOTE: Reverse function is disabled. If FWD/REV is needed set M06B23 (DISABLE REV ROT) to 0 and M06B17 (EN KEYPAD FWD/RV) ← 1

3.7.2.a “3-Wire or “Momentary Contact” Control with Keypad Speed Reference

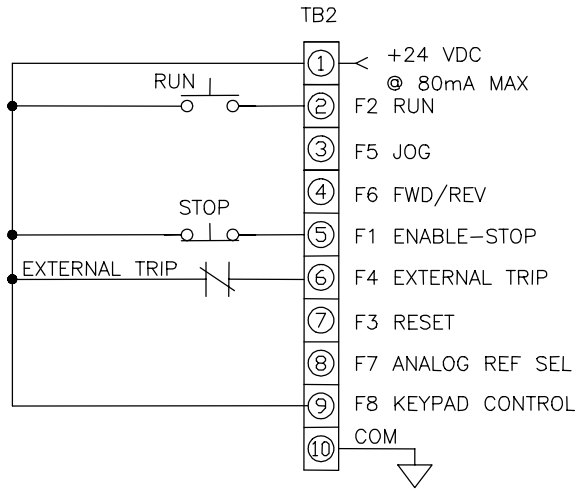

Change the following parameters in the order as shown:
 M06P18 (KEYPAD CONT MODE) ← NO KEYS
 M06B15 (EN KEYPAD RUN) ← 0
 M06B16 (EN KEYPAD STOP) ← 0
 M06B17 (EN KEYPAD FWD/RV) ← 0

Start command: RUN pushbutton at TB2-2-TB2-1.
Stop command: STOP pushbutton at TB2-5-TB2-1.
*FWD/REV command: Contact at TB2-4-TB2-1.
Jog command: JOG contact at TB2-3-TB2-1.
Reset command: keypad STOP/RESET key or pushbutton at TB2-7-TB2-1.
Speed reference source: Keypad reference M00P10.

***Note:** Reverse function is disabled. If FWD/REV function is needed set M06P23 (DISABLE REV ROT) to 0 to enable.

3.7.2.b “2-Wire or “Maintained Contact” Control with Keypad Speed Reference

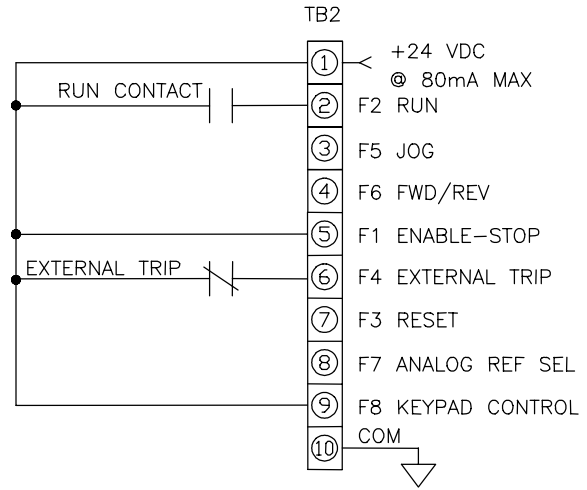

Change the following parameters in the order as shown:
 M06P07 (SEQUENCING MODE) ← 2-WIRE

Note: If analog reference is desired for speed reference, disconnect TB2-9.

Keypad RUN, STOP and FWD/REV are not operational in this mode.

Start/Stop command: RUN contact at TB2-2-TB2-1.
*FWD/REV command: Contact at TB2-4-TB2-1.
Jog command: JOG contact at TB2-3-TB2-1.
Reset command: keypad STOP/RESET key or pushbutton at TB2-7-TB2-1.
Speed reference source: Keypad reference M00P10.

***Note:** Reverse function is disabled. If FWD/REV function is needed set M06P23 (DISABLE REV ROT) to 0 to enable.

3.7.3 “3-Wire or “Momentary Contact” Control

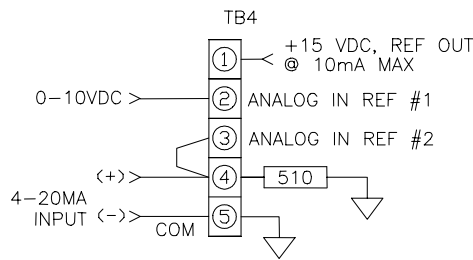
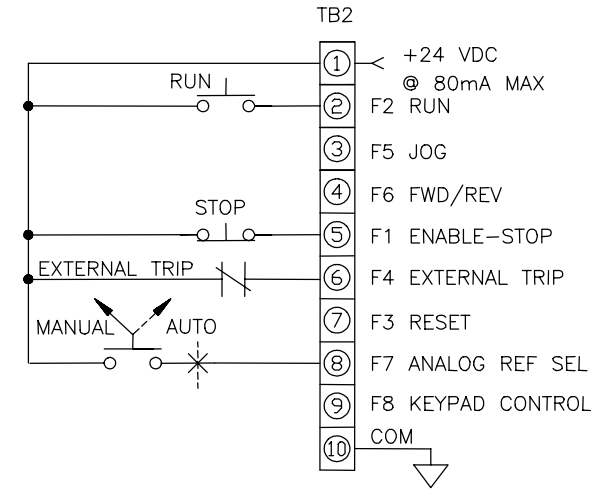

Manual Mode:

Start command: RUN pushbutton at TB2-2-TB2-1.

Stop command: STOP pushbutton at TB2-5-TB2-1.

* FWD/REV command: Contact at TB2-4-TB2-1.

Jog command: JOG contact at TB2-3-TB2-1.

Reset command: keypad STOP/RESET key or pushbutton at TB2-7-TB2-1.

Speed reference source: Analog reference 1, 0-10Vdc operation.

Auto Mode:

Start command: RUN pushbutton at TB2-2-TB2-1.

Stop command: STOP pushbutton at TB2-5-TB2-1.

* FWD/REV command: Contact at TB2-4-TB2-1.

Jog command: JOG contact at TB2-3-TB2-1.

Reset command: keypad STOP/RESET key or pushbutton at TB2-7-TB2-1.

Speed reference source: Analog reference 2, 4-20MA operation with min speed when loss of 4-20MA signal (refer to M07P13 description for other choices).

Note: If TB2-9 is wired to TB2-1, keypad control mode is enabled and the following has priority:

Start command: Keypad RUN key.

Stop command: Keypad STOP key.

FWD/REV command: Keypad USER key.

Jog command: JOG contact at TB2-3-TB2-1.

Reset command: keypad STOP/RESET key or pushbutton at TB2-7-TB2-1.

Speed reference source: Keypad reference M00P10.

***NOTE:** Reverse function is disabled. If FWD/REV is needed set M06B23 (DISABLE REV ROT) to 0 to enable.

3.7.4 “2-Wire” or “Maintained Contact” with Analog Speed Reference

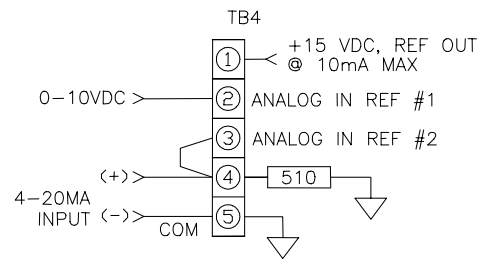
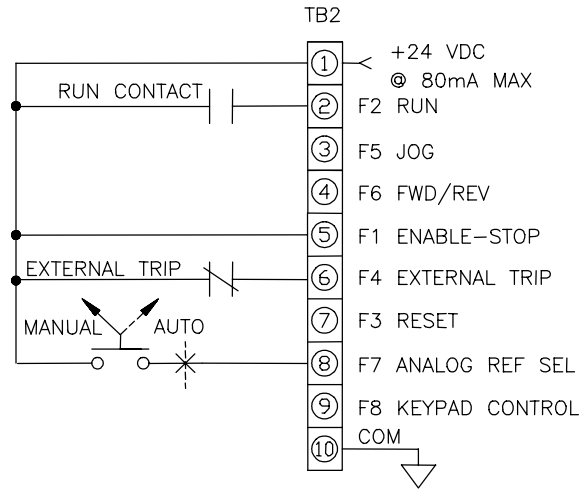

Change the following parameters in the order as shown:

M06P07 (SEQUENCING MODE) ← 2-WIRE

Manual Mode:

Start/Stop command: RUN contact at TB2-2-TB2-1.

* FWD/REV command: Contact at TB2-4-TB2-1.

Jog command: JOG contact at TB2-3-TB2-1.

Reset command: keypad STOP/RESET key or pushbutton at TB2-7-TB2-1.

Speed reference source: Analog reference 1, 0-10Vdc operation.

Auto Mode:

Start/Stop command: RUN contact at TB2-2-TB2-1.

* FWD/REV command: Contact at TB2-4-TB2-1.

Jog command: JOG contact at TB2-3-TB2-1.

Reset command: keypad STOP/RESET key or pushbutton at TB2-7-TB2-1.

Speed reference source: Analog reference 2, 4-20MA operation with min speed when loss of 4-20MA signal (refer to M07P13 description for other choices).

Note: If TB2-9 is wired to TB2-1, keypad speed reference is enabled M00P10.

***NOTE:** Reverse function is disabled. If FWD/REV is needed set M06B23 (DISABLE REV ROT) to 0 to enable.

3.7.5 HAND-AUTO with 2-Wire Control in Auto Mode

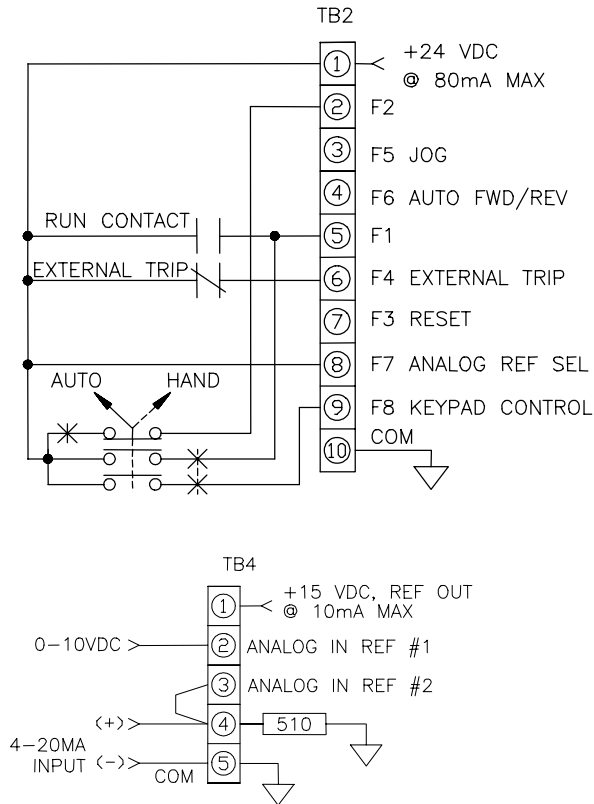

Hand Mode:

- Start command: Keypad RUN key.
- Stop command: Keypad STOP key.
- * FWD/REV command: Keypad FWD/REV key.
- Jog command: JOG contact at TB2-3-TB2-1.
- Reset command: keypad STOP/RESET key or pushbutton at TB2-7-TB2-1.
- Speed reference source: Keypad reference M00P10.

Auto Mode:

- Start/Stop command: RUN contact at TB2-5-TB2-1
- * FWD/REV command: Contact at TB2-4-TB2-1.
- Reset command: keypad STOP/RESET key or pushbutton at TB2-7-TB2-1.
- Speed reference source:
 - When TB2-8 is wired to TB2-1, analog reference 2 is selected for AUTO reference, 4-20MA operation with min speed when loss of 4-20MA signal (refer to M07P13 description for other choices).
 - When TB2-8 is not wired to TB2-1, analog reference 1 is selected for AUTO reference, 0-10Vdc operation.

***NOTE:** Reverse function is disabled. If FWD/REV is needed set M06B23 (DISABLE REV ROT) to 0 and M06P18(KEYPAD CONT MODE) to "ALL KEYS".

3.7.6 HAND-AUTO with 3-Wire Control in Auto Mode

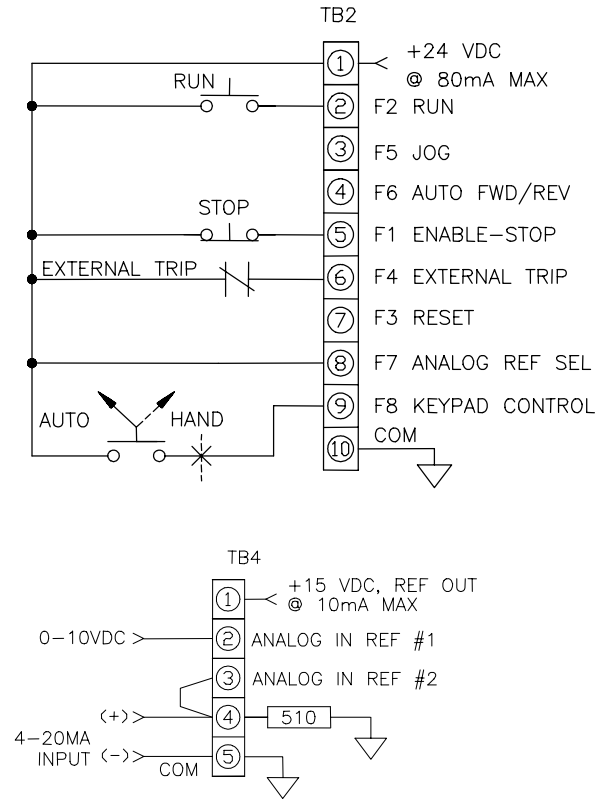

Hand Mode:

- Start command: Keypad RUN key.
- Stop command: Keypad STOP key.
- * FWD/REV command: Keypad FWD/REV key.
- Jog command: JOG contact at TB2-3-TB2-1.
- Reset command: keypad STOP/RESET key or pushbutton at TB2-7-TB2-1.
- Speed reference: Keypad reference M00P10.

Auto Mode:

- Start command: RUN pushbutton at TB2-2-TB2-1.
- Stop command: STOP pushbutton at TB2-5-TB2-1.
- * FWD/REV command: Contact at TB2-4-TB2-1.
- Jog command: JOG contact at TB2-3-TB2-1.
- Reset command: keypad STOP/RESET key or pushbutton at TB2-7-TB2-1.
- Speed reference source:
 - When TB2-8 is wired to TB2-1, analog reference 2 is selected for AUTO reference, 4-20MA operation with min speed when loss of 4-20MA signal (refer to M07P13 description for other choices)
 - When TB2-8 is not wired to TB2-1, analog reference 1 is selected for AUTO reference, 0-10Vdc.

***NOTE:** Reverse function is disabled. If FWD/REV is needed set M06B23 (DISABLE REV ROT) to 0 and M06P18 (KEYPAD CONT MODE) to "ALL KEYS".

3.7.7 HAND-OFF-AUTO #1A Control

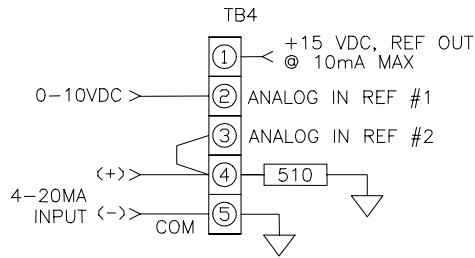
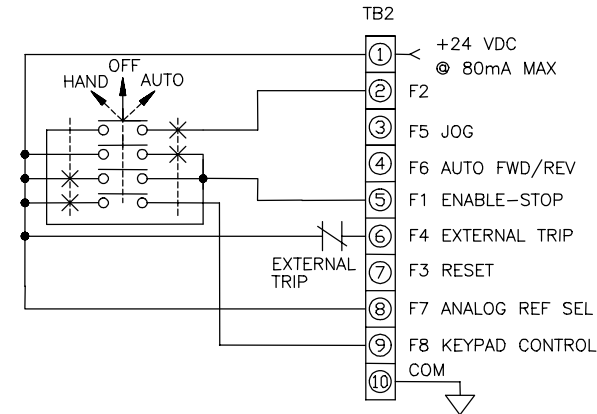

Hand Mode:

Start command: Keypad RUN

Stop command: Keypad STOP

* FWD/REV command: Keypad FWD/REV key.

Jog command: JOG contact at TB2-3-TB2-1.

Reset command: keypad STOP/RESET key or pushbutton at TB2-7-TB2-1.

Speed reference source: Keypad reference M00P10

Auto Mode:

Start/Stop command: Drive starts when HOA switch is thrown to AUTO.

* FWD/REV command: Contact at TB2-4-TB2-1.

Reset command: keypad STOP/RESET key or pushbutton at TB2-7-TB2-1.

Speed reference source:

- When TB2-8 is wired to TB2-1, analog reference 2 is selected for AUTO reference, 4-20MA operation with min speed when loss of 4-20MA signal (refer to M07P13 description for other choices).

- When TB2-8 is not wired to TB2-1, analog reference 1 is selected for AUTO reference, 0-10V operation.

***NOTE:** Reverse function is disabled. If FWD/REV is needed set M06B23 (DISABLE REV ROT) to 0 and M06P18 (KEYPAD CONT MODE) to "ALL KEYS".

3.7.8 HAND-OFF-AUTO #2A Control

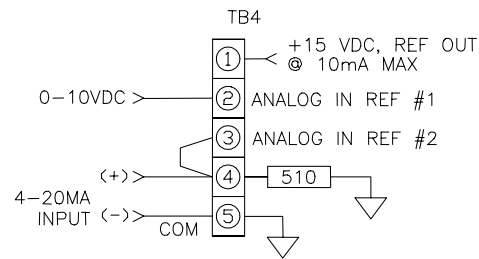
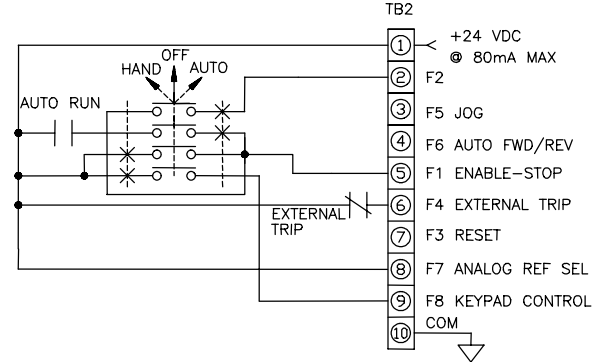

Hand Mode:

Start command: Keypad RUN key.

Stop command: Keypad STOP key.

* FWD/REV command: Keypad FWD/REV key.

Jog command: JOG contact at TB2-3-TB2-1.

Reset command: keypad STOP/RESET key or pushbutton at TB2-7-TB2-1.

Speed reference source: Keypad reference M00P10.

Auto Mode:

Start/Stop command: AUTO Run contact as wired above.

* FWD/REV command: Contact at TB2-4-TB2-1.

Reset command: keypad STOP/RESET key or pushbutton at TB2-7-TB2-1.

Speed reference source:

- When TB2-8 is wired to TB2-1, analog reference 2 is selected for AUTO reference, 4-20MA operation with min speed when loss of 4-20MA signal (refer to M07P13 description for other choices).

- When TB2-8 is not wired to TB2-1, analog reference 1 is selected for AUTO reference, 0-10Vdc operation.

***NOTE:** Reverse function is disabled. If FWD/REV is needed set M06B23 (DISABLE REV ROT) to 0 and M06P18 (KEYPAD CONT MODE) to "ALL KEYS".

3.7.9 HAND-OFF-AUTO #3A Control

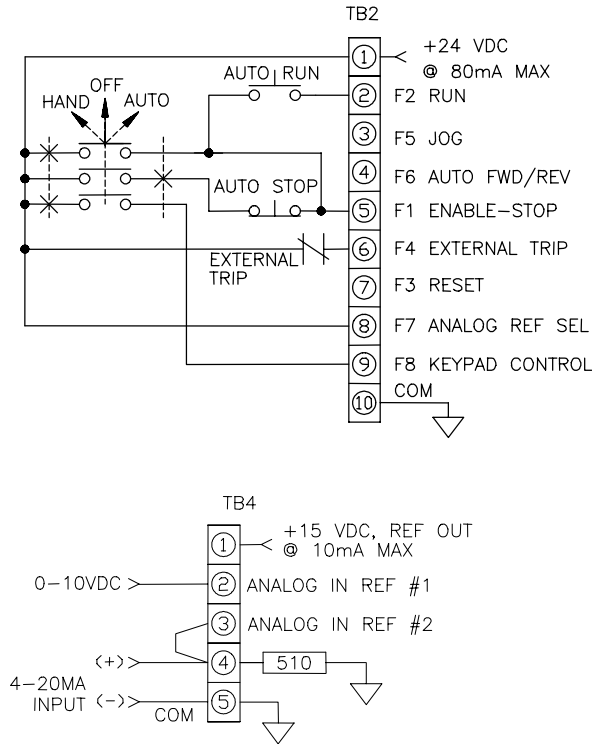

Hand Mode:

- Start command: Keypad RUN key
- Stop command: Keypad STOP key
- * FWD/REV command: Keypad FWD/REV key.
- Jog command: JOG contact at TB2-3-TB2-1.
- Reset command: keypad STOP/RESET key or pushbutton at TB2-7-TB2-1.
- Speed reference: Keypad reference M00P10

Auto Mode:

- Start command: AUTO RUN pushbutton as wired above.
- Stop command: AUTO STOP pushbutton as wired above.
- * FWD/REV command: Contact at TB2-4-TB2-1.
- Jog command: JOG contact at TB2-3-TB2-1.
- Reset command: keypad STOP/RESET key or pushbutton at TB2-7-TB2-1.
- Speed reference source:
 - When TB2-8 is wired to TB2-1, analog reference 2 is selected for AUTO reference, 4-20MA operation with min speed when loss of 4-20MA signal (refer to M07P13 description for other choices)
 - When TB2-8 is not wired to TB2-1, analog reference 1 is selected for AUTO reference, 0-10Vdc operation

*NOTE: Reverse function is disabled. If FWD/REV is needed set M06B23 (DISABLE REV ROT) to 0 and M06P18(KEYPAD CONT MODE) to "ALL KEYS".

3.7.10 HAND-OFF-AUTO #1B Control

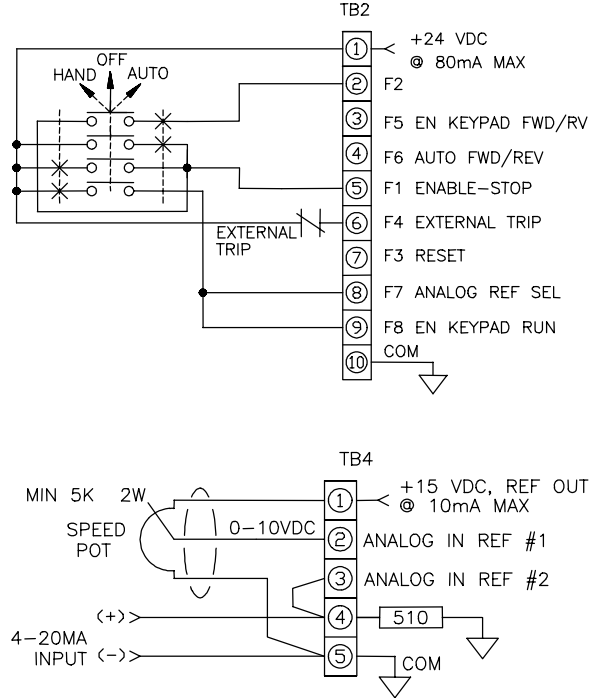

Change the following parameters in the order shown:

- M08P21 (F8 INPUT DESTINA) ← 6.15 (M06P15)
- M01B08 (KEYPAD CONTROL) ← 0
- M06P18 (KEYPAD CONT MODE) ← NO KEYS
- M06B16 (EN KEYPAD STOP) ← 1
- M08P15 (F5 INPUT DESTINA) ← 6.17 (M06P17)
- M08B20 (F7 INVERT) ← 1
- M06B09 (SEQUENCING BIT1) ← 0

Hand Mode:

- Start command: Keypad RUN
- Stop command: Keypad STOP
- * FWD/REV command: Keypad FWD/REV key.
- Reset command: keypad STOP/RESET key or pushbutton at TB2-7-TB2-1.
- Speed reference source: analog reference 1, 0-10V operation (speed potentiometer as shown above).

Auto Mode:

- Start/Stop command: Drive starts when HOA switch is thrown to AUTO.
- * FWD/REV command: Contact at TB2-4-TB2-1.
- Reset command: keypad STOP/RESET key or pushbutton at TB2-7-TB2-1.
- Speed reference source: analog reference 2, 4-20MA operation with min speed when loss of 4-20MA signal (refer to M07P13 description for other choices).

*NOTE: Reverse function is disabled. If FWD/REV is needed set M06B23 (DISABLE REV ROT) to 0 and wire TB2-3 to TB2-9.

3.7.11 HAND-OFF-AUTO #2B Control

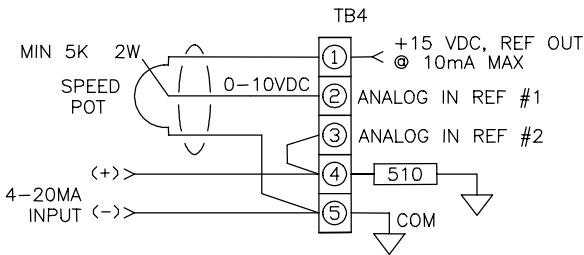
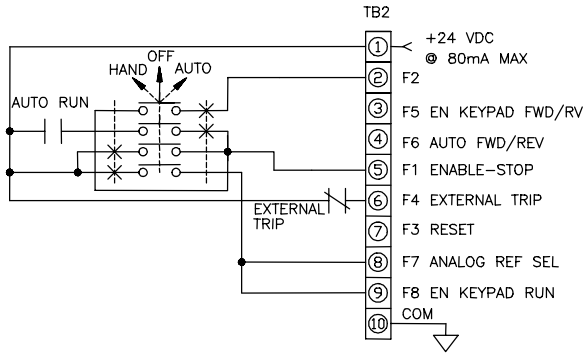

Change the following parameters in the order shown:

- M08P21 (F8 INPUT DESTINA) ← 6.15 (M06P15)
- M01B08 (KEYPAD CONTROL) ← 0
- M06P18 (KEYPAD CONT MODE) ← NO KEYS
- M06B16 (EN KEYPAD STOP) ← 1
- M08P15 (F5 INPUT DESTINA) ← 6.17 (M06P17)
- M08B20 (F7 INVERT) ← 1
- M06B09 (SEQUENCING BIT1) ← 0

Hand Mode:

Start command: Keypad RUN key.
Stop command: Keypad STOP key.

- * FWD/REV command: Keypad FWD/REV key.
- Reset command: keypad STOP/RESET key or pushbutton at TB2-7-TB2-1.

Speed reference source: analog reference 1, 0-10Vdc operation (speed potentiometer as shown above).

Auto Mode:

Start/Stop command: AUTO Run contact as wired above.

- * FWD/REV command: Contact at TB2-4-TB2-1.
- Reset command: keypad STOP/RESET key or pushbutton at TB2-7-TB2-1.

Speed reference source: analog reference 2, 4-20MA operation with min speed when loss of 4-20MA signal (refer to M07P13 description for other choices).

*NOTE: Reverse function is disabled. If FWD/REV is needed set M06B23 (DISABLE REV ROT) to 0 and wire TB2-3 to TB2-9.

3.7.11.a HAND-OFF-AUTO & LOCAL-REMOTE #2B.a

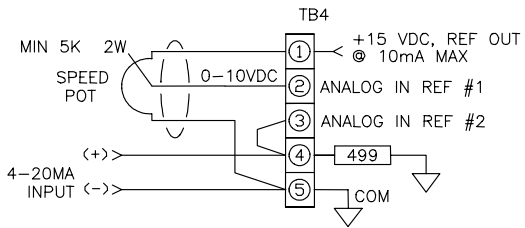
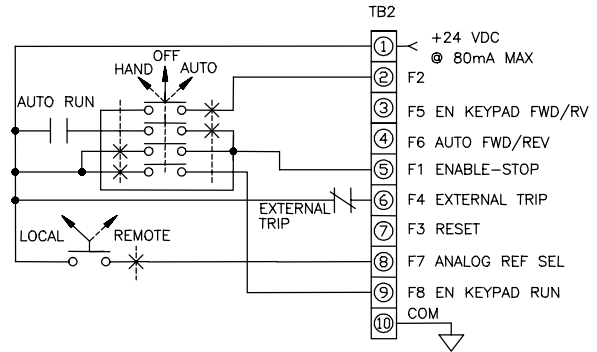

Change the following parameters in the order as shown:

- M08P21 (F8 INPUT DESTINA) ← 6.15 (M06P15)
- M01B08 (KEYPAD CONTROL) ← 0
- M06P18 (KEYPAD CONT MODE) ← NO KEYS
- M06B16 (EN KEYPAD STOP) ← 1
- M08P15 (F5 INPUT DESTINA) ← 6.17 (M06P17)
- M06B09 (SEQUENCING BIT1) ← 0

Hand Mode:

Start command: Keypad RUN key.
Stop command: Keypad STOP key.
 *FWD/REV command: Keypad FWD/REV key.

Reset command: keypad STOP/RESET key or pushbutton at TB2-7-TB2-1.

Auto Mode:

Start/Stop command: AUTO Run contact as wired above.

*FWD/REV command: Contact at TB2-4-TB2-1.

Reset command: keypad STOP/RESET key or pushbutton at TB2-7-TB2-1.

Note: When the H-O-A switch is in the off position the drive stops regardless of the state of the Hand or Auto run commands.

Local Mode:

Speed reference source: analog reference 1, 0-10Vdc operation (speed potentiometer as shown above).

Remote Mode:

Speed reference source: analog reference 2, 4-20MA operation with min speed when loss of 4-20MA signal (refer to M07P13 description for other choices).

*NOTE: Reverse function is disabled. If FWD/REV function is needed set M06P23 (DISABLE REV ROT) to 0 and wire TB2-3 to TB2-9.

3.7.12 HAND-OFF-AUTO #3B Control

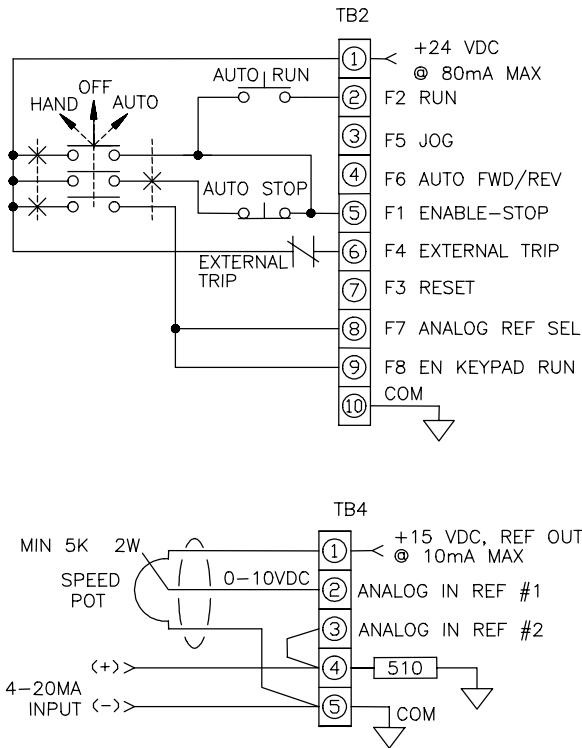

Change the following parameters in the order shown:
 M08P21 (F8 INPUT DESTINA) ← 6.15 (M06P15)
 M01B08 (KEYPAD CONTROL) ← 0
 M06P18 (KEYPAD CONT MODE) ← NO KEYS
 M06B16 (EN KEYPAD STOP) ← 1
 M08B20 (F7 INVERT) ← 1

Hand Mode:

Start command: Keypad RUN key
Stop command: Keypad STOP key
Jog command: JOG contact at TB2-3-TB2-1.
Reset command: keypad STOP/RESET key or pushbutton at TB2-7-TB2-1.
Speed reference source: analog reference 1, 0-10Vdc operation (speed potentiometer as shown above).

Auto Mode:

Start command: AUTO RUN pushbutton as wired above.
Stop command: AUTO STOP pushbutton as wired above.

* FWD/REV command: Contact at TB2-4-TB2-1.
Jog command: JOG contact at TB2-3-TB2-1.
Reset command: keypad STOP/RESET key or pushbutton at TB2-7-TB2-1.
Speed reference source: analog reference 2, 4-20MA operation with min speed when loss of 4-20MA signal (refer to M07P13 description for other choices).

***NOTE:** Reverse function is disabled. If FWD/REV is needed (Auto Mode Only) set M06B23 (DISABLE REV ROT) to 0 to enable.

3.7.13 RUN Forward/ RUN Reverse "2-Wire" Control

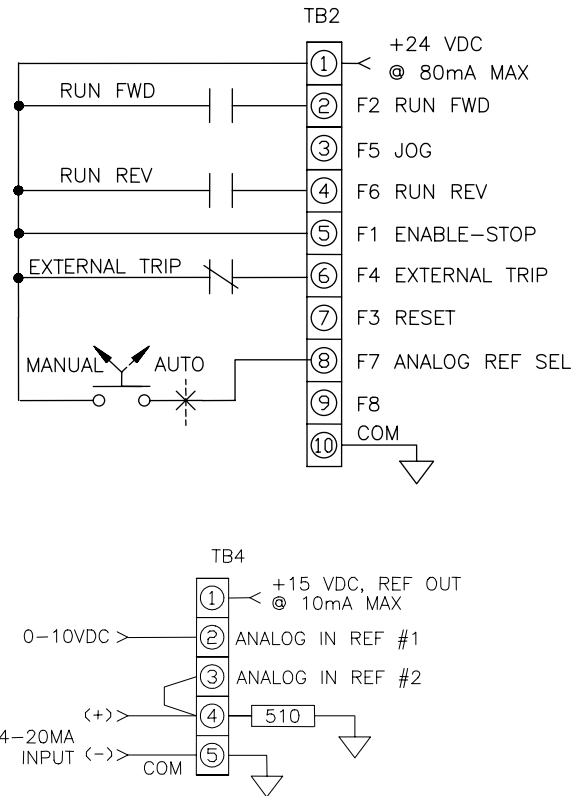

Change the following parameters in the order shown:
 M06P07 (SEQUENCING MODE) ← RFWD RREV
 M06B23 (DISABLE REV ROT) ← 0

- If RUN FWD and RUN REV are asserted at the same time, the drive will stop.
- Keypad RUN, STOP and FWD/REV (user key) are not operational in this sequencing mode.

The following applies for all modes below

- Jog command: JOG contact at TB2-3-TB2-1.
- Reset command: keypad STOP/RESET key or pushbutton at TB2-7-TB2-1.

Manual Mode:

Start/Stop command forward direction: RUN FWD contact at TB2-2-TB2-1.
Start/Stop command forward direction: RUN REV contact at TB2-4-TB2-1.
Speed reference source: Analog reference 1, 0-10Vdc operation.

Auto Mode:

Start/Stop command forward direction: RUN FWD contact at TB2-2-TB2-1.
Start/Stop command forward direction: RUN REV contact at TB2-4-TB2-1.
Speed reference source: Analog reference 2, 4-20MA operation with min speed when loss of 4-20MA signal (refer to M07P13 description for other choices).

Note: If TB2-9 is wired to TB2-1, keypad reference is enabled (speed reference).

3-16 DRIVE PROGRAMMING

3.7.14 RUN Forward/ RUN Reverse "3-Wire" Control

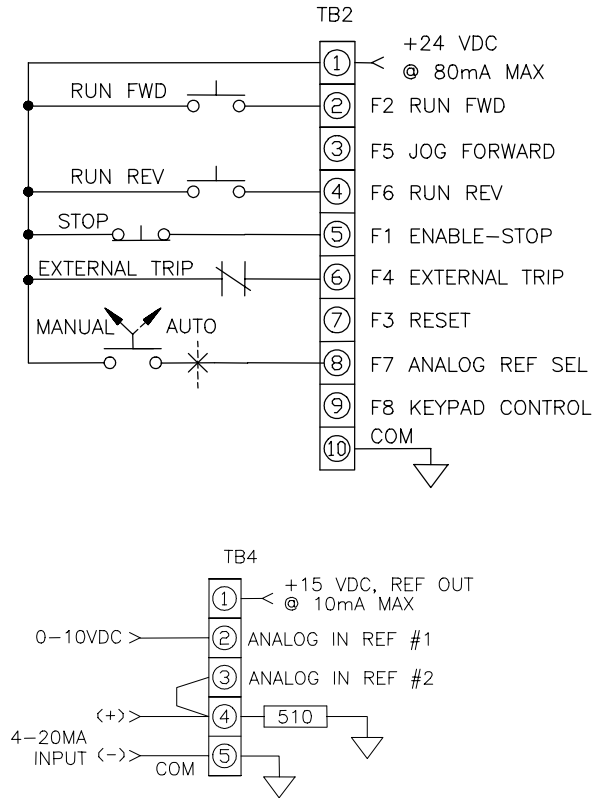

Change the following parameters in the order shown:

M06P07 (SEQUENCING MODE) ← 3-WIRE SP

M06B23 (DISABLE REV ROT) ← 0

The following applies for all modes below:

- JOG forward command: JOG FWD contact at TB2-3-TB2-1
- Reset command: pushbutton at TB2-7-TB2-1

Manual Mode:

Start command forward direction: RUN FWD pushbutton at TB2-2-TB2-1.

Start command forward direction: RUN REV pushbutton at TB2-4-TB2-1.

Stop command: STOP pushbutton at TB2-5-TB2-1.

Speed reference source: Analog reference 1, 0-10Vdc operation.

Auto Mode:

Start command forward direction: RUN FWD pushbutton at TB2-2-TB2-1.

Start command forward direction: RUN REV pushbutton at TB2-4-TB2-1.

Stop command: STOP pushbutton at TB2-5-TB2-1.

Speed reference source: Analog reference 2, 4-20MA operation with min speed when loss of 4-20MA signal (refer to M07P13 description for other choices).

Note: If TB2-9 is wired to TB2-1, keypad control mode is enabled and the following has priority:

Start command: Keypad RUN key.

Stop command: Keypad STOP key.

FWD/REV command: Keypad USER key.

Speed reference source: Keypad reference M00P10.

3.7.15 Hand-Off-Auto #4A Control

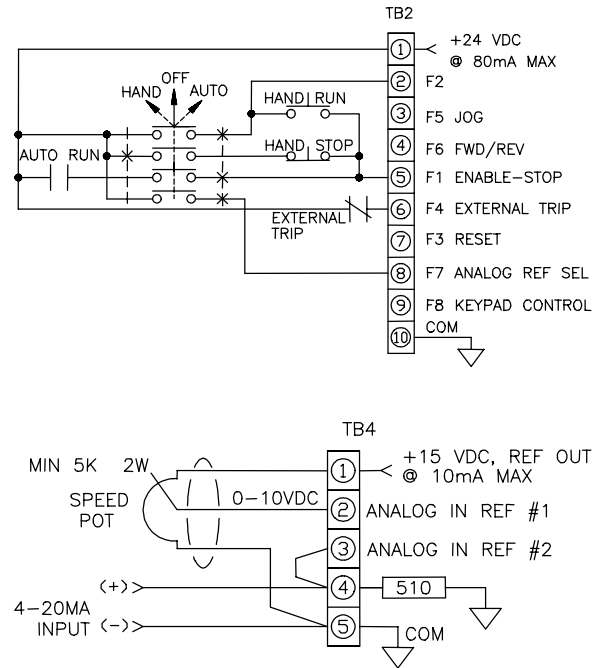

Hand Mode:

Start command: HAND RUN pushbutton as wired above.

Stop command: HAND STOP pushbutton as wired above.

* FWD/REV command: Contact at TB2-4-TB2-1.

Jog command: JOG contact at TB2-3-TB2-1.

Reset command: keypad STOP/RESET key or pushbutton at TB2-7-TB2-1.

Speed reference source: Analog reference 1, 0-10V operation (speed potentiometer as shown above).

Auto Mode:

Start/Stop command: AUTO Run contact as wired above.

* FWD/REV command: Contact at TB2-4-TB2-1.

Reset command: keypad STOP/RESET key or pushbutton at TB2-7-TB2-1.

Speed reference source: Analog reference 2, 4-20MA operation with min speed when loss of 4-20MA signal (refer to M07P13 description for other choices).

***NOTE:** Reverse function is disabled. If FWD/REV is needed set M06B23 (DISABLE REV ROT) to 0 to enable.

3.7.16 Motorized Potentiometer with “2-Wire” Control

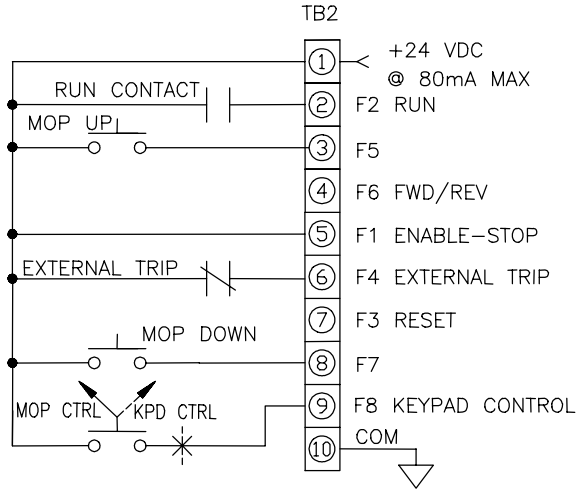

Change the following parameters in the order shown:

- M06P07 (SEQUENCING MODE) ← 2-WIRE
- M08P15 (F5 INPUT DESTINA) ← 6.27 (M06B27)
- M08P19 (F7 INPUT DESTINA) ← 6.28 (M06B28)
- M01B07 (SEL PRESET SPEED) ← 1
- M06P31 (MOP DESTINATION) ← 1.25** (M01P25)
- M06P30 (MOP SCALE FACTOR) ← .060***

Keypad Control (KPD CTRL):

- Start/Stop command: RUN contact at TB2-2-TB2-1.
- * FWD/REV command: Contact at TB2-4-TB2-1.
- Reset command: keypad STOP/RESET key or pushbutton at TB2-7-TB2-1.
- Speed reference: Keypad reference M00P10

MOP Control (MOP CTRL):

- Start/Stop command: RUN pushbutton at TB2-2-TB2-1.
- Speed increase: MOP UP contact at TB2-3-TB2-1.
- Speed decrease: MOP DOWN contact TB2-8-TB2-1.
- * FWD/REV command: Contact at TB2-4-TB2-1.
- Reset command: keypad STOP/RESET key or pushbutton at TB2-7-TB2-1.

**Since the motorized potentiometer in this example controls the speed, one of the preset speed parameters (M01P25 “PRESET FREQ 1”) is used as MOP destination.

***For 60Hz speed range, scale factor = 60/1000 (60 is 60Hz and 1000 is maximum value of parameter M01P25 “PRESET FREQ 1”).

Use M06P26 to program ramp rate. Refer to M06P25 & M06P29 for other MOP features.

*NOTE: Reverse function is disabled. If FWD/REV is needed set M06B23 (DISABLE REV ROT) to 0.

3.7.17 Motorized Potentiometer with “3-Wire” Control

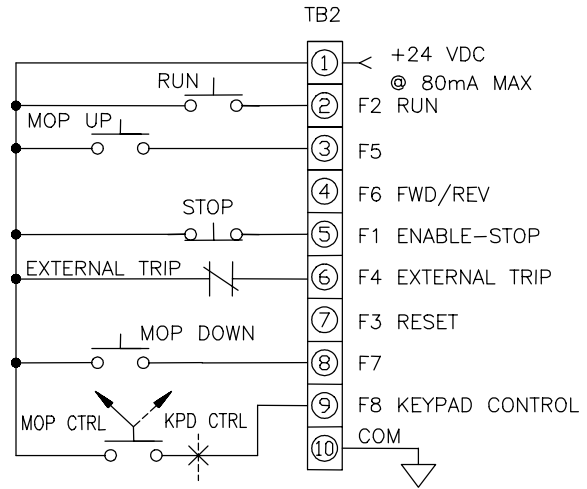

Change the following parameters in the order shown:

- M08P15 (F5 INPUT DESTINA) ← 6.27 (M06B27)
- M08P19 (F7 INPUT DESTINA) ← 6.28 (M06B28)
- M01B07 (SEL PRESET SPEED) ← 1
- M06P31 (MOP DESTINATION) ← 1.25** (M01P25)
- M06P30 (MOP SCALE FACTOR) ← .060***

Keypad Control (KPD CTRL):

- Start command: Keypad RUN key.
- Stop command: Keypad STOP key.
- * FWD/REV command: Keypad FWD/REV key.
- Reset command: keypad STOP/RESET key or pushbutton at TB2-7-TB2-1.
- Speed reference source: Keypad reference M00P10

MOP Control (MOP CTRL):

- Start command: RUN pushbutton at TB2-2-TB2-1.
- Stop command: STOP pushbutton at TB2-5-TB2-1.
- Speed increase: MOP UP contact at TB2-3-TB2-1.
- Speed decrease: MOP DOWN contact TB2-8-TB2-1.
- * FWD/REV command: Contact at TB2-4-TB2-1.
- Reset command: keypad STOP/RESET key or pushbutton at TB2-7-TB2-1.

**Since the motorized potentiometer in this example controls the speed, one of the preset speed parameters (M01P25 “PRESET FREQ 1”) is used as MOP destination.

***For 60Hz speed range, scale factor = 60/1000 (60 is 60Hz and 1000 is maximum value of parameter M01P25 “PRESET FREQ 1”).

Use M06P26 to program ramp rate. Refer to M06P25 & M06P29 for other MOP features.

*NOTE: Reverse function is disabled. If FWD/REV is needed set M06B23 (DISABLE REV ROT) to 0 and M06P18 (KEYPAD CONT MODE) to “ALL KEYS”.

3.7.18 Motorized Potentiometer with Keypad Start/Stop

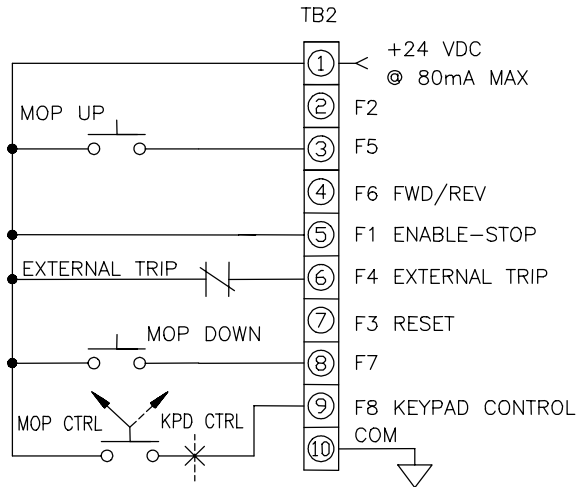

Change the following parameters in the order shown:

- M06P18 (KEYPAD CONT MODE) ← NO KEYS
- M06B15 (EN KEYPAD RUN) ← 1
- M06B16 (EN KEYPAD STOP) ← 1
- M06B17 (EN KEYPAD FWD/RV) ← 0
- M08P15 (F5 INPUT DESTINA) ← 6.27 (M06B27)
- M08P19 (F7 INPUT DESTINA) ← 6.28 (M06B28)
- M01B07 (SEL PRESET SPEED) ← 1
- M06P31 (MOP DESTINATION) ← 1.25** (M01P25)
- M06P30 (MOP SCALE FACTOR) ← .060***

Keypad Control (KPD CTRL):

Start command: Keypad RUN key.
Stop command: Keypad STOP key.
Reset command: keypad STOP/RESET key or pushbutton at TB2-7-TB2-1.

- * FWD/REV command: Keypad FWD/REV key
Speed reference source: Keypad reference M00P10

MOP Control (MOP CTRL):

Start command: Keypad RUN key.
Stop command: Keypad STOP key.
Speed increase: MOP UP contact at TB2-3-TB2-1.
Speed decrease: MOP DOWN contact TB2-8-TB2-1.
 * FWD/REV command: Contact at TB2-4-TB2-1.
Reset command: keypad STOP/RESET key or pushbutton at TB2-7-TB2-1.

**Since the motorized potentiometer in this example controls the speed, one of the preset speed parameters (M01P25 "PRESET FREQ 1") is used as MOP destination.
 ***For 60Hz speed range, scale factor = 60/1000 (60 is 60Hz and 1000 is maximum value of parameter M01P25 "PRESET FREQ 1").
 Use M06P26 to program ramp rate.
 Refer to M06P25 & M06P29 for other MOP features.

***NOTE:** Reverse function is disabled. If FWD/REV is needed set M06B23 (DISABLE REV ROT) to 0 and M06B17 (EN KEYPAD FWD/RV) to 1.

3.7.19 Preset Speeds with "2-Wire" Control

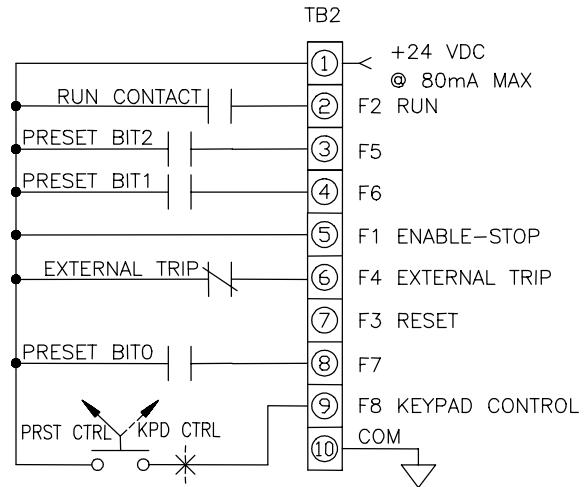

Change the following parameters in the order shown:

- M06P07 (SEQUENCING MODE) ← 2-WIRE
- M01B07 (SEL PRESET SPEED) ← 1
- M02B07 (RAMPS SELECTION) ← 1
- M08P15 (F5 INPUT DESTINA) ← 1.24 (M01B24)
- M08P17 (F6 INPUT DESTINA) ← 1.23 (M01B23)
- M08P19 (F7 INPUT DESTINA) ← 1.22 (M01B22)

Keypad Control (KPD CTRL):

Start/Stop command: RUN contact at TB2-2-TB2-1.
Reset command: keypad STOP/RESET key or pushbutton at TB2-7-TB2-1.
Speed reference source: Keypad reference M00P10

Preset Speed Control (PRST CTRL):

Start/Stop command: RUN contact at TB2-2-TB2-1.
Reset command: keypad STOP/RESET key or pushbutton at TB2-7-TB2-1.
Speed reference source:

BIT2	BIT1	BIT0	DRIVE SPEED	DRIVE ACCEL/DECEL
0	0	0	PRESET FREQ1	ACCEL1/DECEL1
0	0	1	PRESET FREQ2	ACCEL2/DECEL2
0	1	0	PRESET FREQ3	ACCEL3/DECEL3
0	1	1	PRESET FREQ4	ACCEL4/DECEL4
1	0	0	PRESET FREQ5	ACCEL5/DECEL5
1	0	1	PRESET FREQ6	ACCEL6/DECEL6
1	1	0	PRESET FREQ7	ACCEL7/DECEL7
1	1	1	PRESET FREQ8	ACCEL8/DECEL8

Program the following preset speeds and corresponding acceleration/deceleration for the desired speed profile:

- *M01P25 to M01P32: PRESET FREQ 1 to PRESET FREQ 8
- M02P03: ACCEL 1
- M02P11 to M02P17: ACCEL 2 to ACCEL 8
- M02P04: DECEL 1
- M02P21 to M02P27: DECEL 2 to DECEL 8

***NOTE:** Reverse function is disabled. If FWD/REV is needed set M06B23 (DISABLE REV ROT) to 0.
****NOTE:** If some of the preset speeds are negative, reverse rotation is allowed by setting M06B23 (DISABLE REV ROT) to 0 and M01B10 (BIPOLAR SELECT) to 1.

3.7.19.a Preset Speeds with "2-Wire" Control & Speed Pot

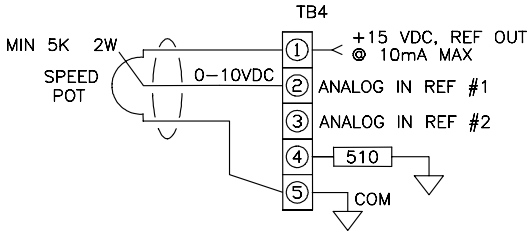
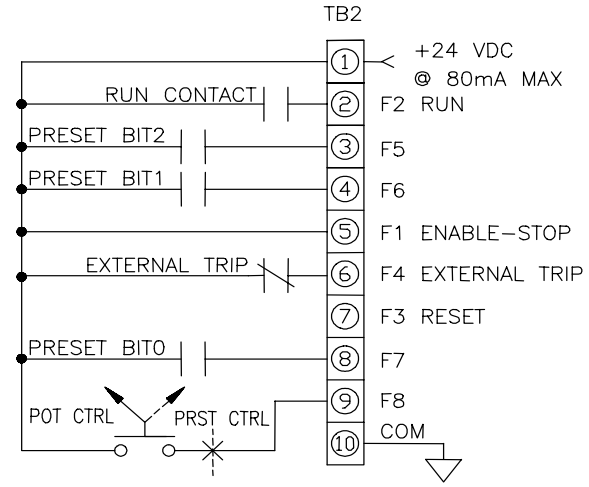

Change the following parameters in the order shown:

- M06P07 (SEQUENCING MODE) ← 2-WIRE
- M02B07 (RAMPS SELECTION) ← 1
- M08P15 (F5 INPUT DESTINA) ← 1.24 (M01B24)
- M08P17 (F6 INPUT DESTINA) ← 1.23 (M01B23)
- M08P19 (F7 INPUT DESTINA) ← 1.22 (M01B22)
- M08P21 (F8 INPUT DESTINA) ← 1.07 (M01B07)
- M01B08 (KEYPAD CONTROL) ← 0

Speed Pot Control (POT CTRL):
Start/Stop command: RUN contact at TB2-2-TB2-1.
Reset command: keypad STOP/RESET key or pushbutton at TB2-7-TB2-1.
Speed reference source: Analog reference 1, 0-10Vdc operation (Speed Potentiometer as shown)

Preset Speed Control (PRST CTRL):
Start/Stop command: RUN contact at TB2-2-TB2-1.
Reset command: keypad STOP/RESET key or pushbutton at TB2-7-TB2-1.
Speed reference source:

BIT2	BIT1	BIT0	DRIVE SPEED	DRIVE ACCEL/DECEL
0	0	0	PRESET FREQ1	ACCEL1/DECEL1
0	0	1	PRESET FREQ2	ACCEL2/DECEL2
0	1	0	PRESET FREQ3	ACCEL3/DECEL3
0	1	1	PRESET FREQ4	ACCEL4/DECEL4
1	0	0	PRESET FREQ5	ACCEL5/DECEL5
1	0	1	PRESET FREQ6	ACCEL6/DECEL6
1	1	0	PRESET FREQ7	ACCEL7/DECEL7
1	1	1	PRESET FREQ8	ACCEL8/DECEL8

Program the following preset speeds and corresponding acceleration/deceleration for the desired speed profile:
 **M01P25 to M01P32: PRESET FREQ 1 to PRESET FREQ 8
 M02P03: ACCEL 1
 M02P11 to M02P17: ACCEL 2 to ACCEL8
 M02P04: DECEL 1
 M02P21 to M02P27: DECEL 2 to DECEL 8

****NOTE:** If some of the preset speeds are negative, reverse rotation is allowed by setting M06B23 (DISABLE REV ROT) to 0 and M01B10 (BIPOLAR SELECT) to 1.

3.7.20 Preset Speeds with "3-Wire" Control

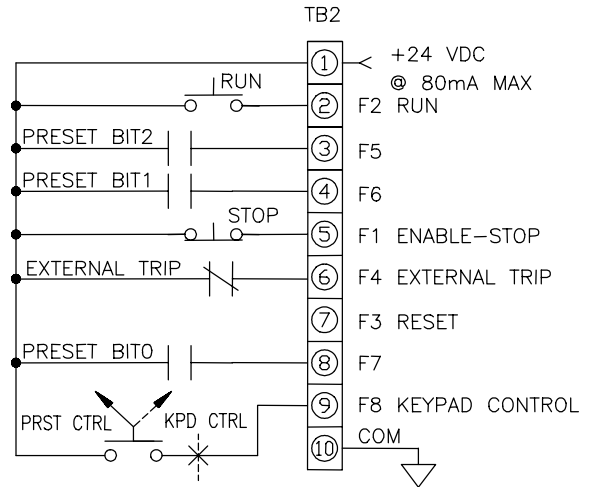

Change the following parameters in the order shown:

- M01B07 (SEL PRESET SPEED) ← 1
- M02B07 (RAMPS SELECTION) ← 1
- M08P15 (F5 INPUT DESTINA) ← 1.24 (M01B24)
- M08P17 (F6 INPUT DESTINA) ← 1.23 (M01B23)
- M08P19 (F7 INPUT DESTINA) ← 1.22 (M01B22)

Keypad Control (KPD CTRL):
Start command: Keypad RUN key.
Stop command: Keypad STOP key.
 * FWD/REV command: Keypad FWD/REV key.
Reset command: keypad STOP/RESET key or pushbutton at TB2-7-TB2-1.
Speed reference source: Keypad reference M00P10

Preset Speed Control (PRST CTRL):
Start command: RUN pushbutton at TB2-2-TB2-1.
Stop command: STOP pushbutton at TB2-5-TB2-1.
Reset command: keypad STOP/RESET key or pushbutton at TB2-7-TB2-1.
Speed reference source:

BIT2	BIT1	BIT0	DRIVE SPEED	DRIVE ACCEL/DECEL
0	0	0	PRESET FREQ1	ACCEL1/DECEL1
0	0	1	PRESET FREQ2	ACCEL2/DECEL2
0	1	0	PRESET FREQ3	ACCEL3/DECEL3
0	1	1	PRESET FREQ4	ACCEL4/DECEL4
1	0	0	PRESET FREQ5	ACCEL5/DECEL5
1	0	1	PRESET FREQ6	ACCEL6/DECEL6
1	1	0	PRESET FREQ7	ACCEL7/DECEL7
1	1	1	PRESET FREQ8	ACCEL8/DECEL8

Program the following preset speeds and corresponding acceleration/deceleration for the desired speed profile:
 **M01P25 to M01P32: PRESET FREQ 1 to PRESET FREQ 8
 M02P03: ACCEL 1
 M02P11 to M02P17: ACCEL 2 to ACCEL8
 M02P04: DECEL 1
 M02P21 to M02P27: DECEL 2 to DECEL 8

***NOTE:** Reverse function is disabled. If FWD/REV is needed set M06B23 (DISABLE REV ROT) to 0 and M06P18 (KEYPAD CONT MODE) to "ALL KEYS".
****NOTE:** If some of the preset speeds are negative, reverse rotation is allowed by setting M06B23 (DISABLE REV ROT) to 0 and M01B10 (BIPOLAR SELECT) to 1.

3-20 DRIVE PROGRAMMING

3.7.21 Preset Speeds with Keypad Start/Stop

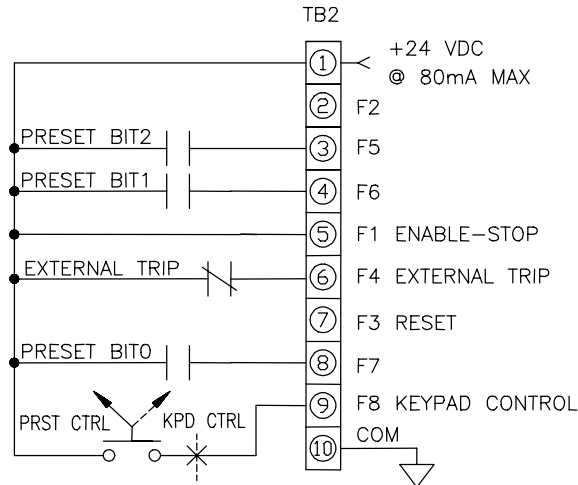

Change the following parameters in the order shown:

M06P18 (KEYPAD CONT MODE)	← NO KEYS
M06B15 (EN KEYPAD RUN)	← 1
M06B16 (EN KEYPAD STOP)	← 1
M06B17 (EN KEYPAD FWD/RV)	← 0
M01B07 (SEL PRESET SPEED)	← 1
M02B07 (RAMPS SELECTION)	← 1
M08P15 (F5 INPUT DESTINA)	← 1.24 (M01B24)
M08P17 (F6 INPUT DESTINA)	← 1.23 (M01B23)
M08P19 (F7 INPUT DESTINA)	← 1.22 (M01B22)

The following applies for all modes below

- Reset command: keypad STOP/RESET key or pushbutton at TB2-7-TB2-1.

Keypad Control (KPD CTRL):

Start command: Keypad RUN key.

Stop command: Keypad STOP key.

- * FWD/REV command: Keypad FWD/REV key.

Speed reference source: Keypad reference M00P10

Preset Speed Control (PRST CTRL):

Start command: RUN pushbutton at TB2-2-TB2-1.

Stop command: STOP pushbutton at TB2-5-TB2-1.

Speed reference source:

			DRIVE	
BIT2	BIT1	BIT0	DRIVE SPEED	ACCEL/DECEL
0	0	0	PRESET FREQ1	ACCEL1/DECEL1
0	0	1	PRESET FREQ2	ACCEL2/DECEL2
0	1	0	PRESET FREQ3	ACCEL3/DECEL3
0	1	1	PRESET FREQ4	ACCEL4/DECEL4
1	0	0	PRESET FREQ5	ACCEL5/DECEL5
1	0	1	PRESET FREQ6	ACCEL6/DECEL6
1	1	0	PRESET FREQ7	ACCEL7/DECEL7
1	1	1	PRESET FREQ8	ACCEL8/DECEL8

Program the following preset speeds and corresponding acceleration/deceleration for the desired speed profile:

- **M01P25 to M01P32: PRESET FREQ 1 to PRESET FREQ 8
- M02P03: ACCEL 1
- M02P11 to M02P17: ACCEL 2 to ACCEL8
- M02P04: DECEL 1
- M02P21 to M02P27: DECEL 2 to DECEL 8

***NOTE:** Reverse function is disabled. If FWD/REV is needed set M06B23 (DISABLE REV ROT) to 0 and M06B17 (EN KEYPAD FWD/RV) to 1.

****NOTE:** If some of the preset speeds are negative, reverse rotation is allowed by setting M06B23 (DISABLE REV ROT) to 0 and M01B10 (BIPOLAR SELECT) to 1.

3.7.21.a Auto Preset Scan Timer with “3-Wire” Control

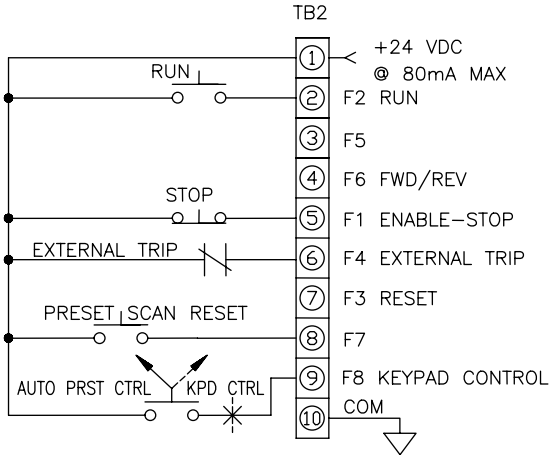

Change the following parameters in the order shown:
 M01B07 (SEL PRESET SPEED) ← 1 (ENABLE PRESET SCAN TIMER)
 M01B42 (PRESET SEL MODE) ← 1
 M01P43 (PRESET SCAN MODE) ← 1CYC&STOP
 M02B07 (RAMPS SELECTION) ← 1 (SYNC RAMPS TO PRESETS)
 M08P19 (F7 INPUT DESTINA) ← 1.45 (PRESET SCAN RSET)
 M09P14 (BIT SEL2 SOURCE1) ← 10.02 (DRIVE RUNNING)
 M09B15 (BIT SEL2 SR1 INV) ← 1
 M09P37 (BITSEL2 OUT DEST) ← 1.46 (PRESET SCAN HALT)

The following applies for all modes below

- Reset command: keypad STOP/RESET key or pushbutton at TB2-7-TB2-1.

Keypad Control (KPD CTRL):

Start command: Keypad RUN key.

Stop command: Keypad STOP key.

* FWD/REV command: Keypad FWD/REV key.

Speed reference source: Keypad reference M00P10

Auto Preset Scan Timer Control (AUTO PRESET CTRL):

Start command: RUN pushbutton at TB2-2-TB2-1.

Stop command: STOP pushbutton at TB2-5-TB2-1.

Preset Scan Reset: Pushbutton at TB2-8-TB2-1.

Speed reference source: PRESET INDICATOR

BIT2	BIT1	BIT0	DRIVE SPEED	DRIVE ACCEL/DECEL	TIME IN PRESETS
0	0	0	PRESET FREQ1	ACCEL1/DECEL1	TIME IN PRESET 1
0	0	1	PRESET FREQ2	ACCEL2/DECEL2	TIME IN PRESET 2
0	1	0	PRESET FREQ3	ACCEL3/DECEL3	TIME IN PRESET 3
0	1	1	PRESET FREQ4	ACCEL4/DECEL4	TIME IN PRESET 4
1	0	0	PRESET FREQ5	ACCEL5/DECEL5	TIME IN PRESET 5
1	0	1	PRESET FREQ6	ACCEL6/DECEL6	TIME IN PRESET 6
1	1	0	PRESET FREQ7	ACCEL7/DECEL7	TIME IN PRESET 7
1	1	1	PRESET FREQ8	ACCEL8/DECEL8	TIME IN PRESET 8

Program the following preset speeds and corresponding acceleration/deceleration and time in presets for the desired speed profile:

**M01P25 to M01P32: PRESET FREQ 1 to PRESET FREQ 8

M02P03: ACCEL 1

M02P11 to M02P17: ACCEL 2 to ACCEL8

M02P04: DECEL 1

M02P21 to M02P27: DECEL 2 to DECEL 8

M01P47 to M01P54: TIME IN PRESET 1 to TIME IN PRESET 8

***NOTE:** Reverse function is disabled. If FWD/REV is needed set M06B23 (DISABLE REV ROT) to 0 and M06B17 (EN KEYPAD FWD/RV) to 1.

****NOTE:** If some of the preset speeds are negative, reverse rotation is allowed by setting M06B23 (DISABLE REV ROT) to 0 and M01B10 (BIPOLAR SELECT) to 1.

Additional Notes:

When Programmed as shown, after the RUN pushbutton is pressed, the drive will run one cycle, then stop. If the drive is stopped by pressing the STOP pushbutton before the cycle has completed, the drive will decelerate using the presently active decel rate and the scan cycle is paused or halted at its present stage. This is because parameter M01B46 (PRESET SCAN HALT) is set at 1 when the drive is not in the RUN state. If the RUN pushbutton is now pressed, the scan cycle will resume from the beginning of the stage when the drive was stopped and the cycle was suspended. If, after the initial stop, one desires to reset the cycle before starting the drive again, press the Preset Scan Reset pushbutton before pressing the RUN pushbutton.

If a fault occurs in the middle of a cycle, the scan cycle is also paused or halted at its present stage. After fault is reset, the scan cycle can be resumed or reset to the beginning as described in the section above.

As a final note, if the resumption of a cycle after stopping or upon clearing a fault is not desired, but instead, it is desired that the cycle restart at the beginning upon pressing the RUN pushbutton, make the following changes:

Eliminate the Preset Scan Reset pushbutton and the programming of parameter M08P19 (F7 INPUT DESTINA).

Reprogram parameter M09P37 (BITSEL2 OUT DEST) to 1.45 (PRESET SCAN RSET).

3.7.21.b Auto Preset Scan Timer with Keypad Start/Stop

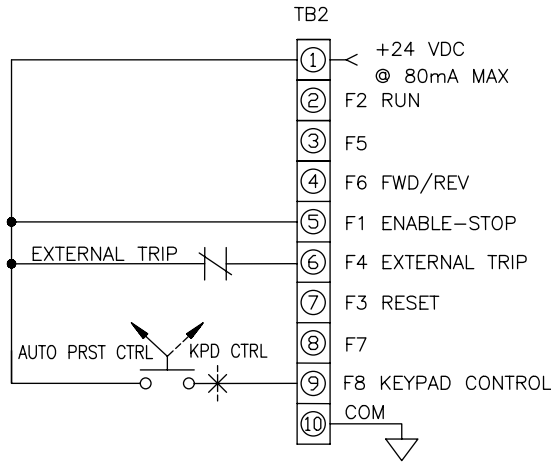

Change the following parameters in the order shown:

- M01B07 (SEL PRESET SPEED) ← 1
- M01B42 (PRESET SEL MODE) ← 1
- M01P43 (PRESET SCAN MODE) ← 1CYC&STOP
- M02B07 (RAMPS SELECTION) ← 1 (SYNC RAMPS TO PRESETS)
- M06P18 (KEYPAD CONT MODE) ← NO KEYS
- M06B15 (EN KEYPAD RUN) ← 1
- M06B16 (EN KEYPAD STOP) ← 1
- M06B17 (EN KEYPAD FWD/RV) ← 0
- M09P08 (BIT SEL1 SOURCE1) ← 6.13 (KEYPAD STOP)
- M09P10 (BIT SEL1 SOURCE2) ← 10.02 (DRIVE RUNNING)
- M09B11 (BIT SEL1 SR2 INV) ← 1
- M09P14 (BIT SEL2 SOURCE1) ← 10.02 (DRIVE RUNNING)
- M09B15 (BIT SEL2 SR1 INV) ← 1
- M09P35 (BITSEL1 OUT DEST) ← 1.45 (PRESET SCAN RSET)
- M09P37 (BITSEL2 OUT DEST) ← 1.46 (PRESET SCAN HALT)

The following applies for all modes below

- Reset command: keypad STOP/RESET key or pushbutton at TB2-7-TB2-1.

Keypad Control (KPD CTRL):

Start command: Keypad RUN key.

Stop command: Keypad STOP key.

* FWD/REV command: Keypad FWD/REV key.

Speed reference source: Keypad reference M00P10

Auto Preset Scan Timer Control (AUTO PRESET CTRL):

Start command: Keypad RUN key.

Stop command: Keypad STOP key.

Preset Scan Reset: Keypad STOP/RESET key when drive is not in RUN state.

Speed reference source: PRESET INDICATOR

			DRIVE	TIME IN PRESETS	
BIT	BIT	BIT	DRIVE SPEED	ACCEL/DECEL	
2	1	0			
0	0	0	PRESET FREQ1	ACCEL1/DECEL1	TIME IN PRESET 1
0	0	1	PRESET FREQ2	ACCEL2/DECEL2	TIME IN PRESET 2
0	1	0	PRESET FREQ3	ACCEL3/DECEL3	TIME IN PRESET 3
0	1	1	PRESET FREQ4	ACCEL4/DECEL4	TIME IN PRESET 4
1	0	0	PRESET FREQ5	ACCEL5/DECEL5	TIME IN PRESET 5
1	0	1	PRESET FREQ6	ACCEL6/DECEL6	TIME IN PRESET 6
1	1	0	PRESET FREQ7	ACCEL7/DECEL7	TIME IN PRESET 7
1	1	1	PRESET FREQ8	ACCEL8/DECEL8	TIME IN PRESET 8

Program the following preset speeds and corresponding acceleration/deceleration and time in presets for the desired speed profile:

**M01P25 to M01P32: PRESET FREQ 1 to PRESET FREQ 8

M02P03: ACCEL 1

M02P11 to M02P17: ACCEL 2 to ACCEL8

M02P04: DECEL 1

M02P21 to M02P27: DECEL 2 to DECEL 8

M01P47 to M01P54: TIME IN PRESET 1 to TIME IN PRESET 8

***NOTE:** Reverse function is disabled. If FWD/REV is needed set M06B23 (DISABLE REV ROT) to 0 and M06B17 (EN KEYPAD FWD/RV) to 1.

****NOTE:** If some of the preset speeds are negative, reverse rotation is allowed by setting M06B23 (DISABLE REV ROT) to 0 and M01B10 (BIPOLAR SELECT) to 1.

Additional Notes:

When Programmed as shown, after the Keypad RUN key is pressed, the drive will run one cycle, then stop. If the drive is stopped by pressing the Keypad STOP key before the cycle has completed, the drive will decelerate using the presently active decel rate and the scan cycle is paused or halted at its present stage. This is because parameter M01B46 (PRESET SCAN HALT) is set at 1 when the drive is not in the RUN state. If the Keypad RUN key is now pressed, the scan cycle will resume from the beginning of the stage when the drive was stopped and the cycle was suspended. If, after the initial stop, one desires to reset the cycle before starting the drive again, press the Keypad STOP key before pressing the Keypad RUN key.

If a fault occurs in the middle of a cycle, the scan cycle is also paused or halted at its present stage. If the fault is reset by using the Keypad STOP key, the scan cycle is also reset to the beginning because of the way the Keypad STOP key has been programmed by the BIT SEL1 parameters. If the fault is reset using pushbutton at TB2-7-TB2-1, the scan cycle will be resumed when the Keypad RUN key is pressed.

As a final note, if the resumption of a cycle after stopping or upon clearing a fault is not desired, but instead, it is desired that the cycle restart at the beginning upon pressing the RUN pushbutton, make the following changes:

De-activate the following parameters by reprogramming them to:

M09P08 (BIT SEL1 SOURCE1) ← 0.0

M09P10 (BIT SEL1 SOURCE2) ← 0.0

M09B11 (BIT SEL1 SR2 INV) ← 0

M09P35 (BITSEL1 OUT DEST) ← 0.0

Reprogram parameter M09P37 (BITSEL2 OUT DEST) to 1.45 (PRESET SCAN RSET).

3.7.22 Auto-Restart Typical Setup

Example #1:

- M06P02 (AUTO-START MODE) ← RUNNING
- M10B25 (ENABLE AUTORESET) ← 1
- M10P26 (RESET DELAY) ← 5
- M10P27 (NO OF AR ATTEMPTS) ← 5
- M10B28 (VFD OK DELAYED) ← 0
- M10P35 (AUTORESET MODE) ← PWR LOSS

Example #2:

- M06P02 (AUTO-START MODE) ← RUNNING
- M10B25 (ENABLE AUTORESET) ← 1
- M10P26 (RESET DELAY) ← 5
- M10P27 (NO OF AR ATTEMPTS) ← 5
- M10B28 (VFD OK DELAYED) ← 1
- M10P35 (AUTORESET MODE) ← PWR LOSS

The following is a description of the parameters above that can be changed to achieve different auto-restart features:

M06P02 "AUTO-START MODE":

There are three modes:

- [0] Disabled: The drive will not automatically start when AC power is applied.
- [1] Always: The drive always starts when AC power is applied.
- [2] Running: The drive starts only if it had been running when AC power was previously removed.

M10B25 "ENABLE AUTORESET":

If set to 1, the drive will be automatically reset when tripped after a programmed delay set in M10P26 "RESET DELAY"

M10P26 "RESET DELAY":

Enter the auto-reset delay in seconds
 When the programmed value of M10P27 "NO OF AR ATTEMPTS" is reached, any further trips of the same type will not cause a reset. A trip of a different type will cause a reset.

M10P27 "NO OF AR ATTEMPTS":

If no trip has occurred for 10 minutes, the reset count is cleared

M10B28 "VFD OK DELAYED"

This parameter can be used to hold "Drive Normal" status bit M10B01 at 1 until the last Auto-Reset Attempt is used.

Set M10B28 to 1 for "Drive Normal" status bit M10B01 to remain set at 1 every time a trip occurs and "Auto-Reset" is going to occur.

Set M10B28 to 0 to immediately clear "Drive Normal" status bit M10B01 at 0 every time a trip occurs, regardless of any Auto-reset that may occur.

M10P35 "AUTORESET MODE"

Use this parameter to select how parameter M10B25 "ENABLE AUTORESET" function operates. If "PWR LOSS" is selected, only the undervoltage fault is cleared and if "ALLFAULTS" is selected than all faults are cleared.

3.7.23 PID with "2-Wire" Control

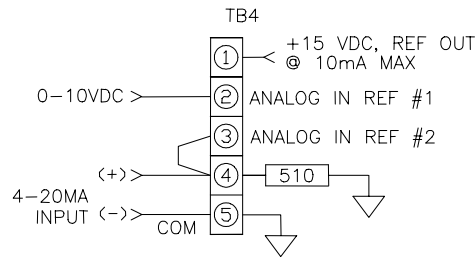
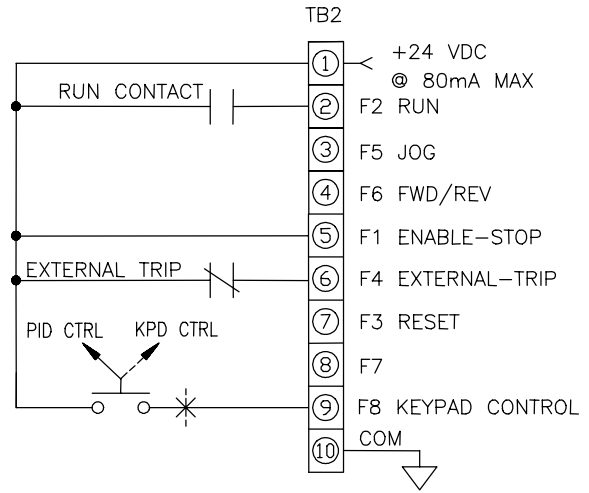

Change the following parameters in the order shown:

- M06P07 (SEQUENCING MODE) ← 2-WIRE
- M01B07 (SEL PRESET SPEED) ← 1
- M14P03 (PID REF SOURCE) ← 1.19 (M01P19)
- M14P04 (PID FEEDBACK SRC) ← 1.20 (M01P20)
- M14B08 (PID ENABLE) ← 1
- M14P15 (PID OUT SCALING) ← 0.060**
- M14P16 (PID OUT DESTINAT) ← 1.25*** (M01P25)

See 3.7.26 PID Additional Notes for more information.

Keypad Control (KPD CTRL):

- Start/Stop command: RUN contact at TB2-2-TB2-1.
- * FWD/REV command: Contact at TB2-4-TB2-1.
- Jog command: JOG contact at TB2-3-TB2-1.
- Reset command: keypad STOP/RESET key or pushbutton at TB2-7-TB2-1.
- Speed reference: Keypad reference M00P10

PID Control (PID CTRL):

- Start/Stop command: RUN contact at TB2-2-TB2-1.
- PID Reference: Analog Ref#1 at TB4-2, 0-10Vdc .
- PID Feedback: Analog Ref#2 at TB4-4, 4-20MA.
- * FWD/REV command: Contact at TB2-4-TB2-1.
- Jog command: JOG contact at TB2-3-TB2-1.
- Reset command: keypad STOP/RESET key or pushbutton at TB2-7-TB2-1.

**For 60Hz motor speed range, scale factor = 60/1000 (60 is 60Hz and 1000 is maximum value of parameter M01P25 "PRESET FREQ 1").

***Since the PID output in this example controls the speed, one of the preset speed parameters M01P25 "PRESET FREQ 1" is used as PID output destination. If the PID is to trim speed then it is suggested that parameter M01P15 "REF OFFSET" is used and set P01M16 "REF OFFSET SEL" to 1.

***NOTE:** Reverse function is disabled. If FWD/REV is needed set M06B23 (DISABLE REV ROT) to 0.

3-24 DRIVE PROGRAMMING

3.7.24 PID with "3-Wire" Control

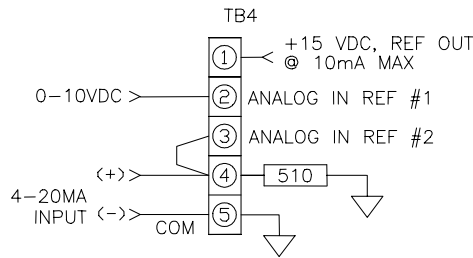
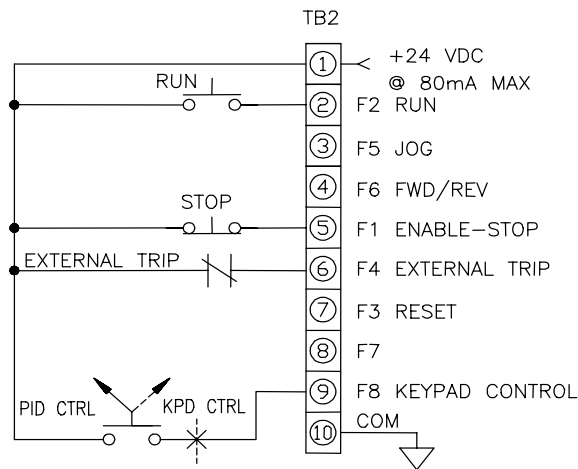

Change the following parameters in the order shown:

- M01B07 (SEL PRESET SPEED) ← 1
- M14P03 (PID REF SOURCE) ← 1.19 (M01P19)
- M14P04 (PID FEEDBACK SRC) ← 1.20 (M01P20)
- M14B08 (PID ENABLE) ← 1
- M14P15 (PID OUT SCALING) ← 0.060**
- M14P16 (PID OUT DESTINAT) ← 1.25*** (M01P25)

See 3.7.26 PID Additional Notes for more information.

Keypad Control (KPD CTRL):

Start command: Keypad RUN key.

Stop command: Keypad STOP key.

* FWD/REV command: Keypad USER key.

Jog command: JOG contact at TB2-3-TB2-1.

Reset command: keypad STOP/RESET key or pushbutton at TB2-7-TB2-1.

Speed reference source: Keypad reference M00P10

PID Control (PID CTRL):

Start command: RUN pushbutton at TB2-2-TB2-1.

Stop command: STOP pushbutton at TB2-5-TB2-1.

PID Reference: Analog Ref#1 at TB4-2, 0-10Vdc .

PID Feedback: Analog Ref#2 at TB4-4, 4-20MA.

* FWD/REV command: Contact at TB2-4-TB2-1.

Jog command: JOG contact at TB2-3-TB2-1.

Reset command: keypad STOP/RESET key or pushbutton at TB2-7-TB2-1.

**For 60Hz motor speed range, scale factor = 60/1000 (60 is 60Hz and 1000 is maximum value of parameter M01P25 "PRESET FREQ 1").

***Since the PID output in this example controls the speed, one of the preset speed parameters M01P25 "PRESET FREQ 1" is used as PID output destination. If the PID is to trim speed then it is suggested that parameter M01P15 "REF OFFSET" is used and set P01M16 "REF OFFSET SEL" to 1.

*NOTE: Reverse function is disabled. If FWD/REV is needed set M06B23 (DISABLE REV ROT) to 0 and M06P18 (KEYPAD CONT MODE) to "ALL KEYS".

3.7.25 PID with Keypad Start/Stop

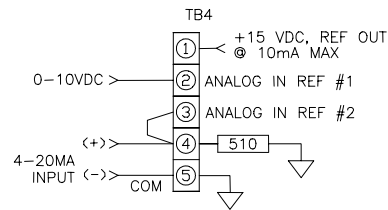
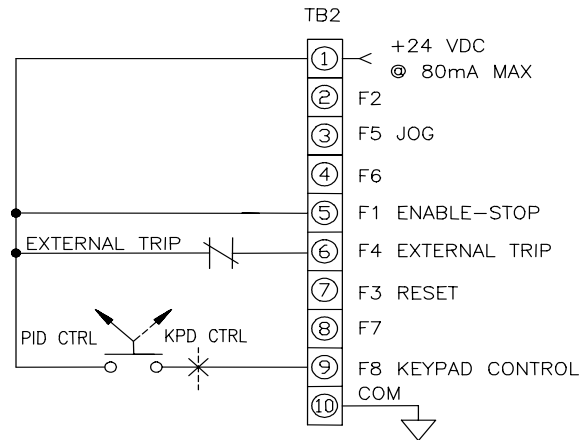

Change the following parameters in the order shown:

- M06P18 (KEYPAD CONT MODE) ← NO KEYS
- M06B15 (EN KEYPAD RUN) ← 1
- M06B16 (EN KEYPAD STOP) ← 1
- M06B17 (EN KEYPAD FWD/RV) ← 0
- M01B07 (SEL PRESET SPEED) ← 1
- M14P03 (PID REF SOURCE) ← 1.19 (M01P19)
- M14P04 (PID FEEDBACK SRC) ← 1.20 (M01P20)
- M14B08 (PID ENABLE) ← 1
- M14P15 (PID OUT SCALING) ← 0.060**
- M14P16 (PID OUT DESTINAT) ← 1.25*** (M01P25)

See 3.7.26 PID Additional Notes for more information.

Keypad Control (KPD CTRL):

Start command: Keypad RUN key.

Stop command: Keypad STOP key.

Jog command: JOG contact at TB2-3-TB2-1.

Reset command: keypad STOP/RESET key or pushbutton at TB2-7-TB2-1.

* FWD/REV command: Keypad USER key

Speed reference source: Keypad reference M00P10

PID Control (PID CTRL):

Start command: Keypad RUN key.

Stop command: Keypad STOP key.

PID Reference: Analog Ref#1 at TB4-2, 0-10Vdc .

PID Feedback: Analog Ref#2 at TB4-4, 4-20MA.

* FWD/REV command: Keypad USER key.

Jog command: JOG contact at TB2-3-TB2-1.

Reset command: keypad STOP/RESET key or pushbutton at TB2-7-TB2-1.

**For 60Hz motor speed range, scale factor = 60/1000 (60 is 60Hz and 1000 is maximum value of parameter M01P25 "PRESET FREQ 1").

***Since the PID output in this example controls the speed, one of the preset speed parameters M01P25 "PRESET FREQ 1" is used as PID output destination. If the PID is to trim speed then it is suggested that parameter M01P15 "REF OFFSET" is used and set P01M16 "REF OFFSET SEL" to 1.

*NOTE: Reverse function is disabled. If FWD/REV is needed set M06B23 (DISABLE REV ROT) to 0 and M06B17 (EN KEYPAD FWD/RV) to 1.

3.7.26 PID Additional Notes:

The following applies to the above PID setups:

In above setups PID setpoint M14P03 is analog ref #1, 0-10Vdc.

In above setups PID feedback M14P04 is analog ref #2, 4-20mA.

If a digital setpoint is desired, one can choose for example a preset frequency parameter such as M01P26 "PRESET FREQ 2".

Note that M00P06 "ACCEL RAMP 1" & M00P07 "DECEL RAMP 1" set the acceleration and deceleration rates of the PID output. Use M14P07 "PID REF SLEWRATE" to ramp the PID setpoint M14P03.

PID proportional gain M14P10, integral gain M14P11 and derivative gain M14P12:

With an error of 100%, if M14P10 = 1.000 the output produced by the proportional term is 100%.

With an error of 100%, if M14P11 = 1.000 the output produced by the integral term will increase linearly by 100% every second.

With an error that is increasing by 100% per second, if M14P12 = 1.000 the output produced by the D term will be 100%.

If a minimum and a maximum are needed for the PID output, use M14P13 "PID HIGH LIMIT" and M14P14 "PID LOW LIMIT".

PID Input Scaling:

All variable inputs to the PID (M14P02, M14P03 & M14P04) are automatically scaled to variables having the range $\pm 100.0\%$, or 0 - 100.0% if they are unipolar.

Example: PID setpoint M14P03 is programmed as M01P26 "PRESET FREQ 2".

Since M01P26 has a range ± 1000.0 a value entered in M01P26 of +1000.0 is automatically scaled to +100% for M14P03 and a value of +500.0 is automatically scaled to 50% for M14P03.

PID Output Scaling:

The output after the scale factor M14P15 is automatically scaled to match the range of the destination parameter.

Example: motor speed range is 60Hz and PID destination is M01P25 "PRESET FREQ 1".

Since M01P25 has a range of ± 1000.0 the PID output scale M14P15 should be set to 0.060 (60/1000).

Displaying PID Setpoint & Feedback:

Use the two programmable display parameters M00P19 & M00P20. M11P19 defines M00P19 and M11P20 defines M11P20.

M14P17 is a parameter that monitors PID reference and internally scaled to $\pm 100\%$.

M14P18 is a parameter that monitors PID feedback and internally scaled to $\pm 100\%$.

M11P19 ← M14P17 (display parameter M00P19 = M14P17)

M11P20 ← M14P18 (display parameter M00P20 = M14P18)

To scale M00P19:

M11P21 ← 1.000 (to display units in % scale = 100% x 1.000).

The scale can be changed to represent a meaningful engineering unit.

To scale M00P20:

M11P22 ← 1.000 (to display units in % scale = 100% x 1.000).

The scale can be changed to represent a meaningful engineering unit.

To change text in M00P19 & M00P20:

M11P31 ← SETPOINT (text for M00P19)

M11P32 ← FEEDBACK (text for M00P20)

Note: A user can setup M00P19 & M00P20 scale factors to mean engineering units such as 250 PSI for range. Also a user can choose M00P19 & M00P20 text from a selection of appropriate texts defined in M11P31 & M11P32.

THIS PAGE INTENTIONALLY LEFT BLANK

4.0 MENU AND PARAMETER DESCRIPTIONS

4.1 MENU DESCRIPTIONS

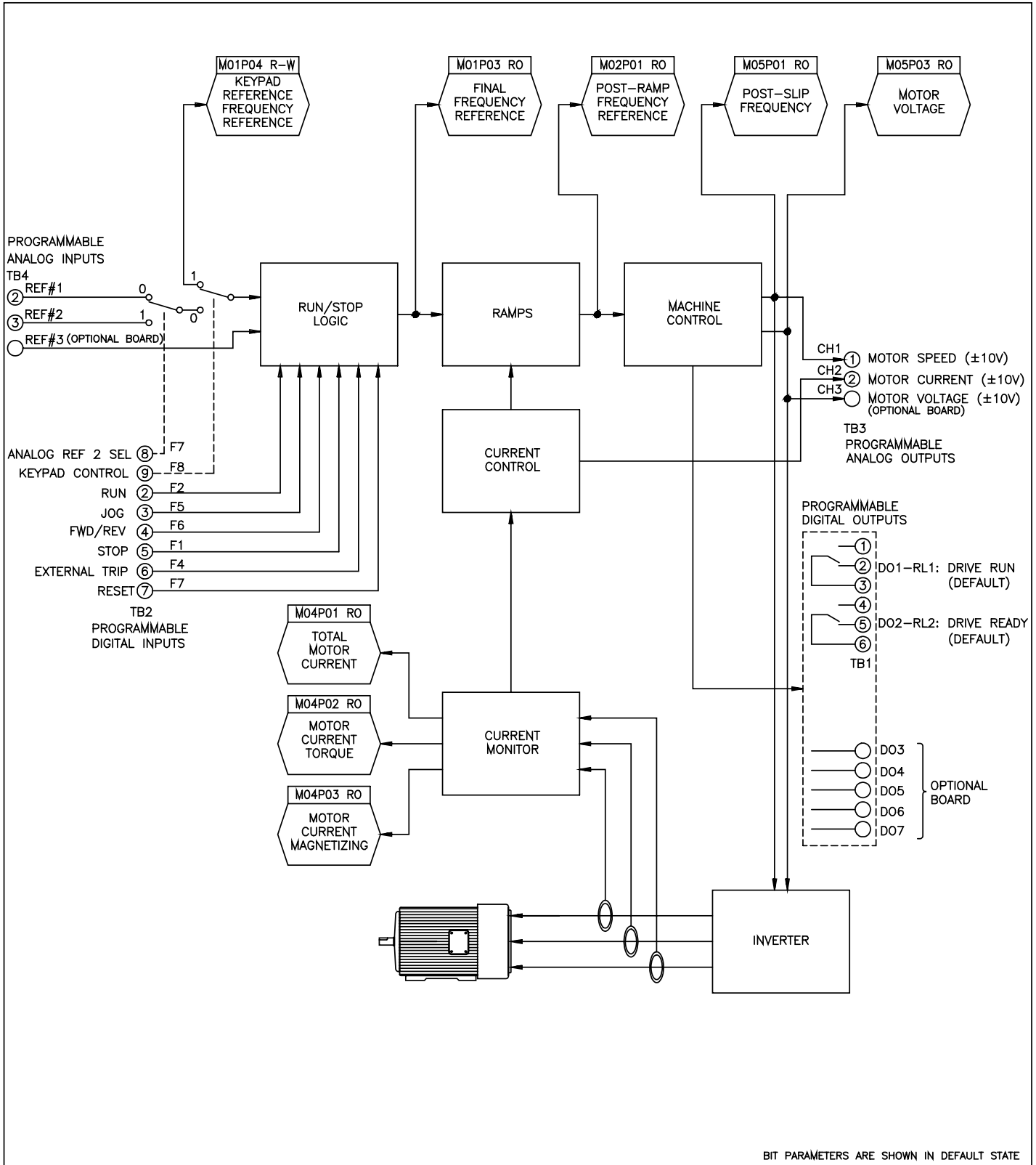

BIT PARAMETERS ARE SHOWN IN DEFAULT STATE

Figure 4-1
Basic Structure of the Control System

4-2 MENU AND PARAMETER DESCRIPTION

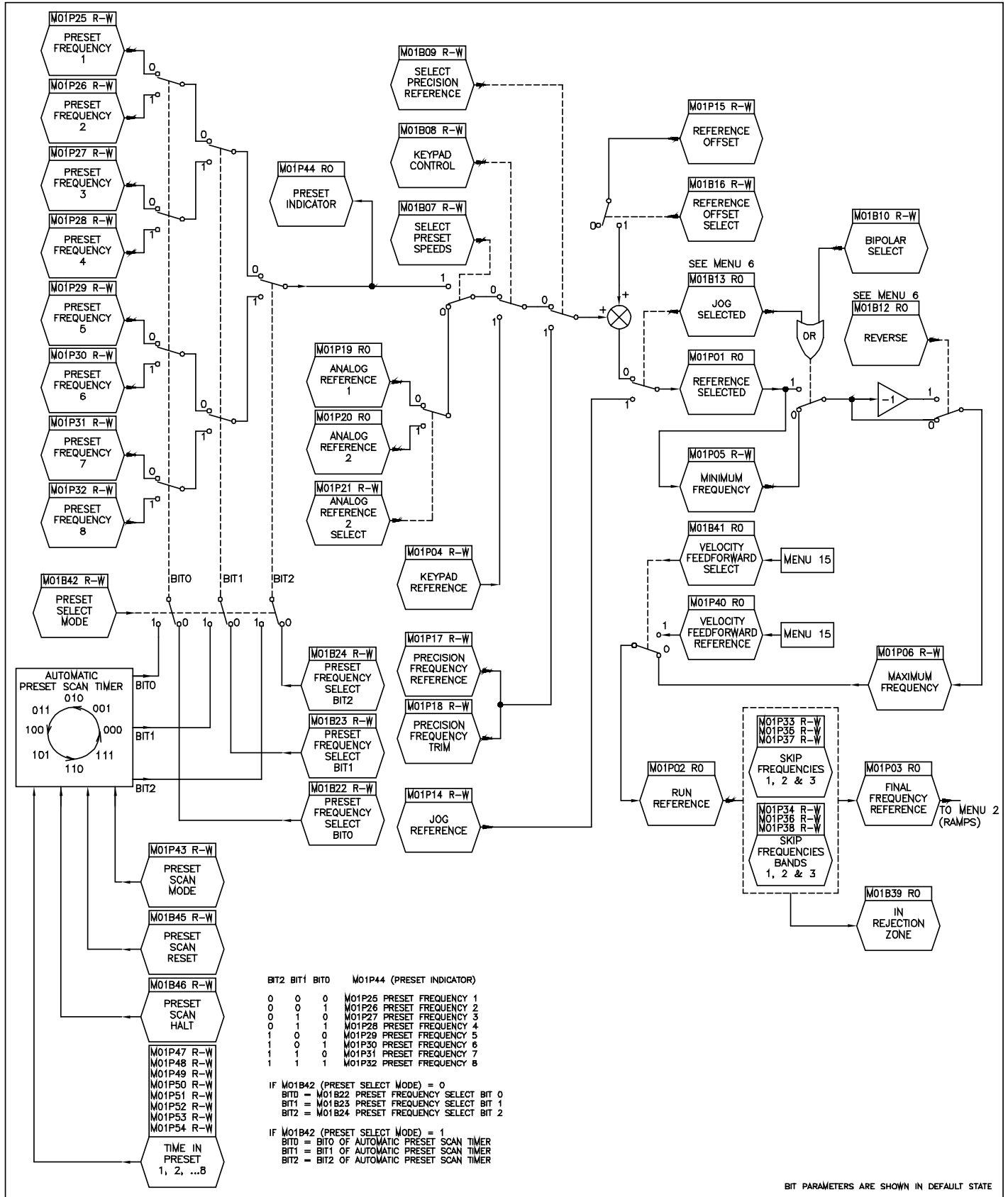

Figure 4-2
Menu 1 - Frequency Reference, Limits and Filters.

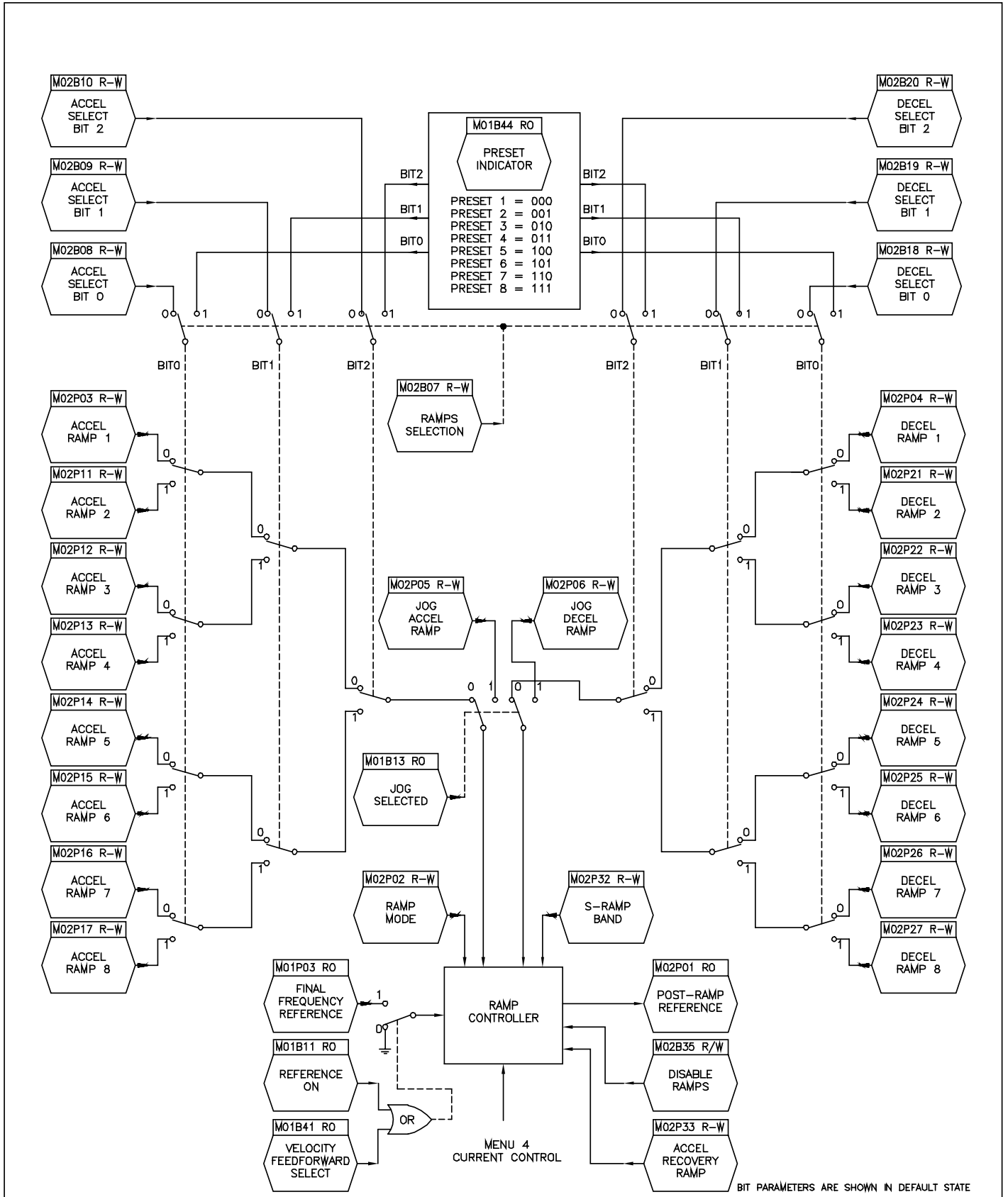

Figure 4-3
Menu 2 - Ramps

4-4 MENU AND PARAMETER DESCRIPTION

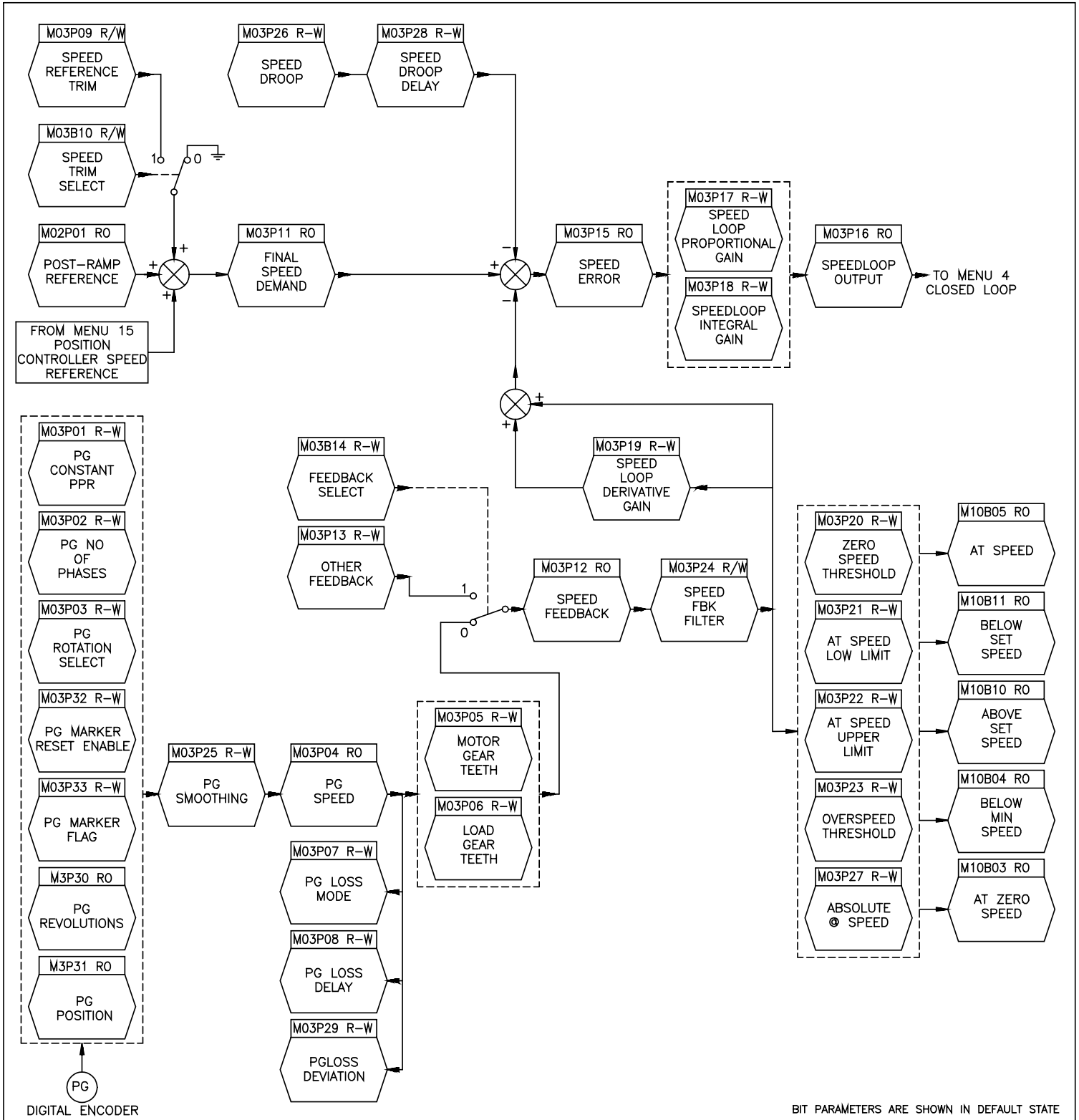

Figure 4-4
Menu 3 - Encoder Input and Speed Loop

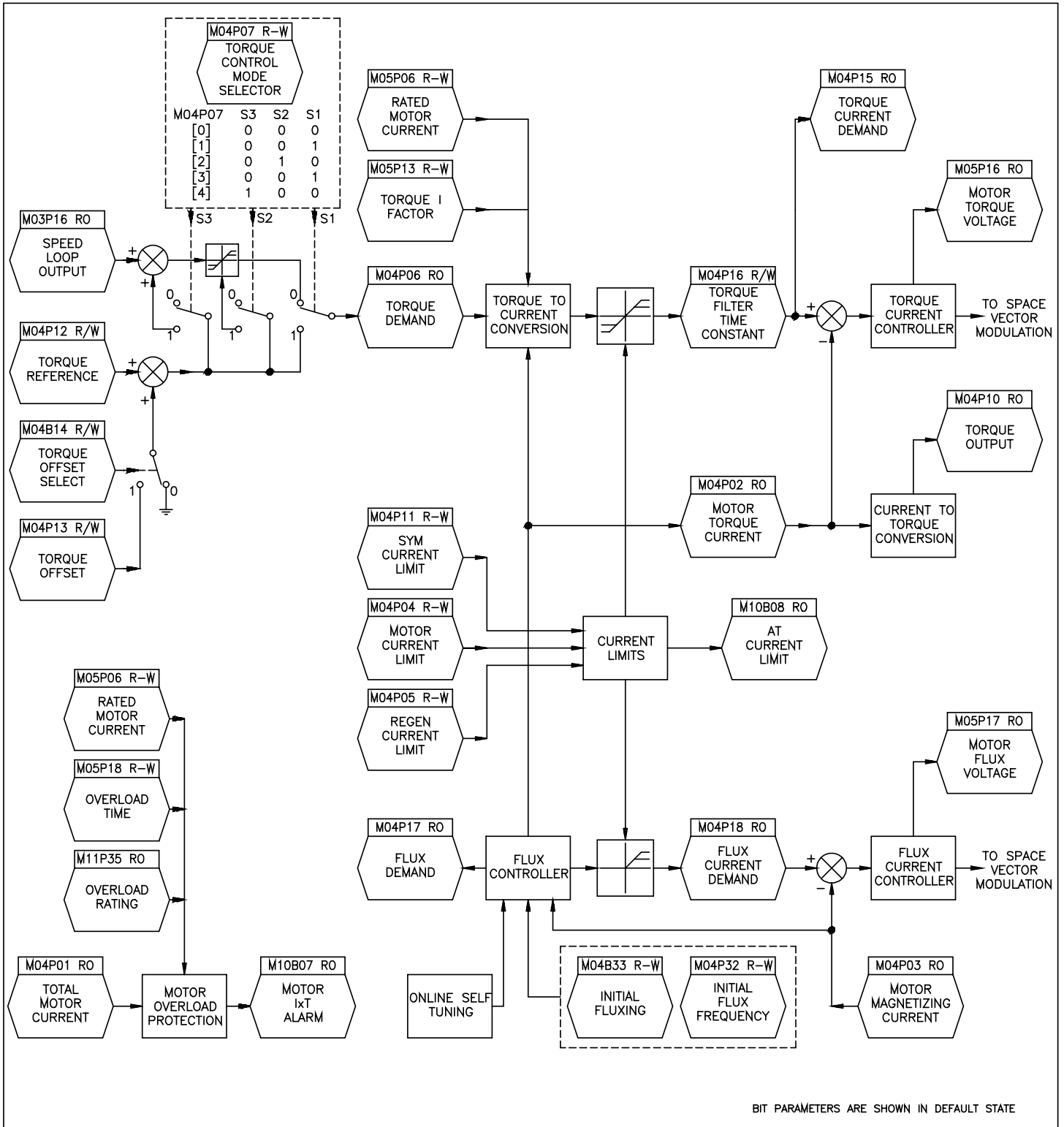

Figure 4-5
Menu 4 - Current Limits, Torque & Flux Control

MOTOR DATA

M05P06	RW	RATED MOTOR CURRENT
M05P07	RW	RATED MOTOR RPM
M05P08	RW	RATED MOTOR VOLTAGE
M05P09	RW	BASE MOTOR FREQUENCY
M05P10	RW	NUMBER OF POLES
M05P13	RW	TORQUE I FACTOR
M05P15	RW	FLUX CURRENT FACTOR

INPUT VOLTAGES

M05P04	RO	DC BUS VOLTAGE
M05P33	RW	RATED LINE VOLTAGE
M05P34	RO	AC LINE VOLTAGE
M05P47	RO	AC LINE RIPPLE
M05P48	RO	DC BUS RIPPLE
M05P50	RO	BUS CAPACITANCE

FREQUENCY CONTROL

M05P35	RO	SLIP FREQUENCY
M05P36	RW	SLIP TIME CONSTANT
M05P37	RW	SLIP CONTROL GAIN
M05P38	RW	SLIP COMP ENABLE

OUTPUT FREQUENCIES

M05P01	RO	POST SLIP FREQUENCY
M05P02	RO	MOTOR SHAFT RPM
M05P35	RO	SLIP FREQUENCY

VOLTAGE BOOST

M05P11	RW	AUTO BOOST VOLTAGE
M05P12	RW	VOLTAGE CONTROL MODE
M05P14	RW	FIXED BOOST VOLTAGE

OUTPUT VOLTAGES

M05P03	RO	MOTOR VOLTAGE
M05P16	RO	MOTOR TORQUE VOLTAGE
M05P17	RO	MOTOR FLUX VOLTAGE

PWM CARRIER

M05P20	RW	MAXIMUM PWM CARRIER
M05P21	RW	MINIMUM PWM CARRIER
M05P22	RW	SPEED @ MAXIMUM CARRIER
M05P23	RW	SPEED @ MINIMUM CARRIER
M05P24	RO	PWM CARRIER FREQUENCY

MOTOR POWER & OVERLOAD SETTING

M05P05	RO	MOTOR POWER
M05P18	RW	OVERLOAD TIME

BIT PARAMETERS ARE SHOWN IN DEFAULT STATE

Figure 4-6
Menu 5 - Motor Control

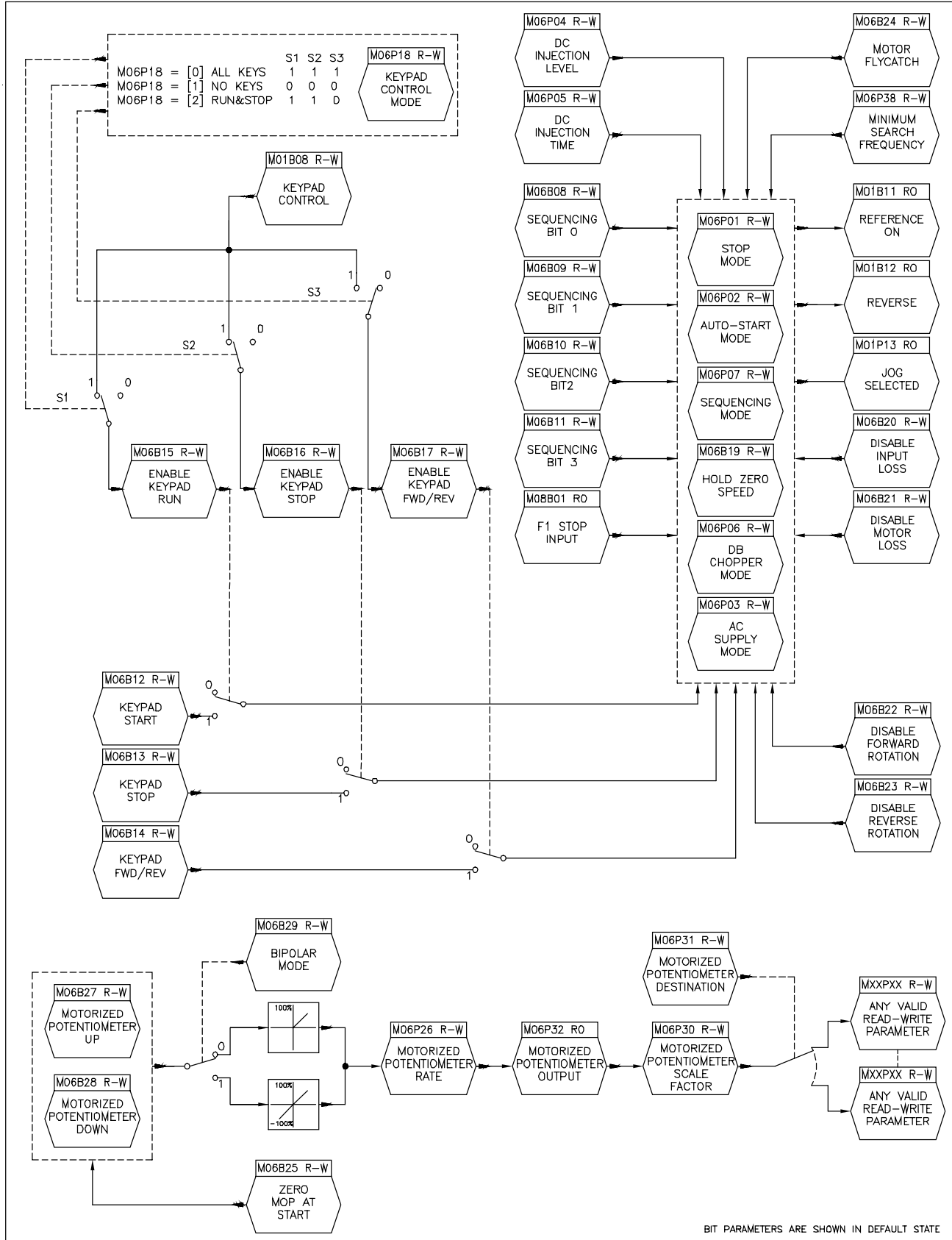

Figure 4-7
Menu 6 - Operational Modes

4-8 MENU AND PARAMETER DESCRIPTION

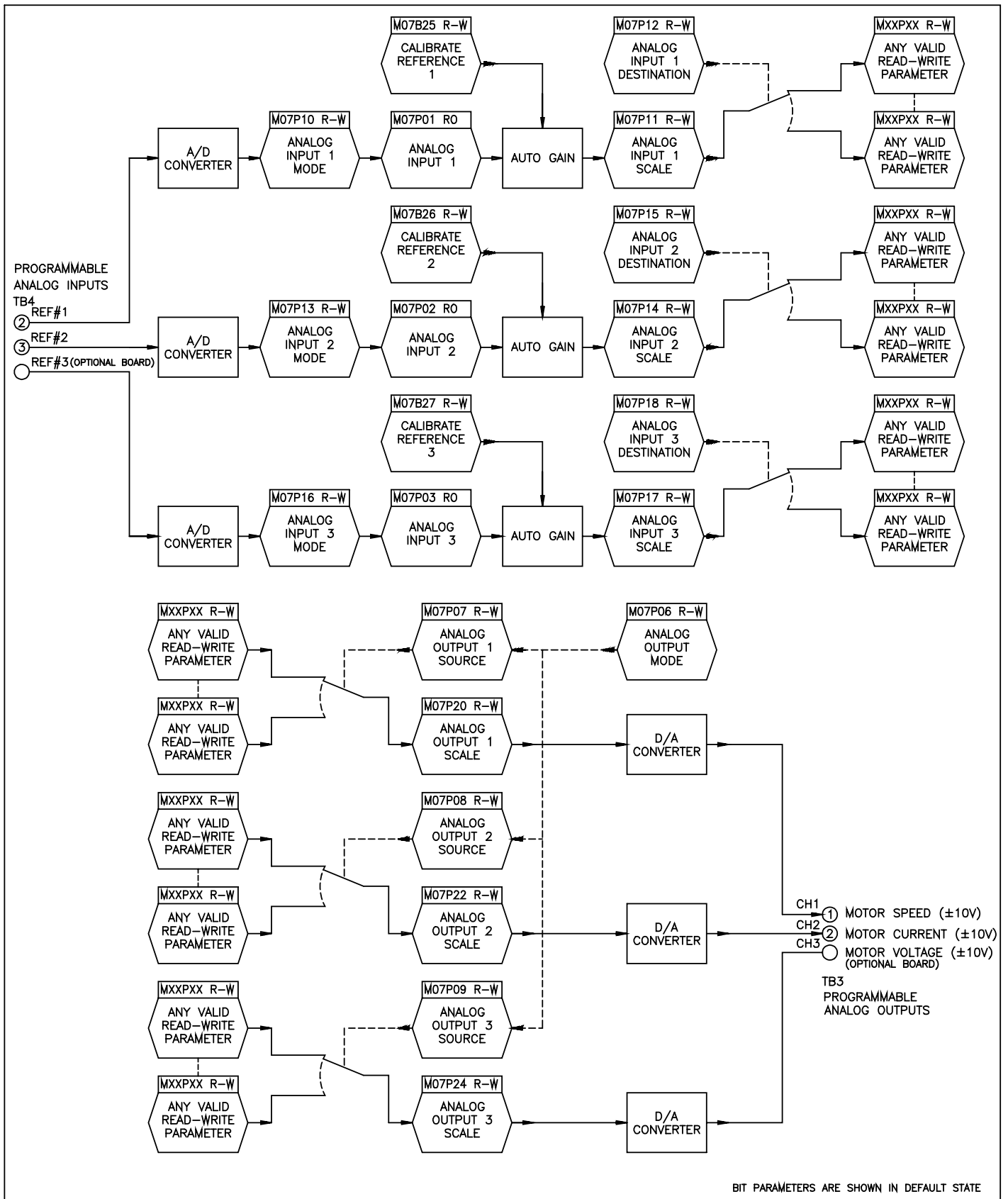

Figure 4-8
Menu 7 - Analog Inputs and Outputs.

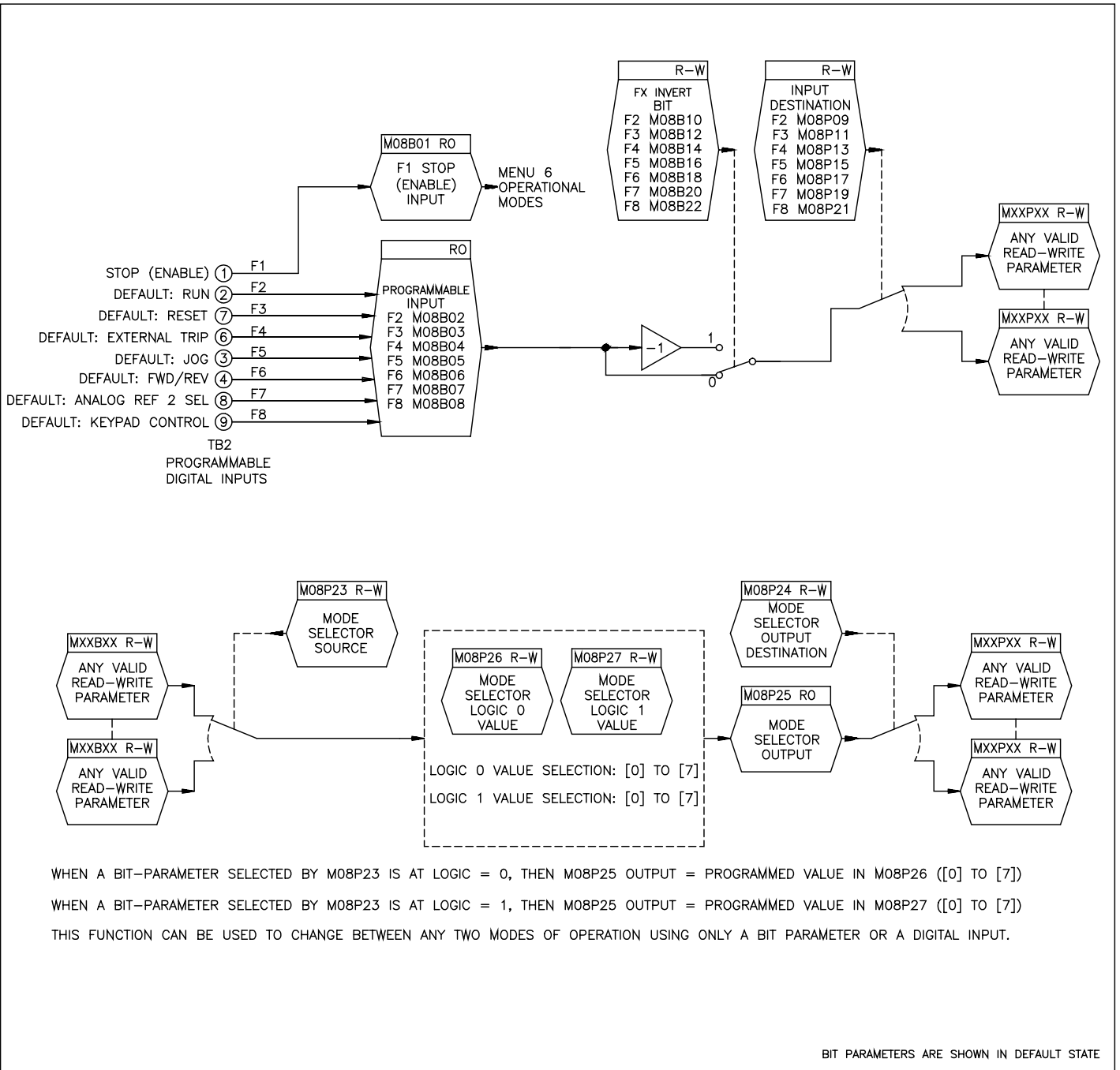

Figure 4-9
Menu 8 - Programmable Digital Inputs and Mode Selector.

4-10 MENU AND PARAMETER DESCRIPTION

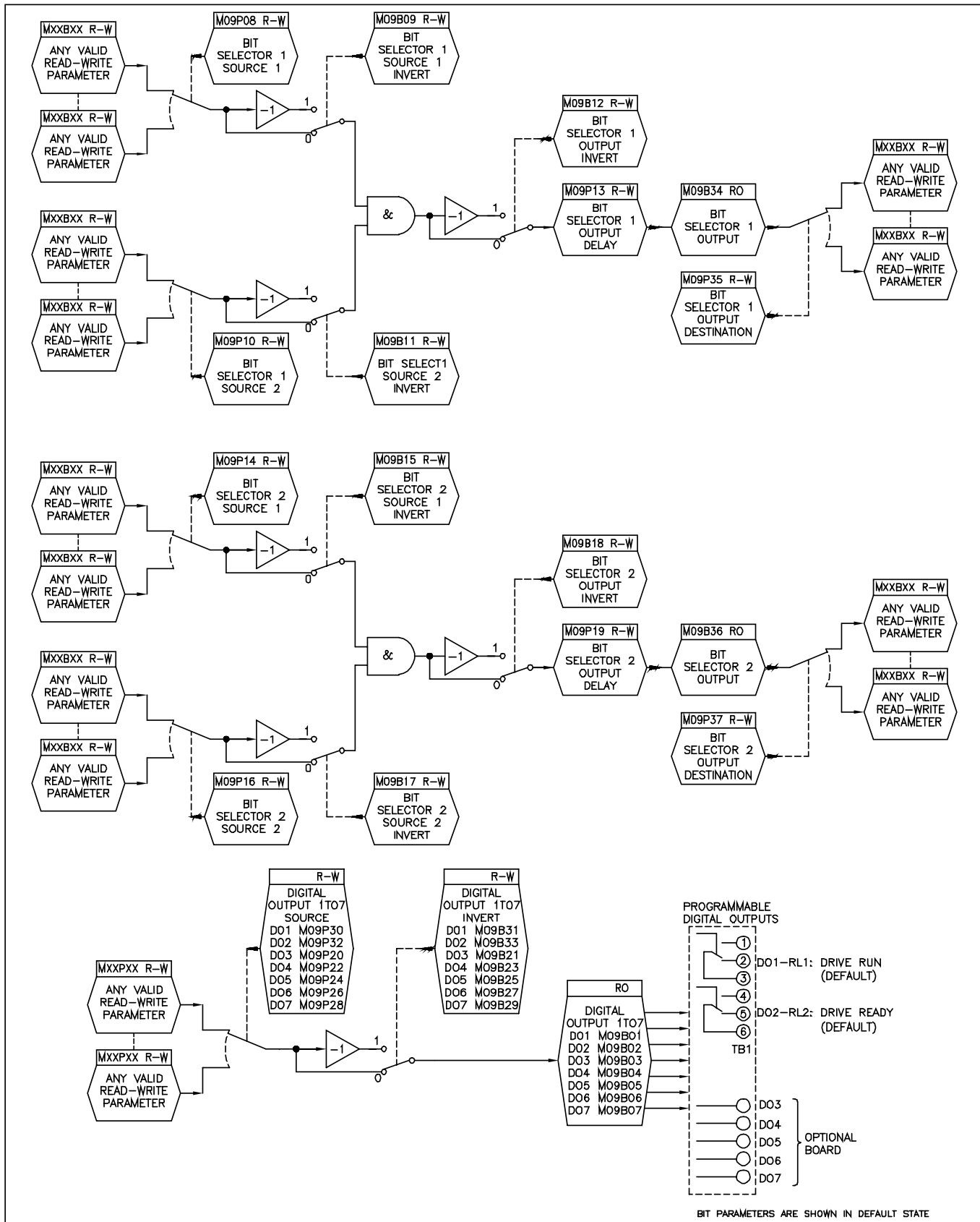

Figure 4-10
Menu 9 - Programmable Digital Outputs and Bit Selectors.

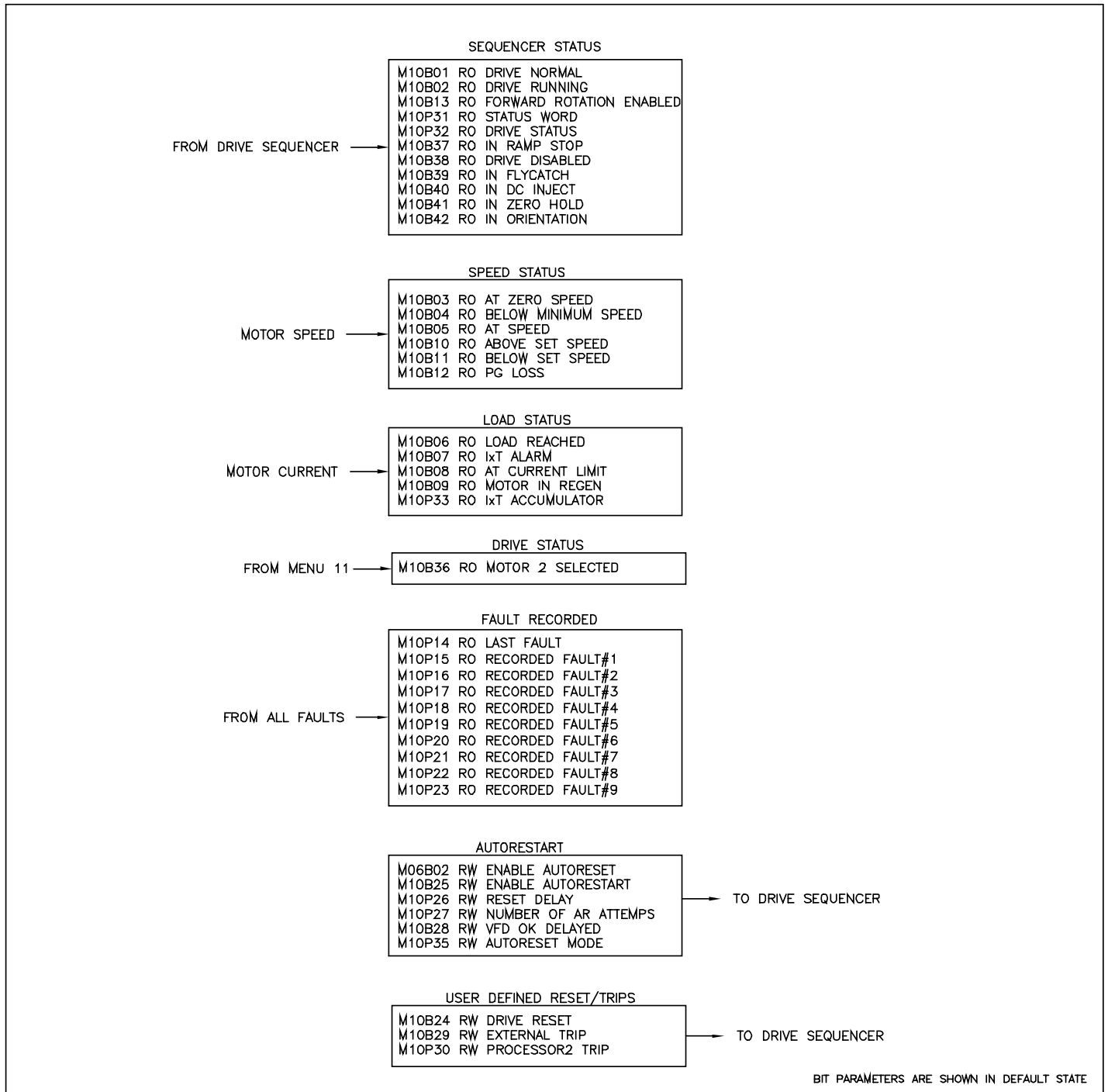

Figure 4-11
Menu 10 Status Logic and Diagnostic Information

MENU 0 CREATION

M11P01 RW DEFINE MOOP01
M11P02 RW DEFINE MOOP02
M11P03 RW DEFINE MOOP03
M11P04 RW DEFINE MOOP04
M11P05 RW DEFINE MOOP05
M11P06 RW DEFINE MOOP06
M11P07 RW DEFINE MOOP07
M11P08 RW DEFINE MOOP08
M11P09 RW DEFINE MOOP09
M11P10 RW DEFINE MOOP10
M11P11 RW DEFINE MOOP11
M11P12 RW DEFINE MOOP12
M11P13 RW DEFINE MOOP13
M11P14 RW DEFINE MOOP14
M11P15 RW DEFINE MOOP15
M11P16 RW DEFINE MOOP16
M11P17 RW DEFINE MOOP17
M11P18 RW DEFINE MOOP18
M11P19 RW DEFINE MOOP19
M11P20 RW DEFINE MOOP20

M11P31 RW TEXT FOR MOOP19
M11P32 RW TEXT FOR MOOP20
M11P21 RW SCALE FOR MOOP19
M11P22 RW SCALE FOR MOOP20

M11P30 RW DISPLAY WHEN PWR

SERIAL PORT DEFINITION

M11P23 RW SERIAL ADDRESS
M11P24 RW SERIAL PARITY
M11P25 RW BAUD RATE
M11P26 RW SERIAL PROTOCOL

SOFTWARE VERSION

M11P27 RO SOFTWARE VERSION
M11P28 RO PROCESSOR 2 VER

SECURITY

M11P29 RW SECURITY CODE
M11P37 RW ACCESS CODE

DRIVE MODEL SETUP/TYPE/DEFAULTS

M11P33 RW DRIVE MODEL NUMBER
M11P34 RO VOLTAGE RATING
M11P35 RO OVERLOAD RATING
M11P36 RW FACTORY DEFAULTS
M11P38 RW DRIVE TYPE
M11P40 RW SELECT 2nd MOTOR

BIT PARAMETERS ARE SHOWN IN DEFAULT STATE

Figure 4-12
Menu 11 - Miscellaneous

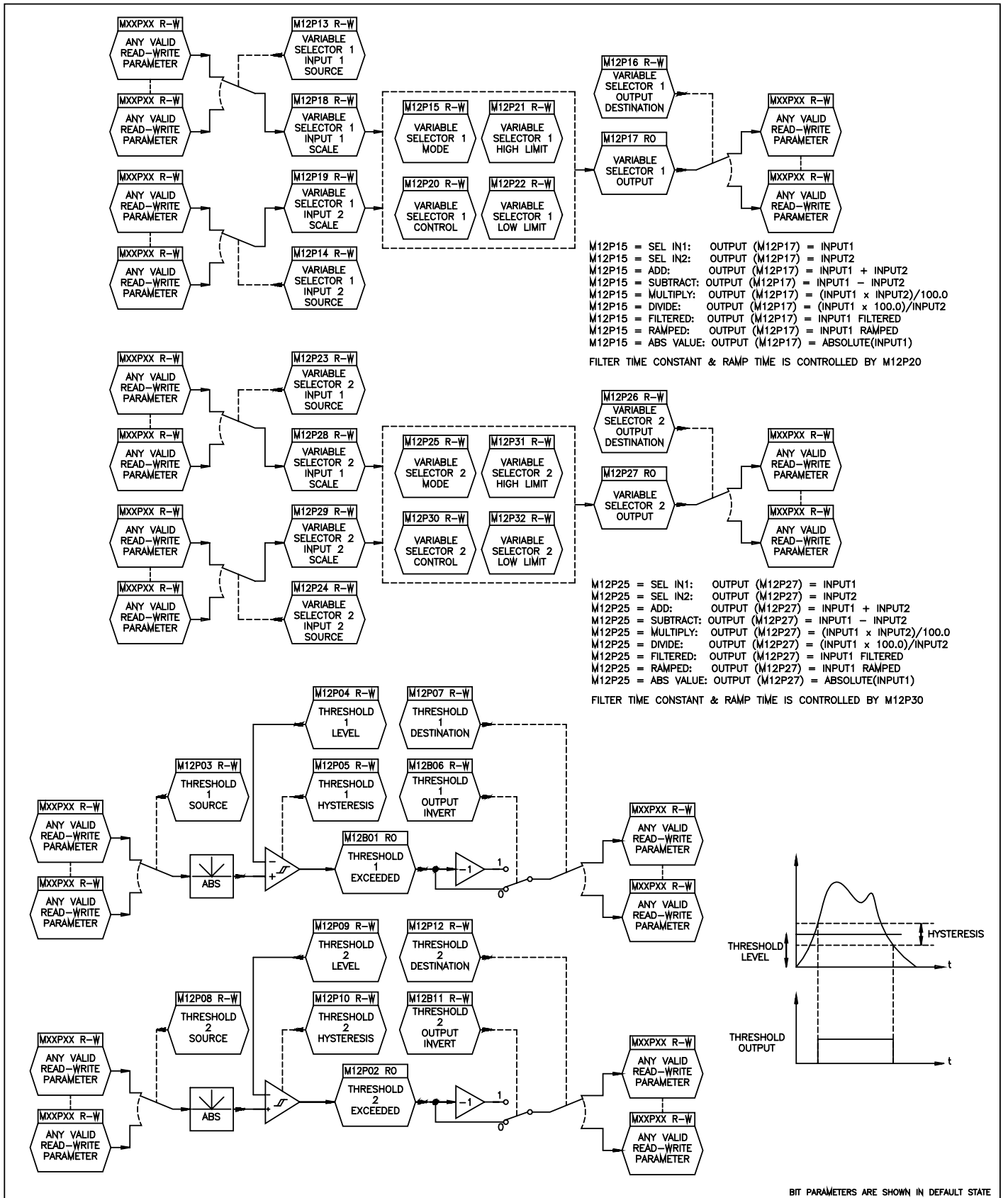

BIT PARAMETERS ARE SHOWN IN DEFAULT STATE

Figure 4-13
Menu 12 - Programmable Thresholds and Variable Selectors

4-14 MENU AND PARAMETER DESCRIPTION

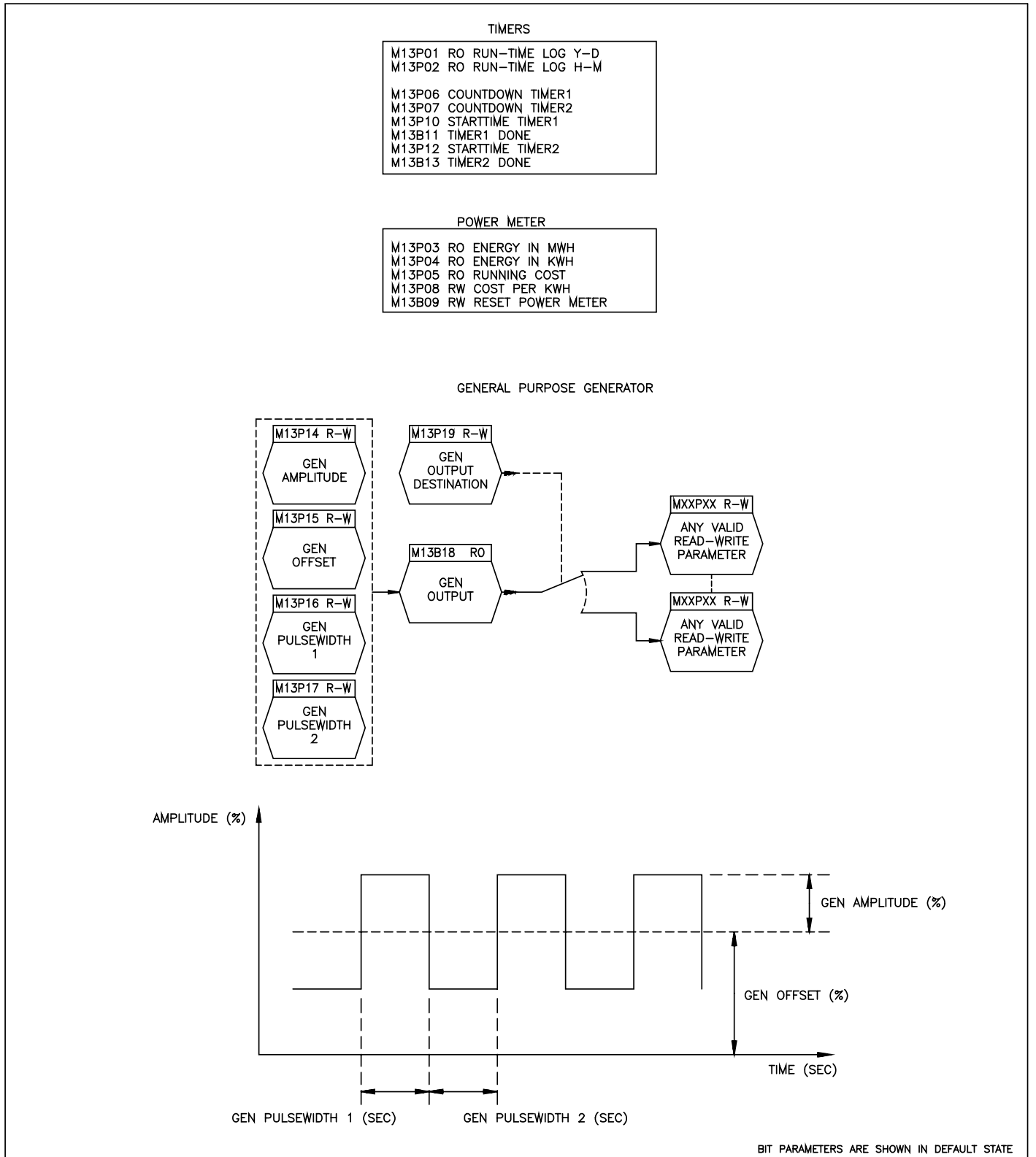
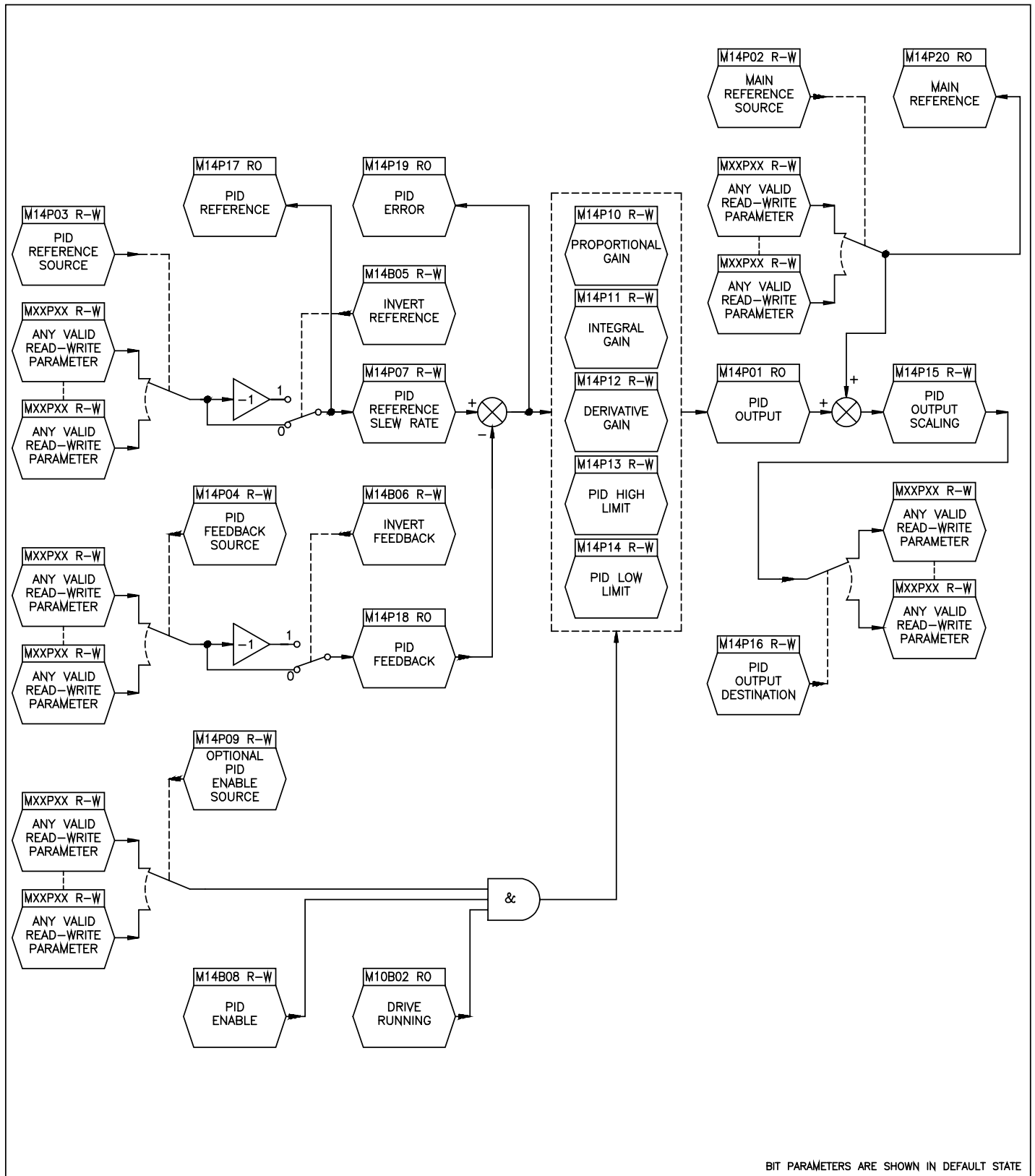

Figure 4-14
Menu 13 - Timers Function & General Purpose Generator



BIT PARAMETERS ARE SHOWN IN DEFAULT STATE

Figure 4-15
Menu 14 - PID Control Loop.

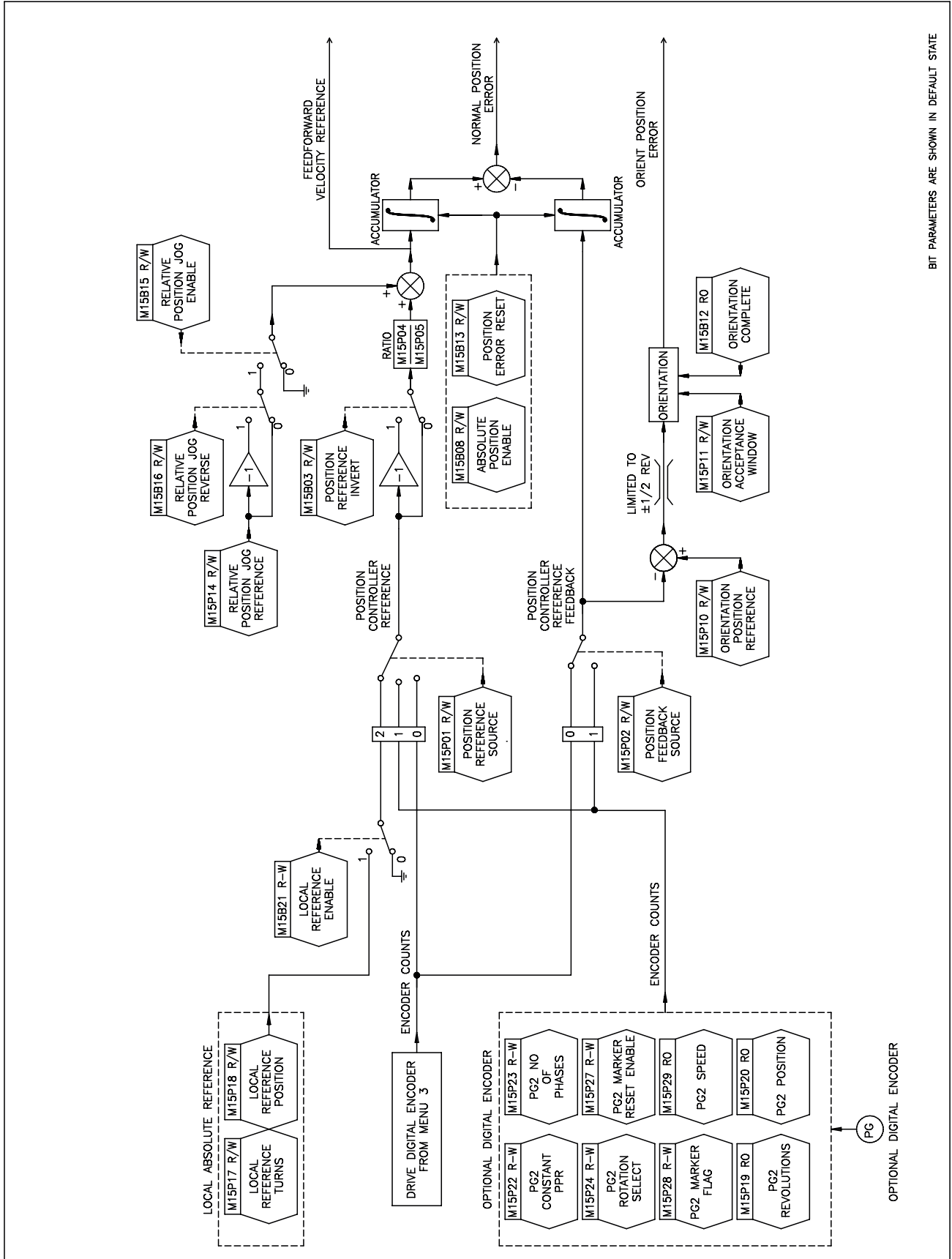

Figure 4-16
Menu 15 - Position Control (1 of 2)

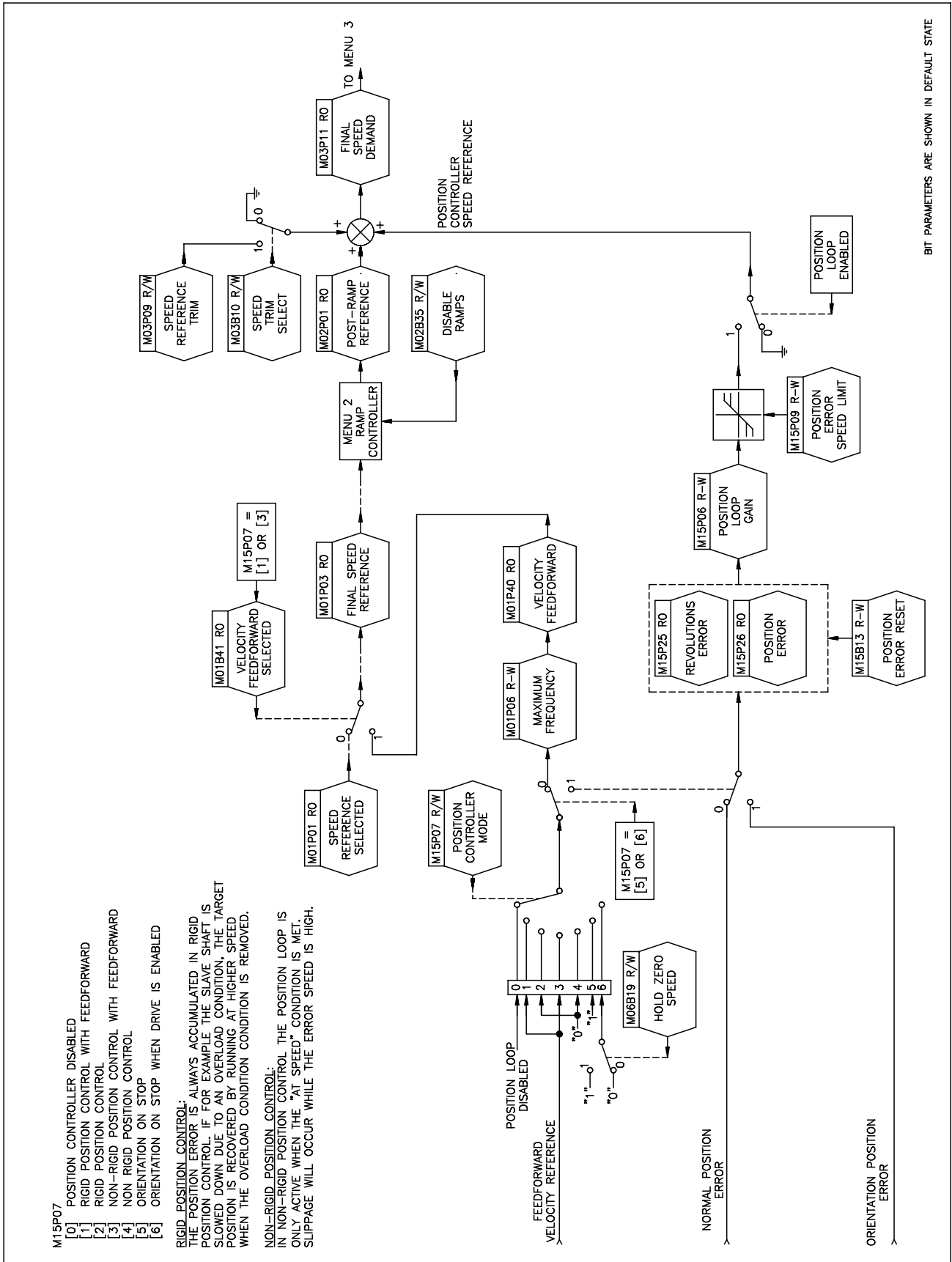

Figure 4-17
 Menu 15 - Position Control (2 of 2)

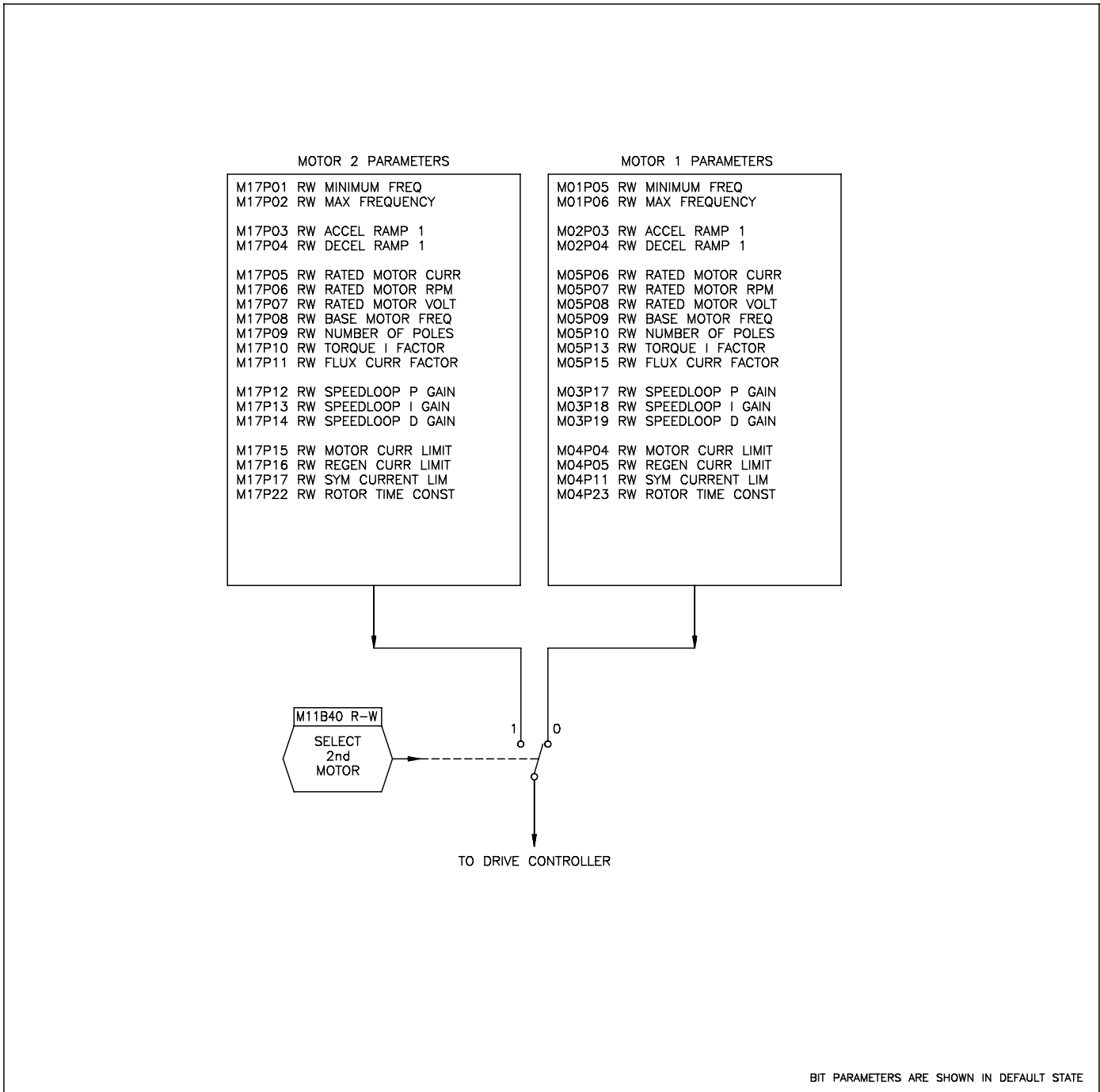

Figure 4-18
Menu 17 - 2nd Motor Parameters

4.2 Parameter Definitions

<p>MXXP00 Parameter 00 is at the beginning of every menu and it is also the menu name:</p> <p>M00P00 QUICK SET UP MENU M01P00 FREQ REFS MENU M02P00 RAMPS MENU M03P00 ENCODER MENU M04P00 CURR-TORQUE CTRL M05P00 MOTOR CONTROL M06P00 OPERATION MODES M07P00 ANALOG I/O MENU M08P00 DIG INS-MODE SEL M09P00 DIG OUTS-BIT SEL M10P00 STATUS-DIAGNOSTIC M11P00 MISCELLANEOUS M12P00 THRESHOLDS-VARSEL M13P00 TIMERS FUNCTIONS M14P00 PID CONTROL LOOP M15P00 POSITION CONTROL M17P00 2nd MOTOR PARAMS</p>	<p>R-O</p>	<p>Range: Default:</p>
<p>M00P01 RATED MOTOR VOLT (M05P08) Enter the value from the motor rating plate in order to define the maximum output voltage of the drive.</p> <p>This parameter assumes the R-W or R-O attribute of the parameter assigned to it.</p>	<p>R-W</p>	<p>Range: 100 to 600 VRMS Default: 240 480 600</p>
<p>M00P02 BASE MOTOR FREQ (M05P09) Enter a value of frequency at which the rated voltage is to be applied to the motor. The motor then enters the constant-power or field-weakening region.</p> <p>This parameter assumes the R-W or R-O attribute of the parameter assigned to it.</p>	<p>R-W</p>	<p>Range: 10.0 to 600.0 Hz Default: 60.0</p>
<p>M00P03 RATED MOTOR CURR (M05P06) When parameter M05P06 is set at a value lower than the default rating of the drive, the maximum current of the drive can be greater than 1.5 times the motor rating. Consequently, the maximum value of current limit and torque parameters (M04P04, M04P05, M04P06, M04P11 and M06P04) can be increased proportionately.</p> <p>For example, if a 180 Amp drive has parameter M05P06 set at 90 Amps, the maximum values of parameters M04P04, M04P05, M04P11 and M06P04 can be 300% (2 x 150%). This allows larger drives to be used for a high starting torque.</p> <p>When the value is increased beyond the default value of M05P06, the values of M04P04, M04P05 and M04P11 are automatically decreased.</p> <p>The value entered affects the following:</p> <ul style="list-style-type: none"> Slip compensation Dynamic V/f lxt detection level 	<p>R-W</p>	<p>Range: 0 to 1800 A Default: Model Dependent</p>

<p><u>Industrial and HVAC applications</u> Industrial applications benefit from a higher percentage of overload current, but have a lower nominal current. HVAC applications benefit from a higher nominal current, but have a lower percentage of overload current (120%). The overload current has the same value in each case.</p> <p>See parameter M05P18.</p> <p>This parameter assumes the R-W or R-O attribute of the parameter assigned to it.</p>		
<p>M00P04 NUMBER OF POLES (M05P10) Enter the value from the motor rating plate for correct slip compensation and RPM indication.</p> <p>This parameter assumes the R-W or R-O attribute of the parameter assigned to it.</p>	R-W	<p>Range: [0] (2 POLES) to [15] (32 POLES) Default: [1] (4 POLES)</p>
<p>M00P05 SYM CURRENT LIM (M04P11) After having set the required value of maximum current in M05P06, you may increase or decrease the percentage overload current using M04P11. The maximum percentage that can be set is limited by the overload current rating of the drive. The limit applies when motoring and regenerating.</p> <p>The value of M04P11 is automatically reduced when the value of M05P06 is increased beyond the default value.</p> <p>This parameter assumes the R-W or R-O attribute of the parameter assigned to it.</p>	R-W	<p>Range: See M04P04 % Default: 120 or 150 minimum</p>
<p>M00P06 ACCEL RAMP 1 (M02P03) Acceleration ramp rate is expressed as the time for the output frequency to increase by 100Hz.</p> <p>For example, a programmed ramp time of 5 seconds causes the frequency to increase or decrease by 50Hz in 2.5 seconds.</p> <p>This parameter assumes the R-W or R-O attribute of the parameter assigned to it.</p>	R-W	<p>Range: 0.1 to 3276 s/100Hz Default: Size 0: 30.0 sec Size 1: 30.0 sec Size 2: 60.0 sec Size 3: 60.0 sec</p>
<p>M00P07 DECEL RAMP 1 (M02P04) Deceleration ramp rate is expressed as the time for the output frequency to decrease by 100Hz.</p> <p>This parameter assumes the R-W or R-O attribute of the parameter assigned to it.</p>	R-W	<p>Range: 0.1 to 3276 s/100Hz Default: Size 0: 30.0 sec Size 1: 30.0 sec Size 2: 60.0 sec Size 3: 60.0 sec</p>
<p>M00P08 MAX FREQUENCY (M01P06) Enter a value to define the absolute maximum output frequency.</p> <p>This parameter assumes the R-W or R-O attribute of the parameter assigned to it.</p>	R-W	<p>Range: 0 to 600.0 Hz Default: 60.0</p>
<p>M00P09 MINIMUM FREQ (M01P05) Use in unipolar mode to define the minimum output frequency of the drive. This can be over-ridden by M01P06 and is inactive during Jog.</p> <p>This parameter assumes the R-W or R-O attribute of the parameter assigned to it.</p>	R-W	<p>Range: 0 to M01P06 Hz Default: 0</p>

<p>M00P10 KEYPAD REFERENCE (M01P04)</p> <p>Enter a value using the Control Keypad.</p> <p>This parameter assumes the R-W or R-O attribute of the parameter assigned to it.</p>	<p>R-W</p>	<p>Range: Bipolar: \pmM01P06 Hz Unipolar: M01P05 to M01P06 Default: 0</p>
<p>M00P11 SOFTWARE VERSION (M11P27)</p> <p>Indicates version of software in the drive.</p> <p>This parameter assumes the R-W or R-O attribute of the parameter assigned to it.</p>	<p>R-O</p>	<p>Range: XXXX Default:</p>
<p>M00P12 DRIVE MODEL NO (M11P33)</p> <p>Indicates the drive model number.</p> <p>This parameter assumes the R-W or R-O attribute of the parameter assigned to it.</p>	<p>R-W</p>	<p>Range: Default:</p>
<p>M00P13 MOTOR VOLTAGE (M05P03)</p> <p>Indicates the RMS voltage applied to the motor.</p> <p>This parameter assumes the R-W or R-O attribute of the parameter assigned to it.</p>	<p>R-O</p>	<p>Range: \pm0 to M05P08 V_{RMS} Default:</p>
<p>M00P14 MOTOR POWER (M05P05)</p> <p>Indicates the real component of the power output.</p> <p>This parameter assumes the R-W or R-O attribute of the parameter assigned to it.</p>	<p>R-O</p>	<p>Range: KW Default:</p>
<p>M00P15 DC BUS VOLTAGE (M05P04)</p> <p>Indicates the DC bus voltage.</p> <p>This parameter assumes the R-W or R-O attribute of the parameter assigned to it.</p>	<p>R-O</p>	<p>Range: 0 to 1000.0 V Default:</p>
<p>M00P16 AC LINE VOLTAGE (M05P34)</p> <p>Indicates RMS voltage of the AC supply.</p> <p>This parameter assumes the R-W or R-O attribute of the parameter assigned to it.</p>	<p>R-O</p>	<p>Range: 0 to 1000.0 V_{RMS} Default:</p>
<p>M00P17 LAST FAULT (M10P14)</p> <p>This parameter assumes the R-W or R-O attribute of the parameter assigned to it.</p>	<p>R-O</p>	<p>Range: Default:</p>
<p>M00P18 MOT CURR-TOTAL (M04P01)</p> <p>Indicates the magnitude of the total motor current.</p> <p>This parameter assumes the R-W or R-O attribute of the parameter assigned to it.</p>	<p>R-O</p>	<p>Range: 0 to \pmM11P35 A Default:</p>
<p>M00P19 FINAL FREQ REF (M01P03)</p> <p>Indicates the final frequency reference. This can be used for setting up the system and fault finding.</p> <p>This parameter is always read only (R-O)</p>	<p>R-O</p>	<p>Range: \pmM01P06 Hz Default: 0.0</p>
<p>M00P20 MOTOR SHAFT RPM (M05P02)</p> <p>Indicates motor shaft RPM. The number of poles must be entered correctly in M00P04 (M05P10), and the slip correction must not be at the maximum frequency limit [if the motor is to run at 60Hz, set M00P08 (M01P06) at a higher value to allow for slip compensation].</p> <p>This parameter is always read only (R-O)</p>	<p>R-O</p>	<p>Range: 0 to 32760 RPM Default:</p>

M01P01	REF SELECTED Indicates the frequency reference. This can be used for setting up the system and fault finding.	R-O	Range: ± 1000.0 Hz Default:
M01P02	RUN REFERENCE Indicated the run frequency reference. This can be used for setting up the system and fault finding.	R-O	Range: $\pm M01P06$ Hz Default: 0.0
M01P03	FINAL FREQ REF Indicates the final frequency reference. This can be used for setting up the system and fault finding.	R-O	Range: $\pm M01P06$ Hz Default: 0.0
M01P04	KEYPAD REFERENCE Enter a value using the Control Keypad.	R-W	Range: Bipolar: $\pm M01P06$ Hz Unipolar: M01P05 to M01P06 Default: 0
M01P05	MINIMUM FREQ Use in unipolar mode to define the minimum output frequency of the drive. This can be over-ridden by M01P06 and is inactive during Jog.	R-W	Range: 0 to M01P06 Hz Default: 0
M01P06	MAX FREQUENCY Enter a value to define the absolute maximum output frequency.	R-W	Range: 0 to 600.0 Hz Default: 60.0
M01B07	SEL PRESET SPEED Set at 1 to select pre-set speeds.	R-W	Range: 0 or 1 Default: 0
M01B08	KEYPAD CONTROL Set at 1 to select control using Keypad keys and Keypad reference, (it forces 1 into M06B15, M06B16, and M06B17 if M06B18 is set to "All Keys".	R-W	Range: 0 or 1 Default: 0
M01B09	SEL PRECIS REF Set at 1 for high resolution (0.001Hz) frequency control. Set at 0 for normal resolution (0.03Hz) frequency control.	R-W	Range: 0 or 1 Default: 0
M01B10	BIPOLAR SELECT Set at 1 to select bipolar speed reference signal. Set at 0 to select unipolar speed reference signal. Negative input signals are then treated as zero. <u>Analog Operation</u> When M01B10 is set at 0, any analog input programmed to parameters M01P19 and M01P20 is scaled so that 100% corresponds to the maximum set for M01P06, and 0% corresponds to the minimum set for M01P05. When M01B10 is set at 1, the analog input programmed to M01P19 or M01P20 is scaled so that $\pm 100\%$ corresponds to the maximum \pm set for M01P06. In addition, if an analog input programmed in voltage mode is directed to one of these parameters and the parameter is selected as the frequency reference, the scan-rate of the analog input is increased.	R-W	Range: 0 or 1 Default: 0

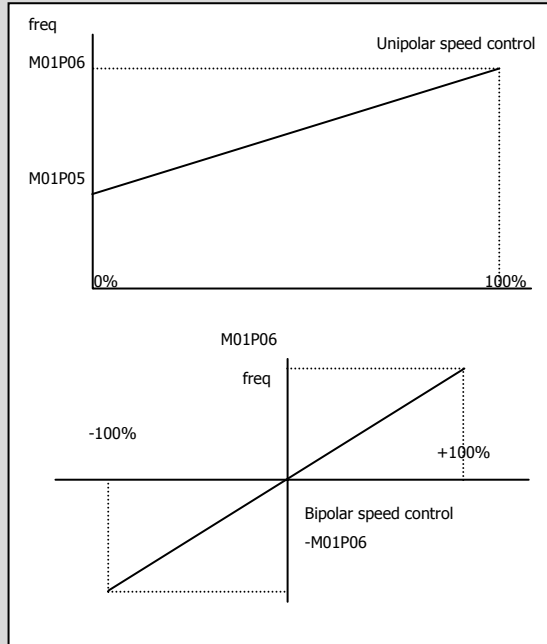
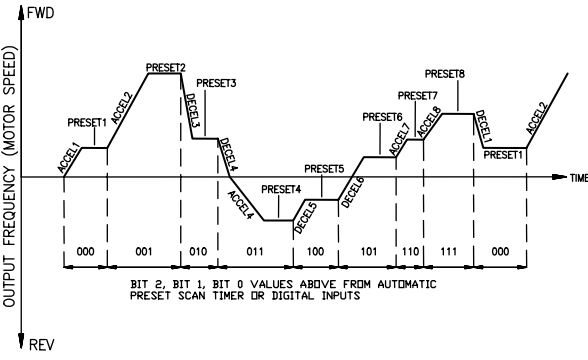
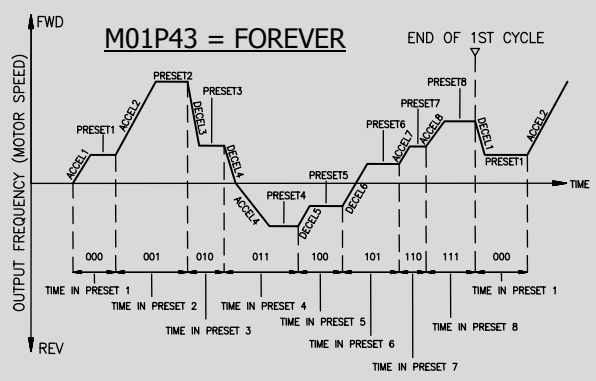

Figure 10-1 Scaling of the analog speed reference input

<p>M01B11 REFERENCE ON M01B12 REVERSE M01B13 JOG SELECTED These parameters are controlled by the drive sequencer.</p>	R-O	Range: 0 or 1 Default: 0
<p>M01P14 JOG REFERENCE Frequency reference for Jog.</p>	R-W	Range: 0 to 1000.0 Hz Default: 5.0
<p>M01P15 REF OFFSET When M01B16 is set at 1, the value entered into M01P15 is added to the selected reference parameter. It is used to trim the selected parameter.</p>	R-W	Range: ±1000.0 Hz Default: 0
<p>M01B16 REF OFFSET SEL Set at 1 to enable addition of the reference offset (M01P15).</p>	R-W	Range: 0 or 1 Default: 0
<p>M01P17 PRECIS FREQ REF</p>	R-W	Range: ±1000.0 Hz Default: 0
<p>M01P18 PRECIS FREQ TRIM</p>	R-W	Range: 0 to 0.099 Hz Default: 0
<p>M01P19 ANALOG REF 1 M01P20 ANALOG REF 2 See parameter M01B10</p>	R-O	Range: M01P06 Hz Default: 0.0
<p>M01B21 ANALOG REF2 SEL M01B22 PRESET FREQ BIT0 M01B23 PRESET FREQ BIT1 M01B24 PRESET FREQ BIT2 Select the required reference.</p>	R-W	Range: 0 or 1 Default: 0
<p>M01P25 PRESET FREQ 1 M01P26 PRESET FREQ 2 M01P27 PRESET FREQ 3 M01P28 PRESET FREQ 4 M01P29 PRESET FREQ 5 M01P30 PRESET FREQ 6 M01P31 PRESET FREQ 7</p>	R-W	Range: ±1000.0 Hz Default: 0

<p>M01P32 PRESET FREQ 8</p> <p>Note that parameter M02B07 (RAMPS SELECTION) must be set at 1 to have the corresponding accel/decel rates selected when the preset speeds are selected.</p> <p>Normal preset frequency references.</p> 		
<p>M01P33 SKIP FREQUENCY 1 Enter a value to avoid a frequency which induces mechanical resonances.</p>	R-W	Range: 0 to 1000.0 Hz Default: 0
<p>M01P34 SKIP FREQ 1 BAND Enter a value to define the frequency range either side of Skip frequency 1 over which frequencies are avoided. The bandwidth is twice that entered into this parameter.</p>	R-W	Range: 0 to 5.0 Hz Default: 0.5
<p>M01P35 SKIP FREQUENCY 2 Enter a value to avoid a frequency which induces mechanical resonances.</p>	R-W	Range: 0 to 1000.0 Hz Default: 0
<p>M01P36 SKIP FREQ 2 BAND Enter a value to define the frequency range either side of Skip frequency 2 over which frequencies are avoided. The bandwidth is twice that entered into this parameter.</p>	R-W	Range: 0 to 5.0 Hz Default: 0.5
<p>M01P37 SKIP FREQUENCY 3 Enter a value to avoid a frequency which induces mechanical resonance's.</p>	R-W	Range: 0 to 1000.0 Hz Default: 0
<p>M01P38 SKIP FREQ 3 BAND Enter a value to define the frequency range either side of Skip frequency 3 over which frequencies are avoided. The bandwidth is twice that entered into this parameter.</p>	R-W	Range: 0 to 5.0 Hz Default: 0.5
<p>M01B39 IN REJECT ZONE Indicates the selected reference is within one of the skip frequency bands. The motor speed does not match the demand.</p>	R-O	Range: 0 or 1 Default: 0
<p>M01P40 VEL FEEDFWD REF This parameter indicates the velocity feed-forward reference when position control is used.</p>	R-O	Range: ± M01P06 Default:
<p>M01B41 FEEDFWD SELECTED This bit indicates that the position controller has selected the velocity feed-forward as a reference for the drive.</p>	R-O	Range: 0 or 1 Default:

<p>M01B42 PRESET SEL MODE Set at 1 to allow the preset timer to sequentially select the preset frequencies. Set at 0 to allow bit parameters M01B22 through M01B24 to select the preset frequencies.</p>	<p>R-W</p>	<p>Range: 0 or 1 Default: 0</p>
<p>M01P43 PRESET SCAN MODE There are three modes for the auto preset scan timer: [0] FOREVER The drive will run the cycle continuously. [1] 1CYC&STOP The drive will run one cycle, then stop. Note that to stop at the end of the cycle, M06P07 (SEQUENCING MODE) must be "2OR3-WIRE" or "3-WIRE SP". [2] 1CYC&CONT The drive will run one cycle and continue at the last preset speed.</p> <p>The preset scan timer is reset and halted and PRESET 1 selected under the following conditions:</p> <ul style="list-style-type: none"> • M01B42 (PRESET SEL MODE) is set at 0. • or M01B45 (PRESET SCAN RSET) is set at 1. • or M01P43 (PRESET SCAN MODE) is changed <p>The preset scan timer is halted at a given stage in the cycle, maintaining the given preset under the following conditions:</p> <ul style="list-style-type: none"> • The drive is in the FAULT state. • or M01B46 (PRESET SCAN HALT) is set at 1. <p>If the preset scan timer is in both the reset and halted states, the reset state dominates.</p> <p>If none of the above conditions are true, the preset scan timer begins running and the presets are selected according to the mode selected. Note that the drive does not have to be in RUN mode for the preset scan timer to run.</p> <p>Also note that parameter M02B07 (RAMPS SELECTION) Must be set at 1 to have the corresponding accel/decel Rates selected when the preset speeds are selected as shown in the figures below.</p>	<p>R-W</p>	<p>Range: [0] to [2] Default: [0] FOREVER</p>



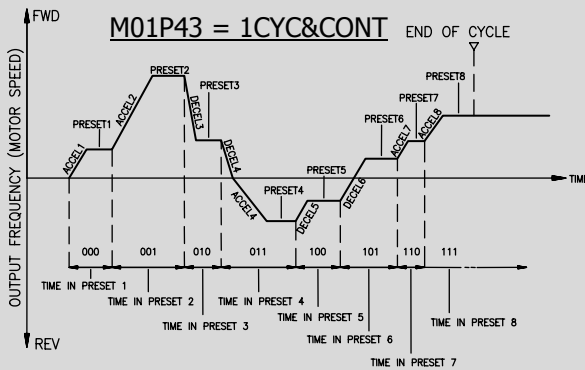
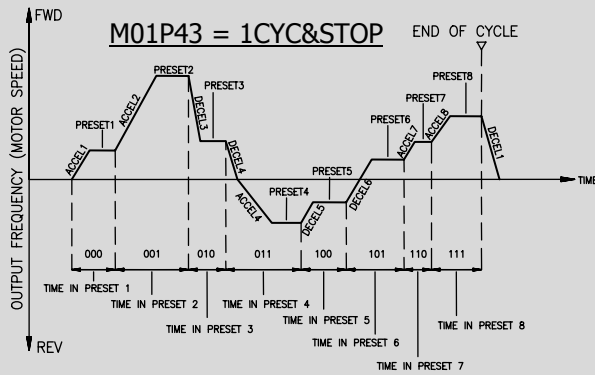

M01P44 PRESET INDICATOR

Indicates which preset frequency is presently being used.

- [0] PRESET 1 000
- [1] PRESET 2 001
- [2] PRESET 3 010
- [3] PRESET 4 011
- [4] PRESET 5 100
- [5] PRESET 6 101
- [6] PRESET 7 110
- [7] PRESET 8 111

R-O

Range: [0] to [7]
Default:

M01B45 PRESET SCAN RSET

Set at 1 to reset the preset timer and select PRESET FREQ 1 (M01P25). This bit parameter can be used to halt an existing preset sequence and start a new one. When this parameter is set at 0, the preset selection follows the preset timer according to the setting of parameter M01P43 (PRESET SCAN MODE).

R-W

Range: 0 or 1
Default: 0

M01B46 PRESET SCAN HALT

Set at 1 to halt or suspend the preset timer at the present point in the cycle. This bit parameter can be used to halt an existing preset sequence and then resume when this parameter is then returned to 0. The drive runs at the halted preset speed until the M01B46 is returned to 0.

R-W

Range: 0 or 1
Default: 0

M01P47 TIME IN PRESET 1 Enter a value to define the time the auto preset sequencer stays in "PRESET 1" (as shown by M01P44), when parameter M01B42 is set to 1.	R-W	Range: 0 to 3276.0 Sec Default: 20.0						
M01P48 TIME IN PRESET 2 Enter a value to define the time the auto preset sequencer stays in "PRESET 2" (as shown by M01P44), when parameter M01B42 is set to 1.	R-W	Range: 0 to 3276.0 Sec Default: 20.0						
M01P49 TIME IN PRESET 3 Enter a value to define the time the auto preset sequencer stays in "PRESET 3" (as shown by M01P44), when parameter M01B42 is set to 1.	R-W	Range: 0 to 3276.0 Sec Default: 20.0						
M01P50 TIME IN PRESET 4 Enter a value to define the time the auto preset sequencer stays in "PRESET 4" (as shown by M01P44), when parameter M01B42 is set to 1.	R-W	Range: 0 to 3276.0 Sec Default: 20.0						
M01P51 TIME IN PRESET 5 Enter a value to define the time the auto preset sequencer stays in "PRESET 5" (as shown by M01P44), when parameter M01B42 is set to 1.	R-W	Range: 0 to 3276.0 Sec Default: 20.0						
M01P52 TIME IN PRESET 6 Enter a value to define the time the auto preset sequencer stays in "PRESET 6" (as shown by M01P44), when parameter M01B42 is set to 1.	R-W	Range: 0 to 3276.0 Sec Default: 20.0						
M01P53 TIME IN PRESET 7 Enter a value to define the time the auto preset sequencer stays in "PRESET 7" (as shown by M01P44), when parameter M01B42 is set to 1.	R-W	Range: 0 to 3276.0 Sec Default: 20.0						
M01P54 TIME IN PRESET 8 Enter a value to define the time the auto preset sequencer stays in "PRESET 7" (as shown by M01P44), when parameter M01B42 is set to 1.	R-W	Range: 0 to 3276.0 Sec Default: 20.0						
M02P01 POST-RAMP REF Frequency reference after the effects of ramps and normal currents limits.	R-O	Range: ±M01P06 Hz Default: 0.0						
M02P02 RAMP MODE Select from: STD RAMP [0] Standard ramp FAST RAMP [1] Fast ramp The Ramp Modes parameter M02P02 controls deceleration ramps only. The settings are as follows: <table style="width: 100%; border-collapse: collapse;"> <thead> <tr> <th style="text-align: left; border-bottom: 1px solid black;">Setting</th> <th style="text-align: left; border-bottom: 1px solid black;">Description</th> </tr> </thead> <tbody> <tr> <td>0 STD RAMP</td> <td>Standard ramp</td> </tr> <tr> <td>1 FAST RAMP</td> <td>Fast ramp</td> </tr> </tbody> </table> Mode 1 – Fast mode The ramp falls at the programmed deceleration rate	Setting	Description	0 STD RAMP	Standard ramp	1 FAST RAMP	Fast ramp	R-W	Range: [0] STD RAMP [1] FAST RAMP Default: [0] STD RAMP
Setting	Description							
0 STD RAMP	Standard ramp							
1 FAST RAMP	Fast ramp							

	<p>subject only to the current limits programmed.</p> <p>This mode is normally used when a AC Regen or braking module is used.</p>		
M02P03	<p>ACCEL RAMP 1 Acceleration ramp rate is expressed as the time for the output frequency to increase by 100Hz.</p> <p>For example, a programmed ramp time of 5 seconds causes the frequency to increase or decrease by 50Hz in 2.5 seconds.</p>	R-W	<p>Range: 0.1 to 3276 s/100Hz Default: Size 0: 30.0 sec Size 1: 30.0 sec Size 2: 60.0 sec Size 3: 60.0 sec</p>
M02P04	<p>DECEL RAMP 1 Deceleration ramp rate is expressed as the time for the output frequency to decrease by 100Hz.</p>	R-W	<p>Range: 0.1 to 3276 s/100Hz Default: Size 0: 30.0 sec Size 1: 30.0 sec Size 2: 60.0 sec Size 3: 60.0 sec</p>
M02P05	<p>JOG ACCEL RAMP Acceleration ramp rate is expressed as the time for the output frequency to increase by 100Hz.</p>	R-W	<p>Range: 0.1 to 3276 s/100Hz Default: 60.0 sec</p>
M02P06	<p>JOG DECEL RAMP Deceleration ramp rate is expressed as the time for the output frequency to decrease by 100Hz.</p>	R-W	<p>Range: 0.1 to 3276 s/100Hz Default: 60.0 sec</p>
M02B07	<p>RAMPS SELECTION When M02B07 is set at 1, M01P44 (PRESET INDICATOR) is used to select the associated ACCEL and DECEL ramps. For example, if M01P44 has a value of "PRESET 2" 010, ACCEL RAMP 2 (M02P11) and DECEL RAMP 2 (M02P21) will be selected. This allows the acceleration and deceleration ramps to change automatically with preset frequencies – whether the preset frequencies are selected by M01B22 through M01B24 or automatically by the preset timer.</p> <p>When M02B07 is set at 0, M02P08 to M02P10 & M02P18 to and M02P20 can be independently written to in order to select the acceleration and deceleration ramps.</p>	R-W	<p>Range: 0 or 1 Default: 0</p>
M02B08 M02B09 M02B10	<p>ACCEL SEL BIT 0 ACCEL SEL BIT 1 ACCEL SEL BIT 2 Binary coded selection of the required acceleration ramp to be used. (e.g. – to select M02P14 – Acceleration ramp 5, set M02B08 and M02B10 at 1.)</p>	R-W	<p>Range: 0 or 1 Default: 0</p>
M02P11 M02P12 M02P13 M02P14 M02P15 M02P16 M02P17	<p>ACCEL RAMP 2 ACCEL RAMP 3 ACCEL RAMP 4 ACCEL RAMP 5 ACCEL RAMP 6 ACCEL RAMP 7 ACCEL RAMP 8 Acceleration ramp rate is expressed as the time for the output frequency to increase by 100Hz.</p>	R-W	<p>Range: 0.1 to 3276 s/100Hz Default: 60.0 sec</p>
M02B18 M02B19 M02B20	<p>DECEL SEL BIT 0 DECEL SEL BIT 1 DECEL SEL BIT 2</p>	R-W	<p>Range: 0 or 1 Default: 0</p>

M03P02	<p>PG NO OF PHASES Select [0] if only A phase or B phase is used. Select [1] if A & B phases are used.</p> <p>[0] ONE PHASE One phase A or B from PG [1] TWO PHASE Two phases A & B from PG</p>	R-W	Range: [0]-[1] Default: [1] TWO PHASE
M03P03	<p>PG ROTATION SEL</p> <p>[0] CLOCKWISE Clockwise rotation [1] C-CLOCKWS Counterclockwise rotation</p> <p>This setting determines how the drive interprets the rotation of the motor. This parameter can be used to change the direction of the motor without having to change the encoder (pulse generator) wiring.</p>	R-W	Range: [0]-[1] Default: [0] CLOCKWISE
M03P04	<p>PG SPEED This parameter Indicates encoder speed.</p>	R-O	Range: ± 32760 RPM Default
M03P05	<p>MOTOR GEAR TEETH</p> <p>Parameter M03P05 & M03P06 are to set the gear ratio between the motor and the load when the <u>encoder (pulse generator) is connected to load side.</u></p> $\text{Motor speed (RPM)} = \text{EncoderSpeed} \times \frac{\text{LoadGearTeeth}}{\text{MotorGearTeeth}}$	R-W	Range: 1 to 1000 Default: 1
M03P06	<p>LOAD GEAR TEETH See parameter M03P05</p>	R-W	Range: 1 to 1000 Default: 1
M03P07	<p>PG LOSS MODE Closed Loop Parameter</p> <p>Set to determine the stopping method or Alarm only when an encoder loss (PG LOSS) is detected. A PG LOSS is detected when the signal is interrupted and no pulses are received or the encoder frequency is different from output frequency by a M03P29 value. PG LOSS detection time can be adjusted using parameter M03P08.</p> <p>When zero speed is commanded PG LOSS is disabled.</p> <p>[0] COASTSTOP Coast stop when PG Loss [1] RAMP STOP Ramp stop when PG Loss [2] ALARMONLY Alarm only when PG Loss</p> <p>[0] <u>Coast Stop</u>: PG Loss will cause the motor to coast stop and set a "PG LOSS" fault. In this mode M10B01 "Drive Normal" parameter is set to 0 indicating drive tripped.</p> <p>[1] <u>Ramp Stop</u>: PG Loss will cause the motor to ramp stop and set a "PG LOSS" fault. In this mode M10B01 "Drive Normal" parameter is set to 0 indicating drive tripped at the end of ramp stop.</p> <p>[2] <u>Alarm Only</u>: PG Loss will cause the drive to continue running in Open Loop mode and displays a "ALARM MESSAGE PG LOSS" message. In this mode M10B01 (Drive Normal) is kept set to 1 indicating Drive Normal (not tripped).</p>	R-W	Range: [0]-[2] Default: [0] COSTSTOP

	In all modes when PG Loss is detected M10B12 PG Loss status bit is set to 1. M10B12 is cleared when the drive is stopped and a reset is initiated via Stop/Reset keypad Key or digital input Reset via terminal block.		
M03P08	PG LOSS DELAY Closed Loop Parameter Encoder (pulse generator) loss delay as described above in parameter M03P07.	R-W	Range: 0 to 10.0 sec Default: 1.0
M03P09	SPEED REF TRIM Closed loop parameter Use this parameter as speed reference trim.	R-W	Range: ±M01P06 Hz Default: 0.0
M03B10	SPEED TRIM SELEC Closed loop parameter Set at 1 to select addition of the speed reference trim M03P09.	R-W	Range: 0 or 1 Default: 0
M03P11	FINAL SPD DEMAND Closed loop parameter Final speed demand to speed loop circuit.	R-O	Range: max range in % Default:
M03P12	SPEED FEEDBACK Closed loop parameter Speed feedback from the encoder or some other device via parameter M03P13	R-O	Range: max range in % Default:
M03P13	OTHER FEEDBACK Closed loop parameter Enter the parameter number to use as an alternate feedback reference.	R-W	Range: MXXPXX Default: M00P00 (00.00)
M03B14	FEEDBACK SELECT Closed loop parameter Set at 1 to select an alternate speed feedback reference M03P13.	R-W	Range: 0 or 1 Default: 0
M03P15	SPEED ERROR Closed loop parameter Speed error is the difference between the final speed demand and the speed feedback reference after modification by the speed regulator.	R-O	Range: max range in % Default:
M03P16	SPEEDLOOP OUTPUT Closed loop parameter Speed loop output is the output of the speed regulator, which forms a torque demand. Speed loop output = P x e + I x e e = Final Speed Demand – Speed Feedback x D Where: P: proportional gain M03P17 I: integral gain M03P18 D: differential gain M03P19 e: speed error M03P15	R-O	Range: max range % Default:
M03P17	SPEEDLOOP P GAIN Closed loop parameter Speed loop regulator proportional gain See Parameter M03P16	R-W	Range: 0 to 10000 Default: 150
M03P18	SPEEDLOOP I GAIN Closed loop parameter Speed loop regulator integral gain See Parameter M03P16	R-W	Range: 0 to 10000 Default: 375
M03P19	SPEEDLOOP D GAIN Closed Loop Parameter Speed loop regulator differential gain. See parameter M03P16.	R-W	Range: 0 to 1000.0% Default: 0
M03P20	ZERO SPEED THSLD Closed & open loop parameter Open Loop: If the absolute value of the motor speed (M05P01) falls below the level defined by this parameter, the AT ZERO SPEED M10B03 is set to 1.	R-W	Range: 0 to 20.0 Hz Default: 1.0

	<p>Closed Loop: If the absolute value of the speed feedback (M03P12) falls below the level defined by this parameter, the AT ZERO SPEED M10B03 is set to 1.</p>		
M03P21	<p>AT SPEED LOW LIM Closed & open loop parameter This parameter defines the lower threshold for the AT SPEED parameter M10B05. See parameter M03P27 for more details.</p>	R-W	Range: 0 to 1000.0 HZ Default: 1.0
M03P22	<p>AT SPEED UP LIM Closed & open loop parameter This parameter defines the upper threshold for the AT SPEED parameter M10B05. See parameter M03P27 for more details.</p>	R-W	Range: 0 to 1000.0 HZ Default: 1.0
M03P23	<p>OVERSPEED THRSLD Closed & open loop parameter This parameter defines the speed at which the drive will trip due over-speed.</p>	R-W	Range: 0 to 1000.0 HZ Default: 1000.0
M03P24	<p>SPEED FBK FILTER Closed loop parameter This parameter is used to filter the speed feedback.</p>	R-W	Range: 5 to 200 msec Default: 25
M03P25	<p>PG SMOOTHING A sliding window filter is provided to smoothen the encoder speed feedback. The length of the sliding window is specified by this parameter. This number represents the sliding window time in milliseconds. This is useful to ensure a more accurate pulse count to increase speed feedback smoothness. If the encoder speed is not filtered, the torque current demand can include a high level of ripple.</p>	R-W	Range: 1 to 10 Default: 3
M03P26	<p>SPEED DROOP Closed loop parameter This parameter is used to set the percentage of speed droop as a function of torque load. The value entered represents the percent of base speed droop in speed at full torque load. This function can be used to balance the loads of two or more motors or to use a motor as a helper to a main motor.</p>	R-W	Range: 0 to 100.0 % Default: 0.0
M03B27	<p>ABSOLUTE @ SPEED</p> <p><u>M03P27 = 0 reference window detection:</u> Open Loop: The At Speed parameter (M10P05) is set to 1 when the motor frequency (M05P01) is within the At Speed band defined by (reference - lower limit) to (reference + upper limit): $M05P01 \geq (M01P03 - M03P21) \text{ AND } M05P01 \leq (M01P03 + M03P22)$</p> <p>Closed Loop: The At Speed parameter (M10P05) is set to 1 when the speed feedback (M03P12) is within the At Speed band defined by (reference - lower limit) to (reference + upper limit): $M03P12 \geq (M01P03 - M03P21) \text{ AND } M03P12 \leq (M01P03 + M03P22)$</p> <p><u>M03P27 = 1 absolute window detection:</u> Open Loop: The At Speed parameter (M10P05) is set to 1 when the motor frequency (M05P01) is within the At Speed band</p>	R-W	Range: 0 or 1 Default: 0

	<p>defined by the lower limit and the upper limit: $M05P01 \geq M03P21$ AND $M05P01 \leq M03P22$</p> <p>Closed Loop: The At Speed parameter (M10P05) is set to 1 when the speed feedback (M03P12) is within the At Speed band defined by the lower limit and the upper limit: $M03P12 \geq M03P21$ AND $M03P12 \leq M03P22$</p>		
M03P28	<p>SPEEDDROOP DELAY Closed Loop Parameter Use this parameter to change the responsiveness of the Speed Droop Controller.</p> <p>Selection:</p> <p>[0] 0 MSEC [1] 5 MSEC [2] 43 MSEC [3] 85 MSEC [4] 171 MSEC [5] 341 MSEC [6] 683 MSEC [7] 1370 MSEC</p>	R-W	<p>Range: 0 MSEC to 1370 MSEC Default: 43 MSEC</p>
M03P29	<p>PGLOSS DEVIATION Closed Loop Parameter Use this parameter to set the PG LOSS detection level for speed deviation between the encoder and the output frequency. See M03P07 for more information.</p>	R-W	<p>Range: 0 to 50 % Default: 10</p>
M03P30	<p>PG REVOLUTIONS This parameter indicates the position in terms of revolutions of the drive encoder.</p>	R-O	<p>Range: ± 32767 Revolutions Default:</p>
M03P31	<p>PG POSITION This parameter indicates the position in terms of fractions of a revolution of the drive encoder, where 32768 = 1 revolution.</p>	R-O	<p>Range: ± 32767 (± 1 turn) Default:</p>
M03B32	<p>PG MARKER RST EN The drive encoder (pulse generator) marker channel can be used to reset the drive encoder position (M03P31) and revolutions (M03P30) (if M15P32 = 1), but only if M03B33 is initially = 0.</p>	R-W	<p>Range: 0 or 1 Default: 0</p>
M03B33	<p>PG MARKER FLAG The drive encoder (pulse generator) marker channel can be used to reset the encoder position M03P31 and revolutions M03P30 if M03B32 = 1, and set the marker flag M03B33. The marker flag is set when the marker input becomes active, but it is not reset by the drive. The user must reset this flag.</p>	R-W	<p>Range: 0 or 1 Default: 0</p>
M04P01	<p>MOT CURR-TOTAL Indicates the magnitude of the total motor current.</p>	R-O	<p>Range: 0 to $\pm M11P35$ A Default:</p>
M04P02	<p>MOT CURR-TORQ Indicates the magnitude of the torque-producing motor current.</p>	R-O	<p>Range: 0 to $\pm M11P35$ A Default:</p>
M04P03	<p>MOT CURR-MAGNETZ Indicates the magnitude of the magnetizing motor current.</p>	R-O	<p>Range: 0 to $\pm M11P35$ A Default:</p>
M04P04	<p>MOTOR CURR LIMIT Normal current limit See parameter M05P06.</p>	R-W	<p>Range: 0 to $\frac{M11P35}{M05P06} \times 100\%$ Default: Max Number</p>

M04P05	REGEN CURR LIMIT Normal current limit. See parameter M05P06.	R-W	Range: 0 to $\frac{M11P35}{M05P06} \times 100\%$ Default: Max Number
M04P06	TORQUE DEMAND The torque demand can be derived either from the speed loop output or programmed separately depending on the value of M04P07. The units of the torque demand are % of rated torque, where 100% rated torque is defined by the user. 100% rated torque is defined by the settings of the drive parameters as shown in the following example: Rated Motor Current M05P08 = 180A Torque I Factor M05P13 = 0.95 Assuming frequency is at or below rated motor frequency. At 100% torque, Rated torque current = $180 \times 0.95 = 171A$ A positive value of torque demand indicates motoring torque in the positive direction, or regenerating torque in the reverse direction. A negative value indicates regenerative torque in the positive direction and motoring torque in the reverse direction.	R-O	Range: 0 to $\frac{M11P35}{M05P06} \times 100\%$ Default:
M04P07	TORQ MODE SELECT <u>Open Loop</u> [0] SPEED CTR Speed control mode [1] TORQ CONT Torque control [2] TORQ SPD Torque limited speed control <u>Closed Loop</u> [0] SPEED CTR Speed control mode [1] TORQ CONT Torque control [2] TORQ SPD Torque limited speed control [3] WINDER Wind-unwind torque control [4] TRQ FDFWD Speed control with torque feed-forward <u>[0] SPEED CTR Speed control mode</u> The torque demand is equal to the speed loop output M03P16. <u>[1] TORQ CONT Torque control</u> The torque demand is given by the sum of the torque reference and the torque offset, if enabled. The speed is not limited, however, the drive will trip if the speed exceeds the OVERSPEED threshold M03P23. <u>[2] TORQ SPD Torque limited speed control</u> The SPEED LOOP OUTPUT M03P16 defines the torque demand, but is limited by the torque demand (M04P12 + M04P13). The speed controller will try and accelerate the machine to the final speed demand M03P11 level with a torque demand defined by M04P12 + M04P13. This mode of operation can be used when torque control is required, but maximum speed must be limited. <u>[3] WINDER Wind-Unwind Torque Control</u> WHEN FINAL SPEED DEMAND M03P11 IS Positive:	R-W	Range: [0] to [4] Default: [0] SPEED CTR

<p>- A positive torque demand (M04P12 + M04P13) will provide torque control with a positive speed limit defined by the FINAL SPEED DEMAND M03P16. A negative torque demand (M04P12 + M04P13) will provide torque control with a negative speed limit defined by the Zero Speed Threshold M03P20.</p> <p>When FINAL SPEED DEMAND M03P11 IS NEGATIVE:</p> <p>- A negative torque demand will provide torque control with a negative speed limit defined by the FINAL SPEED DEMAND M03P16. A positive torque demand will provide torque control with a positive speed limit defined by the Zero Speed Threshold M03P20.</p> <p><u>[4] TRQ FDFWD Speed control with torque feed-forward</u> The drive operates under speed control, with a torque reference (M04P12 + M04P13) value added to the speed controller output M03P16. This can be useful to improve the regulation of some systems where the speed loop gains need to be low.</p>		
<p>M04P10 TORQUE OUTPUT Indicates torque in the motor as % of rated torque.</p> <p>Below rated frequency, the torque output is equal to the torque-producing current relative to $i_{\text{torq rated}}$.</p> <p>Above rated frequency, the torque is compensated to allow for the reducing flux in the motor.</p>	R-O	Range: Max M05P06 % of max Default:
<p>M04P11 SYM CURRENT LIM After having set the required value of maximum current in M05P06, you may increase or decrease the percentage overload current using M04P11. The maximum percentage that can be set is limited by the overload current rating of the drive. The limit applies when motoring and regenerating.</p> <p>The value of M04P11 is automatically reduced when the value of M05P06 is increased beyond the default value.</p>	R-W	Range: See M04P04 % Default: 120 or 150 min
<p>M04P12 TORQUE REFERENCE Closed loop parameter Torque reference in %</p>	R-W	Range: 0 to $\frac{M11P35}{M05P06} \times 100\%$ Default: 0
<p>M04P13 TORQUE OFFSET Closed loop parameter Parameter for an offset to be added to the main torque reference.</p>	R-W	Range: 0 to $\frac{M11P35}{M05P06} \times 100\%$ Default: 0
<p>M04B14 TORQ OFFSET SEL Closed loop parameter If set to 1 the torque offset is added to the torque reference.</p>	R-W	Range: 0 or 1 Default: 0
<p>M04P15 TORQ CURR DEMAND Closed loop parameter The current demand is derived from the torque demand. Provided the motor is not in the field weakened the torque and current demands are the same. In the field weakening range the current demand is increased with reduced flux. The level of flux is derived from the motor model within the drive controller. M04P15 = M04P06 x flux / rated flux</p>	R-O	Range: 0 to $\frac{M11P35}{M05P06} \times 100\%$ Default:

M04P16	TORQ TIME CONST This parameter could be used to filter excessive torque changes.	Closed loop parameter	R-W	Range: 0 to 1000 msec Default: 0
M04P17	FLUX DEMAND Flux demand is constant below motor base speeds. In the field weakening region the flux demand is reduced and torque current demand is increased. The level of flux is derived from the motor model within the drive controller.	Closed loop parameter	R-O	Range: 0 to 100.0 % Default:
M04P18	FLUX CURR DEMAND The current demand is derived from the flux demand.	Closed loop parameter	R-O	Range: 0 to $\frac{M11P35}{M05P06} \bullet 100\%$ Default:
M04P23	ROTOR TIME CONST Motor rotor time constant.	Closed loop parameter	R-W	Range: 0 to 10000 msec Default: Model dependent
M04P32	INITIAL FLUX FRQ This parameter is used to select initial fluxing frequency at rated flux current at the start. Initial fluxing of the motor is used to enhance acceleration performance. It results shorter overall acceleration and improved torque response at the start.	Closed Loop Parameter	R-W	Range: 0.0 10.0 Hz Default: 0
M04B33	INITIAL FLUXING Use this parameter to enable or disable the initial fluxing function.	Closed loop parameter	R-W	Range: 0 or 1 Default: 1
M05P01	POST-SLIP FREQ Final frequency applied to the motor after the effects of current limits and slip compensation.		R-O	Range: $\pm M01P06$ Hz Default:
M05P02	MOTOR SHAFT RPM Indicates motor shaft RPM. The number of poles must be entered correctly in M00P04 (M05P10).		R-O	Range: ± 32760 RPM Default:
M05P03	MOTOR VOLTAGE Indicates the RMS voltage applied to the motor.		R-O	Range: ± 0 to M05P08 VRMS Default:
M05P04	DC BUS VOLTAGE Indicates the DC bus voltage.		R-O	Range: 0 to 1000.0 V Default:
M05P05	MOTOR POWER Indicates the real component of the power output.		R-O	Range: 0 to $\pm M05P03 \times M11P35 \times \frac{\sqrt{3}}{1000}$ KW Default:
M05P06	RATED MOTOR CURR When parameter M05P06 is set at a value lower than the default rating of the drive, the maximum current of the drive can be greater than 1.5 times the motor rating. Consequently, the maximum value of current limit and torque parameters (M04P04, M04P05, M04P06, M04P11 and M06P04) can be increased proportionately. For example, if a 180 Amp drive has parameter M05P06 set at 90 Amps, the maximum values of parameters M04P04, M04P05, M04P11 and M06P04 can be 300% (2 x 150%). This allows larger drives to be used for a high starting torque.		R-W	Range: 0-1800 A Default: Model Dependent

<p>When the value is increased beyond the default value of M05P06, the values of M04P04, M04P05 and M04P11 are automatically decreased.</p> <p>The value entered affects the following: Slip compensation Dynamic V/f Ixt detection level</p> <p>Industrial and HVAC applications Industrial applications benefit from a higher percentage of overload current, but have a lower nominal current. HVAC applications benefit from a higher nominal current, but have a lower percentage of overload current (120%). The overload current has the same value in each case.</p> <p>See parameter M05P18.</p>		
<p>M05P07 RATED MOTOR RPM</p> <p>The rated full load rpm is used with the motor rated frequency to calculate the rated slip of induction motors in Hz.</p> $\text{RatedSlip} = \text{M05P09} - \frac{\text{M05P10} \times \text{M05P07}}{120}$ <p>M05P07 is Rated Motor RPM M05P09 is Base Motor Frequency M05P10 is Number of Poles</p> <p><u>Open loop:</u> If SLIP COMP ENABLE (M05B38) is set to 0 slip compensation is disabled. If slip compensation is required, M05P07 should be set to the nameplate value and M05B38 should be set at 1. Slip compensation is normally used to prevent droop in the motor shaft speed as load is applied.</p> <p><u>Closed Loop:</u> Motor full load rpm is used with motor rated frequency to determine the full load slip of the motor necessary for closed loop vector control.</p>	R-W	<p>Range: 0 to 32760 RPM Default: Model Dependent</p>
<p>M05P08 RATED MOTOR VOLT</p> <p>Enter the value from the motor rating plate in order to define the maximum output voltage of the drive.</p>	R-W	<p>Range: 100 to 600 VRMS Default: 240 480 575</p>
<p>M05P09 BASE MOTOR FREQ</p> <p>Enter a value of frequency at which the rated voltage is to be applied to the motor. The motor then enters the constant-power or field-weakening region.</p>	R-W	<p>Range: 10.0 to 600 Hz Default: 60.0</p>
<p>M05P10 NUMBER OF POLES</p> <p>Enter the value from the motor rating plate for correct slip compensation and RPM indication.</p>	R-W	<p>Range: [0] (2 POLES) to [15] (32 POLES) Default: [1] (4 POLES)</p>
<p>M05P11 AUTO BOOST VOLT</p> <p>The level of boost is determined by: Autoboot = Voltage boost x I_{torq}/I_{torq} rated</p> <p>Use this parameter when using the drive in applications where the load is hard to start.</p> <p>Set the following parameters as follow: M05P11 (AUTO BOOST VOLT) = 3% to 6% for size 0 2% to 4% for size 1 2% to 3% for size 2</p>	R-W	<p>Range: 0 to 25.5% of M05P08 Default: Size 0: 1% Size 1: 1% Size 2: 0.5% Size 3: 0.3%</p>

	<p>1% to 2% for size 3 M05P14 (FIXED BOOST VOLT) = 2.0% for size 0 1.5% for size 1 1.0% for size 2 0.5% for size 3</p> <p>Do not increase M05P11 & M05P14 above the recommended values before checking with the factory.</p>		
M05P12	<p>VOLT CONTR MODE</p> <p>[0] AUTO Auto boost only [1] FIXED Fixed boost only [2] AUTO+ FIXD Auto boost & fixed boost only</p>	R-W	<p>Range: [0] to [2] Default: [2] AUTO + FIXD</p>
M05P13	<p>TORQUE I FACTOR</p> <p>Torque current which produces rated torque in the motor in percent of RATED MOTOR CURRENT M05P06.</p>	R-W	<p>Range: 0 to 100.0% Default: Model dependent</p>
M05P14	<p>FIXED BOOST VOLT</p> <p>Sets voltage boost at 0Hz as a percentage of the rated motor voltage. Use this parameter when using the drive in applications where the load is hard to start. Set the following parameters as follow: M05P11 (AUTO BOOST VOLT) = 3% to 6% for size 0 2% to 4% for size 1 2% to 3% for size 2 1% to 2% for size 3 M05P14 (FIXED BOOST VOLT) = 2.0% for size 0 1.5% for size 1 1.0% for size 2 0.5% for size 3</p> <p>Do not increase M05P11 & M05P14 above the recommended values before checking with the factory.</p>	R-W	<p>Range: 0 to 25.5% of M05P08 Default: Size 0: 1.0% Size 1: 0.8% Size 2: 0.4% Size 3: 0.2%</p>
M05P15	<p>FLUX CURR FACTOR Closed loop parameter</p> <p>Magnetizing current which produces rated flux in the motor in percent of RATED MOTOR CURRENT M05P06.</p>	R-W	<p>Range: 0 to 100.0% Default: Model dependent</p>
M05P16	<p>MOTOR TORQUE VOLT</p> <p>Torque voltage command to motor.</p>	R-O	<p>Range: 0 to M05P08 Vrms Default:</p>
M05P17	<p>MOTOR FLUX VOLT</p> <p>Flux voltage command to motor.</p>	R-O	<p>Range: 0 to M08P08 Vrms Default:</p>
M05P18	<p>OVERLOAD TIME</p> <p>Enter a value for the required duration of maximum overload current M11P35.</p>	R-W	<p>Range: 0 to 60 S Default: 60</p>
M05P20	<p>MAX PWM CARRIER</p> <p>Sets maximum PWM carrier frequency in Hz</p>	R-W	<p>Range: 1000 to 3000 Default: Size 0: 2000 Hz Size 1: 2000 Hz Size 2: 1800 Hz Size 3: 1200 Hz</p>
M05P21	<p>MIN PWM CARRIER</p> <p>Sets minimum PWM carrier frequency in Hz</p>	R-W	<p>Range: 10 to M05P20 Default: 1000</p>
M05P22	<p>SPEED @ MAX CARRIER</p> <p>Set drive speed to correspond to maximum PWM carrier frequency M05P20</p>	R-W	<p>Range: 10 to M05P20 Default: 60 Hz</p>
M05P23	<p>SPEED @ MIN CARRIER</p> <p>Set drive speed to correspond to minimum PWM carrier frequency M05P21</p>	R-W	<p>Range: 0 to (M05P22-1) Default: 10 Hz</p>

M05P24	PWM CARRIER FREQ This parameter shows PWM carrier frequency	R-O	Range: M05P21 to M05P22 Hz Default:
M05P33	RATED LINE VOLTS Enter a value of voltage at which the rated voltage is to be applied to the input of the drive.	R-W	Range: 200-250V for D2 Models 380-500V for D4 Models 500-600V for D5 Models Default: 240V for D2 Models 480V for D4 Models 575V for D5 Models
M05P34	AC LINE VOLTAGE Indicates RMS voltage of the AC supply.	R-O	Range: 0 to 1000.0 VRMS Default:
M05P35	SLIP FREQUENCY Closed loop parameter This parameter displays motor slip frequency.	R-O	Range: 0 to 30.00 Hz Default:
M05B38	SLIP COMP ENABLE Open loop only parameter Set M06B38 to 1 to enable slip compensation.	R-W	Range: 0 or 1 Default: 0
M05P47	AC LINE RIPPLE Indicates the peak to peak ripple on the rectified AC line input voltage. The input AC line voltage is continuously monitored for excessive AC line voltage imbalance or for phase loss. An INPUTLOSS fault is generated when excessive AC line voltage imbalance or phase loss is detected.	R-O	Range: 0.0 to 1000.0 V Default:
M05P48	DC BUS RIPPLE Indicates the peak to peak ripple on the DC bus voltage. The DC bus voltage is continuously monitored for excessive ripple when the drive is running. A BUSRIPPLE FAULT is generated when the ripple becomes excessive in order to protect the drive. The BUSRIPPLE fault can be caused due to excessive AC line voltage imbalance, phase loss or defective DC bus capacitors.	R-O	Range: 0.0 to 1000.0 V Default:
M05P50	BUS CAPACITANCE Represents the DC bus capacitance of the drive measured at power-down. This value is model dependent is used mainly for troubleshooting.	R-O	Range: 0.0 to 32767 $\mu\text{sec}/\text{V}^2$ Default:
M06P01	STOP MODE Parameter M06P01 controls the stopping mode in the speed control mode. In Torque Mode, regardless of M06P01 value, the stopping method is always coast to stop. Open Loop [0] RAMP The drive ramps to zero speed [1] COAST Coast to stop [2] RAMP+DC Ramp + DC injection braking [3] DC INJECT Automatic DC injection braking [4] TIMED DC Timed DC injection braking Closed Loop [0] RAMP The drive ramps to zero speed [1] COAST Coast to stop [2] RAMP+DC Ramp + Hold at Zero speed The settings are described below: [0] Ramp stop: Open or Closed Loop The drive ramps to zero speed during the first phase; in the second phase the output is disabled.	R-W	Range: [0] to [4] Open Loop [0] to [2] Closed Loop Default: [0] RAMP

<p><u>[1] Coast to Stop: Open or Closed Loop</u> The inverter output is disabled as soon as a STOP command is received, and the motor coasts to rest. The inverter cannot be re-enabled for a time delay "de-flux time". The de-flux time allows the rotor flux to decay in induction motors. The de-flux time is model dependent.</p> <p><u>[2] Ramp plus DC injection braking: Open Loop</u> The drive ramps to zero speed during the first phase; in thesecond phase injection braking is used at a current level programmed in parameter M06P04 for a time specified by M06P05.</p> <p><u>[2] Ramp + Hold at zero speed: Closed Loop</u> The drive ramps to zero speed during the first phase; in the second phase the drive holds zero speed for a time specified by M06P05.</p> <p><u>[3] Automatic DC injection braking Open Loop only</u> In the first phase after a stop command the inverter output is disabled for a time to de-flux the rotor. In the second phase injection braking is used at a current level programmed in parameter M06P04 for a time automatically determined by the drive when zero speed is detected. The drive automatically senses zero speed and therefore it adjusts the injection time to suit the application. If the injection current level specified in M06P04 is too small the drive will not sense zero speed (normally a minimum of 50 - 60% is required for M06P04)</p> <p><u>[4] Timed DC injection braking Open loop only</u> In the first phase after a stop command the inverter output is disabled for a time to de-flux the rotor. In the second phase injection braking is used at a current level programmed in parameter M06P04 for a time specified by M06P05.</p>		
<p>M06P02 AUTO-START MODE There are three modes:</p> <p>[0] DISABLED The drive will not automatically start when AC power is applied.</p> <p>[1] ALWAYS The drive always starts when AC power is applied.</p> <p>[2] RUNNING The drive starts only if it had been running when AC power was previously removed.</p> <p>The Auto-start modes are as follows: The Auto-start modes define the behavior of the drive when AC power is applied.</p> <p><u>Mode[0] – DISABLED</u> The drive will not automatically start when AC power is applied.</p> <p><u>Mode [1] – ALWAYS</u> The drive always starts irrespective of the state before AC</p>	<p>R-W</p>	<p>Range: [0] to [2] Default: [0] DISABLED</p>

<p>power was removed. The STOP input switch must be closed.</p> <p><u>Mode [2] – RUNNING (Power-down dependent)</u> The drive starts only if it had been running when AC power was removed. The STOP input switch must be closed.</p>																	
<p>M06P03 AC SUPPLY MODE This parameter is used to tell the drive if the AC line voltage source is from a three phase supply or a single phase supply. Note: set this parameter to 1-PHASE only if the drive is factory engineered for single phase operation or the drive is derated. The derating factor is usually 50%, but this is not always true. Contact the factory if single phase operation is required.</p> <p>[0] 1-PHASE Single phase operation [1] 3-PHASE Three phase operation</p>	R-W	Range: 1-PHASE or 3-PHASE Default: 3-PHASE															
<p>M06P04 DC INJECT LEVEL DC Current level at injection.</p>	R-W	Range: 0 to $\frac{M11P35}{M05P06} \times 100$ % of FLC Default: 100															
<p>M06P05 DC INJECT TIME When M06P01 is set at [2] or [4], enter the required injection time.</p>	R-W	Range: 0.5 to 25.5 Default: 5.0															
<p>M06B06 DB CHOPPER MODE Use this parameter to enable or disable the Brake Chopper Function when the drive is not running. - When M06P06 is set at 0 Brake Chopper function is enabled even when the drive is not running. - When M06P06 is set at 1 Brake Chopper function is disabled when the drive is not running.</p>	R-W	Range: 0 or 1 Default: 0															
<p>M06P07 SEQUENCING MODE</p> <p>[0] 2OR3-WIRE: 2 or 3-wire logic [1] 3-WIRE SP: 3-wire Run Fwd / Run Rev [2] RFWD RREV: Run Fwd / Run Rev logic [3] 2-WIRE: 2-wire logic</p>	R-W	Range: [0] to [3] Default: [0] 2OR3-WIRE															
<p>M06B08 SEQUENCING BIT 0 M06B09 SEQUENCING BIT 1 M06B10 SEQUENCING BIT 2 M06B11 SEQUENCING BIT 3 Binary coded selection of sequencer mode.</p> <p>There are four sequencing modes as shown below. Any terminal can be used for any of the function in each mode.</p> <p>[0] [2OR3-WIRE] 2 or 3-wire logic [1] [3-WIRE-SP] 3-wire Run Fwd / Run Rev [2] [RFWD RREV] Run Fwd / Run Rev logic [3] [2-WIRE] 2-wire logic</p> <p><u>[0] 2OR3-WIRE: 2 or 3-wire logic</u></p> <table style="margin-left: auto; margin-right: auto;"> <thead> <tr> <th></th> <th></th> <th style="text-align: center;">TB2 default pin number</th> </tr> </thead> <tbody> <tr> <td>Sequencing bit 0</td> <td>Run (latching)</td> <td style="text-align: center;">2</td> </tr> <tr> <td>Sequencing bit 1</td> <td>Jog</td> <td style="text-align: center;">3</td> </tr> <tr> <td>Sequencing bit 2</td> <td>Reverse</td> <td style="text-align: center;">4</td> </tr> <tr> <td>Sequencing bit 3</td> <td>Not used</td> <td></td> </tr> </tbody> </table>			TB2 default pin number	Sequencing bit 0	Run (latching)	2	Sequencing bit 1	Jog	3	Sequencing bit 2	Reverse	4	Sequencing bit 3	Not used		R-W	Range: 0 or 1 Default: 0
		TB2 default pin number															
Sequencing bit 0	Run (latching)	2															
Sequencing bit 1	Jog	3															
Sequencing bit 2	Reverse	4															
Sequencing bit 3	Not used																

When Keypad mode is enabled, sequencing bit 0 can be over-ridden by the RUN key and sequencing bit 2 can be over-ridden by the FWD-REV key.

[1] 3-WIRE-SP: 3-wire Run Fwd / Run Rev

		TB2 default pin number
Sequencing bit 0	Run forward (latching)	2
Sequencing bit 1	Jog forward	3
Sequencing bit 2	Run Reverse (latching)	4
Sequencing bit 3	Jog Reverse	

When Keypad mode is enabled, the RUN key can also start the drive, and the FWD-REV key can change the direction (unless one of the sequencing bit signals is being held, in which case the sequencing bits have priority). Jog states always over-ride run.

[2] RFWD RREV: Run Fwd / Run Rev logic

		TB2 default pin number
Sequencing bit 0	Run forward	2
Sequencing bit 1	Jog	3
Sequencing bit 2	Run Reverse	4
Sequencing bit 3	Not used	

For the drive to run, parameter M08P01 (Stop input), and sequencing bit 0 or 2 must be set at 1.

To Jog forward or reverse, the Jog sequencing bit must be set at 1, together with the appropriate direction sequencing bit. Pressing the RUN, STOP and FWD-REV keys has no effect.

[3] 2-WIRE: 2- wire logic

		TB2 default pin number
Sequencing bit 0	Run	2
Sequencing bit 1	Jog	3
Sequencing bit 2	Reverse	4
Sequencing bit 3	Not used	

Read-only parameter M08B01 (Stop input) indicates that the drive is enabled or disabled. When M08B01 = 0, the drive is disabled.

Sequencing bit 0 must be set at 1 for the drive to run. When sequencing bit 0 is set at 0 the drive stops.

To jog forward or reverse the jog sequencing bit must be active together with the run bit and the appropriate direction selected.

Because this mode requires signals to be continuously applied to the control signal terminals for the drive to run, the RUN, STOP and FWD-REV keys are inactive.

<p>M06B12 KEYPAD START M06B13 KEYPAD STOP M06B14 KEYPAD FWD/REV</p> <p>When a key is pressed the related parameter is set at 1.</p>	<p>R-W</p>	<p>Range: 0 or 1 Default: 0</p>
<p>M06B15 EN KEYPAD RUN M06B16 EN KEYPAD STOP M06B17 EN KEYPAD FWD/RV</p> <p>Use these parameters to enable or disable individual keys of the Control Keypad.</p> <p>When M06P18 is set at 0 and M01B08 (Keypad reference) is set at 1, these parameters are automatically set at 1.</p>	<p>R-W</p>	<p>Range: 0 or 1 Default: 0</p>
<p>M06P18 KEYPAD CONT MODE</p> <p>Set at "NO KEYS" to disable M01P08 from controlling the Keypad Keys: M06B15, M06B16, and M06B17.</p> <p>[0] ALL KEYS M06B15, M06B16, and M06B17 controlled by M01P08. [1] NO KEYS M06B15, M06B16, and M06B17 not controlled by M01P08. [2] RUN & STOP M06B15 and M06B16 controlled by M01P08.</p>	<p>R-W</p>	<p>Range: [0] TO [2] Default: [2] RUN & STOP</p>
<p>M06B19 HOLD ZERO SPEED</p> <p>When this parameter is set to 1 the drive remains active even when the run command has been removed and the motor has reached standstill. The drive goes to the "ZERO HOLD" state instead of the "READY" state.</p>	<p>R-W</p>	<p>Range: 0 or 1 Default: 0</p>
<p>M06B20 DISABL INPUTLOSS</p> <p>This parameter is used only when the drive is operated from a 3-PHASE AC line supply to detect a phase loss or excessive voltage imbalance. This parameter is defaulted at 0 (enable input loss). If an INPUTLOSS fault occurs, check for excessive supply voltage imbalance or phase loss. This is a protective feature and it may be disabled temporarily only for diagnostic purposes.</p>	<p>R-W</p>	<p>Range: 0 or 1 Default: 0 (enable)</p>
<p>M06B21 DISABL MOTORLOSS</p> <p>This parameter is defaulted at 0 (enable motor loss). This feature is used to protect the drive. Disable only when running a drive without the motor connected for testing purposes and make sure to re-enable when testing is done. A MOTORLOSS fault is generated when the motor current is not detected or the motor current is below what it should be when the drive is in the RUN state.</p>	<p>R-W</p>	<p>Range: 0 or 1 Default: 0 (enable)</p>
<p>M06B22 DISABLE FWD ROT</p> <p>Set at 1 to prevent the drive producing forward rotation of the motor.</p>	<p>R-W</p>	<p>Range: 0 or 1 Default: 0</p>
<p>M06B23 DISABLE REV ROT</p> <p>Set at 0 to enable the drive to reverse the rotation of the motor.</p>	<p>R-W</p>	<p>Range: 0 or 1 Default: 1</p>
<p>M06B24 MOTOR FLYCATCH</p> <p>Set M06B24 at 1 to select this feature.</p> <p>Enable or disable drive flycatcher (catch a spinning motor) feature.</p>	<p>R-W</p>	<p>Range: 0 or 1 Default: 0</p>

M06B25	<p>ZERO MOP AT STRT When M06P25 is set at 1, and AC power is applied to the drive, the motorized potentiometer output is set at zero.</p> <p>When M06P25 is set at 0, and AC power is applied to the drive, the motorized potentiometer output returns to the level that existed when AC power was previously removed.</p>	R-W	Range: 0 or 1 Default: 0
M06P26	<p>MOP RATE The value in parameter M06P26 defines the time taken for the motorized potentiometer function to ramp from 0 to 100.0%. Twice this time will be taken to adjust the output from – 100.0% to +100.0%.</p>	R-W	Range: 5 to 255 s/100% Default: 20
M06B27 M06B28	<p>MOP UP MOP DOWN To control these motorized potentiometer parameters, two digital inputs must be programmed. Apply signals to these inputs to control the up and down functions.</p>	R-W	Range: 0 or 1 Default: 0
M06B29	<p>BIPOLAR MOP Set M06P29 at 1 to allow the motorized potentiometer to go negative, otherwise the output remains positive only.</p>	R-W	Range: 0 or 1 Default: 0
M06P30	<p>MOP SCALE FACTOR This parameter can be used to restrict the output of the motorized potentiometer to operate over a reduced range so that it can be used as a trim, for example.</p>	R-W	Range: 0.000 to 10.000 Default: 1.000
M06P31	<p>MOP DESTINATION Program the destination parameter that the motorized potentiometer is to control. If the motorized potentiometer is to control speed, it is suggested that one of the preset speed parameters is entered in M06P31. If the motorized potentiometer is to trim speed, it is suggested that M01P15 (offset parameter) is entered in M06P31. Factory defaulted to an unused parameter M00P00.</p>	R-W	Range: MXXPXX Default: M00P00 (00.00)
M06P32	<p>MOP OUTPUT Saved at power down.</p> <p>This parameter indicates the current level of the motorized potentiometer. The value is saved when AC power is removed from the drive.</p>	R-O	Range: ±100.00 % Default:
M06P38	<p>MIN SEARCH FREQ Motor Flycatch min search frequency in % of Max Frequency (M01P06). The search always starts from the previous speed in which the drive last ran only if the speed was above the Min Search Frequency. The Min Search Frequency can be set at a higher level above set speed in applications where the motor is load-sharing or overhauled to make sure the search always starts at least at or above motor speed at the time of the search.</p>	R-W	Range: 0-100% Default: 50%
M07P01 M07P02 M07P03	<p>ANALOG IN 1 ANALOG IN 2 ANALOG IN 3 Displays the amplitude of the signal applied to Analog input 1, 2 or 3. *Analog input 3 is optional.</p>	R-O	Range: ±100% for voltage input Default:

<p>M07P06 ANALOG OUT MODE</p> <p>[0] NORMAL Normal analog output per user selection [1] SPD/TORQI Speed and torque current at high rate</p> <p>In NORMAL mode the analog outputs are user programmable using M07P07, M07P08 and M07P09. In SPD/TORQI mode analog 1 is set to speed and analog 2 is set to torque current. The outputs are updated at a fast rate. This is useful to fine-tune the drive control loops.</p>	R-W	<p>Range: [0] to [1] Default: [0] NORMAL</p>																														
<p>M07P07 ANALOG OUT 1 SRC M07P08 ANALOG OUT 2 SRC M07P09 ANALOG OUT 3 SRC</p> <p>Enter the parameter number that is required to supply a value to Analog output 1, 2 or 3. * Analog output 3 is optional.</p>	R-W	<p>Range: MXXPXX Default: M05P01 (05.01) M04P01 (04.01) M05P03 (05.03)</p>																														
<p>M07P10 ANALOG IN 1 MODE</p> <table border="1" style="width: 100%; border-collapse: collapse;"> <thead> <tr> <th style="text-align: left;">Set</th> <th style="text-align: left;">Display</th> <th style="text-align: left;">Mode</th> </tr> </thead> <tbody> <tr> <td>[0]</td> <td>VOLT IN</td> <td>Voltage input</td> </tr> <tr> <td>[1]</td> <td>0-20 MA</td> <td>0 – 20 mA</td> </tr> <tr> <td>[2]</td> <td>20-0 MA</td> <td>20 – 0 mA</td> </tr> <tr> <td>[3]</td> <td>4-20MA TP</td> <td>4 – 20 mA Trip on current loop loss</td> </tr> <tr> <td>[4]</td> <td>20-4MA TP</td> <td>20 – 4 mA Trip on current loop loss</td> </tr> <tr> <td>[5]</td> <td>4-20MA MS</td> <td>4 – 20 mA Min speed current loop loss</td> </tr> <tr> <td>[6]</td> <td>20-4MA MS</td> <td>20 – 4 mA Min speed on current loop loss</td> </tr> <tr> <td>[7]</td> <td>4-20MA LS</td> <td>4 – 20 mA Last speed on current loop loss</td> </tr> <tr> <td>[8]</td> <td>20-4MA LS</td> <td>20 – 4 mA Last speed on current loop loss</td> </tr> </tbody> </table> <p>In 4-20mA and 20-4mA operation, the threshold for current-loop loss is 3mA.</p> <p>Read-only parameters and some other sensitive parameters (such as switching frequency) cannot be controlled using the analog inputs.</p> <p>When 0-20MA, 20-0MA, 4-20MA, or 20-4MA is used, wire the current signal to the on-board burden resistor at TB4-4 & TB4-5. Jumper TB4-4 to the either analog reference #1 (TB4-2) or analog reference #2 (TB4-3). The on-board burden resistor converts current to voltage before the signal is sent to analog reference #1 or #2.</p> <p>If an inverse function is desired using 10V to 0V signal (10V = lower speed & 0V = upper speed), program ANALOG IN MODE to [2] 20-0MA and wire to analog reference #1 (TB4-2) or analog reference #2 (TB4-3) directly. Do not use the burden resistor in this case, since the signal is already a voltage.</p>	Set	Display	Mode	[0]	VOLT IN	Voltage input	[1]	0-20 MA	0 – 20 mA	[2]	20-0 MA	20 – 0 mA	[3]	4-20MA TP	4 – 20 mA Trip on current loop loss	[4]	20-4MA TP	20 – 4 mA Trip on current loop loss	[5]	4-20MA MS	4 – 20 mA Min speed current loop loss	[6]	20-4MA MS	20 – 4 mA Min speed on current loop loss	[7]	4-20MA LS	4 – 20 mA Last speed on current loop loss	[8]	20-4MA LS	20 – 4 mA Last speed on current loop loss	R-W	<p>Range: [0] to [8] Default: [0] VOLT IN</p>
Set	Display	Mode																														
[0]	VOLT IN	Voltage input																														
[1]	0-20 MA	0 – 20 mA																														
[2]	20-0 MA	20 – 0 mA																														
[3]	4-20MA TP	4 – 20 mA Trip on current loop loss																														
[4]	20-4MA TP	20 – 4 mA Trip on current loop loss																														
[5]	4-20MA MS	4 – 20 mA Min speed current loop loss																														
[6]	20-4MA MS	20 – 4 mA Min speed on current loop loss																														
[7]	4-20MA LS	4 – 20 mA Last speed on current loop loss																														
[8]	20-4MA LS	20 – 4 mA Last speed on current loop loss																														
<p>M07P11 ANALOG IN 1 SCAL</p> <p>Enter a value to scale Analog input 1.</p> <p>NOTE: In most cases, adjustment of M07P11, M07P14 and M07P17 is not necessary since the inputs are automatically scaled so that 100% input signal sets the</p>	R-W	<p>Range: 0 to 10.000 Default: 1.000</p>																														

	<p>destination parameter at 60 Hz.</p> <p>When a speed pot is used (wired as shown in Figure 2-5), You may want to set ANALOG IN 1 SCAL to 0.800 so that maximum pot travel corresponds to 60Hz (value of MAX FREQUENCY M01P06)</p>		
M07P12	<p>ANALOG IN 1 DEST Enter the parameter that Analog input 1 is to control.</p>	R-W	<p>Range: MXXPXX Default: M01P19 (01.19)</p>
M07P13	<p>ANALOG IN 2 MODE See parameter M07P10.</p>	R-W	<p>Range: [0] to [8] Default: [5] 4 to 20MA MS</p>
M07P14	<p>ANALOG IN 2 SCAL Enter a value to scale Analog input 2. See M07P11 for details.</p>	R-W	<p>Range: 0 to 10.000 Default: 1.000</p>
M07P15	<p>ANALOG IN 2 DEST Enter the parameter that Analog input 2 is to control.</p>	R-W	<p>Range: MXXPXX Default: M01P20</p>
M07P16	<p>ANALOG IN 3 MODE See parameter M07P10. * Analog input 3 is optional.</p>	R-W	<p>Range: [0] to [8] Default: [0] VOLT IN</p>
M07P17	<p>ANALOG IN 3 SCAL Enter a value to scale Analog input 3. See M07P11 for details.</p>	R-W	<p>Range: 0 to 10.000 Default: 1.000</p>
M07P18	<p>ANALOG IN 3 DEST Enter the parameter that Analog input 3 is to control. Factory defaulted to an unused parameter M00P00. * Analog input 3 is optional.</p>	R-W	<p>Range: MXXPXX Default: M00P00 (00.00)</p>
M07P20	<p>ANALOG OUT1 SCAL Enter a value to scale Analog output 1.</p> <p>NOTE: In most cases, adjustment of M07P20, M07P22 and M07P24 is not necessary since the output is automatically scaled so that 100% output signal is produced when the source parameter is at maximum.</p>	R-W	<p>Range: 0 to ±10.000 Default: 1.000</p>
M07P22	<p>ANALOG OUT2 SCAL Enter a value to scale Analog output 2.</p>	R-W	<p>Range: 0 to ±10.000 Default: 1.000</p>
M07P24	<p>ANALOG OUT3 SCAL Enter a value to scale Analog output 3. * Analog input 3 is optional.</p>	R-W	<p>Range: 0 to ±10.000 Default: 1.000</p>
M07B25 M07B26 M07B27	<p>CALIBRATE REF 1 CALIBRATE REF 2 CALIBRATE REF 3</p> <p>When set at 1 the signal applied to analog input# 1, 2, or 3 is automatically scaled so that the applied input signal corresponds to the maximum value of the destination parameter times a multiplier.</p> <p>Example: ANALOG INPUT DESTINATION (M07P12) its destination is defaulted to ANALOG REFERENCE 1 (M01P19). When M07B25 is set to 1, the applied signal at analog input#1 at TB4-2 is automatically scaled to correspond to 60Hz (value of MAX FREQUENCY M01P06).</p>	R-W	<p>Range: 0 or 1 Default: 0</p>
M08B01 M08B02	<p>F1 ENABLE –STOP INPUT F2 PROGRAM INPUT</p>	R-O	<p>Range: 0 or 1 Default:</p>

<p>M08B03 M08B04 M08B05 M08B06 M08B07 M08B08</p>	<p>F3 PROGRAM INPUT F4 PROGRAM INPUT F5 PROGRAM INPUT F6 PROGRAM INPUT F7 PROGRAM INPUT F8 PROGRAM INPUT</p> <p>Bit parameters M08B01 to M08B08 indicate the logic states of the programmable digital inputs F1 to F8 as follows:</p> <p>0 = Inactive (logic 0) 1 = Active (logic 1)</p> <p>The input destination parameters (M08B09, etc.) define the parameter that the related programmable input (F2, etc.) is to control.</p> <p>Variable parameters, read-only parameters and Keypad control parameters (M06P12 to M06P14) cannot be controlled by the programmable digital inputs.</p>		
<p>M08P09</p>	<p>F2 INPUT DESTINA Enter the parameter number to use as the destination for input F2. Default: Sequencing bit 0 (run).</p>	<p>R-W</p>	<p>Range: MXXPXX Default: M06B08 (06.08)</p>
<p>M08B10</p>	<p>F2 INVERT Set to 1 to invert the logic sense of F2.</p>	<p>R-W</p>	<p>Range: 0 or 1 Default: 0</p>
<p>M08P11</p>	<p>F3 INPUT DESTINA Enter the parameter number to use as the destination for input F3. Default: Reset</p>	<p>R-W</p>	<p>Range: MXXPXX Default: M10B24 (10.24)</p>
<p>M08B12</p>	<p>F3 INVERT Set to 1 to invert the logic sense of F3.</p>	<p>R-W</p>	<p>Range: 0 or 1 Default: 0</p>
<p>M08P13</p>	<p>F4 INPUT DESTINA Enter the parameter number to use as the destination for input F4. Default: External Trip</p>	<p>R-W</p>	<p>Range: MXXPXX Default: M10B29 (10.29)</p>
<p>M08B14</p>	<p>F4 INVERT Set to 1 to invert the logic sense of F4.</p>	<p>R-W</p>	<p>Range: 0 or 1 Default: 0</p>
<p>M08P15</p>	<p>F5 INPUT DESTINA Enter the parameter number to use as the destination for input F5. Default: Sequencing bit 1 (Jog).</p>	<p>R-W</p>	<p>Range: MXXPXX Default: M06B09 (06.09)</p>
<p>M08B16</p>	<p>F5 INVERT Set to 1 to invert the logic sense of F5.</p>	<p>R-W</p>	<p>Range: 0 or 1 Default: 0</p>
<p>M08P17</p>	<p>F6 INPUT DESTINA Enter the parameter number to use as the destination for input F6. Default: Sequencing bit 2 (Reverse).</p>	<p>R-W</p>	<p>Range: MXXPXX Default: M06B10 (06.10)</p>
<p>M08B18</p>	<p>F6 INVERT Set to 1 to invert the logic sense of F6.</p>	<p>R-W</p>	<p>Range: 0 or 1 Default: 0</p>

M08P19	F7 INPUT DESTINA Enter the parameter number to use as the destination for input F7. Default: Analog reference 2 select (Auto).	R-W	Range: MXXPXX Default: M01B21 (01.21)
M08B20	F7 INVERT Set to 1 to invert the logic sense of F7.	R-W	Range: 0 or 1 Default: 0
M08P21	F8 INPUT DESTINA Enter the parameter number to use as the destination for input F8. Default: Control Keypad select.	R-W	Range: MXXPXX Default: M01B08 (01.08)
M08B22	F8 INVERT Set to 1 to invert the logic sense of F8.	R-W	Range: 0 or 1 Default: 0
M08P23	MODE SELECT SRC Enter the bit parameter number to be used as a source for the mode selector. The mode selector is available to the user to change between any two modes of operation using only a bit parameter or a digital input. Factory defaulted to an unused parameter M00B00.	R-W	Range: MXXBXX Default: M00B00 (00.00)
M08P24	MODESEL OUT DEST Define the destination of the mode selector output. The destination must be a valid R-W mode parameter, a parameter with multiple choice. Factory defaulted to an unused parameter M00P00.	R-W	Range: MXXPXX Default: M00P00 (00.00)
M08P25	MODE SELECT OUT This parameter shows the selected mode output value of the mode selector output.	R-O	Range: [0] to [8] Default:
M08P26	MODE SEL LOGIC 0 Enter the desired mode number when the mode selector source bit parameter is at logic 0	R-W	Range: [0] to [8] Default: [0]
M08P27	MODE SEL LOGIC 1 Enter the desired mode number when the mode selector source bit parameter is at logic 1	R-W	Range: [0] to [8] Default: [1]
M09B01 M09B02 M09B03 M09B04 M09B05 M09B06 M09B07	DIGITAL OUTPUT 1 DIGITAL OUTPUT 2 DIGITAL OUTPUT 3 DIGITAL OUTPUT 4 DIGITAL OUTPUT 5 DIGITAL OUTPUT 6 DIGITAL OUTPUT 7 These parameters show the logic state of the 7 digital outputs. * Digital outputs 3 to 7 are optional.	R-O	Range: 0 or 1 Default: 0
M09P08	BIT SEL1 SOURCE1 Enter the bit parameter number to be used as source 1 for bit selector 1. Factory defaulted to an unused parameter M00P00 which is equivalent to setting the source to 1.	R-W	Range: MXXBXX Default: M00B00 (00.00)
M09B09	BIT SEL1 SR1 INV Set at 1 to invert the logic state of source 1 for bit selector 1.	R-W	Range: 0 or 1 Default: 0
M09P10	BIT SEL1 SOURCE2 Enter the bit parameter number to be used as source 2 for	R-W	Range: MXXBXX Default: M00B00 (00.00)

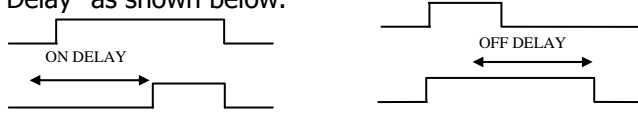
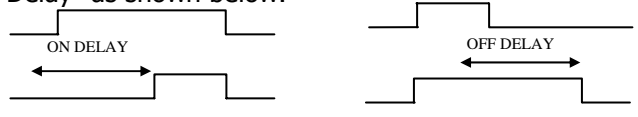
	<p>bit selector 1. Factory defaulted to an unused parameter M00P00 which is equivalent to setting the source to 1.</p>		
M09B11	<p>BIT SEL1 SR2 INV Set at 1 to invert the logic state of source 2 for bit selector 1.</p>	R-W	Range: 0 or 1 Default: 0
M09B12	<p>BIT SEL1 OUT INV Set at 1 to invert the logic state of bit selector 1 output.</p>	R-W	Range: 0 or 1 Default: 0
M09P13	<p>BIT SEL 1 DELAY Enter a value for the required delay for selector 1 output to become active (logic 1). If the parameter value is positive, the delay is an "ON Delay" as shown below. If the parameter value is negative, the delay is an "OFF Delay" as shown below.</p> 	R-W	Range: 0 to ±3276.0 Sec Default: 0
M09P14	<p>BIT SEL2 SOURCE1 Enter the bit parameter number to be used as source 1 for bit selector 2. Factory defaulted to an unused parameter M00P00 which is equivalent to setting the source to 1.</p>	R-W	Range: MXXBXX Default: M00B00 (00.00)
M09B15	<p>BIT SEL2 SR1 INV Set at 1 to invert the logic state of source 1 for bit selector 2.</p>	R-W	Range: 0 or 1 Default: 0
M09P16	<p>BIT SEL2 SOURCE2 Enter the bit parameter number to be used as source 2 for bit selector 2. Factory defaulted to an unused parameter M00P00 which is equivalent to setting the source to 1.</p>	R-W	Range: MXXBXX Default: M00B00 (00.00)
M09B17	<p>BIT SEL2 SR2 INV Set at 1 to invert the logic state of source 2 for bit selector 2.</p>	R-W	Range: 0 or 1 Default: 0
M09B18	<p>BIT SEL2 OUT INV Set at 1 to invert the logic state of bit selector 2 output.</p>	R-W	Range: 0 or 1 Default: 0
M09P19	<p>BIT SEL 2 DELAY Enter a value for the required delay for selector 1 output to become active (logic 1). If the parameter value is positive, the delay is an "ON Delay" as shown below. If the parameter value is negative, the delay is an "OFF Delay" as shown below.</p> 	R-W	Range: 0 to ±3276.0 Sec Default: 0
M09P20	<p>DIGITAL OUT3 SRC Enter the bit parameter number to be used as source for digital output 3. The default setting indicates when drive is at below minimum frequency. * Digital outputs 3 to 7 are optional.</p>	R-W	Range: MXXBXX Default: M10B04 (10.04)

M09B21	DIGITAL OUT3 INV Set at 1 to invert the logic state of digital output 3.	R-W	Range: 0 or 1 Default: 0
M09P22	DIGITAL OUT4 SRC Enter the bit parameter number to be used as source for digital output 4. The default setting indicates when the drive is At speed. * Digital outputs 3 to 7 are optional.	R-W	Range: MXXBXX Default: M10B05 (10.05)
M09B23	DIGITAL OUT4 INV Set at 1 to invert the logic state of digital output 4. * Digital outputs 3 to 7 are optional.	R-W	Range: 0 or 1 Default: 0
M09P24	DIGITAL OUT5 SRC Enter the bit parameter number to be used as source for digital output 5. The default setting indicates when the drive is in Current limit. * Digital outputs 3 to 7 are optional.	R-W	Range: MXXBXX Default: M10B08 (10.08)
M09B25	DIGITAL OUT5 INV Set at 1 to invert the logic state of digital output 5. * Digital outputs 3 to 7 are optional.	R-W	Range: 0 or 1 Default: 0
M09P26	DIGITAL OUT6 SRC Enter the bit parameter number to be used as source for digital output 6. The default setting indicates when Forward direction is demanded. * Digital outputs 3 to 7 are optional.	R-W	Range: MXXBXX Default: M10B13 (10.13)
M09B27	DIGITAL OUT6 INV Set at 1 to invert the logic state of digital output 6. * Digital outputs 3 to 7 are optional.	R-W	Range: 0 or 1 Default: 0
M09P28	DIGITAL OUT7 SRC Enter the bit parameter number to be used as source for digital output 7. The default setting indicates load reached. * Digital outputs 3 to 7 are optional.	R-W	Range: MXXBXX Default: M10B06 (10.06)
M09B29	DIGITAL OUT7 INV Set at 1 to invert the logic state of digital output 7. * Digital outputs 3 to 7 are optional.	R-W	Range: 0 or 1 Default: 0
M09P30	DIGITAL OUT1 SRC Enter the bit parameter number to be used as source for digital output 1. The default setting indicates when drive is running.	R-W	Range: MXXBXX Default: M10B02 (10.02)
M09B31	DIGITAL OUT1 INV Set at 1 to invert the logic state of digital output 1.	R-W	Range: 0 or 1 Default: 0
M09P32	DIGITAL OUT2 SRC Enter the bit parameter number to be used as source for digital output 2. The default setting indicates when drive is normal (not faulted).	R-W	Range: MXXBXX Default: M10B01 (10.01)
M09B33	DIGITAL OUT2 INV Set at 1 to invert the logic state of digital output 2.	R-W	Range: 0 or 1 Default: 0

M09P34 BIT SEL1 OUTPUT This parameter monitors the output of the bit selector 1.	R-O	Range: 0 or 1 Default:
M09P35 BITSEL1 OUT DEST Enter the destination for the output of the bit selector 1. Factory defaulted to an unused parameter M00B00.	R-W	Range: MXXBXX Default: M00B00 (00.00)
M09P36 BIT SEL2 OUTPUT This parameter monitors the output of the bit selector 2.	R-O	Range: 0 or 1 Default:
M09P37 BITSEL2 OUT DEST Enter the destination for the output of the bit selector 2. Factory defaulted to an unused parameter M00B00.	R-W	Range: MXXBXX Default: M00B00 (00.00)
M10B01 DRIVE NORMAL M10B01 = 0 indicates the drive is tripped. M10B01 = 1 indicates the drive is normal (not tripped),or if M10B28 = 1, the drive is tripped but an auto reset is going to occur.	R-O	Range: 0 or 1 Default:
M10B02 DRIVE RUNNING M10B02 = 1 indicates the output bridge of the drive is active.	R-O	Range: 0 or 1 Default: 0
M10B03 AT ZERO SPEED Open Loop: This parameter is set to 1 when the absolute value of the motor frequency (M05P01) is below the Zero Speed Threshold (M03P20) Closed Loop: This parameter is set to 1 when the absolute value of the speed feedback (M03P12) is below the Zero Speed Threshold (M03P20)	R-O	Range: 0 or 1 Default:
M10B04 BELOW MIN SPEED Open Loop: This parameter is set to 1 when the drive is running and the absolute value of the motor frequency is below the window defined by Minimum Frequency (M01P05). $ M05P01 \leq (M01P05 + 1HZ)$ Closed Loop: This parameter is set to 1 when the drive is running and the absolute value of the speed feedback is below the window defined by Minimum Frequency (M01P05). $ M03P12 \leq (M01P05 + 1HZ)$ Note: In bipolar mode (M01P10 = 1) this parameter is the same as At Zero Speed (M10P03).	R-O	Range: 0 or 1 Default:
M10B05 AT SPEED Open Loop: This parameter is set to 1 when the drive is running and the absolute value of the motor frequency (M05P01) is within the At speed band defined by M03P21 & M03P22 Closed Loop:	R-O	Range: 0 or 1 Default:

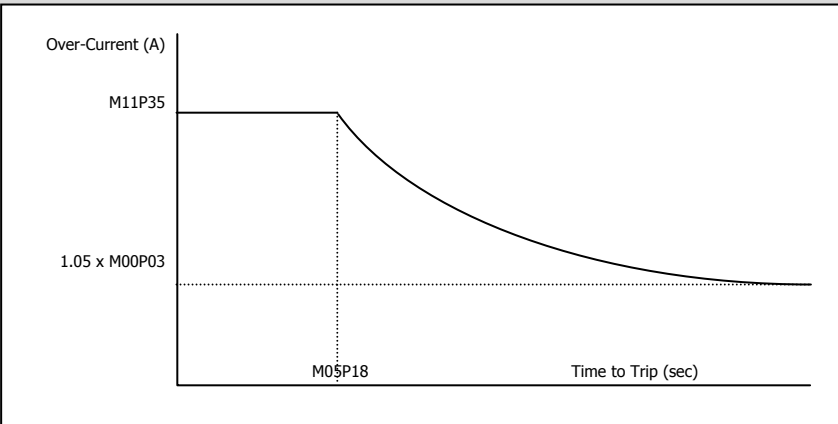
<p>This parameter is set to 1 when the drive is running and the absolute value of the speed feedback (M03P12) is within the At speed band defined by M03P21 & M03P22</p>		
<p>M10B06 LOAD REACHED M10B06 = 1 indicates: Load current ≥ Rated load current Load current = torque component</p>	<p>R-O</p>	<p>Range: 0 or 1 Default: 0</p>
<p>M10B07 IxT ALARM</p>  <p><i>Figure 10-3 Time to Trip is dependent on the extent of current overload</i></p> <p>M10B07 = 1 indicates that motor current is greater than 105% of the programmed motor rated current. If the current is not reduced, the drive will trip on Ixt overload after a period of time that depends on the extent of the overload. For example:</p> <p>If Motor current = M11P35 Time to trip = 60 secs maximum</p> <p>When M10B07 = 1, the keypad fault LED blinks.</p> <p>Time-to-Trip equation:</p> $\text{Time - to - Trip} = \frac{\text{M05P18}}{\left(\frac{\text{Motorcurrent} - 1.05 \times \text{M00P03}}{\text{M11P35} - 1.05 \times \text{M00P03}} \right)} \text{Seconds}$ <p>M05P18 is factory defaulted to 60 seconds.</p> <p>Example: For D4-0500CT: M11P35 =900A (150% rated drive 600x1.5) & M05P18 =60 SEC (factory default value) If a user enters 600A in M00P03 and if the drive is running at 765A motor current:</p> $\text{Time - to - Trip} = \frac{60}{\left(\frac{765 - 630}{900 - 630} \right)} = 120\text{sec}$ <p>If a user enters 300A in M00P03 and 20sec in M05P18 and if the drive is running at 765A motor current:</p> $\text{Time - to - Trip} = \frac{20}{\left(\frac{765 - 315}{900 - 315} \right)} = 26\text{sec}$	<p>R-O</p>	<p>Range: 0 or 1 Default:</p>

M10B08	AT CURRENT LIMIT M10B08 = 1 indicates the normal current limit is active.	R-O	Range: 0 or 1 Default: 0
M10B09	MOTOR IN REGEN M10B09 = 1 indicates the output bridge is transferring power from the motor to the DC bus.	R-O	Range: 0 or 1 Default: 0
M10B10	ABOVE SET SPEED Open Loop: This parameter is set to 1 when the drive is running and the absolute value of the motor frequency (M05P01) is above the At Speed window as defined by M03P22 and M03P27 Closed Loop: This parameter is set to 1 when the drive is running and the absolute value of the speed feedback (M03P12) is above the At Speed window defined by M03P22 and M03P27	R-O	Range: 0 or 1 Default:
M10B11	BELOW SET SPEED Open Loop: This parameter is set to 1 when the drive is running and the absolute value of the motor frequency (M05P01) is below the At Speed window as defined by M03P21 and M03P27 Closed Loop: This parameter is set to 1 when the drive is running and the absolute value of the speed feedback (M03P12) is below the At Speed window defined by M03P21 and M03P27	R-O	Range: 0 or 1 Default:
M10B12	PG LOSS Closed loop parameter M10B12 = 1 indicates PG loss as described in M03P07.	R-O	Range: 0 or 1 Default:
M10B13	FWD ROTATIO EN M10B13 = 1 indicates the pre-ramp reference is positive.	R-O	Range: 0 or 1 Default 0
M10P14 M10P15 M10P16 M10P17 M10P18 M10P19 M10P20 M10P21 M10P22 M10P23	LAST FAULT RECORDED FAULT#1 RECORDED FAULT#2 RECORDED FAULT#3 RECORDED FAULT#4 RECORDED FAULT#5 RECORDED FAULT#6 RECORDED FAULT#7 RECORDED FAULT#8 RECORDED FAULT#9 These parameters indicate Recorded Fault#1 is most recent.	R-O	Range: Default:
M10B24	DRIVE RESET Set at 1 to reset the drive. If the drive is to be reset by an input signal, a programmable digital input must be programmed to control this parameter. F3 input destination default is M10B24.	R-W	Range: 0 or 1 Default: 0
M10B25	ENABLE AUTORESET If set to 1, the drive will automatically reset trips when tripped after a programmed delay set in M10P26 "RESET DELAY". Auto-reset function resets only the faults as specified in parameter M10P35 "AUTORESET MODE".	R-W	Range: 0 or 1 Default: 0
M10P26	AUTORESET DELAY Enter the auto-reset delay in seconds. This parameter defines the time between a trip and an auto-reset.	R-W	Range: 0 to 3276.0 Sec Default: 5

M10P27	NO OF AR ATTEMPTS	R-W	Range: 0 to 10 Default: 0
<p>If this parameter is set to zero then no auto-reset attempts are made. Any other value will cause the drive to automatically reset following a trip. When the programmed value of M10P27 is reached, any further trips of the same type will not cause an auto-reset. A trip of a different type will cause an auto-reset. If there has been no trip for 10 minutes then the reset count is cleared.</p>			
M10B28	VFD OK DELAYED	R-W	Range: 0 or 1 Default: 0
<p>This parameter can be used to hold "Drive Normal" status bit M10B01 at 1 until the last Auto-Reset Attempt is used.</p> <p>Set M10B28 to 1 for "Drive Normal" status bit M10B01 to remain set at 1 every time a trip occurs and "Auto-Reset" is going to occur.</p> <p>Set M10B28 to 0 to immediately clear "Drive Normal" status bit M10B01 at 0 every time a trip occurs, regardless of any Auto-reset that may occur.</p>			
M10B29	EXTERNAL TRIP	R-W	Range: 0 or 1 Default: 1
<p>When an external trip signal is required to control this parameter, use a programmable digital input and ensure that the input state is at logic 1 to prevent the drive tripping.</p> <p>M10B29 = 0 the drive will trip.</p> <p>F4 input destination fault is M10B29.</p>			
M10P30	PROCESSOR2 TRIP	R-W	Range: 0 to 69 Default: 0
<p>When a user-defined trip occurs and causes a command from an expansion card or serial communications to be sent to the drive, parameter M10P30 can be used to trip the drive and display a relevant trip code.</p> <p>The expansion card should enter a valid trip code into M10P31.</p> <p>If a standard Trip code is entered in M10P30, the Trip code will be shown and the drive tripped accordingly.</p> <p>The drive can be reset by setting M10P30 at 70.</p>			
M10P31	STATUS WORD	R-O	Range: 0 to 32761 Default: 0
<p>Parameter M10P31 contains a binary coded number. This indicates the current state of the read-only parameters that indicate the status of the drive. The coded number can be used to control indicators on a separate display panel.</p> <p>The binary codes that are produced when the parameters are at logic 1 are as follows:</p>			
Parameter	Parameter Name	Description	Binary
	Number		
M10B01	DRIVE NORMAL	Drive normal (not tripped)	2 ⁰
M10B02	DRIVE RUNNING	Drive is running	2 ¹
M10B03	AT ZERO SPEED	Zero frequency or stopped	2 ²
M10B04	BELOW MIN SPEED	Running at or below minimum frequency	2 ³
M10B05	AT SPEED	Drive running at set speed	2 ⁴
M10B06	LOAD REACHED	Load reached	2 ⁵
M10B07	IxT ALARM	IxT motor overload	2 ⁶
M10B08	AT CURRENT LIMIT	Drive output is at current limit	2 ⁷
M10B09	MOTOR IN REGEN	Motor regenerating	2 ⁸

M10B10	ABOVE SET SPEED	Drive running above set speed	2 ⁹		
M10B11	BELOW SET SPEED	Drive running below set speed	2 ¹⁰		
M10B12	PG LOSS	PG loss (encoder loss)	2 ¹¹		
M10B13	FWD ROTATIO EN	Forward rotation commanded	2 ¹²		
M10B25	ENABLE AUTORESET	Enable auto-reset	2 ¹³		
M10B34	CLOSED LP STATUS	Drive in Closed Loop operation	2 ¹⁴		
M10B36	MOTOR 2 SELECTED	Drive is using 2 nd Motor (map) parameters	2 ¹⁵		
M10P32	DRIVE STATUS			R-O	Range: [0] to [9] Default:
	This parameter indicates the drive status				
	[0]	READY			
	[1]	RUNNING Drive run state			
	[2]	RAMP STOP Drive ramp stop state			
	[3]	DISABLED Drive is disabled			
	[4]	FLYCATCH Drive is catching a spinning motor			
	[5]	DC INJECT Drive in DC injection braking state			
	[6]	FAULT Drive tripped			
	[7]	RESET Drive reset			
	[8]	ZERO HOLD Drive active and holding zero speed			
	[9]	ORIENT Orientation state			
M10P33	IxT ACCUMULATOR			R-O	Range: 0.0 to 100.0 % Default:
	When the motor current exceeds 105% of the programmed Motor Rated Current (M00P03 or M05P06), the IxT accumulator will display a value greater than 0. If the current is not reduced the accumulator value will eventually reach 100 % and the drive will trip on IxT overload fault.				
	When the accumulator value is greater than 0 the IxT Alarm parameter bit (M10B07) is set at 1 and the keypad fault LED blinks.				
M10B34	CLOSED LP STATUS			R-O	Range: 0 or 1 Default:
	M10B34 = 1 indicates the drive in Closed Loop operation.				
M10P35	AUTORESET MODE			R-W	Range: [0] to [1] Default: [0] PWR LOSS
	Use this parameter to select how parameter M10B25 "ENABLE AUTORESET" function operates.				
	<u>Select from:</u>				
	[0]	PWR LOSS Reset UNDERVOLTAGE fault only			
	[1]	ALLFAULTS Reset all faults			
M10B36	MOTOR 2 SELECTED			R-O	Range: 0 or 1 Default: 0
	M10B36 = 1 indicates that the 2 nd Motor (Map) parameters are active.				
M10B37	IN RAMP STOP			R-O	Range: 0 or 1 Default:
	M10B37 = 1 indicates the drive is in the RAMP STOP state (Drive is ramping down to a stop) as indicated by parameter M10P32 (DRIVE STATUS).				
M10B38	DRIVE DISABLED			R-O	Range: 0 or 1 Default:
	M10B38 = 1 indicates the drive is in the DISABLED state as indicated by parameter M10P32 (DRIVE STATUS).				
M10B39	IN FLYCATCH			R-O	Range: 0 or 1 Default:
	M10B39 = 1 indicates the drive is in the FLYCATCH state as indicated by parameter M10P32 (DRIVE STATUS).				
M10B40	IN DC INJECT			R-O	Range: 0 or 1 Default:
	M10B40 = 1 indicates the drive is in the DC INJECT state as indicated by parameter M10P32 (DRIVE STATUS).				

M10B41 IN ZERO HOLD M10B41 = 1 indicates the drive is active and holding zero speed.	R-O	Range: 0 or 1 Default:																																																															
M10B42 IN ORIENTATION M10B42 = 1 indicates the drive is in the orientation state.	R-O	Range: 0 or 1 Default:																																																															
M11P01 DEFINE M00PXX to M11P20 Use the Menu 11 parameters in the following table to assign parameters in the Advanced menus to the User menu (Menu 0). The default assignments are shown. The Menu 11 parameters in the table are read-write. <table border="1" data-bbox="261 617 911 1346"> <thead> <tr> <th>Parameter number</th> <th>Menu 0 User parameter</th> <th>Default assignment</th> </tr> </thead> <tbody> <tr><td>M11P01</td><td>M05P08</td><td>RATED MOTOR VOLT</td></tr> <tr><td>M11P02</td><td>M05P09</td><td>RATED MOTOR FREQ</td></tr> <tr><td>M11P03</td><td>M05P06</td><td>RATED MOTOR CURR</td></tr> <tr><td>M11P04</td><td>M05P10</td><td>NUMBER OF POLES</td></tr> <tr><td>M11P05</td><td>M04P11</td><td>SYM CURRENT LIM</td></tr> <tr><td>M11P06</td><td>M02P03</td><td>ACCEL RAMP 1</td></tr> <tr><td>M11P07</td><td>M02P04</td><td>DECEL RAMP 1</td></tr> <tr><td>M11P08</td><td>M01P06</td><td>MAX FREQUENCY</td></tr> <tr><td>M11P09</td><td>M01P05</td><td>MIN FREQUENCY</td></tr> <tr><td>M11P10</td><td>M01P04</td><td>KEYPAD REFERENCE</td></tr> <tr><td>M11P11</td><td>M11P27</td><td>SOFTWARE VERSION</td></tr> <tr><td>M11P12</td><td>M11P33</td><td>DRIVE MODEL NO</td></tr> <tr><td>M11P13</td><td>M05P03</td><td>MOTOR VOLTAGE</td></tr> <tr><td>M11P14</td><td>M05P05</td><td>MOTOR POWER</td></tr> <tr><td>M11P15</td><td>M05P04</td><td>DC BUS VOLTAGE</td></tr> <tr><td>M11P16</td><td>M05P34</td><td>AC LINE VOLTAGE</td></tr> <tr><td>M11P17</td><td>M10P14</td><td>LAST FAULT</td></tr> <tr><td>M11P18</td><td>M04P01</td><td>MOT CURR-TOTAL</td></tr> <tr><td>M11P19</td><td>M01P03</td><td>FINAL FREQ REF</td></tr> <tr><td>M11P20</td><td>M05P02</td><td>MOTOR SHAFT RPM</td></tr> </tbody> </table> <p>For parameters programmed into M11P19 and M11P20, a scale factor can be applied using M11P21 and M11P22 in order to indicate some meaningful unit such as gallons per minute. Also a text can be applied using M11P31 & M11P32.</p>	Parameter number	Menu 0 User parameter	Default assignment	M11P01	M05P08	RATED MOTOR VOLT	M11P02	M05P09	RATED MOTOR FREQ	M11P03	M05P06	RATED MOTOR CURR	M11P04	M05P10	NUMBER OF POLES	M11P05	M04P11	SYM CURRENT LIM	M11P06	M02P03	ACCEL RAMP 1	M11P07	M02P04	DECEL RAMP 1	M11P08	M01P06	MAX FREQUENCY	M11P09	M01P05	MIN FREQUENCY	M11P10	M01P04	KEYPAD REFERENCE	M11P11	M11P27	SOFTWARE VERSION	M11P12	M11P33	DRIVE MODEL NO	M11P13	M05P03	MOTOR VOLTAGE	M11P14	M05P05	MOTOR POWER	M11P15	M05P04	DC BUS VOLTAGE	M11P16	M05P34	AC LINE VOLTAGE	M11P17	M10P14	LAST FAULT	M11P18	M04P01	MOT CURR-TOTAL	M11P19	M01P03	FINAL FREQ REF	M11P20	M05P02	MOTOR SHAFT RPM	R-W	Range: Default:
Parameter number	Menu 0 User parameter	Default assignment																																																															
M11P01	M05P08	RATED MOTOR VOLT																																																															
M11P02	M05P09	RATED MOTOR FREQ																																																															
M11P03	M05P06	RATED MOTOR CURR																																																															
M11P04	M05P10	NUMBER OF POLES																																																															
M11P05	M04P11	SYM CURRENT LIM																																																															
M11P06	M02P03	ACCEL RAMP 1																																																															
M11P07	M02P04	DECEL RAMP 1																																																															
M11P08	M01P06	MAX FREQUENCY																																																															
M11P09	M01P05	MIN FREQUENCY																																																															
M11P10	M01P04	KEYPAD REFERENCE																																																															
M11P11	M11P27	SOFTWARE VERSION																																																															
M11P12	M11P33	DRIVE MODEL NO																																																															
M11P13	M05P03	MOTOR VOLTAGE																																																															
M11P14	M05P05	MOTOR POWER																																																															
M11P15	M05P04	DC BUS VOLTAGE																																																															
M11P16	M05P34	AC LINE VOLTAGE																																																															
M11P17	M10P14	LAST FAULT																																																															
M11P18	M04P01	MOT CURR-TOTAL																																																															
M11P19	M01P03	FINAL FREQ REF																																																															
M11P20	M05P02	MOTOR SHAFT RPM																																																															
M11P21 SCALE FOR M00P19 Enter a value to scale M00P19 to represent a meaningful unit, such as gallons per minute. To change text use parameter M11P31.	R-W	Range: 0.0 to ±10.000 Default: 1.000																																																															
M11P22 SCALE FOR M00P20 Enter a value to scale M00P20 to represent a meaningful unit, such as gallons per minute. To change text use parameter M11P32.	R-W	Range: 0.0 to ±10.000 Default: 1.000																																																															
M11P23 SERIAL ADDRESS Enter an address for serial communications.	R-W	Range: 1 to 255 Default: 1																																																															
M11P24 SERIAL PARITY Select the required mode of operation for serial communications.	R-W	Range: [0] to [2] Default: [0] NO PARITY																																																															

	[0] NO PARITY No Parity [1] OD PARITY Odd Parity [2] EV PARITY Even Parity		
M11P25	BAUD RATE [0] = 4800 BAUD [1] = 9600 BAUD [2] = 19.2 KBD	R-W	Range: [0] to [2] Default: [1] 9600 BAUD
M11P26	SERIAL PROTOCOL Use this parameter to select the serial protocol. [0] MODBUSUSD Modbus US Drives Protocol [1] METASYSN2 Johnson Controls Metasys N2 Protocol [2] MODBUSRTU Modbus RTU Protocol	R-W	Range: [0] to [2] Default: [0] MODBUSUSD
M11P27	SOFTWARE VERSION Indicates version of software in the drive.	R-O	Range: XXXX Default:
M11P28	PROCESSOR 2 VER Indicates software version present on any optional card fitted.	R-O	Range: XXXX Default:
M11P29	SECURITY CODE User can create his own security code using a four-digit number to lock parameter editing. For more details refer to section 3.4.8	R-W	Range: 0 to 9999 Default: 0
M11P30	DISPLAY WHEN PWR Enter the number of the parameter that is to be displayed when AC power is applied.	R-W	Range: M00P00 to M00P20 Default: M00P20 (00.20)
M11P31	TEXT FOR M00P19 Use this parameter to change parameter M00P19 text. When scrolling through the list [0] to [18], the text choice will be shown on the text field (upper row). When the Enter key is hit, the chosen text will be the text for M00P19 and the M11P31 text field will revert to show TEXT FOR M00P19. Note: When [0] is selected the M00P19 text is the text of the parameter assigned to M00P19. [0] * [1] CURRENT (Can be edited using Drive Master) [2] CURRENT [3] FEEDBACK [4] FLOW [5] FREQUENCY [6] INPUT [7] LOAD [8] OUTPUT [9] POWER [10] PRESSURE [11] REFERENCE [12] SETPOINT [13] SPEED [14] TEMPERATURE [15] TENSION [16] TORQUE [17] VOLTAGE [18] VOLUME *Text is the text of the parameter assigned to M00P19.	R-W	Range: [0] to [18] Default: [0]

<p>M11P32 TEXT FOR M00P20</p> <p>Use this parameter to change parameter M00P20 text. When scrolling through the list [0] to [18], the text choice will be shown on the text field (upper row). When the Enter key is hit, the chosen text will be the text for M00P20 and the M11P32 text field will revert to show TEXT FOR M00P20.</p> <p>Note: When [0] is selected the M00P20 text is the text of the parameter assigned to M00P20.</p> <p>[0] * [1] CURRENT [2] CURRENT (Can be edited using Drive Master) [3] FEEDBACK [4] FLOW [5] FREQUENCY [6] INPUT [7] LOAD [8] OUTPUT [9] POWER [10] PRESSURE [11] REFERENCE [12] SETPOINT [13] SPEED [14] TEMPERATURE [15] TENSION [16] TORQUE [17] VOLTAGE [18] VOLUME</p> <p>*Text is the text of the parameter assigned to M00P20.</p>	R-W	Range: [0] to [18] Default: [0]
<p>M11P33 DRIVE MODEL NO Indicates the drive model number.</p>	R-W	Range: Default:
<p>M11P34 VOLTAGE RATING Indicates the voltage rating of the drive. [0] 200 – 250V = Low voltage range [1] 380 – 500V = Standard voltage range [2] 500 – 600V = High Voltage</p>	R-O	Range: [0] to [2] Default:
<p>M11P35 OVERLOAD RATING Indicates maximum overload current in Amps of the drive.</p>	R-O	Range: Default:
<p>M11P36 FACTORY DEFAULTS [0] NO [1] YES To set all parameter to the factory defaults</p>	R-W	Range: [0] to [1] Default: NO
<p>M11P37 ACCESS CODE User to enter access code to unlock parameter editing. For more details refer to section 3.4.8</p>	R-W	Range: 0 to 10000 Default: 0
<p>M11P38 DRIVE TYPE [0] OPEN LOOP Open loop vector (sensorless) [1] CLOSED LP Closed loop vector (with speed feedback)</p>	R-W	Range: [0] or [1] Default: [0] OPEN LOOP
<p>M11B40 SELECT 2nd MOTOR Set at 1 to select the 2nd Motor (map) parameters. This parameter is read-only (R-O) while the drive is running.</p>	R-W	Range: 0 or 1 Default: 0
<p>M12B01 THRSLD 1 EXCEEDED M12B01 = 1 indicates input variable is above Threshold 1. M12B01 = 0 indicates input variable is below Threshold 1.</p>	R-O	Range: 0 or 1 Default: 0

M12B02 THRSLD 2 EXCEEDED M12B02 = 1 indicates input variable is above Threshold 2. M12B02 = 0 indicates input variable is below Threshold 2.	R-O	Range: 0 or 1 Default:
M12P03 THRESHOLD 1 SRC Enter the number of the parameter to be used as the source for threshold 1. The absolute value of the source is taken as the input to the Threshold comparator. Factory defaulted to an unused parameter M00P00.	R-W	Range: MXXPXX Default: M00P00 (00.00)
M12P04 THRESHOLD1 LEVEL User-defined threshold 1 level entered as a percentage of the source maximum.	R-W	Range: 0.0 to 100.0 % Default: 0
M12P05 THRESHOLD1 HYST Defined band where no change will occur to the comparator output. Upper limit for switching: Level + [hyst ÷ 2] Lower limit: Level – [hyst ÷ 2]	R-W	Range: 0 to 25.5 % Default: 0
M12B06 THRSHLD1 OUT INV Set at 1 to invert threshold comparator 1 output.	R-W	Range: 0 or 1 Default: 0
M12P07 THRESHOLD1 DEST Define the destination of the threshold comparator 1 output. The destination must be a R-w bit parameter. A new value entered in M12P07. Factory defaulted to an unused parameter M00P00.	R-W	Range: MXXPXX Default: M00P00 (00.00)
M12P08 THRESHOLD2 SRC Refer to the notes for M12P03 to M12P07. Factory defaulted to an unused parameter M00P00 which is equivalent to setting the source signal to 0.	R-W	Range: MXXPXX Default: M00P00 (00.00)
M12P09 THRESHOLD2 LEVEL Refer to the notes for M12P03 to M12P07.	R-W	Range: 0.0 to 100.0 % Default: 0
M12P10 THRESHOLD2 HYST Refer to the notes for M12P03 to M12P07.	R-W	Range: 0 to 25.5 % Default: 0
M12B11 THRSHLD2 OUT INV Refer to the notes for M12P03 to M12P07.	R-W	Range: 0 or 1 Default: 0
M12P12 THRESHOLD2 DEST Refer to the notes for M12P03 to M12P07. Factory defaulted to an unused parameter M00P00. Factory defaulted to an unused parameter M00P00.	R-W	Range: MXXPXX Default: M00P00 (00.00)
M12P13 VAR SEL1 IN1 SRC Enter the source for variable selector 1 input 1. There are two variable selectors available to the user. Each variable selector allows two input parameter values defined by (M12P13, M12P14) & (M12P23, M12P24) to be manipulated as defined by the mode M12P15 & M12P25. The result of the input parameters is limited by (M12P21, M12P22) & (M12P31, M12P32) and routed to a destination parameter defined M12P16 & M12P26. This feature is useful to reroute, smooth & combine any variable parameter. The end result can be used for display or monitoring purposes, or can be as an input to another parameter or function. Please refer to Menu 12 flowchart in the previous section of the instruction manual.	R-W	Range: MXXPXX Default: M00P00 (00.00)

M12P14	VAR SEL1 IN2 SRC Enter the source for variable selector 1 input 2. See M12P13 description.	R-W	Range: MXXPXX Default: M00P00 (00.00)
M12P15	VAR SEL 1 MODE Use to select the mode for the variable selector 1 as defined below: [0] SEL IN 1 Output = Input 1 [1] SEL IN 2 Output = Input 2 [2] ADD Output = Input 1 + Input 2 [3] SUBTRACT Output = Input 1 – Input 2 [4] MULTIPLY Output = (Input 1 x Input 2)/100.0 [5] DIVIDE Output = (Input 1 x 100.0)/Input 2 [6] FILTERED Output = Input 1/(M12P20 x S + 1) [7] RAMPED Output = Input 1 via ramp: M12P20 (sec) [8] ABS VALUE Output = (Input 1) in Mode [6] "S" in the equation is the Laplace identifier and M12P20 is the time constant for the 1 st order filter. See M12P13 description.	R-W	Range: [0] to [8] Default: [0] SEL IN 1
M12P16	VARSEL1 OUT DEST Enter the destination for the output of the variable selector 1. Factory defaulted to an unused parameter M00P00. See M12P13 description.	R-W	Range: MXXPXX Default: M00P00 (00.00)
M12P17	VAR SEL 1 OUTPUT This parameter monitors the result of the variable selector 1. See M12P13 description.	R-O	Range: ±100.0% Default:
M12P18	VSEL1 IN1 SCALE Enter a value to scale the variable selector 1 input 1 parameter. See M12P13 description.	R-W	Range: ±10.000 Default: 1.000
M12P19	VSEL1 IN2 SCALE Enter a value to scale the variable selector 1 input 2 parameter. See M12P13 description.	R-W	Range: ±10.000 Default: 1.000
M12P20	VAR SEL1 CONTROL Enter a value for the variable selector 1 control parameter. This parameter serves as a filter time constant or a ramp time in sec depending on the mode defined by parameter M12P15 See M12P13 description.	R-W	Range: 0.00 to 100.00 sec Default: 0.00
M12P21	VARSEL1 HI LIMIT The maximum positive selector 1 output can be limited by this parameter. See M12P13 description.	R-W	Range: 0 to 100.0 % Default: 100.0
M12P22	VARSEL1 LO LIMIT The maximum negative or minimum positive selector 1 output can be limited by this parameter. See M12P13 description.	R-W	Range: -100.0 to 100.0 % Default: -100.0
M12P23	VAR SEL2 IN1 SRC Enter the source for variable selector 2 input 1. See M12P13 description.	R-W	Range: MXXPXX Default: M00P00 (00.00)

M12P24	VAR SEL2 IN2 SRC Enter the source for variable selector 2 input 2. See M12P13 description.	R-W	Range: MXXPXX Default: M00P00 (00.00)
M12P25	VAR SEL 2 MODE Use to select the mode for the variable selector 2 as defined below: [0] SEL IN 1 Output = Input 1 [1] SEL IN 2 Output = Input 2 [2] ADD Output = Input 1 + Input 2 [3] SUBTRACT Output = Input 1 – Input 2 [4] MULTIPLY Output = (Input 1 x Input 2)/100.0 [5] DIVIDE Output = (Input 1 x 100.0)/Input 2 [6] FILTERED Output = Input 1/(M12P30 x S + 1) [7] RAMPED Output = Input 1 via ramp: M12P30 (sec) [8] ABS VALUE Output = (Input 1) in Mode [6] "S" in the equation is the Laplace identifier and M12P30 is the time constant for the 1 st order filter. See M12P13 description.	R-W	Range: [0] to [8] Default: [0] SEL IN 1
M12P26	VARSEL2 OUT DEST Enter the destination for the output of the variable selector 2 See M12P13 description.	R-W	Range: MXXPXX Default: M00P00 (00.00)
M12P27	VAR SEL 2 OUTPUT This parameter monitors the result of the variable selector 2. See M12P13 description.	R-O	Range: ±100.0% Default:
M12P28	VSEL2 IN1 SCALE Enter a value to scale the variable selector 2 input 1 parameter. See M12P13 description.	R-W	Range: ±10.000 Default: 1.000
M12P29	VSEL2 IN2 SCALE Enter a value to scale the variable selector 2 input 2 parameter. See M12P13 description.	R-W	Range: ±10.000 Default: 1.000
M12P30	VAR SEL2 CONTROL Enter a value for the variable selector 2 control parameter. This parameter serves as a filter time constant or a ramp time in sec depending on the mode defined by parameter M12P25 See M12P13 description.	R-W	Range: 0.00 to 100.00 sec Default: 0.00
M12P31	VARSEL2 HI LIMIT The maximum positive selector 1 output can be limited by this parameter. See M12P13 description.	R-W	Range: 0 to 100.0 % Default: 100.0
M12P32	VARSEL2 LO LIMIT The maximum negative or minimum positive selector 2 output can be limited by this parameter. See M12P13 description.	R-W	Range: -100.0 to 100.0 % Default: -100.0
M13P01	RUN-TIME LOG Y-D Indicates years and days of the total running time of the drive.	R-O	Range: 0.000 to 9.364 y.ddd Default:

M13P02	RUN-TIME LOG H-M Indicates the hours and minutes of the total running time of the drive.	R-O	Range: 00.00 to 23.59 hh.mm Default:
M13P03	ENERGY IN MWH Indicates MWh of energy consumed.	R-O	Range: 0 to 10000 MWh Default:
M13P04	ENERGY IN KWH Indicates kWh of energy consumed.	R-O	Range: 000.0 to 1000.0 kWh Default:
M13P05	RUNNING COST Continuously indicates the running cost/hour. Requires the correct value to be entered in M13P08.	R-O	Range: 0 to XXXX M13P08/h Default:
M13P06	COUNTDOWN TIMER1 Indicates the running time remaining until timer1 has counted down to zero.	R-O	Range: 0 to 10000 h Default:
M13P07	COUNTDOWN TIMER2 Indicates the running time remaining until timer2 has counted down to zero.	R-O	Range: 0 to 10000 h Default:
M13P08	COST PER KWH Enter electricity cost for use by M13P05.	R-W	Range: 00.00 to 100.00 Currency Default: 0
M13B09	RESET POWER MTR Set at 1 to reset M13P03 and M13P04.	R-W	Range: 0 or 1 Default: 0
M13P10	STARTTIME TIMER1 Enter the running time the drive must operate before timer1 counts down to zero.	R-W	Range: 0 to 10000 h Default: 0
M13B11	TIMER1 DONE M13B11 is automatically set at 1 when M13P06 = 0. Set M13B11 at 0 to reset countdown timer1. This causes M13P06 to be loaded with the value of M13P10.	R-W	Range: 0 or 1 Default: 0
M13P12	STARTTIME TIMER2 Enter the running time the drive must operate before timer2 counts down to zero.	R-W	Range: 0 to 10000 h Default: 0
M13B13	TIMER2 DONE M13B13 is automatically set at 1 when M13P07 = 0. Set M13B13 at 0 to reset countdown timer2. This causes M13P07 to be loaded with the value of M13P12.	R-W	Range: 0 or 1 Default: 0
M13P14	GEN AMPLITUDE Use this parameter to set the amplitude of the square wave signal produced by the generator in percent.	R-W	Range: 0 to 200.0% Default: 0
M13P15	GEN OFFSET Use this parameter to set the offset of the square wave signal produced by the generator in percent.	R-W	Range: -200.0 to +200.0% Default: 0
M13P16	GEN PULSEWIDTH 1 Use this parameter to set the pulse width of the square wave high-signal produced by the generator in msec.	R-W	Range: 0.1 to 3276 sec Default: 1
M13P17	GEN PULSEWIDTH 2 Use this parameter to set the pulse width of the square wave low-signal produced by the generator in msec.	R-W	Range: 0.1 to 3276 sec Default: 1
M13P18	GEN OUTPUT This parameter monitors the generator output.	R-O	Range: MXXPXX Default:
M13P19	GEN DESTINATION Enter the parameter number to use as the destination for the generator output signal. Factory defaulted to an unused parameter.	R-W	Range: MXXPXX Default: M00P00 (00.00)

<p>M14P01 PID OUTPUT The inputs to the PID controller are automatically scaled to the range ±100.0%. The PID controller output is also within this range.</p> <p>Although it would appear that the variables have only a 10-bit resolution, internal calculations are made at a higher resolution for greater accuracy. The displayed values are scaled versions of the internal variables.</p> <p>The output after the scale factor M14P15 is automatically scaled to match the range of the destination parameter.</p> <p>Gain parameters are actual units, as follows:</p> $\text{PID output} = Pe + Ie/s + Des$ <p>Where: P, I and D are the programmed gains e is the input error to the PID controller s is the Laplace identifier</p> <p>With an error of 100%, if P = 1.000 the output produced by the proportional term is 100%.</p> <p>With an error of 100%, if I = 1.000 the output produced by the integral term will increase linearly by 100% every second.</p> <p>With an error that is increasing by 100% per second, if D = 1.000 the output produced by the D term will be 100%.</p>	R-O	Range: ±100.0 % Default:
<p>M14P02 MAIN REF SOURCE See parameter M14P01.</p> <p>Factory defaulted to an unused parameter M00P00 which is equivalent to setting the source signal to 0.</p> <p>If a non-valid parameter is programmed the input value is taken as 0. All variable inputs to the PID are automatically scaled to variables having the range ±100.0%, or 0 - 100.0% if they are unipolar.</p>	R-W	Range: MXXPXX Default: M00P00 (00.00)
<p>M14P03 PID REF SOURCE See parameter M14P01.</p> <p>Factory defaulted to an unused parameter M00P00 which is equivalent to setting the source signal to 0.</p> <p>If a non-valid parameter is programmed the input value is taken as 0. All variable inputs to the PID are automatically scaled to variables having the range ±100.0%, or 0 - 100.0% if they are unipolar.</p>	R-W	Range: MXXPXX Default: M00P00 (00.00)
<p>M14P04 PID FEEDBACK SRC See parameter M14P01.</p> <p>Factory defaulted to an unused parameter M00P00 which is equivalent to setting the source signal to 0.</p> <p>If a non-valid parameter is programmed the input value is taken as 0. All variable inputs to the PID are automatically scaled to variables having the range ±100.0%, or 0 - 100.0% if they are unipolar.</p>	R-W	Range: MXXPXX Default: M00P00 (00.00)

M14B05	INVERT REFERENCE See parameter M14P01. This parameter is used to change the sense of the PID reference signal. Setting this parameter to a 1 causes the signal seen by the input to be inverted.	R-W	Range: 0 or 1 Default: 0
M14B06	INVERT FEEDBACK See parameter M14P01. This parameter is used to change the sense of the PID feedback signal. Setting this parameter to a 1 causes the signal seen by the input to be inverted.	R-W	Range: 0 or 1 Default: 0
M14P07	PID REF SLEWRATE See parameter M14P01. This parameter defines the time taken for the reference input to ramp from 0 to 100.0% following a 0 to 100% step change in input. Changes from -100.0% to +100.0% will take twice this time.	R-W	Range: 0.1 to 3276 Sec Default: 0.1
M14B08	PID ENABLE See parameter M14P01. This parameter must be at 1 for the PID controller to operate, if it is 0 the PID output will be 0.	R-W	Range: 0 or 1 Default: 0
M14P09	PID ENABLE SRC See parameter M14P01. This parameter can be used to control when the PID function is enabled via a bit parameter. This bit parameter is ANDed with the PID enable parameter M14B08 to enable the PID function. If a non-valid parameter is programmed the input to the PID controller is taken as a 1. Any valid optional enable programmed must be a 1 for the PID controller to operate; if it is a 0 then the output will be 0. Factory defaulted to an unused parameter M00P00 which is equivalent to setting the source to 1.	R-W	Range: MXXPXX Default: M00P00 (00.00)
M14P10	PROPORTIONAL GAIN See parameter M14P01. This is the proportional gain applied to the PID error.	R-W	Range: 0 to 10.000 Default: 1.000
M14P11	INTEGRAL GAIN See parameter M14P01. This is the gain applied to the PID error before being integrated.	R-W	Range: 0 to 10.000 Default: 0.500
M14P12	DERIVATIVE GAIN See parameter M14P01. This is the gain applied to the PID error before being differentiated.	R-W	Range: 0 to 10.000 Default: 0
M14P13	PID HIGH LIMIT See parameter M14P01. The maximum positive PID output can be limited by this parameter.	R-W	Range: 0 to 100.0 % Default: 100.0

M14P14	PID LOW LIMIT See parameter M14P01. The maximum negative or minimum positive PID output can be limited by this parameter.	R-W	Range: -100.0 to +100.0 % Default: -100.0
M14P15	PID OUT SCALING See parameter M14P01. This parameter scales the final addition of the PID OUTPUT and the MAIN REFERENCE.	R-W	Range: 0.000 to ±10.000 Default: 1.000
M14P16	PID OUT DESTINAT See parameter M14P01. Factory defaulted to an unused parameter M00P00. This destination parameter defines the parameter to be controlled by the PID function. If a non-valid parameter is programmed the output is not routed anywhere. If the PID is to control speed then it is suggested that one of the preset speed parameters is entered here. If the PID is to trim speed then it is suggested that the offset parameter M01P15 is entered here. The output after the scale factor M14P15 is automatically scaled to match the range of the destination parameter.	R-W	Range: MXXPXX Default: M00P00 (00.00)
M14P17	PID REFERENCE This parameter monitors the PID controller reference.	R-O	Range: ±100.0% Default:
M14P18	PID FEEDBACK This parameter monitors the PID controller feedback.	R-O	Range: ±100.0% Default:
M14P19	PID ERROR This parameter monitors the PID controller error.	R-O	Range: ±100.0% Default:
M14P20	MAIN REFERENCE This parameter monitors the PID controller main reference.	R-O	Range: ±100.0% Default:
M15P01	POS REF SOURCE This parameter is used to select the position reference source. The reference can be taken from the drive encoder or an optional encoder or a local reference. If the reference and feedback sources are the same the position controller is disabled. [0] DRIVE PG Drive encoder [1] PG # 2 Optional encoder [2] LOCAL REF Local reference	R-W	Range: [0]-[2] Default: [0] DRIVE PG
M15P02	POS FEEDBACK SRC This parameter is used to select the position feedback source. The feedback can be taken from the drive encoder or an optional encoder. If the feedback and reference sources are the same the position controller is disabled. [0] DRIVE PG Drive encoder [1] PG # 2 Optional encoder	R-W	Range: [0]-[1] Default: [0] DRIVE PG
M15B03	POS REF INVERT This parameter can be used to invert the position reference.	R-W	Range: 0 or 1 Default: 0
M15P04	RATIO NUMERATOR An exact ratio can be applied to the position reference with a numerator and denominator parameters. Example: With M15P04 = 3000, and M15P05 = 1000, the	R-W	Range: 0 to 4000 Default: 1000

	ratio will be 3000/1000, or 3. With this ratio, for every revolution of the master drive, the follower drive will make three revolutions.		
M15P05	RATIO DENOMINATR See M15P04 for description.	R-W	Range: 1 to 1000 Default: 1000
M15P06	POS LOOP GAIN The gain of the position controller is controlled by this parameter.	R-W	Range: 0.00 to 100.00 rad/sec/rad Default: 5.00
M15P07	<p>POS CONTROL MODE This parameter is used to set the position controller mode as described below:</p> <p>[0] DISAB POS Position controller disabled [1] RIGD FFWD Rigid control with feed forward [2] RIGID Rigid position control [3] NRIGDFFWD Non-rigid control with feed-forward [4] NON RIGID Non-rigid position control [5] ORIENT ST Orientation on stop [6] ORIENT SE Orientation on stop when drive is enabled</p> <p><u>Rigid Position Control:</u> The position error is always accumulated in Rigid Position Control. If for example the slave shaft is slowed down due to an overload condition, the target position is recovered by running at higher speed when the overload condition is removed.</p> <p><u>Non-Rigid Position Control:</u> In Non-Rigid Position control the position loop is only active when the "AT SPEED" condition is met. Slippage will occur while the error speed is high.</p> <p><u>Velocity Feed-Forward:</u> The position controller can generate a velocity feed-forward value from the speed of the reference encoder. The feed-forward value is passed thru menu 1 so ramps may be included if required. Because the position controller only has a proportional gain, it is necessary to use velocity feed-forward to prevent a constant position error that would be proportional to the speed of the reference position. If for any reason the user wishes to provide the velocity feed forward from a source other than the reference position, the feed-forward system can be made inactive i.e. M15P07 = 2 or 4. The external feed-forward can be provided via Menu 1 from any of the frequency/speed references. However, if this feed-forward level is not correct a constant position error will exist.</p> <p><u>Orientation on Stop:</u> The drive orientates the motor following a stop command. If HOLD ZERO SPEED is enabled (M06P19 = 1) the drive remains in position control when orientation is complete and holds the orientation position. If HOLD ZERO SPEED is not enabled the drive is disabled when orientation is complete.</p> <p><u>Orientation on stop and when drive is enabled:</u> The drive orientates the motor following a stop command and whenever the drive is enabled provided that hold zero</p>	R-W	Range: [0] - [6] Default: [0] DISAB POS

<p>speed is enabled (M06B19 = 1). This ensures that the spindle is always held in the same position following the drive being enabled. When orientating from a stop command the drive goes through the following sequence:</p> <ul style="list-style-type: none"> - The motor is decelerated or accelerated to the speed limit programmed in M15P09, using ramps if these are enabled, in the direction the motor was previously running. - When the ramp output reaches the speed set in M15P09, ramps are disabled and the motor continues to rotate until the position is found to be close to the target position. At this point the speed demand is set to 0 and the position loop is closed. - When the position is within the window defined by M15P11, the orientation complete indication is given in M15P12. The STOP MODE selected by M06P01 has no effect if orientation is enabled <p><u>NOTES:</u> The position controller is disabled and the error integrator is also reset under the following conditions:</p> <ul style="list-style-type: none"> - The drive is ready, disabled, or tripped. - The POSITION CONTROL MODE M15P07 is [0] "DISAB POS". - The reference or feedback position sources are invalid. - The POSITION CONTROL MODE M15P07 is changed. - The ABSOLUTE POSITION ENABLE M15P08 is changed. - The POSITION ERROR RESET M15P13 is set to one <p>The position error is not accumulated under the following condition:</p> <ul style="list-style-type: none"> - The position error is not being reset and the POSITION CONTROL MODE M15P07 is in "NRIGDFFWD" or "NON RIGID" and the drive is not at speed. <p>The position loop is enabled under the following conditions:</p> <ul style="list-style-type: none"> - The POSITION CONTROL MODE M15P07 is in "RIGID", "RIGD FFWD", orienting, and the drive is in RUN mode. - POSITION CONTROL MODE M15P07 is in "NRIGDFFWD" or "NON RIGID" and "AT SPEED". 		
<p>M15B08 ABS POS ENABLE When this parameter is set to 1 and the POSITION CONTROLLER MODE M15P07 is 1 or 2, the position error integrator is loaded with the absolute position error defined by the position sources when the position controller is disabled. Therefore when this parameter M15P08= 1 the position controller operates on the absolute position from the reference and feedback. If the feedback device is not absolute then the absolute position is the change of position since the drive was powered-up.</p> <p>When this parameter is zero or the position control mode is not 1 or 2 the error integrator is loaded with zero when the position controller is disabled. Therefore the position controller operates on the relative position changes of the reference and feedback from the point when the position</p>	<p>R-W</p>	<p>Range: 0 or 1 Default: 0</p>

	<p>controller is re-enabled. It should be noted that the value of this parameter does not affect the operation of the marker reset for any position source. If the drive MARKER RESET ENABLE M03P32 is 1, the position controller takes the position source including the effect of the marker. When a marker event occurs the position and turns are reset to zero. If the MARKER RESET ENABLE M03P32 =0 then the marker events have no effect on the position source used by the position controller.</p>		
M15P09	<p>POS ERR SPD LMT This parameter limits the velocity correction applied by the position controller. This value is also used as the reference during orientation.</p>	R-W	Range: 0 to M01P06 Hz Default: 5.0 HZ
M15P10	<p>ORIENT POS REF Use this parameter to enter a value for the orientation position reference. This parameter is in terms of fractions of a revolution of the feedback encoder, where 32768 =1 revolution.</p>	R-W	Range: 0 to 32767 (1 turn) Default: 16383
M15P11	<p>ORIENT OK WINDOW Use this parameter to enter a value for the orientation OK window. This parameter is in terms of fractions of a revolution of the feedback encoder, where 32768 =1 revolution.</p>	R-W	Range: 0 to 4096 (1/8 turn) Default: 256
M15B12	<p>ORIENT COMPLETE When the position is within the window defined by M12P11 indicates orientation is complete.</p>	R-O	Range: 0 or 1 Default:
M15B13	<p>POS ERROR RESET The position error integrator is preset to the absolute error when M15P07 = 1 or 2, and M15P08 =1; otherwise it is set to zero when M15B13 is set to one.</p> <p>The position controller is disabled and the error integrator is also reset under the following conditions:</p> <ul style="list-style-type: none"> - The drive is ready, disabled or tripped. - The reference or feedback position sources are invalid. - The POSITION CONTROL MODE M15P07 is changed. - The ABSOLUTE POSITION ENABLE M15P08 is changed. - The POSITION ERROR RESET M15P13 is set to one. 	R-W	Range: 0 or 1 Default: 0
M15P14	<p>RELATIVE JOG REF This parameter can used for relative jog reference to move the feedback position relative to the reference position.</p>	R-W	Range: 0 to 1000.0 Hz Default: 0
M15B15	<p>REL JOG ENABLE Set at 1 to enable relative jog to move the feedback position relative to the reference position at a speed defined by M15P14.</p>	R-W	Range: 0 or 1 Default: 0
M15B16	<p>RELATIVE JOG REV Set at 1 to invert the relative jog reference.</p>	R-W	Range: 0 or 1 Default: 0
M15P17	<p>LOCAL REF TURNS The local reference can be used to control the position of the motor shaft. If the LOCAL REFERENCE ENABLE parameter M15B21 is 1 the previously written value is used. This allows the two parts of the local reference position to be changed without data skew problems. This parameter is in terms of revolutions of the feedback encoder.</p>	R-W	Range: ±32767 Revolutions Default: 0

M15P18 LOCAL REF POSITN See above description. Use this parameter to set the local reference in terms of fractions of a revolution of the feedback encoder, where 32768 = 1 revolution.	R-W	Range: ± 32767 (± 1 turn) Default: 0
M15P19 PG2 REVOLUTIONS This parameter indicates the position in terms of revolutions of the encoder #2 (optional encoder).	R-O	Range: ± 32767 Revolutions Default:
M15P20 PG2 POSITION This parameter indicates the position in terms of fractions of a revolution of the encoder #2 (optional encoder), where 32768 = 1 revolution.	R-O	Range: ± 32767 (± 1 turn) Default:
M15B21 LOCAL REF ENABLE See M15P17 description.	R-W	Range: 0 or 1 Default: 0
M15P22 PG2 CONSTANT PPR Use this parameter to set the pulse per revolution (ppr) of the encoder # 2 (optional encoder).	R-W	Range: 0 to 8192 ppr Default: 1024
M15P23 PG2 NO OF PHASES Select [0] if only A phase or B phase is used. Select [1] if A & B phases are used (quadrature). [0] ONE PHASE One phase A or B [1] TWO PHASE Two phase A & B (quadrature)	R-W	Range: [0] – [1] Default: [1] TWO PHASE
M15P24 PG2 ROTATION SEL This setting determines how the drive interprets the rotation of the encoder #2 (optional encoder). This parameter can be used to change the direction of the motor without having to change the encoder wiring. [0] CLOCKWISE Clockwise rotation [1] C-CLOCKWS Counterclockwise rotation	R-W	Range: [0] – [1] Default: [0] CLOCKWISE
M15P25 REVOLUTIONS ERR This parameter indicates the position error in terms of revolutions of the feedback encoder.	R-O	Range: ± 32767 Revolutions Default:
M15P26 POSITION ERROR This parameter indicates the position error in terms of fractions of a revolution of the feedback encoder, where 32768 = 1 revolution.	R-O	Range: ± 32767 (± 1 turn) Default:
M15B27 PG2 MARKR RST EN Use this parameter to enable the encoder marker channel to reset the encoder position and encoder revolutions, but only if M15B28 is initially = 0. An incremental digital encoder may have a marker channel. When this channel becomes active it may be used to reset the encoder position and revolutions and set the ENCODER #2 MARKER FLAG M15B27. When the position is reset by the marker, M15P19 and M15P20 are reset to zero. The marker flag is set when the marker input becomes active, but it is not reset by the drive, this must be done by the user.	R-W	Range: 0 or 1 Default: 0
M15B28 PG2 MARKR FLAG See M15P27 description.	R-W	Range: 0 or 1 Default: 0

M15P29	PG2 SPEED This parameter indicates the speed of encoder #2 (optional encoder).	R-O	Range: \pm 32760 RPM
M17P01	MINIMUM FREQ Motor 2 parameter Use in unipolar mode to define the minimum output frequency of the drive. This can be over-ridden by M17P02 and is inactive during Jog. Corresponding Motor 1 parameter: M01P05	R-W	Range: 0 to M17P02 Hz Default: 0
M17P02	MAX FREQUENCY Motor 2 parameter Enter a value to define the absolute maximum output frequency. Corresponding Motor 1 parameter: M01P06	R-W	Range: 0 to 600.0 Hz Default: 60.0
M17P03	ACCEL RAMP 1 Motor 2 parameter Acceleration ramp rate is expressed as the time for the output frequency to increase by 100Hz. For example, a programmed ramp time of 5 seconds causes the frequency to increase or decrease by 50Hz in 2.5 seconds. Corresponding Motor 1 parameter: M02P03	R-W	Range: 0.1 to 3276 s/100Hz Default: Size 0: 30.0 sec Size 1: 30.0 sec Size 2: 60.0 sec Size 3: 60.0 sec
M17P04	DECEL RAMP 1 Motor 2 parameter Deceleration ramp rate is expressed as the time for the output frequency to decrease by 100Hz. Corresponding Motor 1 parameter: M02P04	R-W	Range: 0.1 to 3276 s/100Hz Default: Size 0: 30.0 sec Size 1: 30.0 sec Size 2: 60.0 sec Size 3: 60.0 sec
M17P05	RATED MOTOR CURR Motor 2 parameter When parameter M17P05 is set at a value lower than the default rating of the drive, the maximum current of the drive can be greater than 1.5 times the motor rating. Consequently, the maximum value of current limit and torque parameters (M17P15, M17P16, M04P06, M17P17 and M06P04) can be increased proportionately. For example, if a 180 Amp drive has parameter M17P05 set at 90 Amps, the maximum values of parameters M17P15, M17P16, M17P17 and M06P04 can be 300% (2 x 150%). This allows larger drives to be used for a high starting torque. When the value is increased beyond the default value of M17P05, the values of M17P15, M17P16 and M17P17 are automatically decreased. The value entered affects the following: Slip compensation Dynamic V/f Ixt detection level Industrial and HVAC applications Industrial applications benefit from a higher percentage of overload current, but have a lower nominal current. HVAC	R-W	Range: 0-1800 A Default: Model Dependent

<p>applications benefit from a higher nominal current, but have a lower percentage of overload current (120%). The overload current has the same value in each case.</p> <p>See parameter M05P18. Corresponding Motor 1 parameter: M05P06</p>		
<p>M17P06 RATED MOTOR RPM Motor 2 parameter The rated full load rpm is used with the motor rated frequency to calculate the rated slip of induction motors in Hz.</p> $\text{RatedSlip} = \text{M17P08} - \frac{\text{M17P09} \times \text{M17P06}}{120}$ <p>M17P06 is Rated Motor RPM M17P08 is Base Motor Frequency M17P09 is Number of Poles</p> <p><u>Open loop:</u> If SLIP COMP ENABLE (M05B38) is set to 0 slip compensation is disabled. If slip compensation is required, M17P06 should be set to the nameplate value and M05B38 should be set at 1. Slip compensation is normally used to prevent droop in the motor shaft speed as load is applied.</p> <p><u>Closed Loop:</u> Motor full load rpm is used with motor rated frequency to determine the full load slip of the motor necessary for closed loop vector control.</p> <p>Corresponding Motor 1 parameter: M05P07</p>	R-W	Range: 0 to 32760 RPM Default: Model Dependent
<p>M17P07 RATED MOTOR VOLT Motor 2 parameter Enter the value from the motor rating plate in order to define the maximum output voltage of the drive.</p> <p>Corresponding Motor 1 parameter: M05P08</p>	R-W	Range: 100 to 600 VRMS Default: 240 480 575
<p>M17P08 BASE MOTOR FREQ Motor 2 parameter Enter a value of frequency at which the rated voltage is to be applied to the motor. The motor then enters the constant-power or field-weakening region.</p> <p>Corresponding Motor 1 parameter: M05P09</p>	R-W	Range: 10.0 to 600 Hz Default: 60.0
<p>M17P09 NUMBER OF POLES Motor 2 parameter Enter the value from the motor rating plate for correct slip compensation and RPM indication.</p> <p>Corresponding Motor 1 parameter: M05P10</p>	R-W	Range: [0] (2 POLES) to [15] (32 POLES) Default: [1] (4 POLES)
<p>M17P10 TORQUE I FACTOR Motor 2 parameter Torque current which produces rated torque in the motor in percent of RATED MOTOR CURRENT M17P05.</p> <p>Corresponding Motor 1 parameter: M05P13</p>	R-W	Range: 0 to 100.0% Default: Model dependent

M17P11	FLUX CURR FACTOR Motor 2 parameter Magnetizing current which produces rated flux in the motor in percent of RATED MOTOR CURRENT M17P05. Corresponding Motor 1 parameter: M05P15	Closed loop parameter	R-W	Range: 0 to 100.0% Default: Model dependent
M17P12	SPEEDLOOP P GAIN Motor 2 parameter Speed loop regulator proportional gain See Parameter M03P16 Corresponding Motor 1 parameter: M03P17	Closed loop parameter	R-W	Range: 0 to 10000 Default: 150
M17P13	SPEEDLOOP I GAIN Motor 2 parameter Speed loop regulator integral gain See Parameter M03P16 Corresponding Motor 1 parameter: M03P18	Closed loop parameter	R-W	Range: 0 to 10000 Default: 375
M17P14	SPEEDLOOP D GAIN Motor 2 parameter Speed loop regulator differential gain. See parameter M03P16. Corresponding Motor 1 parameter: M03P19	Closed Loop Parameter	R-W	Range: 0 to 1000.0% Default: 0
M17P15	MOTOR CURR LIMIT Motor 2 parameter Normal current limit See parameter M17P05. Corresponding Motor 1 parameter: M04P04		R-W	Range: 0 to $\frac{M11P35}{M17P05} \times 100$ % Default: Max Number
M17P16	REGEN CURR LIMIT Motor 2 parameter Normal current limit. See parameter M17P05. Corresponding Motor 1 parameter: M04P05		R-W	Range: 0 to $\frac{M11P35}{M17P05} \times 100$ % Default: Max Number
M17P17	SYM CURRENT LIM Motor 2 parameter After having set the required value of maximum current in M17P05, you may increase or decrease the percentage overload current using M17P17. The maximum percentage that can be set is limited by the overload current rating of the drive. The limit applies when motoring and regenerating. The value of M17P17 is automatically reduced when the value of M17P05 is increased beyond the default value. Corresponding Motor 1 parameter: M04P11		R-W	Range: See M17P15 % Default: 120 or 150 minimum
M17P22	ROTOR TIME CONST Motor 2 parameter Motor rotor time constant. Corresponding Motor 1 parameter: M04P23	Closed loop parameter	R-W	Range: 0 to 10000 msec Default: Model dependent

List of parameters that cannot be used as destination for other parameters:
 All read-only (R-O) parameters are of course included but not shown in the list below.

M00P01 TO M00P20	M08P09 F2 INPUT DESTINA	M11P26 SERIAL PROTOCOL
M01P04 KEYPAD REFERENCE	M08P11 F3 INPUT DESTINA	M11P29 SECURITY CODE
M01P06 MAX FREQUENCY	M08P13 F4 INPUT DESTINA	M11P30 DISPLAY WHEN PWR
M02P33 ACEL RECOVR RAMP	M08P15 F5 INPUT DESTINA	M11P33 DRIVE MODEL NO
	M08P17 F6 INPUT DESTINA	M11P36 FACTORY DEFAULTS
	M08P19 F7 INPUT DESTINA	M11P37 ACCESS CODE
M03P01 PG CONSTANT	M08P21 F8 INPUT DESTINA	M11P38 DRIVE TYPE
M03P02 PG NO OF PHASES	M08P23 MODE SELECT SRC	
M03P03 PG ROTATION SEL	M08P24 MODESEL OUT DEST	M12P03 THRESHOLD 1 SRC
M03P05 MOTOR GEAR TEETH		M12P07 THRESHOLD1 DEST
M03P06 LOAD GEAR TEETH	M09P08 BIT SEL1 SOURCE1	M12P08 THRESHOLD2 SRC
M03P13 OTHER FEEDBACK	M09P10 BIT SEL1 SOURCE2	M12P12 THRESHOLD2 DEST
M03P20 ZERO SPEED THSLD	M09P14 BIT SEL2 SOURCE1	M12P13 VAR SEL1 IN1 SRC
M03P24 SPEED FBK FILTER	M09P16 BIT SEL2 SOURCE2	M12P14 VAR SEL1 IN2 SRC
M03P29 PGLOSS DEVIATION	M09P20 DIGITAL OUT3 SRC	M12P16 VARSEL1 OUT DEST
	M09P22 DIGITAL OUT4 SRC	M12P23 VAR SEL2 IN1 SRC
M04P16 TORQ TIME CONST	M09P24 DIGITAL OUT5 SRC	M12P24 VAR SEL2 IN2 SRC
M04P23 ROTOR TIME CONST	M09P26 DIGITAL OUT6 SRC	M12P26 VARSEL2 OUT DEST
	M09P28 DIGITAL OUT7 SRC	
M05P06 RATED MOTOR CURR	M09P30 DIGITAL OUT1 SRC	M13P08 COST PER KWH
M05P07 RATED MOTOR RPM	M09P32 DIGITAL OUT2 SRC	M13P19 GEN DESTINATION
M05P08 RATED MOTOR VOLT	M09P35 BITSEL1 OUT DEST	
M05P09 BASE MOTOR FREQ	M09P37 BITSEL2 OUT DEST	M14P02 MAIN REF SOURCE
M05P10 NUMBER OF POLES		M14P03 PID REF SOURCE
M05P11 AUTOBOOST VOLT	M10B25 ENABLE AUTORESET	M14P04 PID FEEDBACK SRC
M05P13 TORQUE I FACTOR	M10P27 NO OF AR ATTEMPS	M14P09 PID ENABLE SRC
M05P14 FIXED BOOST VOLT	M10P30 PROCESSOR 2 TRIP	M14P16 PID OUT DESTINAT
M05P15 FLUX CURR FACTOR		
M05P20 MAX PWM CARRIER	M11P01 DEFINE M00P01	M15P01 POS REF SOURCE
M05P21 MIN PWM CARRIER	M11P02 DEFINE M00P02	M15P02 POS FEEDBACK SRC
M05P22 SPEED@MAX CARRIER	M11P03 DEFINE M00P03	M15P22 PG2 CONSTANT PPR
M05P23 SPEED@MIN CARRIER	M11P04 DEFINE M00P04	M15P23 PG2 NO OF PHASES
M05P33 RATED LINE VOLTS	M11P05 DEFINE M00P05	M15P24 PG2 ROTATION SEL
	M11P06 DEFINE M00P06	
M06P02 AUTO-START MODE	M11P07 DEFINE M00P07	M17P02 MAX FREQUENCY
M06P06 DB CHOPPER MODE	M11P08 DEFINE M00P08	M17P05 RATED MOTOR CURR
M06B12 KEYPAD START	M11P09 DEFINE M00P09	M17P06 RATED MOTOR RPM
M06B13 KEYPAD STOP	M11P10 DEFINE M00P10	M17P07 RATED MOTOR VOLT
M06B14 KEYPAD FWD/REV	M11P11 DEFINE M00P11	M17P08 BASE MOTOR FREQ
M06P31 MOP DESTINATION		M17P09 NUMBER OF POLES
M06P38 MIN SEARCH FREQ	M11P12 DEFINE M00P12	M17P10 TORQUE I FACTOR
	M11P13 DEFINE M00P13	M17P11 FLUX CURR FACTOR
M07P06 ANALOG OUT MODE	M11P14 DEFINE M00P14	M17P22 ROTOR TIME CONST
M07P07 ANALOG OUT 1 SCR	M11P15 DEFINE M00P15	
	M11P16 DEFINE M00P16	
M07P08 ANALOG OUT 2 SRC	M11P17 DEFINE M00P17	
M07P09 ANALOG OUT 3 SRC	M11P18 DEFINE M00P18	
M07P10 ANALOG IN 1 MODE		
M07P12 ANALOG IN 1 DEST	M11P19 DEFINE M00P19	
M07P13 ANALOG IN 2 MODE	M11P20 DEFINE M00P20	
M07P15 ANALOG IN 2 DEST	M11P23 SERIAL ADDRESS	
M07P16 ANALOG IN 3 MODE	M11P24 SERIAL PARITY	
M07P18 ANALOG IN 3 DEST	M11P25 BAUD RATE	

THIS PAGE INTENTIONALLY LEFT BLANK

<u>FAULT DESCRIPTION</u>	
FAULT NUMBER-DISPLAY	DESCRIPTION
[1] CUR LOSS1: Loss of current loop 1	When parameter M07P10 is set at 3 or 4, this trip occurs when analog speed reference 1 current input (4-20mA or 20-4mA) is less than 3.0mA.
[2] EXT FAULT: External Fault	A fault signal has been detected, an input contact opened at TB2 terminal 6. Refer to parameter M08P13 and M10B29.
[3] MTR OVRD: Motor overload	Actual motor current has exceeded the rated current of the motor for an excessive period. (Value of parameter M04P01 {current feedback} 105% of parameter M05P06 {motor rated current}).
[4] OVERTEMP: Heatsink over-temperature	The drive heatsink has reached its upper working temperature. Inadequate cooling.
[5] OVERCURR: Instantaneous AC over-current trip	Excessive current in the output of the drive, possibly indicating an external short-circuit or excessive "AUTO BOOST VOLT" (M05P11) or "FIXED BOOST VOLT" (M05P14) settings.
[6] OVERVOLT: Bus over-voltage	Over-voltage of the AC supply, or motor regeneration, causing the DC bus to exceed the maximum level. If an over-voltage only occurs right after a run command, check for a short to ground at the output of the drive.
[7] INPUTLOSS: Input Loss	Excessive AC line voltage imbalance or phase loss detected. Refer to parameter M06B20
[8] PWR FAIL: Control power fail	Control Power supply dropped below normal. Consult the supplier of the drive.
[9] MOTORLOSS: Motor Loss	Motor current not detected or motor current below what it should be when the drive is in the RUN state. MOTORLOSS could also be caused by excessive "AUTO BOOST VOLT" (M05P11) or "FIXED BOOST VOLT" (M05P14) settings.
[10] GROUNDFLT: Ground fault	Ground fault detected in one of the motor leads.
[11] GATE FLT: Gate drive fault	IGBT driver power supply loss, power board hardware fault. Consult the supplier of the drive.
[12] PRECH AUX: Precharge aux fail	DC bus precharge contactor opened when it is supposed to be closed. Consult the supplier of the drive .
[13] UNDERVOLT: Under voltage	The DC bus voltage dropped below the minimum level.
[14] DRV OVRD: Drive Overload	Actual current has exceeded the drive capacity. This could be caused by excessive "AUTO BOOST VOLT" (M05P11) or "FIXED BOOST VOLT" (M05P14) settings.
[15] Reserved	
[16] CUR LOSS2: Loss of current loop 2	When parameter M07P13 is set at 3 or 4, this trip occurs when analog speed reference 2 current input (4-20 mA or 20-4 mA) is less than 3.0mA.
[17] CUR LOSS3: Loss of current loop 3	When parameter M07P16 is set at 3 or 4, this trip occurs when analog speed reference 3 current input (4-20 mA or 20-4 mA) is less than 3.0mA.
[18] EEPROM: Eeprom fault	Control board hardware fault. Consult the supplier of the drive.
[19] PROCESSR2: Processor 2 fault	Indicates a malfunction in the optional system card.

[20] PRECHTIME: Precharge contactor timeout	DC bus precharge contactor failed to close on AC power-up.
[21] BUSRIPPLE: Bus Ripple	Excessive bus voltage ripple detected. This fault can be caused due to severe AC line voltage imbalance or phase loss or defective DC bus capacitors.
[22] OVERSPEED: Overspeed	Indicates that the drive speed has exceeded the overspeed threshold.
[23] Reserved	
[24] PG LOSS	Indicates loss of PG.
[25] M1 OVERVLT: Over-voltage power module no. 1	Over-voltage power module no. 1 Over-voltage of the AC supply, or motor regeneration, causing the DC bus to exceed the maximum level. If an over-voltage only occurs right after a run command, check for a short to ground at the output of the drive.
[26] M2 OVRVLT: Over-voltage power module no. 2	Over-voltage power module no. 2 Over-voltage of the AC supply, or motor regeneration, causing the DC bus to exceed the maximum level. If an over-voltage only occurs right after a run command, check for a short to ground at the output of the drive.
[27] M3 OVRVLT: Over-voltage power module no. 3	Over-voltage power module no. 3 Over-voltage of the AC supply, or motor regeneration, causing the DC bus to exceed the maximum level. If an over-voltage only occurs right after a run command, check for a short to ground at the output of the drive.
[28] M1 OVRVLT: Excessive current in power module no. 1	Excessive current in power module no. 1 Excessive current in the output of the drive, possibly indicating an external short-circuit.
[29] M2 OVRVLT: Excessive current in power module no. 2	Excessive current in power module no. 2 Excessive current in the output of the drive, possibly indicating an external short-circuit.
[30] M3 OVRVLT: Excessive current in power module no. 3	Excessive current in power module no. 3 Excessive current in the output of the drive, possibly indicating an external short-circuit.
[31] M1 GNDFLT: Ground fault power module no. 1	Ground fault power module no. 1 Ground fault detected in one of the motor leads.
[32] M2 GNDFLT: Ground fault power module no. 2	Ground fault power module no. 2 Ground fault detected in one of the motor leads.
[33] M3 GNDFLT: Ground fault power module no. 3	Ground fault power module no. 3 Ground fault detected in one of the motor leads.
[34] M1 IGBTFT: IGBT fault power module no. 1	IGBT fault power module no. 1 Fault detected in the power switching device
[35] M2 IGBTFT: IGBT fault power module no. 2	IGBT fault power module no. 2 Fault detected in the power switching device

<p>[36] M3 IGBTFT: IGBT fault power module no. 3</p>	<p>IGBT fault power module no. 3 Fault detected in the power switching device</p>
<p>[37] M1 GTFLT: Gate fault power module no. 1</p>	<p>Gate fault power module no. 1 Fault detected in the switch mode power supply for the IGBT gate driver</p>
<p>[38] M2 GTFLT: Gate fault power module no. 2</p>	<p>Gate fault power module no. 2 Fault detected in the switch mode power supply for the IGBT gate driver</p>
<p>[39] M3 GTFLT: Gate fault power module no. 3</p>	<p>Gate fault power module no. 3 Fault detected in the switch mode power supply for the IGBT gate driver</p>
<p>[40] M1 OVRTMP: Overtemp fault inverter power mod no. 1</p>	<p>Overtemp fault inverter power module no. 1 The drive heatsink has reached its upper working temperature. Inadequate cooling.</p>
<p>[41] M2 OVRTMP: Overtemp fault inverter power mod no. 2</p>	<p>Overtemp fault inverter power module no. 2 The drive heatsink has reached its upper working temperature. Inadequate cooling.</p>
<p>[42] M3 OVRTMP: Overtemp fault inverter power mod no. 3</p>	<p>Overtemp fault inverter power module no. 3 The drive heatsink has reached its upper working temperature. Inadequate cooling.</p>
<p>[43] M1 NUIS: Nuisance fault from power module no. 1</p>	<p>Nuisance fault from power module no. 1 Fault detected in module 1 but type not recognized</p>
<p>[44] M2 NUIS: Nuisance fault from power module no. 2</p>	<p>Nuisance fault from power module no. 3 Fault detected in module 2 but type not recognized</p>
<p>[45] M3 NUIS: Nuisance fault from power module no. 3</p>	<p>Nuisance fault from power module no. 3 Fault detected in module 3 but type not recognized</p>
<p>[46] PM NUIS: Nuisance fault from unknown module</p>	<p>Fault detected from unknown module number but type not recognized</p>

THIS PAGE INTENTIONALLY LEFT BLANK

COMMON OPTIONS AND INTERCONNECTS

WARNING: To avoid a hazard of electric shock, after the input and control power is removed from the drive and the ROM display is no longer lit, wait five (5) minutes for DC bus capacitors to fully discharge before opening the drive to install the encoder card. Verify that the voltage on the DC bus capacitors has discharged by measuring the DC bus voltage at the +DC & -DC terminals of the drive. The voltage must be zero.

CAUTION: This drive contains ESD (Electrostatic Discharge) sensitive parts and assemblies. Static control precautions are required when installing, testing, servicing or repairing this assembly. Component damage may result if ESD control procedures are not followed.

Standard Drive with Manual Bypass Setup & Diagram 1 of 2

All standard drives with Manual Bypass are wired per this setup (same HOA described in 3.7.8) and no programming is needed.

Hand Mode:

Start command: Keypad RUN key.

Stop command: Keypad STOP key.

*FWD/REV command: Keypad USER key.

Jog command: JOG contact at TB2-3-TB2-1.

Reset command: keypad STOP/RESET key or pushbutton at TB2-7-TB2-1.

Speed reference source: Keypad reference M00P10.

Auto Mode:

Start/Stop command: Customer supplied AUTO Run contact.

*FWD/REV command: Contact at TB2-4-TB2-1.

Jog command: JOG contact at TB2-3-TB2-1.

Reset command: keypad STOP/RESET key or pushbutton at TB2-7-TB2-1.

Speed reference source:

- When TB2-8 is wired to TB2-1, analog reference 2 is selected for AUTO reference, 4-20MA operation with min speed when loss of 4-20MA signal (refer to M07P13 description for other choices).
- When TB2-8 is not wired to TB2-1, analog reference 1 is selected for AUTO reference, 0-10Vdc operation.

*Note: Reverse function is disabled. IF FWD/REV is needed set M06P23 (DISABLE REV ROT) to 0 and M06P18 (KEYPAD CONT MODE) to "ALL KEYS".

WARNING:

In the following steps, rotation of the motor in an undesired direction can occur. To guard against possible equipment damage, it is recommended that the motor be disconnected from the load before proceeding.

VFD Motor Rotation Check:

Sections 3.6.5 and 3.6.6 should first be performed with the "VFD-OFF-BYP" switch is in the "VFD" position and the "HAND-OFF-AUTO" switch in the "HAND" position. Follow all instructions using the Keypad frequency reference. If motor rotation is incorrect, as stated in section 3.6.5 interchange any two of the three customer "OUTPUT TO MOTOR" leads, U, V, or W. Under no circumstances should the internal drive wiring be interchanged. This completes the check for motor rotation in VFD mode.

Bypass Motor Rotation Check:

After stopping the VFD by pressing the ROM stop key, place the "HAND-OFF-AUTO" switch in the "OFF" position. Start the motor in BYPASS mode by placing the "VFD-OFF-BYP" switch in the "BYP" position. If the motor direction is incorrect, remove and lock-out input and control power to the drive. When the ROM is no longer illuminated, wait for five (5) minutes for the bus capacitors to fully discharge. Open the drive door and interchange any two of the three customer AC LINE INPUT leads, L1, L2, or L3. Under no circumstances should the internal drive wiring be interchanged. This completes the check for motor rotation in BYPASS mode.

APPENDIX A-4

3-15 PSI SIGNAL BOARD P/N: 3000-4045

INPUTS:

PSI signal input: pneumatic neoprene 1/8" ID hose to transducer nipple.

SUPPLY VOLTAGE 24VDC :	TB1: TERMINAL # 1
SUPPLY COMMON:	TB1: TERMINAL # 2

OUTPUT:

OUTPUT VOLTAGE REFERENCE:	TB1: TERMINAL # 3
OUTPUT CURRENT REFERENCE:	TB1: TERMINAL # 4

POTENTIOMETERS:

A) Calibration for output voltage reference 0-10V at "VOLT OUT".

1a. With air pressure of 3 PSI applied, adjust POT1 "BIAS" for zero volts at "VOLT OUT" at TB1 TERM#3.

2a. With air pressure of 15 PSI applied, adjust POT2 "GAIN" for 10 volts at "VOLT OUT" at TB1 TERM#3.

3a. Check bias and calibration by repeating step 1a and 2a.

B) Calibration for output current reference 4-20mA at "CURR OUT".

1b. With air pressure of 3 PSI applied, adjust POT1 "BIAS" for 4mA at "CURR OUT" at TB1 TERM#4.

2b. With air pressure of 15 PSI applied, adjust POT2 "GAIN" for 20mA at "CURR OUT" at TB1 TERM#4.

3b. Check bias and calibration by repeating step 1b and 2b.

PROCESS SIGNAL FOLLOWER BOARD P/N:3000-4040 & 3000-4040-120

INPUTS:

FOR INPUT VOLTAGE (DC) USE: TB1: TERMINAL # 1 (+) , TERMINAL # 3 (-) **Max input voltage: per table below**
 FOR INPUT CURRENT USE: TB1: TERMINAL # 2 (+) , TERMINAL # 3 (-) **Max input current: 75mA**

OUTPUT:

OUTPUT VOLTAGE REFERENCE: TB2: TERMINAL # 3 **0-10Vdc at 4 mA max**
 OUTPUT CURRENT REFERENCE: TB2: TERMINAL # 4 **4-20mA at 500W max**
 COMMON, RETURN: TB2: TERMINAL # 2

SUPPLY VOLTAGE:

FOR BOARD P/N 3000-4040-120: TB3 TERMINAL#1 (HOT), TERMINAL#2 (NEUTRAL): 120VAC 50/60HZ 100MA MAX

FOR BOARD P/N 3000-4040: TB2 TERMINAL#1 (+), TERMINAL#2 (-): 24VDC 100MA MAX

JUMPER PROGRAMMING:

JP1 PROGRAMMING	
POSITION	MAX INPUT VOLTAGE
12V	12V
24V	24V
48V	48V
96V	96V
192V	192V

JP2 PROGRAMMING	
POSITION	INPUT
V-IN	VOLTAGE
I-IN	4-20 mA @ 250 Ω

POTENTIOMETERS:

Bias pot, used to set output to zero volts or 4mA at either zero volts input or 4mA current input.

- Voltage input: with input voltage set to zero volts, adjust POT1 BIAS for zero voltage at VOLT OUT.
- Voltage input: with input voltage set to zero volts, adjust POT1 BIAS for 4 mA at CURR OUT.
- Current input: current set to 4mA, adjust POT1 BIAS for zero voltage at VOLT OUT.
- Current input: current set to 4mA, adjust POT1 BIAS for 4 mA at CURR OUT.

Gain Pot, used to set output to 10Vdc or 20mA at maximum input voltage or 20mA input current.

- Voltage input: with input voltage set to maximum volts, adjust POT2 GAIN for 10Vdc at VOLT OUT.
- Voltage input: with input voltage set to maximum volts, adjust POT2 GAIN for 20mA at CURR OUT.
- Current input: current set to 20mA, adjust POT2 GAIN for 10Vdc at VOLT OUT.
- Current input: current set to 20mA, adjust POT2 GAIN for 20 mA at CURR OUT.

Isolated Communication Card - 3000-4135-1 (1 of 2)

PHOENIX DX TO LAPTOP PC RS232 CONNECTION

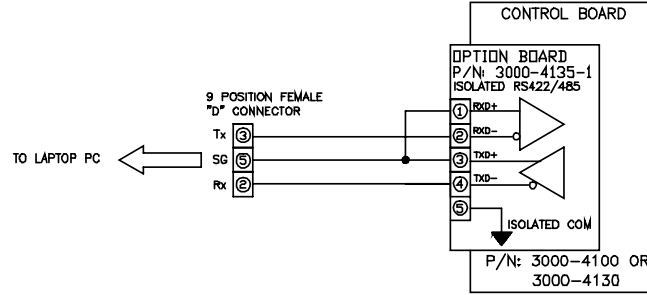

PHOENIX DX TO COMPUTER: RS422 CONNECTION

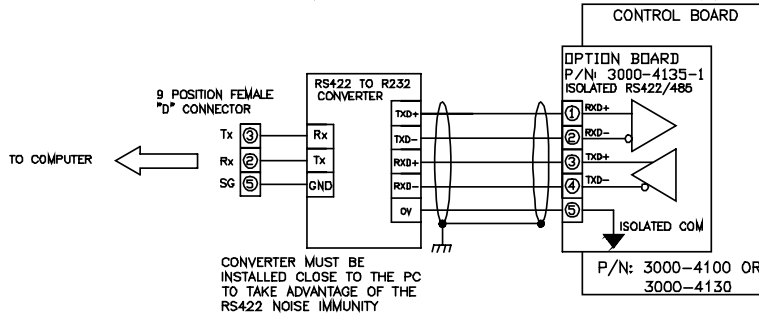

PHOENIX DX TO COMPUTER: RS485 4-WIRE PARTY-LINE CONNECTION

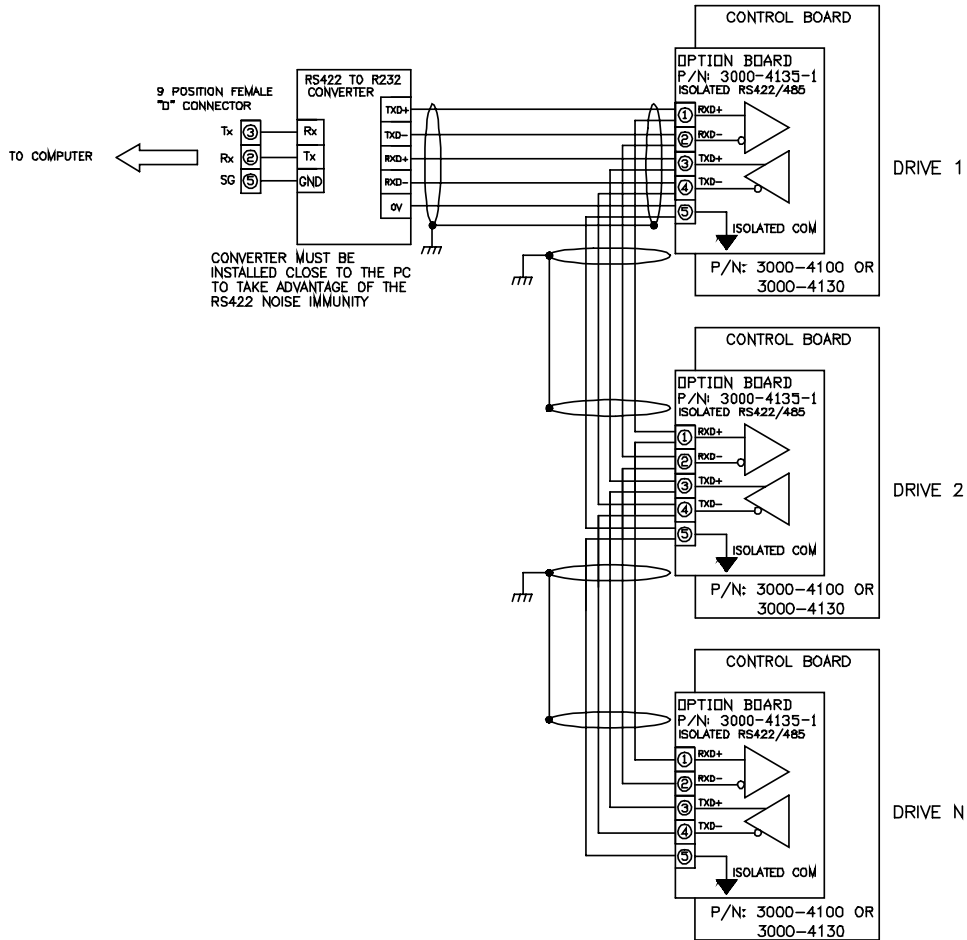

Isolated Communication Card - 3000-4135-1 (2 of 2)

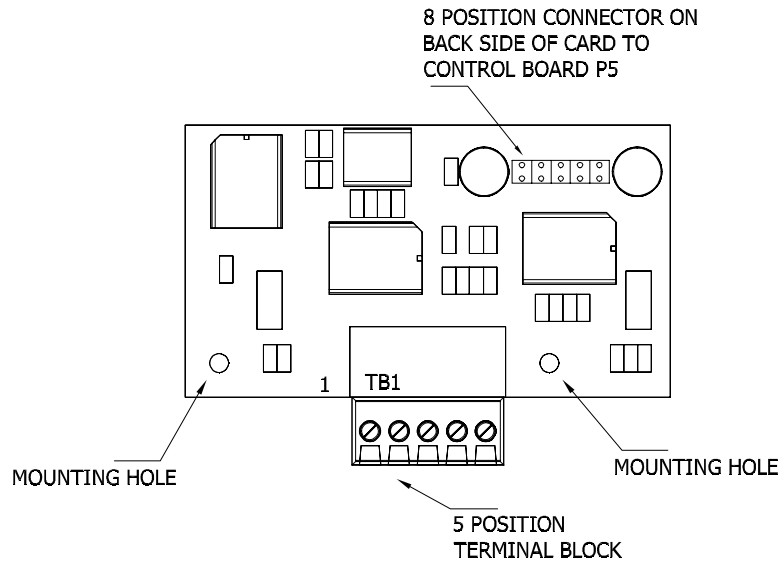

TB1 CONNECTION DATA:

MAXIMUM TORQUE: 2.2 Lb-in [0.25 N-m]
WIRE SIZE: 26-16 AWG [0.14 - 1 mm]

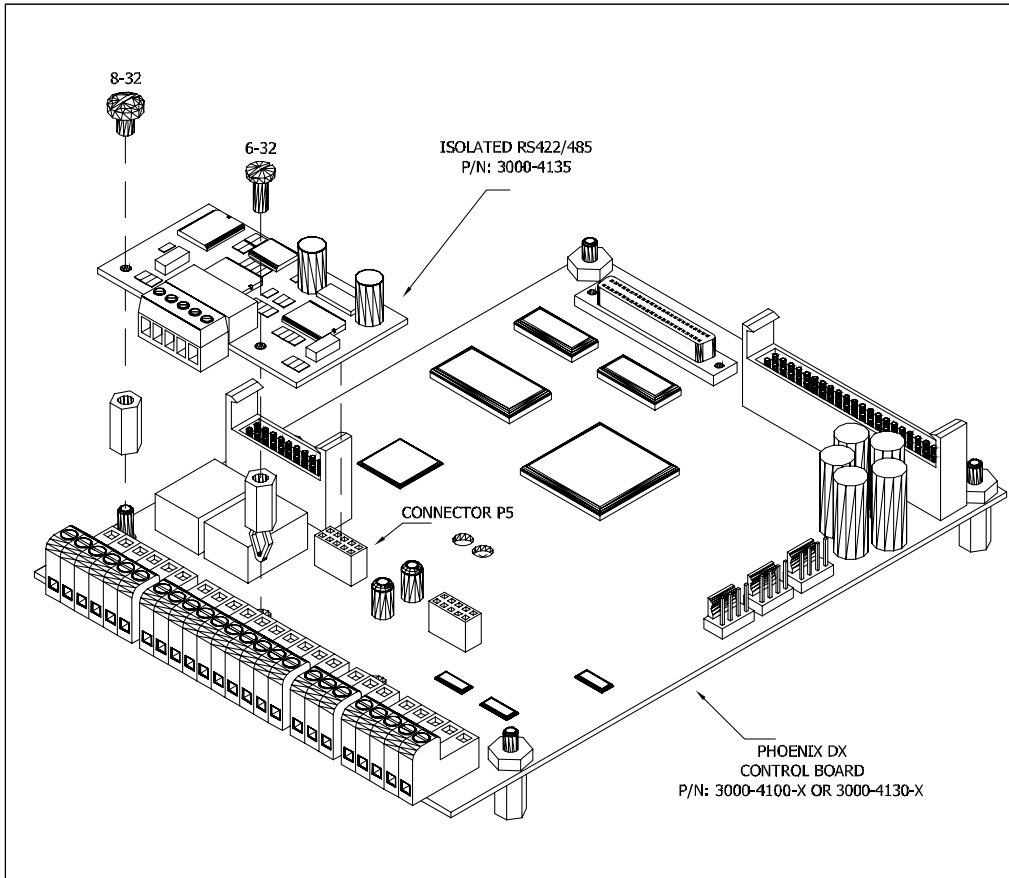

Mounting Diagram

Digital Encoder Card P/N: 3000-4140-1 (1 of 3)

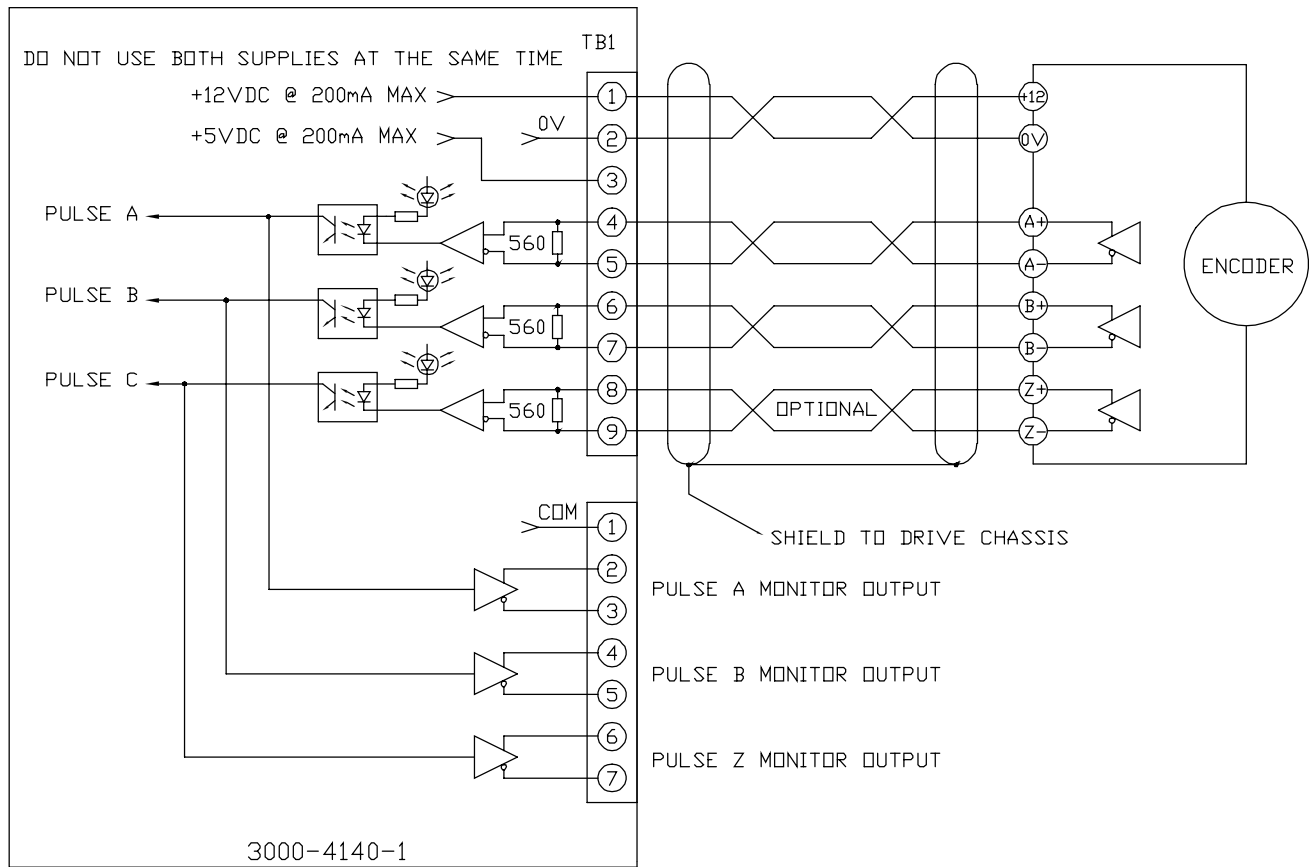

Terminal Block	No.	Signal	
TB1	1	+12VDC	Isolated Power Supply 12VDC, 200mA Max
	2	0VDC	Isolated Power Supply Common 0VDC
	3	+5VDC	Isolated Power Supply 5VDC, 200mA Max
	4	A+	A Phase Differential Input: 5 to 12VDC Max @ 20mA Max Maximum Input Frequency = 300Khz
	5	A-	
	6	B+	B Phase Differential Input: 5 to 12VDC Max @ 20mA Max Maximum Input Frequency = 300Khz
	7	B-	
	8	Z+	Z Phase Differential Input (optional): 5 to 12VDC Max @ 20mA Max Maximum Input Frequency = 300Khz
	9	Z-	
TB2	1	COM	0V reference for A, B, & Z outputs
	2	A+	A Phase Differential Output: 5VDC Max @ 20mA max
	3	A-	
	4	B+	B Phase Differential Output: 5VDC Max @ 20mA max
	5	B-	
	6	Z+	Z Phase Differential Output: 5VDC Max @ 20mA max
	7	Z-	

Digital Encoder Card P/N: 3000-4140-1 (2 of 3)

Notes:

- 5VDC and 12VDC cannot be used at the same time. External supply must be supplied to the encoder if the supply current exceeds 200mA
- Do not use the encoder power supply for anything else other than the encoder.
- Encoder must be differential-line-driver quadrature type 5-12VDC outputs, capable of supplying 20mA per channel
- Maximum input frequency is 300Khz. Use the following equation to check the encoder maximum frequency:

$$F_{\text{encoder-Max}}(\text{Hz}) = \frac{\text{MotorSpeed}}{60} * \text{EncoderPPR}$$

Where MotorSpeed = Maximum operating speed of the motor in RPM.

EncoderPPR = Encoder resolution in PPR

Example: Maximum operating motor speed = 3600 rpm

Encoder resolution = 1024 PPR

$$F_{\text{encoder-Max}}(\text{Hz}) = \frac{3600 \cdot \text{RPM}}{60} * 1024 \cdot \text{PPR} = 61.44\text{Khz}$$

- The encoder cable must be kept from power cables. To prevent erroneous operation caused by noise interference, use shielded cable for control signal and limit distance to 100 meters (330 feet) or less.
- The encoder cable should be made of shielded twisted pair. Twist the shield wires together and connect it through the shortest possible route to the nearest ground terminal at the drive.
- The recommended wire for encoder input/outputs is: cable with pairs individually shielded:
 - Belden 9773 or equivalent - 18 AWG with three pairs individually shielded.
 - Belden 9873 or equivalent - 20 AWG with three pairs individually shielded.
 - Belden 8777 or equivalent - 22 AWG with three pairs individually shielded.
- The encoder should be insulated electrically from stator or rotor to prevent forming of current path through the encoder. The usual coupling-type encoder must have an electrically insulating coupling. When a hollow-shaft type pulse encoder is used, the insulation can be implemented by insulating the ball joints of the engaging arm, or by insulating the bar of the engaging arm. Shield of the encoder cable should be insulated from the encoder frame.

Digital Encoder Card P/N: 3000-4140-1 (3 of 3)

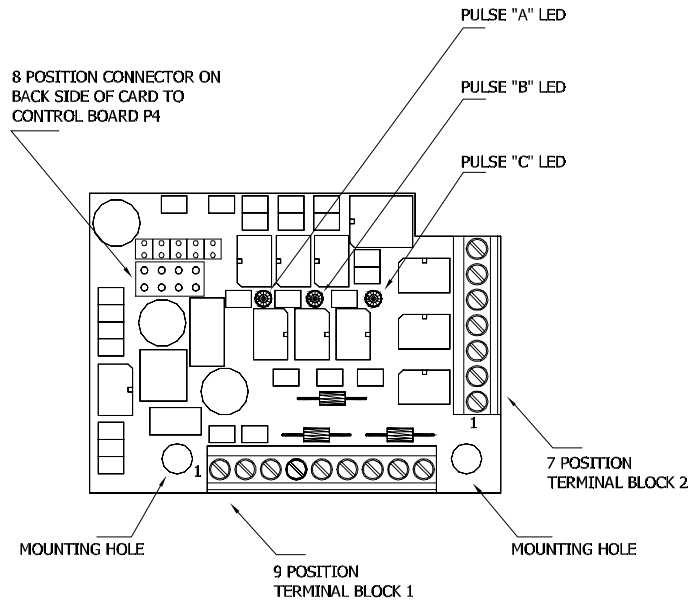

TB1-TB2 CONNECTION DATA:

MAXIMUM TORQUE: 2.2 Lb-in [0.25 N-m]
 WIRE SIZE: 26-16 AWG [0.14 - 1 mm]

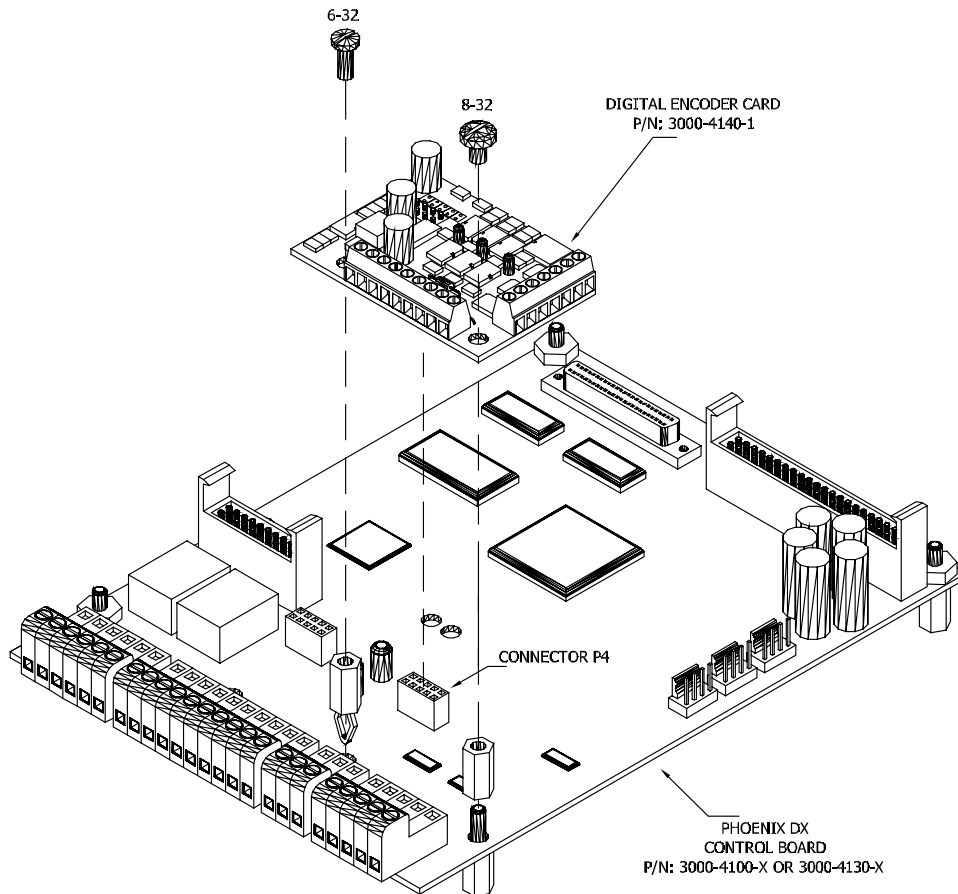

Mounting Diagram

I/O Expansion Board 3000-4150 (1 of 2)

Phoenix DX and Phoenix EX AC Drives include 8 Digital Inputs, 2 Digital Outputs, 2 Analog Inputs, and 2 Analog Outputs as standard. If additional Inputs and Outputs are required, the Phoenix DX/EX I/O Expansion Board may be added. With the addition of the Phoenix DX/EX I/O Expansion Board, the drive can support up to 8 Digital Inputs, 7 Digital Outputs, 3 Analog Inputs, and 3 Analog Outputs.

The Phoenix DX/EX I/O Expansion Board is fully configurable. You may add up to 5 Digital Outputs, 1 Analog Input, and 1 Analog Output. Catalog Numbering is as follows:

Part Numbering:

3000-4150 - AI - AO - D5

Analog Input

AI = Installed
= Not Installed

Analog Output

AO = Installed
= Not Installed

Digital Outputs

D1 = 1 Installed
D2 = 2 Installed
D3 = 3 Installed
D4 = 4 Installed
D5 = 5 Installed
= None Installed

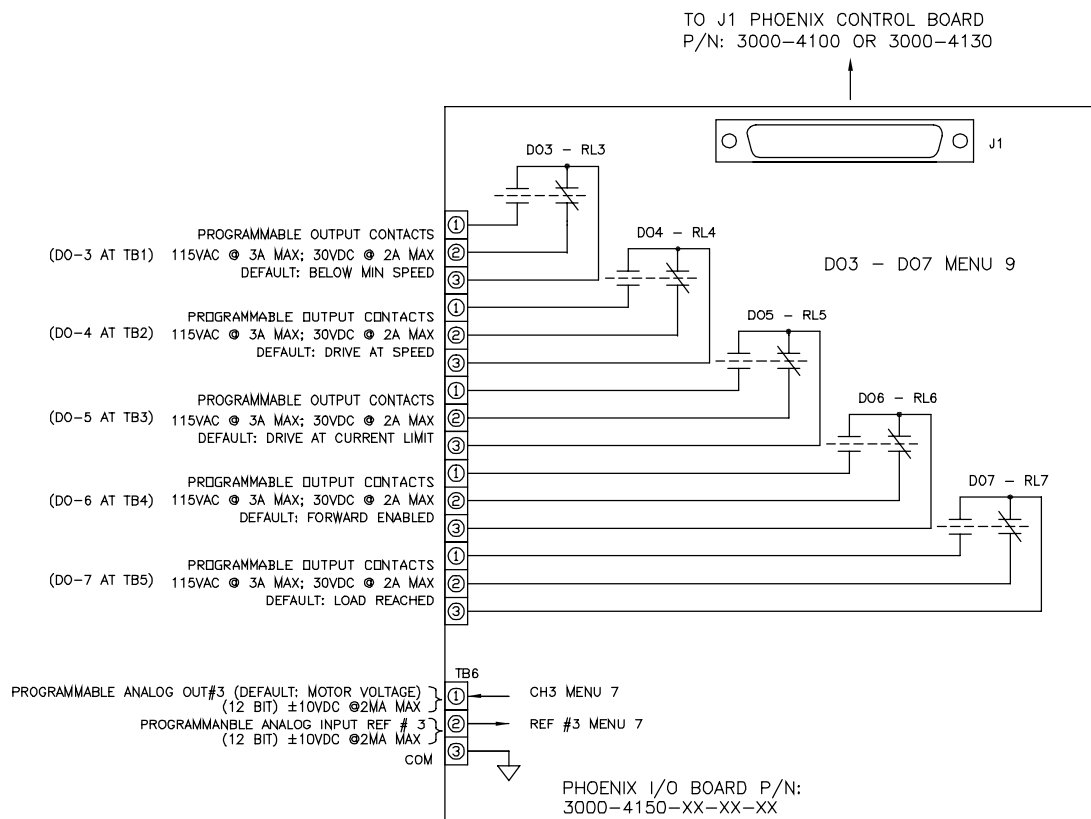

I/O Expansion Board 3000-4150 (2 of 2)

CONNECTOR ON BACK SIDE OF CARD
TO CONTROL BOARD J1

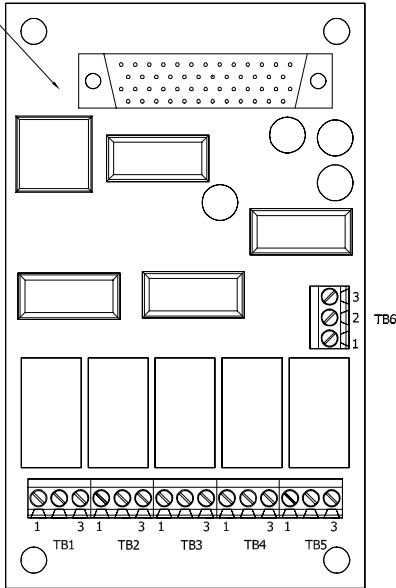

TB1-TB6 CONNECTION DATA:
 MAXIMUM TORQUE: 2.2 Lb-in [0.25 N-m]
 WIRE SIZE: 26-16 AWG [0.14 - 1 mm]

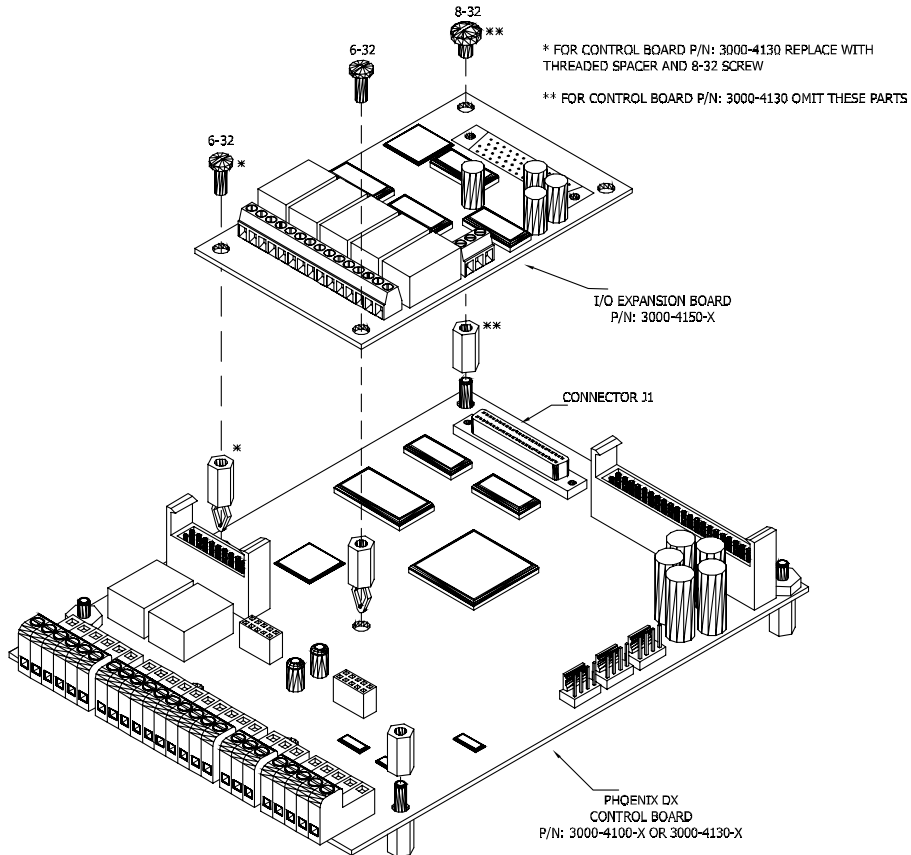

Mounting Diagram

Digital Encoder #2 3000-4160 (Page 1 of 3)

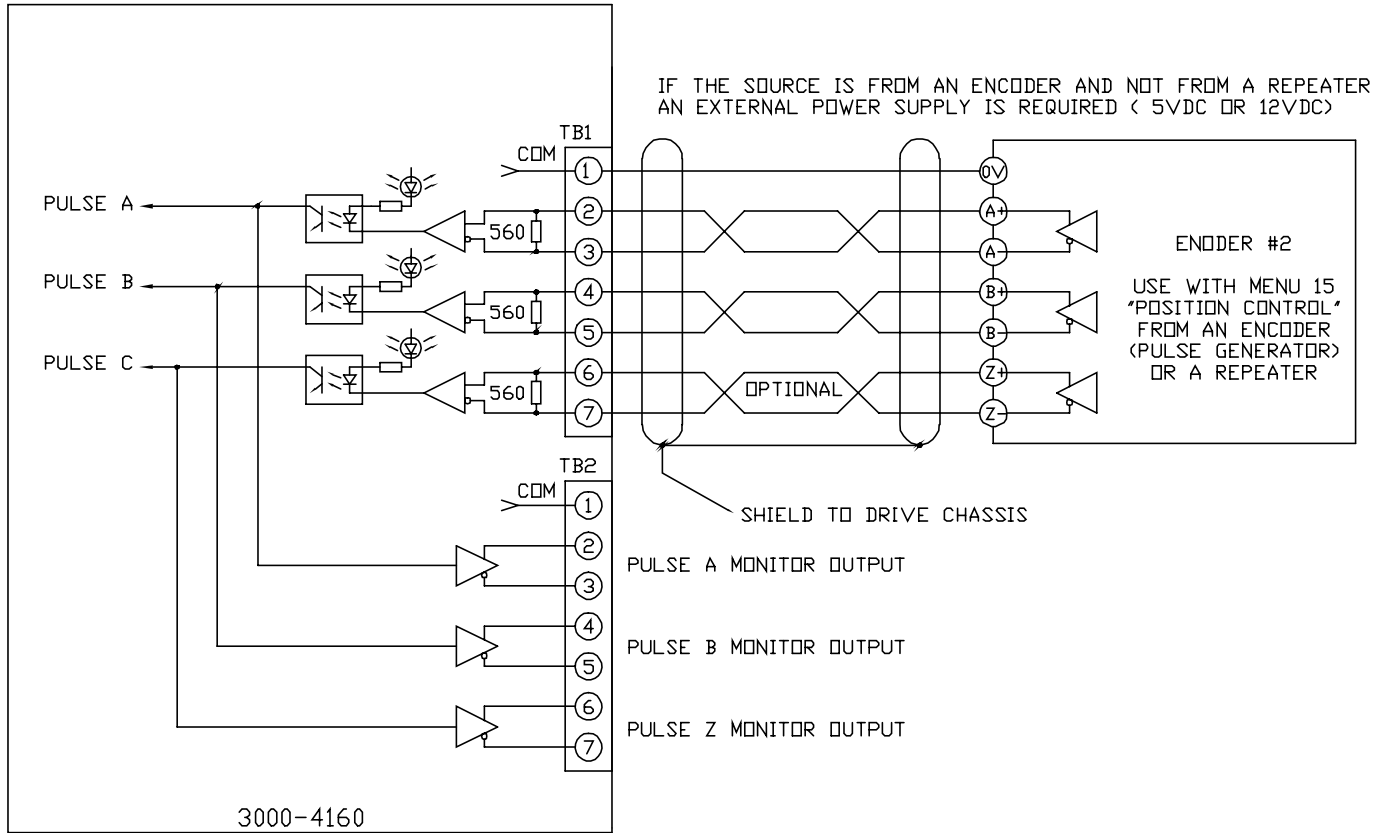

Terminal Block	No.	Signal	
TB1	1	COM	0V reference for A, B, & Z inputs
	2	A+	A Phase Differential Input: 5 to 12VDC Max @ 20mA Max Maximum Input Frequency = 300Khz
	3	A-	
	4	B+	B Phase Differential Input: 5 to 12VDC Max @ 20mA Max Maximum Input Frequency = 300Khz
	5	B-	
	6	Z+	Z Phase Differential Input (optional): 5 to 12VDC Max @ 20mA Max Maximum Input Frequency = 300Khz
	7	Z-	
TB2	1	COM	0V reference for A, B, & Z outputs
	2	A+	A Phase Differential Output: 5VDC Max @ 20mA max
	3	A-	
	4	B+	B Phase Differential Output: 5VDC Max @ 20mA max
	5	B-	
	6	Z+	Z Phase Differential Output: 5VDC Max @ 20mA max
	7	Z-	

This card is used with Menu 15 "Position Control".

Digital Encoder #2 3000-4160 (Page 2 of 3)

Notes:

- If the source is from an encoder and not from an repeater an external power supply is required (5Vdc or 12Vdc)
- Encoder must be differential-line-driver quadrature type 5-12VDC outputs, capable of supplying 20mA per channel
- Maximum input frequency is 300Khz. Use the following equation to check the encoder maximum frequency:

$$F_{\text{encoder-Max}}(\text{Hz}) = \frac{\text{MotorSpeed}}{60} * \text{EncoderPPR}$$

Where MotorSpeed = Maximum operating speed of the motor in RPM.

EncoderPPR = Encoder resolution in PPR

Example: Maximum operating motor speed = 3600 rpm
Encoder resolution = 1024 PPR

$$F_{\text{encoder-Max}}(\text{Hz}) = \frac{3600 \cdot \text{RPM}}{60} * 1024 \cdot \text{PPR} = 61.44\text{Khz}$$

- The encoder cable must be kept from power cables. To prevent erroneous operation caused by noise interference, use shielded cable for control signal and limit distance to 100 meters (330 feet) or less.
- The encoder cable should be made of shielded twisted pair. Twist the shield wires together and connect it through the shortest possible route to the nearest ground terminal at the drive.
- The recommended wire for encoder input/outputs is: cable with pairs individually shielded:
 - Belden 9773 or equivalent - 18 AWG with three pairs individually shielded.
 - Belden 9873 or equivalent - 20 AWG with three pairs individually shielded.
 - Belden 8777 or equivalent - 22 AWG with three pairs individually shielded.
- The encoder should be insulated electrically from stator or rotor to prevent forming of current path through the encoder. The usual coupling-type encoder must have an electrically insulating coupling. When a hollow-shaft type pulse encoder is used, the insulation can be implemented by insulating the ball joints of the engaging arm, or by insulating the bar of the engaging arm. Shield of the encoder cable should be insulated from the encoder frame.

Digital Encoder #2 3000-4160 (Page 3 of 3)

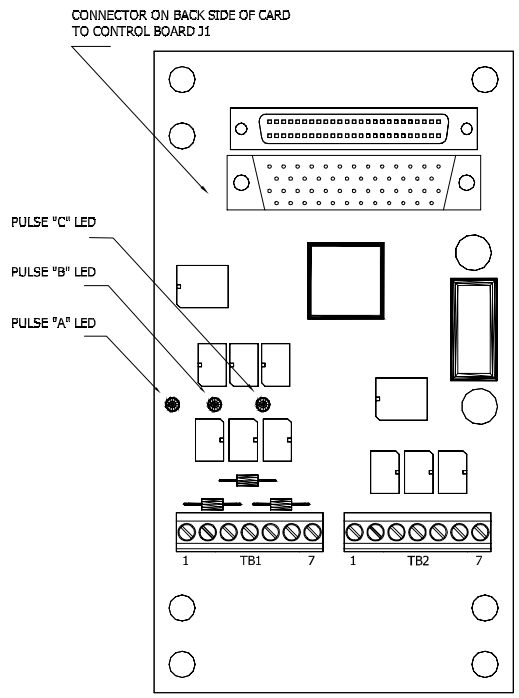

TB1-TB2 CONNECTION DATA:
 MAXIMUM TORQUE: 2.2 Lb-in [0.25 N-m]
 WIRE SIZE: 26-16 AWG [0.14 - 1 mm]

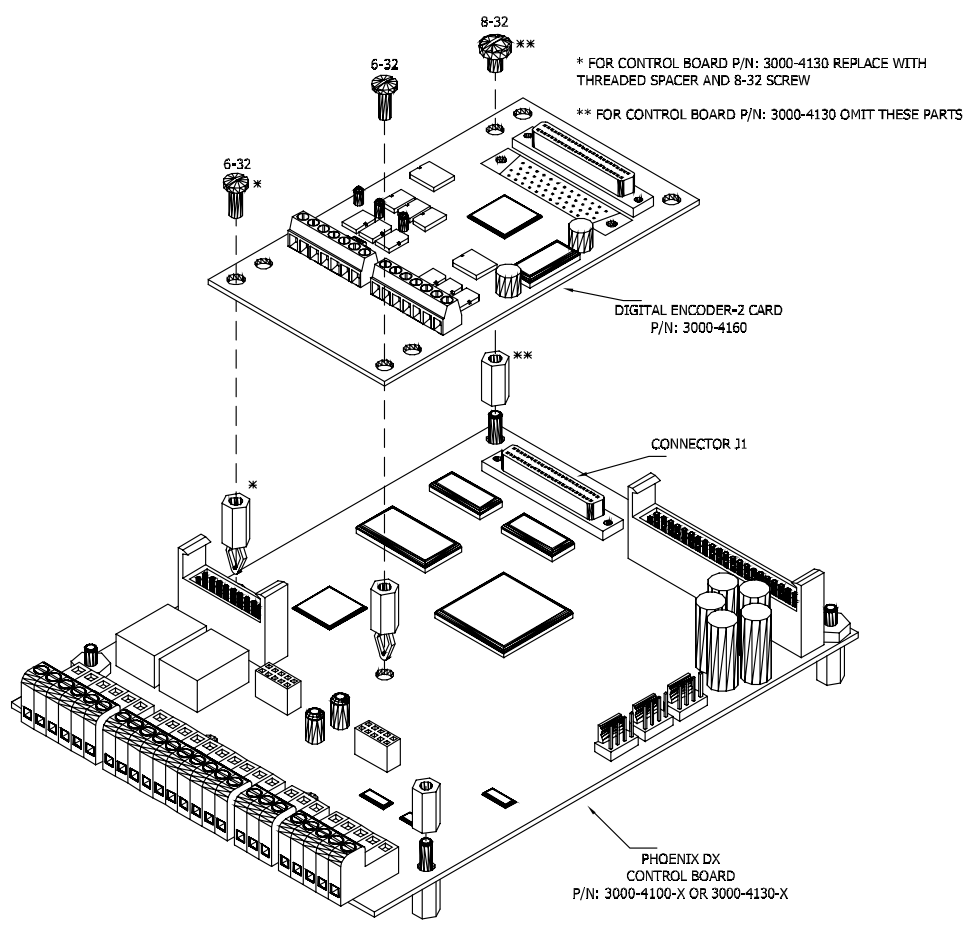

Mounting Diagram

POWER CIRCUIT TEST

WARNING: To avoid a hazard of electric shock, after the input and control power is removed from the drive and the ROM display is no longer lit, wait five (5) minutes for DC bus capacitors to fully discharge before opening the drive to install the encoder card. Verify that the voltage on the DC bus capacitors has discharged by measuring the DC bus voltage at the +DC & -DC terminals of the drive. The voltage must be zero.

CAUTION: This drive contains ESD (Electrostatic Discharge) sensitive parts and assemblies. Static control precautions are required when installing, testing, servicing or repairing this assembly. Component damage may result if ESD control procedures are not followed.

APPENDIX B-2

PHOENIX POWER CIRCUIT TEST TABLE

WARNING

To avoid a hazard of electric shock, after the input and control power is removed from the drive and the ROM display is no longer lit, wait five (5) minutes for DC bus capacitors to fully discharge before opening the drive to make this test. Verify that the voltage on the DC bus capacitors has discharged by measuring the DC bus voltage at the +DC & -DC terminals of the drive. The voltage must be zero.

Fuse Check :

Check all fuses. Do not replace any fuse before performing the following checks. Please note if an on-board fuse (soldered to the control or power board) is open do not attempt to replace it. An open on-board fuse indicates a damaged board.

Visual Check:

Check all fuses, boards, wire harnesses, connectors, bus bars and enclosure walls for discoloration & damage of components.

Ohmic Check

Size 0:

Check D7 through D18 for shorts using meter set for diode check. These diodes are located on inverter board (lower board). To access these diodes remove only bottom endplate (2.5"x8.75") held by two screws only. In the same area also check for burnt or discolored resistors R19 to R30.

Size 1, 2 & 3:

Check IGBT personality boards P/N: 3000-2020, 3000-2025, 3000-2030, 2085 for the following:

- Burnt or discolored resistors R1, R2, & R3 (6 sets per drive)
- Shorted D1 & D2 using meter set for diode check (6 sets per drive).

These personality boards are either soldered or screwed on the IGBT's (power transistors).

Size 0 Through 3

+ Lead	- Lead	Meter setting	Reading
L1	L2	20k ohms	OL
L2	L3	20k ohms	OL
L1	L3	20k ohms	OL
U	V	200K ohms	10-30K Ω
V	W	200K ohms	10-30K Ω
W	U	200K ohms	10-30K Ω
DC +	DC -	DIODE	Charge to OL
DC -	DC +	DIODE	0.5V-0.8V
L1, L2, L3	DC +	DIODE	0.5V-0.8V
DC +	L1, L2, L3	DIODE	Charge to OL
DC -	L1, L2, L3	DIODE	0.5V
L1, L2, L3	DC -	DIODE	Charge to OL
L1, L2, L3, DC+	GND	200k ohms	OL
DC -, U, V, W	GND	200k ohms	OL
DC-	U, V, W	DIODE	0.3V-0.5V
U, V, W	DC+	DIODE	0.3V-0.5V

Size 0 DC+ and DC- are on connector P11 (Vc+ & Vc-) top board (4000-4130).

For Size 2 Drive:

U, V, W	- Right side of bus fuse	DIODE	0.3V-0.5V
Left side of bus fuse	- Right side of bus fuse	20K	0.002-0.005K Ω

Bus fuse located at bottom of enclosure.

For Size 3 Drive:

Bottom of bus fuse	U, V, W	DIODE	0.3V-0.5V
Top of bus fuse	- Bottom of bus fuse	20K	0.002-0.005K Ω

Bus fuse located at bottom of enclosure.

WARRANTY

US Drives, Inc. (hereinafter referred to as "US Drives") warrants the equipment described in this manual for thirty-six (36) months from the day of purchase, not to exceed forty (40) months from date of manufacture. US Drives further warrants that such goods are free of defects in materials and workmanship.

If the goods fail to perform to US Drives published specifications, then the Buyer must contact US Drives to obtain a Material Return Authorization ("MRA"), prepare the goods for shipment, and return the goods to US Drives for repair or replacement at US Drives Option. The buyer will bear all costs of transportation to and from US Drives factory, risk of loss for goods not at US Drives factory, and any cost required to remove or prepare the goods for shipment to US Drives factory and to reinstall equipment subsequent to repair.

In no event and under no circumstances shall the manufacturer be liable for: (a) damages and failures due to improper use or installation; (b) damage in shipment; (c) damage to abnormal conditions of temperature, dust, or corrosives, or failures due to operation above rated capacities, whether intentional or unintentional; (d) non-authorized service, repair, modification, transportation or installation. Nor shall the manufacturer ever be liable for consequential or incidental damages including any lost profits or lost savings.

There are no other warranties, expressed or implied, which extend beyond that described herein. The warranty set forth is exclusive and no other warranty, whether written or oral, is expressed or implied. US Drives specifically disclaims the implied warranties of merchantability and fitness for a particular purpose.

The warranty is effective only if a written notification of any claim under this warranty is received by US Drives at the address indicated below within thirty (30) days of recognition of defect by buyer.

US Drives reserves the right to make changes and improvements in its goods without incurring any obligation to similarly alter goods previously purchased. US Drives neither assumes nor authorizes any representative or any other person to assume for US Drives any other liability in connection with the sale or any shipment of its goods.

US DRIVES, INC.

2221 Niagara Falls Boulevard
P.O. Box 281
Niagara Falls, NY 14304-0281
Tel: (716) 731-1606 Fax: (716) 731-1524

SERVICE ASSISTANCE:

During Normal Hours: (8:00am to 5:00pm Eastern Time) (716) 731-1606

After Normal Business Hours: 1-800-836-2337 then enter 72602,

After tone enter your phone number

Visit us at www.usdrivesinc.com

"THE HIGH HORSEPOWER DESIGN EXPERTS"

**US Drives Inc.
2221 Niagara Falls Boulevard
P.O. Box 281
Niagara Falls, NY 14304-0281
Tel: (716) 731-1606 Fax: (716) 731-1524
Visit us at www.usdrivesinc.com**

Products Designed And Manufactured
In The United States Of America



Rev. 09/20/05 Printed in U.S.A.
