

F7 Drive User Manual

*This Manual
also available on
www.drives.com*



Warnings and Cautions

This Section provides warnings and cautions pertinent to this product, that if not heeded, may result in personal injury, fatality, or equipment damage. Yaskawa is not responsible for consequences of ignoring these instructions.

WARNING

YASKAWA manufactures component parts that can be used in a wide variety of industrial applications. The selection and application of YASKAWA products remain the responsibility of the equipment designer or end user. YASKAWA accepts no responsibility for the way its products are incorporated into the final system design. Under no circumstances should any YASKAWA product be incorporated into any product or design as the exclusive or sole safety control. Without exception, all controls should be designed to detect faults dynamically and fail safely under all circumstances. All products designed to incorporate a component part manufactured by YASKAWA must be supplied to the end user with appropriate warnings and instructions as to that part's safe use and operation. Any warnings provided by YASKAWA must be promptly provided to the end user. YASKAWA offers an express warranty only as to the quality of its products in conforming to standards and specifications published in the YASKAWA manual. **NO OTHER WARRANTY, EXPRESS OR IMPLIED, IS OFFERED.** YASKAWA assumes no liability for any personal injury, property damage, losses, or claims arising from misapplication of its products.

WARNING

- Read and understand this manual before installing, operating, or servicing this Drive. All warnings, cautions, and instructions must be followed. All activity must be performed by qualified personnel. The Drive must be installed according to this manual and local codes.
- Do not connect or disconnect wiring while the power is on. Do not remove covers or touch circuit boards while the power is on. Do not remove or insert the digital operator while power is on.
- Before servicing, disconnect all power to the equipment. The internal capacitor remains charged even after the power supply is turned off. The charge indicator LED will extinguish when the DC bus voltage is below 50Vdc. To prevent electric shock, wait at least five minutes after all indicators are OFF and measure DC bus voltage level to confirm safe level.
- Do not perform a withstand voltage test on any part of the unit. This equipment uses sensitive devices and may be damaged by high voltage.

WARNING

- The Drive is suitable for circuits capable of delivering not more than 100,000 RMS symmetrical Amperes, 240Vac maximum (200V Class) and 480Vac maximum (400V Class). Install adequate branch circuit short circuit protection per applicable codes. Failure to do so may result in equipment damage and/or personal injury. Refer to Appendix E for further details.
- Do not connect unapproved LC or RC interference suppression filters, capacitors, or overvoltage protection devices to the output of the Drive. These devices may generate peak currents that exceed Drive specifications.

- To avoid unnecessary fault displays caused by contactors or output switches placed between Drive and motor, auxiliary contacts must be properly integrated into the control logic circuit.
- YASKAWA is not responsible for any modification of the product made by the user; doing so will void the warranty. This product must not be modified.
- Verify that the rated voltage of the Drive matches the voltage of the incoming power supply before applying power.
- To meet CE directives, proper line filters and proper installation are required.
- Some drawings in this manual may be shown with protective covers or shields removed, to describe details. These must be replaced before operation.
- Observe electrostatic discharge procedures when handling circuit boards to prevent ESD damage.
- The equipment may start unexpectedly upon application of power. Clear all personnel from the Drive, motor, and machine area before applying power. Secure covers, couplings, shaft keys, and machine loads before energizing the Drive.
- Please do not connect or operate any equipment with visible damage or missing parts. The operating company is responsible for any injuries or equipment damage resulting from failure to heed the warnings in this manual.

■ Intended Use

Drives are intended for installation in electrical systems or machinery.

The Drives are designed and manufactured in accordance with applicable UL and cUL standards, and CE directives.

For use in the European Union, the installation in machinery and systems must conform to the following product standards of the Low Voltage Directive:

EN 50178: 1997-10, Electronic Equipment for Use in Power Installations

EN 60201-1: 1997-12 Machine Safety and Equipping with Electrical Devices
Part 1: General Requirements (IEC 60204-1:1997)

EN 61010: 1997-11 Safety Requirements for Information Technology Equipment
(IEC 950:1991 + A1:1992 + A2:1993 + A3:1995 + A4:1996, modified)

The F7 series Drives comply with the provisions of the Low Voltage Directive 73/23/EEC as amended by 93/68/EEC. These Drives conform to the following standard: EN 50178: 1997-10.

Your supplier or Yaskawa representative must be contacted when using leakage current circuit breaker in conjunction with frequency inverters.

In certain systems it may be necessary to use additional monitoring and safety devices in compliance with the relevant safety and accident prevention regulations. The frequency inverter hardware must not be modified.

Introduction

This section describes the applicability of the manual.

This manual is applicable to F7 Drives defined by model numbers of CIMR-F7U□□□□. This manual reflects the Software Version 3020.

The F7 Drive is a Pulse Width Modulated Drive for AC 3-Phase induction motors. This type of Drive is also known as an Adjustable Frequency Drive, Variable Frequency Drive, AC Drive, AFD, ASD, VFD, VSD, and Inverter. In this manual, the F7 Drive will be referred to as the “Drive”.

The LCD keypad/operator is equipped with local/remote functions, copy feature, 7 language choices, and 5 lines of display with 16 characters per line. User parameter settings can be recovered at any time via “user initialization” when enabled. Optional Drive Wizard software allows upload/download, as well as graphing and monitoring of Drive parameters from a PC for ease of Drive management.

This manual may describe trademarked equipment, which is the property of other companies, who are the registered owners.

Other Documents and Manuals are available to support special use or installation of this product. These documents may be provided with the product or upon request. Contact Yaskawa Electric America, Inc. as required. Documents may include the following:

- TM.F7.02.Programming...Manual included on CD ROM with product
- TM.F7.01....Manual included on CD ROM with product
- DriveWizard...Software and Manual...Included on CD ROM with product
- Option Instructions... Included on CD ROM with product

This manual is subject to change as product improvements occur. The latest version of the manual can be obtained from the Yaskawa website: www.drives.com. The date shown on the rear cover is changed when revisions are made. The latest version of Drive software is also shown.

The Drive’s capacity is categorized based on two types of load characteristics: Heavy Duty and Normal Duty. See Table i.1 below for the differences between Heavy Duty and Normal Duty.

Parameter C6-01	Rated Output Current	Overload Capacity	Current Limit	Carrier Frequency	Maximum Output Frequency
0: Heavy Duty (default)	Standard rating (varies by model*)	150% for 1 min.	150%	Low (2kHz)	300Hz
2: Normal Duty	Extended rating (varies by model*)	Approx. 110% for 1 min. (varies by model*)	120%	High (varies by model*)	400Hz

* See Drive Specifications

This manual references the various Drive capacities according to its model number CIMR-F7U□□□□. See Drive Output Specifications Table i.2 and Table i.3 on the following pages for rated capacities and Drive specifications.

Drive Output Specifications

The standard Drive specifications are listed in the following tables.

◆ 208-240Vac

Table i.2 208-240Vac Drive Specifications																					
		208-240Vac											208-230Vac								
Model Number CIMR-F7U		20P4	20P7	21P5	22P2	23P7	25P5	27P5	2011	2015	2018	2022	2030	2037	2045	2055	2075	2090	2110		
Output ratings	Heavy Duty ^{*1}	Rated output capacity (kVA)	1.2	1.6	2.7	3.7	5.7	8.8	12.0	17.0	22.0	27.0	32.0	44.0	55.0	69.0	82.0	110.0	130.0	N/A	
		Horsepower ^{*2}	0.5/0.75	1	2	3	5	7.5	10	15	20	25	30	40	50	60	75	100	125		
		Rated output current (A)	3.2	4.2	7.0	9.6	15.2	23.0	31.0	45.0	58.0	71	85.0	115.0	145.0	180.0	215	283.0	346.0		
		Overload capacity ^{*3} (% of rated output current for 60 sec.)	150																		
		Current limit (% of rated output current)	150																		
		Carrier frequency ^{*4}	2kHz																		
		Maximum output frequency	300.0Hz																		
	Normal Duty ^{*1}	Rated output capacity (kVA)	1.4	1.8	3.0	4.1	6.4	8.8	12.0	18.0	23.0	29.0	34.0	44.0	62.0	73.0	82.0	120.0	140.0	160.0	
		Horsepower ^{*2}	0.5/0.75	1	2	3	5	7.5	10	15	20	25	30	40	50/60	75	75	100/125	150	150	
		Rated output current (A)	3.6	4.6	7.8	10.8	16.8	23.0	31.0	46.2	59.4	74.8	88.0	115.0	162.0	192.0	215	312.0	360.0	415.0	
		Overload capacity ^{*3} (% of rated output current for 60 sec.)	107	107	108	107	107	120	120	117	117	114	116	120	107	113	120	109	115	120	
		Current limit (% of rated output current)	120																		
		Carrier frequency (kHz) ^{*5}	10	10	10	8	10	15	15	8	10	10	10	10	5	5	8	2	2	2	
		Maximum output frequency	400.0Hz																		
Maximum output voltage	3-phase; 200, 208, 220, 230, or 240Vac (Proportional to input voltage)																				

*1 The difference between Heavy Duty ratings and the Normal Duty ratings for the Drive are the rated input and output current, overload capacity, carrier frequency, current limit, and maximum output frequency. Parameter C6-01 must be set to value of "0" for Heavy Duty ratings and "2" for Normal Duty ratings. Factory default is Heavy Duty (C6-01=0).

*2 Horsepower ratings are based on 230V or 460V NEC Table 430.150. The maximum applicable motor output is given for a standard 4-pole motor. When selecting the actual motor and Drive, be sure that the Drive's rated output current is appropriate for the motor's rated current.

*3 Models 2110, 4220, 4300 have an overload rating of 120% of rated output current for 60 seconds.

*4 2kHz is the Maximum carrier frequency value and default carrier frequency value for all models.

*5 Each value shown is the Maximum carrier frequency and default carrier frequency.

◆ 480Vac

Table i.3 480Vac Drive Specifications

Model Number CIMR-F7U		40P4	40P7	41P5	42P2	43P7	44P0	45P5	47P5	4011	4015	4018	4022		
Output ratings	Heavy Duty*1	Rated output capacity (kVA)	1.4	1.6	2.8	4.0	5.8	6.6	9.5	13.0	18.0	24.0	30.0	34.0	
		Horsepower*2	0.5/0.75	1	1.5/2	3	5	-	7.5	10	15	20	25	30	
		Rated output current (A)	1.8	2.1	3.7	5.3	7.6	8.7	12.5	17.0	24.0	31.0	39.0	45.0	
		Overload capacity*3 (% of rated output current for 60 sec.)	150												
		Current limit (% of rated output current)	150												
		Carrier frequency*4	2kHz												
		Maximum output frequency	300.0Hz												
	Normal Duty*1	Rated output capacity (kVA)	1.4	1.6	2.8	4.0	5.8	6.6	9.5	13.0	21.0	26.0	30.0	38.0	
		Horsepower*2	0.5/0.75	1	1.5/2	3	5	-	7.5	10	15/20	25	30	30	
		Rated output current (A)	1.8	2.1	3.7	5.3	7.6	8.7	12.5	17.0	27.0	34.0	40.0	50.4	
		Overload capacity*3 (% of rated output current for 60 sec.)	120	120	120	120	120	120	120	120	107	109	117	107	
		Current limit (% of rated output current)	120												
		Carrier frequency (kHz)*5	15	15	15	15	15	15	15	15	15	8	10	10	10
		Maximum output frequency	400.0Hz												
Maximum output voltage		3-phase; 380, 400, 415, 440, 460, or 480Vac (Proportional to input voltage)													

Model Number CIMR-F7U		4030	4037	4045	4055	4075	4090	4110	4132	4160	4185	4220	4300		
Output ratings	Heavy Duty*1	Rated output capacity (kVA)	46.0	57.0	69.0	85.0	110.0	140.0	160.0	200.0	230.0	280.0	N/A		
		Horsepower*2	40	50	60	75	100	125/150	-	200	250	300			
		Rated output current (A)	60.0	75.0	91.0	112.0	150.0	180.0	216.0	260.0	304.0	370.0			
		Overload capacity*3 (% of rated output current for 60 sec.)	150												
		Current limit (% of rated output current)	150												
		Carrier frequency*4	2kHz												
		Maximum output frequency	300.0Hz												
	Normal Duty*1	Rated output capacity (kVA)	51.0	59.0	73.0	95.0	120.0	140.0	180.0	200.0	230.0	315.0	390.0	510.0	
		Horsepower*2	40/50	60	75	100	125	150	200	-	250	300/350	400/450	500+	
		Rated output current (A)	67.2	77.0	96.0	125.0	156.0	180.0	240.0	260.0	304.0	414.0	515.0	675.0	
		Overload capacity*3 (% of rated output current for 60 sec.)	107	117	114	108	115	120	108	120	120	107	118	120	
		Current limit (% of rated output current)	120												
		Carrier frequency (kHz)*5	8	8	8	5	5	8	5	5	5	5	2	2	2
		Maximum output frequency	400.0Hz												
Maximum output voltage		3-phase, 380, 400, 415, 440, 460 or 480Vac (Proportional to input voltage)													

*1 The difference between Heavy Duty ratings and the Normal Duty ratings for the Drive are the rated input and output current, overload capacity, carrier frequency, current limit, and maximum output frequency. Parameter C6-01 must be set to value of "0" for Heavy Duty ratings and "2" for Normal Duty ratings. Factory default is Heavy Duty (C6-01=0).

*2 Horsepower ratings are based on 230V or 460V NEC Table 430.150. The maximum applicable motor output is given for a standard 4-pole motor. When selecting the actual motor and Drive, be sure that the Drive's rated output current is appropriate for the motor's rated current.

*3 Models 2110, 4220, 4300 have an overload rating of 120% of rated output current for 60 seconds.

*4 2kHz is the Maximum carrier frequency value and default carrier frequency value for all models.

*5 Each value shown is the Maximum carrier frequency and default carrier frequency.

Notes:

Table of Contents

Warnings and Cautions	i
Introduction	iii
Table of Contents	vii

Chapter 1- Physical Installation1-1

F7 Model Number, Enclosure, Heat Loss, and Weight	1-2
Confirmations Upon Delivery	1-3
Component Names	1-5
Exterior and Mounting Dimensions	1-7
Checking and Controlling Installation Site.....	1-11
Installation Orientation and Clearances	1-12
Removing and Attaching the Terminal Cover.....	1-13
Removing/Attaching the Digital Operator and Front Cover	1-14

Chapter 2- Electrical Installation.....2-1

Terminal Block Configuration	2-2
Wiring Main Circuit Terminals.....	2-3
Control Wiring	2-20
Electromagnetic Compatibility (EMC)	2-26
Installing and Wiring Option Boards.....	2-30

Chapter 3- Digital Operator.....3-1

Digital Operator Display	3-2
Digital Operator Keys	3-3
Drive Mode Indicators	3-4
Drive Main Menus	3-6
Quick Setting Menu (-QUICK-).....	3-11
Programming Menu (-ADV-).....	3-12
Example of Changing a Parameter	3-15

Chapter 4- Start-Up	4-1
Drive Start-Up Preparation	4-2
Drive Start-Up Procedures	4-5
Chapter 5- Basic Programming	5-1
Description of Parameter Tables	5-2
Control Method.....	5-2
Speed Command Source	5-3
Run Command Source.....	5-4
Stopping Method	5-5
Accel/Decel Time	5-8
Carrier Frequency	5-9
Preset Reference	5-10
Input Voltage Setting	5-11
V/F Pattern	5-11
Motor Setup.....	5-19
PG Option	5-19
Analog Output Gain.....	5-20
Motor Overload Fault	5-21
Stall Prevention	5-22
Chapter 6- Diagnostic & Troubleshooting	6-1
Fault Detection	6-2
Alarm Detection.....	6-9
Operator Programming Errors (OPE).....	6-13
Auto-Tuning Faults	6-15
Digital Operator COPY Function Faults	6-17
Troubleshooting	6-18
Main Circuit Test Procedure	6-26
Drive Date Stamp Information	6-29

Chapter 7- Maintenance 7-1

Periodic Inspection 7-2
Preventative Maintenance..... 7-3
Periodic Maintenance of Parts 7-4
Heatsink Cooling Fan Replacement..... 7-5
Removing and Mounting the Terminal Card..... 7-7

Appendix A - Parameters A-1

F7 Parameter List.....A-3
F7 Monitor ListA-40
F7 Fault Trace ListA-43
F7 Fault Trace History.....A-43

Appendix B - Capacity Related Parameters B-1

Drive Capacity SelectionB-2
Parameters Affected by Drive Capacity SettingB-3

Appendix C - Specifications C-1

Standard Drive Specifications C-2

Appendix D - Communications D-1

Using Modbus Communication D-2
Modbus Function Code Details D-8
Modbus Data Tables D-10
Modbus Self-Diagnosis D-18

Appendix E - Peripheral Devices E-1

Branch Circuit Short Circuit Protection.....E-2

Branch Circuit Overload Protection.....E-5

Peripheral DevicesE-6

Appendix F - Spare PartsF-1

F7 Primary Spare Parts - 208/230/240Vac..... F-2

F7 Primary Spare Parts - 480Vac..... F-3

Index Index-1

Support Services..... Inside rear cover

Chapter 1

Physical Installation

This chapter describes the requirements for receiving and installing the F7 Drive.

F7 Model Number, Enclosure, Heat Loss, and Weight.	1-2
Confirmations upon Delivery	1-3
Component Names.....	1-5
Exterior and Mounting Dimensions.....	1-7
Checking and Controlling the Installation Site	1-11
Installation Orientation and Clearances.....	1-12
Removing and Attaching the Terminal Cover	1-13
Removing/Attaching the Digital Operator and Front Cover.....	1-14

F7 Model Number, Enclosure, Heat Loss, and Weight

Table 1.1 F7 Model Number and Enclosure Style

Input Voltage 3-Phase	F7 Model Number	Enclosure Style	Weight lb(kg)	Heat Loss(watts)		
				Heatsink	Internal	Total
208-240Vac	CIMR-F7U20P4	NEMA Type 1 (IP20)	6.6(3.0)	19	39	58
	CIMR-F7U20P7	NEMA Type 1 (IP20)		26	42	68
	CIMR-F7U21P5	NEMA Type 1 (IP20)		48	50	98
	CIMR-F7U22P2	NEMA Type 1 (IP20)		68	59	127
	CIMR-F7U23P7	NEMA Type 1 (IP20)	8.8(4.0)	110	74	184
	CIMR-F7U25P5	NEMA Type 1 (IP20)		164	84	248
	CIMR-F7U27P5	NEMA Type 1 (IP20)	13.2(6.0)	219	113	332
	CIMR-F7U2011	NEMA Type 1 (IP20)	15.4(7.0)	357	168	525
	CIMR-F7U2015	NEMA Type 1 (IP20)	24.2(11.0)	416	182	598
	CIMR-F7U2018	NEMA Type 1 (IP20)		472	208	680
	CIMR-F7U2022	NEMA Type 1 (IP20)	53(24)	583	252	835
CIMR-F7U2030	NEMA Type 1 (IP20)	59(27)	883	333	1216	
208-230Vac	CIMR-F7U2037	Open Chassis (IP00)	125(57)	1010	421	1431
	CIMR-F7U2045	Open Chassis (IP00)	139(63)	1228	499	1727
	CIMR-F7U2055	Open Chassis (IP00)	189(86)	1588	619	2207
	CIMR-F7U2075	Open Chassis (IP00)	191(87)	1956	844	2800
	CIMR-F7U2090	Open Chassis (IP00)	238(108)	2194	964	3158
	CIMR-F7U2110	Open Chassis (IP00)	330(150)	2733	1234	3967
480Vac	CIMR-F7U40P4	NEMA Type 1 (IP20)	6.6(3.0)	14	39	53
	CIMR-F7U40P7	NEMA Type 1 (IP20)		17	41	58
	CIMR-F7U41P5	NEMA Type 1 (IP20)		36	48	84
	CIMR-F7U42P2	NEMA Type 1 (IP20)	8.8(4.0)	59	56	115
	CIMR-F7U43P7	NEMA Type 1 (IP20)		80	68	148
	CIMR-F7U44P0	NEMA Type 1 (IP20)		90	70	160
	CIMR-F7U45P5	NEMA Type 1 (IP20)		127	81	208
	CIMR-F7U47P5	NEMA Type 1 (IP20)	13.2(6.0)	193	114	307
	CIMR-F7U4011	NEMA Type 1 (IP20)		232	158	390
	CIMR-F7U4015	NEMA Type 1 (IP20)	22(10)	296	169	465
	CIMR-F7U4018	NEMA Type 1 (IP20)		389	201	590
	CIMR-F7U4022	NEMA Type 1 (IP20)	53(24)	420	233	653
	CIMR-F7U4030	NEMA Type 1 (IP20)		691	298	989
	CIMR-F7U4037	NEMA Type 1 (IP20)	88(40)	801	332	1133
	CIMR-F7U4045	NEMA Type 1 (IP20)		901	386	1287
	CIMR-F7U4055	NEMA Type 1 (IP20)		1204	478	1682
	CIMR-F7U4075	Open Chassis (IP00)	194(88)	1285	562	1847
	CIMR-F7U4090	Open Chassis (IP00)	196(89)	1614	673	2287
	CIMR-F7U4110	Open Chassis (IP00)	224(102)	1889	847	2736
	CIMR-F7U4132	Open Chassis (IP00)	265(120)	2388	1005	3393
	CIMR-F7U4160	Open Chassis (IP00)	352(160)	2791	1144	3935
CIMR-F7U4185	Open Chassis (IP00)	572(259)	2636	1328	3964	
CIMR-F7U4220	Open Chassis (IP00)	616(279)	3797	1712	5509	
CIMR-F7U4300	Open Chassis (IP00)	891(404)	5838	2482	8320	

Confirmations upon Delivery

◆ Receiving Checks

Check the following items as soon as the Drive is received.

Table 1.2 Receiving Checks	
Item	Method
Has the correct model of Drive been delivered?	Check the model number on the nameplate on the right side of the Drive. Reconcile with packing slip and/or order information.
Is the Drive damaged in any way?	Inspect the entire exterior of the Drive to see if there are any dents, scratches or other damage resulting from shipping.
Are any screws or other components loose?	Use a screwdriver or other tool to check for tightness.

If there are any irregularities in the above items, contact the shipping company, or the distributor / representative who sold the Drive, or a Yaskawa office immediately.

◆ Nameplate Information

A nameplate is attached to the right side of each Drive. The following nameplate is an example for a standard Drive.



Note: The Drive Model Number, Drive Spec Number, Software Number, and Serial Number are required to completely identify a Drive.
 HD - Heavy Duty; ND - Normal Duty

Fig 1.1 F7 Drive Nameplate

◆ Drive Model Numbers

The model number on the nameplate indicates the design specification, voltage, and rating of the Drive in alphanumeric codes.

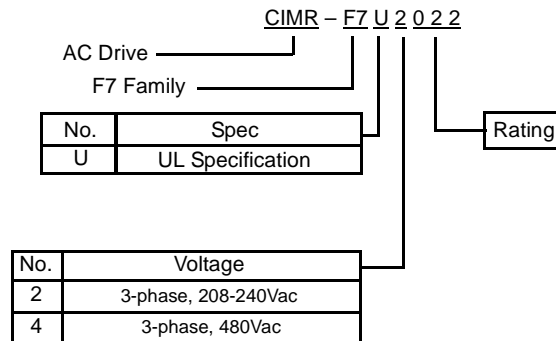

Fig 1.2 Drive Model Number Structure

◆ Drive Enclosure and Revision Code

The SPEC number on the nameplate indicates the voltage, Drive rating, enclosure type, and the revision code of the Drive in alphanumeric codes. The SPEC number for Drives that have custom features, i.e. CASE software, will have a SPEC number that indicates the custom features installed.

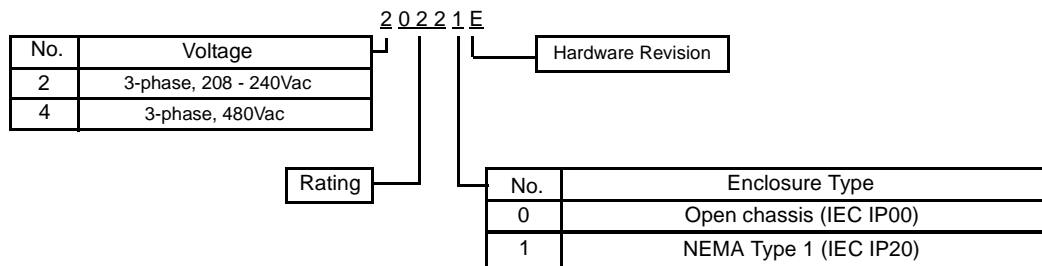

Fig 1.3 SPEC Number Structure

TERMS

Open Chassis Type (IEC IP00)

Protected so that parts of the human body cannot reach electrically charged parts from the front when the Drive is mounted in a control panel, also called protected chassis.

NEMA Type 1 (IEC IP20)

The Drive is shielded from the exterior, and can thus be mounted to the interior wall of a building (not necessarily enclosed in a control panel). The protective structure conforms to the standards of NEMA 1 in the USA. All protective covers (Fig 1.4 and Fig 1.6) must be installed to conform with IEC IP20 and NEMA Type 1 requirements.

Component Names

◆ Models CIMR-F7U20P4 thru 2018 and 40P4 thru 4018

The external appearance, component names, and terminal arrangement of the Drive are shown in Fig 1.4. and 1.5.

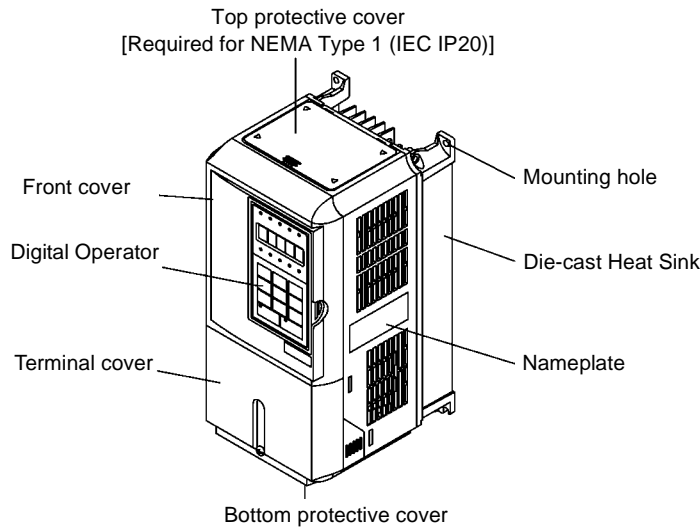

Fig 1.4 Drive Appearance

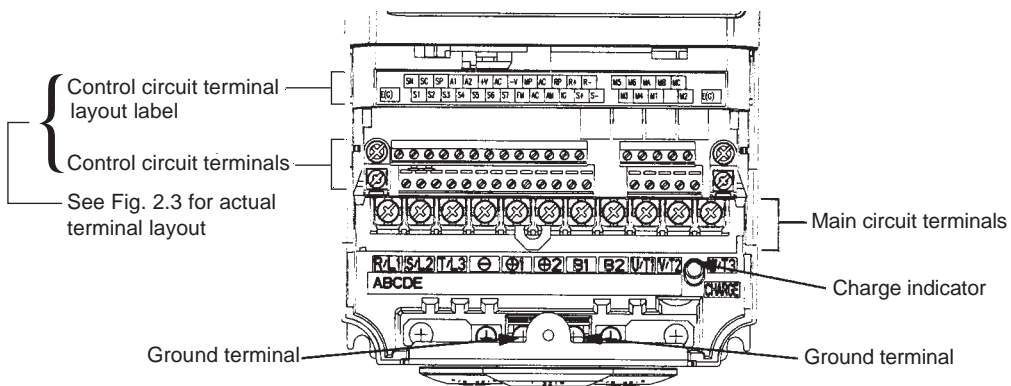

Fig 1.5 Terminal Arrangement (Terminal Cover Removed)

◆ Models CIMR-F7U2022 thru 2110 and 4030 thru 4300

The external appearance, component names, and terminal arrangement of the Drive are shown in Fig 1.6 and 1.7.

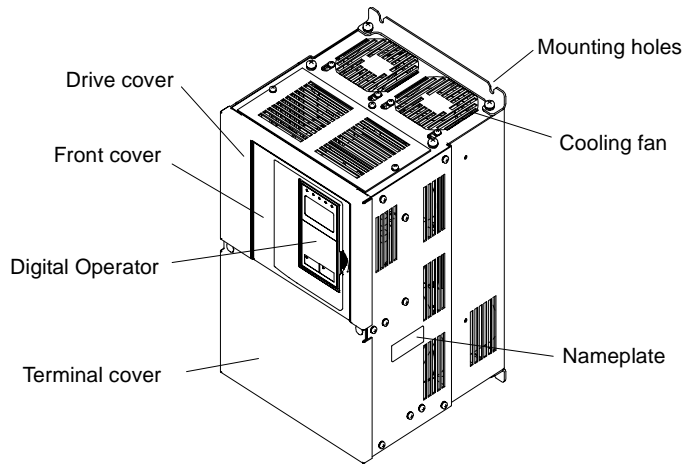

Fig 1.6 Drive Appearance

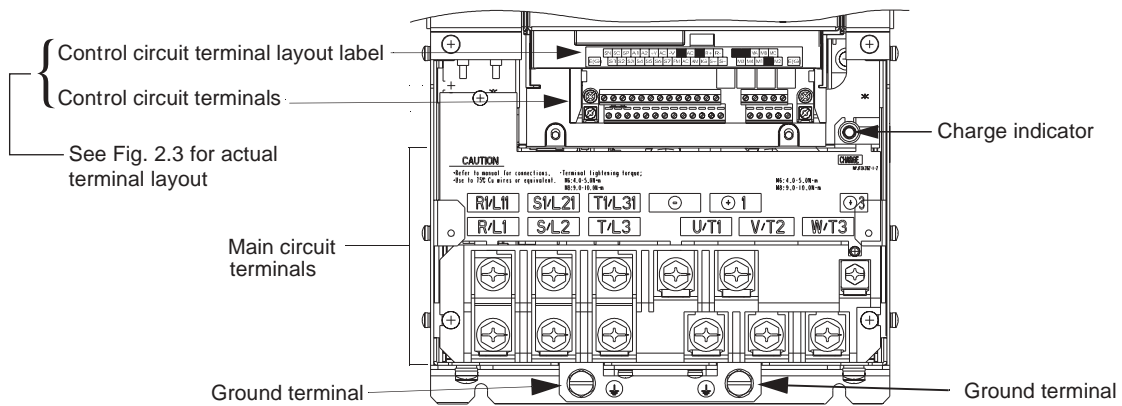
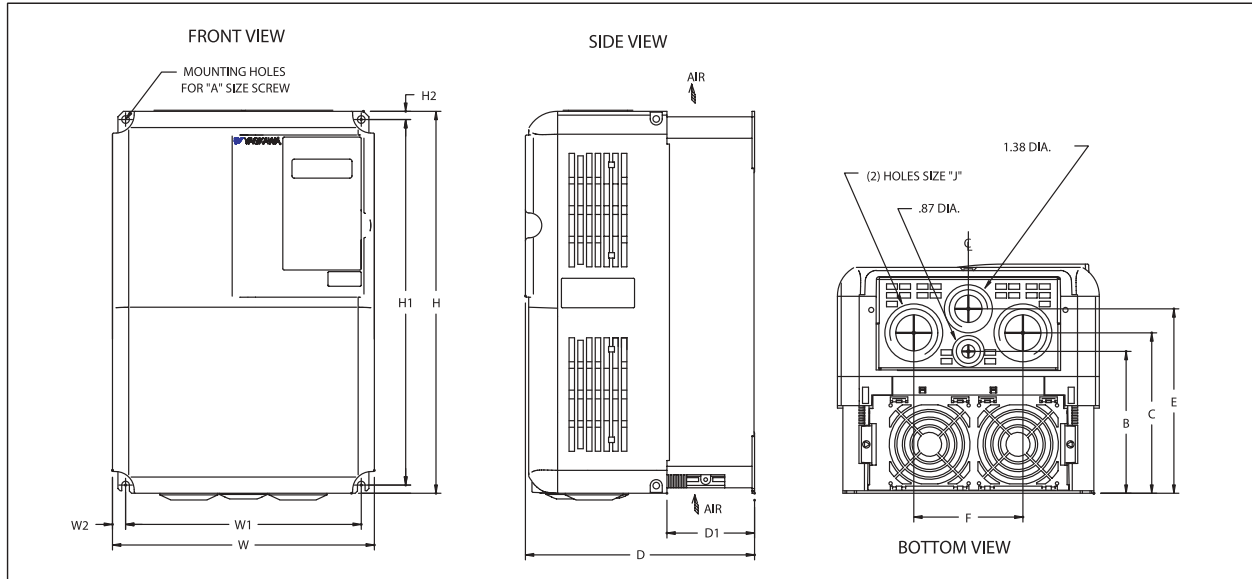

Fig 1.7 Terminal Arrangement (Terminal Cover Removed)

Exterior and Mounting Dimensions

DIMENSIONS: F7 (NEMA 1) 208-240V (F7U20P4-2018) 480V (F7U40P4-4018)



RATED INPUT	MODEL CIMR-F7U	RATED OUTPUT CURRENT HD/ND* (AMPS)	NOMINAL HP HD/ND*	DIMENSIONS IN INCHES														APPROX. WEIGHT (LBS.)
				MOUNTING		H	W	H2	W2	D	D1	A	B	C	E	F	J	
				H1	W1													
208V	20P4	3.2/3.6	0.5/0.5-0.75	10.47	4.96	11.02	5.51	.28	.28	6.30	1.54	#10	--	3.35	4.73	1.97	1.10	6.6
	20P7	4.1/4.6	0.75/1	10.47	4.96	11.02	5.51	.28	.28	6.30	1.54	#10	--	3.35	4.73	1.97	1.10	6.6
	21P5	7.0/7.8	1-1.5/2	10.47	4.96	11.02	5.51	.28	.28	6.30	1.54	#10	--	3.35	4.73	1.97	1.10	6.6
	22P2	9.6/10.8	2/3	10.47	4.96	11.02	5.51	.28	.28	6.30	1.54	#10	--	3.35	4.73	1.97	1.10	6.6
	23P7	15.0/16.8	3/5	10.47	4.96	11.02	5.51	.28	.28	7.09	2.32	#10	--	4.14	5.52	1.97	1.10	8.8
	25P5	23.0/23.0	5/NA	10.47	4.96	11.02	5.51	.28	.28	7.09	2.32	#10	--	4.14	5.52	1.97	1.10	8.8
	27P5	31.0/31.0	7.5-10/7.5-10	11.22	7.32	11.81	7.87	.28	.28	7.87	2.58	1/4	4.63	5.11	6.21	3.07	1.38	13.2
	2011	45.0/46.2	NA/15	11.22	7.32	12.20	7.87	.28	.28	7.87	2.58	1/4	4.63	5.11	6.21	3.07	1.38	15.4
	2015	58.0/59.4	15/20	13.19	8.50	13.78	9.45	.30	.47	8.27	3.07	1/4	5.12	5.79	6.65	3.94	1.73	24.2
2018	71.0/74.8	20/25	13.19	8.50	14.96	9.45	.30	.47	8.27	3.07	1/4	5.12	5.79	6.65	3.94	1.73	24.2	
240V	20P4	3.2/3.6	0.5-0.75/0.5-0.75	10.47	4.96	11.02	5.51	.28	.28	6.30	1.54	#10	--	3.35	4.73	1.97	1.10	6.6
	20P7	4.1/4.6	NA/1	10.47	4.96	11.02	5.51	.28	.28	6.30	1.54	#10	--	3.35	4.73	1.97	1.10	6.6
	21P5	7.0/7.8	1-2/2	10.47	4.96	11.02	5.51	.28	.28	6.30	1.54	#10	--	3.35	4.73	1.97	1.10	6.6
	22P2	9.6/10.8	3/3	10.47	4.96	11.02	5.51	.28	.28	6.30	1.54	#10	--	3.35	4.73	1.97	1.10	6.6
	23P7	15.0/16.8	NA/5	10.47	4.96	11.02	5.51	.28	.28	7.09	2.32	#10	--	4.14	5.52	1.97	1.10	8.8
	25P5	23.0/23.0	5-7.5/7.5	10.47	4.96	11.02	5.51	.28	.28	7.09	2.32	#10	--	4.14	5.52	1.97	1.10	8.8
	27P5	31.0/31.0	10/10	11.22	7.32	11.81	7.87	.28	.28	7.87	2.58	1/4	4.63	5.11	6.21	3.07	1.38	13.2
	2011	45.0/46.2	15/15	11.22	7.32	12.20	7.87	.28	.28	7.87	2.58	1/4	4.63	5.11	6.21	3.07	1.38	15.4
	2015	58.0/59.4	20/20	13.19	8.50	13.78	9.45	.30	.47	8.27	3.07	1/4	5.12	5.79	6.65	3.94	1.73	24.2
2018	71.0/74.8	25/25	13.19	8.50	14.96	9.45	.30	.47	8.27	3.07	1/4	5.12	5.79	6.65	3.94	1.73	24.2	
480V	40P4	1.8/1.8	0.5-0.75/0.5-0.75	10.47	4.96	11.02	5.51	.28	.28	6.30	1.54	#10	--	3.35	4.73	1.97	1.10	6.6
	40P7	2.1/2.1	1/1	10.47	4.96	11.02	5.51	.28	.28	6.30	1.54	#10	--	3.35	4.73	1.97	1.10	6.6
	41P5	3.7/3.7	1.5-2/1.5-2	10.47	4.96	11.02	5.51	.28	.28	6.30	1.54	#10	--	3.35	4.73	1.97	1.10	6.6
	42P2	5.3/5.3	3/3	10.47	4.96	11.02	5.51	.28	.28	7.09	2.32	#10	--	4.14	5.52	1.97	1.10	8.8
	43P7	7.6/7.6	5/5	10.47	4.96	11.02	5.51	.28	.28	7.09	2.32	#10	--	4.14	5.52	1.97	1.10	8.8
	44P0	8.7/8.7	NA/NA	10.47	4.96	11.02	5.51	.28	.28	7.09	2.32	#10	--	4.14	5.52	1.97	1.10	8.8
	45P5	12.5/12.5	7.5/7.5	10.47	4.96	11.02	5.51	.28	.28	7.09	2.32	#10	--	4.14	5.52	1.97	1.10	8.8
	47P5	17.0/17.0	10/10	11.22	7.32	11.81	7.87	.28	.28	7.87	2.58	1/4	4.63	5.11	6.21	3.07	1.38	13.2
	4011	24.0/27.0	15/15-20	11.22	7.32	11.81	7.87	.28	.28	7.87	2.58	1/4	4.63	5.11	6.21	3.07	1.38	13.2
	4015	31.0/34.0	20/25	13.19	8.50	13.78	9.45	.30	.47	8.27	3.07	1/4	5.12	5.79	6.65	3.94	1.73	22
4018	39.0/40.0	25/30	13.19	8.50	13.78	9.45	.30	.47	8.27	3.07	1/4	5.12	5.79	6.65	3.94	1.73	22	

FOR REFERENCE ONLY UNLESS PROPERLY ENDORSED.

IN ORDER TO ACHIEVE ADEQUATE COOLING THE DRIVE MUST BE POSITIONED TO ALLOW A MINIMUM OF FREE AIR SPACE OF 1.2 INCHES ON SIDES AND 4.75 INCHES TOP AND BOTTOM

* THE DIFFERENCE BETWEEN HEAVY DUTY (HD) AND NORMAL DUTY (ND) IS THE RATED HORSEPOWER, RATED OUTPUT CURRENT, AND THE OVERLOAD CAPACITY. PARAMETER C6-01 MUST BE SET TO VALUE OF "0" FOR HEAVY DUTY AND "2" FOR NORMAL DUTY. FACTORY DEFAULT SETTING IS HEAVY DUTY (C6-01=0).



DR BY EK 03.12.03
 REV. JCM 03.17.03
 APPVL. JAC 03.17.03

DIMENSIONS: F7 (NEMA 1)

208-240V (F7U2022-2030) 480V (F7U4022-4055)

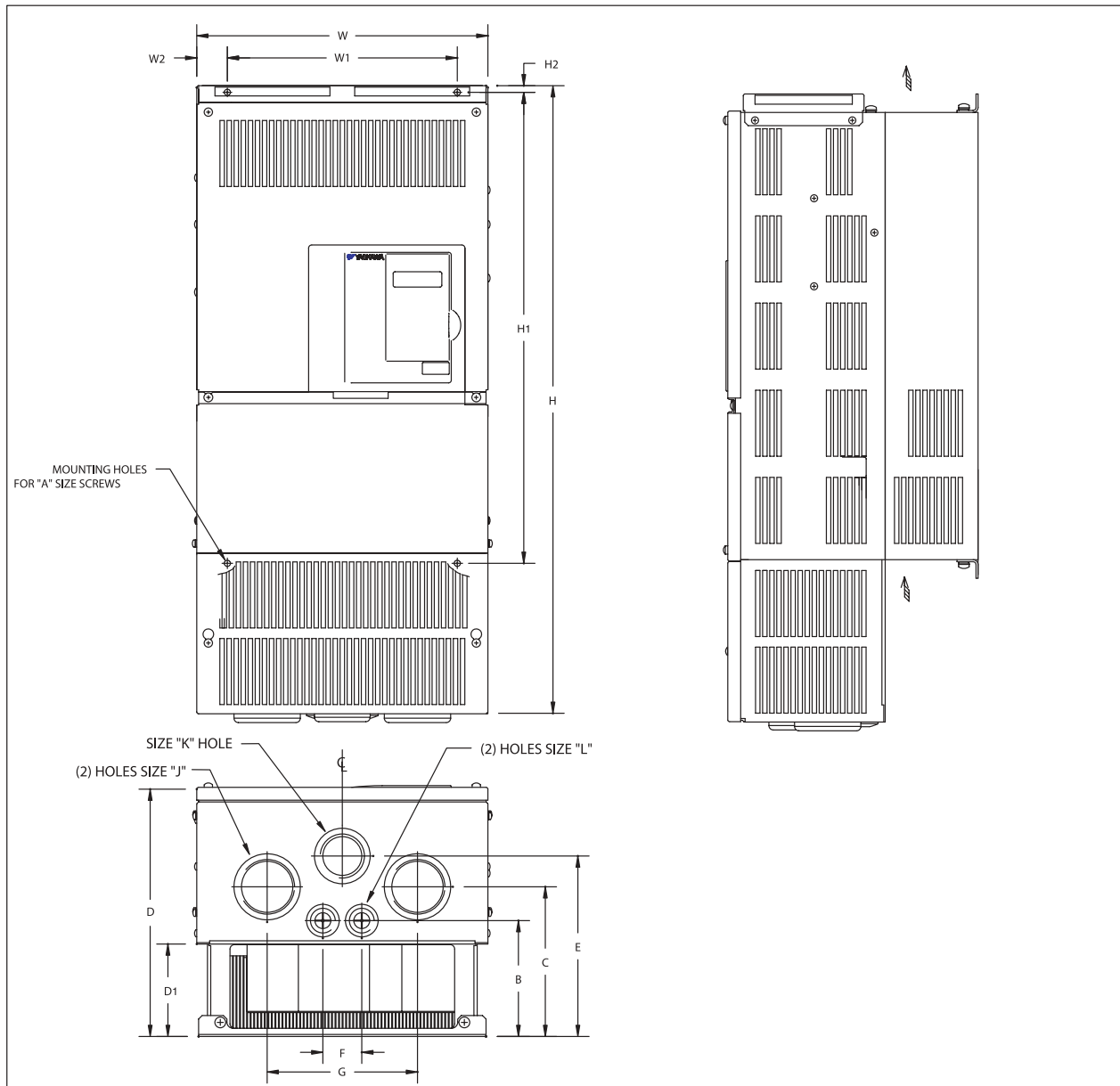

RATED INPUT	MODEL CIMR-F7U	RATED OUTPUT CURRENT HD/ND* (AMPS)	NOM. HP HD/ND*	DIMENSIONS IN INCHES																	APPROX. WEIGHT (LBS.)
				MOUNTING		H	W	H2	W2	D	D1	A	B	C	E	F	G	J	K	L	
				H1	W1																
208V	2022	85/88	25/30	15.16	7.68	21.06	10.00	0.30	1.16	10.24	3.94	1/4	4.98	6.50	7.87	1.73	5.91	2.44	1.97	1.10	53
	2030	115/115	30/40	17.13	8.66	24.21	10.98	0.30	1.16	10.24	3.94	1/4	4.98	6.50	7.87	1.73	5.91	2.44	1.97	1.10	59
240V	2022	85/88	30/30	15.16	7.68	21.06	10.00	0.30	1.16	10.24	3.94	1/4	4.98	6.50	7.87	1.73	5.91	2.44	1.97	1.10	53
	2030	115/115	40/40	17.13	8.66	24.21	10.98	0.30	1.16	10.24	3.94	1/4	4.98	6.50	7.87	1.73	5.91	2.44	1.97	1.10	59
480V	4022	45/50.4	30/NA	17.13	8.66	21.06	10.98	0.30	1.16	10.24	3.94	1/4	4.98	6.50	7.87	1.73	5.91	1.97	1.97	1.10	53
	4030	60/67.2	40/40-50	17.13	8.66	21.06	10.98	0.30	1.16	10.24	3.94	1/4	4.98	6.50	7.87	1.73	5.91	1.97	1.97	1.10	53
	4037	75/77	50/60	21.06	10.24	25.00	12.95	0.30	1.36	11.22	4.13	1/4	5.18	6.69	8.07	1.73	6.69	1.97	1.97	1.10	88
	4045	91/96	60/75	21.06	10.24	28.15	12.95	0.30	1.36	11.22	4.13	1/4	5.18	6.69	8.07	1.73	6.69	2.44	1.97	1.10	88
	4055	112/125	75/100	21.06	10.24	28.15	12.95	0.30	1.36	11.22	4.13	1/4	5.18	6.69	8.07	1.73	6.69	2.44	1.97	1.10	88

FOR REFERENCE ONLY UNLESS PROPERLY ENDORSED.

IN ORDER TO ACHIEVE ADEQUATE COOLING THE DRIVE MUST BE POSITIONED TO ALLOW A MINIMUM OF FREE AIR SPACE OF 1.2 INCHES ON SIDES AND 4.75 INCHES TOP AND BOTTOM

* THE DIFFERENCE BETWEEN HEAVY DUTY (HD) AND NORMAL DUTY (ND) IS THE RATED HORSEPOWER, RATED OUTPUT CURRENT, AND THE OVERLOAD CAPACITY. PARAMETER C6-01 MUST BE SET TO VALUE OF "0" FOR HEAVY DUTY AND "2" FOR NORMAL DUTY. FACTORY DEFAULT SETTING IS HEAVY DUTY (C6-01=0).



DR BY EK 03.12.03
 REV. JCM 03.17.03
 APPVL. JAC 03.17.03

DIMENSIONS: F7 (PROTECTED CHASSIS)

208-230V (F7U2037-2110)

480V (F7U4075-4160)

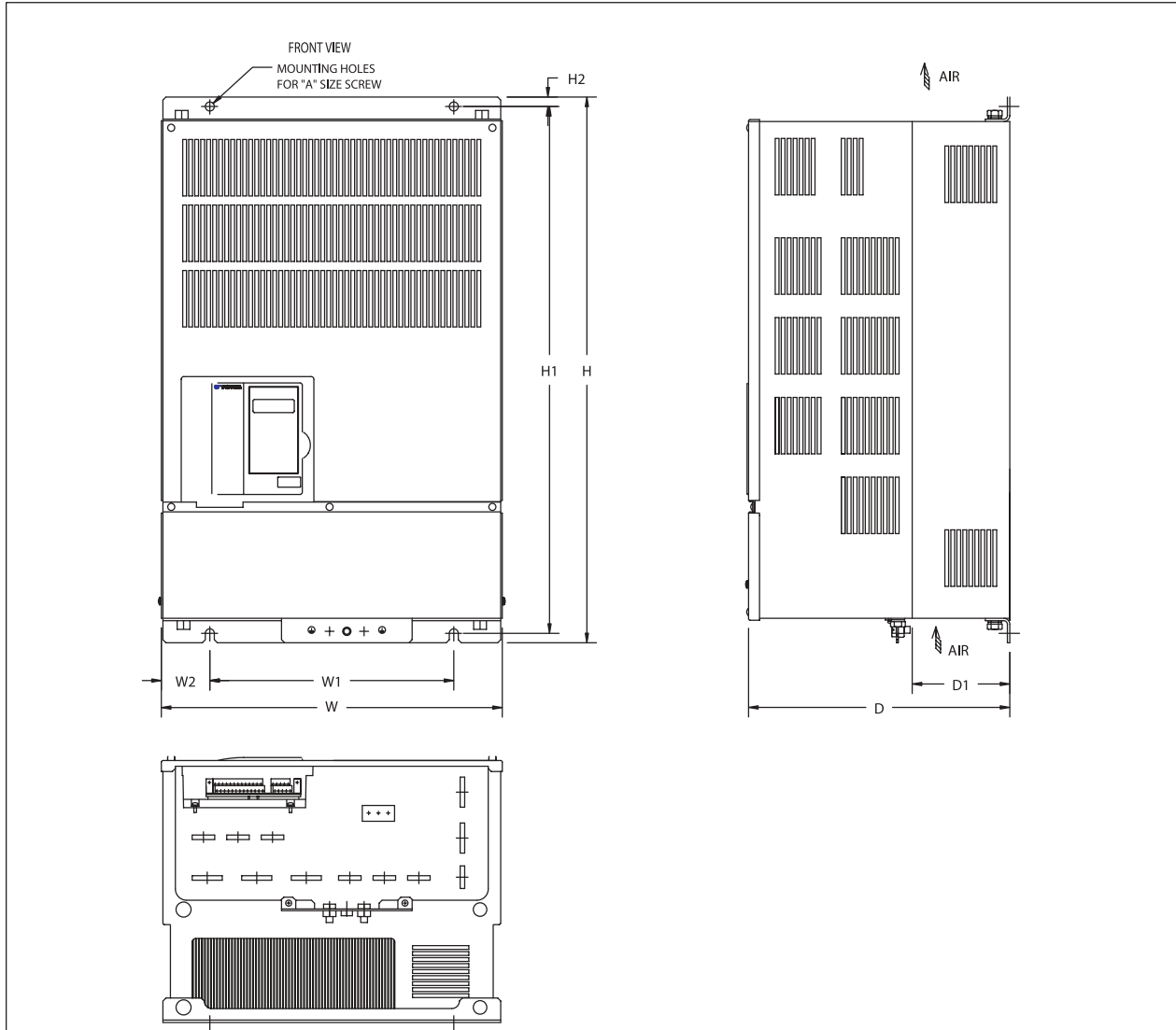

RATED INPUT	MODEL CIMR-F7U	RATED OUTPUT CURRENT HD/ND* (AMPS)	NOM. HP HD/ND*	DIMENSIONS IN INCHES										APPROX. WEIGHT (LBS.)
				MOUNTING		H	W	H2	W2	D	D1	A		
				H1	W1									
208V	2037	145/162	40-50/50	22.64	9.84	23.62	14.76	0.49	2.46	11.81	3.94	3/8	125	
	2045	180/192	60/60	22.64	9.84	23.62	14.76	0.49	2.46	12.99	5.12	3/8	139	
	2055	215/215	75/75	27.56	12.80	28.54	17.72	0.49	2.46	13.78	5.12	3/8	189	
	2075	283/312	100/100	27.56	12.80	28.54	17.72	0.49	2.46	13.78	5.12	3/8	191	
	2090	346/360	125/125	32.28	14.57	33.46	19.69	0.59	2.56	14.17	5.12	3/8	238	
	2110	415/415	150/150	33.66	17.52	34.84	22.64	0.59	2.56	14.88	5.51	3/8	330	
230V	2037	145/162	50/50-60	22.64	9.84	23.62	14.76	0.49	2.46	11.81	3.94	3/8	125	
	2045	180/192	60/75	22.64	9.84	23.62	14.76	0.49	2.46	12.99	5.12	3/8	139	
	2055	215/215	75/NA	27.56	12.80	28.54	17.72	0.49	2.46	13.78	5.12	3/8	189	
	2075	283/312	100/100-125	27.56	12.80	28.54	17.72	0.49	2.46	13.78	5.12	3/8	191	
	2090	346/360	125/150	32.28	14.57	33.46	19.69	0.59	2.56	14.17	5.12	3/8	238	
	4075	150/156	100/125	27.56	12.80	28.54	17.72	0.49	2.46	13.78	5.12	3/8	194	
480V	4090	180/180	125-150/150	27.56	12.80	28.54	17.72	0.49	2.46	13.78	5.12	3/8	196	
	4110	216/240	NA/200	32.28	14.57	33.46	19.69	0.59	2.56	14.17	5.12	3/8	224	
	4132	260/260	200/NA	32.28	14.57	33.46	19.69	0.59	2.56	14.17	5.12	3/8	265	
	4160	304/304	250/250	33.66	17.52	36.06	22.64	0.59	2.56	14.88	5.51	3/8	352	

FOR REFERENCE ONLY UNLESS PROPERLY ENDORSED.
 IN ORDER TO ACHIEVE ADEQUATE COOLING THE DRIVE MUST BE POSITIONED TO ALLOW A MINIMUM OF FREE AIR SPACE OF 1.2 INCHES ON SIDES AND 4.75 INCHES TOP AND BOTTOM



DR BY EK 03.12.03
 REV. JCM 03.17.03
 APPVL. JAC 03.17.03

* THE DIFFERENCE BETWEEN HEAVY DUTY (HD) AND NORMAL DUTY (ND) IS THE RATED HORSEPOWER, RATED OUTPUT CURRENT, AND THE OVERLOAD CAPACITY. PARAMETER C6-01 MUST BE SET TO VALUE OF "0" FOR HEAVY DUTY AND "2" FOR NORMAL DUTY. FACTORY DEFAULT SETTING IS HEAVY DUTY (C6-01=0).

DIMENSIONS: F7 (PROTECTED CHASSIS)

480V (F7U4185-4300)

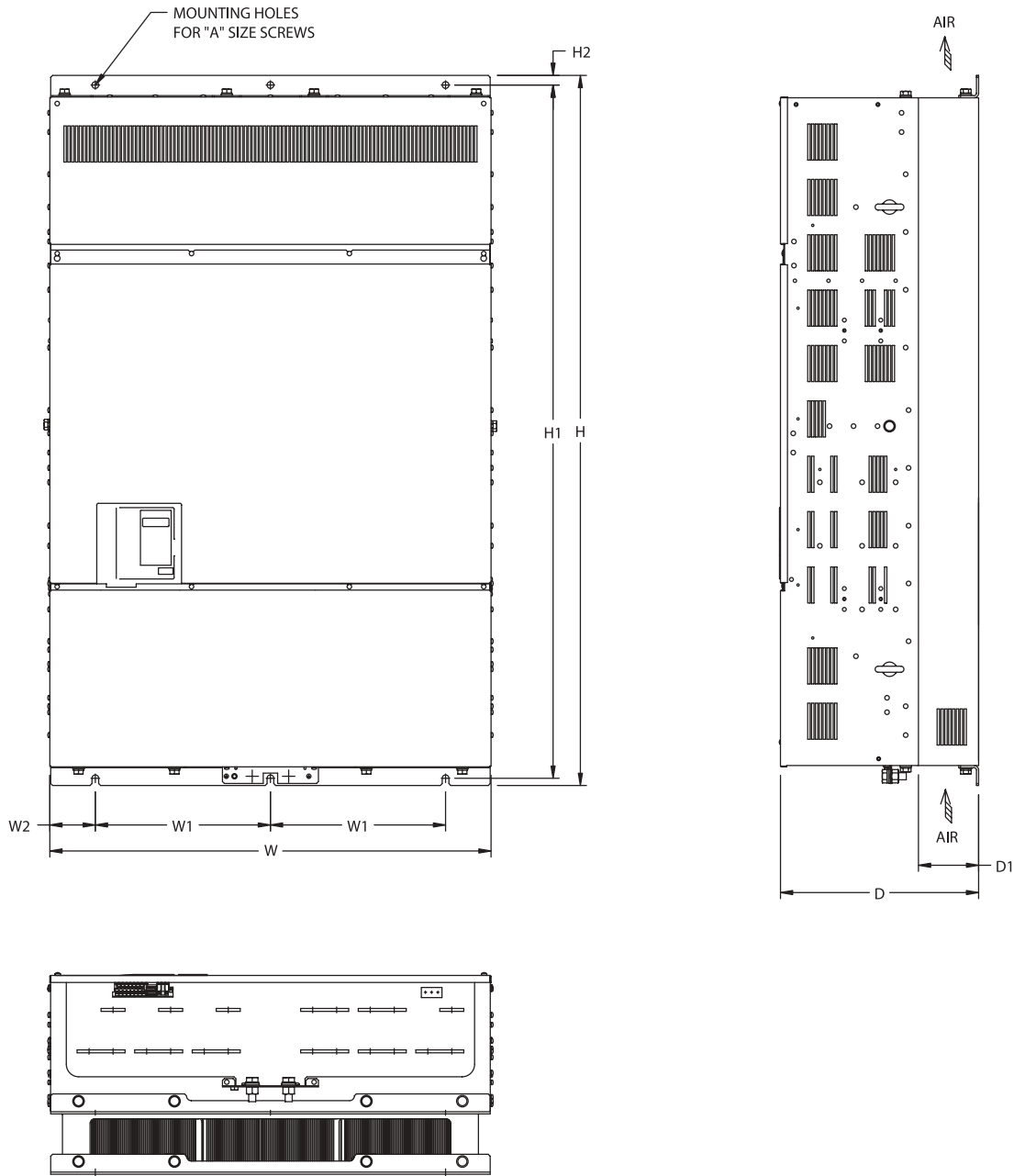

RATED INPUT	MODEL CIMR-F7U	RATED OUTPUT CURRENT HD/ND* (AMPS)	NOM. HP HD/ND*	DIMENSIONS IN INCHES								APPROX. WEIGHT (LBS.)	
				MOUNTING		H	W	H2	W2	D	D1		A
				H1	W1								
480V	4185	370/414	300/300-350	50.00	10.63	51.38	27.95	0.79	3.35	16.26	4.94	3/8	572
	4220	506/515	350-400/400-450	50.00	10.63	51.38	27.95	0.79	3.35	16.26	4.94	3/8	616
	4300	675/675	450-500/500	56.70	14.37	58.07	36.06	0.79	3.66	16.26	4.94	3/8	891

FOR REFERENCE ONLY UNLESS PROPERLY ENDORSED.
 IN ORDER TO ACHIEVE ADEQUATE COOLING, THE DRIVE MUST BE POSITIONED TO ALLOW A MINIMUM OF FREE AIR OF 1.2 INCHES ON SIDES AND 4.75 INCHES TOP AND BOTTOM (MODEL CIMR-F7U4300 REQUIRES 11.8 INCHES TOP CLEARANCE)

* THE DIFFERENCE BETWEEN HEAVY DUTY (HD) AND NORMAL DUTY (ND) IS THE RATED HORSEPOWER, RATED OUTPUT CURRENT, AND THE OVERLOAD CAPACITY. PARAMETER C6-01 MUST BE SET TO VALUE OF "0" FOR HEAVY DUTY AND "2" FOR NORMAL DUTY. FACTORY DEFAULT SETTING IS HEAVY DUTY (C6-01=0).



DR BY EK 03.12.03
 REV. JCM 03.17.03
 APPVL. JAC 03.17.03

Checking and Controlling the Installation Site

Install the Drive as described below and maintain optimum conditions.

◆ Installation Site

Install the Drive to a non-combustible surface under the following conditions in UL Pollution Degree 2 environments. This excludes wet locations where pollution may become conductive due to moisture, and locations containing conductive foreign matter.

Type	Ambient Operating Temperature	Humidity	Plenum Rated
NEMA Type 1	14°F to 104°F (-10 to +40°C)	95% RH or less (no condensation)	Yes
Open Chassis	14°F to 113°F (-10 to +45°C)	95% RH or less (no condensation)	No

Protective covers are attached to the top and bottom of the Drive. It is recommended to remove the protective covers before operating a NEMA Type 1 Drive (Models CIMR-F7U2030/4055 and smaller) in a panel to obtain the 113° (45°C) ambient operating temperature.

Observe the following precautions when installing the Drive. Make sure to install:

- in a clean location which is free from oil mist and dust.
- in an environment where metal shavings, oil, water, or other foreign materials do not get into the Drive.
- in a location free from radioactive materials and combustible materials (e.g. wood).
- in a location free from harmful gases and liquids.
- in a location free from excessive vibration.
- in a location free from chlorides.
- in a location away from direct sunlight.

◆ Controlling the Ambient Temperature

To enhance the reliability of operation, the Drive should be installed in an environment free from extreme temperature variation. If the Drive is installed in an enclosure, use a cooling fan or air conditioner to maintain the internal air temperature below 113°F (45°C).

◆ Protecting the Drive from Foreign Matter

During Drive installation and project construction, it is possible to have foreign matter such as metal shavings or wire clippings fall inside the Drive. To prevent foreign matter from falling into the Drive, place a temporary cover over the Drive.

Always remove the temporary cover from the Drive before start-up. Otherwise, ventilation will be reduced, causing the Drive to overheat.

Installation Orientation and Clearances

Install the Drive vertically so as not to reduce the cooling efficiency. When installing the Drive, always provide the following installation clearances to allow normal heat dissipation and air flow. Ensure that the heatsink is against a closed surface to avoid diverting cooling air around the heatsink.

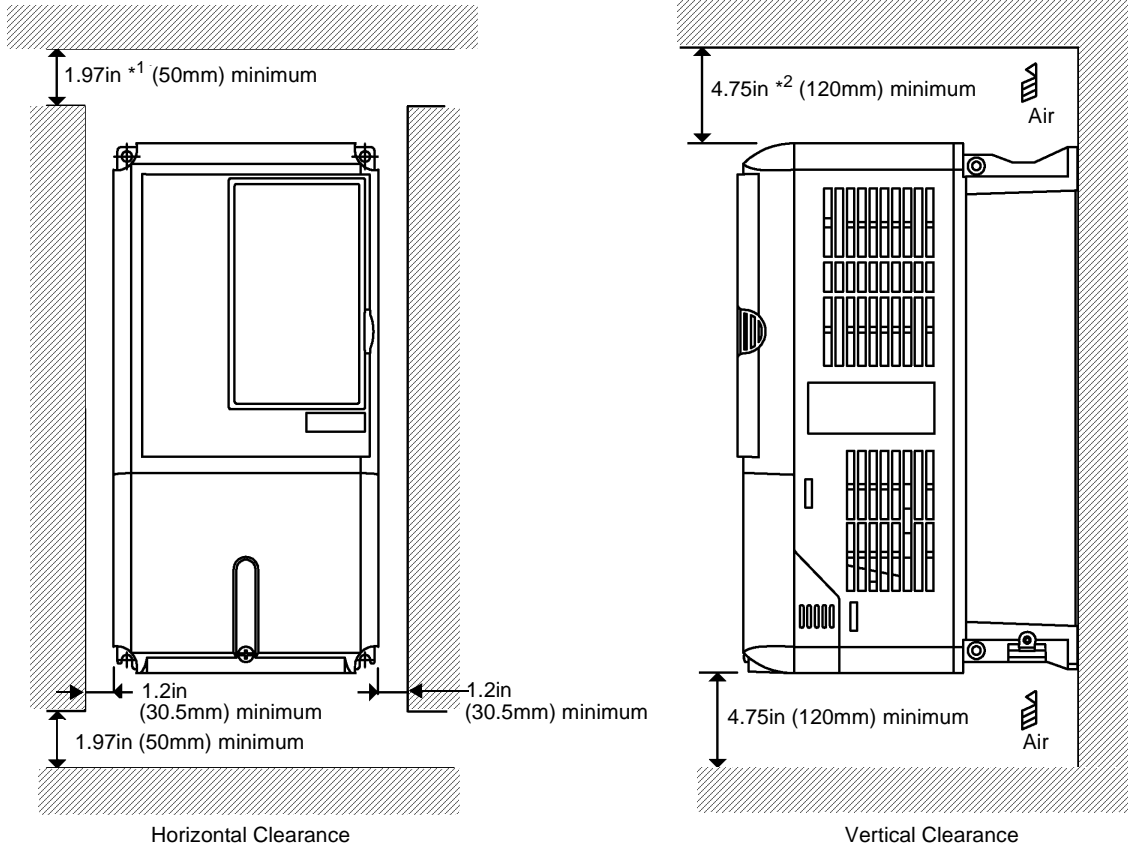

*¹ For Drive models F7U2110, F7U4160, and F7U4220, this clearance dimension is 4.75in (120mm) minimum. For Drive model F7U4300, this clearance dimension is 11.8in (300mm) minimum. All other models require 1.97in (50mm) minimum.

*² For Drive model F7U4300, this clearance dimension is 11.8in (300mm) minimum. All other models require 4.75in (120mm) minimum.

Fig 1.8 Drive Installation Orientation and Clearance

IMPORTANT

1. The same clearance is required horizontally and vertically for both Open Chassis (IP00) and NEMA Type 1 Drives.
2. Always remove the top and bottom protection covers before installing a CIMR-F7U2018/4018 and smaller Drive in a panel.
3. Always provide enough clearance for lifting eye bolts and the main circuit wiring when installing a CIMR-F7U2022/4030 and larger Drive in a panel.

Removing and Attaching the Terminal Cover

Remove the terminal cover to connect cables to the control circuit and main circuit terminals.

◆ Removing the Terminal Cover

■ Models CIMR-F7U20P4 thru 2018 and 40P4 thru 4018

Loosen the screw at the bottom of the terminal cover, press in on the sides of the terminal cover in the directions of arrows 1, and then lift up on the terminal in the direction of arrow 2.

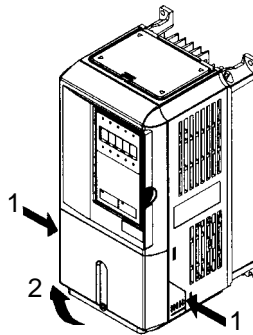

Fig 1.9 Removing the Terminal Cover

■ Models CIMR-F7U2022 thru 2110 and 4030 thru 4300

Loosen the screws on the left and right at the top of the terminal cover, pull down the terminal cover in the direction of arrow 1, and then lift up on the terminal cover in the direction of arrow 2.

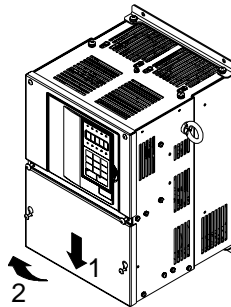

Fig 1.10 Removing the Terminal Cover

◆ Attaching the Terminal Cover

After wiring the terminal block, attach the terminal cover by reversing the removal procedure.

For Models CIMR-F7U2018/4018 and smaller, insert the tab on the top of the terminal cover into the groove on the Drive, and press in on the bottom of the terminal cover until it clicks into place.

For Drives CIMR-F7U2022/4030 and larger, insert the tab on the top of the terminal cover into the groove on the Drive, and secure the terminal cover by lifting it up toward the top of the Drive.

Removing/Attaching the Digital Operator and Front Cover

◆ Models CIMR-F7U20P4 thru 2018 and 40P4 thru 4018

For Models CIMR-F7U2018/4018 and smaller, remove the terminal cover and then use the following procedures to remove the Digital Operator and front cover.

■ Removing the Digital Operator

Press on the side of the Digital Operator in the direction of arrow 1 to unlock, then lift the Digital Operator in the direction of arrow 2 to remove it as shown in Fig 1.11.

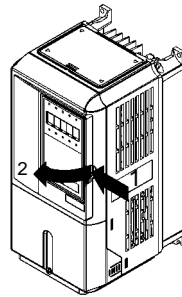

Fig 1.11 Removing the Digital Operator

■ Removing the Front Cover

Press the left and right sides of the front cover in the direction of arrows 1 and lift the bottom of cover in the direction of arrow 2 to remove it as shown in Fig 1.12.

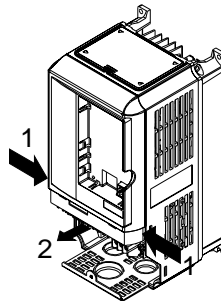

Fig 1.12 Removing the Front Cover

■ Mounting the Front Cover

Mount the front cover to the Drive by performing the steps to remove the front cover in reverse order.

1. Do not mount the front cover with the Digital Operator attached as this may cause the Digital Operator to malfunction due to improper mating with its connector.
2. Insert the tab of the upper part of the front cover into the groove of the Drive and press the lower part of the front cover onto the Drive until it snaps into place.

■ Mounting the Digital Operator

After attaching the front cover, mount the Digital Operator onto the Drive using the following procedure:

1. Hook the Digital Operator at A (two locations) on the left side of the opening on the front cover by moving in the direction of arrow 1 as shown in the following illustration.
2. Press the Digital Operator in the direction of arrow 2 until it snaps in place at B (two locations).

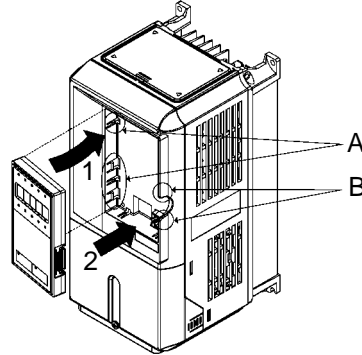

Fig 1.13 Mounting the Digital Operator

IMPORTANT

1. Do not remove or attach the Digital Operator and do not mount or remove the front cover using methods other than those described above, or damage to the Digital Operator or Drive may occur.
2. Never attach the front cover to the Drive with the Digital Operator already attached. Damage to the Digital Operator may occur. Always attach the front cover to the Drive first, and then attach the Digital Operator to the front cover.

◆ Models CIMR-F7U2022 thru 2110 and 4030 thru 4300

For Models CIMR-F7U2022/4030 and larger, remove the terminal cover and then use the following procedures to remove the Digital Operator and front cover.

■ Removing the Digital Operator

Use the same procedure for Models CIMR-F7U20P4 thru 2018 and 40P4 thru 4018.

■ Removing the Front Cover

Loosen all screws on the front cover. Lift up at the location labelled 1 at the top of the control circuit terminal card and move in the direction of arrow 2.

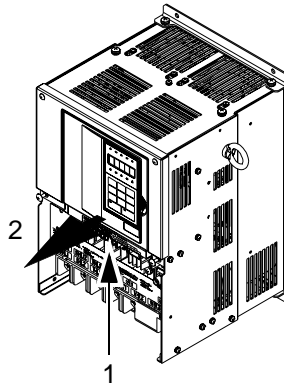

Fig 1.14 Removing the Front Cover

■ Mounting the Front Cover

Attach the front cover by reversing the procedure to remove it.

1. Confirm that the Digital Operator is not mounted on the front cover. If the cover is attached while the Digital Operator is mounted to it, the Digital Operator may malfunction due to improper mating with its connector.
2. Insert the tab on the top of the front cover into the slot on the Drive and press in on the cover until it clicks into place on the Drive.

■ Mounting the Digital Operator

Use the same procedure for Models CIMR-F7U20P4 thru 2018 and 40P4 thru 4018.

Chapter 2

Electrical Installation

This chapter describes wiring terminals, main circuit terminal connections, main circuit terminal wiring specifications, control circuit terminals, and control circuit wiring specifications.

Terminal Block Configuration	2-2
Wiring Main Circuit Terminals.....	2-3
Control Wiring	2-20
Electromagnetic Compatibility (EMC).....	2-26
Installing and Wiring Option Boards	2-30

Terminal Block Configuration

The wiring terminals are shown in Fig 2.1, Fig 2.2 and Fig 2.3.

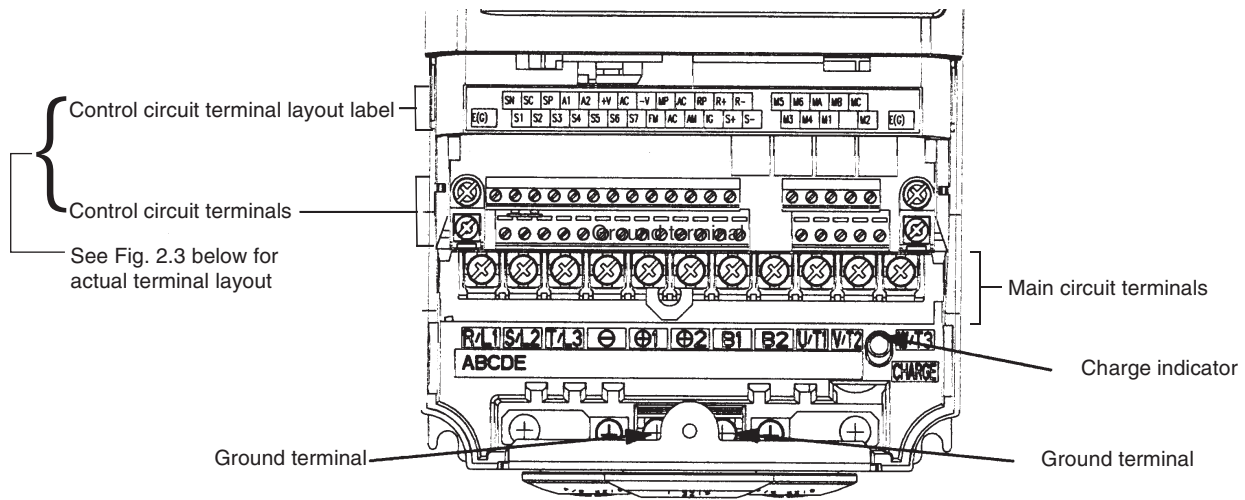

Fig 2.1 Terminal Configuration for Models CIMR-F7U2018/4018 and smaller

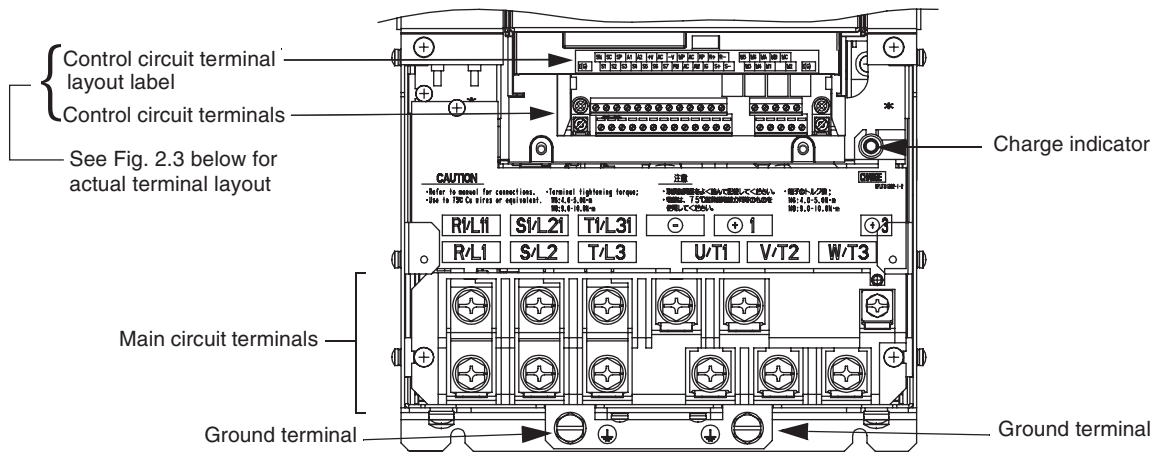

Fig 2.2 Terminal Configuration for Models CIMR-F7U2022/4022 and larger

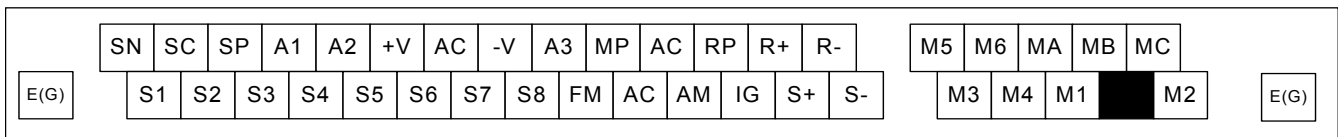

Fig 2.3 Control Circuit Terminal Layout

Wiring Main Circuit Terminals

◆ Applicable Wire Sizes and Closed-loop Connectors

Select the appropriate wires and crimp terminals from Table 2.1 and Table 2.2. Refer to instruction manual TOE-C726-2 for Braking Resistor Unit and Braking Unit wire sizes.

Table 2.1 208-240Vac Wire Sizes and Connector Specifications						
Drive Model CIMR-F7U	Terminal Symbol	Terminal Screws	Clamping Torque lb. in. (N•m)	Possible Wire Sizes AWG (mm ²) *1	Recommended Wire Size AWG (mm ²) *2	Wire Type
20P4	R/L1, S/L2, T/L3, ⊖, ⊕1, ⊕2, B1, B2 U/T1, V/T2, W/T3	M4	10.6 to 13.2 (1.2 to 1.5)	14 to 10 (2 to 5.5)	14 (2)	600Vac UL Approved vinyl-sheathed or equivalent
	⊕					
20P7	R/L1, S/L2, T/L3, ⊖, ⊕1, ⊕2, B1, B2 U/T1, V/T2, W/T3	M4	10.6 to 13.2 (1.2 to 1.5)	14 to 10 (2 to 5.5)	14 (2)	
	⊕					
21P5	R/L1, S/L2, T/L3, ⊖, ⊕1, ⊕2, B1, B2 U/T1, V/T2, W/T3	M4	10.6 to 13.2 (1.2 to 1.5)	14 to 10 (2 to 5.5)	14 (2)	
	⊕					
22P2	R/L1, S/L2, T/L3, ⊖, ⊕1, ⊕2, B1, B2 U/T1, V/T2, W/T3	M4	10.6 to 13.2 (1.2 to 1.5)	14 to 10 (2 to 5.5)	14 (2)	
	⊕					
23P7	R/L1, S/L2, T/L3, ⊖, ⊕1, ⊕2, B1, B2 U/T1, V/T2, W/T3	M4	10.6 to 13.2 (1.2 to 1.5)	12 to 10 (3.5 to 5.5)	12 (3.5)	
	⊕					
25P5	R/L1, S/L2, T/L3, ⊖, ⊕1, ⊕2, B1, B2 U/T1, V/T2, W/T3	M4	10.6 to 13.2 (1.2 to 1.5)	12 to 10 (3.5 to 5.5)	10 (5.5)	
	⊕					
27P5	R/L1, S/L2, T/L3, ⊖, ⊕1, ⊕2, B1, B2 U/T1, V/T2, W/T3	M5	21.99 (2.5)	8 to 6 (8 to 14)	8 (8)	
	⊕					
2011	R/L1, S/L2, T/L3, ⊖, ⊕1, ⊕2, B1, B2	M5	21.99 (2.5)	6 to 4 (14 to 22)	4 (22)	
	U/T1, V/T2, W/T3				6 (14)	
	⊕					
2015	R/L1, S/L2, T/L3, ⊖, ⊕1, ⊕2	M6	35.2 to 43.99 (4.0 to 5.0)	4 to 2 (22 to 38)	3 (30)	
	U/T1, V/T2, W/T3				4 (22)	
	B1, B2	M5	21.99 (2.5)	8 to 6 (8 to 14)	Application Dependent	
	⊕	M6	35.2 to 43.99 (4.0 to 5.0)	4 (22)	4 (22)	
2018	R/L1, S/L2, T/L3, ⊖, ⊕1, ⊕2	M8	79.2 to 87.97 (9.0 to 10.0)	3 to 2 (30 to 38)	2 (38)	
	U/T1, V/T2, W/T3				3 (30)	
	B1, B2	M5	21.99 (2.5)	8 to 6 (8 to 14)	Application Dependent	
	⊕	M6	35.2 to 43.99 (4.0 to 5.0)	4 (22)	4 (22)	
2022	R/L1, S/L2, T/L3, ⊖, ⊕1, R1/L11, S1/L21, T1/L31	M8	79.2 to 87.97 (9.0 to 10.0)	N/A	1 (50)	
	U/T1, V/T2, W/T3,				2 (38)	
	⊕3	M6	35.2 to 43.99 (4.0 to 5.0)	N/A	Application Dependent	
	⊕	M8	79.2 to 87.97 (9.0 to 10.0)	N/A	4 (22)	
2030	R/L1, S/L2, T/L3, ⊖, ⊕1 U/T1, V/T2, W/T3, R1/L11, S1/L21, T1/L31	M8	79.2 to 87.97 (9.0 to 10.0)	N/A	1/0 (60)	
	⊕3	M6	35.2 to 43.99 (4.0 to 5.0)	N/A	Application Dependent	
	⊕	M8	79.2 to 87.97 (9.0 to 10.0)	N/A	4 (22)	

Table 2.1 208-240Vac Wire Sizes and Connector Specifications (Continued)

Drive Model CIMR-F7U	Terminal Symbol	Terminal Screws	Clamping Torque lb. in. (N•m)	Possible Wire Sizes AWG (mm ²) *1	Recommended Wire Size AWG (mm ²) *2	Wire Type
2037	R/L1, S/L2, T/L3, ⊖, ⊕ ₁ U/T1, V/T2, W/T3, R1/L11, S1/L21, T1/L31	M10	154.8 to 197.9 (17.6 to 22.5)	N/A	4/0 (100)	600Vac UL Approved vinyl-sheathed or equivalent
	⊕ ₃	M8	77.4 to 95.0 (8.8 to 10.8)	N/A	Application Dependent	
	⊖	M10	154.8 to 197.9 (17.6 to 22.5)	N/A	2 (38)	
	r/l1, s/l2	M4	11.4 to 12.3 (1.3 to 1.4)	N/A	16 (1.25)	
2045	R/L1, S/L2, T/L3, ⊖, ⊕ ₁ , R1/L11, S1/L21, T1/L31	M10	154.8 to 197.9 (17.6 to 22.5)	N/A	300 (150)	
	U/T1, V/T2, W/T3				250 (125)	
	⊕ ₃	M8	77.4 to 95.0 (8.8 to 10.8)	N/A	Application Dependent	
	⊖	M10	154.8 to 197.9 (17.6 to 22.5)	N/A	1 (50)	
	r/l1, s/l2	M4	11.4 to 12.3 (1.3 to 1.4)	N/A	16 (1.25)	
2055	R/L1, S/L2, T/L3, ⊖, ⊕ ₁ , U/T1, V/T2, W/T3, R1/L11, S1/L21, T1/L31	M10	154.8 to 197.9 (17.6 to 22.5)	N/A	1/0 X 2P (60 X 2P)	
	⊕ ₃	M8	77.4 to 95.0 (8.8 to 10.8)	N/A	Application Dependent	
	⊖	M10	154.8 to 197.9 (17.6 to 22.5)	N/A	1/0 (60)	
	r/l1, s/l2	M4	11.4 to 12.3 (1.3 to 1.4)	N/A	16 (1.25)	
2075	R/L1, S/L2, T/L3, R1/L11, S1/L21, T1/L31	M10	154.8 to 197.9 (17.6 to 22.5)	N/A	4/0 X 2P (100 X 2P)	
	U/T1, V/T2, W/T3			N/A	3/0 X 2P (80 X 2P)	
	⊖, ⊕ ₁	M12	276.2 to 344.8 (31.4 to 39.2)	N/A	3/0 X 2P (80 X 2P)	
	⊕ ₃	M8	77.4 to 95.0 (8.8 to 10.8)	N/A	Application Dependent	
	⊖	M12	276.2 to 344.8 (31.4 to 39.2)	N/A	3/0 (80)	
	r/l1, s/l2	M4	11.4 to 12.3 (1.3 to 1.4)	N/A	16 (1.25)	
2090	R/L1, S/L2, T/L3, ⊖, ⊕ ₁ , R1/L11, S1/L21, T1/L31	M12	276.2 to 344.8 (31.4 to 39.2)	N/A	250 X 2P (125 X 2P)	
	U/T1, V/T2, W/T3			N/A	4/0 X 2P (100 X 2P)	
	⊕ ₃	M8	77.4 to 95.0 (8.8 to 10.8)	N/A	Application Dependent	
	⊖	M12	276.2 to 344.8 (31.4 to 39.2)	N/A	2/0 X 2P (70 X 2P)	
	r/l1, s/l2	M4	11.4 to 12.3 (1.3 to 1.4)	N/A	16 (1.25)	
2110	R/L1, S/L2, T/L3, ⊖, ⊕ ₁ , R1/L11, S1/L21, T1/L31	M12	276.2 to 344.8 (31.4 to 39.2)	N/A	350 X 2P (200 X 2P)	
	U/T1, V/T2, W/T3			N/A	300 X 2P (150 X 2P)	
	⊕ ₃	M8	77.4 to 95.0 (8.8 to 10.8)	N/A	Application Dependent	
	⊖	M12	276.2 to 344.8 (31.4 to 39.2)	N/A	300 X 2P (150 X 2P)	
	r/l1, s/l2	M4	11.4 to 12.3 (1.3 to 1.4)	N/A	16 (1.25)	

*1 Wire size range provided for Drives using insulated screw-type terminal blocks. All other models require the use of UL listed connectors. Refer to Table 2.3.
 *2 Recommended wire sizes are based on the normal duty (ND) current ratings and NEC Article 310 Table 310.16, 75 degree Celsius copper or equivalent.
 When sizing wiring based on the heavy duty (HD) current ratings, consult NEC Article 430 and any other applicable codes.

Table 2.2 480Vac Wire Sizes and Connector Specifications

Drive Model CIMR-F7U	Terminal Symbol	Terminal Screws	Clamping Torque lb. in. (N•m)	Possible Wire Sizes AWG (mm ²) *1	Recommended Wire Size AWG (mm ²) *2	Wire Type
40P4	R/L1, S/L2, T/L3, ⊖, ⊕1, ⊕2, B1, B2 U/T1, V/T2, W/T3	M4	10.6 to 13.2 (1.2 to 1.5)	14 to 10 (2 to 5.5)	14 (2)	600Vac UL Approved vinyl-sheathed or equivalent
	⊕					
40P7	R/L1, S/L2, T/L3, ⊖, ⊕1, ⊕2, B1, B2 U/T1, V/T2, W/T3	M4	10.6 to 13.2 (1.2 to 1.5)	14 to 10 (2 to 5.5)	14 (2)	
	⊕					
41P5	R/L1, S/L2, T/L3, ⊖, ⊕1, ⊕2, B1, B2 U/T1, V/T2, W/T3	M4	10.6 to 13.2 (1.2 to 1.5)	14 to 10 (2 to 5.5)	14 (2)	
	⊕					
42P2	R/L1, S/L2, T/L3, ⊖, ⊕1, ⊕2, B1, B2 U/T1, V/T2, W/T3	M4	10.6 to 13.2 (1.2 to 1.5)	14 to 10 (2 to 5.5)	14 (2)	
	⊕					
43P7 44P0	R/L1, S/L2, T/L3, ⊖, ⊕1, ⊕2, B1, B2 U/T1, V/T2, W/T3	M4	10.6 to 13.2 (1.2 to 1.5)	14 to 10 (2 to 5.5)	12 (3.5)	
	⊕				14 (2)	
45P5	R/L1, S/L2, T/L3, ⊖, ⊕1, ⊕2, B1, B2 U/T1, V/T2, W/T3	M4	10.6 to 13.2 (1.2 to 1.5)	12 to 10 (3.5 to 5.5)	12 (3.5)	
	⊕			14 to 10 (2 to 5.5)	14 (2)	
47P5	R/L1, S/L2, T/L3, ⊖, ⊕1, ⊕2, B1, B2 U/T1, V/T2, W/T3	M4	15.6 (1.8)	10 (5.5)	10 (5.5)	
	⊕			12 to 10 (3.5 to 5.5)	12 (3.5)	
4011	R/L1, S/L2, T/L3, ⊖, ⊕1, ⊕2, B1, B2	M5	21.99 (2.5)	10 to 6 (5.5 to 14)	8 (8)	
	U/T1, V/T2, W/T3				10 (5.5)	
	⊕					
4015	R/L1, S/L2, T/L3, ⊖, ⊕1, ⊕2, B1, B2 U/T1, V/T2, W/T3	M5	21.99 (2.5)	8 to 6 (8 to 14)	8 (8)	
	⊕	M5	21.99 (2.5)	10 to 6 (5.5 to 14)	10 (5.5)	
		M6	35.2 to 43.99 (4.0 to 5.0)			
4018	R/L1, S/L2, T/L3, ⊖, ⊕1, ⊕2	M6	35.2 to 43.99 (4.0 to 5.0)	8 to 2 (8 to 38)	6 (14)	
	U/T1, V/T2, W/T3				8 (8)	
	B1, B2	M5	21.99 (2.5)	8 (8)	8 (8)	
	⊕	M6	35.2 to 43.99 (4.0 to 5.0)	8 to 4 (8 to 22)	8 (8)	
4022	R/L1, S/L2, T/L3, ⊖, ⊕1, ⊕3, R1/L11, S1/L21, T1/L31	M6	35.2 to 43.99 (4.0 to 5.0)	N/A	4 (22)	
	U/T1, V/T2, W/T3				6 (14)	
	⊕	M8	79.2 to 87.97 (9.0 to 10.0)	N/A	6 (14)	

Table 2.2 480Vac Wire Sizes and Connector Specifications (Continued)

Drive Model CIMR-F7U	Terminal Symbol	Terminal Screws	Clamping Torque lb. in. (N•m)	Possible Wire Sizes AWG (mm ²) *1	Recommended Wire Size AWG (mm ²) *2	Wire Type
4030	R/L1, S/L2, T/L3, ⊖, ⊕1, ⊕3, R1/L11, S1/L21, T1/L31	M6	35.2 to 43.99 (4.0 to 5.0)	N/A	3 (30)	600Vac UL Approved vinyl-sheathed or equivalent
	U/T1, V/T2, W/T3				4 (22)	
	⊕	M8	79.2 to 87.97 (9.0 to 10.0)	N/A	4 (22)	
4037	R/L1, S/L2, T/L3, ⊖, ⊕1, R1/L11, S1/L21, T1/L31	M8	79.2 to 87.97 (9.0 to 10.0)	N/A	2 (38)	
	U/T1, V/T2, W/T3				3 (30)	
	⊕3	M6	35.2 to 43.99 (4.0 to 5.0)	N/A	Application Dependent	
	⊕	M8	79.2 to 87.97 (9.0 to 10.0)	N/A	4 (22)	
4045	R/L1, S/L2, T/L3, ⊖, ⊕1, R1/L11, S1/L21, T1/L31	M8	79.2 to 87.97 (9.0 to 10.0)	N/A	1/0 (60)	
	U/T1, V/T2, W/T3				1 (50)	
	⊕3	M6	35.2 to 43.99 (4.0 to 5.0)	N/A	Application Dependent	
	⊕	M8	79.2 to 87.97 (9.0 to 10.0)	N/A	4 (22)	
4055	R/L1, S/L2, T/L3, ⊖, ⊕1, U/T1, V/T2, W/T3, R1/L11, S1/L21, T1/L31	M8	79.2 to 87.97 (9.0 to 10.0)	N/A	2/0 (70)	
	⊕3	M6	35.2 to 43.99 (4.0 to 5.0)	N/A	Application Dependent	
	⊕	M8	79.2 to 87.97 (9.0 to 10.0)	N/A	4 (22)	
4075	R/L1, S/L2, T/L3, ⊖, ⊕1, R1/L11, S1/L21, T1/L31	M10	154.8 to 197.5 (17.6 to 22.5)	N/A	4/0 (100)	
	U/T1, V/T2, W/T3				N/A	3/0 (80)
	⊕3	M8	77.4 to 95.0 (8.8 to 10.8)	N/A	Application Dependent	
	⊕	M10	154.8 to 197.5 (17.6 to 22.5)	N/A	2 (38)	
	r/l1, Ⓢ200/ℓ2200, Ⓢ400/ℓ2400	M4	11.4 to 12.3 (1.3 to 1.4)	N/A	16 (1.25)	
4090	R/L1, S/L2, T/L3, ⊖, ⊕1, R1/L11, S1/L21, T1/L31	M10	154.8 to 197.5 (17.6 to 22.5)	N/A	250 (125)	
	U/T1, V/T2, W/T3				N/A	4/0 (100)
	⊕3	M8	77.4 to 95.0 (8.8 to 10.8)	N/A	Application Dependent	
	⊕	M10	154.8 to 197.5 (17.6 to 22.5)	N/A	1 (50)	
	r/l1, Ⓢ200/ℓ2200, Ⓢ400/ℓ2400	M4	11.4 to 12.3 (1.3 to 1.4)	N/A	16 (1.25)	
4110	R/L1, S/L2, T/L3, ⊖, ⊕1, R1/L11, S1/L21, T1/L33	M10	154.8 to 197.5 (17.6 to 22.5)	N/A	2/0 × 2P (70 × 2P)	
	U/T1, V/T2, W/T3				N/A	1/0 × 2P (60 × 2P)
	⊕3	M8	77.4 to 95.0 (8.8 to 10.8)	N/A	Application Dependent	
	⊕	M12	276.2 to 344.8 (31.4 to 39.2)	N/A	2/0 (70)	
	r/l1, Ⓢ200/ℓ2200, Ⓢ400/ℓ2400	M4	11.4 to 12.3 (1.3 to 1.4)	N/A	16 (1.25)	

Table 2.2 480Vac Wire Sizes and Connector Specifications (Continued)

Drive Model CIMR-F7U	Terminal Symbol	Terminal Screws	Clamping Torque lb. in. (N*m)	Possible Wire Sizes AWG (mm ²) *1	Recommended Wire Size AWG (mm ²) *2	Wire Type
4132	R/L1, S/L2, T/L3, ⊖, ⊕1, R1/L11, S1/L21, T1/L33	M10	154.8 to 197.5 (17.6 to 22.5)	N/A	3/0 × 2P (80 × 2P)	
	U/T1, V/T2, W/T3				2/0 × 2P (70 × 2P)	
	⊕3	M8	77.4 to 95.0 (8.8 to 10.8)	N/A	Application Dependent	
	⊖	M12	276.2 to 344.8 (31.4 to 39.2)	N/A	4/0 (100)	
	r/l1, a200/l2200, a400/l2400	M4	11.4 to 12.3 (1.3 to 1.4)	N/A	16 (1.25)	
4160	R/L1, S/L2, T/L3, ⊖, ⊕1, R1/L11, S1/L21, T1/L33	M12	276.2 to 344.8 (31.4 to 39.2)	N/A	4/0 × 2P (100 × 2P)	
	U/T1, V/T2, W/T3				3/0 × 2P (80 × 2P)	
	⊕3	M8	77.4 to 95.0 (8.8 to 10.8)	N/A	Application Dependent	
	⊖	M12	276.2 to 344.8 (31.4 to 39.2)	N/A	1/0 × 2P (60 × 2P)	
	r/l1, a200/l2200, a400/l2400	M4	11.4 to 12.3 (1.3 to 1.4)	N/A	16 (1.25)	
4185	R/L1, S/L2, T/L3, U/T1, V/T2, W/T3, R1/L11, S1/L21, T1/L33	M16	693.9 to 867.4 (78.4 to 98.0)	N/A	300 x 2P (150 x 2P)	
	⊖, ⊕1				600 X 2P (325 X 2P)	
	⊕3				Application Dependent	
	⊖				3/0 x 2P (80 x 2P)	
	r/l1, a200/l2200, a400/l2400	M4	11.4 to 12.3 (1.3 to 1.4)	N/A	16 (1.25)	
4220	R/L1, S/L2, T/L3, R1/L11, S1/L21, T1/L33	M16	693.9 to 867.4 (78.4 to 98.0)	N/A	500 x 2P (325 x 2P)	
	U/T1, V/T2, W/T3				400 x 2P (200 x 2P)	
	⊖, ⊕1				250 X 4P (125 X 4P)	
	⊕3				Application Dependent	
	⊖				250 x 2P (125 x 2P)	
	r/l1, a200/l2200, a400/l2400	M4	11.4 to 12.3 (1.3 to 1.4)	N/A	16 (1.25)	
4300	R/L1, S/L2, T/L3, R1/L11, S1/L21, T1/L33	M16	693.9 to 867.4 (78.4 to 98.0)	N/A	250 x 4P (125 x 4P)	
	U/T1, V/T2, W/T3				4/0 x 4P (100 x 4P)	
	⊖, ⊕1				400 X 4P (200 X 4P)	
	⊕3				Application Dependent	
	⊖				400 x 2P (203 x 2P)	
	r/l1, a200/l2200, a400/l2400	M4	11.4 to 12.3 (1.3 to 1.4)	N/A	16 (1.25)	

*1 Wire size range provided for Drives using insulated screw-type terminal blocks. All other models require the use of UL listed connectors. Refer to Table 2.3.

*2 Recommended wire sizes are based on the normal duty (ND) current ratings and NEC Article 310 Table 310.16, 75 Degree Celsius copper or equivalent. When sizing wiring based on the heavy duty (HD) current ratings, consult NEC Article 430 and any other applicable codes.

IMPORTANT

Determine the wire size for the main circuit so that line voltage drop is within 2% of the rated voltage. Line voltage drop is calculated as follows:

$$\text{Line voltage drop (V)} = \sqrt{3} \times \text{wire resistance } (\Omega/\text{km}) \times \text{wire length (m)} \times \text{current (A)} \times 10^{-3}$$

The use of UL listed closed-loop connectors or CSA certified ring connectors sized for the selected wire gauge is recommended to maintain proper clearances when wiring the Drive. Install connectors per manufacturer recommendation using the correct crimp tool. Table 2.3 lists a suitable closed-loop connector manufactured by JST Corporation.

Wire Size *		Terminal Screw	Ring Tongue (R-Type) Closed-Loop Connectors (Lugs) JST Corporation Part Numbers **
AWG	mm ²		
20	0.5	M3.5	1.25 - 3.7
		M4	1.25 - 4
18	0.75	M3.5	1.25 - 3.7
		M4	1.25 - 4
16	1.25	M3.5	1.25 - 3.7
		M4	1.25 - 4
14	2	M3.5	2 - 3.7
		M4	2 - 4
		M5	2 - 5
		M6	2 - 6
		M8	2 - 8
12 / 10	3.5 / 5.5	M4	5.5 - 4
		M5	5.5 - 5
		M6	5.5 - 6
		M8	5.5 - 8
8	8	M5	8 - 5
		M6	8 - 6
		M8	8 - 8
6	14	M5	14 - 5
		M6	14 - 6
		M8	14 - 8
4	22	M5	22 - 5
		M6	22 - 6
		M8	22 - 8
3 / 2	30 / 38	M6	38 - 6
		M8	38 - 8
1 / 1/0	50 / 60	M8	60 - 8
		M10	60 - 10
2/0	70	M8	70 - 8
		M10	70 - 10
3/0	80	M10	80 - 10
		M16	80 - 16
4/0	100	M10	100 - 10
		M12	100 - 12
		M16	100 - 16
250 / 300MCM	125 / 150	M10	150 - 10
		M12	150 - 12
		M16	150 - 16
400MCM	200	M12	200 - 12
650MCM	325	M12 x 2	325 - 12
		M16	325 - 16

* Wire sizes are based on 75 degrees Celsius copper wire.
 ** Equivalent connector can be used.

◆ Main Circuit Terminal Functions

Main circuit terminal functions are summarized according to terminal symbols in Table 2.4. Wire the terminals correctly for the desired purpose.

Table 2.4 Main Circuit Terminal Functions (208-240Vac and 480Vac)			
Purpose	Terminal Designation	Model: CIMR-F7U□□□□	
		208-240Vac	480Vac
Main circuit power input	R/L1, S/L2, T/L3	20P4 to 2110	40P4 to 4300
	R1/L11, S1/L21, T1/L31	2022 to 2110	4030 to 4300
Drive outputs	U/T1, V/T2, W/T3	20P4 to 2110	40P4 to 4300
DC power input	⊕1, ⊖	20P4 to 2110	40P4 to 4300
Braking Resistor Unit Connection	B1, B2	20P4 to 2018	40P4 to 4018
Braking Transistor Unit Connection	⊕3, ⊖	2022 to 2110	4022 to 4300
DC link choke connection	⊕1, ⊕2	20P4 to 2018	40P4 to 4018
Ground	⊖	20P4 to 2110	40P4 to 4300

◆ Main Circuit Configurations 208-240Vac

The 208-240Vac main circuit configurations of the Drive are shown in Table 2.5.

Table 2.5 Drive Main Circuit Configurations	
208-240Vac	
<p>CIMR-F7U20P4 to 2018</p>	<p>CIMR-F7U2022 and 2030</p>
<p>CIMR-F7U2037 to 2110</p>	<p>—</p>
<p>*1 Input fuses or molded case circuit breakers are required for proper branch circuit protection for all Drives. Failure to use recommended fuses/circuit breakers (See Appendix E) may result in damage to the Drive and/or personal injury.</p> <p>*2 Consult your Yaskawa representative before using 12-pulse rectification circuit configuration.</p>	

◆ Main Circuit Configurations 480Vac

The 480Vac main circuit configurations of the Drive are shown in Table 2.6.

Table 2.6 Drive Main Circuit Configurations	
480Vac	
<p style="text-align: center;">CIMR-F7U40P4 to 4018</p>	<p style="text-align: center;">CIMR-F7U4022 to 4055</p>
<p style="text-align: center;">CIMR-F7U4075 to 4300</p>	<p style="text-align: center;">-</p>
<p>*1 Input fuses or molded case circuit breakers are required for proper branch circuit protection for all Drives. Failure to use recommended fuses/circuit breakers (See Appendix E) may result in damage to the Drive and/or personal injury.</p> <p>*2 Consult your Yaskawa representative before using 12-pulse rectification circuit configuration.</p>	

Cable Length between Drive and Motor

If the cable between the Drive and the motor is long, the high-frequency leakage current will increase, causing the Drive output current to increase as well. This may affect peripheral devices. To prevent this, reduce cable length, or if necessary, adjust the carrier frequency (set in parameter C6-02) as shown in Table 2.7.

Table 2.7 Motor Cable Length vs. Carrier Frequency			
Motor Cable Length	164 ft. (50m) maximum	328 ft. (100m) maximum	More than 328 ft.(100m)
Carrier Frequency	15kHz maximum	10kHz maximum	5kHz maximum

■ Ground Wiring

Observe the following precautions when connecting the ground wire:

1. 208-240Vac Drives should have a ground connection with resistance of less than 100Ω .
2. 480Vac Drives should have a ground connection with resistance of less than 10Ω .
3. Do not share the ground wire with other devices, such as welding machines or large-current electrical equipment.
4. Always use a ground wire that complies with technical standards on electrical equipment and minimize the length of the ground wire. Leakage current flows through the Drive. Therefore, if the distance between the ground rod and the ground terminal is too long, potential on the ground terminal of the Drive could develop.
5. When using more than one Drive, be careful not to loop the ground wire. See Fig 2.4.

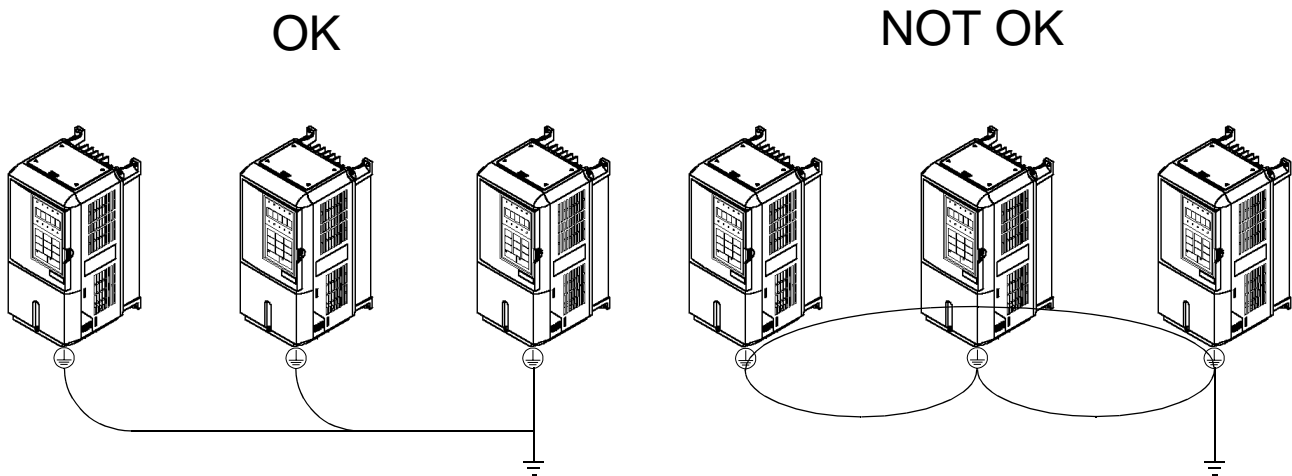

Fig 2.4 Ground Wiring Examples

◆ Dynamic Braking Connections

■ General

Dynamic braking (DB) enables the motor to be brought to a smooth and rapid stop. This is achieved by dissipating the regenerative energy of the AC motor across the resistive components of the Dynamic Braking option. For further details on dynamic braking operation, see the instruction sheet shipped with dynamic braking components.

Drives F7U20P4 thru F7U2018 and F7U40P4 thru F7U4018 have an integral braking transistor and require the addition of a Remote Mounted Resistor Unit or a Heat Sink Mount Resistor (ERF). All higher rated Drives require the use of a Braking Transistor Unit (CDBR) and a Remote Mount Resistor Unit.

Remote Mount Resistor Units typically mount outside of the electrical enclosure. Braking Transistor Units mount inside of the electrical enclosure. Heat Sink Mount Resistors mount to the back of the Drive, attaching directly to the heat sink.

Table 2.8 Heat Sink Mount Dynamic Braking Resistor - 3% Duty Cycle

Drive		Heat Sink Mount Resistor							
Rated Input Vac	Drive Model No. F7U	Part No.	Qty. Reqd.	Resistance (Ohms)	Power (Watts)	Approx. Braking Torque (%)	Dimensions (Inches)		
							Height	Width	Depth
208-240	20P4	R7505	1	200	150	220	7.16	1.73	0.51
	20P7	R7505	1	200	150	125	7.16	1.73	0.51
	21P5	R7504	1	100	150	125	7.16	1.73	0.51
	22P2	R7503	1	70	150	120	7.16	1.73	0.51
	23P7	R7510	1	62	150	100	7.16	1.73	0.51
480	40P4	R7508	1	750	150	230	7.16	1.73	0.51
	40P7	R7508	1	750	150	130	7.16	1.73	0.51
	41P5	R7507	1	400	150	125	7.16	1.73	0.51
	42P2	R7506	1	115	150	115	7.16	1.73	0.51
	43P7	R7505	1	200	150	110	7.16	1.73	0.51

■ Installation

This option should only be installed by a technically qualified individual who is familiar with this type of equipment and the hazards involved.



Hazardous voltages can cause severe injury or death. Lock all power sources feeding the Drive in the “OFF” position. Failure to follow these installation steps may cause equipment damage or personal injury.

Preliminary Procedures

1. Disconnect all electrical power to the Drive.
2. Remove Drive front cover.
3. Use a voltmeter to verify that voltage is disconnected from incoming power terminals and that the DC bus has dissipated.

Heat Sink Mount Resistor Installation

1. Remove the Drive from its mounting for access to the rear of the heat sink.
2. Attach the Heat Sink Mount Resistor on the back of the Drive's heat sink with screws M4 x 10mm (0.7mm pitch), as shown in figure below.
3. Remove the rubber plug and run the braking resistor wires into the hole that leads to the terminal block.
4. Reinstall the Drive in its mounting position.
5. Connect the leads from the Heat Sink Mount Resistor to the Drive terminals B1 and B2.
6. Proceed to "Adjustments" section on page 2-18.

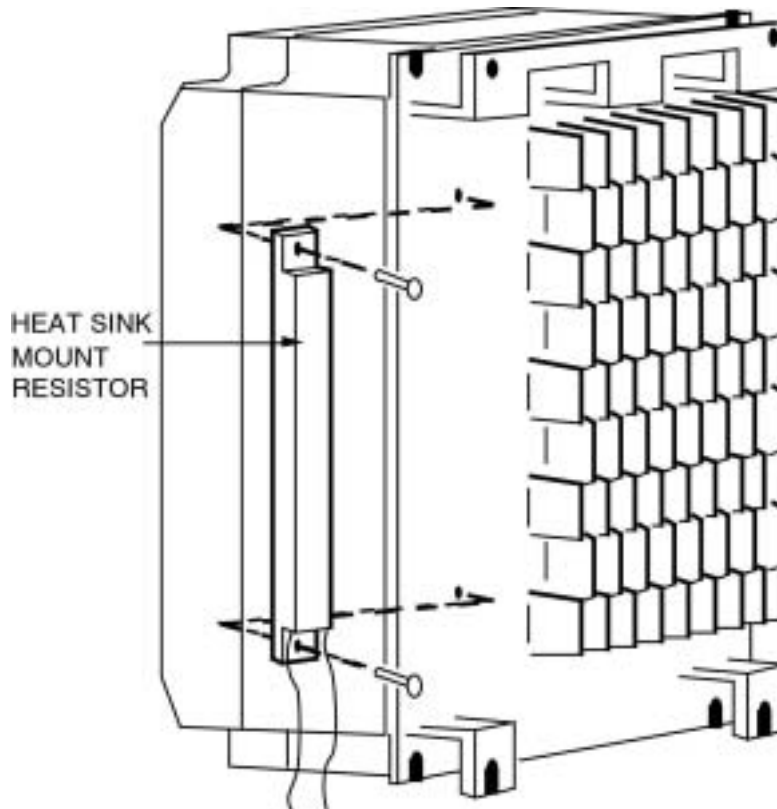

Fig 2.5 Attaching Heat Sink Mount Resistor on Heat Sink

**Remote Mount Resistor Unit Installation Using Internal Braking Transistor
(for F7U20P4 thru F7U2018 and F7U40P4 thru F7U4018)**

Since the Remote Mount Resistor Unit generates heat during dynamic braking operation, install it in a location away from other equipment.

1. Install the Remote Mount Resistor Unit to a noncombustible surface, maintaining a minimum 1.97 inches (50mm) clearance on each side and a minimum 7.87 inches (200mm) clearance on top.
2. Remove the Remote Mount Resistor Unit cover to access its terminal block. Connect the Remote Mount Resistor Unit to the Drive and to external control circuitry according to Fig 2.6 below.

Table 2.9 Wire Size for Remote Mount Resistor Unit		
Terminals	B, P, R1, R2	1, 2*
Wire Size (AWG)	12-10	18-14*
Wire Type	600V Ethylene propylene rubber insulated, or equivalent	
Terminal Screw	M4	

* Power Leads for the Remote Mount Resistor Unit generate high levels of electrical noise - these signal leads must be grouped separately.

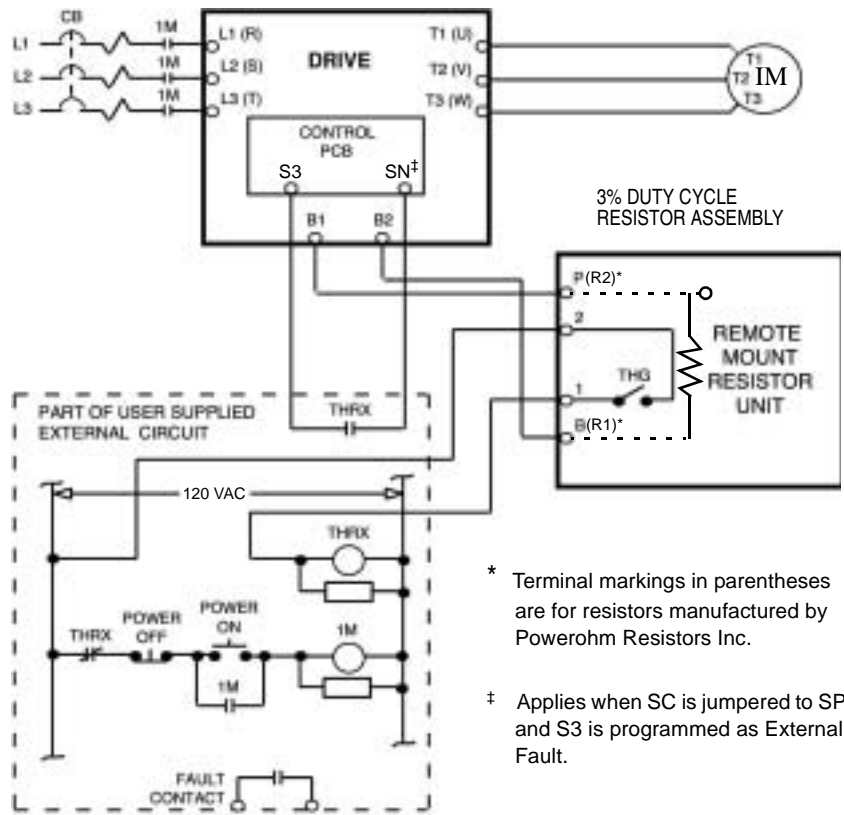

Fig 2.6 Wiring Remote Mount Resistor Unit (for F7U20P4 thru F7U2018 and F7U40P4 thru F7U4018)

3. Reinstall and secure Remote Mount Resistor Unit cover and Drive front cover.
4. Proceed to “Adjustments” section on Page 2-18.

Braking Transistor Unit(s) and Remote Mount Resistor Unit(s) Installation (for F7U2022 thru F7U2110 and F7U4022 thru F7U4300)

Since the Remote Mount Resistor Unit generates heat during dynamic braking operation, install it to a noncombustible surface in a location away from other equipment.

Select mounting locations for Braking Transistor Unit(s) and Remote Mount Resistor Unit(s) so that wiring between the Drive and the Braking Transistor Unit is 16 feet (5m) or less, and the wiring between each Braking Transistor Unit and its associated Remote Mount Resistor Unit, is less than 33 feet (10m).

1. Mount the Braking Transistor Unit(s) on a vertical surface. The Braking Transistor Unit requires a minimum of 1.18 inches (30mm) clearance on each side and a minimum 3.94 inches (100mm) clearance top and bottom. Attach the Remote Mount Resistor Unit maintaining a minimum 1.97 inches (50mm) clearance on each side and a minimum 7.87 inches (200mm) clearance on top.
2. In each Braking Transistor Unit, set the nominal line voltage jumper plug to the correct setting for the installation; this is factory set at the 220V/440V/575V position. To access jumper plugs, remove the plastic cover.



- Be sure to set the nominal line voltage selection jumper to match the level of the AC supply being applied to the Drive.
 - Failure to do so may result in improper operation.
3. If multiple Braking Transistor Units are being installed, the unit closest to the Drive should have the Slave/Master jumper plug set to the “Master” position (factory setting); all others must have this jumper plug set to the “Slave” position.
 4. If a single Braking Transistor Unit and Remote Mount Resistor Unit are being installed, connect them to the Drive and external control circuitry according to the chart and figure below.
 5. Power leads for the Remote Mount Resistor Unit generate high levels of electrical noise - these power leads must be grouped separately from all other leads.

Table 2.10 Wire Size for Remote Mount Resistor Unit and Braking Transistor Unit

Name	Circuit	Terminals	Wire Size AWG (mm ²)	Wire Type	Terminal Screw
Braking Transistor Unit (Models CDBR-2015B, -2022B, -4030B, -4045B)	Main	⊕ ⊕0 ⊖ ⊖0	12-10 (3.5-5.5)	600V vinyl sheathed wire or equivalent	M4
	Control	1 2 3 4 5 6	18-14 (0.75-2)		
Braking Transistor Unit (Model CDBR-2045, -4090)	Main	P, Po, N, B	12-10 (3.5-5.5)	600V vinyl sheathed wire or equivalent	M5
	Control	1 2 3 4 5 6	18-14 (0.75-2)		M4
Braking Transistor Unit (Model CDBR-2110)	Main	P, Po, N, B	4 (22) 8-6 (8-14) *1	600V vinyl sheathed wire or equivalent	M6
		r s	12-10 (3.5-5.5)		M4
	Control	1 2 3 4 5 6	18-14 (0.75-2)		
Braking Transistor Unit (Model CDBR-4220)	Main	P, Po, N, B	4 (22) 8-6 (8-14) *1	600V vinyl sheathed wire or equivalent	M6
		r s	12-10 (3.5-5.5)		M4
	Control	1 2 3 4 5 6	18-14 (0.75-2)		
Braking Resistor Unit (Model LKEB-□)	Main	B P	12-10 (3.5-5.5)	600V vinyl sheathed wire or equivalent	M4 (M5) *2
	Control	1 2	18-14 (0.75-2)		M4

*1 For wire size of 8-6 (8-14), use UL1283 heat-resistant vinyl-insulated wire or equivalent.
 *2 M4 for Models LKEB-20P7 to -27P5 or -40P7 to -4015.
 M5 for Models LKEB-2011 to -2022 or -4018 to -4045.

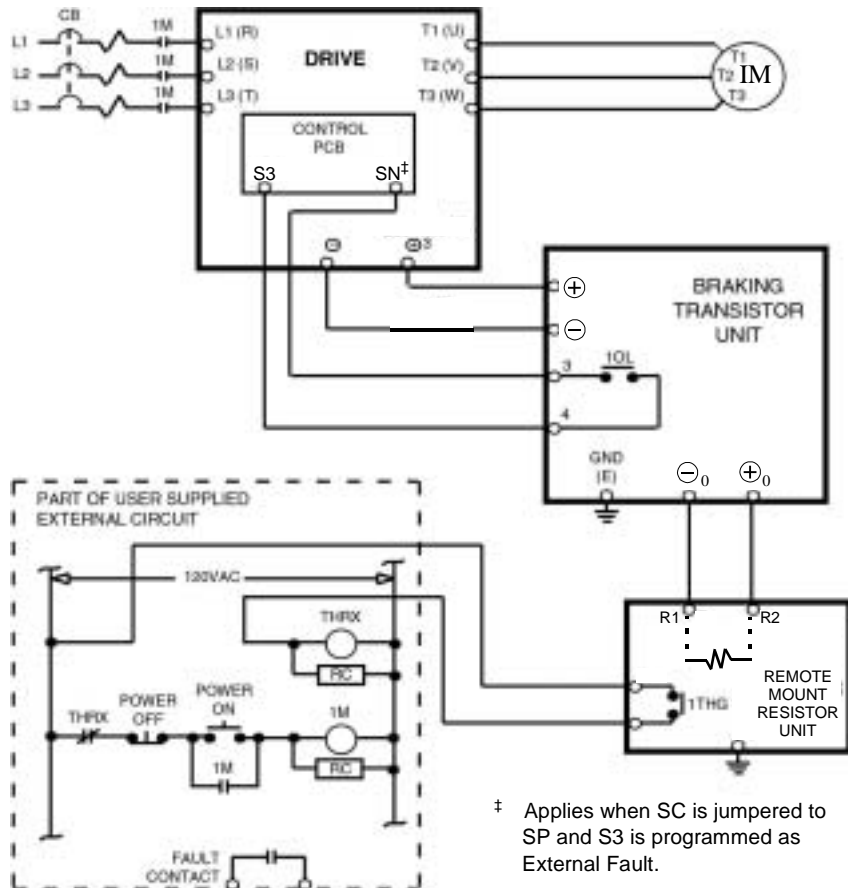
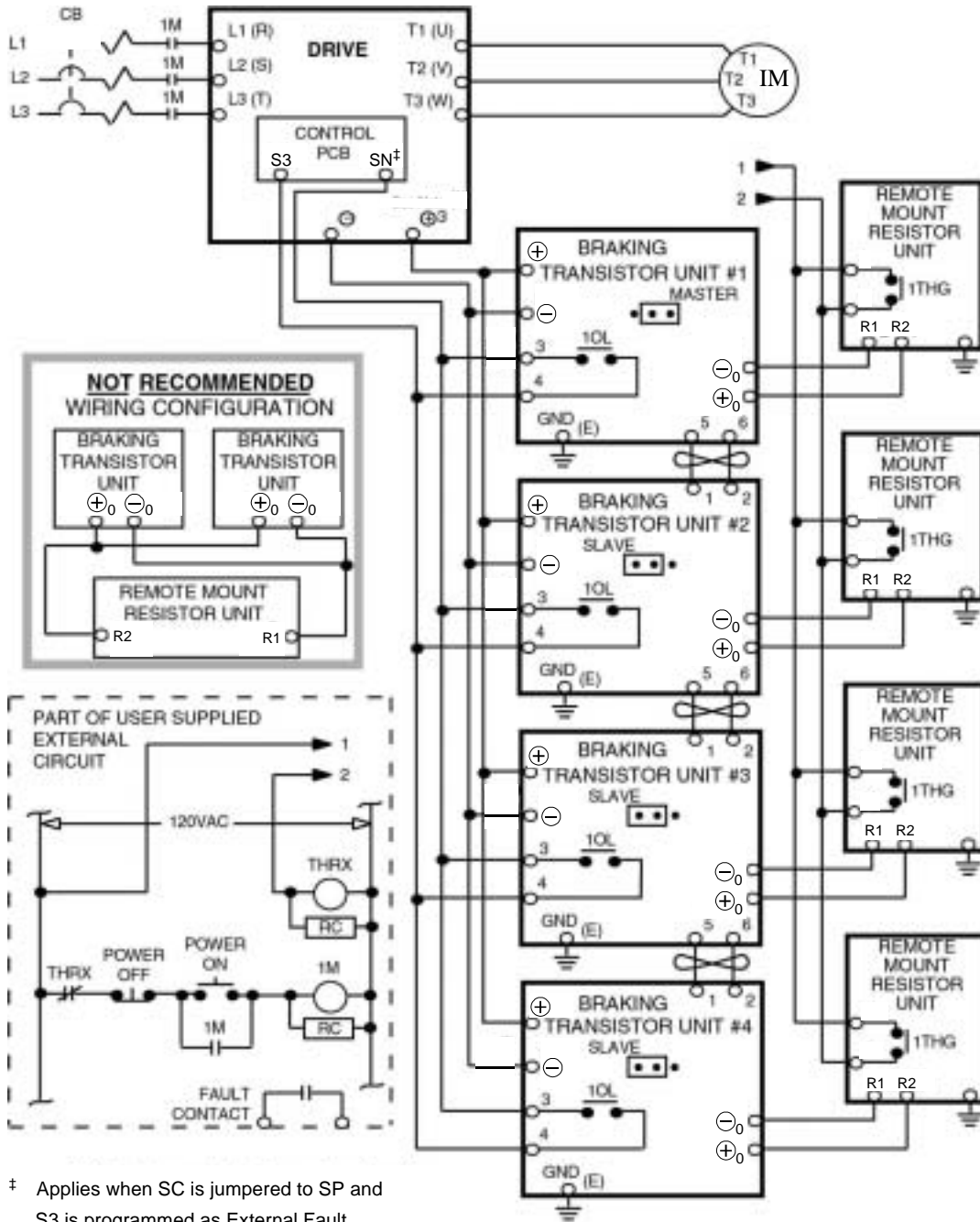

Fig 2.7 Wiring Single Braking Transistor Unit and Remote Mount Resistor Unit to Drive (F7U2022 thru F7U2110 and F7U4022 thru F7U4300)

6. If two or more Braking Transistor Units and Remote Mount Resistor Units are being installed, connect them to the Drive and to external circuitry according to Fig 2.8.



Note: Connect only the number of braking transistor units and remote mount resistor units required for the application.

Fig 2.8 Wiring Multiple Braking Transistor Units and Remote Mount Resistor Units to Drive (F7U2022 thru F7U2110 and F7U4022 thru F7U4300)

Adjustments

7. All Drives: Program Parameter L3-04 to “0” or “3” to disable stall prevention during deceleration.
8. Heat Sink Mount Resistor Only: Program L8-01 to “1” to enable overheat protection for heat sink mount braking resistor.

Operation Check

9. During dynamic braking, verify that the “BRAKE” lamp inside the Braking Unit is lit. This lamp illuminates only when dynamic braking is activating (during quick deceleration).
10. During dynamic braking, ensure that the required deceleration characteristic is obtained. If not, contact Yaskawa for assistance.
11. Reinstall and secure covers on the Braking Transistor Units, Remote Mount Resistor Units, and the Drive.

Terminal Connections

Connections to Drive terminals are shown in Fig 2.9.

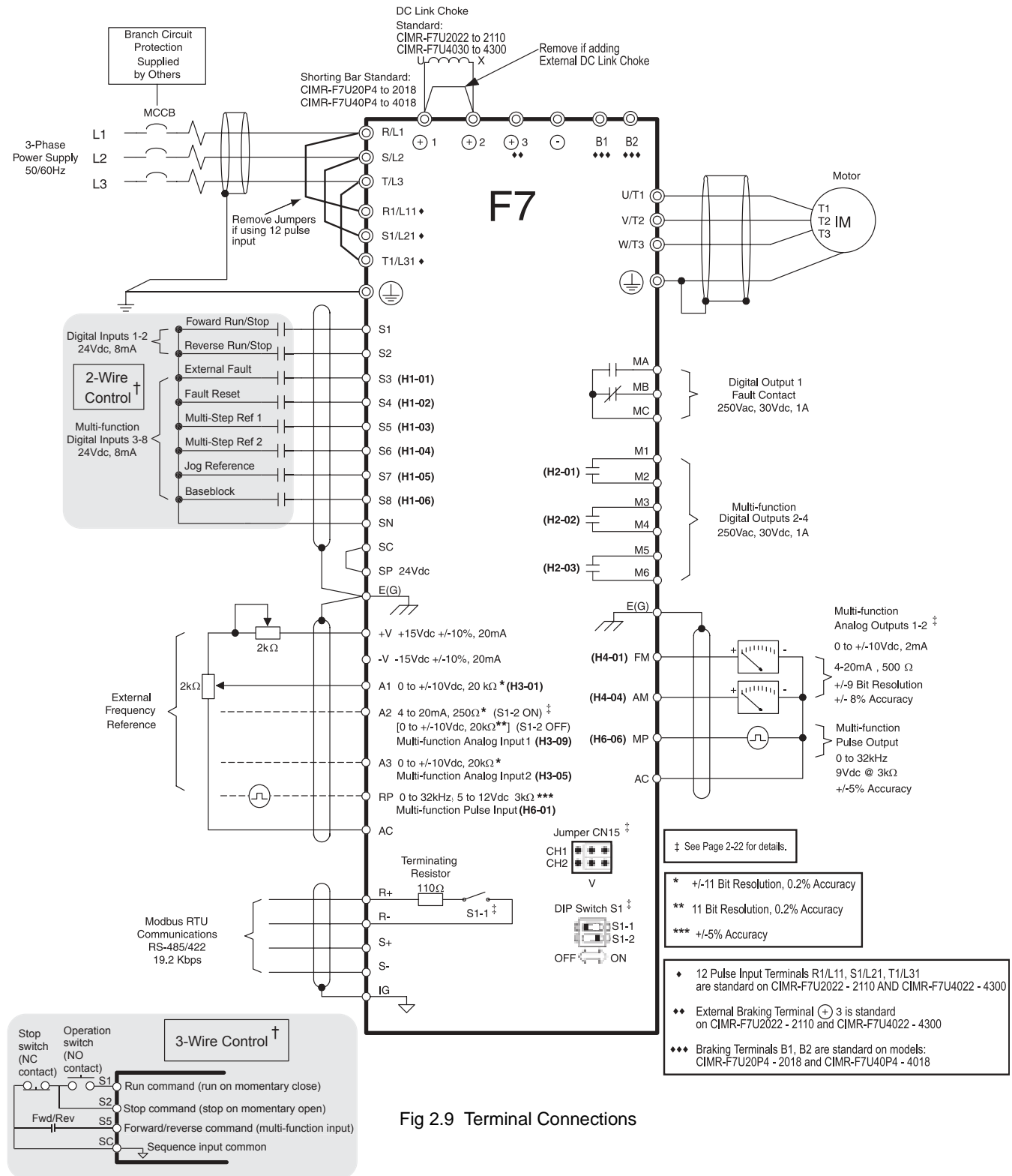

Fig 2.9 Terminal Connections

Control Wiring

◆ Control Circuit Terminal Functions

The factory default functions of the control circuit terminals for 2-wire control are shown in Table 2.11.

Type	No.	Default Function	Description	Signal Level	
Digital Input Signals	S1	Forward run/stop command	Forward run when CLOSED; stopped when OFF.	24Vdc, 8mA Photocoupler isolation	
	S2	Reverse run/stop command	Reverse run when CLOSED; stopped when OFF.		
	S3	External fault input	Fault when CLOSED.		Multi-function digital inputs. Functions set by H1-01 to H1-06.
	S4	Fault reset	Reset when CLOSED.		
	S5	Multi-step speed reference 1 (Master/auxiliary switch)	Auxiliary frequency reference when CLOSED.		
	S6	Multi-step speed reference 2	Multi-step setting 2 when CLOSED.		
	S7	Jog frequency reference	Jog frequency when CLOSED.		
	S8	External baseblock N.O.	Shuts off Drive's output when CLOSED.		
	SN	Digital input supply common	Refer to Table 2.15 for connection details.		
	SC	Digital input photocoupler			
SP	Digital input supply +24Vdc				
Analog Input Signals	+V	+15Vdc power output	+15Vdc power supply for analog inputs or transmitters.	+15Vdc (Max. current: 20mA)	
	-V	-15Vdc power output	-15Vdc power supply for analog inputs or transmitters.	-15Vdc (Max. current: 20mA)	
	A1	Analog input or speed command	0 to +10Vdc/100% 0 to +/-10Vdc / 100% (H3-01)	0 to +10V(20kΩ)	
	A2	Add to terminal A1	4 to 20mA/100% 0 to +10Vdc / 100% (H3-08)	Multi-function analog input 2. Function set by H3-09. 4 to 20mA(250Ω) 0 to +/-10V(20kΩ)	
	A3	Aux. frequency reference 1	0 to +10Vdc/100% 0 to +/-10Vdc / 100% (H3-04)	Multi-function analog input 3. Function set by H3-05 0 to +/-10V(20kΩ)	
	AC	Analog common	–	–	
	E(G)	Shield wire, optional ground line connection point	–	–	
Digital Output Signals	M1	During run (N.O. contact)	CLOSED during operation.	Multi-function digital output. Function set by H2-01.	
	M2				
	M3	Remote/auto operation (N.O. contact)	CLOSED when in local control.	Multi-function digital output. Function set by H2-02.	
	M4				
	M5	Frequency agree (N.O. contact)	CLOSED when set frequency matches output frequency.	Multi-function digital output. Function set by H2-03.	
	M6				
	MA	Fault output signal (SPDT)	MA/MC: CLOSED during fault condition MB/MC: OPEN during fault condition	Form C Dry contacts capacity: 1A max. at 250Vac 1A max. at 30Vdc	
	MB				
MC					

Type	No.	Default Function	Description		Signal Level
Analog Output Signals	FM	Output frequency	0 to +10Vdc / 100% frequency -10 to +10Vdc / 100% frequency 4 to 20mA / 100% frequency	Multi-function analog output 1. Function set by H4-01.	0 to +10Vdc -10 to +10Vdc (Max current 2mA) 4 to 20mA, 500Ω
	AM	Output current	0 to +10Vdc / 100% Drive's rated output current -10 to +10Vdc / 100% Drive's rated output current 4 to 20mA / 100% Drive's rated output current	Multi-function analog output 2. Function set by H4-04.	
	AC	Analog common	-		
Pulse I/O	RP	Pulse input	Pulse input frequency reference	Function set by H6-01.	0 to 32kHz (3kΩ) ±5% High level voltages 3.5 to 13.2 Low level voltages 0.0 to 0.8 Duty Cycle (on/off) 30% to 70%
	MP	Pulse monitor	Pulse output frequency	Function set by H6-06.	0 to 32kHz +5V output (Load: 1.5kΩ)
RS-485/422	R+	Modbus communication input	For 2-wire RS-485, jumper R+ and S+ and jumper R- and S-.		Differential input, PHC isolation
	R-				
	S+	Modbus communication output			Differential output, PHC isolation
	S-				
IG	Signal common	-	-		

Terminals	Terminal Screws	Tightening Torque lb-in (N•m)	Possible Wire Sizes AWG (mm ²)	Recommended Wire Size AWG (mm ²)	Wire Type
S1, S2, S3, S4, S5, S6, S7, S8, SN, SC, SP, +V, -V, A1, A2, A3, AC, RP, M1, M2, M3, M4, M5, M6, MA, MB, MC, FM, AC, AM, MP, R+, R-, S+, S-, IG	Phoenix type *3	4.2 to 5.3 (0.5 to 0.6)	Stranded wire: 26 to 16 (0.14 to 1.5)	18 (0.75)	<ul style="list-style-type: none"> Shielded, twisted-pair wire *1 Shielded, polyethylene-covered, vinyl sheath cable *2
E(G)	M3.5	7.0 to 8.8 (0.8 to 1.0)	20 to 14 (0.5 to 2)	12 (1.25)	

*1 Use shielded twisted-pair cables to wire an external speed command.
*2 Yaskawa recommends using straight solderless terminals on digital inputs to simplify wiring and improve reliability.
*3 Yaskawa recommends using a thin-slot screwdriver with a 3.5mm blade width.

◆ DIP Switch S1 and Jumper CN15

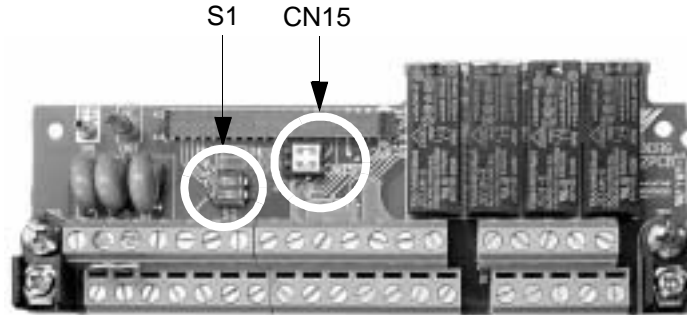

Fig 2.10 DIP Switch S1 and Jumper CN15 Location

■ Dip Switch S1

DIP Switch S1 is described in this section. The functions of DIP switch S1 are shown in Table 2.13.

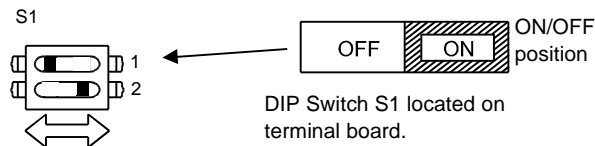









Fig 2.11 DIP Switch S1 Function

Name	Function	Setting
S1-1	RS-485 and RS-422 terminating resistance	OFF: No terminating resistance ON: Terminating resistance of 110Ω Factory Default = OFF
S1-2	Input method for analog input A2	OFF: 0 to 10Vdc or -10 to 10Vdc (internal resistance: 20KΩ) ON: 4-20mA (internal resistance: 250Ω) Factory Default = ON

■ Jumper CN15

Jumper CN15 is described in this section. The jumper position of CH1 and CH2 determines the signal level of the multi-function analog output FM and AM, respectively. The functions and positions of CN15 are shown in Table 2.14.

Jumper CN15 Configuration	Analog Output Monitor Configuration
CH1  CH2 	Voltage Output (0-10Vdc) for terminals FM-AC (CH1) and AM-AC (CH2)
CH1  CH2 	Current Output (4-20mA) for terminals FM-AC (CH1) and AM-AC (CH2)
CH1  CH2 	Voltage Output (0-10Vdc) for terminals FM-AC (CH1) Current Output (4-20mA) for terminals AM-AC (CH2)
CH1  CH2 	Current Output (4-20mA) for terminals FM-AC (CH1) Voltage Output (0-10Vdc) for terminals AM-AC (CH2)

◆ Sinking/Sourcing Mode

The multi-function digital input terminal logic can be switched between sinking mode (0Vdc common) and sourcing mode (+24Vdc common) by using the terminals SN, SC, and SP. An external power supply can also be connected, providing more freedom in signal input methods.

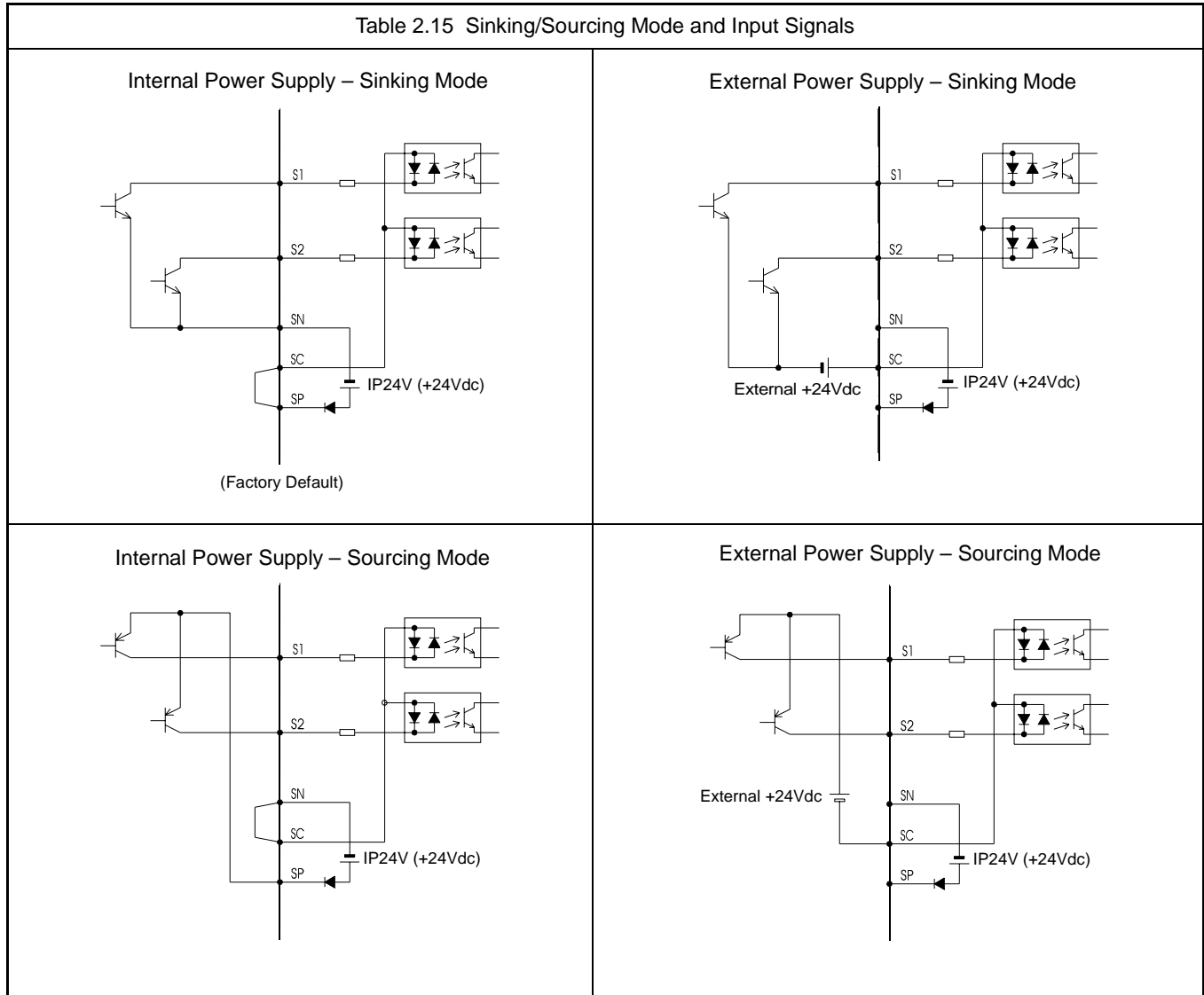

◆ Control Circuit Wiring Precautions

Observe the following precautions when wiring control circuits:

1. Low voltage wires shall be wired with Class 1 wiring.
2. Separate control wiring from power/motor wiring (terminals R/L1, S/L2, T/L3, U/T1, V/T2, W/T3, B1, B2, \ominus , $\oplus 1$, $\oplus 2$, and $\oplus 3$) and other high-power lines.
3. Separate wiring for control circuit terminals MA, MB, MC, M1, M2, M3, M4, M5, and M6 (digital outputs) from wiring to other control circuit terminals.
4. If using an optional external power supply, ensure it is a UL Listed Class 2 power supply source.
5. Use twisted-pair or shielded twisted-pair cables for control circuits to prevent operating faults. Prepare cable ends as shown in Fig 2.12.
6. Connect the shield wire to terminal E(G).
7. Insulate the shield with tape to prevent contact with other signal lines and equipment.

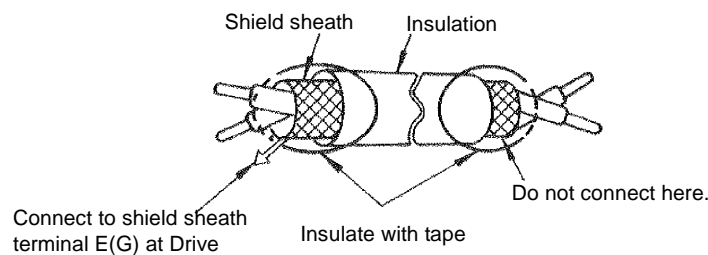

Fig 2.12 Preparing the Ends of Twisted-pair Cables

◆ Control Circuit Wire Sizes

For remote operation, keep the length of the control wiring to 50m or less. Separate the control wiring from high-power lines (input power, motor leads or relay sequence circuits) to reduce noise induction from peripheral devices.

When setting speed commands from an external speed potentiometer, use shielded twisted-pair wires and ground the shield to terminal E(G), as shown above. Terminal numbers and wire sizes are shown in Table 2.12.

◆ Wiring Checks

After all wiring is completed, perform the following checks:

1. Is all wiring correct?
2. Have all wire clippings, screws or other foreign material been removed from the Drive enclosure?
3. Are all terminal screws tight?

◆ Field Wiring Diagram

Use this diagram to document field wiring. It may be helpful to copy this page.

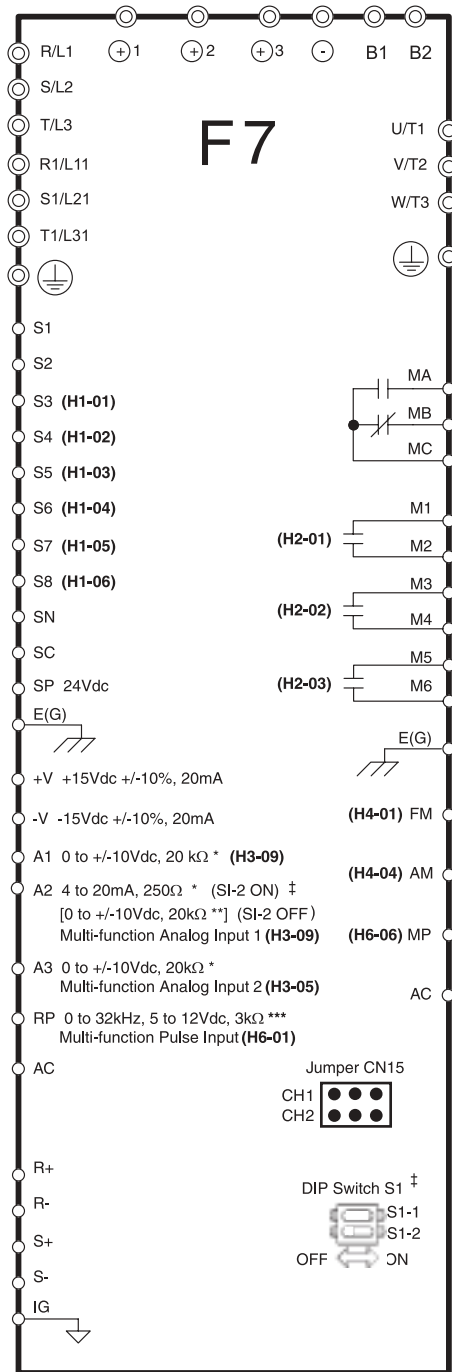

Fig 2.13 Field Wiring Diagram

Electromagnetic Compatibility (EMC)

◆ Introduction

This section describes the measures necessary to comply with the EMC (Electro Magnetic Compatibility) Directive. The manual's installation and wiring instructions must be followed for compliance.

Yaskawa products are tested by certified independent test laboratories for compliance toward the EMC Directive 89/336/EEC as amended by 91/263/EEC, 92/31/EEC, 93/68/EEC.

The F7 series Drives meet/conform to the following standards:

EN 61800-3: 1996, A11: 2000-01	EN 61000-4-5: 1995-03	VDE0847 Part 4-13: 1996
EN55011: 2000-05	EN 61000-4-6: 1996-97	IEC 61000-2-1: 1994
EN 61000-4-2: 1995-03	EN 61000-4-11: 1994	IEC 1000-4-27: 1997
EN 61000-4-3: 1997	CISPR 11: 1997	
EN 61000-4-4: 1995-03	VDE0847 Part 4-28: 1997	

◆ Measures to Ensure Conformity of Installed Yaskawa Drives to EMC Directive

Yaskawa Drives are not required to be installed in an EMC compatible enclosure.

It is not possible to give detailed instructions for all possible types of installations; therefore, this manual provides general guidelines.

All electrical equipment produces radio and line-borne interference at various frequencies. The power leads pass this on to the surrounding environment like an antenna. Connecting an item of electrical equipment (e.g. Drive) to a supply without a line filter can allow High Frequency (HF) or Low Frequency (LF) interference to penetrate the power distribution system. The basic countermeasures are isolation of the wiring of control and power components, proper grounding, and shielding of cables.

A large contact area is necessary for low-impedance grounding of HF interference. The use of grounding straps, instead of cables, is therefore highly recommended.

Cable shields must be connected with ground clips.

CE certification for EMC can be achieved using the line filters specified in this manual and following the appropriate installation instructions.

◆ Cable Installation

Measures against line-borne interference:

Use a power cable with a well-grounded shield. Use a shielded motor cable not exceeding 82 feet (25m) in length. Arrange all grounds to maximize the end of the lead area in contact with ground (e.g. metal plate).

Use a shielded cable with braided shield and ground the maximum possible area of the shield. It is advisable to ground the shield by connecting the cable to the ground plate with metal clips (see Fig 2.14).

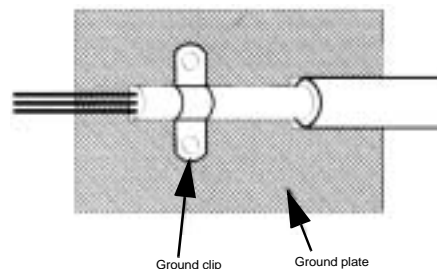

Fig 2.14 Grounding Surface Layout

The grounding surfaces must be highly conductive bare metal. Remove any varnish or paint from grounding surfaces. Be sure to ground the motor of the machine/application. Line filter and Drive must be mounted on the same metal plate. Mount the two components as close to each other as possible, with cables kept as short as possible, not exceeding 15.75" (see Fig 2.15). See Table 2.16 for recommended filters.

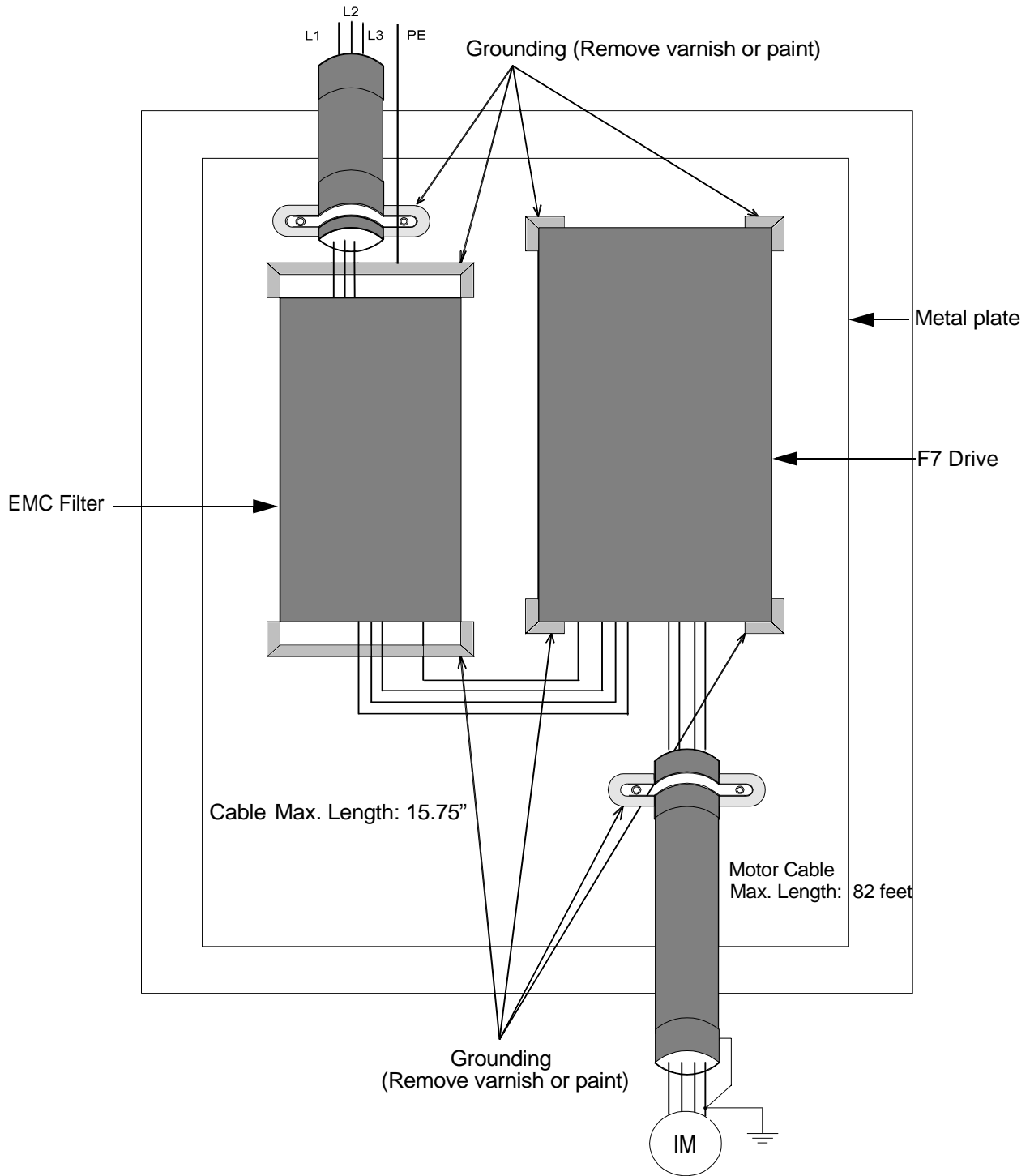

Fig 2.15 EMC Filter Layout

◆ Recommended EMC Filters

Table 2.16 Recommended EMC Filters

Drive Model CIMR-F7U	EMC Filter				
	Model Number	EN 55011 Class*	Current Rating	Weight lb. (kg)	Dimensions inches (mm)
200Vac Class					
20P4	FS5972-10-07	B	10A	2.43 (1.1)	5.500 x 13 x 1.875 (141 x 330 x 46)
20P7					
21P5					
22P2	FS5972-18-07	B	18A	2.87 (1.3)	5.500 x 13 x 1.875 (141 x 330 x 46)
23P7	FS5973-35-07	B	35A	3.09 (1.4)	5.500 x 13 x 1.875 (141 x 330 x 46)
25P5					
27P5	FS5973-60-07	B	60A	6.61 (3)	8 x 14 x 2.375 (206 x 355 x 60)
2011					
2015	FS5973-100-07	A	100A	10.8 (4.9)	9.3125 x 16 x 3.125 (236 x 408 x 80)
2018					
2022	FS5973-130-35	A	130A	9.48 (4.3)	3.5315 x 14.40625 x 7 (90 x 366 x 180)
2030					
2037	FS5973-160-40	A	160A	13.23 (6)	4.750 x 17.750 x 6.6875 (120 x 451 x 170)
2045	FS5973-240-37	A	240A	24.25 (11)	5.125 x 24 x 9.4375 (130 x 610 x 240)
2055					
2075	FS5973-500-37	A	500A	42.99 (19.5)	11.81 x 22.20 x 6.30 (300 x 564 x 160)
2090					
2110					
400Vac Class					
40P4	FS5972-10-07	B	10A	2.43 (1.1)	5.500 x 13 x 1.875 (141 x 330 x 46)
40P7					
41P5					
42P2					
43P7					
44P0	FS5972-18-07	B	18A	2.87 (1.3)	5.50 x 13 x 1.875 (141 x 330 x 46)
45P5					
47P5	FS5972-21-07	B	21A	3.97 (1.8)	8.11 x 13.98 x 1.97 (206 x 355 x 50)
4011	FS5972-35-07	B	35A	4.63 (2.1)	8.11 x 13.98 x 1.97 (206 x 355 x 50)
4015	FS5972-60-07	B	60A	8.82 (4)	9.250 x 16 x 2.50 (236 x 408 x 65)
4018					
4022	FS5972-70-52	B	70A	7.5 (3.4)	3 x 13 x 7.250 (80 x 329 x 185)
4030					
4037	FS5972-100-35	B	100A	9.92 (4.5)	3.54 x 12.83 x 5.9 (90 x 326 x 150)
4045					

Table 2.16 Recommended EMC Filters (Continued)

Drive Model CIMR-F7U	EMC Filter				
	Model Number	EN 55011 Class*	Current Rating	Weight lb. (kg)	Dimensions inches (mm)
4055	FS5972-130-35	B	130A	10.36 (4.7)	3.54 x 14.375 x 7 (90 x 366 x 180)
4075	FS5972-170-40	B	170A	13.23 (6)	4.75 x 17.75 x 6.6675 (120 x 451 x 170)
4090	FS5972-250-37	A	250A	24.25 (11)	5.125 x 24 x 9.475 (130 x 610 x 240)
4110					
4132	FS5972-410-99	A	410A	23.15 (10.5)	10.24 x 15.20 x 4.53 (260 x 386 x 115)
4160					
4185					
4220	UFI000032	A	600A	24.25 (11)	10.24 x 15.20 x 5.31 (260 x 386 x 135)
4300	UFI000033	A	800A	68.34 (31)	11.81 x 28.19 x 6.30 (300 x 716 x 160)
* Maximum Voltage: 480Vac 3-phase Ambient Temperature: 45 Degrees Celsius (maximum) Maximum motor cable length: 50m Class B, 50m Class A Permissible emission of power drive systems for commercial and light environment (EN61800-3, A11) (General availability, 1st environment)					

Installing and Wiring Option Boards

◆ Option Board Models and Specifications

Up to three Option Boards can be mounted in the Drive. You can mount one board into each of the three option slots on the control board (A, C, and D) shown in Fig 2.16. The following Table 2.17 lists the type of Option Boards and their specifications.

Option Board	Model	Specifications	Mounting Location
PG Speed Control Boards	PG-A2	Single open-collector feedback	A (4CN)
	PG-B2	Single A/B open collector encoder feedback	A (4CN)
	PG-D2	Single line-driver feedback	A (4CN)
	PG-X2	Single A/B/Z line-driver encoder feedback	A (4CN)
	PG-W2	Dual A/B/Z line-driver encoder feedback	A (4CN)
Speed Reference Boards	AI-14U	Analog input 0 to 10Vdc (20k Ω), 1 channel 4 to 20mA (250 Ω), 1 channel Input resolution: 14-bit	C (2CN)
	AI-14B	Analog input 0 to 10Vdc (20k Ω) 4 to 20mA (250 Ω), 3 channels (V or I) Input resolution: 13-bit plus sign bit	C (2CN)
	AI-14B2	Isolated analog input 0 to 10Vdc (20k Ω) 4 to 20mA (250 Ω), 3 channels (V or I) Input resolution: 13-bit plus sign bit	C (2CN)
	DI-08	8-bit digital input	C (2CN)
	DI-16H2	16-bit digital input	C (2CN)
DeviceNet Communications Board	SI-NX	DeviceNet communications	C (2CN)
Profibus-DP Communications Board	SI-PX	Profibus-DP communications	C (2CN)
InterBus-S Communications Board	SI-RX	InterBus-S communications	C (2CN)
CANopen Communications Board	SI-SX	CANopen communications	C (2CN)
Analog Monitor Boards	AO-08	Analog output, 8-bit 2 channels	D (3CN)
	AO-12	Analog output, 11-bit plus sign bit, 2 channels	D (3CN)
	AO-12B	Isolated analog output, 11-bit plus sign bit, 2 channels	D (3CN)
Digital Output Boards	DO-08	Six photocoupler outputs and 2 relay outputs	D (3CN)
	DO-02C	2 relay outputs	D (3CN)
	PO-36F	Pulse-train output	D (3CN)

◆ Installation

Before mounting an Option Board, remove power from the Drive and wait for the CHARGE LED to go out. Remove the Digital Operator, front cover, and option clip. Option Clip can be easily removed by squeezing the protruding portions of the clip and then pulling it out. Then, mount the Option Board(s).

The A Option Board uses a mounting spacer to secure the board to the control board. Insert the mounting spacer as shown in Fig 2.16.

After installing an Option Board into slot C or D, insert the Option Clip to prevent the side with the connector from rising.

Refer to documentation provided with the Option Board for detailed mounting instructions for option slots A, C, and D.

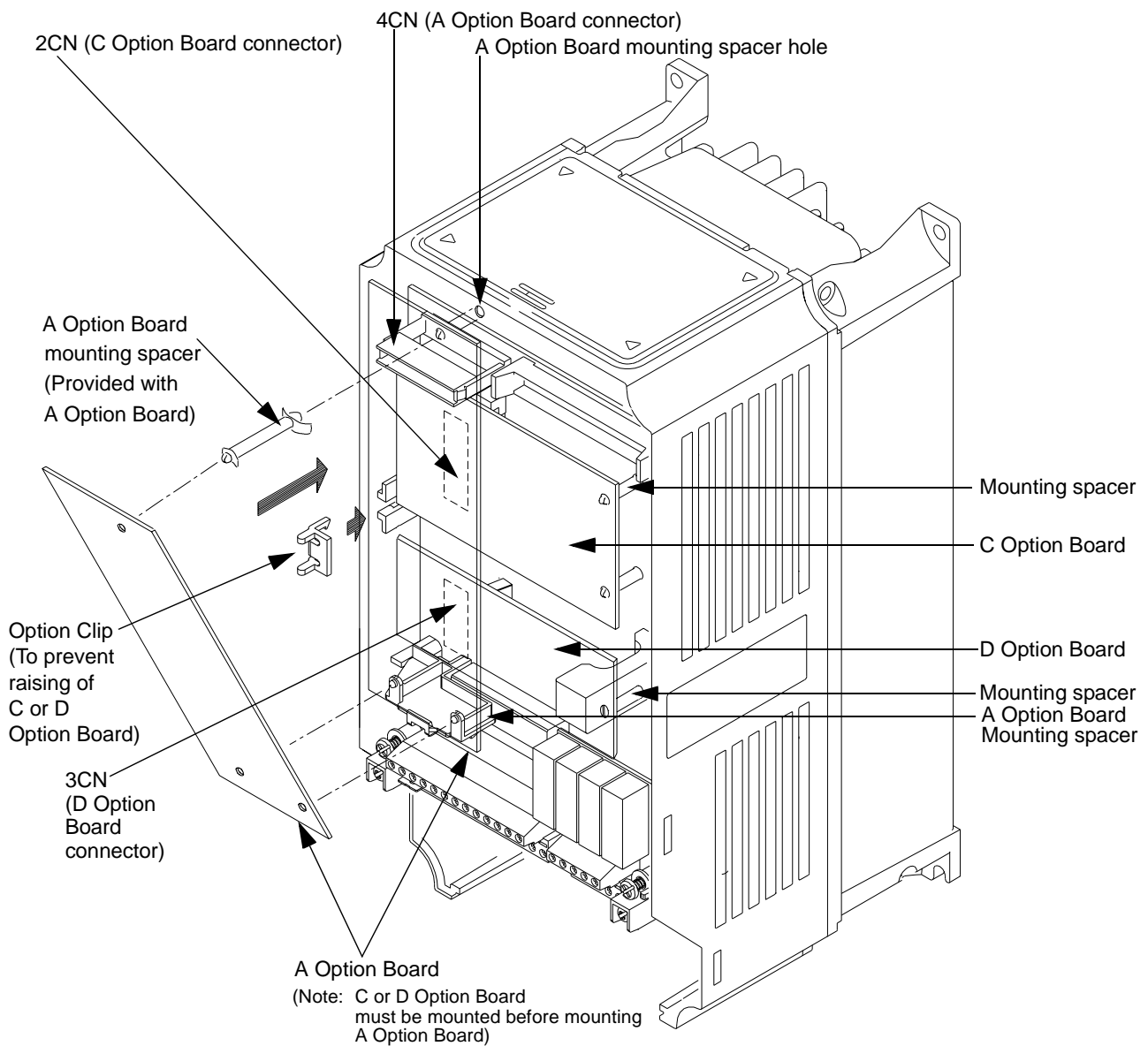

Fig 2.16 Mounting Option Boards

◆ PG (Encoder) Feedback Board Terminal Specifications and Wiring Examples

■ PG-A2

The terminal specifications for the PG-A2 are given in Table 2.18.

Terminal	No.	Contents	Specifications
TA1	1	Power supply for pulse generator	12Vdc ($\pm 5\%$), 200mA max.
	2		0Vdc (GND for power supply)
	3	+12V/open collector switching terminals	Terminals for switching between 12Vdc voltage input and open collector input. For open collector input, short across 3 and 4.
	4		
	5	A-phase pulse input terminals	H: +4 to 12V; L: +1V max. (Maximum response frequency: 30kHz)
	6		Pulse input common
	7	A-phase pulse monitor output terminals	12Vdc ($\pm 10\%$), 20mA max.
	8		Pulse monitor output common
TA2	(E)	Shield connection terminal	-

■ Wiring the PG-A2

Wiring examples are provided in the following figures for the PG-A2.

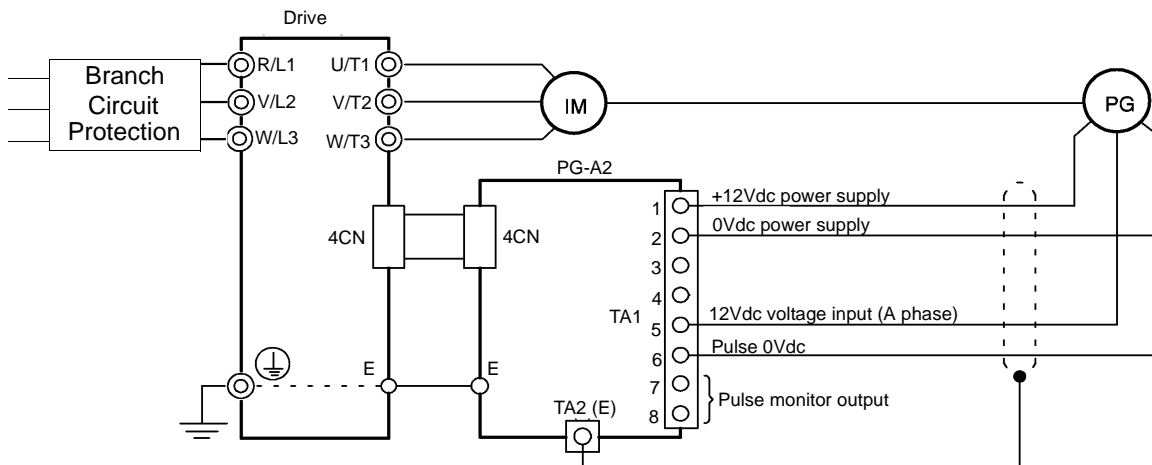

- Shielded twisted-pair wires must be used for signal lines.
- Do not use the PG-A2's power supply for anything other than the pulse generator (encoder). Using it for another purpose can cause malfunctions due to noise.
- The length of the pulse generator's wiring must not be more than 100 meters.

Fig 2.17 PG-A2 Open-Collector Input Wiring - Sourcing PG

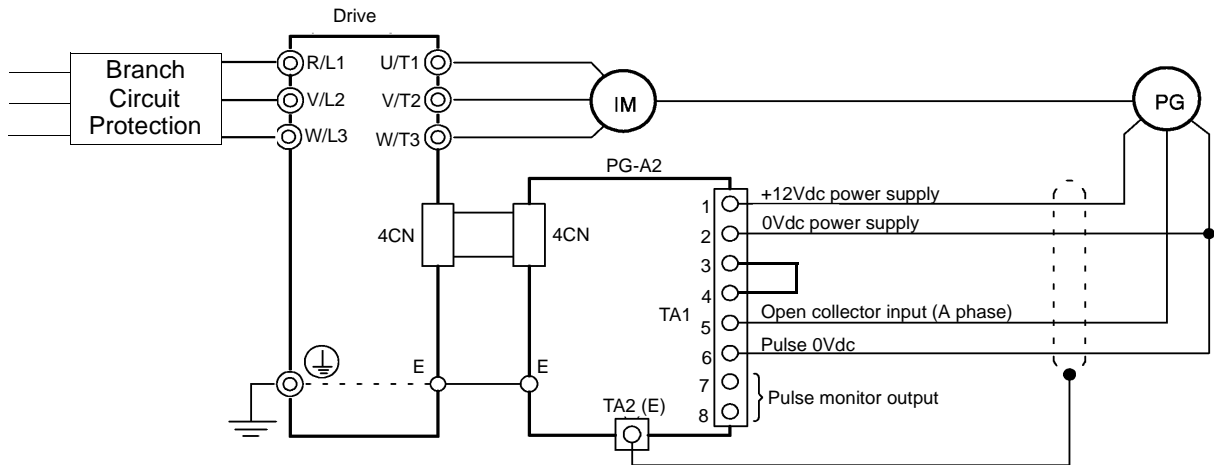

- Shielded twisted-pair wires must be used for signal lines.
- Do not use the PG-A2's power supply for anything other than the pulse generator (encoder). Using it for another purpose can cause malfunctions due to noise.
- The length of the pulse generator's wiring must not be more than 100 meters.

Fig 2.18 PG-A2 Open-Collector Input Wiring - Sinking PG

■ PG-B2

The terminal specifications for the PG-B2 are given in Table 2.19.

Terminal	No.	Contents	Specifications
TA1	1	Power supply for pulse generator	12Vdc ($\pm 5\%$), 200mA max.
	2		0Vdc (GND for power supply)
	3	A-phase pulse input terminals	H: +8 to 12Vdc L: +1Vdc max. (Maximum response frequency: 30 kHz)
	4		Pulse input common
	5	B-phase pulse input terminals	H: +8 to 12Vdc L: +1Vdc max. (Maximum response frequency: 30 kHz)
	6		Pulse input common
TA2	1	A-phase monitor output terminals	Open collector output, 24Vdc, 30mA max.
	2		A-phase monitor output common
	3	B-phase monitor output terminals	Open collector output, 24Vdc, 30mA max.
	4		B-phase monitor output common
TA3	(E)	Shield connection terminal	-

■ Wiring the PG-B2

Wiring examples are provided in Fig 2.19 and Fig. 2.20 for the PG-B2.

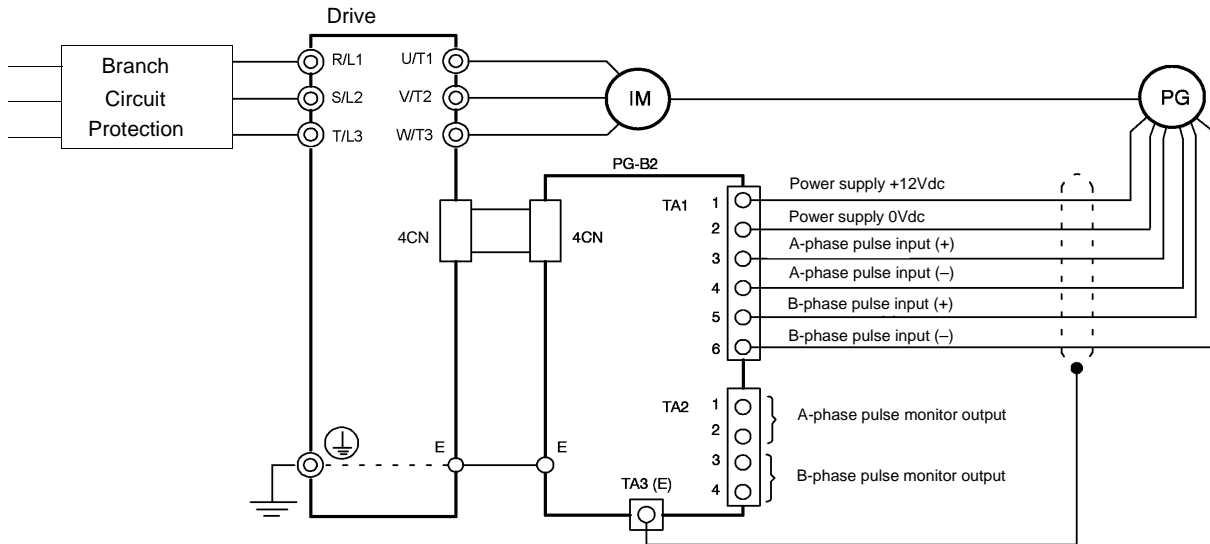

- Shielded twisted-pair wires must be used for signal lines.
- Do not use the PG-B2's power supply for anything other than the pulse generator (encoder). Using it for another purpose can cause malfunctions due to noise.
- The length of the pulse generator's wiring must not be more than 100 meters.
- The direction of rotation of the PG can be set in parameter F1-05 (PG Rotation). The factory preset is for forward rotation, A-phase advancement.

Fig 2.19 PG-B2 Open-Collector Input Wiring - Sourcing PG

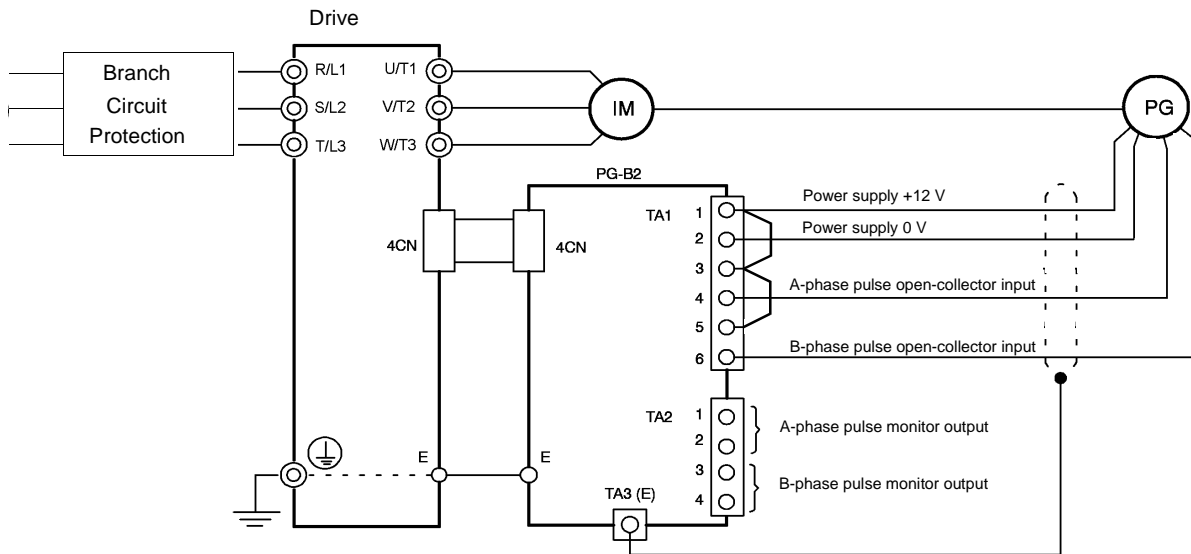

- Shielded twisted-pair wires must be used for signal lines.
- Do not use the PG-B2's power supply for anything other than the pulse generator (encoder). Using it for another purpose can cause malfunctions due to noise.
- The length of the pulse generator's wiring must not be more than 100 meters.
- The direction of rotation of the PG can be set in parameter F1-05 (PG Rotation). The factory preset is for forward rotation, A-phase advancement.

Fig 2.20 PG-B2 Open-Collector Input Wiring - Sinking PG

■ PG-D2

The terminal specifications for the PG-D2 are given in Table 2.20.

Table 2.20 PG-D2 Terminal Specifications			
Terminal	No.	Contents	Specifications
TA1	1	Power supply for pulse generator	12Vdc ($\pm 5\%$), 200mA max.*
	2		0Vdc (GND for power supply)
	3		5Vdc ($\pm 5\%$), 200mA max.*
	4	Pulse input terminals	Line driver input (RS-422 level)
	5		Maximum response frequency: 300kHz
	6	Common terminal	-
	7	Pulse monitor output terminals	Line driver output (RS-422 level)
	8		
TA2	(E)	Shield connection terminal	-

* 5Vdc and 12Vdc cannot be used at the same time.

■ Wiring the PG-D2

Wiring examples are provided in Fig 2.21 for the PG-D2.

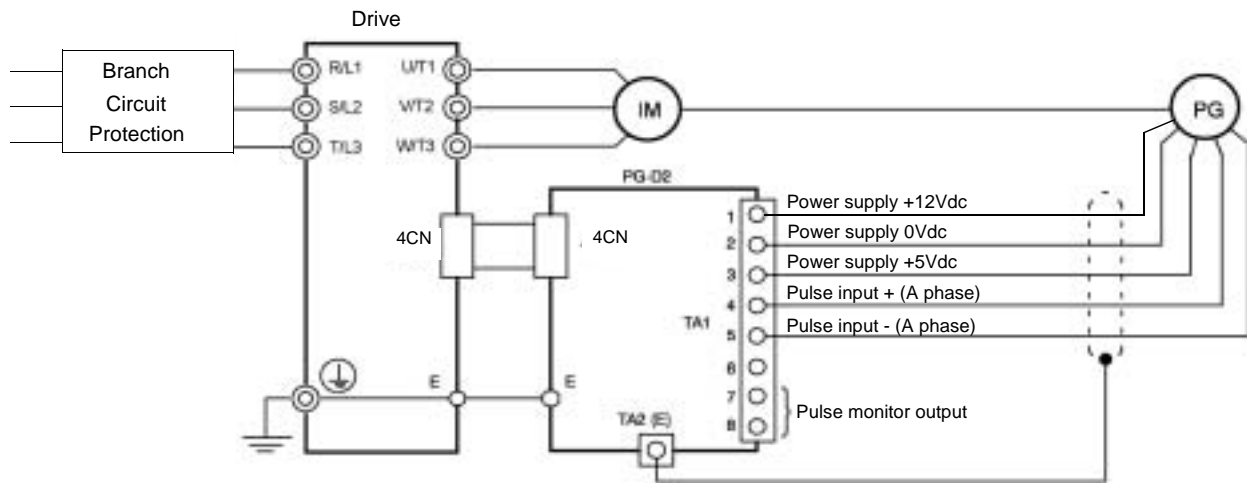

- Shielded twisted-pair wires must be used for signal lines.
- Do not use the PG-D2's power supply for anything other than the pulse generator (encoder). Using it for another purpose can cause malfunctions due to noise.
- The length of the pulse generator's wiring must not be more than 100 meters.

Fig 2.21 PG-D2 Wiring

■ PG-X2

The terminal specifications for the PG-X2 are given in Table 2.21.

Terminal	No.	Contents	Specifications
TA1	1	Power supply for pulse generator	12Vdc ($\pm 5\%$), 200mA max.*
	2		0Vdc (GND for power supply)
	3		5Vdc ($\pm 5\%$), 200mA max.*
	4	A-phase input terminals	Line driver input (RS-422 level) Maximum response frequency: 300kHz
	5		
	6		
	7	B-phase input terminals	
	8	Z-phase input terminals	
	9	Common terminal	0Vdc (GND for power supply)
	TA2	1	A-phase output terminals
2			
3			
4		B-phase output terminals	
5			
6			
7		Z-phase output terminals	
7	Control circuit common	Isolated control circuit GND	
TA3	(E)	Shield connection terminal	-

* 5Vdc and 12Vdc cannot be used at the same time.

■ Wiring the PG-X2

Wiring examples are provided in Fig 2.22 for the PG-X2.

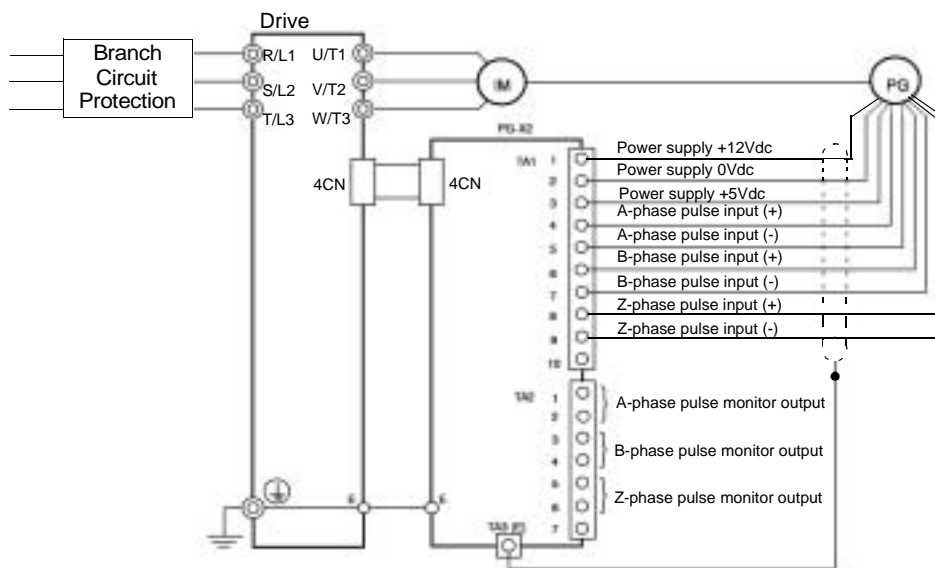

- Shielded twisted-pair wires must be used for signal lines.
- Do not use the PG-X2's power supply for anything other than the pulse generator (encoder). Using it for another purpose can cause malfunctions due to noise.
- The length of the pulse generator's wiring must not be more than 100 meters.
- The direction of rotation of the PG can be set in parameter F1-05 (PG Rotation). The factory preset is for motor forward rotation, A-phase advancement.

Fig 2.22 PG-X2 Wiring

■ **PG-W2**

The terminal specifications for the PG-W2 are given in Table 2.22.

Table 2.22 PG-W2 Terminal Specifications				
Terminal	No.	Contents	Specifications	
J2	1	Power supply for Pulse Generator	12Vdc ($\pm 5\%$), 200mA max.	
	2		0Vdc (GND for power supply)	
	3	A1-phase input terminals	Pulse generator 1 input Line driver input (RS-422 level input)	
	4			
	5	B1-phase input terminals		
	6			
	7	Z1-phase input terminals		
	8			
	9	Shield		-
	10	A2-phase input terminals		Pulse generator 2 input Line driver input (RS-422 level input)
11				
12	B2-phase input terminals			
J1	13	Z2-phase input terminals		
	14			
	15			
	16	Shield connection terminal	-	
	17	A-phase output terminals	Pulse monitor output. Source depends on software parameter Line driver output (RS-422 level output)	
	18			
	19	B-phase output terminals		
	20			
	21	Z-phase output terminals		
	22			
23	Shield connection terminal	-		
24	0Vdc	For pulse monitor terminals 17-22		

■ Wiring the PG-W2

Wiring examples are provided in Fig 2.23 for the PG-W2.

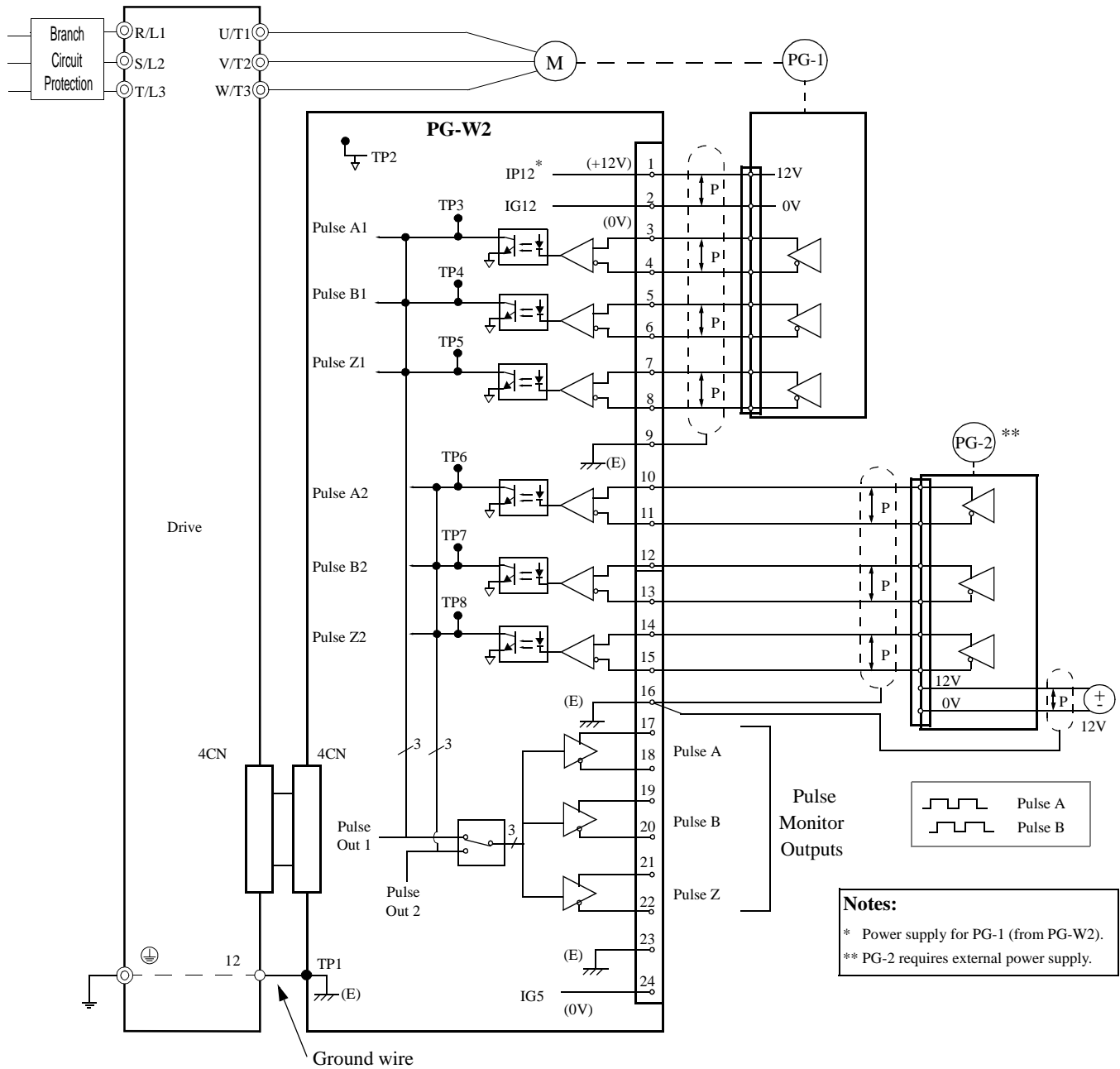

- Shielded twisted-pair wires must be used for signal lines.
- Do not use the PG-W2's power supply for anything other than the pulse generator (encoder). Using it for another purpose can cause malfunctions due to noise.
- The length of the pulse generator's wiring must not be more than 100 meters.
- Do not use PG-W2 to supply both PG units.

Fig 2.23 PG-W2 Wiring

◆ Wiring Terminal Blocks

■ Wire Sizes (Same for All Models)

Terminal wire sizes are shown in Table 2.23.

Terminal	Terminal Screws	Wire Thickness AWG (mm ²)	Wire Type
Pulse generator power supply Pulse input terminal Pulse monitor output terminal	-	Stranded wire: 20 to 17 (0.5 to 1.0) Single wire: 20 to 17 (0.5 to 1.0)	• Shielded, twisted-pair wire • Shielded, polyethylene-covered, vinyl sheath cable • Belden 9504, Hitachi KPEV-S, or equivalent
Shield connection terminal	M3.5	20 to 16 (0.5 to 1.5)	

■ Wiring Method and Precautions

Observe the following precautions when wiring.

- Separate the control signal lines for the PG (Encoder) Feedback Board from main circuit lines and power lines.
- Connect the shield when connecting a PG (Encoder). The shield must be connected to prevent operational errors caused by noise. Also, do not use any lines that are more than 100m long. Refer to Fig 2.12 for details on connecting the shield.
- Do not solder the ends of wires. Doing so may cause contact faults.
- When straight solderless terminals are not used, strip the wires to a length of approximately 5.5mm.
- Use shielded, twisted-pair wires for pulse inputs and pulse output monitor wires, and connect the shield to the shield connection terminal.

◆ Selecting the Number of PG (Encoder) Pulses

The setting for the number of PG pulses depends on the model of PG Speed Control Board being used. Set the correct number for your model.

■ PG-A2/PG-B2

The maximum response frequency is 32,767Hz.

Use a PG that outputs a maximum frequency of approximately 20kHz for the rotational speed of the motor.

$$f_{PG} \text{ (Hz)} = \frac{\text{Motor speed at maximum frequency output (RPM)}}{60} \times \text{PG rating (PPR)}$$

Some examples of PG output frequency (number of pulses) for the maximum frequency output are shown in Table 2.24.

Motor's Maximum Speed (RPM)	PG Rating (PPR)	PG Output Frequency (Hz)
1800	600	18,000
1500	800	20,000
1200	1000	20,000
900	1200	18,000

A separate power supply is required if the PG power supply capacity is greater than 200mA. (If momentary power loss must be handled, use a backup capacitor or other method). See Fig 2.24.

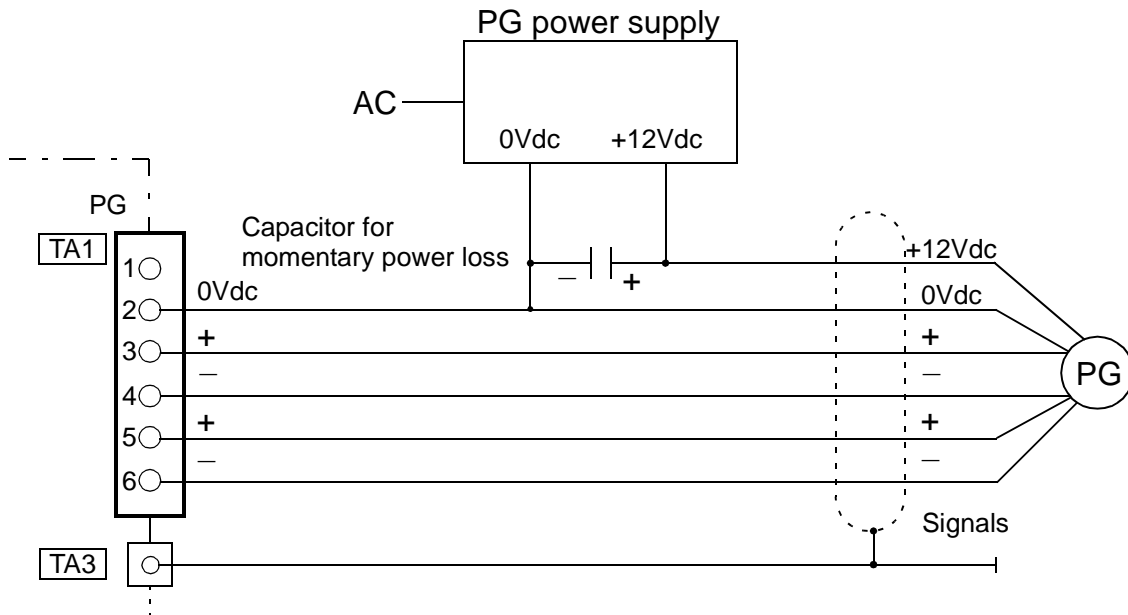

Fig 2.24 PG-B2 Connection Example For External +12Vdc PG Power Supply

■ **PG-D2/PG-X2/PG-W2**

The maximum response frequency is 300kHz.

Use the following equation to compute the output frequency of the PG (f_{PG}).

$$f_{PG} \text{ (Hz)} = \frac{\text{Motor speed at maximum frequency output (RPM)}}{60} \times \text{PG rating (PPR)}$$

A separate power supply is required if the PG power supply capacity is greater than 200mA. (If momentary power loss must be handled, use a backup capacitor or other method). See Fig 2.25.

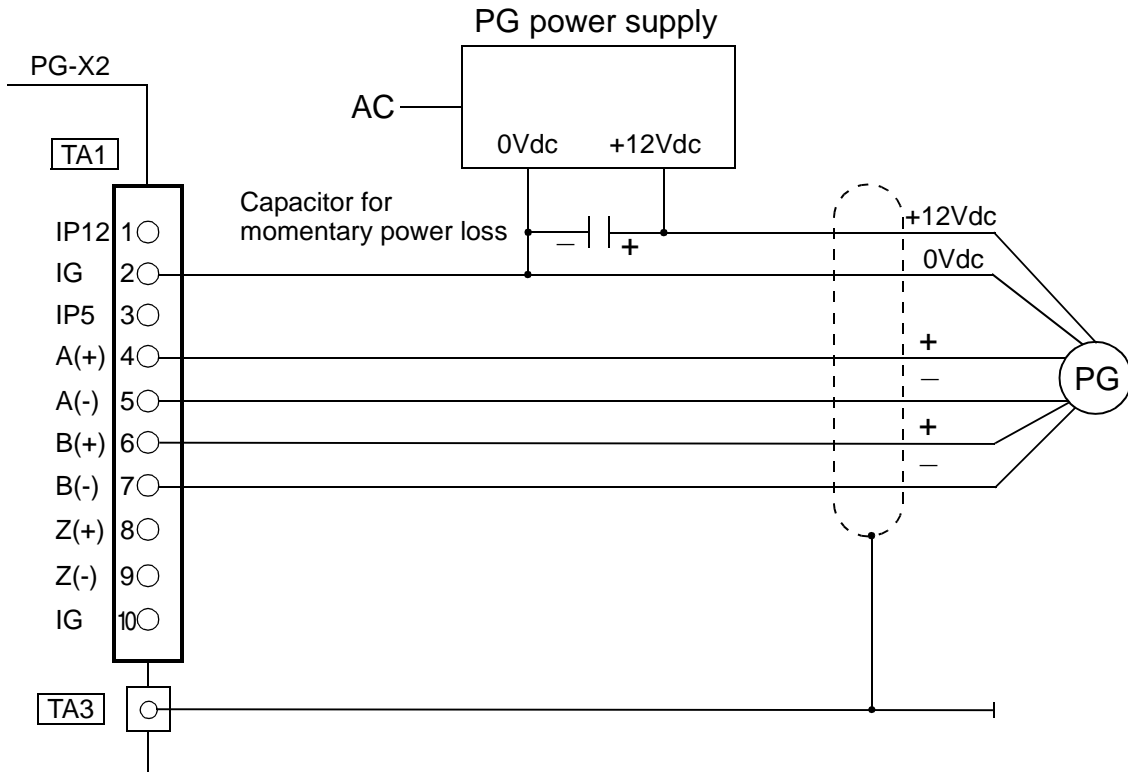

Fig 2.25 PG-X2 Connection Example For External +12V PG Power Supply

Chapter 3

Digital Operator

This chapter describes the displays and functions of the Digital Operator.

Digital Operator Display.....	3-2
Digital Operator Keys	3-3
Drive Mode Indicators.....	3-4
Drive Main Menus.....	3-6
Quick Setting Menu (-QUICK-)	3-11
Programming Menu (-ADV-)	3-12
Example of Changing a Parameter	3-15

Digital Operator Display

The Digital Operator is used for programming, operating, monitoring, and copying the Drive's parameters. To copy parameters, F7 Drives must have the same software version, model, and control method. The various items included on the Digital Operator are described below.

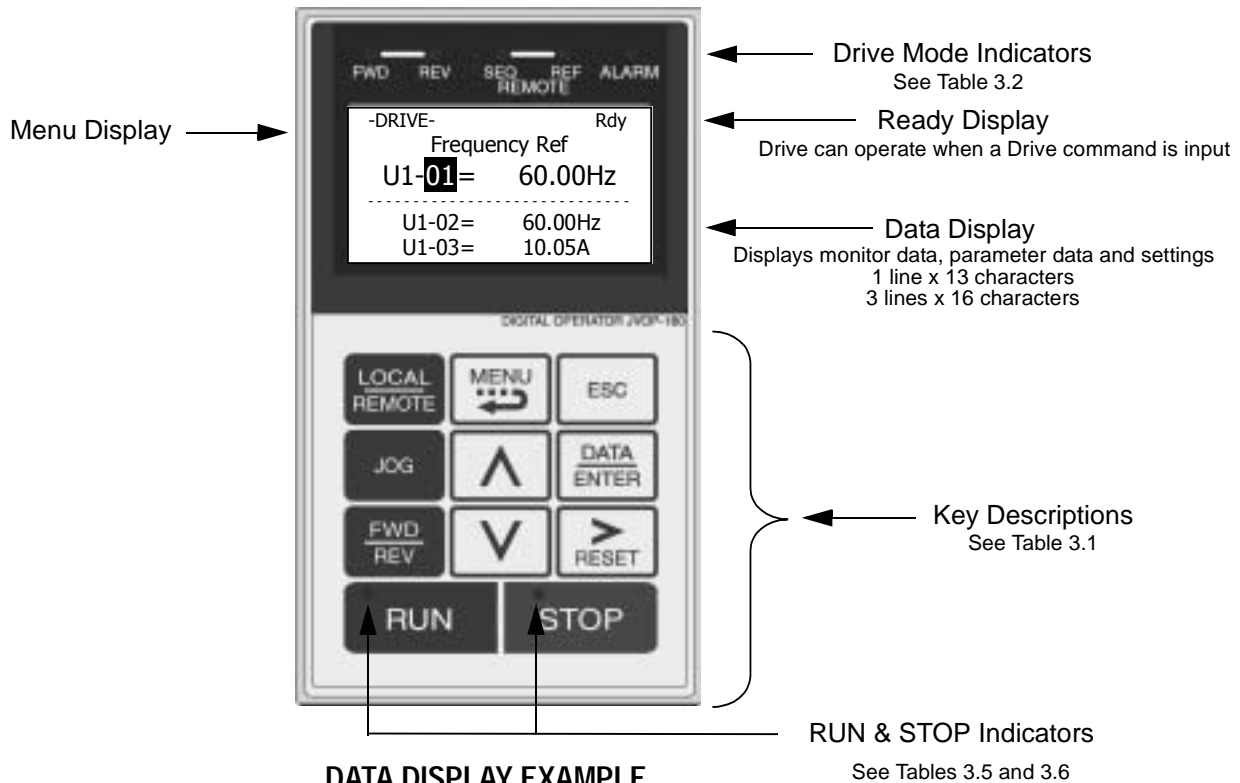

DATA DISPLAY EXAMPLE

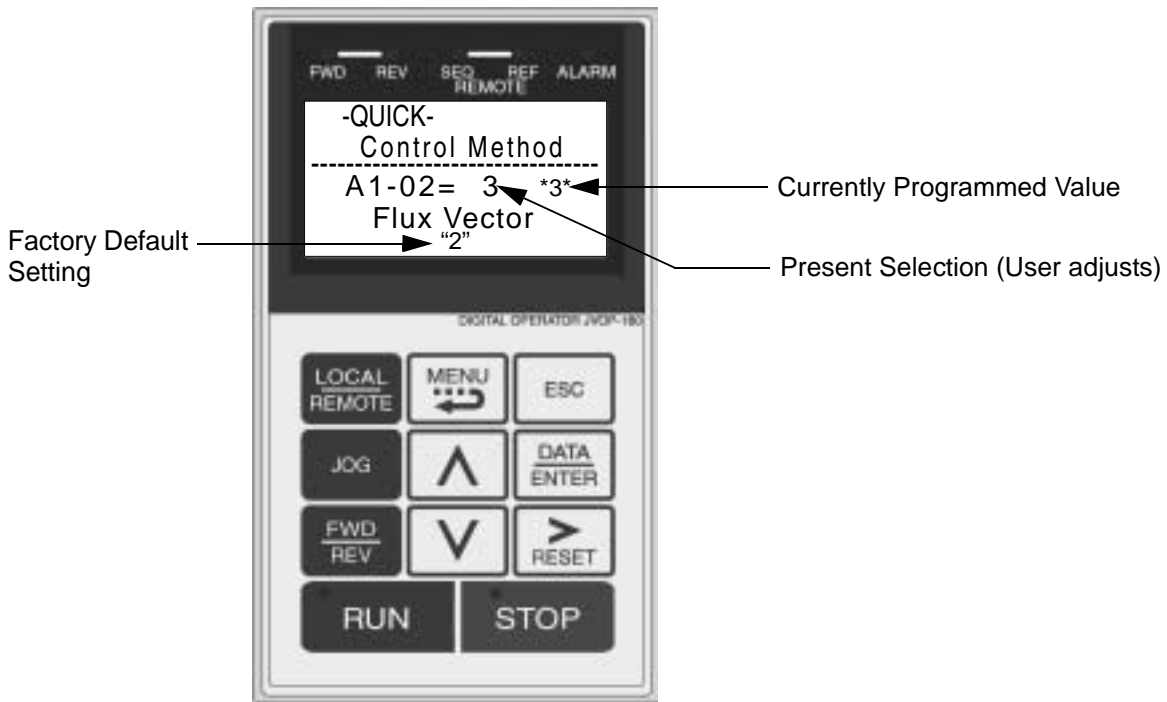













Fig 3.1 Digital Operator Component Names and Functions

Digital Operator Keys

The names and functions of the Digital Operator Keys are described in Table 3.1.

Table 3.1 Digital Operator Keys		
Key	Name	Function
	LOCAL / REMOTE	<ul style="list-style-type: none"> Switches between operation via the Digital Operator (LOCAL) and the settings in parameter b1-01 (Frequency Reference Selection) and b1-02 (Run Command Selection) (REMOTE). This key can be enabled or disabled by the setting in parameter o2-01. The Drive must be in a stopped condition before it can be transferred to “LOCAL” or “REMOTE” mode.
	MENU	<ul style="list-style-type: none"> Scrolls through the five main menus: Operation (-DRIVE-), Quick Setting (-QUICK-), Programming (-ADV-), Modified Constants (-VERIFY-), and Auto-Tuning (-A.TUNE-).
	ESCAPE	<ul style="list-style-type: none"> Returns to the previous display, before the DATA/ENTER key was pressed.
	JOG	<ul style="list-style-type: none"> Enables jog operation when the Drive is being operated from the Digital Operator (LOCAL).
	FWD / REV	<ul style="list-style-type: none"> Selects the rotation direction of the motor when the Drive is being operated from the Digital Operator (LOCAL).
	INCREASE	<ul style="list-style-type: none"> Increases parameter numbers and set values. Used to move to the next item or data value.
	DECREASE	<ul style="list-style-type: none"> Decreases parameter numbers and set values. Used to move to the previous item or data value.
	SHIFT/RESET	<ul style="list-style-type: none"> Selects the digit to be changed. The selected digit will blink. Also resets the Drive when a fault has occurred. The run command must be removed before the reset command will be accepted.
	DATA/ENTER	<ul style="list-style-type: none"> Enter menus and parameters as well as to set values.
	RUN	<ul style="list-style-type: none"> Starts Drive operation when the Drive is being controlled by the Digital Operator (LOCAL).
	STOP Key	<ul style="list-style-type: none"> Stops Drive operation. This key can be enabled or disabled when operating from the external terminal or communications by setting user parameter o2-02.

Drive Mode Indicators

The definition of the Drive mode indicators are shown in Table 3.2.

Table 3.2 Drive Mode Indicators	
Indicator	Definition
FWD	Lit when a forward run command is input.
REV	Lit when a reverse run command is input.
REMOTE SEQ	See Table 3.3.
REMOTE REF	See Table 3.4.
ALARM	Lit when a fault has occurred. Flashes when an Alarm has occurred.

◆ REMOTE Sequence (SEQ) Indicator

The status of the “REMOTE” Sequence (SEQ) indicator is shown in Table 3.3. This indicator is always “Off” when the Drive is in the “LOCAL” mode. When the Drive is in the “REMOTE” mode, the SEQ indicator status is dependent on the setting of parameter b1-02 (Run Command Selection). See Table 3.3.

Table 3.3 REMOTE Sequence (SEQ) Indicator	
Indicator Status	Condition
On	Parameter b1-02 (Run Command Selection) is set to terminal strip, communications, or an option board as indicated below: b1-02=1 (Terminals) =2 (Communications) =3 (Option PCB)
Off	Parameter b1-02 (Run Command Selection) is set to Digital Operator as indicated below: b1-02=0 (Operator)

◆ REMOTE Reference (REF) Indicator

The status of the “REMOTE” Reference (REF) indicator is shown in Table 3.4. This indicator is always “Off” when the Drive is in the “LOCAL” mode. When the Drive is in the “REMOTE” mode, the REF indicator status is dependent on the setting of parameter b1-01 (Frequency Reference Selection). See Table 3.4.

Indicator Status	Condition
On	Parameter b1-01 (Frequency Reference Selection) is set to terminal strip, communications, option board, or pulse train as indicated below: b1-01 =1 (Terminals) =2 (Communications) =3 (Option PCB) =4 (Pulse Train)
Off	Parameter b1-01 (Frequency Reference Selection) is set to digital operator as indicated below: b1-01=0 (Operator)

◆ Run Indicator

The status of the “RUN” indicator is shown in Table 3.5 when the Drive is in either the “LOCAL” or “REMOTE” mode.

Indicator Status	Condition
On	Drive is running.
Blinking	Drive is decelerating to a stop.
Off	Drive is stopped.

◆ Stop Indicator

The status of the “STOP” indicator is shown in Table 3.6 when the Drive is in either the “LOCAL” or “REMOTE” mode.

Indicator Status	Condition
On	Drive is decelerating to a stop or stopped.
Blinking	Drive is in a run condition but the frequency reference is less than the minimum output frequency E1-09, or the Drive is running in “REMOTE” mode and the “STOP” key on has been pressed.
Off	Drive is running.

Drive Main Menus

The Drive's parameters and monitoring functions are organized into groups called menus that make it easier to read and set parameters. The Drive is equipped with five menus. The five menus and their primary functions are shown in Table 3.7.

Table 3.7 Drive Main Menus	
Main Menu	Primary Functions
Operation - DRIVE -	The Drive can run in this menu. Use this menu for monitoring values such as frequency reference or output current, displaying fault history or displaying the fault traces.
Quick Setting - QUICK -	The Drive can be programmed in this menu. Use this menu to set/read the most commonly used parameters.
Programming - ADV -	The Drive can be programmed in this menu or parameters can be copied into the Digital Operator. Use this menu to set/read every parameter.
Modified Constants - VERIFY -	The Drive can be programmed in this menu. Use this menu to set/read the parameters that have been modified from their factory default settings.
Auto-Tuning - A.TUNE -	The Drive can be programmed in this menu. Use this menu to Auto-Tune the Drive in order to optimize motor control. The motor parameters are calculated and set automatically after successfully completing Auto-Tuning.

◆ Main Menu Structure

The menu selection display will appear when the MENU key is pressed from a monitor or setting display. While viewing the menu selection display, press the MENU key repeatedly to scroll between the menu selections. Press the DATA/ENTER key to enter the desired menu selection.

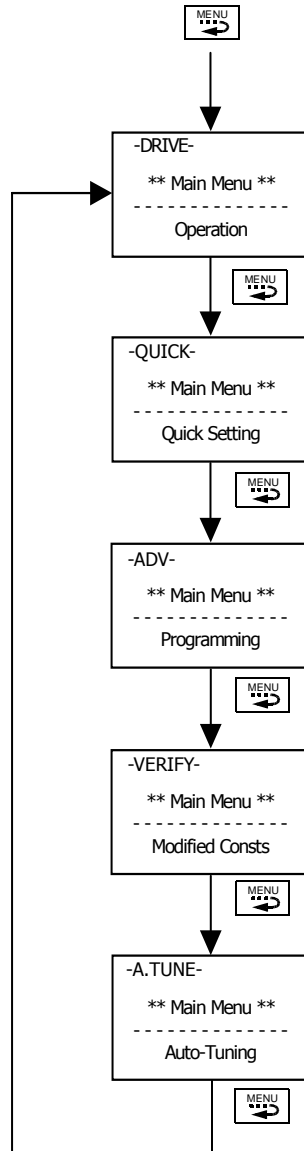

Fig 3.2 Main Menu Structure

◆ Operation Menu (-DRIVE-)

This menu is used for setting the frequency reference (Local Mode) or monitoring values such as output frequency and output current. It is also used for displaying the fault history and the fault traces. The Drive must be in this menu in order to run. See parameter b1-08 (Run Command Selection During Program).

■ U1 Monitor List

Follow the key operations below (Fig 3.3) to access the Operation Menu:

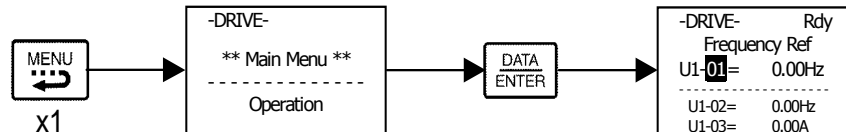

Fig 3.3 U1 Monitor List Access Procedure



Use  and  keys to scroll through the U1 “Monitor” parameter list. See Appendix A for functional description.

Table 3.8 U1 Monitor List			
Monitors			
U1-01	Frequency Reference	U1-21	ASR Input
U1-02	Output Frequency	U1-22	ASR Output
U1-03	Output Current	U1-24	PI Feedback Value
U1-04	Control Method	U1-25	DI-16 H2 Input Status
U1-05	Motor Speed	U1-26	Output Voltage Reference (Vq)
U1-06	Output Voltage	U1-27	Output Voltage Reference (Vd)
U1-07	DC Bus Voltage	U1-28	CPU Number
U1-08	Output Power	U1-29	kWh (Lower 4 digits)
U1-09	Torque Reference	U1-30	MWh (Upper 5 digits)
U1-10	Input Terminal Status	U1-32	ACR(q) Output
U1-11	Output Terminal Status	U1-33	ACR(d) Output
U1-12	Drive Operation Status	U1-34	OPE Detected
U1-13	Cumulative Operation Time	U1-35	Zero Servo Pulse Count
U1-14	Software Number	U1-36	PID Input
U1-15	Terminal A1 Input Voltage	U1-37	PID Output
U1-16	Terminal A2 Input Voltage	U1-38	PID Setpoint
U1-17	Terminal A3 Input Voltage	U1-39	Modbus Error Code
U1-18	Motor Secondary Current (Iq)	U1-40	Cooling Fan Elapsed Time
U1-19	Motor Excitation Current (Id)	U1-44	ASR Output with or without Filter
U1-20	Output Frequency after Soft-start	U1-45	Feed Forward Control Output
Note: Some monitors are not available for all Control Modes (A1-02).			

■U2 Fault Trace List

After viewing the “Monitor” parameter list, follow the key operations below (Fig 3.4) to access the “Fault Trace” parameter list.

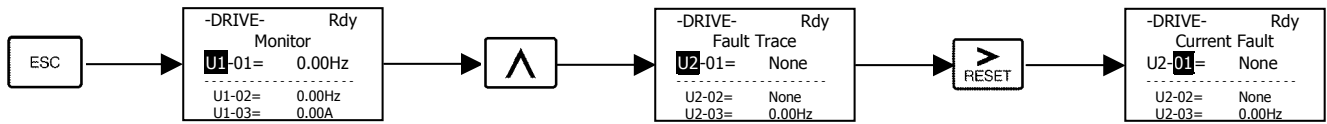

Fig 3.4 U2 Fault Trace List Access Procedure

Use and keys to scroll through the U2 “Fault Trace” parameter list.

Table 3.9 U2 Fault Trace List	
Fault Trace Parameters	
U2-01	Current Fault
U2-02	Previous Fault
U2-03	Frequency Reference at Fault*
U2-04	Output Frequency at Fault*
U2-05	Output Current at Fault*
U2-06	Motor Speed at Fault*
U2-07	Output Voltage at Fault*
U2-08	DC Bus Voltage at Fault*
U2-09	Output Power at Fault*
U2-10	Torque Reference at Fault
U2-11	Input Terminal Status at Fault*
U2-12	Output Terminal Status at Fault*
U2-13	Drive Operation Status at Fault*
U2-14	Cumulative Operation Time at Fault*
* Represents fault condition prior to current fault state. Note: Fault trace is not executed at CPF00, CPF01, CPF03, UV1, and UV2.	

■U3 Fault History List

After viewing the “Fault Trace” parameter list, follow the key operations below (Fig 3.5) to access the “Fault History” parameter list.

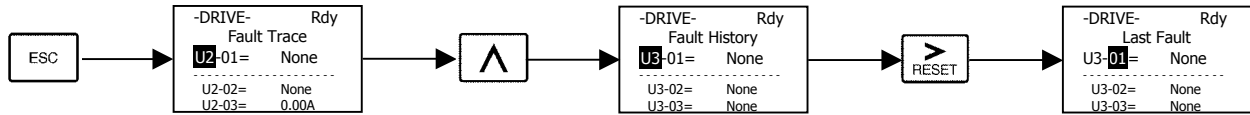

Fig 3.5 U3 Fault History Access Procedure



Use  and  keys to scroll through the U3 “Fault History” parameter list.

Table 3.10 Fault History List	
Fault History Parameters	
U3-01	Last Fault
U3-02	Fault Message 2
U3-03	Fault Message 3
U3-04	Fault Message 4
U3-05	Elapsed Time 1
U3-06	Elapsed Time 2
U3-07	Elapsed Time 3
U3-08	Elapsed Time 4
U3-09	Fault Message 5
U3-10	Fault Message 6
U3-11	Fault Message 7
U3-12	Fault Message 8
U3-13	Fault Message 9
U3-14	Fault Message 10
U3-15	Elapsed Time 5
U3-16	Elapsed Time 6
U3-17	Elapsed Time 7
U3-18	Elapsed Time 8
U3-19	Elapsed Time 9
U3-20	Elapsed Time 10
Note: Fault trace is not executed at CPF00, CPF01, CPF03, UV1, and UV2.	

Quick Setting Menu (-QUICK-)

This menu is used to set/read the most commonly used parameters in the Drive. Follow the key operations in Fig 3.6 to access the Quick Setting Menu:

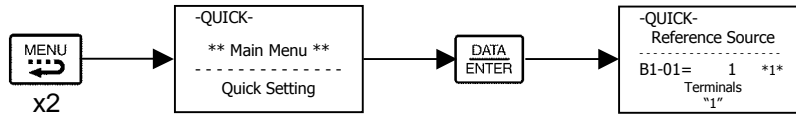

Fig 3.6 Quick Setting Parameter Access Procedure



Use  and  keys to scroll through the “Quick Setting” parameter list.

Table 3.11 Quick Setting Parameter List	
Parameter Number	Parameter Name
A1-02	Control Method Selection
b1-01	Frequency Reference Selection
b1-02	Run Command Selection
b1-03	Stopping Method Selection
C1-01	Acceleration Time 1
C1-02	Deceleration Time 1
C6-02	Carrier Frequency Selection
d1-01	Frequency Reference 1
d1-02	Frequency Reference 2
d1-03	Frequency Reference 3
d1-04	Frequency Reference 4
d1-17	Jog Reference
E1-01	Input Voltage Setting
E1-03	V/F Pattern Selection
E1-04	Maximum Output Frequency
E1-05	Maximum Output Voltage
E1-06	Base Frequency
E1-09	Minimum Output Frequency
E1-13	Base Voltage
E2-01	Motor Rated Current
E2-04	Number of Motor Poles
E2-11	Motor Rated Output
F1-01	PG Pulses / Revolution
H4-02	Terminal FM Gain Setting
H4-05	Terminal AM Gain Setting
L1-01	Motor Overload Protection Selection
L3-04	Stall Prevention Selection During Decel
Note: Refer to Appendix A for control method dependent parameters.	

Programming Menu (-ADV-)

This menu is used to set/read every parameter in the Drive. Follow the key operations below (Fig 3.7) to access the Programming Menu.

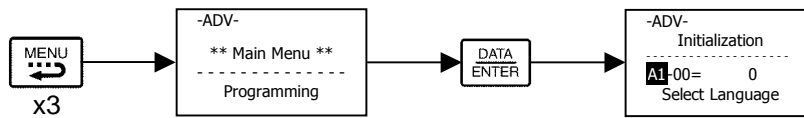

Fig 3.7 Programming Menu Access Procedure

Use , , and  keys to scroll through the “Programming” parameter group list. For complete parameter listing see appendix A.

Table 3.12 Programming Parameter Group List

Parameter Group Functions	
A1 Initialization	F2 AI-14 Setup
A2 User Parameters	F3 DI-08, 16 Setup
b1 Sequence	F4 AO-08, 12 Setup
b2 DC Injection Braking	F5 DO-02, 08 Setup
b3 Speed Search	F6 Communications Option Setup
b4 Delay Timers	H1 Digital Inputs
b5 PID Control	H2 Digital Outputs
b6 Reference Hold	H3 Analog Inputs
b7 Droop control	H4 Analog Outputs
b8 Energy Saving	H5 Serial Communications Setup
b9 Zero Servo	H6 Pulse I/O Setup
C1 Accel/Decel	L1 Motor Overload
C2 S-Curve Accel/Decel	L2 Power Loss Ridethru
C3 Motor-Slip Compensation	L3 Stall Prevention
C4 Torque Compensation	L4 Reference Detection
C5 ASR Tuning	L5 Fault Restart
C6 Carrier Frequency	L6 Torque Detection
d1 Preset Reference	L7 Torque Limit
d2 Reference Limits	L8 Hardware Protection
d3 Jump Frequencies	n1 Hunting Prevention
d4 Sequence (MOP & Trim Control)	n2 AFR Tuning
d5 Torque Control	n3 High Slip Braking
d6 Field-Weakening	n5 Feed Forward
E1 V/F Pattern	o1 Monitor Select
E2 Motor Setup	o2 Key Selections
E3 V/F Pattern 2	o3 COPY Function
E4 Motor Setup 2	T1 Auto-Tuning
F1 PG Option Setup	-

Note: Refer to Appendix A for control method dependent programming parameter groups.

◆ Modified Constants Menu (-VERIFY-)

This menu is used to set/read the parameters that have been modified from their original factory default settings. Follow the key operations below (Fig 3.8) to access the Modified Constants Parameter Menu.

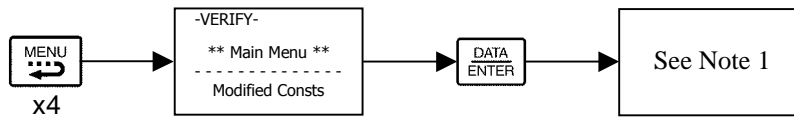

Fig 3.8 Modified Constants Menu Access Procedure

Note 1: If there are no parameters that have been modified from their original factory default settings, then the display will

state “None Modified”. Otherwise, use  and  keys to scroll through the “Modified Constants” list.

◆ Auto-Tuning Menu (-A.TUNE-)

This menu is used to Auto-Tune the Drive in order to calculate the required motor parameters to optimize motor performance. Ideally, perform Auto-Tuning with the motor uncoupled from the load.

When the motor cannot be disconnected from the load, perform static or terminal resistance Auto-Tuning. To set motor parameters by hand calculation, contact your Yaskawa representative. Follow the key operations below (Fig 3.9) to access the Auto-Tuning Menu.

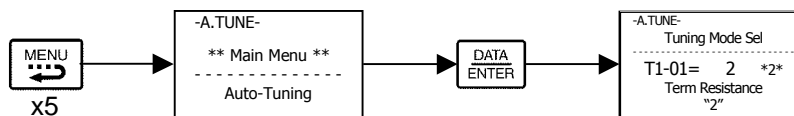

Fig 3.9 Auto-Tuning Menu Access Procedure



Use  and  keys to scroll through the “Auto-Tuning” parameter list. Depending on the Control Method (A1-02) setting, only certain Auto-Tuning parameters will be accessible. See table below.

Table 3.13 Auto-Tuning Parameter List					
Auto-Tuning Parameters		Control Method			
		V/F	V/F w/PG	OLV	Flux Vector
T1-01	Tuning Mode Selection	O	O	O	O
T1-02	Motor Rated Power	O	O	O	O
T1-03	Rated Voltage	X	X	O	O
T1-04	Rated Current	O	O	O	O
T1-05	Rated Frequency	X	X	O	O
T1-06	Number of Poles	X	X	O	O
T1-07	Rated Speed	X	X	O	O
T1-08	PG Pulses/Rev	X	X	X	O

O = Accessible

After setting Auto-Tuning parameters according to motor nameplate specifications, press  so that the following screen appears on the Digital Operator.

```

-A.TUNE-          Rdy
  Auto-Tuning
-----
    0Hz/ 0.00A
  Tuning Ready ?
  Press RUN key
  
```

Press the RUN key on the Digital Operator to start Auto-Tuning. The motor will automatically run. During this process the motor parameters will be automatically set in the Drive according to the measured values.

Example of Changing a Parameter

Table 3.14 provides an example of how to change parameter “C1-02” (Deceleration Time 1) from 30 seconds to 40 seconds.

Table 3.14 Changing a Parameter in the Programming Menu		
Step Number	Digital Operator Display	Description
1	<pre> -DRIVE- Rdy Frequency Ref U1-01= 0.00Hz ----- U1-02= 0.00Hz U1-03= 0.00A </pre>	The Drive is first powered up.
2	<pre> -DRIVE- ** Main Menu ** ----- Operation </pre>	Press the MENU key to scroll to “Operation” menu.
3	<pre> -QUICK- ** Main Menu ** ----- Quick Setting </pre>	Press the MENU key to scroll to “Quick Setting” menu.
4	<pre> -ADV- ** Main Menu ** ----- Programming </pre>	Press the MENU key to scroll to “Programming” menu.
5	<pre> -ADV- Initialization ----- A1-01= 0 Select Language </pre>	Press the DATA/ENTER key to enter “Programming” menu.
6	<pre> -ADV- Accel/Decel ----- C1-01= 1.0sec Accel Time 1 </pre>	Press the INCREASE key until C1-01 (Accel/Decel) is displayed.
7	<pre> -ADV- Accel Time 1 ----- C1-01= 30.0sec (0.0~6000.0) "30.0sec" </pre>	Press the SHIFT/RESET key to move flashing digit to the right.

Table 3.14 Changing a Parameter in the Programming Menu (continued)

Step Number	Digital Operator Display	Description
8	<div style="border: 1px solid black; padding: 5px; width: fit-content; margin: auto;"> -ADV- Decel Time 1 ----- C1-02= 30.0sec (0.0~6000.0) "30.0sec" </div>	Press the INCREASE key to display C1-02 (Decel Time 1).
9	<div style="border: 1px solid black; padding: 5px; width: fit-content; margin: auto;"> -ADV- Decel Time 1 ----- C1-02= 030.0sec (0.0~6000.0) "30.0sec" </div>	Press the DATA/ENTER key to access setting display.
10	<div style="border: 1px solid black; padding: 5px; width: fit-content; margin: auto;"> -ADV- Decel Time 1 ----- C1-02= 0030.0sec (0.0~6000.0) "30.0sec" </div>	Press the SHIFT/RESET key to move the flashing digit to the right.
11	<div style="border: 1px solid black; padding: 5px; width: fit-content; margin: auto;"> -ADV- Decel Time 1 ----- C1-02= 0030.0sec (0.0~6000.0) "30.0sec" </div>	Press the SHIFT/RESET key to move the flashing digit to the right.
12	<div style="border: 1px solid black; padding: 5px; width: fit-content; margin: auto;"> -ADV- Decel Time 1 ----- C1-02= 0040.0sec (0.0~6000.0) "30.0sec" </div>	Press the INCREASE key to increase the set data.
13	<div style="border: 1px solid black; padding: 5px; width: fit-content; margin: auto;"> -ADV- Entry Accepted </div>	Press the DATA/ENTER key to enter the set data. "Entry Accepted" is displayed for 1.0 sec after the data setting has been confirmed.
14	<div style="border: 1px solid black; padding: 5px; width: fit-content; margin: auto;"> -ADV- Decel Time 1 ----- C1-02= 40.0sec (0.0~6000.0) "30.0sec" </div>	The screen returns to the C1-02 display.
15	<div style="border: 1px solid black; padding: 5px; width: fit-content; margin: auto;"> -DRIVE- ** Main Menu ** ----- Operation </div>	Press the MENU key to scroll to "Operation" menu.
16	<div style="border: 1px solid black; padding: 5px; width: fit-content; margin: auto;"> -DRIVE- Rdy Frequency Ref U1-01= 0.00Hz ----- U1-02= 0.00Hz U1-03= 0.00A </div>	Press the DATA/ENTER key to enter "Operation" menu.

Chapter 4

Start-Up

This chapter describes the procedures to prepare the Drive for start-up and the procedures to conduct a Drive start-up.

Drive Start-Up Preparation	4-2
Drive Start-Up Procedures	4-5

Drive Start-Up Preparation

In order to provide the most reliable Drive available and to avoid any extra costs related to loss or reduction of warranty coverage, an authorized Yaskawa service representative should complete this start-up procedure. Please complete the following checklist and maintain it in a secure location as technical service personnel may request information from this checklist.

◆ Drive Start-Up Preparation

Date: _____

Start-Up Person:

Company Name: _____

Start-Up Location: _____

Sales Order #: _____

Serial #: _____

Printed Name: _____

Drive Location: _____

Phone #: _____

Signature: _____

Owners Representative:

Printed Name: _____

Phone #: _____

Company: _____

Signature: _____

Step

- 1. The Drive is thoroughly tested at the factory. The start-up person should verify that the Drive is free of shipping and installation damage. Shipping damage is not covered by the Yaskawa warranty. Claims must be filed with the shipping company as soon as possible for any potential recovery via insurance.
- 2. Review the F7 User Manual (TM.F7.01) shipped with the Drive.
- 3. Verify that the model number and voltage ratings in the purchase order match the nameplate data for each unit.
- 4. Location of the Drive is important to achieve proper performance and normal operating life. The unit should be installed in an area where it is protected from:
 - Direct sunlight, rain or moisture
 - Corrosive gases or liquids
 - Vibration, airborne dust or metallic particles
- 5. Ensure the Drive is on a vertical surface with adequate space for air circulation (4.75" above and below, 1.2" on each side). Refer to Fig 1-8.
- 6. Verify that the proper branch circuit protection is installed in front of the Drive. Refer to Appendix E - Peripheral Devices for proper input fuse or circuit breaker sizing.

- 7. Avoid running input and output wiring in the same conduit.
- 8. Avoid routing power wiring near equipment sensitive to electrical noise.
- 9. Never allow wire leads to touch metal surfaces. Short-circuit may result.
- 10. Never connect AC main power to output terminals U/T1, V/T2 and W/T3.
- 11. Never connect power factor correction capacitors or noise filters to the Drive output.
- 12. Use 600Vac vinyl-sheathed wire or equivalent. Wire size should be determined considering voltage drop of leads.
Line voltage drop (V) = $\sqrt{3}$ x wire resistance (Ω /km) x wire length (m) x current (A) x 10^{-3}
- 13. It is recommended that the motor lead length not exceed 164 feet (50 meters) and motor wiring be run in a separate conduit from the power wiring. If lead length must exceed this distance, reduce the carrier frequency (See Table 2.6) and consult Yaskawa toll free at 1-800-YASKAWA (927-5292) for other motor protection measures.
- 14. Signal and control leads must be separated from main circuit leads (R/L1, S/L2, T/L3, U/T1, V/T2, W/T3).
- 15. Determine proper wire size for power and motor leads. Refer to Tables 2.1 and 2.2 for details.
- 16. Review proper ground connections for the Drive. Refer to Chapter 2 – Electrical Installation for details. The Drive must be solidly grounded using the main circuit ground terminal. Ground resistance should be less than 100 Ω for a 208-240Vac Drive. Ground resistance should be less than 10 Ω for a 480Vac Drive. Select wire size suitable for the size of terminal screw. Make the length as short as possible. Never ground the Drive in common with welding machines, other motors, or other large-current electrical equipment. Where several Drives are used, ground each Drive directly or daisy-chain to the ground pole(s). DO NOT FORM A LOOP WITH THE GROUND LEADS. See Fig 2.4.
- 17. Review terminal functions of signal and control circuits. Refer to Table 2.11.
- 18. Verify if any customer safety devices are required (e.g. firestat, freezestat, high static pressure).
- 19. Record the following motor nameplate information:
Motor Rated Power (KW): _____ Voltage: _____ Full Load Amps: _____
Rated Frequency: _____ Number of Poles: _____ Rated Speed (RPM): _____
- 20. Verify that the commercial power supply is within the rated Drive input voltage:
Power Supply: _____ VAC Drive Input Voltage: _____ VAC
- 21. Verify that the leads in the 3-Phase electric motor conduit box are configured for the proper voltage.
- 22. Ensure Motor Rated Current is less than or equal to Drive Output Amps. If multiple motors are being used, make sure that the Motor Rated Current sum is less than or equal to Drive Output Amp rating. Please note that if multiple motors are being operated from one Drive, each motor must have its own overload and short circuit protection.

- 23. Wire all necessary input power leads to the Drive. **DO NOT CONNECT MOTOR TO DRIVE YET.**
- 24. Wire all necessary ground wires to the Drive.
- 25. Wire all necessary control wires to the Drive.
- 26. Ensure that the power leads are connected to the R/L1, S/L2 and T/L3 terminals in the Drive.
- 27. Tighten all of the three-phase power and ground connections. Please check that all control and signal terminations are tight.
- 28. For Drive models F7U4075 thru F7U4300, set the power supply voltage jumper. Insert the jumper into the voltage connector nearest to the actual power supply voltage. The jumper is factory-set to 460Vac when shipped. Be sure the power is off and the CHARGE indicator is gone out before changing the jumper setting.

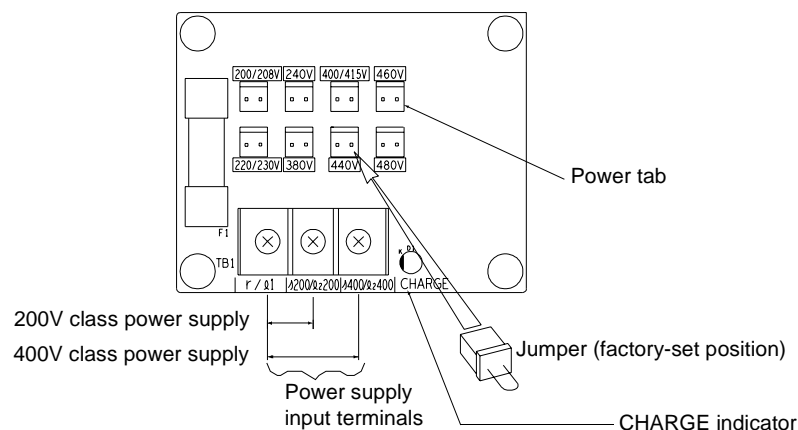

Figure 4.1 Power Supply Voltage Jumper

- 29. Inspect the control circuit connections (including the shield) and determine if a motor “safety circuit” is connected. If normally closed, these contacts may be wired in series with the **RUN** command contacts, which are between terminals **S1** and **SN** of the Drive. No special programming is required. Refer to Chapter 2 – Electrical Installation (Fig 2.10). Alternately, these contacts could be wired between terminals **S3** and **SN** as **External Fault Inputs**, and may be either normally closed or normally open contacts.
- 30. Inspect any option cards for proper installation and wiring. Refer to Chapter 2 - Option Cards.
- 31. If Braking Resistors and/or Braking Transistor Units are used, check the terminal connections. Refer to Chapter 2 - Braking Resistors.
- 32. If a contactor is used between the Drive and motor, wire the contactor so that the Drive controls the pull-in and drop-out of the contactor. Use the “Run” multi-function output and necessary auxiliary circuitry to energize the contactor coil. Consult the factory for wiring details.
- 33. Record any other connections to the Drive using the blank terminal connection drawing in Chapter 2 – Electrical Installation (Fig 2.13) to determine if special programming is required for the following: (refer to Appendix A)
 - Multi-function Inputs, Outputs, Digital Inputs, and Analog Outputs
 - Serial Communications

THIS COMPLETES THE DRIVE START-UP PREPARATION.

Drive Start-Up Procedures

- 1. Confirm that all three phases are present and that the input voltage is correct for the Drive being set up. Measure the voltage on the line side of the Drive's Molded Case Circuit Breaker/disconnect and record below.

Measurement Location	Voltage (Vac)
L1 – L2	
L2 – L3	
L1 – L3	

- 2. If the voltage level is within the Drive's specification, **APPLY POWER** to energize the Drive. The **STOP**, **AUTO SEQ** and **AUTO REF** indicators should be lit on the keypad.
- 3. **REMOVE POWER** from the Drive. Wait for the Red CHARGE LED (near the power terminals) to go out.
- 4. Connect the motor leads to the Drive at terminals U/T1, V/T2 and W/T3.
- 5. **APPLY POWER** to the Drive.
- 6. Determine the proper control method for the application: V/F Control, V/F with PG Control, Open Loop Vector, or Flux Vector Control.
- 7. If the selected control method requires a PG encoder on the motor (V/F with PG Control and Flux Vector Control), verify that the proper PG card is installed in the Drive and that all encoder wiring is correct. Check the line driver type (8830, 88C30), output levels, quadrature (A+, A-, B+, B-, etc.), and encoder PPR (pulses per revolution). Refer to Chapter 2 - Electrical Installation for details.
- 8. Proceed to the correct Control Method Start-up Procedure:

Control Method	Section
V/F	V/F Start-up
V/F w/ PG Feedback	V/F w/ PG Start-up
Open Loop Vector	Open Loop Vector Start-up
Flux Vector	Flux Vector Start-up

◆ V/F Start-up

- 9. Apply input power to the Drive.
- 10. Set the control method of the Drive to V/F Control by pressing the **MENU** key twice for the **Quick Setting** menu. Press the **ENTER** key to display A1-02 “Control Method”. Use the **UP** and **DOWN** keys and the **DATA/ENTER** key to set this parameter to “0: V/F Control”. Ensure the **DATA/ENTER** key is pressed to enter the selection in the Drive. “Entry Accepted” will briefly appear.
- 11. Set the Drive input voltage measured in Step 1. In the **Quick Setting** menu, go to parameter E1-01 “Input Voltage”. This parameter sets the nominal input voltage the Drive will receive.

Table 4.3 Input Voltage Setting

Parameter No.	Parameter Name Digital Operator Display	Setting Range	Factory Setting	Menu Location
E1-01	Input Voltage Setting Input Voltage	155.0 to 255.0 (208-240Vac)	240.0 (208-240Vac)	Quick Setting or Programming
		310.0 to 510.0 (480Vac)	480.0 (480Vac)	

- 12. Select an appropriate V/F pattern per the application. Go to parameter E1-03 “V/F Selection” and set this parameter per the application. A standard V/F pattern for a 60Hz motor is “1: 60Hz Saturation “.
- 13. Set the Drive to Local control. Press the **MENU** key once to display the **Operation** menu. Then, press **DATA/ENTER** to display “Frequency Reference”. Press the **LOCAL/REMOTE** key once. This puts the Drive in the Local Mode, allowing run/stop and speed commands by the Digital Operator. The **AUTO SEQ** and **AUTO REF** indicators turn off, and the **FWD** light turns on.



**THE NEXT KEY-PRESS WILL CAUSE THE MOTOR TO ROTATE.
TAKE APPROPRIATE PRECAUTIONS.**

- 14. Check the motor rotation. Press and hold the **JOG** key to check motor rotation. The **RUN** light turns on and the **STOP** light is off. “Frequency Ref” (U1-01) now displays 6.00Hz on the Digital Operator. The frequency reference for this operation comes from parameter d1-17 “Jog Reference” with factory default setting of 6.00Hz. The motor should ramp up to speed. If the motor rotation is incorrect, swap any two motor leads (U/T1, V/T2, W/T3) on the Drive terminal, and repeat the motor rotation check.
- 15. Proceed to the Auto-Tuning section.

◆ V/F w/ PG Start-up

- 1-8. See Drive Start-Up Procedures on Page 4-5.
- 9. Apply input power to the Drive.
- 10. Set the control method of the Drive to V/F w/ PG Feedback Control by pressing the **MENU** key twice for the **Quick Setting** menu. Press the **ENTER** key to display A1-02 “Control Method”. Use the **UP** and **DOWN** keys and the **DATA/ENTER** key to set this parameter to “1: V/F w/PG Fdbk”. Ensure the **DATA/ENTER** key is pressed to enter the selection in the Drive. “Entry Accepted” will briefly appear.
- 11. Set the Drive input voltage measured in Step 1. In the **Quick Setting** menu, go to parameter E1-01 “Input Voltage”. This parameter sets the nominal input voltage the Drive will receive.

Table 4.4 Input Voltage Setting

Parameter No.	Parameter Name Digital Operator Display	Setting Range	Factory Setting	Menu Location
E1-01	Input Voltage Setting Input Voltage	155.0 to 255.0 (208-240Vac)	240.0 (208-240Vac)	Quick Setting or Programming
		310.0 to 510.0 (480Vac)	480.0 (480Vac)	

- 12. Select an appropriate V/F pattern per the application. Press the **UP** key once to display parameter E1-03 “V/F Selection”. To set this parameter press the **DATA/ENTER** key once. Use the **UP** and **DOWN** keys and the **DATA/ENTER** key to set this parameter per the application. A standard V/F pattern for a 60Hz motor is “1: 60Hz Saturation “.
- 13. Set the PG Pulses/Rev of the PG (Encoder) to the correct value. In the **Quick Setting** menu, go to parameter F1-01 “PG Pulses/Rev”. Use the **UP**, **DOWN**, and **RESET** keys and the **DATA/ENTER** key to set the encoder PPR.
- 14. Display motor speed monitor U1-05 “Motor Speed” in the **Operation** menu.
- 15. Rotate the motor shaft by hand in the forward direction for the machine. A low positive speed should be displayed (PG-B2, PG-X2, PG-W2). As the shaft is turned in reverse, a low negative speed should be displayed. If the speed doesn’t change when the motor shaft is rotated, check the encoder wiring and connections. If the polarity is wrong, swap A+ and A- wires (terminals 4 and 5 on the PG-X2).
- 16. Set the Drive to Local control. Press the **MENU** key once to display the **Operation** menu. Then, press **DATA/ENTER** to display “Frequency Reference”. Press the **LOCAL/REMOTE** key once. This puts the Drive in the Local Mode, allowing run/stop and speed commands by the Digital Operator. The **AUTO SEQ** and **AUTO REF** indicators turn off, and the **FWD** light turns on.
- 17. Display monitor U1-01 “Frequency Ref” in the **Operation** menu.



**THE NEXT KEY-PRESS WILL CAUSE THE MOTOR TO ROTATE.
TAKE APPROPRIATE PRECAUTIONS.**

- 18. Check the motor rotation. Press and hold the **JOG** key to check motor rotation. The **RUN** light turns on and the **STOP** light is off. U1-01 “Frequency Ref” now displays 6.00Hz on the Digital Operator. The frequency reference for this operation comes from parameter d1-17 “Jog Reference” with factory default setting of 6.00Hz. The motor should ramp up to speed. If the motor rotation is incorrect, swap any two motor leads (U/T1, V/T2, W/T3) on the Drive terminal, and repeat the motor rotation check. The encoder phasing (polarity) may also need to be reversed.
- 19. Proceed to the Auto-Tuning section.

◆ Open Loop Vector Start-up

- 1-8. See Drive Start-Up Procedures on Page 4-5.
- 9. Apply input power to the Drive.
- 10. Set the control method of the Drive to Open Loop Vector Control by pressing the **MENU** key twice for the **Quick Setting** menu. Press the **ENTER** key to display A1-02 “Control Method”. Use the **UP** and **DOWN** keys and the **DATA/ENTER** key to set this parameter to “2: Open Loop Vector”. Ensure the **DATA/ENTER** key is pressed to enter the selection in the Drive. “Entry Accepted” will briefly appear.
- 11. Set the Drive to Local control. Press the **MENU** key once to display the **Operation** menu. Then, press **DATA/ENTER** to display “Frequency Reference”. Press the **LOCAL/REMOTE** key once. This puts the Drive in the Local Mode, allowing run/stop and speed commands by the Digital Operator. The **AUTO SEQ** and **AUTO REF** indicators turn off. The **FWD** light turns on.



**THE NEXT KEY-PRESS WILL CAUSE THE MOTOR TO ROTATE.
TAKE APPROPRIATE PRECAUTIONS.**

- 12. Check the motor rotation. Press and hold the **JOG** key to check motor rotation. The **RUN** light turns on and the **STOP** light is off. “Frequency Ref” (U1-01) now displays 6.00Hz on the Digital Operator. The frequency reference for this operation comes from parameter d1-17 “Jog Reference” with a factory default setting of 6.00Hz. The motor should ramp up to speed. If the motor rotation is incorrect, swap any two motor leads (U/T1, V/T2, W/T3) on the Drive terminal, and repeat the motor rotation check.
- 13. Proceed to the Auto-Tuning section.

◆ Flux Vector Start-up

- 1-8. See Drive Start-Up Procedures on Page 4-5.
- 9. Apply input power to the Drive.
- 10. Set the control method of the Drive to Flux Vector Control by pressing the **MENU** key twice for the **Quick Setting** menu. Press the **ENTER** key to display A1-02 “Control Method”. Use the **UP** and **DOWN** keys and the **DATA/ENTER** key to set this parameter to “3: Flux Vector”. Ensure the **DATA/ENTER** key is pressed to enter the selection in the Drive. “Entry Accepted” will briefly appear.
- 11. Set the PG Pulses/Rev of the PG (Encoder) to the correct value. In the **Quick Setting** menu, go to parameter F1-01 “PG Pulses/Rev”. Use the **UP**, **DOWN**, and **RESET** keys and the **DATA/ENTER** key to set the encoder PPR.
- 12. Display motor speed monitor U1-05 “Motor Speed” in the **Operation** menu.
- 13. Rotate the motor shaft by hand in the forward direction of the machine. A low positive speed should be displayed (PG-B2, PG-X2, PG-W2). As the shaft is turned in reverse, a low negative speed should be displayed. If the speed doesn’t change when the motor shaft is rotated, check the encoder wiring and connections. If the polarity is wrong, swap A+ and A- wires (terminals 4 and 5 on the PG-X2).
- 14. Set the Drive to Local control. Press the **MENU** key once to display the **Operation** menu. Then, press **DATA/ENTER** to display “Frequency Reference”. Press the **LOCAL/REMOTE** key once. This puts the Drive in the Local Mode, allowing run/stop and speed commands by the Digital Operator. The **AUTO SEQ** and **AUTO REF** indicators turn off, and the **FWD** light turns on.
- 15. Display monitor U1-01 “Frequency Ref” in the **Operation** menu.



**THE NEXT KEY-PRESS WILL CAUSE THE MOTOR TO ROTATE.
TAKE APPROPRIATE PRECAUTIONS.**

- 16. Check the motor rotation. Press and hold the **JOG** key to check motor rotation. The **RUN** light turns on and the **STOP** light is off. U1-01 “Frequency Ref” displays 6.00Hz on the Digital Operator. The frequency reference for this operation comes from parameter d1-17 “Jog Reference” with a factory default setting of 6.00Hz. The motor should ramp up to speed. If the motor rotation is incorrect, swap any two motor leads (U/T1, V/T2, W/T3) on the Drive terminal, and repeat the motor rotation check. The encoder polarity may need to be reversed.
- 17. Proceed to the Auto-Tuning section.

◆ Auto-Tuning

Auto-Tuning the motor is required for smooth operation. Use the following flow chart to determine which one of the three Auto-Tuning Mode Selections to use.

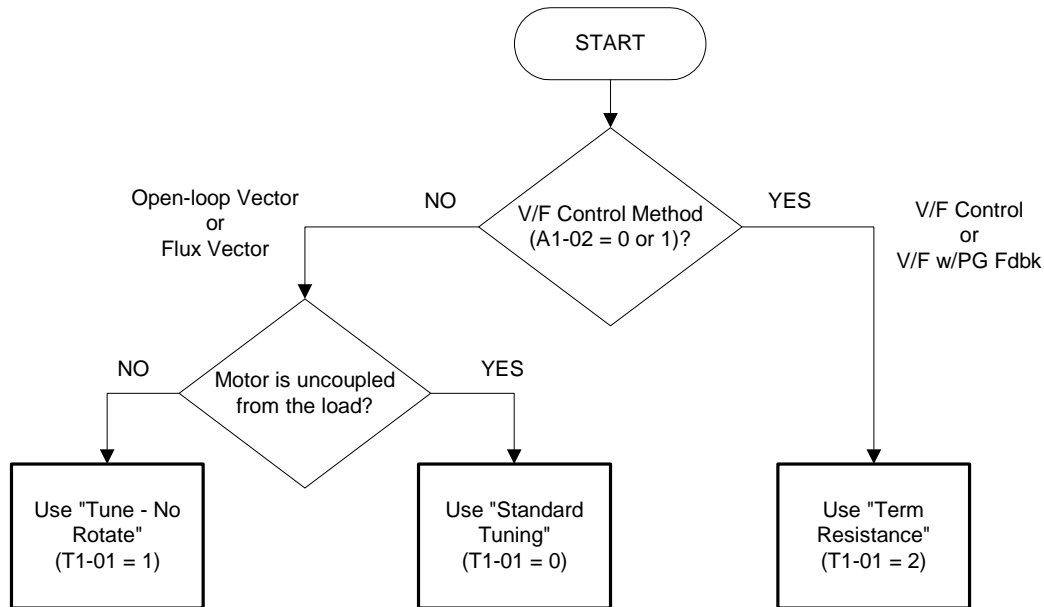

Figure 4.2 Auto-Tuning Selection Flow chart

■ Standard Tuning

Always use Standard Tuning when operating in Open Loop Vector or Flux Vector (A1-02 = 2 or 3) and it is possible to run the motor uncoupled from the load.

- 1. Select the Auto-Tuning Menu. Then, select “Standard Tuning” in the “Tuning Mode Sel” parameter (T1-01 = 0).
- 2. Set the motor output power (T1-02), motor rated voltage (T1-03), motor rated current (T1-04), motor base frequency (T1-05), number of motor poles (T1-06), motor rated speed (T1-07) obtained from the motor nameplate information. If the Control Method is Flux Vector (A1-02 = 3), be sure to set the encoder pulses per revolution (PPR) (T1-08). After entering all of the motor parameters press the **UP** key to display “0Hz/ 0.00A Tuning Ready?”.



**THE NEXT KEY-PRESS WILL CAUSE THE MOTOR TO ROTATE.
TAKE APPROPRIATE PRECAUTIONS.**

- 3. Confirm that the motor is uncoupled from the load and make sure it is safe to rotate the motor. Press the RUN key to start Auto-Tuning. The Drive will energize the motor without rotating it for approximately 1 minute. Then, the Drive will set the required motor parameters automatically while rotating the motor for approximately 1 minute. If the Auto-Tuning was successful, the operator keypad will display “Tune Successful”.
- 4. Proceed to the Quick Setting Parameters section.

■No Rotate Tuning

Use No Rotate Tuning when operating in Open Loop Vector or Flux Vector control (A1-02 = 2 or 3) and it is impossible to uncouple the load from the motor.

- 1. Select the Auto-Tuning Menu. Then, select “Tune-No Rotate” in the “Tuning Mode Sel” parameter (T1-01 = 1).
- 2. Set the motor output power (T1-02), motor rated voltage (T1-03), motor rated current (T1-04), motor base frequency (T1-05), number of motor poles (T1-06), and motor rated speed (T1-07) obtained from the motor nameplate information. After entering all of the motor parameters press the **UP** key to display “0Hz/0.00A Tuning Ready?”.
- 3. Press the RUN key to start Auto-Tuning. The Drive will set the required motor parameters automatically while energizing the motor (without rotation) for approximately 1 minute. If the Auto-Tuning is successful, the operator keypad will display “Tune Successful”.
- 4. Proceed to the Quick Setting Parameters section.

■Terminal Resistance Tuning

Terminal Resistance Tuning is the only Auto-Tuning method available when using V/F or V/F w/ Feedback control (A1-02 = 0 or 1).

- 1. Select the Auto-Tuning Menu. Then, select “Term Resistance” in the “Tuning Mode Sel” parameter (T1-01 = 2).
- 2. Set the motor output power (T1-02) and motor rated current (T1-04) obtained from the motor nameplate information. After entering all of the motor parameters press the **UP** key to display “0Hz/ 0.00A Tuning Ready?”.
- 3. Press the RUN key to start Auto-Tuning. The Drive will set the required motor parameter automatically while energizing the motor (without rotation) for approximately 30 seconds. If the Auto-Tuning is successful, the Digital Operator keypad will display “Tune Successful”.
- 4. Proceed to the Quick Setting Parameters section.

◆ Quick Setting Parameters

The following Drive parameters located in the Quick Setting menu need to be set according to the application. Refer to Chapter 5 Basic Programming section for more details on each parameter.

Note: Not all parameters are available for all Control Methods. See Control Method column.

Parameter No.	Parameter Name Digital Operator Display	Description	Setting Range	Factory Setting	Control Method			
					V/F	V/F w/ PG	OLV	FV
A1-02	Control Method Selection Control Method	Selects the Control Method of the Drive. 0: V/F control without PG 1: V/F control with PG 2: Open Loop Vector 3: Flux Vector (Closed Loop Vector)	0 to 3	0	Q	Q	Q	Q
b1-01	Frequency Reference Selection Reference Source	Selects the frequency reference input source. 0: Operator - Digital preset speed U1-01 or d1-01 to d1-17. 1: Terminals - Analog Input Terminal A1 (Terminal A2 sums together with terminal A1 when H3-09=0) 2: Serial Com - Modbus RS-422/485 terminals R+, R-, S+ and S- 3: Option PCB - Option board connected on 2CN 4: Pulse Input	0 to 4	1	Q	Q	Q	Q
b1-02	Run Command Selection Run Source	Selects the run command input source. 0: Operator - RUN and STOP keys on Digital Operator 1: Terminals - Contact closure on terminals S1 or S2 2: Serial Com - Modbus RS-422/485 terminals R+, R-, S+ and S- 3: Option PCB - Option board connected on 2CN	0 to 3	1	Q	Q	Q	Q
b1-03	Stopping Method Selection Stopping Method	Selects the stopping method when the run command is removed. 0: Ramp to Stop 1: Coast to Stop 2: DC Injection to Stop 3: Coast with Timer (A new run command is ignored if input before the timer expires.)	0 to 3	0	Q	Q	Q	Q
C1-01 ◆	Acceleration Time 1 Accel Time 1	Sets the time to accelerate from zero to maximum frequency (E1-04).	0.0 to 6000.0	10.0sec	Q	Q	Q	Q
C1-02 ◆	Deceleration Time 1 Decel Time 1	Sets the time to decelerate from maximum frequency to zero (E1-04).			Q	Q	Q	Q
C6-02	Carrier Frequency Selection CarrierFreq Sel	Selects the number of pulses per second of the output voltage waveform. Setting range determined by C6-01 setting. 0: Low noise 1: Fc = 2.0 kHz 2: Fc = 5.0 kHz 3: Fc = 8.0 kHz 4: Fc = 10.0 kHz 5: Fc = 12.5 kHz 6: Fc = 15.0 kHz F: Program (Determined by the settings of C6-03 thru C6-05)	1 to F	Varies by kVA	Q	Q	Q	Q
d1-01 ◆	Frequency Reference 1 Reference 1	Setting units are affected by o1-03.	0.00 to E1-04 Value	0.00Hz	Q	Q	Q	Q
d1-02 ◆	Frequency Reference 2 Reference 2	Frequency reference when multi-function input "Multi-step speed reference 1" is ON. Setting units are affected by o1-03.		0.00Hz	Q	Q	Q	Q
d1-03 ◆	Frequency Reference 3 Reference 3	Frequency reference when multi-function input "Multi-step speed reference 2" is ON. Setting units are affected by o1-03.		0.00Hz	Q	Q	Q	Q
d1-04 ◆	Frequency Reference 4 Reference 4	Frequency reference when multi-function input "Multi-step speed reference 1,2" is ON. Setting units are affected by o1-03.		0.00Hz	Q	Q	Q	Q
d1-17 ◆	Jog Frequency Reference Jog Reference	Frequency reference when: "Jog Frequency Reference", "Forward Jog", or "Reverse Jog" is selected via multi-function input terminals or JOG key is pressed on the operator keypad. Jog reference has priority over frequency reference 1 to 4. Setting units are affected by o1-03.		6.00Hz	Q	Q	Q	Q

◆ Denotes that parameter can be changed when the Drive is running.

Parameter No.	Parameter Name Digital Operator Display	Description	Setting Range	Factory Setting	Control Method			
					V/F	V/F w/ PG	OLV	FV
E1-01	Input Voltage Setting Input Voltage	Set to the nominal voltage of the incoming line, sets maximum/base voltage used by preset V/F patterns (E1-03 = 0 to E), adjusts the levels of Drive protective features (i.e. Overvoltage, braking resistor turn-on, stall prevention, etc.).	155 to 255.0 (240V) 310 to 510.0 (480V)	240V 480V	Q	Q	Q	Q
E1-03	V/F Pattern Selection V/F Selection	Set to the type of motor being used and the type of application. The Drive operates utilizing a set V/F pattern to determine the appropriate output voltage level for each commanded speed. There are 15 different preset V/F patterns to select from (E1-03 = 0 to E) with varying voltage profiles, base levels (base level = frequency at which maximum voltage is reached), and maximum frequencies. There are also settings for Custom V/F patterns that will use the settings of parameters E1-04 through E1-13. E1-03 = F selects a custom V/F pattern with an upper voltage limit and E1-03 = FF selects a custom V/F pattern without an upper voltage limit. 0: 50Hz 1: 60Hz 2: 60Hz (50Hz Base) 3: 72Hz (60Hz Base) 4: 50Hz VT1 5: 50Hz VT2 6: 60Hz VT1 7: 60Hz VT2 8: 50Hz HST1 9: 50Hz HST2 A: 60Hz HST1 B: 60Hz HST2 C: 90Hz (60Hz Base) D: 120Hz (60Hz Base) E: 180Hz (60Hz Base) F: Custom V/F FF: Custom w/o limit	0 to FF	F	Q	Q	-	-
E1-04	Maximum Output Frequency Max Frequency	<p>These parameters are only applicable when V/F Pattern Selection is set to Custom (E1-03 = F or FF). To set V/F characteristics in a straight line, set the same values for E1-07 and E1-09. In this case, the setting for E1-08 will be disregarded. Always ensure that the four frequencies are set in the following manner: E1-04 ≥ E1-12 ≥ E1-06 > E1-07 ≥ E1-09 E2-04 is automatically set during Auto-Tuning.</p>	HD: 40.0 to 300.0 ND2: 40.0 to 400.0	60.0Hz	Q	Q	Q	Q
E1-05	Maximum Output Voltage Max Voltage		0 to 255.0 (240V) 0 to 510.0 (480V)	240V 480V	Q	Q	Q	Q
E1-06	Base Frequency Base Frequency		0.0 to 200.0	60.0Hz	Q	Q	Q	Q
E1-09	Minimum Output Frequency Min Frequency		0.0 to 200.0	1.5Hz	Q	Q	Q	A
E1-13	Base Voltage Base Voltage		0 to 255.0 (240V) 0 to 510.0 (480V)	0.0VAC	A	A	Q	Q
E2-01	Motor Rated Current Motor Rated FLA		Varies by kVA	Varies by kVA	Q	Q	Q	Q
E2-04	Number of Motor Poles Number of Poles		2 to 48	4	-	Q	-	Q
E2-11	Motor Rated Output Motor Rated Power	Set to the motor rated power in KW. This value is automatically set during Auto-Tuning.	0.00 to 650.00	Varies by kVA	Q	Q	Q	Q
F1-01	PG Parameter PG Pulse/Rev	Sets the number of pulses per revolution of the encoder (pulse generator). This value is automatically set during Auto-Tuning.	0 to 60000	1024	-	Q	-	Q

◆Denotes that parameter can be changed when the Drive is running.

Parameter No.	Parameter Name Digital Operator Display	Description	Setting Range	Factory Setting	Control Method			
					V/F	V/F w/ PG	OLV	FV
H4-02 ◆	Terminal FM Gain Setting Terminal FM Gain	Sets terminal FM output voltage (in percent of 10Vdc) when selected monitor is at 100% output.	0.0 to 1000.0	100.0%	Q	Q	Q	Q
H4-05 ◆	Terminal AM Gain Setting Terminal AM Gain	Sets terminal AM output voltage (in percent of 10Vdc) when selected monitor is at 100% output.	0.0 to 1000.0	50.0%	Q	Q	Q	Q
L1-01	Motor Overload Protection Selection MOL Fault Select	Sets the motor thermal overload protection (OL1) based on the cooling capacity of the motor. 0: Disabled 1: Standard Fan Cooled (<10:1 motor) 2: Standard Blower Cooled (10:1 motor) 3: Vector Motor (1000:1 motor)	0 to 1	1	Q	Q	Q	Q
L3-04	Stall Prevention Selection During Decel StallP Decel Sel	When using a braking resistor, use setting "0". Setting "3" is used in very specific applications. 0: Disabled - The Drive decelerates at the active deceleration rate. If the load is too large or the deceleration time is too short, an OV fault may occur. 1: General Purpose - The Drive decelerates at the active deceleration rate, but if the main circuit DC bus voltage reaches the stall prevention level (380/760 Vdc), deceleration will stop. Deceleration will continue once the DC bus level drops below the stall prevention level. 2: Intelligent - The active deceleration rate is ignored and the Drive decelerates as fast as possible w/o hitting OV fault level. Range: C1-02/10. 3: Stall Prevention w/ Braking Resistor	0 to 3	1	Q	Q	Q	Q

◆Denotes that parameter can be changed when the Drive is running.

◆ Trial Run

- 1. Press the **LOCAL/REMOTE** key once. This puts the Drive in the Local Mode, allowing run/stop and speed commands by the Digital Operator. The **AUTO SEQ** and **AUTO REF** indicators turn off, and the **FWD** light turns on.
- 2. Run the Drive at different frequencies and record monitor values. With the Drive in Local Mode, press the **ENTER** key at Frequency Reference Monitor (U1-01). Use the **UP**, **DOWN**, and **RESET** keys to set the frequency reference. Then, press the **DATA/ENTER** key to accept the frequency reference entered. Run the Drive at the set frequency reference by pressing the **RUN** key. Use the **UP** and **DOWN** keys to view Output Current (U1-03), Output Voltage (U1-06), and DC Bus Voltage (U1-07) while running the Drive throughout its entire speed range. Record the following information at each speed:

Frequency (Hz) Monitor U1-01	Output Current (A) Monitor U1-03	Output Voltage (Vac) Monitor U1-06	DC Bus Voltage (Vdc) Monitor U1-07
6.0			
10.0			
15.0			
20.0			
25.0			
30.0			
35.0			
40.0			
45.0			
50.0			
55.0			
60.0			

When this table is complete, press the **STOP** key. The Drive will stop and the **FWD** light remains on. This step provides benchmark data for the application from the initial start-up.

- 3. Press the **MENU** key once to display “Operation”. Press the **DATA/ENTER** key to display “Frequency Ref”. If using a remote speed command, press the **LOCAL/REMOTE** key so the **REMOTE SEQ** and **REMOTE REF** indicators are on. This puts the Drive in REMOTE mode.

- 4. If using an external speed command, determine whether the speed command is a 0-10Vdc or a 4-20mA signal. Connect the positive side of a 0-10Vdc signal to terminal **A1**. Connect the positive side of a 4-20mA signal to terminal **A2**. Connect the COMMON of the speed command to terminal **AC**.

Note: Connect only one input. The factory default is 0-10Vdc. To change to 4-20mA, adjust parameter H3-08 to “2: 4 – 20mA” and ensure DIP Switch S1-2 (located on the terminal board) is in the ON position.

- 5. Check the signal for proper polarity. Observe if the speed command can achieve the minimum and maximum speeds desired. If not, perform the following:

For 0-10Vdc input (Terminal **A1**)

1. With no input, adjust Bias (**H3-03** setting) until an output of “0.0Hz” is obtained.
2. With full-scale input, adjust Gain (**H3-02** setting) until an output of “60.0Hz” (or other desired maximum frequency) is obtained.

For 4-20mA input (Terminal **A2**)

1. With 4mA input, adjust Bias (**H3-11** setting) until an output of “0.0Hz” is obtained.
2. With 20mA input, adjust Gain (**H3-10** setting) until an output of “60.0Hz” (or other desired maximum frequency) is obtained.

THIS COMPLETES THE DRIVE START-UP PROCEDURE.

Chapter 5

Basic Programming

This chapter describes basic programming for the Drive.

Description of Parameter Tables	5-2
Control Method	5-2
Speed Command Source	5-3
Run Command Source	5-4
Stopping Method.....	5-5
Accel/Decel Time	5-8
Carrier Frequency.....	5-9
Preset Reference.....	5-10
Input Voltage Setting	5-11
V/F Pattern	5-11
Motor Setup	5-19
PG Option.....	5-19
Analog Output Gain	5-20
Motor Overload Fault.....	5-21
Stall Prevention.....	5-22

F7 Basic Programming Parameters

◆ Description of Parameter Tables

This chapter details all of the parameters in the Quick Setting Menu (-QUICK-). Some parameters are not available for all Control Methods. See Appendix A for details. Setting range and factory default value of the parameter follows the control method table for each parameter.

◆ Control Method

■ A1-02 Control Method Selection

Setting	Description
0	V/F Control (<i>factory default</i>)
1	V/F with PG Feedback
2	Open Loop Vector
3	Flux Vector

The setting of parameter A1-02 determines which control method the Drive will use for operation. Select the control method best suited for the application:

V/F Control is for general purpose and multiple motor applications.

V/F with PG Feedback is for general purpose applications requiring closed loop speed control.

Open Loop Vector is for applications requiring precise speed control, quick response, and higher torque at low speeds (150% torque below 1Hz).

Flux Vector Control is for applications requiring very precise speed and torque control at a wide speed range including zero speed. It requires encoder feedback.

◆ Speed Command Source

■ b1-01 Reference Source Selection

Setting	Description
0	Operator - Monitor U1-01 or parameter d1-01
1	Terminals - Analog input terminal A1 (Terminal A2 sums together with terminal A1 when H3-09=0) (<i>factory default</i>)
2	Modbus Serial Communication - RS-422/485 terminals R+, R-, S+, and S-
3	Option Board - Option board connected on 2CN
4	Pulse Train Input - Terminal RP and AC

In order to run the Drive and motor in REMOTE mode, the Drive must receive a run command and a speed command from an external source. Parameter b1-01 specifies from where the speed command will be accepted. To switch into the “REMOTE” mode press the LOCAL/REMOTE button on the Digital Operator while the Drive is stopped.

IMPORTANT

If the set speed command is less than the minimum output frequency (E1-09) with a run command input, the RUN indicator on the Digital Operator will turn on and the STOP indicator on the Digital Operator will blink.

To have the Drive follow the speed command set by the Digital Operator:

Set b1-01=0. The speed command can then be entered into the U1-01 monitor or in parameter d1-01.

To have the Drive follow an analog speed command:

Set b1-01 = 1 and connect a 0 to 10Vdc or -10 to +10Vdc signal to terminals A1 and AC. Be sure to set parameter H3-01 to the proper setting. Or, connect a 4 – 20mA signal to terminals A2 and AC. Make sure the S1-2 switch and corresponding parameter H3-08 is properly set up when using terminal A2

To have the Drive receive the speed command from Modbus serial communication:

Set b1-01 = 2 and connect the RS-485/422 serial communications cable to terminals R+, R-, S+, and S- on the removable terminal block. Make sure the S1-1 switch and the Modbus H5 parameters are properly set.

To use an option board to input the speed command:

Set b1-01 = 3 and install a communications analog input, or digital input option board into the 2CN port on the Drive control board. Consult the manual supplied with the option board for instructions on integrating the Drive and communications option board.

IMPORTANT

If b1-01=3 but an option board is not installed in 2CN, an OPE05 Fault will be displayed on the digital operator and the Drive will not run.

To use pulse train to input a speed command:

Set b1-01 = 4 and connect the pulse train signal to terminals RP and AC. Make sure the H6 parameters are properly set.

◆ Run Command Source

■ b1-02 Run Source Selection

Setting	Description
0	Operator - RUN and STOP keys on Digital Operator
1	Terminals - Contact closure between terminal S1 and SN (<i>factory default</i>)
2	Modbus Serial Communication - RS-422/485 terminals R+, R-, S+, and S-
3	Option Board - Option board connected to 2CN

In order to run the Drive and motor in REMOTE mode, the Drive must receive a run command and a speed command from an external source. Parameter b1-02 specifies from where the RUN command will be accepted.

To issue a run command from the Digital Operator:

Set b1-02=0 and use the RUN and STOP keys on the Digital Operator to start and stop the Drive.

To issue the run command from the terminals:

Set b1-02=1 and select between 2-wire and 3-wire operation according to the following:

2-Wire Control: The factory setting is for 2-wire operation. In the 2-wire configuration, a closure between S1 and SN will be interpreted as a Forward run command by the Drive. A closure between S2 and SN will be interpreted as a Reverse run command. If both S1 and S2 are closed, the Drive will alarm and the Digital Operator will flash an EF fault. The Drive will not run in this condition.

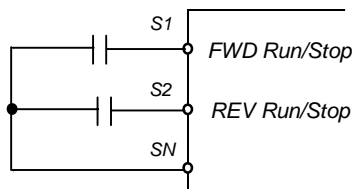

Fig 5.1 2-Wire Control

3-Wire Control: When any of the multi-function digital input parameters, H1-01 through H1-05, is set to 0, terminals S1 and S2 become Run and Stop, respectively. The multi-function digital input that was set to 0 will function as a Forward/Reverse input for the Drive. When the Forward/Reverse input is open the Drive will run in the Forward direction and when the input is closed, the Drive will run in the Reverse direction.

In 3-wire operation, a momentary closure (> 50ms) between S1 and SN will cause the Drive to run provided that S2 and SN is held closed. The Drive will stop any time the S2-SN connection is broken. If the 3-wire configuration is implemented via a 3-wire Initialization (A1-03=3330), terminal S3 becomes the Forward/Reverse input.

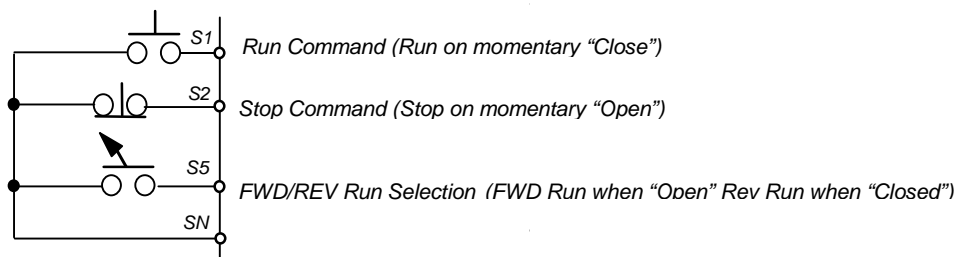

Fig 5.2 3-Wire Control

To issue a run command via Modbus serial communication:

Set b1-02=2 (Modbus communication) and connect the Modbus RS-485/422 serial communication cable to R+, R-, S+, and S- on the removable terminal block. Make sure the S1-1 switch and the Modbus H5 parameters are properly set.

To issue the RUN command via an option card:

Set b1-02=3 and install an option board into the 2CN port on the control board. Consult the manual supplied with the option board for instructions on integrating the Drive and communication option board.

IMPORTANT

If b1-01=3 but an option board is not installed in 2CN, an OPE05 operator programming error will be displayed on the Digital Operator and the Drive will not run.

◆ Stopping Method

■ b1-03 Stopping Method Selection

Setting	Description
0	Ramp to Stop (<i>factory default</i>)
1	Coast to Stop
2	DC Injection to Stop
3	Coast to Stop with Timer

There are four methods of stopping the Drive when the RUN command is removed.

0: Ramp to stop: When the run command is removed, the Drive will decelerate the motor to minimum output frequency (E1-09) and then shut off. The rate of deceleration is determined by the active deceleration time. The factory default Decel Time is parameter C1-02.

When the output frequency has dropped below the DC Injection Start Frequency (b2-01) or the minimum output frequency (E1-09) (whichever is greater), deceleration will stop and DC current will be injected into the motor at the current level set in b2-02 for the time set in b2-04.

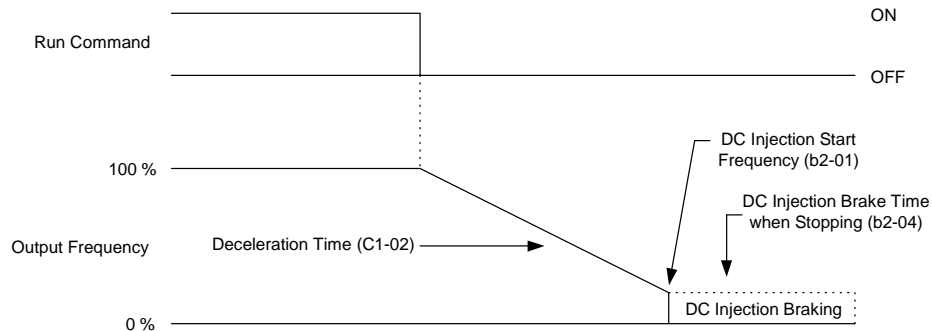

Fig 5.3 Deceleration to Stop

The actual deceleration time can be determined by the following formula:

$$\text{Time to stop} = \frac{\text{Output frequency at time of stop command}}{\text{Maximum frequency (E1-04)}} \times \text{Active deceleration time}$$

IMPORTANT | If S-Curve characteristics are set in the Drive programming, they will add to the total time to stop.

1: Coast to stop: When the run command is removed, the Drive will turn off its output transistors. The friction of the driven equipment will eventually overcome any residual inertia of the system and the motor will stop.

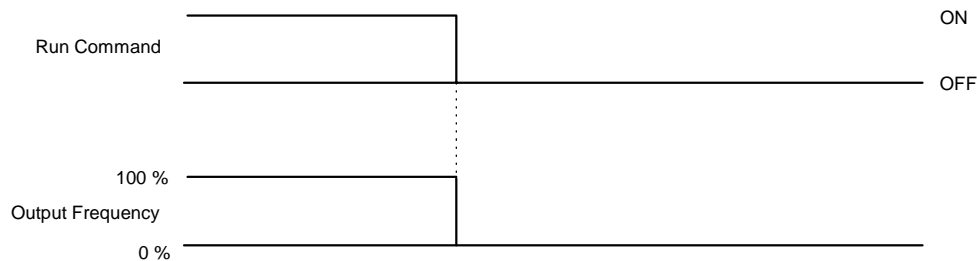

Fig 5.4 Coast to Stop

IMPORTANT | After a stop is initiated, subsequent run commands will be ignored until the Minimum Baseblock Time (L2-03) has expired.

2: DC Injection to Stop: When the run command is removed, the Drive will Baseblock (turn off all output transistors) for the Minimum Baseblock Time (L2-03). Once the Minimum Baseblock Time has expired, the Drive will inject DC current into the motor windings to try and lock the motor shaft. The stopping time will be reduced as compared to Coast to Stop. The level of DC Injection current is set by parameter b2-02. The DC Injection brake time is determined by the set value in b2-04 and the output frequency at the time the run command is removed.

$$\text{DC Injection Brake Time} = \frac{(b2 - 04) \times 10 \times \text{Output Frequency}}{\text{Maximum Frequency (E1 - 04)}}$$

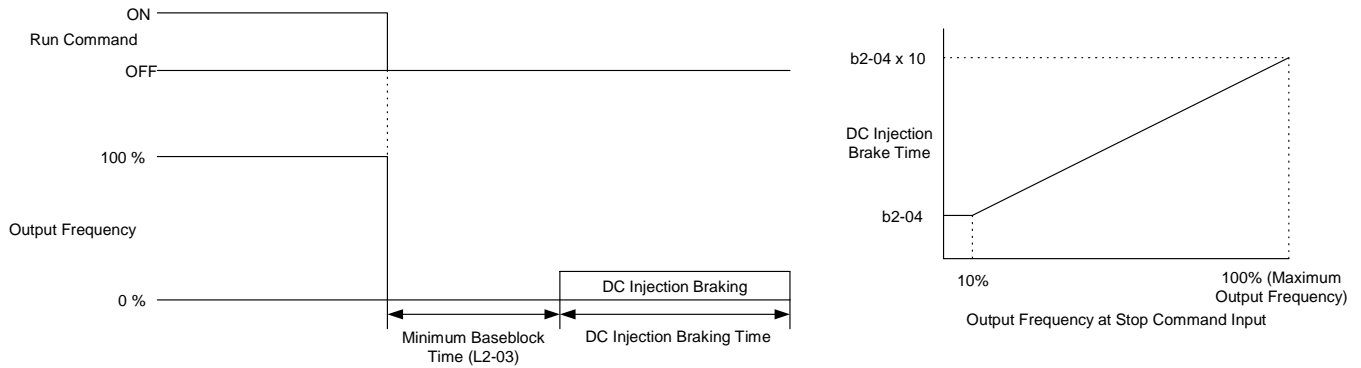

Fig 5.5 DC Injection Braking to Stop

IMPORTANT

If an overcurrent (OC) fault occurs during DC Injection Braking to Stop, lengthen the Minimum Baseblock Time (L2-03) until the fault no longer occurs.

3: Coast to Stop with Timer: When the run command is removed, the Drive will turn off its output transistors and the motor will coast to a stop. If a run command is input before the timer expires, the Drive will not run and the run command will be ignored. The timer value is determined by the active deceleration time and the output frequency when the run command is removed.

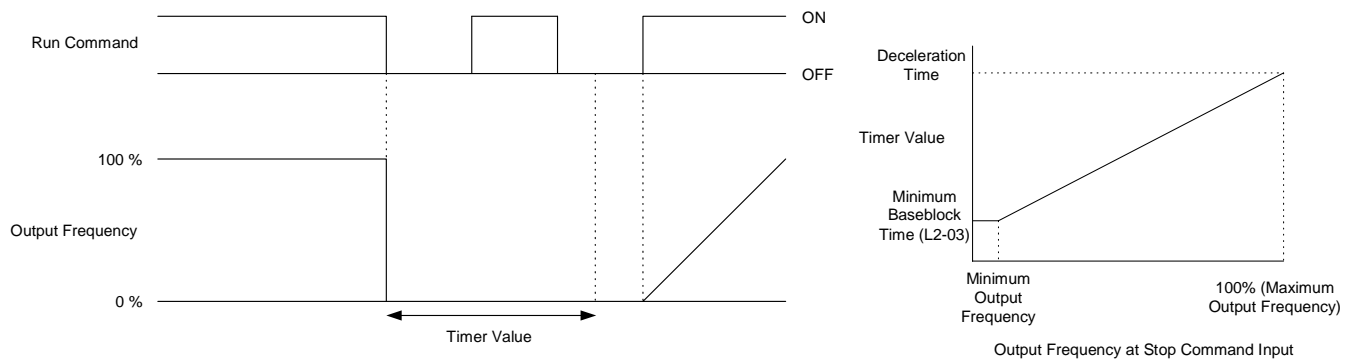

Fig 5.6 Coast to Stop with Timer

◆ Accel/Decel Time

■ C1-01 Acceleration Time 1

■ C1-02 Deceleration Time 1

Setting Range: 0.0 to 6000.0

Factory Default: 10.0sec

C1-01 (Acceleration Time 1) sets the time to accelerate from zero to maximum output frequency (E1-04). C1-02 (Deceleration Time 1) sets the time to decelerate from maximum output frequency to zero. C1-01 and C1-02 are the factory default active accel/decel settings. Alternate accel/decel settings (C1-03 through C1-08) can be activated by multi-function digital inputs (H1-0□ = 7 and 1A), or specified by the switch over frequency (C1-11). See Fig 5.7 below.

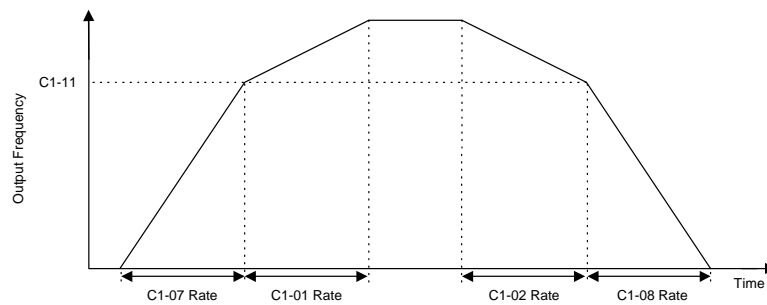

Fig 5.7 Acceleration/deceleration Time Switch Over Frequency

◆ Carrier Frequency

■ C6-02 Carrier Frequency Selection

Setting	Description
0	Low Noise
1	Fc=2.0 kHz
2	Fc=5.0 kHz
3	Fc=8.0 kHz
4	Fc=10.0 kHz
5	Fc=12.5 kHz
6	Fc=15.0 kHz
F	Program

*The factory default setting is model dependent

Parameter C6-02 sets the switching frequency of the Drive's output transistors. It can be changed in order to reduce audible carrier noise and also reduce leakage current. Cases that may require adjustment to the C6-02 include:

- If the wiring length between the Drive and the motor is long, decrease the carrier frequency.

Wiring Length	164 ft or less	328 ft or less	Over 328 ft
C6-02 (carrier frequency) setting	1 to 6 (15 kHz max.)	1 to 4 (10 kHz max.)	1 to 2 (5 kHz max.)

- If speed and torque are inconsistent at low speeds, decrease the carrier frequency.
- If leakage current from the Drive is large, decrease the carrier frequency.
- If the audible motor noise is too great, increase the carrier frequency.

The setting range depends on setting of parameter C6-01 Heavy/Normal Duty Selection.

If Heavy Duty is selected (C6-01=0), the Carrier Frequency Selection range is "0" (Low Noise) to "1" (2.0 kHz).

If Normal Duty 1 (C6-01=1) or Normal Duty 2 (C6-01=2) is selected, Carrier Frequency Selection range is "0" (Low Noise) to "F" (Program).

Setting of "F: Program" allows the carrier frequency to be varied according to parameters C6-03 (Carrier Frequency Upper Limit), C6-04 (Carrier Frequency Lower Limit), and C6-05 (Carrier Frequency Proportional Gain).

◆ Preset Reference

■ d1-01 Frequency Reference 1

■ d1-02 Frequency Reference 2

■ d1-03 Frequency Reference 3

■ d1-04 Frequency Reference 4

Setting Range: 0.0 to E1-04 (Maximum Output Frequency)

Factory Default: 0.0Hz

■ d1-17 Jog Reference

Setting Range: 0.0 to E1-04 (Maximum Output Frequency)

Factory Default: 6.0Hz

Up to 17 preset references (including Jog Reference) can be set through multi-function inputs S3 to S8. The first 4 preset references and Jog Reference are accessible through the Quick Setting menu. It is a two-step process to set the Drive up for preset speeds. First, d1-01 through d1-04 and d1-17 must be programmed with the desired preset speeds and the desired jog speed, respectively. Next, three of the Drive's digital inputs need to be programmed and wired as Multi-step Speed Reference 1, Multi-step Speed Reference 2, and Jog Frequency.

Table 5.1 Preset Speed

Preset Speed	Terminal programmed as Multi-step Reference 1	Terminal programmed as Multi-step Reference 2	Terminal programmed as Jog Reference	Details
1	OFF	OFF	OFF	Frequency Reference 1 (d1-01) or analog input A1
2	ON	OFF	OFF	Frequency Reference 2 (d1-02) or analog input A2
3	OFF	ON	OFF	Frequency Reference 3 (d1-03)
4	ON	ON	OFF	Frequency Reference 4 (d1-04)
5	-	-	ON*	Jog Frequency (d1-17)

* The Jog Frequency input is given priority over the multi-step speeds.

As shown in the above table, it is possible to use analog inputs in place of Frequency Reference 1 and Frequency Reference 2.

- If b1-01 = 1, then the analog input A1 will be used instead of Frequency Reference 1 for the first preset speed. If b1-01=0 then Frequency Reference 1 (d1-01) will be used.
- If H3-05 = 2, then the analog input A2 will be used instead of Frequency Reference 2 (d1-02) for the second preset speed. If H3-05 ≠ 2, then Frequency Reference 2 will be used.

IMPORTANT

The programming of d1-01 through d1-17 will be in the units specified by the display scaling parameter (o1-03).

◆ Input Voltage Setting

■ E1-01 Input Voltage Setting

Setting Range: 155.0V to 255.0V (240V Models)
310.0V to 510.0V (480V Models)

Factory Defaults: 230.0V (240V Models)
460.0V (480V Models)

Set the Input Voltage parameter (E1-01) to the nominal voltage of the connected AC power supply. This parameter adjusts the levels of some protective features of the Drive (i.e. Overvoltage, Built-in Braking Transistor Turn-on, Stall Prevention, etc.). E1-01 also serves as the Maximum/Base Voltage used by the Preset V/F curves (E1-03=0 to E).



DRIVE INPUT VOLTAGE (NOT MOTOR VOLTAGE) MUST BE SET IN E1-01 FOR THE PROTECTIVE FEATURES OF THE DRIVE TO FUNCTION PROPERLY. FAILURE TO DO SO MAY RESULT IN EQUIPMENT DAMAGE AND/OR PERSONAL INJURY.

◆ V/F Pattern

■ E1-03 V/F Pattern Selection

Setting	Description
0	50Hz
1	60Hz
2	60Hz (with 50Hz Base)
3	72Hz (with 60Hz Base)
4	50Hz VT1
5	50Hz VT2
6	60Hz VT1
7	60Hz VT2
8	50Hz HST1
9	50Hz HST2
A	60Hz HST1
B	60Hz HST2
C	90Hz (with 60Hz Base)
D	120Hz (with 60Hz Base)
E	180Hz (with 60Hz Base)
F	Custom V/F (<i>factory default</i>)
FF	Custom w/o limit

Note: VT = Variable Torque, HST = High Starting Torque

This parameter is only available in the V/F or V/F with PG control methods (A1-02 = 0 or 1).

The Drive operates utilizing a set V/F pattern to determine the appropriate output voltage level for each commanded speed. There are 15 different preset V/F patterns to select from (E1-03 = 0 to E) with varying voltage profiles, base level (base level = frequency at which maximum voltage is reached), and maximum frequencies.

There are also settings for Custom V/F patterns that will use the settings of parameters E1-04 through E1-13. E1-03 = F selects a custom V/F pattern with an upper voltage limit and E1-03 = FF selects a custom V/F pattern without an upper voltage limit. See Fig 5.8 below for the upper voltage limit.

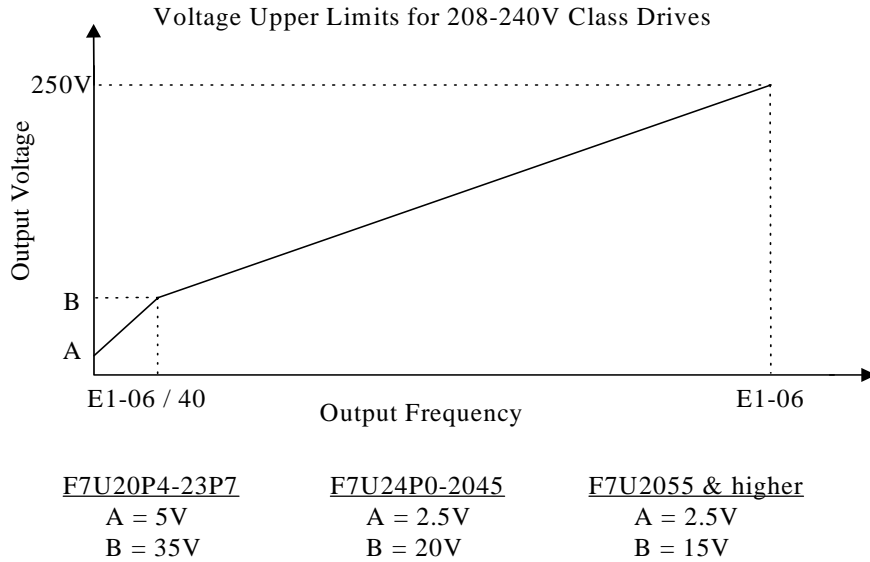

For 480V class Drives, the values are twice that of 208-240V class Drives.

Fig 5.8 V/F Pattern Voltage Upper Limit

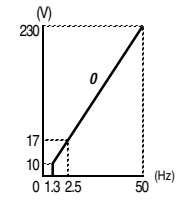
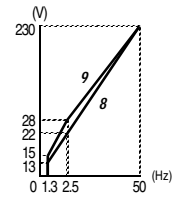
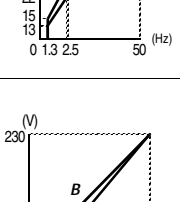
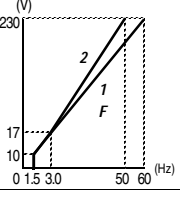
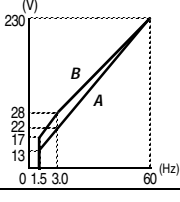
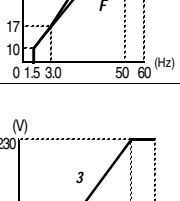
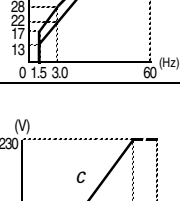
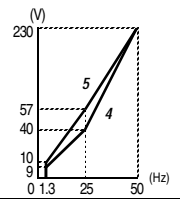
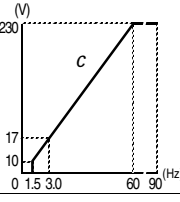
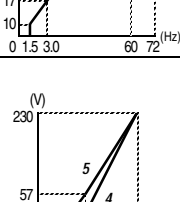
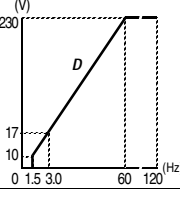
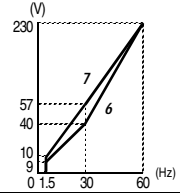
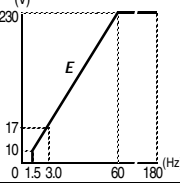
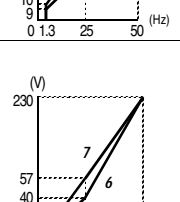
Table 5.2 Preset V/F Patterns									
		Specifications	E1-03	V/F Pattern			Specifications	E1-03	V/F Pattern
General-purpose	50Hz		0		High Starting Torque	50Hz	High Starting Torque 1	8	
			High Starting Torque 2	9					
	60Hz	1 or F		60Hz		High Starting Torque 1	A		
	60Hz (with 50Hz Base)	2		High Starting Torque 2		B			
Variable Torque	50Hz	Variable Torque 1	4		High Speed Operation	90Hz (with 60Hz Base)	C		
		Variable Torque 2	5				120Hz (with 60Hz Base)	D	
	60Hz	Variable Torque 1	6			180Hz (with 60Hz Base)		E	
		Variable Torque 2	7						

IMPORTANT

When a factory initialization is performed and the setting of E1-03 = F or FF, E1-03 is unaffected, but the settings of E1-04 through E1-13 are returned to their factory default settings.

■ **E1-04 Maximum Output Frequency**

Setting Range: 40.0 to 400.0Hz
 Factory Default: 60.0Hz

■ **E1-05 Maximum Output Voltage**

Setting Range: 0.0 to 255.0V (240V Models)
 0.0 to 510.0V (480V Models)
 Factory Defaults: 230.0V (240V Models)
 460.0V (480V Models)

■ **E1-06 Base Frequency**

Setting Range: 0.0 to 400.0Hz
 Factory Default: 60.0Hz

■ **E1-09 Minimum Output Frequency**

Setting Range: 0.0 to 400.0Hz (Normal Duty)
 0.0 to 300.0Hz (Heavy Duty)
 Factory Default: 1.5Hz

■ **E1-13 Base Voltage**

Setting Range: 0.0 to 255.0V (240V Models)
 0.0 to 510.0V (480V Models)
 Factory Defaults: 0.0V (240V Models)
 0.0V (480V Models)

To set up a custom V/F pattern, program the points shown in the diagram below using parameters E1-04 through E1-13. Be sure that the following condition is true:

$$E1-09 \leq E1-07 < E1-06 \leq E1-11 \leq E1-04$$

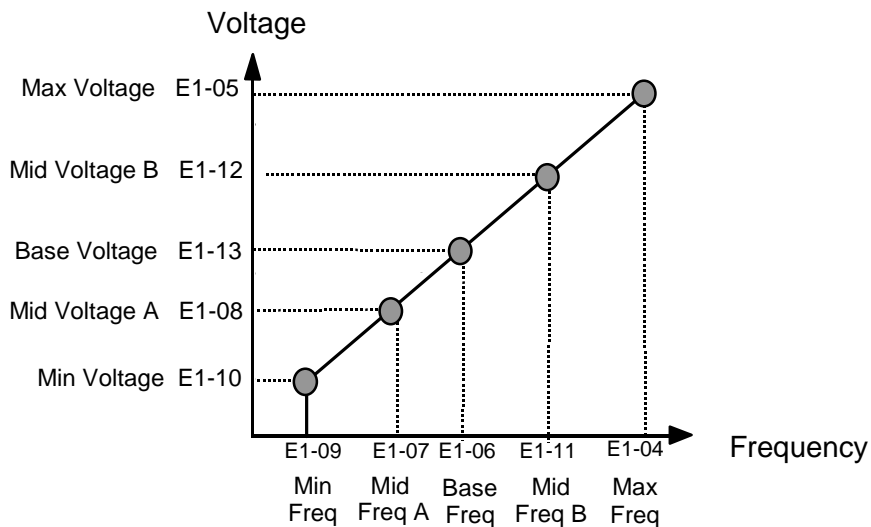

Fig 5.9 V/F Pattern Parameters

Parameters E1-07, E1-08, E1-10, E1-11, and E1-12 are accessible through the Programming Menu.

Tables 5.3 to 5.5 list the factory settings of V/F patterns when V/F without PG or V/F with PG control method is selected (A1-02 = 0 or 1).

Table 5.3 V/F Pattern for Drive Capacities F7U20P4 - 21P5 for 200V Class										
Parameter No.	Name	Unit	Factory Setting							
E1-03	V/F Pattern Selection	—	0	1	2	3	4	5	6	7
E1-04	Max. Output Frequency	Hz	50.0	60.0	60.0	72.0	50.0	50.0	60.0	60.0
E1-05	Max. Output Voltage	V	230.0	230.0	230.0	230.0	230.0	230.0	230.0	230.0
E1-06	Base Frequency	Hz	50.0	60.0	50.0	60.0	50.0	50.0	60.0	60.0
E1-07	Mid. Output Frequency	V	2.5	3.0	3.0	3.0	25.0	25.0	30.0	30.0
E1-08	Mid. Output Voltage	V	17.2	17.2	17.2	17.2	40.2	57.5	40.2	57.5
E1-09	Min. Output Frequency	Hz	1.3	1.5	1.5	1.5	1.3	1.3	1.5	1.5
E1-10	Min. Output Voltage	V	10.3	10.3	10.3	10.3	9.2	10.3	9.2	10.3

1. For 400V class units, the voltage values are twice that of 200V class units.
2. These default values are for V/F or V/F with PG control methods (A1-02 = 0 or 1)

Table 5.3 V/F Pattern for Drive Capacity F7U20P4 - 21P5 for 200V Class (continued)										
Parameter No.	Name	Unit	Factory Setting							
E1-03	V/F Pattern Selection	—	8	9	A	B	C	D	E	F & FF
E1-04	Max. Output Frequency	Hz	50.0	50.0	60.0	60.0	90.0	120.0	180.0	60.0
E1-05	Max. Output Voltage	V	230.0	230.0	230.0	230.0	230.0	230.0	230.0	230.0
E1-06	Base Frequency	Hz	50.0	50.0	60.0	60.0	60.0	60.0	60.0	60.0
E1-07	Mid. Output Frequency	V	2.5	2.5	3.0	3.0	3.0	3.0	3.0	3.0
E1-08	Mid. Output Voltage	V	21.8	27.6	21.8	27.6	17.2	17.2	17.2	17.2
E1-09	Min. Output Frequency	Hz	1.3	1.3	1.5	1.5	1.5	1.5	1.5	1.5
E1-10	Min. Output Voltage	V	12.6	14.9	12.6	17.2	10.3	10.3	10.3	10.3

1. For 400V class units, the voltage values are twice that of 200V class units.
2. These default values are for V/F or V/F with PG control methods (A1-02 = 0 or 1)

Table 5.4 V/F Pattern for Drive Capacity F7U22P2 - 2045 for 200V Class

Parameter No.	Name	Unit	Factory Setting							
			0	1	2	3	4	5	6	7
E1-03	V/F Pattern Selection	—	0	1	2	3	4	5	6	7
E1-04	Max. Output Frequency	Hz	50.0	60.0	60.0	72.0	50.0	50.0	60.0	60.0
E1-05	Max. Output Voltage	V	230.0	230.0	230.0	230.0	230.0	230.0	230.0	230.0
E1-06	Base Frequency	Hz	50.0	60.0	50.0	60.0	50.0	50.0	60.0	60.0
E1-07	Mid. Output Frequency	V	2.5	3.0	3.0	3.0	25.0	25.0	30.0	30.0
E1-08	Mid. Output Voltage	V	16.1	16.1	16.1	16.1	40.2	57.5	40.2	57.5
E1-09	Min. Output Frequency	Hz	1.3	1.5	1.5	1.5	1.3	1.3	1.5	1.5
E1-10	Min. Output Voltage	V	8.0	8.0	8.0	8.0	6.9	8.0	6.9	8.0

1. For 400V class units, the voltage values are twice that of 200V class units.
2. These default values are for V/F or V/F with PG control methods (A1-02 = 0 or 1)

Table 5.4 V/F Pattern for Drive Capacity F7U22P2 - 2045 for 200V Class (continued)

Parameter No.	Name	Unit	Factory Setting							
			8	9	A	B	C	D	E	F & FF
E1-03	V/F Pattern Selection	—	8	9	A	B	C	D	E	F & FF
E1-04	Max. Output Frequency	Hz	50.0	50.0	60.0	60.0	90.0	120.0	180.0	60.0
E1-05	Max. Output Voltage	V	230.0	230.0	230.0	230.0	230.0	230.0	230.0	230.0
E1-06	Base Frequency	Hz	50.0	50.0	60.0	60.0	60.0	60.0	60.0	60.0
E1-07	Mid. Output Frequency	V	2.5	2.5	3.0	3.0	3.0	3.0	3.0	3.0
E1-08	Mid. Output Voltage	V	20.7	26.4	20.7	26.4	16.1	16.1	16.1	16.1
E1-09	Min. Output Frequency	Hz	1.3	1.3	1.5	1.5	1.5	1.5	1.5	1.5
E1-10	Min. Output Voltage	V	10.3	12.6	10.3	14.9	8.0	8.0	8.0	8.0

1. For 400V class units, the voltage values are twice that of 200V class units.
2. These default values are for V/F or V/F with PG control methods (A1-02 = 0 or 1)

Table 5.5 V/F Pattern for Drive Capacity F7U2055 and higher for 200V Class

Parameter No.	Name	Unit	Factory Setting							
			0	1	2	3	4	5	6	7
E1-03	V/F Pattern Selection	–	0	1	2	3	4	5	6	7
E1-04	Max. Output Frequency	Hz	50.0	60.0	60.0	72.0	50.0	50.0	60.0	60.0
E1-05	Max. Output Voltage	V	230.0	230.0	230.0	230.0	230.0	230.0	230.0	230.0
E1-06	Max. Voltage Frequency	Hz	50.0	60.0	50.0	60.0	50.0	50.0	60.0	60.0
E1-07	Mid. Output Frequency	V	2.5	3.0	3.0	3.0	25.0	25.0	30.0	30.0
E1-08	Mid. Output Voltage	V	13.8	13.8	13.8	13.8	40.2	57.5	40.2	57.5
E1-09	Min. Output Frequency	Hz	1.3	1.5	1.5	1.5	1.3	1.3	1.5	1.5
E1-10	Min. Output Voltage	V	6.9	6.9	6.9	6.9	5.7	6.9	5.7	6.9

1. For 400V class units, the voltage values are twice that of 200V class units.
2. These default values are for V/F or V/F with PG control methods (A1-02 = 0 or 1)

Table 5.5 V/F Pattern for Drive Capacity F7U2055 and higher for 200V Class (continued)

Parameter No.	Name	Unit	Factory Setting							
			8	9	A	B	C	D	E	F & FF
E1-03	V/F Pattern Selection	–	8	9	A	B	C	D	E	F & FF
E1-04	Max. Output Frequency	Hz	50.0	50.0	60.0	60.0	90.0	120.0	180.0	60.0
E1-05	Max. Output Voltage	V	230.0	230.0	230.0	230.0	230.0	230.0	230.0	230.0
E1-06	Base Frequency	Hz	50.0	50.0	60.0	60.0	60.0	60.0	60.0	60.0
E1-07	Mid. Output Frequency	V	2.5	2.5	3.0	3.0	3.0	3.0	3.0	3.0
E1-08	Mid. Output Voltage	V	17.2	23.0	17.2	23.0	13.8	13.8	13.8	13.8
E1-09	Min. Output Frequency	Hz	1.3	1.3	1.5	1.5	1.5	1.5	1.5	1.5
E1-10	Min. Output Voltage	V	8.0	10.3	8.0	12.6	6.9	6.9	6.9	6.9

1. For 400V class units, the voltage values are twice that of 200V class units.
2. These default values are for V/F or V/F with PG control methods (A1-02 = 0 or 1)

Table 5.6 lists the factory settings of V/F patterns when open loop vector or flux vector control method is selected (A1-02 = 2 or 3).

Table 5.6 V/F Pattern for 200V Class Drives				
Parameter No.	Name	Unit	Factory Setting	
			Open Loop Vector	Flux Vector
E1-04	Max. Output Frequency	Hz	60.0	60.0
E1-05	Max. Output Voltage	V	230.0	230.0
E1-06	Base Frequency	Hz	60.0	60.0
E1-07	Mid. Output Frequency	V	3.0	0.0
E1-08	Mid. Output Voltage	V	12.6	0.0
E1-09	Min. Output Frequency	Hz	0.5	0.0
E1-10	Min. Output Voltage	V	2.3	0.0

1. For 400V class units, the voltage values are twice that of 200V class units.
2. These default values are for open loop vector or flux vector control methods (A1-02 = 2 or 3)

◆ Motor Setup

■ E2-01 Motor Rated Current

Setting Range: Model Dependent
Factory Default: Model Dependent

The Motor Rated Current parameter (E2-01) is used by the Drive to protect the motor and for proper Vector control when using Open Loop Vector or Flux Vector control methods (A1-02 = 2 or 3). The motor protection parameter L1-01 is enabled by default. Set E2-01 to the full load amps (FLA) stamped on the motor's nameplate.

During Auto-Tuning, it is required for the operator to enter the motor's rated current (T1-04) in the Auto-Tuning menu. If the Auto-Tuning operation completes successfully, the value entered into T1-04 will automatically be written into E2-01.

■ E2-04 Number of Motor Poles

Setting Range: 2 to 48
Factory Default: 4

This parameter sets the number of motor poles. During Auto-Tuning, it is required for the operator to enter the number of motor poles (T1-06) in the Auto-Tuning menu. If the Auto-Tuning operation completes successfully, the value entered into T1-06 will automatically be written into E2-04.

■ E2-11 Motor Rated Power

Setting Range: 0.00 to 650.00kW
Factory Default: Varies by kVA

This parameter sets the motor rated power is set in kilowatts (kW).
1HP = 0.746kW

During Auto-Tuning, it is required for the operator to enter the motor's rated power (T1-02) in the Auto-Tuning menu. If the Auto-Tuning operation completes successfully, the value entered into T1-02 will automatically be written into E2-11.

◆ PG Option

■ F1-01 PG Pulses / Revolution

Setting Range: 0 to 60000
Factory Default: 1024

If a PG encoder option is used with the Drive, the number of PG pulses per motor revolution (PPR) must be set. During Auto-Tuning, it is required for the operator to enter the PG pulses per revolution (T1-08) in the Auto-Tuning menu. If the Auto-Tuning operation completes successfully, the value entered into T1-08 will automatically be written into F1-01.

◆ Analog Output Gain

■ H4-02 Terminal FM Gain

Setting Range: 0.0 to 1000.0

Factory Default: 100.0%

■ H4-05 Terminal AM Gain

Setting Range: 0.0 to 1000.0

Factory Default: 50.0%

These parameters set the gains for the analog output terminals FM and AM. The analog outputs are used for external monitoring of Drive conditions, such as output frequency, output current, PID feedback, and others. To obtain the output level, multiply the monitor output level by the gain set in H4-02 or H4-05.

For example, if H4-02=150%, then the FM analog output will output 10Vdc when the assigned output function reaches the 67% level. The analog output has a maximum of 10Vdc.

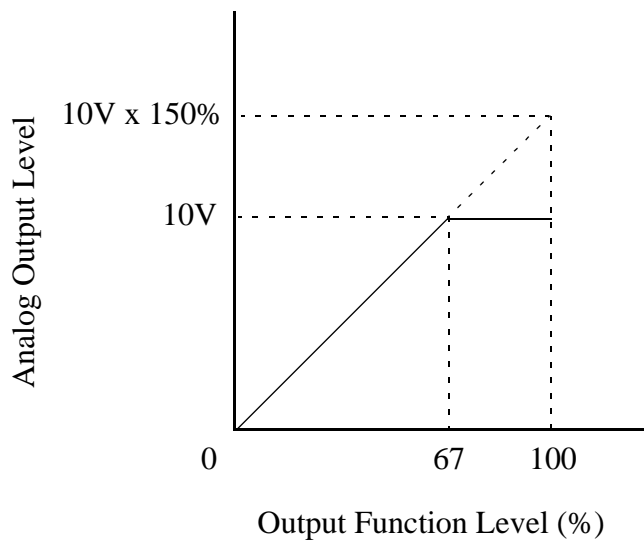

Fig 5.10 Analog Output Gain Setting Example

◆ Motor Overload Fault

■ L1-01 Motor Overload Fault Selection

Setting	Description
0	Disabled
1	Standard Fan Cooled Motor (<10:1 motor) (<i>factory default</i>)
2	Standard Blower Cooled Motor (≥10:1 motor)
3	Vector Motor (≤1000:1 motor)

The Drive has an electronic overload protection function (OL1) for protecting the motor from overheating. The Drive bases the protection on time, output current, and output frequency. The electronic thermal overload function is UL-recognized, so an external thermal overload relay is not required for single motor operation.

This parameter selects the motor overload curve used according to the type of motor applied.

Setting L1-01 = 1 selects a motor with limited cooling capability below rated (base) speed when running at 100% load. The OL1 function derates the motor any time it is running below base speed.

Setting L1-01 = 2 selects a motor capable of cooling itself over a 10:1 speed range when running at 100% load. The OL1 function derates the motor when it is running at 1/10 of its rated speed or less.

Setting L1-01 = 3 selects a motor capable of cooling itself at any speed when running at 100% load. This includes zero speed. The OL1 function does not derate the motor at any speed.

If the Drive is connected to a single motor, the motor overload protection should be enabled (L1-01=1, 2, or 3) unless another means of preventing motor thermal overload is provided. When the electronic thermal overload function is activated, an OL1 fault occurs, shutting OFF the Drive's output thus preventing additional overheating of the motor. The motor temperature is continually calculated as long as the Drive is powered up.

When operating several motors with one Drive, install a thermal relay on each motor and disable the motor overload protection (L1-01=0).

◆ Stall Prevention

■ L3-04 Stall Prevention During Deceleration Selection

Setting	Description
0	Disabled
1	General purpose (Enabled) (<i>factory default</i>)
2	Intelligent stall prevention (Enabled)
3	Stall prevention with DB resistor (Enabled)

The stall prevention during deceleration function adjusts the deceleration time in order to prevent OV fault trips during deceleration. If L3-04=0, stall prevention is disabled, and if the load is large and the deceleration time short enough, the Drive may fault and stop.

If L3-04=1, the standard stall prevention function is enabled. If, during deceleration, the DC Bus voltage exceeds the stall prevention level (see table below), the Drive will discontinue decelerating and maintain speed. Once the DC Bus voltage has dropped below the stall prevention level, deceleration will continue. Fig 5.11 demonstrates deceleration when L3-04=1.

Drive Voltage		Stall Prevention Level during Deceleration
240Vac		380Vdc
480Vac	E1-01 \geq 400Vac	760Vdc
	E1-01 $<$ 400Vac	660Vdc

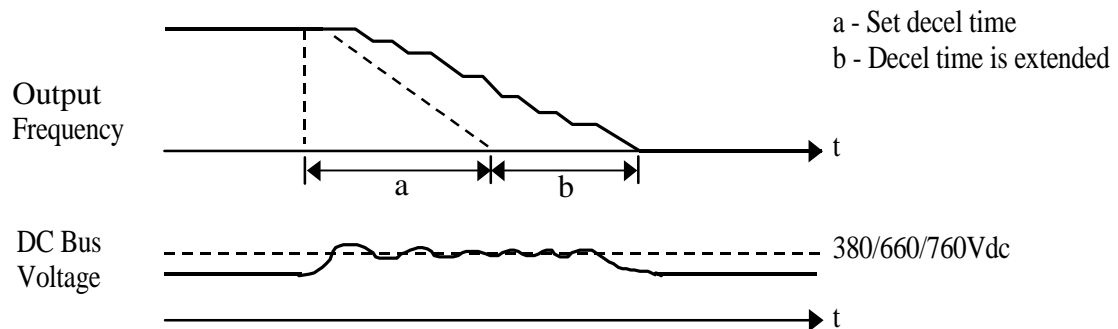

Fig 5.11 Stall Prevention

If L3-04=2, the intelligent stall prevention function is enabled. The active deceleration time is used as a starting point and the Drive will attempt to decelerate as quickly as possible without causing the DC Bus voltage to exceed the stall prevention level. The fastest time possible is 1/10 the active deceleration time.

If L3-04=3, the stall prevention with braking resistor function is enabled. The DC bus voltage level is controlled during fast deceleration and allows for a faster than normal deceleration time. Use this setting with a braking resistor when overvoltage fault (OV) sometimes occurs even under settings 1 or 2.

IMPORTANT | In Flux Vector Control Mode (A1-02=3), setting stall prevention with DB resistor (L3-04=3) cannot be done.

Chapter 6

Diagnostics & Troubleshooting

This chapter describes diagnostics and troubleshooting for the Drive.

Fault Detection	6-2
Alarm Detection	6-9
Operator Programming Errors (OPE).....	6-13
Auto-Tuning Faults	6-15
Digital Operator COPY Function Faults	6-17
Troubleshooting	6-18
Main Circuit Test Procedure.....	6-26
Drive Date Stamp Information.....	6-29

Fault Detection

When the Drive detects a fault, the fault information is displayed on the Digital Operator, the fault contact closes, and the motor coasts to stop. (However, a fault with selectable stopping method will operate according to the stopping method selected.)

- If a fault occurs, take appropriate action according to the table by investigating the cause.
- To restart, reset the fault with any of the following procedures:
 - Set “14: Fault Reset” to a multi-function digital input (H1-01 to H1-06). Then, close and open the input.
 - Press the RESET key of the Digital Operator.
 - Shut off the Drive input power, and then turn on again.

Table 6.1 Fault Displays and Processing

Digital Operator Display	Description	Cause	Corrective Action
BUS Option Com Err	Option Communication Error After initial communication was established, the connection was lost.	Connection was broken and/or master controller stopped communicating.	Check all connections and verify all user-side software configurations.
CE Memobus Com Err	Modbus Communication Error Control data was not received correctly for two seconds. This fault is detected when H5-05=1 and H5-04=0 to 2.	Connection was broken and/or master has stopped communicating.	Check all connections and verify all user-side software configurations.
CF Out of Control	Control Fault A torque limit was reached continuously for 3 seconds or longer during a ramp to stop while in open-loop vector control.	Motor parameters were not set properly.	Check motor parameters. Perform Auto-Tuning.
CPF00 COM-ERR(OP&INV)	Operator Communication Fault Transmission between the Drive and the Digital Operator was not established within 5 seconds after supplying power.	Digital Operator cable was not securely connected, Digital Operator defective, and/or control board defective	Remove the Digital Operator, and then reinstall it.
	External RAM of CPU was defective.	Control circuit was damaged.	Cycle power to the Drive. Replace the control board.
CPF01 COM-ERR(OP&INV)	Operator Communication Fault After communication started with the Digital Operator, communication stopped for 2 seconds or more.	Digital Operator cable was not securely connected, Digital Operator defective, and/or control board defective.	Remove the Digital Operator once and then reinstall it.
			Cycle power to the Drive.
			Replace the Digital Operator and/or the control board.
CPF02 BB Circuit Err	Baseblock Circuit Fault Baseblock circuit fault at power-up.	Gate array hardware failure during power-up.	Perform a factory initialization
			Cycle power to the Drive.
			Replace the control board.
CPF03 EEPROM Error	EEPROM Fault Check sum was not valid.	Noise or spike was on the control circuit input terminals.	Perform factory initialization.
			Cycle power to the Drive.
			Replace the control board.
CPF04 Internal A/D Err	CPU Internal A/D Converter Fault	Noise or spike was on the control circuit input terminals.	Perform factory initialization.
			Cycle power to the Drive.
			Replace the control board.

Table 6.1 Fault Displays and Processing (continued)

Digital Operator Display	Description	Cause	Corrective Action
CPF05 External A/D Err	External A/D Converter Fault	Noise or spike was on the control circuit input terminals.	Perform a factory initialization.
			Cycle power to the Drive.
			Replace the control board.
CPF06 Option Error	Option Board Connection Error	The option board was not connected properly.	Turn off the power and reinstall the option board.
		The Drive or option board was damaged.	Replace the option board or the Drive.
CPF07 RAM-Err	ASIC Internal RAM Fault	Control circuit failure/damage.	Cycle power to the Drive.
		Control circuit damage.	Replace the Drive.
CPF08 WAT-Err	Watchdog Timer Fault	Control circuit failure/damage.	Cycle power to the Drive.
		Control circuit damage.	Replace the Drive.
CPF09 CPU-Err	CPU-ASIC Mutual Diagnosis Fault	Control circuit failure/damage.	Cycle power to the Drive.
		Control circuit damage.	Replace the Drive.
CPF10 ASIC-Err	ASIC Version Fault	Control circuit damage.	Replace the Drive.
CPF20 Option A/D Error	Option Card Fault	Option board input fault.	Remove all inputs to the option board.
		Option card A/D convert fault.	Perform a factory initialization.
			Cycle power to the Drive.
			Replace the option board.
CPF21 Option CPU Down	Self-diagnosis Fault of Option Board	Noise or spike was on the communication line and/or defective option board.	Replace the control board.
			Perform a factory initialization.
			Cycle power to the Drive.
			Replace the option board.
CPF22 Option Type Err	Option Board Code Number Fault	Unrecognizable option board was connected to the control board.	Remove any option boards.
			Cycle power to the Drive.
			Perform a factory initialization.
			Replace the option board.
CPF23 Option DPRAM Err	Option Board Interconnection Fault	An option board was not correctly connected to the control board, or an option board that was not made for the Drive was attached to the control board.	Replace the control board.
			Remove power to the Drive.
			Reconnect the option board.
			Perform a factory initialization.
			Cycle power to the Drive.
			Replace the option board.
			Replace the control board.

Table 6.1 Fault Displays and Processing (continued)

Digital Operator Display	Description	Cause	Corrective Action
DEV Speed Deviation	Excessive Speed Deviation Detected when F1-04 = 0 to 2 and in Flux Vector control method A1-02 = 3. The speed deviation is greater than the setting in F1-10 for a time longer than the setting in F1-11.	The load is locked.	Reduce the load.
		The acceleration or deceleration time is too short.	Lengthen the acceleration time and deceleration time.
		The load is too large.	Check the mechanical system.
		The settings in F1-10 and F1-11 are not appropriate for the application.	Check the settings in F1-10 and F1-11.
		Braking mechanism is engaged	Check that the brake is released when using brake (motor).
		Encoder wiring and/or encoder settings (F1 group) are incorrect	Check for proper encoder wiring and verify the parameter settings are correct.
EF0 Opt External Flt	Option Board External Fault	An external fault condition is present.	Check for an external condition.
			Verify the parameters.
			Verify communication signal.
EF3 Ext Fault S3	External Fault at Terminal S3 - S8 Detected when terminals S3 - S8 (H1-01 to H1-06) are programmed for external fault function that stops the Drive using ramp to stop, coast to stop, or fast stop.	An external fault condition is present that is connected to a multi-function digital input.	Eliminate the cause of the external fault condition.
EF4 Ext Fault S4			
EF5 Ext Fault S5			
EF6 Ext Fault S6			
EF7 Ext Fault S7			
EF8 Ext Fault S8			
E-15 SI-F/G Com Err	SI-F/G Communication Error Detected A communication error is detected when a run command or frequency reference is set from the SI-F/G Option Card (b1-01=3, b1-02=3) and communication is lost.	Communication has been lost to the SI-F/G option card connected and b1-01=3 and/or b1-02=3.	Check the communication signals.
			Check the settings of b1-01 and b1-02.
			Check the setting of F6-01.
			Check the host side (master) communication configuration.
FBL Feedback Loss	PID Feedback Loss This fault occurs when PID Feedback Loss Detection is programmed to fault (b5-12 = 2) and the PID Feedback < PID Feedback Loss Detection Level (b5-13) for the PID Feedback Loss Detection Time (b5-14).	PID feedback source (e.g. transducer, sensor, building automation signal) is not installed correctly or is not working.	Verify Drive is programmed to receive the PID feedback source signal.
			Check to ensure the PID feedback source is installed and working properly.

Table 6.1 Fault Displays and Processing (continued)

Digital Operator Display	Description	Cause	Corrective Action
GF Ground Fault	Output Ground Fault Drive output grounding current has exceeded 50% of the Drive rated output current and L8-09 = 1 (enabled).	Motor lead was shorted to ground and/or a DCCT was defective.	Remove the motor and run the Drive without the motor.
			Check the motor for a phase to ground short.
			Check the output current with a clamp on meter to verify the DCCT reading.
LF Output Phase Loss	Output Open-phase An open-phase occurred at the Drive output This fault is detected when output current has exceeded 5% imbalance and L8-07 = 1 (enabled).	There was a broken wire in the output cable. There was a broken wire in the motor winding. The output terminals were loose.	Check the wiring to the motor. Check the motor for phase to ground short.
		The motor being used has a capacity less than 5% of the Drive's maximum motor capacity.	Check the motor and Drive capacity.
		Low impedance motor was used.	Add additional impedance.
OC Over Current	Overcurrent Drive output current exceeded the overcurrent detection level (approximately 200% of Drive rated output current).	Shorted Drive output phase to phase, shorted motor, locked rotor, load too heavy, accel/ decel time too short, contactor on the Drive output is opened or closed, a special motor or a motor with a FLA rating larger than Drive rated output current.	Remove the motor and run the Drive without the motor.
			Check the motor for a phase-to-phase short.
			Check the Drive for a phase-to-phase short at the output.
			Verify C1-01 and C1-02 are set correctly.
			Check load conditions.
OH Heatsink Overtemp	Heatsink Overheat The temperature of the Drive's heatsink exceeded the setting in L8-02 and L8-03 = 0 to 2. Drive's internal cooling fan stopped (F7U2018 / F7U4018 and larger).	There was a heat source nearby.	Check for dirt build-up on the fans and heatsink.
		The ambient temperature was too high.	Reduce the ambient temperature around the Drive.
		The Drive's cooling fan(s) stopped.	Replace the cooling fan.
		The Drive's internal cooling fan(s) stopped.	
OH1 Heatsink Max Temp	Heatsink Overheat The temperature of the Drive's heatsink exceeded 105 degrees C. Drive's internal cooling fan stopped (F7U2011 / F7U4011 and larger capacities).	There was a heat source nearby.	Check for dirt build-up on the fans and heatsink.
		The ambient temperature was too high.	Reduce the ambient temperature around the Drive.
		The Drive's cooling fan(s) stopped.	Replace the cooling fan.
		The Drive's internal cooling fan(s) stopped.	

Table 6.1 Fault Displays and Processing (continued)

Digital Operator Display	Description	Cause	Corrective Action
OH3 Motor Overheat 1	Motor Overheating 1 Detected when A2 or A3, programmed for motor temperature (H3-09 or H3-05 = E), exceeds 1.17V for time L1-05 and L1-03 = 0 to 2.	Overheating of motor as measured by the motor thermistor.	Recheck the cycle time and the size of the load.
			Recheck the accel/decel time (C1-01 and C1-02).
			Recheck the V/F pattern (E1-01 thru E1-13).
			Recheck the motor rated current value (E2-01).
OH4 Motor Overheat 2	Motor Overheating 2 Detected when A2 or A3, programmed for motor temperature (H3-09 or H3-05 = E), exceeds 2.34V for time L1-05 and L1-03 = 0 to 2.	Overheating of motor as measured by the motor thermistor.	Recheck the cycle time and the size of the load.
			Recheck the accel/decel time (C1-01 and C1-02).
			Recheck the V/F pattern (E1-01 thru E1-13).
			Recheck the motor rated current value (E2-01).
OL1 Motor Overloaded	Motor Overload Detected when L1-01 = 1 to 3 and the Drive's output current exceeded the motor overload curve. The overload curve is adjustable using parameter E2-01, L1-01, and L1-02.	The load was too large. The cycle time was too short at the accel/decel time.	Recheck the cycle time and the size of the load as well as the times set in C1-01 and C1-02
		The voltage of the V/F pattern was incorrect for the application.	Review the V/F pattern parameters, E1-01 thru E1-13.
		Motor rated current setting was improper.	Check the motor rated current value in E2-01.
OL2 Inv Overload	Drive Overload The Drive output current exceeded the Drive's overload curve.	The load was too large, or the accel/decel times are too short.	Recheck the cycle time and the size of the load as well as the times set in C1-01 and C1-02.
		The voltage of the V/F pattern was incorrect for the application.	Review the V/F pattern parameters, E1-01 thru E1-13.
		The size of the Drive was too small.	Change to a larger size Drive.
OL3 Overtorque Det 1	Overtorque Detection 1 Drive output current > L6-02 for more than the time set in L6-03 and L6-01 = 3 or 4.	Motor was overloaded.	Ensure the values in L6-02 and L6-03 are appropriate. Check application/machine status to eliminate fault.
OL4 Overtorque Det 2	Overtorque Detection 2 Drive output current > L6-05 for more than the time set in L6-06 and L6-04 = 3 or 4.	Motor was overloaded.	Ensure the values in L6-05 and L6-06 are appropriate. Check application/machine status to eliminate fault.
OL7 HSB OL	High Slip Braking OL The output frequency stayed constant for longer than the time set in n3-04 during high slip braking.	The inertia of the load is too large.	Make sure the load is an inertial. If possible, reduce the load inertia.

Table 6.1 Fault Displays and Processing (continued)

Digital Operator Display	Description	Cause	Corrective Action
OPR Oper Disconnect	Digital Operator Connection Fault Detected when the Digital Operator is removed and the Drive is commanded to run through the Digital Operator (b1-02 = 0).	The Digital Operator was not attached, or the Digital Operator connector was broken.	Attach the Digital Operator.
			Check the Digital Operator connector.
			Verify the setting of o2-06.
OS Overspeed Det	Motor Overspeed Detected when F1-03 = 0 to 2 and A1-02 = 1 or 3. The motor speed feedback (U1-05) exceeded the setting in F1-08 for a longer time than the setting in F1-09.	Overshooting/Undershooting was occurring.	Adjust the ASR settings in the C5 parameter group.
		The reference was too high.	Check the reference circuit and reference gain.
		The settings in F1-08 and F1-09 are not appropriate.	Check the settings in F1-08 and F1-09.
OV DC Bus Overvolt	DC Bus Overvoltage The DC bus voltage has exceeded the trip point. 208-240Vac: Trip point is 410Vdc 480Vac: Trip point is 820Vdc	High input voltage at R/L1, S/L2 and T/L3.	Check the input circuit and reduce the input power to within specifications.
		The deceleration time is set too short.	Extend the time in C1-02 or other active decel settings used such as C1-04, C1-06, C1-08, or C1-09 (time).
		Power factor correction capacitors are being used on the input or output to the Drive.	Remove the power factor correction capacitors.
PF Input Pha Loss	Input Phase Loss Drive input power supply has an open phase or has a large imbalance of voltage. Detected when L8-05 = 1 (enabled).	Open phase on the input of the Drive.	Check the input voltage.
		Loose terminal screws at R/L1, S/L2 or T/L3.	Tighten the terminal screws.
		Momentary power loss occurred.	Check the input voltage.
		Input voltage fluctuation too large.	Check the input voltage.
PGO PG Open	PG Disconnection Detected when F1-02 = 0 to 2 and A1-02 = 1 or 3. Detected when no PG (encoder) pulses are received for a time longer than the setting in F1-14.	There was a break in the PG wiring.	Fix the broken / disconnected wiring.
		The PG was wired incorrectly.	Fix the wiring.
		Power wasn't being supplied to the PG.	Supply power to the PG properly.
		Braking mechanism is possibly engaged.	Check for open circuit when using brake (motor).
PUF DC Bus Fuse Open	DC Bus Fuse Detects if the DC bus fuse has opened. Warning: Never run the Drive after replacing the DC bus fuse without checking for shorted components.	Shorted output transistor(s) or terminals.	Remove power from the Drive.
			Disconnect the motor.
			Perform the checks without power in Table 6.6.
			Replace the shorted component(s).
			Replace the defective fuse.

Table 6.1 Fault Displays and Processing (continued)

Digital Operator Display	Description	Cause	Corrective Action
RH DynBrk Resistor	Dynamic Braking Resistor The protection of the heatsink mount resistor is activated when L8-01 = 1. This fault is only applicable when using the 3% duty cycle resistor, which is mounted on the Drive's heatsink. For all other resistors, set L8-01 = 0.	Overhauling load, extended dynamic braking duty cycle, defective dynamic braking resistor.	Verify dynamic braking duty cycle.
			Monitor DC bus voltage.
			Replace dynamic braking resistor.
RR DynBrk Transistr	Dynamic Braking Transistor The built-in dynamic braking transistor failed.	High DC bus voltage, defective or failed dynamic braking resistor.	Cycle power to the Drive.
			Replace defective dynamic braking transistor or resistor
			Monitor DC bus voltage.
SVE Zero Servo Fault	Zero Servo Fault The motor position moved more than 10,000 revolutions during zero servo operation.	The torque limit was too small.	Increase the torque limit.
		The load torque was too large.	Reduce the load torque.
		Control circuit fault	Check for signal noise.
UL3 Undertorq Det 1	Undertorque Detection 1 Drive output current < L6-02 for more than the time set in L6-03 when L6-01 = 7 or 8.	Motor was underloaded.	Ensure the values in L6-02 and L6-03 are appropriate.
			Check application/machine status to eliminate fault.
UL4 Undertorq Det 2	Undertorque Detection 2 Drive output current < L6-05 for more than the time set in L6-06 when L6-04 = 7 or 8.	Motor was underloaded.	Ensure the values in L6-05 and L6-06 are appropriate.
			Check application/machine status to eliminate fault.
UV1 DC Bus Undervolt	DC Bus Undervoltage 208-240Vac: Default trip point is ≤ 190Vdc 480Vac: Default trip point is ≤ 380Vdc Trip point is adjustable in L2-05. Detected when the DC bus voltage is ≤ L2-05.	Low input voltage at R/L1, S/L2 and T/L3.	Check the input circuit and increase the input power to within specifications.
		The acceleration time is set too short.	Extend the time in C1-01 or other active accel settings used such as C1-03, C1-05, or C1-07 (time).
		Voltage fluctuation of the input power is too large.	Check the input voltage.
UV2 CTL PS Undervolt	Control Power Supply Undervoltage Undervoltage of the control circuit when running.	External load was pulling down the Drive's power supplies, or there was an internal short in the power/gate Drive board.	Cycle power to the Drive.
			Remove all control wiring and test Drive or disconnect control terminal strip.
			Repair or replace the Power PCB/ Gate Drive PCB.
UV3 MC Answerback	Soft Charge Circuit Fault The pre-charge contactor opened while the Drive was running.	Contacts on the soft charge contactor were dirty and the soft charge contactor does not function mechanically.	Cycle power to the Drive.
			Check the condition of the soft charge contactor.
			Repair or replace the Power PCB/ Gate Drive PCB.

Alarm Detection

Alarms are Drive protection functions that do not operate the fault contact. The Drive will automatically return to its original status once the cause of the alarm has been removed.

During an alarm condition, the Digital Operator display flashes and an alarm output is generated at the multi-function outputs (H2-01 to H2-03) if programmed.

When an alarm occurs, take appropriate corrective action according to the table below.

Table 6.2 Alarm Displays and Processing			
Digital Operator Display	Description	Cause	Corrective Action
BUS Option Com Err (Flashing)	Option Communication Error After initial communication is established, the connection was lost.	Connection is broken, master controller has stopped communicating.	Check all connections, verify all user side software configurations.
CALL SI-F/G ComCall (Flashing)	Serial communication transmission error. Communication has not yet been established.	Connection was not made properly, or user software was not configured to the proper baud rate or configuration.	Check all connections, verify all user side software configurations.
CE MEMOBUS Com Err (Flashing)	Modbus Communications Error Enabled when H5-05 = 1 and H5-04 = 3.	Normal communication was not possible for 2 seconds or longer after control data was received.	Check the communications devices and signals.
DEV Speed Deviation (Flashing)	Excessive Speed Deviation Detected when F1-04 = 3 and A1-02 = 1 or 3. The speed deviation is greater than the setting in F1-10 for longer than the setting in F1-11.	The load was locked.	Reduce the load.
		The acceleration time and deceleration times were too short.	Lengthen the acceleration and deceleration times.
		The load was too large.	Check the mechanical system.
		The settings in F1-10 and F1-11 were not appropriate.	Check the settings in F1-10 and F1-11.
DNE Drive not Enable (Flashing)	Detected when a multi-function digital input (H1-01 to H1-06) is programmed for 6A: Drive enable. The Drive does not have the enable command when the run command is applied. This alarm stops the motor.	Enable command was lost while Drive was running.	Check the input terminal programmed for enable command.
		The Run command was applied prior to the enable signal.	Apply and maintain the enable command before applying the run command.
EF External Fault	Both the forward and the reverse run commands are input simultaneously for 500ms or more. This alarm stops the motor.	An external forward and reverse command were input simultaneously.	Check external sequence logic, so only one input is received at a time.
EFO Opt External Flt (Flashing)	Communication Option Card External Fault	An external fault condition was present.	Check for an external condition.
			Verify the parameters.
			Verify communication signal.

Table 6.2 Alarm Displays and Processing (continued)

Digital Operator Display	Description	Cause	Corrective Action
EF3 Ext Fault S3 (Flashing)	External Fault at Terminal S3 - S8 Detected when terminals S3 - S8 (H1-01 to H1-06) are programmed for external fault function that alarms only and continues to run the Drive.	An external fault condition exists that was connected to a multi-function digital input.	Eliminate the cause of an external fault condition.
EF4 Ext Fault S4 (Flashing)			
EF5 Ext Fault S5 (Flashing)			
EF6 Ext Fault S6 (Flashing)			
EF7 Ext Fault S7 (Flashing)			
EF8 Ext Fault S8 (Flashing)			
E-15 SI-F/G Com Err	SI-F/G Communications Error Detected A communication error is detected when a run command or frequency reference is set from the SI-F/G Option Card (b1-01=3, b1-02=3) and communication is lost.	Communication has been lost to the SI-F/G option card connected and b1-01=3 and/or b1-02=3.	Check the communications signals. Check the settings of b1-01 and b1-02. Check the setting of F6-01. Check the host side (master) communication configuration.
FBL Feedback Loss	PID Feedback Loss This alarm occurs when PID Feedback Loss Detection is programmed to alarm (b5-12 = 1) and the PID feedback < PID feedback loss detection level (b5-13) for the PID feedback loss detection time (b5-14).	PID Feedback source (e.g. transducer, sensor, building automation signal) was not installed correctly or was not working.	Verify Drive is programmed to receive the PID Feedback source signal. Check to ensure the PID Feedback source is installed and working properly.
OH Heatsnk Overtemp (Flashing)	Cooling Fin/Cooling Fin Fan Overheat The temperature of the Drive's heatsink exceeded the temperature programmed in parameter L8-02. Enabled when L8-03=3.	Cooling fan(s) were not working, high ambient temperature, a heat source in close proximity to Drive present, or dirty heatsink.	Check for dirt build-up on the fans and cooling fins. Reduce the ambient temperature around the Drive. Remove the heating unit.
OH2 Over Heat 2 (Flashing)	Drive overheat alarm signal is input from a multi-function digital input terminal S3-S8 (H1-01 to H1-06) that is programmed for B: overheat alarm.	An external overheat condition exists that was connected to one of the multi-function input terminals S3 - S8.	Check for an external condition. Verify the program parameters H1-01 thru H1-06.

Table 6.2 Alarm Displays and Processing (continued)

Digital Operator Display	Description	Cause	Corrective Action
OH3 Motor Overheat 1 (Flashing)	Motor Overheating Alarm Detected when A2 or A3, programmed for motor temperature (H3-09 or H3-05 = E), exceeds 1.17V for time L1-05 and L1-03 = 3.	Overheating of the motor as measured by the motor thermistor.	Recheck the cycle time and the size of the load.
			Recheck the accel/decel time (C1-01 and C1-02).
			Recheck the V/F pattern (E1-01 thru E1-13).
			Recheck the motor rated current value (E2-01).
OL3 Overtorque Det 1 (Flashing)	Overtorque Detection 1 Drive output current > L6-02 for more than the time set in L6-03 and L6-01 = 1 or 2.	Motor was overloaded.	Ensure the values in L6-02 and L6-03 are appropriate.
			Check application/machine status to eliminate fault.
OL4 Overtorque Det 2 (Flashing)	Overtorque Detection 2 Drive output current > L6-05 for more than the time set in L6-06 and L6-04 = 1 or 2.	Motor was overloaded.	Ensure the values in L6-05 and L6-06 are appropriate.
			Check application/machine status to eliminate fault.
OS Overspeed Det (Flashing)	Overspeed The motor speed feedback (U1-05) exceeded the value set in F1-08 for a time longer than the setting in F1-09. Detected when A1-02 = 1 or 3 and F1-03 = 3.	Overshooting/Undershooting was occurring.	Adjust the ASR settings in the C5 parameter group.
		The reference was too high.	Check the reference circuit and reference gain.
		The settings in F1-08 and F1-09 were not appropriate.	Check the settings in F1-08 and F1-09.
OV DC Bus Overvolt (Flashing)	DC Bus Overvoltage The DC bus voltage has exceeded the trip point. Default: 208-240Vac: Trip point is 410Vdc 480Vac: Trip point is 820Vdc Detected when the Drive is in a stopped condition. E1-01 affects the trip level.	High input voltage at R/L1, S/L2 and T/L3	Check the input circuit and reduce the input power to within specifications.
		The deceleration time is set too short.	Extend the time in C1-02 or other active decel settings used such as C1-04, C1-06, C1-08 or C1-09 (time).
		Power factor correction capacitors are being used on the input or output to the Drive.	Remove the power factor correction capacitors.
PGO PG Open (Flashing)	PG Disconnection Detected when F1-02 = 3 and A1-02 = 1 or 3. Detected when no PG (encoder) pulses are received for a time longer than the setting in F1-14.	There was a break in the PG wiring.	Fix the broken / disconnected wiring.
		The PG was wired incorrectly.	Fix the wiring.
		Power wasn't being supplied to the PG.	Supply power to the PG properly.
		Brake mechanism is possibly engaged	Check for open circuit when using brake (motor).

Table 6.2 Alarm Displays and Processing (continued)

Digital Operator Display	Description	Cause	Corrective Action
UL3 Undertorq Det 1 (Flashing)	Undertorque Detection 1 Drive output current < L6-02 for more than the time set in L6-03 when L6-01 = 5 or 6.	Motor was underloaded.	Ensure the values in L6-02 and L6-03 are appropriate.
			Check application/machine status to eliminate fault.
UL4 Undertorq Det 2 (Flashing)	Undertorque Detection 2 Drive output current < L6-05 for more than the time set in L6-06 when L6-04 = 5 or 6.	Motor was underloaded.	Ensure the values in L6-05 and L6-06 are appropriate.
			Check application/machine status to eliminate fault.
UV DC Bus Undervolt (Flashing)	DC Bus Undervoltage The DC bus voltage is \leq L2-05. Default: 208-240Vac: Trip point is 190Vdc 480Vac: Trip point is 380Vdc Detected while Drive is in a stopped condition.	Low input voltage was at R/L1, S/L2 and T/L3.	Check the input circuit and increase the input power to within specifications.
		The acceleration time was set too short.	Extend the time in C1-01 or other active accel settings used such as C1-03, C1-05, or C1-07 (time).
		Voltage fluctuation of the input power was too large.	Check the input voltage.
UV2 CTL PS Undervolt	Control Power Supply Undervoltage Undervoltage of the control circuit when running.	External load was pulling down the Drive's power supplies, or there was an internal short in the power/gate Drive board.	Cycle power to the Drive.
			Repair or replace the Power PCB/ Gate Drive PCB.
UV3 MC Answerback	Soft Charge Circuit Fault The pre-charge contactor opened while the Drive was running.	Contacts on the soft charge contactor were dirty and the soft charge contactor does not function mechanically.	Remove all control wiring and test Drive.
			Cycle power to the Drive.
			Check the condition of the soft charge contactor.
			Repair or replace the Power PCB/ Gate Drive PCB.

Operator Programming Errors (OPE)

An Operator Programming Error (OPE) occurs when an inapplicable parameter is set or an individual parameter setting is inappropriate. The Drive will not operate until the parameter is set correctly; however, no alarm or fault outputs will occur. If an OPE occurs, change the appropriate parameter by checking the cause shown in Table 6.3. When OPE error is displayed, press the ENTER key to display U1-34 (OPE fault constant). This monitor will display the parameter that is causing the OPE error.

Table 6.3 OPE Error Displays			
Digital Operator Display	Description	Cause	Corrective Action
OPE01 kVA Selection	Drive kVA Setting Error	The control board was replaced and the kVA parameter is set incorrectly.	Enter the correct kVA setting (o2-04) by referring to the Drive model number in Appendix B - Table B.1.
OPE02 Limit	Parameter Setting Out of Range	Parameter setting was outside of the allowable range. In some cases, parameter range may depend on other parameter settings. For example, when $E2-03 \geq E2-01$.	Verify the parameter settings.
OPE03 Terminal	Multi-function Input Selection Error	Duplicate functions were selected, up/down commands or trim control increase/decrease were not set simultaneously. Speed search from maximum frequency and set frequency were set simultaneously. PID is enabled and up input is programmed. More than one of the speed search inputs were set simultaneously, or HSB and KEB functions were set simultaneously. N.O. and N.C. fast stop are both set, or Drive enable and DC injection input are both set.	Verify parameter settings (H1-01 to H1-06).
OPE05 Sequence Select	Run Command Selection Error The run command selection parameter b1-02 is set to 3 but no option board is installed.	Serial communication or other option board is not installed, or is installed incorrectly.	Verify that the option board is installed. Remove power to the Drive and connect the option board once more.
OPE06 PG Opt Missing	Control Method Selection Error	Control method with PG feedback was selected A1-02 = 1 or 3, but a PG option board is not installed, or is installed incorrectly.	Verify the control method in A1-02 and/or the installation of the PG option board.
OPE07 Analog Selection	Multi-function Analog Input Error	Duplicate functions were selected for the analog inputs (A2 and A3) or for either of the analog inputs (A2 or A3) and the pulse input (RP) selection. H3-09 = B and H6-01 = 1 H3-09 = C and H6-01 = 2 b1-01 (Reference Selection) was set to 4 (pulse input), and H6-01 (Pulse Train Input) was set to a value other than 0 (frequency reference).	Check parameters b1-01, H3-05, H3-09, and H6-01 and correct the errors.
OPE08 Constant Selection	Function Selection Error	A setting has been made that was not applicable in the current control method. Example: a function used only in open-loop vector control was selected while in V/F control.	Verify the control method and the function in question.

Table 6.3 OPE Error Displays (continued)

Digital Operator Display	Description	Cause	Corrective Action
OPE09 PID Selection	PID Control Setup Error	The following settings have been made at the same time: b5-01 (PID Control Method Selection) has been set to a value other than 0. b5-15 (PID Sleep Function Start Level) has been set to a value other than 0. b1-03 (Stopping Method Selection) was set to 2 or 3.	Check parameters b5-01, b5-15, and b1-03 and correct the error.
OPE10 V/F Ptrn Setting	V/F Parameter Setting Error	V/F parameter settings were out of range. A minimum frequency value is set higher than the maximum frequency.	Check parameters (E1-04 ~ E1-11).
OPE11 CarrFrq/On-Delay	Carrier Frequency Parameter Setting Error occurs when: C6-05 > 6 and C6-04 > C6-03 or C6-01 = 0 and C6-02 ≠ 0,1 or C6-01 = 1 and C6-02 ≠ 0 thru 6, F	Parameter setting was incorrect.	Check the parameter settings and correct the errors.
ERR EEPROM R/W Err	EEPROM Write Error The NV-RAM data does not match the EEPROM data.	Power supply is turned OFF.	Cycle power to the Drive. Do a factory initialization (A1-03).

Auto-Tuning Faults

Auto-Tuning faults are shown below. When the following faults are detected, the fault is displayed on the Digital Operator and the motor coasts to a stop. No fault or alarm outputs will occur.

Table 6.4 Auto-Tuning Fault Displays and Processing

Digital Operator Display	Description	Probable Cause	Corrective Action
Er - 01 Fault	Motor Data Fault	<ul style="list-style-type: none"> • There is an error in the data input for Auto-Tuning. • There is an error in the relationship between the motor output and the motor rated current. • There is an error between the no-load current setting and the input motor rated current (when Auto-Tuning only line-to-line resistance is performed for vector control). 	<ul style="list-style-type: none"> • Check Auto-Tuning input data (T1 parameters). • Check Drive and motor capacity for compatibility. • Check motor rated current and no-load current (E2-03 and T1-04).
Er - 02 Minor Fault	Alarm	An alarm is detected during Auto-Tuning.	<ul style="list-style-type: none"> • Check Auto-Tuning input data (T1 parameters). • Check output/motor wiring. • Check the load.
Er - 03 STOP key	STOP Key Input	The STOP key is pressed during Auto-Tuning, and the Auto-Tuning is interrupted.	–
Er - 04 Resistance	Line-to-Line Resistance Fault	Auto-Tuning is not completed within the specified time. The Auto-Tuning result is outside the parameter setting range.	<ul style="list-style-type: none"> • Check Auto-Tuning input data (T1 parameters). • Check motor wiring. • If the motor and the machine are connected, disconnect the motor from the machine. • For Er-08, if the setting of T1-03 is higher than the Drive's input voltage, change the input voltage setting.
Er - 05 No-Load Current	No-Load Current Fault		
Er - 08 Rated Slip	Rated Slip Fault		
Er - 09 Accelerate	Acceleration Fault Detected only for rotational Auto-Tuning.	The motor did not accelerate in the specified time (C1-01 + 10 seconds).	<ul style="list-style-type: none"> • Increase C1-01 (Accel Time 1) • Increase L7-01 and L7-02 (Forward/Reverse Torque Limits) if they are low. • If the motor and load are connected, disconnect the motor from the load.
Er - 11 Motor Speed	Motor Speed Fault Detected only for rotational Auto-Tuning.	The torque reference exceeded 100% during acceleration. Detected when A1-02 = 2 or 3 (vector control).	<ul style="list-style-type: none"> • Increase C1-01 (Accel Time 1) • Check the input data [particularly the number of PG pulses (F1-01) and the number of motor poles (E2-04)]. • If the motor and load are connected, disconnect the motor from the load.
Er - 12 I-det. Circuit	Current Detection Fault	<ul style="list-style-type: none"> • Current exceeded the motor rated current. • Any of U/T1, V/T2, and W/T3 has open-phase. 	<ul style="list-style-type: none"> • Check that the motor is unloaded (uncoupled and brake is released). • Check Drive wiring and mounting. • Check the motor connections for continuity (on Drive output terminals and in motor junction box).

Table 6.4 Auto-Tuning Fault Displays and Processing (continued)

Digital Operator Display	Description	Probable Cause	Corrective Action
Er - 13 Leakage Inductance Fault	Leakage Inductance Fault	Auto-Tuning did not finish within the set time. Auto-Tuning result is outside the parameter setting range.	<ul style="list-style-type: none"> • Check Auto-Tuning input data (T1 parameters). • Check motor wiring for proper connection configuration.
End - 1 V/F Over Setting	V/F Settings Alarm Displayed after Auto-Tuning is complete.	The torque reference exceeded 100%, and the no-load current exceeded 70% during Auto-Tuning.	<ul style="list-style-type: none"> • Check and correct the motor settings (T1 parameters). • If the motor is coupled to the load, disconnect the motor from the load.
End - 2 Saturation	Motor Core Saturation Fault Detected only for rotational Auto-Tuning.	During Auto-Tuning, the measured values of motor iron-core saturation coefficient 1 and 2 (E2-07 and E2-08) exceeded its setting range. A temporary value was set: E2-07 = 0.75, E2-08 = 0.50.	<ul style="list-style-type: none"> • Check Auto-Tuning input data (T1 parameters). • Check the motor wiring. • If the motor and the load are connected, disconnect the motor from the load.
End - 3 Rated FLA Alm	Rated Current Setting Alarm Displayed after Auto-Tuning is complete.	During Auto-Tuning, the measured value of motor rated current (E2-01) was greater than the set value.	<ul style="list-style-type: none"> • Check the motor rated current value (E2-01).

Digital Operator COPY Function Faults

These faults can occur during the Digital Operator COPY function. When a fault occurs, the fault content is displayed on the operator. A fault does not activate the fault contact output or alarm output.

Table 6.5 Digital Operator COPY Function Faults

Function	Digital Operator Display	Probable Causes	Corrective Action
READ Function	PRE READ IMPOSSIBLE	o3-01 was set to 1 to write parameters when the Digital Operator was write-protected (o3-02 = 0).	Set o3-02 to 1 to enable writing parameters into the Digital Operator.
	IFE READ DATA ERROR	The data file read from the Drive was of the wrong size indicating corrupted data.	<ul style="list-style-type: none"> • Retry the Read (o3-01=1). • Check the Digital Operator cable. • Replace Digital Operator.
	RDE DATA ERROR	Low Drive voltage has been detected.	Check the Drive's main incoming voltage and verify control wiring is correct.
An attempted write of the Drive data to the Digital Operator's EEPROM failed.		<ul style="list-style-type: none"> • Repeat the read. • Replace Digital Operator. 	
COPY Function	CPE ID UNMATCHED	The Drive type or software number was different than the stored data in the Digital Operator.	Use stored data for the F7 Drive and software number (U1-14).
	VAE INV. KVA UNMATCH	The capacity of the Drive and the capacity of the stored data are different.	Use stored data for the same Drive capacity (o2-04).
	CRE CONTROL UNMATCHED	The control method of the Drive and the control method of the stored data in the Digital Operator were different.	Use stored data for the same control method (A1-02).
	CYE COPY ERROR	A parameter setting written to the Drive was different than the setting stored in the Digital Operator.	Retry the Copy function (o3-01 = 2).
	CSE SUM CHECK ERROR	Upon completion of the COPY function, the Drive's data checksum was different than the Digital Operator's data checksum.	Retry the Copy function (o3-01 = 2).
Verify Function	VYE VERIFY ERROR	The set value of the Digital Operator and the Drive do not match.	Retry the Verify function (o3-01 = 3).

Troubleshooting

Due to parameter setting errors, faulty wiring, etc., the Drive and motor may not operate as expected when the system is started. If this occurs, use this section as a reference and apply the appropriate measures.

If a fault or alarm is displayed on the Digital Operator, refer to Table 6.1 and Table 6.2.

◆ If A Parameter Cannot Be Set

Use the following information if a Drive parameter cannot be set.

■ The display does not change when the INCREASE and DECREASE keys are pressed.

The following causes are possible:

The Drive is operating (Drive mode).

There are some parameters that cannot be set during operation. Remove the run command and then set the parameter.

Parameter write enable is input.

This occurs when "parameter write enable" (set value: 1B) is set for a multi-function digital input terminal (H1-01 to H1-06). If the terminal is open, the Drive parameters cannot be changed. Close the terminal and then set the parameters.

Passwords do not match (Only when a password is set.)

If the parameter A1-04 (Password) and A1-05 (Password Setting) settings are different, the parameters for the initialize mode cannot be changed. Enter the correct password in A1-04.

If you cannot remember the password, display A1-05 (Password Setting) by pressing the Shift/Reset Key and the MENU Key simultaneously while in the A1-04 display. Reset the password and input the reset password in parameter A1-04.

■ OPE01 through OPE11 is displayed.

The set value for the parameter is wrong. Refer to Table 6.3 OPE Error Displays in this chapter and correct the setting.

■ CPF00 or CPF01 is displayed.

This is a Digital Operator communication error. The connection between the Digital Operator and the Drive may be faulty. Remove the Digital Operator and then re-install it.

◆ If the Motor Does Not Operate Properly

The following causes are possible:

■ Ensure the Digital Operator is securely connected to the Drive.

■ The motor does not operate when the RUN key on the Digital Operator is pressed.

The following causes are possible:

The Local/Remote mode is not selected properly.

The status of the SEQ and REF REMOTE LEDs should be OFF for Local mode. Press the LOCAL/REMOTE key to switch.

The Drive is not in Drive mode.

If the Drive is not in Drive mode, it will remain in ready status and will not start. Press the MENU key once and then press the DATA/ENTER key. The Drive is now in Drive mode.

The Speed Command is too low.

If the Speed Command is set below the frequency set in E1-09 (Minimum Output Frequency), the Drive will not operate.

Raise the Speed Command to at least the minimum output frequency.

■ The motor does not operate when an external run command is input.

The following causes are possible:

The Drive is not in Drive mode.

If the Drive is not in Drive mode, it will remain in ready status and will not start. Press the MENU key once and then press the DATA/ENTER key. The Drive is now in Drive mode.

The Local/Remote mode is not selected properly.

The status of the SEQ and REF REMOTE LEDs should be ON for Local mode. Press the LOCAL/REMOTE key to switch.

The Speed Command is too low.

If the Speed Command is set below the frequency set in E1-09 (Minimum Output Frequency), the Drive will not operate. Raise the Speed Command to at least the minimum output frequency.

■ The motor stops during acceleration or when a load is connected.

The load may be too large. The motor's responsiveness limit may be exceeded if it is accelerated too rapidly by the Drive's stall prevention function or automatic torque boost function. Increase the acceleration time (CI-01) or reduce the motor load. Also, consider increasing the motor size.

■ The motor only rotates in one direction.

"Reverse run prohibited" may be selected. If b1-04 (Prohibition of Reverse Operation) is set to 1 (reverse run prohibited), the Drive will not accept any reverse run commands.

◆ If The Direction of the Motor Rotation is Reversed

If the motor rotates in the wrong direction, the motor output wiring may be incorrect. When the Drive operates in the forward direction, the forward direction of the motor will depend on the manufacturer and the motor type, so be sure to check the motor specification.

The direction of motor rotation can be reversed by switching any two wires among U/T1, V/T2, and W/T3. If using an encoder, the polarity will also have to be switched.

◆ If the Motor Stalls or Acceleration is Slow

The following causes are possible:

■ The stall prevention level during acceleration is too low.

If the value set for L3-02 (Stall Prevention Acceleration Level) is set too low, the acceleration time will be increased. Check that the set value is suitable and that the load is not too large for the motor.

■ The stall prevention level during running is too low.

If the value set for L3-06 (Stall Prevention Level during Running) is too low, the motor speed and torque will be limited. Check that the values set are suitable.

◆ If the Motor Operates at a Higher Speed Than the Speed Command

The following causes are possible:

■ PID is enabled.

If the PID mode is enabled (b5-01 = 1 to 4), the Drive output frequency will change to regulate the process variable to the desired setpoint. The PID can command a speed up to maximum output frequency (E1-04).

◆ If There is Low Speed Control Accuracy Above Base Speed in Open-loop Vector Control Method

The Drive's maximum output voltage is determined by its input voltage (For example, if 230Vac is input, then the maximum output voltage will be 230Vac). Vector control uses voltage to control the currents within the motor. If the vector control voltage reference value exceeds the Drive output voltage capability, the speed control accuracy will decrease because the motor currents cannot be properly controlled. Use a motor with a low rated voltage compared to the input voltage, or change to flux vector control.

◆ If Motor Deceleration is Slow

The following causes are possible:

■The deceleration time is long even when a braking resistor is connected.

The following causes are possible:

“Stall prevention during deceleration enabled” is set.

When a braking resistor is connected, set parameter L3-04 (Stall Prevention Selection During Deceleration) to 0 (disabled) or 3 (with braking resistor). When this parameter is set to 1 (enabled, factory default), the stall prevention function will interfere with the braking resistor.

The deceleration time setting is too long.

Check the active deceleration time setting (parameters C1-02, C1-04, C1-06, or C1-08).

Motor torque is insufficient.

If the parameters are correct and there is no overvoltage fault, then the motor's power may be insufficient. Consider increasing the motor and Drive's capacity.

The torque limit has been reached.

When a torque limit is reached (L7-01 to L7-04), the motor torque will be limited. This can cause the deceleration time to be extended. Check to be sure that the value set for the torque limit is suitable.

If a torque limit has been set for the multi-function analog input terminals A2 or A3, parameters H3-09 or H3-05 (set value: 10, 11, 12, or 15), check to be sure that the analog input value is suitable.

◆ If the Vertical-axis Load Drops (Droops) When a Mechanical Brake is Applied

The brake sequence is incorrect.

To ensure that the brake holds, set frequency detection 2 (H2-01 = 5) for the multi-function contact output terminals (M1 and M2) so that the contacts will turn OFF when the output frequency is greater than L4-01 (3.0 to 5.0Hz). (The contacts will turn ON below L4-01).

There is a hysteresis in the frequency detection 2 function (i.e., a frequency detection width, L4-02 = 2.0Hz). Change the setting to approximately 0.5Hz if there is a load droop during stop. Do not use the multi-function contact output run signal (H2-01 = 0) for the brake ON / OFF signal.

◆ If the Motor Overheats

The following causes are possible:

■The load is too large.

If the motor load is too large and the torque exceeds the motor's rated torque, the motor may overheat. Reduce the load amount by either reducing the load or increasing the acceleration/deceleration times. Also consider increasing the motor size.

■The ambient temperature is too high.

The motor rating is determined by a particular ambient operating temperature range. The motor will overheat if it is run continuously at the rated torque in an environment where the maximum ambient operating temperature rating is exceeded. Lower the motor's ambient temperature to within its acceptable range.

■Auto-Tuning has not been performed for Vector Control

Vector Control may not perform optimally if Auto-Tuning has not been performed. Therefore, perform Auto-Tuning. Alternatively, change the Control Method Selection (A1-02) to V/F Control (0 or 1).

◆ If Peripheral Devices Like PLCs or Others are Influenced by Starting or Running Drive

The following solutions are possible:

1. Change the Drive's Carrier Frequency Selection (C6-02) to lower the carrier frequency. This will help to reduce the amount of transistor switching noise.
2. Install an Input Noise Filter at the Drive's input power terminals.
3. Install an Output Noise Filter at the Drive's motor terminals.
4. Use conduit. Electrical noise can be shielded by metal, so run the Drive's power leads in a conduit or shielded cable.
5. Ground the Drive and motor.
6. Separate main circuit wiring from control wiring.

◆ If the Ground Fault Interrupter Operates When the Drive is Run

The Drive's output is a series of high frequency pulses (PWM), so there is a certain amount of leakage current. This may cause the ground fault interrupter to operate and cut off the power supply. Change to a ground fault interrupter with a higher leakage current detection level (i.e., a sensitivity current of 200mA or greater per Unit, with an operating time of 0.1s or more), or one that incorporates high frequency countermeasures (i.e., one designed for use with a Drive). It will also help to change the Drive's Carrier Frequency Selection (C6-02) to lower the carrier frequency. In addition, remember that the leakage current increases as the cable is lengthened.

◆ If There is Mechanical Vibration

Use the following information when there is mechanical vibration.

■ The application is making unusual sounds.

The following causes are possible:

There may be resonance between the mechanical system's natural frequency and the carrier frequency.

This is characterized by the motor running with no noise generation, but the machinery vibrates with a high-pitched whine. To prevent this type of resonance, adjust the carrier frequency with parameters C6-02 to C6-05.

There may be resonance between the mechanical system's natural frequency and the output frequency of the Drive.

To prevent this from occurring, use the jump frequency function in parameters d3-01 to d3-04, or have the driven motor and load balanced to reduce vibration.

■ Oscillation and hunting occur with V/F control.

The torque compensation parameter settings may be incorrect for the machine. Adjust parameters C4-01 (Torque Compensation Gain), C4-02 (Torque Compensation Primary Delay Time Parameter), n1-02 (Hunting Prevention Gain), C2-01 (S-curve Characteristic Time at Acceleration Start), and C3-02 (Slip Compensation Primary Delay Time) in order. Lower the gain parameters and raise the primary delay time parameters.

■ Oscillation and hunting occur with V/F w/PG control.

The Speed Control Loop Gain (ASR) parameter setting (C5-01) may be incorrect for the machine. Change the gain to a more effective level.

If the oscillation cannot be eliminated in this way, set the Hunting Prevention Selection n1-01 = 0 (disabled). Then try re-adjusting the gain.

■ Oscillation and hunting occur with Open-Loop Vector control.

The torque compensation parameter settings may be incorrect for the machine. Adjust parameters C4-01 (Torque Compensation Gain), C4-02 (Torque Compensation Primary Delay Time Parameter), C2-01 (S-curve Characteristic Time at Acceleration Start), and C3-02 (Slip Compensation Primary Delay Time) in order. Lower the gain parameters and raise the primary delay time parameters.

Vector Control may not perform optimally if Auto-Tuning has not been performed. Therefore, perform Auto-Tuning. Alternatively, change the Control Method Selection (A1-02) to V/F Control (0 or 1).

■ Oscillation and hunting occur with Flux Vector control.

The gain adjustment may be insufficient. Adjust the speed control loop (ASR) gain (C5-01). If the oscillation points overlap with those of the machine and cannot be eliminated, increase the ASR primary time delay constant (C5-06), and then readjust the ASR gain (C5-01).

Vector Control may not perform optimally if Auto-Tuning has not been performed. Therefore, perform Auto-Tuning. Alternatively, change the Control Method Selection (A1-02) to V/F Control (0 or 1).

■ Oscillation and hunting occur with PID control.

If there is oscillation or hunting during PID control, check the oscillation cycle and individually adjust the P, I, and D parameters.

- Disable Integral (I) and Derivative time (D) control.
- Reduce the proportional gain (P) until hunting stops.
- Reintroduce the integral function, starting with long integral time values, to eliminate the P offset.
- Reintroduce the derivative time and adjust with small increments to eliminate oscillation.

◆ If the Motor Rotates Even When Drive Output is Stopped

If the motor rotates even when the Drive is stopped due to a large internal load, DC-injection braking may be necessary. Adjust the DC injection braking as follows:

- Increase parameter b2-04 (DC Injection Braking (initial excitation) Time at Stop).
- Increase parameter b2-02 (DC Injection Braking Current).

◆ If Output Frequency Does Not Rise to the Frequency Reference

Use the following information if the output frequency does not match the frequency reference.

■The frequency reference is within the jump frequency range.

When the jump frequency function is used, the output frequency does not change within the jump frequency range. Check to be sure that the Jump Frequency (d3-01 to d3-03) and Jump Frequency Width (d3-04) settings are suitable.

■The frequency reference upper limit has been reached.

The output frequency upper limit is determined by the following formula:

$$\text{Freq Ref Upper Limit} = \text{Maximum Output Frequency (E1-04)} \times \text{Frequency Reference Upper Limit (d2-01)} / 100$$

Check to be sure that the parameter E1-04 and d2-01 settings are suitable.

Main Circuit Test Procedure

Before attempting any troubleshooting checks, make sure that the three-phase power is disconnected and locked out. With power removed from the unit, the DC bus capacitors will stay charged for several minutes. The Charge LED in the Drive will glow red until the DC bus voltage is below 10Vdc. To ensure that the DC bus is completely discharged, measure between the positive and negative bus with a DC voltmeter set to the highest scale.

Table 6.6 Main Circuit Test Procedure	
Check	Procedure
Measure DC Bus Voltage	<ol style="list-style-type: none"> 1. Set the digital multi-meter to its highest Vdc scale. 2. Measure between ⊕ 1 and (-) for the following check: Place the positive (red) meter lead on ⊕ 1. Place the negative (black) meter lead on (-). 3. If the measured voltage is < 10Vdc, it is safe to work inside the Drive. If not, wait until the DC Bus has completely discharged.
Input Diodes (D1-D12 or Q1)	<p>The input diodes rectify or transform the three-phase input AC voltage into a DC voltage.</p> <ol style="list-style-type: none"> 1. Set a digital multi-meter to the Diode Check setting. 2. Place the positive (red) meter lead on terminal R/L1. Place the negative (black) meter lead on terminal ⊕ 1. Expected reading is about 0.5Vdc. 3. Place the positive (red) meter lead on terminal S/L2. Place the negative (black) meter lead on terminal ⊕ 1. Expected reading is about 0.5Vdc. 4. Place the positive (red) meter lead on terminal T/L3. Place the negative (black) meter lead on terminal ⊕ 1. Expected reading is about 0.5Vdc. 5. Place the positive (red) meter lead on terminal R/L1. Place the negative (black) meter lead on terminal (-). Expected reading is OL displayed. 6. Place the positive (red) meter lead on terminal S/L2. Place the negative (black) meter lead on terminal (-). Expected reading is OL displayed. 7. Place the positive (red) meter lead on terminal T/L3. Place the negative (black) meter lead on terminal (-). Expected reading is OL displayed. 8. Place the positive (red) meter lead on terminal (-). Place the negative (black) meter lead on terminal R/L1. Expected reading is about 0.5Vdc. 9. Place the positive (red) meter lead on terminal (-). Place the negative (black) meter lead on terminal S/L2. Expected reading is about 0.5Vdc. 10. Place the positive (red) meter lead on terminal (-). Place the negative (black) meter lead on terminal T/L3. Expected reading is about 0.5Vdc. 11. Place the positive (red) meter lead on terminal ⊕ 1. Place the negative (black) meter lead on terminal R/L1. Expected reading is OL displayed. 12. Place the positive (red) meter lead on terminal ⊕ 1. Place the negative (black) meter lead on terminal S/L2. Expected reading is OL displayed. 13. Place the positive (red) meter lead on terminal ⊕ 1. Place the negative (black) meter lead on terminal T/L3. Expected reading is OL displayed.

Table 6.6 Main Circuit Test Procedure (continued)

Check	Procedure
<p>Soft Charge Resistor Check (R1, R2, 6PCB)</p>	<p>The soft charge resistor works in conjunction with the soft charge contactor to slowly charge the DC bus capacitors to minimize the inrush current when power is applied to the Drive.</p> <ol style="list-style-type: none"> 1. Conduct a visual inspection. Check for physical damage. 2. Set a digital multi-meter to the R x 1 scale. 3. If the resistor is damaged, the measured value will be infinite Ω.
<p>Soft Charge Contactor (K1)</p>	<p>The purpose of the soft charge contactor is to bypass the soft charge resistor after the DC bus voltage has reached its normal operating level.</p> <ol style="list-style-type: none"> 1. Conduct a visual inspection. Check for physical damage. 2. Set a digital multi-meter to the R x 1 scale. 3. On Drives with a board-mounted contactor, verify that each contact resistance measures infinite Ω. 4. On Drives without a board-mounted contactor, press the plunger in, and verify that each contact measures 0Ω. 5. On Drives without a board-mounted contactor, release the plunger, and verify that the resistance is the ohmic value of the soft charge resistor. 6. On Drives with a board-mounted contactor, verify that the contactor coil measures about 300Ω. The coil can be tested by applying the appropriate voltage to verify the contacts change states. 7. On Drives without a board-mounted contactor, verify that the 230Vac contactor coil measures about 175Ω. The coil can be tested by applying the appropriate voltage to verify the contacts change states. 8. On Drives without a board-mounted contactor, verify that the 24Vdc auxiliary coil measures about $2.2M\Omega$. The coil can be tested by applying the appropriate voltage to verify the contacts change states.
<p>DC Bus Fuse (F1)</p>	<p>The DC bus fuse is located in the negative portion of the DC Bus. The DC bus fuse is used to protect the main circuit components if the output transistors short. If the DC bus fuse is open, at least one of the output transistors has failed. When a transistor fails, there is a short between the positive and negative portions of the DC Bus. The DC bus fuse does not protect the transistors, but protects the rest of the main circuit from the high current present during a short. <i>Never replace the DC bus fuse without first checking all of the output transistors.</i></p> <ol style="list-style-type: none"> 1. Set a digital multi-meter to the R x 1 scale. 2. Place one lead of the multi-meter on one side of the fuse and place the other lead of the multi-meter on the other side of the fuse. 3. If the fuse is good, the measured value will be 0Ω. If the fuse is bad, the measured value will be infinite Ω.

Table 6.6 Main Circuit Test Procedure (continued)

Check	Procedure
<p>Output Transistors (Q1-Q12)</p>	<p>The output transistors are used to switch the DC bus voltage to allow current to flow to the motor. The following checks will read erroneously if the DC bus fuse is open.</p> <ol style="list-style-type: none"> 1. Set a digital multi-meter to the Diode Check setting. 2. Place the positive (red) meter lead on terminal U/T1. Place the negative (black) meter lead on terminal ⊕ 1. Expected reading is about 0.5Vdc. 3. Place the positive (red) meter lead on terminal V/T2. Place the negative (black) meter lead on terminal ⊕ 1. Expected reading is about 0.5Vdc. 4. Place the positive (red) meter lead on terminal W/T3. Place the negative (black) meter lead on terminal ⊕ 1. Expected reading is about 0.5Vdc. 5. Place the positive (red) meter lead on terminal U/T1. Place the negative (black) meter lead on terminal (-). Expected reading is OL displayed. 6. Place the positive (red) meter lead on terminal V/T2. Place the negative (black) meter lead on terminal (-). Expected reading is OL displayed. 7. Place the positive (red) meter lead on terminal W/T3. Place the negative (black) meter lead on terminal (-). Expected reading is OL displayed. 8. Place the positive (red) meter lead on terminal (-). Place the negative (black) meter lead on terminal U/T1. Expected reading is about 0.5Vdc. 9. Place the positive (red) meter lead on terminal (-). Place the negative (black) meter lead on terminal V/T2. Expected reading is about 0.5Vdc. 10. Place the positive (red) meter lead on terminal (-). Place the negative (black) meter lead on terminal W/T3. Expected reading is about 0.5Vdc. 11. Place the positive (red) meter lead on terminal ⊕ 1. Place the negative (black) meter lead on terminal U/T1. Expected reading is OL displayed. 12. Place the positive (red) meter lead on terminal ⊕ 1. Place the negative (black) meter lead on terminal V/T2. Expected reading is OL displayed. 13. Place the positive (red) meter lead on terminal ⊕1. Place the negative (black) meter lead on terminal W/T3. Expected reading is OL displayed.
<p>Control Power Fuse</p>	<p>All Drives have a Control Power Fuse. The fuse is located on either the Power PCB (3PCB) or the Gate Drive PCB (3PCB). The Control Power Fuse protects the primary switching mode power supply.</p> <ol style="list-style-type: none"> 1. Set a digital multi-meter to the R x 1 scale. 2. Place one lead of the multi-meter on one side of the fuse and place the other lead of the multi-meter on the other side of the fuse. 3. If the fuse is good, the measured value will be 0Ω If the fuse is bad, the measured value will be infinite Ω

Table 6.6 Main Circuit Test Procedure (continued)	
Check	Procedure
24Vdc Cooling Fans (Heat Sink & Internal)	<p>The Heat Sink & Internal Cooling Fans cool the heat sink as well as the output transistor modules of the Drive.</p> <ol style="list-style-type: none"> 1. Conduct a visual inspection to ensure the fan turns freely. 2. If there is no physical evidence that the fan is bad, the fan motor can be checked with a digital multi-meter. 3. Set the digital multi-meter to the R x 1 scale. 4. Measure across the fan motor terminals. If 0Ω are measured, conclude that the fan motor is shorted. If infinite Ω are measured, conclude that the fan motor is burned open. 5. If the fan is not working, then disconnect the fan and apply 24Vdc to the fan to test the motor.
230/240Vac Cooling Fans (Heat Sink)	<p>The Heat Sink Cooling Fans cool the heat sink to remove heat from the Drive.</p> <ol style="list-style-type: none"> 1. Conduct a visual inspection to ensure the fan turns freely. 2. If there is no physical evidence that the fan is bad, the motor can be checked with a digital multi-meter. 3. Set a digital multi-meter to the R x 1 scale. 4. Measure across the fan motor terminals. If the fan motor is good, the measured value should be about 500Ω. If 0Ω are measured, conclude that the fan motor is shorted. If infinite ohms are measured, conclude that the fan motor is burned open. 5. If the fan is not working, then disconnect the fan and apply 230/240Vac to the fan to test the motor.
Cooling Fan Fuse	<p>Large Drive units contain a Cooling Fan Fuse. It is located on either the Gate Drive Board (3PCB) or the Tap Change Board (8PCB). If the Cooling Fan Fuse is open, then the 230/240Vac cooling fans may be defective.</p> <ol style="list-style-type: none"> 1. Set a digital multi-meter to the R x 1 scale. 2. Place one lead of the multi-meter on one side of the fuse and place the other lead of the multi-meter on the other side of the fuse. 3. If the fuse is good, the measured value will be 0Ω. If the fuse is bad, the measured value will be infinite Ω.

Drive Date Stamp Information

This information is used to determine when a Drive was built to see if it is within its warranty period. The date stamp is located on the lower right side of the Drive.

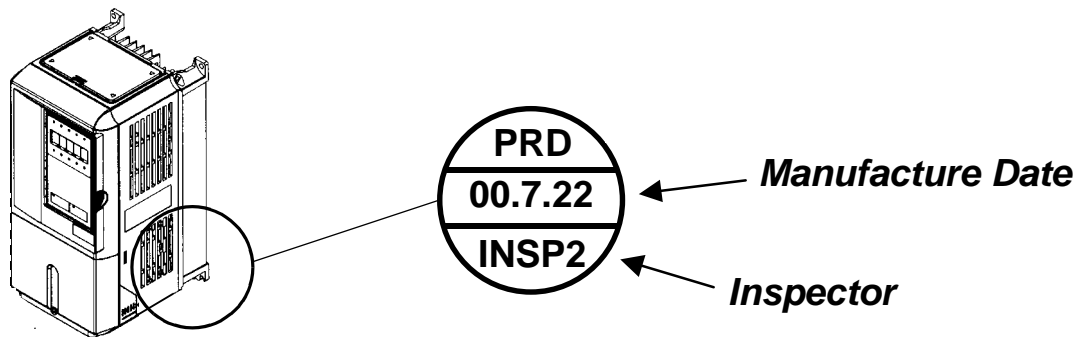

Fig 6.1 Date Stamp Location

Notes:

Chapter 7

Maintenance

This chapter describes basic maintenance and inspection of the Drive. Please refer to these instructions to ensure that the Drive receives the proper maintenance to maintain overall performance.

Periodic Inspection	7-2
Preventive Maintenance	7-3
Periodic Maintenance of Parts.....	7-4
Heatsink Cooling Fan Replacement	7-5
Removing and Mounting the Terminal Card	7-7

Periodic Inspection

Check the following items during periodic maintenance.

- The motor should not be vibrating or making unusual noises.
- There should be no abnormal heat generation from the Drive or motor.
- The ambient temperature should be within the Drive specification of -10°C to 40°C (14°F to 104°F).
- The output current value shown on U1-03 should not be higher than the motor or Drive rated current for an extended period of time.
- The cooling fan in the Drive should be operating normally.

Before attempting any maintenance checks, make sure that the three-phase power is disconnected and locked out. With power removed from the unit, the DC bus capacitors will stay charged for several minutes. The Charge LED in the Drive will glow red until the DC bus voltage is below 10Vdc. To ensure that the DC bus is completely discharged, measure between the positive and negative bus with a DC voltmeter set to the highest scale. Be sure not to touch terminals immediately after the power has been turned off. Doing so can result in electric shock. Please refer to Warnings starting on page i.

Table 7.1 Periodic Inspections With no Power Applied		
Item	Inspection	Corrective Action
External terminals, mounting bolts, connectors, etc.	Are all screws and bolts tight?	Tighten loose screws and bolts firmly.
	Are connectors tight?	Reconnect the loose connectors.
Cooling fins	Are the fins dirty or dusty?	Clean off any dirt and dust with an air gun using clean and dry air at a pressure between 55-85 psi.
Control PCB Terminal PCB Power PCB Gate Drive PCBs	Is there any conductive dirt or oil mist on the PCBs?	Clean off any dirt and dust with an air gun using clean and dry air at a pressure between 55-85 psi. Replace the boards if they cannot be made clean.
Input Diodes IPMs Output Transistors	Is there any conductive dirt or oil mist on the modules or components?	Clean off any dirt and dust with an air gun using clean and dry air at a pressure between 55-85 psi. Replace the boards if they cannot be made clean.
DC bus capacitors	Are there any irregularities, such as discoloration or odor?	Replace the capacitors or Drive.

Apply power to the Drive and conduct the following inspection.

Table 7.2 Periodic Inspections With Power Applied		
Item	Inspection	Corrective Action
Cooling fan(s)	Is there any abnormal noise or vibration, or has the total operating time exceeded 20,000 hours. Check U1-40 for elapsed cooling fan operation time.	Replace Cooling Fan

Preventive Maintenance

Table 7.3 Preventive Maintenance				
Inspection Points	Item	Check Points	Every 3-6 Months	Yearly
General	Environment	Ambient temperature Humidity Dust Harmful gas Oil mist	X X X X X	
	Equipment	Abnormal vibration or noise	X	
	AC Power Supply	Main circuit & control voltage	X	
AC Power Circuit & Devices	Conductors & Wire Connections	Loose lugs, screws & wires Hot spots on parts Corrosion Bent conductors Breakage, cracking or discoloration Check spacing		X X X X X X
	Transformers & Reactors	Discoloration or noise	X	
	Terminal Blocks	Loose, damaged		X
	DC Bus Capacitors	Leakage Ruptures, broken, expansion Capacitance & insulation resistance		X X X
	Relays & Contactors	Noisy Contact discoloration		X X
	Soft Charge Resistors	Cracked Discoloration		X X
Control Circuits	Operation	Speed reference voltage/current I/O contact operation		X X
Cooling System	Cooling Fans/Fins & Heatsink	Abnormal fan noise	X	
		Loose connectors Free of accumulation	X	X
Keypad/Display	Digital Operator	LEDs Monitor display values Key functionality Clean	X X	X X

If the Drive is used under the following conditions, it may be necessary to inspect more often:

- High ambient temperatures, humidity or altitudes above 3,300 feet.
- Frequent starting and stopping.
- Fluctuations of the AC power supply or load.
- Excessive vibration and/or shock loading.
- Poor environment, including dust, metal dust, salt, sulfuric acid, chlorine.
- Poor storage conditions.

Periodic Maintenance of Parts

In order to keep the Drive operating normally over a long period of time, and to prevent down time due to an unexpected failure, it is necessary to perform periodic inspections and replace parts according to their service life.

The data indicated in the following table is to be used as a general guideline only. Periodic inspection standards vary depending on the Drive's installation environment conditions and usage. The Drive's suggested maintenance periods are noted below.

Table 7.4 Part Replacement Guidelines		
Part	Standard Replacement Period	Replacement Method
Cooling fan(s)	2 to 3 years (20,000 hours)	Replace with new part.
DC bus capacitors	5 years	Replace with new part. (Determine need by inspection.)
Soft charge contactor	-	Determine need by inspection.
DC bus fuse Control power fuse	10 years	Replace with new part.
PCB capacitors	5 years	Replace with new board. (Determine need by inspection.)
Note: The standard replacement period is based on the following usage conditions: Ambient temperature: Yearly average of 86°F/ 30°C Load factor: 80% maximum Operating time: 12 hours maximum per day		

Heatsink Cooling Fan Replacement

◆ Models CIMR-F7U20P4 thru 2018 and 40P4 thru 4018

A cooling fan is attached to the bottom of the Drive.

If the Drive is installed using the mounting holes on the back of the Drive, the cooling fan can be replaced without removing the Drive from the installation panel.

If the Drive is mounted with the heatsink external to the enclosure, the cooling fan can only be replaced by removing the Drive from the enclosure.

■ Removing the Heatsink Cooling Fan

1. Always turn OFF the input power before removing and installing the heatsink cooling fan.
2. Press in on the right and left sides of the fan cover in the direction of arrows “1” and then pull the fan out in the direction of arrow “2”.
3. Pull out the cable connected to the fan from the fan cover and disconnect the power connector. See Fig 7.1.
4. Open the fan cover on the left and right sides in the direction of arrows “3” and remove the fan cover from the fan.

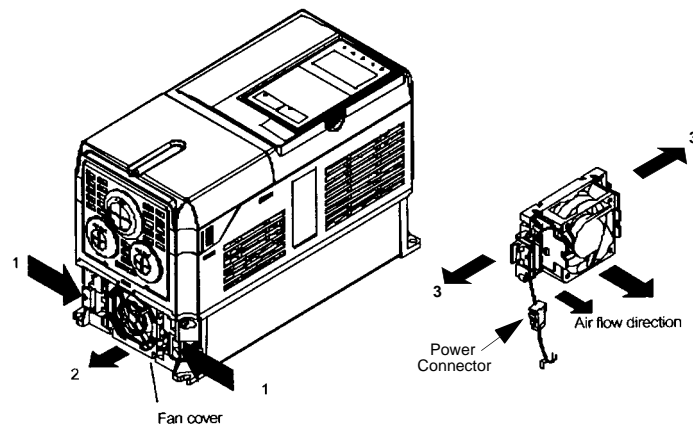

Fig 7.1 Cooling Fan Replacement Procedure

■ Installing the Heatsink Cooling Fan

1. Attach the fan cover to the cooling fan. Be sure that the air flow direction indicated by the arrows above faces into the Drive.
2. Connect the power connector securely and place the power connector and cable into the fan cover.
3. Mount the fan cover on the Drive. Be sure that the tabs on the sides of the fan cover click into place on the Drive.

◆ Models CIMR-F7U2022 thru 2110 and 4030 thru 4300

These Drives have an internal cooling fan assembly and a heatsink cooling fan assembly. The heatsink cooling fan assembly is attached to the top of the heatsink inside the Drive. The cooling fan(s) can be replaced without removing the Drive from the installation panel.

Removing the Heatsink Cooling Fan Assembly

1. Always turn OFF the input power before removing and installing the heatsink cooling fan assembly.
2. Remove the terminal cover, Drive cover, Digital Operator, and front cover from the front of the Drive.
3. Remove the Control PCB bracket (if necessary) to which the cards are mounted. Remove all cables connected to the Control PCB and remove the cooling fan power connector from the fan board (13 PCB) positioned near the top of the Drive.
4. Remove the cooling fan power connectors from the gate drive board (3PCB) positioned at the back of the Drive.
5. Remove the fan assembly screws and pull out the fan assembly from the Drive.
6. Remove the cooling fan(s) from the fan assembly.

Mounting the Heatsink Cooling Fan Assembly

After attaching a new cooling fan, reverse the above procedure to attach all of the components.

When attaching the cooling fan to the mounting bracket, be sure that the air flow goes toward the top of the Drive.

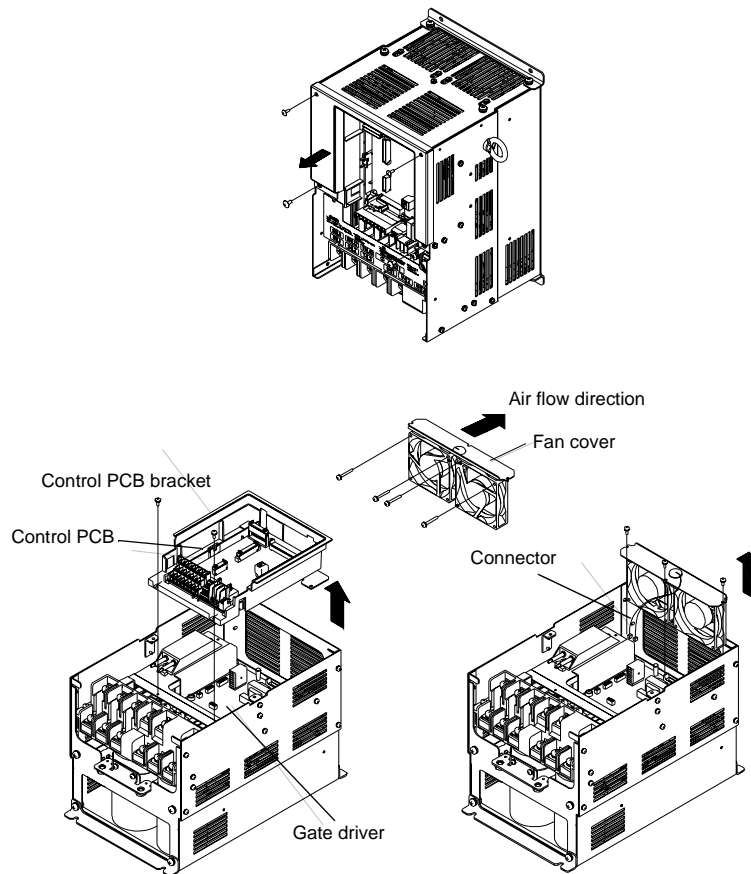

Fig 7.2 Cooling Fan Assembly Replacement Procedure

Removing and Mounting the Terminal Card

The terminal card can be removed and mounted without disconnecting the control wiring.

IMPORTANT

Always confirm that input power is removed and the Charge LED is not lit before removing or mounting the terminal card.

■Removing the Terminal Card

- 1.) Remove the terminal cover on the Drive.
- 2.) Remove the Digital Operator and front cover from the Drive.
- 3.) Remove the wires connected to FE and/or NC on the terminal card.
- 4.) Loosen the mounting screws on the left and right sides of the terminal card until they are free. It is not necessary to remove the mounting screws completely. They are captive and self-rising.
- 5.) Pull the terminal card out in the direction of the block arrow.

■Mounting the Terminal Card

Reverse the removal procedure to mount the terminal card.

Confirm that the terminal card and the Control PCB properly meet at connector CN8 before insertion.

The connector pins may be damaged if the terminal card is forced into place, possibly preventing correct Drive operation.

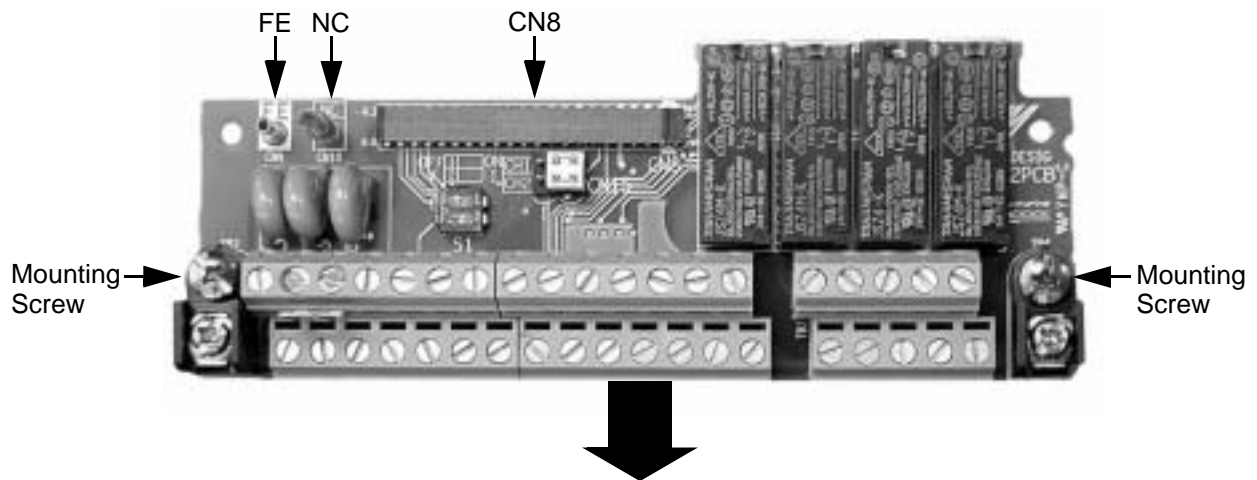

Fig 7.3 Terminal Card Removal Procedure

Notes:

Appendix A Parameters

This appendix lists all the parameter numbers and names, along with a description of each. The abbreviated name as it appears on the Digital Operator display/keypad is shown in bold type.

F7 Parameter List	A-3
F7 Monitor List	A-40
F7 Fault Trace List.....	A-43
F7 Fault History List.....	A-43

Some parameters in the following tables are not available for all Control Methods (A1-02). Use the key below to determine which parameters are available for the selected Control Method.

V/F	V/F w/PG	Open Loop Vector	Flux Vector
Q	Q	A	-

Q: Parameters which can be monitored and set in either Quick Setting or Advanced Programming Menu

A: Parameters which can be monitored and set in only Advanced Programming Menu

-: Parameters which cannot be monitored or set for the selected Control Method.

F7 Parameter List

Table A.1 F7 Parameter List								
Parameter No.	Parameter Name Digital Operator Display	Description	Setting Range	Factory Setting	Control Method			
					V/F	V/F w/ PG	Open Loop Vector	Flux Vector
Initialization								
A1-00 ◆	Language Selection Select Language	Language selection for the Digital Operator. This parameter is not reset to the factory setting by A1-03. 0: English 1: Japanese 2: Deutsch 3: Francais 4: Italiano 5: Espanol 6: Portugues	0 to 6	0	A	A	A	A
A1-01 ◆	Access Level Selection Access Level	Selects which parameters are accessible via the Digital Operator. 0: Operation Only 1: User Level (only available if A2 parameters have been set) 2: Advanced Level	0 to 2	2	A	A	A	A
A1-02	Control Method Selection Control Method	Selects the Control Method of the Drive. 0: V/F control without PG 1: V/F control with PG 2: Open Loop Vector 3: Flux Vector (Closed Loop Vector)	0 to 3	2	Q	Q	Q	Q
A1-03	Initialize Parameters Init Parameters	Used to return all parameters to their factory or user default settings. (Initializes and then returns A1-03 to zero.) 0: No Initialize 1110: User Initialize (The user must first set their own parameter values and then store them using parameter o2-03.) 2220: 2-Wire Initialization 3330: 3-Wire Initialization	0 to 3330	0	A	A	A	A
A1-04	Password 1 Enter Password	When the value set into A1-04 does NOT match the value set into A1-05, parameters A1-01 thru A1-03 and A2-01 thru A2-32 cannot be changed. All other parameters as determined by A1-01 can be changed. Parameter A1-05 can be accessed by pressing the MENU key while holding the RESET key.	0 to 9999	0	A	A	A	A
A1-05	Password 2 Select Password		0 to 9999	0	A	A	A	A
User Parameters								
A2-01	User Parameter 1 User Param 1	Selects the parameters to be available in the User Access Level (A1-01 = 1). These parameters are not related to the User Initialize function.	b1-01 to o3-02	—	A	A	A	A
A2-02	User Parameter 2 User Param 2			—	A	A	A	A
A2-03	User Parameter 3 User Param 3			—	A	A	A	A
A2-04	User Parameter 4 User Param 4			—	A	A	A	A
A2-05	User Parameter 5 User Param 5			—	A	A	A	A
A2-06	User Parameter 6 User Param 6			—	A	A	A	A
A2-07	User Parameter 7 User Param 7			—	A	A	A	A
A2-08	User Parameter 8 User Param 8			—	A	A	A	A
A2-09	User Parameter 9 User Param 9			—	A	A	A	A
◆Denotes that parameter can be changed when the Drive is running.								

Table A.1 F7 Parameter List (Continued)

Parameter No.	Parameter Name Digital Operator Display	Description	Setting Range	Factory Setting	Control Method			
					V/F	V/F w/ PG	Open Loop Vector	Flux Vector
A2-10	User Parameter 10 User Param 10	Selects the parameters to be available in the User Access Level (A1-01 = 1). These parameters are not related to the User Initialize function.	b1-01 to o3-02	—	A	A	A	A
A2-11	User Parameter 11 User Param 11			—	A	A	A	A
A2-12	User Parameter 12 User Param 12			—	A	A	A	A
A2-13	User Parameter 13 User Param 13			—	A	A	A	A
A2-14	User Parameter 14 User Param 14			—	A	A	A	A
A2-15	User Parameter 15 User Param 15			—	A	A	A	A
A2-16	User Parameter 16 User Param 16			—	A	A	A	A
A2-17	User Parameter 17 User Param 17			—	A	A	A	A
A2-18	User Parameter 18 User Param 18			—	A	A	A	A
A2-19	User Parameter 19 User Param 19			—	A	A	A	A
A2-20	User Parameter 20 User Param 20			—	A	A	A	A
A2-21	User Parameter 21 User Param 21			—	A	A	A	A
A2-22	User Parameter 22 User Param 22			—	A	A	A	A
A2-23	User Parameter 23 User Param 23			—	A	A	A	A
A2-24	User Parameter 24 User Param 24			—	A	A	A	A
A2-25	User Parameter 25 User Param 25			—	A	A	A	A
A2-26	User Parameter 26 User Param 26			—	A	A	A	A
A2-27	User Parameter 27 User Param 27			—	A	A	A	A
A2-28	User Parameter 28 User Param 28			—	A	A	A	A
A2-29	User Parameter 29 User Param 29			—	A	A	A	A
A2-30	User Parameter 30 User Param 30			—	A	A	A	A
A2-31	User Parameter 31 User Param 31			—	A	A	A	A
A2-32	User Parameter 32 User Param 32			—	A	A	A	A

◆Denotes that parameter can be changed when the Drive is running.

Table A.1 F7 Parameter List (Continued)

Parameter No.	Parameter Name Digital Operator Display	Description	Setting Range	Factory Setting	Control Method			
					V/F	V/F w/ PG	Open Loop Vector	Flux Vector
Sequence								
b1-01	Frequency Reference Selection Reference Source	Selects the frequency reference input source. 0: Operator - Digital preset speed U1-01 or d1-01 to d1-17. 1: Terminals - Analog input terminal A1 (or terminal A2 based on parameter H3-09). 2: Serial Com - Modbus RS-422/485 terminals R+, R-, S+, and S-. 3: Option PCB - Option board connected on 2CN. 4: Pulse Input (Terminal RP)	0 to 4	1	Q	Q	Q	Q
b1-02	Run Command Selection Run Source	Selects the run command input source. 0: Operator - RUN and STOP keys on Digital Operator. 1: Terminals - Contact closure on terminals S1 or S2. 2: Serial Com - Modbus RS-422/485 terminals R+, R-, S+, and S-. 3: Option PCB - Option board connected on 2CN.	0 to 3	1	Q	Q	Q	Q
b1-03	Stopping Method Selection Stopping Method	Selects the stopping method when the run command is removed. 0: Ramp to Stop 1: Coast to Stop 2: DC Injection to Stop 3: Coast with Timer (A new run command is ignored if received before the timer expires).	0 to 3	0	Q	Q	Q	Q
b1-04	Reverse Operation Selection Reverse Oper	Determines the forward rotation of the motor, and if reverse operation is disabled. 0: Reverse Enabled 1: Reverse Disabled 2: Exchange Phase - Change direction of forward motor rotation.	0 to 2	0	A	A	A	A
b1-05	Minimum Output Frequency (E1-09) or Less Operation Selection Zero-Speed Oper	Operation method when frequency reference is less than minimum output frequency set in E1-09. 0: Operates according to frequency reference (E1-09 is disabled) 1: Output shuts off (coast to stop if less than E1-09) 2: Operates according to E1-09 (frequency reference set to E1-09) 3: Zero speed (frequency reference of zero is less than E1-09)	0 to 3	0	-	-	-	A
b1-06	Digital Input Scan Time Cntl Input Scans	Sets the scan rate of terminals S1 to S8. 0: 2ms - 2 scans (for quick response) 1: 5ms - 2 scans (for noisy environments)	0 to 1	1	A	A	A	A
b1-07	Local/Remote Run Selection LOC/REM RUN Sel	0: Cycle External RUN - If the run command is closed when switching from local mode to remote mode, the Drive will not run. 1: Accept External RUN - If the run command is closed when switching from local mode to remote mode, the Drive WILL run.	0 to 1	0	A	A	A	A
b1-08	Run Command Selection During Program RUN CMD at PRG	0: Disabled - Run command accepted only in the operation menu. 1: Enabled - Run command accepted in all menus (except when b1-02 = 0).	0 to 1	0	A	A	A	A
DC Injection Braking								
b2-01	DC Injection Braking Start Frequency DCInj Start Freq	Sets the frequency at which DC injection braking starts when ramp to stop (b1-03 = 0) is selected. If b2-01 < E1-09, DC Injection braking starts at E1-09.	0.0 to 10.0	0.5Hz	A	A	A	A
b2-02	DC Injection Braking Current DCInj Current	Sets the DC injection braking current as a percentage of the Drive rated current.	0 to 100	50%	A	A	A	-
b2-03	DC Injection Braking Time at Start DCInj Time @Start	Sets the time of DC injection braking at start in units of 0.01 seconds.	0.00 to 10.00	0.00sec	A	A	A	A
b2-04	DC Injection Braking Time at Stop DCInj Time @Stop	Sets the time length of DC injection braking at stop in units of 0.01 seconds. 1. When b1-03 = 2, actual DC Injection time is calculated as follows: b2-04 * 10 * Output Frequency / E1-04. 2. When b1-03 = 0, this parameter determines the amount of time DC Injection is applied to the motor at the end of the decel ramp. 3. This should be set to a minimum of 0.50 seconds when using HSB. This will activate DC injection during the final portion of HSB and help ensure that the motor stops completely.	0.00 to 10.00	0.00sec	A	A	A	A
b2-08	Magnetic Flux Compensation Capacity Field Comp	Sets the magnetic flux compensation as a percentage of the no-load current value (E2-03).	0 to 1000	0%	-	-	A	-

♦Denotes that parameter can be changed when the Drive is running.

Table A.1 F7 Parameter List (Continued)

Parameter No.	Parameter Name Digital Operator Display	Description	Setting Range	Factory Setting	Control Method			
					V/F	V/F w/ PG	Open Loop Vector	Flux Vector
Speed Search								
b3-01	Speed Search Selection SpdSrch at Start	<p>Enables/disables and selects the speed search function at start.</p> <p>0: Speed Estimation Speed Search Disable - Speed search at start is disabled (however the estimated speed method is used for multi-function input, power loss ridthrough, auto fault retry)</p> <p>1: Speed Estimation Speed Search Enable - The speed estimation method of speed search is enabled at run command.</p> <p>2: Current Detection Speed Search Disable - Speed search at start is disabled (however the current detection method is used for multi-function input, power loss ride through, auto fault retry)</p> <p>3: Current Detection Speed Search Enable - The current detection method of speed search is enabled at run command.</p> <p>Speed Estimation Method: Motor speed and direction are measured using residual motor flux.</p> <p>Current Detection Method: Motor speed is measured using current feedback levels (unidirectional only).</p>	0 to 3	2	A	A	A	-
b3-02	Speed Search Deactivation Current SpdSrch Current	Used only when b3-01 = 2 or 3. Sets the speed search operation current as a percentage of Drive rated current.	0 to 200	120%	A	-	A	-
b3-03	Speed Search Deceleration Time SpdSrch Dec Time	Used only when b3-01 = 2 or 3. Sets the deceleration time during speed search.	0.1 to 10.0	2.0sec	A	-	A	-
b3-05	Speed Search Delay Time Search Delay	Delays the speed search operation after a momentary power loss to allow time for an external output contactor to re-energize.	0.0 to 20.0	0.2sec	A	A	A	A
b3-10	Speed Search Detection Compensation Gain Srch Detect Comp	Sets the gain for the frequency at which the Drive starts speed estimation speed search. Use only when b3-01 = 0 or 1.	1.00 to 1.20	1.10	A	-	A	-
b3-14	Bi-directional Speed Search Selection Bidir Search Sel	<p>This parameter enables the Drive to detect the direction of rotation of the motor during speed search.</p> <p>0: Disable - Drive uses frequency reference direction.</p> <p>1: Enable - Drive uses detected direction</p>	0 to 1	1	A	A	A	-
Delay Timers								
b4-01	Timer Function ON-Delay Time Delay-ON Timer	Used in conjunction with a multi-function digital input and a multi-function digital output programmed for the timer function. This sets the amount of time between when the digital input is closed, and the digital output is energized.	0.0 to 3000.0	0.0sec	A	A	A	A
b4-02	Timer Function OFF-Delay Time Delay-OFF Timer	Used in conjunction with a multi-function digital input and a multi-function digital output programmed for the timer function. This sets the amount of time the output stays energized after the digital input is opened.	0.0 to 3000.0	0.0sec	A	A	A	A
PID Control								
b5-01	PID Function Setting PID Mode	<p>This parameter determines the function of the PID control.</p> <p>0: Disabled</p> <p>1: D = Feedback</p> <p>2: D = Feed-Forward</p> <p>3: Freq. Ref. + PID output (D = Feedback)</p> <p>4: Freq. Ref. + PID output (D = Feed-Forward)</p>	0 to 4	0	A	A	A	A
b5-02 ◆	Proportional Gain Setting PID Gain	Sets the proportional gain of the PID controller.	0.00 to 25.00	1.00	A	A	A	A
b5-03 ◆	Integral Time Setting PID I Time	Sets the integral time for the PID controller. A setting of zero disables integral control.	0.0 to 360.0	1.0sec	A	A	A	A
b5-04 ◆	Integral Limit Setting PID I Limit	Sets the maximum output possible from the integrator. Set as a percentage (%) of maximum frequency.	0.0 to 100.0	100.0%	A	A	A	A
b5-05 ◆	Derivative Time PID D Time	Sets D control derivative time. A setting of 0.00 disables derivative control.	0.00 to 10.00	0.00sec	A	A	A	A
b5-06 ◆	PID Output Limit PID Limit	Sets the maximum output possible from the entire PID controller. Set as a percentage (%) of maximum frequency.	0.00 to 100.0	100.0%	A	A	A	A

◆Denotes that parameter can be changed when the Drive is running.

Table A.1 F7 Parameter List (Continued)

Parameter No.	Parameter Name Digital Operator Display	Description	Setting Range	Factory Setting	Control Method			
					V/F	V/F w/ PG	Open Loop Vector	Flux Vector
b5-07 ◆	PID Offset Adjustment PID Offset	Sets the amount of offset of the output of the PID controller. Set as a percentage (%) of maximum frequency. The offset is summed with the PID output. This can be used to artificially kick-start a slow starting PID loop.	-100.0 to +100.0	0.0%	A	A	A	A
b5-08 ◆	PID Primary Delay Time Constant PID Delay Time	Sets the amount of time for the filter on the output of the PID controller.	0.00 to 10.00	0.00sec	A	A	A	A
b5-09	PID Output Level Selection Output Level Sel	Determines whether the PID controller will be direct or reverse acting. 0: Normal Output (direct acting) 1: Reverse Output (reverse acting)	0 to 1	0	A	A	A	A
b5-10	PID Output Gain Setting Output Gain	Sets the output gain of the PID controller.	0.0 to 25.0	1.0	A	A	A	A
b5-11	PID Output Reverse Selection Output Rev Sel	0: 0 limit (when PID output goes negative, Drive stops). 0 limit is automatic when reverse prohibit is selected using b1-04. 1: Reverse (when PID goes negative, Drive reverses).	0 to 1	0	A	A	A	A
b5-12	PID Feedback Reference Missing Detection Selection Fb los Det Sel	0: Disabled 1: Alarm 2: Fault	0 to 2	0	A	A	A	A
b5-13	PID Feedback Loss Detection Level Fb los Det Lvl	Sets the PID feedback loss detection level as a percentage (%) of maximum frequency (E1-04).	0 to 100	0%	A	A	A	A
b5-14	PID Feedback Loss Detection Time Fb los Det Time	Sets the PID feedback loss detection delay time in terms of seconds.	0.0 to 25.5	1.0sec	A	A	A	A
b5-15	PID Sleep Function Start Level PID Sleep Level	Sets the sleep function start frequency.	Varies by Duty Rating*	0.0Hz	A	A	A	A
b5-16	PID Sleep Delay Time PID Sleep Time	Sets the sleep function delay time in terms of seconds.	0.0 to 25.5	0.0sec	A	A	A	A
b5-17	PID Accel/Decel Time PID Acc/Dec Time	Applies an accel/decel time to the PID setpoint reference. The Drive's standard softstarter (C1-XX and S-curve) still affects the output of the PID algorithm.	0.0 to 25.5	0.0sec	A	A	A	A
b5-18	PID Setpoint Selection PID Setpoint Sel	Allows the b5-19 setting to be the PID target setpoint value. 0: Disabled 1: Enabled	0 to 1	0	A	A	A	A
b5-19	PID Setpoint Value PID Setpoint	Sets the PID target value. Use only when b5-18 = 1	0.0 to 100.0	0.0%	A	A	A	A

◆Denotes that parameter can be changed when the Drive is running.

* For Heavy Duty (HD) Rating (C6-01=0): Setting Range=0.0 to 300.0. For Normal Duty (ND) Rating (C6-01=2): Setting Range=0.0 to 400.0.

Table A.1 F7 Parameter List (Continued)

Parameter No.	Parameter Name Digital Operator Display	Description	Setting Range	Factory Setting	Control Method			
					V/F	V/F w/ PG	Open Loop Vector	Flux Vector
Reference Hold (Dwell)								
b6-01	Dwell Reference at Start Dwell Ref @Start	Temporarily holds the frequency reference. 	0.0 to 400.0	0.0Hz	A	A	A	A
b6-02	Dwell Time at Start Dwell Time @Start		0.0 to 10.0	0.0sec	A	A	A	A
b6-03	Dwell Frequency at Stop Dwell Ref @Stop		0.0 to 400.0	0.0Hz	A	A	A	A
b6-04	Dwell Time at Stop Dwell Time @Stop		0.0 to 10.0	0.0sec	A	A	A	A
Droop Control								
b7-01 ◆	Droop Control Level Droop Quantity	Sets the speed decrease as a percentage of maximum output frequency (E1-04) when the motor is at 100% load torque. Setting of 0.0 disables droop control.	0.0 to 100.0	0.0%	-	-	-	A
b7-02 ◆	Droop Control Delay Time Droop Delay Time	Determines the droop control delay time in response to a load change.	0.03 to 2.00	0.05sec	-	-	-	A
Energy Saving								
b8-01	Energy Saving Control Selection Energy Save Sel	Energy Savings function enable/disable selection. 0: Disabled 1: Enabled	0 to 1	0	A	A	A	A
b8-02	Energy Saving Gain Energy Save Gain	Sets energy savings control gain when in vector control method.	0.0 to 10.0	1.0	-	-	A	A
b8-03	Energy Saving Control Filter Time Constant Energy Saving F.T	Sets energy saving control filter time constant when in vector control method.	0.00 to 10.00	Varies by kVA	-	-	A	A
b8-04	Energy Saving Coefficient Value Energy Save COEF	Used to fine-tune the energy savings function when in V/F control method.	0.0 to 655.00	Varies by kVA	A	A	-	-
b8-05	Power Detection Filter Time kW Filter Time		0 to 2000	20ms	A	A	-	-
b8-06	Search Operation Voltage Limit Search V Limit		0 to 100	0%	A	A	-	-
Zero Servo								
b9-01	Zero Servo Gain Zero Servo Gain	Sets the position loop gain for Zero Servo command. This function is effective when multi-function input "zero servo command" is set.	0 to 100	5	-	-	-	A
b9-02	Zero Servo Completion Width Zero Servo Count	Sets number of pulses used for the multi-function output of "zero servo completion".	0 to 16383	10 pulses	-	-	-	A

◆Denotes that parameter can be changed when the Drive is running.

Table A.1 F7 Parameter List (Continued)

Parameter No.	Parameter Name Digital Operator Display	Description	Setting Range	Factory Setting	Control Method			
					V/F	V/F w/ PG	Open Loop Vector	Flux Vector
Accel / Decel								
C1-01 ◆	Acceleration Time 1 Accel Time 1	Sets the time to accelerate from zero to maximum frequency.	0.0 to 6000.0	10.0sec	Q	Q	Q	Q
C1-02 ◆	Deceleration Time 1 Decel Time 1	Sets the time to decelerate from maximum frequency to zero.			Q	Q	Q	Q
C1-03 ◆	Acceleration Time 2 Accel Time 2	Sets the time to accelerate from zero to maximum frequency when selected via a multi-function input.			A	A	A	A
C1-04 ◆	Deceleration Time 2 Decel Time 2	Sets the time to decelerate from maximum frequency to zero when selected via a multi-function input.			A	A	A	A
C1-05	Acceleration Time 3 Accel Time 3	Sets the time to accelerate from zero to maximum frequency when selected via a multi-function input.			A	A	A	A
C1-06	Deceleration Time 3 Decel Time 3	Sets the time to decelerate from maximum frequency to zero when selected via a multi-function input.			A	A	A	A
C1-07	Acceleration Time 4 Accel Time 4	Sets the time to accelerate from zero to maximum frequency when selected via a multi-function input.			A	A	A	A
C1-08	Deceleration Time 4 Decel Time 4	Sets the time to decelerate from maximum frequency to zero when selected via a multi-function input.			A	A	A	A
C1-09	Fast Stop Time Fast Stop Time	Sets the time to decelerate from maximum frequency to zero for the multi-function input "Fast Stop" function.	0.0 to 6000.0	10.0sec	A	A	A	A
C1-10	Accel/Decel Time Setting Unit Acc/Dec Units	Sets the setting resolution of C1-01 to C1-09 0: 0.01 sec (0.00 to 600.00 sec) 1: 0.1 sec (0.0 to 6000.0 sec)	0 to 1	1	A	A	A	A
C1-11	Accel/Decel Switch Frequency Acc/Dec SW Freq	Sets the frequency for automatic switching of accel / decel times. Fout < C1-11: Accel/Decel Time 4 Fout ≥ C1-11: Accel/Decel Time 1 Multi-function inputs "Multi-Acc/Dec 1" and "Multi-Acc/Dec 2" have priority over C1-11.	Varies by Duty Rating*	0.0Hz	A	A	A	A
S-Curve Accel/Decel								
C2-01	S-Curve Characteristic at Accel Start SCrv Acc @ Start	<p>S-curve is used to further soften the starting and stopping ramp. The longer the S-curve time, the softer the starting and stopping ramp.</p>	0.00 to 2.50	0.20sec	A	A	A	A
C2-02	S-Curve Characteristic at Accel End SCrv Acc @ End			0.20sec	A	A	A	A
C2-03	S-Curve Characteristic at Decel Start SCrv Dec @ Start			0.20sec	A	A	A	A
C2-04	S-Curve Characteristic at Decel End SCrv Dec @ End			0.00sec	A	A	A	A
<p>◆ Denotes that parameter can be changed when the Drive is running. * For Heavy Duty (HD) Rating: Setting Range=0.0 to 300.0. For Normal Duty (ND) Rating: Setting Range=0.0 to 400.0.</p>								

Table A.1 F7 Parameter List (Continued)

Parameter No.	Parameter Name Digital Operator Display	Description	Setting Range	Factory Setting	Control Method			
					V/F	V/F w/ PG	Open Loop Vector	Flux Vector
Motor-Slip Compensation								
C3-01 ◆	Slip Compensation Gain Slip Comp Gain	This parameter is used to increase motor speed to account for motor slip by boosting the output frequency. If the speed is lower than the frequency reference, increase C3-01. If the speed is higher than the frequency reference, decrease C3-01.	0.0 to 2.5	1.0	A	-	A	A
C3-02	Slip Compensation Primary Delay Time Slip Comp Time	This parameter adjusts the filter on the output of the slip compensation function. Increase to add stability, decrease to improve response.	0 to 10000	200ms	A	-	A	-
C3-03	Slip Compensation Limit Slip Comp Limit	This parameter sets the upper limit for the slip compensation function. It is set as a percentage of motor rated slip (E2-02).	0 to 250	200%	A	-	A	-
C3-04	Slip Compensation Selection During Regeneration Slip Comp Regen	Determines whether slip compensation is enabled or disabled during regenerative operation. 0: Disabled 1: Enabled	0 to 1	0	A	-	A	-
C3-05	Output Voltage Limit Operation Selection V/F Slip Cmp Sel	Determines if the motor magnetic flux is automatically decreased when output voltage saturation occurs. 0: Disabled 1: Enabled	0 to 1	0	-	-	A	A
Torque Compensation								
C4-01 ◆	Torque Compensation Gain Torq Comp Gain	This parameter sets the gain for the Drive's automatic torque boost function to match the Drive's output voltage to the motor load. This parameter helps to produce better starting torque. It determines the amount of torque or voltage boost based upon motor current, motor resistance, and output frequency.	0.00 to 2.50	1.00	A	A	A	-
C4-02	Torque Compensation Primary Delay Time Torq Comp Time	This parameter adjusts the filter on the output of the torque compensation function. Increase to add stability, decrease to improve response.	0 to 10000	20ms	A	A	A	-
C4-03	Torque Compensation at Forward Start F TorqCmp @ start	Sets torque compensation at forward start as a percentage of motor torque.	0.0 to 200.0	0.0%	-	-	A	-
C4-04	Torque Compensation at Reverse Start R TorqCmp @ start	Sets torque compensation at reverse start as a percentage of motor torque.	-200.0 to 0.0	0.0%	-	-	A	-
C4-05	Torque Compensation Time Constant TorqCmp Delay T	Sets the time constant for torque compensation at forward start and reverse start (C4-03 and C4-04). The filter is disabled if the time is set to 4ms or less.	0 to 200	10ms	-	-	A	-
◆Denotes that parameter can be changed when the Drive is running.								

Table A.1 F7 Parameter List (Continued)

Parameter No.	Parameter Name Digital Operator Display	Description	Setting Range	Factory Setting	Control Method			
					V/F	V/F w/ PG	Open Loop Vector	Flux Vector
ASR Tuning								
C5-01 ◆	ASR Proportional Gain 1 ASR P Gain 1	Sets the proportional gain of the speed control loop (ASR)	1.00 to 300.00	20.00	-	A	-	A
C5-02 ◆	ASR Integral Time 1 ASR I Time 1	Sets the integral time of the speed control loop (ASR)	0.000 to 10.000	0.500 sec	-	A	-	A
C5-03 ◆	ASR Proportional Gain 2 ASR P Gain 2	Sets the speed control gain 2 and integral time 2 of the speed control loop (ASR). 	1.00 to 300.00	20.00	-	A	-	A
C5-04 ◆	ASR Integral Time 2 ASR I Time 2			0.000 to 10.000	0.500 sec	-	A	-
C5-05	ASR Limit ASR Limit	Sets the upper limit for the speed control loop (ASR) as a percentage of the maximum output frequency (E1-04).	0.0 to 20.0	5.0%	-	A	-	-
C5-06	ASR Primary Delay Time Constant ASR Delay Time	Sets the filter time constant for the time from the speed loop to the torque command output.	0.000 to 0.500	0.004 sec	-	-	-	A
C5-07	ASR Gain Switching Frequency ASR Gain SW Freq	Sets the frequency for switching between Proportional Gain 1, 2 and Integral Time 1, 2.	0.0 to 400.0	0.0Hz	-	-	-	A
C5-08	ASR Integral Limit ASR I Limit	Sets the ASR integral upper limit and rated load as a percentage of maximum output frequency (E1-04).	0 to 400	400%	-	-	-	A
Carrier Frequency								
C6-01	Drive Duty Selection Heavy/Normal Duty	Selects Drive's rated input and output current, overload capacity, carrier frequency, current limit, and maximum output frequency. See Introduction for details. 0: Heavy Duty (C6-02 = 0 to 1) 1: Normal Duty 1 (C6-02 = 0 to F) 2: Normal Duty 2 (C6-02 = 0 to F)	0 to 2	0	A	A	A	A
C6-02	Carrier Frequency Selection CarrierFreq Sel	Selects the number of pulses per second of the output voltage waveform. Setting range determined by C6-01 setting. 0: Low noise 1: Fc = 2.0 kHz 2: Fc = 5.0 kHz 3: Fc = 8.0 kHz 4: Fc = 10.0 kHz 5: Fc = 12.5 kHz 6: Fc = 15.0 kHz F: Program (Determined by the settings of C6-03 thru C6-05)	0 to F	Varies by kVA	Q	Q	Q	Q
C6-03	Carrier Frequency Upper Limit CarrierFreq Max	Maximum carrier frequency allowed when C6-02 = F.	0.4 to 15.0 kHz	Varies by kVA	A	A	A	A
C6-04	Carrier Frequency Lower Limit CarrierFreq Min	Minimum carrier frequency allowed when C6-02 = F.	0.4 to 15.0 kHz	Varies by kVA	A	A	-	-
C6-05	Carrier Frequency Proportional Gain CarrierFreq Gain	Sets the relationship of output frequency to carrier frequency when C6-02 = F.	0 to 99	0	A	A	-	-
◆Denotes that parameter can be changed when the Drive is running.								

Table A.1 F7 Parameter List (Continued)

Parameter No.	Parameter Name Digital Operator Display	Description	Setting Range	Factory Setting	Control Method			
					V/F	V/F w/ PG	Open Loop Vector	Flux Vector
Preset Reference								
d1-01 ◆	Frequency Reference 1 Reference 1	Setting units are affected by o1-03.	0.00 to E1-04 Value	0.00Hz	Q	Q	Q	Q
d1-02 ◆	Frequency Reference 2 Reference 2	Frequency reference when multi-function input "Multi-step speed reference 1" is ON. Setting units are affected by o1-03.		0.00Hz	Q	Q	Q	Q
d1-03 ◆	Frequency Reference 3 Reference 3	Frequency reference when multi-function input "Multi-step speed reference 2" is ON. Setting units are affected by o1-03.		0.00Hz	Q	Q	Q	Q
d1-04 ◆	Frequency Reference 4 Reference 4	Frequency reference when multi-function input "Multi-step speed reference 1,2" is ON. Setting units are affected by o1-03.		0.00Hz	Q	Q	Q	Q
d1-05 ◆	Frequency Reference 5 Reference 5	Frequency reference when multi-function input "Multi-step speed reference 3" is ON. Setting units are affected by o1-03.		0.00Hz	A	A	A	A
d1-06 ◆	Frequency Reference 6 Reference 6	Frequency reference when multi-function input "Multi-step speed reference 1,3" is ON. Setting units are affected by o1-03.		0.00Hz	A	A	A	A
d1-07 ◆	Frequency Reference 7 Reference 7	Frequency reference when multi-function input "Multi-step speed reference 2,3" is ON. Setting units are affected by o1-03.		0.00Hz	A	A	A	A
d1-08 ◆	Frequency Reference 8 Reference 8	Frequency reference when multi-function input "Multi-step speed reference 1,2,3" is ON. Setting units are affected by o1-03.		0.00Hz	A	A	A	A
d1-09 ◆	Frequency Reference 9 Reference 9	Frequency reference when multi-function input "Multi-step speed reference 4" is ON. Setting units are affected by o1-03.		0.00Hz	A	A	A	A
d1-10 ◆	Frequency Reference 10 Reference 10	Frequency reference when multi-function input "Multi-step speed reference 1,4" is ON. Setting units are affected by o1-03.		0.00Hz	A	A	A	A
d1-11 ◆	Frequency Reference 11 Reference 11	Frequency reference when multi-function input "Multi-step speed reference 2,4" is ON. Setting units are affected by o1-03.		0.00Hz	A	A	A	A
d1-12 ◆	Frequency Reference 12 Reference 12	Frequency reference when multi-function input "Multi-step speed reference 1,2,4" is ON. Setting units are affected by o1-03.		0.00Hz	A	A	A	A
d1-13 ◆	Frequency Reference 13 Reference 13	Frequency reference when multi-function input "Multi-step speed reference 3,4" is ON. Setting units are affected by o1-03.		0.00Hz	A	A	A	A
d1-14 ◆	Frequency Reference 14 Reference 14	Frequency reference when multi-function input "Multi-step speed reference 1,3,4" is ON. Setting units are affected by o1-03.		0.00Hz	A	A	A	A
d1-15 ◆	Frequency Reference 15 Reference 15	Frequency reference when multi-function input "Multi-step speed reference 2,3,4" is ON. Setting units are affected by o1-03.		0.00Hz	A	A	A	A
d1-16 ◆	Frequency Reference 16 Reference 16	Frequency reference when multi-function input "Multi-step speed reference 1,2,3,4" is ON. Setting units are affected by o1-03.		0.00Hz	A	A	A	A
d1-17 ◆	Jog Frequency Reference Jog Reference	Frequency reference when: "Jog frequency reference" is selected via multi-function input terminals. "Jog frequency reference" has priority over "multi-step speed reference 1 to 4". d1-17 is also the reference for the JOG key on the Digital Operator, and the multi-function inputs "forward jog" and "reverse jog". Setting units are affected by o1-03.		6.00Hz	Q	Q	Q	Q
Reference Limits								
d2-01	Frequency Reference Upper Limit Ref Upper Limit	Determines maximum frequency reference, set as a percentage of maximum output frequency (E1-04). If the frequency reference is above this value, actual Drive speed will be limited to this value. This parameter applies to all frequency reference sources.	0.0 to 110.0	100.0%	A	A	A	A
d2-02	Frequency Reference Lower Limit Ref Lower Limit	Determines minimum frequency reference, set as a percentage of maximum output frequency (E1-04). If frequency reference is below this value, actual Drive speed will be set to this value. This parameter applies to all frequency reference sources.	0.0 to 110.0	0.0%	A	A	A	A
d2-03	Master Speed Reference Lower Limit Ref1 Lower Limit	Determines minimum frequency reference, set as a percentage of maximum output frequency (E1-04). If frequency reference from analog input (A1, A2, and A3) is below this value, actual Drive speed will be set to this value. This parameter applies only to analog inputs A1, A2, and A3.	0.0 to 110.0	0.0%	A	A	A	A

◆Denotes that parameter can be changed when the Drive is running.

Table A.1 F7 Parameter List (Continued)

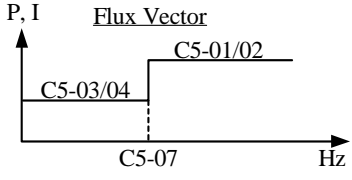
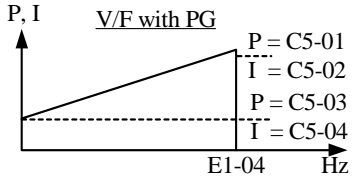
Parameter No.	Parameter Name Digital Operator Display	Description	Setting Range	Factory Setting	Control Method			
					V/F	V/F w/ PG	Open Loop Vector	Flux Vector
Jump Frequencies								
d3-01	Jump Frequency 1 Jump Freq 1	These parameters allow programming of up to three prohibited frequency reference points for eliminating problems with resonant vibration of the motor / machine. This feature does not actually eliminate the selected frequency values, but will accelerate and decelerate the motor through the prohibited bandwidth.	Varies by Duty Rating*	0.0Hz	A	A	A	A
d3-02	Jump Frequency 2 Jump Freq 2			0.0Hz	A	A	A	A
d3-03	Jump Frequency 3 Jump Freq 3			0.0Hz	A	A	A	A
d3-04	Jump Frequency Width Jump Bandwidth	This parameter determines the width of the deadband around each selected prohibited frequency reference point. A setting of "1.0" will result in a deadband of +/- 1.0Hz.	0.0 to 20.0	1.0Hz	A	A	A	A
Sequence (MOP & Trim Control)								
d4-01	Frequency Reference Hold Function Selection MOP Ref Memory	This parameter is used to retain the held frequency reference in U1-01 (d1-01) when power is removed. This function is available when the multi-function inputs "accel/decel ramp hold" or "up/down" commands are selected (H1-XX = A or 10 and 11). 0: Disabled 1: Enabled	0 to 1	0	A	A	A	A
d4-02	Trim Control Level Trim Control Lvl	Sets the amount of frequency reference to be added or subtracted as a percentage of maximum output frequency (E1-04) when multi-function inputs "trim control increase" and "trim control decrease" are selected (H1-XX = 1C and 1D).	0 to 100	10%	A	A	A	A
Torque Control								
d5-01	Torque Control Selection Torq Control Sel	Selects speed or torque control. The torque reference is set via analog input A2 or A3 when it is set for "torque reference" (H3-05 or H3-09 = 13). Torque reference is set as a percentage of motor rated torque. To use this function for switching between speed and torque control, set to 0 and set a multi-function input to "speed/torque control change" (H1-XX = 71). 0: Speed Control (controlled by C5-01 to C5-07) 1: Torque Control	0 to 1	0	-	-	-	A
d5-02	Torque Reference Delay Time Torq Ref Filter	Sets the torque reference delay time in ms units. This function can be used to correct for noise in the torque control signal or the responsiveness with the host controller. When oscillation occurs during torque control, increase the set value.	0 to 1000	0ms	-	-	-	A
d5-03	Speed Limit Selection Speed Limit Sel	Sets the speed limit command method for the torque control method. 1: Analog Input - Limited by the output of the soft starter (b1-01 selection and active acceleration/deceleration and S-curve settings). 2: Program Setting - Limited by d5-04 setting value.	1 to 2	1	-	-	-	A
d5-04	Speed Limit Speed Lmt Value	Sets the speed limit during torque control as a percentage of the maximum output frequency (E1-04). This function is enabled when d5-03 is set to 2. Directions are as follows. +: run command direction -: run command opposite direction	-120 to 120	0%	-	-	-	A
d5-05	Speed Limit Bias Speed Lmt Bias	Sets the speed limit bias as a percentage of the maximum output frequency (E1-04). Bias is given to the specified speed limit. It can be used to adjust the margin for the speed limit.	0 to 120	10%	-	-	-	A
d5-06	Speed/Torque Control Switchover Timer Ref Hold Time	Set the delay time from inputting the multi-function input "speed/torque control change" (from On to OFF or OFF to ON) until the control is actually changed. This function is enabled when the multi-function input "speed/torque control change" (H1-XX = 71) is set. While in the speed/torque control switching timer, the analog inputs hold the value present when the "speed/torque control change" is received.	0 to 1000	0ms	-	-	-	A
<p>◆ Denotes that parameter can be changed when the Drive is running. * For Heavy Duty (HD) Rating: Setting Range=0.0 to 300.0. For Normal Duty (ND) Rating: Setting Range=0.0 to 400.0.</p>								

Table A.1 F7 Parameter List (Continued)

Parameter No.	Parameter Name Digital Operator Display	Description	Setting Range	Factory Setting	Control Method			
					V/F	V/F w/ PG	Open Loop Vector	Flux Vector
Field-Weakening								
d6-01	Magnetic Field Weakening Level Field-Weak Lvl	Sets the Drive output voltage when the multi-function input "field weakening command" is input (H1-XX = 63). Sets as a percentage taking the voltage set in the V/F pattern as 100%.	0 to 100	80%	A	A	-	-
d6-02	Magnetic Field Frequency Field-Weak Freq	Sets the lower limit (in Hz) of the frequency range where field weakening control is valid. The field weakening command is valid only at frequencies above this setting and only when output frequency is in agreement with the current output frequency (speed agree).	Varies by Duty Rating*	0.0Hz	A	A	-	-
d6-03	Magnetic Field Forcing Function Selection Field Force Sel	Sets the magnetic field forcing function. 0: Disabled 1: Enabled	0 to 1	0	-	-	-	A
d6-06	Magnetic Field Forcing Limit Field Force Limit	Sets the upper limit of the excitation current command during magnetic field forcing. A setting of 100% is equal to motor no-load current, E2-03.	100 to 400	400%	-	-	A	A
V/F Pattern								
E1-01	Input Voltage Setting Input Voltage	Set to the nominal voltage of the incoming line. Sets the maximum and base voltage used by preset V/F patterns (E1-03 = 0 to E), adjusts the levels of Drive protective features (e.g. Overvoltage, braking resistor turn-on, stall prevention, etc.). <div style="text-align: center;">  WARNING DRIVE INPUT VOLTAGE (NOT MOTOR VOLTAGE) MUST BE SET IN E1-01 FOR THE PROTECTIVE FEATURES OF THE DRIVE TO FUNCTION PROPERLY. FAILURE TO DO SO MAY RESULT IN EQUIPMENT DAMAGE AND/OR PERSONAL INJURY. </div>	155.0 to 255.0 (240V) 310.0 to 510.0 (480V)	230.0V or 460.0V	Q	Q	Q	Q
E1-03	V/F Pattern Selection V/F Selection	Set to the type of motor being used and the type of application. The Drive operates utilizing a set V/F pattern to determine the appropriate output voltage level for each commanded speed. There are 15 different preset V/F patterns to select from (E1-03 = 0 to E) with varying voltage profiles, base levels (base level = frequency at which maximum voltage is reached), and maximum frequencies. There are also settings for Custom V/F patterns that will use the settings of parameters E1-04 through E1-13. E1-03 = F selects a custom V/F pattern with an upper voltage limit and E1-03 = FF selects a custom V/F pattern without an upper voltage limit. 0: 50Hz 1: 60Hz Saturation 2: 50Hz Saturation 3: 72Hz (60Hz Base) 4: 50Hz VT1 5: 50Hz VT2 6: 60Hz VT1 7: 60Hz VT2 8: 50Hz HST1 9: 50Hz HST2 A: 60Hz HST1 B: 60Hz HST2 C: 90Hz (60Hz Base) D: 120Hz (60Hz Base) E: 180Hz (60Hz Base) F: Custom V/F FF: Custom w/o limit	0 to FF	F	Q	Q	-	-
<p>◆ Denotes that parameter can be changed when the Drive is running. * For Heavy Duty (HD) Rating: Setting Range=0.0 to 300.0. For Normal Duty (ND) Rating: Setting Range=0.0 to 400.0.</p>								

Table A.1 F7 Parameter List (Continued)

Parameter No.	Parameter Name Digital Operator Display	Description	Setting Range	Factory Setting	Control Method				
					V/F	V/F w/ PG	Open Loop Vector	Flux Vector	
E1-04	Maximum Output Frequency Max Frequency	<p>These parameters are only applicable when V/F Pattern Selection is set to Custom (E1-03 = F or FF). To set V/F characteristics in a straight line, set the same values for E1-07 and E1-09. In this case, the setting for E1-08 will be disregarded. Be sure that the four frequencies are set in the following manner or else an OPE10 fault will occur: $E1-04 \geq E1-11 \geq E1-06 > E1-07 \geq E1-09$</p> <p>Note: Setting parameter E1-01=0 is also acceptable</p>	Varies by Duty Rating*	60.0Hz	Q	Q	Q	Q	
E1-05	Maximum Output Voltage Max Voltage		0.0 to 255.0 (240V) 0.0 to 510.0 (480V)	230.0V or 460.0V	Q	Q	Q	Q	
E1-06	Base Frequency Base Frequency		0.0 to 400.0	60.0Hz	Q	Q	Q	Q	
E1-07	Mid Output Frequency A Mid Frequency A		0.0 to 400.0	3.0Hz	A	A	A	-	
E1-08	Mid Output Voltage A Mid Voltage A		0.0 to 255.0 (240V) 0.0 to 510.0 (480V)	12.6 Vac or 25.3 Vac	A	A	A	-	
E1-09	Minimum Output Frequency Min Frequency		0.0 to 400.0	0.5Hz	Q	Q	Q	A	
E1-10	Minimum Output Voltage Min Voltage		0.0 to 255.0 (240V) 0.0 to 510.0 (480V)	2.3 Vac or 4.6 Vac	A	A	A	-	
E1-11	Mid Output Frequency B Mid Frequency B		0.0 to 400.0	0.0Hz	A	A	A	A	
E1-12	Mid Output Voltage B Mid Voltage B		Set only when the V/F pattern is finely adjusted in the constant power (HP) area above base speed. Adjustment is not normally required.	0.0 to 255.0 (240V) 0.0 to 510.0 (480V)	0.0Vac	A	A	A	A
E1-13	Base Voltage Base Voltage		Set only when the V/F pattern is finely adjusted in the constant power (HP) area above base speed. Adjustment is not normally required. If E1-13 = 0.0, then value in E1-05 is used for E1-13. Auto-Tuning sets this value.	0.0 to 255.0 (240V) 0.0 to 510.0 (480V)	0.0Vac	A	A	Q	Q

◆ Denotes that parameter can be changed when the Drive is running.

* For Heavy Duty (HD) Rating: Setting Range=40.0 to 300.0. For Normal Duty (ND) Rating: Setting Range=40.0 to 400.0.

Table A.1 F7 Parameter List (Continued)

Parameter No.	Parameter Name Digital Operator Display	Description	Setting Range	Factory Setting	Control Method			
					V/F	V/F w/ PG	Open Loop Vector	Flux Vector
Motor Setup								
E2-01	Motor Rated Current Motor Rated FLA	Set to the motor nameplate full load current in amperes (A). This value is automatically set during Auto-Tuning.	Varies by kVA	Varies by kVA	Q	Q	Q	Q
E2-02	Motor Rated Slip Motor Rated Slip	Set to the motor rated slip in hertz (Hz). This value is automatically set during rotational Auto-Tuning.	Varies by kVA	Varies by kVA	A	A	A	A
E2-03	Motor No-Load Current No-Load Current	Set to the magnetizing current of the motor as a percentage of full load amps (E2-01). This value is automatically set during rotational Auto-Tuning.	Varies by kVA	Varies by kVA	A	A	A	A
E2-04	Number of Motor Poles Number of Poles	Set to the number of motor poles. This value is automatically set during Auto-Tuning.	2 to 48	4	-	Q	-	Q
E2-05	Motor Line-to-Line Resistance Term Resistance	Set to the phase-to-phase motor resistance in ohms (Ω). This value is automatically set by Auto-Tuning.	0.000 to 65.000	Varies by kVA	A	A	A	A
E2-06	Motor Leakage Inductance Leak Inductance	Set to the voltage drop due to motor leakage inductance as a percentage of motor rated voltage. This value is automatically set during Auto-Tuning.	0.0 to 40.0%	Varies by kVA	-	-	A	A
E2-07	Motor Iron-core Saturation Coefficient 1 Saturation Comp 1	Set to the motor iron saturation coefficient at 50% of magnetic flux. This value is automatically set during rotational Auto-Tuning.	0.00 to 0.50	0.50	-	-	A	A
E2-08	Motor Iron-core Saturation Coefficient 2 Saturation Comp 2	Set to the motor iron saturation coefficient at 75% of magnetic flux. This value is automatically set during rotational Auto-Tuning.	0.50 to 0.75	0.75	-	-	A	A
E2-09	Motor Mechanical Loss Mechanical Loss	Set to the motor mechanical loss as a percentage of motor rated power (kW) capacity. Adjust in the following circumstances: <ul style="list-style-type: none"> • When torque loss is large due to motor bearing friction. • When the torque loss in the load is large. 	0.0 to 10.0	0.0%	-	-	A	A
E2-10	Motor Iron Loss for Torque Compensation Tcomp Iron Loss	Set to the motor iron loss in watts (W).	0 to 65535 W	Varies by kVA	A	A	-	-
E2-11	Motor Rated Output Mtr Rated Power	Set to the motor rated power in kilowatts (kW). This value is automatically set during Auto-Tuning. 1HP = 0.746kW	0.00 to 650.00 kW	Varies by kVA	Q	Q	Q	Q
E2-12	Motor Iron-core Saturation Coefficient 3 Saturation Comp 3	Set to the motor iron saturation coefficient at 130% of magnetic flux. This value is automatically set during rotational Auto-Tuning.	0.0 to 1.60	1.30	-	-	A	A

◆ Denotes that parameter can be changed when the Drive is running.

Table A.1 F7 Parameter List (Continued)

Parameter No.	Parameter Name Digital Operator Display	Description	Setting Range	Factory Setting	Control Method			
					V/F	V/F w/ PG	Open Loop Vector	Flux Vector
V/F Pattern 2								
E3-01	Motor 2 Control Method Selection Control Method	0: V/F control 1: V/F control with PG 2: Open-loop vector control 3: Flux vector control	0 to 3	2	A	A	A	A
E3-02	Motor 2 Maximum Output Frequency Max Frequency	<p>Output voltage (V)</p> <p>Frequency (Hz)</p> <p>To set V/F characteristics in a straight line, set the same values for E3-05 and E3-07. In this case, the setting for E3-06 will be disregarded. Be sure that the four frequencies are set in the following manner or else an OPE10 fault will occur: E3-02 ≥ E3-04 ≥ E3-05 ≥ E3-07</p>	Varies by Duty Rating*	60.0Hz	A	A	A	A
E3-03	Motor 2 Maximum Output Voltage Max Voltage		0.0 to 255.0 (240V) 0.0 to 510.0 (480V)	230.0V or 460.0V	A	A	A	A
E3-04	Motor 2 Base Frequency Base Frequency		0.0 to 400.0	60.0Hz	A	A	A	A
E3-05	Motor 2 Mid Output Frequency Mid Frequency		0.0 to 400.0	3.0Hz	A	A	A	-
E3-06	Motor 2 Mid Output Voltage VA Mid Voltage		0.0 to 255.0 (240V) 0.0 to 510.0 (480V)	12.6 Vac or 25.3 Vac	A	A	A	-
E3-07	Motor 2 Minimum Output Frequency Min Frequency		0.0 to 400.0	0.5Hz	A	A	A	A
E3-08	Motor 2 Minimum Output Voltage Min Voltage		0.0 to 255.0 (240V) 0.0 to 510.0 (480V)	2.3Vac or 4.6Vac	A	A	A	-
Motor Setup 2								
E4-01	Motor 2 Rated Current Motor Rated FLA	Set to the motor 2 nameplate full load current in amperes (A). This value is automatically set during Auto-Tuning.	Varies by kVA	Varies by kVA	A	A	A	A
E4-02	Motor 2 Rated Slip Motor Rated Slip	Set to the rated slip of motor 2 in hertz (Hz). This value is automatically set during rotational Auto-Tuning.	Varies by kVA	Varies by kVA	A	A	A	A
E4-03	Motor 2 No-Load Current No-Load Current	Set to the magnetizing current of motor 2 in percentage of full load current (E4-01). This value is automatically set during rotational Auto-Tuning.	Varies by kVA	Varies by kVA	A	A	A	A
E4-04	Motor 2 Number of Poles Number of Poles	Set to the number of poles of motor 2. This value is automatically set during Auto-Tuning.	2 to 48	4	-	A	-	A
E4-05	Motor 2 Line-to-Line Resistance Term Resistance	Set to the phase-to-phase resistance of motor 2 in ohms (Ω). This value is automatically set by the Auto-Tuning.	0.000 to 65.000	Varies by kVA	A	A	A	A
E4-06	Motor 2 Leakage Inductance Leak Inductance	Set to the voltage drop due to motor leakage inductance as a percentage of rated voltage of motor 2. This value is automatically set during Auto-Tuning.	0.0 to 40.0%	Varies by kVA	-	-	A	A
E4-07	Motor 2 Rated Output Mtr Rated Power	Set to the rated power of motor 2 in kilowatts (kW). This value is automatically set during Auto-Tuning.	0.00 to 650.00 kW	Varies by kVA	A	A	A	A

◆Denotes that parameter can be changed when the Drive is running.

* For Heavy Duty (HD) Rating: Setting Range=40.0 to 300.0. For Normal Duty (ND) Rating: Setting Range=40.0 to 400.0.

Table A.1 F7 Parameter List (Continued)

Parameter No.	Parameter Name Digital Operator Display	Description	Setting Range	Factory Setting	Control Method			
					V/F	V/F w/ PG	Open Loop Vector	Flux Vector
PG Option Setup								
F1-01	PG Parameter PG Pulses/Rev	Sets the number of pulses per revolution (PPM) of the encoder (pulse generator).	0 to 60000	1024	-	Q	-	Q
F1-02	Operation Selection at PG Open Circuit (PGO) PG Fdbk Loss Sel	Sets stopping method when a PG open circuit fault (PGO) occurs. See parameter F1-14. 0: Ramp to stop - Decelerate to stop using the active deceleration time. 1: Coast to stop 2: Fast - Stop - Decelerate to stop using the deceleration time in C1-09. 3: Alarm Only - Drive continues operation.	0 to 3	1	-	A	-	A
F1-03	Operation Selection at Overspeed (OS) PG Oversped Sel	Sets the stopping method when an overspeed (OS) fault occurs. See F1-08 and F1-09. 0: Ramp to stop - Decelerate to stop using the active deceleration time. 1: Coast to stop 2: Fast - Stop - Decelerate to stop using the deceleration time in C1-09. 3: Alarm Only - Drive continues operation.	0 to 3	1	-	A	-	A
F1-04	Operation Selection at Deviation PG Deviation Sel	Sets the stopping method when a speed deviation (DEV) fault occurs. See F1-10 and F1-11. 0: Ramp to stop - Decelerate to stop using the active deceleration time. 1: Coast to stop 2: Fast - Stop - Decelerate to stop using the deceleration time in C1-09. 3: Alarm Only - Drive continues operation.	0 to 3	3	-	A	-	A
F1-05	PG Rotation Selection PG Rotation Sel	0: Fwd=C.C.W. - Phase A leads with forward run command. (Phase B leads with reverse run command.) 1: Fwd=C.W. - Phase B leads with forward run command. (Phase A leads with reverse run command.)	0 to 1	0	-	A	-	A
F1-06	PG Division Rate (PG Pulse Monitor) PG Output Ratio	Sets the division ratio for the pulse monitor of the PG-B2 encoder feedback option board. This function is not available with the PG-X2 option board. Division ratio = $(1 + n) / m$ ($n=0$ to 1, $m=1$ to 32) The first digit of the value of F1-06 stands for n, the second and the third stand for m. (from left to right). The possible division ratio settings are: $1/32 \leq F1-06 \leq 1$	1 to 132	1	-	A	-	A
F1-07	Integral function during accel/decel selection PG Ramp PI/I Sel	Sets integral control during acceleration/deceleration to either enabled or disabled. 0: Disabled - The integral function is not used while accelerating or decelerating. 1: Enabled - The integral function is used at all times.	0 to 1	0	-	A	-	-
F1-08	Overspeed detection level PG Overspd Level	Configures the overspeed fault (OS) detection. OS fault will occur, if the motor speed feedback is greater than the F1-08 setting for a time longer than F1-09. F1-08 is set as a percentage of the maximum output frequency (E1-04). See F1-03.	0 to 120	115%	-	A	-	A
F1-09	Overspeed detection delay time PG Overspd Time		0.0 to 2.0	0.0 sec	-	A	-	A
F1-10	Excessive speed deviation detection level PG Deviate Level	Configures the speed deviation fault (DEV) detection. DEV fault will occur if the speed deviation is greater than the F1-10 setting for a time longer than F1-11. F1-10 is set as a percentage of the maximum output frequency (E1-04). Speed deviation is the difference between actual motor speed and the frequency reference command. See F1-04.	0 to 50	10%	-	A	-	A
F1-11	Excessive speed deviation detection delay time PG Deviate Time		0.0 to 10.0	0.5 sec	-	A	-	A

◆Denotes that parameter can be changed when the Drive is running.

Table A.1 F7 Parameter List (Continued)

Parameter No.	Parameter Name Digital Operator Display	Description	Setting Range	Factory Setting	Control Method			
					V/F	V/F w/ PG	Open Loop Vector	Flux Vector
F1-12	Number of PG gear teeth 1 PG # Gear Teeth1	Sets the gear ratio between the motor shaft and the encoder (PG). $\frac{\text{Input pulses from PG (PPR)} \times 60}{F1-01} \times \frac{F1-13}{F1-12}$ A gear ratio of 1 will be used if either of these parameters is set to 0. This function is not available in flux vector control.	0 to 1000	0	-	A	-	-
F1-13	Number of PG gear teeth 2 PG # Gear Teeth2			0	-	A	-	-
F1-14	PG open-circuit detection time PGO Detect Time	Configures the PG open (PGO) function. PGO will be detected if no PG pulses are detected for a time longer than F1-14. See F1-02.	0.0 to 10.0	2.0 sec	-	A	-	A
AI-14 Setup								
F2-01	AI-14 Input Selection AI-14 Input Sel	Sets the function for channel 1 to 3 of the AI-14B analog input reference option board. 0: 3-channel individual (Channel 1: terminal A1, Channel 2: terminal A2, Channel 3: terminal A3) 1: 3-channel addition (Summed values of channels 1 to 3 is the frequency reference) When set to 0, select 1 for b1-01. In this case, the multi-function input "Option/Inverter selection" cannot be used.	0 to 1	0	A	A	A	A
DI-08, 16 Setup								
F3-01	DI-08 / DI-16H2 Input Selection DI Input	Sets the function of the DI-08 or the DI-16H2 digital input option board. 0: BCD 1% unit 1: BCD 0.1% unit 2: BCD 0.01% unit 3: BCD 1Hz unit 4: BCD 0.1Hz unit 5: BCD 0.01Hz unit 6: BCD (5-digit) 0.01Hz unit (only effective when DI-16H2 is used.) 7: Binary input When o1-03 is set to 2 or higher, the input will be BCD, and the units will change to the o1-03 setting.	0 to 7	0	A	A	A	A
AO-08, 12 Setup								
F4-01	AO-08/AO-12 Channel 1 Monitor Selection AO Ch1 Sel	Sets the number of the monitor item to be output. (U1-□□) The following settings cannot be set: 4, 10 to 14, 25, 28, 29, 30, 34, 35, 39, 40, 41.	1 to 45	2	A	A	A	A
F4-02	AO-08/AO-12 Channel 1 Gain AO Ch1 Gain	Sets the channel 1 gain. Ex: Set F4-02 = 50% to output 100% at 5.0V output.	0.0 to 1000.0	100.0%	A	A	A	A
F4-03	AO-08/AO-12 Channel 2 Monitor Selection AO Ch2 Sel	Sets the number of the monitor item to be output. (U1-□□) The following settings cannot be set: 4, 10 to 14, 25, 28, 29, 30, 34, 39, 40, 41.	1 to 45	3	A	A	A	A
F4-04	AO-08/AO-12 Channel 2 Gain AO Ch2 Gain	Sets the channel 2 gain. Ex: Set F4-04 = 50% to output 100% at 5.0V output.	0.0 to 1000.0	50.0%	A	A	A	A
F4-05	AO-08/AO-12 Channel 1 Output Bias AO Ch1 Bias	Sets the channel 1 bias (100%/10V). Ex: Set F4-05 = 50% to output 0% at 5.0V output.	-110.0 to 110.0	0.0%	A	A	A	A
F4-06	AO-08/AO-12 Channel 2 Output Bias AO Ch2 Bias	Sets the channel 2 bias (100%/10V). Ex: Set F4-06 = 50% to output 0% at 5.0V output.	-110.0 to 110.0	0.0%	A	A	A	A
F4-07	AO-12 Channel 1 Signal Level AO Opt Level Ch1	Sets the range of the voltage output. 0: 0 to 10Vdc 1: -10 to +10Vdc	0 to 1	0	A	A	A	A
F4-08	AO-12 Channel 2 Signal Level AO Opt Level Ch2	Sets the range of the voltage output. 0: 0 to 10Vdc 1: -10 to +10Vdc	0 to 1	0	A	A	A	A

◆Denotes that parameter can be changed when the Drive is running.

Table A.1 F7 Parameter List (Continued)

Parameter No.	Parameter Name Digital Operator Display	Description	Setting Range	Factory Setting	Control Method			
					V/F	V/F w/ PG	Open Loop Vector	Flux Vector
DO-02, 08 Setup								
F5-01	DO-02/DO-08 Channel 1 Output Selection DO Ch1 Select	Sets the digital output function number for channel 1. See the H2 parameter group for possible selections. Effective when digital output card DO-02 or DO-08 is used.	0 to 38	0	A	A	A	A
F5-02	DO-02/DO-08 Channel 2 Output Selection DO Ch2 Select	Sets the digital output function number for channel 2. See the H2 parameter group for possible selections. Effective when digital output card DO-02 or DO-08 is used.	0 to 38	1	A	A	A	A
F5-03	DO-08 Channel 3 Output Selection DO Ch3 Select	Sets the digital output function number for channel 3. See the H2 parameter group for possible selections. Effective when digital output card DO-02 or DO-08 is used.	0 to 38	2	A	A	A	A
F5-04	DO-08 Channel 4 Output Selection DO Ch4 Select	Sets the digital output function number for channel 4. See the H2 parameter group for possible selections. Effective when digital output card DO-02 or DO-08 is used.	0 to 38	4	A	A	A	A
F5-05	DO-08 Channel 5 Output Selection DO Ch5 Select	Sets the digital output function number for channel 5. See the H2 parameter group for possible selections. Effective when digital output card DO-02 or DO-08 is used.	0 to 38	6	A	A	A	A
F5-06	DO-08 Channel 6 Output Selection DO Ch6 Select	Sets the digital output function number for channel 6. See the H2 parameter group for possible selections. Effective when digital output card DO-02 or DO-08 is used.	0 to 38	37	A	A	A	A
F5-07	DO-08 Channel 7 Output Selection DO Ch7 Select	Sets the digital output function number for channel 7. See the H2 parameter group for possible selections. Effective when digital output card DO-02 or DO-08 is used.	0 to 38	F	A	A	A	A
F5-08	DO-08 Channel 8 Output Selection DO Ch8 Select	Sets the digital output function number for channel 8. See the H2 parameter group for possible selections. Effective when digital output card DO-02 or DO-08 is used.	0 to 38	F	A	A	A	A
F5-09	DO-08 Output Mode Selection DO-08 Selection	Sets the function of the DO-08 digital output option board. 0: 8-channel individual outputs. 1: Binary code output. 2: 8-channel Selected - Output according to F5-01 to F5-08 settings.	0 to 2	0	A	A	A	A
Communications Option Setup								
F6-01	Operation Selection after Communication Error Comm Bus Flt Sel	Selects the stopping method for a communication option board fault (BUS). Active only when a communication option board is installed and b1-01 or b1-02 = 3. 0: Ramp to Stop 1: Coast to Stop 2: Fast-Stop 3: Alarm Only	0 to 3	1	A	A	A	A
F6-02	Selection of External Fault from Communication Option Board EF0 Detection	Selects the condition in which an EF0 fault is detected from a communication option board. Active only when a communication option board is installed and b1-01 or b1-02 = 3. 0: Always detected 1: Detected only during operation	0 to 1	0	A	A	A	A
F6-03	Stopping Method for External Fault from Communication Option Board EF0 Fault Action	Selects the stopping method for an external fault from a communication option board (EF0). Active only when a communication option board is installed and b1-01 or b1-02 = 3. 0: Ramp to Stop 1: Coast to Stop 2: Fast-Stop 3: Alarm Only	0 to 3	1	A	A	A	A
F6-04	Trace Sampling from Communications Option Board Trace Sample Tim	Sets the sample trace for the CP-916 option board.	0 to 60000	0	A	A	A	A
F6-05	Current Monitor Display Unit Selection Current Unit Sel	Selects the current monitor scaling when using a communication option board. 0: Displayed in Amps 1: 100%/8192 (12 bit binary number with 8192=100% Drive's rated current)	0 to 1	0	A	A	A	A
F6-06	Torque reference/torque limit selection from communications option Torq Ref/Lmt Sel	Selects torque reference/limit when using communications option board. 0: Disabled -Torque reference/limit from option board disabled 1: Enabled - Torque reference/limit from option board enabled.	0 to 1	0	-	-	-	A
◆Denotes that parameter can be changed when the Drive is running.								

Table A.1 F7 Parameter List (Continued)

Parameter No.	Parameter Name Digital Operator Display	Description	Setting Range	Factory Setting	Control Method			
					V/F	V/F w/ PG	Open Loop Vector	Flux Vector
Digital Inputs								
H1-01	Multi-Function Digital Input Terminal S3 Function Selection Terminal S3 Sel	<p>Selects the function of terminals S3 to S8.</p> <p>0: 3-wire control FWD/REV selection for 3-wire sequence.</p> <p>1: Local/Remote Selection Closed = Local, Open = Remote.</p> <p>2: Option/Inv Selection Selects source of frequency reference and sequence. Closed = Option Card, Open = b1-01 & b1-02.</p> <p>3: Multi-Step Frequency Reference 1 Based on status of Multi-Step Reference 1 to 4 (d1-16).</p> <p>4: Multi-Step Frequency Reference 2 Based on status of Multi-Step Reference 1 to 4 (d1-16).</p> <p>5: Multi-Step Frequency Reference 3 Based on status of Multi-Step Reference 1 to 4 (d1-16).</p> <p>6: Jog Frequency Reference Closed = frequency reference from d1-17</p> <p>7: Accel/Decel Time Selection 1 Based on status of Accel/Decel Time Selection 1 and 2.</p> <p>8: External BaseBlock N.O. Closed = Output transistors forced off. Open = Normal operation.</p> <p>9: External BaseBlock N.C. Closed = Normal operation. Open = Output transistors forced off.</p> <p>A: Acc/Dec Ramp Hold Closed = Acceleration suspended and speed held.</p> <p>B: External Overheat Alarm (OH2) Closed = OH2 alarm.</p> <p>C: Terminal A2 Enable Closed = Terminal A2 is active. Open = Terminal A2 is disabled.</p> <p>D: V/F Control with PG Disabled Closed = Speed feedback control disabled.</p> <p>E: ASR Integral Reset Closed = Integral reset.</p> <p>F: Terminal Not Used Terminal closure has no effect.</p> <p>10: MOP Increase Closed = frequency reference increases. Open = frequency reference held. Must be set in conjunction with MOP Decrease and b1-01 must be set to 1.</p> <p>11: MOP Decrease Closed = frequency reference decreases. Open = frequency reference held. Must be set in conjunction with MOP Increase and b1-01 must be set to 1.</p> <p>12: Forward Jog Closed = Drive runs forward at frequency reference entered into parameter d1-17.</p> <p>13: Reverse Jog Closed = Drive runs in reverse at frequency reference entered into parameter d1-17.</p> <p>14: Fault Reset Closed = Resets the Drive after the fault and the run command have been removed.</p>	0 to 78	24	A	A	A	A
H1-02	Multi-Function Digital Input Terminal S4 Function Selection Terminal S4 Sel	<p>(Continued on following page).</p>	0 to 78	14	A	A	A	A

◆Denotes that parameter can be changed when the Drive is running.

Table A.1 F7 Parameter List (Continued)

Parameter No.	Parameter Name Digital Operator Display	Description	Setting Range	Factory Setting	Control Method			
					V/F	V/F w/ PG	Open Loop Vector	Flux Vector
H1-03	Multi-Function Digital Input Terminal S5 Function Selection Terminal S5 Sel	15: Fast-Stop N.O. Closed = Drive decelerates using C1-09, regardless of run command status. 16: Motor 2 Selection Closed = Motor 2 (E3-□□, E4-□□) Open = Motor 1 (A1-02, E1-□□, E2-□□) 17: Fast-Stop N.C. Closed = Normal operation Open = Drive decelerates using C1-09, regardless of run command status. 18: Timer Function Input for independent timer, controlled by b4-01 and b4-02. Used in conjunction with the multi-function digital output function H2-□□ = 12 "timer output". 19: PID Disable Closed = Turns off the PID controller. 1A: Accel / Decel Time Selection 2 Based on status of Accel/Decel Time Selection 1 and 2. 1B: Program Lockout Closed = All parameter settings can be changed. Open = Only U1-01 can be changed. 1C: Trim Control Increase Closed = Increase frequency reference by value in d4-02. Open = Return to normal frequency reference. Not effective when Preset References are selected (Multi-step speed digital inputs are closed). Must be used in conjunction with Trim Ctrl Decrease. 1D: Trim Control Decrease Closed = Decrease frequency reference by value in d4-02 Open = Return to normal frequency reference. Not effective when Preset References are selected (Multi-step speed digital inputs are closed). Must be used in conjunction with Trim Ctrl Increase. 1E: Reference Sample Hold Analog frequency reference is sampled then held at time of input closure.	0 to 78	3: 2-wire 0: 3-wire	A	A	A	A
H1-04	Multi-Function Digital Input Terminal S6 Function Selection Terminal S6 Sel	20: External Fault, Normally Open, Always Detected, Ramp To Stop 21: External Fault, Normally Closed, Always Detected, Ramp To Stop 22: External Fault, Normally Open, During Run, Ramp To Stop 23: External Fault, Normally Closed, During Run, Ramp To Stop 24: External Fault, Normally Open, Always Detected, Coast To Stop 25: External Fault, Normally Closed, Always Detected, Coast To Stop 26: External Fault, Normally Open, During Run, Coast To Stop 27: External Fault, Normally Closed, During Run, Coast To Stop 28: External Fault, Normally Open, Always Detected, Fast-Stop 29: External Fault, Normally Closed, Always Detected, Fast-Stop 2A: External Fault, Normally Open, During Run, Fast-Stop 2B: External Fault, Normally Closed, During Run, Fast-Stop 2C: External Fault, Normally Open, Always Detected, Alarm Only 2D: External Fault, Normally Closed, Always Detected, Alarm Only 2E: External Fault, Normally Open, During Run, Alarm Only 2F: External Fault, Normally Closed, During Run, Alarm Only (Continued on following page).	0 to 78	4: 2-wire 3: 3-wire	A	A	A	A

◆Denotes that parameter can be changed when the Drive is running.

Table A.1 F7 Parameter List (Continued)

Parameter No.	Parameter Name Digital Operator Display	Description	Setting Range	Factory Setting	Control Method			
					V/F	V/F w/ PG	Open Loop Vector	Flux Vector
Digital Inputs								
H1-05	Multi-Function Digital Input Terminal S7 Function Selection Terminal S7 Sel	30:PID integral reset Closed = Set integrator value to 0. 31: PID integral hold Closed = Hold integrator at its present level. 32: Multi-Step Reference 4 Based on the status of Multi-Step Reference 1 to 4 (d1-16). 34: PID Soft Starter Cancel Closed = b5-17 is ignored. 35: PID Input (Error) Polarity Change Closed = PID error signal polarity is reversed (1 to -1 or -1 to 1). 60: DC Injection Braking Closed = Apply DC injection current as set in parameter b2-02. 61: Speed Search 1 Closed = While a run command is given, Drive does a speed search starting at maximum frequency (E1-04). Speed search based on b3-01. 62: Speed Search 2 Closed = While a run command is given, Drive does a speed search starting at frequency reference. Speed search based on b3-01. 63: Field Weakening Command (Energy Savings) Closed = Field weakening control set for d6-01 and d6-02. 64: Speed Search 3 Closed = And a run command is given, Drive does a speed search starting at output frequency. Speed search based on b3-01. 65: Kinetic Energy Braking Ride-thru N.C. Closed = Normal operation Open = KEB ride-thru is enabled. 66: Kinetic Energy Braking Ride-thru N.O. Closed = KEB ride-thru is enabled. 67: Communications Test Mode Used to test Modbus RS-485/422 interface. 68: High Slip Braking Closed = Drive stops using High Slip Braking regardless of run command status. 69: Jog 2 Closed = Drive runs at frequency reference entered into parameter d1-17. Direction determined by fwd/rev input. 3-wire control Only. 6A: Drive Enable - Closed = Drive will accept run command. Open = Drive will not run. If running, Drive will stop per b1-03. 71: Speed / Torque Control Selection Closed = Torque control operation. Open = Speed control operation. 72: Zero-Servo Command Closed = Zero-Servo ON 77: ASR Gain Switch Open = ASR proportional gain is set according to C5-01. Closed = ASR proportional gain is set according to C5-03. 78: Polarity Reversing Command for External Torque Control Closed = Reverse polarity.	0 to 78	6: 2-wire 4: 3-wire	A	A	A	A
H1-06	Multi-Function Digital Input Terminal S8 Function Selection Terminal S8 Sel	62: Speed Search 2 Closed = While a run command is given, Drive does a speed search starting at frequency reference. Speed search based on b3-01. 63: Field Weakening Command (Energy Savings) Closed = Field weakening control set for d6-01 and d6-02. 64: Speed Search 3 Closed = And a run command is given, Drive does a speed search starting at output frequency. Speed search based on b3-01. 65: Kinetic Energy Braking Ride-thru N.C. Closed = Normal operation Open = KEB ride-thru is enabled. 66: Kinetic Energy Braking Ride-thru N.O. Closed = KEB ride-thru is enabled. 67: Communications Test Mode Used to test Modbus RS-485/422 interface. 68: High Slip Braking Closed = Drive stops using High Slip Braking regardless of run command status. 69: Jog 2 Closed = Drive runs at frequency reference entered into parameter d1-17. Direction determined by fwd/rev input. 3-wire control Only. 6A: Drive Enable - Closed = Drive will accept run command. Open = Drive will not run. If running, Drive will stop per b1-03. 71: Speed / Torque Control Selection Closed = Torque control operation. Open = Speed control operation. 72: Zero-Servo Command Closed = Zero-Servo ON 77: ASR Gain Switch Open = ASR proportional gain is set according to C5-01. Closed = ASR proportional gain is set according to C5-03. 78: Polarity Reversing Command for External Torque Control Closed = Reverse polarity.	0 to 78	8	A	A	A	A

◆Denotes that parameter can be changed when the Drive is running.
 Note: Some digital inputs are control method dependent.

Table A.1 F7 Parameter List (Continued)

Parameter No.	Parameter Name Digital Operator Display	Description	Setting Range	Factory Setting	Control Method			
					V/F	V/F w/ PG	Open Loop Vector	Flux Vector
Digital Outputs								
H2-01	Terminal M1-M2 Function Selection Term M1-M2 Sel	<p>Selects the function of terminals M1 to M6.</p> <p>0: During RUN 1 Closed = When a run command is input or the Drive is outputting voltage.</p> <p>1: Zero Speed Closed = When Drive output frequency is less than minimum output frequency (E1-09) or less than DC Injection Braking Start Frequency (b2-01) when in Flux Vector Control Method.</p> <p>2: Fref/Fout Agree 1 Closed = When Drive output frequency equals the frequency reference +/- the hysteresis of L4-02.</p> <p>3: Fref/Set Agree 1 Closed = When the Drive output frequency and the frequency reference are equal to the value in L4-01 +/- the hysteresis of L4-02.</p> <p>4: Frequency Detection 1 Closed = When the Drive output frequency is less than or equal to the value in L4-01 with hysteresis determined by L4-02.</p> <p>5: Frequency Detection 2 Closed = When the Drive output frequency is greater than or equal to the value in L4-01, with hysteresis determined by L4-02.</p> <p>6: Inverter Ready Closed = When the Drive is powered up, not in a fault state, and in the DRIVE mode.</p> <p>7: DC Bus Undervoltage Closed = When the DC bus voltage falls below the UV trip level set in L2-05.</p> <p>8: Base Block 1 N.O. Closed = When the Drive is not outputting voltage.</p> <p>9: Option Reference Closed = When the frequency reference is coming from the Digital Operator.</p> <p>A: LOCAL/REMOTE Operation Closed = When the run command is coming from the Digital Operator.</p> <p>B: Torque Detection 1 N.O. Closed = When the output current/torque exceeds the torque value set in parameter L6-02 for more time than is set in parameter L6-03.</p> <p>C: Loss of Reference Closed = When the Drive has detected a loss of the analog frequency reference. Frequency reference is considered lost when it drops 90% in 0.4 seconds. Parameter L4-05 determines Drive reaction to a loss of frequency reference.</p> <p>D: Braking Resistor Fault Closed = When braking resistor or transistor is overheating or has faulted. Only active when L8-01 = 1.</p> <p>E: Fault Closed = When the Drive experiences a major fault.</p> <p>F: Not Used</p> <p>10: Minor Fault - Alarm Closed = When Drive experiences an alarm.</p> <p style="text-align: center;">(Continued on following page)</p>	0 to 38	0	A	A	A	A
<p>◆ Denotes that parameter can be changed when the Drive is running.</p>								

Table A.1 F7 Parameter List (Continued)

Parameter No.	Parameter Name Digital Operator Display	Description	Setting Range	Factory Setting	Control Method			
					V/F	V/F w/ PG	Open Loop Vector	Flux Vector
H2-02	Terminal M3-M4 Function Selection Term M3-M4 Sel	11: Reset Command Active Closed = When the Drive receives a reset command from a digital input terminal or serial communication. 12: Timer Output Output for independent timer, controlled by b4-01 and b4-02. Used in conjunction with the digital input H1-□□ = 18 "timer function". 13: Fref/Fout Agree 2 Closed = When Drive output frequency equals the frequency reference +/- the hysteresis of L4-04. 14: Fref/Set Agree 2 Closed = When the Drive output frequency and the frequency reference are equal to the value in L4-03 +/- the hysteresis of L4-04. 15: Frequency Detection 3 Closed = When the Drive output frequency is less than or equal to the value in L4-03 with the hysteresis determined by L4-04. 16: Frequency Detection 4 Closed = When the Drive output speed is greater than or equal to the value in L4-03, with the hysteresis determined by L4-04. 17: Torque Detection 1 N.C. Open = When the output current/torque exceeds the value set in parameter L6-02 for more time than is set in parameter L6-03. 18: Torque Detection 2 N.O. Closed = When the output current/torque exceeds the value set in parameter L6-05 for more time than is set in parameter L6-06. 19: Torque Detection 2 N.C. Open = when the output current/torque exceeds the value set in parameter L6-05 for more time than is set in parameter L6-06.	0 to 38	1	A	A	A	A
H2-03	Terminal M5-M6 Function Selection Term M5-M6 Sel	1A: Reverse Direction Closed = When the Drive is running in the reverse direction. 1B: Baseblock 2 N.C. Open = When Drive is not outputting voltage. 1C: Motor 2 Selection Closed = When motor 2 is selected by multi-function input "motor 2 selection". 1D: Regenerating Closed = When in regenerating mode. 1E: Restart Enabled Closed = When the Drive is performing an automatic restart attempt. Automatic restart is configured by parameter L5-01. 1F: Overload (OL1) Closed = When OL1 function is at 90% of its trip point or greater. 20: OH Prealarm Closed = When the Drive's heatsink temperature exceeds the setting of parameter L8-02. 30: During Torque Limit (when in speed control) Closed = When in torque limit. 31: During Speed Limit Closed = When in speed limit. 32: During Speed Limit (when in torque control) Closed = When motor frequency is at the speed limit value when running in torque control. 33: Zero-Servo Complete Closed = When Zero Servo is complete within the b9-02 zero servo completion width. 37: During Run 2 Closed = When Drive is operating (except during baseblock or DC braking). 38: Drive Enable Closed = When the Drive enable input is active.	0 to 38	2	A	A	A	A

◆ Denotes that parameter can be changed when the Drive is running.
 Note: Some digital outputs are control method dependent.

Table A.1 F7 Parameter List (Continued)

Parameter No.	Parameter Name Digital Operator Display	Description	Setting Range	Factory Setting	Control Method			
					V/F	V/F w/ PG	Open Loop Vector	Flux Vector
Analog Inputs								
H3-01	Terminal A1 Signal Level Selection Term A1 Lvl Sel	Sets the signal level of terminal A1. 0: 0 to 10Vdc 1: -10 to +10Vdc	0 to 1	0	A	A	A	A
H3-02 ◆	Terminal A1 Gain Setting Terminal A1 Gain	Sets the output level when 10V is input, as a percentage of the maximum output frequency (E1-04).	0.0 to 1000.0	100.0%	A	A	A	A
H3-03 ◆	Terminal A1 Bias Setting Terminal A1 Bias	Sets the output level when 0V is input, as a percentage of the maximum output frequency (E1-04).	-100.0 to +100.0	0.0%	A	A	A	A
H3-04	Terminal A3 Signal Level Selection Term A3 Signal	Sets the signal level of terminal A3. 0: 0 to 10Vdc 1: -10 to +10Vdc	0 to 1	0	A	A	A	A

Table A.1 F7 Parameter List (Continued)

Parameter No.	Parameter Name Digital Operator Display	Description	Setting Range	Factory Setting	Control Method			
					V/F	V/F w/ PG	Open Loop Vector	Flux Vector
H3-05	Terminal A3 Function Selection Terminal A3 Sel	<p>Selects the function of terminal A3.</p> <p>0: Frequency Bias (Adds with terminal A1) 100% = Maximum output frequency (E1-04)</p> <p>1: Frequency Reference Gain (FGAIN) 100% = Frequency reference command value A1 Total gain = Internal gain (H3-02) x FGAIN</p> <p>2: Aux Frequency Reference 1 Used in conjunction with multi-function inputs "multi-step frequency reference 1-4" (d1-16). 100% = Maximum output frequency (E1-04)</p> <p>3: Aux Frequency Reference 2 Used in conjunction with multi-function inputs "multi-step frequency reference 1-4" (H1-xx=3,4,5). 100% = Maximum output frequency (E1-04)</p> <p>4: Output Voltage Bias 100% = Motor rated voltage (E1-05). Voltage boost after V/F pattern.</p> <p>5: Accel / Decel Time Coefficient 100% = Active accel / decel time (C1-01 thru C1-08)</p> <p>6: DC Injection Braking Current 100% = Drive rated current. Parameter b2-02 is disabled.</p> <p>7: Overtorque / Undertorque Detection Level Used for multi-function digital output for "overtorque/undertorque". 100% = motor rated torque (OLV, FV) or Drive rated current (V/F, V/F w/PG). Internal overtorque detection level (L6-02) disabled.</p> <p>8: Stall Prevention Level During Run 100% = L3-06.</p> <p>9: Frequency Reference Lower Limit 100% = Maximum output frequency (E1-04). Either d2-02 setting or A3 input level, whichever is greater, becomes effective.</p> <p>A: Jump Frequency 4 100% = Maximum output frequency (E1-04).</p> <p>B: PID Feedback 100% = Maximum output frequency (E1-04).</p> <p>C: PID Set Point 100% = Maximum output frequency (E1-04). Frequency reference no longer acts as a PID setpoint.</p> <p>D: Frequency Reference Bias 2 (FBIAS2) 100% = Maximum output frequency (E1-04). Total bias = Internal bias (H3-03) + FBIAS (H3-07) + A3 input level</p> <p>E: Motor Temperature See parameters L1-03 & L1-04.</p> <p>10: FWD Torque Limit (Quadrant 1) 100% = Motor rated torque.</p> <p>11: REV Torque Limit (Quadrant 3) 100% = Motor rated torque.</p> <p>12: Regenerative Torque Limit (Quadrants 2 and 4) 100% = Motor rated torque.</p> <p>13: Torque Reference (in Torque Control); Torque Limit (in Speed Control) (Quadrants 1, 2, 3, 4) 100% = Motor rated torque.</p> <p>14: Torque Compensation 100% = Motor rated torque.</p> <p>15: FWD / REV Torque Limit (Quadrants 1 and 3) 100% = Motor rated torque.</p> <p>1F: Not Used</p>	0 to 1F	2	A	A	A	A
<p>◆ Denotes that parameter can be changed when the Drive is running. Note: Some analog inputs are control method dependent.</p>								

Table A.1 F7 Parameter List (Continued)

Parameter No.	Parameter Name Digital Operator Display	Description	Setting Range	Factory Setting	Control Method			
					V/F	V/F w/ PG	Open Loop Vector	Flux Vector
H3-06 ◆	Terminal A3 Gain Setting Terminal A3 Gain	Sets the output level when 10V is input.	0.0 to 1000.0	100.0%	A	A	A	A
H3-07 ◆	Terminal A3 Bias Setting Terminal A3 Bias	Sets the frequency reference when 0V is input.	-100.0 to +100.0	0.0%	A	A	A	A
H3-08	Terminal A2 Signal Level Selection Term A2 Signal	Selects the signal level of terminal A2. 0: 0 to 10Vdc (switch S1-2 must be in the OFF position). 1: -10 to +10Vdc (switch S1-2 must be in the OFF position). 2: 4 to 20mA (switch S1-2 must be in the ON position)	0 to 2	2	A	A	A	A
H3-09	Terminal A2 Function Selection Terminal A2 Sel	Selects the function of terminal A2. Same choices as Terminal A3 Function Selection (H3-05).	0 to 1F	0	A	A	A	A
H3-10 ◆	Terminal A2 Gain Setting Terminal A2 Gain	Sets the output level when 10V is input.	0.0 to 1000.0	100.0%	A	A	A	A
H3-11 ◆	Terminal A2 Bias Setting Terminal A2 Bias	Sets the output level when 0V is input.	-100.0 to +100.0	0.0%	A	A	A	A
H3-12	Analog Input Filter Time Constant Filter Avg Time	This parameter adjusts the filter on all 3 analog inputs. Increase to add stability, decrease to improve response.	0.00 to 2.00	0.03sec	A	A	A	A

◆Denotes that parameter can be changed when the Drive is running.

Table A.1 F7 Parameter List (Continued)

Parameter No.	Parameter Name Digital Operator Display	Description	Setting Range	Factory Setting	Control Method			
					V/F	V/F w/ PG	Open Loop Vector	Flux Vector
Analog Outputs								
H4-01	Terminal FM Monitor Selection Terminal FM Sel	Selects which monitor will be output on terminals FM and FC. 1: Frequency Reference 100% = Maximum output frequency E1-04. 2: Output Frequency 100% = Maximum output frequency E1-04. 3: Output Current 100% = Drive rated current. 5: Motor Speed 100% = Maximum output frequency E1-04. 6: Output Voltage 100% = 200/400Vac depending on Drive voltage rating. 7: DC Bus Voltage 100% = 400/800Vdc depending on Drive voltage rating. 8: Output kWatts 100% = Drive rated power. 9: Torque Reference 100% = Motor rated torque. 15: Terminal A1 Input Level 100% = 10Vdc 16: Terminal A2 Input Level 100% = 10Vdc or 20mA 17: Terminal A3 Input Level 100% = 10Vdc 18: Motor Secondary Current 100% = Motor rated secondary current. 19: Motor Excitation Current 100% = Motor rated magnetizing current. 20: SFS Output 100% = Maximum output frequency E1-04. 21: ASR Input 100% = Maximum output frequency E1-04. 22: ASR Output 100% = Maximum output frequency E1-04. 24: PID Feedback 100% = Maximum output frequency E1-04. 26: Output Voltage Reference Vq 100% = E1-05, default 240V or 480V. 27: Output Voltage Reference Vd 100% = E1-05, default 240V or 480V. 31: Not Used 32: ACR q Output (100% = Motor rated secondary current) 33: ACR d Output (100% = Motor rated magnetizing current) 36: PID Input 100% = Maximum output frequency E1-04. 37: PID Output 100% = Maximum output frequency E1-04. 38: PID Setpoint 100% = Maximum output frequency E1-04. 44: ASR Output Without Filter 45: Feedforward Control Output 100% = Motor rated secondary current.	1 to 45	2	A	A	A	A
H4-02 ◆	Terminal FM Gain Setting Terminal FM Gain	Sets terminal FM output level when selected monitor is at 100%.	0.0 to 1000.0	100.0%	Q	Q	Q	Q
H4-03 ◆	Terminal FM Bias Setting Terminal FM Bias	Sets terminal FM output level when selected monitor is at 0%.	-110.0 to 110.0	0.0%	A	A	A	A
H4-04	Terminal AM Monitor Selection Terminal AM Sel	Selects which monitor will be the output on terminals AM and FC. Same function choices as H4-01.	1 to 45	3	A	A	A	A
H4-05 ◆	Terminal AM Gain Setting Terminal AM Gain	Sets terminal AM output voltage (in percent of 10Vdc) when selected monitor is at 100% output.	0.0 to 1000.0	50.0%	Q	Q	Q	Q
H4-06 ◆	Terminal AM Bias Setting Terminal AM Bias	Sets terminal AM output voltage (in percent of 10Vdc) when selected monitor is at 0% output.	-110.0 to 110.0	0.0%	A	A	A	A
H4-07	Terminal FM Signal Level Selection FM Level Select 1	Selects the signal level of terminal FM. 0: 0 to 10Vdc 1: -10 to +10Vdc 2: 4 to 20mA* *Set the analog output jumper CN15 in the proper position.	0 or 2	0	A	A	A	A
H4-08	Terminal AM Signal Level Selection AM Level Select 2	Selects the signal level of terminal AM. 0: 0 to 10Vdc 1: -10 to +10Vdc 2: 4 to 20mA* *Set the analog output jumper CN15 in the proper position.	0 or 2	0	A	A	A	A

◆ Denotes that parameter can be changed when the Drive is running.

Note: Some analog outputs are control method dependent.

Table A.1 F7 Parameter List (Continued)

Parameter No.	Parameter Name Digital Operator Display	Description	Setting Range	Factory Setting	Control Method			
					V/F	V/F w/ PG	Open Loop Vector	Flux Vector
Serial Communications Setup								
H5-01	Drive Node Address Serial Comm Adr	Selects Drive station node number (address) for Modbus terminals R+, R-, S+, S-. The Drive's power must be cycled for the setting to take effect.	0 to 20 Hex	1F	A	A	A	A
H5-02	Communication Speed Selection Serial Baud Rate	Selects the baud rate for Modbus terminals R+, R-, S+ and S-. The Drive's power must be cycled for the setting to take effect. 0: 1200 bps 1: 2400 bps 2: 4800 bps 3: 9600 bps 4: 19200 bps	0 to 4	3	A	A	A	A
H5-03	Communication Parity Selection Serial Com Sel	Selects the communication parity for Modbus terminals R+, R-, S+ and S-. The Drive's power must be cycled for the setting to take effect. 0: No Parity 1: Even Parity 2: Odd Parity	0 to 2	0	A	A	A	A
H5-04	Stopping Method After Communication Error Serial Fault Sel	Selects the stopping method when a communication timeout fault (CE) is detected. 0: Ramp to Stop 1: Coast to Stop 2: Fast-Stop 3: Alarm Only	0 to 3	3	A	A	A	A
H5-05	Communication Fault Detection Selection Serial Flt Dct	Enables or disables the communications timeout fault (CE). 0: Disabled - A communication loss will not cause a communication fault. 1: Enabled - If communication is lost for more than 2 seconds, a CE fault will occur.	0 to 1	1	A	A	A	A
H5-06	Drive Transmit Wait Time Transmit WaitTIM	Set the delay time from when the Drive receives data to when the Drive sends data.	5 to 65	5ms	A	A	A	A
H5-07	RTS Control Selection RTS Control Sel	Enables or disables "request to send" (RTS) control: 0: Disabled - RTS is always on 1: Enabled - RTS turns on only when sending	0 to 1	1	A	A	A	A
Pulse I/O Setup								
H6-01	Terminal RP Pulse Train Input Function Selection Pulse Input Sel	Selects the function of pulse train terminal RP. 0: Frequency reference 1: PID feedback value 2: PID setpoint value	0 to 2	0	A	A	A	A
H6-02 ◆	Pulse Train Input Scaling Pulse In Scaling	Sets the number of pulses (in Hz) that is equal to the maximum output frequency E1-04.	1000 to 32000	1440Hz	A	A	A	A
H6-03 ◆	Pulse Train Input Gain Pulse Input Gain	Sets the output level when the pulse train input is at 100% as a percentage of maximum output frequency E1-04.	0.0 to 1000.0	100.0%	A	A	A	A
H6-04 ◆	Pulse Train Input Bias Pulse Input Bias	Sets the output level when the pulse train input is 0Hz as a percentage of maximum output frequency E1-04.	-100.0 to 100.0	0.0%	A	A	A	A
H6-05 ◆	Pulse Train Input Filter Time Pulse In Filter	Sets the pulse train input filter time constant in seconds.	0.00 to 2.00	0.10sec	A	A	A	A
H6-06 ◆	Terminal MP Pulse Train Monitor Selection Pulse Moni Sel	Select the pulse train monitor output terminal MP function (value of the □□ part of U1-□□). See Table A2 for the list of U1 monitors.	1, 2, 5, 20, 24, 31, 36	2	A	A	A	A
H6-07 ◆	Pulse Train Monitor Scaling Pulse Moni Scale	Sets the number of output pulses when the monitor is 100% (in Hz). Set H6-06 to 2, and H6-07 to 0, to make the pulse train monitor output synchronous to the output frequency.	0 to 32000	1440Hz	A	A	A	A
◆ Denotes that parameter can be changed when the Drive is running.								

Table A.1 F7 Parameter List (Continued)

Parameter No.	Parameter Name Digital Operator Display	Description	Setting Range	Factory Setting	Control Method			
					V/F	V/F w/ PG	Open Loop Vector	Flux Vector
Motor Overload								
L1-01	Motor Overload Protection Selection MOL Fault Select	Sets the motor thermal overload protection (OL1) based on the cooling capacity of the motor. 0: Disabled 1: Standard Fan Cooled (< 10:1 motor) 2: Standard Blower Cooled (≥ 10:1 motor) 3: Vector Motor (≤ 1000:1 motor)	0 to 3	1	Q	Q	Q	Q
L1-02	Motor Overload Protection Time MOL Time Const	Sets the motor thermal overload protection (OL1) time. A larger L1-02 time will increase the time before an OL1 fault will occur.	0.1 to 20.0	8.0min	A	A	A	A
L1-03	Motor Overheat Alarm Operation Selection Mtr OH Alarm Sel	Sets operation selection when the motor temperature analog input (H3-09 = E) exceeds the OH3 alarm level (1.17V) 0: Ramp to Stop 1: Coast to Stop 2: Fast-Stop 3: Alarm Only	0 to 3	3	A	A	A	A
L1-04	Motor Overheat Fault Operation Selection Mtr OH Fault Sel	Sets stopping method when the motor temperature analog input (H3-09 = E) exceeds the OH4 fault level (2.34V). 0: Ramp to Stop 1: Coast to Stop 2: Fast-Stop	0 to 2	1	A	A	A	A
L1-05	Motor Temperature Input Filter Time Mtr Temp Filter	This parameter adjusts the filter on the motor temperature analog input (H3-09 = E). Increase to add stability, decrease to improve response.	0.00 to 10.00	0.20sec	A	A	A	A
Power Loss Ridethru								
L2-01	Momentary Power Loss Detection Selection PwrL Selection	Enables and disables the momentary power loss function. 0: Disabled - Drive trips on (UV1) fault when power is lost. 1: Power Loss Ride Thru Time - Drive will restart if power returns within the time set in L2-02.* 2: CPU Power Active - Drive will restart if power returns prior to control power supply shut down.* * In order for a restart to occur, the run command must be maintained throughout the ride thru period.	0 to 2	0	A	A	A	A
L2-02	Momentary Power Loss Ride-thru Time PwrL Ridethru t	Sets the power loss ride-thru time. This value is dependent on the capacity of the Drive. Only effective when L2-01 = 1.	0.0 to 25.5sec	Varies by kVA	A	A	A	A
L2-03	Momentary Power Loss Minimum Base Block Time PwrL Baseblock t	Sets the minimum time to wait to allow the residual motor voltage to decay before the Drive output turns back on during power loss ride thru. After a power loss, if L2-03 is greater than L2-02, operation resumes after the time set in L2-03.	0.1 to 5.0sec	Varies by kVA	A	A	A	A
L2-04	Momentary Power Loss Voltage Recovery Ramp Time PwrL V/F Ramp t	Sets the time it takes the output voltage to return to the preset V/F pattern after speed search (current detection mode) is complete.	0.0 to 5.0sec	Varies by kVA	A	A	A	A
L2-05	Undervoltage Detection Level PUV Det Level	Sets the Drive's DC Bus undervoltage trip level. If this is set lower than the factory setting, additional AC input reactance or DC bus reactance may be necessary. Consult the factory before changing this parameter setting.	150 to 210	190 Vdc	A	A	A	A
L2-06	KEB Deceleration Rate KEB Decel Time	Sets the time required to decelerate to zero speed when a KEB command is input from a multi-function input.	0.0 to 200.0	0.0sec	A	A	A	A
L2-07	Momentary Recovery Time UV Return Time	Set the time (in seconds) to accelerate to the set speed after recovery from a momentary power loss. If setting = 0.0, then active acceleration time is used instead.	0.0 to 25.5	0.0sec	A	A	A	A
L2-08	Frequency Reduction Gain at KEB Start KEB Frequency	Sets the percentage of output frequency reduction at the beginning of deceleration when a KEB command is input from multi-function input. Reduction = slip frequency before KEB operation × L2-08 × 2	0 to 300	100%	A	A	A	A

◆Denotes that parameter can be changed when the Drive is running.

Table A.1 F7 Parameter List (Continued)

Parameter No.	Parameter Name Digital Operator Display	Description	Setting Range	Factory Setting	Control Method			
					V/F	V/F w/ PG	Open Loop Vector	Flux Vector
Stall Prevention								
L3-01	Stall Prevention Selection During Accel StallP Accel Sel	Selects the stall prevention method used to prevent excessive current during acceleration. 0: Disabled - Motor accelerates at active acceleration rate. The motor may stall if load is too heavy or accel time is too short. 1: General Purpose - When output current exceeds L3-02 level, acceleration stops. Acceleration will continue when the output current level falls below the L3-02 level. 2: Intelligent - The active acceleration rate is ignored. Acceleration is completed in the shortest amount of time without exceeding the current value set in L3-02.	0 to 2	1	A	A	A	-
L3-02	Stall Prevention Level During Acceleration StallP Accel Lvl	This function is enabled when L3-01 is "1" or "2". Drive rated current is 100%. Decrease the set value if stalling or excessive current occurs with factory setting.	0 to 200	Varies by Duty Rating*	A	A	A	-
L3-03	Stall Prevention Limit During Acceleration StallP CHP Lvl	Sets the lower limit for stall prevention during acceleration, as a percentage of the Drive's rated current, when operation is in the frequency range above E1-06 (constant power region).	0 to 100	50%	A	A	A	-
L3-04	Stall Prevention Selection During Deceleration StallP Decel Sel	When using a braking resistor, use setting "0". Setting "3" is used in specific applications. 0: Disabled - The Drive decelerates at the active deceleration rate. If the load is too large or the deceleration time is too short, an OV fault may occur. 1: General Purpose - The Drive decelerates at the active deceleration rate, but if the main circuit DC bus voltage reaches the stall prevention level (380/760Vdc), deceleration will stop. Deceleration will continue once the DC bus level drops below the stall prevention level. 2: Intelligent - The active deceleration rate is ignored and the Drive decelerates as fast as possible w/o hitting OV fault level. Range: C1-02 / 10. 3: Stall Prevention w/ Braking Resistor - Stall prevention during deceleration is enabled in coordination with dynamic braking. (Not available in Flux Vector)	0 to 3	1	Q	Q	Q	Q
L3-05	Stall Prevention Selection During Running StallP Run Sel	Selects the stall prevention method to use to prevent Drive faults during run. 0: Disabled - Drive runs a set frequency. A heavy load may cause the Drive to trip on an OC or OL fault. 1: Decel Time 1 - In order to avoid stalling during heavy loading, the Drive will decelerate at Decel time 1 (C1-02) if the output current exceeds the level set by L3-06. Once the current level drops below the L3-06 level, the Drive will accelerate back to its frequency reference at the active acceleration rate. 2: Decel Time 2 - Same as setting 1 except the Drive decelerates at Decel Time 2 (C1-04). When output frequency is 6Hz or less, stall prevention during running is disabled regardless of L3-05 setting.	0 to 2	1	A	A	-	-
L3-06	Stall Prevention Level During Running StallP Run Level	This parameter is enabled when L3-05 is set to "1" or "2". Drive rated current is set as 100%. Decrease the set value if stalling or excessive current occurs with factory setting.	30 to 200	Varies by Duty Rating*	A	A	-	-
L3-11	OV Suppression Function Selection OV Inhibit Sel	Enables or disables OV suppression function, which allows the Drive to change the output frequency as the load changes, to prevent OV fault. 0: Disabled 1: Enabled	0 to 1	0	-	-	A	A
L3-12	OV Suppression Function Voltage Level OV Inhbt VoltLvl	Sets the DC bus voltage level at which the OV suppression function is active.	350 to 390 (240V) 700 to 780 (480V)	380V or 760V	-	-	A	A

◆Denotes that parameter can be changed when the Drive is running.

* For Heavy Duty (HD) Rating: Factory Setting=150%. For Normal Duty (ND) Rating: Factory Setting=120%.

Table A.1 F7 Parameter List (Continued)

Parameter No.	Parameter Name Digital Operator Display	Description	Setting Range	Factory Setting	Control Method			
					V/F	V/F w/ PG	Open Loop Vector	Flux Vector
Reference Detection								
L4-01	Speed Agreement Detection Level Spd Agree Level	These parameters configure the multi-function output (H2-□□) settings "Fref/Fout agree 1", "Fref/Set agree 1", "Frequency detection 1," and "Frequency detection 2". Parameter L4-01 sets the level while parameter L4-02 sets the hysteresis for the speed detection output function.	Varies by Duty Rating*1	0.0Hz	A	A	A	A
L4-02	Speed Agreement Detection Width Spd Agree Width		0.0 to 20.0	2.0Hz	A	A	A	A
L4-03	Speed Agreement Detection Level (+/-) Spd Agree Lvl +/-	These parameters configure the multi-function output (H2-□□) settings "Fref/Fout agree 2", "Fref/Set agree 2", "Frequency detection 3," or "Frequency detection 4". Parameter L4-03 sets the level while parameter L4-04 sets the hysteresis for the speed detection output function.	Varies by Duty Rating*2	0.0Hz	A	A	A	A
L4-04	Speed Agreement Detection Width (+/-) Spd Agree Wdth +/-		0.0 to 20.0	2.0Hz	A	A	A	A
L4-05	Frequency Reference Loss Detection Selection Ref Loss Sel	Determines how the Drive will react when the frequency reference is lost. The frequency reference is considered lost when reference drops 90% or more of its current value in less than 400ms. 0: Stop - Drive will stop. 1: Run at L4-06 PrevRef - Drive will run at the percentage set in L4-06 of the frequency reference level at the time frequency reference was lost.	0 to 1	0	A	A	A	A
L4-06	Frequency Reference Level at Loss Frequency Fref at Floss	If the frequency reference loss function is enabled (L4-05=1) and frequency reference is lost, the Drive will run at a reduced frequency reference determined by the following formula: Fref = Fref at time of loss * L4-06.	0 to 100.0	80.0%	A	A	A	A
Fault Restart								
L5-01	Number of Auto Restart Attempts Num of Restarts	Sets the counter for the number of times the Drive will perform an automatic restart on the following faults: GF, LF, OC, OV, PF, PUF, RH, RR, OL1, OL2, OL3, OL4, UV1. Auto restart will check to see if the fault has cleared every 5ms. When no fault is present, the Drive will attempt an auto restart. If the Drive faults after an auto restart attempt, the counter is incremented. When the Drive operates without fault for 10 minutes, the counter will reset to the value set in L5-01.	0 to 10	0	A	A	A	A
L5-02	Auto Restart Operation Selection Restart Sel	Determines if the fault contact activates during an automatic restart attempt. 0: No Fault Relay - fault contact will not activate during an automatic restart attempt. 1: Fault Relay Active - fault contact will activate during an automatic restart attempt.	0 to 1	0	A	A	A	A
<p>◆Denotes that parameter can be changed when the Drive is running. *1 For Heavy Duty (HD) Rating: Setting Range=0.0 to 300.0. For Normal Duty (ND) Rating: Setting Range=0.0 to 400.0. *2 For Heavy Duty (HD) Rating: Setting Range= -300.0 to 300.0. For Normal Duty (ND) Rating: Setting Range= -400.0 to 400.0.</p>								

Table A.1 F7 Parameter List (Continued)

Parameter No.	Parameter Name Digital Operator Display	Description	Setting Range	Factory Setting	Control Method			
					V/F	V/F w/ PG	Open Loop Vector	Flux Vector
Torque Detection								
L6-01	Torque Detection Selection 1 Torq Det 1 Sel	Determines the Drive's response to an Overtorque/Undertorque condition. Overtorque and Undertorque are determined by the settings in parameters L6-02 and L6-03. The multi-function output settings "B" and "17" in the H2-□□ parameter group are also active if programmed. 0: Disabled 1: OL3 at Speed Agree - Alarm (Overtorque Detection only active during Speed Agree and Operation continues after detection). 2: OL3 at RUN - Alarm (Overtorque Detection is always active and operation continues after detection). 3: OL3 at Speed Agree - Fault (Overtorque Detection only active during Speed Agree and Drive output will shut down on an OL3 fault). 4: OL3 at RUN - Fault (Overtorque Detection is always active and Drive output will shut down on an OL3 fault). 5: UL3 at Speed Agree - Alarm (Undertorque Detection is only active during Speed Agree and operation continues after detection). 6: UL3 at RUN - Alarm (Undertorque Detection is always active and operation continues after detection). 7: UL3 at Speed Agree - Fault (Undertorque Detection only active during Speed Agree and Drive output will shut down on an OL3 fault). 8: UL3 at RUN - Fault (Undertorque Detection is always active and Drive output will shut down on an OL3 fault).	0 to 8	0	A	A	A	A
L6-02	Torque Detection Level 1 Torq Det 1 Lvl	Sets the Overtorque/Undertorque detection level as a percentage of Drive rated current or torque for torque detection 1. Current detection for A1-02 = 0 or 1. Torque detection for A1-02 = 2 or 3.	0 to 300	150%	A	A	A	A
L6-03	Torque Detection Time 1 Torq Det 1 Time	Sets the length of time an Overtorque/Undertorque condition must exist before torque detection 1 recognized by the Drive.	0.0 to 10.0	0.1sec	A	A	A	A
L6-04	Torque Detection Selection 2 Torq Det 2 Sel	Determines the Drive's response to an Overtorque/Undertorque condition. Overtorque and Undertorque are determined by the settings in parameters L6-05 and L6-06. The multi-function output settings "18" and "19" in the H2-□□ parameter group are also active if programmed. 0: Disabled 1: OL4 at Speed Agree - Alarm (Overtorque Detection only active during Speed Agree and Operation continues after detection). 2: OL4 at RUN - Alarm (Overtorque Detection is always active and operation continues after detection). 3: OL4 at Speed Agree - Fault (Overtorque Detection only active during Speed Agree and Drive output will shut down on an OL4 fault). 4: OL4 at RUN - Fault (Overtorque Detection is always active and Drive output will shut down on an OL4 fault). 5: UL4 at Speed Agree - Alarm (Undertorque Detection is only active during Speed Agree and operation continues after detection). 6: UL4 at RUN - Alarm (Undertorque Detection is always active and operation continues after detection). 7: UL4 at Speed Agree - Fault (Undertorque Detection only active during Speed Agree and Drive output will shut down on an OL4 fault). 8: UL4 at RUN - Fault (Undertorque Detection is always active and Drive output will shut down on an OL4 fault).	0 to 8	0	A	A	A	A
L6-05	Torque Detection Level 2 Torq Det 2 Lvl	Sets the Overtorque/Undertorque detection level as a percentage of Drive rated current or torque for torque detection 2. Current detection for A1-02 = 0 or 1. Torque detection for A1-02 = 2 or 3.	0 to 300	150%	A	A	A	A
L6-06	Torque Detection Time 2 Torq Det 2 Time	Sets the length of time an Overtorque/Undertorque condition must exist before torque detection 2 is recognized by the Drive.	0.0 to 10.0	0.1sec	A	A	A	A

◆Denotes that parameter can be changed when the Drive is running.

Table A.1 F7 Parameter List (Continued)

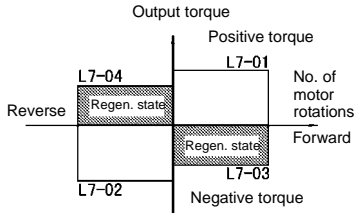
Parameter No.	Parameter Name Digital Operator Display	Description	Setting Range	Factory Setting	Control Method			
					V/F	V/F w/ PG	Open Loop Vector	Flux Vector
Torque Limit								
L7-01	Forward Torque Limit Torq Limit Fwd	Sets the torque limit value as a percentage of the motor rated torque. Four individual quadrants can be set. 	0 to 300	200%	-	-	A	A
L7-02	Reverse Torque Limit Torq Limit Rev		0 to 300	200%	-	-	A	A
L7-03	Forward Regenerative Torque Limit Torq Lmt Fwd Rgn		0 to 300	200%	-	-	A	A
L7-04	Reverse Regenerative Torque Limit Torq Lmt Rev Rgn		0 to 300	200%	-	-	A	A
Hardware Protection								
L8-01	Internal Dynamic Braking Resistor Protection Selection DB Resistor Prot	Selects the DB protection only when using 3% duty cycle heatsink mount Yaskawa braking resistor. This parameter does not enable or disable the DB function of the Drive. 0: Not Provided 1: Provided	0 to 1	0	A	A	A	A
L8-02	Overheat Alarm Level OH Pre-Alarm Lvl	When the cooling fin temperature exceeds the value set in this parameter, an overheat alarm (OH) will occur.	50 to 130	95°C	A	A	A	A
L8-03	Overheat Pre-Alarm Operation Selection OH Pre-Alarm Sel	Selects the Drive operation upon an OH pre-alarm detection. 0: Ramp to Stop 1: Coast to Stop 2: Fast-Stop 3: Alarm Only	0 to 3	3	A	A	A	A
L8-05	Input Phase Loss Protection Selection Ph Loss In Sel	Selects the detection of input current phase loss, power supply voltage imbalance, or main circuit electrostatic capacitor deterioration. 0: Disabled 1: Enabled	0 to 1	1	A	A	A	A
L8-07	Output Phase Loss Protection Ph Loss Out Sel	Selects the detection of output current open-phase. When applied motor capacity is too small for Drive capacity, output phase loss may be detected inadvertently. In this case, set to 0. 0: Disabled 1: 1-phase Loss Detection 2: 2/3-phase Loss Detection	0 to 1	1	A	A	A	A
L8-09	Output Ground Fault Detection Selection Ground Fault Sel	Enables and disables the Drive's output ground fault detection. 0: Disabled 1: Enabled	0 to 1	1	A	A	A	A
L8-10	Heatsink Cooling Fan Operation Selection Fan On/Off Sel	Controls the heatsink cooling fan operation. 0: Fan On-Run Mode - Fan will operate only when the Drive is running and for L8-11 seconds after RUN is removed. 1: Fan Always On - Cooling fan operates whenever the Drive is powered up.)	0 to 1	0	A	A	A	A
L8-11	Heatsink Cooling Fan Operation Delay Time Fan Delay Time	This parameter sets the delay time for the cooling fan turn off after the run command is removed when L8-10 = 0.	0 to 300	60sec	A	A	A	A
L8-12	Ambient Temperature Setting Ambient Temp	When the Drive is installed in an ambient temperature exceeding its rating, the Drive overload (OL2) protection level is adjusted.	45 to 60	45°C	A	A	A	A

◆Denotes that parameter can be changed when the Drive is running.

Table A.1 F7 Parameter List (Continued)

Parameter No.	Parameter Name Digital Operator Display	Description	Setting Range	Factory Setting	Control Method			
					V/F	V/F w/ PG	Open Loop Vector	Flux Vector
L8-15	OL2 Characteristic Selection at Low Speeds OL2 Sel @ L-Spd	This parameter assists in protecting the output transistors from overheating when output current is high and output frequency is low (6Hz and less). 0: Disabled 1: Enabled (L8-18 is active)	0 to 1	0	A	A	A	A
L8-18	Soft CLA Selection Soft CLA Sel	Enables and disables the software current limit function. Consult the factory before disabling. 0: Disabled 1: Enabled	0 to 1	1	A	A	A	A
Hunting Prevention								
n1-01	Hunting Prevention Selection Hunt Prev Select	If the motor vibrates while lightly loaded, hunting prevention may reduce the vibration. 0: Disabled 1: Enabled	0 to 1	1	A	A	-	-
n1-02	Hunting Prevention Gain Setting Hunt Prev Gain	Sets the gain for the Hunting Prevention Function. If the motor vibrates while lightly loaded and n1-01=1, increase the gain by 0.1 until vibration ceases. If the motor stalls while n1-01=1, decrease the gain by 0.1 until the stalling ceases.	0.00 to 2.50	1.00	A	A	-	-
AFR Tuning								
n2-01	Speed Feedback Detection Control (AFR) Gain AFR Gain	Sets the internal speed feedback detection control gain in the automatic frequency regulator (AFR). Normally, there is no need to change this setting. Adjust this parameter as follows: • If hunting occurs, increase the set value. • If response is low, decrease the set value. Adjust the setting by 0.05 units at a time, while checking the response.	0.00 to 10.00	1.00	-	-	A	-
n2-02	Speed Feedback Detection Control (AFR) Time Constant AFR Time	Sets the time constant to control the rate of change in the speed feedback detection control.	0 to 2000	50ms	-	-	A	-
n2-03	Speed Feedback Detection Control (AFR) Time Constant 2 AFR Time 2	Sets the time constant to control the amount of change in the speed at low speed.	0 to 2000	750ms	-	-	A	-
High Slip Braking								
n3-01	High Slip Braking Deceleration Frequency Width HSB Decel Width	Sets how aggressively the Drive decreases the output frequency as it stops the motor using high slip braking (HSB). If Overvoltage (OV) faults occur during HSB, this parameter may need to be increased.	1 to 20	5%	A	A	-	-
n3-02	High Slip Braking Current Limit HSB Current Ref	Sets the maximum current to be drawn during an HSB stop. Higher n3-02 settings will shorten motor stopping times but cause increased motor current, and therefore increased motor heating.	100 to 200	150%	A	A	-	-
n3-03	High Slip Braking Dwell Time at Stop HSB DwellTim@ Stp	Sets the amount of time the Drive will dwell at E1-09 (Minimum Frequency) at the end of deceleration. If this time is set too low, the machine inertia can cause the motor to rotate slightly after the HSB stop is complete and the Drive output is shut off.	0.0 to 10.0	1.0sec	A	A	-	-
n3-04	High Slip Braking Overload Time HSB OL Time	Sets the time required for an HSB overload fault (OL7) to occur when the Drive output frequency does not change for some reason during an HSB stop. Normally this does not need to be adjusted.	30 to 1200	40sec	A	A	-	-
◆Denotes that parameter can be changed when the Drive is running.								

Table A.1 F7 Parameter List (Continued)

Parameter No.	Parameter Name Digital Operator Display	Description	Setting Range	Factory Setting	Control Method			
					V/F	V/F w/ PG	Open Loop Vector	Flux Vector
Monitor Select								
o1-01 ◆	User Monitor Selection User Monitor Sel	Selects which monitor will be displayed in the operation menu upon power-up when o1-02 = 4.	4 to 45	6	A	A	A	A
o1-02	User Monitor Selection After Power-Up Power-On Monitor	Selects which monitor will be displayed upon power-up. 1: Frequency Reference (U1-01) 2: Output Frequency (U1-02) 3: Output Current (U1-03) 4: User Monitor (set by o1-01)	1 to 4	1	A	A	A	A
o1-03	Digital Operator Display Selection Display Scaling	<p>Sets the units of the Frequency References (d1-01 to d1-17), the Frequency Reference Monitors (U1-01, U1-02, U1-05), and the Modbus communication frequency reference.</p> <p>0: Hz 1: % (100% = E1-04) 2 to 39: RPM (Enter the number of motor poles). 40 to 39999: User display.</p> <p><input type="text"/> <input type="text"/> <input type="text"/> <input type="text"/> Set the number desired at maximum output frequency. 4 digit number Number of digits from the right of the decimal point</p>  <p>Example 1: o1-03 = 12000, will result in frequency reference from 0.0 to 200.0 (200.0 = Fmax). Example 2: o1-03 = 21234, will result in frequency reference from 0.00 to 12.34 (12.34 = Fmax).</p>	0 to 39999	0	A	A	A	A
o1-04	Setting unit for frequency parameters related to V/F characteristics Display Units	Sets the setting units related to V/F pattern frequency related parameters (E1-04, -06, -09, -11) 0: Hertz 1: RPM	0 to 1	0	-	-	-	A
o1-05	LCD Brightness Adjustment LCD Contrast	Sets the contrast of the Digital Operator LCD. A setting of "1" is the lightest contrast and a setting of "5" is the darkest contrast.	0 to 5	3	A	A	A	A
◆Denotes that parameter can be changed when the Drive is running.								

Table A.1 F7 Parameter List (Continued)

Parameter No.	Parameter Name Digital Operator Display	Description	Setting Range	Factory Setting	Control Method			
					V/F	V/F w/ PG	Open Loop Vector	Flux Vector
Key Selections								
o2-01	Local/Remote Key Function Selection Local/Remote Key	Determines if the Digital Operator Local/Remote key is functional. 0: Disabled 1: Enabled	0 to 1	1	A	A	A	A
o2-02	STOP Key Function Selection Oper STOP Key	Determines if the STOP key on the Digital Operator will stop the Drive when Drive is operating from external terminals or serial communication. 0: Disabled 1: Enabled	0 to 1	1	A	A	A	A
o2-03	User Parameter Default Value User Defaults	Allows storing of parameter settings as a User Initialization Selection. 0: No Change 1: Set Defaults - Saves current parameter settings as user initialization. A1-03 now allows selecting <1110> for user initialization and returns o2-03 to zero. 2: Clear All - Clears the currently saved user initialization. A1-03 no longer allows selecting <1110> and returns o2-03 to zero.	0 to 2	0	A	A	A	A
o2-04	Drive/kVA Selection Inverter Model #	Sets the kVA of the Drive. Enter the number based on Drive model number. Use the last four digits of the model number. CIMR-F7U□□□□. This parameter only needs to be set when installing a new control board. Do not change for any other reason. Refer to Table B.1.	0 to FF	Varies by kVA	A	A	A	A
o2-05	Frequency Reference Setting Method Selection Operator M.O.P.	Determines if the Data/Enter key must be used to input a frequency reference from the Digital Operator. 0: Disabled - Data/Enter key must be pressed to enter a frequency reference. 1: Enabled - Data/Enter key is not required. The frequency reference is adjusted by the up and down arrow keys on the Digital Operator without having to press the data/enter key.	0 to 1	0	A	A	A	A
o2-06	Operation Selection when Digital Operator is Disconnected Oper Detection	Determines if the Drive will stop when the Digital Operator is removed when in LOCAL mode or b1-02=0. 0: Disabled - The Drive will not stop when the Digital Operator is removed. 1: Enabled - The Drive will fault (OPR) and coast to stop when the Digital Operator is removed.	0 to 1	1	A	A	A	A
o2-07	Cumulative Operation Time Setting Elapsed Time Set	Sets the initial value of the elapsed operation timer U1-13.	0 to 65535	0H	A	A	A	A
o2-08	Cumulative Operation Time Selection Elapsed Time Run	Sets how time is accumulated for the elapsed operation timer U1-13. 0: Power-On Time - Time accumulates when the Drive is powered. 1: Running Time - Time accumulates only when the Drive is running.	0 to 1	0	A	A	A	A
o2-09	Initialization Specification Selection Init Mode Sel	Determines parameter default values after a Drive initialization (A1-03) is executed. This should always be set to "1" for North American installations. 1: American spec 2: European spec	1 to 2	1	A	A	A	A
o2-10	Cumulative Cooling Fan Operation Time Setting Fan ON Time Set	Sets the initial value of the heatsink fan operation time monitor U1-40.	0 to 65535	0H	A	A	A	A
o2-12	Fault Trace/Fault History Clear Function FLT Trace Init	Clears the fault memory contained in the U2 and U3 monitors. 0: Disabled - no effect 1: Enabled - resets U2 and U3 monitors, and returns o2-12 to zero.	0 to 1	0	A	A	A	A
o2-14	kWh User Monitor Initialization kWH MonitorClear	Used to reset the kilowatt-hour monitor U1-29 to zero. 0: Disabled - no change 1: Enabled - Resets U1-29 to zero and returns o2-14 to zero.	0 to 1	0	A	A	A	A

◆Denotes that parameter can be changed when the Drive is running.

Table A.1 F7 Parameter List (Continued)

Parameter No.	Parameter Name Digital Operator Display	Description	Setting Range	Factory Setting	Control Method			
					V/F	V/F w/ PG	Open Loop Vector	Flux Vector
COPY Function								
o3-01	Copy Function Selection Copy Function Sel	<p>This parameter controls the copying of parameters to and from the Digital Operator.</p> <p>0: COPY SELECT (no function)</p> <p>1: INV -> OP READ - All parameters are copied from the Drive to the Digital Operator.</p> <p>2: OP -> INV WRITE - All parameters are copied from the Digital Operator to the Drive.</p> <p>3: OP<->INV VERIFY - Parameter settings in the Drive are compared to those in the Digital Operator.</p> <p>NOTE: When using the copy function, the Drive model number (o2-04), software number (U1-14), and control method (A1-02) must match or an error will occur.</p>	0 to 3	0	A	A	A	A
o3-02	Copy Allowed Selection Read Allowable	<p>Enables and disables the Digital Operator copy functions.</p> <p>0: Disabled - No Digital Operator copy functions are allowed.</p> <p>1: Enabled - Copying allowed.</p>	0 to 1	0	A	A	A	A
Auto-Tuning								
T1-00	Motor Selection 1 / 2 Select Motor	<p>Selects which set of motor parameters are to be used and set during Auto-Tuning. If Motor 2 selection (H1-XX=16) is not selected, this parameter will not be displayed.</p> <p>1: 1st Motor - E1 to E2</p> <p>2: 2nd Motor - E3 to E4</p>	1, 2	1	A	A	A	A
T1-01	Auto-Tuning mode selection Tuning Mode Sel	<p>Selects the Auto-Tuning mode.</p> <p>0: Rotational Auto-Tuning (A1-02 = 2 or 3)</p> <p>1: Stationary Auto-Tuning (A1-02 = 2 or 3)</p> <p>2: Terminal resistance only, (stationary) Auto-Tuning (A1-02 = 0, 1, 2, or 3)</p>	0 to 2	0	A	A	A	A
T1-02	Motor Rated Power Mtr Rated Power	<p>Set the motor rated power in kilowatts (kW).</p> <p>NOTE: If motor power is given in horsepower, power in kW can be calculated using the following formula: kW = Hp * 0.746</p>	0.00 to 650.00 kW	Varies by kVA	A	A	A	A
T1-03	Motor rated voltage Rated Voltage	Set the motor rated voltage in Volts (V).	0.0 to 255.0 (240V) 0.0 to 510.0 (480V)	230Vac or 460Vac	-	-	A	A
T1-04	Motor Rated Current Rated Current	Set the motor rated current in Amperes (A).	Varies by kVA	Varies by kVA	A	A	A	A
T1-05	Motor Base Frequency Rated Frequency	Set the base frequency of the motor in Hertz (Hz).	Varies by Duty Rating*	60.0Hz	-	-	A	A
T1-06	Number of Motor Poles Number of Poles	Set the number of motor poles.	2 to 48	4 poles	-	-	A	A
T1-07	Motor Base Speed Rated Speed	Set the base speed of the motor in revolutions per minute (RPM).	0 to 24000	1750 RPM	-	-	A	A
T1-08	Number of PG Pulses PG Pulses / Rev	Set the number of pulses per revolution (PPR) for the encoder (pulse generator) being used without any multiplication factor.	0 to 60000	1024 PPR	-	-	-	A
<p>◆ Denotes that parameter can be changed when the Drive is running.</p> <p>* For Heavy Duty (HD) Rating: Setting Range=0.0 to 300.0. For Normal Duty (ND) Rating: Setting Range=0.0 to 400.0.</p>								

F7 Monitor List

Table A.2 F7 Monitor List			
Parameter No.	Parameter Name Digital Operator Display	Description	Display Units
Monitor			
U1-01	Frequency Reference Frequency Ref	Frequency reference (speed command) monitor when in REMOTE mode, frequency reference (speed command) setting location when in local mode or b1-01 = 0.	Set by o1-03.
U1-02	Output Frequency Output Freq	Output frequency	Set by o1-03.
U1-03	Output Current Output Current	Output current	0.01A
U1-04	Control Method Control Method	Control method set in A1-02. 0 = V/F without PG 1 = V/F with PG 2 = Open Loop Vector 3 = Flux Vector	-
U1-05	Motor Speed Motor Speed	Motor speed feedback	Set by o1-03.
U1-06	Output Voltage Output Voltage	Output voltage	0.1Vac
U1-07	DC Bus Voltage DC Bus Voltage	DC Bus Voltage	1Vdc
U1-08	Output Power Output kWatts	Output power	0.1kW
U1-09	Torque Reference Torque Reference	Torque reference	0.1%
U1-10	Input Terminal Status Input Term Sts	Input terminal status 	-
U1-11	Output Terminal Status Output Term Sts	Output terminal status. 	-

Table A.2 F7 Monitor List (Continued)

Parameter No.	Parameter Name Digital Operator Display	Description	Display Units
U1-12	Drive Operation Status Int Ctl Sts 1	<p>Internal Drive status</p>	-
U1-13	Cumulative Operation Time Elapsed Time	Total operating or power-on time of the Drive.	1hr
U1-14	Software Number FLASH ID	Last 5 digits of the Drive's software number.	-
U1-15	Terminal A1 Input Voltage Term A1 Level	Input voltage on Terminal A1, as a percentage of $\pm 10\text{Vdc}$.	0.1%
U1-16	Terminal A2 Input Voltage Term A2 level	Displays the input current (or voltage) on Terminal A2, as a percentage of $\pm 10\text{Vdc}$.	0.1%
U1-17	Terminal A3 Input Voltage Term A3 level	Input voltage on Terminal A3, as a percentage of $\pm 10\text{Vdc}$.	0.1%
U1-18	Motor Secondary Current (I_q) Mot SEC Current	Current being used by the motor to produce torque (I_q).	0.1%
U1-19	Motor Excitation Current (I_d) Mot EXC Current	Current being used by the motor for excitation (I_d).	0.1%
U1-20	Output Frequency After Soft Start SFS Output	Frequency reference (speed command) after the accel and decel ramps and S-curve.	0.01Hz
U1-21	ASR Input ASR Input	Input error to the speed control loop (ASR). The maximum output frequency E1-04 corresponds to 100%.	0.01%
U1-22	ASR Output with Filter ASR Output w Fil	Output from the speed control loop (ASR). The motor rated secondary current corresponds to 100%.	0.01%
U1-24	PI Feedback Value PID Feedback	Feedback signal level when PID control is used.	0.01%
U1-25	DI-16H2 Input Status DI-16 Reference	Reference value from a DI-16H2 Digital Reference Card. The value will be displayed in binary or BCD depending on user constant F3-01.	Set by F3-01
U1-26	Output voltage reference (V_q) Voltage Ref (Vq)	Internal voltage reference for motor secondary current control.	0.1Vac
U1-27	Output voltage reference (V_d) Voltage Ref (Vd)	Internal voltage reference for motor excitation current control.	0.1Vac
U1-28	CPU Number CPU ID	Control board hardware revision.	-
U1-29	kWh kWh Lo 4 Digits	Accumulated kilowatt-hours.	0.1kWh
U1-30	MWh kWh Hi 5 Digits	Accumulated megawatt-hours.	1MWh
U1-32	ACR output of q axis ACR(q) Output	Current control output value for the motor secondary current.	0.1%
U1-33	ACR output of d axis ACR(d) Output	Current control output value for the motor excitation current.	0.1%
U1-34	First Parameter Causing an OPE OPE Detected	Parameter number causing an "OPE" fault.	-
U1-35	Zero Servo Pulse Count Zero Servo Pulse	Number of PG pulses times 4 for the movement range when stopped at zero servo.	1 pulse
U1-36	PID Input PID Input	Input error to the PID regulator (PID Setpoint - PID Feedback).	0.01%
U1-37	PID Output PID Output	Output of the PID regulator as a percentage of maximum frequency (E1-04).	0.01%

Table A.2 F7 Monitor List (Continued)

Parameter No.	Parameter Name Digital Operator Display	Description	Display Units
U1-38	PID Setpoint PID Setpoint	Setpoint of the PID regulator (PID reference + PID bias).	0.01%
U1-39	Modbus Communication Error Code Transmit Err	<p>Modbus serial communication error codes.</p> <p>0 0 0 0 0 0 0 0</p> <ul style="list-style-type: none"> 1: CRC error 1: Data length error 0: Not used. Always 0. 1: Parity error 1: Overrun error 1: Framing error 1: Timeout 0: Not used. Always 0. 	-
U1-40	Heatsink Cooling Fan Operation Time FAN Elapsed Time	Total operating time of the heatsink cooling fan.	1hr
U1-44	ASR output without filter ASR out w/o Fil	Output from the speed control loop (ASR) before the ASR primary delay filter (C5-06). 100% is displayed for rated secondary current of the motor.	0.01%
U1-45	Feed forward control output FF Cont Output	Output from feed forward control. 100% is displayed for rated secondary current of the motor.	0.01%

F7 Fault Trace List

Table A.3 F7 Fault Trace List	
Fault Trace	
U2-01	Current Fault. Current Fault
U2-02	Previous Fault. Last Fault
U2-03	Frequency Reference at Previous Fault. Frequency Ref
U2-04	Output Frequency at Previous Fault. Output Freq
U2-05	Output Current at Previous Fault. Output Current
U2-06	Motor Speed at Previous Fault. Motor Speed
U2-07	Output Voltage at Previous Fault. Output Voltage
U2-08	DC Bus Voltage at Previous Fault. DC Bus Voltage
U2-09	Output Power at Previous Fault. Output kWatts
U2-10	Torque Reference at Previous Fault. Torque Reference
U2-11	Input Terminal Status at Previous Fault. The format is the same as for U1-10. Input Term Sts
U2-12	Output Terminal Status at Previous Fault. The format is the same as for U1-11. Output Term Sts
U2-13	Drive Operation Status at Previous Fault. The format is the same as for U1-12. Inverter Status
U2-14	Cumulative Operation Time at Previous Fault. Elapsed time
Note: Fault trace is not executed at CPF00, CPF01, CPF03, UV1, and UV2.	

F7 Fault History List

Table A.4 F7 Fault History List	
Fault History	
U3-01	Most Recent Fault Last Fault
U3-02	2 nd Most Recent Fault Fault Message 2
U3-03	3 rd Most Recent Fault Fault Message 3
U3-04	4 th Most Recent Fault Fault Message 4
U3-05	Cumulative Operation Time at Most Recent Fault Elapsed Time 1
U3-06	Cumulative Operation Time at 2 nd Most Recent Fault Elapsed Time 2
U3-07	Cumulative Operation Time at 3 rd Most Recent Fault Elapsed Time 3
U3-08	Cumulative Operation Time at 4 th Most Recent Fault Elapsed Time 4
U3-09	5 th Most Recent Fault Fault Message 5
U3-10	6 th Most Recent Fault Fault Message 6
U3-11	7 th Most Recent Fault Fault Message 7
U3-12	8 th Most Recent Fault Fault Message 8
U3-13	9 th Most Recent Fault Fault Message 9
U3-14	10 th Most Recent Fault Fault Message 10
U3-15	Cumulative Operation Time at 5 th Most Recent Fault Elapsed Time 5
U3-16	Cumulative Operation Time at 6 th Most Recent Fault Elapsed Time 6
U3-17	Cumulative Operation Time at 7 th Most Recent Fault Elapsed Time 7
U3-18	Cumulative Operation Time at 8 th Most Recent Fault Elapsed Time 8
U3-19	Cumulative Operation Time at 9 th Most Recent Fault Elapsed Time 9
U3-20	Cumulative Operation Time at 10 th Most Recent Fault Elapsed Time 10
Note: Faults such as CPF00, CPF01, CPF02, CPF03, UV1, and UV2 are not stored in fault history.	

Notes:

Appendix B

Capacity Related Parameters

This appendix lists the parameters affected by the Drive Capacity setting of o2-04.

Drive Capacity Selection.....	B-2
Parameters Affected by Drive Capacity Setting.....	B-3

Drive Capacity Selection

Parameter o2-04 sets the Drive capacity according to the model number. Parameter o2-04 needs to be adjusted only when replacing a control board. Do not change the o2-04 setting for any other reason.

If the Drive's control board is replaced, the next time the Drive is powered up, parameter o2-04 must be set to the appropriate value listed in Table B.1 for the Drive model number. This will automatically program the values of all other parameters listed in Table B.2 to the factory settings for that particular Drive rating.

Table B.1 Drive Capacity Selection		
Voltage	F7 Model Number	o2-04 Setting
208-240Vac	CIMR-F7U20P4	0
	CIMR-F7U20P7	1
	CIMR-F7U21P5	2
	CIMR-F7U22P2	3
	CIMR-F7U23P7	4
	CIMR-F7U25P5	5
	CIMR-F7U27P5	6
	CIMR-F7U2011	7
	CIMR-F7U2015	8
	CIMR-F7U2018	9
	CIMR-F7U2022	A
CIMR-F7U2030	B	
208-230Vac	CIMR-F7U2037	C
	CIMR-F7U2045	D
	CIMR-F7U2055	E
	CIMR-F7U2075	F
	CIMR-F7U2090	10
	CIMR-F7U2110	11
480Vac	CIMR-F7U40P4	20
	CIMR-F7U40P7	21
	CIMR-F7U41P5	22
	CIMR-F7U42P2	23
	CIMR-F7U43P7	24
	CIMR-F7U44P0	25
	CIMR-F7U45P5	26
	CIMR-F7U47P5	27
	CIMR-F7U4011	28
	CIMR-F7U4015	29
	CIMR-F7U4018	2A
	CIMR-F7U4022	2B
	CIMR-F7U4030	2C
	CIMR-F7U4037	2D
	CIMR-F7U4045	2E
	CIMR-F7U4055	2F
	CIMR-F7U4075	30
	CIMR-F7U4090	31
	CIMR-F7U4110	32
	CIMR-F7U4132	33
CIMR-F7U4160	34	
CIMR-F7U4185	35	
CIMR-F7U4220	36	
CIMR-F7U4300	37	

Parameters Affected by Drive Capacity Setting

The factory setting of the parameters in Table B.2 may change when the Drive capacity is changed via parameter o2-04. See Table B.3 and B.4 for a complete list.

Table B.2 Parameters Affected by o2-04

Parameter Number	Parameter Name Digital Operator Display	Parameter Number	Parameter Name Digital Operator Display
b8-03	Energy Saving Control Filter Time Constant Energy Saving F.T	E4-02	Motor 2 Rated Slip Motor Rated Slip
b8-04	Energy Saving Coefficient Value Energy Save COEF	E4-03	Motor 2 No-Load Current No-Load Current
C6-01	Carrier Frequency Duty Heavy/Normal Duty	E4-05	Motor 2 Line-to-Line Resistance Term Resistance
E2-01	Motor Rated Current Motor Rated FLA	E4-06	Motor 2 Leakage Inductance Leakage Inductance
E2-02	Motor Rated Slip Motor Rated Slip	E4-07	Motor 2 Rated Output Motor 2 Rated KW
E2-03	Motor No-load Current No-load Current	L2-02	Momentary Power Loss Ride-thru Time PwrL Ridethru t
E2-05	Motor Line-to-Line Resistance Term Resistance	L2-03	Momentary Power Loss Minimum Base Block Time PwrL Baseblock t
E2-06	Motor Leakage Inductance Leakage Inductance	L2-04	Momentary Power Loss Voltage Recovery Ramp Time PwrL V/F Ramp t
E2-10	Motor Iron Loss for Torque Compensation Tcomp Iron Loss	L8-02	Overheat Pre-Alarm Level OH Pre-Alarm Lvl
E2-11	Motor Rated Output Motor Rated KW	o2-04	Drive/kVA Selection Inverter Model #
E4-01	Motor 2 Rated Current Motor Rated FLA	-	-

Table B.3 Parameter Defaults 208-240V									
Parameter	208-240V: Model Number CIMR-F7U-								
	20P4	20P7	21P5	22P2	23P7	25P5	27P5	2011	2015
b8-03	0.50	0.50	0.50	0.50	0.50	0.50	0.50	0.50	0.50
b8-04	288.20	223.70	169.40	156.80	122.90	94.75	72.69	70.44	63.13
C6-01	0	0	0	0	0	0	0	0	0
E2-01 / E4-01	1.90	3.30	6.20	8.50	14.00	19.60	26.60	39.7	53.0
E2-02 / E4-02	2.90	2.50	2.60	2.90	2.73	1.50	1.30	1.70	1.60
E2-03 / E4-03	1.20	1.80	2.80	3.00	4.50	5.10	8.00	11.2	15.2
E2-05 / E4-05	9.842	5.156	1.997	1.601	0.771	0.399	0.288	0.230	0.138
E2-06 / E4-06	18.2	13.8	18.5	18.4	19.6	18.2	15.5	19.5	17.2
E2-10	14	26	53	77	112	172	262	245	272
E2-11 / E4-07	0.4	0.75	1.5	2.2	3.7	5.5	7.5	11	15
L2-02	0.1	0.2	0.3	0.5	1.0	1.0	1.0	2.0	2.0
L2-03	0.1	0.2	0.3	0.4	0.5	0.6	0.7	0.8	0.9
L2-04	0.3	0.3	0.3	0.3	0.3	0.3	0.3	0.3	0.6
L8-02	95	95	95	100	95	95	95	95	90
o2-04	0	1	2	3	4	5	6	7	8

Table B.3 Parameter Defaults 208-240V (continued)									
Parameter	208-240V: Model Number CIMR-F7U-								
	2018	2022	2030	2037	2045	2055	2075	2090	2110
b8-03	0.50	0.50	0.50	0.50	0.50	2.00	2.00	2.00	2.00
b8-04	57.87	51.79	46.27	38.16	35.78	31.35	23.10	20.65	18.12
C6-01	0	0	0	0	0	0	0	0	1
E2-01 / E4-01	65.8	77.2	105.0	131.0	160.0	190.0	260.0	260.0	260.0
E2-02 / E4-02	1.67	1.70	1.80	1.33	1.60	1.43	1.39	1.39	1.39
E2-03 / E4-03	15.7	18.5	21.9	38.2	44.0	45.6	72.0	72.0	72.0
E2-05 / E4-05	0.101	0.079	0.064	0.039	0.030	0.022	0.023	0.023	0.023
E2-06 / E4-06	20.1	19.5	20.8	18.8	20.2	20.5	20.0	20.0	20.0
E2-10	505	538	699	823	852	960	1200	1200	1200
E2-11 / E4-07	18.5	22	30	37	45	55	75	90	110
L2-02	2.0	2.0	2.0	2.0	2.0	2.0	2.0	2.0	2.0
L2-03	1.0	1.0	1.1	1.1	1.2	1.2	1.3	1.5	1.7
L2-04	0.6	0.6	0.6	0.6	0.6	1.0	1.0	1.0	1.0
L8-02	100	90	90	95	100	105	110	100	95
o2-04	9	A	B	C	D	E	F	10	11

Table B.4 Parameter Defaults 480V									
Parameter	Model Number CIMR-F7U-								
	40P4	40P7	41P5	42P2	43P7	44P0	45P5	47P5	4011
b8-03	0.50	0.50	0.50	0.50	0.50	0.50	0.50	0.50	0.50
b8-04	576.40	447.40	338.80	313.60	245.80	236.44	189.50	145.38	140.88
C6-01	0	0	0	0	0	0	0	0	0
E2-01 / E4-01	1.00	1.60	3.10	4.20	7.00	7.00	9.80	13.30	19.9
E2-02 / E4-02	2.90	2.60	2.50	3.00	2.70	2.70	1.50	1.30	1.70
E2-03 / E4-03	0.60	0.80	1.40	1.50	2.30	2.30	2.60	4.00	5.6
E2-05 / E4-05	38.198	22.459	10.100	6.495	3.333	3.333	1.595	1.152	0.922
E2-06 / E4-06	18.2	14.3	18.3	18.7	19.3	19.3	18.2	15.5	19.6
E2-10	14	26	53	77	130	130	193	263	385
E2-11 / E4-07	0.4	0.75	1.5	2.2	3.7	4.0	5.5	7.5	11
L2-02	0.1	0.1	0.2	0.3	0.5	0.5	0.8	0.8	1.0
L2-03	0.1	0.2	0.3	0.4	0.5	0.6	0.6	0.7	0.8
L2-04	0.3	0.3	0.3	0.3	0.3	0.3	0.3	0.3	0.3
L8-02	95	95	95	95	95	95	95	95	95
o2-04	20	21	22	23	24	25	26	27	28

Table B.4 Parameter Defaults 480V (continued)									
Parameter	Model Number CIMR-F7U-								
	4015	4018	4022	4030	4037	4045	4055	4075	4090
b8-03	0.50	0.50	0.50	0.50	0.50	0.50	2.00	2.00	2.00
b8-04	126.26	115.74	103.58	92.54	76.32	71.56	67.20	46.20	38.91
C6-01	0	0	0	0	0	0	0	0	0
E2-01 / E4-01	26.5	32.9	38.6	52.3	65.6	79.7	95.0	130.0	156.0
E2-02 / E4-02	1.60	1.67	1.70	1.80	1.33	1.60	1.46	1.39	1.40
E2-03 / E4-03	7.6	7.8	9.2	10.9	19.1	22.0	24.0	36.0	40.0
E2-05 / E4-05	0.550	0.403	0.316	0.269	0.155	0.122	0.088	0.092	0.056
E2-06 / E4-06	17.2	20.1	23.5	20.7	18.8	19.9	20.0	20.0	20.0
E2-10	440	508	586	750	925	1125	1260	1600	1760
E2-11 / E4-07	15	18.5	22	30	37	45	55	75	90
L2-02	2.0	2.0	2.0	2.0	2.0	2.0	2.0	2.0	2.0
L2-03	0.9	1.0	1.0	1.1	1.1	1.2	1.2	1.3	1.5
L2-04	0.3	0.6	0.6	0.6	0.6	0.6	1.0	1.0	1.0
L8-02	95	98	78	85	85	90	90	98	108
o2-04	29	2A	2B	2C	2D	2E	2F	30	31

Table B.4 Parameter Defaults 480V (continued)						
Parameter	Model Number CIMR-F7U-					
	4110	4132	4160	4185	4220	4300
b8-03	2.00	2.00	2.00	2.00	2.00	2.00
b8-04	36.23	32.79	30.13	30.57	27.13	21.76
C6-01	0	0	0	0	1	1
E2-01 / E4-01	190.0	223.0	270.0	310.0	370.0	500.0
E2-02 / E4-02	1.40	1.38	1.35	1.30	1.30	1.25
E2-03 / E4-03	49.0	58.0	70.0	81.0	96.0	130.0
E2-05 / E4-05	0.046	0.035	0.029	0.025	0.020	0.014
E2-06 / E4-06	20.0	20.0	20.0	20.0	20.0	20.0
E2-10	2150	2350	2850	3200	3700	4700
E2-11 / E4-07	110	132	160	185	220	300
L2-02	2.0	2.0	2.0	2.0	2.0	2.1
L2-03	1.7	1.7	1.8	1.9	2.0	2.1
L2-04	1.0	1.0	1.0	1.0	1.0	1.0
L8-02	100	110	108	95	100	95
o2-04	32	33	34	35	36	37

Notes:

Appendix C Specifications

This appendix details the standard Drive specifications.

Standard Drive Specifications C-2

Standard Drive Specifications

The standard Drive specifications are listed in the following tables.

◆ 208-240Vac

Table C.1 208-240Vac Drive Specifications

		208-240Vac Drives											208-230Vac Drives							
Model Number CIMR-F7U		20P4	20P7	21P5	22P2	23P7	25P5	27P5	2011	2015	2018	2022	2030	2037	2045	2055	2075	2090	2110	
Output ratings	Rated output capacity (kVA)	1.2	1.6	2.7	3.7	5.7	8.8	12.0	17.0	22.0	27.0	32.0	44.0	55.0	69.0	82.0	110.0	130.0	N/A	
	Horsepower ^{*2}	0.5/0.75	1	2	3	5	7.5	10	15	20	25	30	40	50	60	75	100	125		
	Rated output current (A)	3.2	4.2	7.0	9.6	15.2	23.0	31.0	45.0	58.0	71	85.0	115.0	145.0	180.0	215	283.0	346.0		
	Overload capacity ^{*3} (% of rated output current for 60 sec)	150																		
	Current limit (% of rated output current)	150																		
	Carrier frequency ^{*5}	2kHz																		
	Maximum output frequency	300.0Hz																		
	Rated output capacity (kVA)	1.4	1.8	3.0	4.1	6.4	8.8	12.0	18.0	23.0	29.0	34.0	44.0	62.0	73.0	82.0	120.0	140.0	160.0	
	Horsepower ^{*2}	0.5/0.75	1	2	3	5	7.5	10	15	20	25	30	40	50/60	75	-	100/125	150	-	
	Rated output current (A)	3.6	4.6	7.8	10.8	16.8	23.0	31.0	46.2	59.4	74.8	88.0	115.0	162.0	192.0	215	312.0	360.0	415.0	
	Overload capacity ^{*3} (% of rated output current for 60 sec.)	107	107	108	107	107	120	120	117	117	114	116	120	107	113	120	109	115	120	
	Current limit (% of rated output current)	120																		
	Carrier frequency (kHz) ^{*6}	10	10	10	8	10	15	15	8	10	10	10	10	5	5	8	2	2	2	
	Maximum output frequency	400.0Hz																		
Maximum output voltage	3-phase; 200, 208, 220, 230, or 240Vac (Proportional to input voltage)																			
Rated voltage	3-phase, 200/208/220/230/240Vac, 50/60Hz											3-phase, 200/208/220/230Vac, 50/60Hz								
Rated frequency																				
Rated input current - Heavy Duty ^{*1} (A)	3.8	4.9	8.4	11.5	18	24	37	52	68	84	94	120	160	198	237	317	381	457		
Rated input current - Normal Duty ^{*1} (A)	4.3	5.5	9.4	13	20	24	37	53	70	89	98	120	180	212	237	350	396	457		
Allowable voltage fluctuation	+ 10%, - 15%																			
Allowable frequency fluctuation	±5%																			
Control characteristics	Measures for power supply harmonics	DC Reactor	Optional										Built-in							
		12-Pulse Rectification	Not possible										Possible ^{*4}							

*1 The difference between Heavy Duty ratings and the Normal Duty ratings for the Drive are the rated input and output current, overload capacity, carrier frequency, current limit, and maximum output frequency. Parameter C6-01 must be set to value of "0" for Heavy Duty ratings and "2" for Normal Duty ratings. Factory default is Heavy Duty (C6-01=0).

*2 Horsepower ratings are based on 230V or 460V NEC Table 430.150. The maximum applicable motor output is given for a standard 4-pole motor. When selecting the actual motor and Drive, be sure that the Drive's rated output current is appropriate for the motor's rated current.

*3 Models 2110, 4220, 4300 have an overload rating of 120% of rated output current for 60 seconds.

*4 A 3-wire phase-shifting transformer is required on the power supply for 12-pulse rectification.

*5 2kHz is the Maximum carrier frequency value and default carrier frequency value for all models.

*6 Each value shown is the Maximum carrier frequency and default carrier frequency.

◆ 480Vac

Table C.2 480Vac Drive Specifications

Table C.2 480Vac Drive Specifications															
Model Number	CIMR-F7U	40P4	40P7	41P5	42P2	43P7	44P0	45P5	47P5	4011	4015	4018	4022		
Output ratings	Heavy Duty*1	Rated output capacity (kVA)	1.4	1.6	2.8	4.0	5.8	6.6	9.5	13.0	18.0	24.0	30.0	34.0	
		Horsepower*2	0.5/0.75	1	2	3	5	-	7.5	10	15	20	25	30	
		Rated output current (A)	1.8	2.1	3.7	5.3	7.6	8.7	12.5	17.0	24.0	31.0	39.0	45.0	
		Overload capacity*3 (% of rated output current for 60 sec)	150												
		Current limit (% of rated output current)	150												
		Carrier frequency*4	2kHz												
		Maximum output frequency	300.0Hz												
	Normal Duty*1	Rated output capacity (kVA)	1.4	1.6	2.8	4.0	5.8	6.6	9.5	13.0	21.0	26.0	30.0	38.0	
		Horsepower*2	0.5/0.75	1	2	3	5	-	7.5	10	15/20	25	30	-	
		Rated output current (A)	1.8	2.1	3.7	5.3	7.6	8.7	12.5	17.0	27.0	34.0	40.0	50.4	
		Overload capacity*3 (% of rated output current for 60 sec)	120	120	120	120	120	120	120	120	120	107	109	117	107
		Current limit (% of rated output current)	120												
		Carrier frequency (kHz)*5	15	15	15	15	15	15	15	15	15	8	10	10	10
		Maximum output frequency	400.0Hz												
Maximum output voltage	3-phase; 380, 400, 415, 440, 460, or 480Vac (Proportional to input voltage.)														
Power supply characteristics	Rated voltage Rated frequency	3-phase, 380, 400, 415, 440, 460 or 480Vac, 50/60Hz													
	Rated input current - Heavy Duty*1 (A)	2.2	2.5	4.4	6.4	9.0	10.4	15	20	29	37	47	50		
	Rated input current - Normal Duty*1 (A)	2.2	2.5	4.4	6.4	9.0	10.4	15	20	33	40	48	55		
	Allowable voltage fluctuation	+ 10%, - 15%													
	Allowable frequency fluctuation	±5%													
Control characteristics	Measures for power supply harmonics	DC Reactor	Optional												
		12-pulse Rectification	Not possible												
*1 The difference between Heavy Duty ratings and the Normal Duty ratings for the Drive are the rated input and output current, overload capacity, carrier frequency, current limit, and maximum output frequency. Parameter C6-01 must be set to value of "0" for Heavy Duty ratings and "2" for Normal Duty ratings. Factory default is Heavy Duty (C6-01=0).															
*2 Horsepower ratings are based on 230V or 460V NEC Table 430.150. The maximum applicable motor output is given for a standard 4-pole motor. When selecting the actual motor and Drive, be sure that the Drive's rated output current is appropriate for the motor's rated current.															
*3 Models 2110, 4220, 4300 have an overload rating of 120% of rated output current for 60 seconds.															
*4 2kHz is the Maximum carrier frequency value and default carrier frequency value for all models.															
*5 Each value shown is the Maximum carrier frequency and default carrier frequency.															

◆ Common Specifications

Table C.2 480Vac Drive Specifications (Continued)														
Model Number CIMR-F7U		4030	4037	4045	4055	4075	4090	4110	4132	4160	4185	4220	4300	
Output ratings	Heavy Duty*1	Rated output capacity (kVA)	46.0	57.0	69.0	85.0	110.0	140.0	160.0	200.0	230.0	280.0	N/A	
		Horsepower*2	40	50	60	75	100	125/150	-	200	250	300		
		Rated output current (A)	60.0	75.0	91.0	112.0	150.0	180.0	216.0	260.0	304.0	370.0		
		Overload capacity*3 (% of rated output current for 60 sec)	150											
		Current limit (% of rated output current)	150											
		Carrier frequency*5	2kHz											
		Maximum output frequency	300.0Hz											
	Normal Duty*1	Rated output capacity (kVA)	51.0	59.0	73.0	95.0	120.0	140.0	180.0	200.0	230.0	315.0	390.0	510.0
		Horsepower*2	40/50	60	75	100	125	150	200	-	250	300/350	400/450	500+
		Rated output current (A)	67.2	77.0	96.0	125.0	156.0	180.0	240.0	260.0	304.0	414.0	515.0	675.0
		Overload capacity*3 (% of rated output current for 60 sec.)	107	117	114	108	115	120	108	120	120	107	118	120
		Current limit (% of rated output current)	120											
		Carrier frequency (kHz)*6	8	8	8	5	5	8	5	5	5	2	2	2
		Maximum output frequency	400.0Hz											
Maximum output voltage		3-phase, 380, 400, 415, 440, 460 or 480Vac (Proportional to input voltage)												
Power supply characteristics	Rated voltage		3-phase, 380, 400, 415, 440, 460, or 480Vac, 50/60Hz											
	Rated frequency		3-phase, 380, 400, 415, 440, 460, or 480Vac, 50/60Hz											
	Rated input current - Heavy Duty*1 (A)		66	83	100	120	165	198	238	286	334	407	537	743
	Rated input current - Normal Duty*1 (A)		74	85	106	134	172	198	264	286	334	456	567	743
	Allowable voltage fluctuation		+ 10%, - 15%											
Allowable frequency fluctuation		±5%												
Control characteristics	Measures for power supply harmonics	DC Reactor	Built-in											
		12-Pulse Rectification	Possible*4											
*1 The difference between Heavy Duty ratings and the Normal Duty ratings for the Drive are the rated input and output current, overload capacity, carrier frequency, current limit, and maximum output frequency. Parameter C6-01 must be set to value of "0" for Heavy Duty ratings and "2" for Normal Duty ratings. Factory default is Heavy Duty (C6-01=0).														
*2 Horsepower ratings are based on 230V or 460V NEC Table 430.150. The maximum applicable motor output is given for a standard 4-pole motor. When selecting the actual motor and Drive, be sure that the Drive's rated output current is appropriate for the motor's rated current.														
*3 Models 2110, 4220, 4300 have an overload rating of 120% of rated output current for 60 seconds.														
*4 A 3-wire phase-shifting transformer is required on the power supply for 12-pulse rectification.														
*5 2kHz is the Maximum carrier frequency value and default carrier frequency value for all models.														
*6 Each value shown is the Maximum carrier frequency and default carrier frequency.														

The following specifications apply to both 200Vac and 400Vac Class Drives.

Table C.3 Common F7 Drive Specifications		
Model Number CIMR-F7U	Specification	
Control Characteristics	Control method	Sine wave PWM V/F control, V/F control with PG, Open Loop Vector control, Flux Vector Control
	Speed control range	100:1 (1000:1 with PG)
	Speed control accuracy	±0.2% (±0.02% with PG) (77°F ± 50°F) (25°C ± 10°C)
	Speed response	5Hz (30Hz with PG)
	Torque limit	Can be set by parameter, analog input, or serial communication: 4 quadrant control
	Torque accuracy	±5%
	Torque response	20Hz (40Hz with PG)
	Frequency control range	0.01 to 400.00Hz
	Frequency accuracy (temperature characteristics)	Digital references: ± 0.01% (14°F to 104°F) (-10°C to +40°C)
		Analog references: ±0.1% (77°F ± 50°F) (25°C ± 10°C)
	Frequency setting resolution	Digital references: 0.01Hz
		Analog references: 0.03 @60Hz (10 bit with sign)
	Output frequency resolution	0.001Hz
	Analog setting signal	-10 to +10Vdc, 0 to +10Vdc, 4 to 20mA
	Acceleration/Deceleration time	0.0 to 6000.0 sec (4 selectable combinations of independent acceleration and deceleration settings)
Internal braking torque	Approximately 20%	
Main control functions	Restarting from momentary power loss, bi-directional speed search, Overtorque/Undertorque detection, 17 preset speeds, acceleration/deceleration time changes, S-curve acceleration, 3-wire sequence, Auto-Tuning, cooling fan ON/OFF control, torque compensation, speed control/torque control switch, jump frequencies, upper and lower limits for frequency references, DC braking for starting and stopping, high-slip braking, PID control (with sleep function), energy-saving control, Modbus communications (RS-485/422, 19.2 kbps maximum), fault reset, and copy function.	
Protective Functions	Motor protection	UL recognized electronic thermal overload relay (I ² T)
	Instantaneous overcurrent protection	Stops at approximately 200% of rated output current
	Main circuit protection	Fuse in DC bus circuit
	Overload protection	Normal Duty (C6-01 = 2) - Approximately 110% of rated output current for 60 seconds
		Heavy Duty (C6-01 = 0) - 150% of rated output current for 60 seconds
	Overvoltage protection	208-240Vac: Stops when main-circuit DC voltage is above 410Vdc
		480Vac: Stops when main-circuit DC voltage is above 820Vdc
	Undervoltage protection	208-240Vac: Stops when main-circuit DC voltage is below 190Vdc
		480Vac: Stops when main-circuit DC voltage is below 380Vdc
	Momentary power loss ride-thru	Two selectable methods: 1. Time base for up to 2 seconds. 2. Until control power is active.
	Heatsink over-temperature	Protection by thermistor
Stall prevention	Stall prevention during acceleration, deceleration, and running	
Ground fault protection	Protection by electronic circuit (50% of inverter rated current)	
DC bus charge	Lit when the main circuit DC voltage is approximately 50Vdc or more	
Enclosure Type		Enclosed wall-mounted type (NEMA 1): CIMR-F7U20P4 thru 2018 and 40P4 thru 4018 Open chassis type (IP00): CIMR-F7U2022 thru 2110 and 4030 thru 4300
Environment	Ambient operating temperature	14°F to 104°F (-10°C to 40°C) NEMA 1 type
		14°F to 113°F (-10°C to 45°C) Open chassis type
	Ambient operating humidity	95% max. (with no condensation)
	Storage temperature	-4°F to 140°F (- 20°C to + 60°C) short-term temperature during transportation
	Mounting location	Indoor (no corrosive gas, dust, etc.)
	Altitude	3300 feet (1000 m) (higher altitudes by derate)
Vibration	10 to 20Hz, 32 ft/sec ² (9.8 m/s ²) max.; 20 to 50Hz, 6.5 ft/sec ² (2 m/s ²) max.	

Notes:

Appendix D Communications

This appendix details the specifications, connections, and programming of the Drive for Modbus communication.

Using Modbus Communication.....	D-2
Modbus Function Code Details.....	D-8
Modbus Data Tables	D-10
Modbus Self-Diagnosis.....	D-18

Using Modbus Communication

Serial communication can be performed with Program Logic Controllers (PLCs) or similar master devices using the Modbus protocol.

◆ Modbus Communication Configuration

Modbus communication is configured using 1 master (PLC) and a maximum of 31 slaves. Serial communication between master and slave is normally initiated by the master and responded to by the slaves.

The master performs serial communication with one slave at a time. Consequently, the slave address of each slave must be initially set, so that the master can perform serial communication using that address. Slaves receiving commands from the master perform the specified functions, and send a response back to the master.

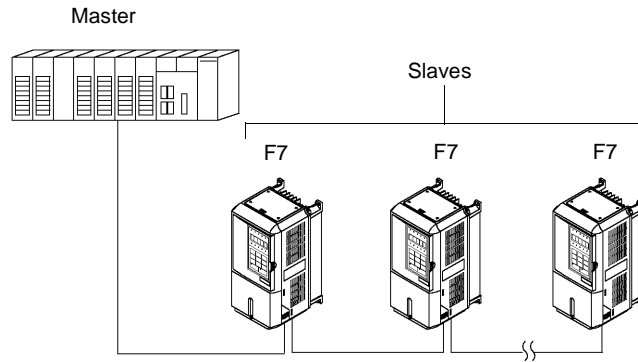

Fig D. 1 Example of Connections between Master and Drive

◆ Communication Specifications

The Modbus communication specifications are shown below:

Item	Specifications
Interface	RS-422, RS-485
Communications Cycle	Asynchronous (Start-stop synchronization)
Communications Parameters	Baud rate: Select from 1200, 2400, 4800, 9600, and 19200 bps. Data length: 8 bits fixed Parity: Select from even, odd, or none. Stop bits: 1 bit selected
Communications Protocol	Modbus RTU
Number of Connectable Units	31 units maximum

◆ Communication Connection Terminal

Modbus communication uses the following terminals: S+, S-, R+, and R-. The terminating resistor must be turned ON only if the Drive is at the very end of the serial communication chain. Set the terminating resistor by turning ON pin 1 of switch S1.

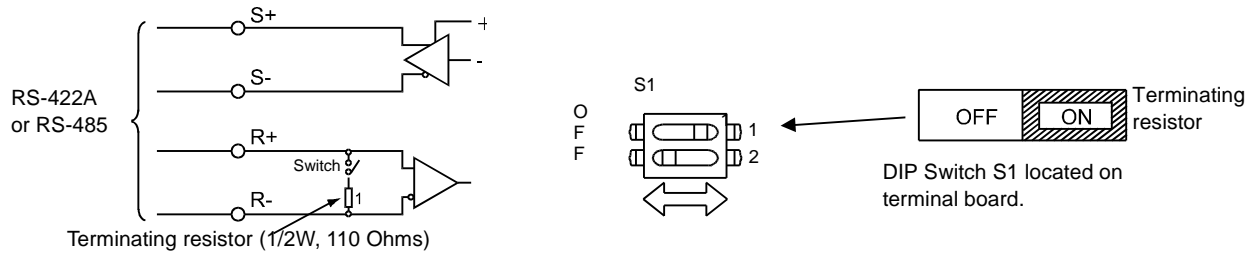

Fig. D.2 Communication Connection Terminals and Terminating Resistor

IMPORTANT

1. Separate the communication cables from the main circuit cables and control circuit wiring.
2. Use shielded cables for the communication cable, and use proper shield clamps. Shield at one end only.
3. When using RS-485 communication, connect S+ to R+, and S- to R-, on the control circuit terminal board. See Fig D.3 below.

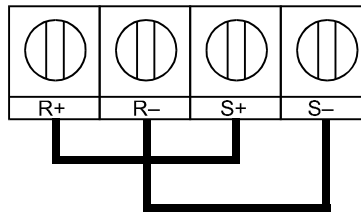

Fig. D.3 RS-485 Communication Connection

◆ Procedure for Setting Up Communication

Use the following procedure to perform communication with the PLC.

1. Turn OFF the input to the Drive power and connect the communication cable between the PLC (or other master device) and the Drive.
2. Turn ON the input power to the Drive.
3. Set the required communication parameters (H5-01 to H5-07) using the Digital Operator.
4. Turn OFF the input to the Drive power, and check that the Digital Operator display has completely extinguished.
5. Turn ON the input power to the Drive once again.
6. Perform communication with the master device.

■ Related Parameters

Table D.2 Serial Communication Related Parameters

Parameter No.	Parameter Name Digital Operator Display	Description	Setting Range	Factory Setting	Control Method			
					V/F	V/F w/ PG	Open Loop Vector	Flux Vector
b1-01	Frequency Reference Selection Reference Source	Selects the frequency reference input source. 0: Operator - Digital preset speed U1-01 or d1-01 to d1-17. 1: Terminals - Analog input terminal A1 (or terminal A2 based on parameter H3-13). 2: Serial Com - Modbus RS-422/485 terminals R+, R-, S+, and S-. 3: Option PCB - Option board connected to 2CN. 4: Pulse Input (Terminal RP)	0 to 4	1	Q	Q	Q	Q
b1-02	Run Command Selection Run Source	Selects the run command input source. 0: Operator - RUN and STOP keys on Digital Operator. 1: Terminals - Contact closure on terminals S1 or S2. 2: Serial Com - Modbus RS-422/485 terminals R+, R-, S+, and S-. 3: Option PCB - Option board connected to 2CN.	0 to 3	1	Q	Q	Q	Q
H5-01	Drive Node Address Serial Comm Adr	Selects Drive station node number (address) for Modbus terminals R+, R-, S+, S-. The Drive's power must be cycled for the setting to take effect. Set H5-01 to 0 to disable Drive responses to Modbus communications.	0 to 20 Hex	1F	A	A	A	A
H5-02	Communication Speed Selection Serial Baud Rate	Selects the baud rate for Modbus terminals R+, R-, S+ and S-. The Drive's power must be cycled for the setting to take effect. 0: 1200 bps 1: 2400 bps 2: 4800 bps 3: 9600 bps 4: 19200 bps	0 to 4	3	A	A	A	A
H5-03	Communication Parity Selection Serial Com Sel	Selects the communication parity for Modbus terminals R+, R-, S+ and S-. The Drive's power must be cycled for the setting to take effect. 0: No Parity 1: Even Parity 2: Odd Parity	0 to 2	0	A	A	A	A
H5-04	Stopping Method After Communication Error Serial Fault Sel	Selects the stopping method when a communication timeout fault (CE) is detected. 0: Ramp to Stop 1: Coast to Stop 2: Fast-Stop 3: Alarm Only 4: Run at d1-04	0 to 3	3	A	A	A	A
H5-05	Communication Fault Detection Selection Serial Flt Dctt	Enables or disables the communications timeout fault (CE). 0: Disabled - A communication loss will not cause a communication fault. 1: Enabled - If communication is lost for more than 2 seconds, a CE fault will occur.	0 to 10	1	A	A	A	A
H5-06	Drive Transmit Wait Time Transmit WaitTIM	Set the delay time from when the Drive receives data to when the Drive sends data.	5 to 65	5ms	A	A	A	A
H5-07	RTS Control Selection RTS Control Sel	Enables or disables "request to send" (RTS) control: 0: Disabled (RTS is always on) 1: Enabled (RTS turns on only when sending)	0 to 1	1	A	A	A	A

Modbus communication can perform the following operations regardless of the settings in b1-01 and b1-02:

1. Monitor the operation status of the Drive.
2. Set and read Drive parameters.
3. Reset faults.
4. Input multi-function digital input commands.
5. Control multi-function digital and analog outputs.

IMPORTANT

An OR operation is performed between the multi-function command input from the master device and the command input from multi-function digital input terminals S3 to S8.

■ Message Format

In Modbus communication, the master sends commands to the slave, and the slave responds. The message format is configured for both sending and receiving as shown below. The length of the data packet is controlled by the command (function) contents.

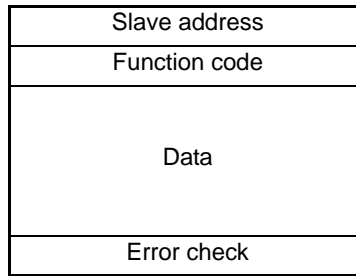

Fig. D.4 Message Format

The space between messages must support the following:

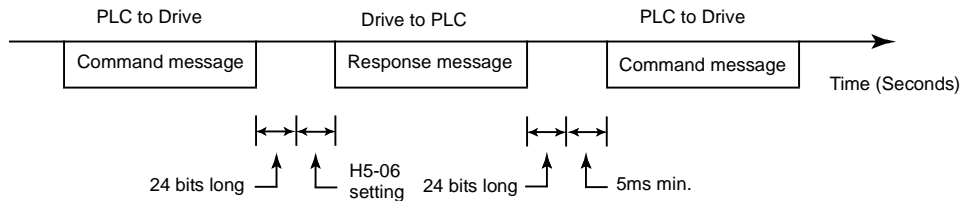

Fig. D.5 Message Spacing

Slave Address

Set the Drive address from 0 to 20 Hex. If 0 is selected, commands from the master will be broadcast (i.e., the Drive will not return a response message).

Function Code

The function code specifies command type. There are four function codes, as shown below.

Table D.3 Modbus Function Codes					
Function Code (Hexadecimal)	Function	Command Message		Response Message	
		Min. (Bytes)	Max. (Bytes)	Min.* (Bytes)	Max. (Bytes)
03H	Reading/Holding Register Contents	8	8	7	37
06H	Write In Single Holding Register	8	8	8	8
08H	Loopback Test	8	8	8	8
10H	Write In Several Holding Registers	11	41	8	8

* Minimum bytes for a normal Response Message (error response message is always 5 bytes).

Data

Configure consecutive data by combining the storage register address (test code for a loopback address) and the data the register contains. The data length changes depending on the command details.

Error Check

Errors are detected during communication using CRC-16. Perform calculations using the following method:

1. The factory setting for CRC-16 communication is typically zero, but when using the Modbus system, set the factory setting to one (e.g., set all 16 bits to 1).
2. Calculate CRC-16 using MSB as slave address LSB, and LSB as the MSB of the final data.
3. Calculate CRC-16 for response messages from the slaves and compare them to the CRC-16 in the response messages.

CRC-16

At the end of the message, the data for CRC error checking is sent in order to detect errors in signal transmission. In Modbus RTU, the error check is conducted in the form of a CRC-16 (Cyclical Redundancy Check). The CRC field checks the contents of the entire message. It is applied regardless of any parity check method used for the individual characters of the message.

The CRC field is two bytes, containing 16-bit binary value. The CRC value is calculated by the transmitting device, which appends the CRC to the message. The receiving device recalculates a CRC during receipt of the message, and compares the calculated value to the actual value it received in the CRC field. If the two values are not equal, an error results.

The CRC is started by first preloading a 16-bit register to all 1's. Then, a process begins of applying successive 8-bit bytes of the message to the current contents of the register. Start and stop bits and the parity bit (if one is used) do not apply to the CRC.

During generation of the CRC, each 8-bit character is exclusive OR'ed with the register contents. Then the result is shifted in the direction of the least significant bit (LSB), with a zero filled into the most significant bit (MSB) position. The LSB is extracted and examined. If the LSB is a 1, the register is then exclusive OR'ed with a preset, fixed value (A001h). If the LSB is a 0, no exclusive OR takes place.

This process is repeated until eight shifts have been performed. After the last (eighth) shift, the next 8-bit byte is exclusive OR'ed with the register's current value, and the process repeats for eight more shifts as described above. The final contents of the register, after all the bytes of the message have been applied, is the CRC value.

For applications using a host computer, detailed examples of a CRC generation using Quick Basic and in C are shown on the following pages.

Typical CRC-16 Calculation Program in Quick Basic

```
crcsum# = &HFFFF&
crcshift# = &H0&
crcconst# = &HA001&

CLS
PRINT "*****"
PRINT
PRINT "          CRC-16 Calculator          "
PRINT
PRINT "*****"
PRINT "If entering data in hex, precede the data with '&H'"
PRINT "  Example: 32decimal = 20hex = &H20"
PRINT "*****"
PRINT
```

```
INPUT "Enter the number of bytes in the message: ", maxbyte
```

```
FOR bytenum = 1 TO maxbyte STEP 1
  PRINT "Enter byte "; bytenum; "":
  INPUT byte&
  byte& = byte& AND &HFF&
  crcsum# = (crcsum# XOR byte7) AND &HFFFF&
  FOR shift = 1 TO 8 STEP 1
    crcshift# = (INT(crcsum# / 2)) AND &H7FFF&
    IF crcsum# AND &H1& THEN
      crcsum# = crcshift# XOR crcconst#
    ELSE
      crcsum# = crcshift#
    END IF
  NEXT shift
NEXT bytenum
```

```
lower& = crcsum# AND &HFF&
upper& = (INT(crcsum# / 256)) AND &HFF&
```

```
PRINT "Lower byte (1st) = ", HEX$(lower&)
PRINT "Upper byte (2nd) = ", HEX$(upper&)
```

Typical CRC-16 Calculation Program in C

```
// *buf      pointer to character array that contains the characters used to calculate CRC
// *bufLen   number of characters to calculate CRC for
// *crc      pointer to the array that contains the calculated CRC

void getMBCRC(char *buf, int bufLen, char *crc) {
    unsigned long crc_0 = 0xffff;           // Declare and initialize variables
    unsigned long crc_1 = 0x0000;
    int i,j;
    for (i=0; i<bufLen; i++) {
        crc_0 ^= ((unsigned long)buf[i] & 0x0ff); // Loop through characters of input array
        for (j=0; j<8; j++){ // XOR current character with 0x00ff
            crc_1 = (crc_0 >> 1) & 0x7fff; // Loop through character bits
            if (crc_0 & 0x0001) // Shift result right one place and store
                crc_0 = (crc_1 ^ 0xa001); // if pre-shifted value bit 0 is set
            else // XOR the shifted value with 0xa001
                crc_0 = crc_1; // if pre-shifted value bit 0 is not set
            // set the pre-shifted value equal to the shifted value
        }
    }
    crc[0] = (unsigned char)((crc_0/256) & 0x00ff); // Hi byte
    crc[1] = (unsigned char)((crc_0 & 0x00ff); // Lo byte
return;
}
```

No Response Message

The Drive disregards the command message and does not return the response message in the following cases:

1. In simultaneous broadcasting of data (slave address field is 0), all slaves execute but do not respond.
2. When a communication error (overrun, framing, parity, or CRC-16) is detected in the command message.
3. When the slave address in the command message does not coincide with the address set in the slave.
4. When the command message data length is not proper.

Modbus Function Code Details

◆ Reading/Holding Register Contents (03H)

Read the contents of the storage register only for specified quantities. The addresses must be consecutive, starting from a specified address. The data content of the storage register are separated into higher 8 bits and lower 8 bits.

The following table shows message examples when reading status signals, error details, data link status, and frequency references from the slave 2 Drive.

Command Message			Response Message (During Normal Operation)			Response Message (During Error)		
Slave Address		02H	Slave Address		02H	Slave Address		02H
Function Code		03H	Function Code		03H	Function Code		83H
Start Address	Higher	00H	Data quantity		08H	Error code		03H
	Lower	20H	1st storage register	Higher	00H	CRC-16	Higher	F1H
Quantity	Higher	00H		Lower	65H		Lower	31H
	CRC-16	Higher	45H	Next storage register	Higher	00H		
Lower		F0H	Lower		00H			
			Next storage register	Higher	00H			
				Lower	00H			
			Next storage register	Higher	01H			
				Lower	F4H			
			CRC-16	Higher	AFH			
				Lower	82H			

Fig. D.6 Function Code 03H Message Example

◆ Write In Single Holding Register (06H)

Command Message			Response Message (During Normal Operation)			Response Message (During Error)		
Slave address		01H	Slave address		01H	Slave address		01H
Function code		06H	Function code		06H	80H + Function code		86H
Register Address	Higher	00H	Register Address	Higher	00H	Error Code		21H
	Lower	01H		Lower	01H	CRC-16	Higher	82H
Setting Data	Higher	00H	Setting Data	Higher	00H		Lower	78H
	Lower	03H		Lower	03H			
CRC-16	Higher	98H	CRC-16	Higher	98H			
	Lower	0BH		Lower	0BH			

Fig. D.7 Function Code 06H Message Example

◆ Loopback Test (08H)

The loopback test returns the command message directly as the response message without changing the contents to check the communications between the master and slave. Set user-defined test code and data values.

The following table shows a message example when performing a loopback test with the slave 1 Drive.

Command Message			Response Message (During Normal Operation)			Response Message (During Error)		
Slave address		01H	Slave address		01H	Slave address		01H
Function code		08H	Function code		08H	Function code		88H
Test Code	Higher	00H	Test Code	Higher	00H	Error Code		01H
	Lower	00H		Data	Lower	00H	CRC-16	Higher
Data	Higher	A5H	Data		Higher	A5H		CRC-16
	Lower	37H		CRC-16	Lower	37H		
CRC-16	Higher	DAH	CRC-16		Higher	DAH		
	Lower	8DH		CRC-16	Lower	8DH		

Fig. D.8 Function Code 08H Message Example

◆ Write In Several Holding Registers (10H)

Write the specified data to the registers from the specified addresses. The written data must be consecutive, starting from the specified address in the command message: Higher 8 bits, then lower 8 bits, in storage register address order. The following table shows an example of a message when a forward run command and a speed command of 60.0Hz has been set in slave 1 by the PLC.

IMPORTANT Set the number of data specified using command messages as quantity of specified messages x 2. Handle response messages in the same way.

Command Message			Response Message (During Normal Operation)			Response Message (During Error)		
Slave Address		01H	Slave Address		01H	Slave Address		01H
Function Code		10H	Function Code		10H	Function Code		90H
Start Address	Higher	00H	Start Address	Higher	00H	Error code		02H
	Lower	01H		Quantity	Lower	01H	CRC-16	Higher
Quantity	Higher	00H	Quantity		Higher	00H		CRC-16
	Lower	02H		CRC-16	Lower	02H		
No. of data		04H	CRC-16		Higher	10H		
Lead data	Higher	00H		CRC-16	Lower	08H		
	Lower	01H						
Next data	Higher	02H						
	Lower	58H						
CRC-16	Higher	63H						
	Lower	39H						

* No. of data = 2 x (quantity)

Fig. D.9 Function Code 10H Message Example

Modbus Data Tables

The data tables are shown below. The types of data are as follows: Reference data, monitor data, broadcast data, and parameter data.

◆ Reference Data

The reference data table is shown below. Reference data can be read and written to.

Table D.4 Reference Data		
Register No.	Contents	
0000H	Reserved	
0001H	Input terminal status	
	Bit 0	Run Forward command Run = 1 Stop = 0
	Bit 1	Run Reverse command Run = 1 Stop = 0
	Bit 2	External fault: Fault (EFO) = 1
	Bit 3	Fault reset: Reset command = 1
	Bit 4	ComNet
	Bit 5	ComCtrl
	Bit 6	Multi-function digital input command 3 (terminal S3)
	Bit 7	Multi-function digital input command 4 (terminal S4)
	Bit 8	Multi-function digital input command 5 (terminal S5)
	Bit 9	Multi-function digital input command 6 (terminal S6)
	Bit A	Multi-function digital input command 7 (terminal S7)
	Bit B	Multi-function digital input command 8 (terminal S8)
Bits C to F	Not used	
0002H	Frequency reference (Set units using parameter o1-03)	
0003H to 0005H	Not used	
0006H	PID Setpoint	
0007H	Analog output 1 (terminal FM) setting (-11V = 726 to 11V = 726) → 10V = 660	
0008H	Analog output 2 (terminal AM) setting (-11V = 726 to 11V = 726) → 10V = 660	
0009H	Multi-function contact output settings	
	Bit 0	Digital output 1 (terminal M1-M2): ON = 1 OFF = 0
	Bit 1	Digital output 2 (terminal M3-M4): ON = 1 OFF = 0
	Bit 2	Digital output 3 (terminal M5-M6): ON = 1 OFF = 0
	Bits 3 to 5	Not used
	Bit 6	Set Fault contact (terminal MA-MC) output using bit 7: ON = 1 OFF = 0
	Bit 7	Fault contact (terminal MA-MC): ON = 1 OFF = 0
Bits 8 to F	Not used	
000AH to 000EH	Not used	
000FH	Reference selection settings	
	Bit 0	Not used
	Bit 1	Input PID setpoint 1: Enabled 0: Disabled
	Bits 3 to B	Not used
	C	Broadcast data terminal S5 input: Enabled = 1 Disabled = 0
	D	Broadcast data terminal S6 input: Enabled = 1 Disabled = 0
	E	Broadcast data terminal S7 input: Enabled = 1 Disabled = 0
F	Broadcast data terminal S8 input: Enabled = 1 Disabled = 0	
000CH to 000FH	Refer to Table D.6, broadcast data, when using bits 000CH through 000FH	
Note: Write 0 to all unused bits. Do not write data to reserved or "Not Used" registers and bits.		

Monitor Data

The following table shows the monitor data. Monitor data can only be read.

Table D.5 Monitor Data		
Register No.	Contents	
0010H	Status signal	
	Bit 0	Run command
	Bit 1	At zero speed
	Bit 2	Reverse operation
	Bit 3	Fault reset signal
	Bit 4	Speed agree
	Bit 5	Drive ready
	Bit 6	Alarm
	Bit 7	Fault
	Bits 8 to D	Not used
	Bit E	ComRef
Bit F	ComCtrl	
0011H	Fault details	
	Bit 0	OPE error
	Bit 1	Err error
	Bit 2	Program mode
	Bit 3	ICN status
	Bit 4	
Bit 5 to F	Not used	
0012H	oPE details	oPE error code (OPE01=1, OPE02=2, OPE03=3, OPE06=6, OPE10=10, OPE11=11)
0013H	Not used	
0014H	Fault content 1	
	Bit 0	Fuse blown (FU)
	Bit 1	DC bus undervoltage (UV1)
	Bit 2	Control power supply undervoltage (UV2)
	Bit 3	Main circuit answerback (UV3)
	Bit 4	Not used
	Bit 5	Ground fault (GF)
	Bit 6	Overcurrent (OC)
	Bit 7	Overvoltage (OV)
	Bit 8	Heatsink overtemperature (OH)
	Bit 9	Drive overheat (OH1)
	Bit A	Motor overload (OL1)
	Bit B	Drive overload (OL2)
	Bit C	Overtorque 1 (OL3)
	Bit D	Overtorque 2 (OL4)
	Bit E	Dynamic Braking Transistor (RR)
Bit F	Dynamic Braking Resistor (RH)	
Note: Write 0 to all unused bits. Do not write data to reserved or "Not Used" registers and bits.		

Table D.5 Monitor Data (Continued)

Register No.	Contents	
0015H	Fault content 2	
	Bit 0	External fault 3 (EF3)
	Bit 1	External fault 4 (EF4)
	Bit 2	External fault 5 (EF5)
	Bit 3	External fault 6 (EF6)
	Bit 4	External fault 7 (EF7)
	Bit 5	External fault 8 (EF8)
	Bit 6	Not used
	Bit 7	Overspeed (OS)
	Bit 8	Speed deviation (DEV)
	Bit 9	PG open (PGO)
	Bit A	Input phase loss (PF)
	Bit B	Output phase loss (LF)
	Bit C	DCCT fault (CF)
	Bit D	Operator disconnect (OPR)
Bit E	EEPROM write-in fault (ERR)	
Bit F	Not used	
0016H	Fault content 3	
	Bit 0	Modbus communication error (CE)
	Bit 1	Bus error (BUS)
	Bit 2	E-15, SI-F/G communications error (E-15)
	Bit 3	E-10, SI-F/G fail
	Bit 4	Control fault (CF)
	Bit 5	Zero servo fault (SVE)
	Bit 6	External fault (EF0)
Bits 7 to F	Not used	
0017H	CPF content 1	
	Bit 0	Not used
	Bit 1	Not used
	Bit 2	CPF02 fault
	Bit 3	CPF03 fault
	Bit 4	CPF04 fault
	Bit 5	CPF05 fault
	Bit 6	CPF06 fault
Bits 7 to F	Not used	
0018H	CPF content 2	
	Bit 0	CPF20 fault
	Bit 1	CPF21 fault
	Bit 2	CPF22 fault
	Bit 3	CPF23 fault
Bits 4 to F	Not used	

Note: Write 0 to all unused bits. Do not write data to reserved or "Not Used" registers and bits.

Table D.5 Monitor Data (Continued)

Register No.	Contents	
0019H	Alarm content 1	
	Bit 0	Undervoltage (UV)
	Bit 1	Overvoltage (OV)
	Bit 2	Heatsink overtemperature (OH)
	Bit 3	Drive overheat fault (OH1)
	Bit 4	Overtorque 1 detection (OL3)
	Bit 5	Overtorque 2 detection (OL4)
	Bit 6	2-wire sequence input (EF)
	Bit 7	External Baseblock (BB)
	Bit 8	External fault 3 (EF3)
	Bit 9	External fault 4 (EF4)
	Bit A	External fault 5 (EF5)
	Bit B	External fault 6 (EF6)
	Bit C	External fault 7 (EF7)
	Bit D	External fault 8 (EF8)
Bit E	Cooling fan (FAN)	
Bit F	Overspeed (OS)	
001AH	Alarm content 2	
	Bit 0	Speed deviation (DEV)
	Bit 1	PG open (PGO)
	Bit 2	Operator disconnected (OPR)
	Bit 3	Modbus communication (CE)
	Bit 4	Bus error (BUS)
	Bit 5	Waiting for transmission (CALL)
	Bit 6	Motor overload (OL1)
	Bit 7	Drive overload (OL2)
	Bit 8	SI-R/G alarm (E-15)
	Bit 9	External fault (EF0)
Bits A to F	Not used	
001BH	Not used	
001CH	Not used	
001DH	Not used	
001FH	Not used	
0020H	Drive status	
	Bit 0	Operation: Operating = 1 Stopped = 0
	Bit 1	Reverse operation: Reverse operation 0: Forward operation
	Bit 2	Drive start-up complete: Completed = 1 Not completed = 0
	Bit 3	Fault: Fault = 1
	Bit 4	Data setting error: Error = 1
	Bit 5	Multi-function digital output 1 (terminal M1 - M2): ON = 1 OFF = 0
	Bit 6	Multi-function digital output 2 (terminal M3 - M4): ON = 1 OFF = 0
	Bit 7	Multi-function digital output 3 (terminal M5 - M6): ON = 1 OFF = 0
Bits 8 to F	Not used	
Note: Communication error details are stored until an error reset is input (errors can be reset while the Drive is operating).		
Note: Write 0 to all unused bits. Do not write data to reserved or "Not Used" registers and bits.		

Table D.5 Monitor Data (Continued)

Register No.	Contents	
0021H	Fault details	
	Bit 0	Overcurrent (OC) or Ground fault (GF)
	Bit 1	Main circuit overvoltage (OV)
	Bit 2	Drive overload (OL2)
	Bit 3	Drive overheat (OH1, OH2)
	Bit 4	Not used
	Bit 5	Fuse blown (PUF)
	Bit 6	PID feedback reference lost (FbL)
	Bit 7	External error (EF, EFO)
	Bit 8	Hardware error (CPF)
	Bit 9	Motor overload (OL1) or Overtorque 1 (OL3) detected
	Bit A	PG open detected (PGO), Overspeed (OS) or Speed deviation (DEV)
	Bit B	Main circuit undervoltage (UV) alarm
	Bit C	Main circuit undervoltage (UV1), control power supply error (UV2), Soft charge circuit error (UV3)
	Bit D	Output phase loss (LF)
Bit E	Modbus communication error (CE)	
Bit F	Operator disconnected (OPR)	
0022H	Data link status	
	Bit 0	Writing data
	Bit 1	Not used
	Bit 2	Not used
	Bit 3	Upper and lower limit errors
	Bit 4	Data integrity error
	Bits 5 to F	Not used
0023H	Frequency reference	U1-01
0024H	Output frequency	U1-02
0025H	Output voltage reference	U1-06
0026H	Output current	U1-03
0027H	Output power	U1-08
0028H	Torque reference	U1-09
0029H	Not used	
002AH	Not used	
002BH	Sequence input status	
	Bit 0	Input terminal S1: ON = 1 OFF = 0
	Bit 1	Input terminal S2: ON = 1 OFF = 0
	Bit 2	Multi-function digital input terminal S3: ON = 1 OFF = 0
	Bit 3	Multi-function digital input terminal S4: ON = 1 OFF = 0
	Bit 4	Multi-function digital input terminal S5: ON = 1 OFF = 0
	Bit 5	Multi-function digital input terminal S6: ON = 1 OFF = 0
	Bit 6	Multi-function digital input terminal S7: ON = 1 OFF = 0
	Bit 7	Multi-function digital input terminal S8: ON = 1 OFF = 0
Bits 8 to F	Not used	

Note: Write 0 to all unused bits. Do not write data to reserved or "Not Used" registers and bits.

Table D.5 Monitor Data (Continued)

Register No.	Contents	
002CH	Drive status	
	Bit 0	Operation: Operating = 1
	Bit 1	Zero speed: Zero speed = 1
	Bit 2	Frequency agree: Matched = 1
	Bit 3	Desired frequency agree: Matched = 1
	Bit 4	Frequency detection 1: Output frequency \leq L4-01 = 1
	Bit 5	Frequency detection 2: Output frequency \geq L4-01 = 1
	Bit 6	Drive start-up completed: Start-up completed = 1
	Bit 7	Low voltage detection: Detected = 1
	Bit 8	Baseblock: Drive output baseblock = 1
	Bit 9	Frequency reference mode: Not communication = 1 Communication = 0
	Bit A	Run command mode: Not communication = 1 Communication = 0
	Bit B	Overtorque detection: Detected = 1
	Bit C	Frequency reference lost: Lost = 1
	Bit D	Retrying error: Retrying = 1
Bit E	Error (including Modbus communications time-out): Error occurred = 1	
Bit F	Modbus communications time-out Timed out = 0	
002DH	Multi-function digital output status	
	Bit 0	Multi-function digital output 1 (terminal M1-M2): ON = 1 OFF = 0
	Bit 1	Multi-function digital output 2 (terminal M3-M4): ON = 1 OFF = 0
	Bit 2	Multi-function digital output 3 (terminal M5-M6): ON = 1 OFF = 0
	Bits 3 to F	Not used
002EH - 0030H	Not used	
0031H	Main circuit DC voltage	
0032H - 0037H	Not used	
0038H	PID feedback level (Input equivalent to 100%/Max. output frequency; 10/1%; without sign)	
0039H	PID input level ($\pm 100\%/\pm$ Max. output frequency; 10/1%; with sign)	
003AH	PID output level ($\pm 100\%/\pm$ Max. output frequency; 10/1%; with sign)	
003BH	CPU software number	
003CH	Flash software number	
003DH	Communication error details	
	Bit 0	CRC error
	Bit 1	Invalid data length
	Bit 2	Not used
	Bit 3	Parity error
	Bit 4	Overrun error
	Bit 5	Framing error
	Bit 6	Time-out
	Bits 7 to F	Not used
003EH	kVA setting	
003FH	Control method	
Note: Communication error details are stored until an error reset is input (errors can be reset while the Drive is operating).		
Note: Write 0 to all unused bits. Do not write data to reserved or "Not Used" registers and bits.		

Broadcast Data

The following table shows the broadcast data.

Register Address	Contents	
0001H	Operation signal	
	Bit 0	Run command: Running = 1 Stopped = 0
	Bit 1	Run direction: Reverse = 1 Forward = 0
	Bits 2 and 3	Not used
	Bit 4	External fault (set using H1-01): Fault = 1
	Bit 5	Fault reset (set using H1-02): Reset = 1
	Bits 6 to B	Not used
	Bit C	Multi-function digital input terminal S5 input
	Bit D	Multi-function digital input terminal S6 input
	Bit E	Multi-function digital input terminal S7 input
	Bit F	Multi-function digital input terminal S8 input
0002H	Frequency reference	30000/100%
Note: Bit signals not defined in the broadcast operation signals use local node data signals continuously. Note: Refer to register 000FH, bits 000CH through 000FH, in Table D.4 when using bits 000CH through 000FH of broadcast data registerz 0001H.		

Enter Command

When writing parameters to the Drive from the master using Modbus communication, the parameters are temporarily stored in the constant data area in the Drive, and they will be lost if power to the Drive is shut OFF. To enable these parameters in the parameter data area, which is retained when power is removed, use the Enter command.

There are two types of Enter commands:

1. Enter command that enables parameter data in RAM.
2. Enter command that writes data to EEPROM (non-volatile memory) in the Drive and also enables data in RAM.

The following table shows the Enter command registers. Enter command registers can only be written.

The Enter command is enabled by writing 0 to register number 0900H or 0910H.

Register No.	Contents
0900H	Write parameter data to EEPROM.
0910H	Parameter data is not written to EEPROM, but refreshed in RAM only.

IMPORTANT

The maximum number of times you can write to EEPROM using the Drive is 100,000. Do not frequently execute Enter command (0900H) written to EEPROM.
 The Enter command registers are write-only. Consequently, if reading these registers, the register address will become invalid (Error code: 02H).

Error Codes

The following table shows Modbus communication error codes.

Error Code	Contents
01H	Function code error A function code other than 03H, 08H, or 10H has been set by the master.
02H	Invalid register number error <ul style="list-style-type: none">• The register address you are attempting to access is not recorded anywhere.• With broadcast sending, a start address other than 0000H, 0001H, or 0002H has been set.
03H	Invalid quantity error <ul style="list-style-type: none">• The number of data packets being read or written is outside the range of 1 to 16.• In write mode, the number of data packets in the message is not No. of packets x 2.
21H	Data setting error <ul style="list-style-type: none">• Upper limit or lower limit error has occurred in the control data or when writing parameters.• When writing parameters, the parameter setting is invalid.
22H	Write mode error <ul style="list-style-type: none">• Attempting to write parameters to the Drive during run.• Attempting to write via Enter commands during run.• Attempting to write parameters other than A1-00 to A1-05, E1-03, or 02-04 when a CPF03 (defective EEPROM) fault has occurred.• Attempting to write read-only data.
23H	Writing during main circuit undervoltage (UV) fault <ul style="list-style-type: none">• Writing parameters to the Drive during UV (main circuit undervoltage) alarm.• Writing via Enter commands during UV (main circuit undervoltage) alarm.
24H	Writing error during parameters processing Attempting to write parameters while processing parameters in the Drive.

Slave Not Responding

In the following cases, the slave will ignore the write function.

- When a communication error (overrun, framing, parity, or CRC-16) is detected in the command message.
- When the slave address in the command message and the slave address in the Drive do not agree.
- When the data that configures the message and the data time length exceed 24 bits.
- When the command message data length is invalid.

IMPORTANT

If the slave address specified in the command message is 0, all slaves execute the write function, but do not return response messages to the master.

Modbus Self-Diagnosis

The Drive has a built-in function for self-diagnosing the operations of the serial communication interface circuits. The self-diagnosis function tests the serial communications hardware of the Drive by jumpers the send and receive terminals to receive the same message as the Drive sends.

Perform the self-diagnosis function using the following procedure.

1. Turn ON the power supply to the Drive, and set parameter H1-05 (Terminal S7 function selection) to 67 (communication test mode).
2. Turn OFF the power supply to the Drive.
3. Jumper the following terminals while the power supply is turned OFF (see diagram below):

Connect S+ to R+.

Connect S- to R-.

Connect S7 to SC.

4. Turn ON the terminating resistor. (Turn ON pin 1 on DIP switch 1).
5. Turn ON the power supply to the Drive again.

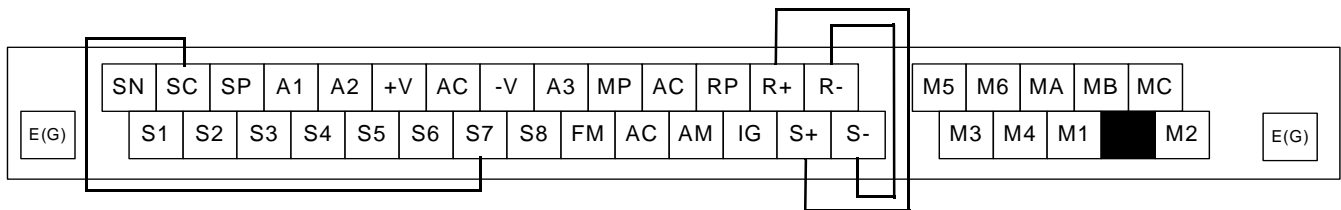

Fig. D.10 Communication Terminal Connection for Self -Diagnosis Function

6. During normal self-diagnostic operation, the Digital Operator displays the frequency reference value. If an error occurs, a CE (Modbus communication error) alarm will be displayed on the Digital Operator, the fault contact output will be turned ON, and the Drive operation ready signal will be turned OFF.

Appendix E Peripheral Devices

This appendix describes recommended branch short circuit protection and peripheral devices.

Branch Circuit Short Circuit Protection.....	E-2
Branch Circuit Overload Protection.....	E-5
Peripheral Devices	E-6

Branch Circuit Short Circuit Protection

The following peripheral devices may be required between the AC main circuit power supply and the Drive input terminals L1(R), L2(S), and L3(T). Refer to applicable codes to determine the devices necessary for a given installation. Use Table E.1 or E.2 when selecting fuses and circuit breakers per the NEC. When selecting semiconductor fuses to provide Drive input I²t protection and comply with UL, CSA, NEC, and CEC branch circuit short circuit protection requirements, select one of the fuses in Table E.3 or E.4.

Fuse Type: UL designated Time-Delay or Non-Time-Delay Fuse
 Class: CC, J, T, RK1 or RK5
 Designators (typical):KTK, FNQ, FRS, LPJ, LPS, JKS, JJN, or JJS
 Voltage Rating: 250V for Drives with 208-240V input
 600V for Drives with 480V input

Circuit Breaker Type: Inverse Time (MCCB) or Instantaneous Trip (MCP)
 Voltage Rating: 600V

Table E.1 Recommended Fuse and Circuit Breaker Ratings per NEC (208-240Vac Input)

Model CIMR-F7U	Hp	Input Amps *1 (Continuous Rating)	Output Amps *1 (Continuous Rating)	Fuse Selection Criteria		Circuit Breaker Selection Criteria
				Maximum Time-Delay Fuse Rating (A)	Maximum Non-Time-Delay Fuse Rating (A)	Maximum CB Rating (A)
20P4	0.5/0.75	4.3	3.6	6	12	15
20P7	1	5.5	4.6	8	12	15
21P5	1.5/2	9.4	7.8	15	15	15
22P2	3	13	10.8	20	20	20
23P7	5	20	16.8	30	30	35
25P5	7.5	24	23	40	50	45
27P5	10	37	31	60	80	80
2011	15	53	46.2	80	80	100
2015	20	70	59.4	110	125	125
2018	25	89	74.8	125	150	150
2022	30	98	88	150	150	175
2030	40	120	115	200	200	225
2037	50	180	162	250	250	300
2045	60	212	192	300	300	350
2055	75	237	215	350	350	450
2075	75/100	350	312	450	450	600
2090	125	396	360	600	600	700
2110	150	457	415	700	700	900

*1 Input and Output Amps are based on the Normal Duty (ND) current rating. Consult the Specification section for details on the Heavy Duty (HD) and Normal Duty (ND) ratings.

Table E.2 Recommended Fuse and Circuit Breaker Ratings per NEC (480Vac Input)

Model CIMR-F7U	Hp	Input Amps *1 (Continuous Rating)	Output Amps *1 (Continuous Rating)	Fuse Selection Criteria		Circuit Breaker Selection Criteria
				Maximum Time-Delay Fuse Rating (A)	Maximum Non-Time-Delay Fuse Rating (A)	Maximum CB Rating (A)
40P4	0.5/0.75	2.2	1.8	4	10	15
40P7	1	2.5	2.1	4	10	15
41P5	1.5/2	4.4	3.7	8	12	15
42P2	3	6.4	5.3	10	15	15
43P7	5	9	7.6	15	20	20
44P0	-	10.4	8.7	15	30	20
45P5	7.5	15	12.5	25	30	30
47P5	10	20	17	30	30	40
4011	15/20	33	27	45	50	60
4015	25	40	34	60	70	80
4018	30	48	40	70	80	90
4022	-	55	50.4	80	80	100
4030	40/50	74	67.2	100	100	125
4037	60	85	77	125	125	150
4045	75	106	96	150	150	200
4055	100	134	125	200	200	225
4075	125	172	156	250	250	300
4090	150	198	180	300	300	400
4110	200	264	240	350	350	450
4132	-	286	260	400	400	600
4160	250	334	304	450	450	700
4185	300/350	456	414	600	600	800
4220	400/450	567	515	700	700	1000
4300	500+	743	675	900	900	1200

*1 Input and Output Amps are based on the Normal Duty (ND) current rating. Consult the Specification section for details on the Heavy Duty (HD) and Normal Duty (ND) ratings.

Table E.3 Semiconductor Fuses for Drive I²t Protection and Branch Circuit Short Circuit Protection (200V Series)

Drive Model No. CIMR-F7*	Recommended			Alternate 1			Alternate 2		
	Fuse Mfr.	Model No.	Rating	Fuse Mfr.	Model No.	Rating	Fuse Mfr.	Model No.	Rating
20P4	Ferraz	A60Q12-2	600V, 12A	Ferraz	A070GRB006T13	700V, 6A	Bussmann	FWH-20A14F	500V, 20A
20P7	Ferraz	A60Q12-2	600V, 12A	Ferraz	A070GRB006T13	700V, 6A	Bussmann	FWH-20A14F	500V, 20A
21P5	Ferraz	A60Q15-2	600V, 15A	Ferraz	A70QS25-22F	700A, 25A	Bussmann	FWH-20A14F	500V, 20A
22P2	Ferraz	A60Q20-2	600V, 20A	Ferraz	6,900CPGRC14.51/25	690V, 25A	Bussmann	FWH-25A14F	500V, 25A
23P7	Ferraz	A60Q30-2	600V, 30A	Ferraz	A70QS32-14F	700A, 32A	Bussmann	FWH-45B	500V, 45A
25P5	Ferraz	A50P50-4	500V, 50A	Ferraz	A70QS50-14F	700V, 50A	Bussmann	FWH-80B	500V, 80A
27P5	Ferraz	A50P80-4	500V, 80A	Ferraz	A50QS70-4	500V, 70A	Bussmann	FWH-80B	500V, 80A
2011	Ferraz	A50P80-4	500V, 80A	Ferraz	A50QS100-4	500V, 100A	Bussmann	FWH-100B	500V, 100A
2015	Ferraz	A50P125-4	500V, 125A	Ferraz	A50QS150-4	500V, 150A	Bussmann	FWH-175B	500V, 175A
2018	Ferraz	A50P150-4	500V, 150A	Ferraz	A50QS175-4	500V, 175A	Bussmann	FWH-200B	500V, 200A
2022	Ferraz	A50P150-4	500V, 150A	Ferraz	A50QS200-4	500V, 200A	Bussmann	FWH-200B	500V, 200A
2030	Ferraz	A50P200-4	500V, 200A	Bussmann	FWH-200B	500V, 200A	Bussmann	FWH-225B	500V, 225A
2037	Ferraz	A50P250-4	500V, 250A	Ferraz	A30QS275-4	300V, 275A	Bussmann	170M4610	690V, 315A
2045	Ferraz	A50P300-4	500V, 300A	Ferraz	A30QS350-4	300V, 350A	Bussmann	FWH-350A	500V, 350A
2055	Ferraz	A50P350-4	500V, 350A	Bussmann	FWH-400A	500V, 400A	Bussmann	FWH-450A	500V, 450A
2075	Ferraz	A50P450-4	500V, 450A	Ferraz	A070URD33KI0550	700V, 550A	Bussmann	FWH-500A	500V, 500A
2090	Ferraz	A50P600-4	500V, 600A	Ferraz	A70P600-4	700V, 600A	Bussmann	FWH-600A	500V, 600A
2110	Ferraz	A50P600-4	500V, 600A	Ferraz	A70P700-4	700V, 700A	Bussmann	FWH-700A	500V, 700A

* Denotes letter A through Z

Table E.4 Semiconductor Fuses for Drive I²t Protection and Branch Circuit Short Circuit Protection (400V Series)

Drive Model No. CIMR-F7*	Recommended			Alternate 1			Alternate 2		
	Fuse Mfr.	Model No.	Rating	Fuse Mfr.	Model No.	Rating	Fuse Mfr.	Model No.	Rating
40P4	Ferraz	A60Q10-2	600V, 10A	Ferraz	A070GRB006T13	700V, 6A	Ferraz	A70QS16-14F	690V, 16A
40P7	Ferraz	A60Q10-2	600V, 10A	Ferraz	A070GRB006T13	700V, 6A	Ferraz	A70QS16-14F	690V, 16A
41P5	Ferraz	A60Q12-2	600V, 12A	Ferraz	6,900CPGRC14.51/25	690V, 25A	Ferraz	A70QS20-14F	690V, 20A
42P2	Ferraz	A60Q15-2	600V, 15A	Ferraz	A70QS25-22F	700V, 25A	Ferraz	A70QS20-14F	690V, 20A
43P7	Ferraz	A60Q20-2	600V, 20A	Ferraz	A70QS20-14F	700V, 20A	Ferraz	A70QS25-14F	690V, 25A
44P0	Ferraz	A60Q30-2	600V, 30A	Ferraz	A70QS32-14F	700V, 32A	Ferraz	A70QS40-14F	690V, 40A
45P5	Ferraz	A60Q30-2	600V, 30A	Ferraz	A70QS32-14F	700V, 32A	Ferraz	A70QS40-14F	690V, 40A
47P5	Ferraz	A60Q30-2	600V, 30A	Ferraz	A70QS40-14F	700V, 40A	-	-	-
4011	Ferraz	A70P50-4	700V, 50A	Ferraz	A50QS50-4	500V, 50A	Bussmann	FWH-80B	500V, 80A
4015	Ferraz	A70P70-4	700V, 70A	Ferraz	A50QS80-4	500V, 80A	Bussmann	FWH-100B	500V, 100A
4018	Ferraz	A70P80-4	700V, 80A	Ferraz	A50QS100-4	500V, 100A	Bussmann	FWH-125B	500V, 125A
4022	Ferraz	A70P80-4	700V, 80A	Ferraz	A50QS100-4	500V, 100A	Bussmann	FWH-125B	500V, 125A
4030	Ferraz	A70P100-4	700V, 100A	Ferraz	A50QS125-4	500V, 125A	Bussmann	FWH-125B	500V, 125A
4037	Ferraz	A70P125-4	700V, 125A	Ferraz	A50QS125-4	500V, 125A	Bussmann	FWH-150B	500V, 150A
4045	Ferraz	A70P150-4	700V, 150A	Ferraz	A50QS150-4	500V, 150A	Bussmann	FWH-175B	500V, 175A
4055	Ferraz	A70P200-4	700V, 200A	Ferraz	A70QS200-4	700V, 200A	Bussmann	FWH-200B	500V, 200A
4075	Ferraz	A70P250-4	700V, 250A	Ferraz	A50QS250-4	500V, 250A	Bussmann	FWH-250A	500V, 250A
4090	Ferraz	A70P300-4	700V, 300A	Ferraz	A50QS300-4	500V, 300A	Bussmann	170M4611	690V, 350A
4110	Ferraz	A70P350-4	700V, 350A	Ferraz	A50P350-4	500V, 350A	Bussmann	170M4611	690V, 350A
4132	Ferraz	A70P400-4	700V, 400A	Ferraz	A70P500-4	700V, 500A	Bussmann	170M5610	690V, 500A
4160	Ferraz	A70P450-4	700V, 450A	Ferraz	A70QS700-4	700V, 700A	Bussmann	FWH-600A	500V, 600A
4185	Ferraz	A70P600-4	700V, 600A	Ferraz	A70QS700-4	700V, 700A	Bussmann	FWH-700A	500V, 700A
4220	Ferraz	A70P700-4	700V, 700A	Bussmann	FWH-800A	500V, 800A	Bussmann	FWH-1000A	500V, 1000A
4300	Ferraz	A70P900-4	700V, 900A	Bussmann	FWH-1000A	500V, 1000A	Bussmann	FWH-1200A	500V, 1200A

* Denotes letter A through Z

Branch Circuit Overload Protection

All models have built-in UL evaluated motor overload protection. Motor overload protection is also provided in accordance with the NEC and CEC. Additional branch circuit overload protection is not required for single motor applications.

Peripheral Devices

The following peripheral devices may be required to be mounted between the AC main circuit power supply and the Drive input terminals R/L1, S/L2, and T/L3.

CAUTION

Never connect a general LC/RC noise filter to the Drive output circuit.
Never connect a phase-advancing capacitor to the input or output sides, or a surge suppressor to the output side of the Drive. When magnetic contactor is installed between the Drive and the motor, never turn it on or off during operation.

For more details on peripheral devices, contact the manufacturer.

Magnetic Contactor

Mount a surge protector on the coil. When using a magnetic contactor to start and stop the Drive, do not exceed one start per hour.

AC and DC reactor

When using models F7U20P4 thru F7U2018 and F7U40P4 thru F7U4018 on a power supply transformer with a capacity of 600kVA or more, install an AC or DC reactor. The reactor improves the input power factor and provides protection to the rectifier circuit within the Drive.

Noise filter

Use a noise filter exclusively for the Drive if radio noise generated from the Drive causes other control devices to malfunction. See Chapter 2.

Appendix F Spare Parts

This appendix lists the primary spare parts that may be needed to maintain or service the Drive.

F7 Primary Spare Parts - 208/230/240Vac F-2
F7 Primary Spare Parts - 480Vac F-3

F7 Primary Spare Parts - 208/230/240Vac

Table F.1 208-240Vac F7 Primary Spare Parts

Drive Model CIMR-F7U	Hp	Power PCB (3PCB)	Gate Drive PCB (3PCB)	Control PCB (1PCB)	Terminal PCB (2PCB)	Diode Module
20P4	0.5/0.75	ETP617012	N/A	ETC618390-S3020	ETC618410	Inside the Power Module
20P7	1	ETP617012	N/A	ETC618390-S3020	ETC618410	Inside the Power Module
21P5	1.5/2	ETP617022	N/A	ETC618390-S3020	ETC618410	Inside the Power Module
22P2	3	ETP617032	N/A	ETC618390-S3020	ETC618410	Inside the Power Module
23P7	5	ETP617042	N/A	ETC618390-S3020	ETC618410	Inside the Power Module
25P5	7.5	ETP617052	N/A	ETC618390-S3020	ETC618410	Inside the Power Module
27P5	10	ETP617062	N/A	ETC618390-S3020	ETC618410	Inside the Power Module
2011	15	ETP617422	N/A	ETC618390-S3020	ETC618410	SID003114 (D1)
2015	20	N/A	ETC617032	ETC618390-S3020	ETC618410	SID003113 (D1)
2018	25	N/A	ETC617042	ETC618390-S3020	ETC618410	SID003113 (D1)
2022	30	N/A	ETC617053	ETC618390-S3020	ETC618410	SID003114 (D1,D2)
2030	40	N/A	ETC617063	ETC618390-S3020	ETC618410	SID003113 (D1,D2)
2037	50	N/A	ETC617073	ETC618390-S3020	ETC618410	SID003130 (D1,D2)
2045	60	N/A	ETC617083	ETC618390-S3020	ETC618410	SID003115 (D1,D2)
2055	75	N/A	ETC617093	ETC618390-S3020	ETC618410	SID003115 (D1,D2)
2075	75/100	N/A	ETC617103	ETC618390-S3020	ETC618410	SID003116 (D1-D6)
2090	125	N/A	ETC617113	ETC618390-S3020	ETC618410	SID003116 (D1-D6)
2110	150	N/A	ETC617531	ETC618390-S3020	ETC618410	SID003108 (D1-D12)

Table F.1 208-240Vac F7 Primary Spare Parts (Continued)

Drive Model CIMR-F7U	Hp	Power Module	Transistor Module	DC Bus Fuse	Heat Sink Fan	Internal Fan
20P4	0.5/0.75	STR001297 (Q1)	N/A	FU-002029 (F1)	N/A	N/A
20P7	1	STR001297 (Q1)	N/A	FU-002029 (F1)	N/A	N/A
21P5	1.5/2	STR001299 (Q1)	N/A	FU-002029 (F1)	N/A	N/A
22P2	3	STR001301 (Q1)	N/A	FU-002030 (F1)	N/A	N/A
23P7	5	STR001303 (Q1)	N/A	FU-002031 (F1)	FAN001066 (B1)	N/A
25P5	7.5	STR001304 (Q1)	N/A	FU-002099 (F1)	FAN001066 (B1)	N/A
27P5	10	STR001278 (Q1)	N/A	FU-002107 (F1)	FAN001066 (B1,B2)	N/A
2011	15	N/A	STR001315 (Q1)	FU-002108 (F1)	FAN001066 (B1,B2)	FAN001043 (B3)
2015	20	N/A	STR001315 (Q1)	FU-002108 (F1)	FAN001065 (B1,B2)	N/A
2018	25	N/A	STR001320 (Q1)	FU-002109 (F1)	FAN001065 (B1,B2)	FAN001043 (B3)
2022	30	N/A	STR001314 (Q1)	FU-002110 (F1)	FAN001039 (B1,B2)	N/A
2030	40	N/A	STR001323 (Q1)	FU-002110 (F1)	FAN001039 (B1,B2)	N/A
2037	50	N/A	STR001293 (Q1-Q3)	FU-002102 (F1)	FAN001049 (B1,B2)	FAN001053 (B4)
2045	60	N/A	STR001335 (Q1-Q3)	FU-000925 (F1)	FAN001049 (B1,B2)	FAN001053 (B4)
2055	75	N/A	STR001335 (Q1-Q3)	FU-000938 (F1)	FAN001052 (B1,B2)	FAN001054 (B4)
2075	75/100	N/A	STR001349 (Q1-Q6)	FU-000926 (F1)	FAN001056 (B1,B2)	FAN001054 (B4)
2090	125	N/A	STR001338 (Q1-Q6)	FU-002105 (F1)	FAN001056 (B1,B2)	FAN001054 (B4)
2110	150	N/A	STR001351 (Q1-Q12)	FU-002106 (F1)	FAN001056 (B1,B2)	FAN001054 (B4)

F7 Primary Spare Parts - 480Vac

Drive Model CIMR-F7U	Hp	Power PCB (3PCB)	Gate Drive PCB (3PCB)	Control PCB (1PCB)	Terminal PCB (2PCB)	Diode Module
40P4	0.5/0.75	ETP617082	N/A	ETC618390-S3020	ETC618410	Inside the Power Module
40P7	1	ETP617082	N/A	ETC618390-S3020	ETC618410	Inside the Power Module
41P5	1.5/2	ETP617092	N/A	ETC618390-S3020	ETC618410	Inside the Power Module
42P2	3	ETP617102	N/A	ETC618390-S3020	ETC618410	Inside the Power Module
43P7	5	ETP617112	N/A	ETC618390-S3020	ETC618410	Inside the Power Module
44P0	-	ETP617122	N/A	ETC618390-S3020	ETC618410	Inside the Power Module
45P5	7.5	ETP617132	N/A	ETC618390-S3020	ETC618410	Inside the Power Module
47P5	10	ETP617142	N/A	ETC618390-S3020	ETC618410	Inside the Power Module
4011	15	ETP617152	N/A	ETC618390-S3020	ETC618410	Inside the Power Module
4015	20	ETP617162	N/A	ETC618390-S3020	ETC618410	SID003112 (D1)
4018	25	ETP617172	N/A	ETC618390-S3020	ETC618410	SID000605 (D1)
4022	30	N/A	ETC617141	ETC618390-S3020	ETC618410	SID003112 (D1,D2)
4030	40	N/A	ETC617151	ETC618390-S3020	ETC618410	SID003112 (D1,D2)
4037	50	N/A	ETC617161	ETC618390-S3020	ETC618410	SID003112 (D1,D2)
4045	60	N/A	ETC617171	ETC618390-S3020	ETC618410	SID000605 (D1,D2)
4055	75	N/A	ETC617181	ETC618390-S3020	ETC618410	SID000605 (D1,D2)
4075	100	N/A	ETC617190	ETC618390-S3020	ETC618410	SID003117 (D1,D2)
4090	125/150	N/A	ETC617200	ETC618390-S3020	ETC618410	SID003117 (D1,D2)
4110	-	N/A	ETC617210	ETC618390-S3020	ETC618410	SID003109 (D1-D6)
4132	200	N/A	ETC617220	ETC618390-S3020	ETC618410	SID003118 (D1-D6)
4160	250	N/A	ETC617230	ETC618390-S3020	ETC618410	SID003119 (D1-D6)
4185	300	N/A	ETC617240	ETC618390-S3020	ETC618410	SID003119 (D1-D6)
4220	350/400	N/A	ETC617250	ETC618390-S3020	ETC618410	SID003131 (D1-D6)
4300	450/500+	N/A	ETC617260	ETC618390-S3020	ETC618410	SID003119(D1-D12)

Drive Model CIMR-F7U	Hp	Power Module	Transistor Module	DC Bus Fuse	Heat Sink Fan	Internal Fan
40P4	0.5/0.75	STR001298 (Q1)	N/A	FU-002029 (F1)	N/A	N/A
40P7	1	STR001298 (Q1)	N/A	FU-002029 (F1)	N/A	N/A
41P5	1.5/2	STR001298 (Q1)	N/A	FU-002029 (F1)	N/A	N/A
42P2	3	STR001298 (Q1)	N/A	FU-002029 (F1)	FAN001066 (B1)	N/A
43P7	5	STR001300 (Q1)	N/A	FU-002031 (F1)	FAN001066 (B1)	N/A
44P0	-	N/A	N/A	FU-002031 (F1)	FAN001066 (B1)	N/A
45P5	7.5	STR001302 (Q1)	N/A	FU-002031 (F1)	FAN001066 (B1)	N/A
47P5	10	STR001279 (Q1)	N/A	FU-002032 (F1)	FAN001066 (B1,B2)	N/A
4011	15	N/A	STR001280 (Q1)	FU-002037 (F1)	FAN001066 (B1,B2)	FAN001043 (B3)
4015	20	N/A	STR001318 (Q1)	FU-002038 (F1)	FAN001065 (B1,B2)	N/A
4018	25	N/A	STR001318 (Q1)	FU-002038 (F1)	FAN001065 (B1,B2)	FAN001043 (B3)
4022	30	N/A	STR001324 (Q1)	FU-002038 (F1)	FAN001039 (B1,B2)	N/A
4030	40	N/A	STR001324 (Q1)	FU-002039 (F1)	FAN001039 (B1,B2)	N/A
4037	50	N/A	STR001316 (Q1-Q3)	FU-002040 (F1)	FAN001044 (B1,B2)	N/A
4045	60	N/A	STR001317 (Q1-Q3)	FU-002040 (F1)	FAN001044 (B1,B2)	N/A
4055	75	N/A	STR001317 (Q1-Q3)	FU-002101 (F1)	FAN001044 (B1,B2)	N/A
4075	100	N/A	STR001294 (Q1-Q3)	FU-002112 (F1)	FAN001052 (B1,B2)	FAN001054 (B4)
4090	125/150	N/A	STR001336 (Q1-Q6)	FU-002113 (F1)	FAN001052 (B1,B2)	FAN001054 (B4)
4110	-	N/A	STR001336 (Q1-Q6)	FU-002114 (F1)	FAN001056 (B1,B2)	FAN001054 (B4)
4132	200	N/A	STR001322 (Q1-Q6)	FU-000894 (F1)	FAN001056 (B1,B2)	FAN001054 (B4)
4160	250	N/A	STR001322 (Q1-Q3)	FU-000895 (F1)	FAN001056 (B1,B2)	FAN001054 (B4)
4185	300	N/A	STR001339 (Q1-Q12)	FU-000895 (F1)	FAN001056 (B1-B4)	FAN001054 (B6,B7)
4220	350/400	N/A	STR001341 (Q1-Q12)	FU-002116 (F1)	FAN001056 (B1-B4)	FAN001054 (B6,B7)
4300	450/500+	N/A	STR001342 (Q1-Q12)	FU-002117 (F1)	FAN001082 (B1-B5)	FAN001054 (B6,B7)

Notes:

A

AC and DC Reactor	E-6
Accel/Decel	5-8
Accel/Decel Time	
C1-01 Acceleration Time 1	4-12, 5-8
C1-02 Deceleration Time 1	4-12, 5-8
Alarm Detection	6-9
Alarm Displays and Processing	6-9
Ambient Temperature	1-11
Analog Output Gain	5-20
H4-02 Terminal FM Gain	5-20
H4-05 Terminal AM Gain	5-20
Auto-Tuning	4-10
No Rotate Tuning	4-11
Standard Tuning	4-10
Terminal Resistance Tuning	4-11
Auto-Tuning Faults	6-15
Auto-Tuning Fault Displays and Processing	6-15
Auto-Tuning Menu (-A.TUNE-)	3-13
T1-01 Tuning Mode Selection	3-14
T1-02 Motor Rated Power	3-14
T1-03 Rated Voltage	3-14
T1-04 Rated Current	3-14
T1-05 Rated Frequency	3-14
T1-06 Number of Poles	3-14
T1-07 Rated Speed	3-14
T1-08 PG Pulses/Rev	3-14

B

Base Frequency	4-13
Base Voltage	4-13
Braking Transistor Unit(s)	
Installation	2-15
Adjustments	2-18
Operation Check	2-18
Branch Circuit Overload Protection	E-5
Branch Circuit Short Circuit Protection	E-2

C

Capacity Related Parameters	B-1
Carrier Frequency	5-9
Carrier Frequency Selection	4-12, 5-9
Checking and Controlling the Installation Site	1-11
Coast to stop	5-6
Communication Connection Terminal	D-3
Communication Specifications	D-2
Communications	D-1
Component Names	1-5, 1-6, 3-2

Control Circuit	1-13, 1-16, 2-14, 2-15, 2-24, 2-36, 4-3, 4-4, 6-2, 6-3, 6-8, 6-12
Preventive Maintenance	7-3
Terminal Functions	2-20
+15Vdc power output	2-20
+24Vdc common	2-20
+24Vdc internal	2-20
-15Vdc power output	2-20
Add to terminal A1	2-20
Analog common	2-20, 2-21
Analog input or speed command	2-20
Aux. frequency reference 1	2-20
Digital input common	2-20
During run (N.O. contact)	2-20
External baseblock N.O.	2-20
External fault input	2-20
Fault output signal (SPDT)	2-20
Fault reset	2-20
Forward run/stop command	2-20
Frequency agree (N.O. contact)	2-20
Jog frequency reference	2-20
Modbus communication input	2-21
Modbus communication output	2-21
Multi-step speed reference 1	2-20
Multi-step speed reference 2	2-20
Output current	2-21
Output frequency	2-21
Pulse input	2-21
Pulse monitor	2-21
Remote/auto operation (N.O. contact)	2-20
Reverse run/stop command	2-20
Shield wire, optional ground	
line connection point	2-20
Signal common	2-21
Terminals	1-5
Terminal Layout	2-2
Wire sizes	2-24
Wiring Precautions	2-24
Control circuit failure/damage	6-3
Control circuit fault	6-8
Control Method	5-2
Control Method Selection	4-12
Control Wiring	2-20

D

Deceleration Time 1	4-12
Delivery	
Confirmation	1-3
Receiving Checks	1-3
Diagnostics & Troubleshooting	6-1
Digital Operator	1-5, 1-6, 1-16, 4-15, 4-7, 5-3

Alarm Detection	6-9
Attaching	1-14
Auto-Tuning Faults	6-15, 16
Connection Fault	6-7
Contrast	A-37
COPY Function	A-39
COPY Function Faults	6-17
Display	3-2, 3-15
Display Scaling	A-37
Fault Detection	6-2
Keys	3-3
Mounting	1-15
Operating Programming Errors (OPE)	6-13
Parameter List	A-3
Preventive Maintenance	7-3
Removing	1-14
RUN Key	5-4
Trouble Shooting	6-18
DIP Switch S1	2-22
Drive Capacity Setting	
Selection	B-2
Parameters Affected	B-3
Drive Date Stamp Information	6-29
Drive Enclosure and Revision Code	1-4
Drive Main Circuit Configurations	2-10
Drive Main Menus	3-6
Auto-Tuning	3-6
Modified Constants	3-6
Operation	3-6
Programming	3-6
Quick Setting	3-6
Drive Mode Indicators	3-4
Drive Model Numbers	1-4
Drive rating	1-4
Drive rating	B-2
Drive Start-Up Preparation	4-2
Drive Start-Up Procedures	4-5
Auto-Tuning	4-10
Flux Vector Start-up	4-9
Open Loop Vector Start-up	4-8
V/F Start-up	4-6
V/F w/ PG Start-up	4-7
Dynamic braking (DB)	2-12
Dynamic Braking Connections	
General	2-12
Installation	2-12

E

Electrical Installation	2-1
Electromagnetic Compatibility (EMC)	2-26
Cable Installation	2-26
EMC Directive	2-26
Recommended EMC Filters	2-28
Enclosure type	1-4, C-5
Example of Changing a Parameter	3-15
Exterior and Mounting Dimensions	1-7

F

F7 Basic Programming Parameters	
Control Method	5-2
Description of Parameter Tables	5-2
F7 Basic Programming Parameters	5-2
Fault Detection	6-2
Fault Displays and Processing	6-2
Fault History List	A-43
Fault Trace List	A-43
Field Wiring Diagram	2-25
Frequency Reference	3-8
Frequency Reference 1	4-12
Frequency Reference 2	4-12
Frequency Reference 3	4-12
Frequency Reference 4	4-12
Frequency Reference Selection	4-12
Front cover	1-5, 1-6
Removing/Attaching	1-14
Function Code	D-5
Modbus	D-5

G

Ground Wiring	2-11
---------------------	------

H

Heat Sink	2-12, 6-29
Die-cast	1-5
Heat Sink Mount Dynamic Braking Resistor	2-12
Heat Sink Mount Resistor (ERF)	2-12
Installation	2-13
Heatsink Cooling Fan Replacement	7-5
Installing the Heatsink Cooling Fan	7-5
Mounting the Heatsink Cooling Fan Assembly	7-6
Removing the Heatsink Cooling Fan	7-5
Removing the Heatsink Cooling Fan Assembly	7-6
High Frequency (HF)	2-26
High Speed Operation	5-13
High Starting Torque	5-13

I		
Input Voltage Setting.....	4-13	
E1-01 Input Voltage Setting	5-11	
Installation Orientation and Clearances	1-12	
Installation Site		
Checking and Controlling	1-11	
Specifications	1-11	
Installing and Wiring Option Boards	2-30	
Installation	2-31	
Option Board Models and Specifications	2-30	
PG (Encoder) Feedback Board Terminal		
Specifications and Wiring Examples	2-32	
PG-A2	2-32	
PG-B2	2-34	
PG-D2	2-35	
PG-W2	2-37	
PG-X2	2-36	
J		
Jog Frequency Reference	4-12	
Jumper CN15	2-22	
L		
Low Frequency (LF)	2-26	
M		
Magnetic Contactor	E-6	
Main Circuit Configurations	2-9	
Main Circuit Terminal Functions	2-9	
Main Circuit Terminals		
Wiring	2-3	
Applicable Wire Sizes and Closed-loop		
Connectors	2-3	
Recommended Connectors for		
Terminal Connections	2-8	
Main Circuit Test Procedure		
Flowchart	6-26	
Main Circuit Test Procedure	6-26	
Main Menu Structure	3-7	
Maintenance	7-1	
Maximum Output Frequency	4-13	
Maximum Output Voltage	4-13	
Message Format	D-5	
Minimum Output Frequency	4-13	
Modbus Communication	D-2	
Configuration	D-2	
Modbus Data Tables	D-10	
Broadcast Data	D-16	
Enter Command	D-16	
Error Codes	D-17	
Monitor Data	D-11	
Reference Data	D-10	
Slave Not Responding	D-17	
Modbus Function Code Details		
Loopback Test (08H)	D-9	
Reading/Holding Register Contents (03H)	D-8	
Write In Several Holding Registers (10H)	D-9	
Write In Single Holding Register (06H)	D-8	
Modbus Function Code Details	D-8	
Modbus Function Codes	D-5	
Modbus Self-Diagnosis	D-18	
Modified Constants Menu (-VERIFY-)	3-13	
Monitor List	A-40	
Motor Overload Fault	5-21	
L1-01 Motor Overload Fault Selection	5-21	
Motor Overload Protection Selection	4-14	
Motor Rated Current	4-13	
Motor Rated Output	4-13	
Motor Setup	5-19	
E2-01 Motor Rated Current	5-19	
E2-04 Number of Motor Poles	5-19	
E2-11 Motor Rated Power	5-19	
Mounting hole	1-5, 7-5	
Multiple Braking Transistor Units	2-15	
N		
Nameplate		
Information	1-3	
Nameplate	1-3, A-16	
No Response Message	D-7	
Noise Filter	E-6	
Number of Motor Poles	4-13	
O		
Open Chassis Type	1-4, C-5	
Operation Menu (-DRIVE-)		
U1 Monitor List.....	3-8	
U1-01 Frequency Reference	3-8	
U1-02 Output Frequency	3-8	
U1-03 Output Current	3-8	
U1-04 Control Method	3-8	
U1-05 Motor Speed	3-8	
U1-06 Output Voltage	3-8	
U1-07 DC Bus Voltage	3-8	
U1-08 Output Power	3-8	
U1-09 Torque Reference	3-8	
U1-10 Input Terminal Status	3-8	
U1-11 Output Terminal Status	3-8	

U1-12 Drive Operation Status	3-8	U3-05 Elapsed Time 1	3-10
U1-13 Cumulative Operation Time	3-8	U3-06 Elapsed Time 2	3-10
U1-14 Software Number	3-8	U3-07 Elapsed Time 3	3-10
U1-15 Terminal A1 Input Voltage	3-8	U3-08 Elapsed Time 4	3-10
U1-16 Terminal A2 Input Voltage	3-8	U3-09 Fault Message 5	3-10
U1-17 Terminal A3 Input Voltage	3-8	U3-10 Fault Message 6	3-10
U1-18 Motor Secondary Current	3-8	U3-11 Fault Message 7	3-10
U1-19 Motor Excitation Current	3-8	U3-12 Fault Message 8	3-10
U1-20 Output Frequency after Soft-Start	3-8	U3-13 Fault Message 9	3-10
U1-21 ASR Input	3-8	U3-14 Fault Message 10	3-10
U1-22 ASR Output	3-8	U3-15 Elapsed Time 5	3-10
U1-24 PI Feedback Value	3-8	U3-16 Elapsed Time 6	3-10
U1-25 DI-16 H2 Input Status	3-8	U3-17 Elapsed Time 7	3-10
U1-26 Output Voltage Reference	3-8	U3-18 Elapsed Time 8	3-10
U1-27 Output Voltage Reference	3-8	U3-19 Elapsed Time 9	3-10
U1-28 CPU Number	3-8	U3-20 Elapsed Time 20	3-10
U1-29 kWh (Lower 4 digits)	3-8	Operation Menu (-DRIVE-)	3-8
U1-29 MWh (Upper 5 digits)	3-8	Operator Programming Errors (OPE)	6-13
U1-32 ACR(q) Output	3-8	OPE Error Displays	6-13
U1-33 ACR(d) Output	3-8		
U1-34 OPE Detected	3-8	P	
U1-35 Zero Servo Pulse Count	3-8	Parameter	
U1-36 PID Input	3-8	Affected by Drive Capacity Setting	B-3
U1-37 PID Output	3-8	Basic Programming	5-2
U1-38 PID Setpoint	3-8	Copy	3-2
U1-39 Modbus Error Code	3-8	Description of Parameter Tables	5-2
U1-40 Cooling Fan Elapsed Time	3-8	Group List	3-12
U1-41 Heatsink Temperature	3-8	Motor Parameters	3-13
U1-44 ASR Output with or without Filter	3-8	Parameter List	A-3
U1-45 Feed Forward Control Output	3-8	Serial Communication	D-4
U1-46 Feed Forward Set Speed	3-8	Set/read modified	3-13
U1-49 CPU Share	3-8	Setting	3-12
U2 Fault Trace List	3-9	Part Replacement Guidelines	7-4
U2-01 Current Fault	3-9	Periodic Inspection	7-2
U2-02 Previous Fault	3-9	Periodic Inspections With no Power Applied	7-2
U2-03 Frequency Reference at Fault	3-9	Periodic Inspections With Power Applied	7-2
U2-04 Output Frequency at Fault	3-9	Periodic Maintenance of Parts	7-4
U2-05 Output Current at Fault	3-9	Peripheral Devices	E-6
U2-06 Motor Speed at Fault	3-9	AC and DC reactor	E-6
U2-07 Output Voltage at Fault	3-9	Magnetic Contactor	E-6
U2-08 DC Bus Voltage at Fault	3-9	Noise filter	E-6
U2-09 Output Power at Fault	3-9	PG (Encoder) Feedback Board Terminal	
U2-11 Input Terminal Status at Fault	3-9	Specifications and Wiring Examples	2-32
U2-12 Output Terminal Status at Fault	3-9	PG Option	5-19
U2-13 Drive Operation Status at Fault	3-9	F1-01 PG Pulses / Revolution	5-19
U2-14 Cumulative Operation Time at Fault	3-9	PG Parameter	4-13
U3 Fault History List	3-10	Preset Reference	5-10
U3-01 Last Fault	3-10	d1-01 Frequency Reference 1	5-10
U3-02 Fault Message 2	3-10	d1-02 Frequency Reference 2	5-10
U3-03 Fault Message 3	3-10	d1-03 Frequency Reference 3	5-10
U3-04 Fault Message 4	3-10		

d1-04 Frequency Reference 4	5-10
d1-17 Jog Reference	5-10
Preventive Maintenance	7-3
Flowchart	7-3
Procedure for Setting Up Communication	D-3
Programming Menu (-ADV-)	3-12
A1 Initialization	3-12
A2 User Parameters	3-12
b1 Sequence	3-12
b2 DC Injection Braking	3-12
b3 Speed Search	3-12
b4 Delay Timers	3-12
b5 PID Control	3-12
b6 Reference Hold	3-12
b7 Droop control	3-12
b8 Energy Saving	3-12
b9 Zero Servo	3-12
C1 Accel/Decel	3-12
C2 S-Curve Accel/Decel	3-12
C3 Motor-Slip Compensation	3-12
C4 Torque Compensation	3-12
C5 ASR Tuning	3-12
C6 Carrier Frequency	3-12
d1 Preset Reference	3-12
d2 Reference Limits	3-12
d3 Jump Frequencies	3-12
d4 Sequence (MOP & Trim Control)	3-12
d5 Torque Control	3-12
d6 Field-Weakening	3-12
E1 V/F Pattern	3-12
E2 Motor Setup	3-12
E3 V/F Pattern 2	3-12
E4 Motor Setup 2	3-12
F1 PG Option Setup	3-12
F2 AI-14 Setup	3-12
F3 DI-08, 16 Setup	3-12
F4 AO-08, 12 Setup	3-12
F5 DO-02, 08 Setup	3-12
F6 Communications Option Setup	3-12
H1 Digital Inputs	3-12
H2 Digital Outputs	3-12
H3 Analog Inputs	3-12
H4 Analog Outputs	3-12
H5 Serial Communications Setup	3-12
H6 Pulse I/O Setup	3-12
L1 Motor Overload	3-12
L2 Power Loss Ridethru	3-12
L3 Stall Prevention	3-12
L4 Reference Detection	3-12
L5 Fault Restart	3-12
L6 Torque Detection	3-12

L7 Torque Limit	3-12
L8 Hardware Protection	3-12
n1 Hunting Prevention	3-12
n2 AFR Tuning	3-12
n3 High Slip Braking	3-12
n5 Feed Forward	3-12
o1 Monitor Select	3-12
o2 Key Selections	3-12
o3 COPY Function	3-12
T1 Auto-Tuning	3-12
Protecting the Drive from Foreign Matter	1-11

Q

Quick Setting Menu (-QUICK-)	3-11
A1-02 Control Method Selections	3-11
b1-01 Frequency Reference Selections	3-11
b1-02 Run Command Selections	3-11
b1-03 Stopping Method Selections	3-11
C1-01 Acceleration Time 1	3-11
C1-02 Deceleration Time 1	3-11
C6-02 Carrier Frequency Selection	3-11
d1-01 Frequency Reference 1	3-11
d1-02 Frequency Reference 2	3-11
d1-03 Frequency Reference 3	3-11
d1-04 Frequency Reference 4	3-11
d1-17 Jog Reference	3-11
E1-01 Input Voltage Setting	3-11
E1-03 Input Voltage Setting	3-11
E1-04 Maximum Output Frequency	3-11
E1-05 Maximum Output Voltage	3-11
E1-06 Base Frequency	3-11
E1-09 Minimum Output Frequency	3-11
E1-13 Base Voltage	3-11
E2-01 Motor Rated Current	3-11
E2-04 Number of motor poles	3-11
E2-11 Motor Rated Output	3-11
F1-01 PG Pulses / Revolutions	3-11
H4-02 Terminal FM Gain Setting	3-11
H4-05 Terminal AM Gain Setting	3-11
L1-01 Motor Overload Protection Selection	3-11
L3-04 Stall Prevention Selection During Decel	3-11
Quick Setting Parameters	4-12

R

Remote Mount Resistor Unit	
Installation Using Internal Braking Transistor	2-14
Remote Mount Resistor Unit(s)	
Installation	2-15
REMOTE Reference (REF) Indicator	3-5
REMOTE Sequence (SEQ) Indicator	3-4

Revision code	1-4
Run Command Source	5-4
b1-02 Run Source Selection	5-4
2-Wire Control	5-4
3-Wire Control	5-4
Run Command Selection	4-12
Run Indicator	3-5

S

Serial Communication	
Parameters	D-4
Sinking/Sourcing Mode	2-23
Slave Address	D-5
Spare Parts	F-1
Primary Spare Parts	F-2
SPEC number	1-4
Specifications	C-1
Common	C-5
Speed Command Source	5-3
Reference Source Selection	5-3
Stall Prevention	5-22
L3-04 Stall Prevention During	
Deceleration Selection	5-22
Stall Prevention Selection During Decel	4-14
Standard Drive Specifications	C-2
Stop Indicator	3-5
Stopping Method	5-5
b1-03 Stopping Method Selection	5-5
Stopping Method Selection	4-12, 5-5
Coast to stop	5-6
Coast to Stop with Timer	5-7
DC Injection to Stop	5-7

T

Terminal AM Gain Setting	4-14
Terminal arrangement	1-5, 1-6
Terminal Block Configuration	2-2
Terminal Card	7-7
Mounting the Terminal Card	7-7
Removing the Terminal Card	7-7
Terminal Connections	
Recommended Connectors	2-8
Terminal Connections	2-19

Terminal cover	1-6
Attaching	1-13
Removing	1-13
Removing and Attaching	1-13
Terminal FM Gain Setting	4-14
Terminal Numbers and Wire Sizes	2-21
Top protective cover	1-5
Trial Run	4-15
Troubleshooting	6-18

V

V/F Pattern	5-11
E1-03 V/F Pattern Selection	5-11
E1-04 Maximum Output Frequency	5-14
E1-05 Maximum Output Voltage	5-14
E1-06 Base Frequency	5-14
E1-09 Minimum Output Frequency	5-14
E1-13 Based Voltage	5-14
V/F Pattern Selection	4-13
V/F Pattern Voltage Upper Limit	5-12

W

Wire Size for Remote Mount Resistor	
Unit and Braking Transistor Unit	2-15
Wire Sizes and Connector Specifications	2-3
Wiring Checks	2-24
Wiring Diagram	2-25
Wiring Terminal Blocks	2-39
Wire Sizes (Same for All Models)	2-39
Wiring Method and Precautions	2-39

Drives Technical Support in USA and Canada

Technical Support for Inverters and Drives is available by phone as follows:

Normal: Monday through Friday during the hours of 8 a.m. to 5:00 p.m. C.S.T.

Emergency: After normal hours, 7 days a week including weekends and holidays

To contact Drives Technical Support, please call 1-800-YASKAWA (927-5292).

From the menu, dial 2 for Inverter and Drive Products, then 5 for Technical Support.

Drives Technical Support can also be reached by e-mail at DriveSupport@yaskawa.com.

Support information, such as technical manuals, FAQs, instruction sheets and software downloads are available at our website, www.drives.com.

When calling for technical support, please have the following materials available:

The appropriate Technical Manual in hand because the support associate may refer to this

Complete nameplate information from the drive and the motor.

(Confirm that Drive Nameplate Output amps is greater than Motor Nameplate amps)

list with your parameter settings

A sketch of the electrical powertrain, from AC line to motor, including filters and disconnects

Field Service, Start Up Assistance, Factory Repair, Replacement Parts, and Other Support

Contact Drives Technical Support for help with any of these needs.

Technical Training

Training is conducted at Yaskawa training centers, at customer sites, and via the internet.

For information, visit www.drives.com or call 1-800-YASKAWA (927-5292).

From the phone menu, dial 2 for Inverter and Drive Products, then 4 for Product Training.

Support in Other Countries

Yaskawa is a multi-national company with offices and service representation around the world.

To obtain support, always contact the local distributor first for guidance and assistance.

Contact the closest Yaskawa office listed for further assistance.

YASKAWA ELECTRIC AMERICA, INC.

Drives Division
16555 W. Ryerson Rd., New Berlin, WI 53151, U.S.A.
Phone: (800) YASKAWA (800-927-5292) Fax: (262) 782-3418
Internet: <http://www.drives.com>

YASKAWA ELECTRIC AMERICA, INC.

Chicago-Corporate Headquarters
2121 Norman Drive South, Waukegan, IL 60085, U.S.A.
Phone: (800) YASKAWA (800-927-5292) Fax: (847) 887-7310
Internet: <http://www.yaskawa.com>

MOTOMAN INC.

805 Liberty Lane, West Carrollton, OH 45449, U.S.A.
Phone: (937) 847-6200 Fax: (937) 847-6277
Internet: <http://www.motoman.com>

YASKAWA ELECTRIC CORPORATION

New Pier Takeshiba South Tower, 1-16-1, Kaigan, Minatoku, Tokyo, 105-0022, Japan
Phone: 81-3-5402-4511 Fax: 81-3-5402-4580
Internet: <http://www.yaskawa.co.jp>

YASKAWA ELETRICO DO BRASIL COMERCIO LTDA.

Avenida Fagundes Filho, 620 Bairro Saude Sao Paulo-SP, Brasil CEP: 04304-000
Phone: 55-11-5071-2552 Fax: 55-11-5581-8795
Internet: <http://www.yaskawa.com.br>

YASKAWA ELECTRIC EUROPE GmbH

Am Kronberger Hang 2, 65824 Schwalbach, Germany
Phone: 49-6196-569-300 Fax: 49-6196-888-301

MOTOMAN ROBOTICS AB

Box 504 S38525, Torsas, Sweden
Phone: 46-486-48800 Fax: 46-486-41410

MOTOMAN ROBOTEC GmbH

Kammerfeldstrabe 1, 85391 Allershausen, Germany
Phone: 49-8166-900 Fax: 49-8166-9039

YASKAWA ELECTRIC UK LTD.

1 Hunt Hill Orchardton Woods Cumbernauld, G68 9LF, Scotland, United Kingdom
Phone: 44-12-3673-5000 Fax: 44-12-3645-8182

YASKAWA ELECTRIC KOREA CORPORATION

Paik Nam Bldg. 901 188-3, 1-Ga Euljiro, Joong-Gu, Seoul, Korea
Phone: 82-2-776-7844 Fax: 82-2-753-2639

YASKAWA ELECTRIC (SINGAPORE) PTE. LTD.

Head Office: 151 Lorong Chuan, #04-01, New Tech Park Singapore 556741, Singapore
Phone: 65-282-3003 Fax: 65-289-3003

TAIPEI OFFICE (AND YATEC ENGINEERING CORPORATION)

10F 146 Sung Chiang Road, Taipei, Taiwan
Phone: 886-2-2563-0010 Fax: 886-2-2567-4677

YASKAWA JASON (HK) COMPANY LIMITED

Rm. 2909-10, Hong Kong Plaza, 186-191 Connaught Road West, Hong Kong
Phone: 852-2803-2385 Fax: 852-2547-5773

BEIJING OFFICE

Room No. 301 Office Building of Beijing International Club,
21 Jianguomanwai Avenue, Beijing 100020, China
Phone: 86-10-6532-1850 Fax: 86-10-6532-1851

SHANGHAI OFFICE

27 Hui He Road Shanghai 200437 China
Phone: 86-21-6553-6600 Fax: 86-21-6531-4242

SHANGHAI YASKAWA-TONJI M & E CO., LTD.

27 Hui He Road Shanghai 200437 China
Phone: 86-21-6533-2828 Fax: 86-21-6553-6677

BEIJING YASKAWA BEIKE AUTOMATION ENGINEERING CO., LTD.

30 Xue Yuan Road, Haidian, Beijing 100083 China
Phone: 86-10-6232-9943 Fax: 86-10-6234-5002

SHOUGANG MOTOMAN ROBOT CO., LTD.

7, Yongchang-North Street, Beijing Economic & Technological Development Area,
Beijing 100076 China
Phone: 86-10-6788-0551 Fax: 86-10-6788-2878

YEA, TAICHUNG OFFICE IN TAIWAN

B1, 6F, No.51, Section 2, Kung-Yi Road, Taichung City, Taiwan, R.O.C.
Phone: 886-4-2320-2227 Fax: 886-4-2320-2239