



**UNITED
TECHNOLOGIES
CARRIER**

Commercial Division
Carrier Corporation

BULLETIN: CA-SB-19-D-77-85
DATE: 7/15/77
PAGE: 1 OF: 2

SERVICE BULLETIN

SUBJECT:
OIL PUMP DESIGN CHANGE: NEW TERMINAL (FUSITE)

SUPERSEDE
BULLETIN:
DATE:
PAGE: OF:

Installation, repair and service and equipment referenced in this Service Bulletin should be undertaken only by qualified persons. Carrier Corporation (1) makes no representations or warranties, expressed or implied, concerning the accuracy, completeness or right to use the information contained herein, and (2) disclaims all liability for injuries, damages, infringements and other losses which may arise on account of, or which may result from, the use or application of any information, method or apparatus disclosed herein.

PURPOSE

To inform the field of the availability in the Service Parts Center of a new oil pump terminal (Fusite), and that it will be used in future production.

MACHINES AFFECTED

19DG, 19EA, and 19FA machines shipped from the factory after October 1977 will have the new terminal (Fusite).

19 Series machines which used spark-plug terminals (Fig. 1) or compression-type terminals (Fig. 3) may be changed to Fusite.

PROCEDURE

Any spark-plug terminal, Part No. 19EA41-2082 (Fig.1), which is found to be leaking should be replaced by the Fusite (Fig. 2).

The new Fusite Terminal Kit, Part No. 19DA66-0003, will contain:

<u>Quantity</u>	<u>Item</u>
3	Terminal, Part No. HY85FP060
3	Reducer Bushing, 1/4 x 1/8 NPT
3	Right Angle Solderless Terminal Connector
1	Installation Instructions

The compression-type terminals (Fig. 3), used in the 19D, DA, and early DG machines, are inserted into 7/16" holes in the casting. The tap drill size for 1/4 NPT is 7/16, so these holes can be tapped for 1/4 NPT and then the terminal kit can be used.

INSTALLATION INSTRUCTIONS

The installation instructions included in the Fusite Terminal Kit read:

- Disconnect external leads and remove oil pump.
- Disassemble oil pump and disconnect internal leads.
- Remove existing terminals.
- Install reducer bushings, using Loctite Filled Pipe Sealant.
- Install terminals, using Loctite Filled Pipe Sealant.
- Connect internal leads and assemble oil pump.
- Replace external lead connections with right angled connectors provided.

SERVICE BULLETIN

SUPERSEDE
BULLETIN:
DATE:
PAGE: OF:

Oil Pump Terminals

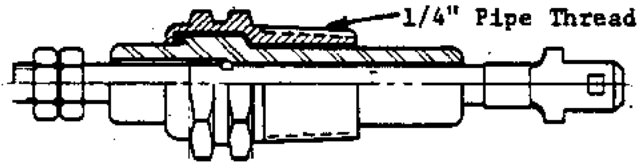

Fig. 1. Auburn Spark-Plug Terminal, Part No. 19EA41-2082

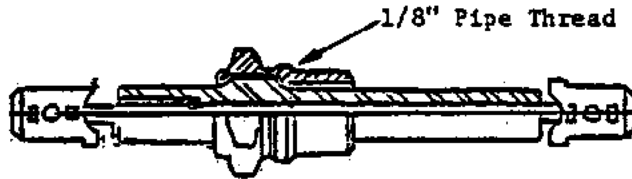

Fig. 2. New Fusite Terminal, Part No. HY85FP060

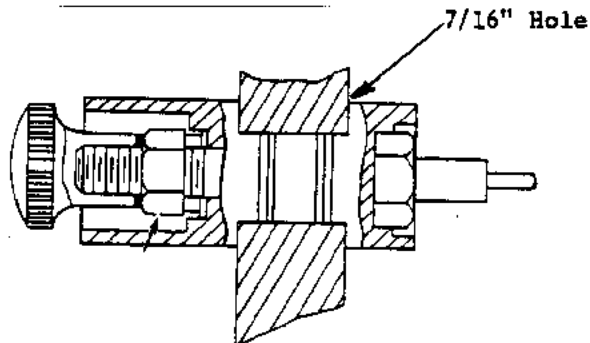

Fig. 3. Compression-Type Terminal