



## SERVICE BULLETIN

---

**Title:** Opto 22 as a Data Logging Interface  
**Models Affected:** All with 3200MP/CCN Controls

**Number:** C9110  
**Date:** 10/15/91  
**Supersedes:**  
**Date:**

**Purpose:**

To provide the information necessary for enabling Opto 22 RS422/RS485 adapter cards to be used as an alternate to the Data Logging Interface.

**File:** Controls–Wiring

**Prepared By:** Todd Young

**Approved By:** Alan M. Johnson

---

This document and the material contained herein are the property of Carrier Corporation and may not be copied, reproduced, or released without written permission of Carrier Corporation.

## Background:

Opto 22 adapter cards have been used to interface with the Building Supervisor as per bulletins 89-009 and 90-022 in file folder SPS-CCN. Those using the 3200MP Data Logging System have asked if it is possible to use these existing cards instead of requiring a Data Logging Interface. This can be done, however, the jumper configuration on the cards must be changed. The following table lists compatible adapter card models and computers.

<b>Model</b>	<b>Computer Type</b>
<b>AC7A</b>	IBM PC/XT, PC/AT, PS2
<b>AC7B</b>	IBM PC/XT, PC/AT, PS2
<b>AC422</b>	IBM PC/XT, 8MHz XT
<b>AC422AT</b>	IBM 6MHz AT/XT286, 8MHz AT
<b>AC24</b>	IBM PC having a 130 Watt power supply, XT, 8MHzXT
<b>AC24AT</b>	IBM 6MHz AT/XT286, 8MHz AT, PS2 30/286
<b>AC34</b>	IBM PS2 55SX

**Note:** Models AC7A/B do not plug into the computer expansion slot. They are external devices as is the Data Logging Interface.

## Procedure:

1. If using a model which plugs into the computer expansion slot, remove ALL jumpers and install the card. The CTS light should be on. Go to step 8 to connect the communications wiring.
2. If using model AC7A/B, remove all jumpers EXCEPT the two positioned horizontally, below the markings "PIN 2 IN" and "PIN 3 OUT."
3. Move these jumpers to the left so that they are below the markings "PIN 2 OUT" and "PIN 3 IN."

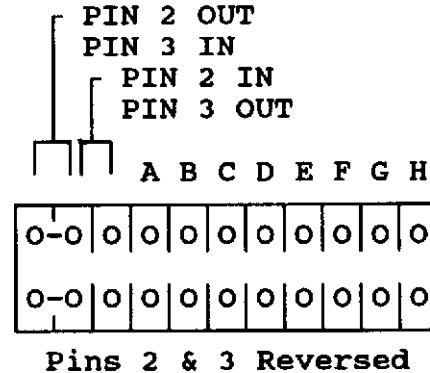
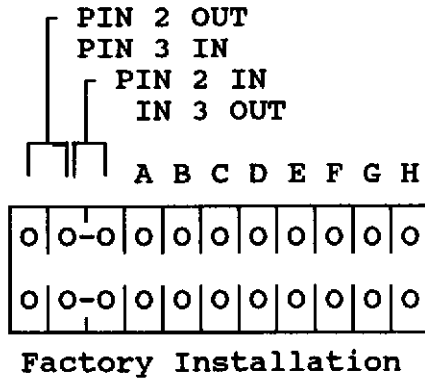

4. Using a standard serial cable, connect the 25 pin connector on the AC7A/B to the serial port on the host computer. Verify the type of connector on the computer to ensure the proper cable is used.

5. Decide whether the 3200MP communications wiring will be connected to the 9 screw terminal block or the DB-9 connector.
6. If using the terminal block, install one set of jumpers between terminals TO+, FO+, and CTS+. Connect the positive data lead to any one of these terminals. Install another set of jumpers to between terminals TO-, FO-, and CTS-. Connect the negative data lead to any one of these terminals. Go to step 9.

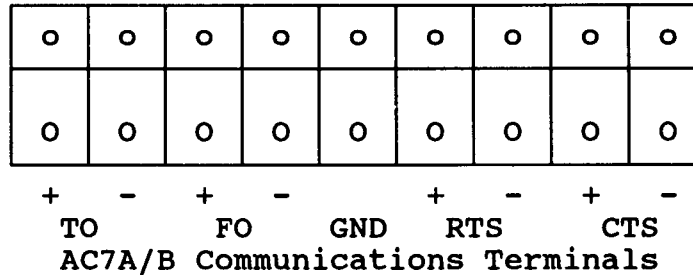

7. Connect 110 VAC to the AC7A. Connect 220 VAC to the AC7B. The CTS light should be on.
8. To use the DB-9 connector, a communications cable must be fabricated. Install a set of jumpers between pins 4, 6, and 8 on a male DB-9 connector. Connect the positive data lead to any one of these pins. Install another set of jumpers between pins 5, 7, and 9. Connect the negative data lead to any one of these pins.

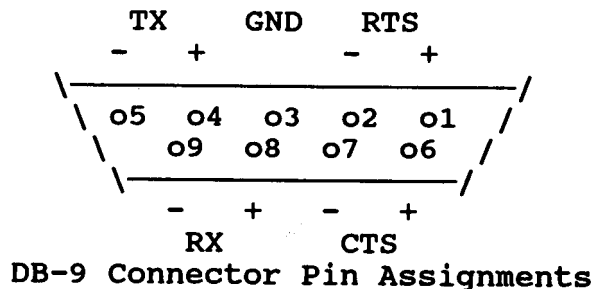

9. Connect the other ends of the positive and negative data leads to the communications terminals 25 and 26, respectively, in the 3200MP control panel.
10. Connect the DB-9 end of the communications cable to the adapter card.
11. When operating, the CTS and RX lights will flash when receiving data from the 3200MP. The TX light will flash once when transmitting data to the host computer, that is, when the Data Logging program is "Reading" or when an "Instant" reading is requested. If the TX light flashes more than once, reverse the polarity of the communications leads.

TO PURCHASE AN ADAPTER CARD OR LOCATE A LOCAL OPTO 22 DISTRIBUTOR, CONTACT:

OPTO 22

15461 SPRINGDALE STREET

HUNTINGTON BEACH, CALIFORNIA 92649

(714) 891-5861 OR (800) 854-8851

TELEX: 692-386