



CHP System Absorption Liquid Chillers/Heaters

Installation, Operation, and Maintenance Instructions

SAFETY CONSIDERATIONS

Absorption liquid chiller/heaters provide safe and reliable service when operated within design specifications. When operating this equipment, use good judgment and safety precautions to avoid damage to equipment and property or injury to personnel.

Be sure you understand and follow the procedures and safety precautions contained in the chiller instructions as well as those listed in this guide.

DANGER

DO NOT USE OXYGEN or air to purge lines, leak test or pressurize a machine. Use nitrogen (N₂) only.

NEVER EXCEED specified test pressures. For the 16DNP machine, the maximum pressure is 12 psig (83 kPa).

WEAR goggles and suitable protective clothing when handling lithium bromide, octyl alcohol, inhibitor, lithium hydroxide and hydrobromic acid. IMMEDIATELY wash any spills from the skin with soap and water. IMMEDIATELY FLUSH EYES with water and consult a physician.

WARNING

DO NOT USE eyebolts or eyebolt holes to rig machine sections or the entire assembly.

DO NOT work on high-voltage equipment unless you are a qualified electrician.

DO NOT WORK ON electrical components, including control panels or switches, until you are sure ALL POWER IS OFF and no residual voltage can leak from capacitor or solid-state components.

LOCK OPEN AND TAG electrical circuits during servicing. IF WORK IS INTERRUPTED, confirm that all circuits are de-energized before resuming work.

NEVER DISCONNECT safety device or bypass electric interlocks and operate the machine. Also never operate the machine when any safety device are adjusted and functioning not normally.

DO NOT siphon lithium bromide or any other chemical by mouth.

WHEN FLAMECUTTING OR WELDING on an absorption machine, some noxious fumes may be produced. Ventilate the area thoroughly to avoid breathing concentrated fumes.

DO NOT perform any welding or flame cutting to a machine while it is under a vacuum or pressurized condition.

DO NOT INCINERATE.

CAUTION

DO NOT climb over a chiller. Use platform, catwalk, or staging. Follow safe practices when using ladders.

DO NOT STEP ON chiller piping. It might break or bend and cause personal injury.

USE MECHANICAL EQUIPMENT (crane, hoist, etc.) to lift or move inspection covers or other heavy components. Even if components are light, use such equipment when there is a risk of slipping or losing your balance.

VALVE OFF AND TAG gas, water or solution lines before opening them.

DO NOT LOOSEN water box cover bolts until the water box has been completely drained.

DO NOT VENT OR DRAIN water boxes containing industrial brines, liquid, gases or semisolids without permission of your process control group.

USE only repaired or replacement parts that meet the code requirements of the original equipment.

DO NOT ALLOW UNAUTHORIZED PERSONS to tamper with chiller safeties, or to make major repairs.

PERIODICALLY INSPECT all valves, fittings, piping, and relief devices for corrosion, rust, leaks, or damage.

PROVIDE A DRAIN connection in the vent line near each pressure relief device to prevent a build-up of condensate or drain water.

IMMEDIATELY wipe or flush the floor if lithium bromide or octyl alcohol is spilled on it.

CONTENTS

	Page		Page
SAFETY CONSIDERATIONS	1	- OVERRIDE OPERATIONS	
INTRODUCTION	4	- TIME SCHEDULE OPERATION	
ABBREVIATIONS	4	- TO VIEW OR CHANGE SETPOINT	
 		PIC SYSTEM FUNCTIONS	25
1. INSTALLATION INSTRUCTION	4-7	- CAPACITY CONTROL	
INTRODUCTION	4	- ENTERING CHILLED WATER CONTROL	
- GENERAL		- CHILLER TIMER	
- JOB DATA		- OCCUPANCY SCHEDULE	
RECEIVEING THE CHILLER	4	PIC CONTROL TESTS	38
- IDENTIFY THE CHILLER		RAMP LOADING CONTROL	39
- INSPECT SHIPMENT		SOLUTION CONCENTRATION CONTROL	40
- CHECK SHIPPING PRESSURE		- CAPACITY OVERRIDES	
- PROVIDE CHILLER PROTECTION		- MANUAL CAPACITY VALVE CONTROL	
MACHINE ROOM CONDITION	4	- SOLUTION HIGH CONCENTRATION	
RIGGING AND POSITIONING	4	REMOTE STRAT/STOP CONTROL	41
- RIGGING THE UNIT		TOVER-FAN RELAY	41
- FOUNDATION		AUTO RESTART AFTER POWER LOSS	41
- POSITION AND LEVEL THE EQUIPMENT		MICRO-TURBINE STATUS MONITORING	41
FIELD PIPING	6	DIVERTER VALVE LEAKAGE	41
- CONNECT WATER PIPING		AIR SEAL BLOWER CONTROL	41
- FUSIBLE PLUG RELIEF PIPING		CONTROL WIRING	41
- CONNECT DIVERTER VALVE		SAFETY CONTROLS	52
- CONNECT EXHAUST GAS DUCT		SERVICE OPERATION	53
- CONNECT EXHAUST DRAIN PIPING		CARRIER COMFORT NETWORK (CCN)	
ELECTRICAL CONNECTIONS	8	INTERFACE	54
- CHECK AVAILABLE POWER SUPPLY AND SAFETY INTERLOCKS		ATTACH TO NETWORK DEVICE	55
- CHILLER CONTROL PANEL AND EXTERNAL WIRING		POWER-UP	55
2. CHILLER DESCRIPTION AND CYCLE	8-13	4. BEFORE INITIAL START-UP	56
CHILLER DESCRIPTION	8	INSPECT FIELD PIPING	56
- CHILLER COMPONENTS		INSPECT FIELD WIRING	56
- HEATING-175 (OPTION)		CHILLER EVACUATION	56
- PURGE SYSTEM		INPUT THE DESIGN SETPOINT	56
- DIVERTER VALVE		INPUT THE SCHEDULE	56
COOLING AND HEATING CYCLE	12	INPUT THE SERVICE CONFIGURATION	56
- COOLING CYCLE		 	
- HEATING-140 CYCLE		5. INITIAL START-UP	57
- HEATING-175 (OPTION) CYCLE		PRELIMINARY CHECK	57
 		COOLING/HEATING OPERATION CHANGEOVER ..	57
3. CONTROLS	17-55	DETERMINE NONCONDENSABLES RATE	57
GENERAL	17	CHECK CHILLER SHUTDOWN	57
PIC SYSTEM COMPONENTS	17	CHECK THE SAFETY SWITCHES SETTING	57
ICVC OPERATIONS AND MENUS	19	 	
- GENERAL		6. START-UP/RUNNING/SHUTDOWN	
- ALARM AND ALERTS		PROCEDURE	58-69
- ICVC MENU ITEMS		LOCAL START	58
- BASIC OPERATIONS		START-UP SEQUENCCE	58
- TO VIEW OR CHANGE POINT STATUS		- COOLING SHUTDOWN	
		- HEATING-140 SHUTDOWN	

	Page
- HEATING-175 (OPTION) SHUTDOWN	
RAMP LOADING MODE.....	62
NORMAL RUN MODE.....	62
- CAPACITY CONTROL	
- TRAVEL LIMIT CONTROL	
- INSUFFICIENT HEAT INPUT AT START -UP	
- G1 HIGH SOLUTION LEVEL	
- VARIABLE FREQUENCY DRIVE CONTROL	
SHUTDOWN SEQUENCE.....	65
- COOLING SHUTDOWN	
- HEATING-140 SHUTDOWN	
- HEATING-175 (OPTION) SHUTDOWN	
RECYCLE CONTROL.....	65
- COOLING MODE	
- HEATING MODE	
SAFETY SHUTDOWN.....	66
7. PERIODIC SCHEDULED MAINTENANCE.....	70
EVERY DAY.....	70
EVERY MONTH.....	70
EVERY 2 MONTHS	70
EVERY 8 MONTHS or COOLING/HEATING	
CHANGEOVER.....	70
EVERY YEAR.....	70
EVERY 2 YEARS.....	70
EVERY 5 YEARS OR 20,000 HOURS.....	70
8. MAINTENANCE PROCEDURES.....	70-75
SERVICE ONTIME.....	70
LOG SHEETS	70
INSPECT THE HEAT EXCHANGER TUBES.....	70
WATER LEAKS	70
WATER TREATMENT.....	70
PURGE PROCEDURE.....	71
- AUTOMATIC PURGE	
- DIRECT PURGE	
- MANUAL PURGE	
VACUUM PUMP OPERATION.....	71
- BASIC CHECK LIST	
- PERIOD OF OIL REPLACEMENT	
- PROCEDURE OF OIL REPLACEMENT	
CHILLER LEAK TEST.....	72
SOLUTION AND REFRIGERANT CHARGING.....	72
- HANDLING LITHIUM BROMIDE SOLUTION	
- CHARGING SOLUTION	
- INITIAL REFRIGERANT CHARGING	
SOLUTION OR REFRIGERANT SAMPLING.....	73
- SOLUTION SAMPLE	
- REFRIGERANT SAMPLE	
SOLUTION ANALYSIS	73
INHIBITOR.....	73

	Page
ADDING OCTYL ALCOHOL.....	73
REFRIGERANT CHARGE ADJUSTMENT.....	74
REFRIGERANT BLOW-DOWN.....	74
INSULATION AND PAINT.....	74

INTRODUCTION

Everyone involved in the installation, operation, and maintenance of the 16DNP chiller should be thoroughly familiar with the following instructions and other necessary job data before installation and before initial start-up and before operating the chiller and its control system or performing chiller maintenance. Procedures are arranged in the sequence required for proper chiller installation, start-up and operation.

ABBREVIATIONS

CCN – Carrier Comfort Network
G1 – High-Stage Generator
G2 – Low-Stage Generator
H1 – High-Temperature Heat Exchanger
H2 – Low-Temperature Heat Exchanger
LCD – Level Control Device
ICVC – International Chiller Visual Controller
CCM – Chiller Controller Module
PIC – Product Integrated Control

1. INSTALLATION INSTRUCTION

Introduction

GENERAL - The 16DNP chiller is factory assembled, wired and leak tested. Installation (not by Carrier) consists primarily of establishing water, exhaust and electrical service to the machine as well as mounting and connector and/or customer. Carrier has no installation responsibilities for the equipment.

JOB DATA - Necessary information consists of:

- Job contract or specification
- Chiller location drawing
- Piping drawing
- Field wiring diagrams
- Chiller certified drawing
- Installation, operation and maintenance instructions

Receiving the Chiller

IDENTIFY THE CHLLER - The chiller model and serial number are stamped on chiller nameplate. Check this information against shipping papers and job data. See Fig. 2-1 and 2-2 for the location of the nameplate on the chiller.

INSPECT SHIPMENT - Chiller is shipped under nitrogen (N₂) pressure. Inspect for shipping damage while chiller and diverter valve are still on shipping conveyance. If either appear to be damaged or has been torn loose from its anchorage, have it examined by transportation inspectors before removal. Forward the claim papers directly to Transportation Company.

Manufacturer is not responsible for any damage incurred in transit,

Check all items against shipping list. Immediately notify your Carrier office if any item is missing.

To prevent loss or damage, leave all parts in original packages until installation.

CHECK SHIPPING PRESSURE - To check for leaks that has occurred during shipment:

The chiller is shipped under nitrogen pressure (7.0 psig [48 kPa]) after vacuum inspection.

If the vessel has lost its pressure, it has acquired a leak during shipping and must be leak tested after positioning. Refer to the Machine Leak Test section for instruction.

PROVIDE CHLLER PROTECTION - If the chiller will not be installed immediately, it is very important to use a drop cloth or plastic covering to protect the machine from construction dirt and moisture before installation. Also, do not remove protective shipping cover on control panel until ready to use.

Machine Room Condition – The 16DNP chiller must have enough space to guarantee stable operation and allow easy maintenance.

1. The machine room must be considered to have sufficient ventilation system. It is recommended to operate the machine where the 20 ~ 80% of relative humidity and 41 to 113 °F (5 to 45 °C) of ambient temperature.
2. For water drain, there must be drain ditch, which has a sufficient volume, around the chiller.
3. The machine room must have enough service space for tube-cleaning and extra maintenance. This clearance information will be provided separately in certified drawing.

Rigging and Positioning

Refer the chiller weight and size as shown in Fig. 1-1 for rigging equipment and procedure.

WARNING

Lifting chiller from points other than those specified may result in serious damage and personal injury. Rigging equipment and procedure must be adequate for chiller weights and size.

Carefully position cable on machine to avoid damage to small piping, control or wiring.

Keep shell horizontal when lifting or lower so all leg contact the floor at the same time.

RIGGING THE UNIT - Lift entire assembly with cable hooks and shackles connected to the 3 lifting holes on the absorber-evaporator assembly and with the center balance point locations as shown in Fig. 1-2 and 1-3. Lifting from other holes or location can damage the chiller. Each lifting cable or chain must be capable of supporting the entire weight of the chiller.

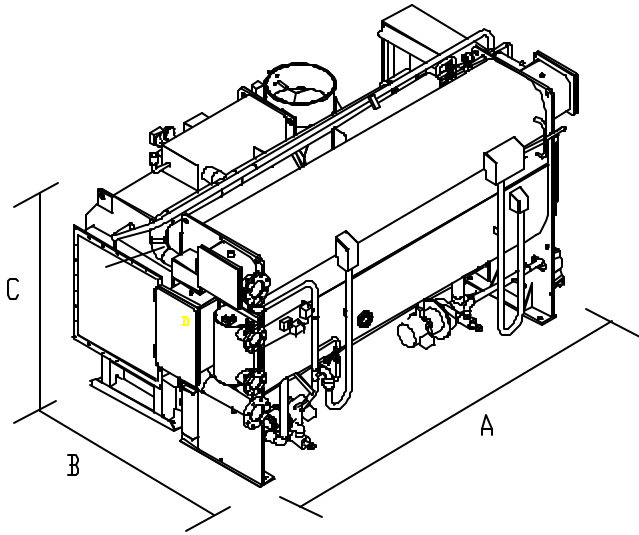

Model	16DN018 (Liquid tube type)		16DN012 (Smoke tube type)	
	ft-in	mm	ft-in	mm
A	12-1	3,680	12-1	3,680
B	6-7	2,019	6-2	1,830
C	6-10	2,081	6-10	2,081

Model	16DN018 (Liquid tube type)		16DN012 (Smoke tube type)	
	lb	kg	lb	kg
Rigging Weight	18,540	8,410	18,078	8,200
Operating Weight	19,731	8,950	19,268	8,740
Diverter Valve Weight	728	330	728	330

Fig.1-1 Dimension Diagram and Rigging Weight

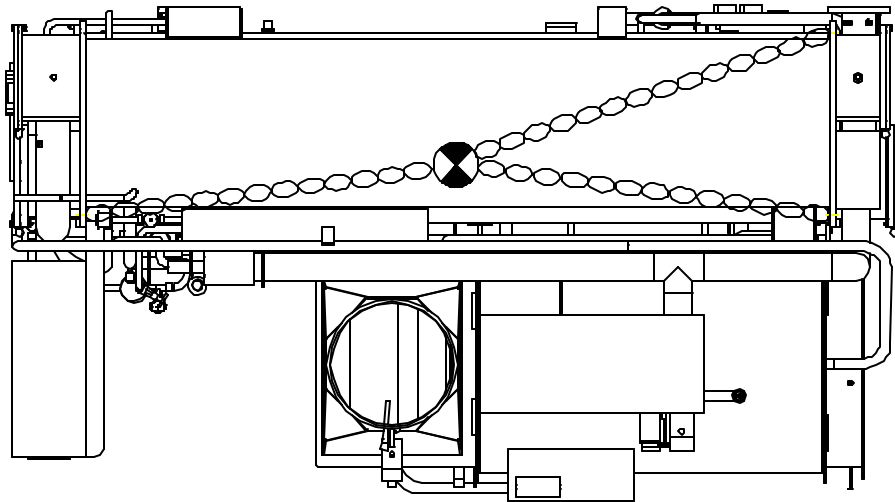

Fig.1-2 Rigging The Unit, Typical, Top View

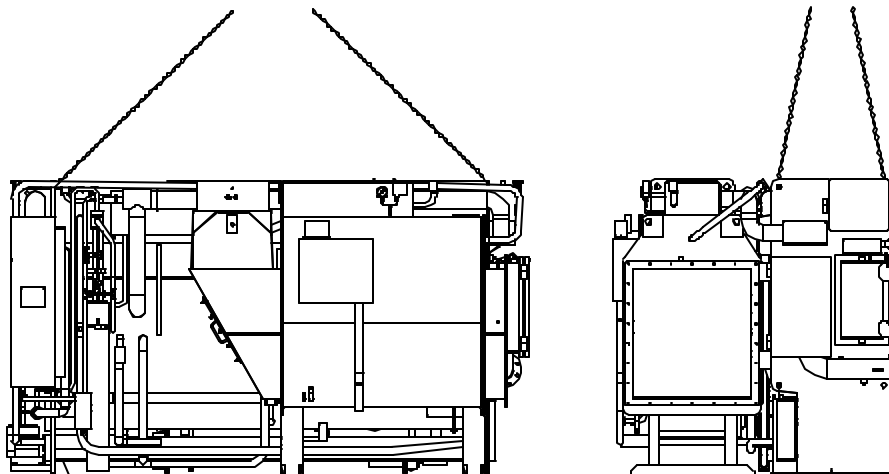

Fig.1-3 Rigging The Unit, Typical, Side and End Views

FOUNDATION

1. Foundation must be developed to support the weight of the chiller before positioning.
2. Install the anchor bolt at proper location. (Fig. 1-4) Refer to certified drawing of foundation for details.

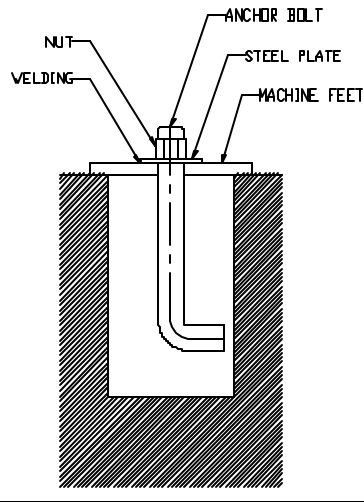

Fig.1-4 Foundation

POSITION AND LEVEL THE EQUIPMENT

1. Position the chiller on the foundation.
2. Completely fill 50ft (15m) length of clear flexible tubing with water.
3. Use water gage and leveling reference of points stamped on tube sheet to level the chiller as shown in Fig. 1-5.
4. Level the chiller with soleplate (e.g. 1.2mm, 2.3mm or 3.2mm of thickness) until the requirement is met. ($\ll 1/1000$ in each direction) Be sure matching piping is in alignment.

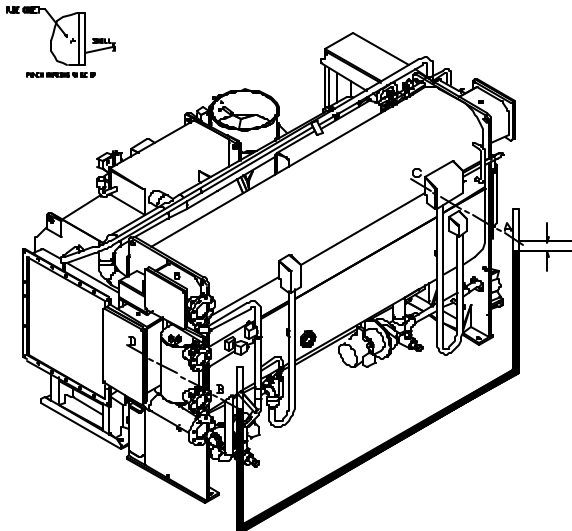

Fig.1-5 Check Machine Level

Field Piping

CONNECT WATER PIPING - Install piping using job data, piping drawing and procedure outlined below. A typical piping installation is shown in Fig.1-6.

1. Make sure all connections to water box covers allow opening of covers for maintenance.
2. Installation and piping should allow sufficient access for cleaning or replacing tubes.
3. Install pipe hangers where needed. Make sure no weight or stress is placed on water box nozzles or flanges.
4. Water flow direction must be as specified in job flow diagram or water flow marking on water boxes and connections must be to the correct entering and leaving water box nozzles.
5. Install water box vent and drain piping in accordance with individual job data. Air vents should be all high points in piping to eliminate water hammer.
6. Location of the chilled/hot water and cooling water pumps as well as the expansion tank must allow for the hydrostatic and water heads to ensure that the total pressure does not exceed the water box design working pressure.
7. A cooling tower bypass valve should be installed if the cooling water temperature might fall down 60.8°F (16°C) during chiller operation.
8. Install pressure gage taps and pressure gages on the entering and leaving chilled/hot water pipe and cooling water pipes.

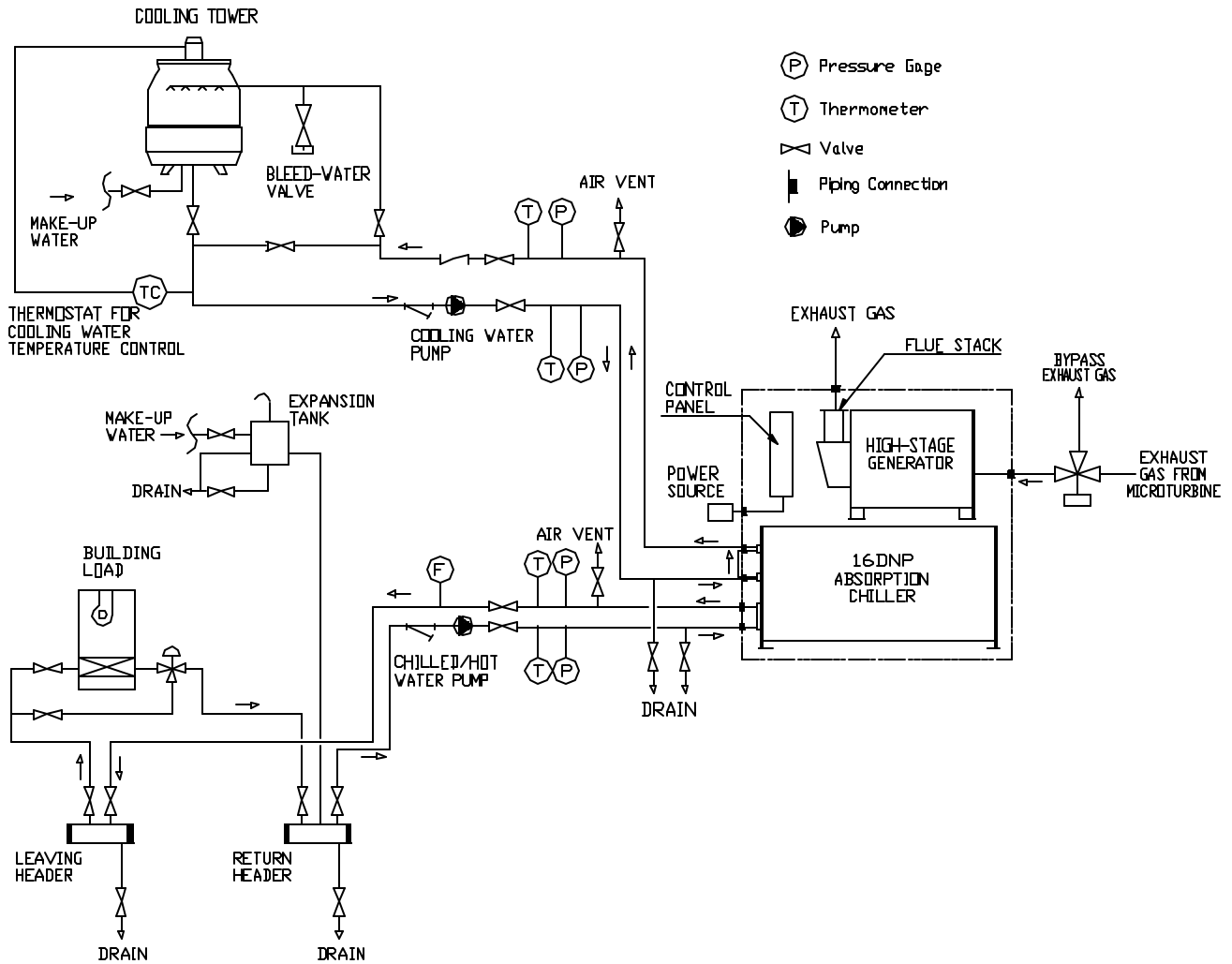

Fig. 1-6 Piping Flow Schematic

FUSIBLE PLUG RELIEF PIPING - Connect relief piping to discharge hot refrigerant vapor from G1 to safe area.

1. Do not loosen or disconnect fusible plug while connecting relief pipe to it.
2. Make sure connection to fusible plug is trenched and allow easy piping removal for leak tested and maintenance.
3. Install pipe hangers where needed to be sure no weight or stress is placed on the fusible plug. (Fig. 1-7)

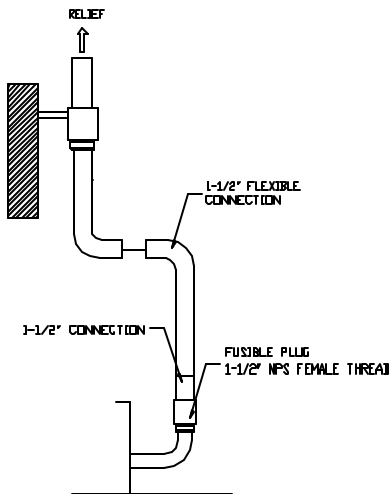

Fig. 1-7 Fusible Plug Relief Piping

CONNECT DIVERTER VALVE - Install diverter valve using job data and general guidelines outlined below.

1. Inspect for shipping damage before installation.
2. Install the diverter valve at the end of micro-turbine exhaust duct as Fig. 1-8. Level the diverter valve by using level gage.
3. Install the transient duct between high-stage generator and diverter valve.
4. Connect the wiring in accordance with wiring diagram #5, #6, #7 and #8. (Fig. 3-15, Fig. 3-16, Fig. 3-17 and Fig. 3-18)

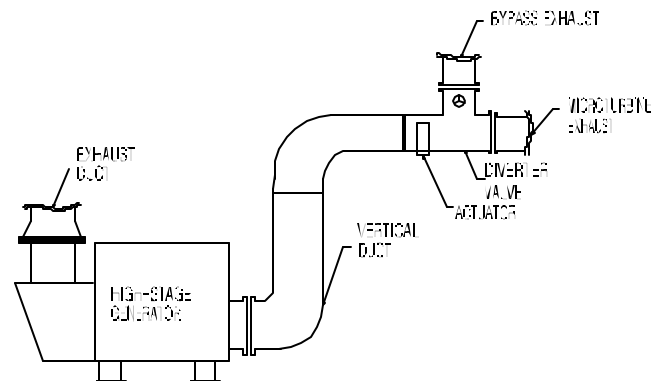

Fig. 1-8 Example of Diverter Valve Installation

CONNECT EXHAUST GAS DUCT - Connect exhaust gas duct using job data and piping drawings. Systems will vary for different application condition.

1. Sharp bend and restrictions should be avoided to allow smooth gas flow.
2. The outlet should be arranged to prevent rainwater entry into the machine exhaust and drain should be provided to remove condensate or water.

CONNECT EXHAUST DRAIN PIPING - Install exhaust drain piping using general guidelines below.

1. Connect the pipe to the end of exhaust drain and put the end of pipe under the 6 inch of water level in sewage.
2. If above method cannot be used at jobsite, install the U trap to the end of exhaust drain, which has 6 inch of height.

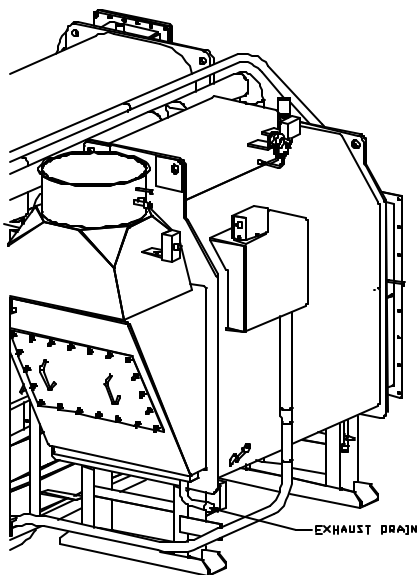

Fig. 1-9 Exhaust Drain Pipe

Electrical Connections

Field wiring must be installed in accordance with job and machine wiring diagram and all applicable electrical codes.

CHECK AVAILABLE POWER SUPPLY AND SAFETY-INTERLOCKS - Check the available power supply and interlocks match the machine equipment. Job voltage and amperage are stated on the machine and diagrams.

CHILLER CONTROL PANEL AND EXTERNAL WIRING

- All machine sensors and controls are factory installed. External field wiring terminals include:

1. Three-phase power supply
2. Control start/stop interlocks for chilled/hot water pump(s), cooling water pump(s) and cooling tower fan(s)
3. Actuator motor power supply and control signal
4. Remote start/stop (when used)
5. Remote status indicator (when used)

For wiring of the chiller, refer to wiring diagrams on CONTROL WIRING section. See the Fig. 1-10 for main power supply cable selection.

UNIT	VOLT	KVA	RLA	MFA	AWG
16DNP 018	208	8.5	23.2	34.8	6
	230	8.5	20.9	31.4	8
	460	8.5	10.6	15.9	10
	575	8.5	8.5	12.8	10

Fig. 1-10 Main Power Supply of Control Panel

2. CHILLER DESCRIPTION AND CYCLE

Chiller Description

CHILLER COMPONENTS - The major sections of the chiller contained in two vessels (Fig. 2-1, 2-2 and 2-3).

The large vessel contains the absorber, evaporator, condenser and low-stage generator (G2). The evaporator and absorber are positioned side by side in lower side. In the evaporator section, the refrigerant water vaporizes in the cooling cycle and cools the chilled water for the air conditioning or cooling process. In the heating cycle, hot water vapor flow into the evaporator section where it condenses and heats the hot water for the heating process. The heat transfer tube bundle in the evaporator is used for both cooling and heating. In the absorber, vaporized refrigerant water is absorbed by lithium bromide solution in the cooling cycle. In the heating cycle, condensed refrigerant water from the evaporator drains into the absorber where it is mixed with the strong solution.

The upper side contains the low-stage generator and condenser. The refrigerant vapor from the high temperature generator passes through the heat transfer tubes of low-stage generator. The intermediate solution in the low-stage generator is heated by the refrigerant vapor. It releases the refrigerant vapor and is re-concentrated. It becomes strong solution. The condensed refrigerant in the heat transfer tube of low-stage generator flows to the condenser. The refrigerant vapor from the low-stage generator is condensed on the heat transfer tubes of condenser. Cooling water from the absorber is heated by condensation heat.

The smaller vessel is the high-stage generator (G1). The diluted solution from the heat exchanger is heated directly by the exhaust gas generated from micro-turbine in the high-stage generator. It releases the refrigerant vapor and is concentrated. It becomes intermediate solution.

The 16DNP chiller also has two solution heat exchangers to improve operating efficiency; an external purge system to maintain chiller vacuum by the removal of non-condensable; hermetic pumps to circulate the solution and refrigerant; and various operational, capacity, and safety devices to provide automatic, reliable chiller performance.

HEATING-175 (Option) - The Heating-175 type chiller has an additional auxiliary heat exchanger on top of the high-stage generator and three changeover valves. The refrigerant vapor generated from high-stage generator is condensed in auxiliary heat exchanger. Three changeover valves isolate high-stage generator from other part of machine. (Fig. 2-7)

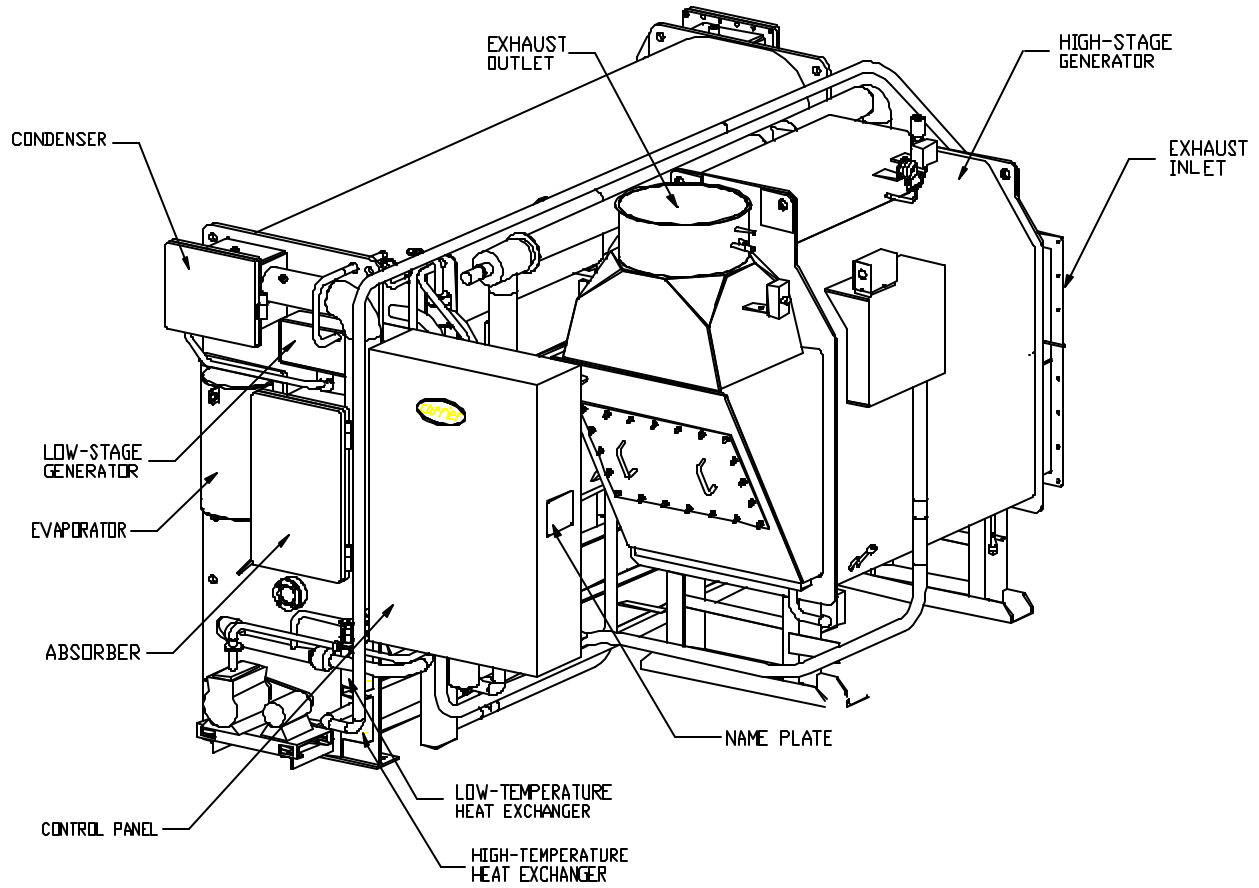

Fig. 2-1 Typical External Schematic, Front View (16DNP018 Liquid tube type chiller)

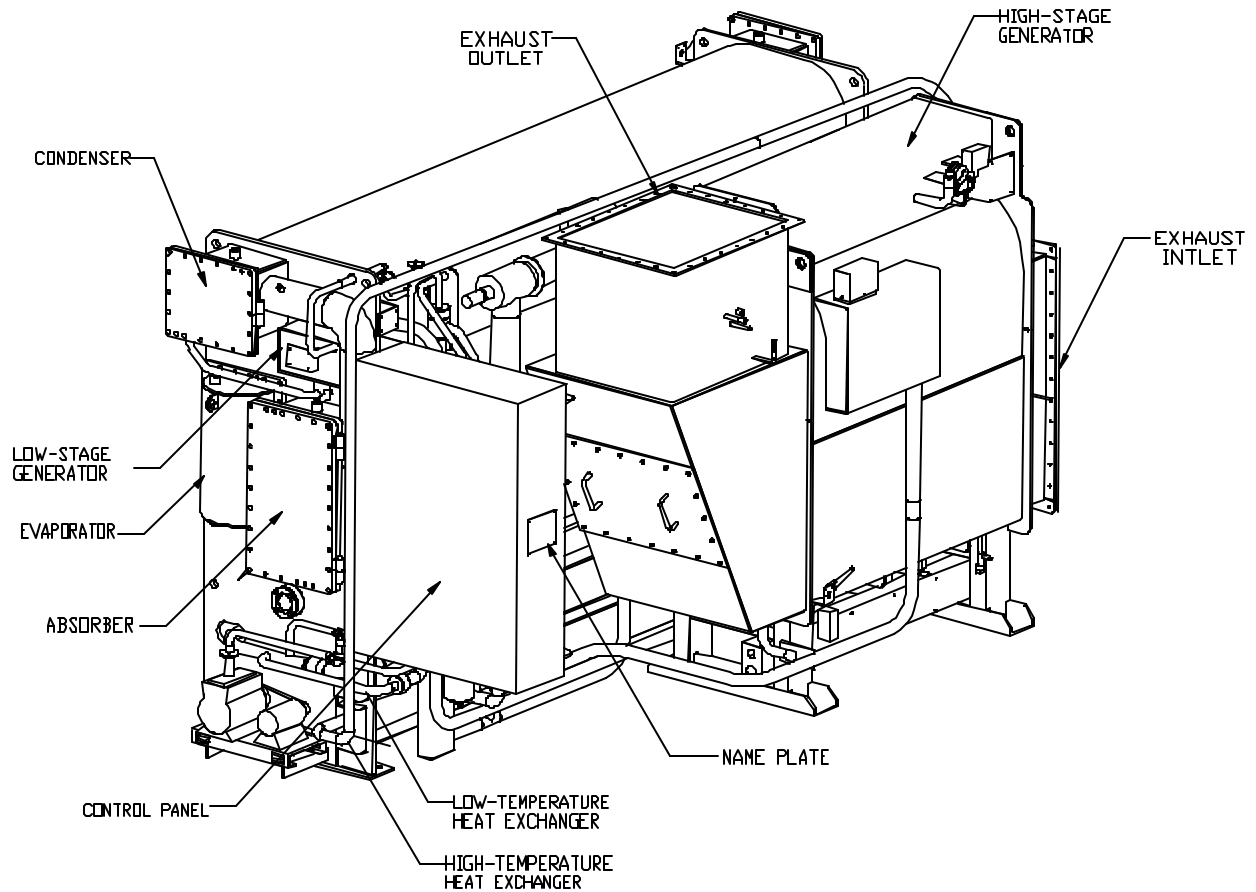
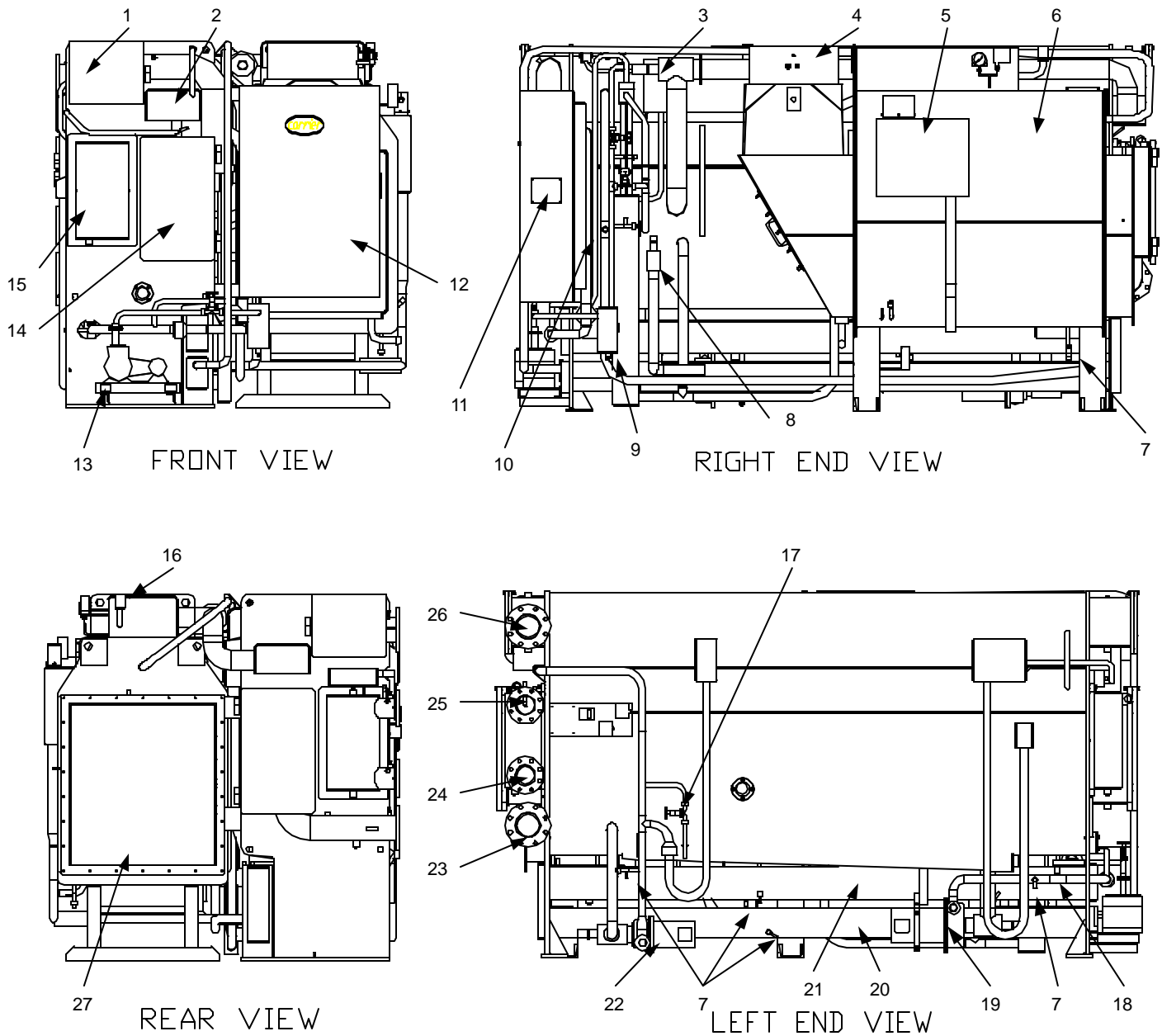

Fig. 2-2 Typical External Schematic, Front View (16DNP012 Smoke tube type chiller)



LEGEND

- | | |
|------------------------------------|---|
| 1 – Condenser | 15 – Evaporator |
| 2 – Low-Stage Generator (G2) | 16 – Fusible Plug |
| 3 – Changeover Valve (Vapor) | 17 – Blow Down Valve |
| 4 – Exhaust Outlet | 18 – Cycle Flow Valve (A to G1) |
| 5 – LCD (Level Control Device) Box | 19 – Solution Pump |
| 6 – High-Stage Generator (G1) | 20 – High-Temperature Heat Exchanger (H1) |
| 7 – Service Valve | 21 – Low-Temperature Heat Exchanger (H2) |
| 8 – Changeover Valve (Liquid) | 22 – Refrigerant Pump |
| 9 – Oil Trap | 23 – Cooling Water Inlet |
| 10 – Cycle Flow Valve (G1 to G2) | 24 – Chilled Water Inlet |
| 11 – Nameplate | 25 – Chilled Water Outlet |
| 12 – Control Panel | 26 – Cooling Water Outlet |
| 13 – Vacuum Pump | 27 – Exhaust Inlet |
| 14 – Absorber | |

Fig. 2-3 Valve and Component Location (16DNP018 Liquid tube type chiller)

PURGE SYSTEM - The purge system automatically removes noncondensables from the machine and transfers them to the storage tank where they cannot affect machine operation. Noncondensables are gases that will not be condensed at the normal chiller operating temperatures and pressures (N_2 , O_2 and H_2 , etc.) and because they reduce the machine vacuum, they would also reduce the chiller capacity.

Hydrogen (H_2) gas is liberated within the chiller during normal operation and non-condensable gas rate might be increased either through a leak (the machine is under a deep vacuum) or during service activities.

While the machine is operating, any non-condensable accumulate in the absorber, which is the lowest pressure area of the machine.

For purging, noncondensables are continuously drawn from the absorber into the lower pressure of purge chamber with an eductor, where they are entrained in solution flowing from the solution pump. The mixture then continues on to the purge chamber. The noncondensables released in a purge chamber go to non-condensable storage tank and the solution flows back to the absorber by way of the generator overflow pipe. Typically most of the non-condensable gas is hydrogen, which is automatically passed out to the atmosphere through a heated palladium membrane cell.

Any other gas accumulates in noncondensables storage tank where it is isolated from the rest of the chiller. It is then removed from the storage tank, when necessary, by a vacuum pump connected to the tank exhaust valve. If the chiller is maintained in a leak-tight condition, as it should be, the storage tank is normally exhausted sometimes. When it is necessary to remove noncondensables directly from chiller, the noncondensables can be removed by a vacuum pump connected to the auxiliary evacuation valve, which is connected directly to the absorber. The ballast valve of vacuum pump should be opened at a turn to remove refrigerant vapor or LiBr while running.

DIVERTER VALVE - The diverter valve controls incoming exhaust gas flow, which is generated from C60 micro-turbines, to the high-stage generator. It has two linked blades, which are double blade and bypass blade, between horizontal and vertical flow direction. (See the Fig. 2-5) If the one of blades is placed in closed position, the other blade is always placed in open position by linkage. When bypass blade is open which means exhaust gas is bypassed from high-stage generator, the air seal blower is turned on automatically to prevent from exhaust gas leaking to the high-stage generator.

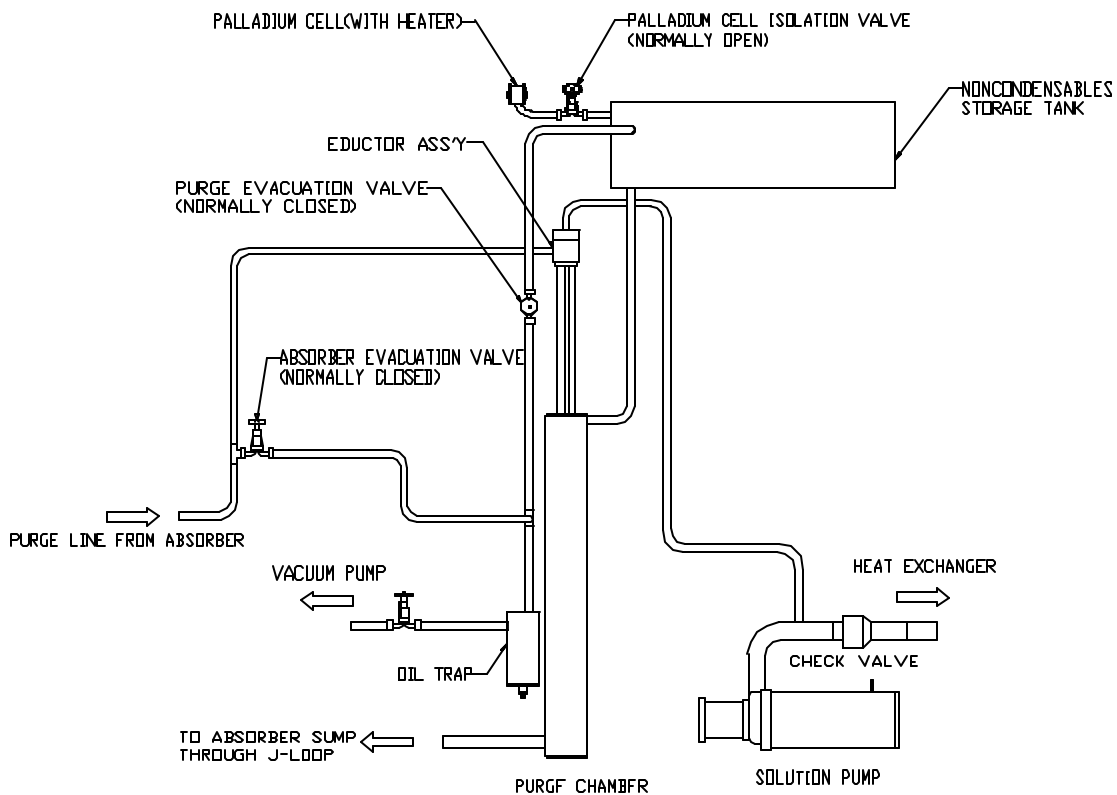
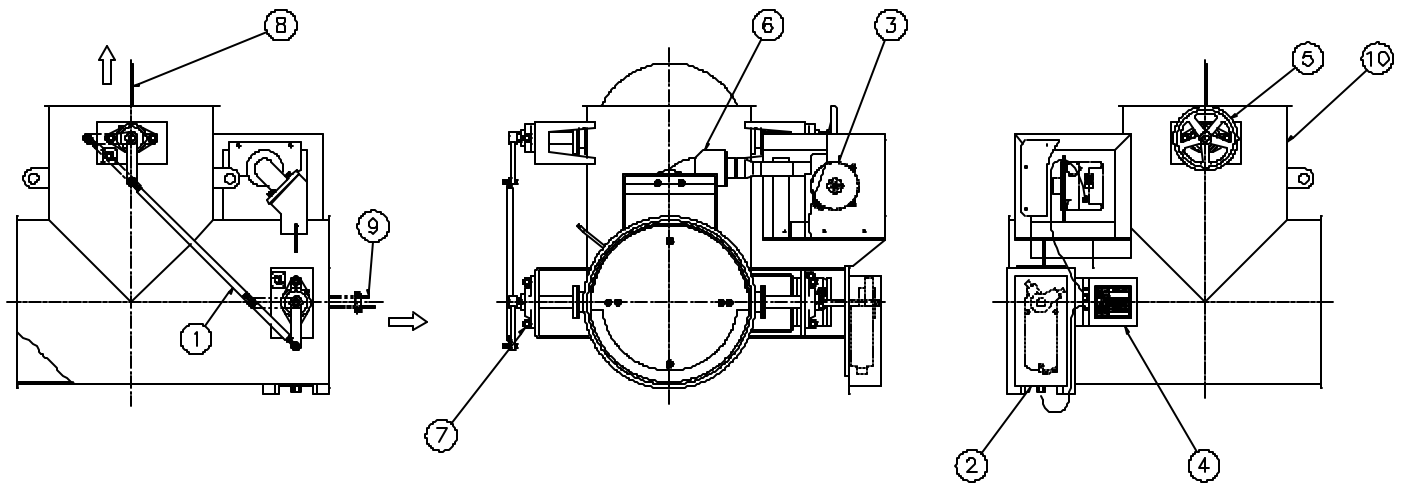

Fig. 2-4 Purge System



LEGEND

- | | |
|-----------------------|------------------|
| 1 – Linkage | 6 – Check Valve |
| 2 – Actuator | 7 – Bearing |
| 3 – Air Seal Blower | 8 – Bypass Blade |
| 4 – Terminal Box Assy | 9 – Double Blade |
| 5 – Hand Wheel | 10 – Body |
| 22 – Refrigerant Pump | |

Fig. 2-5 Diverter Valve, Typical, Rear, Left End and Front View

Cooling and Heating Cycle

COOLING CYCLE – Figure 2-6 illustrates the basic cooling cycle of the 16DNP absorption chiller.

The chilled water is passed through the evaporator tube bundle and is cooled by the evaporation of refrigerant sprayed over the outer surface of the tubes by the recirculating refrigerant pump. The refrigerant vapors are drawn into the absorber section and are absorbed by the LiBr-water solution sprayed over the absorber tubes. The heat picked up from the chilled water is transferred from the absorbed vapor to the cooling water flowing through the absorber tubes.

The solution in the absorber becomes diluted as it absorbs water and loses its ability to continue the absorption process. The solution pump then transfers it to the high-stage generator to be concentrated. All of the weak solution goes to the high-stage generator where it is heated by high temperature exhaust gas from micro-turbine. This boils out its absorbed refrigerant. This vapor passes to the low-stage generator tubes. Concentrated solution in the high-stage generator passes to the shell side of low-stage generator. In the shell side of the low-stage generator, the strong solution is heated by the high temperature refrigerant vapor from the high-stage generator. This boils out its absorbed water.

The refrigerant vapor is boiled from the low-stage generator solution passes into condenser section condenses on tubes containing cooling water inside. This is the same cooling water that had just flowed through the absorber tubes. On the tube side of the low-stage generator, the condensed refrigerant passes into the condenser, where it is cooled to the condenser temperature. The combined condensed refrigerant from the two generators now flows back to the evaporator to begin a new refrigerant cycle.

The strong solution, which is concentrated twice in passing two generators, flows back to the absorber spray headers to begin a new solution cycle. On the way, it passes through solution heat exchangers where heat is transferred from the hot, strong solution to the cooler, weak solution being pumped from absorber to high-stage generator. This heat transfer improves solution cycle efficiency by preheating the relatively cool, weak solution before it enters the high-stage generator and precooling the hotter, strong solution before it enters the absorber.

The weak solution flowing to the high-stage generator is controlled by variable frequency drive driven solution pump. The controller calculates VFD speed to maintain optimum solution flow to the high –stage generator at all operating conditions for maximum efficiency.

Point 1. Represent the strong solution in the absorber, as it begins to absorb water vapor after being sprayed from the absorber nozzles. This condition is internal and cannot be measured.

Point 2. Represents the diluted (weak) solution after it leaves the absorber and before it enters the low temperature heat exchanger. This includes its flow through the solution pump. This point can be measured with a solution sample from the pump discharge.

Point 3. Represents the weak solution leaving the low temperature heat exchanger. It is at the same concentration as Point 2 but at a higher temperature after gaining heat from the strong solution. This temperature can be measured.

Point 4. Represents the weak solution leaving the high temperature heat exchanger and entering the high-stage generator. It is at the same concentration as Point 2 and Point 3, but at a higher temperature after gaining heat from the intermediate solution. This temperature can be measured.

Point 5. Represents the weak solution in the high-stage generator after being preheated to the boiling temperature. The solution will boil at temperatures and concentrations corresponding to a saturated temperature established by the vapor condensing temperature in the low-stage generator tubes. This condition is internal and cannot be measured.

Point 6. Represents the intermediate solution leaving the high-stage generator and entering the high temperature heat exchanger after being re-concentrated by boiling out refrigerant. It can be plotted approximately by measuring the temperatures of the leaving intermediate solution and the condensed vapor leaving the low-stage generator tubes (saturation temperature).

Point 7. Represents the intermediate solution from the high temperature heat exchanger as it flows into the low-stage generator. It is the same concentration as Point 6 but at a cooler temperature after giving up heat to the weak solution.

Point 8. Represents the intermediate solution in the low-stage generator. The solution will boil at temperatures and re-concentrations corresponding to saturation temperature in condenser. This condition is internal and cannot be measured.

Point 9. Represents the strong solution leaving the low-stage generator and entering the low temperature heat exchanger. It can be plotted approximately by measuring the temperatures of the leaving strong solution.

Point 10. Represents the strong solution leaving the low temperature heat exchanger. It is same concentration as Point 9 but cooler temperature after giving up heat to the

weak solution. The temperature can be measured.

Point 11. Represents the strong solution entering the absorber spray nozzles after being mixed with some weak solution from solution pump. The temperature can be measured but the concentration cannot be sampled. After leaving the spray nozzles, the solution is somewhat cooled and concentrated as it flashes to the lower pressure of the absorber.

HEATING-140 CYCLE - Heating cycle has a different vapor flow, does not have absorbing process. Refrigerant vapor that produces from high-stage generator directly send to evaporator, lost heat by hot water and then condenses. Condensed refrigerant overflows to absorber from evaporator, mixed with concentrated solution then it becomes weak solution. The weak solution returns to high-stage generator by solution pump to repeat for producing refrigerant vapor.

HEATING-175 (OPTION) CYCLE - Heating-175 cycle uses only high-stage generator and auxiliary heat exchanger. It is very similar to the boiler. For this operation, high-stage generator should be isolated by valves from other component. (See the section of Cooling to Heating-175 for changeover process). Refrigerant vapor that produces from high-stage generator directly and is sent to upper auxiliary heat exchanger, lost heat by hot water and then condenses. Condensed refrigerant drops to high-stage generator.

Table 2-1. Cooling Cycle Data.

POINT	SOLUTION TEMPERATURE		VAPOR PRESSURE		SOLUTION CONCENTRATION
	°F	°C	In. Hg	mm Hg	%
1	107	42	0.3	6.7	59.0
2	96	36	0.3	6.7	55.3
3	150	66	1.4	35.2	55.3
4	238	114	10.9	277.7	55.3
5	260	127	17.2	436.7	55.3
6	271	137	17.2	436.7	57.9
7	178	81	2.2	56.9	57.9
8	168	76	1.7	44.1	57.9
9	178	81	1.7	44.1	60.4
10	114	45	0.3	6.9	60.4
11	109	43	0.3	6.8	58.9

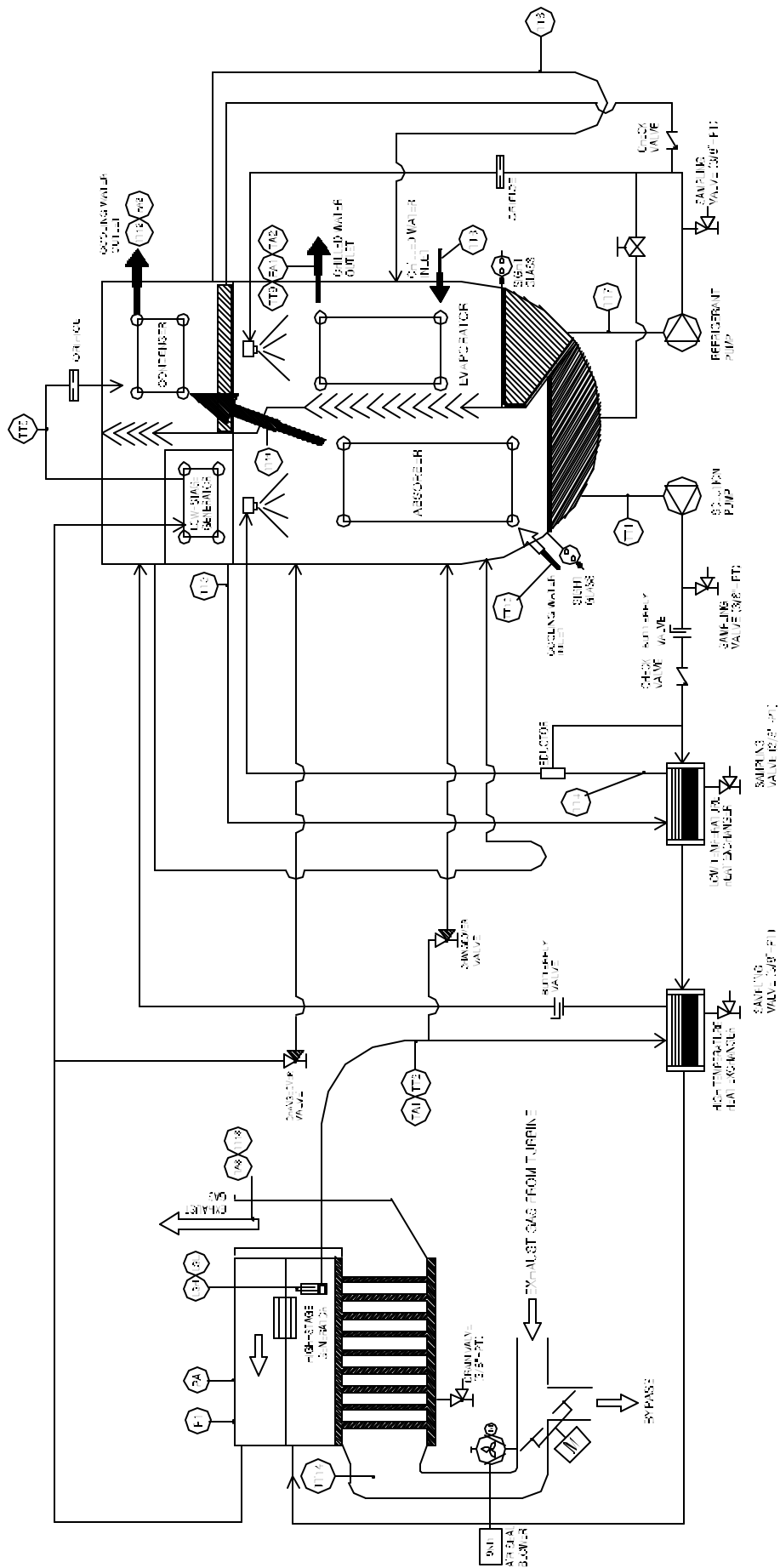

16DNP Standard Cycle

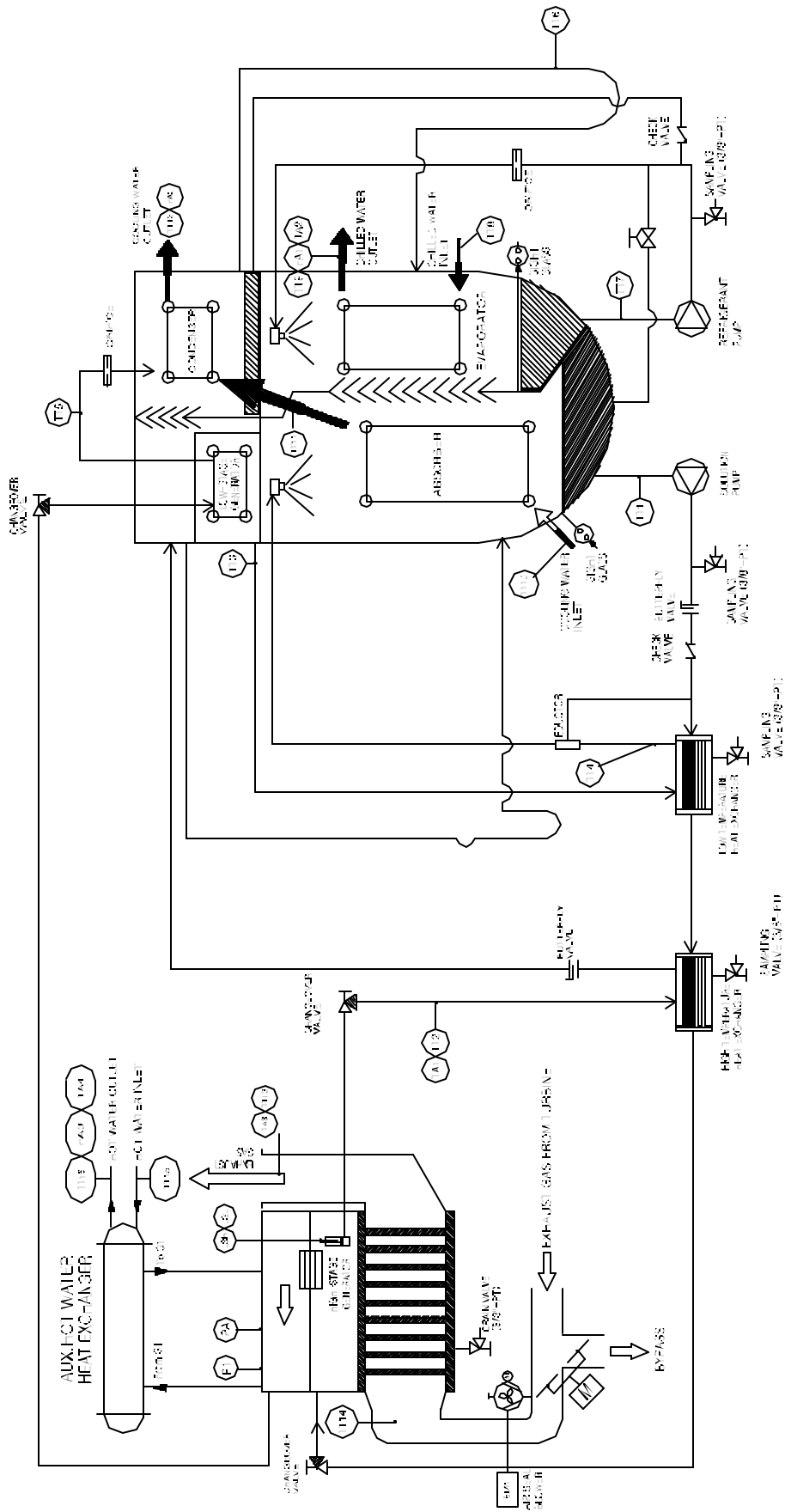

16DNP Heat-175F Cycle

SYMBOL	DESCRIPTION	SYMBOL	DESCRIPTION
TT1	Weak LiBr Leaving Temp. Absorber (5K Ohm)	TT14	G1 Entering Heat Source Temp. (1K Ohm)
TT2	Strong LiBr Leaving Temp. G1(100K Ohm)	TT15	Aux HW Inlet Temp. (5K)
TT3	Strong LiBr Leaving Temp. G2(100K)	TT16	Aux HW Outlet Temp. (5K)
TT4	Strong LiBr Leaving Temp. H2(5K)	PI	G1 Internal Pressure (Gauge)
TT5	Condensate Leaving Temp. G2(5K)	PA	G1 High Pressure S/W
TT6	Vapor Condensate Temp. (5K)	TA1	G1 High Temp. Cutout S/W
TT7	Refrigerant Temp. (5K)	TA2	Low Chilled Water Temp. Cutout S/W
TT8	Chilled Water Entering Temp. (5K)	TA3	Flue Gas Temp. Cutout S/W
TT9	Chilled Water Leaving Temp. (5K)	LSH	G1 High Level S/W
TT10	Cooling Water Entering Temp. Absorber (5K)	LSL	G1 Low Level S/W
TT11	Cooling Water Leaving Temp. Absorber (5K)	FA1	Chilled Water Flow Cutout S/W
TT12	Cooling Water Leaving Temp. Condenser (5K)	FA2	Cooling Water Flow Cutout S/W (Option)
TT13	Flue Gas Temp. (100K)	FA3	Aux HW Flow Cutout S/W (Option)

Fig 2-7 Cooling/Heating Cycle with Data Points

3. CONTROLS

General - The 16DNP chiller contains a microprocessor-based control center that monitors and controls all operations of the chiller. The microprocessor controls system matches the cooling capacity of the chiller to the cooling load while providing state-of-the-art machine protection. The system controls cooling load within the set point plus the dead-band by sensing the leaving chilled water temperature and regulating the diverter valve via a mechanically linked actuator motor.

Movement of the valve causes the exhaust gas rate to increase or decrease, thereby increasing or decreasing the chiller's capacity. The processor protects the chiller by monitoring the digital and analog inputs and executes capacity overrides or safety shutdowns, if required.

PIC System Components - The Product Integrated Control (PIC) is the chiller's control system. The PIC controls the operation of the chiller by monitoring all operating conditions. The PIC can diagnose a problem and let the operator know what the problem is and what to check. It promptly positions the diverter valve to maintain leaving chilled water temperature. It can interface with auxiliary equipment such as pumps and cooling tower fans to turn them on only when required. It continually checks all safeties to prevent any unsafe operating condition.

The PIC can be interface with the Carrier Comfort Network (CCN) if desired. It can communicate with other PIC-equipped chiller and CCN device.

The PIC consists of one controller and three modules housed inside the control panel.

ICVC (International Chiller Visual Controller) - The ICVC contains all the information of control that feed all input signals by SIO from CCM. It controls output making CCM generate output signals. Also it provides user interface by LCD and five keypads. Using CCN, it can communicate with PC or other monitoring systems.

CCM (Chiller Controller Module) : The CCM sends the chiller condition to ICVC, there are 13 of 5KO or 10 KO thermistor inputs, 3 of 0~5V or 4~20mA Inputs, 2 of single-point pressure inputs, 4 of differential pressure inputs and 2 of 4~20mA outputs, 6 of triac outputs which associated with triac/timed-triac.

The PIC system also includes the following components
VFD (Variable Frequency Drive) : The VFD controls solution pump start, stop and motor speed. It receives 4 to 20mA signal from ICVC, then it converts to frequency for the pump motor.

TEMPERATURE SENSORS : Located throughout the chiller, the temperature sensors sense temperature of solution, refrigerant, exhaust gas and water. The temperature is read by ICVC. There are three temperature sensor sizes.

1. The 5K ohm sensor has a range of -40 to 245 °F (-40 to 118.3 °C)
2. The 100 Kohm sensor has a range of 77 to 442 °F (25 to 228 °C). The 100 Kohm sensor is marked with a red band.
3. The 1 Kohm sensor has a range of 36.5 to 820 °F. It is used to detect leaks in the diverter valve.

LEVEL PROBES – Located at high-stage generator, the level probes sense the liquid level in the high-stage generator.

DRY-CONTACT RELAY – A dry-contact relay of at the back of each micro-turbine can be used to infer the ON/OFF status of the micro-turbine.

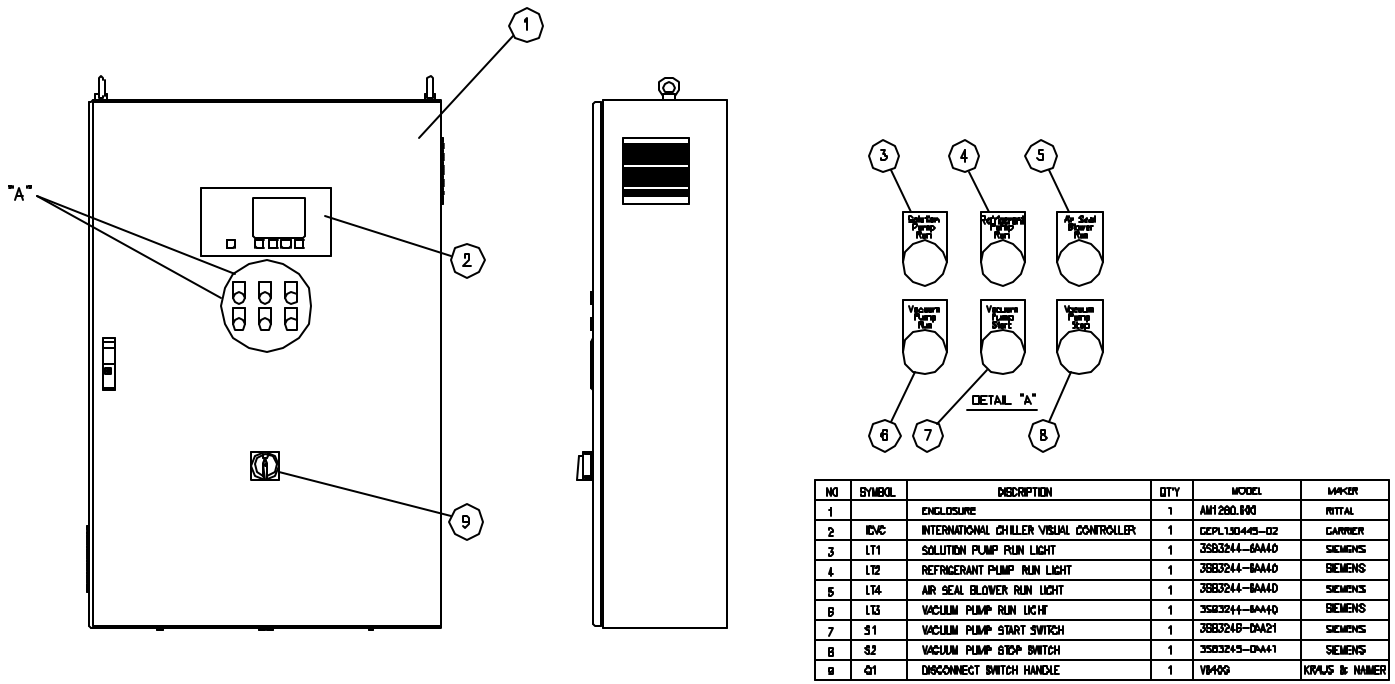

Fig. 3-1 Control Panel, Outside

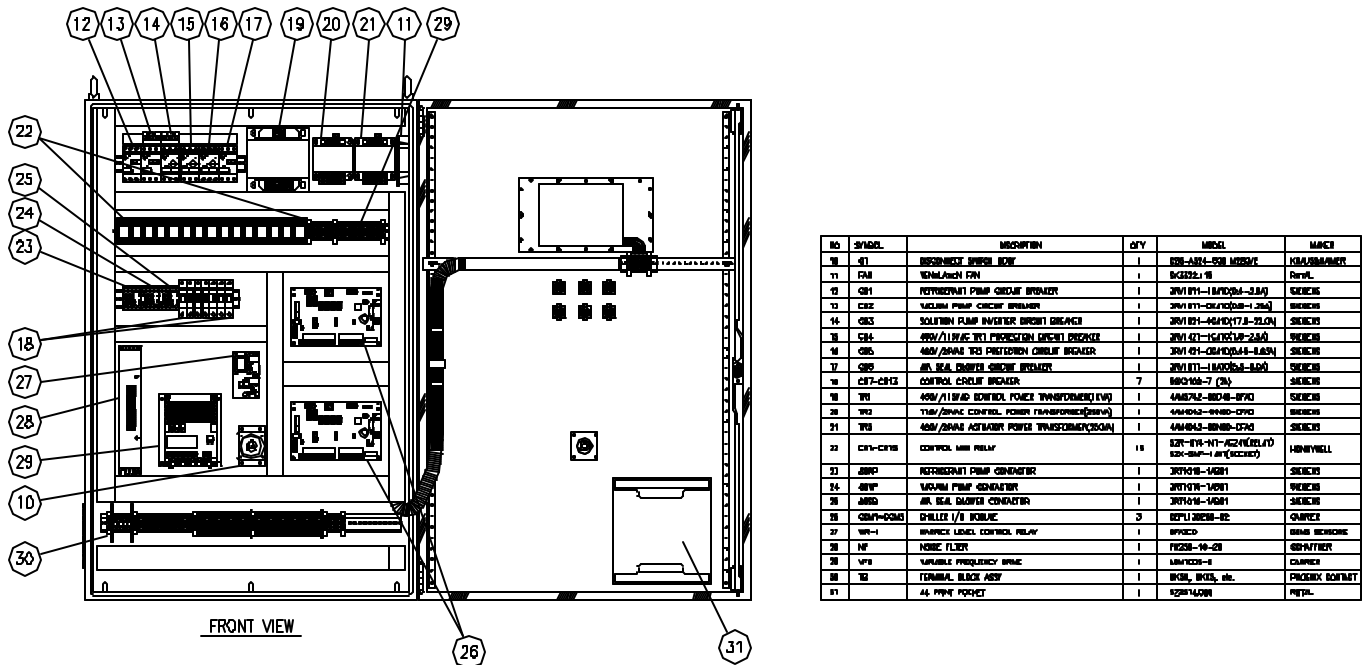

Fig. 3-2 Control Panel, Inside

ICVC Operation & Menus

GENERAL

- The ICVC display will automatically revert to the default screen after 15 minutes if no softkey activity takes place and if the chiller is not in the alarm shutdown. (Fig.3-3)
- When not in the default screen, the upper right-hand corner of the ICVC always displays the name of the screen that you have entered. (Fig.3-4)
- The ICVC may be configured in English or SI units. Use the ICVC CONFIGURATION screen (accessed from the SERVICE menu) to change the units.
- Local Operation: By pressing the **LOCAL** softkey, the PIC is now in the LOCAL operation mode and the control will accept modification to programming from the ICVC only. The PIC will use the Local Time Schedule to determine machine start and stop times.
- CCN(Carrier Comfort Network) Operation: By pressing the **CCN** softkey, the PIC is now in the CCN operation mode and the control will accept modification from any CCN interface or module, as well as the ICVC. The PIC will use the CCN time schedule to determine start and stop time .

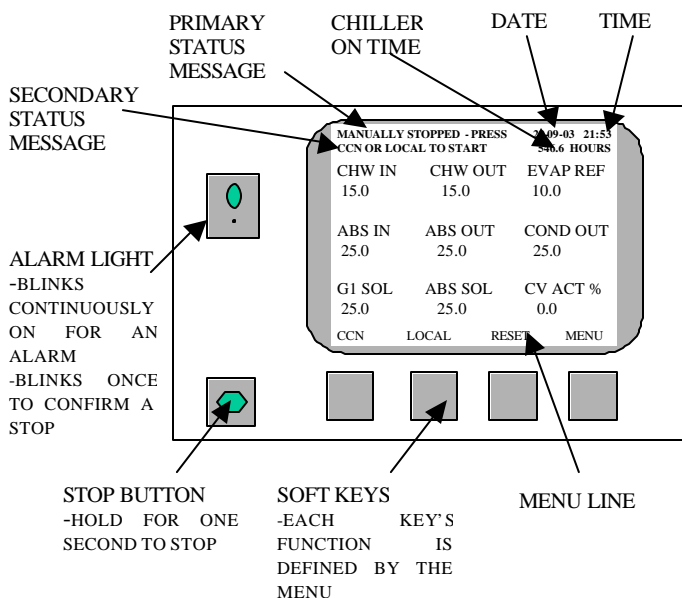

Fig. 3-3 ICVC DEFAULT SCREEN

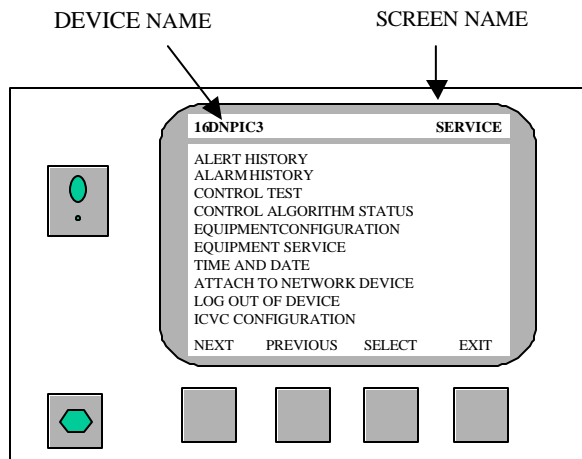

Fig. 3-4 ICVC SERVICE SCREEN

ALARMS AND ALERTS - ALARM (*) and ALERT (!) status are indicated on the STATUS Table. An alarm (*) will shut down the machine. An alert (!) notifies the operator that an unusual condition has occurred. The machine will continue to operate when an alert is shown.

Alarms are indicated when the control center alarm light (!) flashed. The primary alarm message is viewed on the default screen and additional, secondary message and troubleshooting information are sent to the Alarm History table.

NOTE: When an alarm is detected, the ICVC default screen will freeze (stop updating) at the time of alarm. The freeze enables the operator to view the machine conditions at the time of alarm. The status tables will show the updated information. Once all alarms have been cleared (by pressing the **RESET** softkey), the default ICVC screen will return to normal operation.

ICVC MENU ITEMS - To perform any of the operations described below, the PIC must be powered up and have successfully completed its self-test. The self-test takes place automatically, after power-up.

Press the **MENU** softkey to view the following four menu structures: STATUS, SCHEDULE, SETPOINT, and SERVICE.

- The STATUS menu allows for viewing and modification of control points and sensor, relays and contacts, and the operation board.
- The SCHEDULE menu allows for the viewing and modification of the LOCAL Control and CCN Control.
- The SETPOINT menu allows setpoint adjustments, such as the entering chilled water or leaving chilled water temperature setpoint.
- The SERVICE menu can be used to view or modify information on the ALERT HISTORY, ALARM HISTORY, CONTROL TEST, CONTROL ALGORITHM STATUS, EQUIPMENT CONFIGURATION, EQUIPMENT SERVICE, TIME AND DATE, ATTACH TO NETWORK DEVICE, LOG OUT OF DEVICE and ICVC CONFIGURATION.

Fig.3-5, 3-6 and 3-7 provide additional information on the menu structure.

Press the softkey that corresponds to the menu structure you want to view: **STATUS**, **SCHEDULE**, **SETPOINT**, or **SERVICE**. To view or change parameters within any menu structure, use the **NEXT** and **PREVIOUS** softkeys to scroll down to the desired item or table. Use the **SELECT** softkey to select that item. The softkey choices that then appear depend on the table or menu you select. The softkey choices and their functions are listed on page.

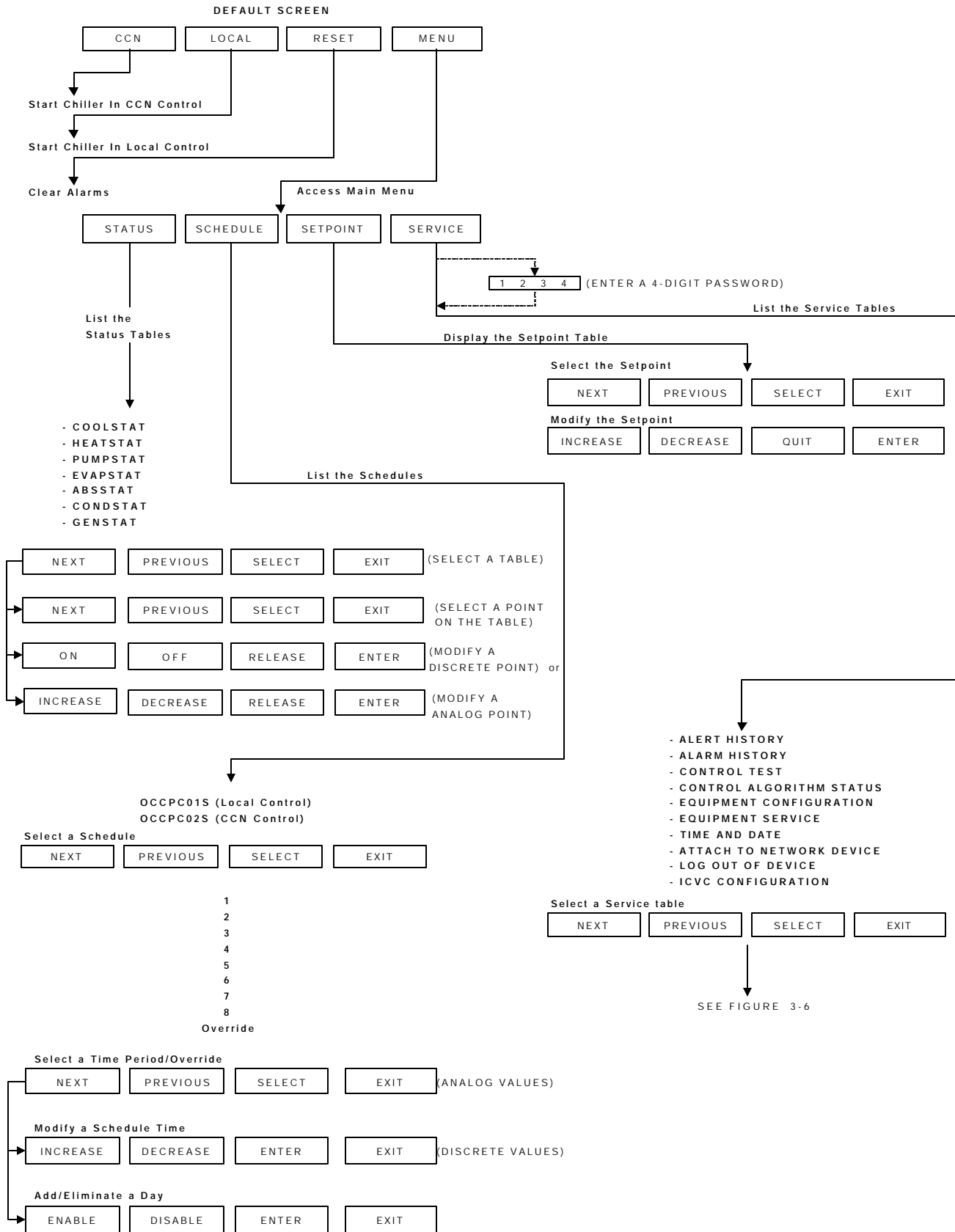
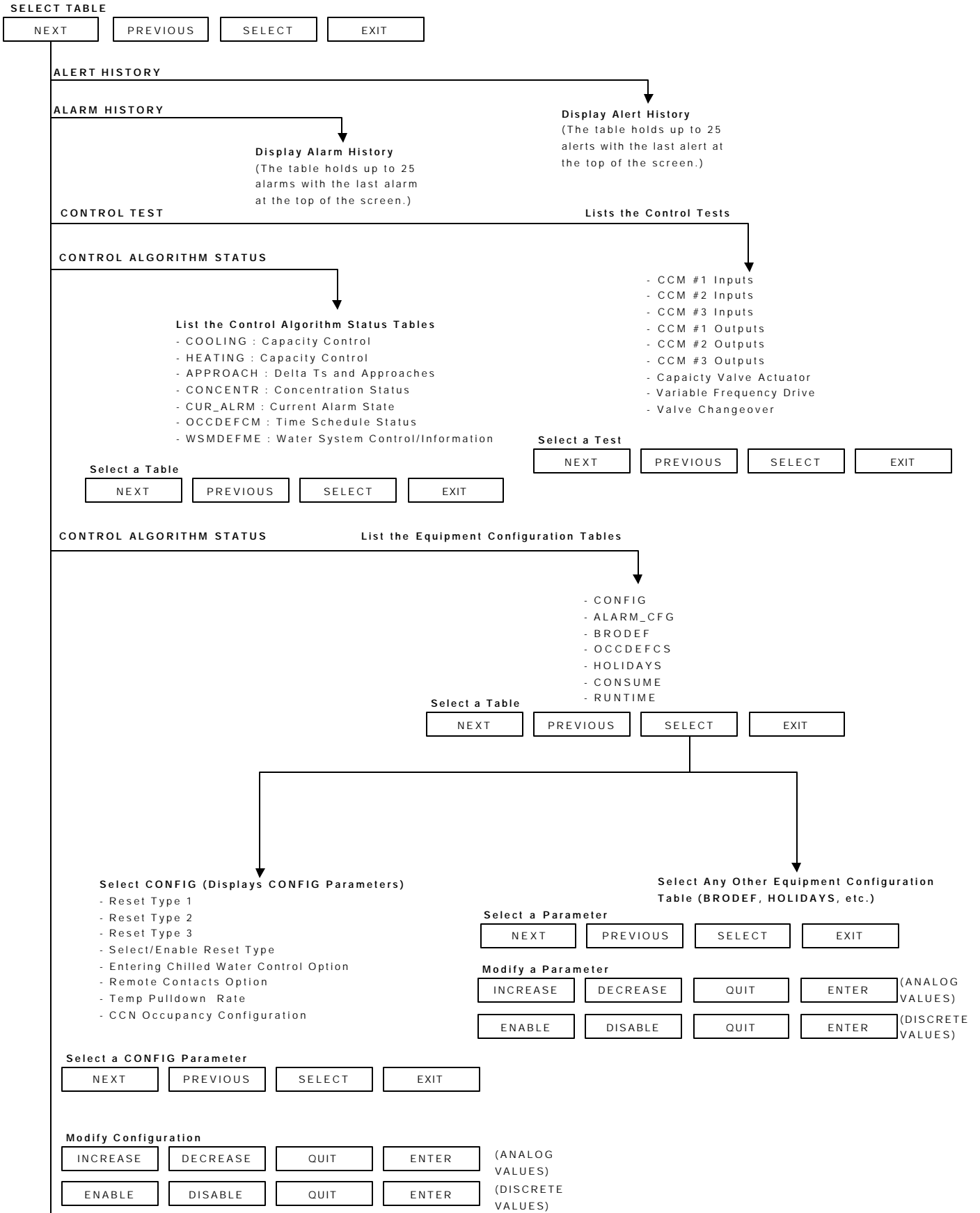

Fig. 3-5 16DNP ICVC MENU STRUCTURE



CONTINUED
ON NEXT PAGE

Fig. 3-6 16DNP SERVICE MENU STRUCTURE (1)

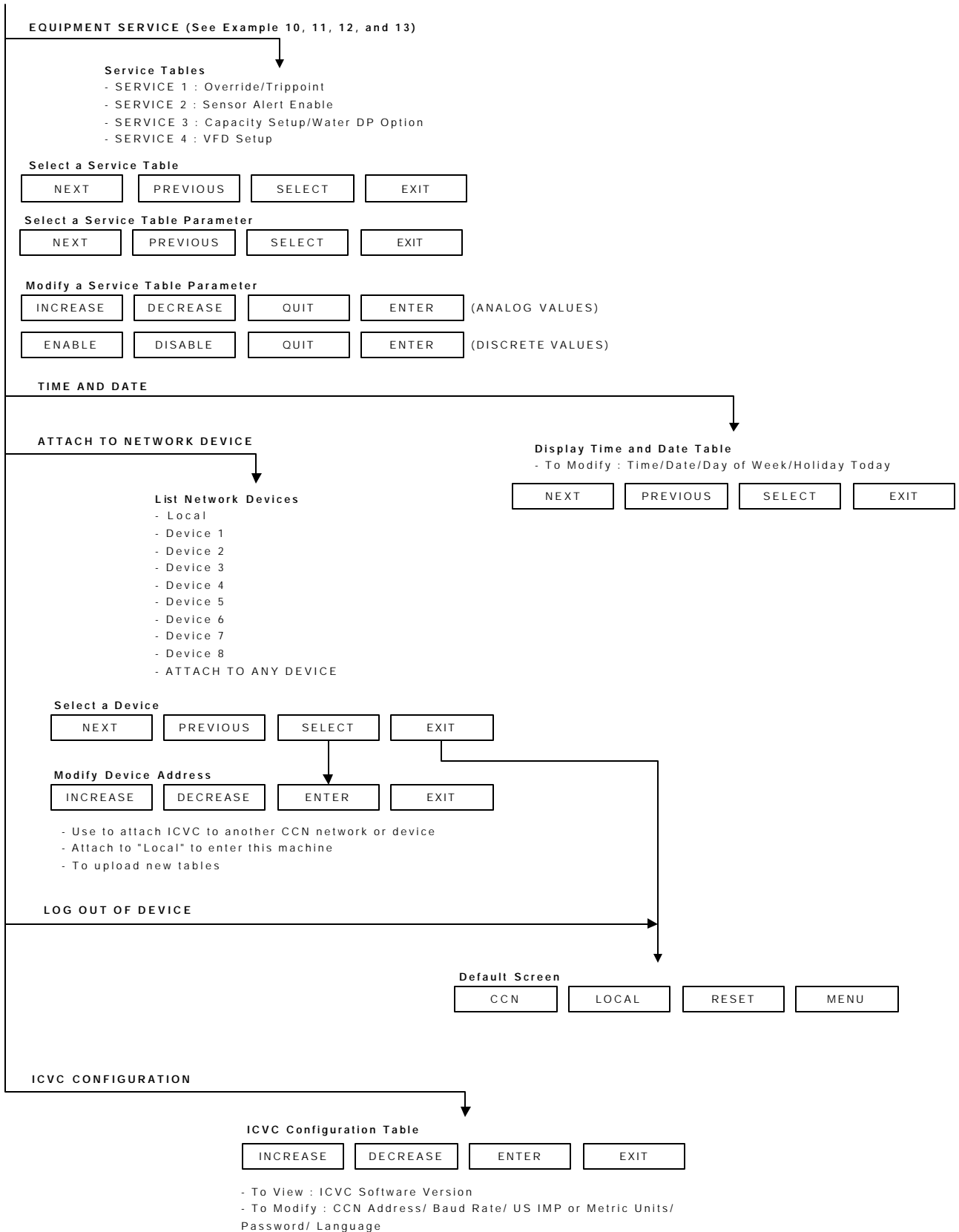
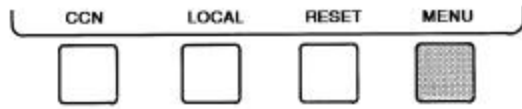

Fig. 3-7 16DNP SERVICE MENU STRUCTURE (2)

BASIC OPERATIONS– To perform any of the operations described below, the PIC must be powered up and have successfully completed its self-test.

1. Press **MENU** to select from the four available options.



2. Press the softkey that corresponds to the desired menu structure.

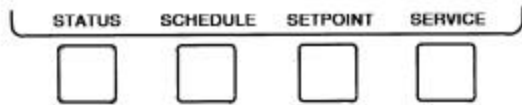

3. Press **NEXT** or **PREVIOUS** to scroll the cursor bar down or up in order to highlight a point or to view more points below the current screen.

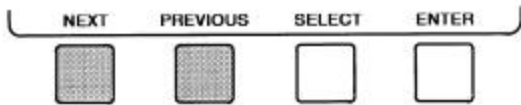

4. Press **SELECT** to view the next screen level (highlighted with the cursor bar) or to override (if allowable) the highlighted point value.

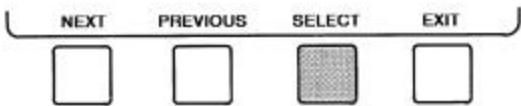

5. Press **QUIT** to leave the selected decision or field without saving any changes.

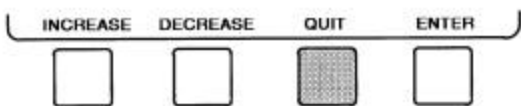

6. Press **EXIT** to return to the previous screen level.

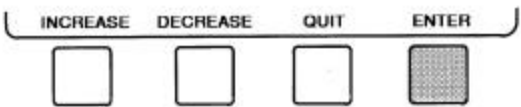

TO VIEW OR CHANGE POINT STATUS - Point Status is the actual value of all of the temperatures, relays and actuators sensed and controlled by PIC.

1. On the MENU screen, press **STATUS** to view the list of POINT STATUS tables.

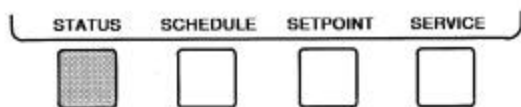

2. Press **NEXT** or **PREVIOUS** to highlight the desired STATUS table. The list of tables includes:
 - COOLSTAT – Status of control points in cooling mode
 - HEATSTAT – Status of control points in heating mode
 - PUMPSTAT – Status of pumps
 - EVAPSTAT – Status of the evaporator
 - ABSSTAT – Status of the absorber
 - CONDSTAT – Status of the condenser
 - GENSTAT – Status of the generator

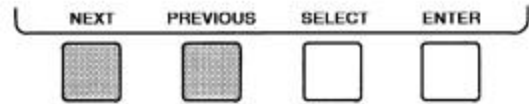

3. Press **SELECT** to view the desired POINT STATUS table.

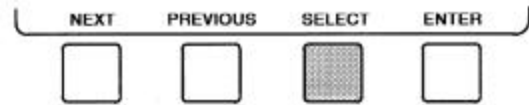

4. On the selected table, press **NEXT** or **PREVIOUS** until desired point is displayed on the screen.

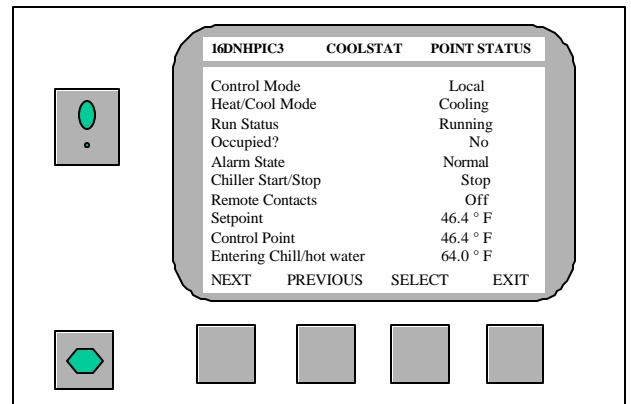
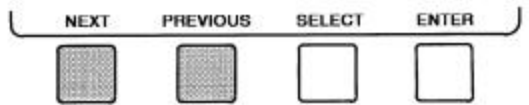
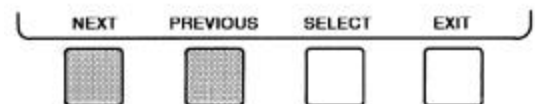

Fig. 3-8 EXAMPLE OF POINT STATUS SCREEN (COOLSTAT)

OVERRIDE OPERATIONS

To Override a Value or Status

1. From any STATUS screen, press **NEXT** or **PREVIOUS** to highlight the desired point.



2. Press **SELECT** to access the highlighted point.

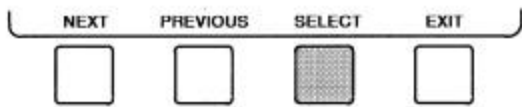

For *Discrete Points* - Press **START** or **STOP**, **ON** or **OFF** to select the desired state.

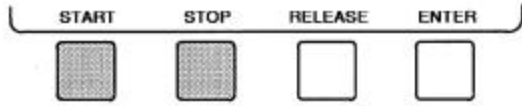

For *Analog Points* - Press **INCREASE** or **DECREASE** to select the desired value.



3. Press **ENTER** to register new value.

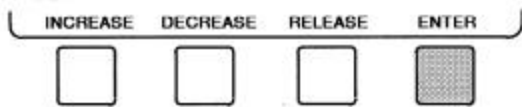

To Remove an Override

1. From any STATUS screen, press **NEXT** or **PREVIOUS** to highlight the desired point.

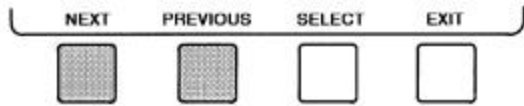

2. Press **SELECT** to access the highlighted point.

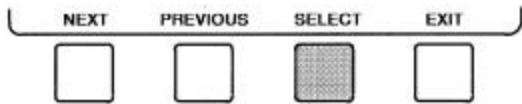

3. Press **RELEASE** to remove the override and return the point to the PIC's automatic control.



Override Indication - An override value is indicated by "SUPVSR" flashing next to the point value on the STATUS table.

TIME SCHEDULE OPERATION

1. On the MENU screen, press **SCHEDULE**.

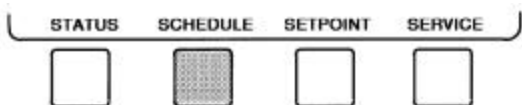

2. Press **NEXT** or **PREVIOUS** to highlight one of the following schedule. The actual CCN Occupied Schedule number is defined on the CONFIG table. The CCN schedule number can change to any value from 02 to 99.

- OCCPC01S : LOCAL TIME SCHEDULE
- OCCPC02S : CCN TIME SCHEDULE

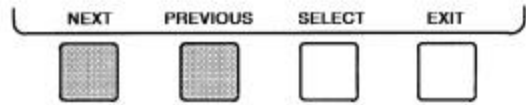

3. Press **SELECT** to access and view the time schedule.

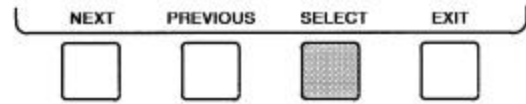

4. Press **NEXT** or **PREVIOUS** to highlight the desired period or override that you wish to change.

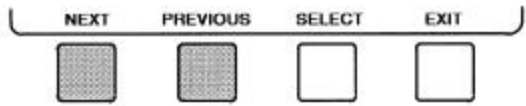

5. Press **SELECT** to access and view the time schedule.

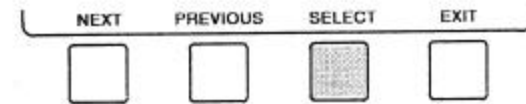

6. A. Press **INCREASE** or **DECREASE** to change the time values.



●

16DNHPIC3 OCCPC01S TIME PERIOD SELECT

PERIOD	ON	OFF	M	T	W	T	F	S	S	H
1	0715	1715	X	X	X	X	X			
2	0715	1300							X	
3	0000	0000								
4	0000	0000								
5	0000	0000								
6	0000	0000								
7	0000	0000								
8	0000	0000								

OVERRIDE 0 HOURS

NEXT
PREVIOUS
SELECT
EXIT

◀

Fig. 3-9 EXAMPLE OF TIME SCHEDULE

B. Press **ENABLE** to select days in the day-of-week fields. Press **DISABLE** to eliminate days from the period.

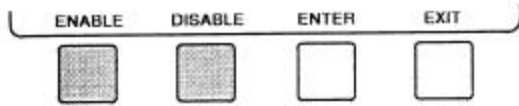

7. Press **ENTER** to register the value and to move horizontally (left to right) within a period.

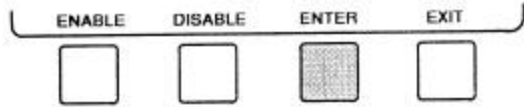

8. Press **EXIT** to leave the period or override.

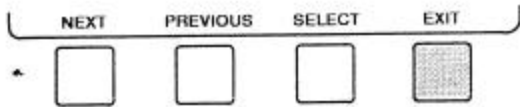

9. Either return to Step 4 to select another period or override, or press **EXIT** again to leave the current time schedule and save the changes.

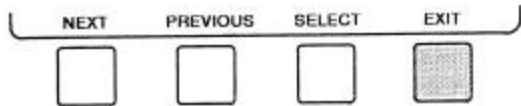

NOTE: Information on setting holiday designations may be found in the Service Operation section.

TO VIEW OR CHANGE SETPOINT

1. To view the SETPOINT table, press **SETPOINT** at the MENU screen.

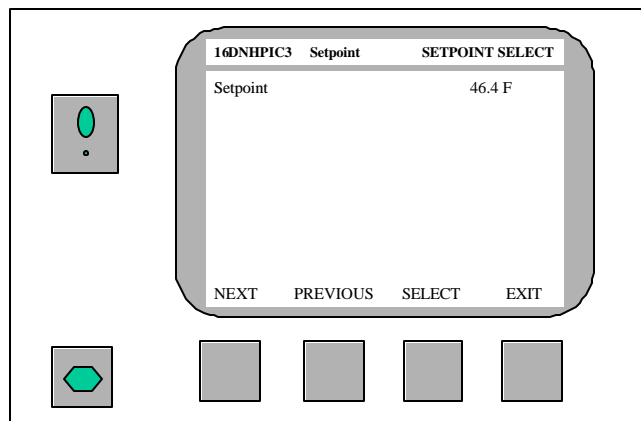
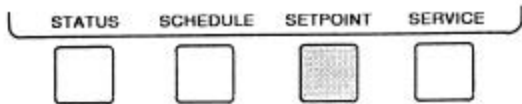
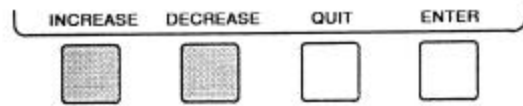

Fig. 3-10 EXAMPLE OF SETPOINT SCREEN

2. Press **INCREASE** or **DECREASE** to change the selected set point value.



3. Press **ENTER** to save the changes and return to the previous screen.



PIC System Functions

CAPACITY CONTROL - The PIC controls the chiller capacity by modulating the capacity valve in response to chilled water temperature changes away from the CONTROL POINT. The CONTROL POINT may be changed by a CCN network device, or is determined by the PIC adding any active chilled water reset to the ECW (Entering Chilled Water) SET POINT or LCW SET POINT. The PIC uses the PID control (PROPORTIONAL GAIN, INTEGRAL GAIN and G1 SOLUTION TEMP GAIN) to determine how fast or slow to respond. CONTROL POINT may be viewed/overridden on the COOLSTAT or HEATSTAT table on the STATUS screen.

Some adjustments are also implemented in capacity control. For Cooling mode, Error = Chill/Hot Water Temperature – Setpoint; for Heating modes, Error = Setpoint - Chill/Hot Water Temperature. And the control logic are:

1. Error > -1.0 °C : Normal PID control.
2. -1.0 °C >= Error > Recycle Shutdown Limit (default – 1.4 °C): Reset Integrator. Capacity valve is controlled by P term only. Target Capacity valve closed.
3. Error <= Recycle Shutdown Limit (default – 1.4 °C): Normal Recycle Shutdown control.

ENTERING CHILLED WATER CONTROL (OPTIONAL) - If this option is enabled, the PIC uses ENTERING CHILLED WATER temperature to modulate the valve instead of LEAVING CHILLED WATER temperature. ENTERING CHILLED WATER control option may be viewed/modified on the EQUIPMENT CONFIGURATION table shown on the CONFIG table.

CHILLER TIMER - The PIC maintains 2 runtime clocks, known as SOLUTION PUMP ONTIME AND SERVICE ONTIME. SOLUTION PUMP ONTIME indicates the total lifetime pump run hours. This timer can register up to 500,000 hours before the clock turns back to zero. The SERVICE ONTIME is a re-settable timer that can be used to indicate the hours since the last service visit or any other reason. The time can be changed through the ICVC to whatever value is desired. This timer can register up to 32,767 hours before it rolls over to zero.

Table 3-1. ICVC SCREENS

NOTE :

1. Only 12 lines of information appear on the ICVC screen at any given time. Press **NEXT** or **PREVIOUS** to highlight a point or to view points below or above the current screen.
2. To access the information shown in Example 9 through 19, enter your 4-digit password after pressing the **SERVICE** softkey. If no softkeys are pressed for 15 minutes, the ICVC screen automatically logs off (to prevent unrestricted access to PIC controls) and reverts to the default screen. If this happens, you must reenter your password to access the tables shown in Example 9 through 19.
3. Terms in the Description column of these tables are listed as they appear on the ICVC screen.
4. The ICVC may be configured in English or SI units, as required, through the ICVC CONFIGURATION screen. See the Service Operation section for instructions on making this change.
5. The items in the REFERENCE POINT NAME column do not appear on the ICVC screen. They are data or variable names used in CCN software.
6. Reference Point Names shown in these tables in all capital letters can be read by CCN software. Of these capitalized names, those preceded by an asterisk (*) can be changes (that is written to) by the CCN and the ICVC. Capitalized Reference Point Names preceded by two asterisks (**) can be changed only from the ICVC.
7. Alarms and Alerts : An asterisk in the far right field of a ICVC status screen indicates that the chiller is in an alarm state; an exclamation point in the far right field of the ICVC screen indicates an alert state. The asterisk (or exclamation point) indicates that the value on that line has exceeded (or is approaching) a limit. For more information on alarms and alerts, see the Alarms and Alerts section.

EXAMPLE 1 - COOLSTAT DISPLAY SCREEN

To access this display from the ICVC default screen :

1. Press **MENU**.
2. Press **STATUS** (COOLSTAT will be highlighted.)
3. Press **SELECT**.

DESCRIPTION	STATUS/RANGE	UNITS	REFERENCE POINT NAME
Control Mode	NOTE 1		C_MODE
Heat/Cool Mode	NOTE 2		HC_STAT
Run Status	NOTE 3		RUN_STAT
Occupied?	0/1	NO/YES	OCCPIED
Alarm State	0/1	NORMAL/ALARM	ALMSTAT
*Chiller Start/Stop	0/1	STOP/START	CHIL_S_S
*Micro Turbine Start/Stop	0/1	STOP/START	MT_S_S
*Remote Contacts	0/1	OFF/ON	REMCON
Setpoint	41 – 175	°F	SETPOINT
*Control Point	41 – 175	°F	LCW_STPT
Entering Chill/hot water	-40 – 245	°F	CHW_IN
Leaving Chill/hot Water	-40 – 245	°F	CHW_OUT
**Target Diverter Valve	0 – 100	%	TRG_DIV
Diverter Valve 4-20ma	0 – 100	%	ACT_DIV
Diverter Pos Feedback	0 – 100	%	DIV_IN
Spare Prot Limit Input	0/1	NORMAL/ALARM	SPR_PL
*Temp Reset 4-20mA	4 – 20	ma	TRES_OPT
*Remote Reset Sensor	-40 – 245	°F	R_RESET
*Common Supply Sensor	-40 – 245	°F	CHWS
*Common Return Sensor	-40 – 245	°F	CHWR
Chiller Run Relay	0/1	OFF/ON	RUNRELAY

NOTE 1 : Reset, Off, Local, CCN

NOTE 2 : Cooling, Heat-140, Heat-175

NOTE 3 : Ctl Test, Ready, Recycle, Prestart, Startup, Ramping, Running, Override, Dilution, Tripout

NOTE 4 : Only values with capital letter reference point names are variables available for read operation to CCN network. Descriptions shown with (*) support write operations from the CCN device and with (**) support write operations from ICVC only.

EXAMPLE 2 – HEATSTAT DISPLAY SCREEN (CON'T)

To access this display from the ICVC default screen :

1. Press **MENU**.
2. Press **STATUS**.
3. Scroll down to highlight HEATSTAT.
4. Press **SELECT**.

DESCRIPTION	STATUS	UNITS	POINT
Control Mode	NOTE 1		C_MODE
Heat/Cool Mode	NOTE 2		HC_STAT
Run Status	NOTE 3		RUN_STAT
Occupied?	0/1	NO/YES	OCCUPIED
Alarm State	0/1	NORMAL/ALARM	ALMSTAT
*Chiller Start/Stop	0/1	STOP/START	CHIL_S_S
*Micro Turbine Start/Stop	0/1	STOP/START	MT_S_S
*Remote Contacts	0/1	OFF/ON	REMCON
Setpoint	41 – 175	°F	SETPOINT
*Control Point	41 – 175	°F	LCW_STPT
Entering Chill/hot water	-40 – 245	°F	CHW_IN
Leaving Chill/hot Water	-40 – 245	°F	CHW_OUT
**Target Diverter Valve	0 – 100	%	TRG_DIV
Diverter Valve 4-20ma	0 – 100	%	ACT_DIV
Diverter Pos Feedback	0 – 100	%	DIV_IN
Aux HW Inlet Temperature	-40 – 245	°F	HW_IN
Aux HW Outlet Temp	-40 – 245	°F	HW_OUT
Aux HW Temp/Press Cutout	0/1	OPEN/CLOSE	AX_HXCUT
Chiller Run Relay	0/1	OFF/ON	RUNRELAY

NOTE 1 : Reset, Off, Local, CCN

NOTE 2 : Cooling, Heat-140, Heat-175

NOTE 3 : Ctl Test, Ready, Recycle, Prestart, Startup, Ramping, Running, Override, Dilution, Tripout

NOTE 4 : Only values with capital letter reference point names are variables available for read operation to CCN network. Descriptions shown with (*) support write operations from the CCN device and with (**) support write operations from ICVC only.

EXAMPLE 3 - PUMPSTAT DISPLAY SCREEN

To access this display from the ICVC default screen :

1. Press **MENU**.
2. Press **STATUS**.
3. Scroll down to highlight PUMPSTAT.
4. Press **SELECT**.

DESCRIPTION	STATUS	UNITS	POINT
**Chill/hot Water Pump	0/1	OFF/ON	CHWP
Chill Water Low Tmp/Flow	0/1	OPEN/CLOSE	LOWWTCUT
**Cooling Water Pump	0/1	OFF/ON	COOLPMP
Cond Water Flow Switch	0/1	OFF/ON	W_SWITCH
**Refrigerant Pump	0/1	OFF/ON	REFPUMP
Ref Pump Overld/HiTemp	0/1	ALARM/NORMAL	RFPMPFLT
**Solution Pump	0/1	OFF/ON	SOLPUMP
Sol Pump VFD/HiTemp	0/1	ALARM/NORMAL	SPMP1FLT
Aux Solution Pump	0/1	OFF/ON	SOLPMP2
Aus Sol Pump Ovrld/HT	0/1	ALARM/NORMAL	SPMP2FLT
Solution Pump Ontime	0 – 500000.0	HOURS	SOLPHOVR
**Service Ontime	0 – 65535	HOURS	SERV_HRS
Solution Pump Starts	0 – 65535		SOLPSTRT
G1 HiLev Starts-Last Hr	0 – 12		SPST_1HR
Aux Hot Water Pump	0/1	OFF/ON	HW_PUMP
Aux HW Temp/Flow Cutout	0/1	ALARM/NORMAL	AXHXCUT

NOTE : Only values with capital letter reference point names are variables available for read operation to CCN network. Descriptions shown with (*) support write operations from the CCN device and with (***) support write operations from ICVC only.

EXAMPLE 4 - EVAPSTAT DISPLAY SCREEN

To access this display from the ICVC default screen :

1. Press **MENU**.
2. Press **STATUS**.
3. Scroll down to highlight EVAPSTAT.
4. Press **SELECT**.

DESCRIPTION	STATUS	UNITS	POINT
Entering Chill/hot Water	-40 – 245	°F	CHW_IN
CHW_IN Pulldown Deg/Min	-10 – 10	^F	CHW_INPD
Leaving Chill/hot Water	-40 – 245	°F	CHW_OUT
CHW_OUT Pulldown Deg/Min	-10 – 10	^F	CHWOUTPD
Refrigerant Temp	-40 – 245	°F	EVAP_REF
**Chill/hot Water Pump	0/1	OFF/ON	CHWP
**Refrigerant Pump	0/1	OFF/ON	REFPUMP
Ref Pump Overld/HiTemp	0/1	ALARM/NORMAL	RFPMPFLT
Chill Water Low Tmp/Flow	0/1	OPEN/CLOSE	LOWWTCUT

NOTE : Only values with capital letter reference point names are variables available for read operation to CCN network. Descriptions shown with (*) support write operations from the CCN device and with (***) support write operations from ICVC only.

EXAMPLE 5 - ABSSTAT DISPLAY SCREEN

To access this display from the ICVC default screen :

1. Press **MENU**.
2. Press **STATUS**.
3. Scroll down to highlight ABSSTAT.
4. Press **SELECT**.

DESCRIPTION	STATUS	UNITS	POINT
Cooling Water Ent Absorb	-40 – 245	°F	ABS_IN
Cooling Water Lvg Absorb	-40 – 245	°F	ABS_OUT
Strong LiBr Lvg Low HX	-40 – 245	°F	SLBLLOHX
Weak LiBr Leaving Absorb	-40 – 245	°F	ABS_SOL
**Solution Pump	0/1	OFF/ON	SOLPUMP
Sol Pump VFD/HiTemp	0/1	ALARM/NORMAL	SPMP1FLT

NOTE : Only values with capital letter reference point names are variables available for read operation to CCN network. Descriptions shown with (*) support write operations from the CCN device and with (**) support write operations from ICVC only.

EXAMPLE 6 - CONDSTAT DISPLAY SCREEN

To access this display from the ICVC default screen :

1. Press **MENU**.
2. Press **STATUS**.
3. Scroll down to highlight CONDSTAT.
4. Press **SELECT**.

DESCRIPTION	STATUS	UNITS	POINT
Cooling Water Lvg Absorb	-40 – 245	°F	ABS_OUT
Cooling Water Lvg Cond	-40 – 245	°F	COND_OUT
Vapor Condensate Temp	-40 – 245	°F	VAPORCD
**Cooling Water Pump	0/1	OFF/ON	COOLPMP
Cond Water Flow Switch	0/1	OFF/ON	W_SWITCH
**Tower Fan Relay	0/1	OFF/ON	TOWERFAN

NOTE : Only values with capital letter reference point names are variables available for read operation to CCN network. Descriptions shown with (*) support write operations from the CCN device and with (**) support write operations from ICVC only.

EXAMPLE 7 - GENSTAT DISPLAY SCREEN

To access this display from the ICVC default screen :

1. Press **MENU**.
2. Press **STATUS**.
3. Scroll down to highlight GENSTAT.
4. Press **SELECT**.

DESCRIPTION	STATUS	UNITS	POINT
Strong LiBr Leaving G1	77 – 442	°F	G1_SOL
Strong LiBr Leaving G2	77 – 442	°F	G2_SOL
Strong LiBr Lvg Low HX	-40 – 245	°F	SLBLLOHX
Condensate Leaving G2	-40 – 245	°F	G1_SAT
Flue Gas Temp	77 – 442	°F	FLUE_GAS
Flue Gas Temp Cutout	0/1	OPEN/CLOSE	FTFG_CUT
Act Command Signal	0/1	OFF/ON	ACT_CMD
MT Status	0,1,2,3,4	NONE	MT_STAT
MT Start/Stop	0/1	STOP/START	MT_S_S
Blower Command Signal	0/1	OFF/ON	BLOW_OUT
G1 Entering Heat Source	0/1	LOW/HIGH	G1_EHS
Generator Hi Temp/Press	0/1	OPEN/CLOSE	G1HITP
Gen High Level Switch	0/1	OPEN/CLOSE	G1HILEV
Gen Low Level Switch	0/1	OPEN/CLOSE	G1LOWLEV
VFD Speed	0 – 100	%	VFDOUT
VFD Manual Speed	0 – 100	%	VFD_MAN

NOTE : Only values with capital letter reference point names are variables available for read operation to CCN network. Descriptions shown with (*) support write operations from the CCN device and with (**) support write operations from ICVC only.

EXAMPLE 8 - SETPOINT DISPLAY SCREEN

To access this display from the ICVC default screen :

1. Press **MENU**.
2. Press **SETPOINT**.

DESCRIPTION	STATUS	UNITS	POINT	DEFAULT
Setpoint	41-175	°F	SETPOINT	50.0

EXAMPLE 9 – CONFIGURATION (CONFIG) DISPLAY SCREEN

To access this display from the ICVC default screen :

1. Press **MENU**.
2. Press **SERVICE**.
3. Scroll down to highlight EQUIPMENT CONFIGURATION.
4. Press **SELECT**.
5. Scroll down to highlight CONFIG.
6. Press **SELECT**.

DESCRIPTION	STATUS	UNITS	POINT	DEFAULT
Temperature Reset				
RESET TYPE 1				
Degrees Reset at 20mA	-30 – 30	°F	DEG_20MA	10
RESET TYPE 2				
Remote Temp ->No Reset	-40 – 245	°F	RES_RT1	85
Remote Temp ->Full Reset	-40 – 245	°F	RES_RT2	65
Degrees Reset	-30 – 30	°F	DEG_RT	10
RESET TYPE 3				
CHW Delta T->No Reset	0 – 15	^F	RESTD_1	10
CHW Delta T->Full Reset	0 – 15	^F	RESTD_2	0
Degrees Reset	-30 – 30	DEG F	DEG_CHW	5
Enable Reset Type	0 – 3		RES_SEL	0
CHW_IN Control Option	0/1	DS/ENABLE	CWI_OPT	DSABLE
Remote Contacts Option	0/1	DS/ENABLE	R_CONTCT	DSABLE
Temp Pulldown Ramp	2 – 10		TMP_PULL	3
CCN Occupancy Config				
Schedule Number	2 – 99		OCCPCXXE	2
Broadcast Option	0 – 1	DS/ENABLE	OCCBRCST	DSABLE

NOTE: No VARIABLES ARE AVAILABLE FOR CCN READ OR WRITE OPERATION.

EXAMPLE 10 – SERVICE1 DISPLAY SCREEN

To access this display from the ICVC default screen :

1. Press **MENU**.
2. Press **SERVICE**.
3. Scroll down to highlight EQUIPMENT SERVICE.
4. Press **SELECT**.
5. Scroll down to highlight SERVICE1.
6. Press **SELECT**.

DESCRIPTION	STATUS	UNITS	POINT	DEFAULT
Refrigerant Trippoint	36 – 42	°F	REF_TRIP	38
Refrig Override Delta T	2 – 5	^F	REFOVRDT	2.0
Water Flow Verify Time	0.5 – 5	min	WFLOW_T	0.5
Recycle Control				
Restart Delta T	2.0 – 10.0	^F	RCYCR_DT	5.0
Shutdown Delta T	2.0 – 10.0	^F	RCYCS_DT	2.5
Weak LiBr Lvg Abs Alert*	100-150(cooling)	°F	WLBLABAL	110(cooling)
	100-200(heating)	°F		150(heating)
G2 Condensate Override	199 – 212	°F	G2CNDOVL	210
G1 Strong LiBr Override	311 – 325	°F	G1SLBOVL	311
Subcool Adjustment				
Subcool at 1 EVAP	1 – 9	^F	SUB_MAX	8
Subcool at 10 EVAP	1 – 9	^F	SUB_MIN	4.5

* Alert for Cooling mode, Alarm for Heating mode

NOTE: No variables are available for CCN read operation; Forcing shall not be supported on service screens.

EXAMPLE 11 - SERVICE2 DISPLAY SCREEN

To access this display from the ICVC default screen :

1. Press **MENU**.
2. Press **SERVICE**.
3. Scroll down to highlight EQUIPMENT SERVICE.
4. Press **SELECT**.
5. Scroll down to highlight SERVICE2.
6. Press **SELECT**.

DESCRIPTION	STATUS	UNITS	POINT	DEFAULT
SENSOR ALERT ENABLE Disable=0,High=1,Low=2 Temp = Alert Threshold				
CHWS Temp Enable	0 – 2		CHWS_TEN	0
CHWS Temp Alert	-40 – 245	°F	CHWS_TAL	245
CHWR Temp Enable	0 – 2		CHWR_TEN	0
CHWR Temp Alert	-40 – 245	°F	CHWR_TAL	245
Reset Temp Enable	0 – 2		RRES_TEN	0
Reset Temp Alert	-40 – 245	°F	RRES_TAL	245

NOTE: This screen provides the means to generate Alert messages based on exceeding the "Temp Alert" threshold for each point listed. If the "Enable" is set to 1, a value above the "Temp Alert" threshold shall generate an Alert message. If the "Enable" is set to 2, a value below the "Temp Alert" threshold shall generate an Alert message. If the "Enable" is set to 0, Alert generation is disabled.

NOTE: No variables are available for CCN read operation; Forcing shall not be supported on service screens.

EXAMPLE 12 - SERVICE3 DISPLAY SCREEN

To access this display from the ICVC default screen :

1. Press **MENU**.
2. Press **SERVICE**.
3. Scroll down to highlight EQUIPMENT SERVICE.
4. Press **SELECT**.
5. Scroll down to highlight SERVICE3.
6. Press **SELECT**.

DESCRIPTION	STATUS	UNITS	POINT	DEFAULT
Diverter Valve Setup				
G1 Solution Temp Gain	0.000 – 100.0		K_FB	0.000
Integral Gain	0.000 – 2.000		K_I	0.020
Proportional Gain	0.000 – 20.000		K_P	10.000
Running Travel Limit	30 – 100	%	RUN_LIM	100
Cooling/Heating Ratio	0.5 – 1.0		CH_RATIO	1.0
Pulse Interval Gain	0.1 – 10		INT_GAIN	1.0
Startup Travel Limit	50 – 100	%	START_TL	100
Ref Pump Dilution Timer	0 – 15	Min	REFPTIME	3
Solution Pump:				
Overtime	0–500000.0	HOURS	RUN_TIME	0
Starts	0–65534		SOL_STRT	0
Solution Pump Delay Constant	-5000.0 – 5000.0		DLYCONST	39.3
Maximum DV Position	0 – 10	%	DV_ASB	5
Diverter ON Limit	3.0 – 7.0	°F	DL_ONTH	5
Diverter OFF Limit	0.0 – 3.0	°F	DL_OFFTH	2.5
Diverter Position Error	0 – 50	%	DVP_ERR	20
DV Leak Threshold 1	260 – 350	°F	DV_LKTH1	320
DV Leak Threshold 2	200 – 300	°F	DV_LKTH2	250

Note: No variable are available for CCN read operation; Forcing shall not be supported on service screens.

EXAMPLE 13 – SERVICE4 DISPLAY SCREEN

To access this display from the ICVC default screen :

1. Press **MENU**.
2. Press **SERVICE**.
3. Scroll down to highlight EQUIPMENT SERVICE.
4. Press **SELECT**.
5. Scroll down to highlight SERVICE4.
6. Press **SELECT**.

DESCRIPTION	STATUS	UNITS	POINT	DEFAULT
A1: G2 Max Temp	90.0 – 105.0		VFD_A1	98.0
A2: G2 Min Temp	60.0 – 75		VFD_A2	58.2
B: G2 Gain	0.50 – 1.00		VFD_B	1.13
A4: VFD min Speed	10.0 – 40.0		VFD_A4	20.0
C1: Absorb minimum	30.0 – 40.0		VFD_C1	38.0
C2: Frequency Const	50.0 – 60.0		VFD_C2	60.0
C3 : Heating Frequency	35.0 – 60.0		VFD_C3	40.0

Note : No variable are available for CCN read operation; Forcing shall not be supported on service screens.

EXAMPLE 14 – MAINTENANCE (COOLING) DISPLAY SCREEN

To access this display from the ICVC default screen :

1. Press **MEMU**.
2. Press **SERVICE**.
3. Scroll down to highlight CONTROL ALGORITHM STATUS.
4. Press **SELECT**.
5. Scroll down to highlight COOLING

DESCRIPTION	STATUS	UNITS	POINT
COOLING CAPACITY CONTROL			
Control Point	41 – 175	°F	CTRL_PNT
Leaving Chill/hot Water	-40 – 245	°F	CHW_OUT
Entering Chill/hot water	-40 – 245	°F	CHW_IN
Diverter Valve Setup			
Control Point Error	-99.999 - 99.999	°F	CPERR
Diverter Valve Delta	-5.000 – 5.000	%	DVD
Integrator	-999.999 – 999.999		INTEGRAT
Integral Gain * Error	-999.999 – 999.999		INT_ERR
Prop Gain * Error	-999.999 – 999.999		PROP_ERR
Generator Gain * Error	-999.999 – 999.999		GEN_ERR
*Target Diverter Valve	0 – 100	%	TRG_DIV
Diverter Valve 4-20 ma	0 – 100	%	ACT_DIV
Diverter Pos Feedback	0 – 100	%	DIV_IN
Capacity Hold Flag	0/1	NO/YES	CAP_HOLD
Capacity Decrease Flag	0/1	NO/YES	CAP_DEC
Conc. Cap. Decrease Flag	0/1	NO/YES	CON_CAPD

NOTE: all variables with capital letter point names are available for CCN read operation;
Forcing shall not be supported on maintenance screens.

EXAMPLE 15 – MAINTENANCE(HEATING) DISPLAY SCREEN

To access this display from the ICVC default screen :

1. Press **MEMU**.
2. Press **SERVICE**.
3. Scroll down to highlight CONTROL ALGORITHM STATUS.
4. Press **SELECT**.
5. Scroll down to highlight HEATING

DESCRIPTION	STATUS	UNITS	POINT
HEATING CAPACITY CONTROL			
Control Point	100 – 180	°F	CTRL_PT
Aux HW Outlet Temp	-40 – 245	°F	HW_OUT
Aux HW Inlet Temperature	-40 – 245	°F	HW_IN
Diverter Valve Setup			
Control Point Error	-99.999 – 99.999	°F	CPERR
Diverter Valve Delta	-5.000 – 5.000	%	CVD
Integrator	-999.999 – 999.999		INTEGRAT
Integral Gain * Error	-999.999 – 999.999		INT_ERR
Prop Gain * Error	-999.999 – 999.999		PROP_ERR
Generator Gain * Error	-999.999 – 999.999		GEN_ERR
*Target Diverter Valve	0 – 100	%	TRG_DIV
Diverter Valve 4-20ma	0 – 100	%	ACT_DIV
Diverter Pos Feedback	0 – 100	%	DIV_IN
Capacity Hold Flag	0/1	NO/YES	CAP_HOLD
Capacity Decrease Flag	0/1	NO/YES	CAP_DEC
Conc. Cap. Decrease Flag	0/1	NO/YES	CON_CAPD

NOTE: all variables with capital letter point names are available for CCN read operation;
Forcing shall not be supported on maintenance screens.

EXAMPLE 16 - MAINTENANCE(APPROACH) DISPLAY SCREEN

To access this display from the ICVC default screen :

1. Press **MEMU**.
2. Press **SERVICE**.
3. Scroll down to highlight CONTROL ALGORITHM STATUS.
4. Press **SELECT**.
5. Scroll down to highlight APPROACH.

DESCRIPTION	STATUS	UNITS	POINT
Chilled Water Delta T	0 – 50	^F	CHW_DT
Absorber Water Delta T	0 – 50	^F	ABSW_DT
Condenser Water Delta T	0 – 50	^F	CONDW_DT
Absorber Approach	0 – 50	^F	ABS_APPR
Condenser Approach	0 – 50	^F	COND_APP
Evaporator Approach	0 – 50	^F	EVAP_APP

NOTE: all variables with capital letter point names are available for CCN read operation;
Forcing shall not be supported on maintenance screens.

EXAMPLE 17 - MAINTENANCE(OVERRIDE) DISPLAY SCREEN

To access this display from the ICVC default screen :

1. Press **MEMU**.
2. Press **SERVICE**.
3. Scroll down to highlight CONTROL ALGORITHM STATUS.
4. Press **SELECT**.
5. Scroll down to highlight OVERRIDE.

DESCRIPTION	STATUS	UNITS	POINT
OVERRIDE/ALERT STATUS			
Strong LiBr Leaving G1	77 – 442	°F	G1_SOL
G1 Strong LiBr Override	311 – 325	°F	G1SLB_OV
Condensate Leaving G2	-40 – 245	°F	G1_SAT
G2 Condensate Override	199 – 210	°F	CONDG2_OV

NOTE: all variables with capital letter point names are available for CCN read operation; Forcing shall not be supported on maintenance screens.

EXAMPLE 18 - MAINTENANCE(CONCENTR) DISPLAY SCREEN

To access this display from the ICVC default screen :

1. Press **MEMU**.
2. Press **SERVICE**.
3. Scroll down to highlight CONTROL ALGORITHM STATUS.
4. Press **SELECT**.
5. Scroll down to highlight CONCENTR.

DESCRIPTION	STATUS	UNITS	POINT
Point A :			
Strong LiBr Lvg Low HX	-40 – 245	°F	SLBLLOHX
LiBr Concentration	50 – 70	%	CONC_A
LiBr Temp at Crystal	-40 – 245	°F	TSOL_As
Crystallization Conc	50 – 70	%	CONC_Ax
Point B :			
Weak LiBr Leaving Absorb	-40 – 245	°F	ABS_SOL
Saturation Temp B	-40 – 245	°F	TSAT_B
LiBr Concentration	50 – 70	%	CONC_B
Point C :			
LiBr Concentration	50 – 70	%	CONC_C
Point D :			
LiBr concentration	50 – 70	%	CONC_D
Point E :			
Strong LiBr Leaving G1	77 – 442	°F	G1_SOL
Condensate Leaving G2	-40 – 245	°F	G1_SAT
LiBr Concentration	50 – 70	%	CONC_E
Point F :			
LiBr Concentration	50 – 70	%	CONC_F
Point G :			
Strong LiBr Leaving G2	77 – 442	°F	G2_SOL
Vapor Condensate Temp	-40 – 245	°F	VAPORCD
Libr Concentration	50 – 70	%	CONC_G

NOTE: all variables with capital letter point names are available for CCN read operation; Forcing shall not be supported on maintenance screens.

EXAMPLE 19 - MAINTENANCE (WSMDEFME) DISPLAY SCREEN

To access this display from the ICVC default screen :

1. Press **MEMU**.
2. Press **SERVICE**.
3. Scroll down to highlight CONTROL ALGORITHM STATUS.
4. Press **SELECT**.
5. Scroll down to highlight WSMDEFME.

DESCRIPTION	STATUS	UNITS	POINT	DEFAULT
WSM active ?	No/Yes	0/1	WSMSTAT	No
Chilled water temp	0.0 – 99.9	°F	CHWTEMP	0.0
Equipment status	OFF/ ON	0/1	CHLRST	ON
Commanded state	XXXXXXXXXX	TEXT	CHLRENA	None
CHW Setpt Reset value	0.0 – 25.0	°F	CHWRVAL	0.0
Current CHW Setpoint	0.0 – 99.9	°F	CHWSTPT	0.0

NOTE: all variables with capital letter point names are available for CCN read operation;
Forcing shall not be supported on maintenance screens.

OCCUPANCY SCHEDULE - This schedule determine when the chiller can run. Each schedule consists of from 1 to 8 occupied/unoccupied time periods, set by the operator. These time periods can be enabled to be in effect or not in effect, on each day of the week and for holidays. The day begins with 00:00 hours and ends with 24:00 hours. The chiller is in OCCUPIED mode unless an unoccupied time period is in effect.

NOTE: To determine whether or not the chiller is in an occupied state and can be started, access the COOLSTAT (or HEATSTAT) screen and scroll to OCCUPIED?. If the value in the right column is YES, the chiller is in an occupied state and can be started.

Fig. 3-9 shows a schedule for a typical office building time schedule.

EXAMPLE:

Sunday and holiday periods are unoccupied 24 hours per day.

Monday to Friday : 7:15 am ~ 5:15 pm

Saturday : 7:15 am ~ 1:00 pm

The LOCAL schedule number, effective when the chiller is in the LOCAL mode, is 01 (OCCPC01S on the SCHEDULE screen). The CCN schedule number, effective when the chiller is in the CCN mode, is 02 (OCCPC02S on the SCHEDULE screen). The schedule number can change to any value from 02 to 99. If this schedule number is changed on the CONFIG table, the operator must use the ATTACH TO NETWORK DEVICE table to upload the new number into the SCHEDULE screen.

The schedules also can be bypassed by setting the CHILLER START/STOP to START on the COOLSTAT (or HEATSTAT) screen. The schedules also can be overridden to keep the unit in an OCCUPIED mode for up to 4 hours, on a one-time basis.

PIC Control Tests

The PIC has built-in control tests. Starting from the ICVC default screen, press the **MENU** and **SERVICE** softkeys. Use the **NEXT** softkey to highlight CONTROL TEST and press the **SELECT** softkey to access the CONTROL TEST menu. Choose the test you want to run by pressing the **NEXT**, **PREVIOUS**, **SELECT** and **EXIT** softkeys. The CONTROL TEST menu has the following options.

- CCM #1 Inputs
- CCM #2 Inputs
- CCM #3 Inputs
- CCM #1 Outputs
- CCM #2 Outputs
- CCM #3 Outputs
- Capacity Valve Actuator
- Variable Frequency Drive
- Valve Changeover

NOTE : Valve changeover table is used for cooling/heating changeover. It does not related to control test.

Use the **NEXT** and **PREVIOUS** softkeys to scroll through the menu.

Use the **SELECT** softkey to activate the test.

Use the **EXIT** softkey to exit CONTROL TEST menu.

1. Select CCM#1 Inputs from CONTROL TEST. You will see the following 15 inputs on the table.

- Cooling Water Lvg Absorb (5K ohm)	**.* °F
- Cooling Water Ent Absorb (5K ohm)	**.* °F
- Leaving Chill/hot Water (5K ohm)	**.* °F
- Entering Chill/hot Water (5K ohm)	**.* °F
- Strong LiBr Lvg G2 (100K ohm)	**.* °F
- Strong LiBr Lvg G1 (100K ohm)	**.* °F
- Strong LiBr Lvg Low HX (5K ohm)	**.* °F
- Vapor Condensate Temp (5K ohm)	**.* °F
- Refrigerant Temp (5K ohm)	**.* °F
- Common Return Sensor	**.* °F
- Common Supply Sensor	**.* °F
- Remote Reset Sensor	**.* °F
- Cooling Water Lvg Cond (5K ohm)	**.* °F
- Temp Reset 4-20 Ma	*.* Ma
- Diverter Pos Feedback	*.* %

Each input is followed by an appropriate value. Any reading out of the valid range of -40 to 245 °F (-4 C to 118 °C) for 5K ohm thermistors or 77 to 442 °F (25 to 228 °C) for 100K ohm thermistors will display the minimum or maximum temperature followed by a C. For example, if the ambient temperature is below 77 °F (25 °C), it will show a C on the display for 100 Kohm thermistors. This sensor can be placed in a cup of hot water to bring the sensor in range. If an communication failure occurs, a C displays after a minimum temperature. If it occurs, check the temperature sensors and fix it.

REMEMBER not all of the channels are factory installed and following channels will have a C after the -40 °F.

- a. Common Return Sensor
- b. Common Supply Sensor
- c. Remote Reset Sensor

2. Select CCM#2 Inputs from CONTROL TEST. The ICVC displays the following 12 inputs:

- Ref Pump Overld/HiTemp	Normal/Alarm
- Spare Prot Limit Input	Normal/Alarm
- Remote Contacts	Close/Open
- Chill Water Low Temp/Flow	Close/Open
- Condensate Leaving G2 (5K ohm)	**.* °F
- Weak LiBr LVG Absorb (5K ohm)	**.* °F
- Cond Water Flow Switch	Close/Open
- Generator Hi Temp/Press	Normal/Alarm
- Gen Low Level Switch	Close/Open
- Gen High Level Switch	Close/Open
- Aux. Sol Pump Ovrd/HT	Normal/Alarm
- Sol Pu mp VFD/HiTemp	Normal/Alarm

Each input is followed by an appropriate value. For example, Ref Pump Overld/HiTemp is followed by a Normal.

Any reading out of the valid range of -40 to 245 °F (-40 to 118 °C) for 5K ohm thermistors will display the minimum or maximum temperature followed by a C.

3. Select CCM#3 Inputs from CONTROL TEST. You will see the following 6 inputs on the table

- Aux HW Outlet Temperature (*) **.* °F
- Aux HW Inlet Temperature (*) **.* °F
- Flue Gas Temp **.* °F
- Flue Gas Temp Cutout Close/Open
- MT Status Input **.* °F
- Aux HW Temp/Flow Cutout (*) Close/Open

The above 3 inputs with (*) are only applied to Heat-175 (option) type chiller.

Each input is followed by an appropriate value. For example, any reading out of the valid range of -40 to 245°F (-40 to 118 °C) for MT Status Input will display the minimum or maximum temperature followed by a C.

4. Select CCM#1 Output from CONTROL TEST. This test activates 6 outputs. As the outputs are activated, the following displays appear as listed below. To end the test, press the **EXIT** softkey after any of the output checks.

16DNP	CONTROL TEST
CCM#1 OUTPUT TEST IN PROGRESS	
Refrigerant Pump	On
NEXT	EXIT

16DNP	CONTROL TEST
CCM#1 OUTPUT TEST IN PROGRESS	
Solution Pump	On
NEXT	PREVIOUS
	EXIT

16DNP	CONTROL TEST
CCM#1 OUTPUT TEST IN PROGRESS	
Tower Fan Relay	On
NEXT	PREVIOUS
	EXIT

16DNP	CONTROL TEST
CCM#1 OUTPUT TEST IN PROGRESS	
Alarm Relay	On
NEXT	PREVIOUS
	EXIT

16DNP	CONTROL TEST
CCM#1 OUTPUT TEST IN PROGRESS	
Chill/hot Water Pump	On
Chill Water Low Tmp/Flow	Close
NEXT	PREVIOUS
	EXIT

16DNP	CONTROL TEST
CCM#1 OUTPUT TEST IN PROGRESS	
Cooling Water Pump	On
Cond Water Flow Switch	Close
	PREVIOUS
	EXIT

5. Select CCM#2 Output from CONTROL TEST. This test activates 3 outputs. As the outputs are activated, the following displays appear as listed below. To end the test, press the **EXIT** softkey after any of the output checks.

16DNP	CONTROL TEST
CCM#2 OUTPUT TEST IN PROGRESS	
Actuator Command Signal	On
NEXT	PREVIOUS
	EXIT

16DNP	CONTROL TEST
CCM#2 OUTPUT TEST IN PROGRESS	
Aux Solution Pump	On
NEXT	PREVIOUS
	EXIT

16DNP	CONTROL TEST
CCM#2 OUTPUT TEST IN PROGRESS	
Chiller Run Relay	On
	PREVIOUS
	EXIT

6. Select CCM#3 Output from CONTROL TEST. This test activates 2 outputs. As the outputs are activated, the following displays appear as listed below. To end the test, press the **EXIT** softkey after any of the output checks.

16DNP	CONTROL TEST
CCM#3 OUTPUT TEST IN PROGRESS	
Blower Command Signal	On
NEXT	PREVIOUS
	EXIT

16DNP	CONTROL TEST
CCM#2 OUTPUT TEST IN PROGRESS	
Aux Hot Water Pump	On
Aux HW Temp/Flow Cutout	Close
	PREVIOUS
	EXIT

Ramp Loading Control – The ramp loading control slows down the rate at which the chiller loads up. This control can prevent the chiller from loading up during short period of time when the chiller water loop has to be brought down to normal design conditions and helps reduce hot exhaust gas demand by slowly bringing the chiller water to the control point.

Ramp loading is based on chilled water temperature. During ramp loading mode, the LEAVING WATER or ENTERING WATER temperature change is limited to the TEMP PULLDOWN DEG/MIN. This is the rate that the controlled temperature is changed to reach the setpoint. The default rate is 3 °F (1.7 °C) degrees per minute. The diverter valve is allowed full travel to obtain this goal unless an inhibit or close signal is received by the PIC based on another algorithm.

To set or change the temperature pulldown rate, press the **MENU** and **SERVICE** softkeys. Enter your 4-digit password. Access the EQUIPMENT CONFIGURATION screen. Press the **SELECT** softkey to view the CONFIG table. From there, scroll to TEMP PULLDOWN DEG/MIN and press the **SELECT** softkey. Using the **INCREASE** and **DECREASE** softkeys, adjust the setting to the desired value. To store the value, press the **ENTER** softkey. To exit this screen and keep the last value, press the **QUIT** softkey.

Solution Concentration Control - Capacity Overrides can prevent premature safety shutdown caused by solution crystallization, which, in turn, can happen when the PIC determines that the solution is too concentrated, or when temperatures or pressures have exceeded safe limits of operation. The capacity override function allows the operator to set one or more of the override values that determine where the capacity valve control occurs. The three possible stages of capacity valve control are:

- STAGE 1 – The PIC inhibits the capacity valve from opening further. The status line on the ICVC displays a reason for the override.
- STAGE 2 – The PIC closes the capacity valve until the condition decreases below the override termination temperature or concentration. The override termination temperature or concentration is the point at which the override function is no longer in control and the chiller returns to normal run mode.
- STAGE 3 – When the solution temperature or concentration is too high, the capacity valve is closed and the PIC switches to a STOP mode.

CAPACITY OVERRIDES – The operator can configure three capacity valve overrides from the ICVC:

- Refrigerant Low Temperature Override (REFRIGERANT TRIPPOINT and REFRIGERANT OVERRIDE DELTA T)
- G1 High Saturation Temperature Override (G2 CONDENSATE OVERRIDE)
- G1 High Solution Temperature Override (G1 STRONG LiBr OVERRIDE)

The parameters in parentheses are accessed from the SERVICE1 screen. See the table, Example 10.

Refrigerant Low Temperature Override – The refrigerant low temperature override algorithm inhibits the capacity valve from opening or closes the capacity valve to prevent freezing. The operator can establish the setpoints at which this occurs by changing the values for the REFRIGERANT TRIPPOINT and REFRIGERANT OVERRIDE DELTA T. The PIC monitors the REFRIGERANT TEMP and compares it to the REFRIGERANT TRIPPOINT plus the REFRIGERANT OVERRIDE DELTA T. The two override stages are:

- STAGE 1 occurs if the REFRIGERANT TEMP is below the REFRIGERANT TRIPPOINT plus the REFRIGERANT OVERRIDE DELTA T. The capacity valve is inhibited from opening.
- STAGE 2 occurs when the REFRIGERANT TEMP is less than the REFRIGERANT TRIPPOINT plus the REFRIGERANT OVERRIDE DELTA T minus 1 °F (0.56 °C). The capacity valve closes.

This capacity override ends (or returns to normal control) when the temperature increases to 2 °F (1.1°C) above the trippoint plus override set point. When the capacity valve is inhibited or closing, the ICVC displays, RUN CAPACITY LIMITED, LOW REFRIGERANT TEMP.

G1 High Saturation Temperature Override – When the chiller is in a RUN mode and the CONDENSATE TEMP FROM G2 increases above the override threshold, the capacity valve is inhibited or closed to prevent an increase in the heat input to the generator. The two override stages are established when

the operator changes the setpoint for G2 CONDENSATE OVERRIDE.

- STAGE 1 occurs if the G2 CONDENSATE OVERRIDE is exceeded. The capacity valve is inhibited from opening
- STAGE 2 occurs if the G2 CONDENSATE OVERRIDE is exceeded by 1 °F (0.56 °C). The capacity valve is closed.

The capacity override ends when the CONDENSATE TEMP FROM G2 is 2 °F (1.1 °C) below the G2 CONDENSATE OVERRIDE.

G1 High Solution Temperature Override – When the chiller is in the RUN mode and the STRONG LiBr LEAVING G1 increases above the override threshold, the capacity valve is inhibited from opening or forced to close or the chiller is forced to the STOP mode to prevent an increase in the heat input to the generator. The override set points are established when the operator changes the value for G1 STRONG LiBr OVERRIDE. There are three override stages.

- STAGE 1 occurs when the STRONG LiBr LEAVING G1 is greater than the G1 STRONG LiBr OVERRIDE but less than the override plus 4 °F (2.2 °C). This level prohibited the capacity valve from opening.
- STAGE 2 occurs at the temperature between the G1 STRONG LiBr OVERRIDE plus 4 °F (2.2 °C) and G1 STRONG LiBr OVERRIDE plus 18 °F (10 °C). This level causes an ALERT condition and closes the capacity valve.
- STAGE 3 occurs when them temperature greater than the override plus 27 °F (15 °C). This level causes an ALARM condition, and the chiller controller initiates a non-recycle shutdown with dilution cycle. The capacity valve is closed, the chiller is in a high strong solution temperature fault condition, and the ICVC display reads, PROTECTIVE LIMIT, STRONG LiBr LEAVING G1.

The condition will return to normal when the STRONG LiBr LEAVING G1 is 2 °F (1.1 °C) below the G1 STRONG LiBr OVERRIDE. Press the **RESET** softkey to restart the chiller.

MANUAL CAPACITY VALVE CONTROL – When the chiller is under manual capacity valve control, the operator has full control of capacity valve and should continuously monitor the chiller temperature and concentrations.

SOLUTION HIGH CONCENTRATION – The PIC calculates the strong LiBr concentration at Point A in the CONCENTR screen. (Point 10 in the Cooling Cycle). It also calculates Points AX, which is on the crystallization line. There are three thresholds between Point A and AX. The thresholds are referred to as the:

1. Inhibit threshold – When the LiBr solution concentration exceeds the inhibit threshold, capacity valve is prohibited from opening until the it is below the inhibit threshold minus 0.5%.
2. Close threshold – When the LiBr solution concentration exceeds the close threshold, capacity valve is closed to 67% of its current value for 5 minutes until it is below the inhibit threshold minus 0.5%. If the concentration is not reduced the capacity valve is decreased an additional 10% every five minutes until the concentration drops below the inhibit threshold minus 0.5%
3. Safety shutdown – If the LiBr solution concentration exceeds the safety shutdown, then a non-recycle

shutdown with dilution cycle is initiated.

* Delta Conc. = Conc_AX – Conc_A

<u>ERROR</u>	<u>INHIBIT</u>	<u>CLOSE</u>	<u>SHUTDOWN</u>
Delta Conc.*	< 1.0%	< 0.6%	< 0.3%

Remote Start/Stop Controls - A remote device uses a set of contacts, such as a time clock, may be used to start and stop the chiller.

The contacts for Remote Start are wired into the terminal block, TB3-609 and TB3-610. See the certified drawings for further details on contact ratings. The contacts must be dry (no power).

Tower Fan Relay - The chiller must be in the RUNNING mode before the TOWER FAN RELAY algorithm is enabled. The following conditions must also be true:

- The COOLING WATER PUMP is energized, COOLING WATER FLOW is confirmed, and the WEAK LiBr LEAVING ABSORB is greater than 86 °F (30 °C).
- The TOWER FAN RELAY will be de-energized if any of the following conditions occurs: the chiller is not in a run state, the COOLING WATER PUMP de-energized, the COLLING WATER FLOW indication is lost, or WEAK LiBr LEAVING ABSORB is less than 77 ° F (25 °C).

Auto Restart After Power Loss - If the control power is interrupted during operation, the chiller stops immediately without the normal shutdown sequence and dilution. At the same time, diverter valve is closed automatically by spring return type actuator within 30 seconds max.

Solution crystallization can occur if the concentration is high when the chiller was operating with a relatively large load. Conditions will be checked at power-on initialization to determine if there is a need for de-crystallization process to avoid possible solution crystallization. If so, the alarm will be generated to indicate the need for de-crystallization process.

If not, the chiller will start automatically when the power is back on. In this situation, do NOT force to stop the chiller, the chiller may start again if there is any problem on safety limits. When the chiller restarts, run the machine at very low load for a while to let the weak solution go and dilute the solution cycle.

Micro-Turbine Status Monitoring - The exhaust from a multi-pack of C60 micro-turbines provides the source of heat to operate the chiller. A dry-contact relay at the back of each micro-turbine can be used to infer the ON/OFF status of the micro-turbine. The micro-turbines are configured such that it

turns ON when the relay closes and when the relay is open the micro-turbine is OFF.

The micro-turbine status signal is monitored to initiate start up and shutdown of the chiller. Chiller start up will be enabled when a minimum of two micro-turbines are ON. When less than two micro-turbines are ON, the chiller remains in the “Ready to Start” state, pending micro-turbine ON status.

If the chiller successfully passes startup, the micro-turbine status continue to be monitored during running and a shutdown shall be triggered when all the micro-turbines are OFF for longer than 10 minutes.

Diverter Valve Leakage - A platinum RTD sensor, 1000 ohm at 0C, in the G1 inlet shall be detect leaks in the diverter valve when it is commanded to close and/or it malfunctions in the air seal blower. This sensor shall be used as a temperature switch to indicate whether the temperature is above or below the specified threshold value as indicated in the table parameter G1 ENTERING HEAT SOURCE.

Following a shutdown of the chiller, the temperature in the G1 inlet is expected to gradually decrease and reach a level below 320F temperature approximately 1 hour after shutdown, or 250F temperature 2 hour after shutdown. If the temperature is above 320 °F after 1 hour of shutdown and 250 °F after 2 hour of shutdown, it indicates leakage in the diverter valve and alarm state 101 shall be generated to indicate this abnormal condition.

The operator can configure these two thresholds from the SERVICE3 screen.

- DV Leak Threshold 1 : threshold for 1 hour after shutdown
- DV Leak Threshold 2 : threshold for 2 hour after shutdown

Air Seal Blower Control - The air seal blower applies positive pressure to tightly seal the diverter valve when it is in a fully closed position. It is designed to prevent exhaust heat to escape into the high temperature generator when the diverter is fully closed. If following conditions are met, the BLOWER COMMAND SIGNAL shall turn ON to prevent damage due to diverter valve leakage:

- Micro-turbine Status = On and,
- Actuator Command Signal = Off

The BLOWER COMMAND SIGNAL shall be OFF whenever any of the conditions above is not true.

Control Wiring - See Fig. 3-11 ~ 3-20 for typical wiring diagrams and component identification.

NOTE : Those schematics do not show all the options or variations that are available.

LEGEND	
01	DISCONNECT SWITCH
BBSP-O/L	SOLUTION PUMP INVERTER OVERLOAD RELAY
BBFP	REFRIGERANT PUMP CONTACTOR
BBFP-O/L	REFRIGERANT PUMP OVERLOAD RELAY
BBVP	VACUUM PUMP CONTACTOR
BBVP-O/L	VACUUM PUMP OVERLOAD RELAY
BBEB	AIR SEAL BLOWER CONTACTOR
BBEB-O/L	AIR SEAL BLOWER OVERLOAD RELAY
CB1	REFRIGERANT PUMP CIRCUIT BREAKER
CB2	VACUUM PUMP CIRCUIT BREAKER
CB3	SOLUTION PUMP INVERTER CIRCUIT BREAKER
CB4	CIRCUIT BREAKER
CB5	460/115VAC TRANSFORMER (TR3) PROTECTION
CB6	460/24VAC TRANSFORMER (TR2) PROTECTION
CB7	CIRCUIT BREAKER
CB8	AIR SEAL BLOWER CIRCUIT BREAKER
CB9	PALLADIUM CELL POWER CIRCUIT BREAKER
CB10-13	ACTUATOR CIRCUIT BREAKER
TR1	CONTROL MODULE CIRCUIT BREAKER
TR2	460/115VAC CONTROL TRANSFORMER
TR3	115/24VAC CONTROL TRANSFORMER
CR1	460/24VAC ACTUATOR CONTROL TRANSFORMER
CR2	CHILLED WATER PUMP RELAY
CR3	COOLING WATER PUMP RELAY
CR4	COOLING TOWER FAN RELAY
CR5	ALARM SIGNAL RELAY
CR6	CHILLER RUN RELAY
CR7	AUX HOT WATER PUMP RELAY
CR8	01 HIGH TEMP-01 HIGH PRESS. RELAY
CR9	FLUE GAS TEMP RELAY
CR10	LOW CHILLED WATER CUTOFF- FLOW SWITCH RELAY
CR11	VFD START SIGNAL RELAY
CR12	ACTUATOR COMMAND SIGNAL
CR13	01 LOW LEVEL RELAY
CR14	AIR SEAL BLOWER RELAY
CR15	AUX. HW HI TEMP-AUX. FLOW SWITCH RELAY
VFD	MICRO TURBINE STATUS RELAY
VF	VARIABLE FREQUENCY DRIVER
VF	NOISE FILTER
CRNT-3	CHILLER I/O MODULE
ICVC	INTERNATIONAL CHILLER VISUAL CONTROLLER
VR-1	HARBLOCK LEVEL RELAY
LT1	SOLUTION PUMP RUN LIGHT
LT2	REFRIGERANT PUMP RUN LIGHT
LT3	VACUUM PUMP RUN LIGHT
LT4	AIR SEAL BLOWER RUN LIGHT
S1	VACUUM PUMP START SWITCH
S2	VACUUM PUMP STOP SWITCH

SYMBOLS	
	COIL, MOTOR
	INDICATOR LIGHT
	FUSE
	PUSH BUTTON SWITCH - NORMALLY OPEN
	PUSH BUTTON SWITCH - NORMALLY CLOSED
	CIRCUIT BREAKER
	THERMAL OVERLOAD
	LEVEL SWITCH - NORMALLY OPEN
	LEVEL SWITCH - NORMALLY CLOSED
	PRESSURE SWITCH - NORMALLY CLOSED
	TEMPERATURE SWITCH - NORMALLY CLOSED
	RESISTOR/THERMISTOR
	FLOW SWITCH - NORMALLY OPEN
	CONNECTORS
	CONTACT - NORMALLY CLOSED
	CONTACT - NORMALLY OPEN
	TERMINAL BLOCK No.1 (Main power)
	TERMINAL BLOCK No.2 (power)
	TERMINAL BLOCK No.3 (Field wiring)
	TERMINAL BLOCK No.4 (Factory wiring)
	TERMINAL BLOCK No.5 (Ground)
	TERMINAL BLOCK No.6 (115V control power)
	TERMINAL BLOCK No.7 (24V control power)
	TERMINAL BLOCK No.8 (0VDC communication)
	VFD TERMINAL BLOCK
	DIVERTER VALVE ASSY TERMINAL BLOCK

SYMBOLS	
	GROUND
	WIRE NUMBER
	WIRE SPECIFICATIONS
	COLOR, AWG
	CONTINUES ON LINE XXX
	COOLING FAN
	MOTOR
	RELAY
	TRANSFORMER
	VARIABLE FREQUENCY DRIVER
	NOISE FILTER
	MACHINE WIRING (SOLID LINE)
	FIELD WIRING (DASHED LINE)
	OPTION WIRING (DASH DOT LINE)

NOTE:
1. AT FACTORY WIRING, JUST USE THE EXCLUSIVE INSTRUMENT FOR PRESSING TERMINAL TO WIRE

TITLE	SYMBOLS & LEGEND	1	2	3	4	5	6	7	8	9	10
REVISION											
SHEET NUMBER											
	PRIMARY POWER										
	115V/0VDC COMMUNICATION										
	CM1, I/O										
	CM1, I/O										
	CM2, I/O										
	CM3, I/O										
	LEVEL SWITCH RELAYS										
	VFD WIRING										
	FIELD WIRING										

Fig 3-11 Wiring Diagram #1

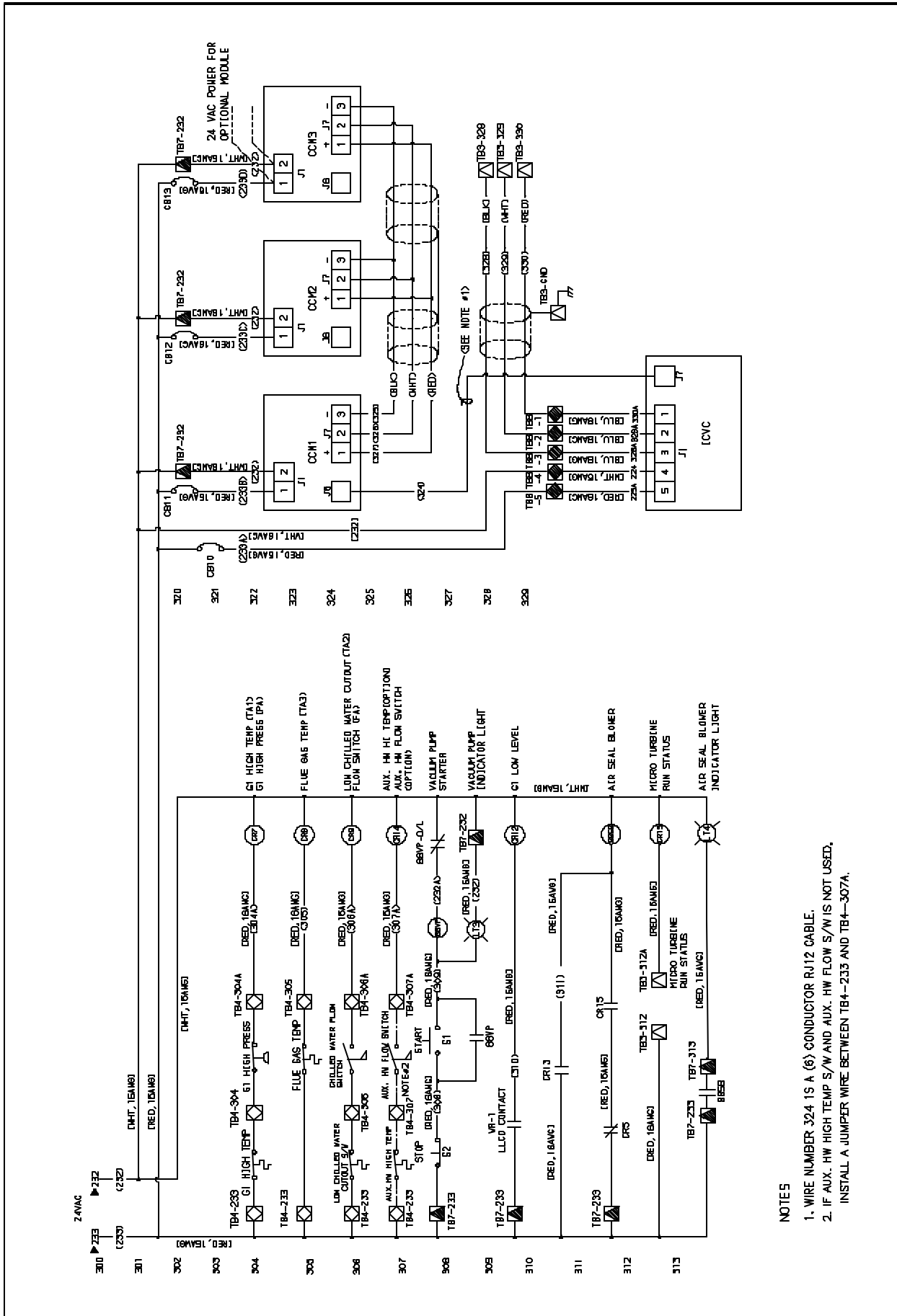

NOTES
 1. WIRE NUMBER 324 IS A (6) CONDUCTOR RJ12 CABLE.
 2. IF AUX. HW HIGH TEMP S/W AND AUX. HW FLOW S/W IS NOT USED, INSTALL A JUMPER WIRE BETWEEN TB4-233 AND TB4-307A.

Fig 3-13 Wiring Diagram #3

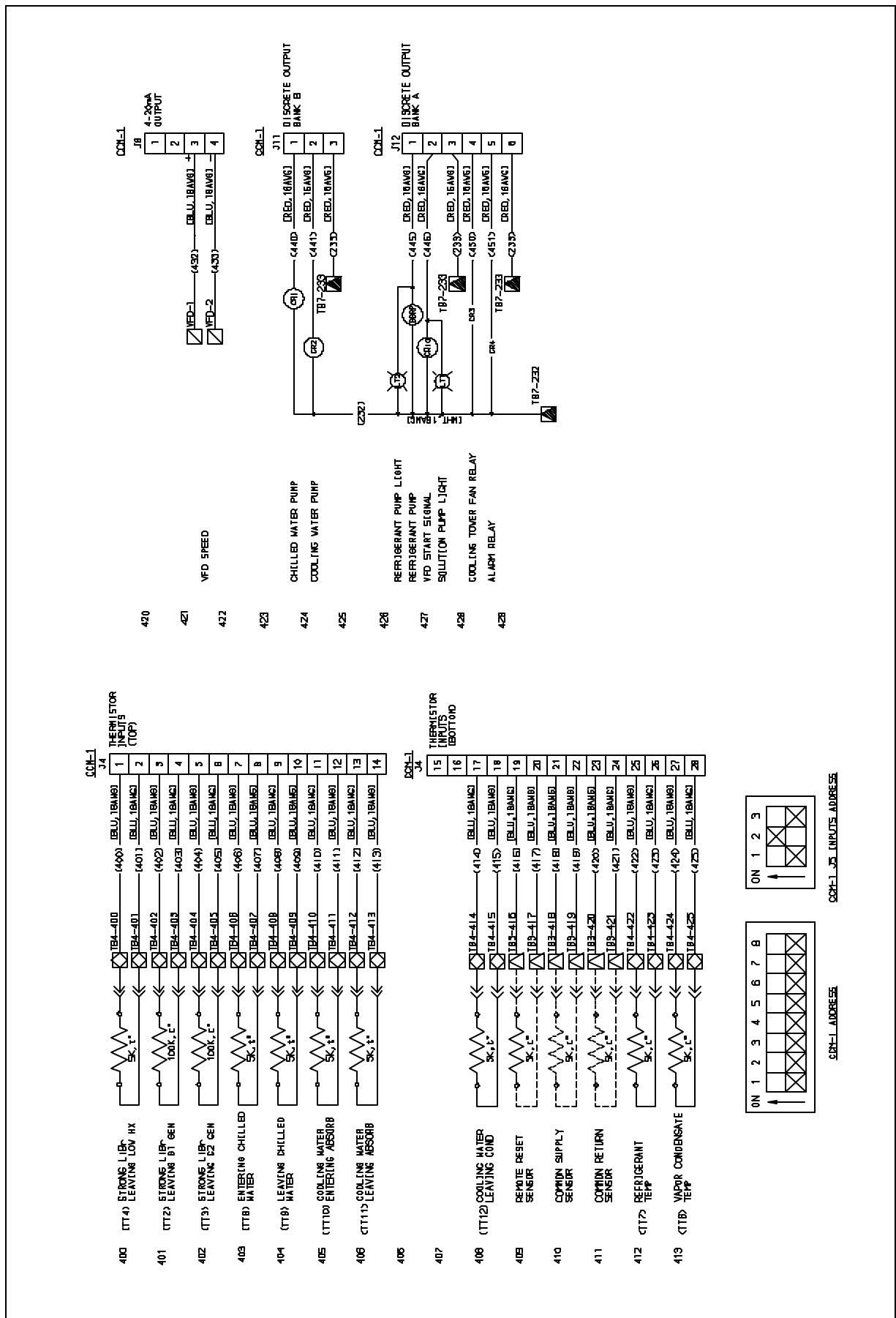

Fig 3-14 Wiring Diagram #4

500
501
502
503
504
505
506
507
508
509
510
511
512
513
514
515
516
517

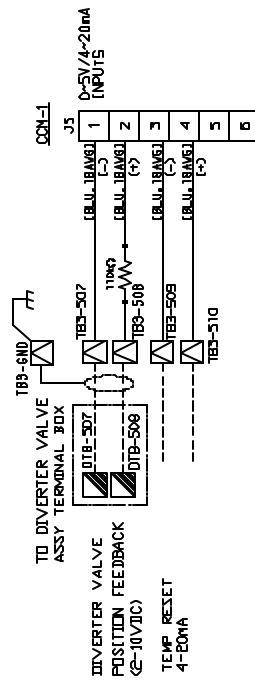

Fig 3-15 Wiring Diagram #5

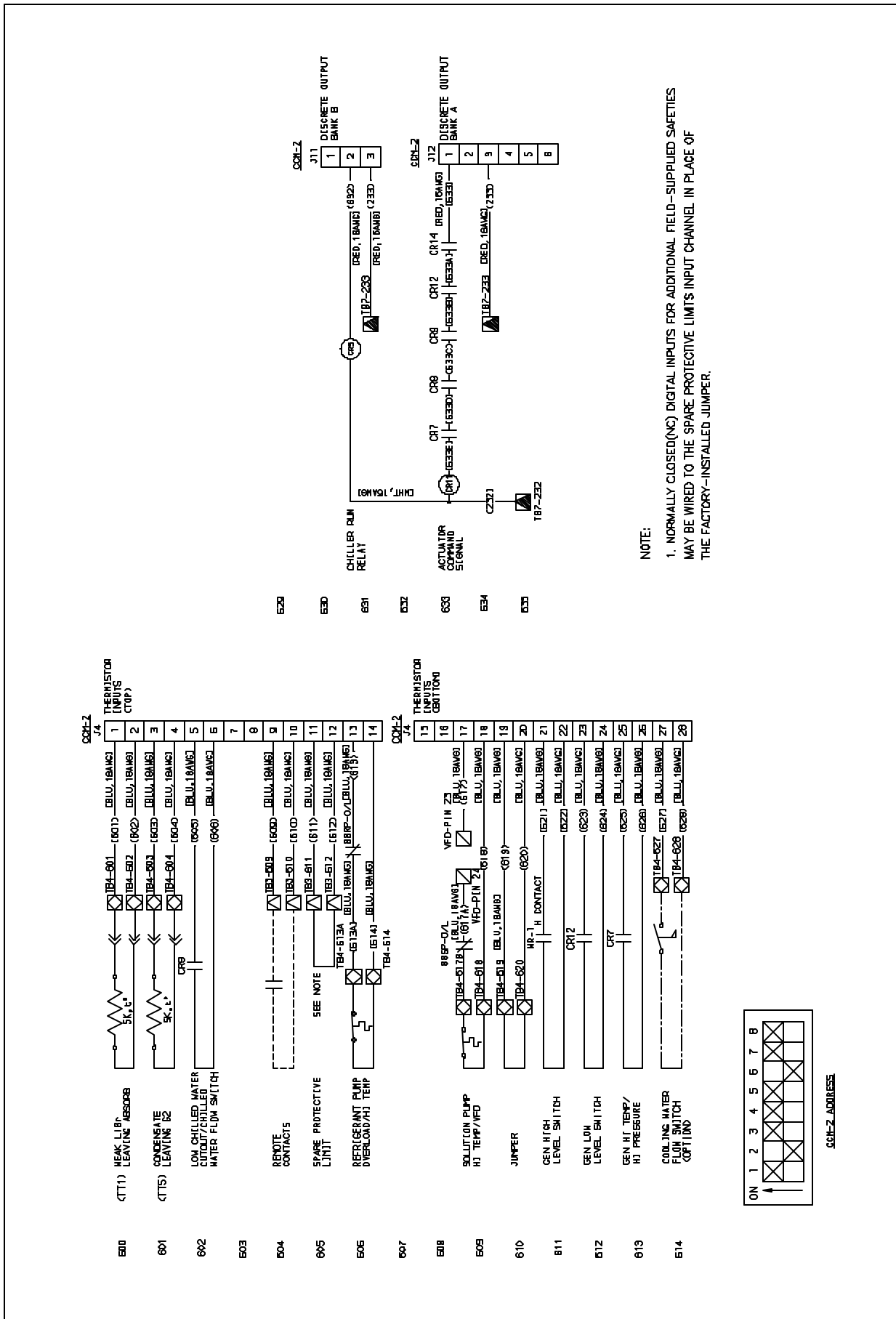

Fig 3-16 Wiring Diagram #6

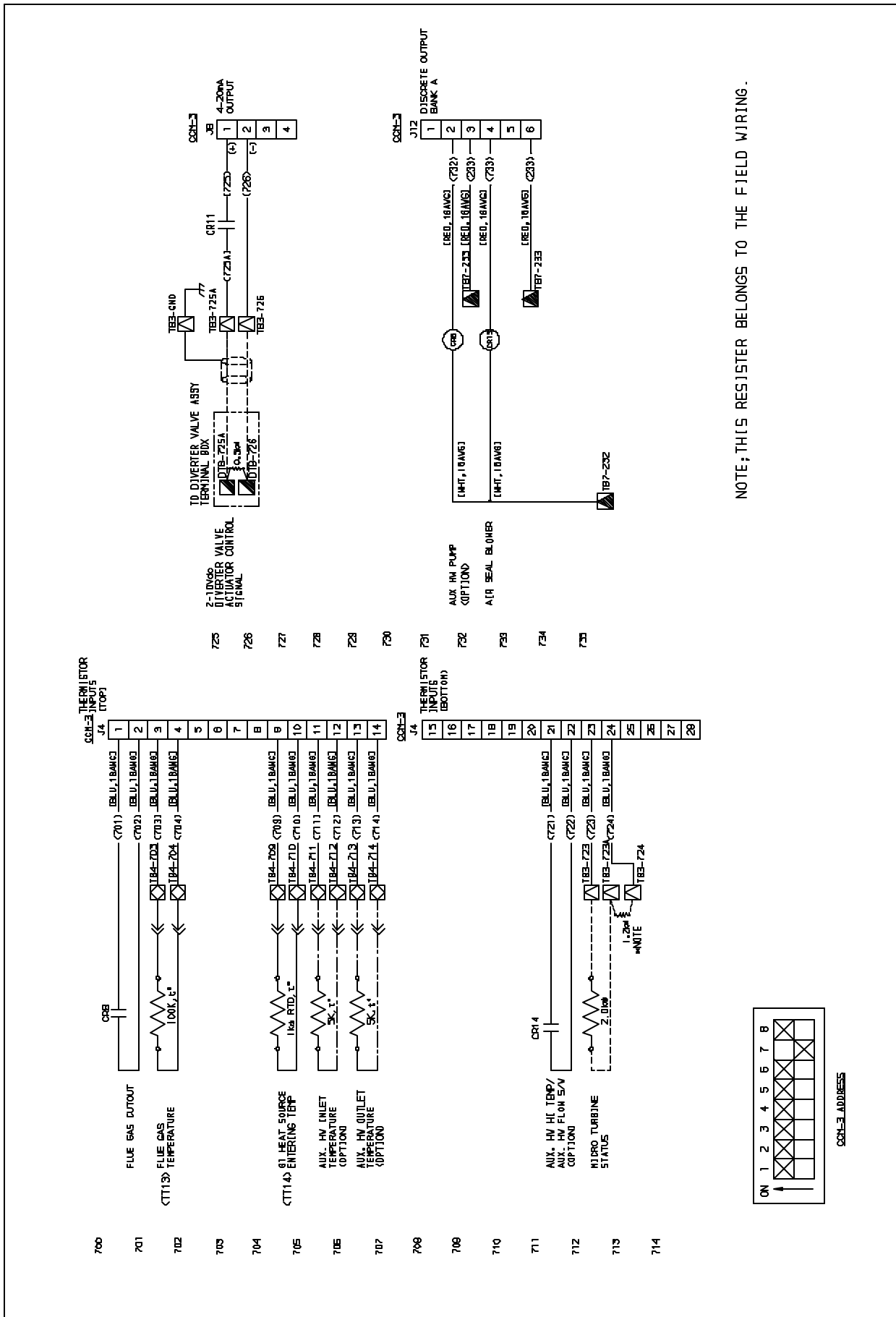

Fig 3-17 Wiring Diagram #7

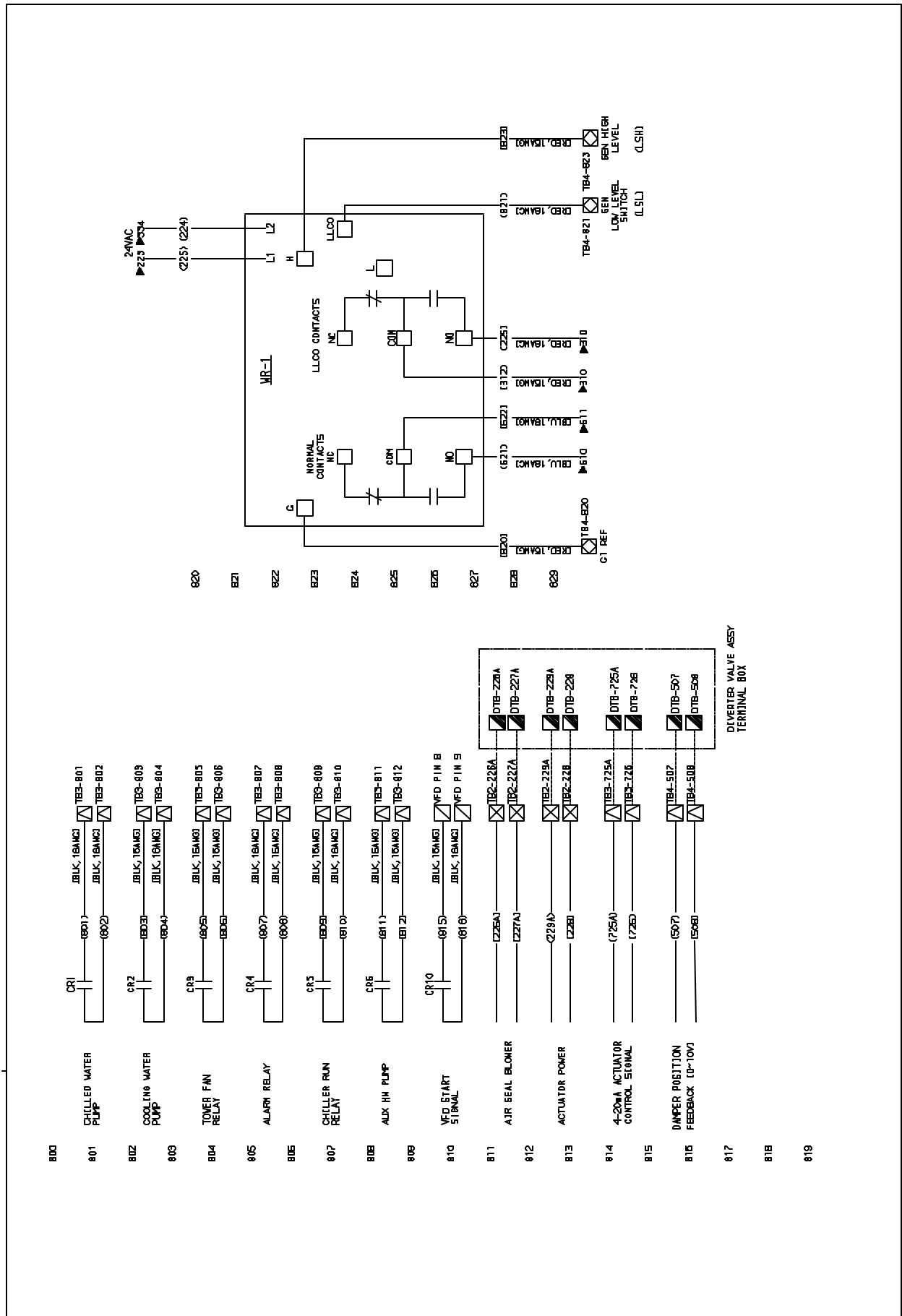
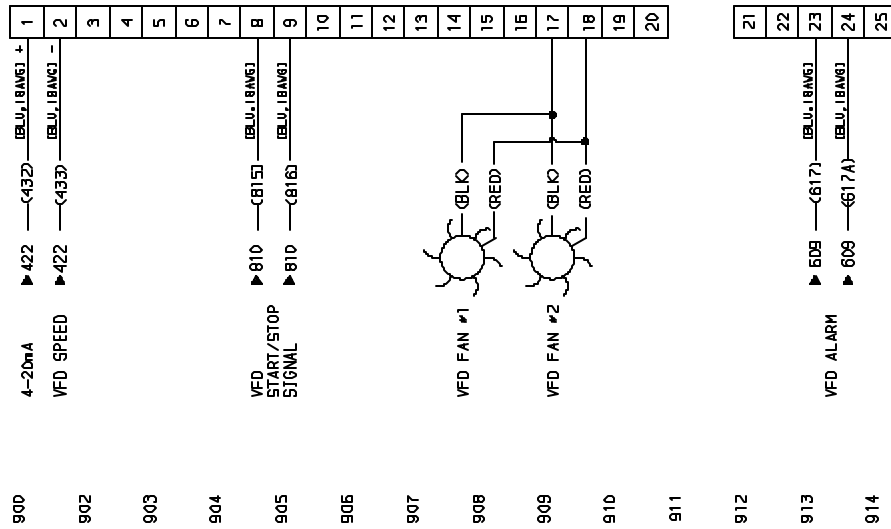
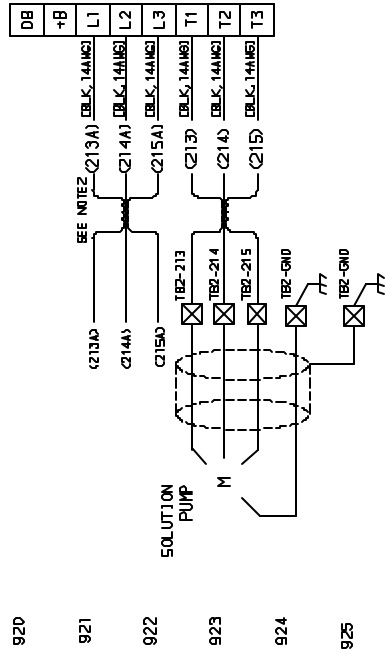

Fig 3-18 Wiring Diagram #8

VFD SIGNAL WIRING



VFD POWER WIRING



- NOTES:
1. THE VFD LAYOUT SHOWN IS FOR A MTS PRODUCTS VFD ONLY. ADM DRIVE BLOCK SERIES
 2. THIS WIRING MUST BE TWISTED.

Fig 3-19 Wiring Diagram #9

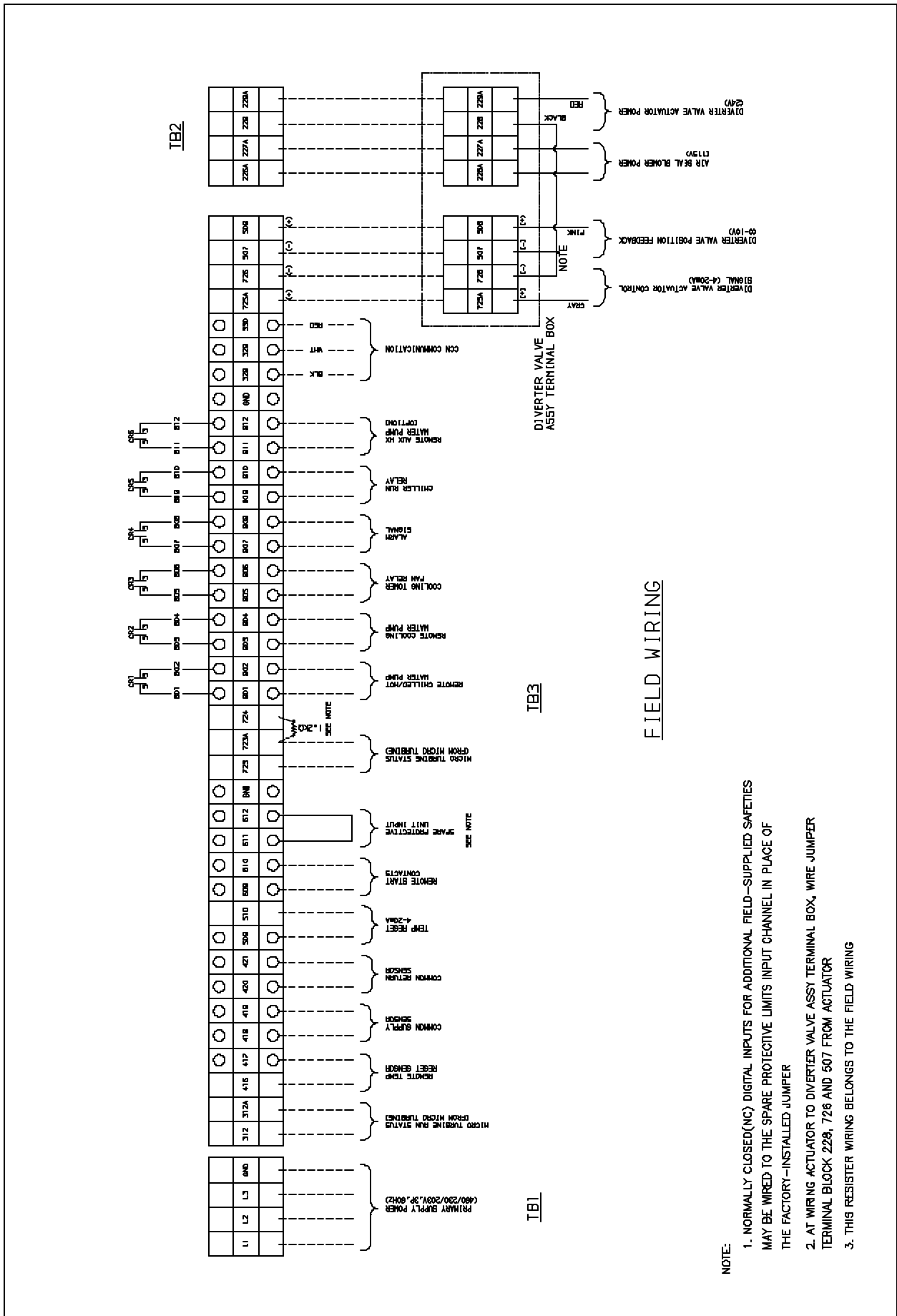

Fig 3- 20 Wiring Diagram #10

Safety Controls - The PIC monitors all safety control inputs, and if required shuts down the chiller or limits the diverter valve to protect the chiller from possible damage from any of the following conditions.

If the controller initiates a safety shutdown, it displays a primary and secondary alarm message on the ICVC screen. It also energizes an alarm relay in the control box and blinks the

alarm light on the control center. The alarm information is stored in memory and can be viewed on the ICVC from the ALARM HISTORY table along with a troubleshooting message. To view the alarm information, press **MENU** and **SERVICE** softkeys, and enter your 4-digit password (to access the SERVICE table). ALARM HISTORY will be highlighted. Press the **SELECT** softkey.

MONITORED PARAMETER	LIMIT	APPLICABLE COMMENTS
TEMPERATURE SENSORS OUT OF RANGE (5K)	-40 TO 245 °F	Must be outside range for 2 seconds.
TEMPERATURE SENSORS OUT OF RANGE (100K)	77 TO 442 °F	Must be outside range for 2 seconds.
G1 HIGH SOLUTION TEMP	G1 Strong LiBr Override. Range 311-320 °F	Configurable on SERVICE 1 screen.
G1 HIGH SATURATION TEMP	G1 Strong LiBr Override. Range 199-212 °F	Configurable on SERVICE 1 screen.
REFRIGERANT TEMP	Refrigerant Trippoint, Range 37-42 °F Override Delta T, Range 2-5 °F	Configurable on SERVICE1 Screen
WEAK LIBR LEAVING ABSORB TEMP	Cooling 100.4 TO 150.8 °F Heating 100.4 TO 199.4 °F	Configurable on SERVICE1 Screen
COOLING WATER ENT ABSORB (HEAT/COOL MODE = COOLING)	< 60 °F	Preset(Checked only when the chiller is in Startup and Running)
COOLING WATER LVG ABSORB (HEAT/COOL MODE = COOLING)	> 100 °F	Preset(Checked only when the chiller is in Startup and Running)
COOLING WATER LVG COND (HEAT/COOL MODE = COOLING)	> 115 °F	Preset(Checked only when the chiller is in Startup or Running)
LEAVING WATER TEMP – SWITCH	< 39 °F	Manually set
G1 LOW LEVEL CONTROL	Open for 60 secs	Preset
G1 HIGH PRESSURE SWITCH	> 14.7 PSI	Manually set
G1 HIGH TEMPERATURE SWITCH	> 330 °F	Manually set
FLUE GAS TEMPERATURE SWITCH	> 400 °F	Manually set
G1 HEAT SOURCE TEMPERATURE	> 320 °F at 1 hour of shutdown or > 250 °F at 2 hour of shutdown	Configurable on SERVICE 3 screen (Checked only when the chiller is in shutdown)

Table 3. Safety Contacts and Alert Limits

Service Operation - Fig. 3-6 and 3-7 shows an overview of the service menus.

TO ACCESS THE SERVICE SCREEN - You must enter a password whenever you access the SERVICE screen.

1. From the MENU screen, press the **SERVICE** softkey. The softkeys now correspond to the numerals 1,2,3,4.
2. Press the four digits of your password, one at a time. An asterisk (*) appears as you enter each digit.

NOTE : The initial factory set password is 1-1-1-1

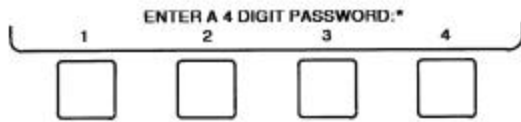

If the password is incorrect, an error message is displayed. If this occurs, return to Step 1 and try to access the SERVICE screens again. If the password is correct, the softkey labels change to **NEXT**, **PREVIOUS**, **SELECT** and **EXIT**, and the ICVC screen displays the following SERVICE tables.

- ALARM HISTORY
- ALERT HISTORY
- CONTROL TEST
- CONTROL ALGORITHM STATUS
- EQUIPMENT CONFIGURATION
- EQUIPMENT SERVICE
- TIME AND DATE
- ATTACH TO NETWORK SERVICE
- LOG OUT OF DEVICE
- ICVC CONFIGURATION

See Fig. 3-6 and 3-7 for additional screens and tables available from the SERVICE screens listed above. Use the **EXIT** softkey to return to the MENU screen.

NOTE : To prevent unauthorized persons from accessing the ICVC service screens, the ICVC automatically signs off and password-protects itself if a key has not been pressed for 15 minutes. The sequence is as follows. Fifteen minutes after the last key is pressed, the default screen displays, the ICVC screen light goes out (analogous to a screen-saver), the ICVC logs out of password-protected SERVICE menu. Other screens and menus, such as the STATUS screen can be accessed without the password by pressing the appropriate softkeys.

TO CHANGE THE PASSWORD - The password may be changed from the ICVC CONFIGURATION screen.

1. Press the **MENU** and **SERVICE** softkeys. Enter your password and highlight ICVC CONFIGURATION. Press the **SELECT** softkey. Only the 5 entries on the CVC CONFIGURATION screen can be changed: BUS #, ADDRESS #, BAUD RATE, US IMP/METRIC, and PASSWORD.
2. Use the **ENTER** softkey to scroll to PASSWORD. The first digit of the password is highlighted on the screen.
3. To change the digit, press the **INCREASE** or **DECREASE** softkey. When you see the digit you want, press the **ENTER** softkey.

4. The next digit is highlighted. Change it and the third and fourth digits in the same way you changed the first digit.
5. After the last digit is changed, the cursor goes to the LID Language variable. Press the **EXIT** softkey to leave that screen and return to the SERVICE menu.

TO CHANGE TIME AND DATE - The time and date must be configured as required.

1. Press the **MENU** and **SERVICE** softkeys. Enter your password and highlight TIME AND DATE. The screen displays 4 entries that can be changed: CURRENT TIME, CURRENT DATE, DAY OF WEEK and HOLIDAY.
2. To change the value, press the **INCREASE** or **DECREASE** softkey. When you see the value you want, press the **ENTER** softkey.

TO SCHEDULE HOLIDAYS - The time schedules may be configured for special operation during a holiday period. When modifying a time period, the "H" at the end of the days of the week field signifies that the period is applicable to a holiday. (See Fig. 3- 21)

The CCN Broadcast function must be activated for the holidays configured in the Holidays table to work properly. Access the BRODEF table in the EQUIPMENT CONFIGURATION table and press **ENABLE** to activate the holiday schedule. If the chiller is connected to a CCN Network, only once chiller or CCN device can be configured to be the broadcast device. The device configured as broadcaster is responsible for transmitting holiday, time and daylight-savings dates throughout the network.

To view or change the holiday periods for up to 18 different holidays, do the following thing:

1. At the MENU screen, press **SERVICE** to access the SERVICE menu.

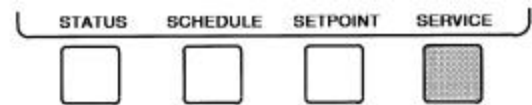

2. If not logged on, follow the instructions for TO LOG ON or To LOG OFF. Once logged on, press **NEXT** until EQUIPMENT CONFIGURATION is highlighted.



3. Once EQUIPMENT CONFIGURATION is highlighted, press **SELECT** to access.

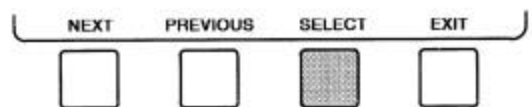

4. Press **NEXT** until HOLIDAYS is highlighted. This is the

screen that allows you to define holidays.

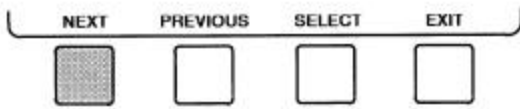

5. Press **SELECT** to view a screen that lists 18 holiday periods.

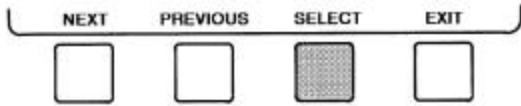

6. Press **NEXT** to highlight the holiday period that you wish to view or change. Each period represents one holiday, starting on a specified date and lasting up to 99 days.

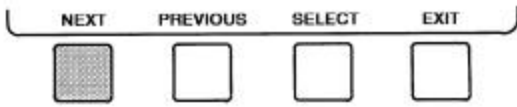

7. Press **SELECT** to access the holiday period. The screen now shows the holiday start month and day, and how many days the holiday period will last.

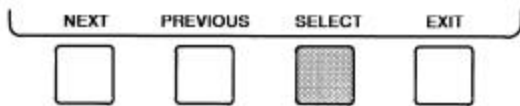

8. Press **NEXT** or **PREVIOUS** to highlight the month, day or duration.

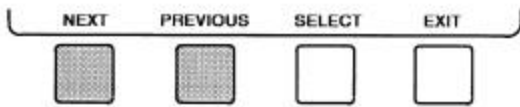

9. Press **SELECT** to select the month, day or duration you wish to modify.

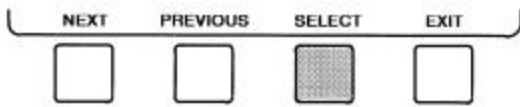

10. Press **INCREASE** or **DECREASE** to change the selected value.



11. Press **ENTER** to save the changes.

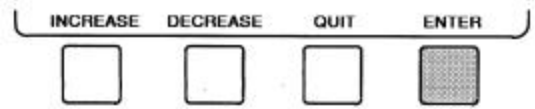

12. Press **EXIT** to return to the previous menu.

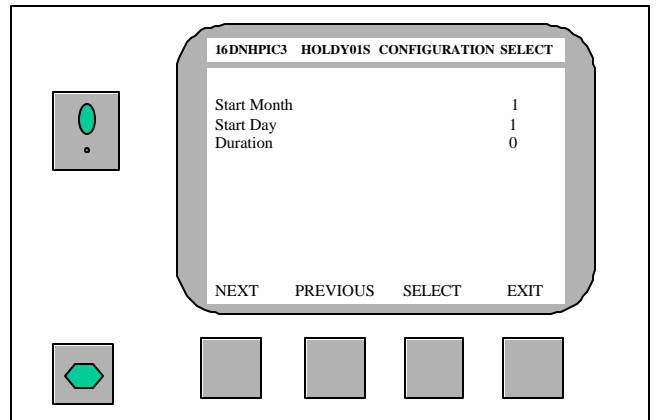
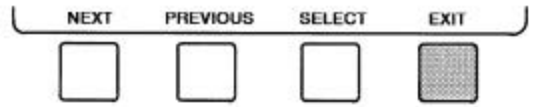

Fig. 3-21 EXAMPLE OF HOLIDAY PERIOD SCREEN

Carrier Comfort Network (CCN) Interface - The Carrier Comfort Network (CCN) communication bus wiring is supplied and installed by the electrical conductor. It consists of shielded, 3-conductor cable with drain wire.

The system elements are connected to the communication bus in a daisy chain arrangement. The positive pin of each system element communication connector must be wired to the positive pin of the system element on either side of it; the signal ground pins must be wired to signal ground pins.

NOTE: Conductors and drain wire must be 20 AWG (American Wire Gage) minimum stranded, tinned copper. Individual conductors must be insulated with PVC, PV/nylon, vinyl, Teflon or polyethylene.

When connecting the CCN communication bus to system element, a color code system for the entire network is recommended to simplify installation and checkout. The following color code is recommended:

SIGNAL TYPE	CCN BUS CONDUCTOR INSULATION COLOR	CCN PLUG PIN NO.
+	RED	1
GROUND	WHITE	2
-	BLACK	3

In each system, tied up with shields of the communication bus cable. If the communication bus is communicated in a building, connect shield wire continuously with a connection. However if the communication bus cable goes from one to another building, have to connect shield wire to connect its

connection of each building where the cables are entered and exit.

To connect 16DNP chiller and network, follow the procedure below.

1. Shut down the PIC control panel
2. Connect a red wire to terminal block No.330.
3. Connect a white wire to terminal block No.329.
4. Connect a black wire to terminal block No.328.

Attach to Network Device - On the SERVICE menu, one of the selections is ATTACH TO NETWORK DEVICE. It serves the following purposes:

- To upload the Occupancy Schedule Number (if changed) for OCCPCS02S, as defined in the SERVICE1 table.
- To attach the ICVC to any CCN device, if the chiller has been connected to a CCN Network. This may include other PIC controlled chillers.
- To change to a new PIC or ICVC module or upgrade software.

Fig. 3-22 illustrates the ATTACH TO NETWORK DEVICE table. The Local description is always the module address of the machine the ICVC is mounted on. Whenever the ICVC configuration is changed, this change is reflected on the bus and address for the LOCAL DEVICE of the ATTACH TO DEVICE screen automatically.

Whenever the ATTACH TO NETWORK DEVICE table is entered, the ICVC erases information on the module to which it was attached in order to make room for another device. Therefore, it is then required to attach to a CCN module when this screen is entered, even if the ICVC is attached back to the original module. When the **ATTACH** softkey is pressed, the message “UPLOADING TABLES, PLEASE WAIT” flashes. The ICVC will then upload the highlighted device or module. If the module address cannot be found, the message “ COMMUNICATION FAILURE” will appear. The ICVC will then revert back to the ATTACH TO NETWORK DEVICE screen. The upload process time for various CCN modules is different for each module. In general, the uploading process will take 3 to 5 minutes.

ATTACHING TO OTHER CCN MODULES - If the chiller ICVC has been connected to a CCN Network or other PIC controlled chillers through CCN wiring, the ICVC can be used to view or change parameters on the other controllers. Other PIC chiller can be viewed and set points changed (if the other unit is in CCN control), if desired from this particular ICVC module.

To view the other devices, move to the ATTACH TO NETWORK DEVICE table. Move the highlight bar to any device number. Press the **SELECT** softkey to change the bus number and address of the module to be viewed. Press **EXIT** softkey to move back to the ATTACH TO NETWORK DEVICE table. If the module number is not valid, the “COMMUNICATION FAILURE” message will show and a new address number should be entered or the wiring checked. If the model is communicating properly, the “UPLOAD IN PROGRESS” message will flash and the new module can now be viewed.

Whenever there is a question regarding which module on

the ICVC is currently begin shown, check the device name descriptor on the upper left hand corner of the ICVC screen.

When CCN device has been viewed, the ATTACH TO NETWORK DEVICE table should now be used to attach to the PIC that is on the chiller. Move to the ATTACH TO NETWORK DEVICE table and press the **ATTACH** softkey to upload the LOCAL device. The ICVC for the 16DNP will now be uploaded.

16DNHPIC3		ATTACH TO DEVICE	
DESCRIPTION	BUS	ADDRESS	
LOCAL	0	1	
DEVICE 1	0	0	
DEVICE 2	0	0	
DEVICE 3	0	0	
DEVICE 4	0	0	
DEVICE 5	0	0	
DEVICE 6	0	0	
DEVICE 7	0	0	
DEVICE 8	0	0	
ATTACH TO ANY DEVICE			
NEXT	PREVIOUS	SELECT	EXIT

Fig. 3-22 EXAMPLE OF ATTACH TO NETWORK DEVICE SCREEN

Power-Up – The ICVC goes through a self-diagnostic test and then displays the default screen. After the chiller is RESET, the PIC reads the ACTUAL CAPACITY VALVE and starts driving it to the fully closed position by setting the TARGET CAPACITY VALVE to 0. Before starting the chiller, reset any alarms and return any fault conditions to a normal range. The ALARM STATE must indicate NORMAL.

4. BEFORE INITIAL START-UP

Inspect Field Piping - Refer to the field piping diagrams for your specific installation, and see the typical piping schematic shown in Fig. 1-6. Inspect the chilled/hot water and cooling water piping.

1. Verify that the location and flow direction of the water lines are specified on the drawings and as marked on the chiller.
2. Check that all water lines are vented and properly supported to prevent stress on water box covers or nozzles.
3. Make sure all water box drains are installed.
4. Ensure that water flow through the evaporator and absorber/condenser meet job requirements. Measure the pressure drops across both evaporator and absorber/condenser when the system has been charged with water and the pumps can be operated.
5. Make sure the chilled/hot water temperature sensors are installed in the leaving chilled/hot water piping. Also check that appropriate thermometers or temperature wells and pressure gage taps have been installed in both entering and leaving sides of the evaporator, absorber, and condenser water piping.

Inspect Field Wiring - Refer to the field and chiller wiring diagrams and inspect the wiring for both power supply and connections to other system equipment (cooling tower, water supply pumps, etc.)

WARNING

Do NOT connect or disconnect any wiring and do NOT touch any bare wires terminals unless power supply disconnects have been locked open and tagged.

1. Examine the wiring for conformance to job wiring diagrams and applicable electrical codes.
2. Check pump and motor nameplates and control panel for agreement with supply voltage and frequency (Hz).
3. Verify the correct overload and fuse sizes for all motors.
4. Check that electrical equipment and controls are properly grounded in accordance with applicable electrical codes.
5. Make sure that customer/contractor has verified proper operation of water pumps, cooling tower fan and associated auxiliary equipment. This includes ensuring that motors are properly lubricated and have proper electrical power supply and proper rotation.

Chiller Evacuation - 16DNP chiller has been factory-charged with solution and refrigerant and then pressurized with nitrogen gas for shipping. Before initial start-up, release the N2 gas through the service valve OPEN at absorber spray inlet pipe until ambient pressure achieved. Then close the service valve and the chiller must be evacuated fully with vacuum pump ON until deep vacuum. Refer to Maintenance Procedure section.

Input the Design Setpoint – To modify the set points, access the SETPOINT menu as described in ICVC Operation & Menus section. The PIC can control a setpoint according to either the leaving or entering chilled water temperature. To change the type of control, access the CONFIG table on the

ICVC. Scroll down to highlight CHW_IN CONTROL OPTION. To control the set point according to the entering chiller water, press the **ENABLE** softkey.

Input the Schedule – To set up the occupied schedule according to the site requirements, access the SCHEDULE menu. If no schedule is available, set it for 24 hours occupied per day, 7 days per week including holidays. This is the default setting. For more information on how to set up a schedule, see the section on TIME SCHEDULE OPERATION section.

If a CCN system is being installed or a secondary schedule is required, configure the CCN occupancy schedule (OCCPC02S). This task is normally done using a CCN Building Supervisor terminal, but it can also be done at the ICVC.

Input the Service Configuration – The following configurations are done from the SERVICE menu on the ICVC.

- Equipment configuration
- Equipment service
- Time and date
- Attach to network device
- Log out of device
- ICVC Configuration

INPUT TIME AND DATE – Access the TIME AND DATE screen from the SERVICE menu. Input the present time of day, date and day of the week. HOLIDAY should be set to YES only if the present day is a holiday.

CHANGE THE ICVC CONFIGURATION, IF NECESSARY – From the ICVC CONFIGURATION screen, the CCN address, units (English or metric), and password can be changed. For the instructions on changing the value, see the Service Operation section.

INPUT THE EQUIPMENT SERVICE PARAMETERS, IF NECESSARY – The EQUIPMENT SERVICE menu has 4 tables: SERVICE 1, SERVICE 2, SERVICE 3 and SERVICE 4. Usually, all values are left at the default settings. These may be changed by the operator as required. See the section on SERVICE Operation.

MODIFY EQUIPMENT CONFIGURATION, AS NECESSARY – The EQUIPMENT CONFIGURATION screen includes CONFIG table. Modify these tables only if requested to do so. Possible modifications include

- Chilled water reset (types 1, 2 and 3)
- Entering chilled water control (enable or disable)
- Remote contact option (enable or disable)
- Temperature pulldown (degrees per minutes)
- CCN occupancy configuration (schedule number and broadcast option)

5. INITIAL START-UP

Preliminary Check – Check the operation of the auxiliary equipment and the status of the system before starting the 16DNP chiller.

PREPARATION

1. Check that the chiller is in vacuum pressure. If not, perform the Chiller evacuation procedure.
2. Supply power to the control panel, chilled water and cooling water pumps. Open the chilled water valves, and cooling water valves.
3. Verify that chilled/hot and cooling water circuit are filled and operative and that the pumps are powered. For manual system operation, start the chilled/hot water pump. With cooling operation, also start the cooling water pump and cooling tower fan.
4. Make sure that diverter valve is in closed position.
5. Press the LOCAL button. For cooling, the status screen will display OCCUPIED MODE and then all pumps should start. For heating, only the solution and chill/hot water pumps will operate.
6. For Heating-175 (optional) operation, only aux hot water pump must start.

WATER PUMP STARTERS AND OVERLOADS

1. Starters for chilled/hot water and cooling water pump motors should be checked individually according to the manufacturer's instructions. When the pump motor trips out, the chiller will shut down on the dilution cycle, the alarm buzzer will sound and the status screen will display LOW CHILLED/HOT WATER FLOW and LOW COOLING WATER FLOW.
2. Press the Reset button on ICVC. Reset the overloads of pump motor. Press the LOCAL button to restart the chiller.

Cooling/Heating Operation Changeover - Switch between cooling and heating cycles by using the following procedures. This can be done only when the chiller is off.

CHANGING FROM COOL TO HEAT-140 MODE

1. Place two changeover valves at vapor side and liquid side in the fully open position. (See the location of changeover valves in Fig. 2-3.)
2. Drain all water in the cooling water piping.
3. Change from cooling to heating mode in VALVE CHANGEOVER table on the CONTROL TEST screen.
4. Start the chiller according to Start Machine section below.

CHANGING FROM HEAT-140 TO COOL MODE

1. Place two changeover valves at vapor side and liquid side in the fully closed position.
2. Fill the cooling water system and vent air from the piping.
3. Change from heating to cooling mode in VALVE CHANGEOVER table on the CONTROL TEST screen.

Determine Noncondensables Rate – When the initial combination run-in period has been completed, normal operation may begin. Evacuate the machine to remove noncondensables if non-condensable rate is higher than 10cc/10min.

Check Chiller Shutdown - Press the STOP button to verify normal shutdown sequence. The diverter valve should be driven to close. The chiller will go through a dilution shutdown period and the pumps will stop according to the Normal Cooling Stop or Normal Heating Stop.

Check the Safety Switches Setting - Adjust all the external safeties and cutout switch to the following values

- Low Chilled Water Flow Switch	2.0 psid (13.8 kPad)
- Low Chilled Water Temperature Switch	39 °F (3.9 °C)
- High G1 Pressure Switch	14.7 psi (101.3 kPa)
- High G1 Solution Temperature Switch	330 °F (165 °C)
- High Flue Gas Temperature Switch	626 °F (330 °C)

The following setting apply to Heat-175 type chiller.

- Aux. H.W. Low Flow Switch	2.0 psid (13.8 kPad)
- Aux. H.W. Temperature Switch	194 °F (90 °C)

6. START-UP/RUNNING/SHUTDOWN SEQUENCE

Local Start-Up - Local start-up (or a manual start-up) is initiated by pressing the **LOCAL** softkey, which is on the default ICVC screen. Local start-up can proceed if the chiller schedule indicates that the current time and date has been established as a run time and date. This condition is referred to as "OCCUPIED". See the section on Time Schedule Operations.

If the current time and date is not established as a run time, the chiller can be forced to start as follows. From the default screen, press the **MENU** and **STATUS** softkeys. Scroll to highlight COOLSTAT (or HEATSTAT). Press the **SELECT** softkey. Scroll to highlight CHILLER START/STOP. Press the **START** softkey to override the schedule and start the chiller.

NOTE : The chiller will continue to run until this forced start is released, regardless of the programmed schedule. To release the forced start, highlight CHILLER START/STOP from the COOLSTAT (or HEATSTAT) screen and press the **RELEASE** softkey. This action returns the chiller to the start and stop times established by the schedule.

NOTE : The chiller may also be started by overriding the time schedule. From the default screen, press the **MENU** and **SCHEDULE** softkeys. Scroll down and select the current schedule. Select the OVERRIDE, and set the desired override time.

Another condition for local start-up must be met for chillers that have the REMOTE CONTACTS OPTION on the EQUIPMENT SERVICE screen set to ENABLE. For these chillers, the REMOTE CONTACTS parameter on the COOLSTAT (or HEATSTAT) must be ON. From the ICVC default screen, press the **MENU** and **STATUS** softkeys. Scroll to highlight COOLSTAT (or HEATSTAT) screen to highlight REMOTE CONTACTS and press the **SELECT** softkey. Then, press the **ON** softkey. To end the override, select REMOTE CONTACTS and press the **RELEASE** softkey.

Start-Up Sequence

COOLING START-UP - Once these conditions are met, the PIC then performs a pre-start check, which is to verify Micro-turbine Status is ON. For more information on the micro-turbine status, see the Micro-Turbine Status Monitoring section. The run status line on the default screen reads 'STARTUP IN PROGRESS'. See Fig. 6-1, a flowchart of the cooling mode start-up procedure.

Then, the PIC begins to monitor water flow, which, if it fails, will abort the start-up sequence. These functions are listed below.

- CHILLED/HOT WATER FLOW not confirmed within the WATER FLOW VERIFY TIME period (default 0.5 min).
- COOLING WATER FLOW not confirmed within the WATER FLOW VERIFY TIME period (default 0.5 min).

After the CHILLED WATER FLOW is verified, the PIC compares the chilled water temperature to the CONTROL POINT. If CHW_IN CONTROL OPTION is DISABLE, LEAVING WATER temperature is used in the comparison.

Otherwise, ENTERING WATER temperature is used. If the chilled water temperature is less than or equal to the CONTROL POINT, the PIC goes into the RECYCLE mode.

If the chilled water temperature is greater than the CONTROL POINT then the COOLING WATER PUMP is energized.

The PIC begins to monitor for the COOLING WATER FLOW to be YES. The PIC waits up to the WATER FLOW VERIFY TIME to confirm flow.

After the COOLING WATER FLOW has been verified, the TOWER FAN CONTROL algorithm is enabled. Then the PIC energizes the SOLUTION PUMP.

After 5 minutes, the REFRIGERANT PUMP is energized, and the PIC starts the ramp loading mode.

HEATING-140 START-UP -Once these conditions are met, the PIC then performs a pre-start check, which is to verify MT Status is ON. The run status line on the default screen reads 'STARTUP IN PROGRESS'. See Fig. 6-2, a flowchart of the heating-140 mode start-up procedure.

Then, the PIC begins to monitor the CHILLED/HOT WATER FLOW to be YES up to the WATER FLOW VERIFY TIME period (default 0.5 min).

After the CHILLED/HOT WATER FLOW is verified, the PIC compares the chilled/hot water temperature to the CONTROL POINT. If CHW_IN CONTROL OPTION is DISABLE, LEAVING WATER temperature is used in the comparison. Otherwise, ENTERING WATER temperature is used. If the chilled/hot water temperature is more than or equal to the CONTROL POINT, the PIC goes into the RECYCLE mode.

If the chilled water temperature is less than the CONTROL POINT, then the PIC energizes the SOLUTION PUMP and the PIC starts the ramp loading mode.

HEATING-175 (Option) START-UP - Once these conditions are met, the PIC then performs a pre-start check, which is to verify MT Status is ON. The run status line on the default screen reads 'STARTUP IN PROGRESS'. See Fig.6-3, a flowchart of the heating-175 mode start-up procedure.

Then, the PIC begins to monitor the AUX HOT WATER FLOW to be YES up to the WATER FLOW VERIFY TIME period (default 0.5 min).

After the AUX HOT WATER FLOW is verified, the PIC compares the aux hot water temperature to the CONTROL POINT. If CHW_IN CONTROL OPTION is DISABLE, Aux HW Outlet Temp is used in the comparison. Otherwise, Aux HW Inlet Temperature is used. If the aux hot water temperature is more than or equal to the CONTROL POINT, the PIC goes into the RECYCLE mode.

If the aux hot water temperature is less than the CONTROL POINT, then the PIC starts the ramp loading mode.

CHP Startup Routine Flowchart

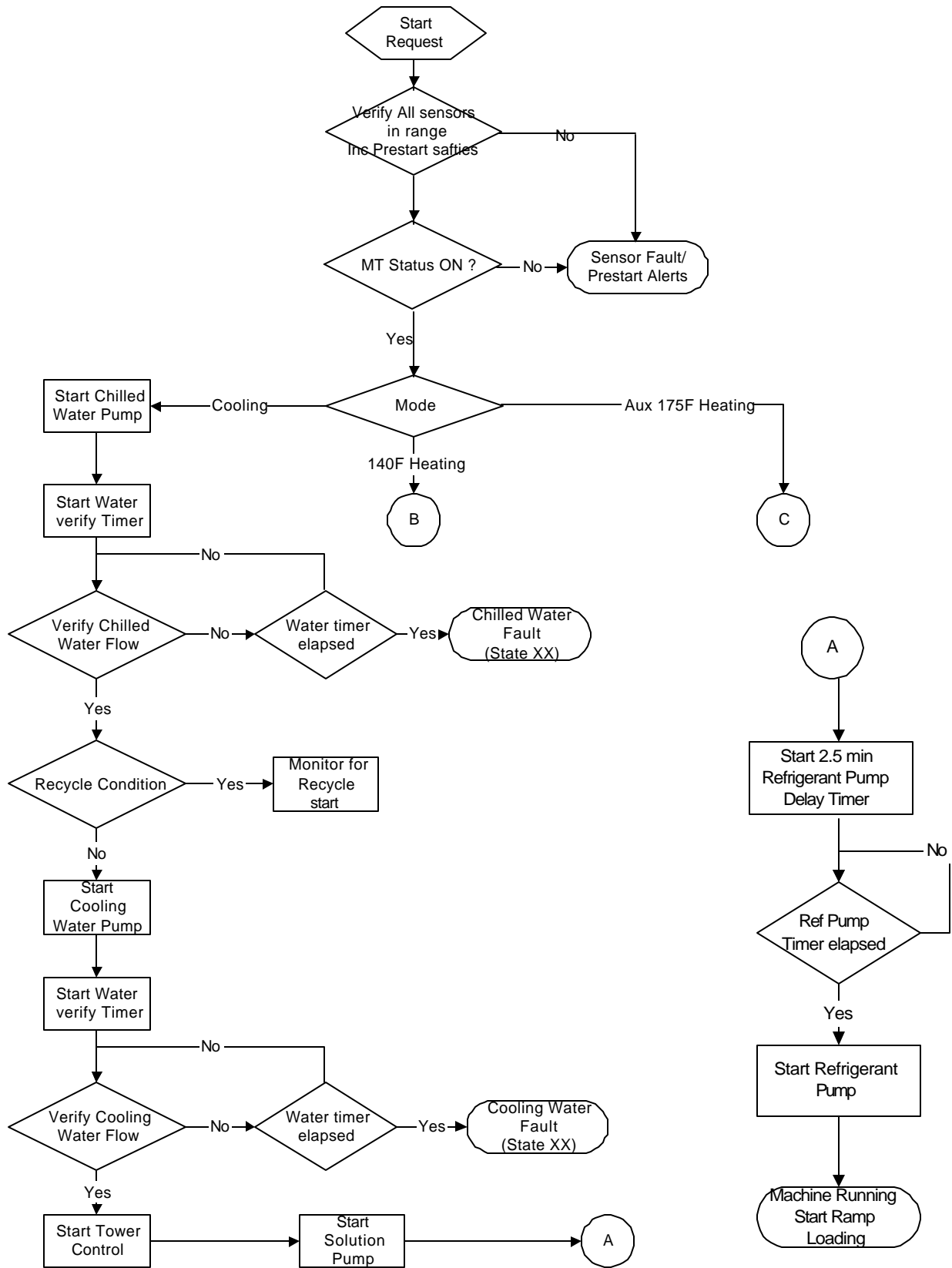

Fig. 6-1 Cooling Start-up Flowchart

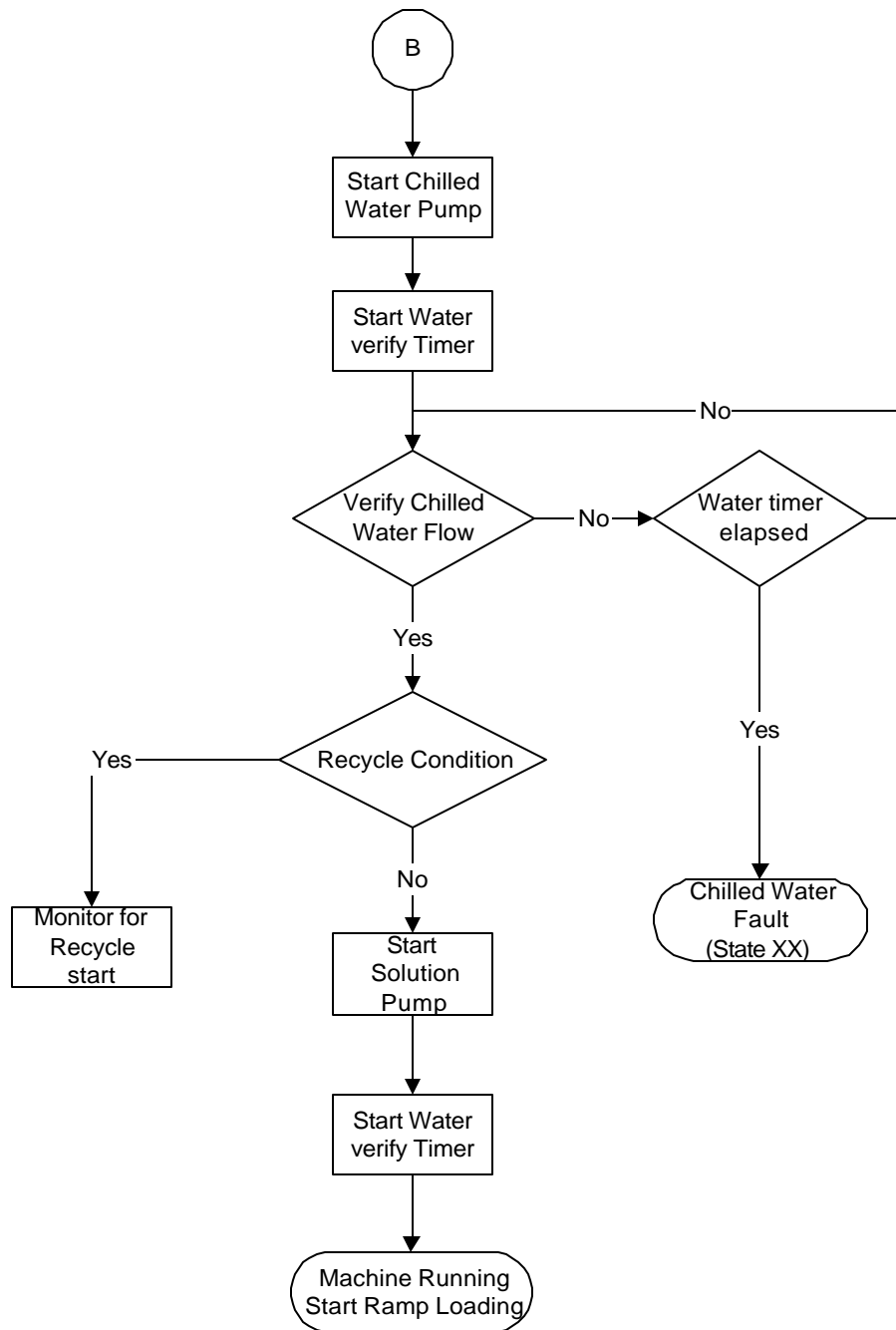

Fig. 6-2 Heating-140 Start-up Flowchart

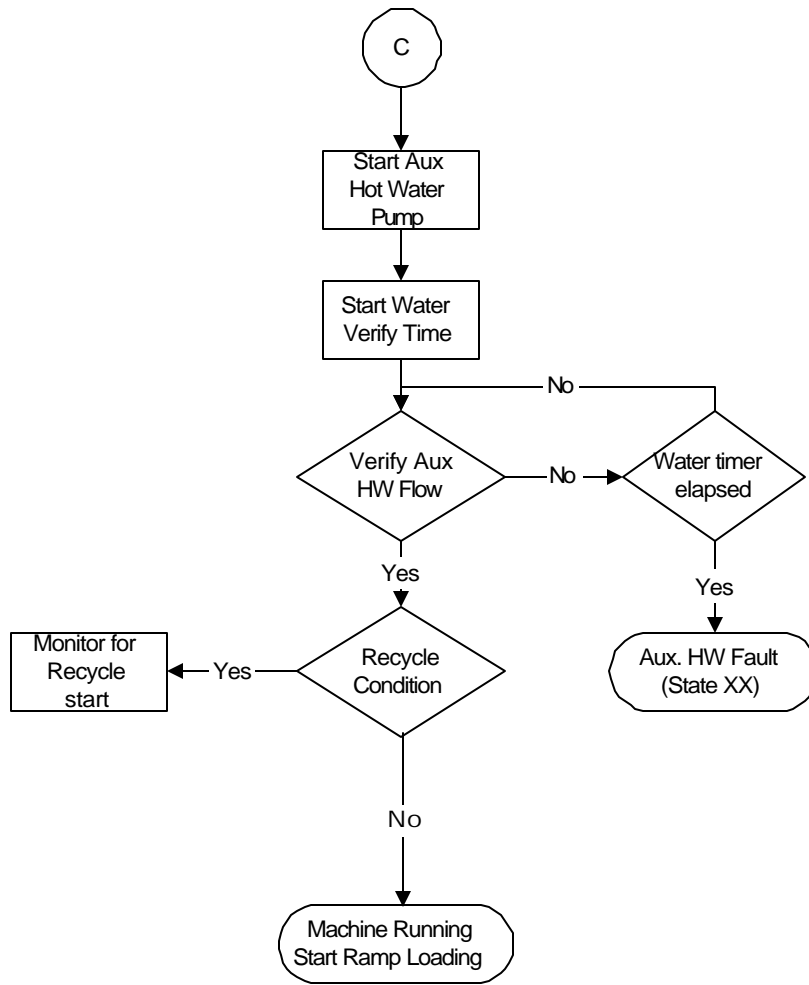

Fig. 6-3 Heating-175 Start-up Flowchart

Ramp Loading Mode - At the completion of a COOLING mode startup, the CAPACITY VALVE starts at 0% and increase as required. The point temperature ramp loading shall limit the rate at which either LEAVING WATER or ENTERING WATER temperature decreases by reducing the pulldown setpoint at the configured rate (refer to CONFIG Screen).

Ramp loading is based on chilled water temperature. During ramp loading mode, the LEAVING WATER or ENTERING WATER temperature change is limited to the TEMP PULLDOWN DEG/MIN. This is the rate that the controlled temperature is changed to reach the setpoint. The default rate is 3 °F (1.7 °C) degrees per minute. The diverter valve is allowed full travel to obtain this goal unless an inhibit or close signal is received by the PIC based on another algorithm.

To set or change the temperature pulldown rate, refer to the Ramp Loading Control section.

Normal Run Mode

CAPACITY CONTROL - Under normal run mode, the PIC controls the diverter valve position in response to the monitored chilled water temperature with resets. The control algorithm uses the PROPORTIONAL GAIN, INTEGRAL GAIN and G1 SOLUTION TEMP GAIN to position the valve. These variables are found on the SERVICE3 screen.

There may be other overrides limiting the capacity valve position, such as RUNNING TRAVEL LIMIT and COOLING/HEATING RATIO. The operator can configure different maximum diverter valve position between cooling and heating mode, as required. The RUNNING TRAVEL LIMIT restricts maximum capacity valve position at heating mode. The COOLING/HEATING RATIO shall be used for adjustment for the RUNNING TRAVEL LIMIT at Cooling mode. It is calculated from :

Running Travel Limit (Cooling) = (Cooling/Heating Ratio) * Running Travel Limit (Heating)

Usually the above values are left at the default settings.
(Running Travel Limit : 100, Cooling /Heating Ratio : 1.0)

TRAVEL LIMIT CONTROL - For smoothly starting up the chiller or for sudden increases when operating from a lightly loaded condition, it is required to limit the maximum heat flow rate into the chiller until the chiller is sufficiently warmed up. For this purpose, the controller monitors the rise rate of the G1 leaving solution temperature (Strong LiBr Leaving G1) over a 30 second period.

If all micro-turbines are running, the diverter valve travel limit is set to a configurable value (Startup Travel Limit),

when the G1 leaving solution temperature is less than 212 °F and the rate of increase of the G1 solution temperature is greater than the configured Diverter Limit On Threshold. The Startup Travel Limit is honored for a minimum of 2 minutes.

After the G1 solution temperature has reached 212 °F and the minimum 2 minute ON requirement has been satisfied, the configured Running Travel Limit will be restored as the travel limit. Alternately, the travel limit shall be restored when the G1 solution temperature is less than 212 °F, the rate of increase over the last 30 seconds is less than the configured Diverter Limit Off Threshold, and the minimum 2 minute ON requirement has been satisfied. Additionally, if the number of micro-turbines running reduces to less than the maximum number of micro-turbines, the Running Travel Limit will be restored immediately.

INSUFFICIENT HEAT INPUT AT START-UP – In cooling mode to determine whether machine has enough G1 heat input flow to complete startup, the sensors for Strong LiBr Leaving G1 and Strong LiBr Leaving G2 are monitored. If both sensors are out of range (associated temperature << 77 °F), this indicates insufficient heat flow.

If both sensor values are out of range at 20 minutes after the ACTUATOR COMMAND SIGNAL is set to ON during startup, then alarm shutdown will occur.

Monitoring for state 221 shall terminate 20 minutes after the ACTUATOR COMMAND Signal is set to ON. Persistence for alarm conditions will be 10 seconds.

G1 HIGH SOLUTION LEVEL CONTROL – This process run only when the Heat/Cool Mode is set to Cooling or Heat-140. An immersion electrode monitors the level of high-stage generator solution. When the level is too high, the electrode energizes the Warrick high-level relay. If that condition persists for 2 seconds, the SOLUTION PUMP is turned OFF. The STRONG LiBr LEAVING G1 is monitored and the solution pump is restarted after a calculated delay time. (See Fig. 6-4)

VARIABLE FREQUENCY DRIVE CONTROL - This process run only when the Heat/Cool Mode is set to Cooling or Heat-140. At cooling mode, the PIC monitors cycle temperatures input and control Variable Frequency Drive speed output. It reads Condensate Leaving G2 and Weak LiBr Leaving Absorb, then calculate the VFD speed output, which will be used for solution pump speed control. (See Fig. 6-5)

If HEAT/COOL Mode is set to Heating-140, VFD speed runs at fixed speed. C3, Heating Frequency is configurable in SERVICE 4 table.

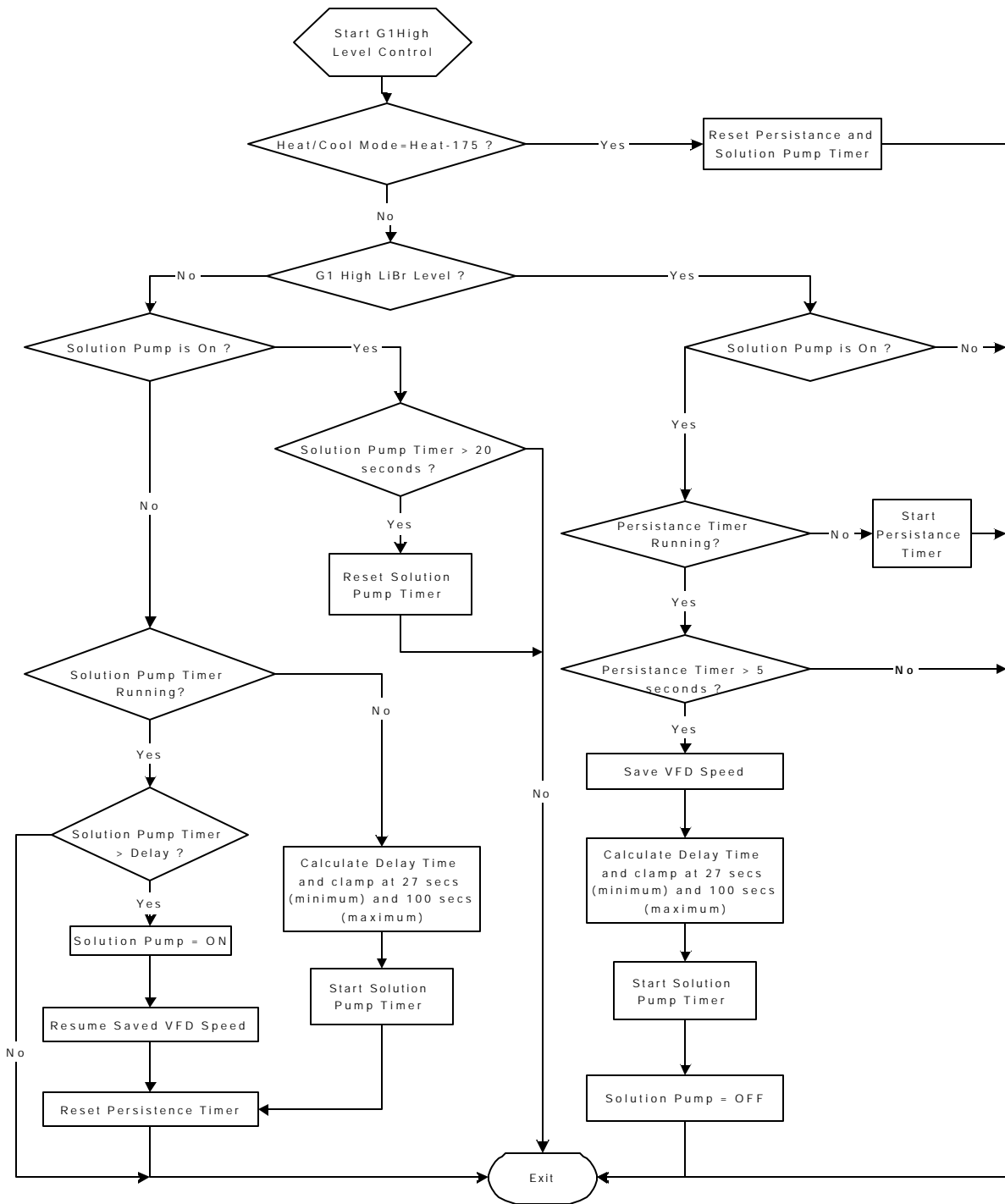

Fig. 6-4 16DNP G1 High Solution Level Flowchart

Notes :

- TAO : Temperature of Absorbent temp. leaving Absorber
- G2R: G2 Refrigerant Condensing temperature
- A1(Maximum G2R):Configurable on ICVC-Default : 95
- A2(Minimum G2R):Configurable on ICVC-Default :68.5
- B(Variable) : Maximum1.13
- A4(Minimum VFD_SPEED):Configurable on ICVC-Default :20
- C1:Configurable on ICVC-Default : 38(38-35.4)
- C2:Configurable on ICVC-Default : 60(60/50, 2 Statures)
- C3:Configurable on ICVC-Default : 40.0 (33)

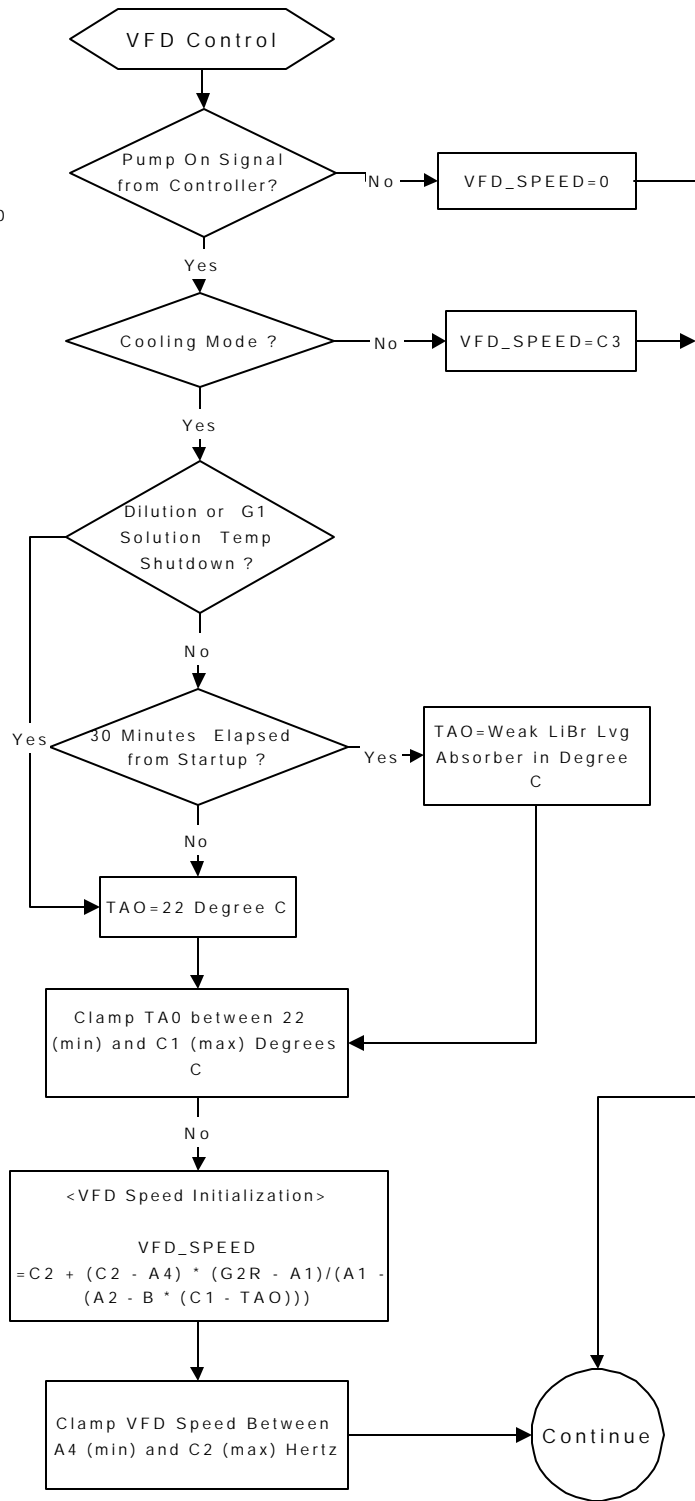

Fig. 6-5 16DNP VFD control Flowchart

Shutdown Sequence - The chiller will shut down if any of the following occurs:

- the STOP button on the control panel is pressed for at least one second (the alarm light will blink once to confirm the stop command)
- a recycle condition is present (see Recycle Mode section)
- the OCCUPIED parameter on the COOLSTAT (or HEATSTAT) screen indicates NO; that is, the chiller is not scheduled to run at the current time and date.
- The chiller's protective limits have been reached and the chiller is in an alarm state.
- The start/stop status has been overridden to STOP from the CCN or the ICVC

COOLING SHUTDOWN - Normal cooling shutdown begins by setting the TARGET CAPACITY VALVE to 0% (CLOSE), setting the COMBUSTION SIGNAL=OFF, setting the SOLUTION PUMP=ON and starting the solution pump timer for 15 minutes. The PIC monitors STRONG LiBr LEAVING G1, if it is below than 212 °F (100 °C), 5 min solution pump timer is triggered. The configurable refrigeration pump timer is also started. The following conditions shall then be checked to identify a normal shutdown condition for which the dilution cycle shall take place.

If any condition does not match the desired state, then an abnormal shutdown shall take place in which the dilution cycle is skipped and the sequence goes immediately to complete shutdown. (See Fig. 6-6 and 6-7)

CHILL/HOT WATER FLOW=	YES
LOW CHILLED WATER TEMP=	NORMAL
SOL PUMP OVERLDR/HITEMP=	NORMAL
REF PUMP OVERLDR/HITEMP=	NORMAL

When the refrigeration pump dilution timer is complete the refrigerant pump shall be turned off.

Following the dilution cycle when the solution pump timer elapses, the REFRIGERANT PUMP and TOWER FAN RELAY are set to OFF. The SOLUTION PUMP output is set to OFF. At this point if it is a non-recycle shutdown (not due to low CHILLED WATER temperature initiated by the RECYCLE CONTROL), the CHILLED/HOT WATER PUMP is set to OFF. If it is a recycle shutdown, the PIC monitors the water temperature to initiate a recycle restart when necessary.

HEATING-140 SHUTDOWN - The Heat-140 shutdown sequence begins by setting the TARGET CAPACITY VALVE to 0% (CLOSE), setting the COMBUSTION SIGNAL=OFF, setting the SOLUTION PUMP =ON and starting the solution pump timer for 5 minutes. The following conditions are then checked to identify a normal shutdown condition for which the 5 minutes solution pump operation takes place. If any condition does not match the desired state, then the sequence goes immediately to complete the shutdown (See Fig. 6-8).

CHILL/HOT WATER FLOW=	YES
LOWCHILLED WATER TEMP=	NORMAL
SOL PUMP OVERLDR/HITEMP=	NORMAL

When the solution pump timer elapses, the CHILL/HOT WATER PUMP and SOLUTION PUMP output are set to OFF. At this point if it is a non-recycle shutdown (not due to high WATER temperature initiated by the RECYCLE CONTROL), the CHILL/HOT WATER PUMP shall be set to OFF. If it is a Recycle Shutdown the CHILL/HOT WATER PUMP is left ON and the PIC monitors the water temperature to initiate a recycle restart when necessary.

HEATING-175 (OPTION) SHUTDOWN - The Heat-175 shutdown sequence begins by setting the TARGET CAPACITY VALVE to 0% (CLOSE), setting the COMBUSTION SIGNAL=OFF, and starting the dilution pump timer for 5 minutes. The following conditions are then checked to identify a normal shutdown condition for which the 5 minutes aux hot water pump operation takes place. If any condition does not match the desired state, then the sequence goes immediately to complete the shutdown (See Fig. 6-8).

AUX HOT WATER FLOW=	YES
---------------------	-----

When the dilution timer elapses, the AUX HOT WATER PUMP output is set to OFF. At this point if it is a non-recycle shutdown (not due to high WATER temperature initiated by the RECYCLE CONTROL), the AUX HOT WATER PUMP shall be set to OFF. If it is a Recycle Shutdown the AUX HOT WATER PUMP is left ON and the PIC monitors the water temperature to initiate a recycle restart when necessary.

Recycle Control - When the chiller is running in a lightly loaded condition, it may cycle off and wait until the load increases before restarting. This cycling is normal and is known as a recycle shutdown.

COOLING MODE - A recycle shutdown is initiated when any of the following conditions occur:

- when the chiller is operating under the control of leaving chilled water temperature (that is, when CHW_IN CONTROL OPTION on the CONFIGURATION display screen is set to DISABLE) and the LEAVING WATER temperature is less than CONTROL POINT minus SHUTDOWN DELTA T for 3 seconds, and the CONTROL POINT has not increased by 1 °F (0.56 °C) in the last 5 minutes. Both LEAVING WATER and CONTROL POINT values may be read from the COOLSTAT display screen on the ICVC.
- when the chiller is operating under the control of entering chilled water temperature (that is, when CHW_IN CONTROL OPTION on the CONFIGURATION display screen is set to ENABLE) and the ENTERING WATER temperature is less than CONTROL POINT minus SHUTDOWN DELTA T for 3 seconds, and the CONTROL POINT has not increased by 1 °F (0.56 °C) in the last 5 minutes. Both ENTERING WATER and CONTROL POINT values may be read from the COOLSTAT display screen on the ICVC.
- when the LEAVING WATER temperature is less than the REFRIGERANT TRIPPOINT plus REFRIG OVERRIDE DELTA T for 5 consecutive seconds.

When the chiller is in RECYCLE mode, the chilled water pump relay stays energized so that the chilled water temperature can be monitored for increasing load. The recycle control uses RECYCLE RESTART DELTA T to check when the chiller should be restarted. RECYCLE RESTART DELTA T is an operator-configured function that defaults to 5 °F (2.8 °C). This value is viewed and/or modified on the SERVICE1 screen. The chiller will restart when:

- the chiller is operating in leaving chilled water control and the LEAVING WATER temperature is greater than the CONTROL POINT plus the RECYCLE RESTART DELTA T for 5 seconds; or
- the chiller is operating in leaving chilled water control and the ENTERING WATER temperature is greater than the CONTROL POINT plus the RECYCLE RESTART DELTA T for 5 seconds.

Once these conditions are met, the chiller will begin a start-up with a normal start-up sequence.

HEATING MODE - A recycle shutdown is initiated when any of the following conditions occur:

- when the chiller is operating under the control of leaving chilled water temperature (that is, when CHW_IN CONTROL OPTION on the CONFIGURATION display screen is set to DISABLE) and the LEAVING WATER temperature is greater than CONTROL POINT plus SHUTDOWN DELTA T for 3 seconds, and the CONTROL POINT has not decreased by 1 °F (0.56 °C) in the last 5 minutes. Both LEAVING WATER and CONTROL POINT values may be read from the HEATSTAT display screen on the ICVC.
- when the chiller is operating under the control of entering chilled water temperature (that is, when CHW_IN CONTROL OPTION on the CONFIGURATION display screen is set to ENABLE) and the ENTERING WATER temperature is greater than CONTROL POINT plus SHUTDOWN DELTA T for 3 seconds, and the CONTROL

POINT has not decreased by 1 °F (0.56 °C) in the last 5 minutes. Both ENTERING WATER and CONTROL POINT values may be read from the HEATSTAT display screen on the ICVC.

When the chiller is in RECYCLE mode, the chilled water pump relay stays energized so that the chilled water temperature can be monitored for increasing load. The recycle control uses RECYCLE RESTART DELTA T to check when the chiller should be restarted. RECYCLE RESTART DELTA T is an operator-configured function that defaults to 5 °F (2.8 °C). This value is viewed and/or modified on the SERVICE1 screen. The chiller will restart when:

- the chiller is operating in leaving chilled water control and the LEAVING WATER temperature is less than the CONTROL POINT minus the RECYCLE RESTART DELTA T for 5 seconds; or
- the chiller is operating in leaving chilled water control and the ENTERING WATER temperature is less than the CONTROL POINT minus the RECYCLE RESTART DELTA T for 5 seconds.

Once these conditions are met, the chiller will begin a start-up with a normal start-up sequence.

Safety Shutdown - A safety shutdown is identical to a manual shutdown with the exception that the ICVC will display the reason for the shutdown, the alarm light will blink continuously, the default screen display will freeze, and the spare alarm contacts will be energized. A safety shutdown requires that the **RESET** softkey be pressed to clear the alarm. Before pressing the **RESET** softkey, record the default screen values. If the alarm is still present, the alarm light will continue to blink. Once the alarm is cleared (by fixing the problem and pressing the **RESET** softkey), operator must press the **CCN** or **LOCAL** softkey to restart the chiller.

Shutdown Routine Flowchart

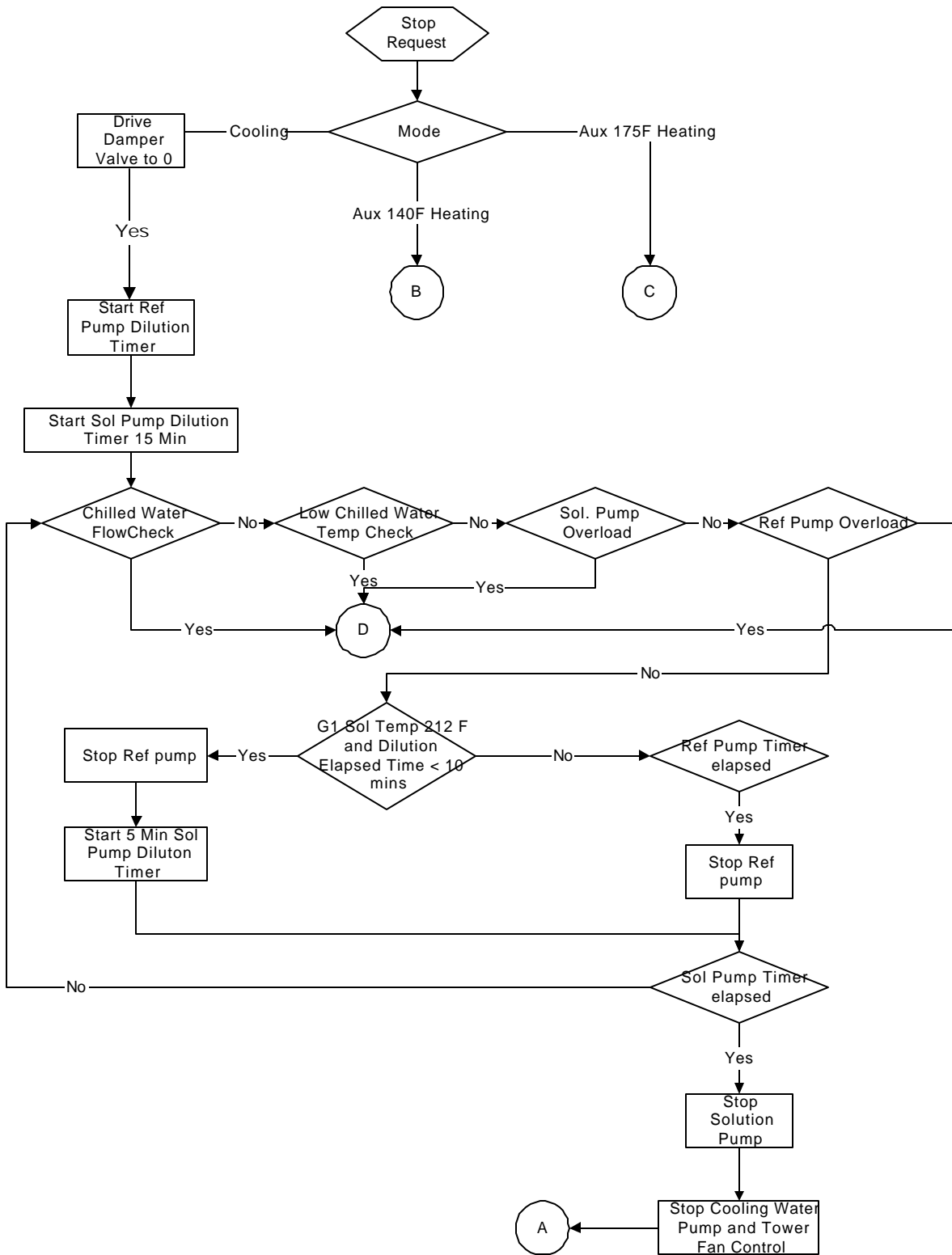

Fig. 6-6 Cooling Shutdown Flowchart (1)

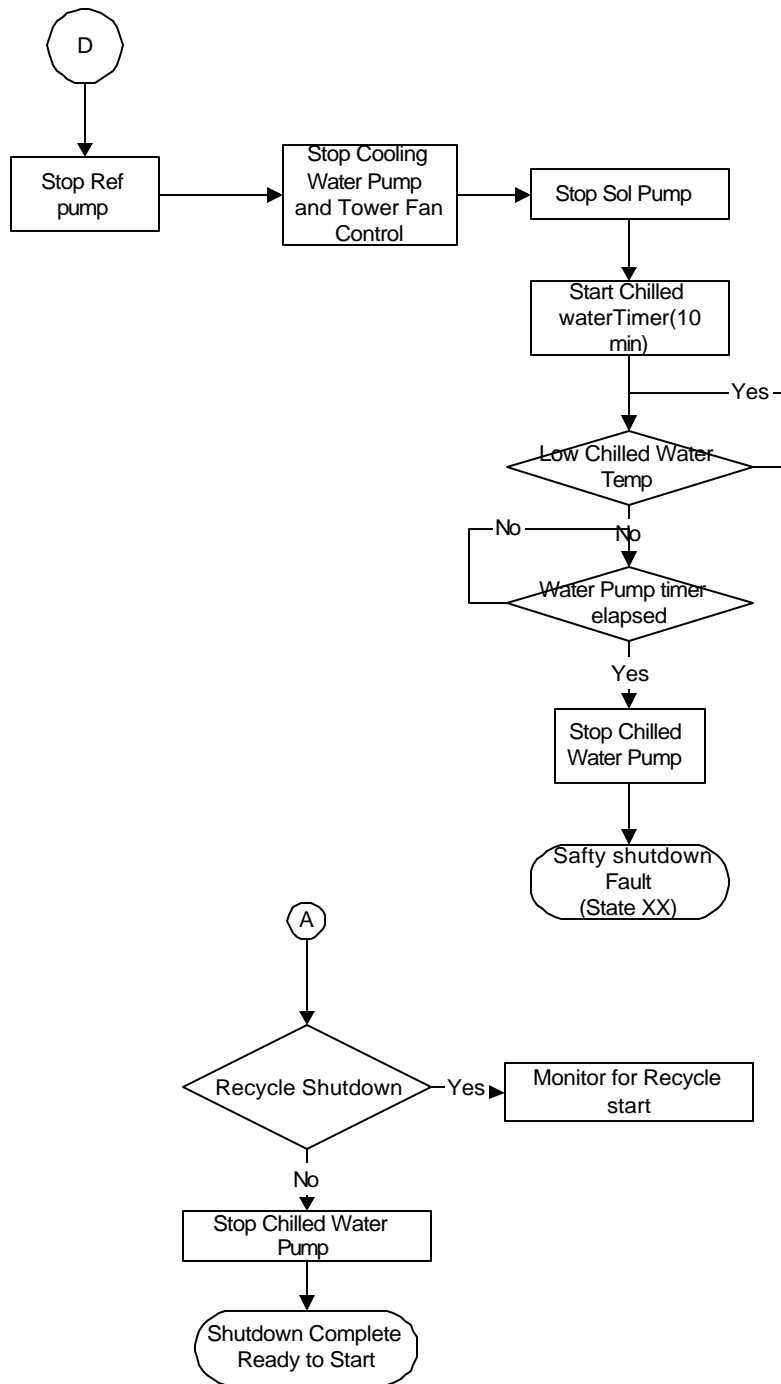

Fig. 6-7 Cooling Shutdown Flowchart (2)

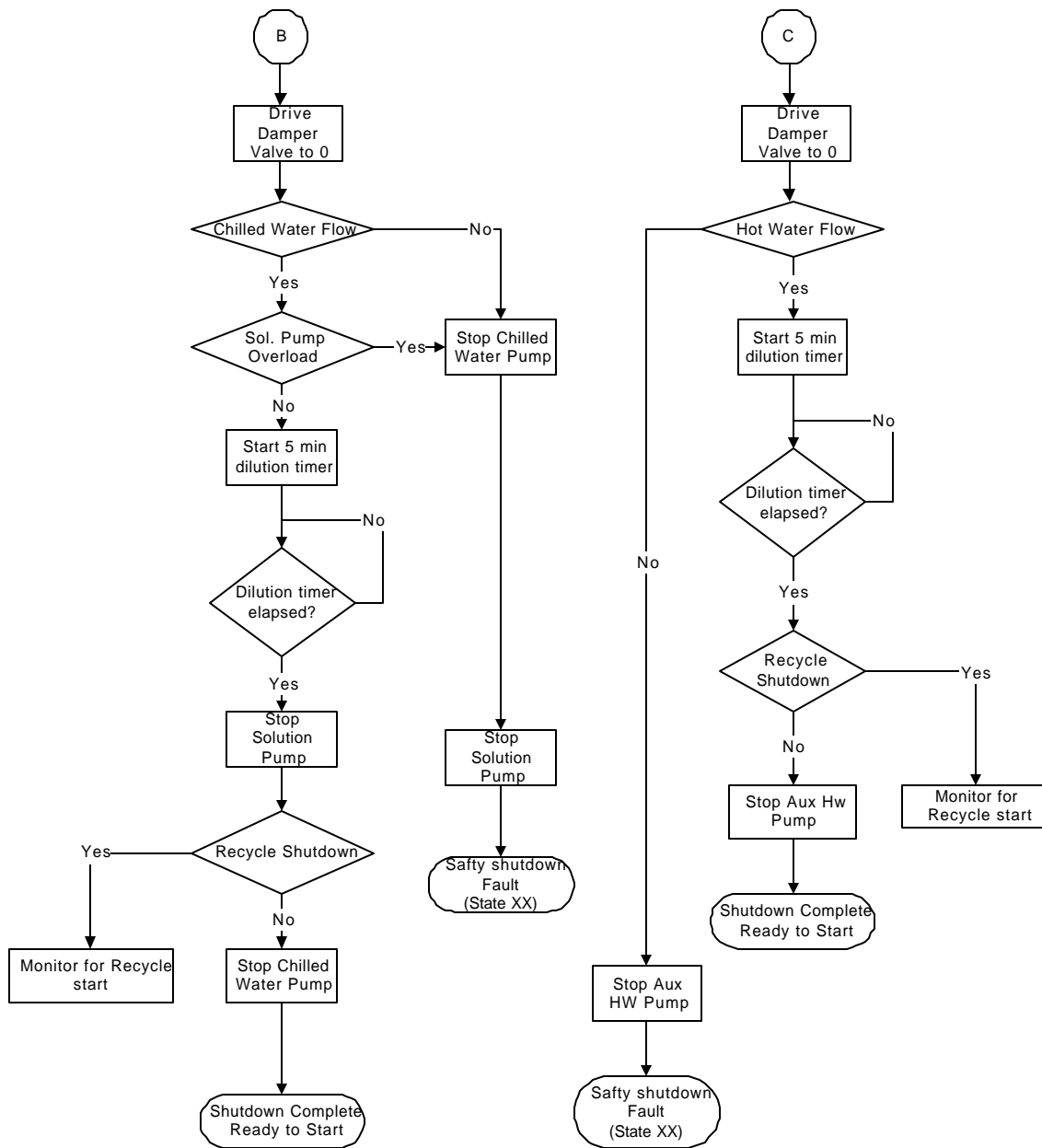

Fig. 6-8 Heating Shutdown Flowchart

7. PERIODIC SCHEDULED MAINTENANCE

Normal preventive maintenance for 16DNP absorption chiller requires periodic, scheduled inspection and service. Each item in the list below is detailed in the Maintenance Procedures section.

Every Day

1. Log the chiller and system readings.
2. Check for water/ exhaust leakage, vibration, abnormal temperature and unusual noise.

Every Month

1. Check non-condensable accumulation rate.
2. Check diverter valve control and leakage.
3. Exhaust purge tank.

Every 2 Months

1. Check low temperature cutout (cooling only).
2. Check other limit and safety devices.

Every 6 Months or Cooling/Heating changeover

1. Check refrigerant charge (cooling only).
2. Check octyl alcohol (cooling only).
3. Take solution sample to be analyzed.

Every Year

1. Check tubes for scale and fouling.
2. Check/adjust level electrodes in high temperature generator.

Every 2 Years

1. Replace valve diaphragms.
2. Replace high-temperature generator level electrodes.
3. Check/replace palladium cell heater.
4. Check thermostats and pressure switches; replace as necessary.

Every 5 Years or 20,000 Hours (Whichever Is Shorter)

1. Inspect hermetic pumps.
2. Filter or regenerate the solution.
3. Check actuator and replace as necessary.
4. Check cooling/heating changeover valve and replace parts as necessary.

8. MAINTENANCE PROCEDURES

Establish a regular maintenance schedule based on the actual chiller requirements, such as chiller load, run hours, and water quality. The time intervals listed in this section are offered as guides to service.

Service Ontime – The ICVC displays a SERVICE ONTIME value on the PUMPSTAT screen. This value should be reset to zero by the service person or the operator each time major service work is completed so that the time between services can be seen.

Log Sheets - Readings of machine and system pressure-temperature conditions should be recorded daily to aid the operator in recognizing both normal and abnormal machine conditions. The record also aids in planning a preventive maintenance schedule and in diagnosing machine problem. A typical log sheet is shown in Fig. 8-3.

Inspect the Heat Exchanger Tubes

EVAPORATOR – Inspect and clean the evaporator tubes at the end of the first operating season. The tube condition determines the scheduled frequency for cleaning and indicates whether water treatment is adequate in the chilled water line. Inspect the entering and leaving chilled water temperature sensors for signs of corrosion or scale. Replace the sensor if it is corroded or remove any scale if found.

ABSORBER/CONDENSER – Since this water circuit is usually an open system, the tubes may be subject to contamination and scale. Clean the tubes with a tube cleaning system at least once per year and more often if the water is contaminated. Inspect the entering and leaving absorber and condenser water sensors for signs of corrosion or scale. Replace the sensors if corroded or remove any scale if found.

Water Leaks – Water can infiltrate from the evaporator, absorber, or condenser circuits. Water accumulation is indicated during chiller operation when refrigerant level increases and the capacity decreases.

Water Treatment – Untreated or improperly treated water may result in corrosion, scaling, erosion, or algae. The services of a qualified water treatment specialist should be obtained to develop and monitor a treatment program.

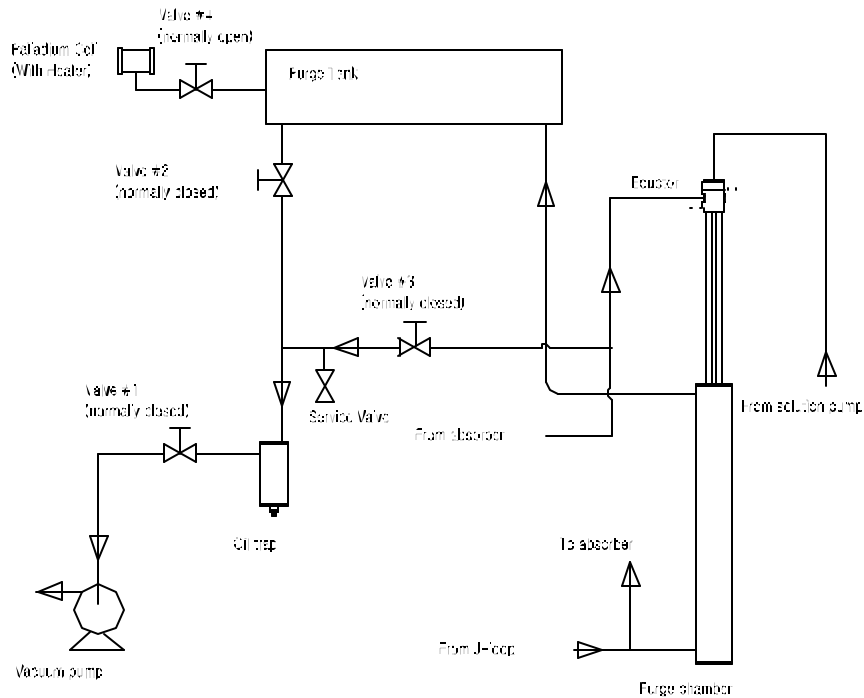

Fig. 8-1 Purge procedure

Purge Procedure - See the Chiller Description for an explanation of the purge system.

AUTOMATIC PURGE – Hydrogen gas, which is generated normally in the chiller, is exhausted to the atmosphere from the purge tank through the heated palladium membrane cell. This is done automatically and continuously during chiller cooling and heating operation. For the automatic purge, the valve #4 (Fig. 8-1) is normally placed in open position.

DIRECT PURGE – Direct purge is required for the removal of excessive noncondensables from chiller, such as pressurized N₂ gas evacuation during chiller shutdown. In this case, purge tank is not used, but noncondensables are evacuated directly from absorber to the atmosphere by vacuum pump.

1. Inspect the vacuum pump as described in Vacuum Pump Operation section.
2. Turn the vacuum pump ON with ballast valve a little open. Initially, valve #1, #2 and #3 should be placed in closed position. See the Fig. 8-1 for valve location.
3. Open the valve #1 firstly and then, valve #3 secondly.
4. Keep purging until deep vacuum achieved. During purge operation, if oil color is changed due to noncondensables, solution or refrigerant, change the oil as to Vacuum Pump Operation procedure.
5. Once direct purge completed, close the valve #3 and then valve #1. Keep the vacuum pump ON with ballast valve open to make the oil dry for 30minutes.
6. Turn the vacuum pump OFF.

MANUAL PURGE – During cooling operation, manual purge is required to improve purge capacity in addition to automatic purge. Excessive noncondensables stored in purge tank are removed by vacuum pump in addition to palladium cell. During heating operation, manual purge is not recommended.

1. Inspect the vacuum pump as described in Vacuum Pump

Operation section.

2. Turn the vacuum pump ON with ballast valve a little open. Initially, valve #1, #2 and #3 should be placed in closed position.
3. Open the valve #1 firstly and after then, valve #2 secondly.
4. Keep purging in 2~3 minutes to empty the purge tank.
5. Close the valve #2 and then valve #1. Keep the vacuum pump ON with ballast valve open to make the oil dry for 30minutes. After then, turn the vacuum pump OFF.

Vacuum Pump Operation – The one of important maintenance item for 16DNP absorption chiller is vacuum pump. See the Fig. 8-2 for vacuum pump components.

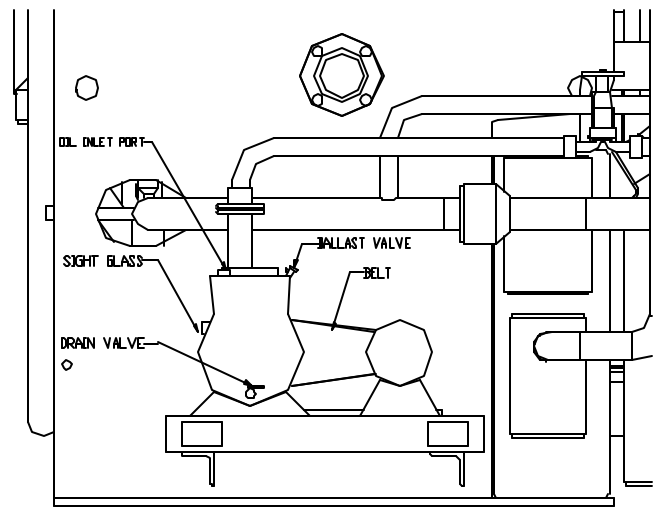

Fig. 8-2 Vacuum pump

BASIC CHECK LIST

1. Before the pump starts, check the oil is filled up to half level of sight glass. If level is above the center-line, drain the oil. If lower, refill the oil until half of sight glass.
2. After pump starts, check if the direction of rotation is correct. Refer to the rotation sticker on the belt cover for rotation check.
3. When the pump is not rotated while motor is powered on, turn the pump off immediately, then check the V-belt tension.
4. Keep the ballast valve a little open to remove humid air from oil and prevent oil flowing backward at pump off.

PERIOD OF OIL REPLACEMENT

1. Initially 50 hours, and then every 500 hours in normal operation.
2. When the cooling or heating season is done, change the oil for next season.

PROCEDURE OF OIL REPLACEMENT

1. Make sure that the valves, #1, #2 and #3, are placed in closed position. (See the Fig. 8-1.)
2. Drain the oil after warm-up with pump operation for approximately 30 minutes.
3. Prepare the container beneath the drain valve and open the oil inlet port, ballast and drain valve.
4. When the oil is not drained, close the drain valve and put the new oil a little through the oil inlet port. Then operate the pump at atmospheric pressure for 30 seconds. Then stop the pump and open the drain valve to drain the oil left.
5. After drain completed, close the drain valve and put the new oil to the center of sight glass.
6. Close the oil inlet port.
7. Turn the pump ON with ballast valve a little open to make the oil dry for a couple of minutes.

Chiller Leak Test - All joint welded at machine installation must be leak tested before initial start-up of machine. Joints must also be leak tested after repair. If there is any indication of air leakage, leak test the entire machine.

1. Be sure auxiliary evacuation valve, purge exhaust valve and all service valves are closed
2. Break machine vacuum with dry nitrogen. Pressurize machine to 5.7 psig (0.4 ? /? G) with tracer gas. Charge the nitrogen and refrigerant through the auxiliary evacuation valve.
3. Use dry nitrogen to raise machine pressure to 11.4 psig (0.8? /? G).

Do NOT exceed 11.4 psig (0.8 ? /? G)

4. Leak test all joints with an electronic leak detector.
5. Correct all leak; retest to ensure repair.
6. Release machine pressure and perform chiller evacuation.

Solution and Refrigerant Charging

WARNING

Lithium bromide can irritate the skin and eyes. Wash off any solution with soap and water. If solution enters the eyes, wash the eye with fresh water and consult a physician immediately. Lithium bromide is a strong salt solution; do NOT siphon by mouth.

HANDLING LITHIUM BROMIDE SOLUTION - Solution of lithium bromide and water are nontoxic, nonflammable, non-explosive and can easily be handled in open containers. The solution is chemically stable and does not undergo any appreciable change in properties even after years of use in the absorption chiller. Its general chemical properties are similar to those of table salt.

CHARGING SOLUTION

IMPORTANT

Because lithium bromide salt can corrode metal in the presence of air, wipe off any solution spilled on metal parts of tools and rinse the part with fresh water as soon as possible. After rinsing, coat the tools with a light film of oil to prevent rust. After emptying metal containers of solution, rinse the container with fresh water to prevent corrosion. Immediately wipe or flush the floor if lithium bromide or octyl alcohol is spilled on it.

Lithium bromide for absorption machine use should be kept only in the original container or in a completely clean container. Used lithium bromide solution should be disposed of by a reputable chemical disposal company.

CAUTION

Follow the start-up sequence in order described. To ensure the quick, even formation of a solid protective film on the internal steel surfaces and particularly in the high-stage generator, a day after the refrigerant and lithium bromide have been charged into the chiller. The vacuum pump also must be in operation during the entire charging and start-up period. This protective film is required to prevent local corrosion in the machine during normal operation.

Also do NOT apply power to hermetic pumps or attempt to start the machine until it has been charged with lithium bromide solution and refrigerant. The pump will be severely damaged if rotated without the full liquid charge.

If solution or refrigerant is drained out of the machine during maintenance work, after then, it must be charged. Solution must be charged separately into both the high-stage generator (G1) and the absorber, while the hermetic pumps remain off. Charge amount ratio between absorber and G1 would be approximately 60 : 40. To minimize chance of air entering the machine, the solution should NOT be drawn directly from a small container. The vacuum pump should remain in operation continuously while the solution is being charged into the chiller.

1. Connect a flexible hose to a 3/8" flared nut and pipe. The pipe should be longer than the height of the solution container. Fill both pipe and hose with water to minimize any air entry into the machine.
2. Insert the 3/8-in. pipe into the container (be sure it goes to the bottom) and connect the flexible hose to the drain valve at the high-stage generator.
3. Continue charging until solution level is near bottom of container and quickly close the valve. *Do NOT allow the air to be drawn into machine.*

4. Disconnect the hose from the high-stage generator drain valve, fill the hose and pipe with water and reconnect the hose to the solution pump service valve.
5. Repeat previous steps until the remaining solution charge into absorber.
6. Remove the hose and immediately continue with the refrigerant charging.

INITIAL REFRIGERANT CHARGING - The refrigerant charging must be either distilled or softened water. Do not use tap water without first having it de-ionized or tested for the following requirement.

PH	7.0 ± 0.2 at 77 °F (25 °C)
Hardness CaCO ₃	2.0 ppm or less
Silica	0.2 ppm or less
Ammonia NH ₄ ⁺	None
Specific Resistance	more than 5 x 10 ⁵ Ω/? at 77 °F (25°C)

To charging refrigerant into the evaporator, fill clean solution containers with the distilled or softened water. Charge the water through the refrigerant pump service valve, following the appropriate steps in Charging Solution section, above.

When the solution and refrigerant charging has been completed, keep the vacuum pump running to remove any noncondensables.

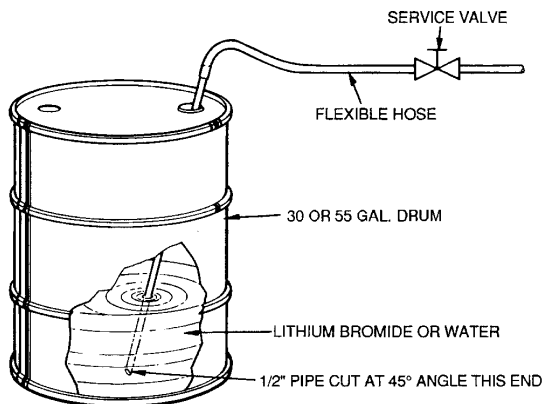

Fig. 8-3 Charging Solution and Refrigerant

Solution or Refrigerant Sampling - See the precaution pertaining to handling lithium bromide solution as described in Solution and Refrigeration charging section.

Take solution or refrigerant samples from service valve at pump discharge or suction while the pump is operating. See the Fig. 2-3 for valve location.

Before taking a sample for analysis, be sure machine is operating with steady load and that has not been any refrigerant overflow within 10 minutes prior to sampling.

Attach a hose adaptor to the pump service valve. Do NOT use copper or brass fittings when taking samples for analysis; copper oxide can form and contaminate samples

The solution pump normally discharges at the above atmospheric pressure, but the refrigerant pump discharges at a vacuum, so the respective sampling procedures are different.

SOLUTION SAMPLE

1. Make sure that the pump discharge pressure is positive with pressure gage before taking sample. Generally, when variable frequency drive speed is above 70%, it must be a positive pressure.
2. Connect the flexible tubing with hose adaptor to the service valve at solution pump discharge pipe. Place the free end in a container.
3. Open service valve slowly and fill the sample container.
4. Close the service valve and remove hose and adaptor.

REFRIGERANT SAMPLE

1. Connect a clean, empty vacuum container to the pump service valve with a length of flexible hose.
2. Connect a vacuum pump to the vacuum container with a flexible hose and isolation valve.
3. Pull a deep vacuum on the container and close the isolation valve.
4. Open the service valve slightly to drain refrigerant sample into the container.
5. Close the service valve, remove hose and adaptor and disconnect vacuum pump.

Solution Analysis - Laboratory analysis of a solution sample gives indication of change in solution alkalinity and depletion of inhibitor and may indicate the degree of machine leak tightness.

Have the solution analyzed at least once a year or whenever there is an indication of noncondensables problem. Take the sample from the solution pump service valve while the machine is running (see the Solution or Refrigerant Sampling section). The sample concentration should be between 58% and 62% by weight for best results.

Solution analysis should be done by an approved laboratory. The analysis interpretation and the adjustment recommendations should be made by a trained absorption specialist.

Inhibitor - Lithium molybdate (Li₂MoO₄) inhibitor is charged into the machine with the initial charge of lithium bromide. The inhibitor is used in conjunction with alkalinity control to minimize the amount of noncondensables normally generated within the machine. Excessive non-condensable generation interferes with machine performance.

The inhibitor is gradually depleted during machine operation and occasional replenishment is necessary. Solution alkalinity also changes over a period of time and must be adjusted (see the Solution Analysis).

Adding Octyl Alcohol - Octyl alcohol may be required when leaving chilled water temperature starts to rise above design temperature without alteration of the control setpoint. Since the rise in temperature can also be caused by fouled tubes or other problems, use the following procedure to determine whether a lack of octyl alcohol is the cause:

NOTE: Add octyl alcohol only during cooling operation.

1. Take a sample of solution. (See the Solution or Refrigerant Sampling section). If the solution has no odor of alcohol (very pungent), add about 1/2 gal. (2L) of octyl alcohol. The addition of octyl alcohol also may be required after the machine has been evacuated or after an extended period of

operation.

2. Fill a length of flexible tubing with water and connect one end to the service valve at low temperature heat exchanger (H2). Insert the other end in a container of octyl alcohol. Open the service valve to allow alcohol to be drawn into the machine. *Close valve before air can be drawn into the hose.*

Refrigerant Charge Adjustment - The refrigerant charge adjustment must be made to ensure that normal solution concentrations can be achieved for full capacity and that refrigerant overflow will occur with excessive solution concentrations to prevent crystallization.

The adjustment should be made only when:

1. Chiller is operating at cooling full load with stable temperature.
2. Refrigerant specific gravity is 1.02 or less.

- If it is increased up to the half of the sight glass (overflow level), the refrigerant must be overflowed to absorber. It means chiller may have too much refrigerant. Remove water through the refrigerant pump discharge valve. Continue to remove water increments until the overflow stops. Wait about 10 minutes between reductions to allow for temperature changes to be noted. Refrigerant overflow will change chiller operating conditions.

- If it is decreased much lower than half of the sight glass, the chiller may have too little refrigerant. Add water through the refrigerant pump service valve. *Do NOT allow air to be drawn into the chiller.* Continue to add water increments until overflow just starts. Wait about 10 minutes between additions to allow for temperature changes to be noted. However, any extra refrigerant pump discharge pressure is below atmospheric pressure and vacuum bottle is required to remove refrigerant.

Refrigerant Blow-down - LiBr can be transferred manually by placing the blow-down valve to open the valve while the machine is running and the capacity control valve is open. When the refrigerant level is decreased too low, refrigerant pump start cavitating, then close the valve. If level comes up, open the valve again. To get the refrigerant specific gravity below 1.02, repeat this procedure.

Insulation and Paint - If customer required, chiller would be insulated in jobsite.

Insulation - Apply insulation as indicated in job data, after machine assembly and field piping have been completed. If shipping vacuum or pressure test indicate possible leakage, do not apply insulation until leak has been corrected.

Most of the chiller and diverter valve surfaces become hot during the heating cycle and those areas should be insulated with heat-resistant material. High-temperature, fire resistant material should be used in the high temperature generator shell, refractory door, exhaust gas duct and diverter valve. All wiring should be external to the finished insulation. The insulation should be applied so all flanged service connections can be easily opened and all valves, controls and sensor locations should be easily accessible.

FINAL PAINT COAT - Paint the chiller as indicated in job data. After installation assembly, leak testing and insulation

have been completed.

CAUTION

Use only octyl alcohol. Other types of alcohol have a detrimental effect on machine performance.

NAME _____

DATE _____

JOB NAME _____

MODEL NO _____ SERIAL NO _____

		DATE :				
		AMBIENT TEMP:				
TIME OF DATA						
CHILLED/ HOT WATER	Entering Temperature					
	Leaving Temperature					
	Pressure Drop					
COOLING WATER	Entering Absorber Temp.					
	Leaving Absorber Temp.					
	Leaving Condenser Temp.					
	Pressure Drop					
EXHAUST GAS	Capacity Valve Position					
	Exhaust Gas Inlet Temp.					
	Exhaust Gas Outlet Temp.					
	Pressure Drop					
CYCLE	Strong LiBr Leaving G1 Temp.					
	Strong LiBr Leaving G2 Temp.					
	Condensate Leaving G2 Temp.					
	Vapor Condensate Temp.					
	Refrigerant Temp.					
OTHERS	VFD Speed					
	Note					

Fig. 8-4 Sample Log sheet for 16DNP chiller