



16JT  
60 Hz

## Double-Effect Hermetic Absorption Liquid Chillers Units 810-880, 080-150, 080L-150L

# Start-Up, Operation, and Maintenance Instructions

### SAFETY CONSIDERATIONS

**Absorption liquid chillers provide safe and reliable service when operated within design specifications. When operating this equipment, use good judgment and safety precautions to avoid damage to equipment and property or injury to personnel.**

**Be sure you understand and follow the procedures and safety precautions contained in the machine instructions as well as those listed in this guide.**

#### **▲ DANGER**

DO NOT USE OXYGEN or air to purge lines, leak test, or pressurize a machine. Use nitrogen.

NEVER EXCEED specified test pressures. For the 16JT chiller, the maximum pressure is 12 psig (83 kPa).

WEAR goggles and suitable protective clothing when handling lithium bromide, octyl alcohol, inhibitor, lithium hydroxide, and hydrobromic acid. IMMEDIATELY wash any spills from the skin with soap and water. IMMEDIATELY FLUSH EYES with water and consult a physician.

#### **▲ WARNING**

DO NOT USE eyebolts or eyebolt holes to rig machine sections or the entire assembly.

DO NOT work on high-voltage equipment unless you are a qualified electrician.

DO NOT WORK ON electrical components, including control panels or switches, until you are sure ALL POWER IS OFF and no residual voltage can leak from capacitors or solid-state components.

LOCK OPEN AND TAG electrical circuits during servicing. IF WORK IS INTERRUPTED, confirm that all circuits are deenergized before resuming work.

NEVER DISCONNECT safety devices or bypass electric interlocks and operate the machine. Also, never operate the machine when any safety devices are not adjusted and functioning normally.

DO NOT syphon lithium bromide or any other chemical by mouth.

BE SURE all hydrogen has been exhausted before cutting into purge chambers. Hydrogen mixed with air can explode when ignited.

WHEN FLAMECUTTING OR WELDING on an absorption machine, some noxious fumes may be produced. Ventilate the area thoroughly to avoid breathing concentrated fumes.

DO NOT perform any welding or flamecutting to a machine while it is under a vacuum or pressurized condition.

NEVER APPLY an open flame or live steam to a refrigerant cylinder. Dangerous overpressure can result. When necessary to heat a cylinder, use only warm (110 F [43 C]) water.

DO NOT REUSE disposable (nonreturnable) cylinders or attempt to refill them. It is DANGEROUS AND ILLEGAL. When cylinder is emptied, evacuate remaining gas pressure, loosen the collar and unscrew and discard the valve stem. DO NOT INCINERATE.

DO NOT ATTEMPT TO REMOVE fittings, covers, etc., while machine is under pressure or while machine is running.

#### **▲ CAUTION**

DO NOT climb over a machine. Use platform, catwalk, or staging. Follow safe practices when using ladders.

DO NOT STEP ON machine piping. It might break or bend and cause personal injury.

USE MECHANICAL EQUIPMENT (crane, hoist, etc.) to lift or move inspection covers or other heavy components. Even if components are light, use such equipment when there is a risk of slipping or losing your balance.

VALVE OFF AND TAG steam, water, or brine lines before opening them.

DO NOT LOOSEN waterbox cover bolts until the water box has been completely drained.

DO NOT VENT OR DRAIN waterboxes containing industrial brines, liquid, gases, or semisolids without permission of your process control group.

BE AWARE that certain automatic start arrangements can engage starters. Open the disconnects ahead of the starters in addition to shutting off the machine or pump.

USE only repaired or replacement parts that meet the code requirements of the original equipment.

DO NOT ALLOW UNAUTHORIZED PERSONS to tamper with machine safeties or to make major repairs.

PERIODICALLY INSPECT all valves, fittings, piping, and relief devices for corrosion, rust, leaks, or damage.

PROVIDE A DRAIN connection in the vent line near each pressure relief device to prevent a build-up of condensate or rain water.

IMMEDIATELY wipe or flush the floor if lithium bromide or octyl alcohol is spilled on it.

# CONTENTS

	Page		Page
<b>SAFETY CONSIDERATIONS</b> .....	1	<b>Final Adjustment of Capacity Controls</b> .....	25
<b>INTRODUCTION</b> .....	3	• WITH THE MANUAL PROCEDURE .....	25
<b>MACHINE DESCRIPTION</b> .....	3-9	• WITH THE AUTOMATIC PROCEDURE .....	25
Basic Absorption Cycle .....	3	<b>Final Refrigerant Charge Adjustment</b> .....	25
Double-Effect Reconcentration .....	3	<b>Check Machine Shutdown</b> .....	27
Machine Construction .....	3	<b>Check Low-Evaporator Level Operation</b> .....	27
Flow Circuits .....	6	<b>Determine Noncondensable Accumulation Rate</b> .....	27
<b>Equilibrium Diagram and Chiller Solution Cycle</b> .....	7	<b>OPERATING INSTRUCTIONS</b> .....	27-30
• PLOTTING THE SOLUTION CYCLE .....	9	<b>Operator Duties</b> .....	27
<b>Purge System</b> .....	9	<b>Before Starting Machine</b> .....	27
<b>MACHINE CONTROLS</b> .....	10-19	<b>Start Machine</b> .....	27
<b>Start-Stop Systems</b> .....	10	<b>Start-Up After Limited Shutdown</b> .....	28
• SEMI-AUTOMATIC START-STOP .....	10	<b>Start-Up After Extended Shutdown</b> .....	28
• FULL AUTOMATIC START-STOP .....	10	<b>Start-Up After Below Freezing Conditions</b> .....	28
<b>Control Wiring</b> .....	10	<b>Machine Shutdown — Normal Conditions</b> .....	28
<b>Control Panel</b> .....	10	<b>Machine Shutdown — Below Freezing Conditions</b> .....	28
<b>Typical Control Sequence, Normal Start</b> .....	14	<b>Actions After Abnormal Shutdown</b> .....	29
<b>Typical Control Sequence, Normal Stop</b> .....	16	<b>Actions After Power Interruption</b> .....	29
<b>Typical Control Sequence, Abnormal Stop</b> .....	17	<b>PERIODIC SCHEDULED MAINTENANCE</b> .....	29
<b>Capacity Control</b> .....	18	<b>Every Day of Operation</b> .....	29
• CONTROLLER .....	18	<b>Every Month of Operation</b> .....	29
<b>High Concentration Limit</b> .....	19	<b>Every 2 Months of Operation</b> .....	29
<b>Low Concentration Limit</b> .....	19	<b>Every 6 Months of Operation</b> .....	29
<b>High-Stage Generator Level Limit</b> .....	19	<b>Every Year of Operation</b> .....	29
<b>BEFORE INITIAL START-UP</b> .....	19-22	<b>Every 3 Years of Operation</b> .....	29
<b>Job Data and Tools Required</b> .....	19	<b>Every 5 Years or 20,000 Hours of Operation</b> .....	29
<b>Inspect Field Piping</b> .....	20	<b>MAINTENANCE PROCEDURES</b> .....	29-40
<b>Inspect Field Wiring</b> .....	20	<b>Log Sheets</b> .....	29
<b>Standing Vacuum Test</b> .....	20	<b>Purge Manual Exhaust Procedure</b> .....	31
• LONG INTERVAL TEST .....	20	<b>Absorber Loss Determination</b> .....	31
• SHORT INTERVAL TEST .....	20	<b>Noncondensable Accumulation Rate</b> .....	31
<b>Machine Evacuation</b> .....	21	<b>Machine Leak Test</b> .....	33
<b>Solution and Refrigerant Charging</b> .....	21	<b>Machine Evacuation</b> .....	33
• HANDLING LITHIUM BROMIDE SOLUTION .....	21	<b>Solution or Refrigerant Sampling</b> .....	34
• CHARGING SOLUTION .....	21	• SOLUTION SAMPLE .....	34
• CHARGING FOR CONDITIONS OTHER THAN NOMINAL .....	21	• REFRIGERANT SAMPLE .....	34
• INITIAL REFRIGERANT CHARGING .....	21	<b>Solution Analysis</b> .....	34
<b>INITIAL CONTROL CHECKOUT AND ADJUSTMENT</b> .....	22-24	<b>Inhibitor</b> .....	34
<b>Preparation</b> .....	22	<b>Adding Octyl Alcohol</b> .....	35
<b>Energize Control Circuit</b> .....	22	<b>Removing Lithium Bromide from Refrigerant</b> .....	35
<b>Check Solution and Refrigerant Pump Starters</b> .....	22	<b>Refrigerant Charge Adjustment</b> .....	35
<b>Check Pump Starter Overloads</b> .....	22	<b>Capacity Control Adjustment</b> .....	35
<b>Check Low-Temperature Cutout</b> .....	22	<b>Low-Temperature Cutout Adjustment</b> .....	35
<b>Check Cycle-Guard™ Valve</b> .....	23	<b>Cycle-Guard™ System Operation</b> .....	35
<b>Check Solution Thermostwitch</b> .....	23	<b>Thermostwitch Adjustment</b> .....	36
<b>Check High-Stage Generator Temperature Thermostwitch</b> .....	23	<b>Low-Refrigerant Level Operation</b> .....	36
<b>Check High-Stage Generator Pressure Switch</b> .....	23	<b>Internal Service</b> .....	36
<b>Check Rotation of Solution and Refrigerant Pumps</b> .....	23	<b>Service Valve Diaphragm Replacement</b> .....	36
<b>Check Capacity Control Operation</b> .....	23	<b>Hermetic Pump Inspection</b> .....	36
<b>Completion</b> .....	24	• DISASSEMBLY .....	36
<b>INITIAL START-UP</b> .....	25-27	• INSPECTION .....	36
<b>Preliminary Check</b> .....	25	• REASSEMBLY .....	36
• PREPARATION .....	25	• COMPLETION .....	36
		<b>Solution Decrystallization</b> .....	40
		<b>Condensing Water Tube Scale</b> .....	40
		<b>Water Treatment</b> .....	40
		<b>TROUBLESHOOTING GUIDE</b> .....	41,42

## INTRODUCTION

Everyone involved in the start-up, operation, and maintenance of the 16JT machine should be thoroughly familiar with the following instructions and other necessary job data before initial start-up, and before operating the machine and its control system or performing machine maintenance. Procedures are arranged in the sequence required for proper machine start-up and operation.

## MACHINE DESCRIPTION

**Basic Absorption Cycle** — The 16JT absorption chiller uses water as the refrigerant in vessels maintained under a deep vacuum. The chiller operates on the simple principle that under low absolute pressure (vacuum), water takes up heat and vaporizes (boils) at a low temperature. For example, at the very deep vacuum of 0.25 in. (6.4 mm) of mercury absolute pressure, water boils at the relatively cool temperature of only 40 F (4 C). To obtain the energy required for this boiling, it takes heat from, and therefore chills, another fluid (usually water). The chilled fluid then can be used for cooling purposes.

To make the cooling process continuous, the refrigerant vapor must be removed as it is produced. For this, a solution of lithium bromide salt in water is used to absorb the water vapor. Lithium bromide has a high affinity for water, and will absorb it in large quantities under the right conditions. The removal of the refrigerant vapor by absorption keeps the machine pressure low enough for the cooling vaporization to continue. However, this process dilutes the solution and reduces its absorption capacity. Therefore the diluted lithium bromide solution is pumped to separate vessels where it is heated to release (boil off) the previously absorbed water. Relatively cool condensing water from a cooling tower or other source removes enough heat from this vapor to condense it again into liquid for reuse in the cooling cycle. The reconcentrated lithium bromide solution is returned to the original vessel to continue the absorption process.

**Double-Effect Reconcentration** — The 16JT reconcentrates solution in 2 stages to improve the operating efficiency. Approximately half of the diluted solution is pumped to a high-temperature vessel (high stage) where it is heated directly from high-pressure steam for reconcentration. The other half of the solution flows to a low-temperature vessel (low stage) where it is heated for reconcentration by hot water vapor released in the high-temperature vessel. The low stage acts as the condenser for the high stage, so the heat energy first applied in the high-stage vessel is used again in

the low-stage vessel. This cuts the heat input to almost half of that required for an absorption chiller with a single reconcentrator.

**Machine Construction** — The major sections of the machine are contained in several vessels (Fig. 1 - 6, and Table 1).

The large lower shell contains the evaporator and absorber sections. The evaporator and absorber are positioned side by side in units 16JT810-880, but the evaporator is positioned above the absorber in units 16JT080-150, 080L-150L. In the evaporator section, the refrigerant water vaporizes and cools the chilled water for the air conditioning or cooling process. In the absorber, vaporized water from the evaporator is absorbed by lithium bromide solution.

The smaller vessel above the evaporator/absorber assembly is the high-stage generator. Here, approximately half of the diluted solution from the absorber is heated and reconcentrated to recover slightly over half of the water previously absorbed.

The other shell above the evaporator/absorber assembly contains the low-stage generator and condenser. The other half of the diluted solution is heated and reconcentrated in the low-stage generator by high temperature water vapor from the high-stage generator. The water vapor released from the solution in this process is condensed to liquid in the condenser section.

This chiller also has: two solution heat exchangers and a steam condensate heat exchanger to improve operating economy; an external purge system to maintain machine vacuum by the removal of noncondensables; hermetic pumps to circulate the solution and refrigerant; and various operational, capacity, and safety devices to provide automatic, reliable machine performance.

**Table 1 — 16JT Description**

UNIT 16JT	ABSORBER/ EVAPORATOR	SOLUTION PUMPS	PURGE POINTS AND EDUCTORS
810-854	Side-by-side	1	1
857,865	Side-by-side	1	2
873,880	Side-by-side	2	2
080-120	Over-and-under	2	4
135, 150	Over-and-under	2 or 3	4
080L-120L	Over-and-under	2	4
135L,150L	Over-and-under	2 or 3	4

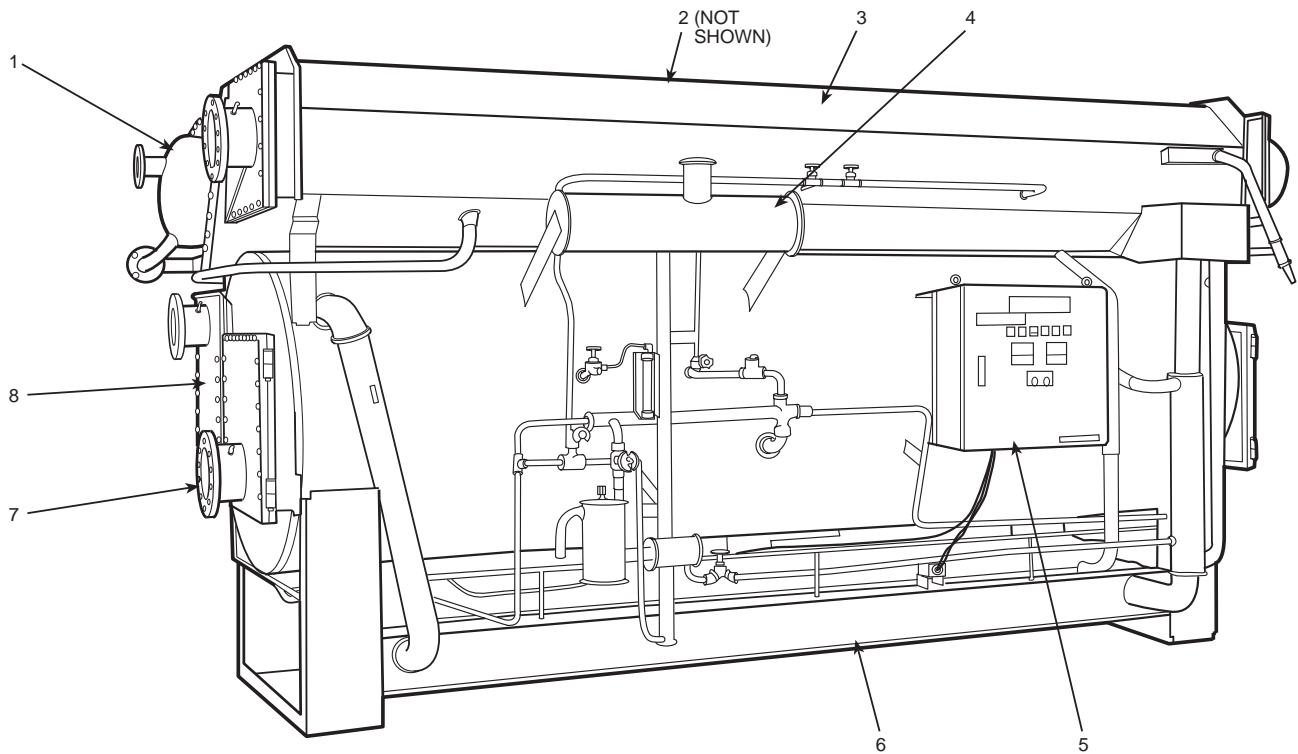

LEGEND

- |                           |                             |
|---------------------------|-----------------------------|
| 1 — High-Stage Generator  | 5 — Control Panel           |
| 2 — Low-Stage Generator   | 6 — Solution Heat Exchanger |
| 3 — Condenser             | 7 — Absorber                |
| 4 — Purge Storage Chamber | 8 — Evaporator              |

**Fig. 1 — Typical Machine Components, 16JT810-880**

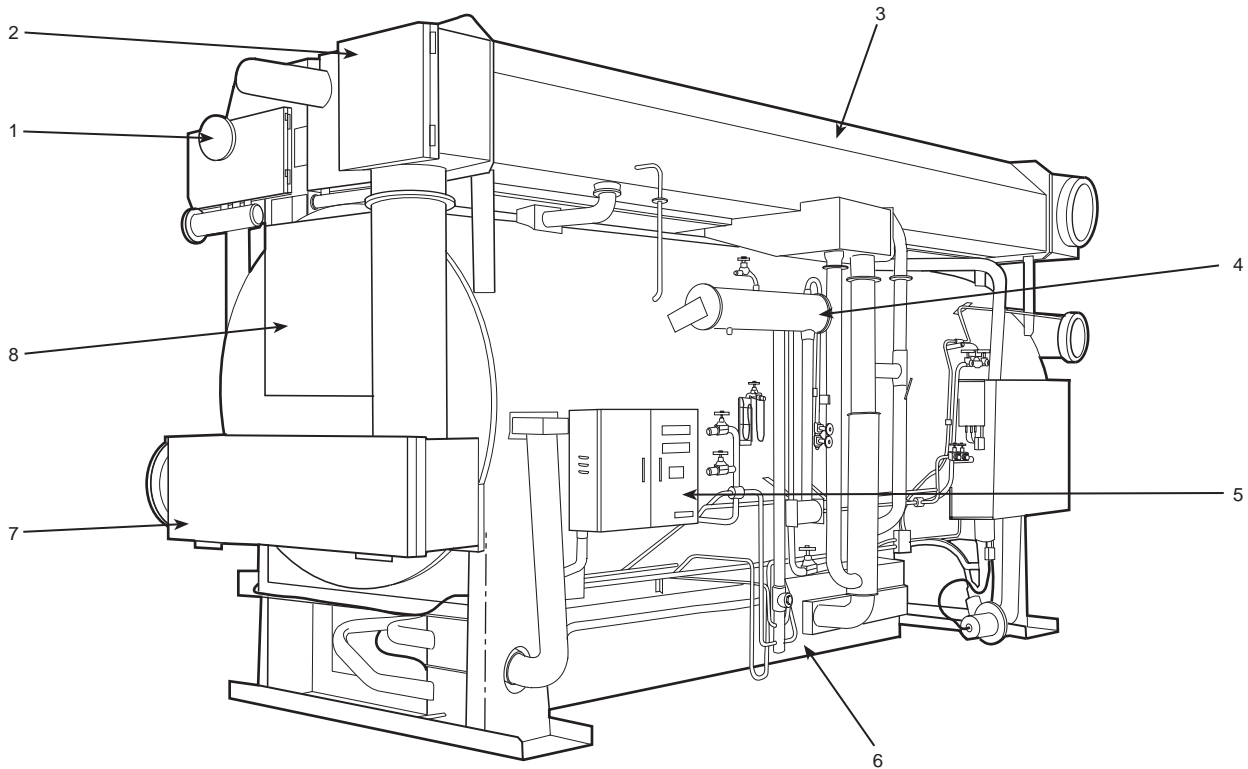

LEGEND

- |                           |                             |
|---------------------------|-----------------------------|
| 1 — High-Stage Generator  | 5 — Control Panel           |
| 2 — Low-Stage Generator   | 6 — Solution Heat Exchanger |
| 3 — Condenser             | 7 — Absorber                |
| 4 — Purge Storage Chamber | 8 — Evaporator              |

**Fig. 2 — Typical Machine Components, 16JT080-150, 080L-150L**

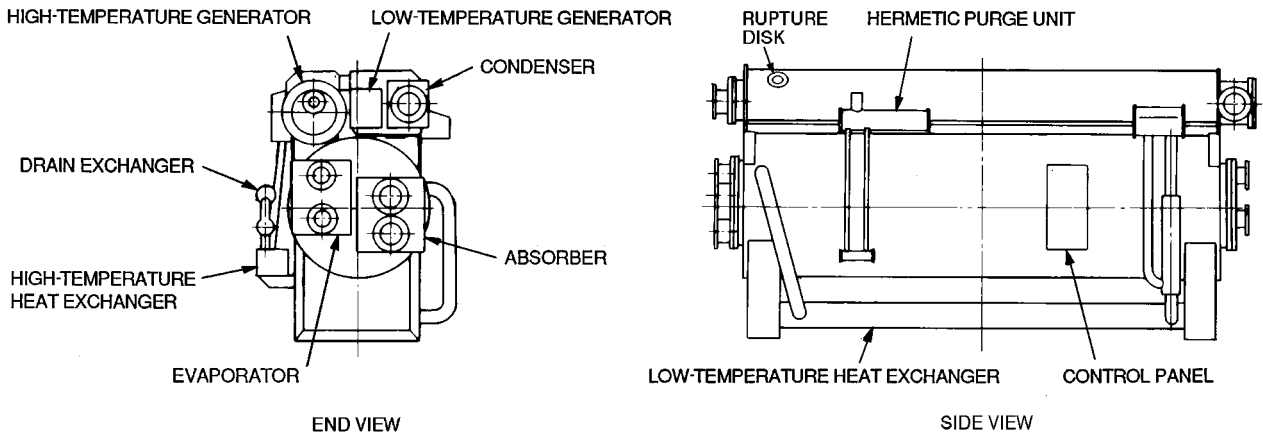

**Fig. 3 — 16JT810-880 Machine Components, External Schematic (Typical)**

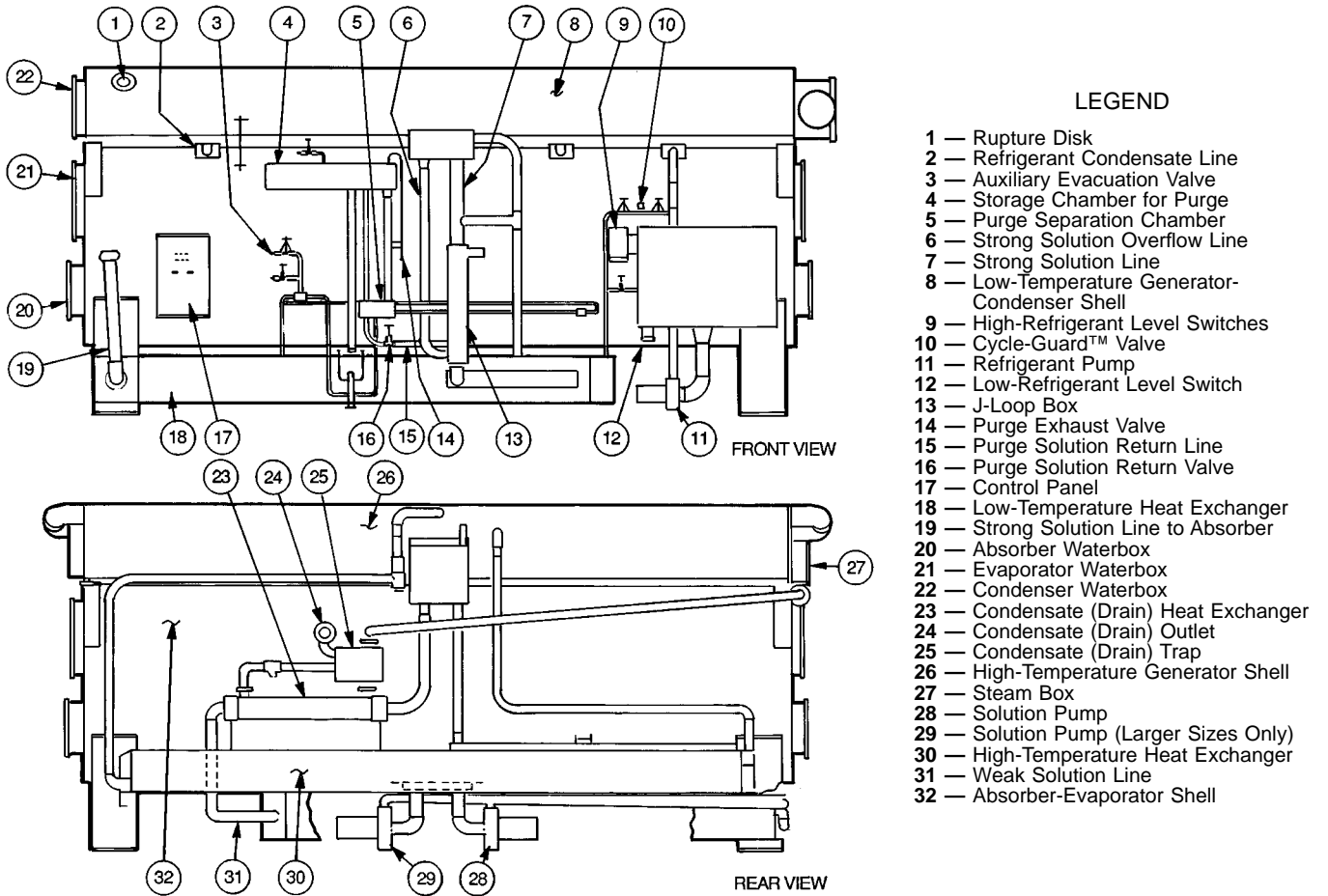

**Fig. 4 — 16JT080-150 and 16JT080L-150L Machine Components, External Schematic (Typical)**

**Flow Circuits** — Figures 5 and 6 illustrate the basic flow circuits of the 16JT absorption chiller.

The liquid to be chilled is passed through the evaporator tube bundle and is cooled by the evaporation of refrigerant water sprayed over the outer surface of the tubes by the recirculating refrigerant pump. The refrigerant vapors are drawn into the absorber section and are absorbed by the lithium bromide-water solution sprayed over the absorber tubes. The heat picked up from the chilled liquid is transferred from the absorbed vapor to cooling water flowing through the absorber tubes.

The solution in the absorber becomes diluted as it absorbs water, and loses its ability to continue the absorption. It is then transferred by the solution pump to the generator sections to be reconcentrated. Approximately half of the weak (diluted) solution goes to the high-stage generator where it is heated directly by high-pressure steam to boil out its absorbed water. This vapor passes to the low-stage generator tubes. In the low-stage generator, the rest of the weak solution is heated by the high-temperature vapor from the high-stage generator, to boil out its absorbed water.

This water vapor from the low-stage generator solution passes into the condenser section and condenses on tubes containing cooling water. This is the same cooling water which had just flowed through the absorber tubes. The condensed high-temperature water from the low-stage generator tubes also passes over the condenser tubes where it is

cooled to the condenser temperature. The combined condensed refrigerant liquid from the two generators now flows back to the evaporator to begin a new refrigerant cycle.

The strong (reconcentrated) solution flows from the two generators back to the absorber spray headers to begin a new solution cycle. On the way, it passes through solution heat exchangers where heat is transferred from the hot, strong solution to the cooler, weak solution being pumped to the generators. Solution to and from the high-stage generator passes through both a high-temperature heat exchanger and a low-temperature heat exchanger. Solution to and from the low-stage generator passes through only the low-temperature heat exchanger, mixed with the high-stage generator solution. This heat transfer improves solution cycle efficiency by preheating the relatively cool, weak solution before it enters the generators, and precooling the hotter, strong solution before it enters the absorber. The efficiency is further improved by transferring heat to the cooler, weak solution from the hot steam condensate in the condensate drain heat exchanger and trap.

The weak solution flowing to the generators passes through a flow control valve which is positioned by a float in the high-stage generator overflow box. The purpose of the valve is to automatically maintain optimum solution flow to the two generators at all operating conditions for maximum efficiency.

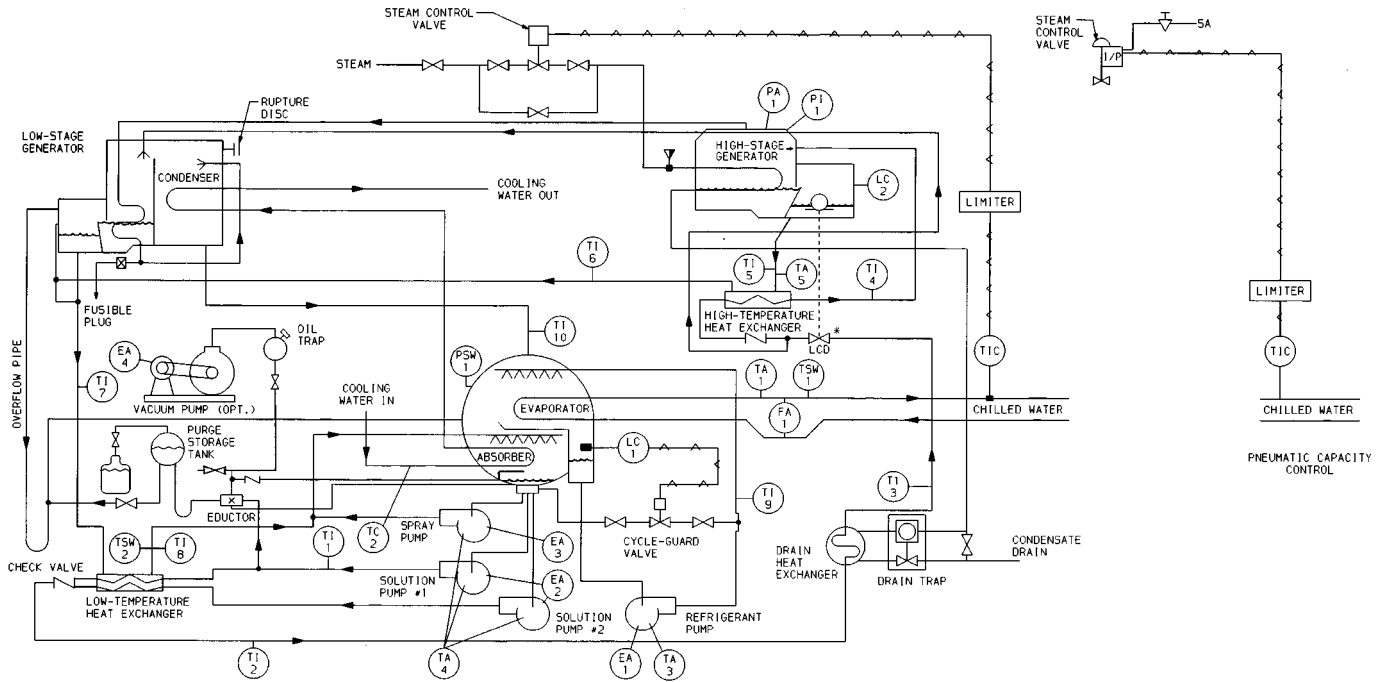

**LEGEND**

- EA — Refrigerant Pump Overload Cutout
- EA1 — Refrigerant Pump Overload Cutout
- EA2 — Solution Pump Overload Cutout
- EA3 — Solution Spray Pump Motor Overload Cutout
- EA4 — Vacuum Pump Motor Overload
- FA1 — Chilled Water Low-Flow Cutout
- I/P — Current/Pneumatic Transducer
- LC — Refrigerant Cutout Level Switches (High, Mid, Low)
- PA1 — High-Pressure Switch (High-Stage Temperature Generator)
- P1 — Compound Gage (High-Temperature Generator)
- PWS1 — Absorber Pressure Switch

- SA — Pneumatic Supply Air
- TA1 — Chilled-Water Low-Temperature Cutout
- TA3 — Refrigerant Pump Motor Coil High-Temperature Cutout
- TA4 — Solution Pump Motor Coil High-Temperature Cutout
- TA5 — Solution High-Temperature Cutout
- TC2 — Cooling Water Temperature Cutout
- TIC — Chilled Water Outlet Temperature Control
- TI 1-4 — Weak Solution Thermometers
- TI 5-8 — Strong Solution Thermometers
- TI 9-10 — Refrigerant Thermometers

- TSW1 — Automatic Start-Stop Thermostat
- TSW2 — Cycle-Guard™ Thermostat
- Control Wiring
- Piping Connections
- Valve

- NOTES:**
1. Spray pump and second solution pump are located on large sizes only.
  2. Vacuum pump is optional.
  3. Electric capacity control is shown. (Pneumatic is optional.)

\*The LCD valve is physically located with the float in the high stage generator overflow box, not where it is schematically shown in the illustration.

**Fig. 5 — Typical Flow Circuits, with Data Points, Shown for 16JT080-150,080L-150L Arrangements**

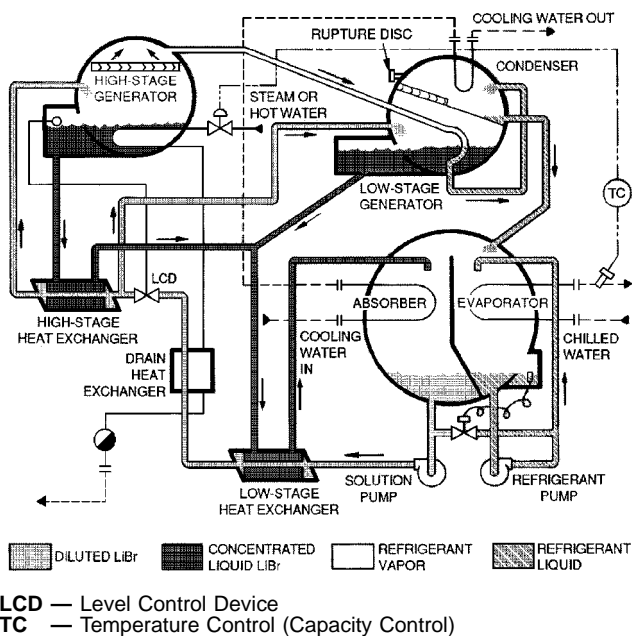

**Fig. 6 — Typical Flow Circuits, (Simplified) Arrangement Shown for 16JT810-880**

During high load operation, some abnormal conditions can cause the lithium bromide concentration to increase above normal, with the strong solution concentration close to crystallization (see Equilibrium Diagram and Chiller Solution Cycle.) If, for some reason, the machine controls do not prevent strong solution crystallization during abnormal operating conditions and flow blockage does occur, the strong-solution overflow pipe will reverse or limit the crystallization until the cause can be corrected. The overflow pipe is located between the low-temperature generator discharge box and the absorber, bypassing the heat exchanger, as shown in Fig. 5.

If crystallization occurs, it generally takes place in the shell side of the low-temperature heat exchanger, blocking the flow of strong solution from the generator. The strong solution then backs up in the discharge box and spills over into the overflow pipe, which returns it directly to the absorber sump. The solution pump then returns the hot solution through the heat exchanger tubes, automatically heating and decrystallizing the shell side.

**Equilibrium Diagram and Chiller Solution Cycle** — The solution cycle can be illustrated by plotting it on a basic equilibrium diagram for lithium bromide in solution with water (Fig. 7). The diagram is also used for performance analyses and troubleshooting.

The left scale on the diagram indicates solution and water vapor pressures at equilibrium conditions. The right scale indicates the corresponding saturation (boiling or condensing) temperatures for both the refrigerant (water) and the solution.

The bottom scale represents solution concentration, expressed as percentage of lithium bromide by weight in solution with water. For example, a lithium bromide concentration of 60% means 60% lithium bromide and 40% water by weight.

The curved lines running diagonally left to right are solution temperature lines (not to be confused with the horizontal saturation temperature lines). The single curved line beginning at the lower right represents the crystallization line. The solution becomes saturated at any combination of temperature and concentration to the right of this line, and it will begin to crystallize (solidify) and restrict flow.

The slightly sloped lines extending from the bottom of the diagram are solution-specific gravity lines. The concentration of a lithium bromide solution sample can be determined by measuring its specific gravity with a hydrometer and reading its solution temperature. Then, plot the intersection point for these 2 values and read straight down to the percent lithium bromide scale. The corresponding vapor pressure can also be determined by reading the scale straight to the left of the point, and its saturation temperature can be read on the scale to the right.

**PLOTTING THE SOLUTION CYCLE** — An absorption solution cycle at typical full load conditions is plotted in Fig. 7 from Points 1 through 13. The corresponding values for these typical points are listed in Table 2. Note that these values will vary with different loads and operating conditions.

**Point 1** represents the strong solution in the absorber, as it begins to absorb water vapor after being sprayed from the absorber nozzles. This condition is internal and cannot be measured.

**Point 2** represents the diluted (weak) solution after it leaves the absorber and before it enters the low-temperature heat exchanger. This includes its flow through the solution pump. This point can be measured with a solution sample from the pump discharge.

**Point 3** represents the weak solution leaving the low-temperature heat exchanger. It is at the same concentration as Point 2, but at a higher temperature after gaining heat from the strong solution. This temperature can be measured.

**Point 4** represents the weak solution leaving the drain heat exchanger. It is at the same concentration as Point 3, but at a higher temperature after gaining heat from the steam condensate. This temperature can be measured. At this point the weak solution first flows through the level control device (LCD) valve and then it is split, with approximately half going to the low-stage generator, and the rest going on to the high-temperature heat exchanger.

**Point 5** represents the weak solution in the low-stage generator after being preheated to the boiling temperature. The solution will boil at temperatures and concentrations corresponding to a saturation temperature established by the vapor condensing temperature in the condenser. This condition is internal and cannot be measured.

**Point 6** represents the weak solution leaving the high-temperature heat exchanger and entering the high-stage generator. It is at the same concentration as Point 4 but at a higher temperature after gaining heat from the strong solution. This temperature can be measured.

**Point 7** represents the weak solution in the high-stage generator after being preheated to the boiling temperature. The solution will boil at temperatures and concentrations corresponding to a saturation temperature established by the vapor condensing temperature in the low-stage generator tubes. This condition is internal and cannot be measured.

**Point 8** represents the strong solution leaving the high-stage generator and entering the high-temperature heat exchanger after being reconcentrated by boiling out refrigerant. It can be plotted approximately by measuring the temperatures of the leaving strong solution and the condensed vapor leaving the low-stage generator tubes (saturation temperature). This condition cannot be measured accurately.

**Point 9** represents the strong solution from the high-temperature heat exchanger as it flows between the two heat exchangers. It is the same concentration as Point 8 but at a cooler temperature after giving up heat to the weak solution. The temperature can be measured on those models which have separate solution heat exchangers.

Point 10 represents the strong solution leaving the low-stage generator and entering the low-temperature heat exchanger. It is at a weaker concentration than the solution from the high-stage generator, and can be plotted approximately by measuring the temperatures of the leaving strong solution and vapor condensate (saturation temperature). This condition cannot be measured accurately.

Point 11 represents the mixture of strong solution from the high-temperature heat exchanger and strong solution from the low-stage generator as they both enter the low-temperature heat exchanger. The temperature can be measured on those models which have separate solution heat exchangers.

Point 12 represents the combined strong solution before it leaves the low-temperature heat exchanger after giving up heat to the weak solution. This condition is internal and cannot be measured.

Point 13 represents the strong solution leaving the low-temperature heat exchanger and entering the absorber spray nozzles, after being mixed with some weak solution in the heat exchanger. The temperature can be measured, but the concentration cannot be sampled. After leaving the spray nozzles, the solution is somewhat cooled and concentrated as it flashes to the lower pressure of the absorber, at Point 1.

**Table 2 — Typical Full Load Cycle Equilibrium Data**

POINT	SOLUTION TEMPERATURE		VAPOR PRESSURE		SOLUTION PERCENTAGE (Lithium Bromide)	SATURATED TEMPERATURE	
	F	C	in. Hg	mm Hg		F	C
1	110	43	0.24	6	62.2	40	4
2	95	35	0.24	6	58.0	40	4
3	149	65	1.10	29	58.0	83	28
4	160	71	1.50	39	58.0	93	34
5	167	75	2.00	50	58.0	100	38
6	277	136	19.00	490	58.0	191	88
7	289	143	24.00	600	58.0	200	93
8	318	159	24.00	600	63.6	200	93
9	167	75	1.10	28	63.6	82	28
10	180	82	2.00	49	61.3	100	38
11	176	80	1.60	40	62.2	93	34
12	117	47	0.31	8	62.2	46	8
13	111	44	0.28	7	61.5	43	6

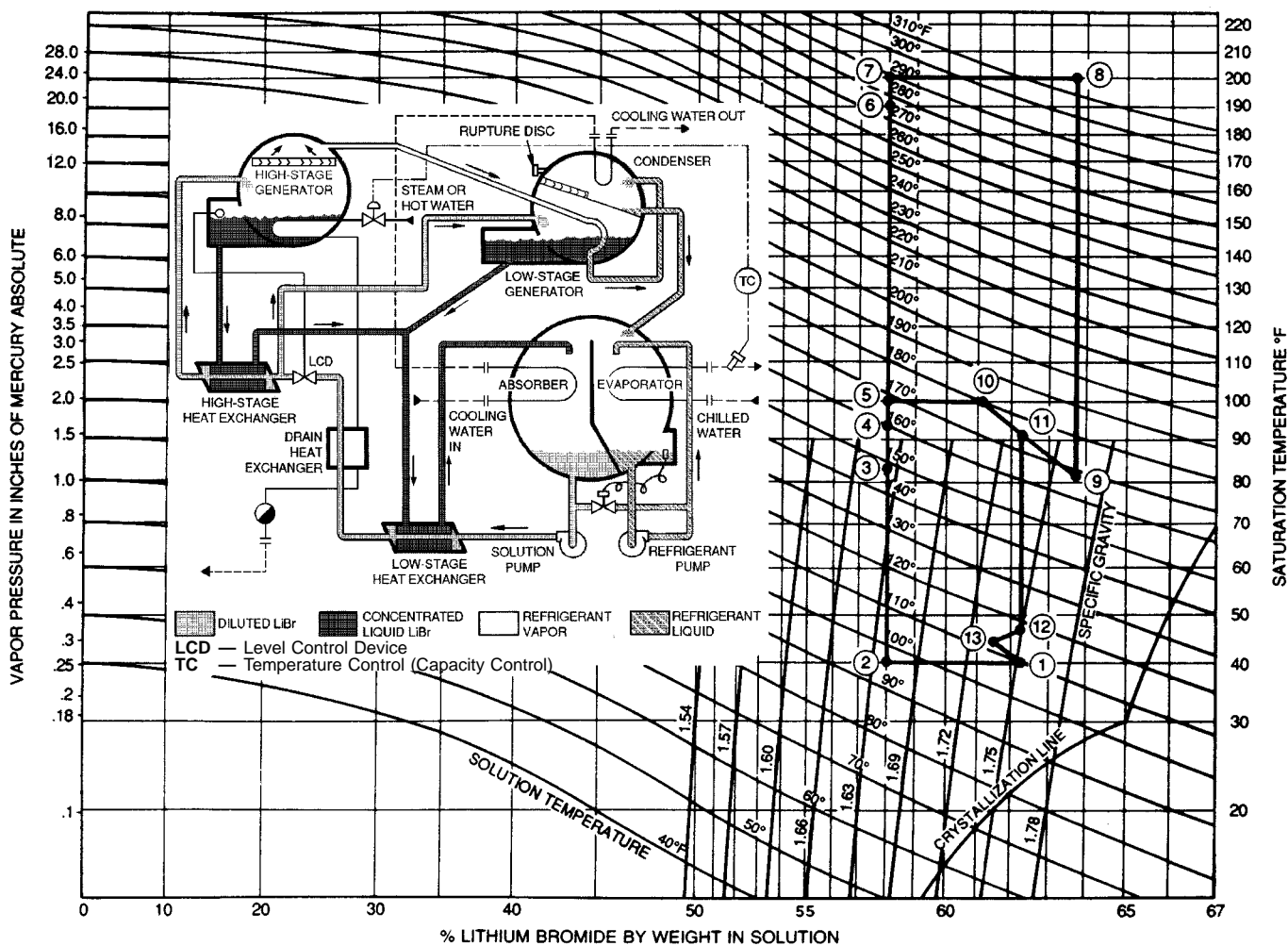

**Fig. 7 — Equilibrium Diagram and Chiller Solution Cycle**

**Purge System** — The basic components and flow circuits of the motorless purge are shown in Fig. 8 and 9.

The purge system automatically removes noncondensables from the machine and transfers them to a storage chamber where they cannot affect machine operation. Noncondensables are gases such as N<sub>2</sub>, O<sub>2</sub>, and H<sub>2</sub> which will not condense at the normal chiller operating temperatures and pressures and, because they reduce the machine vacuum, they reduce the machine capacity.

Some hydrogen (H<sub>2</sub>) gas is liberated within the machine during normal operation and its rate of generation is controlled by the solution inhibitor. The presence of most other gases in the machine would occur either through a leak (the machine is under a deep vacuum) or by entrainment in the refrigerant and solution at initial charging. During operation, any noncondensables accumulate in the absorber, which is the lowest pressure area of the machine.

For purging, the gases are continuously drawn from the absorber into the lower pressure of eductors, where they are entrained in solution flowing from the solution pump. The mixture then continues on to the purge storage tank. The noncondensables are released in a separator and the solution flows back to the absorber by way of the generator overflow pipe.

Noncondensables accumulate in the purge storage tank where they are isolated from the rest of the machine. The storage chamber is initially filled with solution that is displaced as the chamber gradually fills with noncondensables. These gases then must be periodically exhausted from the storage chamber by a manual procedure. This is begun by closing a solution return valve to force solution from the pump into the chamber to compress the noncondensables to above atmospheric pressure. Then an exhaust valve is opened to bleed the noncondensables to the atmosphere through solution in an exhaust bottle. This operation is described in the Maintenance Procedures, Purge Manual Exhaust Procedure section, page 31.

Some chillers also have an optional, permanently installed vacuum pump system (as shown in Fig. 5) to remove noncondensables directly from the absorber for machine evacuation at initial start-up and after service work.

The pump is wired into the chiller control circuit for power.

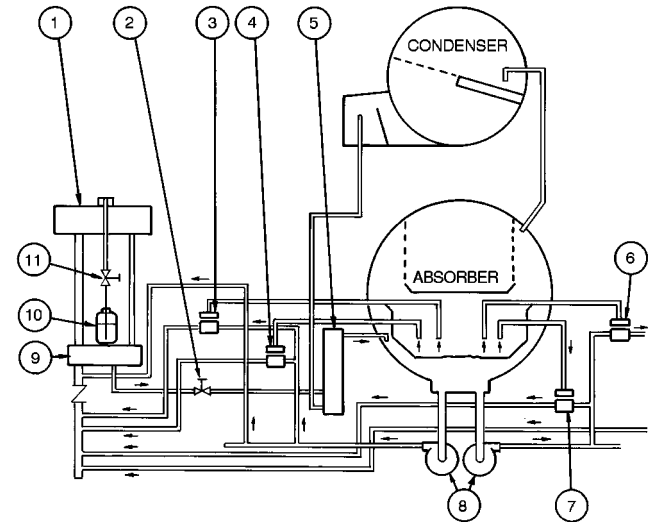

**LEGEND**

- |                           |                             |
|---------------------------|-----------------------------|
| 1 — Storage Chamber       | 7 — Eductor                 |
| 2 — Solution Return Valve | 8 — Hermetic Solution Pumps |
| 3 — Eductor               | 9 — Separation Chamber      |
| 4 — Eductor               | 10 — Exhaust Bottle         |
| 5 — J-Loop Box            | 11 — Exhaust Valve          |
| 6 — Eductor               |                             |

NOTE: Number of eductors varies from one on smaller sizes to 4 on larger sizes.

**Fig. 9 — Purge System, 16JT080-150, 080L-150L**

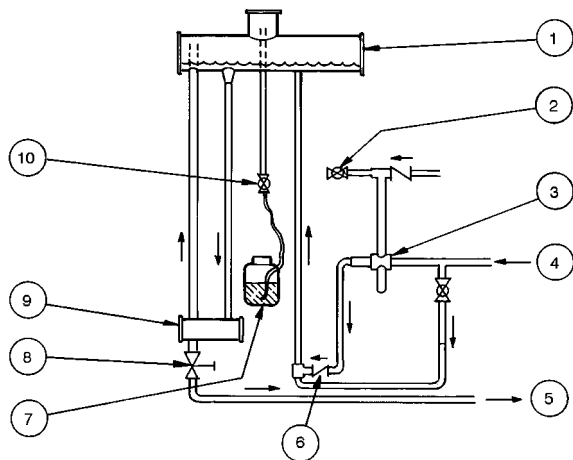

**LEGEND**

- |                                    |                                |
|------------------------------------|--------------------------------|
| 1 — Storage Chamber                | 6 — Check Valve                |
| 2 — Auxiliary Valve                | 7 — Exhaust Liquid Seal Bottle |
| 3 — Eductor Device                 | 8 — Solution Return Valve      |
| 4 — Solution from Solution Pump    | 9 — Separation Chamber         |
| 5 — Solution Returning to Absorber | 10 — Exhaust Valve             |

**Fig. 8 — Purge System, 16JT810-880**

## MACHINE CONTROLS

**Start-Stop Systems** — The type of start-stop system is selected by the customer. The most commonly used systems are described below. Review the descriptions and determine which type applies to your system.

**SEMI-AUTOMATIC START-STOP** — In this basic system, auxiliary equipment is wired into the machine control circuit and the machine is started and stopped manually with the machine's Start and Stop buttons. Two variations are used:

**With Pilot Relays** — The coils for the chilled water and condensing water pump starters (or other auxiliary equipment) are wired into the machine control circuit so that the auxiliary equipment operates whenever the machine operates. The starter contacts and starter overloads remain in the external pump circuits. The flow interlocks for each pump are also wired into the machine control circuit and must be closed in order for the machine to operate.

**With Manual Auxiliaries** — With this system, the auxiliaries must be started manually and independently from the machine start, and they must be operating before the machine can start. As with the pilot relay system above, the

flow interlocks are in the machine control circuit and must be closed for the machine to operate.

**FULL AUTOMATIC START-STOP** — This system is basically the same as the semi-automatic system with pilot relays described above. Machine and auxiliary start and stop, however, are controlled by a field-supplied thermostat, timer, or other automatic device, and the machine Start and Stop manual switch and indicator lights remain in the START mode.

As with all the Start-Stop systems, the machine's Start button must be depressed and released on initial start, and after power interruption. After an abnormal shutdown, the Stop button must be depressed to reset the circuit and silence the alarm buzzer before depressing Start.













**Control Wiring** — See Fig. 10 and 11 for typical wiring schematics and component identification.

NOTE: These schematics do not show all the options or variations that are available.

**Control Panel** — The control panel includes the controller, switches, pilot lights, and relays that operate the machine (Fig. 12 and 13).

### LEGEND FOR FIGURES 10 AND 11

1X1,2	—	Start-Stop Relays
1Y1,2	—	Shutdown Dilution Relays
2X	—	Run Relay
2T1	—	Time Delay Relay, Chilled Water Flow
3-1	—	Manual Start Switch Button
3-5	—	Manual Stop Switch Button
3-BZ	—	Alarm Buzzer Stop Button
3-VP	—	Manual Vacuum Pump On-Off Buttons
3X	—	Auto Start Relay
4X	—	Safety Device Relay
4Y	—	Safety Interlock Relay
20RV	—	Cycle-Guard™ Valve
23C	—	Low Load Limit Switch
26CW	—	Low Chilled Water Temperature Limit
26GH	—	Generator Solution High-Temperature Limit
26MX	—	Hermetic Pump Fault Relay
26RP	—	Refrigerant Pump Motor High-Temperature Limit
26SH	—	Absorber Solution High-Temperature Limit
26SP1	—	Solution Pump No. 1 Motor High-Temperature Limit
26SP2	—	Solution Pump No. 2 Motor High-Temperature Limit
26SSP	—	Solution Spray Pump Motor High-Temperature Limit
30X1,2	—	Safety Stop Interlock Relays
33RD	—	Refrigerant Dilution Level Switch
33RH	—	Refrigerant High-Level Switch
33RHX	—	Refrigerant High-Level Relay
33RL	—	Refrigerant Low-Level Switch
33RM	—	Refrigerant Mid-Level Switch
33RMX	—	Dilution Level Control Relay
33W	—	Generator Level Control Relay
43R	—	Remote-Local Switch
43RV	—	Cycle-Guard Auto.-Manual Selector Switch
51CP	—	Condensing Water Pump Overload
51CT	—	Cooling Tower Fan Overload
51EP	—	Chilled Water Pump Overload
51RP	—	Refrigerant Pump Overload Relay
51SP-1	—	Solution Pump No. 1 Overload Relay
51SP-2	—	Solution Pump No. 2 Overload Relay (Larger Sizes Only)
51SSP	—	Solution Spray Pump Overload Relay (Some Larger Chillers)
51VP	—	Vacuum Pump Overload Relay (Optional)
62T1	—	Time Delay Relay, Shutdown Dilution
62T2	—	Time Delay Relay, Refrigerant Pump Start-Stop
62T3	—	Time Delay Relay, Capacity Control Soft Start
62T6	—	Time Delay Relay, Solution Pump Start-Stop
63GH	—	Generator High-Pressure Limit
63GX	—	Generator Fault Relay
69CW	—	Low-Chilled Water Flow Switch
88EP	—	Chilled Water Pump Starter
88CP	—	Condensing Water Pump Starter
88CT	—	Cooling Tower Fan Starter
88RP	—	Refrigerant Pump Starter
88SP-1	—	Solution Pump No. 1 Starter
88SP-2	—	Solution Pump No. 2 Starter (Larger Chillers Only)
88SSP	—	Solution Spray Pump Starter (Some Larger Chillers)

88VP	—	Vacuum Pump Starter (Optional)
ABS	—	Absorber Pressure Switch
ABSX	—	Absorber Pressure Switch Relay
BZ	—	Alarm Buzzer
BZX	—	Alarm Buzzer Relay
CWX	—	Low Water Flow or Temperature Fault Relay
HM	—	Hour Meter
LIX	—	Load Limiter Relay
MCB	—	Main Circuit Breaker
RTD	—	Temperature Sensor
RY1	—	Auxiliary System Run Relay
T1,T2	—	Water Pump Time Delay Relay
TIC	—	Temperature Indicating Capacity Controller
TR	—	Transformer
Z	—	Surge Suppressor
	—	Terminals on Control Panel Terminal Strip
	—	Component Connection (Unmarked)
	—	Component Connection (Marked)
	—	External Terminal
	GL	— Run Light
	OL1	— Low Water Flow or Temperature Alarm Light
	OL2	— Hermetic Pump Fault Alarm Light
	OL3	— Generator Fault Alarm Light
	OL4	— Vacuum Pump Fault Alarm Light
	RL	— Stop Light
	WL1	— Shutdown Dilution On Light
	WL2	— High-Refrigerant Level Light

### NOTES FOR FIG. 10

- The following items are not by Carrier:
  - Chilled water pump, condensing water pump starters and disconnects
  - Rigid or flexible conduit and junction boxes for wire and piping; coded, except as noted
- Solution and refrigerant pump starters are across-the-line definite purpose type.

- Solution and refrigerant pump motors are hermetic, 3-phase and operate  $\pm 10\%$  of rated voltage.

Rated Voltage	Hz (Cycle)
200/220	60
400/440	60
575	60

- Controls are for 1-phase, 60 Hz, 110 v. The maximum permissible current rating which all holding relays have is 12 amps inrush, 3 amps continuous, and 0.8 amps interruption. Make sure that the wiring does not exceed above values.





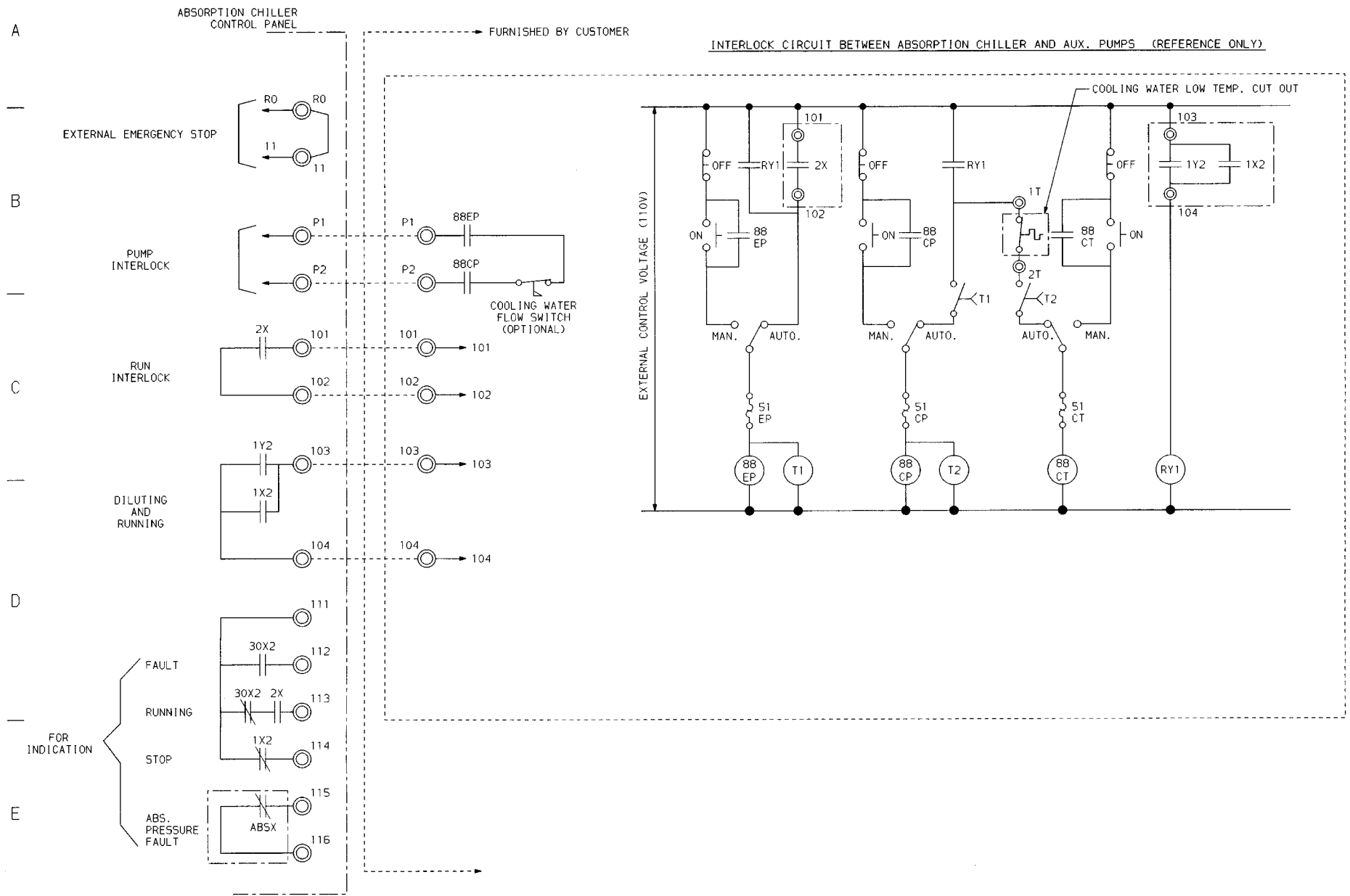

13

Fig. 11 — Typical Control Wiring

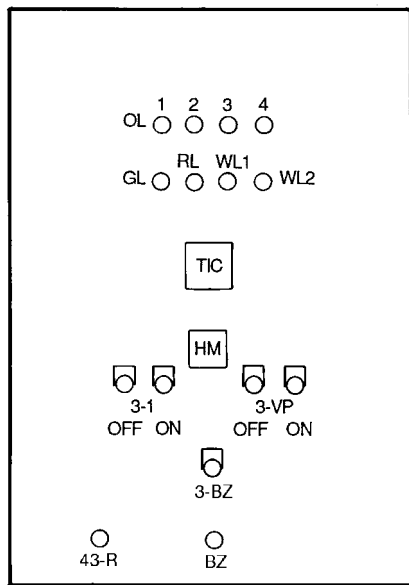

- 3-1 (ON) — Start Chiller
- 3-1 (OFF) — Stop Chiller
- 3-BZ — Buzzer Silencer
- BZ — Alarm Buzzer
- 3-VP (ON) — Optional Start Vacuum Pump
- 3-VP (OFF) — Optional Stop Vacuum Pump
- 43-R — Remote Local Switch
- GL — Chiller Running Lamp
- HM — Running Hour Meter
- OL1 — Low Flow, Low Chilled Water Temperature Lamp
- OL2 — Hermetic Pump Fault Lamp
- OL3 — Generator Fault Lamp
- OL4 — Optional Vacuum Pump Fault Lamp
- RL — Chiller Stopped Lamp
- TIC — Temperature Indicating Controller
- WL1 — Refrigerant High Level Lamp
- WL2 — Dilution Operation Lamp

**Fig. 12 — Typical Control Panel Door**

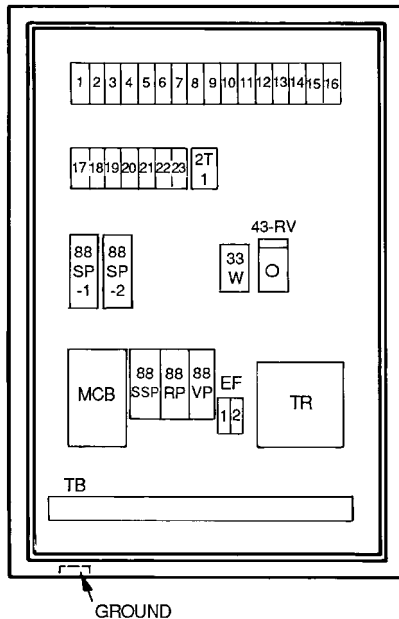

- LEGEND
- 1-23 — Auxiliary Relays
  - 2T1 — Time Delay Relay
  - 33W — Generator Level Control Relay
  - 43-RV — Cycle-Guard Auto. Man.
  - 88RP — Refrigerant Pump Starter
  - 88SP1 — Solution Pump Starter, No. 1
  - 88SP2 — Solution Pump Starter, No. 2 (Large Sizes Only)
  - 88SSP — Solution Spray Pump Starter (Some Larger Sizes Only)
  - 88VP — Optional Vacuum Pump Starter
  - EF1,2 — Fuses
  - MCB — Main Circuit Breaker
  - TB — Field Wiring Terminals
  - TR — Transformer

**Fig. 13 — Typical Control Panel Components Arrangement**

### Typical Control Sequence, Normal Start (Fig. 10 and 14)

1. When power is supplied to the chiller control panel and the chiller is not in operation, the Stop light (RL) is on.
2. To start up machine, the Cycle-Guard™ switch (43-RV) should be placed in the AUTO. position.

When the Start button is depressed, start relay (3X) latches the ready state. If the Local/Remote switch is in the local position, the Run light (GL) also goes on and the run relay (2X) energizes to start the chiller. If the switch is in the remote position, the Run light will go on and 2X will start the chiller only when the remote control start contacts close.

The run relay (2X) also starts the chilled water pump if it is tied into the chiller control circuit for auto. start/stop and its water pump safety contacts are closed.

3. If the low load contacts (23C) in the temperature controller are closed with a demand for cooling, the start relays (1X1 and 1X2) are energized to turn off the Stop light (RL) and lock out the shutdown dilution function (62T1). Relay 1X2 also starts the cooling water pump and cooling tower fan if they are tied into the chiller control circuit for auto. start/stop and their interlocks and safeties are closed.
4. When the chilled water flow switch (69CW) closes, the pump interlock timer (2T1) energizes and closes its contacts in about 2 seconds. If, at that time, the chilled water and cooling water pump contacts (88EP and 88CP), and the low-chilled water temperature safety (26CW) are all closed, the system water pump safety interlock relay (CWX) is energized.

When the absorber pressure switch relay (ABSX), machine pump safeties (26MX), and 1X1 contacts are also closed, interlock relays (1Y1 and 1Y2) are energized for self-latching and for normal operation of the refrigerant and solution pumps, generator level control, and Cycle-Guard operation.

5. If the safeties for the generator conditions (63GX) are also closed, the safety device relay (4X) energizes to latch in the safety interlock relay (4Y), and to lock out the safety stop relays (30X1 and 30X2), and the alarm buzzer (BZ). The 4X relay also switches the Cycle-Guard valve (20RV) to automatic level switch control, and releases the capacity control valve from the closed position. However, the load limiter relay (LIX) is initially deenergized, keeping the valve at a mid-open position for a soft start. After about 15 minutes, time delay relay 62T3 contacts close to energize LIX, releasing the capacity control valve to normal full range control, unless LIX remains deenergized by the open contacts of the high refrigerant level relay (33RHX).

If the solution level in the high-stage generator is not too high for normal operation, as determined by the level control electrode and relay (33W), the generator pump(s) (88SP) starts when 1Y2 closes. If it is too high, the pump(s) will start after the generator solution has fallen to a normal level.

If the evaporator refrigerant level is above the low-level safety switch (33RL) when start relay 1X1 is energized, the refrigerant pump start delay timer (62T2) energizes. After approximately 5 minutes, the refrigerant pump (88RP) starts if 1Y2 is also closed. If the evaporator level is too low, the timer is not energized until the generator can concentrate the solution enough to raise the refrigerant level above the low-level switch.

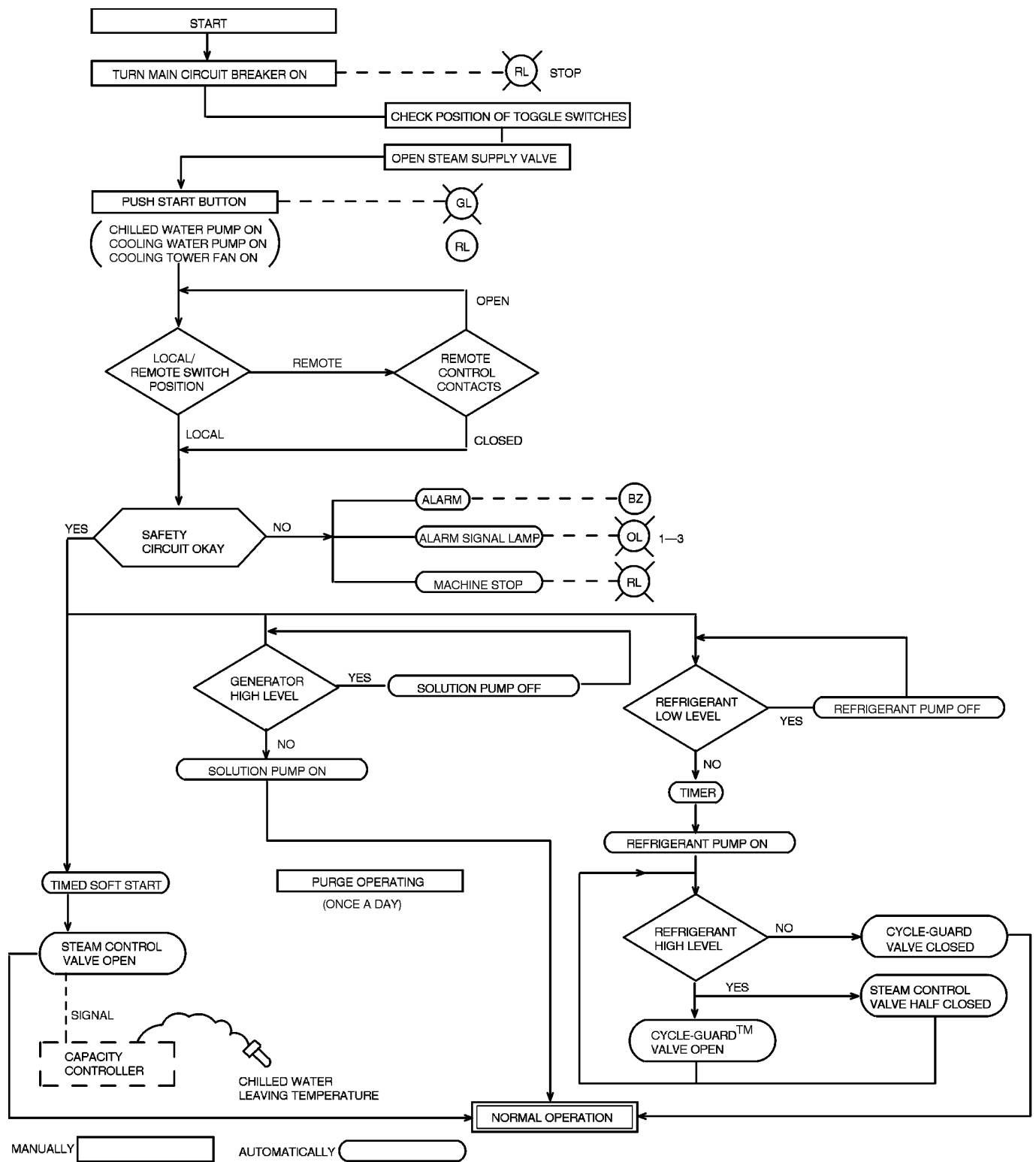

LEGEND

- BZ — Alarm Buzzer
- GL — Run Light
- OL1 — Chilled and Cooling Water Fault Indicator Light
- OL2 — Refrigerant and Solution Pump Fault Indicator Light
- OL3 — High-Stage Generator Fault Indicator Light
- RL — Stop Light

Fig. 14 — Typical Control Sequence, Normal Start

## Typical Control Sequence, Normal Stop (Fig. 10 and 15)

1. If the Local Remote switch is in the remote position, the shutdown sequence begins when the remote control contacts open. The run relay (2X) deenergizes, and the Run light (GL) is turned off, ready for auto restart. When the machine Stop button is depressed, with the Local/Remote switch in either position, the start relay (3X) and run relay (2X) are deenergized, and the Run light (GL) is turned off.
2. Start relays (1X1 and 1X2) deenergize to begin the shutdown sequence, and alarm latching relay (4Y) de-energizes to lock out the alarm shutdown relays (30X1 and 30X2). Normally closed 1X1 contacts turn the Stop light (RL) on.
3. Normally open 1X2 contacts deenergize the safety device relay (4X) and timer 62T3. This deenergizes LIX and normally open 4X contacts drive the capacity control valve to the closed position.
4. Other normally closed 1X1 contacts start the shutdown dilution timer (62T1) and illuminate the Dilution light

(WL1). When 4X relay deenergizes, its normally closed contacts energize the Cycle-Guard™ valve to transfer refrigerant into the solution for dilution. The refrigerant pump and Cycle-Guard valve continue to be energized until the evaporator refrigerant drops to the dilution level switch, which opens to deenergize the refrigerant pump delay-start timer (62T2). The normally open timer contacts then stop the Cycle-Guard valve and refrigerant pump. (Normally open 1X1 contacts transferred control of the 62T2 timer from the evaporator low-level switch to the dilution level switch when 1X1 was deenergized.)

5. When shutdown timer (62T1) times out after about 15 minutes, its contacts open to deenergize interlock relays (1Y1 and 1Y2). Normally open 1Y1 and 1Y2 contacts unlatch the relays to keep them open, and others open to stop the solution pump(s), as well as the refrigerant pump and Cycle-Guard if they have not already stopped. The chilled water pump, cooling water pump, and cooling tower fan stop if they are tied into the chiller control circuit for auto. start/stop. When 62T1 times out, it also shuts off the Dilution light.

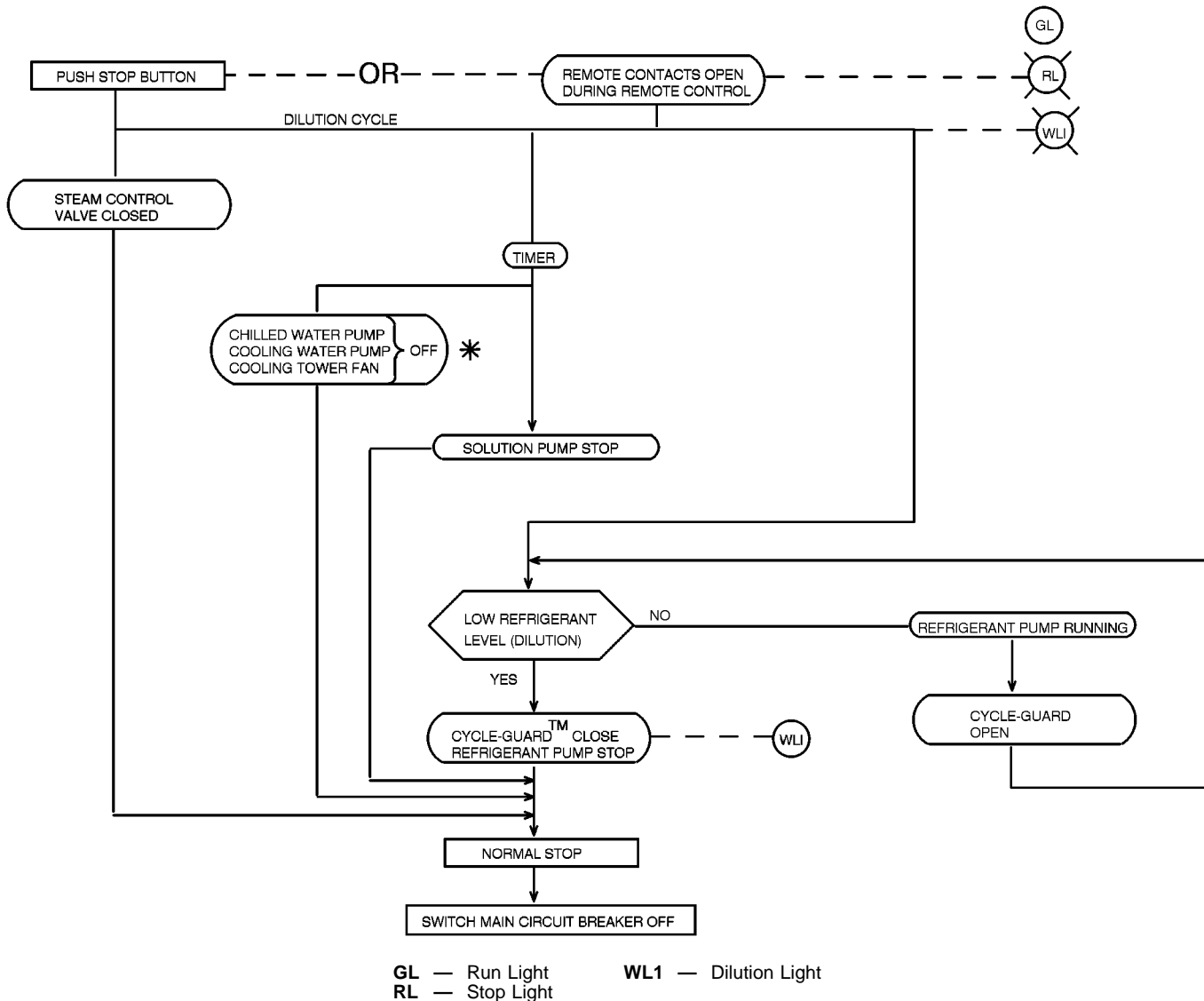

\*When chilled water, cooling water and/or cooling tower fan are not interlocked during auto. start-stop cycle, they must be manually stopped after completion of the dilution cycle.

NOTE: Leave steam supply valve open during auto.-stop.

Fig. 15 — Typical Control Sequence, Normal Stop

## Typical Control Sequence, Abnormal Stop (Fig. 10 and 16)

1. Abnormal shutdown occurs automatically when any of the chiller safety devices sense a condition which might be potentially damaging to the chiller. The safeties are grouped in 4 categories, each with its own fault relay:
  - a. High-temperature generator problems (fault relay 63GX), with shutdown dilution
  - b. Hermetic pump motor high-temperature or overloads (fault relay 26MX), without shutdown dilution
  - c. Water system flow interlocks or low-chilled water temperature (fault relay CWX), without shutdown dilution
  - d. High absorber pressure (ABSX), without shutdown dilution
2. When a safety is activated, its contacts open to de-energize the fault relay for its group. The fault relay's normally closed contacts illuminate the indicator light for groups a, b, or c and normally open contacts deenergize the safety device relay (4X) and timer 62T3. This deenergizes load limiter relay LIX.
3. Normally open 4X contacts drive the capacity control valve to the closed position.
4. Normally closed 4X contacts energize shutdown alarm relays (30X1 and 30X2), and energize the alarm buzzer. These relays remain energized through 4Y self-latching contacts.
5. The 30X1 contacts open to deenergize start relays (1X1 and 1X2). To begin the shutdown sequence, normally closed 1X1 contacts turn the Stop light (RL) on.
6. The 2X run relay remains energized, as does the Run light (GL). If the chilled water pump is tied into the chiller control circuit for auto. start/stop, the 2X relay will keep it running unless it has stopped on its own safety.
- 7a. *If there are problems with high absorber pressure (relay ABSX) or with the hermetic pumps (relay 26MX) or with the cooling or chilled water (relay CWX), interlock relays 1Y1 and 1Y2 immediately deenergize. Normally open 1Y2 contacts immediately stop the solution and refrigerant pumps without shutdown dilution. If the cooling water pump and cooling tower fan are tied into the chiller control circuit for auto. start/stop, then other normally open 1Y2 contacts also stop them.*
- 7b. *For problems with the high-temperature generator (relay 63GX), interlock relays (1Y1 and 1Y2) remain energized to keep all pumps operating. Normally closed 1X1 contacts start the shutdown dilution timer (62T1).*

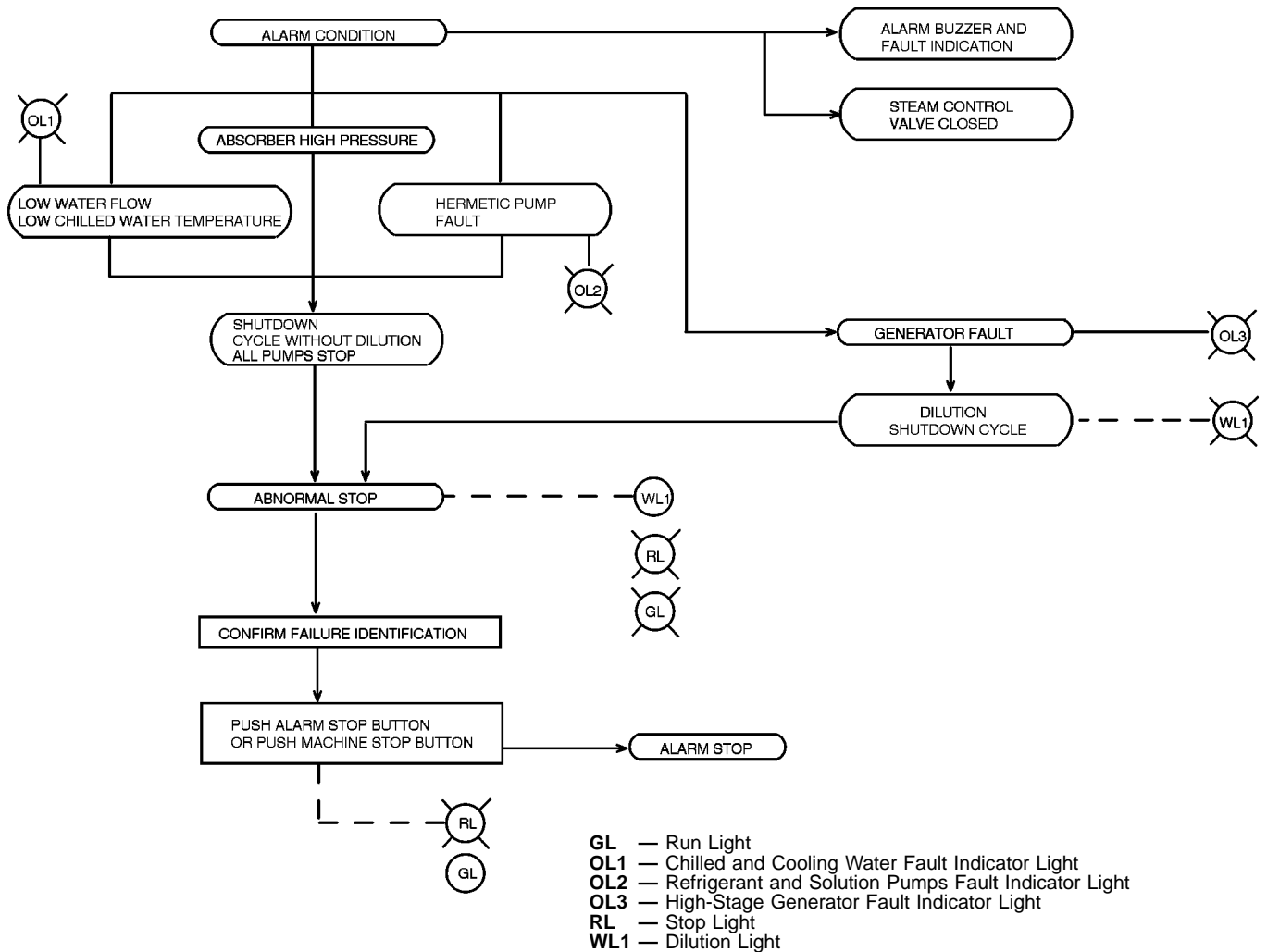

Fig. 16 — Typical Control Sequence, Abnormal Stop

Normally closed 4X contacts energize the Cycle-Guard™ valve to transfer refrigerant into the solution for dilution. The refrigerant pump and Cycle-Guard valve will continue to be energized until the evaporator refrigerant drops to the dilution level switch, which opens to deenergize the refrigerant pump delay start timer (62T2). The normally open timer contacts then stop the Cycle-Guard valve and refrigerant pump. (Normally open 1X1 contacts transferred control of the 62T2 timer from the evaporator low-level switch to the dilution level switch when 1X1 was deenergized.)

When shutdown timer (62T1) times out after about 15 minutes, its contact opens to deenergize interlock relays (1Y1 and 1Y2). Normally open 1Y2 contacts stop the solution pump(s), as well as refrigerant pump and Cycle-Guard valve if they have not already stopped. The chilled water pump, cooling water pump, and cooling tower fan also stop if they are tied into the chiller control circuit for auto. start/stop. When 62T1 times out, it also shuts off the Dilution light.

8. The Stop button may be depressed to silence the buzzer, turn off the fault indicator light, and reset the control circuit for restart; or, the Alarm Buzzer stop button (3-BZ) may be depressed to silence the buzzer while the control circuit remains in the shutdown alarm mode for troubleshooting.

**Capacity Control** — This is the controller that governs the positioning of a capacity control valve and senses the leaving chilled water temperature to determine the required valve positioning. This valve regulates the flow of steam or hot water to the generator, matching machine capacity to the load, and maintains the selected chilled water temperature.

At full-load conditions, the capacity control valve is wide open. As the load is reduced and the chilled water temperature starts to fall below design temperature, the valve throttles the steam or hot water flow until, at no-load condition, the valve is fully closed.

During start-up and shutdown periods, and with prolonged Cycle-Guard operation, the chiller control circuit overrides the signal to the steam valve to limit the valve opening.

The 16JT is available with either electronic or pneumatic capacity control valve actuators, but both are positioned by a microprocessor-based controller.

A temperature sensor inserted in the chilled water outlet pipe continuously measures chilled water temperature and provides a proportional signal to the controller in the machine control panel. The signal is electronically converted by the controller which provides a variable signal for the valve actuator.

**CONTROLLER** — The microprocessor-based controller can be field programmed by using its own interface keys, display, and alternate inputs and outputs for many control variations, but is normally set up for proportional valve positioning in direct relationship to changes in the leaving chilled water temperature.

When the AUTO. mode has been selected on the controller AUTO.-MAN. button for normal automatic operation, both the temperature control set point and the actual chilled water temperature are shown on the controller display. The control temperature set point can be raised or lowered in that mode by pressing the up or down arrows on the controller.

When the MAN. mode has been selected on the controller AUTO.-MAN. button, the control signal to the capacity control valve is displayed as 0 to 100% open, and the valve can be manually opened or closed in that mode by pressing the up (▲) or down (▼) arrows on the controller.

**Electronic Valve Actuator** (Fig. 17) — The proportional milliamp output signal from the controller is supplied directly to the electronic valve actuator for positioning control. When safety device relay (4X) is deenergized in a chiller shutdown condition, its contacts remain open so that the actuator sees a “0” amp signal and remains closed. When the load limiter relay (LIX) is deenergized during chiller start-up or Cycle-Guard operation, the current limiter is in control and provides a preset control signal to hold the actuator at a mid-open position for a preset time delay period.

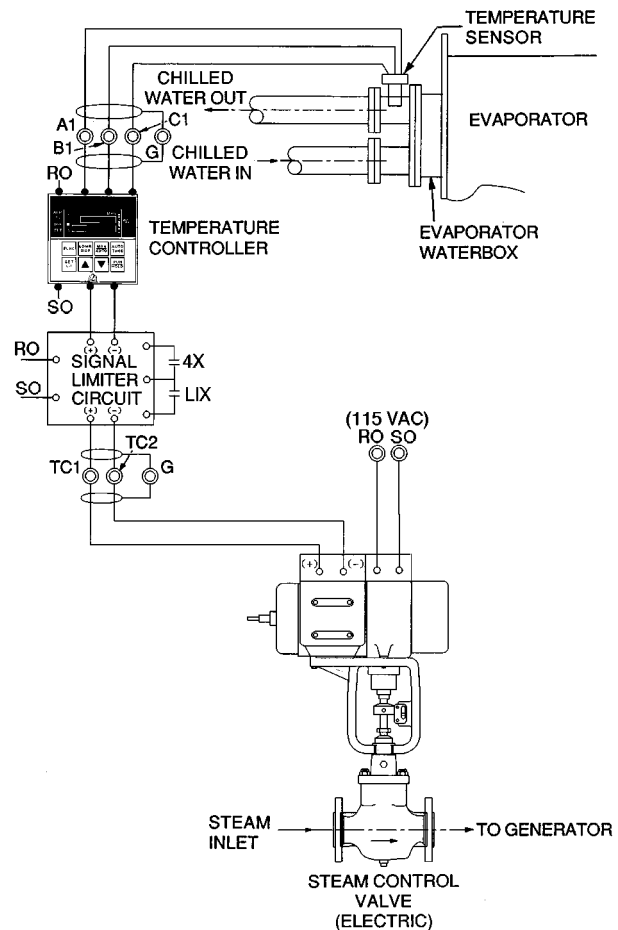

LEGEND  
 ◎ Wiring Terminals

NOTE: See Fig. 10 for Control Circuit Connections.

Fig. 17 — Electronic Valve Actuator

**Pneumatic Valve Actuator** (Fig. 18) — The proportional milliamp output signal from the controller is converted to a proportional pneumatic signal in the current/pneumatic (I/P) transducer mounted on the valve operator. When safety device relay (4X) is deenergized in a chiller shutdown condition, its contacts remain open so that the transducer sees a “0” amp signal. The pneumatic control signal is therefore bled off, so the actuator sees a “0” psig signal and remains closed.

When the load limiter relay (LIX) is deenergized during chiller startup or Cycle-Guard™ operation, the current limiter is in control and provides a preset control signal to hold the actuator at a mid-open position for a preset time delay period.

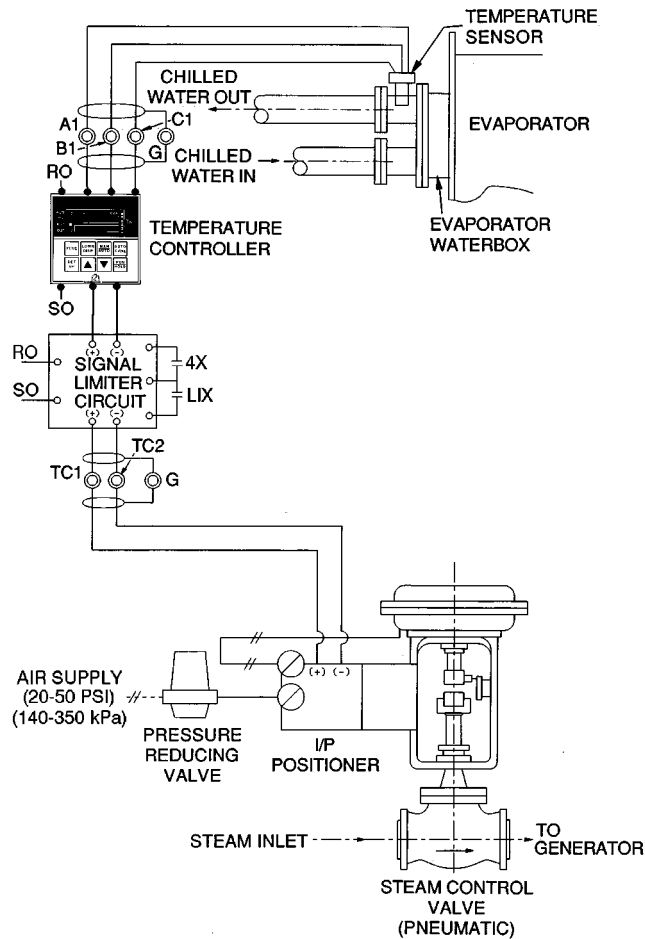

**LEGEND**

⊙ Wiring Terminals

--- Air Tubing Provided

-#-#- Air Tubing to be Done at Site by Contractor

NOTE: See Fig. 10 for Control Circuit Connections.

**Fig. 18 — Pneumatic Valve Actuator**

**High Concentration Limit** — During high load operation, some abnormal conditions can cause the concentration of the lithium bromide solution to increase above normal. When this happens, the Cycle-Guard valve opens to transfer a small amount of refrigerant into the solution circuit to limit the concentration. This is necessary to keep the strong solution concentration from crystallizing.

The Cycle-Guard valve is controlled by the evaporator refrigerant level, which has a direct relationship to solution concentration. As the concentration increases (the solution has less water), so does the refrigerant level. And, because solution crystallization is also related to temperature, a solution thermostat is used with two evaporator refrigerant level switches to provide stepped control of the Cycle-Guard valve with varying condensing water temperatures.

With normal condensing water temperatures, the Cycle-Guard valve is controlled by the higher level switch (33RH) through the refrigerant level relay (33RHX). But with lower condensing water temperatures, and with corresponding lower solution temperatures, thermostats (26SH) contacts close to control the Cycle-Guard valve at the lower level switch (33RM) and, therefore, at a slightly lower solution concentration. A High Refrigerant Level light (WL2) goes on when the 33RHX level relay energizes for Cycle-Guard operation. Also, 33RHX relay contacts open to drive the capacity control valve to a mid-open position (LIX), to reduce heat supply to the generator until the high level has been corrected.

The concentrations at which the Cycle-Guard valve is activated are determined by the amount of refrigerant that is charged into the machine. This charge should be trimmed at start-up, and should be checked periodically during operation for correct Cycle-Guard operation.

**Low Concentration Limit** — During low-load operation with low condensing water temperatures, the normal dilution of the solution lowers the refrigerant level in the evaporator. Before the level becomes low enough to cause pump cavitation and damage to the hermetic pump motor, the evaporator low-level switch (33RL) opens to deenergize 62T2, which, temporarily stops the refrigerant pump. This will happen only when the condensing water temperature falls below the design limit. When the refrigerant level subsequently rises enough to close the low-level switch, the refrigerant pump start-delay timer (62T2) is energized. After about 5 minutes, the timer contacts close to start the refrigerant pump and resume normal operation.

**High-Stage Generator Level Limit** — A sensing electrode with a level relay (33W) monitors the solution level in the high-stage generator. If the level is too high, 33W relay contacts stop the solution pump(s), which allow solution to drain normally from the generator. When the solution level drops below the electrode level, the relay restarts the solution pump(s).

**BEFORE INITIAL START-UP**

**Job Data and Tools Required**

1. Job specifications and job sheets, including list of applicable design temperatures and pressures
2. Machine assembly and field layout drawings
3. Controls and wiring drawings
4. 16JT Installation Instructions
5. Mechanic’s hand tools
6. Absolute pressure gage or water-filled wet-bulb vacuum indicator graduated with 0.1-in. (2 mm) of mercury increments. *Do not use manometer or gage containing mercury.*

7. Auxiliary evacuation pump, 5 cfm (2.5 l/s) or greater, with oil trap, flexible connecting hose and connection fittings
8. Compound pressure gage, 30-in. vacuum to 30 psig (75 cm vacuum to 200 kPa)
9. Digital volt-ohmmeter and clamp-on ammeter
10. Liquid charging hose consisting of flexible 3/4-in. (20-mm) hose connected to a 3-ft (1-m) long x 1/2-in. (15-mm) pipe trimmed at a 45-degree angle at one end, with a 1/2-in. MPT connector
11. Leak detector
12. Hydrometer and insertion thermometer

**Inspect Field Piping** — Refer to the field piping diagrams (Fig. 19) and inspect the chilled water and cooling water piping.

1. Verify that location and flow direction of the water lines are as specified on the drawings and as marked on the machine.
2. Check that all water lines are vented and properly supported to prevent stress on waterbox covers or nozzles.
3. Make sure all waterbox drains are installed.
4. Ensure that water flow through the evaporator and condenser meet job requirements. Measure the pressure drops across both cooler and condenser.
5. Make sure chilled water temperature sensors are installed in the leaving chilled water piping. Also check that appropriate thermometers or temperature wells and pressure gage taps have been installed in both entering and leaving sides of the evaporator, absorber, and condenser water piping.

**Inspect Field Wiring** — Refer to the field and machine wiring diagrams and inspect the wiring for both power supply and connections to other system equipment (cooling tower, water supply pumps, auto. start if used, etc.)

### CAUTION

Do not apply power to hermetic pumps or attempt to start the machine until it has been charged with lithium bromide solution and refrigerant. The pumps will be severely damaged if rotated without the full liquid charge.

1. Examine wiring for conformance to job wiring diagrams and applicable electrical codes.
2. Check pump and motor nameplates and control panel for agreement with supply voltage and frequency (Hz).
3. Verify correct overload and fuse sizes for all motors.
4. Check that electrical equipment and controls are properly grounded in accordance with applicable electrical codes.
5. Make sure customer/contractor has verified proper operation of water pumps, cooling tower fan, and associated auxiliary equipment. This includes ensuring that motors are properly lubricated and have proper electrical supply and proper rotation.

**Standing Vacuum Test** — Before machine is energized or placed in operation, check for air leaks with a standing vacuum test. Examine the 2 test procedures described below and select the one that applies to your job application.

**LONG INTERVAL TEST** — Use this test procedure if an absolute pressure reading has been recorded at least 4 weeks previously and the reading was not more than 1 in. (25 mm) of mercury.

1. Connect an absolute pressure gage to the auxiliary evacuation valve and record the pressure reading. (Do not use mercury gage.)
2. If the pressure has increased by more than 0.1 in. (2.5 mm) of mercury since the initial reading, an air leak is indicated. Leak test the machine as described in the Maintenance Procedures section, page 33, then perform the short interval test which follows.

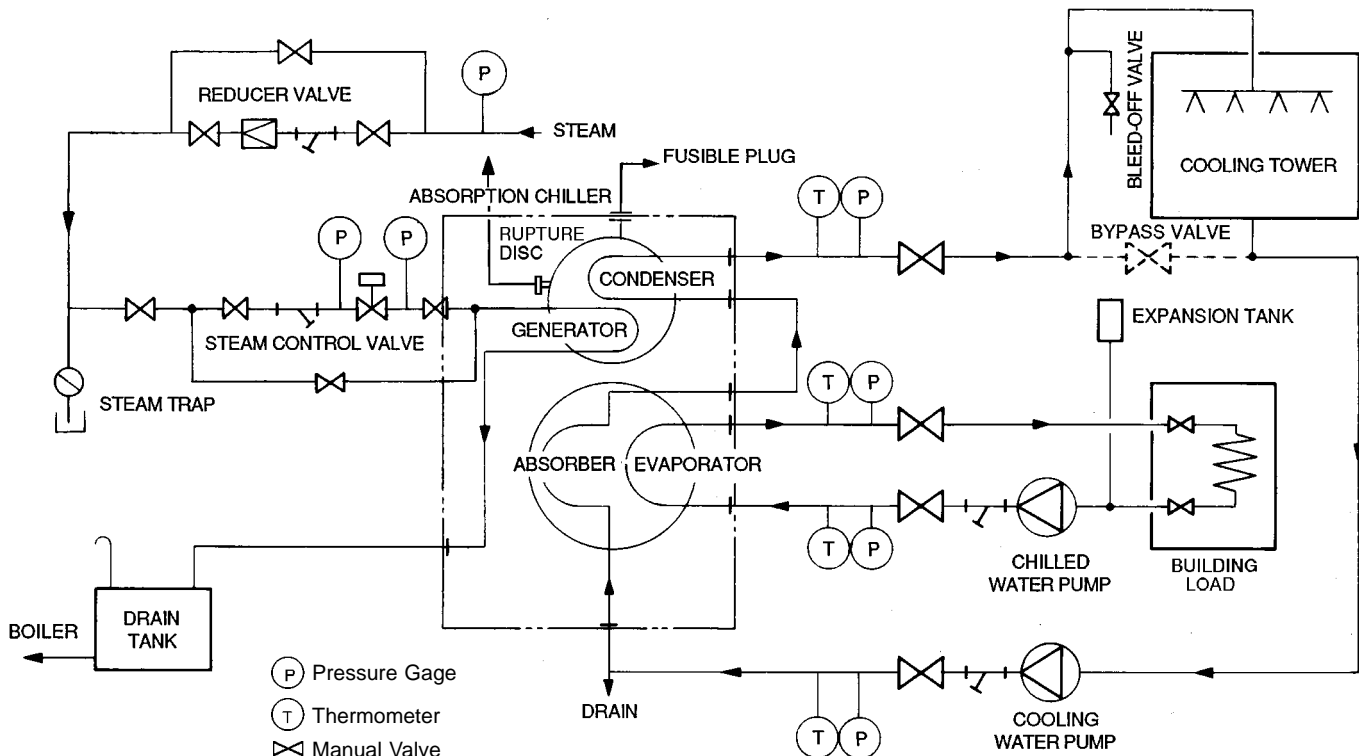

Fig. 19 — Typical Piping

SHORT INTERVAL TEST — Use this test procedure if:

1. No previous absolute pressure readings have been recorded, OR
2. Previous absolute pressure reading was made less than 4 weeks ago, or reading indicated a machine pressure of more than 1 in. (25 mm) of mercury, OR
3. Machine had to be leak tested after long interval test.

**Procedure**

1. Connect absolute pressure gage to auxiliary evacuation valve and record pressure reading.
2. If the reading is more than 1 in. (25 mm) of mercury absolute, evacuate the machine as described in the Maintenance Procedures section, page 33.
3. Record the absolute pressure reading and the ambient temperature.
4. Let machine stand for at least 24 hours.
5. Note the absolute pressure reading when ambient temperature is within 15° F (8° C) of the ambient temperature recorded in Step 3.
6. If there is any noticeable increase in pressure, an air leak is indicated. Leak test the machine as described in Maintenance Procedures section, then repeat short interval vacuum test to ensure results.

**Machine Evacuation** — When machine absolute pressure is greater than 1 in. (25 mm) of mercury absolute, machine must be evacuated as described in Maintenance Procedures section, page 33.

**Solution and Refrigerant Charging**

**HANDLING LITHIUM BROMIDE SOLUTION**

**⚠ WARNING**

Lithium bromide and its lithium chromate inhibitor can irritate the skin and eyes. Wash off any solution with soap and water. If solution enters the eye, wash the eye with fresh water and consult a physician immediately. Lithium bromide is a strong salt solution; do not syphon by mouth.

Liquid materials that are added to lithium bromide solution such as lithium hydroxide, hydrobromic acid, octyl alcohol, and lithium chromate inhibitor, are classified as hazardous materials. These materials, and any lithium bromide solution they are in, must be handled in accordance with current Occupational Safety and Health Administration (OSHA) and Environmental Protection Agency (EPA) regulations.

Solutions of lithium bromide and water are nontoxic, nonflammable, nonexplosive, and can easily be handled in open containers. The solution is chemically stable and does not undergo any appreciable change in properties even after years of use in the absorption machine. Its general chemical properties are similar to those of table salt.

Because lithium bromide salt can corrode metal in the presence of air, wipe off any solution spilled on metal parts or tools and rinse the part with fresh water as soon as possible. After rinsing, coat the tools with a light film of oil to prevent rust. After emptying metal containers of solution, rinse the container with fresh water to prevent corrosion. Immediately wipe or flush the floor if lithium bromide or octyl alcohol is spilled on it.

Lithium bromide should be stored only in the original container or in a completely clean container. Used lithium bromide solution should be disposed of by a reputable chemical disposal company.

**CHARGING SOLUTION** — Solution is drawn into the absorber through the solution pump service valve while the

pump is off. To minimize the chance of air entering the machine, the solution should *not* be drawn in directly from a small container. A vacuum pump should be in operation while the solution is being charged into the chiller to remove entrained noncondensables.

1. Connect a flexible hose to a 1/2-in. MPT adapter and a 1/2-in. (15-mm) pipe. Fill both pipe and hose with water to minimize any air entry into the machine.
2. Insert the 1/2-in. (15-mm) pipe into the container (be sure it goes to the bottom), and connect the flexible hose to the solution pump service valve (Fig. 20). The lithium bromide container must have yellow, "Lithium Chromate Inhibitor" markings, and a 55% concentration solution must be used.
3. Open the service valve. Continue charging until solution level is near the bottom of the container. *Do not allow air to be drawn into machine.*
4. Repeat with other containers as required until the amount specified in Table 3 has been charged into the chiller.

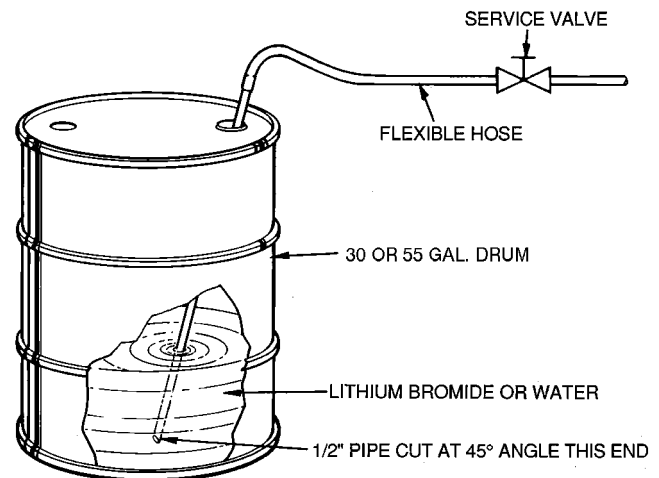

**Fig. 20 — Charging Solution and Refrigerant**

**CHARGING FOR CONDITIONS OTHER THAN NOMINAL** — The solution quantity can be adjusted to compensate for other than nominal values for design chilled water temperature, condensing water temperature or flow. *The solution quantity can be increased or decreased by up to 10% of the nominal charge listed in Table 3. Adjust quantity as follows:*

1. Increase (decrease) the nominal solution charge by 1% for each degree F (.56° C) that the design chilled water temperature is below (above) 44 F (7 C).
2. Increase (decrease) the nominal solution charge by 1% for each 2° F (1.1° C) that the design condensing water temperature is above (below) 85 F (29 C).
3. Increase the nominal solution charge by 1% for each 10% reduction in design condensing water flow below nominal 100%.
4. Do not adjust nominal charge for changes in steam pressure.

**INITIAL REFRIGERANT CHARGING** — The refrigerant charge must be either distilled or deionized water. Do not use tap water without first having it tested for the following requirements:

pH	7.0 ± 0.2 at 77 F (25 C)
Hardness CaCO <sub>3</sub>	2.0 ppm or less
Silica	0.2 ppm or less
Ammonia NH <sub>4</sub> <sup>+</sup>	None
Specific Resistance	5 x 10 <sup>5</sup> ohms/cm at 77 F (25 C)

To charge refrigerant into the evaporator, fill clean solution containers with the distilled or deionized water. Charge the water through the refrigerant pump service valve, following the appropriate steps in Charging Solution section.

Charge in at least the amount listed in Table 3 under Initial Refrigerant amount. This charge must be adjusted after start-up to achieve optimal Cycle-Guard™ control conditions to limit the maximum solution concentration (which prevents solution crystallization). However, any extra refrigerant should be limited because the normal refrigerant pump discharge pressure is below atmospheric pressure and a vacuum bottle is required to remove refrigerant (see Final Refrigerant Charge Adjustment section, page 25).

**Table 3 — Nominal Machine Charges\***

UNIT 16JT	LiBr SOLUTION		INITIAL REFRIGERANT	
	Gal	Kg	Gal	Kg
810,812,814	137	840	87	330
816,818,821	200	1225	106	400
824	246	1505	92	350
828	257	1575	92	350
832	309	1890	114	430
836	314	1925	114	430
841	366	2240	137	520
847	400	2450	137	520
854	440	2695	165	625
857	463	2835	165	625
865	514	3150	203	770
873	560	3430	232	880
880	623	3815	285	1080
080	754	4620	177	670
090	846	5180	201	760
100	903	5530	215	815
110	1017	6230	202	765
120	1097	6720	206	780
135	1263	7740	238	900
150	1377	8435	271	1025
080L	823	5040	197	745
090L	922	5650	211	800
100L	1006	6160	225	850
110L	1114	6825	219	830
120L	1200	7350	238	900
135L	1380	8450	277	1050
150L	1504	9210	304	1150

\*Based on 55% concentration of solution, 44 F (7 C) leaving chilled water, 85 F (29 C) entering condensing water.

### INITIAL CONTROL CHECKOUT AND ADJUSTMENT

The checkout procedures in this section are for semi-automatic control systems. The purpose of the checkout is to ensure that control circuits have not been affected by shipping or installation damage or altered in the process of making field wiring connections.

NOTE: Some thermostats adjustments are scaled in Celsius, hence that is the temperature stated first in some of the instructions in this manual.

#### ⚠ CAUTION

Follow the checkout sequence in detail. Machine must be charged with solution and refrigerant before starting checkout. Chilled water and condensing water circuits must be filled and operative, but the manual steam or hot water valve must remain closed.

Do not rotate hermetic pumps until machine is charged with lithium bromide-water solution and refrigerant.

### Preparation

1. Open the control panel and place the main circuit breaker in OFF position (Fig. 13) to deenergize the control circuit and pump motor.
2. Disconnect leads for solution pump motor and refrigerant pump motor at secondary starter terminals. Wrap the ends of the disconnected wires with electrical tape and mark for proper identification at reinstallation.

3. If starters for condensing water pump and chilled water pump are operated by manual start-stop, temporarily place an insulated jumper between terminals P1 and P2 to override the external interlock. Remove fuses from starters for the condensing water pump motor and chilled water pump motor. (Starters for these motors are field supplied on external voltage lines and are not located in control panel.)

If condensing and chilled water flow switches are used, manually block the switches closed.

**IMPORTANT:** Do not open manual steam or hot water valves.

### Energize Control Circuit

1. Place the main circuit breaker in the ON position to energize control circuit. (Stop light turns red.)
2. Depress the Stop button to clear any safety fault conditions and to prepare the control circuit for starting.
3. Place the control panel settings in the following positions:

SETTINGS	POSITION
Capacity Control	AUTO.
Cycle Guard Switch	AUTO.
Local/Remote Switch	LOCAL

4. Depress the Start button momentarily to start the machine. The Run light turns green and the start cycle begins. With normal operation, the solution pump starts immediately and the refrigerant pump starts after about 5 minutes.

### Check Solution and Refrigerant Pump Starters

1. Make sure the solution and refrigerant pump starters are energized.
2. Depress the Stop button momentarily (Run light deenergizes). Both starters remain energized for approximately 15 minutes during dilution cycle (Dilution light energizes).

### Check Pump Starter Overloads

1. Depress the Start button, and wait for the pumps to start.
2. Push the trip bar on the side of the refrigerant pump starter overload. All pump starters deenergize, the alarm buzzer sounds, and the fault light identifies the fault category.
3. Depress the Stop button (to silence the alarm) and the starter reset bar.
4. Repeat Steps 1 - 3 with other control panel starters. Refer to the wiring diagrams for the set point of each starter.
5. Starters for auxiliary equipment must be similarly checked, according to the manufacturers' instructions.

### Check Low-Temperature Cutout

1. Turn the differential adjustment screw until differential set point is at 4 C (7.2 F).
2. Place control sensing bulb in a water bath maintained at 9° F (5° C) below design leaving chilled water temperature (but not below 36 F [2 C]). This is the correct low-temperature cutout setting.
3. Depress the Start button.

Slowly turn cutout adjustment knob clockwise until contacts open. Chilled water, condensing water, solution and refrigerant pump starters, and Run light should deenergize, the alarm buzzer should sound, and the fault light should identify the fault category.

Depress the Stop button to silence the alarm.

Marks on the indicator plate are for reference only and are not calibrated in degrees.

4. Allow water bath to warm until contacts close. Depress the Start button. Starters and Run light should energize. Contacts should have a 7.2° F (4° C) differential between opened and closed positions.

Cutout Temperature = Cut-in Temperature – Differential

5. Fill low-temperature cutout well (located on chilled water nozzle) with heat conductive compound. Insert sensing element into well.

NOTE: Usually low-temperature cutouts are preset at the factory, with contacts set to open at 36 F (2 C) and to close at 43 F (6 C).

**Check Cycle-Guard™ Valve** — (This valve is located between refrigerant pump discharge line and solution pump inlet.)

1. Place Cycle-Guard switch in MANUAL position. Cycle-Guard valve should energize (denoted by an audible click).
2. Use clamp-on ammeter to check current in wire to Cycle-Guard valve. Current reading should be 0.2 amps or less.
3. Place Cycle-Guard switch in AUTO. position. Cycle-Guard valve should deenergize.
4. Place jumper wire between panel terminal **RC** and **41** in the panel to simulate high evaporator level. Terminal **RO** is hot. Cycle-Guard light and valve should energize.
5. Remove jumper wire between panel terminal **RO** and **41**. Cycle-Guard light and valve should deenergize.

### Check Solution Thermostat

1. Place jumper wire between panel terminal **RO** and terminal **15** to simulate mid-level switch operation. Terminal **RO** is hot.
2. Place control sensing bulb on temperature cutout in water bath maintained at ambient temperature. Slowly turn switch adjustment screw clockwise until contacts close. Cycle-Guard valve should energize. Note the difference (if any) between actual thermometer reading and the reading on the thermostat adjustment scale.

Using any temperature differential described above as a correction factor, set adjustment screw to close at 47 C (117 F). The switch has a fixed differential of 3° C (5.4° F).

3. Remove jumper wire between panel terminal **RO** and terminal **15**. Cycle-Guard valve should deenergize.
4. Fill thermowell (located on the absorber strong solution line between heat exchanger and spray header) with heat conductive compound and insert sensing element into it.

### Check High-Stage Generator Temperature Thermostat

— The switch is factory set to open on a rise in temperature above 170 C (338 F) and close on a cooling below 163 C (325 F). Verify the approximate scale position setting (170 C [338 F]) and closed switch contacts. The switch range is 50 to 320 C (122 to 608 F).

NOTE: The switch operation setting cannot be easily checked in the field. It requires a precise scale adjustment so do not reposition if not necessary.

### Check High-Stage Generator Pressure Switch

— The switch is factory set to open on a rise in pressure above –20 mm Hg G (–0.8 in. Hg) and close with a

reduction in pressure below –205 mm Hg G (–8 in. Hg). Verify the approximate scale position setting (–20 mm Hg G [–0.8 in. Hg]) and closed switch contacts. The switch range is –500 mm Hg G (–20 in. Hg) to 580 kPa (85 psig).

NOTE: The switch operation setting cannot be easily checked in the field without breaking machine vacuum. It requires a precise scale adjustment, so do not reposition if not necessary.

### Check Rotation of Solution and Refrigerant Pumps

1. Place main circuit breaker in OFF position and reconnect pump motor wires previously disconnected.
2. Place main circuit breaker in ON position.
3. Install compound pressure gage on refrigerant pump service valve, depress Start button, and check pump discharge pressure.
4. Place the main circuit breaker in OFF position and reverse any two motor power leads at starter to reverse pump rotation.
5. Place the main circuit breaker in ON position and depress Start button. Compare the noise of both rotation directions and check discharge pressure. Correct rotation is the direction that produces the highest discharge pressure reading and the least noise.
6. Repeat Steps 3 - 5 for rotation of solution pump(s).
7. To check chilled water pump and condensing water pump rotation, refer to pump manufacturers' instructions.

### Check Capacity Control Operation (Fig. 21)

— The microprocessor-based controller is programmable for a particular application by using its interface keys, display, and selectable inputs and outputs. It can be set up for many different control variations. It is supplied originally configured with default values for typical use, and is custom configured in the factory when it is mounted in the chiller control panel.

Proportional capacity control valve positioning is usually in direct relationship to changes in the leaving chilled water temperature at a selected control temperature. Variations can include such things as remote set point, dual set points, auto. chiller start at a selected chilled water temperature, dual inputs, and computer control input and output interfaces.

The following checkout and adjustment procedure is for standard use. The standard 16JT configuration set-up list, with temperature measurement in degrees F, and 110 V, 60 Hz control power, is shown in Table 4. See the UDC 3000 Universal Digital Controller product manual for specific description, configuration, operation, and troubleshooting information.

#### CAUTION

Do not depress the AUTO, TUNE and RUN/HOLD keys or use the SET UP and FUNCTION keys for reviewing the configuration without a thorough understanding of their use because the configuration could be inadvertently altered. Also, do not intentionally change any configuration without a thorough understanding of both the method and the resulting effects.

1. Verify factory customized configuration by checking the controller displays: The letter F (Fahrenheit) in the upper left area; either an A (automatic control) or MAN. (manual control) in the upper right area; and the actual temperature at the sensor in the middle right area of the display.

The lower display will show the letters SP (set point) and the set point temperature when in the A (AUTO.) mode, and the letters OUT (for output) and a value in the range of 0.0 to 100.0 (percent output signal to the

valve actuator) in the MAN. (MANUAL) mode. Press the MAN./AUTO. button to switch between the two modes. The actual output value is not important at this time. (Preferably, the temperatures have been configured for display [and processing] with the decimal located for tenths of a degree, but that is not critical.)

The red bars on the right of the temperature display indicate deviation between actual and set point temperatures in  $\pm 10\%$  increments of the sensor span. The LOWR DISP button will allow the following values to be shown in either MAN. or AUTO. in the lower display: the set point (SP); the deviation between the actual and set point temperatures; and the OUT control signal in percent of range. A flashing code indicates a wiring fault or missing configuration.

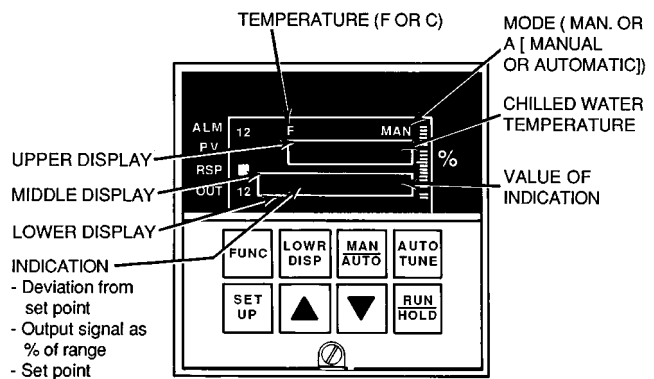

Fig. 21 — Operator Interface

NOTE: For the following procedure, the up arrow ( $\blacktriangle$ ) and the down arrow ( $\blacktriangledown$ ) are used to increase or decrease the set point, output, and set-up configuration values, respectively. To quickly make large changes to set point or manual control output values, press the arrow indicative of the direction of change, then press the opposite arrow to move the adjustment one digit to the left. To move the adjustment an additional digit to the left, continue pressing the arrow indicative of the direction of change, and then press the opposite arrow again.

- 2a. Place the controller in the AUTOMATIC mode by pressing the AUTO./MAN. button until A is displayed.
- b. Use the arrows to change the temperature set point (SP) on the lower display to a few degrees below the actual temperature on the middle display in order to open the capacity control valve signal.
- c. Press the chiller START button. The capacity control valve should open to a mid-open position (soft start) for the time period set on adjustable time delay relay 62T3, typically about 15 minutes. The valve limit position can be varied by adjusting the high limit setting knob under the cover of the current limiter (see Fig. 17 or Fig. 18).
3. After completion of the 62T3 soft-start time period, place the controller in the MANUAL mode by pressing the AUTO.-MAN. button until MAN. is displayed. Use the arrows to verify that the capacity control valve will open and close in proportion to the output signal (OUT) over its entire range. "OUT" is displayed as 0.0 to 100.0% of the 4 to 20 mA output control signal.
- 4a. Return the controller to the AUTOMATIC mode by pressing the AUTO.-MAN. button until A is displayed.
- b. Use the arrows to change the temperature set point (SP) close to the actual temperature on the upper display, and wait briefly to allow the OUT signal to stabilize. Then use the up arrow to change the set point several degrees above the actual temperature to verify that the control valve OUT signal will gradually change towards the closed position. Next, use the down arrow to change the set point several degrees below the actual temperature to verify that the control valve output signal will gradually change towards the open position.
5. Use the arrows to reset the set point temperature at the desired chilled water control temperature for normal operation. Leave the controller in the A (AUTO.) mode.

**Completion** — Replace fuses from starters for condensing water pump motor and chilled water pump motor, then unblock water flow switches. Also, remove jumper wire from terminals P1 and P21 and any other jumpers which might have been connected for controls checkout.

Table 4 — Standard Controller Configurations

SET UP	FUNCTION	SELECTION	
<b>TUNING</b>	PROP BD	10.0	
	RATE MIN	0.00	
	RSET RPM	1.00	
	LOCKOUT	<u>+ CONF</u>	
<b>SET POINT RAMP</b>	SP RAMP	DISABL	
	<b>AUTOTUNE</b>	AT ENABL AT ERROR	DISABL <u>NONE</u>
<b>ALGORITHM</b>	CONT ALG	PID A	
	INPUT 2	DISABL	
	OUT ALG	<u>CURRNT</u>	
<b>INPUT 1</b>	DECIMAL UNITS	<u>XXX.X</u> DEG F	
	IN 1 TYPE	<u>100 LO</u>	
	IN 1 HI	<u>300.0</u>	
	IN 1 LO	0.0	
	BIAS IN 1	0.0	
	FILTER 1	10	
	BURNOUT	<u>NONE</u>	
	PWR FREQ	60 HZ	
	<b>CONTROL</b>	PID SETS	1 ONLY
		SP SOURC	1LOCAL
		RATIO	1.0
		BIAS	0.0
		POWER UP	<u>A LSP</u>
SP HILIM		<u>100.0</u>	
SP LOLIM		<u>41.0</u>	
ACTION		<u>DIRECT</u>	
OUTHILIM		<u>100.0</u>	
OUTLOLIM		0.0	
DROPOFF		5.0	
FAILSALE	0.0		
PBorGAIN	<u>PB PCT</u>		
MINorRPM	<u>RPM</u>		
<b>OPTIONS</b>	AUX OUT	DISABL	
	REM SW	NONE	
<b>COM</b>	ComSTATE	DISABL	
<b>ALARMS</b>	A1S1VAL	40.5*	
	A1S1TYPE	PV*	
	A1S2TYPE	NONE	
	A2S1TYPE	NONE	
	A2S2TYPE	NONE	
	A1S1 H L	LO*	
	AL HYST	2.0*	

\*Used for low chilled water temperature cutout.

NOTE: Controller configuration selections not listed here have been automatically deleted from the controller set-up display by the above configuration selections. Selections which have been changed from original default values are underlined.

## INITIAL START-UP

The following start-up procedures are based on a semi-automatic system in which all pumps energize when the start-stop switch is placed in the START position.

**Preliminary Check** — Check the operation of auxiliary equipment and status of system before starting the absorption machine.

### PREPARATION

1. Add the amount of octyl alcohol specified in Table 5 through the solution pump service valve. (Refer to Maintenance Procedures, Adding Octyl Alcohol section, page 35.) Do not allow air to be drawn into machine.
2. Supply power to control panel, chilled water, and condensing water pumps. Open manual steam supply valves, chilled water valves, and cooling water valves.
3. Place the capacity control and Cycle-Guard™ settings in AUTO. position and Local/Remote switch in the Local position. Depress the Start button.
4. When the solution is warm (strong solution below 140 F [60 C]), place the capacity control auto.-man. button in MANUAL position and depress the down arrow until valve is fully closed.
5. Determine the machine absorber loss as described in Maintenance Procedures, Absorber Loss Determination section, page 31.

If absorber loss is 5° F (2.8° C) or less, place capacity control valve on AUTO. and allow machine to operate.

If the absorber loss is greater than 5° F (2.8° C), evacuate the machine (see Maintenance Procedures, Machine Evacuation section, page 33) to remove any noncondensables that might prevent normal operation. As an alternate procedure, limit steam pressure to keep strong solution temperature under 140 F (60 C) and allow the purge to remove the noncondensables.

After the absorber loss has been reduced to below 5° F (2.8° C) by either of the above procedures, place machine on automatic operation, with capacity control button in AUTO. position and steam pressure normal. The purge will evacuate the machine to the normal absorber loss of 2° F (1.1° C) or less.

**Table 5 — Octyl Alcohol Initial Charge**

16JT	OCTYL ALCOHOL	
	Gal	L
810,812,814	1	3.8
816,818,821,824	2	7.6
828,832,836	2	7.6
841,847,854	3	11.4
857,865,873	4	15.2
880	5	19.0
080	6	22.7
080L,090	7	26.5
090L,100	8	30.3
100L,110	10	37.9
110L,120	12	45.5
120L,135	14	53.1
135L,150	16	60.6
150L	18	68.2

**Final Adjustment of Capacity Controls** — Allow the chiller to operate long enough with a fairly stable load for the system to reach equilibrium. Verify that the chilled water temperature is close to the set point and the system is stable (with little capacity control valve cycling or searching). See Initial Control Checkout and Adjustment, Check Capacity Control Operation section, page 23, for set point and control adjustment procedures.

The controller tuning parameters have been factory-configured for control stability with typical applications.

However, if necessary, the parameters can be adjusted for improved stability with either manual or automatic reconfiguration procedures.

WITH THE MANUAL PROCEDURE, the configuration for proportional band, rate, and reset are adjusted until the system is stable.

WITH THE AUTOMATIC PROCEDURE, the controller has AUTOTUNE capability to automatically calculate and adjust a particular cooling system's optimal tuning parameters.

See the UDC 3000 Universal Digital Controller product manual for specific description, configuration, operation, and troubleshooting information.

**Final Refrigerant Charge Adjustment** — The adjustment should be made after:

1. Machine is operating with stable temperatures at 40 to 100% of full load.
2. Absorber loss is 3° F (1.7° C) or less.
3. Refrigerant specific gravity is 1.02 or less.

The refrigerant charge is adjusted so that the Cycle-Guard™ system can limit maximum solution concentration and avoid solution crystallization. Proceed as follows:

1. Place Cycle-Guard Switch (43RV) in the AUTO. position. Then, if the Cycle-Guard valve remains off at least 10 minutes, proceed to Step 2. If not, gradually reduce the load on the chiller (to reduce the solution concentration) until the Cycle-Guard valve remains off. The valve will be energized when the refrigerant high level light is ON.
2. Remove a solution sample from the solution pump service valve and measure the specific gravity and temperature.
3. Locate the intersection point of the specific gravity and temperature values on equilibrium diagram (Fig. 22A or 22B). Read down from this point to the solution concentration scale to determine the percent lithium bromide by weight in the weak solution.
4. Determine the approximate percent of full load on the machine by comparison of chilled water temperature spread, and flow in relation to design. Enter Table 6 at this percent load and find the corresponding weak solution concentrations required for refrigerant charge adjustment.

**Table 6 — Weak Solution Concentrations for Adjusting Refrigerant Charge**

REFRIGERANT LEVEL	PERCENT LOAD ON MACHINE						
	100	90	80	70	60	50	40
	Weak Solution Concentration (%)						
High	60	60.4	60.8	61.2	61.6	61.9	62.2
Mid	58	58.4	58.7	59.1	59.4	59.8	60.1

NOTE: Concentrations listed in Table 6 are for nominal design conditions. For special design conditions, obtain the special concentration settings from the factory.

5. Adjust machine operating conditions until machine operates with stable temperatures at either of the weak solution concentrations ( $\pm 0.1\%$ ) listed in Table 6 under the selected percent load.

To increase the concentration:

- a. Increase the load.
- b. Lower chilled water temperature (set point adjuster setting).
- c. Raise condensing water temperature (or throttle condensing water flow).

After adjusting conditions, repeat Steps 2 and 3 to verify solution concentration.

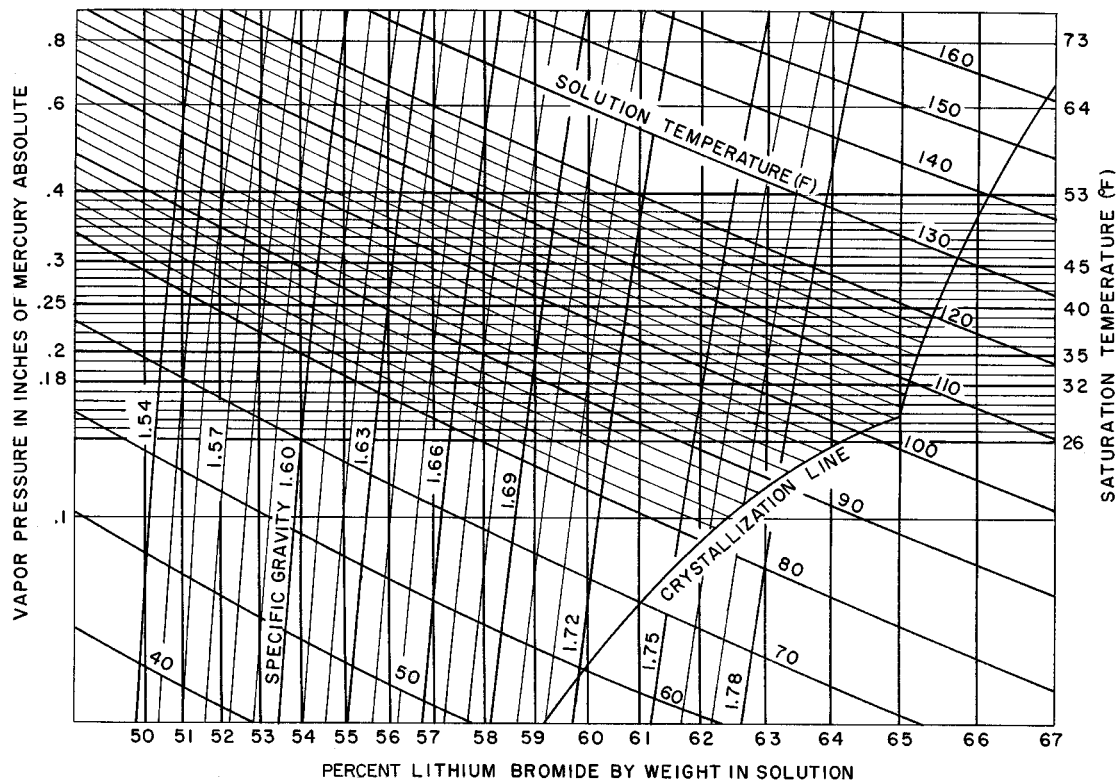

Fig. 22A — Equilibrium Diagram for Lithium Bromide in Solution (F)

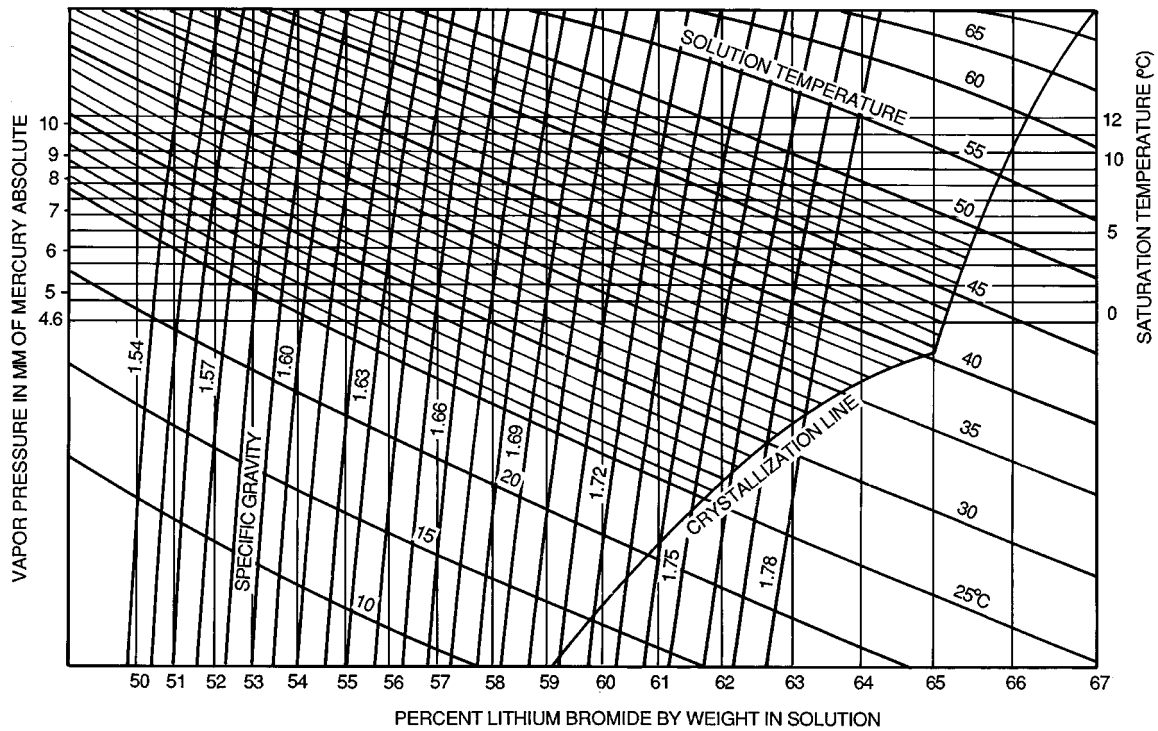
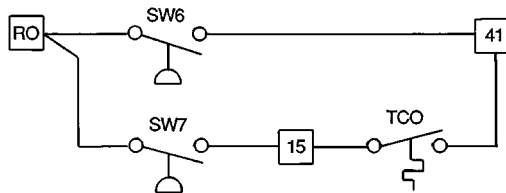

Fig. 22B — Equilibrium Diagram for Lithium Bromide in Solution (C)

- The refrigerant charge can be adjusted at either refrigerant level. In Table 6, use the refrigerant level that corresponds to the weak solution concentration in the machine at the percent load determined in Step 4. Proceed as follows, at the appropriate refrigerant level (Fig. 23):

HIGH LEVEL — Remove temperature cutout wire from terminal **15**.

MID LEVEL — Install jumper between terminals **15** and **41**.



TCO — Temperature Cutout

**Fig. 23 — Refrigerant Levels Connection**

- Check status of Cycle-Guard™ valve. If it is open, gradually remove water from refrigerant pump service valve until Cycle-Guard valve closes. (See Solution or Refrigerant Sampling section, page 34.) If Cycle-Guard valve is closed, add small quantities of water to machine until Cycle-Guard valve opens. Water can be drawn into the machine through the refrigerant pump service valve when the refrigerant pump is off. The pump can be stopped without a dilution cycle by pressing the trip bar on the pump starter overload, then depressing the Stop button and the overload reset. Fill the charging hose with water before opening the pump service valve. *Do not allow any air to be drawn into the machine.*

Turn the refrigerant pump on after adding water. The Cycle-Guard valve cannot be energized while the pump is off.

Add or remove water to change the solution concentration as needed. *When adding or removing water, allow approximately 10 minutes for temperatures and concentrations to stabilize. Periodically check weak solution concentration while adjusting refrigerant charge. Readjust machine conditions, if necessary, to maintain controlled concentration.*

- Remove jumpers from thermoswitch terminals **15** and **41**. Replace wire connections removed in Step 6.
- If solution charge has been increased (decreased) for design conditions other than nominal, decrease (increase) refrigerant charge by an equal amount. (Refer to Solution and Refrigerant Charging — Charging for Conditions Other than Nominal, page 21.)

**Check Machine Shutdown** — Depress the Stop button momentarily. The capacity control valve closes and the Cycle-Guard valve opens to dilute the solution. When the solution has been sufficiently diluted, a refrigerant level switch shuts down the machine.

Depending on solution concentration before shutdown, the shutdown can take up to 20 minutes. If machine does not shut down correctly, check operation of capacity controls, refrigerant level switches, Cycle-Guard valve, and machine wiring.

**Check Low-Evaporator Level Operation** — *After machine has completed a normal shutdown:*

- Depress the Start button to start the machine. Place the capacity control AUTO.-MAN. button in MAN. and use (▼) to keep the valve closed.
- Wait 5 minutes for the refrigerant pump to start then place the Cycle-Guard switch in MANUAL to transfer refrigerant from the evaporator, lowering the refrigerant level until it reaches the low-level switch. The refrigerant pump should stop. If the pump becomes noisy, it might be in cavitation from a low-level switch malfunction. Do NOT allow the pump to remain in operation with this condition.
- Return the Cycle-Guard switch and capacity control button to AUTO. for normal operation. When enough refrigerant has been recovered from the solution to raise the evaporation level above the low-level switch, the refrigerant pump restarts.

**Determine Noncondensable Accumulation Rate**

— After approximately 200 hours of machine operation, the rate of noncondensable accumulation in the purge should be measured to be sure that the machine does not have an air leak. If a leak is indicated, it must be corrected as soon as possible to minimize internal corrosion damage. Refer to Maintenance Procedures, Noncondensable Accumulation Rate section on page 31 for checking procedures.

**OPERATING INSTRUCTIONS**

**Operator Duties**

- Become familiar with absorption machine and related equipment before operating. See Introduction and Machine Description sections, pages 3-9.
- Start and stop machine as required.
- Inspect equipment; make routine adjustments; maintain machine vacuum and proper refrigerant level; exhaust purge as required.
- Keep log of operating conditions and recognize abnormal readings.
- Protect system against damage during shutdown.

**Before Starting Machine** — Be sure that:

- Power is on to condensing water and chilled water pump starters, cooling tower fan, and absorption machine control panel (chiller Stop light is on).
- Cooling tower has proper water level.
- Chilled and condensing water circuits are full and valves are open.
- Correct steam or hot water supply is available.
- Air supply for pneumatic controls is adequate.
- Alarm indicator lights are off.

**Start Machine** — If machine has manual auxiliary start, first energize the auxiliaries.

To re-energize the control circuit after a safety shutdown, depress the Stop button and then the Start button.

Now follow one of the 2 procedures described below as it applies to your machine:

- Start-Up After Limited Shutdown — If machine has been shut down for less than 3 weeks
- Start-Up After Extended Shutdown — If machine has been shut down for 3 weeks or more

## Start-Up After Limited Shutdown

1. Place the capacity control, Cycle-Guard,<sup>TM</sup> and Local-Remote settings in the position indicated in Table 7.

**Table 7 — Start-Up Setting Positions**

SETTINGS	POSITION
Capacity Control	AUTO.
Cycle-Guard Switch	AUTO.
Local-Remote Switch	AS APPROPRIATE

2. Depress the Start button.

Machine should start in normal manner and the Run light should be on. The refrigerant pump will start about 5 minutes after chiller starts; the solution typically heats up to normal operating conditions within 20 to 30 minutes.

If, however, machine does not lower leaving chilled water temperature to design, noncondensables may be present. In this case, take an absorber loss reading (see Maintenance Procedures, Absorber Loss Determination section, page 31).

If absorber loss is 5° F (3° C) or less, the chilled water temperature should drop to design within a short period as the automatic purge evacuates the machine. A completely evacuated machine normally has an absorber loss of 2° F (1° C) or less.

If absorber loss is greater than 5° F (3° C), follow the procedure for Start-Up After Extended Shutdown.

## Start-Up After Extended Shutdown

1. Start the machine in the normal manner by placing the capacity control and Cycle-Guard settings in the positions indicated in Table 7.
2. Depress the Start button.

When refrigerant pump starts and solution is warm (strong solution approximately 100 to 130 F [38 to 55 C]), place capacity control operation button in MANUAL position and press the positioning button (▼) to shut the steam valve.

3. Determine machine absorber loss (see Maintenance Procedures, Absorber Loss Determination section, page 31). If absorber loss is 5° F (3° C) or less, open capacity control valve by placing capacity control button in AUTO. position and allow machine to operate. The purge will evacuate the machine to the normal absorber loss of 2° F (1° C) or less.

If absorber loss is more than 5° F (3° C), evacuate machine to remove noncondensables that can prevent normal operation (see Maintenance Procedures, Machine Evacuation section, page 33). An alternative procedure is to limit steam pressure so that low-stage generator strong solution temperature remains below 140 F (60 C) while machine purge removes the noncondensables.

4. When absorber loss is reduced to 5° F (3° C) or less, place capacity control switch in AUTO. position, return steam pressure to normal and allow purge to establish the normal 2° F (1° C) or less absorber loss rate.
5. After evacuation, check the noncondensable accumulation rate to determine machine tightness (see Maintenance Procedures, Noncondensable Accumulation Rate section, page 31).

## Start-Up After Below-Freezing Conditions —

Refill all water circuits if previously drained. Then follow procedure for Start-Up After Extended Shutdown.

Remove solution from the refrigerant circuit by following the procedure, Removing Lithium Bromide from Refrigerant, page 35.

## Machine Shutdown — Normal Conditions

1. Depress the Stop button momentarily. Machine goes through automatic dilution for about 15 minutes and shuts down.
2. Close the main steam valve and stop system pumps. Leave machine in this condition until the next start-up.

## Machine Shutdown — Below Freezing Conditions

1. Depress the Stop button momentarily. Wait until automatic dilution is complete (about 15 minutes) and all machine pumps stop.
2. Close the main steam valve and stop system pumps.
3. Completely drain all tube bundles and flush all tubes with an antifreeze chemical such as glycol.
4.
  - a. The refrigerant circuit requires special treatment. Fill a hose with water (to avoid letting air into the machine), and connect it between the solution pump and refrigerant pump service valves.
  - b. Start the machine and open both service valves. Keep the steam valve closed. If the machine has a refrigerant pump with above atmospheric discharge pressure, it must be stopped for this procedure.
  - c. Allow solution pump to run for 10 minutes. This will transfer lithium bromide solution into the refrigerant, lowering the refrigerant freezing point. Close the service valves and remove the hose.
  - d. Leave the machine running with all machine pumps operating for about one minute to be sure lithium bromide has been mixed throughout the refrigerant circuit.
  - e. Depress the Stop button.

**Actions After Abnormal Shutdown** — Abnormal stop occurs automatically when any of the safety devices in Table 8 sense a condition which might be potentially damaging to the chiller. When this happens the steam valve closes completely, the alarm buzzer sounds, and the type of problem is indicated by one of the three fault lights. Also, both the Stop and Run lights will be on.

The buzzer can be silenced and the circuit reset for restart by depressing the Stop button, but this should be done only after noting which fault light is on; or the alarm buzzer stop button may be depressed to silence the buzzer while the control circuit remains in a shutdown alarm mode for troubleshooting. If the fault is a type which does not allow shutdown dilution, the condition should be corrected and the chiller either restarted, or started and stopped for normal

dilution, as quickly as possible to avoid solution crystallization when the machine cools down.

**Actions After Power Interruption** — If the control power is interrupted during operation, the chiller stops immediately without the normal shutdown sequence and dilution. The capacity control valve might be open so the steam supply valve should be closed immediately.

Solution crystallization can occur if the concentration is high (e.g., chiller was operating with a relatively large load). If so, depress the Start button to restart the machine as soon as possible after the power is restored. The machine will not restart automatically when power is recovered. If the chiller cannot be operated because of crystallization, follow the de-crystallization instructions in the Maintenance Procedures section, page 40.

**Table 8 —Automatic Stop Safety Devices**

CONDITION	CONTROL SYMBOL	SAFETY RELAY	SHUTDOWN DILUTION	SAFETY INDICATOR
Low chilled water flow (below 50%)	69CW	CWX	No	LD1
Low chilled water temperature (below 36 F [2 C])	26CW	CWX	No	LD1
Chilled water pump auxiliary contact	88EP	CWX	No	LD1
Cooling water pump auxiliary contact	88CP	CWX	No	LD1
Solution pump motor high temperature	26SP	26MX	No	LD2
Refrigerant pump motor high temperature	26RP	26MX	No	LD2
Solution pump motor current overload	51SP	26MX	No	LD2
Refrigerant pump motor current overload	51RP	26MX	No	LD2
High-stage generator high pressure (above $-0.8$ in. Hg [ $-20$ mm])	63GH	63GX	Yes	LD3
High-stage generator high temperature (above 338 F [170 C])	26GH	63GX	Yes	LD3
High absorber pressure (above $-400$ mm Hg [ $-15.8$ in. Hg])	ABS	ABSX	No	NONE

**PERIODIC SCHEDULED MAINTENANCE**

Normal preventive maintenance for 16JT absorption chillers requires periodic, scheduled inspection and service. Each item in the list below is detailed in the Maintenance Procedures section.

**Every Day of Operation**

1. Log machine and system readings.
2. Exhaust purge.

**Every Month of Operation**

1. Determine absorber loss.
2. Determine noncondensable accumulation rate.
3. Check capacity control adjustment.

**Every 2 Months of Operation**

1. Check low-temperature cutout.
2. Check Cycle-Guard™ operation.

**Every 6 Months of Operation**

1. Check refrigerant charge.
2. Check octyl alcohol.

**Every Year of Operation**

1. Have solution analyzed.
2. Check tubes for scale and fouling.

**Every 3 Years of Operation** — Replace service valve diaphragms.

**Every 5 Years or 20,000 Hours of Operation** — (Whichever comes first.)

1. Inspect hermetic pumps.
2. Filter or regenerate the solution if necessary.

**MAINTENANCE PROCEDURES**

**Log Sheets** — Readings of machine and system pressure-temperature conditions should be recorded daily to aid the operator in recognizing both normal and abnormal machine conditions. The record also aids in planning a preventive maintenance schedule and in diagnosing machine problems. A typical log sheet is shown in Fig. 24.

ENGINEER \_\_\_\_\_ DATE \_\_\_\_\_

JOB NAME \_\_\_\_\_ MACHINE SIZE \_\_\_\_\_ SERIAL NO. \_\_\_\_\_

TIME OF DATA									
PURGE EXHAUST AMOUNT/NUMBER									
CHILLED WATER	Temperature Entering								
	Temperature Leaving								
	Pressure Entering								
	Pressure Leaving								
COOLING WATER	Temperature Entering Absorber								
	Temperature Leaving Absorber								
	Temperature Leaving Condenser								
	Pressure Entering Absorber								
	Pressure Leaving Absorber								
	Pressure Leaving Condenser								
STEAM/ HOT WATER	Supply Pressure								
	Pressure/Temperature to Machine								
	Valve Position								
	Condensate/Leaving Water Temperature								
REFRIG- ERANT	Pump Discharge Temperature								
	Specific Gravity								
	High-Stage Vapor Condensing Temperature								
	Low-Stage Vapor Condensing Temperature								
	Cycle-Guard™ Operation?								
WEAK SOLUTION	Actual Temperature								
	Sample Temperature								
	Specific Gravity								
	Concentration								
	Saturation Temperature								
	Alcohol in Sample?								
	Temperature Leaving Low-Temperature Heat Exchanger								
	Temperature Leaving High-Temperature Heat Exchanger								
STRONG SOLUTION	Temperature Leaving High-Stage Generator								
	Temperature Leaving Low-Stage Generator								
	Temperature To Sprays								
	Temperature Leaving High-Stage Heat Exchanger								

Fig. 24 — Typical 16JT Maintenance Record Log Sheet

### Purge Manual Exhaust Procedure (Fig. 25) —

See also Machine Description section, pages 3-9, for explanation of the purge operation, component identification, and illustrations.

NOTE: The following does not apply to optional vacuum pump operation.

#### ⚠ CAUTION

NEVER LEAVE the machine during purging operation. A failure to close the exhaust valve will disable the machine, and could cause crystallization of the solution.

OPERATE THE VALVES in the correct sequence.

NEVER LET AIR leak into the machine.

MAKE SURE that the tip of the vinyl tube is at the bottom of the plastic bottle at all times.

NEVER SPILL any solution from the plastic bottle. If spilled on personnel or the floor, follow the warning pertaining to Handling Lithium Bromide Solution, page 21.

1. Exhaust purge only when machine and solution pump are operating, because the exhaust pressure is supplied by the solution pump.
2. Keep end of plastic tube below the liquid level in plastic bottle.
3. Close the solution return valve.
4. Wait approximately 5 minutes for storage chamber pressure to rise above atmospheric.
5. Slowly open the exhaust valve. If the liquid level in the exhaust bottle drops, close valve and wait approximately 2 minutes.
6. Slowly reopen the exhaust valve. If bubbles appear in the exhaust bottle, leave exhaust valve open until bubbles stop and solution level in bottle begins to rise. Close valve; purge is now exhausted.
7. Open the solution return valve to resume purge operation.
8. Slowly open the exhaust valve and allow solution in the bottle to be drawn into the purge tube. Lower the solution level until bottle is one-third to one-half full. Close exhaust valve before solution level in bottle nears the tube end. *Do not allow air to be drawn into the purge tube.*
9. Log the date and time of purge evacuation to provide an indication of changes in the rate of noncondensable accumulation.

**Absorber Loss Determination** — Take absorber loss readings when machine is operating with stable temperatures.

1. Make sure that Cycle-Guard™ valve is closed and has not operated for at least 10 minutes before taking readings.
2. Fill thermometer wells on discharge lines of solution and refrigerant pumps with oil or heat conductive compound and insert thermometers.
3. Take refrigerant and solution samples (see Solution or Refrigerant Sampling, page 34), and determine the specific gravity and temperature of each sample. The samples can be returned to the machine through the purge exhaust bottle.
4. Using the equilibrium diagram (Fig. 22A or 22B), plot the intersection point of the specific gravity and temperature of the solution sample. Extend this point

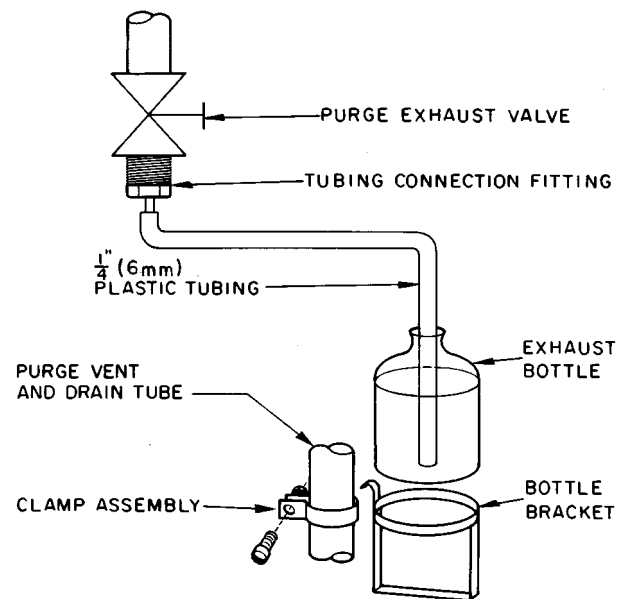

Fig. 25 — Purge Exhaust Assembly

- horizontally to the right and read the saturation temperature. Repeat with refrigerant sample, using Fig. 26A or 26B and reading to the left for saturation temperature.
5. Subtract the solution saturation temperature from the refrigerant saturation temperature. The difference is the absorber loss. Repeat the readings with a second sample to verify steady state conditions. (On larger chillers with multiple solution pumps, determine saturation temperature for each pump.) If the absorber loss is greater than 5° F (3° C), machine evacuation is necessary because excessive noncondensables may interfere with normal operation before they can be removed by the purge (see Machine Evacuation section, page 33).

For probable causes and suggested remedies for high absorber loss, refer to the Troubleshooting Guide, pages 41 and 42.

**Noncondensable Accumulation Rate** — The most important maintenance item on the absorption machine is the maintenance of machine vacuum within acceptable limits. Machine vacuum tightness can be checked by determining the rate at which noncondensables accumulate. Some noncondensables are normally generated within the machine; but an air leak or the need for additional inhibitor is indicated if the accumulation rate increases.

After machine evacuation or other service, operate machine for at least 200 hours before determining noncondensable accumulation rate. Then proceed as follows (Fig. 27):

1. Fill a length of flexible tubing with water and connect to the purge exhaust connection. Insert free end into a container of water. Exhaust purge completely (see Purge Manual Exhaust Procedure section, on this page).
2. Operate machine for 24 hours with purge operating normally.
3. Fill a 2-pint (1000 cm<sup>3</sup>) bottle with water and invert it in a clean container filled with water.
4. Insert the free end of water-filled hose into the bottle.
5. Follow the purge exhaust procedure. Noncondensables displace water in the inverted bottle. Continue until bubbling in the bottle ceases and only solution flows from exhaust tubing.

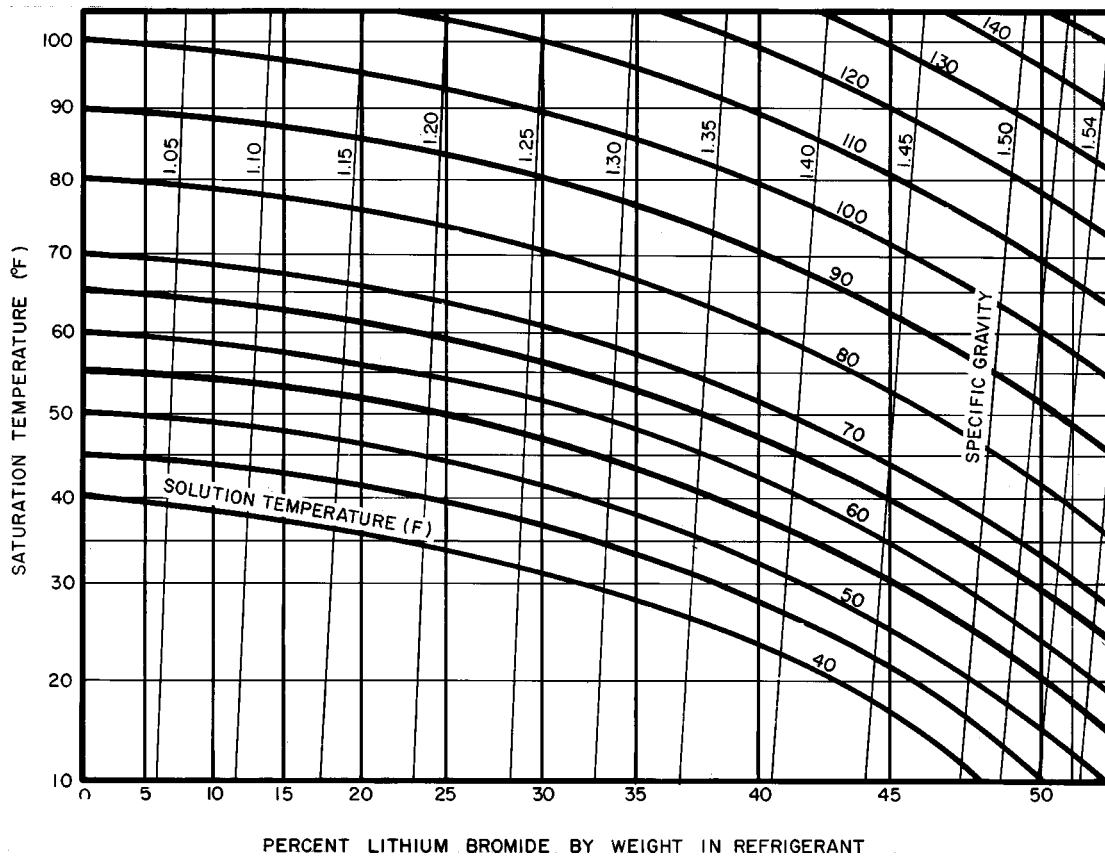

Fig. 26A — Equilibrium Diagram for Lithium Bromide in Refrigerant (F)

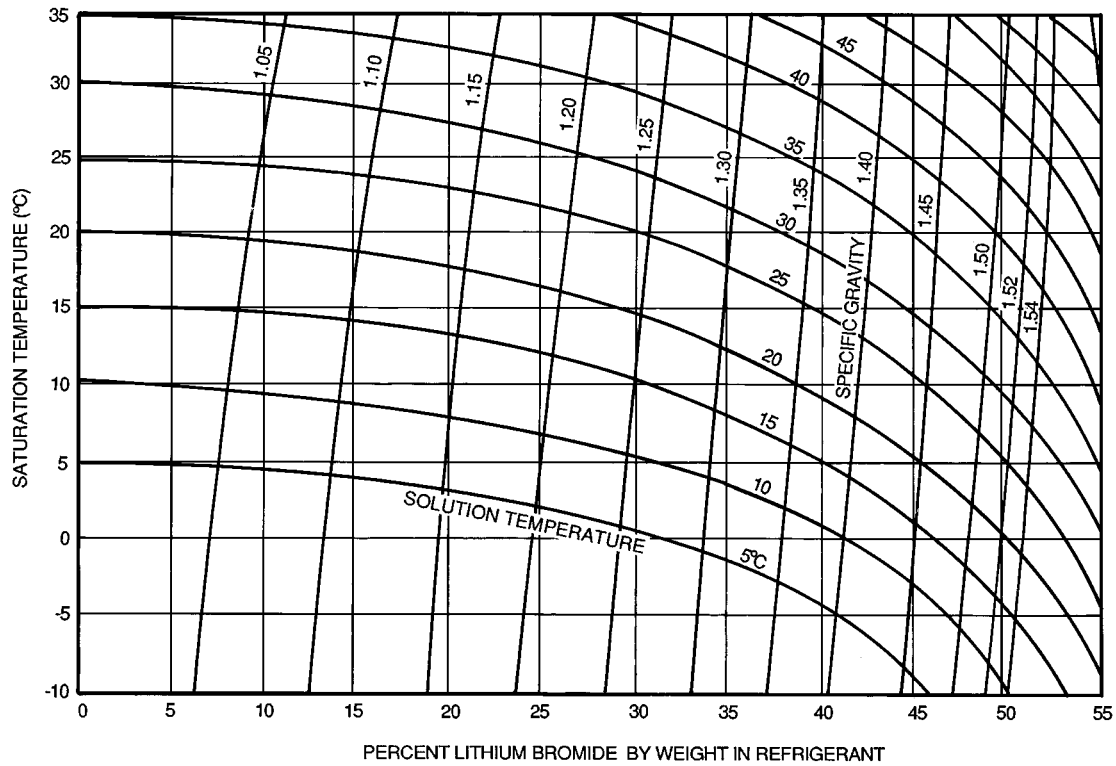

Fig. 26B — Equilibrium Diagram for Lithium Bromide in Refrigerant (C)

6. Close exhaust valve and mark liquid level on inverted bottle. Remove bottle from container.
7. Return purge to normal operation. Replace exhaust bottle (Fig. 25). Open solution return valve (Fig. 8 and 9).
8. Measure the amount of noncondensables removed. If a graduated bottle is used, the amount (volume) of noncondensables removed is indicated by mark on bottle. If a nongraduated bottle is used, empty the bottle and then fill the bottle with liquid to the exhaust mark. Pour the liquid into a graduated container to measure the volume displaced.
9. If the operating accumulation rate has increased substantially from previous rates, machine has an air leak or requires additional inhibitor. Have a solution sample analyzed (see Solution Analysis section, page 34, to determine the proper corrective action. *If a leak is indicated, it must be found and repaired as soon as possible to minimize internal corrosion damage.*)

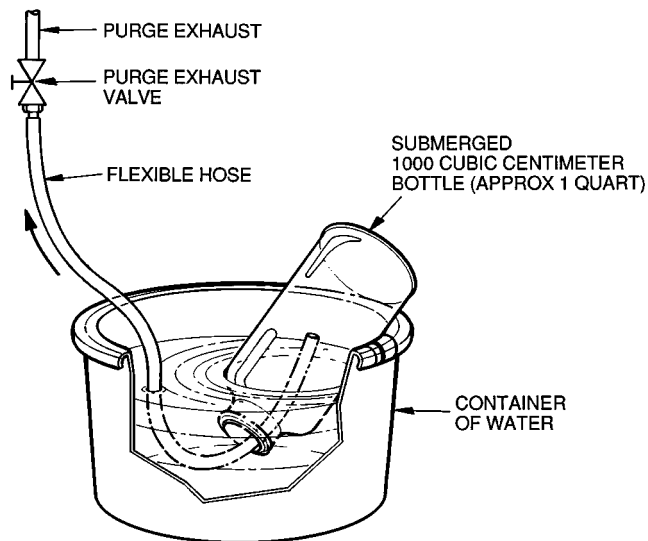

Fig. 27 — Collecting Noncondensables

**Machine Leak Test** — All joints welded at machine installation must be leak tested before initial start-up of machine. Joints must also be leak tested after repair. If there is any indication of air leakage, leak test the entire machine.

1. Be sure auxiliary evacuation valve, purge exhaust valve, and all pump service valves are closed.
2. Break machine vacuum with dry nitrogen. Pressurize machine to 6 psig (40 kPa) with tracer gas. Charge the nitrogen and refrigerant through the auxiliary evacuation valve.
3. Use dry nitrogen to raise machine pressure to 12 psig (80 kPa). *Do not exceed 12 psig (80 kPa).*
4. Leak test all joints with an electronic leak detector.
5. Correct all leaks; retest to ensure repair.
6. Release machine pressure and perform machine evacuation.

**Machine Evacuation** — Evacuation is required for the removal of excessive noncondensables from the machine. The machine must be evacuated after air has entered the machine during service work or when absorber loss is greater than 5° F (3° C) during operation.

1. Connect an auxiliary evacuation device to the auxiliary evacuation valve (Fig. 28). Use a line size at least equal to the connection size on the auxiliary device and keep the line as short as possible. *A check valve must be used on the suction lines. Be sure all connections are vacuum tight.*

A vacuum pump oil trap can also serve as a cold trap if it has a center well to hold dry ice or a mixture of salt and ice. Any water vapor that can contaminate the oil in the vacuum pump is condensed and removed by the cold trap. The cold trap reduces the time required for evacuation and eliminates the need for frequent replacement of the pump oil charge.

2. Start evacuation device. After one minute, open auxiliary evacuation valve. If the machine is not operating, reduce machine absolute pressure to the pressure equivalent of the saturation temperature of the refrigerant. If the machine is operating, evacuate until absorber loss is 5° F (3° C) or less.
3. Close auxiliary evacuation valve and turn off the auxiliary evacuation device.
4. Machine evacuation can remove octyl alcohol. Check a solution sample for the presence of octyl alcohol and add if necessary (see Adding Octyl Alcohol, page 35.)

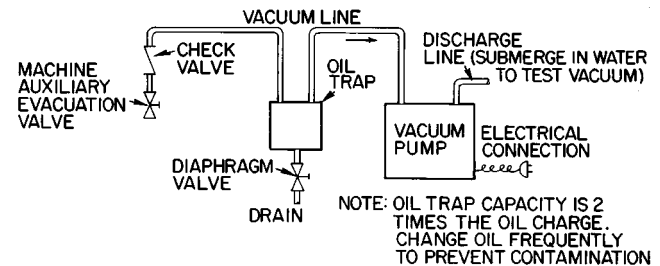

Fig. 28 — Machine Evacuation Device

**Solution or Refrigerant Sampling** — (See precautions pertaining to handling lithium bromide solution as described in Solution and Refrigerant Charging section, page 21.)

Take solution or refrigerant samples from the pump service valve while the pump is operating.

Before taking a sample for analysis or absorber loss determination, be sure machine is operating with steady load and that Cycle-Guard™ valve has not been energized within 10 minutes prior to sampling.

Attach a hose adapter to the pump service valve. Do not use copper or brass fittings when taking samples for analysis; copper oxide can form and contaminate samples.

The solution pump normally discharges at above atmospheric pressure, but the refrigerant pump discharges at a vacuum, so the respective sampling procedures are different.

### SOLUTION SAMPLE

1. Fill a length of flexible tubing with water and connect one end to the hose adapter. Place the free end in a container of water. Be sure end is submerged (Fig. 29).
2. Open valve slightly. When container water level rises, wait several seconds to purge the water from the tube. Then remove tube end from water and fill sample container.
3. Turn off service valve and remove hose and adapter.

### REFRIGERANT SAMPLE (Fig. 30)

1. Connect a clean, empty vacuum container to the pump service valve with a length of flexible hose and isolation valve.
2. Connect a vacuum pump to the vacuum container with a flexible hose and isolation valve.
3. Pull a deep vacuum on the container and close the isolation valve.
4. Open the service valve slightly to drain refrigerant sample into the container.
5. Turn off service valve, remove hose and adapter, and disconnect vacuum pump.

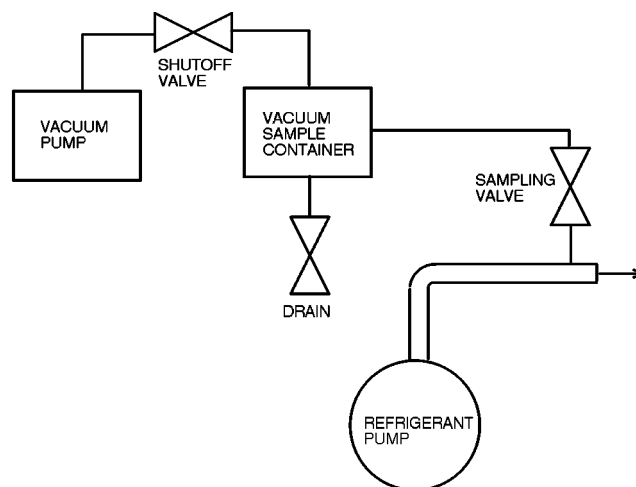

**Fig. 30 — Refrigerant Sampling Technique**

**Solution Analysis** — Laboratory analysis of a solution sample gives indication of change in solution alkalinity and depletion of inhibitor, and may indicate the degree of machine leak tightness.

Have the solution analyzed at least once a year or whenever there is an indication of a noncondensable problem. Take the sample from the solution pump service valve while the machine is running (see Solution or Refrigerant Sampling section, this page). The sample concentration should be between 58% and 62% by weight for best results.

Solution analysis should be done by an approved laboratory. The analysis interpretation and the adjustment recommendations should be made by a trained absorption specialist.

**Inhibitor** — The initial charge of lithium bromide includes a lithium chromate inhibitor. The inhibitor is used in conjunction with alkalinity control to minimize the amount of hydrogen normally generated within the machine. Excessive hydrogen generation interferes with machine performance.

The inhibitor is gradually depleted during machine operation and occasional replenishment is necessary. Solution alkalinity also changes over a period of time and must be adjusted (see Solution Analysis, on this page).

**IMPORTANT:** Altering the inhibitor or using solution and internal surface treatments not specified by the equipment manufacturer may result in performance deterioration and damage to the absorption machine.

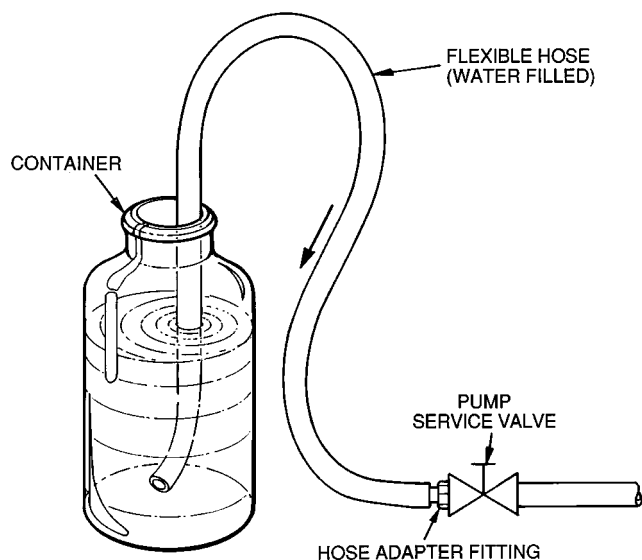

**Fig. 29 — Adding or Removing Fluid**

**Adding Octyl Alcohol** — Octyl alcohol may be required when leaving chilled water temperature starts to rise above design temperature without alteration of the control set point. Since the rise in temperature can also be caused by fouled tubes or other problems, use the following procedure to determine whether a lack of octyl alcohol is the cause:

1. Remove a sample of solution from the solution pump service valve (see Solution or Refrigerant Sampling section, page 34). If the solution has no odor of alcohol (very pungent), add about ½ gal. (2 L) of octyl alcohol.

The addition of octyl alcohol also may be required after the machine has been evacuated or after an extended period of operation.

### ▲ CAUTION

Use only octyl alcohol. Other types of alcohol have a detrimental effect on machine performance.

2. Fill a length of flexible tubing with water and connect one end to the solution pump service valve (see Fig. 29). Insert the other end in a container of octyl alcohol. Stop the solution pump. The pump can be stopped without a dilution cycle by pressing the trip bar on the pump starter overload, then pressing the Stop button and the overload reset. Then open the service valve to allow alcohol to be drawn into the machine. *Close valve before air can be drawn into the hose.* Restart the chiller and solution pump.

### Removing Lithium Bromide from Refrigerant

— During normal operation, some lithium bromide may be carried over into the refrigerant. Lithium bromide in the refrigerant is automatically transferred back to the absorber by the Cycle-Guard™ valve when it is needed. The refrigerant flows through the Cycle-Guard valve into the solution circuit and separation is made in the generator in the normal manner.

Lithium bromide recovery can also be initiated by placing the Cycle-Guard switch in MANUAL position while the machine is running and the capacity control valve is open. When the refrigerant specific gravity drops below 1.02, return the Cycle-Guard switch to AUTO. to close the Cycle-Guard valve.

**Refrigerant Charge Adjustment** — Check the evaporator refrigerant (water) charge after every 6 months of operation. An increase in the amount of water in the machine indicates tube leakage. Furthermore, the correct refrigerant charge must be maintained for accurate operation of the Cycle-Guard system.

For charge adjustment, refer to Initial Start-Up, Final Refrigerant Charge Adjustment section, page 25.

**Capacity Control Adjustment** — Check the leaving chilled water temperature. If design temperature is not being maintained, reset the control set point in the machine control panel (see Check Capacity Control Operation section, page 23).

If machine still fails to maintain design temperature, refer to the Troubleshooting section entitled Problem/Symptom — Leaving Chilled Water Temperature Too High or Too Low, page 41.

**Low-Temperature Cutout Adjustment** — This machine safety serves to prevent freeze-up damage to the evaporator tubes. Check the cutout periodically to confirm trip at the selected setting.

NOTE: If the cutout sensor has been exposed to temperatures above 120 F (49 C), the control must be recalibrated.

1. Remove the control sensing element from its well in the chilled water pipe. Immerse the element in a container of cool water. Slowly stir crushed ice into the water so that the temperature goes down at a rate not exceeding 1° F (0.5° C) per minute.
2. Observe the cutout temperature. It should be 9° F (5° C) below design leaving chilled water temperature or a minimum of 36 F (2 C). *If control fails to cut out by 36 F (2 C), stop machine immediately and recalibrate control as described in Check Low-Temperature Cutout section, page 22.*
3. When control cuts out, machine shuts down immediately without going through dilution cycle. Control cuts in when sensing element warms up 7.2° F (4° C).

If necessary, reset cutout adjustment knob and recalibrate. Restart machine by depressing the Stop button and then the Start button. Replace sensing elements in wells.

**Cycle-Guard™ System Operation** — To check operation, place Cycle-Guard switch in MANUAL position. The Cycle-Guard transfer valve energizes. The flow of refrigerant will cause the transfer line between valve and solution pump inlet to feel cold to the touch. This line should not feel cold when the transfer valve is closed (not energized). If the line is cold when valve is deenergized, the valve is leaking and must be repaired. Return Cycle-Guard switch to AUTO. position.

During normal operation, the Cycle-Guard valve is controlled by a thermostic switch (26SH), which senses the strong solution temperature as it flows to the absorber spray header and by 2 refrigerant level switches (33RH and 33RM), located in the evaporator.

For nominal operating conditions, switch 26SH closes on temperature drops below 118 F (48 C). Special operating conditions may require special settings.

Level switches 33RH and 33RM close with rising refrigerant levels that correspond to increasing solution concentrations of approximately 59.5% and 60.0% respectively, for nominal full load operating conditions. (See Maintenance Procedures entitled Refrigerant Charge Adjustment and Thermostic Switch Adjustment, pages 35 and 36.)

Cycle-Guard system malfunction makes the machine susceptible to solution crystallization. See Troubleshooting Guide, Solution Crystallization During Operation, page 42.

**Thermoswitch Adjustment** — Check the 26SH thermoswitch while machine is operating.

1. A thermowell is located on the absorber spray supply pipe near the thermoswitch sensing bulb well. Place heat conductive compound or oil in the thermowell and insert a thermometer with a range of about 0° to 300 F or about 0° to 150 C).
2. Turn the thermoswitch adjustment knob fully counterclockwise and then slowly clockwise until the contacts close. Note the difference (if any) between the actual thermometer reading and the reading on the thermoswitch adjustment scale as the contacts close. Allow for this difference in setting the thermoswitch control point. (Example: As switch contacts close, thermometer reads 110 F (43.3 C) and thermoswitch scale reads 107 F (41.7 C), an error of 3° F (1.6° C). To have contacts close at a selected temperature of 118 F (47.8 C), knob must be set at scale reading of 115 F (46.1 C).

Allowing for any temperature difference as described above, set adjustment knob as required to make contacts close at 118 F (48 C) thermowell temperature.

NOTE: Special operating conditions may require other thermoswitch settings. Check job data. Use same adjustment procedure.

**Low-Refrigerant Level Operation** — During low-load operation, with low condensing water temperature, the normal dilution of the solution will lower the refrigerant level in the evaporator. If the level goes down enough to open the low refrigerant level switch 33RL, the refrigerant pump stops to prevent cavitation in the refrigerant pump and subsequent pump motor failure.

To check the operation of the low-level switch, first place the capacity control in MANUAL and ▼ position (which closes the steam valve) and the Cycle-Guard switch in MANUAL. This will transfer refrigerant to the solution circuit, lowering the refrigerant level in the evaporator. When the refrigerant level reaches the low-level switch, the refrigerant pump stops. Then return both the Cycle-Guard switch and the capacity control to AUTO. positions. If the pump becomes noisy, it might be in cavitation from a low level switch malfunction. Do NOT allow the pump to remain in operation with this condition.

**Internal Service** — To prevent corrosion from air inside the machine, break vacuum with nitrogen when opening the machine for maintenance or repair.

While the machine is open, it is good practice to minimize the amount of air entering by continuously feeding nitrogen into the machine at approximately 1 psig (7 kPa) pressure.

Perform service work promptly and efficiently and close the machine as soon as possible. Do not rely on the inhibitor for corrosion protection unless all lithium bromide and refrigerant have been removed and the machine has been completely flooded with a lithium chromate inhibitor-water solution prior to machine opening.

Leak test the machine thoroughly after the machine has been closed up.

### ⚠ WARNING

When flamecutting or welding on an absorption machine, some noxious fumes may be produced. Ventilate the area thoroughly to avoid breathing concentrated fumes.

Never cut into the purge chamber unless the purge has been exhausted to remove any hydrogen gas that might be present in the chamber. Hydrogen can form an explosive mixture in the air.

**Service Valve Diaphragm Replacement** — To replace valve diaphragms:

1. Break machine vacuum with nitrogen. Solution and refrigerant can be transferred to opposite sumps within the machine or removed from the machine. If removed from the machine, store it in clean containers for recharging.
2. Remove old valve diaphragms and replace. Torque valve bolts to approximately 3 lb-ft.
3. Test all affected connections for leakage (see Machine Leak Test section, page 33).
4. Reevacuate machine after servicing (see Machine Evacuation section, page 33).
5. Replace solution and refrigerant in machine (the same quantity that was removed).

**Hermetic Pump Inspection** — Figure 31 is a sectional structural schematic of a typical refrigerant or solution pump used on the 16JT chiller. These centrifugal pumps are hermetic and do not require seals. The rotor assembly is enclosed in a thin stainless steel can, and some of the pump discharge liquid (refrigerant or solution) is circulated around the rotor assembly for cooling the motor and for lubricating the bearings. The following instructions are general procedures for a typical pump version. Details will vary slightly for different pump models.

### ⚠ CAUTION

Never run hermetic pump motor dry. Even momentary operation without machine filled with liquid will damage bearings and overheat the motor. Use only the current value specified in the control circuit diagram when setting the pump starter overloads.

## DISASSEMBLY

### ⚠ WARNING

Disconnect all primary power to the pumps; lock and tag all disconnect switches.

1. Break vacuum with nitrogen if not already performed.
2. Remove solution and refrigerant from the machine. Store in clean containers until recharging.



3. Open the motor wiring terminal box (Item 11) and disconnect the motor power leads. Mark the leads to ensure proper reassembly.
4. Remove nuts (Item 21) holding motor adapter flange to pump casing (Item 23). With the larger motors which have a hanger support, disconnect the hanger. Place matching orientation marks on the two flanges.

NOTE: Use blocking to support the weight of the motor before moving it and before removing hanger support.

5. If pump has a circulation pipe (Item 1) connected to the pump discharge pipe, disconnect the circulation pipe at this time.
6. Use jack screw to loosen motor from pump casing. Pull motor straight back from pump casing until impeller (Item 25) has cleared the housing.
7. Remove and discard casing flange gasket (Item 22).
8. Straighten locking tabs on impeller locking washer (Item 30), and remove locking screw (Item 31). Prevent impeller from rotating while removing the locking screw.
9. Remove impeller with impeller/gear puller. Remove shaft key (Item 32).

10. Remove bolts (Item 24) for motor wear ring housing (Item 33), and, using one bolt as a jack screw, carefully loosen the wear ring housing from the motor adapter flange. Place matching orientation marks on the two pieces. Pull the wear ring housing straight back from the motor while supporting the impeller shaft (Item 17), being careful to not damage the bearings or the stator and rotor cans (Items 14 and 15).

11. Remove the impeller end radial and thrust bearings (Items 34 and 35), and mark them for both location and direction (i.e., which end of the bearing faces the impeller end of the motor).

12. While continuing to support the impeller shaft, pull the rotor (Item 16) straight out of the rotor cavity, being careful to not damage the bearings or the stator and rotor cans.

13. Remove the bolts (Items 3 and 40) from the circulating pipe connecting flange(s), if not previously done, to disconnect the pipe from the end of the motor.

14. Remove and discard O-rings (Items 2 and 39).

15. Remove the bolts (Item 4) on the motor end cover (Item 5) and use one as a jacking screw to loosen the end cover from the motor end flange. Place matching orientation marks on the two pieces. Remove the cover.

16. Remove the motor end radial and thrust bearings (Items 7 and 8), and mark them for both location and direction (i.e., which end of the bearing faces the impeller end of the motor).

17. NOTE: Remove and discard motor end cover gasket (Item 6).

NOTE: Do not remove the plug (Item 18) on the top of the motor (Item 12) except when leak testing or drying the motor windings.

## INSPECTION

1. Check circulation passages in motor and circulating pipe. Clean if necessary.
2. Inspect rotor and stator cans for scratches, rubbing, or punctures. Severe damage will require motor replacement.
3. Inspect the radial bearing cavities in the motor end cover and wear ring housing. If the internal surface is rough or worn more than the maximum diameter in Table 9, replace the part.

**Table 9 — Maximum Radial Bearing Cavity Measurement**

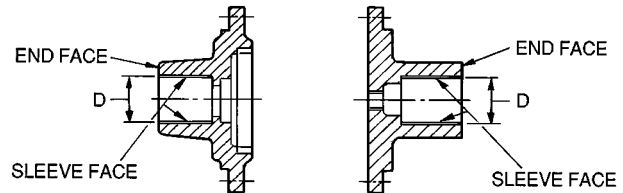

MOTOR SIZE kW	MAX. DIAMETER (D)	
	in.	mm
1.5	1.27	32.3
3.7	1.51	38.3
5.5	1.98	50.3
7.5	1.98	50.3

4. Inspect the radial and thrust bearings. If the surface is very rough or deeply scratched, or if worn to a thickness less than listed in Table 10, replace the bearing. The thrust bearing on the impeller end normally receives the greatest wear.

**Table 10 — Minimum Bearing Thickness Measurement**

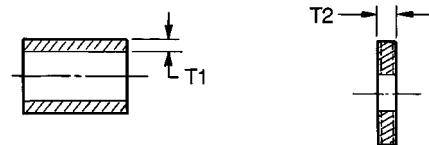

MOTOR SIZE kW	MIN. RADIAL THICKNESS (T1)		MIN. THRUST THICKNESS (T2)	
	in.	mm	in.	mm
1.5	0.13	3.3	0.18	4.6
3.7	0.15	3.8	0.18	4.6
5.5	0.19	4.8	0.22	5.6
7.5	0.19	4.8	0.22	5.6

- Check the impeller wear surfaces. If very rough or worn to outside diameters less than listed in Table 11, replace the impeller.

**Table 11 — Maximum Wear Ring Inner Diameters**

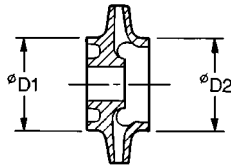

MOTOR SIZE	MAX. MOTOR RING (D1)		MAX. CASING RING (D2)	
	in.	mm	in.	mm
1.5	3.47	88.2	3.00	76.2
3.7	3.95	100.2	3.95	100.2
5.5	3.95	100.2	3.95	100.2
7.5	3.95	100.2	3.95	100.2

- Check the wear rings. If the wear surfaces are very rough or deeply scratched, or are worn to inner diameters less than listed in Table 12, replace the wear ring. They are retained by setscrews (Items 26 and 27).

**Table 12 — Minimum Impeller Wear Diameters**

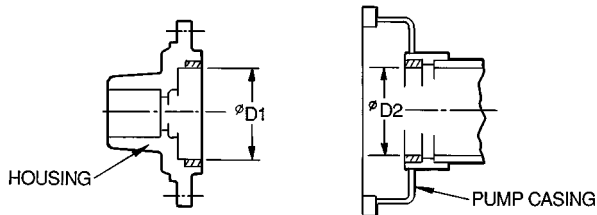

MOTOR SIZE	MIN. MOTOR SIDE (D1)		MIN. MOTOR SIDE (D2)	
	in.	mm	in.	mm
1.5	3.45	87.6	2.98	75.6
3.7	3.92	99.6	3.92	99.6
5.5	3.92	99.6	3.92	99.6
7.5	3.92	99.6	3.92	99.6

- Check the condition of the thrust collars (Items 9 and 36) on the rotor shaft. If very rough, deeply scratched, or severely worn, they should be replaced. They are retained by pins (Items 10 and 37).
- Check the condition of the radial bearing sleeve faces on the rotor shaft. If very rough, deeply scratched, or severely worn, they should be replaced. They are retained by pins.
- Check the motor insulation resistance. If less than 10 milliamps, the windings must be dried.

## REASSEMBLY

- Clean all parts, gasket surfaces, and O-ring grooves. Use new gaskets (Items 6 and 22) and new O-rings (Items 2 and 39).
- Install motor end radial bearing (Item 7) in the motor end cover (Item 5) and apply a small amount of gasket paste to both sides of the gasket (Item 6). Mount the motor end cover and gasket, aligning the match marks applied during disassembly. The internal flow passage "A" should be at the top as the pump is installed on the chiller.
- Place thrust bearings (Items 8 and 35) against their respective thrust collars on the rotor shaft (Item 17). Carefully guide rotor (Item 16) into position within the stator (Item 13) to avoid damage to the bearings, rotor liner (Item 15), and stator can (item 14).
- Install radial bearing (Item 34) and motor side wear ring (Item 27) in the wear ring housing (Item 33). Mount the wear ring housing, aligning the match marks applied during disassembly. The internal flow passage "A" should be at the top as the pump is installed on the chiller.
- Install impeller (Item 25) with impeller key (Item 32), lock washer (Item 30) and locking screw (Item 31). Bend washer tabs over flats of locking screw head.
- Turn impeller by hand to be sure it rotates easily.
- Install new O-rings (Items 2 and 39) in flanges for circulation pipe (Item 1) and mount pipe in place.
- Install pump casing wear ring (Item 29) if not already in place.
- Apply a small amount of gasket paste to both sides of gasket (Item 22) and position on pump casing flange. Slide motor stator housing and adaptor flange assembly into pump casing, aligning the match marks applied during disassembly. Use blocking to support the motor stator until all bolts have been tightened and the motor support, if used, has been reconnected.

## COMPLETION

- Leak test affected joints to be sure all pump connections are tight. (See Machine Leak Test section, page 33.)
- Evacuate machine (see Machine Evacuation section, page 33).
- Recharge machine with same quantity of solution and refrigerant as removed.
- Reconnect motor power leads to motor wires in same arrangement as when disconnected and replace junction box cover.
- Restore power supply to pump and chiller controls.
- Record inspection date and results.

**Solution Decrystallization** — Crystallization occurs when strong solution concentration and temperature cross over to the right of the crystallation line on the equilibrium diagram (Fig. 22A and 22B). It should not occur if machine controls are correctly adjusted and machine is properly operated. Refer to the Troubleshooting Guide, pages 41 and 42, for probable causes and remedies.

If crystallization occurs, it generally takes place in the shell side of the low-temperature heat exchanger and blocks the flow of strong solution from the low-stage generator. The strong solution then overflows into a pipe that returns it directly to the absorber sump. The solution pump(s) then returns the hot solution through the heat exchanger tubes, automatically heating and decrystallizing the shell side.

If crystallization results from a long, unscheduled shut-down (such as from a power failure) without proper dilution, the solution pump(s) may become bound and fail to rotate. This will cause the overloads to trip out. In such a case, decrystallize as follows:

1. Heat the solution pump casing and adjacent lines with steam.

**▲ CAUTION**

Under no circumstances apply heat directly to pump motor or controls when warming the casing. Do not apply direct heat to any flange connections; high temperature can deteriorate the gasket material.

2. Rotation of a hermetic pump cannot be viewed directly. Check the solution pump rotation by installing a compound gage on the pump service valve and reading discharge pressure. Reset the pump overloads in the control panel if they are tripped.

If the pump is rotating normally, the gage will show a reading above atmospheric pressure. If the pump casing and discharge line are completely blocked, the gage will show zero atmospheric pressure. If the pump interior is only partially blocked, a deep vacuum will indicate that the pump is not rotating.

3. Continue heating the casing until gage pressure shows above atmospheric pressure with pump overloads reset. *Do not reset pump overloads more than once in any 7-minute period.*

If the heat exchanger is also blocked, the decrystallization process will begin as soon as the solution pump starts rotating and the adjacent weak solution lines have decrystallized. If the heat exchanger or adjacent piping does not decrystallize automatically, heat the blocked area externally with steam or a soft torch flame. Crystallization in purge piping can be broken up by applying heat in the same manner.

4. If the strong solution line from heat exchanger to absorber spray nozzles is blocked, turn off the condensing water pump and operate the machine with capacity control valve open. Turn the Cycle-Guard™ switch to MANUAL to dilute the solution. The entire unit will pick up heat and the crystallization will dissolve. Do not heat solution leaving absorber above 140 F (60 C) to avoid overheating the solution pump motor. If severe crystallization is present, it may take 4 to 6 hours to fully decrystallize.

When heating the machine in this manner, remove the low-temperature cutout (LTCO) and thermostatic sensing bulbs from their wells and insulate them to prevent overheating. When machine temperatures return to normal, recalibrate the LTCO and thermostats (see Low-Temperature Cutout Adjustment and Thermostatic Adjustment section, pages 35 and 36).

**Condensing Water Tube Scale** is indicated if the temperature difference between condensing water leaving the condenser and refrigerant condensate from the condenser is greater than the normal 4 to 7° F (2 to 4° C) difference at full load (capacity control valve fully open). Scale reduces heat transfer, increases steam consumption, and limits machine capacity. Scale can also cause serious corrosion damage to the tubes.

Soft scale can be removed from tubes with cleaning brushes, specially designed to avoid scraping or scratching the tube walls. The brushes are available through your Carrier representative. *Do not use wire brushes.*

**▲ CAUTION**

Hard scale may require chemical treatment for its prevention or removal. Consult a water treatment specialist for proper treatment.

**Water Treatment** — Untreated or improperly treated water may result in corrosion, scaling, erosion, or algae. The services of a qualified water treatment specialist should be obtained to develop and monitor a treatment program.

**▲ CAUTION**

Water must be within design flow limits, clean, and treated to ensure proper machine performance and reduce the potential of tubing damage due to corrosion, scaling, or erosion. Carrier assumes no responsibility for chiller damage resulting from untreated or improperly treated water.

## TROUBLESHOOTING GUIDE

PROBLEM/SYMPTOM	PROBABLE CAUSE	REMEDY
<b>Machine Will Not Start or Shuts Down</b> (Panel RUN light out, pumps off.)	No power to control panel	Check for building power failure. Check main circuit breaker.
	Control panel fuse blown	Examine circuits for ground or short. Replace fuse.
	Control panel main circuit breaker open	Close main circuit breaker.
	Control panel switches not set correctly	Depress Stop button after safety shutdown. Place capacity control and Cycle-Guard™ selections in AUTO. and depress Start button.
	Chilled water or condensing water pump overloads or flow switches open	Check chilled water and condensing water pumps, starters and valves.
	Solution pump overloads open	Push overload reset button. Measure pump discharge pressure to check for solution crystallization (see Solution Decrystallization section on page 40).
	Refrigerant pump overloads open	Push overload reset button.
	Low temperature cutout	Depress Start button after chilled water has warmed at least 7° F (4° C). Measure chilled water temperature. Recalibrate or replace switch if temperature is above set point. Check capacity control setting and operation if temperature is below switch setting (see Check Capacity Control Operation section on page 23).
	High generator solution temperature or pressure, high absorber pressure.	Check cooling water temperature and flow. Check absorber pressure.
<b>Leaving Chilled Water Temperature Too High</b> (Machine running, chilled water temperature above design.)	Steam control valve not open	Verify capacity control is positioned at AUTO. Check capacity control operation per Initial Control Checkout and Adjustment section, pages 22-24.
	Set point too high	Reset temperature control in control panel.
	Excessive cooling load (machine at capacity)	Check for cause of excessive load.
	Excessive chilled water flow (above design)	Check pressure drop per selection data and reset flow.
	Low condensing water flow (below design)	Check pressure drop per selection data and reset flow.
	High supply condensing water temperature (above design)	Check cooling tower operation and temperature controls.
	Low steam pressure (below design)	Raise to design per selection data.
	Inadequate steam condensate drainage (condensate backs up into tube bundle)	Check operation of steam traps, strainers, valves, and condensate receivers.
	Fouled tubes (poor heat transfer)	Clean tubes. Determine if water treatment is necessary.
	Machine needs octyl alcohol	Check solution sample and add octyl alcohol if necessary (see Adding Octyl Alcohol section on page 35).
	Noncondensables in machine	Check absorber loss (see Absorber Loss Determination section on page 31). If above 5° F (3° C), see Causes and Remedies under Inadequate Purging (high absorber loss) section on page 42.
	Capacity control malfunction	Check calibration and operation of capacity controls (see Check Capacity Control Operation section on page 23).
	Solution crystallization (solution flow blockage)	See Causes and Remedies under Solution Crystallization on page 42.
	Low refrigerant level	Check the low-level switch operation and check for low condensing water temperature.
	Cycle-Guard control malfunction (low solution concentration)	Check refrigerant charge and thermoswitch calibration. (See Refrigerant Charge Adjustment, Cycle-Guard System Operation and Thermoswitch Adjustment sections on pages 35 and 36). Verify Cycle-Guard switch in AUTO.
<b>Leaving Chilled Water Temperature Too Low</b> (Machine running, chilled water temperature below design.)	Set point too low	Reset temperature control in control panel.
	Capacity control malfunction	Check calibration and operation of capacity control (see Check Capacity Control Operation section on page 23).
<b>Leaving Chilled Water Temperature Fluctuates</b> (Machine running, capacity control hunting.)	Chilled water flow or load cycling	Check chilled water system, controls and load.
	Condensing water flow or temperature cycling	Check condensing water temperature control and cooling tower operation.
	Steam pressure cycling	Check steam pressure control.
	Inadequate steam condensate drainage (condensate backs up into tube bundle)	Check operation of steam traps, strainer, valves, and condensate receivers.
	Capacity control malfunctions	Check calibration and operation of capacity control (see Check Capacity Control Operation section on page 23).

## TROUBLESHOOTING GUIDE (cont)

PROBLEM/SYMPTOM	PROBABLE CAUSE	REMEDY
<b>Inadequate Purging</b> (Low machine capacity and high absorber loss — see Absorber Loss Determination, page 31.)	Air leakage in vacuum side of machine (high noncondensable accumulation rate)	Have solution analyzed for indication of air leaks. Leak test and repair if necessary (see Noncondensable Accumulation Rate, Solution Analysis, and Machine Leak Test sections on pages 31, 34, and 31, respectively).
	Inhibitor depleted (high noncondensable accumulation rate)	Have solution analyzed. Add inhibitor and adjust solution alkalinity if necessary (see Noncondensable Accumulation Rate, Solution Analysis, and Inhibitor sections on pages 31, 32, respectively).
	Purge valves not positioned correctly	Check valve positions (see Purge Manual Exhaust Procedure section on page 31).
	Purge solution supply lines crystallized (not able to exhaust purge)	Heat solution supply lines (see Purge Manual Exhaust procedure and Solution Decrystallization sections on pages 31 and 40).
<b>Solution Crystallization During Operation</b> (Strong solution overflow pipe hot.)	Cycle-Guard™ control malfunction (solution overconcentration)	Check refrigerant charge, thermostatic calibration, and transfer valve operation. (see Refrigerant Charge Adjustment, Cycle-Guard System Operation, and Thermostatic Adjustment sections on pages 35, 35, and 36, respectively).
	Noncondensables in machine (high absorber loss)	Check absorber loss (see Absorber Loss Determination section on page 31). If above 5° F (2.8° C), see Causes and Remedies under Inadequate Purging above.
	High steam pressure or hot water temperature (above design)	See Machine Selection Data provided with the machine. Set at design.
	Absorber tubes fouled (poor heat transfer)	Clean tubes. Determine if water treatment is necessary.
	Octyl alcohol depletion	Check solution sample and add octyl alcohol if necessary (see Adding Octyl Alcohol section on page 35).
<b>Solution Crystallization at Shutdown</b> (Crystallization symptoms when machine is started.)	Insufficient solution dilution at shutdown	After shutdown, restart machine and measure concentration of weak solution (see Solution or Refrigerant Sampling section on page 34). If above 56%, check dilution level switch and Cycle-Guard transfer valve.
<b>Abnormal Noise from Solution Pump</b>	Cavitation of solution pump (low solution level in absorber)	Open the Cycle-Guard valve manually (toggle switch 43-RV) for about 3 minutes while machine is running.
<b>Abnormal Noise from Refrigerant Pump</b>	Temperature of cooling water supply below 59 F (15 C).	Raise cooling water temperature above 59 F (15 C). Stop the machine and then restart it about 20 minutes later.
<b>Frequent Cycle-Guard Operation</b>	Fouled absorber or evaporator tubes	Clean tubes.
	Excessive noncondensable gas (high absorber loss)	See Inadequate Purging.
	Refrigerant overcharge or tube leak.	Remove refrigerant to trim charge, per start-up instructions. Repair tube leak.



