

Start-Up, Operation and Maintenance Instructions

SAFETY CONSIDERATIONS

Centrifugal liquid chillers are designed to provide safe and reliable service when operated within design specifications. When operating this equipment use good judgment and safety precautions to avoid damage to equipment and property or injury to personnel.

Be sure you understand and follow the procedures and safety precautions contained in the machine instructions as well as those listed in this guide.

▲ DANGER

DO NOT USE OXYGEN to purge lines or to pressurize a machine for any purpose. Oxygen gas reacts violently with oil, grease and other common substances.

NEVER EXCEED specified test pressures. VERIFY the allowable test pressure by checking the instruction literature and the design pressures on the equipment nameplate.

DO NOT VALVE OFF any safety device.

BE SURE that all pressure relief devices are properly installed and functioning before operating any machine.

▲ WARNING

DO NOT WELD OR FLAME CUT any refrigerant line or vessel until all refrigerant (*liquid and vapor*) has been removed from chiller. Traces of vapor should be displaced with dry air or nitrogen and the work area should be well ventilated. *Refrigerant in contact with an open flame produces toxic gases.*

DO NOT USE eyebolts or eyebolt holes to rig machine sections or the entire assembly.

DO NOT work on high-voltage equipment unless you are a qualified electrician.

DO NOT WORK ON electrical components, including control panels, switches, starters or oil heater until you are sure ALL POWER IS OFF and no residual voltage can leak from capacitors or solid-state components.

LOCK OPEN AND TAG electrical circuits during servicing. IF WORK IS INTERRUPTED, confirm that all circuits are de-energized before resuming work.

DO NOT syphon refrigerant by mouth.

AVOID SPILLING liquid refrigerant on skin or getting it into the eyes. USE SAFETY GOGGLES. Wash any spills from the skin with soap and water. If any enters the eyes, IMMEDIATELY FLUSH EYES with water and consult a physician.

NEVER APPLY an open flame or live steam to a refrigerant cylinder. Dangerous overpressure can result. When necessary to heat refrigerant, use only warm (110 F/43 C) water.

DO NOT REUSE disposable (nonreturnable) cylinders nor attempt to refill them. It is DANGEROUS AND ILLEGAL. When cylinder is emptied, evacuate remaining gas pressure, loosen the collar and unscrew and discard the valve stem. DO NOT INCINERATE.

CHECK THE REFRIGERANT TYPE before charging

machine. High-pressure refrigerant in a low-pressure machine can cause vessels to rupture if the relief devices cannot handle the refrigerant volume.

DO NOT ATTEMPT TO REMOVE fittings, covers, etc. while machine is under pressure or while machine is running. Be sure pressure is at zero psig before breaking any refrigerant connection.

CAREFULLY INSPECT all relief valves, rupture discs and other relief devices AT LEAST ONCE A YEAR. If machine operates in a corrosive atmosphere, inspect the devices at more frequent intervals.

DO NOT ATTEMPT TO REPAIR OR RECONDITION any relief valve when corrosion or build-up of foreign material (rust, dirt, scale, etc.) is found within the valve body or mechanism. Replace the valve.

DO NOT VENT refrigerant relief valves within a building; refer to ANSI/ASHRAE 15-1978. The accumulation of refrigerant in an enclosed space can displace oxygen and cause asphyxiation.

DO NOT install relief valves in series or backwards.

USE CARE when working near or in line with a compressed spring. Sudden release of the spring can cause it and objects in its path to act as projectiles.

▲ CAUTION

DO NOT STEP on refrigerant lines. Broken lines can whip about and cause personal injury.

DO NOT climb over a machine. Use platform, catwalk or staging. Follow safe practices when using ladders.

USE MECHANICAL EQUIPMENT (crane, hoist, etc.) to lift or move inspection covers or other heavy components. Even if components are light, use such equipment when there is a risk of slipping or losing your balance.

BE AWARE that certain automatic start arrangements CAN ENGAGE THE STARTER. Open the disconnect ahead of the starter in addition to shutting off the machine or pump.

USE only repair or replacement parts that meet the code requirements of the original equipment.

DO NOT VENT OR DRAIN water boxes containing industrial brines, liquid, gases or semisolids without permission of your Process Control Group.

DO NOT LOOSEN water box cover bolts until the water box has been completely drained.

DOUBLE-CHECK that coupling nut wrenches, dial indicators or other items have been removed before rotating any shafts.

DO NOT LOOSEN a packing gland nut before checking that the nut has a positive thread engagement.

PERIODICALLY INSPECT all valves, fittings and piping for corrosion, rust, leaks or damage.

PROVIDE A DRAIN connection in the vent line near each pressure relief device to prevent a build-up of condensate or rain water.

Manufacturer reserves the right to discontinue, or change at any time, specifications or designs without notice and without incurring obligations.

Book | 2
Tab | 5a

PC 211

Catalog No. 531-962

Printed in U.S.A.

Form 19DM-3SSM

Pg 1

5-87

Replaces: 19DM-2SSM

For replacement items use Carrier Specified Parts.

List of Tables

List of Figures

Introduction

Abbreviations

Definitions

Controls

- General

- Processor Board

- Input/Output Board

- Set Point/Display Board

- Safety Controls

- Reset Pushbutton

- Deadband

- Proportional Band

Ramp Loading

Capacity Overrides

Diffuser Wall Position Control

Excessive Purge Pump Run Time

Oil Heater and Thermostat

Remote Start/Stop Controls

Spare Safety Inputs

Start-Up Sequence

Shutdown Sequence

Control Configuration

Controls Test

Before Initial Start-Up

Job Data Required

Equipment Required

Check Machine Tightness

Inspect Piping

Charge Refrigerant

Inspect Wiring

Check Starter

Oil Charge

Check Oil Heater

Check Machine Safety Control Settings

Configure DIP Switches

Check Safety Control Operation

Initial Start-Up

Preparation

Start-Up

Calibrate Motor Current Demand

Check Machine Operating Condition

Trim Refrigerant Charge

Instruct the Customer Operator

Compressor-Motor Assembly

Unishell

Purge System

Lubrication System

Control System

Auxiliary Equipment

Describe Machine Cycles

Review Maintenance

Safety Devices and Procedures

Check Operator Knowledge

Review Operating and Maintenance Instructions

Operating Instructions

Operator Duties

Prepare Machine for Start-Up

To Start Machine

Check Running System

To Stop Machine

After Limited Shutdown

Extended Shutdown

After Extended Shutdown

Manual Operation

Refrigeration Log

Weekly Maintenance

- Check Lubrication System

- Check Purge Operation

Scheduled Maintenance

- Inspect Control Center

- Check Safety and Operating Controls

- Change Oil and Oil Filter

- Change Volute Drain Strainer and Refrigerant Filter

- Compressor Bearing Maintenance

- Inspect Purge

- Inspect Refrigerant Flow Chamber

- Inspect Unishell Tubes

- Inspect Starting Equipment

- Ordering Replacement Parts

General Maintenance

Refrigerant Properties

Charging Refrigerant

Removing Refrigerant

Trimming Refrigerant Charge

Refrigerant Loss

Air and Water Leaks

Guide Vane Linkage

Sensor Test Procedure

Diffuser Wall Potentiometer Test Procedure

General Data

Machine Informative Plate

System Components

Refrigeration Cycle

Motor Cooling Cycle

Lubrication Cycle

- Summary

- Details

Purge Cycle

- Purge Operation

Compressor Fits and Clearances

Control Troubleshooting

- Test Points

- Processor Board Replacement

- Input/Output Board Replacement

- Set Point/Display Board Replacement

List of Tables

- Table 1 — Safety Limits and Control Settings
- Table 2 — Capacity Override Set Points
- Table 3 — Configuration (DIP) Switch Settings
- Table 4 — Controls Test
- Table 5 — Machine Charge
- Table 6 — Oil Charge
- Table 7a — Sensor Resistance and Temperature (F)
- Table 7b — Sensor Resistance and Temperature (C)
- Table 8 — Purge Operating Switch Settings
- Table 9 — Diagnostic Codes and Troubleshooting Guide

List of Figures

- Figure 1 — 19DM Machine Components
- Figure 2 — Control Center
- Figure 3 — Control Wiring Schematic
- Figure 4 — Control Sequence
- Figure 5 — 19DM Leak Test Sequence and Procedures
- Figure 6 — Purge Valve and Switch Settings
- Figure 7 — Purge Component Location
- Figure 8 — Flow Chamber Poppet Valve Detail
- Figure 9 — Guide Vane Linkage (Closed Position)
- Figure 10 — Refrigeration and Motor Cooling Cycles
- Figure 11a — Diffuser Hydraulic Oil Flow
- Figure 11b — Lubrication Cycle
- Figure 12 — Purge Cycle
- Figure 13 — Compressor Fits and Clearances

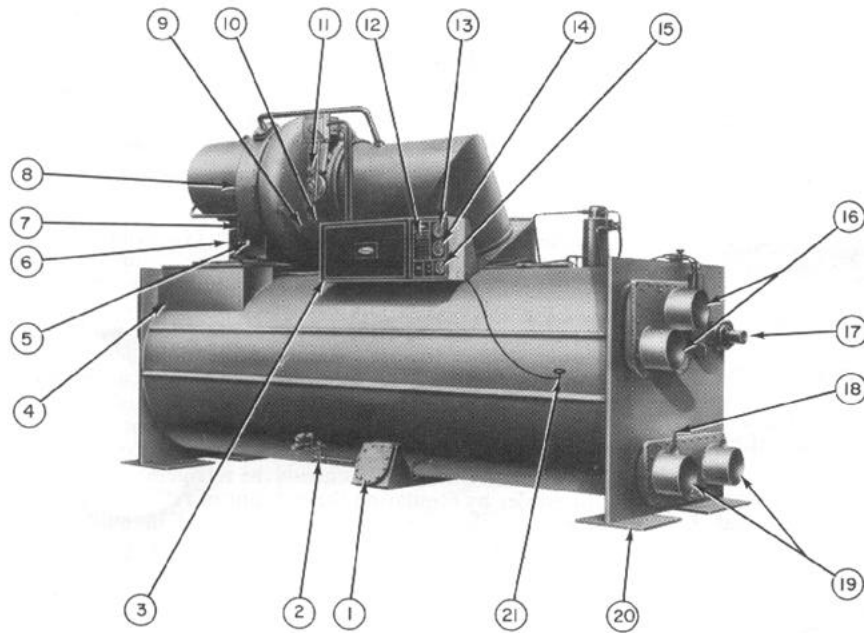

FRONT VIEW

- 1 — Flow Valve Chamber
- 2 — Cooler Charging Valve
- 3 — Field Wiring Knockouts
- 4 — Machine Informative Plate Location
- 5 — Oil Reservoir Temperature Gage
- 6 — Oil Heater and Thermostat Terminal Box
- 7 — Oil Level Sight Glass
- 8 — Return-Oil Temperature Gage (Hidden)
- 9 — Bellows Seal (Hidden)
- 10 — Diffuser Feedback Potentiometer (Hidden)
- 11 — Vane Seal Oiler
- 12 — Microprocessor Control Panel
- 13 — Condenser Pressure Gage
- 14 — Cooler Pressure Gage
- 15 — Oil Pump Differential Pressure Gage
- 16 — Condenser Water Nozzles
- 17 — Safety Relief Device (Rupture Disc)
- 18 — Chilled Water Temperature Sensor
- 19 — Cooler Water Nozzles
- 20 — Support Plates
- 21 — Condenser Refrigerant Temperature Sensor Location

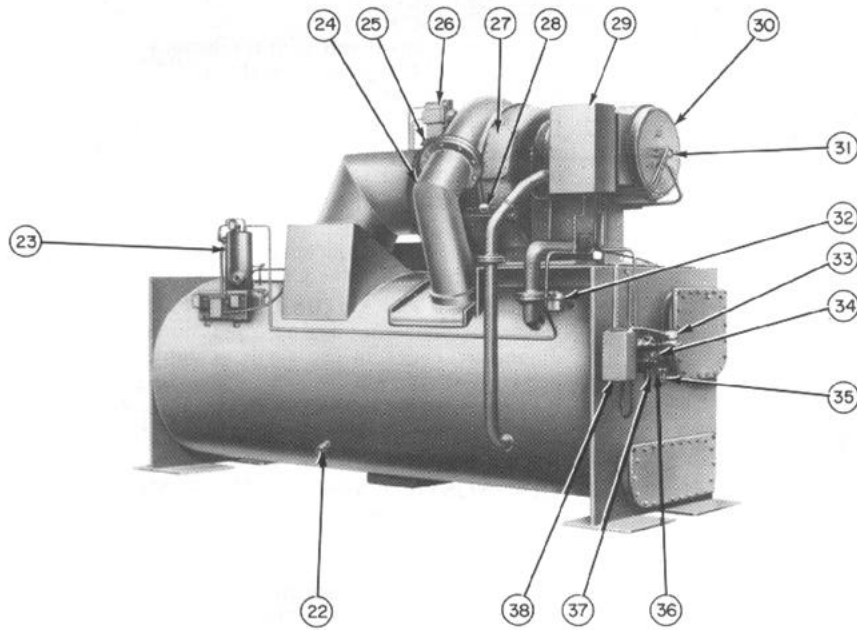

REAR VIEW

- 22 — Cooler Refrigerant Temperature Sensor
- 23 — Purge Assembly (see Fig. 7)
- 24 — Discharge Temperature Sensor (Hidden)
- 25 — Diffuser Solenoid Valves (Hidden)
- 26 — Guide Vane Actuator
- 27 — Compressor Access Plate
- 28 — Inlet Volute Drain Strainer
- 29 — Compressor Terminal Box
- 30 — Motor End Cover
- 31 — Motor Rotation Sight Glass
- 32 — Refrigerant Filter
- 33 — Oil Cooler Solenoid Valve and Water Throttling Valve
- 34 — Oil Pump, Cooler and Filter Assembly
- 35 — Oil Cooler Drain Plug
- 36 — Oil Charging Valve
- 37 — Oil Pressure Regulating Valve (Factory Set)
- 38 — Oil Pump Starter, Factory Installed

Fig. 1 — 19DM Machine Components

INTRODUCTION

Everyone involved in the start-up, operation and maintenance of the 19DM machine should be thoroughly familiar with these instructions and other necessary job data before initial start-up. This book is outlined so that you may become familiar with the control system before performing start-up procedures. Procedures are arranged in the sequence required for proper machine start-up and operation.

▲ WARNING

This unit uses a microprocessor control system. Do not short or jumper between terminations on printed-circuit boards; control or board failure may result.

Be aware of electrostatic discharge (static electricity) when handling or making contact with the printed-circuit boards. Always touch a chassis (grounded) part to dissipate body electrostatic charge before working inside control center.

Use extreme care when handling tools near boards and when connecting or disconnecting terminal plugs. Circuit boards can easily be damaged. Always hold boards by edges and avoid touching components and pin connections.

This equipment uses and can radiate radio frequency energy and if not installed and used in accordance with the instruction manual may cause interference to radio communications. It has been tested and found to comply with the limits for a Class A computing device pursuant to Subpart J of Part 15 of FCC Rules, which are designed to provide reasonable protection against such interference when operated in a commercial environment. Operation of this equipment in a residential area is likely to cause interference, in which case the user, at his own expense, will be required to take whatever measures may be required to correct the interference.

Always store and transport replacement or defective boards in anti-static shipping bag.

ABBREVIATIONS

A/D	— Analog to Digital
CPU	— Central Processing Unit
DIP	— Dual Inline Package
I/O	— Input/Output
LCD	— Liquid Crystal Display
L/R	— Local/Remote
POR	— Power-On Reset
RLA	— Rated Load Amps
S/D	— Set Point/Display

DEFINITIONS

An analog signal varies in proportion to the monitored source. It quantifies values between operating limits. (Example: A temperature sensor is an analog device because its resistance changes in proportion to the temperature, generating many values.)

A digital (discrete) signal is a 2-position representation of the value of a monitored source. (Example: A switch is a digital device because it only indicates whether a

value is above or below a set point or boundary by generating an ON/OFF, HIGH/LOW, or OPEN/CLOSED signal.)

Volatile memory — Memory that is incapable of being sustained if power is lost and subsequently restored. The central processing unit (CPU) memory is volatile.

CONTROLS

General — The 19DM hermetic centrifugal liquid chiller contains a microprocessor-based control center that monitors and controls all operations of the machine. The microprocessor control system matches the cooling capacity of the machine to the cooling load while providing state-of-the-art machine protection. The system controls cooling load within the set point deadband by sensing the leaving chilled water or brine temperature and regulating the inlet guide vane via a mechanically linked actuator motor. The guide vane is a variable flow prewhirl assembly that controls the refrigeration effect in the cooler by regulating the amount of refrigerant vapor flow into the compressor. An increase in guide vane opening increases capacity. A decrease in guide vane opening decreases capacity. Machine protection is provided by monitoring certain digital and analog inputs and executing capacity overrides or safety shutdowns, if required.

The controller consists of a processor board, an input/output board (I/O), and a set point/display board (S/D). (See Fig. 1 and 2.) These 3 components, along with supporting peripheral devices, comprise a control system with the following features:

1. **CAPACITY CONTROL** — Controls chilled water or brine temperature within a selectable 1° F (0.56 C) or 2 F (1°C) deadband with a selectable 5 F (2.8 C) or 15 F (8.3 C) proportional band regardless of machine load.
2. **DIFFUSER WALL CONTROL** — Monitors compressor load and lift and positions diffuser wall for optimum compressor efficiency.
3. **CONSTANT DATA CONFIGURATION** — If control power is lost and subsequently restored, control and safety limit set points will automatically be re-established in the CPU memory.
4. **LIQUID CRYSTAL DISPLAY (LCD)** — Displays status of machine during operation or displays diagnostic codes in the event of control overrides or safety shutdowns.
5. **SAFETY PROTECTION** — Monitors digital and analog safety limits and shuts down the machine when a limit is exceeded.
6. **DIAGNOSTIC CAPABILITIES** — Monitors individual analog and digital inputs for control malfunction and displays troubleshooting information.
7. **CONTROLS TEST** — A self-diagnostic routine that displays individual status of peripheral control inputs and outputs. Exercises operating controls to confirm proper operation.
8. **SHUTDOWN STATUS RECALL** — Stores in volatile memory and displays on command the reasons for the last 5 safety shutdowns, beginning with the most recent.

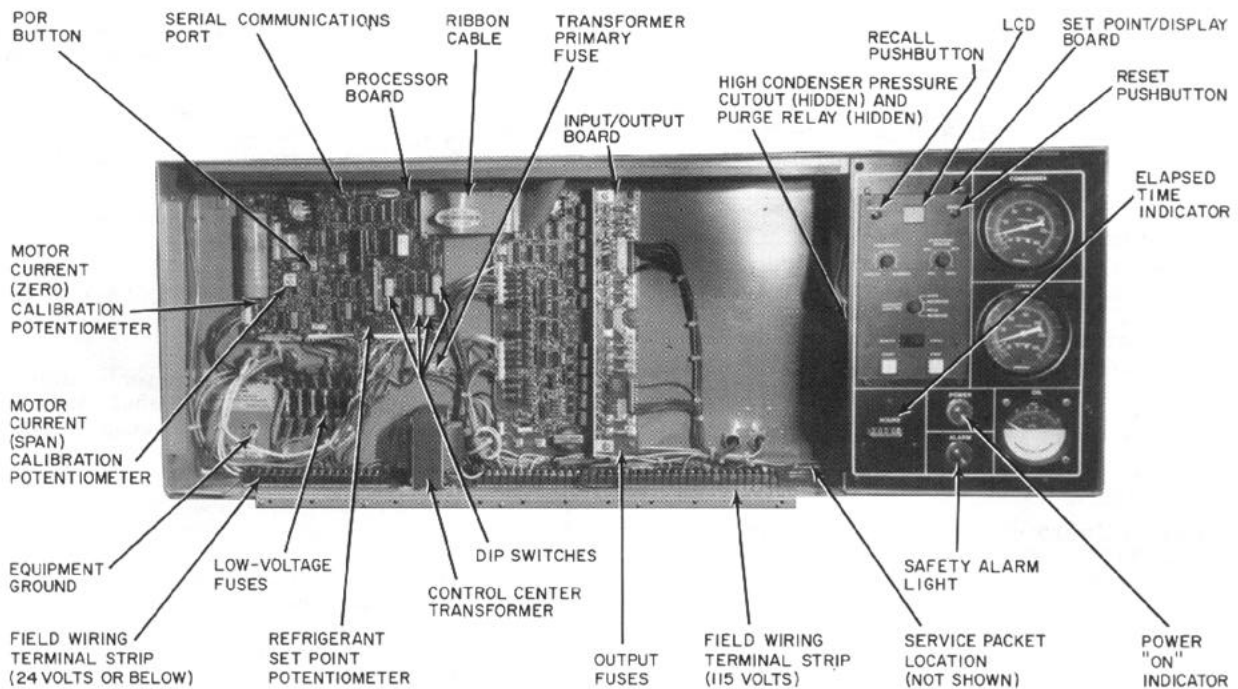

Fig. 2 — Control Center

9. **SELECTABLE RAMP LOADING RATE** — Allows 8 different leaving temperature pulldown rates during start-up, to prevent rapid increases in compressor loading and IKW.
10. **THERMOSTAT CONTROL** — Permits local adjustment of leaving chilled water temperature between 35 F and 65 F (1.67 C and 18.3 C) or brine temperature between 0° F and 45 F (-17.8 C and 7.0 C).
11. **CAPACITY OVERRIDE CONTROL** — Inhibits or closes the guide vanes to suppress a safety shutdown that may be caused when refrigerant, motor winding temperature or motor current conditions approach the safety limit.
12. **ELECTRICAL DEMAND CONTROL** — Limits maximum compressor current down to 40% of rated load amps (RLA).
13. **CAPACITY CONTROL KNOB** — Four-position switch permits selection of automatic or manual control over guide vane actuator position.
14. **SEQUENCING OF PUMPS AND TOWER FANS** — Starts and stops cooler and condenser water pumps and cooling tower fan individually, based on operating mode.
15. **SAFETY SHUTDOWN ALARM** — Panel-mounted alarm light and output channel is provided for installation of field-supplied remote alarm.
16. **REMOTE START/STOP** — Input channel is provided for manual start-up and shutdown by time clock or other contact closure.
17. **SPARE SAFETY INPUT** — Input channel is provided for monitoring and initiating a machine shutdown upon request from additional field-supplied safeties.
18. **POWER "ON" INDICATION** — Power lamp indicates when control center is energized.
19. **COMPRESSOR ANTI-RECYCLE** — Start inhibit timers prevent rapid manual compressor restart by limiting start-to-start time to 15 minutes minimum and stop-to-start time to 3 minutes minimum.
20. **COMPRESSOR STARTS REMINDER** — Inhibits manual compressor start after recommended limit of 8 manual starts per 12-hour period. Override of start counter requires a manual reset.
21. **VOLTAGE PROTECTION** — Monitors power supply for high, low, or loss of line voltage and initiates a safety shutdown if limits are exceeded.
22. **LIMITS MOTOR ACCELERATION TIME** — Monitors motor inrush current to guard against excessive motor acceleration time.
23. **LIMITS STARTER TRANSITION TIME** — Monitors transition time to prevent motor and starter damage that could occur if limit is exceeded.

24. **FAILSAFE SHUTDOWN SEQUENCE** — Keeps oil pump, water pumps and tower fan relay outputs energized if starter contacts fail to open on a shutdown command.
25. **CONTROL EXPANDIBILITY** — Easily accommodates a variety of control options and also interfaces with a higher level controller (Expanded Services Panel) for maximizing control automation and energy management.
26. **LOW-LOAD RECYCLE** — Stops the machine when chilled water or brine load drops below a temperature indicating minimum machine capacity. Automatically restarts the machine when the leaving temperature rises to a point indicating the need for further cooling and the start inhibit timers have expired.
27. **PURGE OPERATION** — Monitors machine and purge pump operation and inhibits or prevents purge pump run time under abnormal conditions.

Processor Board — The processor board is mounted inside the control center panel and functions as the central computing and control unit for the system. It contains the logic (CPU) and time base necessary to perform all machine control functions. The processor board controls the I/O board and the S/D board, and directly monitors and converts all analog inputs to digital outputs. These include temperatures, motor current signal conditioning, and diffuser wall positioning. In addition, the board monitors digital inputs from the I/O board and initiates capacity overrides or safety shutdowns when required.

The processor board also contains the configuration (DIP) switches, motor current zero and span adjustments, refrigerant and temperature set point potentiometer (for brine duty), the power-on reset (POR) pushbutton, and the serial communications port.

Input/Output Board — The I/O board is mounted inside the control center panel and functions as a logical block for interfacing 115-vac input and output control signals to the low-voltage processor board. Inputs are optically isolated from the processor board. Outputs are optically coupled triac drivers. All triacs are fused to provide overcurrent protection. The I/O board contains a 5-vdc regulator for its power supply and a line voltage monitor capable of detecting high, low or loss of voltage and generating an interrupt to the processor board.

Set Point/Display Board — The S/D board is mounted in the control center gage panel and allows the operator to interface with the CPU when the local/remote switch is positioned in local. It is the input center for all local machine set points and operating commands or for a stop command during remote operation.

The following components are located on the S/D board:

1. **NUMERICAL 2-DIGIT LCD** for displaying diagnostic codes and operational data.
2. **LOCAL/REMOTE** rocker switch for selecting local or remote machine control.
3. **START AND STOP PUSHBUTTONS** for initiating and terminating machine operation.
4. **RESET PUSHBUTTON** for clearing a lockout due to a condition exceeding a safety limit (after the

condition is within limits); advancing through the controls test; or overriding the 8 manual starts per 12-hour counter.

5. **RECALL PUSHBUTTON** for displaying up to 5 stored safety shutdown codes.
6. **DEMAND LIMIT CONTROL KNOB** for limiting motor current down to 40% of RLA.
7. **TEMPERATURE CONTROL KNOB** for adjusting the leaving chilled water or brine temperature set point.
8. **FOUR-POSITION CAPACITY CONTROL KNOB** for selecting automatic operation or manual control of guide vane position.

Safety Controls — The microprocessor monitors all safety control inputs and if required shuts down the machine to protect it against possible damage from any of the following conditions:

- High bearing temperature
- High motor winding temperature
- High discharge temperature
- Low oil pressure
- Low cooler refrigerant temperature
- Condenser high pressure
- Inadequate water flow
- High, low or loss of voltage
- Excessive motor acceleration time
- Excessive starter transition time
- Low load recycle with motor current greater than 65%

In addition, compressor motor overload can shut down the machine.

If the controller initiates a safety shutdown, it displays a blinking diagnostic code on the LCD indicating the reason, and energizes the safety alarm output. The diagnostic code will also be stored in volatile memory for recall and display by depressing the recall pushbutton. Safety control limits are listed in Table 1. Diagnostic codes are listed in the Troubleshooting section.

Reset Pushbutton — A start lockout due to a condition exceeding a safety limit can be cleared by correcting the cause, positioning the L/R switch to local and depressing the reset pushbutton. The reset pushbutton may be used to clear a purge pump lockout when code 37 (excessive purging) appears on the LCD or to override the 8 manual starts/ 12-hour counter when code 41 (more than 8 starts in past 12 hours) appears on the LCD. One additional start will be permitted after the depression. The reset pushbutton is also used to advance through the controls test.

Deadband is the tolerance on the leaving chilled water or brine temperature set point. If the leaving temperature goes outside the deadband, the microprocessor opens or closes the guide vane until it is within tolerance. The microprocessor may be configured with a 1° F (0.56 C) or 2 F (1° C) deadband. The 1° F setting controls leaving temperature within 0.5 F (0.28 C) of the set point with more frequent guide vane position corrections. The 2 F (1° C) setting controls within 1° F (0.56 C) of the set point with less frequent corrections. The latter setting is recommended when load frequently fluctuates, causing control to hunt.

Table 1 — Safety Limits and Control Settings
ANALOG SAFETY CONTROL LIMITS

CONTROLLED PARAMETER	LIMIT	APPLICABLE SETTING/COMMENTS
Compressor Discharge Temperature	$\geq 220 \pm 10$ F (104 ± 5.6 C)	Preset, configure DIP switch for analog sensor.
Evaporator Refrigerant Temperature	≤ 33 F (0.56 C) (for water chilling) $\leq 1^\circ$ F (0.56 C) below design refrigerant temperature [set point adjustable from -20 to 35 F (-28.9 to 1.67 C) for brine chilling]	Preset, configure DIP switch for water chilling. Configure DIP switch for brine chilling. Adjust set point during field test with refrigerant temperature set point potentiometer on processor board. Set point will be displayed and updated on LCD.
Motor Winding Temperature	$\geq 220 \pm 10$ F (104 ± 5.6 C)	Preset, configure DIP switch for analog sensor; resets at 190 ± 10 F (88 ± 5.6 C).
Thrust Bearing Temperature	$\geq 220 \pm 10$ F (104 ± 5.6 C)	Preset, configure DIP switch for analog sensor.
Motor Acceleration Time (Determined by decrease in inrush current below 100% RLA)	$> 45 \pm .5$ sec $> 10 \pm .5$ sec	For machine with reduced voltage (wye/delta) starter. Preset, based on machine and starter type. Selected with DIP switches. For machine with full-voltage (X-line) starter. Preset, based on machine and starter type. Selected with DIP switches.
Starter Transition Time	$> 90 \pm .5$ sec	For machine with reduced inrush starter. Preset, based on machine and starter type. Selected with DIP switches.
Line Voltage Loss	< 57.5 volts $\pm 5\%$ for one cycle	Preset, based on 115-v control center voltage supply and line frequency. Selected with DIP switch.
High-Line Voltage	> 135.7 volts $\pm 3\%$ for one minute	
Low-Line Voltage	< 94.3 volts $\pm 3\%$ for one minute	

MECHANICAL SAFETY LIMITS AND CONTROL SETTINGS

Oil Low-Pressure Cutout

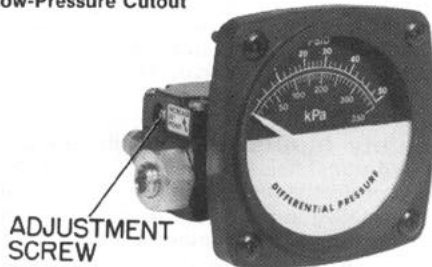

Switch is part of oil pressure gage assembly. Unscrew switch/gage assembly from the gage panel to gain access. Connect high-pressure side of switch (marked HP) to a metered supply of air. Open low-pressure side to atmosphere. Quickly plug tube ends to prevent loss of machine vacuum. Switch should close at 17 ± 1 psi (117 ± 6.9 kPa) differential between reservoir pressure connection and oil pressure connection. Switch should open when pressure is reduced to 13 ± 1 psi (90 ± 6.9 kPa) differential.

Condenser High-Pressure Cutout

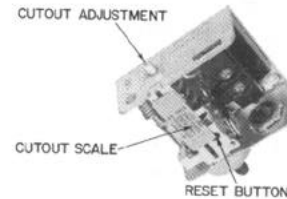

The condenser high-pressure cutout is factory set to shut machine down when condenser pressure reaches approximately 15 psig (103 kPa). Isolate the switch and check setting with a metered supply of air. Disconnect and quickly plug tube end. Test switch with metered air supply. Contacts should open at 15 ± 1 psig (103 ± 6.9 kPa) on pressure increase. Reset switch manually as pressure is reduced below 9 psig (62 kPa).

Flow Switches (Field Supplied)

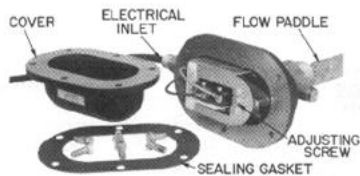

Operate water pumps with machine off. Manually reduce water flow and observe switch for proper cutout. Safety shutdown occurs when cutout time exceeds 5 seconds.

Oil Heater Thermostat

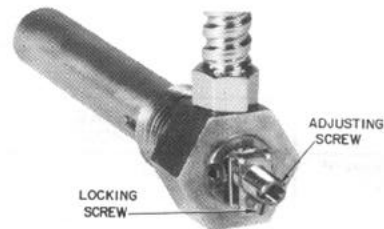

Set the oil heater thermostat to maintain a minimum oil reservoir temperature of 140 F (60 C) at shutdown. Turn screw counter-clockwise to raise set point.

Proportional Band is the rate at which the guide vane position is corrected in proportion to how far the leaving chilled water or brine temperature is from the set point. The farther away from the set point, the faster the guide vane moves. The nearer to the set point, the slower it moves. The microprocessor may be configured with a 5 F (2.8 C) or 15 F (8.3 C) proportional band. At the 5 F (2.8 C) setting, continuous guide vane position correction occurs when the leaving chilled water or brine temperature is approximately 1.5 F (0.8 C) below the set point or 5 F (2.8 C) above the set point. At the 15 F (8.3 C) setting, continuous correction occurs when the leaving chilled water or brine temperature is approximately 1.5 F (0.8 C) below the set point or 15 F (8.3 C) above the set point.

Ramp Loading slows the rate of guide vane opening during start-up to prevent rapid increases in compressor loading and to limit the average rate that the leaving chilled water or brine temperature can decrease in degrees/minute. Ramp loading rate is established by DIP switch setting as outlined in Table 1. During a recycle start-up, the ramp loading rate is fixed at 0.625 F/minute (.347 C/minute), regardless of the rate established by the DIP switch setting. Ramp loading is overridden when the capacity control knob is in the INC (increase) position. When using ramp loading to "soft load" the machine, ramp loading duration (in minutes) can be calculated with the following formula:

$$\text{Ramp Loading Duration} = \frac{\text{Leaving Temp at Start-Up} - \text{Leaving Temp Set Point}}{\text{Ramp Loading Rate}}$$

Capacity Overrides — The refrigerant low temperature, motor high temperature and motor current demand limit have 2 steps of override control to reduce the chance of nuisance safety trips occurring. The first step inhibits the guide vane from opening further and displays a blinking diagnostic code indicating the reason for the override. The second step drives the guide vane closed until the condition is below the override set point, terminating the override and returning the machine to temperature control. If either condition reaches the trip limit, a safety shutdown will be initiated. Override conditions are listed in Table 2.

Diffuser Wall Position Control — The 19DM utilizes a movable diffuser wall which adjusts to maintain optimum compressor efficiency. The microprocessor computes the desired diffuser wall position based on compressor lift and load. In order to make this computation, the dip switches must be set according to compressor code (Table 3).

Excessive Purge Pump Run Time — If purge pump run time exceeds one minute, the microprocessor de-energizes K1 relay and prohibits reactivation of the pump for 10 minutes. If 3 consecutive one minute on/10-minute off cycles occur in succession, the microprocessor de-energizes K1 relay, displays the excessive purging status code and prohibits purge pump operation until a safety reset is initiated. This prevents release of excessive amounts of refrigerant if the purge control system malfunctions.

Oil Heater and Thermostat — These controls are field wired from a separate power source as shown in Fig. 3. During machine shutdown, keep heater energized to maintain 140 - 145 F (60 - 63 C) and minimize refrigerant absorption by the oil.

Remote Start/Stop Controls — A remote device, such as a time clock, may be used to start and stop the machine. However, the device should not be programmed to start the machine in excess of 8 times in 12 hours. Any attempt to do so will result in a failure to start and the display of code 41 indicating the reason. A reset will be required to override the 8 manual start/12-hour counter. If the machine is operating from a remote contact and shuts down due to a loss of voltage (power), code 67 will be displayed if the contact remains closed when power is restored.

Spare Safety Inputs — Normally closed digital inputs for additional field-supplied safeties may be wired to the spare protective limits input channel in place of the factory-installed jumper. (Wire multiple inputs in series.) The opening of any contact will result in a safety shutdown and display of code 79.

Table 2 — Capacity Override Set Points

OVERRIDE CONTROL	1ST-STAGE SET POINT	2ND-STAGE SET POINT	OVERRIDE TERMINATION
Low Refrigerant Temperature	≤ 1°F (0.56 C) Above Trip Limit	≤ 0.5 F (0.28 C) Above Trip Limit	> 1°F (0.56 C) Above Trip Limit
High Motor Temperature	≥ 200 F (93.3 C)	≥ 210 F (98.9 C)	< 200 F (93.3 C)
Motor Current Demand Limit	≥ 100% of Set Point	≥ 105% of Set Point	< 100% of Set Point



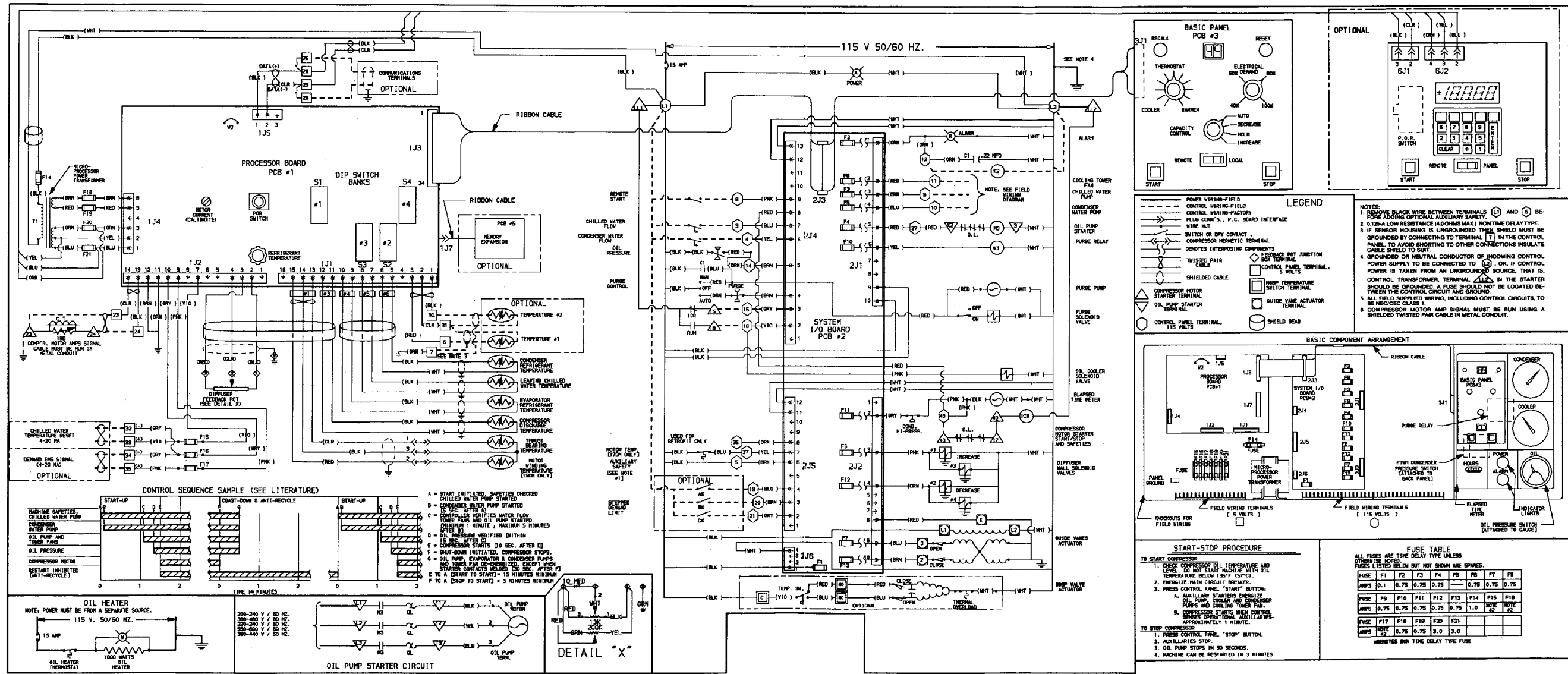

Fig. 3 — Control Wiring Schematic

Table 3 — Configuration (DIP) Switch Settings

SWITCH FUNCTION	SWITCH BANK	SWITCH POSITION	SWITCH STATUS	CONFIGURATION DESCRIPTION
Machine Type	1	1	Off On	Other 19DM
		2	Off On	19DM Other
Controller Identification Number (Optional configuration used as communications address when optional engineer's services panel is used.)	2	1,2,3	Off-Off-Off	0
			On-Off-Off	1
			Off-On-Off	2
			On-On-Off	3
			Off-Off-On	4
			On-Off-On	5
			Off-On-On	6
			On-On-On	7
LCD Temperature Read-Out (F/C)	2	4	Off On	°F Display °C Display
Leaving Chilled Water or Brine Temperature Deadband	1	3	Off	1°F (0.56 C) Deadband
			On	2 F (1°C) Deadband*
Leaving Chilled Water or Brine Temperature Proportional Band	1	4	Off	5 F (2.8 C) Proportional Band*
			On	15 F (8.3 C) Proportional Band
Line Frequency	1	5	Off	60 Hz
			On	50 Hz
Starter Type	1	6	Off	Reduced Voltage (Wye/Delta)
			On	Full Voltage (X-Line)
Motor Winding Sensor Type	1	7	Off	Analog (19DM)
			On	Digital (Other)
Thrust Bearing Sensor Type	1	8	Off	Analog (19DM)
			On	Digital (Other)
Chilled Medium	3	1	Off On	Water Brine
Ramp Loading Rate (Pulldown or Soft Loading)	3	6,7,8	Off-Off-On	°F/Minute (°C/Minute)
			On-Off-Off	0.38 (0.21)
			Off-On-Off	0.75 (0.42)
			On-On-Off	1.13 (0.63)
			Off-Off-Off	1.5 (0.83)
			On-Off-Off	2.25 (1.25)*
			Off-Off-On	3.00 (1.67)
			On-On-On	5.25 (2.92)
On-On-On	10.50 (5.83)			
Compressor Identification Code	2	5,6,7,8	Off-Off-Off-Off	42 through 46
			On-Off-Off-Off	49 through 53
			Off-On-Off-Off	56 through 60
			On-On-Off-Off	63 through 67
			Off-Off-On-Off	72 through 76
			On-Off-On-Off	79 through 83
			Off-On-On-Off	86 through 90
			On-On-On-Off	93 through 97
			On-Off-Off-On	C2 through C6
			Off-Off-Off-On	B2 through B6
			Off-Off-On-Off	204
			Off-Off-Off-Off	205,206
			On-On-Off-On	224
			On-Off-On-Off	225,226
			Off-On-On-On	254
			Off-Off-On-Off	255,256
			On-Off-Off-Off	284
			On-On-Off-Off	285,286
			Off-Off-Off-On	305,306
			Off-Off-Off-Off	314
			On-On-Off-On	315,316
			On-On-On-Off	354
			Off-Off-Off-On	355,356
			Off-Off-On-On	404
On-On-Off-Off	405,406			
On-Off-Off-Off	454			
On-On-On-Off	455,456			
On-Off-Off-On	505,506			
	4	1,2	Off-Off	All 2-digit number and letter codes
			Off-Off	204
			On-Off	205,206,224,225,226,254
			Off-Off	255,256
			Off-On	284
			Off-Off	285,286,305,306
			Off-On	314
			On-Off	315,316
			Off-On	354
			Off-Off	355,356
			Off-On	404,405,406
			On-On	454
Off-Off	455,456,505,506			



Table 3 — Configuration (DIP) Switch Settings (cont)

SWITCH FUNCTION	SWITCH BANK	SWITCH POSITION	SWITCH STATUS	CONFIGURATION DESCRIPTION
Compressor Identification Code (cont)	3	2,3,4,5	On-Off-Off-On Off-Off-Off-Off On-Off-Off-Off Off-On-Off-Off On-On-Off-Off On-Off-Off-Off Off-On-Off-Off On-On-Off-Off	42,49,56,63,B2,72,79,86,93,C2 43,50,57,64,B3,73,80,87,94,C3 44,51,58,65,B4,74,81,88,95,C4 45,52,59,66,B5,75,82,89,96,C5 46,53,60,67,B6,76,83,90,97,C6 204,224,254,284,314,354,404,454,504 205,225,255,285,305,315,355,405,455,505 206,226,256,286,306,316,356,406,456,506
Compressor Selection Factor	4	3,4,5	Off-Off-Off On-Off-Off Off-On-Off On-On-Off Off-Off-On On-Off-On Off-On-On On-On-On	Zonet 1 2 3 4 5 6 7 8
Compressor Motor Amps Correction Factor† (Unseen internal correction to % amperage based on the difference in motor power factor at various loads)	4	6,7,8	Off-On-Off On-Off-Off Off-Off-Off On-On-Off Off-Off-On On-Off-On Off-On-On On-On-On	Increase ↑ 0.0 ↓ Decrease

*Recommended setting for average conditions.
†For correct setting, refer to Machine Configuration Switch Settings label on machine control panel.

NOTE: Switch banks and switch positions not designated above are not applicable to this machine and do not require setting.

Start-Up Sequence

MANUAL START-UP is initiated external to the micro-processor. Manual start-up can be initiated after the internal 15-minute start-to-start and 3-minute stop-to-start inhibit timers have expired by positioning the L/R switch to local and depressing the START pushbutton, or by positioning the L/R switch to remote and closing the remote start/stop device contact. The controller will perform a series of prestart checks to verify that all safeties are within limits shown in Table 1. If the checks are successfully completed, the evaporator pump relay will be energized; 5 seconds later the condenser water pump relay will be energized; one minute later, the controller will begin monitoring the evaporator and condenser flow switch contacts and will wait up to 5 minutes to verify closure. Once flows are verified, the tower fan relay will be energized; if the oil pressure switch contact is open, the oil pump relay will be energized and the controller will wait up to 15 seconds for verification of oil pressure via contact closure. If a diffuser wall calibration has not been established by the controller, or has been lost from its memory due to a power failure or POR, a calibration will be established by the controller at this time. Failure to verify any of the requirements up to this point will result in the controller aborting the start and displaying the applicable prestart failure code. Any failure after the compressor start relay (ICR) is energized results in a safety shutdown and display of the applicable shutdown status code. A prestart failure does not advance the 8 manual starts/12-hour counter. Ten seconds after verification of oil pressure, the controller will energize the elapsed time meter and the ICR relay and wait up to 2 seconds for verification of starter contact closure via ICR auxiliary contact opening. After verification, the controller advances the 8 manual starts/12-hour counter; initializes the internal 15-minute start-to-start inhibit timer; monitors the condenser high-pressure switch

contact for closure; and monitors motor acceleration time and, if applicable, starter transition time for enactment within the time limits specified in Table 1. If successful, the machine enters the run mode. See Control Sequence, Fig. 4.

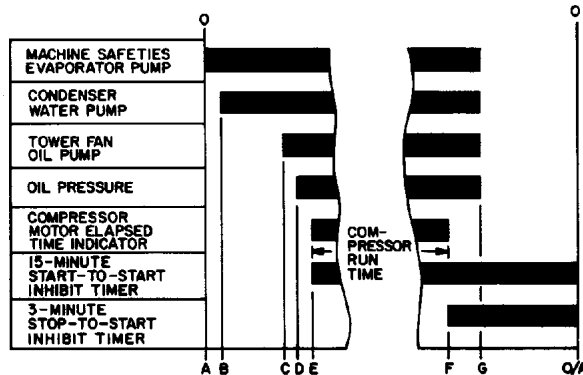

- A — Start initiated — prestart checks made, evaporator pump started.
- B — Condenser water pump started (5 seconds after A).
- C — Water flows verified — tower fan and oil pump started (one minute minimum; 5 minutes maximum after B).
- D — Oil pressure verified (one second minimum; 15 seconds maximum after C).
- E — Compressor motor starts — 15-minute inhibit timer starts; elapsed time indicator starts (10 seconds after D).
- F — Shutdown initiated — compressor motor stops, elapsed time indicator stops, 3-minute inhibit timer starts.
- G — Oil pump, tower fan, evaporator and condenser water pumps de-energized.
- O/A — Restart permitted (both inhibit timers expired) (minimum 15 minutes after E and minimum 3 minutes after F).

Fig. 4 — Control Sequence



RECYCLE START-UP — A recycle start-up will be automatically activated by the microprocessor following a recycle shutdown when the leaving chilled water or brine temperature has risen more than 5 F (2.8 C) above the set point and the 15-minute and 3-minute internal start inhibit counters have expired. A recycle start-up is identical to a manual start-up with the following exceptions: during a recycle start-up, a fixed 0.625 F/minute (0.347 C/minute) ramp loading rate is initiated; the 8 starts/12-hour counter is not advanced; and the chilled water pump is not started.

Shutdown Sequence

MANUAL SHUTDOWN is initiated external to the microprocessor. Manual shutdown will be initiated any time the STOP pushbutton is depressed, regardless of the position of the L/R switch. However, if the STOP pushbutton is depressed with the L/R switch in remote, this will be considered a safety shutdown and will require a manual reset. A manual remote shutdown is initiated if the L/R switch is positioned in remote and the remote start/stop device contact opens.

The controller implements a shutdown by de-energizing the ICR relay and monitoring it for deactivation. If ICR does not deactivate within one second after de-energization, the controller closes the guide vanes and the diffuser wall energizes the safety alarm and displays the applicable diagnostic code. Oil pump, water pumps and tower fan relay outputs remain energized.

If ICR relay deactivation is verified, the controller initializes the 3-minute internal stop-to-start inhibit timer; energizes the guide vane close output and the diffuser wall close solenoids; and 30 seconds later, de-energizes the oil pump, condenser water pump, evaporator pump, and tower fan relay outputs. See Control Sequence, Fig. 4.

RECYCLE SHUTDOWN — A recycle shutdown is automatically initiated by the microprocessor during the run mode whenever the leaving chilled water or brine temperature is more than 5 F (2.8 C) below the set point or within 3 F (1.67 C) of the low refrigerant temperature set point. With the exception of de-energizing the evaporator pump relay, the recycle shutdown sequence is identical to the manual shutdown sequence.

SAFETY SHUTDOWN — A safety shutdown is identical to a manual shutdown with the exception that a diagnostic code indicating the reason for the shutdown will be displayed on the LCD and stored in volatile memory for recall. A safety shutdown requires a safety reset to put the machine back into operation.

Control Configuration — The microprocessor control program is configured by 4 DIP switch banks located on the processor board (Fig. 2). Each switch bank consists of 8 two-position switches protected by a plastic cover. Each switch must be set to the ON or OFF position according to function and description as outlined in Table 3. To identify an individual DIP switch, note switch bank number and switch position on bank. Always replace plastic cover after configuration is completed.

Controls Test — The controls test is a 34-step program that utilizes the LCD on the S/D board. The test verifies microprocessor controller inputs and outputs by exercising or displaying the status of peripheral control devices. The test can be initiated any time the machine is not operating by positioning the L/R switch to local and depressing the POR pushbutton. The LCD will show 03 minutes.

▲ WARNING

Never depress the POR pushbutton while the machine is operating. Serious damage may result.

▲ CAUTION

Depressing the POR pushbutton causes a system reset and a loss of all volatile memory. Always recall and record shutdown code history before initiating a POR.

To enter the test mode, depress the reset pushbutton within 10 seconds after the POR pushbutton has been depressed. The number of the first step (0.1) will be displayed. (For each test step, the reset pushbutton must be depressed twice. The first depression displays the number of the test step. The second depression displays the results or exercises the command for the test step number.) The results of test step number 0.1 is the display of 88. This test confirms if the elements in the LCD are operable. The test step is distinguished from the test results by a decimal point between the 2 digits in the test step number (i.e., the test step number is always a decimal fraction and the test step result is always a whole number [integer]). Flashing of a test results integer indicates a negative value. Successive depressions of the reset pushbutton will display the test numbers and results of the remaining steps as outlined in Table 4.

To recheck a step while in the test mode, the test can be reinitiated with the POR and reset pushbuttons or the program can be recycled by advancing past the last test step number (3.4) and back to the desired test step number by depressing the reset pushbutton in succession.

To exit the controls test program, depress the POR pushbutton and allow the time on the display to decrease until it goes blank (time 0).

Table 4 — Controls Test

STEP NUMBER	TEST DESCRIPTION	DISPLAY CODE OR ACTION
0.1	Display 88 to verify proper operation	88 — OK XX — Faulty
0.2	Display set point of evaporator refrigerant temperature	33 — Water XX — Brine Temperature (Adjust with refrigerant temperature set point potentiometer and note set point displayed in LCD.)
0.3	Display % RLA of compressor motor current	00 — OK XX — Faulty Calibration (End controls test, set capacity control knob to HOLD and adjust motor current zero potentiometer until display reads 0.0. Re-enter controls test and check reading on LCD.)
0.4	Display controller identification number (00 to 07)	XX — Confirm
0.5	Display leaving chilled water sensor input status	1 — OK 0 — Faulty
0.6	Display condenser refrigerant sensor input	1 — OK 0 — Faulty
0.7	Display compressor discharge sensor input status	1 — OK 0 — Faulty
0.8	Display evaporator refrigerant temperature sensor input status	1 — OK 0 — Faulty
0.9	Display motor winding sensor input status	1 — OK 0 — Faulty 2 — Faulty Configuration
1.0	Display thrust bearing sensor input status	1 — OK 0 — Faulty 2 — Faulty Configuration
1.1	Display leaving chilled medium set point potentiometer input status	1 — OK 0 — Faulty
1.2	Display demand limit set point potentiometer input status	1 — OK 0 — Faulty
1.3	Display diffuser wall potentiometer status	1 — OK 0 — Faulty Configuration 2 — Faulty Configuration
1.4	Energize oil pump starter relay*	14 — Response (Confirm oil pump starter energized)
1.5	Energize leaving chilled water pump starter relay*	15 — Response (Confirm leaving chilled water pump energized)
1.6	Energize condenser water pump starter relay*	16 — Response (Confirm condenser water pump energized)
1.7	Energize tower fan starter relay*	17 — Response (Confirm tower fan energized)
1.8	Energize increase diffuser wall position solenoid and oil pump	18 — Response (Confirm increase diffuser wall position solenoid and oil pump energized)
1.9	Energize decrease diffuser wall position solenoid and oil pump	19 — Response (Confirm decrease diffuser wall position solenoid and oil pump energized)
2.0	Energize increase guide vane position digital output* (Capacity control switch in AUTO.)	20 — Response (Confirm increase guide vane position digital output energized)
2.1	Energize decrease guide vane position digital output* (Capacity control switch in AUTO.)	21 — Response (Confirm decrease guide vane position digital output energized)
2.2	Energize purge pump relay	22 — Response (Confirm purge pump energized)
2.3	Energize alarm output indicating safety limit has been exceeded*	23 — Response (Confirm alarm output indicating safety limit has been exceeded energized)
2.4	Display configuration status	1 — OK 0 — Faulty Configuration
2.5	Display configuration status	1 — OK 0 — Faulty Configuration
2.6	Display purge operating switch status	1 — OK (Closed) 0 — Faulty (Open)
2.7	Display configuration status	1 — OK 0 — Faulty Jumper Between 1J2-11 and 1J2-12
2.8	Display spare safety input status	1 — OK (Closed) 0 — Faulty (Open)
2.9	Display chilled water flow switch contact status	1 — OK — Open, Pump Off (Confirm) 0 — Closed, Pump On (Confirm)
3.0	Display condenser water flow switch contact status	1 — OK — Open, Pump Off (Confirm) 0 — Closed, Pump On (Confirm)
3.1	Display oil pressure switch status	1 — OK (Open) 0 — Faulty (Closed)
3.2	Display 1CR auxiliary contact status	1 — OK (Closed) 0 — Faulty (Open)
3.3	Display starter run contact	1 — OK (Open) 0 — Faulty (Closed)
3.4	Cycle back to first test (depress reset pushbutton) End controls test (depress POR pushbutton)	0.1 03 Minutes

XX — Represents any other numbers displayed.

*Energize command can be cancelled by depressing reset pushbutton within one second after test number is displayed.



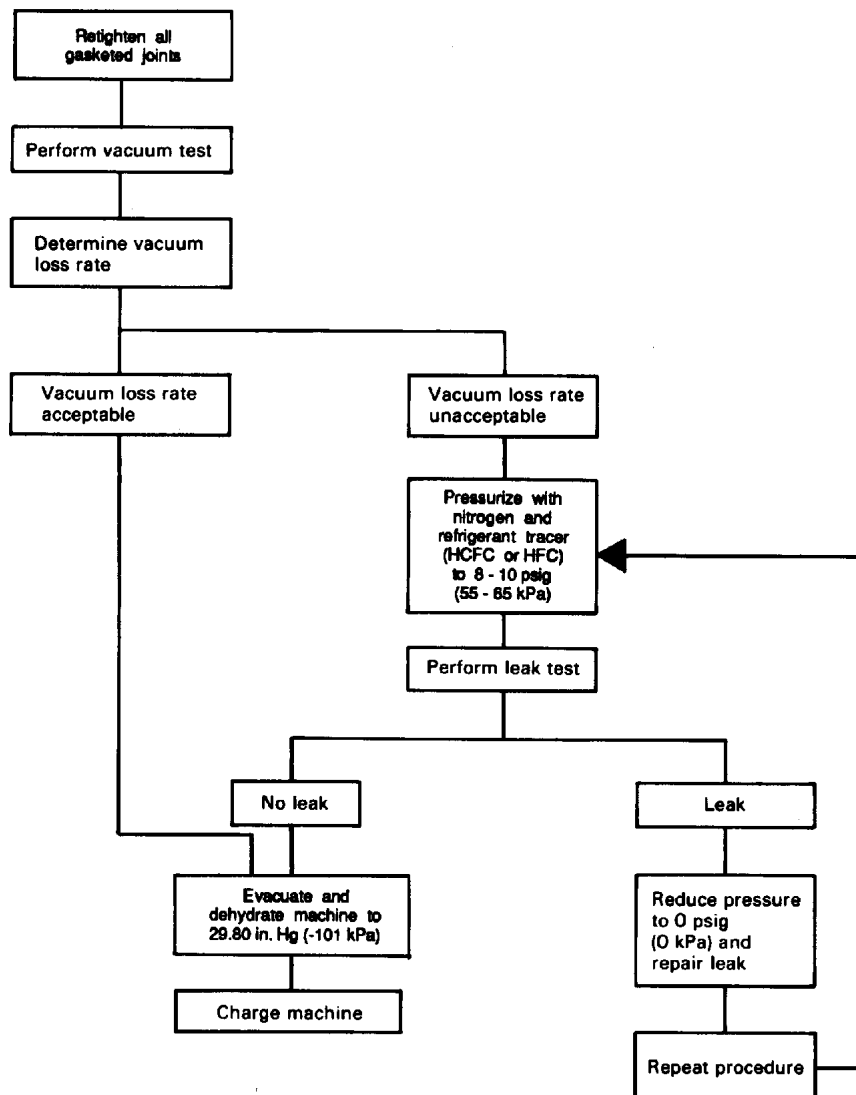

→ Fig. 5 — 19DM Leak Test Sequence and Procedures

BEFORE INITIAL START-UP

Job Data Required

1. List of applicable design temperatures and pressures (product data submittal).
2. Machine assembly, wiring and piping diagrams.
3. Starting equipment details and wiring diagrams.
4. Diagrams and instructions for special controls.
5. 19DM Installation Instructions.

Equipment Required

1. Mechanic's tools (refrigeration).
2. Digital volt-ohmmeter (DVM) and clamp-on ammeter.
3. Electronic leak detector.
4. Absolute pressure manometer or wet-bulb vacuum indicator.
5. Five to 10 ft (1.5 to 3 m) of copper tubing or plastic hose to fit 5/8-in. SAE connections.
6. 500-v insulation tester (megohmmeter) for compressor motors with nameplate voltage of 600 volts or less, or a 5000-v insulation tester for compressor motors with nameplate voltage above 600 volts.
7. Refrigerant drum charging valve.
8. 5/8-in. SAE x 3/4-in. MPT adapter.

Check Machine Tightness — Figure 5 outlines the proper sequence and procedures for leak testing.

→ Torque all gasketed joints before leak testing.

19DM machines are shipped under refrigerant-side vacuum. Over a period of time, during shipment or storage, part of this vacuum may be lost. Perform vacuum test to determine whether the vacuum loss, if any, is within Carrier's machine tightness standards.

VACUUM TEST

1. Check machine for open valve or other open connection. Correct before proceeding.

2. Install absolute pressure manometer or wet bulb indicator at cooler charging valve. A dial gage cannot indicate the small amount of leakage acceptable.
3. Pull a vacuum of 25 in. Hg (-84 kPa) ref 30-in. bar. (2.5 psia) (17 kPa). Use external vacuum pump.
4. Let machine stand with vacuum for 24 hours or more. Then determine vacuum loss rate by this formula:

$$\text{Vacuum loss rate} = \frac{\text{vacuum difference}}{\text{no. days between readings}}$$
5. If loss rate is 0.05 in. Hg (.17 kPa) or less in 24 hours, machine is sufficiently tight. Perform Machine Dehydration.
6. If loss rate is 0.05 in. Hg (.17 kPa) in 24 hours, perform Refrigerant Pressure Test, repair leaks and then dehydrate machine.

REFRIGERANT PRESSURE TEST

1. Pull a vacuum of 5.0 in. Hg (-17.0 kPa) ref 30-in. bar. (12.5 psia) (86 kPa) using an external vacuum pump attached to refrigerant charging valve.
- 2. Charge approximately 2 lb (.91 kg) of HCFC or HFC refrigerant tracer through purge valve No. 3 (Fig. 7).
3. Raise machine pressure to 8-10 psig (55-69 kPa) with nitrogen. Procedure is described under Pressurizing the Machine, page 22. Do not exceed 10 psig (69 kPa).
4. Test all valves, joints, fittings, etc. with an electronic leak detector.
5. Reduce machine pressure to near 0 psig (0 kPa); repair any leaks and then retest to ensure repair.

OPERATION	VALVE NUMBER			SWITCH Purge
	1	2	3	
1 Automatic	Close	Open	Close	Auto.
2 Remove water (See Note)	Open	Close	Close	Off

NOTE: Start machine and allow purge pressure to rise above atmospheric. Open valve No. 1 and allow water to drain from top of refrigerant. Close valve No. 1 after removing water.

Fig. 6 — Purge Valve and Switch Settings

MACHINE DEHYDRATION — The refrigerant side of the 19DM machine is dehydrated at the factory. If the machine has been open for a considerable period of time due to compressor removal, or if there has been excessive loss of shipping vacuum, dehydration should be repeated.

Dehydration is readily accomplished at normal or high room temperature. At low room temperature, special techniques must be employed; contact your field service representative.

⚠ CAUTION

Do not start compressor oil pump, even for a rotation check, nor apply test voltage of any kind while machine is under dehydration vacuum. Motor insulation breakdown and serious damage can result.

1. Connect dehydration pump to cooler charging valve.
2. Close all valves on purge assembly. Valves are identified on purge valve operation chart (Fig. 6).

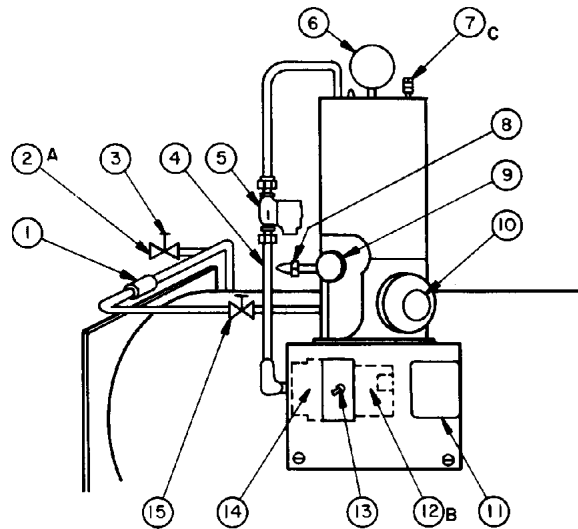

- 1 — Strainer-Orifice Assembly
- 2 — Connection A, 1/2-in. flare
- 3 — Valve No. 3
- 4 — Tubing D (solenoid valve to purge pump suction), 1/2 x 1/2 in.
- 5 — Solenoid Valve
- 6 — Purge Pressure Gage
- 7 — Connection C to purge operating switch
- 8 — Valve No. 1 (water drain)
- 9 — Water Sight Glass
- 10 — Refrigerant Level Sight Glass
- 11 — Purge Operating Switch, P2
- 12 — Pump Discharge, Connection B 1/4-in. FPT (under purge base)
- 13 — Purge Pump Switch (AUTO.-OFF-MANUAL)
- 14 — Purge Pump (under purge base)
- 15 — Valve No. 2

Fig. 7 — Purge Component Location

3. Connect an absolute pressure manometer to purge connection A (Fig. 7).
4. Operate dehydration pump until a vacuum of 29.80 in. Hg (-101 kPa) ref 30-in. bar. (0.1 psia) (0.7 kPa) is reached. Continue to operate pump for 2 more hours.
5. Close cooler charging valve; stop dehydration pump; record manometer reading.
6. After a 2-hour wait, read manometer again. If vacuum has not decreased, dehydration is complete. If vacuum has decreased, repeat steps 4, 5 and 6.
7. If vacuum fails to hold after several dehydration attempts, check for a machine leak by repeating Refrigerant Pressure Test. After repairing leak, repeat Vacuum Test and Machine Dehydration.

Inspect Piping — Refer to piping diagrams provided in Job Data and inspect piping to cooler, condenser and oil cooler. Be sure that flow directions are correct and that all piping specifications are met.

Piping systems must be properly vented, with no stress on water box nozzles or covers.

Water flow through cooler and condenser must meet job requirements. Measure pressure drop across cooler and across condenser.

Oil cooler water and piping must meet the specifications set forth in Job Data and in 19DM Installation Instructions. If city water is used, make sure that drainage is visible. Adjustment of water throttling valve (item 33, Fig. 1), to provide proper bearing temperature, is made after compressor start.

Charge Refrigerant — Refrigerant supplied with the machine is more than that required for initial charging. Refer to Table 5 for correct amount of charge. Machine vacuum will draw refrigerant from drum.

1. Connect short piece of plastic hose or copper tubing from refrigerant drum valve to cooler charging valve (item 2, Fig. 1).
2. Circulate chilled water during the charging process.
3. Charge refrigerant as a gas from the upright refrigerant drum until cooler vacuum becomes less than 18 in. Hg (-61 kPa); (6 psia) (41 kPa).

▲ CAUTION

At a vacuum of 18 in. Hg (-61 kPa) or greater, liquid Refrigerant 11 flashes into gas and can cause tube freeze-up and extensive damage.

4. Be sure that oil heater (item 6, Fig. 1) is energized during the charging process. Refer to the Check Oil Heater section on page 17.

After machine has been started, adjust charge as required for optimum machine performance. Refer to Trim Refrigerant Charge, page 18.

Table 5 — Machine Charge

UNISHELL SIZE	MACHINE CHARGE			
	Refrig (R-11)		Water	
	lb	kg	lb	kg
50	575	261	530	240
51	575	261	560	254
53	600	272	600	272
55	625	283	635	288
57	625	283	690	313
61	775	352	985	447
63	810	367	1030	467
65	850	386	1120	508
71	975	442	1140	517
72	985	447	1190	540
73	1010	458	1250	567
76	1100	499	1400	635
77	1150	522	1520	689
78	1200	544	1630	739

Inspect Wiring

▲ WARNING

Do not check high-voltage supply without proper equipment and precautions. Serious injury may result. Follow power company recommendations.

1. Examine wiring for conformance to job wiring diagrams and applicable electrical codes.

2. Check nameplates of oil pump, oil heater, and machine control panel for agreement with supply voltage, phase and Hertz.
3. Check motor starter ratings against motor voltage and amperage requirements. Motor overload relay selection must satisfy electrical code requirements.
4. Starter for centrifugal compressor motor must contain the components and terminals required for refrigeration machine control. Check job drawings.
5. Check that fused disconnects have been supplied for oil pump and oil heater.
6. Check that electrical equipment and controls are properly grounded in accordance with applicable electrical codes.
7. Make sure customer/contractor has verified proper operation of water pumps, cooling tower fan and associated auxiliary equipment. This includes ensuring that motors are properly lubricated and have proper electrical supply and proper rotation.

▲ CAUTION

Do not apply test voltage of any kind while compressor is under dehydration vacuum.

8. Test machine compressor motor and its power lead insulation resistance with a 500-volt insulation tester such as a megohmmeter. For compressor motors with nameplate voltage higher than 600 v, use a 5000-v tester; start test at 500 v and increase voltage setting after each successful testing until test voltage exceeds nameplate voltage.

a. *Open starter main disconnect switch.*

b. With tester connected to the motor side of the starter contactor in the starter, take 10-second and 60-second megohm readings as follows:

Six-lead motor — Tie all 6 terminals together and test between terminal group and ground. Next tie terminals in pairs, 1 and 4, 2 and 5, 3 and 6. Test between each pair while grounding the third pair.

Three-lead motor — Tie terminals 1, 2 and 3 together and test between group and ground.

c. Divide the 60-second resistance reading by the 10-second reading. The ratio (or polarization index) must be 1.15 to 1 or higher. Both the 10-second and 60-second reading must be at least 50 megohms. If the readings are unsatisfactory, repeat the test at the motor terminals with the power leads disconnected. Satisfactory readings in this second test indicate that the fault is in the power leads.

Check Starter

▲ CAUTION

BE AWARE that certain automatic start arrangements can engage the starter. Open the disconnect ahead of the starter in addition to shutting off the machine or pump.

1. Remove contactor arc chutes. Be sure that contactors move freely and that shipping string has been removed. Replace arc chutes.



2. Check contactors for dirt and rust. Clean contact magnet surfaces lightly with sandpaper. *Do not sandpaper or file silverplated contacts.* Apply a very thin coat of petroleum jelly to magnet surfaces and then wipe it off. If starter has been in a dusty atmosphere, vacuum clean cabinet and wipe with lint-free cloth.
3. Remove fluid cups from magnetic overload relays. Add dashpot oil to cups per instructions on relay nameplate. Oil is usually shipped in small vials attached to starter frame near relays. Use only dashpot oil supplied with starter. *Do not substitute.* Overload relays are factory set at 108% of motor full load amperage.
4. Check transfer timer for proper setting. On reduced voltage starters, timer has an adjustable range up to one minute and is factory set at 30 seconds.
5. With main disconnect open, manually open and close main control relay ICR to be sure that it operates freely.

Oil Charge — The oil charge (see Table 6) is shipped in the oil reservoir. Oil level should be visible at about 1/2 sight glass. If oil is added, it must meet Carrier specifications for hermetic centrifugal compressor usage.

Table 6 — Oil Charge

COMPRESSOR SIZE 19DM	OIL CHARGE	
	Gal.	Liter
212	16	57
312	22	79

Charge oil through the oil reservoir charging valve (item 36, Fig. 1). With machine under vacuum, oil is drawn from the oil container. Continue charging until oil reaches middle of sight glass.

Check Oil Heater — Energize the oil heater (item 6, Fig. 1) to minimize absorption of refrigerant by the oil. An indicator light goes on when the oil heater is energized. The oil heater thermostat has been factory set to maintain 140 – 145 F (60 – 63 C) temperature at machine shutdown. Adjust if required.

Check Machine Safety Control Settings

▲ WARNING

Do not operate machine before safety control settings, configuration switch (DIP switch) settings and controls test have been satisfactorily completed. Protection by safety controls cannot be assumed until all control settings have been confirmed.

ANALOG SAFETY CONTROL SETTINGS — Analog inputs are monitored by the microprocessor to prevent machine operation outside acceptable limits. Most analog safeties have preset limits based on proper DIP switch setting. Follow procedures given in Table 1. Confirm DIP switch settings during controls test and recheck during operation if noted.

MECHANICAL SAFETY AND OPERATING CONTROL SETTINGS — With the exception of the oil heater thermostat and the flow switches, these

controls are most conveniently checked with machine off and unishell pressure at 0 psig (0 kPa). If switches are checked during leak test, be sure to tag each switch with setting and date. Follow setting procedures given in Table 1.

Configure DIP Switches — Refer to Control Configuration in Controls section. Using Table 3, page 10 and 11 (Configuration Switch Settings), position DIP switches according to function and description that match the requirements or best suit the machine's operating duty. For multiple choice selections, see recommended settings (identified by asterisk [*]) or refer to Machine Configuration Settings label on machine control panel.

Check Safety Control Operation — Check safety control status by performing a controls test. Refer to Controls Test in Controls section. Then check operation by manually tripping safety controls during a trial run condition. As the checks are made, the machine should shut down, and the appropriate diagnostic code should be displayed. After each check, depress the POR pushbutton to override the 15-minute timer and initialize the 3-minute timer.

To operate the machine in a trial run condition:

1. Open disconnects to remove all power from starter and control panel.
2. Disconnect main motor leads from starter and secure. Re-energize starter and control center.
3. Manually trip and reset compressor motor overloads in starter and condenser high-pressure switch.
4. Start pumps (if not automatic) and start machine. Immediately after machine enters ramp loading (code 29), check each safety as follows and observe display for proper safety shutdown diagnostic code.

NOTE: Checks must be made within one minute after code 29 appears.

- a. Open oil pump disconnect (code 65).
- b. Manually trip condenser high-pressure switch, reset before next test (code 73).
- c. De-energize chilled water or brine pump (code 70).
- d. De-energize condenser water pump (code 71).
- e. If installed, manually trip spare safety or safeties (code 79). Reset if required.
- f. Simulate a welded starter contact condition: De-energize control center and install a temporary switch between (L1) and terminal (18) in control center. Open switch and re-energize control center. Set capacity control switch at INC. Depress START pushbutton and wait until guide vane opens part way. Approximately 15 seconds after code 29 appears, close switch and depress STOP pushbutton; guide vane should be driven closed, alarm should energize and diagnostic code 77 should be displayed. Oil pump, water pumps and tower fan should remain energized.
5. After confirming checks, de-energize control center, remove temporary switch and replace motor leads from starter.



INITIAL START-UP

Preparation — Before starting machine, check that:

1. Power is on to main starter, oil pump starter, water pump starters, tower fan starter, oil heater and machine control center.
2. Cooling tower water is at proper level and temperature.
3. Machine is charged with refrigerant and all refrigerant and purge valves are in the normal operating position.
4. Oil is visible in reservoir sight glass.
5. Oil reservoir temperature is 140 to 150 F (60 to 66 C).
6. Oil cooler water throttling valve (item 33, Fig. 1) is partially open.
7. Valves in evaporator and condenser water circuits are open.

NOTE: If pumps are not automatic, make sure water is circulating properly.

▲ WARNING

Do not permit water or brine warmer than 100 F (38 C) to flow through cooler. Refrigerant overpressure may burst rupture disc and result in loss of refrigerant charge.

Start-Up — Set capacity control switch at DEC. Depress machine START pushbutton. Compressor starts after prestart sequence is completed and oil pump has operated about 20 seconds (see Control Sequence). As compressor motor begins to turn, check for clockwise motor rotation through motor end bell sight glass. Let compressor come up to speed. Note oil differential pressure gage reading; it should be 20 to 25 psid (138 to 172 kPa).

Depress STOP pushbutton and listen for any unusual sounds from the compressor as it coasts to a stop.

If rotation is not clockwise (as viewed through sight glass), reverse power leads on any 2 of 3 phases entering the motor starter and recheck rotation.

▲ CAUTION

Do not check motor rotation during coastdown; rotation may reverse during equalization of vessel pressures.

Calibrate Motor Current Demand

1. Place ammeter on line motor load current transformer on the motor side of power factor correction (if provided). Start compressor and establish a steady motor current value between 50% and 99% RLA by manually opening guide vane (set capacity control at INC while gradually adjusting thermostat towards cooler). Do not exceed 105% of nameplate RLA.

NOTE: At 100% RLA, the 2-digit display blinks. Above 100% RLA, code 30 is displayed.

2. Set capacity control at HOLD; % RLA will be displayed. If % RLA exceeds electrical demand setting, code 30 is displayed. Measure motor current at selected condition and calculate its percentage of RLA using nameplate RLA rating.

$$\% \text{ RLA} = \frac{\text{Measured Current}}{\text{Nameplate RLA}} \times 100$$

3. Compare percentage calculated with percentage displayed on LCD.

If percentage displayed does not match percentage calculated, use calibration tool provided in service packet to adjust motor current calibration potentiometer; turn clockwise to decrease or counterclockwise to increase display reading until display matches calculated percentage.

NOTE: When adjusting motor current calibration potentiometer, allow for a time lag of several seconds caused by feedback capacitance in the motor current circuit.

4. Check the foregoing motor current calibration with machine under AUTO. control as follows:
 - a. Allow machine to operate and stabilize near full load in AUTO. Set capacity control to HOLD and note percent current displayed.
 - b. Close guide vane manually (capacity control at DEC) and set demand limit below value noted on display in step a.
 - c. Turn capacity control to AUTO. Guide vane should stop opening at electrical demand setting in b; if not, note direction of error and repeat calibration procedure.

If control cannot be calibrated with above procedure, check voltage signal and signal resistor in starter. At 100% RLA, voltage between terminals 23 and 24 inside control center must be $0.5 \pm .10$ volts. If voltage is not within this range, check sizing of signal resistor and current transformer in starter.

Check Machine Operating Condition — Be sure machine temperatures, pressures, water flows and oil and refrigerant levels indicate that the system is functioning properly. Refer to Check Running System in the Operating Instructions section.

Trim Refrigerant Charge — If it is necessary to adjust the refrigerant charge to obtain optimum machine performance, operate the machine at full load and add or remove refrigerant slowly until the difference between leaving chilled water temperature and cooler refrigerant temperature reaches design conditions or becomes a minimum.

INSTRUCT THE CUSTOMER OPERATOR

Be sure that the operator carefully reads and understands all operating and maintenance instructions. Point out the various machine components and explain their functions.

Compressor-Motor Assembly — Guide vane, actuator motor and linkage, motor cooling system, transmission, temperature sensors.

Unishell — Cooler, condenser, flow chamber, relief device, water circuits, vents and drains, sight glasses and charging valve.

Purge System — Importance of proper operation, valves and system operation, sight glasses, pressure gage.

Lubrication System — Oil pump, starter, cooler, filter, solenoid valve, plug valve, heater, thermostat, temperature and pressure gages, oil quality, oil level and temperature.

Control System — LOCAL/REMOTE switch; STOP, START, RESET, RECALL and POR push-buttons; LCD; pressure gages; safety controls, operating controls, auxiliary and optional controls.

Auxiliary Equipment — Starters and disconnects, separate electrical sources, pumps, cooling tower.

Describe Machine Cycles — Refrigerant, motor cooling, lubrication.

Review Maintenance — Scheduled, routine, extended shutdown, importance of log sheet, importance of water treatment.

Safety Devices and Procedures — Electrical disconnects, relief valve maintenance, handling refrigerant.

Check Operator Knowledge — Start, stop and shutdown procedures, safety and operating controls, refrigerant and oil charging, job safety.

Review Operating and Maintenance Instructions.

OPERATING INSTRUCTIONS

Operator Duties

1. Become familiar with refrigeration machine and related equipment before operating.
2. Prepare system for start-up; start and stop machine; place system in shutdown condition.
3. Maintain log of operating conditions and recognize abnormal readings.
4. Inspect equipment, make routine adjustments and controls tests, maintain proper levels of oil, water and refrigerant.
5. Protect system from damage during shutdown.

Prepare Machine for Start-Up — Follow all steps described under Preparation in the Initial Start-Up section.

To Start Machine

1. Start water pumps, if not automatic.
2. Allow 3-minute stop-to-start inhibit timer to expire and blank out the display.
3. Depress START pushbutton; machine follows start-up sequence as described in the Controls section.

Check Running System — After compressor starts, operator should monitor the display codes and observe the following indications of normal operation.

Oil reservoir temperature should be 140 – 150 F (60 – 66 C).

Oil heater will be off at normal bearing oil return temperatures.

Bearing oil return temperature, read on bearing oil thermometer (item 6, Fig. 1), should be 150 – 175 F (66 – 80 C). Oil cooler water flow may require some adjustment to maintain temperature; open or close water throttling valve (item 33, Fig. 1) as required. If thermometer reads more than 180 F (82 C) with oil pump and oil cooler water operating, *stop machine and determine cause. DO NOT restart machine until corrected.*

Oil cooler water should be visible if discharged into open sight drain.

Oil level should be at about 1/2 sight glass (item 7, Fig. 1).

Oil pressure should read 20 – 25 psi (138 – 172 kPa) differential at control center gage.

Condenser pressure varies with machine design conditions. Range is usually between 0 and 11 psig (0 – 76 kPa).

Condenser leaving water should be above 65 F (18 C) for most applications; check your design data.

Cooler pressure also varies with design conditions. Range is usually 15 to 18 in. Hg vacuum (-51 to -61 kPa).

Purge pressure will be somewhere between cooler and condenser pressures. In the absence of noncondensables the purge pressure will be closer to cooler pressure. As noncondensables are collected, the purge pressure will approach the condenser pressure.

NOTE: The compressor may operate at full capacity for a short time after ramp loading has ended, even though the building cooling load is small. The electrical demand control can be adjusted to limit compressor IKW and avoid a high demand charge for the short period of full capacity operation.

To Stop Machine — Depress STOP pushbutton; machine follows shutdown sequence as described in the Controls section. *If machine fails to stop, in addition to action taken by the microprocessor, the operator should close guide vanes and reduce machine load by turning capacity control switch to DEC (decrease); then open main disconnect. Do not attempt to stop machine by opening an isolating knife switch. High intensity arcing may occur. DO NOT restart machine until malfunction is corrected.*

After Limited Shutdown — No special preparations should be necessary. Follow regular preliminary checks and starting procedures.

Extended Shutdown — Ordinarily, refrigerant charge may be kept in machine. Under high ambient temperatures (90 F [32 C] and above), removal and storage of refrigerant is recommended. (See Removing Refrigerant, page 22.)

If freezing temperatures are liable to occur in machine area, drain chilled water, condenser water and oil cooler water circuits to avoid freeze-up. Clear oil cooler lines with air. Keep water box drains open.

If refrigerant is left in machine and water lines are not drained, check refrigerant level weekly. An increase in refrigerant level indicates a water leak. Locate and repair such leaks immediately.

Leave the oil charge in the machine with the oil heater (item 6, Fig. 1) energized to keep oil temperature at 140 – 145 F (60 – 63 C).

After Extended Shutdown — Close water box drains. If the refrigerant has been removed, recharge the machine as directed in Charging Refrigerant section. Observe freeze-up precautions while charging.

Carefully make all regular preliminary and running system checks. If compressor oil level appears abnormally high, oil may have absorbed refrigerant; raise oil thermostat setting (item 6, Fig. 1) to drive off any refrigerant.

Manual Operation — The capacity control switch permits the operator to increase leaving chilled water or brine temperature above the set point without altering the automatic temperature control settings.

Manual control is useful in checking control operation or controlling the machine in an emergency.

Turn the capacity control switch to DEC (decrease) to close the guide vanes, decrease machine capacity and increase chilled medium temperature. HOLD maintains guide vane position and displays the % RLA on the LCD. INC (increase) opens the guide vanes, increases machine capacity and lowers chilled medium temperature to the thermostat set point.

NOTE: The INC (increase) position overrides ramp loading during start-up. Motor current above the electrical demand setting or above motor RLA, evaporator refrigerant temperature below the set point or chilled water or brine temperature below the set point overrides the INC capacity control setting. For description and set points, refer to Capacity Overrides in the Controls section.

Refrigeration Log — The Carrier log sheet for 19D Series machines provides a convenient check list for routine maintenance and forms a continuing record of machine performance. It is an aid in scheduling maintenance and in diagnosing machine problems.

The log sheet is available from Carrier in pads of 50 each. When ordering, specify by form number E-56A, found at the lower left corner of the log sheet.

WEEKLY MAINTENANCE

Check Lubrication System — Mark oil level on reservoir sight glass (item 7, Fig. 1) and observe level each week while machine is shut down. Record date and amount of oil added. Added oil must meet Carrier specifications for centrifugal compressor usage.

To add oil while machine is under vacuum, attach a tube to the oil charging valve (item 36, Fig. 1) and place the other end in an oil container. Keep tube end submerged to prevent air from entering machine. With machine at vacuum, oil is drawn from the container. Charge until oil reaches middle of sight glass.

If machine pressure is above atmospheric, a small hand pump will be required for pumping the oil into the reservoir.

A 1000-watt oil heater and a thermostat maintain oil reservoir at 140 – 145 F (60 – 63 C). The heater pilot light should be on whenever the heater is on. If the pilot light is out and the reservoir is warm, check heater terminals with a voltmeter to determine if the contacts are closed. Replace bulb if necessary.

If the pilot light is out and the reservoir is colder than normal, the thermostat may be set too low, thermostat may be faulty or power may be off. Check power source, reset thermostat, replace thermostat if necessary.

Do not operate machine when oil temperature is less than 135 F (57 C).

Vane seal O-rings require oil for lubrication. Remove spring-loaded cap and fill oiler (item 11, Fig. 1) with lubrication oil.

Check Purge Operation — Frequent operation of the purge pump (several times an hour) or the display of

code 37 (excessive purging) is an indication that air is entering the machine. Locate and repair any such leaks. For leak test procedures, see Check Machine Tightness.

If water is visible in the water level sight glass (item 9, Fig. 7) drain the water per Operation 2 on the purge valve operation chart (Fig. 6).

Measure and record the amount removed. If water is continually being removed, determine the source. If water is allowed to remain in the machine refrigerant side, serious damage will result.

SCHEDULED MAINTENANCE

Establish a regular maintenance schedule based on your actual machine requirements (determined by machine load, hours of operation, water quality, etc.). The time intervals listed in this section are offered as guides.

Inspect Control Center — Maintenance is normally limited to general cleaning, tightening of connections and checking of safety and operating controls. In the event of machine control malfunction, refer to Controls section and Troubleshooting Guide in this publication for control checks and adjustment procedures.

Check Safety and Operating Controls — To ensure machine protection, a controls test should be done at least once monthly and the mechanical safety controls should be checked at least once during the operating season, or at least once every 6 months if the machine is operated continuously. See Table I for control illustrations and setting procedures.

Change Oil and Oil Filter (see item 34, Fig. 1) yearly or if machine is opened for repairs.

→ To remove the oil, turn off the oil heater and raise machine pressure to slightly above 0 psig (0 kPa) (see the Leak Testing section on page 22). Attach a tube to oil charging valve (item 36, Fig. 1) and drain the oil into a container. Drain the oil filter compartment through the drain plug (item 35, Fig. 1).

With machine pressure at approximately 0 psig (0 kPa), remove lubrication package coverplate. Quickly install a new filter cartridge. Cartridges can be obtained through your nearest Carrier office. Remove any metallic particles from magnetic plug in coverplate.

Add new oil charge (see Table 6) through oil charging valve, using a hand pump. Charge to approximately 1/3 sight glass.

Warm oil to 140–145 F (60–63 C) with oil heater. Operate oil pump for 2 minutes and add oil, if required, to maintain original level.

Oil should be visible at reservoir sight glass under all operating and shutdown conditions. Use only high grade oil which conforms to the following specifications:

Viscosity at 100 F (at 38 C)	300 ± 25 SSU (59.2 to 70.1 mm ² /s)
Viscosity at 210 F (at 99 C)	50 to 55 SSU (7.3 to 8.8 mm ² /s)
Viscosity index (min)	95
Pour point (max)	-5 F (-21 C)
Flash point (min)	400 F (204 C)

Rust inhibiting characteristics: material shall pass ASTM Rust Test D665, latest revision. Use Procedure A with test period of 24 hours.

Oxidation resistance: material shall pass ASTM Oxidation Test D943, latest revision, for a minimum of 2000 hours. Acid number at end of test shall not exceed 2.0 mg, KOH per gram.

→ **Change Volute Drain Strainer and Refrigerant Filter** — (Item 28 and 32, Fig. 1). Reduce machine pressure to 0 psig (0 kPa) and quickly change the strainer and filter to minimize refrigerant loss. Item 28 is an in-line strainer; remove and replace it yearly. Item 32 is an in-line filter; remove the steel bolt, lower the bottom half of the filter housing and replace the filter cartridge yearly. Cartridges or strainer may be ordered through your Carrier representative.

Compressor Bearing Maintenance — The best bearing maintenance consists of maintaining clean oil at proper temperature and pressure in the lubricating system.

→ All liquid refrigerant and refrigerant gas must be recovered from the chiller before the compressor can be opened for bearing inspection.

Examine bearings on a scheduled basis for signs of wear. The frequency of examination is determined by the condition of the lubrication system, hours of machine operation, type of load on machine, etc.

The removal and examination of bearings should be done only by a trained service mechanic.

Excessive bearing wear can sometimes be detected through increased vibration or increased bearing temperature.

Inspect Purge — A purge in good repair protects the machine against corrosive mixtures and can prevent damage to major components.

1. Remove the cover of the purge refrigerant float chamber and thoroughly clean the chamber and float valve. Make sure that the valve operates freely through its full travel.
2. Remove and examine the float valve plunger. Replace the plunger and seat assembly if there are signs of wear.
3. Reassemble components, using a new O-ring on chamber cover.
4. Clean the 1/16-in. (1.6-mm) orifice in the purge sampling line (see Purge Cycle, page 29).
5. Replace the strainer element in the orifice-strainer assembly.

Yearly replacement of the purge pump inlet and outlet valves is recommended.

→ **Inspect Refrigerant Flow Chamber** — Remove refrigerant (see page 22) and break vacuum with nitrogen. With machine pressure at 0 psig (0 kPa), remove the access cover and thoroughly clean the chamber and mesh screen. Check the clearance between the flow control valve and the mounting plate as indicated in Fig. 8. Make sure that the area is free of rust, scale or debris.

CHECK VALVE TRAVEL — Refer to identification number on the valve face. Then read the proper travel for that valve on the Fig. 8 chart. Press the valve inward to make sure that it moves freely throughout its full travel.

CHECK GASKET — Examine access cover gasket and replace if necessary.

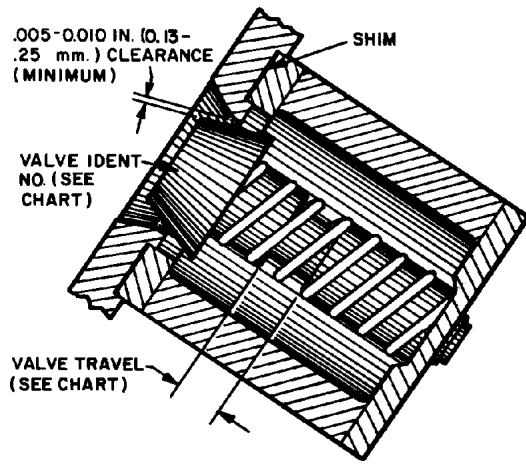

VALVE IDENT NO.	VALVE TRAVEL	
	in. ± .003	mm ± .08
DK117	.237	6.02
DK217	.325	8.26
DK237	.421	10.69
DK317	.622	15.80
DK417	.774	19.66

Fig. 8 — Flow Chamber Poppet Valve Detail

Inspect Unishell Tubes

COOLER — Inspect and clean cooler tubes at end of first operating season. Tube condition at this time will establish the required frequency for cleaning and will indicate whether water treatment is needed in the chilled water circuit.

CONDENSER — Since this water circuit is usually an open system, the tubes may be subject to contamination by foreign matter and scale. Clean the condenser tubes at least once a year, and more often if the water is contaminated.

Higher than normal condenser pressures, together with inability to reach full refrigeration load, usually indicates dirty tubes, or air in the machine.

If the refrigeration log indicates a rise above normal condenser pressures, check the pressure against actual refrigerant condensing temperature.

If the temperature reading is more than 2 F (1.1 C) below the temperature corresponding to the existing pressure (see condenser pressure gage), air is present in the machine. Confirm that purge valves and switches are in AUTOMATIC position (Fig. 6). Air should vent automatically. If not, check purge operation as indicated in the Troubleshooting Guide section.

If, however, the temperature reading and the pressure correspond, the high condenser pressure is caused by dirty tubes or by abnormal conditions in the condensing water circuit, such as restricted flow, etc. Check operation of condensing water circuit. If water conditions (flow and temperature) appear normal, the tubes should be cleaned.

Tube cleaning brushes, specially designed to avoid scraping or scratching the tube walls, are available through your Carrier office. Do not use wire brushes.



Hard scale may require chemical treatment for its prevention or removal. Consult a water treatment specialist for proper treatment.

Inspect Starting Equipment — Before working on any starter, shut off machine and open disconnect ahead of starter.

⚠ WARNING

Never open isolating knife switches while equipment is operating. Electrical arcing can cause serious injury.

Inspect starter contact surfaces for wear or pitting. Do not sandpaper or file silverplated contacts. Follow starter manufacturer's instructions for contact replacement, lubrication and other maintenance requirements.

Ordering Replacement Parts — When ordering Carrier Specified Parts, the following information must accompany order:

1. Machine model number and serial number.
2. Name, quantity and part number of part required.
3. Delivery address and method of shipment.

GENERAL MAINTENANCE

Refrigerant Properties — At normal atmospheric pressure, Refrigerant 11 is a colorless liquid which boils at 74.8 F (23.8 C). The vapor is much heavier than air and will, therefore, remain in an open container with little loss by evaporation. Above 74.8 F (23.8 C), closed containers of Refrigerant 11 are under pressure and should be opened with care.

Refrigerant 11 is practically odorless and is non-toxic (except in open flame) and noncombustible. It will, however, dissolve natural rubbers and oil, dry the skin and in heavy concentrations *displaces oxygen and may cause asphyxiation*. When handling refrigerant, protect hands and eyes and avoid breathing fumes.

Charging Refrigerant — Follow the instructions in the section entitled Charge Refrigerant, page 16.

→ Removing Refrigerant

1. Raise cooler pressure to 5 – 8 psig (35 – 55 kPa) as described under Pressurizing a Machine When Liquid Refrigerant is present.
2. Connect a length of plastic hose or copper tube between the refrigerant charging valve and a valve on the refrigerant container.
3. Connect a vent line between the machine and the refrigerant container.
4. Open the charging valve and allow refrigerant to flow into the container.
5. Use a refrigerant condensing unit to remove refrigerant gas down to 25 or 29 in. Hg (–85 kPa or –98.2 kPa) depending on the rating of the refrigerant transfer unit.
6. Leave a space of about 3 in. (75 mm) above the liquid in the container to allow for refrigerant expansion. Above 75 F (24 C), Refrigerant 11 develops pressure in closed containers. Store containers in a cool place and open with care.

Trimming Refrigerant Charge — Follow procedure given in Trim Refrigerant Charge, page 18.

Refrigerant Loss — Some refrigerant is discharged from the machine when the purge unit removes air and

noncondensables. Any leak which causes frequent purge cycling should therefore be repaired without delay.

Air and Water Leaks — Air in the machine causes higher than normal condenser pressure, compressor surge at start-up and frequent purge cycling. Locate and repair any air leaks as soon as possible.

Higher than normal condenser pressure can also be caused by dirty tubes, high entering water temperature or lack of condensing water. To determine if air is the cause, check condenser and refrigerant temperatures as described under Inspect Unishell Tubes, page 21.

→ **LEAK TESTING** — Pressurize the machine as described on this page and then test all joints and flanges with a halide or electronic leak detector. Be sure room is free of concentrations of refrigerant when leak testing.

Water leaks during machine operation are indicated by frequent and excessive accumulation of water in the purge separation chamber. Water leaks should be repaired immediately.

⚠ CAUTION

Machine must be dehydrated after repair of water leaks. See Machine Dehydration, page 15.

→ Pressurizing a Machine When Liquid Refrigerant is Not Present

— Whenever the machine vacuum must be broken for service work or for extended shutdown, nitrogen is recommended. Dry nitrogen is preferable to air as it does not introduce moisture into the machine. *Never use oxygen for pressurizing*. To pressurize with nitrogen or dry air:

If the refrigerant is removed, charge approximately 2 lb (1 kg) of HCFC or HFC refrigerant into machine before pressurizing.

1. Connect high-pressure hose or tubing from pressure cylinder to cooler charging valve. Never apply full cylinder pressure to the pressurizing line. Follow the steps below in proper sequence.
2. Open cooler charging valve fully.
3. Open cylinder regulating valve slowly.
4. Observe cooler pressure gage and close cylinder regulating valve when test pressure of 5 – 8 psig (35 – 55 kPa) is reached. *Do not exceed 10 psig (69 kPa)!*
5. Close cooler charging valve. Remove high-pressure hose or tubing if no longer required.

→ Pressurizing a Machine When Liquid Refrigerant is Present

⚠ CAUTION

Do not add nitrogen to a machine still charged with liquid refrigerant because excessive amounts of refrigerant will be lost when the nitrogen is purged.

Machine pressure can be raised to 0 psig (0 kPa) for minor service or to leak test pressures by heating the refrigerant in the cooler. The refrigerant can be heated by heat blankets on the cooler or by circulating warm water through the cooler.

TESTING AT HIGHER PRESSURE — If leaks are undetected at normal test pressure (5 – 8 psig) (35 – 55 kPa), tests may be made at a maximum of 15 psig (103 kPa) with the following provision: The pressure must be equalized across the rupture disc to prevent failure of the disc.

Guide Vane Linkage — 19DM guide vane and linkage assembly is carefully adjusted at factory.

When the machine is off, the guide vanes are closed and the vane actuator is stopped at the position shown in Fig. 9.

If motor crankarm is in proper position at machine shutdown, but vane crankarm is not, guide vanes are not fully closed. Loosen vane crankarm linkage connector; close vanes tightly by hand and reconnect linkage.

If motor crankarm is not in proper position or if arm fails to move, loosen setscrews and examine shaft for slippage marks. If none, actuator windings may be defective. Check for proper voltage at actuator terminals. If voltage is correct, replace actuator.

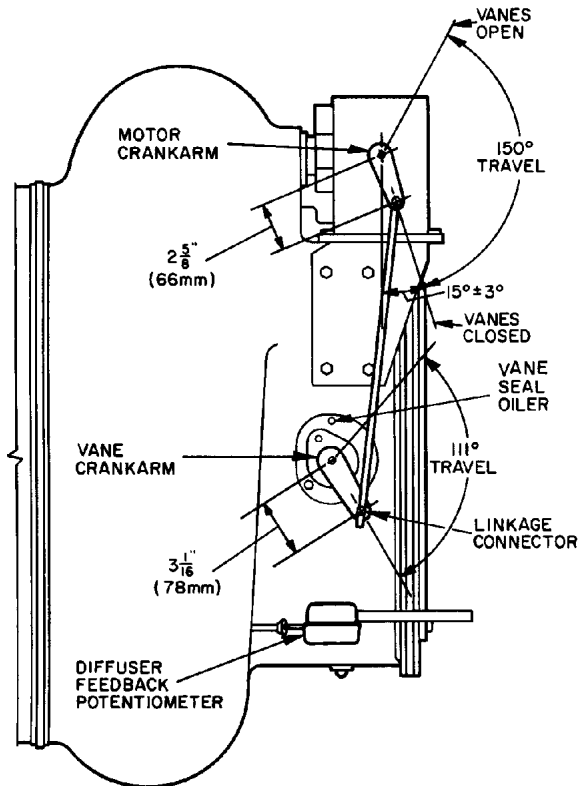

Fig. 9 — Guide Vane Linkage (Closed Position)

Sensor Test Procedure — Temperature sensors are connected to the processor board in the machine control center.

1. Determine sensor temperature by measuring voltage drop or resistance and comparing readings to values listed in Table 7.

VOLTAGE DROP — Using a digital volt-ohmmeter, the voltage drop across any sensor can be measured at the connector plug while the machine is operating or for a particular sensor when performing the applicable controls test. Table 7 indicates the relationship between temperature and sensor voltage drop (volts dc measured across an energized sensor). Exercise care when measuring voltage to prevent damage to the sensor leads, the connector plugs and the processor board.

RESISTANCE — Turn off control power and disconnect terminal plug 1J1 from the processor board. Measure sensor resistance between receptacles designated by wiring diagram with a digital ohmmeter. Table 7 shows the relationship between resistance and temperature.

2. Check sensor accuracy. Place the sensor in a medium of known temperature and compare that temperature to the temperature indicated by the measured resistance values or voltage drop (shown in Table 7). The thermometer used to determine the temperature of the test medium should be of laboratory quality with 0.5 degree graduations. Sensor accuracy should be within 2 degrees F (approximately 1 degree C).

Diffuser Wall Potentiometer Test Procedure —

The diffuser wall feedback potentiometer can be checked and calibrated by measuring the voltage drop. With power energized, depress POR pushbutton and immediately depress reset pushbutton to enter controls test. Initiate test step to drive diffuser wall fully closed. Connect a digital voltmeter (range 0 – 1 vdc) across terminals as designated by control wiring schematic. Adjust the thumbwheel on the actuator rod until this voltage is between 0.4 and 0.5 volts dc. Tighten the locknut on the actuator rod. Change voltmeter range to 0 – 5 vdc. While initiating the test step to drive the wall fully open, note that the voltage signal increases proportionally with wall position. Recheck for an acceptable reading at a fully closed condition.

GENERAL DATA

Machine Informative Plate (item 4, Fig. 1) is located on the compressor support base at the left of the machine control center.

System Components include cooler and condenser heat exchangers within a single shell (unishell), motor-compressor, lubrication package, purge and control center.

COOLER — This heat exchanger, in the bottom portion of the unishell, is maintained at low temperature-pressure so that evaporating refrigerant can remove heat from water flowing through its tubes.

CONDENSER — Heat exchanger, in the unishell upper portion, operates at a higher temperature-pressure at which heat may be removed from the refrigerant and be passed out of the system.

MOTOR-COMPRESSOR maintains system temperature-pressure differences and moves the heat carrying refrigerant from cooler to condenser.

LUBRICATION PACKAGE, consisting of oil pump, filter, cooler and thermostatically controlled heater, lubricates the motor-compressor, maintains the oil at proper operating temperature and pressure and removes foreign particles.

The lubrication oil is also used to hydraulically position the diffuser wall. Four solenoid valves, controlled by the diffuser module, direct the oil flow.

PURGE automatically separates air or other non-condensables from the refrigerant and collects any water for periodic manual removal.

CONTROL CENTER regulates machine capacity as required, registers cooler, condenser and lubricating system pressures, shows machine operating condition through status codes, contains machine safety devices and records machine operating hours. Machine start, stop and recycle is sequenced under microprocessor control.



Table 7a — Sensor Resistance and Temperature (F)

TEMP (F)	RESISTANCE (Ohms)	VOLTAGE DROP (v)	TEMP (F)	RESISTANCE (Ohms)	VOLTAGE DROP (v)	TEMP (F)	RESISTANCE (Ohms)	VOLTAGE DROP (v)	TEMP (F)	RESISTANCE (Ohms)	VOLTAGE DROP (v)
-25.0	98009.6	4.684	38.0	13825.5	3.373	101.0	2834.9	1.500	184.0	765.3	0.527
-24.0	94707.1	4.673	39.0	13449.2	3.343	102.0	2773.2	1.476	185.0	749.5	0.518
-23.0	91521.5	4.662	40.0	13084.2	3.312	103.0	2713.1	1.453	186.0	734.2	0.509
-22.0	88448.9	4.651	41.0	12730.1	3.281	104.0	2654.7	1.430	187.0	719.2	0.501
-21.0	85485.5	4.640	42.0	12386.6	3.250	105.0	2597.8	1.407	188.0	704.6	0.493
-20.0	82627.2	4.628	43.0	12053.3	3.219	106.0	2542.3	1.385	189.0	690.4	0.484
-19.0	79870.8	4.616	44.0	11730.0	3.187	107.0	2488.3	1.362	190.0	676.6	0.476
-18.0	77212.0	4.604	45.0	11416.1	3.156	108.0	2435.8	1.341	191.0	663.3	0.468
-17.0	74647.9	4.591	46.0	11111.5	3.124	109.0	2384.5	1.319	192.0	650.3	0.461
-16.0	72175.1	4.578	47.0	10815.8	3.093	110.0	2334.6	1.298	193.0	637.7	0.453
-15.0	69790.3	4.565	48.0	10528.7	3.061	111.0	2285.9	1.277	194.0	625.5	0.446
-14.0	67490.4	4.551	49.0	10250.0	3.029	112.0	2238.5	1.256	195.0	613.8	0.438
-13.0	65272.4	4.537	50.0	9979.3	2.997	113.0	2192.2	1.236	196.0	602.3	0.431
-12.0	63133.3	4.523	51.0	9716.5	2.965	114.0	2147.0	1.216	197.0	591.3	0.424
-11.0	61070.3	4.509	52.0	9461.3	2.933	115.0	2103.0	1.196	198.0	580.7	0.417
-10.0	59080.6	4.494	53.0	9213.4	2.901	116.0	2060.0	1.176	199.0	570.3	0.410
- 9.0	57161.7	4.479	54.0	8972.6	2.869	117.0	2018.0	1.157	200.0	560.5	0.403
- 8.0	55310.9	4.463	55.0	8738.6	2.837	118.0	1977.0	1.138	201.0	550.9	0.397
- 7.0	53525.8	4.448	56.0	8511.4	2.805	119.0	1936.9	1.120	202.0	541.7	0.390
- 6.0	51804.0	4.431	57.0	8290.6	2.772	120.0	1897.8	1.101	203.0	532.9	0.384
- 5.0	50143.2	4.415	58.0	8076.1	2.740	121.0	1859.5	1.083	204.0	524.4	0.378
- 4.0	48541.1	4.398	59.0	7867.7	2.708	122.0	1822.1	1.065	205.0	516.2	0.371
- 3.0	46995.6	4.381	60.0	7665.1	2.676	123.0	1785.5	1.048	206.0	508.4	0.365
- 2.0	45504.7	4.363	61.0	7468.3	2.644	124.0	1749.7	1.030	207.0	500.8	0.360
- 1.0	44066.3	4.345	62.0	7277.1	2.612	125.0	1714.7	1.013	208.0	493.6	0.354
0.0	42678.5	4.327	63.0	7091.2	2.581	126.0	1680.4	0.997	209.0	486.5	0.348
1.0	41339.3	4.308	64.0	6910.6	2.549	127.0	1646.8	0.980	210.0	479.9	0.342
2.0	40047.1	4.289	65.0	6735.1	2.517	128.0	1613.8	0.964	211.0	473.4	0.337
3.0	38800.0	4.270	66.0	6564.4	2.486	129.0	1581.6	0.948	212.0	467.2	0.332
4.0	37596.4	4.250	67.0	6398.6	2.454	130.0	1550.0	0.932	213.0	461.2	0.326
5.0	36434.7	4.230	68.0	6237.5	2.423	131.0	1519.0	0.917	214.0	455.6	0.321
6.0	35313.3	4.209	69.0	6080.8	2.391	132.0	1488.6	0.902	215.0	450.0	0.316
7.0	34230.7	4.188	70.0	5928.8	2.360	133.0	1458.8	0.887	216.0	444.5	0.311
8.0	33185.4	4.167	71.0	5780.6	2.329	134.0	1429.6	0.872	217.0	439.2	0.306
9.0	32176.2	4.145	72.0	5636.8	2.299	135.0	1400.9	0.857	218.0	434.4	0.301
10.0	31201.5	4.123	73.0	5497.0	2.268	136.0	1372.7	0.843	219.0	429.2	0.297
11.0	30260.1	4.101	74.0	5361.2	2.237	137.0	1345.1	0.829	220.0	424.1	0.292
12.0	29350.9	4.078	75.0	5229.1	2.207	138.0	1318.0	0.815	221.0	419.4	0.288
13.0	28472.5	4.055	76.0	5100.8	2.177	139.0	1291.3	0.802	222.0	414.6	0.283
14.0	27623.8	4.032	77.0	4976.0	2.147	140.0	1265.2	0.788	223.0	410.2	0.279
15.0	26803.7	4.008	78.0	4854.8	2.117	141.0	1239.5	0.775	224.0	405.3	0.274
16.0	26011.2	3.984	79.0	4736.9	2.088	142.0	1214.3	0.762	225.0	400.8	0.270
17.0	25245.1	3.959	80.0	4622.4	2.058	143.0	1189.5	0.750	226.0	396.2	0.266
18.0	24504.6	3.934	81.0	4511.1	2.029	144.0	1165.2	0.737	227.0	391.2	0.262
19.0	23788.7	3.909	82.0	4402.9	2.000	145.0	1141.3	0.725	228.0	386.4	0.258
20.0	23096.4	3.883	83.0	4297.7	1.972	146.0	1117.8	0.713	229.0	381.6	0.254
21.0	22426.9	3.858	84.0	4195.5	1.943	147.0	1094.8	0.701	230.0	376.7	0.250
22.0	21779.3	3.831	85.0	4096.1	1.915	148.0	1072.2	0.689	231.0	371.6	0.247
23.0	21152.8	3.805	86.0	3999.6	1.887	149.0	1049.9	0.678	232.0	366.1	0.243
24.0	20546.7	3.778	87.0	3905.7	1.859	150.0	1028.1	0.666	233.0	360.7	0.239
25.0	19960.2	3.751	88.0	3814.4	1.832	151.0	1006.8	0.655	234.0	355.8	0.236
26.0	19392.5	3.723	89.0	3725.8	1.805	152.0	985.8	0.644	235.0	349.8	0.232
27.0	18843.0	3.696	90.0	3639.5	1.778	153.0	965.2	0.634	236.0	343.7	0.229
28.0	18311.0	3.668	91.0	3555.7	1.751	154.0	945.0	0.623	237.0	337.8	0.225
29.0	17795.8	3.639	92.0	3474.2	1.725	155.0	925.3	0.613	238.0	331.7	0.222
30.0	17297.0	3.611	93.0	3395.0	1.699	156.0	905.9	0.602	239.0	325.0	0.219
31.0	16813.8	3.582	94.0	3318.0	1.673	157.0	887.0	0.592	240.0	318.4	0.215
32.0	16345.7	3.553	95.0	3243.1	1.647	158.0	868.3	0.582	241.0	311.4	0.212
33.0	15892.2	3.523	96.0	3170.3	1.622	159.0	850.2	0.573	242.0	304.4	0.209
34.0	15452.7	3.494	97.0	3099.4	1.597	160.0	832.4	0.563	243.0	296.9	0.206
35.0	15026.7	3.464	98.0	3030.5	1.572	161.0	815.1	0.554	244.0	289.4	0.203
36.0	14613.9	3.434	99.0	2963.5	1.548	162.0	798.1	0.545	245.0	281.6	0.200
37.0	14213.6	3.404	100.0	2898.4	1.523	163.0	781.5	0.536			
38.0	13825.5	3.373	101.0	2834.9	1.500	164.0	765.3	0.527			



Table 7b — Sensor Resistance and Temperature (C)

TEMP (C)	RESISTANCE (Ohms)	VOLTAGE DROP (v)	TEMP (C)	RESISTANCE (Ohms)	VOLTAGE DROP (v)	TEMP (C)	RESISTANCE (Ohms)	VOLTAGE DROP (v)	TEMP (C)	RESISTANCE (Ohms)	VOLTAGE DROP (v)	TEMP (C)	RESISTANCE (Ohms)	VOLTAGE DROP (v)
-32.0	100049.0	4.690	- 4.0	20075.9	3.756	24.0	5203.2	2.201	52.0	1694.0	1.003	80.0	602.4	0.431
-31.5	97006.4	4.680	- 3.5	19580.8	3.732	24.5	5088.1	2.174	52.5	1683.5	0.988	80.5	592.4	0.425
-31.0	94060.8	4.671	- 3.0	19080.6	3.707	25.0	4976.0	2.147	53.0	1633.5	0.974	81.0	582.8	0.418
-30.5	91209.3	4.661	- 2.5	18574.8	3.682	25.5	4866.8	2.120	53.5	1604.1	0.959	81.5	573.4	0.412
-30.0	88449.0	4.651	- 2.0	18102.9	3.656	26.0	4760.2	2.094	54.0	1575.2	0.945	82.0	564.4	0.406
-29.5	85777.0	4.641	- 1.5	17644.5	3.631	26.5	4656.4	2.067	54.5	1546.9	0.931	82.5	555.7	0.400
-29.0	83190.7	4.630	- 1.0	17199.1	3.605	27.0	4552.2	2.041	55.0	1519.0	0.917	83.0	547.2	0.394
-28.5	80687.1	4.620	- 0.5	16766.3	3.579	27.5	4456.6	2.015	55.5	1491.6	0.903	83.5	539.1	0.388
-28.0	78263.9	4.609	0.0	16345.7	3.553	28.0	4360.4	1.989	56.0	1464.7	0.890	84.0	531.2	0.383
-27.5	75918.3	4.597	0.5	15936.9	3.526	28.5	4266.7	1.963	56.5	1438.3	0.876	84.5	523.6	0.377
-27.0	73648.0	4.586	1.0	15539.5	3.500	29.0	4175.4	1.938	57.0	1412.3	0.863	85.0	516.2	0.371
-26.5	71450.6	4.574	1.5	15153.1	3.473	29.5	4086.3	1.912	57.5	1386.8	0.850	85.5	509.2	0.366
-26.0	69323.7	4.562	2.0	14777.5	3.446	30.0	3999.6	1.887	58.0	1361.8	0.837	86.0	502.3	0.361
-25.5	67265.0	4.550	2.5	14412.2	3.419	30.5	3915.0	1.862	58.5	1336.9	0.825	86.5	495.7	0.355
-25.0	65272.4	4.537	3.0	14056.9	3.392	31.0	3832.5	1.837	59.0	1312.6	0.812	87.0	489.4	0.350
-24.5	63343.7	4.525	3.5	13711.4	3.364	31.5	3752.1	1.813	59.5	1288.7	0.800	87.5	483.2	0.345
-24.0	61476.9	4.512	4.0	13375.3	3.337	32.0	3673.7	1.789	60.0	1265.2	0.788	88.0	477.4	0.340
-23.5	59670.0	4.499	4.5	13048.3	3.309	32.5	3597.3	1.764	60.5	1242.1	0.776	88.5	471.8	0.335
-23.0	57920.9	4.485	5.0	12730.1	3.281	33.0	3522.9	1.741	61.0	1219.3	0.765	89.0	466.1	0.331
-22.5	56227.9	4.471	5.5	12420.5	3.253	33.5	3450.2	1.717	61.5	1196.9	0.753	89.5	460.8	0.326
-22.0	54589.1	4.457	6.0	12119.2	3.225	34.0	3379.4	1.693	62.0	1174.8	0.742	90.0	455.6	0.321
-21.5	53002.7	4.443	6.5	11826.0	3.197	34.5	3310.4	1.670	62.5	1153.2	0.731	90.5	450.6	0.317
-21.0	51467.0	4.428	7.0	11540.5	3.169	35.0	3243.1	1.647	63.0	1131.8	0.720	91.0	445.7	0.312
-20.5	49980.4	4.413	7.5	11262.7	3.140	35.5	3177.5	1.624	63.5	1110.9	0.709	91.5	440.9	0.308
-20.0	48541.1	4.398	8.0	10992.1	3.112	36.0	3113.4	1.602	64.0	1090.2	0.698	92.0	436.3	0.303
-19.5	47147.7	4.383	8.5	10728.8	3.083	36.5	3051.0	1.579	64.5	1069.9	0.688	92.5	431.8	0.299
-19.0	45798.6	4.367	9.0	10472.3	3.054	37.0	2990.1	1.557	65.0	1050.0	0.678	93.0	427.4	0.295
-18.5	44492.4	4.351	9.5	10222.6	3.026	37.5	2930.7	1.536	65.5	1030.3	0.667	93.5	423.0	0.291
-18.0	43227.6	4.334	10.0	9979.3	2.997	38.0	2872.8	1.514	66.0	1011.0	0.657	94.0	418.8	0.287
-17.5	42002.9	4.318	10.5	9742.5	2.968	38.5	2816.2	1.492	66.5	992.1	0.648	94.5	414.5	0.283
-17.0	40818.9	4.301	11.0	9511.7	2.939	39.0	2761.1	1.471	67.0	973.4	0.638	95.0	410.3	0.279
-16.5	39668.3	4.283	11.5	9287.0	2.911	39.5	2707.2	1.450	67.5	955.1	0.628	95.5	406.0	0.275
-16.0	38555.9	4.266	12.0	9068.0	2.882	40.0	2654.7	1.430	68.0	937.1	0.619	96.0	401.8	0.271
-15.5	37478.4	4.248	12.5	8854.7	2.853	40.5	2603.4	1.409	68.5	919.4	0.609	96.5	397.6	0.267
-15.0	36434.7	4.230	13.0	8646.9	2.824	41.0	2553.3	1.389	69.0	902.1	0.600	97.0	393.3	0.264
-14.5	35423.7	4.211	13.5	8444.5	2.795	41.5	2504.4	1.369	69.5	885.1	0.591	97.5	389.0	0.260
-14.0	34444.2	4.193	14.0	8247.2	2.766	42.0	2456.6	1.349	70.0	868.4	0.582	98.0	384.7	0.257
-13.5	33495.2	4.174	14.5	8055.0	2.737	42.5	2410.0	1.330	70.5	852.0	0.574	98.5	380.3	0.253
-13.0	32575.6	4.154	15.0	7867.7	2.708	43.0	2364.4	1.311	71.0	836.0	0.565	99.0	375.8	0.250
-12.5	31684.6	4.135	15.5	7685.1	2.680	43.5	2319.9	1.292	71.5	820.2	0.557	99.5	371.1	0.246
-12.0	30821.0	4.115	16.0	7507.2	2.651	44.0	2276.3	1.273	72.0	804.8	0.548	100.0	366.5	0.243
-11.5	29984.0	4.094	16.5	7333.9	2.622	44.5	2233.8	1.254	72.5	789.8	0.540	100.5	361.6	0.240
-11.0	29172.7	4.074	17.0	7164.9	2.593	45.0	2192.2	1.236	73.0	775.0	0.532	101.0	356.7	0.236
-10.5	28386.3	4.053	17.5	7000.3	2.565	45.5	2151.5	1.218	73.5	760.6	0.524	101.5	351.5	0.233
-10.0	27623.8	4.032	18.0	6839.8	2.536	46.0	2111.7	1.200	74.0	746.5	0.516	102.0	346.3	0.230
- 9.5	26884.4	4.010	18.5	6683.4	2.508	46.5	2072.8	1.182	74.5	732.8	0.508	102.5	341.1	0.227
- 9.0	26167.5	3.989	19.0	6530.9	2.479	47.0	2034.7	1.165	75.0	719.2	0.501	103.0	335.3	0.224
- 8.5	25472.2	3.967	19.5	6382.3	2.451	47.5	1997.4	1.148	75.5	706.1	0.493	103.5	329.7	0.221
- 8.0	24797.8	3.944	20.0	6237.5	2.423	48.0	1960.9	1.131	76.0	693.3	0.486	104.0	323.8	0.218
- 7.5	24143.6	3.922	20.5	6096.3	2.395	48.5	1925.1	1.114	76.5	680.8	0.479	104.5	317.9	0.215
- 7.0	23509.0	3.899	21.0	5958.7	2.367	49.0	1890.1	1.098	77.0	668.8	0.472	105.0	311.6	0.212
- 6.5	22893.2	3.876	21.5	5824.6	2.339	49.5	1855.7	1.081	77.5	656.8	0.465	105.5	305.3	0.209
- 6.0	22295.6	3.852	22.0	5693.9	2.311	50.0	1822.1	1.065	78.0	645.2	0.458	106.0	298.6	0.206
- 5.5	21715.7	3.829	22.5	5566.4	2.283	50.5	1789.1	1.049	78.5	634.0	0.451	106.5	292.1	0.204
- 5.0	21152.8	3.805	23.0	5442.2	2.256	51.0	1756.8	1.034	79.0	623.2	0.444	107.0	285.2	0.201
- 4.5	20606.4	3.781	23.5	5321.2	2.228	51.5	1725.1	1.019	79.5	612.6	0.437			
- 4.0	20075.9	3.756	24.0	5203.2	2.201	52.0	1694.0	1.003	80.0	602.4	0.431			



REFRIGERATION CYCLE

The compressor continuously draws refrigerant vapor from the cooler, at a rate set by the amount of guide vane and diffuser wall opening. As the compressor suction reduces the pressure in the cooler, the remaining refrigerant boils at a fairly low temperature (typically 34 - 38 F [1 - 3 C]). The energy required for boiling is obtained from the water flowing through the cooler tubes. With heat energy removed, the water becomes cold enough for use in an air conditioning circuit or process liquid cooling.

After taking heat from the water, the refrigerant vapor is compressed. Compression adds still more heat energy and the refrigerant is quite warm (typically 100 - 105 F [38 - 41 C]) when it is discharged from compressor into condenser.

Relatively cool (typically 65 - 85 F [18 - 29 C]) water flowing through the condenser tubes removes heat from the refrigerant and the vapor condenses to liquid.

The liquid refrigerant passes through orifices into the FLASC (Flash Subcooler) chamber (see Fig. 10). Since the FLASC chamber is at a lower pressure, part of the liquid refrigerant flashes to vapor, thereby cooling the remaining liquid. The FLASC vapor is recondensed on the tubes which are cooled by entering condenser water.

The liquid drains into a flow chamber between the FLASC chamber and cooler. Here a poppet valve forms a liquid seal to keep FLASC chamber vapor from entering the cooler and to maintain a pressure difference of at least 6 - 8 psi (41 - 55 kPa) between FLASC chamber and cooler.

When liquid refrigerant passes through the valve, some of it flashes to vapor in the reduced pressure on the cooler side. In flashing, it removes heat from the remaining liquid. The refrigerant is now at temperature and pressure at which the cycle began.

At low loads, the poppet valve allows small amounts of FLASC chamber gas to pass into the cooler. The gas agitates the liquid refrigerant, which raises the effective refrigerant level and improves heat transfer.

MOTOR COOLING CYCLE

The motor is cooled by refrigerant taken from the poppet valve chamber at FLASC pressure. The flow is maintained by pressure difference in the system.

The liquid refrigerant first flows through a sub-cooler coil at the bottom of the cooler (Fig. 10). It then passes through a filter to spray nozzles at the end of the rotor. The spray nozzles direct the refrigerant over both the rotor and the stator. The cycle is completed by the return of the refrigerant to the cooler.

When the condensing temperature and pressure are low, as at start-up and low load, the poppet valve (Fig. 8 and 10) remains closed until cooler-condenser pressure difference is sufficient for good refrigerant flow through the motor cooling circuit.

The compressor motor is protected against high temperature by a sensor imbedded in the windings. Above-normal motor temperature will override the temperature capacity control and shut the machine down if it exceeds the safety limit.

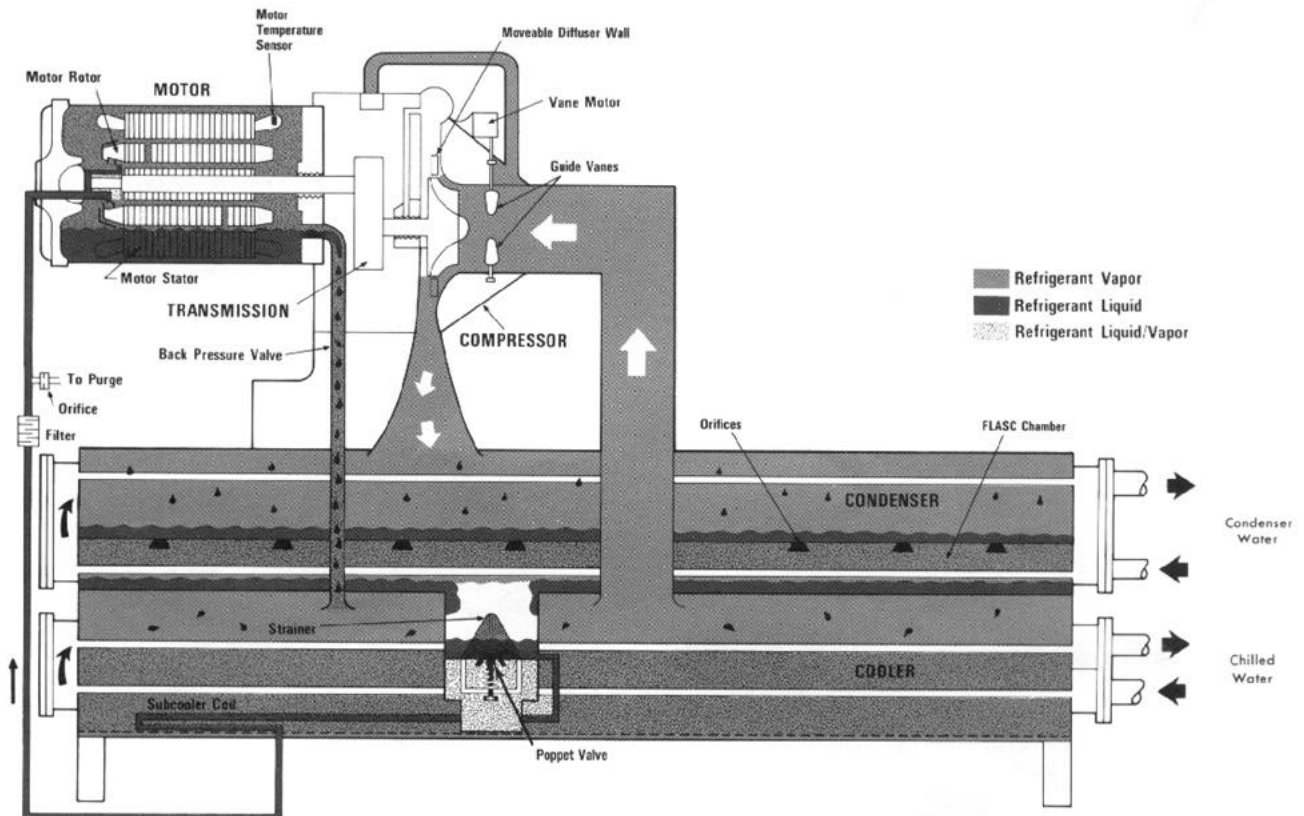

Fig. 10 — Refrigeration and Motor Cooling Cycles

LUBRICATION CYCLE

Summary — The oil pump, filter and cooler make up a package located partially within the end of the unishell (Fig. 11). The oil is pumped through the filter-cooler to remove foreign particles and excess heat. A portion of the lubrication oil is used to position the diffuser wall. Part of the oil flow is directed to the compressor motor end bearing. The remaining flow lubricates the compressor transmission, journal and thrust bearings. Oil then drains into the reservoir to complete the cycle.

Details — Oil is charged into the lubrication package through a hand valve. A sight glass in the oil reservoir permits oil level observation.

Oil pump discharges oil through oil filter and oil cooler coils. Oil cooler water flow may be adjusted by a throttling valve to maintain proper oil temperature (140 – 150 F) (60 – 66 C). If desired, the customer may install a regulating valve for this purpose. A solenoid valve shuts off the water supply at machine shutdown.

An oil pressure relief valve maintains 20 – 25 psi (138 – 172 kPa) differential pressure in the system. This differential pressure can be read by subtracting oil reservoir pressure from oil supply pressure.

Oil leaving the filter cooler passes over a magnetic plug which removes any metallic particles. A portion of the oil then flows to the motor end bearing and to the diffuser wall solenoids. The balance lubricates the compressor thrust and journal bearings and the transmission. As the oil leaves the transmission and main bearings, its temperature is registered on a gage.

The diffuser wall is hydraulically positioned using lubrication oil. Oil flow is supplied to the diffuser assembly via 4 solenoid valve (see Fig. 11a, page 28). These solenoids are controlled by the microprocessor, as described in the Controls section.

The oil now drains into a reservoir at the base of the compressor. Gages on the compressor casing register the temperature and pressure of the oil in the reservoir. An oil heater, with thermostat and indicating light, maintains oil reservoir temperature at 140 – 145 F (60 – 63 C) on machine shutdown.

To ensure proper compressor lubrication during start-up and coastdown, a program timer in the machine control center energizes the oil pump for about 15 seconds before the compressor starts and keeps the pump running for about 30 seconds after the compressor motor is de-energized.

Ramp loading slows the rate of guide vane opening to minimize oil foaming at start-up. If the guide vanes open quickly, the sudden drop in suction pressure can cause any refrigerant in the oil to flash. The resulting oil foam cannot be pumped efficiently; oil pressure falls off and lubrication is poor.

If oil pressure drops to approximately 13 psi (69 kPa) differential, an oil low-pressure cutout will shut down the machine.

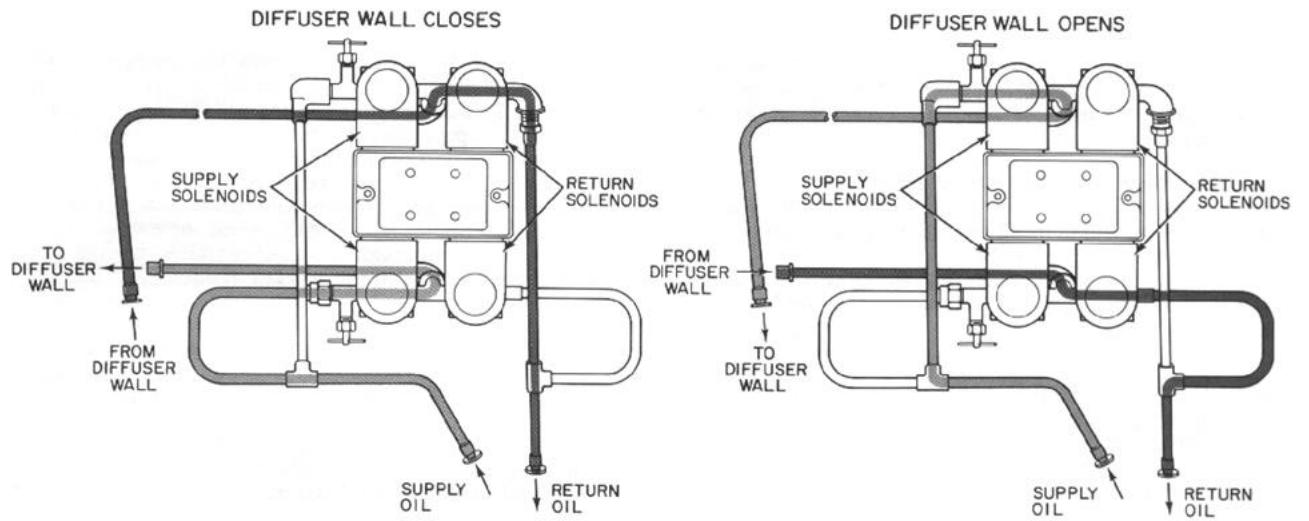

Fig. 11a — Diffuser Hydraulic Oil Flow

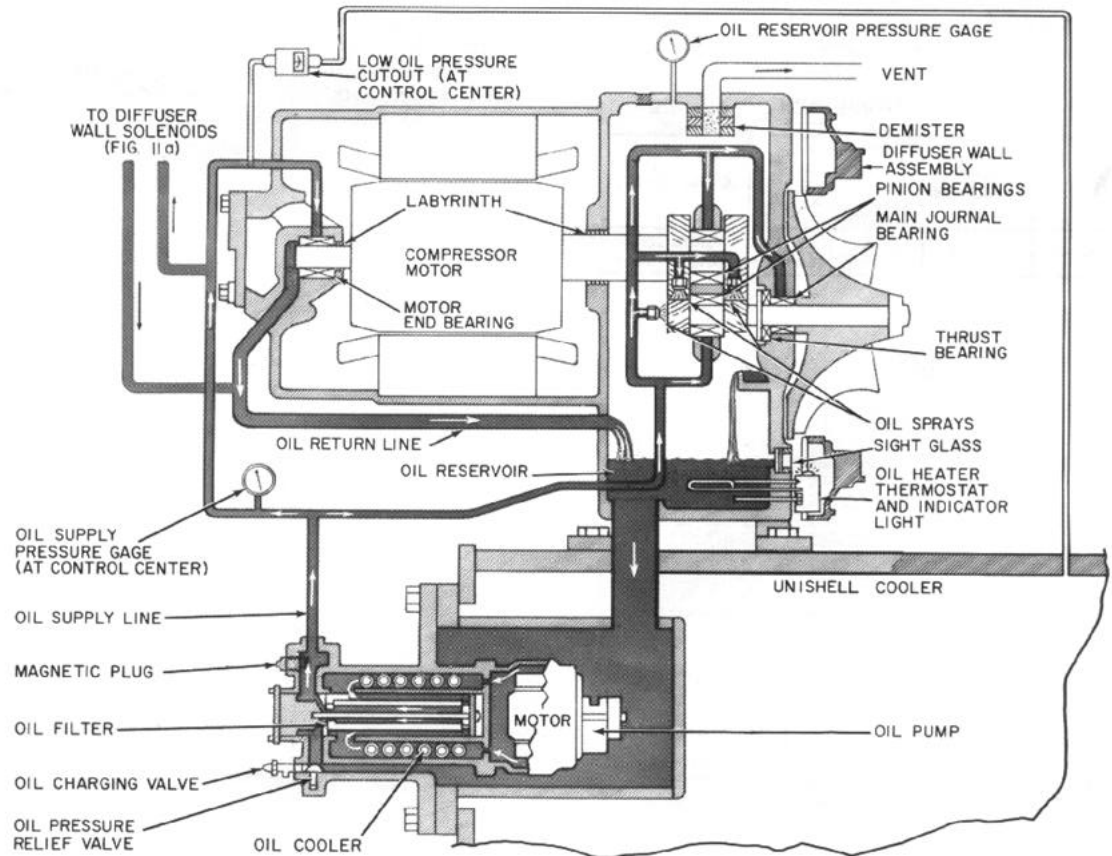

Fig. 11b — Lubrication Cycle

PURGE CYCLE

The purge removes water, air or other noncondensable gases from the refrigerant system. It indicates air and water leaks and may be used to evacuate or pressurize the machine.

A sampling line from the condenser (Fig. 12) continually brings refrigerant gas, and any contaminants, into the purge condensing chamber. Here the gas-vapor mixture passes over a cooling coil. Since the refrigerant liquid within the coil is colder than the mixture surrounding it, the refrigerant gas and water are condensed to liquid.

Water, if present, separates from and floats on the heavier refrigerant. The water level may be observed through a sight glass and the water may be withdrawn manually at the water drain valve (Fig. 7). The liquid refrigerant flows through a U-trap and a float valve back to the cooler.

Purge Operation — The standard operating mode is AUTOMATIC. The purge MANUAL-OFF-AUTO switch is placed at AUTO. position. As the machine starts up, the purge operating switch will open.

As air and other noncondensable gases accumulate in the upper part of the condensing chamber, raising the chamber pressure to within 2 psi (14 kPa) of machine condenser pressure, the purge operating switch closes, sending a signal to the microprocessor. (See Table 8.)

Table 8 — Purge Operating Switch Settings

SWITCH	NORMAL POSITION	DIFFERENTIAL PRESSURE SETTING		CONNECTION
		Cutout	Cut-in	
Purge Oper (P2)	Closed	4 psi (28 kPa)	2 psi (14 kPa)	Purge Cond- Machine Cond

At this point, if the compressor has operated a minimum of 2 minutes, and the condensing temperature is at least 24 degrees F (13.3 degrees C) higher than the suction temperature, the microprocessor energizes the purge pump and opens the purge vent solenoid. The air is then discharged through connection B (item 12, Fig. 7). When the pressure difference increases to 4 psi (28 kPa), the purge operating switch opens, de-energizing the purge. The compressor must be energized for the purge to discharge while in the AUTO. mode.

Since machine condenser pressure and purge chamber pressure also equalize at machine shutdown, air and then refrigerant could be discharged each time the machine stops. To prevent this, K1 relay opens whenever cooler and condenser temperature difference drops below 24 degrees F (13.3 degrees C). The K1 relay deactivates the purge AUTO. circuit until machine operation again builds up temperature differences within the refrigerant system.

When the chamber pressure drops during air discharge, the pump and solenoid valve will be de-energized by the purge operating switch. Excessive purging will be prohibited by the microprocessor as described under Excessive Purge Pump Run Time.

If the control switch is placed at the MANUAL position, the purge pump will operate continuously without regard to whether K1 or the purge operating switch is closed. Manual operation is used for removing air from the machine after service work.

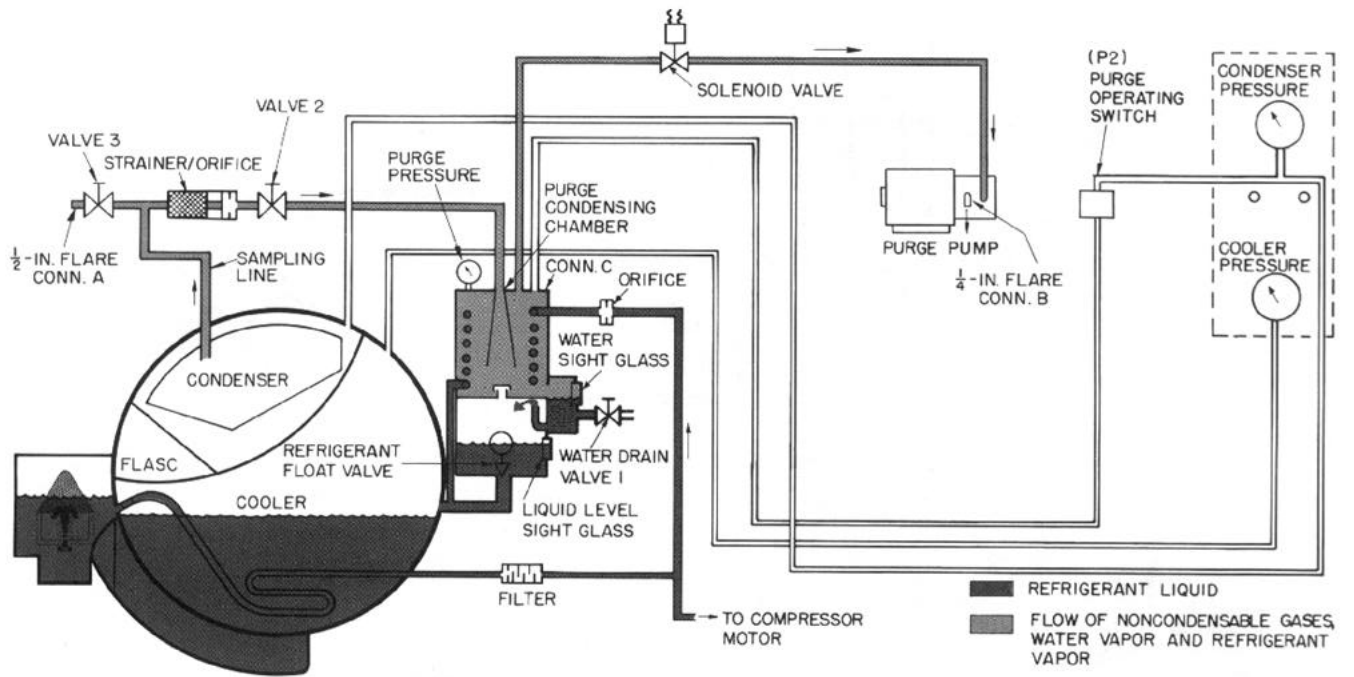

Fig. 12 — Purge Cycle

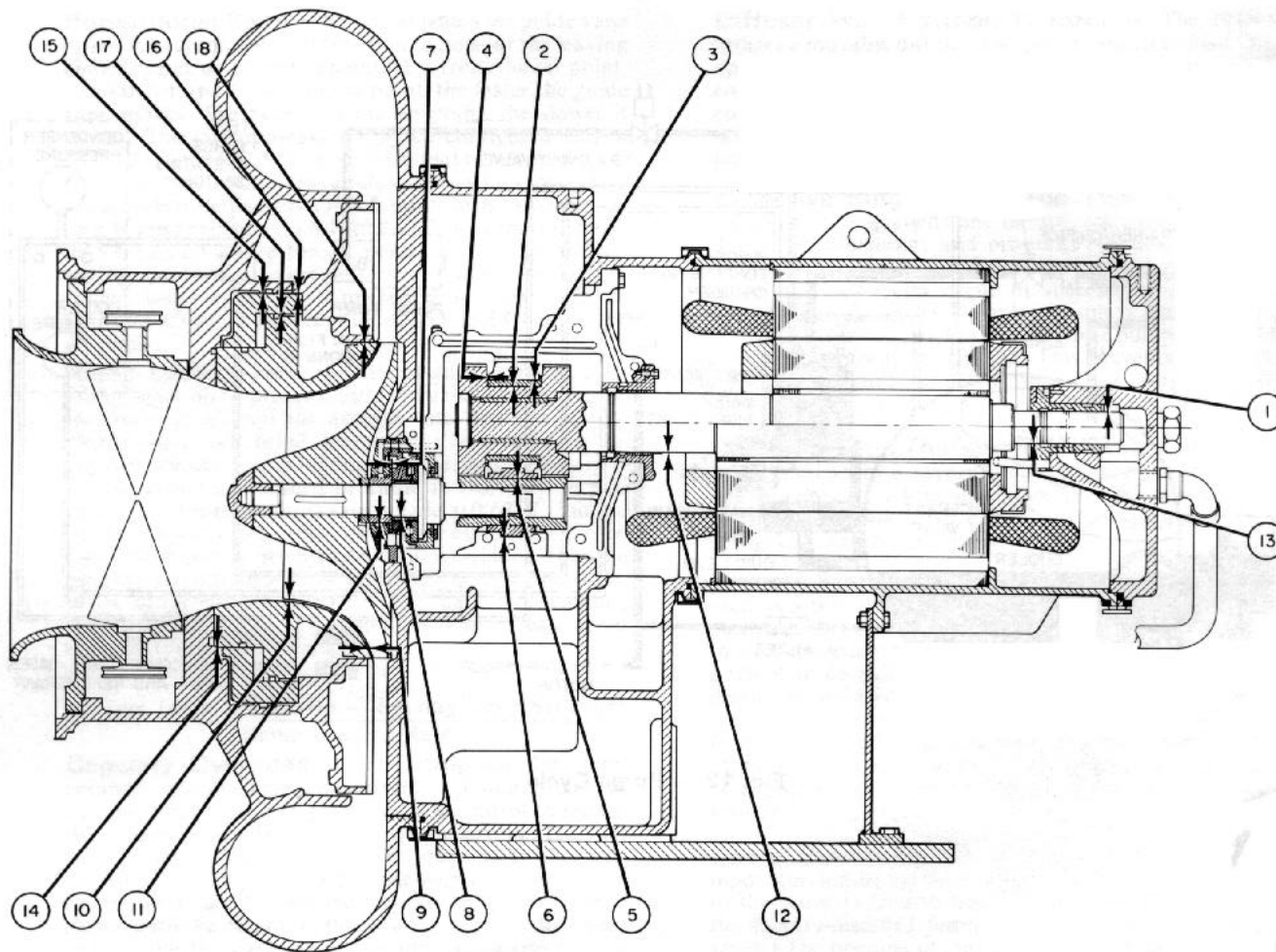

Fig. 13 — Compressor Fits and Clearances

CONTROL TROUBLESHOOTING

The microprocessor control system used in this unit contains extensive diagnostic capabilities. Diagnostic information is displayed on the 2-digit LCD in code form. Diagnostic codes should be used in conjunction with Table 9, Diagnostic Codes and Troubleshooting Guide, to resolve most control problems.

If a problem is suspected, use the following procedures:

1. Check display for diagnostic code and refer to Table 9.
2. Recall and record stored codes before turning off control center power or depressing the POR pushbutton.

IMPORTANT: Displayed and stored diagnostic codes will be lost if power is turned off or a POR is performed.

3. Compare displayed code with recalled code(s) for a pattern or similarities.

4. If control center is energized and there is no diagnostic code and no stored code(s), inquire about power loss.
5. If control center is not energized or controls test malfunctions, check for loose jumper block or ribbon cable connections or blown fuses and check control center transformer as follows:
 - a. De-energize control center and remove terminal plug 1J4 from the processor board. Re-energize control center transformer.
 - b. Check for 19 vac $\pm 15\%$ between transformer orange and blue leads (terminals 1 and 3). Replace transformer if voltage is outside these limits.
 - c. Check for 18 vac $\pm 15\%$ between transformer brown and red leads (terminals 5 and 6). Replace transformer if voltage is outside these limits. De-energize control center. Reconnect terminal plug 1J4 and re-energize control center.
6. Perform controls test and make visual inspection of machine and starter. If everything is correct, start machine and monitor closely. If not correct, check processor, I/O and S/D boards to determine if replacement is required.

Table for Fig. 13

ITEM	DESCRIPTION	COMPR SIZE*	CLEARANCE				TYPE OF MEASURE
			Minimum		Maximum		
			In.	mm	In.	mm	
1	Motor End Bearing	212	.0015	.038	.0030	.076	Diam
		312					
2	Gear Journal Bearing	212	.0025	.064	.0040	.102	Diam
		312					
3	Driving Gear Bearing to Housing	212	.002	.051	.004	.101	Diam
		312					
4	Thrust Clearance on Gear Bearing (each side)	212	.010	.254	.018	.460	Axial
		312					
5	Pinion Gear Journal Bearing	212	.0025	.064	.0040	.102	Diam
		312					
6	Pinion Gear Bearing to Housing	212	.001	.025	.003	.076	Diam
		312					
7	Thrust Bearing	212	.008	.203	.014	.356	Axial
		312					
8	High Speed Journal Bearing	212	.0017	.043	.0028	.071	Diam
		312					
9	Front of Impeller to Volute Wall	212	.030	.762	.035	.889	Axial
		312					
10	Impeller Eye to ID of Inlet Ring	212	.024	.610	.042	1.067	Radius
		312					
11	Labyrinth Behind Impeller to Spacer Ring	212	.007	.178	.011	.279	Diam
		312					
12	Labyrinth Behind Transmission and Motor Shell	212	.006	.152	.010	.254	Diam
		312					
13	End-Bell Bearing Labyrinth	212	.0045	.114	.0070	.178	Diam
		312					
14	Piston to Shroud	212	.003	.076	.007	.178	Diam
		312					
15	Piston to Volute	212	.020	.508	.036	.914	Diam
		312					
16	Piston to Diffuser Housing	212	.002	.051	.010	.254	Diam
		312					
17	Piston to Shroud	212	.020	.508	.036	.914	Diam
		312					
18	Shroud to Diffuser Housing	212	.003	.076	.007	.178	Diam
		312					

*Refer to model no. machine informative plate.

Test Points — When checking the 3 boards to determine if replacement is required, use reference voltages given at certain test points. These test points are labeled on the particular board as TP "X", where X is the number of the test point. The voltages are listed in the following sections on board replacement. When taking readings at test points, connect ground side of DVM to negative (lower) side of large capacitor on processor board or to terminal plug 1J3-1.

Processor Board Replacement — The processor board should be replaced if one or more of the following abnormalities exist with proper power supply from the control center transformer and with terminal plugs 1J1 and 1J2 disconnected.

1. The voltage at terminal pin 1J3-7 exceeds -12 ± 3 vdc; the voltage at terminal pin 1J3-6 exceeds $+12 \pm 3$ vdc; or the voltage at any of the following test points is exceeded.

TEST POINT	VOLTAGE RANGE (vdc)
TP1	4.8 to 6
TP2	4.8 to 6
TP4	4.8 to 6
TP8	-4.8 to -6
TP9	9 to 14
TP15	11 to 17

2. Both types of inputs (analog and digital) malfunction or indicate faulty during the controls test.
3. The display on the S/D board and outputs from the I/O board malfunction at the same time during the controls test.
4. The control sequence is not followed.
5. An out-of-range sensor reading is displayed but sensor resistance is within limits.
6. The circuit board or any component on the circuit board has been damaged.

Input/Output Board Replacement — The I/O board should be replaced if one of the following abnormalities exist and the processor board has been checked and is functioning properly.

1. The voltage at TP1 exceeds $-5 \pm .2$ vdc; the voltage at TP2 exceeds $+5 \pm .2$ vdc; or the voltage at TP4 exceeds $+5 \pm .2$ vdc.
2. An input channel from a peripheral device malfunctions during a controls test when the signal from the device is correct. (Example: Microprocessor indicates flow switch open when flow switch is closed and voltage is at the input channel.)
3. An output channel to a peripheral device malfunctions during a controls test when the LCD indicates that the command is being executed. (Example: Microprocessor indicates water pump relay is energized but no power is on relay.)

4. A safety trip occurs due to a high, low or loss of power indication when the power supply is within limits.
5. A 110-vac open or close signal is applied to the guide vane actuator when the DIP switches are properly configured.
6. The circuit board or any component on the circuit board has been damaged.

Set Point/Display Board Replacement — The S/D board should be replaced if the following abnormalities exist and the processor board has been checked and is functioning properly.

1. The voltage at the center terminal on the START or STOP pushbutton exceeds $+5 \pm .2$ vdc.
2. An 88 is not displayed on the LCD during the first-step results of the control test.
3. The demand limit or leaving chilled medium set point potentiometer status indicates faulty.

Table 9 — Diagnostic Codes and Troubleshooting Guide

TYPE	CODE NO.	DESCRIPTION/MALFUNCTION	PROBABLE CAUSE/REMEDY
TIMER	00-15	Time Remaining Until Restart (Decreases at one-minute intervals)	15-minute or 3-minute start inhibit timers not expired.
START STATUS	25	Recycle Restart Pending	Leaving chilled water or brine temperature too low for recycle start-up (≤ 5 F [2.8 C] above set point).
	26	Start-Up in Progress	Prestart checks being performed, water flows and oil pressure being established.
RUN STATUS	28	Temperature Capacity Control	Machine operating normally under temperature control.
	29	Ramp Loading Capacity Control	Leaving temperature pulldown rate being limited by ramp loading.
	30	Demand Limit Capacity Control	Compressor motor current $>$ demand limit set point — check motor current calibration.
	35	Motor Temperature Override	Motor temperature $>$ 200 F (93.3 C) — check motor temperature immediately, check sensor resistance.
	36	Refrigerant Temperature Override	Refrigerant temperature $\leq 1^\circ$ F (0.56 C) above trip limit — check refrigerant temperature, check sensor resistance, check refrigerant charge.
	37	Excessive Purging	See description/malfunction Purge Cycles Often in AUTO. Position.
PRESTART FAILURE STATUS	40	Motor Winding Temperature Too High to Start	Motor temperature $>$ 190 F (87.8 C) — check motor temperature, reset when $<$ 190 F (87.8 C), check sensor resistance.
	41	More Than 8 Starts in Past 12 Hours	Start inhibited by 8 Starts/12-Hour counter. Depress reset pushbutton if additional start is required.
	42	Failure of Condenser Pump to Establish Flow	Check pump operation, check power supply and pilot relay, check flow switch, check water valves, check for air in water lines.
	43	Failure of Evaporator Pump to Establish Flow	Check pump operation, check power supply and pilot relay, check flow switch, check water valves, check for air in water lines.
	44	Defective Oil Pump Pressure Switch	Oil pressure switch contact closed with pump de-energized; check contacts. Check setting.
	45	Out-of-Range Sensor Readings	Perform controls test to check for defective set point potentiometer(s) or open or shorted sensors; check sensor resistance.
	46	Oil Pressure Switch Not Closed Within 15 Seconds After Pump is Energized (Failure to develop pressure)	Check power to pump, check oil level, check oil pressure switch setting, check for dirty oil filters.
48	Low/High Line Voltage	Control center voltage supply $<$ 94.3 VAC or $>$ 135.7 VAC for one minute. Check voltage supply. Check control center transformer, check circuit loading, consult power utility if line voltage is low. See I/O Board Replacement.	
SHUTDOWN STATUS	60	Compressor Discharge Temperature $>$ 220 F (104 C)	Check discharge temperature immediately, check sensor resistance, check for proper condenser water flow and temperature, check oil reservoir temperature, check condenser for air or water leaks.
	61	Evaporator Refrigerant Temperature $<$ Limit	Check refrigerant temperature, check sensor resistance, check refrigerant charge.
	62	Motor Winding Temperature $>$ 220 F (104 C) Resets at 190 F (88 C)	Check motor temperature immediately, check sensor resistance and connections at compressor junction box, check motor cooling system for restrictions.



Table 9 — Diagnostic Codes and Troubleshooting Guide (cont)

TYPE	CODE NO.	DESCRIPTION/MALFUNCTION	PROBABLE CAUSE/REMEDY
SHUTDOWN STATUS (cont)	63	Thrust Bearing Temperature > 220 F (104 C)	Check oil reservoir temperature, check oil cooler water flow and solenoid, check oil heater thermostat setting, check sensor resistance and connections at compressor junction box, check journal and thrust bearings if other checks OK.
	64	Sensor Out-of-Range	Perform controls test to check for defective set point potentiometer(s) or open or shorted sensors; check sensor resistance. Check for motor current signal as compressor starts. Check diffuser wall feedback potentiometer calibration.
	65	Oil Pressure < Limit	Check power to pump, check oil level, check oil pressure switch setting, check for dirty oil filters, check for oil foaming at start-up, reduce ramp loading rate if oil foaming is noted.
	66	Motor Overload Trip	Check motor overload dashpots and setting (do not attempt field calibration), check motor current demand calibration. Check optional compressor motor starter protective devices (e.g., phase loss, ground fault, etc.).
	67	Temporary Loss of Line Voltage	Control center voltage < 57.5 VAC for one cycle — depress reset pushbutton and restart.
	68	Low-Line Voltage	Control center voltage < 94.3 VAC for one minute; check control center voltage, check control center transformer, check circuit loading, consult power.
	69	High-Line Voltage	Control center voltage > 135.7 VAC for one minute. Check control center voltage, check control center transformer, check power company.
	70	Loss of Chilled Water Flow	Check pilot relay, check power to pump, check flow switch, check water valves.
	71	Loss of Condenser Water Flow	Check pilot relay, check power to pump, check flow switch, check water valves.
	72	Faulty Jumper	Check grounded jumper wire.
	73	High Condenser Pressure	Check high condenser pressure switch setting, check for proper condenser water flow and temperature, check for fouled tubes.
	74	Failure of Starter to Complete Transition	Check starter, check run contact, check DIP switch configuration for proper starter type.
	75	Excessive Motor Acceleration Time	Check to ensure guide vane is closed at start-up, check starter transfer time, check guide vane linkage. Check DIP switch configuration for proper starter type.
	76	Illegal Configuration	Check for proper unit configuration.
	77	Run/Transition Contacts Failed to Deactivate On Shutdown	Check run contact, check 1CR relay, check starter for welded contacts. Check for 0 volts at  , replace ribbon cable.
	78	Manual Override Shutdown	Stop pushbutton depressed with L/R switch in remote position — reset.
	79	Spare Safety Limit Exceeded	Check spare safety contact(s), check spare safety operation.
	80	Recycle with Motor Current > 65% of RLA	Check for proper cooler and condenser water flows and temperatures, check leaving chilled water/brine sensor resistance, check motor current calibration, check guide vane actuator and linkage.
	81*	Loss of Communication	Communication between the basic controller and the ESP not initialized or lost for more than 15 seconds after being initialized. See ESP Operating Instructions.
	—	—	Chilled Water Temperature Too High (Machine running)

*Applies only to options available with the ESP (Expanded Services Panel).



Table 9 — Diagnostic Codes and Troubleshooting Guide (cont)

TYPE	CODE NO.	DESCRIPTION/MALFUNCTION	PROBABLE CAUSE/REMEDY
—	—	Chilled Water or Brine Temperature Too Low (Machine running)	<p>THERMOSTAT SET TOO LOW — Return thermostat to proper setting.</p> <p>GUIDE VANES FAIL TO CLOSE — Be sure that capacity control switch is in <i>AUTO.</i> position. Check chilled water sensor resistance, check guide vane linkage. Check for defective actuator — replace, check that sensor is connected to proper terminals.</p> <p>DEFECTIVE SENSOR — Check sensor resistance.</p> <p>EVAPORATOR REFRIGERANT TEMPERATURE SET POINT IMPROPERLY SET (Brine Chilling Only) — Check refrigerant temperature set point.</p>
—	—	Chilled Water Temperature Fluctuates; Vanes Hunt	<p>DEADBAND TOO NARROW (Erratic Flow or Temperature) — Configure DIP switch for 2 F (1°C) deadband.</p> <p>PROPORTIONAL BAND TOO NARROW (Erratic Flow or Temperature) — Configure DIP switch for 15 F (8.3 C) proportional band.</p> <p>LOOSE GUIDE VANE LINKAGE — Adjust guide vane linkage.</p> <p>DEFECTIVE VANE ACTUATOR — Replace actuator.</p> <p>DEFECTIVE SENSOR — Check sensor resistance.</p>
—	—	Oil Reservoir Temperature Too Low	<p>OIL COOLER WATER FLOW TOO HIGH — Throttle water to reduce flow.</p> <p>THERMOSTAT IMPROPERLY SET OR DEFECTIVE — Check voltage across thermostat while adjusting; if contacts do not close, replace thermostat.</p> <p>OIL HEATER DEFECTIVE — If light indicates power but unit does not heat, check unit for open or short. Replace unit if required.</p>
—	—	Oil Reservoir Temperature Too High	<p>THERMOSTAT IMPROPERLY SET — Adjust thermostat.</p> <p>OIL COOLER WATER FLOW TOO LOW — Open plug valve.</p> <p>OIL COOLER SOLENOID VALVE OPERATING IMPROPERLY — Check electrical operation of solenoid. Inspect valve; if screen is fouled, clean and install a 20-mesh strainer ahead of valve.</p> <p>OIL COOLER COIL FOULED — Clean coil; replace cooler if required.</p>
—	—	Purge Cycles Often in <i>AUTO.</i> Position	<p>Purge valves not tightly closed. Check valve settings per purge valve chart (see Fig. 6). Close applicable valves securely.</p> <p>Solenoid and check valve leaking. Allow smoke to drift past connection B (Fig. 12). If smoke is drawn into line, repair or replace valves.</p> <p>Incorrect purge operating switch setting. Check switch per Table 8 with metered supply of air. Recalibrate or replace as required.</p> <p>Excessive air leakage into machine. Check machine for leaks per Air and Water Leaks section, page 22.</p> <p>Purge condensing chamber float valve stuck in closed position or return line plugged. (Refrigerant level will be above sight glass.)</p> <p>Purge liquid supply orifice blocked or excessive flashing in the line ahead of the orifice.</p>
—	—	Excessive Refrigerant Loss	<p>Purge pump cycles often. See Purge Cycles Often in <i>AUTO.</i> Position, above.</p>
—	—	Purge Does Not Operate in <i>AUTO.</i> Position	<p>Normal. Purge pump does not operate unless purge pressure is within 2 to 4 psi (14 to 28 kPa) of condenser pressure. Check gage readings. See Purge Operation.</p> <p>Blown fuse. (On some units.) Check 15-amp fuse inside purge electrical switch box (on some units).</p> <p>Loose connections or broken wires. Check purge control switch connections.</p> <p>Check circuit to purge motor, indicator light, solenoid switch and solenoid valve by switching to <i>MANUAL.</i></p> <p>Check purge operating switch and K1 relay connections.</p> <p>Defective purge operating switch. Check switch continuity; replace switch if required.</p> <p>Incorrect purge or operating switch settings. Check switch per Table 8 with metered supply of air. Recalibrate or replace as required.</p> <p>Purge condensing chamber float valve stuck in open position (indicated by low refrigerant level).</p> <p>The difference between suction temperature and condensing temperature is less than 24 F (13.3 C).</p>



Copyright 1987 Carrier Corporation

Manufacturer reserves the right to discontinue, or change at any time, specifications or designs without notice and without incurring obligations.

Book | 2 PC 211 Catalog No. 531-962 Printed in U.S.A. Form 19DM-3SSM Pg 37 295 5-87 Replaces: 19DM-2SSM
Tab | 5a

For replacement items use Carrier Specified Parts.

