



ComfortLink™

AquaSnap Service Manual

30RAN Air-Cooled Chillers Series 0 and 1

This document is not intended for general distribution. It is to be used by Carrier Distributor Service or Carrier Commercial Service personnel only, and may not be distributed to individuals not employed within these organizations. This document is intended as a guide only. There is no guarantee of the accuracy of the information contained within.

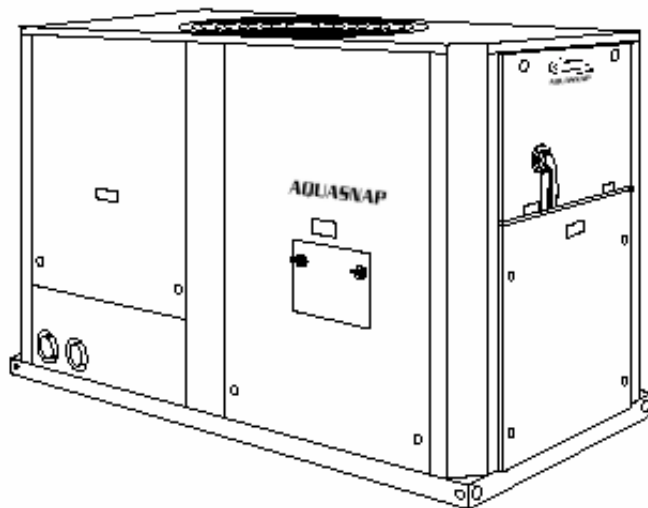

Table of Contents

Safety Considerations	8
Introduction	9
Model Number Significance	9
Factory Installed Options	11
Application.....	11
Chilled Water Temperature Limits	11
Chilled Water Loop	12
Volume	12
Chilled Water Storage Tank.....	12
Coil Protection Grilles	15
Cooler Freeze Protection.....	15
Medium Temperature Brine Applications, 15 to 39.9 °F (-9.4 to 4.4 °C).....	16
Low Ambient Protection	16
Electrical Information	17
Power Connections	17
Generator Operation.....	18
Ground Fault Interrupter Convenience Outlet.....	19
Hail Guards.....	19
Head Pressure Control	21
Hydronic Package.....	22
Pump Motor Specifications	22
Minimum Load Control.....	23
Vibration Isolation.....	23
Spring Isolation	23
Vibration Isolation Pads	23
Controls.....	24
Carrier Comfort Network.....	24
Alarm Routing Control.....	24
Communication Bus Wiring.....	25
Carrier Comfort Network Interface Devices	27
BacLink™	27
DataLink™	27
DataPort™	27
Chilled Water Pump Control	27
Cooler Pump Sequence of Operation	28
No Integral Pump - Single External Pump Control.....	29
No Integral Pump - Dual External Pump Control	29
Single Integral Pump Control.....	30
Dual Integral Pump Control	31
Compressor Loading	33
Close Control	33
Lead /Lag	33
Circuit Loading	34
Compressors within the Circuit.....	34

Display/Interface	34
Navigator.....	34
Adjusting the Contrast	35
Adjusting the Backlight Brightness	36
Scrolling Marquee Display	36
Remote Enhanced Display.....	38
Demand Limit Control.....	38
2-Stage Switch Controlled Demand Limit.....	39
4 to 20 mA Controlled Externally Powered Demand Limit.....	39
CCN Loadshed Controlled Demand Limit	40
Dual Chiller Control.....	40
Energy Management Module (EMM).....	42
Factory Default Configuration	43
Heater Control (Cooler, Pump, Storage Tank).....	55
Heat Operation	55
Low Sound Mode.....	56
Minimum Load Control.....	57
Operating Modes	57
MD01 – FSM Controlling Chiller.....	57
MD02 – WSM Controlling Chiller.....	57
MD03 – Master/Slave Control	58
MD05 – Ramp Load Limited.....	58
MD06 – Timed Override In Effect.....	58
MD07 – Low Cooler Suction TempA.....	58
MD08 – Low Cooler Suction TempB.....	58
MD09 – Slow Change Override.....	59
MD10 – Minimum Off Time Active.....	59
MD13 – Dual Setpoint	59
MD14 – Temperature Reset.....	59
MD15 – Demand/Sound Limited	60
MD16 – Cooler Freeze Protection.....	60
MD17 – Low Temperature Cooling	60
MD18 – High Temperature Cooling.....	60
MD19 – Making Ice	60
MD20 – Storing Ice	60
MD21 – High SCT Circuit A	61
MD22 – High SCT Circuit B	61
MD23 – Minimum Comp On Time.....	61
MD24 – Pump Off Time Delay	61
MD25 – Low Sound Mode.....	61
MD26 – Short Loop Override	61
Remote Alarm Relay.....	62
Remote Cooler Application.....	63
Software Revisions	63
Version 4.0 (CESR131279-04-00)	64
Version 3.0 (CESR131279-03-00)	64

30RA AquaSnap Chiller Service Manual

Version 2.0 (CESR131279-02-00)	66
Version 1.0 (CESR131279-01-00)	66
Return Gas Sensor	66
Space Temperature Sensor.....	67
Temperature Reset.....	67
4-20 ma Temperature Reset	68
Outdoor Air Temperature Reset.....	69
Return Water Reset	70
Space Temperature Reset	72
Temperature Set Point.....	73
Single Set Point/Switch Control.....	74
Dual Set Point, Switch/Switch Control.....	74
Ice Build, Switch/Switch Control.....	74
Single Set Point/Occupancy	75
Holiday Schedule Programming	75
Local Schedule Operation	75
CCN Global Schedule Operation.....	77
Dual Set Point/Occupancy	78
Ice Build/Occupancy	78
4 to 20 mA Input/Switch Control.....	79
Time Clock Function	80
Setting the Date	80
Setting the Internal Clock.....	81
Literature	83
Service	86
Troubleshooting.....	86
Alarms and Alerts Codes	87
Communication Failure	87
T051 – Compressor A1 Failure	87
T052 – Compressor A2 Failure	89
T055 – Compressor B1 Failure	89
T056 – Compressor B2 Failure	89
T077 – Circuit A Saturated Suction Temperature Exceeds Cooler Leaving Fluid Temperature	89
T078 – Circuit B Saturated Suction Temperature Exceeds Cooler Leaving Fluid Temperature	89
T090 – Circuit A Discharge Pressure Transducer Failure.....	90
T091 – Circuit B Discharge Pressure Transducer Failure.....	90
T092 – Circuit A Suction Pressure Transducer Failure	90
T093 – Circuit B Suction Pressure Transducer Failure	90
T112 – Circuit A High Saturated Suction Temperature	90
T113 – Circuit B High Saturated Suction Temperature	90
T114 – Circuit A Low Cooler Suction Superheat.....	90
T115 – Circuit B Low Cooler Suction Superheat.....	90
T116 – Circuit A Low Cooler Suction Temperature.....	91
T117 – Circuit B Low Cooler Suction Temperature.....	91

T126 – Circuit A High Discharge Pressure.....	91
T127 – Circuit B High Discharge Pressure.....	91
T133 – Circuit A Low Suction Pressure.....	92
T134 – Circuit B Low Suction Pressure.....	92
T140 – Reverse Rotation Detection	93
T150 – Emergency Stop	93
T151 – Illegal Configuration	93
T174 – 4 to 20 mA Cooling Set Point Input Failure Alert.....	94
T176 – 4 to 20 mA Temperature Reset Input Failure Alert.....	95
T177 – 4 to 20 mA Demand Limit Input Failure Alert	95
A189 – Cooler Pump and Aux Contact Input Miswired Alarm	96
T190 – Cooler Pump 1 Aux Contacts Failed to Close at Start-Up Alert	96
T191 – Cooler Pump 2 Aux Contacts Failed to Close at Start-Up Alert	96
T192 – Cooler Pump 1 Failed to Provide Flow at Start-Up Alert	97
T193 – Cooler Pump 2 Failed to Provide Flow at Start-Up Alert	97
T194 – Cooler Pump 1 Contacts Opened During Normal Operation Alert	97
T195 – Cooler Pump 2 Contacts Opened During Normal Operation Alert	97
T196 – Flow Lost While Pump 1 Running Alert.....	97
T197 – Flow Lost While Pump 2 Running Alert.....	97
T198 – Cooler Pump 1 Aux Contacts Closed While Pump Off Alert	98
T199 – Cooler Pump 2 Aux Contacts Closed While Pump Off Alert	98
A200 – Cooler Flow/Interlock Failed to Close at Start-Up Alarm.....	98
A201 - Cooler Flow/Interlock Contacts Opened During Normal Operation Alarm ..	99
A202 – Cooler Pump Interlock Closed When Pump is Off Alarm.....	99
A207 – Cooler Freeze Protection Alarm.....	99
Resetting Alarms and Alerts.....	100
Alarm History.....	100
Chilled Water Storage Tank.....	101
Chilled Water Storage Tank Serial Number	101
Chilled Water Storage Tank Heaters.....	102
ComfortLink Control Boards	102
Interface Devices	102
Scrolling Marquee Display	102
Navigator	103
Energy Management Board (EMM).....	106
Main Base Board (MBB)	106
Compressor	108
Connection Information.....	109
Crankcase Heaters	109
Nominal Input Horsepower.....	110
Power Factor.....	110
Oil.....	111
Oil Sightglass	111
Compressor Replacement	111
Danfoss-Maneurop Scroll Compressor Unit Serial Numbers	112
Weights	112

30RA AquaSnap Chiller Service Manual

Condenser Coil	114
Non-E-coat Coil Cleaning	114
E-Coat Coil Cleaning	114
Condenser Fan System	116
Condenser Fan Blade	116
Condenser Fan Motor	116
Condenser Fan Motor Data	116
Condenser Fan Motor Usage	116
Control Circuit	117
Cooler	117
Failure Analysis	117
Cooler Heaters	117
Expansion Device	118
Hydronic Package	119
Chilled Water Flow Switch	119
Chilled Water Pump	120
Pump Replacement	121
Pump Seal	121
Chilled Water Pump Heaters	121
Expansion Tank	122
Strainer	122
Minimum Load Control	123
Head Pressure Control	123
MotorMaster V Control	123
Current Limiter	124
Installation	124
Troubleshooting	125
Transducer	125
CL – Current Limit	126
LCS – Loss of Control Signal	126
PF – Current Overload Fault	127
Current Limiter Failure	127
Network Service Tool IV	128
Non-Fused Disconnect	128
Series 0 (Square D Non-Fused Disconnects)	128
Series 1 (Siemens Non-Fused Disconnects)	128
Defeating the Non-Fused Disconnect Handle	129
Paint	130
Pressure Transducers	130
Refrigerant	131
Refrigerant Moisture Limit	131
Refrigerant Service Ports	132
Service Test Mode	133
Service Valves	134
Thermistors	134
Maintenance	136

30RA AquaSnap Chiller Service Manual

Winter Shutdown Preparation 137
Spring Start-Up Preparation 137
Recommended Spare Parts List 137
 30RAN Series 0 Spare Parts List..... 138
 30RAN Series 1 Spare Parts List..... 140
Appendix A – Alphabetical Listing of Points 143
Appendix B – DataPort™, DataLink™, BAClink™ Object Definition 154
Appendix C – Overload Settings 160
Appendix D – RCD Service Kits 161
Title 161
Index 163

Not for Distribution

SAFETY CONSIDERATIONS

Installing, starting up, and servicing this equipment can be hazardous due to system pressures, electrical components, and equipment location (roof, elevated structures, etc.). Only trained, qualified installers and service mechanics should install, start-up, and service this equipment.

When working on this equipment, observe precautions in the literature, and on tags, stickers, and labels attached to the equipment and any other safety precautions that apply. Follow all safety codes. Wear safety glasses and work gloves. Use care in handling, rigging, and setting this equipment, and in handling all electrical components.

WARNING

Electrical shock can cause personal injury and death. Shut off all power to this equipment during installation and service. There may be more than one disconnect switch. Tag all disconnect locations to alert others not to restore power until work is complete.

WARNING

This unit uses a microprocessor-based electronic control system. Do not use jumpers or other tools to short out components or to bypass or otherwise depart from recommended procedures. Any short-to-ground of the control board or accompanying wiring may destroy the electronic modules or electrical components.

WARNING

To prevent potential damage to heat exchanger tubes always run fluid through heat exchangers when adding or removing refrigerant charge. Use appropriate brine solutions in cooler and condenser fluid loops to prevent the freezing of heat exchangers when the equipment is exposed to temperatures below 32 °F (0 °C).

DO NOT VENT refrigerant valves within a building. Outlet from relief valves must be vented outdoors in accordance with the latest edition of ANSI/ASHRAE (American National Standards Institute/American Society of Heating, Refrigeration and Air Conditioning Engineers) 15 (Safety Code for Mechanical Refrigeration). The accumulation of refrigerant in an enclosed space can displace oxygen and cause asphyxiation. Provide adequate ventilation in enclosed or low overhead areas. Inhalation of high concentrations of vapor is harmful and may cause heart irregularities, unconsciousness or death. Misuse can be fatal. Vapor is heavier than air and reduces the amount of oxygen available for breathing. Product causes eye and skin irritation. Decomposition products are hazardous.

WARNING

DO NOT attempt to unbrazed factory joints when servicing this equipment. Compressor oil is flammable and there is no way to detect how much oil may be in any of the refrigerant lines. Cut lines with a tubing cutter as required when performing service. Use a pan to catch any oil that may come out of the lines and as a gage for how much oil to add to the system. DO NOT re-use compressor oil. DO NOT leave refrigerant system open to air any longer than necessary. Seal circuits being serviced and charge with dry nitrogen to prevent oil contamination when timely repairs cannot be completed.

INTRODUCTION

This information should be used with the Installation Instructions, and the Controls, Start-Up, Operation, Service and Troubleshooting book for these machines. Follow all safety precautions and procedures.

AquaSnap Series 0 production began with serial numbers starting with 1801F.

AquaSnap Series 1 machines began limited production starting 2902F, with full production beginning 3202F. This modification introduced Siemens as the control box manufacturer.

AquaSnap production ceased in the McMinnville, TN plant with serial number 2804F. Full production of AquaSnap machines started in the Charlotte, NC plant 2904Q.

Model Number Significance

The following chart is a model number breakdown for the AquaSnap Machines.

30RA AquaSnap Chiller Service Manual

Position	1-5	6-8	9	10	11	12	13	14	15-16
Description	30RAN	045	J	-	-	6	1	1	KA

Air-Cooled AquaSnap Chiller

Nominal Capacity

Hydronic System Options

- = Standard Unit – No Pump
- A = Single Pump, 1.5 Hp, (010-030)
- B = Single Pump, 2 Hp, (010-055)
- C = Single Pump, 2 Hp High Head, (010-030)
- D = Single Pump, 3 Hp, (010-055)
- E = Single Pump, 5 Hp, (032-055)
- F = Dual Pump, 1.5 Hp, (010-030)
- G = Dual Pump, 2 Hp, (010-055)
- H = Dual Pump, 2 Hp High Head, (010-030)
- J = Dual Pump, 3 Hp, (010-055)
- K = Dual Pump, 5 Hp, (032-055)
- N = No Pump with Cooler Heater¹

Control Options

- = Scrolling Marquee Display
- E = Scrolling Marquee Display, Energy Management Module
- S = Scrolling Marquee Display, Energy Management Module, Ground Fault Interrupter Convenience Outlet (60 Hz Only)

Condenser Coil Options

- = Copper Tube/Aluminum Fin
- K = Copper Tube/Pre-coated Aluminum Fin
- C = Copper Tube/Copper Fin
- E = Copper Tube/Aluminum Fin w/E-coat
- F = Copper Tube/Copper Fin w/E-coat

Voltage Options

- 1 = 575-3-60
- 2 = 380-3-60
- 4 = 230-3-60
- 5 = 208/230-3-60
- 6 = 460-3-60
- 8 = 230-3-50
- 9 = 380/415-3-50

Design Series

- 0 = Original Production
- 1 = Siemens Control Box

Packaging/Grille Options

- 1 = Standard Domestic – (Coil Cover and Bottom Skid)
- 3 = Standard Export (Coil Cover, Top and Bottom Skid, Shipping Bag)
- 4 = Full Export Crate
- 5 = Option #1 with Factory Installed Security Grilles
- 7 = Option #3 with Factory Installed Security Grilles
- 8 = Option #4 with Factory Installed Security Grilles

Factory Installed Options

See Factory Installed Options below

¹ Used for a short period of time with the Series 1 introduction. Designation was used to denote no pump and a cooler heater. The control box was later changed to always include the cooler heater contactor a no pump option remained as a “-“.

Factory Installed Options

Factory installed options are determined by Positions 15 and 16 of the model number and are based on the following options:

Option Code	Description
2	<u>Brine Operation</u> For use with Leaving Water Temperatures from 15 °F to 40 °F. An inhibited antifreeze solution of the appropriate concentration must be added to the loop. Motormaster V. (Option 7 is also required with this option.)
7	<u>Low Ambient Motormaster V Control</u> For operation to –20 °F. Required for operation below 45 °F (010-018), 32 °F (022-055). Field installed Wind Baffles are required if wind velocities exceed 5 mph. Water loop volumes of at least 6-10 gallons per ton are recommended for prolonged operation at low ambient conditions. An inhibited antifreeze solution of the appropriate concentration must be added to the loop.
9	<u>Minimum Load Control</u> For operation below standard lowest capacity step. Water loop volumes of at least 6-10 gallons per ton are recommended for prolonged operation at low load.
10	<u>Cooler Heater</u> For freeze protection to –20 °F. An inhibited antifreeze solution of the appropriate concentration is the only sure means of protecting the water loop.
12	<u>Non-Fused Disconnect</u> For a unit mounted electrical service disconnection.

Code	Options	Code	Options	Code	Options
AB	2, 7, 10	FC	7, 10	NS	7, 10, 12
AL	12	GA	7	PK	9, 10, 12
AV	2, 7, 10, 12	HW	2, 7, 9, 10	PP	9, 12
BA	2, 7	HX	7, 9	PT	10, 12
CX	7, 9, 10, 12	JJ	2, 7, 9	PV	2, 7, 12
DT	7, 9, 10	KA	10	QK	2, 7, 9, 10, 12
EU	7, 9, 12	KD	9	QM	2, 7, 9, 12
EW	7, 12	KJ	9, 10		

APPLICATION**Chilled Water Temperature Limits**

Below is table for the operating limits for the 30RA machines.

Maximum Entering Water Temperature	65 °F (18.3 °C)
Pulldown Temperature Limit	95 °F (35.0 °C)

30RA AquaSnap Chiller Service Manual

Maximum Leaving Water Temperature	55 °F (12.8 °C)
Minimum Leaving Water Temperature	40 °F (4.4 °C)
Minimum Leaving Brine Temperature	15 °F (-9.4 °C)

Originally, the units were approved for operation with a maximum Leaving Water Temperature of 70 °F (21.1 °C) and a maximum Entering Water Temperature of 85 °F (29.4 °C). Due to potential compressor reliability concerns, the operating envelope was restricted to the numbers listed above.

Chilled Water Loop

Volume

It is recommended that the chilled water loop be at least 4.5 gallons per nominal ton for the 30RAN010-015. For the 30RAN018-055, a loop volume of at least 3 gallons per nominal ton should be used.

For low ambient or process applications, use the following recommendations:

Unit	Loop Volume
30RAN010-015	12 gallons/ton
30RAN018-030	10 gallons/ton
30RAN035-040	8 gallons/ton
30RAN045-055	6 gallons/ton

With AquaSnap units with pumps, always confirm that the expansion tank supplied will handle the volume of the loop. A different expansion tank may be required.

Chilled Water Storage Tank

There are 3 Chilled Water Storage Tanks offered for the 30RA chillers that provide at least 6 gallons/ton (6.5 liters/kW) of loop volume.

	Chilled Water Storage Tank		
	30RA-900---001	30RA-900---009	30RA-900---010
Used on:	30RAN010-018	30RAN022-030	30RAN032-055
Volume, gal (liters)	110 (416)	152 (575)	305 (1155)
Weight, Empty lbs. (kg)	1260 (572)	1490 (676)	2910 (1320)
Weight, Filled† lbs. (kg)	2150 (975)	2750 (1247)	5430 (2463)
Operating Pressure, psi (kPa)	150 (1034)		

Note: † - Filled with water or brine.

The heater control circuit must be field connected to the base unit for control power. The heaters are not thermostatically controlled.

30RA AquaSnap Chiller Service Manual

The piping between the chiller and the accessory tank can be done to allow the tank to be on the return side of the chiller (tank piped to chiller inlet) or the supply side of the chiller (tank piped to the chiller outlet). However, it is recommended that the tank be piped to the return side of the chiller to buffer any changes in load to allow more stable chiller operation.

A separate 230-1-50/60 volt power supply is required for the heater circuit. Several Price Pages incorrectly listed the power supply as 115 V.

Bulletins pertaining to this item:

- 111-03-51 – 30RAN Price Page Correction
This bulletin advised of the incorrect separate power connection for the Storage Tank power supply.
- Application TIP129 – 30RA Base Rails
This bulletin discussed the mounting of the chiller with and without a storage tank. Base rail cross-sections for both the unit and the storage tanks are also included.

The 30RA Storage Tanks heaters are not regulated. In some cases, high water temperatures have been reported while the ambient temperature is close to the cutout point of the heater control. As long as power is applied, the heaters will also be energized if the Emergency Switch is placed in the OFF position.

To control the water temperatures in the storage tank, a thermostat must be installed. The instructions and parts required are listed below.

Description	Manufacturer	Manufacturer Part No.
Temperature Controller Temperature Setting, 40-180 °F Capillary Length, 8 feet	Honeywell	T4031C1004
Bulb Well * ¾" NPT Connection 3" Insulation Depth	Honeywell	121371M
Bulb Well * ½" NPT Connection 1-½" Insulation Depth	Honeywell	121371A
Bushing * 2" to ¾" bushing 2" to ½" bushing		
Thermal Conductive Grease		

Note: * - Select only one well with the required bushing.

Instructions

Safety Considerations:

Installing, starting up, and servicing this equipment can be hazardous due to system pressures, electrical components, and equipment location (roof, elevated structures, etc.). Only trained, qualified installers and service mechanics should install, start-up, and service this equipment.

When working on this equipment, observe precautions in the literature, and on tags, stickers, and labels attached to the equipment and any other safety precautions that apply. Follow all safety codes. Wear safety glasses and work gloves. Use care in handling, rigging, and setting this equipment, and in handling all electrical components.

WARNING

Electrical shock can cause personal injury and death. Shut off all power to this equipment during installation and service. There may be more than one disconnect switch. Tag all disconnect locations to alert others not to restore power until work is complete.

Since the Temperature Controller is not weatherproof, it must be installed in a protected area, such as the control box of the storage tank. Find a suitable location within the control box and mount the temperature controller. The unit control box can also be used, however the temperature bulb/capillary should be routed to the side of the cabinet and then to the storage tank drain.

Isolate the storage tanks from the system. Drain the storage tanks. Install the bulb well in the bushing. Install the bushing/well assembly in place of the drain plug. Route the capillary from the control box to the bushing/well assembly. Insert the bulb in the well with a small amount of thermal conductive grease.

Set the controller to 50 °F. The controller has a deadband of 5 °F. When a call for the heating is made, the heater will turn on at 45 °F and off at 50 °F, as long as power is applied. Wire the controller to control the heater contactor as shown below.

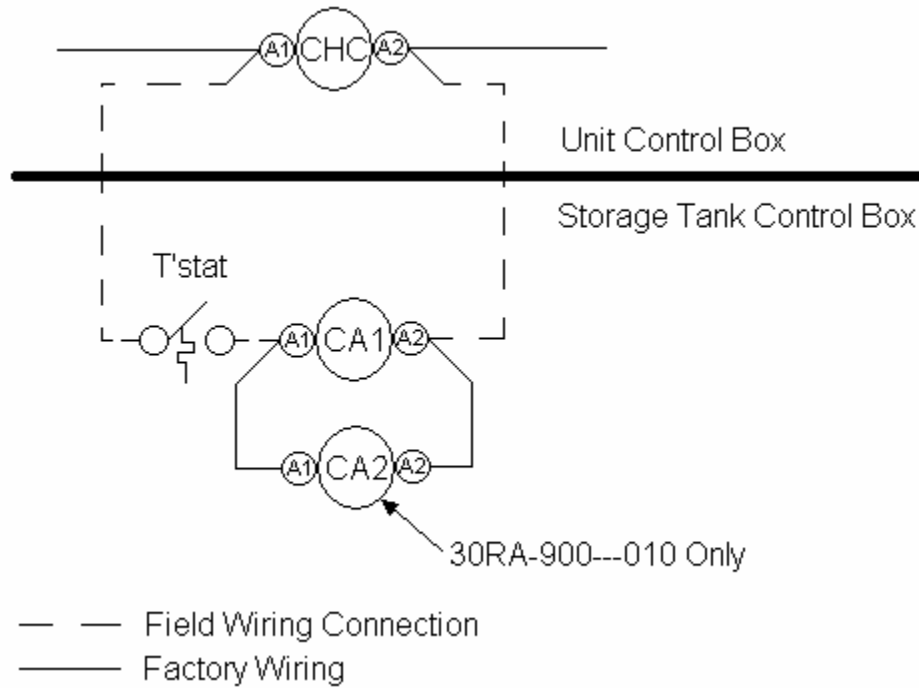

Figure 1 - Thermostat Wiring

Fill the storage tanks. Check the bushing and well for a leak. Restore power to the machine. Check operation.

Coil Protection Grilles

Coil Protection Grilles are coated wire grilles, with 1" x 4" (25 mm x 101 mm) to protect the coil from physical damage.

Unit 30RA	Coil Protection Grille Part Number and Order Quantity		
	30RA-900---008	30RA-900---011	30RA-900---012
010-018	1		
022-025		1	
030			1
032-040	1	1	
042-050		2	
055			2

Early versions of SalesPro were not clear as to which kits were required.

Cooler Freeze Protection

Freeze protection for the cooler and hydronic package is available as a factory installed option. Since power is sometimes lost for extended periods during winter storms, freeze protection provided by heater tapes will be effective only if a back-up power

supply can be assured for the unit's control circuit, heater and cooler pump. If not protected with an antifreeze solution, draining the cooler and outdoor piping is recommended if the system will not be used during freezing weather conditions. Sodium Chloride or Calcium Chloride solutions are not recommended for these machines, and should not be used.

For chillers that must operate during cold weather conditions, the use of antifreeze is highly recommended. Two conditions that must be considered when determining antifreeze concentration are leaving water set point and ambient freeze conditions. These two conditions determine the recommended concentration level. After comparing these conditions, the condition indicating the use of a higher concentration level must be used to adequately protect the machine.

NOTE: Use only antifreeze solutions approved for heat exchanger duty.

Bulletins pertaining to this issue:

- Application TIP122 – Air Cooled Chiller Winterizing: Freeze Protection
This bulletin discussed various freeze protection methods.

Medium Temperature Brine Applications, 15 to 39.9 °F (-9.4 to 4.4 °C)

For applications in which the leaving water temperature set point is less than 40 F (4.4 C), a suitable inhibited antifreeze solution must be used. The solution concentration must be sufficient to protect the chilled water loop to a freeze protection (first crystals) concentration of at least 15° F (8.3° C) below the leaving water temperature set point. Sodium Chloride or Calcium Chloride solutions are not recommended for these machines, and should not be used.

Low Ambient Protection

If the chiller refrigerant or fluid lines are in an area where ambient conditions fall below 34° F (1° C), it is recommended that an antifreeze solution be added to protect the unit and fluid piping to a temperature of 15° F (8.3° C) below the lowest anticipated ambient temperature.

Select concentration based on either burst or freeze protection as dictated by the application. If the chiller does not operate during the winter, nor is a start-up expected, a burst protection concentration is recommended. This concentration may not be high enough to pump the fluid through the system. Burst protection is typically a lower concentration that will provide better performance. If the chiller does operate during winter, a freeze protection concentration is recommended. This concentration will be high enough to keep the fluid in a condition that it can be pumped at low ambient conditions. Sodium Chloride or Calcium Chloride solutions are not recommended for these machines, and should not be used.

IMPORTANT: Adding antifreeze solution is the only certain means of protecting the unit from freeze-up if the cooler heater fails or electrical service is interrupted during low

ambient temperatures.

Electrical Information

Power Connections

Two power connection devices are offered, a terminal block or a non-fused disconnect. Below is a table listing the wire sizes that can be applied to each device. The device does not change with the addition of pump packages.

**Table 1 - Terminal Block/Non-Fused Disconnect Wire Size Range
(Series 1 Machines Only)**

Unit 30RAN	Voltage V-Hz	Maximum Incoming Wire Size †	
		Standard Unit (Terminal Block)	Optional Non-Fused Disconnect
010	230-60	# 2/0	# 1
	208/230-60	# 2/0	# 1
	460-60	# 2/0	# 1
	575-60	# 2/0	# 1
	380-60	# 2/0	# 1
015	230-60	# 2/0	# 1
	208/230-60	# 2/0	# 1
	460-60	# 2/0	# 1
	575-60	# 2/0	# 1
	380-60	# 2/0	# 1
018	230-60	# 2/0	# 1
	208/230-60	# 2/0	# 1
	460-60	# 2/0	# 1
	575-60	# 2/0	# 1
	380-60	# 2/0	# 1
022	230-60	# 2/0	350 kcmil
	208/230-60	# 2/0	350 kcmil
	460-60	# 2/0	# 1
	575-60	# 2/0	# 1
	380-60	# 2/0	# 1
025	230-60	# 2/0	350 kcmil
	208/230-60	# 2/0	350 kcmil
	460-60	# 2/0	# 1
	575-60	# 2/0	# 1
	380-60	# 2/0	# 1
030	230-60	# 2/0	350 kcmil
	208/230-60	# 2/0	350 kcmil
	460-60	# 2/0	# 1
	575-60	# 2/0	350 kcmil
	380-60	# 2/0	# 1
035	230-60	350 kcmil	350 kcmil
	208/230-60	350 kcmil	350 kcmil
	460-60	350 kcmil	# 1
	575-60	350 kcmil	350 kcmil
	380-60	350 kcmil	# 1
040	230-60	350 kcmil	350 kcmil
	208/230-60	350 kcmil	350 kcmil

30RA AquaSnap Chiller Service Manual

Unit 30RAN	Voltage V-Hz	Maximum Incoming Wire Size †	
		Standard Unit (Terminal Block)	Optional Non-Fused Disconnect
	460-60	350 kcmil	# 1
	575-60	350 kcmil	350 kcmil
	380-60	350 kcmil	# 1
045	230-60	350 kcmil	350 kcmil
	208/230-60	350 kcmil	350 kcmil
	460-60	350 kcmil	350 kcmil
	575-60	350 kcmil	350 kcmil
	380-60	350 kcmil	350 kcmil
050	230-60	350 kcmil	350 kcmil
	208/230-60	350 kcmil	350 kcmil
	460-60	350 kcmil	350 kcmil
	575-60	350 kcmil	350 kcmil
	380-60	350 kcmil	350 kcmil
055	230-60	350 kcmil	350 kcmil
	208/230-60	350 kcmil	350 kcmil
	460-60	350 kcmil	350 kcmil
	575-60	350 kcmil	350 kcmil
	380-60	350 kcmil	350 kcmil

Note: † - All wire sizes for 75 °C, Copper wire, AWG (American Wire Gage).

Generator Operation

Frequently, there are specifications for 2-point power connections on air-cooled chillers. This specification stems from the utilization of an undersized generator for back-up power, to provide minimum cooling. Typically, the specification calls for the chiller to have one power feed from the utility and the other supplied from both the utility and a generator with a transfer switch. Carrier can provide the power modification under Quote Control. There are other, more effective solutions to meet this requirement that should be considered.

As an alternative to the dual power supply, Carrier recommends using the Demand Limit function provided by the ComfortLink Control System. The Energy Management Module and a dry switch closure are required for this option to function. Demand Limit is a function that limits the capacity of the machine. This function uses both circuits to achieve the desired cooling limit. When the generator is enabled, a switch closure to the Energy Management Module forces the chiller into a pre-set demand limit level. The benefit of this control

EMM J7

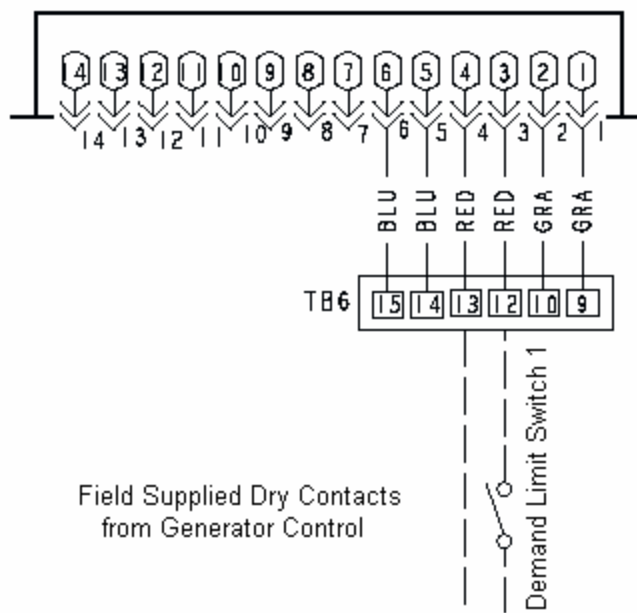

scheme is that it does not rely on one circuit to provide the minimum cooling. For example, assume that the chiller's B circuit is connected to the generator. A service technician has the same circuit down for scheduled maintenance, or has faulted due to a problem. During a power failure, the generator starts, but because the circuit is down, no cooling can be provided. Using the Demand Limit function allows the control to start the available circuit and provide the desired minimum cooling requested. Utilizing the Demand Limit function also allows for single point power, reducing the associated costs with supplying an additional power supply.

There are several other items that must be reviewed in order to provide for the requirement.

- The control system runs on a separate power supply. If the control power is absent, the machine will not operate. With the use of the control transformer, control power can be supplied from the main generator feed.
- Chilled Water Pumps must also be operational. Without chilled water flow, the chiller will not operate.

For additional information, see TIP132 – Generator Operation.

Ground Fault Interrupter Convenience Outlet

Offered on this product family is a Ground Fault Interrupter Convenience Outlet both from the factory as a Factory Installed Option and an Accessory. It is only available for the 115 volt, 60 Hz control circuit.

The accessory kit for the original Series 0 machines is as follows:

Voltage	Accessory Kit Number
208/230-3-60, 230-3-60, 460-3-60	30RA-900---020
575-3-60	30RA-900---021

The accessory kit for Series 1 changed due to the change of the control box supplier and is listed below.

Voltage	Accessory Kit Number
208/230-3-60, 230-3-60, 460-3-60	30RA-900---022
575-3-60	30RA-900---023

Hail Guards

Hail Guards consist of a sheet metal hood with 1" x 4" (25 mm x 101 mm) coated wire grilles, to protect the coil against hail and physical damage.

Unit 30RA	Hail Guard Part Number and Order Quantity		
	30RA-900---004	30RA-900---013	30RA-900---014
010-018	1		
022-025		1	
030			1
032-040	1	1	
042-050		2	
055			2

Early versions of SalesPro were not clear as to which kits were required.

The Condenser Hail Guards do add to the dimensions of the unit when installed. Below is a typical dimensional diagram for all Condenser Hail Guards. Hail Guards will cover all surfaces of condenser coil. Be sure to add this dimension to all exposed coil areas.

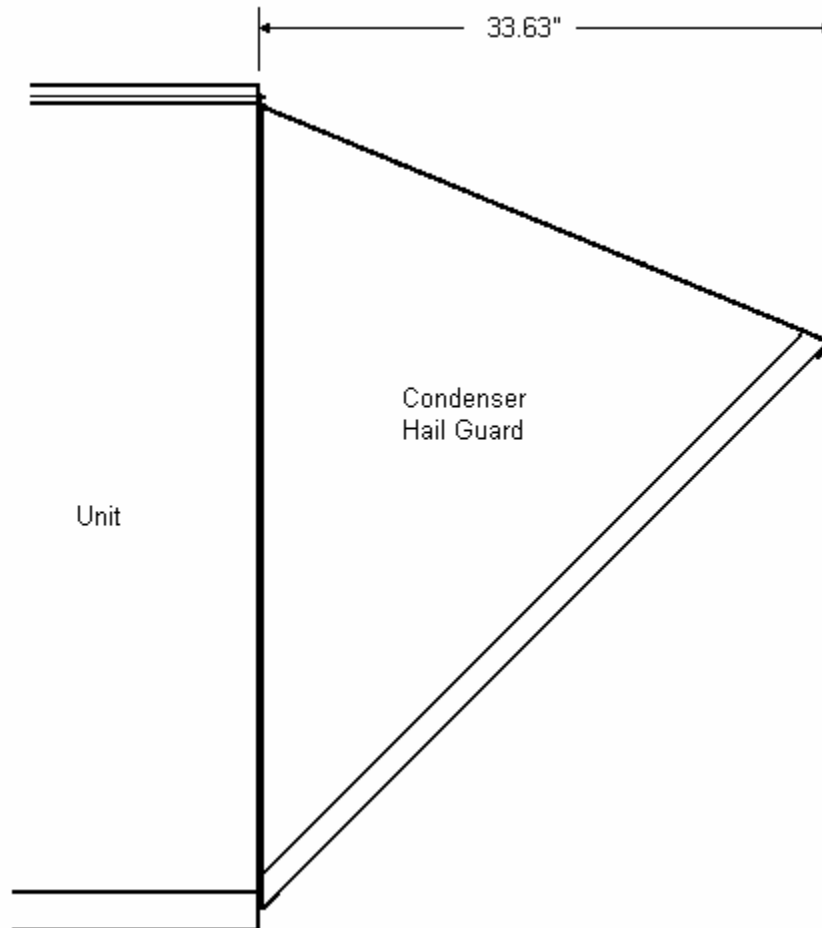

Figure 2 - Condenser Hail Guard Dimension (Typical)

Head Pressure Control

The head pressure control device offered for head pressure control has been the MotorMaster V controller. In areas where sustained wind velocity of 5 mph or greater is expected during low ambient operation, wind baffles must be field-installed.

This is a Variable Frequency Drive device that requires a VFD compatible motor. There were several field-installed packages offered depending on voltage and the number of motors controlled. The original field installed accessories are as follows:

Unit	Voltage	Accessory Part Number	Quantity Required
30RAN010-030	208/230-3-60 230-3-50	30RA-900---006	1
30RAN010-030	380-3-60 380/415-3-50 460-3-60	30RA-900---015	1
30RAN010-030	575-3-60	30RA-900---016	1
30RAN032-055	208/230-3-60 230-3-50	30RA-900---017	1
30RAN032-055	380-3-60 380/415-3-50 460-3-60	30RA-900---018	1
30RAN032-055	575-3-60	30RA-900---019	1

These kits were obsoleted by Product Bulletin 111-04-04, Dated: 01/13/04.

Beginning with serial numbers 4203F, the control of the MotorMaster V control was changed to using the Run-Stop contact feature of the MotorMaster V. As a result, the packages changed to include this control contact relay. This product change was announced in Product Bulletin 111-04-04, Dated: 01/13/04.

Unit	Voltage	Accessory Part Number	Quantity Required
30RAN010-030	208/230-3-60 230-3-50	30RA-900---024	1
30RAN010-030	380-3-60 380/415-3-50 460-3-60	30RA-900---025	1
30RAN010-030	575-3-60	30RA-900---026	1
30RAN032-055	208/230-3-60 230-3-50	30RA-900---027	1
30RAN032-055	380-3-60 380/415-3-50 460-3-60	30RA-900---028	1
30RAN032-055	575-3-60	30RA-900---029	1

Hydronic Package

AquaSnap offers several options for a hydronic package.

Pump Option	Description	Availability	
		30RAN010-030	30RAN032-055
-	No pump installed	X	X
A	Single Pump, 1.5 Hp	X	
B	Single Pump, 2 Hp, Low Head	X	X
C	Single Pump, 2 Hp, High Head	X	
D	Single Pump, 3 Hp	X	X
E	Single Pump, 5 Hp		X
F	Dual Pump, 1.5 Hp	X	
G	Dual Pump, 2 Hp, Low Head	X	X
H	Dual Pump, 2 Hp, High Head	X	
J	Dual Pump, 3 Hp	X	X
K	Dual Pump, 5 Hp		X

The Hydronic Package is supplied from Bell & Gossett with the following ancillary equipment:

- A Paddle-style Chilled Water Flow Switch
- Chilled Water Pump Heater
- Strainer with Blow Down Valve
- Balancing Valve
- Drain
- Vent
- Bladder-style Expansion Tank

The expansion tank is connected to the suction side of the pumps via a braided stainless steel line with copper NPT fittings for connections. It is pre-charged to 40 psi (277 kPa).

- Pressure Gauges with Petcocks
- Check Valves (Dual Pump Packages Only)

Pump Motor Specifications

The following characteristics are true for 60 Hz motors only.

Horsepower	Motor Type	RPM	Service Factor	Full Load Efficiency
1.5	TEFC	3500	1.25	82.5
2.0			1.25	84
3.0			1.15	84
5.0			1.00	84

All pump motors except the 5 Hp motors, options “E” and “K” are built with VFD compatible motors.

Minimum Load Control

This option is both a factory installed option and a field installed accessory. This refrigerant control accessory reduces the capacity of the machine below the standard lowest step. This capacity reduction provides more precise control of leaving fluid temperature during light load conditions. A solenoid valve limits the amount of gas that can be bypassed from the condenser without impacting oil return.

The field installed accessory part number is 30RA-900---003. This kit includes the solenoid valve required for two circuits. The original literature 30RA-3SI, incorrectly indicated that 2 kits were required for the 30RAN035-055 machines.

Vibration Isolation

Spring Isolation

Vibration isolation for the 30RA machines can be accomplished directly without the use of a perimeter rail. If the machine is installed with the accessory storage tank, a perimeter rail is recommended.

Bulletins pertaining to this issue:

- Application TIP129 – 30RA Base Rails
This bulletin discussed the mounting of the chiller with and without a storage tank. Base rail cross-sections for both the unit and the storage tanks are also included.

Vibration Isolation Pads

Vibration Isolation Pads are available as an accessory. The 30RA Vibration Isolation Pads are made of a synthetic rubber based elastomer that is oil resistant. The pad has a Hardness, Durometer A of 45-60 per ASTM D676. The recommended loading of the vibration pad is 20-70 psi (140-490 kPa).

The field installed accessory part number is 30RA-900---005. This kit includes 4 pads.

If the vibration isolation pads are used with the accessory storage tank, mounting the 30RA chiller on vibration isolation pads between the chiller and the accessory tank is allowed but not required. The pads will work if installed under the accessory storage tank. If using the 30RA-900---010 storage tank, 6 pads are required.

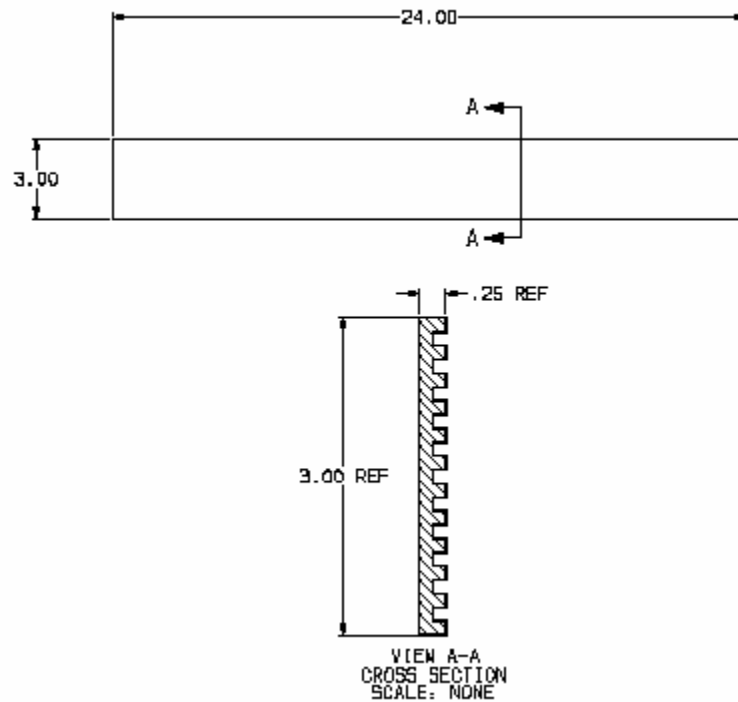

Figure 3- 30RA Vibration Isolation Pads

Bulletins pertaining to this issue:

- Application TIP129 – 30RA Base Rails
This bulletin discussed the mounting of the chiller with and without a storage tank. Base rail cross-sections for both the unit and the storage tanks are also included.

CONTROLS

Within this document, points are referred to in CAPITAL LETTERS. Mode and Sub-mode information is in [Brackets]. Value expansions are in (*Italics*).

Carrier Comfort Network

The 30RA chiller units can be connected to the CCN, if desired.

Alarm Routing Control

Alarms recorded on the 30RAN chiller can be routed through the CCN. To configure for this option, the ComfortLink Control must be configured to determine which elements will receive and process alarms sent by the ComfortLink Control. Input for the decision consists of eight digits, each of which can be set to either 0 or 1. Setting a digit to 1 specifies that alarms will be sent to the system element that corresponds to that digit.

Setting all digits to 0 disables alarm processing. The factory default is 0000000. This is based on the assumption that the unit will not be connected to a network. If the network does not contain a ComfortView, ComfortWorks, Building Supervisor, AutoDial Gateway or Alarm Printer Interface Module (APIM), enabling this feature will only add unnecessary activity to the CCN Communication Bus.

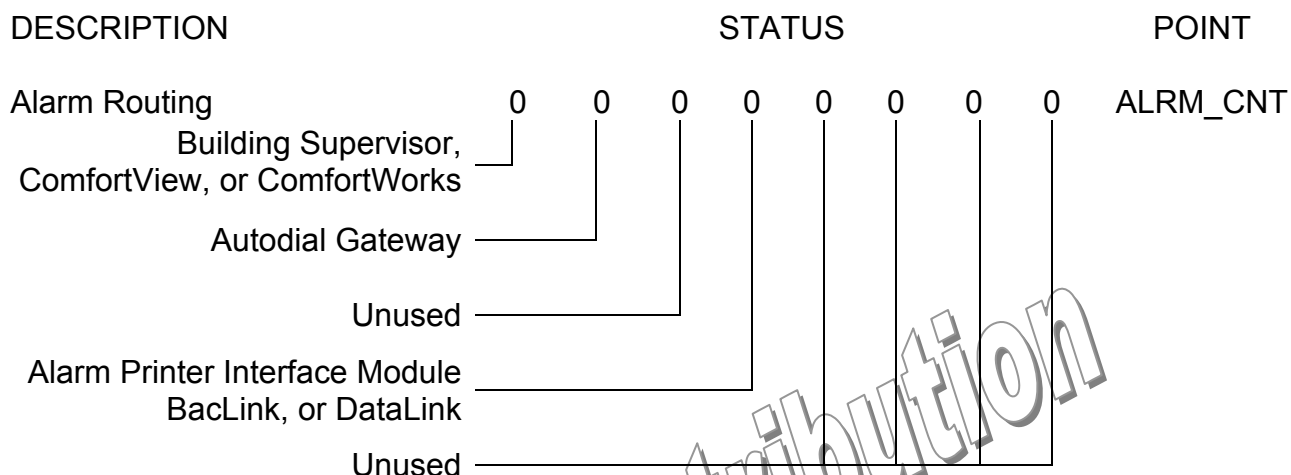

Network Service Tool is required to configure the ComfortLink Control System of the chiller. With Network Service Tool attached to the chiller, go to:

Modify> Controller>ALARMDEF and change Alarm Routing Control to the desired configuration.

Typical configuration of Alarm Routing is 11010000. This Alarm Routing status will transmit alarms to:

- Building Supervisor, ComfortView, or ComfortWorks;
- Autodial Gateway; and
- BacLink or DataLink

Communication Bus Wiring

The communication bus wiring is a shielded, 3-conductor cable with drain wire and is supplied and installed in the field.

CCN Communication Bus Wiring		
Manufacturer	Part Number	
	Regular Wiring	Plenum Wiring
Alpha	1895	-
American	A21451	A48301
Belden	8205	884421
Columbia	D6451	-
Manhattan	M13402	M64430
Quabik	6130	-

The system elements are connected to the communication bus in a daisy chain arrangement. The positive pin of each system element communication connector must be wired to the positive pins of the system elements on either side of it. This is also required for the negative and signal ground pins of each system element. Wiring connections for CCN should be made at TB3. Consult the CCN Contractor's Manual for further information.

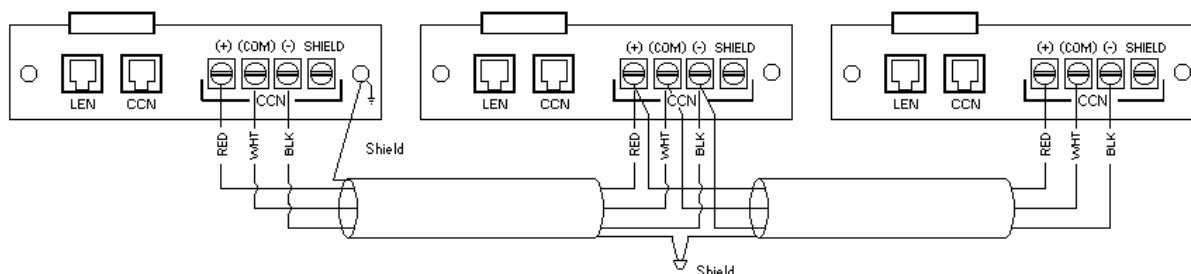

Figure 4 - TB3 - CCN Wiring

A problem with TB3 was uncovered on machines produced between 0102F and 1904F where the TB3 “-” and Shield were connect by an internal trace connection. If the shield was connected CCN Communication failure alarms were generated. To alleviate this problem, connect the ground to the mounting screw instead of the Shield terminal.

Service Bulletins pertaining to this condition:

- SMB040026 – ComfortLink and CCN Communication Problems
This bulletin was described the TB3 “-” and Shield internal trace problem.

NOTE: Conductors and drain wire must be 20 AWG (American Wire Gage) minimum stranded, tinned copper. Individual conductors must be insulated with PVC, PVC/nylon, vinyl, Teflon, or polyethylene. An aluminum/polyester 100% foil shield and an outer jacket of PVC, PVC/nylon, chrome vinyl, or Teflon with a minimum operating temperature range of -20 C to 60 C is required. Wire manufactured by Alpha (2413 or 5463), American (A22503), Belden (8772), or Columbia (02525) meets the above mentioned requirements.

It is important when connecting to a CCN communication bus that a color coding scheme be used for the entire network to simplify the installation. It is recommended that red be used for the signal positive, black for the signal negative, and white for the signal ground. Use a similar scheme for cables containing different colored wires. At each system element, the shields of its communication bus cables must be tied together. If the communication bus is entirely within one building, the resulting continuous shield must be connected to a ground at one point only. If the communication bus cable exits from one building and enters another, the shields must be connected to grounds at the lightning suppressor in each building where the cable enters or exits the building (one point per building only). To connect the unit to the network:

1. Turn off power to the control box.
2. Cut the CCN wire and strip the ends of the red (+), white (ground), and black (–) conductors. Substitute appropriate colors for different colored cables.
3. Connect the red wire to (+) terminal on TB3 of the plug, the white wire to COM terminal, and the black wire to the (–) terminal.
4. The RJ14 CCN connector on TB3 can also be used, but is only intended for temporary connection (for example, a laptop computer running Service Tool).

IMPORTANT: A shorted CCN bus cable will prevent some routines from running and may prevent the unit from starting. If abnormal conditions occur, disconnect the machine from the CCN Network. If conditions return to normal, check the CCN connector and cable. Run new cable if necessary. A short in one section of the bus can cause problems with all system elements on the bus.

Carrier Comfort Network Interface Devices

Several options for interfaces to other Building Control Systems exist and are listed below.

BacLink™

BacLink functions as a gateway between a CCN and a BacNet system. Information from the 30RAN chiller control to support the interface is listed in Appendix B – DataPort™, DataLink™, BAClink™ Object Definition on page 154.

DataLink™

DataLink is an interface device that allows other HVAC control systems to read and change “read/Write” values in system elements connected to a CCN bus. This device requests data from a specified CCN system element and translates this data into ASCII characters off network. Information from the 30RAN chiller control to support the interface is listed in Appendix B – DataPort™, DataLink™, BAClink™ Object Definition on page 154.

DataPort™

DataPort is an interface device that allow other HVAC control systems to “read only” values in system elements connected to a CCN communication bus. Information from the 30RAN chiller control to support the interface is listed in Appendix B – DataPort™, DataLink™, BAClink™ Object Definition on page 154.

Chilled Water Pump Control

ComfortLink machines are configured from the factory with the CPC (*Cooler Pump Control*) [Configuration Mode, Sub-mode OPT1] ON if pumps are supplied with the machine. It is recommended that this option be used to control the integral chilled water pump. If there is no integral cooler pump, the CPC (*Cooler Pump Control*) [Configuration Mode, Sub-mode OPT1] will be set to OFF from the factory. During

normal operation, the Cooler Pump Relay will still operate as described below. It is recommended that the chiller control the chilled water pump. If this option is not used, a 10-minute time delay is required after the command to shut the machine down is sent before the chilled water pump is turned off.

With this option enabled, the cooler pump relay will be energized when the machine enters an occupied period. An A207 - Cooler Freeze Protection Alarm will energize the cooler pump relay also, as an override even if the option is not enabled. The cooler pump relay will be ON if the machine is in MODE 10 – Minimum Off Time.

AquaSnap machines can be supplied with 0, 1 or 2 pumps from the factory. If no pumps are supplied in the machine and Cooler Pump Control is desired, a field-installed relay, CWPR must be installed and connected between TB5-11 and TB5-13. The relay should have a 24 vac coil voltage and maximum coil ratings of: 5 va sealed, 10 va inrush.

The early versions of the Product Data (30RA-1PD, 30RA-2PD, 30RA-3PD), Submittal Bulletin (30RA-1SB), Installation Instructions (30RA-1SI, and 30RA-12SI) and the Controls and Troubleshooting (30RA-1T and 30RA-2T) incorrectly listed the 30RAN032-055 Chilled Water Pump Relay requirements as 115 VAC, 75 va sealed and 360 va inrush.

Cooler Pump Sequence of Operation

At anytime the unit is in an occupied mode, as defined by the one of the following conditions, the cooler pump relay will be enabled.

- The Enable-Off-Remote Switch in ENABLE,
- Enable-Off-Remote Switch in REMOTE with a Start-Stop remote contact closure
- An Occupied Time Period from an Occupancy Schedule
- A CCN Start-Stop Command to Start

As stated before, there are certain alarm conditions and Operating Modes that will turn the cooler pump relay ON. This sequence will describe the normal operation of the pump control algorithm.

When the unit cycles from an occupied mode to an off state, the cooler pump will remain ON for the *PM.DY Cooler Pump Shutdown Delay* (Configuration Mode, Sub-mode OPT1). This is a field configurable parameter from 0 to 10 minutes. The factory default is 1 minute. If the pump was off during the transition period, the pump will not be turned ON.

With the Dual Chiller algorithm enabled, the lead chiller pump will start when the master chiller is signaled to start. The lag chiller pump will not start until the lag chiller is commanded to start by the Dual Chiller algorithm. With dual pump units, each individual unit will control it's pumps as if it were a stand alone machine, with the automatic change over and fault changeover.

No Integral Pump - Single External Pump Control

With a single external pump, the following options must be configured:
CPC *Cooler Pump Control* (Configuration Mode, Sub-mode OPT1) OFF.
PM1E *Cooler Pump 1 Enable* (Configuration Mode, Sub-mode UNIT) NO
PM2E *Cooler Pump 2 Enable* (Configuration Mode, Sub-mode UNIT) NO

The maximum load allowed for the Chilled Water Pump Starter is 5 VA sealed, 10 VA inrush at 24 volts. The starter coil is powered from the chiller control system. The starter should be wired between TB5-11 and TB5-13. If equipped, a field installed chilled water pump interlock should be connected in series with the chilled water flow switch.

The Cooler Pump Relay will be energized when the machine is occupied. The chilled water pump interlock circuit consists of a chilled water flow switch and a field installed chilled water pump interlock. If the chilled water pump interlock circuit does not close within five (5) minutes of starting, an A200 – Cooler Flow/Interlock failed to close at Start-Up will be generated and chiller will not be allowed to start.

If the chilled water pump interlock or chilled water flow switch opens for at least three (3) seconds after initially being closed, an A201 - Cooler Flow/Interlock Contacts Opened During Normal Operation Alarm will be generated and the machine will stop.

If CPC *Cooler Pump Control* (Configuration Mode, Sub-mode OPT1) is ON and the control detects that the chilled water pump interlock and chilled water flow switch circuit is closed for at least five (5) minutes with the pump output OFF, an A202 – Cooler Pump Interlock Closed When Pump is Off Alarm will be generated and the unit will not be allowed to start.

No Integral Pump - Dual External Pump Control

With two external pumps, the following options must be configured:
CPC *Cooler Pump Control* (Configuration Mode, Sub-mode OPT1) ON.
PM1E *Cooler Pump 1 Enable* (Configuration Mode, Sub-mode UNIT) YES
PM2E *Cooler Pump 2 Enable* (Configuration Mode, Sub-mode UNIT) YES

The maximum load allowed for the Chilled Water Pump Starters is 5 VA sealed, 10 VA inrush at 24 volts. The starter coil is powered from the chiller control system. The starter for Chilled Water Pump 1 should be wired between TB5-11 and TB5-13. The starter for Chilled Water Pump 2 should be wired between TB5-15 and TB5-13. A field installed chilled water pump interlock for each pump must be connected to each pump's interlock points on the Main Base Board. The Chilled Water Pump 1 Interlock, CWP1 must be connected to MBB-J7-1 and -2. The Chilled Water Pump 2 Interlock, CWP2 must be connected to MBB-J7-3 and -4.

Operation of this control scheme will be the same as for the Dual Integral Pump found on page 31.

Single Integral Pump Control

With a single pump, the following options must be configured:

CPC Cooler Pump Control (Configuration Mode, Sub-mode UNIT) ON

PM1E Cooler Pump 1 Enable (Configuration Mode, Sub-mode UNIT) YES

With a single integral pump, the Cooler Pump Contactor will be energized when the machine is occupied. As part of the factory installed package, an auxiliary set of contacts is wired to the MBB to serve as Chilled Water Pump Interlock. When the mechanical cooling is called for, the pump interlock and flow switch are checked. If the circuits are closed, the machine starts its capacity routine. If the auxiliary contact interlock does not close within 26 seconds of the ON command, a T190 – Cooler Pump 1 Aux Contacts Failed to Close at Start-Up Alert will be generated and the pump shut down. The unit will not be allowed to start. If the chilled water flow switch does not close within one (1) minute, two alarms will be generated. A T192 – Cooler Pump 1 Failed to Provide Flow at Start-Up Alert and an A200 – Cooler Flow/Interlock failed to close at Start-Up will be generated and chiller will not be allowed to start.

If the chilled water flow switch opens for at least three (3) seconds after initially being closed, a T196 – Flow Lost While Pump 1 Running Alert and an A201 - Cooler Flow/Interlock Contacts Opened During Normal Operation Alarm will be generated and the machine will stop.

If the control detects the chilled water pump interlock open for 26 seconds after initially being closed, a T194 – Cooler Pump 1 Contacts Opened During Normal Operation Alert is generated and the unit is shut down.

If *CPC Cooler Pump Control* (Configuration Mode, Sub-mode OPT1) is ON and the control detects the chilled water flow switch circuit closed for at least five (5) minutes with the pump output OFF, an A202 – Cooler Pump Interlock Closed When Pump is Off Alarm will be generated and the unit will not be allowed to start.

If the control detects that the chilled water pump auxiliary contacts are closed for at least 26 seconds while the pump is OFF, a T198 – Cooler Pump 1 Aux Contacts Closed While Pump Off Alert is generated. The chiller will not be allowed to start.

If the control starts a pump and the wrong interlock circuit closes for at least 10 seconds, an A189 – Cooler Pump and Aux Contact Input Miswire Alarm will be generated. The unit will be prevented from starting. MBB Version 4.0 software increased this time to 20 seconds.

As part of a pump maintenance routine, the pump can be started to maintain lubrication to the pump seal. To utilize this function, *PM.P.S Cooler Pmp Periodic Start* (Configuration Mode, Sub-mode UNIT) must be set to YES. This option is set to NO as the factory default. With this feature enabled, if the pump is not operating, it will be started and operated for two (2) seconds starting at 1400 hours. If the pump is

operating, this routine is skipped. If the pump has failed and an Alarm/Alert condition is active, the pump will not start that day.

Dual Integral Pump Control

With a dual integral pump package, the following options must be configured:

CPC *Cooler Pump Control* (Configuration Mode, Sub-mode UNIT) ON

PM1E *Cooler Pump 1 Enable* (Configuration Mode, Sub-mode UNIT) YES

PM2E *Cooler Pump 2 Enable* (Configuration Mode, Sub-mode UNIT) YES

Pump Start Selection is a field configurable choice. PM.SL *Cooler Pump Select* (Configuration Mode, Sub-Mode UNIT) is factory defaulted to 0 (Automatic). This value can be changed to 1 (Pump 1 Starts First) or 2 (Pump 2 Starts First). If PM.SL is 0 (Automatic), the pump selection is based on two criteria: the alert status of a pump and the operational hours on the pump. If a pump has an active Alert condition, it will not be considered for the lead pump. The pump with the lowest operational hours will be the lead pump. A pump is selected by the control to start and continues to be the lead pump until the PM.DT *Pump Changeover Hours* (Configuration Mode, Sub-mode UNIT) is reached. The LD.PM *Lead Pump* (Inputs Mode, Sub-mode GEN.I) indicates the pump that has been selected as the lead pump; 1 (Pump 1), 2 (Pump 2), 3 (No Pump). The Pump Changeover Hours is factory defaulted to 500 hours. Regardless of the Cooler Pump Selection, any pump that has an active alert will not be allowed to start.

With the dual integral pump package, the Cooler Pump Contactor will be energized when the machine is in an occupied period. As part of the factory installed package, an auxiliary set of contacts is wired to the MBB to serve as Chilled Water Pump Interlock, one set for each pump to individual channels on the MBB. With a call for mechanical cooling, the specific pump interlock and flow switch are checked. If the circuits are closed, the machine starts its capacity routine. If Pump 1 starts and the auxiliary contact interlock does not close within 26 seconds of the ON command, a T190 – Cooler Pump 1 Aux Contacts Failed to Close at Start-Up Alert will be generated and the pump shut down. The unit will not be allowed to start. If the chilled water flow switch does not close within 1 minute, two alarms will be generated. A T192 – Cooler Pump 1 Failed to Provide Flow at Start-Up Alert and an A200 – Cooler Flow/Interlock failed to close at Start-Up will be generated and chiller will not be allowed to start. In either fault case listed above, Pump 2 will be commanded to start once Pump 1 has failed.

If Pump 2 starts and the auxiliary contact interlock does not close within 26 seconds of the ON command, a T191 – Cooler Pump 2 Aux Contacts Failed to Close at Start-Up Alert will be generated and the pump shut down. The unit will not be allowed to start. If the chilled water flow switch does not close within one (1) minute, two alarms will be generated. A T193 – Cooler Pump 2 Failed to Provide Flow at Start-Up Alert and an A200 – Cooler Flow/Interlock failed to close at Start-Up will be generated and chiller will not be allowed to start. In either fault case listed above, Pump 1 will be commanded to start once Pump 2 has failed.

If the chilled water flow switch opens for at least three (3) seconds after initially being closed, a T196 – Flow Lost While Pump 1 Running Alert or T197 – Flow Lost While Pump 2 Running Alert for the appropriate pump and an A201 - Cooler Flow/Interlock Contacts Opened During Normal Operation Alarm will be generated and the machine will stop. If available, the other pump will be started. If flow is proven, the machine will be allowed to restart.

If the chilled water pump interlock opens for 26 seconds after initially being closed is detected by the control, the appropriate T194 – Cooler Pump 1 Contacts Opened During Normal Operation Alert or T195 – Cooler Pump 2 Contacts Opened During Normal Operation Alert is generated and the unit is shut down. If available, the other pump will be started. If flow is proven, the machine will be allowed to restart.

If CPC *Cooler Pump Control* (Configuration Mode, Sub-mode OPT1) is ON and the control detects that the chilled water flow switch circuit is closed for at least five (5) minutes with the pump output OFF, an A202 – Cooler Pump Interlock Closed When Pump is Off Alarm will be generated and the unit will not be allowed to start.

If the control detects that the chilled water pump auxiliary contacts are closed for at least 26 seconds while the pump is OFF, the appropriate T198 – Cooler Pump 1 Aux Contacts Closed While Pump Off or Alert T199 – Cooler Pump 2 Aux Contacts Closed While Pump Off Alert is generated. The chiller will not be allowed to start.

If the control starts a pump and the wrong interlock circuit closes for at least 10 seconds, an A189 – Cooler Pump and Aux Contact Input Miswire Alarm will be generated. The unit will be prevented from starting. MBB Version 4.0 software increased this time to 20 seconds.

The control will allow for pump changeover. Two methods will change the pump sequence. Before the changeover can occur, the unit must be at Capacity Stage 0. During the transition and for 10 seconds after the chilled water flow switch input is ignored to avoid a nuisance alarm.

With PM.SL *Cooler Pump Select* (Configuration Mode, Sub-Mode UNIT) set to 0 (Automatic) and when the differential time limit PM.DT *Pump Changeover Hours* (Configuration Mode, Sub-mode UNIT) is reached, the lead pump will be turned OFF. Approximately one (1) second later, the lag pump will start. With Version 3.0 Software and earlier, manual changeover can be accomplished by changing ROT.P *Rotate Cooler Pump Now* (Configuration Mode, Sub-mode UNIT) to YES only if the machine is at Capacity Stage 0 and the differential time limit PM.DT *Pump Changeover Hours* (Configuration Mode, Sub-mode UNIT) is reached. If the PM.DT is not satisfied, the changeover will not occur. With the machine at Capacity Stage 0, the pumps would rotate automatically as part of the normal routine.

With PM.SL *Cooler Pump Select* (Configuration Mode, Sub-Mode UNIT) set to 1 (Pump 1 Starts First) or 2 (Pump 2 Starts First), a manual changeover can be accomplished by

changing PM.SL only. The machine Remote-Off-Enable Switch must be in the OFF position to change this variable. With MBB Version 3.0 Software and earlier, the ROT.P *Rotate Cooler Pump Now* (Configuration Mode, Sub-mode UNIT) feature does not work for these configuration options.

As part of a pump maintenance routine, the pumps can be started to maintain lubrication to the pump seal. To utilize this function, PM.P.S *Cooler Pmp Periodic Start* (Configuration Mode, Sub-mode UNIT) must be set to YES. This option is set to NO as the factory default. If feature is enabled and the pump(s) are not operating, then the pumps will be operated every other day for two (2) seconds. If a pump has failed and has an active Alert condition, it will not be started that day.

Troubleshooting:

If the cooler pump relay is cycling the chilled water pump rapidly, check the chilled water flow switch for a short to ground.

Compressor Loading

There are a number of possibilities for configuring compressor staging.

Close Control

When the machine is configured for Close Control, the control uses the Minimum Load Valve(s) in addition to the compressor staging to maintain better regulation of the leaving fluid temperature. This feature requires the installation of the Minimum Load Valve(s). With Close Control enabled, the Minimum Load Control is used as additional stages of capacity throughout the staging routine. This feature will not add any additional stages for single compressor machines, 30RAN010 and 30RAN015 (60 Hz only). For this feature to be active, the following items must be configured: MLV.S *Minimum Load Valve Select* (Configuration Mode, Sub-mode OPT1) set for YES and CLS.C *Close Control Select* (Configuration Mode, Sub-mode OPT2) set for ENBL.

In MBB Version 3.0 Software and earlier, the 4 compressor units, 30RAN042-055 may not reach full capacity. Typically, the machines stop at around 72%. A temporary fix is to disable CLS.C until the software can be upgraded.

Lead /Lag

There are several options allowed for determining which circuit starts for multiple circuit machines. This is a configurable choice and is factory set to be automatic for all units. The value, LLCS *Lead/Lag Circuit Select* (Configuration Mode, Sub-mode OPT2) can be changed to Circuit A or Circuit B leading as desired. Set at automatic, the control will sum the current number of logged circuit starts and one-quarter of the current operating hours for each circuit. The circuit with the lowest sum is started first. Changes to which circuit is the lead circuit and which is the lag are also made when total machine capacity is at 100% or when there is a change in the direction of capacity (increase or decrease) and each circuit's capacity is equal.

To set the Lead/Lag Circuit Select to Automatic change LLCS to “1”.
To set the Lead/Lag Circuit Select to Circuit A Leads change LLCS to “2”.
To set the Lead/Lag Circuit Select to Circuit B Leads change LLCS to “3”.

Circuit Loading

Two options for circuit loading are offered with the AquaSnap control, equal or staged. The factory default is “Equal”. With “Equal” staging, each circuit alternates adding a stage of capacity. With “Staged” a circuit is loaded completely before the next circuit is started. This is field configured with the value, *LOAD Loading Sequence Select* (Configuration Mode, Sub-mode OPT2).

To set the Loading Sequence Select to Equal, change LOAD to “1”.
To set the Loading Sequence Select to Staged, change LOAD to “2”.

Compressors within the Circuit

There is lead/lag routine within a circuit in the AquaSnap control logic. It is an automatic function with no user adjustments required. It is based on run time, off time and leaving water and saturated condensing temperature on the circuit when ready to start again. The routine was added for oil management.

Display/Interface

AquaSnap offers to separate interface display modules. The Scrolling Marquee is the standard module and provides a 4-character display. The optional Navigator is a 4-line display. Both displays feature an expandable clear language text display.

Navigator

This display is the standard display used on these machines. The display is a portable hand-held display module with a 4-line by 40-character backlit LCS (liquid crystal diode) screen. Four keys control the display menus, which provide clear language descriptions of all menu items, operating modes, configuration points and alarm diagnostics. A coiled extension cord capable of extending to 12 feet (5.6 m) allows the display to be moved around the chiller. Magnets attached to the back of the display hold the display module to any sheet metal panel to allow hands-free operation. Display module has a NEMA 4x housing suitable for use in outdoor environments. The display has a backlight and contrast adjustment for easy viewing in bright sunlight or night conditions. The display module also has raised surface buttons with positive tactile response.

The Navigator module provides a mobile user interface to the ComfortLink control system. It can be a Factory installed Option or a Field Installed Accessory. The display has up and down arrow keys, an [ENTER] key, and an [ESCAPE] key. These keys are used to navigate through the different levels of the display structure. Press the [ESCAPE] key until ‘Select a Menu Item’ is displayed to move through the top 11 mode levels indicated by LEDs on the left side of the display.

Once within a Mode or sub-mode, a “>” indicates the currently selected item on the display screen. Pressing the [ENTER] and [ESCAPE] keys simultaneously will put the Navigator into expanded text mode where full meaning of all sub-modes, items and their values can be displayed. Pressing the [ENTER] and [ESCAPE] keys when the display says ‘Select Menu Item’ (Mode LED level) will return the Navigator to its default menu of rotating display items (those items in the VIEW sub-mode under the Run Status mode). In addition, the password will be disabled requiring that it be entered again before changes can be made to password protected items. The Service Test function should be used to verify proper protected items. Press the [ESCAPE] key to exit out of the expanded text mode.

NOTE: When the LANG *Language Selection* (Configuration Mode, Sub-mode DISP), variable is changed, all appropriate display expansions will immediately change to the new language. No power-off or control reset is required when reconfiguring languages.

When a specific item is located, the item name appears on the left of the display, the value will appear near the middle of the display and the units (if any) will appear on the far right of the display. Press the [ENTER] key at a changeable item and the value will begin to flash. Use the up and down arrow keys to change the value, and confirm the value by pressing the [ENTER] key.

Two items, OAT *Outside Air Temperature* (Temperature Mode, Sub-mode UNIT) and SPT *Space Temperature* (Temperature Mode, Sub-mode UNIT) can be forced to a value at the Navigator. Use the procedure outlined above to change and force the value. If one of these two points has been forced, a flashing “f” indicating the force will appear next to the value. To remove the force, select the item. Press the [ENTER] key so that the value is flashing. Press the up and down arrow keys simultaneously and the force will be removed.

Changing item values or testing outputs is accomplished in the same manner. Locate and display the desired item. Press [ENTER] so that the item value flashes. Use the arrow keys to change the value or state of an item and press the key to accept it. Press the [ESCAPE] key to return to the next higher level of structure. Repeat the process as required for other items.

Items in the Configuration and Service Test modes are password protected. The words ‘Enter Password’ will be displayed when required, with the default password also being displayed. Use the arrow keys to change the number and press [ENTER] to enter the digit. Continue with the remaining digits of the password. The default password is 1111. The password can only be changed at the Navigator or through CCN devices such as ComfortWORKS[®], ComfortView[™] and Service Tool.

Adjusting the Contrast

The contrast of the display can be adjusted to suit ambient conditions. To adjust the contrast of the Navigator, press the [ESCAPE] key until the display reads, “Select a

menu item.” Using the arrow keys move to the Configuration mode. Press [ENTER] to obtain access to this mode. The display will read:

```
> TEST      OFF
  METR      OFF
  LANG      ENGLISH
```

Pressing [ENTER] will cause the “OFF” to flash. Use the up or down arrow to change “OFF” to “ON”. Pressing [ENTER] will illuminate all LEDs and display all pixels in the view screen. Pressing [ENTER] and [ESCAPE] simultaneously allows the user to adjust the display contrast. The display will read:

```
Adjust Contrast
---+-----
```

Use the up or down arrows to adjust the contrast. The screen’s contrast will change with the adjustment. Press [ENTER] to accept the change. The Navigator will keep this setting as long as it is plugged in to the LEN bus.

Adjusting the Backlight Brightness

The backlight of the display can be adjusted to suit ambient conditions. The factory default is set to the highest level. To adjust the backlight of the Navigator, press the [ESCAPE] key until the display reads, “Select a menu item.” Using the arrow keys move to the Configuration mode. Press [ENTER] to obtain access to this mode. The display will read:

```
> TEST      OFF
  METR      OFF
  LANG      ENGLISH
```

Pressing [ENTER] will cause the “OFF” to flash. Use the up or down arrow keys to change “OFF” to “ON”. Pressing [ENTER] will illuminate all LEDs and display all pixels in the view screen. Pressing the up and down arrow keys simultaneously allows the user to adjust the display brightness. The display will read:

```
Adjust Brightness
-----+
```

Use the up or down arrow keys to adjust the brightness. The screen’s brightness will change with the adjustment. Press [ENTER] to accept the change. The Navigator will keep this setting as long as it is plugged in to the LEN bus.

Scrolling Marquee Display

The Scrolling Marquee Display is the standard interface display to the ComfortLink Control System for the AquaSnap machines. The display has up and down arrow keys, an [ENTER] key, and an [ESCAPE] key. These keys are used to navigate through the

different levels of the display structure. Press the [ESCAPE] key until the display is blank to move through the top 11 mode levels indicated by LEDs on the left side of the display.

Once within a Mode or Sub-mode, pressing the [ENTER] and [ESCAPE] keys simultaneously will put the Scrolling Marquee Display into expanded text mode where full meaning of all sub-modes, items and their values can be displayed for the current selection. Pressing the [ENTER] and [ESCAPE] keys when the display is blank (Mode LED level) will return the Scrolling Marquee Display to its default menu of rotating display items (those items in the Run Status Mode, sub-mode VIEW). In addition, the password will be disabled requiring that it be entered again before changes can be made to password protected items. The Service Test function should be used to verify proper protected items. Press the [ESCAPE] key to exit out of the expanded text mode.

NOTE: When the LANG *Language Selection* (Configuration Mode, Sub-mode DISP), variable is changed, all appropriate display expansions will immediately change to the new language. No power-off or control reset is required when reconfiguring languages.

When a specific item is located, the item name alternates with the value on the display. Press the [ENTER] key at a changeable item and the value will be displayed. Press [ENTER] again and the value will begin to flash indicating that the value can be changed. Use the up and down arrow keys to change the value, and confirm the value by pressing the [ENTER] key.

Two items, OAT *Outside Air Temperature* (Temperature Mode, Sub-mode UNIT) and SPT *Space Temperature* (Temperature Mode, Sub-mode UNIT) can be forced to a value at the Scrolling Marquee Display. Use the procedure outlined above to change the value. If one of these two points has been forced, a flashing “•” in the lower right hand corner of the display indicates the force next to the value. To remove the force, select the item. Press the [ENTER] key so that the value is flashing. Press the up and down arrow keys simultaneously and the force will be removed.

Changing item values or testing outputs is accomplished in the same manner. Locate and display the desired item. Press [ENTER] so that the item value flashes. Use the arrow keys to change the value or state of an item and press the key to accept it. Press the [ESCAPE] key to return to the next higher level of structure. Repeat the process as required for other items.

Items in the Configuration and Service Test modes are password protected. The words ‘PASS’ and ‘WORD’ will alternate on the display when required. Press [ENTER] and the default password 1111 will be displayed. Press [ENTER] again and the first digit will begin to flash. Use the arrow keys to change the number and press [ENTER] to enter the digit. Continue with the remaining digits of the password. The password can only be changed at the Navigator or through CCN devices such as ComfortWORKS[®], ComfortView[™] and Service Tool.

Remote Enhanced Display

The remote enhanced display is a network access local interface with a 16-line by 40-character backlit LCD (liquid crystal diode) screen and 4 soft keys for menu driven selections below the display screen. The enhanced display allows the operator to view all key unit operating data on a single screen. The remote enhanced display supplements the standard user interface that is supplied with the 30RA chillers. The remote enhanced display is mounted outside of the chiller control box (but inside a building) for convenient viewing and access. The standard user interface that is mounted on the chiller control box does not have to be removed to use the remote enhanced display.

Demand Limit Control

Demand Limit is a feature that allows the unit capacity to be limited during periods of peak energy usage. There are 3 types of demand limiting that can be configured. The first type is through 2-stage switch control, which will reduce the maximum capacity to 2 user-configurable percentages. The second type is by 4 to 20 mA signal input which will reduce the maximum capacity linearly between 100% at a 4 mA input signal (no reduction) down to the user-configurable level at a 20 mA input signal. The third type uses the CNN Loadshed module and has the ability to limit the current operating capacity to maximum and further reduce the capacity if required. The 2-stage switch control and 4- to 20-mA input signal types of demand limiting require the Energy Management Module (EMM). To use Demand Limit, select the type of demand limiting to use. Then configure the Demand Limit set points based on the type selected.

With Software Versions 3.0 and earlier, a known software problem with the Demand Limit function exists. The function does not work.

Configuration Mode					
Sub-Mode	Keypad Entry	Item	Display	Item Expansion	Comment
RSET	[ENTER]	DMDC	X	Demand Limit Select	0=None 1=Switch 2=4-20 mA Input 3=CCN LoadShed
	[▼]	DM20	XXX %	Demand Limit at 20 mA	Default: 100% Range: 0 to 100%
	[▼]	SHNM	XXX	Loadshed Group Number	Default: 0 Range: 0 to 99
	[▼]	SHDL	XXX %	Loadshed Demand Delta	Default: 0 % Range: 0 to 60 %
	[▼]	SHTL	XXX	Maximum Loadshed Time	Default: 60 minutes Range: 0 to 120 minutes
	[▼]	DLS1	XXX %	Demand Limit Switch 1	Default: 80% Range: 0 to 100%
	[▼]	DLS2	XXX %	Demand Limit Switch 2	Default: 50% Range: 0 to 100%

Use care in selecting the DM20 *Demand Limit at 20 mA*, SHDL *Load Shed Demand Delta*, DLS1 *Demand Limit Switch 1*, and DLS2 *Demand Limit Switch 2*. There is a +/- 15% tolerance to the selection. If the machine is running at a capacity of 15% greater than the selected point, a stage is removed. If the machine is running at a capacity of 15% less than the selected point, a stage is removed. If the value selected for the selected point is between capacity stages, the compressors will cycle. In the example below, a 2-compressor machine without Minimum Load Control has been configured for any one of the Demand Limit Options and various levels of demand limit have been selected with the results shown to the side.

Demand Limit Selection	Capacity Range		Comment
	-15%	+15%	
75%	90%	60%	Cycles between Capacity Stage 1 (50%) and 2 (100%)
50%	65%	35%	No cycling, limited to Capacity Stage 1 (50%)
25%	40%	10%	Cycles between Capacity Stage 0 (0%) and 1 (50%)

2-Stage Switch Controlled Demand Limit

To configure Demand Limit for 2-stage switch control set the Demand Limit Select (DMDC) to 1. Then configure the 2 Demand Limit Switch points (DLS1 and DLS2) to the desired capacity limit. Capacity steps are controlled by 2 relay switch inputs field wired to TB6. Demand Limit Step 1 connects to TB6-12 and TB6-13. Demand Limit Step 2 connects to TB6-14 and TB6-15. For Demand Limit by 2-stage switch control, closing the first stage demand limit contact will put the unit on the first demand limit level. The unit will not exceed the percentage of capacity entered as Demand Limit Switch 1 set point. Closing contacts on the second demand limit switch prevents the unit from exceeding the capacity entered as Demand Limit Switch 2 set point. The demand limit stage that is set to the lowest demand takes priority if both demand limit inputs are closed. If the demand limit percentage does not match unit staging, the unit will limit capacity to the closest capacity stage. To disable demand limit configure the DMDC to 0.

Operation with this option enabled, activates MD15 – Demand/Sound Limited Mode.

4 to 20 mA Controlled Externally Powered Demand Limit

This option requires the Energy Management Module. To configure Demand Limit for 4 to 20 mA control set the Demand Limit Select (DMDC) to 2. Then configure the Demand Limit at 20 mA (DM20) to the maximum loadshed value desired. The control will reduce allowable capacity to this level for the 20 mA signal. A 4-20 mA signal generator is required for this option. Care should be taken when interfacing with other manufacturer's control systems, due to power supply differences, full wave bridge versus half wave rectification. The two different power supplies cannot be mixed. ComfortLink controls use half wave rectification. A signal isolation device should be utilized if a full wave bridge signal generating device is used. The 4-20 mA "+" signal should be connected to TB6-1. The 4-20 mA "-" signal should be connected to TB6-5.

There is a small label next to TB5 and TB6, 30RA500099. Rev. 2.0 has a known error for the connection of the 4-20 mA signal. The label diagram for the machine is correct and should be followed.

0-10 or 2-10 vdc inputs cannot be used without further modification. Failure to modify the signal will result in damage to the board. If this is a requirement, a signal converter is recommended.

Operation with this option enabled, activates MD15 – Demand/Sound Limited Mode.

CCN Loadshed Controlled Demand Limit

To configure Demand Limit for CCN Loadshed control set the Demand Limit Select (DMDC) to 3. Then configure the Loadshed Group Number (SHNM), Loadshed Demand Delta (SHDL), and Maximum Loadshed Time (SHTM). The CCN system designer establishes the Loadshed Group number. The ComfortLink control will respond to a Redline command from the Loadshed control. When the Redline command is received, the current stage of capacity is set to the maximum stages available. Should the loadshed control send a Loadshed command, the ComfortLink control will reduce the current stages by the value entered for Loadshed Demand delta. The Maximum Loadshed Time is the maximum length of time that a loadshed condition is allowed to exist. The control will disable the Redline/Loadshed command if no Cancel command has been received within the configured maximum loadshed time limit.

Operation with this option enabled, activates MD15 – Demand/Sound Limited Mode.

Dual Chiller Control

ComfortLink controls have the ability to control a slave chiller from a master chiller. Space Temperature Reset is not available with Dual Chiller Control. The option is limited to parallel chiller operation only. Chilled Water pumps can be controlled from each machine.

The ComfortLink Control System has the ability to control 2 machines from one controller.

For machines with pumps connected in parallel, the expansion tank must be removed from the machine and placed in the common header for proper operation.

For Dual Chiller Control, additional hardware is required to complete the installation. A Dual Chiller Leaving Water Thermistor is required. Thermistor and Thermistor Well lengths of 3" and 4" are offered. Depending on chilled water piping size, order the appropriate thermistor and thermistor well for the site conditions.

Part Number	Description	Quantity Required
--HH--79NZ-026	Thermistor, 5k Ohm – 3” Water Temperature Sensor for Dual Chiller Control. Use 10HB-501---068-01, Thermistor Well.	1
10HB-501---068-01	Thermistor Well – 3”	1
--HH--79NZ-029	Thermistor, 5k Ohm – 4” Water Temperature Sensor for Dual Chiller Control. Use 10HB-501---068-02, Thermistor Well.	1
10HB-501---068-02	Thermistor Well – 4”	1

Earlier SalesPro, Price Pages and Product Ordering Data did not include this information.

For Parallel Dual Chiller Operation an additional thermistor must be installed in the common supply water header. The sensor should be located in a straight section of pipe, at least 5 pipe diameters from an elbow or tee to insure proper temperature sensing.

Several thermistor wells are available. All have 1/4” NPT fittings for securing the well in the piping. An appropriate fitting must be supplied for the fitting. Select a location that will allow for removal of the thermistor without any restrictions.

Well Part Number	“A” Dimension, in. (mm)	“B” Dimension, in. (mm)
10HB50106801	3.10 (78.7)	1.55 (39.4)
10HB50106802	4.10 (104.1)	1.28 (32.5)

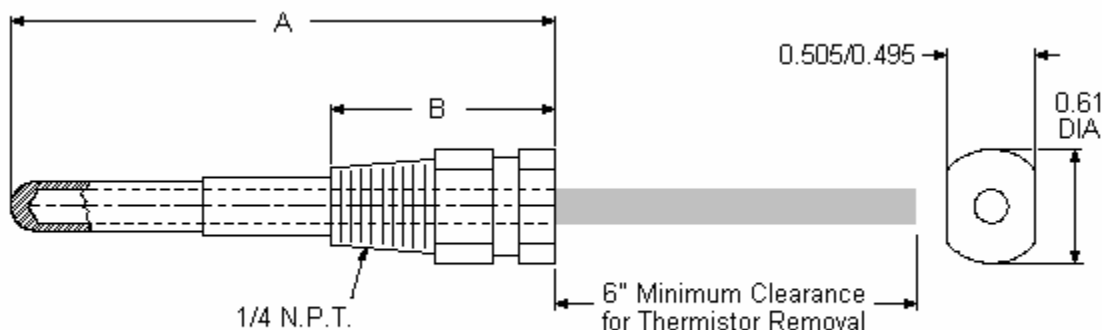

Figure 5 - Dual Leaving Water Thermistor Well

The thermistor should be inserted into the well with a small amount of Heat Sink Compound, 38AQ680001 (Dow Corning #340, or General Electric #641).

Once the well is inserted and the thermistor is in place, it is recommended that a thermistor wire loop be made and secured with a wire tie at the collar of the thermistor well. This will aid in thermistor retention in the well.

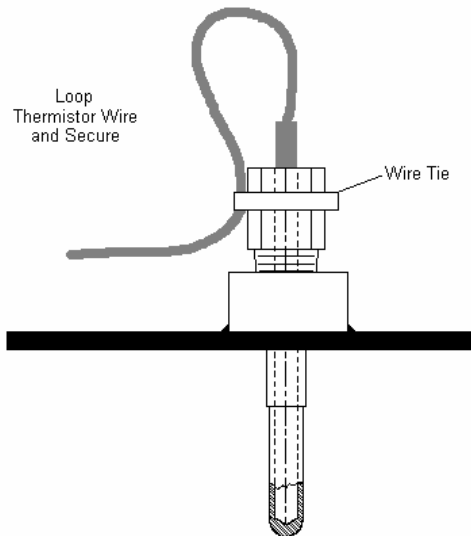

Figure 6 - Dual Leaving Water Thermistor

Units with dual pumps installed in dual chiller applications produced with Version 3.0 software or earlier, will experience lag chiller second pump cycling while the machine is off. If this condition is encountered, upgrade the software.

For machines in parallel flow without the benefit of isolation valves or machines installed in series, Cooler Pump Control enabled will cause nuisance alarms on the off chiller when it starts. To correct this situation, change the Chilled Water Pump Relay to a Double-Pole, Single Throw, normally open relay. One relay contact should be used to control the Chilled Water Pump and the other should be added in series with the Chilled Water Pump Interlock to open the circuit when the machine is to be off.

Energy Management Module (EMM)

The Energy Management Module (EMM) is available as a factory-installed option or as a field-installed accessory. The EMM module receives 4 to 20 mA inputs for the leaving fluid temperature reset, cooling set point and demand limit functions. The EMM module also receives the switch inputs for the field-installed 2-stage demand limit and ice done functions. All connections are made to a terminal block, TB6. The EMM module communicates the status of all inputs with the Main Base Board (MBB), and the MBB adjusts the control point, capacity limit, and other functions according to the inputs received.

The original TB6 label incorrectly depicted the 4-20 mA connection points. The wiring diagram and literature is correct. The label, 30RA500099 Rev. 3.0 is correct and is shown below.

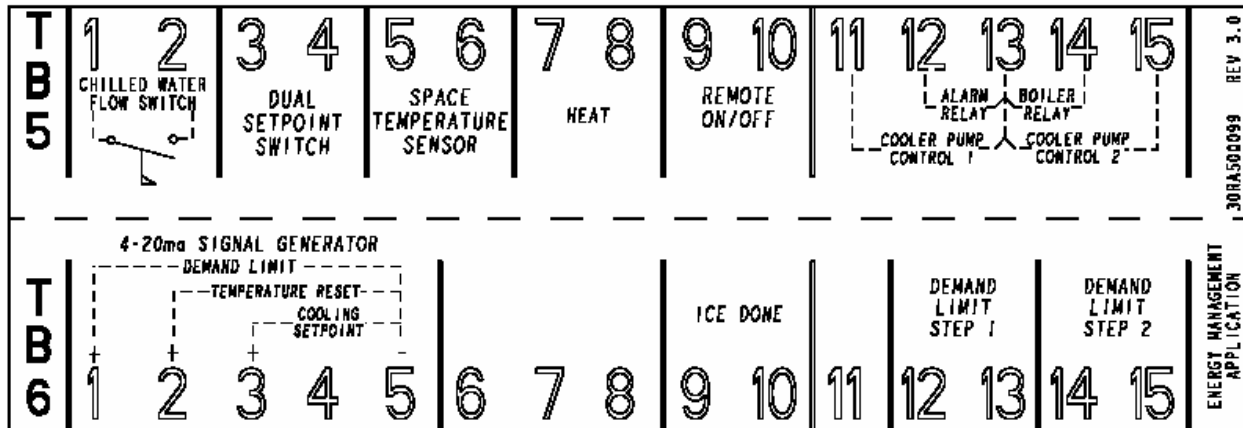

Figure 7 - TB5 & TB6 Terminal Designation

Factory Default Configuration

The following tables show the factory default settings for AquaSnap ComfortLink Controls.

Not for Distribution

30RA AquaSnap Chiller Service Manual

Mode	Sub-Mode	Item	Factory Default Settings					
			30RAN010-60 HZ	30RAN015-60 HZ	30RAN018-60 HZ	30RAN022-60 HZ	30RAN025-60 HZ	30RAN030-60 HZ
Set Point	COOL	CSP.1	44.0 (6.6)	44.0 (6.6)	44.0 (6.6)	44.0 (6.6)	44.0 (6.6)	44.0 (6.6)
		CSP.2	44.0 (6.6)	44.0 (6.6)	44.0 (6.6)	44.0 (6.6)	44.0 (6.6)	44.0 (6.6)
		CSP.3	32.0 (0.0)	32.0 (0.0)	32.0 (0.0)	32.0 (0.0)	32.0 (0.0)	32.0 (0.0)
	HEAD	HD.P.A	113.0 (45.0)	113.0 (45.0)	113.0 (45.0)	113.0 (45.0)	113.0 (45.0)	113.0 (45.0)
		HD.P.B	113.0 (45.0)	113.0 (45.0)	113.0 (45.0)	113.0 (45.0)	113.0 (45.0)	113.0 (45.0)
	FRZ	BR.FZ	34.0 (1.1)	34.0 (1.1)	34.0 (1.1)	34.0 (1.1)	34.0 (1.1)	34.0 (1.1)
Configuration	DISP	TEST	OFF	OFF	OFF	OFF	OFF	OFF
		METR	OFF	OFF	OFF	OFF	OFF	OFF
		LANG	0	0	0	0	0	0
		PAS.E	ENBL	ENBL	ENBL	ENBL	ENBL	ENBL
		PASS	1111	1111	1111	1111	1111	1111
	UNIT	SZA.1	10	15	9	9	13	15
		SZA.2	0	0	9	13	13	15
		SZB.1	0	0	0	0	0	0
		SZB.2	0	0	0	0	0	0
		SH.SP	15 (8.3)	15 (8.3)	15 (8.3)	15 (8.3)	15 (8.3)	15 (8.3)
		REFG	1	1	1	1	1	1
		FAN.S	1	1	1	2	2	2
		FLUD	1	1	1	1	1	1
	OPT1	MLV.S †	NO	NO	NO	NO	NO	NO
		MMR.S †	NO	NO	NO	NO	NO	NO
		RG.EN	DSBL	DSBL	DSBL	DSBL	DSBL	DSBL
		CPC	ON	ON	ON	ON	ON	ON
		PM1E †	NO	NO	NO	NO	NO	NO
		PM2E †	NO	NO	NO	NO	NO	NO
		PM.P.S	NO	NO	NO	NO	NO	NO
		PM.SL	0	0	0	0	0	0
		PM.DY	1	1	1	1	1	1
		PM.DT	500	500	500	500	500	500
ROT.P	NO	NO	NO	NO	NO	NO		
EMM †	NO	NO	NO	NO	NO	NO		

30RA AquaSnap Chiller Service Manual

Mode	Sub-Mode	Item	Factory Default Settings					
			30RAN010-60 Hz	30RAN015-60 Hz	30RAN018-60 Hz	30RAN022-60 Hz	30RAN025-60 Hz	30RAN030-60 Hz
Configuration	OPT2	CTRL	0	0	0	0	0	0
		CCNA	1	1	1	1	1	1
		CCNB	0	0	0	0	0	0
		BAUD	3	3	3	3	3	3
		LOAD	1	1	1	1	1	1
		LLCS	1	1	1	1	1	1
		LCWT	60 (15.6)	60 (15.6)	60 (15.6)	60 (15.6)	60 (15.6)	60 (15.6)
		DELY	0	0	0	0	0	0
		ICE.M	DSBL	DSBL	DSBL	DSBL	DSBL	DSBL
		CLS.C	DSBL	DSBL	DSBL	DSBL	DSBL	DSBL
		LS.MD	1	1	1	1	1	1
		LS.ST	0:00	0:00	0:00	0:00	0:00	0:00
		LS.ND	0:00	0:00	0:00	0:00	0:00	0:00
		LS.LT	100	100	100	100	100	100
	CRST	0	0	0	0	0	0	
	MA.DG	0.0 (0.0)	0.0 (0.0)	0.0 (0.0)	0.0 (0.0)	0.0 (0.0)	0.0 (0.0)	
	RM.NO	125.0 (51.7)	125.0 (51.7)	125.0 (51.7)	125.0 (51.7)	125.0 (51.7)	125.0 (51.7)	
	RM.F	0.0 (-17.8)	0.0 (-17.8)	0.0 (-17.8)	0.0 (-17.8)	0.0 (-17.8)	0.0 (-17.8)	
	RM.DG	0.0 (0.0)	0.0 (0.0)	0.0 (0.0)	0.0 (0.0)	0.0 (0.0)	0.0 (0.0)	
	RT.NO	10.0 (5.6)	10.0 (5.6)	10.0 (5.6)	10.0 (5.6)	10.0 (5.6)	10.0 (5.6)	
	RT.F	0.0 (0.0)	0.0 (0.0)	0.0 (0.0)	0.0 (0.0)	0.0 (0.0)	0.0 (0.0)	
	RT.DG	0.0 (0.0)	0.0 (0.0)	0.0 (0.0)	0.0 (0.0)	0.0 (0.0)	0.0 (0.0)	
	DMDC	0	0	0	0	0	0	
	DM20	100	100	100	100	100	100	
	SHNM	0	0	0	0	0	0	
	SHDL	0	0	0	0	0	0	
	SHTM	60	60	60	60	60	60	
	DLS1	80	80	80	80	80	80	
	DLS2	50	50	50	50	50	50	
	LLEN	DSBL	DSBL	DSBL	DSBL	DSBL	DSBL	
	MSSL	MAST	MAST	MAST	MAST	MAST	MAST	
	SLVA	2	2	2	2	2	2	
	LLBL	0	0	0	0	0	0	
	LLBD	168	168	168	168	168	168	
	LLDY	5	5	5	5	5	5	
	PARA	YES	YES	YES	YES	YES	YES	
	CLSP	0	0	0	0	0	0	
	RL.S	ENBL	ENBL	ENBL	ENBL	ENBL	ENBL	
	CRMP	1.0 (0.6)	1.0 (0.6)	1.0 (0.6)	1.0 (0.6)	1.0 (0.6)	1.0 (0.6)	
	SCHD	1	1	1	1	1	1	
	Z.GN	2.0	2.0	2.0	2.0	2.0	2.0	
		RSET						
		SLCT						

30RA AquaSnap Chiller Service Manual

Mode	Sub-Mode	Item	Factory Default Settings					
			30RAN010-60 HZ	30RAN015-60 HZ	30RAN018-60 HZ	30RAN022-60 HZ	30RAN025-60 HZ	30RAN030-60 HZ
Configuration	SERV	EN.A1	ENBL	ENBL	ENBL	ENBL	ENBL	ENBL
		EN.A2	DSBL	DSBL	ENBL	ENBL	ENBL	ENBL
		EN.B1	DSBL	DSBL	DSBL	DSBL	DSBL	DSBL
		EN.B2	DSBL	DSBL	DSBL	DSBL	DSBL	DSBL

Note: † - Indicates this value may be different depending upon Factory Installed Option or Field Installed Accessories.
 () - Values in () are in °C.

Not for Distribution

30RA AquaSnap Chiller Service Manual

Mode	Sub-Mode	Item	Factory Default Settings				
			30RAN035-60 HZ	30RAN040-60 HZ	30RAN045-60 HZ	30RAN050-60 HZ	30RAN055-60 HZ
Set Point	COOL	CSP.1	44.0 (6.6)	44.0 (6.6)	44.0 (6.6)	44.0 (6.6)	44.0 (6.6)
		CSP.2	44.0 (6.6)	44.0 (6.6)	44.0 (6.6)	44.0 (6.6)	44.0 (6.6)
		CSP.3	32.0 (0.0)	32.0 (0.0)	32.0 (0.0)	32.0 (0.0)	32.0 (0.0)
	HEAD	HD.P.A	113.0 (45.0)	113.0 (45.0)	113.0 (45.0)	113.0 (45.0)	113.0 (45.0)
		HD.P.B	113.0 (45.0)	113.0 (45.0)	113.0 (45.0)	113.0 (45.0)	113.0 (45.0)
	FRZ	BR.FZ	34.0 (1.1)	34.0 (1.1)	34.0 (1.1)	34.0 (1.1)	34.0 (1.1)
Configuration	DISP	TEST	OFF	OFF	OFF	OFF	OFF
		METR	OFF	OFF	OFF	OFF	OFF
		LANG	0	0	0	0	0
		PAS.E	ENBL	ENBL	ENBL	ENBL	ENBL
		PASS	1111	1111	1111	1111	1111
	UNIT	SZA.1	9	13	10	13	15
		SZA.2	13	13	13	13	15
		SZB.1	15	15	10	13	15
		SZB.2	0	0	13	13	15
		SH.SP	15 (8.3)	15 (8.3)	15 (8.3)	15 (8.3)	15 (8.3)
		REFG	1	1	1	1	1
		FAN.S	3	3	4	4	4
		FLUD	1	1	1	1	1
	OPT1	MLV.S †	NO	NO	NO	NO	NO
		MMR.S †	NO	NO	NO	NO	NO
		RG.EN	DSBL	DSBL	DSBL	DSBL	DSBL
		CPC	ON	ON	ON	ON	ON
		PM1E †	NO	NO	NO	NO	NO
		PM2E †	NO	NO	NO	NO	NO
		PM.P.S	NO	NO	NO	NO	NO
		PM.SL	0	0	0	0	0
		PM.DY	1	1	1	1	1
		PM.DT	500	500	500	500	500
ROT.P	NO	NO	NO	NO	NO		
EMM †	NO	NO	NO	NO	NO		

30RA AquaSnap Chiller Service Manual

Mode	Sub-Mode	Item	Factory Default Settings				
			30RAN035-60 Hz	30RAN040-60 Hz	30RAN045-60 Hz	30RAN050-60 Hz	30RAN055-60 Hz
Configuration	OPT2	CTRL	0	0	0	0	0
		CCNA	1	1	1	1	1
		CCNB	0	0	0	0	0
		BAUD	3	3	3	3	3
		LOAD	1	1	1	1	1
		LLCS	1	1	1	1	1
		LCWT	60 (15.6)	60 (15.6)	60 (15.6)	60 (15.6)	60 (15.6)
		DELY	0	0	0	0	0
		ICE.M	DSBL	DSBL	DSBL	DSBL	DSBL
		CLS.C	DSBL	DSBL	DSBL	DSBL	DSBL
		LS.MD	1	1	1	1	1
		LS.ST	0:00	0:00	0:00	0:00	0:00
		LS.ND	0:00	0:00	0:00	0:00	0:00
		LS.LT	100	100	100	100	100
	CRST	0	0	0	0	0	
	MA.DG	0.0 (0.0)	0.0 (0.0)	0.0 (0.0)	0.0 (0.0)	0.0 (0.0)	
	RM.NO	125.0 (51.7)	125.0 (51.7)	125.0 (51.7)	125.0 (51.7)	125.0 (51.7)	
	RM.F	0.0 (-17.8)	0.0 (-17.8)	0.0 (-17.8)	0.0 (-17.8)	0.0 (-17.8)	
	RM.DG	0.0 (0.0)	0.0 (0.0)	0.0 (0.0)	0.0 (0.0)	0.0 (0.0)	
	RT.NO	10.0 (5.6)	10.0 (5.6)	10.0 (5.6)	10.0 (5.6)	10.0 (5.6)	
	RT.F	0.0 (0.0)	0.0 (0.0)	0.0 (0.0)	0.0 (0.0)	0.0 (0.0)	
	RT.DG	0.0 (0.0)	0.0 (0.0)	0.0 (0.0)	0.0 (0.0)	0.0 (0.0)	
	DMDC	0	0	0	0	0	
	DM20	100	100	100	100	100	
	SHNM	0	0	0	0	0	
	SHDL	0	0	0	0	0	
	SHTM	60	60	60	60	60	
	DLS1	80	80	80	80	80	
	DLS2	50	50	50	50	50	
	LLEN	DSBL	DSBL	DSBL	DSBL	DSBL	
	MSSL	MAST	MAST	MAST	MAST	MAST	
	SLVA	2	2	2	2	2	
	LLBL	0	0	0	0	0	
	LLBD	168	168	168	168	168	
	LLDY	5	5	5	5	5	
	PARA	YES	YES	YES	YES	YES	
	CLSP	0	0	0	0	0	
	RL.S	ENBL	ENBL	ENBL	ENBL	ENBL	
	CRMP	1.0 (0.6)	1.0 (0.6)	1.0 (0.6)	1.0 (0.6)	1.0 (0.6)	
	SCHD	1	1	1	1	1	
	Z.GN	2.0	2.0	2.0	2.0	2.0	

30RA AquaSnap Chiller Service Manual

Mode	Sub-Mode	Item	Factory Default Settings				
			30RAN035-60 HZ	30RAN040-60 HZ	30RAN045-60 HZ	30RAN050-60 HZ	30RAN055-60 HZ
Configuration	SERV	EN.A1	ENBL	ENBL	ENBL	ENBL	ENBL
		EN.A2	ENBL	ENBL	ENBL	ENBL	ENBL
		EN.B1	ENBL	ENBL	ENBL	ENBL	ENBL
		EN.B2	DSBL	DSBL	ENBL	ENBL	ENBL

Note: † - Indicates this value may be different depending upon Factory Installed Option or Field Installed Accessories.
 () - Values in () are in °C.

Not for Distribution

30RA AquaSnap Chiller Service Manual

Mode	Sub-Mode	Item	Factory Default Settings					
			30RAN010-50 Hz	30RAN015-50 Hz	30RAN018-50 Hz	30RAN022-50 Hz	30RAN025-50 Hz	30RAN032-50 Hz
Set Point	COOL	CSP.1	44.0 (6.6)	44.0 (6.6)	44.0 (6.6)	44.0 (6.6)	44.0 (6.6)	44.0 (6.6)
		CSP.2	44.0 (6.6)	44.0 (6.6)	44.0 (6.6)	44.0 (6.6)	44.0 (6.6)	44.0 (6.6)
		CSP.3	32.0 (0.0)	32.0 (0.0)	32.0 (0.0)	32.0 (0.0)	32.0 (0.0)	32.0 (0.0)
	HEAD	HD.P.A	113.0 (45.0)	113.0 (45.0)	113.0 (45.0)	113.0 (45.0)	113.0 (45.0)	113.0 (45.0)
		HD.P.B	113.0 (45.0)	113.0 (45.0)	113.0 (45.0)	113.0 (45.0)	113.0 (45.0)	113.0 (45.0)
	FRZ	BR.FZ	34.0 (1.1)	34.0 (1.1)	34.0 (1.1)	34.0 (1.1)	34.0 (1.1)	34.0 (1.1)
Configuration	DISP	TEST	OFF	OFF	OFF	OFF	OFF	OFF
		METR	OFF	OFF	OFF	OFF	OFF	OFF
		LANG	0	0	0	0	0	0
		PAS.E	ENBL	ENBL	ENBL	ENBL	ENBL	ENBL
		PASS	1111	1111	1111	1111	1111	1111
	UNIT	\$ZA.1	11	7	9	11	13	8
		\$ZA.2	0	7	9	11	13	11
		\$ZB.1	0	0	0	0	0	0
		\$ZB.2	0	0	0	0	0	0
		SH.SP	15 (8.3)	15 (8.3)	15 (8.3)	15 (8.3)	15 (8.3)	15 (8.3)
		REFG	1	1	1	1	1	1
		FAN.S	1	1	1	2	2	3
	OPT1	FLUD	1	1	1	1	1	1
		MLV.S †	NO	NO	NO	NO	NO	NO
		MMR.S †	NO	NO	NO	NO	NO	NO
		RG.EN	DSBL	DSBL	DSBL	DSBL	DSBL	DSBL
		CPC	ON	ON	ON	ON	ON	ON
		PM1E †	NO	NO	NO	NO	NO	NO
		PM2E †	NO	NO	NO	NO	NO	NO
		PM.P.S	NO	NO	NO	NO	NO	NO
		PM.SL	0	0	0	0	0	0
		PM.DY	1	1	1	1	1	1
		PM.DT	500	500	500	500	500	500
ROT.P	NO	NO	NO	NO	NO	NO		
EMM †	NO	NO	NO	NO	NO	NO		

30RA AquaSnap Chiller Service Manual

Mode	Sub-Mode	Item	Factory Default Settings						
			30RAN010-50 Hz	30RAN015-50 Hz	30RAN018-50 Hz	30RAN022-50 Hz	30RAN025-50 Hz	30RAN032-50 Hz	
Configuration	OPT2	CTRL	0	0	0	0	0	0	
		CCNA	1	1	1	1	1	1	
		CCNB	0	0	0	0	0	0	
		BAUD	3	3	3	3	3	3	
		LOAD	1	1	1	1	1	1	
		LLCS	1	1	1	1	1	1	
		LCWT	60 (15.6)	60 (15.6)	60 (15.6)	60 (15.6)	60 (15.6)	60 (15.6)	
		DELY	0	0	0	0	0	0	
		ICE.M	DSBL	DSBL	DSBL	DSBL	DSBL	DSBL	
		CLS.C	DSBL	DSBL	DSBL	DSBL	DSBL	DSBL	
		LS.MD	1	1	1	1	1	1	
		LS.ST	0:00	0:00	0:00	0:00	0:00	0:00	
		LS.ND	0:00	0:00	0:00	0:00	0:00	0:00	
		LS.LT	100	100	100	100	100	100	
	RSET	CRST	0	0	0	0	0	0	
		MA.DG	0.0 (0.0)	0.0 (0.0)	0.0 (0.0)	0.0 (0.0)	0.0 (0.0)	0.0 (0.0)	
		RM.NO	125.0 (51.7)	125.0 (51.7)	125.0 (51.7)	125.0 (51.7)	125.0 (51.7)	125.0 (51.7)	
		RM.F	0.0 (-17.8)	0.0 (-17.8)	0.0 (-17.8)	0.0 (-17.8)	0.0 (-17.8)	0.0 (-17.8)	
		RM.DG	0.0 (0.0)	0.0 (0.0)	0.0 (0.0)	0.0 (0.0)	0.0 (0.0)	0.0 (0.0)	
		RT.NO	10.0 (5.6)	10.0 (5.6)	10.0 (5.6)	10.0 (5.6)	10.0 (5.6)	10.0 (5.6)	
		RT.F	0.0 (0.0)	0.0 (0.0)	0.0 (0.0)	0.0 (0.0)	0.0 (0.0)	0.0 (0.0)	
		RT.DG	0.0 (0.0)	0.0 (0.0)	0.0 (0.0)	0.0 (0.0)	0.0 (0.0)	0.0 (0.0)	
		DMDC	0	0	0	0	0	0	
		DM20	100	100	100	100	100	100	
		SHNM	0	0	0	0	0	0	
		SHDL	0	0	0	0	0	0	
		SHTM	60	60	60	60	60	60	
		DLS1	80	80	80	80	80	80	
		DLS2	50	50	50	50	50	50	
		LLEN	DSBL	DSBL	DSBL	DSBL	DSBL	DSBL	
		MSSL	MAST	MAST	MAST	MAST	MAST	MAST	
		SLVA	2	2	2	2	2	2	
		LLBL	0	0	0	0	0	0	
		LLBD	168	168	168	168	168	168	
		LLDY	5	5	5	5	5	5	
		PARA	YES	YES	YES	YES	YES	YES	
		SLCT	CLSP	0	0	0	0	0	0
			RL.S	ENBL	ENBL	ENBL	ENBL	ENBL	ENBL
			CRMP	1.0 (0.6)	1.0 (0.6)	1.0 (0.6)	1.0 (0.6)	1.0 (0.6)	1.0 (0.6)
			SCHD	1	1	1	1	1	1
	Z.GN		2.0	2.0	2.0	2.0	2.0	2.0	

30RA AquaSnap Chiller Service Manual

Mode	Sub-Mode	Item	Factory Default Settings					
			30RAN010-50 HZ	30RAN015-50 HZ	30RAN018-50 HZ	30RAN022-50 HZ	30RAN025-50 HZ	30RAN032-50 HZ
Configuration	SERV	EN.A1	ENBL	ENBL	ENBL	ENBL	ENBL	ENBL
		EN.A2	DSBL	ENBL	ENBL	ENBL	ENBL	ENBL
		EN.B1	DSBL	DSBL	DSBL	DSBL	DSBL	DSBL
		EN.B2	DSBL	DSBL	DSBL	DSBL	DSBL	DSBL

Note: † - Indicates this value may be different depending upon Factory Installed Option or Field Installed Accessories.
 () - Values in () are in °C.

Not for Distribution

30RA AquaSnap Chiller Service Manual

Mode	Sub-Mode	Item	Factory Default Settings		
			30RAN035-50 Hz	30RAN042-50 Hz	30RAN045-50 Hz
Set Point	COOL	CSP.1	44.0 (6.6)	44.0 (6.6)	44.0 (6.6)
		CSP.2	44.0 (6.6)	44.0 (6.6)	44.0 (6.6)
		CSP.3	32.0 (0.0)	32.0 (0.0)	32.0 (0.0)
	HEAD	HD.P.A	113.0 (45.0)	113.0 (45.0)	113.0 (45.0)
		HD.P.B	113.0 (45.0)	113.0 (45.0)	113.0 (45.0)
	FRZ	BR.FZ	34.0 (1.1)	34.0 (1.1)	34.0 (1.1)
Configuration	DISP	TEST	OFF	OFF	OFF
		METR	OFF	OFF	OFF
		LANG	0	0	0
		PAS.E	ENBL	ENBL	ENBL
		PASS	1111	1111	1111
	UNIT	SZA.1	13	11	13
		SZA.2	13	11	13
		SZB.1	13	11	13
		SZB.2	0	11	13
		SH.SP	15 (8.3)	15 (8.3)	15 (8.3)
		REFG	1	1	1
		FAN.S	3	4	4
	OPT1	FLUD	1	1	1
		MLV.S †	NO	NO	NO
		MMR.S †	NO	NO	NO
		RG.EN	DSBL	DSBL	DSBL
		CPC	ON	ON	ON
		PM1E †	NO	NO	NO
		PM2E †	NO	NO	NO
		PM.P.S	NO	NO	NO
		PM.SL	0	0	0
		PM.DY	1	1	1
		PM.DT	500	500	500
ROT.P	NO	NO	NO		
EMM †	NO	NO	NO		

30RA AquaSnap Chiller Service Manual

Mode	Sub-Mode	Item	Factory Default Settings			
			30RAN035-50 Hz	30RAN042-50 Hz	30RAN045-50 Hz	
Configuration	OPT2	CTRL	0	0	0	
		CCNA	1	1	1	
		CCNB	0	0	0	
		BAUD	3	3	3	
		LOAD	1	1	1	
		LLCS	1	1	1	
		LCWT	60 (15.6)	60 (15.6)	60 (15.6)	
		DELY	0	0	0	
		ICE.M	DSBL	DSBL	DSBL	
		CLS.C	DSBL	DSBL	DSBL	
		LS.MD	1	1	1	
		LS.ST	0:00	0:00	0:00	
		LS.ND	0:00	0:00	0:00	
	LS.LT	100	100	100		
	RSET	CRST	0	0	0	
		MA.DG	0.0 (0.0)	0.0 (0.0)	0.0 (0.0)	
		RM.NO	125.0 (51.7)	125.0 (51.7)	125.0 (51.7)	
		RM.F	0.0 (-17.8)	0.0 (-17.8)	0.0 (-17.8)	
		RM.DG	0.0 (0.0)	0.0 (0.0)	0.0 (0.0)	
		RT.NO	10.0 (5.6)	10.0 (5.6)	10.0 (5.6)	
		RT.F	0.0 (0.0)	0.0 (0.0)	0.0 (0.0)	
		RT.DG	0.0 (0.0)	0.0 (0.0)	0.0 (0.0)	
		DMDC	0	0	0	
		DM20	100	100	100	
		SHNM	0	0	0	
		SHDL	0	0	0	
		SHTM	60	60	60	
		DLS1	80	80	80	
		DLS2	50	50	50	
		LLEN	DSBL	DSBL	DSBL	
		MSSL	MAST	MAST	MAST	
		SLVA	2	2	2	
		LLBL	0	0	0	
		LLBD	168	168	168	
		LLDY	5	5	5	
		PARA	YES	YES	YES	
		SLCT	CLSP	0	0	0
			RL.S	ENBL	ENBL	ENBL
			CRMP	1.0 (0.6)	1.0 (0.6)	1.0 (0.6)
			SCHD	1	1	1
Z.GN			2.0	2.0	2.0	

Mode	Sub-Mode	Item	Factory Default Settings		
			30RAN035-50 Hz	30RAN042-50 Hz	30RAN045-50 Hz
Configuration	SERV	EN.A1	ENBL	ENBL	ENBL
		EN.A2	ENBL	ENBL	ENBL
		EN.B1	ENBL	ENBL	ENBL
		EN.B2	DSBL	ENBL	ENBL

Note: † - Indicates this value may be different depending upon Factory Installed Option or Field Installed Accessories.
 () - Values in () are in °C.

Heater Control (Cooler, Pump, Storage Tank)

A contactor energized by the control system based on the Outdoor Air Thermistor (OAT) controls all heaters. The same output from the Main Base Board signals the Cooler Heater Contactor, which controls the cooler and pump heaters if equipped and a Storage Tank Relay (TNK R) for the Storage Tank Heaters.

The heater will be energized if any of the following conditions are met:

- The machine's capacity is 0%, the Leaving Water Temperature is less than 50 °F (10.0 °C), and the Outdoor Air Temperature is at or below 36 °F (2.2 °C). If the Leaving Water Thermistor has failed, the Entering Water Temperature – 30 °F (16.7 °C) will be used in place of the Leaving Water Temperature value.
- If the Outdoor Air Thermistor has failed and the unit capacity is 0%.
- The Emergency ON-OFF switch is placed in the OFF position, the Cooler Heater Contactor (CHC) is energized as long as power is applied to the machine.

The heater will be de-energized if any of the following conditions are met:

- The machine's capacity is greater than 0%
- The Outdoor Air Temperature is at or above 40 °F (4.4 °C)
- The Leaving Water Temperature is greater than 100 °F (37.8 °C). If the Leaving Water Thermistor has failed, the Entering Water Temperature – 30 °F (16.7 °C) will be used in place of the Leaving Water Temperature value.

Heat Operation

The Heat Operation control algorithm is standard on all AquaSnap machines and requires an input from an external source. This algorithm allows for pump operation while disabling mechanical cooling.

The machine must be “Enabled”, either by the Remote Contact-Off-Enable switch in the “Enable” position or in the “Remote Contact” position with the remote contacts closed. This function requires a Heat Relay (HR). The Heat Relay (HR) should be a SPST relay rated for dry circuit applications capable of handling a 24 vac load up to 50 mA. The relay contacts should be wired to TB5-7 and TB5-8.

When the Heat Relay is energized and the contacts close, mechanical cooling is locked out and the chilled water pump will start. Water circulating through the cooler should not exceed 100 °F (37.8 °C). This limit is imposed because of a temperature limit on the Hydronic Package Expansion Tank. Additionally, if the compressor were to start with this water temperature, it would operate outside of its operational envelope. Provisions must be made to disable the Heat Relay if the water temperature reaches this limit.

Low Sound Mode

AquaSnap has the option to reduce the sound level during operation. All models were originally factory configured with the Low Sound Mode enabled. Machines with serial numbers starting with ??02F have the Low Sound Mode disabled due to nuisance T051-T056 alerts.

Items for the low sound mode, LS.MD, *Low Sound Mode Select* (Configuration Mode, Sub-mode OPT2), LS.ST, *Low Sound Start Time* (Configuration Mode, Sub-mode OPT2), LS.ND, *Low Sound End Time* (Configuration Mode, Sub-mode OPT2) and LS.LT *Low Sound Capacity Limit* (Configuration Mode, Sub-mode OPT2) are factory configured so that the chiller always runs as quietly as possible. This results in operation at increased saturated condensing temperature. As a result, some models may not be able to achieve rated efficiency. For chiller operation at rated efficiency, disable the low sound mode or adjust the low sound mode start and stop times accordingly or set both times to 00:00 for rated efficiency operation 24 hours per day. In addition, the low sound capacity limit can be used to reduce overall chiller capacity, if required, by limiting the capacity to a user-configured percentage.

Use care in selecting the LS.LT *Low Sound Capacity Limit*. There is a +/-15% tolerance to the selection. If the machine is running at a capacity of 15% greater than LS.LT, a stage is removed. If the machine is running at a capacity of 15% less than LS.LT, a stage is removed. If the value selected for LS.LT *Low Sound Capacity Limit* is between capacity stages, the compressors will cycle. In the example below, a 2-compressor machine without Minimum Load Control has been configured for Low Sound Mode Operation with LS.LT set at various levels with the results shown to the side.

LS.LT	Capacity Range		Comment
	-15%	+15%	
75%	90%	60%	Cycles between Capacity Stage 1 (50%) and 2 (100%)
50%	65%	35%	No cycling, limited to Capacity Stage 1 (50%)
25%	40%	10%	Cycles between Capacity Stage 0 (0%) and 1 (50%)

Operation with this option enabled, activates MD25 – Low Sound Mode. If capacity reduction is also allowed, MD15 – Demand/Sound Limited will be active.

Minimum Load Control

A metering solenoid valve that acts as an orifice accomplishes Minimum Load Control for the AquaSnap Machines. Minimum Load Control alters the first stage of capacity by energizing the Minimum Load Valve Relay. Once the control requires more capacity, the Minimum Load Valve relay is de-energized and normal capacity staging resumes. For this feature to be active, the following items must be configured: MLV.S *Minimum Load Valve Select* (Configuration Mode, Sub-mode OPT1) set for YES

Operating Modes

ComfortLink controls provide information about capacity control overrides as indicated by Operating Modes.

MD01 – FSM Controlling Chiller

This operating mode indicates that a Flotronic System Manager (FSM) is configured to be in charge of loading the chiller and the controller is responding to these commands. If the FSM stops communicating with the chiller, then the mode is disabled and the chiller will operate as a stand-alone chiller.

The unit's capacity may be reduced while this mode is in effect.

MD02 – WSM Controlling Chiller

This operating mode indicates that a Water System Manager (WSM) is configured to be in charge of loading the chiller and the controller is responding to these commands. If the WSM stops communicating with the chiller, then the mode is disabled and the chiller will operate as a stand-alone chiller.

The unit's capacity may be reduced while this mode is in effect.

MD03 – Master/Slave Control

This operating mode indicates that the local dual chiller algorithm is controlling the chiller. The Master chiller will display this mode at all times, regardless of occupancy. The Slave chiller will display this mode only when the machine is in an occupied period only.

MD05 – Ramp Load Limited

This operating mode indicates that the unit's capacity is being limited by Ramp Loading. At least one stage must be on and *RL.S Ramp Load Select* (Configuration Mode, Sub-mode SLCT) must be ENBL, for this mode to be in effect. If the Leaving Water Temperature is more than 4 °F (2.2 °C) above the *CTPT Control Point* (Run Status Mode, Sub-mode VIEW), and the negative rate of change of LWT is less than CRMP (Configuration Mode, Sub-mode SLCT), no additional stages of capacity will be added.

In the following example, the Ramp Load function is enabled, Cooling Ramp Loading is set for 1.0 °F/minute (0.5 °C/minute), and the Set Point is 44 °F (6.6 °C). At the start of the first stage of capacity, the Leaving Water Temperature is 54 °F (12.2 °C) and 30 seconds later the leaving water temperature is 53.8 °F (12.1 °C). The negative rate of change is 0.4 °F/minute (0.2 °C/minute). In this example, the operating mode will be in effect, and no further stages will be added.

The unit's capacity may be reduced while this mode is in effect.

MD06 – Timed Override In Effect

The operating mode indicates that a Carrier Comfort Network device, such as Building Supervisor or ComfortWorks has initiated a schedule override for a specified period of time. Timed Override cannot be accessed through the Navigator.

MD07 – Low Cooler Suction TempA

MD08 – Low Cooler Suction TempB

This operating mode is a cooler freeze protection control mode.

Before this mode can be enabled, at least one compressor must be on, and the Saturated Suction Temperature is not increasing greater than 1.1 °F (0.6 °C) in 10 seconds. There are 2 criteria that will trigger this operating mode.

1. If the saturated suction temperature is less than the BR.FZ, *Brine Freeze Point*, (Set Point mode, sub-mode FRZ) minus 3 °F (1.7 °C) and also less than the leaving fluid temperature minus 14 °F (7.8 °C).
2. If the saturated suction temperature is less than BR.FZ, *Brine Freeze Point*, (Set Point mode, sub-mode FRZ) minus 14 °F, (7.8 °C).

The controller will attempt to correct the problem for either criterion by initiating Mode 7 – Low Suction TempA for Circuit A or Mode 8 – Low Suction TempB for Circuit B.

If Criteria 1 is the trigger and the condition has existed for 2 minutes, a stage of capacity will be removed from the circuit. Additional stages of capacity will be removed every 2 minutes while the condition exists.

If Criteria 2 is the trigger, and the condition has existed for 90 seconds, a stage of capacity will be removed from the circuit. Additional stages of capacity will be removed every 90 seconds while the condition exists.

If capacity stages are reduced six times without a 30 minute interval between reductions, the corresponding T116/T117 Circuit A/B Low Cooler Suction Temperature Alert will be generated.

The unit's capacity may be reduced while this mode is in effect.

MD09 – Slow Change Override

This operating mode prohibits the control from adding a capacity stage needlessly. If the Leaving Water Temperature is near the CTPT *Control Point* (Run Status Mode, Sub-mode VIEW), and is not moving rapidly away from the Control Point. This mode will be active and will prohibit the controller from adding a stage needlessly. For instance, if EWT/LWT = 50/44.2, and the Control Point is 44, and the LWT is not changing, then the integrator would eventually call for another stage to be added. Slow change override keeps it off.

MD10 – Minimum Off Time Active

This operating mode indicates that the unit start has been delayed by a configured time period, DELY *Minutes Off Time* (Configuration Mode, Sub-mode OPT2).

MD13 – Dual Setpoint

This operating mode is displayed if the control is configured and operating at a set point other than single set point control, CLSP *Cooling Setpoint Select* (Configuration Mode, Sub-mode SLCT).

The unit's capacity may be reduced while this mode is in effect.

MD14 – Temperature Reset

This operating mode indicates that the unit's capacity will be reduced due to chilled water temperature reset, either by return water, Outdoor Air, Space Temperature or from a temperature reset command from an external building automation system.

The unit's capacity may be reduced while this mode is in effect.

MD15 – Demand/Sound Limited

This operating mode indicates that the unit's capacity will be reduced due to a demand limit command from an external building automation system, or during low sound mode.

The unit's capacity may be reduced while this mode is in effect.

MD16 – Cooler Freeze Protection

This operating mode occurs prior to an A207 – Cooler Freeze Protection Alarm. This mode is active when the leaving water temperature is at or below BR.FZ, *Brine Freeze Point* (Set Point Mode, Sub-mode FRZ) + 2 °F (1.1 °C). While operating in this mode, the Chilled Water Pump relay will be energized, even if the CPC *Cooler Pump Control* (Configuration Mode, Sub-mode OPT1) is OFF and a stage of capacity will be removed. No additional stages of capacity will be removed or added for 30 seconds. The mode will be deactivated, if the leaving water temperature rises to BR.FZ, *Brine Freeze Point* (Set Point Mode, Sub-mode FRZ) + 2 °F (1.1 °C).

While operating in this mode, the unit's capacity may be reduced.

MD17 – Low Temperature Cooling

MD18 – High Temperature Cooling

This operating mode will be displayed if the Leaving Water Temperature is above the set point and is moving away from the set point rapidly. If this condition is detected, the control will add a stage of capacity.

MD19 – Making Ice

This operating mode indicates that the machine is in the ice building mode. The unit is configured to make ice, ICE.M *Ice Mode Enable* (Configuration Mode, Sub-mode OPT2) set to YES, the unoccupied cooling set point is in effect and the Ice Done Switch is open. When this mode is in effect, CSP3 *Cooling Setpoint 3* (Set Point Mode, Sub Mode COOL), the Ice Making Set Point is in effect.

MD20 – Storing Ice

This operating mode indicates that the machine is in the ice storing mode. The unit is configured to make ice, ICE.M *Ice Mode Enable* (Configuration Mode, Sub-mode OPT2) set to YES, the unoccupied cooling set point is in effect and the Ice Done Switch is closed. When this mode is active, CSP2 *Cooling Setpoint 2* (Set Point Mode, Sub-mode COOL) is in effect.

MD21 – High SCT Circuit A

MD22 – High SCT Circuit B

MD23 – Minimum Comp On Time

MD24 – Pump Off Time Delay

MD25 – Low Sound Mode

This operating mode will be displayed anytime the Low Sound Mode is active. During operation with this mode, the unit's capacity may be affected.

This mode will be active if, *LS.MD Low Sound Mode*, (Configuration Mode, Sub-mode OPT2) is set to 1 (Fan Noise Only) or 2 (Fan/Compressor Noise), and the current time is between the *LS.ST Low Sound Start Time* (Configuration Mode, Sub-mode OPT2) and *LS.ND Low Sound End Time* (Configuration Mode, Sub-mode OPT2). If *LS.MD Low Sound Mode* is set to 2 (Fan/Compressor Noise), *LS.LT Low Sound Capacity Limit* (Configuration Mode, Sub-mode OPT2) must also be set.

With *LS.MD Low Sound Mode*, is set to 1 (Fan Noise Only), and the current time between the *LS.ST Low Sound Start Time* and *LS.ND Low Sound End Time*, the control will adjust the fan on point up and off point down based on the system conditions to keep the fan operating at the lowest speed possible for noise reduction and still keep the machine within its normal operating limits. This is the only option that can be applied to the single compressor machines, 30RAN010 and 30RAN015 (60 Hz) without Minimum Load Control. The unit's capacity and efficiency may be affected by this routine due to the possibility of a higher condensing temperature.

With *LS.MD Low Sound Mode*, is set to 2 (Fan/Compressor Noise), and the current time between the *LS.ST Low Sound Start Time* and *LS.ND Low Sound End Time*, both fan noise and compressor noise will be reduced. Fan noise will be reduced as described above. Compressor noise will be reduced by demand limiting the compressor by the amount specified in *LS.LT Low Sound Capacity Limit*. This option cannot be applied to the single compressor machines, 30RAN010 and 30RAN015 (60 Hz) without Minimum Load Control. The unit's capacity and efficiency may be affected by this routine due to the possibility of a higher condensing temperature.

MD26 – Short Loop Override

This mode will be displayed when the machine is being held off to limit the number of compressor starts. The control tracks the number of starts of the compressors to maintain the desired leaving water temperature. The number of starts will be limited to ensure proper oil return and prevent premature compressor failures. If this mode is encountered, check the chilled water loop for adequate volume. Low loop volume contributes to compressor cycling. Check the chilled water loop load. Low load conditions, below the minimum capacity stage will result in compressor cycling.

The algorithm is as follows:

The mode will be on if,

Stage = 0, and $SAG_{MINUS} > 1$

or

Stage = 1, $SAG_{PLUS} > 1$, $LWT < \text{Set Point}$, and $\text{Run Time} < 450$ seconds.

Where,

LWT – Leaving Water Temperature

SAG - Self Adjusting Gain

SAG (Self Adjusting Gain) is a calculated value. There are two SAG values, SAG_{MINUS} and SAG_{PLUS} for each compressor. Values for each compressor could be different due to the compressor capacity and the load of the system. The default value for both is 1.0 and adjusts the run time similar to that caused by the *Z.GN Deadband Multiplier* (Configuration Mode, Sub-mode SLCT). The SAG values are multiplied with the Z.GN factor to determine the staging during the first 5 minutes of operation of the circuit as long as the machine is not in an override condition and is ignored if the circuit alarms. If the stage increases to 2, the mode is disabled.

The SAG values change by the following formula:

$$SAG = \frac{300 \text{ (sec)}}{\text{Run Time (sec)}} \times SAG_i$$

Where,

SAG – Self Adjusting Gain

SAG_i – Self Adjusting Gain initial value

Each SAG (SAG_{MINUS} and SAG_{PLUS}) value is calculated after every start-to-stop sequence. The SAG_{MINUS} is used to start the circuit. SAG_{PLUS} is used to stop the circuit. The SAG_{PLUS} will be limited so as not to allow the water temperature to drop to a freeze condition.

This algorithm is to protect the compressor. Reports of very warm water temperatures and the machine in Mode 26 have been received. To start the machine, increase the *Z.GN Deadband Multiplier* (Configuration Mode, Sub-Mode SLCT).

This mode can be disabled with Network Service Tool only. Under OPTIONS2 Table is an item, "Enable Short Loop Gain". The factory default is "Enable". Changing the value to "Disable" will disable this algorithm.

Remote Alarm Relay

AquaSnap machines have the ability to signal a remote alarm contact in the event an alarm/alert condition is encountered. If desired, the Remote Alarm Relay ALM-R must

be installed and connected between TB5-12 and TB5-13. The relay should have a 24 vac coil voltage and a maximum coil ratings of: 5 va sealed, 10 va inrush.

The early versions of the Product Data (30RA-1PD, 30RA-2PD, and 30RA-3PD), Submittal Bulletin (30RA-1SB), Installation Instructions (30RA-1SI and 30RA-12SI), and the Controls and Troubleshooting (30RA-1T and 30RA-2T) incorrectly listed the 30RAN032-055 Alarm Relay requirements as 115 VAC, 75 va sealed and 360 va inrush.

Remote Cooler Application

The AquaSnap Chiller cooler can be remotely mounted. A separation limit of 50 feet (15.2 m) and no more than 15 feet (4.6 m) over the chiller is recommended. Since the cooler is located in an area that is difficult to reach, if this option is to be used, all modifications should be done by the factory as part of a Special Order Quote Control. The Hydronic Package is not available with this option.

Unit	Hz	Circuit A/B Split	Circuit Information			
			Without Hot Gas Bypass Minimum Capacity		With Hot Gas Bypass Minimum Capacity	
			Circuit A	Circuit B	Circuit A	Circuit B
30RA010	60	N/A	100%	N/A	69%	N/A
30RA010	50	N/A	100%	N/A	71%	N/A
30RA015	60	N/A	100%	N/A	79%	N/A
30RA015	50	N/A	50%	N/A	28%	N/A
30RA018	60	N/A	50%	N/A	32%	N/A
30RA018	50	N/A	50%	N/A	31%	N/A
30RA022	60	N/A	42%	N/A	27%	N/A
30RA022	50	N/A	50%	N/A	35%	N/A
30RA025	60	N/A	50%	N/A	38%	N/A
30RA025	50	N/A	50%	N/A	37%	N/A
30RA030	60	N/A	50%	N/A	39%	N/A
30RA032	50	59.8/40.2	42%	100%	25%	75%
30RA035	60	59.8/40.2	42%	100%	27%	79%
30RA035	50	66.7/33.3	50%	100%	37%	75%
30RA040	60	63.4/36.6	50%	100%	38%	79%
30RA042	50	50/50	50%	50%	35%	35%
30RA045	60	50/50	44%	44%	30%	30%
30RA045	50	50/50	50%	50%	37%	37%
30RA050	60	50/50	50%	50%	38%	38%
30RA055	60	50/50	50%	50%	39%	39%

Software Revisions

There have been a number of software updates to the 30RAN software. Outlined below is a summary of the changes with their implementation date.

There have been several software improvements since the release of ComfortLink Version 1.0 for Aquasnap chillers. Outlined below is a synopsis of the changes.

Version 4.0 (CESR131279-04-00)

Serial Number Start: 4902F

- Corrected capacity staging on 4 compressor machines with Close Control and Minimum Load Control enabled. The machines would not load to full capacity.
- Minimum Load Valve capacity fixed at 3 tons for capacity calculation.
- Added SMZ *Load Factor* (Run Status Mode, Sub-mode VIEW) to default display.
- LD.PM *Lead Pump* (Run Status, Sub-mode VIEW) value expansion has been corrected to now display: 1 *PUMP 1*, 2 *PUMP 2*, or 3 *NO PUMP*.
- Improved Head Pressure Control Routine.
- Corrected text for circuit B nominal head pressure set point. It was listed as “Nominal HSPA”.
- Changed configuration logic to only allow compressor enabling EN.A1 *Enable Compressor A1*, EN.A2 *Enable Compressor A2*, EN.B1 *Enable Compressor B1*, or EN.B2 *Enable Compressor B2* (Configuration Mode, Sub-mode SERV) when the machine is in the OFF mode.
- Increase upper limit on STAT *Control Mode* (Run Status Mode, Sub-mode VIEW) point from 7 to 9 to account for “Heat Enabled” and “Pump Delay”.
- Added logic to check to be sure that the last fan stage is on before issuing a High Saturated Condensing Temperature Mode, MD21 High SCT Circuit A or MD22 High SCT Circuit B.
- Corrected Low Sound Mode fan set point adjustment to address nuisance high pressure trips.
- Corrected Dual Chiller routine to start the lag chiller when the lead chiller has failed.
- Correct Rotate Pump algorithm to allow for the rotation of the pumps. Pump changeover occurs whenever hours indicate need to change. Unit does not have to be at stage 0 for changeover. Pump changeover keeps both pumps on for 10 seconds, then only the “new” pump stays on.
- Correct Periodic Pump Start algorithm. ?
- Changed A189 - Cooler Pump and Aux Contact Input Alarm time criteria to 20 seconds from 10 seconds before declaring a pump miswire alarm. This allows for both pumps being on during automatic pump changeover. They are both on for 10 seconds.
- The lag chiller water pump now stays off if the chiller is commanded off by the master chiller.

Version 3.0 (CESR131279-03-00)

Serial Number Start: 0302F

- Corrected problem in version 2.0 with regenerating existing alarms on power up.
- Corrected problem with BEST access to points list. It will now read a numeric value instead of “*****”.
- Corrected problem with occasional Energy Management Module Loss of Communication failure.

- Corrected a problem where automatic reset alarms were not being put back into alarm history if the history was cleared, then power is cycled.
- Removed duplicate LS_LIMIT from RESETCO table. It should be only in the OPTIONS2 table.
- Corrected problem that if Pump 1 was down for an alarm and Pump 2 was running when the alarm for Pump 1 was cleared Pump 1 would restart and Pump 2 would shut down. Pump 2 now remains running.
- Corrected problem that High Saturated Suction Temperature alert was not detected unless Return Gas Temperature sensors were enabled.
- Mode 26 was added to indicate that short loop override is in effect.
- Corrected a problem that if a T077/T078 – Circuit A/B Saturated Suction Temperature Exceeds Cooler Leaving Fluid Temperature was generated, it automatically reset when the compressor shut off. Alert is now manual reset.
- Corrected problem that if circuit B has a low Saturated Suction Temperature condition the corrective action and Alert was generated for circuit A.
- Added LEADPUMP point to the A_UNIT display.
- Setting the service interval to 0 hours will now disable the PM alerts.
- Modified the FSM Loss of Communication message to indicate a “System Manager” Loss of Communication, not a specific system manager.
- System Manager forces are removed when a Loss of Communication error first occurs.
- Logic added to take the unit out of short loop override mode if it has been in that mode for at least 7.5 minutes (only affects capacity reduction from stage 1 to stage 0).
- Modified short loop override mode logic when reducing capacity from stage 1 to stage 0 and the compressor has been running for more than 7 minutes to always recalculate the short loop gain.
- Corrected problem with CSM control. If the chiller is removed from the active chillers list, but is still in the list of available chillers, the polling rate from the CSM to the chiller changes from 10 seconds to every minute. Currently the chiller generates a Loss of Communication error if the CSM doesn't communicate within 50 seconds. Increased Loss of Communication failure timeout to 5 minutes.
- Brine freeze point can now be lowered for all fluid types. Range is -20 to 34 °F (-28.9 to 1.1 °C).
- Broadcast configuration tables were added to standard display. Allows configuration of daylight savings time.
- Corrected problem with Z_GAIN setting.
- Corrected problem with sequence type override based on OAT. If the OAT is less than 32°F, then use staged loading. If the OAT is above 40°F, use the configured loading type. If the OAT is between 32°F and 40°F, then don't change the loading type.
- Modified pump control logic to delay looking at the chilled water flow switch for 15 seconds after the pump output is energized.
- Removed RHIS *Reset Alarm History* (Alarms Mode, Sub-mode RHIS). This option is no longer available

Version 2.0 (CESR131279-02-00)

Serial Number Start: 2801F

- Added mode 26 (self-adjusting gain in effect).
- First fan stage is brought on when a compressor starts
- High-speed fan is turned on when VFD (MotorMaster V) is in the system.
- Head pressure set point is adjusted by +15 degrees for 35 seconds after a fan stage is added. (Note that this really has no effect now, since there are only either 1 or 2 stages, and the first stage is always on when a compressor is on).

Version 1.0 (CESR131279-01-00)

Serial Number Start: 1801F

Original Software release.

Return Gas Sensor

The AquaSnap ComfortLink Controls have the ability to monitor suction superheat. A field installed accessory is required to enable this feature.

Part Number	Description	Order Quantity	
		30RAN010-032	30RAN035-055
--HH--79NZ-026	Thermistor, 5K Ohm	1	2

Earlier SalesPro, Price Pages and Product Ordering Data did not include this information.

This sensor is required for the superheat calculation and display. If the sensors are not installed and enabled, the SH.A *Suction Superheat Temp* (Temperature Mode, sub-mode CIR.A) and SH.B *Suction Superheat Temp* (Temperature Mode, sub-mode CIR.B) will read 0.0.

Thermistor wells are factory supplied with the machine. The thermistor must be installed in the well with a small amount of thermal conductive grease, 38AQ680001. The thermistor is connected to the control system via an insulation displacement connector at the Main Base Board (MBB). See Thermistors on page 134 for required tools.

Circuit A Return Gas Thermistor, T7 is connected to MBB-J8-1 and MBB-J8-2. Circuit B Return Gas Thermistor, T8 is connected to MBB-J8-3 and MBB-J8-4. In each case, the thermistor lead should be looped back on itself and secured to the well with a wire tie.

Configure the controller to accept the inputs by changing RG.EN *Return Gas Sensor Enable* (Configuration Mode, sub-mode OPT2) from DSBL to ENBL.

Space Temperature Sensor

This device is required for Space Temperature Reset. The device is a 10k Ohm thermistor. Several Options exist for this part number.

Part Number	Description
--HH--51BX-006	Sensor for Space Temperature – Wall Mount
33ZCT55SPT	Space Temperature Reset Thermistor – 10k Ohm with reset button

The thermistor must be connected to TB5-5 and TB5-6. This is the same connection used for the Master/Slave Dual Chiller Leaving Water Temperature Sensor.

Temperature Reset

ComfortLink offers several different control options for Temperature Reset. Return Water, 4-20 mA Input, Space or Outside Air Temperature, can control chilled Water Reset. Temperature Reset is programmed with the following variables:

Configuration Mode					
Sub-Mode	Keypad Entry	Item	Display	Item Expansion	Comment
RSET	[ENTER]	CRST	X	Cooling Reset Type	0=No Reset 1=4-20 mA Input 2=Outdoor Air Temperature 3=Return Fluid 4=Space Temperature
	[▼]	MA.DG	XX.X ΔF (XX.X ΔC)	4-20 Degrees Reset	Default: 0 °F (0 °C) Range: -30 to 30 °F (-16.7 to 16.7 °C)
	[▼]	RM.NO	XXX.X °F (XXX.X °C)	Remote – No Reset Temp	Default: 125 °F (51.7 °C) Range: 0 to 125 °F (-17.8 to 51.7 °C)
	[▼]	RM.F	XXX.X °F (XXX.X °C)	Remote – Full Reset Temp	Default: 0 °F (-17.8 °C) Range: 0 to 125 °F (-17.8 to 51.7 °C)
	[▼]	RM.DG	XX.X ΔF (XX.X ΔC)	Remote – Degrees Reset	Default: 0 °F (0 °C) Range: -30 to 30 °F (-16.7 to 16.7 °C)
	[▼]	RT.NO	XXX.X °F (XXX.X °C)	Return – No Reset Temp	Default: 125 °F (51.7 °C) Range: 0 to 125 °F (-17.8 to 51.7 °C)
	[▼]	RT.F	XXX.X °F (XXX.X °C)	Return – Full Reset Temp	Default: 0 °F (17.8 °C) Range: 0 to 125 °F (-17.8 to 51.7 °C)
	[▼]	RT.DG	XX.X ΔF (XX.X ΔC)	Return – Degrees Reset	Default: 0 °F (0 °C) Range: -30 to 30 °F (-16.7 to 16.7 °C)

Temperature Reset applies to CSP.1, *Cooling Set Point 1* (Set Point Mode, Sub-mode COOL) and CSP.2 *Cooling Set Point 2* (Set Point Mode, Sub-mode COOL) only. CSP.3 *Cooling Set Point 3* (Set Point Mode, Sub-mode COOL), the ice storage set point is not affected.

4-20 ma Temperature Reset

The Energy Management Module is required for this option. This option is designed for 4-20 ma input.

To program this option, CRST, *Cooling Reset Type* (Configuration Mode, Sub-mode RSET) and MA.DG, *4-20 Degrees Reset* (Configuration Mode, Sub-mode RSET) must be set. A 4-20 mA signal generator is required for this option. Care should be taken when interfacing with other manufacturer's control systems, due to power supply differences, full wave bridge versus half wave rectification. The two different power supplies cannot be mixed. ComfortLink controls use half wave rectification. A signal isolation device should be utilized if a full wave bridge signal generating device is used. The 4-20 mA "+" signal should be connected to TB6-2. The 4-20 mA "-" signal should be connected to TB6-5. With a 20 ma signal, the machine will reset the temperature to the value specified in MA.DG.

There is a small label next to TB5 and TB6, 30RA500099. Rev. 2.0 has a known error for the connection of the 4-20 mA signal. The label diagram for the machine is correct and should be followed.

For example, at 20 ma, the machine should reset by 10 °F (5.5 °C).

Configuration Mode					
Sub-Mode	Keypad Entry	Item	Display	Item Expansion	Comment
RSET	[ENTER]	CRST	1	Cooling Reset Type	1=4-20 mA Input
	[▼]	MA.DG	10.0 ΔF (5.5 ΔC)	Degrees Cool Reset	Amount of Temperature Reset at 20 mA.

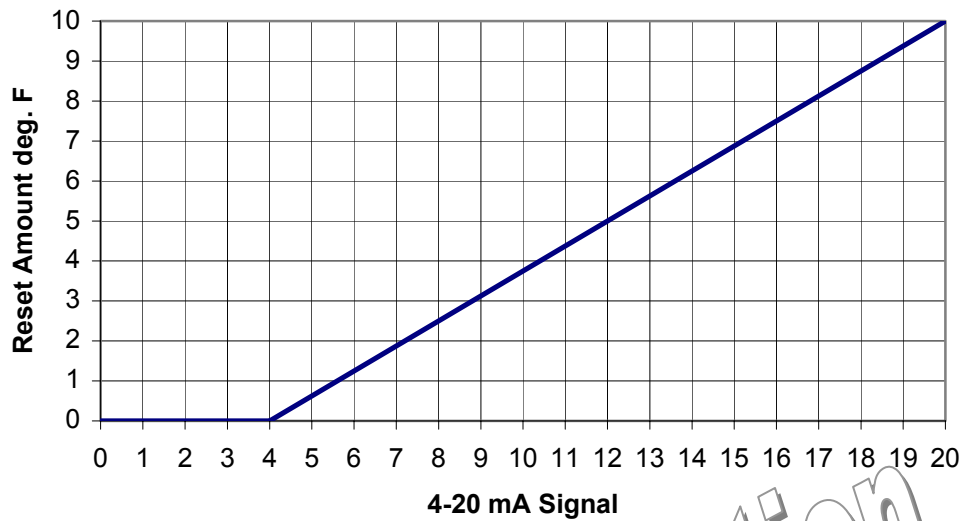

Figure 8 - 4-20 mA Temperature Reset

0-10 or 2-10 vdc inputs cannot be used without further modification. Failure to modify the signal will result in damage to the board. If this is a requirement, a signal converter is required.

Bulletins pertaining to this issue:

- Application TIP127 – 30 Series ComfortLink Control Input Signals
This bulletin provided information on converting various other control systems signals to the ComfortLink requirement of 4-20 mA.

Outdoor Air Temperature Reset

No additional hardware is required for this option, since the outside air sensor is standard on the AquaSnap machines. The Energy Management Module is not required for this option. To set up Outside Air Chilled Water Reset for this control system, follow these steps:

Under the Configuration Mode, these values must be set:

- CRST, *Cooling Reset Type*, (Configuration Mode, Sub-mode RSET)
- RM.NO, *Return – No Reset Temp* (Configuration Mode, Sub-mode RSET)
- RM.F, *Return – Full Reset Temp* (Configuration Mode, Sub-mode RSET)
- RM.DG, *Return – Degrees Reset* (Configuration Mode, Sub-mode RSET).

The following example uses a reset value of 15 °F (8.3 °C) at full reset. No reset occurs at an Outdoor Temperature of 85 °F (29.4 °C). Full reset occurs at an Outdoor Air Temperature of 55 °F (12.8 °C).

Configuration Mode					
Sub-Mode	Keypad Entry	Item	Display	Item Expansion	Comment
RSET	[ENTER]	CRST	2	Cooling Reset Type	2=Outdoor Air Temperature
	[▼]	RM.NO	85.0 °F (29.4 °C)	Return – No Reset Temp	Outdoor Air Temperature at which no reset shall occur.
	[▼]	RM.F	55.0 °F (12.8 °C)	Return – Full Reset Temp	Outdoor Air Temperature at which full reset shall occur.
	[▼]	RM.DG	15.0 ΔF (8.3 ΔC)	Return – Degrees Reset	Amount of reset required.

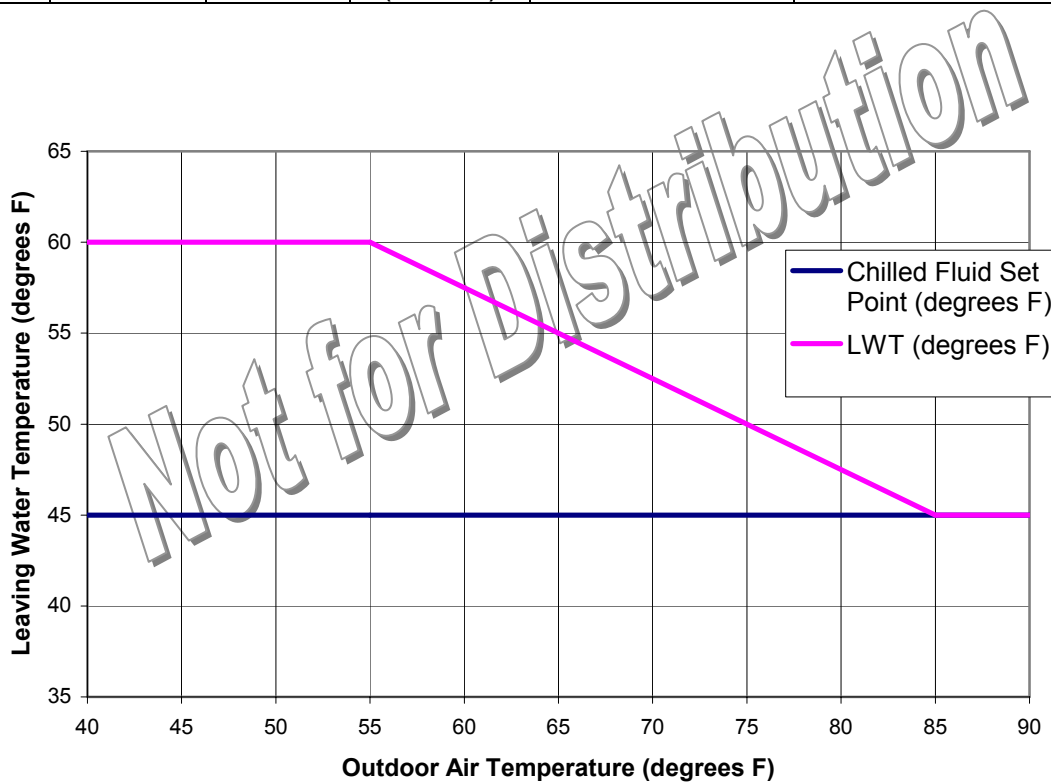

Figure 9 – Outdoor Air Temperature Reset

Return Water Reset

No additional hardware is required for this option. The Energy Management Module is not required for this option. To set up return water reset for this control system, follow these steps:

Under the Configuration Mode, these values must be set:

CRST, *Cooling Reset Type*, (Configuration Mode, Sub-mode RSET)

RT.NO, *Return – No Reset Temp* (Configuration Mode, Sub-mode RSET)
 RT.F, *Return – Full Reset Temp* (Configuration Mode, Sub-mode RSET)
 RT.DG, *Return – Degrees Reset* (Configuration Mode, Sub-mode RSET).

The following example uses a reset value of 10 °F (5.5 °C) at full reset. Full reset is at a 2 °F (1.1 °C) temperature difference across the cooler and no reset at 10 °F (5.5 °C) temperature difference across the cooler.

Configuration Mode					
Sub-Mode	Keypad Entry	Item	Display	Item Expansion	Comment
RSET	[ENTER]	CRST	3	Cooling Reset Type	3=Return Fluid
	[▼]	RT.NO	10.0 °F (5.5 °C)	Return – No Reset Temp	Entering to Leaving Water Temperature difference that has no reset.
	[▼]	RT.F	2.0 °F (1.1 °C)	Return – Full Reset Temp	Entering to Leaving Water Temperature difference that has full reset.
	[▼]	RT.DG	10.0 ΔF (5.5 ΔC)	Return – Degrees Reset	Amount of reset required.

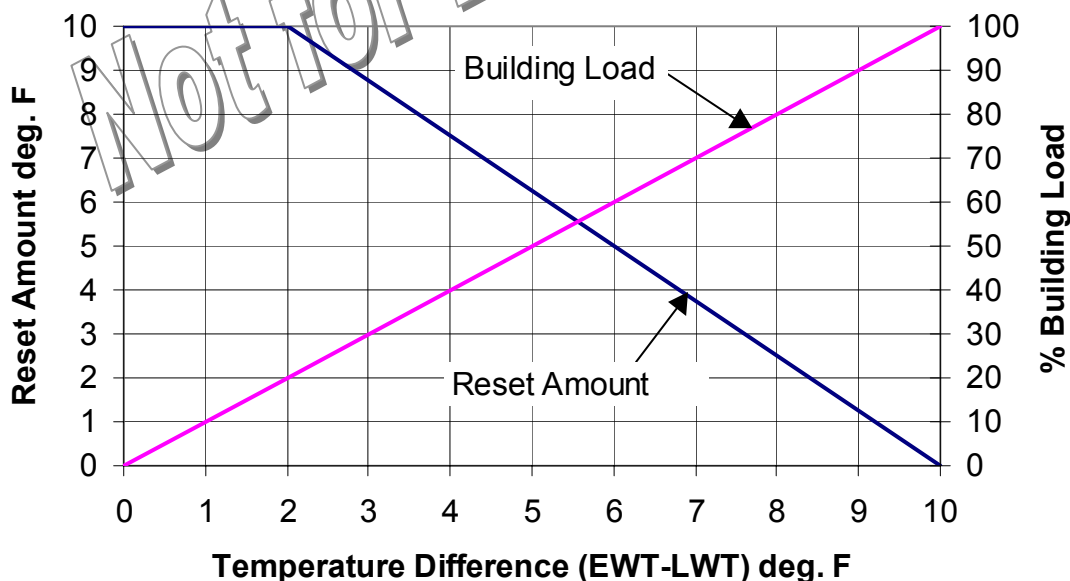

Figure 10 – Return Water Temperature Reset

Space Temperature Reset

Additional hardware is required for this option. A Space Temperature Input is required. See Space Temperature Sensor on page 67 for additional details. This option cannot be combined with Dual Chiller Control. The Energy Management Module is not required for this option. To set up Space Temperature Chilled Water Reset for this control system, follow these steps:

Under the Configuration Mode, these values must be set:

CRST, *Cooling Reset Type*, (Configuration Mode, Sub-mode RSET)

RM.NO, *Return – No Reset Temp* (Configuration Mode, Sub-mode RSET)

RM.F, *Return – Full Reset Temp* (Configuration Mode, Sub-mode RSET)

RM.DG, *Return – Degrees Reset* (Configuration Mode, Sub-mode RSET).

The following example uses a reset value of 6 °F (3.3 °C) at full reset. No reset occurs at a Space Temperature of 72 °F (22.2 °C). Full reset occurs at an Outdoor Air Temperature of 68 °F (20.0 °C).

Configuration Mode					
Sub-Mode	Keypad Entry	Item	Display	Item Expansion	Comment
RSET	[ENTER]	CRST	4	Cooling Reset Type	4=Space Temperature
	[▼]	RM.NO	72.0 °F (22.2 °C)	Return – No Reset Temp	Space Temperature at which no reset shall occur.
	[▼]	RM.F	68.0 °F (20.0 °C)	Return – Full Reset Temp	Space Temperature at which full reset shall occur.
	[▼]	RM.DG	6.0 ΔF (3.3 ΔC)	Return – Degrees Reset	Amount of reset required.

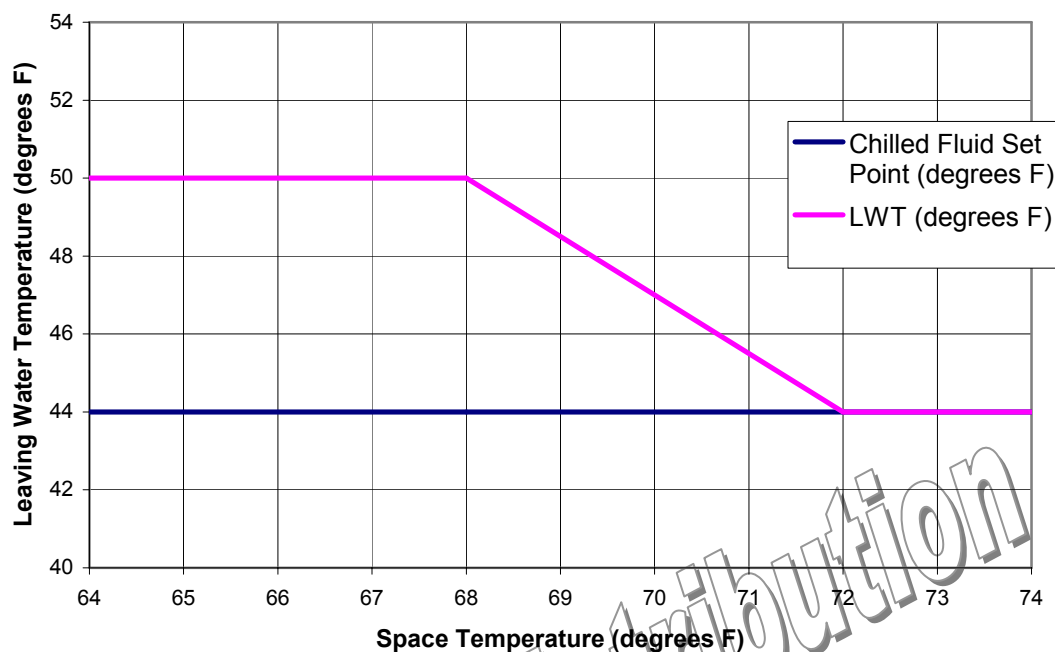

Figure 11 – Space Temperature Reset

Temperature Set Point

There are several options temperature set point options that the ComfortLink control system can utilize. Each option will be addressed independently below with configuration and material required.

There are three independent temperature set points available with the ComfortLink control system: Occupied Temperature Set Point – CSP.1 *Cooling Setpoint 1* (Set Point Mode, Sub-mode COOL), Unoccupied Temperature Set Point – CSP.2 *Cooling Setpoint 2* (Set Point Mode, Sub-mode COOL), and an Ice Build Set Point – CSP.3 *Cooling Setpoint 3* (Set Point Mode, Sub-mode COOL). Each set point has a valid range for the fluid type for the system, FLUD *Cooler Fluid* (Configuration Mode, Sub-mode OPT1) 1-WATER or 2-MEDIUM TEMPERATURE BRINE.

Cooling Set Point (Set Point Mode, Sub-mode COOL)		FLUD <i>Cooler Fluid</i> (Configuration Mode, Sub-mode OPT1)	
		Water	Medium Temperature Brine
CSP.1	Cooling Set Point 1	38 to 70 °F (3.3 to 21.1 °C)	14 to 70 °F (-10.0 to 21.1 °C)
CSP.2	Cooling Set Point 2	38 to 70 °F (3.3 to 21.1 °C)	14 to 70 °F (-10.0 to 21.1 °C)
CSP.3	Cooling Set Point 3	Not Applicable	14 to 32 °F (-10.0 to 0.0 °C)

Single Set Point/Switch Control

This is the factory default configuration. No other devices are required for this option. For this option, CTRL *Control Method* (Configuration Mode, Sub-mode OPT2) must be set to 0 – SWITCH, and CLSP *Cooling Set Point Select* (Configuration Mode, Sub-mode SLCT) set to 0 – SINGLE. Any time the Enable-Off-Remote Switch is in the Enable or Remote position with remote contacts closed, the machine will control the set point to CSP.1 *Cooling Setpoint 1* (Set Point Mode, Sub-mode COOL).

Dual Set Point, Switch/Switch Control

This option allows for a dual set point control of the machine, typically an occupied and unoccupied set point. A Dual Switch input is required connected to TB5-3 and TB5-4. For this option, CTRL *Control Method* (Configuration Mode, Sub-mode OPT2) must be set to 0 – SWITCH, and CLSP *Cooling Set Point Select* (Configuration Mode Sub-mode SLCT) set to 1 – DUAL SWITCH. Operation with this option enabled, activates MD13 Dual Setpoint. Any time the Enable-Off-Remote Switch is in the Enable or Remote position with remote contacts closed, and the Dual Switch is closed, the machine will control the set point to CSP.1 *Cooling Setpoint 1* (Set Point Mode, Sub-mode COOL). With the Dual Switch open, the machine will control the set point to CSP.2 *Cooling Setpoint 2* (Set Point Mode, Sub-mode COOL).

Ice Build, Switch/Switch Control

This option allows for a triple set point control of the machine, an ice, occupied and unoccupied set point. A Dual Switch input is required connected to TB5-3 and TB5-4. An Ice Done Switch is required connected to TB6-9 and TB6-10. The Energy Management Module is also required. For this option, CTRL *Control Method* (Configuration Mode, Sub-mode OPT2) must be set to 0 – SWITCH, CLSP *Cooling Set Point Select* (Configuration Mode, Sub-mode SLCT) set to 1 – DUAL SWITCH, and ICE.M *Ice Mode Enable* (Configuration Mode, Sub-mode OPT2) set to YES. As a result, the EMM *EMM Installed* (Configuration Mode, Sub-mode OPT1) will be set to YES automatically by the controller. Operation with this option enabled activates MD13 – Dual Setpoint. Any time the Enable-Off-Remote Switch is in the Enable or Remote position with remote contacts closed, and the Dual Switch is closed, the machine will control the set point to CSP.1 *Cooling Setpoint 1* (Set Point Mode, Sub-mode COOL). With the Dual Switch open and the Ice Done Switch open, the machine will control the set point to CSP.3 *Cooling Setpoint 3* (Set Point Mode, Sub-mode COOL). This is typically the ice build set point. During operation at this set point, MD19 – Making Ice will be displayed. With the Dual Switch open and the Ice Done Switch closed, the machine will control the set point to CSP.2 *Cooling Setpoint 2* (Set Point Mode, Sub-mode COOL). This is typically the unoccupied set point. During operation at this set point, MD20 – Storing Ice will be displayed.

Single Set Point/Occupancy

This option determines a set point based on a local schedule or a global broadcast schedule that is accessible through the Scrolling Marquee Display, the Navigator, or a Carrier Comfort Network (CCN) interface. No additional hardware devices are required for this option. For this option, CTRL *Control Method* (Configuration Mode, Sub-mode OPT2) must be set to 2-OCCUPANCY, and CLSP *Cooling Set Point Select* (Configuration Mode, Sub-mode SLCT) set to 0 – SINGLE.

The use of this option allows for control of the machine to a preprogrammed schedule for each day and holiday. To use this option, an occupancy schedule for each day and holiday must be programmed.

Holiday Schedule Programming

ComfortLink Controls have 30 holidays that can be programmed with an occupancy schedule. There are no holidays set from the factory. Access to the holiday schedule is restricted to a CCN interface device only. Programming is accomplished by defining the starting month of the holiday, the starting day and the duration in days.

HOLDY01S: Holiday

<u>Description</u>	<u>Value</u>	<u>Units</u>	<u>Name</u>
Holiday Start Month	0		HOL-MON
Start Day	0		HOL-DAY
Duration (days)	0		HOL-LEN

The remaining holiday schedules, HOLDY02S through HOLDY30S have the same format.

To program December 24 and 25 as a holiday, access one of the holiday schedules. In this example, HOLDY 01S will be used.

HOLDY01S: Holiday

<u>Description</u>	<u>Value</u>	<u>Units</u>	<u>Name</u>	<u>Comments</u>
Holiday Start Month	12		HOL-MON	The holiday start month is December
Start Day	24		HOL-DAY	Start the holiday schedule on the 24 th .
Duration (days)	2		HOL-LEN	The holiday covers the 2 days, the 24 th and 25 th .

Local Schedule Operation

To use a local schedule, SCH.N *Schedule Number* (Time Clock Mode, Sub-mode SCH.N) must be set to 1. The factory default for SCH.N is 1. SCHED *Schedule Number* (Configuration Mode, Sub-Mode SLCT) will automatically change to match SCH.N. Changing SCHED will also change SCH.N.

30RA AquaSnap Chiller Service Manual

For this option to function properly, the HH.MM *Hour and Minute* (Time Clock Mode, Sub-mode TIME), MNTH *Month*, DOM *Day of Month*, DAY *Day of Week* and YEAR *Year* (Time Clock Mode, Sub-mode DATE) must be set. The time clock is programmed in a 24-hour format, 00.00 to 24.00. ComfortLink Controls can automatically adjust the time for day light savings time. See Setting the Internal Clock on page 81 for information.

Eight separate time periods are available, PER.1 *Occupancy Period 1*, through PER.8 *Occupancy Period 8* (Time Clock, Sub-mode SCH.N). Each period has an occupied and unoccupied time, all of the days of the week, Monday through Sunday and a Holiday flag. For the day flags: YES is occupied, NO is unoccupied.

To program a time schedule, select a period, access the appropriate day and change the time to the schedule desired. All times are in programmed as a 24-hour clock. Any day that is to remain unoccupied should have its unoccupied time programmed to 00.00. 24-hour operation can be programmed with this option by configuring the occupied time as 00:00 and an unoccupied time as 24:00.

For example, if an occupied time from 6:00 AM to 8:00 PM is desired from Monday through Friday. For Saturday an occupied period from 6:00 AM to 12:00 Noon is desired. Sunday is to remain unoccupied.

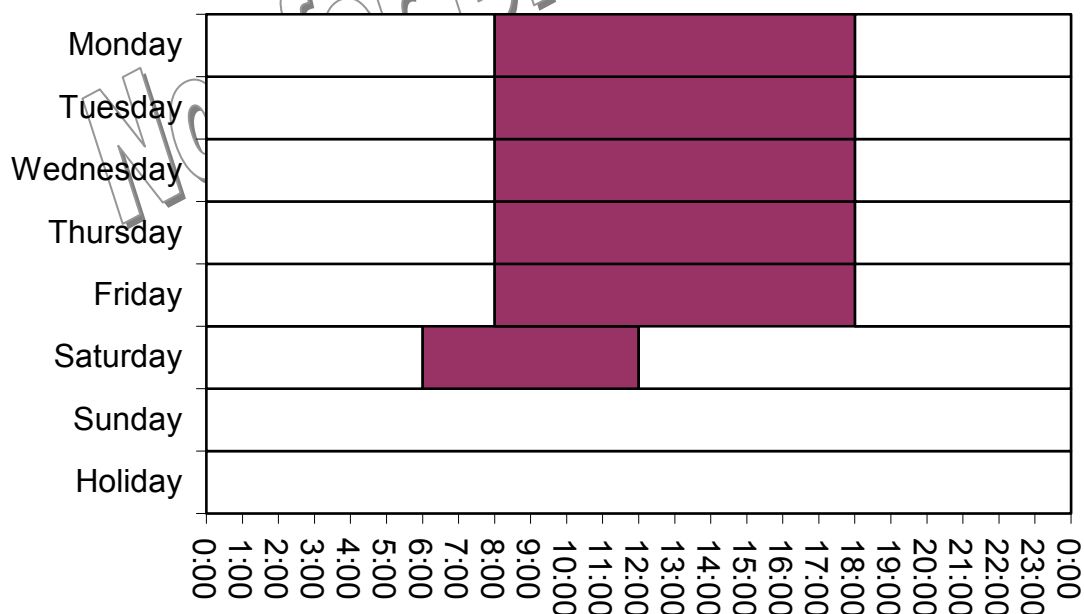

To program this schedule, two time periods will need to be programmed under Time Clock Mode, Sub-mode SCH.L as shown below.

Item	Sub-Item	Display	Expansion	Comment
PER.1			Occupancy Period 1	
	OCC.1	08:00	Period Occupied Time	

30RA AquaSnap Chiller Service Manual

	UNC.1	18:00	Period Unoccupied Time
	MON.1	YES	Monday in Period
	TUE.1	YES	Tuesday in Period
	WED.1	YES	Wednesday in Period
	THU.1	YES	Thursday in Period
	FRI.1	YES	Friday in Period
	SAT.1	NO	Saturday in Period
	SUN.1	NO	Sunday in Period
	HOL.1	NO	Holiday in Period
PER.2			Occupancy Period 2
	OCC.2	06:00	Period Occupied Time
	UNC.2	12:00	Period Unoccupied Time
	MON.2	NO	Monday in Period
	TUE.2	NO	Tuesday in Period
	WED.2	NO	Wednesday in Period
	THU.2	NO	Thursday in Period
	FRI.2	NO	Friday in Period
	SAT.2	YES	Saturday in Period
	SUN.2	NO	Sunday in Period
	HOL.2	NO	Holiday in Period

To modify or access this schedule through CCN, select Time-Sched, and OCCPC01S. The following table will be displayed.

	M	T	W	T	F	S	S	H	Occupied	Unoccupied
Period 1	1	1	1	1	1	0	0	0	06:00	20:00
Period 2	0	0	0	0	0	1	0	0	06:00	12:00
Period 3	0	0	0	0	0	0	0	0	00:00	00:00
Period 4	0	0	0	0	0	0	0	0	00:00	00:00
Period 5	0	0	0	0	0	0	0	0	00:00	00:00
Period 6	0	0	0	0	0	0	0	0	00:00	00:00
Period 7	0	0	0	0	0	0	0	0	00:00	00:00
Period 8	0	0	0	0	0	0	0	0	00:00	00:00

During an occupied time and if the Enable-Off-Remote Switch is in the Enable or Remote position with remote contacts closed, the machine will control the set point to CSP.1 *Cooling Setpoint 1* (Set Point Mode, Sub-mode COOL). If the Enable-Off-Remote Switch is in the Off or Remote position with remote contacts open, the machine will not operate.

CCN Global Schedule Operation

To use a global broadcast schedule, SCH.N *Schedule Number* (Time Clock Mode, Sub-mode SCH.N) must be set to the Global Broadcast Schedule. Global Broadcast Schedule Numbers range from 65 to 99. SCHED *Schedule Number* (Configuration

Mode, Sub-Mode SLCT) will automatically change to match SCH.N. Changing SCHD will also change SCH.N.

During an occupied time determined by the Global Broadcast Schedule and if the Enable-Off-Remote Switch is in the Enable or Remote position with remote contacts closed, the machine will control the set point to CSP.1 *Cooling Setpoint 1* (Set Point Mode, Sub-mode COOL).

Dual Set Point/Occupancy

This option determines a set point based on a local schedule or a global broadcast schedule that is accessible through the Scrolling Marquee Display, the Navigator, or a Carrier Comfort Network (CCN) interface. No additional hardware devices are required for this option. For this option, CTRL *Control Method* (Configuration Mode, Sub-mode OPT2) must be set to 2 – OCCUPANCY, and CLSP *Cooling Set Point Select* (Configuration Mode, Sub-mode SLCT) set to 2 – DUAL CCN OCCUPIED.

The use of this option allows for control of the machine to a preprogrammed schedule for each day and holiday and operate to a chilled water set point based on the occupied or unoccupied time period the unit is in. To use this option, an occupancy schedule for each day and holiday must be programmed. Programming the occupancy schedule is shown in Single Set Point/Occupancy on page 75.

Operation with this option enabled, activates MD13 Dual Setpoint. During an occupied period with the Enable-Off-Remote Switch in the Enable or Remote position with remote contacts closed, the machine will control the set point to CSP.1 *Cooling Setpoint 1* (Set Point Mode, Sub-mode COOL). During an unoccupied period and the Enable-Off-Remote Switch in the Enable or Remote position with remote contacts closed, the machine will control the set point to CSP.2 *Cooling Setpoint 2* (Set Point Mode, Sub-mode COOL).). If the Enable-Off-Remote Switch is in the Off or Remote position with remote contacts open, the machine will not operate.

Ice Build/Occupancy

This option determines a set point based on a local schedule or a global broadcast schedule that is accessible through the Scrolling Marquee Display, the Navigator, or a Carrier Comfort Network (CCN) interface and allows for triple set point control of the machine, an ice, occupied and unoccupied set point. An Ice Done Switch is required and must be connected to TB6-9 and TB6-10. The Energy Management Module is also required. For this option, CTRL *Control Method* (Configuration Mode, Sub-mode OPT2) must be set to 2 – OCCUPANCY, CLSP *Cooling Set Point Select* (Configuration Mode, Sub-mode SLCT) set to 2 – DUAL CCN OCCUPIED, and ICE.M *Ice Mode Enable* (Configuration Mode, Sub-mode OPT2) set to YES. As a result, the EMM *EMM Installed* (Configuration Mode, Sub-mode OPT1) will be set to YES automatically by the controller.

To use this option, an occupied and unoccupied schedule for each day must be programmed. Programming the occupancy schedule is shown in Single Set Point/Occupancy.

Operation with this option enabled activates MD13 – Dual Setpoint. During an occupied period, with the Enable-Off-Remote Switch is in the Enable or Remote position with remote contacts closed, the machine will control the set point to CSP.1 *Cooling Setpoint 1* (Set Point Mode, Sub-mode COOL). During an unoccupied period and the Ice Done Switch open, the machine will control the set point to CSP.3 *Cooling Setpoint 3* (Set Point Mode, Sub-mode COOL). This is typically the ice build set point. During operation at this set point, MD19 – Making Ice will be displayed. Still in an unoccupied period and the Ice Done Switch closed, the machine will control the set point to CSP.2 *Cooling Setpoint 2* (Set Point Mode, Sub-mode COOL). This is typically the unoccupied set point. During operation at this set point, MD20 – Storing Ice will be displayed. If the Enable-Off-Remote Switch is in the Off or Remote position with remote contacts open, the machine will not operate.

4 to 20 mA Input/Switch Control

This option requires the Energy Management Module. For this option, CTRL *Control Method* (Configuration Mode, Sub-mode OPT2) must be set to SWITCH, and CLSP *Cooling Set Point Select* (Configuration Mode, Sub-mode SLCT) set to 4 – 4-20 MA INPUT. As a result, the EMM *EMM Installed* (Configuration Mode, Sub-mode OPT1) will be set to YES automatically by the controller. A 4-20 mA signal generator is required for this option. Care should be taken when interfacing with other manufacturer's control systems, due to power supply differences, full wave bridge versus half wave rectification. The two different power supplies cannot be mixed. ComfortLink controls use half wave rectification. A signal isolation device should be utilized if a full wave bridge signal generating device is used. The 4-20 mA "+" signal should be connected to TB6-3. The 4-20 mA "-" signal should be connected to TB6-5.

There is a small label next to TB5 and TB6, 30RA500099. Rev. 2.0 has a known error for the connection of the 4-20 mA signal. The label diagram for the machine is correct and should be followed.

Any time the Enable-Off-Remote Switch is in the Enable or Remote position with remote contacts closed, the machine will control the set point to CSP.1 *Cooling Setpoint 1* (Set Point Mode, Sub-mode COOL). This option functions on a linear relation between 10 to 80 °F (-12.2 to 26.7 °C). The equations are listed below:

$$^{\circ}F = 4.375(mA) - 7.5 \quad (^{\circ}C = 2.43(mA) - 21.92)$$

The function is limited at the low end depending on the FLUD, *Cooler Fluid* (Configuration Mode, Sub-mode OPT1). If FLUD is set for WATER, the lower limit is 38 °F (3.3 °C). If FLUD is set for MEDIUM TEMPERATURE BRINE or LOW TEMPERATURE BRINE, the lower limit is 14 °F (-10.0 °C). If this option is used, the

chilled water loop must be protected to at least 0 °F (-17.1 °C) to protect the loop from freezing if the signal sent incorrectly. The function is also clamped at the upper limit not to exceed 70 °F (21.1 °C).

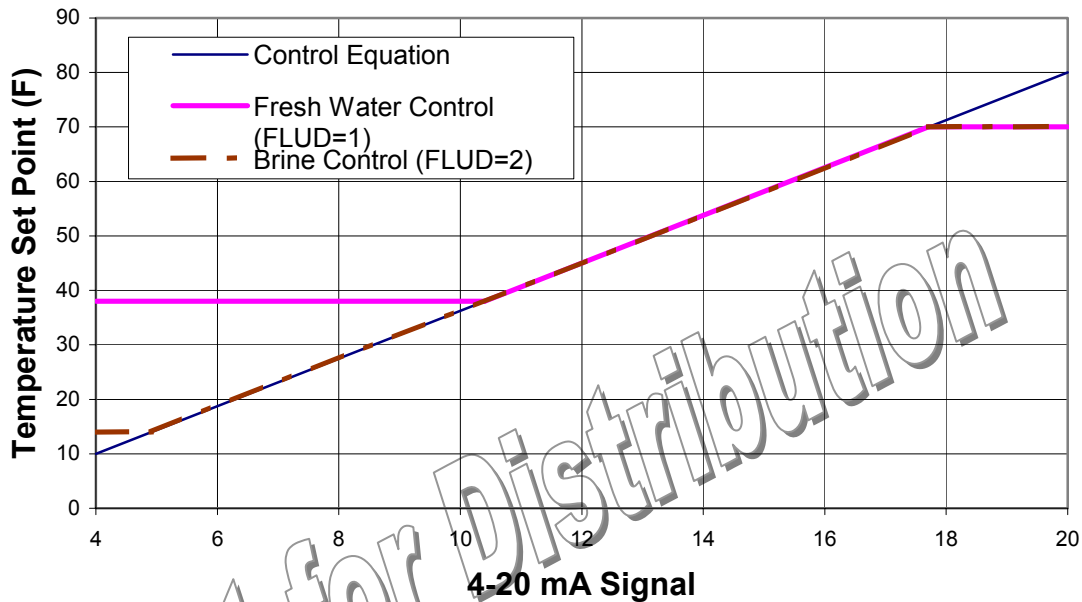

Figure 12 – 4-20 mA Temperature Set Point

Time Clock Function

ComfortLink Controls has an internal clock, which includes the date, day of week, and time. Provisions for automatic Daylight Savings Time corrections are also included in the ComfortLink Control system. This function is used by many other operational functions for the machine, from time and date stamps for alarms to occupancy schedule timing.

Setting the Date

The internal calendar is set when the program is loaded. The date, day of week, and time should be checked at start-up for accuracy, as well as after a software download.

To verify or program the internal clock, access the function under Time Clock Mode, Sub-mode DATE as shown below.

Sub-mode	Item	Display	Expansion	Comment
DATE			Month, Date, Day, and Year	
	MNTH	NN	Month	Range: 1-12 1 – January 2 – February 3 – March 4 – April 5 – May 6 – June 7 – July 8 – August 9 – September 10 – October 11 – November 12 – December
	DOM	NN	Day of Month	Range 1-31
	DAY	N	Day of Week	Range 1-7 1 – Monday 2 – Tuesday 3 – Wednesday 4 – Thursday 5 – Friday 6 – Saturday 7 – Sunday
	YEAR	NNNN	Year of Century	

In the 30RA-1T and 30RA-2T Controls and Troubleshooting book, an error in the description of the DAY field was found. The correct correlation from the number to the day of week is shown in the table above, and can be confirmed by pressing [ENTER] and [ESCAPE] together for the text expansion.

Setting the Internal Clock

The internal time clock is set when the program is loaded. The date, day of week, and time should be checked at start-up for accuracy, as well as after a software download.

To verify or program the internal clock, access the function under Time Clock Mode, Sub-mode TIME as shown below. The time function is displayed in a 24-hour format.

Sub-mode	Item	Display	Expansion	Comment
TIME			Time of Day	
	HH:MM		Hour and Minute	24 hour format

Daylight Savings Time can be automatically activated. To enable this function, T.D.BC (Configuration Mode, sub-mode BCST) must be set to YES. Access the configuration of this feature under Time Clock Mode, Sub-mode DST as shown below.

30RA AquaSnap Chiller Service Manual

Sub-mode	Item	Display	Expansion	Comment
DST			Daylight Savings Time	
	STR.M		Month	Starting Month Default: 4, Range: 1-12 1 – January 2 – February 3 – March 4 – April 5 – May 6 – June 7 – July 8 – August 9 – September 10 – October 11 – November 12 – December
	STR.W		Week	Starting Week Default: 1, Range: 1-5 1 – 1 st Week 2 – 2 nd Week 3 – 3 rd Week 4 – 4 th Week 5 – Last Week of Month
	STR.D		Day	Starting Day Default: 7, Range: 1-7 1 – Monday 2 – Tuesday 3 – Wednesday 4 – Thursday 5 – Friday 6 – Saturday 7 – Sunday
	MIN.A		Minutes to Add	Default: 60, Range: 0-99

30RA AquaSnap Chiller Service Manual

Sub-mode	Item	Display	Expansion	Comment
	STP.M		Month	Stop Month Default: 4, Range: 1-12 1 – January 2 – February 3 – March 4 – April 5 – May 6 – June 7 – July 8 – August 9 – September 10 – October 11 – November 12 – December
	STP.W		Week	Stop Week Default: 5, Range: 1-5 1 – 1 st Week 2 – 2 nd Week 3 – 3 rd Week 4 – 4 th Week 5 – Last Week of Month
	STP.D		Day	Stop Day Default: 7, Range: 1-7 1 – Monday 2 – Tuesday 3 – Wednesday 4 – Thursday 5 – Friday 6 – Saturday 7 – Sunday
	MIN.S		Minutes to Subtract	Default: 60, Range: 0-99

LITERATURE

Below is a list of literature for the 30RAN AquaSnap machines. Shaded literature is obsolete literature.

Form Number	Catalog Number	Title	Print Date	Reprint Date	Superceded By
Product Data					
30RA-1PD	523-067	AquaSnap 30RAN010-055 Air Cooled Chillers 50/60 Hz	5/01		30RA-2PD
30RA-2PD	523-072	AquaSnap 30RAN010-055 Air Cooled Chillers 50/60 Hz	7/02		30RA-3PD
30RA-3PD	523-074	AquaSnap 30RAN010-055 Air Cooled Chillers 50/60 Hz	11/02		

30RA AquaSnap Chiller Service Manual

Form Number	Catalog Number	Title	Print Date	Reprint Date	Superseded By
Selection Software					
		30 Series Chiller Selection, Version 2.8			
Application Information					
	811-019	Lunch & Learn Series – Environmental Corrosion Protection			
	811-217	Selection Guide: Environmental Corrosion Protection.	9/99		811-20062
	811-10121	Meeting ASHRAE 90.1-1999 (2001) Energy Standard for Buildings – A Reference Guide to Meeting the New Minimum Efficiency Requirements for HVAC Equipment with Carrier Products	12/02		
	811-20062	Selection Guide: Environmental Corrosion Protection.	10/04		
TIP122		Air Cooled Chiller Winterizing: Freeze Protection	4/01		
TIP124		AquaSnap Hydronics: More Than Just a Pump!	6/01		
TIP125		Factory Testing: 30GT, GU, GX & RA Air Cooled Chillers	7/01		
TIP126		30RA AquaSnap FAQ's	9/01		
TIP127		30 Series ComfortLink Control, Signal Inputs	4/02		
TIP129		30RA Base Rails	8/02		
TIP132		Generator Operation	1/05		
Product Bulletin					
111-01-27		Introducing AquaSnap Air-Cooled Chillers with Integrated Hydronic System	04/27/01		
111-01-28		New 30RA010-055 AquaSnap Air-Cooled Chiller Phase-In/Phase Out	04/12/01		
111-01-31		AquaSnap Show Unit Offer	04/27/01		
111-01-51		AquaSnap Lunch & Learn Mailing	05/11/01	06/22/01	
111-02-32		30RA Product Ordering Data Additions	05/09/02		
111-02-11-E		30RA Product Ordering Data Additions	05/09/02		
111-02-59		Export Product Obsolescence	08/02/02		
111-02-22-E		Export Product Obsolescence	08/02/02		
111-02-63		Air Cooled Chiller Global Sourcing	09/07/02		
111-02-25-E		Air Cooled Chiller Global Sourcing	09/27/02		
111-03-51		30RAN Price Page Correction	09/26/03		
111-03-16-E		30RAN Price Page Correction	09/26/03		
111-03-52		30RAN010-030 Refrigerant Charge	09/26/03		
111-04-04		MotorMaster V Low Ambient Control Revision	01/13/04		
111-04-02-E		MotorMaster V Low Ambient Control Revision	01/13/04		
111-04-57		Air-Cooled Chiller Product Offering	10/04		111-05-25
111-05-25		Air-Cooled Chiller Product Offering	04/29/05		111-05-39
111-05-05-E		Air-Cooled Chiller Product Offering	04/29/05		
111-05-39		Air-Cooled Chiller Product Offering	5/27/05		
Promotional Information					
	830-086	30RA AquaSnap Air-Cooled Chiller with Integrated Hydronic System, 9-53 tons	03/2001		830-090
	830-090	AquaSnap Air-Cooled Chillers	10/2004		04-830090-25
	04-830090-25	Aqua Series Air-Cooled Chillers	05/2005		
	848-113	Enviro-Shield Corrosion Protection	08/1999		
Submittal Bulletin					
30RA-1SB	513-475	AquaSnap 30RAN010-055 Air Cooled Chillers	04/2001	07/2001	
Installation Instructions					

30RA AquaSnap Chiller Service Manual

Form Number	Catalog Number	Title	Print Date	Reprint Date	Superceded By
30RA-1SI	533-00017	30RAN010-055 AquaSnap Liquid Chillers with ComfortLink Controls, 50/60 Hz	6/01	7/01, 7/01A, 2/02	30RA-12SI
30RA-12SI	533-00045	30RAN010-055 AquaSnap Liquid Chillers with ComfortLink Controls, 50/60 Hz	7/02		
Controls, Start-Up, Operation, Service and Troubleshooting					
30RA-1T	533-00018	30RAN010-055 AquaSnap Liquid Chillers with ComfortLink Controls, 50/60 Hz	6/01		30RA-2T
30RA-2T	533-00047	30RAN010-055 AquaSnap Liquid Chillers with ComfortLink Controls, 50/60 Hz	1/03		
Accessory Installation Instructions					
30/48/50-4SI	533-00028	ComfortLink Series Units and 30GX080-350, 30HX076-271, 48/50 EJ,EK,EW,EY024-068 Remote Enhanced Display Accessory, 50/60 Hz	6/01		
30G,H,R-1SI	533-00031	30GTN015-035, 30RA010-055, 30GTN,GTR,GUN,GUR040-420, 30HK040-060, 30HL050-060, 30HW018-040 ComfortLink Navigator Accessory Display Module, 50/60 Hz	7/01		
30G,R-2SI	533-00030	30GN,GT,GU040-420, 30GTR,GUN,GUR040-420, 30GTN015-420, 30RA010-055, 30GXN,R080-528, 30GX080-350 Accessory Unit Control Display Access Door	7/01	1/02	
30RA-2SI	533-00020	30RA010-055 Energy Management Module (EMM) Accessory, 50/60 Hz	7/01	7/02	
30RA-3SI	533-00021	AquaSnap 30RAN,R010-055 Minimum Load Control Accessory	6/01		
30RA-4SI	533-00022	30RA010-055 Vibration Isolation Accessory Kit	7/01		
30RA-5SI	533-00023	AquaSnap 30RA010-050 Accessory Hail Guard Hood	6/01		
30RA-6SI	533-00024	AquaSnap 30RA010-055 Accessory Low Ambient Operation Motormaster V Electronic Control, 50/60 Hz	8/01		30RA-11SI
30RA-7SI	533-00025	AquaSnap 30RA010-055 Chilled Water Storage Tank, 50/60 Hz	8/01	10/01	
30RA-8SI		AquaSnap 30RA010-055 Remote Cooler Mounting Accessory, 50/60 Hz (Not Released to Distribution)	8/01	10/01	
30RA-9SI	533-00027	AquaSnap 30RAN,R010-055 Accessory Security Grille Package	6/01		
30RA-10SI	533-00029	30RA010-055 Ground-Fault Interrupter Convenience Outlet Accessory	7/01		30RA-13SI
30RA-11SI	533-00044	AquaSnap 30RA010-055 Accessory Low Ambient Operation Motormaster V Electronic Control, 50/60 Hz	2/02	7/02	30RA-14SI
30RA-13SI	533-00046	30RA010-055 Ground-Fault Interrupter Convenience Outlet Accessory	9/02		
30RA-14SI	533-00056	AquaSnap 30RA010-055 Accessory Low Ambient Operation Motormaster V Electronic Control, 50/60 Hz	10/03	12/03, 12/03A	
Wiring Diagrams					
30RA-1W	533-00019	AquaSnap 30RA Sizes 010-055 Air-Cooled Chillers, 50/60 Hz	7/01		30RA-2W
30RA-2W	533-00048	AquaSnap 30RA010-055 Air-Cooled Chillers, 50/60 Hz	7/02		
Warranty Certificate					
UED-1855	590-033	Standard Product Warranty		8/92	
Technical Training					

30RA AquaSnap Chiller Service Manual

Form Number	Catalog Number	Title	Print Date	Reprint Date	Superceded By
30RA-02	023-063	30RA AquaSnap Chiller with ComfortLink Controls			
30RA-01CD	023-062	30RA AquaSnap Chiller with ComfortLink Controls (PowerPoint Presentation)			
TDP-622C	796-054	Technical Development Program – Air-Cooled Chillers	10/04		

SERVICE

Troubleshooting

The following is an abbreviated list of symptoms, probable causes and potential remedies:

Symptom	Possible Cause	Possible Remedy
Unit does not run	Check for power to unit	<ul style="list-style-type: none"> • Check Overcurrent Protection Device • Check Non-Fused Disconnect (if equipped) • Restore Power to unit
	Wrong/Incorrect unit configuration	<ul style="list-style-type: none"> • Check Unit Configuration
	Active Alarm	<ul style="list-style-type: none"> • Check Alarm status. See separate Alarm and follow troubleshooting instructions
	Active Operating Mode	<ul style="list-style-type: none"> • Check for Operating Modes. See Operating Modes and follow troubleshooting instructions
Unit operates too long or continuously	Low refrigerant charge	<ul style="list-style-type: none"> • Check for leak and add refrigerant.
	Compressor or control contacts welded	<ul style="list-style-type: none"> • Replace contactor or relay.
	Air in Chilled Water Loop	<ul style="list-style-type: none"> • Purge water loop
	Non-condensibles in Refrigerant circuit.	<ul style="list-style-type: none"> • Remove refrigerant and recharge.
Circuit does not run	Active Alarm	<ul style="list-style-type: none"> • Check Alarm status. See separate Alarm and follow troubleshooting instructions
	Active Operating Mode	<ul style="list-style-type: none"> • Check for Operating Modes. See Operating Modes and follow troubleshooting instructions
Circuit does not load	Active Alarm	<ul style="list-style-type: none"> • Check Alarm status. See separate Alarm and follow troubleshooting instructions
	Active Operating Mode	<ul style="list-style-type: none"> • Check for Operating Modes. See Operating Modes and follow troubleshooting instructions
	Low Saturated Suction Temperature	<ul style="list-style-type: none"> • See Operating Modes 7 and 8.

Symptom	Possible Cause	Possible Remedy
Compressor does not run	Active Alarm	<ul style="list-style-type: none"> Check Alarm status. See separate Alarm and follow troubleshooting instructions
	Active Operating Mode	<ul style="list-style-type: none"> Check for Operating Modes. See Operating Modes and follow troubleshooting instructions
	Inoperative Compressor Contactor	<ul style="list-style-type: none"> Check control wiring Check Contactor Operation, replace if necessary.
Chilled Water Pump is ON, but the machine is OFF	Cooler Freeze Protection	<ul style="list-style-type: none"> Check sensors

Alarms and Alerts Codes

Alarm and Alert Codes are displayed as 4 digit codes. To determine the expansion of the alarm/alert code, press the [ENTER] and [ESCAPE] keys together once the item is selected.

As a general rule, codes preceded by a “T” are alerts indicating that a circuit has been shut down. Codes preceded by an “A” are alarms indicating that the unit has been shut down.

Any Alarm condition that shuts down the machine will also turn off the chilled water pumps. There are some alarm conditions that the chilled water pump will remain on. These are noted below.

Communication Failure

Action taken by control: Machine is shut down

Reset Method: Automatic once communication is restored (MBB)

This alarm is generated any time the LEN (Local Equipment Network) communication is lost. An A152 may be generated also.

If this condition is encountered, check the following items:

- Check the MBB Instance Jumper. It should be set to “1”. If it is missing or installed on “2”, this alarm will be generated.
- Check the LEN for a wiring error or short to ground.
- Check all Input connections for a short to ground.
- Check the machine grounding.
- Check the power supply for the Main Base Board. It should be 24 vac. Voltages less than 18 can cause this problem.

T051 – Compressor A1 Failure

Action Taken by Control: See below

Reset Method: Manual

On the 30RAN machines, compressor feedback is accomplished with auxiliary contacts attached to the compressor contactors. This alarm/alert is generated when the auxiliary contact status does not match the commanded state. If the compressor is on, the auxiliary contact should be closed. If the compressor is off, the auxiliary contact should be open. The most common cause of this alarm/alert is the feedback circuit is open when the compressor is commanded on. If this alarm is encountered, the machine shuts down (30RAN010, 30RAN015–60 Hz) or the compressor shuts down (30RAN015-50 Hz, 30RAN018-055). When this fault is declared, the chilled water pump will be turned off, if no other compressors are available. (The chilled water pump lockout via the alarm is overridden in the event of a freeze protection mode.)

If this condition is encountered, check the following items:

- Check the High Pressure Switch status.
- Consider disabling the LS.MD *Low Sound Mode*, (Configuration Mode, Sub-mode OPT2). A known software bug in Software Version 3.0 and earlier could create a nuisance high pressure switch trip.
- Check the Condenser Fan for proper operation
- Check the internal protector for the compressor for continuity. The SM110 compressors used in the 30RAN015 (50Hz) and 30RAN018 (60Hz) use line break devices internal to the motor. All other size units use compressors with internal discharge gas thermostats that open our control circuit and shut off the compressor due to overload conditions.
- Check the compressor contactor.
- Confirm proper control wiring.
- Check the auxiliary contacts on the compressor contactor.
- Check the liquid line for any restriction, either plugged filter driers, or closed or partially closed liquid line service valves.
- Check the coils for debris or air recirculation.
- Confirm that the machine charge is correct.
- Check for non-condensables in the circuit.
- On 208/230-volt units, check to be sure that the correct tap on the control transformer is utilized. If the 230-volt tap is used on a 208-volt system cycling frequently, the compressor contactor may not pull in.

If the compressor is commanded off, and the auxiliary contacts remain closed, the alarm is also generated. In this case, all other compressors are shut off, and the chilled water pump remains on.

If this condition is encountered, check the following items:

- Check the compressor contactor for welded contacts.
- Confirm proper control wiring
- Check the auxiliary contacts on the compressor contactor.

T052 – Compressor A2 Failure

Action Taken by Control: See Alarm explanation

Reset Method: Manual

See T051 explanation.

T055 – Compressor B1 Failure

Action Taken by Control: See Alarm explanation

Reset Method: Manual

See T051 explanation.

T056 – Compressor B2 Failure

Action Taken by Control: See Alarm explanation

Reset Method: Manual

See T051 explanation.

T077 – Circuit A Saturated Suction Temperature Exceeds Cooler Leaving Fluid Temperature

T078 – Circuit B Saturated Suction Temperature Exceeds Cooler Leaving Fluid Temperature

Action taken by control: Circuit shut down.

Reset Method: Manual (MBB)

This alert is generated when the following criteria has been met:

1. A compressor in the circuit is ON
2. The circuit Saturated Suction Temperature exceeds the Cooler Leaving Water Temperature for at least 5 minutes.

If the timer is currently enabled, it will be reset if the $LWT > SST - 1\text{ }^{\circ}\text{F}$ ($0.6\text{ }^{\circ}\text{C}$).

If this condition is encountered, check the following items:

- Check the Leaving Water Thermistor to be sure that it is firmly seated in the well.
- Check the Leaving Water Thermistor for accuracy.
- Check the Suction Pressure transducer for accuracy.
- Check for a thermistor or transducer wiring error or problem.
- Check for moisture in the transducer connection.
- Check the TXV for proper operation.

T090 – Circuit A Discharge Pressure Transducer Failure

T091 – Circuit B Discharge Pressure Transducer Failure

T092 – Circuit A Suction Pressure Transducer Failure

T093 – Circuit B Suction Pressure Transducer Failure

Action taken by control: Circuit shut down.

Reset Method: Automatic (MBB)

This alarm will be generated if the voltage ratio ($\text{Voltage}_{\text{Measured}} / \text{Voltage}_{\text{Reference}}$) by the Main Base Board (MBB) is greater than 99.9% or less than 0.5%.

If this condition is encountered, check the following items:

- Check for a faulty transducer.
- Check for a wiring error or problem between transducer and the MBB.
- Check for a faulty power supply from the MBB.
- Check for moisture in the transducer connection.

T112 – Circuit A High Saturated Suction Temperature

T113 – Circuit B High Saturated Suction Temperature

Action taken by control: Circuit shutdown

Reset Method: Manual (MBB)

This alert is generated when the following criteria has been met:

1. Circuit is ON
2. The circuit Saturated Suction Temperature exceeds 60 °F (15.6 °C) for at least 5 minutes.

If this condition is encountered, check the following items:

- Check the Suction Pressure transducer for accuracy.
- Check for a transducer wiring error or problem.
- Check for moisture in the transducer connection.
- Check the TXV for proper operation.

T114 – Circuit A Low Cooler Suction Superheat

T115 – Circuit B Low Cooler Suction Superheat

Action taken by control: Circuit shutdown

Reset Method: Manual (MBB)

This alert requires that the Return Gas Sensor be installed and RG.EN *Return Gas Sensor Enable* (Configuration Mode, Sub-mode OPT1) is “ENBL”. If the suction superheat is less than SH.SP *Superheat Setpoint* (Configuration Mode, Sub-mode UNIT) by more than 10 °F (5.6 °C) for 5 minutes.

If this condition is encountered, check the following items:

- Check the TXV operation.

- Check the refrigerant charge. An excessive overcharge condition can lead to this problem.
- Check the Suction Pressure Transducer for accuracy.
- Check to be sure that there is a Return Gas Thermistor installed, if enabled.
- Check the accuracy of the Return Gas Thermistor.
- Check the head pressure control operation.
- Check SH.SP *Superheat Setpoint* (Configuration Mode, Sub-mode Unit). The value has a factory default of 15 °F (8.3 °C).

T116 – Circuit A Low Cooler Suction Temperature

T117 – Circuit B Low Cooler Suction Temperature

Action taken by control: Circuit shutdown

Reset Method: Manual (MBB)

This alarm will be generated if the capacity stages are reduced six times without a 30 minute interval between capacity reductions due to Mode 7 or Mode 8, the corresponding T116/T117 Circuit A/B Low Cooler Suction Temperature Alert will be generated.

If this condition is encountered, check the following items:

- Check the TXV operation.
- Check the TXV superheat setting. Adjust if necessary.
- Check the refrigerant charge.
- Check for a refrigerant restriction, plugged filter drier, partially closed service valve.
- Check chilled water flow rate and strainer, clean as necessary.
- Check for cooler fouling.
- Check suction pressure transducer accuracy.
- Check to be sure that the BR.FZ, *Brine Freeze Point*, (Set Point mode, sub-mode FRZ) is set correctly.
- If the problem is occurring during low ambient operation start-up, consider changing the MotorMaster V P34 parameter from 18 to between 23 and 24. This will raise the head pressure control point to approximately 200 psi (1379 kPa). Additionally, consider changing the BR.FZ, *Brine Freeze Point*, (Set Point mode, sub-mode FRZ) to 31 °F (-0.5 °C). Additionally, for (T116) on 30RAN022-055, Circuit A second fan (non-MotorMaster), and for (T117) on 30RAN045-055 Circuit B second fan (non-Motormaster), add a Fan Cycling Pressure Switch, HK02YB159. This switch closes at 260 psi, opens at 160 psi. Install the switch on the liquid line access fitting provided, where the MotorMaster transducer is installed. You will need to install an access tee.

T126 – Circuit A High Discharge Pressure

T127 – Circuit B High Discharge Pressure

Action taken by control: Circuit shut down.

Reset Method: Automatic for first 3 daily occurrences, manual restart thereafter (MBB)

This alert is generated if the Saturated Condensing Temperature is greater than the Maximum Condensing Temperature as determined by the operating envelope equation noted below:

If Saturated Suction Temperature is greater than 32 °F (0 °C):

$$\text{Maximum Condensing Temperature} = \text{Saturated Suction Temperature} \times 0.278 + 140.1 \text{ } ^\circ\text{F}$$

If Saturated Suction Temperature is less than or equal to 32 °F (0 °C):

$$\text{Maximum Condensing Temperature} = \text{Saturated Suction Temperature} \times 1.189 + 110.95 \text{ } ^\circ\text{F}$$

If the above criterion is met, the machine will alert, and the circuit will be shut down. The circuit will automatically restart for the first 3 trips that day if the Outdoor Air Thermostat senses a 5 °F (2.8 °C) ambient temperature reduction.

If this condition is encountered, check the following items:

- Check the Discharge Pressure Transducer accuracy, replace as necessary.
- Check the condenser fan operation.
- Check the condenser coil for debris or corrosion.
- Check for non-condensibles.

T133 – Circuit A Low Suction Pressure

T134 – Circuit B Low Suction Pressure

Action taken by control: Circuit shut down.

Reset Method: Automatic for first daily occurrence, manual restart thereafter (MBB)

This alert is generated if one of the two following conditions is satisfied: the circuit suction pressure is below 15 psig (103.4 kPa) for 8 seconds, or the suction pressure is below 8 psig (55.1 kPa).

If this condition is encountered, check the following items:

- Check the TXV operation
- Check the TXV superheat adjustment
- Check the refrigerant charge
- Check the liquid line for any restriction, partially or closed liquid line service valve, plugged liquid line filter drier.
- Check head pressure control operation. If not equipped, consider adding head pressure control.
- For air-cooled systems, check for wind baffles. Consider adding wind baffles, if required.
- Maximum Operating Pressure (MOP) type valves are used on all machines and are subject to cross ambient conditions. When the ambient is 20 °F (11 °C) or more colder than the suction line, the gas in the bulb condenses in the power

head of the TXV. The liquid in the power head interferes with the operation of the TXV, and does not allow it to open. As a result, the cooler is starved of refrigerant, and the unit trips on low refrigerant pressure. If this condition is encountered, the TXV power head should be wrapped with self-regulating heater tape. Wrapping the power head will keep the temperature of power head higher than the bulb and not allow the gas to condense on the power head. The heater should be wired to turn on and off with cooler heater.

T140 – Reverse Rotation Detection

Action taken by control: Chiller shut down.

Reset Method: Manual (MBB)

This alarm will be generated when the control detects a reverse rotation of the compressor. This alarm is only checked when the machine is started. The control monitors the pressure difference between the high and low sides of the machine for 1 minute after the first compressor starts. The smallest pressure difference monitored during this time is noted as the pressure reference. If the pressure difference does not increase by 10 psig (68 kPa) over the pressure reference at the end of the first minute of operation, then the alarm is tripped.

After the first compressor is started, subsequent compressors are not checked for this alarm condition. Use caution when replacing compressors to insure that they are properly wired and phased correctly.

If this condition is encountered, check the following items:

- Check compressor circuit breakers to be sure that none have opened.
- Check the compressor contactors for proper operation.
- Check compressors for proper wiring and rotation.

T150 – Emergency Stop

Action taken by control: Chiller shut down.

Reset Method: Automatic once CCN EMSTOP command returns to “Emstop”

This alarm is generated if the CCN control transmits an Emergency Stop command to the unit. The alarm will clear once the force is removed.

If this condition is encountered, check the following items:

- Check control system (CCN, DataLink, BacLink, or LON) for a force to the EMSTOP variable. “Enable” will stop the machine. “Emstop” will allow the chiller to operate.

T151 – Illegal Configuration

Action taken by control: Chiller shut down.

Reset Method: Manual (MBB)

This alarm is generated if the control detects an illegal configuration. This error must be corrected before the machine can be started. Within the alarm code will be a text string indicating the illegal configuration.

There are only 3 illegal configurations on the Aquasnap chiller control:

A151 Illegal Configuration - Fluid Is Water, Ice Making Enabled

If this condition is encountered, check the following items:

- Check FLUD *Cooler Fluid* (Configuration Mode, Sub-mode OPT1) value. Check ICE.M *Ice Mode Enable* (Configuration Mode, Sub-mode OPT2) value. If ICE.M is ENBL, then FLUD must be 2 (Medium Temperature Brine).

A151 Illegal Configuration - Invalid Refrigerant Type Selected

If this condition is encountered, check the following items:

- Check REFG *Refrigerant* (Configuration Mode, Sub-mode UNIT) value. R-22 is the only refrigerant supported. REFG must be 1 (R-22).

A151 Illegal Config - Low Sound Cap Limit With Single Stage Unit

If this condition is encountered, check the following items:

- Check LS.LT *Low Sound Capacity Limit* (Configuration Mode, Sub-mode OPT2) value. For single compressor machines, the machine must have Minimum Load Control installed and enabled for this option to function.

Note: Currently, there are no language translations for Low Sound Cap Limit with Single Stage Unit text string. If the language is not English, a number will be displayed for the illegal configurations for the other 3 languages. See the descriptions above for actions to be taken.

A151 Sub Code	Illegal Configuration Description
-01	Fluid Is Water, Ice Making Enabled
-02	Invalid Refrigerant Type Selected
-03	Low Sound Cap Limit With Single Stage Unit

T174 – 4 to 20 mA Cooling Set Point Input Failure Alert

Action taken by control: Set Point function disabled. Chiller controls to CSP.1.

This alert will be generated if the 4-20 mA signal is less than 2 mA or greater than 22 mA. The EMM module must be enabled for this option.

Care should be taken when interfacing with other manufacturer's control systems, due to power supply differences, full wave bridge versus half wave rectification. The two

different power supplies cannot be mixed. ComfortLink controls use half wave rectification. A signal isolation device should be utilized if a full wave bridge signal generating device is used.

If this condition is encountered, check the following items:

- Check the configuration of the EMM *Energy Management Module* (Configuration Mode, Sub-mode OPT1). It should be set to YES.
- Check the signal input reading, CSP 4-20 mA Cooling Set Point (Inputs Mode, Sub-mode 4-20)
- Check the wiring of the 4-20 mA signal generator for proper connection and polarity. There is a small label next to TB5 and TB6, 30RA500099. Rev. 2.0 has a known error for the connection of the 4-20 mA signal. The label diagram for the machine is correct and should be followed.
- Check the 4-20 mA signal generator for a proper signal.
- Check the Energy Management Module connections for a bad channel.

T176 – 4 to 20 mA Temperature Reset Input Failure Alert

Action taken by control: Temperature Reset function disabled. Chiller returns to normal temperature control.

This alert will be generated if the 4-20 mA signal is less than 2 mA or greater than 22 mA. The EMM module must be enabled for this option.

Care should be taken when interfacing with other manufacturer's control systems, due to power supply differences, full wave bridge versus half wave rectification. The two different power supplies cannot be mixed. ComfortLink controls use half wave rectification. A signal isolation device should be utilized if a full wave bridge signal generating device is used.

If this condition is encountered, check the following items:

- Check the configuration of the EMM *Energy Management Module* (Configuration Mode, Sub-mode OPT1). It should be set to YES.
- Check the signal input reading, RSET 4-20 mA Reset Signal (Inputs Mode, Sub-mode 4-20)
- Check the wiring of the 4-20 mA signal generator for proper connection and polarity. There is a small label next to TB5 and TB6, 30RA500099. Rev. 2.0 has a known error for the connection of the 4-20 mA signal. The label diagram for the machine is correct and should be followed.
- Check the 4-20 mA signal generator for a proper signal.
- Check the Energy Management Module connections for a bad channel.

T177 – 4 to 20 mA Demand Limit Input Failure Alert

Action taken by control: Demand Limit function disabled. Chiller returns to 100% Demand Limit.

This alert will be generated if the 4-20 mA signal is less than 2 mA or greater than 22 mA. The EMM module must be enabled for this option.

Care should be taken when interfacing with other manufacturer's control systems, due to power supply differences, full wave bridge versus half wave rectification. The two different power supplies cannot be mixed. ComfortLink controls use half wave rectification. A signal isolation device should be utilized if a full wave bridge signal generating device is used.

If this condition is encountered, check the following items:

- Check the configuration of the EMM *Energy Management Module* (Configuration Mode, Sub-mode OPT1). It should be set to YES.
- Check the signal input reading, DMND *4-20 mA Demand Signal* (Inputs Mode, Sub-mode 4-20)
- Check the wiring of the 4-20 mA signal generator for proper connection and polarity. There is a small label next to TB5 and TB6, 30RA500099. Rev. 2.0 has a known error for the connection of the 4-20 mA signal. The label diagram for the machine is correct and should be followed.
- Check the 4-20 mA signal generator for a proper signal.
- Check the Energy Management Module connections for a bad channel.

A189 – Cooler Pump and Aux Contact Input Miswired Alarm

Action taken by control: Chiller prevented from starting.

This alarm will be generated if the lag pump's auxiliary contacts close for at least 10 seconds when the lead pump is commanded to start.

With MBB Version 4.0 Software, the time limit changed to 20 seconds.

If this condition is encountered, check the following items:

- Check the wiring of the auxiliary contacts
- Check the wiring to the cooler pump relay.

T190 – Cooler Pump 1 Aux Contacts Failed to Close at Start-Up Alert

T191 – Cooler Pump 2 Aux Contacts Failed to Close at Start-Up Alert

Action taken by control: Chiller prevented from starting.

Reset Method: Manual (MBB)

This alarm will be generated if the auxiliary contacts on the chilled water pump contactor supplied as part of the hydronic package do not close within 26 seconds of the pump being commanded on. If available, the other pump will be started.

If this condition is encountered, check the following items:

- Check the wiring of the auxiliary contacts
- Check the pump contactor for proper operation.
- Check the pump contactor auxiliary contacts.
- Check the pump overload.
- Check the 24 vac inputs to the MBB and EMM board for a short. If the voltage drops below the minimum, the control will not recognize the circuit closure.

T192 – Cooler Pump 1 Failed to Provide Flow at Start-Up Alert

T193 – Cooler Pump 2 Failed to Provide Flow at Start-Up Alert

Action taken by control: Chiller prevented from starting.

Reset Method: Automatic/Manual (MBB)

This alert will be generated if the chilled water flow switch does not close within one (1) minute. The affected pump will be shut down and if available the other pump will be started. Additionally an A200 – Cooler Flow/Interlock failed to close at Start-Up will be generated and chiller will not be allowed to start.

If this condition is encountered, check the following items:

- Check the chilled water flow switch for proper operation.
- Check the chilled water pump interlock circuit for proper operation
- Check the pump electrical circuit for power.
- Check the pump circuit breaker and contactor for proper operation.
- Check the chilled water pump for proper operation.

T194 – Cooler Pump 1 Contacts Opened During Normal Operation Alert

T195 – Cooler Pump 2 Contacts Opened During Normal Operation Alert

Action taken by control: Chiller shutdown.

Reset Method: Automatic/Manual (MBB)

This alert is generated if the integral chilled water pump auxiliary contact interlock opens for 26 seconds after initially being closed. The affected pump will be shut down and if available the other pump will be started.

If this condition is encountered, check the following items:

- Check the wiring of the auxiliary contacts
- Check the pump contactor for proper operation.
- Check the pump contactor auxiliary contacts.
- Check the pump overload.

T196 – Flow Lost While Pump 1 Running Alert

T197 – Flow Lost While Pump 2 Running Alert

Action taken by control: Chiller shutdown.

Reset Method: Automatic/Manual (MBB)

This alert will be generated for the appropriate pump if the chilled water flow switch opens for at least three (3) seconds after initially being closed, and an A201 - Cooler Flow/Interlock Contacts Opened During Normal Operation Alarm will be generated and the machine will stop. If available, the other pump will be started. If flow is proven, the machine will be allowed to restart.

If this condition is encountered, check the following items:

- Check the chilled water flow switch for proper operation.
- Check the pump electrical circuit for power.
- Check the pump circuit breaker
- Check the pump contactor for proper operation.
- Check the chilled water pump for proper operation.

T198 – Cooler Pump 1 Aux Contacts Closed While Pump Off Alert

T199 – Cooler Pump 2 Aux Contacts Closed While Pump Off Alert

Action taken by control: Chiller not allowed to start.

Reset Method: Automatic/Manual (MBB)

If the control detects that the chilled water pump auxiliary contacts are closed for at least 26 seconds while the pump is OFF, the appropriate is generated. The chiller will not be allowed to start.

If this condition is encountered, check the following items:

- Check the wiring of the auxiliary contacts
- Check the pump contactor for proper operation.
- Check the pump contactor auxiliary contacts.

A200 – Cooler Flow/Interlock Failed to Close at Start-Up Alarm

Action taken by control: Chiller shut down or prevented from starting.

Reset Method: Automatic/Manual (MBB)

This alarm will be generated if CPC *Chilled Water Pump Control* (Configuration Mode, Sub-mode UNIT) is ON and the chilled water flow switch does not close within 1 minute. If the machine is equipped with dual pumps, the second pump will be started. If CPC is OFF, this alarm will be generated if the chilled water flow switch and if equipped the chilled water pump interlock circuit does not close within 5 minutes.

If this condition is encountered, check the following items:

- Check the chilled water flow switch for proper operation.
- Check the chilled water pump interlock circuit for proper operation
- Check the pump electrical circuit for power.
- Check the pump circuit breaker
- Check the pump contactor for proper operation.

- Check the chilled water pump for proper operation.

A201 - Cooler Flow/Interlock Contacts Opened During Normal Operation Alarm

Action taken by control: Chiller shut down.

Reset Method: Automatic/Manual (MBB)

This alert will be generated for the appropriate pump if the chilled water flow switch opens for at least three (3) seconds after initially being closed, and an A201 - Cooler Flow/Interlock Contacts Opened During Normal Operation Alarm will be generated and the machine will stop. If available, the other pump will be started. If flow is proven, the machine will be allowed to restart.

If this condition is encountered, check the following items:

- Check the chilled water flow switch for proper operation.
- Check the chilled water loop to be sure that it is completely filled with water.
- Check the chilled water pump interlock circuit for proper operation
- Check the pump electrical circuit for power.
- Check the pump circuit breaker
- Check the pump contactor for proper operation.
- Check the chilled water pump for proper operation. Look for overload trips.
- Check the chilled water strainer for a restriction.
- Check to be sure that all isolation valves are open completely.

A202 – Cooler Pump Interlock Closed When Pump is Off Alarm

Action taken by control: Chiller shut down.

Reset Method: Automatic/Manual (MBB)

This alarm will be generated if the *CPC Cooler Pump Control* (Configuration Mode, Sub-mode OPT1) is ON and the control detects that the chilled water pump interlock and/or chilled water flow switch circuit is closed for at least five (5) minutes with the pump output OFF. If this detected, the unit will not be allowed to start.

If this condition is encountered, check the following items:

- Check the wiring of the auxiliary contacts
- Check the pump contactor for proper operation.
- Check the pump contactor auxiliary contacts.
- Check the chilled water flow switch for proper operation.
- Check the chilled water pump interlock circuit for proper operation

A207 – Cooler Freeze Protection Alarm

Action taken by control: Chiller shut down or prevented from starting. Chilled Water Pump will be turned on.

Reset Method: Automatic/Manual (MBB)

This alarm will be generated when the leaving water temperature is below BR.FZ, *Brine Freeze Point* (Set Point Mode, Sub-mode FRZ). When this condition is encountered, the machine will enter Mode 16, and the Chilled Water Pump relay will be energized, even if the CPC *Cooler Pump Control* (Configuration Mode, Sub-mode OPT1) is OFF. If the machine is equipped with a pump, the pump will run for a minimum of 5 minutes. The unit will be shut down or prevented from starting.

The control will allow the machine to reset automatically if the leaving chilled water temperature rises above the BR.FZ *Brine Freeze Point* (Set Point Mode, Sub-mode FRZ) plus 6 °F (3.3 °C). If the alarm is generated again during the same day, it shall be a manual reset.

If this condition is encountered, check the following items:

- Check the entering or leaving water thermistor for accuracy.
- Check water flow rate.
- Check for freezing conditions.
- Check the heat tape and other freeze protection means for proper operation.
- Check glycol concentration and adjust BR.FZ accordingly.

Resetting Alarms and Alerts

The method to reset any alarm or alert depends upon the alarm or alert, automatic or manual. Before any alarm or alert is reset, first find the cause of the alarm or alert and correct the situation.

Automatic Alarm or Alert:

An automatic alarm or alert will reset itself, without operator intervention if the condition corrects itself.

Manual Alarm or Alert:

One or more of the following methods must be used to reset the manual alarm or alert.

To reset a MBB alarm or alert, once the condition has been corrected, from the Navigator. Changing the RCRN *Reset All Current Alarms* (Alarms Mode, Sub-mode RCRN) from NO to YES. Another method is to move the LOCAL-OFF-REMOTE switch from "LOCAL" or "REMOTE" to "OFF" for less than four (4) seconds and back to its original position to reset the alarm or alert.

Alarm History

All Alarms and Alerts are date and time stamped and written to the Alarm History. The Alarm History can be found under HIST *Alarm History* (Alarms Mode, Sub-mode HIST). This buffer will hold the last 20 alarms/alerts. Once the buffer is full, the oldest alarms are lost as the newer alarms enter the buffer.

An option to clear the Alarm History was provided in the earlier versions of the AquaSnap software. By toggling RHIS *Reset Alarm History* (Alarms Mode, Sub-mode RHIS) to YES, the alarm history would be cleared. This option was removed with Version 3.0 software.

Chilled Water Storage Tank

Optional field installed storage tanks are available for these machines. The tanks are designed for installation under the AquaSnap units. The tanks can be installed elsewhere. If the tanks are installed outdoors not under the machine, a cover must be field fabricated to cover the tank assembly.

Original production storage tanks had a 2" NPT pipe plug with a 2-1/2" hex head for the drain connection. For storage tanks with serial numbers starting with approximately 0303 (year, week), the 2-1/2" hex head was changed to a 1-5/16" square head to make it easier to remove.

Sockets for these plugs can be difficult to obtain. Listed below is Snap-On Part Numbers for sockets and accessories that will work. There are other suppliers who can supply the same items at reduced prices and should be consulted first. The parts listed below assume that the technician has a 3/4" drive Ratchet or T-Handle. The drain plug is approximately 8" in from the outside perimeter of the storage tank skin. As a result an extension to reach the plug is also needed.

Serial Number	Drain Plug Style	Snap-On Part Number	Description
0118 through 0302	2-1/2" Hex	L803	Socket, Shallow, 2-1/2", 6 point, 1" Drive
		GLA72A	Adaptor, 3/4" Internal Drive x 1" External Drive, 2-5/8"
0303 and later	1-5/16" Square	IM642	Socket, Impact, Shallow, Double Square, 1-5/16", 8 point, 3/4" Drive

Chilled Water Storage Tank Serial Number

The Storage Tank Serial Number is a 10-digit number. The format is shown below.

Position	1-2	3-4	5-10
Example	02	19	-00003

Last 2 digits of Year of Production

Week of Production

Sequential Number

In the example above, this storage tank serial number 0219-00003 indicates that it was produced week 19 of 2002.

Chilled Water Storage Tank Heaters

Storage Tank Heaters are available. The number of heaters depends upon the size of the storage tank. The blanket-style heater, 30RA401216 is rated at 1620 +5%/-10% watts and are rated for 230 volts only. Cold resistance is 32.7 +3.2/-1.6 ohms at 75 °F.

Storage Tank	No. of Heaters
30RA-900---001	2
30RA-900---009	2
30RA-900---010	4

A separate control box for electrical connections is provided.

For information on the storage tank heater control, see Heater Control (Cooler, Pump, Storage Tank) on page 55.

ComfortLink Control Boards

All connections to the Comfortlink Control Boards are made with trifurcated crimp terminals in board connectors. Use the following tool to make the crimp connections for the board connector for all connections other than thermistors. For thermistor connections, see Thermistors on page 134.

Table 2 - ComfortLink Board Connection Terminating Tools

Description	Manufacturer	Part Number
Crimper, Micro Pin	Packard Electric	3157075
	Paladin Tools	1631

Interface Devices

Scrolling Marquee Display

Troubleshooting:

Communications

The following table has the design resistance in ohms as measured between the pins of the connector listed. Values to as little as half of the listed resistance can be expected to perform without any problems. All measurements are to be made with power removed from the board and no connections to either the LEN or CCN ports.

Table 3 - Scrolling Marquee LEN Resistance Chart

Part Number			Serial Number	(LEN) Resistance between Pins / Connector		
With Software	Without Software	Vendor		Pins 1 to 3	Pins 1 to 2	Pins 2 to 3
HK50AA031	HK50AA030	CEPL130347-01	Prior to 4802N	40K Ω J1	20K Ω J1	20K Ω J1
			Starting 4802N	287K Ω J1	7.25M Ω J1	5.9M Ω J1

If the arrow, [ENTER], or [ESCAPE] keys do not respond when pushed, check the seating of the printed circuit board into the casing of the scrolling marquee. If the board is not seated, the keys will not respond when pushed.

Service Bulletins pertaining to this condition:

- SMB020070 – ComfortLink Scrolling Marquee Failures
This bulletin addressed erratic operation of the keys and described the proper seating of the display to the circuit board for proper operation.

Navigator

Cleaning

The Navigator can be cleaned with a mild detergent. Isopropyl alcohol or a glass cleaner can be used on all Navigator surfaces.

Connection Cord/Plug Assembly Replacement

If the RJ14 plug is damaged, it can be replaced. If it is replaced, the wiring to the plug must be as shown below:

	Pin					
	1	2	3	4	5	6
Wire Color	Black	Green	Blue	Yellow	Red	White

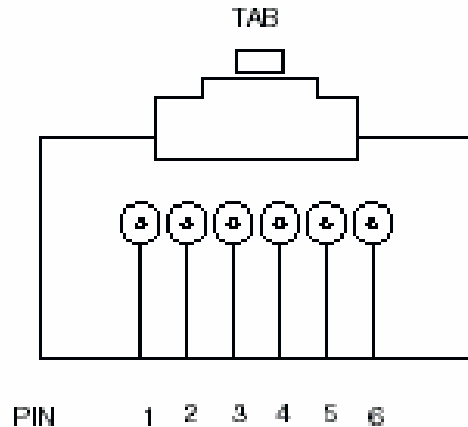

Figure 13 - Navigator Connection Diagram

The connection cable can be replaced if damaged. Replacement cables are available from Replacement Components Division. Remove the Navigator from the LEN connection before proceeding.

1. Remove the 6 screws from the back of the case to gain access to the internal plug for the device, and keep them for installation later.
2. The back cover is connected to the touch pad by a ribbon cable. The ribbon cable is not long enough to allow the two halves to be completely separated. To be able to access the plug connection, slightly offset the back cover. Be careful not to damage the ribbon cable.
3. Unplug the damaged cable.
4. Plug in the new cable.
5. Insert the rubber grommet (included with new cable assembly) into the cable entrance hole.
6. Realign the two halves of the Navigator. Be sure that the grommet is properly seated in the cable entrance hole.
7. Reinstall the 6 screws previously removed.

NOTE: Failure to properly seal the Navigator with the screws and grommet will compromise the watertight integrity of the device.

Troubleshooting:

Communications

The following table has the design resistance in ohms as measured between the pins of the connector listed. Values to as little as half of the listed resistance can be expected

to perform without any problems. All measurements are to be made with power off and no connections to either the LEN or CCN ports. Due to the difficulty in accessing the RJ14 connection, it is recommended the LEN resistance be measured at TB3. With the Navigator plugged into the TB3 RJ14 Port use the TB3 board connector pins after the internal harness has been disconnected to find the resistance.

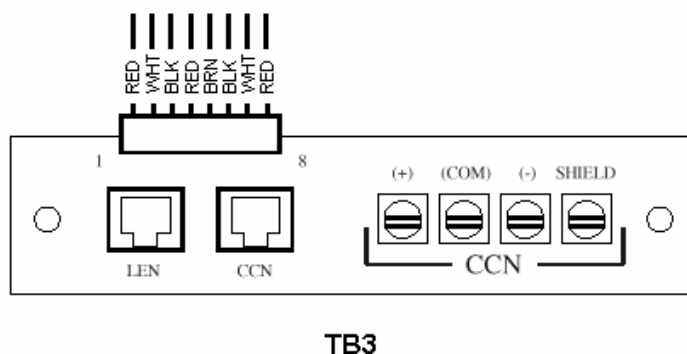

Figure 14 - TB3 Field Connections - LEN/CCN

Table 4 - Navigator LEN Resistance Chart

Part Number			Serial Number	(LEN) Resistance between Pins / Connector		
With Software	Without Software	Vendor		Pins 1 to 3	Pins 1 to 2	Pins 2 to 3
HK50AA033		CEPL130435-01	All	220 Ω TB3	1000 Ω TB3	1000 Ω TB3

Loss of Communication

This failure is identified by a “Communication Failure” on the Navigator and a “COMM FAIL” on the Scrolling Marquee Display.

The Navigator to be very sensitive to the polarity of the 24 vac power connection. If the polarity of the power source is not correct, a Communication Failure will occur. Additionally, check the ground wire at TB3. This wire is a shielded wire and is not connected to the terminal block. It should be trimmed and insulated. If this wire comes in contact with the 24 vac power connection, the same problem can result.

If this condition is encountered, check the following items:

- Check the wiring from the MBB to TB3.
- Check for the proper polarity of the power supply.
- Check the ground wire at TB3. It should be insulated.
- Check the resistance of the Navigator.
- Disconnect all of the remaining Boards from the LEN connection. This will allow for a check of the communication chips of the other control boards. With the

Navigator plugged in, check to see if the alarm disappears. If it does, reconnect the devices individually to see which board is suspect.

- Disconnect all inputs to the MBB. A grounded input to the MBB can also cause a communication alarm.

Service Bulletins pertaining to this condition:

- SMB000067 – Navigator Failures
This bulletin described the potential wiring problems that can lead to a Communication Failure.

Energy Management Board (EMM)

The EMM is available as a factory-installed option or as a field-installed accessory. The EMM receives 4 to 20 mA inputs for the temperature reset, cooling set point reset and demand limit functions. The EMM also receives the switch inputs for the field-installed 2-stage demand limit and ice done functions. The EMM communicates the status of all inputs with the MBB, and the MBB adjusts the control point, capacity limit, and other functions according to the inputs received.

Addressing

The EMM board has 4-position DIP switch that must be set to “ON” for proper addressing.

Troubleshooting:

Communications

The following table has the design resistance in ohms as measured between the pins of the connector listed. Values as little as half of the listed resistance can be expected to perform without any problems. All measurements are to be made with power removed from the board and no connections to either the LEN ports.

Table 5 - Energy Management Board LEN Resistance Chart

Part Number			Serial Number	(LEN) Resistance between Pins / Connector		
With Software	Without Software	Vendor		Pins 1 to 3	Pins 1 to 2	Pins 2 to 3
30GT515218	HK50AA028	CEPL130351-01	Prior to 4902N	40K Ω J3 & J4	20K Ω J3 & J4	20K Ω J3 & J4
			Starting 4902N	287K Ω J3 & J4	7.25M Ω J3 & J4	5.9M Ω J3 & J4

Main Base Board (MBB)

This board contains the majority of the control system operating software and controls the operation of the machine. It has 11 input channels and 11 output channels. The MBB continuously monitors input/output channel information received from all the

modules and controls all output signals for all output channels. The processor module also controls the EXD driver module, commanding it to open or close each expansion device in order to maintain the proper refrigerant level in the cooler. Information is transmitted between the MBB; ComfortLink Compressor Protection (CCP) boards, the EXD driver module, the Screw Compressor Board (SCB), the Energy Management Module (EMM) and the Navigator modules through a 3-wire communications bus called the Local Equipment Network (LEN). The remote enhanced display is connected to the MBB through a 3-wire communications bus, but uses a different communication bus called the Carrier Comfort Network (CCN). The CCN bus is also used to communicate to other CCN devices when the unit is installed in a network application.

Addressing

The Main Base Board (MBB) has an Instance Jumper on the board that must be set to “1”.

Troubleshooting:

Communications

The following table has the design resistance in ohms as measured between the pins of the connector listed. Values to as little as half of the listed resistance can be expected to perform without any problems. All measurements are to be made with power removed from the board and no connections to either the LEN or CCN ports.

Table 6 - Main Base Board LEN Resistance Chart

Part Number			Serial Number	(LEN) Resistance between Pins / Connector		
With Software	Without Software	Vendor		Pins 1 to 3	Pins 1 to 2	Pins 2 to 3
30RA501102	HK50AA029	CEPL130346-01	Prior to 4702N	15K Ω J3, J4, & J5	7.5K Ω J3, J4, & J5	7.5K Ω J3, J4, & J5
			Starting 4702N	18.9K Ω J3, J4, & J5	9.9K Ω J3, J4, & J5	9.9K Ω J3, J4, & J5

Table 7 - Main Base Board CCN Resistance Chart

Part Number			Serial Number	(CCN) Resistance between Pins / Connector		
With Software	Without Software	Vendor		Pins 5 to 7	Pins 5 to 6	Pins 6 to 7
30RA501102	HK50AA029	CEPL130346-01	Prior to 4702N	15K Ω J5	7.5K Ω J5	7.5K Ω J5
			Starting 4702N	18.9K Ω J5	9.9K Ω J5	9.9K Ω J5

Loss of Communication

If this condition is encountered, check the following items:

- Check the LEN connections for proper connection.

- If the machine is connected to a CCN network, check the connections to TB3. Be sure that only one end of the CCN wiring is connected.
- Disconnect all external input devices to the MBB. A short on any of these devices can cause the communications to be lost.
- If this does not correct the problem, disconnect the internal input devices on MBB-J6 and MBB-J7. Voltage across any device connection should be between 24 and 27 vac. Placing a jumper across any device pin should be registered by the MBB and can be verified under the Inputs Mode.

Machine does not start.

If this condition is encountered, check the following items:

- Check STAT *Control Mode* (Run Status, Sub-mode VIEW) for the machine status. LOCAL OFF means there is no signal to start. Check the Remote-Off-Enable Switch to be sure that is in the proper position. It must be in Enable even if the machine is controlled by CCN.
- Check the Remote-Off-Enable Switch to be sure it is correctly wired.
- If the Remote-Off-Enable switch is in the Remote position, check the remote contacts for a closure.
- Disconnect all external input devices to the MBB. A short on any of these devices can cause the communications to be lost.
- If this does not correct the problem, disconnect the internal input devices on MBB-J6 and MBB-J7. Voltage across any device connection should be between 24 and 27 vac. Placing a jumper across any device pin should be registered by the MBB and can be verified under the Inputs Mode.

Compressor

Danfoss-Maneurop Scroll compressors are used in AquaSnap Chillers.

The following table shows the compressor usage for the AquaSnap machines.

30RAN	Frequency	Compressor			
		A1	A2	B1	B2
010	60	SM125	-	-	-
010	50	SM160	-	-	-
015	60	SM185	-	-	-
015	50	SM110	SM110	-	-
018	60	SM110	SM110	-	-
018	50	SM125	SM125	-	-
022	60	SM115	SM160	-	-
022	50	SM160	SM160	-	-
025	60	SM160	SM160	-	-
025	50	SM185	SM185	-	-
030	60	SM185	SM185	-	-
032	50	SM115	SM160	SM185	-
035	60	SM115	SM160	SM185	-
035	50	SM185	SM185	SM185	-
040	60	SM160	SM160	SM185	-
042	50	SM160	SM160	SM160	SM160
045	60	SM125	SM160	SM125	SM160
045	50	SM185	SM185	SM185	SM185
050	60	SM160	SM160	SM160	SM160
055	60	SM185	SM185	SM185	SM185

Connection Information

Compressor	Suction	Discharge	Oil Equalizer
SM110	1-3/8" ODF	7/8" ODF	3/8" SAE Flare
SM115	1-3/8" ODF	7/8" ODF	3/8" SAE Flare
SM125	1-3/8" ODF	7/8" ODF	3/8" SAE Flare
SM160	1-5/8" ODF	1-1/8" ODF	3/8" SAE Flare
SM185	1-5/8" ODF	1-1/8" ODF	3/8" SAE Flare

Original production compressors were supplied with steel refrigerant connections. In March 2003, Danfoss began supplying these compressors with copper-clad steel refrigerant connections.

Crankcase Heaters

The standard product produced up to serial number 2204F or 2204Q, did not include crankcase heaters. Crankcase heaters were included with Remote Cooler Special Order. Machines produced with serial numbers starting with 2304F included crankcase heaters. Maneurop has existing part numbers for belly-band style heaters in 120, 240, 400, 460, and 575 volts only. The SM110, SM115, SM125 and SM160 compressors all use the same heaters. The SM185 compressor uses different heaters.

Compressor Model Number	Voltage-Hz	Carrier Part Number	Danfoss Part Number	Watts
SM110, SM115, SM125, SM160	120-60	-	7773010	50
	240-60	HT32BH640	7773003	50
	380-60 400-50	HT32BH750	7773009	50
	460-60	HT32BH754	7773006	50
	575-60	HT32BH930	7773119	75
SM185	120-60	-	7773012	100
	240-60	HT32BH642	7773007	100
	380-60 400-50	HT32BH752	7773011	75
	460-60	HT32BH756	7773015	75
	575-60	HT32BH932	7773120	75

Carrier Part Number	Danfoss Part Number	Voltage-Hz	Watts	Resistance Range, Ohms
-	7773010	120-60	50	
-	7773012	120-60	100	
HT32BH640	7773003	240-60	50	1,094 - 1,209
HT32BH642	7773007	240-60	100	547 - 605
HT32BH750	7773009	380-60	50	3,040 - 3,360
		400-50		
HT32BH752	7773011	380-60	75	2,026 - 2,240
		400-50		
HT32BH754	7773006	460-60	50	4,020 - 4,444
HT32BH756	7773015	460-60	75	2,918 - 3,226
HT32BH930	7773119	575-60	75	4,188 - 4,628
HT32BH932	7773120	575-60	75	4,188 - 4,628

Nominal Input Horsepower

The following table lists the individual input horsepower ratings for the compressors.

Compressor	Nominal Input Horsepower	
	60 Hz	50 Hz
SM110	12.5	10.5
SM115	13.5	11.2
SM125	14.7	12.0
SM160	19.1	15.6
SM185	21.8	18.3

Power Factor

Compressor power factor ratings are as follows.

Compressor	Power Factor at ARI 45F/130F/11,1K/8,3K	
	400V/50Hz	460V/60Hz
SM110S4	74.5	79.6
SM115S4	79	83.5
SM125S4	80.9	84.4
SM160T4	81.2	85.3
SM185S4	78.3	83.5

Oil

The Maneurop scroll compressors use a mineral oil with anti-wear additives. The correct oil is listed below:

Table 8 - Compressor Oils

Manufacturer	Designation	RCD Part Number	Qty
Penreco	Sontex 160 LT-A	PP680002	1 gallon

The original Controls and Troubleshooting book incorrectly listed this oil.

If a complete oil charge is required, only the PP680002 must be used. Danfoss has approved the use of 3GS Mineral Oil for compressors that have already been charged with oil, but are low on oil.

Oil Sightglass

Each of the 30RAN compressors is equipped with a sightglass on the side of the compressor. RCD has set-up replacement parts as listed below. Before placing an order, confirm the part numbers with EPIC.

Part Number	Description
6204001	Sightglass
8156013	Sightglass gasket

Compressor Replacement

When replacing a compressor, use caution to insure the proper wiring and phasing of the compressor. The Reverse Rotation Alarm checks the first compressor starting only. It is recommended that the compressor be started and checked for proper rotation, without the other compressors running. This can be accomplished in the Service Test Mode of the ComfortLink Controls.

RCD replacement compressors are shipped with an operating charge of oil.

Danfoss-Maneurop Scroll Compressor Unit Serial Numbers

Serial Numbers are composed of 2 alpha characters followed by a sequential number. Blocks of sequential numbers are assigned to a manufacturing location. The sequential number is essentially the unique serial number of the compressor. The number of digits included in the sequential number continues to increase with time. The year and month code are present for UL Listing purposes only.

Table 9 - Compressor Serial Number Significance Chart

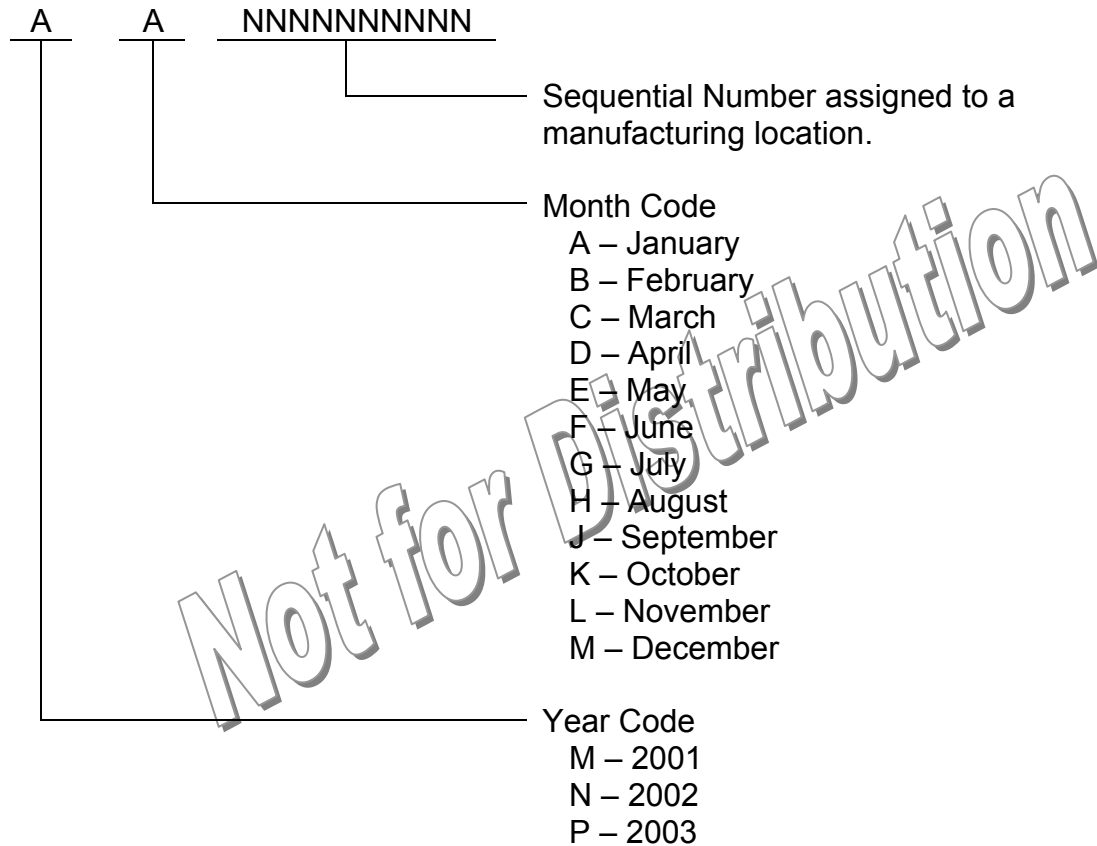

Weights

The following table lists the individual compressor weights. The RCD Replacement Part Number is for reference only.

30RA AquaSnap Chiller Service Manual

Compressor	Carrier Part Number	Voltage	RCD Replacement Part Number	Weight, lbs. (kg)
SM110	GC45UV001	200/230-3-60	P040-9951 † P040-10751	176 (80)
	GC45UR001	230-3-50	P059-8851	
	GC45UC001	380-3-60	P040-10761	
	GC45UT001	400-3-50 460-3-60	P040-9971 † P040-10771	
	GC45UL001	575-3-60	P040-9981 † P040-10781	
SM115	GC45VV001	200/230-3-60	P040-9952 † P040-11551	176 (80)
	GC45VR001	230-3-50	P059-9551	
	GC45VC001	380-3-60	P040-11561	
	GC45VT001	400-3-50 460-3-60	P040-9972 † P040-11571	
	GC45VL001	575-3-60	P040-9982 † P040-11581	
SM125	GC45WV001	200/230-3-60	P040-9953 † P040-12651	176 (80)
	GC45WR001	230-3-50	P059-10251	
	GC45WC001	380-3-60	P040-12661	
	GC45WT001	400-3-50 460-3-60	P040-9973 † P040-12671	
	GC45WL001	575-3-60	P040-9983 † P040-12681	
SM160	GC45XV001	200/230-3-60	P040-9954 † P040-16351	207 (94)
	GC45XR001	230-3-50	P059-13351	
	GC45XC001	380-3-60	P040-16361	
	GC45XT001	400-3-50 460-3-60	P040-9974 † P040-16371	
	GC45XL001	575-3-60	P040-9984 † P040-16381	
SM185	GC45YV001	200/230-3-60	P040-9955 † P040-18551	227 (103)
	GC45YR001	230-3-50	P059-15551	
	GC45YC001	380-3-60	P040-18561	
	GC45YT001	400-3-50 460-3-60	P040-9975 † P040-18571	
	GC45YL001	575-3-60	P040-9985 † P040-18581	

Note: † - Part Number is no longer valid – superseded to the one below by RCD.

Condenser Coil

Several condenser coil options are offered for corrosion protection.

Position 11 in the model number indicates the coil option

- “-“ Standard Aluminum Fin/Copper Tube Coil
- “C” Copper Fin/Copper Tube Coil
- “E” Aluminum Fin/Copper Tube Coil with E-Coat
- “F” Copper Fin/Copper Tube Coil with E-Coat
- “K” Aluminum Pre-coast Fin/Copper Tube

Table 10 - Condenser Fins/inch

30RA	Condenser Coil Option – Fins/inch				
	-	C	E	F	K
030	19.0				
050	19.0	17.0	19.0	17.0	19.0
055	19.0				

Non-E-coat Coil Cleaning

For standard aluminum, copper and pre-coated aluminum fin coils, clean the coils with a vacuum cleaner, fresh water, compressed air, or a bristle brush (not wire). Units installed in corrosive environments should have coil cleaning as part of a planned maintenance schedule. In this type of application, all accumulations of dirt should be cleaned off the coil. When condenser cleaning is complete, enter “Yes” for CL.MN, *Coil Maint. Done* (Run Status Mode, Sub-Mode PM/COIL).

CAUTION

Do not use high-pressure water or air to clean coils — fin damage may result.

E-Coat Coil Cleaning

Follow the outlined procedure below for proper care, cleaning and maintenance of E-coated aluminum or copper fin coils:

Coil Maintenance and Cleaning Recommendations — Routine cleaning of coil surfaces is essential to maintain proper operation of the unit. Elimination of contamination and removal of harmful residues will greatly increase the life of the coil and extend the life of the unit.

Remove Surface Loaded Fibers — Surface loaded fibers or dirt should be removed with a vacuum cleaner. If a vacuum cleaner is not available, a soft brush may be used. In either case, the tool should be applied in the direction of the fins. Coil surfaces can be easily damaged (fin edges bent over) if the tool is applied across the fins. NOTE: Use of a water stream, such as a garden hose, against a surface loaded coil will drive the fibers and dirt into the coil. This will make cleaning efforts more difficult. Surface loaded fibers must be completely removed prior to using low velocity clean water rinse.

Periodic Clean Water Rinse — A periodic clean water rinse is very beneficial for coils that are applied in coastal or industrial environments. However, it is very important that the water rinse is made with very low velocity water stream to avoid damaging the fin edges. Monthly cleaning as described below is recommended.

Routine Cleaning of Coil Surfaces — Monthly cleaning with Environmentally Sound Coil Cleaner is essential to extend the life of coils. It is recommended that all coils, including standard aluminum, pre-coated, copper/copper or E-coated coils are cleaned with the Environmentally Sound Coil Cleaner as described below. Coil cleaning should be part of the units regularly scheduled maintenance procedures to ensure long life of the coil. Failure to clean the coils may result in reduced durability in the environment.

Environmentally Sound Coil Cleaner is non-flammable, hypo allergenic, non-bacterial, USDA accepted biodegradable and 100% ecologically safe agent that will not harm the coil or surrounding components such as electrical wiring, painted metal surfaces or insulation. Use of non-recommended coil cleaners is strongly discouraged since coil and unit durability could be affected.

Environmentally Sound Coil Cleaner Application Equipment

- 2-1/2 Gallon Garden Sprayer
- Water Rinse with Low Velocity Spray Nozzle

Environmentally Sound Coil Cleaner Application Instructions:

- Although Environmentally Sound Coil Cleaner is harmless to humans, animals, and marine life, proper eye protection such as safety glasses is recommended during mixing and application.
- Remove all surface loaded fibers and dirt with a vacuum cleaner as described above.
- Thoroughly wet finned surfaces with clean water and a low velocity garden hose being careful not to bend fins.
- Mix Environmentally Sound Coil Cleaner in a 2-1/2 gallon garden sprayer according to the instructions included with the Enzyme Cleaner. The optimum solution temperature is 100 °F (38 °C). NOTE: DO NOT USE water in excess of 130 °F (55 °C) as the enzymatic activity will be destroyed.
- Thoroughly apply Environmentally Sound Coil Cleaner solution to all coil surfaces including finned area, tube sheets and coil headers.
- Hold garden sprayer nozzle close to finned areas and apply cleaner with a vertical, up-and-down motion.
- Avoid spraying in horizontal pattern to minimize potential for fin damage.
- Ensure cleaner thoroughly penetrates deep into finned areas.
- Interior and exterior finned areas must be thoroughly cleaned.
- Finned surfaces should remain wet with cleaning solution for 10 minutes.
- Ensure surfaces are not allowed to dry before rinsing. Reapply cleaner as needed to ensure 10-minute saturation is achieved.
- Thoroughly rinse all surfaces with low velocity clean water using downward rinsing motion of water spray nozzle. Protect fins from damage from the spray nozzle.

CAUTION

Harsh Chemical and Acid Cleaners — Harsh chemical, household bleach or acid cleaners should not be used to clean outdoor or indoors coils of any kind. These cleaners can be very difficult to rinse out of the coil and can accelerate corrosion at the fin/tube interface where dissimilar materials are in contact. If there is dirt below the surface of the coil, use the Environmentally Sound Coil Cleaner as described above.

High Velocity Water or Compressed Air — High velocity water from a pressure washer, garden hose or compressed air should never be used to clean a coil. The force of the water or air jet will bend the fin edges and increase airside pressure drop. Reduced unit performance or nuisance unit shutdown may occur.

When condenser cleaning is complete, enter “Yes” for CL.MN, *Coil Maint. Done* (Run Status Mode, Sub-Mode PM/COIL).

Condenser Fan System**Condenser Fan Blade****Condenser Fan Motor**

Two types of motors are used depending on the size of the machine and the number of condenser fans per circuit. See Condenser Fan Motor Usage on page 116 for further details.

Condenser Fan Motor Data

Fan Motor	Applied RPM		Nominal Input Horsepower	
	60 Hz	50 Hz	60 Hz	50 Hz
HD56AE380	850	-	1.0	
HD56AE460	850	700	1.0	1.0
HD56AE576	850	-	1.0	-

Condenser Fan Motor Usage

Unit	V-Hz	Condenser Fan Motor			
		A1	A2	B1	B2
30RAN022	380-60	HD56AE380	HD56AE380	-	-
30RAN055	208/230-60 230-60	HD56AE460	HD56AE460	HD56AE460	HD56AE460
	575-60	HD56AE576	HD56AE576	HD56AE576	HD56AE576

Control Circuit

The control circuit of the AquaSnap machines is powered via a control transformer that is factory supplied.

All 208/230 volt machines are supplied from the factory with the primary voltage tap connected on the 230 volt tap. If the machine is applied on a 208 volt system, it must primary tap of the control transformer must be connected to the 208 volt tap.

30RAN032-055 Series 0 machines were equipped with a 3.2 amp for CB2 to protect the control circuit. Series 1 machines increased the size of CB2 to 5.0 amps.

Cooler

The AquaSnap machines employ SWEP brazed plate heat exchangers. The heat exchangers are rated to a maximum waterside pressure of 150 psig (1034 kPa).

30RA Cooler							
30RAN	Cooler Part Number	Empty Weight lbs. (kg)	Water Side		Refrigerant		Volume, ft ³ (m ³)
			Connection Size, in. †	Volume, gal. (l)	Connection Size, in. [IDS]		
					Suction	Liquid	
055	LL01SB021	288.0 (160.0)	2-1/2		2.132/2.138	0.882/0.888	1.142

Note: † - Victaulic-type connection to internal piping.

Failure Analysis

The cause of all cooler failures should be determined, so as not to repeat the failure. Check the water strainer for proper application. It is recommended that a water sample be obtained and analyzed to determine if any corrosive materials are present.

SWEP Brazed Plate Heat Exchangers should not be exposed to chloride ions.

Cooler Heaters

AquaSnap uses a line voltage heater of 192 (+5%/-10%) watts. There are 2 types of heaters, based on voltage.

Table 11 - Cooler Heater Resistance

Heater	Voltage	Resistance (ohms) @ 75 °F
HT38KN013	208/230, 230	275.5 +30.6/-13.6
	380, 400, 460	1102.1 +122.4/-82.0
HT38KN014	575	1722.0 +191.3/-86.1

A plug assembly with a nut and grommet connects the heaters to the controls. A special connector is required to connect this assembly to the control box.

For information on the cooler heater control, see Heater Control (Cooler, Pump, Storage Tank) on page 55.

Expansion Device

The AquaSnap machines use adjustable superheat Thermostatic Expansion Valves as the expansion device. The valves are Maximum Operating Pressure (MOP) type valves. The valve will not allow the saturated suction temperature to rise above 60 °F (15.6 °C). The valve is factory set to maintain between 8 to 12 °F (4.4 to 6.7 °C) of superheat entering the compressor(s). Check suction superheat after conditions have stabilized.

If the superheat must be adjusted, make the adjustment ½ turn at a time. Allow the system to stabilize before measuring the suction superheat and making further adjustments. Turn stem counterclockwise to decrease superheat and clockwise to increase superheat.

MOP type valves are subject to cross ambient conditions. When the ambient is 20 °F (11 °C) or more colder than the suction line, the gas in the bulb condenses in the power head of the TXV. The liquid in the power head interferes with the operation of the TXV, and does not allow it to open. As a result, the cooler is starved of refrigerant, and the unit trips on low refrigerant pressure. If this condition is encountered, the TXV power head should be wrapped with self-regulating heater tape. Wrapping the power head will keep the temperature of power head higher than the bulb and not allow the gas to condense on the power head. The heater should be wired to turn on and off with cooler heater.

Initial production machines (1800F-0602F) were produced with Alco TXVs. The TXV bulbs were fastened with wire ties.

Unit	Alco TXV Part Numbers			
	Standard		Brine	
	Circuit A	Circuit B	Circuit A	Circuit B
30RAN010	EA02CG425	-	EA02CG425	-
30RAN015	EA02CG496	-	EA02CG425	-
30RAN018	EA02CG526	-	EA02CG526	-
30RAN022	EA02CG524	-	EA02CG511	-
30RAN025	EA02CG524	-	EA02CG511	-
30RAN030	EA02CG524	-	EA02CG511	-
30RAN032	EA02CG524	EA02CG496	EA02CG425	EA02CG425
30RAN035	EA02CG524	EA02CG496	EA02CG425	EA02CG425
30RAN040	EA02CG524	EA02CG496	EA02CG425	EA02CG425
30RAN042	EA02CG524	EA02CG524	EA02CG425	EA02CG511

30RAN045	EA02CG524	EA02CG524	EA02CG425	EA02CG511
30RAN050	EA02CG524	EA02CG524	EA02CG425	EA02CG511
30RAN055	EA02CG524	EA02CG524	EA02CG425	EA02CG511

Machines starting with serial numbers 0702F use Danfoss TXVs. With the implementation of the Danfoss TXVs, TXV bulb clamps were utilized to secure the bulbs to the suction line.

Unit	Danfoss TXV Part Numbers			
	Standard		Brine	
	Circuit A	Circuit B	Circuit A	Circuit B
30RAN010	EA02ZF510	-	EA02ZF510	-
30RAN015	EA02ZF511	-	EA02ZF510	-
30RAN018	EA02ZF512	-	EA02ZF511	-
30RAN022	EA02ZF512	-	EA02ZF511	-
30RAN025	EA02ZF512	-	EA02ZF511	-
30RAN030	EA02ZF513	-	EA02ZF512	-
30RAN035	EA02ZF512	EA02ZF511	EA02ZF511	EA02ZF510
30RAN040	EA02ZF512	EA02ZF511	EA02ZF511	EA02ZF510
30RAN045	EA02ZF512	EA02ZF512	EA02ZF511	EA02ZF511
30RAN050	EA02ZF512	EA02ZF512	EA02ZF511	EA02ZF511
30RAN055	EA02ZF513	EA02ZF513	EA02ZF512	EA02ZF512

Some Danfoss TXVs have been incorrectly set at the supplier, resulting in superheats of 25 to 30 °F (13.9 to 16.7 °C). The incorrect superheat setting results in T116 – Circuit A Low Cooler Suction Temperature or T117 – Circuit B Low Cooler Suction Temperature Alerts. The table listed below shows the correction and the week of the supplier production. This date may not coincide with the AquaSnap Serial Number.

TXV Part Number	Comment
EA02ZF510	Danfoss setting change effective Week 19, 2003
EA02ZF511	No change to superheat setting
EA02ZF512	Danfoss setting change effective Week 26, 2003
EA02ZF513	Danfoss setting change effective Week 49, 2002

Note: Dates provided are Supplier Production Dates.

Hydronic Package

Chilled Water Flow Switch

A factory installed, paddle-type chilled water flow switch is standard on all machines. The factory-installed, vapor-proof, paddle-type flow switch is preferred over the differential pressure switches. The factory provided flow switch is Carrier Part Number, HR81LG005 (McDonnell & Miller P/N: FS8-W). The switch is rated for waterside pressures of 150 psig (1034 kPa), fluid and ambient temperatures down to 32 °F (0 °C)

during operation. This switch is acceptable in lower ambients if the chilled water loop is drained and winterized.

NOTE: HR81LG005 has two manufacturers: McDonnell & Miller FS7-4W and Johnson Controls/Penn F61MG-1. The John controls/Penn switch will not fit on Aquasnap units with hydronic pump packages. The location of other components within the pump assembly enclosure prevents turning the switch's head when installing. For such units only the McDonnell & Miller switch is usable. Starting at the end of 2004 (approximately) RCD was shipping only this latter switch when HR81LG005 was ordered.

If the application is outside of this temperature range, a different flow switch must be field installed. Carrier Part Number HR81LG010 (originally McDonnell & Miller P/N: FS7-4W, with a rating of at least 150 psig (1034 kPa), for fluid and ambient temperatures down to -65 °F (-53 °C)) has been recommended for this application. Currently HR81LG010 specifies Dwyer V4-2U-MV which is rated for fluid and ambient temperatures down to -20° F (- 29°C). NOTE: The HR81LG010 switch will not fit on units with the pump package.

With both switches, the conduit connection to the flow switch must be sealed. Failure to do so will allow water to accumulate on the switch head. If the alternate flow switch is installed, the paddle must be trimmed for the appropriate size pipe. See the manufacturer's instructions supplied with the switch.

Very early production no-pump units used a 2" paddle for the flow switch. Beginning with serial numbers 2601F for the 30RAN010-030, and 3301F for the 30RAN032-055, the paddle length was changed to 1".

Pump packages used on the 30RAN010-030 units use the 1" paddle for the flow switch.

Pump packages used on the 30RAN032-055 units use both the 1" paddle and 2" paddle trimmed to 1-5/8" from the mounting hole center (overall length, 1-7/8") for the flow switch.

On units without a pump package, the flow switch conduit opening was not sealed. Beginning with models produced with serial numbers 0403F, the conduit opening will be sealed from the factory.

Chilled Water Pump

The AquaSnap machines have the option of single or dual pump factory installed and tested pump packages for varying external available heads. The pump packages are rated for a maximum waterside pressure of 150 psig (1034 kPa).

Pump Replacement

If a pump must be replaced, it is suggested that a pump assembly not be purchased. The pump volute is connected to the system by sweat connections. There are no unions in the piping. A Pump Motor Assembly is the recommended part to use. This kit includes the Motor, Water Slinger, Motor Bracket, Shaft Sleeve, Seal Kit, Impeller, Impeller Lockwasher and Impeller Nut with a Volute Gasket. The volute will remain in place.

Pump Option	Description	Pump Assembly less Volute		
		208-230/460-3-60	380-3-60	575-3-60
A	Single Pump, 1.5 Hp	168216	168226	168221
B	Single Pump, 2 Hp, Low Head	168218	168228	168223
C	Single Pump, 2 Hp, High Head	168217	168227	168222
D	Single Pump, 3 Hp	168219	168229	168224
E	Single Pump, 5 Hp	168220	168230	168225
F	Dual Pump, 1.5 Hp	168216	168226	168221
G	Dual Pump, 2 Hp, Low Head	168218	168228	168223
H	Dual Pump, 2 Hp, High Head	168217	168227	168222
J	Dual Pump, 3 Hp	168219	168229	168224
K	Dual Pump, 5 Hp	168220	168230	168225

Pump Seal

There is a mechanical seal for the pump shaft. RCD has seal kits available for service replacement. The seal kit 186921, includes the following parts: volute gasket, seal kit, shaft sleeve, and water slinger. Before ordering the seal kit, see EPIC2000 to confirm the part numbers.

Troubleshooting:

If a pump seal fails prematurely, check the following items:

- Check the fluid. High suspended solids can wear the seal out quicker.
- Check the fluid. Concentrations of glycol greater than 50% can cause the seal to fail. In some cases reducing the concentration can allow the seal to re-seal.
- Check the fluid. Be sure that the only solutions being pumped are approved in this application, such as fresh water, propylene or ethylene glycol are the only approved solutions.
- Check the motor shaft for concentricity. A bent shaft may result in a seal failure.

Chilled Water Pump Heaters

AquaSnap uses a line voltage heater of 192 (+5%/-10%) watts internal to the pump package enclosure. There are 2 types of heaters, based on voltage.

Table 12 - Chilled Water Pump Heater Resistance

Heater	Voltage	Resistance (ohms) @ 75 °F
HT38KN013	208/230, 230	275.5 +30.6/-13.6
	380, 400, 460	1102.1 +122.4/-82.0
HT38KN014	575	1722.0 +191.3/-86.1

A plug assembly with a nut and grommet connects the heaters to the controls. A special connector is required to connect this assembly to the control box.

For information on the pump heater control, see Heater Control (Cooler, Pump, Storage Tank) on page 55.

Expansion Tank

As part of the Hydronic Package, an expansion tank is connected ahead of the pump suction.

The tank is connected to the return water (pump suction) line via brass connections. For all machines, a flexible braided smooth bore Teflon hose is used. The flexible hose has a ½" NPT male and ½" swivel NPT male for connections. The hose is 36" long.

Strainer

The cooler piping supplied by the factory includes a 20 mesh stainless steel, Y-type strainer. This strainer is installed in both the No Cooler Pump Packages as well as machines with the Cooler Pump Packages.

Early AquaSnap large chassis machines (032-055) without pumps were supplied with a Y-type strainer that was piped from the factory backwards. Units produced beginning 4401F21487 are correct.

Early AquaSnap large chassis machines (032-055) may have a 2" rather than a 2-1/2" strainer resulting in a higher water system pressure drops. This was a substitution was done by the supplier without authorization. A letter was sent to the affected distributors.

The following pressure drop table is for fresh water applications. It is intended as a guide only.

Table 13 - Strainer Pressure Drop (Fresh Water)

Flow		Strainer Size					
		2"			2-1/2"		
gpm	lpm	psid	ft w.g.	kPad	psid	ft w.g.	kPad
10	38	0.10	0.23	0.69	0.10	0.23	0.69
20	76	0.10	0.23	0.69	0.10	0.23	0.69
30	114	0.10	0.23	0.69	0.10	0.23	0.69
40	152	0.20	0.46	1.38	0.10	0.23	0.69
50	190	0.30	0.69	2.07	0.20	0.46	1.38
60	228	0.50	1.16	3.45	0.25	0.58	1.72
70	266	0.70	1.62	4.83	0.30	0.69	2.07
80	304	1.00	2.31	6.89	0.40	0.92	2.76
90	342	1.50	3.47	10.34	0.45	1.04	3.10
100	380	2.00	4.62	13.79	0.50	1.16	3.45
120	456	2.50	5.78	17.24	0.60	1.39	4.14
140	532	3.40	7.85	23.44	0.90	2.08	6.20
160	608	4.50	10.40	31.02	0.95	2.19	6.55
180	684	5.00	11.55	34.47	1.00	2.31	6.89
200	760	6.50	15.02	44.81	1.20	2.77	8.27
225	855	8.00	18.48	55.15	1.50	3.47	10.34
250	950	9.50	21.95	65.49	1.80	4.16	12.41
300	1140	11.00	25.41	75.83	2.50	5.78	17.24
400	1520	-	-	-	4.30	9.93	29.64
500	1900	-	-	-	6.10	14.09	42.05
600	2280	-	-	-	8.50	19.64	58.60

Minimum Load Control

AquaSnap Chillers have a fixed orifice solenoid that allows for a metered amount of refrigerant to be bypassed. At nominal rating conditions, the valve will bypass approximately 4 to 5 tons.

**Head Pressure Control
MotorMaster V Control**

Beginning with Serial Number 4203F, the control of the MotorMaster V device was changed to use the Run-Stop jumper on the MotorMaster V.

Beginning with Serial Number 4303F, the head pressure set point parameter of the MotorMaster V, P34 was changed from 18 to 24. This change raised the approximate setting from 140 psi to 200 psi.

MotorMaster V requires the use of a jeweler’s screwdriver. A standard control screwdriver is too large for the controller’s screw terminal block.

The controller operates based on liquid line pressure. It is recommended that a tee be installed on the liquid line pressure port. Connecting the transducer to one port allows for an open port for service. The transducer should be wired to the controller as follows.

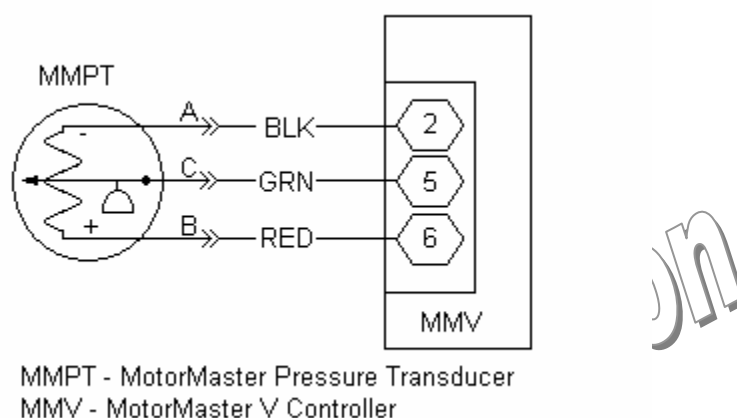

Figure 15 - MotorMaster V Pressure Transducer Wiring

Current Limiter

A current limiter plug protects the drive, which is voltage dependent. Each plug has a set of three Inrush Current Protectors.

Unit Voltage	Current Limiter Plug Part Number	Inrush Current Protector Manufacturer Part Number	Resistance at 77 °F (25 °C)
208/230-3-60 230-3-50	30RA501350	SL22 7R010	7.0 Ω ± 20% (5.6 - 8.4 Ω)
380-3-60 380/415-3-50 460-3-60 575-3-60	30RA501351	SL22 20005	20.0 Ω ± 20% (16.0 – 24.0 Ω)

Beginning with Serial Numbers starting with 4203F, The Current Limiter device was removed from the electrical circuit when the control was changed to use the Run-Stop jumper feature of the MotorMaster V.

Installation

In the larger 035-055 machines with the Run-Stop Contact control scheme, a 2 and 5 horsepower drive is sent in the accessory kits. The 5 horsepower drive will not fit in the control box without a modification of the inner panel. The inner panel was included in the accessory kits beginning with Week ?, 2004. If the provided kit did not come with the panel and clearance hole, the template below can be used. This hole is

dimensioned from the lower left hand corner of the inner panel. All dimensions are in inches.

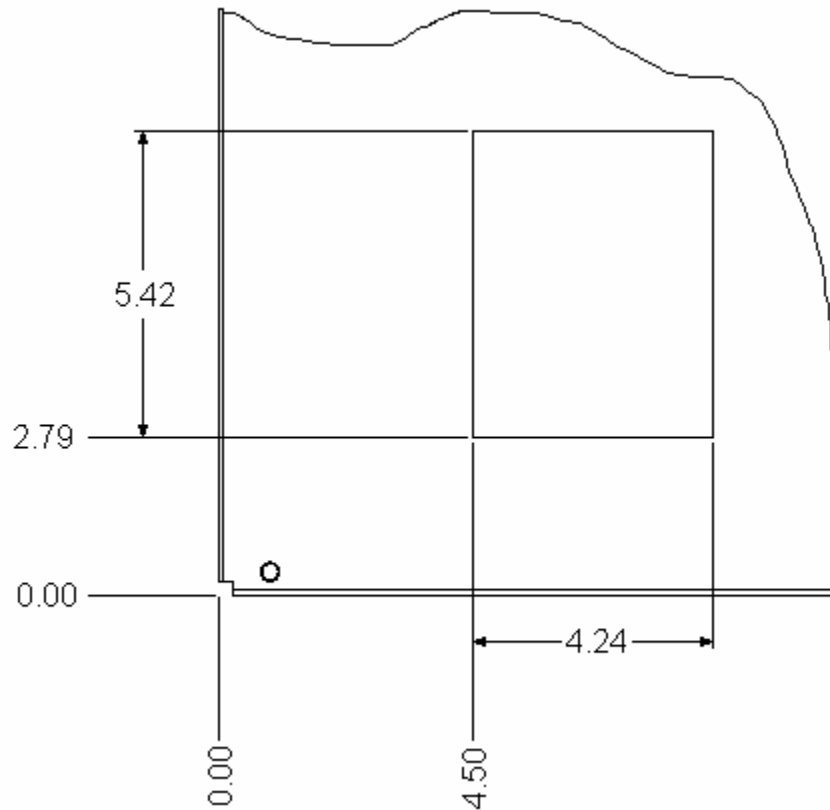
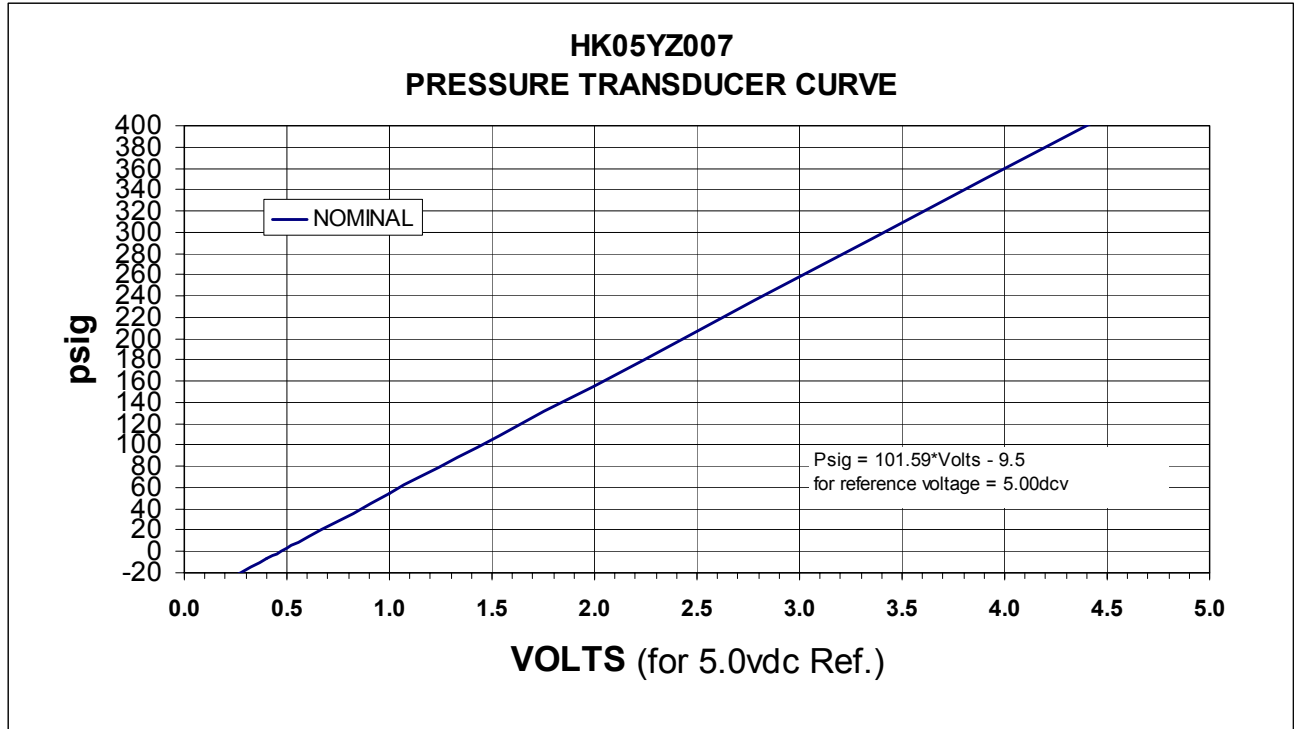

Figure 16 - Control Box Hole for MotorMaster V, 5 Hp Drive (30RAN032-055)

Troubleshooting

Transducer

A transducer on the liquid line provides the input to the drive for speed control. Either an HK05YZ002 or HK05YZ007 can be used. Both transducers have the same operating characteristics.



The MotorMaster V has several operating modes and fault codes to determine failures. They are listed below:

CL – Current Limit

Action taken by Control: Reduced speed output

Type: Operating Mode

Reset Method: None

This operating mode is generated if the output has exceeded the Current Limit setting (Parameter P25) and the drive is reducing the output frequency to reduce the output current. If the drive remains in this alarm for too long, it can trip into a Current Overload fault (PF).

If this condition is encountered, check the following items:

- Check P25 setting. It should be set to 104.
- Check for a faulty motor.
- Check for a voltage imbalance.

LCS – Loss of Control Signal

Action taken by Control: Operation at default speed

Type: Fault Code

Reset Method: Cycle Power or Start Command Jumper

If the control signal is lost, the MotorMaster V will flash 57 and LCS for 60 Hz operation, or 47 and LCS for 50 Hz operation. While in this fault condition, the drive will operate at 57 Hz for 60 Hz operation or 47 Hz for 50 Hz operation, until the fault is reset, or the start command is removed.

If this condition is encountered, check the following items:

- Check the transducer wiring.
- Check for a faulty transducer.
- Check TB6 to TB2 for a 5 vdc output.
- Check TB5 to TB2 for voltage. It should be between 0 and 5 vdc. Compare this value with P69 on the MotorMaster V controller.
- Check the internal wiring of the MotorMaster V controller. There is a wiring connector between the TB and the controller board.

PF – Current Overload Fault

Action taken by Control: Operation at default speed

Type: Fault Code

Reset Method:

This alarm is generated if the output has exceeded the Current Limit setting (Parameter P25).

If this condition is encountered, check the following items:

- Check P25 setting. It should be set to 104.
- Check for a faulty motor.
- Check for a voltage imbalance.

Current Limiter Failure

The current limiter is housed in a translucent Amp plug and will brown somewhat during normal operation. The current limiter operating temperatures can reach up to 350 °F (176.7 °C).

Current Limiter Failure

If Current Limiter Failures are found, check the following:

- Verify the overload setting is correct.
- Check the current limiter resistance.
- Modify the following Drive Parameters:
 - Change P19 from 10 to 20
 - Change P25 from 110 to 104
 - Change P64 from 4 to 3.5
 - Change P66 from 5 to 10.

This device was removed when the control scheme was changed to the Run-Stop Jumper control.

Network Service Tool IV

Network Service Tool can be a useful diagnostic tool.

When using Service Tool and incorrect data is displayed, remove and add the current unit. This is especially true if new software has been loaded since the last time the unit was viewed through Service Tool. New versions of software may include table structure changes. In order for the information to be correct, the unit must be removed and added within Service Tool to have the new table structure created. If changes to the program did change the table structure, the software version will be incremented by a whole number, such as 1.0 to 2.0. If changes to the program did not change the table structure, the software will increment by a revision number, such as 2.0 to 2.1.

Troubleshooting:

If communications cannot be established with the control, check the following items:

- Check the B&B Converter.
- Confirm the CCNA *CCN Address* (Configuration Mode, Sub-mode OPT2) and CCNB *CCN Bus Number* (Configuration Mode, Sub-mode OPT2) of the device.
- Confirm the BAUD *CCN Baud Rate* (Configuration Mode, Sub-mode OPT2). It should be set for 3 (9600).

Non-Fused Disconnect

Carrier 30 Series Chillers can be supplied with Non-Fused Disconnects. These are factory installed devices that provide an electrical disconnect at the machine. In accordance with good safety practices and regulations, always check with a voltmeter to insure that the power is OFF to all phases, even though the switch handle may indicate OFF. Electrical shock can cause personal injury and death. All power sources should be open and tagged before any service work is started.

With the Non-Fused Disconnects, the actuating shaft extends from the body to the door where the handle is installed.

Series 0 (Square D Non-Fused Disconnects)

Series 1 (Siemens Non-Fused Disconnects)

The following Table shows the Non-Fused Disconnects used in the Series 1 machines. These part numbers are for reference only and should be confirmed before ordering replacement parts.

Series 1 Machines					
Unit	Voltage				
30RAN	208/230-3-60	230-3-60	380-3-60	460-3-60	575-3-60
010	CQD3100	CQD3100	CQD3100	CQD3100	CQD3100

015	CQD3100	CQD3100	CQD3100	CQD3100	CQD3100
018	CQD3100	CQD3100	CQD3100	CQD3100	CQD3100
022	FXD 250		CQD3100	CQD3100	CQD3100
025	FXD 250		CQD3100	CQD3100	CQD3100
030	FXD 250			CQD3100	
035	FXD 250			CQD3100	
040	FXD 250			CQD3100	
045	FXD 250			FXD 250	
050	FXD 250			FXD 250	
055	FXD 250			FXD 250	

Defeating the Non-Fused Disconnect Handle

Defeating the handle depends upon device. See the individual instructions listed below.

WARNING
Defeating the Non-Fused Disconnect handle allows power to remain energized after the control box door is opened. Electric shock can cause personal injury or death. Do not leave control box unattended while the Non-Fused Disconnect handle is defeated.

CQD3100

In order to defeat the Non-Fused Disconnect, a small drift pin punch, 3/32" or 1/16" is needed. With the handle in the ON position, look at the plastic base of the handle that is against the outer panel. On the bottom side there is a small indentation in the plastic, just under 1/8" in diameter. Use the punch to break through the plastic there.

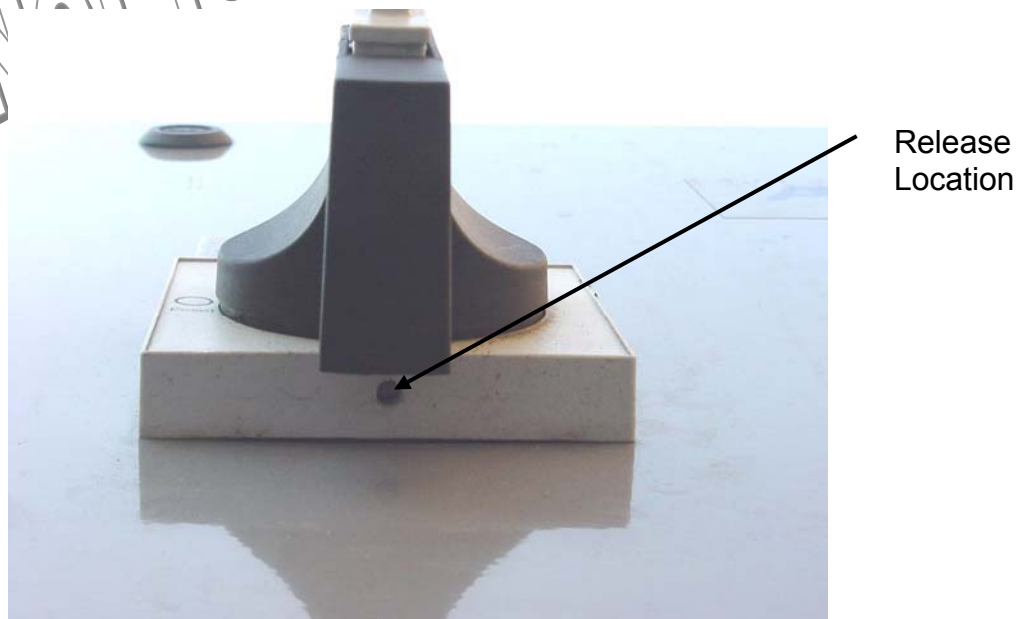

Then use a small straight pin punch, (1/16" in diameter) and insert in this opening about 3/8". Pull out on the handle at the same time. The door should open. Push the door closed on the shaft when done and it will snap lock back in place.

FXD 250

In order to defeat the Non-Fused Disconnect, a small screw driver is required. There is a shiny slotted screw visible just to the left of the handle when ON. Turn this screw slightly when the switch is in the ON position and the door will pull open. Push the door closed on the shaft when done and it will snap lock back in place, no screwdriver needed.

Paint

All chillers are painted in American Sterling Grey. RCD stocks a touch-up can of paint for this color under the part number, 313974-751.

Pressure Transducers

AquaSnap chillers are equipped with two pressure transducers on each circuit. There are different pressure transducers for the high and low side. These transducers cannot be calibrated.

The transducers are mounted on a schrader fitting.

The transducers operate on a 5 vdc power supply from the Main Base Board.

Troubleshooting:

If a transducer is suspected of being faulty, first check the supply voltage to transducer. Supply voltage should be 5 vdc \pm 0.2 v. If supply voltage is correct, compare pressure reading displayed on the Scrolling Marquee or Navigator display module against pressure shown on a calibrated pressure gauge. Suction pressure should be within \pm 2 psig. Discharge pressure should be within \pm 5 psig. If the two readings are not reasonably close, replace the pressure transducer.

An error in EPIC incorrectly indicated the pressure transducers for both the high and low side. The correct part numbers are:

Part Number	Location
HK05YZ001	Suction Pressure Transducer
HK05YZ007	Discharge Pressure Transducer

The pressure transducer harness was not set-up separately in EPIC, originally. The transducer harness was part of the control box harness. If a new transducer harness is required, use 30GT415784. This transducer harness is 15 ft (4.57 m) in length and a stripped wire termination. If terminals are required, order HY57MP008. These terminals are trifurcated terminals and require a special tool. See ComfortLink Control Boards on page 102 for termination tools.

Refrigerant

The 30RAN machines all use R-22.

Unit	Refrigerant lbs. (kg)	
	Circuit A	Circuit B
30RAN010	16.0 (7.3)	-
30RAN015	24.0 (10.9)	-
30RAN018	31.0 (14.1)	-
30RAN022	44.0 (20.0)	-
30RAN025	45.0 (20.5)	-
30RAN030	55.0 (25.0)	-
30RAN032	44.0 (20.0)	30.0 (13.6)
30RAN035	44.0 (20.0)	30.0 (13.6)
30RAN040	45.0 (20.5)	30.0 (13.6)
30RAN042	44.0 (20.0)	44.0 (20.0)
30RAN045	44.0 (20.0)	44.0 (20.0)
30RAN050	45.0 (20.5)	45.0 (20.5)
30RAN055	55.0 (25.0)	55.0 (25.0)

Starting with the original production until 0803F, the single circuit machines, 30RA010-030 were being charged with an amount of refrigerant. The correct charge is listed on the Unit nameplate. Incorrect charge amounts were listed in the Product Data Books (30RA-1PD, 30RAN-2PD, and 30RA-3PD), and in the Service and Installation books (30RA-1SI, 30RA-12SI).

Bulletins pertaining to this issue;

- 111-03-52 – 30RAN010-030 Refrigerant Charge
This bulletin listed the correct charge amounts for the 30RAN010-030 units.
- 111-03-16-E – 30RAN010-030 Refrigerant Charge
This export bulletin listed the correct charge amounts for the 30RAN010-030 units.

Refrigerant Moisture Limit

The upper limit for moisture in a system is based on the water saturation limit at 35 °F (1.6 °C).

Criteria	Specification Requirement*	Acceptable Limit
Moisture	10 ppm	≤650 ppm

Note: * - The specification requirement refers to the acceptability criteria for new oil based on Carrier Material Specification PS10-22.

If higher moisture content is found, check the following:

- Check for a cooler leak

If a high moisture content condition is found, repair the leak, evacuate and dehydrate the system using standard refrigerant practices.

Refrigerant Service Ports

Several refrigerant service ports are provided on the 30RA machines. The suction service port is located on the compressor.



Figure 17 - Compressor Suction Service Port

The liquid service port is located on the liquid line ball valve (1800F-2202F). A service port was added to the liquid line beginning 2302F when the service valve was removed. Machines with MotorMaster V utilize this port for pressure sensing.

No discharge service ports are provided for field access. If such a port is desired, a refrigerant tee must be placed between the discharge pressure transducer and the fitting.

A high flow charging port is located on the suction line before it enters the compressor. The factory uses this device during the manufacturing process. The fitting is only accessible with a special adapter. RCD has the adapter set-up.

RCD Part Number	Description
A-62PF221	1/4" SAE Flare Coupler Assembly
A-62PF321	3/8" SAE Flare Coupler Assembly

Service Bulletins pertaining to this component:

- SMB030009 – 30GX, 30HX, 30RA Refrigerant Access
This bulletin described the use of the high flow schrader factory access ports and the adapters required to use them.

Relief Devices

Fusible plugs are used as refrigerant relief devices.

Series 1				
Size	Circuit A		Circuit B	
30RAN	Part Number	Location	Part Number	Location
055	EK41JK101	Liquid Line leaving the condenser	EK41JK101	Liquid Line leaving the condenser

Fusible Plug Physical Data

Carrier Part Number	Open Temperature	Connection Side	Vent Connection
EK41JK101	208-220 °F (97.8-104.4 °C)	¼" NPT	¼" Flare

Before ordering ANY part number, confirm with EPIC to be sure that the proper part number is supplied.

Service Test Mode

The Service Test function should be used to verify proper operation of condenser fan(s), compressors, minimum load valve solenoid (if installed), cooler pump(s) and remote alarm relay. To use the Service Test mode, the Enable/Off/Remote Contact switch must be in the OFF position. Press [ESCAPE] until the Scrolling Marquee is blank, or the Navigator screen reads "Select Mode." Using the arrow keys, move the Mode LED to Service Test and press [ENTER]. Press [ENTER] twice so that OFF flashes. Enter the password, if required. Use either arrow key to change the TEST value to the ON position and press [ENTER]. Move the Enable/Off/Remote Contact switch to ENABLE. Press the [ESCAPE] and [▼] keys to enter the OUTS or COMP sub-modes. Test the condenser fans, cooler pump(s) and alarm relay by changing the item values from OFF to ON. These discrete outputs are then turned off if there is no keypad activity for 10 minutes. Test the compressor and minimum load valve solenoid (if installed) outputs in a similar manner. The minimum load valve solenoids will be turned off if there is no keypad activity for 10 minutes. Compressors will stay on until the operator turns them off. The Service Test mode will remain enabled for as long as there is one or more compressors running. All safeties are monitored during this test and will turn a compressor, circuit or the machine off if required. Any other mode or sub-mode can be accessed, viewed, or changed during the TEST mode. The STAT item (Run Status Mode, Sub-mode VIEW) will display "0" as long as the Service mode is enabled. The

TEST sub-mode value must be changed back to OFF before the chiller can be switched to Enable or Remote contact for normal operation.

In software versions 4.0 and earlier, if the service test mode was enabled and the Enable/Off/Remote Contact switch shut off the machine, the compressors will continue to run until a safety trips the circuit. This was corrected in Version 5.0?

Service Valves

The original production AquaSnap machines included a liquid line service valve only. This valve was discontinued starting 2302F.

Thermistors

The electronic control uses 3 to 6 thermistors to sense temperatures for controlling chiller operation. These sensors are outlined below. Thermistors T1, T2, T9 and accessory return gas thermistors T7, T8 are 5k Ω at 77 °F (25 °C) and are identical in temperature versus resistance and voltage drop performance. Thermistor T10 is 10k Ω at 77 °F (25 °C) and has a different temperature vs resistance and voltage drop performance.

T1 – Cooler Leaving Fluid Sensor - On 30RA010-030 sizes, this thermistor is installed in a friction fit well at the bottom of the brazed-plate heat exchanger on the control box side. For 30RA032-055 sizes, this thermistor is installed in a well in the factory-installed leaving fluid piping coming from the bottom of the brazed-plate heat exchanger opposite the control box side.

T2 – Cooler Entering Fluid Sensor - On 30RA010-030 sizes, this thermistor is installed in a friction fit well at the top of the brazed-plate heat exchanger on the control box side. For 30RA032-055 sizes, this thermistor is installed in a well in the factory-installed entering fluid piping leading to the top of the brazed-plate heat exchanger opposite the control box side.

T7, T8 – Compressor Return Gas Temperature Sensor – Sensor T7 and T8 are accessory sensors. A well for this sensor is factory installed in each circuit's suction line. If desired, a 5k Ω thermistor can be installed in this well and connected to the Main Base Board. A small amount of thermal conductive grease should be added to the well prior to inserting the thermistor. Use the Scrolling Marquee display to configure the sensor, RG.EN *Return Gas Sensor Enable* (Configuration Mode, Sub-mode OPT1) should be set to ENBL.

T9 – Outdoor Air Temperature Sensor – This sensor is factory-installed on a bracket at the left side of compressor A1 on 30RA010-030 models. For models 30RA032-055, it is installed behind the panel below the control box center door.

T10 – Remote Space Temperature Sensor - Sensor T10 is an accessory sensor that is remotely mounted in the controlled space and used for space temperature reset. This sensor is connected to TB5-5 and TB5-6. The sensor should be installed as a wall mounted thermostat would be (in the conditioned space where it will not be subjected to either a cooling or heating source or direct exposure to sunlight, and 4 to 5 ft above the floor). This sensor cannot be used with Dual Chiller Control.

T10 – Dual Chilled Water Sensor - T10 is an accessory sensor used for dual chiller control. This sensor is connected to TB5-5 and TB5-6. A field installed well for this sensor is recommended in the common header chilled water supply pipe. The thermistor is a 5k Ω thermistor and is connected to the Main Base Board via a terminal block. With Dual Chiller Control the Remote Space Temperature Sensor cannot be used.

Troubleshooting:

Thermistor/Temperature Sensor Check – A high quality digital volt-ohmmeter is required to perform this check.

1. Connect the digital voltmeter across the appropriate thermistor terminals at the J8 terminal strip on the Main Base Board.
2. Using the voltage reading obtained, read the sensor temperature from the Thermistor Voltage Drop/Resistance Tables in the Controls and Troubleshooting Book.
3. To check thermistor accuracy, measure temperature at probe location with an accurate thermocouple-type temperature measuring instrument. Insulate thermocouple to avoid ambient temperatures from influencing reading. Temperature measured by thermocouple and temperature determined from thermistor voltage reading should be close, $\pm 5^{\circ}$ F (3° C) if care was taken in applying thermocouple and taking readings.

If a more accurate check is required, unit must be shut down and thermistor removed and checked at a known temperature (freezing point or boiling point of water) using either voltage drop measured across thermistor at the J8 terminal, by determining the resistance with chiller shut down and thermistor disconnected from J8. Compare the values determined with the value read by the control in the Temperatures mode using the Scrolling Marquee or Navigator display.

Replacing Thermistors

Thermistors T1, T2, T7, T8 and T9 are connected to the Main Base Board (MBB) with insulation displacement connectors.

All thermistor are terminated at the ComfortLink Control boards with IDC (Insulation Displacement Connector) type connectors. The tools required to make these connections are as follows:

Manufacturer	Part Number	Description
Tyco Electronics (Amp)	58580-1	Hand Tool with Terminating Head
	58074-1	Hand Tool (included in 58580-1)
	58247-1	Terminating Head (included in 58580-1)
Ideal Industries	45-165	UTP/Coax Stripper

The cable stripper is easier to strip the gray jacket of the thermistor cable. It is not required.

For Thermistors T1, T2, T7, and T8, add a small amount of thermal conductive grease to the thermistor well and end of probe. Thermistors are friction-fit thermistors, which must be slipped into receivers in the cooler (010-030) or fluid piping (032-055). For sizes 032-055, tighten the retaining nut ¼ turn past finger tight.

MAINTENANCE

Recommended Maintenance Schedule

The following are only recommended guidelines. Job site conditions may dictate that maintenance schedules be performed more often than recommended.

Routine:

For machines with E-coat Condenser Coils:

- Check condenser coils for debris, clean as necessary
- Periodic clean water rinse, especially in coastal and industrial applications.

Every month:

For machines with E-coat Condenser Coils:

- Check condenser coils for debris, clean as necessary
- Coil cleaning with Environmentally Sound Coil Cleaner.

Every 3 months:

For all machines:

- Check all refrigerant joints and valves for refrigerant leaks, repair as necessary
- Check chilled water flow switch operation
- Check Sightglass Dry Eye for moisture
- Check condenser coils for debris, clean as necessary
- Check condenser fan operation
- Inspect pump seal, if equipped with a pump package

Every 12 months:

For all machines:

- Check all electrical connections for tightness, tighten as necessary.
- Check calibration of all transducers for each circuit, replace as necessary
- Check accuracy of thermistors, replace if greater than ± 2 °F (1 °C)
- Obtain and test an oil sample, change as necessary
- Check cooler approach (Cooler Leaving Water Temperature – Saturated Suction Temperature), clean cooler if appropriate
- Check to be sure that the proper concentration of antifreeze is present in the chilled water loop
- Check to be sure that the proper amount of inhibitor is present in the chilled water loop.
- Check all refrigerant filter driers for pressure drops, replace/clean as necessary
- Check chilled water strainers, clean as necessary
- Check cooler heater operation

Winter Shutdown Preparation

Spring Start-Up Preparation

At the beginning of the cooling season, perform the following procedure:

1. Check refrigerant circuit(s) for pressure. If the system is without charge, locate and repair leaks before filling the chilled water loop.
2. Fill the chilled water loop with water or brine with an appropriate corrosion inhibitor.
3. Re-engerize the cooler heater circuit, if equipped.
4. Perform the normal start-up procedure outlined in the Controls and Troubleshooting Book.

RECOMMENDED SPARE PARTS LIST

The following recommended spare parts list is divided into critical and recommended replacement parts. Critical parts are components that, if they fail, will cause the equipment to stop functioning, or otherwise fail to deliver the required cooling capacity. Without these parts, the machine cannot be made operational. Recommended parts are components that, if they fail, could cause deterioration of the system performance. If a recommended part fails, the system can be usually made somewhat functional, even if only partial operation, until the correct part can be obtained. If the deterioration of the system performance is not acceptable by the customer, then the recommended, should be treated as critical parts.

30RA AquaSnap Chiller Service Manual

Refer to RCD's EPIC 2000 for the appropriate part number and quantity of parts for each machine.

In the Comments Section the following abbreviations are used:

PSN – Prior Serial Number

SSN – Starting Serial Number

30RAN Series 0 Spare Parts List

Serial Number Range: 1801F-3102F

30RAN Series 0 - Critical Parts:		
Part Number	Description	Comments
HH79NZ029	Thermistor	Leaving Water Thermistor
HH83ZB001	Circuit Breaker	CB1
HK05YZ001	Pressure Transducer	SPTA, SPTB
HK05YZ007	Pressure Transducer	DPTA, DPTB
HR53VK120	Switch, Enable-Off-Remote	SW1
30RA501102	Main Base Board w/ Software	HK50AA029 w/o Software
	Circuit Breaker	CB2, See EPIC 2000 for appropriate usage
	Fuse, Control	See EPIC 2000 for appropriate usage
	Transformer	TRAN1, See EPIC 2000 for appropriate usage

30RAN Series 0 - Recommended Parts:		
Part Number	Description	Comments
EK41JK101	Fusible Plug	
HR53VK121	Switch, ON/OFF	SW2
HK02ZA428	High Pressure Switch	
HK05YZ007	MotorMaster V Transducer	If equipped
HK50AA031	Scrolling Marquee Display	
HH79NZ029	Thermistor	Entering Water Temperature, Outdoor Air Temperature, Return Gas Temperature,
HR81LG005	Chilled Water Flow Switch	Factory Standard Switch. May have been changed for Medium Temperature Brine operation
PP680002	Compressor, Oil	
30GT515218	Energy Management Module	w/o software HK50AA028
30GX400152	Fan Blade	
30RA401350 or 30RA401351	MotorMaster V Current Limiter/Protector	If equipped, see EPIC 2000 for appropriate part numbers

30RA AquaSnap Chiller Service Manual

30RAN Series 0 - Recommended Parts:		
Part Number	Description	Comments
32MP660022	EMM Connector Kit	
32MP660023	MBB Connector Kit	
	Compressors	See EPIC 2000 for appropriate part numbers.
	Compressor Starter	See EPIC 2000 for appropriate part numbers.
	Compressor Contactor	See EPIC 2000 for appropriate part numbers.
	Compressor Auxiliary Contacts	See EPIC 2000 for appropriate usage
	Fan Motor	See EPIC 2000 for appropriate part numbers.
	Fan Motor Contactor	See EPIC 2000 for appropriate part numbers.
	Fan Motor Starter	See EPIC 2000 for appropriate part numbers.
	Filter Drier	See EPIC 2000 for appropriate part numbers.
	Liquid Line Sightglass	See EPIC 2000 for appropriate part numbers.
	MotorMaster V Controller	If equipped, see EPIC 2000 for appropriate part numbers.
	Pump	If equipped, see EPIC 2000 for appropriate part numbers.
	Pump Motor	If equipped, see EPIC 2000 for appropriate part numbers.
	Pump Motor Contactor	If equipped, see EPIC 2000 for appropriate part numbers.
	Pump Motor Starter	If equipped, see EPIC 2000 for appropriate part numbers.
	Pump Shaft Sleeve	If equipped, see EPIC 2000 for appropriate part numbers.
	Pump Seal	If equipped, see EPIC 2000 for appropriate part numbers.
	Strainer Basket/Seal	See EPIC 2000 for appropriate part numbers.
	TXV	See EPIC 2000 for appropriate part numbers.

30RAN Series 0 - Recommended Tools:		
Part Number	Description	Comments
30GX680004	Direct Download Cable	Cable Connection for bench top

30RA AquaSnap Chiller Service Manual

30RAN Series 0 - Recommended Tools:		
Part Number	Description	Comments
		software downloads using SmartLoader.
30GX680005	ComfortLink Power Cube	Power Cube with Connection for bench top software downloads using SmartLoader.

30RAN Series 1 Spare Parts List

Serial Number Range: 3202F-

30RAN Series 1 - Critical Parts:		
Part Number	Description	Comments
HH79NZ029	Thermistor	Leaving Water Thermistor
HH83ZB001	Circuit Breaker	CB1
HK05YZ001	Pressure Transducer	SPTA, SPTB
HK05YZ007	Pressure Transducer	DPTA, DPTB
HR53VK120	Switch, Enable-Off-Remote	SW1
30RA501102	Main Base Board w/ Software	HK50AA029 w/o Software
	Circuit Breaker	CB2, See EPIC 2000 for appropriate usage
	Fuse, Control	See EPIC 2000 for appropriate usage
	Transformer	TRAN1, See EPIC 2000 for appropriate usage

30RAN Series 1 - Recommended Parts:		
Part Number	Description	Comments
EK41JK101	Fusible Plug	
HR53VK121	Switch, ON/OFF	SW2
HK02ZA428	High Pressure Switch	
HK05YZ007	MotorMaster V Transducer	If equipped
HK50AA031	Scrolling Marquee Display	
HH79NZ029	Thermistor	Entering Water Temperature, Outdoor Air Temperature, Return Gas Temperature,
HR81LG005	Chilled Water Flow Switch	Factory Standard Switch. May have been changed for Medium Temperature Brine operation
PP680002	Compressor, Oil	
30GT515218	Energy Management Module	w/o software HK50AA028
30GX400152	Fan Blade	

30RA AquaSnap Chiller Service Manual

30RAN Series 1 - Recommended Parts:		
Part Number	Description	Comments
30RA401350 or 30RA401351	MotorMaster V Current Limiter/Protector	If equipped, see EPIC 2000 for appropriate part numbers. PSN: 4103F
32MP660022	EMM Connector Kit	
32MP660023	MBB Connector Kit	
	Compressors	See EPIC 2000 for appropriate part numbers.
	Compressor Circuit Breaker	CCB-1, CCB-2, CCB-3, CCB-4, See EPIC 2000 for appropriate part numbers.
	Compressor Overload Relay	See EPIC 2000 for appropriate part numbers.
	Compressor Contactor	See EPIC 2000 for appropriate part numbers.
	Compressor Auxiliary Contacts	See EPIC 2000 for appropriate usage
	Fan Motor	See EPIC 2000 for appropriate part numbers.
	Fan Motor Contactor	See EPIC 2000 for appropriate part numbers.
	Fan Motor Starter	See EPIC 2000 for appropriate part numbers.
	Filter Drier	See EPIC 2000 for appropriate part numbers.
	Liquid Line Sightglass	See EPIC 2000 for appropriate part numbers.
	MotorMaster V Controller	If equipped, see EPIC 2000 for appropriate part numbers.
	Pump	If equipped, see EPIC 2000 for appropriate part numbers.
	Pump Motor	If equipped, see EPIC 2000 for appropriate part numbers.
	Pump Motor Contactor	If equipped, see EPIC 2000 for appropriate part numbers.
	Pump Motor Starter	If equipped, see EPIC 2000 for appropriate part numbers.
	Pump Shaft Sleeve	If equipped, see EPIC 2000 for appropriate part numbers.
	Pump Seal	If equipped, see EPIC 2000 for appropriate part numbers.
	Strainer Basket/Seal	See EPIC 2000 for appropriate part numbers.
	TXV	See EPIC 2000 for appropriate part numbers.

30RAN Recommended Tools:		
Part Number	Description	Comments
30GX680004	Direct Download Cable	Cable Connection for bench top software downloads using SmartLoader.
30GX680005	ComfortLink Power Cube	Power Cube with Connection for bench top software downloads using SmartLoader.

Not for Distribution

APPENDIX A – ALPHABETICAL LISTING OF POINTS

Item	Description	Mode	Submode and Item			Comment
4-20	4-20 mA Inputs Sub-mode	Inputs				
ALRM	Current Alarms & Alerts	Run Status	VIEW			
BAUD	CCN Baud Rate	Configuration	OPT2			
BC.AK	CCN Broadcast Ack'er	Configuration	BCST			Added In Version 3.0
BCST	Broadcast Configuration Sub-mode	Configuration				Added In Version 3.0
BR.FZ	Brine Freeze Point	Set Point	FRZ			
C.L.M0	Coil Maintenance Date 0	Run Status	PM	COIL	CL.DT	
C.L.M1	Coil Maintenance Date 1	Run Status	PM	COIL	CL.DT	
C.L.M2	Coil Maintenance Date 2	Run Status	PM	COIL	CL.DT	
C.L.M3	Coil Maintenance Date 3	Run Status	PM	COIL	CL.DT	
C.L.M4	Coil Maintenance Date 4	Run Status	PM	COIL	CL.DT	
C.L.MN	Coil Maintenance Done	Run Status	PM	COIL		
C.WP1	Cooler Pump Relay 1	Outputs	GEN.O			
C.WP2	Cooler Pump Relay 2	Outputs	GEN.O			
CAP	Percent Total Capacity	Run Status	VIEW			
CC.A1	Compressor A1 Relay	Service Test	CMPA			
CC.A1	Compressor A1 Relay	Outputs	CIR.A			
CC.A2	Compressor A2 Relay	Service Test	CMPA			
CC.A2	Compressor A2 Relay	Outputs	CIR.A			
CC.B1	Compressor B1 Relay	Service Test	CMPB			
CC.B1	Compressor B1 Relay	Outputs	CIR.B			
CC.B2	Compressor B2 Relay	Service Test	CMPB			
CC.B2	Compressor B2 Relay	Outputs	CIR.B			
CCNA	CCN Address	Configuration	OPT2			
CCNB	CCN Bus Number	Configuration	OPT2			
CEWT	Cooler Entering Fluid	Temperature	UNIT			
CIR.A	Circuit A Temperatures Sub-mode	Temperature				
CIR.A	Circuit A Outputs Sub-mode	Outputs				
CIR.B	Circuit B Temperatures Sub-mode	Temperature				
CIR.B	Circuit B Outputs Sub-mode	Outputs				
CL.DT	Coil Maintenance Dates	Run Status	PM	COIL		
CL.HT	Cooler/Pump Heater	Service Test	OUTS			
CLHT	Cooler/Pump Heater	Outputs	GEN.O			
CLP.1	Cooler Pump 1 Relay	Service Test	OUTS			
CLP.2	Cooler Pump 2 Relay	Service Test	OUTS			
CLS.C	Close Control Select	Configuration	OPT2			
CLSP	Cooling Set Point Select	Configuration	SLCT			
CLWT	Cooler Leaving Fluid	Temperature	UNIT			

30RA AquaSnap Chiller Service Manual

Item	Description	Mode	Submode and Item	Comment
CMPA	Circuit A Compressor Test Sub-mode	Service Test		
CMPB	Circuit B Compressor Test Sub-mode	Service Test		
COIL	Coil Maintenance	Run Status	PM	
COOL	Cooling Set Points Sub-mode	Set Point		
CPC	Cooler Pump Control	Configuration	OPT1	
CRCT	Circuit Inputs Sub-mode	Inputs		
CRMP	Cooling Ramp Loading	Configuration	SLCT	
CRNT	Currently Active Alarms Sub-Mode	Alarms		
CRST	Cooling Reset Select	Configuration	RSET	
CSP	4-20 mA Cooling Set Point	Inputs	4-20	
CSP.1	Cooling Set Point 1	Set Point	COOL	
CSP.2	Cooling Set Point 2	Set Point	COOL	
CSP.3	Ice Set Point	Set Point	COOL	
CTPT	Control Point	Run Status	VIEW	
CTRL	Control Method	Configuration	OPT2	
DATE	Day of Month	Run Status	VIEW	
DATE	Month, Date, Day and Year Sub-mode	Time Clock		
DAY	Day of Week	Time Clock	DATE	
DELY	Minutes Off Time	Configuration	OPT2	
DISP	Display Configuration Sub-mode	Configuration		
DLS.1	Demand Limit Switch 1	Inputs	GEN.I	
DLS.2	Demand Limit Switch 2	Inputs	GEN.I	
DLS1	Demand Limit Switch 1	Configuration	RSET	
DLS2	Demand Limit Switch 2	Configuration	RSET	
DLWT	Lead/Lag Leaving Fluid	Temperature	UNIT	
DM20	Demand Limit at 20 mA	Configuration	RSET	
DMDC	Demand Limit Select	Configuration	RSET	
DMND	4-20 mA Demand Signal	Inputs	4-20	
DOM	Day of Month	Time Clock	DATE	
DP.A	Circuit A Discharge Pressure	Pressure	PRC.A	
DP.B	Circuit B Discharge Pressure	Pressure	PRC.B	
DST	Daylight Savings Time Sub-mode	Time Clock		
DUAL	Dual Set Point Switch	Inputs	GEN.I	
EMM	Energy Management Module Software Version	Run Status	VERS	
EMM	Energy Management Module Installed	Configuration	OPT1	
EN.A1	Enable Compressor A1	Configuration	SERV	

30RA AquaSnap Chiller Service Manual

Item	Description	Mode	Submode and Item		Comment
EN.A2	Enable Compressor A2	Configuration	SERV		
EN.B1	Enable Compressor B1	Configuration	SERV		
EN.B2	Enable Compressor B2	Configuration	SERV		
EWT	Entering Fluid Temp	Run Status	VIEW		
FAN.S	Fan Staging Select	Configuration	UNIT		
FAN1	Fan 1 Relay	Service Test	OUTS		
FAN1	Fan 1 Relay	Outputs	GEN.O		
FAN2	Fan 2 Relay	Service Test	OUTS		
FAN2	Fan 2 Relay	Outputs	GEN.O		
FKA1	Compressor A1 Feedback	Inputs	CRCT		
FKA2	Compressor A2 Feedback	Inputs	CRCT		
FKB1	Compressor B1 Feedback	Inputs	CRCT		
FKB2	Compressor B2 Feedback	Inputs	CRCT		
FLOW	Cooler Flow Switch	Inputs	GEN.I		
FLUD	Cooler Fluid	Configuration	OPT1		
FRI.1	Friday in Period	Time Clock	SCH.L	PER.1	
FRI.2	Friday in Period	Time Clock	SCH.L	PER.2	
FRI.3	Friday in Period	Time Clock	SCH.L	PER.3	
FRI.4	Friday in Period	Time Clock	SCH.L	PER.4	
FRI.5	Friday in Period	Time Clock	SCH.L	PER.5	
FRI.6	Friday in Period	Time Clock	SCH.L	PER.6	
FRI.7	Friday in Period	Time Clock	SCH.L	PER.7	
FRI.8	Friday in Period	Time Clock	SCH.L	PER.8	
FRZ	Brine Freeze Set Point Sub-mode	Set Point			
G.S.BC	Global Schedule Broadcst	Configuration	BCST		Added In Version 3.0
GEN.I	General Inputs Sub-mode	Inputs			
GEN.O	General Outputs Sub-mode	Outputs			
HD.P.A	Circuit A Calculated Head Pressure Set Point	Set Point	HEAD		
HD.P.B	Circuit B Calculated Head Pressure Set Point	Set Point	HEAD		
HEAD	Head Pressure Set Point Sub-mode	Set Point			
HH.MM	Hour and Minute	Time Clock	TIME		
HIST	Alarm History Sub-mode	Alarms			
HOL.1	Holiday in Period	Time Clock	SCH.L	PER.1	
HOL.2	Holiday in Period	Time Clock	SCH.L	PER.2	
HOL.3	Holiday in Period	Time Clock	SCH.L	PER.3	
HOL.4	Holiday in Period	Time Clock	SCH.L	PER.4	
HOL.5	Holiday in Period	Time Clock	SCH.L	PER.5	
HOL.6	Holiday in Period	Time Clock	SCH.L	PER.6	
HOL.7	Holiday in Period	Time Clock	SCH.L	PER.7	
HOL.8	Holiday in Period	Time Clock	SCH.L	PER.8	

30RA AquaSnap Chiller Service Manual

Item	Description	Mode	Submode and Item	Comment
HOURL	Circuit and Compressors Operating Hours Sub-mode	Run Status		
HR.A1	Compressor A1 Run Hours	Run Status	HOUR	
HR.A2	Compressor A2 Run Hours	Run Status	HOUR	
HR.B1	Compressor B1 Run Hours	Run Status	HOUR	
HR.B2	Compressor B2 Run Hours	Run Status	HOUR	
HR.P1	Pump 1 Run Hours	Run Status	RUN	
HR.P2	Pump 2 Run Hours	Run Status	RUN	
HRS.A	Circuit A Run Hours	Run Status	HOUR	
HRS.B	Circuit B Run Hours	Run Status	HOUR	
HRS.U	Machine Operating Hours	Run Status	RUN	
HT.RQ	Heat Request	Inputs	GEN.I	
ICE.M	Ice Mode Enable	Configuration	OPT2	
ICED	Ice Done	Inputs	GEN.I	
LANG	Language Selection	Configuration	DISP	
LCWT	High Leaving Chilled Water Alert Limit	Configuration	OPT2	
LD.PM	Lead Pump	Inputs	GEN.I	Added In Version 3.0
LLBD	Lead/Lag Balance Delta	Configuration	RSET	
LLBL	Lead/Lag Balance Select	Configuration	RSET	
LLCS	Lead/Lag Circuit Select	Configuration	OPT2	
LLDY	Lag Start Delay	Configuration	RSET	
LLEN	Lead/Lag Chiller Enable	Configuration	RSET	
LOAD	Loading Sequence Select	Configuration	OPT2	
LOD.F	Load/Unload Factor	Run Status	VIEW	Added In Version 3.0
LS.AC	Low Sound Mode Active	Run Status	VIEW	Changed from NH.AC in Version 3.0
LS.LT	Low Sound Capacity Limit	Configuration	OPT2	
LS.MD	Low Sound Mode Select	Configuration	OPT2	
LS.ND	Low Sound End Time	Configuration	OPT2	
LS.ST	Low Sound Start Time	Configuration	OPT2	
LWT	Leaving Fluid Temp	Run Status	VIEW	
MA.DG	4-20 mA Degrees Reset	Configuration	RSET	
MARQ	Scrolling Marquee Software Version	Run Status	VERS	
MBB	MBB Software Version	Run Status	VERS	
MD01	FSM Controlling Chiller	Operating Modes	MODE	
MD02	WSM Controlling Chiller	Operating Modes	MODE	
MD03	Master/Slave Control	Operating Modes	MODE	
MD05	Ramp Load Limited	Operating Modes	MODE	
MD06	Timed Override in Effect	Operating Modes	MODE	

30RA AquaSnap Chiller Service Manual

Item	Description	Mode	Submode and Item		Comment
MD07	Low Cooler Suction TempA	Operating Modes	MODE		
MD08	Low Cooler Suction TempB	Operating Modes	MODE		
MD09	Slow Change Override	Operating Modes	MODE		
MD10	Minimum Off Time Active	Operating Modes	MODE		
MD13	Dual Set Point	Operating Modes	MODE		
MD14	Temperature Reset	Operating Modes	MODE		
MD15	Demand/Sound Limited	Operating Modes	MODE		
MD16	Cooler Freeze Protection	Operating Modes	MODE		
MD17	Low Temperature Cooling	Operating Modes	MODE		
MD18	High Temperature Cooling	Operating Modes	MODE		
MD19	Making Ice	Operating Modes	MODE		
MD20	Storing Ice	Operating Modes	MODE		
MD21	High SCT Circuit A	Operating Modes	MODE		
MD22	High SCT Circuit B	Operating Modes	MODE		
MD23	Minimum Comp On Time	Operating Modes	MODE		
MD24	Pump Off Delay Time	Operating Modes	MODE		
MD25	Low Sound Mode	Operating Modes	MODE		
MD26	Short Loop Override	Operating Modes	MODE		Added in Version 2.0
METR	Metric Display	Configuration	DISP		
MIN.A	Minutes to Add	Time Clock	DST		
MIN.A	Minutes to Subtract	Time Clock	DST		
MLV	Minimum Load Valve Relay	Service Test	CMPA		
MLV	Minimum Load Valve Relay	Service Test	CMPB		
MLV.R	Minimum Load Valve Relay	Outputs	GEN.O		
MLV.S	Minimum Load Valve Select	Configuration	OPT1		
MMR.S	Motormaster Select	Configuration	OPT1		
MNTH	Month of Year	Run Status	VIEW		
MNTH	Month of Year	Time Clock	DATE		
MODE	Override Modes in Effect	Run Status	VIEW		
MODE	Modes Controlling Unit Sub-Mode	Operating Modes			
MON.1	Monday in Period	Time Clock	SCH.L	PER.1	
MON.2	Monday in Period	Time Clock	SCH.L	PER.2	
MON.3	Monday in Period	Time Clock	SCH.L	PER.3	
MON.4	Monday in Period	Time Clock	SCH.L	PER.4	
MON.5	Monday in Period	Time Clock	SCH.L	PER.5	
MON.6	Monday in Period	Time Clock	SCH.L	PER.6	
MON.7	Monday in Period	Time Clock	SCH.L	PER.7	
MON.8	Monday in Period	Time Clock	SCH.L	PER.8	
MSSL	Master/Slave Select	Configuration	RSET		

30RA AquaSnap Chiller Service Manual

Item	Description	Mode	Submode and Item			Comment
NAVI	Navigator Software Version	Run Status	VERS			
NH.AC	Night Mode Active	Run Status	VIEW			Changed to LS.AC in Version 3.0
OAT	Aoutside Air Temperature	Temperature	UNIT			
OAT.B	CCN OAT Broadcast	Configuration	BCST			Added In Version 3.0
OCC	Occupied	Run Status	VIEW			
OCC.1	Period Occupied Time	Time Clock	SCH.L	PER.1		
OCC.2	Period Occupied Time	Time Clock	SCH.L	PER.2		
OCC.3	Period Occupied Time	Time Clock	SCH.L	PER.3		
OCC.4	Period Occupied Time	Time Clock	SCH.L	PER.4		
OCC.5	Period Occupied Time	Time Clock	SCH.L	PER.5		
OCC.6	Period Occupied Time	Time Clock	SCH.L	PER.6		
OCC.7	Period Occupied Time	Time Clock	SCH.L	PER.7		
OCC.8	Period Occupied Time	Time Clock	SCH.L	PER.8		
OPT1	Unit Options - Hardware Sub-mode	Configuration				
OPT2	Unit Options - Software Sub-mode	Configuration				
OUTS	Outputs Sub-mode	Service Test				
OVR	Schedule Override Sub-mode	Time Clock				
OVR.L	Override Time Limit	Time Clock	OVR			
OVR.T	Timed Override Hours	Time Clock	OVR			
P.1.DN	Pump 1 Service Countdown	Run Status	PM	PUMP		
P.1.M0	Pump 1 Maintenance Date 0	Run Status	PM	PUMP	PMDT	
P.1.M1	Pump 1 Maintenance Date 1	Run Status	PM	PUMP	PMDT	
P.1.M2	Pump 1 Maintenance Date 2	Run Status	PM	PUMP	PMDT	
P.1.M3	Pump 1 Maintenance Date 3	Run Status	PM	PUMP	PMDT	
P.1.M4	Pump 1 Maintenance Date 4	Run Status	PM	PUMP	PMDT	
P.1.MN	Pump 1 Maintenance Done	Run Status	PM	PUMP		
P.2.DN	Pump 2 Service Countdown	Run Status	PM	PUMP		
P.2.M0	Pump 2 Maintenance Date 0	Run Status	PM	PUMP	PMDT	
P.2.M1	Pump 2 Maintenance Date 1	Run Status	PM	PUMP	PMDT	
P.2.M2	Pump 2 Maintenance Date 2	Run Status	PM	PUMP	PMDT	
P.2.M3	Pump 2 Maintenance Date 3	Run Status	PM	PUMP	PMDT	
P.2.M4	Pump 2 Maintenance Date 4	Run Status	PM	PUMP	PMDT	

30RA AquaSnap Chiller Service Manual

Item	Description	Mode	Submode and Item			Comment
P.2.MN	Pump 2 Maintenance Done	Run Status	PM	PUMP		
PARA	Parallel Configuration	Configuration	RSET			
PAS.E	Password Enable	Configuration	DISP			
PER.1	Occupancy Period 1	Time Clock	SCH.L			
PER.2	Occupancy Period 2	Time Clock	SCH.L			
PER.3	Occupancy Period 3	Time Clock	SCH.L			
PER.4	Occupancy Period 4	Time Clock	SCH.L			
PER.5	Occupancy Period 5	Time Clock	SCH.L			
PER.6	Occupancy Period 6	Time Clock	SCH.L			
PER.7	Occupancy Period 7	Time Clock	SCH.L			
PER.8	Occupancy Period 8	Time Clock	SCH.L			
PM	Preventative Maintenance Sub-mode	Run Status				
PM.DT	Pump Changeover Hours	Configuration	OPT1			
PM.DY	Cooler Pump Delay	Configuration	OPT1			
PM.F.1	Cooler Pump 1 Interlock	Inputs	GEN.I			
PM.F.2	Cooler Pump 2 Interlock	Inputs	GEN.I			
PM.P.S	Cooler Pump Periodic Start	Configuration	OPT1			
PM.SL	Cooler Pump Select	Configuration	OPT1			
PM1E	Cooler Pump 1 Enable	Configuration	OPT1			
PM2E	Cooler Pump 2 Enable	Configuration	OPT1			
PMDT	Pump Maintenance Dates	Run Status	PM	PUMP		
PRC.A	Circuit A Pressures Sub-mode	Pressure				
PRC.B	Circuit B Pressures Sub-mode	Pressure				
PUMP	Pump Maintenance	Run Status	PM			
REFG	Refrigerant	Configuration	UNIT			
RG.EN	Return Gas Sensor Enable	Configuration	OPT1			
RGT.A	Circuit A Return Gas Temperature	Temperature	CIR.A			
RGT.B	Circuit B Return Gas Temperature	Temperature	CIR.B			
RHIS	Reset Alarm History Sub-mode	Alarms				Removed in Version 3.0
RL.S	Ramp Load Select	Configuration	SLCT			
RM.DG	Remote - Degrees Reset	Configuration	RSET			
RM.F	Remote - Full Reset Temp	Configuration	RSET			
RM.NO	Remote - No Reset Temp	Configuration	RSET			
RMT.A	Remote Alarm Relay	Service Test	OUTS			
ROT.P	Rotate Cooler Pumps Now	Configuration	OPT1			
RRN	Reset All Current Alarms Sub-Mode	Alarms				

30RA AquaSnap Chiller Service Manual

Item	Description	Mode	Submode and Item			Comment
RSET	4-20 mA Reset Signal	Inputs	4-20			
RSET	Reset Cooling Temperature Sub-mode	Configuration				
RT.DG	Return - Degrees Reset	Configuration	RSET			
RT.F	Return - Full Reset Temp	Configuration	RSET			
RT.NO	Return - No Reset Temp	Configuration	RSET			
RUN	Unit Operating Hours/Starts Sub-mode	Run Status				
S.L.DN	Coil Service Countdown	Run Status	PM	COIL		
S.T.DN	Strainer Service Countdown	Run Status	PM	STRN		
S.T.M0	Strainer Maintenance Date 0	Run Status	PM	STRN	ST.DN	
S.T.M1	Strainer Maintenance Date 1	Run Status	PM	STRN	ST.DN	
S.T.M2	Strainer Maintenance Date 2	Run Status	PM	STRN	ST.DN	
S.T.M3	Strainer Maintenance Date 3	Run Status	PM	STRN	ST.DN	
S.T.M4	Strainer Maintenance Date 4	Run Status	PM	STRN	ST.DN	
S.T.MN	Strainer Maintenance Done	Run Status	PM	STRN		
SAT.1	Saturday in Period	Time Clock	SCH.L	PER.1		
SAT.2	Saturday in Period	Time Clock	SCH.L	PER.2		
SAT.3	Saturday in Period	Time Clock	SCH.L	PER.3		
SAT.4	Saturday in Period	Time Clock	SCH.L	PER.4		
SAT.5	Saturday in Period	Time Clock	SCH.L	PER.5		
SAT.6	Saturday in Period	Time Clock	SCH.L	PER.6		
SAT.7	Saturday in Period	Time Clock	SCH.L	PER.7		
SAT.8	Saturday in Period	Time Clock	SCH.L	PER.8		
SCH.L	Local Occupancy Schedule Sub-mode	Time Clock				
SCH.N	Schedule Number Sub-mode	Time Clock				
SCHD	Schedule Number	Configuration	SLCT			
SCT.A	Circuit A Saturated Condensing Temperature	Temperature	CIR.A			
SCT.B	Circuit B Saturated Condensing Temperature	Temperature	CIR.B			
SERV	Service Configuration Sub-mode	Configuration				
SETP	Active Set Point	Run Status	VIEW			
SH.A	Circuit A Superheat Temperature	Temperature	CIR.A			
SH.B	Circuit B Superheat Temperature	Temperature	CIR.B			
SH.SP	Superheat Set Point	Configuration	UNIT			
SHDL	Loadshed Demand Delta	Configuration	RSET			

30RA AquaSnap Chiller Service Manual

Item	Description	Mode	Submode and Item		Comment
SHNM	Loadshed Group Number	Configuration	RSET		
SHTM	Maximum Loadshed Time	Configuration	RSET		
SI.CL	Coil Service Interval	Run Status	PM	COIL	
SI.PM	Pump Service Interval	Run Status	PM	PUMP	
SI.ST	Strainer Service Interval	Run Status	PM	STRN	
SLCT	Set Point and Ramp Load Sub-mode	Configuration			
SLVA	Slave Address	Configuration	RSET		
SP.A	Circuit A Suction Pressure	Pressure	PRC.A		
SP.B	Circuit B Suction Pressure	Pressure	PRC.B		
SPT	Space Temperature	Temperature	UNIT		
SST.A	Circuit A Saturated Suction Temperature	Temperature	CIR.A		
SST.B	Circuit B Saturated Suction Temperature	Temperature	CIR.B		
ST.A1	Compressor A1 Starts	Run Status	STRT		
ST.A2	Compressor A2 Starts	Run Status	STRT		
ST.B1	Compressor B1 Starts	Run Status	STRT		
ST.B2	Compressor B2 Starts	Run Status	STRT		
ST.DN	Strainer Maintenance Dates	Run Status	PM	STRN	
STAT	Control Mode	Run Status	VIEW		
STGE	Requested Stage	Run Status	VIEW		
STP.D	Stop Day	Time Clock	DST		
STP.M	Stop Month	Time Clock	DST		
STP.W	Stop Week	Time Clock	DST		
STR.D	Start Day	Time Clock	DST		
STR.M	Start Month	Time Clock	DST		
STR.U	Machine Starts	Run Status	RUN		
STR.W	Start Week	Time Clock	DST		
STRN	Strainer Maintenance	Run Status	PM		
STRT	Circuit and Compressor Starts Sub-mode	Run Status			
STST	Start/Stop Switch	Inputs	GEN.I		
SUN.1	Sunday in Period	Time Clock	SCH.L	PER.1	
SUN.2	Sunday in Period	Time Clock	SCH.L	PER.2	
SUN.3	Sunday in Period	Time Clock	SCH.L	PER.3	
SUN.4	Sunday in Period	Time Clock	SCH.L	PER.4	
SUN.5	Sunday in Period	Time Clock	SCH.L	PER.5	
SUN.6	Sunday in Period	Time Clock	SCH.L	PER.6	
SUN.7	Sunday in Period	Time Clock	SCH.L	PER.7	
SUN.8	Sunday in Period	Time Clock	SCH.L	PER.8	
SZA.1	Compressor A1 Size	Configuration	UNIT		
SZA.2	Compressor A2 Size	Configuration	UNIT		
SZB.1	Compressor B1 Size	Configuration	UNIT		
SZB.2	Compressor B2 Size	Configuration	UNIT		

30RA AquaSnap Chiller Service Manual

Item	Description	Mode	Submode and Item			Comment
T.D.BC	CCN Time/Date Broadcast	Configuration	BCST			Added In Version 3.0
T.OVR	Timed Override	Time Clock	OVR			
TEST	Service Test Mode Sub-mode	Service Test				
TEST	Test Display LEDs	Configuration	DISP			
THU.1	Thursday in Period	Time Clock	SCH.L	PER.1		
THU.2	Thursday in Period	Time Clock	SCH.L	PER.2		
THU.3	Thursday in Period	Time Clock	SCH.L	PER.3		
THU.4	Thursday in Period	Time Clock	SCH.L	PER.4		
THU.5	Thursday in Period	Time Clock	SCH.L	PER.5		
THU.6	Thursday in Period	Time Clock	SCH.L	PER.6		
THU.7	Thursday in Period	Time Clock	SCH.L	PER.7		
THU.8	Thursday in Period	Time Clock	SCH.L	PER.8		
TIME	Time of Day	Run Status	VIEW			
TIME	Time of Day Sub-mode	Time Clock				
TUE.1	Tuesday in Period	Time Clock	SCH.L	PER.1		
TUE.2	Tuesday in Period	Time Clock	SCH.L	PER.2		
TUE.3	Tuesday in Period	Time Clock	SCH.L	PER.3		
TUE.4	Tuesday in Period	Time Clock	SCH.L	PER.4		
TUE.5	Tuesday in Period	Time Clock	SCH.L	PER.5		
TUE.6	Tuesday in Period	Time Clock	SCH.L	PER.6		
TUE.7	Tuesday in Period	Time Clock	SCH.L	PER.7		
TUE.8	Tuesday in Period	Time Clock	SCH.L	PER.8		
UNC.1	Period Unoccupied Time	Time Clock	SCH.L	PER.1		
UNC.2	Period Unoccupied Time	Time Clock	SCH.L	PER.2		
UNC.3	Period Unoccupied Time	Time Clock	SCH.L	PER.3		
UNC.4	Period Unoccupied Time	Time Clock	SCH.L	PER.4		
UNC.5	Period Unoccupied Time	Time Clock	SCH.L	PER.5		
UNC.6	Period Unoccupied Time	Time Clock	SCH.L	PER.6		
UNC.7	Period Unoccupied Time	Time Clock	SCH.L	PER.7		
UNC.8	Period Unoccupied Time	Time Clock	SCH.L	PER.8		
UNIT	Entering and Leaving Unit Temperatures Sub-mode	Temperature				
UNIT	Unit Configuration Sub-mode	Configuration				
VERS	Software Versions Sub-mode	Run Status				
VIEW	Operating Parameters Sub-mode	Run Status				
WED.1	Wednesday in Period	Time Clock	SCH.L	PER.1		
WED.2	Wednesday in Period	Time Clock	SCH.L	PER.2		
WED.3	Wednesday in Period	Time Clock	SCH.L	PER.3		
WED.4	Wednesday in Period	Time Clock	SCH.L	PER.4		
WED.5	Wednesday in Period	Time Clock	SCH.L	PER.5		
WED.6	Wednesday in Period	Time Clock	SCH.L	PER.6		

30RA AquaSnap Chiller Service Manual

Item	Description	Mode	Submode and Item			Comment
WED.7	Wednesday in Period	Time Clock	SCH.L	PER.7		
WED.8	Wednesday in Period	Time Clock	SCH.L	PER.8		
YEAR	Year	Run Status	VIEW			
YEAR	Year	Time Clock	DATE			
Z.GN	Deadband Multiplier	Configuration	SLCT			

Not for Distribution

APPENDIX B – DATAPORT™, DATALINK™, BACLINK™ OBJECT DEFINITION

30RAN w/ Software Versions 1.0 and 2.0							
CCN Table Name	Description	Status	Units	Point	DataPort	DataLink	BAClink
A_UNIT	GENERAL PARAMETERS						
	Control Mode	0 = Service Test 1 = OFF Local 2 = OFF CCN 3 = OFF Time 4 = OFF Emrgcy 5 = ON Local 6 = ON CCN 7 = ON Time 8 = Ht Enabled 9 = Pump Delay		STAT	RO	RO	RO
	Occupied	No/Yes		OCC	RO	RO	RO
	CCN Chiller	Start/Stop		CHIL_S_S	RO	RW	RW
	Low Sound Active	No/Yes		LSACTIVE	RO	RO	NA
	Alarm State	Normal/Alert/Alarm		ALM	RO	RO	RO
	Active Demand Limit	0 to 100	%	DEM_LIM	RO	RW	RW
	Override Modes In Effect	No/Yes		MODE	RO	RO	NA
	Percent Total Capacity	0 to 100	%	CAP_T	RO	RO	RO
	Requested Stage	0 to 99		STAGE	RO	RO	NA
	Active Setpoint	-20 to 70 (-28.8 to 21.1)	dF (dC)	SP	RO	RO	NA
	Control Point	-20 to 70 (-28.8 to 21.1)	dF (dC)	CTRL_PNT	RO	RW	RW
	Entering Fluid Temp	snnn.n	dF (dC)	EWT	RO	RO	RO
	Leaving Fluid Temp	snnn.n	dF (dC)	LWT	RO	RO	RO
	Emergency Stop	Enable/Emstop		EMSTOP	RO	RW	RW
	Minutes Left for Start PUMPS	00:00 to 15:00	Minutes	MIN_LEFT	RO	RO	NA
	Cooler Pump Relay 1	Off/On		COOLPMP1	RO	RO	NA
	Cooler Pump Relay 2	Off/On		COOLPMP2	RO	RO	NA
	Cooler Pump 1 Interlock	Open/Close		PMP1_FBK	RO	RO	NA
	Cooler Pump 2 Interlock	Open/Close		PMP2_FBK	RO	RO	NA
Cooler Flow Switch	Off/On		COOLFLOW	RO	RO	NA	
Rotate Cooler Pumps Now	No/Yes		ROT_PUMP	RO	RW	NA	
Heat/Cool Select	Heat/Cool		HC_SEL	RO	RO	NA	
CIRCADIO	CIRC. A DISCRETE OUTPUTS						
	Compressor A1 Relay	Off/On		K_A1_RLY	RO	RO	RO
	Compressor A2 Relay	Off/On		K_A2_RLY	RO	RO	RO
	Minimum Load Valve Relay	Off/On		MLV_RLY	RO	RO	NA
CIRCADIO	CIRC. A DISCRETE INPUTS						
	Compressor A1 Feedback	Off/On		K_A1_FBK	RO	RO	NA
	Compressor A2 Feedback	Off/On		K_A2_FBK	RO	RO	NA
CIRCA_AN	CIRCUIT A ANALOG VALUES						
	Percent Total Capacity	0 to 100	%	CAPA_T	RO	RO	RO
	Percent Available Cap.	0 to 100	%	CAPA_A	RO	RO	RO
	Discharge Pressure	nnn.n	PSIG (KPA)	DP_A	RO	RO	RO
	Suction Pressure	nnn.n	PSIG (KPA)	SP_A	RO	RO	RO
	Calculated HP Setpoint A	nnn.n	dF (dC)	HSP_A	RO	RO	NA
	Saturated Condensing Tmp	snnn.n	dF (dC)	TMP_SCTA	RO	RO	RO
	Saturated Suction Temp	snnn.n	dF (dC)	TMP_SSTA	RO	RO	RO
	Compr Return Gas Temp	snnn.n	dF (dC)	TMP_RGTA	RO	RO	NA
Suction Superheat Temp	snnn.n	^F (^C)	SH_A	RO	RO	RO	
CIRCBADIO	CIRC. B DISCRETE OUTPUTS						
	Compressor B1 Relay	Off/On		K_B1_RLY	RO	RO	RO
	Compressor B2 Relay	Off/On		K_B2_RLY	RO	RO	RO
	Minimum Load Valve Relay	Off/On		MLV_RLY	RO	RO	NA
	CIRC. B DISCRETE INPUTS						
	Compressor B1 Feedback	Off/On		K_B1_FBK	RO	RO	NA
Compressor B2 Feedback	Off/On		K_B2_FBK	RO	RO	NA	

30RA AquaSnap Chiller Service Manual

30RAN w/ Software Versions 1.0 and 2.0							
CCN Table Name	Description	Status	Units	Point	DataPort	DataLink	BAClink
CIRCB_AN	CIRCUIT B ANALOG VALUES						
	Percent Total Capacity	0 to 100	%	CAPB_T	RO	RO	RO
	Percent Available Cap.	0 to 100	%	CAPB_A	RO	RO	RO
	Discharge Pressure	nnn.n	PSIG (KPA)	DP_B	RO	RO	RO
	Suction Pressure	nnn.n	PSIG (KPA)	SP_B	RO	RO	RO
	Calculated HP Setpoint B	nnn.n	dF (dC)	HSP_B	RO	RO	NA
	Saturated Condensing Tmp	snnn.n	dF (dC)	TMP_SCTB	RO	RO	RO
	Saturated Suction Temp	snnn.n	dF (dC)	TMP_SSTB	RO	RO	RO
	Compr Return Gas Temp	snnn.n	dF (dC)	TMP_RGTB	RO	RO	NA
	Suction Superheat Temp	snnn.n	^F (^C)	SH_B	RO	RO	RO
OPTIONS	FANS						
	Fan 1 Relay	Off/On		FAN_1	RO	RO	RO
	Fan 2 Relay	Off/On		FAN_2	RO	RO	RO
	Cooler/Pump Heater	Off/On		COOL_HTR	RO	RO	NA
	UNIT ANALOG VALUES						
	Cooler Entering Fluid	snnn.n	dF (dC)	COOL_EWT	RO	RO	RO
	Cooler Leaving Fluid	snnn.n	dF (dC)	COOL_LWT	RO	RO	RO
	Lead/Lag Leaving Fluid	snnn.n	dF (dC)	DUAL_LWT	RO	RO	NA
	TEMPERTURE RESET						
	4-20 mA Reset Signal	nn.n	ma	RST_MA	RO	RO	RO
	Outside Air Temperature	snnn.n	dF (dC)	OAT	RO	RW	NA
	Space Temperature	snnn.n	dF (dC)	SPT	RO	RW	NA
	DEMAND LIMIT						
	4-20 mA Demand Signal	nn.n	ma	LMT_MA	RO	RO	RO
	Demand Limit Switch 1	Off/On		DMD_SW1	RO	RO	NA
	Demand Limit Switch 2	Off/On		DMD_SW2	RO	RO	NA
	CCN Loadshed Signal	0 = Normal 1 = Redline 2 = Loadshed		DL_STAT	RO	RO	RO
	MISCELLANEOUS						
	Heat Request	Off/On		HEAT_REQ	RO	RO	NA
	Dual Setpoint Switch	Off/On		DUAL_IN	RO	RO	NA
Cooler LWT Setpoint	snnn.n	dF (dC)	LWT_SP	RO	RO	NA	
Ice Done	Off/On		ICE_DONE	RO	RO	NA	
SETPOINT	COOLING						
	Cooling Setpoint 1	-20 to 70 (-28.8 to 21.1)	dF (dC)	CSP1	NA	RW	RW
	Cooling Setpoint 2	-20 to 70 (-28.8 to 21.1)	dF (dC)	CSP2	NA	RW	NA
	Ice Setpoint	-20 to 32 (-28.8 to 0.0)	dF (dC)	CSP3	NA	RW	NA
	RAMP LOADING						
Cooling Ramp Loading	0.2 to 2.0 (0.1 to 1.1)		CRAMP	NA	RW	NA	
Brine Freeze Point	-20 to 34 (-28.8 to 1.1)	dF (dC)	BRN_FRZ	NA	RW	NA	

30RA AquaSnap Chiller Service Manual

30RAN w/ Software Versions 1.0 and 2.0							
CCN Table Name	Description	Status	Units	Point	DataPort	DataLink	BAClink
OCCPC01S	Timed Override Hours	0	Hours	OVR-EXT	NA	RW	RW
	Period 1 DOW (MTWTFSSH)	00000000		DOW1	NA	RW	RW
	Occupied Time	00:00		OCCTOD1	NA	RW	RW
	Unoccupied Time	00:00		UNOCTOD1	NA	RW	RW
	Period 2 DOW (MTWTFSSH)	00000000		DOW2	NA	RW	RW
	Occupied Time	00:00		OCCTOD2	NA	RW	RW
	Unoccupied Time	00:00		UNOCTOD2	NA	RW	RW
	Period 3 DOW (MTWTFSSH)	00000000		DOW3	NA	RW	RW
	Occupied Time	00:00		OCCTOD3	NA	RW	RW
	Unoccupied Time	00:00		UNOCTOD3	NA	RW	RW
	Period 4 DOW (MTWTFSSH)	00000000		DOW4	NA	RW	RW
	Occupied Time	00:00		OCCTOD4	NA	RW	RW
	Unoccupied Time	00:00		UNOCTOD4	NA	RW	RW
	Period 5 DOW (MTWTFSSH)	00000000		DOW5	NA	RW	RW
	Occupied Time	00:00		OCCTOD5	NA	RW	RW
	Unoccupied Time	00:00		UNOCTOD5	NA	RW	RW
	Period 6 DOW (MTWTFSSH)	00000000		DOW6	NA	RW	RW
	Occupied Time	00:00		OCCTOD6	NA	RW	RW
	Unoccupied Time	00:00		UNOCTOD6	NA	RW	RW
	Period 7 DOW (MTWTFSSH)	00000000		DOW7	NA	RW	RW
	Occupied Time	00:00		OCCTOD7	NA	RW	RW
	Unoccupied Time	00:00		UNOCTOD7	NA	RW	RW
	Period 8 DOW (MTWTFSSH)	00000000		DOW8	NA	RW	RW
	Occupied Time	00:00		OCCTOD8	NA	RW	RW
Unoccupied Time	00:00		UNOCTOD8	NA	RW	RW	

- Note: dC - Degrees Celsius
dF - Degrees Fahrenheit
^F - Delta Degrees Fahrenheit
^C - Delta Degrees Celsius
NA - Not Available
RO - Read Only
RW - Read/Write

In order to write to any point with DataLink or BAClink, the machine must be configured for CCN control. CTRL *Control Method* (Configuration Mode, sub-mode OPT2) must be set to 3=CCN Control.

30RA AquaSnap Chiller Service Manual

30RAN w/ Software Versions 3.0 and later								
CCN Table Name	Description	Status	Units	Point	DataPort	DataLink	BAClink	
A_UNIT	GENERAL PARAMETERS							
	Control Mode	0 = Service Test 1 = OFF Local 2 = OFF CCN 3 = OFF Time 4 = OFF Emrgcy 5 = ON Local 6 = ON CCN 7 = ON Time 8 = Ht Enabled 9 = Pump Delay		STAT	RO	RO	RO	
	Occupied	No/Yes		OCC	RO	RO	RO	
	CCN Chiller	Start/Stop		CHIL_S_S	RO	RW	RW	
	Low Sound Active	No/Yes		LSACTIVE	RO	RO	NA	
	Alarm State	Normal/Alert/Alarm		ALM	RO	RO	RO	
	Active Demand Limit	0 to 100	%	DEM_LIM	RO	RW	RW	
	Override Modes In Effect	No/Yes		MODE	RO	RO	NA	
	Percent Total Capacity	0 to 100	%	CAP_T	RO	RO	RO	
	Requested Stage	0 to 99		STAGE	RO	RO	NA	
	Active Setpoint	-20 to 70 (-28.8 to 21.1)	dF (dC)	SP	RO	RO	NA	
	Control Point	-20 to 70 (-28.8 to 21.1)	dF (dC)	CTRL_PNT	RO	RW	RW	
	Entering Fluid Temp	snnn.n	dF (dC)	EWT	RO	RO	RO	
	Leaving Fluid Temp	snnn.n	dF (dC)	LWT	RO	RO	RO	
	Emergency Stop	Enable/Emstop		EMSTOP	RO	RW	RW	
	Minutes Left for Start	00:00 to 15:00	Minutes	MIN_LEFT	RO	RO	NA	
	PUMPS							
	Cooler Pump Relay 1	Off/On		COOLPMP1	RO	RO	NA	
	Cooler Pump Relay 2	Off/On		COOLPMP2	RO	RO	NA	
	Cooler Pump 1 Interlock	Open/Close		PMP1_FBK	RO	RO	NA	
	Cooler Pump 2 Interlock	Open/Close		PMP2_FBK	RO	RO	NA	
	Cooler Flow Switch	Off/On		COOLFLOW	RO	RO	NA	
	Lead Pump	0 = Automatic 1 = Pump 1 2 = Pump 2		LEADPUMP	RO	RO	NA	
Rotate Cooler Pumps Now	No/Yes		ROT_PUMP	RO	RO	NA		
Heat/Cool Select	Heat/Cool		HC_SEL	RO	RO	NA		
CIRCADIO	CIRC. A DISCRETE OUTPUTS							
	Compressor A1 Relay	Off/On		K_A1_RLY	RO	RO	RO	
	Compressor A2 Relay	Off/On		K_A2_RLY	RO	RO	RO	
CIRCADIO	Minimum Load Valve Relay	Off/On		MLV_RLY	RO	RO	NA	
	CIRC. A DISCRETE INPUTS							
	Compressor A1 Feedback	Off/On		K_A1_FBK	RO	RO	NA	
CIRCADIO	Compressor A2 Feedback	Off/On		K_A2_FBK	RO	RO	NA	
	CIRCA_AN	CIRCUIT A ANALOG VALUES						
		Percent Total Capacity	0 to 100	%	CAPA_T	RO	RO	RO
Percent Available Cap.		0 to 100	%	CAPA_A	RO	RO	RO	
Discharge Pressure		nnn.n	PSIG (KPA)	DP_A	RO	RO	RO	
Suction Pressure		nnn.n	PSIG (KPA)	SP_A	RO	RO	RO	
Calculated HP Setpoint A		nnn.n	dF (dC)	HSP_A	RO	RO	NA	
Saturated Condensing Tmp		snnn.n	dF (dC)	TMP_SCTA	RO	RO	RO	
Saturated Suction Temp		snnn.n	dF (dC)	TMP_SSTA	RO	RO	RO	
Compr Return Gas Temp		snnn.n	dF (dC)	TMP_RGTA	RO	RO	NA	
Suction Superheat Temp		snnn.n	^F (^C)	SH_A	RO	RO	RO	
CIRCBUDIO	CIRC. B DISCRETE OUTPUTS							
	Compressor B1 Relay	Off/On		K_B1_RLY	RO	RO	RO	
	Compressor B2 Relay	Off/On		K_B2_RLY	RO	RO	RO	
CIRCBUDIO	Minimum Load Valve Relay	Off/On		MLV_RLY	RO	RO	NA	
	CIRC. B DISCRETE INPUTS							
	Compressor B1 Feedback	Off/On		K_B1_FBK	RO	RO	NA	
CIRCBUDIO	Compressor B2 Feedback	Off/On		K_B2_FBK	RO	RO	NA	

30RA AquaSnap Chiller Service Manual

30RAN w/ Software Versions 3.0 and later							
CCN Table Name	Description	Status	Units	Point	DataPort	DataLink	BAClink
CIRCB_AN	CIRCUIT B ANALOG VALUES						
	Percent Total Capacity	0 to 100	%	CAPB_T	RO	RO	RO
	Percent Available Cap.	0 to 100	%	CAPB_A	RO	RO	RO
	Discharge Pressure	nnn.n	PSIG (KPA)	DP_B	RO	RO	RO
	Suction Pressure	nnn.n	PSIG (KPA)	SP_B	RO	RO	RO
	Calculated HP Setpoint B	nnn.n	dF (dC)	HSP_B	RO	RO	NA
	Saturated Condensing Tmp	snnn.n	dF (dC)	TMP_SCTB	RO	RO	RO
	Saturated Suction Temp	snnn.n	dF (dC)	TMP_SSTB	RO	RO	RO
	Compr Return Gas Temp	snnn.n	dF (dC)	TMP_RGTB	RO	RO	NA
	Suction Superheat Temp	snnn.n	^F (^C)	SH_B	RO	RO	RO
OPTIONS	FANS						
	Fan 1 Relay	Off/On		FAN_1	RO	RO	RO
	Fan 2 Relay	Off/On		FAN_2	RO	RO	RO
	Cooler/Pump Heater	Off/On		COOL_HTR	RO	RO	NA
	UNIT ANALOG VALUES						
	Cooler Entering Fluid	snnn.n	dF (dC)	COOL_EWT	RO	RO	RO
	Cooler Leaving Fluid	snnn.n	dF (dC)	COOL_LWT	RO	RO	RO
	Lead/Lag Leaving Fluid	snnn.n	dF (dC)	DUAL_LWT	RO	RO	NA
	TEMPERTURE RESET						
	4-20 mA Reset Signal	nn.n	ma	RST_MA	RO	RO	RO
	Outside Air Temperature	snnn.n	dF (dC)	OAT	RO	RW	NA
	Space Temperature	snnn.n	dF (dC)	SPT	RO	RW	NA
	DEMAND LIMIT						
	4-20 mA Demand Signal	nn.n	ma	LMT_MA	RO	RO	RO
	Demand Limit Switch 1	Off/On		DMD_SW1	RO	RO	NA
	Demand Limit Switch 2	Off/On		DMD_SW2	RO	RO	NA
	CCN Loadshed Signal	0 = Normal 1 = Redline 2 = Loadshed		DL_STAT	RO	RO	RO
	MISCELLANEOUS						
	Heat Request	Off/On		HEAT_REQ	RO	RO	NA
	Dual Setpoint Switch	Off/On		DUAL_IN	RO	RO	NA
Cooler LWT Setpoint	snnn.n	dF (dC)	LWT_SP	RO	RO	NA	
Ice Done	Off/On		ICE_DONE	RO	RO	NA	
SETPOINT	COOLING						
	Cooling Setpoint 1	-20 to 70 (-28.8 to 21.1)	dF (dC)	CSP1	NA	RW	RW
	Cooling Setpoint 2	-20 to 70 (-28.8 to 21.1)	dF (dC)	CSP2	NA	RW	NA
	Ice Setpoint	-20 to 32 (-28.8 to 0.0)	dF (dC)	CSP3	NA	RW	NA
	RAMP LOADING						
Cooling Ramp Loading	0.2 to 2.0 (0.1 to 1.1)		CRAMP	NA	RW	NA	
Brine Freeze Point	-20 to 34 (-28.8 to 1.1)	dF (dC)	BRN_FRZ	NA	RW	NA	

30RA AquaSnap Chiller Service Manual

30RAN w/ Software Versions 3.0 and later							
CCN Table Name	Description	Status	Units	Point	DataPort	DataLink	BAClink
OCCPC01S	Timed Override Hours	0	Hours	OVR-EXT	NA	RW	RW
	Period 1 DOW (MTWTFSSH)	00000000		DOW1	NA	RW	RW
	Occupied Time	00:00		OCCTOD1	NA	RW	RW
	Unoccupied Time	00:00		UNOCTOD1	NA	RW	RW
	Period 2 DOW (MTWTFSSH)	00000000		DOW2	NA	RW	RW
	Occupied Time	00:00		OCCTOD2	NA	RW	RW
	Unoccupied Time	00:00		UNOCTOD2	NA	RW	RW
	Period 3 DOW (MTWTFSSH)	00000000		DOW3	NA	RW	RW
	Occupied Time	00:00		OCCTOD3	NA	RW	RW
	Unoccupied Time	00:00		UNOCTOD3	NA	RW	RW
	Period 4 DOW (MTWTFSSH)	00000000		DOW4	NA	RW	RW
	Occupied Time	00:00		OCCTOD4	NA	RW	RW
	Unoccupied Time	00:00		UNOCTOD4	NA	RW	RW
	Period 5 DOW (MTWTFSSH)	00000000		DOW5	NA	RW	RW
	Occupied Time	00:00		OCCTOD5	NA	RW	RW
	Unoccupied Time	00:00		UNOCTOD5	NA	RW	RW
	Period 6 DOW (MTWTFSSH)	00000000		DOW6	NA	RW	RW
	Occupied Time	00:00		OCCTOD6	NA	RW	RW
	Unoccupied Time	00:00		UNOCTOD6	NA	RW	RW
	Period 7 DOW (MTWTFSSH)	00000000		DOW7	NA	RW	RW
	Occupied Time	00:00		OCCTOD7	NA	RW	RW
	Unoccupied Time	00:00		UNOCTOD7	NA	RW	RW
	Period 8 DOW (MTWTFSSH)	00000000		DOW8	NA	RW	RW
	Occupied Time	00:00		OCCTOD8	NA	RW	RW
Unoccupied Time	00:00		UNOCTOD8	NA	RW	RW	

- Note: dC - Degrees Celsius
dF - Degrees Fahrenheit
^F - Delta Degrees Fahrenheit
^C - Delta Degrees Celsius
NA - Not Available
RO - Read Only
RW - Read/Write

In order to write to any point with DataLink or BAClink, the machine must be configured for CCN control. CTRL *Control Method* (Configuration Mode, sub-mode OPT2) must be set to 3=CCN Control.

APPENDIX C – OVERLOAD SETTINGS

Series 0 Machines – Square D Controls

Not for Distribution

APPENDIX D – RCD SERVICE KITS

RCD Kit Number	Includes the following Items		
30GT680001	Title	Communication Harness	
	Used on	ComfortLink Machines – 30GTN/GTR, 30GUN/GUR 30GXN/GXR, 30HK/HL, 30HW, 30HXA/HXC, 30RA	
	Comment		
	Part Number	Qty	Description
		1	MBB-J4 to Scrolling Marquee Display Harness
		1	MBB-J5 to TB3 Harness
30GX660017	Title	Fan Kit	
	Used on	30GX, 30RA	
	Comment		
	Part Number	Qty	Description
	30GX400152	1	Fan Assembly with Cover
	09DC507752	1	Motor Spacer
	AS90BD040	4	Speed Clip
	99TA520019	1	Instruction Sheet

Not for Distribution

APPENDIX E – CCN TABLES

A_UNIT (General Unit Parameters)

DESCRIPTION	VALUE	UNITS	POINT NAME	FORCEABLE
Control Mode	0 = Test 1 = Local Off 2 = CCN Off 3 = Clock Off 4 = Emergency Stop 5 = Local On 6 = CCN On 7 = Clock On 8 = Heat Enabled 9 = Pump Delay		STAT	N
Occupied	No/Yes		OCC	N
CCN Chiller	Start/Stop		CHIL_S_S	Y
Low Sound Active	No/Yes		LSACTIVE	N
Alarm State	Normal/Alert/Alarm		ALM	N
Active Demand Limit	0 to 100	%	DEM_LIM	Y
Override Modes in Effect	No/Yes		MODE	N
Percent Total Capacity	0 to 100	%	CAP_T	N
Requested Stage	0 to 99		STAGE	N
Active Set Point	-20 to 70	°F	SP	N
Control Point	-20 to 70	°F	CTRL_PNT	Y
Entering Fluid Temp	snnn.n	°F	EWT	N
Leaving Fluid Temp	snnn.n	°F	LWT	N
Emergency Stop	Enable/Emstop	Enable	EMSTOP	Y
Minutes Left for Start	00:00 to 15:00	minutes	MIN_LEFT	N
PUMPS				
Cooler Pump Relay 1	Off/On		COOLPMP1	N
Cooler Pump Relay 2	Off/On		COOLPMP2	N
Cooler Pump 1 Interlock	Open/Close		PMP1_FBK	N
Cooler Pump 2 Interlock	Open/Close		PMP2_FBK	N
Cooler Flow Switch	Open/Close		COOLFLOW	N
Rotate Cooler Pumps Now	No/Yes		ROT_PUMP	Y
Heat/Cool Select	Heat/Cool		HC_SEL	N

INDEX

Alarm	85	Cleaning - Non-E-Coat	111
History.....	99	Condenser Fan Motor	113
Reset History.....	99	Nominal Horsepower.....	113
Resetting	98	RPM.....	113
Alert	<i>See Alarm</i>	Usage.....	113
BacLink™	27	Control Circuit	113
Carrier Comfort Network.....	24	Convenience Outlet.....	18
Alarm Routing Control	24	Cooler.....	114
Communication Bus Wiring	25	Heater	114
Carrier Comfort Network Interface Devices	26	Remote	62
Chilled Water Flow Switch.....	<i>See Hydronic Package, Chilled Water Flow Switch</i>	Cooler Heater Control... <i>See Heater Control</i>	
Chilled Water Loop Volume.....	12	Cooler Pump Control..... <i>See Chilled Water Pump Control</i>	
Chilled Water Pump. <i>See Hydronic Package, Chilled Water Pump</i>		DataLink™	27
Chilled Water Pump Control	27	DataPort™	27
Chilled Water Storage Tank.....	12, 99	Daylight Savings.... <i>See Time Clock, Setting</i>	
Heaters	100	Demand Limit	37
Serial Number Significance.....	99	2 Stage Switch Control	39
Close Control	<i>See Compressor Loading, Close Control</i>	4-20 mA	39
Coil Protection Grilles	14	CCN Loadshed.....	39
ComfortLink Control Boards.....	100	Dual Chiller Control	40
ComfortLink Controls		Electrical Information	16
Energy Management Module.....	42	Power Connections	16
Factory Default Configuration.....	42	Energy Management Board (EMM).....	104
Compressor	105	Expansion Device	114
Crankcase Heater	106	Expansion Tank	<i>See Hydronic Package, Expansion Tank</i>
Nominal Input Horsepower.....	107	Generator Operation.....	17
Oil	107	Ground Fault Interrupter <i>See Convenience Outlet</i>	
Power Factor	107	Hail Guards	19
Replacement.....	108	Heat Operation	54
Serial Number	109	Heater Control.....	54
Weights	109	Hot Gas Bypass... <i>See Minimum Load Control</i>	
Compressor Loading.....	32	Hydronic Package	21, 116
Circuit Loading	33	Chilled Water Flow Switch.....	116
Close Control	32	Chilled Water Pump.....	117
Compressor Start.....	33	Expansion Tank	118
Lead/Lag	33	Heaters	118
Condenser Coil.....	111	Strainer	118
Cleaning - E-Coat	111	Low Ambient Head Pressure Control..... <i>See MotorMaster V</i>	

30RA AquaSnap Chiller Service Manual

Low Sound Mode.....	55	Setting the Day of Year.....	<i>See</i> Time Clock
Main Base Board (MBB).....	104	Software Revisions	63
Maintenance Schedule	130	Version 1.0.....	65
Minimum Load Control	22, 56, 119	Version 2.0.....	65
Model Number Significance.....	9	Version 3.0.....	64
Factory Installed Option Codes	11	Version 4.0.....	63
MotorMaster V.....	20, 119	Space Temperature Sensor.....	66
Current Limiter	120	Spring Start-Up	132
Navigator.....	34, 101	Storage Tank Heater Control	<i>See</i> Heater Control
Backlight Adjustment	36	Strainer.....	<i>See</i> Hydronic Package, Strainer
Cleaning	101	Temperature Reset	66
Connection Cord/Plug Assembly		4-20 mA	67
Replacement.....	101	Outdoor Air Temperature	69
Contrast Adjustment	35	Return Water.....	70
Network Service Tool IV.....	123	Space Temperature.....	71
Non-Fused Disconnect.....	123	Temperature Set Point.....	73
Oil	<i>See</i> Compressor, Oil	4-20 mA Input/Switch Control	78
Operating Modes.....	56	Dual Set Point/Occupancy	77
Paint		Dual Switch Set Point/Switch Control..	73
Touch-up.....	125	Ice Build Switch/Switch Control	73
Pressure Transducers	125	Ice Build/Occupancy.....	78
Pump Heater Control	<i>See</i> Heater Control	Single Set Point/Occupancy.....	74
Recommended Spare Parts List.....	132	Single Set Point/Switch Control	73
Refrigerant	125	Thermistors	128
Moisture Limit	126	Time Clock.....	80
Refrigerant Service Ports.....	127, 128	Setting the Date.....	80
Remote Alarm Relay.....	62	Setting the Time.....	81
Remote Enhanced Display.....	37	TXV	<i>See</i> Expansion Device
Return Gas Sensor.....	65, 129	Vibration Isolation	
Scrolling Marquee Display	36, 100	Pads.....	23
Setting the Date.....	<i>See</i> Time Clock	Spring Isolation.....	23
Setting the Day of Month.....	<i>See</i> Time Clock	Winterization.....	132
Setting the Day of Week.....	<i>See</i> Time Clock		