

Installation Instructions

Part Numbers — 32GB400274, 32GB400284

INTRODUCTION

The Demand Limit Control Module (DLCM) provides 2 demand limit steps. The first step is between 50% and 100% of maximum compressor displacement, and the second step is between 0% and 49%, displacement. The exact percentage depends on the available steps of capacity. The 2 steps must be controlled through an external switching device that determines when to limit unit capacity.

Unit Application

UNITS	PART NUMBERS	
	32GB400274	32GB400284
	V-Ph-Hz	
	208/230-3-60 460-3-60 575-3-60	380-3-60, 230-3-50, 380/415-3-50, 346-3-50
30GT040-110 Flotronic Chillers	X	X
30GT130-210 Flotronic Chillers	X	X
30GT225,250,280 Flotronic Chillers	X	X
30GT240,270,300-420 Flotronic Chillers*	X	X
48DK024-104 VAV Rooftops (Flotronic)	X	—
50DK024-104 VAV Rooftops (Flotronic)	X	—
50DY024-074 VAV Rooftops (Flotronic)	X	—

LEGEND

VAV — Variable Air Volume

*Modular units which require 2 boards, one for each module.
 For 240B and 270B, follow instructions for sizes 080-110. For all other units, follow instructions for sizes 130-210.

OPERATION

Two adjustable potentiometers are used to set the 2 demand limit set points. Potentiometer P1 is used to set a demand limit set point in the range from 100% to 50% capacity. Potentiometer P2 is used to cover the range from 49% to 0% capacity.

When power is not supplied to DLCM, all capacity stages can be used if required.

When power is supplied to terminal INT1 only, by field-supplied and controlled SW1, the first stage of demand limit is energized. In this mode, the capacity is reduced to the setting of P1. See Fig. 1 and 2.

When power is supplied to INT2 only by field-supplied and controlled SW2, or to both INT1 and INT2, capacity is reduced to the setting of P2. See Fig. 1 and 2.

When the DLCM is signalled to begin, Code 22 appears on the LCD (liquid crystal display) of the set point controller board (Fig. 3-9) when display button is pressed. The unit capacity will be reduced to the amount set for the demand limit.

INSTALLATION

Inspect the Package Contents — If any damage is found, file a claim with the shipping agent. Be sure the DLCM is correct for the job requirements (50 or 60 Hz, 115-v or 230-v control power). Check the DLCM against Fig. 1. If there is any error, notify your Carrier representative. Pigtail plug must be wired as shown.

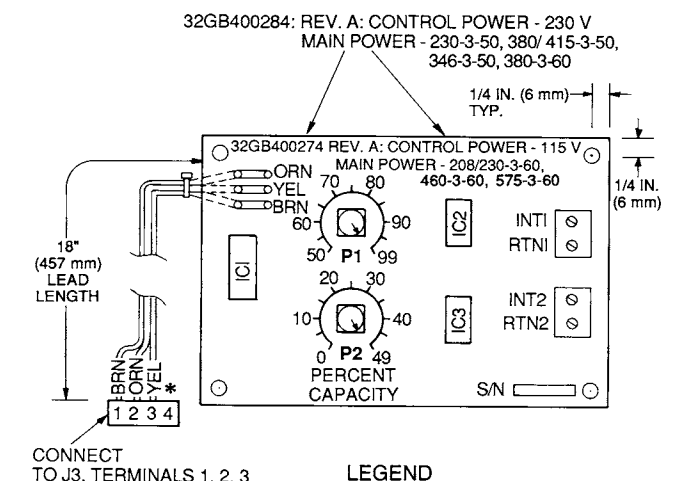

CONNECT TO J3, TERMINALS 1, 2, 3

LEGEND

INT — Input Terminal
 RTN — Return Terminal

*Connector wiring must be as shown.

Fig. 1 — Accessory Demand Limit Control Module (DLCM)

Mount and Connect the DLCM

CAUTION

Before proceeding, shut off all power to the unit, and tag all disconnects.

1. Open control box doors and remove the sheet metal cover over the processor board.
2. Remove plastic cover over the DIP (dual in-line package) switches on the processor board (Fig. 3-9) and set switch no. 5 to the ON position. Replace plastic cover.

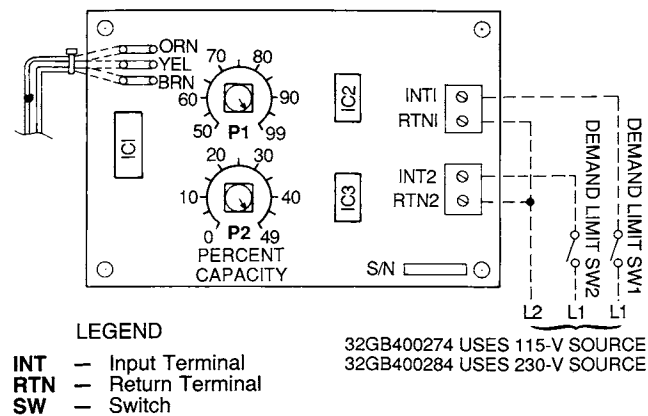

Fig. 2 - Control Power Connections

3. FOR 48/50DK, 50DY UNITS: Mount the DLCM circuit board in the control box as shown in Fig. 3-6. Use the circuit board as a template and drill 4 holes in the back panel of the control box. Fasten with 4 field-supplied no. 8B-18 x 3/4-in. (19 mm) long mounting screws.

FOR 30GT UNITS: Locate the DLCM circuit board in the control box as shown in Fig. 7-9. Mount the circuit board using the 4 corner holes and four no. 8B-18 x 3/4-in. (19 mm) long field-supplied mounting screws.

4. Attach the connector at the end of the DLCM wires to terminals 1-4 on connector J3 on the processor board. On 48/50DK, 50DY units so equipped, remove the connector that connects the demand limit input on the microprocessor at J3 to terminal strip as indicated:

SIZE	TERMINAL STRIP
024-030,050	J3 to TB2 (Fig. 3)
034-044	J3 to TB3 (Fig. 4)
054-074	J3 to TB4 (Fig. 5)
084-104	J3 to TB3 (Fig. 6)

5. Connect the field input control power wires to the terminal strips marked INT1, RTN1 and INT2, RTN2 which are pressure-type connectors; strip the insulation from the wires before inserting. The connector can accept up to 12 AWG (American Wire Gage) (3.3 mm²) wire. SW1 and SW2 are field-supplied, normally open switches (toggle switches or relay contacts). See Fig. 2.
6. Set the potentiometers to the desired capacity limit.
7. Check the operation, using the Quick Test procedure described in unit Installation Instructions or the Controls and Troubleshooting booklet. Verify that DIP switch and potentiometers are properly set.
8. Close and secure the control box door.

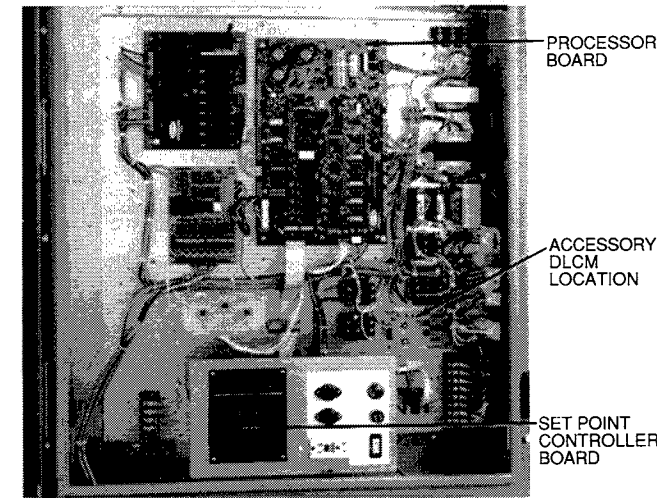

Fig. 7 - Units 30GT040-110 Accessory Demand Limit Control Module (DLCM) Mounting Location

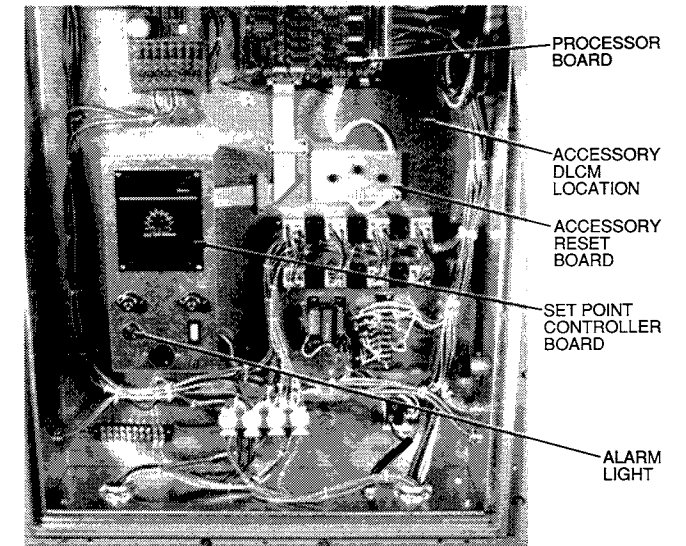

Fig. 9 - Units 30GT225-280 Accessory Demand Limit Control Module (DLCM) Mounting Location

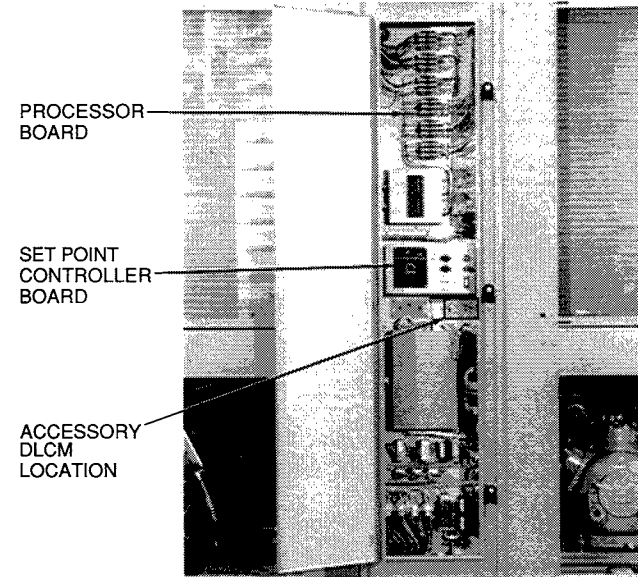

Fig. 8 - Units 30GT130-210 Accessory Demand Control Limit Module (DLCM) Mounting Location

- *Incorrect potentiometer setting* — The potentiometer is turned fully clockwise, or fully counterclockwise, outside the valid range.
- *Wiring problem* — Wiring between potentiometer and processor is incorrect.
- *Potentiometer failure* — Potentiometer is shorted or open.

If a problem with the DLCM board is suspected, use the following test procedure and a digital volt-ohmmeter. A good quality analog meter is acceptable.

The board can only be checked when it is connected to the microprocessor and the microprocessor is energized so that the DLCM is being supplied with 5 vdc power.

The terminals referenced in the procedure are on the J3 connector shown in Fig. 1.

CAUTION

Be careful to avoid damaging the connector or the processor board when taking the voltage readings. P1 and P2 refer to the DLCM potentiometers.

- Condition 1: No power to INT1 or INT2.
 Terminal 1 to 2 4.5 vdc ± 0.1 v
 Terminal 2 to 3 5.0 vdc ± 0.1 v
- Condition 2: Power to INT2 only or to both INT1 and INT2.
 P2 set at 25%.
 Terminal 1 to 2 1.5 vdc ± 0.1 v
 Voltage should vary between 0.5 vdc and 2.5 vdc as the setting of P2 is varied between 0% and 49%.
 Terminal 2 to 3 5.0 vdc ± 0.1 v
- Condition 3: Power to INT1 only.
 P1 set at 50%.
 Terminal 1 to 2 2.5 vdc ± 0.1
 Terminal 2 to 3 5.0 vdc ± 0.1
 Voltage should vary between 2.5 vdc and 4.5 vdc as the setting of P1 is varied between 50% and 100%.
 If the voltages listed are not obtained during this check, the board is defective and must be replaced.

SERVICE

Diagnostic Code 85 — There is only one failure code that can appear if a problem with the DLCM occurs. If this failure occurs, demand limit will be terminated. *Code 85* (demand limit potentiometer failure) is applicable only if demand limit is being used. DIP switch 5 must be on. For both potentiometers, the control recognizes only 10 to 90% of the potentiometer's full range resistance. If the resistance value is outside this range, the processor energizes the alarm light and displays Code 85 when the display button is pressed. This automatically resets when the problem is corrected. If this failure occurs, one of the following is the probable cause:

- *DIP switch no. 5* — Switch is ON and demand limit potentiometers are not used.

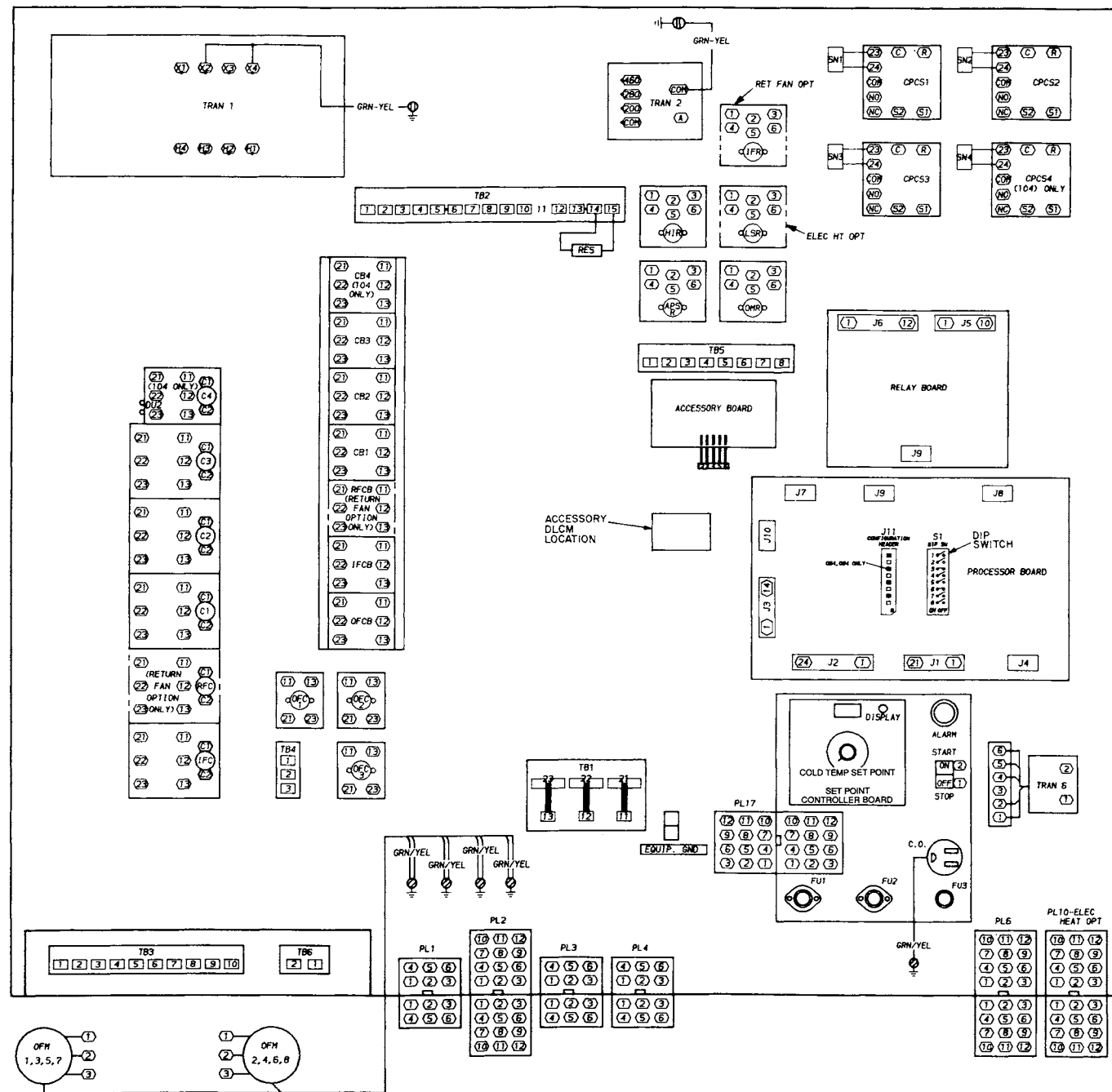

Fig. 6 - Units 48/50DK084-104 Accessory Demand Limit Control Module (DLCM) Mounting Location

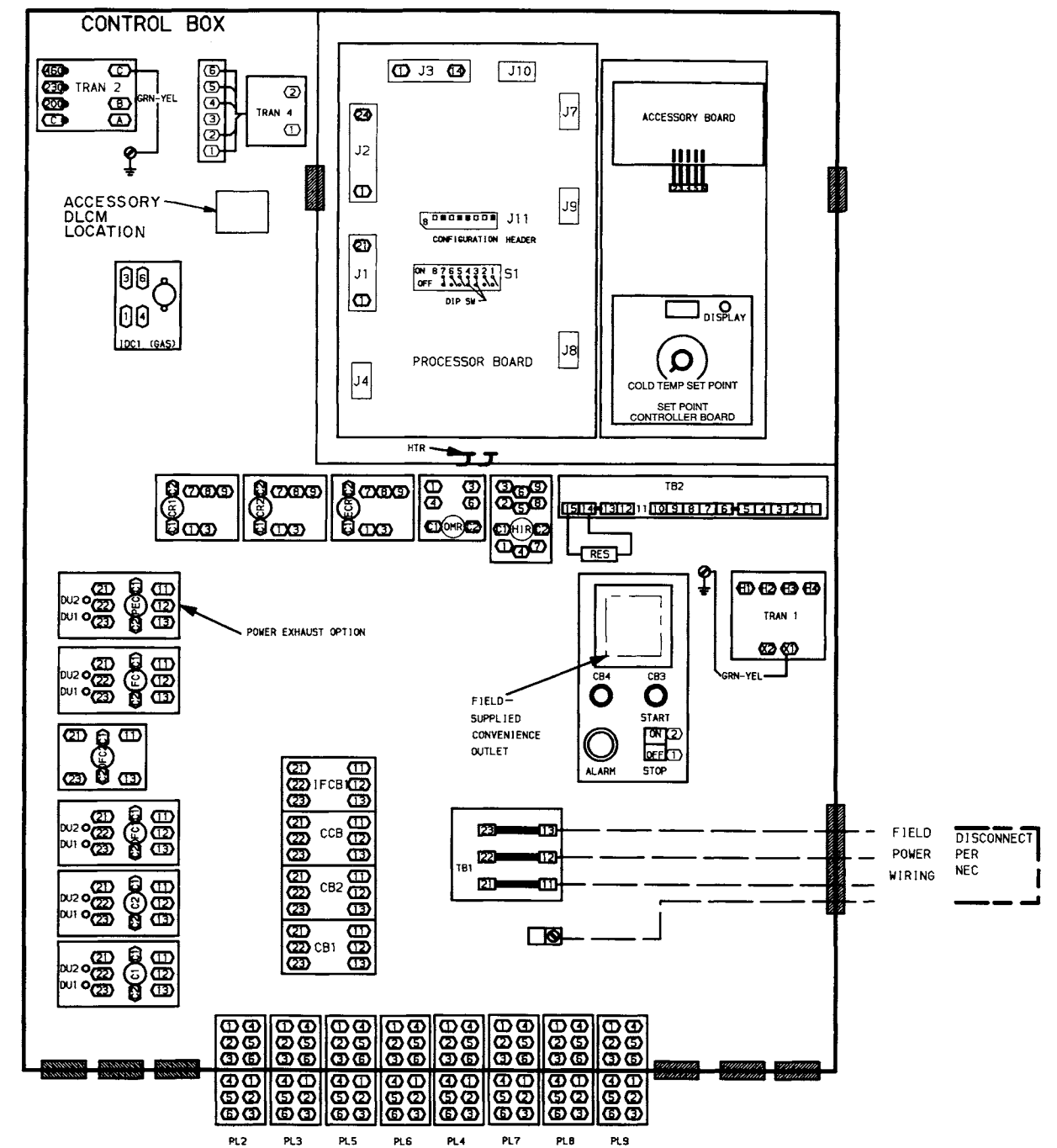

Fig. 3 - Units 48/50DK024-030 and 50DY024-030 Accessory Demand Limit Control Module (DLCM) Mounting Location

LEGEND (Fig. 3-6)

- | | | |
|--|--|---|
| ALM - Alarm | FU - Fuse | OFM - Outdoor Fan Motor |
| APSR - Air Pressure Switch Relay | HIR - Heater Interlock Relay | OMR - Occupied Mode Relay |
| C - Contactor | HT - Heater Thermostat | PEC - Powered Exhaust Contactor |
| CB - Circuit Breaker | HTR - Heater | PECB - Power Exhaust Circuit Breaker |
| CCB - Compressor Circuit Breaker | IDC - Induced Draft Contactor | PL - Plug |
| CO - Convenience Outlet | IFC - Indoor-Fan Contactor | PRI - Primary |
| CPCS - Compressor Protection Control System | IFCB - Indoor-Fan Circuit Breaker | RES - Resistor |
| CR - Control Relay | IFR - Indoor-Fan Relay | RET FAN - Return Fan Option |
| DIP SW - Dual In-Line Package Switch | J1, J2, etc. - Connectors | OPT - Option |
| DLCM - Demand Limit Control Module | LSR - Limit Switch Relay | RFCB - Return-Fan Circuit Breaker |
| DU - Dummy Terminal | NEC - National Electrical Code (U.S.A.) | RFCB - Return-Fan Circuit Breaker |
| ECR - Economizer Closed Relay | OFC - Outdoor-Fan Contactor | SEC - Secondary |
| ELEC HT OPT - Electric Heat Option | OFCB - Outdoor-Fan Circuit Breaker | SW - Switch |
| EOR - Economizer Open Relay | | TB - Terminal Board |
| | | TRAN - Transformer |

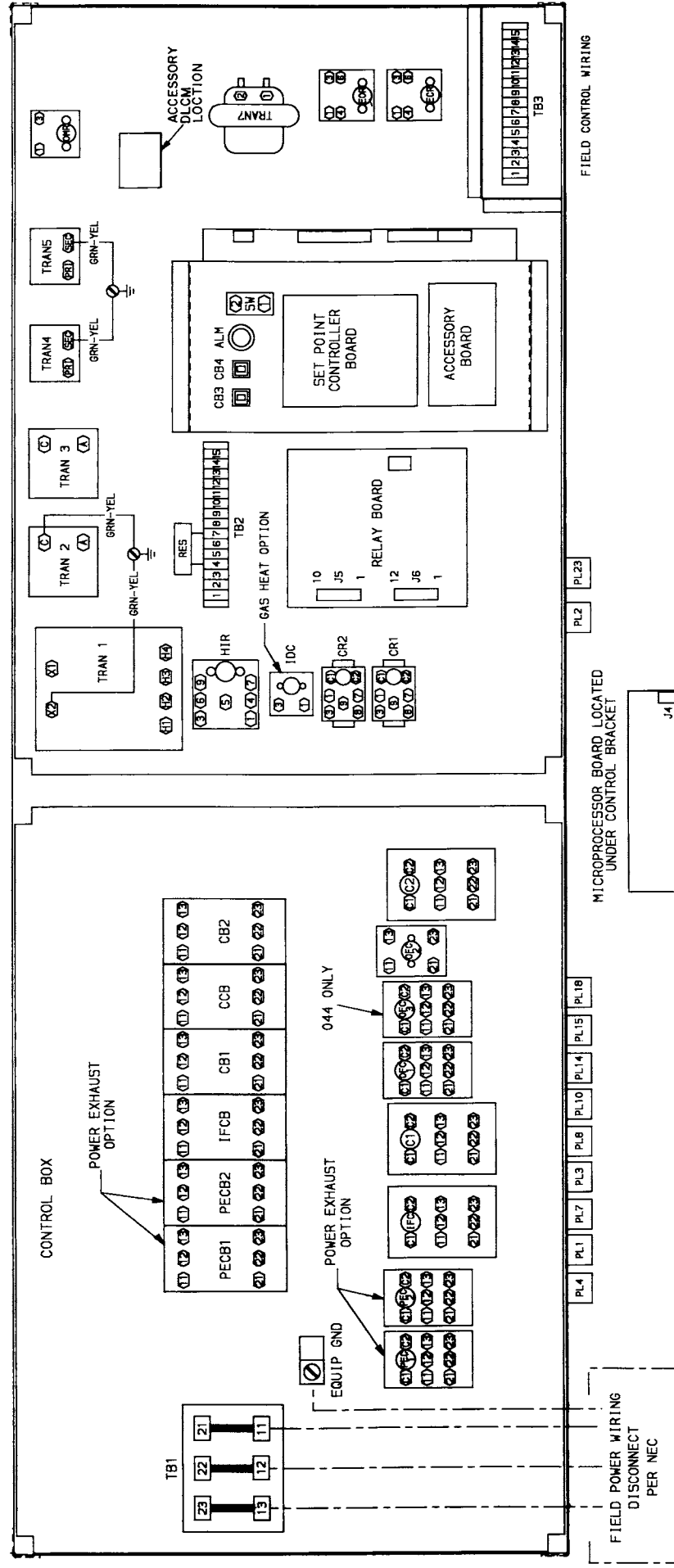

Fig. 4 — Units 48/50DK034,044 and 50DY034,044 Accessory Demand Limit Control Module (DLCM) Mounting Location

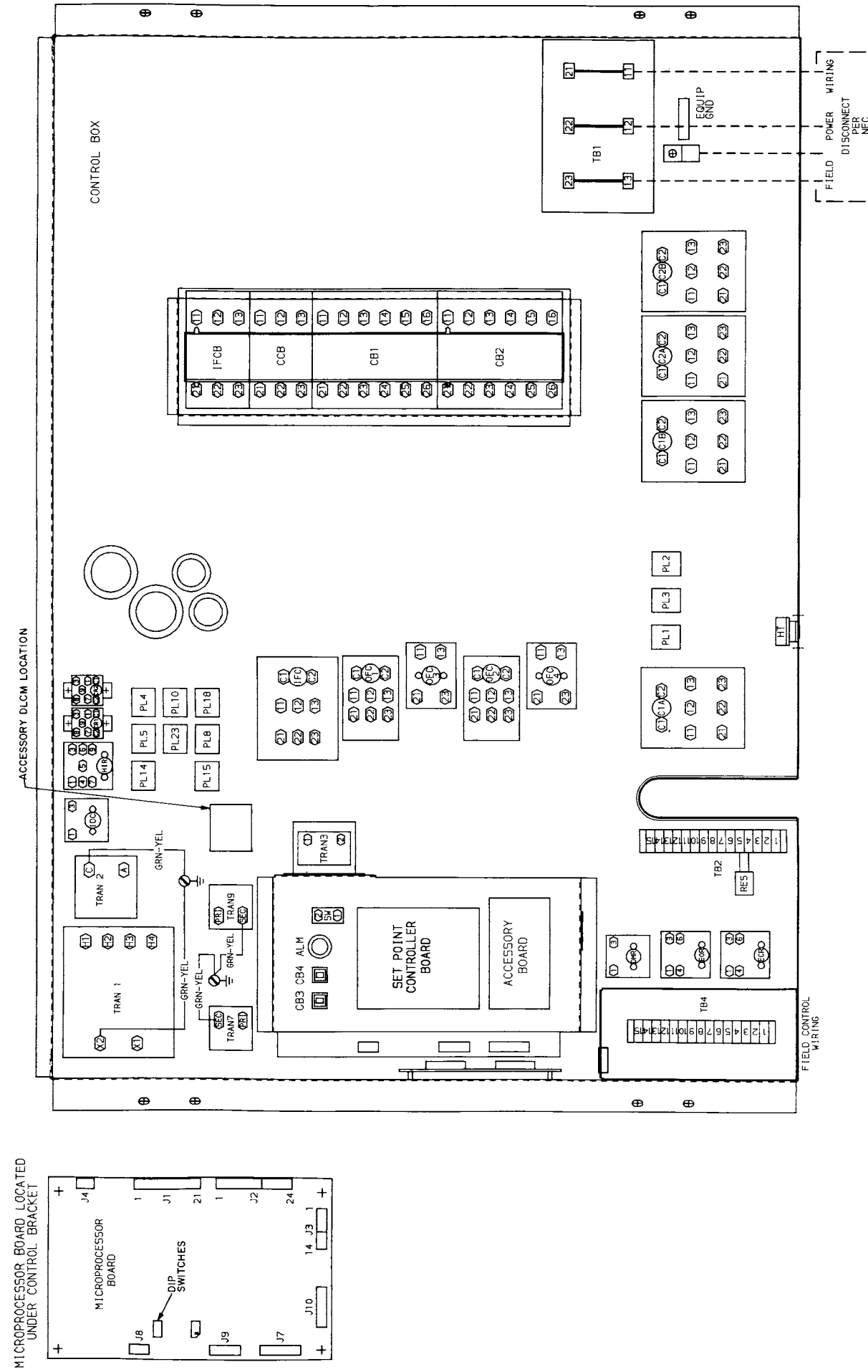

Fig. 5 — Units 48/50DK054-074 and 50DY054-074 Accessory Demand Limit Control Module (DLCM) Mounting Location