



# Installation, Start-Up and Service Instructions

## SAFETY CONSIDERATIONS

Installing, starting up, and servicing this equipment can be hazardous due to system pressures, electrical components, and equipment location.

Only trained, qualified installers and service mechanics should install, start up, and service this equipment.

Untrained personnel can perform basic maintenance functions, such as cleaning coils. All other operations should be performed by trained service personnel.

When working on the equipment, observe precautions in the literature, and on tags, stickers, and labels attached to the equipment.

- Follow all safety codes.
- Wear safety glasses and work gloves.
- Use care in handling, rigging, and setting bulky equipment.

	<p><b>ELECTRIC SHOCK HAZARD.</b></p> <p>Open all remote disconnects before servicing this equipment.</p>
--	--

**IMPORTANT:** This equipment generates, uses, and can radiate radio frequency energy and if not installed and used in accordance with these instructions may cause radio interference. It has been tested and found to comply with the limits of a Class A computing device as defined by FCC (Federal Communications Commission, U.S.A.) regulations, Subpart J of Part 15, which are designed to provide reasonable protection against such interference when operated in a commercial environment.

## CONTENTS

	Page
<b>SAFETY CONSIDERATIONS</b> .....	1
<b>INTRODUCTION</b> .....	2
<b>INSTALLATION</b> .....	2-43
<b>Step 1 — Rig and Place the Unit</b> .....	2
<b>Step 2 — Join Modules A and B (230-420 Units Only)</b> .....	27
<b>Step 3 — Check Compressor Mounting</b> .....	27
<b>Step 4 — Cooler Fluid and Drain Piping Connections</b> .....	27
• PREPARATION FOR YEAR-ROUND OPERATION	
• PREPARATION FOR WINTER SHUTDOWN	
<b>Step 5 — Make Electrical Connections</b> .....	28
• FIELD POWER CONNECTIONS	
• FIELD CONTROL POWER CONNECTIONS	

<b>Step 6 — Install Accessories</b> .....	43
• ELECTRICAL	
• LOW-AMBIENT OPERATION	
• HOT GAS BYPASS	
• MISCELLANEOUS ACCESSORIES	
<b>PRE-START-UP</b> .....	43-50
<b>System Check</b> .....	43
<b>Quick Test</b> .....	44
• A. QUICK TEST STEPS 1-15: UNIT CONFIGURATION	
• B. QUICK TEST STEPS 16-30: THERMISTORS AND SET POINT POTENTIOMETERS	
• C. QUICK TEST STEPS 31-42: OUTPUT RELAYS	
<b>START-UP AND OPERATION</b> .....	50-56
<b>Digital Display Action</b> .....	50
<b>Actual Start-Up</b> .....	50
<b>Operating Limitations</b> .....	50
• TEMPERATURES	
• VOLTAGE	
• MINIMUM FLUID LOOP VOLUME	
• FLOW RATE REQUIREMENTS	
<b>Operation Sequence</b> .....	51
• UNITS WITH ELECTRONIC EXPANSION VALVE (EXV)	
• 30GT080-110 UNITS WITH OPTIONAL THERMOSTATIC EXPANSION VALVE (TXV)	
• LOAD SHED	
• TEMPERATURE RESET	
• HEAD PRESSURE CONTROL	
• REMOTE ON-OFF	
• REMOTE ALARM	
<b>SERVICE</b> .....	57-68
<b>Diagnostics and Troubleshooting</b> .....	57
<b>Refrigerant Circuit</b> .....	57
• LEAK TESTING	
• DEHYDRATION	
• REFRIGERANT CHARGE	
<b>Electronic Components</b> .....	57
• CONTROL COMPONENTS	
• 30GT080-110 AND 230B-315B UNIT CONTROL BOX	
• 30GT130-210, 230A-315A, AND 330A/B-420A/B UNIT CONTROL AND MAIN POWER BOXES	
<b>Compressors</b> .....	57
• COMPRESSOR REMOVAL	
• OIL CHARGE	
<b>Cooler</b> .....	58
• COOLER REMOVAL	
• REPLACING COOLER	
• SERVICING COOLER	

## CONTENTS (cont)

	Page
<b>Condenser Coils</b> .....	60
• COIL CLEANING	
<b>Condenser Fans</b> .....	60
<b>Refrigerant Feed Components</b> .....	60
• ELECTRONIC EXPANSION VALVE (EXV)	
• THERMOSTATIC EXPANSION VALVE (TXV) (080-110 ONLY)	
• MOISTURE-LIQUID INDICATOR	
• FILTER DRIER	
• LIQUID LINE SOLENOID VALVE	
• LIQUID LINE SERVICE VALVE	
<b>Thermistors</b> .....	65
• LOCATION	
• TO REPLACE THERMISTOR T2 (Cooler)	
• TO REPLACE THERMISTORS T1, T5, T6, T7, AND T8	
• THERMISTORS T3 AND T4	
• THERMISTOR/TEMPERATURE SENSOR CHECK	
<b>Safety Devices</b> .....	67
• COMPRESSOR PROTECTION	
• LOW OIL PRESSURE PROTECTION	
• CRANKCASE HEATERS	
• COOLER PROTECTION	
<b>Relief Devices</b> .....	68
• HIGH-SIDE PROTECTION	
• LOW-SIDE PROTECTION	
• PRESSURE RELIEF VALVES	
<b>Other Safeties</b> .....	68
<b>START-UP CHECKLIST</b> .....	CL-1 to CL-4

## INTRODUCTION

These instructions cover installation, start-up, and service of 30GT080-420 Flotronic™ liquid chillers with electronic controls and units with factory-installed options (FIOPs).

Chillers are equipped with electronic expansion valves (EXV) as standard. Conventional thermostatic expansion valves (TXV) and liquid line solenoid valves are included as options on 30GT080-110 units only (NOT on associated modular units). Differences in quick test procedures and operation sequences between the standard and optional units should be carefully noted when following these instructions.

NOTE: Unit sizes 230-420 are modular units which are shipped in separate sections as modules A and B. Installation directions specific to these units are noted in these instructions. For modules 230B-315B, follow all general instructions as noted for unit sizes 080-110. For **all** remaining modules, follow instructions for unit sizes 130-210. See Table 1 for a listing of unit sizes and modular combinations.

Inspect the unit upon arrival for damage. If damage is found, file a claim right away with the shipping company. When considering location for the unit, be sure to consult National Electrical Code (NEC, U.S.A.) and local code requirements. Allow sufficient space for airflow, wiring, piping, and service. See Fig. 1-4. See Fig. 5 for optional non-fused disconnect location on 130-210, 230A-315A, and 330A/B-420A/B units. Be sure surface beneath the unit is level, and is capable of supporting the operating weight of the unit. See Fig. 6-8 and Tables 2A-3B for unit mounting and operating weights.

NOTE: To facilitate refrigerant vent piping, unit sizes 130-210, 230A-315A, and 330A/B-420A/B will have fusible plugs with 3/8-in. SAE (Society of Automotive Engineers, U.S.A.) flares if required by local codes.

**Table 1 — Unit Sizes and Modular Combinations**

UNIT MODEL 30GT	NOMINAL TONS	SECTION A UNIT 30GT	SECTION B UNIT 30GT
080	80	—	—
090	90	—	—
100	100	—	—
110	110	—	—
130	125	—	—
150	145	—	—
170	160	—	—
190	180	—	—
210	200	—	—
230	220	150	080
245	230	150	090
255	240	150	100
270	260	170	100
290	280	190	110
315	300	210	110
330	325	170	170
360	350	190	190/ 170*
390	380	210	190
420	400	210	210

\*60 Hz units/50 Hz units.

## INSTALLATION

**Step 1 — Rig and Place the Unit** — These units are designed for overhead rigging and *it is important that this method be used*. Holes are provided in frame base channels, marked for rigging (see rigging label on unit). It is recommended that field-supplied 2-in. Schedule 40 steel pipes be passed through these holes, extending beyond frame enough to attach cables or chains on both sides for 080-110 and 230B-315B units. All other units come with 6 lifting lugs. Use spreader bars to keep cables or chains clear of unit sides. As further protection for the coil faces, plywood sheets may be placed against sides of unit, behind cables or chains. Run cables or chains to a central suspension point so that angle from horizontal is not less than 45 degrees. Raise and set unit down carefully. See Fig. 6-8 for rigging centers of gravity.

### ⚠ CAUTION

1. Do not use forklift trucks on these units.
2. Modular (230-420) units **MUST** be rigged and placed as separate sections.

For shipping, some domestic units and all export units are mounted on a wooden skid under entire base of unit. Skid can be removed before unit is moved to installation site. *Lift the unit from above to remove skid*. See Fig. 6-8 rigging for centers of gravity. On export units, the top skid can be used as the spreader bars. If the unit is shipped with coil protection, it must be removed before start-up. The shipping bag for export units must be removed before start-up. On export units with a full crate, the crate sides must be removed to aid in rigging.

If overhead rigging is not available, the unit can be moved on rollers or dragged. When unit is moved on rollers, the unit skid, if equipped, must be removed. To lift the unit, use jacks at the rigging points. Use a minimum of 3 rollers to distribute the load. If the unit is to be dragged, lift the unit as described above, and place unit on a pad. *Apply moving force to the pad, and not the unit*. When in its final location, raise the unit and remove the pad.

*Instructions continued on page 27.*

NOTES:

- Unit must have clearances for airflow (from solid surfaces) as follows:  
 Top — Do not restrict in any way  
 Ends — 5 ft [1524 mm]  
 Sides — 6 ft [1829 mm]
- Mounting holes may be used to mount unit to concrete pad. They are not recommended for spring isolator location.
- If spring isolators are used, a perimeter support channel between the unit and the isolators is recommended.
- Dimensions in [ ] are in millimeters.
- Thru-the-door handles for non-fused disconnect option on 380/415 v and 460 v units only. When unit has non-fused disconnect option, power-side door opens from right side, NOT left side as shown for standard units.

CENTER OF GRAVITY  
(ft-in.)

30GT SIZE	080,230B	090,245B
A	5-9 <sup>5</sup> / <sub>8</sub> [1769]	5-7 <sup>5</sup> / <sub>16</sub> [1710]
B	3-6 [1067]	3-2 <sup>3</sup> / <sub>4</sub> [984]

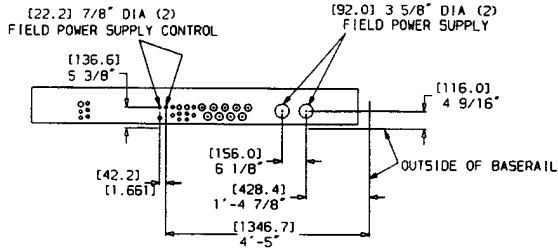

VIEW A-A  
TOP VIEW OF CONTROL BOX SHELF  
WITH FIELD POWER SUPPLY CONNECTIONS

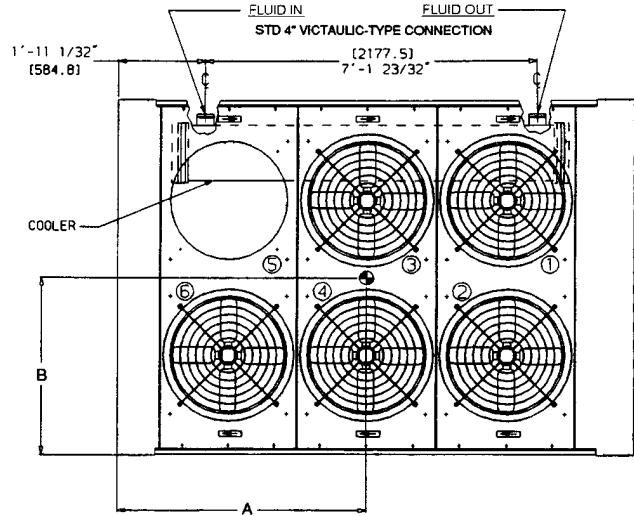

TOP VIEW

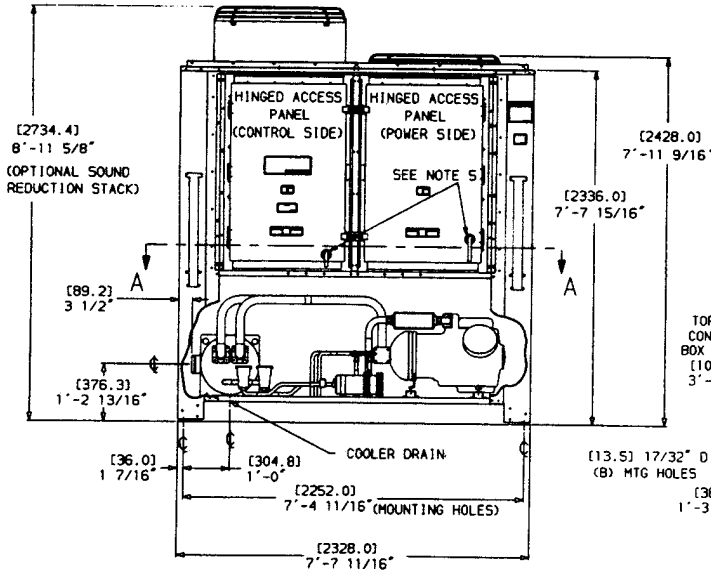

END VIEW

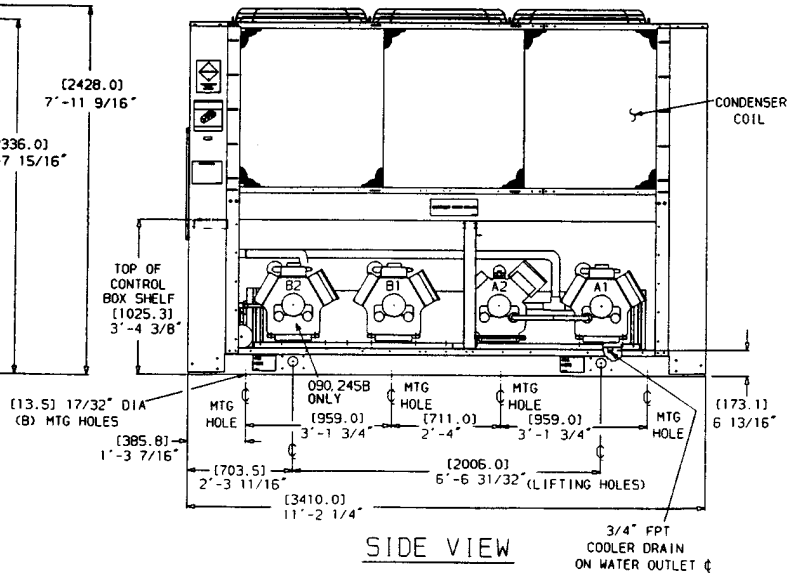

SIDE VIEW

Fig. 1 — Dimensions; 30GT080,090,230B,245B

NOTES:

- Unit must have clearances for airflow (from solid surfaces) as follows:  
 Top — Do not restrict in any way  
 Ends — 5 ft [1524 mm]  
 Sides — 6 ft [1829 mm]
- Mounting holes may be used to mount unit to concrete pad. They are not recommended for spring isolator location.
- If spring isolators are used, a perimeter support channel between the unit and the isolators is recommended.
- Dimensions in [ ] are in millimeters.
- Thru-the-door handles for non-fused disconnect option on 380/415 v and 460 v units only. When unit has non-fused disconnect option, power-side door opens from right side, NOT left side as shown for standard units.

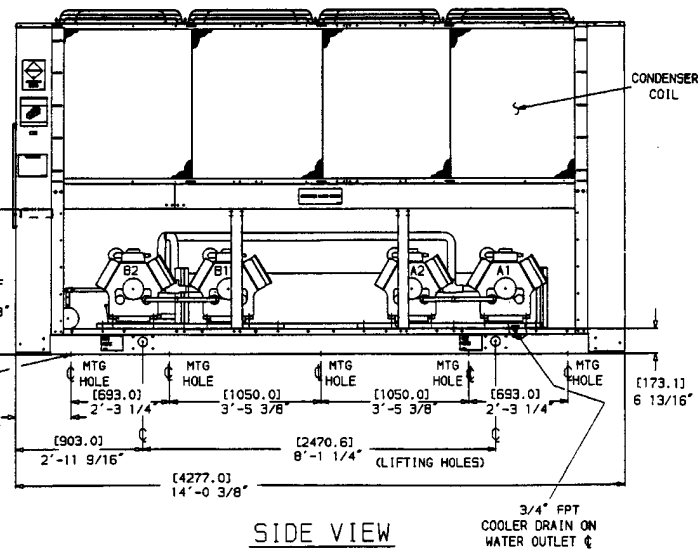
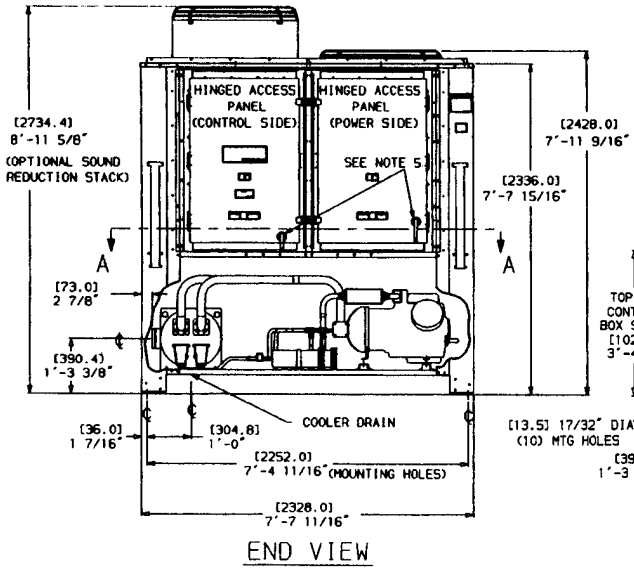
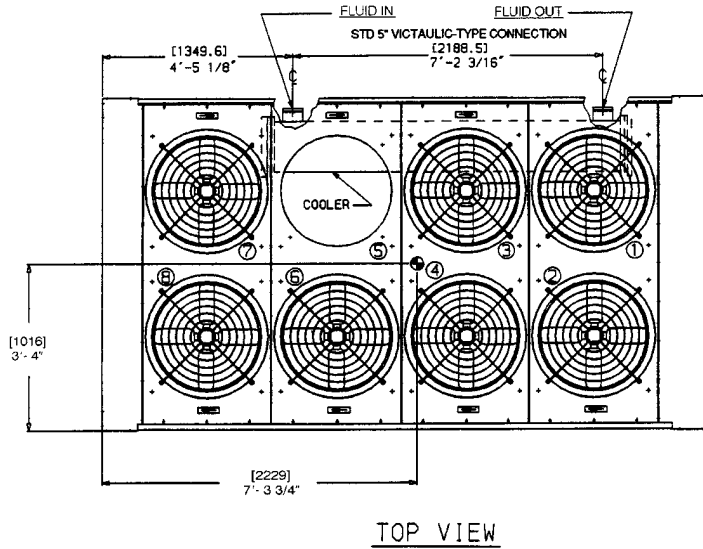
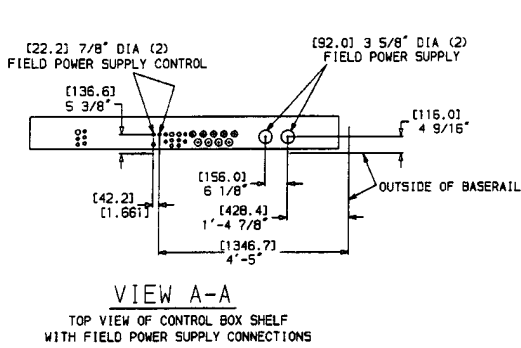

Fig. 2 —Dimensions; 30GT100,110,255B-315B

NOTES:

- Unit must have clearances for airflow (from solid surfaces) as follows:  
 Top — Do not restrict in any way  
 Ends — 5 ft [1524 mm]  
 Sides — 6 ft [1829 mm]
- Mounting holes may be used to mount unit to concrete pad. They are not recommended for spring isolator location.
- If spring isolators are used, a perimeter support channel between the unit and the isolators is recommended.
- Dimensions in [ ] are in millimeters.

CENTER OF GRAVITY  
(ft-in.)

30GT UNIT SIZE	A	B	C	D
130	9-4½ [2858]	4-17⁄8 [1267]	1-4¾ [425]	0-9½ [242]
150, 230A-255A	9-4½ [2849]	4-2½ [1283]	1-4¾ [425]	0-9½ [242]
170, 270A, 330A/B, 360B (50 Hz)	9-47⁄8 [2865]	4-2½ [1283]	1-55⁄8 [448]	0-85⁄8 [219]

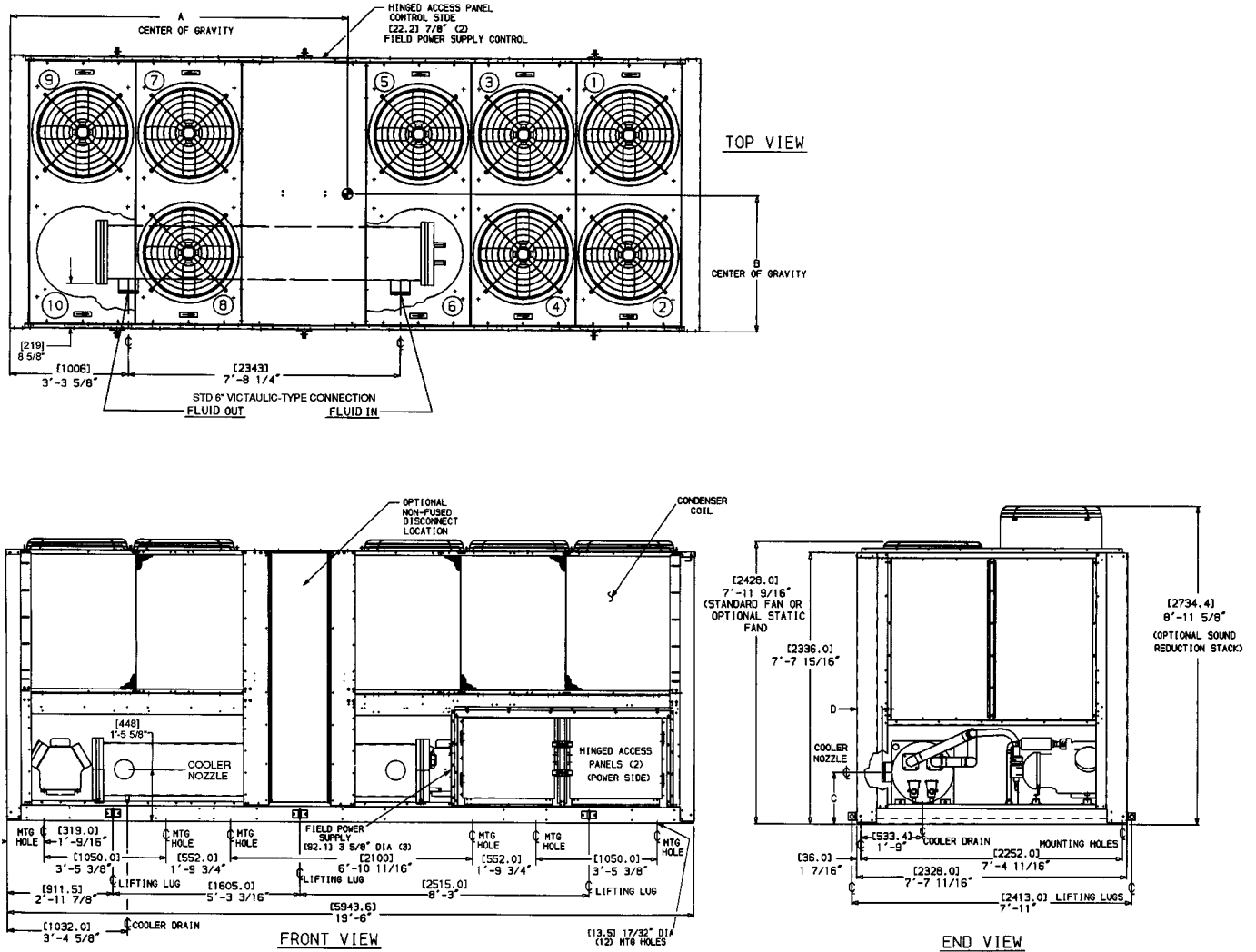
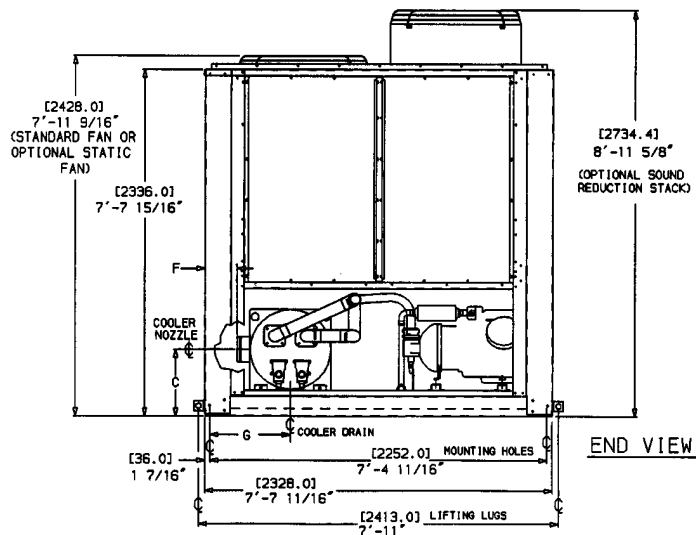

Fig. 3 — Dimensions; 30GT130-170, 230A-270A, 330A/B, 360B (50 Hz)

DIMENSIONS (ft-in.)

30GT UNIT SIZE	A	B	C	D	E	F	G	H
190,290A,360A (50 Hz), 360A/B (60 Hz), 390B	11-4 [3454]	4-2½ [1283]	1-5⅝ [448]	6- 37/16 [1916]	7-8¼ [2343]	8⅝ [219]	1- 9 [533.4]	6- 47/16 [1941.3]
210,315A, 390A,420A/B	11-3⅝ [3444]	4-29/16 [1285]	1-67/16 [468]	5-11½ [1816]	8-29/16 [2504]	9½ [242]	1-11 [584]	5-11½ [1816.2]



NOTES:

- Unit must have clearances for airflow (from solid surfaces) as follows:  
Top — Do not restrict in any way  
Ends — 5 ft [1524 mm]  
Sides — 6 ft [1829 mm]
- Mounting holes may be used to mount unit to concrete pad. They are not recommended for spring isolator location.
- If spring isolators are used, a perimeter support channel between the unit and the isolators is recommended.
- Dimensions in [ ] are in millimeters.

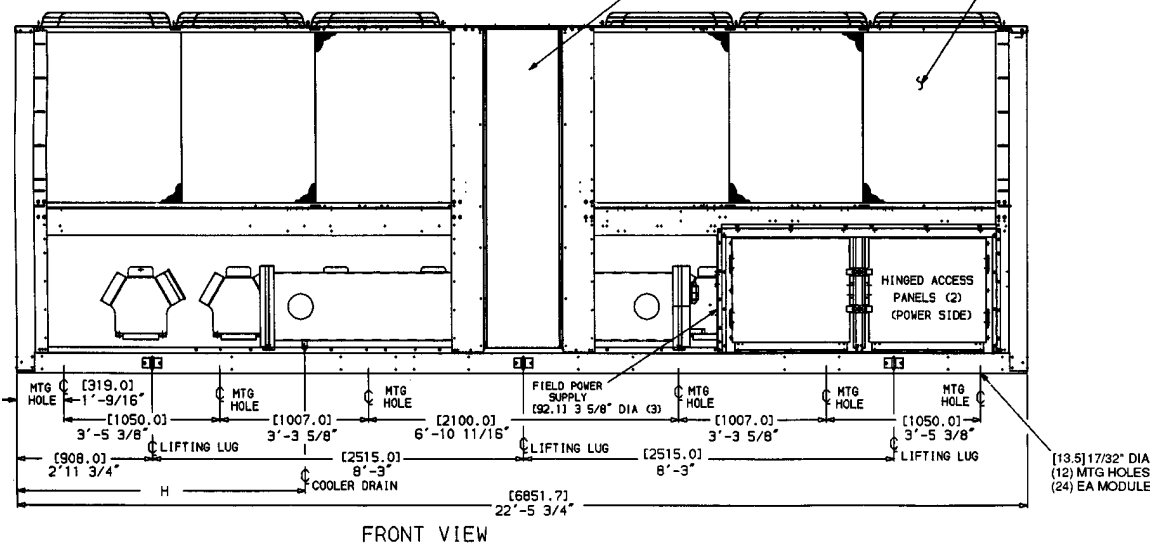
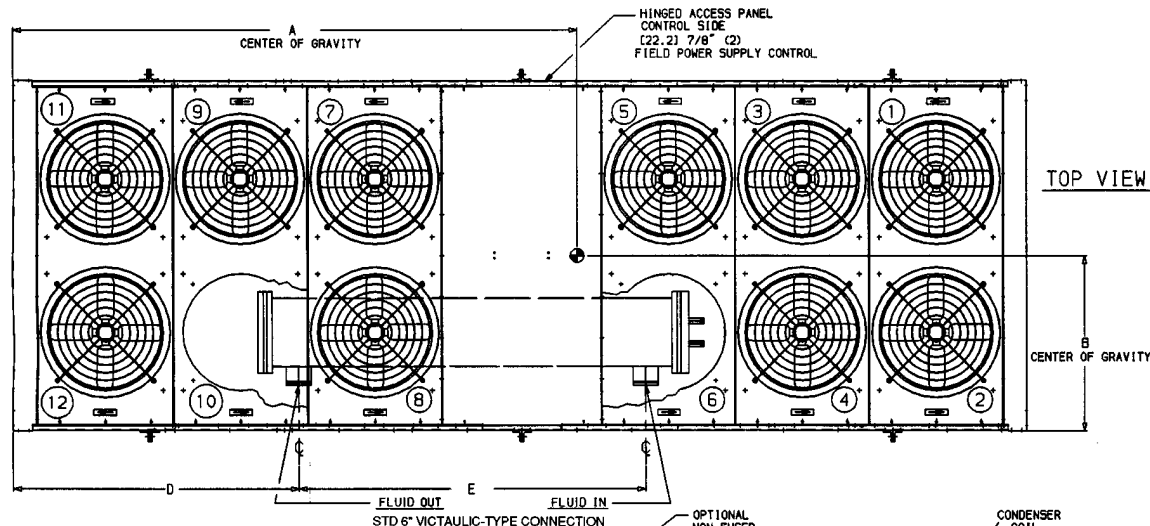
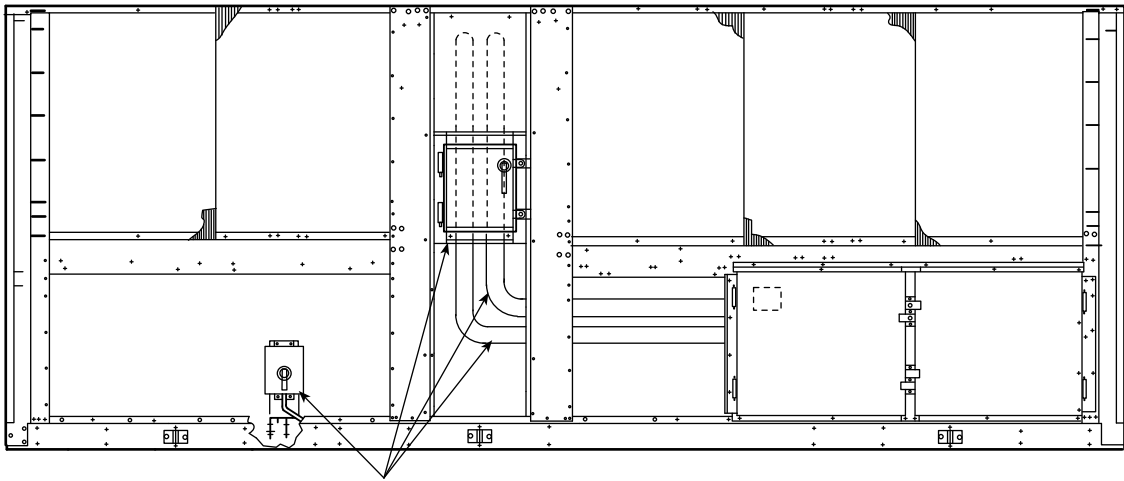
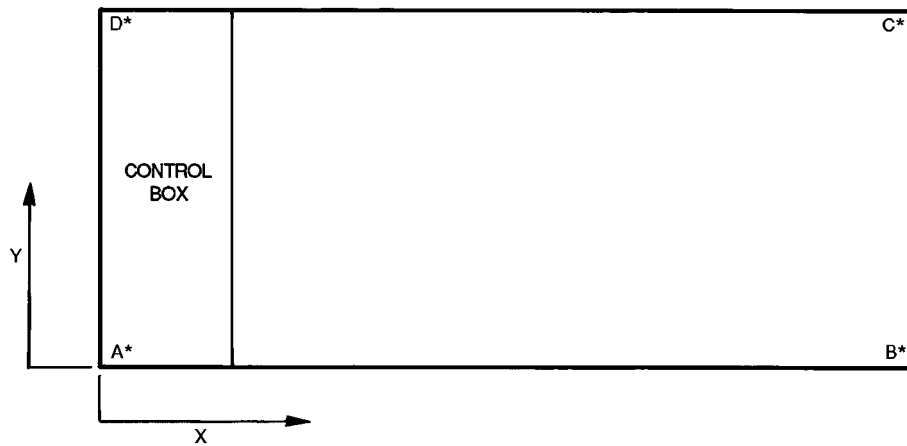

Fig. 4 — Dimensions; 30GT190,210,290A,315A,360A (50 Hz),360A/B (60 Hz), 390A/B, 420A/B



NON-FUSED DISCONNECT OPTION

**Fig. 5 — Location of Optional Non-Fused Disconnect; 130-210 and 230A-315A,330A/B-420A/B Units (130-170,230A-270A,330A/B,360B 50 Hz Shown)**



\*Points A, B, C, and D are in the corners of the unit. See Fig. 1 and 2 for dimensions.

60 Hz

30GT UNIT SIZE	CONDENSER COIL	lb				kg			
		A	B	C	D	A	B	C	D
080,230B	C-AL	1624	1690	1666	1650	738	768	757	750
	C-C	1797	1880	1847	1831	817	854	840	832
090,245B	C-AL	1817	1793	1720	1685	826	815	782	766
	C-C	1997	1970	1893	1880	908	895	860	855
100,255B,270B	C-AL	2185	2185	2120	2120	993	993	964	964
	C-C	2420	2420	2360	2360	1100	1100	1073	1073
110,290B,315B	C-AL	2191	2217	2136	2116	996	1007	970	962
	C-C	2428	2454	2374	2354	1104	1115	1079	1070

50 Hz

30GT UNIT SIZE	CONDENSER COIL	lb				kg			
		A	B	C	D	A	B	C	D
080,230B	C-AL	1650	1730	1680	1660	750	786	764	755
	C-C	1830	1910	1863	1842	832	868	847	837
090,245B	C-AL	1833	1864	1724	1714	833	847	784	779
	C-C	2014	2040	1907	1899	915	927	867	863
100,255B,270B	C-AL	2222	2222	2133	2133	1010	1010	970	970
	C-C	2460	2460	2370	2370	1118	1118	1077	1077
110,290B,315B	C-AL	2271	2271	2149	2149	1032	1032	976	976
	C-C	2508	2508	2387	2387	1140	1140	1085	1085

LEGEND

C-AL — Copper Tubing — Aluminum Fins  
 C-C — Copper Tubing — Copper Fins

NOTE: If spring isolators are used, a perimeter support channel between the unit and the isolators is recommended.

RIGGING CENTER OF GRAVITY

30GT UNIT SIZE	080,230B		090,245B		100,110,255B-315B	
	in.	mm	in.	mm	in.	mm
X Dimension	69.6	1768	87.8	2229	87.8	2229
Y Dimension	42.0	1067	38.8	984	40.0	1016

Fig. 6 — Unit Mounting Weights (Approximate); 30GT080-110 and 230B-315B

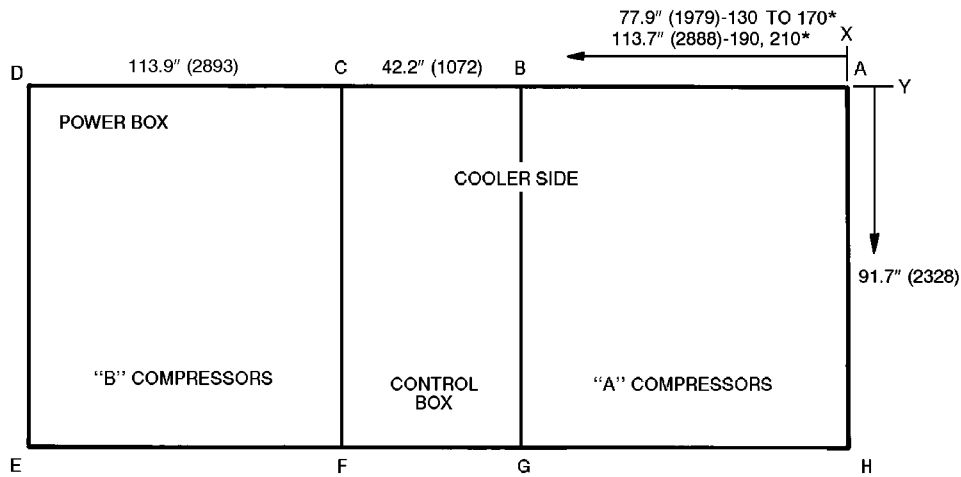

60 Hz

30GT UNIT SIZE	CONDENSER COIL	lb							
		A	B	C	D	E	F	G	H
130	C-AL	923	1466	1156	825	1411	1365	1469	1439
	C-C	1051	1593	1283	952	1601	1556	1659	1622
150,230A-255A	C-AL	926	1563	1160	834	1438	1375	1747	1438
	C-C	1053	1690	1287	961	1628	1566	1938	1629
170,270A,330A/B	C-AL	962	1732	1333	862	1497	1629	1816	1462
	C-C	1089	1860	1460	990	1688	1819	2007	1653
190,290A,360A/B,390B	C-AL	1346	1942	1793	1111	1385	1799	1733	1567
	C-C	1536	2132	1983	1301	1575	1989	1923	1757
210,315A,390A,420A/B	C-AL	1376	2128	1871	1120	1407	1846	2037	1595
	C-C	1566	2318	2061	1310	1597	2036	2227	1784

60 Hz

30GT UNIT SIZE	CONDENSER COIL	kg							
		A	B	C	D	E	F	G	H
130	C-AL	419	666	525	375	641	620	668	650
	C-C	478	723	583	433	728	707	754	737
150, 230A-255A	C-AL	420	710	527	379	653	625	794	653
	C-C	478	768	585	436	285	711	880	740
170,270A,330A/B	C-AL	437	787	605	392	680	740	825	664
	C-C	495	845	663	450	767	826	912	751
190,290A,360A/B,390B	C-AL	611	882	815	505	629	817	787	712
	C-C	698	969	901	591	715	904	874	798
210,315A,390A,420A/B	C-AL	625	967	850	509	639	384	925	725
	C-C	711	1053	937	595	725	925	1012	810

LEGEND

C-AL — Copper Tubing — Aluminum Fins

C-C — Copper Tubing — Copper Fins

\*And associated modules.

NOTE: Dimensions in ( ) are millimeters.

RIGGING CENTER OF GRAVITY

30GT UNIT SIZE	130		150,230A-255A		170,270A, 330A/B		190,290A, 360A/B,390B		210,315A,390A, 420A/B	
	in.	mm	in.	mm	in.	mm	in.	mm	in.	mm
X Dimension	112.5	2858	112.1	2849	112.8	2865	136.0	3454	135.6	3444
Y Dimension	49.9	1267	50.5	1283	50.5	1283	50.5	1283	50.6	1285

Fig. 7 — Unit Mounting Weights (Approximate); 30GT130-210, 230A-315A, 330A/B-420A/B (60 Hz)

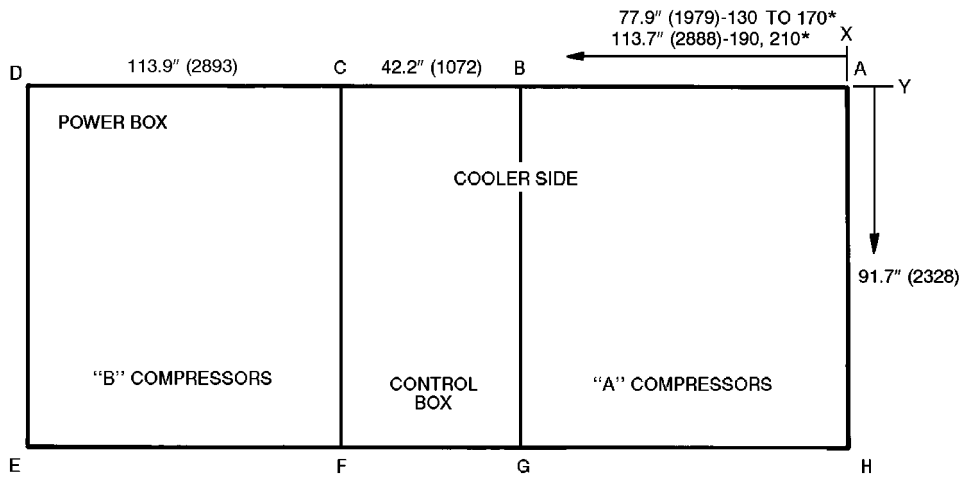

50 Hz

30GT UNIT SIZE	CONDENSER COIL	lb							
		A	B	C	D	E	F	G	H
130	C-AL	928	1569	1160	834	1438	1375	1764	1444
	C-C	1056	1696	1287	961	1628	1566	1954	1635
150,230A-255A	C-AL	948	1591	1160	834	1438	1375	1829	1502
	C-C	1075	1719	1287	961	1628	1566	2020	1692
170,270A,330A/B,360B	C-AL	963	1744	1348	873	1527	1673	1849	1466
	C-C	1090	1871	1475	1000	1718	1864	2040	1657
190,290A,360A,390B	C-AL	1365	1953	1807	1127	1430	1839	1765	1621
	C-C	1555	2143	1997	1316	1620	2029	1955	1811
210,315A,390A,420A/B	C-AL	1383	2151	1876	1128	1430	1860	2102	1615
	C-C	1573	2341	2066	1318	1620	2050	2292	1805

50 Hz

30GT UNIT SIZE	CONDENSER COIL	kg							
		A	B	C	D	E	F	G	H
130	C-AL	422	714	527	379	654	625	802	656
	C-C	480	770	585	436	740	711	888	743
150,230A-255A	C-AL	430	723	527	379	653	625	831	682
	C-C	486	781	585	437	740	711	918	769
170,270A,330A/B,360B	C-AL	437	792	612	397	694	760	840	666
	C-C	495	850	670	454	780	847	927	753
190,290A,360A,390B	C-AL	620	887	821	512	650	835	802	736
	C-C	707	974	907	598	736	922	977	823
210,315A,390A,420A/B	C-AL	628	977	852	512	650	845	955	734
	C-C	715	1064	940	599	736	931	1042	820

LEGEND

C-AL — Copper Tubing — Aluminum Fins

C-C — Copper Tubing — Copper Fins

\*And associated modules.

NOTE: Dimensions in ( ) are millimeters.

RIGGING CENTER OF GRAVITY

30GT UNIT SIZE	130		150,230A-255A		170,270A, 330A/B,360B		190,290A, 360A,390B		210,315A,390A, 420A/B	
	in.	mm	in.	mm	in.	mm	in.	mm	in.	mm
X Dimension	112.5	2858	112.1	2849	112.8	2865	136.0	3454	135.6	3444
Y Dimension	49.9	1267	50.5	1283	50.5	1283	50.5	1283	50.6	1285

Fig. 8 — Unit Mounting Weights (Approximate); 30GT130-210, 230A-315A, 330A/B-420A/B (50 Hz)

**Table 2A — Physical Data — 60 Hz, English**

	080	090	100	110	130	150	170	190	210
<b>30GT UNIT SIZE</b>									
<b>APPROX OPERATING WEIGHT — lb</b>									
C-AL	6630	7015	8610	8660	10,046	10,481	11,293	12,676	13,380
C-C	7355	7740	9560	9610	11,318	11,753	12,565	14,195	14,899
<b>REFRIGERANT CHARGE — lb</b>									
R-22	78/15	78/15	98/20	98/20	133/28	143/35	153/45	178/30	190/40
Ckt A	78/15	78/15	105/20	105/20	137/28	144/35	162/45	173/30	185/40
Ckt B									
<b>COMPRESSORS, Type...rpm</b>									
<b>06E*</b>	(1) 250, (1) 275	(1) 250, (1) 265	(1) 265, (1) 275	(1) 265, (1) 275	(1) 275, (1) 299	(3) 265	(3) 275	(1) 265, (1) 275, (1) 299	(3) 265, (1) 275
(Qty) Ckt A	(1) 299	(2) 265	(1) 265, (1) 275	(1) 265, (1) 275	(1) 275, (1) 299	(2) 299	(3) 275	(1) 265, (1) 275, (1) 299	(1) 275, (2) 299
(Qty) Ckt B									
<b>Oil Charge — Compressor/pt</b>									
<b>Capacity Control Steps (Standard Unit)</b>									
% Cap.	6	8	8	8	8	10	12	6	7
Ckt A	56	47	50	54	50	50	50	50	50
Ckt B	44	53	50	46	50	50	50	50	50
Minimum Step Capacity (%)	22	18	15	14	14	11	11	14	12
<b>CONDENSER FANS — Type</b>									
<b>Standard/Low Noise</b>									
Fan Speed — rpm	1140	1140	1140	1140	1140	1140	1140	1140	1740
No. Blades...Diameter — in.	4...30	4...30	4...30	4...30	4...30	4...30	4...30	4...30	4...30
No. Fans...Total kW	6...9.4	6...9.4	8...12.7	8...12.7	10...15.9	10...15.9	10...15.9	12...19.1	12...19.1
Total Airflow — cfm	57,000	57,000	76,000	76,000	100,000	100,000	100,000	120,000	120,000
<b>High Static</b>									
Fan Speed — rpm	1750	1750	1750	1750	1740	1740	1740	1740	1740
No. Blades...Diameter — in.	12...30	12...30	12...30	12...30	12...30	12...30	12...30	12...30	12...30
No. Fans...Total kW	6...22.2	6...22.2	8...29.6	8...29.6	10...37.0	10...37.0	10...37.0	12...44.4	12...44.4
Total Airflow...cfm†	60,000	60,000	80,000	80,000	100,000	100,000	100,000	120,000	120,000
<b>CONDENSER COILS — Type</b>									
<b>Tubes (Copper), OD — in.</b>	0.375	0.375	0.375	0.375	0.375	0.375	0.375	0.375	0.375
No. Rows — Ckt A or B	3	3	3	3	3	3	3	3	3
Face Area sq ft — Ckt A and B Total	128.3	128.3	168	168	225.1	225.1	225.1	268.9	268.9
Max Working Pressure Refrigerant — psig	450	450	450	450	450	450	450	450	450
<b>COOLER — No. ... Type</b>									
<b>Weight (empty) — lb</b>	745	745	860	860	1320	1320	1630	1630	1865
No. Refrigerant Circuits	2	2	2	2	2	2	2	2	2
Net Water Volume — Gal. (includes nozzles)	24.5	24.5	30.3	30.3	52.0	52.0	61.0	61.0	70.4
Max Working Pressure									
Refrigerant Side/Fluid Side — psig	278/300	278/300	278/300	278/300	278/300	278/300	278/300	278/300	278/300
<b>FLUID CONNECTIONS — in.</b>									
Inlet and Outlet	4	4	5	5	6	6	6	6	6
Drain (NPT)					¾				

**LEGEND**

- C-AL — Copper Tubing — Aluminum Fins Condenser Coil
- C-C — Copper Tubing — Copper Fins Condenser Coil
- Ckt — Circuit
- ESP — External Static Pressure
- OD — Outside Diameter

\*06E250 compressors have 4 cylinders; all others have 6.  
 †Based on rated ESP of 0.4 in. wg or 1.0 in. wg as appropriate.

NOTE: When facing the compressors, Circuit A is on the right and Circuit B is on the left.

**Table 2A — Physical Data — 60 Hz, English (cont)**

SYSTEM MODULES	230			245			255			270		
	A	B	Total	A	B	Total	A	B	Total	A	B	Total
<b>APPROX OPERATING WEIGHT — lb</b>												
C-AL	10,481	6630	17,111	10,481	7015	17,496	10,481	8610	19,091	11,293	8610	19,903
C-C	11,753	7355	19,108	11,753	7740	19,493	11,753	9560	21,313	12,565	9560	22,125
<b>REFRIGERANT CHARGE — lb</b>												
R-22	143/35	78/15	—/—	143/35	78/15	—/—	143/35	98/20	—/—	153/45	98/20	—/—
Ckt A Total/Over	144/35	78/15	—/—	144/35	78/15	—/—	144/35	105/20	—/—	162/45	105/20	—/—
Ckt B Clear Glass												
<b>COMPRESSORS, Type...rpm</b>												
06E*	(3) 265	(1) 250, (1) 275	—/—	(3) 265	(1) 265, (1) 250	—/—	(3) 265	(1) 265, (1) 275	—/—	(3) 275	(1) 265, (1) 275	—/—
(Qty) Ckt A	(2) 299	(1) 299	—/—	(2) 299	(2) 265	—/—	(2) 299	(1) 265, (1) 275	—/—	(3) 275	(1) 265, (1) 275	—/—
(Qty) Ckt B												
<b>Oil Charge — Compressor/pt</b>	265/19.0,	250/14.0, 275/19.0,	—	265/19.0,	250/14.0,	—	265/19.0,	265/19.0,	—	275/19.0,	265/19.0,	—
	299/19.0	299/19.0		299/19.0	265/19.0		299/19.0	275/19.0		275/19.0	275/19.0	
<b>Capacity Control Steps</b>												
% Cap.	10	6	—	10	8	—	10	8	—	12	8	—
Ckt A	50	56	—	50	47	—	50	50	—	50	50	—
Ckt B	50	44	—	50	53	—	50	50	—	50	50	—
Minimum Step Capacity (%)	11	22	—	11	18	—	11	15	—	11	15	—
<b>CONDENSER FANS — Type</b>												
Standard/Low Noise												
Fan Speed — rpm	1140	1140	—	1140	1140	—	1140	1140	—	1140	1140	—
No. Blades...Diameter — in.	4...30	4...30	—	4...30	4...30	—	4...30	4...30	—	4...30	4...30	—
No. Fans...total kW	10...15.9	6...9.4	16...25.3	10...15.9	6...9.4	16...25.3	10...15.9	8...12.7	18...28.6	10...15.9	8...12.7	18...28.6
Total Airflow — cfm	100,000	57,000	157,000	100,000	57,000	157,000	100,000	76,000	176,000	100,000	76,000	176,000
High Static												
Fan Speed — rpm	1740	1750	—	1740	1750	—	1740	1750	—	1740	1750	—
No. Blades...Diameter — in.	12...30	12...30	—	12...30	12...30	—	12...30	12...30	—	12...30	12...30	—
No. Fans...Total kW	10...37.0	6...22.2	16...59.2	10...37.0	6...22.2	16...59.2	10...37.0	8...29.6	18...66.6	10...37.0	8...29.6	18...66.6
Total Airflow — cfm†	100,000	60,000	160,000	100,000	60,000	160,000	100,000	80,000	180,000	100,000	80,000	180,000
<b>CONDENSER COILS — Type</b>												
Tubes (Copper), OD — in.	0.375	0.375	—	0.375	0.375	—	0.375	0.375	—	0.375	0.375	—
No. Rows — Ckt A or B	3	3	—	3	3	—	3	3	—	3	3	—
Face Area sq ft — Ckt A and B Total	225.1	128.3	353.4	225.1	128.3	353.4	225.1	168	393.1	225.1	168	393.1
Max Working Pressure Refrigerant — psig	450	450	—	450	450	—	450	450	—	450	450	—
<b>COOLER — No. ... Type</b>												
Weight (empty) — lb	1320	745	2065	1320	745	2065	1320	860	2180	1630	860	2490
No. Refrigerant Circuits	2	2	4	2	2	4	2	2	4	2	2	4
Net Fluid Volume — Gal. (includes nozzles)	52.0	24.5	76.5	52.0	24.5	76.5	52.0	30.3	82.3	61.0	30.3	91.3
Max Working Pressure	278/300	278/300	—/—	278/300	278/300	—/—	278/300	278/300	—/—	278/300	278/300	—/—
Refrigerant Side/Fluid Side — psig												
<b>FLUID CONNECTIONS — in.</b>												
Inlet and Outlet	6	4	—	6	4	—	6	4	—	6	4	—
Drain (NPT)	3/4	3/4	—	3/4	3/4	—	3/4	3/4	—	3/4	3/4	—

**LEGEND**

- C-AL — Copper Tubing — Aluminum Fins Condenser Coil
- C-C — Copper Tubing — Copper Fins Condenser Coil
- Ckt — Circuit
- ESP — External Static Pressure
- OD — Outside Diameter

\*06E250 compressors have 4 cylinders; all others have 6.  
 †Based on rated ESP of 0.4 in. wg or 1.0 in. wg as appropriate.

NOTE: When facing the compressors, Circuit A is on the right and Circuit B is on the left.

Table 2A — Physical Data — 60 Hz, English (cont)

SYSTEM MODULES	290			315			330			360		
	A	B	Total	A	B	Total	A	B	Total	A	B	Total
<b>APPROX OPERATING WEIGHT — lb</b>												
C-AL	12,676	8660	21,336	13,380	8660	22,040	11,293	11,293	22,586	12,676	12,676	25,352
C-C	14,195	9610	23,805	14,899	9610	24,509	12,565	12,565	25,130	14,195	14,195	28,390
<b>REFRIGERANT CHARGE — lb</b>												
R-22	178/30	98/20	—/—	190/40	98/20	—/—	153/45	153/45	—/—	178/30	178/30	—/—
Ckt A Total/Over	173/30	105/20	—/—	185/40	105/20	—/—	162/45	162/45	—/—	173/30	173/30	—/—
<b>COMPRESSORS, Type...rpm</b>												
06E*	(1) 265, (1) 275, (1) 299	(1) 265, (1) 299	—	(3) 265, (1) 275	(1) 265, (1) 299	—	(3) 275	(3) 275	—	(1) 265, (1) 275, (1) 299	(1) 265, (1) 275, (1) 299	—
(Qty) Ckt A	(1) 265, (1) 275, (1) 299	(1) 265, (1) 299	—	(1) 275, (2) 289	(1) 265, (1) 275	—	(3) 275	(3) 275	—	(1) 265, (1) 275, (1) 299	(1) 265, (1) 275, (1) 299	—
Oil Charge — Compressor/pt	265/19.0, 275/19.0, 299/19.0	265/19.0, 275/19.0, 299/19.0	—	265/19.0, 275/19.0, 299/19.0	265/19.0, 275/19.0, 299/19.0	—	275/19.0	275/19.0	—	265/19.0, 275/19.0, 299/19.0	265/19.0, 275/19.0, 299/19.0	—
<b>Capacity Control Steps</b>	6	8	—	7	8	—	12	12	—	6	6	—
% Cap.	50	54	—	50	54	—	50	50	—	50	50	—
Ckt A	50	46	—	50	46	—	50	50	—	50	50	—
Ckt B	14	14	—	12	14	—	11	11	—	14	14	—
<b>CONDENSER FANS — Type</b>												
Standard/Low Noise	Propeller, Direct Drive	Propeller, Direct Drive	—	Propeller, Direct Drive	Propeller, Direct Drive	—	Propeller, Direct Drive	Propeller, Direct Drive	—	Propeller, Direct Drive	Propeller, Direct Drive	—
Fan Speed — rpm	1140	1140	—	1740	1140	—	1140	1140	—	1140	1140	—
No. Blades...Diameter — in.	4...30	4...30	—	4...30	4...30	—	4...30	4...30	—	4...30	4...30	—
Total kW	12...19.1	8...12.7	20...31.8	12...19.1	8...12.7	20...31.8	10...15.9	10...15.9	20...31.8	12...19.1	12...19.1	24...38.2
Total Airflow — cfm	120,000	76,000	196,000	120,000	76,000	196,000	100,000	100,000	200,000	120,000	120,000	240,000
High Static	—	—	—	—	—	—	—	—	—	—	—	—
Fan Speed — rpm	1740	1750	—	1740	1750	—	1740	1740	—	1740	1740	—
No. Blades...Diameter — in.	12...30	12...30	—	12...30	12...30	—	12...30	12...30	—	12...30	12...30	—
No. Fans...Total kW	12...44.4	8...29.6	20...74.0	12...44.4	8...29.6	20...74.0	10...37.0	10...37.0	20...74	12...44.4	12...44.4	24...88.8
Total Airflow — cfm†	120,000	80,000	200,000	120,000	80,000	200,000	100,000	100,000	200,000	120,000	120,000	240,000
<b>CONDENSER COILS — Type</b>												
Tubes (Copper), OD — in.	0.375	0.375	—	0.375	0.375	—	0.375	0.375	—	0.375	0.375	—
No. Rows — Ckt A or B	3	3	—	3	3	—	3	3	—	3	3	—
Face Area sq ft	268.9	168	436.9	268.9	168.0	436.9	225.1	225.1	450.2	268.9	268.9	537.8
— Ckt A and B Total	—	—	—	—	—	—	—	—	—	—	—	—
Max Working Pressure	450	450	—	450	450	—	450	450	—	450	450	—
Refrigerant — psig	—	—	—	—	—	—	—	—	—	—	—	—
<b>COOLER — No. ...Type</b>												
Weight (empty) — lb	1630	860	2490	1865	860	2725	1630	1630	3260	1630	1630	3260
No. Refrigerant Circuits	2	2	4	2	2	4	2	2	4	2	2	4
Net Fluid Volume — Gal.	61.0	30.3	91.3	70.4	30.3	100.7	61.0	61.0	122	61.0	61.0	122
(includes nozzles)	—	—	—	—	—	—	—	—	—	—	—	—
Max Working Pressure	278/300	278/300	—/—	278/300	278/300	—/—	278/300	278/300	—/—	278/300	278/300	—/—
Refrigerant Side/Fluid Side — psig	—	—	—	—	—	—	—	—	—	—	—	—
<b>FLUID CONNECTIONS — in.</b>												
Inlet and Outlet	6	5	—	6	5	—	6	5	—	6	5	—
Drain (NPT)	¾	¾	—	¾	¾	—	¾	¾	—	¾	¾	—

LEGEND

- C-AL — Copper Tubing — Aluminum Fins Condenser Coil
- C-C — Copper Tubing — Copper Fins Condenser Coil
- Ckt — Circuit
- ESP — External Static Pressure
- OD — Outside Diameter
- \*06E250 compressors have 4 cylinders; all others have 6.
- †Based on rated ESP of 0.4 in. wg or 1.0 in. wg as appropriate.

NOTE: When facing the compressors, Circuit A is on the right and Circuit B is on the left.

Table 2A — Physical Data — 60 Hz, English (cont)

SYSTEM MODULES	390			420		
	A	B	Total	A	B	Total
<b>APPROX OPERATING WEIGHT — lb</b>						
C-AL	13,380	12,676	26,056	13,380	13,380	26,760
C-C	14,899	14,195	29,094	14,899	14,899	29,798
<b>REFRIGERANT CHARGE — lb</b>						
R-22	190/40	178/30	—/—	190/40	190/40	—/—
Ckt A Total/Over	185/40	173/30	—/—	185/40	185/40	—/—
Ckt B Clear Glass						
<b>COMPRESSORS, Type...rpm</b>						
06E*	(3) 265, (1) 275	(1) 265, (1) 275, (1) 299	Reciprocating, Semi-Hermetic...1750	(3) 265, (1) 275	(3) 265, (1) 275	—
(Qty) Ckt A	(1) 275, (2) 299	(1) 275, (1) 299		(1) 275, (2) 299	(1) 275, (2) 299	—
(Qty) Ckt B						—
<b>Oil Charge — Compressor/pt</b>	265/19.0, 275/19.0, 299/19.0	265/19.0, 275/19.0, 299/19.0	—	265/19.0, 275/19.0, 299/19.0	265/19.0, 275/19.0, 299/19.0	—
<b>Capacity Control Steps</b>						
% Cap.	7	6	—	7	7	—
Ckt A	50	50	—	50	50	—
Ckt B	50	50	—	50	50	—
Minimum Step Capacity (%)	12	14	—	12	12	—
<b>CONDENSER FANS — Type</b>						
Standard/Low Noise						
Fan Speed — rpm	1740	1140	—	1740	1740	—
No. Blades...Diameter — in.	4...30	4...30	—	4...30	4...30	—
No. Fans...Total kW	12...19.1	12...19.1	24...38.2	12...19.1	12...19.1	24...38.2
Total Airflow — cfm	120,000	120,000	240,000	120,000	120,000	240,000
High Static						
Fan Speed — rpm	1740	1740	—	1740	1740	—
No. Blades...Diameter — in.	12...30	12...30	—	12...30	12...30	—
No. Fans...Total kW	12...44.4	12...44.4	24...88.8	12...44.4	12...44.4	24...88.8
Total Airflow — cfm†	120,000	120,000	240,000	120,000	120,000	240,000
<b>CONDENSER COILS — Type</b>						
Tubes (Copper), OD — in.	0.375	0.375	—	0.375	0.375	—
No. Rows — Ckt A or B	3	3	—	3	3	—
Face Area sq ft — Ckt A and B Total	268.9	268.9	537.8	268.9	268.9	537.8
Max Working Pressure Refrigerant — psig	450	450	—	450	450	—
<b>COOLER — No. Type</b>						
Weight (empty) — lb	1865	1630	3495	1865	1865	3730
No. Refrigerant Circuits	2	2	4	2	2	4
Net Fluid Volume — Gal. (includes nozzles)	70.4	61.0	131.4	70.4	70.4	140.8
Max Working Pressure Refrigerant Side/Fluid Side — psig	278/300	278/300	—/—	278/300	278/300	—/—
<b>FLUID CONNECTIONS — in.</b>						
Inlet and Outlet	6	6	—	6	6	—
Drain (NPT)	3/4	3/4	—	3/4	3/4	—

LEGEND

- C-AL — Copper Tubing — Aluminum Fins Condenser Coil
- C-C — Copper Tubing — Copper Fins Condenser Coil
- Ckt — Circuit
- ESP — External Static Pressure
- OD — Outside Diameter

\*06E250 compressors have 4 cylinders; all others have 6.  
 †Based on rated ESP of 0.4 in. wg or 1.0 in. wg as appropriate.

NOTE: When facing the compressors, Circuit A is on the right and Circuit B is on the left.

**Table 2B — Physical Data — 60 Hz, SI**

	080	090	100	110	130	150	170	190	210
<b>30GT UNIT SIZE</b>									
<b>APPROX OPERATING WEIGHT — kg</b>									
C-AL	3013	3189	3914	3935	4566	4754	5133	5761	6081
C-C	3343	3518	4346	4368	5144	5342	5711	6452	6772
<b>REFRIGERANT CHARGE — kg</b>									
R-22	35.4/6.8	35.4/6.8	44.5/9.1	44.5/9.1	60.5/12.7	65.0/15.9	69.5/20.5	80.9/13.6	86.4/18.2
Ckt A	35.4/6.8	35.4/6.8	47.7/9.1	47.7/9.1	62.3/12.7	65.0/15.9	73.6/20.5	78.6/13.6	84.1/18.2
Ckt B	35.4/6.8	35.4/6.8	47.7/9.1	47.7/9.1	62.3/12.7	65.0/15.9	73.6/20.5	78.6/13.6	84.1/18.2
<b>COMPRESSORS, Type...r/s</b>									
06E* (Qty) Ckt A	(1) 250, (1) 275	(1) 250, (1) 265	(1) 265, (1) 275	(1) 265, (1) 299	(1) 275, (1) 299	(3) 265	(3) 275	(1) 265, (1) 275, (1) 299	(3) 265, (1) 275
(Qty) Ckt B	(1) 299	(2) 265	(1) 265, (1) 275	(1) 265, (1) 275	(1) 275, (1) 299	(2) 299	(3) 275	(1) 265, (1) 275, (1) 299	(1) 275, (2) 299
Reciprocating, Semi-Hermetic...29.2									
250/6.6, 265/9.0, 275/9.0, 299/9.0									
<b>Oil Charge — Compressor/L</b>									
Capacity Control Steps (Standard Unit)									
% Cap.	6	8	8	8	8	10	12	6	7
Ckt A	56	47	50	54	50	50	50	50	50
Ckt B	44	53	50	46	50	50	50	50	50
Minimum Step Capacity (%)	22	18	15	14	14	11	11	14	12
<b>CONDENSER FANS — Type</b>									
Standard/Low Noise									
Fan Speed — r/s	19	19	19	19	19	19	19	19	19
No. Blades...Diameter — mm	4...762	4...762	4...762	4...762	4...762	4...762	4...762	4...762	4...762
No. Fans...Total kW	6...9.4	6...9.4	8...12.7	8...12.7	10...15.9	10...15.9	10...15.9	12...19.1	12...19.1
Total Airflow — L/s	26 898	26 898	35 864	35 864	47 190	47 190	47 190	56 630	56 630
High Static									
Fan Speed — r/s	29	29	29	29	29	29	29	29	29
No. Blades...Diameter — mm	12...762	12...762	12...762	12...762	12...762	12...762	12...762	12...762	12...762
No. Fans...Total kW	6...22.2	6...22.2	8...29.6	8...29.6	10...37.0	10...37.0	10...37.0	12...44.4	12...44.4
Total Airflow...L/s†	28 315	28 315	37 750	37 750	47 190	47 190	47 190	56 630	56 630
Vertical and Horizontal, Plate Fin, Enhanced Tubing									
<b>CONDENSER COILS — Type</b>									
Tubes (Copper), OD — mm	9.53	9.53	9.53	9.53	9.53	9.53	9.53	9.53	9.53
No. Rows — Ckt A or B	3	3	3	3	3	3	3	3	3
Face Area sq m — Ckt A and B Total	11.92	11.92	15.61	15.61	20.92	20.92	20.92	20.92	20.92
Max Working Pressure Refrigerant — kPa	3103	3103	3103	3103	3103	3103	3103	3103	3103
<b>COOLER — No. ...Type</b>									
Weight (empty) — kg	338	338	391	391	600	600	741	741	848
No. Refrigerant Circuits	2	2	2	2	2	2	2	2	2
Net Water Volume — L (Includes nozzles)	92.9	92.9	114.6	114.6	197	197	229	229	267
Max Working Pressure Refrigerant Side/Fluid Side — kPa	1916/2068	1916/2068	1916/2068	1916/2068	1916/2068	1916/2068	1916/2068	1916/2068	1916/2068
<b>FLUID CONNECTIONS — in.</b>									
Inlet and Outlet	4	4	5	5	6	6	6	6	6
Drain (NPT)					<sup>3</sup> / <sub>4</sub>				

**LEGEND**

- C-AL — Copper Tubing — Aluminum Fins Condenser Coil
- C-C — Copper Tubing — Copper Fins Condenser Coil
- Ckt — Circuit
- ESP — External Static Pressure
- OD — Outside Diameter

\*06E250 compressors have 4 cylinders; all others have 6.  
 †Based on rated ESP of 100 Pa or 250 Pa as appropriate.

NOTE: When facing the compressors, Circuit A is on the right and Circuit B is on the left.

Table 2B — Physical Data — 60 Hz, SI (cont)

SYSTEM MODULES	230			245			255			270		
	A	B	Total	A	B	Total	A	B	Total	A	B	Total
<b>APPROX OPERATING WEIGHT — kg</b>												
C-AL	4754	3013	7747	4754	3189	7943	4754	3914	8668	5133	3914	9047
C-C	5342	3343	8685	5342	3518	8860	5342	4346	9688	5711	4346	10057
<b>REFRIGERANT CHARGE — kg</b>												
R-22	60.5/15.9	35.4/6.8	—/—	65.0/15.9	35.4/6.8	—/—	65.0/15.9	44.5/9.1	—/—	69.5/20.5	44.5/9.1	—/—
Ckt A Total/Over	65.0/15.9	35.4/6.8	—/—	65.0/15.9	35.4/6.8	—/—	65.0/15.9	47.7/9.1	—/—	73.6/20.5	47.7/9.1	—/—
Ckt B Clear Glass												
<b>COMPRESSORS, Type.../s</b>												
06E*	(3) 265	(1) 250, (1) 275	—/—	(3) 265	Reciprocating, Semi-Hermetic...29.2	—/—	(3) 265	(1) 265, (1) 275	—	(3) 275	(1) 265, (1) 275	—
(Qty) Ckt A	(2) 299	(1) 299	—/—	(2) 299	(1) 265, (1) 250	—/—	(2) 299	(1) 265, (1) 275	—	(3) 275	(1) 265, (1) 275	—
(Qty) Ckt B	265/9.0, 299/9.0	250/6.6, 275/9.0, 299/9.0	—	265/9.0, 299/9.0	250/6.6, 265/9.0	—	265/9.0, 299/9.0	265/9.0, 275/9.0	—	275/9.0	265/9.0, 275/9.0	—
<b>Oil Charge — Compressor/L</b>												
Capacity Control Steps	10	6	—	10	8	—	10	8	—	12	8	—
% Cap.	50	56	—	50	47	—	50	50	—	50	50	—
Ckt A	50	44	—	50	53	—	50	50	—	50	50	—
Ckt B	11	22	—	11	18	—	11	15	—	11	15	—
<b>Minimum Step Capacity (%)</b>												
<b>CONDENSER FANS — Type</b>												
Standard/Low Noise												
Fan Speed — /s	19	19	—	19	19	—	19	19	—	19	19	—
No. Blades...Diameter — mm	4...762	4...762	—	4...762	4...762	—	4...762	4...762	—	4...762	4...762	—
No. Fans...Total kW	10...15.9	6...9.4	16...25.3	10...15.9	6...9.4	16...25.3	10...15.9	8...12.7	18...28.6	10...15.9	8...12.7	18...28.6
Total Airflow — L/s	47 190	26 898	74 088	47 190	26 898	74 088	47 190	35 864	85 054	47 190	35 864	83 054
High Static												
Fan Speed — /s	29	29	—	29	29	—	29	29	—	29	29	—
No. Blades...Diameter — mm	12...762	12...762	—	12...762	12...762	—	12...762	12...762	—	12...762	12...762	—
No. Fans...Total kW	10...37.0	6...22.2	16...59.2	10...37.0	6...22.2	16...59.2	10...37.0	8...29.6	18...66.6	10...37.0	8...29.6	18...66.6
Total Airflow — L/s†	47 190	28 315	75 505	47 190	28 315	75 505	47 190	37 750	84 940	47 190	37 750	84 940
<b>CONDENSER COILS — Type</b>												
Tubes (Copper), OD — mm	9.53	9.53	—	9.53	9.53	—	9.53	9.53	—	9.53	9.53	—
No. Rows — Ckt A or B	3	3	—	3	3	—	3	3	—	3	3	—
Face Area sq m — Ckt A and B Total	20.92	11.92	32.84	20.92	11.92	32.84	20.92	15.61	36.53	20.92	15.61	36.53
Max Working Pressure Refrigerant — kPa	3103	3103	—	3103	3103	—	3103	3103	—	3103	3103	—
<b>COOLER — No. ...Type</b>												
Weight (empty) — kg	600	338	938	600	338	938	600	391	991	741	391	1132
No. Refrigerant Circuits	2	2	4	2	2	4	2	2	4	2	2	4
Net Fluid Volume — L (includes nozzles)	197.0	92.9	289.9	197.0	92.9	289.9	197.0	114.6	311.6	229	114.6	343.6
Max Working Pressure												
Refrigerant Side/Fluid Side — kPa	1916/2068	1916/2068	—/—	1916/2068	1916/2068	—/—	1916/2068	1916/2068	—/—	1916/2068	1916/2068	—/—
<b>FLUID CONNECTIONS — in.</b>												
Inlet and Outlet	6	4	—	6	4	—	6	5	—	6	5	—
Drain (NPT)	¾	¾	—	¾	¾	—	¾	¾	—	¾	¾	—

LEGEND

- C-AL — Copper Tubing — Aluminum Fins Condenser Coil
- C-C — Copper Tubing — Copper Fins Condenser Coil
- Ckt — Circuit
- ESP — External Static Pressure
- OD — Outside Diameter

\*06E250 compressors have 4 cylinders; all others have 6.  
 †Based on rated ESP of 100 Pa or 250 Pa as appropriate.

NOTE: When facing the compressors, Circuit A is on the right and Circuit B is on the left.

**Table 2B — Physical Data — 60 Hz, SI (cont)**

SYSTEM MODULES	290			315			330			360		
	A	B	Total	A	B	Total	A	B	Total	A	B	Total
<b>APPROX OPERATING WEIGHT — kg</b> C-AL C-C	5761 6452	3935 4368	9 696 10 820	6081 6772	3935 4368	10 016 11 140	5133 5711	5133 5711	10 266 11 422	5761 6452	5761 6452	11 522 12 904
<b>REFRIGERANT CHARGE — kg</b> R-22 Ckt A Total/Over Ckt B Clear Glass	80.9/13.6 78.6/13.6	44.5/9.1 47.7/9.1	—/— —/—	86.4/18.2 84.1/18.2	44.5/9.1 47.7/9.1	—/— —/—	69.5/20.5 73.6/20.5	69.5/20.5 73.6/20.5	—/— —/—	80.9/13.6 78.6/13.6	80.9/13.6 78.6/13.6	—/— —/—
<b>COMPRESSORS, Type.../rs</b> 06E* (Qty) Ckt A (Qty) Ckt B	(1) 265, (1) 275, (1) 299 (1) 265, (1) 275, (1) 299	(1) 265, (1) 299 (1) 265, (1) 275	—	(3) 265, (1) 275 (1) 275, (2) 299	(1) 265, (1) 299 (1) 265, (1) 275	—	(3) 275 (3) 275	(3) 275 (3) 275	—	(1) 265, (1) 275, (1) 299 (1) 265, (1) 275, (1) 299	(1) 265, (1) 275, (1) 299 (1) 265, (1) 275, (1) 299	—
<b>Oil Charge — Compressor/L</b>	265/9.0, 275/9.0, 299/9.0	265/9.0, 275/9.0, 299/9.0	—	265/9.0, 275/9.0, 299/9.0	265/9.0, 275/9.0, 299/9.0	—	275/9.0	275/9.0	—	265/9.0, 275/9.0, 299/9.0	265/9.0, 275/9.0, 299/9.0	—
<b>Capacity Control Steps</b> % Cap. Ckt A Ckt B Minimum Step Capacity (%)	6 50 50 14	8 54 46 14	—	7 50 50 12	8 54 46 14	—	12 50 50 11	12 50 50 11	—	6 50 50 14	6 50 50 14	—
<b>CONDENSER FANS — Type</b> Standard/Low Noise Fan Speed — r/s No. Blades...Diameter — mm No. Fans...Total kW Total Airflow — L/s High Static Fan Speed — r/s No. Blades...Diameter — mm No. Fans...Total kW Total Airflow — L/s†	Propeller, Direct Drive 19 4...762 12...19.1 56 630	Propeller, Direct Drive 19 4...762 8...12.7 35 864	—	Propeller, Direct Drive 19 4...762 12...19.1 56 630	Propeller, Direct Drive 19 4...762 8...12.7 35 864	—	Propeller, Direct Drive 19 4...762 10...15.9 47 190	Propeller, Direct Drive 19 4...762 10...15.9 47 190	—	Propeller, Direct Drive 19 4...762 12...762 12...44.4 56 630	Propeller, Direct Drive 19 4...762 12...762 12...44.4 56 630	—
<b>CONDENSER COILS — Type</b> Tubes (Copper), OD — mm No. Rows — Ckt A or B Face Area sq m — Ckt A and B Total Max Working Pressure Refrigerant — kPa	9.53 3 20.92 3103	9.53 3 15.61 3103	—	9.53 3 20.92 3103	9.53 3 15.61 3103	—	9.53 3 20.92 3103	9.53 3 20.92 3103	—	9.53 3 20.92 3103	9.53 3 20.92 3103	—
<b>COOLER — No. ...Type</b> Weight (empty) kg No. Refrigerant Circuits Net Fluid Volume — L (Includes nozzles) Max Working Pressure Refrigerant Side/Fluid Side — kPa	741 2 229.0	391 2 114.6	1132 4 343.6	848 2 267.0	391 2 114.6	—	741 2 229	741 2 229	1482 4 458	741 2 229	741 2 229	1482 4 458
<b>FLUID CONNECTIONS — in.</b> Inlet and Outlet Drain (NPT)	1916/2068	1916/2068	—/—	1916/2068	1916/2068	—/—	1916/2068	1916/2068	—/—	1916/2068	1916/2068	—/—
	6 3/4	5 3/4	—	6 3/4	5 3/4	—	6 3/4	6 3/4	—	6 3/4	6 3/4	—

**LEGEND**

- C-AL — Copper Tubing — Aluminum Fins Condenser Coil
- C-C — Copper Tubing — Copper Fins Condenser Coil
- Ckt — Circuit
- ESP — External Static Pressure
- OD — Outside Diameter

\*06E250 compressors have 4 cylinders; all others have 6.  
†Based on rated ESP of 100 Pa or 250 Pa as appropriate.

NOTE: When facing the compressors, Circuit A is on the right and Circuit B is on the left.

**Table 2B —Physical Data — 60 Hz, SI (cont)**

SYSTEM MODULES	390			420		
	A	B	Total	A	B	Total
<b>APPROX OPERATING WEIGHT — kg</b> C-AL C-C	6081 6772	5761 6452	11 842 13 224	6081 6772	6081 6772	12 162 13 544
<b>REFRIGERANT CHARGE — kg</b> R-22 Ckt A Total/Over Ckt B Clear Glass	86.4/18.2 84.1/18.2	80.9/13.6 78.6/13.6	—/— —/—	86.4/18.2 84.1/18.2	86.4/18.2 84.1/18.2	—/— —/—
<b>COMPRESSORS, Type.../s</b> 06E* (Qty) Ckt A (Qty) Ckt B	(3) 265, (1) 275 (1) 275, (2) 299	(1) 265, (1) 275, (1) 299 (1) 265, (1) 275, (1) 299	Reciprocating, Semi-Hermetic...29.2	(3) 265, (1) 275 (1) 275, (2) 299	(3) 265, (1) 275 (1) 275, (2) 299	— —
<b>Oil Charge — Compressor/L</b>	265/9.0, 275/9.0, 299/9.0	265/9.0, 275/9.0, 299/9.0	—	265/9.0, 275/9.0, 299/9.0	265/9.0, 275/9.0, 299/9.0	—
<b>Capacity Control Steps</b> % Cap. Ckt A Ckt B	7 50 50 12	6 50 50 14	— — — —	7 50 50 12	7 50 50 12	— — — —
<b>CONDENSER FANS — Type</b> Standard/Low Noise Fan Speed — r/s No. Blades...Diameter — mm No. Fans...Total kW Total Airflow — L/s High Static Fan Speed — r/s No. Blades...Diameter — mm No. Fans...Total kW Total Airflow — L/s†	19 4...762 12...19.1 56 630 29 12...762 12...44.4 56 630	19 4...762 12...19.1 56 630 29 12...762 12...44.4 56 630	— 24...38.2 113 260	19 4...762 12...19.1 56 630 29 12...762 12...44.4 56 630	19 4...762 12...19.1 56 630 29 12...762 12...44.4 56 360	— 24...38.2 113 260 — 24...88.8 113 260
<b>CONDENSER COILS — Type</b> Tubes (Copper), OD — mm No. Rows — Ckt A or B Face Area sq m — Ckt A and B Total Max Working Pressure Refrigerant — kPa	9.53 3 20.92 3103	9.53 3 20.92 3103	— — 41.84 —	9.53 3 20.92 3103	9.53 3 20.92 3103	— — 41.84 —
<b>COOLER — No. ...Type</b> Weight (empty) kg No. Refrigerant Circuits Net Fluid Volume — L (includes nozzles) Max Working Pressure Refrigerant Side/Fluid Side — kPa	848 2 267.0	741 2 229.0	1589 4 496	848 2 267.0	848 2 257.0	1696 4 534
<b>FLUID CONNECTIONS — in.</b> Inlet and Outlet Drain (NPT)	1916/2068 6 ¾	1916/2068 6 ¾	—/— — —	1916/2068 6 ¾	1916/2068 6 ¾	—/— — —

**LEGEND**  
 C-AL — Copper Tubing — Aluminum Fins Condenser Coil  
 C-C — Copper Tubing — Copper Fins Condenser Coil  
 Ckt — Circuit  
 ESP — External Static Pressure  
 OD — Outside Diameter

\*06E250 compressors have 4 cylinders; all others have 6.  
 †Based on rated ESP of 100 Pa or 250 Pa as appropriate.

NOTE: When facing the compressors, Circuit A is on the right and Circuit B is on the left.

**Table 3A — Physical Data — 50 Hz, English**

30GT UNIT SIZE		080	090	100	110	130	150	170	190	210
<b>APPROX OPERATING WEIGHT — lb</b>										
C-AL		6,720	7,135	8,710	8,840	10,511	10,676	11,443	12,906	13,545
C-C		7,445	7,860	9,660	9,790	11,783	11,948	12,715	14,425	15,064
<b>REFRIGERANT CHARGE — lb</b>										
R-22		78/15	78/15	98/20	98/20	133/28	143/35	153/45	178/30	190/40
Ckt A		78/15	78/15	105/20	105/20	137/28	143/35	162/45	173/30	185/40
<b>COMPRESSORS, Type...rpm</b>										
06E*	(Qty) Ckt A	(1) 265, (1) 299	(1) 265, (1) 275	(1) 265, (1) 299	(2) 299	(1) 265, (2) 275	(3) 299	(2) 275, (1) 299	(3) 299	(2) 265, (2) 299
	(Qty) Ckt B	(1) 299	(1) 275	(1) 299	(2) 299	(2) 299	(2) 299	(1) 275, (2) 299	(3) 299	(3) 299
Oil Charge — Compressor/pt										
Capacity Control Steps (Standard Unit)										
% Cap.	Ckt A	6	8	8	8	10	10	12	6	7
	Ckt B	38	54	50	50	52	50	48	50	52
Minimum Step Capacity (%)		16	46	13	17	10	13	10	17	10
<b>CONDENSER FANS — Type</b>										
Standard/Low Noise										
Fan Speed — rpm		950	950	950	950	950	950	950	950	950
No. Blades...Diameter — in.		6...30	6...30	6...30	6...30	6...30	6...30	6...30	6...30	6...30
Total Airflow — cfm		57,000	57,000	76,000	76,000	100,000	100,000	100,000	120,000	120,000
High Static										
Fan Speed — rpm		1445	1445	1445	1445	1445	1445	1445	1445	1445
No. Blades...Diameter — in.		12...30	12...30	12...30	12...30	12...30	12...30	12...30	12...30	12...30
No. Fans...Total kW		6...22.2	6...22.2	8...29.6	8...29.6	10...37.0	10...37.0	10...37.0	12...44.4	12...44.4
Total Airflow...cfm†		60,000	60,000	80,000	80,000	100,000	100,000	100,000	120,000	120,000
<b>CONDENSER COILS — Type</b>										
Tubes (Copper), OD — in.		0.375	0.375	0.375	0.375	0.375	0.375	0.375	0.375	0.375
No. Rows — Ckt A or B		3	3	3	3	3	3	3	3	3
Face Area sq ft — Ckt A and B Total		128.3	128.3	168	168	225.1	225.1	225.1	268.9	268.9
Max Working Pressure Refrigerant — psig		450	450	450	450	450	450	450	450	450
<b>COOLER — No. ... Type</b>										
Weight (empty) — lb		745	745	860	860	1320	1320	1630	1630	1865
No. Refrigerant Circuits		2	2	2	2	2	2	2	2	2
Net Water Volume — Gal. (Includes nozzles)		24.5	24.5	30.3	30.3	52.0	52.0	61.0	61.0	70.4
Max Working Pressure Refrigerant Side/Fluid Side — psig		278/300	278/300	278/300	278/300	278/300	278/300	278/300	278/300	278/300
<b>FLUID CONNECTIONS — in.</b>										
Inlet and Outlet		4	4	5	5	6	6	6	6	6
Drain (NPT)						¾				

**LEGEND**  
 C-AL — Copper Tubing — Aluminum Fins Condenser Coil  
 C-C — Copper Tubing — Copper Fins Condenser Coil  
 Ckt — Circuit  
 ESP — External Static Pressure  
 OD — Outside Diameter

\*06E250 compressors have 4 cylinders; all others have 6.  
 †Based on rated ESP of 0.4 in. wg or 1.0 in. wg as appropriate.

NOTE: When facing the compressors, Circuit A is on the right and Circuit B is on the left.

Table 3A — Physical Data — 50 Hz, English (cont)

SYSTEM MODULES	30GT UNIT SIZE			245			255			270		
	A	B	Total	A	B	Total	A	B	Total	A	B	Total
APPROX OPERATING WEIGHT — lb												
C-AL	10,676	6720	17,396	10,676	7135	17,811	10,676	8710	19,386	11,443	8710	20,153
C-C	11,948	7445	19,393	11,948	7660	19,608	11,948	9660	21,608	12,715	9660	22,375
REFRIGERANT CHARGE — lb												
Ckt A Total/Over	143/35	78/15	—/—	143/35	78/15	—/—	143/35	98/20	—/—	153/45	98/20	—/—
Ckt B Clear Glass	143/35	78/15	—/—	143/35	78/15	—/—	143/35	105/20	—/—	162/45	105/20	—/—
COMPRESSORS, Type...rpm												
06E <sup>†</sup>	(3) 299	(1) 265, (1) 299	—/—	(3) 299	(1) 265, (1) 299	—/—	(3) 299	(1) 265, (1) 299	—/—	(2) 275, (1) 299	(1) 265, (1) 299	—
(Qty) Ckt A	(2) 299	(1) 299	—/—	(2) 299	(1) 265, (1) 275	—/—	(2) 299	(1) 265, (1) 299	—/—	(1) 275, (2) 299	(1) 265, (1) 299	—
Oil Charge — Compressor/pt	299/19.0	265/19.0, 299/19.0	—	299/19.0	265/19.0, 275/19.0, 299/19.0	—	299/19.0	265/19.0, 299/19.0	—	275/19.0, 299/19.0	265/19.0, 299/19.0	—
Capacity Control Steps	10	6	—	10	8	—	10	8	—	12	8	—
% Cap.	60	62	—	60	54	—	60	50	—	48	50	—
Ckt A	40	38	—	40	46	—	40	40	—	52	50	—
Ckt B	13	16	—	13	14	—	13	13	—	10	13	—
Minimum Step Capacity (%)												
CONDENSER FANS — Type												
Standard/Low Noise	Propeller, Direct Drive	Propeller, Direct Drive	Propeller, Direct Drive	Propeller, Direct Drive	Propeller, Direct Drive	Propeller, Direct Drive	Propeller, Direct Drive	Propeller, Direct Drive	Propeller, Direct Drive	Propeller, Direct Drive	Propeller, Direct Drive	Propeller, Direct Drive
Fan Speed — rpm	950	950	—	950	950	—	950	950	—	950	950	—
No. Blades...Diameter — in.	6...30	6...30	16...25.3	6...30	6...30	16...25.3	6...30	6...30	18...28.6	6...30	6...30	18...28.6
No. Fans...Total kW	10...15.9	6...9.4	157,000	10...15.9	6...9.4	157,000	10...15.9	8...12.7	100,000	10...15.9	8...12.7	176,000
Total Airflow — cfm	100,000	57,000	157,000	100,000	57,000	157,000	100,000	76,000	176,000	100,000	76,000	176,000
High Static												
Fan Speed — rpm	1445	1445	—	1445	1445	—	1445	1445	—	1445	1445	—
No. Blades...Diameter — in.	12...30	12...30	16...59.2	12...30	12...30	16...59.2	12...30	12...30	18...66.6	12...30	12...30	18...66.6
No. Fans...Total kW	10...37.0	6...22.2	160,000	10...37.0	6...22.2	160,000	10...37.0	8...29.6	180,000	10...37.0	8...29.6	180,000
Total Airflow — cfm <sup>†</sup>	100,000	60,000	160,000	100,000	60,000	160,000	100,000	80,000	180,000	100,000	80,000	180,000
CONDENSER COILS — Type												
Tubes (Copper), OD — in.	0.375	0.375	—	0.375	0.375	—	0.375	0.375	—	0.375	0.375	—
No. Rows — Ckt A or B	3	3	353.4	3	3	353.4	3	3	393.1	3	3	393.1
Face Area sq ft — Ckt A and B Total	225.1	128.3	—	225.1	128.3	—	225.1	168.0	—	225.1	168.0	—
Max Working Pressure Refrigerant — psig	450	450	—	450	450	—	450	450	—	450	450	—
COOLER — No. ...Type												
Weight (empty) lb	1320	745	2065	1320	745	2065	1320	860	2180	1630	860	2490
No. Refrigerant Circuits	2	2	4	2	2	4	2	2	4	2	2	4
Net Fluid Volume — Gal. (includes nozzles)	52.0	24.5	76.5	52.0	24.5	76.5	52.0	30.3	82.3	61.0	30.3	91.3
Max Working Pressure Refrigerant Side/Fluid Side — psig	278/300	278/300	—/—	278/300	278/300	—/—	278/300	278/300	—/—	278/300	278/300	—/—
FLUID CONNECTIONS — in.												
Inlet and Outlet	6	4	—	6	4	—	6	5	—	6	5	—
Drain (NPT)	3/4	3/4	—	3/4	3/4	—	3/4	3/4	—	3/4	3/4	—

LEGEND

- C-AL — Copper Tubing — Aluminum Fins Condenser Coil
- C-C — Copper Tubing — Copper Fins Condenser Coil
- Ckt — Circuit
- ESP — External Static Pressure
- OD — Outside Diameter

\*06E250 compressors have 4 cylinders; all others have 6.

†Based on rated ESP of 0.4 in. wg or 1.0 in. wg as appropriate.

NOTE: When facing the compressors, Circuit A is on the right and Circuit B is on the left.

**Table 3A — Physical Data — 50 Hz, English (cont)**

SYSTEM MODULES	290			315			330			360		
	A	B	Total	A	B	Total	A	B	Total	A	B	Total
<b>APPROX OPERATING WEIGHT — lb</b>												
C-AL	12,906	8840	21,746	13,545	8840	22,385	11,443	8840	22,886	12,906	8840	24,349
C-C	14,425	9790	24,215	15,064	9790	24,854	12,715	9790	25,430	14,425	9790	38,140
<b>REFRIGERANT CHARGE — lb</b>												
R-22	178/30	98/20	—/—	190/40	98/20	—/—	153/45	153/45	—/—	178/30	153/45	—/—
Ckt A Total/Over	178/30	105/20	—/—	185/40	105/20	—/—	162/45	162/45	—/—	178/30	162/45	—/—
Ckt B Clear Glass	178/30	105/20	—/—	185/40	105/20	—/—	162/45	162/45	—/—	178/30	162/45	—/—
<b>COMPRESSORS, Type...rpm</b>												
06E <sup>†</sup>	(3) 299	(2) 299	—	(2) 265, (2) 299	(2) 299	—	(2) 275, (1) 299	(2) 299	—	(3) 299	(2) 275, (1) 299	—
(Qty) Ckt A	(3) 299	(2) 299	—	(3) 299	(2) 299	—	(1) 275, (2) 299	(2) 299	—	(3) 299	(1) 275, (2) 299	—
Oil Charge — Compressor/pt	299/19.0	299/19.0	—	265/19.0, 299/19.0	299/19.0	—	275/19.0, 299/19.0	275/19.0, 299/19.0	—	299/19.0	275/19.0, 299/19.0	—
Capacity Control Steps	6	8	—	7	8	—	12	12	—	6	12	—
% Cap.	50	50	—	52	50	—	48	48	—	50	48	—
Ckt A	50	50	—	48	50	—	52	52	—	50	52	—
Ckt B	17	17	—	10	17	—	10	10	—	17	10	—
<b>CONDENSER FANS — Type</b>												
Standard/Low Noise	Propeller, Direct Drive	Propeller, Direct Drive	Propeller, Direct Drive	Propeller, Direct Drive	Propeller, Direct Drive	Propeller, Direct Drive	Propeller, Direct Drive	Propeller, Direct Drive	Propeller, Direct Drive	Propeller, Direct Drive	Propeller, Direct Drive	Propeller, Direct Drive
Fan Speed — rpm	950	950	—	950	950	—	950	950	—	950	950	—
No. Blades...Diameter — in.	6...30	6...30	—	6...30	6...30	—	6...30	6...30	—	6...30	6...30	—
Total Airflow — cfm	12...19.1	8...12.7	20...31.8	12...19.1	8...12.7	20...31.8	10...15.9	10...15.9	20...15.9	12...19.1	10...15.9	22...35
High Static	120,000	76,000	196,000	120,000	76,000	196,000	100,000	100,000	200,000	120,000	100,000	220,000
Fan Speed — rpm	1445	1445	—	1445	1445	—	1445	1445	—	1445	1445	—
No. Blades...Diameter — in.	12...30	12...30	—	12...30	12...30	—	12...30	12...30	—	12...30	12...30	—
Total Airflow — cfm	12...44.4	8...29.6	20...74.0	12...44.4	8...29.6	20...74.0	10...37.0	10...37.0	20...74.0	12...44.4	10...37.0	22...81.4
	120,000	80,000	200,000	120,000	80,000	200,000	100,000	100,000	200,000	120,000	100,000	220,000
<b>CONDENSER COILS — Type</b>												
Tubes (Copper), OD — in.	0.375	0.375	—	0.375	0.375	—	0.375	0.375	—	0.375	0.375	—
No. Rows — Ckt A or B	3	3	—	3	3	—	3	3	—	3	3	—
Face Area sq ft — Ckt A and B Total	268.9	168.0	436.9	268.9	168.0	436.9	225.1	225.1	450.2	268.9	225.1	494
Max Working Pressure Refrigerant — psig	450	450	—	450	450	—	450	450	—	450	450	—
<b>COOLER — No. ...Type</b>												
Weight (empty) — lb	1630	860	2490	1865	860	2725	1630	1630	3260	1630	1630	3260
No. Refrigerant Circuits	2	2	4	2	2	4	2	2	4	2	2	4
Net Fluid Volume — Gal. (includes nozzles)	61.0	30.3	91.3	70.4	30.3	100.7	61.0	61.0	122.0	61.0	61.0	122
Max Working Pressure	278/300	278/300	—/—	278/300	278/300	—/—	278/300	278/300	—/—	278/300	278/300	—/—
Refrigerant Side/Fluid Side — psig	278/300	278/300	—/—	278/300	278/300	—/—	278/300	278/300	—/—	278/300	278/300	—/—
<b>FLUID CONNECTIONS — in.</b>												
Inlet and Outlet	Victaulic Type	Victaulic Type	—	Victaulic Type	Victaulic Type	—	Victaulic Type	Victaulic Type	—	Victaulic Type	Victaulic Type	—
Drain (NPT)	6	5	—	6	5	—	6	6	—	6	6	—
	¾	¾	—	¾	¾	—	¾	¾	—	¾	¾	—

**LEGEND**

- C-AL — Copper Tubing — Aluminum Fins Condenser Coil
- C-C — Copper Tubing — Copper Fins Condenser Coil
- Ckt — Circuit
- ESP — External Static Pressure
- OD — Outside Diameter

\*06E250 compressors have 4 cylinders; all others have 6.  
 †Based on rated ESP of 0.4 in. wg or 1.0 in. wg as appropriate.

NOTE: When facing the compressors, Circuit A is on the right and Circuit B is on the left.

Table 3A — Physical Data — 50 Hz, English (cont)

SYSTEM MODULES	390			420		
	A	B	Total	A	B	Total
APPROX OPERATING WEIGHT — lb						
C-AL	13,545	12,906	26,451	13,545	13,545	27,090
C-C	15,064	14,425	29,489	15,064	15,064	30,128
REFRIGERANT CHARGE — lb						
R-22	190/40	178/30	—/—	190/40	190/40	—/—
Ckt A Total/Over	185/40	173/30	—/—	185/40	185/40	—/—
Ckt B Clear Glass						
COMPRESSORS, Type...rpm						
*06E <sup>†</sup> (Qty) Ckt A	(2) 265, (2) 299	(3) 299	Reciprocating	Semi-Hermetic...1450	(2) 265, (2) 299	(2) 265, (2) 299
(Qty) Ckt B	(3) 299	(3) 299	—	(3) 299	(3) 299	(3) 299
Oil Charge — Compressor/pt	265/19.0, 299/19.0	299/19.0	—	265/19.0, 299/19.0	265/19.0, 299/19.0	—
Capacity Control Steps						
% Cap.	7	6	—	7	7	—
Ckt A	52	50	—	52	52	—
Ckt B	48	50	—	48	48	—
Minimum Step Capacity (%)	10	17	—	10	10	—
CONDENSER FANS — Type						
Standard/Low Noise	Propeller, Direct Drive			Propeller, Direct Drive		
Fan Speed — rpm	950	950	—	950	950	—
No. Blades...Diameter — in.	6...30	6...30	24...38.2	6...30	6...30	24...38.2
No. Fans...Total kW	12...19.1	12...19.1	240,000	12...19.1	12...19.1	240,000
Total Airflow — cfm	120,000	120,000	—	120,000	120,000	—
High Static						
Fan Speed — rpm	1445	1445	—	1445	1445	—
No. Blades...Diameter — in.	12...30	12...30	24...88.8	12...30	12...30	24...88.8
No. Fans...Total kW	12...44.4	12...44.4	240,000	12...44.4	12...44.4	240,000
Total Airflow — cfm	120,000	120,000	—	120,000	120,000	—
CONDENSER COILS — Type						
Tubes (Copper), OD — in.	0.375	0.375	Vertical and Horizontal, Plate Fin, Enhanced Tubing	0.375	0.375	—
No. Rows — Ckt A or B	3	3	—	3	3	—
Face Area sq ft — Ckt A and B Total	268.9	268.9	537.8	268.9	268.9	537.8
Max Working Pressure Refrigerant — psig	450	450	—	450	450	—
COOLER — No. ...Type						
Weight (empty) — lb	1865	1630	3495	1865	1865	3730
No. Refrigerant Circuits	2	2	4	2	2	4
Net Fluid Volume — Gal. (includes nozzles)	70.4	61.0	131.4	70.4	70.4	140.8
Max Working Pressure						
Refrigerant Side/Fluid Side — psig	278/300	278/300	—/—	278/300	278/300	—/—
FLUID CONNECTIONS — in.						
Inlet and Outlet	6	6	—	6	6	—
Drain (NPT)	¾	¾	—	¾	¾	—

LEGEND

- C-AL — Copper Tubing — Aluminum Fins Condenser Coil
- C-C — Copper Tubing — Copper Fins Condenser Coil
- Ckt — Circuit
- ESP — External Static Pressure
- OD — Outside Diameter

\*06E250 compressors have 4 cylinders; all others have 6.  
 †Based on rated ESP of 0.4 in. wg or 1.0 in. wg as appropriate.

NOTE: When facing the compressors, Circuit A is on the right and Circuit B is on the left.

**Table 3B — Physical Data — 50 Hz, SI**

	080	090	100	110	130	150	170	190	210
<b>30GT UNIT SIZE</b>									
<b>APPROX OPERATING WEIGHT — kg</b>									
C-AL	3055	3243	3960	4018	4778	4852	5201	5866	6156
C-C	3384	3573	4390	4450	5335	5430	5779	6556	6847
<b>REFRIGERANT CHARGE — kg</b>									
R-22	35.4/6.8	35.4/6.8	44.5/9.1	44.5/9.1	60.5/12.7	65.0/15.9	69.5/20.5	80.9/13.6	86.4/18.2
Ckt A	35.4/6.8	35.4/6.8	47.7/9.1	47.7/9.1	62.3/12.7	65.0/15.9	73.6/20.5	78.6/13.6	84.1/18.2
Ckt B									
<b>COMPRESSORS, Type...r/s</b>									
06E*	(1) 265, (1) 299	(1) 265, (1) 299	(1) 265, (1) 299	(2) 299	(1) 265, (2) 275	(3) 299	(2) 275, (1) 299	(3) 299	(2) 265, (2) 299
(Qty) Ckt A	(1) 299	(1) 265, (1) 275	(1) 265, (1) 299	(2) 299	(2) 299	(2) 299	(1) 275, (2) 299	(3) 299	(3) 299
(Qty) Ckt B									
Reciprocating, Semi-Hermetic...24.2									
Oil Charge — Compressor/L									
265/9.0, 275/9.0, 299/9.0									
<b>Capacity Control Steps (Standard Unit)</b>									
% Cap.	6	8	8	8	10	10	12	6	7
Ckt A	36	54	50	50	52	60	48	50	52
Ckt B	16	46	50	50	48	40	52	50	48
Minimum Step Capacity (%)		14	13	17	10	13	10	17	10
<b>CONDENSER FANS — Type</b>									
Standard/Low Noise									
Fan Speed — r/s	15.8	15.8	15.8	15.8	15.8	15.8	15.8	15.8	15.8
No. Blades...Diameter — mm	6...762	6...762	6...762	6...762	6...762	6...762	6...762	6...762	6...762
No. Fans...Total kW	6...9.4	6...9.4	8...12.7	8...12.7	10...15.9	10...15.9	10...15.9	12...19.1	12...19.1
Total Airflow — L/s	26 898	26 898	35 864	35 864	47 190	47 190	47 190	56 630	56 630
High Static									
Fan Speed — r/s	24	24	24	24	24	24	24	24	24
No. Blades...Diameter — mm	12...762	12...762	12...762	12...762	12...762	12...762	12...762	12...762	12...762
No. Fans...Total kW	6...22.2	6...22.2	8...29.6	8...29.6	10...37.0	10...37.0	10...37.0	12...44.4	12...44.4
Total Airflow — L/s†	28 315	28 315	37 750	37 750	47 190	47 190	47 190	56 630	56 630
<b>CONDENSER COILS — Type</b>									
Tubes (Copper), OD — mm									
No. Rows — Ckt A or B	9.53	9.53	9.53	9.53	9.53	9.53	9.53	9.53	9.53
Face Area sq m — Ckt A and B Total	11.92	11.92	15.61	15.61	20.92	20.92	20.92	24.98	24.98
Max Working Pressure Refrigerant — kPa	3103	3103	3103	3103	3103	3103	3103	3103	3103
<b>COOLER — No. ...Type</b>									
Weight (empty) — kg									
No. Refrigerant Circuits	338	338	391	391	600	600	741	741	848
Net Water Volume — L (includes nozzles)	2	2	2	2	2	2	2	2	2
Max Working Pressure Refrigerant Side/Fluid Side — kPa	92.9	92.9	114.6	114.6	197	197	229	229	267
<b>FLUID CONNECTIONS — in.</b>									
Inlet and Outlet	4	4	5	5	6	6	6	6	6
Drain (NPT)					3/4				

**LEGEND**

- C-AL — Copper Tubing — Aluminum Fins Condenser Coil
- C-C — Copper Tubing — Copper Fins Condenser Coil
- Ckt — Circuit
- ESP — External Static Pressure
- OD — Outside Diameter

\*06E250 compressors have 4 cylinders; all others have 6.  
 †Based on rated ESP of 100 Pa or 250 Pa as appropriate.

NOTE: When facing the compressors, Circuit A is on the right and Circuit B is on the left.

Table 3B — Physical Data — 50 Hz, SI (cont)

SYSTEM MODULES	30GT UNIT SIZE			245			255			270		
	A	B	Total	A	B	Total	A	B	Total	A	B	Total
APPROX OPERATING WEIGHT — kg												
C-AL	4852	3055	7907	4852	3243	8095	4852	3960	8812	5201	3960	9161
C-C	5430	3384	8814	5430	4390	9003	5430	4390	9820	5779	4390	10169
REFRIGERANT CHARGE — kg												
R-22	65.0/15.9	35.4/6.8	—/—	65.0/15.9	35.4/6.8	—/—	65.0/15.9	44.5/9.1	—/—	69.5/20.5	44.5/9.1	—/—
Ckt A Total/Over	65.0/15.9	35.4/6.8	—/—	65.0/15.9	35.4/6.8	—/—	65.0/15.9	47.7/9.1	—/—	73.6/20.5	47.7/9.1	—/—
Ckt B Clear Glass												
COMPRESSORS, Type...r/s												
06E* (Qty) Ckt A	(3) 299	(1) 285, (1) 299	—	(3) 299	(1) 285, (1) 299	—	(3) 299	(1) 285, (1) 299	—	(2) 275, (1) 299	(1) 285, (1) 299	—
(Qty) Ckt B	(2) 299	(1) 299	—	(2) 299	(1) 285, (1) 275	—	(2) 299	(1) 285, (1) 299	—	(1) 275, (2) 299	(1) 265, (1) 299	—
Oil Charge — Compressor/L	299/9.0	265/9.0, 299/9.0	—	299/9.0	265/9.0, 275/9.0, 299/9.0	—	299/9.0	265/9.0, 299/9.0	—	275/9.0, 299/9.0	265/9.0, 299/9.0	—
Capacity Control Steps												
% Cap.	10	6	—	10	8	—	10	8	—	12	8	—
Ckt A	60	62	—	60	54	—	60	50	—	48	50	—
Ckt B	40	38	—	40	46	—	40	50	—	52	50	—
Minimum Step Capacity (%)	13	16	—	13	14	—	13	13	—	10	13	—
CONDENSER FANS — Type												
Standard/Low Noise												
Fan Speed — r/s	15.8	15.8	—	15.8	15.8	—	15.8	15.8	—	15.8	15.8	—
No. Blades...Diameter — mm	6...762	6...762	—	6...762	6...762	—	6...762	6...762	—	6...762	6...762	—
No. Fans...Total kW	10...15.9	6...9.4	16...25.3	10...15.9	6...9.4	16...25.3	10...15.9	8...12.7	18...28.6	10...15.9	8...12.7	18...28.6
Total Airflow — L/s	47 190	26 898	74 088	47 190	26 898	74 088	47 190	35 864	83 054	47 190	35 864	83 054
High Static												
Fan Speed — r/s	24	24	—	24	24	—	24	24	—	24	24	—
No. Blades...Diameter — mm	12...762	12...762	—	12...762	12...762	—	12...762	12...762	—	12...762	12...762	—
No. Fans...Total kW	10...37.0	6...22.2	16...59.2	10...37.0	6...22.2	16...59.2	10...37.0	8...29.6	18...66.6	10...37.0	8...29.6	18...66.6
Total Airflow — L/st	47 190	28 315	75 505	47 190	28 315	75 505	47 190	37 750	84 940	47 190	37 750	84 940
CONDENSER COILS — Type												
Tubes (Copper), OD — mm	9.53	9.53	—	9.53	9.53	—	9.53	9.53	—	9.53	9.53	—
No. Rows — Ckt A or B	3	3	—	3	3	—	3	3	—	3	3	—
Face Area sq m — Ckt A and B Total	20.92	11.92	32.84	20.92	11.92	32.84	20.92	15.61	36.53	20.92	15.61	36.53
Max Working Pressure Refrigerant — kPa	3103	3103	—	3103	3103	—	3103	3103	—	3103	3103	—
COOLER — No. ...Type												
Weight (empty) — kg	600	338	938	600	338	938	600	391	991	741	391	1132
No. Refrigerant Circuits	2	2	4	2	2	4	2	2	4	2	2	4
Net Fluid Volume — L (Includes nozzles)	197.0	92.9	289.9	197.0	92.9	289.9	197.0	114.6	311.6	229	114.6	343.6
Max Working Pressure Refrigerant Side/Fluid Side — kPa	1916/2068	1916/2068	—/—	1916/2068	1916/2068	—/—	1916/2068	1916/2068	—/—	1916/2068	1916/2068	—/—
FLUID CONNECTIONS — In.												
Inlet and Outlet	6	4	—	6	4	—	6	4	—	6	4	—
Drain (NPT)	3/4	3/4	—	3/4	3/4	—	3/4	3/4	—	3/4	3/4	—

LEGEND

- C-AL — Copper Tubing — Aluminum Fins Condenser Coil
- C-C — Copper Tubing — Copper Fins Condenser Coil
- Ckt — Circuit
- ESP — External Static Pressure
- OD — Outside Diameter

\*06E250 compressors have 4 cylinders; all others have 6.  
 †Based on rated ESP of 100 Pa or 250 Pa as appropriate.

NOTE: When facing the compressors, Circuit A is on the right and Circuit B is on the left.

**Table 3B — Physical Data — 50 Hz, SI (cont)**

SYSTEM MODULES	290			315			330			360		
	A	B	Total	A	B	Total	A	B	Total	A	B	Total
<b>APPROX OPERATING WEIGHT — kg</b>												
C-AL	5866	4018	9 884	6156	4018	10 174	5201	5201	10 402	5866	5201	11 067
C-C	6556	4450	11 006	6847	4450	11 297	5779	5779	11 558	6556	5779	12 335
<b>REFRIGERANT CHARGE — kg</b>												
R-22 Ckt A Total/Over	80.9/13.6	44.5/9.1	—/—	86.4/18.2	44.5/9.1	—/—	69.5/20.5	69.5/20.5	—/—	80.9/13.6	69.5/20.5	—/—
Ckt B Clear Glass	78.6/13.6	47.7/9.1	—/—	84.1/18.2	47.7/9.1	—/—	73.6/20.5	73.6/20.5	—/—	78.6/13.6	73.6/20.5	—/—
<b>COMPRESSORS, Type...r/s</b>												
06E* (Qty) Ckt A	(3) 299	(2) 299	—	(2) 265, (2) 299	(2) 299	—	Reciprocating, Semi-Hermetic, 24.2	(2) 265, (1) 299	—	(3) 299	(2) 275, (1) 299	—
(Qty) Ckt B	(3) 299	(2) 299	—	(3) 299	(2) 299	—	(1) 275, (2) 299	(1) 275, (2) 299	—	(3) 299	(1) 275, (2) 299	—
Oil Charge — Compressor/L	299/9.0	299/9.0	—	265/9.0, 299/9.0	299/9.0	—	275/9.0, 299/9.0	275/9.0, 299/9.0	—	299/9.0	275/9.0, 299/9.0	—
Capacity Control Steps	6	8	—	7	8	—	8	12	—	6	12	—
% Cap. Ckt A	50	50	—	52	50	—	50	48	—	50	48	—
Ckt B	50	50	—	48	50	—	52	52	—	50	52	—
Minimum Step Capacity (%)	17	17	—	10	17	—	17	10	—	17	10	—
<b>CONDENSER FANS — Type</b>												
Standard/Low Noise	Propeller, Direct Drive	Propeller, Direct Drive	Propeller, Direct Drive	Propeller, Direct Drive	Propeller, Direct Drive	Propeller, Direct Drive	Propeller, Direct Drive	Propeller, Direct Drive	Propeller, Direct Drive	Propeller, Direct Drive	Propeller, Direct Drive	Propeller, Direct Drive
Fan Speed — r/s	15.8	15.8	—	15.8	15.8	—	15.8	15.8	—	15.8	15.8	—
No. Blades, Diameter — mm	6, 762	6, 762	—	6, 762	6, 762	—	6, 762	6, 762	—	6, 762	6, 762	—
No. Fans, Total kW	12, 19.1	8, 12.7	20, 31.8	12, 19.1	8, 12.7	20, 31.8	10, 15.9	10, 15.9	20, 31.8	12, 19.1	10, 15.9	22, 35
Total Airflow — L/s	56 630	35 864	92 494	56 630	35 864	92 494	47 190	47 190	94 380	56 630	47 190	103 820
High Static	24	24	—	24	24	—	24	24	—	24	24	—
Fan Speed — r/s	12, 762	12, 762	20, 74.0	12, 762	12, 762	20, 74.0	12, 762	12, 762	20, 74.0	12, 762	12, 762	—
No. Fans, Total kW	12, 44.4	8, 29.6	94 380	12, 44.4	8, 29.6	94 380	10, 37.0	10, 37.0	20, 74.0	12, 44.4	10, 37.0	22, 81.4
Total Airflow — L/s†	56 630	37 750	94 380	56 630	37 750	94 380	47 190	47 190	94 380	56 630	47 190	103 820
<b>CONDENSER COILS — Type</b>												
Tubes (Copper), OD — mm	9.53	9.53	—	9.53	9.53	—	9.53	9.53	—	9.53	9.53	—
No. Rows — Ckt A or B	3	3	—	3	3	—	3	3	—	3	3	—
Face Area sq m — Ckt A and B Total	24.98	15.61	40.59	24.98	15.61	40.59	20.92	20.92	41.84	24.98	20.92	45.9
Max Working Pressure Refrigerant — kPa	3103	3103	—	3103	3103	—	3103	3103	—	3103	3103	—
<b>COOLER — No. ...Type</b>												
Weight (empty) — kg	741	391	1132	848	391	1239	741	741	1482	741	741	1482
No. Refrigerant Circuits	2	2	4	2	2	4	2	2	4	2	2	4
Net Fluid Volume — L (includes nozzles)	229.0	114.6	343.6	267.0	114.6	381.6	229	229	458	229	229	458
Max Working Pressure Refrigerant Side/Fluid Side — kPa	1916/2068	1916/2068	—/—	1916/2068	1916/2068	—/—	1916/2068	1916/2068	—/—	1916/2068	1916/2068	—/—
<b>FLUID CONNECTIONS — in.</b>												
Inlet and Outlet	6	5	—	6	5	—	6	6	—	6	6	—
Drain (NPT)	3/4	3/4	—	3/4	3/4	—	3/4	3/4	—	3/4	3/4	—

**LEGEND**

- C-AL — Copper Tubing — Aluminum Fins Condenser Coil
  - C-C — Copper Tubing — Copper Fins Condenser Coil
  - Ckt — Circuit
  - ESP — External Static Pressure
  - OD — Outside Diameter
- \*06E250 compressors have 4 cylinders; all others have 6.  
 †Based on rated ESP of 100 Pa or 250 Pa as appropriate.

NOTE: When facing the compressors, Circuit A is on the right and Circuit B is on the left.

**Table 3B — Physical Data — 50 Hz, SI (cont)**

SYSTEM MODULES	390			420			Total
	A	B	Total	A	B	Total	
<b>APPROX OPERATING WEIGHT — kg</b>							
C-AL	6156	5866	12 022	6156	6156	12 312	12 312
C-C	6847	6556	13 403	6847	6847	13 694	13 694
<b>REFRIGERANT CHARGE — kg</b>							
R-22	86.4/18.2	80.9/13.6	—/—	86.4/18.2	86.4/18.2	—/—	—/—
Ckt A Total/Over	84.1/18.2	78.6/13.6	—/—	84.1/18.2	84.1/18.2	—/—	—/—
Ckt B Clear Glass							
<b>COMPRESSORS, Type...r/s</b>							
06E*	(2) 265 (2) 299	(3) 299	Reciprocating, Semi-Hermetic, 24.2	(2) 265 (2) 299	(2) 265 (2) 299	—	—
(Qty) Ckt A	(3) 299	(3) 299		(3) 299	(3) 299	—	—
(Qty) Ckt B	265/9.0, 299/9.0	299/9.0		265/9.0, 299/9.0	265/9.0, 299/9.0	—	—
<b>Oil Charge — Compressor/L</b>							
Capacity Control Steps	7	6	—	7	7	—	—
% Cap.	52	50	—	52	52	—	—
Ckt A	48	50	—	48	48	—	—
Ckt B	10	17	—	10	10	—	—
Minimum Step Capacity (%)							
<b>CONDENSER FANS — Type</b>							
Standard/Low Noise	Propeller, Direct Drive	Propeller, Direct Drive		Propeller, Direct Drive	Propeller, Direct Drive		
Fan Speed — r/s	15.8	15.8	—	15.8	15.8	—	—
No. Blades...Diameter — mm	6...762	6...762	—	6...762	6...762	—	—
No. Fans...Total kW	12...19.1	12...19.1	24...38.2	12...19.1	12...19.1	24...38.2	24...38.2
Total Airflow — L/s	56 630	56 630	113 260	56 630	56 630	113 260	113 260
High Static							
Fan Speed — r/s	24	24	—	24	24	—	—
No. Blades...Diameter — mm	12...762	12...762	—	12...762	12...762	—	—
No. Fans...Total kW	12...44.4	12...44.4	24...88.8	12...44.4	12...44.4	24...88.8	24...88.8
Total Airflow — L/s†	56 630	56 630	113 260	56 630	56 630	113 260	113 260
<b>CONDENSER COILS — Type</b>							
Tubes (Copper), OD — mm	9.53	9.53	—	9.53	9.53	—	—
No. Rows — Ckt A or B	3	3	—	3	3	—	—
Face Area sq m — Ckt A and B Total	24.98	24.98	49.96	24.98	24.98	49.96	49.96
Max Working Pressure Refrigerant — kPa	3103	3103	—	3103	3103	—	—
<b>COOLER — No. ...Type</b>							
Weight (empty) — kg	848	741	1589	848	848	1696	1696
No. Refrigerant Circuits	2	2	4	2	2	4	4
Net Fluid Volume — L (includes nozzles)	267	229	496	267	267	534	534
Max Working Pressure Refrigerant Side/Fluid Side — kPa	1916/2068	1916/2068	—/—	1916/2068	1916/2068	—/—	—/—
<b>FLUID CONNECTIONS — in.</b>							
Inlet and Outlet	6	6	—	6	6	—	—
Drain (NPT)	3/4	3/4	—	3/4	3/4	—	—

**LEGEND**

- C-AL — Copper Tubing — Aluminum Fins Condenser Coil
- C-C — Copper Tubing — Copper Fins Condenser Coil
- Ckt — Circuit
- ESP — External Static Pressure
- OD — Outside Diameter

\*06E250 compressors have 4 cylinders; all others have 6.

†Based on ESP of 100 Pa or 250 Pa as appropriate.

NOTE: When facing the compressors, Circuit A is on the right and Circuit B is on the left.

Locate the unit so that the condenser airflow is unrestricted both above and on the sides of the unit. See Fig. 1-5 for required clearances. The unit may be mounted on a level pad directly on the base rails or on a raised perimeter rail around the unit. If unit is mounted on a raised perimeter rail, fasten the unit to the rail using the mounting holes provided.

NOTE: Once the unit is in place, check to be sure unit is level so that oil will equalize properly.

**IMPORTANT:** When placing unit modules for unit sizes 330-420, either end of module A can be placed next to either end of module B. When placing unit modules for unit sizes 230-315, make sure modules are placed to permit access to the control box located in module B.

**Step 2 — Join Modules A and B (230-420 Units Only)** — If accessory trim kit has been purchased to join the modules together, install it now. Refer to accessory installation instructions for installation details.

**Step 3 — Check Compressor Mounting** — Compressors are mounted on rails. Each rail is mounted on springs (one at each end, and one between each compressor) when applicable. For shipping, the rails are secured to the frame base at each support. Before start-up, loosen the hold-down bolts so that the compressor rails float freely. See Fig. 9 and 10 for views of compressor mounting.

**Step 4 — Cooler Fluid and Drain Piping Connections** — When facing cooler side of unit, inlet (return) fluid connection is on the right. It is recommended that a screen strainer with a minimum size of 20 mesh be installed ahead of the cooler inlet to prevent debris from damaging internal tubes of cooler. Outlet (supply) fluid connection is on the left. The cooler has fluid-side Victaulic-type connections (follow connection directions as provided by the coupling manufacturer). If compressor and cooler grilles have been added, holes must be cut in grilles for field piping and insulation.

NOTE: For 130-210 and associated modular units (see Table 1), be sure that cooler piping does not interfere with the electrical connections.

Although cooler has an air vent, it is recommended that field-supplied air vents be installed in system to facilitate servicing. Field-supplied shut-off valves should also be installed to facilitate servicing and flow balancing. Locate valves in return and supply cooler fluid lines as close to the chiller as possible. Locate air vents at highest point of the cooler fluid system.

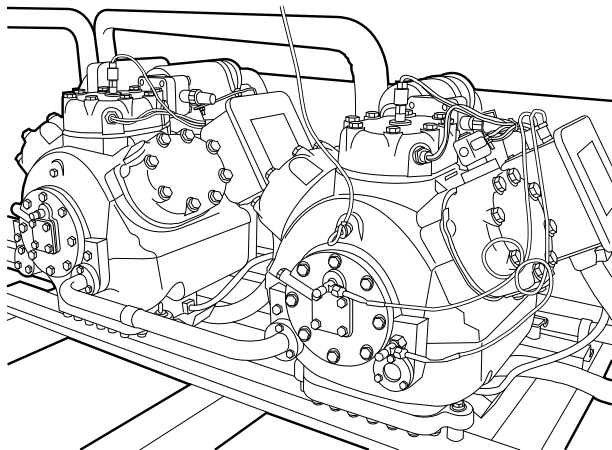

**Fig. 9 — Compressor Mounting View**

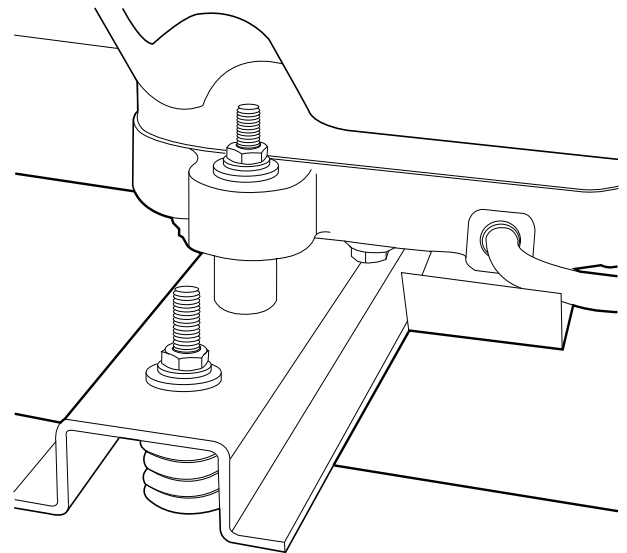

**Fig. 10 — Compressor Mounting Bolts**

**IMPORTANT:** Before starting unit, be sure all of the air has been purged from the system.

Upon completion of the field piping installation, in areas where the piping is exposed to 32 F (0° C) or lower ambient temperatures, freeze-up protection is recommended using inhibited ethylene glycol or other suitable corrosion-inhibited anti-freeze solution and electric heater tapes. Heater tapes should have a rating for area ambient temperatures and should be covered with a suitable thickness of closed-cell insulation. Route power for the heater tapes from a separate fused disconnect. Mount the disconnect within sight from the unit per NEC or local codes. Label disconnect as heater tape power source with warning that power must not be turned off except when servicing the unit.

A drain connection is located at leaving fluid (supply) end of cooler. See Fig. 1-4 for connection location.

**PREPARATION FOR YEAR-ROUND OPERATION** — If unit is to operate all year, add sufficient inhibited ethylene glycol or other suitable corrosion-inhibited anti-freeze solution to the cooler fluid to prevent freeze-up under cold operating conditions. Consult local water authority on characteristics of area water and a recommended inhibitor for the cooler fluid loop.

**PREPARATION FOR WINTER SHUTDOWN** — *Do not shut off control power disconnect during off-season shutdown.*

At end of cooling season:

1. If unit has optional heater tapes on cooler, remove fuse no. 1.

**⚠ CAUTION**

Failure to remove fuse no. 1 before draining heater-equipped coolers can result in heater tape and insulation damage.

2. Drain the fluid from the system.
3. Replace the drain plug and add 2 gallons (8 liters) (080-110 and associated modular units), 3 gallons (11.4 liters) (130-190 and associated modular units), or 4 gallons (15.1 liters) (210 and associated modular units) of inhibited ethylene glycol or other suitable corrosion corrosion-inhibited anti-freeze solution to the cooler to prevent freezing of any remaining water in system. Anti-freeze can be added through the vent on top of cooler.

4. Open one of the thermistor connections to allow air to escape the vessel and the anti-freeze to enter.
5. At the beginning of the next cooling season, refill cooler, add recommended inhibitor, and replace FU1 (if removed).

**Step 5 — Make Electrical Connections** — The electrical characteristics of the available power supply must agree with the unit nameplate rating. Supply voltage must be within the limits shown. The control box is divided into field power side on the right, and control power supply on the left (when facing control box) on 080-110 and associated modular units. (See Table 1.) On 130-210 and associated modular units (see Table 1), the power box is located on the cooler side of the unit, and the control box is located on the compressor side.

**FIELD POWER CONNECTIONS** (See Fig. 11-15) — All power wiring must comply with applicable local and national codes. Install field-supplied, branch circuit fused disconnect(s) of a type that can be locked off or open. Disconnect(s) must be located within sight from and readily accessible from unit in compliance with NEC Article 440-14. See Tables 4A-7 for unit electrical data.

**IMPORTANT:** The 30GT080-420 units have a factory-installed option for a non-fused disconnect for power and control entry. If the unit is equipped with this option, all field wiring should be to the non-fused disconnect rather than the terminal blocks.

**30GT080-110 and 230B-315B Units** — All field power enters the unit through the control box at the left end when facing the compressors. An access hole is under the control box. All units have a single location for power connection to simplify the field power wiring. Maximum wire size that the unit terminal block will accept is 500 kcmil. Unit may use copper, copper-clad aluminum, or aluminum conductors at all voltages, except 30GT110, 290B, and 315B 346-3-50 units and 30GT110, 290B, and 315B 380/415-3-50 part wind units. These units require copper conductors.

For 208/230-3-60 units, larger than 500 kcmil conductors are required. Power must be supplied by 6 parallel conductors for these units.

LEGEND AND NOTES FOR WIRING DIAGRAMS (FIG. 11-15)

LEGEND

<b>EQUIP</b> —	Equipment
<b>GND</b> —	Ground
<b>TB</b> —	Terminal Block
<b>KCMIL</b> —	Thousand Circular Mills
<b>NEC</b> —	National Electrical Code (U.S.A.)
—	Field Power Wiring
—	Factory Installed Wiring

NOTES:

1. Factory wiring is in accordance with NEC. Field modifications or additions must be in compliance with all applicable codes.
2. Wiring for main field power supply must be rated 75° C minimum. Use copper, copper-clad aluminum, or aluminum conductors for all units, except use copper conductors only for the following units: 30GT110, 290B, and 315B 346-v; 30GT110, 290B, and 315B 380/415-v part-wind start; 30GT210, 315A, 390A, 420A/B 208/230-volts.
3. Dimensions in [ ] are millimeters.

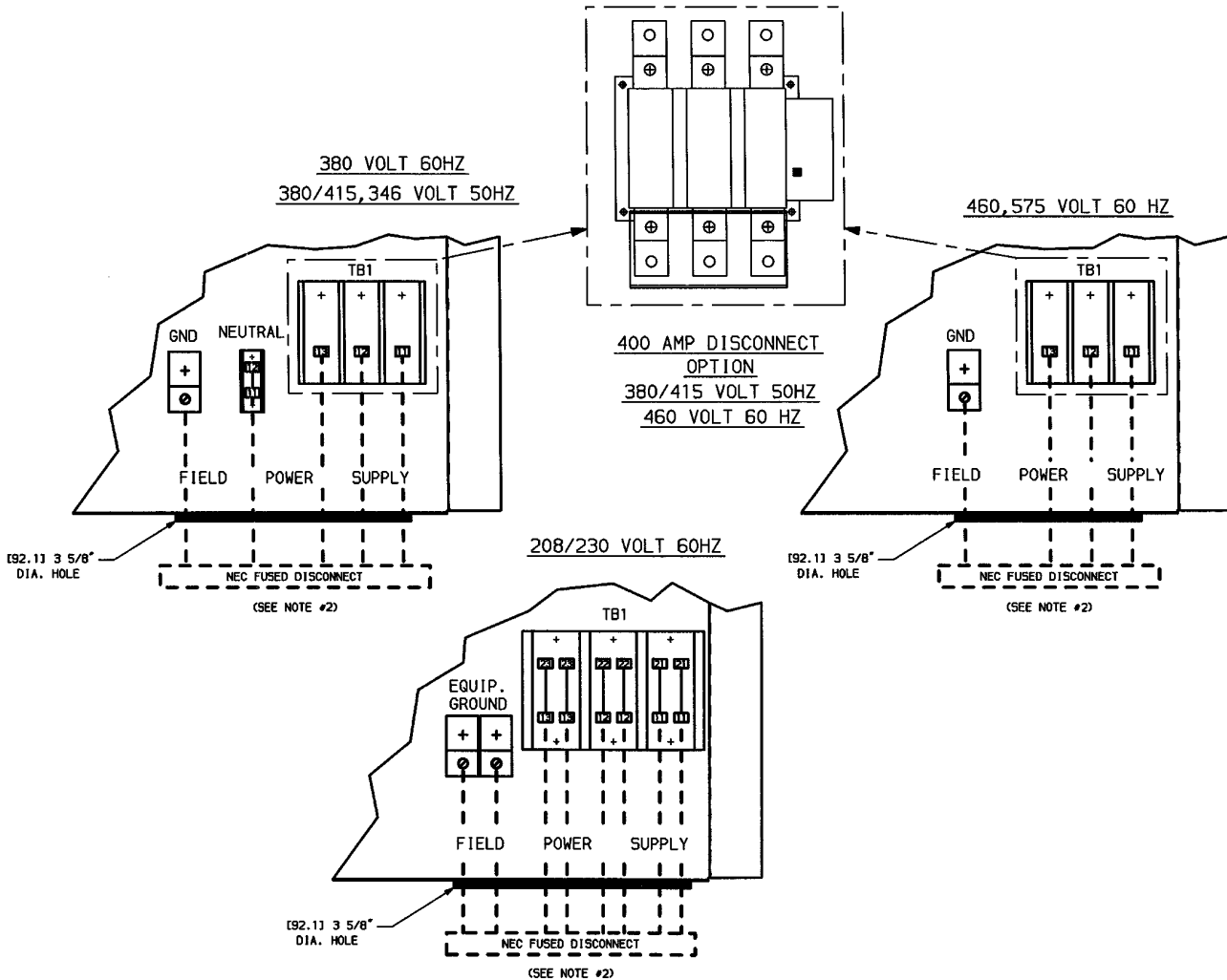

Fig. 11 — Field Power Wiring; Unit Sizes 080-110

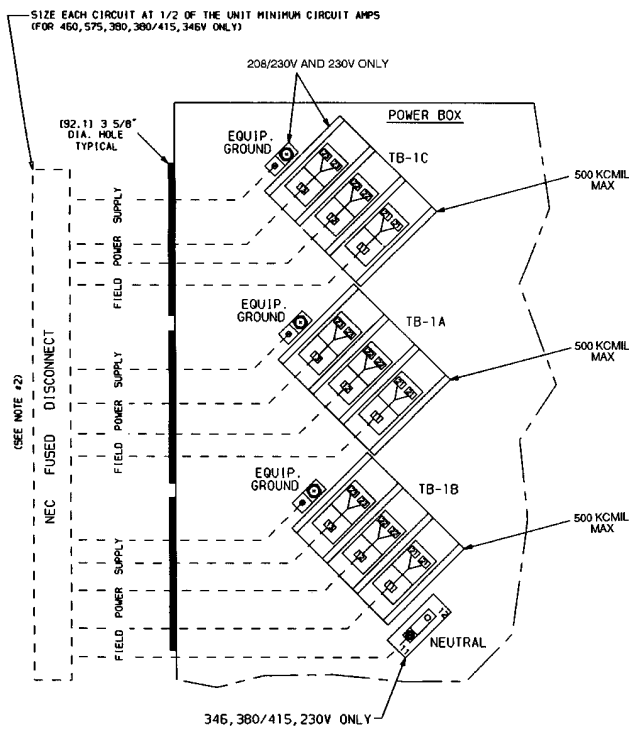

Fig. 12 — Field Power Wiring; Unit Sizes 130-210

30GT130-210, 230A-315A, and 330-420 Units — The field power wiring enters the unit through the left side of the cooler side power box. The control power enters the control box on the compressor side of the unit.

NOTE: If optional non-fused disconnect is installed, power wiring must enter through center panel of unit (disconnect location).

**IMPORTANT:** Do not obstruct the field cooler connections when installing field power into the power box. Use 90-degree liquid-tight conduit fittings to connect field power to the unit and avoid the cooler piping area.

All units have a single location for power connection (one per module on 230-420 units) to simplify field power wiring. The maximum acceptable wire size for the terminal block is 500 kcmil. Copper, copper-clad aluminum, or aluminum conductors are acceptable for all units except 30GT210, 315A, 390A, and 420A/B 208/230-3-60 units. These units require copper conductors. For 208/230-3-60 and 230-3-50 units, 9 parallel conductors are required. All other voltages require 6 parallel conductors.

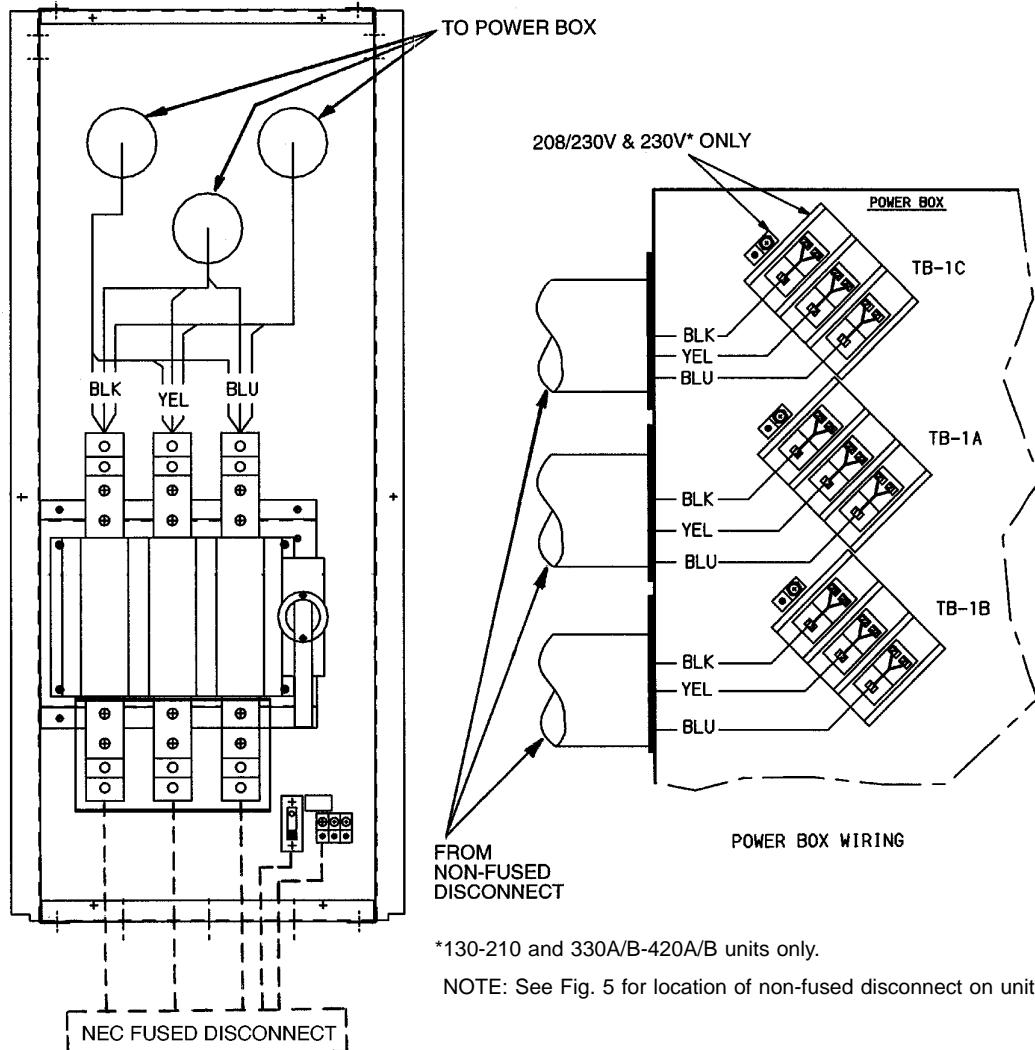
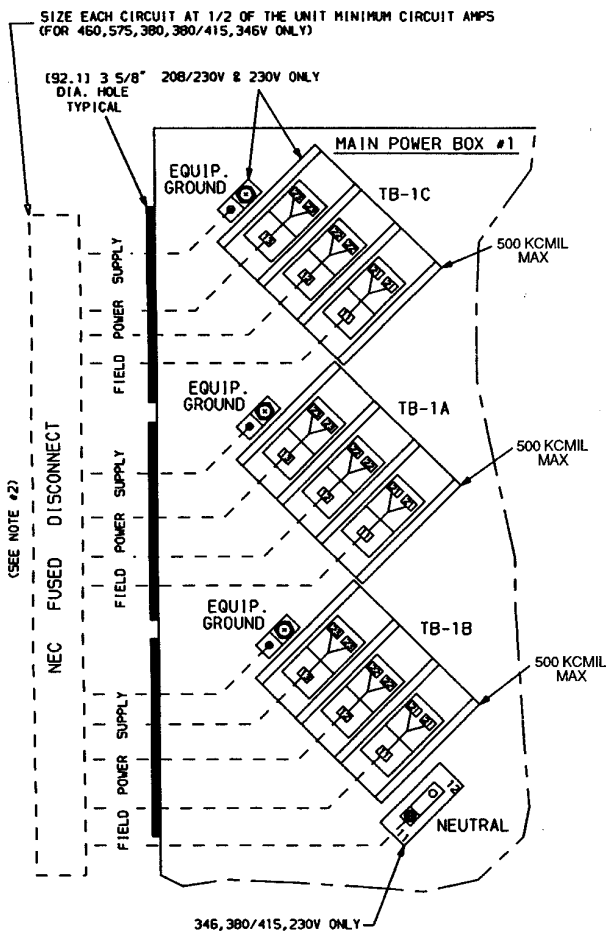

Fig. 13 — Field Power Wiring; Unit Sizes 130-210, 230A-315A, 330A/B-420A/B with Non-Fused Disconnect Option



NOTE: The 230-v unit is only available in 330 and larger sizes.

**Fig. 14 — Field Power Wiring; Unit Sizes 230A-315A, 330A/B-420A/B**

**FIELD CONTROL POWER CONNECTIONS** (See Fig. 16 and 17) — *For 208/230-, 460- and 575-3-60 units:* If the accessory transformer is not used, provide a 115-1-60 power source for the control circuit, through a field-supplied fused disconnect (per NEC). This conductor *must be copper only*. Control power enters the control box through a 7/8-in. (22.2-mm) conduit connection located on the right side of the control section.

*For 30GT080-110 and 230B-315B units with 380-3-60 or 380/415-3-50 power:* Control circuit voltage is taken from the line voltage, therefore, no additional power supply is required. If a separate power source is required, follow these instructions and disconnect the wires between the control and power terminal blocks.

*For 30GT080-110 and 230B-315B Units with 230-3-50 or 346-3-50 power:* A separate 230-1-50 control power source is required. Provide a 230-1-50 power source for the control circuit through a field-supplied fused disconnect (per NEC or local code). This conductor *must be copper only*. Control power enters the control box through a 7/8-in. (22 mm) conduit connection located on the right side of the control section.

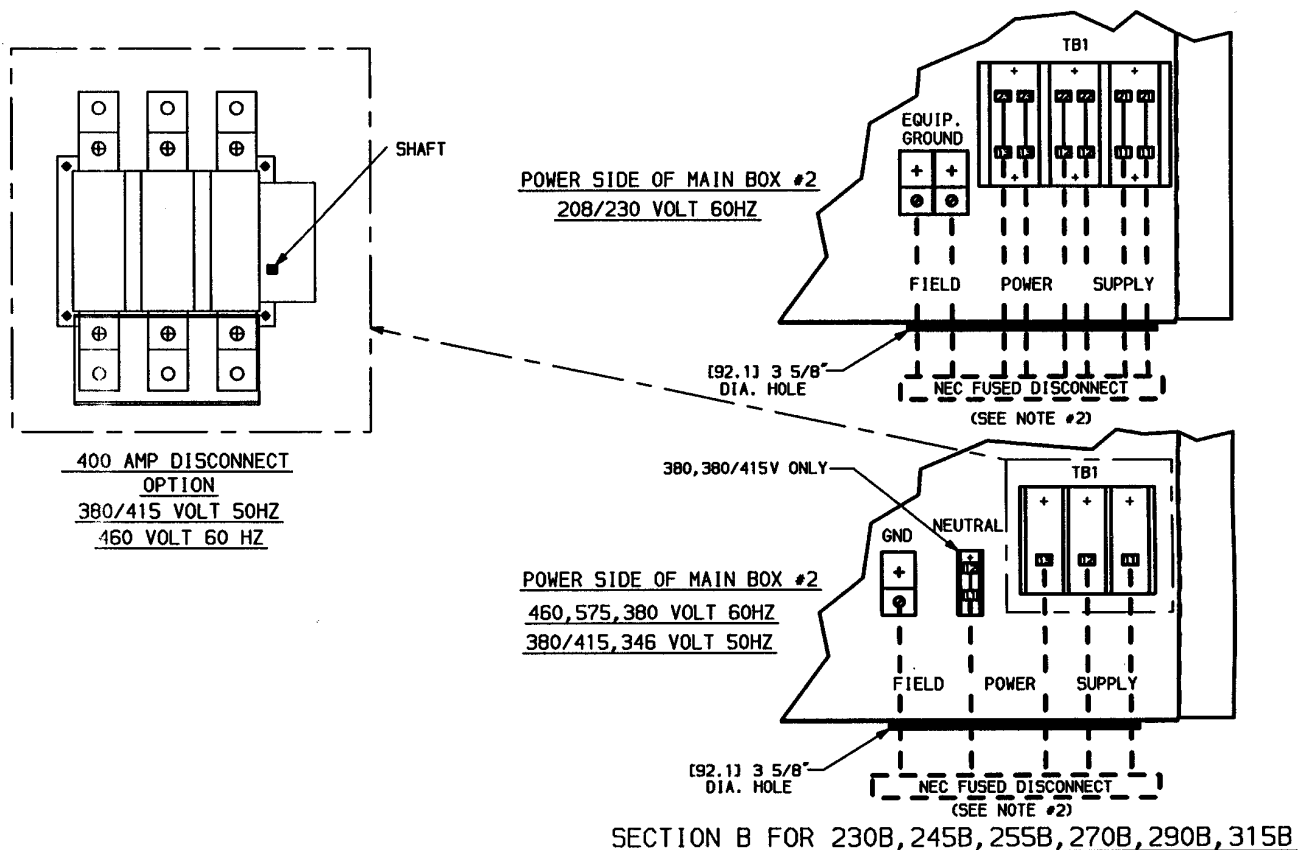

**Fig. 15 — Field Power Wiring; Unit Sizes 230B-315B**

For 30GT130-210, 230A-315A, and 330A/B-420A/B units with 380-3-60 and 380/415-3-50 power: Control voltage is tapped from line to neutral. No additional power supply is required. If a separate power source is required, follow these instructions and disconnect the wires between the control and power terminal blocks.

Units with a power supply of 380-3-60 have 230-1-60 control circuit power, which is taken from the unit's power supply voltage. Units with a power supply of 380/415-3-50 have 230-1-50 control circuit power, which is also taken from the unit's power supply voltage. For control circuit current draw, see Table 5.

For 30GT130-210, 230A-315A, and 330A/B-420A/B Units with 230-3-50 or 346-3-50 power: A separate 230-1-50 control power source is required. Provide a 230-1-50 power source for the control circuit through a field-supplied fused disconnect (per NEC or local code). This conductor *must be copper only*. Control power enters the control box through a 7/8-in. (22 mm) conduit connection located on the right side of the control section.

All Units: Control circuit power draw includes the compressor crankcase heaters at 180 w each, the 8 cooler heaters (if equipped) at 210 w each, and the electronic board heater at 120 w.

**CAUTION**

Crankcase heaters, cooler heaters, and board heater are all wired into the control circuit ahead of the control circuit switch. Therefore, they are always active even if the control circuit switch is off.

An interlock circuit for external safeties, such as the chilled fluid flow switch (CWFS), remote on-off, and chilled fluid

pump interlock (CWPI) is provided between terminals TB6-3 and TB6-4 for field use. To use this circuit, remove the factory jumper and install the switches.

LEGEND AND NOTES FOR WIRING DIAGRAMS (Fig. 16 and 17)

LEGEND

- A — Alarm
- CWFS — Chilled Water (Fluid) Flow Switch
- CWPI — Chilled Water (Fluid) Pump Interlock
- EQUIP — Equipment
- NEC — National Electrical Code
- O.A. — Outdoor Air
- TB — Terminal Block
- Field Power Wiring
- - - - - Field Control Wiring
- Factory Installed Wiring

NOTES:

1. Factory wiring is in accordance with NEC (U.S.A.). Field modifications or additions must be in compliance with all applicable codes.
2. Wiring for main field power supply must be rated 75° C minimum. Use copper, copper-clad aluminum, or aluminum conductors for all units, except use copper conductors only for the following units: 30GT110, 290B, 315B 346-v; 30GT110, 290B, 315B 380/415-v part-wind start; 30GT210, 315A, 390A, 420A/B 208/230-volts.
3. Power for control circuit should be supplied from a separate source through a field-supplied fused disconnect. See Table 5 for required amp value for disconnect. Connect control circuit power to terminals 1 and 2 of TB4. Connect neutral side of supply to terminal 2 of TB4. Control circuit conductors for all units must be copper only.
4. Terminals 3 and 4 of TB6 are for field connection for remote ON-OFF control, CWPI, and CWFS. The contacts must be rated for dry circuit application capable of reliably switching a 5 vdc, 0.5 mA load. Remove jumper between 3 and 4 of TB6 if remote ON-OFF is installed.
5. The maximum load allowed for the remote alarm circuit is 75 va sealed, 360 va inrush at 115-v or 230-v, depending on model. Remove resistor across terminals TB5-1 and TB5-2 (080-110 and 230B-315B units) when using remote alarm.
6. Dimensions in [ ] are millimeters.

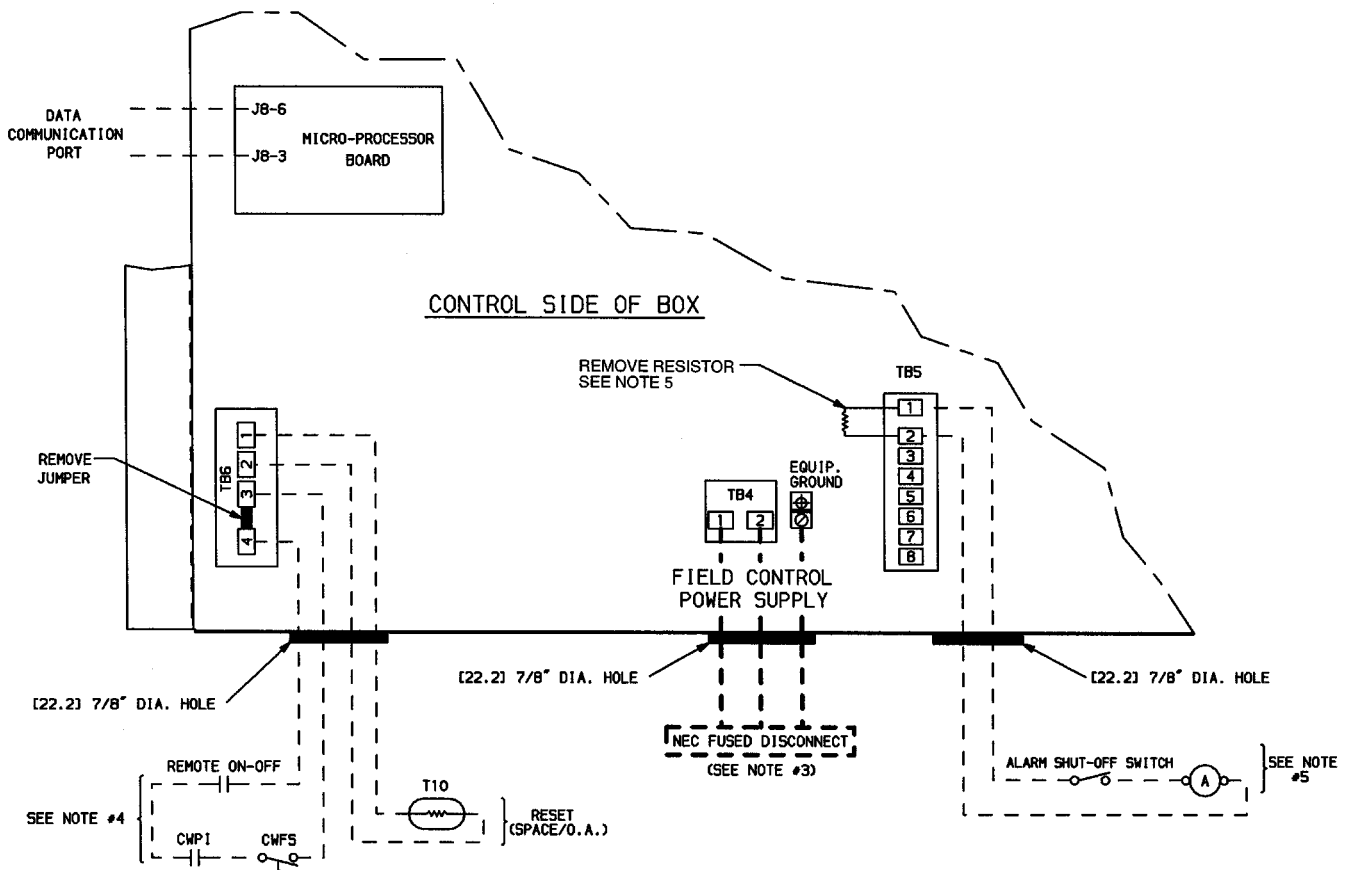

Fig. 16 — Field Control Power Wiring; Unit Sizes 080-110, 230B-315B

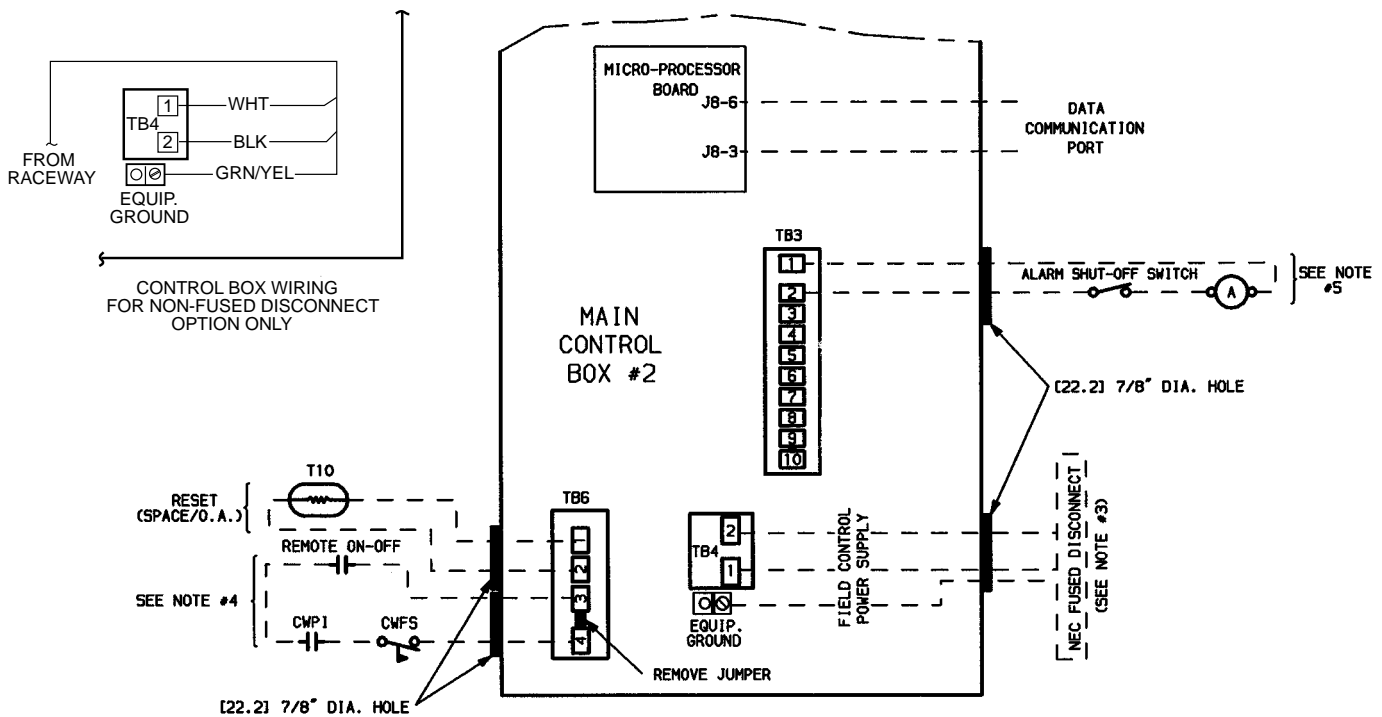

Fig. 17 — Field Control Power Wiring; Unit Sizes 130-210, 230A-315A, 330A/B-420A/B

Table 4A — Unit Electrical Data, 30GT080-110

30GT UNIT SIZE	VOLTAGE			STANDARD CONDENSER FAN						HIGH-STATIC CONDENSER FAN					
	Nameplate V-Hz (3 Phase)	Supplied*		MCA	MOCP	Rec Fuse Size		ICF		MCA	MOCP	Rec Fuse Size		ICF	
		Min	Max			XL	PW	XL	PW			XL	PW	XL	PW
080	208/230-60	187	253	398.5	500	450	450	896.9	620.9	446.5	500	500	500	951.9	675.9
	460-60	414	506	185.8†	250	200	225	442.8	305.4	204.7	250	225	225	464.2	326.8
	575-60	518	633	160.9	200	200	175	365.6	246.9	171.8	225	200	200	376.4	257.7
	380-60	342	418	209.9	250	250	250	492.6	339.5	230.9	300	250	300	513.6	360.5
	346-50	325	380	250.1	300	275	275	532.8	379.8	276.0	350	250	300	558.6	405.6
	380/415-50	342	440	218.5†	250	250	250	472.0	292.9	234.6	250	300	300	497.8	257.7
090	208/230-60	187	253	397.4	450	450	450	722.3	547.9	447.0	500	500	500	780.9	602.9
	460-60	414	506	198.0†	225	225	225	361.2	273.5	217.0	250	225	250	382.6	294.9
	575-60	518	633	168.0	200	200	175	286.2	213.2	178.6	200	200	200	297.0	230.4
	380-60	342	418	205.9	250	225	225	396.0	294.5	226.9	250	250	250	417.0	315.5
	346-50	325	380	269.3	300	275	275	552.0	399.0	295.2	350	300	300	577.8	424.8
	380/415-50	342	440	244.1†	300	250	250	497.0	363.5	267.2	300	300	300	522.8	389.3
100	208/230-60	187	253	470.1	500	500	500	835.2	633.2	535.6	600	600	600	908.6	706.6
	460-60	414	506	224.8†	250	250	250	408.8	312.3	242.9	250	300	300	437.4	336.4
	575-60	518	633	191.1	225	225	200	289.4	233.1	205.5	225	225	200	331.0	261.0
	380-60	342	418	242.1	250	300	300	454.8	342.8	268.6	300	300	300	482.8	370.8
	346-50	325	380	303.8	350	350	350	586.5	433.5	366.3	400	350	350	648.9	495.9
	380/415-50	342	440	270.2†	300	300	300	521.6	388.7	292.8	350	350	350	556.0	418.0
110	208/230-60	187	253	521.4	600	600	600	1019.2	743.2	587.2	700	600	700	1092.6	816.6
	460-60	414	506	248.9†	300	250	300	500.8	367.3	273.8	300	300	300	529.4	395.9
	575-60	518	633	212.0	250	225	200	416.6	292.1	208.8	250	200	225	394.6	306.5
	380-60	342	418	274.1	350	300	300	556.8	403.8	302.2	350	300	350	585.2	431.8
	346-50	325	380	373.0	450	400	400	655.7	502.7	407.5	450	350	400	690.1	537.1
	380/415-50	342	440	316.4†	350	350	350	565.2	434.7	344.9	400	350	400	599.6	467.6

NOTE: See legend and notes on page 33.

**Table 4B — Unit Electrical Data, 30GT130-210**

30GT UNIT SIZE	VOLTAGE			STANDARD CONDENSER FAN						HIGH STATIC CONDENSER FAN					
	Nameplate V-Hz (3 Phase)	Supplied*		MCA	MOCP	Rec Fuse Size		ICF		MCA	MOCP	Rec Fuse Size		ICF	
		Min	Max			XL	PW	XL	PW			XL	PW		
130	208/230-60	187	253	610.2	700	700	700	1111.1	835.1	701.8	800	800	800	1202.7	926.7
	460-60	414	506	271.8†	300	300	300	534.1	397.0	303.8	350	350	350	567.0	429.0
	575-60	518	633	245.9	300	300	300	350.5	318.5	263.9	300	300	300	368.5	336.5
	380-60	342	418	331.1	400	400	400	612.8	460.8	366.1	400	400	400	647.8	495.8
	230-50	207	253	559.1	600	600	600	969.5	751.5	617.1	700	700	700	1027.5	809.5
	346-50	325	380	382.9	450	400	400	682.6	522.6	425.9	500	450	450	725.6	565.6
380/415-50	342	440	338.6†	350	350	350	583.0	463.7	377.6†	400	400	400	622.0	502.7	
150	208/230-60	187	253	664.2	800	800	800	1165.1	889.1	755.8	800	800	800	1256.7	980.7
	460-60	414	506	312.9	350	350	350	576.1	438.1	334.9	400	400	400	608.1	470.1
	575-60	518	633	272.3	300	300	300	440.9	344.9	290.3	350	350	350	458.9	362.9
	380-60	342	418	359.9	400	400	400	641.6	489.6	394.9	450	450	450	676.6	524.6
	230-50	207	253	629.4	700	700	700	1039.8	821.8	629.4	700	800	800	1039.8	879.8
	346-50	325	380	465.1	500	450	450	764.8	604.8	508.1	600	500	500	807.8	647.8
380/415-50	342	440	377.9	400	400	400	641.0	503.0	416.9	450	450	450	680.0	542.0	
170	208/230-60	187	253	727.5	800	800	800	1098.9	896.9	819.1	1000	1000	1000	1190.5	988.5
	460-60	414	506	323.6	350	350	350	518.0	417.0	355.5	400	400	400	550.0	449.0
	575-60	518	633	294.6	300	350	350	418.5	348.5	312.6	350	350	350	436.5	366.5
	380-60	342	418	387.8	400	450	450	598.0	486.0	422.8	450	450	450	633.0	521.0
	230-50	207	253	677.7	700	800	800	1088.1	870.1	735.7	800	800	800	1146.1	928.1
	346-50	325	380	472.1	500	500	500	771.8	611.8	515.1	600	600	600	814.8	654.8
380/415-50	342	440	387.3	450	450	450	650.4	512.4	426.3	450	450	450	689.4	551.4	
190	208/230-60	187	253	800.0	800	1000	1000	1301.5	1025.5	910.6	1000	1000	1000	1411.5	1135.5
	460-60	414	506	368.2	400	400	400	631.4	493.4	406.2	450	450	450	669.4	531.4
	575-60	518	633	325.9	350	350	350	494.5	398.5	347.5	400	400	400	516.1	420.1
	380-60	342	418	432.5	500	450	450	714.2	562.2	474.5	500	500	500	756.2	604.2
	230-50	207	253	749.9	800	800	800	1160.3	942.3	819.5	700	1000	1000	1229.9	1011.9
	346-50	325	380	554.1	600	600	600	853.8	693.8	605.7	1000	700	700	905.4	745.4
380/415-50	342	440	515.7	500	500	500	669.4	575.3	497.0	500	600	600	760.1	622.1	
210	208/230-60	187	253	890.4	1000	1000	1000	1391.3	1115.3	1000.0	1000	1200	1200	1501.3	1225.3
	460-60	414	506	413.1	450	450	450	676.3	538.3	451.1	500	500	500	714.3	576.3
	575-60	518	633	362.5	400	400	400	531.1	435.1	384.1	400	400	400	552.7	456.7
	380-60	342	418	479.3	500	500	500	761.0	609.0	521.3	600	600	600	803.0	651.0
	230-50	207	253	796.2	800	800	800	1206.6	988.3	865.8	1000	800	800	1276.2	1058.2
	346-50	325	380	567.5	600	600	600	867.2	707.2	619.1	700	700	700	918.8	758.8
380/415-50	342	440	474.5	500	500	500	737.6	599.6	521.3	600	600	600	784.4	646.4	

**LEGEND AND NOTES FOR TABLES 4A to 7**

- LEGEND**
- FLA** — Full Load Amps (Fan Motors)
  - ICF** — Maximum Instantaneous Current Flow during starting (the point in the starting sequence where the sum of the LRA for the starting compressor, plus the total RLA for all running compressors, plus the total FLA for all running fan motors is maximum)
  - kW** — Total condenser fan motor power input
  - LRA** — Locked Rotor Amps
  - MCA** — Minimum Circuit Amps (for wire sizing) — complies with NEC Section 430-24
  - MOCP** — Maximum Overcurrent Protective Device Amps
  - NEC** — National Electrical Code, U.S.A.
  - Rec Fuse Size** — Recommended dual-element fuse amps; 150% of largest compressor RLA plus 100% of sum of remaining compressor RLAs. Size up to the next larger standard fuse size.
  - PW** — Part Wind
  - RLA** — Rated Load Amps (Compressors)
  - XL** — Across-the-Line

4. Units have the following power wiring terminal blocks and parallel conductors:

30GT UNIT SIZE	VOLTAGE	TERMINAL BLOCKS	PARALLEL CONDUCTORS
080 to 110, 230B to 315B	208/230	1	6
	460	1	3
	575	1	3
	380	1	3
	346	1	3
	380/415	1	3
130 to 210, 230A to 315A, 330A/B to 420A/B	208/230	3	9
	460	2	6
	575	2	6
	380	2	6
	230**	3	9
	346	2	6
380/415	2	6	

\*Units are suitable for use on electrical systems where voltage supplied to the unit terminals is not below or above the listed minimum and maximum limits. Maximum allowable phase imbalance is: voltage, 2%; amps, 10%.  
 †Wherever XL and PW data differ, the higher value of the two is listed.  
 \*\*130-210 and 330A/B-420A/B units only.

**NOTES:**

1. All modules have single point primary power connection. (Each module requires its own power supply.) Main power must be supplied from a field-supplied disconnect.
2. The unit control circuit power (115 v, single-phase for 208/230-, 460-, and 575-v units; 230 v, single-phase for all other voltages) must be supplied from a separate source through a field-supplied disconnect. The control circuit transformer accessory may be applied to power from primary unit power.
3. Crankcase and cooler heaters are wired into the control circuit so they are always operable as long as the control circuit power supply disconnect is on, even if any safety device is open, and the unit ON/OFF switch is in the OFF position.

5. Maximum incoming wire size for each terminal block is 500 kcmil.
6. Power draw of control circuits includes both crankcase heaters and cooler heaters (where used). Each compressor has a crankcase heater which draws 180 w of power.

Units ordered with cooler heater option have 8 cooler heaters, 210 w each.



**Table 4C — Unit Electrical Data, 30GT230-420**

30GT UNIT SIZE	VOLTAGE			MODULE A											
				Standard Condenser Fan						High-Static Condenser Fan					
	Nameplate V-Hz (3 Phase)	Supplied*		MCA	MOCP	Rec Fuse Size		ICF		MCA	MOCP	Rec Fuse Size		ICF	
		Min	Max			XL	PW	XL	PW			XL	PW		
230	208/230-60	187	253	664.2	800	800	800	1165.1	889.1	755.8	800	800	800	1256.7	980.7
	460-60	414	506	312.9	350	350	350	576.1	438.1	334.9	400	400	400	608.1	470.1
	575-60	518	633	272.3	300	300	300	440.9	344.9	290.3	350	350	350	458.9	362.9
	380-60	342	418	359.9	400	400	400	641.6	489.6	394.9	450	450	450	676.6	524.6
	346-50	325	380	465.1	500	450	450	764.8	604.8	508.1	600	500	500	807.8	647.8
380/415-50	342	440	377.9	400	400	400	641.0	503.0	416.9	450	450	450	680.0	542.0	
245	208/230-60	187	253	664.2	800	800	800	1165.1	889.1	755.8	800	800	800	1256.7	980.7
	460-60	414	506	312.9	350	350	350	576.1	438.1	334.9	400	400	400	608.1	470.1
	575-60	518	633	272.3	300	300	300	440.9	344.9	290.3	350	350	350	458.9	362.9
	380-60	342	418	359.9	400	400	400	641.6	489.6	394.9	450	450	450	676.6	524.6
	346-50	325	380	465.1	500	450	450	764.8	604.8	508.1	600	500	500	807.8	647.8
380/415-50	342	440	377.9	400	400	400	641.0	503.0	416.9	450	450	450	680.0	542.0	
255	208/230-60	187	253	664.2	800	800	800	1165.1	889.1	755.8	800	800	800	1256.7	980.7
	460-60	414	506	312.9	350	350	350	576.1	438.1	334.9	400	350	400	608.1	470.1
	575-60	518	633	272.3	300	300	300	440.9	344.9	290.3	350	300	350	458.9	362.9
	380-60	342	418	359.9	400	400	400	641.6	489.6	394.9	450	400	450	676.6	524.6
	346-50	325	380	465.1	500	450	450	764.8	604.8	508.1	600	450	500	807.8	647.8
380/415-50	342	440	377.9	400	400	400	641.0	503.0	416.9	450	400	450	680.0	542.0	
270	208/230-60	187	253	727.5	800	800	800	1098.9	896.9	819.1	1000	1000	1000	1190.5	988.5
	460-60	414	506	323.5	350	350	350	518.0	417.0	355.5	400	400	400	550.0	449.0
	575-60	518	633	294.6	300	350	350	418.5	348.5	312.6	350	350	350	436.5	366.5
	380-60	342	418	387.8	400	450	450	598.0	486.0	422.8	450	350	450	633.0	521.0
	346-50	325	380	472.1	500	500	500	771.8	611.8	515.1	600	600	600	814.8	654.8
380/415-50	342	440	387.3	450	450	450	650.4	512.4	426.3	450	450	450	689.4	551.4	
290	208/230-60	187	253	800.0	800	1000	1000	1301.5	1025.5	910.6	1000	1000	1000	1411.5	1135.5
	460-60	414	506	368.2	400	400	400	631.4	493.4	406.2	450	450	450	669.4	531.4
	575-60	518	633	325.9	350	350	350	494.5	398.5	347.5	400	400	400	516.1	420.1
	380-60	342	418	432.5	500	450	450	714.2	562.2	474.5	500	500	500	756.2	604.2
	346-50	325	380	554.1	600	600	600	853.8	693.8	605.7	1000	700	700	905.4	745.4
380/415-50	342	440	515.7	500	500	500	669.4	575.3	497.0	500	600	600	760.1	622.1	
315	208/230-60	187	253	890.4	1000	1000	1000	1391.3	1115.3	1000.0	1000	1200	1200	1501.3	1225.3
	460-60	414	506	413.1	450	450	450	676.3	538.3	451.1	450	500	500	714.3	576.3
	575-60	518	633	362.5	400	400	400	531.1	435.1	384.1	400	400	400	552.7	456.7
	380-60	342	418	479.3	500	500	500	761.0	609.0	521.3	600	600	600	803.0	651.0
	346-50	325	380	567.5	600	600	600	867.2	707.2	619.1	700	700	700	918.8	758.8
380/415-50	342	440	474.5	500	500	500	737.6	599.6	521.3	500	600	600	784.4	646.4	
330	208/230-60	187	253	727.5	800	800	800	1098.9	896.9	819.1	1000	1000	1000	1190.5	988.5
	460-60	414	506	323.5	350	350	350	518.0	417.0	355.5	400	400	400	550.0	449.0
	575-60	518	633	294.6	300	350	350	418.5	348.5	312.6	350	350	350	436.5	366.5
	380-60	342	418	387.8	400	450	450	598.0	486.0	422.8	450	450	450	633.0	521.0
	230-50	207	253	677.7	700	800	800	1088.1	870.1	735.7	800	800	800	1146.1	928.1
346-50	325	380	472.1	500	500	500	771.8	611.8	515.1	600	600	600	814.8	654.8	
380/415-50	342	440	387.6	450	450	450	650.4	512.4	426.3	450	450	450	689.4	551.4	
360	208/230-60	187	253	800.0	800	1000	1000	1301.5	1025.5	910.6	1000	1000	1000	1411.5	1135.5
	460-60	414	506	368.2	400	400	400	631.4	493.4	406.2	450	450	450	669.4	531.4
	575-60	518	633	325.9	350	350	350	494.5	398.5	347.5	400	400	400	516.1	420.1
	380-60	342	418	432.5	500	450	450	714.2	562.2	474.5	500	500	500	756.2	604.2
	230-50	207	253	749.9	800	800	800	1160.3	942.3	819.5	700	1000	1000	1229.9	1011.9
346-50	325	380	554.1	600	600	600	853.8	693.8	605.7	1000	700	700	905.4	745.4	
380/415-50	342	440	515.7	500	500	500	669.4	575.3	497.0	500	600	600	760.1	622.1	
390	208/230-60	187	253	890.4	1000	1000	1000	1391.3	1115.3	1000.0	1000	1200	1200	1501.3	1225.3
	460-60	414	506	413.1	450	450	450	676.3	538.3	451.1	500	500	500	714.3	576.3
	575-60	518	633	362.5	400	400	400	531.1	435.1	384.1	400	400	400	552.7	456.7
	380-60	342	418	479.3	500	500	500	761.0	609.0	521.3	600	600	600	803.0	651.0
	230-50	207	253	796.2	800	800	800	1206.6	988.3	865.8	1000	800	800	1276.2	1058.2
346-50	325	380	567.5	600	600	600	867.2	707.2	619.1	700	700	700	918.8	758.8	
380/415-50	342	440	474.5	500	500	500	737.6	599.6	521.3	600	600	600	784.4	646.4	
420	208/230-60	187	253	890.4	1000	1000	1000	1391.3	1115.3	1000.0	1000	1200	1200	1501.3	1225.3
	460-60	414	506	413.1	450	450	450	676.3	538.3	451.1	500	500	500	714.3	576.3
	575-60	518	633	362.5	400	400	400	531.1	435.1	384.1	400	400	400	552.7	456.7
	380-60	342	418	479.3	500	500	500	761.0	609.0	521.3	600	600	600	803.0	651.0
	230-50	207	253	796.2	800	800	800	1206.6	988.3	865.8	1000	800	800	1276.2	1058.2
346-50	325	380	567.5	600	600	600	867.2	707.2	619.1	700	700	700	918.8	758.8	
380/415-50	342	440	474.5	500	500	500	737.6	599.6	521.3	600	600	600	784.4	646.4	

NOTE: See legend and notes on page 33.

**Table 4C — Unit Electrical Data, 30GT230-420 (cont)**

30GT UNIT SIZE	VOLTAGE			MODULE B											
				Standard Condenser Fan						High-Static Condenser Fan					
	Nameplate V-Hz (3 Phase)	Supplied*		MCA	MOCP	Rec Fuse Size		ICF		MCA	MOCP	Rec Fuse Size		ICF	
		Min	Max			XL	PW	XL	PW			XL	PW		
230	208/230-60	187	253	398.5	500	450	450	896.9	620.9	446.5	500	500	500	951.9	675.9
	460-60	414	506	185.8	250	200	225	442.8	305.4	204.7	225	225	250	464.2	326.8
	575-60	518	633	160.9	200	200	175	365.6	246.9	171.8	200	200	225	376.4	257.7
	380-60	342	418	209.9	250	250	250	492.6	339.5	230.9	250	300	300	513.6	360.5
	346-50	325	380	250.1	300	275	275	532.8	379.8	276.0	250	250	300	558.6	405.6
380/415-50	342	440	218.5	250	250	250	472.0	337.8	234.6	300	300	300	497.8	257.7	
245	208/230-60	187	253	397.4	450	450	450	722.3	547.9	447.0	500	500	500	780.9	602.9
	460-60	414	506	198.0	225	225	225	361.2	273.5	217.0	225	250	250	382.6	294.9
	575-60	518	633	168.0	200	200	175	286.2	213.2	178.6	200	200	200	297.0	230.4
	380-60	342	418	205.9	250	225	225	396.0	294.5	226.9	250	250	250	417.0	315.5
	346-50	325	380	269.3	300	275	275	552.0	399.0	295.2	300	300	300	577.8	424.8
380/415-50	342	440	244.1	300	250	250	497.0	363.5	267.2	300	300	300	522.8	389.3	
255	208/230-60	187	253	470.1	500	500	500	835.2	633.2	535.6	600	600	600	908.6	706.6
	460-60	414	506	224.8	250	250	250	408.8	312.3	242.9	300	300	300	437.4	336.4
	575-60	518	633	191.1	225	225	200	289.4	233.1	205.5	225	225	200	331.0	261.0
	380-60	342	418	242.1	250	300	300	454.8	342.8	268.6	300	300	300	482.8	370.8
	346-50	325	380	303.8	350	350	350	586.5	433.5	366.3	350	350	350	648.9	495.9
380/415-50	342	440	270.2	300	300	300	521.6	388.7	292.8	350	350	350	556.0	418.0	
270	208/230-60	187	253	470.1	500†	500	500	896.9	620.9	535.6	600	600	600	908.6	706.6
	460-60	414	506	224.8	250†	250	250	408.8	312.3	242.9	300	300	300	437.4	336.4
	575-60	518	633	191.1	225†	225	200	289.4	233.1	205.5	225	225	200	331.0	261.0
	380-60	343	418	242.1†	250†	300	300	492.6	339.5	268.6	300	300	300	482.8	370.8
	346-50	325	380	303.8†	350†	350	350	532.8	379.8	366.3	350	350	350	648.9	495.9
380/415-50	342	440	270.2	300†	350	300	521.6	388.7	292.8	350	350	350	556.0	418.0	
290	208/230-60	187	253	521.4	600	600	600	1019.2	743.2	587.2	700	600	700	1092.6	816.6
	460-60	414	506	248.9	300	250	300	500.8	367.3	273.8	300	300	300	529.4	395.9
	575-60	518	633	212.0	250	225	200	416.6	292.1	208.8	200	200	225	394.6	306.5
	380-60	342	418	274.1	350	300	300	556.8	403.8	302.2	300	300	350	585.2	431.8
	346-50	325	380	373.0	450	400	400	655.7	502.7	407.5	350	350	400	690.1	537.1
380/415-50	342	440	316.4	350	350	350	565.2	434.7	344.9	350	350	400	599.6	467.6	
315	208/230-60	187	253	521.4	600	600	600	1019.2	743.2	587.2	600	600	700	1092.6	816.6
	460-60	414	506	248.9	300	250	300	500.8	367.3	273.8	300	300	300	529.4	395.9
	575-60	518	633	212.0	250	225	200	416.6	292.1	208.8	200	200	225	394.6	306.5
	380-60	342	418	274.1	350	300	300	556.8	403.8	302.2	300	300	350	585.2	431.8
	346-50	325	380	373.0	450	400	400	655.7	502.7	407.5	350	350	400	690.1	537.1
380/415-50	342	440	316.4	350	350	350	565.2	434.7	344.9	350	350	400	599.6	467.6	
330	208/230-60	187	253	727.5	800	800	800	1098.9	896.9	819.1	1000	1000	1000	1190.5	988.5
	460-60	414	506	323.5	350	350	350	518.0	417.0	355.5	400	400	400	550.0	449.0
	575-60	518	633	294.6	300	350	350	418.5	348.5	312.6	350	350	350	436.5	366.5
	380-60	342	418	387.8	400	450	450	598.0	486.0	422.8	450	450	450	633.0	521.0
	230-50	207	253	677.7	700	800	800	1088.1	870.1	735.7	800	800	800	1146.1	928.1
346-50	325	380	472.1	500	500	500	771.8	611.8	515.1	600	600	600	814.8	654.8	
380/415-50	342	440	387.3	450	450	450	650.4	512.4	426.3	450	450	450	689.4	551.4	
360	208/230-60	187	253	800.0	800	1000	1000	1301.5	1025.5	910.6	1000	1000	1000	1411.5	1135.5
	460-60	414	506	368.2	400	400	400	631.4	493.4	406.2	450	450	450	669.4	531.4
	575-60	518	633	325.9	350	350	350	494.5	398.5	347.5	400	400	400	516.1	420.1
	380-60	342	418	432.5	500	450	450	714.2	562.2	474.5	500	500	500	756.2	604.2
	230-50	207	253	677.7	700	800	800	1088.1	870.1	735.7	800	800	800	1146.1	928.1
346-50	325	380	472.1	500	500	500	771.8	611.8	515.1	600	600	600	814.8	654.8	
380/415-50	342	440	387.3	450	450	450	650.4	512.4	426.3	450	450	450	689.4	551.4	
390	208/230-60	187	253	800.0	800	1000	1000	1301.5	1025.5	910.6	1000	1000	1000	1411.5	1135.5
	460-60	414	506	368.2	400	400	400	631.4	493.4	406.2	450	450	450	669.4	531.4
	575-60	518	633	325.9	350	350	350	494.5	398.5	347.5	400	400	400	516.1	420.1
	380-60	342	418	432.5	500	450	450	714.2	562.2	474.5	500	500	500	756.2	604.2
	230-50	207	253	749.9	800	800	800	1160.3	942.3	819.5	1000	1000	700	1229.9	1011.9
346-50	325	380	554.1	600	600	600	853.8	693.8	605.7	700	700	1000	905.4	745.4	
380/415-50	342	440	515.7	500	500	500	669.4	575.3	497.0	500	600	600	760.1	622.1	
420	208/230-60	187	253	890.4	1000	1000	1000	1391.3	1115.3	1000.0	1200	1200	1200	1501.3	1225.3
	460-60	414	506	413.1	450	450	450	676.3	538.3	451.1	500	500	500	714.3	576.3
	575-60	518	633	362.5	400	400	400	531.1	435.1	384.1	400	400	400	552.7	456.7
	380-60	342	418	479.3	500	500	500	761.0	609.0	521.3	600	600	600	803.0	651.0
	230-50	207	253	796.2	800	800	800	1206.6	988.3	865.8	800	800	800	1276.2	1058.2
346-50	325	380	567.5	600	600	600	867.2	707.2	619.1	700	700	700	918.8	758.8	
380/415-50	342	440	474.5	500	500	500	737.6	599.6	521.3	600	600	600	784.4	646.4	

NOTE: See legend and notes on page 33.

**Table 5 — Control Circuit**

UNIT POWER SUPPLY (V-Ph-Hz)	CONTROL POWER			AMPS			
	V-Ph-Hz	Min	Max	080-110 and 230B-315B Units		130-210,230A-315A, and 330A/B-420A/B Units	
				With Cooler Heater	Without Cooler Heater	With Cooler Heater	Without Cooler Heater
203/230-3-60	115-1-60	104	127	30	30	30	30
460-3-60	115-1-60	104	127	30	30	30	30
575-3-60	115-1-60	104	127	30	30	30	30
380-3-60	230-1-60	207	254	15	5	15	10
346-3-50	230-1-50	198	254	15	5	15	10
230-3-50**	230-1-50	198	254	—	—	15	10
380/415-3-50	230-1-50	198	254	15	5	15	10

See legend and notes on page 33.

**Table 6A — Compressor Electrical Data, 30GT080-110**

30GT UNIT SIZE	NAMEPLATE V-Hz (3 Phase)	COMPRESSOR NUMBERS							
		A1		A2		B1		B2	
		RLA	LRA	RLA	LRA	RLA	LRA	RLA	LRA
080-XL	208/230-60	106.4	506	67.9	345	147.7	690	—	—
	460-60	46.8	253	34.6	173	65.4	345	—	—
	575-60	40.4	176	28.8	120	57.1	276	—	—
	380-60	52.6	280	34.6	191	78.8	382	—	—
	346-50	44.9	247	79.5	382	79.5	382	—	—
	380/415-50	43.6	223	65.4	345	65.4	345	—	—
080-PW	208/230-60	106.4	304	67.9	207	147.4	414	—	—
	460-60	48.7	152	33.3	104	67.9	207	—	—
	575-60	33.3	106	28.2	72	53.8	165	—	—
	380-60	53.8	168	33.3	115	79.5	229	—	—
	346-50	44.9	148	79.5	229	79.5	229	—	—
	380/415-50	44.9	134	67.9	207	67.9	207	—	—
090-XL	208/230-60	89.7	446	67.9	345	89.7	446	89.7	446
	460-60	43.6	223	34.6	173	43.6	223	43.6	223
	575-60	36.5	164	28.8	120	36.5	164	36.5	164
	380-60	45.5	247	34.6	191	45.5	247	45.5	247
	346-50	44.9	247	79.5	382	44.9	247	53.8	280
	380/415-50	43.6	223	65.4	345	43.6	223	46.8	280
090-PW	208/230-60	89.7	268	67.9	207	89.7	268	89.7	268
	460-60	44.9	134	33.3	104	44.9	134	44.9	134
	575-60	33.3	98	28.2	72	33.3	98	33.3	98
	380-60	44.9	148	33.3	115	44.9	148	44.9	148
	346-50	44.9	148	79.5	229	44.9	148	53.8	168
	380/415-50	43.6	134	67.9	207	44.9	134	48.7	152
100-XL	208/230-60	89.7	446	106.4	506	89.7	446	106.4	506
	460-60	43.6	223	46.8	253	43.6	223	46.8	253
	575-60	36.5	164	40.4	176	36.5	164	40.4	176
	380-60	45.5	247	52.6	280	45.5	247	52.6	280
	346-50	44.9	247	79.5	382	44.9	247	79.5	382
	380/415-50	43.6	223	65.4	345	43.6	223	65.4	345
100-PW	208/230-60	89.7	268	106.4	304	89.7	268	106.4	304
	460-60	44.9	134	48.7	152	44.9	134	48.7	152
	575-60	33.3	98	33.3	106	33.3	98	33.3	106
	380-60	44.9	148	53.8	168	44.9	148	53.8	168
	346-50	44.9	148	79.5	229	44.9	148	79.5	229
	380/415-50	44.9	134	67.9	207	44.9	134	67.9	207
110-XL	208/230-60	89.7	446	147.4	690	89.7	446	106.4	506
	460-60	43.6	223	65.4	345	43.6	223	46.8	253
	575-60	36.5	164	57.1	276	36.5	164	40.4	176
	380-60	45.5	247	78.8	382	45.5	247	52.6	280
	346-50	79.5	382	79.5	229	79.5	382	79.5	382
	380/415-50	65.4	345	65.4	207	65.4	345	65.4	345
110-PW	208/230-60	89.7	268	147.4	414	89.7	268	106.4	304
	460-60	44.9	134	67.9	207	44.9	134	48.7	152
	575-60	33.3	98	53.8	165	33.3	98	33.3	106
	380-60	44.9	148	79.5	229	44.9	148	53.8	168
	346-50	79.5	229	79.5	229	79.5	229	79.5	229
	380/415-50	67.9	207	67.9	207	67.9	207	67.9	207

NOTE: See legend and notes on page 33.

Table 6B — Compressor Electrical Data, 30GT130-210

30GT UNIT SIZE	NAMEPLATE V-Hz (3 Phase)	COMPRESSOR NUMBERS													
		A1		A2		A3		A4		B1		B2		B3	
		RLA	LRA	RLA	LRA	RLA	LRA	RLA	LRA	RLA	LRA	RLA	LRA	RLA	LRA
130-XL	208/230-60	107.7	506	151.3	690	—	—	—	—	107.7	506	151.3	690	—	—
	460-60	46.8	253	64.5	345	—	—	—	—	46.8	253	64.5	345	—	—
	575-60	41.7	176	57.1	176	—	—	—	—	41.7	176	57.1	176	—	—
	380-60	55.8	280	80.2	382	—	—	—	—	55.8	280	80.2	382	—	—
	346-50	46.8	259	55.8	294	55.8	294	—	—	80.2	400	80.2	400	—	—
	230-50	77.0	342	87.9	366	87.9	366	—	—	107.7	545	107.7	545	—	—
	380/415-50	44.9	223	46.8	253	46.8	253	—	—	65.5	345	65.5	345	—	—
130-PW	208/230-60	107.7	304	151.3	414	—	—	—	—	107.7	304	151.3	414	—	—
	460-60	46.8	152	65.4	207	—	—	—	—	46.8	152	65.4	207	—	—
	575-60	41.7	106	57.1	144	—	—	—	—	41.7	106	57.1	144	—	—
	380-60	55.8	168	80.2	230	—	—	—	—	55.8	168	80.2	230	—	—
	346-50	46.8	155	55.8	155	55.8	155	—	—	80.2	240	80.2	240	—	—
	230-50	77.0	206	87.9	220	87.9	220	—	—	107.7	327	107.7	327	—	—
	380/415-50	44.9	134	65.5	207	46.8	152	—	—	65.5	207	65.5	207	—	—
150-XL	208/230-60	89.8	446	89.8	446	89.8	446	—	—	151.3	690	151.3	690	—	—
	460-60	44.9	223	44.9	223	44.9	223	—	—	65.4	345	65.4	345	—	—
	575-60	36.6	164	36.6	164	36.6	164	—	—	57.1	240	57.1	240	—	—
	380-60	46.8	247	46.8	247	46.8	247	—	—	80.2	382	80.2	382	—	—
	346-50	80.2	400	80.2	400	80.2	400	—	—	80.2	400	80.2	400	—	—
	230-50	107.7	545	107.7	545	107.7	545	—	—	107.7	545	107.7	545	—	—
	380/415-50	65.5	345	65.5	345	65.5	345	—	—	65.5	345	65.5	345	—	—
150-PW	208/230-60	89.8	268	89.8	268	89.8	268	—	—	151.3	414	151.3	414	—	—
	460-60	44.9	134	44.9	134	44.9	134	—	—	65.4	207	65.4	207	—	—
	575-60	36.6	99	36.6	99	36.6	99	—	—	57.1	144	57.1	144	—	—
	380-60	46.8	149	46.8	149	46.8	149	—	—	80.2	230	80.2	230	—	—
	346-50	80.2	240	80.2	240	80.2	240	—	—	80.2	240	80.2	240	—	—
	230-50	107.7	268	107.7	268	107.7	268	—	—	107.7	327	107.7	327	—	—
	380/415-50	65.5	207	65.5	207	65.5	207	—	—	65.5	207	65.5	207	—	—
170-XL	208/230-60	107.7	506	107.7	506	107.7	506	—	—	107.7	506	107.7	506	107.7	506
	460-60	46.8	253	46.8	253	46.8	253	—	—	46.8	253	46.8	253	46.8	253
	575-60	41.7	176	41.7	176	41.7	176	—	—	41.7	176	41.7	176	41.7	176
	380-60	55.8	280	55.8	280	55.8	280	—	—	55.8	280	55.8	280	55.8	280
	346-50	55.8	294	55.8	294	80.2	400	—	—	55.8	294	80.2	400	80.2	400
	230-50	87.9	366	87.9	366	107.7	545	—	—	87.9	366	107.7	545	107.7	545
	380/415-50	46.8	253	46.8	253	65.5	345	—	—	46.8	253	65.5	345	65.5	345
170-PW	208/230-60	107.7	304	107.7	304	107.7	304	—	—	107.7	304	107.7	304	107.7	304
	460-60	46.8	152	46.8	152	46.8	152	—	—	46.8	152	46.8	152	46.8	152
	575-60	41.7	106	41.7	106	41.7	106	—	—	41.7	106	41.7	106	41.7	106
	380-60	55.8	168	55.8	168	55.8	168	—	—	55.8	168	55.8	168	55.8	168
	346-50	55.8	177	55.8	177	80.2	240	—	—	55.8	177	80.2	240	80.2	240
	230-50	87.9	220	87.9	220	107.7	327	—	—	87.9	220	107.7	327	107.7	327
	380/415-50	46.8	152	46.8	152	65.5	207	—	—	46.8	152	65.5	207	65.5	207
190-XL	208/230-60	89.8	446	107.7	506	151.3	690	—	—	89.8	446	107.7	506	151.3	690
	460-60	44.9	223	46.8	253	65.4	345	—	—	44.9	223	46.8	253	65.4	345
	575-60	36.6	164	41.7	176	57.1	240	—	—	36.6	164	41.7	176	57.1	240
	380-60	46.8	247	55.8	280	80.2	382	—	—	46.8	247	55.8	280	80.2	382
	346-50	80.2	400	80.2	400	80.2	400	—	—	80.2	400	80.2	400	80.2	400
	230-50	107.7	545	107.7	545	107.7	545	—	—	107.7	545	107.7	545	107.7	545
	380/415-50	65.5	345	65.5	345	65.5	345	—	—	65.5	345	65.5	345	65.5	345
190-PW	208/230-60	89.8	268	107.7	304	151.3	414	—	—	89.8	268	107.7	304	151.3	414
	460-60	44.9	134	46.8	152	65.4	207	—	—	44.9	134	46.8	152	65.4	207
	575-60	36.6	99	41.7	106	57.1	144	—	—	36.6	99	41.7	106	57.1	144
	380-60	46.8	149	55.8	168	80.2	230	—	—	46.8	149	55.8	168	80.2	230
	346-50	80.2	240	80.2	240	80.2	240	—	—	80.2	240	80.2	240	80.2	240
	230-50	107.7	327	107.7	327	107.7	327	—	—	107.7	327	107.7	327	107.7	327
	380/415-50	65.5	207	65.5	207	65.5	207	—	—	65.5	207	65.5	207	65.5	207
210-XL	208/230-60	89.8	446	89.8	446	89.8	446	107.7	506	107.7	506	151.3	690	151.3	690
	460-60	44.9	223	44.9	223	44.9	223	46.8	253	46.8	253	65.4	345	65.4	345
	575-60	36.6	164	36.6	164	36.6	164	41.7	176	41.7	176	57.1	240	57.1	240
	380-60	46.8	247	46.8	247	46.8	247	55.8	280	55.8	280	80.2	382	80.2	382
	346-50	46.8	259	46.8	259	80.2	400	80.2	400	80.2	400	80.2	400	80.2	400
	230-50	77.0	342	77.0	342	107.7	545	107.7	545	107.7	545	107.7	545	107.7	545
	380/415-50	44.9	223	44.9	223	65.5	345	65.5	345	65.5	345	65.5	345	65.5	345
210-PW	208/230-60	89.8	268	89.8	268	89.8	268	107.7	304	107.7	304	151.3	414	151.3	414
	460-60	44.9	134	44.9	134	44.9	134	46.8	152	46.8	152	65.4	207	65.4	207
	575-60	36.6	99	36.6	99	36.6	99	41.7	106	41.7	106	57.1	144	57.1	144
	380-60	46.8	149	46.8	149	46.8	149	55.8	168	55.8	168	80.2	230	80.2	230
	346-50	46.8	155	46.8	155	80.2	240	80.2	240	80.2	240	80.2	240	80.2	240
	230-50	77.0	206	77.0	206	107.7	327	107.7	327	107.7	327	107.7	327	107.7	327
	380/415-50	44.9	134	44.9	134	65.5	207	65.5	207	65.5	207	65.5	207	65.5	207

NOTE: See legend and notes on page 33.

**Table 6C — Compressor Electrical Data, 30GT230-420**

30GT UNIT SIZE	NAMEPLATE V-Hz (3 Phase)	MODULE A													
		Compressor Numbers													
		A1		A2		A3		A4		B1		B2		B3	
RLA	LRA	RLA	LRA	RLA	LRA	RLA	LRA	RLA	LRA	RLA	LRA	RLA	LRA	RLA	LRA
230-XL	208/230-60	89.8	446	89.8	446	89.8	446			151.3	690	151.3	690		
	460-60	44.9	223	44.9	223	44.9	223			65.4	345	65.4	345		
	575-60	36.6	164	36.6	164	36.6	164	—	—	57.1	240	57.1	240	—	—
	380-60	46.8	247	46.8	247	46.8	247			80.2	382	80.2	382		
	346-50	80.2	400	80.2	400	80.2	400			80.2	400	80.2	400		
	380/415-50	65.5	345	65.5	345	65.5	345			65.5	345	65.5	345		
230-PW	208/230-60	89.8	268	89.8	268	89.8	268			151.3	414	151.3	414		
	460-60	44.9	134	44.9	134	44.9	134			65.4	207	65.4	207		
	575-60	36.6	99	36.6	99	36.6	99	—	—	57.1	144	57.1	144	—	—
	380-60	46.8	149	46.8	149	46.8	149			80.2	230	80.2	230		
	346-50	80.2	240	80.2	240	80.2	240			80.2	240	80.2	240		
	380/415-50	65.5	207	65.5	207	65.5	207			65.5	207	65.5	207		
245-XL	208/230-60	89.8	446	89.8	446	89.8	446			151.3	690	151.3	690		
	460-60	44.9	223	44.9	223	44.9	223			65.4	345	65.4	345		
	575-60	36.6	164	36.6	164	36.6	164	—	—	57.1	240	57.1	240	—	—
	380-60	46.8	247	46.8	247	46.8	247			80.2	382	80.2	382		
	346-50	80.2	400	80.2	400	80.2	400			80.2	400	80.2	400		
	380/415-50	65.5	345	65.5	345	65.5	345			65.5	345	65.5	345		
245-PW	208/230-60	89.8	268	89.8	268	89.8	268			151.3	414	151.3	414		
	460-60	44.9	134	44.9	134	44.9	134			65.4	207	65.4	207		
	575-60	36.6	99	36.6	99	36.6	99	—	—	57.1	144	57.1	144	—	—
	380-60	46.8	149	46.8	149	46.8	149			80.2	230	80.2	230		
	346-50	80.2	240	80.2	240	80.2	240			80.2	240	80.2	240		
	380/415-50	65.5	207	65.5	207	65.5	207			65.5	207	65.5	207		
255-XL	208/230-60	89.8	446	89.8	446	89.8	446			151.3	690	151.3	690		
	460-60	44.9	223	44.9	223	44.9	223			65.4	345	65.4	345		
	575-60	36.6	164	36.6	164	36.6	164	—	—	57.1	240	57.1	240	—	—
	380-60	46.8	247	46.8	247	46.8	247			80.2	382	80.2	382		
	346-50	80.2	400	80.2	400	80.2	400			80.2	400	80.2	400		
	380/415-50	65.5	345	65.5	345	65.5	345			65.5	345	65.5	345		
255-PW	208/230-60	89.8	268	89.8	268	89.8	268			151.3	414	151.3	414		
	460-60	44.9	134	44.9	134	44.9	134			65.4	207	65.4	207		
	575-60	36.6	99	36.6	99	36.6	99	—	—	57.1	144	57.1	144	—	—
	380-60	46.8	149	46.8	149	46.8	149			80.2	230	80.2	230		
	346-50	80.2	240	80.2	240	80.2	240			80.2	240	80.2	240		
	380/415-50	65.5	207	65.5	207	65.5	207			65.5	207	65.5	207		
270-XL	208/230-60	107.7	506	107.7	506	107.7	506			107.7	506	107.7	506	107.7	506
	460-60	46.8	253	46.8	253	46.8	253			46.8	253	46.8	253	46.8	253
	575-60	41.7	176	41.7	176	41.7	176	—	—	41.7	176	41.7	176	41.7	176
	380-60	55.8	280	55.8	280	55.8	280			55.8	280	55.8	280	55.8	280
	346-50	55.8	294	55.8	294	80.2	400			55.8	294	80.2	400	80.2	400
	380/415-50	46.8	253	46.8	253	65.5	345			46.8	253	65.5	345	65.5	345
270-PW	208/230-60	107.7	304	107.7	304	107.7	304			107.7	304	107.7	304	107.7	304
	460-60	46.8	152	46.8	152	46.8	152			46.8	152	46.8	152	46.8	152
	575-60	41.7	106	41.7	106	41.7	106	—	—	41.7	106	41.7	106	41.7	106
	380-60	55.8	168	55.8	168	55.8	168			55.8	168	55.8	168	55.8	168
	346-50	55.8	177	55.8	177	80.2	240			55.8	177	80.2	240	80.2	240
	380/415-50	46.8	152	46.8	152	46.8	207			46.8	152	65.5	207	65.5	207
290-XL	208/230-60	89.8	446	107.7	506	151.3	690			89.8	446	107.7	506	151.3	690
	460-60	44.9	223	46.8	253	65.4	345			44.9	223	46.8	253	65.4	345
	575-60	36.6	164	41.7	176	57.1	240	—	—	36.6	164	41.7	176	57.1	240
	380-60	46.8	247	55.8	280	80.2	382			46.8	247	55.8	280	80.2	382
	346-50	80.2	400	80.2	400	80.2	400			80.2	400	80.2	400	80.2	400
	380/415-50	65.5	345	65.5	345	65.5	345			65.5	345	65.5	345	65.5	345
290-PW	208/230-60	89.8	268	107.7	304	151.3	414			89.8	268	107.7	304	151.3	414
	460-60	44.9	134	46.8	152	65.4	207			44.9	134	46.8	152	65.4	207
	575-60	36.6	99	41.7	106	57.1	144	—	—	36.6	99	41.7	106	57.1	144
	380-60	46.8	149	55.8	168	80.2	230			46.8	149	55.8	168	80.2	230
	346-50	80.2	240	80.2	240	80.2	240			80.2	240	80.2	240	80.2	240
	380/415-50	65.5	207	65.5	207	65.5	207			65.5	207	65.5	207	65.5	207

NOTE: See legend and notes on page 33.

**Table 6C — Compressor Electrical Data, 30GT230-420 (cont)**

30GT UNIT SIZE	NAMEPLATE V-Hz (3 Phase)	MODULE B													
		Compressor Numbers													
		A1		A2		A3		A4		B1		B2		B3	
RLA	LRA	RLA	LRA	RLA	LRA	RLA	LRA	RLA	LRA	RLA	LRA	RLA	LRA	RLA	LRA
230-XL	208/230-60	106.4	506	67.9	345					147.7	690				
	460-60	46.8	253	34.6	173					65.4	345				
	575-60	40.4	176	28.8	120	—	—	—	—	57.1	276	—	—	—	—
	380-60	52.6	280	34.6	191					78.8	382				
	346-50	44.9	247	79.5	382					79.5	382				
	380/415-50	43.6	223	65.4	345					65.4	345				
230-PW	208/230-60	106.4	304	67.9	207					147.4	414				
	460-60	48.7	152	33.3	104					67.9	207				
	575-60	33.3	106	28.2	72	—	—	—	—	53.8	165	—	—	—	—
	380-60	53.8	168	33.3	115					79.5	229				
	346-50	44.9	148	79.5	229					79.5	229				
	380/415-50	44.9	134	67.9	207					67.9	207				
245-XL	208/230-60	89.7	446	67.9	345					89.7	446	89.7	446		
	460-60	43.6	223	34.6	173					43.6	223	43.6	223		
	575-60	36.5	164	28.8	120	—	—	—	—	36.5	164	36.5	164	—	—
	380-60	45.5	247	34.6	191					45.5	247	45.5	247		
	346-50	44.9	247	79.5	382					44.9	247	53.8	280		
	380/415-50	43.6	223	65.4	345					43.6	223	46.8	280		
245-PW	208/230-60	89.7	268	67.9	207					89.7	268	89.7	268		
	460-60	44.9	134	33.3	104					44.9	134	44.9	134		
	575-60	33.3	98	28.2	72	—	—	—	—	33.3	98	33.3	98	—	—
	380-60	44.9	148	33.3	115					44.9	148	44.9	148		
	346-50	44.9	148	79.5	229					44.9	148	53.8	168		
	380/415-50	43.6	134	67.9	207					44.9	134	48.7	152		
255-XL	208/230-60	89.7	446	106.4	506					89.7	446	106.4	506		
	460-60	43.6	223	46.8	253					43.6	223	46.8	253		
	575-60	36.5	164	40.4	176	—	—	—	—	36.5	164	40.4	176	—	—
	380-60	45.5	247	52.6	280					45.5	247	52.6	280		
	346-50	44.9	247	79.5	382					44.9	247	79.5	382		
	380/415-50	43.6	223	65.4	345					43.6	223	65.4	345		
255-PW	208/230-60	89.7	268	106.4	304					89.7	268	106.4	304		
	460-60	44.9	134	48.7	152					44.9	134	48.7	152		
	575-60	33.3	98	33.3	106	—	—	—	—	33.3	98	33.3	106	—	—
	380-60	44.9	148	53.8	168					44.9	148	53.8	168		
	346-50	44.9	148	79.5	229					44.9	148	79.5	229		
	380/415-50	44.9	134	67.9	207					44.9	134	67.9	207		
270-XL	208/230-60	89.7	446	106.4	506					89.7	446	106.4	506		
	460-60	43.6	223	46.8	253					43.6	223	46.8	253		
	575-60	36.5	164	40.4	176	—	—	—	—	36.5	164	40.4	176	—	—
	380-60	45.5	247	52.6	280					45.5	247	52.6	280		
	346-50	44.9	247	79.5	382					44.9	247	79.5	382		
	380/415-50	43.6	223	65.4	345					43.6	223	65.4	345		
270-PW	208/230-60	89.7	268	106.4	304					89.7	268	106.4	304		
	460-60	44.9	134	48.7	152					44.9	134	48.7	152		
	575-60	33.3	98	33.3	106	—	—	—	—	33.3	98	33.3	106	—	—
	380-60	44.9	148	53.8	168					44.9	148	53.8	168		
	346-50	44.9	148	79.5	229					44.9	148	79.5	229		
	380/415-50	44.9	134	67.9	207					44.9	134	67.9	207		
290-XL	208/230-60	89.7	446	147.4	690					89.7	446	106.4	506		
	460-60	43.6	223	65.4	345					43.6	223	46.8	253		
	575-60	36.5	164	57.1	276	—	—	—	—	36.5	164	40.4	176	—	—
	380-60	45.5	247	78.8	382					45.5	247	52.6	280		
	346-50	79.5	382	79.5	229					79.5	382	79.5	382		
	380/415-50	65.4	345	65.4	207					65.4	345	65.4	345		
290-PW	208/230-60	89.7	268	147.4	414					89.7	268	106.4	304		
	460-60	44.9	134	67.9	207					44.9	134	48.7	152		
	575-60	33.3	98	53.8	165	—	—	—	—	33.3	98	33.3	106	—	—
	380-60	44.9	148	79.5	229					44.9	148	53.8	168		
	346-50	79.5	229	79.5	229					79.5	229	79.5	229		
	380/415-50	67.9	207	67.9	207					67.9	207	67.9	207		

NOTE: See legend and notes on page 33.

**Table 6C — Compressor Electrical Data, 30GT230-420 (cont)**

30GT UNIT SIZE	NAMEPLATE V-Hz (3 Phase)	MODULE A													
		Compressor Numbers													
		A1		A2		A3		A4		B1		B2		B3	
		RLA	LRA	RLA	LRA	RLA	LRA	RLA	LRA	RLA	LRA	RLA/	LRA	RLA	LRA
315-XL	208/230-60	89.8	446	89.8	446	89.8	446	107.7	506	107.7	506	151.3	690	151.3	690
	460-60	44.9	223	44.9	223	44.9	223	46.8	253	46.8	253	65.1	345	65.4	345
	575-60	36.6	164	36.6	164	36.6	164	41.7	176	41.7	176	57.1	240	57.1	240
	380-60	46.8	247	46.8	247	46.8	247	55.8	280	55.8	280	80.2	382	80.2	382
	346-50	46.8	259	46.8	259	80.2	400	80.2	400	80.2	400	80.2	400	80.2	400
	380/415-50	44.9	223	44.9	223	65.5	345	65.5	345	65.5	345	65.5	345	65.5	345
315-PW	208/230-60	89.8	268	89.8	268	89.8	268	107.7	304	107.7	304	151.3	414	151.3	414
	460-60	44.9	134	44.9	134	44.9	134	46.8	152	46.8	152	65.4	207	65.4	207
	575-60	36.6	99	36.6	99	36.6	99	41.7	106	41.7	106	57.1	144	57.1	144
	380-60	46.8	149	46.8	149	46.8	149	55.8	168	55.8	168	80.2	230	80.2	230
	346-50	46.8	155	46.8	155	80.2	240	80.2	240	80.2	240	80.2	240	80.2	240
	380/415-50	44.9	134	44.9	134	65.5	207	65.5	207	65.5	207	65.5	207	65.5	207
330-XL	208/230-60	107.7	506	107.7	506	107.7	506			107.7	506	107.7	506	107.7	506
	460-60	46.8	253	46.8	253	46.8	253			46.8	253	46.8	253	46.8	253
	575-60	41.7	176	41.7	176	41.7	176	—	—	41.7	176	41.7	176	41.7	176
	380-60	55.8	280	55.8	280	55.8	280			55.8	280	55.8	280	55.8	280
	346-50	55.8	294	55.8	294	80.2	400			55.8	294	80.2	400	80.2	400
	230-50	87.9	366	87.9	366	107.7	545			87.9	366	107.7	545	107.7	545
380/415-50	46.8	253	46.8	253	65.5	345			46.8	253	65.5	345	65.5	345	
330-PW	208/230-60	107.7	304	107.7	304	107.7	304			107.7	304	107.7	304	107.7	304
	460-60	46.8	152	46.8	152	46.8	152			46.8	152	46.8	152	46.8	152
	575-60	41.7	106	41.7	106	41.7	106	—	—	41.7	106	41.7	106	41.7	106
	380-60	55.8	168	55.8	168	55.8	168			55.8	168	55.8	168	55.8	168
	346-50	55.8	177	55.8	177	80.2	240			55.8	177	80.2	240	80.2	240
	230-50	87.9	220	87.9	220	107.7	327			87.9	220	107.7	327	107.7	327
380/415-50	46.8	152	46.8	152	65.5	207			46.8	152	65.5	207	65.5	207	
360-XL	208/230-60	89.8	446	107.7	506	151.3	690			89.8	446	107.7	506	151.3	690
	460-60	44.9	223	46.8	253	65.4	345			44.9	223	46.8	253	65.4	345
	575-60	36.6	164	41.7	176	57.1	240			36.6	164	41.7	176	57.1	240
	380-60	46.8	247	55.8	280	80.2	382	—	—	46.8	247	55.8	280	80.2	382
	346-50	80.2	400	80.2	400	80.2	400			80.2	400	80.2	400	80.2	400
	230-50	107.7	545	107.7	545	107.7	545			107.7	545	107.7	545	107.7	545
380/415-50	65.5	345	65.5	345	65.5	345			65.5	345	65.5	345	65.5	345	
360-PW	208/230-60	89.8	268	107.7	304	151.3	414			89.8	268	107.7	304	151.3	414
	460-60	44.9	134	46.8	152	65.4	207			44.9	134	46.8	152	65.4	207
	575-60	36.6	99	41.7	106	57.1	144			36.6	99	41.7	106	57.1	144
	380-60	46.8	149	55.8	168	80.2	230	—	—	46.8	149	55.8	168	80.2	230
	346-50	80.2	240	80.2	240	80.2	240			80.2	240	80.2	240	80.2	240
	230-50	107.7	327	107.7	327	107.7	327			107.7	327	107.7	327	107.7	327
380/415-50	65.5	207	65.5	207	65.5	207			65.5	207	65.5	207	65.5	207	

NOTE: See legend and notes on page 33.

**Table 6C — Compressor Electrical Data, 30GT230-420 (cont)**

30GT UNIT SIZE	NAMEPLATE V-Hz (3 Phase)	MODULE B													
		Compressor Numbers													
		A1		A2		A3		A4		B1		B2		B3	
RLA	LRA	RLA	LRA	RLA	LRA	RLA	LRA	RLA	LRA	RLA	LRA	RLA	LRA	RLA	LRA
315-XL	208/230-60	89.7	446	147.4	690					89.7	446	106.4	506		
	460-60	43.6	223	65.4	345					43.6	223	46.8	253		
	575-60	36.5	164	57.1	276	—	—	—	—	36.5	164	40.4	176	—	—
	380-60	45.5	247	78.8	382					45.5	247	52.6	280		
	346-50	79.5	382	79.5	229					79.5	382	79.5	382		
	380/415-50	65.4	345	65.4	207					65.4	345	65.4	345		
315-PW	208/230-60	89.7	268	147.4	414					89.7	268	106.4	304		
	460-60	44.9	134	67.9	207					44.9	134	48.7	152		
	575-60	33.3	98	53.8	165	—	—	—	—	33.3	98	33.3	106	—	—
	380-60	44.9	148	79.5	229					44.9	148	53.8	168		
	346-50	79.5	229	79.5	229					79.5	229	79.5	229		
	380/415-50	67.9	207	67.9	207					67.9	207	67.9	207		
330-XL	208/230-60	107.7	506	107.7	506	107.7	506			107.7	506	107.7	506	107.7	506
	460-60	46.8	253	46.8	253	46.8	253			46.8	253	46.8	253	46.8	253
	575-60	41.7	176	41.7	176	41.7	176	—	—	41.7	176	41.7	176	41.7	176
	380-60	55.8	280	55.8	280	55.8	280			55.8	280	55.8	280	55.8	280
	346-50	55.8	294	55.8	294	80.2	400			55.8	294	80.2	400	80.2	400
	230-50	87.9	366	87.9	366	107.7	545			87.9	366	107.7	545	107.7	545
	380/415-50	46.8	253	46.8	253	65.5	345			46.8	253	65.5	345	65.5	345
330-PW	208/230-60	107.7	304	107.7	304	107.7	304			107.7	304	107.7	304	107.7	304
	460-60	46.8	152	46.8	152	46.8	152			46.8	152	46.8	152	46.8	152
	575-60	41.7	106	41.7	106	41.7	106	—	—	41.7	106	41.7	106	41.7	106
	380-60	55.8	168	55.8	168	55.8	168			55.8	168	55.8	168	55.8	168
	346-50	55.8	177	55.8	177	80.2	240			55.8	177	80.2	240	80.2	240
	230-50	87.9	220	87.9	220	107.7	327			87.9	220	107.7	327	107.7	327
	380/415-50	46.8	152	46.8	152	65.5	207			46.8	152	65.5	207	65.5	207
360-XL	208/230-60	89.8	446	107.7	506	151.3	690			89.8	446	107.7	506	151.3	690
	460-60	44.9	223	46.8	253	65.4	345			44.9	223	46.8	253	65.4	345
	575-60	36.6	164	41.7	176	57.1	240			36.6	164	41.7	176	57.1	240
	380-60	46.8	247	55.8	280	80.2	382	—	—	46.8	247	55.8	280	80.2	382
	346-50	55.8	294	55.8	294	80.2	400			55.8	294	80.2	400	80.2	400
	230-50	87.9	366	87.9	366	107.7	545			87.9	366	107.7	545	107.7	545
	380/415-50	46.8	253	46.8	253	65.5	345			46.8	253	65.5	345	65.5	345
360-PW	208/230-60	89.8	268	107.7	304	151.3	414			89.8	268	107.7	304	151.3	414
	460-60	44.9	134	46.8	152	65.4	207			44.9	134	46.8	152	65.4	207
	575-60	36.6	99	41.7	106	57.1	144			36.6	99	41.7	106	57.1	144
	380-60	46.8	149	55.8	168	80.2	230	—	—	46.8	149	55.8	168	80.2	230
	346-50	55.8	177	55.8	177	80.2	240			55.8	177	80.2	240	80.2	240
	230-50	87.9	220	87.9	220	107.7	327			87.9	220	107.7	327	107.7	327
	380/415-50	46.8	152	46.8	152	65.5	207			46.8	152	65.5	207	65.5	207

NOTE: See legend and notes on page 33.

Table 6C — Compressor Electrical Data, 30GT230-420 (cont)

30GT UNIT SIZE	NAMEPLATE V-Hz (3 Phase)	MODULE A													
		Compressor Numbers													
		A1		A2		A3		A4		B1		B2		B3	
		RLA	LRA	RLA	LRA	RLA	LRA	RLA	LRA	RLA	LRA	RLA	LRA	RLA	LRA
390-XL	208/230-60	89.8	446	89.8	446	89.8	446	107.7	506	107.7	506	151.3	690	151.3	690
	460-60	44.9	223	44.9	223	44.9	223	46.8	253	46.8	253	65.4	345	65.4	345
	575-60	36.6	164	36.6	164	36.6	164	41.7	176	41.7	176	57.1	240	57.1	240
	380-60	46.8	247	46.8	247	46.8	247	55.8	280	55.8	280	80.2	382	80.2	382
	346-50	46.8	259	46.8	259	80.2	400	80.2	400	80.2	400	80.2	400	80.2	400
	230-50	77.0	342	77.0	342	107.7	545	107.7	545	107.7	545	107.7	545	107.7	545
380/415-50	44.9	223	44.9	223	65.5	345	65.5	345	65.5	345	65.5	345	65.5	345	
390-PW	208/230-60	89.8	268	89.8	268	89.8	268	107.7	304	107.7	304	151.3	414	151.3	414
	460-60	44.9	134	44.9	134	44.9	134	46.8	152	46.8	152	65.4	207	65.4	207
	575-60	36.6	99	36.6	99	36.6	99	41.7	106	41.7	106	57.1	144	57.1	144
	380-60	46.8	149	46.8	149	46.8	149	55.8	168	55.8	168	80.2	230	80.2	230
	346-50	46.8	155	46.8	155	80.2	240	80.2	240	80.2	240	80.2	240	80.2	240
	230-50	77.0	206	77.0	206	107.7	327	107.7	327	107.7	327	107.7	327	107.7	327
380-415-50	44.9	134	44.9	134	65.5	207	65.5	207	65.5	207	65.5	207	65.5	207	
420-XL	208/230-60	89.8	446	89.8	446	89.8	446	107.7	506	107.7	506	151.3	690	151.3	690
	460-60	44.9	223	44.9	223	44.9	223	46.8	253	46.8	253	65.4	345	65.4	345
	575-60	36.6	164	36.6	164	36.6	164	41.7	176	41.7	176	57.1	240	57.1	240
	380-60	46.8	247	46.8	247	46.8	247	55.8	280	55.8	280	80.2	382	80.2	382
	346-50	46.8	259	46.8	259	80.2	400	80.2	400	80.2	400	80.2	400	80.2	400
	230-50	77.0	342	77.0	342	107.7	545	107.7	545	107.7	545	107.7	545	107.7	545
380/415-50	44.9	223	44.9	223	65.5	345	65.5	345	65.5	345	65.5	345	65.5	345	
420-PW	208/230-60	89.8	268	89.8	268	89.8	268	107.7	304	107.7	304	151.3	414	151.3	414
	460-60	44.9	134	44.9	134	44.9	134	46.8	152	46.8	152	65.4	207	65.4	207
	575-60	36.6	99	36.6	99	36.6	99	41.7	106	41.7	106	57.1	144	57.1	144
	380-60	46.8	149	46.8	149	46.8	149	55.8	168	55.8	168	80.2	230	80.2	230
	346-50	46.8	155	46.8	155	80.2	240	80.2	240	80.2	240	80.2	240	80.2	240
	230-50	77.0	206	77.0	206	107.7	327	107.7	327	107.7	327	107.7	327	107.7	327
380/415-50	44.9	134	44.9	134	65.5	207	65.5	207	65.5	207	65.5	207	65.5	207	

30GT UNIT SIZE	NAMEPLATE V-Hz (3 Phase)	MODULE B													
		Compressor Numbers													
		A1		A2		A3		A4		B1		B2		B3	
		RLA	LRA	RLA	LRA	RLA	LRA	RLA	LRA	RLA	LRA	RLA	LRA	RLA	LRA
390-XL	208/230-60	89.8	446	107.7	506	151.3	690			89.8	446	107.7	506	151.3	690
	460-60	44.9	223	46.8	253	65.4	345			44.9	223	46.8	253	65.4	345
	575-60	36.6	164	41.7	176	57.1	240	—	—	36.6	164	41.7	176	57.1	240
	380-60	46.8	247	55.8	280	80.2	382			46.8	247	55.8	280	80.2	382
	346-50	80.2	400	80.2	400	80.2	400			80.2	400	80.2	400	80.2	400
	230-50	107.7	545	107.7	545	107.7	545			107.7	545	107.7	545	107.7	545
380/415-50	65.5	345	65.5	345	65.5	345			65.5	345	65.5	345	65.5	345	
390-PW	208/230-60	89.8	268	107.7	304	151.3	414			89.8	268	107.7	304	151.3	414
	460-60	44.9	134	46.8	152	65.4	207			44.9	134	46.8	152	65.4	207
	575-60	36.6	99	41.7	106	57.1	144	—	—	36.6	99	41.7	106	57.1	144
	380-60	46.8	149	55.8	168	80.2	230			46.8	149	55.8	168	80.2	230
	346-50	80.2	240	80.2	240	80.2	240			80.2	240	80.2	240	80.2	240
	230-50	107.7	327	107.7	327	107.7	327			107.7	327	107.7	327	107.7	327
380/415-50	65.5	207	65.5	207	65.5	207			65.5	207	65.5	207	65.5	207	
420-XL	208/230-60	89.8	446	89.8	446	89.8	446	107.7	506	107.7	506	151.3	690	151.3	690
	460-60	44.9	223	44.9	223	44.9	223	46.8	253	46.8	253	65.4	345	65.4	345
	575-60	36.6	164	36.6	164	36.6	164	41.7	176	41.7	176	57.1	240	57.1	240
	380-60	46.8	247	46.8	247	46.8	247	55.8	280	55.8	280	80.2	382	80.2	382
	346-50	46.8	259	46.8	259	80.2	400	80.2	400	80.2	400	80.2	400	80.2	400
	230-50	77.0	342	77.0	342	107.7	545	107.7	545	107.7	545	107.7	545	107.7	545
380/415-50	44.9	223	44.9	223	65.5	345	65.5	345	65.5	345	65.5	345	65.5	345	
420-PW	208/230-60	89.8	268	89.8	268	89.8	268	107.7	304	107.7	304	151.3	414	151.3	414
	460-60	44.9	134	44.9	134	44.9	134	46.8	152	46.8	152	65.4	207	65.4	207
	575-60	36.6	99	36.6	99	36.6	99	41.7	106	41.7	106	57.1	144	57.1	144
	380-60	46.8	149	46.8	149	46.8	149	55.8	168	55.8	168	80.2	230	80.2	230
	346-50	46.8	155	46.8	155	80.2	240	80.2	240	80.2	240	80.2	240	80.2	240
	230-50	77.0	206	77.0	206	107.7	327	107.7	327	107.7	327	107.7	327	107.7	327
380/415-50	44.9	134	44.9	134	65.5	207	65.5	207	65.5	207	65.5	207	65.5	207	

NOTE: See legend and notes on page 33.

**Table 7 — Condenser Fan Electrical Data**

30GT UNIT SIZE	NAMEPLATE VOLTAGE (V-Ph-Hz)	STANDARD/LOW NOISE CONDENSER FANS					HIGH STATIC CONDENSER FANS				
		Total Quantity	Hp	kW	(Quantity) FLA (ea)	(Quantity) LRA (ea)	Total Quantity	Hp	kW	(Quantity) FLA (ea)	(Quantity) LRA (ea)
<b>080,090, 230B,245B</b>	208/230-3-60	6	1	0.746	(4) 6.6, (2) 5.5	(4) 31.6, (2) 30.0	6	5	3.73	(6) 14.6	(6) 41.6
	460-3-60				(4) 3.3, (2) 2.8	(4) 31.6, (2) 30.0				(6) 6.3	(6) 41.6
	575-3-60				(6) 3.4	(6) 30.0				(6) 5.2	(6) 42.0
	380-3-60				(6) 3.9	(6) 20.9				(6) 7.4	(6) 54.0
	346-3-50				(6) 4.4	(6) 20.9				(6) 8.7	(6) 53.0
	380/415-3-50				(6) 3.4	(6) 30.0				(6) 7.3	(6) 41.0
<b>100,110, 255B,270B, 290B,315B</b>	208/230-3-60	8	1	0.746	(6) 6.6, (2) 5.5	(6) 31.6, (2) 30.0	8	5	3.73	(8) 14.6	(8) 41.6
	460-3-60				(6) 3.3, (2) 2.8	(6) 31.6, (2) 30.0				(8) 6.3	(8) 41.6
	575-3-60				(8) 3.4	(8) 30.0				(8) 5.2	(8) 42.0
	380-3-60				(8) 3.9	(8) 20.9				(8) 7.4	(8) 54.0
	346-3-50				(8) 4.4	(8) 20.9				(8) 8.7	(8) 53.0
	380/415-3-50				(8) 3.4	(8) 30.0				(8) 7.3	(8) 41.0
<b>130-170 230A-270A, 330A/B,360B (50 Hz)</b>	208/230-3-60	10	1	0.746	(6) 6.6, (4) 5.5	(6) 31.6, (4) 30.0	10	5	3.73	(10) 14.6	(10) 41.6
	460-3-60				(6) 3.3, (4) 2.8	(6) 31.6, (4) 30.0				(10) 6.3	(10) 41.6
	575-3-60				(10) 3.4	(10) 30.0				(10) 5.2	(10) 42.0
	380-3-60				(10) 3.9	(10) 20.9				(10) 7.4	(10) 54.0
	346-3-50				(10) 4.4	(10) 20.9				(10) 8.7	(10) 53.0
	230-3-50**				(10) 6.4	(10) 30.3				(10) 12.2	(10) 41.6
380/415-3-50	(10) 3.4	(10) 30.0	(10) 7.3	(10) 41.0							
<b>190,210, 290A,315A, 360A/B (60 Hz), 360A (50 Hz), 390A/B,420A/B</b>	208/230-3-60	12	1	0.746	(8) 6.6, (4) 5.5	(8) 31.6, (4) 30.0	12	5	3.73	(12) 14.6	(12) 41.6
	460-3-60				(8) 3.3, (4) 2.8	(8) 31.6, (4) 30.0				(12) 6.3	(12) 41.6
	575-3-60				(12) 3.4	(12) 30.0				(12) 5.2	(12) 42.0
	380-3-60				(12) 3.9	(12) 20.9				(12) 7.4	(12) 54.0
	346-3-50				(12) 4.4	(12) 20.9				(12) 8.7	(12) 53.0
	230-3-50				(12) 6.4	(12) 30.3				(12) 12.2	(12) 41.6
380/415-3-50	(12) 3.4	(12) 30.0	(12) 7.3	(12) 41.0							

**Step 6 — Install Accessories**

ELECTRICAL — A number of electrical accessories are available to provide the following optional features (for details, refer to the Controls and Troubleshooting book):

- Accessory temperature reset board and accessory thermistor (used for any of the following types of temperature reset):
  - Return fluid temperature reset
  - Space temperature reset (requires accessory thermistor)
  - Outdoor air temperature reset (requires accessory thermistor)
- Chilled fluid flow switch

LOW-AMBIENT OPERATION — If operating temperatures below 0° F (-18 C) are expected, refer to separate installation instructions for low-ambient operation, Motormaster® III control.

HOT GAS BYPASS — Hot gas bypass usually is *not* recommended because it results in application of equipment out of its normal design application range. However, if its use is required, the appropriate hot gas bypass package may be used. For installation details, refer to separate instructions supplied with the accessory package.

MISCELLANEOUS ACCESSORIES — For applications requiring special accessories, the following packages are available: condenser hail guard, gage panel, sound reduction kit, convenience outlet, and security grille package.

**PRE-START-UP**

**IMPORTANT:** Before beginning Pre-Start-Up or Start-Up, complete Start-Up Checklist for Flotronic™ Chiller Systems at center of this publication (page CL-1). The Checklist assures proper start-up of a unit, and provides a record of unit condition, application requirements, system information, and operation at initial start-up.

Do not attempt to start the chiller until following checks have been completed.

**System Check**

1. Check all auxiliary components, such as the chilled fluid circulating pump, air-handling equipment, or other equipment to which the chiller supplies liquid. Consult manufacturer's instructions. If the unit has field-installed accessories, be sure all are properly installed and wired correctly. Refer to unit wiring diagrams.
2. Backseat (open) compressor suction and discharge shut-off valves. Close valves one turn to allow refrigerant pressure to reach the test gages.
3. Open liquid line service valves.
4. Fill the chiller fluid circuit with clean water (with recommended inhibitor added) or other noncorrosive fluid to be cooled. Bleed all air out of high points of system. An air vent is included with the cooler. If

outdoor temperatures are expected to be below 32 F (0° C), sufficient inhibited ethylene glycol or other suitable corrosion-inhibited antifreeze should be added to the chiller water circuit to prevent possible freeze-up.

5. Check tightness of all electrical connections.
6. Oil should be visible in the compressor sight glass. See Fig. 18. An acceptable oil level in the compressor is from 1/8 to 3/8 of sight glass. Adjust the oil level as required. No oil should be removed unless the crankcase heater has been energized for at least 24 hours. See Oil Charge section on page 57 for Carrier-approved oils.
7. Electrical power source must agree with unit nameplate.
8. *Crankcase heaters must be firmly locked into compressors, and must be on for 24 hours prior to start-up.*
9. Fan motors are 3 phase. Check rotation of fans during the quick test (see Quick Test section below). Fan rotation is clockwise as viewed from top of unit. If fan is not turning clockwise, reverse 2 of the power wires.
10. Check compressor suspension. Mounting rails must be floating freely on the springs.
11. Perform quick test to verify proper settings. See Controls and Troubleshooting literature for more details.

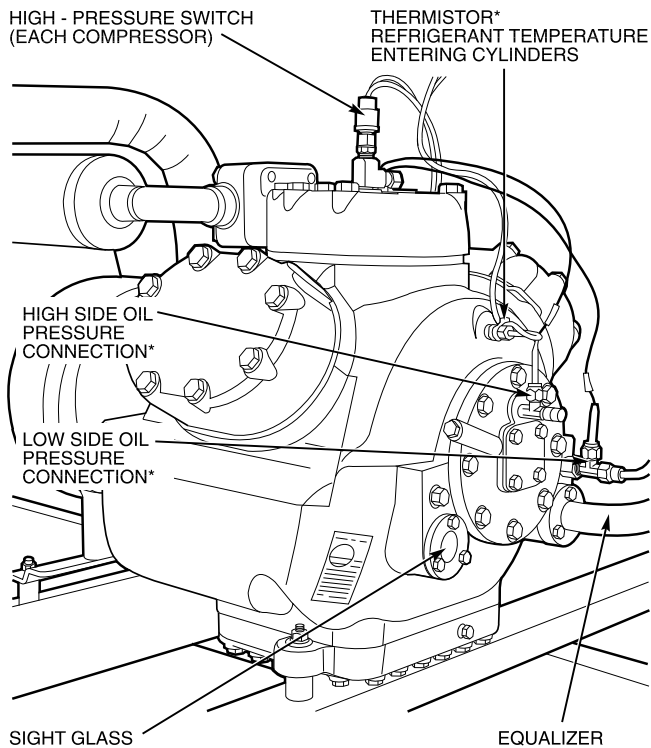

\*Lead compressor only.

**Fig. 18 — Compressor Connections  
(Lead Compressor Shown)**

**Quick Test (See Fig. 19 and Table 8)** — Both main power and control circuit power must be on.

The quick test program utilizes a 2-digit LED (light-emitting diode) display (Fig. 19) on set point board to show status of all input and output signals to microprocessor control. Display action and quick test procedure are described as follows:

The quick test is a 42-step program that provides a means of checking all input and output signals of microprocessor control prior to unit start-up. This check ensures that all control options, thermistors, and status switches are in proper working order.

To initiate the quick test program, first turn unit control switch to the ON position. When **20** appears in display, immediately press display button *once*. An **88** will appear in display; this indicates that microprocessor in control system is ready to run quick test program.

**IMPORTANT:** Do not allow unit control circuit to remain energized with **20** showing in display for more than 2 minutes. If display button is not pressed within this time, control will attempt to start unit.

For each step of the 42-step program, display button must be pressed *twice*. On first press, step number is displayed; second press initiates required action, and code as shown in Table 8 is displayed.

**NOTE:** Step number is a numeral followed by a decimal point (a 2-digit number has a decimal point after *each* numeral). Action code number is one or 2 digits with no decimal point(s).

**IMPORTANT:** Once quick test is initiated, display button must be pressed at least once every 10 minutes for control to remain in quick test mode. If button is not pressed within this time, control will attempt to start unit.

To recheck any step in quick test, control must be recycled by turning unit control circuit switch off for a few seconds, then on again. Restart quick test program as described above and proceed through quick test steps. Press display button *twice* for each step until step to be rechecked is reached.

The quick test program is divided into 3 sections as described below and shown in Table 8. For more detailed information, refer to Controls and Troubleshooting literature.

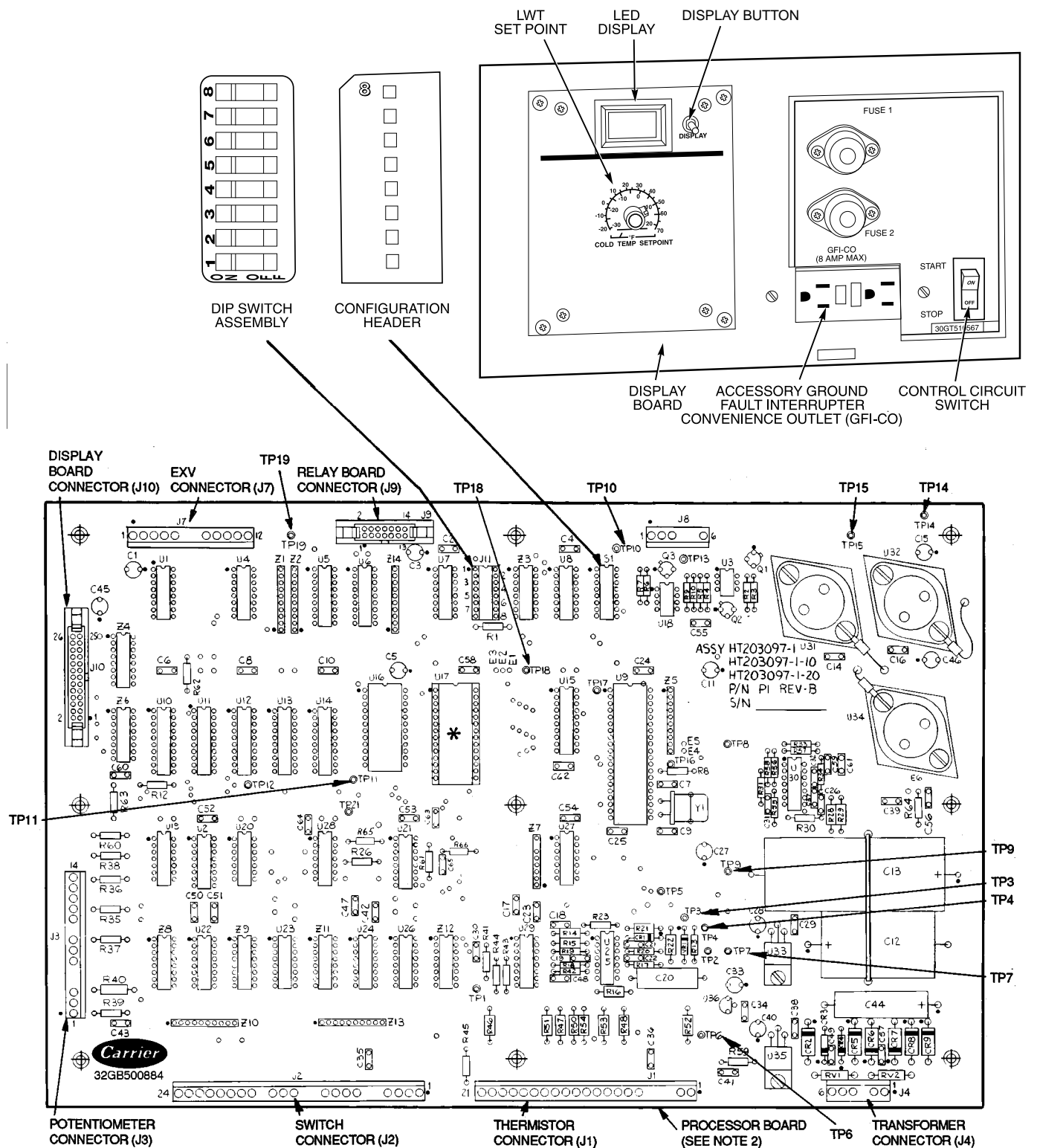

\*EPROM HT207101-1-XX.

**LEGEND**

- DIP — Dual In-Line Package
- EPROM — Erasable, Programmable, Read-Only Memory
- EXV — Electronic Expansion Valve
- LED — Light-Emitting Diode
- LWT — Leaving Water (Fluid) Temperature
- TP — Test Pin

**NOTES:**

1. Refer to Controls and Troubleshooting literature for details.
2. Processor board is rotated 90 degrees counterclockwise from position shown when installed in unit.
3. Do not remove label covering EPROM. Removal causes program to be erased.

**Fig. 19 — Center of Flotronic™ Control System (080-110 and 230B-315B Shown)**

**A. QUICK TEST STEPS 1 - 15: UNIT CONFIGURATION** — Microprocessor in unit control system is programmed by 2 switch assemblies located on processor board (Fig. 19). Configuration header is factory set and cannot be changed in the field. The DIP switch assembly contains 8 microswitches that must be set in accordance with various options and accessories selected. As shipped from factory, all DIP switches except those controlling pull-down option (switch no. 3) and compressor unloaders (switch no. 7 on 30GT080-330, and 360B 50 Hz units) are in OFF position. Switch no. 8 is in OFF position for water units, and ON position for brine units. All DIP switches should be checked and set to proper position for options selected during quick test.

The DIP switch assembly, functions, and display codes are shown in Fig. 19 and in Tables 8 and 9. Refer to Controls and Troubleshooting literature for details.

**B. QUICK TEST STEPS 16 - 30: THERMISTORS AND SET POINT POTENTIOMETERS** — In these steps, microprocessor checks resistance values of all sensors and set point potentiometers to ensure they are functional and set within proper range for unit configuration.

Nominal resistance values for all sensors range from 363,000 to 216 ohms. Normal display code for good sensors and potentiometers is **1**. Display code **0** indicates a faulty potentiometer, thermistor, or wiring. A **0** display can also indicate a particular option is not being used, i.e., demand limit not installed.

Tables 8 and 10 show set point potentiometer functions, locations, and quick test display codes.

**C. QUICK TEST STEPS 31 - 42: OUTPUT RELAYS** — These quick test steps allow microprocessor to check output signals from relay boards in unit control system. In addition, operation of all condenser fans and compressors is checked at each step.

Normal display code for steps **3.1** through **3.4** is **1**. In steps **3.5** through **4.2**, when appropriate, each compressor is started and allowed to run for approximately 10 seconds. At start-up **0** appears, followed by **1** in a few seconds. At end of 10-second test, code test, code **0** returns to display indicating that test step has been successfully completed. Code **1** indicated that compressor protection circuit (CPCS) or control relay (CR) was tested.

Fan and compressor operating sequence for quick test steps **3.1** through **4.2** are shown in Table 8 and Fig. 20.

If quick test steps do not operate as described, a defect exists in one or more of the following: relay being tested, electronic control, and/or unit wiring. Refer to Controls and Troubleshooting literature for additional information.

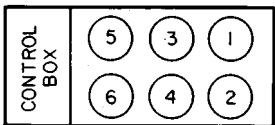
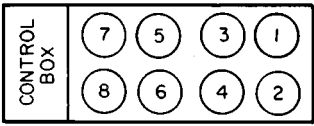
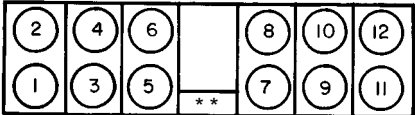
FAN ARRANGEMENT	FAN NO.	QUICK TEST DISPLAY NUMBER*	CONTROLLED BY
<b>30GT080,090,230B,245B</b> 	1	3.5.	Compressor No. A1
	2	3.9.	Compressor No. B1
	3,4	3.1.	First Stage of Condenser Fans
	5,6	3.2.	Second Stage of Condenser Fans
<b>30GT100,110,255B-315B</b> 	1	3.5.	Compressor No. A1
	2	3.9.	Compressor No. B1
	3,4	3.1.	First Stage of Condenser Fans
	5,6,7,8	3.2.	Second Stage of Condenser Fans
<b>30GT130-210 230A-315, 330A/B-420A/B†</b> 	5,7	3.5.	Compressor No. A1
	6,8	3.9.	Compressor No. B1
	3,4,9,10	3.1.	First Stage of Condenser Fans
	1,2,11,12	3.2.	Second Stage of Condenser Fans

\*During quick test only.

†Fan numbers 11 and 12 apply only to 190 and 210 and associated modular units (see Table 1).

\*\*Control box.

**Fig. 20 — Condenser Fan Sequence**

**Table 8 — Quick Test 88**  
**SECTION A. — Configuration and Switch Check**

QUICK TEST STEP NO.	NORMAL DISPLAY	STEP DESCRIPTION	HEADER POSITION OR CONTROL SWITCH
<span style="border: 1px solid black; padding: 0 2px;">1</span>	<span style="border: 1px solid black; padding: 0 2px;">00</span>	Type Unit — Air-Cooled Chiller	Configuration Header: 1 and 2
<span style="border: 1px solid black; padding: 0 2px;">2</span>	<span style="border: 1px solid black; padding: 0 2px;">3</span> through <span style="border: 1px solid black; padding: 0 2px;">7</span>	No. of Compressors  <span style="border: 1px solid black; padding: 0 2px;">3</span> = 080, 230B <span style="border: 1px solid black; padding: 0 2px;">4</span> = 090-110, 130 (60 Hz), 245B-315B <span style="border: 1px solid black; padding: 0 2px;">5</span> = 130 (50 Hz), 150, 230A-255A <span style="border: 1px solid black; padding: 0 2px;">6</span> = 170, 190, 270A, 290A, 330A/B, 360A/B, 390B <span style="border: 1px solid black; padding: 0 2px;">7</span> = 210, 315A, 390A, 420A/B	Configuration Header: 3, 4, and 5
<span style="border: 1px solid black; padding: 0 2px;">3</span>	<span style="border: 1px solid black; padding: 0 2px;">0</span> or <span style="border: 1px solid black; padding: 0 2px;">2</span>	No. of Unloaders  <span style="border: 1px solid black; padding: 0 2px;">0</span> = Switch 6 Off, Switch 7 Off <span style="border: 1px solid black; padding: 0 2px;">1</span> = Switch 6 On, Switch 7 Off <span style="border: 1px solid black; padding: 0 2px;">2</span> = Switch 6 Off, Switch 7 On  NOTE: There are no unloaders on 190, 210 and associated modular units.	DIP Switches 6 and 7
<span style="border: 1px solid black; padding: 0 2px;">4</span>	<span style="border: 1px solid black; padding: 0 2px;">0</span> or <span style="border: 1px solid black; padding: 0 2px;">1</span>	 <span style="border: 1px solid black; padding: 0 2px;">0</span> = Water <span style="border: 1px solid black; padding: 0 2px;">1</span> = Brine*	DIP Switch 8
<span style="border: 1px solid black; padding: 0 2px;">5</span>	<span style="border: 1px solid black; padding: 0 2px;">1</span> or <span style="border: 1px solid black; padding: 0 2px;">0</span>	 <span style="border: 1px solid black; padding: 0 2px;">1</span> = EXV <span style="border: 1px solid black; padding: 0 2px;">0</span> = TXV	Configuration Header: 6
<span style="border: 1px solid black; padding: 0 2px;">6</span>	<span style="border: 1px solid black; padding: 0 2px;">50</span> or <span style="border: 1px solid black; padding: 0 2px;">60</span>	 <span style="border: 1px solid black; padding: 0 2px;">50</span> = 50 Hz <span style="border: 1px solid black; padding: 0 2px;">60</span> = 60 Hz	Configuration Header: 7
<span style="border: 1px solid black; padding: 0 2px;">7</span>	<span style="border: 1px solid black; padding: 0 2px;">0</span> or <span style="border: 1px solid black; padding: 0 2px;">1</span>	 <span style="border: 1px solid black; padding: 0 2px;">0</span> = External Reset <span style="border: 1px solid black; padding: 0 2px;">1</span> = Return Fluid Reset	DIP Switch 1
<span style="border: 1px solid black; padding: 0 2px;">8</span>	<span style="border: 1px solid black; padding: 0 2px;">0</span> or <span style="border: 1px solid black; padding: 0 2px;">1</span>	 <span style="border: 1px solid black; padding: 0 2px;">0</span> = Reset Disabled <span style="border: 1px solid black; padding: 0 2px;">1</span> = Reset Enabled	DIP Switch 2
<span style="border: 1px solid black; padding: 0 2px;">9</span>	<span style="border: 1px solid black; padding: 0 2px;">0</span> or <span style="border: 1px solid black; padding: 0 2px;">1</span>	 <span style="border: 1px solid black; padding: 0 2px;">0</span> = Pulldown Disabled <span style="border: 1px solid black; padding: 0 2px;">1</span> = Pulldown Enabled	DIP Switch 3
<span style="border: 1px solid black; padding: 0 2px;">10</span>	<span style="border: 1px solid black; padding: 0 2px;">0</span> or <span style="border: 1px solid black; padding: 0 2px;">1</span>	 <span style="border: 1px solid black; padding: 0 2px;">0</span> = Demand Limit Disabled <span style="border: 1px solid black; padding: 0 2px;">1</span> = Demand Limit Enabled	DIP Switch 5
<span style="border: 1px solid black; padding: 0 2px;">11</span>	<span style="border: 1px solid black; padding: 0 2px;">0</span> or <span style="border: 1px solid black; padding: 0 2px;">1</span>	 <span style="border: 1px solid black; padding: 0 2px;">0</span> = Remote On/Off — Switch/Jumper Open <span style="border: 1px solid black; padding: 0 2px;">1</span> = Remote On/Off — Switch/Jumper Closed	TB6-3 and TB6-4
<span style="border: 1px solid black; padding: 0 2px;">12</span>	<span style="border: 1px solid black; padding: 0 2px;">0</span> or <span style="border: 1px solid black; padding: 0 2px;">1</span>	 <span style="border: 1px solid black; padding: 0 2px;">0</span> = Loss-of-Charge Switch A Open <span style="border: 1px solid black; padding: 0 2px;">1</span> = Loss-of-Charge Switch A Closed	Circuit A Loss-of-Charge Switch
<span style="border: 1px solid black; padding: 0 2px;">13</span>	<span style="border: 1px solid black; padding: 0 2px;">0</span> or <span style="border: 1px solid black; padding: 0 2px;">1</span>	 <span style="border: 1px solid black; padding: 0 2px;">0</span> = Loss-of-Charge Switch B Open <span style="border: 1px solid black; padding: 0 2px;">1</span> = Loss-of-Charge Switch B Closed	Circuit B Loss-of-Charge Switch
<span style="border: 1px solid black; padding: 0 2px;">14</span>	<span style="border: 1px solid black; padding: 0 2px;">0</span> or <span style="border: 1px solid black; padding: 0 2px;">1</span>	 <span style="border: 1px solid black; padding: 0 2px;">0</span> = Low Oil Pressure Switch A Open <span style="border: 1px solid black; padding: 0 2px;">1</span> = Low Oil Pressure Switch A Closed	Circuit A Low Oil Pressure Switch
<span style="border: 1px solid black; padding: 0 2px;">15</span>	<span style="border: 1px solid black; padding: 0 2px;">0</span> or <span style="border: 1px solid black; padding: 0 2px;">1</span>	 <span style="border: 1px solid black; padding: 0 2px;">0</span> = Low Oil Pressure Switch B Open <span style="border: 1px solid black; padding: 0 2px;">1</span> = Low Oil Pressure Switch B Closed	Circuit B Low Oil Pressure Switch

See legend and notes on page 49.

**Table 8 — Quick Test 88 (cont)**  
**SECTION B. — Thermistor and Potentiometer Checkout**

QUICK TEST STEP NO.	NORMAL DISPLAY	STEP DESCRIPTION	THERMISTOR OR POTENTIOMETER
<span style="border: 1px solid black; padding: 0 2px;">1.6.</span>	<span style="border: 1px solid black; padding: 0 2px;">1</span>	<span style="border: 1px solid black; padding: 0 2px;">1</span> — Thermistor OK <span style="border: 1px solid black; padding: 0 2px;">0</span> — Thermistor Faulty	T1 — Cooler Leaving Fluid Thermistor
<span style="border: 1px solid black; padding: 0 2px;">1.7.</span>	<span style="border: 1px solid black; padding: 0 2px;">1</span>	<span style="border: 1px solid black; padding: 0 2px;">1</span> — Thermistor OK <span style="border: 1px solid black; padding: 0 2px;">0</span> — Thermistor Faulty	T2 — Cooler Entering Fluid Thermistor
<span style="border: 1px solid black; padding: 0 2px;">1.8.</span>	<span style="border: 1px solid black; padding: 0 2px;">1</span>	<span style="border: 1px solid black; padding: 0 2px;">1</span> — Thermistor OK <span style="border: 1px solid black; padding: 0 2px;">0</span> — Thermistor Faulty	T3 — Saturated Condensing Thermistor, Circuit A
<span style="border: 1px solid black; padding: 0 2px;">1.9.</span>	<span style="border: 1px solid black; padding: 0 2px;">1</span>	<span style="border: 1px solid black; padding: 0 2px;">1</span> — Thermistor OK <span style="border: 1px solid black; padding: 0 2px;">0</span> — Thermistor Faulty	T4 — Saturated Condensing Thermistor, Circuit B
<span style="border: 1px solid black; padding: 0 2px;">2.0.</span>	<span style="border: 1px solid black; padding: 0 2px;">1</span> or <span style="border: 1px solid black; padding: 0 2px;">0</span>	<span style="border: 1px solid black; padding: 0 2px;">1</span> † — Thermistor OK <span style="border: 1px solid black; padding: 0 2px;">0</span> — Thermistor Faulty or Not Used	T5 — Cooler Thermistor, Circuit A (EXV Units)
<span style="border: 1px solid black; padding: 0 2px;">2.1.</span>	<span style="border: 1px solid black; padding: 0 2px;">1</span> or <span style="border: 1px solid black; padding: 0 2px;">0</span>	<span style="border: 1px solid black; padding: 0 2px;">1</span> † — Thermistor OK <span style="border: 1px solid black; padding: 0 2px;">0</span> — Thermistor Faulty or Not Used	T6 — Cooler Thermistor, Circuit B (EXV Units)
<span style="border: 1px solid black; padding: 0 2px;">2.2.</span>	<span style="border: 1px solid black; padding: 0 2px;">1</span> or <span style="border: 1px solid black; padding: 0 2px;">0</span>	<span style="border: 1px solid black; padding: 0 2px;">1</span> † — Thermistor OK <span style="border: 1px solid black; padding: 0 2px;">0</span> — Thermistor Faulty or Not Used	T7 — Compressor Thermistor, Circuit A ( EXV Units)
<span style="border: 1px solid black; padding: 0 2px;">2.3.</span>	<span style="border: 1px solid black; padding: 0 2px;">1</span> or <span style="border: 1px solid black; padding: 0 2px;">0</span>	<span style="border: 1px solid black; padding: 0 2px;">1</span> † — Thermistor OK <span style="border: 1px solid black; padding: 0 2px;">0</span> — Thermistor Faulty or Not Used	T8 — Compressor Thermistor, Circuit B (EXV Units)
<span style="border: 1px solid black; padding: 0 2px;">2.4.</span>	<span style="border: 1px solid black; padding: 0 2px;">1</span> or <span style="border: 1px solid black; padding: 0 2px;">0</span>	<span style="border: 1px solid black; padding: 0 2px;">1</span> — Thermistor OK <span style="border: 1px solid black; padding: 0 2px;">0</span> — Thermistor Faulty or Not Used	T10 — Accessory Remote Thermistor
<span style="border: 1px solid black; padding: 0 2px;">2.5.</span>	<span style="border: 1px solid black; padding: 0 2px;">1</span>	<span style="border: 1px solid black; padding: 0 2px;">1</span> — Potentiometer OK <span style="border: 1px solid black; padding: 0 2px;">0</span> — Potentiometer Faulty	P1 — Leaving Fluid Set Point Potentiometer
<span style="border: 1px solid black; padding: 0 2px;">2.6.</span>	<span style="border: 1px solid black; padding: 0 2px;">0</span>	No Significance	—
<span style="border: 1px solid black; padding: 0 2px;">2.7.</span>	<span style="border: 1px solid black; padding: 0 2px;">1</span> or <span style="border: 1px solid black; padding: 0 2px;">0</span>	<span style="border: 1px solid black; padding: 0 2px;">1</span> — Potentiometer OK <span style="border: 1px solid black; padding: 0 2px;">0</span> — Potentiometer Faulty or Option Not Used	P3 — Accessory Reset Limit Potentiometer
<span style="border: 1px solid black; padding: 0 2px;">2.8.</span>	<span style="border: 1px solid black; padding: 0 2px;">1</span> or <span style="border: 1px solid black; padding: 0 2px;">0</span>	<span style="border: 1px solid black; padding: 0 2px;">1</span> — Potentiometer(s) OK <span style="border: 1px solid black; padding: 0 2px;">0</span> — Potentiometer(s) Faulty or Option Not Used	P4 — Accessory Demand Limit Potentiometer(s)
<span style="border: 1px solid black; padding: 0 2px;">2.9.</span>	<span style="border: 1px solid black; padding: 0 2px;">1</span> or <span style="border: 1px solid black; padding: 0 2px;">0</span>	<span style="border: 1px solid black; padding: 0 2px;">1</span> — Potentiometer OK <span style="border: 1px solid black; padding: 0 2px;">0</span> — Potentiometer Faulty or Option Not Used	P5 — Accessory Reset Ratio Potentiometer
<span style="border: 1px solid black; padding: 0 2px;">3.0.</span>	<span style="border: 1px solid black; padding: 0 2px;">1</span> or <span style="border: 1px solid black; padding: 0 2px;">0</span>	<span style="border: 1px solid black; padding: 0 2px;">1</span> — Potentiometer OK <span style="border: 1px solid black; padding: 0 2px;">0</span> — Potentiometer Faulty or Option Not Used	P6 — Accessory Reset Set Point Potentiometer

NOTE: See legend and notes on page 49.

**Table 8 — Quick Test 88 (cont)**  
**SECTION C. — Output Relay Check**

QUICK TEST STEP NO.	NORMAL DISPLAY	STEP DESCRIPTION	RELAY NO.
<span style="border: 1px solid black; padding: 0 2px;">3.1.</span>	<span style="border: 1px solid black; padding: 0 2px;">1</span>	Energize First Stage of Condenser Fans 080-110** — OFM3, OFM4 130-210** — OFM3, OFM4, OFM9, OFM10	K11
<span style="border: 1px solid black; padding: 0 2px;">3.2.</span>	<span style="border: 1px solid black; padding: 0 2px;">1</span>	Energize Second Stage of Condenser Fans 080, 090** — OFM5, OFM6 100, 110** — OFM5, OFM6, OFM7, OFM8 130-170** — OFM1, OFM2 190, 210** — OFM1, OFM2, OFM11, OFM12	K12
<span style="border: 1px solid black; padding: 0 2px;">3.3.</span>	<span style="border: 1px solid black; padding: 0 2px;">1</span>	Energize Liquid Line Solenoid Valve (080-110, TXV only), Circuit A	K9
<span style="border: 1px solid black; padding: 0 2px;">3.4.</span>	<span style="border: 1px solid black; padding: 0 2px;">1</span>	Energize Liquid Line Solenoid Valve (080-110, TXV only), Circuit B	K10
<span style="border: 1px solid black; padding: 0 2px;">3.5.</span>	<span style="border: 1px solid black; padding: 0 2px;">0</span> → <span style="border: 1px solid black; padding: 0 2px;">1</span> → <span style="border: 1px solid black; padding: 0 2px;">0</span> ††	Energize Compressor A1 and OFM1 (008-110**) Energize Compressor A1, OFM5, and OFM7 (all other unit sizes)	K1
<span style="border: 1px solid black; padding: 0 2px;">3.6.</span>	<span style="border: 1px solid black; padding: 0 2px;">0</span> → <span style="border: 1px solid black; padding: 0 2px;">1</span> → <span style="border: 1px solid black; padding: 0 2px;">0</span> ††	Energize Compressor A2	K2
<span style="border: 1px solid black; padding: 0 2px;">3.7.</span>	<span style="border: 1px solid black; padding: 0 2px;">0</span>	No Action (080-110, 130 [60 Hz]**)	K3
	<span style="border: 1px solid black; padding: 0 2px;">0</span> → <span style="border: 1px solid black; padding: 0 2px;">1</span> → <span style="border: 1px solid black; padding: 0 2px;">0</span> ††	Energize Compressor A3 (130 [50 Hz], 150-210**)	
<span style="border: 1px solid black; padding: 0 2px;">3.8.</span>	<span style="border: 1px solid black; padding: 0 2px;">0</span>	Energize Unloader A1 (080-170**)	K4
	<span style="border: 1px solid black; padding: 0 2px;">0</span> → <span style="border: 1px solid black; padding: 0 2px;">1</span> → <span style="border: 1px solid black; padding: 0 2px;">0</span> ††	Energize Compressor A4 (210**)	
<span style="border: 1px solid black; padding: 0 2px;">3.9.</span>	<span style="border: 1px solid black; padding: 0 2px;">0</span> → <span style="border: 1px solid black; padding: 0 2px;">1</span> → <span style="border: 1px solid black; padding: 0 2px;">0</span> ††	Energize Compressor B1, OFM2 (080-110**) Energize Compressor B1, OFM6, and OFM8 (all other unit sizes)	K5
<span style="border: 1px solid black; padding: 0 2px;">4.0.</span>	<span style="border: 1px solid black; padding: 0 2px;">0</span> → <span style="border: 1px solid black; padding: 0 2px;">1</span> → <span style="border: 1px solid black; padding: 0 2px;">0</span> ††	No Action (080**) Energize Compressor B2 (all other unit sizes)	K6
<span style="border: 1px solid black; padding: 0 2px;">4.1.</span>	<span style="border: 1px solid black; padding: 0 2px;">0</span>	No Action (080-150**)	K7
	<span style="border: 1px solid black; padding: 0 2px;">0</span> → <span style="border: 1px solid black; padding: 0 2px;">1</span> → <span style="border: 1px solid black; padding: 0 2px;">0</span> ††	Energize Compressor B3 (170-210)	
<span style="border: 1px solid black; padding: 0 2px;">4.2.</span>	<span style="border: 1px solid black; padding: 0 2px;">0</span>	Energize Unloader B1 (080-170) No Action (190-210**)	K8

**LEGEND**

- CPCS** — Compressor Protection Control System
- CR** — Control Relay
- DIP** — Dual, In-Line Package
- EXV** — Electronic Expansion Valve
- FIOP** — Factory-Installed Option
- OFM** — Outdoor (Condenser) Fan Motor
- TB** — Terminal Block
- TXV** — Thermostatic Expansion Valve

\*Do not change select switch to brine on units that do not have modifications for brine. Special modifications are required. Contact Carrier for details.

†Display is 1 for Flotronic™ EXV units only.

Display is 0 for 080-110 Flotronic FIOP units (with TXV).

\*\*And associated modular units.

††Compressors will be energized for 10 seconds. 0 indicates open CPCS or CR module contacts (compressor energized). 1 indicates closed CPCS or CR contacts (compressor deenergized).

**Table 9 — DIP Switch Functions**

DIP SWITCH NO.	SELECTED FUNCTION*
1	Type of Reset
2	Reset
3	Pull Down Limit
4	Not Used
5	Demand Limit
6	1 Unloader
7	2 Unloaders
8	Brine

**LEGEND**

**DIP** — Dual In-Line Package

\*Refer to Table 8, Quick Test steps 3. through 1.0.

**Table 10 — Potentiometer Locations**

POTENTIOMETER	LOCATION
<b>P1 — Leaving Fluid Set Point</b>	Set Point Board (Standard)
<b>P3 — Reset Limit Set Point</b>	Accessory Board (Option)
<b>P4 — Demand Limit Set Point</b>	Accessory Board (Option)
<b>P5 — Reset Ratio Set Point</b>	Accessory Board (Option)
<b>P6 — Reset Temp Set Point</b>	Accessory Board (Option)

**START-UP AND OPERATION**

NOTE: Complete Start-Up Checklist at center of publication (page CL-1) prior to starting unit.

**Digital Display Action** — The electronic control system uses a 2-digit LED display located on display set point board (see Fig. 19) to show operational information and diagnostic codes.

When control ON-OFF switch is turned to ON position, display shows **20** for 2 minutes to indicate control is in initialization mode. The EXV will be closed as part of initialization sequence. This does not occur on FIOP units, where a conventional TXV is used.

After a 2-minute period, display turns off and unit is allowed to start. If button is pressed after the **20** has been removed from display, operational status codes or diagnostic information will be shown as long as button is held in. Code numbers on display have following significance:

CODE NUMBER	OPERATIONAL STATUS
<b>0-12</b>	Capacity stage
<b>20-26</b>	Operational information
<b>51-87</b>	Overload information

Under normal operation, only stage number is displayed. If an operational status code or an overload code is displayed, the display rotates every 2 seconds and displays up to 3 numbers. Overload information will take priority over all other codes. The codes are stored by the microprocessor as long as board is energized.

**IMPORTANT:** The alarm memory is cleared when control power is removed.

**Actual Start-Up** — *Actual start-up should be done only under supervision of a qualified refrigeration mechanic.*

1. Be sure all service valves are open. The unit is shipped from the factory with the suction, discharge, and liquid line service valves closed.
2. Set leaving fluid temperature. No cooling range adjustment is necessary.

3. If accessory reset boards are used, set potentiometers properly. Refer to Controls and Troubleshooting literature for details.
4. Start chilled fluid pump.
5. Turn ON-OFF switch to ON position. The display will read **20**. During this time the machine checks all potentiometers and thermistors for valid readings. In approximately 2 minutes, the **20** reading is no longer displayed, and the machine is operational.

Allow the unit to operate and confirm that everything is functioning properly. Check the leaving fluid temperature and be sure that it agrees with the set point potentiometer P1. If the temperature setting does not agree, the set point can be compensated by shifting the control point slightly. If temperature reset is in effect, the leaving fluid temperature may not agree with the set point.

**Operating Limitations**

**TEMPERATURES** (See Table 11) — If unit is to be used in an area with high solar radiation, mounted position should be such that control box is not exposed to direct solar radiation. Exposure to direct solar radiation could affect the temperature switch controlling cooler heaters.

**Table 11 — Temperature Limits**

TEMPERATURES	F	C
<b>Maximum Ambient Temp</b>	125	52
<b>Minimum Ambient Temp</b>	0	-18
<b>Maximum Cooler EWT*</b>	95	35
<b>Maximum Cooler LWT</b>	70	21
<b>Minimum Cooler LWT†</b>	40	4.5

**LEGEND**

**EWT** — Entering Fluid (Water) Temperature  
**LWT** — Leaving Fluid (Water) Temperature

\*For sustained operation, it is recommended that EWT *NOT* exceed 85 F (29.4 C).

†Unit and/or DIP (dual-in-line package) switch requires modification below this temperature.

**Low-Ambient Operation** — If operating temperatures below 0° F (-18 C) are expected, refer to separate installation instructions for low-ambient operation/Motormaster® III control. Contact your Carrier representative for details.

**High Cooler LCWT (Leaving Chilled Water [Fluid] Temperature)** — During start-up with leaving fluid temperatures above approximately 60 F (16 C), expansion valves (EXV and FIOP TXV for 080-110 sizes) limit suction pressure to approximately 90 psig (620 kPa) to avoid overloading compressor.

**Low Cooler LCWT** — Application of chillers within 39.9 F to 34 F (4.4 C to 1.1 C) temperature range is possible in some situations with proper field change of control configuration. This requires that DIP switch no. 8 (brine switch) of J11 on the processor board be set to ON position. See Tables 8 and 9.

**⚠ WARNING**

Do not operate with leaving water temperature below 34 F (1.1 C). Application in the range 34 F to 15 F (1° C to -9.4 C) requires chiller with factory modification for brine duty (only applicable to certain units). Contact your Carrier representative for details.

## VOLTAGE

**Main Power Supply** — Minimum and maximum acceptable supply voltages are listed in Tables 4A-4C.

**Unbalanced 3-Phase Supply Voltage:**

Never operate a motor where a phase imbalance between phases is greater than 2%. To determine percentage of voltage imbalance:

$$\% \text{ Voltage Imbalance} = 100 \times \frac{\text{max voltage deviation from avg voltage}}{\text{average voltage}}$$

The maximum voltage deviation is the largest difference between a voltage measurement across 2 legs and the average across all 3 legs.

EXAMPLE: Supply voltage is 240-3-60.

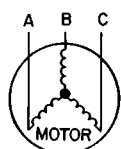

AB = 243 v

BC = 236 v

AC = 238 v

$$\begin{aligned} \text{Average voltage} &= \frac{243 + 236 + 238}{3} \\ &= \frac{717}{3} \\ &= 239 \text{ v} \end{aligned}$$

Determine maximum deviation from average voltage:

(AB) 243 – 239 = 4 v

(BC) 239 – 236 = 3 v

(AC) 239 – 238 = 1 v

Maximum deviation is 4 v.

Determine percentage of voltage imbalance:

$$\begin{aligned} \% \text{ Voltage Imbalance} &= 100 \times \frac{4}{239} \\ &= 1.7\% \end{aligned}$$

This voltage imbalance is satisfactory as it is below the maximum allowable 2%.

**IMPORTANT:** If the supply voltage phase imbalance is more than 2%, contact your local electric utility company immediately. Do not operate unit until imbalance condition is corrected.

**Control Circuit Power** — Electronic control includes logic to detect low control circuit voltage. Acceptable voltage range is shown in Table 5.

**MINIMUM FLUID LOOP VOLUME** — To obtain proper temperature control, loop fluid volume must be at least 3 gal per ton (3.25 L per kW) of chiller nominal capacity for air conditioning and at least 6 gal per ton (6.5 L per kW) for process applications or systems that must operate in low ambients (below 32 F [0° C]). Refer to application information in Product Data literature for details.

**FLOW RATE REQUIREMENTS** — Standard chillers should be applied with nominal flow rates approximating those listed in Table 12. Higher or lower flow rates are permissible to obtain lower or higher temperature rises. Minimum flow rates *must be maintained or exceeded* to assure turbulent flow and proper heat transfer in the cooler.

### **⚠ WARNING**

Operation below minimum flow could subject tubes to frost pinching in tube sheet, resulting in failure of cooler.

Consult application data and job design requirements to determine flow rate requirements for particular installation.

**Table 12 — Nominal and Minimum Cooler Fluid Flow Rates**

30GT UNIT SIZE	NOMINAL FLOW RATE*		MINIMUM FLOW RATE (See Notes)	
	Gpm	L/s	Gpm	L/s
080,230B	192	12.11	66.7	4.2
090,245B	216	13.62	66.7	4.2
100,255B,270B	240	15.14	84.1	5.3
110,290B,315B	264	16.65	84.1	5.3
130	300	18.9	110	6.9
150,230A,245A,255A	348	21.9	110	6.9
170,270A,330,360B (50 Hz)	384	24.2	120	7.5
190,290A,360A/B (60 Hz), 360A (50 Hz), 390B	432	27.2	120	7.5
210,315A,390A,420A/B	480	30.2	148	9.3

#### LEGEND

**ARI** — Air Conditioning and Refrigeration Institute (U.S.A.)

**Gpm** — Gallons per minute (U.S.A.)

**L/s** — Liters per second

**N** — Liters per kW

**V** — Gallons per ton

\*Nominal flow rates required at ARI conditions 44 F (7 C) leaving fluid temperature, 54 F (12 C) entering fluid temperature, 95 F (35 C) ambient. Fouling factor .00025 ft<sup>2</sup> · hr · F/Btu (.000044 m<sup>2</sup> · K/W).

#### NOTES:

- Minimum flow based on 1.0 fps (0.30 m/s) velocity in cooler without special cooler baffling.
- Minimum Loop Volumes:  
Gallons = V x ARI Cap. (tons)  
Liters = N x ARI Cap. (kW)

APPLICATION	V	N
Normal Air Conditioning	3	3.25
Process Type Cooling	6 to 10	6.5 to 10.8
Low Ambient Unit Operation	6 to 10	6.5 to 10.8

**Operation Sequence** — During unit off cycle, crankcase heaters are energized. If ambient temperature is below 36 F (2 C), cooler heaters and a microprocessor board heater are also energized.

When control ON-OFF switch is turned to ON position, control first goes through a 2-minute initialization period, during which the display continuously shows **20**. Ninety (90) seconds after **20** leaves display, control begins to bring on compressors. Rate at which compressors are started depends on leaving chilled fluid temperature and rate of change of leaving fluid temperature.

An automatic lead-lag feature in control system on all units determines by random selection whether circuit A or B starts first.

At first call for cooling, microprocessor starts first compressor, deenergizes crankcase heater, and starts one condenser fan.

## UNITS WITH ELECTRONIC EXPANSION VALVE (EXV)

— The EXV remains closed for 10 seconds to purge cooler and suction line of any liquid refrigerant that may have migrated to these areas during off period. After 10 seconds, EXV starts to open. As more cooling is required, control brings on additional stages of capacity. Loading sequence for compressors is shown in Table 13. Automatic lead-lag control is provided on all units.

Lag compressor will shut down, and lead compressor will continue to run. After lag compressor has shut down, the EXV is signaled to close. Lead compressor remains on until EXV is less than 300 steps open, and the saturated suction temperature is less than 25 F (–4 C) as sensed by cooler thermistor T5 or T6, or until one minute has elapsed.

## 30GT080-110 UNITS WITH OPTIONAL THERMOSTATIC EXPANSION VALVE (TXV)

NOTE: The TXV option is available for 080-110 units only and does not apply to associated modular units.

Liquid line solenoid valve is not energized for first 10 seconds of compressor operation. This is called pre-pumpout cycle.

Microprocessor determines how rapidly capacity stages are added or subtracted based on deviation from leaving chilled fluid temperature set point and rate of change of leaving fluid temperature. If fluid temperature is very warm and pulldown option is being used, microprocessor limits rate of temperature drop of leaving fluid to 1° F (0.56° C) per minute to avoid high peak kW charges. If the capacity is being limited by pulldown, the control display shows **24** when the display button is pressed. Once capacity has been satisfied, the unit starts to shut down.

Lag compressor will be shut down and lead compressor continues to run for 10 seconds to purge cooler of any refrigerant.

**LOAD SHED** — If load shed option is being used, control limits maximum capacity to load shed input value. Refer to Controls and Troubleshooting literature for details. If capacity is limited by a load shed signal, display shows **22** when display button is pressed.

**TEMPERATURE RESET** — If temperature reset is being used, microprocessor adjusts leaving fluid temperature to obtain greater part-load efficiency. Refer to Controls and Troubleshooting literature for details. If leaving fluid temperature is being reset, display shows **21** when the display button is pressed.

## HEAD PRESSURE CONTROL

*Units with EXV* — Microprocessor controls EXV to maintain a superheat of 30° F (16.7° C) entering compressor cylinders.

Microprocessor control also cycles condenser fans on and off to maintain an adequate pressure differential across EXVs. Fans are controlled by position of EXV and saturated condensing temperature thermistors. When EXV is fully open and superheat is greater than 40° F (22° C), fan stages are removed; when the valve is approximately half open, fan stages are added. This allows unit to run at very low condensing temperatures at part load. Thus chiller has very high part-load EERs (energy efficiency ratios). Fan sequence is shown in Fig. 20. Refer to Controls and Troubleshooting literature for more head pressure control information.

*Units with TXV (30GT080-110 Only)* — There is one TXV for each refrigerant circuit, and each TXV is factory set to maintain 8 to 10° F (5 to 6° C) superheat of vapor leaving cooler to control flow of liquid refrigerant into cooler. Superheat can be reset but should be reset only if necessary.

Logic to cycle microprocessor-controlled fans is based on saturated condensing temperature only. This temperature is sensed by thermistors T3 and T4 (Fig. 21 and 22). The microprocessor turns on an additional stage of fans when either coil thermistor (T3 or T4) is greater than 113 F (45 C) and turns off a fan stage when T3 and T4 are both below 73 F (23 C). Between each change in fan stage, control waits one minute to allow head pressure to stabilize unless either T3 or T4 is greater than 125 F (52 C), in which case all microprocessor-controlled fans come on immediately.

Condenser fan sequence is shown in Fig. 20.

**REMOTE ON-OFF** — In applications where controlling the starting and stopping of the chiller from a remote location is desired, such as a remote timeclock, the remote on-off feature is used. See Fig. 16 and 17 for wiring information. If the chiller is being held off by the remote on-off switch, **2b** appears in the display when the display button is pressed.

NOTE: DO NOT USE FLUID PUMP to cycle chiller on and off except as a safety feature. Cycling of chiller must be accomplished through the remote on-off switch, since the fluid pump must continue to run for 1 minute after initialization of pumpdown.

**REMOTE ALARM** — See Fig. 16 and 17 for remote alarm field wiring.

**Table 13 — Capacity Control Steps**

30GT UNIT SIZE	CONTROL STEPS	LOADING SEQUENCE A		LOADING SEQUENCE B	
		% Displ.	Compressors	% Displ.	Compressors
080,230B (60 Hz) A1†, B1†	1	22	A1*	29	B1*
	2	52	A1*,B1*	52	A1*,B1*
	3	67	A1*, B1	63	A1,B1*
	4	78	A1,B1	78	A1,B1
	5	89	A1*,A2,B1	89	A1*,A2,B1
	6	100	A1,A2,B1	100	A1,A2,B1
080,230B (50 Hz) A1†, B1†	1	16	A1*	25	B1*
	2	42	A1*,B1*	42	A1*,B1*
	3	54	A1*,B1	50	A1,B1*
	4	62	A1,B1	62	A1,B1
	5	92	A1*,A2,B1	92	A1*,A2,B1
	6	100	A1,A2,B1	100	A1,A2,B1
090,245B (60 Hz) A1†, B1†	1	18	A1*	18	B1*
	2	35	A1*,B1*	35	A1*,B1*
	3	44	A1*,B1	44	A1,B1*
	4	53	A1,B1	53	A1,B1
	5	65	A1*,A2,B1	71	A1,B1*,B2
	6	73	A1,A2,B1	80	A1,B1,B2
	7	91	A1*,A2,B1,B2	91	A1,A2,B1*,B2
	8	100	A1,A2,B1,B2	100	A1,A2,B1,B2
090,245B (50 Hz) A1†, B1†	1	14	A1*	14	B1*
	2	29	A1*,B1*	29	A1*,B1*
	3	36	A1*,B1	36	A1,B1*
	4	43	A1,B1	43	A1,B1
	5	68	A1*,A2,B1	60	A1,B1*,B2
	6	75	A1,A2,B1	67	A1,B1,B2
	7	93	A1*,A2,B1,B2	93	A1,A2,B1*,B2
	8	100	A1,A2,B1,B2	100	A1,A2,B1,B2
100,255B,270B (60 Hz) A1†, B1†	1	15	A1*	15	B1*
	2	31	A1*,B1*	31	A1*,B1*
	3	39	A1*,B1	39	A1,B1*
	4	46	A1,B1	46	A1,B1
	5	65	A1*,A2,B1	65	A1,B1*,B2
	6	73	A1,A2,B1	73	A1,B1,B2
	7	92	A1*,A2,B1,B2	92	A1,A2,B1*,B2
	8	100	A1,A2,B1,B2	100	A1,A2,B1,B2
100,255B,270B (50 Hz) A1†, B1†	1	13	A1*	13	B1*
	2	26	A1*,B1*	26	A1*,B1*
	3	33	A1*, B1	33	A1,B1*
	4	40	A1,B1	40	A1,B1
	5	63	A1*,A2,B1	63	A1,B1*,B2
	6	70	A1,A2,B1	70	A1,B1,B2
	7	93	A1*,A2,B1,B2	93	A1,A2,B1*,B2
	8	100	A1,A2,B1,B2	100	A1,A2,B1,B2
110,290B,315B (60 Hz) A1†, B1†	1	14	A1*	14	B1*
	2	29	A1*,B1*	29	A1*,B1*
	3	36	A1*,B1	36	A1,B1*
	4	43	A1,B1	43	A1,B1
	5	68	A1*,A2,B1	60	A1,B1*,B2
	6	75	A1,A2,B1	67	A1,B1,B2
	7	93	A1*,A2,B1,B2	93	A1,A2,B1*,B2
	8	100	A1,A2,B1,B2	100	A1,A2,B1,B2
110,290B,315B (50 Hz) A1†, B1†	1	17	A1*	17	B1*
	2	33	A1*,B1*	33	A1*,B1*
	3	42	A1*,B1	42	A1,B1*
	4	50	A1,B1	50	A1,B1
	5	67	A1*,A2,B1	67	A1,B1*,B2
	6	75	A1,A2,B1	75	A1,B1,B2
	7	92	A1*,A2,B1,B2	92	A1,A2,B1*,B2
	8	100	A1,A2,B1,B2	100	A1,A2,B1,B2

**LEGEND**

**Displ.** — Displacement (Approximate)

\*Compressor unloaded.

†Compressor unloader, standard.

\*\*Compressor unloader, accessory.

**NOTES:**

- The microprocessor selects loading sequence A or B, which in turn determines the compressor circuit that is energized first. This evens out operating hours on each circuit over an extended period of time.
- The staging of modular units (30GT230-420) will be random due to variables within the system. The loading sequence of each individual module will be as listed.
- If unit operation is anticipated with system load below minimum unloaded capacity of chiller:
  - Consider using 2 smaller units in place of the larger unit.
  - Increase fluid loop volume to ensure adequate run time (see Application Data section in Product Data literature).
  - Consider adding accessory hot gas bypass package.

**Table 13 — Capacity Control Steps (cont)**

30GT UNIT SIZE	CONTROL STEPS	LOADING SEQUENCE A		LOADING SEQUENCE B	
		% Displ. (Approx)	Compressors	% Displ. (Approx)	Compressors
130 (60 Hz) A1†, B1†	1	14	A1*	14	B1*
	2	29	A1*,B1*	29	A1*,B1*
	3	36	A1*,B1	36	A1,B1*
	4	43	A1,B1	43	A1,B1
	5	64	A1*,A2,B1	64	A1,B1*,B2
	6	72	A1,A2,B1	72	A1,B1,B2
	7	93	A1*,A2,B1,B2	93	A1,A2,B1*,B2
	8	100	A1,A2,B1,B2	100	A1,A2,B1,B2
130 (50 Hz) A1†, B1†	1	10	A1*	16	B1*
	2	21	A1*,B1*	21	A1*,B1*
	3	29	A1*,B1	32	A1,B1*
	4	34	A1,B1	34	A1,B1
	5	47	A1*,A2,B1	56	A1*,B1,B2
	6	58	A1,A2,B1	64	A1,B1,B2
	7	77	A1*,A2,B1,B2	74	A1,A2,B1*,B2
	8	82	A1,A2,B1,B2	82	A1,A2,B1,B2
	9	95	A1*,A2,A3,B1,B2	92	A1,A2,A3,B1*,B2
	10	100	A1,A2,A3,B1,B2	100	A1,A2,A3,B1,B2
150,230A,245A,255A (60 Hz) A1†, B1†	1	11	A1*	17	B1*
	2	19	A1*,B1*	19	A1*,B1*
	3	28	A1*,B1	33	A1,B1*
	4	33	A1,B1	33	A1,B1
	5	44	A1*,A2,B1	58	A1*,B1,B2
	6	58	A1,A2,B1	67	A1,B1,B2
	7	78	A1*,A2,B1,B2	75	A1,A2,B1*,B2
	8	83	A1,A2,B1,B2	83	A1,A2,B1,B2
	9	94	A1*,A2,A3,B1,B2	92	A1,A2,A3,B1*,B2
	10	100	A1,A2,A3,B1,B2	100	A1,A2,A3,B1,B2
150,230A,245A,255A (50 Hz) A1†, B1†	1	13	A1*	13	B1*
	2	27	A1*,B1*	27	A1*,B1*
	3	33	A1*,B1	33	A1,B1*
	4	40	A1,B1	40	A1,B1
	5	53	A1*,A2,B1	53	A1*,B1,B2
	6	60	A1,A2,B1	60	A1,B1,B2
	7	73	A1*,A2,B1,B2	73	A1,A2,B1*,B2
	8	80	A1,A2,B1,B2	80	A1,A2,B1,B2
	9	93	A1*,A2,A3,B1,B2	93	A1,A2,A3,B1*,B2
	10	100	A1,A2,A3,B1,B2	100	A1,A2,A3,B1,B2
170,270A,330A/B (60 Hz) A1†, B1†	1	11	A1*	11	B1*
	2	22	A1*,B1*	22	A1*,B1*
	3	28	A1*,B1	28	A1,B1*
	4	33	A1,B1	33	A1,B1
	5	44	A1*,A2,B1	44	A1,B1*,B2
	6	50	A1,A2,B1	50	A1,B1,B2
	7	61	A1*,A2,B1,B2	61	A1,A2,B1*,B2
	8	67	A1,A2,B1,B2	67	A1,A2,B1,B2
	9	78	A1*,A2,A3,B1,B2	78	A1,A2,B1*,B2,B3
	10	83	A1,A2,A3,B1,B2	83	A1,A2,B1,B2,B3
	11	94	A1*,A2,A3,B1,B2,B3	94	A1,A2,A3,B1*,B2,B3
	12	100	A1,A2,A3,B1,B2,B3	100	A1,A2,A3,B1,B2,B3
170,270A,330A/B,360B (50 Hz) A1†, B1†	1	10	A1*	10	B1*
	2	24	A1*,B1*	24	A1*,B1*
	3	29	A1*,B1	24	A1,B1*
	4	29	A1,B1	28	A1,B1
	5	43	A1*,A2,B1	43	A1,B1*,B2
	6	43	A1,A2,B1	48	A1,B1,B2
	7	57	A1*,A2,B1,B2	57	A1,A2,B1*,B2
	8	62	A1,A2,B1,B2	62	A1,A2,B1,B2
	9	76	A1*,A2,A3,B1,B2	76	A1,A2,B1*,B2,B3
	10	81	A1,A2,A3,B1,B2	81	A1,A2,B1,B2,B3
	11	95	A1*,A2,A3,B1,B2,B3	95	A1,A2,A3,B1*,B2,B3
	12	100	A1,A2,A3,B1,B2,B3	100	A1,A2,A3,B1,B2,B3

**LEGEND**

**Displ.** — Displacement (Approximate)

\*Compressor unloaded.

†Compressor unloader, standard.

\*\*Compressor unloader, accessory.

**NOTES:**

- The microprocessor selects loading sequence A or B, which in turn determines the compressor circuit that is energized first. This evens out operating hours on each circuit over an extended period of time.
- The staging of modular units (30GT230-420) will be random due to variables within the system. The loading sequence of each individual module will be as listed.
- If unit operation is anticipated with system load below minimum unloaded capacity of chiller:
  - Consider using 2 smaller units in place of the larger unit.
  - Increase fluid loop volume to ensure adequate run time (see Application Data section in Product Data literature).
  - Consider adding accessory hot gas bypass package.

**Table 13 — Capacity Control Steps (cont)**

30GT UNIT SIZE	CONTROL STEPS	LOADING SEQUENCE A		LOADING SEQUENCE B	
		% Displ. (Approx)	Compressors	% Displ. (Approx)	Compressors
190,290A, 360A/B,390B (60 Hz)	1	14	A1	14	B1
	2	27	A1,B1	27	A1,B1
	3	43	A1,A2,B1	43	A1,B1,B2
	4	59	A1,A2,B1,B2	59	A1,A2,B1,B2
	5	79	A1,A2,A3,B1,B2	79	A1,A2,B1,B2,B3
	6	100	A1,A2,A3,B1,B2,B3	100	A1,A2,A3,B1,B2,B3
190,290A, 360A/B,390B (60 Hz) A1**	1	9	A1*	9	A1*
	2	14	A1	14	A1
	3	23	A1*,B1	23	A1*,B1
	4	27	A1,B1	27	A1,B1
	5	38	A1*,A2,B1	38	A1*,A2,B1
	6	43	A1,A2,B1	43	A1,A2,B1
	7	54	A1*,A2,B1,B2	54	A1*,A2,B1,B2
	8	59	A1,A2,B1,B2	59	A1,A2,B1,B2
	9	75	A1*,A2,A3,B1,B2	75	A1*,A2,A3,B1,B2
	10	79	A1,A2,A3,B1,B2	79	A1,A2,A3,B1,B2
	11	95	A1*,A2,A3,B1,B2,B3	95	A1*,A2,A3,B1,B2,B3
	12	100	A1,A2,A3,B1,B2,B3	100	A1,A2,A3,B1,B2,B3
190,290A, 360A/B,390B (60 Hz) A1** & B1**	1	9	A1*	9	B1*
	2	18	A1*,B1*	18	A1*,B1*
	3	23	A1*,B1	23	A1,B1*
	4	27	A1,B1	27	A1,B1
	5	38	A1*,A2,B1	38	A1,B1*,B2
	6	43	A1,A2,B1	43	A1,B1,B2
	7	54	A1*,A2,B1,B2	54	A1,A2,B1*,B2
	8	59	A1,A2,B1,B2	59	A1,A2,B1,B2
	9	75	A1*,A2,A3,B1,B2	75	A1,A2,B1*,B2,B3
	10	79	A1,A2,A3,B1,B2	79	A1,A2,B1,B2,B3
	11	95	A1*,A2,A3,B1,B2,B3	95	A1,A2,A3,B1*,B2,B3
	12	100	A1,A2,A3,B1,B2,B3	100	A1,A2,A3,B1,B2,B3
190,290A, 360A,390B (50 Hz)	1	17	A1	17	B1
	2	33	A1,B1	33	A1,B1
	3	50	A1,A2,B1	50	A1,B1,B2
	4	67	A1,A2,B1,B2	67	A1,A2,B1,B2
	5	83	A1,A2,A3,B1,B2	83	A1,A2,B1,B2,B3
	6	100	A1,A2,A3,B1,B2,B3	100	A1,A2,A3,B1,B2,B3
190,290A, 360A,390B (50 Hz) A1**	1	11	A1*	11	A1*
	2	17	A1	17	A1
	3	28	A1*,B1	28	A1*,B1
	4	33	A1,B1	33	A1,B1
	5	44	A1*,A2,B1	44	A1*,A2,B1
	6	50	A1,A2,B1	50	A1,A2,B1
	7	61	A1*,A2,B1,B2	61	A1*,A2,B1,B2
	8	67	A1,A2,B1,B2	67	A1,A2,B1,B2
	9	78	A1*,A2,A3,B1,B2	78	A1*,A2,A3,B1,B2
	10	83	A1,A2,A3,B1,B2	83	A1,A2,A3,B1,B2
	11	94	A1*,A2,A3,B1,B2,B3	94	A1*,A2,A3,B1,B2,B3
	12	100	A1,A2,A3,B1,B2,B3	100	A1,A2,A3,B1,B2,B3
190,290A, 360A,390B (50 Hz) A1** & B1**	1	11	A1*	11	B1*
	2	22	A1*,B1*	22	A1*,B1*
	3	28	A1*,B1	28	A1,B1*
	4	33	A1,B1	33	A1,B1
	5	44	A1*,A2,B1	44	A1,B1*,B2
	6	50	A1,A2,B1	50	A1,B1,B2
	7	61	A1*,A2,B1,B2	61	A1,A2,B1*,B2
	8	67	A1,A2,B1,B2	67	A1,A2,B1,B2
	9	78	A1*,A2,A3,B1,B2	78	A1,A2,B1*,B2,B3
	10	83	A1,A2,A3,B1,B2	83	A1,A2,B1,B2,B3
	11	94	A1*,A2,A3,B1,B2,B3	94	A1,A2,A3,B1*,B2,B3
	12	100	A1,A2,A3,B1,B2,B3	100	A1,A2,A3,B1,B2,B3
210,315A, 390A,420A/B (60 Hz)	1	12	A1	14	B1
	2	26	A1,B1	26	A1,B1
	3	37	A1,A2,B1	44	A1,B1,B2
	4	56	A1,A2,B1,AB2	56	A1,A2,B1,B2
	5	68	A1,A2,A3,B1,B2	74	A1,A2,B1,B2,B3
	6	86	A1,A2,A3,B1,B2,B3	86	A1,A2,A3,B1,B2,B3
	7	100	A1,A2,A3,A4,B1,B2,B3	100	A1,A2,A3,A4,B1,B2,B3
210,315A, 390A,420A/B (50 Hz)	1	10	A1	16	B1
	2	26	A1,B1	26	A1,B1
	3	37	A1,A2,B1	42	A1,B1,B2
	4	52	A1,A2,B1,B2	52	A1,A2,B1,B2
	5	68	A1,A2,A3,B1,B2	68	A1,A2,B1,B2,B3
	6	84	A1,A2,A3,B1,B2,B3	84	A1,A2,A3,B1,B2,B3
	7	100	A1,A2,A3,A4,B1,B2,B3	100	A1,A2,A3,A4,B1,B2,B3

See legend on page 54.

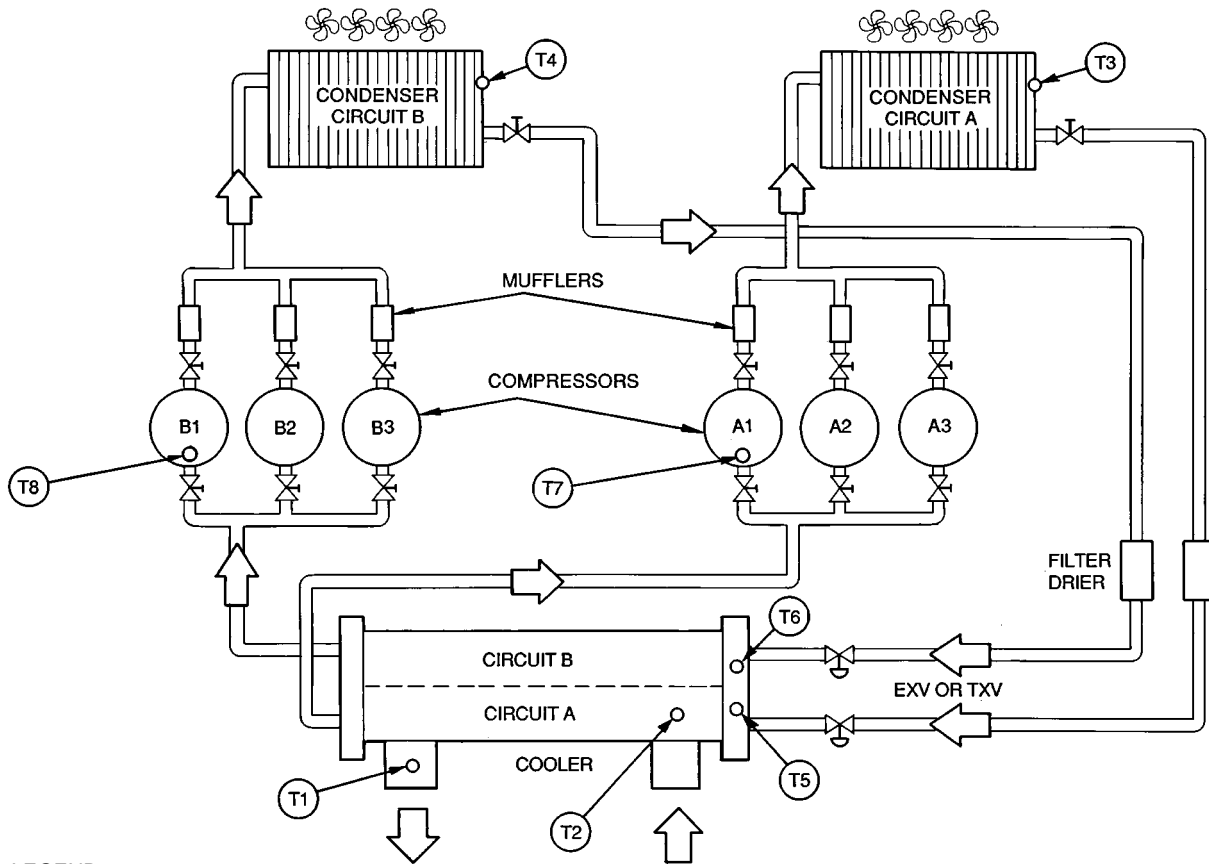

- LEGEND
- EXV — Electronic Expansion Valve
  - T — Thermistor
  - TXV — Thermostatic Expansion Valve

**Fig. 21 — Typical Thermistor Locations**

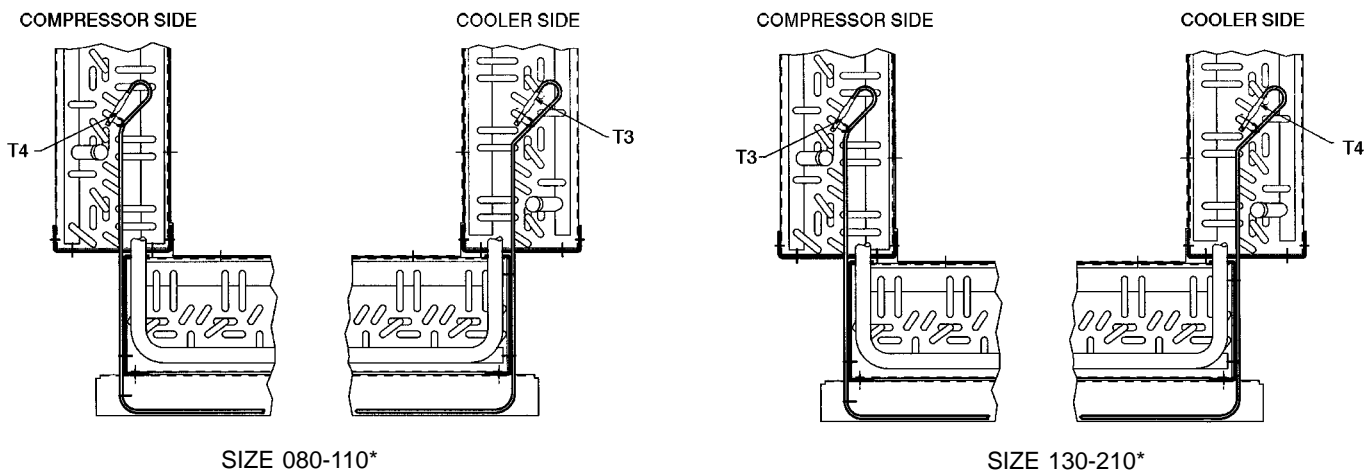

\*And associated modular units (see Table 1).

**Fig. 22 — Thermistor T3 and T4 Locations**

## SERVICE



### ELECTRIC SHOCK HAZARD.

Turn off all power to unit before servicing. The ON-OFF switch on control panel does *not* shut off control power; *use field disconnect.*

**Diagnostics and Troubleshooting** — Refer to Controls and Troubleshooting literature.

For field service use, a Ground Fault Interrupter (GFI) convenience outlet is available as a field-installed accessory for all units. The GFI is rated for 15 amps. However, in units with active cooler heaters, only 8 amps are available.

### Refrigerant Circuit

**LEAK TESTING** — Units are shipped with complete operating charge of refrigerant R-22 (see Tables 2A-3B) and should be under sufficient pressure to conduct a leak test. If there is no pressure in the system, use standard refrigeration practices to search for the leak. Repair the leak using good refrigeration practices. After leaks are repaired, system must be evacuated and dehydrated.

**DEHYDRATION** — Refer to Carrier Standard Service Techniques Manual, Chapter 1, Refrigerants, Sections 6 and 7 for details. *Do not use compressor to evacuate system.*

**REFRIGERANT CHARGE** (Refer to Tables 2A-3B) — Immediately ahead of filter drier in each circuit is a factory-installed liquid line service valve. Each valve has a 1/4-in. Schrader connection for charging liquid refrigerant.

**Charging with Unit Off and Evacuated** — Close liquid line service valve before charging. Weigh in charge shown on unit nameplate (also in Tables 2A-3B). Open liquid line service valve; start unit and allow it to run several minutes fully loaded. Check for a clear sight glass. Be sure clear condition is liquid and not vapor.

**Charging with Unit Running** — If charge is to be added while unit is operating, all condenser fans and compressors must be operating. It may be necessary to block condenser coils at low ambient temperatures to raise condensing pressure to approximately 280 psig (1931 kPa) to turn all condenser fans on. Do not totally block a coil to do this. Partially block all coils in uniform pattern. Charge each circuit until sight glass shows clear liquid, then weigh in amount over a clear sight glass as listed in Tables 2A-3B.

**IMPORTANT:** When adjusting refrigerant charge, circulate fluid through cooler continuously to prevent freezing and possible damage to the cooler. Do not overcharge, and never charge liquid into low-pressure side of system.

### Electronic Components

**CONTROL COMPONENTS** — Unit uses an advanced electronic control system that normally does not require service. For details on controls refer to Controls and Troubleshooting literature.

**30GT080-110 AND 230B-315B UNIT CONTROL BOX** — Viewed facing compressors, main control box is at left end of unit. All incoming power enters through main box. Control box contains power components and electronic controls.

Outer panels are hinged and latched for easy opening. Remove screws to remove inner panels. Outer panels can be held open for service and inspection by using door retainer on each panel. Remove bottom pin from door retainer assembly, swing retainer out horizontally, engage pin in one of the retainer ears and the hinge assembly.

**30GT130-210, 230A-315A, AND 330A/B-420A/B UNIT CONTROL AND MAIN POWER BOXES** — The main power box is on the cooler side of the unit, and the control box is on the compressor side. Outer panels are hinged and latched for easy opening. Remove screws to remove inner panels.

**Compressors** — If lead compressor on either refrigerant circuit becomes inoperative for any reason, circuit is locked off and *cannot* be operated due to features built in the electronic control system. *Do not attempt to bypass controls to force compressors to run.*

**COMPRESSOR REMOVAL** — Access to the pump end of the compressor is from the compressor side of the unit. Access to the motor end of the compressor is from the inside of the unit. All compressors can be removed from the compressor side of the unit.

**IMPORTANT:** All compressor mounting hardware and support brackets removed during servicing must be reinstalled prior to start-up.

Following the installation of the new compressor:

Tighten discharge service valve bolts to —	<b>Compressor(s)</b>
20 to 25 ft-lb (27 to 34 N-m)	06E250
80 to 90 ft-lb (109 to 122 N-m)	06E265,275,299

Tighten suction service valve bolts to —	
80 to 90 ft-lb (109 to 122 N-m)	06E250
90 to 120 ft-lb (122 to 163 N-m)	06E265,275,299

Tighten the following fittings to —	
120 in.-lb (13.5 N-m)	High Pressure Switch
120 in.-lb (13.5 N-m)	Loss of Charge Switch

**OIL CHARGE** (Refer to Tables 2A-3B) — All units are factory charged with oil. Acceptable oil level for each compressor is from 1/8 to 3/8 of sight glass (see Fig. 18).

When additional oil or a complete charge is required, use only Carrier-approved compressor oil.

Approved oils are as follows:

Petroleum Specialties, Inc. — Cryol 150 (factory oil charge)  
 Texaco, Inc. — Capella WF-32  
 Witco Chemical Co. — Suniso 3GS

COMPRESSOR	OIL REQUIRED	
	Pts	L
<b>06E250</b>	14	6.6
<b>06E265</b>	19	9.0
<b>06E275</b>	19	9.0
<b>06E299</b>	19	9.0

*Do not reuse drained oil and do not use any oil that has been exposed to atmosphere.*

**Cooler** — The cooler is easily accessible from the cooler side of the unit. The refrigerant feed components are accessible from the control box end of the unit.

**COOLER REMOVAL** — Cooler can be removed from the cooler side of the unit as follows:

**⚠ CAUTION**

Open and tag all electrical disconnects before any work begins. Note that cooler is heavy and both fluid-side and refrigerant-side may be under pressure.

1. To ensure the refrigerant is in the condenser, follow this procedure:
  - a. Open the circuit breakers and close the discharge valves for the lag compressors (A2, A3, A4, B2, and B3), and close the discharge valves for these compressors.

**⚠ WARNING**

Do not close the discharge valve of an operating compressor. Severe damage to the compressor can result.

- b. After the lag compressors have shut down, close the liquid line service valve for one circuit. Allow the lead compressor to pump down that circuit until it reaches approximately 10 to 15 psig (68.8 to 103.2 kPa).
  - c. As soon as the system reaches that pressure, shut down the lead compressor by opening the compressor circuit breaker, then quickly close the discharge service valve for that compressor.
  - d. Repeat the procedure for the other circuit.

2. Close the shutoff valves, if installed, in the cooler fluid lines, and remove the cooler fluid piping. Remove the cooler fluid-side strainer (130-210, 230A-315A, and 330A/B-420A/B only).
3. Open the air vent at the top of the cooler, and open the drain on the bottom of the cooler (near the leaving fluid outlet) to drain the cooler. Both the drain and the air vent are located on the leaving-fluid end of cooler. See Fig. 23.
4. Disconnect the conduit and cooler heater wires, if equipped. Remove all thermistors from the cooler, being sure to label all thermistors as they are removed. Thermistor T2 is immersed directly in the fluid. Thermistors T1, T5, and T6 are friction-fit well-type thermistors. See Fig. 23.
5. Remove the insulation on the refrigerant connection end of the cooler.
6. Unbolt the suction flanges from the cooler head. Save the bolts.
7. Remove the liquid lines by breaking the silver-soldered joints at the cooler liquid line nozzles.
8. On 30GT080-110 and 230B-315B units, remove the two vertical supports under the condenser coil, in front of the cooler. *Provide temporary support as needed.* Save all screws for reinstallation later.
9. Remove the screws in the cooler feet. Slide the cooler slightly to the left to clear the refrigerant tubing. Save all screws.

Removing the cooler can be accomplished in one of 2 ways, depending on the jobsite. Either continue sliding the cooler toward the end of the unit opposite the tubing and carefully remove, or pivot the cooler and remove it from the cooler side of the unit.

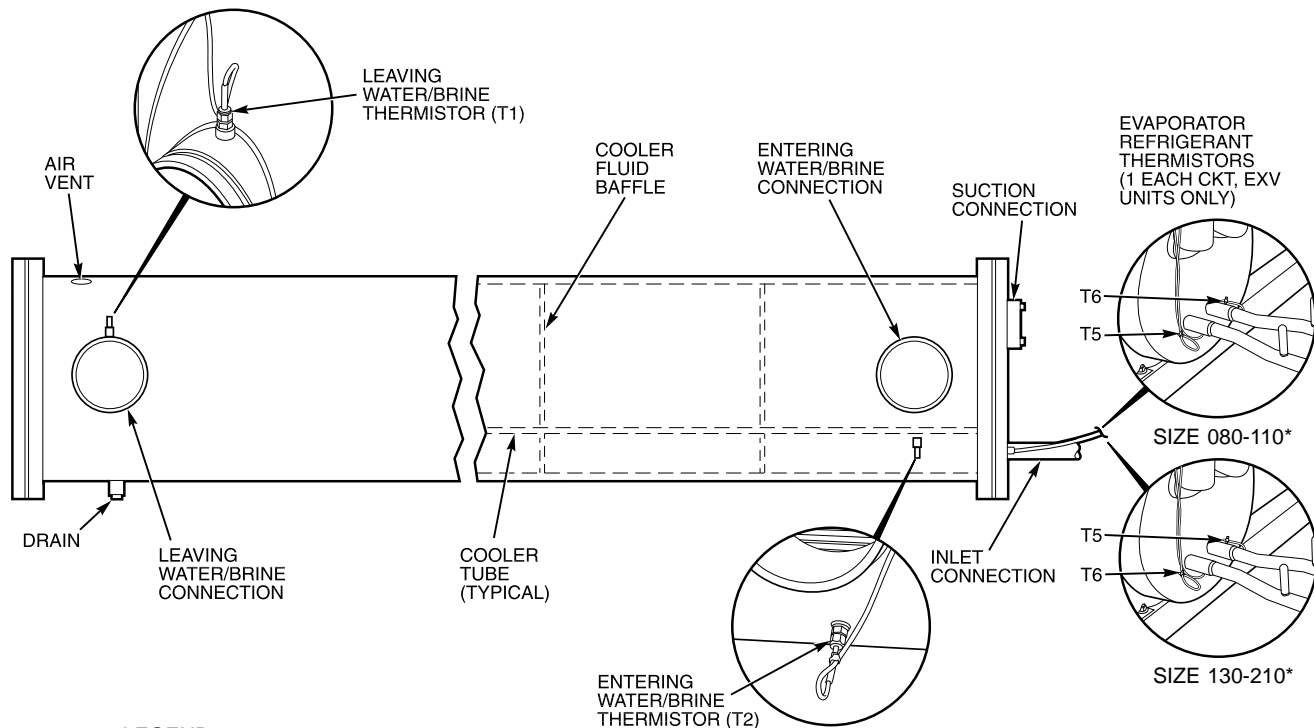

**LEGEND**

**EXV** — Electronic Expansion Valve  
**T** — Thermistor

\*And associated modular units (see Table 1).

**Fig. 23 — Cooler Thermistor Locations**

**REPLACING COOLER** — To replace the cooler:

1. Insert new cooler carefully into place. Reattach the screws into the cooler feet (using saved screws).  
On 30GT080-110 and 230B-315B units, reattach the 2 vertical supports under the condenser coil in front of the cooler using screws saved.
2. Replace the liquid lines and solder at the cooler liquid line nozzles.
3. Rebolt the suction flanges onto the cooler head using bolts saved during removal. Use new gaskets for the suction line flanges. Use compressor oil to aid in gasket sealing and tighten the suction flange bolts to 70 to 90 ft-lb (94 to 122 N-m).

NOTE: The suction flange has a 4-bolt pattern. See Carrier specified parts for replacement part number, if necessary.

4. Using adhesive, reinstall the cooler insulation on the refrigerant connection end of the cooler.
5. Reinstall the thermistors. Refer to Thermistors section on page 65, and install as follows:
  - a. Apply pipe sealant to the 1/4-in. NPT threads on the replacement coupling for the fluid side, and install it in place of the original.

**CAUTION**  
Do not use the packing nut to tighten the coupling. Damage to the ferrules will result.

- b. Reinstall thermistor T1 well, and insert thermistor T1 into well.
  - c. Install thermistor T2 (entering fluid temperature) so that it is not touching an internal refrigerant tube, but so that it is close enough to sense a freeze condition. The recommended distance is 1/8 in. (3.2 mm) from the cooler tube. Tighten the packing nut finger tight, and then tighten 1 1/4 turns more using a back-up wrench.
6. Install the cooler heater and conduit (if equipped), connecting the wires as shown in the unit wiring schematic located on the unit.
  7. Close the air vent at the top of the cooler, and close the drain on the bottom of the cooler near the leaving fluid outlet. Both the drain and the air vent are located on the leaving fluid end of the cooler. See Fig. 23.
  8. Reconnect the cooler fluid piping, and open the shutoff valves (if installed). Purge the fluid of all air before starting unit.
  9. Open the discharge service valves, close the circuit breakers, and open the liquid line service valves for the compressors.

**SERVICING COOLER** — When cooler heads and partition plates are removed, tube sheets are exposed showing ends of tubes.

**CAUTION**  
Certain tubes in the 10HB coolers cannot be removed. Eight tubes in the bundle are secured inside the cooler to the baffles and *cannot be removed*. These tubes are marked by a dimple on the tube sheet. See Fig. 24. *If any of these tubes have developed a leak, plug the tube(s) as described under Tube Plugging section below.*

**Tube Plugging** — A leaky tube can be plugged until retubing can be done. The number of tubes plugged determines how soon cooler *must* be retubed. Tubes plugged in the following locations will affect the performance of the

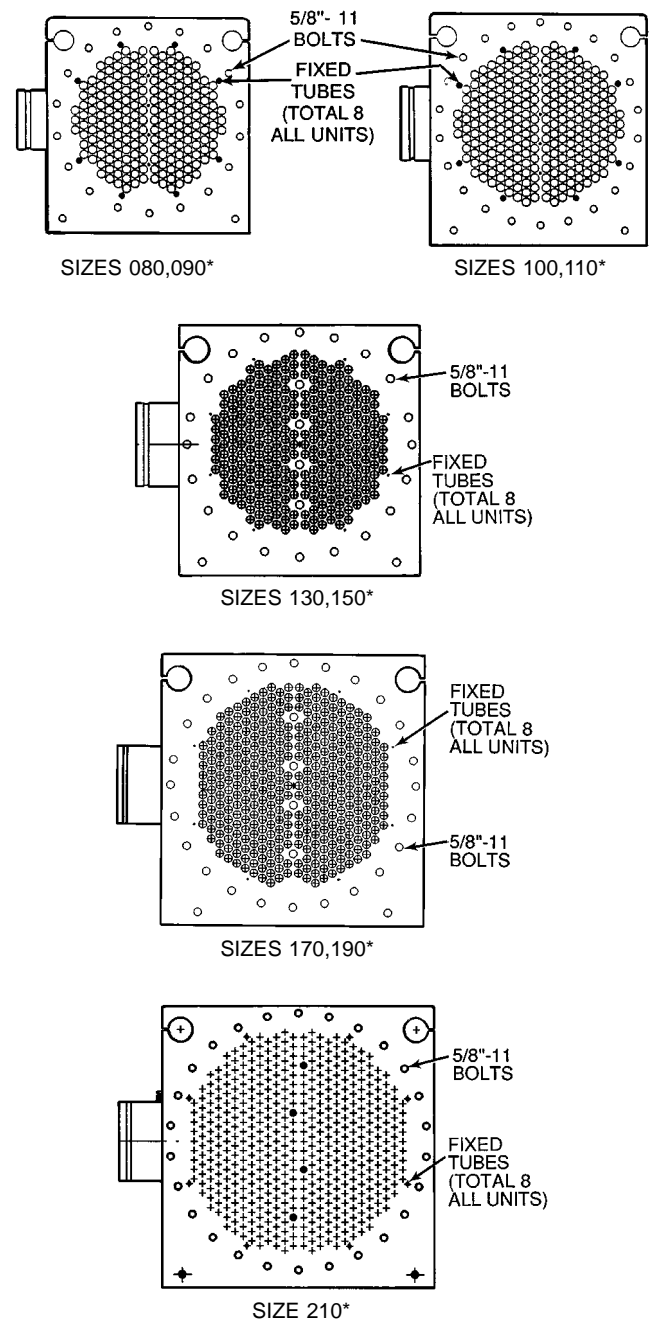

\*And associated modular units (see Table 1).

**Fig. 24 — Typical Tube Sheets, Cover Off (Non-Removable Tubes)**

unit: Any tube in the area of thermistor T2, particularly the tube that thermistor T2 is adjacent to, will affect unit reliability and performance. Thermistor T2 is used in the freeze protection algorithm for the controller. If several tubes require plugging, check with your local Carrier representative to find out how number and location can affect unit capacity.

Figure 25 shows an Elliott tube plug and a cross-sectional view of a plug in place.

**CAUTION**  
Use extreme care when installing plugs to prevent damage to the tube sheet section between the holes.

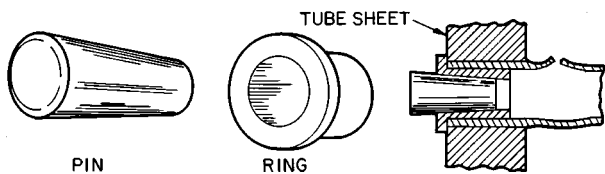

**Fig. 25 — Elliott Tube Plug**

**Retubing** (See Table 14) — When retubing is to be done, obtain service of qualified personnel experienced in boiler maintenance and repair. Most standard procedures can be followed when retubing the 10HB coolers. An 8% crush is recommended when rolling replacement tubes into the tube sheet. An 8% crush can be achieved by setting the torque on the gun at 48 to 50 in.-lb (5.4 to 5.6 N-m).

The following Elliott Co. tube rolling tools are required:

- B3400 Expander Assembly
- B3401 Cage
- B3405 Mandrel
- B3408 Rolls

Place one drop of Loctite No. 675 or equivalent on top of tube prior to rolling. This material is intended to “wick” into the area of the tube that is not rolled into the tube sheet, and prevent fluid from accumulating between the tube and the tube sheet.

Tube information follows:

	in.	mm
• Tube sheet hole diameter	0.631	16.03
• Tube OD	0.625	15.87
• Tube ID after rolling (includes expansion due to clearance)	0.581 to 0.588	14.76 to 14.94

NOTE: Tubes next to gasket webs must be flush with tube sheet (both ends).

**Table 14 — Plugs**

COMPONENTS FOR PLUGGING	PART NUMBER
<b>For Tubes</b>	
Brass Pin	853103-500*
Brass Ring	853002-570*
<b>For Holes without Tubes</b>	
Brass Pin	853103-1*
Brass Ring	853002-631*
Loctite	No. 675†
Locquic	“N”†

\*Order directly from: Elliott Tube Company, Dayton, Ohio

†Can be obtained locally.

**Tightening Cooler Head Bolts**

**Gasket Preparation** — When reassembling cooler heads, always use new gaskets. Gaskets are neoprene-based and are brushed with a light film of compressor oil. *Do not soak gasket or gasket deterioration will result.* Use new gaskets within 30 minutes to prevent deterioration. Reassemble cooler nozzle end or plain end cover of the cooler with the gaskets. Torque all cooler bolts to the following specification and sequence:

- 5/8-in. Diameter Perimeter Bolts . . . . . 150 to 170 ft-lb (201 to 228 N-m)
- 1/2-in. Diameter Flange Bolts . . . . . 70 to 90 ft-lb (94 to 121 N-m)

1. Install all bolts finger tight.
2. Bolt tightening sequence is outlined in Fig. 26. Follow the numbering sequence so that pressure is evenly applied to gasket.
3. Apply torque in one-third steps until required torque is reached. Load *all* bolts to each one-third step before proceeding to next one-third step.
4. No less than one hour later, retighten all bolts to required torque values.
5. After refrigerant is restored to system, check for refrigerant leaks with soap solution or Halide device.
6. Replace cooler insulation.

**Condenser Coils**

**COIL CLEANING** — Clean coils with a vacuum cleaner, fresh water, compressed air, or a bristle brush (not wire). Units installed in corrosive environments should have coil cleaning as part of a planned maintenance schedule. In this type of application, all accumulations of dirt should be cleaned off the coil.

**▲ CAUTION**

Do not use high-pressure water or air — fin damage may result.

**Condenser Fans** — Each fan is supported by a formed wire mount bolted to fan deck and covered with a wire guard. The exposed end of fan motor shaft is protected from weather by grease. If fan motor must be removed for service or replacement, be sure to regrease fan shaft, and reinstall fan guard. For proper performance, fan should be positioned as in Fig. 27 (standard and low-noise applications). Tighten set-screws to 15 ± 1 ft-lb (20 ± 1.3 N-m).

If the unit is equipped with the high static fan option, the fan must be set from the top of the fan deck to the plastic ring or center of the fan to a distance of 2.13 in. ± 0.13 in. (54 ± 3 mm). This is different from standard fans, since there is no area available to measure from the top of the orifice ring to the fan hub itself. See Fig. 28.

IMPORTANT: Check for proper fan rotation (clockwise viewed from above). If necessary, switch any 2 power leads to reverse fan rotation.

**Refrigerant Feed Components** — Each circuit has all necessary refrigerant controls.

**ELECTRONIC EXPANSION VALVE (EXV)** — A cutaway view of valve is shown in Fig. 29.

High-pressure liquid refrigerant enters valve through bottom. A series of calibrated slots have been machined in side of orifice assembly. As refrigerant passes through orifice, pressure drops and refrigerant changes to a 2-phase condition (liquid and vapor). To control refrigerant flow for different operating conditions, sleeve moves up and down over orifice and modulates orifice size. Sleeve is moved by a linear stepper motor. Stepper motor moves in increments and is controlled directly by processor board. As stepper motor rotates, motion is transferred into linear movement by lead screw. Through stepper motor and lead screw, 1500 discrete steps of motion are obtained. The large number of steps and long stroke results in very accurate control of refrigerant flow. The valve orifice begins to be exposed at 320 steps. Since there is not a tight seal with the orifice and the sleeve, the minimum position for operation is 120 steps.

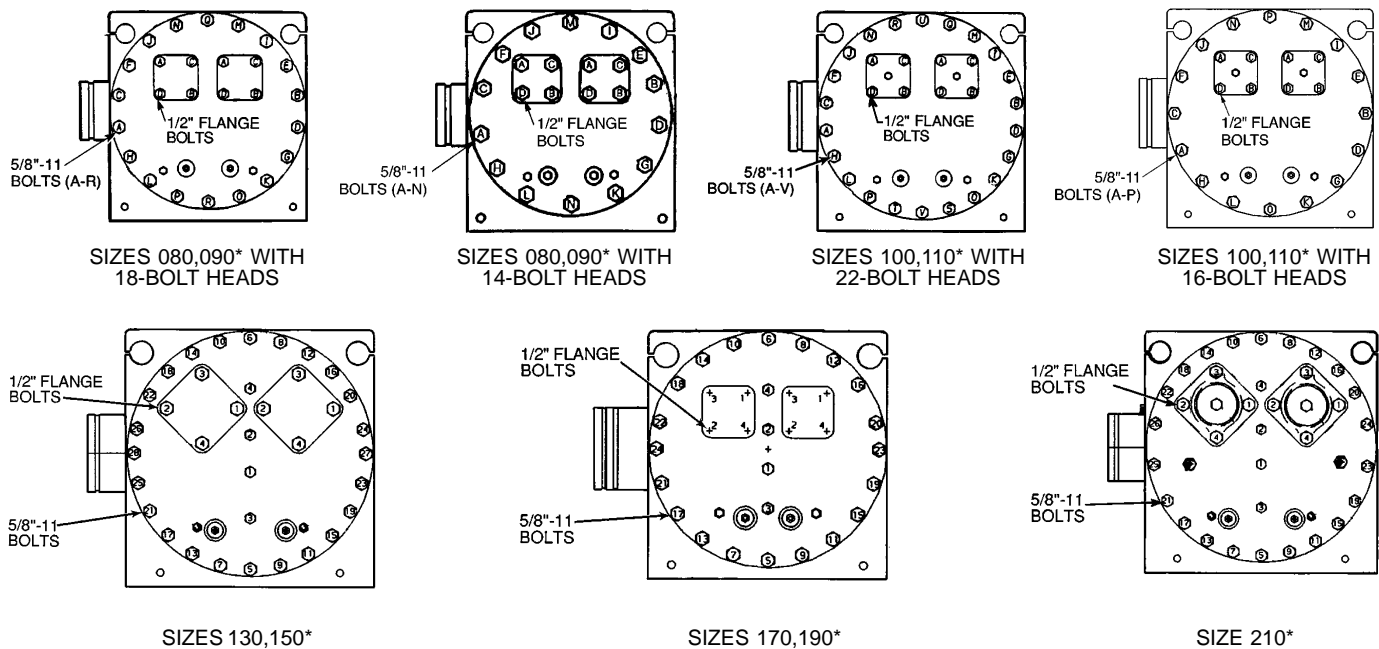

\*And associated modular units (see Table 1).

**Fig. 26 — Cooler Head Bolt Tightening Sequence (Typical Tube Sheet)**

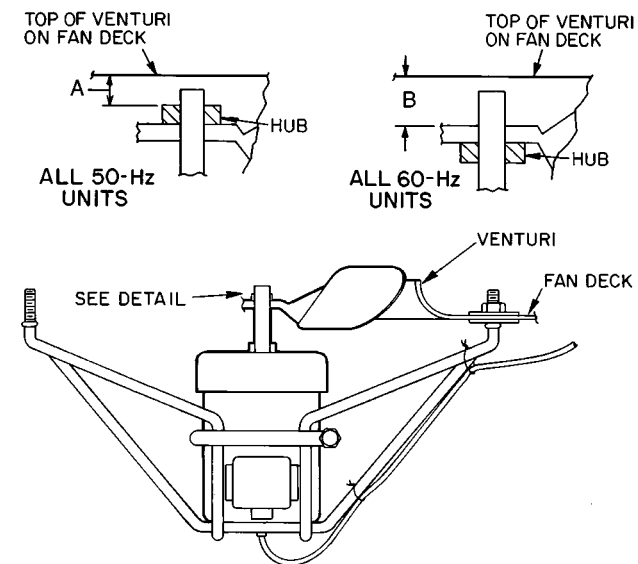

DIMENSION	FAN TYPE	
	Standard	Low-Noise (Optional)
A	0.50" (13 mm)	1.50" (38 mm)
B	0.88" (22 mm)	1.13" (29 mm)

NOTE: Fan rotation is clockwise as viewed from top of unit.

**Fig. 27 — Condenser Fan Adjustment**

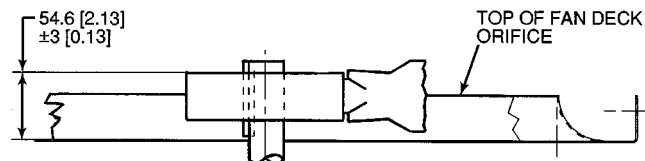

NOTE: Dimensions are in millimeters. Dimensions in [ ] are in inches.

**Fig. 28 — Condenser Fan Adjustment, Units with High Static Fan Option**

The microprocessor controls the valve. Two thermistor temperature sensors are used to determine superheat. One thermistor is located in cooler and other is located in passage between compressor motor and cylinders. The difference between the 2 temperatures controls superheat. On a normal TXV or EXV system, superheat leaving evaporator is normally 10° F (5.6° C) and motor then adds approximately 15° to 20° F (8° to 11° C) resulting in approximately 30° F (16.7° C) superheat entering cylinders.

Because EXVs are controlled by the processor board, it is possible to track valve position. By this means, head pressure is controlled and unit is protected against loss of charge and a faulty valve. During initial start-up, EXV is fully closed. After initialization period, valve position is tracked by processor by constantly observing amount of valve movement.

The EXV is also used to limit cooler saturated suction temperature to 55 F (13 C). This makes it possible for the chiller to start at higher cooler fluid temperatures without overloading the compressor. This is commonly referred to as MOP (maximum operating pressure).

If it appears that EXV is not properly controlling operating suction pressure or superheat, there are a number of checks that can be made using quick test and initialization features built into the microprocessor control. See Controls and Troubleshooting literature.

Follow steps below to diagnose and correct EXV problems.

**Step 1 — Check Processor EXV Outputs** — Check EXV output signals at appropriate terminals on J4 terminal strip, as follows:

1. Turn power off.
2. Connect positive test lead of meter to terminal 8 on connector J7 (see Fig. 30).

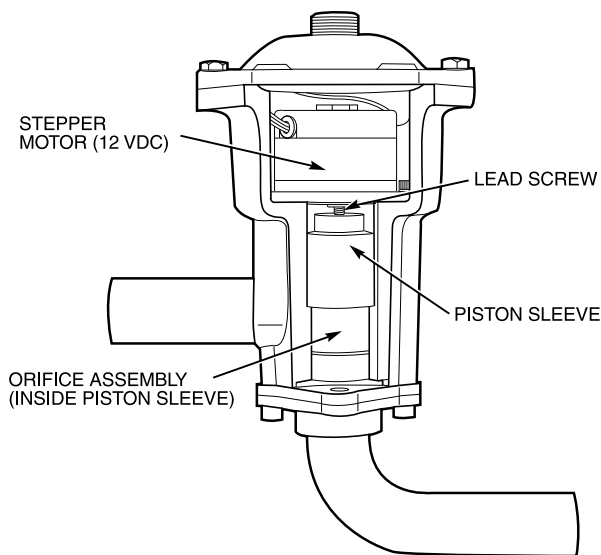

**Fig. 29 — Electronic Expansion Valve (EXV)**

**PROCESSOR BOARD**

**J7**

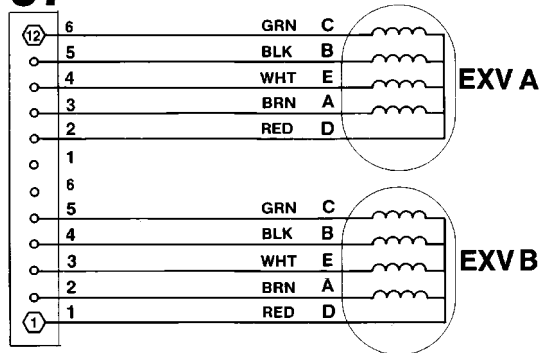

**EXV** — Electronic Expansion Valve

**Fig. 30 — Processor Board Connections**

- Set meter for approximately 20 vdc.
- Turn power on, but do not enter quick test mode. For the first 100 seconds, valve motor windings will be alternately energized to close valve in circuit 1.
- During this time, connect negative test lead to terminals 9, 10, 11, and 12 in succession. Voltage should rise and fall at each pin. If it remains constant at a voltage or at 0 v, remove connector and recheck. If problem is still there, replace processor board. If it is no longer there, check EXV.
- Turn power off and connect positive lead to terminal 1 on connector J7.
- Turn power on. After 100 seconds, motor windings in circuit 2 valve will begin to be energized.
- During this time, connect negative test lead to terminals 2, 3, 4, and 5. Voltage should rise and fall at each pin. If it remains constant at a voltage or at 0 v, remove connector and recheck. If problem is still there, replace processor board. If there is no longer a problem there, check EXV.

**Step 2 — Check EXV Wiring** — Check wiring to EXVs from J7 terminal strip on processor board (see Fig. 30).

- Check color coding and wire connections. Make sure wires are connected to correct terminals at J7 and EXV plug connections.
- Check for continuity and tight connection at all pin terminals.
- Check plug connections at J7 and at EXVs. Be sure EXV connections are not crossed.

**Step 3 — Check Resistance of EXV Motor Windings** — Remove plug at J7 terminal strip and check resistance between common lead (red wire, terminal D) and remaining leads A, B, C, and E. Resistance should be 25 ohms  $\pm$  2 ohms.

**Step 4 — Check Thermistors that Control EXV** — Check thermistors that control processor output voltage pulses to EXVs. Circuit A thermistors are T5 and T7, and circuit B thermistors are T6 and T8. Refer to Fig. 21 for location.

- Use quick test steps 2.0. through 2.3. to determine if thermistors are shorted or open.
- Check thermistor calibration at a known temperature by measuring actual resistance and comparing value measured with values listed in Tables 15 and 16.
- Make sure that thermistor leads are connected to proper pin terminals at J1 terminal strip on processor board and that thermistor probes are located in proper position in refrigerant circuit (Fig. 21 and 23).

When above checks have been completed, actual operation of EXV can be checked by using procedures outlined in Step 5 — Check Operation of the EXV section below. During quick test steps 3.5. and 3.9., each EXV is opened approximately 500 steps by processor. This quick test feature, along with initialization mode **20**, can be used to verify proper valve operation.

**Step 5 — Check Operation of the EXV** — Use following procedure to check actual operation of EXVs.

- Close liquid line service valve for circuit to be checked and run through appropriate quick test step 3.5. or 3.9. to pump down low side of system. Repeat quick test step 3 times to ensure all refrigerant has been pumped from low side and that EXV has been driven fully open (1500 steps open).

**NOTE:** Do not use control ON-OFF switch to recycle control during this step, and be sure to allow compressors to run full 10 seconds at each step.

- Turn control circuit switch and compressor circuit breaker(s) to OFF position. Close compressor service valves and remove any remaining refrigerant from low side of system.
- Remove screws holding top cover of EXV. Carefully remove top cover, using caution to avoid damage to the O-ring seal and motor leads. If EXV plug was disconnected during this process, reconnect it after the cover is removed.
- Note position of lead screw (see Fig. 29). If valve has responded properly to processor signals in Step 5.1 above, valve should be fully open and lead screw should protrude approximately 1/4 in. (6 mm) to 3/4 in. (19 mm) above top of motor.
- Recycle control by turning control circuit switch to ON position. This puts control in initialization mode **20**. During first 100 seconds of initialization mode, each valve is driven to fully closed position (zero steps open) by processor. With cover lifted off EXV valve body, observe operation of valve motor and lead screw. The motor should turn in the counterclockwise (CCW) direction and lead screw should move down into motor hub until valve is fully closed. Lead screw movement should be smooth and uniform from fully open to fully closed position.

**Table 15 — Sensor Temperature (°F) vs Resistance/Voltage Drop; Flotronic™ Chiller**

TEMPERATURE (F)	VOLTAGE DROP (V)	RESISTANCE (OHMS)	TEMPERATURE (F)	VOLTAGE DROP (V)	RESISTANCE (OHMS)	TEMPERATURE (F)	VOLTAGE DROP (V)	RESISTANCE (OHMS)
-25	4.684	98,010	63	2.581	7,091	151	0.655	1,007
-24	4.673	94,707	64	2.549	6,911	152	0.644	986
-23	4.662	91,522	65	2.517	6,735	153	0.634	965
-22	4.651	88,449	66	2.486	6,564	154	0.623	945
-21	4.640	85,485	67	2.454	6,399	155	0.613	925
-20	4.628	82,627	68	2.423	6,237	156	0.602	906
-19	4.616	79,871	69	2.391	6,081	157	0.592	887
-18	4.604	77,212	70	2.360	5,929	158	0.582	868
-17	4.591	74,648	71	2.329	5,781	159	0.573	850
-16	4.578	72,175	72	2.299	5,637	160	0.563	832
-15	4.565	69,790	73	2.268	5,497	161	0.554	815
-14	4.551	67,490	74	2.237	5,361	162	0.545	798
-13	4.537	65,272	75	2.207	5,229	163	0.536	782
-12	4.523	63,133	76	2.177	5,101	164	0.527	765
-11	4.509	61,070	77	2.147	4,976	165	0.518	749
-10	4.494	59,081	78	2.117	4,855	166	0.509	734
-9	4.479	57,162	79	2.088	4,737	167	0.501	719
-8	4.463	55,311	80	2.058	4,622	168	0.493	705
-7	4.448	53,526	81	2.029	4,511	169	0.484	690
-6	4.431	51,804	82	2.000	4,403	170	0.476	677
-5	4.415	50,143	83	1.972	4,298	171	0.468	663
-4	4.398	48,541	84	1.943	4,195	172	0.461	650
-3	4.381	46,996	85	1.915	4,096	173	0.453	638
-2	4.363	45,505	86	1.887	4,000	174	0.446	626
-1	4.345	44,066	87	1.859	3,906	175	0.438	614
0	4.327	42,678	88	1.832	3,814	176	0.431	602
1	4.308	41,339	89	1.805	3,726	177	0.424	591
2	4.289	40,047	90	1.778	3,640	178	0.417	581
3	4.270	38,800	91	1.751	3,556	179	0.410	570
4	4.250	37,596	92	1.725	3,474	180	0.403	560
5	4.230	36,435	93	1.699	3,395	181	0.397	551
6	4.209	35,313	94	1.673	3,318	182	0.390	542
7	4.188	34,231	95	1.647	3,243	183	0.384	533
8	4.167	33,185	96	1.622	3,170	184	0.378	524
9	4.145	32,176	97	1.597	3,099	185	0.371	516
10	4.123	31,201	98	1.572	3,031	186	0.365	508
11	4.101	30,260	99	1.548	2,964	187	0.360	501
12	4.078	29,351	100	1.523	2,898	188	0.354	494
13	4.055	28,472	101	1.500	2,835	189	0.348	487
14	4.032	27,624	102	1.476	2,773	190	0.342	480
15	4.008	26,804	103	1.453	2,713	191	0.337	473
16	3.984	26,011	104	1.430	2,655	192	0.332	467
17	3.959	25,245	105	1.407	2,598	193	0.326	461
18	3.934	24,505	106	1.385	2,542	194	0.321	456
19	3.909	23,789	107	1.362	2,488	195	0.316	450
20	3.883	23,096	108	1.341	2,436	196	0.311	444
21	3.858	22,427	109	1.319	2,385	197	0.306	439
22	3.831	21,779	110	1.298	2,335	198	0.301	434
23	3.805	21,153	111	1.277	2,286	199	0.297	429
24	3.778	20,547	112	1.256	2,238	200	0.292	424
25	3.751	19,960	113	1.236	2,192	201	0.288	419
26	3.723	19,392	114	1.216	2,147	202	0.283	415
27	3.696	18,843	115	1.196	2,103	203	0.279	410
28	3.668	18,311	116	1.176	2,060	204	0.274	405
29	3.639	17,796	117	1.157	2,018	205	0.270	401
30	3.611	17,297	118	1.138	1,977	206	0.266	396
31	3.582	16,814	119	1.120	1,937	207	0.262	391
32	3.553	16,346	120	1.101	1,898	208	0.258	386
33	3.523	15,892	121	1.083	1,860	209	0.254	382
34	3.494	15,453	122	1.065	1,822	210	0.250	377
35	3.464	15,027	123	1.048	1,786	211	0.247	372
36	3.434	14,614	124	1.030	1,750	212	0.243	366
37	3.404	14,214	125	1.013	1,715	213	0.239	361
38	3.373	13,826	126	0.997	1,680	214	0.236	356
39	3.343	13,449	127	0.980	1,647	215	0.232	350
40	3.312	13,084	128	0.964	1,614	216	0.229	344
41	3.281	12,730	129	0.948	1,582	217	0.225	338
42	3.250	12,387	130	0.932	1,550	218	0.222	332
43	3.219	12,053	131	0.917	1,519	219	0.219	325
44	3.187	11,730	132	0.902	1,489	220	0.215	318
45	3.156	11,416	133	0.887	1,459	221	0.212	311
46	3.124	11,111	134	0.872	1,430	222	0.209	304
47	3.093	10,816	135	0.857	1,401	223	0.206	297
48	3.061	10,529	136	0.843	1,373	224	0.203	289
49	3.029	10,250	137	0.829	1,345	225	0.200	282
50	2.997	9,979	138	0.815	1,318			
51	2.965	9,717	139	0.802	1,291			
52	2.933	9,461	140	0.788	1,265			
53	2.901	9,213	141	0.775	1,239			
54	2.869	8,973	142	0.762	1,214			
55	2.837	8,739	143	0.750	1,189			
56	2.805	8,511	144	0.737	1,165			
57	2.772	8,291	145	0.725	1,141			
58	2.740	8,076	146	0.713	1,118			
59	2.708	7,868	147	0.701	1,095			
60	2.676	7,665	148	0.689	1,072			
61	2.644	7,468	149	0.678	1,050			
62	2.612	7,277	150	0.666	1,028			

**Table 16 — Sensor Temperature (°C) vs Resistance/Voltage Drop; Flotronic™ Chiller**

TEMPERATURE (C)	VOLTAGE DROP (V)	RESISTANCE (OHMS)	TEMPERATURE (C)	VOLTAGE DROP (V)	RESISTANCE (OHMS)	TEMPERATURE (C)	VOLTAGE DROP (V)	RESISTANCE (OHMS)
-32.0	4.690	100 049	16.0	2.651	7507	64.0	0.698	1090
-31.5	4.680	97 006	16.5	2.622	7334	64.5	0.688	1070
-31.0	4.671	94 061	17.0	2.593	7165	65.0	0.678	1050
-30.5	4.661	91 209	17.5	2.565	7000	65.5	0.667	1030
-30.0	4.651	88 449	18.0	2.536	6840	66.0	0.657	1011
-29.5	4.641	85 777	18.5	2.508	6683	66.5	0.648	992
-29.0	4.630	83 191	19.0	2.479	6531	67.0	0.638	973
-28.5	4.620	80 687	19.5	2.451	6382	67.5	0.628	955
-28.0	4.609	78 264	20.0	2.423	6237	68.0	0.619	937
-27.5	4.597	75 918	20.5	2.395	6096	68.5	0.609	919
-27.0	4.586	73 648	21.0	2.367	5959	69.0	0.600	902
-26.5	4.574	71 451	21.5	2.339	5825	69.5	0.591	885
-26.0	4.562	69 324	22.0	2.311	5694	70.0	0.582	868
-25.5	4.550	67 265	22.5	2.283	5566	70.5	0.574	852
-25.0	4.537	65 272	23.0	2.256	5442	71.0	0.565	836
-24.5	4.525	63 344	23.5	2.228	5321	71.5	0.557	820
-24.0	4.512	61 477	24.0	2.201	5203	72.0	0.548	805
-23.5	4.499	59 670	24.5	2.174	5088	72.5	0.540	790
-23.0	4.485	57 921	25.0	2.147	4976	73.0	0.532	775
-22.5	4.471	56 228	25.5	2.120	4867	73.5	0.524	761
-22.0	4.457	54 589	26.0	2.094	4760	74.0	0.516	746
-21.5	4.443	53 003	26.5	2.067	4656	74.5	0.508	733
-21.0	4.428	51 467	27.0	2.041	4555	75.0	0.501	719
-20.5	4.413	49 980	27.5	2.015	4457	75.5	0.493	706
-20.0	4.398	48 541	28.0	1.989	4360	76.0	0.486	693
-19.5	4.383	47 148	28.5	1.963	4267	76.5	0.479	681
-19.0	4.367	45 799	29.0	1.938	4175	77.0	0.472	669
-18.5	4.351	44 492	29.5	1.912	4086	77.5	0.465	657
-18.0	4.334	43 228	30.0	1.887	4000	78.0	0.458	645
-17.5	4.318	42 003	30.5	1.862	3915	78.5	0.451	634
-17.0	4.301	40 817	31.0	1.837	3832	79.0	0.444	623
-16.5	4.283	39 668	31.5	1.813	3752	79.5	0.437	613
-16.0	4.266	38 556	32.0	1.789	3674	80.0	0.431	602
-15.5	4.248	37 478	32.5	1.764	3597	80.5	0.425	592
-15.0	4.230	36 435	33.0	1.741	3523	81.0	0.418	583
-14.5	4.211	35 424	33.5	1.717	3450	81.5	0.412	573
-14.0	4.193	34 444	34.0	1.693	3379	82.0	0.406	564
-13.5	4.174	33 495	34.5	1.670	3310	82.5	0.400	556
-13.0	4.154	32 576	35.0	1.647	3243	83.0	0.394	547
-12.5	4.135	31 685	35.5	1.624	3177	83.5	0.388	539
-12.0	4.115	30 821	36.0	1.602	3113	84.0	0.383	531
-11.5	4.094	29 984	36.5	1.579	3051	84.5	0.377	524
-11.0	4.074	29 173	37.0	1.557	2990	85.0	0.371	516
-10.5	4.053	28 386	37.5	1.536	2931	85.5	0.366	509
-10.0	4.032	27 624	38.0	1.514	2873	86.0	0.361	502
- 9.5	4.010	26 884	38.5	1.492	2816	86.5	0.355	496
- 9.0	3.989	26 168	39.0	1.471	2761	87.0	0.350	489
- 8.5	3.967	25 472	39.5	1.450	2707	87.5	0.345	483
- 8.0	3.944	24 798	40.0	1.430	2655	88.0	0.340	477
- 7.5	3.922	24 144	40.5	1.409	2603	88.5	0.335	472
- 7.0	3.899	23 509	41.0	1.389	2553	89.0	0.331	466
- 6.5	3.876	22 893	41.5	1.369	2504	89.5	0.326	461
- 6.0	3.852	22 296	42.0	1.349	2457	90.0	0.321	456
- 5.5	3.829	21 716	42.5	1.330	2410	90.5	0.317	451
- 5.0	3.805	21 153	43.0	1.311	2364	91.0	0.312	446
- 4.5	3.781	20 606	43.5	1.292	2320	91.5	0.308	441
- 4.0	3.756	20 076	44.0	1.273	2276	92.0	0.303	436
- 3.5	3.732	19 561	44.5	1.254	2234	92.5	0.299	432
- 3.0	3.707	19 061	45.0	1.236	2192	93.0	0.295	427
- 2.5	3.682	18 575	45.5	1.218	2152	93.5	0.291	423
- 2.0	3.656	18 103	46.0	1.200	2112	94.0	0.287	419
- 1.5	3.631	17 645	46.5	1.182	2073	94.5	0.283	415
- 1.0	3.605	17 199	47.0	1.165	2035	95.0	0.279	410
- 0.5	3.579	16 766	47.5	1.148	1997	95.5	0.275	406
0.0	3.553	16 346	48.0	1.131	1961	96.0	0.271	402
0.5	3.526	15 937	48.5	1.114	1925	96.5	0.267	398
1.0	3.500	15 539	49.0	1.098	1890	97.0	0.264	393
1.5	3.473	15 153	49.5	1.081	1856	97.5	0.260	389
2.0	3.446	14 777	50.0	1.065	1822	98.0	0.257	385
2.5	3.419	14 412	50.5	1.049	1789	98.5	0.253	380
3.0	3.392	14 057	51.0	1.034	1757	99.0	0.250	376
3.5	3.364	13 711	51.5	1.019	1725	99.5	0.246	371
4.0	3.337	13 375	52.0	1.003	1694	100.0	0.243	367
4.5	3.309	13 048	52.5	0.988	1663	100.5	0.240	362
5.0	3.281	12 730	53.0	0.974	1634	101.0	0.236	357
5.5	3.253	12 420	53.5	0.959	1604	101.5	0.233	352
6.0	3.225	12 119	54.0	0.945	1575	102.0	0.230	346
6.5	3.197	11 826	54.5	0.931	1547	102.5	0.227	341
7.0	3.169	11 541	55.0	0.917	1519	103.0	0.224	335
7.5	3.140	11 263	55.5	0.903	1492	103.5	0.221	330
8.0	3.112	10 992	56.0	0.890	1465	104.0	0.218	324
8.5	3.083	10 729	56.5	0.876	1438	104.5	0.215	318
9.0	3.054	10 472	57.0	0.863	1412	105.0	0.212	312
9.5	3.026	10 223	57.5	0.850	1387	105.5	0.209	305
10.0	2.997	9 979	58.0	0.837	1362	106.0	0.206	299
10.5	2.968	9 742	58.5	0.825	1337	106.5	0.204	292
11.0	2.939	9 512	59.0	0.812	1313	107.0	0.201	285
11.5	2.911	9 287	59.5	0.800	1289			
12.0	2.882	9 068	60.0	0.788	1265			
12.5	2.853	8 855	60.5	0.776	1242			
13.0	2.824	8 647	61.0	0.765	1219			
13.5	2.795	8 444	61.5	0.753	1197			
14.0	2.766	8 247	62.0	0.742	1175			
14.5	2.737	8 055	62.5	0.731	1153			
15.0	2.708	7 868	63.0	0.720	1132			
15.5	2.680	7 685	63.5	0.709	1111			

- When test has been completed, carefully reassemble EXV. Be careful not to damage motor or O-ring when reassembling valve. Open compressor service valves and close compressor circuit breakers. Open liquid line service valve. Turn control circuit switch to ON position, and allow unit to operate. Verify proper operation of unit.

This process of opening and closing EXV can be repeated by repeating quick test steps 3.5. or 3.9. and recycling control as described in preceding steps. If valve does not operate as described (when properly connected to processor and receiving correct signals), replace valve.

If operating problems persist after reassembly, they may be due to out-of-calibration thermistor(s), or intermittent connections between processor board terminals and EXV plug. Recheck all wiring connections and voltage signals.

Another possible cause of improper refrigerant flow control could be restrictions in liquid line. Check for plugged filter drier(s), stuck liquid line solenoid valve(s), or restricted metering slots in the EXV. Formation of ice or frost on lower body of EXV is one symptom of restricted metering slots. Clean or replace valve if necessary.

NOTE: Frosting of valve is normal during quick test steps 3.5. and 3.9., and at initial start-up. Frost should dissipate after 5- to 10-minute operation of a system that is operating properly. If valve is to be replaced, wrap valve with a wet cloth to prevent excessive heat from damaging internal components. Superheat control built into valve is *not* adjustable.

NOTE: The EXV orifice is a screw-in type that can be removed for inspection and cleaning. Once the top cover has been removed, the EXV motor may be taken out by removing the 2 cap screws securing motor to valve body. Pull motor, lead screw, and the slide assembly up off the orifice assembly. A slot has been cut in top of orifice assembly to facilitate removal using a large screwdriver. Turn orifice assembly counterclockwise to remove.

When cleaning or reinstalling orifice assembly, be careful not to damage orifice assembly seals. The bottom seal acts as a liquid shut-off, replacing a liquid line solenoid valve.

Reassembly of valve is made easier by screwing the slide and lead screw assembly out of the motor. Align hole in top of slide with the guide pin in orifice assembly and gently push slide and lead screw onto orifice assembly about half way. Screw motor onto lead screw and secure EXV motor with cap screws. Be careful not to twist or pull on wires from EXV motor to valve cover pin connections. Check EXV operation in quick step steps outlined on page 44.

**THERMOSTATIC EXPANSION VALVE (TXV) (080-110 ONLY)** — The chiller with optional TXV is equipped with 2 conventional TXVs (one per circuit). This control system necessitates use of a liquid line solenoid valve. TXVs are factory set to maintain 8° to 10° F (4.4° to 5.6° C) superheat of vapor leaving cooler by controlling flow of refrigerant into cooler. *Superheat can be reset but should be reset only if absolutely necessary.*

When optional TXVs are used, thermistors T5, T6, T7, and T8 are eliminated (see Fig. 21).

The TXVs also incorporate an MOP (maximum operating pressure) feature to limit cooler suction to 55 F (13 C), making it possible for compressor to start at higher cooler fluid temperatures without overloading.

NOTE: The TXV option is not available on 080-110 units used as part of a modular system.

**MOISTURE-LIQUID INDICATOR** — Clear flow of liquid refrigerant indicates sufficient charge in system. Bubbles in the sight glass indicate undercharged system or presence of noncondensables. Moisture in system, measured in parts per million (ppm), changes color of indicator:

*Green* — moisture is below 45 ppm;

*Yellow-green (chartreuse)* — 45 to 130 ppm (caution);

*Yellow (wet)* — above 130 ppm.

Change filter drier at first sign of moisture in system.

**IMPORTANT:** Unit must be in operation at least 12 hours before moisture indicator can give an accurate reading. With unit running, indicating element must be in contact with liquid refrigerant to give true reading.

**FILTER DRIER** — Whenever moisture-liquid indicator shows presence of moisture, replace filter drier(s). There is one filter drier on each circuit. Refer to Carrier Standard Service Techniques Manual, Chapter 1, Refrigerants, for details on servicing filter driers.

**LIQUID LINE SOLENOID VALVE** — All units have a liquid line solenoid valve to prevent liquid refrigerant migration to low side of system during the off cycle.

**LIQUID LINE SERVICE VALVE** — This valve is located immediately ahead of filter drier, and has a 1/4-in. Schrader connection for field charging. In combination with compressor discharge service valve, each circuit can be pumped down into the high side for servicing.

**Thermistors** — Electronic control uses 4 to 9 thermistors to sense temperatures used to control the operation of chiller. See Table 17.

**Table 17 — Thermistor Designations**

SENSOR	TEMPERATURE
<b>T1</b>	Cooler Leaving Fluid
<b>T2</b>	Cooler Entering Fluid
<b>T3</b>	Saturated Condensing Temperature — Circuit A
<b>T4</b>	Saturated Condensing Temperature — Circuit B
<b>T5*</b>	Evaporator Refrigerant Temperature — Circuit A
<b>T6*</b>	Evaporator Refrigerant Temperature — Circuit B
<b>T7*</b>	Compressor Return Gas Temperature — Circuit A
<b>T8*</b>	Compressor Return Gas Temperature — Circuit B
<b>T10</b>	Remote Temperature Sensor (Accessory)

\*Not used on units with optional TXV (080-110 only).

All thermistors are identical in their temperature vs resistance and voltage drop performance. Resistances at various temperatures are listed in Table 15 or 16.

**LOCATION** — General locations of thermistor sensors are shown in Fig. 21.

**Cooler Leaving Fluid Thermistor, T1** — Thermistor T1 is located in the leaving fluid nozzle. The probe is in a well immersed in the fluid. Actual location is shown in Fig. 21 and 23.

**Cooler Entering Fluid Thermistor, T2** — Thermistor T2 is located in the cooler shell in first baffle space, in close proximity to tube bundle. The connection is made through a 1/4-in. coupling (Fig. 31). Actual location is shown in Fig. 21 and 23.

### Saturated Condensing Temperature Thermistors, T3 and T4

— Thermistors T3 and T4 are each clamped to the outside of a return bend on condenser coil. Exact locations for all units are shown in Fig. 21 and 22.

**Evaporator Refrigerant Thermistors, T5 and T6** — Thermistors T5 and T6 are located next to refrigerant inlet in cooler head. Thermistors are well-type thermistors. Typical location is shown in Fig. 21 and 23. (Not used on units with TXV.)

**Compressor Return Gas Thermistors, T7 and T8** — Thermistors T7 and T8 are located in lead compressor in each circuit in a suction passage between motor and cylinders above oil pump. They are well-type thermistors. Location is shown in Fig. 21. (Not used on units with TXV.)

**Remote Thermistor, T10** — Thermistor T10 is an accessory and is mounted remotely from unit. It is used for outdoor air or space temperature reset.

To troubleshoot a Thermistor, refer to separate Controls and Troubleshooting literature.

### TO REPLACE THERMISTOR T2 (Cooler):

#### ⚠ CAUTION

Thermistor T2 is installed directly in the fluid circuit. Relieve all pressure or drain fluid before removing.

1. Remove and discard original thermistor and coupling. Do not disassemble new coupling. Install assembly as received.
2. Apply pipe sealant to 1/4-in. NPT threads on replacement coupling, and install in place of original. Do not use the packing nut to tighten coupling. Damage to ferrules will result.
3. Thermistor T2 (entering fluid temperature) should not be touching an internal refrigerant tube, but should be close enough to sense a freeze condition. Recommended distance is 1/8 in. (3.2 mm) from cooler tube. Tighten packing nut finger-tight to position ferrules, then tighten 1 1/4 turns more using a back-up wrench. Ferrules are now attached to the thermistor, which can be withdrawn from coupling for service.

**TO REPLACE THERMISTORS T1, T5, T6, T7, AND T8** — Add a small amount of thermal conductive grease to thermistor well. Thermistors are friction-fit thermistors, which must be slipped into receivers located in the cooler leaving fluid nozzle for T1, in the cooler head for T5 or T6, and in the compressor pump end for T7 or T8.

NOTE: Thermistor T1 is on all units; thermistors T5, T6, T7, and T8 are on EXV units only.

**THERMISTORS T3 AND T4** — These thermistors are located on header end of condenser coil. They are clamped on a return bend.

**THERMISTOR/TEMPERATURE SENSOR CHECK** — A high quality digital volt-ohmmeter is required to perform this check.

1. Connect the digital voltmeter across the appropriate thermistor terminals at the J1 terminal strip on the processor board (see Fig. 32 and Fig. 19). Using the voltage reading obtained, read the sensor temperature from Table 15 or 16. To check thermistor accuracy, measure temperature at probe location with an accurate thermocouple-type temperature measuring instrument. Insulate thermocouple to avoid ambient temperatures from influencing

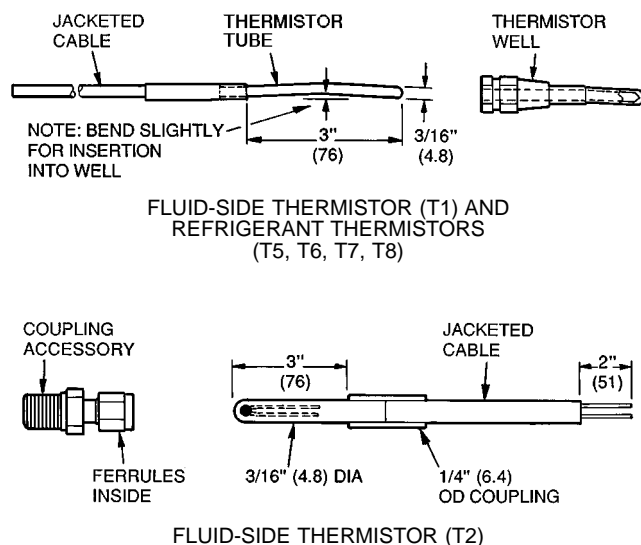
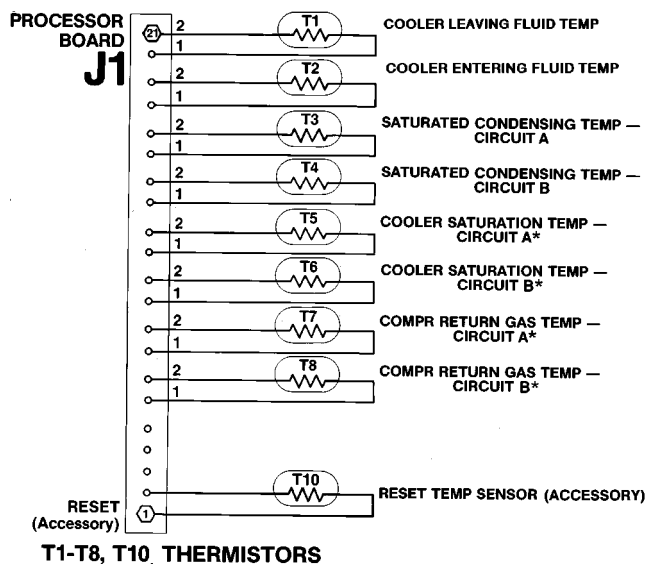

Fig. 31 — Thermistors



LEGEND  
COMPR — Compressor

\*Not used on 080-110 units with optional TXV (thermostatic expansion valve).

Fig. 32 — Thermistor Connections to J1, Processor Board

reading. Temperature measured by thermocouple and temperature determined from thermistor voltage reading should be close,  $\pm 5^\circ\text{F}$  ( $3^\circ\text{C}$ ) if care was taken in applying thermocouple and taking readings.

2. If a more accurate check is required, unit must be shut down. Remove thermistor and check at a known temperature (freezing point or boiling point of water) using either voltage drop measured across thermistor at the J1 terminals with unit in quick test mode **88** or by determining the resistance with chiller shut down and thermistor disconnected from J1.

**Safety Devices** — Chillers contain many safety devices and protection logic built into electronic control. Following is a brief summary of major safeties. For complete details, refer to Controls and Troubleshooting literature.

**COMPRESSOR PROTECTION**

**Circuit Breaker** — One manual reset calibrated-trip magnetic circuit breaker for each compressor protects against over-current. Do not bypass or increase size of a breaker to correct problems. Determine cause for trouble and correct before resetting breaker. Circuit breaker must-trip amps (MTA) are listed on individual circuit breakers, and on unit label diagrams.

**30GT080-110 AND 230B-315B Compressor Protection Board (CPCS)** — The CPCS is used to control and protect compressors and crankcase heaters. Board provides following features:

- Compressor contactor control
- Crankcase heater control
- Ground current protection
- Status communication to processor board
- High-pressure protection

One large relay is located on CPCS board that controls crankcase heater and compressor contactor. In addition, relay provides a set of contacts that microprocessor monitors to determine operating status of compressor. If processor board determines that compressor is not operating properly through signal contacts, control locks compressor off.

The CPCS contains logic that can detect if current-to-ground of any winding exceeds 2.5 amps; if so, compressor shuts down.

A high-pressure switch with a trip pressure of 426 ± 7 psig (2,936 ± 48 kPa) is mounted on each compressor; switch setting is shown in Table 18. Switch is wired in series with the CPCS. If switch opens, CPCS relay opens, processor detects it through signal contacts and compressor locks off.

If any of these switches open during operation, the compressor stops and the failure is detected by processor when signal contacts open. If lead compressor in either circuit is shut down by high pressure switch, ground current protector, loss of charge switch, or oil pressure switch, all compressors in the circuit are locked off.

**Table 18 — Pressure Switch Settings, psig (kPa)**

SWITCH	CUTOUT	CUT-IN
High Pressure	426 ± 7 (2936 ± 48)	320 ± 20 (2205 ± 138)
Loss-of-Charge	7 (48.2)	22 (151.6)

**30GT130-210, 230A-315A, AND 330A/B-420A/B** — A control relay in conjunction with a ground fault module replaces the function of the CPCS. To reset, press the push-button switch on the module.

**LOW OIL PRESSURE PROTECTION** — Lead compressor in each circuit is equipped with a switch to detect low oil pressure. Switch is connected directly to processor board. Switch is set to open at approximately 5 psig (35 kPa) and to close at 9 psig (62 kPa) maximum. If switch opens when compressor is running, processor board stops all compressors in circuit. During start-up, switch is bypassed for 2 minutes.

**CRANKCASE HEATERS** — Each compressor has a 180-w crankcase heater to prevent absorption of liquid refrigerant by oil in crankcase when compressor is not running. Heater power source is auxiliary control power, independent of main unit power. This assures compressor protection even when main unit power disconnect switch is off.

**IMPORTANT:** Never open any switch or disconnect that deenergizes crankcase heaters unless unit is being serviced or is to be shut down for a prolonged period. After a prolonged shutdown or a service job, energize crankcase heaters for 24 hours before starting unit.

**COOLER PROTECTION**

**Freeze Protection** — Cooler can be wrapped with heater cables as shown in Fig. 33, which are wired through an ambient temperature switch set at 36 F (2 C). Entire cooler is covered with closed-cell insulation, applied over heater cables. Heaters plus insulation protect cooler against low ambient temperature freeze-up to 0° F (-18 C).

**IMPORTANT:** If unit is installed in an area where ambient temperatures fall below 32 F (0° C), it is recommended that inhibited ethylene glycol or other suitable corrosion-inhibitive antifreeze solution be used in chilled-liquid circuit.

**⚠ CAUTION**

If coolers are equipped with heaters and the coolers are drained during the non-cooling season, the cooler heaters **MUST** be disconnected by removing fuse no. 1. Without fluid in the cooler, the heater could reach a temperature that damages the cooler insulation.

**Low Fluid Temperature** — Microprocessor is programmed to shut chiller down if leaving fluid temperature drops below 35 F (1.7 C). When fluid temperature rises to 6° F (3.3° C) above leaving fluid set point, safety resets and chiller restarts.

**Loss of Fluid Flow Protection** — Microprocessor contains internal logic that protects cooler against loss of cooler flow. Entering and leaving fluid temperature sensors in cooler detect a no-flow condition. Leaving sensor is located in leaving fluid nozzle and entering sensor is located in first cooler baffle space in close proximity to cooler tubes, as shown in Fig. 23. When there is no cooler flow and the compressors start, leaving fluid temperature does not change. However, entering fluid temperature drops rapidly as refrigerant enters cooler through EXV. Entering sensor detects this temperature drop and when entering temperature is 5° F (2.8° C) below leaving temperature, unit stops and is locked off.

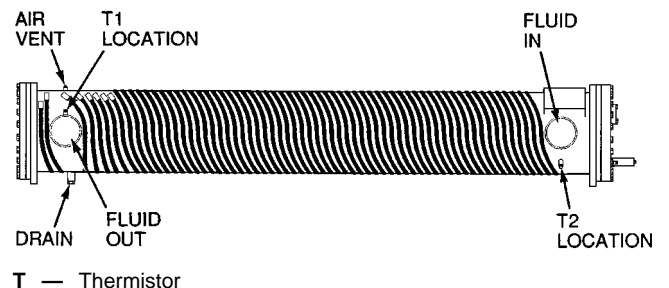

**Fig. 33 — Cooler Heater Cables**

**Loss-of-Charge** — A pressure switch connected to high side of each refrigerant circuit protects against total loss-of-charge. Switch settings are listed in Table 18. If switch is open, unit cannot start; if switch opens during operation, unit locks out and cannot restart until switch is closed. Low charge is also monitored by the processor when an EXV is used.

A low charge is detected by monitoring EXV position and superheat entering the compressor. If EXV is wide open, superheat is greater than 50 F (28 C) and saturated cooler suction is less than 55 F (13 C), circuit is stopped and locked off.

**Relief Devices** — Fusible plugs are located in each circuit to protect against damage from excessive pressures.

**HIGH-SIDE PROTECTION** — One device is located between condenser and filter drier; a second is on filter drier. These are both designed to relieve pressure on a temperature rise to approximately 210 F (99 C).

**LOW-SIDE PROTECTION** — A device is located on suction line, designed to relieve pressure on a temperature rise to approximately 170 F (77 C).

**PRESSURE RELIEF VALVES** — Where relief valves are installed, there is one in each circuit. The valves are designed to relieve at 450 psig (3103 kPa). *These valves should not be capped.* If a valve relieves, it should be replaced. If valve is not replaced, it may relieve at a lower pressure, or leak due to trapped dirt from the system which may prevent resealing.

The pressure relief valves are equipped with a 3/8-in. SAE flare for field connection. Some local building codes require that relieved gases be removed. This connection will allow conformance to this requirement.

**Other Safeties** — There are several other safeties that are provided by microprocessor control. For details refer to Controls and Troubleshooting literature.