



# Wiring Diagrams

## DIAGRAM INDEX

POWER SCHEMATICS			
Unit 30GXN,R	Voltage	Figure Number	Label Diagram No. 30GX
080-178*	ALL	1	505429
204-350* XL START	ALL	2	505436
204-350* YD START	ALL	3	505435

CONTROL SCHEMATICS			
Unit 30GXN,R	Voltage	Figure Number	Label Diagram No. 30GX
080-350*	24	4	505423
			505431
080-178* STD FAN	115, 230	5	505430
			505433
080-178* HIGH STATIC FAN	115, 230	6	505432
			505434
204-350* STD FAN	115, 230	7	505437
			505439
204-350* HIGH STATIC FAN	115, 230	8	505438
			505440

FAN POWER			
Unit 30GXN,R	Voltage	Figure Number	Label Diagram No. 30GX
080-178*	ALL	9	505422
204-350* STD FAN	ALL	10	505425
204-350* HIGH STATIC FAN	ALL	11	505427

COMPONENT ARRANGEMENTS			
Unit 30GXN,R	Voltage	Figure Number	Label Diagram No. 30GX
080-178*	ALL	12	505424
204-350*	ALL	13	505426

LEGEND

**XL** — Across-the-Line Start  
**YD** — Wye-Delta

\*And associated modular units. Refer to Table 1 for Duplex unit size combinations.

NOTE: For operating sequence, refer to Controls, Start-Up, Operation, Service, and Troubleshooting literature.











**Table 1 — 30GXN,R Duplex Combinations**

<b>SIZE</b>	<b>MODULE A</b>	<b>MODULE B</b>
220 (50 Hz only)	125	090
240 (50 Hz only)	125	115
275 (50 Hz only)	135	135
283 (60 Hz & 50 Hz)	153	138
300 (50 Hz only)	160	135
303 (60 Hz & 50 Hz)	163	138
320 (50 Hz only)	160	160
328 (60 Hz & 50 Hz)	178	153
345 (50 Hz only)	175	175
353 (60 Hz & 50 Hz)	178	178
365 (50 Hz only)	250	135
370 (60 Hz only)	225	150
373 (60 Hz & 50 Hz)	253	138
390 (60 Hz only)	264	135
393 (60 Hz & 50 Hz)	253	153
395 (50 Hz only)	264	135
410 (50 Hz only)	225	205
415 (60 Hz only)	264	160
418 (60 Hz & 50 Hz)	268	153
440 (50 Hz only)	225	225
450 (60 Hz only)	225	225
453 (60 Hz & 50 Hz)	228	228
470 (50 Hz only)	250	225
475 (60 Hz only)	249	225
478 (60 Hz & 50 Hz)	253	228
495 (50 Hz only)	250	250
500 (60 Hz only)	249	249
503 (60 Hz & 50 Hz)	253	253
520 (50 Hz only)	264	264
525 (60 Hz only)	264	264
528 (60 Hz & 50 Hz)	268	268

## LEGEND

<b>ALM</b>	— Alarm
<b>C</b>	— Contactor, Compressor
<b>CB</b>	— Circuit Breaker
<b>CCP</b>	— <i>ComfortLink™</i> Compressor Protection
<b>CH</b>	— Cooler Heater
<b>CHC</b>	— Cooler Heater
<b>CLHR</b>	— Cooler Heater Relay
<b>COMP</b>	— Compressor
<b>CR</b>	— Control Relay
<b>CWFS</b>	— Chilled Water Flow Switch
<b>CWP</b>	— Chilled Water Pump
<b>CWPI</b>	— Chilled Water Pump Interlock
<b>DGT</b>	— Discharge Gas Thermistor
<b>DPT</b>	— Discharge Pressure Transducer
<b>ECON</b>	— Economizer
<b>EMM</b>	— Energy Management Module
<b>EPT</b>	— Economizer Pressure Transducer
<b>EQUIP</b>	— Equipment
<b>EXV</b>	— Expansion Valve Board
<b>FC</b>	— Fan Contactor
<b>FCB</b>	— Fan Circuit Breaker
<b>FIOP</b>	— Factory-Installed Option
<b>FM</b>	— Fan Motor
<b>FR</b>	— Fan Relay
<b>FSR</b>	— Flow Switch Relay
<b>FU</b>	— Fuse
<b>GFI-CO</b>	— Ground Fault Interrupter Convenience Outlet
<b>GND</b>	— Ground
<b>HPS</b>	— High-Pressure Switch
<b>HTR</b>	— Heater
<b>LD</b>	— Loader
<b>LL</b>	— Liquid Level
<b>LLSV</b>	— Liquid Line Solenoid Valve
<b>LR</b>	— Loader Relay
<b>LS</b>	— Level Switch
<b>MBB</b>	— Main Base Board
<b>MLC</b>	— Minimum Load Control
<b>MLV</b>	— Minimum Load Valve

<b>MM-F</b>	— Motormaster® Fuse
<b>NEC</b>	— National Electric Code
<b>OAT</b>	— Outdoor Air Temperature Sensor
<b>OL</b>	— Overload
<b>OP</b>	— Oil Pump
<b>OPC</b>	— Oil Pump Contactor
<b>OPT</b>	— Oil Pressure Transducer
<b>PL</b>	— Plug Assembly
<b>PRI</b>	— Primary
<b>S</b>	— Wye Start Contactor
<b>SCB</b>	— Screw Compressor Board
<b>SN</b>	— Sensor (Toroid)
<b>SPT</b>	— Suction Pressure Transducer
<b>SW</b>	— Switch
<b>SW2</b>	— Emergency On/Off
<b>T</b>	— Thermistor
<b>TB</b>	— Terminal Block
<b>TEMP</b>	— Temperature
<b>TRAN</b>	— Transformer
<b>XL</b>	— Across The Line Start
<b>1M</b>	— Comp. Contactor (Wye Delta)
<b>2M</b>	— Comp. Contactor (Delta)

	Terminal Block Connection
	Marked Terminal
	Unmarked Terminal
	Unmarked Splice
	Marked Wire
	Marked Splice
	Factory Wiring
	Field Control Wiring
	Field Power Wiring
	Indicates Common Potential Does Not Represent Wiring
	Accessories or Options

## NOTES

1. Replacement of original wires must be with type 105° C wire or its equivalent.
2. Factory wiring is in accordance with National Electrical Compliance (NEC) U.S.A. Field modifications or additions must be in compliance with all applicable codes.
3. Wiring for main field power supply must be rated 75° C minimum. Use copper conductors for all units. Maximum incoming wire size for each terminal block is 500 kcmil.
4. Power for control circuit should be supplied from a separate source through a field-supplied disconnect with 30-amp maximum protection (50-amp maximum with cooler heaters) for 115-volt control circuit and 15-amp maximum protection (25-amp maximum with cooler heaters) for 230-volt control circuit. Connect control circuit power to terminals 1 and 2 of TB4. Connect neutral side of supply to terminal 2 of TB4. Control power wiring for 380-3-60 and 380/415-3-50 units is factory installed, but requires field-installed neutral connection. If separate power supply is required, disconnect the wires between the control and terminal blocks. Control circuit conductors for all units must be copper only.

**30GXN/R150-160 208/230V ONLY**  
**30GXN/R163-178 208/230V,230V ONLY**

**30GXN/R080-138 ALL VOLTAGES**  
**30GXN/R150-160 ALL EXCEPT 208/230V**  
**30GXN/R163-178 ALL EXCEPT 230,208/230V**

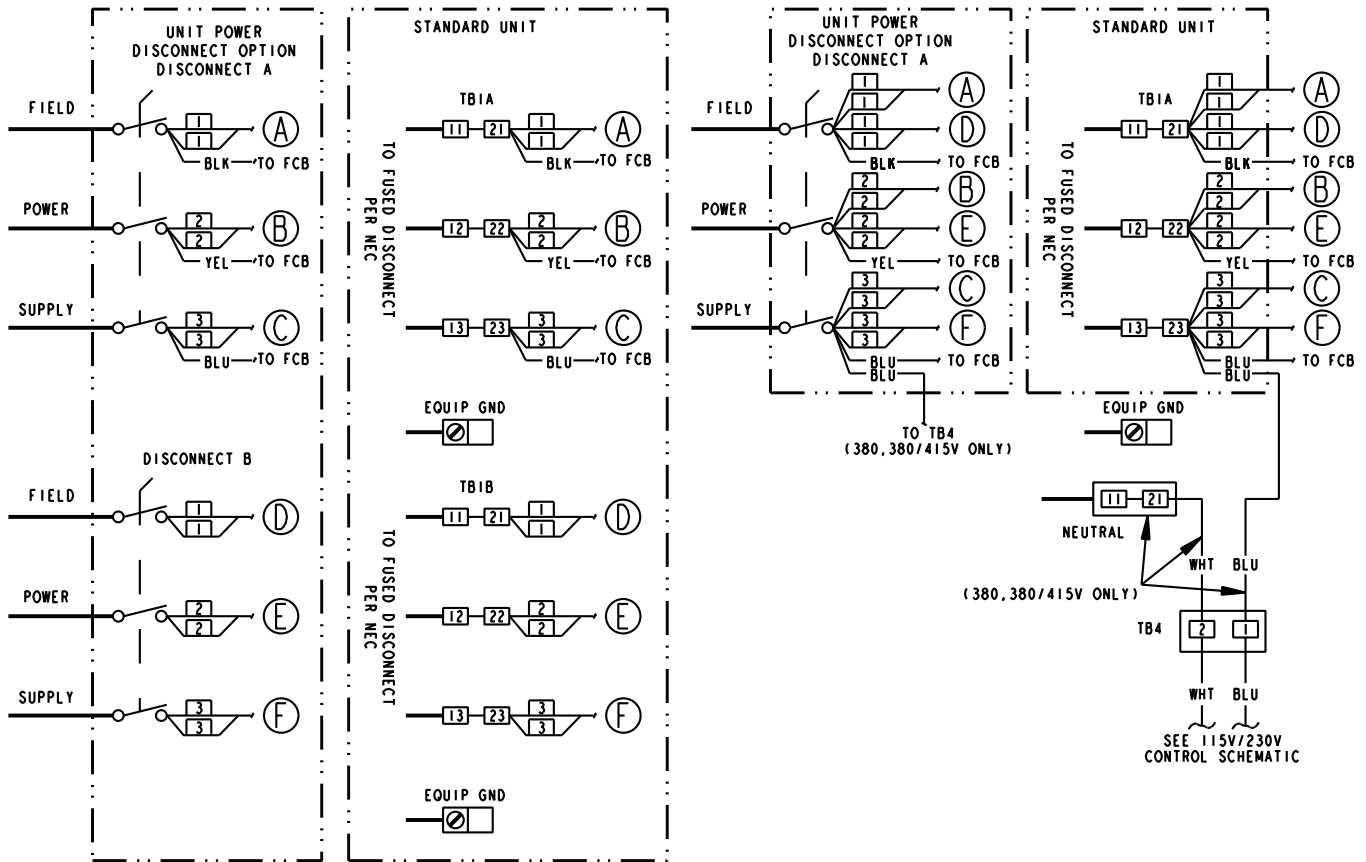

**TO TB1A TERMINALS**

**22 AND 23**

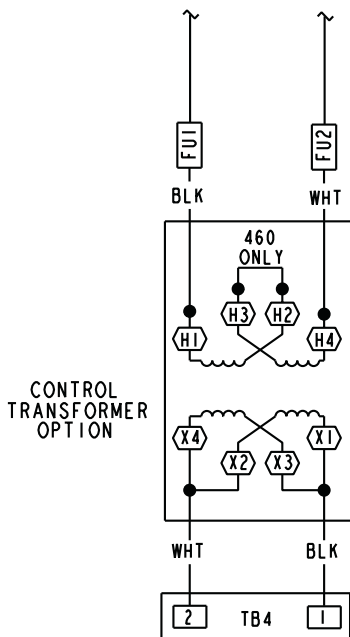

**TO TB1A TERMINALS**

**22 AND 23**

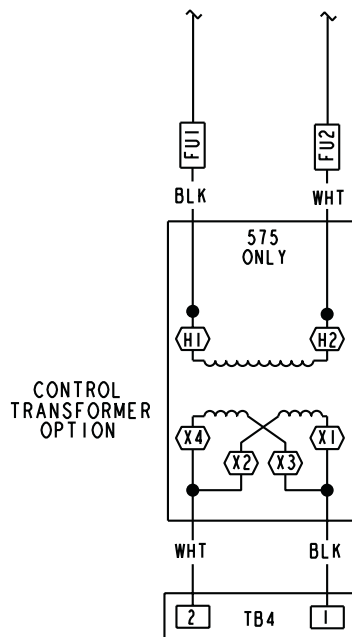

**Fig. 1 — Power Schematic — 30GXN,R080-178 and Associated Modular Sizes**

# XL START

30GXN080-178 ALL EXCEPT 230,208/230V

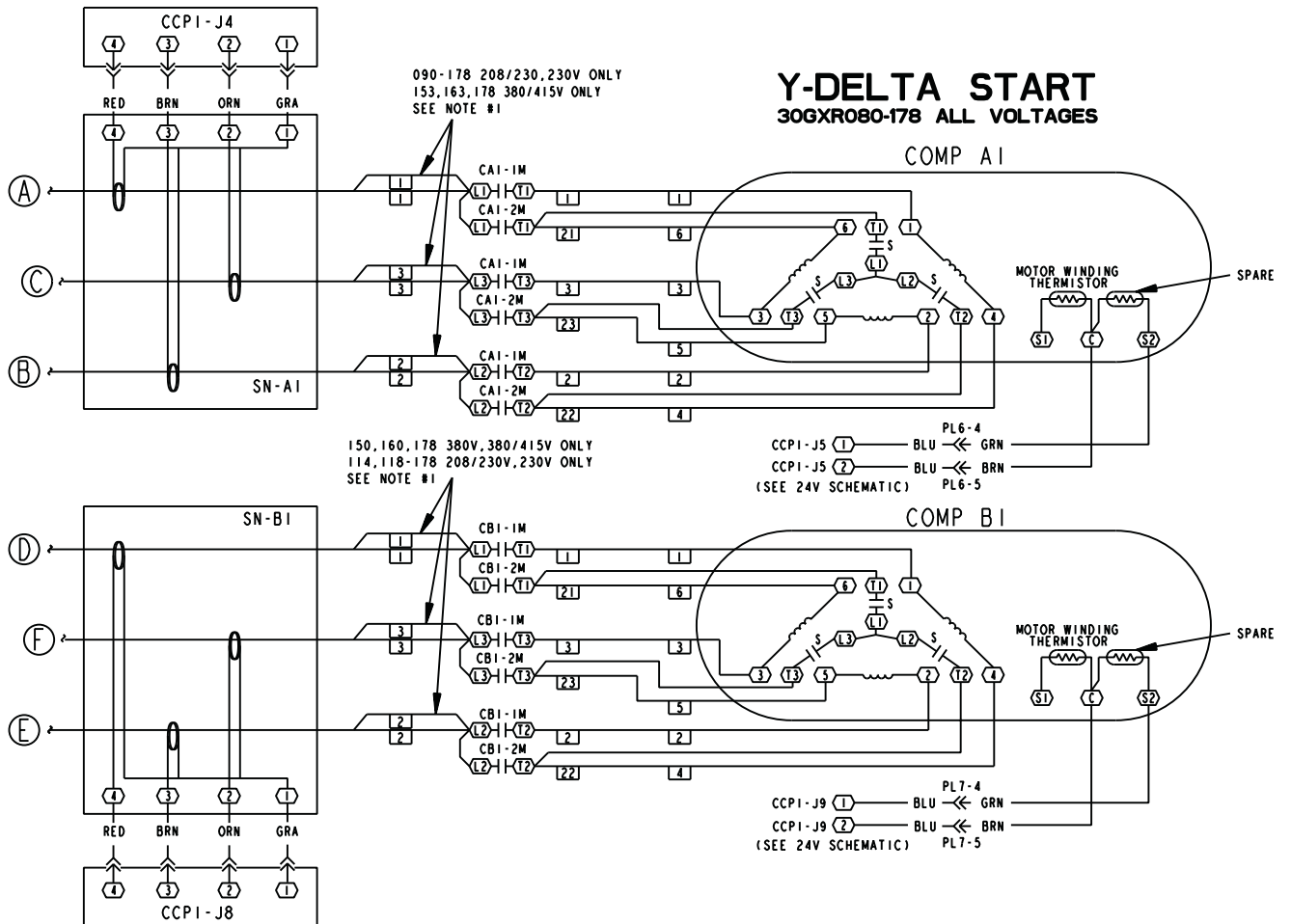
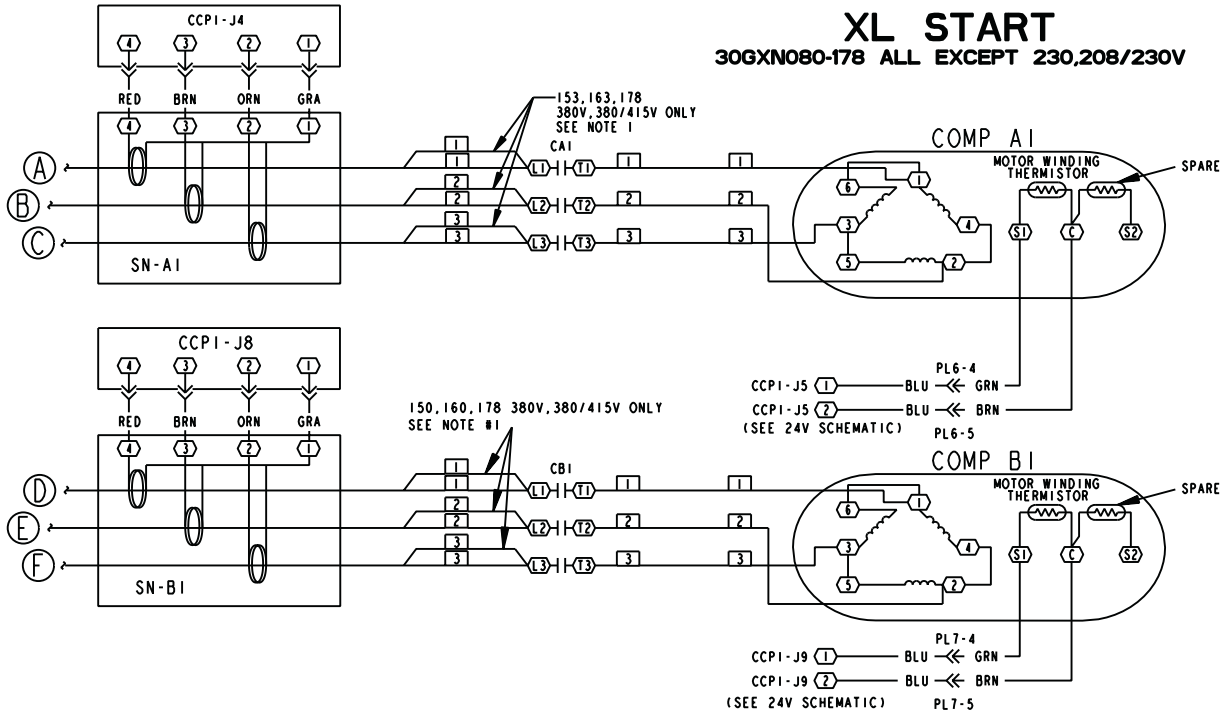

NOTE #1  
 IF TWO WIRES EXIST, BOTH  
 SHOULD PASS THROUGH TOROID (SN-##)

**Fig. 1 — Power Schematic — 30GXN,R080-178 and Associated Modular Sizes (cont)**

**30GXN301-350 380V,380/415V ONLY**

**30GXN204-350 460V,575V  
30GXN204-281 380V,380/415V**

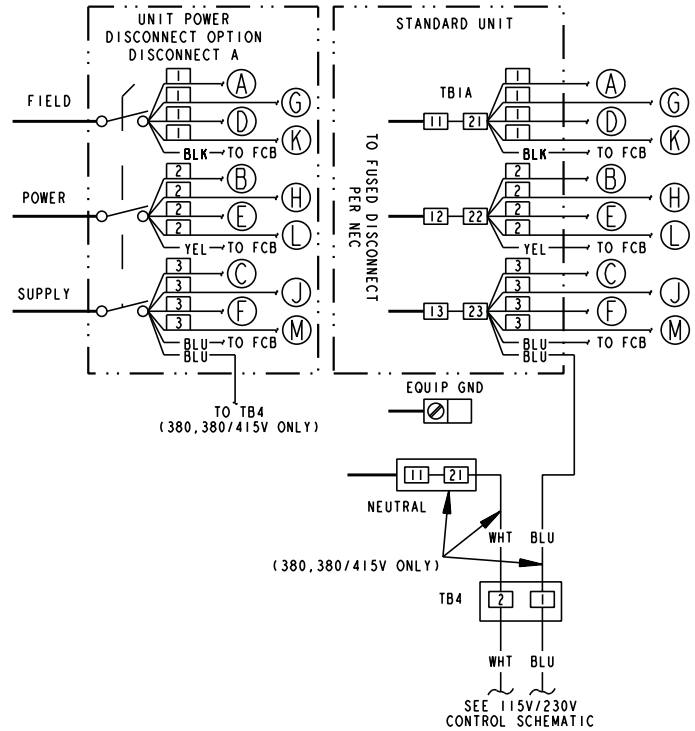
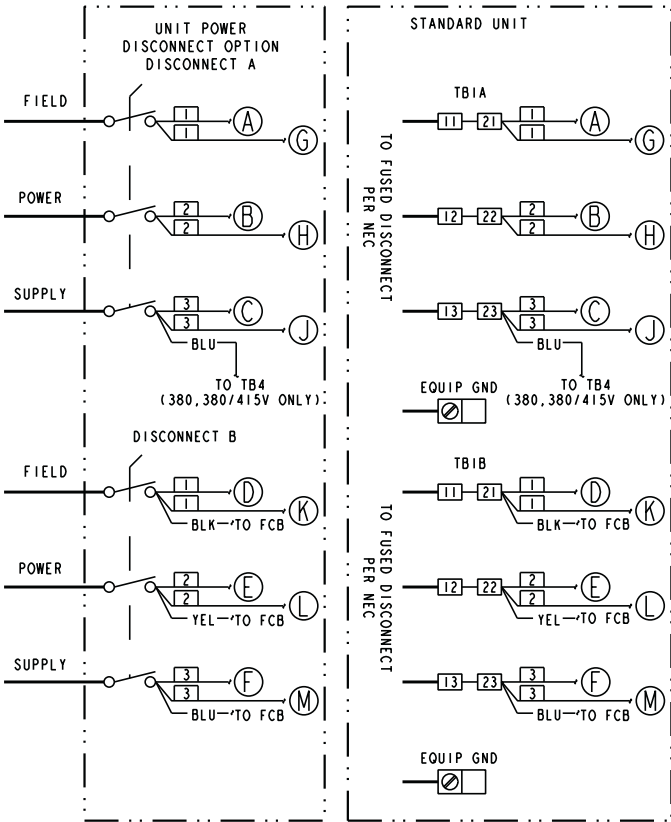

**TO TB1A TERMINALS**

**22 AND 23**

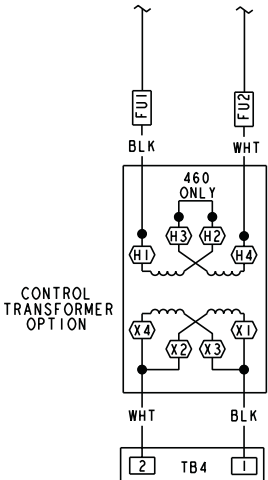

**TO TB1A TERMINALS**

**22 AND 23**

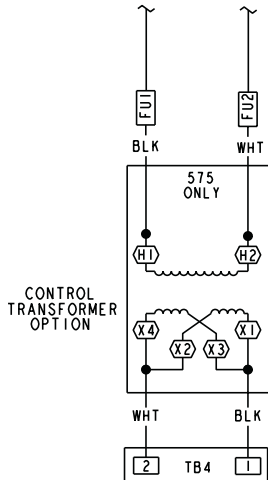

**Fig. 2 — Power Schematic — 30GXN,R204-350 and Associated Modular Units, XL Start**

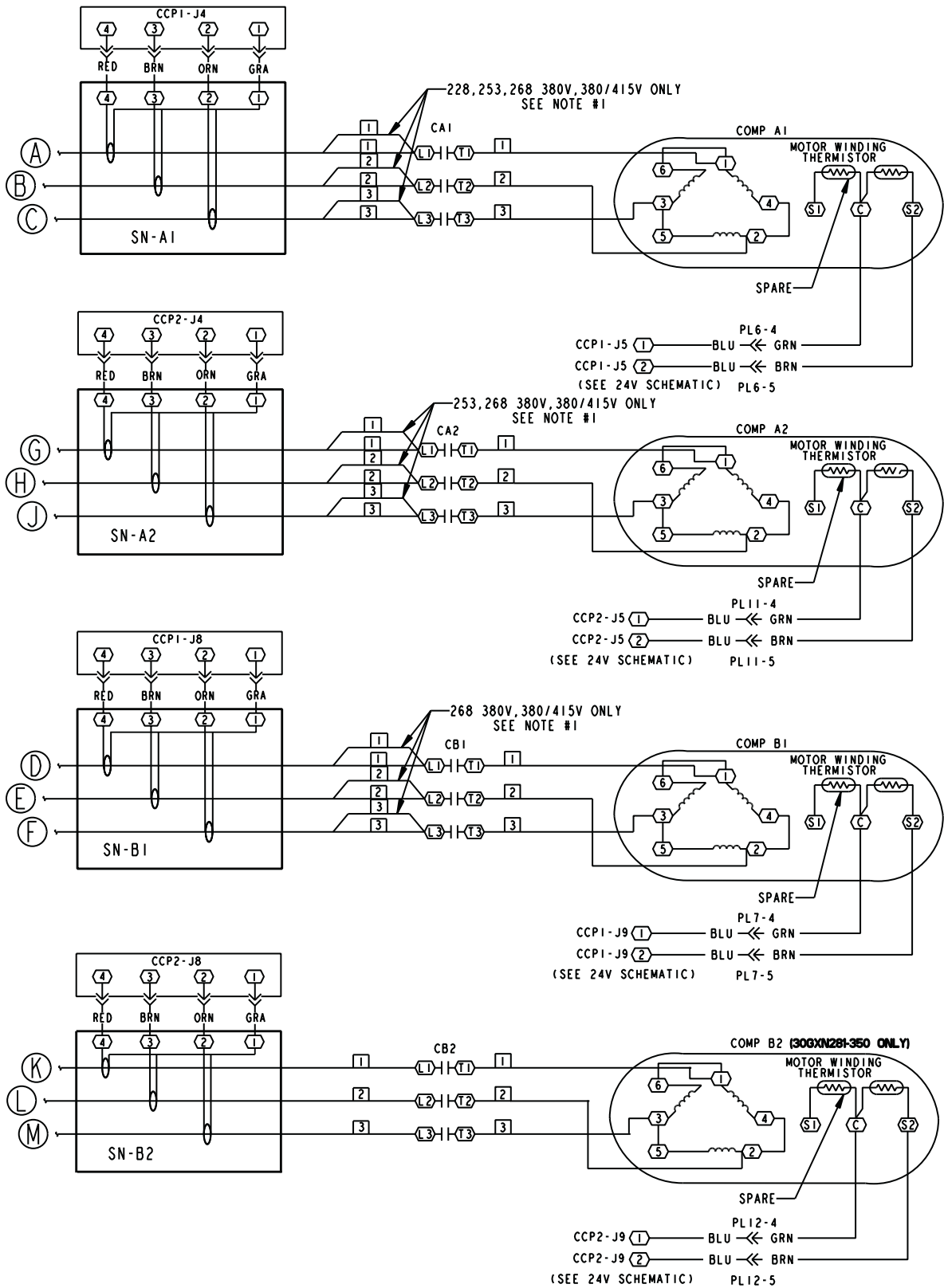
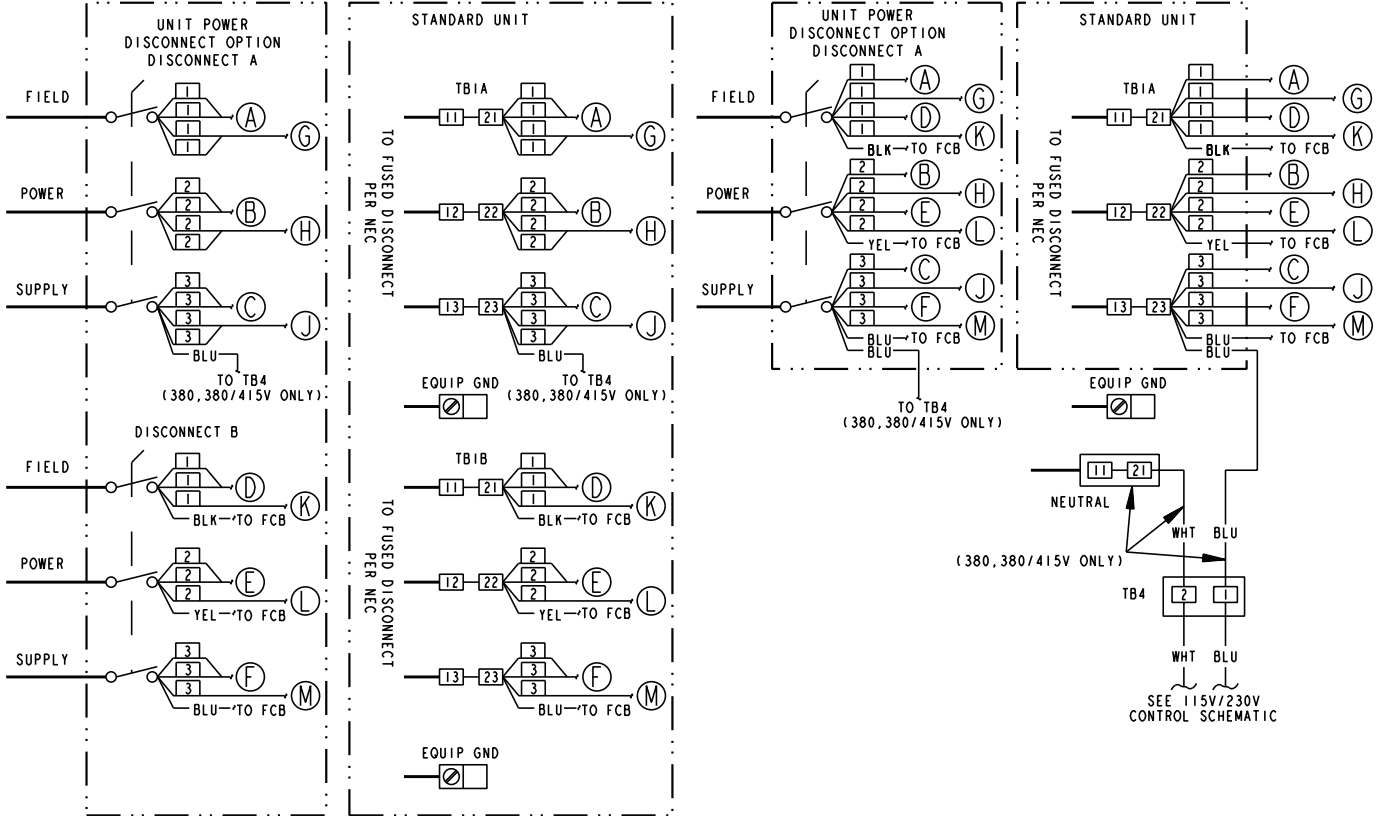

Fig. 2 — Power Schematic — 30GXN,R204-350 and Associated Modular Units, XL Start (cont)

30GXR225 230V ONLY  
 30GXR204,205,208 230V,208/230V ONLY  
 30GXR301-350 380V,380/415V ONLY

30GXR204-268 230V,208/230V ONLY  
 30GXR301-350 380V,380/415V ONLY

30GXR204-350 460V,575V  
 30GXR204-281 380V,380/415V



TO TB1A TERMINALS

TO TB1A TERMINALS

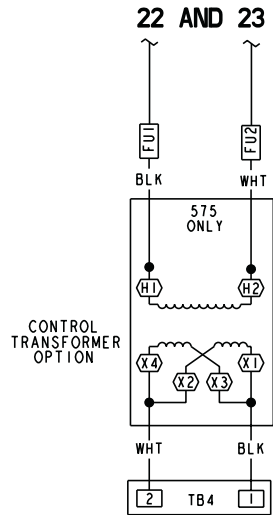
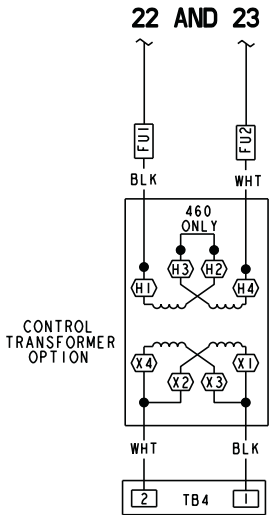
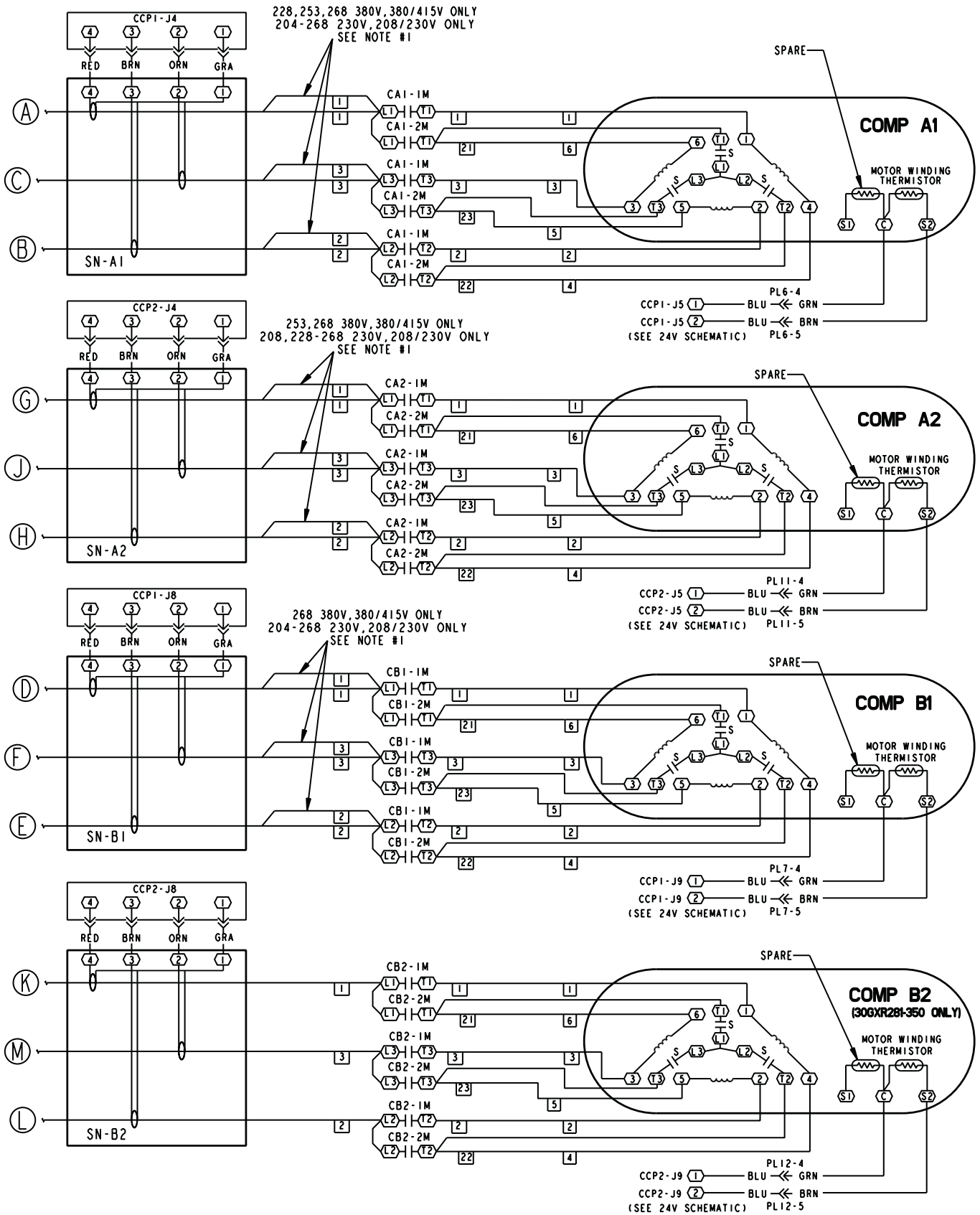

Fig. 3 — Power Schematic — 30GXN,R204-350 and Associated Modular Units, Wye-Delta Start



NOTE #1  
 IF TWO WIRES EXIST, BOTH  
 SHOULD PASS THROUGH TOROID (SN-##)

Fig. 3 — Power Schematic — 30GXN,R204-350 and Associated Modular Units, Wye-Delta Start (cont)

**COMFORTLINK  
LOW VOLTAGE (24V) CONTROL SCHEMATIC  
30GX080-350**

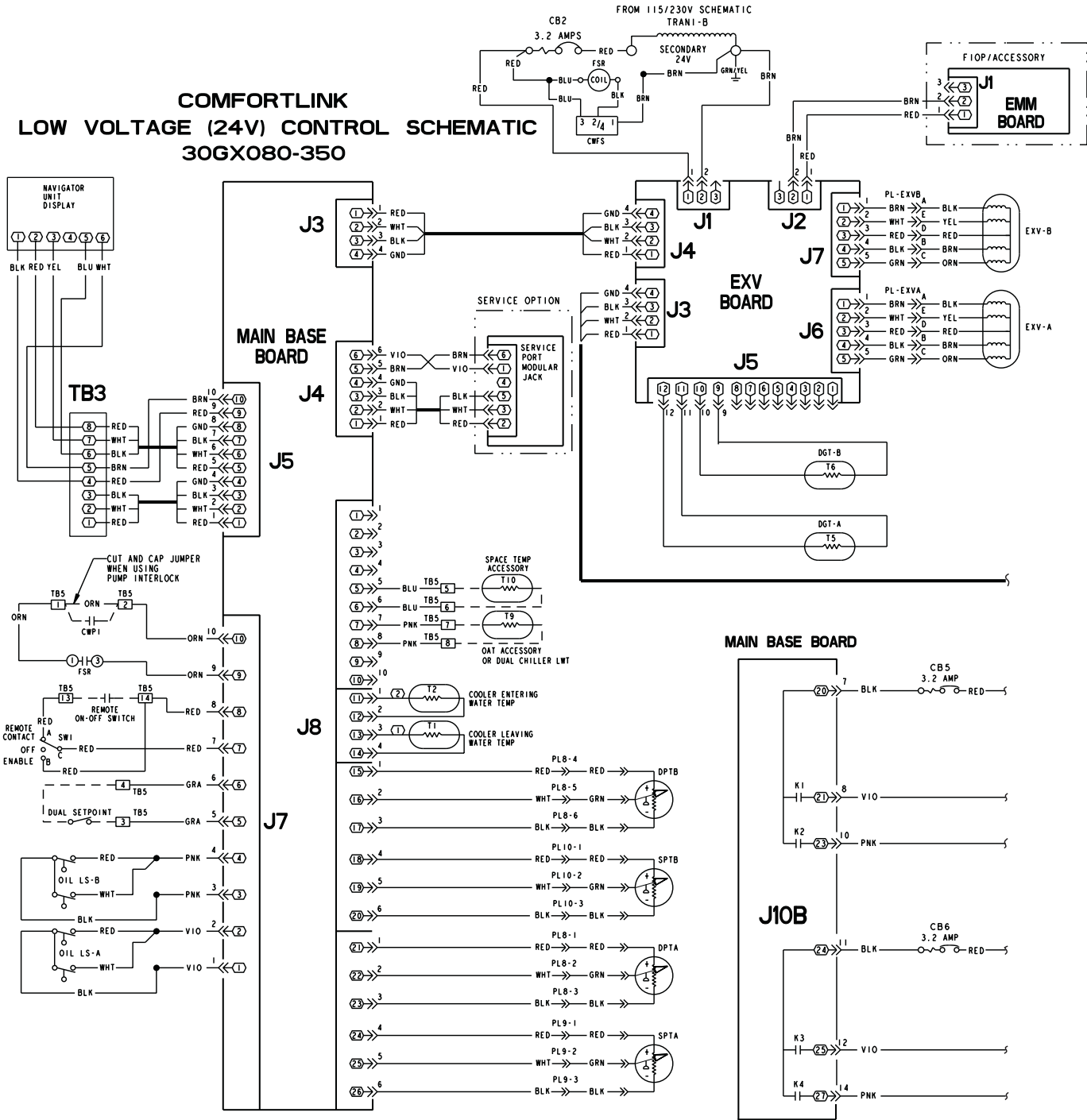

**Fig. 4 — Control Schematic — 30GXN,R080-350 and Associated Modular Units, 24 V**

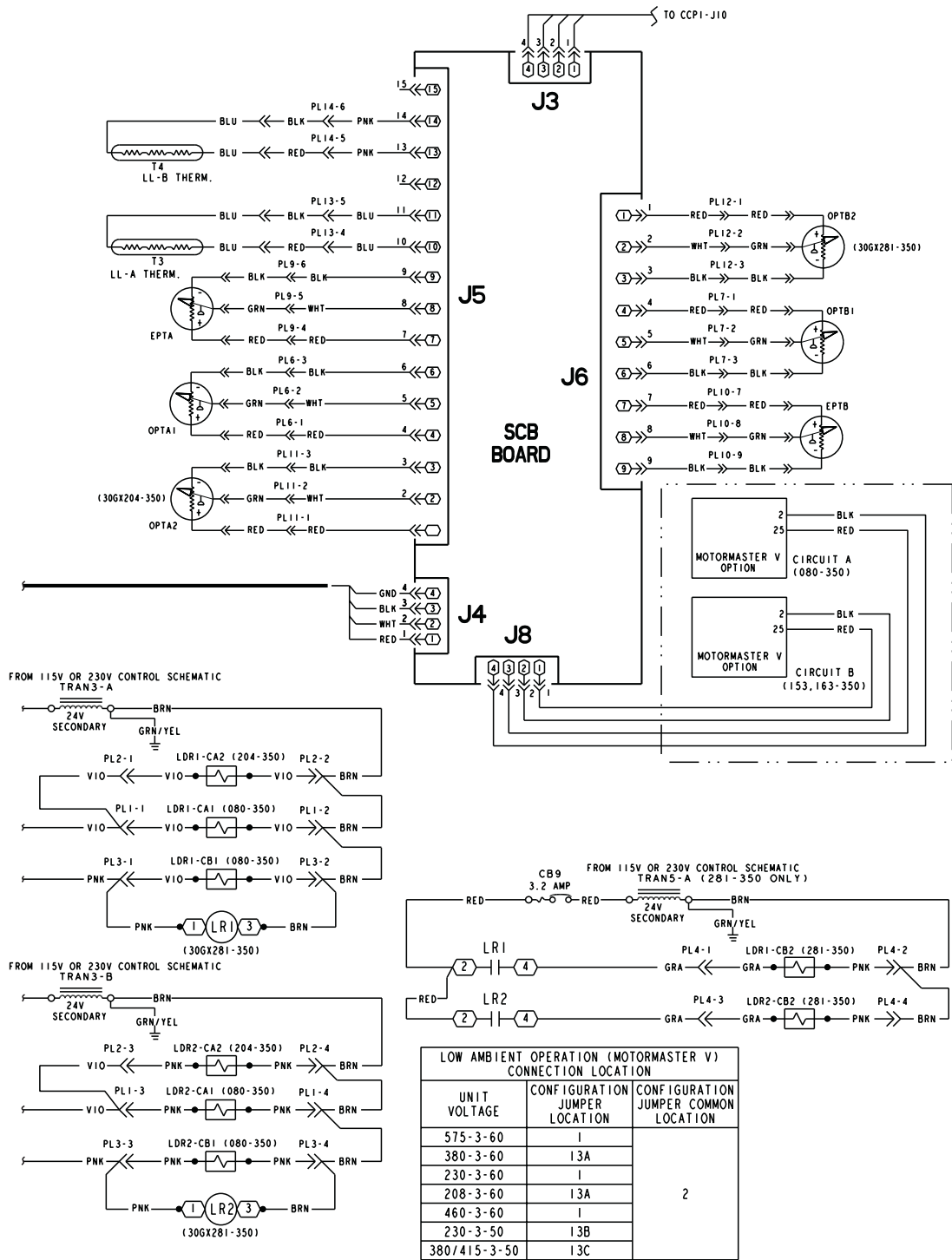
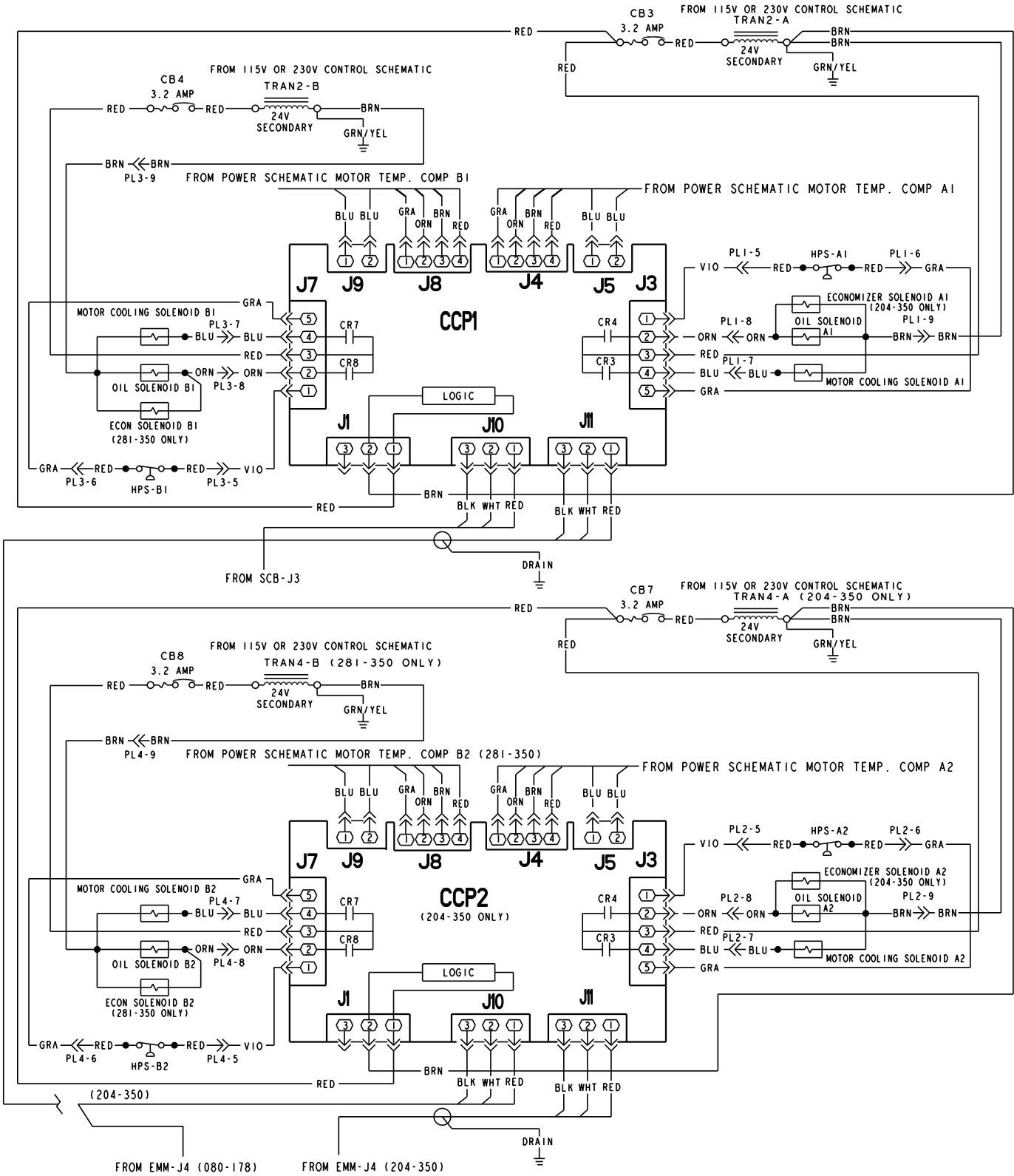

Fig. 4 — Control Schematic — 30GXN,R80-350 and Associated Modular Units, 24 V (cont)

# COMFORTLINK LOW VOLTAGE (24V) CONTROL SCHEMATIC 30GX080-350



**Fig. 4 — Control Schematic — 30GXN,R080-350 and Associated Modular Units, 24 V (cont)**



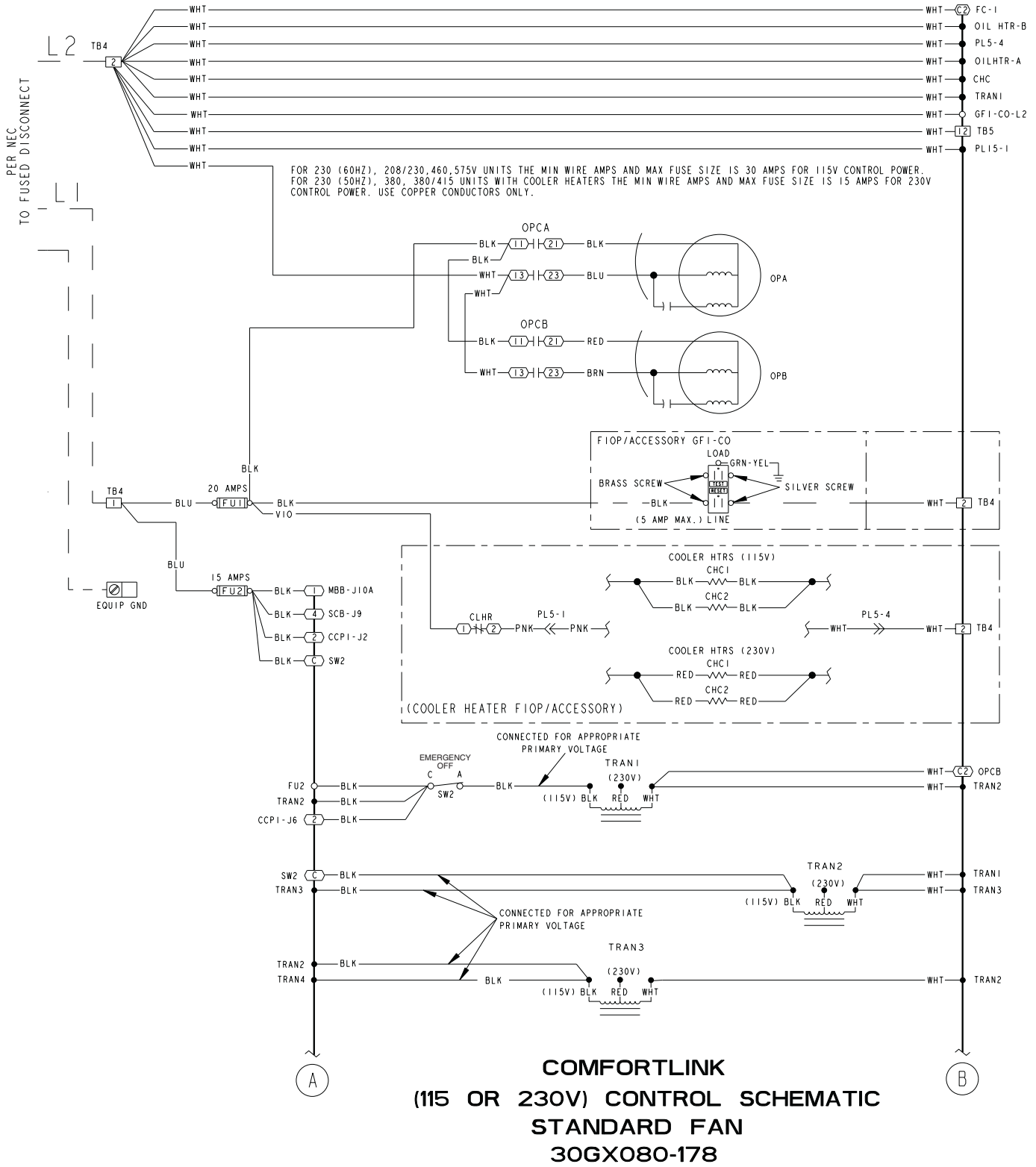

Fig. 5 — Control Schematic — 30GXN,R080-178 and Associated Modular Units, Standard Fan (115, 230 V)

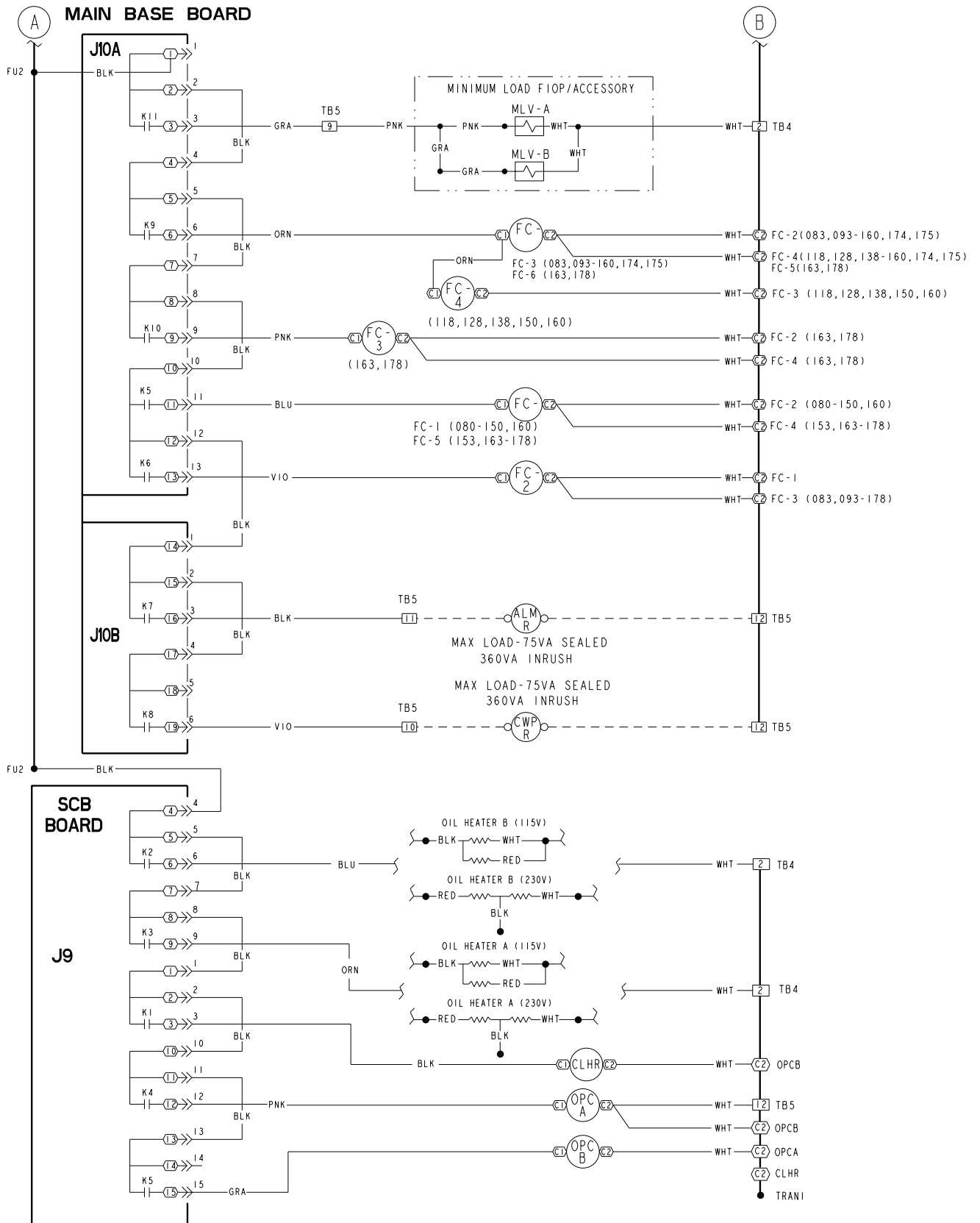

Fig. 5 — Control Schematic — 30GXN,R080-178 and Associated Modular Units, Standard Fan (115, 230 V) (cont)

### 30GX080-178 (115 OR 230V) CONTROL SCHEMATIC STANDARD FAN

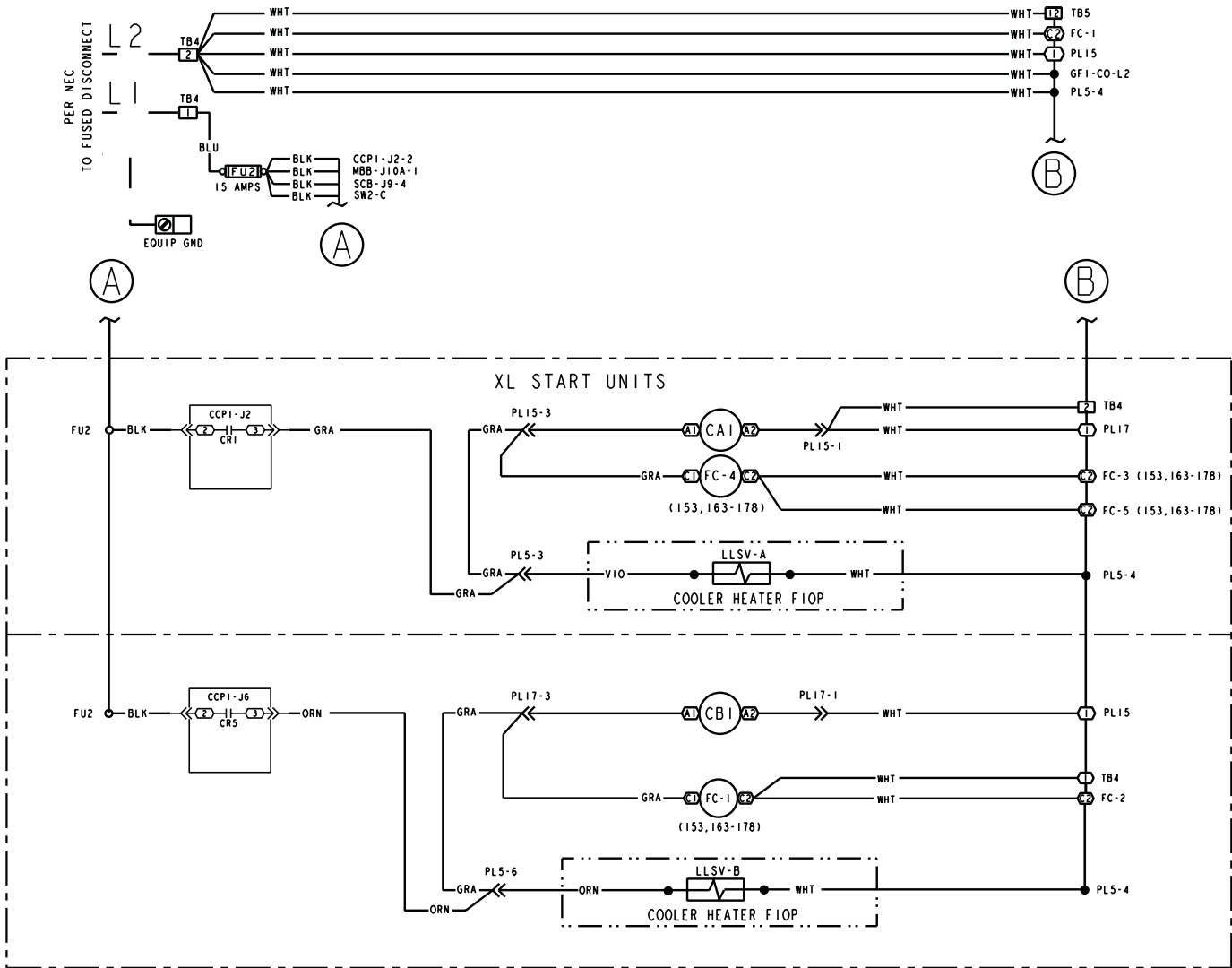

Fig. 5 — Control Schematic — 30GXN,R080-178 and Associated Modular Units, Standard Fan (115, 230 V) (cont)

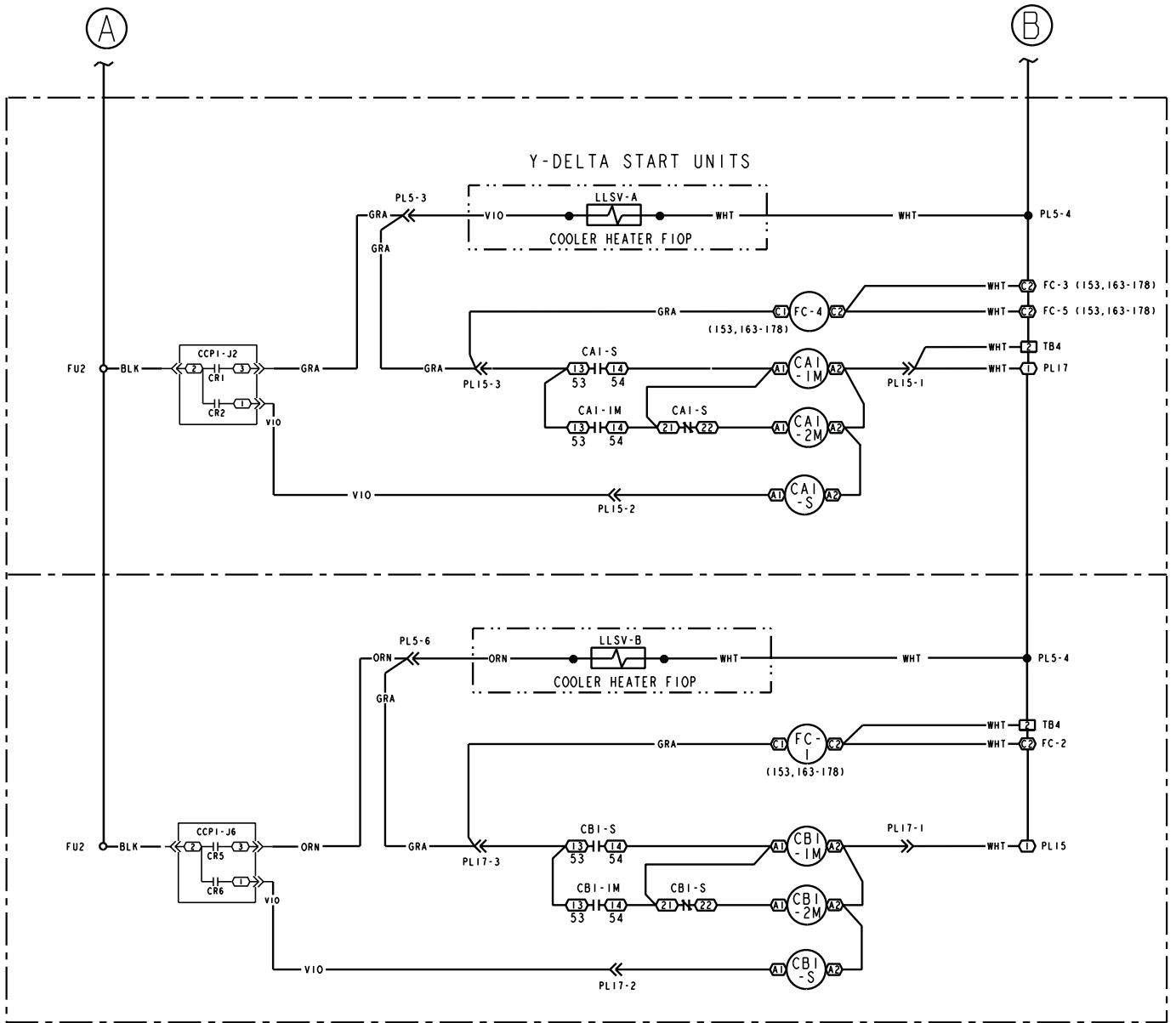

Fig. 5 — Control Schematic — 30GXN,R080-178 and Associated Modular Units, Standard Fan (115, 230 V) (cont)

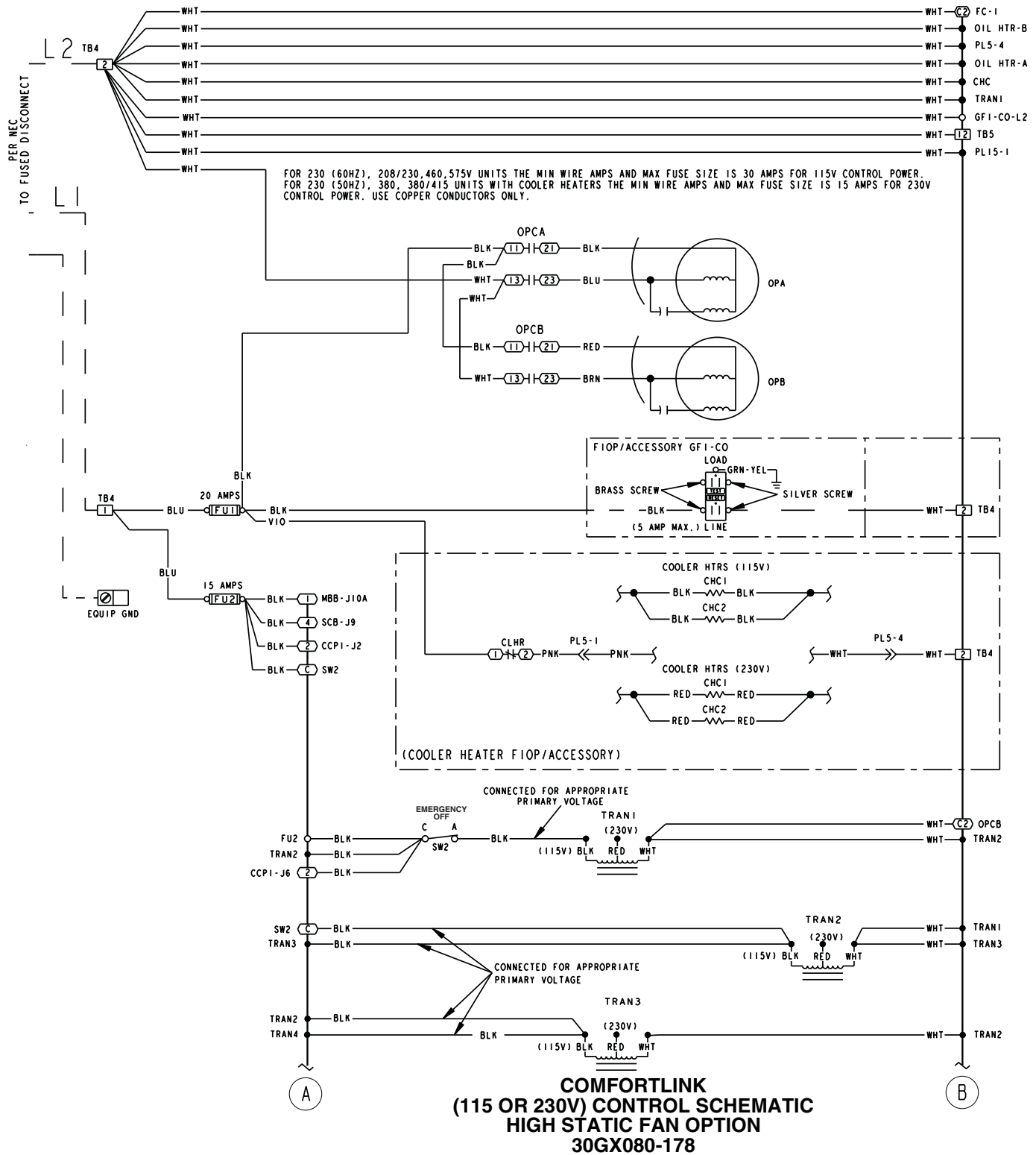

Fig. 6 — Control Schematic — 30GXN,R080-178 and Associated Modular Units, High Static Fan (115, 230 V)

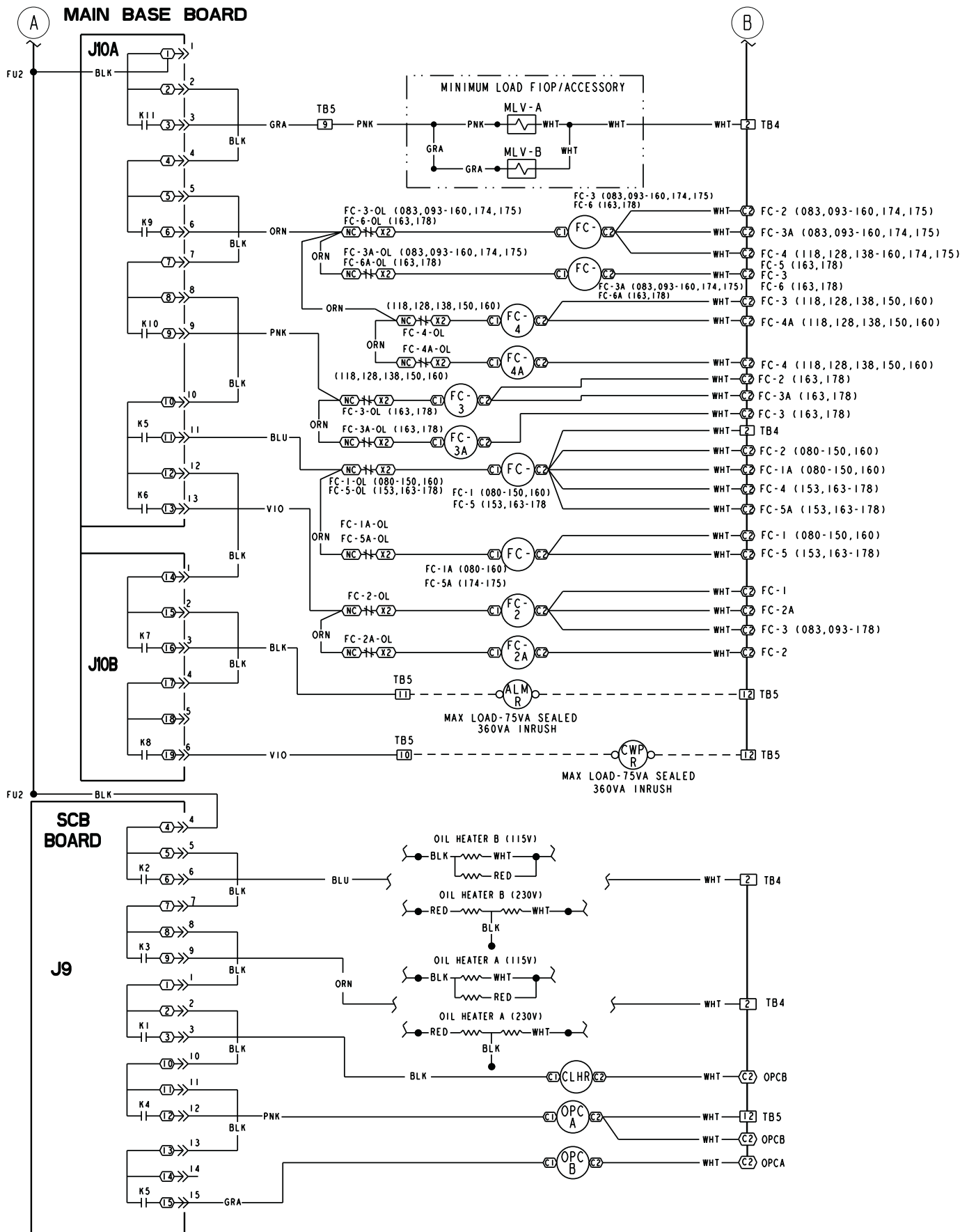

Fig. 6 — Control Schematic — 30GXN,R080-178 and Associated Modular Units, High Static Fan (115, 230 V) (cont)



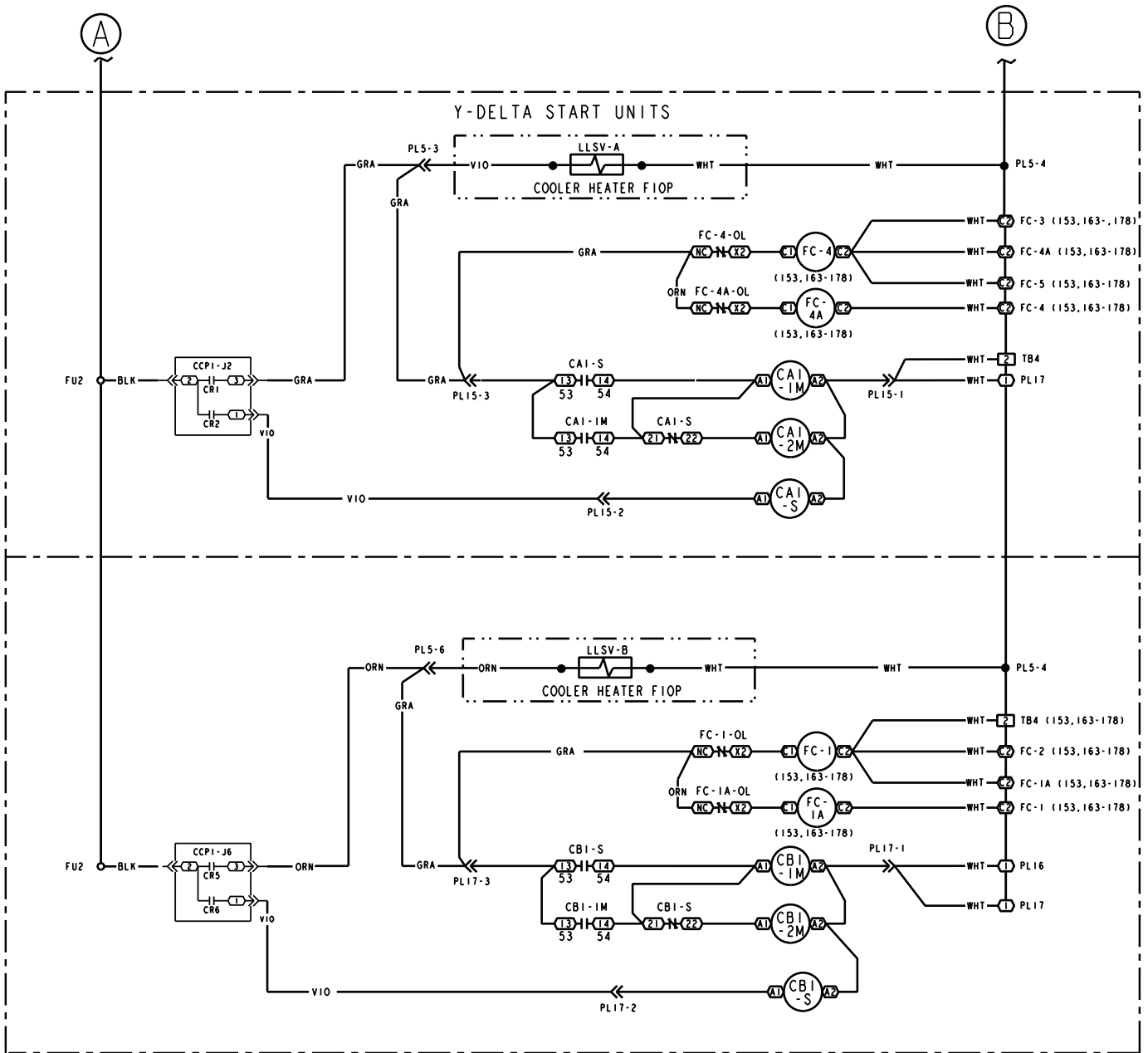

Fig. 6 — Control Schematic — 30GXN,R080-178 and Associated Modular Units, High Static Fan (115, 230 V) (cont)





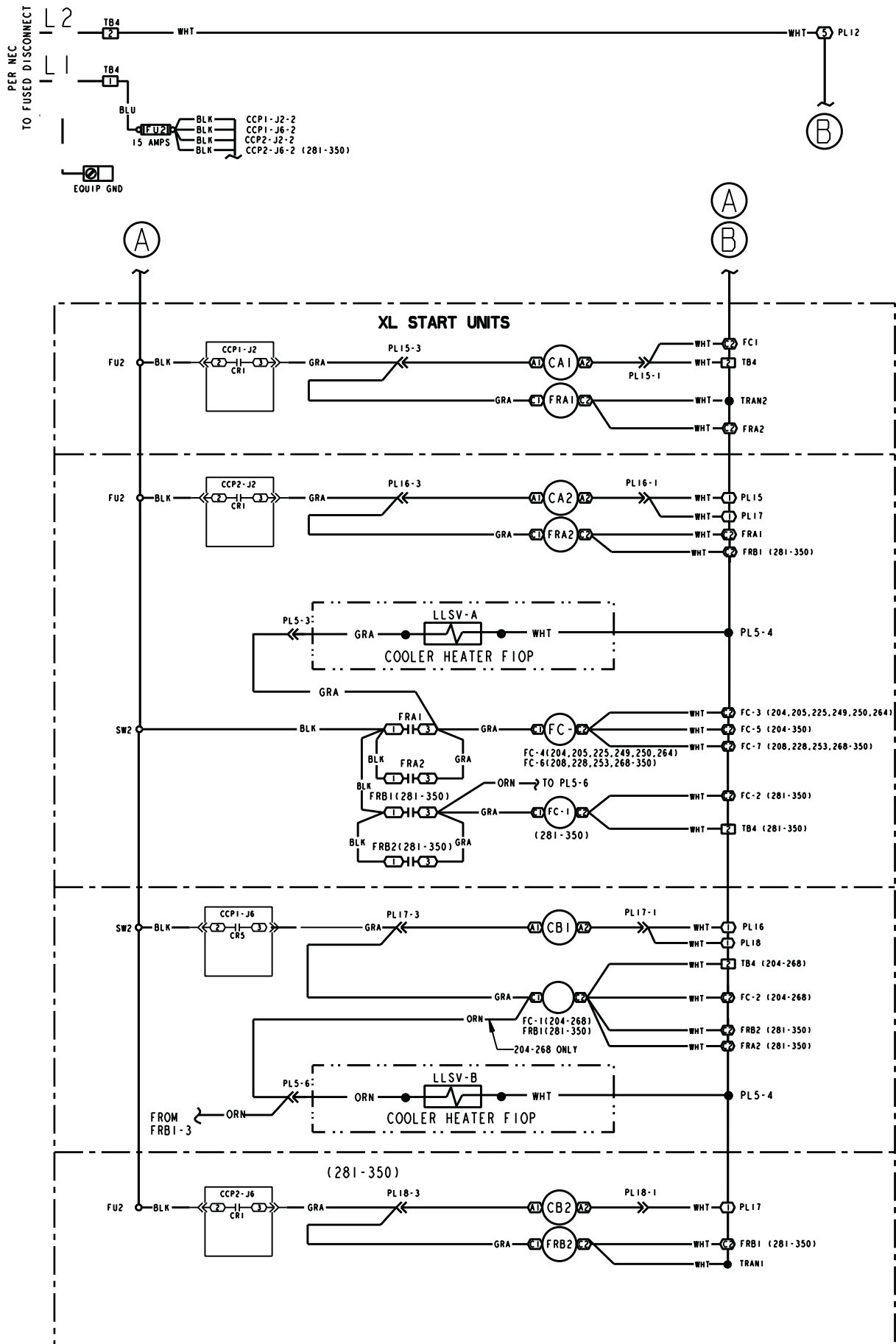

Fig. 7 — Control Schematic — 30GXN,R204-350 and Associated Modular Units, Standard Fan (cont)

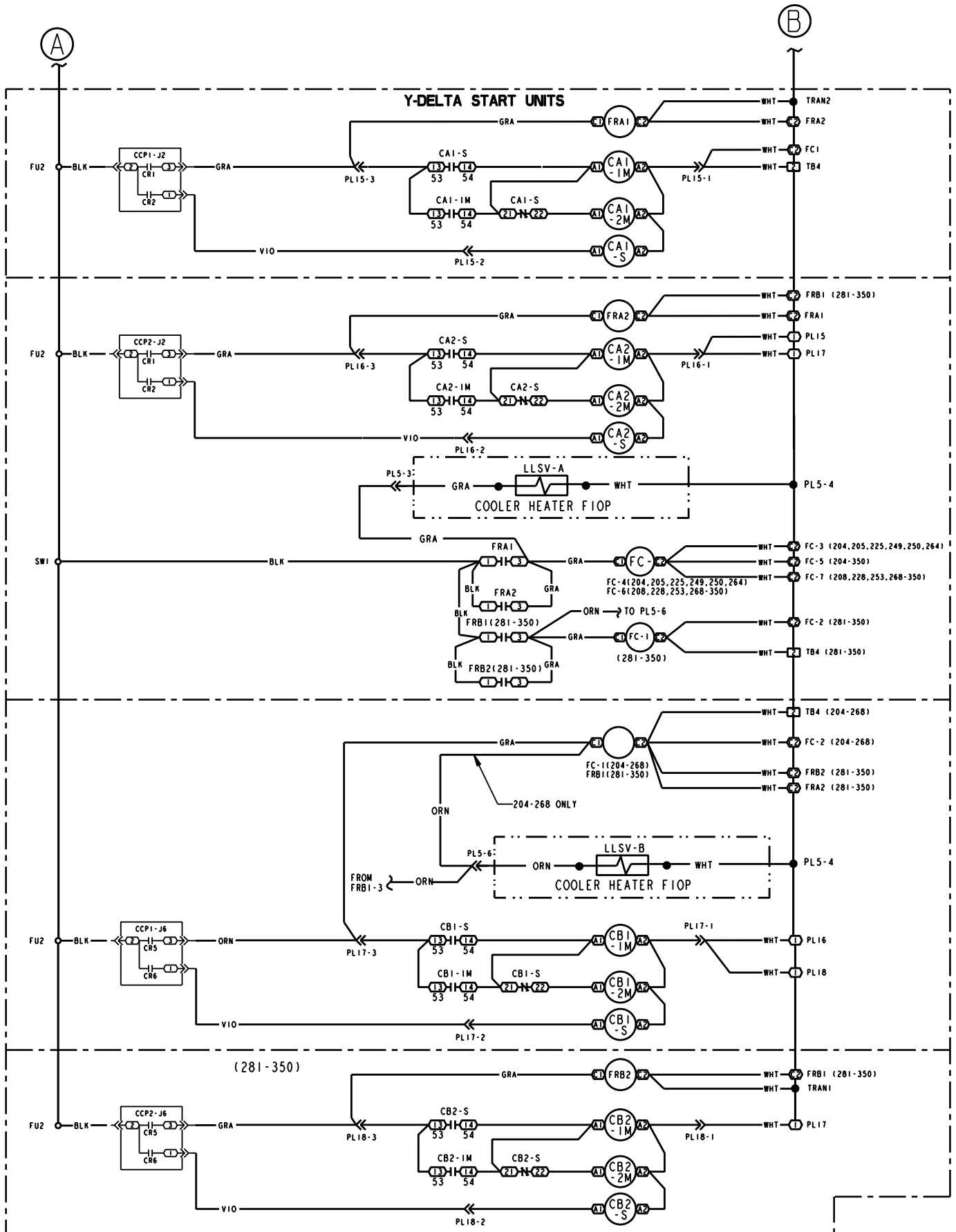

Fig. 7 — Control Schematic — 30GXN,R204-350 and Associated Modular Units, Standard Fan (cont)

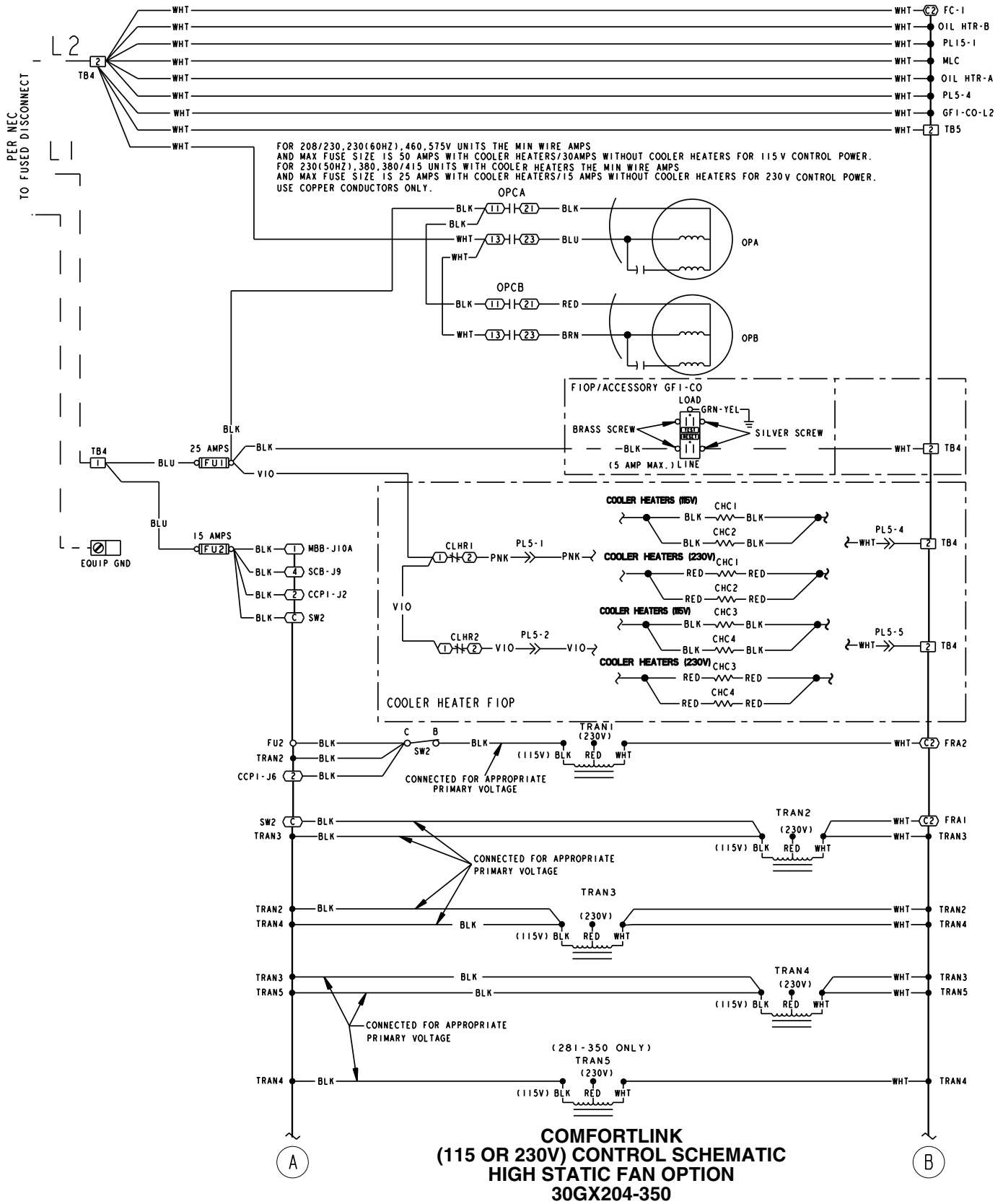

Fig. 8 — Control Schematic — 30GXN,R204-350 and Associated Modular Units, High Static Fan

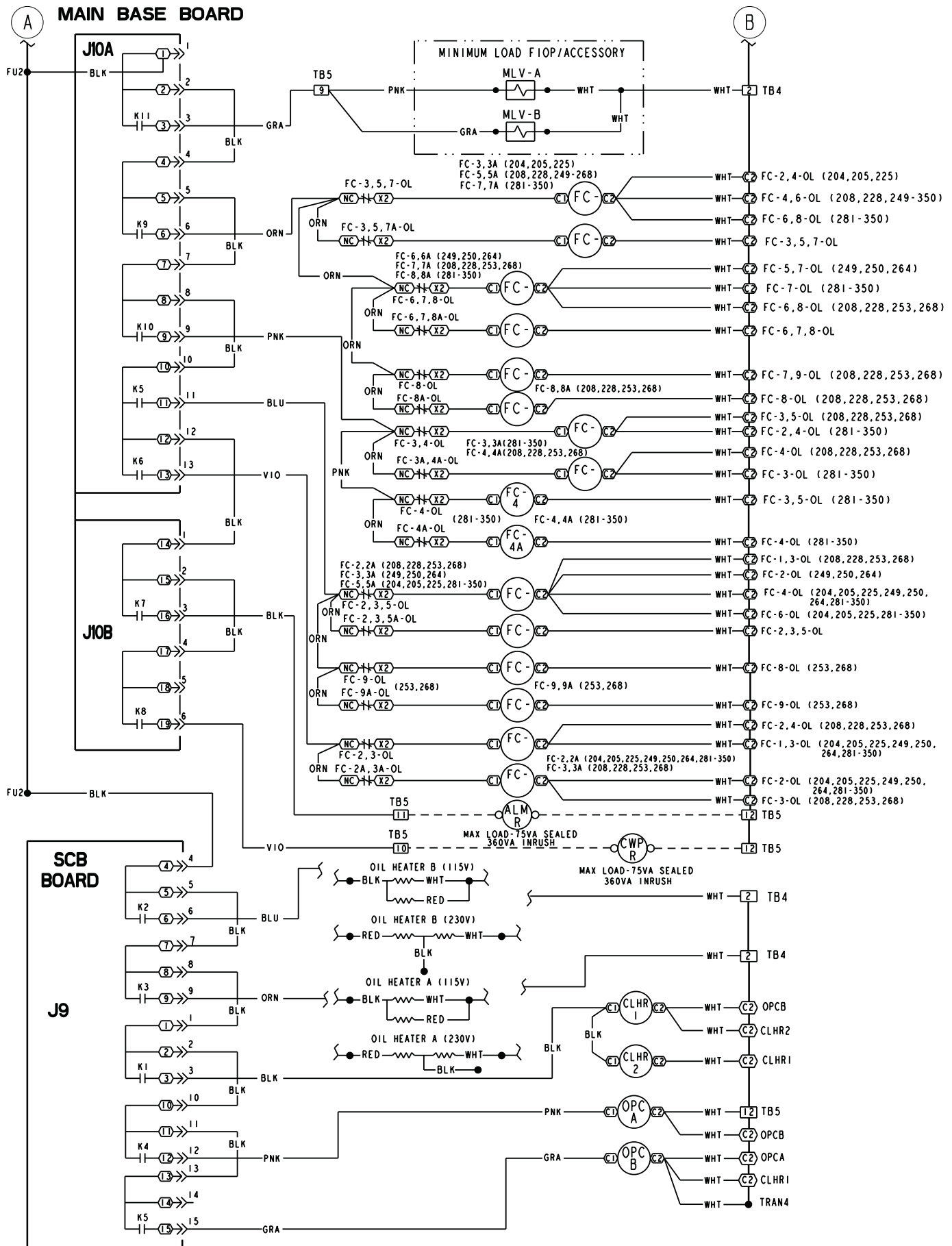

Fig. 8 — Control Schematic — 30GXN, R204-350 and Associated Modular Units, High Static Fan (cont)

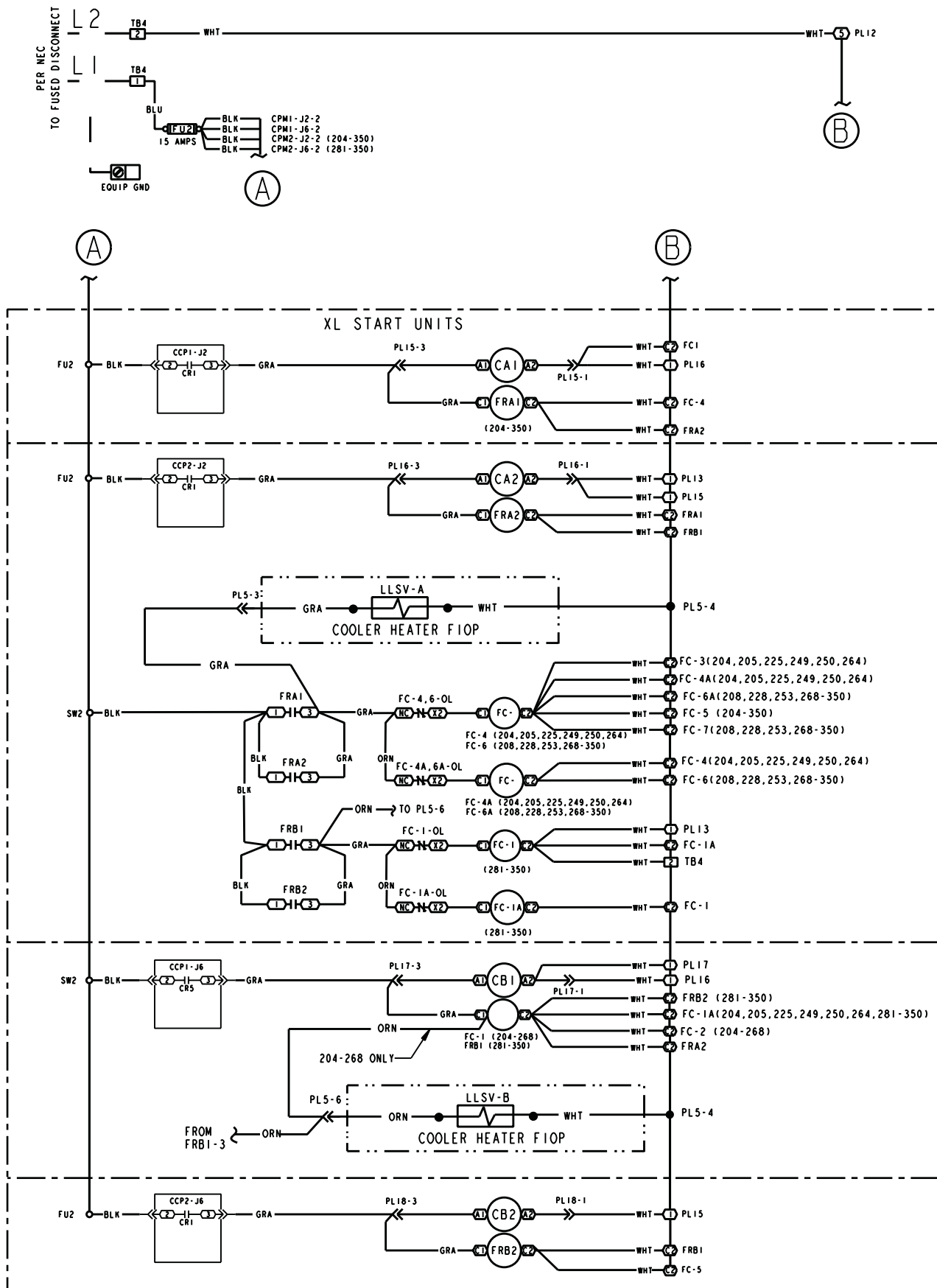

Fig. 8 — Control Schematic — 30GXN,R204-350 and Associated Modular Units, High Static Fan (cont)

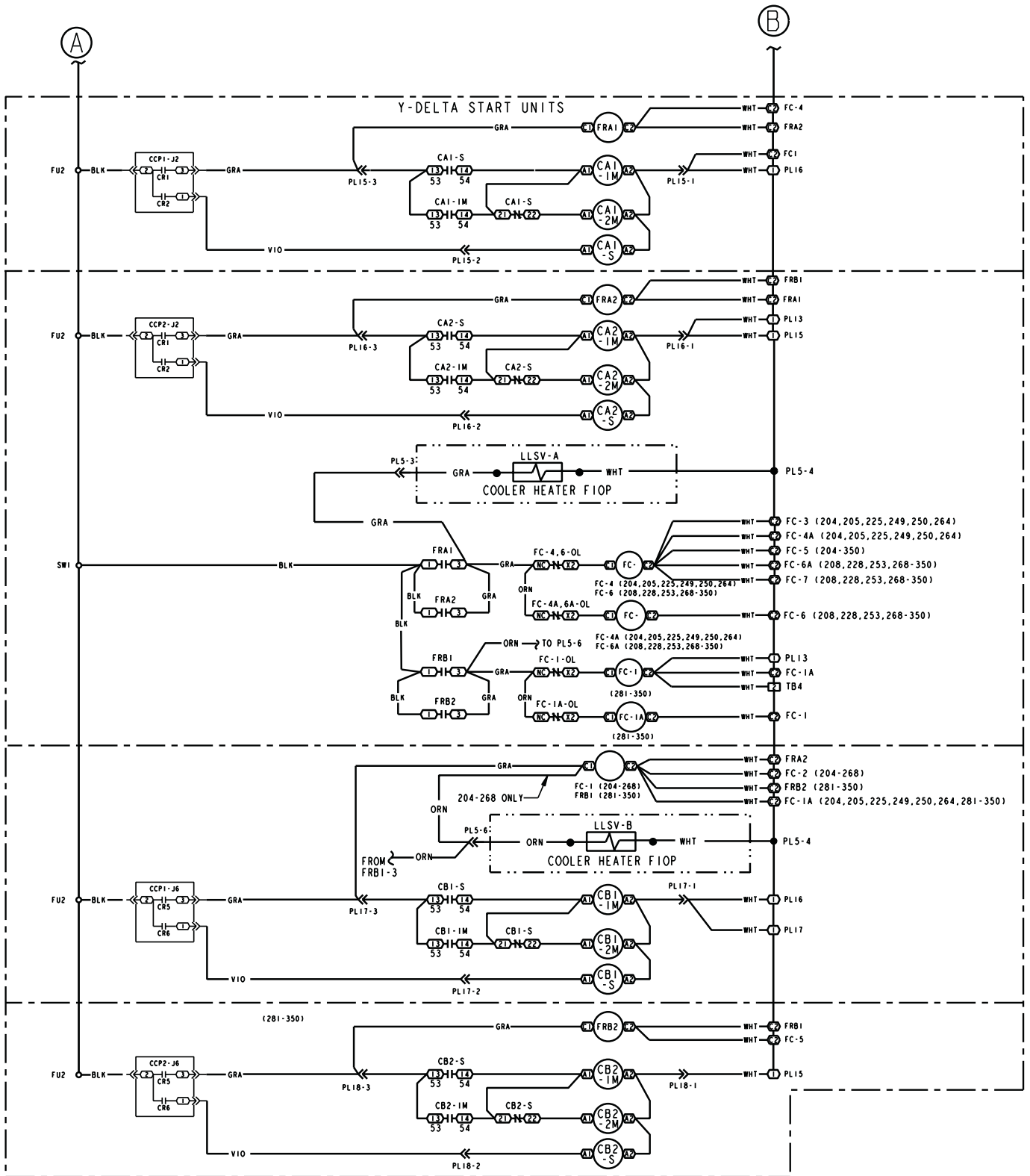
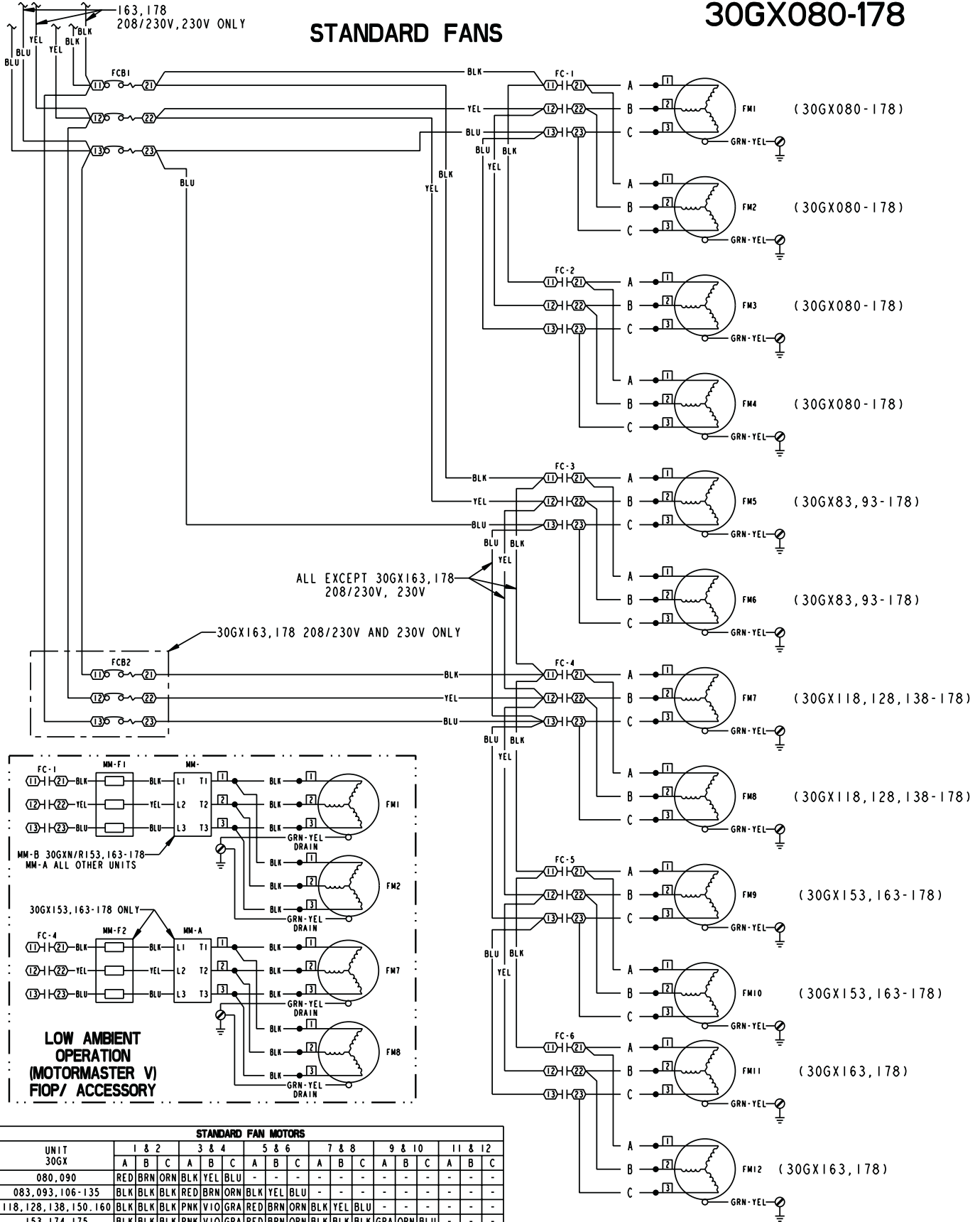

Fig. 8 — Control Schematic — 30GXN,R204-350 and Associated Modular Units, High Static Fan (cont)

TO MAIN POWER TBIA

# 30GX080-178

## STANDARD FANS



ALL EXCEPT 30GX163, 178  
208/230V, 230V

30GX163, 178 208/230V AND 230V ONLY

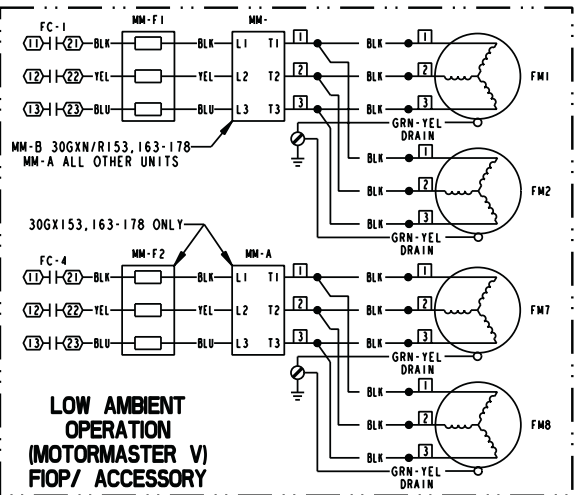

UNIT 30GX	STANDARD FAN MOTORS																	
	1 & 2			3 & 4			5 & 6			7 & 8			9 & 10			11 & 12		
	A	B	C	A	B	C	A	B	C	A	B	C	A	B	C	A	B	C
080, 090	RED	BRN	ORN	BLK	YEL	BLU	-	-	-	-	-	-	-	-	-	-	-	-
083, 093, 106-135	BLK	BLK	BLK	RED	BRN	ORN	BLK	YEL	BLU	-	-	-	-	-	-	-	-	-
118, 128, 138, 150, 160	BLK	BLK	BLK	PNK	VIO	GRA	RED	BRN	ORN	BLK	YEL	BLU	-	-	-	-	-	-
153, 174, 175	BLK	BLK	BLK	PNK	VIO	GRA	RED	BRN	ORN	BLK	BLK	BLK	GRA	ORN	BLU	-	-	-
163, 178	BLK	BLK	BLK	PNK	VIO	GRA	RED	BRN	ORN	BLK	BLK	BLK	GRA	ORN	BLU	PNK	VIO	GRA

Fig. 9 — Fan Power — 30GXN,R080-178 and Associated Modular Units

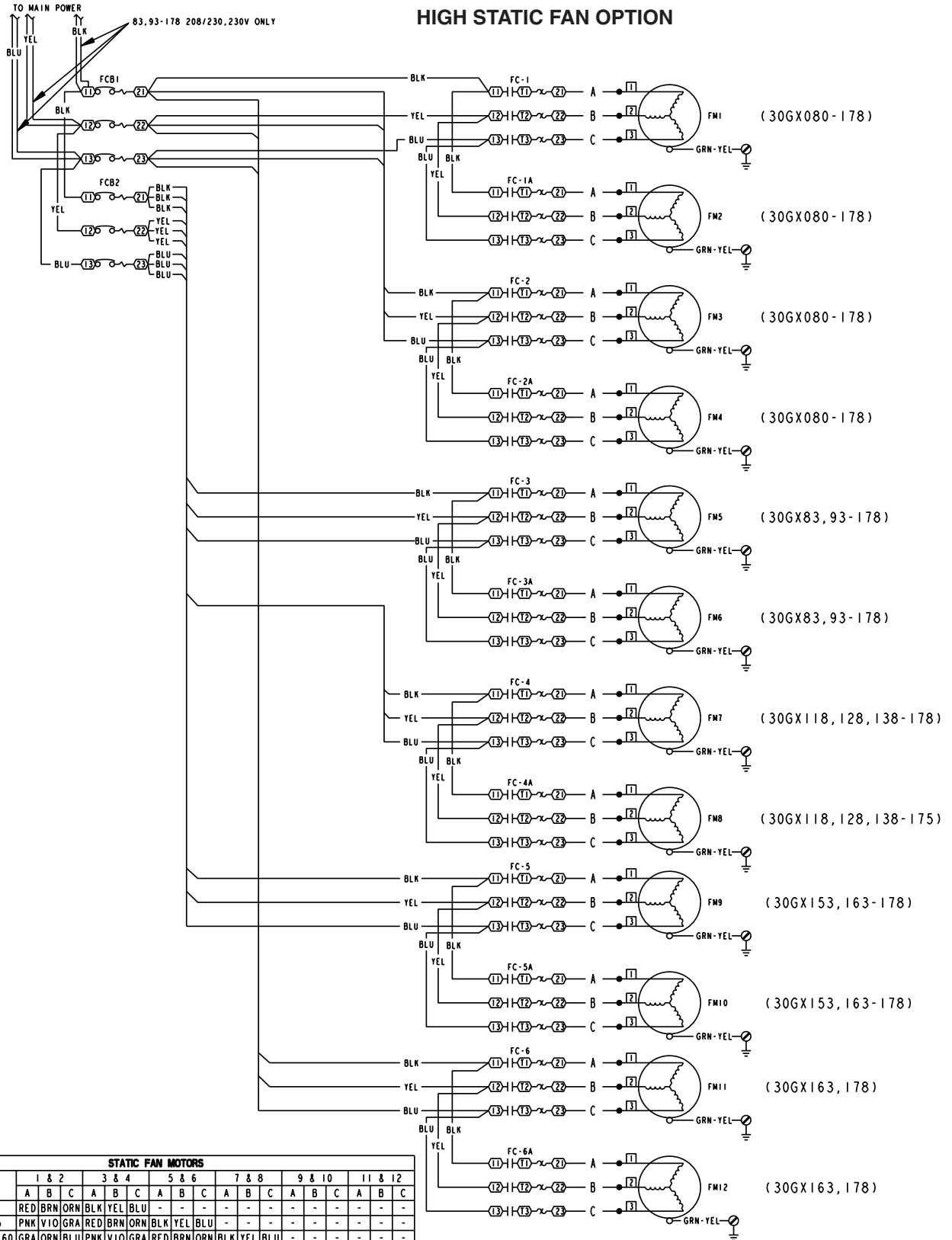

UNIT 30GX	STATIC FAN MOTORS																	
	1 & 2			3 & 4			5 & 6			7 & 8			9 & 10			11 & 12		
	A	B	C	A	B	C	A	B	C	A	B	C	A	B	C	A	B	C
080, 090	RED	BRN	ORN	BLK	YEL	BLU	-	-	-	-	-	-	-	-	-	-	-	-
083, 093, 106-135	PNK	VIO	GRA	RED	BRN	ORN	BLK	YEL	BLU	-	-	-	-	-	-	-	-	-
118, 128, 138, 150, 160	GRA	ORN	BLU	PNK	VIO	GRA	RED	BRN	ORN	BLK	YEL	BLU	-	-	-	-	-	-
153, 174, 175	GRA	ORN	BLU	PNK	VIO	GRA	RED	BRN	ORN	BLK	YEL	BLU	GRA	ORN	BLU	-	-	-
163, 178	GRA	ORN	BLU	PNK	VIO	GRA	RED	BRN	ORN	BLK	YEL	BLU	GRA	ORN	BLU	PNK	VIO	GRA

Fig. 9 — Fan Power — 30GXN,R080-178 and Associated Modular Units (cont)

# 30GXN/R204-350 STANDARD FANS

TB1B 204-268 208/230, 230V  
301-350 380, 380/415V  
TB1A ALL OTHER VOLTAGES

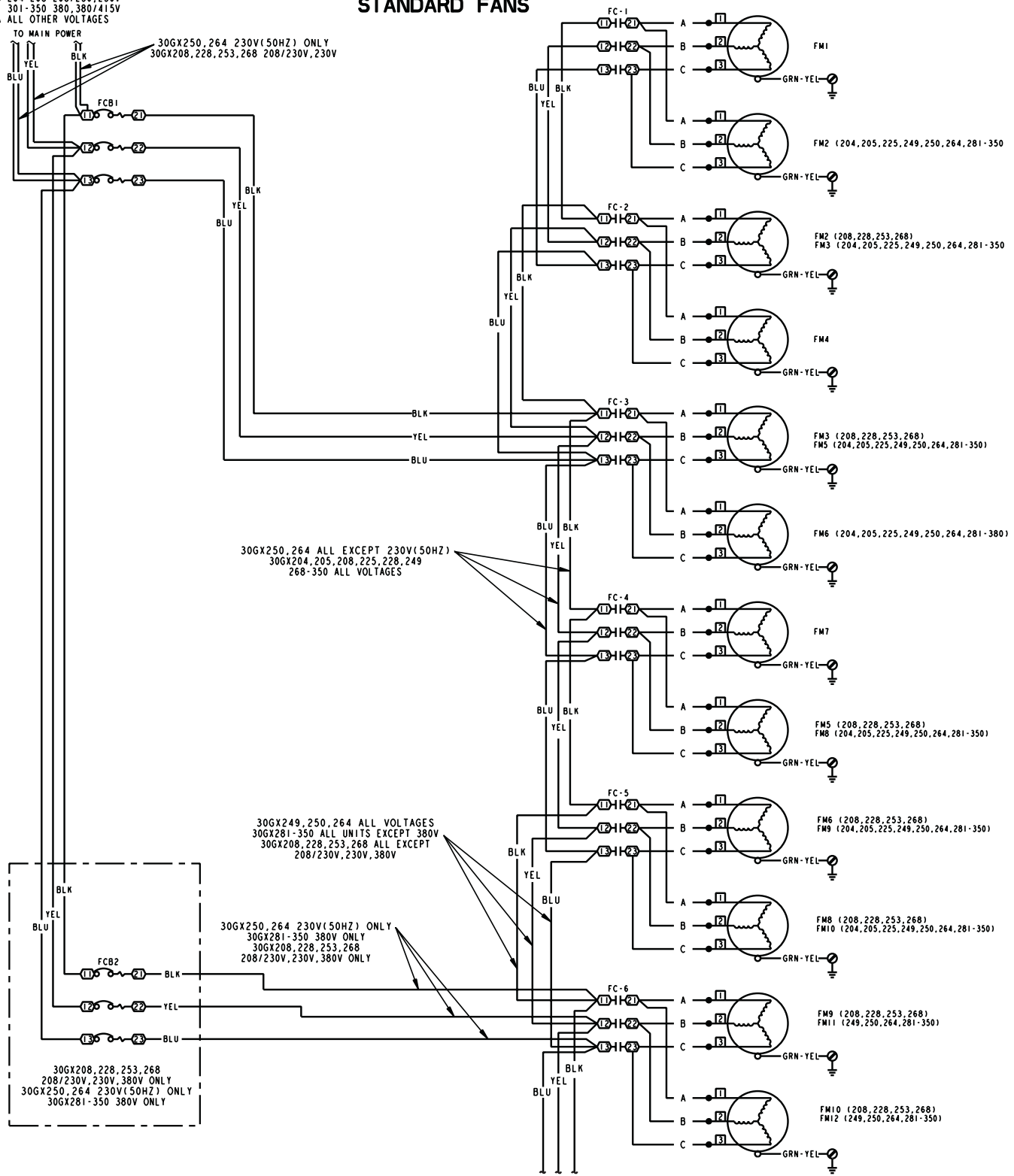

Fig. 10 — Fan Power — 30GXN,R204-350 and Associated Modular Units, Standard Fan

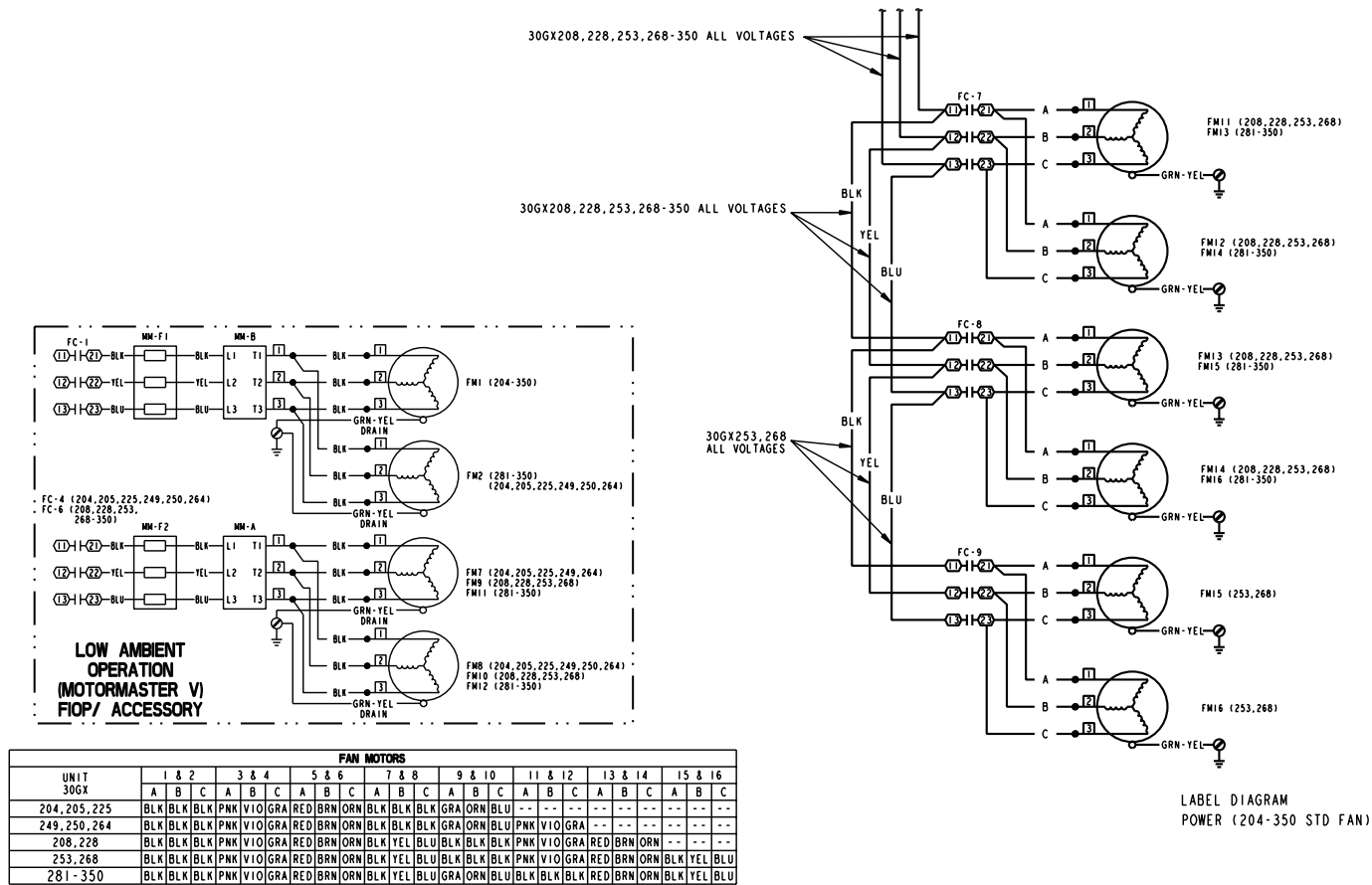
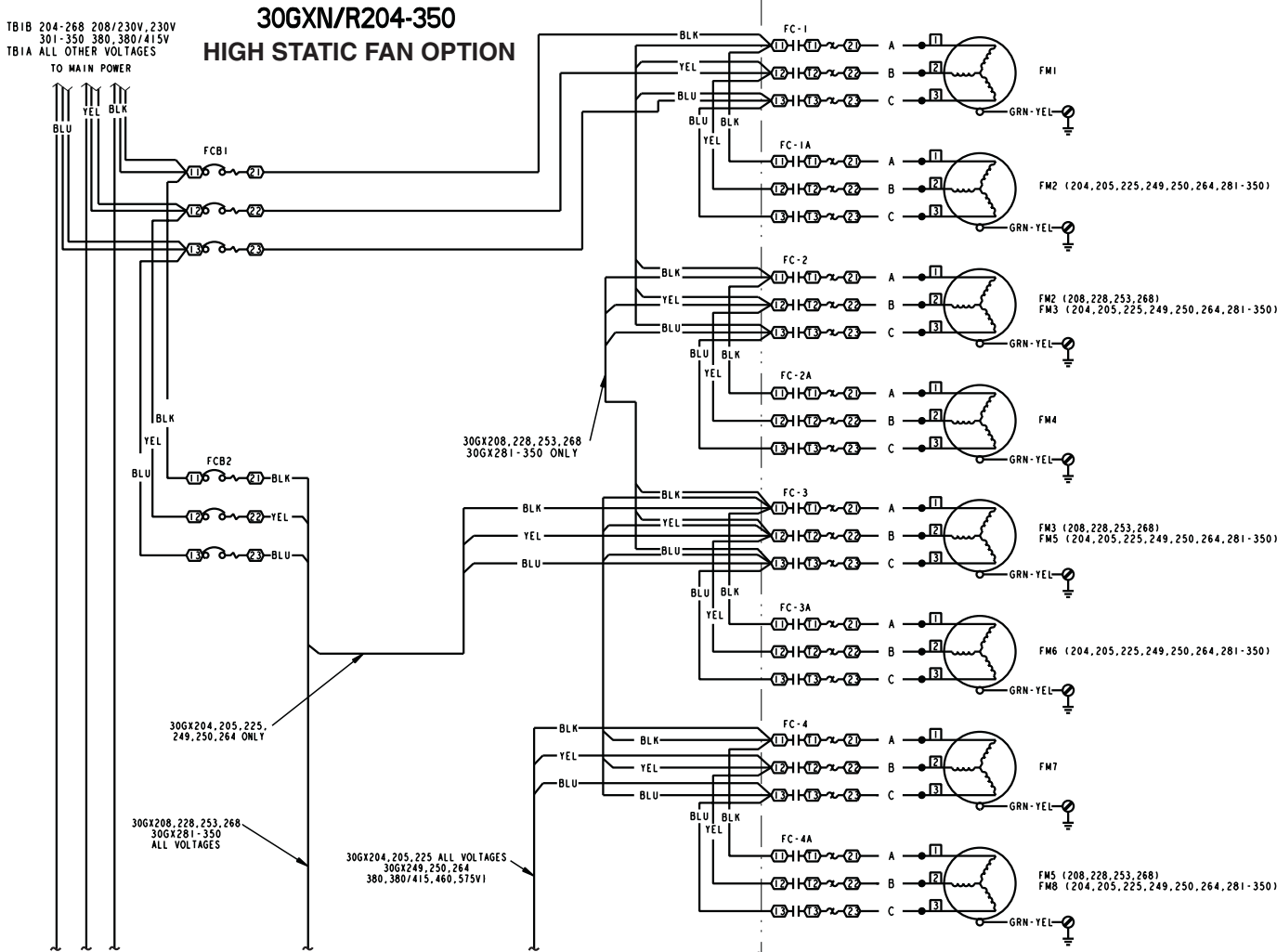
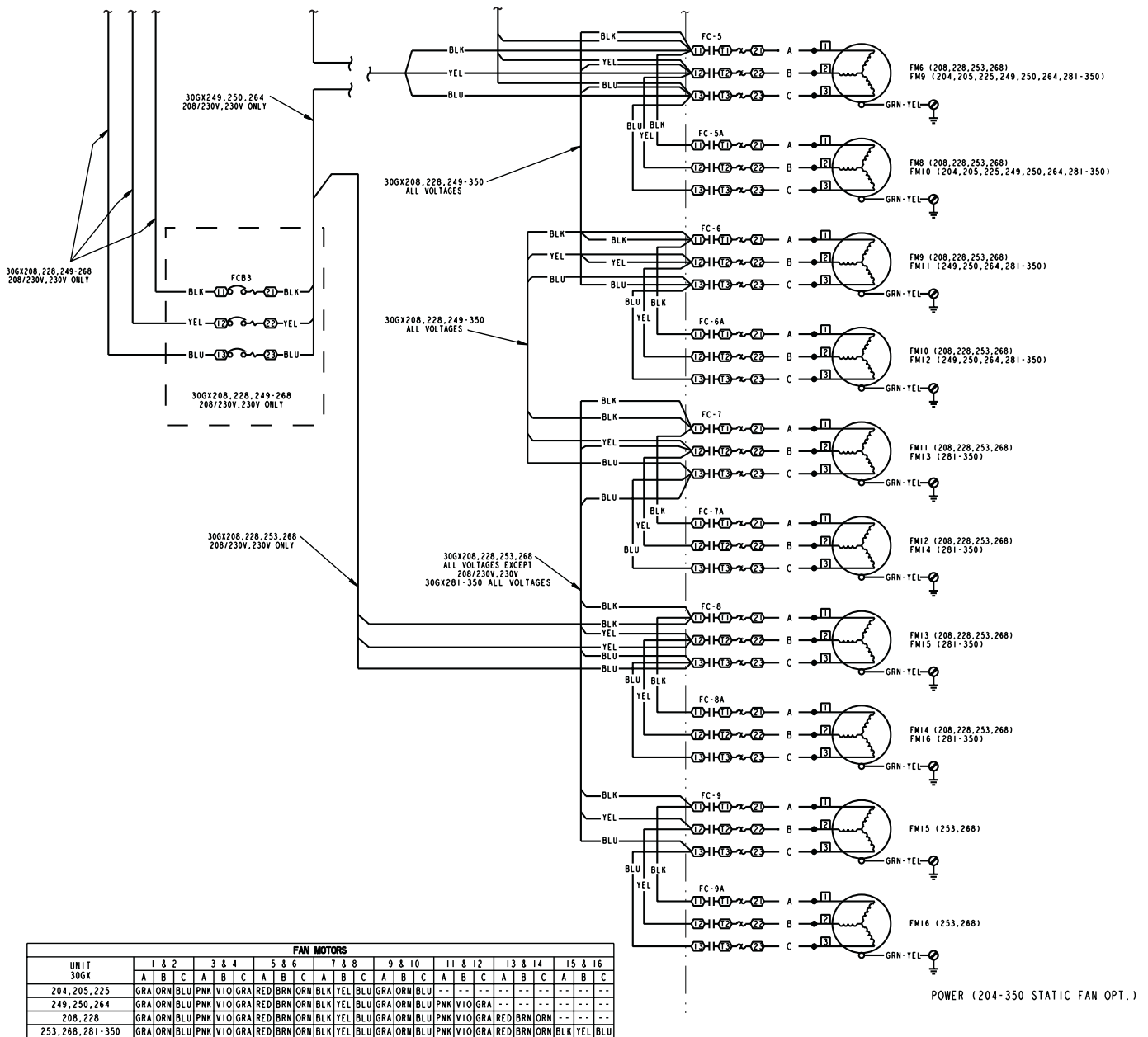

Fig. 10 — Fan Power — 30GXN,R204-350 and Associated Modular Units, Standard Fan (cont)



**Fig. 11 — Fan Power — 30GXN,R204-350 and Associated Modular Units, High Static Fan**



		FAN MOTORS																							
UNIT	30GX	1 & 2			3 & 4			5 & 6			7 & 8			9 & 10			11 & 12			13 & 14			15 & 16		
		A	B	C	A	B	C	A	B	C	A	B	C	A	B	C	A	B	C	A	B	C	A	B	C
204, 205, 225		GRA	ORN	BLU	PNK	VIO	GRA	RED	BRN	ORN	BLK	YEL	BLU	GRA	ORN	BLU	--	--	--	--	--	--	--	--	
249, 250, 264		GRA	ORN	BLU	PNK	VIO	GRA	RED	BRN	ORN	BLK	YEL	BLU	GRA	ORN	BLU	PNK	VIO	GRA	--	--	--	--	--	
208, 228		GRA	ORN	BLU	PNK	VIO	GRA	RED	BRN	ORN	BLK	YEL	BLU	GRA	ORN	BLU	PNK	VIO	GRA	RED	BRN	ORN	--	--	
253, 268, 281-350		GRA	ORN	BLU	PNK	VIO	GRA	RED	BRN	ORN	BLK	YEL	BLU	GRA	ORN	BLU	PNK	VIO	GRA	RED	BRN	ORN	BLK	YEL	BLU

Fig. 11 — Fan Power — 30GXN,R204-350 and Associated Modular Units, High Static Fan (cont)

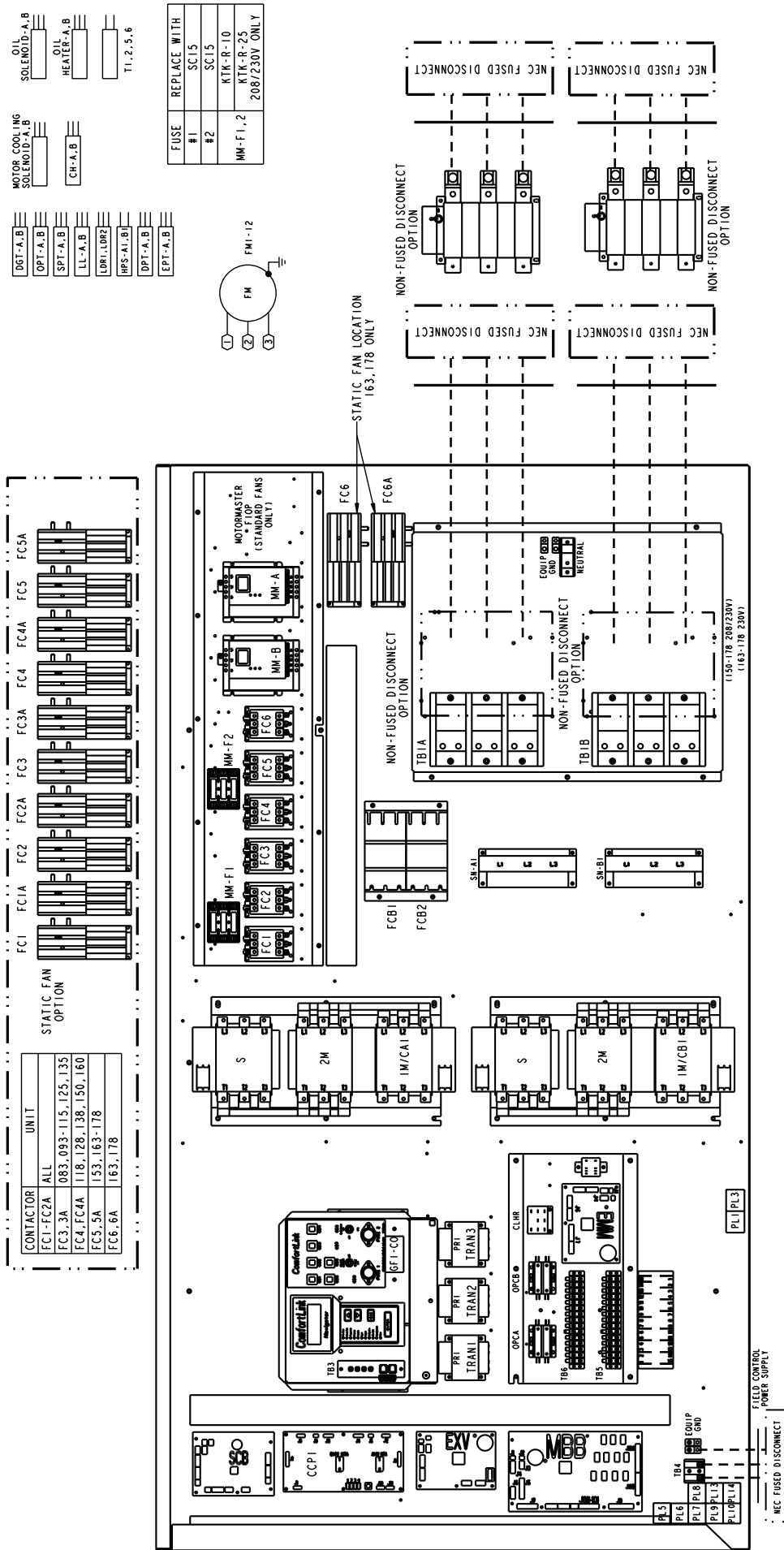
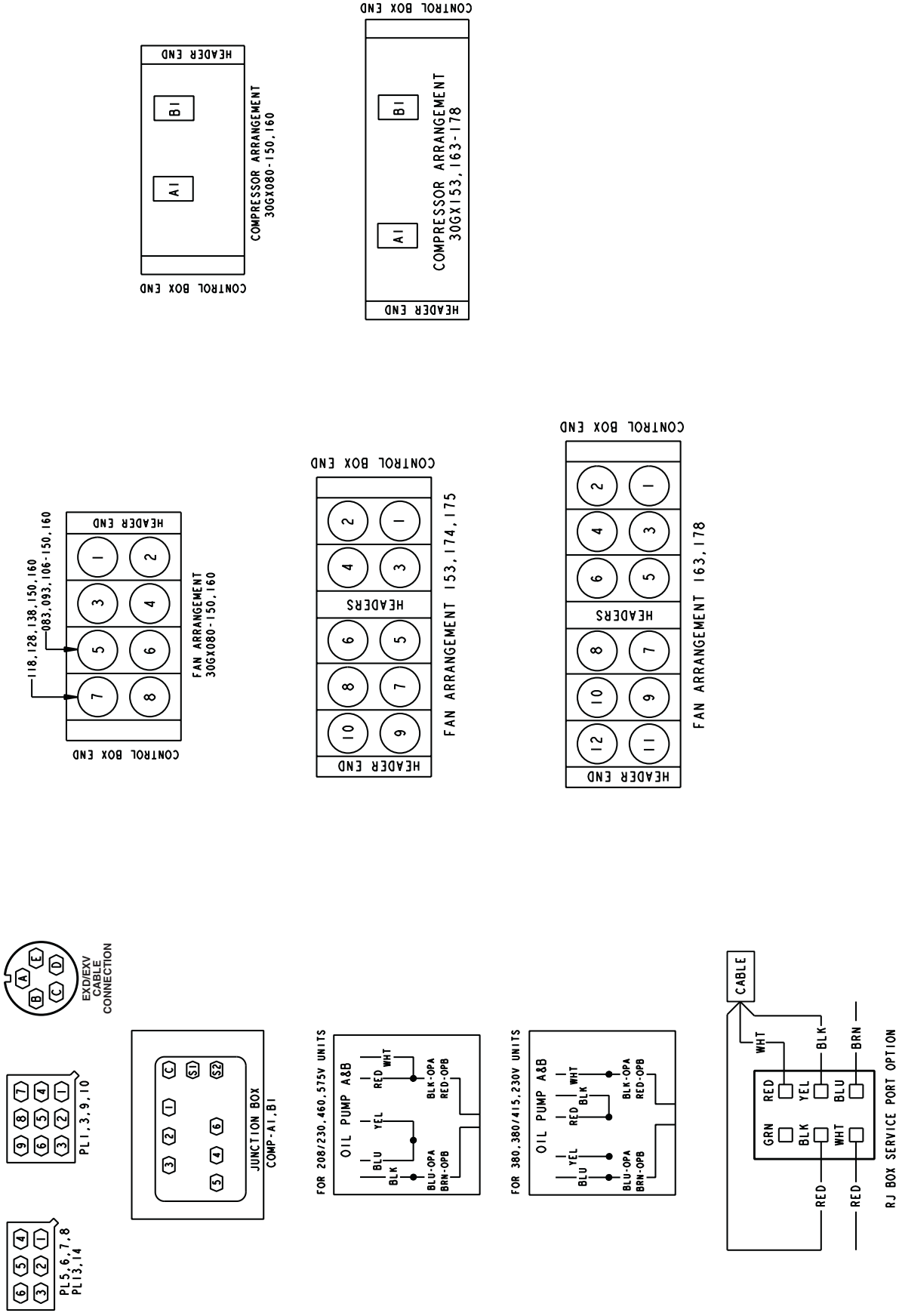

Fig. 12 — Component Arrangement — 30GXN, R080-178 and Associated Modular Units



**Fig. 12 — Component Arrangement — 30GXN, R080-178 and Associated Modular Units (cont)**



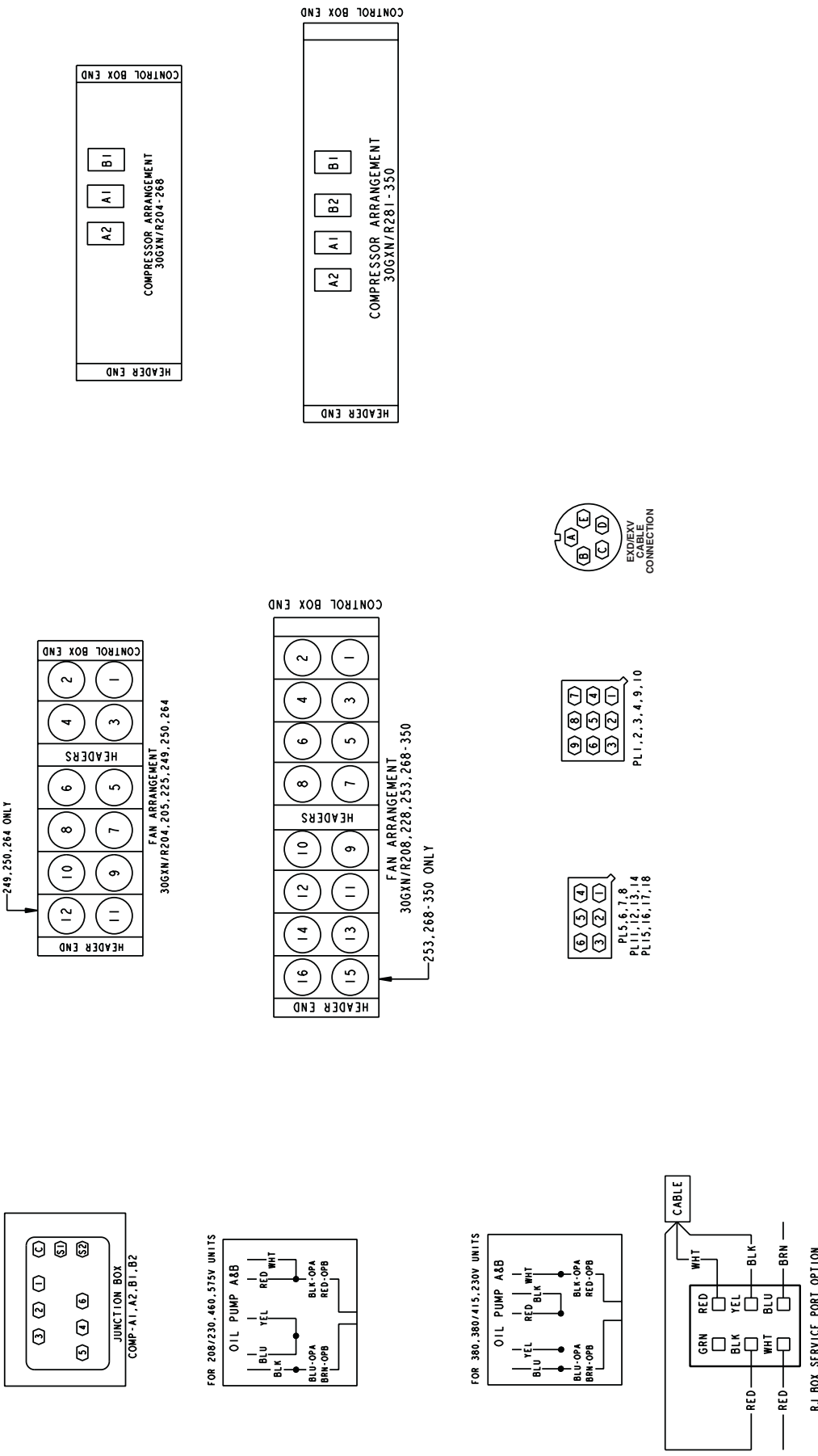

Fig. 13 — Component Arrangement — 30GXXN, R204-350 and Associated Modular Units (cont)

