



# Installation Instructions

## CONTENTS

	Page
<b>SAFETY CONSIDERATIONS</b> .....	1
<b>INTRODUCTION</b> .....	1
<b>INSTALLATION</b> .....	1-39
<b>Step 1 — Inspect Shipment</b> .....	1
<b>Step 2 — Rig and Place Unit</b> .....	16
<b>Step 3 — Piping Connections</b> .....	16
• COOLER FLUID, VENT, AND DRAIN	
• BRINE UNITS	
• PREPARATION FOR YEAR-ROUND OPERATION	
• FILL FLUID LOOP	
• INSULATE COOLER HEADS	
• 30HXA PIPING, VALVE, AND FAN CYCLING PRESSURE SWITCH INSTALLATION	
• 30HXC PIPING AND VALVE INSTALLATION	
• INSTALL PRESSURE RELIEF REFRIGERANT VENT PIPING	
<b>Step 4 — Make Electrical Connections</b> .....	24
• FIELD POWER CONNECTIONS	
• FIELD CONTROL POWER CONNECTIONS	
• CONDENSER FAN CONTROL FOR CONDENSER UNITS USED WITH 30HXA UNITS	
<b>Step 5 — Install Accessories</b> .....	25
• 30HXA LOW-AMBIENT OPERATION	
• MINIMUM LOAD ACCESSORY	
• MISCELLANEOUS ACCESSORIES	
<b>Step 6 — Leak Test Unit</b> .....	25
• 30HXC UNITS	
• 30HXA UNITS	
<b>Step 7 — Refrigerant Charge</b> .....	38
• 30HXC UNITS	
• 30HXA UNITS	

## SAFETY CONSIDERATIONS

Installing, starting up, and servicing this equipment can be hazardous due to system pressures, electrical components, and equipment location. Only trained, qualified installers and service mechanics should install, start up, and service this equipment.

**IMPORTANT:** This equipment generates, uses, and can radiate radio frequency energy. If not installed and used in accordance with these instructions, this equipment may cause radio interference. The equipment has been tested and found to comply with the limits of a Class A computing device as defined by the FCC (Federal Communications Commission, U.S.A.) Regulations, Subpart J of Part 15, which are designed to provide reasonable protection against such interference when operated in a commercial environment.

When working on the equipment, observe precautions in the literature, and on tags, stickers, and labels attached to the equipment.

- Follow all safety codes.
- Wear safety glasses and work gloves.
- Use care in handling, rigging, and setting bulky equipment.

## INTRODUCTION

These instructions cover installation of 30HX liquid chillers with electronic controls and units with factory-installed options (FIOPs).

## INSTALLATION

**Step 1 — Inspect Shipment** — Inspect unit for damage upon arrival. If damage is found, immediately file a claim with the shipping company. Verify proper unit delivery by checking unit nameplate data (see Fig. 1). Do not store units in an area exposed to weather because of sensitive control mechanisms and electronic devices.

<b>30HXC 076 R - - 6 1 AA</b>																																																																		
<table border="1" style="width: 100%; border-collapse: collapse;"> <tr> <td><b>Model Description</b></td> <td></td> </tr> <tr> <td>30HXA — Condenserless Liquid Chiller</td> <td></td> </tr> <tr> <td>30HXC — Water-Cooled Liquid Chiller</td> <td></td> </tr> <tr> <td><b>Nominal Size</b></td> <td></td> </tr> <tr> <td>076 126 186</td> <td></td> </tr> <tr> <td>086 136 206</td> <td></td> </tr> <tr> <td>096 146 246</td> <td></td> </tr> <tr> <td>106 161 261</td> <td></td> </tr> <tr> <td>116 171 271</td> <td></td> </tr> <tr> <td><b>Refrigerant/Cooler Options</b></td> <td></td> </tr> <tr> <td>L = Nitrogen with Minus 1-Pass Cooler</td> <td></td> </tr> <tr> <td>M = R-134a with Minus 1-Pass Cooler</td> <td></td> </tr> <tr> <td>N = Nitrogen with Standard Cooler</td> <td></td> </tr> <tr> <td>P = R-134a with Plus 1-Pass Cooler</td> <td></td> </tr> <tr> <td>Q = Nitrogen with Plus 1-Pass Cooler</td> <td></td> </tr> <tr> <td>R = R-134a with Standard Cooler</td> <td></td> </tr> <tr> <td><b>Electrical Options</b></td> <td></td> </tr> <tr> <td>- = Across The Line Start</td> <td></td> </tr> <tr> <td>A = Non-Fused Disconnect</td> <td></td> </tr> <tr> <td>Y = Y-Delta Starter</td> <td></td> </tr> <tr> <td>Z = Y-Delta and Non-Fused Disconnect</td> <td></td> </tr> </table>	<b>Model Description</b>		30HXA — Condenserless Liquid Chiller		30HXC — Water-Cooled Liquid Chiller		<b>Nominal Size</b>		076 126 186		086 136 206		096 146 246		106 161 261		116 171 271		<b>Refrigerant/Cooler Options</b>		L = Nitrogen with Minus 1-Pass Cooler		M = R-134a with Minus 1-Pass Cooler		N = Nitrogen with Standard Cooler		P = R-134a with Plus 1-Pass Cooler		Q = Nitrogen with Plus 1-Pass Cooler		R = R-134a with Standard Cooler		<b>Electrical Options</b>		- = Across The Line Start		A = Non-Fused Disconnect		Y = Y-Delta Starter		Z = Y-Delta and Non-Fused Disconnect		<table border="1" style="width: 100%; border-collapse: collapse;"> <tr> <td><b>Factory-Installed Option Codes*</b></td> </tr> <tr> <td>AA — 1</td> </tr> <tr> <td>BA — 2</td> </tr> <tr> <td>CA — 3</td> </tr> <tr> <td>KA — 1,2</td> </tr> <tr> <td>LA — 1,3</td> </tr> <tr> <td>TA — 2,3</td> </tr> <tr> <td>ZB — 1,2,3</td> </tr> <tr> <td><b>Packaging Code</b></td> </tr> <tr> <td>1 = Standard Domestic</td> </tr> <tr> <td>2 = Standard Export</td> </tr> <tr> <td><b>Series</b></td> </tr> <tr> <td><b>Voltage Code</b></td> </tr> <tr> <td>1 = 575-3-60</td> </tr> <tr> <td>2 = 380-3-60</td> </tr> <tr> <td>4 = 230-3-60</td> </tr> <tr> <td>5 = 280/230-3-60</td> </tr> <tr> <td>6 = 460-3-60</td> </tr> <tr> <td>8 = 230-3-50</td> </tr> <tr> <td>9 = 380/415-3-50</td> </tr> <tr> <td><b>Display Options</b></td> </tr> <tr> <td>- = Navigator Display</td> </tr> <tr> <td>E = Navigator Display with Energy Management</td> </tr> </table>	<b>Factory-Installed Option Codes*</b>	AA — 1	BA — 2	CA — 3	KA — 1,2	LA — 1,3	TA — 2,3	ZB — 1,2,3	<b>Packaging Code</b>	1 = Standard Domestic	2 = Standard Export	<b>Series</b>	<b>Voltage Code</b>	1 = 575-3-60	2 = 380-3-60	4 = 230-3-60	5 = 280/230-3-60	6 = 460-3-60	8 = 230-3-50	9 = 380/415-3-50	<b>Display Options</b>	- = Navigator Display	E = Navigator Display with Energy Management
<b>Model Description</b>																																																																		
30HXA — Condenserless Liquid Chiller																																																																		
30HXC — Water-Cooled Liquid Chiller																																																																		
<b>Nominal Size</b>																																																																		
076 126 186																																																																		
086 136 206																																																																		
096 146 246																																																																		
106 161 261																																																																		
116 171 271																																																																		
<b>Refrigerant/Cooler Options</b>																																																																		
L = Nitrogen with Minus 1-Pass Cooler																																																																		
M = R-134a with Minus 1-Pass Cooler																																																																		
N = Nitrogen with Standard Cooler																																																																		
P = R-134a with Plus 1-Pass Cooler																																																																		
Q = Nitrogen with Plus 1-Pass Cooler																																																																		
R = R-134a with Standard Cooler																																																																		
<b>Electrical Options</b>																																																																		
- = Across The Line Start																																																																		
A = Non-Fused Disconnect																																																																		
Y = Y-Delta Starter																																																																		
Z = Y-Delta and Non-Fused Disconnect																																																																		
<b>Factory-Installed Option Codes*</b>																																																																		
AA — 1																																																																		
BA — 2																																																																		
CA — 3																																																																		
KA — 1,2																																																																		
LA — 1,3																																																																		
TA — 2,3																																																																		
ZB — 1,2,3																																																																		
<b>Packaging Code</b>																																																																		
1 = Standard Domestic																																																																		
2 = Standard Export																																																																		
<b>Series</b>																																																																		
<b>Voltage Code</b>																																																																		
1 = 575-3-60																																																																		
2 = 380-3-60																																																																		
4 = 230-3-60																																																																		
5 = 280/230-3-60																																																																		
6 = 460-3-60																																																																		
8 = 230-3-50																																																																		
9 = 380/415-3-50																																																																		
<b>Display Options</b>																																																																		
- = Navigator Display																																																																		
E = Navigator Display with Energy Management																																																																		

\*Option Code Descriptions: 1 = Minimum Load Control, 2 = Suction Service Valve, and 3 = Medium Temperature Brine

**Fig. 1 — 30HX Identification**

Locate unit indoors. When considering unit location, consult National Electrical Code (NEC, U.S.A.) and local code requirements. Allow sufficient space for wiring, piping, and service. Install unit in an area which will not be exposed to ambient temperatures below 50 F (10 C). See Fig. 2-10 for clearance details.

Allow the following clearances for service access:

Front .....	3 ft (914 mm)
Rear .....	3 ft (914 mm)
Top .....	.2 ft (610 mm)
Ends .....	tube length at one (either) end; 3 ft (914 mm) at opposite end.

Be sure surface beneath unit is level and is capable of supporting the operating weight of the unit. See Fig. 11 and 12 and Tables 1A and 1B for unit mounting and operating weights. If necessary, add supporting structure (steel beams or reinforced concrete slabs) to floor to transfer weight to nearest beams.

*Copy continued on page 16.*

UNIT	OPERATING WEIGHT - lb (kg)	WGT DISTRIBUTION AT EACH MTG PLATE - lb (kg)									
		1	2	3	4	5	6				
30HXC076	5700 (2586)	45.87 (1165)	45.87 (1165)	32.50 (826)	65.22 (1657)	738 (335)	943 (428)	595 (270)	1110 (503)	1418 (643)	896 (406)
30HXC086	5723 (2597)	45.87 (1165)	45.87 (1165)	32.50 (826)	65.22 (1657)	738 (335)	947 (430)	597 (271)	1112 (504)	1427 (647)	902 (409)
30HXC096	5855 (2657)	54.12 (1375)	37.63 (956)	32.50 (826)	65.22 (1657)	686 (311)	968 (439)	693 (314)	1027 (466)	1447 (656)	1034 (469)
30HXC106	6177 (2803)	54.12 (1375)	37.63 (956)	33.50 (851)	67.22 (1707)	730 (331)	1028 (466)	744 (337)	1073 (487)	1510 (685)	1092 (495)

- NOTES:
- Operating weight includes weight of water and refrigerant.
  - Denotes center of gravity.
  - Dimensions are in inches (mm).
  - Recommended service clearance around machine is 36 in. (914.4 mm).
  - Victaulic nozzles are standard on all models. Flow switch factory installed in cooler outlet victaulic nozzle.

WEIGHT DISTRIBUTION

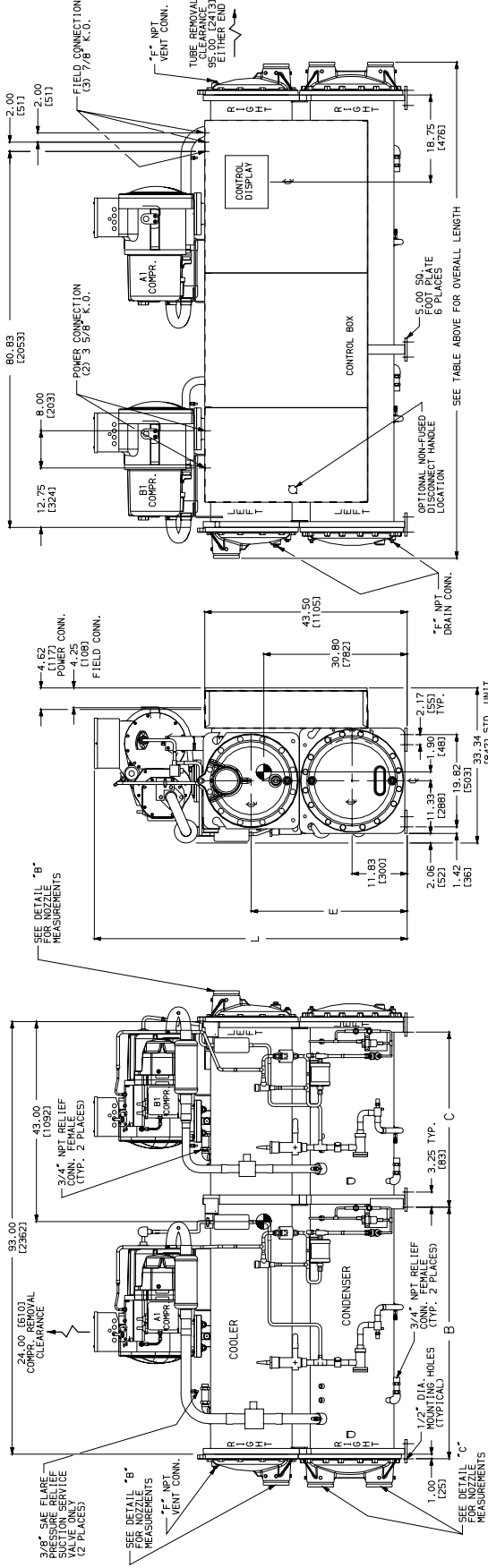
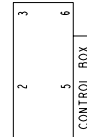

COOLER	CONDENSER	OVERALL LENGTH	OVERALL LENGTH
STANDARD COOLER	STANDARD CONDENSER	106.39	106.70
STANDARD COOLER	MINUS ONE PASS CONDENSER	113.00	113.00
PLUS ONE COOLER	STANDARD CONDENSER	128.70	128.70
PLUS ONE COOLER	MINUS ONE PASS CONDENSER	104.05	104.05
PLUS ONE PASS COOLER	STANDARD CONDENSER	113.00	113.00
PLUS ONE PASS COOLER	MINUS ONE PASS CONDENSER	103.99	103.80
PLUS ONE PASS COOLER	PLUS ONE PASS CONDENSER	113.00	113.00
PLUS ONE PASS COOLER	PLUS ONE PASS CONDENSER	128.70	128.70

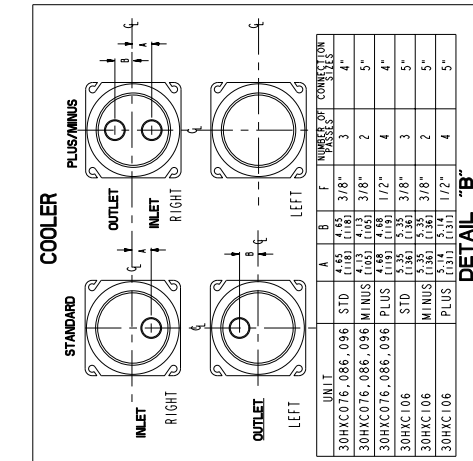
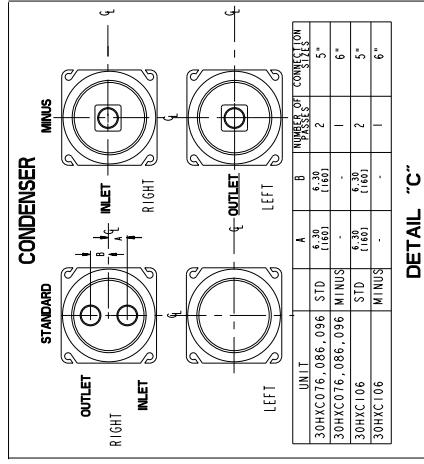

DOOR SWING CLEARANCE

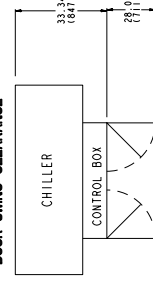
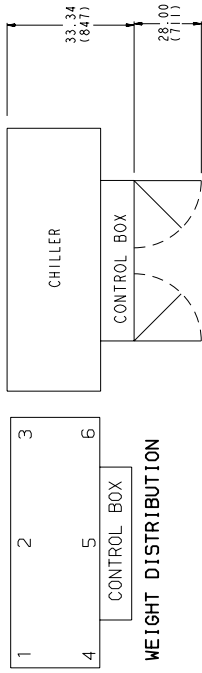

Fig. 2 — Dimensions, 30HXC076-106

UNIT	WGT DISTRIBUTION AT EACH MTG PLATE - lb (kg)					
	1	2	3	4	5	6
30HXC116	6415 (2911)	1114 (505)	777 (352)	1053 (478)	1615 (739)	1127 (511)
30HXC126	6465 (2933)	738 (335)	1127 (511)	780 (354)	1628 (738)	1131 (513)
30HXC136	6688 (3034)	758 (344)	1176 (533)	811 (368)	1083 (491)	1689 (766)
30HXC146	6718 (3048)	763 (346)	1182 (536)	815 (370)	1085 (492)	1697 (770)

- NOTES:
- Operating weight includes weight of water and refrigerant.
  - Denotes center of gravity.
  - Dimensions are in inches (mm).
  - Recommended service clearance around machine is 36 in. (914.4 mm).
  - Vitraulic nozzles are standard on all models. Flow switch factory installed in cooler outlet vitraulic nozzle.

**DOOR SWING CLEARANCE**



**WEIGHT DISTRIBUTION**

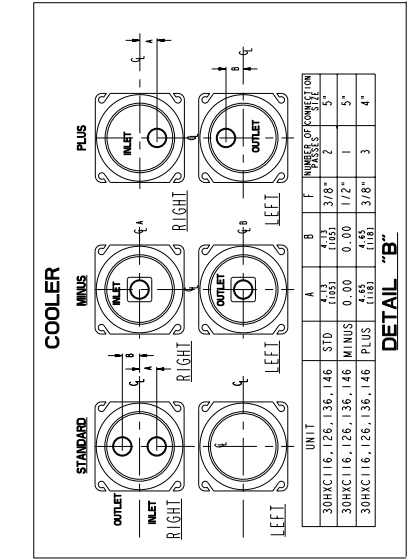
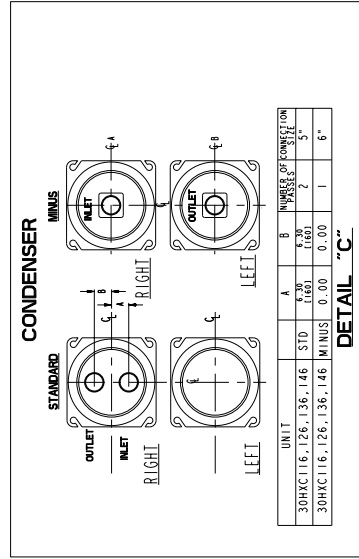
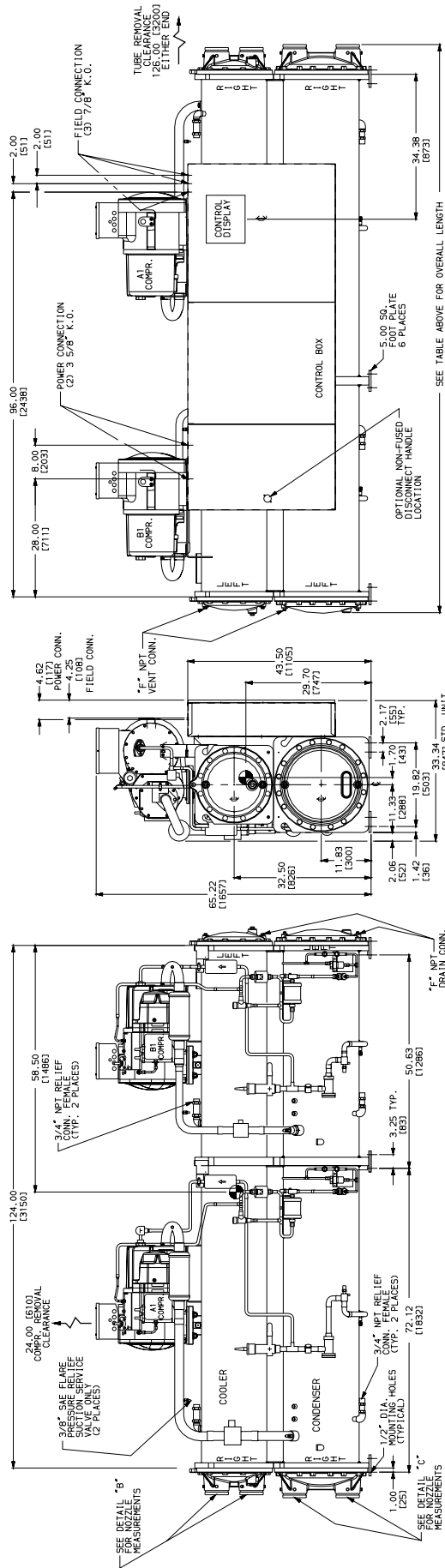
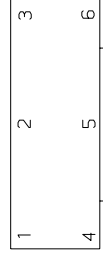

**OVERALL LENGTH TABLE**

COOLER	CONDENSER	OVERALL LENGTH
STANDARD COOLER	STANDARD CONDENSER	134.99 [3429]
STANDARD COOLER	MINUS ONE PASS CONDENSER	144.00 [3658]
PLUS ONE PASS COOLER	STANDARD CONDENSER	134.99 [3429]
PLUS ONE PASS COOLER	MINUS ONE PASS CONDENSER	144.00 [3658]
MINUS ONE PASS COOLER	STANDARD CONDENSER	141.05 [3583]
MINUS ONE PASS COOLER	MINUS ONE PASS CONDENSER	144.00 [3658]

Fig. 3 — Dimensions, 30HXC116-146

**NOTES:**

1. Operating weight includes weight of water and refrigerant.
2. Denotes center of gravity.
3. Dimensions are in inches (mm).
4. Recommended service clearance around machine is 36 in. (914.4 mm).
5. Victaulic nozzles are standard on all models. Flow switch factory installed in cooler outlet victaulic nozzle.

UNIT	OPERATING WEIGHT - lb (kg)	B	C	WGT DISTRIBUTION AT EACH MTG PLATE - lb (kg)					
				1	2	3	4	5	6
30HXC161	7452 (3381)	72.12 (1832)	50.63 (1286)	817 (371)	1272 (412)	908 (553)	1219 (857)	1890 (610)	1346 (610)
30HXC171	7660 (3475)	61.37 (1559)	61.37 (1559)	936 (425)	1318 (598)	840 (381)	1379 (626)	1946 (883)	1241 (563)
30HXC186	7854 (3564)	61.37 (1559)	61.37 (1559)	962 (436)	1361 (617)	860 (390)	1410 (640)	1996 (905)	1265 (574)

**DOOR SWING CLEARANCE**

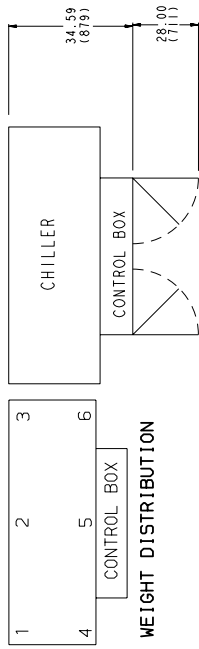

**WEIGHT DISTRIBUTION**

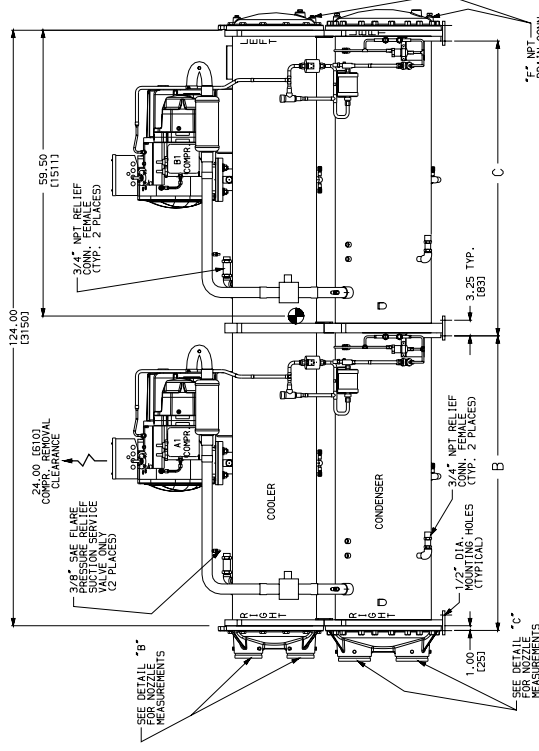
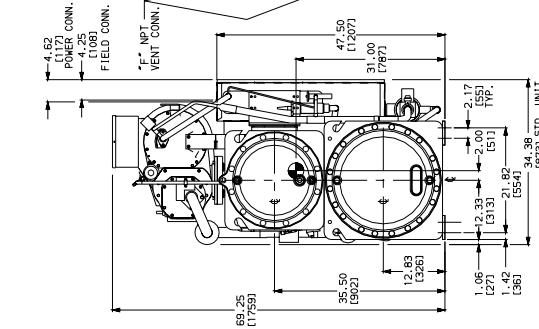
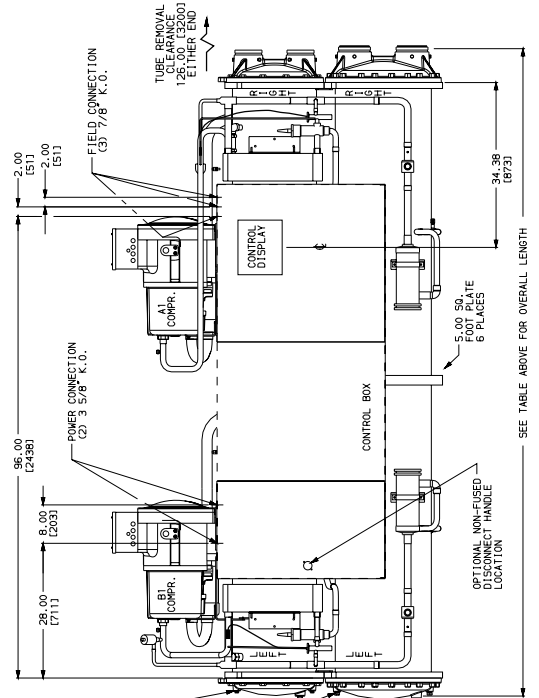
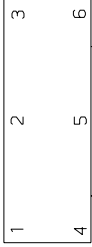

COOLER	CONDENSER	OVERALL LENGTH
STANDARD	STANDARD	132.72 (3372)
STANDARD	STANDARD	134.47 (3415)
STANDARD	MINUS ONE PASS	144.00 (3658)
PLUS ONE STANDARD	STANDARD	138.01 (3506)
PLUS ONE PASS	MINUS ONE PASS	144.00 (3658)
MINUS ONE STANDARD	STANDARD	144.00 (3658)
PLUS ONE MINUS ONE PASS	MINUS ONE PASS	144.00 (3658)
PLUS ONE STANDARD	MINUS ONE PASS	144.00 (3658)
PLUS ONE PLUS ONE PASS	PLUS ONE PASS	144.00 (3658)

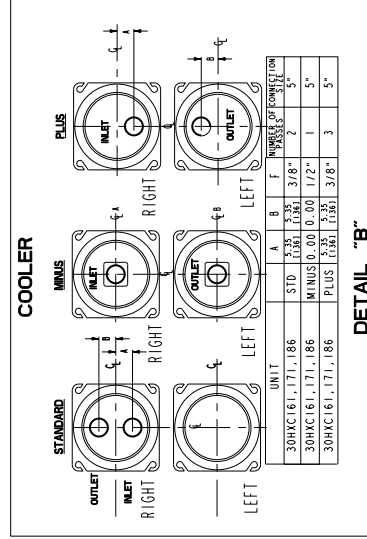
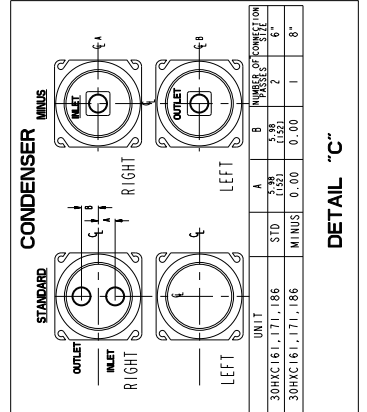

**OVERALL LENGTH TABLE**

COOLER	CONDENSER	OVERALL LENGTH
STANDARD	STANDARD	132.72 (3372)
STANDARD	STANDARD	134.47 (3415)
STANDARD	MINUS ONE PASS	144.00 (3658)
PLUS ONE STANDARD	STANDARD	138.01 (3506)
PLUS ONE PASS	MINUS ONE PASS	144.00 (3658)
MINUS ONE STANDARD	STANDARD	144.00 (3658)
PLUS ONE MINUS ONE PASS	MINUS ONE PASS	144.00 (3658)
PLUS ONE STANDARD	MINUS ONE PASS	144.00 (3658)
PLUS ONE PLUS ONE PASS	PLUS ONE PASS	144.00 (3658)

**Fig. 4 — Dimensions, 30HXC161-186**

UNIT	OPERATING WEIGHT - lb (kg)	WGT DISTRIBUTION AT EACH MTG PLATE - lb (kg)						
		A	1	2	3	4	5	6
30HXC206	10,581 (4799)	33.88 (860)	948 (430)	2406 (1091)	1243 (564)	1201 (545)	3133 (1421)	1650 (748)
30HXC246	10,969 (4976)	34.38 (873)	985 (447)	2515 (1141)	1306 (592)	1154 (523)	3276 (1486)	1733 (786)
30HXC261	10,992 (4986)	34.38 (873)	985 (447)	2520 (1143)	1311 (595)	1154 (523)	3283 (1489)	1739 (789)
30HXC271	11,029 (5003)	34.38 (873)	985 (447)	2529 (1147)	1318 (598)	1154 (523)	3294 (1494)	1749 (793)

NOTES:  
 1. Operating weight includes weight of water and refrigerant.  
 2.  Denotes center of gravity.

- Dimensions are in inches (mm).
- Recommended service clearance around machine is 36 in. (914.4 mm).
- Victaulic nozzles are standard on all models. Flow switch factory installed in cooler outlet victaulic nozzle.

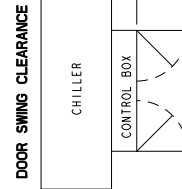
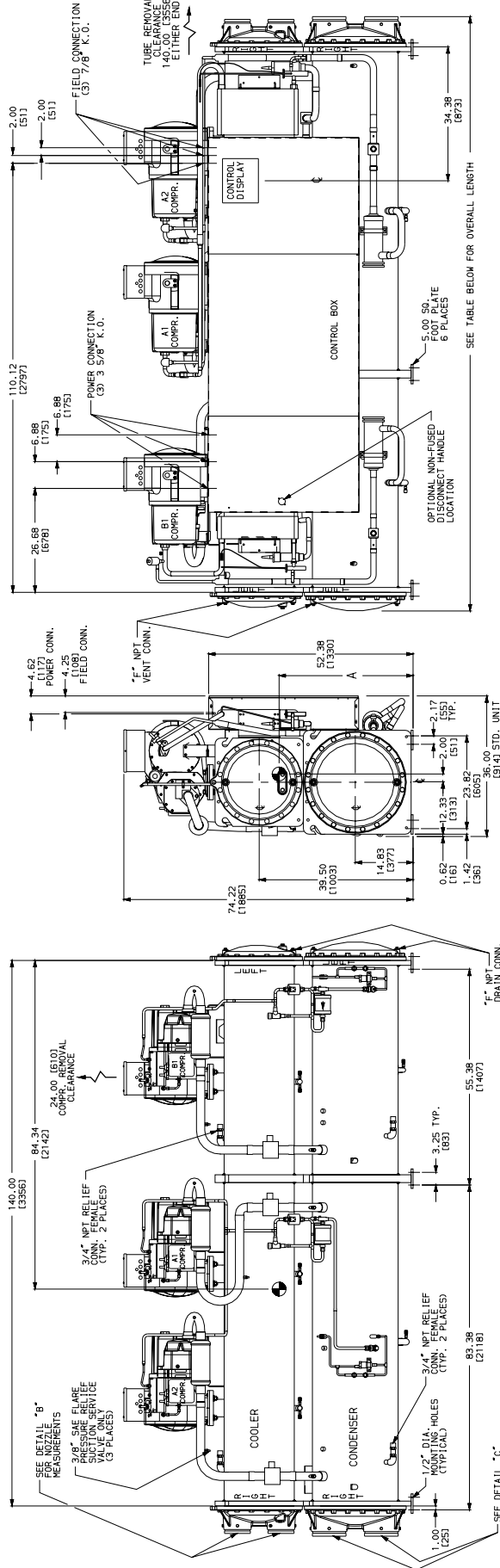

COOLER	CONDENSER	OVERALL LENGTH
STANDARD	STANDARD	52.54 (2108)
STANDARD	MINUS ONE PASS	52.54 (2108)
STANDARD	PLUS ONE PASS	52.54 (2108)
PLUS ONE PASS COOLER	STANDARD	52.54 (2108)
PLUS ONE PASS CONDENSER	STANDARD	52.54 (2108)
PLUS ONE PASS COOLER	MINUS ONE PASS	52.54 (2108)
PLUS ONE PASS CONDENSER	MINUS ONE PASS	52.54 (2108)
PLUS ONE PASS COOLER	PLUS ONE PASS	52.54 (2108)
PLUS ONE PASS CONDENSER	PLUS ONE PASS	52.54 (2108)

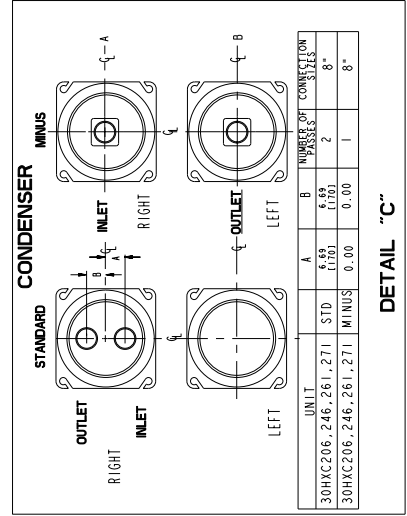
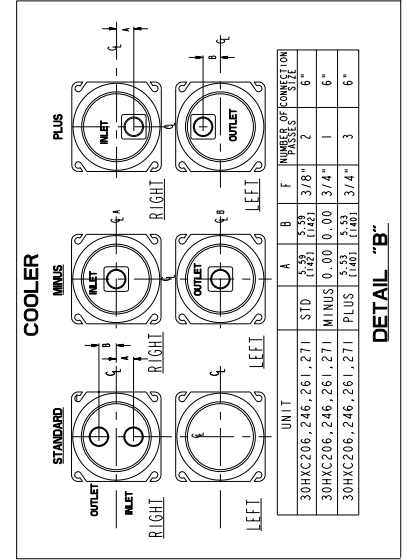
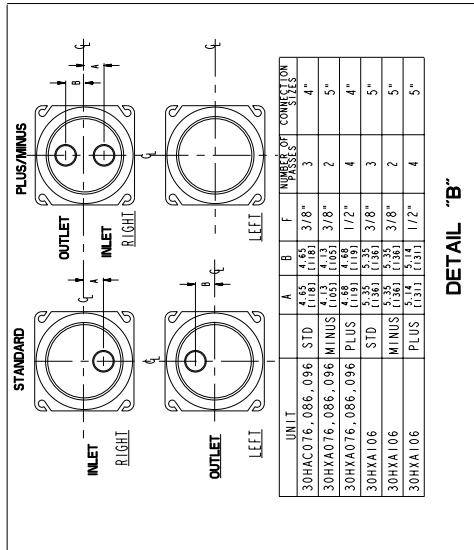
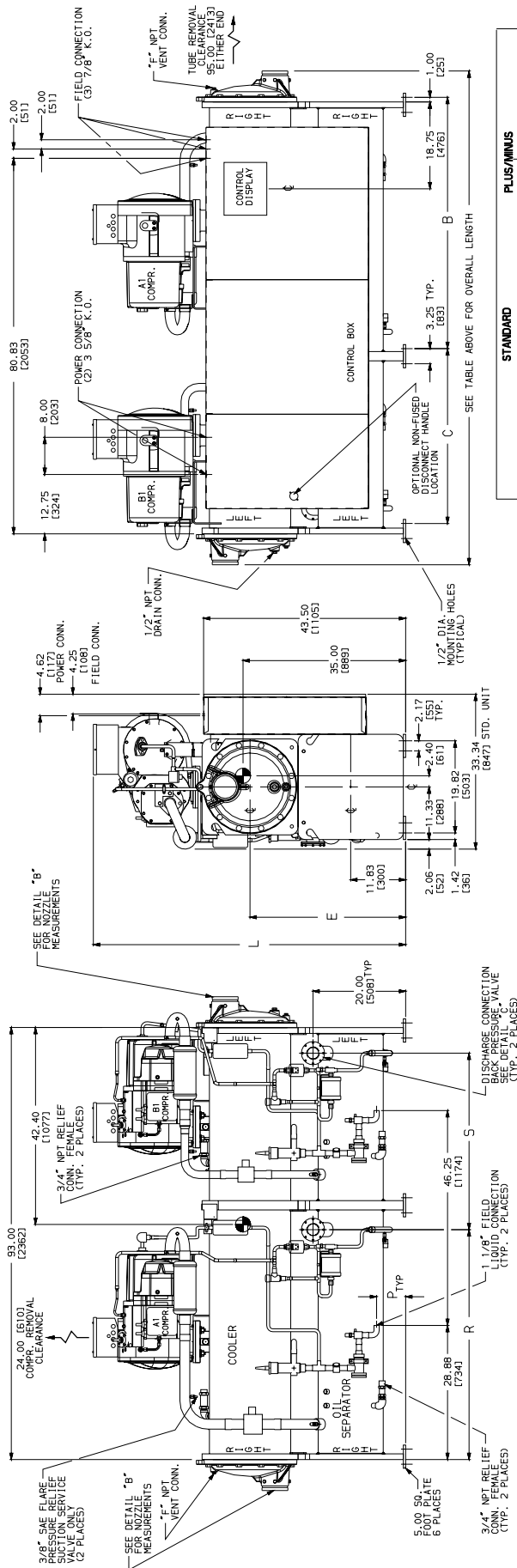
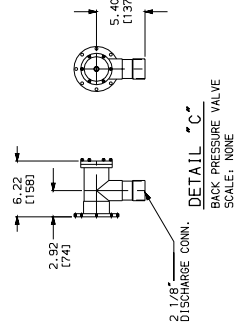

Fig. 5 — Dimensions, 30HXC206-271

UNIT	OPERATING WEIGHT - lb (kg)	WGT DISTRIBUTION AT EACH MTG PLATE - lb (kg)					
		1	2	3	4	5	6
30HXA076	4717 (2140)	555 (252)	793 (360)	418 (190)	926 (420)	1326 (601)	699 (317)
30HXA086	4744 (2152)	555 (252)	798 (362)	418 (190)	928 (421)	1340 (608)	705 (320)
30HXA096	4835 (2194)	509 (231)	808 (367)	493 (224)	848 (385)	1350 (612)	827 (375)
30HXA106	5151 (2337)	555 (252)	869 (394)	541 (245)	896 (406)	1410 (640)	880 (399)

OVERALL LENGTH TABLE	
COOLER	OVERALL LENGTH OVERALL LG. 105.30 (2700)
STANDARD COOLER	105.30 (2700)
MINUS ONE PASS COOLER	103.38 (2656)
PLUS ONE PASS COOLER	107.00 (2718)



**DOOR SWING CLEARANCE**

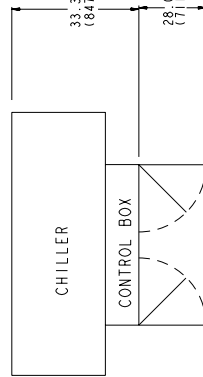

**NOTES:**

- Operating weight includes weight of water and refrigerant.
- Denotes center of gravity.
- Dimensions are in inches (mm).
- Recommended service clearance around machine is 36 in. (914.4 mm).
- Victaulic nozzles are standard on all models. Flow switch factory installed in cooler outlet victaulic nozzle.

**Fig. 6 — Dimensions, 30HXA076-106**



UNIT	OPERATING WEIGHT - lb (kg)	WGT DISTRIBUTION AT EACH MTG PLATE - lb (kg)						T	S	R	C	B	
		1	2	3	4	5	6						
30HXA161	5752 (2610)	50.63 (1286)	67.50 (1715)	51.00 (1295)	48.75 (1238)	560 (254)	954 (438)	1650 (746)	1025 (465)	598 (271)	954 (438)	1650 (746)	1025 (465)
30HXA171	5777 (2621)	61.37 (1559)	56.75 (1441)	61.75 (1532)	44.31 (1125)	627 (284)	988 (439)	1072 (486)	1658 (752)	534 (242)	1072 (486)	1658 (752)	918 (416)
30HXA186	5846 (2698)	61.37 (1559)	56.75 (1441)	61.75 (1532)	44.31 (1125)	648 (294)	1004 (455)	1110 (504)	1703 (772)	552 (250)	1110 (504)	1703 (772)	939 (426)

OVERALL LENGTH TABLE	
COOLER	OVERALL LENGTH
STANDARD COOLER	34.40 (3414)
MINUS ONE PASS COOLER	144.00 (3858)
PLUS ONE PASS COOLER	137.30 (3487)

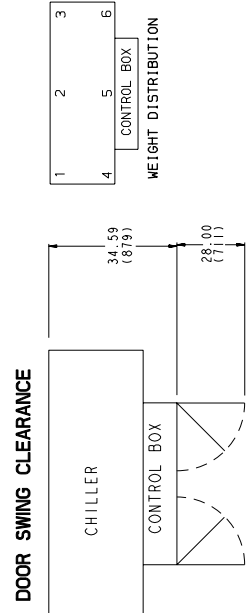
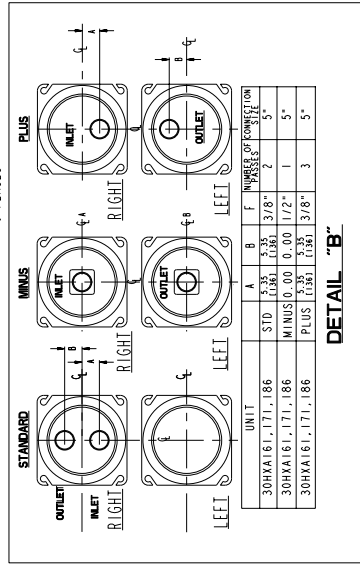
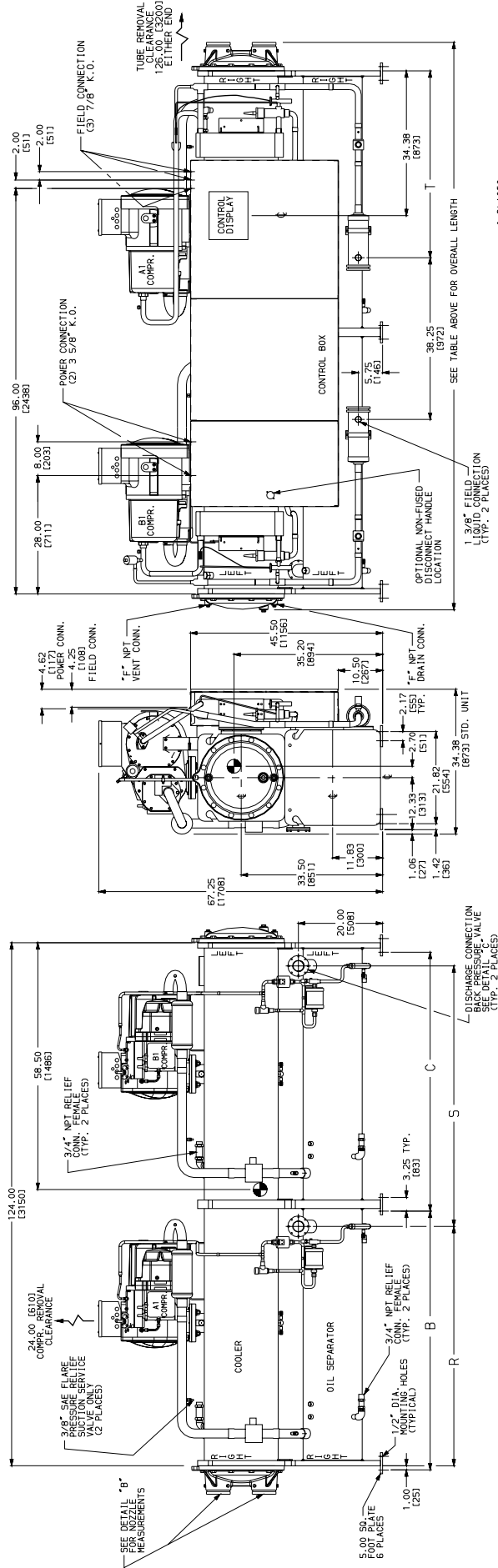
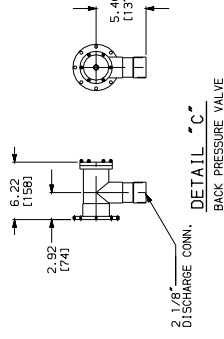

- NOTES:
- Operating weight includes weight of water and refrigerant.
  - Denotes center of gravity.
  - Dimensions are in inches (mm).
  - Recommended service clearance around machine is 36 in. (914.4 mm).
  - Victaulic nozzles are standard on all models. Flow switch factory installed in cooler outlet victaulic nozzle.

Fig. 8 — Dimensions, 30HXA161-186

UNIT	OPERATING WEIGHT - lb (kg)					
	1	2	3	4	5	6
30HXA206	7485 (3395)	1702 (772)	879 (399)	850 (385)	2216 (1005)	1167 (529)
30HXA246	7621 (3457)	1748 (793)	911 (413)	797 (362)	2276 (1032)	1209 (548)
30HXA261	7621 (3457)	1748 (793)	911 (413)	797 (362)	2276 (1032)	1209 (548)
30HXA271	7621 (3457)	1748 (793)	911 (413)	797 (362)	2276 (1032)	1209 (548)

OVERALL LENGTH TABLE	
COOLER	OVERALL LENGTH
STANDARD COOLER	150.95 (3834)
MINUS ONE PASS COOLER	160.00 (4064)
PLUS ONE PASS COOLER	160.00 (4064)

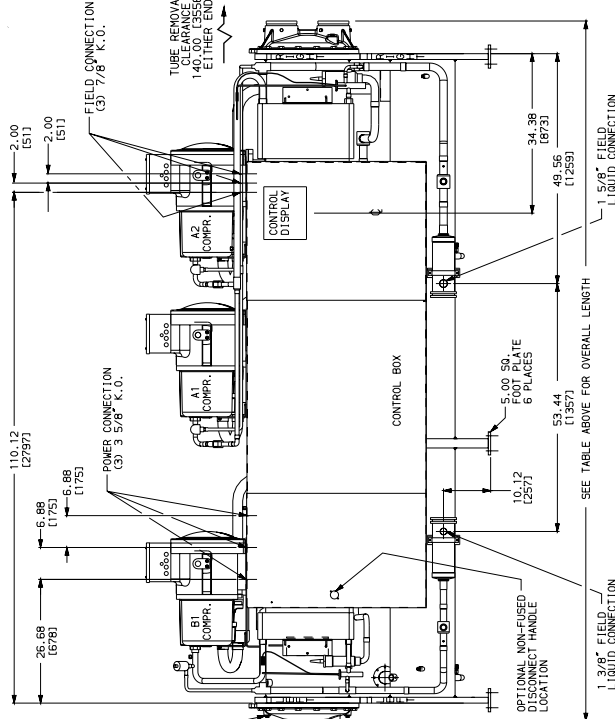
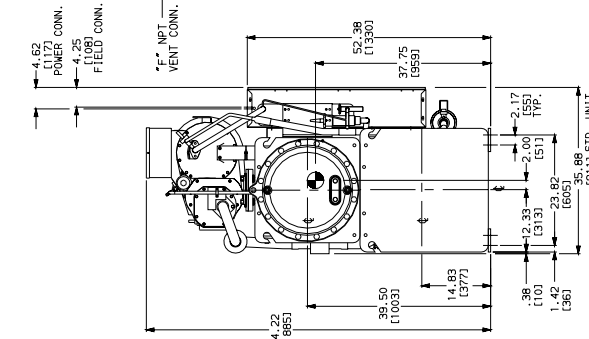
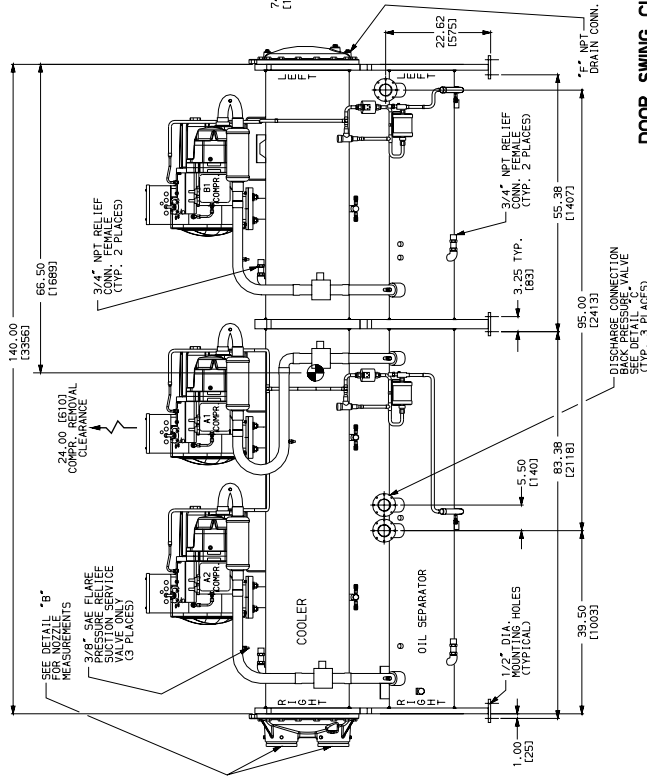
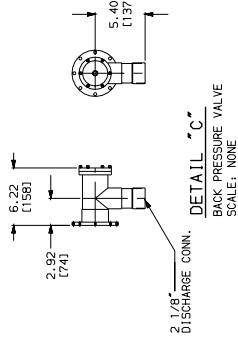

**DOOR SWING CLEARANCE**

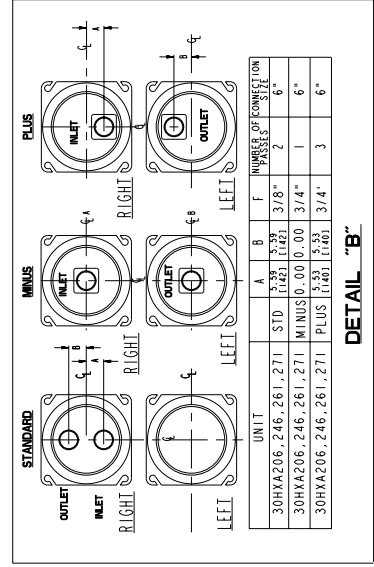
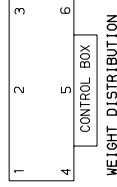
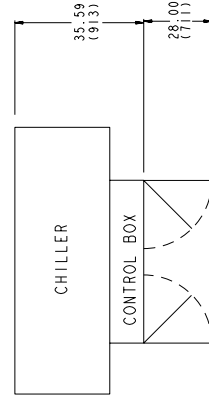

- NOTES:
- Operating weight includes weight of water and refrigerant.
  - Denotes center of gravity.
  - Dimensions are in inches (mm).
  - Recommended service clearance around machine is 36 in. (914.4 mm).
  - Victaulic nozzles are standard on all models. Flow switch factory installed in cooler outlet victaulic nozzle.

**Fig. 9 — Dimensions, 30HXA206-271**

DIMENSIONS — in. (mm)

UNIT	'A'	'B'	'C'	'D'
30HX076.086.096.106	120.00 [3048]	36.00 [915]	21.16 [538]	17.84 [453]
30HX116.126.136.146.161.171.186	168.00 [4267]	60.00 [1525]	36.67 [931]	29.84 [758]
30HX206.246.261.271	168.00 [4267]	60.00 [1525]	37.32 [948]	32.68 [830]

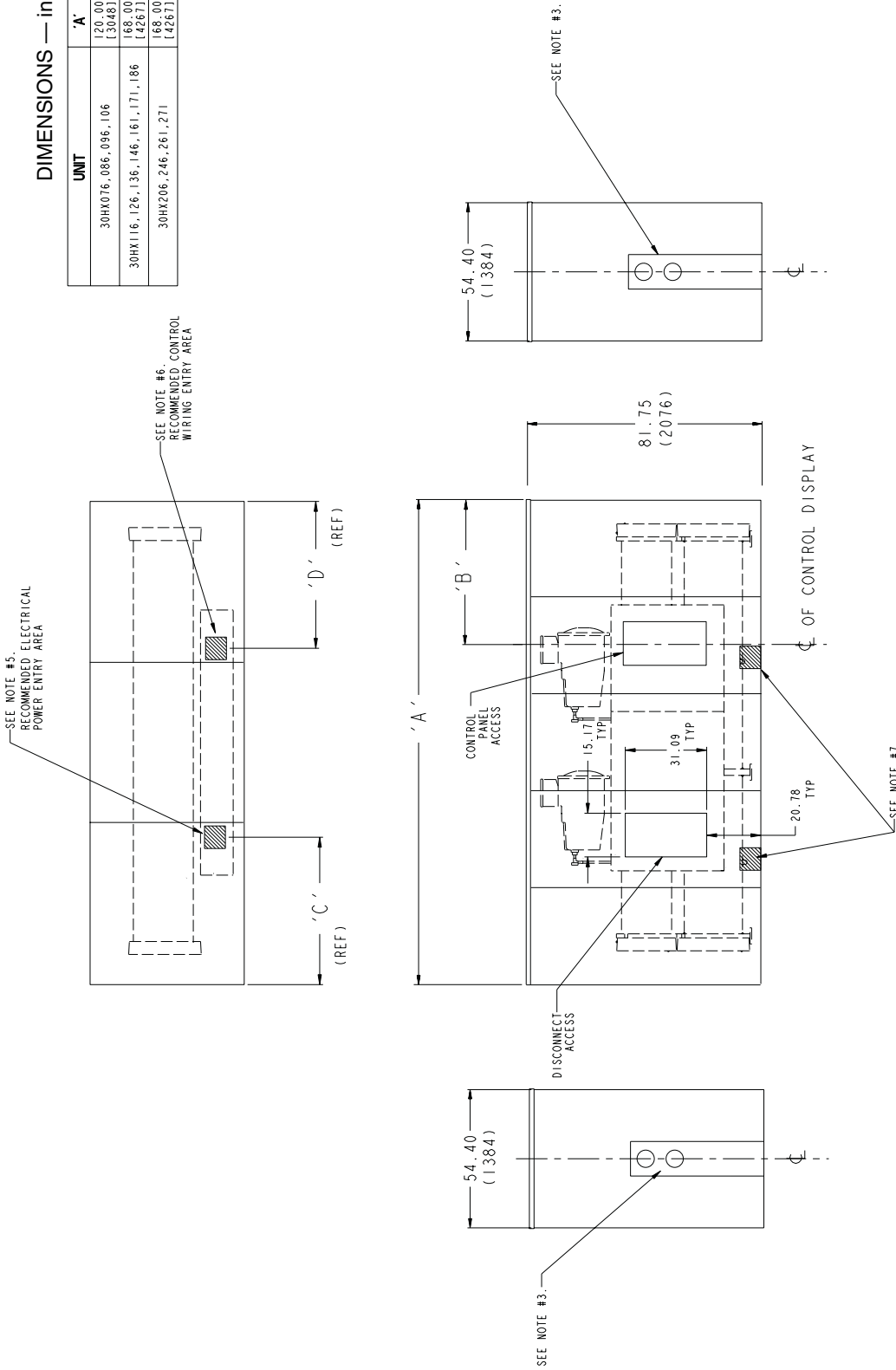

- NOTES:
1. Dimensions are in inches (millimeters).
  2. 36 in. (914.4) recommended service clearance around machine.
  3. Unused portion of piping openings to be closed and insulated for acoustic purposes. Use filler panel in accessory package.
  4. Field fabricated holes must be closed and insulated for acoustic purposes.
  5. Recommended electrical power supply area. Notch to suit and cover/insulate remaining open area for acoustic purposes.
  6. Recommended control wiring entry area. Notch to suit and cover/insulate remaining open area for acoustic purposes.
  7. Recommended cooler relief vent line and 30HXC condenser relief vent line entry area. 30HXA discharge and liquid line entry areas on opposite side. Notch enclosure to suit particular installation.
  8. Model in drawing is typical and represents 30HX116-146 sizes in the 30HX-900---001 accessory.
  9. Sound enclosure accessory should be aligned to the center lines of the control panel access and piping openings.

Fig. 10 — Dimensions, Sound Enclosure

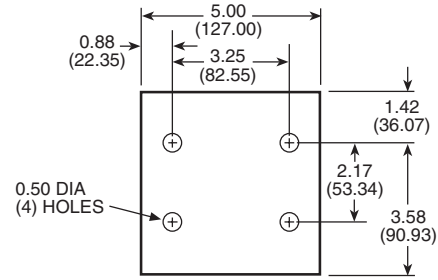
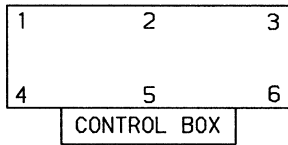

NOTE: Dimensions shown in inches (mm).  
30HX FOOT

WEIGHT DISTRIBUTION AT EACH MOUNTING PLATE,  
30HXC UNITS — lb (kg)

UNIT 30HXC	MOUNTING PLATE NO.					
	1	2	3	4	5	6
076	738 (335)	943 (428)	595 (270)	1110 (503)	1418 (643)	896 (406)
086	738 (335)	947 (430)	597 (271)	1112 (504)	1427 (647)	902 (409)
096	686 (311)	968 (439)	693 (314)	1027 (466)	1447 (656)	1034 (469)
106	730 (331)	1028 (466)	744 (337)	1073 (487)	1510 (685)	1092 (495)
116	728 (330)	1114 (505)	777 (352)	1053 (478)	1615 (733)	1127 (511)
126	738 (335)	1127 (511)	780 (354)	1061 (481)	1628 (738)	1131 (513)
136	758 (344)	1176 (533)	811 (368)	1083 (491)	1689 (766)	1171 (531)
146	763 (346)	1182 (536)	815 (370)	1085 (492)	1697 (770)	1172 (532)
161	817 (371)	1272 (577)	908 (412)	1219 (553)	1890 (857)	1346 (610)
171	936 (425)	1318 (598)	840 (381)	1379 (626)	1946 (883)	1241 (563)
186	962 (436)	1361 (617)	860 (390)	1410 (640)	1996 (905)	1265 (574)
206	948 (430)	2406 (1091)	1243 (564)	1201 (545)	3133 (1421)	1650 (748)
246	985 (447)	2515 (1141)	1306 (592)	1154 (523)	3276 (1486)	1733 (786)
261	985 (447)	2520 (1143)	1311 (595)	1154 (523)	3283 (1489)	1739 (789)
271	985 (447)	2529 (1147)	1318 (598)	1154 (523)	3294 (1494)	1749 (793)

30HXA UNITS — lb (kg)

UNIT 30HXA	MOUNTING PLATE NO.					
	1	2	3	4	5	6
076	555 (252)	793 (360)	418 (190)	926 (420)	1326 (601)	699 (317)
086	555 (252)	798 (362)	418 (190)	928 (421)	1340 (608)	705 (320)
096	509 (231)	808 (367)	493 (224)	848 (385)	1350 (612)	827 (375)
106	555 (252)	869 (394)	541 (245)	896 (406)	1410 (640)	880 (399)
116	530 (240)	895 (406)	540 (245)	855 (388)	1456 (660)	887 (402)
126	540 (245)	905 (410)	541 (245)	864 (392)	1468 (666)	887 (402)
136	548 (249)	926 (420)	555 (252)	874 (396)	1498 (679)	908 (412)
146	551 (250)	930 (422)	555 (252)	883 (400)	1506 (683)	908 (412)
161	560 (254)	965 (438)	598 (271)	954 (433)	1650 (748)	1025 (465)
171	627 (284)	968 (439)	534 (242)	1072 (486)	1658 (752)	918 (416)
186	648 (294)	1004 (455)	552 (250)	1110 (504)	1703 (772)	939 (426)
206	671 (304)	1702 (772)	879 (399)	850 (385)	2216 (1005)	1167 (529)
246	681 (309)	1748 (793)	911 (413)	797 (362)	2276 (1032)	1209 (548)
261	681 (309)	1748 (793)	911 (413)	797 (362)	2276 (1032)	1209 (548)
271	681 (309)	1748 (793)	911 (413)	797 (362)	2276 (1032)	1209 (548)

NOTE: See Fig. 2-9 for center of gravity details.

Fig. 11 — Weight Distribution at Mounting Plates

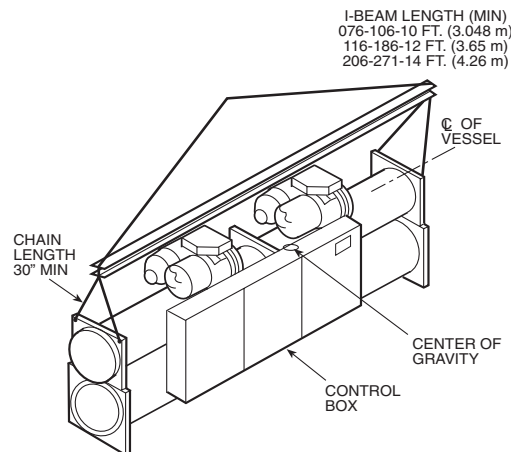

NOTE: Run rigging cables to a central suspension point.

Fig. 12 — Unit Rigging (Size 076-186 Shown, Larger Sizes Similar)

**Table 1A — Physical Data, English**

UNIT SIZE 30HX	076	086	096	106	116	126	136	146
<b>UNIT OPERATING WEIGHT (lb)</b>								
Water-Cooled (HXC)	5700	5723	5855	6177	6415	6465	6688	6718
Condenserless (HXA)	4717	4744	4835	5151	5163	5205	5309	5333
<b>COMPRESSORS</b>	Semi-Hermetic, Twin Screw							
Quantity	2	2	2	2	2	2	2	2
Nominal Capacity per Compressor (tons)	39/39	46/39	56/39	66/39	66/46	66/56	80/56	80/66
Economizer	No	No	No	No	No	No	No	No
No. Capacity Steps								
Standard	6	6	6	6	6	6	6	6
Optional (maximum)	8	8	8	8	8	8	8	8
Minimum Step Capacity (%)								
Standard	20	20	20	20	20	20	20	20
Optional	10	10	10	10	10	10	10	10
<b>REFRIGERANT (HXC)</b>	R-134a							
Charge* (lb) Circuit A/Circuit B	75/75	76/75	94/70	110/70	112/89	112/89	124/89	119/100
<b>COOLER</b>	Shell and Tube with Enhanced Copper Tubes							
Part No. 10HX400-	401	401	402	408	406	406	405	405
Net Fluid Volume (gal)	17.0	17.0	19.0	22.6	21.4	21.4	24.0	24.0
Maximum Refrigerant Pressure (psig)	220	220	220	220	220	220	220	220
Maximum Water-Side Pressure (psig)	300	300	300	300	300	300	300	300
Water Connections								
Inlet and Outlet (in.) (Std Pass)	4	4	4	5	5	5	5	5
Drain (in. NPT) (Std Pass)	3/8	3/8	3/8	3/8	3/8	3/8	3/8	3/8
Relief Valve								
Connection (in. NPTF)	3/4	3/4	3/4	3/4	3/4	3/4	3/4	3/4
Flow Capacity (lb air/min)	31.7	31.7	31.7	31.7	31.7	31.7	31.7	31.7
Relief Setting (psig)	220	220	220	220	220	220	220	220
Standard Number of Passes	3	3	3	3	2	2	2	2
<b>30HXA OIL SEPARATOR</b>								
Part No. 09RX400-	217	217	216	216	215	215	215	215
Maximum Refrigerant Pressure (psig)	320	320	320	320	320	320	320	320
Refrigerant Connections (in.)								
Discharge Circuit A/Circuit B	2 1/8/2 1/8	2 1/8/2 1/8	2 1/8/2 1/8	2 1/8/2 1/8	2 1/8/2 1/8	2 1/8/2 1/8	2 1/8/2 1/8	2 1/8/2 1/8
Liquid Circuit A/Circuit B	1 1/8/1 1/8	1 1/8/1 1/8	1 1/8/1 1/8	1 1/8/1 1/8	1 1/8/1 1/8	1 1/8/1 1/8	1 1/8/1 1/8	1 1/8/1 1/8
Relief Valve								
Connection (in. SAE Flare)	5/8	5/8	5/8	5/8	5/8	5/8	5/8	5/8
Flow Capacity (lb air/min)	21.6	21.6	21.6	21.6	21.6	21.6	21.6	21.6
Relief Setting (psig)	320	320	320	320	320	320	320	320
<b>CONDENSER (HXC)</b>	Shell and Tube with Enhanced Copper Tubes							
Part No. 09RX400-	257	257	258	258	259	259	260	260
Net Fluid Volume (gal)	16.8	16.8	18.3	18.3	23.9	23.9	27.5	27.5
Maximum Refrigerant Pressure (psig)	220	220	220	220	220	220	220	220
Maximum Water-Side Pressure (psig)	300	300	300	300	300	300	300	300
Water Connections (in.)								
Inlet and Outlet (Std Pass)	5	5	5	5	5	5	5	5
Drain (NPT) (Std Pass)	3/8	3/8	3/8	3/8	3/8	3/8	3/8	3/8
Relief Valve								
Connection (in. NPTF)	3/4	3/4	3/4	3/4	3/4	3/4	3/4	3/4
Flow Capacity (lb air/min)	31.7	31.7	31.7	31.7	31.7	31.7	31.7	31.7
Relief Setting (psig)	220	220	220	220	220	220	220	220
Standard Number of Passes	2	2	2	2	2	2	2	2
<b>DISCHARGE LINE†</b>								
Relief Valve								
Connection (in. SAE Flare)	3/8	3/8	3/8	3/8	3/8	3/8	3/8	3/8
Flow Capacity (lb air/min)	6.3	6.3	6.3	6.3	6.3	6.3	6.3	6.3
Setting (psig)	350	350	350	350	350	350	350	350

**LEGEND**

**NPTF** — National Pipe Thread Female  
**SAE** — Society of Automotive Engineers

\*Charges listed are for 30HXC units. The 30HXA units are shipped with a holding charge only. To determine the refrigerant charge requirements for 30HXA units see the System Refrigerant Charge table in the Refrigerant Charge section on page 39.

†Only on units with factory-installed suction service valves.

**Table 1A — Physical Data, English (cont)**

UNIT SIZE 30HX	161	171	186	206	246	261	271
<b>UNIT OPERATING WEIGHT (lb)</b>							
Water-Cooled (HXC)	7452	7660	7854	10,581	10,969	10,992	11,029
Condenserless (HXA)	5752	5777	5946	7,485	7,621	7,621	7,621
<b>COMPRESSORS</b>	Semi-Hermetic, Twin Screw						
Quantity	2	2	2	3	3	3	3
Nominal Capacity per Compressor (tons)	80/56	66/80	80/80	66/39/80	80/56/80	80/66/80	80/80/80
Economizer	Yes	Yes	Yes	Yes	Yes	Yes	Yes
No. Capacity Steps							
Standard	6	6	6	8	8	8	8
Optional (maximum)	8	8	8	11	11	11	11
Minimum Step Capacity (%)							
Standard	20	20	20	13	13	13	13
Optional	10	10	10	7	7	7	7
<b>REFRIGERANT (HXC)</b>				R-134a			
Charge* (lb) Circuit A/Circuit B	157/110	119/140	135/135	200/135	220/135	220/135	220/135
<b>COOLER TYPE</b>	Shell and Tube with Enhanced Copper Tubes						
Part No. 10HX400-	601	611	621	631	632	632	632
Net Fluid Volume (gal)	28.5	28.5	33.4	43.1	47.2	47.2	47.2
Maximum Refrigerant Pressure (psig)	220	220	220	220	220	220	220
Maximum Water-Side Pressure (psig)	300	300	300	300	300	300	300
Water Connections							
Inlet and Outlet (in.) (Std Pass)	5	5	5	6	6	6	6
Drain (NPT) (Std Pass)	3/8	3/8	3/8	3/8	3/8	3/8	3/8
Relief Valve							
Connection (in. NPTF)	3/4	3/4	3/4	3/4	3/4	3/4	3/4
Flow Capacity (lb air/min)	31.7	31.7	31.7	31.7	31.7	31.7	31.7
Relief Setting (psig)	220	220	220	220	220	220	220
Standard Number of Passes	2	2	2	2	2	2	2
<b>30HXA OIL SEPARATOR</b>							
Part No. 09RX400-	215	214	214	213	213	213	213
Maximum Refrigerant Pressure (psig)	320	320	320	320	320	320	320
Refrigerant Connections (in.)							
Discharge Circuit A/Circuit B	2 1/8/2 1/8	2 1/8/2 1/8	2 1/8/2 1/8	(2) 2 1/8/2 1/8	(2) 2 1/8/2 1/8	(2) 2 1/8/2 1/8	(2) 2 1/8/2 1/8
Liquid Circuit A/Circuit B	1 3/8/1 3/8	1 3/8/1 3/8	1 3/8/1 3/8	1 5/8/1 3/8	1 5/8/1 3/8	1 5/8/1 3/8	1 5/8/1 3/8
Relief Valve							
Connection (in. SAE Flare)	5/8	5/8	5/8	5/8	5/8	5/8	5/8
Flow Capacity (lb air/min)	21.6	21.6	21.6	21.6	21.6	21.6	21.6
Relief Setting (psig)	320	320	320	320	320	320	320
<b>CONDENSER (HXC)</b>	Shell and Tube with Enhanced Copper Tubes						
Part No. 09RX400-	261	262	262	263	264	264	264
Net Fluid Volume (gal)	30.6	37.6	37.6	47.6	55.1	55.1	55.1
Maximum Refrigerant Pressure (psig)	220	220	220	220	220	220	220
Maximum Water-Side Pressure (psig)	300	300	300	300	300	300	300
Water Connections (in.)				Victaulic Type Connection			
Inlet and Outlet (Std Pass)	6	6	6	8	8	8	8
Drain (NPT) (Std Pass)	3/8	3/8	3/8	3/8	3/8	3/8	3/8
Relief Valve							
Connection (in. NPTF)	3/4	3/4	3/4	3/4	3/4	3/4	3/4
Flow Capacity (lb air/min)	31.7	31.7	31.7	31.7	31.7	31.7	31.7
Relief Setting (psig)	220	220	220	220	220	220	220
Standard Number of Passes	2	2	2	2	2	2	2
<b>DISCHARGE LINE†</b>							
Relief Valve							
Connection (in. SAE Flare)	3/8	3/8	3/8	3/8	3/8	3/8	3/8
Flow Capacity (lb air/min)	6.3	6.3	6.3	6.3	6.3	6.3	6.3
Setting (psig)	350	350	350	350	350	350	350

**LEGEND**

**NPTF** — National Pipe Thread Female  
**SAE** — Society of Automotive Engineers

\*Charges listed are for 30HXC units. The 30HXA units are shipped with a holding charge only. To determine the refrigerant charge requirements for 30HXA units see the System Refrigerant Charge table in the Refrigerant Charge section on page 39.

†Only on units with factory-installed suction service valves.

**Table 1B — Physical Data, SI**

UNIT SIZE 30HX	076	086	096	106	116	126	136	146
<b>UNIT OPERATING WEIGHT (kg)</b>								
Water-Cooled (HXC)	2586	2597	2657	2803	2911	2933	3034	3048
Condenserless (HXA)	2140	2152	2194	2337	2342	2362	2408	2420
<b>COMPRESSORS</b>	Semi-Hermetic, Twin Screw							
Quantity	2	2	2	2	2	2	2	2
Nominal Capacity per Compressor (kW)	137/137	162/137	197/137	232/137	232/137	232/197	281/197	281/232
Economizer	No	No	No	No	No	No	No	No
No. Capacity Steps								
Standard	6	6	6	6	6	6	6	6
Optional (maximum)	8	8	8	8	8	8	8	8
Minimum Step Capacity (%)								
Standard	20	20	20	20	20	20	20	20
Optional	10	10	10	10	10	10	10	10
<b>REFRIGERANT (HXC)</b>	R-134a							
Charge* (kg) Circuit A/Circuit B	34.1/34.1	34.5/34.1	42.7/31.8	49.9/31.8	50.8/40.4	50.8/40.4	56.3/40.4	54.0/45.4
<b>COOLER</b>	Shell and Tube with Enhanced Copper Tubes							
Part No. 10HX400-	401	401	402	408	406	406	405	405
Net Fluid Volume (L)	64.3	64.3	71.9	85.5	81.0	81.0	90.8	90.8
Maximum Refrigerant Pressure (kPa)	1517	1517	1517	1517	1517	1517	1517	1517
Maximum Water-Side Pressure (kPa)	2068	2068	2068	2068	2068	2068	2068	2068
Water Connections								
Inlet and Outlet (in.) (Std Pass)	4	4	4	5	5	5	5	5
Drain (NPT) (Std Pass)	3/8	3/8	3/8	3/8	3/8	3/8	3/8	3/8
Relief Valve								
Connection (in. NPTF)	3/4	3/4	3/4	3/4	3/4	3/4	3/4	3/4
Flow Capacity (kg air/min)	14.38	14.38	14.38	14.38	14.38	14.38	14.38	14.38
Relief Setting (kPa)	1517	1517	1517	1517	1517	1517	1517	1517
Standard Number of Passes	3	3	3	3	2	2	2	2
<b>30HXA OIL SEPARATOR</b>								
Part No. 09RX400-	217	217	216	216	215	215	215	215
Maximum Refrigerant Pressure (kPa)	2205	2205	2205	2205	2205	2205	2205	2205
Refrigerant Connections (in.)								
Discharge Circuit A/Circuit B	2 1/8/2 1/8	2 1/8/2 1/8	2 1/8/2 1/8	2 1/8/2 1/8	2 1/8/2 1/8	2 1/8/2 1/8	2 1/8/2 1/8	2 1/8/2 1/8
Liquid Circuit A/Circuit B	1 1/8/2 1/8	1 1/8/1 1/8	1 1/8/1 1/8	1 1/8/1 1/8	1 1/8/1 1/8	1 1/8/1 1/8	1 1/8/1 1/8	1 1/8/1 1/8
Relief Valve								
Connection (in. SAE Flare)	5/8	5/8	5/8	5/8	5/8	5/8	5/8	5/8
Flow Capacity (kg air/min)	9.80	9.80	9.80	9.80	9.80	9.80	9.80	9.80
Relief Setting (kPa)	2206	2206	2206	2206	2206	2206	2206	2206
<b>CONDENSER (HXC)</b>	Shell and Tube with Enhanced Copper Tubes							
Part No. 09RX400-	257	257	258	258	259	259	260	260
Net Fluid Volume (L)	63.6	63.6	69.3	69.3	90.5	90.5	104.1	104.1
Maximum Refrigerant Pressure (kPa)	1517	1517	1517	1517	1517	1517	1517	1517
Maximum Water-Side Pressure (kPa)	2068	2068	2068	2068	2068	2068	2068	2068
Water Connections (in.)								
Inlet and Outlet (Std Pass)	5	5	5	5	5	5	5	5
Drain (NPT) (Std Pass)	3/8	3/8	3/8	3/8	3/8	3/8	3/8	3/8
Relief Valve								
Connection (in. NPTF)	3/4	3/4	3/4	3/4	3/4	3/4	3/4	3/4
Flow Capacity (kg air/min)	14.38	14.38	14.38	14.38	14.38	14.38	14.38	14.38
Relief Setting (kPa)	1517	1517	1517	1517	1517	1517	1517	1517
Standard Number of Passes	2	2	2	2	2	2	2	2
<b>DISCHARGE LINE†</b>								
Relief Valve								
Connection (in. SAE Flare)	3/8	3/8	3/8	3/8	3/8	3/8	3/8	3/8
Flow Capacity (kg air/min)	2.9	2.9	2.9	2.9	2.9	2.9	2.9	2.9
Relief Pressure (kPa)	2413	2413	2413	2413	2413	2413	2413	2413

**LEGEND**

**NPTF** — National Pipe Thread Female  
**SAE** — Society of Automotive Engineers

\*Charges listed are for 30HXC units. The 30HXA units are shipped with a holding charge only. To determine the refrigerant charge requirements for 30HXA units see the System Refrigerant Charge table in the Refrigerant Charge section on page 39.  
 †Only on units with factory-installed suction service valves.

**Table 1B — Physical Data, SI (cont)**

UNIT SIZE 30HX	161	171	186	206	246	261	271
<b>UNIT OPERATING WEIGHT (kg)</b>							
Water-Cooled (HXC)	3381	3475	3564	4799	4976	4986	5003
Condenserless (HXA)	2610	2621	2698	3395	3457	3457	3457
<b>COMPRESSORS</b>	Semi-Hermetic, Twin Screw						
Quantity	2	2	2	3	3	3	3
Nominal Capacity per Compressor (kW)	281/197	232/281	281/281	232/137/281	281/197/281	281/232/281	281/281/281
Economizer	Yes	Yes	Yes	Yes	Yes	Yes	Yes
No. Capacity Steps							
Standard	6	6	6	8	8	8	8
Optional (maximum)	8	8	8	11	11	11	11
Minimum Step Capacity (%)							
Standard	20	20	20	13	13	13	13
Optional	10	10	10	7	7	7	7
<b>REFRIGERANT (HXC)</b>	R-134a						
Charge* (kg) Circuit A/Circuit B	71.3/49.9	54.0/63.6	61.3/61.3	90.8/61.3	99.9/61.3	99.9/61.3	99.9/61.3
<b>COOLER</b>	Shell and Tube with Enhanced Copper Tubes						
Part No. 10HX400-	601	611	621	631	632	632	632
Net Fluid Volume (L)	107.9	107.9	126.4	163.2	178.7	178.8	178.7
Maximum Refrigerant Pressure (kPa)	1517	1517	1517	1517	1517	1517	1517
Maximum Water-Side Pressure (kPa)	2068	2068	2068	2068	2068	2068	2068
Water Connections							
Inlet and Outlet (in.) (Std Pass)	5	5	5	6	6	6	6
Drain (NPT) (Std Pass)	3/8	3/8	3/8	3/8	3/8	3/8	3/8
Relief Valve							
Connection (in. NPTF)	3/4	3/4	3/4	3/4	3/4	3/4	3/4
Flow Capacity (kg air/min)	14.28	14.38	14.38	14.38	14.38	14.38	14.38
Relief Setting (kPa)	1517	1517	1517	1517	1517	1517	1517
Standard Number of Passes	2	2	2	2	2	2	2
<b>30HXA OIL SEPARATOR</b>							
Part No. 09RX400-	215	214	214	213	213	213	213
Maximum Refrigerant Pressure (kPa)	2205	2205	2205	2205	2205	2205	2205
Refrigerant Connections (in.)							
Discharge Circuit A/Circuit B	2 1/8/2 1/8	2 1/8/2 1/8	2 1/8/2 1/8	(2) 2 1/8/2 1/8	(2) 2 1/8/2 1/8	(2) 2 1/8/2 1/8	(2) 2 1/8/2 1/8
Liquid Circuit A/Circuit B	1 3/8/1 3/8	1 3/8/1 3/8	1 3/8/1 3/8	1 5/8/1 3/8	1 5/8/1 3/8	1 5/8/1 3/8	1 5/8/1 3/8
Relief Valve							
Connection (in. SAE Flare)	5/8	5/8	5/8	5/8	5/8	5/8	5/8
Flow Capacity (kg air/min)	9.80	9.80	9.80	9.80	9.80	9.80	9.80
Relief Setting (kPa)	2206	2206	2206	2206	2206	2206	2206
<b>CONDENSER (HXC)</b>	Shell and Tube with Enhanced Copper Tubes						
Part No. 09RX400-	261	262	262	263	264	264	264
Net Fluid Volume (L)	115.8	142.3	142.3	177.9	208.6	208.6	208.6
Maximum Refrigerant Pressure (kPa)	1517	1517	1517	1517	1517	1517	1517
Maximum Water-Side Pressure (kPa)	2068	2068	2068	2068	2068	2068	2068
Water Connections (in.)				Victaulic Type Connection			
Inlet and Outlet (Std Pass)	6	6	6	8	8	8	8
Drain (NPT) (Std Pass)	3/8	3/8	3/8	3/8	3/8	3/8	3/8
Relief Valve							
Connection (in. NPTF)	3/4	3/4	3/4	3/4	3/4	3/4	3/4
Flow Capacity (kg air/min)	14.38	14.38	14.38	14.38	14.38	14.38	14.38
Relief Setting (kPa)	1517	1517	1517	1517	1517	1517	1517
Standard Number of Passes	2	2	2	2	2	2	2
<b>DISCHARGE LINE†</b>							
Relief Valve							
Connection (in. SAE Flare)	3/8	3/8	3/8	3/8	3/8	3/8	3/8
Flow Capacity (kg air/min)	2.9	2.9	2.9	2.9	2.9	2.9	2.9
Relief Pressure (kPa)	2413	2413	2413	2413	2413	2413	2413

**LEGEND**

**NPTF** — National Pipe Thread Female  
**SAE** — Society of Automotive Engineers

\*Charges listed are for 30HXC units. The 30HXA units are shipped with a holding charge only. To determine the refrigerant charge requirements for 30HXA units see the System Refrigerant Charge table in the Refrigerant Charge section on page 39.  
†Only on units with factory-installed suction service valves.

## Step 2 — Rig and Place Unit

### ⚠ CAUTION

Rig unit from the top heat exchanger only. Rigging from the bottom heat exchanger will cause the unit to be lifted unsafely. Personal injury or damage to the unit may occur.

**IMPORTANT:** Install unit in area which will not be exposed to ambient temperatures below 50 F (10 C).

Do not remove unit from skid until unit is in its final location. Rig from the rigging holes provided in the top heat exchanger. See Fig. 2-9, 11, and 12 for rigging and center of gravity information. Lower the unit carefully onto the floor or roller. Push or pull only on the skid, **not the unit**. If the unit is moved on rollers, use a minimum of 3 evenly spaced rollers.

Areas where unit mounting points will be located must be level to within  $1/16$  in. per ft (5 mm per m) along the long axis of the unit. Once unit is in place and level, bolt unit to the floor. Use isolation pads under the unit to aid in vibration isolation as required.

**Step 3 — Piping Connections** — See Fig. 13, 14A, and 14B for typical piping applications.

**COOLER FLUID, VENT, AND DRAIN** — The inlet (return) fluid connection is always the lower of the 2 cooler connections. See Fig. 13 for locations. A screen strainer with a minimum of 20 mesh must be installed ahead of the cooler inlet (within 10 ft [3.05 m]) to prevent debris from damaging internal tubes of the cooler. Outlet (supply) fluid connection is the upper connection of the 2 cooler connections.

The cooler has victaulic nozzles to connect to the field-supplied piping. Plan the piping arrangement in accordance with good piping practices and so that the piping does not cross in front of the cooler head. Use flexible connections on cooler piping to reduce vibration transmission. Offset the piping to permit removal of the cooler head for maintenance. Install pipe hangers where needed. Make sure no weight or stress is placed on the water nozzle.

### ⚠ CAUTION

Cooler and condenser heads are cast iron. Welding is not recommended. In the event that welding must be performed, remove the chilled water flow switch and entering and leaving fluid thermistors before welding. Reinstall flow switch and thermistors after welding is complete. Failure to remove these devices may cause component damage.

1. The cooler flow switch (CWFS) is factory installed in the inlet nozzle and wired. If a cooler pump interlock is used, the contacts must be wired to TB5. Refer to unit wire diagrams.

**IMPORTANT:** Loss of flow protection is required for all 30HX chillers.

2. Provide openings in fluid piping for pressure gages and thermometers (if used). These openings should be 5 to 10 pipe diameters from the unit water nozzles. For thorough mixing and temperature stabilization, wells in the leaving fluid pipe should extend at least 2 in. (50 mm) into the pipe.

Although cooler has an air vent, it is recommended that a field-supplied air vent be installed in the system to facilitate servicing. Field-supplied shut-off and balancing valves should also be installed to facilitate servicing and flow balancing.

Locate valves in return and supply fluid lines as close to the chiller as possible. Locate air vent at highest point of the cooler fluid system. See Fig. 13.

Provide drain connections at all low points to permit complete drainage of the system.

**BRINE UNITS** — Special factory modifications to the units are required to allow them to operate at fluid temperatures less than 34 F (1.1 C). Be sure that the fluid has sufficient inhibited ethylene glycol or other suitable corrosion-resistant antifreeze solution to prevent cooler freeze up. Condenser water flow must be maintained to prevent freeze-up on unit applications where condenser water does not contain antifreeze.

**IMPORTANT:** On brine applications where leaving cooler water is less than 34 F (1.1 C), a minimum water flow of 0.75 gpm/ton (0.14 L/s per kW) should be maintained through the condenser at all times. In addition to the factory-installed chilled water flow switch, a factory-supplied condenser water flow switch must be installed per the switch manufacturer's instructions. The chiller must control both the chilled water pump and the condenser pump and utilize cooler and condenser pump interlocks. The cooler pump must operate for minimum of 10 minutes after the chiller has shut down and the condenser pump must operate for 30 minutes after the chiller has shut down. In the event of loss of condenser water flow, the flow of chilled fluid to the evaporator must be stopped or an isolation valve must be closed. Condenser head pressure control valve must be coordinated with condenser flow switch to insure the minimum valve position does not prevent flow detection. This is necessary to reduce the possibility of condenser freeze-up.

**PREPARATION FOR YEAR-ROUND OPERATION** — In areas where the piping or unit is exposed to 32 F (0° C) or lower ambient temperatures, freeze-up protection is recommended using inhibited ethylene glycol or other suitable corrosion-resistant antifreeze solution and electric heater tapes. Heater tapes should have a rating for area ambient temperatures and be covered with a suitable thickness of closed-cell insulation. Route power for the heater tapes from a separately fused disconnect. Mount the disconnect within sight from the unit per local or NEC codes. Identify disconnect as heater tape power source with warning that power must not be turned off except when servicing unit.

**IMPORTANT:** Use of electric heat will not prevent freeze up in the event of a power failure.

**FILL FLUID LOOP** — Fill the fluid loop with water (or brine) and a corrosion-resistant inhibitor suitable for the water of the area. Consult the local water authority for characteristics of area water and a recommended inhibitor for the cooler fluid loop.

A drain connection is located at the bottom of the cooler head. See Fig. 2-9 for connection location. Install shut-off valves to the drain line before filling the system with fluid.

**INSULATE COOLER HEADS** — Once the cooler water lines and drain and vent lines have been installed and checked for leaks, insulate the cooler heads with a suitable thickness of closed-cell insulation. This will minimize the amount of condensation that forms on the cooler heads. When insulating the cooler heads, allow for service access and removal of heads.

**IMPORTANT:** Before starting the unit, be sure all of the air has been purged from the system.

**NOTES:**

1. Wiring and piping shown are for general point-of-connection only and are not intended to show details for a specific installation. Certified field wiring and dimensional diagrams are available upon request. The 30HXA and 30HXC units should be installed using certified drawings.
2. All wiring must comply with applicable codes.
3. Refer to Carrier System Design Manual for details regarding piping techniques.
4. Piping, wiring, switches, valves, vent gages, strainers, drain, and vibration isolation are all field supplied.
5. Water connections are shown on left side of control box in this figure. Actual connections are on right side of control box.

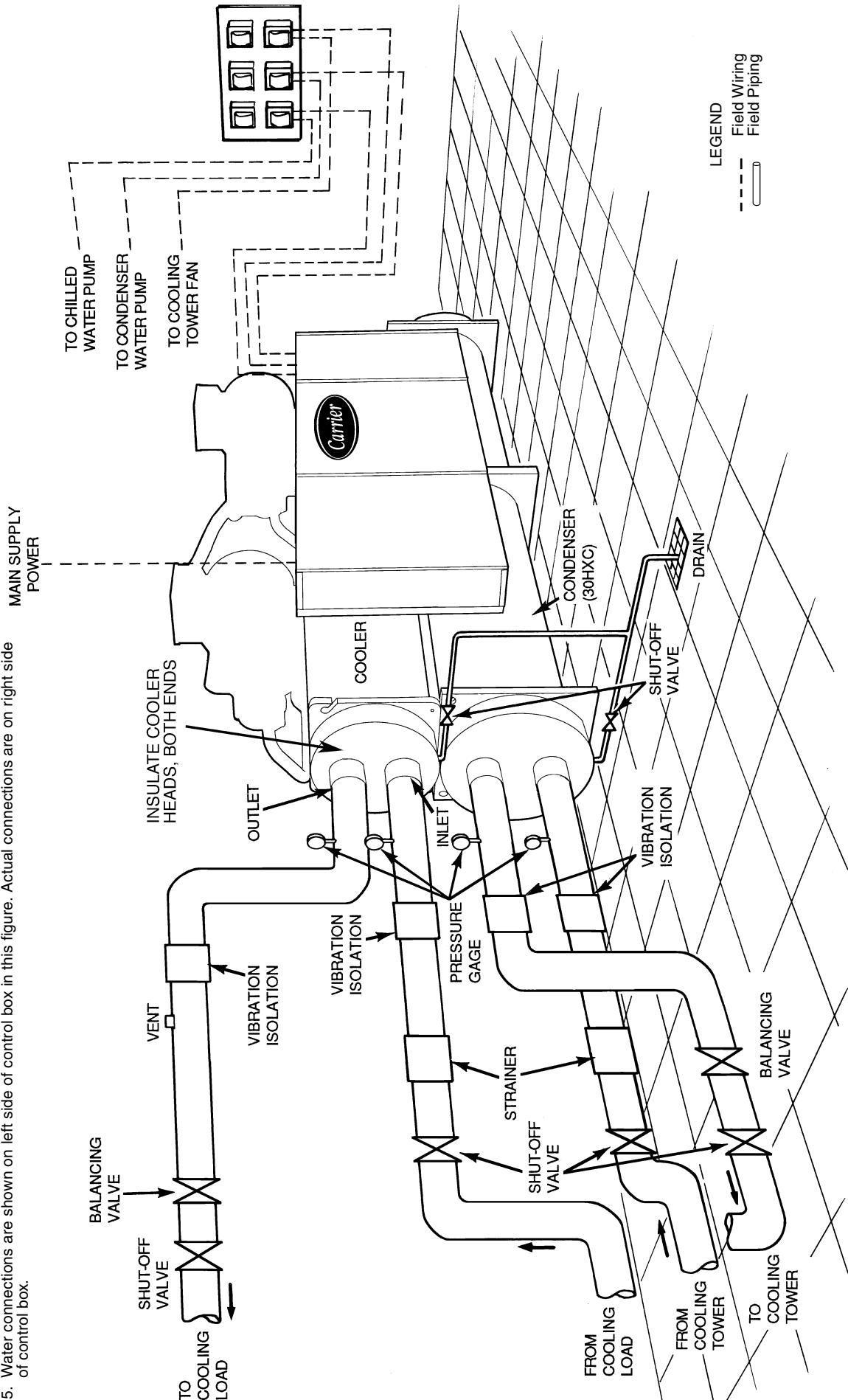

**Fig. 13 — Typical Cooler (30HXA, HXC) and Condenser (30HXC Only) Piping and Wiring**

**NOTES:**

1. Piping shown is for general point-of-connection only and is not intended to show details for a specific installation. Certified field wiring and dimensional drawings are available upon request. The 30HXA units should be installed using certified drawings.
2. Refer to Carrier System Design Manual for details regarding piping techniques.
3. Refrigerant piping, liquid line solenoid valves, liquid line filter driers and pressure relief devices are field supplied.
4. Relief valve vent piping per local codes.
5. If unit is equipped with accessory sound enclosure, run lines down to floor and notch bottom of enclosure to clear lines.

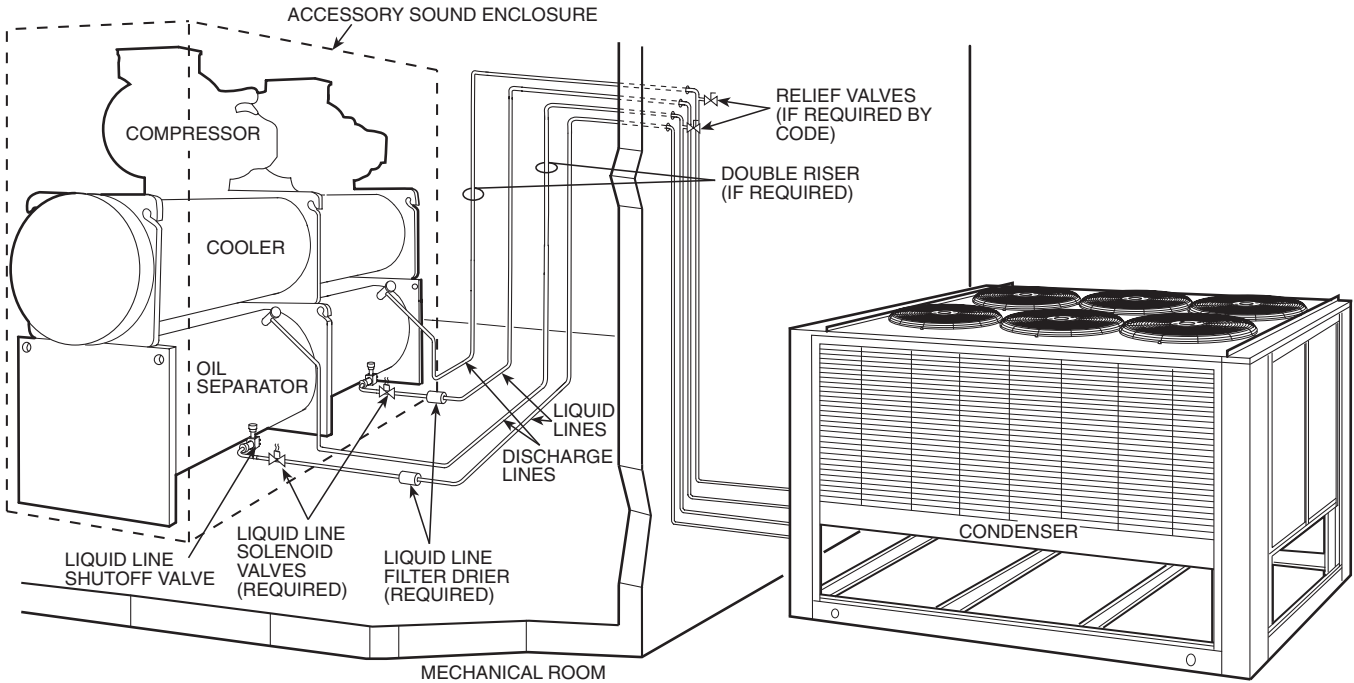

**Fig. 14A — Typical 30HXA Refrigerant Piping to Remote Condenser (076-186 Sizes Shown)**

**NOTES:**

1. Piping shown is for general point-of-connection only and is not intended to show details for a specific installation. Certified field wiring and dimensional drawings are available upon request. The 30HXA units should be installed using certified drawings.
2. Refer to Carrier System Design Manual for details regarding piping techniques.
3. Refrigerant piping, liquid line solenoid valves, liquid line filter driers and pressure relief devices are field supplied.
4. Relief valve vent piping per local codes.
5. If unit is equipped with accessory sound enclosure, run lines down to floor and notch bottom of enclosure to clear lines.

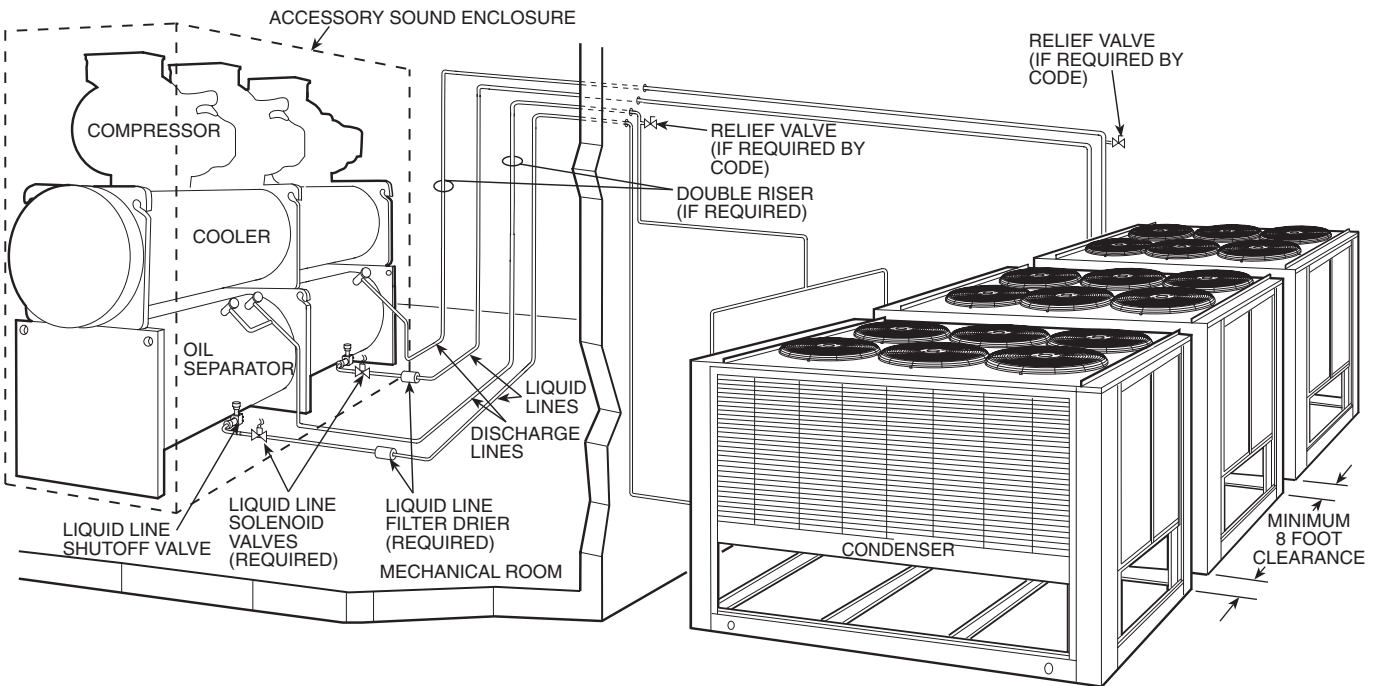

**Fig. 14B — Typical 30HXA Refrigerant Piping to Remote Condenser(s) (206-271 Sizes Shown)**

### 30HXA PIPING, VALVE, AND FAN CYCLING PRESSURE SWITCH INSTALLATION

**Relieve Pressure and Recover Refrigerant** — The 30HXA units are shipped from the factory with a holding charge of nitrogen or R-134a. Before opening the refrigerant system, relieve system pressure and recover system refrigerant through the access fitting on the cooler.

**30HXA Refrigerant Piping (See Fig. 14A and 14B)** — When running the refrigerant piping from the 30HXA unit to the remote condenser(s), avoid excessive pressure drops. *Minimizing line pressure drop is critical to the proper operation of the unit expansion device.* The pressure drop using R-134a refrigerant is different than when using R-22 refrigerant. See Tables 2 and 3 for an example for a 2 F (1.1 C) pressure drop in saturated temperature in the discharge (hot gas) line and liquid line, respectively. Refer to Fig. 15 and 16 for line sizing information for the discharge and liquid lines for 30HXA (R-134a) units.

**Table 2 — Discharge Line 2 F (1.1 C) Drop in Saturated Temperature Example**

SATURATED DISCHARGE TEMP		PRESSURE			
		R-134a		R-22	
F	C	Psig	kPa	Psig	kPa
126	52.2	187.5	1293	281.6	1942
124	51.1	182.0	1255	274.3	1891
Δ PRESSURE		5.5	38	7.3	51

**Table 3 — Liquid Line 2 F (1.1 C) Drop in Saturated Temperature Example**

SATURATED LIQUID TEMP		PRESSURE			
		R-134a		R-22	
F	C	Psig	kPa	Psig	kPa
100	37.8	124.3	857	195.9	1351
98	36.7	120.1	828	190.2	1311
Δ PRESSURE		4.2	29	5.7	40

An inverted trap should be installed in the discharge line at the condenser to prevent refrigerant from flowing back to the oil separator and compressor during unit shutdown. The inverted trap must extend to the height of the condenser. The discharge line must be brazed to the back-pressure valve located on the top of the oil separator. Be sure to wrap back-pressure valve when brazing discharge line to avoid damaging the valve. Liquid line solenoid valves with manual lift stems should be installed between the field-supplied liquid line filter driers and the unit. For proper electrical connections see Fig. 17.

**30HXA Low-Ambient Considerations** — In installations where outdoor ambient temperatures may be below 34 F (1.1 C), it is recommended that inhibited ethylene glycol or other suitable corrosion-resistant antifreeze solution be used in the cooler loop to prevent cooler freeze-up.

If valves are installed in the liquid lines, it is recommended that field-supplied pressure relief valves be installed in each liquid line and the pressure setting should be 320 psig (2205 kPa). Most local codes require that the relief valves be vented directly outdoors. The vent must not be smaller than the relief valve outlet.

**Fan-Cycling Pressure Switches** — In order to provide proper head-pressure control in 30HXA units, install fan-cycling pressure switches in each circuit in the liquid line between the separate condenser unit and expansion device. Two switches are shipped from the factory with the 30HXA units. Refer to

the Carrier 09DK condenser installation literature for details on the location and installation of the switches. Since the 30HXA is an HFC-134a unit, switch selection is based on R-134a refrigerant pressures.

**NOTES:** The switches that are standard with the Carrier 09DK condensers are designed for R-22 operation and must *not* be used. Instead use the switches shipped with the chiller (Part No. HK02YB097). Switches open at 97 psig ( $\pm 10$  psi), and close at 185 psig ( $\pm 10$  psi).

**Back-Pressure Valve, 30HXA Units (See Fig. 18A and 18B)** — The 30HXA back-pressure valves are supplied with an integral mounting flange. The valves mount on the 30HXA oil separator. This reduces brazing when installing the discharge piping, and allows the installer to orient the valve in any desired position.

**IMPORTANT:** The back-pressure valves are *not* mounted to the 30HXA chiller at the factory. They are packaged and supplied attached to the unit shipping skid. These valves *must* be installed at the time of chiller installation. Failure to install the back-pressure valves will result in improper unit operation.

Complete the steps below to install the flanged back-pressure valves on the 30HXA chiller before running discharge piping. Follow these steps for both refrigerant circuits.

1. Be sure to remove nitrogen charge or properly recover refrigerant charge before removing the blank-off plate. Remove the blank-off plate from the mating flange on top of the oil separator by removing the screws from the flange. See Fig. 18A for location.
2. Using the screws that were removed in Step 1, bolt the flanged back-pressure valve to the mating flange on top of the oil separator. An O-ring is included in the box with the back-pressure valve for sealing the flange.  
The valve may be oriented in any desired position in to make discharge piping easier. Install pipe hangers where needed. Make sure no weight or stress is placed on the back-pressure valve.
3. Once the back-pressure valve has been mounted to the mating flange, and the piping is properly supported, a field-supplied 1/4-in. (6.4 mm) copper line *must* be run from the 1/4-in. NPT port on the back-pressure valve cap to the 1/4-in. SAE flare fitting on the motor cooling line. The equalizer line must be installed in order for the unit to function properly.  
**NOTE:** A ball valve can be installed in the equalizer line to facilitate servicing.
4. After mounting the back-pressure valve to the unit, properly supporting it, and running the 1/4-in. equalizer line, the discharge piping may be installed.
5. Repeat Steps 1-4 for the other refrigerant circuit.

**IMPORTANT:** Be sure that any Schrader core installed in the fittings is removed prior to equalizer line installation. Failure to remove core will result in the unit not functioning properly.

The 30HXA206-271 machines have two back pressure valves on circuit A. The equalizer line should connect to the 1/4-in. NPT ports on each valve then tee together and run to the 1/4-in. SAE flare tee provided in the circuit A economizer transducer connection. The discharge piping from each valve should tee together as close to the machine as possible. See Fig. 18B.

**Evacuation and Dehydration** — Because the 30HXA systems use polyolester oil, which can absorb moisture, it is important to minimize the amount of time that the system interior is left exposed to the atmosphere. Minimizing the exposure time of the oil to the atmosphere will minimize the amount of moisture that needs to be removed during evacuation.

Once all of the piping connections are complete, leak test the unit and then pull a deep dehydration vacuum. Connect the vacuum pump to the charging valve at the bottom of the oil separator *and* to the liquid line service valve. For best results, it is recommended that a vacuum of at least 500 microns (0.5 mm Hg) be obtained. Afterwards, to ensure that no moisture is present in the system, perform a standing vacuum-rise test.

With the unit in deep vacuum (500 microns or less), isolate the vacuum pump from the system. Observe the rate-of-rise of the vacuum in the system. If the vacuum rises by more than 50 microns in a 30-minute time period, then continue the dehydration process. Maintain a vacuum on the system until the standing vacuum requirement is met. This will ensure a dry system.

By following these evacuation and dehydration procedures, the amount of moisture present in the system will be minimized. It is required that replaceable core liquid line filter driers be installed between the condenser(s) and the expansion devices to capture any foreign debris and provide additional moisture removal capacity. Be sure to consider the pressure drop of the filter drier when determining piping requirements. The factory-supplied strainer may be removed to reduce pressure drop provided the filter drier is located as close to the unit as possible.

For further 30HXA piping instructions, proceed to the section titled Install Pressure Relief Refrigerant Vent Piping, page 23.

### 30HXC PIPING AND VALVE INSTALLATION

**30HXC Condenser Connections** — The inlet fluid connection is always the lower of the 2 condenser connections. A

screen strainer with a minimum of 20 mesh be installed ahead of the condenser inlet (within 10 ft [3.05 m]) to prevent debris from damaging the internal condenser tubes.

The outlet water connection is the upper connection of the 2 connections. The condenser has victaulic nozzles to connect field-supplied piping. Plan the piping arrangement in accordance with good piping practices and so that the piping does not cross in front of the condenser head. Use flexible connections on the condenser piping to reduce vibration transmission. Offset the piping to permit condenser head removal for maintenance purposes. Install pipe hangers where needed. Make sure no weight or stress is placed on the water nozzle.

#### **▲ CAUTION**

Remove any sensors on the condenser nozzles before welding connecting piping. Reinstall after welding is complete. Failure to remove these devices may cause unit damage. Heads are cast iron, welding is **not** recommended.

Provide openings in water piping for pressure gages and thermometers (if used). These openings should be 5 to 10 pipe diameters from the unit water nozzles. For thorough mixing and temperature stabilization, wells in the leaving water pipe should extend at least 2 in. (50 mm) into the pipe.

Although condenser has an air vent, it is recommended that a field-supplied air vent be installed in the system to facilitate servicing. Field-supplied shut-off and balancing valves should also be installed to facilitate servicing and flow balancing. Locate valves in inlet and outlet lines as close to the chiller as possible. Locate air vents at the highest point of the system loop. See Fig. 13.

Provide drain connections at all low points in the loop to permit complete system drainage.

**IMPORTANT:** Before starting the unit, be sure all of the air has been purged from the system.

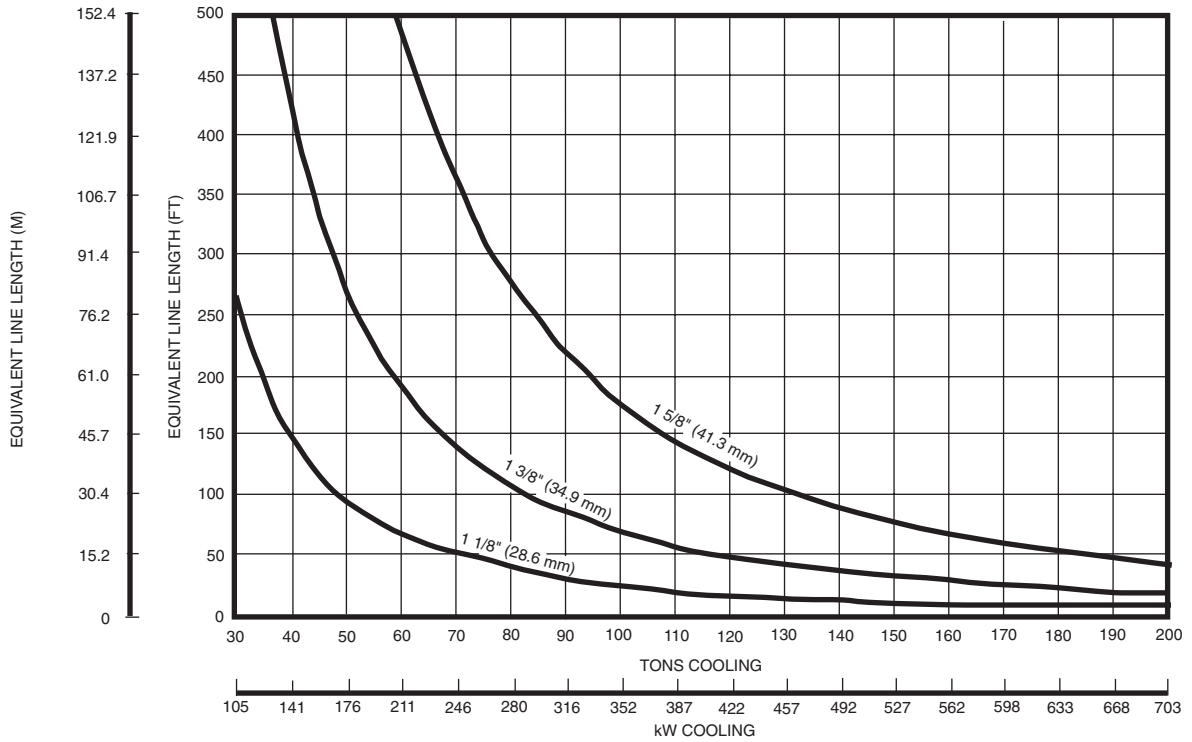

**NOTES:**

1. Values are for a 2° F (1.1° C) pressure drop at 125 F (51.7 C) saturated discharge temperature, and 105 F (40.6 C) liquid refrigerant temperature.
2. Size each circuit separately.

**Fig. 15 — R-134a Liquid Line Sizing, 30HXA Units**

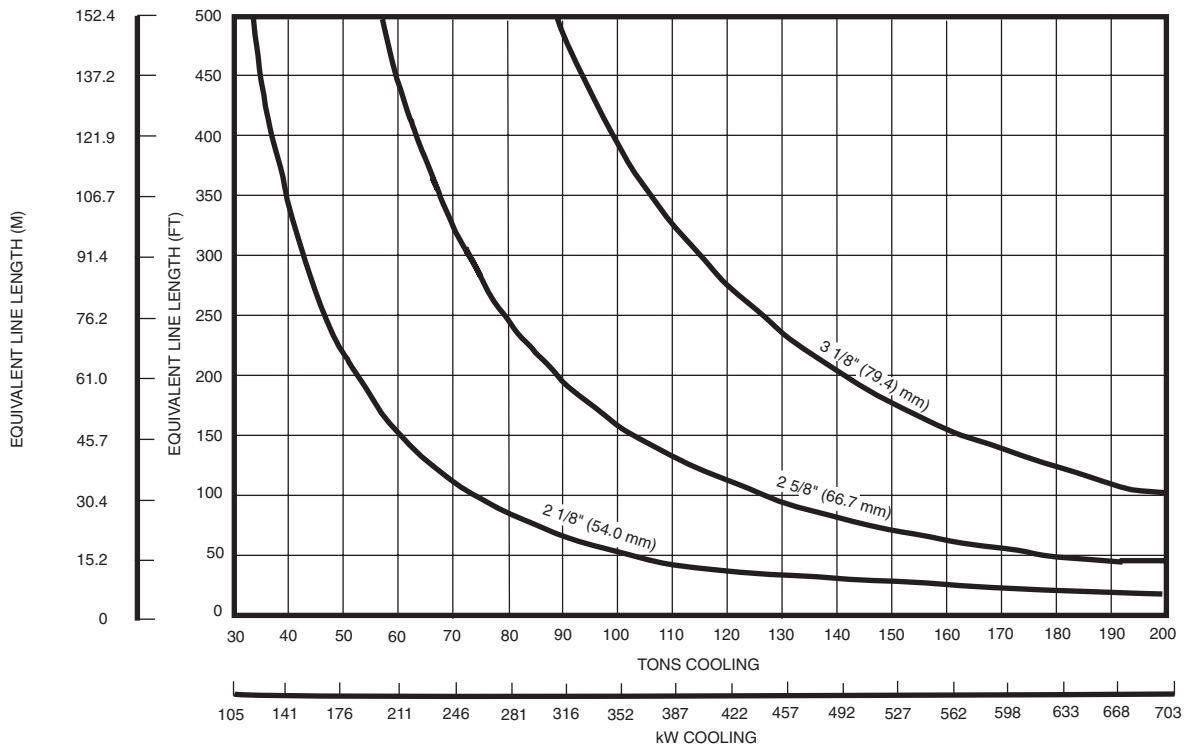

**NOTES:**

1. Values are for a 2° F (1.1° C) pressure drop at 125 F (51.7 C) saturated discharge temperature, and 105 F (40.6 C) liquid refrigerant temperature.
2. Size each circuit separately.

**Fig. 16 — R-134a Discharge Line Sizing, 30HXA Units**

**STANDARD POWER**

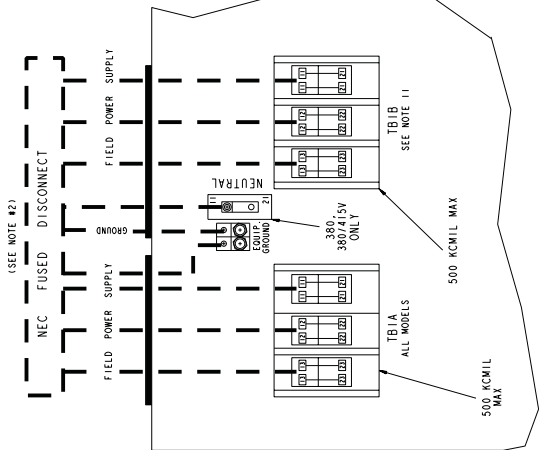

**NON-FUSED DISCONNECT OPTION**

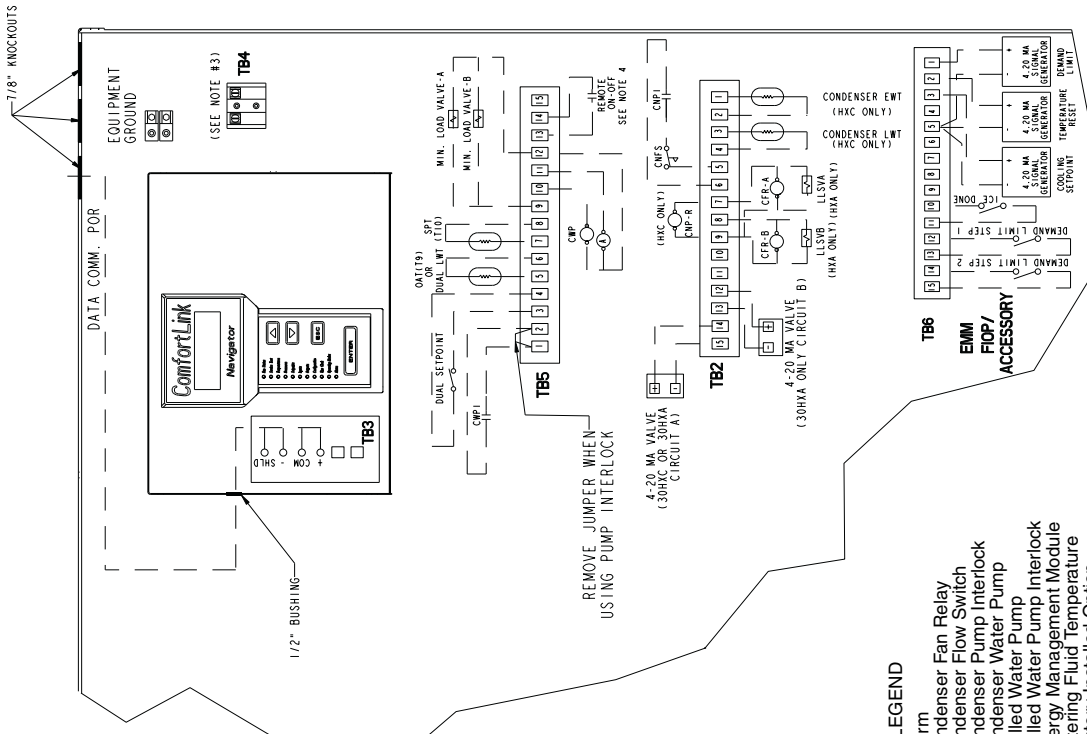
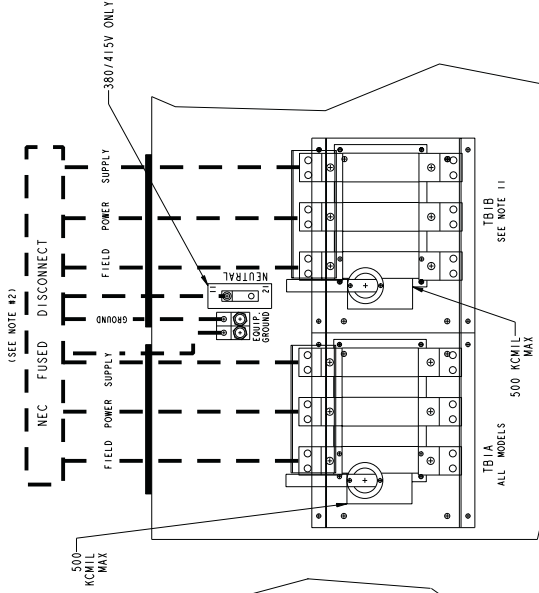

**LEGEND**

- A Alarm
- CFR Condenser Fan Relay
- CNFS Condenser Flow Switch
- CNPI Condenser Pump Interlock
- CWP Condenser Water Pump
- CWPI Chilled Water Pump
- EMM Chilled Water Pump Interlock
- EWT Energy Management Module
- FLOP Factory-Installed Option
- LLSV Liquid Line Solenoid Valve
- LWT Leaving Fluid Temperature
- OAT Outdoor-Air Temperature
- SPT Space Temperature
- TB Terminal Block
- Field Power Wiring
- Field Control Wiring
- Factory-Installed Wiring

- NOTES:**
- Factory wiring is in accordance with National Electrical Code (NEC). Field modifications or additions must be in compliance with all applicable codes.
  - Wiring for main field supply must be rated 75° C minimum. Use copper for all units. Maximum incoming wire size for each terminal block is 500 kcmil.
  - Power for control circuit should be supplied from a separate source (except 380/415-v units) through a field-supplied disconnect with 15-amp maximum protection for 115-volt control circuits and 15-amp maximum protection for 230-volt control circuit. Connect control circuit power to terminals 1 and 2 of TB4. Control circuit conductors for all units must be copper only. Control circuit power is factory wired for 380/415-v units.
  - Terminals 13 and 14 of TB5 are for field external connection for remote on-off. The contacts must be capable of handling a 24-vac load up to 50 mA. Control relay should be located in unit control box.
  - Terminals 1 and 2 of TB5 are for chilled water pump interlock (CWP) functions. If added, chilled water pump interlock contacts must be wired in series with flow switch contacts. The contacts must be rated for dry circuit application capable of handling a 24-vac to 50 mA load. Chilled water flow switch (CWFS) is factory installed.
  - Terminals 10 and 12 of TB5 are for control of chilled water pump starter. The maximum load allowed for the chilled water pump relay is 75 va sealed, 360 va inrush at 115 or 230 volt. Field power supply is not required.
  - Terminals 11 and 12 of TB5 are for alarm relay. The maximum load allowed for the alarm relay is 75 va sealed, 360 va inrush at 115 or 230 volt. Field power supply is not required.
  - Terminals 7 and 9 of TB2 are for condenser water pump (HXC only) or circuit A condenser fan contactor (HXA only). Terminals 8 and 9 of TB2 are for circuit B condenser fan contactor (HXB only) or liquid line solenoid valves (factory wired 30HXC brine). The maximum load allowed is 75 va sealed 360 va inrush at 115 or 230 volt. Separate field power supply is not required. Liquid line solenoid valves (30HXA only) must be connected in parallel with condenser fan contactors as shown.
  - Terminals 5 and 6 of TB2 are for condenser flow switch (CNFS) and/or condenser pump interlock (CNPI). The contacts must be rated for dry circuit application capable of handling a 24-vac load up to 50 mA.
  - Make appropriate connections to TB6 as shown for Energy Management Board options. The contacts for demand limit and ice done options must be rated for dry circuit application capable of handling a 24-vac load up to 50 mA.
  - TB1B supplied on 30HXA186 208/230-v, y-delta, 30HXA206-271, 208/230, 230-v y-delta and by special order.

**Fig. 17 — Field Wiring, 30HXA, C076-271**

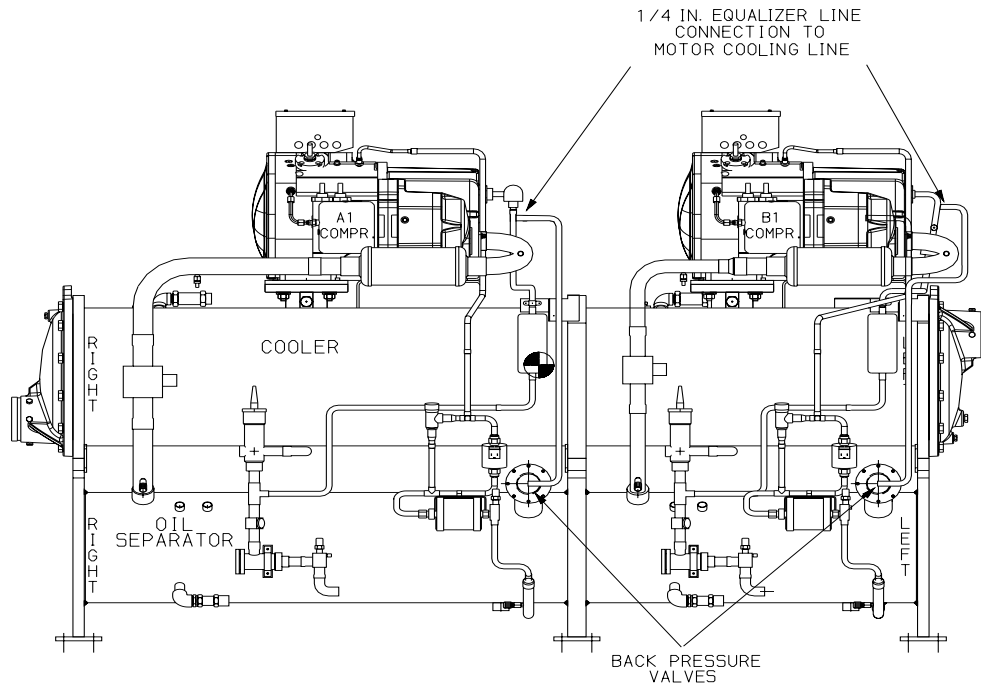

**Fig. 18A — 30HXA Units Back Pressure Valve Equalizer Line Connection (076-186 Sizes Shown)**

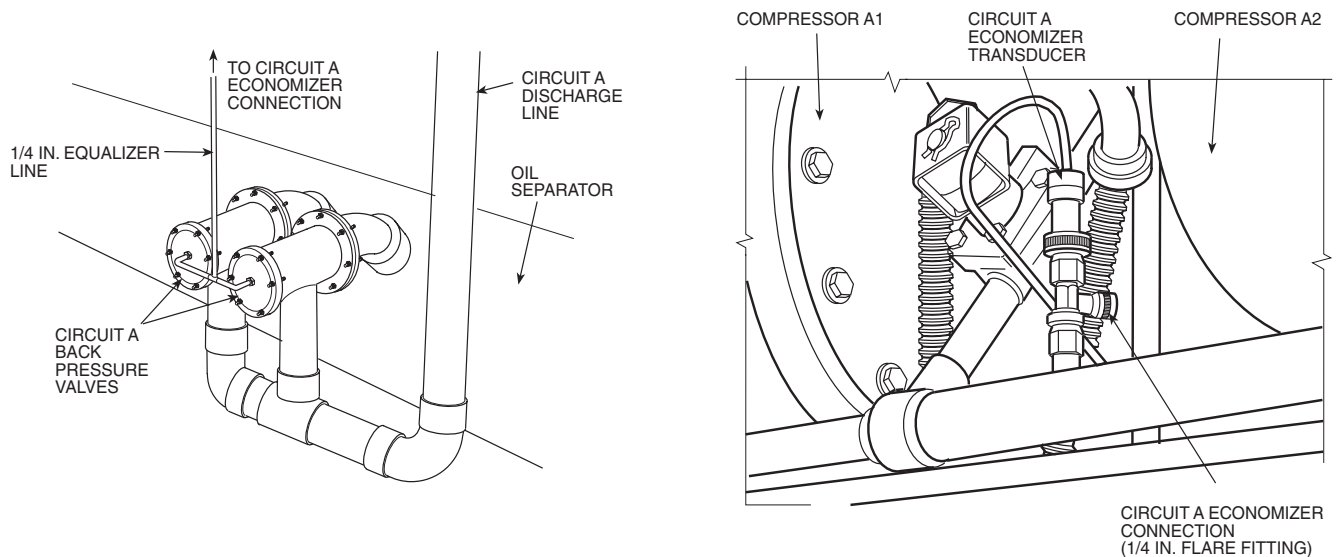

**Fig. 18B — 30HXA206-271 Back Pressure Valve Equalizer Line Connection (Circuit A)**

**30HXC Condenser Temperature Regulating Valve** — For installations where entering condensing water temperature could be below 70 F (21.1 C), a field-supplied leaving water temperature regulating valve is required. Operation below 70 F (21.1 C) without this valve may cause the unit to shut down on low oil pressure alarms.

**NOTE:** This valve should be a temperature-controlled valve (DO NOT USE a pressure-controlled valve) which controls to 80 F (26.7 C) leaving water temperature. A valve that can be controlled by a 4 to 20 mA signal is also supported by the *ComfortLink™* control system. Figure 19 shows the installation details for the regulating valve.

**IMPORTANT:** A separate, field-supplied power supply must be used with the 4 to 20 mA valve. Failure to use a separate power supply may result in damage to the electronic chiller components.

**IMPORTANT:** On brine applications where leaving cooler water is less than 34 F (1.1 C), a minimum water flow of 0.75 gpm/ton (0.14 L/s per kW) should be maintained through the condenser at all times.

**INSTALL PRESSURE RELIEF REFRIGERANT VENT PIPING** — The low side relief valves on all units are provided with 3/4-in. female NPT connections, and are located on top of the cooler shell. See Fig. 2-9. There are 2 relief valves for the cooler; one on each circuit. Make the vent connection to the low side relief valve by installing a male NPT to copper OD braze adapter. Braze a 90 degree short-radius elbow to the adapter. This will allow enough space to make vent connections to the elbow.

The 30HXA high side relief valves are provided with a 5/8-in. SAE (Society of Automotive Engineers, U.S.A.) flare connection. The 30HXC high side relief valves are provided with a 3/4-in. female NPT flare connection, and are located on the bottom of the condenser shell.

There are 2 relief valves for the oil separator (30HXA) or condenser (30HXC); one for each circuit. Most local codes require that these devices be piped to the outside. If vent piping is required by local codes, these connections have been provided to aid in the connection of vent piping in accordance with ASHRAE 15 (American Society of Heating, Refrigeration, and Air Conditioning Engineers), Safety Code for Mechanical Refrigeration. If vent piping is required, do not restrict the vent flow in any way.

NOTE: When accessory suction service valve kit is installed, there is one additional high-side pressure relief valve per compressor. These are located on the discharge line between the muffler and the discharge shut-off valve. Pipe these valves per local codes.

**Step 4 — Make Electrical Connections** — The electrical characteristics of the available power supply must agree with the unit nameplate rating. Supply voltage must be within the limits shown.

FIELD POWER CONNECTIONS (See Fig. 17) — All power wiring must comply with applicable local and national codes. Install field-supplied, branch circuit fused disconnect(s) of a

type that can be locked off or open. Disconnect(s) must be located within sight and readily accessible from the unit in compliance with NEC Article 440-14. See Tables 4A and 4B for unit electrical data. See Tables 5A and 5B for compressor electrical data.

**IMPORTANT:** The 30HX units have a factory-installed option available for a non-fused disconnect for unit power supply. If the unit is equipped with this option, all field power wiring should be made to the non-fused disconnect since no terminal blocks are supplied.

All units have a single location for power entry to simplify the field power wiring. Maximum wire size that the unit terminal block or non-fused disconnect will accept is 500 kcmil (except units equipped with 250 amp non-fused disconnects which will accept a maximum wire size of 300 kcmil).

All units require at least one field-supplied power supply. Refer to Fig. 17 for a list of units that require 2 field-supplied power supplies. Units that require 2 power supplies are listed under TB1B in the Standard Power and Non-Fused Disconnect Option sections of Fig. 17.

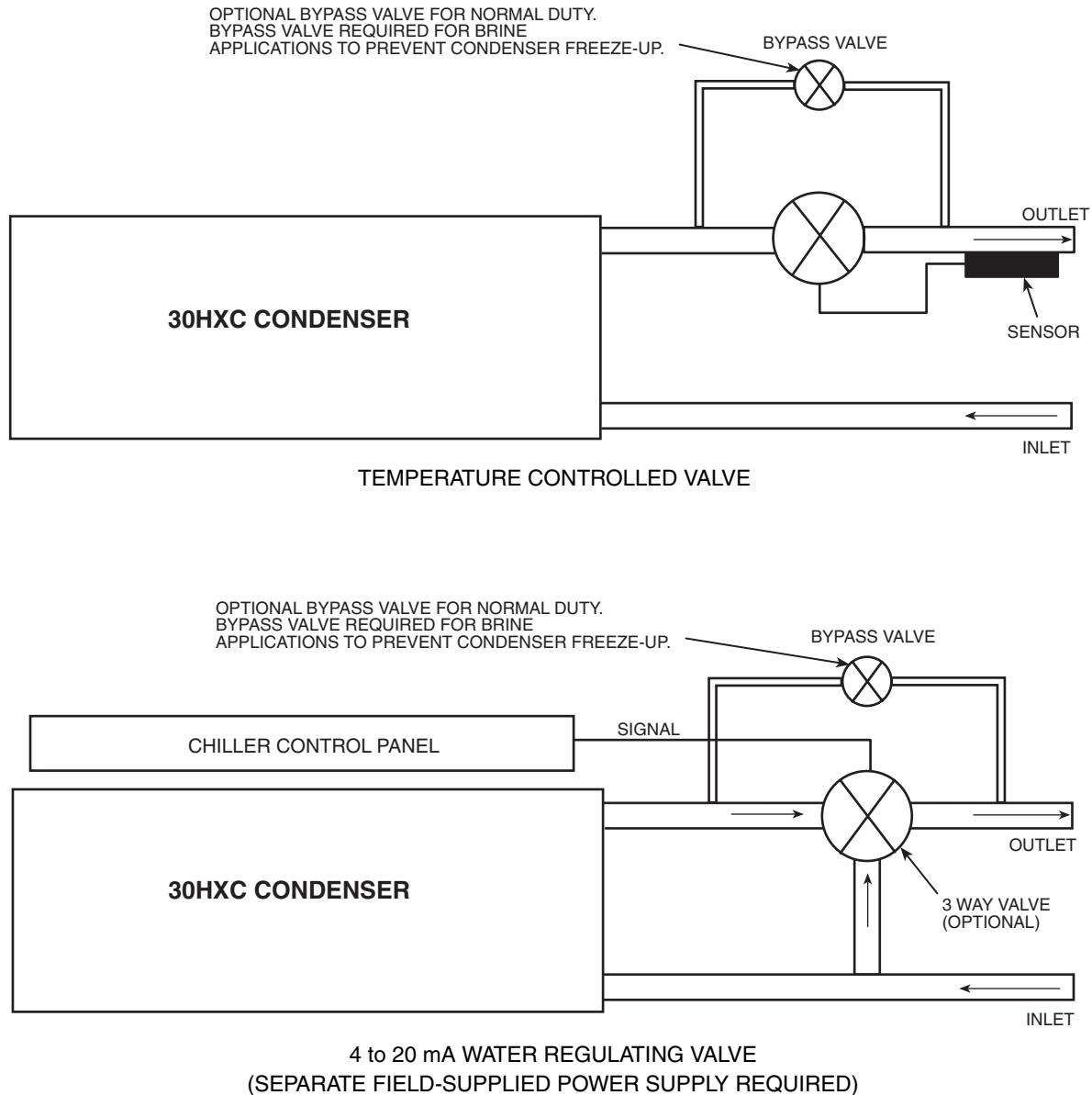

**Fig. 19 — Condenser Temperature Regulating Valve Installation**

**FIELD CONTROL POWER CONNECTIONS** (See Fig. 17) — Units with a power supply of 230 (60 Hz), 208/230, 460, 575-3-60, require a separate 115-1-60 control circuit power supply. Units with a 380/415-3-50 power supply have factory pre-wired 230-1-50 control circuit power. A separate power supply is NOT required for these units. All other units require a separate 230 v control circuit power supply. Field control power connections are made at terminals 1 and 2 of TB4.

**NOTE:** Units with a 380/415 v main power supply do NOT require a separate field-supplied control power supply. These units have factory pre-wired control power.

Terminals TB5-1 and TB5-2 are provided for field installation of a chilled water (fluid) pump interlock (CWPI). Contacts must be capable of handling a 24-vac load up to 50 mA.

An accessory remote on-off switch can be wired into TB5-13 and TB5-14. See Fig. 17 for remote on-off and CWPI wiring. Contacts must be capable of handling a 24-vac to 50 mA.

### ▲ CAUTION

Do not use interlocks or other safety device contacts connected between TB5 terminals 13 and 14 as remote on-off. Connection of safeties or other interlocks between these 2 terminals will result in an electrical bypass if the enable-off-remote contact switch is in the Enable position. If remote on-off unit control is required, a field-supplied relay must be installed in the unit control box and wired as shown in Fig. 17. Failure to wire the remote on-off as recommended will result in tube freeze damage.

Terminals 11 and 12 of TB5 have been provided for a field-supplied remote alarm (ALM). If an audible alarm is installed, an alarm shutoff is also recommended. Power for a field-supplied relay coil is factory-supplied but is limited to 75 va sealed, 360 va inrush. See Fig. 17.

Terminals 10 and 12 of TB5 have been provided for a field-supplied chilled water (fluid) pump relay (CWP). Power for the field-supplied relay coil is factory supplied, but is limited to 75 va sealed and 360 va inrush. See Fig. 17.

Terminals 7 and 9 of TB2 has been provided for a field-supplied Circuit A fan control relay for the remote condenser (30HXA) or a condenser pump relay (30HXC). Use relays with a maximum coil rating of 75 va. Terminals 8 and 9 of TB2 have been provided for a field-supplied Circuit B fan control relay for a remote condenser (30HXA only). Use relays with a coil rating of 75 va. A separate field power supply is NOT required. Maximum Load Allowed for the fan/condenser pump relays is 75 va sealed, 360 va inrush at 115 or 230 volts. See Fig. 17.

**CONDENSER FAN CONTROL FOR CONDENSER UNITS USED WITH 30HXA UNITS** — The Main Base Board provides two control outputs for energizing and deenergizing remote fan contactors. If desired, wire the Circuit A main fan contactor between terminals 7 and 9 of TB2. The Circuit B main fan contactor may be wired between terminals 8 and 9 of TB2. This will cause the main fans to be on when the compressors are on. Refer to Fig. 17 for wiring details.

**NOTE:** The fan contactor relays are pre-wired to unit control power. A separate power supply is NOT required. The maximum load allowed for these relays is 75 va sealed, 360 va inrush at 115 or 230 volts.

**Step 5 — Install Accessories** — Several optional control accessories are available to provide the following features:

- Control transformer
- Cooler pump interlock
- Cooler pump control
- Remote enhanced display
- Remote alarm
- Remote on-off
- Pulldown control
- Occupancy scheduling
- Demand limit control (requires EMM [Energy Management Module])
- Temperature reset (4 to 20 mA, requires EMM module)
- Dual set point control
- Condenser water sensors
- Carrier Comfort Network (CCN)
- Energy management module (EMM)

Refer to Controls, Start-up, Operation, Service, and Troubleshooting literature and separate accessory installation instructions for additional information.

**30HXA LOW-AMBIENT OPERATION** — If outdoor ambient operating temperatures below 60 F (15 C) are expected, refer to separate Carrier 09DK condenser unit installation instructions for low-ambient operation using accessory Motormaster® V control minimum load accessories also required.

**MINIMUM LOAD ACCESSORY** — If minimum load accessory is required, use the appropriate package. Refer to unit Price Pages or contact your local Carrier representative for more details. For installation details, refer to separate installation instructions supplied with the accessory package.

**MISCELLANEOUS ACCESSORIES** — For applications requiring special accessories, the following packages are available: control power transformer, sound reduction enclosure, sound blanket, external vibration isolation, expanded display, and temperature reset sensor. Refer to individual accessory installation instructions for installation details.

**Step 6 — Leak Test Unit** — There are several of Swage-Lok fittings used on the refrigerant piping. If a leak is detected at any of these fittings, tighten outside nut 1/8 turn.

### ▲ CAUTION

DO NOT OVERTIGHTEN THESE FITTINGS. Overtightening will result in the tube being crushed and will cause a refrigerant system leak.

There are several O-ring face seal fittings used in the refrigerant and lubrication piping. If a leak is detected at any of these fittings, tighten the O-ring face seal nut to 85 to 118 in.-lb (9.5 to 12.4 Nm). Always use a back up wrench when tightening the O-ring face seal nut.

**30HXC UNITS** — These units are shipped from the factory with a full charge of R-134a or a nitrogen holding charge (see Tables 1A and 1B). Perform a leak test to ensure that leaks have not developed during unit shipment. Dehydration of the system is not required unless the entire refrigerant charge has been lost.

**30HXA UNITS** — These units are shipped with a holding charge of R-134a or nitrogen. Leak test and dehydrate the complete system (including both field and factory installed piping).

**NOTE:** Proper dehydration of 30HXA units is important to ensure that no moisture is left in the system. Refer to the separate section on Evacuation and Dehydration on page 20.

*Copy continued on page 38.*

Table 4A — Unit Electrical Data, 30HXC Units

UNIT 30HXC	UNIT VOLTAGE			POWER SUPPLY QTY. REQD.	NO. POWER SUPPLY CONDUCTORS	UNIT VOLTAGE						CONTROL CIRCUIT			
	V-Hz (3 Ph)	Supplied				MCA	MOCP	ICF		Rec Fuse Size		V-Hz (Single Ph)	Supplied		MCA and MOCP
		Min	Max					XL	WD	XL	WD		Min	Max	
076	230-60	207	253	1	3	198.7	250	—	297.3	—	225	115-60	104	127	15
	208/230-60	187	253	1	3	220.7	300	—	307.1	—	250	115-60	104	127	15
	460-60	414	506	1	3	99.7	125	374.3	148.3	125	125	115-60	104	127	15
	575-60	518	633	1	3	79.7	110	299.4	118.4	90	90	115-60	104	127	15
	380-60	342	418	1	3	120.8	150	418.7	168.7	150	150	230-60	207	254	15
	380/415-50	342	440	1	3	125.6	175	399.8	164.8	150	150	230-50	198	254	15
	230-50	207	253	1	3	207.2	250	—	266.1	—	250	230-50	207	254	15
086	230-60	207	253	1	3	221.7	300	—	297.3	—	250	115-60	104	127	15
	208/230-60	187	253	1	3	246.4	350	—	307.1	—	300	115-60	104	127	15
	460-60	414	506	1	3	111.3	150	374.3	148.3	125	125	115-60	104	127	15
	575-60	518	633	1	3	88.9	125	299.4	118.4	100	100	115-60	104	127	15
	380-60	342	418	1	3	134.8	175	418.7	168.7	175	175	230-60	207	254	15
	380/415-50	342	440	1	3	140.4	200	478.8	189.8	175	175	230-50	198	254	15
	230-50	207	253	1	3	231.9	300	—	305.1	—	300	230-50	207	254	15
096	230-60	207	253	1	3	251.3	350	—	344.3	—	300	115-60	104	127	15
	208/230-60	187	253	1	3	279.2	400	—	354.1	—	350	115-60	104	127	15
	460-60	414	506	1	3	126.2	175	449.3	172.3	150	150	115-60	104	127	15
	575-60	518	633	1	3	100.8	150	359.4	137.4	125	125	115-60	104	127	15
	380-60	342	418	1	3	152.7	225	501.7	194.7	175	175	230-60	207	254	15
	380/415-50	342	440	1	3	157.9	225	561.8	215.8	200	200	230-50	198	254	15
	230-50	207	253	1	3	260.7	350	—	347.1	—	300	230-50	207	254	15
106	230-60	207	253	1	3	285.6	400	—	395.3	—	350	115-60	104	127	15
	208/230-60	187	253	1	3	317.4	450	—	405.1	—	400	115-60	104	127	15
	460-60	414	506	1	3	143.3	200	529.3	197.3	175	175	115-60	104	127	15
	575-60	518	633	1	3	114.5	175	423.4	158.4	150	150	115-60	104	127	15
	380-60	342	418	1	3	173.6	250	589.7	222.7	200	200	230-60	207	254	15
	380/415-50	342	440	1	3	178.1	250	660.8	246.8	225	225	230-50	198	254	15
	230-50	207	253	1	3	294.2	450	—	397.1	—	350	230-50	207	254	15
116	230-60	207	253	1	3	304.1	450	—	413.7	—	350	115-60	104	127	15
	208/230-60	187	253	1	3	337.9	500	—	425.6	—	400	115-60	104	127	15
	460-60	414	506	1	3	152.6	225	538.6	206.6	175	175	115-60	104	127	15
	575-60	518	633	1	3	121.9	175	430.8	165.8	150	150	115-60	104	127	15
	380-60	342	418	1	3	184.8	250	600.9	233.9	225	225	230-60	207	254	15
	380/415-50	342	440	1	3	190.0	250	672.7	258.7	225	225	230-50	198	254	15
	230-50	207	253	1	3	313.9	450	—	416.8	—	400	230-50	207	254	15
126	230-60	207	253	1	3	327.7	450	—	437.4	—	400	115-60	104	127	15
	208/230-60	187	253	1	3	364.2	500	—	451.9	—	450	115-60	104	127	15
	460-60	414	506	1	3	164.5	225	550.5	218.5	200	200	115-60	104	127	15
	575-60	518	633	1	3	131.4	175	440.3	175.3	150	150	115-60	104	127	15
	380-60	342	418	1	3	199.1	250	615.2	248.2	225	225	230-60	207	254	15
	380/415-50	342	440	1	3	204.0	300	686.7	272.7	250	250	230-50	198	254	15
	230-50	207	253	1	3	337.0	450	—	439.9	—	400	230-50	207	254	15
136	230-60	207	253	1	3	366.7	500	—	497.4	—	450	115-60	104	127	15
	208/230-60	187	253	1	6	407.4	600	—	511.9	—	500	115-60	104	127	15
	460-60	414	506	1	3	183.8	250	645.5	248.5	225	225	115-60	104	127	15
	575-60	518	633	1	3	147.1	200	536.3	199.3	175	175	115-60	104	127	15
	380-60	342	418	1	3	222.8	300	720.2	282.2	300	300	230-60	207	254	15
	380/415-50	342	440	1	3	230.2	300	796.7	307.7	300	300	230-50	198	254	15
	230-50	207	253	1	6	380.3	500	—	495.9	—	450	230-50	207	254	15
146	230-60	207	253	1	6	394.1	500	—	524.9	—	450	115-60	104	127	15
	208/230-60	187	253	1	6	437.9	600	—	542.4	—	500	115-60	104	127	15
	460-60	414	506	1	3	197.5	250	659.2	262.2	225	225	115-60	104	127	15
	575-60	518	633	1	3	158.1	225	547.3	210.3	200	200	115-60	104	127	15
	380-60	342	418	1	3	239.5	350	736.9	298.9	300	300	230-60	207	254	15
	380/415-50	342	440	1	3	246.3	350	812.8	323.8	300	300	230-50	198	254	15
	230-50	207	253	1	6	407.1	600	—	522.7	—	500	230-50	207	254	15

**Table 4A — Unit Electrical Data, 30HXC Units (cont)**

UNIT 30HXC	UNIT VOLTAGE			POWER SUPPLY QTY. REQD.	NO. POWER SUPPLY CONDUCTORS	UNIT VOLTAGE						CONTROL CIRCUIT			
	V-Hz (3 Ph)	Supplied				MCA	MOCP	ICF		Rec Fuse Size		V-Hz (Single Ph)	Supplied		MCA and MOCP
		Min	Max					XL	WD	XL	WD		Min	Max	
161	230-60	207	253	1	6	398.7	600	—	574.8	—	500	115-60	104	127	15
	208/230-60	187	253	1	6	443.0	600	—	590.6	—	600	115-60	104	127	15
	460-60	414	506	1	3	200.1	300	756.2	287.2	250	250	115-60	104	127	15
	575-60	518	633	1	3	159.9	225	604.9	229.9	200	200	115-60	104	127	15
	380-60	342	418	1	3	242.2	350	843.2	325.2	300	300	230-60	207	254	15
	380/415-50	342	440	1	3	249.0	350	944.2	358.2	300	300	230-50	198	254	15
	230-50	207	253	1	6	411.3	600	—	577.7	—	500	230-50	207	254	15
171	230-60	207	253	1	6	428.4	600	—	604.5	—	500	115-60	104	127	15
	208/230-60	187	253	1	6	476.0	700	—	623.6	—	600	115-60	104	127	15
	460-60	414	506	1	3	215.0	300	771.1	302.1	250	250	115-60	104	127	15
	575-60	518	633	1	3	171.8	250	616.8	241.8	200	200	115-60	104	127	15
	380-60	342	418	1	3	260.2	350	861.2	343.2	300	300	230-60	207	254	15
	380/415-50	342	440	1	3	266.6	350	961.8	375.8	300	300	230-50	198	254	15
	230-50	207	253	1	6	440.4	600	—	606.8	—	500	230-50	207	254	15
186	230-60	207	253	1	6	462.3	600	—	638.5	—	600	115-60	104	127	15
	208/230-60	187	253	1	6	513.7	700	—	661.3	—	600	115-60	104	127	15
	460-60	414	506	1	3	232.0	300	788.1	319.1	300	300	115-60	104	127	15
	575-60	518	633	1	3	185.4	250	630.4	255.4	225	225	115-60	104	127	15
	380-60	342	418	1	3	280.8	400	881.8	363.8	350	350	230-60	207	254	15
	380/415-50	342	440	1	3	289.4	400	984.6	398.6	350	350	230-50	198	254	15
	230-50	207	253	1	6	478.1	600	—	644.5	—	600	230-50	207	254	15
206	230-60	207	253	1	6	524.5	700	—	700.7	—	600	115-60	104	127	15
	208/230-60	187	253	1	6	582.8	800	—	730.4	—	700	115-60	104	127	15
	460-60	414	506	1	3	263.2	350	819.3	350.3	300	300	115-60	104	127	15
	575-60	518	633	1	3	210.4	250	655.4	280.4	250	250	115-60	104	127	15
	380-60	342	418	1	3	318.6	400	919.6	401.6	350	350	230-60	207	254	15
	380/415-50	342	440	1	3	326.8	450	1022.0	436.0	400	400	230-50	198	254	15
	230-50	207	253	1	6	539.8	700	—	706.2	—	600	230-50	207	254	15
246	230-60	207	253	1	6	604.1	800	—	780.3	—	700	115-60	104	127	15
	208/230-60	187	253	1	6	671.3	800	—	818.9	—	800	115-60	104	127	15
	460-60	414	506	1	3	303.2	400	859.3	390.3	350	350	115-60	104	127	15
	575-60	518	633	1	3	242.3	300	687.3	312.3	300	300	115-60	104	127	15
	380-60	342	418	1	3	367.0	450	968.0	450.0	400	400	230-60	207	254	15
	380/415-50	342	440	1	3	377.6	500	1072.8	486.8	450	450	230-50	198	254	15
	230-50	207	253	1	6	623.8	800	—	790.2	—	700	230-50	207	254	15
261	230-60	207	253	1	6	633.8	800	—	810.0	—	700	115-60	104	127	15
	208/230-60	187	253	1	6	704.3	800	—	851.9	—	800	115-60	104	127	15
	460-60	414	506	1	3	318.1	400	874.2	405.2	350	350	115-60	104	127	15
	575-60	518	633	1	3	254.2	300	699.2	324.2	300	300	115-60	104	127	15
	380-60	342	418	1	6	385.0	500	986.0	468.0	450	450	230-60	207	254	15
	380/415-50	342	440	1	6	395.2	500	1090.4	504.4	450	450	230-50	198	254	15
	230-50	207	253	1	6	652.9	800	—	819.3	—	800	230-50	207	254	15
271	230-60	207	253	1	6	667.8	800	—	843.9	—	800	115-60	104	127	15
	208/230-60	187	253	1	6	742.0	800	—	889.6	—	800	115-60	104	127	15
	460-60	414	506	1	3	335.1	400	891.2	422.2	400	400	115-60	104	127	15
	575-60	518	633	1	3	267.8	350	712.8	337.8	300	300	115-60	104	127	15
	380-60	342	418	1	6	405.6	500	1006.6	488.6	450	450	230-60	207	254	15
	380/415-50	342	440	1	6	418.0	500	1113.2	527.2	500	500	230-50	198	254	15
	230-50	207	253	1	6	690.6	800	—	857.0	—	800	230-50	207	254	15

**LEGEND**

- ICF** — Maximum Instantaneous Current Flow during start-up (the point in the starting sequence where the sum of the LRA for the start-up compressor, plus the total RLA for all running compressors is at a maximum)
- LRA** — Locked Rotor Amps
- MCA** — Minimum Circuit Ampacity (for wire sizing)
- MOCP** — Maximum Overcurrent Protection
- RLA** — Rated Load Amps
- WD** — Wye-Delta Start
- XL** — Across-the-Line Start

**NOTES:**

1. Each main power source must be supplied from a field-supplied fused electrical service with a (factory-installed or field-installed) disconnect located in sight from the unit.

2. Control circuit power must be supplied from a separate source through a field-supplied disconnect (except for 380/415-50 units). An accessory control transformer may be used to provide control circuit power from the main unit power supply.
3. Maximum incoming wire size for each terminal block is 500 kcmil.
4. Maximum allowable phase imbalance is: voltage, 2%; amps, 5%.
5. Use copper conductors only.
6. The MOCP is calculated as follows:

MOCP = (2.25) (largest RLA) + the sum of the other RLAs. Size the fuse one size down from the result. The RLAs are listed on the nameplate.

The recommended fuse size in amps (RFA) is calculated as follows:  
RFA = (1.50) (largest RLA) + the sum of the other RLAs. Size the fuse one size up from the result. The RLAs are listed on the nameplate.



Table 4B — Unit Electrical Data, 30HXA Units

UNIT 30HXA	UNIT VOLTAGE			POWER SUPPLY QTY. REQD.	NO. POWER SUPPLY CONDUCTORS	UNIT VOLTAGE						CONTROL CIRCUIT			
	V-Hz (3 Ph)	Supplied				MCA	MOCP	ICF		Rec Fuse Size		V-Hz (Single Ph)	Supplied		MCA and MOCP
		Min	Max					XL	WD	XL	WD		Min	Max	
076	230-60	207	253	1	3	291.2	400	—	436.4	—	350	115-60	104	127	15
	208/230-60	187	253	1	3	323.6	450	—	450.8	—	400	115-60	104	127	15
	460-60	414	506	1	3	146.0	200	549.9	217.9	175	175	115-60	104	127	15
	575-60	518	633	1	3	116.8	150	439.9	174.9	150	150	115-60	104	127	15
	380-60	342	418	1	3	177.1	250	614.7	247.7	200	200	230-60	207	254	15
	380/415-50	342	440	1	3	183.4	250	686.5	272.5	225	225	230-50	198	254	15
230-50	207	253	1	3	303.3	400	—	439.8	—	350	230-50	207	254	15	
086	230-60	207	253	1	3	322.8	450	—	496.4	—	400	115-60	104	127	15
	208/230-60	187	253	1	3	358.7	500	—	510.8	—	450	115-60	104	127	15
	460-60	414	506	1	3	161.9	225	644.9	247.9	200	200	115-60	104	127	15
	575-60	518	633	1	3	129.5	175	535.9	198.9	150	150	115-60	104	127	15
	380-60	342	418	1	3	196.2	250	719.7	281.7	225	225	230-60	207	254	15
	380/415-50	342	440	1	3	205.5	300	796.5	307.5	250	250	230-50	198	254	15
230-50	207	253	1	3	339.7	500	—	495.8	—	400	230-50	207	254	15	
096	230-60	207	253	1	3	365.4	500	—	562.4	—	450	115-60	104	127	15
	208/230-60	187	253	1	6	406.1	600	—	576.8	—	500	115-60	104	127	15
	460-60	414	506	1	3	183.4	250	749.9	280.9	225	225	115-60	104	127	15
	575-60	518	633	1	3	146.5	200	599.9	224.9	175	175	115-60	104	127	15
	380-60	342	418	1	3	222.1	300	835.7	317.7	300	300	230-60	207	254	15
	380/415-50	342	440	1	3	231.4	350	937.5	351.5	300	300	230-50	198	254	15
230-50	207	253	1	6	382.6	500	—	566.8	—	450	230-50	207	254	15	
106	230-60	207	253	1	6	416.9	600	—	647.4	—	500	115-60	104	127	15
	208/230-60	187	253	1	6	463.2	700	—	661.8	—	600	115-60	104	127	15
	460-60	414	506	1	3	209.2	300	884.9	323.9	250	250	115-60	104	127	15
	575-60	518	633	1	3	167.2	250	707.9	258.9	200	200	115-60	104	127	15
	380-60	342	418	1	3	253.3	350	984.7	364.7	300	300	230-60	207	254	15
	380/415-50	342	440	1	3	263.3	400	1041.5	384.5	300	300	230-50	198	254	15
230-50	207	253	1	6	435.1	600	—	619.8	—	500	230-50	207	254	15	
116	230-60	207	253	1	6	442.1	600	—	672.7	—	500	115-60	104	127	15
	208/230-60	187	253	1	6	491.3	700	—	689.9	—	600	115-60	104	127	15
	460-60	414	506	1	3	221.9	300	897.6	336.6	300	300	115-60	104	127	15
	575-60	518	633	1	3	177.4	250	718.1	269.1	225	225	115-60	104	127	15
	380-60	342	418	1	3	268.6	400	1000.0	380.0	350	350	230-60	207	254	15
	380/415-50	342	440	1	3	281.0	400	1059.2	402.2	350	350	230-50	198	254	15
230-50	207	253	1	6	464.2	700	—	648.9	—	600	230-50	207	254	15	
126	230-60	207	253	1	6	476.3	700	—	706.8	—	600	115-60	104	127	15
	208/230-60	187	253	1	6	529.2	700	—	727.8	—	600	115-60	104	127	15
	460-60	414	506	1	3	239.1	350	914.8	353.8	300	300	115-60	104	127	15
	575-60	518	633	1	3	191.0	250	731.7	282.7	225	225	115-60	104	127	15
	380-60	342	418	1	3	289.3	400	1020.7	400.7	350	350	230-60	207	254	15
	380/415-50	342	440	1	3	301.7	400	1079.9	422.9	350	350	230-50	198	254	15
230-50	207	253	1	6	498.5	700	—	683.2	—	600	230-50	207	254	15	
136	230-60	207	253	1	6	539.1	800	—	769.8	—	700	115-60	104	127	15
	208/230-60	187	253	1	6	599.1	800	—	790.8	—	700	115-60	104	127	15
	460-60	414	506	1	3	270.7	400	1014.8	385.8	350	350	115-60	104	127	15
	575-60	518	633	1	3	216.2	300	811.7	308.7	250	250	115-60	104	127	15
	380-60	342	418	1	3	327.5	450	1131.7	435.7	400	400	230-60	207	254	15
	380/415-50	342	440	1	3	343.4	500	1345.9	506.9	400	400	230-50	198	254	15
230-50	207	253	1	6	567.3	800	—	817.2	—	700	230-50	207	254	15	
146	230-60	207	253	1	6	580.3	800	—	811.0	—	700	115-60	104	127	15
	208/230-60	187	253	1	6	644.8	800	—	836.5	—	800	115-60	104	127	15
	460-60	414	506	1	3	291.3	400	1035.4	406.4	350	350	115-60	104	127	15
	575-60	518	633	1	3	232.7	300	828.2	325.2	300	300	115-60	104	127	15
	380-60	342	418	1	3	352.5	500	1156.7	460.7	400	400	230-60	207	254	15
	380/415-50	342	440	1	3	368.9	500	1371.4	532.4	450	450	230-50	198	254	15
230-50	207	253	1	6	609.3	800	—	859.2	—	700	230-50	207	254	15	
161	230-60	207	253	1	6	605.6	800	—	955.3	—	700	115-60	104	127	15
	208/230-60	187	253	1	6	672.9	1000	—	978.9	—	800	115-60	104	127	15
	460-60	414	506	1	3	304.0	450	1281.6	477.6	350	350	115-60	104	127	15
	575-60	518	633	1	3	242.9	350	1025.1	382.1	300	300	115-60	104	127	15
	380-60	342	418	1	3	368.0	500	1428.0	539.0	450	450	230-60	207	254	15
	380/415-50	342	440	1	6	384.9	500	1398.4	533.4	450	450	230-50	198	254	15
230-50	207	253	1	6	635.7	800	—	858.3	—	800	230-50	207	254	15	
171	230-60	207	253	1	6	651.5	800	—	1001.2	—	800	115-60	104	127	15
	208/230-60	187	253	1	6	723.9	1000	—	1029.9	—	1000	115-60	104	127	15
	460-60	414	506	1	3	327.0	450	1304.6	500.6	400	400	115-60	104	127	15
	575-60	518	633	1	3	261.4	350	1043.6	400.6	300	300	115-60	104	127	15
	380-60	342	418	1	6	395.9	500	1455.9	566.9	450	450	230-60	207	254	15
	380/415-50	342	440	1	6	413.2	600	1426.7	561.7	500	500	230-50	198	254	15
230-50	207	253	1	6	682.6	1000	—	905.2	—	800	230-50	207	254	15	

**Table 4B — Unit Electrical Data, 30HXA Units (cont)**

UNIT 30HXA	UNIT VOLTAGE			POWER SUPPLY QTY. REQD.	NO. POWER SUPPLY CONDUCTORS	UNIT VOLTAGE						CONTROL CIRCUIT			
	V-Hz (3 Ph)	Supplied				MCA	MOCP	ICF		Rec Fuse Size		V-Hz (Single Ph)	Supplied		MCA and MOCP
		Min	Max					XL	WD	XL	WD		Min	Max	
186	230-60	207	253	1	6	707.9	1000	—	1057.6	—	800	115-60	104	127	15
	208/230-60											115-60	104	127	15
	Ckt A	187	253	1	6	437.0	700	—	743.0	—	600				
	Ckt B	187	253	1	6	437.0	700	—	743.0	—	600				
	460-60	414	506	1	3	355.3	500	1332.9	528.9	400	400	115-60	104	127	15
	575-60	518	633	1	3	284.0	400	1066.2	423.2	350	350	115-60	104	127	15
	380-60	342	418	1	6	430.2	600	1490.2	601.2	500	500	230-60	207	254	15
	380/415-50	342	440	1	6	452.7	600	1466.2	601.2	600	600	230-50	198	254	15
	230-50	207	253	1	6	747.7	1000	—	970.3	—	1000	230-50	207	254	15
206	230-60											115-60	104	127	15
	Ckt A	207	253	1	6	468.6	700.0	—	726.8	—	600				
	Ckt B	207	253	1	3	379.8	600.0	—	743.0	—	500				
	208/230-60											115-60	104	127	15
	Ckt A	187	253	1	6	520.6	800.0	—	743.0	—	600				
	Ckt B	187	253	1	6	422.0	700.0	—	743.0	—	600				
	460-60	414	506	1	6	400.1	500.0	1377.7	573.7	450	450	115-60	104	127	15
	575-60	518	633	1	3	319.9	400.0	1102.1	459.1	400	400	115-60	104	127	15
	380-60	342	418	1	6	484.4	600.0	1544.4	655.4	600	600	230-60	207	254	15
380/415-50	342	440	1	6	505.2	700.0	1518.7	653.7	600	600	230-50	198	254	15	
230-50											230-50	207	254	15	
Ckt A	207	253	1	6	486.0	700.0	—	771.0	—	600					
Ckt B	207	253	1	6	415.4	700.0	—	638.0	—	500					
246	230-60											115-60	104	127	15
	Ckt A	207	253	1	6	592.1	800.0	—	955.3	—	700				
	Ckt B	207	253	1	3	379.8	600.0	—	743.0	—	500				
	208/230-60											115-60	104	127	15
	Ckt A	187	253	1	6	657.9	800.0	—	978.9	—	800				
	Ckt B	187	253	1	6	422.0	700.0	—	743.0	—	600				
	460-60	414	506	1	6	461.9	600.0	1439.5	635.5	600	600	115-60	104	127	15
	575-60	518	633	1	3	369.1	450.0	1151.3	508.3	450	450	115-60	104	127	15
	380-60	342	418	1	6	559.2	700.0	1619.2	730.2	700	700	230-60	207	254	15
380/415-50	342	440	1	6	586.1	700.0	1599.6	734.6	700	700	230-50	198	254	15	
230-50											230-50	207	254	15	
Ckt A	207	253	1	6	635.7	800.0	—	858.3	—	800					
Ckt B	207	253	1	6	415.4	700.0	—	638.0	—	500					
261	230-60											115-60	104	127	15
	Ckt A	207	253	1	6	638.0	800.0	—	1001.2	—	800				
	Ckt B	207	253	1	3	379.8	600.0	—	743.0	—	500				
	208/230-60											115-60	104	127	15
	Ckt A	187	253	1	6	708.9	1000.0	—	1029.9	—	800				
	Ckt B	187	253	1	6	422.0	700.0	—	743.0	—	600				
	460-60	414	506	1	6	484.9	600.0	1462.5	658.5	600	600	115-60	104	127	15
	575-60	518	633	1	6	387.6	500.0	1169.8	526.8	450	450	115-60	104	127	15
	380-60	342	418	1	6	587.1	700.0	1647.1	758.1	700	700	230-60	207	254	15
380/415-50	342	440	1	6	614.4	800.0	1627.9	762.9	700	700	230-50	198	254	15	
230-50											230-50	207	254	15	
Ckt A	207	253	1	6	682.6	1000.0	—	905.2	—	800					
Ckt B	207	253	1	6	415.4	700.0	—	638.0	—	500					
271	230-60											115-60	104	127	15
	Ckt A	207	253	1	6	683.6	800.0	—	1046.8	—	800				
	Ckt B	207	253	1	3	379.8	600.0	—	743.0	—	500				
	208/230-60											115-60	104	127	15
	Ckt A	187	253	1	6	759.6	1000.0	—	1080.6	—	1000				
	Ckt B	187	253	1	6	422.0	700.0	—	743.0	—	600				
	460-60	414	506	1	6	513.2	600.0	1490.8	686.8	600	600	115-60	104	127	15
	575-60	518	633	1	6	410.2	500.0	1192.4	549.4	450	450	115-60	104	127	15
	380-60	342	418	1	6	621.4	800.0	1681.4	792.4	700	700	230-60	207	254	15
380/415-50	342	440	1	6	653.9	800.0	1667.4	802.4	800	800	230-50	198	254	15	
230-50											230-50	207	254	15	
Ckt A	207	253	1	6	747.7	1000.0	—	970.3	—	1000					
Ckt B	207	253	1	6	415.4	700.0	—	638.0	—	500					

**LEGEND**

- ICF** — Maximum Instantaneous Current Flow during start-up (the point in the starting sequence where the sum of the LRA for the start-up compressor, plus the total RLA for all running compressors is at a maximum)
- LRA** — Locked Rotor Amps
- MCA** — Minimum Circuit Ampacity (for wire sizing)
- MOCP** — Maximum Overcurrent Protection
- RLA** — Rated Load Amps
- WD** — Wye-Delta Start
- XL** — Across-the-Line Start

**NOTES:**

1. Each main power source must be supplied from a field-supplied fused electrical service with a (factory-installed or field-installed) disconnect located in sight from the unit.

2. Control circuit power must be supplied from a separate source through a field-supplied disconnect (except for 380/415-50 units). An accessory control transformer may be used to provide control circuit power from the main unit power supply.
3. Maximum incoming wire size for each terminal block is 500 kcmil.
4. Maximum allowable phase imbalance is: voltage, 2%; amps, 5%.
5. Use copper conductors only.
6. The MOCP is calculated as follows:

MOCP = (2.25) (largest RLA) + the sum of the other RLAs. Size the fuse one size down from the result. The RLAs are listed on the nameplate.

The recommended fuse size in amps (RFA) is calculated as follows:  
 RFA = (1.50) (largest RLA) + the sum of the other RLAs. Size the fuse one size up from the result. The RLAs are listed on the nameplate.



**Table 5A — Compressor Electrical Data, 30HXC Units**

UNIT SIZE 30HXC	NAMEPLATE V-Hz (3 Phase)	COMPRESSOR NUMBERS			
		A1		B1	
		RLA	LRA	RLA	LRA
076-XL	208/230-60	*	*	*	*
	230-60	*	*	*	*
	460-60	44.3	330	44.3	330
	575-60	35.4	264	35.4	264
	380-60	53.7	365	53.7	365
	230-50	*	*	*	*
076-WD	380/415-50	55.8	344	55.8	344
	208/230-60	98.1	209	98.1	209
	230-60	88.3	209	88.3	209
	460-60	44.3	104	44.3	104
	575-60	35.4	83	35.4	83
	380-60	53.7	115	53.7	115
086-XL	230-50	92.1	174	92.1	174
	380/415-50	55.8	109	55.8	109
	208/230-60	*	*	*	*
	230-60	*	*	*	*
	460-60	53.6	330	44.3	330
	575-60	42.8	264	35.4	264
086-WD	380-60	64.9	365	53.7	365
	230-50	*	*	*	*
	380/415-50	67.7	423	55.8	344
	208/230-60	118.6	209	98.1	209
	230-60	106.7	209	88.3	209
	460-60	53.6	104	44.3	104
096-XL	575-60	42.8	83	35.4	83
	380-60	64.9	115	53.7	115
	230-50	111.8	213	92.1	174
	380/415-50	67.7	134	55.8	109
	208/230-60	*	*	*	*
	230-60	*	*	*	*
096-WD	460-60	65.5	405	44.3	330
	575-60	52.3	324	35.4	264
	380-60	79.2	448	53.7	365
	230-50	*	*	*	*
	380/415-50	81.7	506	55.8	344
	208/230-60	144.9	256	98.1	209
106-XL	230-60	130.4	256	88.3	209
	460-60	65.5	128	44.3	104
	575-60	52.3	102	35.4	83
	380-60	79.2	141	53.7	115
	230-50	134.9	255	92.1	174
	380/415-50	81.7	160	55.8	109
106-WD	208/230-60	*	*	*	*
	230-60	*	*	*	*
	460-60	79.2	485	44.3	330
	575-60	63.3	388	35.4	264
	380-60	95.9	536	53.7	365
	230-50	*	*	*	*
106-XL	380/415-50	97.8	605	55.8	344
	208/230-60	175.4	307	98.1	209
	230-60	157.9	307	88.3	209
	460-60	79.2	153	44.3	104
	575-60	63.3	123	35.4	83
	380-60	95.9	169	53.7	115
106-WD	230-50	161.7	305	92.1	174
	380/415-50	97.8	191	55.8	109

**LEGEND**

- LRA** — Locked Rotor Amps
- RLA** — Rated Load Amps
- WD** — Wye-Delta Start
- XL** — Across-the-Line Start

\*Units are shipped with wye-delta start as standard. Across-the-line start is not available.

**Table 5A — Compressor Electrical Data, 30HXC Units (cont)**

UNIT SIZE 30HXC	NAMEPLATE V-Hz (3 Phase)	COMPRESSOR NUMBERS			
		A1		B1	
		RLA	LRA	RLA	LRA
116-XL	208/230-60	*	*	*	*
	230-60	*	*	*	*
	460-60	79.2	485	53.6	330
	575-60	63.3	388	42.8	264
	380-60	95.9	536	64.9	365
	230-50	*	*	*	*
116-WD	380/415-50	97.8	605	67.7	423
	208/230-60	175.4	307	118.6	209
	230-60	157.9	307	106.7	209
	460-60	79.2	153	53.6	104
	575-60	63.3	123	42.8	83
	380-60	95.9	169	64.9	115
126-XL	230-50	161.7	305	111.8	213
	380/415-50	97.8	191	67.7	134
	208/230-60	*	*	*	*
	230-60	*	*	*	*
	460-60	79.2	485	65.5	405
	575-60	63.3	388	52.3	324
126-WD	380-60	95.9	536	79.2	448
	230-50	*	*	*	*
	380/415-50	97.8	605	81.7	506
	208/230-60	175.4	307	144.9	256
	230-60	157.9	307	130.4	256
	460-60	79.2	153	65.5	128
136-XL	575-60	63.3	123	52.3	102
	380-60	95.9	169	79.2	141
	230-50	161.7	305	134.9	255
	380/415-50	97.8	191	81.7	160
	208/230-60	*	*	*	*
	230-60	*	*	*	*
136-WD	460-60	94.6	580	65.5	405
	575-60	75.8	484	52.3	324
	380-60	114.9	641	79.2	448
	230-50	*	*	*	*
	380/415-50	118.8	715	81.7	506
	208/230-60	210.0	367	144.9	256
146-XL	230-60	189.0	367	130.4	256
	460-60	94.6	183	65.5	128
	575-60	75.8	147	52.3	102
	380-60	114.9	203	79.2	141
	230-50	196.3	361	134.9	255
	380/415-50	118.8	226	81.7	160
146-WD	208/230-60	*	*	*	*
	230-60	*	*	*	*
	460-60	94.6	580	79.2	485
	575-60	75.8	484	63.3	388
	380-60	114.9	641	95.9	536
	230-50	*	*	*	*
146-XL	380/415-50	118.8	715	97.8	605
	208/230-60	210.0	367	175.4	307
	230-60	189.0	367	157.9	307
	460-60	94.6	183	79.2	153
	575-60	75.8	147	63.3	123
	380-60	114.9	203	95.9	169
146-WD	230-50	196.3	361	161.7	305
	380/415-50	118.8	226	97.8	191

**LEGEND**

- LRA** — Locked Rotor Amps
- RLA** — Rated Load Amps
- WD** — Wye-Delta Start
- XL** — Across-the-Line Start

\*Units are shipped with wye-delta start as standard. Across-the-line start is not available.

**Table 5A — Compressor Electrical Data, 30HXC Units (cont)**

UNIT SIZE 30HXC	NAMEPLATE V-Hz (3 Phase)	COMPRESSOR NUMBERS			
		A1		B1	
		RLA	LRA	RLA	LRA
161-XL	208/230-60	*	*	*	*
	230-60	*	*	*	*
	460-60	103.1	685	71.2	525
	575-60	82.4	548	56.9	420
	380-60	124.8	757	86.2	580
	230-50	*	*	*	*
	380/415-50	128.6	856	88.2	600
161-WD	208/230-60	228.8	433	157.6	350
	230-60	205.5	433	141.8	350
	460-60	103.1	216	71.2	175
	575-60	82.4	173	56.9	140
	380-60	124.8	239	86.2	193
	230-50	212.5	432	145.7	348
	380/415-50	128.6	270	88.2	200
171-XL	208/230-60	*	*	*	*
	230-60	*	*	*	*
	460-60	86.1	580	103.1	685
	575-60	68.8	484	82.4	548
	380-60	104.2	641	124.8	757
	230-50	*	*	*	*
	380/415-50	105.8	715	128.6	856
171-WD	208/230-60	190.6	367	228.8	433
	230-60	171.5	367	205.5	433
	460-60	86.1	183	103.1	216
	575-60	68.8	147	82.4	173
	380-60	104.2	203	124.8	239
	230-50	174.8	361	212.5	432
	380/415-50	105.8	233	128.6	270
186-XL	208/230-60	*	*	*	*
	230-60	*	*	*	*
	460-60	103.1	685	103.1	685
	575-60	82.4	548	82.4	548
	380-60	124.8	757	124.8	757
	230-50	*	*	*	*
	380/415-50	128.6	856	128.6	856
186-WD	208/230-60	228.8	433	228.8	433
	230-60	205.5	433	205.5	433
	460-60	103.1	216	103.1	216
	575-60	82.4	173	82.4	173
	380-60	124.8	239	124.8	239
	230-50	212.5	432	212.5	432
	380/415-50	128.6	270	128.6	270

LEGEND

- LRA** — Locked Rotor Amps
- RLA** — Rated Load Amps
- WD** — Wye-Delta Start
- XL** — Across-the-Line Start

\*Units are shipped with wye-delta start as standard. Across-the-line start is not available.

**Table 5A — Compressor Electrical Data, 30HXC Units (cont)**

UNIT SIZE 30HXC	NAMEPLATE V-Hz (3 Phase)	COMPRESSOR NUMBERS					
		A1		A2		B1	
		RLA	LRA	RLA	LRA	RLA	LRA
206-XL	208/230-60	*	*	*	*	*	*
	230-60	*	*	*	*	*	*
	460-60	86.1	580	48.2	350	103.1	685
	575-60	68.8	484	38.6	280	82.4	548
	380-60	104.2	641	58.4	390	124.8	757
	230-50	*	*	*	*	*	*
206-WD	380/415-50	105.8	715	55.8	344	128.6	856
	208/230-60	190.6	367	106.8	233	228.8	433
	230-60	171.5	367	96.1	233	205.5	433
	460-60	86.1	183	48.2	117	103.1	216
	575-60	68.8	147	38.6	93	82.4	173
	380-60	104.2	203	58.4	130	124.8	239
246-XL	230-50	174.8	361	99.4	260	212.5	432
	380/415-50	105.8	226	60.2	150	128.6	270
	208/230-60	*	*	*	*	*	*
	230-60	*	*	*	*	*	*
	460-60	103.1	685	71.2	485	103.1	685
	575-60	82.4	548	56.9	388	82.4	548
246-WD	380-60	124.8	757	86.2	536	124.8	757
	230-50	*	*	*	*	*	*
	380/415-50	128.6	856	88.2	605	128.6	856
	208/230-60	228.8	433	157.6	307	228.8	433
	230-60	205.5	433	141.8	307	205.5	433
	460-60	103.1	216	71.2	153	103.1	216
261-XL	575-60	82.4	173	56.9	123	82.4	173
	380-60	124.8	239	86.2	169	124.8	239
	230-50	212.5	432	145.7	305	212.5	432
	380/415-50	128.6	270	88.2	191	128.6	270
	208/230-60	*	*	*	*	*	*
	230-60	*	*	*	*	*	*
261-WD	460-60	103.1	685	86.1	580	103.1	685
	575-60	82.4	548	68.8	484	82.4	548
	380-60	124.8	757	104.2	641	124.8	757
	230-50	*	*	*	*	*	*
	380/415-50	128.6	856	105.8	715	128.6	856
	208/230-60	228.8	433	190.6	367	228.8	433
271-XL	230-60	205.5	433	171.5	367	205.5	433
	460-60	103.1	216	86.1	183	103.1	216
	575-60	82.4	173	68.8	147	82.4	173
	380-60	124.8	239	104.2	203	124.8	239
	230-50	212.5	432	174.8	361	212.5	432
	380/415-50	128.6	270	105.8	226	128.6	270
271-WD	208/230-60	*	*	*	*	*	*
	230-60	*	*	*	*	*	*
	460-60	103.1	685	103.1	685	103.1	685
	575-60	82.4	548	82.4	548	82.4	548
	380-60	124.8	757	124.8	757	124.8	757
	230-50	*	*	*	*	*	*
271-XL	380/415-50	128.6	856	128.6	856	128.6	856
	208/230-60	228.8	433	228.8	433	228.8	433
	230-60	205.5	433	205.5	433	205.5	433
	460-60	103.1	216	103.1	216	103.1	216
	575-60	82.4	173	82.4	173	82.4	173
	380-60	124.8	239	124.8	239	124.8	239
271-WD	230-50	212.5	432	212.5	432	212.5	432
	380/415-50	128.6	270	128.6	270	128.6	270

**LEGEND**

- LRA** — Locked Rotor Amps
- RLA** — Rated Load Amps
- WD** — Wye-Delta Start
- XL** — Across-the-Line Start

\*Units are shipped with wye-delta start as standard. Across-the-line start is not available.

**Table 5B — Compressor Electrical Data, 30HXA Units**

UNIT SIZE 30HXA	NAMEPLATE V-Hz (3 Phase)	COMPRESSOR NUMBERS			
		A1		B1	
		RLA	LRA	RLA	LRA
076-XL	208/230-60	*	*	*	*
	230-60	*	*	*	*
	460-60	64.9	485	64.9	485
	575-60	51.9	388	51.9	388
	380-60	78.7	536	78.7	536
	380/415-50	81.5	605	81.5	605
076-WD	208/230-60	143.8	307	143.8	307
	230-60	129.4	307	129.4	307
	460-60	64.9	153	64.9	153
	575-60	51.9	123	51.9	123
	380-60	78.7	169	78.7	169
	380/415-50	81.5	191	81.5	191
086-XL	208/230-60	*	*	*	*
	230-60	*	*	*	*
	460-60	77.6	580	64.9	485
	575-60	62.1	484	51.9	388
	380-60	94.0	641	78.7	536
	380/415-50	99.2	715	81.5	605
086-WD	208/230-60	171.9	367	143.8	307
	230-60	154.7	367	129.4	307
	460-60	77.6	183	64.9	153
	575-60	62.1	147	51.9	123
	380-60	94.0	203	78.7	169
	380/415-50	99.2	226	81.5	191
096-XL	208/230-60	*	*	*	*
	230-60	*	*	*	*
	460-60	94.8	685	64.9	485
	575-60	75.7	548	51.9	388
	380-60	114.7	757	78.7	536
	380/415-50	119.9	856	81.5	605
096-WD	208/230-60	209.8	433	143.8	307
	230-60	188.8	433	129.4	307
	460-60	94.8	216	64.9	153
	575-60	75.7	173	51.9	123
	380-60	114.7	239	78.7	169
	380/415-50	198.2	432	134.8	305
106-XL	208/230-60	*	*	*	*
	230-60	*	*	*	*
	460-60	115.4	820	64.9	485
	575-60	92.2	656	51.9	388
	380-60	139.7	906	78.7	536
	380/415-50	145.4	960	81.5	605
106-WD	208/230-60	255.5	518	143.8	307
	230-60	230.0	518	129.4	307
	460-60	115.4	259	64.9	153
	575-60	92.2	207	51.9	123
	380-60	139.7	286	78.7	169
	380/415-50	240.2	485	134.8	305
	380/415-50	145.4	303	81.5	191

**LEGEND**

- LRA** — Locked Rotor Amps
- RLA** — Rated Load Amps
- WD** — Wye-Delta Start
- XL** — Across-the-Line Start

\*Units are shipped with wye-delta start as standard. Across-the-line start is not available.

**Table 5B — Compressor Electrical Data, 30HXA Units (cont)**

UNIT SIZE 30HXA	NAMEPLATE V-Hz (3 Phase)	COMPRESSOR NUMBERS			
		A1		B1	
		RLA	LRA	RLA	LRA
116-XL	208/230-60	*	*	*	*
	230-60	*	*	*	*
	460-60	115.4	820	77.6	580
	575-60	92.2	656	62.1	484
	380-60	139.7	906	94.0	641
	230-50	*	*	*	*
116-WD	380/415-50	145.4	960	99.2	715
	208/230-60	255.5	518	171.9	367
	230-60	230.0	518	154.7	367
	460-60	115.4	259	77.6	183
	575-60	92.2	207	62.1	147
	380-60	139.7	286	94.0	203
126-XL	230-50	240.2	485	163.9	361
	380/415-50	145.4	303	99.2	226
	208/230-60	*	*	*	*
	230-60	*	*	*	*
	460-60	115.4	820	94.8	685
	575-60	92.2	656	75.7	548
126-WD	380-60	139.7	906	114.7	757
	230-50	*	*	*	*
	380/415-50	145.4	960	119.9	856
	208/230-60	255.5	518	209.8	433
	230-60	230.0	518	188.8	433
	460-60	115.4	259	94.8	216
136-XL	575-60	92.2	207	75.7	173
	380-60	139.7	286	114.7	239
	230-50	240.2	485	198.2	432
	380/415-50	145.4	303	119.9	270
	208/230-60	*	*	*	*
	230-60	*	*	*	*
136-WD	460-60	140.7	920	94.8	685
	575-60	112.4	736	75.7	548
	380-60	170.2	1017	114.7	757
	230-50	*	*	*	*
	380/415-50	178.8	1226	119.9	856
	208/230-60	311.4	581	209.8	433
146-XL	230-60	280.3	581	188.8	433
	460-60	140.7	291	94.8	216
	575-60	112.4	233	75.7	173
	380-60	170.2	321	114.7	239
	230-50	295.3	619	198.2	432
	380/415-50	178.8	387	119.9	270
146-WD	208/230-60	*	*	*	*
	230-60	*	*	*	*
	460-60	140.7	920	115.4	820
	575-60	112.4	736	92.2	656
	380-60	170.2	1017	139.7	906
	230-50	*	*	*	*
146-XL	380/415-50	178.8	1226	145.4	960
	208/230-60	311.4	581	255.5	518
	230-60	280.3	581	230.0	518
	460-60	140.7	291	115.4	259
	575-60	112.4	233	92.2	207
	380-60	170.2	321	139.7	286
146-WD	230-50	295.3	619	240.2	485
	380/415-50	178.8	387	145.4	303

LEGEND

- LRA** — Locked Rotor Amps
- RLA** — Rated Load Amps
- WD** — Wye-Delta Start
- XL** — Across-the-Line Start

\*Units are shipped with wye-delta start as standard. Across-the-line start is not available.

**Table 5B — Compressor Electrical Data, 30HXA Units (cont)**

UNIT SIZE 30HXA	NAMEPLATE V-Hz (3 Phase)	COMPRESSOR NUMBERS			
		A1		B1	
		RLA	LRA	RLA	LRA
161-XL	208/230-60	*	*	*	*
	230-60	*	*	*	*
	460-60	157.9	1175	106.6	790
	575-60	126.2	940	85.1	630
	380-60	191.2	1299	129.0	870
	230-50	*	*	*	*
161-WD	380/415-50	201.2	1265	133.4	1045
	208/230-60	349.6	743	235.9	527
	230-60	314.6	743	212.3	527
	460-60	157.9	371	106.6	263
	575-60	126.2	297	85.1	211
	380-60	191.2	410	129.0	290
171-XL	230-50	332.3	638	220.3	607
	380/415-50	201.2	400	133.4	348
	208/230-60	*	*	*	*
	230-60	*	*	*	*
	460-60	129.6	920	157.9	1175
	575-60	103.6	736	126.2	940
171-WD	380-60	156.9	1017	191.2	1299
	230-50	*	*	*	*
	380/415-50	161.7	1226	201.2	1265
	208/230-60	286.9	581	349.6	743
	230-60	258.2	581	314.6	743
	460-60	129.6	291	157.9	371
186-XL	575-60	103.6	233	126.2	297
	380-60	156.9	321	191.2	410
	230-50	267.2	619	332.3	638
	380/415-50	161.7	387	201.2	400
	208/230-60	*	*	*	*
	230-60	*	*	*	*
186-WD	460-60	157.9	1175	157.9	1175
	575-60	126.2	940	126.2	940
	380-60	191.2	1299	191.2	1299
	230-50	*	*	*	*
	380/415-50	201.2	1265	201.2	1265
	208/230-60	349.6	743	349.6	743
186-XL	230-60	314.6	743	314.6	743
	460-60	157.9	371	157.9	371
	575-60	126.2	297	126.2	297
	380-60	191.2	410	191.2	410
	230-50	332.3	638	332.3	638
	380/415-50	201.2	400	201.2	400

LEGEND

- LRA** — Locked Rotor Amps
- RLA** — Rated Load Amps
- WD** — Wye-Delta Start
- XL** — Across-the-Line Start

\*Units are shipped with wye-delta start as standard. Across-the-line start is not available.

**Table 5B — Compressor Electrical Data, 30HXA Units (cont)**

UNIT SIZE 30HXA	NAMEPLATE V-Hz (3 Phase)	COMPRESSOR NUMBERS					
		A1		A2		B1	
		RLA	LRA	RLA	LRA	RLA	LRA
206-XL	208/230-60	*	*	*	*	*	*
	230-60	*	*	*	*	*	*
	460-60	129.6	920	73.1	580	157.9	1175
	575-60	103.6	736	58.5	484	126.2	940
	380-60	156.9	1017	88.5	641	191.2	1299
	230-50	*	*	*	*	*	*
206-WD	380/415-50	161.7	1226	92.0	715	201.2	1265
	208/230-60	286.9	581	162.0	367	337.6	743
	230-60	258.2	581	145.8	367	303.8	743
	460-60	129.6	291	73.1	183	157.9	371
	575-60	103.6	233	58.5	147	126.2	297
	380-60	156.9	321	88.5	203	191.2	410
246-XL	230-50	267.2	619	152.0	361	332.3	638
	380/415-50	161.7	387	92.0	226	201.2	400
	208/230-60	*	*	*	*	*	*
	230-60	*	*	*	*	*	*
	460-60	157.9	1175	106.6	820	157.9	1175
	575-60	126.2	940	85.1	656	126.2	940
246-WD	380-60	191.2	1299	129.0	906	191.2	1299
	230-50	*	*	*	*	*	*
	380/415-50	201.2	1265	133.4	960	201.2	1265
	208/230-60	337.6	743	235.9	518	337.6	743
	230-60	303.8	743	212.3	518	303.8	743
	460-60	157.9	371	106.6	259	157.9	371
261-XL	575-60	126.2	297	85.1	207	126.2	297
	380-60	191.2	410	129.0	286	191.2	410
	230-50	332.3	638	220.3	485	332.3	638
	380/415-50	201.2	400	133.4	303	201.2	400
	208/230-60	*	*	*	*	*	*
	230-60	*	*	*	*	*	*
261-WD	460-60	157.9	1175	129.6	920	157.9	1175
	575-60	126.2	940	103.6	736	126.2	940
	380-60	191.2	1299	156.9	1017	191.2	1299
	230-50	*	*	*	*	*	*
	380/415-50	201.2	1265	161.7	1226	201.2	1265
	208/230-60	337.6	743	286.9	581	337.6	743
271-XL	230-60	303.8	743	258.2	581	303.8	743
	460-60	157.9	371	129.6	291	157.9	371
	575-60	126.2	297	103.6	233	126.2	297
	380-60	191.2	410	156.9	321	191.2	410
	230-50	332.3	638	267.2	619	332.3	638
	380/415-50	201.2	400	161.7	387	201.2	400
271-WD	208/230-60	*	*	*	*	*	*
	230-60	*	*	*	*	*	*
	460-60	157.9	1175	157.9	1175	157.9	1175
	575-60	126.2	940	126.2	940	126.2	940
	380-60	191.2	1299	191.2	1299	191.2	1299
	230-50	*	*	*	*	*	*
271-XL	380/415-50	201.2	1265	201.2	1265	201.2	1265
	208/230-60	337.6	743	337.6	743	337.6	743
	230-60	303.8	743	303.8	743	303.8	743
	460-60	157.9	371	157.9	371	157.9	371
	575-60	126.2	297	126.2	297	126.2	297
	380-60	191.2	410	191.2	410	191.2	410
271-WD	230-50	332.3	638	332.3	638	332.3	638
	380/415-50	201.2	400	201.2	400	201.2	400

**LEGEND**

- LRA** — Locked Rotor Amps
- RLA** — Rated Load Amps
- WD** — Wye-Delta Start
- XL** — Across-the-Line Start

\*Units are shipped with wye-delta start as standard. Across-the-line start is not available.

## Step 7 — Refrigerant Charge

**IMPORTANT:** These units are designed for use with R-134a only. **DO NOT USE ANY OTHER REFRIGERANT** in these units without first consulting your Carrier representative.

**NOTE:** The liquid charging method is recommended for complete charging or when additional charge is required.

### ⚠ CAUTION

When charging, circulate water through the condenser and cooler at all times to prevent freezing. Freezing damage is considered abuse and may void the Carrier warranty.

### ⚠ CAUTION

**DO NOT OVERCHARGE** system. Overcharging results in higher discharge pressure with higher cooling fluid consumption, possible compressor damage, and higher power consumption.

**30HXC UNITS** — The 30HXC units are shipped from the factory with a full charge of R-134a. Unit should not need to be charged at installation unless a leak was detected in Step 6 — Leak Test Unit section. If dehydration and recharging is necessary, use industry standard practices or refer to Carrier Standard Services Techniques Manual or the Controls, Start-Up, Operation, Service, and Troubleshooting Guide as required.

**30HXA UNITS** — The 30HXA units are shipped with a holding charge of R-134a or nitrogen. The complete charge for the 30HXA, the remote condenser(s), and interconnecting piping must be field supplied.

To charge the 30HXA systems:

1. An initial refrigerant charge must be added after evacuation to allow the unit to start. Add approximately 2 lb/nominal ton (0.26 kg/nominal kW) liquid refrigerant charge to the condenser. This amount of charge should be sufficient to allow the unit to start. The cooler refrigerant capacity is shown in Tables 6 and 7, approximate system charge is shown in Table 8.
2. Raise the compressor discharge pressure to approximately 185 psig (1276 kPa) (125 F [51.7 C] saturated condensing temperature) by throttling the condenser air (or water) intake.
3. Add liquid charge into the cooler until there is approximately 18 to 20 F (10.0 to 11.1 C) of system subcooling (saturated condensing temperature minus actual liquid line temperature entering the electronic expansion valve [EXV]). When adding charge, use the 1/4-in. Schrader-type fitting located on the tube going into the bottom of

the cooler. This fitting is located between the EXV and the cooler.

4. Check for a clear sight glass. If the unit is not fully loaded, the sight glass may be flashing. This condition is normal for a partially loaded unit. If the unit is fully loaded and the sight glass is flashing, check EXV position. If it is greater than 60% add additional charge.

**Table 6 — Cooler Refrigerant Storage Capacity**

UNIT SIZE 30HXA	CKT	TOTAL VOLUME		REFRIGERANT STORAGE CAPACITY (R-134a)	
		Ft <sup>3</sup>	m <sup>3</sup>	lb	kg
076,086	A	2.538	0.072	161	73.0
	B	2.538	0.072	161	73.0
096	A	2.813	0.080	178	80.7
	B	1.929	0.055	122	55.3
106	A	3.945	0.112	250	113.4
	B	2.705	0.077	172	78.0
116,126	A	4.044	0.115	256	116.1
	B	2.810	0.080	178	80.7
136,146	A	3.777	0.107	240	108.9
	B	2.625	0.074	167	75.8
161	A	5.297	0.150	336	152.4
	B	3.682	0.104	234	106.1
171	A	4.490	0.127	285	129.3
	B	4.490	0.127	285	129.3
186	A	4.068	0.115	258	117.0
	B	4.068	0.115	258	117.3
206	A	7.523	0.213	477	216.4
	B	4.946	0.140	314	142.4
246-271	A	7.090	0.201	450	204.1
	B	4.661	0.132	296	134.3

**Table 7 — Fluid Weight of Refrigerant in Liquid Line**

PIPING SIZE (in.)	REFRIGERANT (lb) PER FT OF TUBING LENGTH	REFRIGERANT (kg) PER M OF TUBING LENGTH
1 1/8	0.41	0.61
1 3/8	0.63	0.94
1 5/8	0.89	1.33
2 1/8	1.52	2.26

**NOTE:** For refrigerant line lengths other than 25 ft (7.6 m) calculate the total refrigerant charge by multiplying the liquid line length (in feet) by the factor shown in this table and adding it to the cooler and condenser charge listed in Table 8. Additional charge may be required for the liquid line filter drier. Consult the manufacturer for refrigerant charge information.

**Table 8 — 30HXA Estimated System Refrigerant Charge**

30HXA	REFRIGERANT CIRCUIT	COOLER CHARGE		AIR-COOLED CONDENSER TYPE, SIZE (Qty)*	CONDENSER CHARGE		LIQUID LINE REFRIGERANT PIPE SIZE (in. OD)	PIPING CHARGE†		TOTAL REFRIGERANT CHARGE	
		Lb	Kg		Lb	Kg		Lb	Kg	Lb	Kg
076	A	48	22	09DK 084 (1)	62	28	1 <sup>1</sup> / <sub>8</sub>	10	5	120	55
	B	48	22		62	28	1 <sup>1</sup> / <sub>8</sub>	10	5	120	55
086	A	61	28	09DK 084 (1)	62	28	1 <sup>1</sup> / <sub>8</sub>	10	5	133	61
	B	52	24		62	28	1 <sup>1</sup> / <sub>8</sub>	10	5	124	57
096	A	75	34	09DK 094 (1)	68	31	1 <sup>1</sup> / <sub>8</sub>	10	5	153	70
	B	56	25		68	31	1 <sup>1</sup> / <sub>8</sub>	10	5	134	61
106	A	88	40	09DK 074 (1) and 09DK 044 (1)	82	37	1 <sup>3</sup> / <sub>8</sub>	16	7	186	84
	B	56	25		62	28	1 <sup>3</sup> / <sub>8</sub>	16	7	134	60
	A	88	40	09AZV102FE (1)	24	11	1 <sup>3</sup> / <sub>8</sub>	16	7	128	58
	B	56	25		18	8	1 <sup>3</sup> / <sub>8</sub>	16	7	90	40
116	A	84	38	09DK 074 (1) and 09DK 054 (1)	82	37	1 <sup>3</sup> / <sub>8</sub>	16	7	182	82
	B	61	28		56	25	1 <sup>3</sup> / <sub>8</sub>	16	7	133	60
	A	84	38	09AZV112FE (1)	42	19	1 <sup>3</sup> / <sub>8</sub>	16	7	142	64
	B	61	28		42	19	1 <sup>3</sup> / <sub>8</sub>	16	7	119	54
126	A	90	41	09DK 074 (2)	82	37	1 <sup>3</sup> / <sub>8</sub>	16	7	188	85
	B	71	32		82	37	1 <sup>3</sup> / <sub>8</sub>	16	7	169	76
	A	90	41	09AZV122FE (1)	24	11	1 <sup>3</sup> / <sub>8</sub>	16	7	130	59
	B	71	32		24	11	1 <sup>3</sup> / <sub>8</sub>	16	7	112	50
136	A	99	45	09DK 074 (2)	82	37	1 <sup>3</sup> / <sub>8</sub>	16	7	197	89
	B	71	32		82	37	1 <sup>3</sup> / <sub>8</sub>	16	7	169	76
	A	99	45	09AZV132FE (1)	57	26	1 <sup>3</sup> / <sub>8</sub>	16	7	172	78
	B	71	32		42	19	1 <sup>3</sup> / <sub>8</sub>	16	7	130	58
146	A	95	43	09DK 084 (2)	124	56	1 <sup>3</sup> / <sub>8</sub>	16	7	235	106
	B	80	36		124	56	1 <sup>3</sup> / <sub>8</sub>	16	7	220	99
	A	95	43	09AZV142FE (1)	57	26	1 <sup>3</sup> / <sub>8</sub>	16	7	168	76
	B	80	36		57	26	1 <sup>3</sup> / <sub>8</sub>	16	7	153	69
161	A	120	54	09DK 084 (2)	124	56	1 <sup>3</sup> / <sub>8</sub>	16	7	260	117
	B	88	40		124	56	1 <sup>3</sup> / <sub>8</sub>	16	7	228	103
	A	120	54	09AZV162FE (1)	68	31	1 <sup>3</sup> / <sub>8</sub>	16	7	204	92
	B	88	40		68	31	1 <sup>3</sup> / <sub>8</sub>	16	7	172	78
171	A	95	43	09DK 084 (2)	124	56	1 <sup>3</sup> / <sub>8</sub>	16	7	235	106
	B	112	51		124	56	1 <sup>3</sup> / <sub>8</sub>	16	7	252	114
	A	95	43	09AZV172FE (1)	68	31	1 <sup>3</sup> / <sub>8</sub>	16	7	179	81
	B	112	51		68	31	1 <sup>3</sup> / <sub>8</sub>	16	7	196	89
186	A	108	49	09DK 084 (2)	124	56	1 <sup>3</sup> / <sub>8</sub>	16	7	248	112
	B	108	49		124	56	1 <sup>3</sup> / <sub>8</sub>	16	7	248	112
	A	108	49	09AZV182FE (1)	68	31	1 <sup>3</sup> / <sub>8</sub>	16	7	192	87
	B	108	49		68	31	1 <sup>3</sup> / <sub>8</sub>	16	7	192	87
206	A	160	73	09DK 084 (2) and 09DK 094 (1)	272	123	1 <sup>5</sup> / <sub>8</sub>	22	10	454	206
	B	108	49		124	56	1 <sup>3</sup> / <sub>8</sub>	16	7	248	112
	A	160	73	09AZV101FA (1) and 09AZV091FA(1)	49	22	1 <sup>5</sup> / <sub>8</sub>	22	10	231	105
	B	108	49		37	17	1 <sup>3</sup> / <sub>8</sub>	16	7	161	73
246	A	176	80	09DK 094 (3)	272	123	2 <sup>1</sup> / <sub>8</sub>	38	17	486	220
	B	108	49		136	62	1 <sup>3</sup> / <sub>8</sub>	16	7	260	118
	A	176	80	09AZ 151FA (1) and 09AZV091FA(1)	113	51	2 <sup>1</sup> / <sub>8</sub>	38	17	327	148
	B	108	49		37	17	1 <sup>3</sup> / <sub>8</sub>	16	7	161	73
261	A	176	80	09DK 094 (3)	272	123	2 <sup>1</sup> / <sub>8</sub>	38	17	486	220
	B	108	49		136	62	1 <sup>3</sup> / <sub>8</sub>	16	7	260	118
	A	176	80	09AZ 171FA (1) and 09AZV091FA(1)	136	62	2 <sup>1</sup> / <sub>8</sub>	38	17	350	159
	B	108	49		37	17	1 <sup>3</sup> / <sub>8</sub>	16	7	161	73
271	A	176	80	09DK 094 (3)	272	123	2 <sup>1</sup> / <sub>8</sub>	38	17	486	220
	B	108	49		136	62	1 <sup>3</sup> / <sub>8</sub>	16	7	260	118
	A	176	80	09AZ 181FA (1) and 09AZV091FA(1)	136	62	2 <sup>1</sup> / <sub>8</sub>	38	17	350	159
	B	108	49		37	17	1 <sup>3</sup> / <sub>8</sub>	16	7	161	73

\*Refer to Carrier's electronic catalog for 09AZ/30HX rating data.

†Based on 25 ft (7.6 m) liquid line.

NOTE: For refrigerant lengths other than 25 ft (7.6 m) calculate the total refrigerant charge by multiplying the liquid line length (in feet) by the factor shown in

Table 7 and adding it to the cooler and condenser charge listed in this table. Additional charge may be required for the liquid line filter drier. Consult the manufacturer for refrigerant charge information.

