



Wiring Diagrams

DIAGRAM INDEX











| POWER SCHEMATICS | | | |
|------------------|---------|---------------|------------------------|
| Unit 30HXA,C | Voltage | Figure Number | Label Diagram No. 30HX |
| 076-186 | ALL | 1 | 502347 |
| 206-271 | ALL | 2 | 502349 |

| CONTROL SCHEMATICS | | | |
|--------------------|------------------|---------------|------------------------|
| Unit 30HXA,C | Voltage | Figure Number | Label Diagram No. 30HX |
| 076-271 | 24 (Low Voltage) | 3 | 502503 |
| | 24 | 4 | 502504 |
| | 115, 230 | 5 | 502556 |
| | | | 502557 |

| COMPONENT ARRANGEMENTS | | | |
|------------------------|---------|---------------|------------------------|
| Unit 30HXA,C | Voltage | Figure Number | Label Diagram No. 30HX |
| 076-186 | ALL | 6 | 502301 |
| 206-271 | ALL | 7 | 502356 |

NOTE: For operating sequence, refer to Controls, Start-Up, Operation, Service, and Troubleshooting literature.

LEGEND

| | | | |
|--------------|--------------------------------------|---|---|
| ALM | — Alarm | S | — Shorting |
| C | — Contactor, Compressor | SCB | — Screw Compressor Board |
| CB | — Circuit Breaker | SEC | — Secondary |
| CCP | — ComfortLink™ Compressor Protection | SN | — Sensor (Toroid) |
| CFR | — Condenser Fan Relay | SPT | — Suction Pressure Transducer |
| CNFS | — Condenser Flow Switch | SW | — Switch |
| CNP | — Condenser Pump | T | — Thermistor |
| CNPI | — Condenser Pump Interlock | TB | — Terminal Block |
| COMP | — Compressor | TEMP | — Temperature |
| CWFS | — Chilled Water Flow Switch | TRAN | — Transformer |
| CWP | — Chilled Water Pump | XL | — Across-the-Line |
| CWPI | — Chilled Water Pump Interlock | 1W | — Wye |
| DGT | — Discharge Gas Thermistor | 2W | — Delta |
| DPT | — Discharge Pressure Transducer |  | Terminal Block Connection |
| EMM | — Energy Management |  | Marked Terminal |
| EPT | — Economizer Pressure Transducer |  | Unmarked Terminal |
| EQUIP | — Equipment |  | Unmarked Splice |
| EWI | — Entering Water |  | Marked Wire |
| EXV | — Electronic Expansion Valve |  | Marked Splice |
| FU | — Fuse |  | Factory Wiring |
| GND | — Ground |  | Field Control Wiring |
| HTR | — Heater |  | Field Power Wiring |
| HPS | — High-Pressure Switch |  | Indicates common potential. (Does not represent wiring.) |
| LWT | — Leaving Water |  | Accessories or Options |
| LDR | — Loader | | |
| LL | — Liquid Level | | |
| MBB | — Main Base Board | | |
| MLV | — Minimum Load Valve | | |
| OAT | — Outdoor-Air Thermistor | | |
| OLS | — Oil Level Switch | | |
| OPC | — Oil Pump Contactor | | |
| OPT | — Oil Pressure Transducer | | |
| PL | — Plug Assembly | | |

NOTES

1. Three-phase motors protected against primary single phasing conditions.
2. Replacement of original wires must be with type 105° C wire or its equivalent.
3. Numbers on the right side of label diagrams indicate the line location of applicable contacts. An underlined number signifies normally closed contacts. A plain number denotes normally open contacts. Line numbers are shown on the left side of the diagrams.
4. Factory wiring is in accordance with National Electrical Code (NEC) U.S.A. Field modifications or additions must be in compliance with all applicable codes.
5. Wiring for main field power supply must be rated 75° C minimum. Use copper for all units. Maximum incoming wire size for each terminal block is 500 kcmil.
6. Power for control circuit should be supplied from a separate source (except 380, 380/415 v units) through a field-supplied disconnect with 15-amp maximum protection for 115-volt control circuits and 15-amp maximum protection for 230-volt control circuit. Connect control circuit power to terminals 1 and 2 of TB4. Connect neutral side of supply to terminal 2 of TB4. Control circuit conductors for all units must be copper only. Control circuit power is factory wired for 380, 380/415-v units.
7. Terminals 13 and 14 of TB5 are for field external interlock connection for remote on-off and terminals 1 and 2 of TB5 for CWP interlock. Terminals 5 and 6 of TB2 are for CNP interlock and CNFS. The contacts must be rated for dry circuit application capable of handling a 24-v ac to 50 mA load.
8. Terminals 10 and 12 of TB5 are for control of chilled water pump starter. Terminals 11 and 12 of TB5 are for alarm. The maximum allowable load for each of these circuits is 75-va sealed.
9. Terminals 7 and 9 of TB2 are for condenser fan contactor A (HXA) or condenser water pump (HXC). Terminals 8 and 9 of TB2 are for condenser fan contactor B (HXA). The maximum allowable load for each of these circuits is 360 va inrush, 75 va sealed. Separate field power supply is not required.

30HX076-186

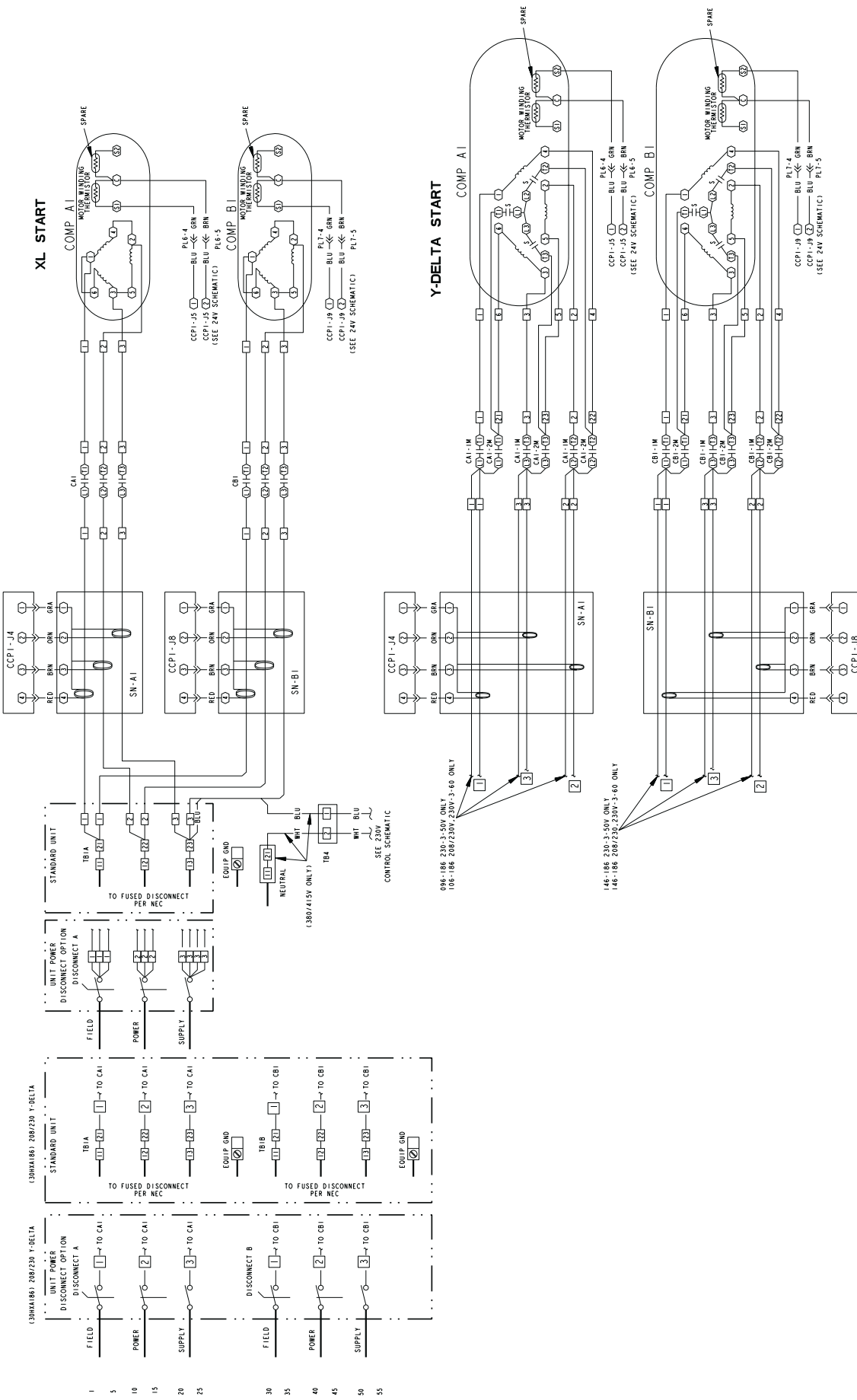
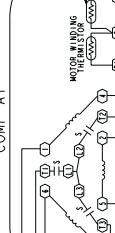
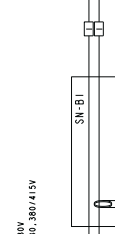
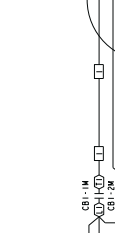
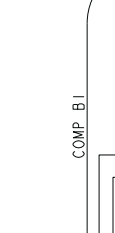
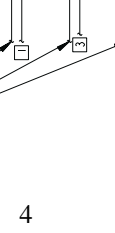
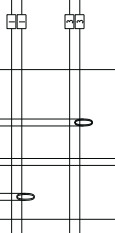
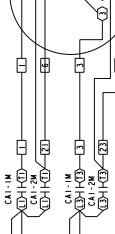
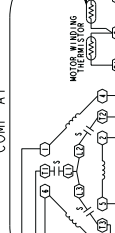
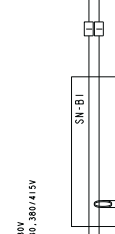
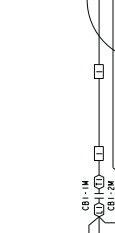
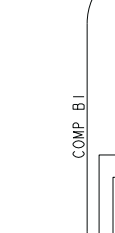
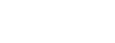
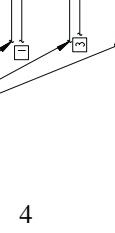
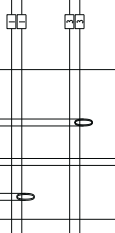
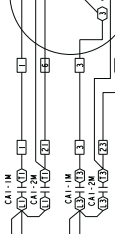
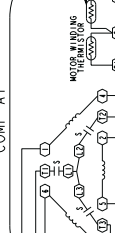
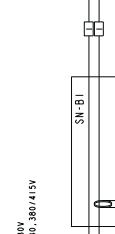
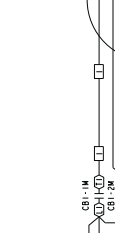
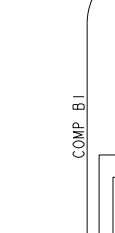
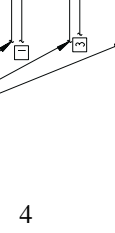
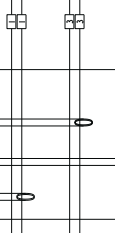
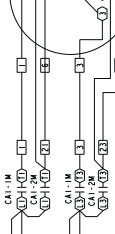
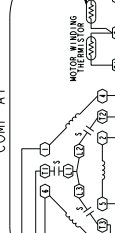
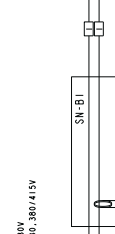
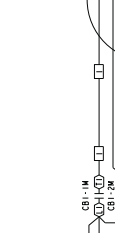
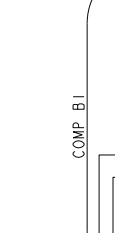
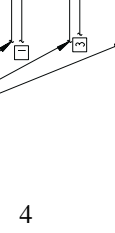
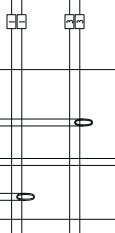
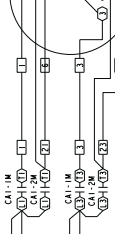
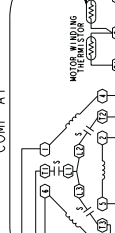
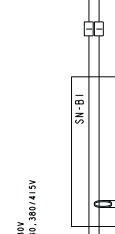
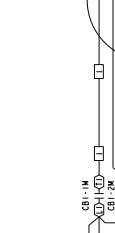
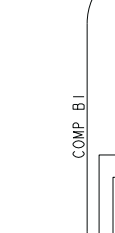
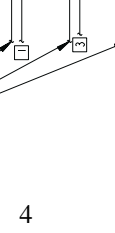
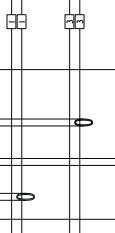
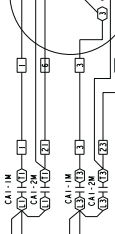
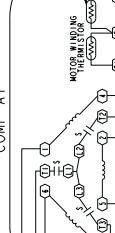
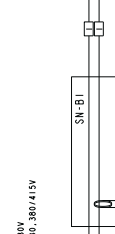
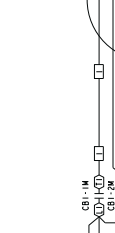
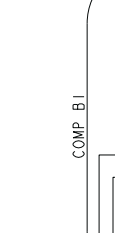
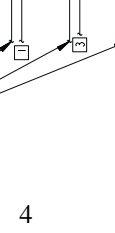
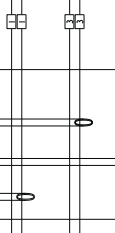
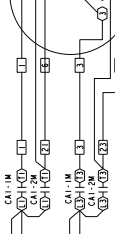
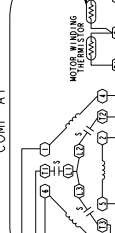
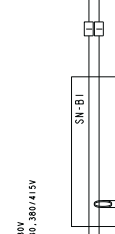
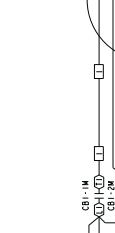
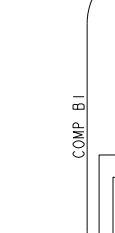
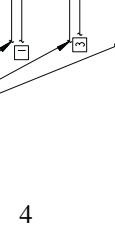
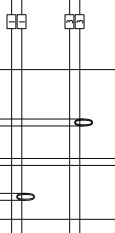
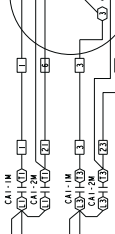
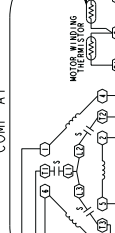
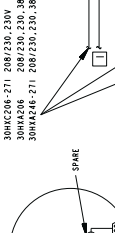
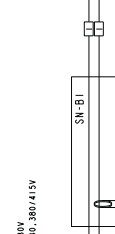
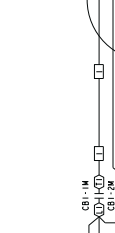
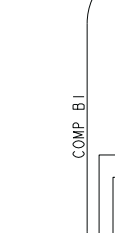
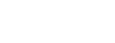
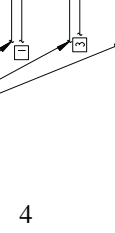
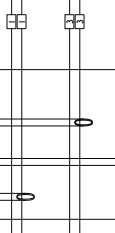
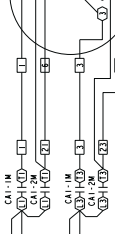
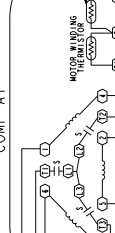
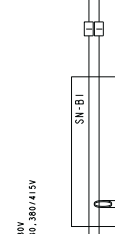
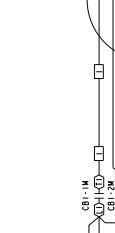
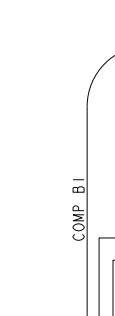
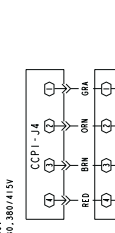
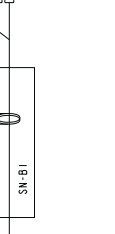
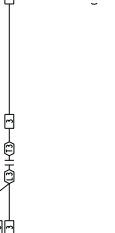
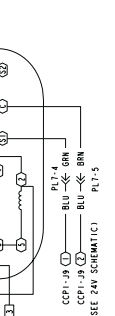
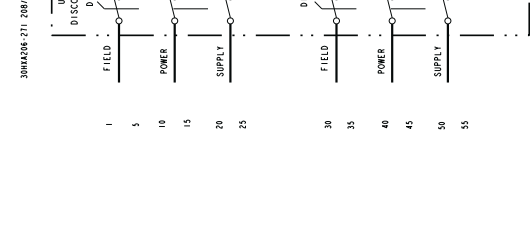
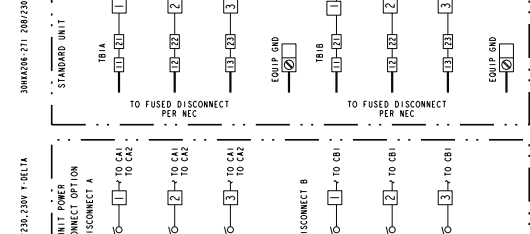
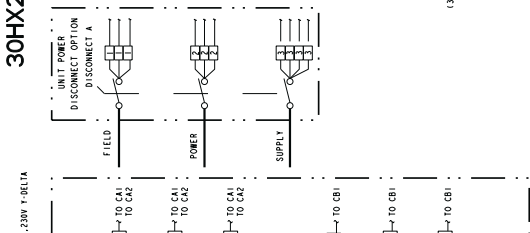
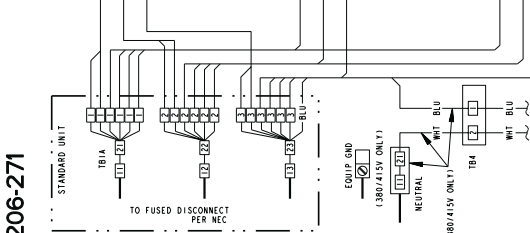
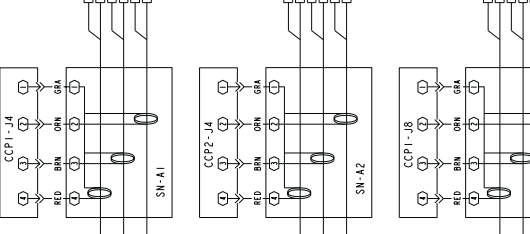
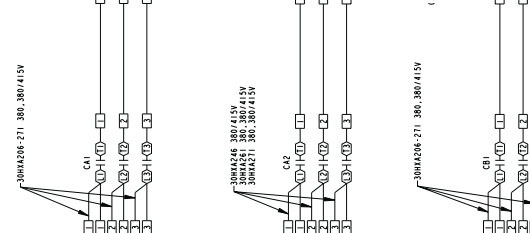
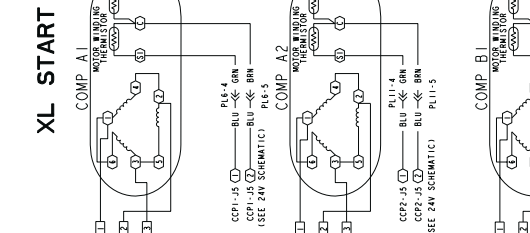
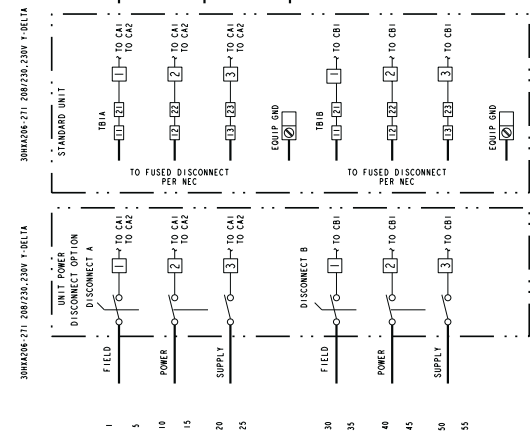

Fig. 1 — Power Wiring, 30HX076-186

30HX206-271



**COMFORTLINK
LOW VOLTAGE (24V) CONTROL SCHEMATIC
30HX076-271**

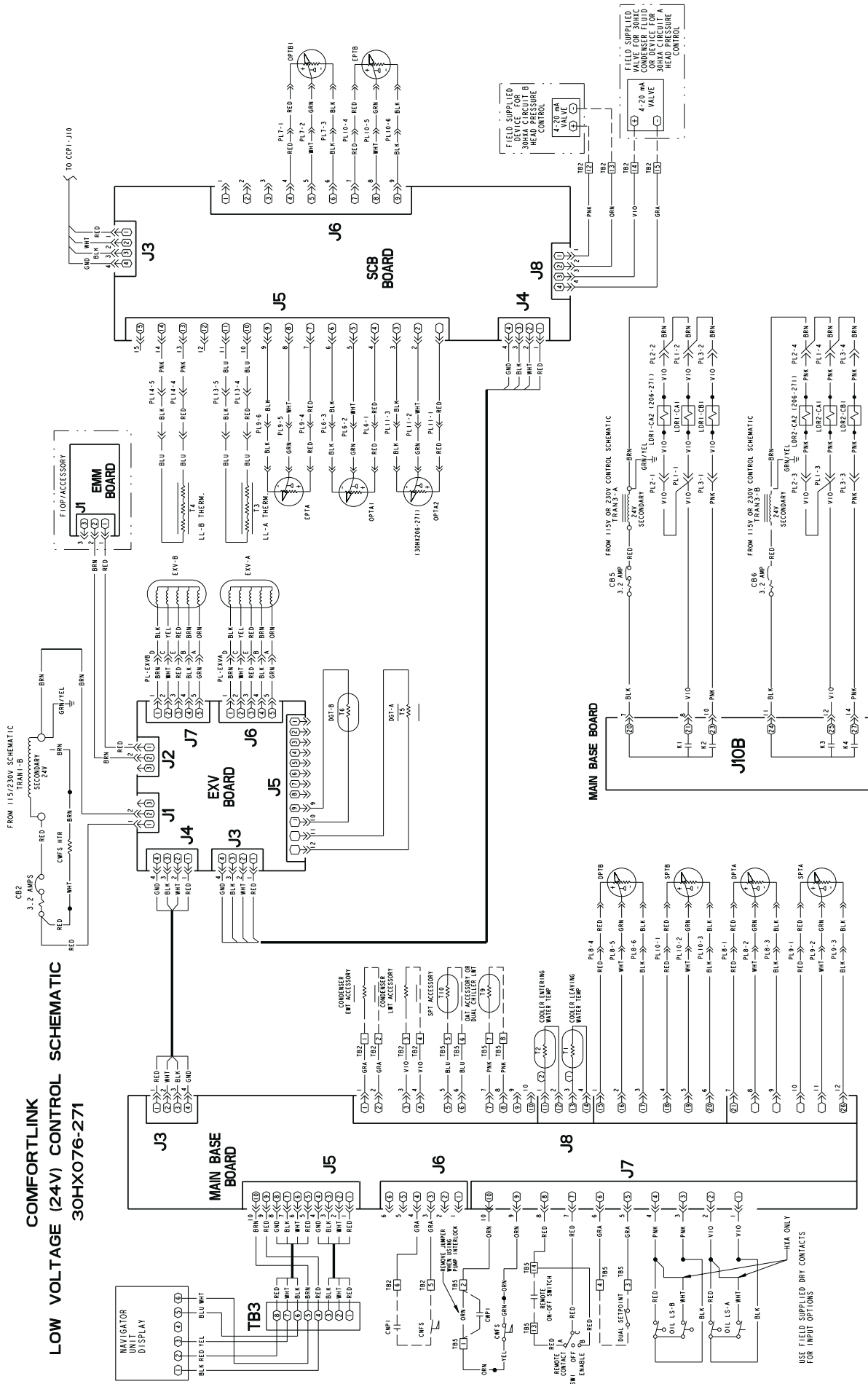

Fig. 3 — Control Wiring, 24 v, Low Voltage 30HX076-271

**COMFORTLINK
(24V) CONTROL SCHEMATIC
30HX076-271**

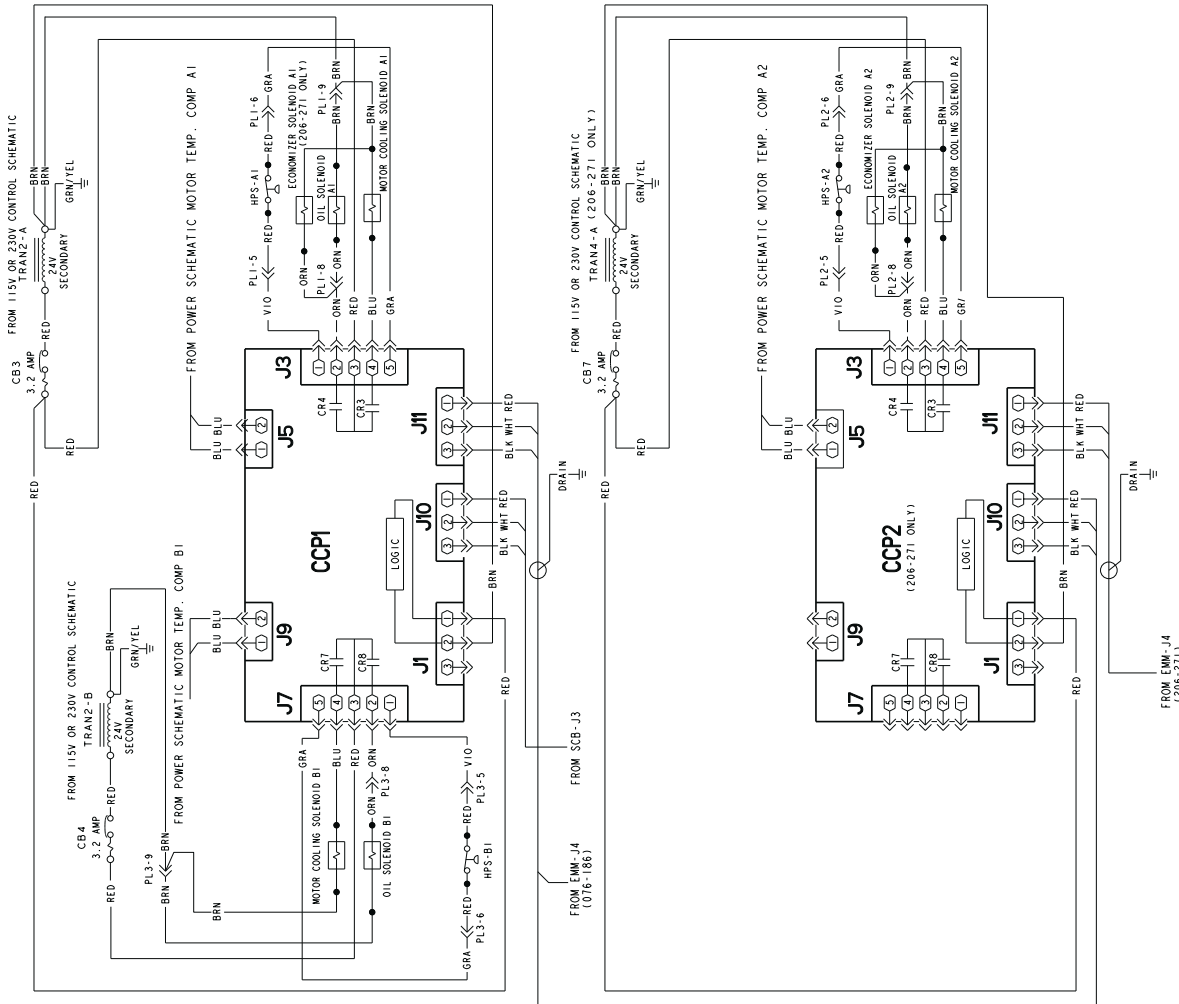
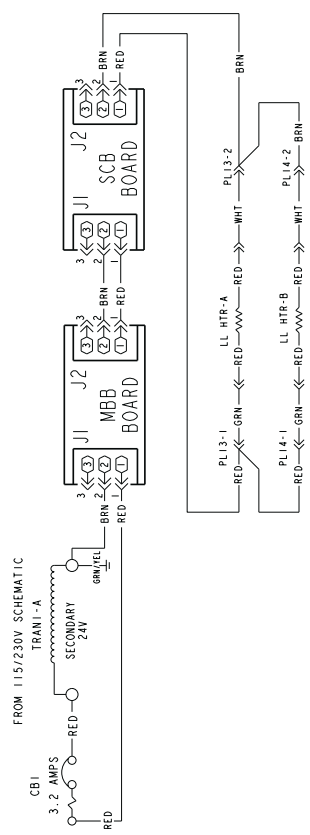
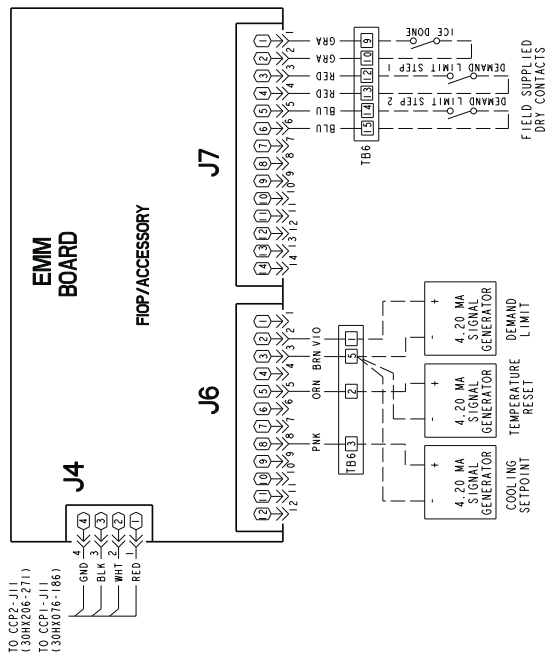
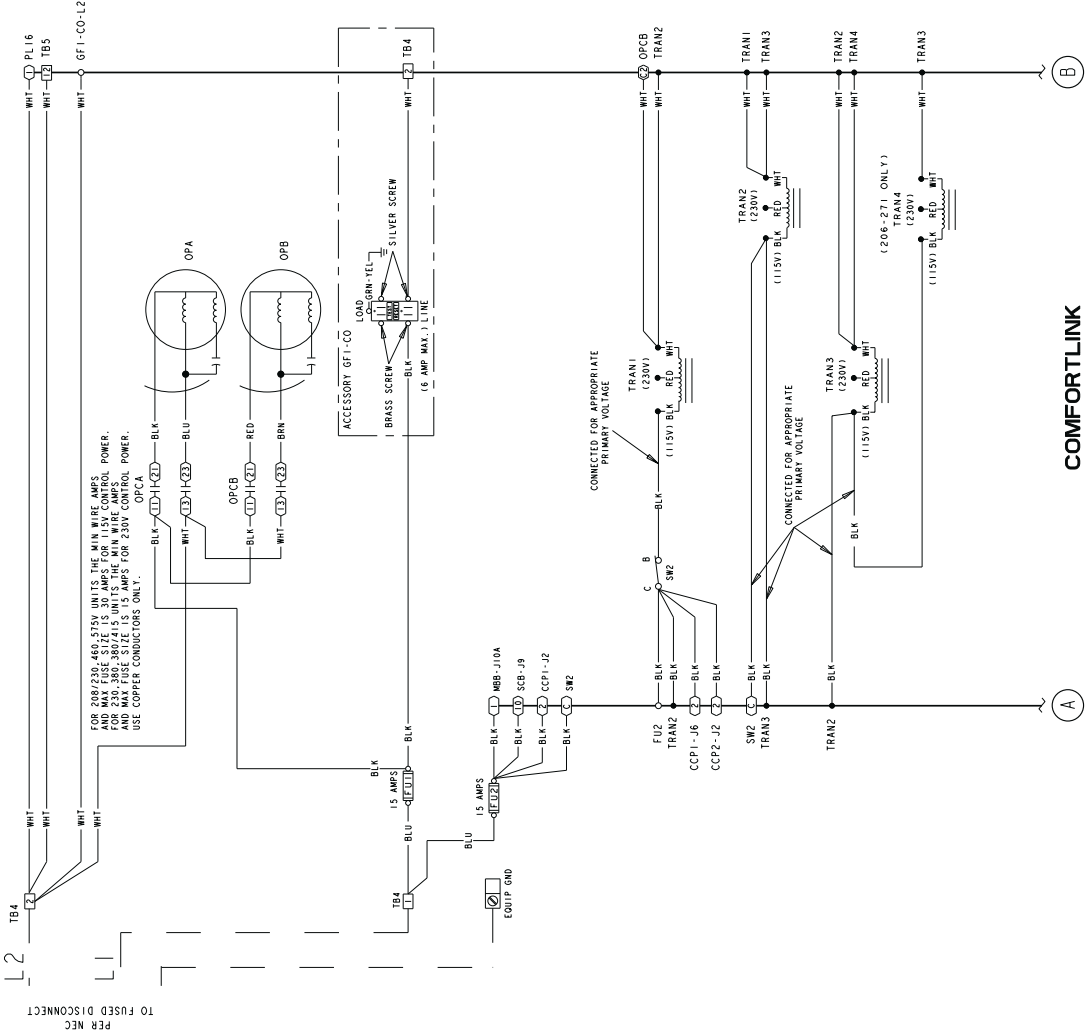
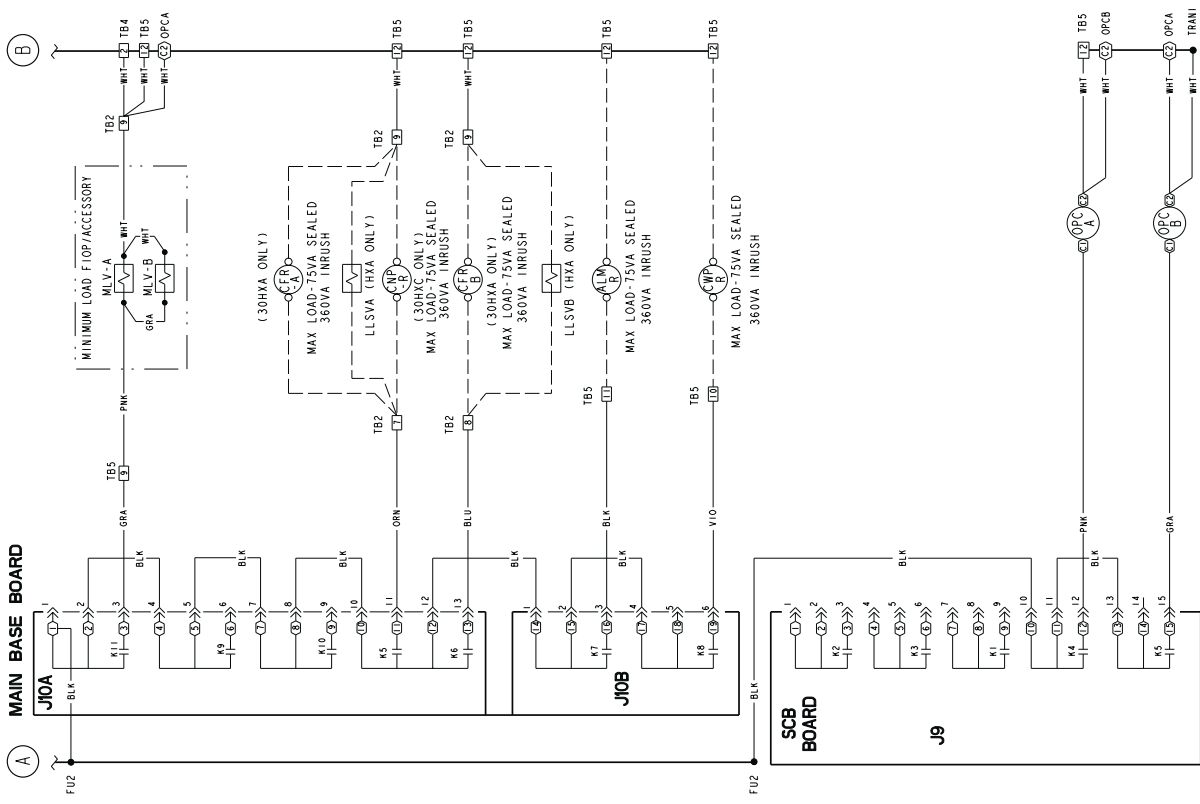

Fig. 4 — Control Wiring, 24 v, 30HX076-271





**COMFORTLINK
(115 OR 230V) CONTROL SCHEMATIC
30HX076-271**

Fig. 5 — Control Wiring, 115 or 230 v, 30HX076-271

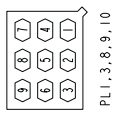
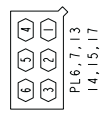
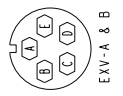
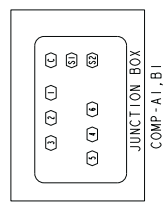
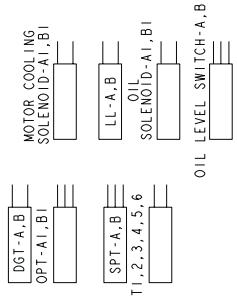
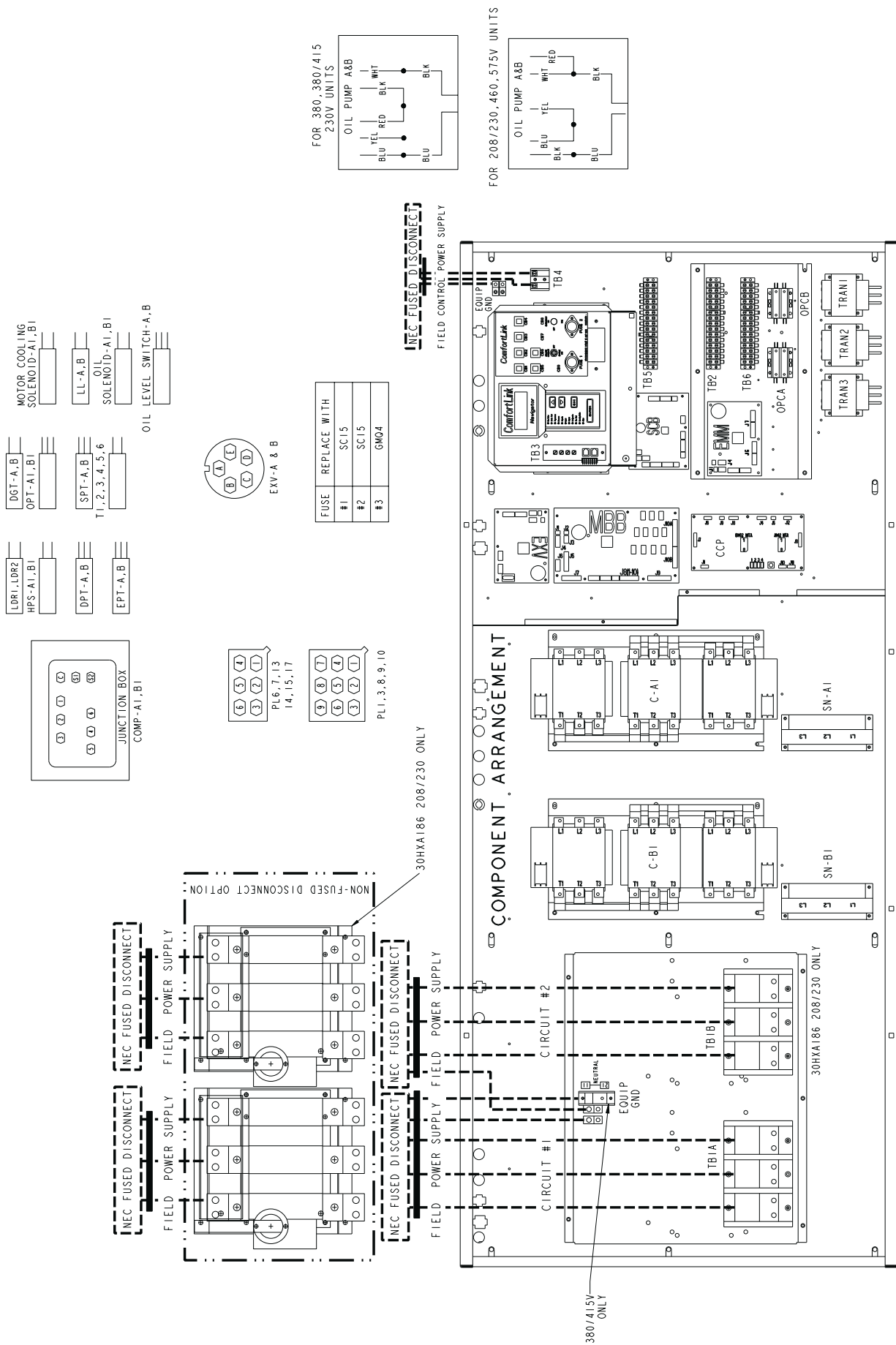

| FUSE | REPLACE WITH |
|------|--------------|
| #1 | SC15 |
| #2 | SC15 |
| #3 | GM04 |

NEC FUSED DISCONNECT

30HX186 208/230 ONLY

30HX186 208/230 ONLY

COMPONENT ARRANGEMENT

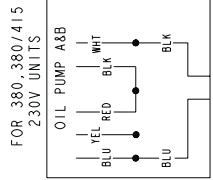

FOR 208/230, 460, 575V UNITS

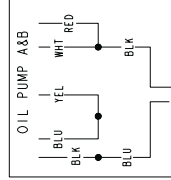

Fig. 6 — Component Arrangement, 30HX076-186

