



Installation Instructions

Part Numbers: 00EFN900000400A, 00EFN900000500A, 00EFN900000600A,
00EFN900000700A, 00EFN900001800A, 00EFN900001900A

CONTENTS

	Page
SAFETY CONSIDERATIONS	1
GENERAL	1
INSPECT SHIPMENT	1,2
INSTALLATION	3-16
Step 1 — Install Field-Fabricated Wind Baffles	3
Step 2 — Wire the Control Panel	4
Step 3 — Mount Low Ambient Temperature Head Pressure Control	9
Step 4 — Configure Unit for Low Ambient Temperature Head Pressure Control Operation	13
Step 5 — Configure Low Ambient Temperature Head Pressure Control	15
Step 6 — Test the Low Ambient Temperature Head Pressure Control	16
TROUBLESHOOTING	16

SAFETY CONSIDERATIONS

Installation, start-up, and servicing air-conditioning can be hazardous due to system pressures, electrical components, and equipment location.

Only trained, qualified installers and service technicians should install, start up, and service this equipment.

When working on air-conditioning equipment, observe precautions in the literature and on tags, stickers, and labels attached to the equipment. Follow all safety codes. Wear safety glasses and work gloves.

⚠ WARNING

Electric shock can cause serious personal injury or death. Shut off all power to this equipment during installation and service. Tag all disconnect locations to alert others not to restore power until work is completed. Be aware that there may be more than one disconnect.

GENERAL

This book contains instructions for the installation of the low ambient temperature head pressure control accessory kit for 30RB060-390 and 30XA080-500 units.

NOTE: Unit sizes 30RB315-390 are modular units that are shipped in separate sections as modules A or B as noted in position 8 of the unit model nameplate. The nameplate for modular units contains only the first two digits of the unit size. For example, 30RB size 315 nameplates read 30RBA31A.... and 30RBA31B..... See Table 1 for a listing of unit sizes and modular combinations.

Table 1 — Modular Combinations

MODULE UNITS	MODULE A	MODULE B
30RBA315	30RBA160	30RBA160
30RBA330	30RBA170	30RBA160
30RBA345	30RBA170	30RBA170
30RBA360	30RBA190	30RBA170
30RBA390	30RBA190	30RBA190

NOTE: An "A" in the 5th position of the model number indicates the design series.

The low ambient temperature control utilizes a variable frequency drive (VFD) to control condenser fan speed based on saturated condensing temperature. The control can only be used with motors rated for use with VFDs. Each circuit's discharge pressure is used by the *ComfortLink™* controls to determine the output to the VFD. The fan board(s) provide a 0 to 10 vdc output to each drive for fan speed control.

All VFDs are microprocessor-controlled and use insulated gate bipolar transistor (IGBT) technology. The pulse width modulation scheme used by the control allows for quiet motor operation. The VFD will vary the motor speed to drive the saturated condensing temperature to the set point. At higher saturated condensing temperatures, the fan will go to full speed and remain there since it cannot go fast enough to bring the pressure down to the set point. When the VFD is at full speed, it operates like a fixed speed fan.

When the saturated condensing temperature drops, a fan running at full speed may draw too much air across the condenser coil to maintain a minimum saturated condensing temperature. During these conditions, the VFD will begin to slow down and begin to maintain a saturated condensing temperature set point.

NOTE: The VFD is phase insensitive in regard to incoming line voltage, which means that the VFD will operate with any phase sequence of the incoming three-phase power.

The standard outdoor-air temperature limitation of 30RB and 30XA chillers is 32 F (0° C). The low ambient temperature controller operation kit can be used to extend unit operation down to -20 F (-29 C).

NOTE: Wind baffles are required if wind velocity is anticipated to be greater than 5 mph (8 km/h).

INSPECT SHIPMENT

Inspect the contents of the accessory package before installing. File a claim with the shipping company if there is shipping damage. Contact your local Carrier representative if any parts are missing. See Table 2 for accessory content usage. See Table 3 for accessory package contents.

Table 2 — Low Ambient Temperature Head Pressure Control Package Usage

UNIT	SIZE	VOLTAGE* (3 ph, 60 Hz)	NUMBER OF CIRCUITS	PACKAGE NO.	NUMBER OF ACCESSORY KITS REQUIRED
30RB	060, 070, 080	208/230	2	00EFN900000600A	1
		380	2	00EFN900000400A	1
		460	2	00EFN900000400A	1
		575	2	00EFN900001800A	1
	090,100,110,120, 130,150,160,170,190	208/230	2	00EFN900000700A	2
		380	2	00EFN900000500A	2
		460	2	00EFN900000500A	2
		575	2	00EFN900001900A	2
	210,225,250,275,300	208/230	3	00EFN900000700A	3
		380	3	00EFN900000500A	3
		460	3	00EFN900000500A	3
		575	3	00EFN900001900A	3
	315,330,345,360,390	208/230	4	00EFN900000700A	4
		380	4	00EFN900000500A	4
		460	4	00EFN900000500A	4
		575	4	00EFN900001900A	4
30XA	080,090,100,110,120,140, 160,180,200,220,240,260, 280,300,325,350	200	2	00EFN900000700A	2
		230	2	00EFN900000700A	2
		380	2	00EFN900000500A	2
		460	2	00EFN900000500A	2
		575	2	00EFN900001900A	2
	400,450,500	380	3	00EFN900000500A	3
		460	3	00EFN900000500A	3
		575	3	00EFN900001900A	3

*Refer to unit nameplate for voltage designation.

Table 3 — Low Ambient Temperature Head Pressure Control Package Contents

ITEM	LOW AMBIENT TEMPERATURE HEAD PRESSURE CONTROL PACKAGE NUMBER					
	00EFN900000400A (380 v, 460 v units)	00EFN900000500A (380 v, 460 v units)	00EFN900000600A (200, 208/230 v units)	00EFN900000700A (200, 208, 230 v units)	00EFN900001800A (575 v units)	00EFN900001900A (575 v units)
Item Description (Qty)						
Dual VFD Panel Accessory (includes 2 VFDs)	SF700168* (1)	—	SF700166* (1)	—	SF700170* (1)	—
Single VFD Panel Accessory	—	SF700167* (1)	—	SF700165* (1)	—	SF700169* (1)
Fan Motor Power Cables (attached to VFD)	(2)	(1)	(2)	(1)	(2)	(1)
Fuse Block	CHCC3 (2)	CHCC3 (1)	CHCC3 (2)	CHCC3 (1)	CHCC3 (2)	CHCC3 (1)
Fuses, 30 Amp	ATMR-30 (6)	ATMR-30 (3)	ATMR-30 (6)	ATMR-30 (3)	ATMR-30 (6)	ATMR-30 (3)
Variable Frequency Drive†	6SE6420UD222BA1 (1)	6SE6420UD222BA1 (1)	6SE6420UC222BA1 (1)	6SE6420UC222BA1 (1)	6SE64402UE240CA1 (1)	6SE64402UE240CA1 (1)
VFD Operator Display Panel	6SE6400BP000AAO (2)	6SE6400BP000AAO (1)	6SE6400BP000AAO (2)	6SE6400BP000AAO (1)	6SE6400BP000AAO (2)	6SE6400BP000AAO (1)
Mounting Plate	00PSN500037100A (2)	00PSN500037100A (1)	00PSN500037100A (2)	00PSN500037100A (1)	00PSN500037100A (2)	00PSN500037100A (1)
Support Plate	00PSN500034400A (2)	00PSN500034400A (1)	00PSN500034400A (2)	00PSN500034400A (1)	00PSN500034400A (2)	00PSN500034400A (1)
Wiring Cover	00PSN500036500A (2)	00PSN500036500A (1)	00PSN500036500A (2)	00PSN500036500A (1)	00PSN500036500A (2)	00PSN500036500A (1)
Wiring Bushing	HY93NH085 (2)	HY93NH085 (1)	HY93NH085 (2)	HY93NH085 (1)	HY93NH085 (2)	HY93NH085 (1)
6mm Screws	00PPN500000302A (18)	00PPN500000302A (9)	00PPN500000302A (18)	00PPN500000302A (9)	00PPN500000302A (18)	00PPN500000302A (9)
8mm Screws	00PPN500000201A (18)	00PPN500000201A (9)	00PPN500000201A (18)	00PPN500000201A (9)	00PPN500000201A (18)	00PPN500000201A (9)
Fan Board 1	32GB500442E**					
Wire Ties	Wire Ties (20)					

LEGEND

AWG — American Wire Gage
VFD — Variable Frequency Drive

*Includes the panel, drives, fuse block, fuses, drive filters, drive wire kit and operator display panel.

†When ordering the VFD for replacement note that the replacement drive does not include the VFD operator panel. The VFD operator panel must be ordered separately.

**Fan board shipped in accessory kit is supplied to replace fan board 1 shipped with the unit (part number 32GB500432E). See page 9, Step 10 for more information.

INSTALLATION

Step 1 — Install Field-Fabricated Wind Baffles

⚠ WARNING

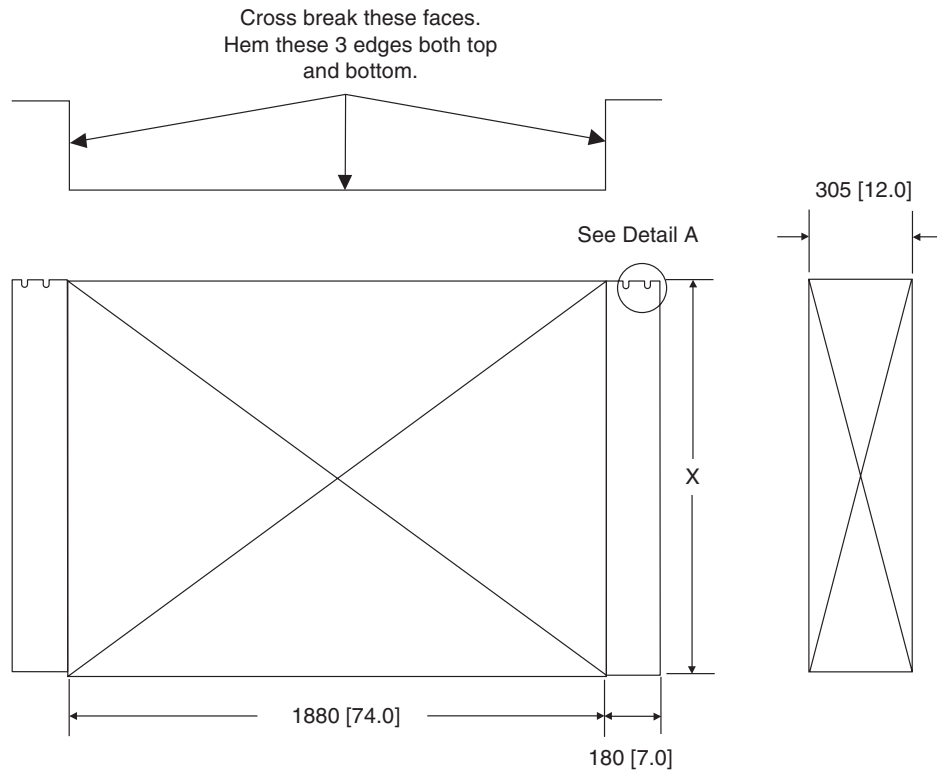
To avoid the possibility of electrical shock, open all disconnects before installing or servicing this accessory.

Field-fabricated and installed wind baffles are required if the wind velocity is anticipated to be greater than 5 mph (8 km/h) on units equipped with the low ambient temperature head pressure control accessory. If the application requires wind baffles, units require two different wind baffle designs, one for both ends of the unit. Wind baffles should be constructed using a minimum 18-gage galvanized sheet metal or other suitable corrosion-resistant material with cross breaks for strength. Use field-supplied screws to attach baffles to the corner posts of the machine. Be sure to hem or turn a flange on all edges to

eliminate sharp edges on the baffles. See Fig. 1 for sizes and details of the baffles required. Mount the smaller height baffle on the control box end. It is recommended that the upper notches be used for mounting the baffles. This reduces the risk of damaging the coil while drilling a mounting hole. Loosen the upper corner post bolts and slide the baffle under the bolt and washer. Tighten the bolt. Drill two holes at the bottom of the baffle through the flange and corner post. Mount baffles with field-supplied screws to secure the baffle to the frame. Repeat the process for the opposite end. See Fig. 2 for typical end views of the chillers with baffles installed.

⚠ CAUTION

To avoid damage to refrigerant coils and electrical components, use extreme care when drilling screw holes and screwing in fasteners.



30RB UNIT SIZE	POSITION	BAFFLE HEIGHT (X)
060-390	Control/Power End	635 [25.0]
	Opposite Control Power End	1040 [41.0]

Material: 18 ga. Corrosion Resistant Sheet Metal.
Dimensions are in mm [inches].

30XA UNIT SIZE	POSITION	BAFFLE HEIGHT	
		Right End	Left End
080-120	Facing Control Box End	1040 [41.0]	635 [25.0]
140-500	Facing Control Box Side	1040 [41.0]	1040 [41.0]

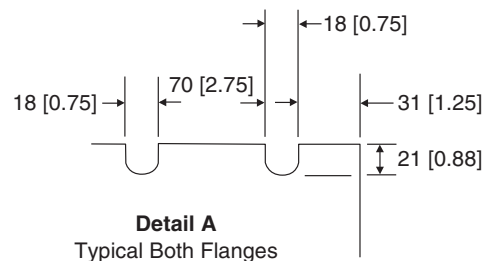


Fig. 1 — Field-Fabricated and Field-Installed Wind Baffles

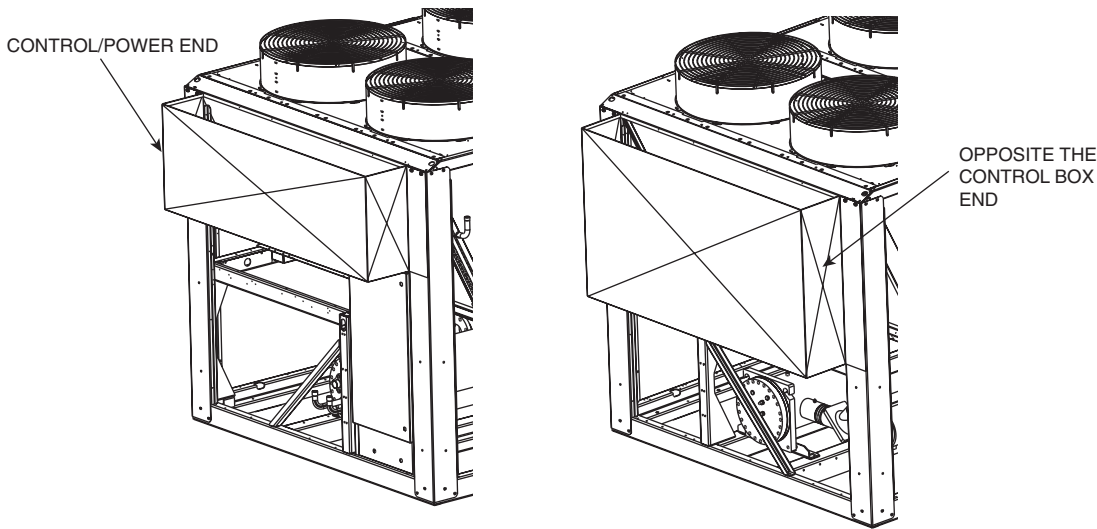


Fig. 2 — Wind Baffles Installed on Ends of 30RB Units

Step 2 — Wire the Control Panel — For the appropriate fan motor, locate the fan contactor in the control panel. See Tables 4A and 4B. See Fig. 3A and 3B for fan motor locations.

NOTE: The C circuit fan contactors and fan board for 30RB250-300 units are in the compressor side power box near the C circuit compressors and not in the fan/control box at the end of the unit. Fan wiring crosses the chiller in a conduit from the coil wiring tray to the back of the C circuit power box.

NOTE: The C circuit fan contactors and fan board for 30XA400-500 units are in the compressor side power box near the C circuit compressors.

Table 4A — 30RB060-390 Fan Motors Controlled by the VFD

30RB UNIT SIZE	CIRCUIT A MOTOR	CIRCUIT B MOTOR	CIRCUIT C MOTOR
060,070	FM1	FM4	—
080	FM1	FM3	—
090-150	FM1	FM5	—
160-190, 315-390	FM1	FM7	—
210-250	FM1	FM5	FM9
275, 300	FM1	FM7	FM13

Table 4B — 30XA080-500 Fan Motors Controlled by the VFD

30XA UNIT SIZE	CIRCUIT A MOTOR	CIRCUIT B MOTOR	CIRCUIT C MOTOR
080	FM5	FM1	—
090-120	FM7	FM1	—
140, 160	FM9	FM1	—
180, 200	FM11	FM1	—
220, 240	FM13	FM1	—
260-300	FM15	FM1	—
325, 350	FM17	FM1	—
400	FM11	FM1	FM19
450, 500	FM13	FM1	FM21

Follow the steps below for each circuit:

1. Remove fan contactor coil wiring to terminals A1 and A2. Using field-supplied wire nuts, cap these wires off individually.
2. Remove the line side wiring from terminals L1, L2 and L3. Do not cap these.
3. Remove the load side wiring from terminals T1, T2, T3 and the fan motor ground wire. The fan motor cable must be pulled out of the control panel and back into the appropriate VFD panel.
4. Remove the contactor from the DIN rail and install a fuse block in its place.
5. Connect the line side wiring removed in Step 2 to the line side of the fuse block.
6. Install 3 fuses in the fuse block and close the fuse block cover.
7. Repeat Steps 1 through 6 for the appropriate motor on each circuit. See Fig. 4 for an example of a 30RB210 chiller with the three fuse blocks installed. See Fig. 5 for a view of typical wiring before and after installation.

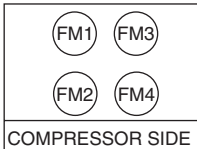
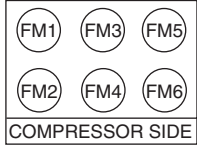
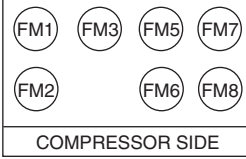
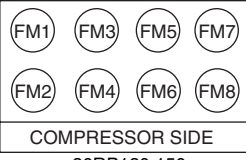
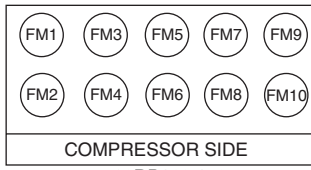
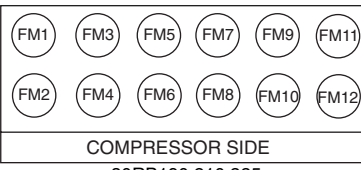
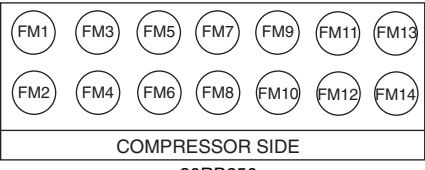
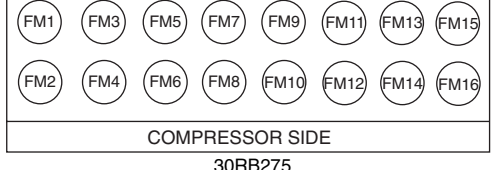
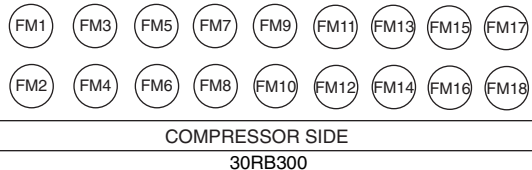
	UNIT SIZE	CIRCUIT	LOCATION	FAN STAGE					
				1	2	3	4	5	6
 <p>COMPRESSOR SIDE 30RB060,070,080</p>	060,070	A	Fan Position	1	3	2	—	—	—
			Fan Board/Channel	FB1/CH1	FB1/CH2	FB1/CH3	—	—	—
		B	Fan Position	4	—	—	—	—	—
			Fan Board/Channel	FB1/CH5	—	—	—	—	—
080	A	Fan Position	1	2	—	—	—		
		Fan Board/Channel	FB1/CH1	FB1/CH2	—	—	—		
B	Fan Position	3	4	—	—	—			
	Fan Board/Channel	FB1/CH5	FB1/CH6	—	—	—			
 <p>COMPRESSOR SIDE 30RB090,100,110</p>	090,100,110	A	Fan Position	1	3	2	—	—	
			Fan Board/Channel	FB1/CH1	FB1/CH2	FB1/CH3	—	—	
		B	Fan Position	5	4	6	—	—	
			Fan Board/Channel	FB1/CH5	FB1/CH6	FB1/CH7	—	—	
 <p>COMPRESSOR SIDE 30RB120</p>	120	A	Fan Position	1	3	2	—	—	
			Fan Board/Channel	FB1/CH1	FB1/CH3/2	FB1/CH2/3	—	—	
		B	Fan Position	5	7	6	8	—	
			Fan Board/Channel	FB1/CH5	FB1/CH6	FB1/CH7	FB1/CH8	—	
 <p>COMPRESSOR SIDE 30RB130,150</p>	130,150	A	Fan Position	1	3	2	4	—	
			Fan Board/Channel	FB1/CH1	FB1/CH2	FB1/CH3	FB1/CH4	—	
		B	Fan Position	5	7	6	8	—	
			Fan Board/Channel	FB1/CH5	FB1/CH6	FB1/CH7	FB1/CH8	—	
 <p>COMPRESSOR SIDE 30RB160,170</p>	160,170	A	Fan Position	1	3	5	2	4	6
			Fan Board/Channel	FB1/CH1	FB1/CH2	FB1/CH3	FB1/CH4	FB1/CH5	FB1/CH6
		B	Fan Position	7	9	8	10	—	
			Fan Board/Channel	FB2/CH1	FB2/CH2	FB2/CH3	FB2/CH4	—	
 <p>COMPRESSOR SIDE 30RB190,210,225</p>	190	A	Fan Position	1	3	5	2	4	6
			Fan Board/Channel	FB1/CH1	FB1/CH2	FB1/CH3	FB1/CH4	FB1/CH5	FB1/CH6
	B	Fan Position	7	9	11	8	10	12	
		Fan Board/Channel	FB2/CH1	FB2/CH2	FB2/CH3	FB2/CH4	FB2/CH5	FB2/CH6	
	210,225	A	Fan Position	1	3	2	4	—	
			Fan Board/Channel	FB1/CH1	FB1/CH2	FB1/CH3	FB1/CH4	—	
B		Fan Position	5	7	6	8	—		
		Fan Board/Channel	FB1/CH5	FB1/CH6	FB1/CH7	FB1/CH8	—		
C	Fan Position	9	11	10	12	—			
	Fan Board/Channel	FB3/CH1	FB3/CH2	FB3/CH3	FB3/CH4	—			
 <p>COMPRESSOR SIDE 30RB250</p>	250	A	Fan Position	1	3	2	4	—	
			Fan Board/Channel	FB1/CH1	FB1/CH2	FB1/CH3	FB1/CH4	—	
		B	Fan Position	5	7	6	8	—	
			Fan Board/Channel	FB1/CH5	FB1/CH6	FB1/CH7	FB1/CH8	—	
		C	Fan Position	9	11	13	10	12	14
			Fan Board/Channel	FB3/CH1	FB3/CH2	FB3/CH3	FB3/CH4	FB3/CH5	FB3/CH6
 <p>COMPRESSOR SIDE 30RB275</p>	275	A	Fan Position	1	3	5	2	4	6
			Fan Board/Channel	FB1/CH1	FB1/CH2	FB1/CH3	FB1/CH4	FB1/CH5	FB1/CH6
		B	Fan Position	7	9	11	8	10	12
			Fan Board/Channel	FB2/CH1	FB2/CH2	FB2/CH3	FB2/CH4	FB2/CH5	FB2/CH6
		C	Fan Position	13	15	14	16	—	—
			Fan Board/Channel	FB3/CH1	FB3/CH2	FB3/CH3	FB3/CH4	—	—
 <p>COMPRESSOR SIDE 30RB300</p>	300	A	Fan Position	1	3	5	2	4	6
			Fan Board/Channel	FB1/CH1	FB1/CH2	FB1/CH3	FB1/CH4	FB1/CH5	FB1/CH6
		B	Fan Position	7	9	11	8	10	12
			Fan Board/Channel	FB2/CH1	FB2/CH2	FB2/CH3	FB2/CH4	FB2/CH5	FB2/CH6
		C	Fan Position	13	15	17	14	16	18
			Fan Board/Channel	FB3/CH1	FB3/CH2	FB3/CH3	FB3/CH4	FB3/CH5	FB3/CH6

Fig. 3A — 30RB Fan Motor Locations

UNIT SIZE	CIRCUIT	LOCATION	FAN STAGE									
<p>30XA080</p>	A	Fan Output Ckt A	1	2	3	4	5	6	7	—		
		Contactor Number	FC A1	FC A2	FC A3	—	FC B1	FC B2	FC B3	—		
		Fan Position	FM5	FM3	FM6	—	FM1	FM4	FM2	—		
	B	Fan Output Ckt B	1	2	3	4	5	6	7	—		
		Contactor Number	FC A1	FC A2	FC A3	—	FC B1	FC B2	FC B3	—		
		Fan Position	FM5	FM3	FM6	—	FM1	FM4	FM2	—		
<p>30XA090-120</p>	A	Fan Output Ckt A	1	2	3	4	5	6	7	8		
		Contactor Number	FC A1	FC A2	FC A3	FC A4	FC B1	FC B2	FC B3	FC B4		
		Fan Position	FM7	FM5	FM8	FM6	FM1	FM3	FM2	FM4		
	B	Fan Output Ckt B	1	2	3	4	5	6	7	8		
		Contactor Number	FC A1	FC A2	FC A3	FC A4	FC B1	FC B2	FC B3	FC B4		
		Fan Position	FM7	FM5	FM8	FM6	FM1	FM3	FM2	FM4		
<p>30XA140, 160</p>	A	Fan Output Ckt A	1	2	3	4	5	6	—	—		
		Contactor Number	FC A1	FC A2	FC A3	FC A4	FC A5	FC A6	—	—		
		Fan Position	FM9	FM7	FM5	FM10	FM8	FM6	—	—		
	B	Fan Output Ckt B	1	2	3	4	—	—	—	—		
		Contactor Number	FC B1	FC B2	FC B3	FC B4	—	—	—	—		
		Fan Position	FM1	FM2	FM3	FM4	—	—	—	—		
<p>30XA180, 200</p>	A	Fan Output Ckt A	1	2	3	4	5	6	—	—		
		Contactor Number	FC A1	FC A2	FC A3	FC A4	FC A5	FC A6	—	—		
		Fan Position	FM11	FM9	FM7	FM12	FM10	FM8	—	—		
	B	Fan Output Ckt B	1	2	3	4	5	6	—	—		
		Contactor Number	FC B1	FC B2	FC B3	FC B4	FC B5	FC B6	—	—		
		Fan Position	FM1	FM3	FM5	FM2	FM4	FM6	—	—		
<p>30XA220, 240</p>	A	Fan Output Ckt A	1	2	3	4	5	6	7	—		
		Contactor Number	FC A1	FC A2	FC A3	FC A4	FC A5	FC A6	FC A7	—		
		Fan Position	FM13	FM11	FM9	FM7	FM14	FM12	FM10	—		
	B	Fan Output Ckt B	1	2	3	4	5	6	—	—		
		Contactor Number	FC B1	FC B2	FC B3	FC B4	FC B5	FC B6	—	—		
		Fan Position	FM1	FM3	FM5	FM2	FM4	FM6	—	—		
<p>30XA260</p>	A	Fan Output Ckt A	1	2	3	4	5	6	7	8		
		Contactor Number	FC A1	FC A2	FC A3	FC A4	FC A5	FC A6	FC A7	FC A8	FC A9	
		Fan Position	FM15	FM13	FM11	FM9	FM7	FM16	FM14	FM12	FM10	
	B	Fan Output Ckt B	1	2	3	4	5	6	—	—		
		Contactor Number	FC B1	FC B2	FC B3	FC B4	FC B5	FC B6	—	—		
		Fan Position	FM1	FM3	FM5	FM2	FM4	FM6	—	—		
<p>30XA280</p>	A	Fan Output Ckt A	1	2	3	4	5	6	7	8		
		Contactor Number	FC A1	FC A2	FC A3	FC A4	FC A5	FC A6	FC A7	FC A8	FC A9	
		Fan Position	FM15	FM13	FM11	FM9	FM7	FM16	FM14	FM12	FM10	
	B	Fan Output Ckt B	1	2	3	4	5	6	7	—		
		Contactor Number	FC B1	FC B2	FC B3	FC B4	FC B5	FC B6	FC B7	—		
		Fan Position	FM1	FM3	FM5	FM8	FM2	FM4	FM6	—		
<p>30XA300</p>	A	Fan Output Ckt A	1	2	3	4	5	6	7	8		
		Contactor Number	FC A1	FC A2	FC A3	FC A4	FC A5	FC A6	FC A7	FC A8	FC A9	FC A10
		Fan Position	FM15	FM13	FM11	FM9	FM7	FM16	FM14	FM12	FM10	FM8
	B	Fan Output Ckt B	1	2	3	4	5	6	—	—		
		Contactor Number	FC B1	FC B2	FC B3	FC B4	FC B5	FC B6	—	—		
		Fan Position	FM1	FM3	FM5	FM2	FM4	FM6	—	—		
<p>30XA325, 350</p>	A	Fan Output Ckt A	1	2	3	4	5	6	7	8		
		Contactor Number	FC A1	FC A2	FC A3	FC A4	FC A5	FC A6	FC A7	FC A8	FC A9	
		Fan Position	FM17	FM15	FM13	FM11	FM9	FM18	FM16	FM14	FM12	
	B	Fan Output Ckt B	1	2	3	4	5	6	7	8		
		Contactor Number	FC B1	FC B2	FC B3	FC B4	FC B5	FC B6	FC B7	FC B8	FC B9	
		Fan Position	FM1	FM3	FM5	FM7	FM10	FM2	FM4	FM6	FM8	

LEGEND

- Ckt** — Circuit
COMP — Compressor
FC — Fan Contactor
FM — Fan Motor
PEB — Power Electrical Box

Fig. 3B — 30XA Fan Motor Locations

UNIT SIZE	CIRCUIT	LOCATION	FAN STAGE																																												
<table border="1" style="width: 100%; text-align: center;"> <tr> <td colspan="3">COMP B</td> <td colspan="3">PEB A/B</td> <td colspan="3">COMP A</td> <td colspan="3">PEB</td> <td colspan="3">COMP C</td> </tr> <tr> <td>FM1</td><td>FM3</td><td>FM5</td><td>FM7</td><td>FM9</td><td>FM11</td><td>FM13</td><td>FM15</td><td>FM17</td><td>FM19</td> <td>FM2</td><td>FM4</td><td>FM6</td><td>FM8</td><td>FM10</td><td>FM12</td><td>FM14</td><td>FM16</td><td>FM18</td><td>FM20</td> </tr> </table> <p style="text-align: center;">30XA400</p>	COMP B			PEB A/B			COMP A			PEB			COMP C			FM1	FM3	FM5	FM7	FM9	FM11	FM13	FM15	FM17	FM19	FM2	FM4	FM6	FM8	FM10	FM12	FM14	FM16	FM18	FM20	A	Fan Output Ckt A	1	2	3	4	5	6	—	—		
	COMP B			PEB A/B			COMP A			PEB			COMP C																																		
	FM1	FM3	FM5	FM7	FM9	FM11	FM13	FM15	FM17	FM19	FM2	FM4	FM6	FM8	FM10	FM12	FM14	FM16	FM18	FM20																											
	Contactor Number	FC A1	FC A2	FC A3	FC A4	FC A5	FC A6	—	—																																						
	Fan Position	FM11	FM9	FM7	FM12	FM10	FM8	—	—																																						
	B	Fan Output Ckt B	1	2	3	4	5	6	—	—																																					
		Contactor Number	FC B1	FC B2	FC B3	FC B4	FC B5	FC B6	—	—																																					
		Fan Position	FM1	FM3	FM5	FM2	FM4	FM6	—	—																																					
	C	Fan Output Ckt C	1	2	3	4	5	6	7	8																																					
		Contactor Number	FC C1	FC C2	FC C3	FC C4	FC C5	FC C6	FC C7	FC C8																																					
		Fan Position	FM19	FM17	FM15	FM13	FM20	FM18	FM16	FM14																																					
	<table border="1" style="width: 100%; text-align: center;"> <tr> <td colspan="3">COMP B</td> <td colspan="3">PEB A/B</td> <td colspan="3">COMP A</td> <td colspan="3">PEB C</td> <td colspan="3">COMP C</td> </tr> <tr> <td>FM1</td><td>FM3</td><td>FM5</td><td>FM7</td><td>FM9</td><td>FM11</td><td>FM13</td><td>FM15</td><td>FM17</td><td>FM19</td><td>FM21</td> <td>FM2</td><td>FM4</td><td>FM6</td><td>FM8</td><td>FM10</td><td>FM12</td><td>FM14</td><td>FM16</td><td>FM18</td><td>FM20</td><td>FM22</td> </tr> </table> <p style="text-align: center;">30XA450, 500</p>	COMP B			PEB A/B			COMP A			PEB C			COMP C			FM1	FM3	FM5	FM7	FM9	FM11	FM13	FM15	FM17	FM19	FM21	FM2	FM4	FM6	FM8	FM10	FM12	FM14	FM16	FM18	FM20	FM22	A	Fan Output Ckt A	1	2	3	4	5	6	7
COMP B			PEB A/B			COMP A			PEB C			COMP C																																			
FM1		FM3	FM5	FM7	FM9	FM11	FM13	FM15	FM17	FM19	FM21	FM2	FM4	FM6	FM8	FM10	FM12	FM14	FM16	FM18	FM20	FM22																									
Contactor Number		FC A1	FC A2	FC A3	FC A4	FC A5	FC A6	FC A7	FC A8																																						
Fan Position		FM13	FM11	FM9	FM7	FM14	FM12	FM10	FM8																																						
B		Fan Output Ckt B	1	2	3	4	5	6	—	—																																					
		Contactor Number	FC B1	FC B2	FC B3	FC B4	FC B5	FC B6	—	—																																					
		Fan Position	FM1	FM3	FM5	FM2	FM4	FM6	—	—																																					
C		Fan Output Ckt C	1	2	3	4	5	6	7	8																																					
		Contactor Number	FC C1	FC C2	FC C3	FC C4	FC C5	FC C6	FC C7	FC C8																																					
		Fan Position	FM21	FM19	FM17	FM15	FM22	FM20	FM18	FM16																																					

LEGEND

- Ckt** — Circuit
- COMP** — Compressor
- FC** — Fan Contactor
- FM** — Fan Motor
- PEB** — Power Electrical Box

Fig. 3B — 30XA Fan Motor Locations (cont)

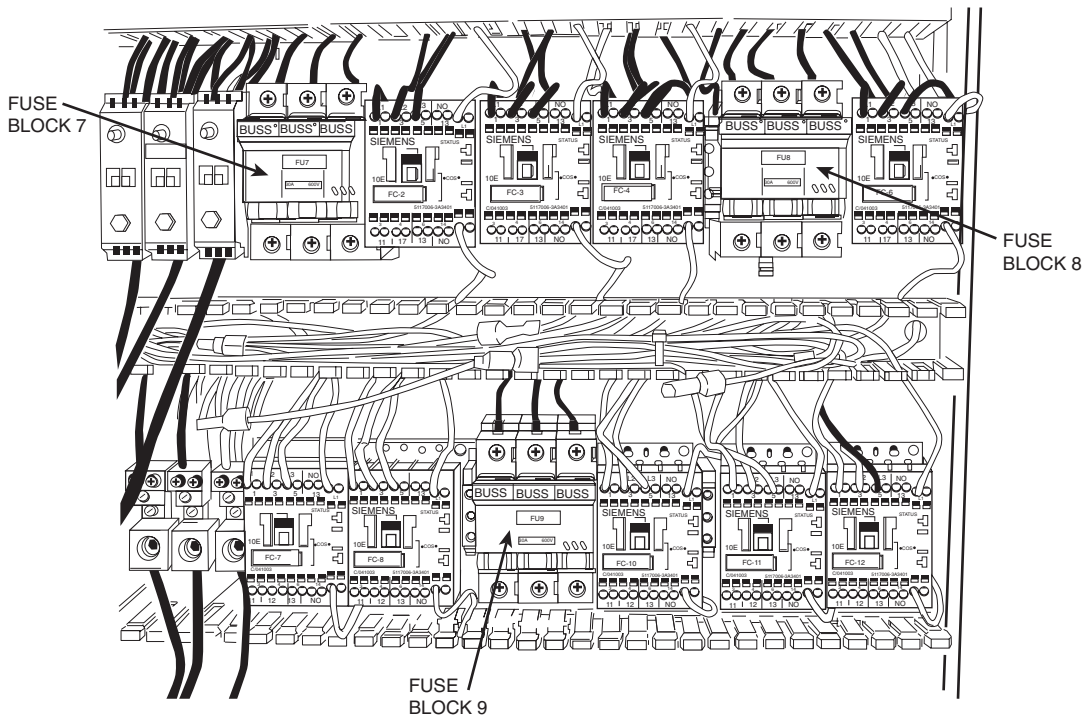


Fig. 4 — Fuse Blocks Installed in Control Panel (30RB210 Unit Shown)

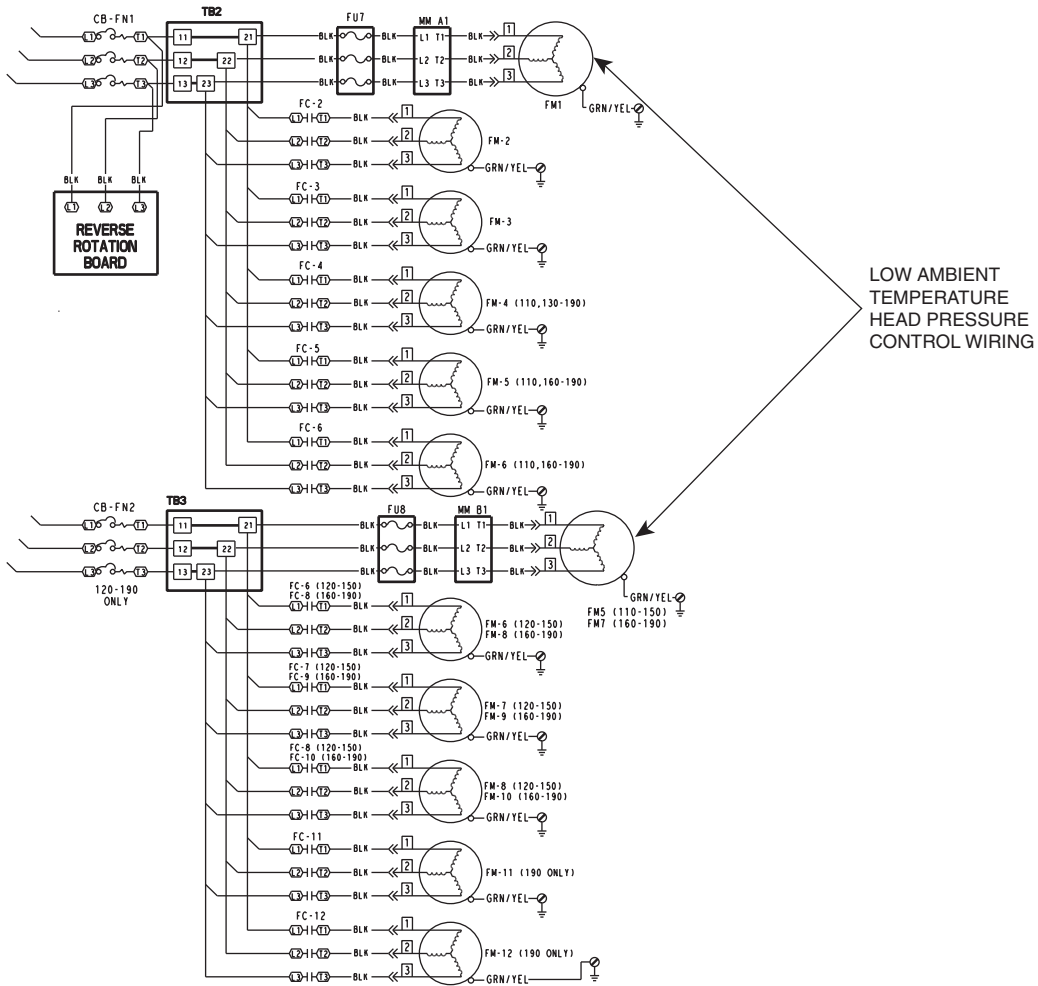


Fig. 5 — Typical Wiring, 30RB060-390 and 30XA080-500 After Low Ambient Temperature Head Pressure Control Installed (30RB110-190 Shown)

Step 3 — Mount the Low Ambient Temperature Head Pressure Control

⚠ WARNING

To avoid electric shock and personal injury open and tag all electrical disconnects before installing or servicing unit. Be aware that there may be more than one disconnect.

⚠ DANGER

Hazard of electric shock! Wait three minutes after disconnecting incoming power before servicing drive. Capacitors retain charge after power is removed.

All units require mounting one mounting plate (Fig. 6), support plate (Fig. 7) and one wiring cover (Fig. 8) per VFD panel assembly. See Fig. 9A and 9B for drive mounting locations and the fan number for each circuit.

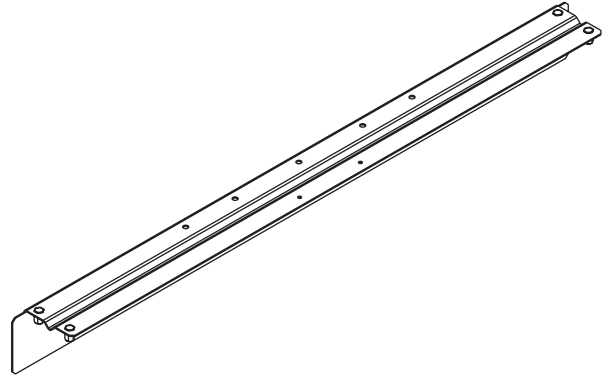
1. Remove the existing wiring tray cover (four 6-mm screws). Retain all screws for later use.
2. The fan motor cables removed from the contactors in the control panel must be routed into the appropriate drive. Locate these cables and pull them back to the drive location. A tag indicating 'Motormaster Option' is secured to the odd numbered fan from each condenser section and should be visible with the tray cover removed.
3. Install the support plate first to the bottom side of the coil rail using 4 of the 8-mm screws supplied.
4. Position the drive in place on this rail and let the front edge rest on the outer coil rail. Secure the back of the drive in place to the rail with one (single VFD panel) or two 8-mm screws (dual VFD panel). Note that the screws come from below and should engage into threaded inserts in the drive panel. See Fig. 10.

NOTE: The 30RB060-080 units contain a *dual VFD panel*, which are two VFDs, one for each circuit, located in one large enclosure. The 30RB090-300 and 30XA080-500 units contain a *single VFD panel*, which is one VFD inside one enclosure, one for each circuit.

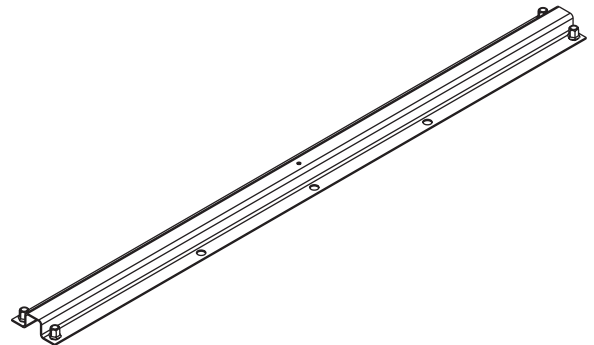
5. Snap the plastic bushing into the hole in the front support rail. See Fig. 11.
6. Pull the existing motor wiring back through this bushing and up into the drive panel. Connect terminals 1, 2 and 3 of the cable to drive terminals U, V and W. The drive should already have existing line wiring, signal wiring (red to 3, black to 4) and two jumpers (2-4 and 5-8 for 200, 208/230, 380 and 460 v; for 575 v, the jumper is connected to 5-9) in place. Ground wires connect to the marked terminals at the bottom front of the drive. See Fig. 12.
7. Route the line side power and signal cables from the drive through the bushing in the opposite direction. These cables go to the main control panel. Connect the line power cable to the appropriate fuse block (FU7 for Circuit A, FU8 for Circuit B or FU9 for Circuit C).
8. Install the mounting plate to the bottom side of the coil rail using (4) of the 8-mm screws supplied. Secure the cover portion of the rail in place using (4) of the 6-mm screws supplied. Secure the front of the drive to the front support rail (screws install from below) with the 6-mm screws supplied. See Fig. 12 for a view of the inside of the drive panel once installed.
9. Using three 6-mm screws supplied, install a wiring cover underneath each panel.
10. For sizes 30RB060-150, replace the existing fan board 1 in the chiller control panel with the one supplied with the kit. Set the new board address to match the old board.

Similarly, for sizes 30RB160-190 and modular unit sizes 30RB315-390, replace both fan boards 1 and 2; for sizes 30RB210-250 replace fan board 1; for sizes 30RB275 and 300 replace both fan boards 1 and 2. For sizes 30RB210-300, it is not necessary to replace fan board 3.

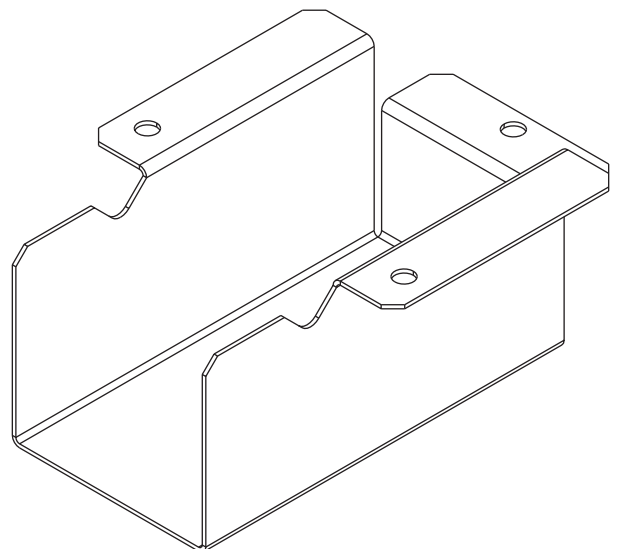
11. The installation kit contains a two-wire assembly with a two-pin connector on one end and quick connects on the other. Connect the signal wiring from each drive to the quick connects (red from cable to violet, black from cable to brown). Plug the two-pin connector into the appropriate fan board according to Tables 5A and 5B. See Fig. 13A and 13B for typical fan board wiring.



**Fig. 6 — Mounting Plate
(Front Support/Coil Tray Cover)
(P/N 00PSN500037100A)**

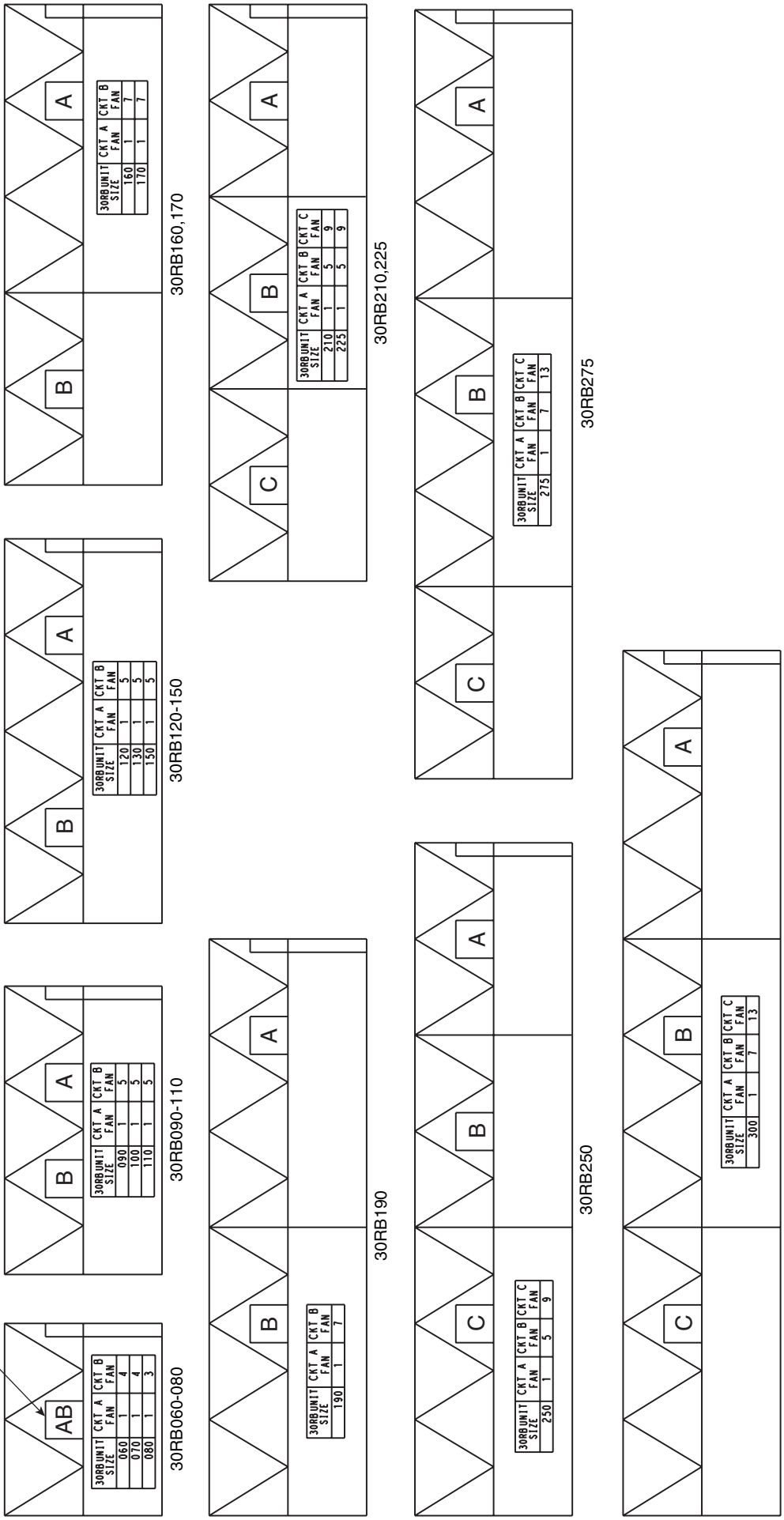


**Fig. 7 — Support Plate (Back Support Rail)
(P/N 00PSN500034400A)**



**Fig. 8 — Wiring Cover
(P/N 00PSN500036500A)**

VFD LOCATION



LEGEND
 CKT — Circuit
 □ VFD

Fig. 9A — 30RB VFD Panel and Fan Location

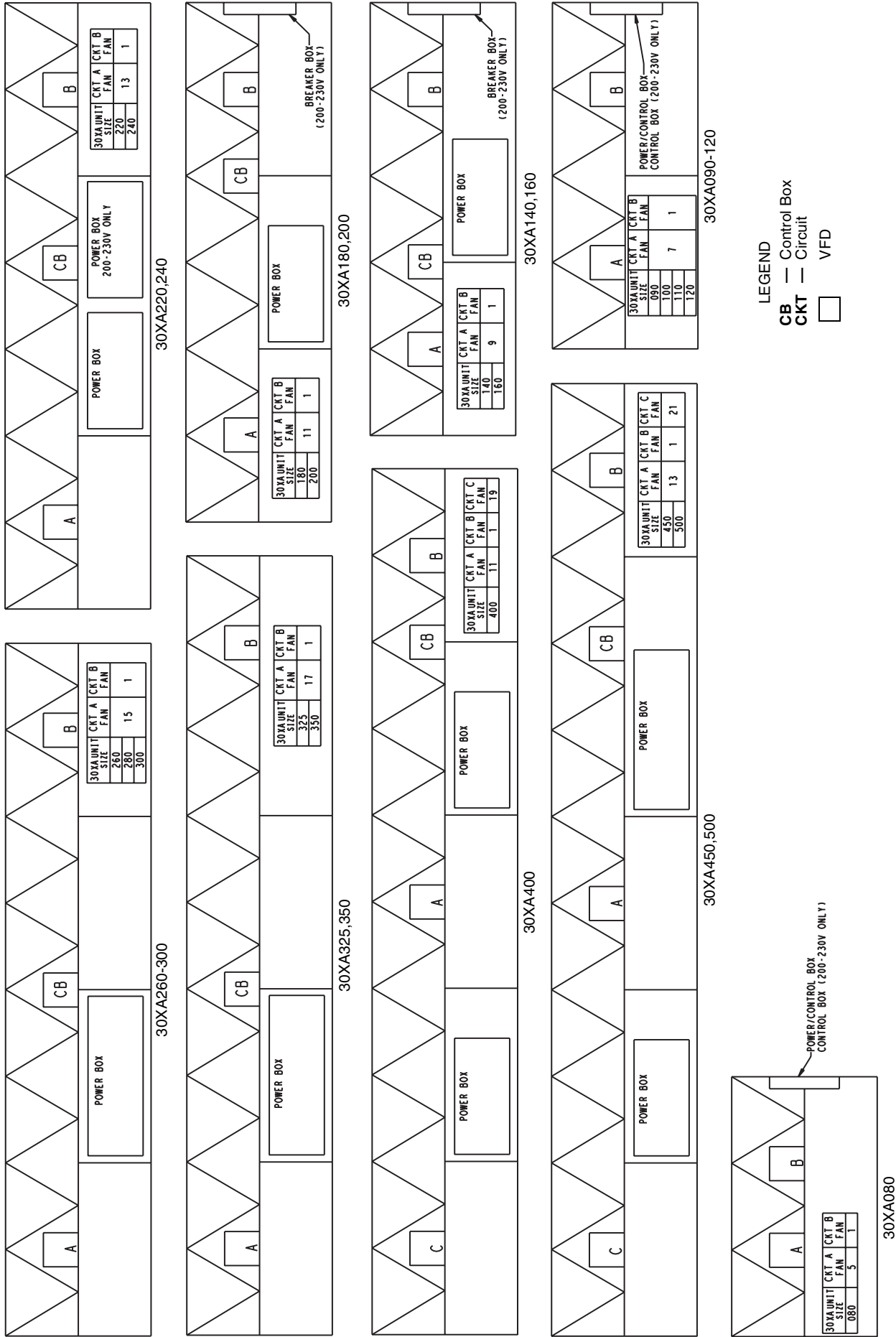


Fig. 9B — 30XA VFD Panel and Fan Location

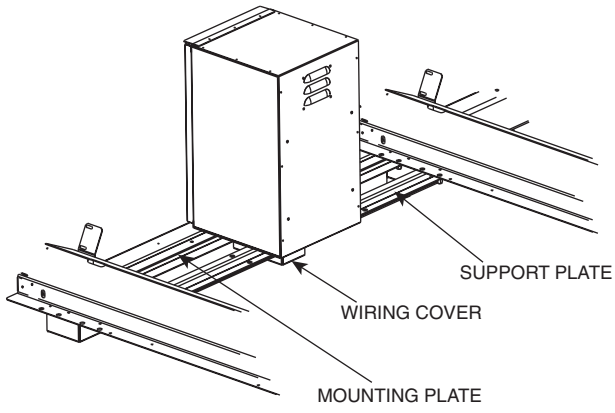


Fig. 10 — Low Ambient Temperature Head Pressure Control Mounting

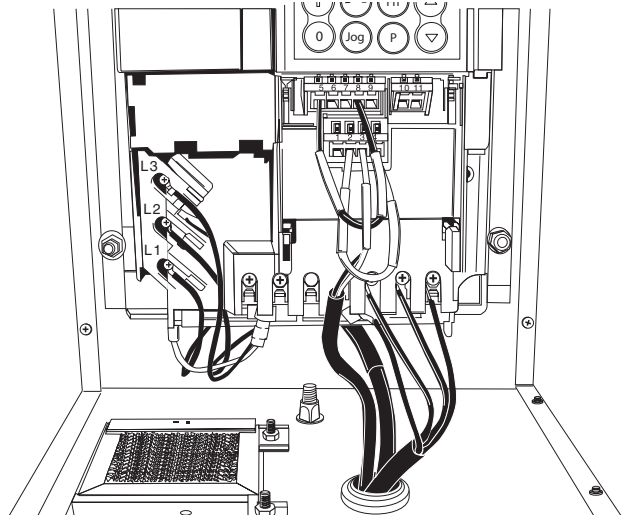


Fig. 12 — Low Ambient Temperature Head Pressure Control Wiring

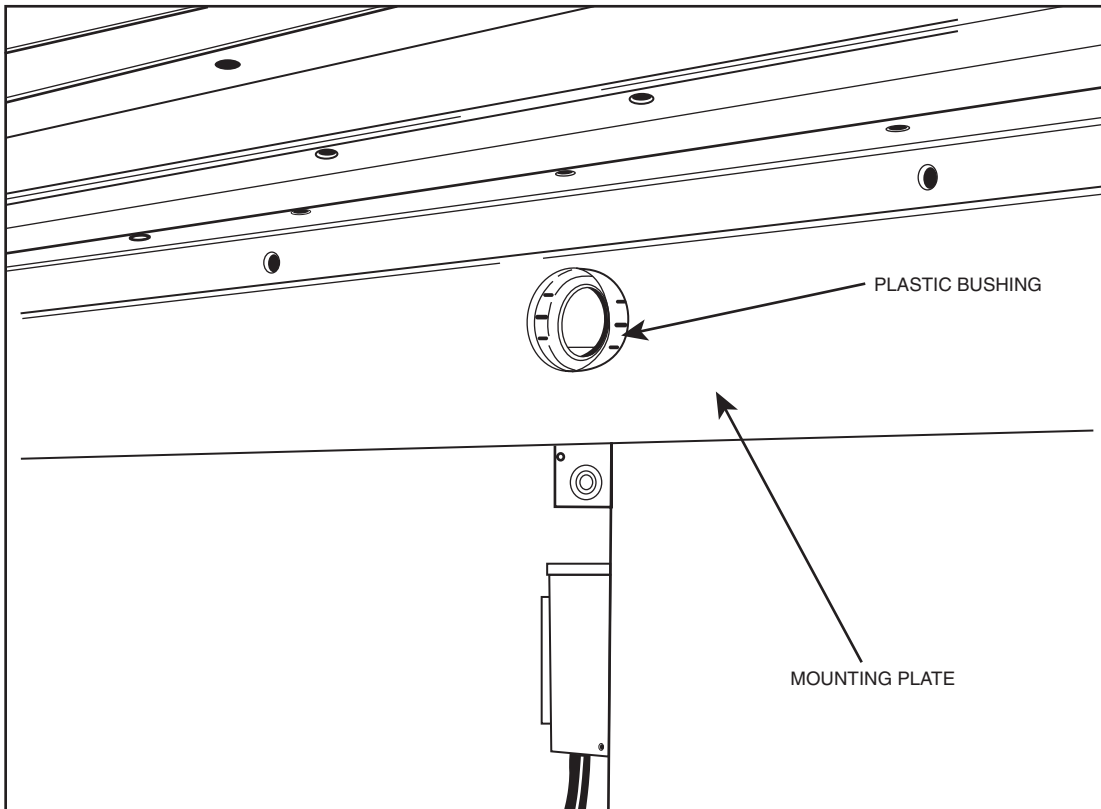


Fig. 11 — Plastic Bushing into Hole Mounting Plate

Table 5A — 30RB060-390 Controller Signal Wiring Location

30RB UNIT SIZE	CIRCUIT A	CIRCUIT B	CIRCUIT C
060-150	Fan Board 1, Channel 9	Fan Board 1, Channel 10	—
160-190, 315-390	Fan Board 1, Channel 9	Fan Board 2, Channel 9	—
210-225	Fan Board 1, Channel 9	Fan Board 1, Channel 10	Fan Board 3, Channel 9
275-300	Fan Board 1, Channel 9	Fan Board 2, Channel 9	Fan Board 3, Channel 9

Table 5B — 30XA080-500 Controller Signal Wiring Location

30XA UNIT SIZE	CIRCUIT A	CIRCUIT B	CIRCUIT C
080-120	Fan Board A, Channel 9	Fan Board A, Channel 10	—
140-350	Fan Board A, Channel 9	Fan Board B, Channel 9	—
400-500	Fan Board A, Channel 9	Fan Board B, Channel 9	Fan Board C, Channel 9

Step 4 — Configure Unit for Low Ambient Temperature Head Pressure Control Operation — The unit must be configured for operation. Use the Scrolling Marquee display (30RB units only) or the Navigator™

module (30RB or 30XA units) to configure the system as follows:

1. Set the Enable/Off/Remote Contact switch to the Off position.
2. Press the ESCAPE key to the top level of the menus and use the arrow key to select the Configuration mode LED.
3. Press ENTER key, then use the down arrow key to select sub-mode 'UNIT', then press ENTER key.
4. Press the down arrow key until 'VAR.A' is displayed.
5. Press ENTER key twice. The words 'PASS' and 'WORD' will flash.
6. Press the Up or Down arrows to display 0 1 1 1 then ENTER key so that '0' flashes.
7. Use arrow keys to change to '1' and press ENTER.
8. Press the down arrow key until 'VAR.B' is displayed.
9. Press ENTER twice so that '0' flashes.
10. Use arrow keys to change to '1' and press ENTER.
11. For sizes 30RB210-300 and 30XA080-500 only, press the down arrow key until 'VAR.C' is displayed.
12. Press ENTER twice so that '0' flashes.
13. Use arrow keys to change to '1' and press ENTER.
14. Press ESCAPE key until display reads 'UNIT'.
15. Cycle control power to chiller.

The chiller is now configured for low ambient temperature control.

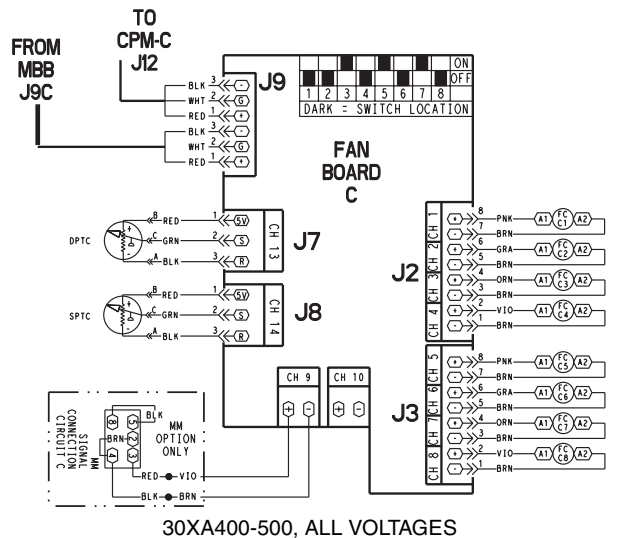
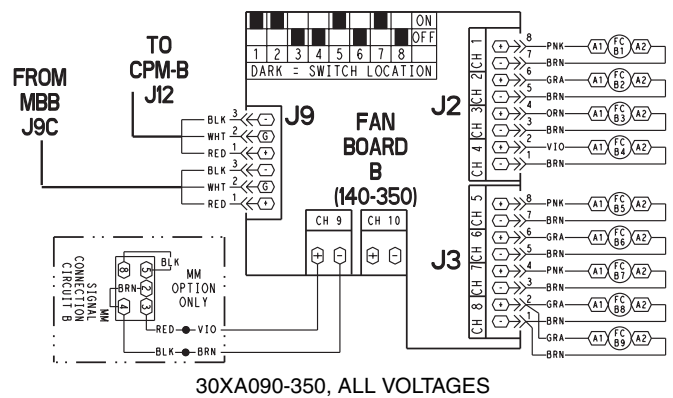
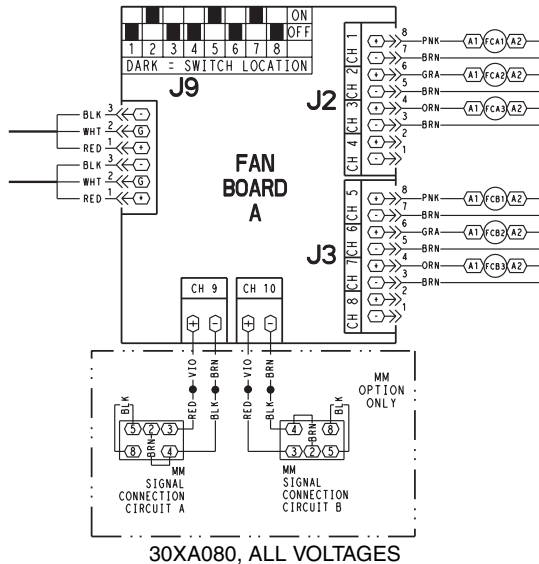
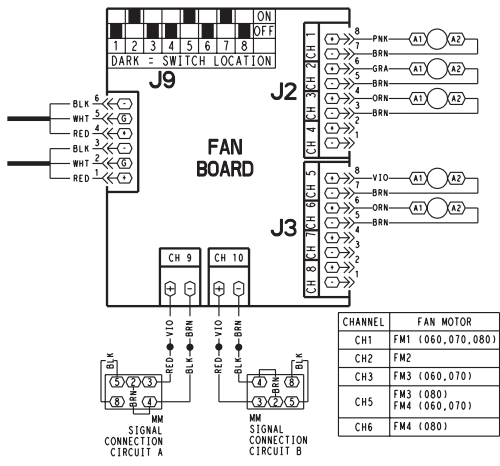
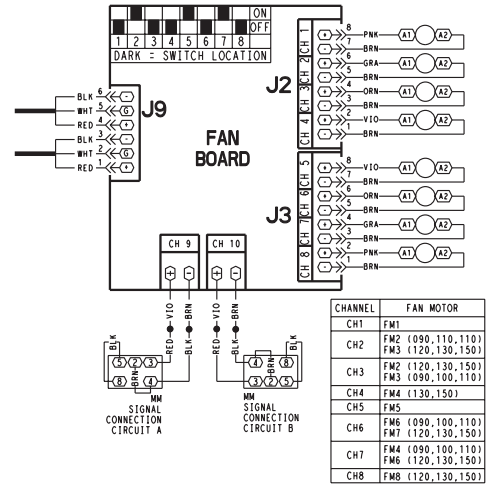


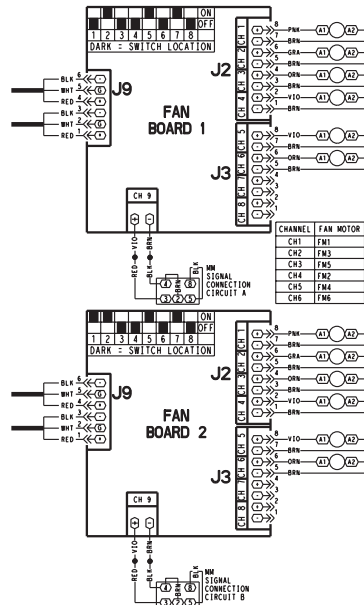
Fig. 13A — Typical 30XA Fan Board Wiring



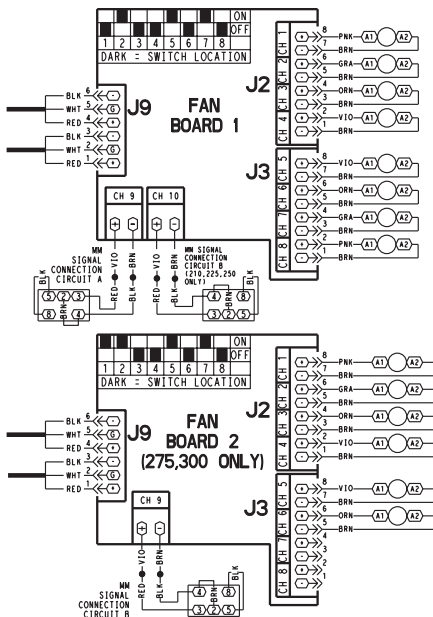
30RB060-080, ALL VOLTAGES



30RB090-150, ALL VOLTAGES



30RB160-190, ALL VOLTAGES



30RB210-300, ALL VOLTAGES

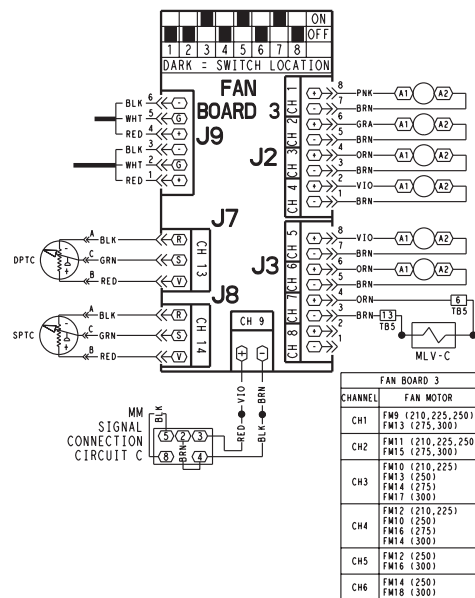


Fig. 13B — Typical 30RB Fan Board Wiring

Step 5 — Configure Low Ambient Temperature Head Pressure Control — The VFDs should be shipped correctly configured. It is recommended that the configuration of the VFD is verified prior to proceeding. To check each drive configuration, complete the following:

1. Open the fuse block to disconnect power to the VFD.
2. Remove the cover below the display by pushing down slightly and pulling out from the top. Remove the lower cover (tabs on each side). Refer to Fig. 14.
3. Remove keypad (press release button and pull out from top) and verify that DIP switch 1 is off and 2 is on. Replace keypad.
4. Jumpers must be in place from terminals 2-4 and 5-8 for 200, 208/230, 380 and 460 v; for 575 v, the jumper is connected to 5-9.
5. Power up drive. Press parameter P key. See Fig. 15.
6. Press up arrow to view parameter P0311. Press P to display the value, which is 1140 for 30RB060-300 units. For 30XA080-500 units with the high ambient temperature option the P0311 value is also 1140. The P0311 value is 850 for 30XA080-500 units with the standard ambient temperature option. Refer to Table 6 for unit nameplate fan motor type. Press P again and Up arrow to parameter P1210. Press P to display the value, which should be 6. If either of these values are incorrect, the drive is not correctly configured and Steps 7 through 17 must be followed. If these two parameters are correct, then the drive is properly configured — proceed to Step 18, then to the Test the Low Ambient Temperature Head Pressure Control section.

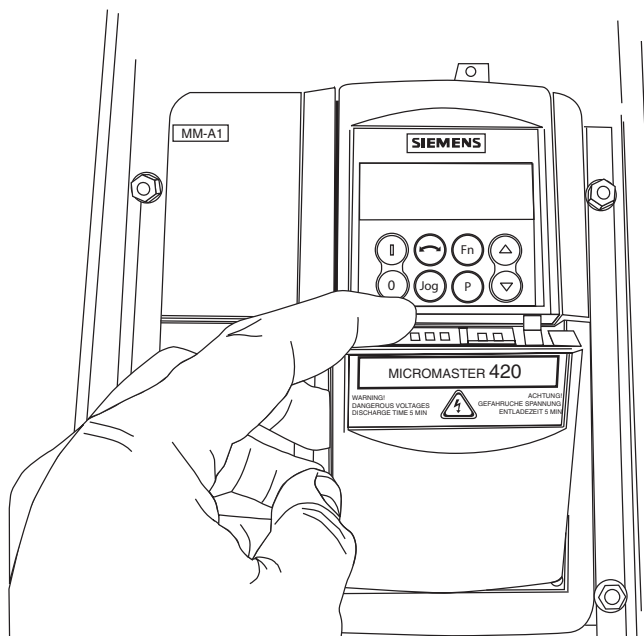


Fig. 14 — Removing Lower Cover



Fig. 15 — Low Ambient Temperature Head Pressure Controller










7. Remove jumper wire from terminal position 8.
8. Press Up arrow to parameter P0010.
9. Press P, then up arrow to change 0 to 1. Press P again to accept change.
10. Press up arrow to parameter P0311. Press P and use down arrow to change this value to 1140. Press P to accept.
11. Press up arrow to parameter P3900. Press P and use up arrow to change this value to 1. Press P to accept.
12. Drive will finish standard programming.
13. Press P again and go to parameter P0003. Press P and use up arrow to change this value to 3. Press P to accept.
14. Press up arrow to parameter P1210. Press P and use up arrow to change this value to 6. Press P to accept.
15. Press the Up arrow to parameter P1310. Press the P and use the down arrow to change this value to a 10. Press P to accept.
16. Press function (Fn) key and then parameter (P) key. Display should now show 0.00 Hz.
17. Replace wire jumper in terminal position 8.
18. The drive is now active. Check fan rotation before testing. If fan is spinning forward, further adjustment is needed. Fan should sit still when commanded speed is 0%. If spinning forward slightly, press parameter P key and up arrow to parameter P0761. Press P and use up arrow to change this value to 0.1. Press P to accept. Check fan. If rotation has stopped no further adjustment is required. If fan is still rotating forward, press P and use up arrow to change this value to 0.2. Press P to accept. Repeat as needed until fan is holding still or is just barely moving in either direction. A value greater than 0.5 would not normally be required and may indicate excess electrical noise on the signal cable. The signal cable drain wire is grounded at both ends. Some applications may require that the drain wire be lifted at the drive end.

Refer to Table 7 for a list of control buttons and functions.

Table 6 — 30XA Condenser Coil/High Ambient Option Nameplate Value

VALUE ON NAMEPLATE, POSITION 10	CONDENSER COIL/HIGH AMBIENT OPTION
—	Aluminum Fin/Copper Tube, High Ambient Temperature
0	Copper Fin/Copper Tube, High Ambient Temperature
1	Copper Pre-coat Fin/Aluminum Tube, High Ambient Temperature
2	Copper E-coat Fin/Aluminum Tube, High Ambient Temperature
3	Copper E-coat Fin/Copper Tube, High Ambient Temperature
4	Microchannel Heat Exchanger, High Ambient Temperature
6	Aluminum Fin/Copper Tube, High Ambient Temperature, Compressor Enclosures
8	Aluminum Pre-Coat Fin/Copper Tube, High Ambient Temperature, Compressor Enclosures
9	Aluminum E-Coat Fin/Copper Tube, High Ambient Temperature, Compressor Enclosures
F	Aluminum Fin/Copper Tube, Standard Ambient Temperature, Compressor Enclosures
H	Aluminum Pre-Coat Fin/Copper Tube, Standard Ambient Temperature, Compressor Enclosures
J	Aluminum E-Coated Fin/Copper Tube, Standard Ambient Temperature, Compressor Enclosures

Table 7 — Low Ambient Temperature Head Pressure Control Operator Panel

PANEL/BUTTON	FUNCTION	DESCRIPTION
	Indicates Status	The LCD displays the settings currently used by the converter.
	Start Converter	The Start Converter button is disabled by default. To enable this button set P0700 = 1.
	Stop Converter	Press the Stop Converter button to cause the motor to come to a standstill at the selected ramp down rate. Disabled by default, to enable set P0700 = 1. Press the Stop Converter button twice (or hold) to cause the motor to coast to a standstill. This function is always enabled.
	Change Direction	Press the Change Direction button to change the direction of rotation of the motor. Reverse is indicated by a minus (-) sign or a flashing decimal point. Disabled by default, to enable set P0700 = 1.
	Jog Motor	Press the Jog Motor button while the inverter has no output to cause the motor to start and run at the preset jog frequency. The motor stops when the button is released. The Jog Motor button is not enabled when the motor is running.
	Functions	The Functions button can be used to view additional information. Press and hold the button to display the following information starting from any parameter during operation: <ol style="list-style-type: none"> 1. DC link voltage (indicated by d – units V). 2. Output current. (A) 3. Output frequency (Hz) 4. Output voltage (indicated by o – units V). 5. The value selected in P0005 (If P0005 is set to show any of the above [3, 4, or 5] then this will not be shown when toggling through the menu). Press the Functions button repeatedly to toggle through displayed values. Jump Function Press of the Fn button from any parameter (rXXXX or PXXXX) to immediately jump to R0000, when another parameter can be changed, if required. Return to R0000 and press the Functions again to return.
	Access Parameters	Allows access to the parameters.
	Increase Value	Press the Increase Value button to increase the displayed value. To change the Frequency Setpoint using the operator panel set P1000 = 1.
	Decrease Value	Press the Decrease Value button to decrease the displayed value. To change the Frequency Setpoint using the operating panel set P1000 = 1.

Step 6 — Test the Low Ambient Temperature Head Pressure Control — Refer to the Controls, Start-Up, Operation, Service and Troubleshooting guide to verify proper operation of the controllers and outdoor-fan motors. Fan speed output is tested using the Quick Test sub-mode under the Service Test mode. Parameters ‘SPD.A,’ ‘SPD.B’ and ‘SPD.C’ can be set to any value from 0 to 100% where 0% output is 0.0 Hz and 100% output is 60.0 Hz.

The VFDs are always powered whenever the main power to the chiller is on. When the system calls for a compressor on any circuit, the VFD for that circuit will be used as the first fan stage. The fan board output signal will command the VFD to operate between 0.0 and 60.0 Hz. This can be seen from the display on each VFD.

TROUBLESHOOTING

A partial list of VFD parameters, fault codes and troubleshooting information can be found in the instructions given in the Controls, Start-Up, Operation, Service and Troubleshooting Guide.

Refer to the documentation on a CD-ROM shipped with the VFD for a complete set of instructions for more information.