



Air-Cooled Liquid Chillers with Integrated Hydronic Module

AQUASNAP™
with PURON® refrigerant



Puron™
the environmentally sound refrigerant

Model shown is with
low-noise option



30RB 182-802

Nominal cooling capacity 175-760 kW

The new generation of Aquasnap Puron liquid chillers features the latest technological innovations:

- ozone-friendly refrigerant R410A
- scroll compressors
- low-noise fans made of a composite material
- auto-adaptive microprocessor control.
- aluminium micro-channel heat exchangers (MCHX)

The Aquasnap can be equipped with an integrated hydronic module, limiting the installation to straight-forward operations like connection of the power supply and the chilled water supply and return piping.

Features

Quiet operation

- Compressors
 - Low-noise scroll compressors with low vibration level
 - The compressor assembly is installed on an independent chassis supported by flexible anti-vibration mountings
 - Dynamic suction and discharge piping support, minimising vibration transmission (Carrier patent)
 - Acoustic compressor enclosure, reducing radiated noise emissions (option)

- Condenser section
 - Condenser coils in V-shape with an open angle, allowing quieter air flow across the coil
 - Low-noise 4th generation Flying Bird fans, made of a composite material (Carrier patent) are now even quieter and do not generate intrusive low-frequency noise
 - Rigid fan installation for reduced noise (Carrier patent)

Easy and fast installation

- Integrated hydronic module (option)
 - Centrifugal low or high-pressure water pump (as required), based on the pressure loss of the hydronic installation
 - Single or dual pump (as required) with operating time balancing and automatic changeover to the back-up pump if a fault develops
 - Water filter protecting the water pump against circulating debris
 - High-capacity membrane expansion tank ensures pressurisation of the water circuit
 - Thermal insulation and frost protection down to -20°C, using an electric resistance heater (see table of options)
 - Pressure gauge to check filter pollution and measure the system water flow rate
 - Water flow control valve

- Simplified electrical connections
 - A single power supply point without neutral (30RB 182-522)
 - Main disconnect switch with high trip capacity (see table of options)
 - 24 V control circuit without risk from a transformer included
- Fast commissioning
 - Systematic factory operation test before shipment
 - Quick-test function for step-by-step verification of the instruments, electrical components and motors

Economical operation

- Increased energy efficiency at part load
 - The refrigerant circuit includes several compressors connected in parallel. At part load, around 99% of the operating time, only the compressors that are absolutely necessary operate. At these conditions the compressors operating are even more energy efficient, as they use the total condenser and evaporator capacity.
 - The electronic expansion device (EXV) allows operation at a lower condensing pressure (EER optimisation).
 - Dynamic superheat management for better utilisation of the evaporator heat exchange surface.
 - All aluminium micro-channel condenser (MCHX), more efficient than a copper/aluminium coil
- Reduced maintenance costs
 - Maintenance-free scroll compressors
 - Fast diagnosis of possible incidents and their history via the Pro-Dialog Plus control
 - R410A refrigerant is easier to use than other refrigerant blends

Environmental care

- Ozone-friendly R410A refrigerant
 - Chlorine-free refrigerant of the HFC group with zero ozone depletion potential
 - High-density refrigerant, therefore less refrigerant required
 - Very efficient - gives an increased energy efficiency ratio (EER)
 - 40% reduction in the refrigerant charge through use of the micro-channel heat exchangers (MCHX)
- Leak-tight refrigerant circuit
 - Brazed refrigerant connections for increased leak-tightness
 - Reduction of leaks as no capillary tubes and flare connections are used
 - Verification of pressure transducers and temperature sensors without transferring refrigerant charge

Superior reliability

- State-of-the-art concept
 - Cooperation with specialist laboratories and use of limit simulation tools (finite element calculations) for the design of the critical components, e.g. motor supports, suction/discharge piping
 - Compressor control box installed on the cold side of the compressor (Carrier patent)
 - All-aluminium micro-channel heat exchanger (MCHX) offers 3.5 times higher corrosion resistance than a conventional coil. The all-aluminium construction eliminates the formation of galvanic currents between aluminium and copper that are responsible for the coil corrosion in saline or corrosive atmospheres.
- Auto-adaptive control
 - Control algorithm prevents excessive compressor cycling and permits reduction of the water quantity in the hydronic circuit (Carrier patent)
 - Automatic compressor unloading in case of abnormally high condensing pressure. If an anomaly occurs (e.g. fouled condenser coil, fan failure) Aquasnap continues to operate, but at reduced capacity.
- Exceptional endurance tests
 - Corrosion resistance tests in salt mist in the laboratory
 - Accelerated ageing test on components that are submitted to continuous operation: compressor piping, fan supports
 - Transport simulation test in the laboratory on a vibrating table. The test is based on a military standard and equivalent to 4000 km by truck.

Pro-Dialog Plus control

- Pro-Dialog Plus combines intelligence with operating simplicity. The control constantly monitors all machine parameters and precisely manages the operation of compressors, expansion devices, fans and of the evaporator water pump for optimum energy efficiency.
- Energy management
 - Internal time schedule clock: permits chiller on/off control and operation at a second set-point
 - Set-point reset based on the outside air temperature or the return water temperature
 - Master/slave control of two chillers operating in parallel with operating time equalisation and automatic change-over in case of a unit fault.
 - Start/stop control based on the air temperature
 - Ease-of-use
 - User interface with synoptic diagram for intuitive display of the principal operating parameters: number of compressors operating, suction/discharge pressure, compressor operating hours, set-point, air temperature, entering/leaving water temperature
 - Ten menus for direct access to all machine commands, including fault history, allowing fast and complete chiller diagnostics



Pro-Dialog Plus operator interface

Remote management (standard)

A simple two-wire communication bus between the RS485 port of the Aquasnap and the Carrier Comfort Network offers multiple remote control, monitoring and diagnostic possibilities. Carrier offers a vast choice of control products, specially designed to control, manage and supervise the operation of an air conditioning system. Please consult your Carrier representative for more information on these products.

- Start/stop: opening of this contact will shut down the unit
- Dual set-point: closing of this contact activates a second set-point (example: unoccupied mode)
- Demand limit: closing of this contact limits the maximum chiller capacity to a predefined value
- User safety: this contact is connected in series with the water flow switch and can be used for any customer safety loop
- Heat reclaim (option): closing of this contact allows heat reclaim mode operation
- Water pump 1 and 2 control*: these outputs control the contactors of one or two evaporator water pumps
- Water pump on reversal*: these contacts are used to detect a water pump operation fault and automatically change over to the other pump
- Operation indication: this volt-free contact indicates that the chiller is operating (cooling load) or that it is ready to operate (no cooling load)
- Alert indication: this volt-free contact indicates the presence of a minor fault
- Alarm indication: this volt-free contact indicates the presence of a major fault that has led to the shut-down of one or two refrigerant circuits

* contacts already supplied with the hydronic module option

Remote management (EMM option)

- Room temperature: permits set-point reset based on the building indoor air temperature (with Carrier thermostat)
- Set point reset: ensures reset of the cooling set-point based on a 4-20 mA or 0-5 V signal
- Demand limit: permits limitation of the maximum chiller demand based on a 4-20 mA or 0-5 V signal
- Demand limit 1 and 2: closing of these contacts limits the maximum chiller capacity to three predefined values
- User safety: this contact can be used for any customer safety loop, closing of the contact generates a specific alarm
- Ice storage end: when ice storage has finished, this input permits return to the second set-point (unoccupied mode)
- Time schedule override: closing of this contact cancels the time schedule effects
- Out of service: this signal indicates that the chiller is completely out of service
- Chiller capacity: this analogue output (0-10 V) gives an immediate indication of the chiller capacity
- Compressor operation: this contact signals that one or several compressors are in operation

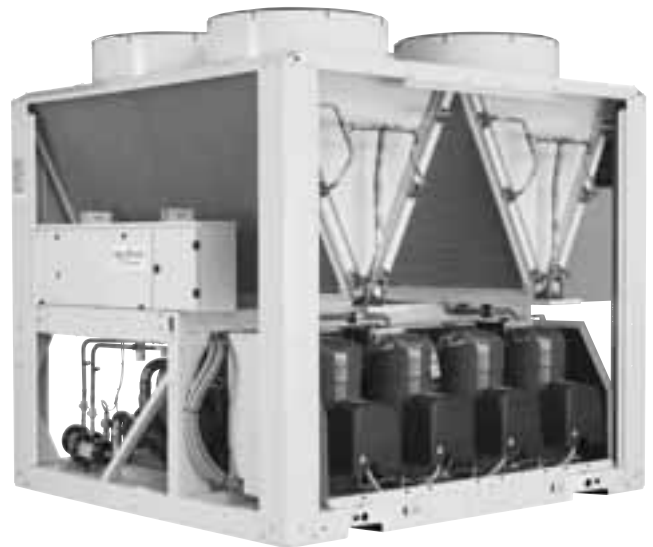

Already utilised in the automobile and aeronautical industries for many years, the MCHX heat exchanger is entirely made of aluminium. This one-piece concept significantly increases its corrosion resistance by eliminating the galvanic currents that are created when two different metals (copper and aluminium) come into contact in traditional heat exchangers. Unlike traditional heat exchangers the MCHX heat exchanger can be used in moderate marine and urban environments.

From an energy efficiency point-of-view the MCHX heat exchanger is approximately 10% more efficient than a traditional coil and allows a 40% reduction in the amount of refrigerant used in the chiller. The low thickness of the MCHX reduces air pressure losses by 50% and makes it less susceptible to fouling (e.g. by sand) than a traditional coil. Cleaning of the MCHX heat exchanger is very fast using a high-pressure washer.

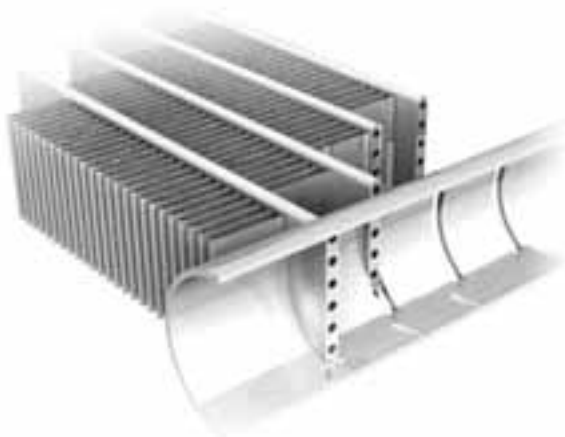

All aluminium micro-channel heat exchanger (MCHX)

Part load performances

With the rapid increase in energy costs and the care about environmental impacts of electricity production, the power consumption of air conditioning equipment has become an important topic. The energy efficiency of a liquid chiller at full load is rarely representative of the actual performance of the units, as on average a chiller works less than 5% of the time at full load.

The heat load of a building depends on many factors, such as the outside air temperature, the exposure to the sun and its occupation.

Consequently it is preferable to use the seasonal energy efficiency, calculated at several operating points that are representative for the unit utilisation.

ESEER (EUROVENT)

The ESEER (European seasonal energy efficiency ratio) permits evaluation of the average energy efficiency at part load, based on four operating conditions defined by Eurovent. The ESEER is the average value of energy efficiency ratios (EER) at different operating conditions, weighted by the operating time.

ESEER (European seasonal energy efficiency ratio)

Load (%)	Air temperature (°C)	Energy efficiency	Operating time, %
100	35	EER ₁	3
75	30	EER ₂	33
50	25	EER ₃	41
25	20	EER ₄	23

$$ESEER = EER_1 \times 3\% + EER_2 \times 33\% + EER_3 \times 41\% + EER_4 \times 23\%$$

Note: Constant leaving water temperature = 7°C

30RB 182 - 802

Part load performances in accordance with Eurovent

30RB	LOAD %	CAP kW	UNIT kW	EER kW/kW	ESEER kW/kW
182	100	173.3	59.3	2.92	3.71
	75	130	37.6	3.45	
	50	86.7	23.1	3.75	
	25	43.3	10.6	4.10	
202	100	192.8	70.1	2.75	3.74
	75	144.6	42.2	3.43	
	50	96.4	25.2	3.82	
	25	48.2	11.5	4.19	
232	100	227.3	72.8	3.12	4.30
	75	170.4	45.4	3.76	
	50	113.6	25.5	4.45	
	25	56.8	11.4	4.98	
262	100	263.4	97.5	2.70	3.86
	75	197.5	59.8	3.31	
	50	131.7	32.6	4.04	
	25	65.8	14.7	4.49	
302	100	293.3	104.5	2.81	3.96
	75	220	62.3	3.53	
	50	146.6	36.1	4.06	
	25	73.3	16.2	4.54	
342	100	327.5	120.9	2.71	3.94
	75	245.6	71.5	3.44	
	50	163.7	40	4.09	
	25	81.9	18.1	4.53	
372	100	358.5	127.5	2.81	4.08
	75	268.9	73.7	3.65	
	50	179.3	42.4	4.22	
	25	89.6	19.4	4.62	
402	100	391	146.6	2.67	3.93
	75	293.2	83.9	3.50	
	50	195.5	48.3	4.05	
	25	97.7	21.7	4.50	
432	100	417.6	150.6	2.77	3.92
	75	313.2	86.7	3.61	
	50	208.8	51.4	4.06	
	25	104.4	24.6	4.24	
462	100	446.8	168.5	2.65	3.86
	75	335.1	93.3	3.59	
	50	223.4	55.5	4.03	
	25	111.7	27.2	4.11	
522	100	506.3	191.4	2.65	3.77
	75	379.7	109.5	3.47	
	50	253.1	63.7	3.97	
	25	126.6	31.6	4.01	
602	100	596.2	218.1	2.73	4.09
	75	447.1	121.9	3.67	
	50	298.1	70.8	4.21	
	25	149	31.9	4.66	
672	100	651.8	240.6	2.71	4
	75	488.8	137	3.57	
	50	325.9	78.8	4.14	
	25	163	36.1	4.52	
732	100	704.2	265.1	2.66	3.96
	75	528.2	148.2	3.56	
	50	352.1	84.3	4.15	
	25	176.1	40.6	4.33	
802	100	757.7	288.1	2.63	3.91
	75	568.3	162.6	3.50	
	50	378.8	92.4	4.10	
	25	189.4	43.9	4.31	

Legend

- Load % - Unit heat load
- Cap kW - Cooling capacity
- Unit kW - Unit power input
- EER - Cooling capacity kW/unit power input kW

Options and accessories

Options	No.	Description	Advantages	Use
Condenser with anti-corrosion post-treatment	2B	Coils with copper tubes and aluminium fins with Blygold Polual treatment	Improved corrosion resistance, recommended for marine, industrial and rural environments	30RB 182-802
Corrosion protection, traditional coils	3A	Fins made of pre-treated aluminium (polyurethane or epoxy)	Improved corrosion resistance, recommended for marine, moderate or urban environments	30RB 182-802
Unit for low leaving water temperature	6	Leaving water temperature from +3°C to -10°C	All low-temperature applications: ice storage, cooling and process cooling applications	30RB 182-402
Unit for indoor installation with discharge ducts	12	Fans with available pressure	Ducted condenser air discharge, optimised condensing temperature control, based on the operating conditions and system characteristics	30RB 182-802
Low noise level	15	Acoustic compressor enclosure	Noise emission reduction	30RB 182-802
Very low noise level	15LS	Acoustic compressor enclosure and low-speed fans	Noise emission reduction	30RB 182-802
Grilles	23	Metallic grilles on all four unit faces (this option includes the supply of enclosure panels)	Improved aesthetics	30RB 182-802
Enclosure panels (for units with copper/aluminium coils only)	23A	Side panels on each end of the coils	Improved aesthetics	30RB 182-802
Electronic starter	25	Electronic starter on each compressor	Reduced start-up current	30RB 182-522
Winter operation down to -20°C	28	Fan speed control via frequency converter	Stable unit operation when the air temperature is between 0°C and -20°C	30RB 182-802
Winter operation down to -10°C	28B	Twin-speed lead fan for each circuit	Stable unit operation when the air temperature is between 0°C and -10°C	30RB 182-802
Evaporator frost protection	41	Electric heater on the evaporator	Evaporator frost protection down to -20°C outside temperature	30RB 182-802
Evaporator and hydronic module frost protection	42A	Electric heaters on the evaporator and hydronic module	Evaporator and hydronic module frost protection down to -20°C outside temperature	30RB 182-262
Partial heat reclaim	49	Partial heat reclaim by desuperheating the compressor discharge gas	Free high-temperature hot-water production simultaneously with chilled water production	30RB 182-802
Total heat reclaim	50	See heat reclaim option. Note: Unit equipped with coils with copper tubes and aluminium fins	Free hot water production simultaneously with chilled water production	30RB 262-522
Twinning	58	Unit equipped with an additional field-installed leaving water temperature sensor, allowing master/slave operation of two chillers connected in parallel	Optimised operation of two chillers connected in parallel with operating time equalisation	30RB 182-802
Main disconnect switch without fuse (standard for sizes 182-262)	70	Factory-installed main electric disconnect switch in the control box	Ease-of-installation and compliance with local electrical regulations	30RB 302-802
Main disconnect switch with fuse	70D	Factory-installed main electric disconnect switch with fuse in the control box	Same advantage as main disconnect switch and reinforced anti-short circuit protection	30RB 302-802
Evaporator with aluminium jacket	88	Evaporator thermal insulation protection by aluminium sheets	Improved resistance to climatic aggression	30RB 182-802
Evaporator and hydronic module with aluminium jacket	88A	Evaporator and water piping thermal insulation protection by aluminium sheets	Improved resistance to climatic aggression	30RB 302-522
Suction valve	92	Shut-off valves on the compressor suction piping (discharge valve as standard)	Simplified maintenance	30RB 302-802
Compressor suction and discharge valves	92A	Shut-off valves on the common compressor suction and discharge piping	Simplified maintenance	30RB 182-262
High-pressure single-pump hydronic module	116B	See hydronic module option	Easy and fast installation	30RB 182-522
High-pressure dual-pump hydronic module	116C	See hydronic module option	Easy and fast installation, operating safety	30RB 182-522
Low-pressure single-pump hydronic module	116F	See hydronic module option	Easy and fast installation	30RB 182-522
Low-pressure dual-pump hydronic module	116G	See hydronic module option	Easy and fast installation, operating safety	30RB 182-522
Direct-expansion free cooling system	118A	See free cooling option. Note: Unit equipped with coils with copper tubes and aluminium fins	Economic chilled-water production at low outside temperature	30RB 232-522
JBus gateway	148B	Two-directional communications board, complies with JBus protocol	Easy connection by communication bus to a building management system	30RB 182-802
Bacnet gateway	148C	Two-directional communications board, complies with Bacnet protocol	Easy connection by communication bus to a building management system	30RB 182-802
LonTalk gateway	148D	Two-directional communications board, complies with LonTalk protocol	Easy connection by communication bus to a building management system	30RB 182-802
Energy Management module EMM	156	See controls manual	Easy connection by wired connection to a building management system	30RB 182-802
Fitted safety valves with sealed ball valve	196	Valve with sealed ball upstream of the safety valves	Safety valve inspection and replacement facilitated without refrigerant loss	30RB 182-802
Conformance with Australian regulations	200	Heat exchanger approved to Australian code	-	30RB 182-802
Storage unit above 48°C	241	Refrigerant charge stored in the condenser. Option not compatible with MCHX coils; Cu/Al coils are required to store the charge.	Unit transport by container only possible with this option	30RB 182-802

Options and accessories

Options	Description	Advantages	Use
Connection sleeve	Piping to be welded with Victaulic connection	Ease-of-installation	30RB 182-802
Energy Management Module EMM	See controls manual	Easy connection by wired connection to a building management system	30RB 182-802
Scrolling Marquee Interface	Remotely installed user interface (communication bus)	Remote chiller control up to 300 m	30RB 182-802
Power cable connection side extension	Side extension on the power control to allow a reduced cable bend radius	Use of thicker power cables	30RB 302-802

Physical data

30RB		182	202	232	262	302	342	372	402	432	462	522	602	672	732	802
Nominal cooling capacity*	kW	173	193	227	263	293	328	359	391	418	447	506	596	652	704	758
Seasonal energy efficiency ratio (ESEER)	kW/kW	3.71	3.74	4.30	3.86	3.96	3.94	4.08	3.93	3.92	3.86	3.77	4.09	4.00	3.96	3.91
Operating weight**																
Unit with option 15	kg	2082	2172	2202	2370	2990	3186	3234	3370	3922	4062	4240	5480	5658	6370	6550
Standard unit	kg	1902	2002	2012	2180	2760	2956	2984	3110	3632	3772	3930	5120	5289	5960	6120
Refrigerant		R410A														
Circuit A	kg	11.4	11.4	14.5	14.5	20	21	21	20.5	26	26.5	26.5	23	23	28	28
Circuit B	kg	13.5	13.5	14	14	14	14	21	21.5	22	21.5	27.5	23	22.5	30	30
Circuit C	kg	-	-	-	-	-	-	-	-	-	-	-	24	28	25	33
Compressors		Hermetic scroll, 48.3 r/s														
Circuit A		1	1	2	2	3	3	3	3	4	4	4	3	3	4	4
Circuit B		2	2	2	2	2	2	3	3	3	3	4	3	3	4	4
Circuit C		-	-	-	-	-	-	-	-	-	-	-	3	4	3	4
No. of control stages		3	3	4	4	5	5	6	6	7	7	8	9	10	11	12
Minimum capacity	%	28	33	25	25	18	20	15	17	13	14	13	11	10	9	8
Control		Pro-Dialog Plus														
Condensers		Grooved copper tubes and aluminium fins														
Fans		Axial FLYING BIRD IV with rotating shroud														
Quantity		4	4	4	4	5	5	6	6	7	7	8	9	10	11	12
Total air flow	l/s	18056	18056	18056	18056	22569	22569	27083	27083	31597	31597	36111	40625	45139	49653	54167
Speed	r/s	16	16	16	16	16	16	16	16	16	16	16	16	16	16	16
Evaporator		Direct expansion, shell-and-tube														
Water volume	l	120	120	110	110	110	125	125	125	113	113	113	284	284	284	284
Max. water-side operating pressure without hydronic module	kPa	1000	1000	1000	1000	1000	1000	1000	1000	1000	1000	1000	1000	1000	1000	1000
Water connections (without hydronic module)		Victaulic														
Diameter	in	3	3	3	3	4	4	4	4	6	6	6	6	6	6	6
Outside tube diameter	mm	88.9	88.9	88.9	88.9	114.3	114.3	114.3	114.3	168.3	168.3	168.3	168.3	168.3	168.3	168.3

* Nominal conditions: evaporator entering/leaving water temperature 12°C/7°C, outside air temperature 35°C, evaporator fouling factor 0.18 x 10⁻⁴ (m² K)/W

** Weights are for guidance only

Sound levels

30RB		182	202	232	262	302	342	372	402	432	462	522	602	672	732	802
Unit with very low noise level option																
Sound power level 10 ⁻¹² W*	dB(A)	84	84	85	85	86	86	87	87	88	88	88	89	89	89	90
Sound pressure level at 10 m**	dB(A)	52	52	53	53	54	54	55	55	55	55	56	56	57	57	57
Unit with low noise level option																
Sound power level 10 ⁻¹² W*	dB(A)	89	89	89	89	90	90	91	91	92	92	92	93	94	93	94
Sound pressure level at 10 m**	dB(A)	57	57	57	57	58	58	59	59	60	60	60	61	61	61	62
Standard unit																
Sound power level 10 ⁻¹² W*	dB(A)	91	91	91	91	92	92	93	93	94	94	94	95	95	96	96
Sound pressure level at 10 m**	dB(A)	59	59	59	59	60	60	61	61	62	62	62	62	63	63	64

* In accordance with ISO 9614-1 and certified by Eurovent

** Average sound pressure level, unit in a free field on a reflective surface

Electrical data

30RB (without hydronic module)		182	202	232	262	302	342	372	402	432	462	522	602	672	732	802
Power circuit																
Nominal power supply	V-ph-Hz	400-3-50														
Voltage range	V	360-440														
Max. connectable power cable section																
Circuit A+B or Circuit C	mm ²	1x240 2x150	1x240 2x150	1x240 2x150	1x240 2x150	2x240	2x240	2x240	2x240	3x240	3x240	3x240	2x240	2x240	3x240	3x240
Circuit C	mm ²	-	-	-	-	-	-	-	-	-	-	-	2x185	2x185	2x185	2x185
Control circuit supply																
24 V, via internal transformer																
Maximum unit power input*																
Circuit A+B	kW	85	98	102	127	140	159	172	191	204	223	255	191	191	255	255
Circuit C	kW	-	-	-	-	-	-	-	-	-	-	-	96	127	96	127
Nominal unit current draw**																
Circuit A+B	A	113	129	135	167	185	209	226	251	269	293	334	251	251	334	334
Circuit C	A	-	-	-	-	-	-	-	-	-	-	-	125	167	125	167
Maximum unit current draw***																
Circuit A+B	A	146	168	175	219	241	274	296	329	351	384	438	329	329	439	438
Circuit C	A	-	-	-	-	-	-	-	-	-	-	-	164	219	164	219
Maximum start-up current, standard unit†																
Circuit A+B	A	353	375	348	426	448	481	502	535	557	590	645	535	535	645	645
Circuit C	A	-	-	-	-	-	-	-	-	-	-	-	371	426	371	426
Cosine phi, unit at nom. capacity																
		0.84	0.84	0.84	0.84	0.84	0.84	0.84	0.84	0.84	0.84	0.84	0.84	0.84	0.84	0.84
Max. start-up current, unit with soft starter (UN)††																
Circuit A+B	A	283	305	277	356	378	411	433	466	489	521	575	-	-	-	-
Circuit C	A	-	-	-	-	-	-	-	-	-	-	-	-	-	-	-
Stability for three-phase short circuits (TN system)																
Unit with main disconnect without fuse†††																
Short-time current (1 s) - rms/peak value																
Circuit A+B	kA/kA	13/26	13/26	13/26	13/26	13/26	13/26	13/26	13/26	15/30	15/30	15/30	13/26	13/26	15/30	15/30
Circuit C	kA/kA	-	-	-	-	-	-	-	-	-	-	-	13/26	13/26	13/26	13/26
Unit with main disconnect with fuse‡																
Current value, rms, circuit A+B																
		kA	NA	NA	NA	NA	50	50	50	50	50	50	50	50	50	50
Current value, rms, circuit C																
		kA	-	-	-	-	-	-	-	-	-	-	50	50	50	50

* Power input of the compressor(s) + fan(s) at maximum unit operating conditions. Values given on the unit name plate.

** Nominal unit current draw at nominal conditions: evaporator entering/leaving water temperature 12°C/7°C, outdoor air temperature 35°C. The current values are given at 400 V nominal voltage.

*** Maximum unit operating current at maximum unit power input and 400 V.

† Maximum instantaneous starting current at 400 V nominal voltage and operating limit values with compressor in across-the-line start (maximum operating current of the smallest compressor(s) + fan current + locked rotor current of the largest compressor).

†† Standard for 30RB 182 to 262 and option for 30RB 302 to 802

‡ Not available for 30RB 182 to 262 and option for 30RB 302 to 802

Note: Units 30RB 602-802 have two electrical connection points.

Operating limits

Evaporator water flow rate

30RB	Min. water flow (l/s)	Max. water flow* (l/s)
182	2.8	28.1
202	2.8	28.1
232	3	26.7
262	3.5	26.7
302	3.9	26.7
342	4.4	29.4
372	4.9	29.4
402	5.2	29.4
432	5.8	31.1
462	6.1	31.1
522	6.9	31.1
602	7.9	50.6
672	8.7	50.6
732	9.6	50.6
802	10.3	50.6

* Maximum flow rate for an evaporator pressure drop of 100 kPa (unit without hydronic module)

Evaporator water temperature

	°C	Minimum	Maximum
Entering water temperature at shut-down	-	-	48
Entering water temperature at start-up		6.8	40
Entering water temperature during operation		6.8	25
Leaving water temperature during operation		3.3	15

Condenser air temperature

	°C	Minimum	Maximum
Standard unit		0	48
With winter operation option (No. 28)		-20	48
With winter operation option (No. 28B)		-10	48

Operating range

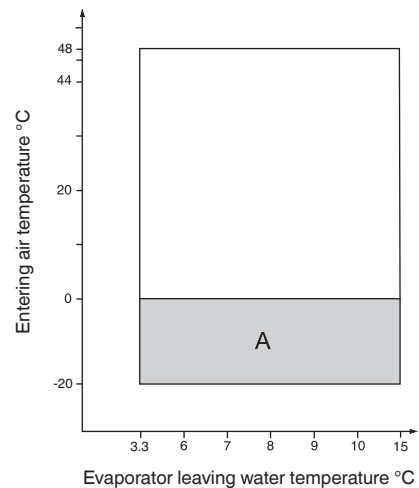

Notes:

1. Evaporator $\Delta T = 5$ K

2. The evaporator must be protected against frost (frost protection option or anti-freeze solution).

A. Operating range with winter operation option

Dimensions/clearances

30RB 182-262

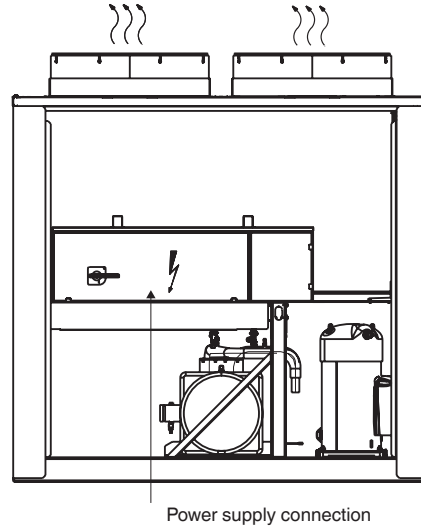
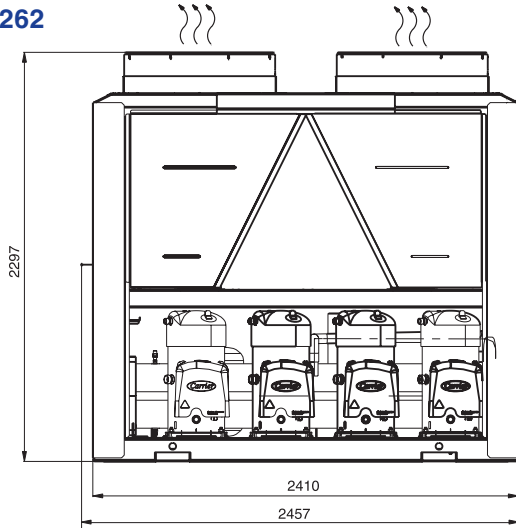

Unit with hydronic module

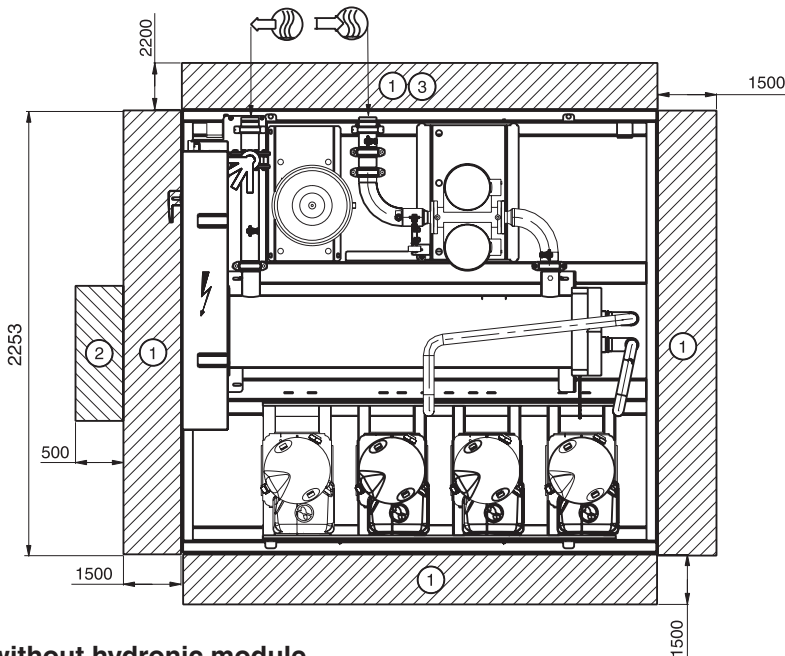

Legend:
All dimensions are given in mm.

- ① Required clearances for maintenance and air flow
- ② Recommended space for evaporator tube removal
- ③ Recommended space for coil removal

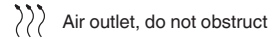

Unit without hydronic module

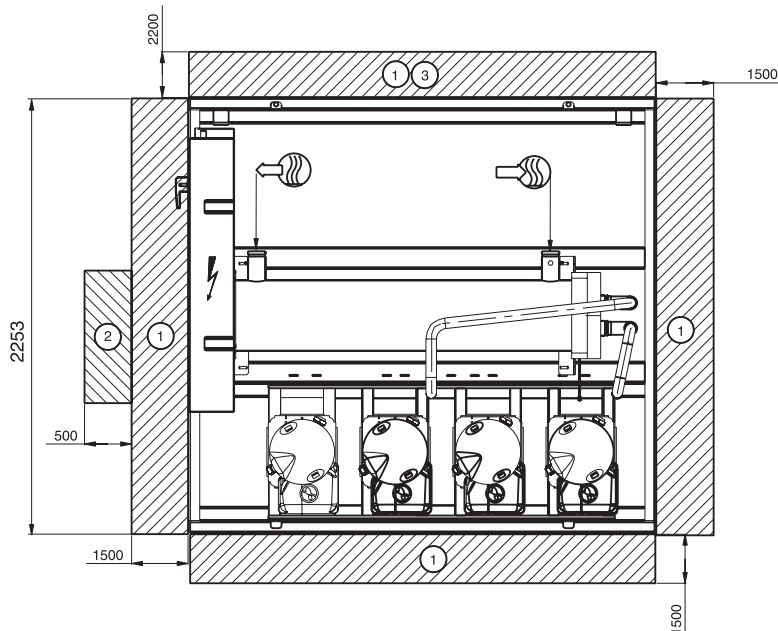

NOTE:
Drawings are not contractually binding. Before designing an installation, consult the certified dimensional drawings, available on request.

Dimensions/clearances

30RB 302-522

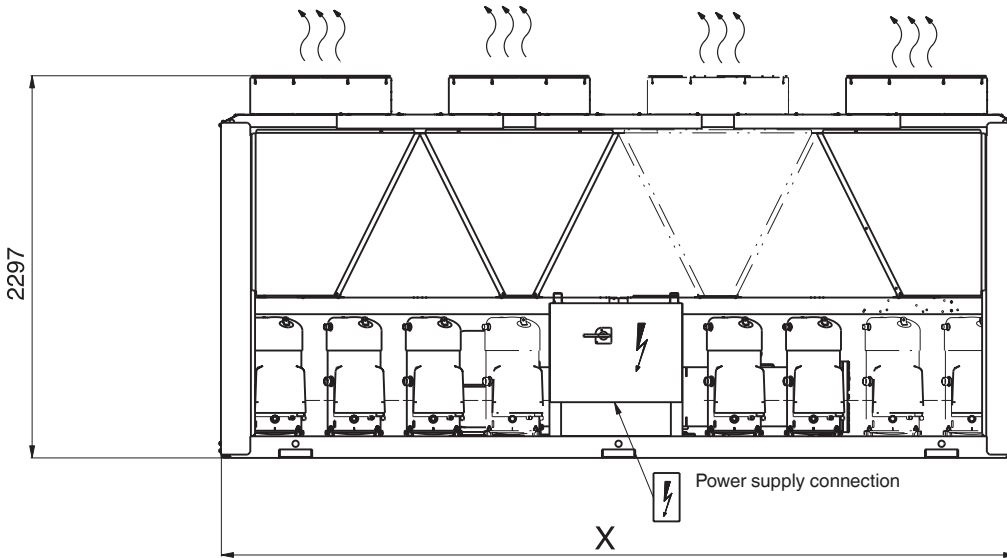

30RB	X	Y
302-402	3604	200
432-522	4798	0

Unit with hydronic module

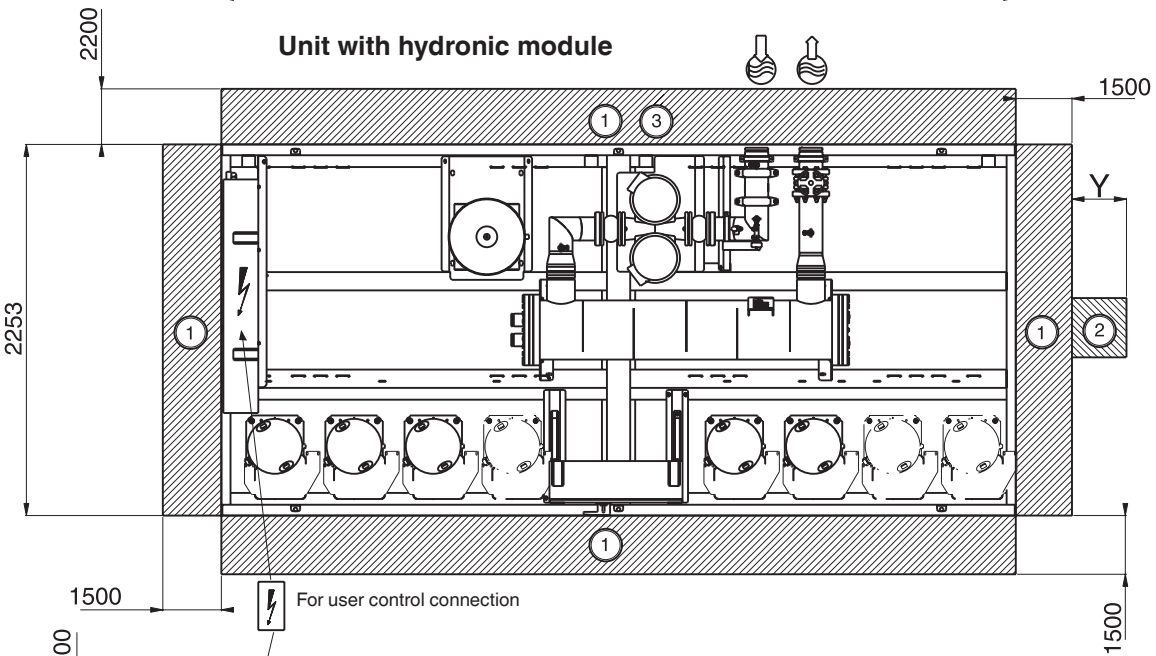

Unit without hydronic module

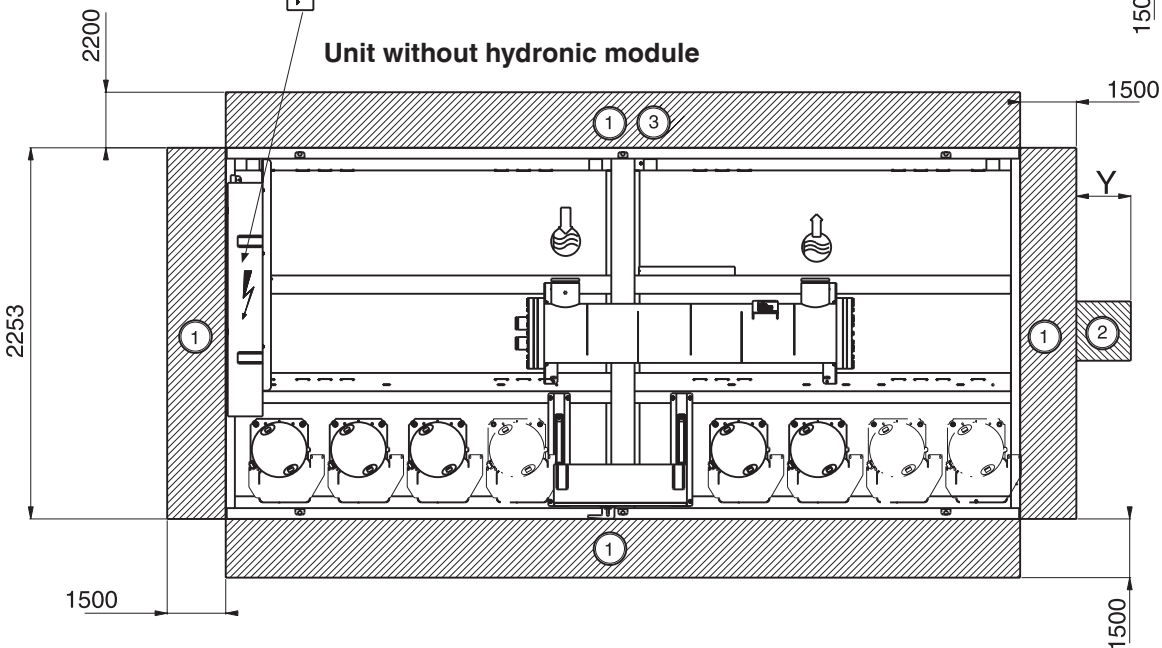

Dimensions/clearances

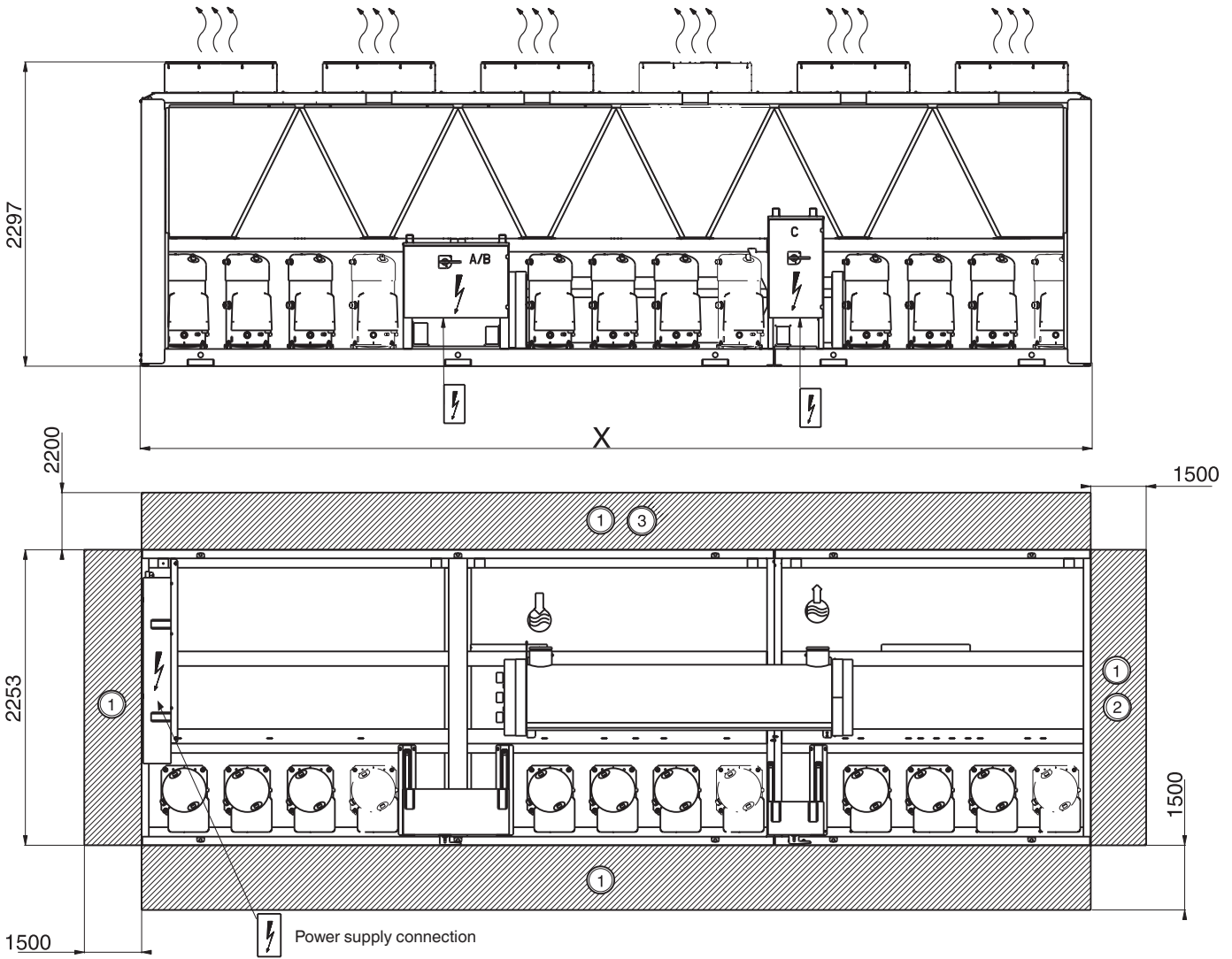

30RB 602-802



30RB	X
602-672	5992
732-802	7186

Legend:

All dimensions are given in mm.

- ① Required clearances for maintenance and air flow
- ② Recommended space for evaporator tube removal
- ③ Recommended space for coil removal
-  Water inlet
-  Water outlet
-  Air outlet, do not obstruct

NOTE:

Drawings are not contractually binding. Before designing an installation, consult the certified dimensional drawings, available on request.

Cooling capacities

30RB 182-802

Condenser entering air temperature, °C

LM °C	30												35												40												45																
	25			30			35			40			45			25			30			35			40			45			25			30			35			40			45										
	CAP kW	COMP kW	UNIT kW	COOL l/s	COOL kPa	CAP kW	COMP kW	UNIT kW	COOL l/s	COOL kPa	CAP kW	COMP kW	UNIT kW	COOL l/s	COOL kPa	CAP kW	COMP kW	UNIT kW	COOL l/s	COOL kPa	CAP kW	COMP kW	UNIT kW	COOL l/s	COOL kPa	CAP kW	COMP kW	UNIT kW	COOL l/s	COOL kPa	CAP kW	COMP kW	UNIT kW	COOL l/s	COOL kPa	CAP kW	COMP kW	UNIT kW	COOL l/s	COOL kPa													
182	5	180	42	49	9	18	170	47	53	8	16	161	52	58	8	15	150	58	64	7	13	138	64	70	7	11	182	5	180	42	49	9	18	170	47	53	8	16	161	52	58	8	15	150	58	64	7	13	138	64	70	7	11
202	5	201	51	58	10	22	191	57	63	9	20	180	62	69	9	18	168	69	75	8	16	155	75	82	7	14	202	5	201	51	58	10	22	191	57	63	9	20	180	62	69	9	18	168	69	75	8	16	155	75	82	7	14
232	5	242	53	60	12	32	230	59	66	11	30	217	66	72	10	27	201	73	79	10	25	184	81	87	9	22	232	5	242	53	60	12	32	230	59	66	11	30	217	66	72	10	27	201	73	79	10	25	184	81	87	9	22
262	5	278	74	80	13	40	264	81	88	13	37	248	89	95	12	34	231	97	104	11	30	213	107	113	10	27	262	5	278	74	80	13	40	264	81	88	13	37	248	89	95	12	34	231	97	104	11	30	213	107	113	10	27
302	5	309	78	86	15	46	294	85	94	14	43	276	94	102	13	39	257	104	112	12	35	237	115	123	11	31	302	5	309	78	86	15	46	294	85	94	14	43	276	94	102	13	39	257	104	112	12	35	237	115	123	11	31
342	5	345	91	99	16	39	327	100	109	16	35	308	110	118	15	32	286	121	129	14	28	264	133	140	13	25	342	5	345	91	99	16	39	327	100	109	16	35	308	110	118	15	32	286	121	129	14	28	264	133	140	13	25
372	5	376	95	105	18	45	357	105	114	17	41	336	115	125	16	37	312	127	136	15	33	286	139	149	14	28	372	5	376	95	105	18	45	357	105	114	17	41	336	115	125	16	37	312	127	136	15	33	286	139	149	14	28
402	5	412	111	121	20	52	391	122	132	19	48	368	134	143	18	43	342	147	156	16	38	316	161	171	15	33	402	5	412	111	121	20	52	391	122	132	19	48	368	134	143	18	43	342	147	156	16	38	316	161	171	15	33
432	5	439	113	124	21	50	418	124	135	20	45	394	136	147	19	41	368	150	161	17	36	339	165	176	16	31	432	5	439	113	124	21	50	418	124	135	20	45	394	136	147	19	41	368	150	161	17	36	339	165	176	16	31
462	5	468	127	138	22	56	445	140	151	21	51	419	153	164	20	46	391	168	179	19	40	361	184	195	17	35	462	5	468	127	138	22	56	445	140	151	21	51	419	153	164	20	46	391	168	179	19	40	361	184	195	17	35
522	5	532	144	158	25	71	507	159	172	24	65	477	174	187	23	58	445	191	203	21	51	412	209	222	20	44	522	5	532	144	158	25	71	507	159	172	24	65	477	174	187	23	58	445	191	203	21	51	412	209	222	20	44
602	5	629	165	180	30	41	597	181	196	28	38	562	199	213	27	34	524	218	232	25	30	484	238	253	23	26	602	5	629	165	180	30	41	597	181	196	28	38	562	199	213	27	34	524	218	232	25	30	484	238	253	23	26
672	5	687	182	198	33	48	653	200	216	31	44	615	220	235	29	39	573	241	256	27	35	531	264	280	25	30	672	5	687	182	198	33	48	653	200	216	31	44	615	220	235	29	39	573	241	256	27	35	531	264	280	25	30
732	5	743	200	218	35	56	705	220	238	34	51	664	241	258	32	46	619	264	281	29	40	573	289	306	27	35	732	5	743	200	218	35	56	705	220	238	34	51	664	241	258	32	46	619	264	281	29	40	573	289	306	27	35
802	5	799	218	237	38	64	759	239	258	36	58	714	262	281	34	52	665	286	305	32	46	615	314	332	29	40	802	5	799	218	237	38	64	759	239	258	36	58	714	262	281	34	52	665	286	305	32	46	615	314	332	29	40
182	6	186	43	49	9	19	177	47	54	8	17	167	52	59	8	16	155	58	64	7	14	143	64	71	7	12	182	6	186	43	49	9	19	177	47	54	8	17	167	52	59	8	16	155	58	64	7	14	143	64	71	7	12
202	6	208	52	59	10	23	197	57	64	9	21	186	63	69	9	19	174	69	76	8	17	160	76	82	8	15	202	6	208	52	59	10	23	197	57	64	9	21	186	63	69	9	19	174	69	76	8	17	160	76	82	8	15
232	6	248	54	60	12	33	235	60	66	11	31	222	66	72	11	28	207	73	79	10	25	190	81	87	9	23	232	6	248	54	60	12	33	235	60	66	11	31	222	66	72	11	28	207	73	79	10	25	190	81	87	9	23
262	6	287	75	81	14	41	272	82	89	13	38	256	90	96	12	35	238	99	105	11	32	220	108	114	10	28	262	6	287	75	81	14	41	272	82	89	13	38	256	90	96	12	35	238	99	105	11	32	220	108	114	10	28
302	6	318	79	87	15	47	302	87	95	14	44	285	95	103	14	41	265	105	113	13	37	245	116	124	12	33	302	6	318	79	87	15	47	302	87	95	14	44	285	95	103	14	41	265	105	113	13	37	245	116	124	12	33
342	6	356	93	101	17	40	358	102	110	16	37	318	112	120	15	33	296	122	130	14	30	273	134	142	13	26	342	6	356	93	101	17	40	358	102	110	16	37	318	112	120	15	33	296	122	130	14	30	273	134	142	13	26
372	6	389	96	106	19	47	369	106	116	18	43	347	117	126	17	39	322	128	138	15	34	297	141	150	14	30	372	6	389	96	106	19	47	369	106	116	18	43	347	117	126	17	39	322	128	138	15	34	297	141	150	14	30
402	6	425	112	122	20	55	403	123	133	19	50	379	135	145	18	45	353	149	158	17	40	327	163	173	16	35	402	6	425	112	122	20	55	403	123	133	19	50	379	135	145	18	45	353	149	158	17	40	327	163	173	16	35
432	6	449	114	125	21	52	449	125	136	20	47	405	138	149	19	43	379	151	163	18	38	351	167	178	17	33	432	6	449	114	125	21	52	449	125	136	20	47	405	138	149	19	43	379	151	163	18	38	351	167	178	17	33
462	6	484	129	140	23	59	460	142	153	22	54	434	155	167	21	48	404	170	181	19	43	374	186	197	18	37	462	6	484	129	140	23	59	460	142	153	22	54	434	155	167	21	48	404	170	181	19	43	374	186	197	18	37
522	6	549	147	160	26	75	523	161	174	25	68	493	177	189	23	61	461	193	206	22	54	427	212	225	20	47	522	6	549	147	160	26	75	523	161	174	25	68	493	177	189	23	61	461	193	206	22	54	427	212	225	20	47
602	6	649	167	182	31	44	616	184	198	29	40	579	201	216	28	35	540	220	234	26	31	499	241	255	24	27	602	6	649	167	182	31	44	616	184	198	29	40	579	201	216	28	35	540	220	234	26	31	499	241	255	24	27
672	6	707	184	201	34	51	672	203	219	32	46	633	222	238	30	41	591	243	259	28	36	547	267	283	26	32	672	6	707	184	201	34	51	672	203	219	32	46	633	222	238	30	41	591	243	259	28	36	547	267	283	26	32
732	6	766	203	221	36	59	727	223	241	35	53	684	244	262	33	48	638	267	285	30	42	590	293																														

Cooling capacities (cont.)

30RB 182-802

Condenser entering air temperature, °C

LM	30												35												40												45											
	25			30			35			40			45			25			30			35			40			45			25			30			35			40			45					
°C	CAP kW	COMP kW	UNIT kW	COOL l/s	COOL kPa	CAP kW	COMP kW	UNIT kW	COOL l/s	COOL kPa	CAP kW	COMP kW	UNIT kW	COOL l/s	COOL kPa	CAP kW	COMP kW	UNIT kW	COOL l/s	COOL kPa	CAP kW	COMP kW	UNIT kW	COOL l/s	COOL kPa	CAP kW	COMP kW	UNIT kW	COOL l/s	COOL kPa	CAP kW	COMP kW	UNIT kW	COOL l/s	COOL kPa													
182	201	44	50	10	22	191	48	55	9	20	180	53	60	9	18	168	59	65	8	16	154	65	71	7	13	142	71	77	8	15	128	77	84	8	16													
202	224	54	60	11	27	212	59	65	10	24	200	65	71	10	22	186	71	77	9	19	172	78	84	8	16	154	84	90	9	21	160	90	97	9	19													
232	258	55	61	12	35	246	61	67	12	32	232	67	73	11	30	217	74	80	10	27	200	82	88	10	24	172	88	94	10	29	188	94	101	10	27													
262	304	77	84	14	44	288	85	91	14	41	271	92	99	13	37	253	101	107	12	34	234	111	117	11	30	188	117	124	12	38	200	124	131	11	30													
302	339	81	89	16	51	322	89	97	15	48	303	98	106	14	44	282	107	115	13	40	261	118	126	12	35	188	126	133	13	44	226	133	140	12	35													
342	379	96	104	18	44	359	105	113	17	41	338	115	123	16	37	315	125	133	15	32	291	137	145	14	28	188	145	152	15	38	242	152	160	14	28													
372	415	99	108	20	52	394	109	118	19	47	370	119	129	18	43	344	131	140	16	38	317	144	153	15	33	188	153	160	16	41	268	160	167	15	33													
402	452	115	125	22	60	429	127	136	20	55	403	139	148	19	49	375	152	161	18	44	348	167	176	17	39	188	176	183	18	47	294	183	190	17	39													
432	477	116	128	23	57	455	128	140	22	52	430	141	152	21	47	402	155	166	19	42	373	170	181	18	36	188	181	188	19	44	300	188	195	18	36													
462	515	133	144	25	66	489	146	157	23	60	460	160	171	22	53	429	174	186	20	47	398	191	202	19	41	188	202	209	20	49	326	209	216	19	41													
522	581	151	164	28	82	552	165	178	26	75	520	181	194	25	67	486	198	211	23	59	451	217	229	22	52	188	229	236	22	57	354	236	243	22	52													
602	691	173	187	33	48	655	189	204	31	44	615	207	221	29	39	572	226	240	27	34	530	247	261	25	30	188	261	268	25	34	382	268	275	25	30													
672	749	189	206	36	56	712	208	224	34	51	671	228	243	32	46	626	249	265	30	40	581	273	289	28	35	188	289	296	28	34	400	296	303	28	35													
732	816	210	228	39	65	773	230	248	37	59	726	251	269	35	53	676	274	292	32	46	626	300	317	30	40	188	317	324	30	34	418	324	331	30	40													
802	878	228	247	42	75	832	250	269	40	68	780	273	292	37	60	728	298	317	35	53	674	326	345	32	46	188	345	352	32	38	436	352	359	32	46													
182	217	45	52	10	25	206	50	56	10	22	194	55	61	9	20	181	60	67	9	18	166	66	72	8	15	142	72	78	9	19	148	78	84	8	15													
202	239	55	62	11	30	227	60	67	11	27	214	66	73	10	24	199	72	79	10	21	184	79	86	9	18	142	86	92	10	23	164	92	98	9	18													
232	272	56	63	13	37	259	62	68	12	34	244	68	75	12	32	228	75	81	11	29	210	83	89	10	25	142	89	95	10	27	184	95	101	10	25													
262	321	79	86	15	47	305	87	93	15	44	286	95	101	14	40	267	104	110	13	36	248	113	120	12	33	142	120	126	12	30	200	126	132	12	33													
302	361	83	91	17	55	343	92	100	16	52	323	101	109	15	47	301	110	118	14	43	278	121	129	13	38	142	129	135	13	35	226	135	141	13	38													
342	403	99	107	19	49	382	109	117	18	45	359	118	126	17	40	334	129	137	16	36	309	141	149	15	31	142	149	155	15	32	252	155	161	15	31													
372	444	102	111	21	57	421	112	121	20	52	395	122	132	19	47	367	134	144	18	42	338	147	156	16	36	142	156	162	16	33	270	162	168	16	36													
402	479	119	129	23	65	455	131	140	22	60	428	142	152	20	54	398	155	165	19	48	369	170	180	18	42	142	180	186	18	39	298	186	192	18	42													
432	506	120	131	24	63	482	132	143	23	58	456	145	156	22	52	426	159	170	20	46	396	174	185	19	40	142	185	191	19	36	316	191	197	19	40													
462	548	137	149	26	73	521	151	162	25	67	489	164	175	23	59	455	179	190	22	52	422	196	207	20	45	142	207	213	20	42	334	213	219	20	45													
522	617	155	168	29	91	587	170	183	28	83	552	186	199	26	74	513	203	215	25	65	476	222	234	23	56	142	234	240	23	49	352	240	246	23	56													
602	734	179	193	35	53	696	196	210	33	48	653	213	227	31	43	608	232	246	29	38	561	253	267	27	33	142	267	273	27	30	370	273	279	27	33													
672	791	195	211	38	61	753	214	230	36	56	709	233	249	34	50	662	255	271	32	44	614	279	295	29	38	142	295	301	29	35	386	301	307	29	38													
732	869	216	234	41	73	824	237	255	39	66	773	258	276	37	59	718	282	299	34	51	664	308	325	32	44	142	325	331	32	38	402	331	337	32	44													
802	935	235	254	45	83	887	257	277	42	75	832	281	300	40	67	773	306	325	37	59	715	335	354	34	51	142	354	360	34	35	418	360	366	34	51													

Legend:

- LWT Leaving water temperature
- CAP kW Cooling capacity
- COMP kW Compressor power input
- UNIT kW Unit power input (compressors, fans and control circuit)
- COOL l/s Evaporator water flow rate
- COOL kPa Evaporator pressure drop

Application data:

- Standard units, refrigerant: R410A
 - Evaporator temperature rise: 5 K
 - Evaporator fluid: chilled water
 - Fouling factor: 0.18 x 10⁻⁴ (m²·K)/W
- Performances in accordance with EN 14511.

Hydronic module (option 116)

The hydronic module option saves a lot of installation time. The chiller is factory-equipped with the main components for the hydronic system: screen filter, water pump, expansion tank, safety valve and water flow control valve.

Several water pump types are available to suit any application: primary single or dual low-pressure pump or single or dual high-pressure pump (30RB 182-522).

A standard automatic pump start-up algorithm protects the heat exchanger and the hydronic module piping against frost down to -10°C outside temperature. If necessary increased frost protection down to -20°C is possible by adding the heater options to the evaporator and hydronic module (see options 41 and 42A). For unit sizes 30RB 302 to 522 only, the hydronic module piping heaters are supplied as standard.

The hydronic module option is integrated into the chiller without increasing its dimensions and saves the space normally used for the water pump.



Hydronic module

Physical and electrical data

These are the same as for the standard unit except:

30RB		182	202	232	262	302	342	372	402	432	462	522
Operating weight*												
Unit with option 15 and dual-pump hydronic module	kg	2332	2412	2442	2610	3300	3496	3584	3710	4272	4462	4662
Hydronic module												
Expansion tank volume	l	50	50	50	50	80	80	80	80	80	80	80
Maximum operating pressure	kPa	400	400	400	400	400	400	400	400	400	400	400
Water filter		Screen filter (Victaulic)										
Low-pressure pump												
Water pump		Single or dual monocell centrifugal pump										
Pump capacity	kW	2	2	2	2	3	3	4	4	4	6	6
Pump power input	kW	2.7	2.7	2.7	2.7	3.6	3.6	4.6	4.6	4.6	6.3	6.3
Maximum pump current drawn	A	4.7	4.7	4.7	4.7	6.4	6.4	8.2	8.2	8.2	11.2	11.2
High-pressure pump												
Water pump		Single or dual monocell centrifugal pump										
Pump capacity	kW	4	4	4	4	6	6	8	8	8	11	11
Pump power input	kW	4.7	4.7	4.7	4.7	6.4	6.4	8.5	8.5	8.5	12.2	12.2
Maximum pump current drawn	A	8.2	8.2	8.2	8.2	11.2	11.2	15.4	15.4	15.4	21.2	21.2
Water connections (with hydronic module)												
		Victaulic type										
Diameter	in	3	3	3	3	4	4	4	4	5	5	5
Outside pipe diameter	mm	88.9	88.9	88.9	88.9	114.3	114.3	114.3	114.3	139.7	139.7	139.7

* Weights are for guidance only

Legend

Components of unit and hydronic module

- 1 Victaulic screen filter
- 2 Expansion tank
- 3 Safety valve
- 4 Available pressure pump
- 5 Pressure tap valve (see Installation Manual)
- 6 Pressure gauge to measure the component pressure loss (see Installation Manual)
- 7 System vent valve, pressure gauge
- 8 Drain valve
- 9 Water flow control valve
- 10 Heat exchanger
- 11 Evaporator heater (option)
- 12 Hydronic module heater (standard for unit sizes 30RB 302-522)
- 13 Air vent (evaporator)
- 14 Water purge (evaporator)
- 16 Flow switch
- 17 Water temperature sensor

System components

- 18 Air vent
- 19 Flexible connection
- 20 Shut-down valves
- 21 Charge valve
- Hydronic module (units with hydronic module)

Notes:

The unit hydronic module is protected against frost by electric heaters. The unit evaporator must be protected against frost (anti-freeze solution or optional electric heater)

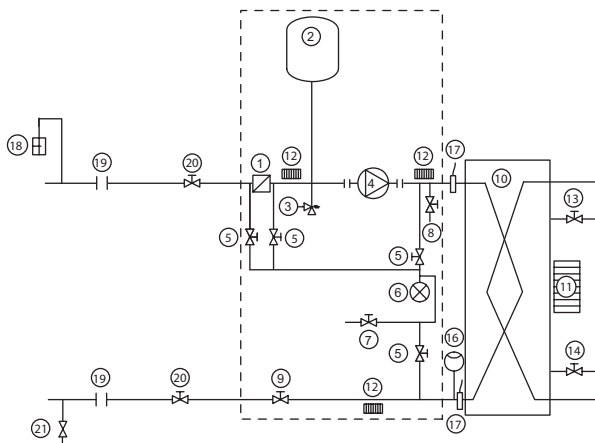

Typical hydronic circuit diagram

Available static system pressure

Low-pressure pump (hydraulic module option)

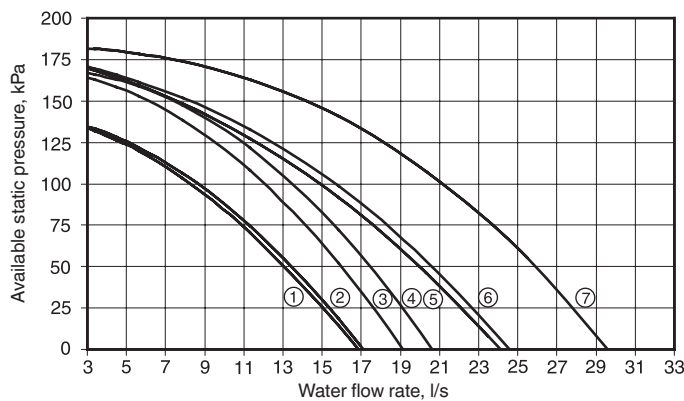

- Legend**
- 1 30RB 232-262
 - 2 30RB 182-202
 - 3 30RB 302
 - 4 30RB 342
 - 5 30RB 372-402
 - 6 30RB 432
 - 7 30RB 462-522

High-pressure pump (hydraulic module option)

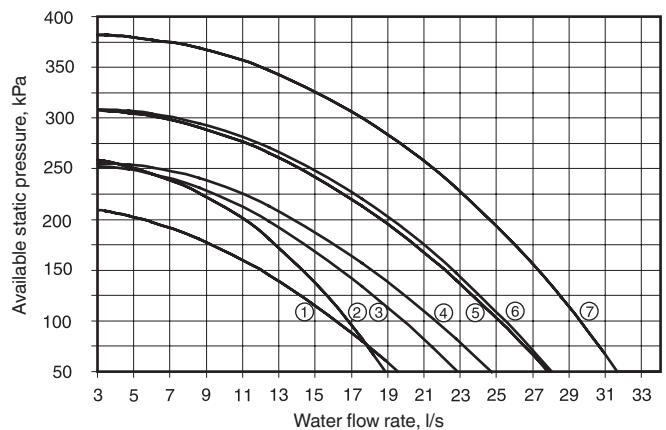

- Legend**
- 1 30RB 182-202
 - 2 30RB 232-262
 - 3 30RB 302
 - 4 30RB 342
 - 5 30RB 372-402
 - 6 30RB 432
 - 7 30RB 462-522

Partial heat reclaim using desuperheaters (option 49)

This option permits the production of free hot water using heat reclaim by desuperheating the compressor discharge gases. The option is available for the whole 30RB range.

A plate heat exchanger is installed in series with the air condenser coils on the compressor discharge line of each circuit.

Physical data, 30RB units with partial heat reclaim

30RB - partial heat reclaim mode		182	202	232	262	302	342	372	402	432	462	522	602	672	732	802
Cooling capacity*	kW	173	193	227	263	293	328	359	391	418	447	506	596	652	704	758
Heating capacity*	kW	42	58	56	87	99	106	110	124	122	146	155	191	203	235	236
Unit power input*	kW	59	70	73	98	105	121	128	147	151	169	191	218	241	265	288
Energy efficiency ratio*	kW/kW	2.92	2.75	3.12	2.70	2.81	2.71	2.81	2.67	2.77	2.65	2.65	2.73	2.71	2.66	2.63
Operating weight**																
Standard unit***	kg	1974	2074	2092	2260	2853	3049	3092	3218	3755	3895	4063	5285	5484	6145	6315
Unit with options****	kg	2154	2244	2282	2450	3083	3279	3342	3478	4045	4185	4373	5645	5833	6555	6745
Unit with options†	kg	2404	2484	2522	2690	3393	3589	3692	3818	4395	4585	4795	-	-	-	-
Desuperheater in circuits A/B/C		Plate heat exchanger														
Water volume circuit A	l	1.75	1.75	3.75	3.75	5.5	5.5	5.5	5.5	7.5	7.5	7.5	5.5	5.5	7.5	7.5
Water volume circuit B	l	3.5	3.5	3.75	3.75	3.75	3.75	5.5	5.5	5.5	5.5	7.5	5.5	5.5	7.5	7.5
Water volume circuit C	l	-	-	-	-	-	-	-	-	-	-	-	5.5	5.7	5.5	7.5
Max. water-side operating pressure	kPa	1000	1000	1000	1000	1000	1000	1000	1000	1000	1000	1000	1000	1000	1000	1000
Water connections		Cylindrical male gas thread														
Connection	in	2	2	2	2	2	2	2	2	2	2	2	2	2	2	2
Outside diameter	mm	60.3	60.3	60.3	60.3	60.3	60.3	60.3	60.3	60.3	60.3	60.3	60.3	60.3	60.3	60.3

* Nominal conditions:
 Evaporator entering and leaving water temperature = 12°C/7°C
 Desuperheater entering and leaving water temperature = 50°C/60°C
 Outside air temperature = 35°C

** Weights shown are a guideline only

*** Standard unit (with MCHX coils) and desuperheater option

**** Unit with option 15 (desuperheater)

† Unit with option 15 and desuperheater and hydraulic module with high-pressure dual pump

Total heat reclaim (option 50)

Suitable for heating, domestic hot water preparation, agriculture and food industry, industrial processes and other hot-water requirements.

With the total heat reclaim option it is possible to reduce the energy consumption bill considerably compared to conventional heating equipment such as fossil fuel boilers or electric water tanks.

Operating principle

If hot water production is required, the compressor discharge gases are directed towards the heat reclaim condenser. The refrigerant releases its heat to the hot water that leaves the condenser at a temperature of up to 55°C. In this way 100% of the heat rejected by the liquid chiller can be used to produce hot water. When the demand for heat is satisfied, the hot gas is again directed towards the air condenser where the heat is rejected to the outside air by the fans. Hot water temperature control is ensured by the chiller Pro-Dialog control that independently controls the reclaim operation of each refrigerant circuit.

Physical data, 30RB units with total heat reclaim

30RB – total heat reclaim mode		262	302	342	372	402	432	462	522
Cooling capacity*	kW	242	263	311	335	361	388	421	467
Heating capacity in heat reclaim mode*	kW	328	358	422	453	496	531	578	653
Total power input (unit)*	kW	91	100	117	125	142	150	166	195
Total energy efficiency ratio (EER/COP)	kW/kW	2.65/3.60	2.64/3.59	2.66/3.61	2.68/3.63	2.54/3.49	2.58/3.53	2.54/3.49	2.39/3.34
Operating weight**									
Standard unit	kg	2610	3200	3420	3480	3610	4290	4430	4620
Unit with option 15	kg	2800	3440	3660	3470	3870	4590	4730	4930
Refrigerant charge									
Circuit A	kg	27	40	41	41.5	42	50	51.5	51.5
Circuit B	kg	27	29	29	41.5	42	46	46	51.5
Heat reclaim condenser									
Twin-circuit shell-and-tube condenser with finned copper tubes									
Water volume	l	22	22	22	22	22	46	46	46
Water connections	Victaulic								
Diameter	in	3	3	3	3	3	4	4	4
Outside diameter	mm	88.9	88.9	88.9	88.9	88.9	114.3	114.3	114.3

* Entering and leaving water temperature: evaporator 12°C/7°C; heat reclaim condenser: 40°C/45°C

** Weights are for guidance only

DX free cooling system (option 118A)

The DX free cooling option permits significant energy savings for all applications that require cooling in winter. In the free cooling mode the compressors are stopped and only the fan and cooling micro-pump are running. The changeover from compressor cooling mode to free cooling mode is automatically controlled by the Pro-Dialog control, based on the chiller heat load and the temperature difference between chilled water and ambient air. Important: In order to optimise chiller performances, it is recommended to use the leaving water set point reset function.

Operating principle

When the chilled water-air temperature difference exceeds a threshold value, the Pro-Dialog control carries out a comparison between the instantaneous chiller cooling capacity and the available free cooling capacity. If the operating conditions allow free cooling operation, the compressors are stopped, a three-way valve on the suction piping connects the evaporator with the condenser, allowing the migration of the refrigerant vapours to the condenser. The refrigerant condenses in the condenser coils, and the cooling micro-pump transports the liquid to the evaporator. The cooling capacity in free cooling mode is controlled by the opening of the electronic expansion valve (EXV).

Advantages of the DX free cooling system

- Operation without glycol
 - Unlike traditional hydronic free-cooling systems that require the use of a glycol solution, the Aquasnap DX free cooling chiller works with pure water. The evaporator is protected against frost down to -20°C by an electric resistance heater (option).
- Low water pressure losses
 - The Aquasnap DX free cooling chiller does not include a three-way valve nor free cooling coils connected in series with the evaporator. The Aquasnap free cooling chiller has the same water pressure losses as a standard chiller.
- Weight and dimensions gain
 - The DX free cooling option has little impact on the weight of the liquid chiller.
 - The Aquasnap free cooling chiller has the same dimensions as a standard chiller.
- Increased energy efficiency
 - In free cooling mode only the fans and the cooling micro-pump run. At an air-water temperature difference of 10 K for example the average chiller energy efficiency (EER) is 15 (kW/kW).
 - In the mechanical cooling mode chiller thermal and energy performances are not reduced by the use of a water-glycol solution.
 - As the pressure losses of the water circuit are low, the water pumps use less energy.

Physical data, 30RB units free-cooling system

30RB (compressor cooling mode)		232	262	302	342	372	402	432	462	522
Nominal cooling capacity*	kW	220	249	283	320	354	377	413	437	488
Unit power input*	kW	76	101	108	125	132	151	156	175	198
Operating weight**										
Unit with option 15	kg	2398	2580	3229	3429	3518	3658	4241	4381	4591
Standard unit	kg	2208	2390	2999	3199	3268	3398	3951	4091	4281
Refrigerant charge		R410A								
Circuit A	kg	29	29	42.5	44	45.5	46	55	57	57
Circuit B	kg	29	29	31	31	45.5	46	47	47	57

* Nominal conditions: evaporator leaving water temperature 12°C/7°C, outside air temperature 35°C.

** Weights are for guidance only

Cooling capacities

30RB 232-522 (free cooling mode)		Condenser entering air temperature, °C								
LWT	30RB (°C)	0			-5			-10		
		Cap kW	Unit kW	EER kW/kW	Cap kW	Unit kW	EER kW/kW	Cap kW	Unit kW	EER kW/kW
	232	117	8	14.6	121	8	15.1	121	4	30.2
	262	117	8	14.6	121	8	15.1	121	4	30.2
	302	145	10	14.5	162	10	16.2	186	8	23.2
	342	145	10	14.5	162	10	16.2	186	8	23.2
	372	173	11	15.7	203	12	16.9	250	12	20.8
	402	173	11	15.7	203	12	16.9	250	12	20.8
	432	211	13	16.2	246	13	18.9	277	13	21.3
	462	211	13	16.2	246	13	18.9	277	13	21.3
	522	248	15	16.5	275	15	18.3	293	15	19.5

Legend
 LWT - Leaving water temperature
 Cap kW - Cooling capacity
 Unit kW - Unit power input (compressors, fans, control)
 EER kW/kW - Energy efficiency

Operating limits

30RB - compressor cooling mode			
Evaporator water temperature	°C	Minimum	Maximum
Entering water at start-up		6.8	40
Entering water during operation		8.5	25
Leaving water during operation		5	15
Condenser air temperature	°C	Minimum	Maximum
Standard free cooling unit		0	48
With winter operation option (No. 28)		-20	48
30RB - free cooling mode			
Evaporator water temperature	°C	Minimum	Maximum
Entering water at start-up		6.8	40
Leaving water during operation		5	26
Condenser air temperature	°C	Minimum	Maximum
		-25	20

Electrical data notes for 30RB units:

- 30RB 182-522 units have a single power connection point at the main disconnect switch; 30RB 602-802 units have two connection points at the main disconnect switch.
- The control box includes the following standard features:
 - Starter and motor protection devices for each compressor and the fan(s)
 - Control devices
- Field connections:
All connections to the system and the electrical installations must be in full accordance with all applicable local codes.
- The Carrier 30RB units are designed and built to ensure conformance with these codes. The recommendations of European standard EN 60 204-1 (corresponds to IEC 60204-1) (machine safety - electrical machine components - part 1: general regulations) are specifically taken into account, when designing the electrical equipment.
- **Electrical reserves:**
Circuit A has disconnect switches and branch sections, designed to supply the evaporator pump power input.

IMPORTANT:

- Generally the recommendations of IEC 60364 are accepted as compliance with the requirements of the installation directives. Conformance with EN 60204 is the best means of ensuring compliance with the Machines Directive § 1.5.1.
- Annex B of EN 60204-1 describes the electrical characteristics used for the operation of the machines.

1. The operating environment for the 30RB units is specified below:
 - a. Environment* - Environment as classified in EN 60721 (corresponds to IEC 60721) :
 - outdoor installation*
 - ambient temperature range: -20°C to +48°C, class 4K3*
 - altitude: ≤ 2000 m
 - presence of hard solids, class 4S2 (no significant dust present)
 - presence of corrosive and polluting substances, class 4C2 (negligible)
 - vibration and shock, class 4M2
 - b. Competence of personnel, class BA4* (trained personnel - IEC 60364)

2. Power supply frequency variation: ± 2 Hz.
3. The neutral (N) line must not be connected directly to the unit (if necessary use a transformer).
4. Overcurrent protection of the power supply conductors is not provided with the unit.
5. The factory-installed disconnect switch(es)/circuit breaker(s) is (are) of a type suitable for power interruption in accordance with EN 60947-3 (corresponds to IEC 60947-3).
6. The units are designed for simplified connection on TN(s) networks (IEC 60364). For IT networks derived currents may interfere with network monitoring elements, and it is recommended to create an IT type divider for the system units that require this and/or a TN type divider for Carrier units. Please consult the appropriate local organisations to define the monitoring and protection elements and carry out the electrical installation.

If short circuit currents above those given in the electrical data table are likely, modifications are required. Please contact your local Carrier representative.

NOTE:

If particular aspects of an actual installation do not conform to the conditions described above, or if there are other conditions which should be considered, always contact your local Carrier representative.

- * The required protection level for this class is IP43B (according to reference document IEC 60529). All 30RB units are protected to IP44C_W and fulfil this protection condition.

Carrier is participating in the Eurovent Certification Programme. Products are as listed in the Eurovent Directory of Certified Products.

This programme covers air-cooled chillers up to 600 kW and water-cooled chillers up to 1500 kW.



Environmental Management System Approval



Order No.: 13438-20.05.2008. Supersedes order No. 13438-20, 07.2007.
Manufacturer reserves the right to change any product specifications without notice.

Manufactured by: Carrier SCS, Montluel, France.
Printed in the Netherlands.