



Installation Instructions

CONTENTS

	Page
SAFETY CONSIDERATIONS	1
INTRODUCTION	1
INSTALLATION	2-70
Storage	2
Step 1 — Inspect Shipment	2
Step 2 — Place, Mount and Rig Unit	2
• PLACING UNIT	
• MOUNTING UNIT	
• RIGGING UNIT	
Step 3 — Cooler Fluid and Drain Piping	
Connections	37
• GENERAL	
• UNITS WITH A HYDRONIC PUMP PACKAGE	
• UNITS WITHOUT A HYDRONIC PUMP PACKAGE	
• DUAL CHILLER CONTROL	
• COOLER FLUID, VENT, AND DRAIN	
• COOLER PUMP CONTROL	
• BRINE UNITS	
• WATER TREATMENT	
• PREPARATION FOR YEAR-ROUND OPERATION	
Step 4 — Fill the Chilled Water Loop	48
• WATER SYSTEM CLEANING	
• WATER TREATMENT	
• SYSTEM PRESSURIZATION	
• FILLING THE SYSTEM	
• SET WATER FLOW RATE	
• PUMP MODIFICATION/TRIMMING	
• FREEZE PROTECTION	
• PREPARATION FOR WINTER SHUTDOWN	
Step 5 — Make Electrical Connections	54
• POWER SUPPLY	
• FIELD POWER CONNECTIONS	
• POWER WIRING	
• FIELD CONTROL POWER CONNECTIONS	
• CARRIER COMFORT NETWORK®	
COMMUNICATION BUS WIRING	
• NON-CCN COMMUNICATION WIRING	
• FIELD CONTROL OPTION WIRING	
• DUAL CHILLER LEAVING WATER SENSOR	
Step 6 — Install Accessories	69
• ENERGY MANAGEMENT MODULE	
• REMOTE ENHANCED DISPLAY	
• LOW AMBIENT TEMPERATURE OPERATION	
• MINIMUM LOAD ACCESSORY	
• UNIT SECURITY/PROTECTION ACCESSORIES	
• COMMUNICATION ACCESSORIES	
• SERVICE OPTIONS	
• CONTROL TRANSFORMER	
Step 7 — Leak Test Unit	70
Step 8 — Refrigerant Charging	70
• DEHYDRATION	
• REFRIGERANT CHARGE	

SAFETY CONSIDERATIONS

Installing, starting up, and servicing this equipment can be hazardous due to system pressures, electrical components, and equipment location. Only trained, qualified installers and service mechanics should install, start up, and service this equipment.

When working on the equipment, observe precautions in the literature, and on tags, stickers, and labels attached to the equipment.

- Follow all safety codes.
- Wear safety glasses and work gloves.
- Use care in handling, rigging, and setting bulky equipment.

⚠ WARNING

Electrical shock can cause personal injury and death. Shut off all power to this equipment during installation. There may be more than one disconnect switch. Tag all disconnect locations to alert others not to restore power until work is completed.

IMPORTANT: This equipment generates, uses, and can radiate radio frequency energy and if not installed and used in accordance with these instructions may cause radio interference. It has been tested and found to comply with the limits of a Class A computing device as defined by FCC (Federal Communications Commission, U.S.A.) regulations, Subpart J of Part 15, which are designed to provide reasonable protection against such interference when operated in a commercial environment.

INTRODUCTION

These instructions cover installation of 30XA080-500 air-cooled liquid chillers with electronic controls and units with factory-installed options (FIOPs). See Fig. 1.

INSTALLATION

Storage — If the unit is to be stored for a period of time before installation or start-up, be sure to protect the machine from construction dirt. Keep protective shipping covers in place until the machine is ready for installation.

Step 1 — Inspect Shipment — Inspect unit for damage upon arrival. If damage is found, immediately file a claim with the shipping company, and contact your local Carrier representative.

Step 2 — Place, Mount, and Rig the Unit — When considering a location for the unit, be sure to consult NEC (National Electrical Code, U.S.A.) and/or local code requirements. Allow sufficient space for airflow, wiring, piping, and service. See Fig. 2-10.

NOTE: To facilitate refrigerant vent piping, all units have fusible plugs with $\frac{1}{4}$ in. SAE (Society of Automotive Engineers) flares and pressure reliefs with $\frac{3}{4}$ in. NPT fittings (if required by local codes).

PLACING UNIT — Locate the unit so that the condenser airflow is unrestricted both above and on the sides of the unit. Airflow and service clearances are 6 ft (1.8 m) around the unit. Acceptable clearance on the sides or ends without control boxes

can be reduced to 3 ft (1 m) without sacrificing performance as long as the remaining three sides are unrestricted. Acceptable clearance on the side with a control box can be reduced to 4 ft (1.3 m) due to NEC regulations, without sacrificing performance as long as the remaining three sides are unrestricted. Provide ample room for servicing and removing the cooler. See Fig. 2-10 for required clearances. Local codes for clearances take precedence over the manufacturer's recommendations when local codes call for greater clearances.

If multiple units are installed at the same site, a separation of 10 ft (3 m) between the sides of the machines is required to maintain proper airflow and minimize the chances of condenser air recirculation.

MOUNTING UNIT — The unit may be mounted on a level pad directly on the base rails, on a raised mounting rail around the unit, or on vibration isolation springs. For all units, ensure placement area is strong enough to support unit operating weight. See Tables 1A and 1B. Mounting holes are provided for securing the unit to the pad, mounting rail or vibration isolation springs. Bolt the unit securely to pad or rails. If vibration isolators (field-supplied) are required for a particular installation, refer to unit weight distribution in Fig. 11A-11C to aid in the proper selection of isolators. The 30XA units can be mounted directly on spring isolators.

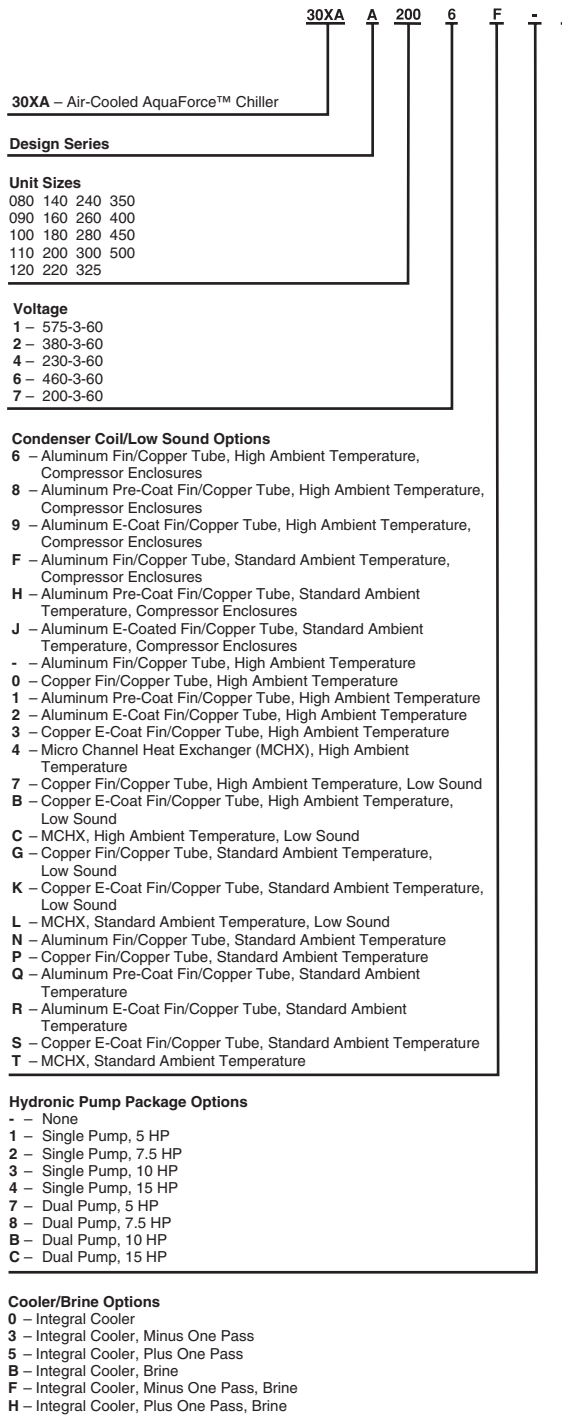

Packaging/Security Options

- L – Coil Face Shipping Protection (CFSP)
- 0 – CFSP, Skid
- 1 – Skid, Top Crate, Bag
- 3 – CFSP, Coil Trim Panels
- 4 – CFSP, Skid, Coil Trim Panels, Shipping
- 5 – Skid, Top Crate, Bag, Coil Trim Panels
- 7 – CFSP, Coil Trim Panels, Upper & Lower Grilles
- 8 – CFSP, Skid, Coil Trim Panels, Upper & Lower Grilles
- 9 – Skid, Top Crate, Bag, Coil Trim Panels, Upper & Lower Grilles
- C – CFSP, Trim Panels, Upper & Lower Grilles, Hail Guards
- D – CFSP, Skid, Coil Trim Panels, Upper & Lower Grilles, Hail Guards
- F – Skid, Top Crate, Bag, Trim Panels, Upper & Lower Grilles, Hail Guards

Controls/Communication Options

- – Navigator™ Display
- 0 – Navigator Display, EMM
- 1 – Navigator Display, Service Option
- 2 – Navigator Display, EMM, Service Option
- 3 – Touch Pilot™ Display
- 4 – Touch Pilot Display, EMM
- 5 – Touch Pilot Display, Service Option
- 6 – Touch Pilot Display, EMM, Service Option
- 7 – Navigator Display, BACnet Translator
- 8 – Navigator Display, BACnet Translator, EMM
- 9 – Navigator Display, BACnet Translator, Service Option
- B – Navigator Display, BACnet Translator, EMM, Service Option
- C – Touch Pilot Display, BACnet Translator
- D – Touch Pilot Display, BACnet Translator, EMM
- F – Touch Pilot Display, BACnet Translator, Service Option
- G – Touch Pilot Display, BACnet Translator, EMM, Service Option
- H – Navigator Display, LON Translator
- J – Navigator Display, LON Translator, EMM
- K – Navigator Display, LON Translator, Service Option
- L – Navigator Display, LON Translator, EMM, Service Option
- M – Touch Pilot Display, LON Translator
- N – Touch Pilot Display, LON Translator, EMM
- P – Touch Pilot Display, LON Translator, Service Option
- Q – Touch Pilot Display, LON Translator, EMM, Service Option

Electrical Options

- – Single Point Power, XL, Terminal Block, No Control Transformer
- 0 – Single Point Power, Wye-Delta, Terminal Block, No Control Transformer
- 3 – Dual Point Power, XL, Terminal Block, No Control Transformer
- 4 – Dual Point Power, Wye-Delta, Terminal Block, No Control Transformer
- 7 – Single Point Power, XL, Disconnect, No Control Transformer
- 8 – Single Point Power, Wye-Delta, Disconnect, No Control Transformer
- C – Dual Point Power, XL, Disconnect, No Control Transformer
- D – Dual Point Power, Wye-Delta, Disconnect, No Control Transformer
- H – Single Point Power, XL, Terminal Block, Control Transformer
- J – Single Point Power, Wye-Delta, Terminal Block, Control Transformer
- M – Dual Point Power, XL, Terminal Block, Control Transformer
- N – Dual Point Power, Wye-Delta, Terminal Block, Control Transformer
- R – Single Point Power, XL, Disconnect, Control Transformer
- S – Single Point Power, Wye-Delta, Disconnect, Control Transformer
- W – Dual Point Power, XL, Disconnect, Control Transformer
- X – Dual Point Power, Wye-Delta, Disconnect, Control Transformer

Refrigeration Circuit Options

- – None
- 1 – Suction Service Valves
- 2 – Low Ambient Temperature Head Pressure Control
- 5 – Suction Service Valves, Low Ambient Temperature Head Pressure Control

LEGEND

- EMM – Energy Management Module
- LON – Local Operating Network
- XL – Across-the-Line Starter

Fig. 1 — AquaForce™ Chiller Model Number Designation

NOTES:

1. Unit must have clearances as follows:
 Top — Do not restrict
 Sides and Ends — 6 ft from solid surface.
2. Temperature relief devices are located on liquid line and economizer assemblies and have 1/4-in. flare connection.
3. 3/8-in. NPT vents and drains located in each cooler head at each end of cooler.
4. Drawing depicts unit with standard two-pass cooler. Refer to the Packaged Chiller Builder program for other configurations.
5. Dimensions are shown in inches; dimensions in brackets are in millimeters.

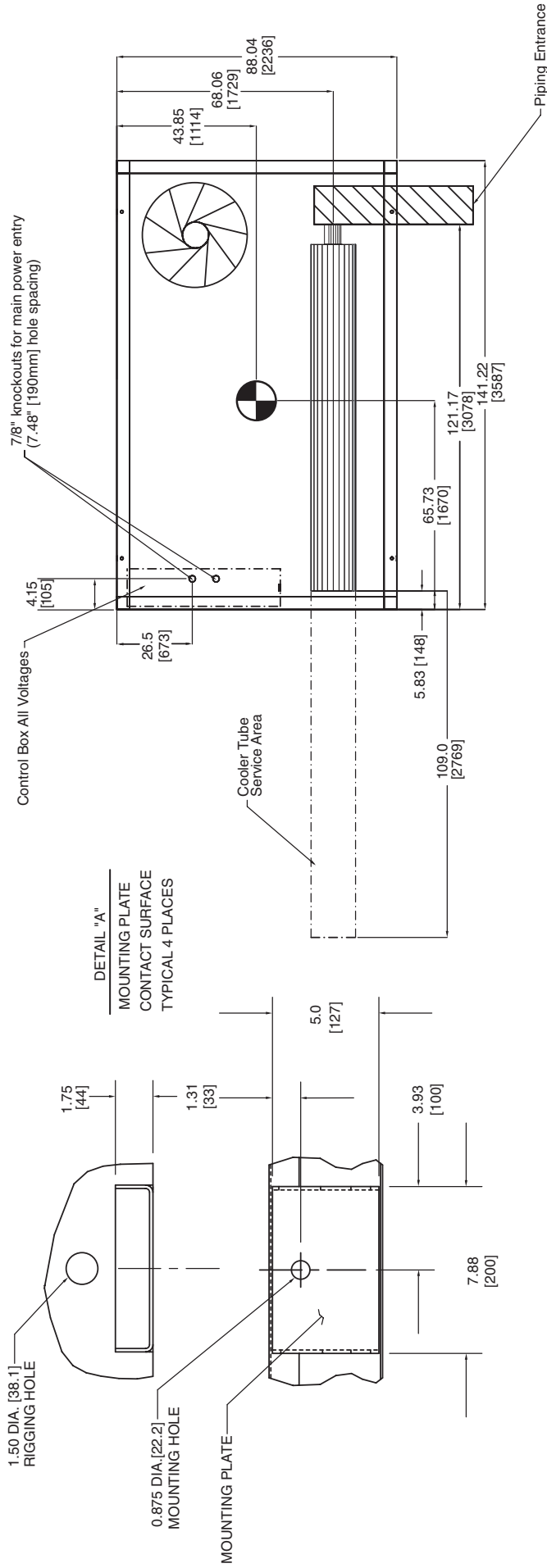

TOP VIEW

Fig. 2 — 30XA080 Air-Cooled Liquid Chiller Dimensions

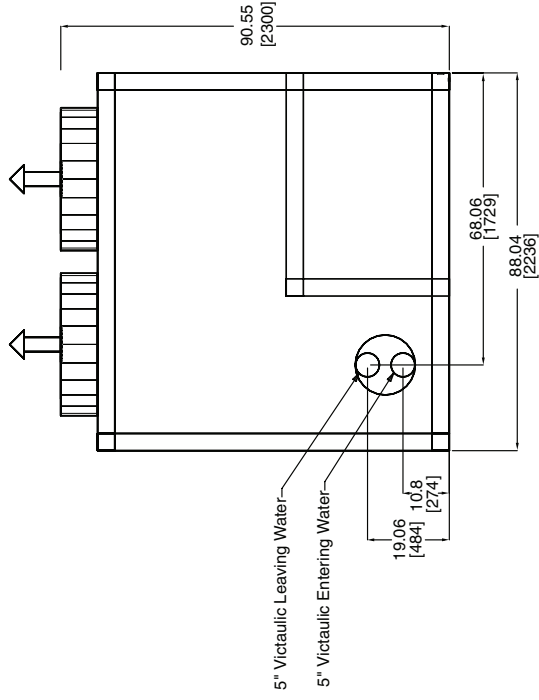

LEFT END VIEW

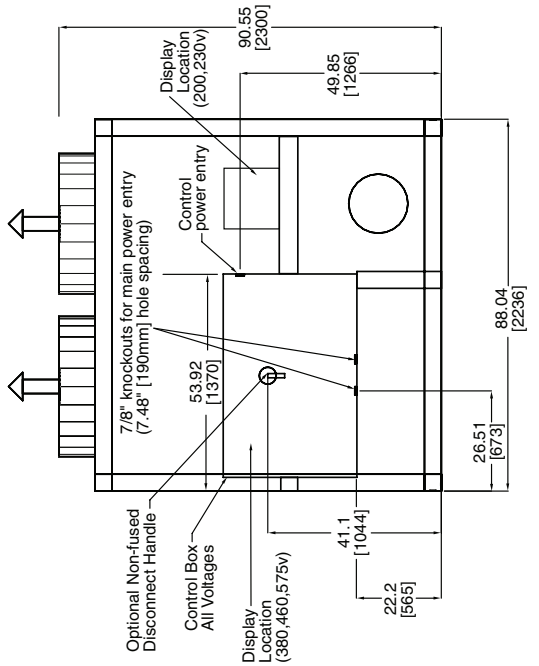

RIGHT END VIEW

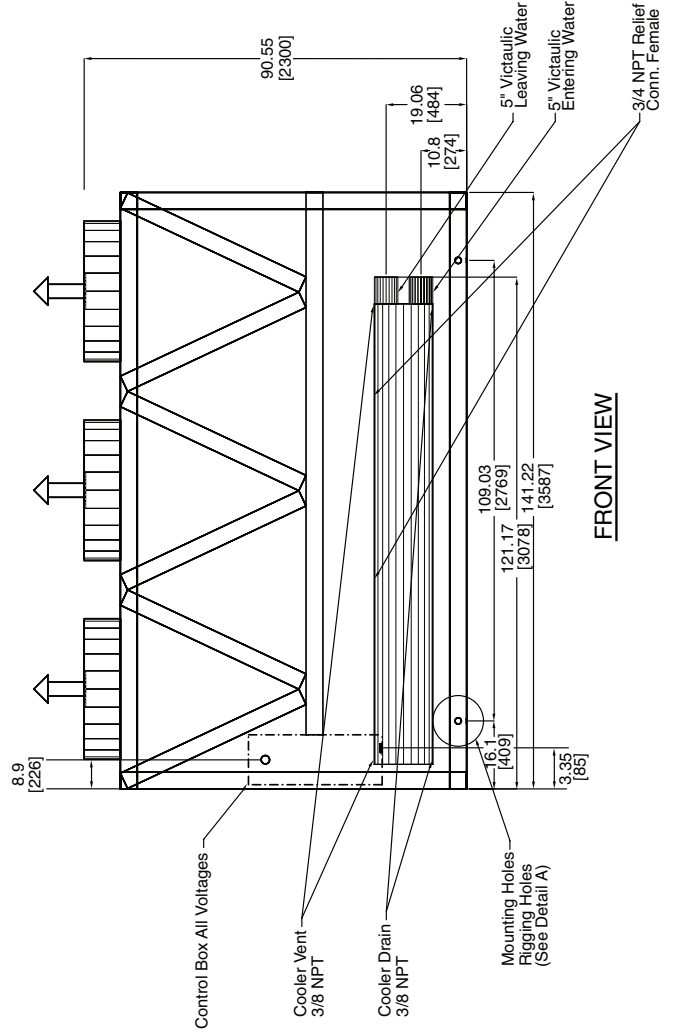

FRONT VIEW

Fig. 2 — 30XA080 Air-Cooled Liquid Chiller Dimensions (cont)

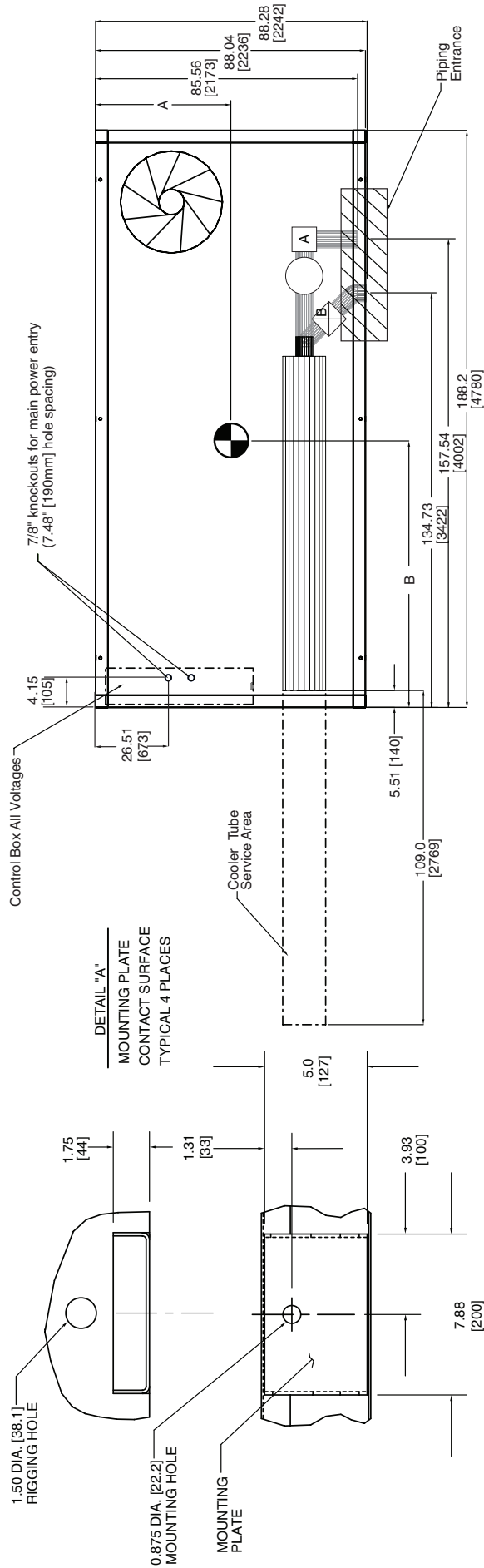

TOP VIEW

30XA UNIT	A	B
090	44.11 [1120]	86.93 [2208]
100	44.11 [1120]	87.22 [2215]
110	44.11 [1120]	87.62 [2226]
120	44.11 [1120]	87.12 [2213]

NOTES:

1. Unit must have clearances as follows:
Top — Do not restrict
Sides and Ends — 6 ft from solid surface.
2. Temperature relief devices are located on liquid line and economizer assemblies and have 1/4-in. flare connection.
3. 3/8-in. NPT vents and drains located in each cooler head at each end of cooler.
4. Drawing depicts unit with single-point power and standard two-pass cooler. Refer to the Packaged Chiller Builder program for other configurations.
5. Dimensions are shown in inches; dimensions in brackets are in millimeters.

Fig. 3 — 30XA090-120 Air-Cooled Liquid Chiller Dimensions

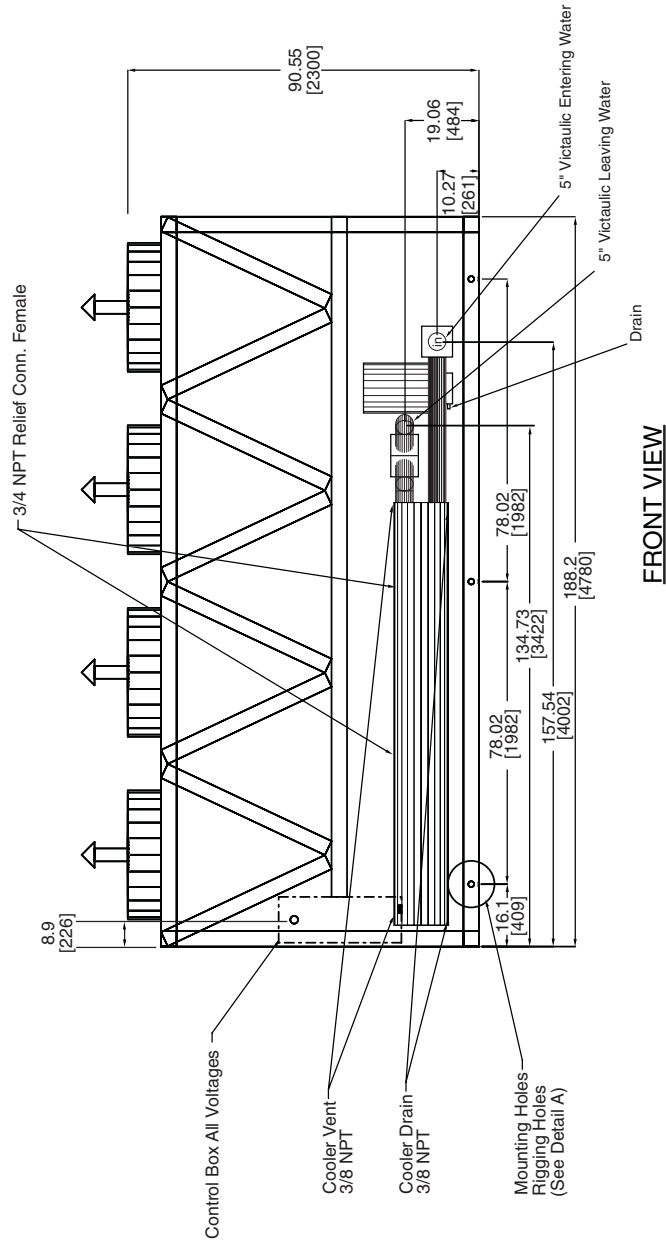
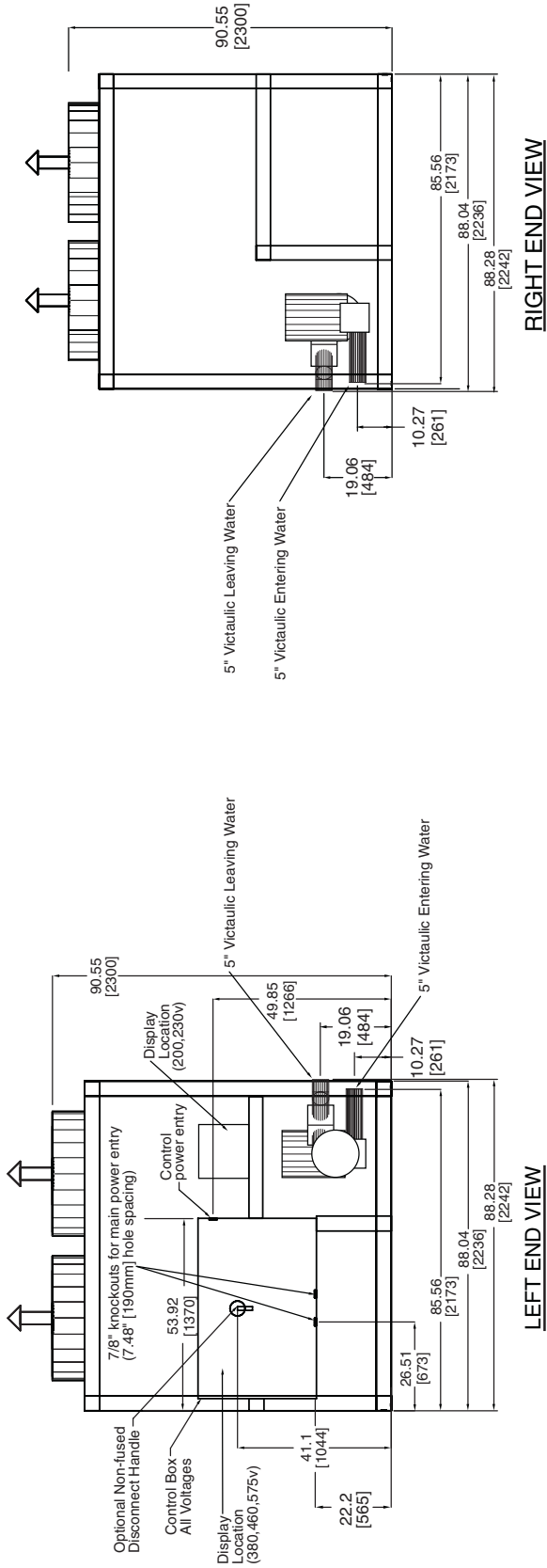
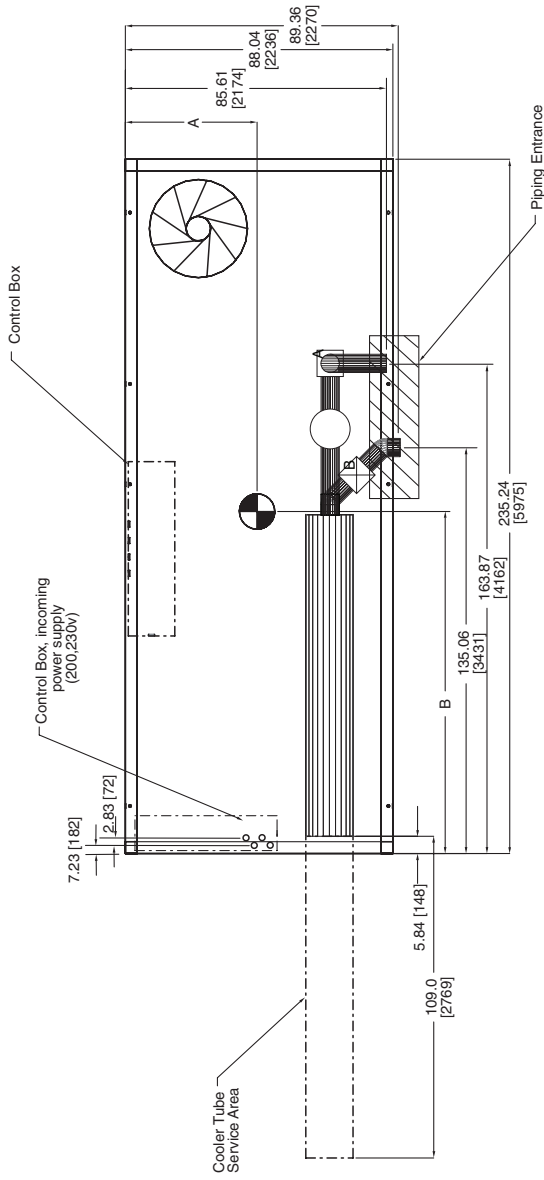

Fig. 3 — 30XA090-120 Air-Cooled Liquid Chiller Dimensions (cont)

- NOTES:**
- Unit must have clearances as follows:
 - Top — Do not restrict
 - Sides and Ends — 6 ft from solid surface.
 - Temperature relief devices are located on liquid line and economizer assemblies and have 1/4-in. flare connection.
 - 3/8-in. NPT vents and drains located in each cooler head at each end of cooler.
 - Drawing depicts unit with standard condenser fans, and standard two-pass cooler. Refer to the Packaged Chiller Builder program for other configurations.
 - Dimensions are shown in inches; dimensions in brackets are in millimeters.

30XA UNIT	A	B
140	44.63 [1134]	115.88 [2943]
160	44.61 [1133]	115.64 [2937]



TOP VIEW

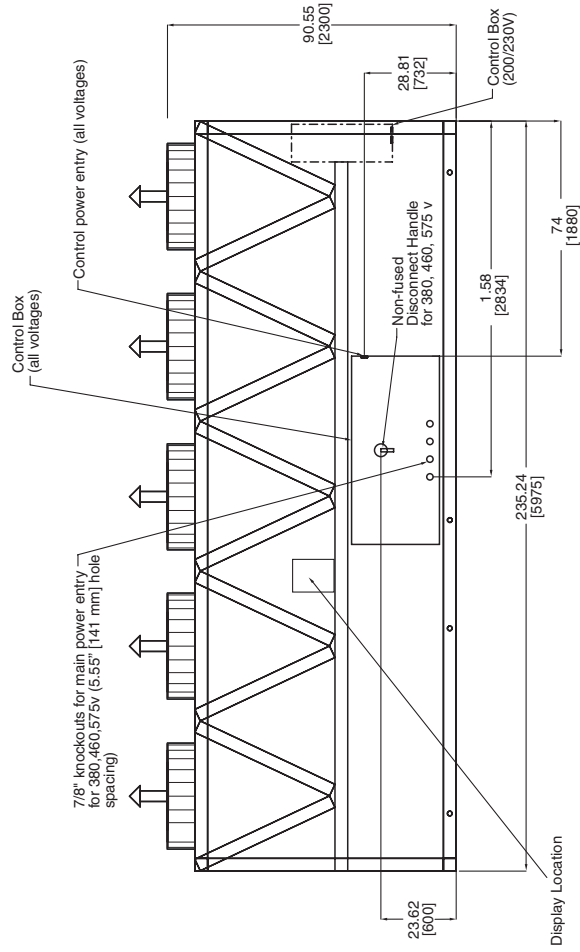

BACK VIEW

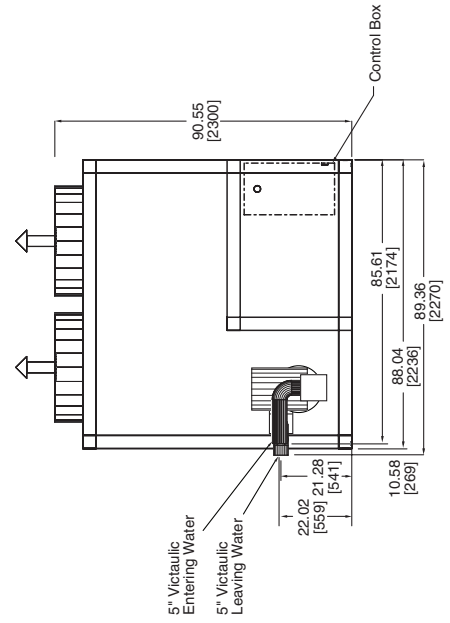

RIGHT END VIEW

Fig. 4 — 30XA140,160 Air-Cooled Liquid Chiller Dimensions

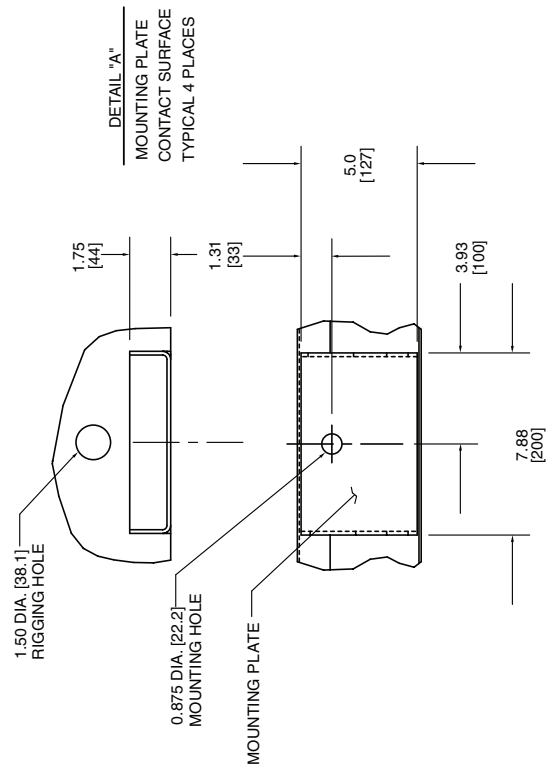
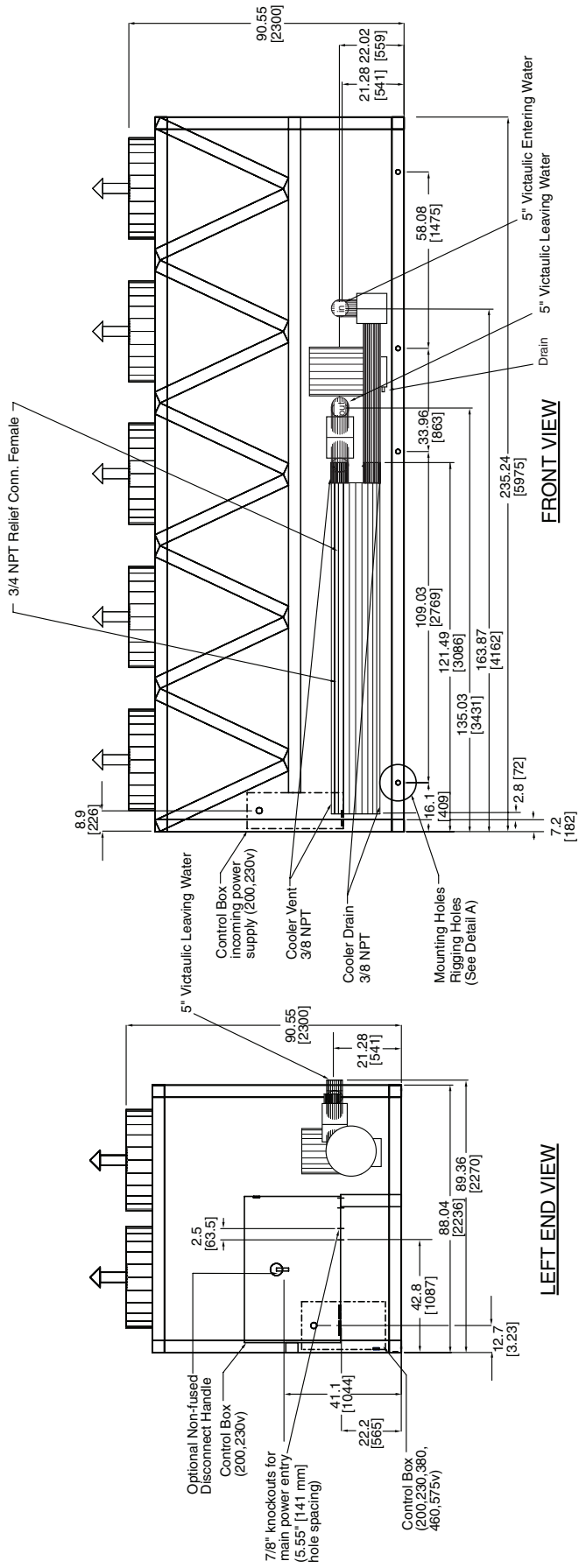
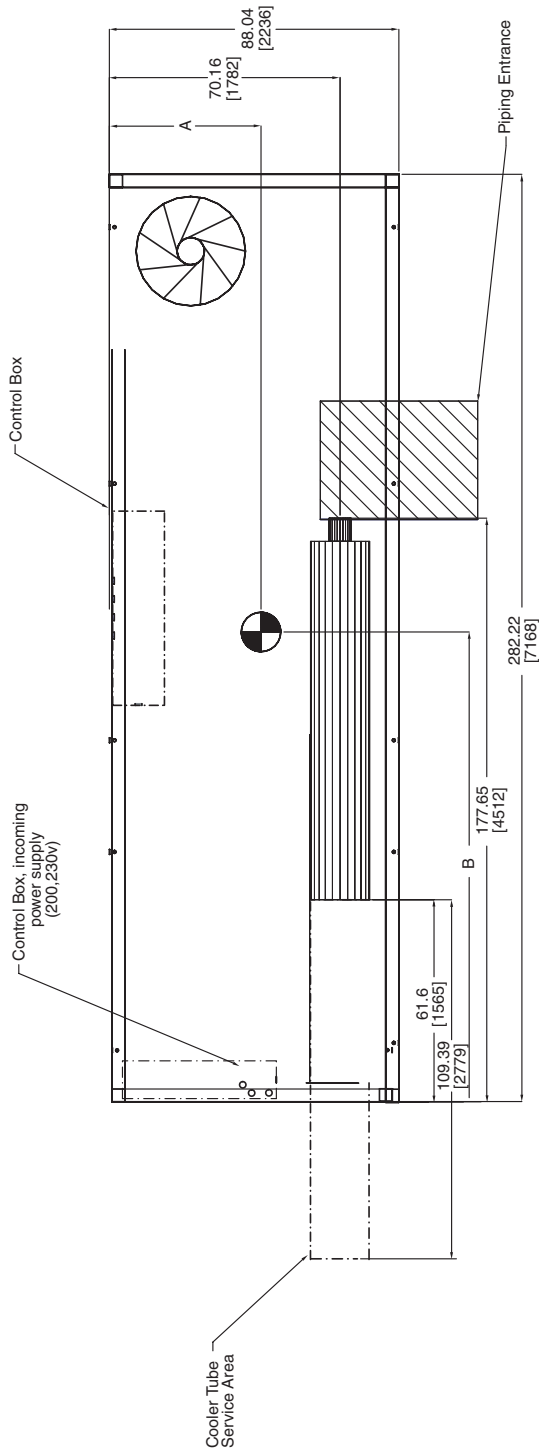

Fig. 4 — 30XA 140,160 Air-Cooled Liquid Chiller Dimensions (cont)

- NOTES:**
1. Unit must have clearances as follows:
 Top — Do not restrict
 Sides and Ends — 6 ft from solid surface.
 2. Temperature relief devices are located on liquid line and economizer assemblies and have 1/4"-in. flare connection.
 3. 3/8-in. NPT vents and drains located in each cooler head at each end of cooler.
 4. Drawing depicts unit with standard condenser fans, and standard two-pass cooler. Refer to the Packaged Chiller Builder program for other configurations.
 5. Dimensions are shown in inches; dimensions in brackets are in millimeters.

30XA UNIT	A	B
180	46.12 [1171]	143.04 [3633]
200	46.15 [1172]	142.97 [3631]



TOP VIEW

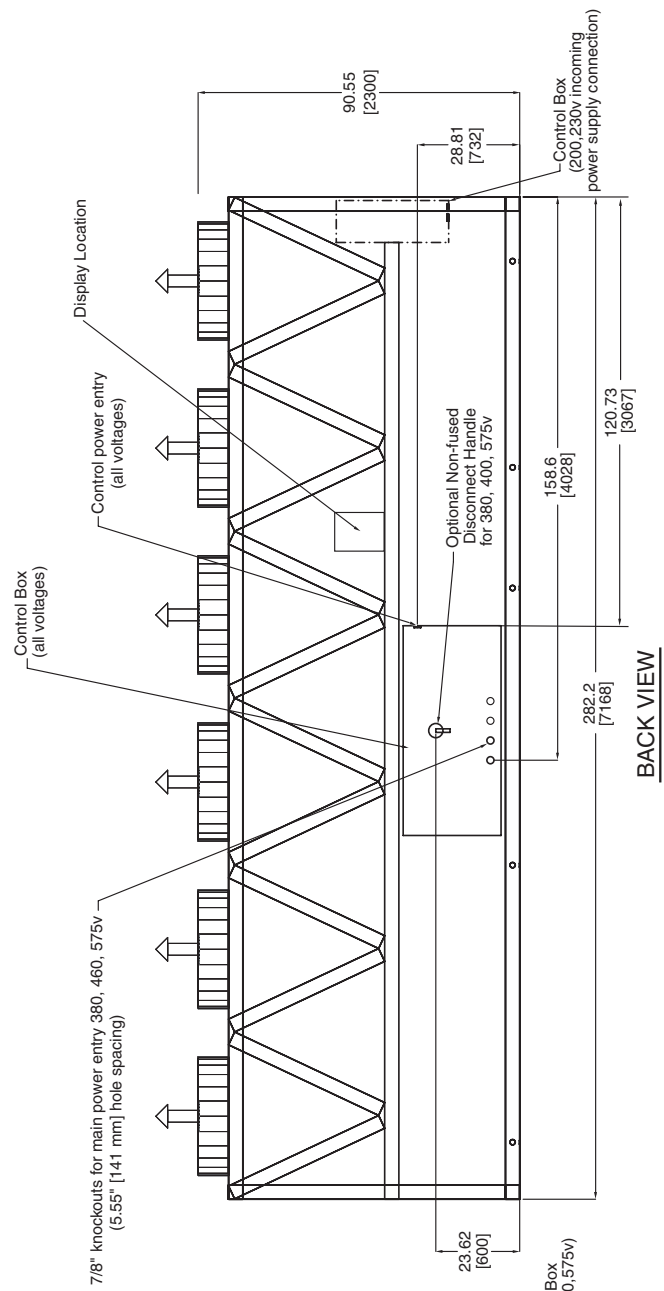

BACK VIEW

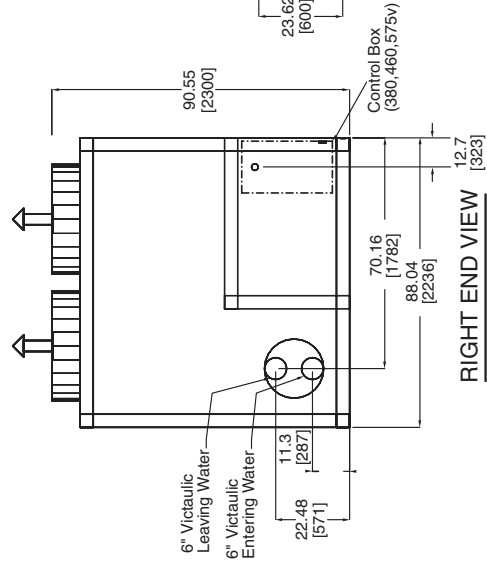

RIGHT END VIEW

Fig. 5 — 30XA180,200 Air-Cooled Liquid Chiller Dimensions

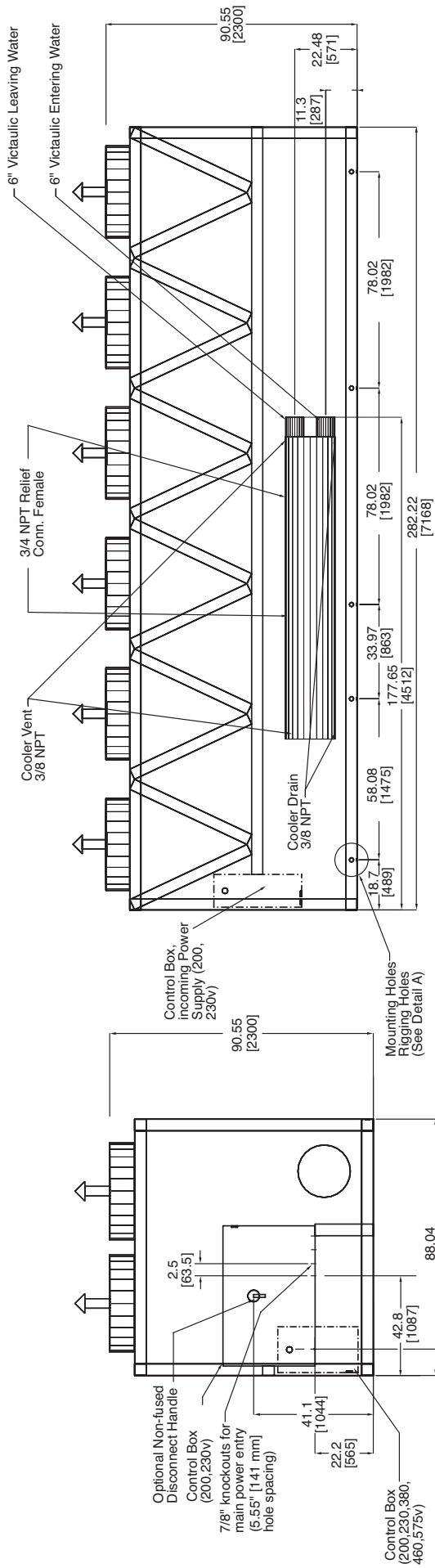

FRONT VIEW

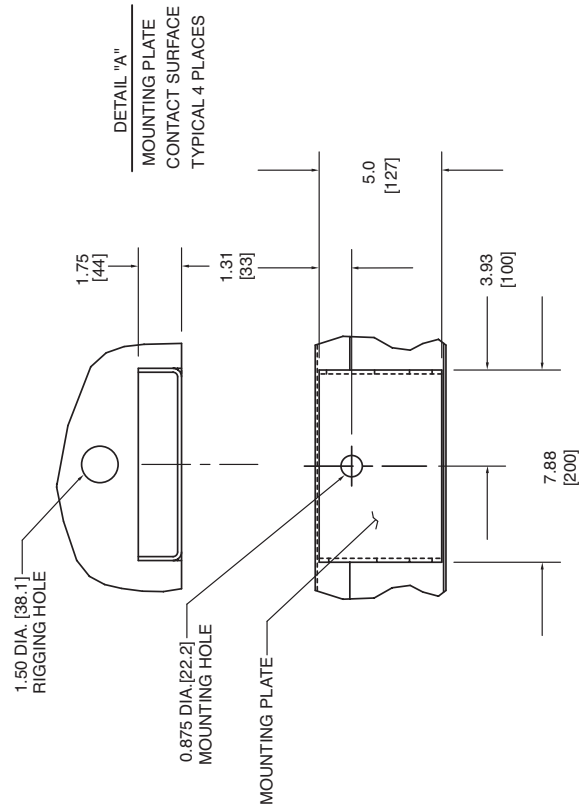

Fig. 5 — 30XA180,200 Air-Cooled Liquid Chiller Dimensions (cont)

- NOTES:**
- Unit must have clearances as follows:
 Top — Do not restrict
 Sides and Ends — 6 ft from solid surface.
 - Temperature relief devices are located on liquid line and economizer assemblies and have 1/4-in. flare connection.
 - 3/8-in. NPT vents and drains located in each cooler head at each end of cooler.
 - Drawing depicts unit with standard condenser fans, and standard two-pass cooler. Refer to the Packaged Chiller Builder program for other configurations.
 - Dimensions are shown in inches; dimensions in brackets are in millimeters.

30XA UNIT	A	B
220	46.17 [1173]	171.42 [4354]
240	46.23 [1174]	170.83 [4339]

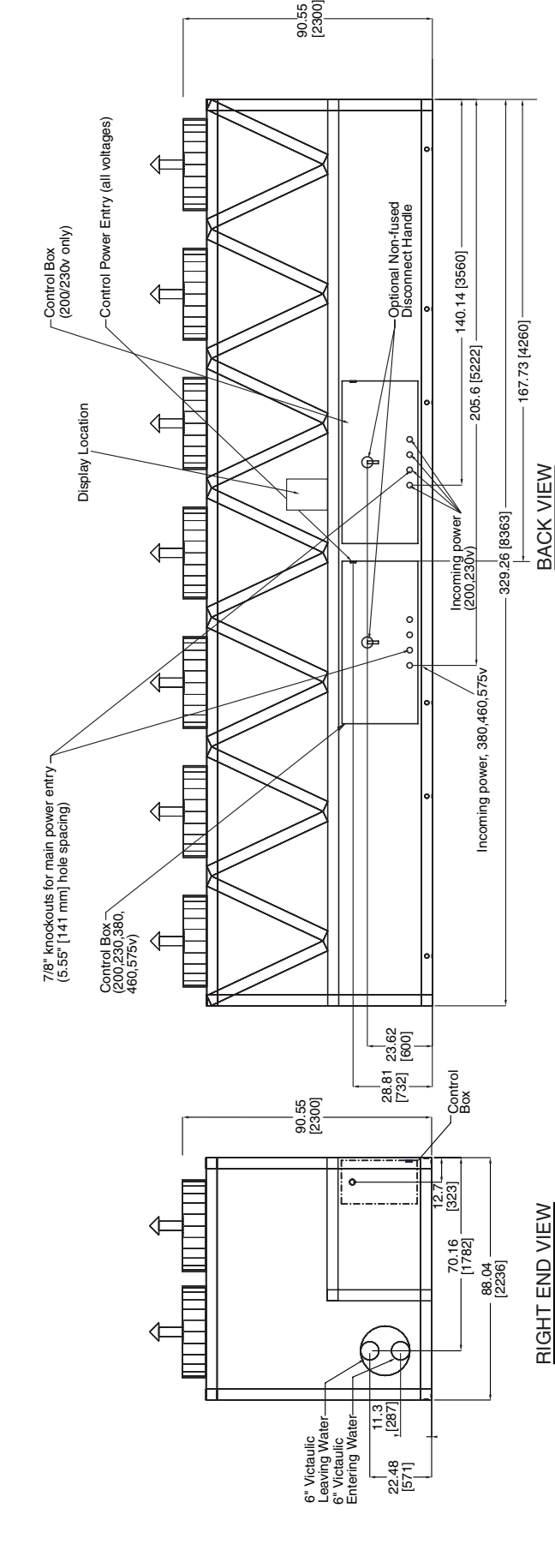
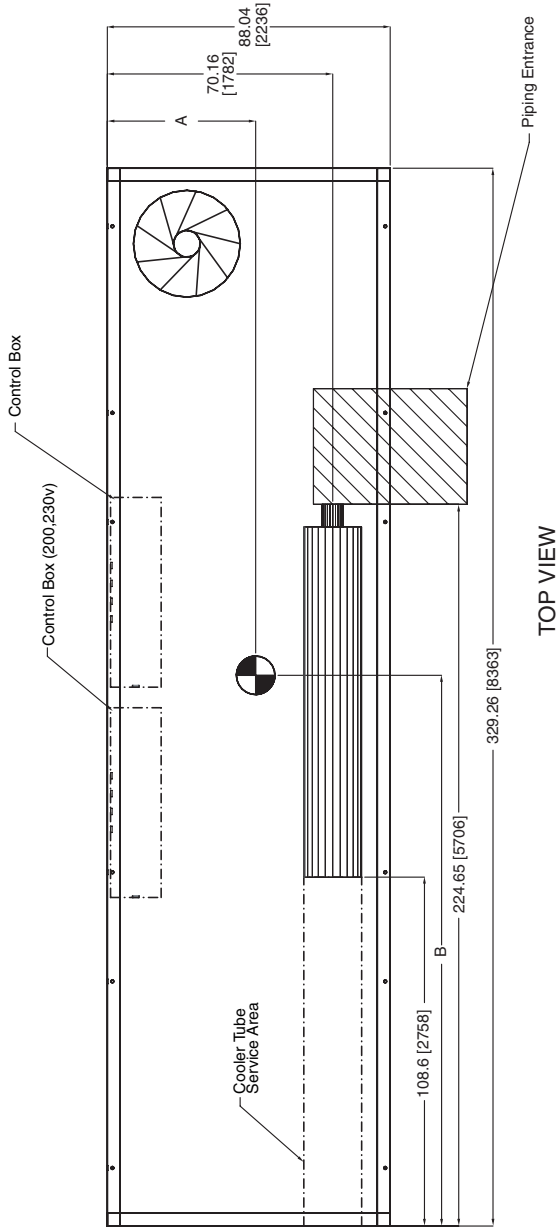

Fig. 6 — 30XA220,240 Air-Cooled Liquid Chiller Dimensions

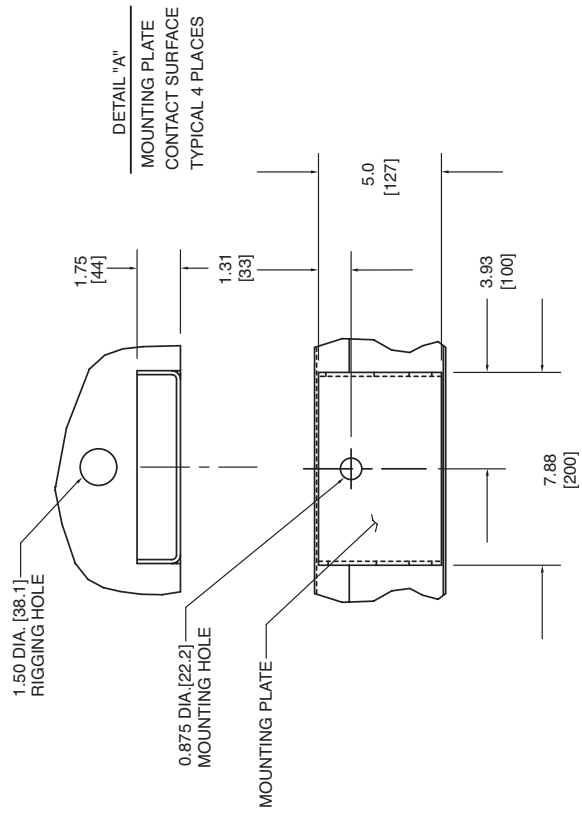
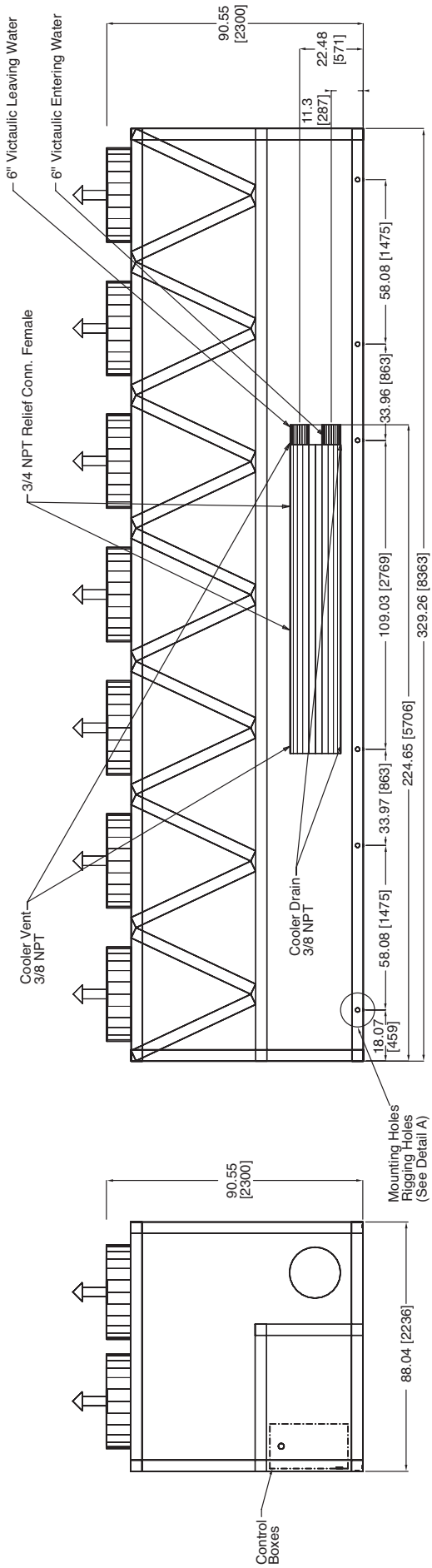
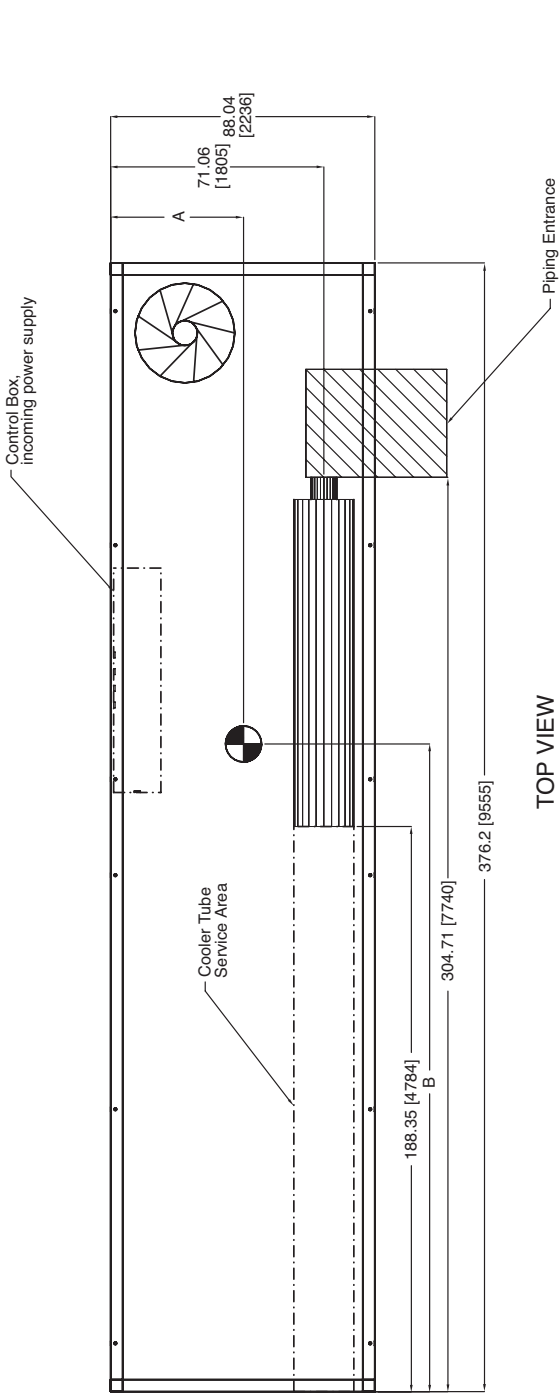

Fig. 6 — 30XA220,240 Air-Cooled Liquid Chiller Dimensions (cont)

- NOTES:**
- Unit must have clearances as follows:
 Top — Do not restrict
 Sides and Ends — 6 ft from solid surface.
 - Temperature relief devices are located on liquid line and economizer assemblies and have 1/4-in. flare connection.
 - 3/8-in. NPT vents and drains located in each cooler head at each end of cooler.
 - Drawing depicts unit with standard condenser fans and standard two-pass cooler. Refer to the Packaged Chiller Builder program for other configurations.
 - Dimensions are shown in inches; dimensions in brackets are in millimeters.



TOP VIEW

30XA UNIT	A	B
260	44.22 [1123]	216.16 [5490]
280	44.30 [1125]	215.86 [5483]
300	44.32 [1126]	216.18 [5491]

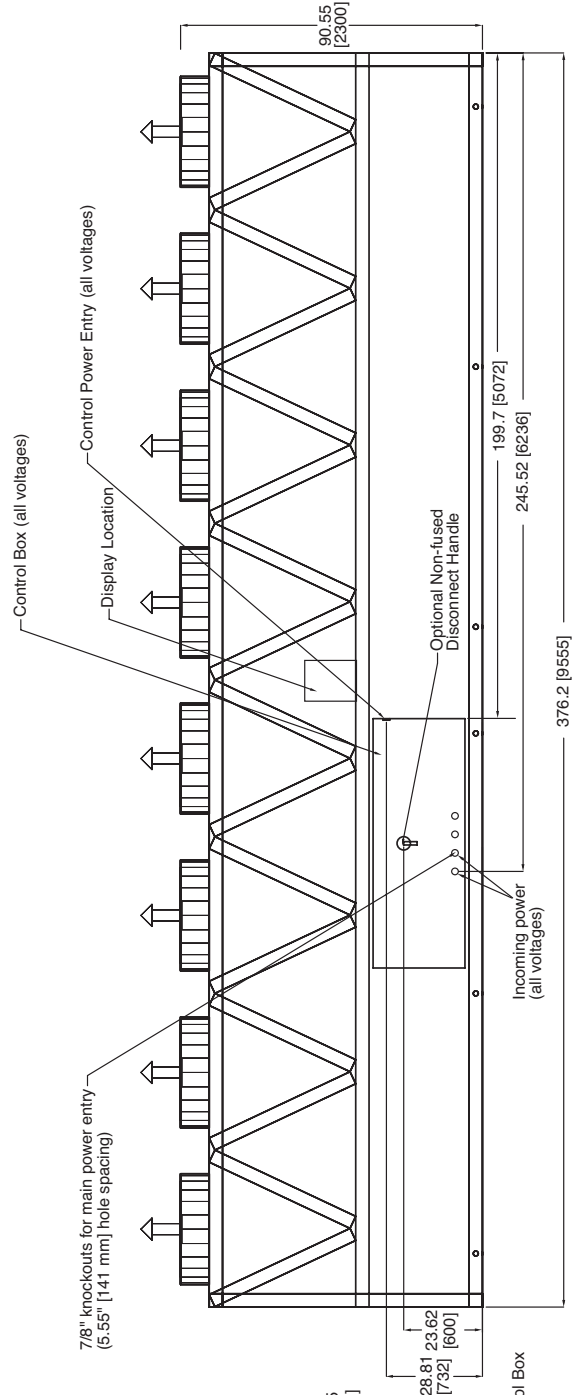

BACK VIEW

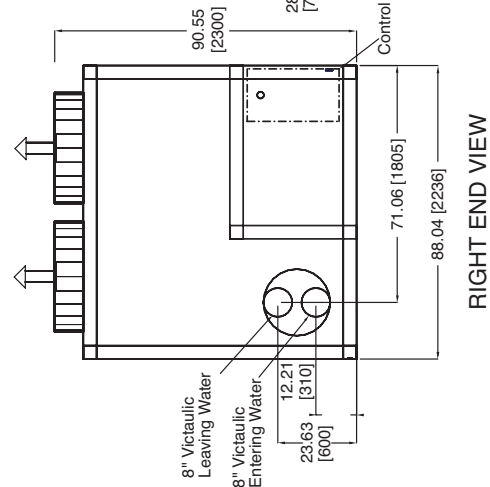

RIGHT END VIEW

Fig. 7 — 30XA260-300 Air-Cooled Liquid Chiller Dimensions

NOTES:

- Unit must have clearances as follows:
 - Top — Do not restrict
 - Sides and Ends — 6 ft from solid surface.
- Temperature relief devices are located on liquid line and economizer assemblies and have 1/4-in. flare connection.
- 3/8-in. NPT vents and drains located in each cooler head at each end of cooler.
- Drawing depicts unit with standard condenser fans and standard two-pass cooler. Refer to the Packaged Chiller Builder program for other configurations.
- Dimensions are shown in inches; dimensions in brackets are in millimeters.

30XA UNIT	A	B
325	42.92 [1090]	246.16 [6252]
350	42.92 [1090]	246.72 [6267]

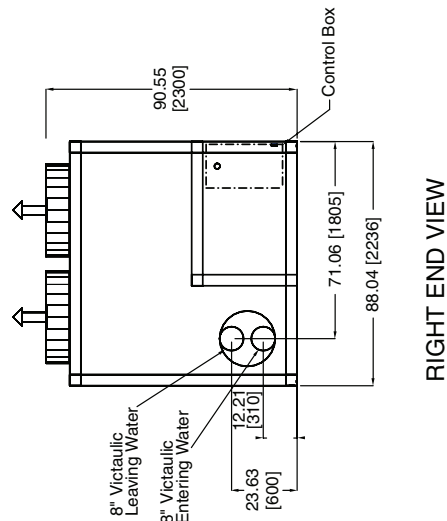
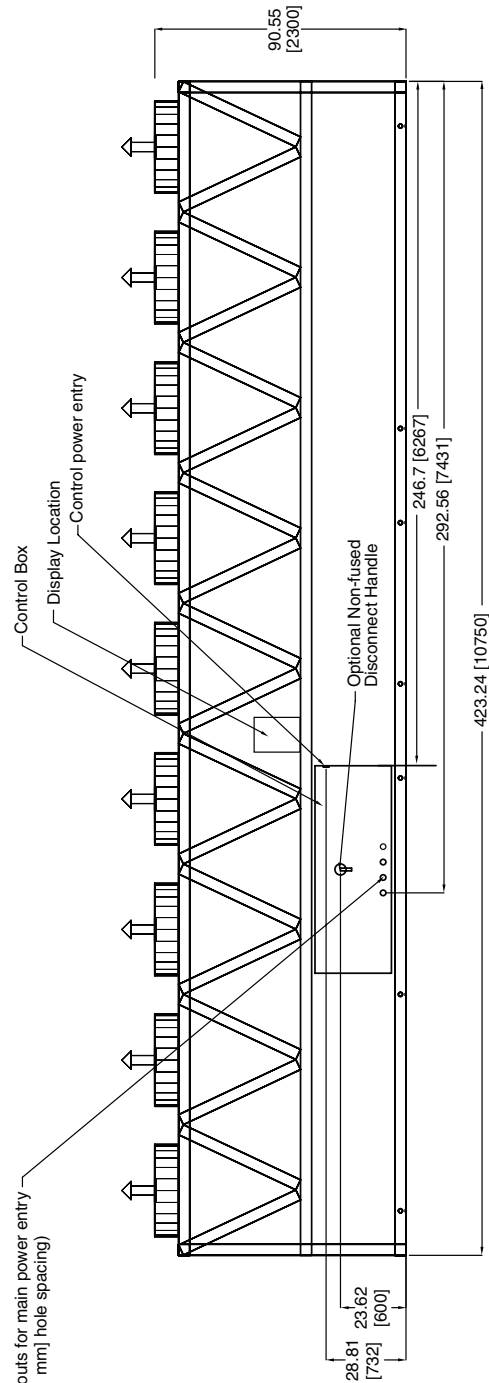
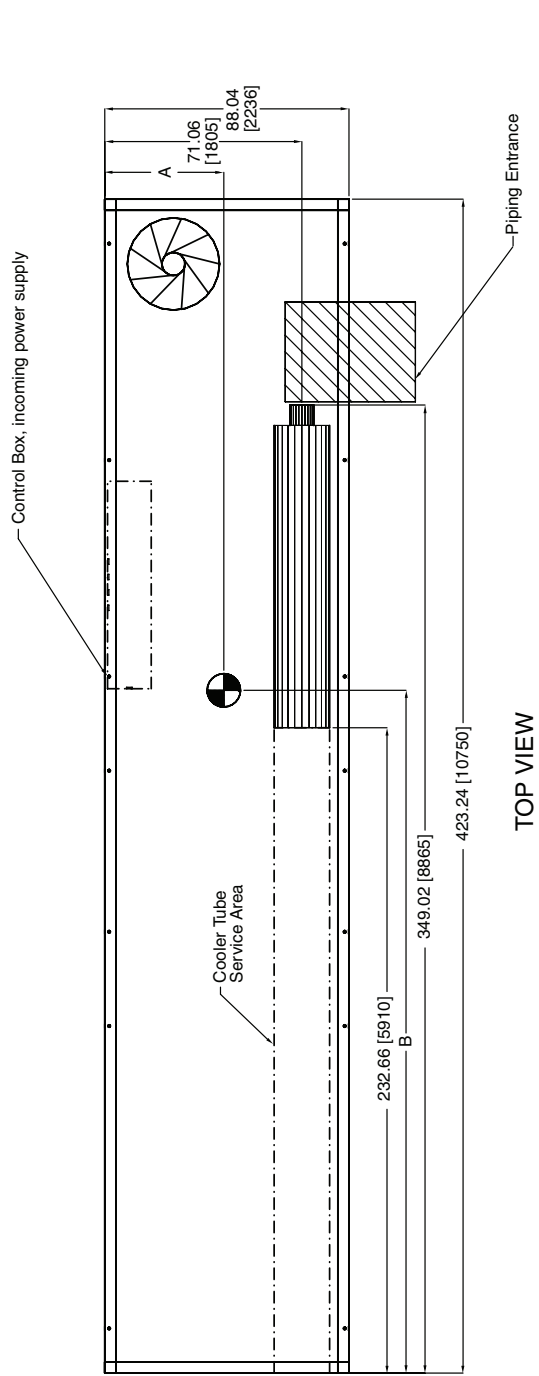
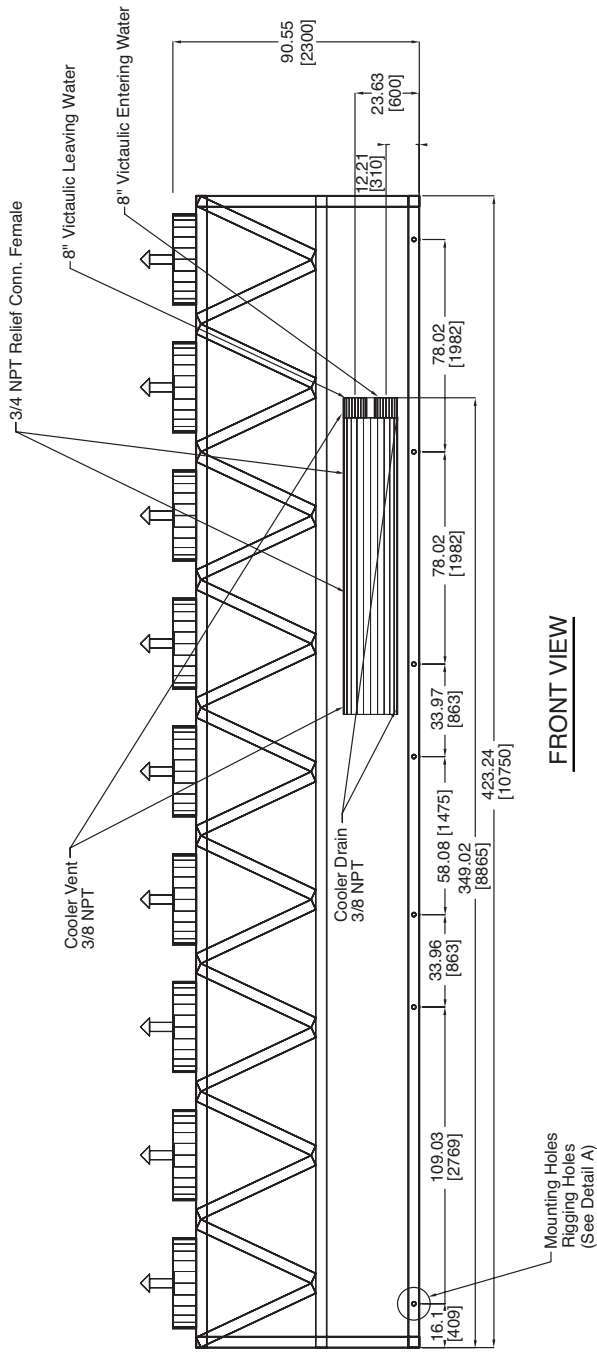
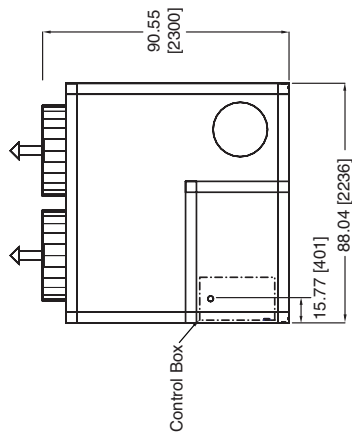

Fig. 8 — 30XA325,350 Air-Cooled Liquid Chiller Dimensions



FRONT VIEW



LEFT END VIEW

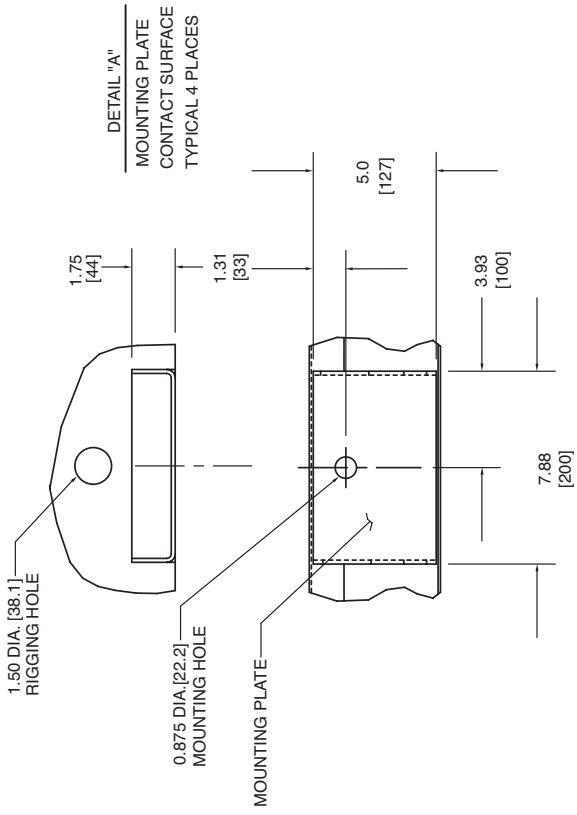
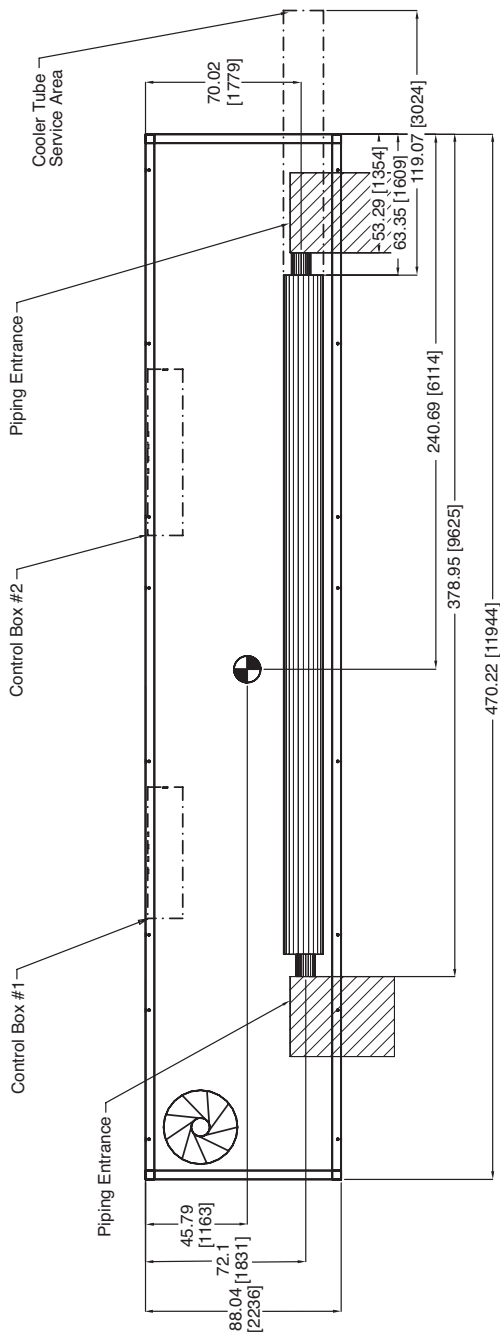
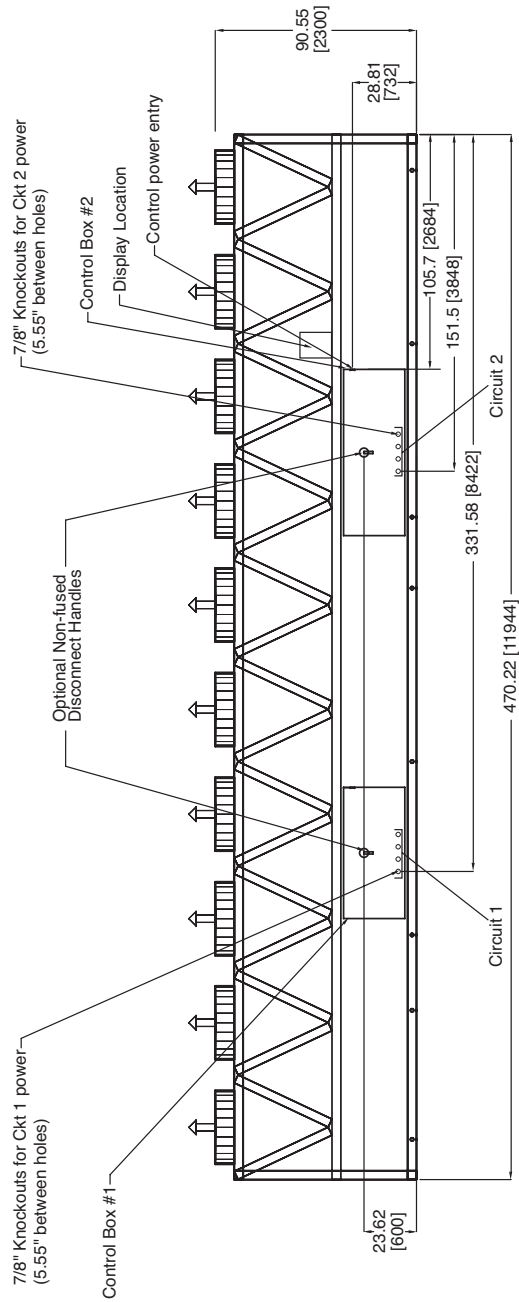

Fig. 8 — 30XA325,350 Air-Cooled Liquid Chiller Dimensions (cont)

- NOTES:**
- Unit must have clearances as follows:
 - Top — Do not restrict
 - Sides and Ends — 6 ft from solid surface.
 - Temperature relief devices are located on liquid line and economizer assemblies and have 1/4-in. flare connection.
 - 3/8-in. NPT vents and drains located in each cooler head at each end of cooler.
 - Drawing depicts unit with dual-point power standard condenser fans and standard one-pass cooler. Refer to the Packaged Chiller Builder program for other configurations.
 - Actual cooler consists of two separate coolers piped in series at the factory. Piping may be split for rigging.
 - Dimensions are shown in inches; dimensions in brackets are in millimeters.



TOP VIEW



BACK VIEW

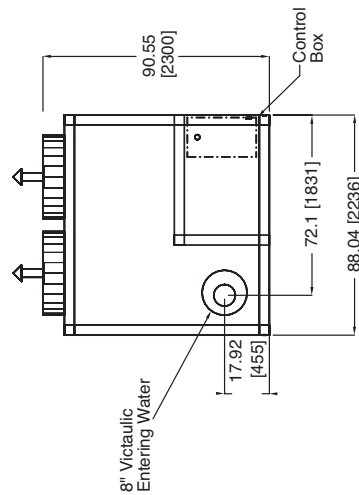

RIGHT END VIEW

Fig. 9 — 30XA400 Air-Cooled Liquid Chiller Dimensions

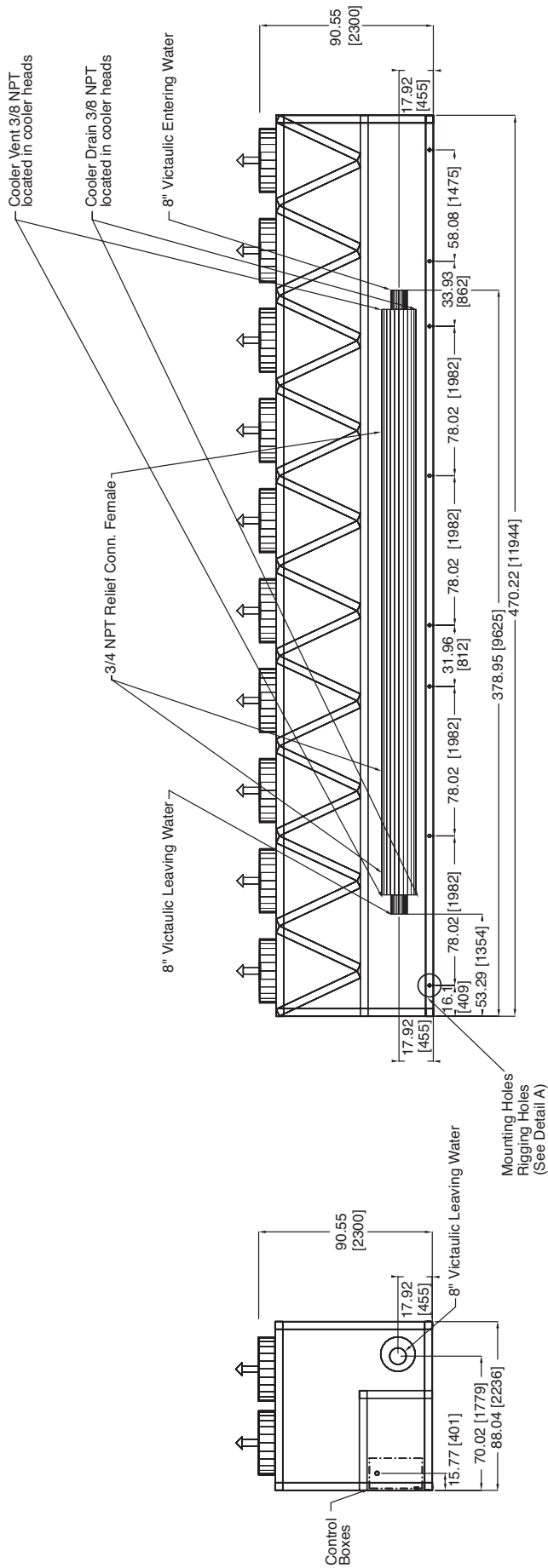

FRONT VIEW

LEFT END VIEW

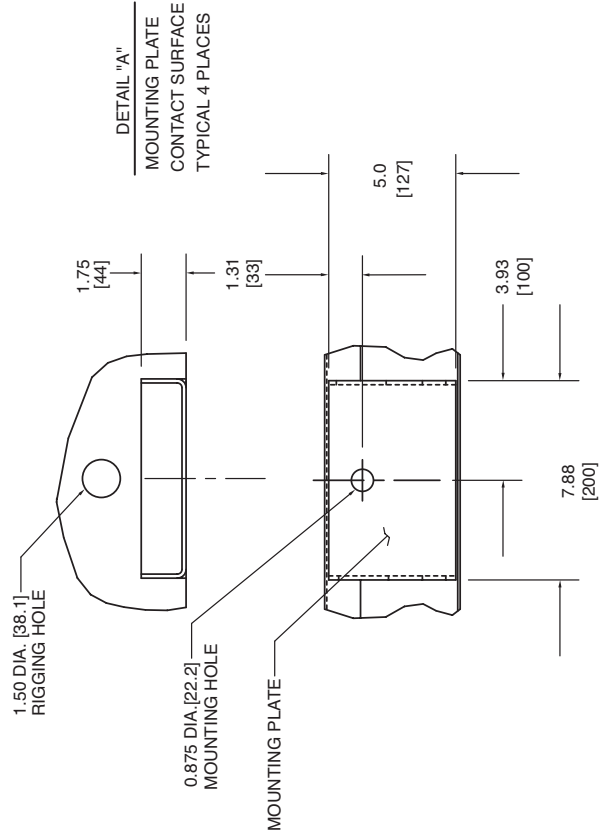
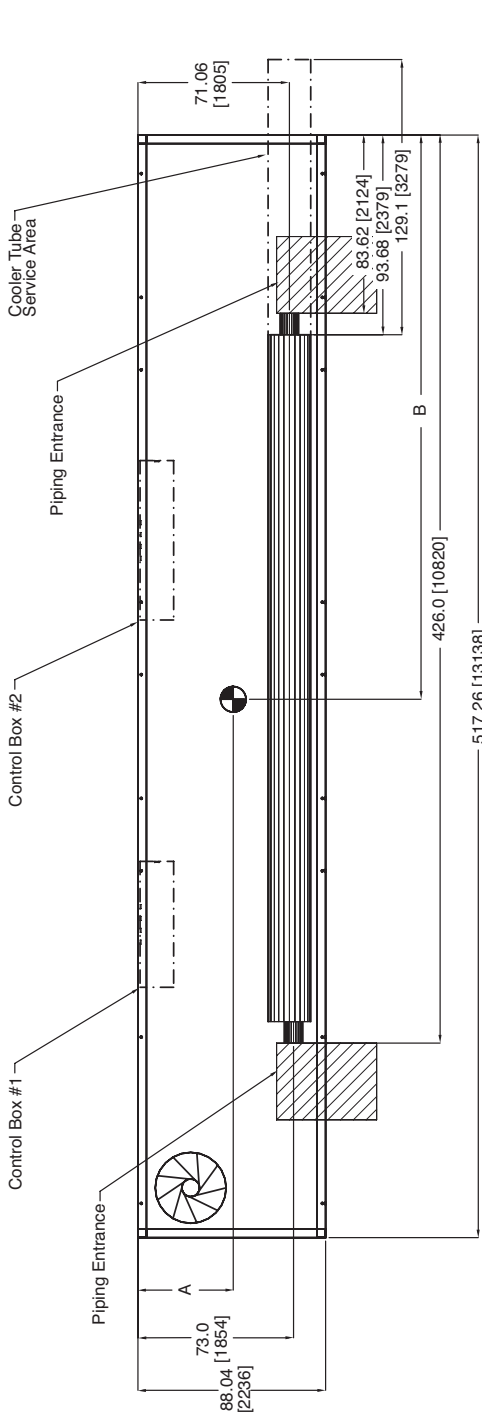

Fig. 9 — 30XA400 Air-Cooled Liquid Chiller Dimensions (cont)

NOTES:

- Unit must have clearances as follows:
Top — Do not restrict
Sides and Ends — 6 ft from solid surface.
- Temperature relief devices are located on liquid line and economizer assemblies and have 1/4-in. flare connection.
- 3/8-in. NPT vents and drains located in each cooler head at each end of cooler.
- Drawing depicts unit with dual-point power standard condenser fans and standard one-pass cooler. Refer to the Packaged Chiller Builder program for other configurations.
- Actual cooler consists of two separate coolers piped in series at the factory. Piping may be split for rigging.
- Dimensions are shown in inches; dimensions in brackets are in millimeters.

30XA UNIT	A	B
450	44.71 [1136]	264.7 [6723]
500	44.78 [1137]	263.99 [6705]



TOP VIEW

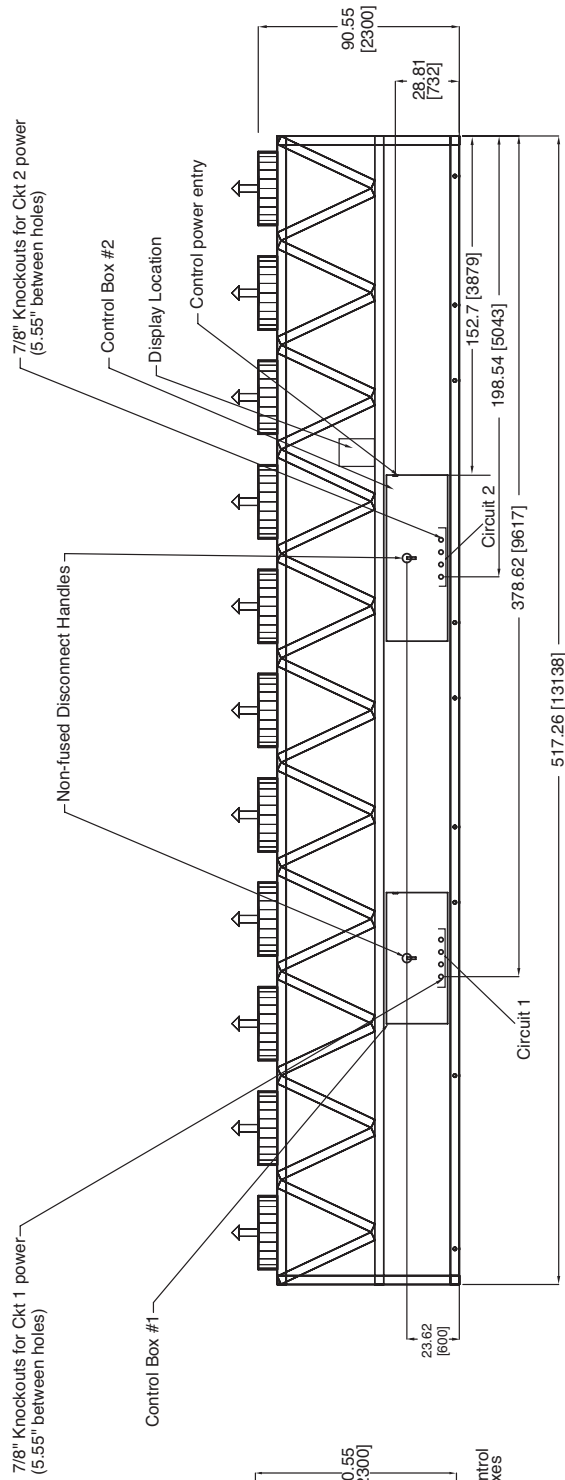

BACK VIEW

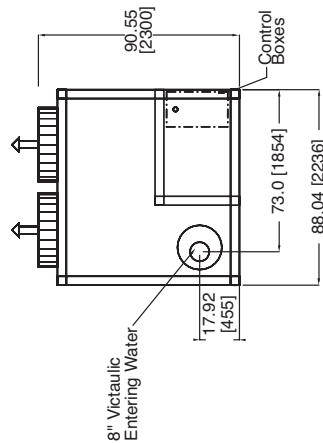

RIGHT END VIEW

Fig. 10 — 30XA450,500 Air-Cooled Liquid Chiller Dimensions

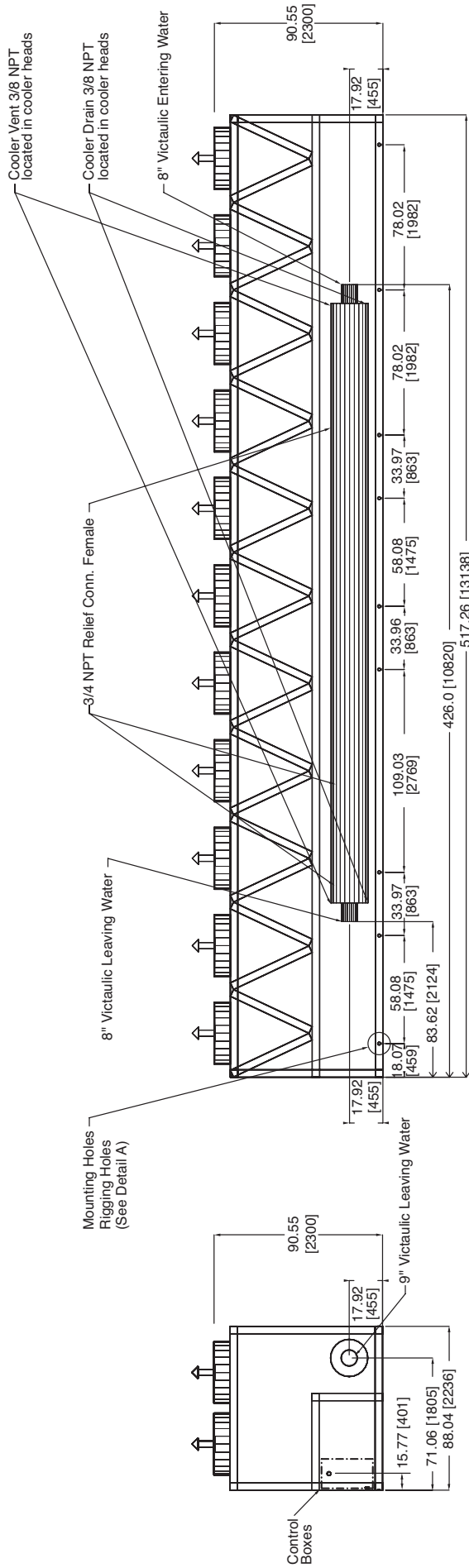

LEFT END VIEW

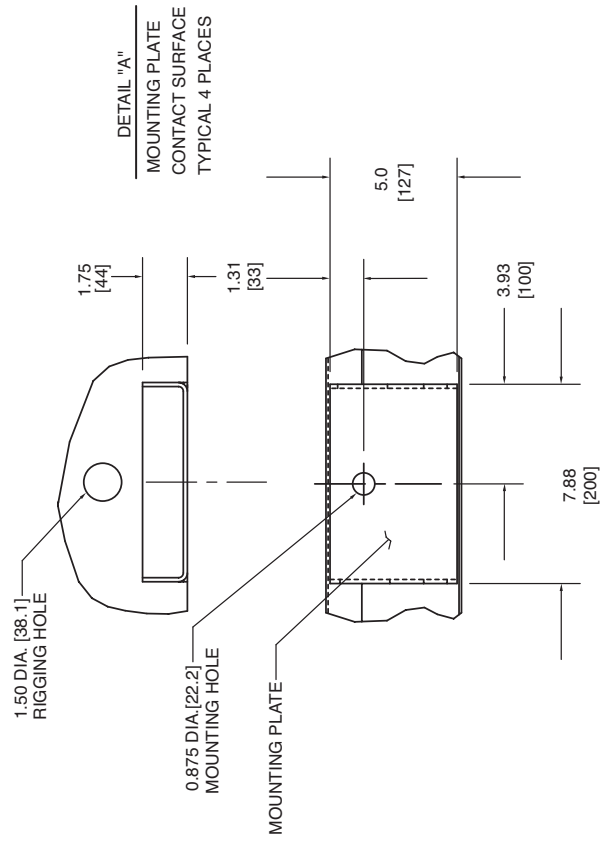

Fig. 10 — 30XA450,500 Air-Cooled Liquid Chiller Dimensions (cont)

UNITS WITHOUT PUMPS — ENGLISH

30XA UNIT SIZE	MOUNTING WEIGHT (lb) MCHX CONDENSER COILS																
	A	B	C	D	Total												
080	1947	1673	1670	1943	7234												
30XA UNIT SIZE	MOUNTING WEIGHT (lb) MCHX CONDENSER COILS																
	A	B	C	D	E	F	Total										
090	1201	2043	750	951	1983	1199	8127										
100	1226	2098	780	981	2038	1224	8348										
110	1239	2136	798	1006	2075	1229	8483										
120	1272	2174	800	1007	2106	1263	8622										
30XA UNIT SIZE	MOUNTING WEIGHT (lb) MCHX CONDENSER COILS																
	A	B	C	D	E	F	G	H	Total								
140	1897	1444	864	1181	1217	883	1584	1699	10,768								
160	1949	1469	878	1206	1246	899	1603	1750	11,000								
30XA UNIT SIZE	MOUNTING WEIGHT (lb) MCHX CONDENSER COILS																
	A	B	C	D	E	F	G	H	I	J	Total						
180	905	1484	1164	1849	1187	1224	1868	840	1289	888	12,699						
200	909	1499	1188	1870	1192	1232	1879	848	1299	893	12,810						
30XA UNIT SIZE	MOUNTING WEIGHT (lb) MCHX CONDENSER COILS																
	A	B	C	D	E	F	G	H	I	J	K	L	Total				
220	813	1196	1592	1498	828	1216	1259	848	1363	1064	1237	832	13,748				
240	829	1218	1617	1520	830	1218	1261	850	1371	1073	1260	849	13,897				
260	495	1431	1630	763	2465	1013	1528	2380	800	1333	1386	495	15,720				
280	497	1451	1663	771	2497	1015	1530	2390	803	1358	1406	497	15,878				
300	502	1465	1686	786	2568	1027	1557	2454	811	1367	1417	502	16,141				
30XA UNIT SIZE	MOUNTING WEIGHT (lb) MCHX CONDENSER COILS																
	A	B	C	D	E	F	G	H	I	J	K	L	M	N	Total		
325	742	742	978	1531	783	2546	1067	1563	2334	804	1646	1247	742	742	17,467		
350	745	745	982	1546	792	2598	1077	1589	2386	808	1651	1249	745	745	17,659		
30XA UNIT SIZE	MOUNTING WEIGHT (lb) MCHX CONDENSER COILS																
	A	B	C	D	E	F	G	H	I	J	K	L	M	N	O	P	Total
400	847	1234	1511	2965	1255	789	2214	1071	1566	2286	747	1265	2152	991	1277	868	23,038
450	856	1179	2160	2282	905	1057	2030	2053	2711	1934	1551	1266	1440	1385	1216	876	24,901
500	843	1236	2207	2334	909	1060	2037	2060	2718	1941	1555	1269	1457	1401	1279	863	25,167

UNITS WITHOUT PUMPS — SI

30XA UNIT SIZE	MOUNTING WEIGHT (kg) MCHX CONDENSER COILS																
	A	B	C	D	Total												
080	883	759	758	882	3281												
30XA UNIT SIZE	MOUNTING WEIGHT (kg) MCHX CONDENSER COILS																
	A	B	C	D	E	F	Total										
090	545	927	340	431	899	544	3686										
100	556	952	354	445	924	555	3786										
110	562	969	362	456	941	558	3848										
120	577	986	363	457	955	573	3911										
30XA UNIT SIZE	MOUNTING WEIGHT (kg) MCHX CONDENSER COILS																
	A	B	C	D	E	F	G	H	Total								
140	860	655	392	536	552	401	719	771	4884								
160	884	666	398	547	565	408	727	794	4990								
30XA UNIT SIZE	MOUNTING WEIGHT (kg) MCHX CONDENSER COILS																
	A	B	C	D	E	F	G	H	I	J	Total						
180	410	673	528	839	538	555	847	381	584	403	5760						
200	412	680	539	848	541	559	852	385	589	405	5811						
30XA UNIT SIZE	MOUNTING WEIGHT (kg) MCHX CONDENSER COILS																
	A	B	C	D	E	F	G	H	I	J	K	L	Total				
220	369	542	722	680	376	552	571	385	618	483	561	378	6236				
240	376	552	734	690	377	553	572	386	622	487	572	385	6304				
260	225	649	740	346	1118	460	693	1079	363	605	629	225	7130				
280	225	658	754	350	1133	461	694	1084	364	616	638	225	7202				
300	228	664	765	357	1165	466	706	1113	368	620	643	228	7322				
30XA UNIT SIZE	MOUNTING WEIGHT (kg) MCHX CONDENSER COILS																
	A	B	C	D	E	F	G	H	I	J	K	L	M	N	Total		
325	337	337	444	695	355	1155	484	709	1058	365	746	565	337	337	7923		
350	338	338	446	701	359	1179	488	721	1082	367	749	567	338	338	8010		
30XA UNIT SIZE	MOUNTING WEIGHT (kg) MCHX CONDENSER COILS																
	A	B	C	D	E	F	G	H	I	J	K	L	M	N	O	P	Total
400	384	560	685	1345	569	358	1004	486	710	1037	339	574	976	450	579	394	10 450
450	388	535	980	1035	411	479	921	931	1230	877	704	574	653	628	551	397	11 295
500	382	561	1001	1059	412	481	924	934	1233	880	705	576	661	635	580	391	11 416

Fig. 11A — Unit Mounting Weights (Units with MCHX Condenser Coils)

30XA080

COOLER SIDE



30XA090-120

COOLER SIDE

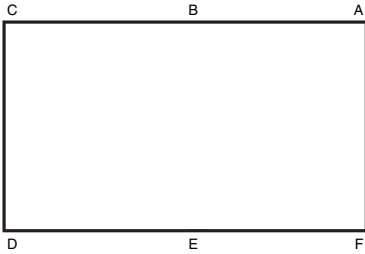

30XA140,160

COOLER SIDE

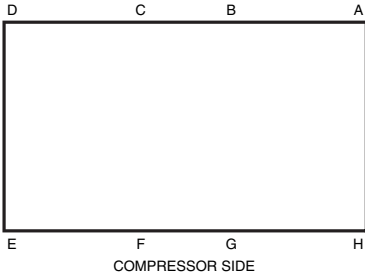

30XA180-200

COOLER SIDE

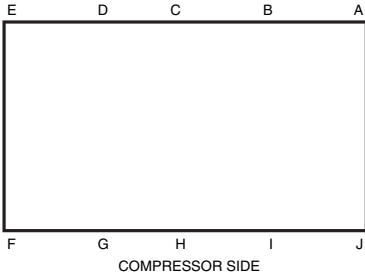

30XA220-300

COOLER SIDE

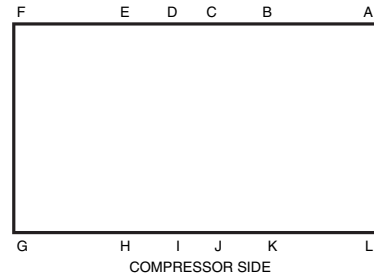

30XA325-350

COOLER SIDE

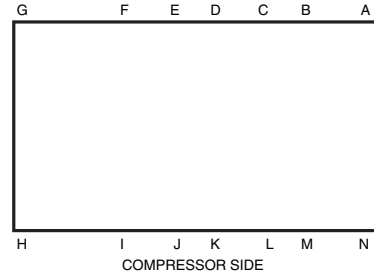

30XA400-500

COOLER SIDE

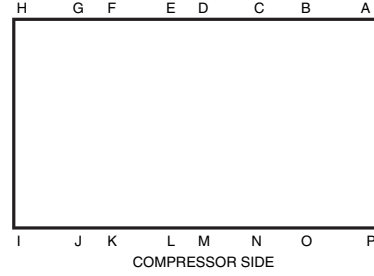

LEGEND

MCHX — Micro-Channel Heat Exchanger

Fig. 11A — Unit Mounting Weights (Units with MCHX Condenser Coils) (cont)

SINGLE PUMP UNITS — ENGLISH

30XA UNIT SIZE	MOUNTING WEIGHT (lb) MCHX CONDENSER COILS						
	A	B	C	D	E	F	Total
090	1201	2754	1087	900	1944	1199	9085
100	1226	2814	1123	924	1995	1224	9306
110	1239	2855	1145	945	2027	1229	9441
120	1272	2893	1147	947	2059	1263	9580

30XA UNIT SIZE	MOUNTING WEIGHT (lb) MCHX CONDENSER COILS								
	A	B	C	D	E	F	G	H	Total
140	1897	1444	1609	1606	1078	810	1584	1699	11,726
160	1949	1469	1626	1635	1103	824	1603	1750	11,958

SINGLE PUMP UNITS — SI

30XA UNIT SIZE	MOUNTING WEIGHT (kg) MCHX CONDENSER COILS						
	A	B	C	D	E	F	Total
090	545	1249	493	408	882	544	4121
100	556	1276	510	419	905	555	4221
110	562	1295	519	429	920	558	4282
120	577	1312	520	430	934	573	4346

30XA UNIT SIZE	MOUNTING WEIGHT (kg) MCHX CONDENSER COILS								
	A	B	C	D	E	F	G	H	Total
140	860	655	730	728	489	367	719	771	5319
160	884	666	737	742	500	374	727	794	5424

30XA090-120

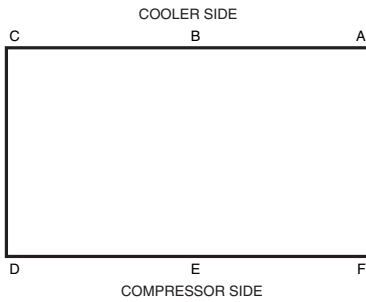

30XA140,160

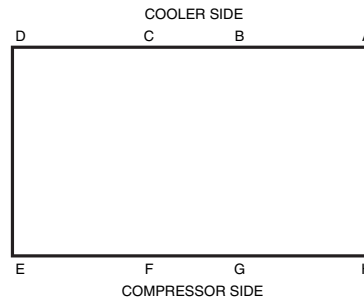

LEGEND

MCHX — Micro-Channel Heat Exchanger

Fig. 11A — Unit Mounting Weights (Units with MCHX Condenser Coils) (cont)

DUAL PUMP UNITS — ENGLISH

30XA UNIT SIZE	MOUNTING WEIGHT (lb) MCHX CONDENSER COILS						
	A	B	C	D	E	F	Total
090	1201	2962	1176	900	1944	1199	9382
100	1226	3022	1212	924	1995	1224	9603
110	1239	3064	1234	945	2027	1229	9738
120	1272	3101	1236	947	2059	1263	9877

30XA UNIT SIZE	MOUNTING WEIGHT (lb) MCHX CONDENSER COILS								
	A	B	C	D	E	F	G	H	Total
140	1897	1444	1818	1694	1078	810	1584	1699	12,023
160	1949	1469	1834	1724	1103	824	1603	1750	12,255

DUAL PUMP UNITS — SI

30XA UNIT SIZE	MOUNTING WEIGHT (kg) MCHX CONDENSER COILS						
	A	B	C	D	E	F	Total
090	545	1343	533	408	882	544	4255
100	556	1371	550	419	905	555	4356
110	562	1390	560	429	920	558	4417
120	577	1407	560	430	934	573	4480

30XA UNIT SIZE	MOUNTING WEIGHT (kg) MCHX CONDENSER COILS								
	A	B	C	D	E	F	G	H	Total
140	860	655	825	769	489	367	719	771	5454
160	884	666	832	782	500	374	727	794	5559

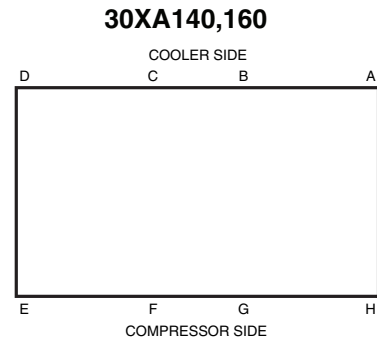
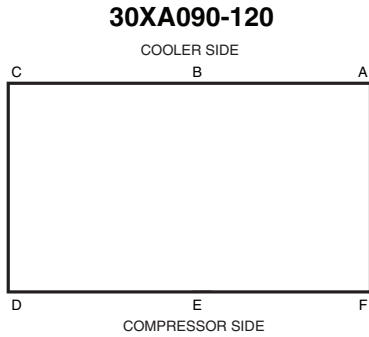

LEGEND

MCHX — Micro-Channel Heat Exchanger

Fig. 11A — Unit Mounting Weights (Units with MCHX Condenser Coils) (cont)

UNITS WITHOUT PUMPS — ENGLISH

30XA UNIT SIZE	MOUNTING WEIGHT (lb) — Al/Cu*																
	A	B	C	D	Total												
080	2059	1785	1778	2051	7674												
30XA UNIT SIZE	MOUNTING WEIGHT (lb) — Al/Cu*																
	A	B	C	D	E	F	Total										
090	1273	2188	822	1023	2127	1271	8704										
100	1299	2244	853	1054	2184	1297	8931										
110	1312	2284	872	1079	2222	1303	9071										
120	1346	2322	874	1082	2255	1337	9216										
30XA UNIT SIZE	MOUNTING WEIGHT (lb) — Al/Cu*																
	A	B	C	D	E	F	G	H	Total								
140	2007	1554	938	1254	1291	957	1695	1809	11,505								
160	2061	1581	953	1281	1321	974	1715	1862	11,748								
30XA UNIT SIZE	MOUNTING WEIGHT (lb) — Al/Cu*																
	A	B	C	D	E	F	G	H	I	J	Total						
180	979	1558	1239	1998	1261	1298	2016	915	1363	962	13,590						
200	984	1574	1263	2020	1267	1308	2029	923	1375	968	13,712						
30XA UNIT SIZE	MOUNTING WEIGHT (lb) — Al/Cu*																
	A	B	C	D	E	F	G	H	I	J	K	L	Total				
220	883	1266	1697	1603	898	1286	1329	918	1468	1169	1307	902	14,727				
240	900	1288	1723	1626	901	1289	1331	921	1477	1179	1331	920	14,887				
260	566	1572	1701	834	2607	1084	1599	2521	871	1404	1528	566	16,853				
280	569	1594	1734	843	2640	1087	1601	2533	875	1429	1549	569	17,022				
300	578	1617	1762	862	2720	1103	1633	2607	887	1444	1570	578	17,362				
30XA UNIT SIZE	MOUNTING WEIGHT (lb) — Al/Cu*																
	A	B	C	D	E	F	G	H	I	J	K	L	M	N	Total		
325	856	856	1054	1607	859	2697	1143	1639	2485	880	1722	1322	856	856	18,834		
350	860	860	1059	1623	869	2752	1153	1666	2539	885	1727	1326	860	860	19,040		
30XA UNIT SIZE	MOUNTING WEIGHT (lb) — Al/Cu*																
	A	B	C	D	E	F	G	H	I	J	K	L	M	N	O	P	Total
400	924	1311	1588	3119	1332	866	2368	1148	1643	2440	824	1342	2306	1069	1354	945	24,578
450	933	1256	2276	2398	982	1134	2184	2207	2866	2089	1629	1343	1556	1501	1293	953	26,600
500	921	1314	2325	2452	987	1139	2194	2217	2875	2098	1633	1348	1575	1519	1357	941	26,894

*Condenser Coil: Aluminum Fins/Copper Tubing.

UNITS WITHOUT PUMPS — SI

30XA UNIT SIZE	MOUNTING WEIGHT (kg) — Al/Cu*																
	A	B	C	D	Total												
080	934	810	807	930	3481												
30XA UNIT SIZE	MOUNTING WEIGHT (kg) — Al/Cu*																
	A	B	C	D	E	F	Total										
090	578	992	373	464	965	576	3948										
100	589	1018	387	478	991	588	4051										
110	595	1036	396	489	1008	591	4115										
120	611	1053	397	491	1023	607	4181										
30XA UNIT SIZE	MOUNTING WEIGHT (kg) — Al/Cu*																
	A	B	C	D	E	F	G	H	Total								
140	910	705	425	569	585	434	769	821	5219								
160	935	717	432	581	599	442	778	845	5329								
30XA UNIT SIZE	MOUNTING WEIGHT (kg) — Al/Cu*																
	A	B	C	D	E	F	G	H	I	J	Total						
180	444	707	562	906	572	589	915	415	618	436	6164						
200	446	714	573	916	575	593	920	419	624	439	6220						
30XA UNIT SIZE	MOUNTING WEIGHT (kg) — Al/Cu*																
	A	B	C	D	E	F	G	H	I	J	K	L	Total				
220	401	574	770	727	407	583	603	416	666	530	593	409	6680				
240	408	584	782	738	409	585	604	418	670	535	604	417	6753				
260	257	713	772	378	1182	492	725	1144	395	637	693	257	7644				
280	258	723	787	382	1197	493	726	1149	397	648	703	258	7721				
300	262	734	799	391	1234	501	741	1182	402	655	712	262	7876				
30XA UNIT SIZE	MOUNTING WEIGHT (kg) — Al/Cu*																
	A	B	C	D	E	F	G	H	I	J	K	L	M	N	Total		
325	388	388	478	729	390	1224	518	744	1127	399	781	600	388	388	8543		
350	390	390	480	736	394	1248	523	756	1152	401	784	601	390	390	8636		
30XA UNIT SIZE	MOUNTING WEIGHT (kg) — Al/Cu*																
	A	B	C	D	E	F	G	H	I	J	K	L	M	N	O	P	Total
400	419	595	720	1415	604	393	1074	521	745	1107	374	609	1046	485	614	428	11 149
450	423	570	1032	1088	446	514	991	1001	1300	948	739	609	706	681	586	432	12 066
500	418	596	1055	1112	448	516	995	1005	1304	952	741	611	714	689	616	427	12 199

*Condenser Coil: Aluminum Fins/Copper Tubing.

Fig. 11B — Unit Mounting Weights (Units with Al/Cu Condenser Coils)

30XA080

COOLER SIDE



COMPRESSOR SIDE

30XA220-300

COOLER SIDE

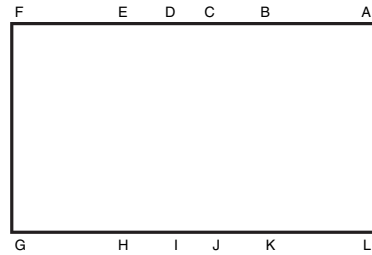

COMPRESSOR SIDE

30XA090-120

COOLER SIDE

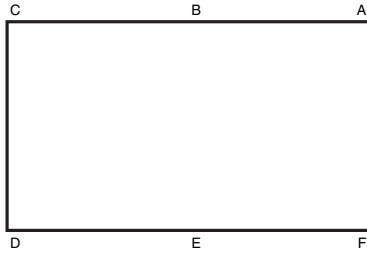

COMPRESSOR SIDE

30XA325-350

COOLER SIDE

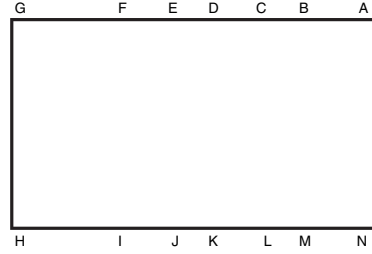

COMPRESSOR SIDE

30XA140,160

COOLER SIDE

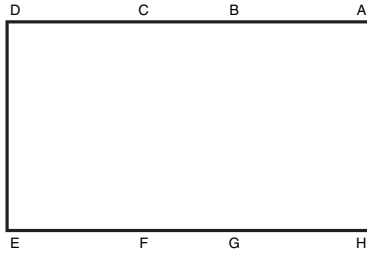

COMPRESSOR SIDE

30XA400-500

COOLER SIDE

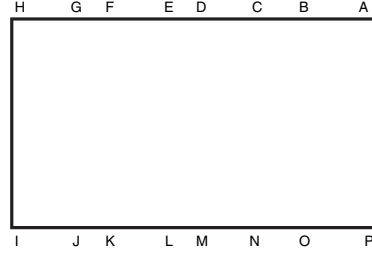

COMPRESSOR SIDE

30XA180-200

COOLER SIDE

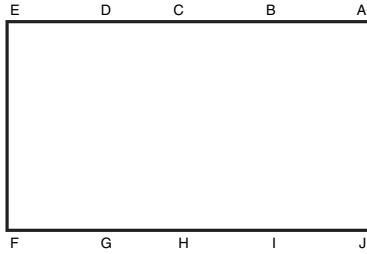

COMPRESSOR SIDE

Fig. 11B — Unit Mounting Weights (Units with Al/Cu Condenser Coils) (cont)

SINGLE PUMP UNITS — ENGLISH

30XA UNIT SIZE	MOUNTING WEIGHT (lb) — Al/Cu*						
	A	B	C	D	E	F	Total
090	1273	2898	1160	972	2089	1271	9,662
100	1299	2959	1196	997	2140	1297	9,889
110	1312	3002	1219	1019	2175	1303	10,029
120	1346	3041	1221	1021	2208	1337	10,174

30XA UNIT SIZE	MOUNTING WEIGHT (lb) — Al/Cu*								
	A	B	C	D	E	F	G	H	Total
140	2007	1554	1683	1679	1152	883	1695	1809	12,463
160	2061	1581	1701	1710	1178	898	1715	1862	12,706

SINGLE PUMP UNITS — SI

30XA UNIT SIZE	MOUNTING WEIGHT (kg) — Al/Cu*						
	A	B	C	D	E	F	Total
090	578	1314	526	441	947	576	4383
100	589	1342	543	452	971	588	4485
110	595	1362	553	462	986	591	4549
120	611	1379	554	463	1001	607	4615

30XA UNIT SIZE	MOUNTING WEIGHT (kg) — Al/Cu*								
	A	B	C	D	E	F	G	H	Total
140	910	705	763	762	523	401	769	821	5653
160	935	717	771	776	534	408	778	845	5763

†Condenser Coil: Copper Fins/Copper Tubing.



Fig. 11B — Unit Mounting Weights (Units with Al/Cu Condenser Coils) (cont)

DUAL PUMP UNITS — ENGLISH

30XA UNIT SIZE	MOUNTING WEIGHT (lb) — Al/Cu*						
	A	B	C	D	E	F	Total
090	1273	3106	1248	972	2089	1271	9,959
100	1299	3168	1285	997	2140	1297	10,186
110	1312	3211	1307	1019	2175	1303	10,326
120	1346	3249	1310	1021	2208	1337	10,471

30XA UNIT SIZE	MOUNTING WEIGHT (lb) — Al/Cu*								
	A	B	C	D	E	F	G	H	Total
140	2007	1554	1891	1768	1152	883	1695	1809	12,760
160	2061	1581	1909	1799	1178	898	1715	1862	13,003

DUAL PUMP UNITS — SI

30XA UNIT SIZE	MOUNTING WEIGHT (kg) — Al/Cu*						
	A	B	C	D	E	F	Total
090	578	1409	566	441	947	576	4517
100	589	1437	583	452	971	588	4620
110	595	1456	593	462	986	591	4684
120	611	1474	594	463	1001	607	4750

30XA UNIT SIZE	MOUNTING WEIGHT (kg) — Al/Cu*								
	A	B	C	D	E	F	G	H	Total
140	910	705	858	802	523	401	769	821	5788
160	935	717	866	816	534	408	778	845	5898

†Condenser Coil: Copper Fins/Copper Tubing.



Fig. 11B — Unit Mounting Weights (Units with Al/Cu Condenser Coils) (cont)

UNITS WITHOUT PUMPS — ENGLISH

30XA UNIT SIZE	MOUNTING WEIGHT (lb) — Cu/Cu†																
	A	B	C	D	Total												
080	2244	1970	1956	2228	8398												
30XA UNIT SIZE	MOUNTING WEIGHT (lb) — Cu/Cu†																
	A	B	C	D	E	F	Total										
090	1394	2429	943	1144	2368	1392	9,669										
100	1420	2485	974	1174	2425	1418	9,896										
110	1433	2525	993	1200	2463	1424	10,036										
120	1467	2563	995	1202	2496	1458	10,181										
30XA UNIT SIZE	MOUNTING WEIGHT (lb) — Cu/Cu†																
	A	B	C	D	E	F	G	H	Total								
140	2188	1735	1058	1375	1411	1078	1876	1990	12,711								
160	2242	1762	1074	1401	1442	1095	1896	2043	12,954								
30XA UNIT SIZE	MOUNTING WEIGHT (lb) — Cu/Cu†																
	A	B	C	D	E	F	G	H	I	J	Total						
180	1099	1679	1359	2239	1382	1419	2258	1035	1483	1083	15,037						
200	1105	1695	1384	2261	1388	1428	2271	1044	1495	1089	15,159						
30XA UNIT SIZE	MOUNTING WEIGHT (lb) — Cu/Cu†																
	A	B	C	D	E	F	G	H	I	J	K	L	Total				
220	995	1378	1865	1771	1010	1398	1441	1030	1636	1337	1419	1014	16,295				
240	1012	1400	1891	1794	1013	1401	1443	1033	1645	1347	1443	1032	16,455				
260	679	1798	1814	947	2833	1197	1712	2748	984	1517	1754	679	18,662				
280	682	1820	1847	956	2866	1200	1715	2759	988	1542	1775	682	18,831				
300	699	1858	1883	983	2962	1224	1754	2848	1008	1564	1811	699	19,292				
30XA UNIT SIZE	MOUNTING WEIGHT (lb) — Cu/Cu†																
	A	B	C	D	E	F	G	H	I	J	K	L	M	N	Total		
325	1037	1037	1175	1728	980	2939	1263	1760	2727	1001	1842	1443	1037	1037	21,005		
350	1041	1041	1180	1743	990	2993	1274	1786	2780	1006	1848	1447	1041	1041	21,211		
30XA UNIT SIZE	MOUNTING WEIGHT (lb) — Cu/Cu†																
	A	B	C	D	E	F	G	H	I	J	K	L	M	N	O	P	Total
400	1045	1432	1708	3361	1453	987	2609	1269	1764	2681	945	1462	2547	1189	1474	1065	26,990
450	1054	1377	2457	2579	1103	1255	2426	2449	3107	2330	1749	1464	1738	1682	1413	1073	29,254
500	1041	1434	2506	2633	1108	1259	2435	2458	3116	2340	1754	1468	1756	1700	1477	1061	29,547

†Condenser Coil: Copper Fins/Copper Tubing.

UNITS WITHOUT PUMPS — SI

30XA UNIT SIZE	MOUNTING WEIGHT (kg) — Cu/Cu†																
	A	B	C	D	Total												
080	1018	893	887	1011	3809												
30XA UNIT SIZE	MOUNTING WEIGHT (kg) — Cu/Cu†																
	A	B	C	D	E	F	Total										
090	632	1102	428	519	1074	631	4386										
100	644	1127	442	533	1100	643	4489										
110	650	1145	450	544	1117	646	4552										
120	665	1163	451	545	1132	661	4618										
30XA UNIT SIZE	MOUNTING WEIGHT (kg) — Cu/Cu†																
	A	B	C	D	E	F	G	Total									
140	992	787	480	624	640	489	851	5766									
160	1017	799	487	636	654	497	860	5876									
30XA UNIT SIZE	MOUNTING WEIGHT (kg) — Cu/Cu†																
	A	B	C	D	E	F	G	H	I	J	Total						
180	499	762	617	1016	627	644	1024	470	673	491	6821						
200	501	769	628	1026	630	648	1030	474	678	494	6876						
30XA UNIT SIZE	MOUNTING WEIGHT (kg) — Cu/Cu†																
	A	B	C	D	E	F	G	H	I	J	K	L	Total				
220	451	625	846	804	458	634	653	467	742	607	644	460	7391				
240	459	635	858	814	460	635	655	469	746	611	654	468	7464				
260	308	816	823	429	1285	543	777	1246	446	688	796	308	8465				
280	309	826	838	434	1300	544	778	1252	448	700	805	309	8542				
300	317	843	854	446	1343	555	796	1292	457	710	821	317	8751				
30XA UNIT SIZE	MOUNTING WEIGHT (kg) — Cu/Cu†																
	A	B	C	D	E	F	G	H	I	J	K	L	M	N	Total		
325	470	470	533	784	445	1333	573	798	1237	454	836	655	470	470	9528		
350	472	472	535	791	449	1358	578	810	1261	456	838	656	472	472	9621		
30XA UNIT SIZE	MOUNTING WEIGHT (kg) — Cu/Cu†																
	A	B	C	D	E	F	G	H	I	J	K	L	M	N	O	P	Total
400	474	649	775	1524	659	447	1183	576	800	1216	428	663	1155	539	669	483	12,243
450	478	624	1114	1170	500	569	1100	1111	1409	1057	793	664	788	763	641	487	13,269
500	472	651	1137	1194	502	571	1105	1115	1413	1061	796	666	797	771	670	481	13,402

†Condenser Coil: Copper Fins/Copper Tubing.

Fig. 11C — Unit Mounting Weights (Units with Cu/CU Condenser Coils)

30XA080

COOLER SIDE



COMPRESSOR SIDE

30XA220-300

COOLER SIDE

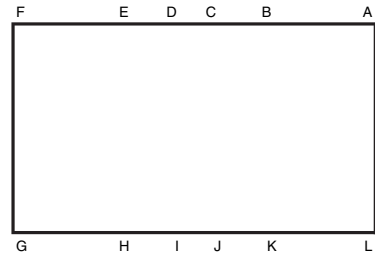

COMPRESSOR SIDE

30XA090-120

COOLER SIDE

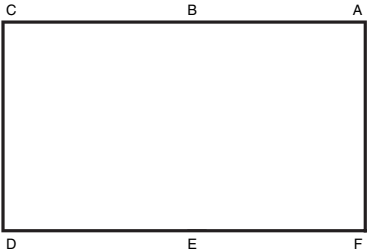

COMPRESSOR SIDE

30XA325-350

COOLER SIDE

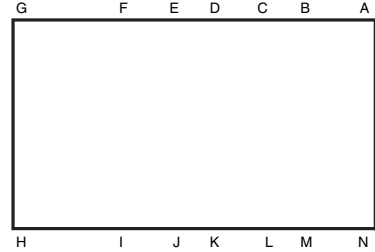

COMPRESSOR SIDE

30XA140,160

COOLER SIDE

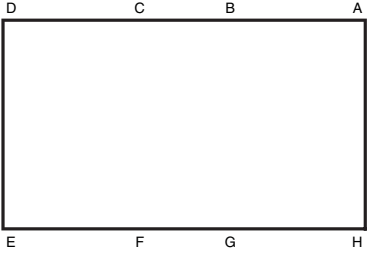

COMPRESSOR SIDE

30XA400-500

COOLER SIDE

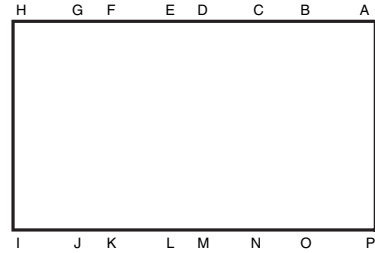

COMPRESSOR SIDE

30XA180-200

COOLER SIDE

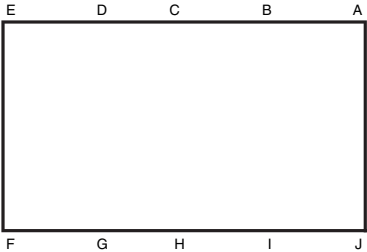

COMPRESSOR SIDE

Fig. 11C — Unit Mounting Weights (Units with Cu/Cu Condenser Coils) (cont)

SINGLE PUMP UNITS — ENGLISH

30XA UNIT SIZE	MOUNTING WEIGHT (lb) — Cu/Cu†						
	A	B	C	D	E	F	Total
090	1394	3139	1280	1093	2330	1392	10,627
100	1420	3201	1317	1117	2382	1418	10,854
110	1433	3244	1339	1139	2416	1424	10,994
120	1467	3282	1342	1142	2449	1458	11,139

30XA UNIT SIZE	MOUNTING WEIGHT (lb) — Cu/Cu†								
	A	B	C	D	E	F	G	H	Total
140	2188	1735	1804	1800	1273	1004	1876	1990	13,669
160	2242	1762	1821	1831	1299	1019	1896	2043	13,912

SINGLE PUMP UNITS — SI

30XA UNIT SIZE	MOUNTING WEIGHT (kg) — Cu/Cu†						
	A	B	C	D	E	F	Total
090	632	1424	581	496	1057	631	4820
100	644	1452	597	507	1080	643	4923
110	650	1471	607	517	1096	646	4987
120	665	1489	609	518	1111	661	5053

30XA UNIT SIZE	MOUNTING WEIGHT (kg) — Cu/Cu†								
	A	B	C	D	E	F	G	H	Total
140	992	787	818	816	577	455	851	903	6200
160	1017	799	826	830	589	462	860	927	6310

†Condenser Coil: Copper Fins/Copper Tubing.



Fig. 11C — Unit Mounting Weights (Units with Cu/Cu Condenser Coils) (cont)

DUAL PUMP UNITS — ENGLISH

30XA UNIT SIZE	MOUNTING WEIGHT (lb) — Cu/Cu†						
	A	B	C	D	E	F	Total
090	1394	3347	1369	1093	2330	1392	10,924
100	1420	3409	1406	1117	2382	1418	11,151
110	1433	3452	1428	1139	2416	1424	11,291
120	1467	3491	1430	1142	2449	1458	11,436

30XA UNIT SIZE	MOUNTING WEIGHT (lb) — Cu/Cu†								
	A	B	C	D	E	F	G	H	Total
140	2188	1735	2012	1889	1273	1004	1876	1990	13,966
160	2242	1762	2029	1919	1299	1019	1896	2043	14,209

DUAL PUMP UNITS — SI

30XA UNIT SIZE	MOUNTING WEIGHT (kg) — Cu/Cu†						
	A	B	C	D	E	F	Total
090	632	1518	621	496	1057	631	4955
100	644	1546	638	507	1080	643	5058
110	650	1566	648	517	1096	646	5122
120	665	1583	649	518	1111	661	5187

30XA UNIT SIZE	MOUNTING WEIGHT (kg) — Cu/Cu†								
	A	B	C	D	E	F	G	H	Total
140	992	787	913	857	577	455	851	903	6335
160	1017	799	921	871	589	462	860	927	6445

†Condenser Coil: Copper Fins/Copper Tubing.



Fig. 11C — Unit Mounting Weights (Units with Cu/Cu Condenser Coils) (cont)

Table 1A — Physical Data, 30XA080-500 — English

UNIT 30XA	080	090	100	110	120	140	160	180	200	220
OPERATING WEIGHT (lb)*										
Al-Cu Condenser Coils	7,674	9,959	10,186	10,326	10,471	12,760	13,003	13,590	13,712	14,727
Cu-Cu Condenser Coils	8,398	10,924	11,151	11,291	11,436	13,966	14,209	15,037	15,159	16,295
MCHX Condenser Coils	7,234	9,382	9,603	9,738	9,877	12,023	12,255	12,699	12,810	13,748
REFRIGERANT TYPE	R-134a, EXV Controlled System									
Refrigerant Charge (lb) Ckt A/Ckt B/Ckt C	86/86/—	97/97/—	108/108/—	135/108/—	135/135/—	202/115/—	225/135/—	205/205/—	225/225/—	270/225/—
Refrigerant Charge (lb) Ckt A/Ckt B/Ckt C (MCHX)	60/60/—	62/62/—	73/73/—	100/73/—	100/100/—	137/79/—	159/100/—	141/141/—	161/161/—	179/161/—
COMPRESSORS	Semi-Hermetic Twin Rotary Screws									
Quantity	2	2	2	2	2	2	2	2	2	2
Speed (rpm)	3500									
(Qty) Compressor Model Number Ckt A	(1) 06TS-137†	(1) 06TS-137	(1) 06TS-155	(1) 06TS-186	(1) 06TS-186	(1) 06TS-266	(1) 06TT-301	(1) 06TT-266	(1) 06TT-301	(1) 06TT-356
(Qty) Compressor Model Number Ckt B	(1) 06TS-137†	(1) 06TS-137	(1) 06TS-155	(1) 06TS-155	(1) 06TS-186	(1) 06TS-155	(1) 06TS-186	(1) 06TT-266	(1) 06TT-301	(1) 06TT-301
(Qty) Compressor Model Number Ckt C	N/A	N/A	N/A	N/A	N/A	N/A	N/A	N/A	N/A	N/A
Oil Charge (gal), Ckt A/Ckt B/Ckt C	5.5/5.5/—	5.5/5.5/—	5.5/5.5/—	5.5/5.5/—	5.5/5.5/—	6.25/5.5/—	6.25/5.5/—	6.25/6.25/—	6.25/6.25/—	6.75/6.25/—
Minimum Capacity Step (%)										
Standard	15	15	15	14	15	11	11	15	15	14
Optional	9	9	9	8	10	7	8	10	10	10
COOLER	Flooded, Shell and Tube Type									
Net Fluid Volume (gal.)	16.5	18.5	18.5	20.0	22.0	25.5	27.5	31.5	34.0	37.0
Maximum Refrigerant Pressure (psig)	220	220	220	220	220	220	220	220	220	220
Maximum Fluid Side Pressure Without Pumps (psig)	300	300	300	300	300	300	300	300	300	300
Maximum Fluid Side Pressure With Pumps (psig)	—	150	150	150	150	150	150	—	—	—
WATER CONNECTIONS										
Drain (NPT, in.)	3/8	3/8	3/8	3/8	3/8	3/8	3/8	3/8	3/8	3/8
Standard, Inlet and Outlet, Victaulic (in.)	5	5	5	5	5	5	5	6	6	6
Number of Passes	2	2	2	2	2	2	2	2	2	2
Minus 1 Pass, Inlet and Outlet, Victaulic (in.)	5	5	5	5	5	5	5	8	8	8
Number of Passes	1	1	1	1	1	1	1	1	1	1
Plus 1 Pass, Inlet and Outlet, Victaulic (in.)	4	4	4	4	4	5	5	6	6	6
Number of Passes	3	3	3	3	3	3	3	3	3	3
CONDENSER FANS	Shrouded Axial Type, Vertical Discharge									
Fan Speed (rpm) Standard/High Ambient**	850/—	850/—	850/—	850/—	850/—	850/1140	850/1140	850/1140	850/1140	850/1140
No. Blades...Diameter (in.)	9...30	9...30	9...30	9...30	9...30	9...30	9...30	9...30	9...30	9...30
No. Fans (Ckt A/Ckt B/Ckt C)	3/3/—	4/4/—	4/4/—	4/4/—	4/4/—	6/4/—	6/4/—	6/6/—	6/6/—	7/6/—
Total Airflow (cfm) 850 rpm	55,800	74,400	74,400	74,400	74,400	93,000	93,000	111,600	111,600	120,900
Total Airflow (cfm) 1140 rpm	—	—	—	—	—	124,000	124,000	148,800	148,800	161,200
CONDENSER COILS										
No. Coils (Ckt A/Ckt B/Ckt C)	3/3/—	4/4/—	4/4/—	4/4/—	4/4/—	6/4/—	6/4/—	6/6/—	6/6/—	7/6/—
Total Face Area (sq ft)	141	188	188	188	188	234	234	281	281	305
HYDRONIC MODULE (Optional)	N/A									
Pump	Pump(s) with pressure/temperature taps and combination valve. Single or Dual, 3600 rpm									
CHASSIS DIMENSIONS (ft.-in.)										
Length	11-10		15-9				19-8		23-7	27-6
Width						7-4 ²⁵ / ₃₂				
Height						7-6 ⁷ / ₁₆				

UNIT 30XA	240	260	280	300	325	350	400	450	500	
OPERATING WEIGHT (lb)										
Al-Cu Condenser Coils	14,887	16,853	17,022	17,362	18,834	19,040	24,578	26,600	26,894	
Cu-Cu Condenser Coils	16,455	18,662	18,831	19,292	21,005	21,211	26,990	29,254	29,547	
MCHX Condenser Coils	13,897	15,720	15,878	16,141	17,467	17,659	23,038	24,901	25,167	
REFRIGERANT TYPE	R-134a, EXV Controlled System									
Refrigerant Charge (lb) Ckt A/Ckt B/Ckt C	270/270/—	375/220/—	375/270/—	415/270/—	375/375/—	415/375/—	270/270/375	415/205/415	415/270/415	
Refrigerant Charge (lb) Ckt A/Ckt B/Ckt C (MCHX)	193/193/—	247/156/—	260/193/—	300/193/—	260/260/—	300/260/—	192/192/258	290/135/290	294/193/294	
COMPRESSORS	Semi-Hermetic Twin Rotary Screws									
Quantity	2	2	2	2	2	2	3	3	3	
Speed (rpm)	3500									
(Qty) Compressor Model Number Ckt A	(1) 06TT-356	(1) 06TU-483	(1) 06TU-483	(1) 06TU-554	(1) 06TU-483	(1) 06TU-554	(1) 06TT-356	(1) 06TU-554	(1) 06TU-554	
(Qty) Compressor Model Number Ckt B	(1) 06TT-356	(1) 06TT-301	(1) 06TT-356	(1) 06TT-356	(1) 06TU-483	(1) 06TU-483	(1) 06TT-356	(1) 06TT-266	(1) 06TT-356	
(Qty) Compressor Model Number Ckt C	N/A	N/A	N/A	N/A	N/A	N/A	(1) 06TU-483	(1) 06TU-554	(1) 06TU-554	
Oil Charge (gal), Ckt A/Ckt B/Ckt C	6.75/6.75/—	7.5/6.75/—	7.5/6.75/—	7.5/6.75/—	7.5/7.5/—	7.5/7.5/—	7.5/6.75/7.5	7.5/6.25/7.5	7.5/6.75/7.5	
Minimum Capacity Step (%)										
Standard	15	11	13	12	15	15	9	6	7	
Optional	10	8	9	7	10	10	10	4	5	
COOLER	Flooded, Shell and Tube Type									
Net Fluid Volume (gal.)	39.0	42.0	44.0	48.5	50.5	53.4	68.0	75.0	83.0	
Maximum Refrigerant Pressure (psig)	220	220	220	220	220	220	220	220	220	
Maximum Fluid Side Pressure Without Pumps (psig)	300	300	300	300	300	300	300	150	150	
Maximum Fluid Side Pressure With Pumps (psig)	—	—	—	—	—	—	—	—	—	
WATER CONNECTIONS										
Drain (NPT, in.)	3/8	3/8	3/8	3/8	3/8	3/8	3/8	3/8	3/8	
Standard, Inlet and Outlet, Victaulic (in.)	6	8	8	8	8	8	8	8	8	
Number of Passes	2	2	2	2	2	2	2	1	1	
Minus 1 Pass, Inlet and Outlet, Victaulic (in.)	8	8	8	8	8	8	—	—	—	
Number of Passes	1	1	1	1	1	1	—	—	—	
Plus 1 Pass, Inlet and Outlet, Victaulic (in.)	6	8	8	8	8	8	—	—	—	
Number of Passes	3	3	3	3	3	3	—	—	—	
CONDENSER FANS	Shrouded Axial Type, Vertical Discharge									
Fan Speed (rpm) Standard/High Ambient†	850/1140	850/1140	850/1140	850/1140	850/1140	850/1140	850/1140	850/1140	850/1140	
No. Blades...Diameter (in.)	9...30	9...30	9...30	9...30	9...30	9...30	9...30	9...30	9...30	
No. Fans (Ckt A/Ckt B/Ckt C)	7/6/—	9/6/—	10/6/—	10/6/—	9/9/—	9/9/—	6/6/8	8/6/8	8/6/8	
Total Airflow (cfm) 850 rpm	120,900	139,500	148,800	148,800	167,400	167,400	186,000	204,600	204,600	
Total Airflow (cfm) 1140 rpm	161,200	186,000	198,400	198,400	223,200	223,200	248,000	272,800	272,800	
CONDENSER COILS										
No. Coils (Ckt A/Ckt B/Ckt C)	7/6/—	9/6/—	10/6/—	10/6/—	9/9/—	9/9/—	6/6/8	8/6/8	8/6/8	
Total Face Area (sq ft)	305	352	375	375	422	422	469	516	516	
HYDRONIC MODULE (Optional)	N/A									
Pump	N/A									
CHASSIS DIMENSIONS (ft.-in.)										
Length	27-6		31-5			35-4		39-3	43-2	
Width					7-4 ³ / ₄					
Height					7-6 ⁷ / ₁₆					

LEGEND

- Cu — Copper
- Al — Aluminum
- EXV — Electronic Expansion Valve
- MCHX — Micro-channel Heat Exchanger
- N/A — Not Applicable

- * Operating weight includes 2 pumps on models 30XA090-160. No pumps are available on 30XA080 or 30XA180-500. See Fig. 11 for operating weights for units without pumps and units with single pump packages.
- † 30XA080 unit does not have an economizer.
- ** The high ambient temperature option is not available on 30XA080-120 units.

Table 1B — Physical Data, 30XA080-500 — SI

UNIT 30XA	080	090	100	110	120	140	160	180	200	220
OPERATING WEIGHT (kg)*										
Al-Cu Condenser Coils	3 481	4 517	4 620	4 684	4 750	5 788	5 898	6 164	6 220	6 680
Cu-Cu Condenser Coils	3 809	4 955	5 058	5 122	5 187	6 335	6 445	6 821	6 876	7 391
MCHX Condenser Coils	3 281	4 255	4 356	4 417	4 480	5 454	5 559	5 760	5 811	6 236
REFRIGERANT TYPE	R-134a, EXV Controlled System									
Refrigerant Charge (kg) Ckt A/Ckt B/Ckt C	39/39/—	44/44/—	49/49/—	49/44/—	102/102/—	91.6/52.2/—	102/61.2/—	93/93/—	102/102/—	122.5/102/—
Refrigerant Charge (kg) Ckt A/Ckt B/Ckt C (MCHX)	27.2/27.2/—	28.1/28.1/—	33.1/33.1/—	45.4/33.1/—	45.4/45.4/—	62.1/35.8/—	72.1/45.4/—	64.0/64.0/—	73.0/73.0/—	81.2/73.0/—
COMPRESSORS	Semi-Hermetic Twin Rotary Screws									
Quantity	2	2	2	2	2	2	2	2	2	2
Speed (r/s)	58.3									
(Qty) Compressor Model Number Ckt A	(1) 06TS-137†	(1) 06TS-137	(1) 06TS-155	(1) 06TS-186	(1) 06TS-186	(1) 06TS-266	(1) 06TT-301	(1) 06TT-266	(1) 06TT-301	(1) 06TT-356
(Qty) Compressor Model Number Ckt B	(1) 06TS-137†	(1) 06TS-137	(1) 06TS-155	(1) 06TS-155	(1) 06TS-186	(1) 06TS-155	(1) 06TS-186	(1) 06TT-266	(1) 06TT-301	(1) 06TT-301
(Qty) Compressor Model Number Ckt C	N/A	N/A	N/A	N/A	N/A	N/A	N/A	N/A	N/A	N/A
Oil Charge (liters), Ckt A/Ckt B/Ckt C	20.8/20.8/—	20.8/20.8/—	20.8/20.8/—	20.8/20.8/—	20.8/20.8/—	23.7/20.8/—	23.7/23.7/—	23.7/23.7/—	23.7/23.7/—	25.6/23.7/—
Minimum Capacity Step (%)										
Standard	15	15	15	14	14	11	11	15	15	14
Optional	9	9	9	8	10	7	8	10	10	10
COOLER	Flooded, Shell and Tube Type									
Net Fluid Volume (liters)	62.5	70.0	70.0	75.7	1516.8	96.5	104.1	119.2	128.7	140.1
Maximum Refrigerant Pressure (kPa)	1516.8	1516.8	1516.8	1516.8	1516.8	1516.8	1516.8	1516.8	1516.8	1516.8
Maximum Fluid Side Pressure Without Pumps (kPa)	2 068	2 068	2 068	2 068	2 068	2 068	2 068	2 068	2 068	2 068
Maximum Fluid Side Pressure With Pumps	—	1 034	1 034	1 034	1 034	1 034	1 034	—	—	—
WATER CONNECTIONS										
Drain (NPT, in.)	3/8	3/8	3/8	3/8	3/8	3/8	3/8	3/8	3/8	3/8
Standard, Inlet and Outlet, Victaulic (in.)	5	5	5	5	5	5	5	6	6	6
Number of Passes	2	2	2	2	2	2	2	2	2	2
Minus 1 Pass, Inlet and Outlet, Victaulic (in.)	5	5	5	5	5	5	5	8	8	8
Number of Passes	1	1	1	1	1	1	1	1	1	1
Plus 1 Pass, Inlet and Outlet, Victaulic (in.)	4	4	4	4	4	5	5	6	6	6
Number of Passes	3	3	3	3	3	3	3	3	3	3
CONDENSER FANS	Shrouded Axial Type, Vertical Discharge									
Fan Speed (r/s) Standard/High Ambient**	14.2/—	14.2/—	14.2/—	14.2/—	14.2/—	14.2/19.0	14.2/19.0	14.2/19.0	14.2/19.0	14.2/19.0
No. Blades...Diameter (mm)	9...762	9...762	9...762	9...762	9...762	9...762	9...762	9...762	9...762	9...762
No. Fans (Ckt A/Ckt B/Ckt C)	3/3/—	4/4/—	4/4/—	4/4/—	4/4/—	6/4/—	6/4/—	6/6/—	6/6/—	7/6/—
Total Airflow (L/s) 14.2 r/s	26 335	35 113	35 113	35 113	35 113	43 891	43 891	52 669	52 669	57 059
Total Airflow (L/s) 19.0 r/s	—	—	—	—	—	58 522	58 522	70 226	70 226	76 078
CONDENSER COILS										
No. Coils (Ckt A/Ckt B/Ckt C)	3/3/—	4/4/—	4/4/—	4/4/—	4/4/—	6/4/—	6/4/—	6/6/—	6/6/—	7/6/—
Total Face Area (sq m)	13	17	17	17	17	22	22	26	26	28
HYDRONIC MODULE (Optional)										
Pump	N/A	Pump(s) with pressure/temperature taps and combination valve. Single or Dual, 58.3 r/s						N/A		
CHASSIS DIMENSIONS (mm)										
Length	3 606		4 800			5 994		7 188		8 382
Width					2 255					
Height					2 296.9					

UNIT 30XA	240	260	280	300	325	350	400	450	500	
OPERATING WEIGHT (kg)										
Al-Cu Condenser Coils	6 753	7 644	7 721	7 876	8 543	8 636	11 149	12 066	12 199	
Cu-Cu Condenser Coils	7 464	8 465	8 542	8 751	9 528	9 621	12 243	13 269	13 402	
MCHX Condenser Coils	6 304	7 130	7 202	7 322	7 923	8 010	10 450	11 295	11 416	
REFRIGERANT TYPE	R-134a, EXV Controlled System									
Refrigerant Charge (kg) Ckt A/Ckt B/Ckt C	122.5/122.5/—	170.1/99.8/—	170.1/122.5/—	188.3/122.5/—	170.1/170.1/—	188.3/170.1/—	122.5/122.5/170.1	188.3/102/188.3	188.3/188.3/122.5	
Refrigerant Charge (kg) Ckt A/Ckt B/Ckt C (MCHX)	87.5/87.5/—	112.0/71.0/—	118.0/88.0/—	136.1/88.0/—	118.0/118.0/—	136.1/118.0/—	87.1/87.1/117.0	131.5/61.2/131.5	133.3/87.5/133.3	
COMPRESSORS	Semi-Hermetic Twin Rotary Screws									
Quantity	2	2	2	2	2	2	3	3	3	
Speed (r/s)	3500									
(Qty) Compressor Model Number Ckt A	(1) 06TT-356	(1) 06TU-483	(1) 06TU-483	(1) 06TU-554	(1) 06TU-483	(1) 06TU-554	(1) 06TT-356	(1) 06TU-554	(1) 06TU-554	
(Qty) Compressor Model Number Ckt B	(1) 06TT-356	(1) 06TT-301	(1) 06TT-356	(1) 06TT-356	(1) 06TU-483	(1) 06TU-483	(1) 06TT-356	(1) 06TT-266	(1) 06TT-356	
(Qty) Compressor Model Number Ckt C	N/A	N/A	N/A	N/A	N/A	N/A	(1) 06TU-483	(1) 06TU-554	(1) 06TU-554	
Oil Charge (liter), Ckt A/Ckt B/Ckt C	25.6/25.6/—	28.4/25.6/—	28.4/25.6/—	28.4/25.6/—	28.4/28.4/—	28.4/28.4/—	25.6/25.6/28.4	28.4/23.7/28.4	28.4/25.6/28.4	
Minimum Capacity Step (%)										
Standard	15	10	13	12	15	14	9	6	7	
Optional	10	8	9	7	10	10	6	4	5	
COOLER	Flooded, Shell and Tube Type									
Net Fluid Volume (liters)	147.6	159.0	166.6	183.6	191.2	202.1	257.4	283.9	314.2	
Maximum Refrigerant Pressure (kPa)	1516.8	1516.8	1516.8	1516.8	1516.8	1516.8	1516.8	1516.8	1516.8	
Maximum Fluid Side Pressure Without Pumps (kPa)	2 068	2 068	2 068	2 068	2 068	2 068	1 034	1 034	1 034	
Maximum Fluid Side Pressure With Pumps	—	—	—	—	—	—	—	—	—	
WATER CONNECTIONS										
Drain (NPT, in.)	3/8	3/8	3/8	3/8	3/8	3/8	3/8	3/8	3/8	
Standard, Inlet and Outlet, Victaulic (in.)	6	8	8	8	8	8	8	8	8	
Number of Passes	2	2	2	2	2	2	1	1	1	
Minus 1 Pass, Inlet and Outlet, Victaulic (in.)	8	8	8	8	8	8	—	—	—	
Number of Passes	1	1	1	1	1	1	—	—	—	
Plus 1 Pass, Inlet and Outlet, Victaulic (in.)	6	8	8	8	8	8	—	—	—	
Number of Passes	3	3	3	3	3	3	—	—	—	
CONDENSER FANS	Shrouded Axial Type, Vertical Discharge									
Fan Speed (r/s) Standard/High Ambient†	14.2/19.0	14.2/19.0	14.2/19.0	14.2/19.0	14.2/19.0	14.2/19.0	14.2/19.0	14.2/19.0	14.2/19.0	
No. Blades...Diameter (mm)	9...762	9...762	9...762	9...762	9...762	9...762	9...762	9...762	9...762	
No. Fans (Ckt A/Ckt B/Ckt C)	7/6/—	9/6/—	10/6/—	10/6/—	9/9/—	9/9/—	6/6/8	8/6/8	8/6/8	
Total Airflow (L/s) 14.2 r/s	57 059	65 837	70 226	70 226	79 004	79 004	87 782	96 561	96 561	
Total Airflow (L/s) 19.0 r/s	76 078	87 782	93 634	93 634	93 634	105 339	117 043	128 747	128 747	
CONDENSER COILS										
No. Coils (Ckt A/Ckt B/Ckt C)	7/6/—	9/6/—	10/6/—	10/6/—	9/9/—	9/9/—	6/6/8	8/6/8	8/6/8	
Total Face Area (sq m)	28	33	35	35	39	39	44	48	48	
HYDRONIC MODULE (Optional)										
Pump	N/A									
CHASSIS DIMENSIONS (mm)										
Length	8 382		9 576			10 770		11 964		13 158
Width					2 255					
Height					2 300					

LEGEND
 Cu — Copper
 Al — Aluminum
 EXV — Electronic Expansion Valve
 MCHX — Micro-channel Heat Exchanger
 N/A — Not Applicable

* Operating weight includes 2 pumps on models 30XA090-160. No pumps are available on 30XA080 or 30XA180-500. See Fig. 11 for operating weights for units without pumps and units with single pump packages.
 † 30XA080 unit does not have an economizer.
 ** The high ambient temperature option is not available on 30XA080-120 units.

RIGGING UNIT (See Fig. 12-14) — The 30XA080-500 units are designed for overhead rigging and it is important that this method be used. Holes are provided in frame base channels, marked for rigging (see rigging label on unit). Field-supplied shackles are required to facilitate lifting. Secure the shackles to the base rails at the points noted on the rigging label. See Table 2 for the number of lifting points for each unit.

Do not use a forklift truck to move the units.

Table 2 — Number of Lifting Points for 30XA080-500

30XA UNIT SIZE	NUMBER OF LIFTING POINTS
080	4
090-120	6
140, 160	8
180, 200	10
220-400	12
450, 500	14

Use spreader bars to keep cables or chains clear of unit sides. As further protection plywood sheets may be placed against sides of unit, behind cables or chains. Run cables or chains to a central suspension point so that angle from horizontal is not less than 45 degrees. Raise and set unit down carefully.

See Fig. 12-14 for rigging centers of gravity.

For shipping, some domestic units and all export units are mounted on a wooden skid under entire base of unit. Skid can be removed before unit is moved to installation site. Lift the unit from above to remove skid. See Fig. 12-14 for rigging center of gravity. On export units, the top skid can be used as the spreader bars. If the unit was shipped with a shipping bag, the bag must be removed to gain access to the rigging holes in the base rail.

If overhead rigging is not available, the unit can be moved on rollers or dragged. When unit is moved on rollers, the unit skid, if equipped, must be removed. To lift the unit, use jacks at the rigging points. Use a minimum number of rollers to distribute the load such that the rollers are no more than 6 ft (1.8 m) apart. If the unit is to be dragged, lift the unit as described above, and place unit on a pad. Apply moving force to the pad, and not the unit. When in its final location, raise the unit and remove the pad. If the unit was shipped with coil protection, it must be removed before start-up. The shipping bag for export units must be removed before start-up.

⚠ CAUTION - NOTICE TO RIGGERS:

ALL PANELS MUST BE IN PLACE WHEN RIGGING. DO NOT ATTEMPT TO FORK THESE UNITS IF NO SKID IS SUPPLIED.

NOTES:

1. 1.50 dia. (38.1mm) lifting holes provided for field supplied clevis.
2. Rig with a minimum of 25 ft (7620mm) length chains or cables.
3. If central lifting point is used, it must be a minimum of 13 ft. (3962mm) above the top of the unit.
4. Spreader bars made from steel or double nailed, and notched 2x6's approximately 8 ft. (2438mm) long, must be placed just above the top of the unit (and stacks) to reduce the risk of damage to the top of the unit and coils.
5. If overhead rigging is not available, the unit can be moved on rollers or dragged. When unit is moved on rollers, the unit skid, if equipped, must be removed. To lift the unit, use jacks at the rigging points. Use a minimum of one roller every 6 ft. (1829mm) to distribute the load. If the unit is to be dragged, lift the unit as described above, and place unit on a pad. Apply moving force to the pad, not the unit. When in its final location, raise the unit and remove the pad.

MODEL NUMBER	MAX. SHIPPING WT. W/O PACKAGING		MAX. SHIPPING WT. WITH PACKAGING		LIFTING HOLES										CENTER OF GRAVITY				
					A1		*A2*		*A3*		*A4*		*A5*		"B" "C"				
	LBS	KGS	LBS	KGS	IN	MM	IN	MM	IN	MM	IN	MM	IN	MM	IN	MM	IN	MM	
30XA080	8849	4021	9829	4466	16.1	408.9	109.03	2769.3	---	---	---	---	---	---	75.5	1919	43.9	1114.1	
30XA080-CU	9573	4350	10553	4795	16.1	408.9	109.03	2769.3	---	---	---	---	---	---	75.1	1908	43.9	1116	
30XA090	9866	4483	10936	4969	16.1	408.9	78.02	1981.7	78.02	1981.7	---	---	---	---	101.3	2573	44.1	1120	
30XA090-CU	10831	4922	11901	5408	16.1	408.9	78.02	1981.7	78.02	1981.7	---	---	---	---	100.6	2555	44.2	1122	
30XA100	11092	4986	11162	5072	16.1	408.9	78.02	1981.7	78.02	1981.7	---	---	---	---	101.0	2568	44.1	1120	
30XA100-CU	11057	5024	12127	5511	16.1	408.9	78.02	1981.7	78.02	1981.7	---	---	---	---	100.4	2549	44.2	1122	
30XA110	10223	4645	11293	5132	16.1	408.9	78.02	1981.7	78.02	1981.7	---	---	---	---	100.6	2556	44.1	1120	
30XA110-CU	11188	5084	12258	5570	16.1	408.9	78.02	1981.7	78.02	1981.7	---	---	---	---	100.0	2540	44.2	1122	
30XA120	10357	4706	11427	5193	16.1	408.9	78.02	1981.7	78.02	1981.7	---	---	---	---	101.1	2569	44.1	1120	
30XA120-CU	11322	5145	12392	5631	16.1	408.9	78.02	1981.7	78.02	1981.7	---	---	---	---	100.5	2552	44.2	1122	
30XA140	12628	5739	13788	6266	16.1	408.9	62.02	1575.3	32.00	812.7	109.03	2769.3	---	---	119.4	3033	44.6	1134	
30XA140-CU	13834	6287	14994	6814	16.1	408.9	62.02	1575.3	32.00	812.7	109.03	2769.3	---	---	119.2	3029	44.7	1134	
30XA160	12858	5843	14018	6371	16.1	408.9	62.02	1575.3	32.00	812.7	109.03	2769.3	---	---	119.6	3039	44.6	1134	
30XA160-CU	14065	6392	15225	6919	16.1	408.9	62.02	1575.3	32.00	812.7	109.03	2769.3	---	---	119.5	3034	44.6	1134	
30XA180	11475	6669	15925	7237	16.1	408.9	78.02	1981.7	78.02	1981.7	32.00	812.7	62.02	1575.3	139.2	3536	46.1	1171	
30XA180-CU	16122	7327	17372	7895	16.1	408.9	78.02	1981.7	78.02	1981.7	32.00	812.7	62.02	1575.3	139.4	3541	46.0	1168	
30XA200	14780	6717	16030	7285	16.1	408.9	78.02	1981.7	78.02	1981.7	32.00	812.7	62.02	1575.3	139.3	3538	46.1	1172	
30XA200-CU	16227	7375	17477	7943	16.1	408.9	78.02	1981.7	78.02	1981.7	32.00	812.7	62.02	1575.3	139.5	3543	46.0	1169	
SUBTRACT THESE VALUES FOR UNITS W/O PUMPS																			
		SINGLE PUMP		DUAL PUMP															
		LBS	KGS	LBS	KGS														
30XA090-160			958	435	1255	569													

Fig. 12 — Unit Rigging Label Detail 30XA080-200

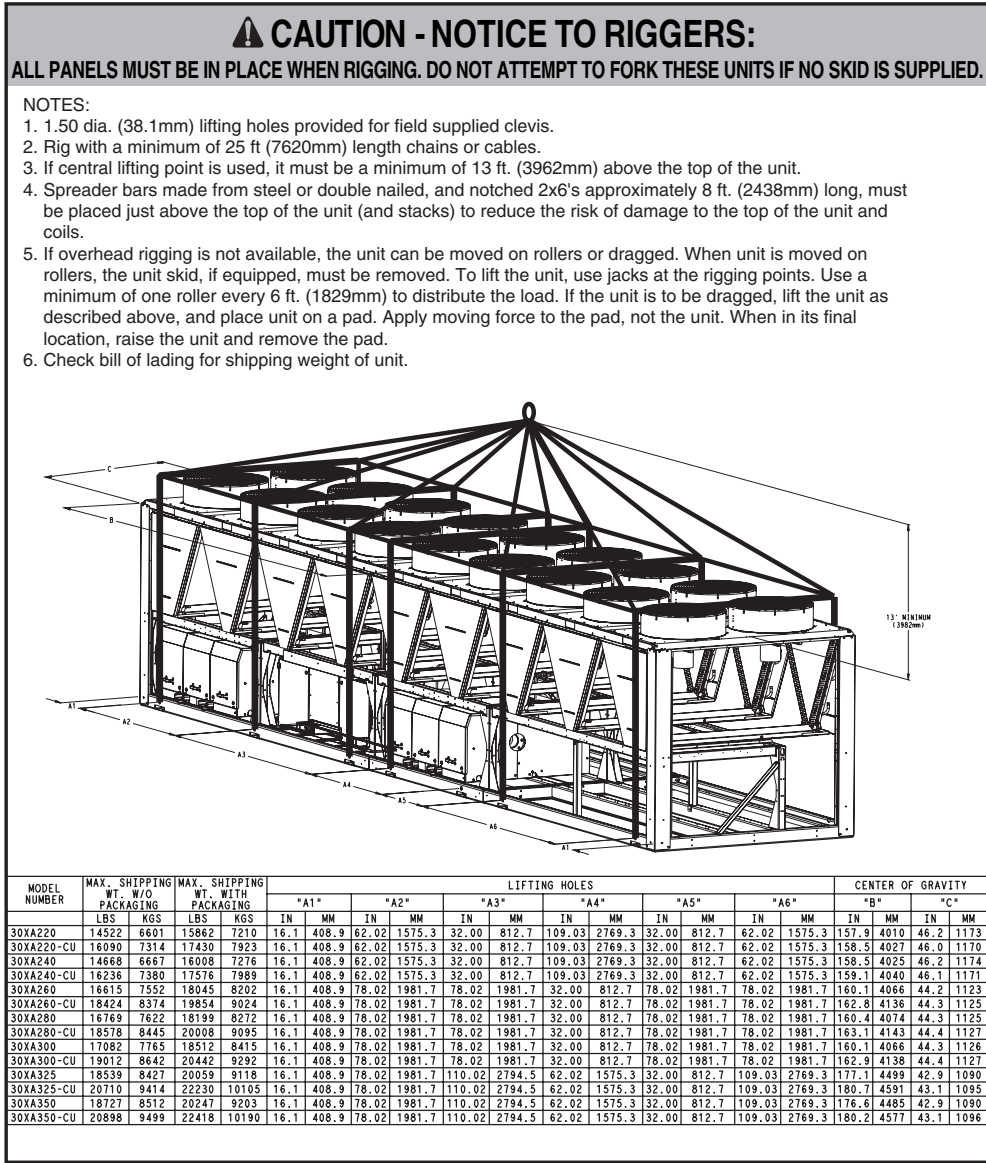

Fig. 13 — Unit Rigging Label Detail 30XA220-350

Step 3 — Cooler Fluid and Drain Piping Connections — See Fig. 15-18 for piping applications.

⚠ CAUTION

Remove the chilled water flow switch, entering and leaving water thermistors before welding connecting piping. Reinstall flow switch and thermistors after welding is complete. Failure to remove these devices may cause unit damage.

GENERAL — The factory-installed victaulic connections allow clamp-on connection of water lines to the coolers in all 30XA units. A flow sensor is factory-installed in the side of the entering fluid nozzle. See Fig. 19. See Table 3 for 30XA unit operating range. See Fig. 16 for cooler option dimensions.

UNITS WITH HYDRONIC PUMP PACKAGE — The 30XA090-160 units can be equipped with a factory-installed hydronic pump package consisting of a suction guide/strainer, pump, combination valve, internal piping and wiring connected at the factory.

The combination valve performs the following functions:

- Drip-tight shut-off valve
- Spring closure design with a non-slam check valve
- Flow-throttling valve

When facing the cooler side of unit, the inlet (return) water connection is on the bottom. The outlet (supply) water connection is on the top. The inlet is connected to the suction guide/strainer of the pump via a Victaulic-type connection. The cooler supply has water-side Victaulic-type connections (follow connection directions as provided by the coupling manufacturer). Provide proper support for the piping. If accessory security grilles have been added, holes must be cut in the grilles for field piping and insulation.

There is a factory supplied, insulated 45-degree elbow pipe and a victaulic coupling shipped with units ordered with a hydronic pump package. Before starting field piping, use the victaulic coupling to connect this elbow pipe to the outlet of the combination valve.

⚠ CAUTION - NOTICE TO RIGGERS:

ALL PANELS MUST BE IN PLACE WHEN RIGGING. DO NOT ATTEMPT TO FORK THESE UNITS IF NO SKID IS SUPPLIED.

NOTES:

1. 1.50 dia. (38.1mm) lifting holes provided for field supplied clevis.
2. Rig with a minimum of 25 ft (7620mm) length chains or cables.
3. If central lifting point is used, it must be a minimum of 13 ft. (3962mm) above the top of the unit.
4. Spreader bars made from steel or double nailed, and notched 2x6's approximately 8 ft. (2438mm) long, must be placed just above the top of the unit (and stacks) to reduce the risk of damage to the top of the unit and coils.
5. If overhead rigging is not available, the unit can be moved on rollers or dragged. When unit is moved on rollers, the unit skid, if equipped, must be removed. To lift the unit, use jacks at the rigging points. Use a minimum of one roller every 6 ft. (1829mm) to distribute the load. If the unit is to be dragged, lift the unit as described above, and place unit on a pad. Apply moving force to the pad, not the unit. When in its final location, raise the unit and remove the pad.
6. Check bill of lading for shipping weight of unit.

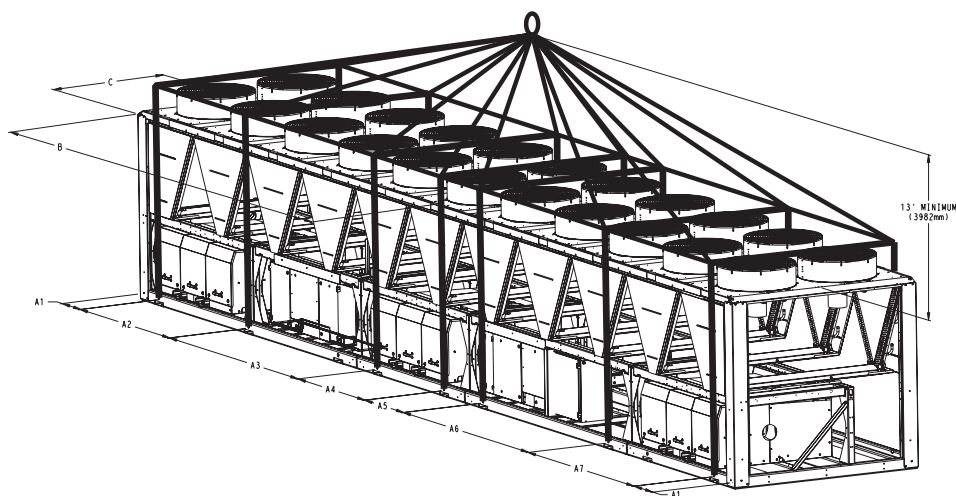

MODEL NUMBER	MAX. SHIPPING WT. W/O PACKAGING		MAX. SHIPPING WT. WITH PACKAGING		LIFTING HOLES														CENTER OF GRAVITY			
					"A1"		"A2"		"A3"		"A4"		"A5"		"A6"		"A7"		"B"		"C"	
	LBS	KGS	LBS	KGS	IN	MM	IN	MM	IN	MM	IN	MM	IN	MM	IN	MM	IN	MM	IN	MM	IN	MM
30XA400	24214	11006	25824	11738	16.1	408.9	78.02	1981.7	110.02	2794.5	78.02	1981.7	110.02	2794.5	62.02	1575.3	---	---	229.6	5831	45.8	1163
30XA400-CU	26626	12103	28236	12835	16.1	408.9	78.02	1981.7	110.02	2794.5	78.02	1981.7	110.02	2794.5	62.02	1575.3	---	---	230.1	5844	45.7	1161
30XA450	26175	11898	27875	12671	16.1	408.9	78.02	1981.7	110.02	2794.5	62.02	1575.3	32.00	812.7	109.03	2769.3	94.02	2388.1	252.6	6416	44.7	1136
30XA450-CU	28829	13104	30529	13877	16.1	408.9	78.02	1981.7	110.02	2794.5	62.02	1575.3	32.00	812.7	109.03	2769.3	94.02	2388.1	253.2	6430	44.7	1136
30XA500	26436	12017	28136	12789	16.1	408.9	78.02	1981.7	110.02	2794.5	62.02	1575.3	32.00	812.7	109.03	2769.3	94.02	2388.1	253.3	6434	44.8	1137
30XA500-CU	29090	13223	30790	13995	16.1	408.9	78.02	1981.7	110.02	2794.5	62.02	1575.3	32.00	812.7	109.03	2769.3	94.02	2388.1	253.8	6447	44.8	1138

Fig. 14 — Unit Rigging Label Detail 30XA400-500

The suction guide/strainer is shipped from the factory with a run-in screen. This screen is a temporary device used during the start-up/clean-up process of the chilled water circuit to prevent construction debris from damaging the pump or internal tubes of the cooler. After all debris has been removed or a maximum of 24 running hours the temporary screen must be removed. See the Start-Up, Controls, Operation and Troubleshooting guide for further information.

⚠ CAUTION

The suction guide/strainer is shipped from the factory with a run-in screen. This temporary screen must be removed after all debris has been removed or a maximum of 24 running hours. Failure to remove the temporary screen may result in damage to the pump or cooler.

NOTE: It is required that a 20 mesh field-supplied strainer be installed in the inlet piping to the cooler on open loop systems.

A 3/4 in. NPT fitting is installed in the inlet piping of the pump for connection to an expansion tank. Install the tank in accordance with the manufacturer's instructions.

Figures 20 and 21 illustrate typical single and dual pump packages.

Three drain connections are provided and are located at leaving water (supply) end of cooler, pump volute, and the suction guide. See Fig. 2-10 for connection location. Insulate the drain piping (in the same manner as the chilled water piping) for at least 12 in. (305 mm) from the cooler.

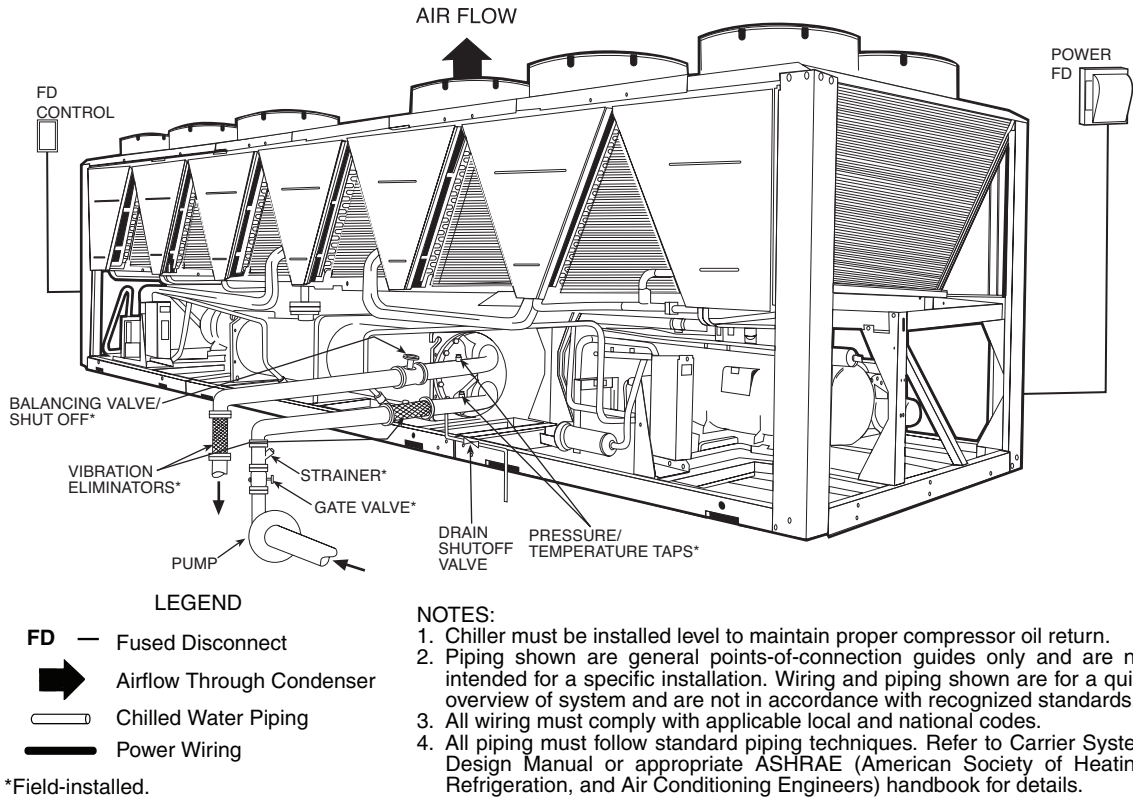

Fig. 15A — 30XA Typical Piping and Wiring (Units without Hydronic Package)

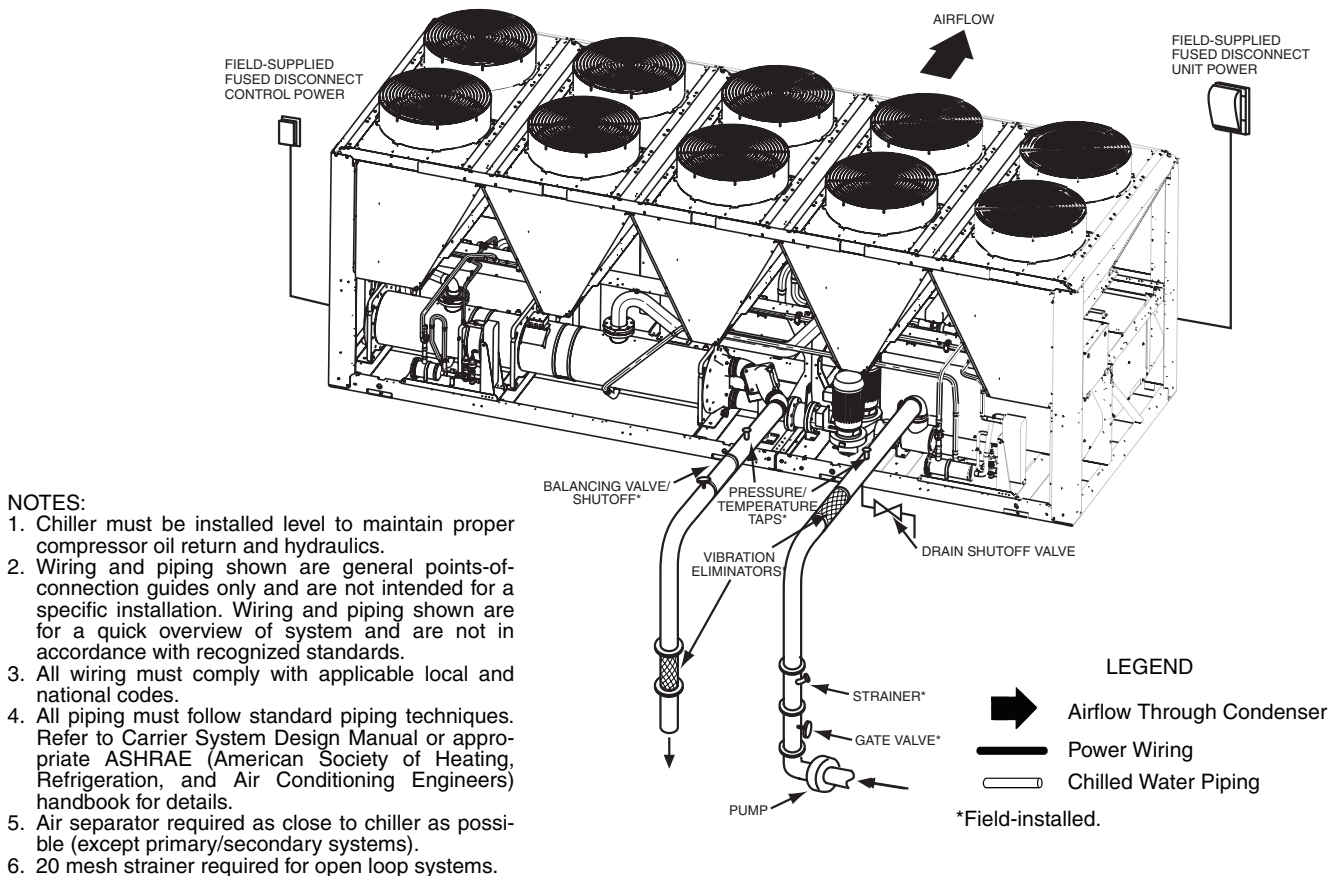

Fig. 15B — 30XA Typical Piping and Wiring (Units with Hydronic Package)

ENGLISH

30XA UNIT SIZE*	STANDARD COOLER					PLUS ONE PASS COOLER					MINUS ONE PASS COOLER				
	Distance to Leaving Water Connection (in.)	Height Leaving Water Connection (in.)	Distance to Entering Water Connection (in.)	Height Entering Water Connection (in.)	Victaulic Connection Size (in.)	Distance to Leaving Water Connection (in.)	Height Leaving Water Connection (in.)	Distance to Entering Water Connection (in.)	Height Entering Water Connection (in.)	Victaulic Connection Size (in.)	Distance to Leaving Water Connection (in.)	Height Leaving Water Connection (in.)	Distance to Entering Water Connection (in.)	Height Entering Water Connection (in.)	Victaulic Connection Size (in.)
080	121.2	19.1	121.2	10.8	5.0	1.5	19.6	121.2	10.3	4.0	-2.2	14.9	124.8	14.9	5.0
090	120.9	19.1	120.9	10.8	5.0	1.2	19.6	120.9	10.3	4.0	-2.5	14.9	124.5	14.9	5.0
100	120.9	19.1	120.9	10.8	5.0	1.2	19.6	120.9	10.3	4.0	-2.5	14.9	124.5	14.9	5.0
110	120.9	19.1	120.9	10.8	5.0	1.2	19.6	120.9	10.3	4.0	-2.5	14.9	124.5	14.9	5.0
120	120.9	19.1	120.9	10.8	5.0	1.2	19.6	120.9	10.3	4.0	-2.5	14.9	124.5	14.9	5.0
140	121.5	21.3	121.5	10.6	5.0	1.2	21.3	121.5	10.6	5.0	-2.2	15.9	124.8	15.9	6.0
160	121.5	21.3	121.5	10.6	5.0	1.2	21.3	121.5	10.6	5.0	-2.2	15.9	124.8	15.9	6.0
180	171.7	22.5	171.7	11.3	6.0	59.6	22.4	180.5	11.4	6.0	53.2	13.2	180.6	13.2	8.0
200	177.3	22.5	177.3	11.3	6.0	59.2	22.4	180.5	11.4	6.0	100.2	13.2	180.2	13.2	8.0
220	224.7	22.5	224.7	11.3	6.0	100.6	22.4	227.6	11.4	6.0	100.6	13.2	227.6	13.2	8.0
240	224.7	22.5	224.7	11.3	6.0	100.6	22.4	227.6	11.4	6.0	100.6	13.2	227.6	13.2	8.0
260	304.7	23.6	304.7	12.2	8.0	180.3	23.4	310.3	12.5	8.0	180.3	16.3	310.3	16.3	8.0
280	304.7	23.6	304.7	12.2	8.0	180.3	23.4	310.3	12.5	8.0	180.3	16.3	310.3	16.3	8.0
300	349.0	23.6	349.0	12.2	8.0	224.7	23.4	354.7	12.5	8.0	224.7	16.3	354.7	16.3	8.0
325	349.0	23.6	349.0	12.2	8.0	224.7	23.4	354.7	12.5	8.0	224.7	16.3	354.7	16.3	8.0
350	349.0	23.6	349.0	12.2	8.0	224.7	23.4	354.7	12.5	8.0	224.7	16.3	354.7	16.3	8.0

SI

30XA UNIT SIZE*	STANDARD COOLER					PLUS ONE PASS COOLER					MINUS ONE PASS COOLER				
	Distance to Leaving Water Connection (mm)	Height Leaving Water Connection (mm)	Distance to Entering Water Connection (mm)	Height Entering Water Connection (mm)	Victaulic Connection Size (mm)	Distance to Leaving Water Connection (mm)	Height Leaving Water Connection (mm)	Distance to Entering Water Connection (mm)	Height Entering Water Connection (mm)	Victaulic Connection Size (mm)	Distance to Leaving Water Connection (mm)	Height Leaving Water Connection (mm)	Distance to Entering Water Connection (mm)	Height Entering Water Connection (mm)	Victaulic Connection Size (mm)
080	3077.8	484.0	1728.7	3077.8	127.0	37.9	497.2	1728.7	261.0	101.6	-55.1	379.1	3170.7	379.1	127.0
090	3069.6	484.0	1728.7	3069.6	127.0	29.7	497.2	1728.7	261.0	101.6	-63.2	379.1	3162.6	379.1	127.0
100	3069.6	484.0	1728.7	3069.6	127.0	29.7	497.2	1728.7	261.0	101.6	-63.2	379.1	3162.6	379.1	127.0
110	3069.6	484.0	1728.7	3069.6	127.0	29.7	497.2	1728.7	261.0	101.6	-63.2	379.1	3162.6	379.1	127.0
120	3069.6	484.0	1728.7	3069.6	127.0	29.7	497.2	1728.7	261.0	101.6	-63.2	379.1	3162.6	379.1	127.0
140	3085.8	540.5	1756.2	3085.8	127.0	30.1	540.5	1756.2	268.7	127.0	-55.0	404.6	3170.8	404.6	152.4
160	3085.8	540.5	1756.2	3085.8	127.0	30.1	540.5	1756.2	268.7	127.0	-55.0	404.6	3170.8	404.6	152.4
180	4512.3	571.0	1782.1	4512.3	152.4	1361.4	569.5	4577.4	288.5	152.4	1361.4	336.0	4577.4	336.0	152.4
200	4502.4	571.0	1782.1	4502.4	152.4	1351.6	569.5	4577.4	288.5	152.4	1351.6	336.0	4577.4	336.0	152.4
220	5706.2	571.0	1782.1	5706.2	152.4	2555.3	569.5	5781.1	288.5	152.4	2555.3	336.0	5781.1	336.0	152.4
240	5706.2	571.0	1782.1	5706.2	152.4	2555.3	569.5	5781.1	288.5	152.4	2555.3	336.0	5781.1	336.0	152.4
260	7739.6	600.2	1804.9	7739.6	203.2	4580.8	593.9	7882.8	316.5	203.2	4580.8	413.3	7882.8	413.3	203.2
280	7739.6	600.2	1804.9	7739.6	203.2	4580.8	593.9	7882.8	316.5	203.2	4580.8	413.3	7882.8	413.3	203.2
300	8865.1	600.2	1804.9	8865.1	203.2	5706.4	593.9	9008.4	316.5	203.2	5706.4	413.3	9008.4	413.3	203.2
325	8865.1	600.2	1804.9	8865.1	203.2	5706.4	593.9	9008.4	316.5	203.2	5706.4	413.3	9008.4	413.3	203.2
350	8865.1	600.2	1804.9	8865.1	203.2	5706.4	593.9	9008.4	316.5	203.2	5706.4	413.3	9008.4	413.3	203.2

*30XA400-500 units are equipped with standard coolers only. Refer to unit dimensional drawings for cooler dimensions.

NOTE: Refer to dimensional drawings for all other unit dimensions.

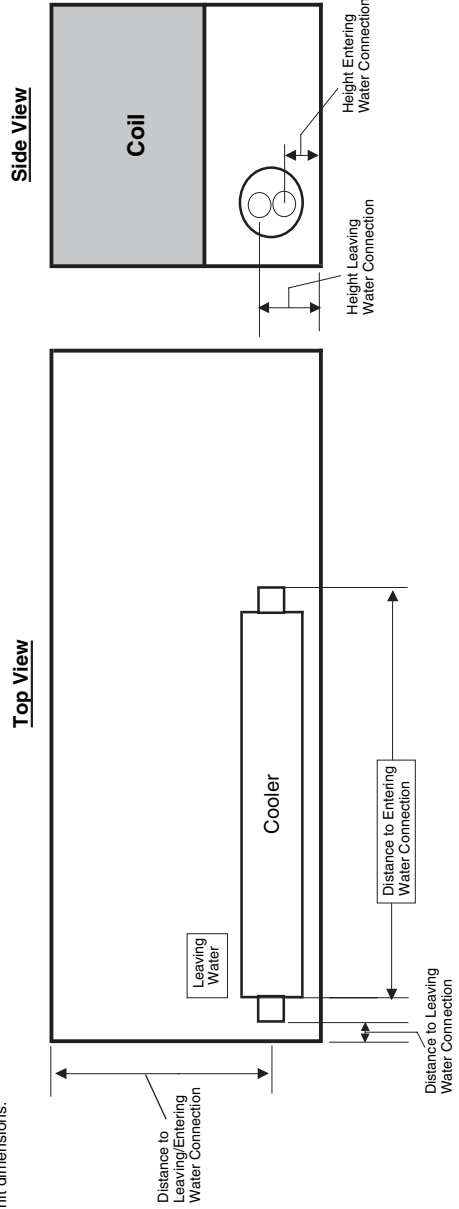
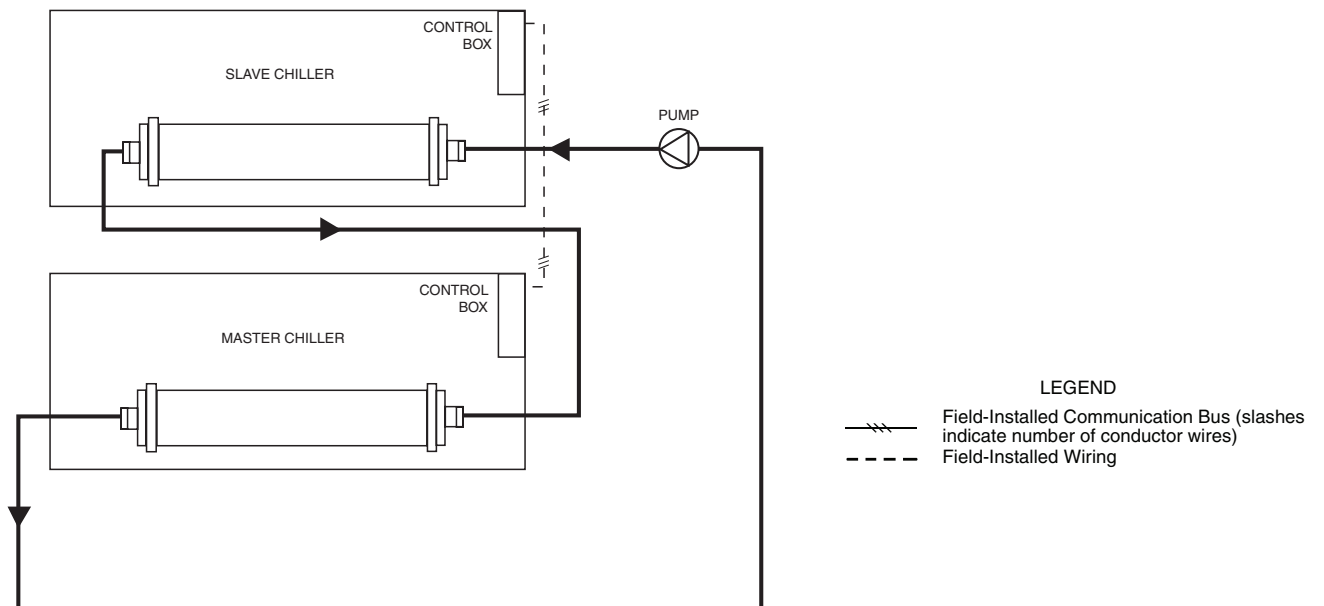
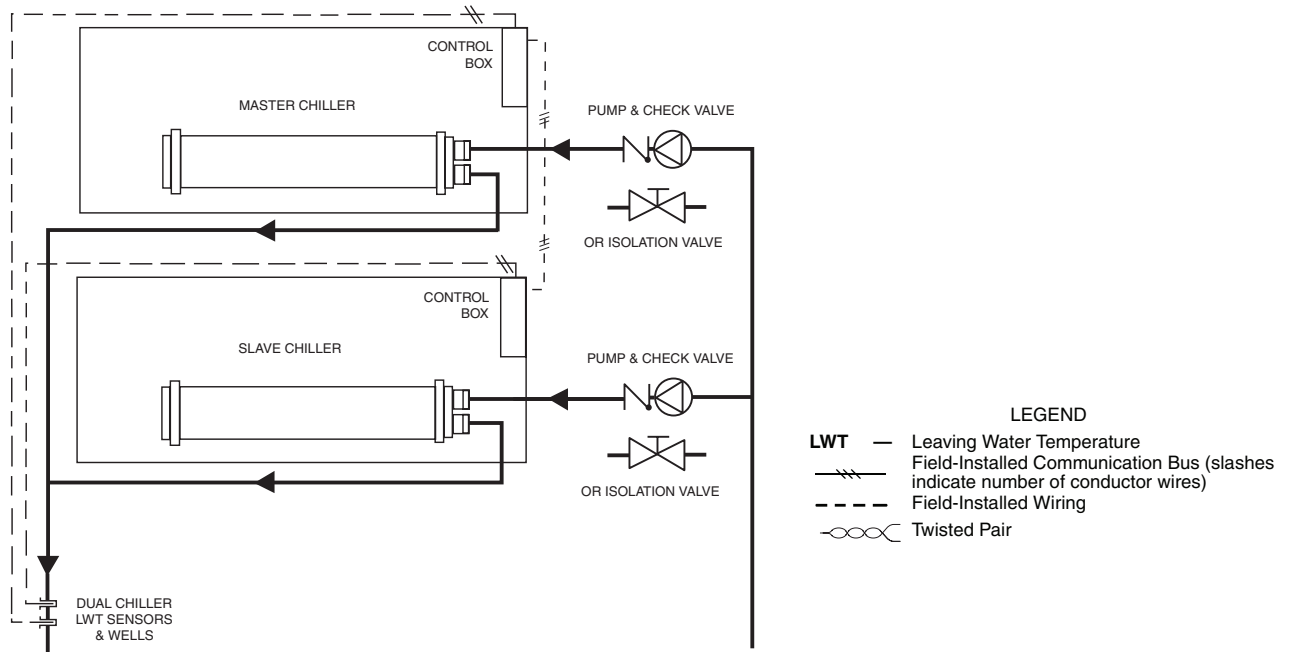

Fig. 16 — Cooler Option Dimensions



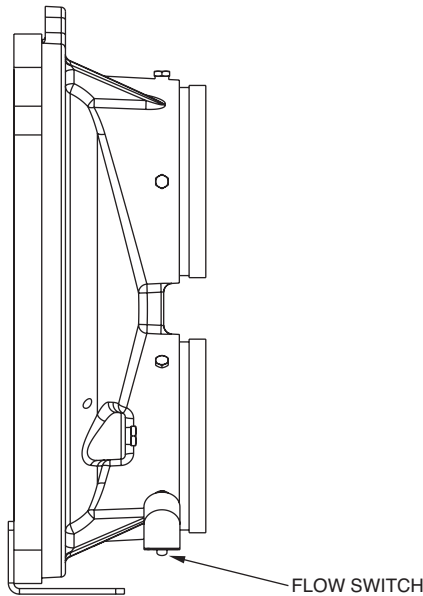

Fig. 19 — Flow Switch

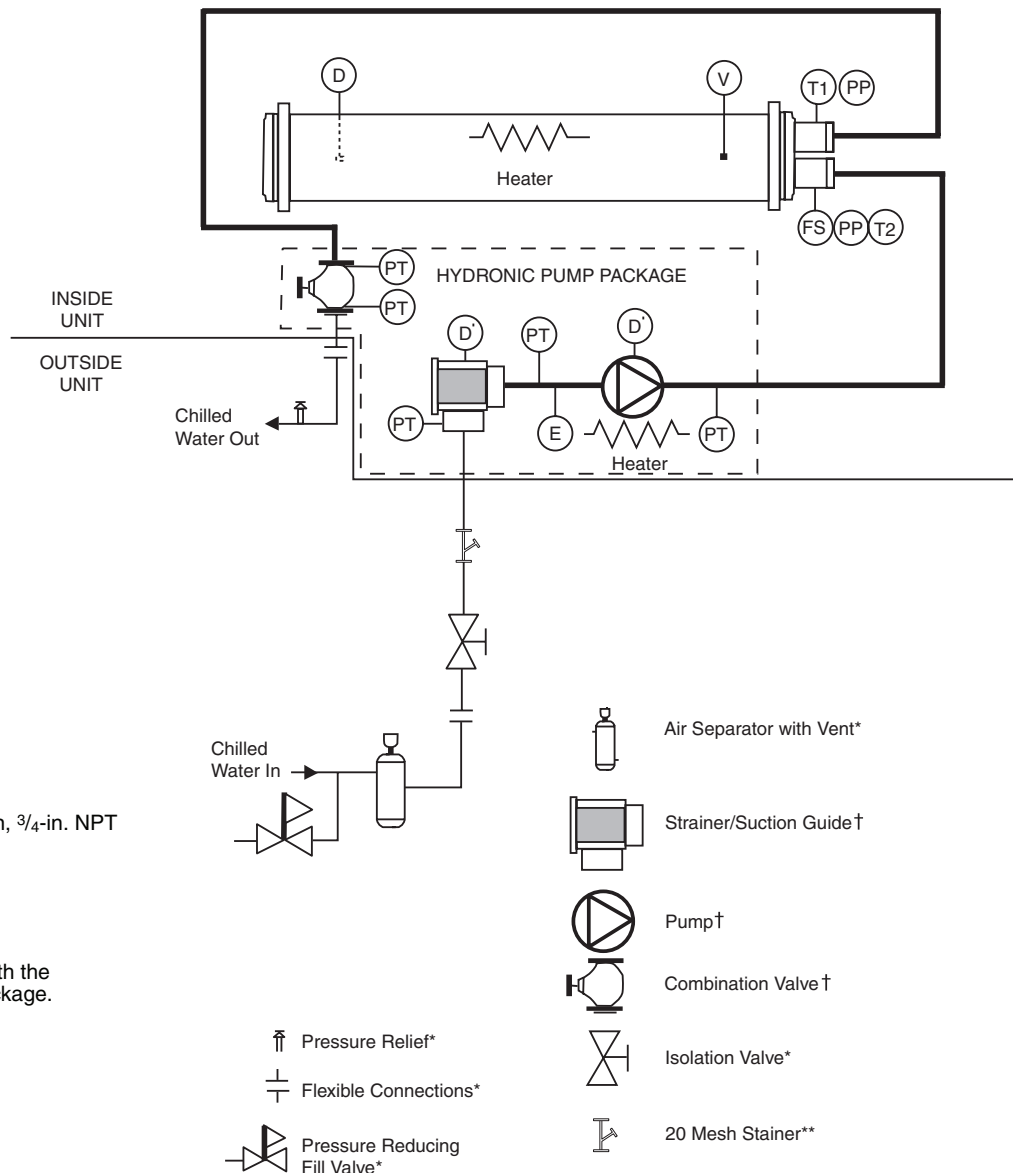

Fig. 20 — Typical Piping Diagram on 30XA Units with Hydronic Package — Single Pump

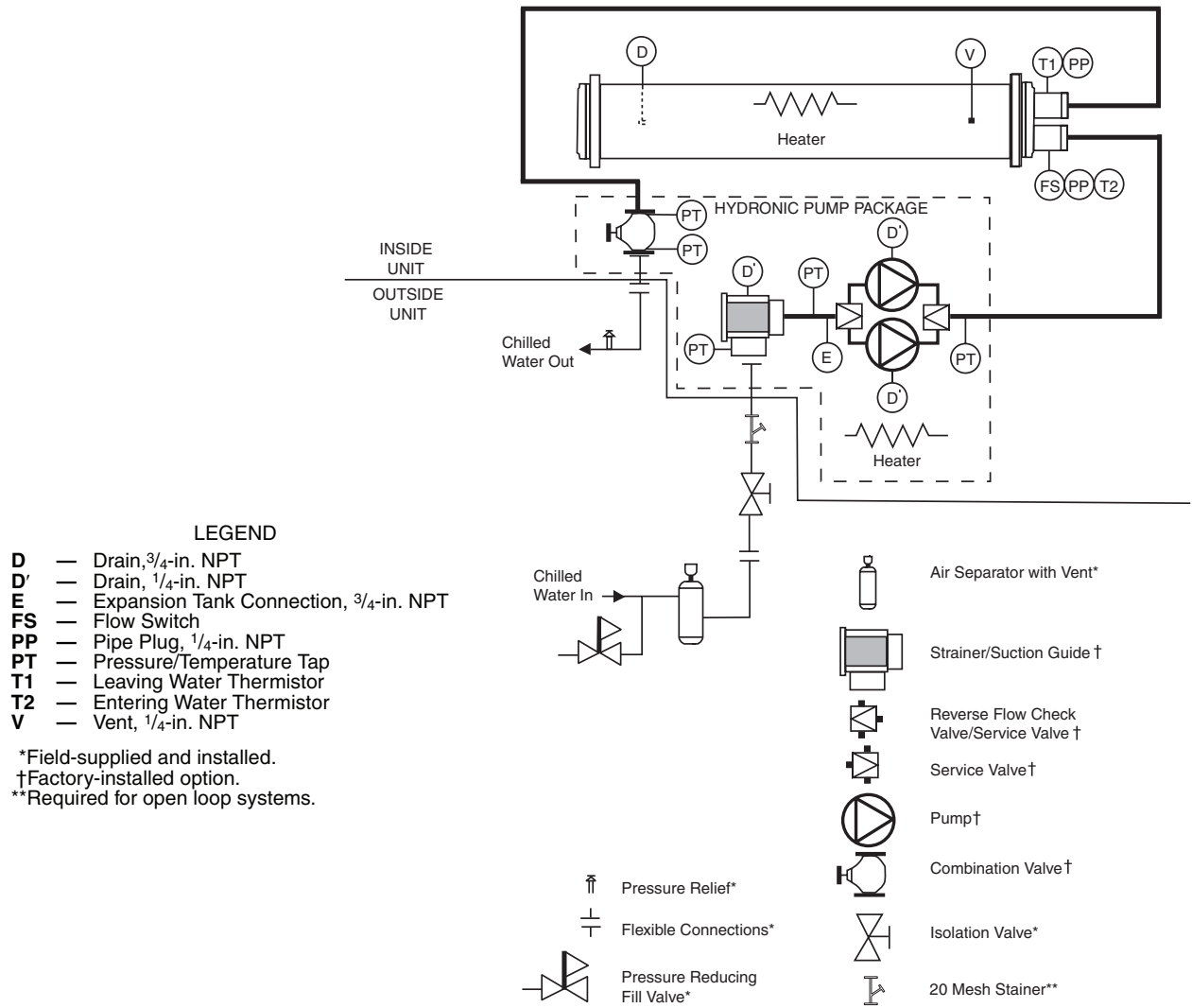

Fig. 21 — Typical Piping Diagram on 30XA Units with Hydronic Package — Dual Pumps

UNITS WITHOUT HYDRONIC PUMP PACKAGE — When facing the cooler side of the unit, the inlet (return) water connection is on the bottom. It is required that a field-supplied strainer with a minimum size of 20 mesh be installed within 10 ft (3.05 m) of the cooler inlet to prevent debris from damaging internal tubes of the cooler. The outlet (supply) water connection is on the top. The cooler has water-side viciaulic-type connections (follow connection directions as provided by the coupling manufacturer). Provide proper support for the piping. If accessory security grilles have been added, holes must be cut in the grilles for field piping and insulation. See Fig. 22 for a typical piping diagram of a 30XA unit without a hydronic pump package.

A drain connection is located at the leaving water (supply) end of cooler. See Fig. 2-10 for connection location. Insulate the drain piping (in the same manner as the chilled water piping) for at least 12 in. (305 mm) from the unit.

Dual Chiller Leaving Water Sensor —If the Dual Chiller algorithm is used, and the machines are installed in parallel, a dual chilled water sensor must be installed for each module. Install the well in the common leaving water header. See Fig. 17. The series dual chiller application is shown in Fig. 18.

Minimum Loop Volume — The preferred minimum loop volume is dependent on the type of application. In order to obtain leaving water temperature stability for comfort cooling applications, a minimum of 3 gallons per ton (3.25 liters per kW) is required on all unit sizes. For process cooling applications, applications where high stability is critical, or operation at ambient temperatures below 32 F (0° C) is expected, the loop

volume should be increased to 6 to 10 gallons per ton (6.46 to 10.76 liters per kW) of cooling. In order to achieve this volume, it may be necessary to add a water storage tank to the water loop. If a storage tank is added to the system, it should be properly vented so that the tank can be completely filled and all air eliminated. Failure to do so could cause lack of pump stability and poor system operation. Any storage tank that is placed in the water loop should have internal baffles to allow thorough mixing of the fluid. See Fig. 23.

System Piping — Proper system design and installation procedures should be followed closely. The system must be constructed with pressure tight components and thoroughly tested for installation leaks. Factory-supplied hydronic systems are available with single or dual (for back-up) pumps. The factory-installed system includes all of the components above the line in Fig. 20 and 21.

Installation of water systems should follow sound engineering practice as well as applicable local and industry standards. Improperly designed or installed systems may cause unsatisfactory operation and/or system failure. Consult a water treatment specialist or appropriate literature for information regarding filtration, water treatment, and control devices. Figures 20 and 21 show a typical installation with components that might be installed with the hydronic package of the 30XA unit.

NOTE: It is recommended for units with the hydronic package that an inlet isolation (shut-off) valve be placed exterior to the unit to allow removal and service of the entire pump assembly, if necessary. The hydronic package is supplied from the factory

with a combination valve for isolation of leaving water. Also, if the unit is isolated with valves, a properly sized pressure relief valve is recommended and should be installed in the piping between the unit and the valves, following all applicable local codes.

Air Separation — For proper system operation, it is essential that water loops be installed with proper means to manage air in the system. Free air in the system can cause noise, reduce terminal output, stop flow, or even cause pump failure due to pump cavitation. For closed systems, equipment should be provided to eliminate all air from the system.

The amount of air that water can hold in solution depends on the pressure and temperature of the water/air mixture. Air is less soluble at higher temperatures and at lower pressures. Therefore, separation can best be done at the point of highest water temperature and lowest pressure. Typically, this point would be on the suction side of the pump as the water is returning from the system or terminals. This is generally the optimal place to install an air separator, if possible.

1. Install automatic air vents at all high points in the system. (If the 30XA unit is located at the high point of the system, a vent can be installed on the piping leaving the heat exchanger on the 1/4 in. NPT female port.)
2. Install an air separator in the water loop, at the place where the water is at higher temperatures and lower pressures — usually in the chilled water return piping. On a primary-secondary system, the highest temperature water is normally in the secondary loop, close to the decoupler. Preference should be given to that point on the system (see Fig. 24). In-line or centrifugal air separators are readily available in the field.

It may not be possible to install air separators at the place of the highest temperature and lowest pressure. In such cases, preference should be given to the points of highest temperature. It is important that the pipe be sized correctly so that free air can be moved to the point of separation. Generally, a water velocity of at least 2 feet per second (0.6 m per second) will keep free air entrained and prevent it from forming air pockets.

Automatic vents should be installed at all physically elevated points in the system so that air can be eliminated during system operation. Provisions should also be made for manual venting during the water loop fill.

IMPORTANT: Automatic vents should be located in accessible locations for maintenance purposes and protected from freezing.

DUAL CHILLER CONTROL — the *ComfortLink*™ controller allows 2 chillers (piped in parallel or series) to operate as a single chilled water plant with standard control functions coordinated through the master chiller controller. This standard

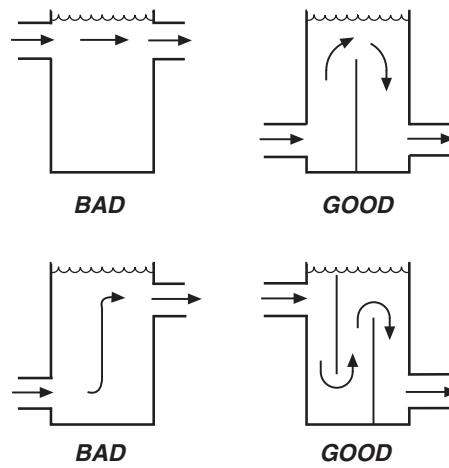

Fig. 23 — Tank Baffling

ComfortLink feature requires a communication link between the 2 chillers.

There are several advantages to this type of control:

- redundancy (multiple circuits)
- better low load control, (lower tonnage capability)
- lower rigging lift weights (2 machines rather than 1 large machine)
- chiller lead-lag operation (evens the wear between the two machines)

Parallel Dual Chiller Operation — Parallel chiller operation is the recommended option for dual chiller control. In this case, each chiller must control its own dedicated pump or isolation valve. Balancing valves are recommended to insure proper flow in each chiller. Two field-supplied and installed dual chiller leaving water temperature sensors are required, one for each module for this function to operate properly.

Consider adding additional isolation valves to isolate each chiller to allow for service on a machine, and still allow for partial capacity from the other chiller. See Fig. 17.

Series Dual Chiller Operation — Series chiller operation is an alternate control method supported by the *ComfortLink*™ control system. Certain applications might require that the two chillers be connected in series. For nominal 10° F (5.6° C) cooler ranges, use the Minus 1 Pass cooler arrangements to reduce the fluid-side pressure drop. Use the standard cooler pass arrangement for low flow, high cooler temperature rise applications.

Consider adding additional piping and isolation valves to isolate each chiller to allow for service on a machine, and still allow for partial capacity from the other chiller. See Fig. 18.

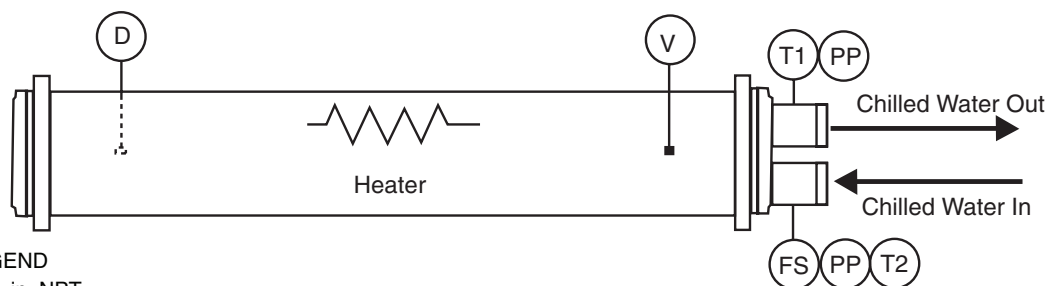

- LEGEND**
- D** — Drain, 3/4-in. NPT
 - FS** — Flow Switch
 - PP** — Pipe Plug, 1/4-in. NPT
 - T1** — Leaving Water Thermistor
 - T2** — Entering Water Thermistor
 - V** — Vent, 1/4-in. NPT

Fig. 22 — Typical Piping Diagram on 30XA Units without Hydronic Package

Table 3 — 30XA Minimum and Maximum Cooler Flow Rates

ITEM			MINIMUM		MAXIMUM		NOMINAL	
Cooler Leaving Water Temperature*			40 F (4.4 C)		60 F (15 C)		—	
Cooler Entering Water Temperature†			45 F (7.2 C)		70 F (21.1 C)		—	
30XA UNIT SIZE	Cooler	Number of Passes	Minimum Flow Rate		Maximum Flow Rate		Nominal Flow Rate	
			(gpm)	(L/s)	(gpm)	(L/s)	(gpm)	(L/s)
080	Standard	2	95	6.0	379	23.9	180.4	11.4
	Plus one pass	3	43	2.7	192	12.1		
	Minus one pass	1	196	12.4	782	49.3		
090	Standard	2	101	6.4	403	25.4	201.9	12.7
	Plus one pass	3	43	2.7	200	12.6		
	Minus one pass	1	229	14.4	917	57.9		
100	Standard	2	101	6.4	403	25.4	225.5	14.2
	Plus one pass	3	43	2.7	200	12.6		
	Minus one pass	1	229	14.4	917	57.9		
110	Standard	2	125	7.9	501	31.6	244.9	15.5
	Plus one pass	3	61	3.8	244	15.4		
	Minus one pass	1	254	16.0	1014	64.0		
120	Standard	2	125	7.9	501	31.6	264.8	16.7
	Plus one pass	3	73	4.6	293	18.5		
	Minus one pass	1	281	17.7	1124	70.9		
140	Standard	2	134	8.5	538	33.9	317.8	20.1
	Plus one pass	3	73	4.6	293	18.5		
	Minus one pass	1	324	20.4	1296	81.8		
160	Standard	2	165	10.4	660	41.6	365.1	23.0
	Plus one pass	3	98	6.2	391	24.7		
	Minus one pass	1	354	22.3	1418	89.5		
180	Standard	2	202	12.7	807	50.9	409.6	25.8
	Plus one pass	3	73	4.6	391	24.7		
	Minus one pass	1	416	26.2	1662	104.9		
200	Standard	2	223	14.1	892	56.3	463.9	29.3
	Plus one pass	3	98	6.2	391	24.7		
	Minus one pass	1	458	28.9	1833	115.6		
220	Standard	2	235	14.8	941	59.4	505.9	31.9
	Plus one pass	3	122	7.7	489	30.9		
	Minus one pass	1	501	31.6	2004	126.4		
240	Standard	2	266	16.8	1063	67.1	545.8	34.4
	Plus one pass	3	147	9.3	587	37.0		
	Minus one pass	1	538	33.9	2151	135.7		
260	Standard	2	257	16.2	1027	64.8	600.3	37.9
	Plus one pass	3	141	8.9	562	35.5		
	Minus one pass	1	584	36.8	2334	147.3		
280	Standard	2	293	18.5	1173	74.0	642.2	40.5
	Plus one pass	3	141	8.9	562	35.5		
	Minus one pass	1	620	39.1	2481	156.5		
300	Standard	2	327	20.6	1308	82.5	687.5	43.4
	Plus one pass	3	174	11.0	697	44.0		
	Minus one pass	1	687	43.3	2750	173.5		
325	Standard	2	361	22.8	1442	91.0	733.4	46.3
	Plus one pass	3	211	13.3	843	53.2		
	Minus one pass	1	724	45.7	2897	182.8		
350	Standard	2	379	23.9	1516	95.6	775.4	48.9
	Plus one pass	3	244	15.4	978	61.7		
	Minus one pass	1	767	48.4	3068	193.6		
400	Standard	1	501	31.6	2004	126.4	917.6	57.9
	Plus one pass	—	—	—	—	—		
	Minus one pass	—	—	—	—	—		
450	Standard	1	501	—	2004	—	1019.3	64.3
	Plus one pass	—	—	—	—	—		
	Minus one pass	—	—	—	—	—		
500	Standard	1	501	—	2004	—	1092.8	68.9
	Plus one pass	—	—	—	—	—		
	Minus one pass	—	—	—	—	—		

*For applications requiring cooler leaving water temperature operation at less than 40 F (4.4 C), the units require the use of antifreeze and application may require one of the special order brine option. Contact your local Carrier representative for more information.

† For applications requiring cooler entering water temperature operation at less than 45 F (7.2 C), contact your local Carrier representative for unit selection using the Carrier electronic catalog.

NOTE: Nominal flow rates required at ARI (Air Conditioning and Refrigeration Institute) conditions 44 F (7 C) leaving fluid temperature, 54 F (12 C) entering water temperature, 95 F (35 C) ambient. Fouling factor 0.00010 ft²-hr-F/Btu (0.000018 m²-K/kW).

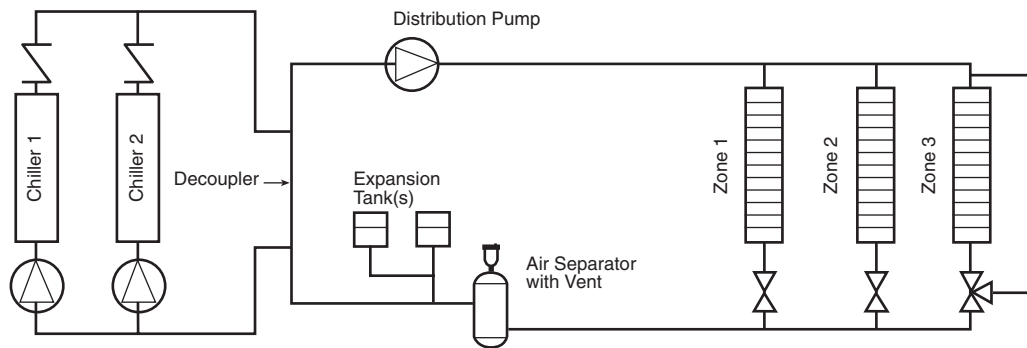

NOTE: Expansion tanks for 30XA hydronic kits must be installed for chillers piped in parallel in the primary water loop.

Fig. 24 — Typical Air Separator and Expansion Tank Location on Primary-Secondary Systems

COOLER PUMP CONTROL — It is recommended that cooler pump control be utilized on all chillers unless the chilled water pump runs continuously or the chilled water system contains a suitable antifreeze solution. Units that are not supplied with a factory-installed hydronic package require installation of the External Pump Control accessory package (Part No. 00EFN900003200A).

If cooler pump control is not utilized it is recommended that the chiller be electrically interlocked with the chilled water pump starter to provide additional protection. The interlock should be wired to terminals TB5-1 and TB5-2. It is also recommended that the cooler pump output be used as an override to the chilled water pump control circuit to provide additional freeze protection, if required.

Refer the Control and Power Wiring Schematic on page 55 for proper connection of the cooler pump output. The cooler pump output will remain energized for 30 seconds after all compressors stop due to an OFF command. In the event a freeze protection alarm is generated, the cooler pump output will be energized regardless of the cooler pump control software configuration. The cooler pump output is also energized anytime a compressor is started and when certain alarms are generated. A thermal flow sensor is factory installed in the entering fluid nozzle to prevent operation without flow through the cooler. See Fig. 25. The flow sensor is factory wired.

Proper software configuration of the cooler pump control parameters is required to prevent possible cooler freeze-up. Refer to the Controls, Start-Up, Operation, Service and Troubleshooting guide for more information.

BRINE UNITS — Special factory modifications to the units are required to allow them to operate at fluid temperatures less than 40 F (4.4 C). Be sure that the fluid has sufficient inhibited glycol or other suitable corrosion-resistant anti-freeze solution to prevent cooler freeze-up.

WATER TREATMENT — Untreated or improperly treated water may result in corrosion, scaling, erosion, or algae. The services of a qualified water treatment specialist should be obtained to develop and monitor a treatment program.

⚠ CAUTION

Water must be within design flow limits, clean, and treated to ensure proper chiller performance and reduce the potential of tube damage due to corrosion, scaling, erosion, and algae. Carrier assumes no responsibility for chiller damage resulting from untreated or improperly treated water.

NOTE: Do not use automobile anti-freeze, or any other fluid that is not approved for heat exchanger duty. Only use appropriately inhibited glycols, concentrated to provide adequate protection for the temperature considered.

PREPARATION FOR YEAR-ROUND OPERATION — In areas where the piping or unit is exposed to 32 F (0° C) or lower ambient temperatures, freeze-up protection is required using inhibited glycol or other suitable corrosion-resistant anti-freeze solution and electric heater tapes. Heater tapes on piping should have a rating for area ambient temperatures and be covered with a suitable thickness of closed-cell insulation. Route power for the heater tapes from a separately fused disconnect. Mount the disconnect within sight from the unit per local or NEC (National Electric Code) codes. Identify disconnect at heater tape power source with a warning that power must not be turned off except when servicing unit.

IMPORTANT: Adding antifreeze solution is the only certain means of protecting the unit from freeze-up if heater fails or electrical power is interrupted or lost while temperatures are below 32 F (0° C).

IMPORTANT: Before starting the unit, be sure all of the air has been purged from the system.

A drain connection is located at the bottom of the cooler head. See Fig. 2-10 for connection location. Install shut-off valves to the drain line before filling the system with fluid.

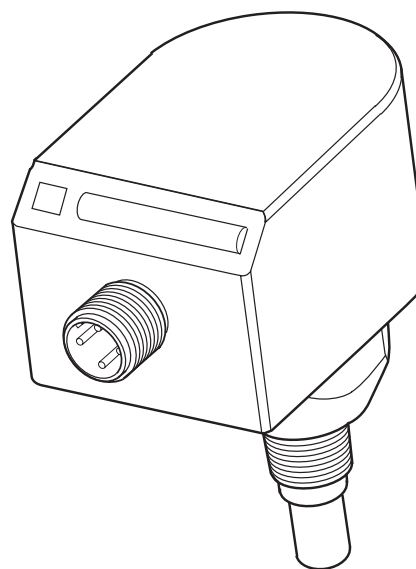

Fig. 25 — Thermal Flow Sensor

Low Ambient Temperature Head Pressure Control — If the unit is equipped with the low ambient temperature head pressure control option, field-fabricated and field-installed wind baffles are required if the wind velocity is anticipated to be greater than 5 mph (8 km/h). Two different baffles may be required, facing the control box. Wind baffles should be constructed with minimum 18-gage galvanized sheet metal or other suitable corrosion-resistance material with cross breaks for strength. See Fig. 26. Use field-supplied screws to attach baffles to the corner posts of the machine. Be sure to hem or turn a flange on all edges to eliminate sharp edges on the baffles.

⚠ WARNING
To avoid possibility of electrical shock, open all disconnects before installing or servicing this accessory.

⚠ CAUTION
To avoid damage to the refrigerant coils and electrical components, use extreme care when drilling screw holes and screwing in fasteners.

Mount the smaller height baffle on units with a control box located on the end of the unit. It is recommended that the upper notches be used for mounting the baffles. This reduces the risk of damaging the coil while drilling a mounting hole. Loosen the upper corner post bolts and slide the baffle under the bolt and washer. Tighten the bolt. Drill holes in the bottom of the flange of the baffle and mount with two screws to secure the bottom of the baffle to the corner post. Repeat the process for the opposite end. See Fig. 26.

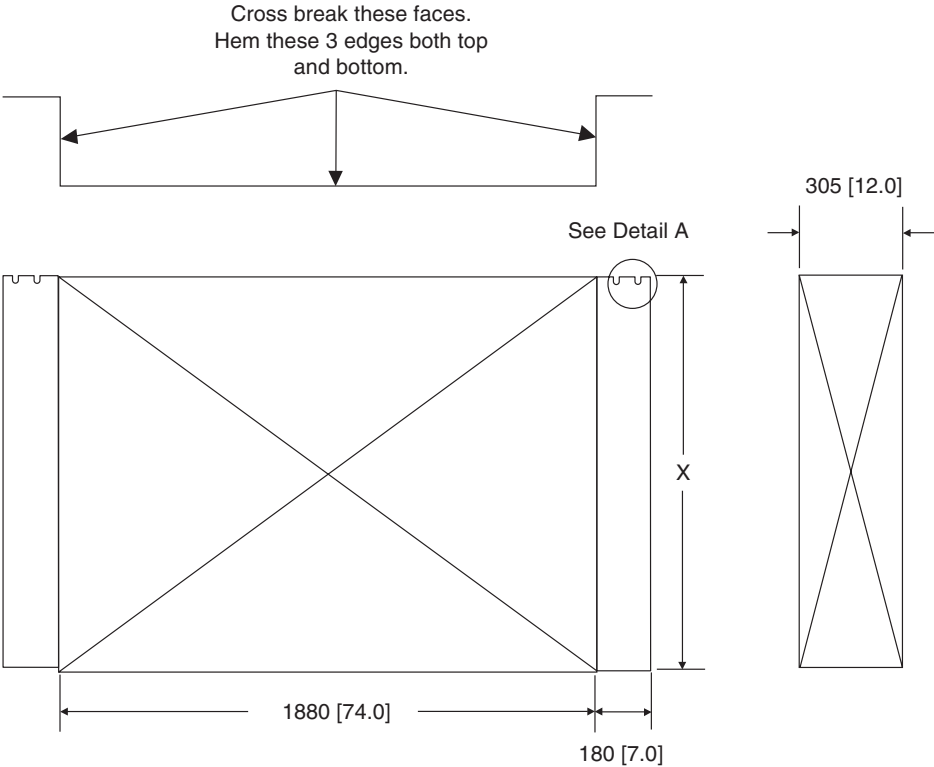

POSITION	BAFFLE HEIGHT (X)	
	RIGHT END	LEFT END
30XA080-120 (Facing the control box end)	1040 [41.0]	635 [25.0]
30XA140-500 (Facing the control box end)	1040 [41.0]	1040 [41.0]

- NOTES:
1. Material: 18 ga. Corrosion Resistant Sheet Metal.
 2. Dimensions are in mm [inches].

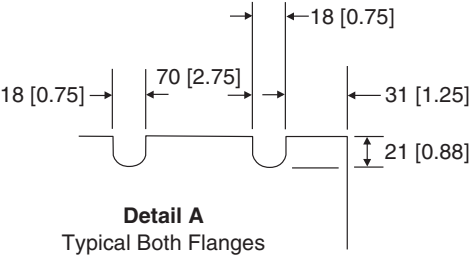

Fig. 26 — Field-Fabricated and Field-Installed Wind Baffles

Step 4 — Fill the Chilled Water Loop

IMPORTANT: Before starting unit, be sure all of the air has been purged from the system.

The chilled water pump (if equipped) is rated for 150 psig (1034 kPa) duty. The maximum cooler fluids side pressure is 300 psig (2068 kPa). Check the pressure rating for all of the chilled water devices installed. Do not exceed the lowest pressure rated device.

WATER SYSTEM CLEANING — Proper water system cleaning is of vital importance. Excessive particulates in the water system can cause excessive pump seal wear, reduce or stop flow, and cause damage of other components.

1. Install a temporary bypass around the chiller to avoid circulating dirty water and particulates into the pump package and chiller during the flush. Use a temporary circulating pump during the cleaning process. Also, be sure that there is capability to fully drain the system after cleaning. See Fig. 27.
2. Be sure to use a cleaning agent that is compatible with all system materials. Be especially careful if the system contains any galvanized or aluminum components. Both detergent-dispersant and alkaline-dispersant cleaning agents are available.
3. It is recommended to fill the system through a water meter. This provides a reference point for the future for loop volume readings, and it also establishes the correct quantity of cleaner needed in order to reach the required concentration.
4. Use a feeder/transfer pump to mix the solution and fill the system. Circulate the cleaning system for the length of time recommended by the cleaning agent manufacturer.
 - a. After cleaning, drain the cleaning fluid and flush the system with fresh water.
 - b. A slight amount of cleaning residue in the system can help keep the desired, slightly alkaline, water pH of 8 to 9. Avoid a pH greater than 10, since this will adversely affect pump seal components.
 - c. A side stream filter is recommended (see Fig. 28 during the cleaning process. Filter side flow rate should be enough to filter the entire water volume every 3 to 4 hours. Change filters as often as necessary during the cleaning process.
 - d. Remove temporary bypass when cleaning is complete.

A suction guide with an internal strainer is standard on all 30XA units with factory-installed hydronic packages. This strainer allows removal of particulates from the chilled water loop. Using the combination valve and the field-installed isolation valve at the inlet, the strainer can be isolated from the chilled water loop to be cleaned.

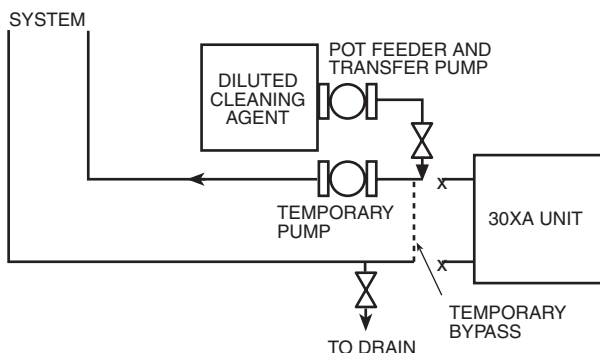

Fig. 27 — Typical Set Up for Cleaning Process

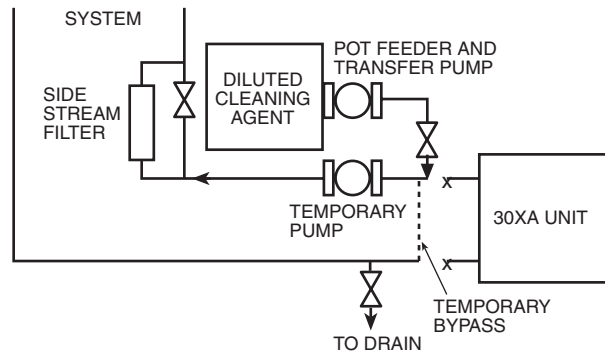

Fig. 28 — Cleaning Using a Side Stream Filter

The Carrier *ComfortLink*TM controls provided have a built-in feature to remind building owners or operators to clean the strainer at a pre-set time interval. Properly installed, cleaned and maintained systems will rarely need the strainer cleaned after the initial fill. This time interval is user-configurable.

Ideally, the chilled water loop will be cleaned before the unit is connected. If the run-in screen is left in the suction guide/strainer, it is recommended that the Service Maintenance be set to alert the operator within 24 hours of start-up to be sure that the run-in screen in the suction guide/strainer is removed after 24 hours of operation.

NOTE: The suction guide/strainer must be removed after the first 24 hours of operation.

To set the time for the parameter, go to Time Clock/MCFG/W.FIL in the handheld NavigatorTM display. To set the time for the parameter with the Touch PilotTM display, go to Main Menu/Service/MAINTCFG/wfilter_c. Values for this item are input in days.

WATER TREATMENT — Fill the fluid loop with water (or brine) and a corrosion-resistant inhibitor suitable for the water of the area. Consult the local water treatment specialist for characteristics of system water and a recommended inhibitor for the cooler fluid loop.

SYSTEM PRESSURIZATION — A proper initial cold fill pressure must be established before filling of the unit. The initial cold fill pressure is the pressure applied at the filling point to fill a system to its highest point, plus a minimum pressure at the top of the system (4 psig minimum [27.6 kPa]) to operate air vents and positively pressurize the system. The expansion tank is very important to system pressurization. The expansion tank serves several purposes:

1. Provide NPSHR (Net Positive Suction Head Required) for the pump to operate satisfactorily.
2. Set system pressure.
3. Accommodate expansion/contraction of water due to temperature changes.
4. Acts as a pressure reference for the pump.

The expansion tank pressure must be set **BEFORE** the system is filled. Follow the manufacturer's recommendation for instructions on setting the pressure in the expansion tank. NPSHR information is provided on the Pump Curves in Fig. 29-32 for units with factory-installed hydronic kits. See Table 4 for pump impeller sizes.

Once the system is pressurized, the pressure at the connection point of the expansion tank to water piping will not change unless the water loop volume changes (either due to addition/subtraction of water or temperature expansion/contraction). The pressure at this point remains the same regardless of whether or not the pump is running.

Since the expansion tank acts as a reference point for the pump, there cannot be two reference points (two expansion tanks) in a system, unless manifolded together. Where two or more 30XA chillers with the hydronic option are installed in parallel, there should not be more than one expansion tank in the system, unless manifolded together as seen in Fig. 24. It is permissible to install the expansion tank(s) in a portion of the return water line that is common to all pumps, providing that the tank is properly sized for combined system volume.

If the application involves two or more chillers in a primary-secondary system, a common place for mounting the expansion tank is in the chilled water return line, just before the decoupler. See Fig. 24 for placement of expansion tank in primary-secondary systems.

If a diaphragm expansion tank is utilized (a flexible diaphragm physically separates the water/air interface) it is not recommended to have any air in the water loop. See the section on air separation on page 44 for instructions on providing air separation equipment.

FILLING THE SYSTEM — The initial fill of the chilled water system must accomplish three goals:

1. The entire piping system must be filled with water.
2. The pressure at the top of the system must be high enough to vent air from the system (usually 4 psig [27.6 kPa] is adequate for most vents).
3. The pressure at all points in the system must be high enough to prevent flashing in the piping or cavitation in the pump.

The pressure created by an operating pump affects system pressure at all points except one — the connection of the expansion tank to the system. This is the only location in the system where pump operation will not give erroneous pressure indications during the fill. Therefore, the best location to install the fill connection is close to the expansion tank. An air vent should be installed close by to help eliminate air that enters during the fill procedure.

When filling the system, ensure the following:

1. Remove temporary bypass piping and cleaning/flushing equipment.

2. Check to make sure all drain plugs are installed.

Normally, a closed system needs to be filled only once. The actual filling process is a fairly simple procedure. All air should be purged or vented from the system. Thorough venting at high points and circulation at room temperature for several hours is highly recommended.

NOTE: Local codes concerning backflow devices and other protection of the city water system should be consulted and followed to prevent contamination of the public water supply. This is critical when anti-freeze is used in the system.

SET WATER FLOW RATE — Once the system is cleaned, pressurized, and filled, the flow rate through the chiller needs to be established. On units with the hydronic package, this can be accomplished by using the balancing valve. Follow the manufacturer's recommendations for setting the balancing valve. Local codes may prohibit restricting the amount of water using the balancing valve for a given motor horsepower. In this case, use the method listed in the Pump Modification/Trimming section. See below for the type of combination valve in 30XA units with the optional hydronic package.

30XA UNIT SIZE	SINGLE/DUAL PUMP
090-160	FTV-5 in.

NOTE: Carrier recommends a differential pressure gage when measuring pressures across the pumps or balancing valves. This provides for greater accuracy and reduces error build-up that often occurs when subtracting pressures made by different gages.

A rough estimate of water flow can also be obtained from the pressure gages across the 30XA heat exchanger.

Figure 29 and 30 shows the relationship between gpm and heat exchanger pressure drop. It should be noted that these curves are for fresh water and “clean” heat exchangers; they do not apply to heat exchangers with fouling. To read the chart, subtract the readings of the two pressure gages on the hydronic kit. This number is the pressure drop across the heat exchanger. Adjust the factory-installed balancing valve or external balancing valve (in units without hydronic package) until the correct pressure drop is obtained for the required flow.

Table 4 — Pump Impeller Sizes

30XA UNIT SIZE	PUMP Hp	SINGLE PUMP				DUAL PUMP			
		Option Code*	Rpm	Impeller Dia. (in.)	Pump Curve	Option Code*	Rpm	Impeller Dia. (in.)	Pump Curve
090-160	5	1	3450	4.5	I	7	3450	4.5	II
	7.5	2	3450	5	I	8	3450	5	II
	10	3	3450	5.4	I	B	3450	5.4	II
	15	4	3450	6.1	I	C	3450	6.1	II

*Option Code refers to the Hydronics Option (position 11) in the model number. See Fig. 1 for option identification.

30XA090,100

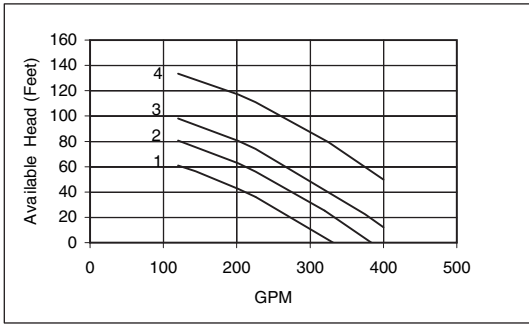

30XA140

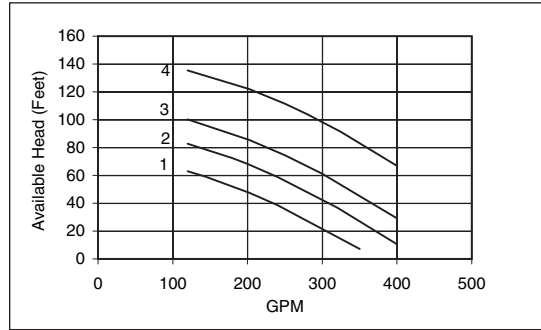

30XA110

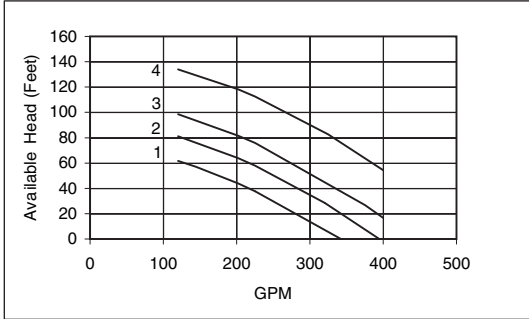

30XA160

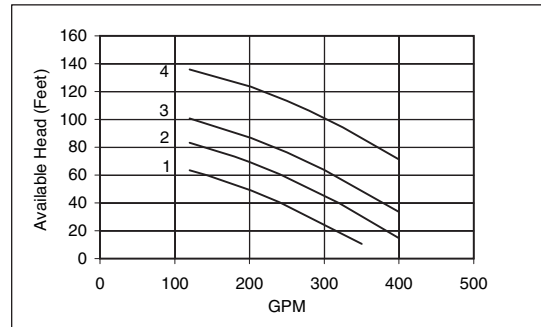

30XA120

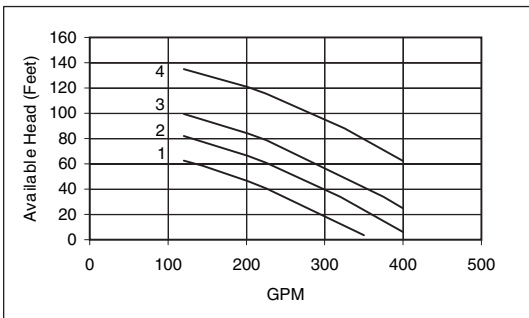

Selection	Pump
1	Single 5HP
2	Single 7.5HP
3	Single 10HP
4	Single 15HP

Fig. 29 — 30XA090-160 Single Pump Envelope Curves

30XA090,100

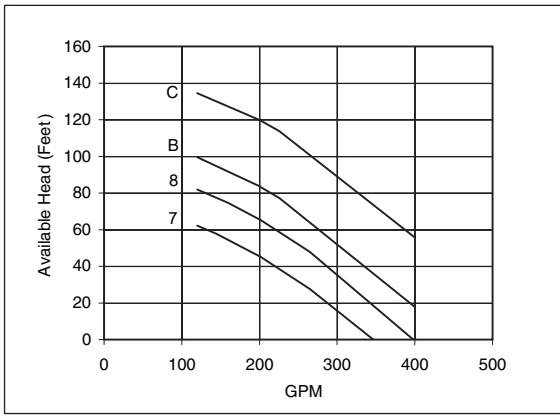

30XA140

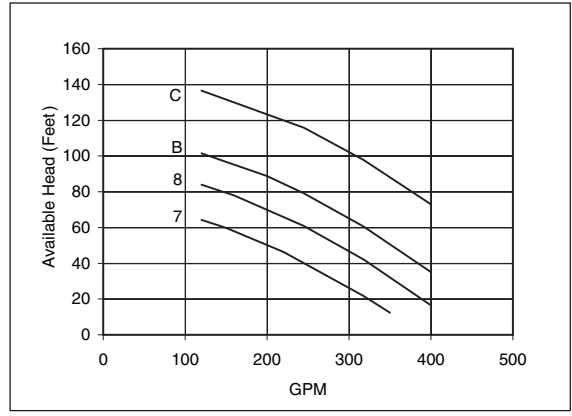

30XA110

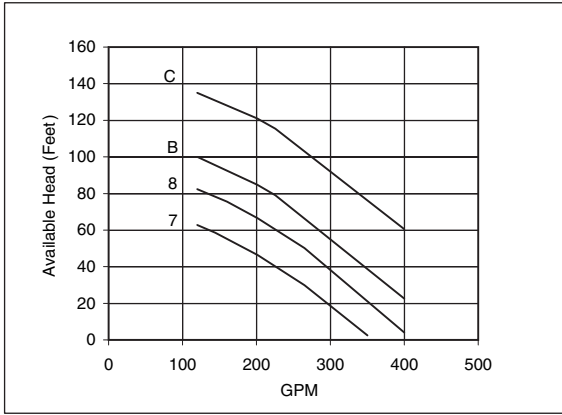

30XA160

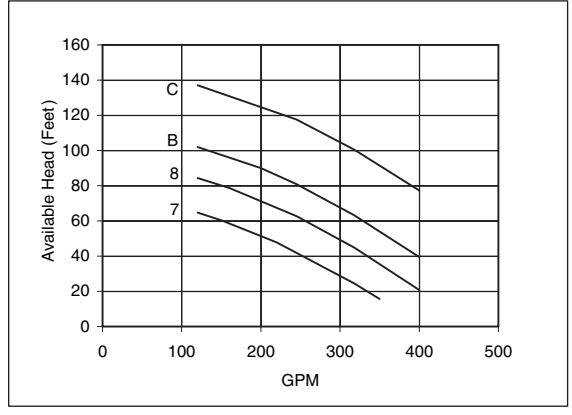

30XA120

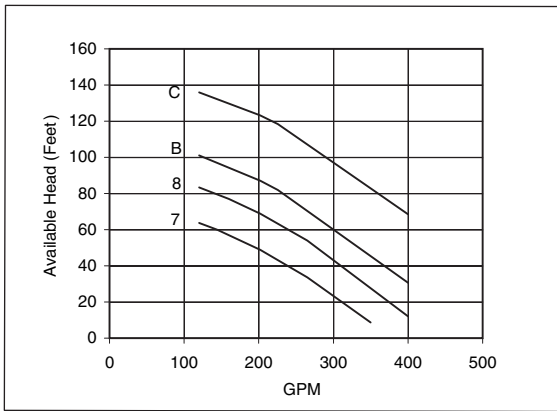

Selection	Pump
7	Dual 5HP
8	Dual 7.5HP
B	Dual 10HP
C	Dual 15HP

Fig. 30 — 30XA090-160 Dual Pump Envelope Curves

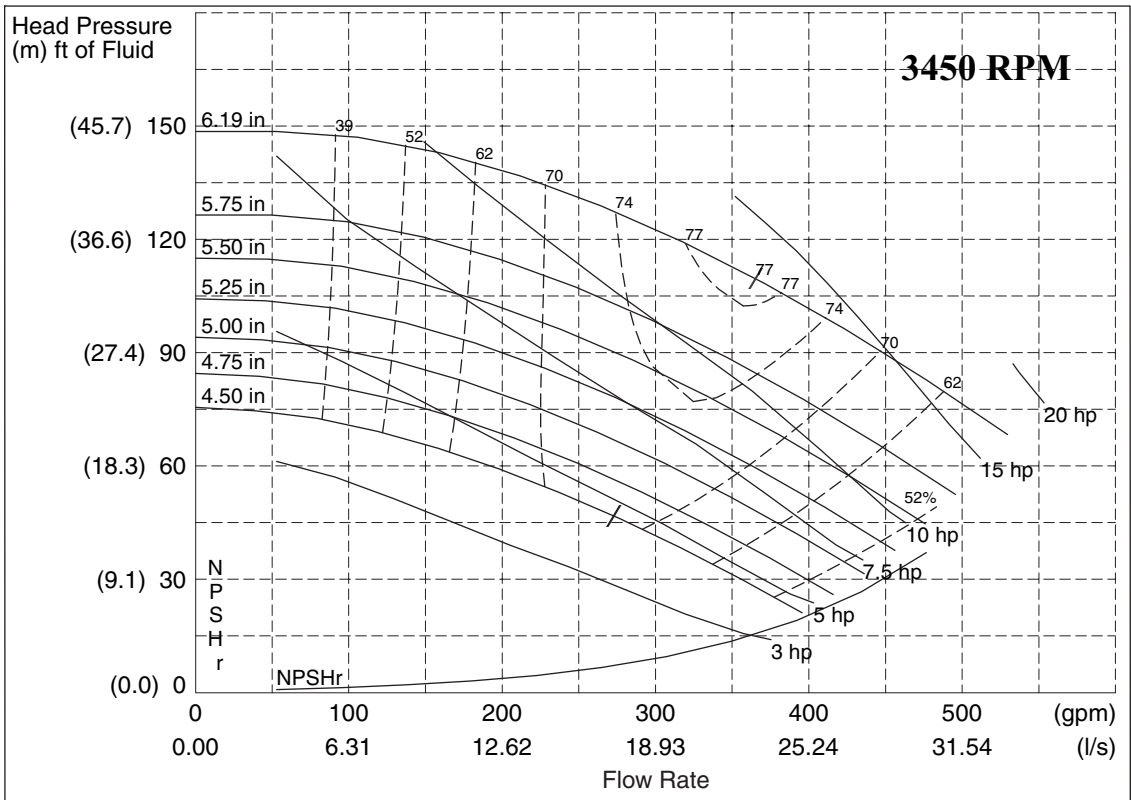

LEGEND

NPSHr — Net Positive Suction Head (Pressure) Required

NOTE: Refer to Fig. 1 for option identification. Refer to Table 4 for more information.

Fig. 31 — Pump Curve I for Hydronic Package Single Pump (Fresh Water)

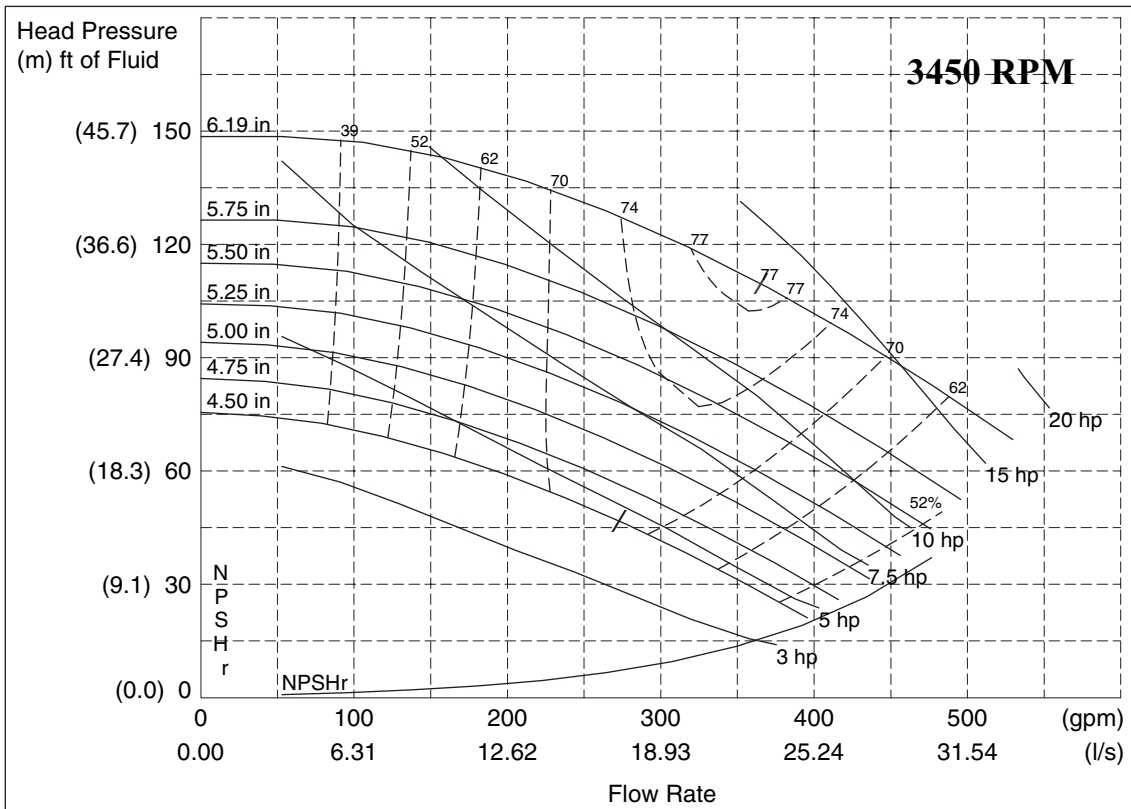

LEGEND

NPSHr — Net Positive Suction Head (Pressure) Required

NOTE: Refer to Fig. 1 for option identification. Refer to Table 4 for more information.

Fig. 32 — Pump Curve II for Hydronic Package Dual Pump (Fresh Water)

PUMP MODIFICATION/TRIMMING — Since the pumps are constant speed, the only way to obtain greater flow with a given pump/impeller is to decrease system head. This will allow the pump to “ride” its curve to the right, resulting in increased flow. If greater flow is necessary, consider opening the combination valve. Also, verify that the strainer is clean, and that no unnecessary system resistance is present, such as partially closed isolation valves.

Once the combination valve is set, note the stem position. If later service work requires the valve to be closed, it will be easier to re-balance the system, if the original balance point is known.

Increasing system resistance by closing the balancing valve will force the pump to “ride” its curve to the left, resulting in less flow. Although this does reduce power consumption slightly, it may not be the desirable method of reducing the flow, especially if a large reduction is needed.

The other method for reducing flow on a constant speed pump is impeller trimming. The impellers in the pumps provided in the 30XA hydronic kit can be easily removed for this purpose. Refer to the vendor literature packet supplied with the hydronic package information on Seal Replacement in the Service Section, and follow instructions for impeller removal and trimming. See Fig. 29 and 30 for pump envelope curve information. Trimming should only be done by a qualified machine shop that has experience in this operation. Contact your local Carrier representative for a recommended machine shop.

▲ CAUTION

After trimming, the impeller **MUST** be balanced. Failure to balance trimmed impellers can result in excessive vibration, noise, and premature bearing failure.

Impeller trimming has the added benefit of maximum bhp (brake horsepower) savings, which can recover the cost incurred by performing the impeller trimming.

FREEZE PROTECTION — The 30XA units are provided with a flow switch to protect against freezing situations that occur from no water flow. While the flow switch is helpful in preventing freezing during no-flow situations, it does not protect the chiller in case of power failure during sub-freezing ambient temperatures, or in other cases where water temperature falls below the freezing mark. Appropriate concentrations of inhibited propylene or ethylene glycol or other suitable inhibited antifreeze solution should be considered for chiller protection where ambient temperatures are expected to fall below 32 F (0° C). Consult local water treatment specialist on characteristics of the system water and add a recommended inhibitor to the chilled water. The Carrier warranty does not cover damage due to freezing.

If the pump will be subjected to freezing temperatures, steps must be taken to prevent freeze damage. If the pump will not be used during this time, it is recommended to drain the pump and hydronic package and these components are back-flushed with inhibited glycol. Otherwise, a glycol-water solution should be considered as the heat transfer fluid. Drains are located on the pump(s) and suction guide/strainer for units with hydronic kits. Units without hydronic kits have a drain plug mounted on the bottom of the cooler head at each end of the cooler.

NOTE: Do not use automobile anti-freeze, or any other fluid that is not approved for heat exchanger duty. Only use appropriately inhibited glycols, concentrated to provide adequate protection for the temperature considered.

Use an electric tape heater for the external piping, if unit will be exposed to freezing temperatures.

Ensure that power is available to the chiller at all times, even during the off-season, so that the pump and cooler heaters have power. Also make sure that the piping tape heaters have power.

On units with pump packages, a heater is supplied with the hydronic package that will protect this section from freezing in outdoor-air temperatures down to –20 F (–29 C), except in the case of a power failure. The Carrier warranty does not cover damage due to freezing.

Cooler heaters that will protect components down to –20 F (–28.9 C) can be ordered as a factory-installed option. Again, it should be noted that these heaters will not protect the cooler from freezing in the event of a power failure. The Carrier warranty does not cover damage due to freezing.

PREPARATION FOR WINTER SHUTDOWN — If the unit is not operational during the winter months, at the end of cooling season complete the following steps.

▲ CAUTION

Failure to remove power before draining heater equipped coolers and hydronic packages can result in heater tape and insulation damage.

1. If the unit has optional heater tapes on the cooler and the cooler will not be drained, do not shut off power disconnect during off-season shutdown. If the unit has optional heater tapes on the cooler and the cooler is drained, open the circuit breaker for the heater, CB-13 or shut off power during off-season shutdown.
2. Draining the fluid from the system is highly recommended. If the unit is equipped with a hydronic package, there are additional drains in the pump housing and strainer that must be opened to allow for all for all of the water to drain.
3. Isolate the cooler from the rest of the system with water shutoff valves.
4. Replace the drain plug and completely fill the cooler with a mixture of water and a suitable corrosion-inhibited antifreeze solution such as propylene glycol. The concentration should be adequate to provide freeze protection to 15° F (8.3° C) below the expected low ambient temperature conditions. Anti-freeze can be added through the vent on top of the cooler. If the unit has a hydronic pump package, the pump must be treated in the same manner.
5. Leave the cooler filled with the antifreeze solution for the winter, or drain if desired. Be sure to deenergize heaters (if installed) as explained in Step 1 to prevent damage. Use an approved method of disposal when removing antifreeze solution.

At the beginning of the next cooling season, be sure that there is refrigerant pressure on each circuit before refilling cooler, add recommended inhibitor, and reset the CB-HT (circuit breaker heater) (if opened) or restore power.

Step 5 — Make Electrical Connections

⚠ WARNING

Electrical shock can cause personal injury and death. Shut off all power to this equipment during installation. There may be more than one disconnect switch. Tag all disconnect locations to alert others not to restore power until work is completed.

POWER SUPPLY — The electrical characteristics of the available power supply must agree with the unit nameplate rating. Supply voltage must be within the limits shown. See Tables 5-11 for electrical and configuration data.

FIELD POWER CONNECTIONS (See Fig. 33) — All power wiring must comply with applicable local and national codes. Install field-supplied, branch circuit fused disconnect(s) of a type that can be locked off or open. Disconnect(s) must be located within sight and readily accessible from the unit in compliance with NEC Article 440-14 (U.S.A.). See Tables 5-11 for unit electrical data.

IMPORTANT: The 30XA units have a factory-installed option available for a non-fused disconnect for unit power supply. If the unit is equipped with this option, all field power wiring should be made to the non-fused disconnect since no terminal blocks are supplied.

Maximum wire size that the unit terminal block or non-fused disconnect will accept is 500 kcmil.

POWER WIRING — All power wiring must comply with applicable local and national codes. Install field-supplied branch circuit fused disconnect per NEC of a type that can be locked OFF or OPEN. Disconnect must be within sight and readily accessible from the unit in compliance with NEC Article 440-14. In the power box, $\frac{7}{8}$ in. holes are provided for power entry. The holes will need to be enlarged to accept the appropriate conduit. NEC also requires all conduits from a conditioned space to the power box(es) be sealed to prevent airflow and moisture into the control box.

The 30XA units require 1 or 2 power supplies, depending on the unit and circuit voltage. See Tables 5-8 for chiller electrical data. Cooler and pump heaters, if factory-installed, are wired in the control circuit. Heaters on chillers with the optional control transformer will be capable of operation only when the main power supply to the chiller is on. On chillers with separate control power, the heaters are capable of operation whenever the control power is supplied.

FIELD CONTROL POWER CONNECTIONS (See Fig. 33) — All units require 115-1-60 control circuit power, unless the control transformer option is installed.

Terminals TB5-1 and TB5-2 are provided for field installation of a chilled water (fluid) pump interlock (CWPI). The chilled water (fluid) flow sensor (CWFS) is factory installed. These devices are to be installed in series. Contacts must be rated for dry-circuit applications capable of handling a 24-vac at 50 mA load.

An accessory remote on-off switch can be wired into TB5-9 and TB5-10. Contacts must be rated for dry-circuit applications capable of handling a 24-vac at 50 mA load.

⚠ CAUTION

Do not use interlocks or other safety device contacts connected between TB5-9 and TB5-10 as remote on-off. Connection of safeties or other interlocks between these 2 terminals will result in an electrical bypass if the ENABLE-OFF-REMOTE contact switch is in the ENABLE position. If remote on-off unit control is required, a field-supplied relay must be installed in the unit control box and wired as shown in Fig. 33. Failure to wire the remote on-off as recommended may result in tube freeze damage.

Terminals 11 and 13 of TB5 are for control of the chilled water pump 1 (PMP1) starter. Terminals 13 and 15 of TB5 are for control of the chilled water pump 2 (PMP2) starter.

Table 5 — 30XA080-350* Electrical Data, Single Point (Standard Condenser Fan Motors)

UNIT 30XA	UNIT VOLTAGE		NUMBER OF COND REQ'D	NO HYDRONIC PACKAGE					5 HP PUMP, 3450 RPM					7.5 HP PUMP, 3450 RPM					CONTROL CIRCUIT		
	V-Hz (3 Ph)	Supplied		MCA	MOCP	ICF		Rec Fuse Size	MCA	MOCP	ICF		Rec Fuse Size	MCA	MOCP	ICF		Rec Fuse Size	Voltage 1 PH, 60 Hz	MCA and MOCP	
		Min				Max	WD				XL	WD				XL	WD				XL
080	230-60	207	253	6	315.5	400	484.2	1170.2	350	—	—	—	—	—	—	—	—	—	115	40	
	200-60	187	220	6	347.6	450	549.6	1338.6	400	—	—	—	—	—	—	—	—	—	115	40	
	460-60	414	506	6	157.7	200	242.1	585.1	175	—	—	—	—	—	—	—	—	—	115	40	
	575-60	518	633	6	121.2	150	191.9	465.9	150	—	—	—	—	—	—	—	—	—	115	40	
	380-60	342	418	6	183.5	250	289.7	704.7	225	—	—	—	—	—	—	—	—	—	115	40	
090	230-60	207	253	8	364.0	450	499.1	1185.1	400	350.0	450	515.1	1201.1	400	357.2	450	522.3	1208.3	400	115	40
	200-60	187	220	8	368.0	500	566.0	1355.0	450	385.7	500	583.7	1372.7	450	393.6	500	591.7	1380.7	450	115	40
	460-60	414	506	8	167.0	225	249.6	592.6	200	175.0	225	257.6	600.6	200	178.6	225	261.2	604.2	200	115	40
	575-60	518	633	8	128.5	175	197.8	471.8	150	134.9	175	204.2	478.2	150	137.7	175	207.0	481.0	150	115	40
	380-60	342	418	8	194.5	250	298.6	713.6	225	204.2	250	308.3	723.3	225	208.6	250	312.6	727.6	250	115	40
100	230-60	207	253	8	364.0	500	536.7	1278.7	400	380.6	500	552.7	1294.7	450	387.8	500	559.9	1301.9	450	115	40
	200-60	187	220	8	401.3	500	607.8	1461.8	450	419.0	500	625.5	1479.5	500	427.0	500	633.5	1487.5	500	115	40
	460-60	414	506	8	182.3	250	268.4	639.4	200	190.3	250	276.4	647.4	225	193.9	250	280.0	651.0	225	115	40
	575-60	518	633	8	139.5	175	211.7	508.7	175	145.9	175	218.1	515.1	175	148.8	200	220.9	517.9	175	115	40
	380-60	342	418	8	212.7	250	321.7	770.7	250	222.4	300	331.3	780.3	250	226.7	300	335.7	784.7	250	115	40
110	230-60	207	253	8	405.7	500	536.7	—	450	421.7	500	552.7	—	500	428.9	600	559.9	—	500	115	40
	200-60	187	220	8	446.2	600	607.8	—	500	463.9	600	625.5	—	600	471.9	600	633.5	—	600	115	40
	460-60	414	506	8	202.4	250	268.4	639.4	225	210.4	250	276.4	647.4	250	214.0	300	280.0	651.0	250	115	40
	575-60	518	633	8	155.5	200	211.7	508.7	175	161.9	225	218.1	515.1	200	164.8	225	220.9	517.9	200	115	40
	380-60	342	418	8	236.4	300	321.7	770.7	300	246.1	300	331.3	780.3	300	250.4	350	335.7	784.7	300	115	40
120	230-60	207	253	8	438.6	600	569.6	—	500	454.6	600	585.6	—	500	461.8	600	592.8	—	600	115	40
	200-60	187	220	8	482.2	600	643.8	—	600	499.9	600	661.5	—	600	507.8	600	669.4	—	600	115	40
	460-60	414	506	8	218.4	300	284.4	655.4	250	226.4	300	292.4	663.4	250	230.0	300	296.0	667.0	300	115	40
	575-60	518	633	8	168.4	225	224.5	521.5	200	174.8	225	230.9	527.9	200	177.7	225	233.8	530.8	200	115	40
	380-60	342	418	8	255.3	350	340.6	789.6	300	265.0	350	350.3	799.3	300	269.4	350	354.7	803.7	300	115	40
140	230-60	207	253	10	534.7	800	796.7	—	700	550.7	800	812.7	—	700	557.9	800	819.9	—	700	115	40
	200-60	187	220	10	588.5	800	906.1	—	700	606.2	800	923.8	—	700	614.1	800	931.8	—	700	115	40
	460-60	414	506	10	267.3	400	398.4	1030.4	350	275.3	400	406.4	1038.4	350	278.9	400	410.0	1042.0	350	115	40
	575-60	518	633	10	205.0	300	315.5	821.5	250	211.4	300	321.9	827.9	250	214.3	300	324.7	830.7	250	115	40
	380-60	342	418	10	311.2	450	478.9	1243.9	350	320.9	450	488.6	1253.6	400	325.3	450	493.0	1258.0	400	115	40
160	230-60	207	253	10	621.1	800	997.6	—	700	637.1	800	1013.6	—	800	644.3	800	1020.8	—	800	115	40
	200-60	187	220	10	682.8	1000	1136.1	—	800	700.5	1000	1153.8	—	800	708.5	1000	1161.7	—	800	115	40
	460-60	414	506	10	309.7	450	498.4	1306.4	350	317.7	450	506.4	1314.4	400	321.3	450	510.0	1318.0	400	115	40
	575-60	518	633	10	238.1	350	396.3	1042.3	300	244.5	350	402.7	1048.7	300	247.4	350	405.6	1051.6	300	115	40
	380-60	342	418	10	361.1	500	598.9	1577.9	450	370.8	500	608.6	1587.6	450	375.2	500	612.9	1591.9	450	115	40
180	230-60	207	253	12	673.2	800	935.2	—	800	—	—	—	—	—	—	—	—	—	—	115	40
	200-60	187	220	12	740.9	1000	1058.5	—	1000	—	—	—	—	—	—	—	—	—	—	115	40
	460-60	414	506	12	336.6	450	467.6	1099.6	400	—	—	—	—	—	—	—	—	—	—	115	40
	575-60	518	633	12	258.3	350	368.8	874.8	300	—	—	—	—	—	—	—	—	—	—	115	40
	380-60	342	418	12	391.5	500	559.2	1324.2	450	—	—	—	—	—	—	—	—	—	—	115	40
200	230-60	207	253	12	769.6	1000	1146.0	—	1000	—	—	—	—	—	—	—	—	—	—	115	40
	200-60	187	220	12	846.0	1000	1299.2	—	1000	—	—	—	—	—	—	—	—	—	—	115	40
	460-60	414	506	12	383.9	500	572.6	1380.6	450	—	—	—	—	—	—	—	—	—	—	115	40
	575-60	518	633	12	294.8	400	453.0	1099.0	350	—	—	—	—	—	—	—	—	—	—	115	40
	380-60	342	418	12	447.2	600	685.0	1664.0	500	—	—	—	—	—	—	—	—	—	—	115	40
220	230-60	207	253	13	850.2	1200	1152.0	—	1000	—	—	—	—	—	—	—	—	—	—	115	40
	200-60	187	220	13	935.1	1200	1305.9	—	1200	—	—	—	—	—	—	—	—	—	—	115	40
	460-60	414	506	13	424.7	600	575.6	1383.6	500	—	—	—	—	—	—	—	—	—	—	115	40
	575-60	518	633	13	326.3	450	455.4	1101.4	400	—	—	—	—	—	—	—	—	—	—	115	40
	380-60	342	418	13	494.5	700	688.6	1667.6	600	—	—	—	—	—	—	—	—	—	—	115	40
240	230-60	207	253	13	910.0	1200	1211.8	—	1200	—	—	—	—	—	—	—	—	—	—	115	40
	200-60	187	220	13	1001.1	1200	1371.8	—	1200	—	—	—	—	—	—	—	—	—	—	115	40
	460-60	414	506	13	455.0	600	605.9	1413.9	600	—	—	—	—	—	—	—	—	—	—	115	40
	575-60	518	633	13	349.6	450	478.7	1124.7	400	—	—	—	—	—	—	—	—	—	—	115	40
	380-60	342	418	13	529.5	700	723.5	1702.5	600	—	—	—	—	—	—	—	—	—	—	115	40
260	460-60	414	506	15	516.5	700	777.6	1999.6	600	—	—	—	—	—	—	—	—	—	—	115	40
	575-60	518	633	15	396.4	500	616.2	1594.2	450	—	—	—	—	—	—	—	—	—	—	115	40
	380-60	342	418	15	600.2	800	933.9	2412.9	700	—	—	—	—	—	—	—	—	—	—	115	40
280	460-60	414	506	16	549.7	800	810.9	2032.9	700	—	—	—	—	—	—	—	—	—	—	115	40
	575-60	518	633	16	422.1	600	641														

Table 5 — 30XA080-350* Electrical Data, Single Point (Standard Condenser Fan Motors) (cont)

UNIT 30XA	UNIT VOLTAGE			NUMBER OF COND REQ'D	10 HP PUMP, 3450 RPM					15 HP PUMP, 3450 RPM					CONTROL CIRCUIT	
	V-Hz (3 Ph)	Supplied			MCA	MOCP	ICF		Rec Fuse Size	MCA	MOCP	ICF		Rec Fuse Size	Voltage 1 PH, 60 Hz	MCA and MOCP
		Min	Max				WD	XL				WD	XL			
080	230-60	207	253	6	—	—	—	—	—	—	—	—	—	115	40	
	200-60	187	220	6	—	—	—	—	—	—	—	—	—	115	40	
	460-60	414	506	6	—	—	—	—	—	—	—	—	—	115	40	
	575-60	518	633	6	—	—	—	—	—	—	—	—	—	115	40	
	380-60	342	418	6	—	—	—	—	—	—	—	—	—	115	40	
090	230-60	207	253	8	364.4	450	529.5	1215.5	400	379.0	500	544.1	1230.1	450	115	40
	200-60	187	220	8	401.6	500	599.6	1388.6	450	417.7	500	615.8	1404.8	500	115	40
	460-60	414	506	8	182.2	225	264.8	607.8	200	189.5	250	272.1	615.1	225	115	40
	575-60	518	633	8	140.6	175	209.9	483.9	175	146.5	175	215.8	489.8	175	115	40
	380-60	342	418	8	212.9	250	317.0	732.0	250	221.8	250	325.8	740.8	250	115	40
100	230-60	207	253	8	395.0	500	567.1	1309.1	450	409.6	500	581.7	1323.7	450	115	40
	200-60	187	220	8	434.9	500	641.5	1495.5	500	451.1	600	657.6	1511.6	500	115	40
	460-60	414	506	8	197.5	250	283.6	654.6	225	204.8	250	290.9	661.9	225	115	40
	575-60	518	633	8	151.7	200	223.8	520.8	175	157.5	200	229.7	526.7	175	115	40
	380-60	342	418	8	231.1	300	340.1	789.1	300	239.9	300	348.9	797.9	300	115	40
110	230-60	207	253	8	436.1	600	567.1	—	500	450.7	600	581.7	—	500	115	40
	200-60	187	220	8	479.9	600	641.5	—	600	496.0	600	657.6	—	600	115	40
	460-60	414	506	8	217.6	300	283.6	654.6	250	224.9	300	290.9	661.9	250	115	40
	575-60	518	633	8	167.7	225	223.8	520.8	200	173.5	225	229.7	526.7	200	115	40
	380-60	342	418	8	254.8	350	340.1	789.1	300	263.6	350	348.9	797.9	300	115	40
120	230-60	207	253	8	469.0	600	600.0	—	600	483.6	600	614.6	—	600	115	40
	200-60	187	220	8	515.8	700	677.4	—	600	531.9	700	693.5	—	600	115	40
	460-60	414	506	8	233.6	300	299.6	670.6	300	240.9	300	306.9	677.9	300	115	40
	575-60	518	633	8	180.5	225	236.7	533.7	200	186.4	250	242.5	539.5	225	115	40
	380-60	342	418	8	273.7	350	359.0	808.0	300	282.6	350	367.9	816.9	350	115	40
140	230-60	207	253	10	565.1	800	827.1	—	700	579.7	800	841.7	—	700	115	40
	200-60	187	220	10	622.1	800	939.7	—	700	638.2	800	955.9	—	800	115	40
	460-60	414	506	10	282.5	400	413.6	1045.6	350	289.8	400	420.9	1052.9	350	115	40
	575-60	518	633	10	217.1	300	327.6	833.6	250	223.0	300	333.5	839.5	250	115	40
	380-60	342	418	10	329.6	450	497.3	1262.3	400	338.5	450	506.2	1271.2	400	115	40
160	230-60	207	253	10	651.5	800	1028.0	—	800	666.1	800	1042.6	—	800	115	40
	200-60	187	220	10	716.4	1000	1169.7	—	1000	732.6	1000	1185.8	—	1000	115	40
	460-60	414	506	10	324.9	450	513.6	1321.6	400	332.2	450	520.9	1328.9	400	115	40
	575-60	518	633	10	250.2	350	408.5	1054.5	300	256.1	350	414.3	1060.3	300	115	40
	380-60	342	418	10	379.5	500	617.3	1596.3	450	388.4	500	626.1	1605.1	450	115	40
180	230-60	207	253	12	—	—	—	—	—	—	—	—	—	—	115	40
	200-60	187	220	12	—	—	—	—	—	—	—	—	—	—	115	40
	460-60	414	506	12	—	—	—	—	—	—	—	—	—	—	115	40
	575-60	518	633	12	—	—	—	—	—	—	—	—	—	—	115	40
	380-60	342	418	12	—	—	—	—	—	—	—	—	—	—	115	40
200	230-60	207	253	12	—	—	—	—	—	—	—	—	—	—	115	40
	200-60	187	220	12	—	—	—	—	—	—	—	—	—	—	115	40
	460-60	414	506	12	—	—	—	—	—	—	—	—	—	—	115	40
	575-60	518	633	12	—	—	—	—	—	—	—	—	—	—	115	40
	380-60	342	418	12	—	—	—	—	—	—	—	—	—	—	115	40
220	230-60	207	253	13	—	—	—	—	—	—	—	—	—	—	115	40
	200-60	187	220	13	—	—	—	—	—	—	—	—	—	—	115	40
	460-60	414	506	13	—	—	—	—	—	—	—	—	—	—	115	40
	575-60	518	633	13	—	—	—	—	—	—	—	—	—	—	115	40
	380-60	342	418	13	—	—	—	—	—	—	—	—	—	—	115	40
240	230-60	207	253	13	—	—	—	—	—	—	—	—	—	—	115	40
	200-60	187	220	13	—	—	—	—	—	—	—	—	—	—	115	40
	460-60	414	506	13	—	—	—	—	—	—	—	—	—	—	115	40
	575-60	518	633	13	—	—	—	—	—	—	—	—	—	—	115	40
	380-60	342	418	13	—	—	—	—	—	—	—	—	—	—	115	40
260	460-60	414	506	15	—	—	—	—	—	—	—	—	—	—	115	40
	575-60	518	633	15	—	—	—	—	—	—	—	—	—	—	115	40
	380-60	342	418	15	—	—	—	—	—	—	—	—	—	—	115	40
280	460-60	414	506	16	—	—	—	—	—	—	—	—	—	—	115	40
	575-60	518	633	16	—	—	—	—	—	—	—	—	—	—	115	40
	380-60	342	418	16	—	—	—	—	—	—	—	—	—	—	115	40
300	460-60	414	506	16	—	—	—	—	—	—	—	—	—	—	115	40
	575-60	518	633	16	—	—	—	—	—	—	—	—	—	—	115	40
	380-60	342	418	16	—	—	—	—	—	—	—	—	—	—	115	40
325	460-60	414	506	18	—	—	—	—	—	—	—	—	—	—	115	40
	575-60	518	633	18	—	—	—	—	—	—	—	—	—	—	115	40
	380-60	342	418	18	—	—	—	—	—	—	—	—	—	—	115	40
350	460-60	414	506	18	—	—	—	—	—	—	—	—	—	—	115	40
	575-60	518	633	18	—	—	—	—	—	—	—	—	—	—	115	40
	380-60	342	418	18	—	—	—	—	—	—	—	—	—	—	115	40

LEGEND

- ICF** — Instantaneous Current Flow
- MCA** — Minimum Circuit Amps
- MOCP** — Maximum Overcurrent Protection
- WD** — Wye-Delta
- XL** — Across-the-Line

*30XA400-500 units are not available with single point power.

NOTES:

1. Units are suitable for use on electrical systems where voltage supplied to the unit terminals is not below or above the listed minimum and maximum limits. Maximum allowable phase imbalance is: voltage, 2%; amps 10%.
2. Cooler heater is wired into the control circuit so it is always operable as long as the control power supply disconnect is on, even if any safety device is open.
3. For MCA that is less than or equal to 380 amps, 3 conductors are required.
For MCA between 381-760 amps, 6 conductors are required.
For MCA between 761-1140 amps, 9 conductors are required.
For MCA between 1141-1520 amps, 12 conductors are required.

Calculation of conductors required is based on 75 C copper wire.

4. Wiring for main field supply must be rated 75 C minimum. Use copper for all units.
 - a. Incoming wire size range for the terminal block is no. 4 AWG (American Wire Gauge) to 500 kcmil.
 - b. Incoming wire size range of non-fused disconnect with MCA up to 599.9 amps is 3/0 to 500 kcmil.
 - c. Incoming wire size range of non-fused disconnect with MCA from 600 to 799.9 amps is 1/0 to 500 kcmil.
 - d. Incoming wire size range of non-fused disconnect with MCA from 800 to 1199.9 amps is 250 kcmil to 500 kcmil.
5. Data provided circuit 1/circuit 2 where there are two circuits.

Table 6 — 30XA080-500 Electrical Data, Dual Point (Standard Condenser Fan Motors)

UNIT 30XA	UNIT VOLTAGE		NUMBER OF COND REQ'D	NO HYDRONIC PACKAGE					5 HP PUMP, 3450 RPM					CONTROL CIRCUIT		
	V-Hz (3 Ph)	Supplied		MCA	MOCP	ICF		Rec Fuse Size	MCA	MOCP	ICF		Rec Fuse Size	Voltage 1 PH, 60 Hz	MCA and MOCP	
		Min				Max	WD				XL	WD				XL
080	230-60	207	253	3/3	173.3/173.3	250/ 250	342.0/342.0	1028.0/1028.0	225/225	—	—	—	—	115	40	
	200-60	187	220	3/3	190.9/190.9	300/ 300	392.9/392.9	1181.9/1181.9	250/250	—	—	—	—	115	40	
	460-60	414	506	3/3	86.6/ 86.6	125/ 125	171.0/171.0	514.0/ 514.0	110/110	—	—	—	—	115	40	
	575-60	518	633	3/3	66.5/ 66.5	110/ 110	137.2/137.2	411.2/ 411.2	80/ 80	—	—	—	—	115	40	
	380-60	342	418	3/3	100.7/100.7	150/ 150	206.9/206.9	621.9/ 621.9	125/125	—	—	—	—	115	40	
090	230-60	207	253	4/4	182.9/182.9	300/ 300	348.0/348.0	1034.0/1034.0	225/225	182.9/182.9	300/300	348.0/364.0	1034.0/1050.0	225/250	115	40
	200-60	187	220	4/4	201.5/201.5	300/ 300	399.5/399.5	1188.5/1188.5	250/250	201.5/219.2	300/350	399.5/417.2	1188.5/1206.2	250/300	115	40
	460-60	414	506	4/4	91.4/ 91.4	150/ 150	174.0/174.0	517.0/ 517.0	110/110	91.4/ 99.4	150/150	174.0/182.0	517.0/ 525.0	110/125	115	40
	575-60	518	633	4/4	70.3/ 70.3	110/ 110	139.6/139.6	413.6/ 413.6	90/ 90	70.3/ 76.7	110/125	139.6/146.0	413.6/ 420.0	90/ 90	115	40
	380-60	342	418	4/4	106.5/106.5	175/ 175	210.5/210.5	625.5/ 625.5	125/125	106.5/116.1	175/175	210.5/220.2	625.5/ 635.2	125/150	115	40
100	230-60	207	253	4/4	199.9/199.9	300/ 300	372.0/372.0	1114.0/1114.0	250/250	199.9/215.9	300/350	372.0/388.0	1114.0/1130.0	250/300	115	40
	200-60	187	220	4/4	220.0/220.0	350/ 350	426.5/426.5	1280.5/1280.5	300/300	220.0/237.7	350/350	426.5/444.2	1280.5/1298.2	300/300	115	40
	460-60	414	506	4/4	99.9/ 99.9	150/ 150	186.0/186.0	557.0/ 557.0	125/125	99.9/107.9	150/175	186.0/194.0	557.0/ 565.0	125/150	115	40
	575-60	518	633	4/4	76.4/ 76.4	125/ 125	148.6/148.6	445.6/ 445.6	90/ 90	76.4/ 82.8	125/125	148.6/155.0	445.6/ 452.0	90/100	115	40
	380-60	342	418	4/4	116.5/116.5	175/ 175	225.5/225.5	674.5/ 674.5	150/150	116.5/126.2	175/200	225.5/235.2	674.5/ 684.2	150/150	115	40
110	230-60	207	253	4/4	241.0/199.9	400/ 300	372.0/372.0	—	300/250	241.0/215.9	400/350	372.0/ 388.0	—	300/300	115	40
	200-60	187	220	4/4	264.9/264.9	450/ 350	426.5/426.5	—	350/300	264.9/237.7	450/350	426.5/444.2	—	350/300	115	40
	460-60	414	506	4/4	120.0/ 99.9	200/ 150	186.0/186.0	557.0/557.0	150/125	120.0/107.9	200/175	186.0/194.0	557.0/ 565.0	150/150	115	40
	575-60	518	633	4/4	92.5/ 76.4	150/ 125	148.6/148.6	445.6/445.6	110/ 90	92.5/ 82.8	150/125	148.6/155.0	445.6/ 452.0	110/100	115	40
	380-60	342	418	4/4	140.2/116.5	225/ 175	225.5/225.5	674.5/674.5	175/150	140.2/126.2	225/200	225.5/235.2	674.5/ 684.2	175/150	115	40
120	230-60	207	253	4/4	241.0/241.0	400/ 400	372.0/372.0	—	300/300	241.0/257.0	400/400	372.0/388.0	—	300/350	115	40
	200-60	187	220	4/4	264.9/264.9	450/ 450	426.5/426.5	—	350/350	264.9/282.6	450/450	426.5/444.2	—	350/350	115	40
	460-60	414	506	4/4	120.0/120.0	200/ 200	186.0/186.0	557.0/557.0	150/150	120.0/128.0	200/200	186.0/194.0	557.0/ 565.0	150/150	115	40
	575-60	518	633	4/4	92.5/ 92.5	150/ 150	148.6/148.6	445.6/445.6	110/110	92.5/ 98.9	150/150	148.6/155.0	445.6/ 452.0	110/125	115	40
	380-60	342	418	4/4	140.2/140.2	225/ 225	225.5/225.5	674.5/674.5	175/175	140.2/149.9	225/250	225.5/235.2	674.5/ 684.2	175/200	115	40
140	230-60	207	253	6/4	370.0/199.9	600/ 300	632.0/372.0	—	450/250	370.0/215.9	600/350	632.0/388.0	—	450/300	115	40
	200-60	187	220	6/4	407.2/220.0	700/ 350	724.8/426.5	—	500/300	407.2/237.7	700/350	724.8/444.2	—	500/300	115	40
	460-60	414	506	6/4	185.0/ 99.9	300/ 150	316.0/186.0	948.0/557.0	225/125	185.0/107.9	300/175	316.0/194.0	948.0/ 565.0	225/150	115	40
	575-60	518	633	6/4	141.9/ 76.4	225/ 125	252.4/148.6	758.4/445.6	175/ 90	141.9/ 82.8	225/125	252.4/155.0	758.4/ 452.0	175/100	115	40
	380-60	342	418	6/4	215.1/116.5	300/ 175	382.8/225.5	1147.8/674.5	300/150	215.1/26.2	350/200	382.8/235.2	1147.8/ 684.2	300/150	115	40
160	230-60	207	253	6/4	423.5/241.0	700/ 400	800.0/372.0	—	600/300	423.5/257.0	700/400	800.0/388.0	—	600/350	115	40
	200-60	187	220	6/4	465.6/264.9	800/ 450	918.8/426.5	—	600/350	465.6/282.6	800/450	918.8/444.2	—	600/350	115	40
	460-60	414	506	6/4	211.3/120.0	350/ 200	400.0/186.0	1208.0/557.0	250/150	211.3/128.0	350/200	400.0/194.0	1208.0/ 565.0	250/150	115	40
	575-60	518	633	6/4	162.2/ 92.5	250/ 150	320.4/148.6	966.4/445.6	200/110	162.2/ 98.9	250/150	320.4/155.0	966.4/ 452.0	200/125	115	40
	380-60	342	418	6/4	246.0/140.2	400/ 225	483.8/225.5	1462.8/674.5	300/175	246.0/149.9	400/250	483.8/235.2	1462.8/ 684.2	300/200	115	40
180	230-60	207	253	6/6	370.0/370.0	600/ 600	632.0/632.0	—	450/450	—	—	—	—	—	115	40
	200-60	187	220	6/6	407.2/407.2	700/ 700	724.8/724.8	—	500/500	—	—	—	—	—	115	40
	460-60	414	506	6/6	185.0/185.0	300/ 300	316.0/316.0	948.0/ 948.0	225/225	185.0/175.0	300/300	316.0/316.0	948.0/ 948.0	225/225	115	40
	575-60	518	633	6/6	141.9/141.9	225/ 225	252.4/252.4	758.4/ 758.4	175/175	141.9/141.9	225/225	252.4/252.4	758.4/ 758.4	175/175	115	40
	380-60	342	418	6/6	215.1/215.1	350/ 350	382.8/382.8	1147.8/1147.8	300/300	215.1/215.1	350/300	382.8/382.8	1147.8/1147.8	300/300	115	40
200	230-60	207	253	6/6	423.5/423.5	700/ 700	800.0/800.0	—	600/600	—	—	—	—	—	115	40
	200-60	187	220	6/6	465.6/465.6	800/ 800	918.8/918.8	—	600/600	—	—	—	—	—	115	40
	460-60	414	506	6/6	211.3/211.3	350/ 350	400.0/400.0	1208.0/1208.0	250/250	211.3/211.3	350/350	400.0/400.0	1208.0/ 1208.0	250/250	115	40
	575-60	518	633	6/6	162.2/162.2	250/ 250	320.4/320.4	966.4/ 966.4	200/200	162.2/162.2	250/250	320.4/320.4	966.4/ 966.4	200/200	115	40
	380-60	342	418	6/6	246.0/246.0	400/ 400	483.8/483.8	1462.8/1462.8	300/300	246.0/246.0	400/400	483.8/483.8	1462.8/1462.8	300/300	115	40
220	230-60	207	253	7/6	504.2/423.5	800/ 700	806.0/800.0	—	600/600	—	—	—	—	—	115	40
	200-60	187	220	7/6	554.7/465.6	800/ 800	925.4/918.8	—	700/600	—	—	—	—	—	115	40
	460-60	414	506	7/6	252.1/211.3	400/ 350	403.0/400.0	1211.0/1208.0	300/250	252.1/211.3	400/350	403.0/400.0	1211.0/1208.0	300/250	115	40
	575-60	518	633	7/6	193.7/162.2	300/ 250	322.8/320.4	968.8/ 966.4	250/200	193.7/162.2	300/250	322.8/320.4	968.8/ 966.4	250/200	115	40
	380-60	342	418	7/6	293.3/246.0	500/ 400	487.4/483.8	1466.4/1462.8	350/300	293.3/246.0	500/400	487.4/483.8	1466.4/1462.8	350/300	115	40
240	230-60	207	253	7/6	504.2/498.2	800/ 800	806.0/800.0	—	600/600	—	—	—	—	—	115	40
	200-60	187	220	7/6	554.7/548.0	800/ 800	925.4/918.8	—	700/700	—	—	—	—	—	115	40
	460-60	414	506	7/6	252.1/249.1	400/ 400	403.0/400.0	1211.0/1208.0	300/300	252.1/249.1	400/400	403.0/400.0	1211.0/1208.0	300/300	115	40
	575-60	518	633	7/6	193.7/191.3	300/ 300	322.8/320.4	968.8/ 966.4	250/250	193.7/191.3	300/300	322.8/320.4	968.8/ 966.4	250/250	115	40
	380-60	342	418	7/6	293.3/289.7	500/ 500	487.4/483.8	1466.4/1462.8	350/350	293.3/289.7	500/500	487.4/483.8	1466.4/1462.8	350/350	115	40
260	460-60	414	506	9/6	343.9/211.3	500/ 350	605.0/400.0	1827.0/1208.0	450/250	343.9/211.3	500/350	605.0/400.0	1827.0/1208.0	450/250	115	40
	575-60	518	633	9/6	263.8/162.2	450/ 250	483.6/320.4	1461.6/ 968.8	350/200	263.8/162.2	450/250	483.6/320.4	1461.6/ 968.8	350/200	115	40
	380-60	342	418	9/6	399.0/246.0	600/ 400	732.7/483.8	2211.7/1462.8	500/300							

Table 6 — 30XA080-500 Electrical Data, Dual Point (Standard Condenser Fan Motors) (cont)

UNIT 30XA	UNIT VOLTAGE			NUMBER OF COND REQ'D	7.5 HP PUMP, 3450 RPM						10 HP PUMP, 3450 RPM						CONTROL CIRCUIT	
	V-Hz (3 Ph)	Supplied			MCA	MOCP	ICF		Rec Fuse Size	MCA	MOCP	ICF		Rec Fuse Size	Voltage 1 Ph, 60 Hz	MCA and MOCP		
		Min	Max				WD	XL				WD	XL					
080	230-60	207	253	3/3	—	—	—	—	—	—	—	—	—	—	115	40		
	200-60	187	220	3/3	—	—	—	—	—	—	—	—	—	—	115	40		
	460-60	414	506	3/3	—	—	—	—	—	—	—	—	—	—	115	40		
	575-60	518	633	3/3	—	—	—	—	—	—	—	—	—	—	115	40		
	380-60	342	418	3/3	—	—	—	—	—	—	—	—	—	—	115	40		
090	230-60	207	253	4/4	182.9/206.1	300/300	348.0/371.2	1034.0/1057.2	225/250	182.9/213.3	300/300	348.0/378.4	1034.0/1064.4	225/250	115	40		
	200-60	187	220	4/4	201.5/227.1	300/350	399.5/425.2	1188.5/1214.2	250/300	201.5/235.1	300/350	399.5/433.2	1188.5/1222.2	250/300	115	40		
	460-60	414	506	4/4	91.4/103.0	150/150	174.0/185.6	517.0/ 528.6	110/125	91.4/106.6	150/150	174.0/189.2	517.0/ 532.2	110/125	115	40		
	575-60	518	633	4/4	70.3/ 79.6	110/125	139.6/148.9	413.6/ 422.9	90/100	70.3/ 82.5	110/125	139.6/151.8	413.6/ 425.8	90/100	115	40		
	380-60	342	418	4/4	106.5/120.5	175/175	210.5/224.6	625.5/ 639.6	125/150	106.5/124.9	175/175	210.5/228.9	625.5/ 643.9	125/150	115	40		
100	230-60	207	253	4/4	199.9/223.1	300/350	372.0/395.2	1114.0/1137.2	250/300	199.9/230.3	300/350	372.0/402.4	1114.0/1144.4	250/300	115	40		
	200-60	187	220	4/4	220.0/245.7	350/400	426.5/452.2	1280.5/1306.2	300/300	220.0/253.6	350/400	426.5/460.2	1280.5/1314.2	300/300	115	40		
	460-60	414	506	4/4	99.9/111.5	150/175	186.0/197.6	557.0/ 568.6	125/150	99.9/115.1	150/175	186.0/201.2	557.0/ 572.2	125/150	115	40		
	575-60	518	633	4/4	76.4/ 85.7	125/125	148.6/157.9	445.6/ 454.9	90/100	76.4/ 88.6	125/125	148.6/160.8	445.6/ 457.8	90/110	115	40		
	380-60	342	418	4/4	116.5/130.6	175/200	225.5/239.6	674.5/ 688.6	150/175	116.5/134.9	175/200	225.5/243.9	674.5/ 692.9	150/175	115	40		
110	230-60	207	253	4/4	241.0/223.1	400/350	372.0/395.2	—	300/300	241.0/230.3	400/350	372.0/402.4	—	300/300	115	40		
	200-60	187	220	4/4	264.9/290.6	450/400	426.5/452.2	—	350/350	264.9/253.6	450/400	426.5/460.2	—	350/300	115	40		
	460-60	414	506	4/4	120.0/111.5	200/175	186.0/197.6	557.0/ 568.6	150/150	120.0/115.1	200/175	186.0/201.2	557.0/ 572.2	150/150	115	40		
	575-60	518	633	4/4	92.5/ 85.7	150/125	148.6/157.9	445.6/ 454.9	110/100	92.5/ 88.6	150/125	148.6/160.8	445.6/ 457.8	110/110	115	40		
	380-60	342	418	4/4	140.2/130.6	225/200	225.5/239.6	674.5/ 688.6	175/175	140.2/134.9	225/200	225.5/243.9	674.5/ 692.9	175/175	115	40		
120	230-60	207	253	4/4	241.0/264.2	400/400	372.0/395.2	—	300/350	241.0/271.4	400/400	372.0/402.4	—	300/350	115	40		
	200-60	187	220	4/4	264.9/290.6	450/450	426.5/452.2	—	350/350	264.9/298.5	450/450	426.5/460.2	—	350/350	115	40		
	460-60	414	506	4/4	120.0/131.6	200/200	186.0/197.6	557.0/ 568.6	150/175	120.0/135.2	200/200	186.0/201.2	557.0/ 572.2	150/175	115	40		
	575-60	518	633	4/4	92.5/101.8	150/150	148.6/157.9	445.6/ 454.9	110/125	92.5/104.6	150/150	148.6/160.8	445.6/ 457.8	110/125	115	40		
	380-60	342	418	4/4	140.2/154.3	225/250	225.5/239.6	674.5/ 688.6	175/200	140.2/158.6	225/250	225.5/243.9	674.5/ 692.9	175/200	115	40		
140	230-60	207	253	6/4	370.0/223.1	600/350	632.0/395.2	—	450/300	370.0/230.3	600/350	632.0/402.4	—	450/300	115	40		
	200-60	187	220	6/4	407.2/245.7	700/400	724.8/452.2	—	500/300	407.2/253.6	700/400	724.8/460.2	—	500/300	115	40		
	460-60	414	506	6/4	185.0/111.5	300/175	316.0/197.6	948.0/ 568.6	225/150	185.0/115.1	300/175	316.0/201.2	948.0/ 572.2	225/150	115	40		
	575-60	518	633	6/4	141.9/ 85.7	225/125	252.4/157.9	758.4/ 454.9	175/100	141.9/ 88.6	225/125	252.4/160.8	758.4/ 457.8	175/110	115	40		
	380-60	342	418	6/4	215.1/130.6	350/200	382.8/239.6	1147.8/ 688.6	300/175	215.1/134.9	350/200	382.8/243.9	1147.8/ 692.9	300/175	115	40		
160	230-60	207	253	6/4	423.5/264.2	700/400	800.0/395.2	—	600/350	423.5/271.4	700/400	800.0/402.4	—	600/350	115	40		
	200-60	187	220	6/4	465.6/290.6	800/450	918.8/452.2	—	600/350	465.6/298.5	800/450	918.8/460.2	—	600/350	115	40		
	460-60	414	506	6/4	211.3/131.6	350/200	400.0/197.6	1208.0/ 568.6	250/175	211.3/135.2	350/200	400.0/201.2	1208.0/ 572.2	250/175	115	40		
	575-60	518	633	6/4	162.2/101.8	250/150	320.4/157.9	966.4/ 454.9	200/125	162.2/104.6	250/150	320.4/160.8	966.4/ 457.8	200/125	115	40		
	380-60	342	418	6/4	246.0/154.3	400/250	483.8/239.6	1462.8/ 688.6	300/200	246.0/158.6	400/250	483.8/243.9	1462.8/ 692.9	300/200	115	40		
180	230-60	207	253	6/6	—	—	—	—	—	—	—	—	—	—	115	40		
	200-60	187	220	6/6	—	—	—	—	—	—	—	—	—	—	115	40		
	460-60	414	506	6/6	—	—	—	—	—	—	—	—	—	—	115	40		
	575-60	518	633	6/6	—	—	—	—	—	—	—	—	—	—	115	40		
	380-60	342	418	6/6	—	—	—	—	—	—	—	—	—	—	115	40		
200	230-60	207	253	6/6	—	—	—	—	—	—	—	—	—	—	115	40		
	200-60	187	220	6/6	—	—	—	—	—	—	—	—	—	—	115	40		
	460-60	414	506	6/6	—	—	—	—	—	—	—	—	—	—	115	40		
	575-60	518	633	6/6	—	—	—	—	—	—	—	—	—	—	115	40		
	380-60	342	418	6/6	—	—	—	—	—	—	—	—	—	—	115	40		
220	230-60	207	253	7/6	—	—	—	—	—	—	—	—	—	—	115	40		
	200-60	187	220	7/6	—	—	—	—	—	—	—	—	—	—	115	40		
	460-60	414	506	7/6	—	—	—	—	—	—	—	—	—	—	115	40		
	575-60	518	633	7/6	—	—	—	—	—	—	—	—	—	—	115	40		
	380-60	342	418	7/6	—	—	—	—	—	—	—	—	—	—	115	40		
240	230-60	207	253	7/6	—	—	—	—	—	—	—	—	—	—	115	40		
	200-60	187	220	7/6	—	—	—	—	—	—	—	—	—	—	115	40		
	460-60	414	506	7/6	—	—	—	—	—	—	—	—	—	—	115	40		
	575-60	518	633	7/6	—	—	—	—	—	—	—	—	—	—	115	40		
	380-60	342	418	7/6	—	—	—	—	—	—	—	—	—	—	115	40		
260	460-60	414	506	9/6	—	—	—	—	—	—	—	—	—	—	115	40		
	575-60	518	633	9/6	—	—	—	—	—	—	—	—	—	—	115	40		
	380-60	342	418	9/6	—	—	—	—	—	—	—	—	—	—	115	40		
280	460-60	414	506	9/7	—	—	—	—	—	—	—	—	—	—	115	40		
	575-60	518	633	9/7	—	—	—	—	—	—	—	—	—	—	115	40		
	380-60	342	418	9/7	—	—	—	—	—	—	—	—	—	—	115	40		
300	460-60	414	506	10/6	—	—	—	—	—	—	—	—	—	—	115	40		
	575-60	518	633	10/6	—	—	—	—	—	—	—	—	—	—	115	40		
	380-60	342	418	10/6	—	—	—	—	—	—	—	—	—	—	115	40		
325	460-60	414	506	9/9	—	—	—	—	—	—	—	—	—	—	115	40		
	575-60	518	633	9/9	—	—	—	—	—	—	—	—	—	—	115	40		
	380-60	342	418	9/9	—	—	—	—	—	—	—	—	—	—	115	40		
350	460-60	414	506	9/9	—	—	—	—	—	—	—	—	—	—	115	40		
	575-60	518	633	9/9	—	—	—	—	—	—	—	—	—	—	115	40		
	380-60	342	418	9/9	—	—	—	—	—	—	—	—	—	—	115	40		
400	460-60	414	506	8/12	—	—	—	—	—	—	—	—	—	—	115	50		
	575-60	518	633	8/12	—	—	—	—	—	—	—	—	—	—	115	50		
	380-60	342	418	8/12	—	—	—	—	—	—	—	—	—	—	115	50		
450	460-60	414	506	8/14	—	—	—	—	—	—	—	—	—	—	115	50		
	575-60	518	633	8/14	—	—	—	—	—	—	—	—	—	—	115	50		
	380-60	342	418	8/14	—	—	—	—	—	—	—	—	—	—	115	50		
500	460-60	414	506	8/14	—	—	—	—	—	—	—	—	—	—	115	50		
	575-60	518	633	8/14	—	—	—	—	—	—	—	—	—	—	115	50		
	380-60	342	418	8/14	—	—	—	—	—	—	—	—	—	—	115	50		

LEGEND

- ICF — Instantaneous Current Flow
- MCA — Minimum Circuit Amps
- MOCP — Maximum Overcurrent Protection
- WD — Wye-Delta
- XL — Across-the-Line

NOTES:

Table 6 — 30XA080-500 Electrical Data, Dual Point (Standard Condenser Fan Motors) (cont)

UNIT 30XA	UNIT VOLTAGE			NUMBER OF COND REQ'D	15 HP PUMP, 3450 RPM					CONTROL CIRCUIT	
	V-Hz (3 Ph)	Supplied			MCA	MOCP	ICF		Rec Fuse Size	Voltage 1 Ph, 60 Hz	MCA and MOCP
		Min	Max				WD	XL			
080	230-60	207	253	3/3	182.9/227.9	300/350	348.0/393.0	1034.0/1079.0	225/300	115	40
	200-60	187	220	3/3	201.5/251.2	300/350	399.5/449.3	1188.5/1238.3	250/300	115	40
	460-60	414	506	3/3	91.4/113.9	150/175	174.0/196.5	517.0/ 539.5	110/150	115	40
	575-60	518	633	3/3	70.3/ 88.3	110/125	139.6/157.6	413.6/ 431.6	90/110	115	40
	380-60	342	418	3/3	106.5/133.7	175/200	210.5/237.8	625.5/ 652.8	125/175	115	40
090	230-60	207	253	4/4	199.9/244.9	300/350	372.0/417.0	1114.0/1159.0	250/300	115	40
	200-60	187	220	4/4	220.0/269.8	350/400	426.5/476.3	1280.5/1330.3	300/350	115	40
	460-60	414	506	4/4	99.9/122.4	150/175	186.0/208.5	557.0/ 579.5	125/150	115	40
	575-60	518	633	4/4	76.4/ 94.4	125/125	148.6/166.6	445.6/ 463.6	90/110	115	40
	380-60	342	418	4/4	116.5/143.8	175/225	225.5/252.8	674.5/ 701.8	150/175	115	40
100	230-60	207	253	4/4	241.0/244.9	400/350	372.0/417.0	—	300/300	115	40
	200-60	187	220	4/4	264.9/269.8	450/400	426.5/476.3	—	350/350	115	40
	460-60	414	506	4/4	120.0/122.4	200/175	186.0/208.5	557.0/ 579.5	150/150	115	40
	575-60	518	633	4/4	92.5/ 94.4	150/125	148.6/166.6	445.6/ 463.6	110/110	115	40
	380-60	342	418	4/4	140.2/143.8	225/225	225.5/252.8	674.5/ 701.8	175/175	115	40
110	230-60	207	253	4/4	241.0/286.0	400/450	372.0/417.0	—	300/350	115	40
	200-60	187	220	4/4	264.9/314.7	450/500	426.5/476.3	—	350/400	115	40
	460-60	414	506	4/4	120.0/142.5	200/225	186.0/208.5	557.0/ 579.5	150/175	115	40
	575-60	518	633	4/4	92.5/110.5	150/175	148.6/166.6	445.6/ 463.6	175/110	115	40
	380-60	342	418	4/4	140.2/167.5	225/250	225.5/252.8	674.5/ 701.8	175/200	115	40
120	230-60	207	253	4/4	370.0/244.9	600/350	632.0/417.0	—	450/300	115	40
	200-60	187	220	4/4	407.2/269.8	700/400	724.8/476.3	—	500/350	115	40
	460-60	414	506	4/4	185.0/122.4	300/175	316.0/208.5	948.0/ 579.5	225/150	115	40
	575-60	518	633	4/4	141.9/ 94.4	225/125	252.4/166.6	758.4/ 463.6	175/110	115	40
	380-60	342	418	4/4	215.1/143.8	350/225	382.8/252.8	1147.8/ 701.8	300/175	115	40
140	230-60	207	253	6/4	423.5/286.0	700/450	800.0/417.0	—	600/350	115	40
	200-60	187	220	6/4	465.6/314.7	800/500	918.8/476.3	—	600/400	115	40
	460-60	414	506	6/4	211.3/142.5	350/225	400.0/208.5	1208.0/ 579.5	250/175	115	40
	575-60	518	633	6/4	162.2/110.5	250/175	320.4/166.6	966.4/ 463.6	200/150	115	40
	380-60	342	418	6/4	246.0/167.5	400/250	483.8/252.8	1462.8/ 701.8	300/200	115	40
160	230-60	207	253	6/4	—	—	—	—	—	115	40
	200-60	187	220	6/4	—	—	—	—	—	115	40
	460-60	414	506	6/4	—	—	—	—	—	115	40
	575-60	518	633	6/4	—	—	—	—	—	115	40
	380-60	342	418	6/4	—	—	—	—	—	115	40
180	230-60	207	253	6/6	—	—	—	—	—	115	40
	200-60	187	220	6/6	—	—	—	—	—	115	40
	460-60	414	506	6/6	—	—	—	—	—	115	40
	575-60	518	633	6/6	—	—	—	—	—	115	40
	380-60	342	418	6/6	—	—	—	—	—	115	40
200	230-60	207	253	6/6	—	—	—	—	—	115	40
	200-60	187	220	6/6	—	—	—	—	—	115	40
	460-60	414	506	6/6	—	—	—	—	—	115	40
	575-60	518	633	6/6	—	—	—	—	—	115	40
	380-60	342	418	6/6	—	—	—	—	—	115	40
220	230-60	207	253	7/6	—	—	—	—	—	115	40
	200-60	187	220	7/6	—	—	—	—	—	115	40
	460-60	414	506	7/6	—	—	—	—	—	115	40
	575-60	518	633	7/6	—	—	—	—	—	115	40
	380-60	342	418	7/6	—	—	—	—	—	115	40
240	230-60	207	253	7/6	—	—	—	—	—	115	40
	200-60	187	220	7/6	—	—	—	—	—	115	40
	460-60	414	506	7/6	—	—	—	—	—	115	40
	575-60	518	633	7/6	—	—	—	—	—	115	40
	380-60	342	418	7/6	—	—	—	—	—	115	40
260	460-60	414	506	9/6	—	—	—	—	—	115	40
	575-60	518	633	9/6	—	—	—	—	—	115	40
	380-60	342	418	9/6	—	—	—	—	—	115	40
280	460-60	414	506	9/7	—	—	—	—	—	115	40
	575-60	518	633	9/7	—	—	—	—	—	115	40
	380-60	342	418	9/7	—	—	—	—	—	115	40
300	460-60	414	506	10/6	—	—	—	—	—	115	40
	575-60	518	633	10/6	—	—	—	—	—	115	40
	380-60	342	418	10/6	—	—	—	—	—	115	40
325	460-60	414	506	9/9	—	—	—	—	—	115	40
	575-60	518	633	9/9	—	—	—	—	—	115	40
	380-60	342	418	9/9	—	—	—	—	—	115	40
350	460-60	414	506	9/9	—	—	—	—	—	115	40
	575-60	518	633	9/9	—	—	—	—	—	115	40
	380-60	342	418	9/9	—	—	—	—	—	115	40
400	460-60	414	506	8/12	—	—	—	—	—	115	50
	575-60	518	633	8/12	—	—	—	—	—	115	50
	380-60	342	418	8/12	—	—	—	—	—	115	50
450	460-60	414	506	8/14	—	—	—	—	—	115	50
	575-60	518	633	8/14	—	—	—	—	—	115	50
	380-60	342	418	8/14	—	—	—	—	—	115	50
500	460-60	414	506	8/14	—	—	—	—	—	115	50
	575-60	518	633	8/14	—	—	—	—	—	115	50
	380-60	342	418	8/14	—	—	—	—	—	115	50

LEGEND

- ICF — Instantaneous Current Flow
- MCA — Minimum Circuit Amps
- MOCP — Maximum Overcurrent Protection
- WD — Wye-Delta
- XL — Across-the-Line

NOTES:

1. Units are suitable for use on electrical systems where voltage supplied to the unit terminals is not below or above the listed minimum and maximum limits. Maximum allowable phase imbalance is: voltage, 2%; amps 10%.
2. Cooler heater is wired into the control circuit so it is always operable as long as the control power supply disconnect is on, even if any safety device is open.
3. For MCA that is less than or equal to 380 amps, 3 conductors are required.

- For MCA between 381-760 amps, 6 conductors are required.
 For MCA between 761-1140 amps, 9 conductors are required.
 For MCA between 1141-1520 amps, 12 conductors are required.
 Calculation of conductors required is based on 75 C copper wire.
4. Wiring for main field supply must be rated 75 C minimum. Use copper for all units.
 - a. Incoming wire size range for the terminal block is no. 4 AWG (American Wire Gauge) to 500 kcmil.
 - b. Incoming wire size range of non-fused disconnect with MCA up to 599.9 amps is 3/0 to 500 kcmil.
 - c. Incoming wire size range of non-fused disconnect with MCA from 600 to 799.9 amps is 1/0 to 500 kcmil.
 - d. Incoming wire size range of non-fused disconnect with MCA from 800 to 1199.9 amps is 250 kcmil to 500 kcmil.
 5. Data provided circuit 1/circuit 2 where there are two circuits.

Table 7 — 30XA140-500 Electrical Data, Single Point (High Ambient Option)

UNIT 30XA	UNIT VOLTAGE			NUMBER OF COND REQ'D	NO HYDRONIC PACKAGE					5 HP PUMP, 3450 RPM					7.5 HP PUMP, 3450 RPM					CONTROL CIRCUIT	
	V-Hz (3 Ph)	Supplied			MCA	MOCP	ICF		Rec Fuse Size	MCA	MOCP	ICF		Rec Fuse Size	MCA	MOCP	ICF		Rec Fuse Size	Voltage 1 PH, 60 Hz	MCA and MOCP
		Min	Max				WD	XL				WD	XL				WD	XL			
140	230-60	207	253	10	562.0	800	838.9	—	700	578.0	800	854.9	—	700	585.2	800	862.1	—	700	115	40
	200-60	187	220	10	618.8	800	952.8	—	700	636.5	800	970.5	—	800	644.4	800	978.5	—	800	115	40
	460-60	414	506	10	281.0	400	419.5	1051.5	350	289.0	400	427.5	1059.5	350	292.6	400	431.1	1063.1	350	115	40
	575-60	518	633	10	216.3	300	332.5	838.5	250	222.7	300	338.9	844.9	250	225.6	300	341.8	847.8	250	115	40
	380-60	342	418	10	328.3	450	504.6	1269.6	400	338.0	450	514.3	1279.3	400	342.3	450	518.7	1283.7	400	115	40
160	230-60	207	253	10	642.7	800	1036.7	—	800	658.7	800	1052.7	—	800	665.9	800	1059.9	—	800	115	40
	200-60	187	220	10	706.9	1000	1179.4	—	800	724.5	1000	1197.1	—	1000	732.5	1000	1205.0	—	1000	115	40
	460-60	414	506	10	320.5	450	518.0	1326.0	400	328.5	450	526.0	1334.0	400	332.1	450	529.6	1337.6	400	115	40
	575-60	518	633	10	247.2	350	412.1	1058.1	300	253.6	350	418.5	1064.5	300	256.5	350	421.4	1067.4	300	115	40
	380-60	342	418	10	374.9	500	622.8	1601.8	450	384.6	500	632.5	1611.5	450	388.9	500	636.8	1615.8	450	115	40
180	230-60	207	253	12	703.9	800	980.8	—	800	—	—	—	—	—	—	—	—	—	—	115	40
	200-60	187	220	12	775.0	1000	1109.1	—	1000	—	—	—	—	—	—	—	—	—	—	115	40
	460-60	414	506	12	351.9	450	490.4	1122.4	400	—	—	—	—	—	—	—	—	—	—	115	40
	575-60	518	633	12	271.1	350	387.3	893.3	300	—	—	—	—	—	—	—	—	—	—	115	40
	380-60	342	418	12	410.8	500	587.2	1352.2	450	—	—	—	—	—	—	—	—	—	—	115	40
200	230-60	207	253	12	795.6	1000	1189.6	—	1000	—	—	—	—	—	—	—	—	—	—	115	40
	200-60	187	220	12	875.0	1200	1347.5	—	1000	—	—	—	—	—	—	—	—	—	—	115	40
	460-60	414	506	12	396.9	500	594.4	1402.4	450	—	—	—	—	—	—	—	—	—	—	115	40
	575-60	518	633	12	305.8	400	470.7	1116.7	350	—	—	—	—	—	—	—	—	—	—	115	40
	380-60	342	418	12	463.8	600	711.7	1690.7	600	—	—	—	—	—	—	—	—	—	—	115	40
220	230-60	207	253	13	876.7	1200	1200.4	—	1000	—	—	—	—	—	—	—	—	—	—	115	40
	200-60	187	220	13	964.6	1200	1359.4	—	1200	—	—	—	—	—	—	—	—	—	—	115	40
	460-60	414	506	13	438.0	600	599.8	1407.8	500	—	—	—	—	—	—	—	—	—	—	115	40
	575-60	518	633	13	337.6	450	475.0	1121.0	400	—	—	—	—	—	—	—	—	—	—	115	40
	380-60	342	418	13	511.5	700	718.3	1697.3	600	—	—	—	—	—	—	—	—	—	—	115	40
240	230-60	207	253	13	933.0	1200	1256.7	—	1200	—	—	—	—	—	—	—	—	—	—	115	40
	200-60	187	220	13	1026.7	1200	1421.6	—	1200	—	—	—	—	—	—	—	—	—	—	115	40
	460-60	414	506	13	466.5	600	628.3	1436.3	600	—	—	—	—	—	—	—	—	—	—	115	40
	575-60	518	633	13	359.5	450	497.0	1143.0	400	—	—	—	—	—	—	—	—	—	—	115	40
	380-60	342	418	13	544.4	700	751.2	1730.2	600	—	—	—	—	—	—	—	—	—	—	115	40
260	460-60	414	506	15	529.1	700	806.6	2028.6	600	—	—	—	—	—	—	—	—	—	—	115	40
	575-60	518	633	15	407.4	500	639.7	1617.7	500	—	—	—	—	—	—	—	—	—	—	115	40
	380-60	342	418	15	616.7	800	969.3	2448.3	700	—	—	—	—	—	—	—	—	—	—	115	40
280	460-60	414	506	16	563.0	800	840.5	2062.5	700	—	—	—	—	—	—	—	—	—	—	115	40
	575-60	518	633	16	433.6	600	665.9	1643.9	500	—	—	—	—	—	—	—	—	—	—	115	40
	380-60	342	418	16	656.2	800	1008.8	2487.8	800	—	—	—	—	—	—	—	—	—	—	115	40
300	460-60	414	506	16	619.6	800	840.5	2062.5	700	—	—	—	—	—	—	—	—	—	—	115	40
	575-60	518	633	16	476.7	600	665.9	1643.9	600	—	—	—	—	—	—	—	—	—	—	115	40
	380-60	342	418	16	722.3	1000	1008.8	2487.8	1000	—	—	—	—	—	—	—	—	—	—	115	40
325	460-60	414	506	18	638.1	800	915.6	2137.6	700	—	—	—	—	—	—	—	—	—	—	115	40
	575-60	518	633	18	491.2	600	723.5	1701.5	600	—	—	—	—	—	—	—	—	—	—	115	40
	380-60	342	418	18	743.0	1000	1095.6	2574.6	1000	—	—	—	—	—	—	—	—	—	—	115	40
350	460-60	414	506	18	694.6	800	915.6	2137.6	800	—	—	—	—	—	—	—	—	—	—	115	40
	575-60	518	633	18	534.2	700	723.5	1701.5	600	—	—	—	—	—	—	—	—	—	—	115	40
	380-60	342	418	18	809.1	1000	1095.6	2574.6	1000	—	—	—	—	—	—	—	—	—	—	115	40

LEGEND

- ICF — Instantaneous Current Flow
- MCA — Minimum Circuit Amps
- MOCP — Maximum Overcurrent Protection
- WD — Wye-Delta
- XL — Across-the-Line

NOTES:

1. Units are suitable for use on electrical systems where voltage supplied to the unit terminals is not below or above the listed minimum and maximum limits. Maximum allowable phase imbalance is: voltage, 2%; amps 10%.
2. Cooler heater is wired into the control circuit so it is always operable as long as the control power supply disconnect is on, even if any safety device is open.
3. For MCA that is less than or equal to 380 amps, 3 conductors are required.

For MCA between 381-760 amps, 6 conductors are required.
 For MCA between 761-1140 amps, 9 conductors are required.
 For MCA between 1141-1520 amps, 12 conductors are required.
 Calculation of conductors required is based on 75 C copper wire.

4. Wiring for main field supply must be rated 75 C minimum. Use copper for all units.
 - a. Incoming wire size range for the terminal block is no. 4 AWG (American Wire Gage) to 500 kcmil.
 - b. Incoming wire size range of non-fused disconnect with MCA up to 599.9 amps is 3/0 to 500 kcmil.
 - c. Incoming wire size range of non-fused disconnect with MCA from 600 to 799.9 amps is 1/0 to 500 kcmil.
 - d. Incoming wire size range of non-fused disconnect with MCA from 800 to 1199.9 amps is 250 kcmil to 500 kcmil.
5. Data provided circuit 1/circuit 2 where there are two circuits.

Table 7 — 30XA140-500 Electrical Data, Single Point (High Ambient Option) (cont)

UNIT 30XA	UNIT VOLTAGE			NUMBER OF COND REQ'D	10 HP PUMP, 3450 RPM					15 HP PUMP, 3450 RPM					CONTROL CIRCUIT	
	V-Hz (3 Ph)	Supplied			MCA	MOCP	ICF		Rec Fuse Size	MCA	MOCP	ICF		Rec Fuse Size	Voltage 1 PH, 60 Hz	MCA and MOCP
		Min	Max				WD	XL				WD	XL			
140	230-60	207	253	10	592.4	800	869.3	—	700	607.0	800	883.9	—	700	115	40
	200-60	187	220	10	652.4	800	986.5	—	800	668.6	800	1002.6	—	800	115	40
	460-60	414	506	10	296.2	400	434.7	1066.7	350	303.5	400	442.0	1074.0	350	115	40
	575-60	518	633	10	228.4	300	344.6	850.6	300	234.3	300	350.5	856.5	300	115	40
	380-60	342	418	10	346.7	450	523.0	1288.0	400	355.5	500	531.9	1296.9	400	115	40
160	230-60	207	253	10	673.1	800	1067.1	—	800	687.7	800	1081.7	—	800	115	40
	200-60	187	220	10	740.5	1000	1213.0	—	1000	756.6	1000	1229.1	—	1000	115	40
	460-60	414	506	10	335.7	450	533.2	1341.2	400	343.0	450	540.5	1348.5	400	115	40
	575-60	518	633	10	259.4	350	424.3	1070.3	300	265.2	350	430.1	1076.1	300	115	40
	380-60	342	418	10	393.3	500	641.2	1620.2	450	402.1	500	650.0	1629.0	450	115	40
180	230-60	207	253	12	—	—	—	—	—	—	—	—	—	—	115	40
	200-60	187	220	12	—	—	—	—	—	—	—	—	—	—	115	40
	460-60	414	506	12	—	—	—	—	—	—	—	—	—	—	115	40
	575-60	518	633	12	—	—	—	—	—	—	—	—	—	—	115	40
	380-60	342	418	12	—	—	—	—	—	—	—	—	—	—	115	40
200	230-60	207	253	12	—	—	—	—	—	—	—	—	—	—	115	40
	200-60	187	220	12	—	—	—	—	—	—	—	—	—	—	115	40
	460-60	414	506	12	—	—	—	—	—	—	—	—	—	—	115	40
	575-60	518	633	12	—	—	—	—	—	—	—	—	—	—	115	40
	380-60	342	418	12	—	—	—	—	—	—	—	—	—	—	115	40
220	230-60	207	253	13	—	—	—	—	—	—	—	—	—	—	115	40
	200-60	187	220	13	—	—	—	—	—	—	—	—	—	—	115	40
	460-60	414	506	13	—	—	—	—	—	—	—	—	—	—	115	40
	575-60	518	633	13	—	—	—	—	—	—	—	—	—	—	115	40
	380-60	342	418	13	—	—	—	—	—	—	—	—	—	—	115	40
240	230-60	207	253	13	—	—	—	—	—	—	—	—	—	—	115	40
	200-60	187	220	13	—	—	—	—	—	—	—	—	—	—	115	40
	460-60	414	506	13	—	—	—	—	—	—	—	—	—	—	115	40
	380-60	342	418	13	—	—	—	—	—	—	—	—	—	—	115	40
260	460-60	414	506	15	—	—	—	—	—	—	—	—	—	—	115	40
	575-60	518	633	15	—	—	—	—	—	—	—	—	—	—	115	40
	380-60	342	418	15	—	—	—	—	—	—	—	—	—	—	115	40
280	460-60	414	506	16	—	—	—	—	—	—	—	—	—	—	115	40
	575-60	518	633	16	—	—	—	—	—	—	—	—	—	—	115	40
	380-60	342	418	16	—	—	—	—	—	—	—	—	—	—	115	40
300	460-60	414	506	16	—	—	—	—	—	—	—	—	—	—	115	40
	575-60	518	633	16	—	—	—	—	—	—	—	—	—	—	115	40
	380-60	342	418	16	—	—	—	—	—	—	—	—	—	—	115	40
325	460-60	414	506	18	—	—	—	—	—	—	—	—	—	—	115	40
	575-60	518	633	18	—	—	—	—	—	—	—	—	—	—	115	40
	380-60	342	418	18	—	—	—	—	—	—	—	—	—	—	115	40
350	460-60	414	506	18	—	—	—	—	—	—	—	—	—	—	115	40
	575-60	518	633	18	—	—	—	—	—	—	—	—	—	—	115	40
	380-60	342	418	18	—	—	—	—	—	—	—	—	—	—	115	40

LEGEND

- ICF — Instantaneous Current Flow
- MCA — Minimum Circuit Amps
- MOCP — Maximum Overcurrent Protection
- WD — Wye-Delta
- XL — Across-the-Line

NOTES:

1. Units are suitable for use on electrical systems where voltage supplied to the unit terminals is not below or above the listed minimum and maximum limits. Maximum allowable phase imbalance is: voltage, 2%; amps 10%.
2. Cooler heater is wired into the control circuit so it is always operable as long as the control power supply disconnect is on, even if any safety device is open.
3. For MCA that is less than or equal to 380 amps, 3 conductors are required.

- For MCA between 381-760 amps, 6 conductors are required.
 For MCA between 761-1140 amps, 9 conductors are required.
 For MCA between 1141-1520 amps, 12 conductors are required.
 Calculation of conductors required is based on 75 C copper wire.
4. Wiring for main field supply must be rated 75 C minimum. Use copper for all units.
 - a. Incoming wire size range for the terminal block is no. 4 AWG (American Wire Gage) to 500 kcmil.
 - b. Incoming wire size range of non-fused disconnect with MCA up to 599.9 amps is 3/0 to 500 kcmil.
 - c. Incoming wire size range of non-fused disconnect with MCA from 600 to 799.9 amps is 1/0 to 500 kcmil.
 - d. Incoming wire size range of non-fused disconnect with MCA from 800 to 1199.9 amps is 250 kcmil to 500 kcmil.
 5. Data provided circuit 1/circuit 2 where there are two circuits.

Table 8 — 30XA140-500 Electrical Data, Dual Point (High Ambient Option)

UNIT 30XA	UNIT VOLTAGE		NUMBER OF COND REQ'D	NO HYDRONIC PACKAGE					5 HP PUMP, 3450 RPM					CONTROL CIRCUIT		
	V-Hz (3 Ph)	Supplied		MCA	MOCP	ICF		Rec Fuse Size	MCA	MOCP	ICF		Rec Fuse Size	Voltage 1 PH, 60 Hz	MCA and MOCP	
		Min				Max	WD				XL	WD				XL
140	230-60	207	253	6/4	383.8/211.9	600/ 300	660.8/391.2	—	450/250	383.8/227.9	600/350	660.8/407.2	—	450/300	115	40
	200-60	187	220	6/4	422.6/233.3	700/ 350	756.7/447.8	—	500/300	422.6/251.0	700/350	756.7/465.5	—	500/300	115	40
	460-60	414	506	6/4	191.9/105.9	300/ 150	330.4/195.6	962.4/ 566.6	225/125	191.9/113.9	300/175	330.4/203.6	962.4/574.6	225/150	115	40
	575-60	518	633	6/4	147.7/ 81.4	225/ 125	263.9/156.3	769.9/ 453.3	175/100	147.7/ 87.8	225/125	263.9/162.7	769.9/459.7	175/110	115	40
	380-60	342	418	6/4	223.9/124.0	350/ 200	400.2/237.1	1165.2/ 686.1	300/150	223.9/133.7	350/200	400.2/246.8	1165.2/695.8	300/175	115	40
160	230-60	207	253	6/4	434.8/249.1	700/ 400	828.8/391.2	—	600/300	434.8/265.1	700/400	828.8/407.2	—	600/350	115	40
	200-60	187	220	6/4	478.1/273.9	800/ 450	950.7/447.8	—	600/350	478.1/291.6	800/450	950.7/465.5	—	600/350	115	40
	460-60	414	506	6/4	216.9/124.1	350/ 200	414.4/195.6	1222.4/ 566.6	300/150	216.9/132.1	350/200	414.4/203.6	1222.4/574.6	300/175	115	40
	575-60	518	633	6/4	167.0/ 95.9	250/ 150	331.9/156.3	977.9/ 453.3	200/125	167.0/102.3	250/150	331.9/162.7	977.9/459.7	200/125	115	40
	380-60	342	418	6/4	253.3/145.4	400/ 225	501.2/237.1	1480.2/ 686.1	300/175	253.3/155.1	400/250	501.2/246.8	1480.2/695.8	300/200	115	40
180	230-60	207	253	6/6	383.8/383.8	600/ 600	660.8/660.8	—	450/450	—	—	—	—	—	115	40
	200-60	187	220	6/6	422.6/422.6	700/ 700	756.7/756.7	—	500/500	—	—	—	—	—	115	40
	460-60	414	506	6/6	191.9/191.9	300/ 300	330.4/330.4	962.4/ 962.4	225/225	191.9/191.9	300/300	330.4/330.4	962.4/ 962.4	225/225	115	40
	575-60	518	633	6/6	147.7/147.7	225/ 225	263.9/263.9	769.9/ 769.9	175/175	147.7/147.7	225/225	263.9/263.9	769.9/ 769.9	175/175	115	40
	380-60	342	418	6/6	223.9/223.9	350/ 350	400.2/400.2	1165.2/1165.2	300/300	223.9/223.9	350/350	400.2/400.2	1165.2/1165.2	300/300	115	40
200	230-60	207	253	6/6	434.8/434.8	700/ 700	828.8/828.8	—	600/600	—	—	—	—	—	115	40
	200-60	187	220	6/6	478.1/478.1	800/ 800	950.7/950.7	—	600/600	—	—	—	—	—	115	40
	460-60	414	506	6/6	216.9/216.9	350/ 350	414.4/414.4	1222.4/1222.4	300/300	216.9/216.9	350/350	414.4/414.4	1222.4/1222.4	300/300	115	40
	575-60	518	633	6/6	167.0/167.0	250/ 250	331.9/331.9	977.9/ 977.9	200/200	167.0/167.0	250/250	331.9/331.9	977.9/ 977.9	200/200	115	40
	380-60	342	418	6/6	253.3/253.3	400/ 400	501.2/501.2	1480.2/1480.2	300/300	253.3/253.3	400/400	501.2/501.2	1480.2/1480.2	300/300	115	40
220	230-60	207	253	7/6	515.9/434.8	800/ 700	839.6/828.8	—	700/600	—	—	—	—	—	115	40
	200-60	187	220	7/6	567.8/478.1	800/ 800	962.6/950.7	—	700/600	—	—	—	—	—	115	40
	460-60	414	506	7/6	258.0/216.9	400/ 350	419.8/414.4	1227.8/1222.4	350/300	258.0/216.9	400/350	419.8/414.4	1227.8/1222.4	350/300	115	40
	575-60	518	633	7/6	198.8/167.0	300/ 250	336.2/331.9	982.2/ 977.9	250/200	198.8/167.0	300/250	336.2/331.9	982.2/ 977.9	250/200	115	40
	380-60	342	418	7/6	301.0/253.3	500/ 400	507.8/501.2	1486.8/1480.2	400/300	301.0/253.3	500/400	507.8/501.2	1486.8/1480.2	400/300	115	40
240	230-60	207	253	7/6	515.9/505.1	800/ 800	839.6/828.8	—	700/600	—	—	—	—	—	115	40
	200-60	187	220	7/6	567.8/555.8	800/ 800	962.6/950.7	—	700/700	—	—	—	—	—	115	40
	460-60	414	506	7/6	258.0/252.6	400/ 400	419.8/414.4	1227.8/1222.4	350/300	258.0/252.6	400/400	419.8/414.4	1227.8/1222.4	350/300	115	40
	575-60	518	633	7/6	198.8/194.5	300/ 300	336.2/331.9	982.2/ 977.9	250/250	198.8/194.5	300/300	336.2/331.9	982.2/ 977.9	250/250	115	40
	380-60	342	418	7/6	301.0/294.5	500/ 450	507.8/501.2	1486.8/1480.2	400/350	301.0/294.5	500/450	507.8/501.2	1486.8/1480.2	400/350	115	40
260	460-60	414	506	9/6	349.1/216.9	500/ 350	626.6/614.4	1848.6/1222.4	450/300	349.1/216.9	500/350	626.6/614.4	1848.6/1222.4	450/300	115	40
	575-60	518	633	9/6	268.6/167.0	450/ 250	500.9/331.9	1478.9/ 977.9	350/200	268.6/167.0	450/250	500.9/331.9	1478.9/ 977.9	350/200	115	40
	380-60	342	418	9/6	406.2/253.3	600/ 400	758.8/501.2	2237.8/1480.2	500/300	406.2/253.3	600/400	758.8/501.2	2237.8/1480.2	500/300	115	40
280	460-60	414	506	9/7	349.1/258.0	500/ 400	626.6/614.4	1848.6/1227.8	450/350	349.1/258.0	500/400	626.6/614.4	1848.6/1227.8	450/350	115	40
	575-60	518	633	9/7	268.6/198.8	450/ 300	500.9/336.2	1478.9/ 982.2	350/250	268.6/198.8	450/300	500.9/336.2	1478.9/ 982.2	350/250	115	40
	380-60	342	418	9/7	406.2/301.0	600/ 500	758.8/507.8	2237.8/1486.8	500/400	406.2/301.0	600/500	758.8/507.8	2237.8/1486.8	500/400	115	40
300	460-60	414	506	10/6	411.0/252.6	600/ 400	632.0/414.4	1854.0/1222.4	500/300	411.0/252.6	600/400	632.0/414.4	1854.0/1222.4	500/300	115	40
	575-60	518	633	10/6	315.9/194.5	500/ 300	505.2/331.9	1483.2/ 977.9	400/250	315.9/194.5	500/300	505.2/331.9	1483.2/ 977.9	400/250	115	40
	380-60	342	418	10/6	478.9/294.5	800/ 450	765.4/501.2	2244.4/1480.2	600/350	478.9/294.5	800/450	765.4/501.2	2244.4/1480.2	600/350	115	40
325	460-60	414	506	9/9	349.1/349.1	500/ 500	626.6/626.6	1848.6/1848.6	450/450	349.1/349.1	500/500	626.6/626.6	1848.6/1848.6	450/450	115	40
	575-60	518	633	9/9	268.6/268.6	450/ 450	500.9/500.9	1478.9/1478.9	350/350	268.6/268.6	450/450	500.9/500.9	1478.9/1478.9	350/350	115	40
	380-60	342	418	9/9	406.2/406.2	600/ 600	758.8/758.8	2237.8/2237.8	500/500	406.2/406.2	600/600	758.8/758.8	2237.8/2237.8	500/500	115	40
350	460-60	414	506	9/9	405.6/349.1	600/ 500	626.6/626.6	1848.6/1848.6	450/450	405.6/349.1	600/500	626.6/626.6	1848.6/1848.6	450/450	115	40
	575-60	518	633	9/9	311.6/268.6	500/ 450	500.9/500.9	1478.9/1478.9	400/350	311.6/268.6	500/450	500.9/500.9	1478.9/1478.9	400/350	115	40
	380-60	342	418	9/9	472.4/406.2	800/ 600	758.8/758.8	2237.8/2237.8	600/500	472.4/406.2	800/600	758.8/758.8	2237.8/2237.8	600/500	115	40
400	460-60	414	506	8/12	343.7/461.1	500/ 600	621.2/622.9	1843.2/1430.9	450/600	343.7/461.1	500/600	621.2/622.9	1843.2/1430.9	450/600	115	50
	575-60	518	633	8/12	264.2/355.2	400/ 450	496.6/492.7	1474.6/1138.7	350/400	264.2/355.2	400/450	496.6/492.7	1474.6/1138.7	350/400	115	50
	380-60	342	418	8/12	399.7/537.9	600/ 700	752.3/744.6	2231.3/1723.6	500/600	399.7/537.9	600/700	752.3/744.6	2231.3/1723.6	500/600	115	50
450	460-60	414	506	8/14	400.2/560.2	600/ 800	621.2/781.2	1843.2/2003.2	500/700	400.2/560.2	600/800	621.2/781.2	1843.2/2003.2	500/700	115	50
	575-60	518	633	8/14	307.3/430.7	500/ 600	496.6/619.9	1474.6/1597.9	400/500	307.3/430.7	500/600	496.6/619.9	1474.6/1597.9	400/500	115	50
	380-60	342	418	8/14	465.8/652.8	700/ 800	752.3/939.2	2231.3/2418.2	600/800	465.8/652.8	700/800	752.3/939.2	2231.3/2418.2	600/800	115	50
500	460-60	414	506	8/14	400.2/608.8	600/ 800	621.2/829.7	1843.2/2051.7	500/700	400.2/608.8	600/800	621.2/829.7	1843.2/2051.7	500/700	115	50
	575-60	518	633	8/14	307.3/468.0	500/ 600	496.6/657.3	1474.6/1635.3	400/600	307.3/468.0	500/600	496.6/657.3	1474.6/1635.3	400/600	115	50
	380-60	342	418	8/14	465.8/709.3	700/1000	752.3/995.7	2231.3/2474.7	600/800	465.8/709.3	700/1000	752.3/995.7	2231.3/2474.7	600/800	115	50

LEGEND

- ICF — Instantaneous Current Flow
- MCA — Minimum Circuit Amps
- MOCP — Maximum Overcurrent Protection
- WD — Wye-Delta
- XL — Across-the-Line

NOTES:

1. Units are suitable for use on electrical systems where voltage supplied to the unit terminals is not below or above the listed minimum and maximum limits. Maximum allowable phase imbalance is: voltage, 2%; amps 10%.
2. Cooler heater is wired into the control circuit so it is always operable as long as the control power supply disconnect is on, even if any safety device is open.
3. For MCA that is less than or

Table 8 — 30XA140-500 Electrical Data, Dual Point (High Ambient Option) (cont)

UNIT 30XA	UNIT VOLTAGE		NUMBER OF COND REQ'D	7.5 HP PUMP, 3450 RPM						10 HP PUMP, 3450 RPM						CONTROL CIRCUIT	
	V-Hz (3 Ph)	Supplied		MCA	MOCP	ICF		Rec Fuse Size	MCA	MOCP	ICF		Rec Fuse Size	Voltage 1 PH, 60 Hz	MCA and MOCP		
		Min				Max	WD				XL	WD				XL	
140	230-60	207	253	6/4	383.8/235.1	600/350	660.8/414.4	—	450/300	383.8/242.3	600/350	660.8/421.6	—	450/300	115	40	
	200-60	187	220	6/4	422.6/259.0	700/400	756.7/473.4	—	500/300	422.6/266.9	700/400	756.7/481.4	—	500/350	115	40	
	460-60	414	506	6/4	191.9/117.5	300/175	330.4/207.2	962.4/578.2	225/150	191.9/121.1	300/175	330.4/210.8	962.4/581.8	225/150	115	40	
	575-60	518	633	6/4	147.7/ 90.7	225/125	263.9/165.6	769.9/462.6	175/110	147.7/ 93.5	225/125	263.9/168.4	769.9/465.4	175/110	115	40	
	380-60	342	418	6/4	223.9/138.0	350/200	400.2/251.2	1165.2/700.2	300/175	223.9/142.4	350/200	400.2/255.5	1165.2/704.5	300/175	115	40	
160	230-60	207	253	6/4	434.8/272.3	700/400	828.8/414.4	—	600/350	434.8/279.5	700/400	828.8/421.6	—	600/350	115	40	
	200-60	187	220	6/4	478.1/299.6	800/450	950.7/473.4	—	600/350	478.1/307.6	800/450	950.7/481.4	—	600/400	115	40	
	460-60	414	506	6/4	218.9/135.7	350/200	414.4/207.2	1222.4/578.2	300/175	218.9/139.3	350/200	414.4/210.8	1222.4/581.8	300/175	115	40	
	575-60	518	633	6/4	167.0/105.2	250/150	331.9/165.6	977.9/462.6	200/125	167.0/108.1	250/150	331.9/168.4	977.9/465.4	200/125	115	40	
	380-60	342	418	6/4	253.3/159.5	400/250	501.2/251.2	1480.2/700.2	300/200	253.3/163.8	400/250	501.2/255.5	1480.2/704.5	300/200	115	40	
180	230-60	207	253	6/6	—	—	—	—	—	—	—	—	—	—	115	40	
	200-60	187	220	6/6	—	—	—	—	—	—	—	—	—	—	115	40	
	460-60	414	506	6/6	—	—	—	—	—	—	—	—	—	—	115	40	
	575-60	518	633	6/6	—	—	—	—	—	—	—	—	—	—	115	40	
	380-60	342	418	6/6	—	—	—	—	—	—	—	—	—	—	115	40	
200	230-60	207	253	6/6	—	—	—	—	—	—	—	—	—	—	115	40	
	200-60	187	220	6/6	—	—	—	—	—	—	—	—	—	—	115	40	
	460-60	414	506	6/6	—	—	—	—	—	—	—	—	—	—	115	40	
	575-60	518	633	6/6	—	—	—	—	—	—	—	—	—	—	115	40	
	380-60	342	418	6/6	—	—	—	—	—	—	—	—	—	—	115	40	
220	230-60	207	253	7/6	—	—	—	—	—	—	—	—	—	—	115	40	
	200-60	187	220	7/6	—	—	—	—	—	—	—	—	—	—	115	40	
	460-60	414	506	7/6	—	—	—	—	—	—	—	—	—	—	115	40	
	575-60	518	633	7/6	—	—	—	—	—	—	—	—	—	—	115	40	
	380-60	342	418	7/6	—	—	—	—	—	—	—	—	—	—	115	40	
240	230-60	207	253	7/6	—	—	—	—	—	—	—	—	—	—	115	40	
	200-60	187	220	7/6	—	—	—	—	—	—	—	—	—	—	115	40	
	460-60	414	506	7/6	—	—	—	—	—	—	—	—	—	—	115	40	
	575-60	518	633	7/6	—	—	—	—	—	—	—	—	—	—	115	40	
	380-60	342	418	7/6	—	—	—	—	—	—	—	—	—	—	115	40	
260	460-60	414	506	9/6	—	—	—	—	—	—	—	—	—	—	115	40	
	575-60	518	633	9/6	—	—	—	—	—	—	—	—	—	—	115	40	
	380-60	342	418	9/6	—	—	—	—	—	—	—	—	—	—	115	40	
280	460-60	414	506	9/7	—	—	—	—	—	—	—	—	—	—	115	40	
	575-60	518	633	9/7	—	—	—	—	—	—	—	—	—	—	115	40	
	380-60	342	418	9/7	—	—	—	—	—	—	—	—	—	—	115	40	
300	460-60	414	506	10/6	—	—	—	—	—	—	—	—	—	—	115	40	
	575-60	518	633	10/6	—	—	—	—	—	—	—	—	—	—	115	40	
	380-60	342	418	10/6	—	—	—	—	—	—	—	—	—	—	115	40	
325	460-60	414	506	9/9	—	—	—	—	—	—	—	—	—	—	115	40	
	575-60	518	633	9/9	—	—	—	—	—	—	—	—	—	—	115	40	
	380-60	342	418	9/9	—	—	—	—	—	—	—	—	—	—	115	40	
350	460-60	414	506	9/9	—	—	—	—	—	—	—	—	—	—	115	40	
	575-60	518	633	9/9	—	—	—	—	—	—	—	—	—	—	115	40	
	380-60	342	418	9/9	—	—	—	—	—	—	—	—	—	—	115	40	
400	460-60	414	506	8/12	—	—	—	—	—	—	—	—	—	—	115	50	
	575-60	518	633	8/12	—	—	—	—	—	—	—	—	—	—	115	50	
	380-60	342	418	8/12	—	—	—	—	—	—	—	—	—	—	115	50	
450	460-60	414	506	8/14	—	—	—	—	—	—	—	—	—	—	115	50	
	575-60	518	633	8/14	—	—	—	—	—	—	—	—	—	—	115	50	
	380-60	342	418	8/14	—	—	—	—	—	—	—	—	—	—	115	50	
500	460-60	414	506	8/14	—	—	—	—	—	—	—	—	—	—	115	50	
	575-60	518	633	8/14	—	—	—	—	—	—	—	—	—	—	115	50	
	380-60	342	418	8/14	—	—	—	—	—	—	—	—	—	—	115	50	

LEGEND

- ICF — Instantaneous Current Flow
- MCA — Minimum Circuit Amps
- MOCP — Maximum Overcurrent Protection
- WD — Wye-Delta
- XL — Across-the-Line

NOTES:

1. Units are suitable for use on electrical systems where voltage supplied to the unit terminals is not below or above the listed minimum and maximum limits. Maximum allowable phase imbalance is: voltage, 2%; amps 10%.
2. Cooler heater is wired into the control circuit so it is always operable as long as the control power supply disconnect is on, even if any safety device is open.
3. For MCA that is less than or equal to 380 amps, 3 conductors are required.

- For MCA between 381-760 amps, 6 conductors are required.
 For MCA between 761-1140 amps, 9 conductors are required.
 For MCA between 1141-1520 amps, 12 conductors are required.
 Calculation of conductors required is based on 75 C copper wire.
4. Wiring for main field supply must be rated 75 C minimum. Use copper for all units.
 - a. Incoming wire size range for the terminal block is no. 4 AWG (American Wire Gage) to 500 kcmil.
 - b. Incoming wire size range of non-fused disconnect with MCA up to 599.9 amps is 3/0 to 500 kcmil.
 - c. Incoming wire size range of non-fused disconnect with MCA from 600 to 799.9 amps is 1/0 to 500 kcmil.
 - d. Incoming wire size range of non-fused disconnect with MCA from 800 to 1199.9 amps is 250 kcmil to 500 kcmil.
 5. Data provided circuit 1/circuit 2 where there are two circuits.

Table 8 — 30XA140-500 Electrical Data, Dual Point (High Ambient Option) (cont)

UNIT 30XA	UNIT VOLTAGE			NUMBER OF COND REQ'D	15 HP PUMP, 3450 RPM					CONTROL CIRCUIT	
	V-Hz (3 Ph)	Supplied			MCA	MOCP	ICF		Rec Fuse Size	Voltage 1 PH, 60 Hz	MCA and MOCP
		Min	Max				WD	XL			
140	230-60	207	253	6/4	383.8/256.9	600/350	660.8/436.2	—	450/300	115	40
	200-60	187	220	6/4	422.6/283.1	700/400	756.7/497.5	—	500/350	115	40
	460-60	414	506	6/4	191.9/128.4	300/175	330.4/218.1	962.4/589.1	225/150	115	40
	575-60	518	633	6/4	147.7/ 99.4	225/150	263.9/174.3	769.9/471.3	175/125	115	40
	380-60	342	418	6/4	223.9/151.2	350/225	400.2/264.4	1165.2/713.4	300/175	115	40
160	230-60	207	253	6/4	434.8/294.1	700/450	828.8/436.2	—	600/350	115	40
	200-60	187	220	6/4	478.1/323.7	800/500	950.7/497.5	—	600/400	115	40
	460-60	414	506	6/4	216.9/146.6	350/225	414.4/218.1	1222.4/589.1	300/175	115	40
	575-60	518	633	6/4	167.0/113.9	250/175	331.9/174.3	977.9/471.3	200/150	115	40
	380-60	342	418	6/4	253.3/172.7	400/250	501.2/264.4	1480.2/713.4	300/200	115	40
180	230-60	207	253	6/6	—	—	—	—	—	115	40
	200-60	187	220	6/6	—	—	—	—	—	115	40
	460-60	414	506	6/6	—	—	—	—	—	115	40
	575-60	518	633	6/6	—	—	—	—	—	115	40
	380-60	342	418	6/6	—	—	—	—	—	115	40
200	230-60	207	253	6/6	—	—	—	—	—	115	40
	200-60	187	220	6/6	—	—	—	—	—	115	40
	460-60	414	506	6/6	—	—	—	—	—	115	40
	575-60	518	633	6/6	—	—	—	—	—	115	40
	380-60	342	418	6/6	—	—	—	—	—	115	40
220	230-60	207	253	7/6	—	—	—	—	—	115	40
	200-60	187	220	7/6	—	—	—	—	—	115	40
	460-60	414	506	7/6	—	—	—	—	—	115	40
	575-60	518	633	7/6	—	—	—	—	—	115	40
	380-60	342	418	7/6	—	—	—	—	—	115	40
240	230-60	207	253	7/6	—	—	—	—	—	115	40
	200-60	187	220	7/6	—	—	—	—	—	115	40
	460-60	414	506	7/6	—	—	—	—	—	115	40
	575-60	518	633	7/6	—	—	—	—	—	115	40
	380-60	342	418	7/6	—	—	—	—	—	115	40
260	460-60	414	506	9/6	—	—	—	—	—	115	40
	575-60	518	633	9/6	—	—	—	—	—	115	40
	380-60	342	418	9/6	—	—	—	—	—	115	40
280	460-60	414	506	9/7	—	—	—	—	—	115	40
	575-60	518	633	9/7	—	—	—	—	—	115	40
	380-60	342	418	9/7	—	—	—	—	—	115	40
300	460-60	414	506	10/6	—	—	—	—	—	115	40
	575-60	518	633	10/6	—	—	—	—	—	115	40
	380-60	342	418	10/6	—	—	—	—	—	115	40
325	460-60	414	506	9/9	—	—	—	—	—	115	40
	575-60	518	633	9/9	—	—	—	—	—	115	40
	380-60	342	418	9/9	—	—	—	—	—	115	40
350	460-60	414	506	9/9	—	—	—	—	—	115	40
	575-60	518	633	9/9	—	—	—	—	—	115	40
	380-60	342	418	9/9	—	—	—	—	—	115	40
400	460-60	414	506	8/12	—	—	—	—	—	115	50
	575-60	518	633	8/12	—	—	—	—	—	115	50
	380-60	342	418	8/12	—	—	—	—	—	115	50
450	460-60	414	506	8/14	—	—	—	—	—	115	50
	575-60	518	633	8/14	—	—	—	—	—	115	50
	380-60	342	418	8/14	—	—	—	—	—	115	50
500	460-60	414	506	8/14	—	—	—	—	—	115	50
	575-60	518	633	8/14	—	—	—	—	—	115	50
	380-60	342	418	8/14	—	—	—	—	—	115	50

LEGEND

- ICF — Instantaneous Current Flow
- MCA — Minimum Circuit Amps
- MOCP — Maximum Overcurrent Protection
- WD — Wye-Delta
- XL — Across-the-Line

NOTES:

1. Units are suitable for use on electrical systems where voltage supplied to the unit terminals is not below or above the listed minimum and maximum limits. Maximum allowable phase imbalance is: voltage, 2%; amps 10%.
2. Cooler heater is wired into the control circuit so it is always operable as long as the control power supply disconnect is on, even if any safety device is open.
3. For MCA that is less than or equal to 380 amps, 3 conductors are required.

For MCA between 381-760 amps, 6 conductors are required.
 For MCA between 761-1140 amps, 9 conductors are required.
 For MCA between 1141-1520 amps, 12 conductors are required.

Calculation of conductors required is based on 75 C copper wire.

4. Wiring for main field supply must be rated 75 C minimum. Use copper for all units.
 - a. Incoming wire size range for the terminal block is no. 4 AWG (American Wire Gage) to 500 kcmil.
 - b. Incoming wire size range of non-fused disconnect with MCA up to 599.9 amps is 3/0 to 500 kcmil.
 - c. Incoming wire size range of non-fused disconnect with MCA from 600 to 799.9 amps is 1/0 to 500 kcmil.
 - d. Incoming wire size range of non-fused disconnect with MCA from 800 to 1199.9 amps is 250 kcmil to 500 kcmil.
5. Data provided circuit 1/circuit 2 where there are two circuits.

Table 9 — Power and Control Connections

30XA	VOLTAGE 3 PH 60 Hz	POWER AND CONTROL CONNECTIONS					
		COMBI*		PEB1†		PEB2†	
		Power	Control	Power	Control	Power	Control
080 090 100 110 120	200	Circuit 1 (& 2)**	Yes				
	230	Circuit 1 (& 2)	Yes				
	380	Circuit 1 (& 2)	Yes				
	460	Circuit 1 (& 2)	Yes				
	575	Circuit 1 (& 2)	Yes				
140 160 180 200	200	Circuit 1 (& 2)	No		Yes		
	230	Circuit 1 (& 2)	No		Yes		
	380			Circuit 1 (& 2)	Yes		
	460			Circuit 1 (& 2)	Yes		
	575			Circuit 1 (& 2)	Yes		
220 240	200				Yes	Circuit 1 (& 2)	No
	230				Yes	Circuit 1 (& 2)	No
	380			Circuit 1 (& 2)	Yes		
	460			Circuit 1 (& 2)	Yes		
	575			Circuit 1 (& 2)	Yes		
260 280 300 325 350	200						
	230						
	380			Circuit 1 (& 2)	Yes		
	460			Circuit 1 (& 2)	Yes		
	575			Circuit 1 (& 2)	Yes		
400 450 500	200						
	230						
	380			Circuit 1	No	Circuit 2	Yes
	460			Circuit 1	No	Circuit 2	Yes
	575			Circuit 1	No	Circuit 2	Yes

*COMBI box is located at the end of the unit.

†PEB1 and PEB2 boxes are located on the side of the unit. If both boxes are used, the one on the left (viewing from the front of the boxes) is PEB1.

**For dual incoming power.

Shaded area means that box is not used on this model.

NOTE: Shaded portions of Table indicate that the power and control connection is not available.

Table 10 — Compressor and Fan Electrical Data

30XA UNIT SIZE	UNIT VOLTAGE V-Hz (3 Ph, 60 Hz)	NUMBER OF COND FANS*	CONDENSER FANS		COMPRESSOR											
					A				B				C			
			FLA		LRA (All Units)		RLA		LRA (All Units)		RLA		LRA (All Units)		RLA	
			High Ambient Temp Cond. Fans (1140 rpm)	Standard Cond. Fans (850 rpm)	XL	WD	High Ambient Temp Cond. Fans (1140 rpm)	Standard Cond. Fans (850 rpm)	XL	WD	High Ambient Temp Cond. Fans (1140 rpm)	Standard Cond. Fans (850 rpm)	XL	WD	High Ambient Temp Cond. Fans (1140 rpm)	Standard Cond. Fans (850 rpm)
080	200	3/3	11.9	6.6	1081.0	345.0	130.9	136.8	1081.0	345.0	130.9	136.8	—	—	—	—
	230	3/3	10.8	6.0	940.0	300.0	118.9	124.2	940.0	300.0	118.9	124.2	—	—	—	—
	380	3/3	6.5	3.6	569.0	182.0	68.8	71.9	569.0	182.0	68.8	71.9	—	—	—	—
	460	3/3	5.5	3.0	470.0	150.0	59.4	62.1	470.0	150.0	59.4	62.1	—	—	—	—
	575	3/3	4.3	2.4	376.0	120.0	45.4	47.5	376.0	120.0	45.4	47.5	—	—	—	—
090	200	4/4	11.9	6.6	1081.0	345.0	134.3	140.0	1081.0	345.0	134.3	140.0	—	—	—	—
	230	4/4	10.8	6.0	940.0	300.0	122.0	127.1	940.0	300.0	122.0	127.1	—	—	—	—
	380	4/4	6.5	3.6	569.0	182.0	70.6	73.5	569.0	182.0	70.6	73.5	—	—	—	—
	460	4/4	5.5	3.0	470.0	150.0	61.0	63.6	470.0	150.0	61.0	63.6	—	—	—	—
	575	4/4	4.3	2.4	376.0	120.0	46.6	48.6	376.0	120.0	46.6	48.6	—	—	—	—
100	200	4/4	11.9	6.6	1357.0	437.0	148.4	154.8	1357.0	437.0	148.4	154.8	—	—	—	—
	230	4/4	10.8	6.0	1180.0	380.0	134.9	140.7	1180.0	380.0	134.9	140.7	—	—	—	—
	380	4/4	6.5	3.6	714.0	230.0	78.3	81.6	714.0	230.0	78.3	81.6	—	—	—	—
	460	4/4	5.5	3.0	590.0	190.0	67.5	70.4	590.0	190.0	67.5	70.4	—	—	—	—
	575	4/4	4.3	2.4	472.0	152.0	51.3	53.5	472.0	152.0	51.3	53.5	—	—	—	—
110	200	4/4	11.9	6.6	1357.0	437.0	180.9	190.7	1357.0	437.0	180.9	190.7	—	—	—	—
	230	4/4	10.8	6.0	1180.0	380.0	164.7	173.6	1180.0	380.0	164.7	173.6	—	—	—	—
	380	4/4	6.5	3.6	714.0	230.0	95.4	100.6	714.0	230.0	95.4	100.6	—	—	—	—
	460	4/4	5.5	3.0	590.0	190.0	82.0	86.4	590.0	190.0	82.0	86.4	—	—	—	—
	575	4/4	4.3	2.4	472.0	152.0	62.9	66.3	472.0	152.0	62.9	66.3	—	—	—	—
120	200	4/4	11.9	6.6	1357.0	437.0	180.9	190.7	1357.0	437.0	180.9	190.7	—	—	—	—
	230	4/4	10.8	6.0	1180.0	380.0	164.7	173.6	1180.0	380.0	164.7	173.6	—	—	—	—
	380	4/4	6.5	3.6	714.0	230.0	95.4	100.6	714.0	230.0	95.4	100.6	—	—	—	—
	460	4/4	5.5	3.0	590.0	190.0	82.0	86.4	590.0	190.0	82.0	86.4	—	—	—	—
	575	4/4	4.3	2.4	472.0	152.0	62.9	66.3	472.0	152.0	62.9	66.3	—	—	—	—
140	200	6/4	11.9	6.6	2162.0	690.0	280.8	293.9	2162.0	690.0	280.8	293.9	—	—	—	—
	230	6/4	10.8	6.0	1880.0	600.0	255.2	267.2	1880.0	600.0	255.2	267.2	—	—	—	—
	380	6/4	6.5	3.6	1138.0	363.0	147.7	154.6	1138.0	363.0	147.7	154.6	—	—	—	—
	460	6/4	5.5	3.0	940.0	300.0	127.6	133.6	940.0	300.0	127.6	133.6	—	—	—	—
	575	6/4	4.3	2.4	752.0	240.0	97.5	102.0	752.0	240.0	97.5	102.0	—	—	—	—
160	200	6/4	11.9	6.6	2714.0	863.0	325.2	340.6	2714.0	863.0	325.2	340.6	—	—	—	—
	230	6/4	10.8	6.0	2360.0	750.0	296.0	310.0	2360.0	750.0	296.0	310.0	—	—	—	—
	380	6/4	6.5	3.6	1428.0	454.0	171.3	179.4	1428.0	454.0	171.3	179.4	—	—	—	—
	460	6/4	5.5	3.0	1180.0	375.0	147.6	154.6	1180.0	375.0	147.6	154.6	—	—	—	—
	575	6/4	4.3	2.4	944.0	300.0	112.9	118.2	944.0	300.0	112.9	118.2	—	—	—	—
180	200	6/6	11.9	6.6	2162.0	690.0	280.8	293.9	2162.0	690.0	280.8	293.9	—	—	—	—
	230	6/6	10.8	6.0	1880.0	600.0	255.2	267.2	1880.0	600.0	255.2	267.2	—	—	—	—
	380	6/6	6.5	3.6	1138.0	363.0	147.7	154.6	1138.0	363.0	147.7	154.6	—	—	—	—
	460	6/6	5.5	3.0	940.0	300.0	127.6	133.6	940.0	300.0	127.6	133.6	—	—	—	—
	575	6/6	4.3	2.4	752.0	240.0	97.5	102.0	752.0	240.0	97.5	102.0	—	—	—	—
200	200	6/6	11.9	6.6	2714.0	863.0	325.2	340.6	2714.0	863.0	325.2	340.6	—	—	—	—
	230	6/6	10.8	6.0	2360.0	750.0	296.0	310.0	2360.0	750.0	296.0	310.0	—	—	—	—
	380	6/6	6.5	3.6	1428.0	454.0	171.3	179.4	1428.0	454.0	171.3	179.4	—	—	—	—
	460	6/6	5.5	3.0	1180.0	375.0	147.6	154.6	1180.0	375.0	147.6	154.6	—	—	—	—
	575	6/6	4.3	2.4	944.0	300.0	112.9	118.2	944.0	300.0	112.9	118.2	—	—	—	—
220	200	7/6	11.9	6.6	2714.0	863.0	387.3	406.6	2714.0	863.0	387.3	406.6	—	—	—	—
	230	7/6	10.8	6.0	2360.0	750.0	352.3	369.8	2360.0	750.0	352.3	369.8	—	—	—	—
	380	7/6	6.5	3.6	1428.0	454.0	204.2	214.3	1428.0	454.0	204.2	214.3	—	—	—	—
	460	7/6	5.5	3.0	1180.0	375.0	176.1	184.9	1180.0	375.0	176.1	184.9	—	—	—	—
	575	7/6	4.3	2.4	944.0	300.0	134.8	141.5	944.0	300.0	134.8	141.5	—	—	—	—
240	200	7/6	11.9	6.6	2714.0	863.0	387.3	406.6	2714.0	863.0	387.3	406.6	—	—	—	—
	230	7/6	10.8	6.0	2360.0	750.0	352.3	369.8	2360.0	750.0	352.3	369.8	—	—	—	—
	380	7/6	6.5	3.6	1428.0	454.0	204.2	214.3	1428.0	454.0	204.2	214.3	—	—	—	—
	460	7/6	5.5	3.0	1180.0	375.0	176.1	184.9	1180.0	375.0	176.1	184.9	—	—	—	—
	575	7/6	4.3	2.4	944.0	300.0	134.8	141.5	944.0	300.0	134.8	141.5	—	—	—	—
260	200	9/6	6.5	3.6	2143.0	684.0	277.9	293.0	2143.0	684.0	277.9	293.0	—	—	—	—
	380	9/6	5.5	3.0	1770.0	565.0	240.4	253.5	1770.0	565.0	240.4	253.5	—	—	—	—
	575	9/6	4.3	2.4	1416.0	452.0	183.7	193.7	1416.0	452.0	183.7	193.7	—	—	—	—
	380	9/7	6.5	3.6	2143.0	684.0	277.9	293.0	2143.0	684.0	277.9	293.0	—	—	—	—
	460	9/7	5.5	3.0	1770.0	565.0	240.4	253.5	1770.0	565.0	240.4	253.5	—	—	—	—
280	200	9/7	6.5	3.6	2143.0	684.0	277.9	293.0	2143.0	684.0	277.9	293.0	—	—	—	—
	380	9/7	5.5	3.0	1770.0	565.0	240.4	253.5	1770.0	565.0	240.4	253.5	—	—	—	—
	575	9/7	4.3	2.4	1416.0	452.0	183.7	193.7	1416.0	452.0	183.7	193.7	—	—	—	—
	380	9/7	6.5	3.6	2143.0	684.0	277.9	293.0	2143.0	684.0	277.9	293.0	—	—	—	—
	460	9/7	5.5	3.0	1770.0	565.0	240.4	253.5	1770.0	565.0	240.4	253.5	—	—	—	—
300	200	9/7	6.5	3.6	2143.0	684.0	277.9	293.0	2143.0	684.0	277.9	293.0	—	—	—	—
	380	9/7	5.5	3.0	1770.0	565.0	240.4	253.5	1770.0	565.0	240.4	253.5	—	—	—	—
	575	9/7	4.3	2.4	1416.0	452.0	183.7	193.7	1416.0	452.0	183.7	193.7	—	—	—	—
	380	9/9	6.5	3.6	2143.0	684.0	277.9	293.0	2143.0	684.0	277.9	293.0	—	—	—	—
	460	9/9	5.5	3.0	1770.0	565.0	240.4	253.5	1770.0	565.0	240.4	253.5	—	—	—	—
325	200	9/9	6.5	3.6	2143.0	684.0	277.9	293.0	2143.0	684.0	277.9	293.0	—	—	—	—
	380	9/9	5.5	3.0	1770.0	565.0	240.4	253.5	1770.0	565.0	240.4	253.5	—	—	—	—
	575	9/9	4.3	2.4	1416.0	452.0	183.7	193.7	1416.0	452.0	183.7	193.7	—	—	—	—
	380	9/9	6.5	3.6	2143.0	684.0	277.9	293.0	2143.0	684.0	277.9	293.0	—	—	—	—
	460	9/9	5.5	3.0	1770.0	565.0	240.4	253.5	1770.0	565.0	240.4	253.5	—	—	—	—
350	200	9/9	6.5	3.6	2143.0	684.0	277.9	293.0	2143.0	684.0	277.9	293.0	—	—	—	—
	380	9/9	5.5	3.0	1770.0	565.0	240.4	253.5	1770.0	565.0	240.4	253.5	—	—	—	—
	575	9/9	4.3	2.4	1416.0	452.0	183.7	193.7	1416.0	452.0	183.7	193.7	—	—	—	—
	380	8/12	6.5	3.6	1428.0	454.0	204.2	214.3	1428.0	454.0	204.2	214.3	293.0	2143.0	277.9	293.0
	460	8/12	5.5	3.0	1180.0	375.0	176.1	184.9	1180.0	375.0	176.1	184.9	253.5	1770.0	240.4	253.5
400	200	8/12	6.5	3.6	1428.0	454.0	204.2	214.3	1428.0	454.0	204.2	214.3	293.0	2143.0	277.9	293.0
	380	8/12	5.5	3.0	1180.0	375.0	176.1	184.9	1180.0	375.0	176.1	184.9	253.5	1770.0	240.4	25

Table 11 — Pump Electrical Data

PUMP HP	UNIT VOLTAGE V-Hz (3 Ph)	HYDRONIC SYSTEM (SINGLE OR DUAL) FLA (Each)	30XA UNIT SIZE
5	230-60	11.6	090-160
	208-60	12.6	
	460-60	5.8	
	575-60	4.6	
	380-60	7.0	
7.5	230-60	17.4	090-160
	208-60	18.5	
	460-60	8.7	
	575-60	7.0	
	380-60	10.4	
10	230-60	23.0	090-160
	208-60	25.0	
	460-60	11.5	
	575-60	9.2	
	380-60	14.0	
15	230-60	34.0	090-160
	208-60	36.7	
	460-60	17.0	
	575-60	14.0	
	380-60	21.0	

FLA — Full Load Amps

CARRIER COMFORT NETWORK® COMMUNICATION BUS WIRING (See Fig. 34) — The communication bus wiring is a shielded, 3-conductor cable with drain wire and is field supplied and installed in the field.

The system elements are connected to the communication bus in a daisy chain arrangement. The positive pin of each system element communication connector must be wired to the positive pins of the system elements on either side of it. This is also required for the negative and signal ground pins of each system element. Wiring connections for CCN (Carrier Comfort Network) should be made at TB (terminal block) 3. Consult the CCN Contractor’s Manual for further information. See Fig. 34.

NOTE: Conductors and drain wire must be 20 AWG (American Wire Gage) minimum stranded, tinned copper. Individual conductors must be insulated with PVC, PVC/nylon, vinyl, Teflon, or polyethylene. An aluminum/polyester 100% foil shield and an outer jacket of PVC, PVC/nylon, chrome vinyl, or Teflon with a minimum operating temperature range of -4 F (-20 C) to 140 F (60 C) is required. See Table 12 for a list of manufacturers that produce CCN bus wiring that meet these requirements.

Table 12 — CCN Communication Bus Wiring

MANUFACTURER	PART NUMBER	
	Regular Wiring	Plenum Wiring
Alpha	1895	—
American	A21451	A48301
Belden	8205	884421
Columbia	D6451	—
Manhattan	M13402	M64430
Quabik	6130	—

It is important when connecting to a CCN communication bus that a color coding scheme be used for the entire network to simplify the installation. It is recommended that red be used for the signal positive, black for the signal negative, and white for the signal ground. Use a similar scheme for cables containing different colored wires. At each system element, the shields of its communication bus cables must be tied together. If the communication bus is entirely within one building, the resulting continuous shield must be connected to a ground at one point only. If the communication bus cable exits from one building and enters another, the shields must be connected to grounds at the lightning suppressor in each building where the cable enters or exits the building (one point per building only).

To connect the unit to the network:

1. Turn off power to the control box.

2. Cut the CCN wire and strip the ends of the red (+), white (ground), and black (-) conductors. Substitute appropriate colors for different colored cables.
3. Connect the red wire to (+) terminal on TB3 of the plug, the white wire to COM terminal, and the black wire to the (-) terminal.
4. The RJ14 CCN connector on TB3 can also be used, but is only intended for temporary connection (for example, a laptop computer running service tool).

IMPORTANT: A shorted CCN bus cable will prevent some routines from running and may prevent the unit from starting. If abnormal conditions occur, disconnect the machine from the CCN. If conditions return to normal, check the CCN connector and cable. Run new cable if necessary. A short in one section of the bus can cause problems with all system elements on the bus.

NON-CCN COMMUNICATION WIRING — The 30XA units offer several non-CCN translators. Refer to the separate installation instructions for additional wiring steps.

FIELD CONTROL OPTION WIRING — Install field control wiring options. Some options, such as 4 to 20 mA demand limit that requires the Energy Management Module, may require that accessories be installed first (if not factory installed) for terminal connections.

DUAL CHILLER LEAVING WATER SENSOR — If the dual chiller algorithm is used and the machines are installed in parallel, an additional chilled water sensor must be installed for each chiller. Install the wells in the common leaving water header. See Fig 35. DO NOT relocate the chiller’s leaving water thermistors. They must remain in place for the unit to operate properly.

The thermistor well is a 1/4 in. NPT fitting for securing the well in the piping. The piping must be drilled and tapped for the well. Select a location that will allow for removal of the thermistor without any restrictions.

Once the well is inserted, install the thermistors. Insert the thermistor into the well until the o-ring reaches the well body. Use the nut on the thermistor to secure the thermistor in place. Once the thermistor is in place, it is recommended that a thermistor wire loop be made and secured with a wire tie to the chilled water pipe. See Fig. 36.

For dual chiller control a CCN bus must be connected between the two modules. See the Carrier Comfort Network Communication Bus Wiring section for additional information.

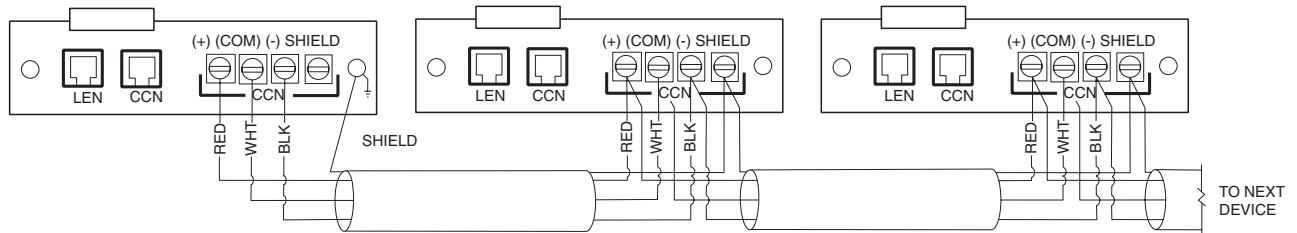

LEGEND
CCN — Carrier Comfort Network®
LEN — Local Equipment Network

Fig. 34 — TB3 — CCN Wiring

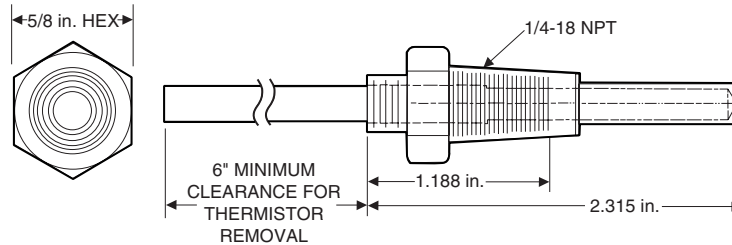

Fig. 35 — Dual Leaving Water Thermistor Well (Part No. OOPPG00008000A)

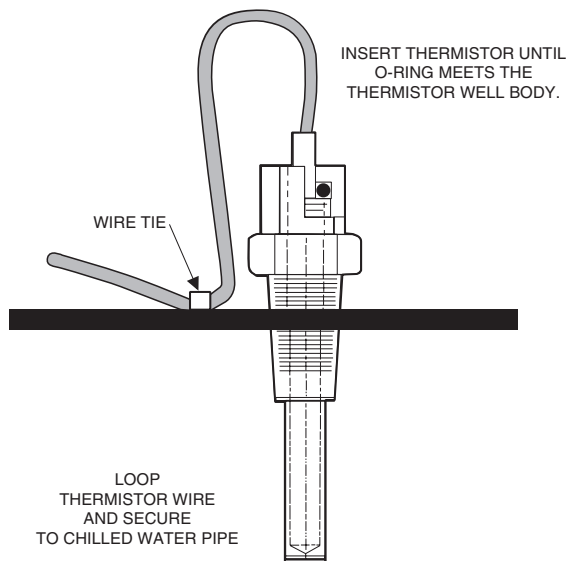

Fig. 36 — Dual Leaving Water Thermistor (Part No. OOPPG00008105A)

Step 6 — Install Accessories — A number of accessories are available to provide the following optional features (for details, refer to the Controls and Troubleshooting guide shipped with the unit).

ENERGY MANAGEMENT MODULE — The Energy Management Module is used for any of the following types of temperature reset, demand limit and ice features:

- 4 to 20 mA inputs for cooling set point reset and capacity limit (requires field-supplied 4 to 20 mA generator)
- 0 to 10 v output for percentage total capacity running
- 24 v discrete outputs for shutdown and running relays
- 10k space temperature input

Discrete inputs for occupancy override, demand limit switch 2 (step 1 demand limit is wired to the base board,

requires field-supplied dry contacts), remote lockout switch and ice done switch (requires field-supplied dry contacts).

REMOTE ENHANCED DISPLAY (OR TOUCH PILOT™ DISPLAY) — For applications where remote monitoring of the equipment is required; the remote enhanced display (or Touch Pilot display) provides an indoor display, capable of monitoring any equipment on the Carrier Comfort Network® (CCN) bus. A CCN bus is required.

LOW AMBIENT TEMPERATURE OPERATION — If outdoor ambient operating temperatures below 32 F (0° C) are expected, refer to separate installation instructions for low-ambient operation using the low ambient temperature head pressure control accessory.

MINIMUM LOAD ACCESSORY — Contact a local Carrier representative for more details if a minimum load accessory is required for a specific application. For installation details, refer to separate installation instructions supplied with the accessory package.

UNIT SECURITY/PROTECTION ACCESSORIES — For applications with unique security and/or protection requirements, several options are available for unit protection. Security grilles and hail guards are available. Contact a local Carrier representative for more details. For installation details, refer to separate installation instructions supplied with the accessory package.

COMMUNICATION ACCESSORIES — A number of communication options are available to meet any requirement. Contact a local Carrier representative for more details. For installation details, refer to separate installation instructions supplied with the accessory package.

SERVICE OPTIONS — Two accessories are available to aid in servicing 30XA units: a ground fault convenience outlet (GFI-CO) and a remote service port.

The GFI-CO is a convenience outlet with a 4-amp GFI receptacle.

The remote service port is housed in a weather-proof enclosure with a communication port to plug in the Navigator™ device.

Contact your local Carrier representative for more details. For installation details, refer to separate installation instructions supplied with each accessory package.

CONTROL TRANSFORMER — The control transformer accessory eliminates the need for a separate power supply.

Step 7 — Leak Test Unit — The 30XA units are shipped with a complete operating charge of R-134a (see Tables 1A and 1B) and should be under sufficient pressure to conduct a leak test.

IMPORTANT: These units are designed for use with R-134a only. **DO NOT USE ANY OTHER** refrigerant in these units.

Perform a leak test to ensure that leaks have not developed during unit shipment. Dehydration of the system is not required unless the entire refrigerant charge has been lost. There are several O-ring face seal fittings utilized in the oil line piping. If a leak is detected at any of these fittings, open the system and inspect the O-ring surface for foreign matter or damage. Do not reuse O-rings. Repair any leak found following good refrigeration practice.

⚠ CAUTION
DO NOT OVERTIGHTEN THESE FITTINGS. Overtightening will result in O-ring damage.

Step 8 — Refrigerant Charging

DEHYDRATION — Refer to Carrier Standard Service Techniques Manual, Chapter 1, Refrigerants, Sections 6 and 7 for details. Do not use compressor to evacuate system.

REFRIGERANT CHARGE

IMPORTANT: These units are designed for use with R-134a only. **DO NOT USE ANY OTHER** refrigerant in these units.

The liquid charging method is recommended for complete charging or when additional charge is required.

⚠ CAUTION
When charging, circulate water through the cooler at all times to prevent freezing. Freezing damage is considered abuse and may void the Carrier warranty.

⚠ CAUTION
DO NOT OVERCHARGE system. Overcharging results in higher discharge pressure with higher cooling fluid consumption, possible compressor damage, and higher power consumption.

The 30XA units are shipped from the factory with a full charge of R-134a. The unit should not need to be charged at installation unless a leak was detected in Step 6 — Leak Test Unit section. If dehydration and recharging is necessary, use industry standard practices or refer to Carrier Standard Service Techniques Manual as required.