



# Installation Instructions

## CONTENTS

	Page
<b>SAFETY CONSIDERATIONS</b> .....	1
<b>INTRODUCTION</b> .....	1
<b>INSTALLATION</b> .....	2-42
<b>Storage</b> .....	2
<b>Step 1 — Inspect Shipment</b> .....	2
<b>Step 2 — Place, Mount and Rig Unit</b> .....	2
• PLACING UNIT	
• MOUNTING UNIT	
• RIGGING UNIT	
<b>Step 3 — Cooler Fluid and Drain Piping</b>	
<b>Connections</b> .....	29
• GENERAL	
• DUAL CHILLER CONTROL	
• COOLER FLUID, VENT, AND DRAIN	
• COOLER PUMP CONTROL	
• BRINE UNITS	
• WATER TREATMENT	
• PREPARATION FOR YEAR-ROUND OPERATION	
• PREPARATION FOR WINTER SHUTDOWN	
<b>Step 4 — Make Electrical Connections</b> .....	34
• POWER SUPPLY	
• FIELD POWER CONNECTIONS	
• FIELD CONTROL POWER CONNECTIONS	
• CARRIER COMFORT NETWORK	
COMMUNICATION BUS WIRING	
• NON-CCN COMMUNICATION WIRING	
• FIELD CONTROL OPTION WIRING	
• DUAL CHILLER LEAVING WATER SENSOR	
<b>Step 5 — Install Accessories</b> .....	41
• ENERGY MANAGEMENT MODULE	
• REMOTE ENHANCED DISPLAY	
• LOW AMBIENT TEMPERATURE OPERATION	
• MINIMUM LOAD ACCESSORY	
• UNIT SECURITY/PROTECTION ACCESSORIES	
• COMMUNICATION ACCESSORIES	
• SERVICE OPTIONS	
• CONTROL TRANSFORMER	
<b>Step 6 — Leak Test Unit</b> .....	41
<b>Step 7 — Refrigerant Charging</b> .....	41
• DEHYDRATION	
• REFRIGERANT CHARGE	

## SAFETY CONSIDERATIONS

Installing, starting up, and servicing this equipment can be hazardous due to system pressures, electrical components, and equipment location. Only trained, qualified installers and service mechanics should install, start up, and service this equipment.

When working on the equipment, observe precautions in the literature, and on tags, stickers, and labels attached to the equipment.

- Follow all safety codes.
- Wear safety glasses and work gloves.
- Use care in handling, rigging, and setting bulky equipment.

**⚠ WARNING**

Electrical shock can cause personal injury and death. Shut off all power to this equipment during installation. There may be more than one disconnect switch. Tag all disconnect locations to alert others not to restore power until work is completed.

**IMPORTANT:** This equipment generates, uses, and can radiate radio frequency energy and if not installed and used in accordance with these instructions may cause radio interference. It has been tested and found to comply with the limits of a Class A computing device as defined by FCC (Federal Communications Commission, U.S.A.) regulations, Subpart J of Part 15, which are designed to provide reasonable protection against such interference when operated in a commercial environment.

## INTRODUCTION

These instructions cover installation of 30XA080-500 air-cooled liquid chillers with electronic controls and units with factory-installed options (FIOPs). See Fig. 1.

## INSTALLATION

**Storage** — If the unit is to be stored for a period of time before installation or start-up, be sure to protect the machine from construction dirt. Keep protective shipping covers in place until the machine is ready for installation.

**Step 1 — Inspect Shipment** — Inspect unit for damage upon arrival. If damage is found, immediately file a claim with the shipping company.

**Step 2 — Place, Mount, and Rig the Unit** — When considering a location for the unit, be sure to consult NEC (National Electrical Code, U.S.A.) and/or local code requirements. Allow sufficient space for airflow, wiring, piping, and service. See Fig. 2-10.

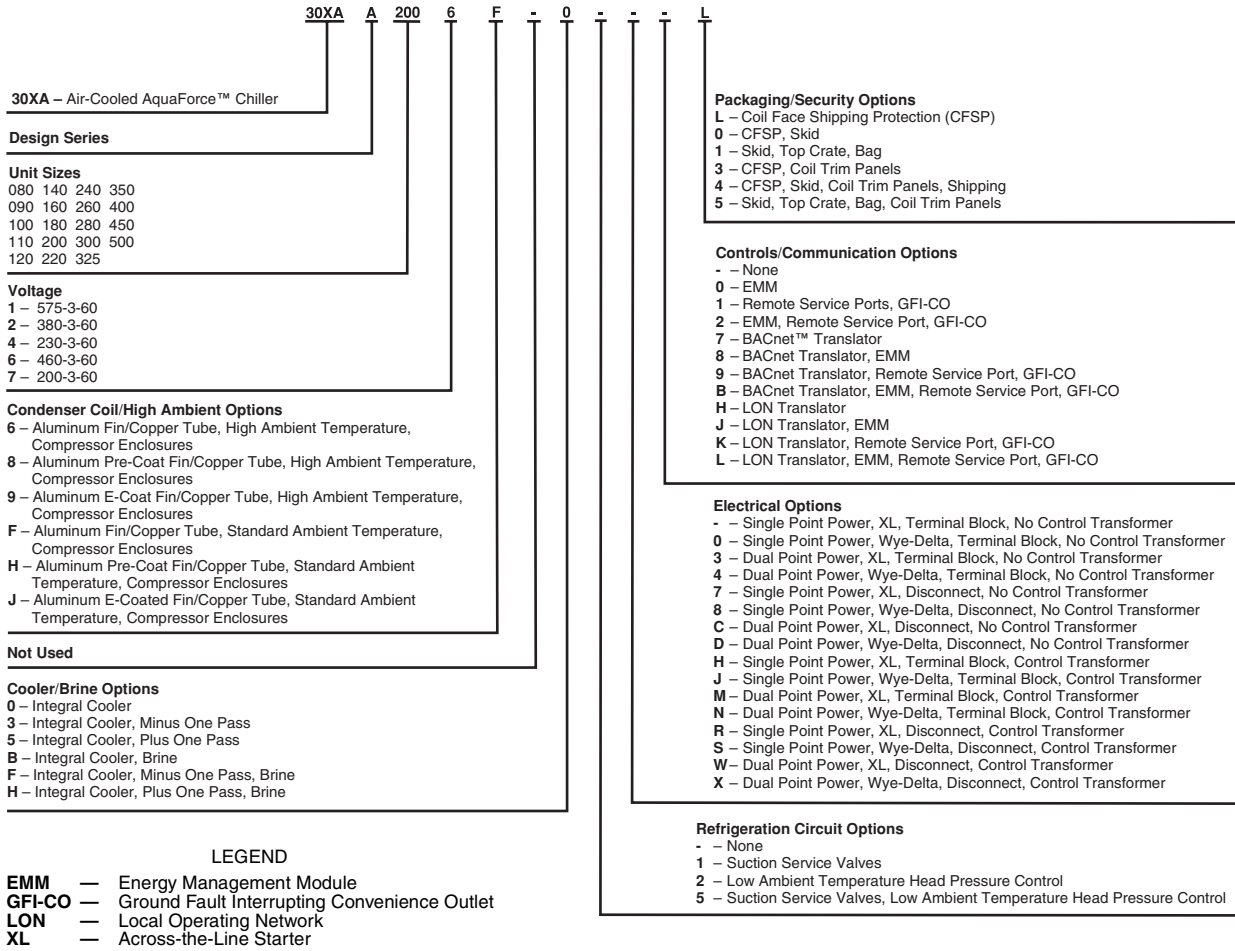
NOTE: To facilitate refrigerant vent piping, all units have fusible plugs with  $\frac{1}{4}$  in. SAE (Society of Automotive Engineers) flares and pressure reliefs with  $\frac{3}{4}$  in. NPT fittings (if required by local codes).

**PLACING UNIT** — Locate the unit so that the condenser airflow is unrestricted both above and on the sides of the unit. Airflow and service clearances are 6 ft (1.8 m) around the unit. Acceptable clearance on the cooler connection side or sides or ends without control boxes can be reduced to 3 ft (1 m) without

sacrificing performance as long as the remaining three sides are unrestricted. Acceptable clearance on the side with a control box can be reduced to 4 ft (1.3 m) due to NEC regulations, without sacrificing performance as long as the remaining three sides are unrestricted. Provide ample room for servicing and removing the cooler. See Fig. 2-10 for required clearances. Local codes for clearances take precedence over the manufacturer's recommendations when local codes call for greater clearances.

If multiple units are installed at the same site, a separation of 10 ft (3 m) between the sides of the machines is required to maintain proper airflow and minimize the chances of condenser air recirculation.

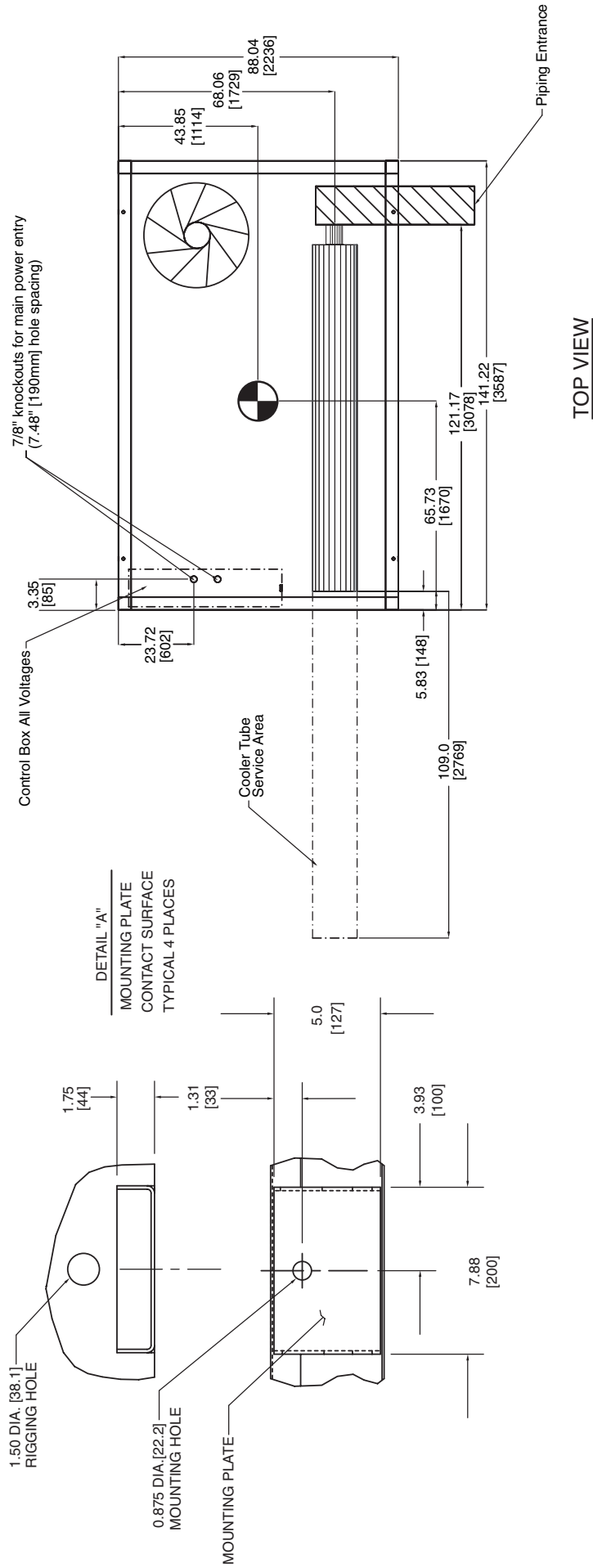
**MOUNTING UNIT** — The unit may be mounted on a level pad directly on the base rails, on a raised mounting rail around the unit, or on vibration isolation springs. For all units, ensure placement area is strong enough to support unit operating weight. See Tables 1A and 1B. Mounting holes are provided for securing the unit to the pad, mounting rail or vibration isolation springs. Bolt the unit securely to pad or rails. If vibration isolators (field-supplied) are required for a particular installation, refer to unit weight distribution in Fig. 11 to aid in the proper selection of isolators. The 30XA units can be mounted directly on spring isolators.



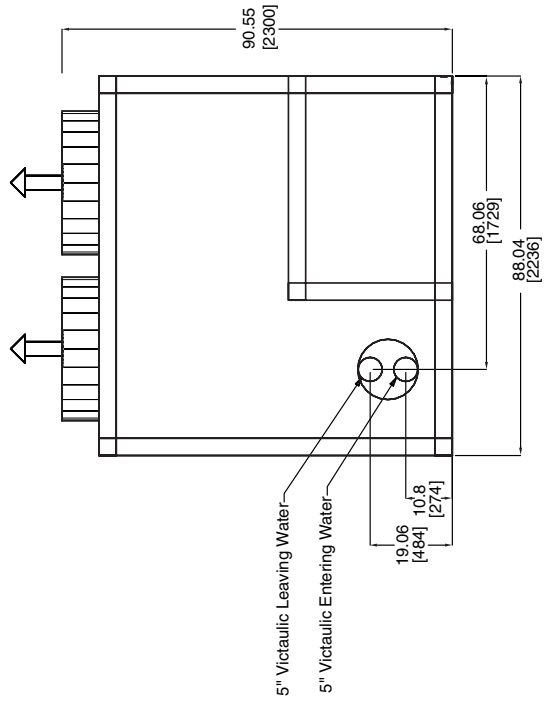
**Fig. 1 — AquaForce™ Chiller Model Number Designation**

**NOTES:**

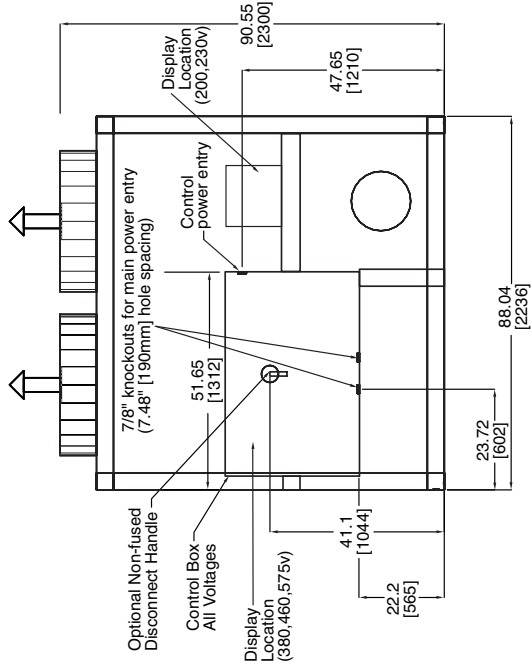
1. Unit must have clearances as follows:  
Top — Do not restrict  
Sides and Ends — 6 ft from solid surface.
2. Temperature relief devices are located on liquid line and economizer assemblies and have 1/4-in. flare connection.
3. 3/8-in. NPT vents and drains located in each cooler head at each end of cooler.
4. Drawing depicts unit with single-point power and standard two-pass cooler. Refer to the Packaged Chiller Builder program for other configurations.
5. Dimensions are shown in inches; dimensions in brackets are in millimeters.



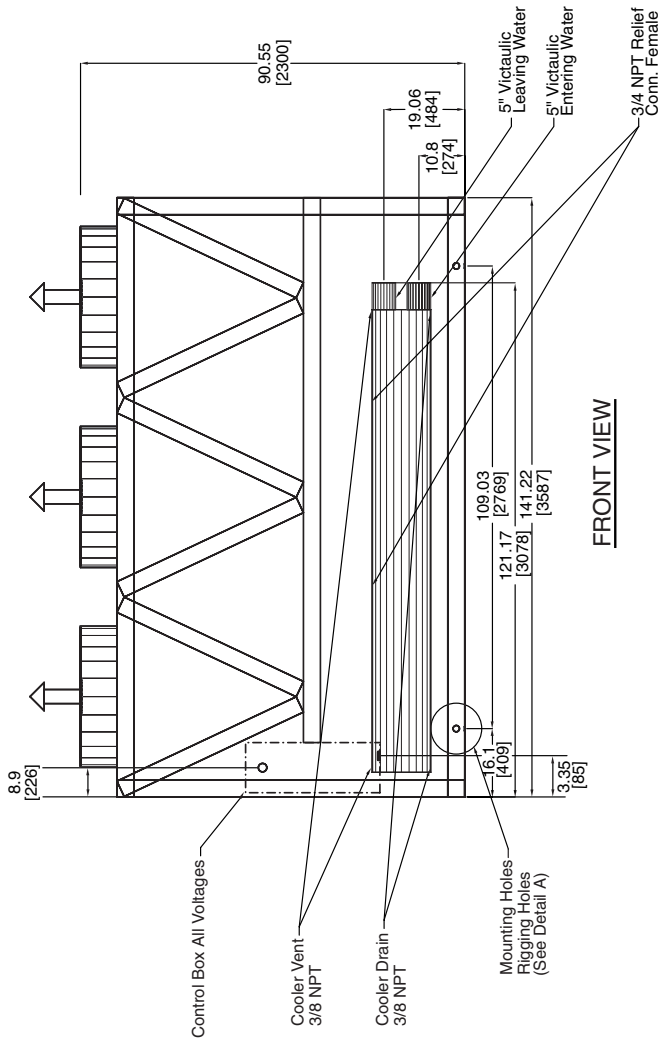
**Fig. 2 — 30XA080 Air-Cooled Liquid Chiller Dimensions**



**LEFT END VIEW**



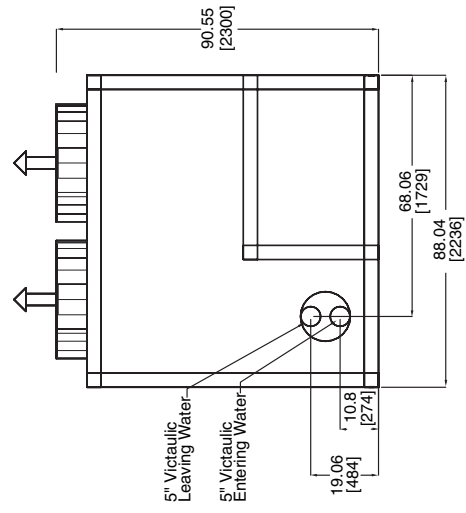
**RIGHT END VIEW**



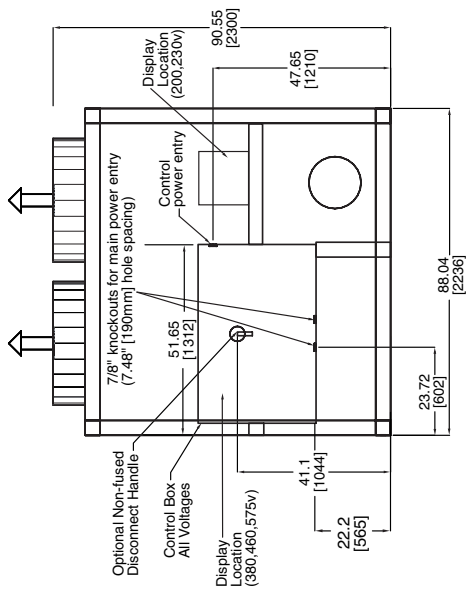
**FRONT VIEW**

**Fig. 2 — 30XA080 Air-Cooled Liquid Chiller Dimensions (cont)**

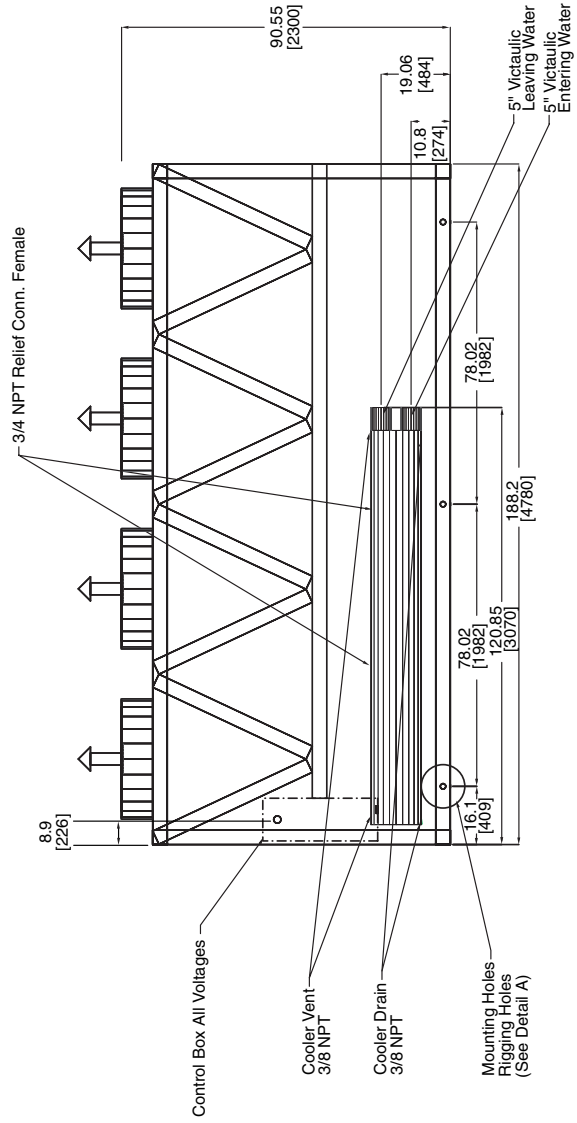




**RIGHT END VIEW**



**LEFT END VIEW**



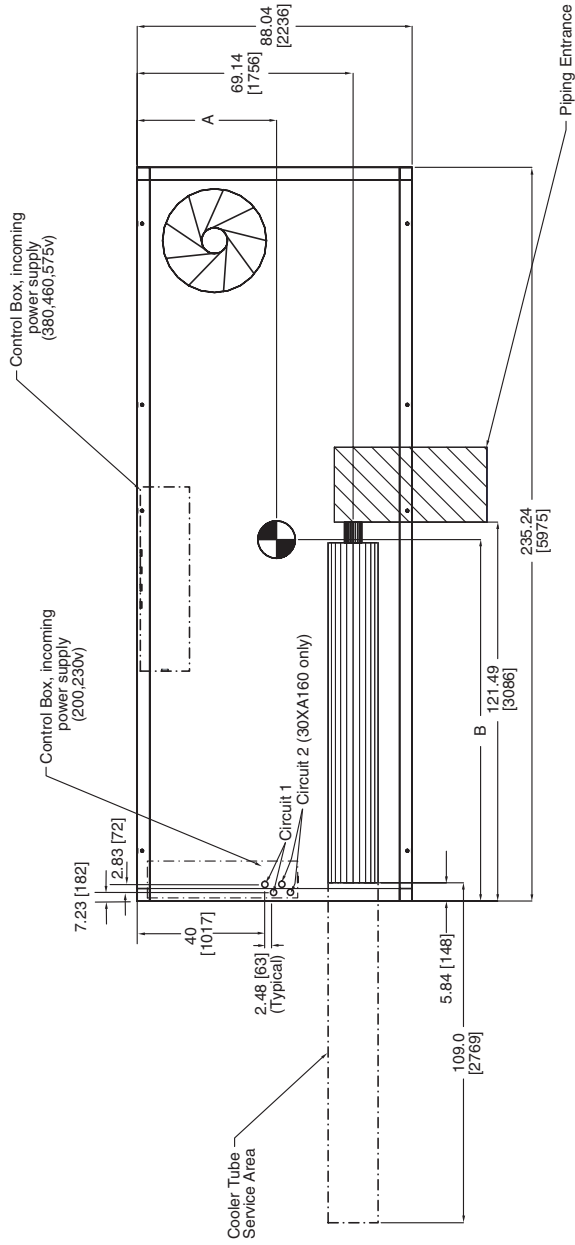
**FRONT VIEW**

**Fig. 3 — 30XA090-120 Air-Cooled Liquid Chiller Dimensions (cont)**

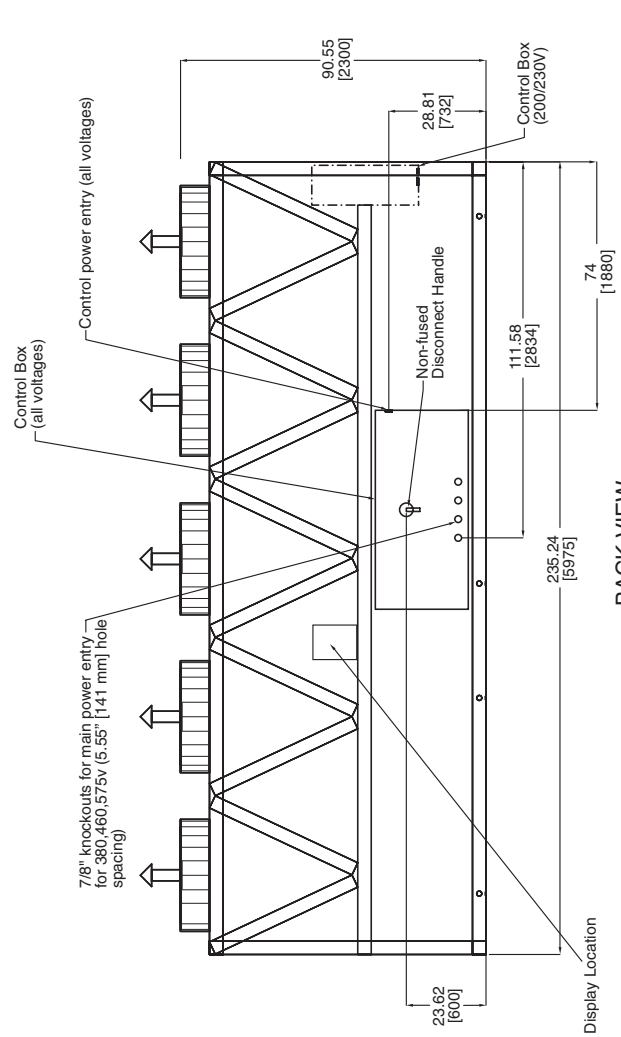
**NOTES:**

- Unit must have clearances as follows:  
Top — Do not restrict  
Sides and Ends — 6 ft from solid surface.
- Temperature relief devices are located on liquid line and economizer assemblies and have 1/4-in. flare connection.
- 3/8-in. NPT vents and drains located in each cooler head at each end of cooler.
- Drawing depicts unit with single-point power, or dual-point power on a 30XA160 (200, 230 v) unit with standard condenser fans, and standard two-pass cooler. Refer to the Packaged Chiller Builder program for other configurations.
- Dimensions are shown in inches; dimensions in brackets are in millimeters.

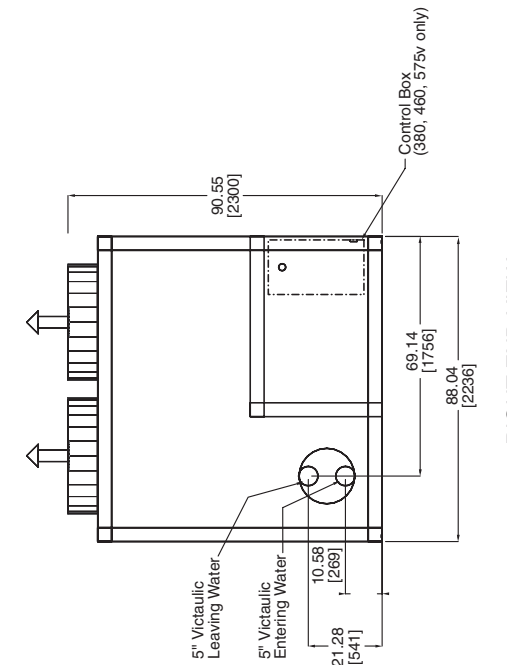
30XA UNIT	A	B
140	44.63 (1134)	115.88 (2943)
160	44.61 (1133)	115.64 (2937)



**TOP VIEW**



**BACK VIEW**



**RIGHT END VIEW**

**Fig. 4 — 30XA140,160 Air-Cooled Liquid Chiller Dimensions**

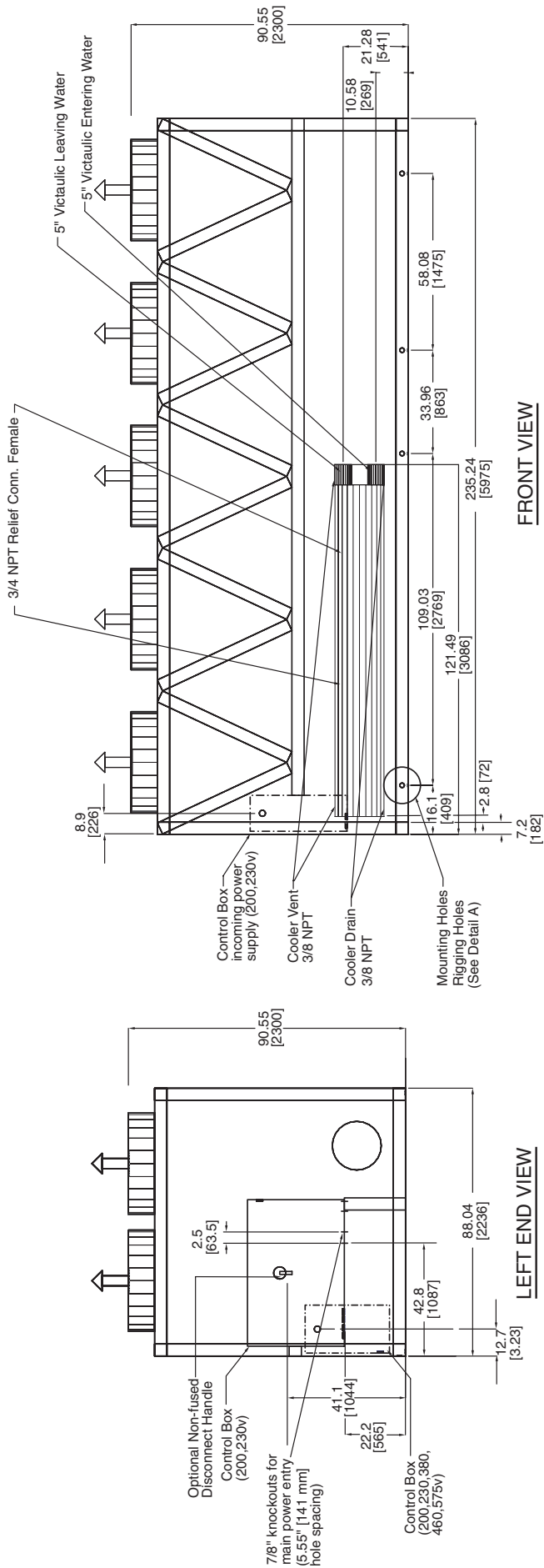
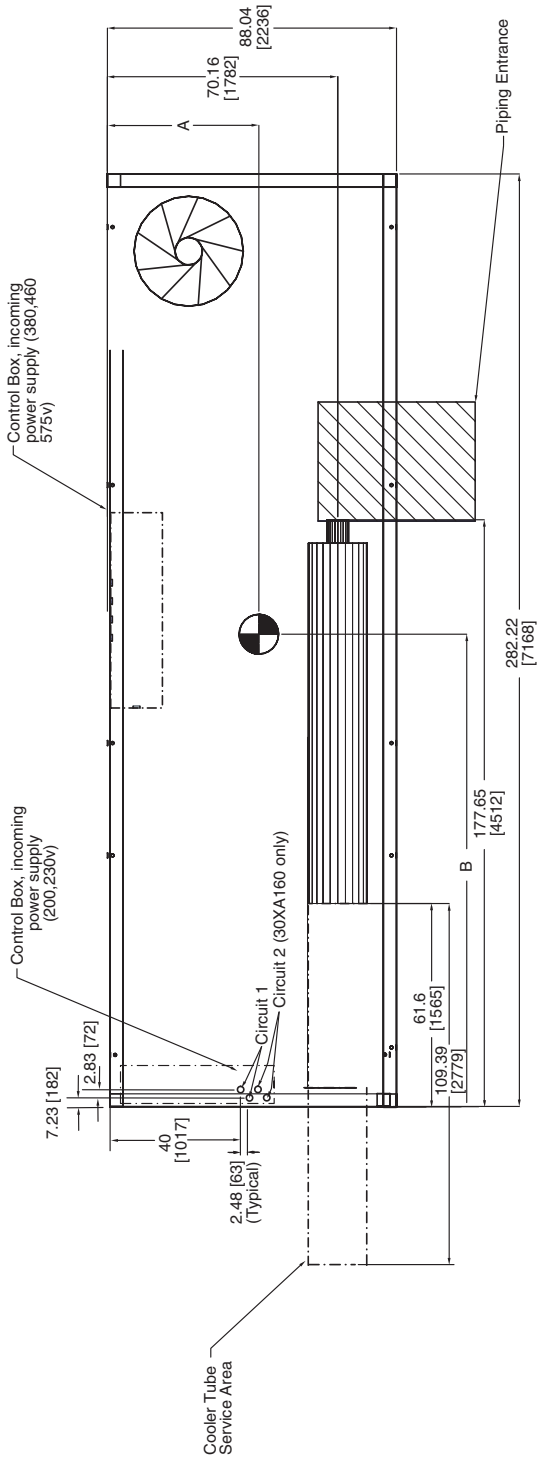


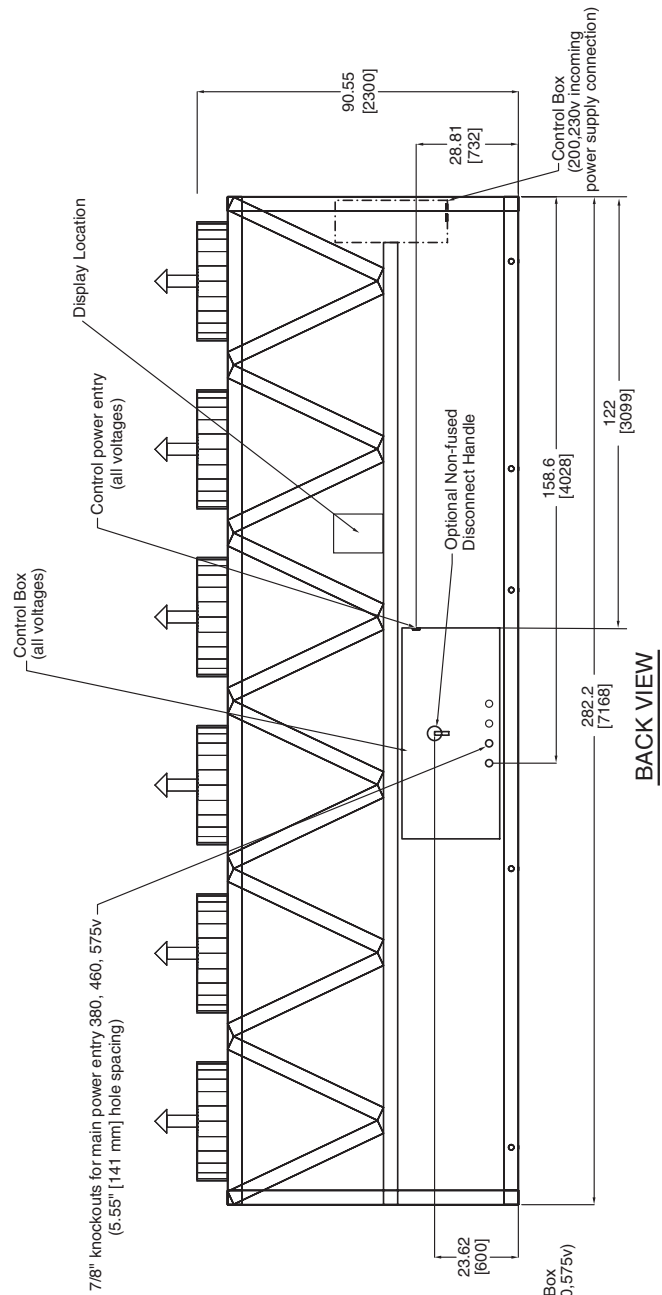
Fig. 4 — 30XA140,160 Air-Cooled Liquid Chiller Dimensions (cont)

- NOTES:**
- Unit must have clearances as follows:  
Top — Do not restrict  
Sides and Ends — 6 ft from solid surface.
  - Temperature relief devices are located on liquid line and economizer assemblies and have 1/4-in. flare connection.
  - 3/8-in. NPT vents and drains located in each cooler head at each end of cooler.
  - Drawing depicts unit with single-point power, or dual-point power on a 30XA180,200 (200, 230 v) unit with standard condenser fans, and standard two-pass cooler. Refer to the Packaged Chiller Builder program for other configurations.
  - Dimensions are shown in inches; dimensions in brackets are in millimeters.

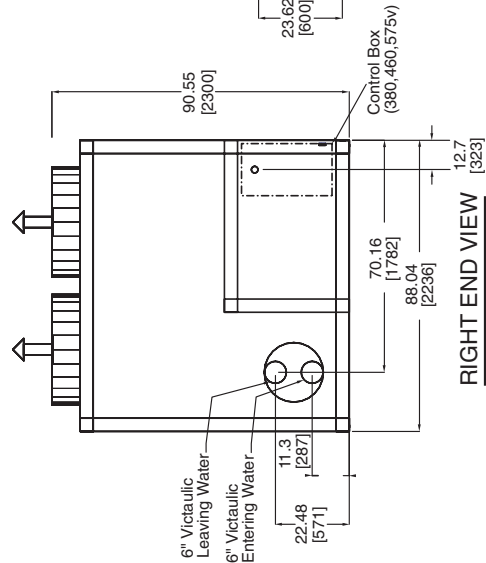
30XA UNIT	A	B
180	46.12 (1171)	143.04 (3633)
200	46.15 (1172)	142.97 (3631)



**TOP VIEW**



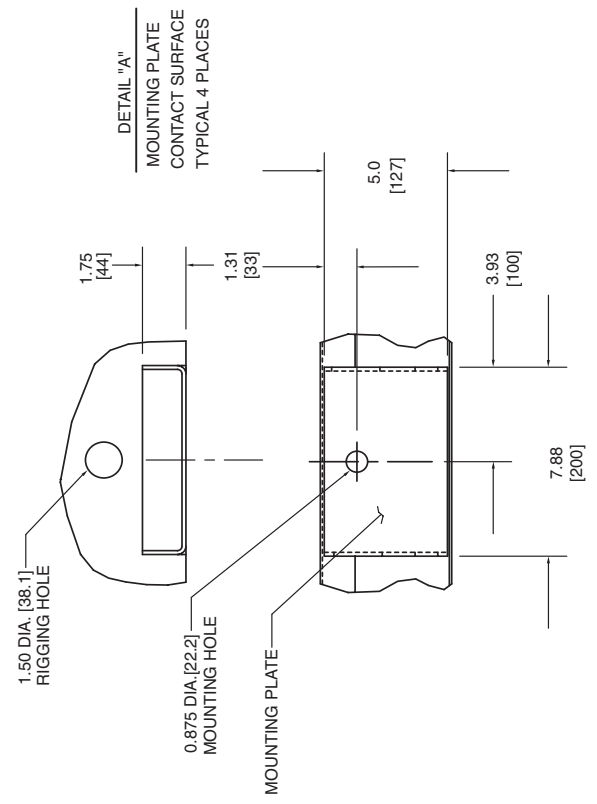
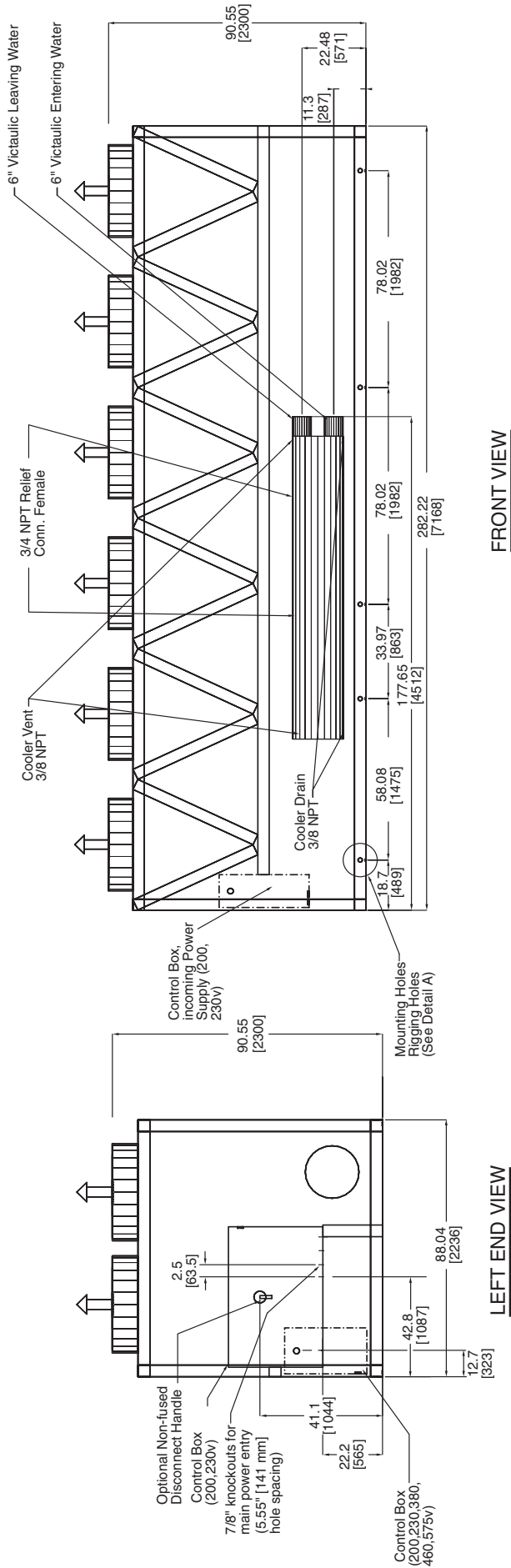
**BACK VIEW**



**RIGHT END VIEW**

7/8" knockouts for main power entry 380, 460, 575v (5.55" [141 mm] hole spacing)

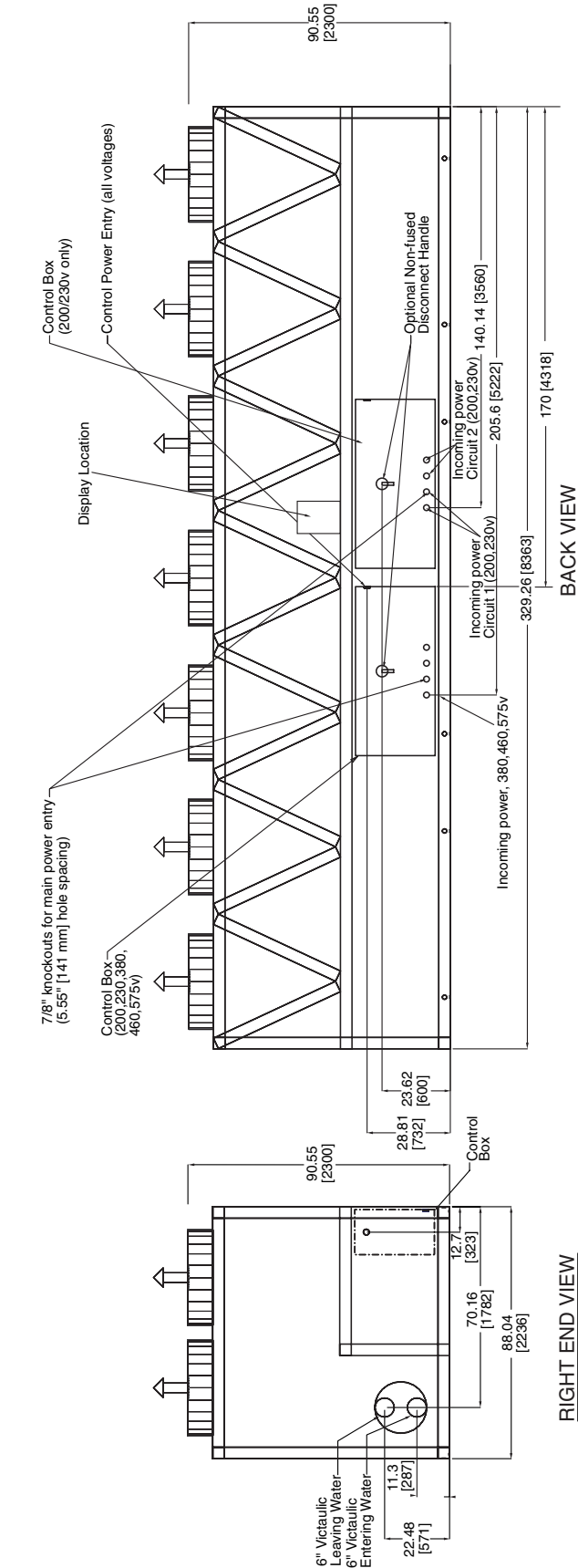
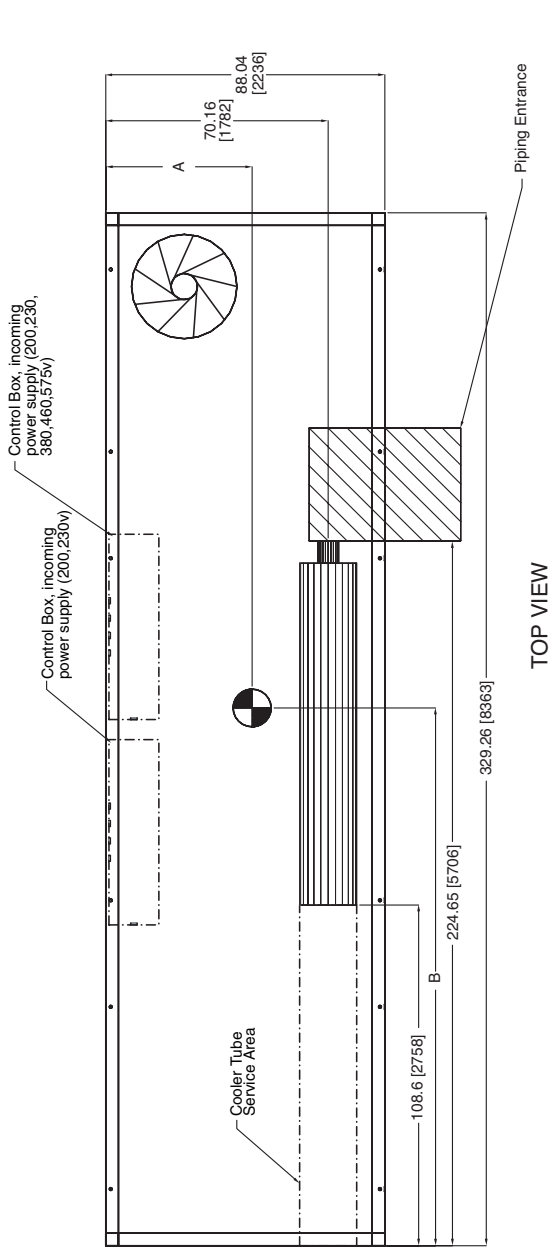
**Fig. 5 — 30XA180,200 Air-Cooled Liquid Chiller Dimensions**



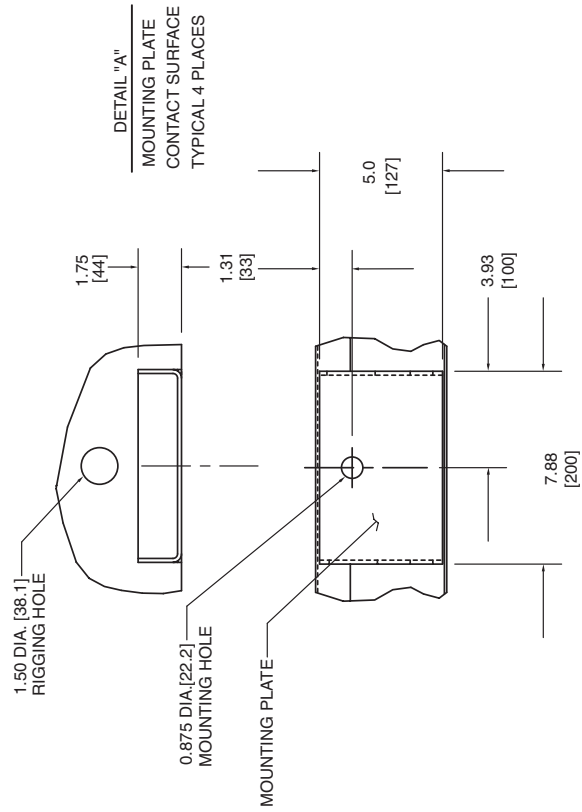
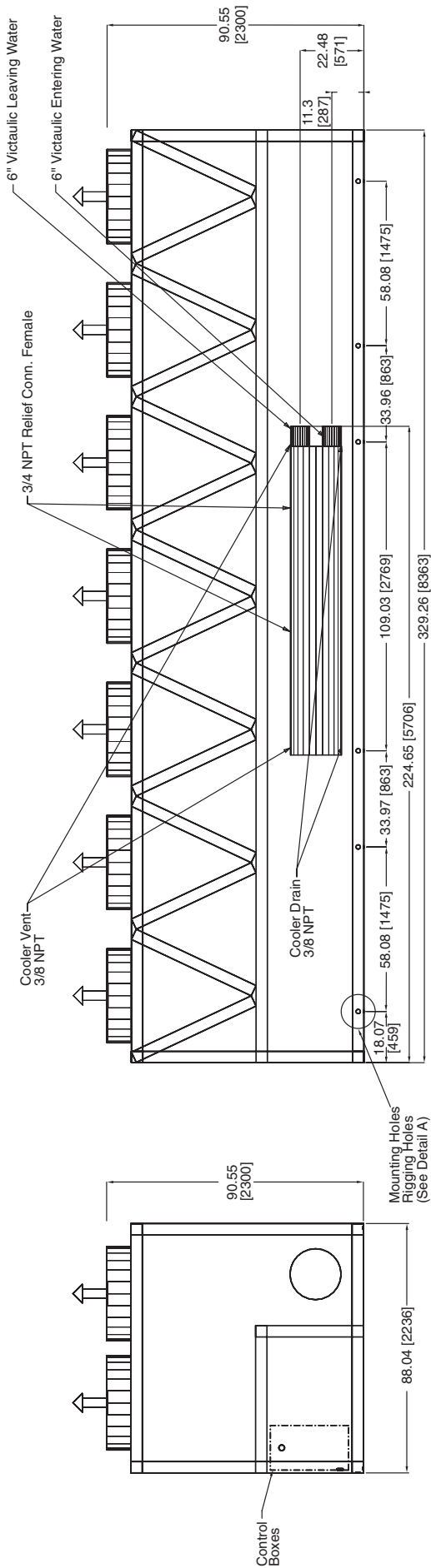
**Fig. 5 — 30XA180,200 Air-Cooled Liquid Chiller Dimensions (cont)**

- NOTES:**
- Unit must have clearances as follows:  
Top — Do not restrict  
Sides and Ends — 6 ft from solid surface.
  - Temperature relief devices are located on liquid line and economizer assemblies and have 1/4-in. flare connection.
  - 3/8-in. NPT vents and drains located in each cooler head at each end of cooler.
  - Drawing depicts unit with single-point power, or dual-point power on a 30XA200,240 (200, 230 v) unit and standard condenser fans, and standard two-pass cooler. Refer to the Packaged Chiller Builder program for other configurations.
  - Dimensions are shown in inches; dimensions in brackets are in millimeters.

30XA UNIT	A	B
220	46.17 (1173)	171.42 (4354)
240	46.23 (1174)	170.83 (4339)



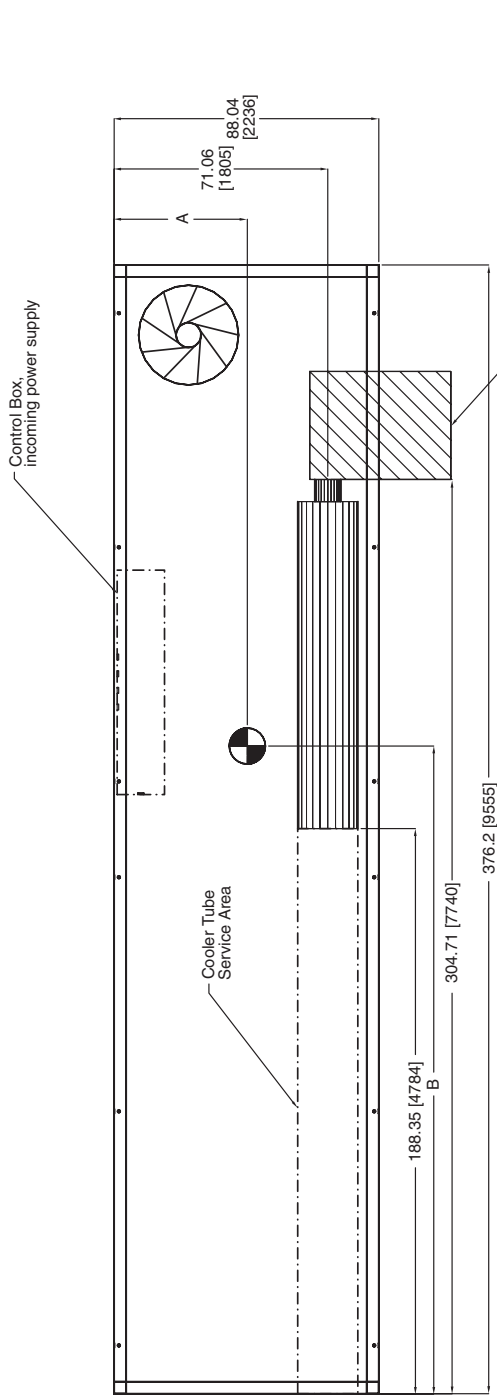
**Fig. 6 — 30XA220,240 Air-Cooled Liquid Chiller Dimensions**



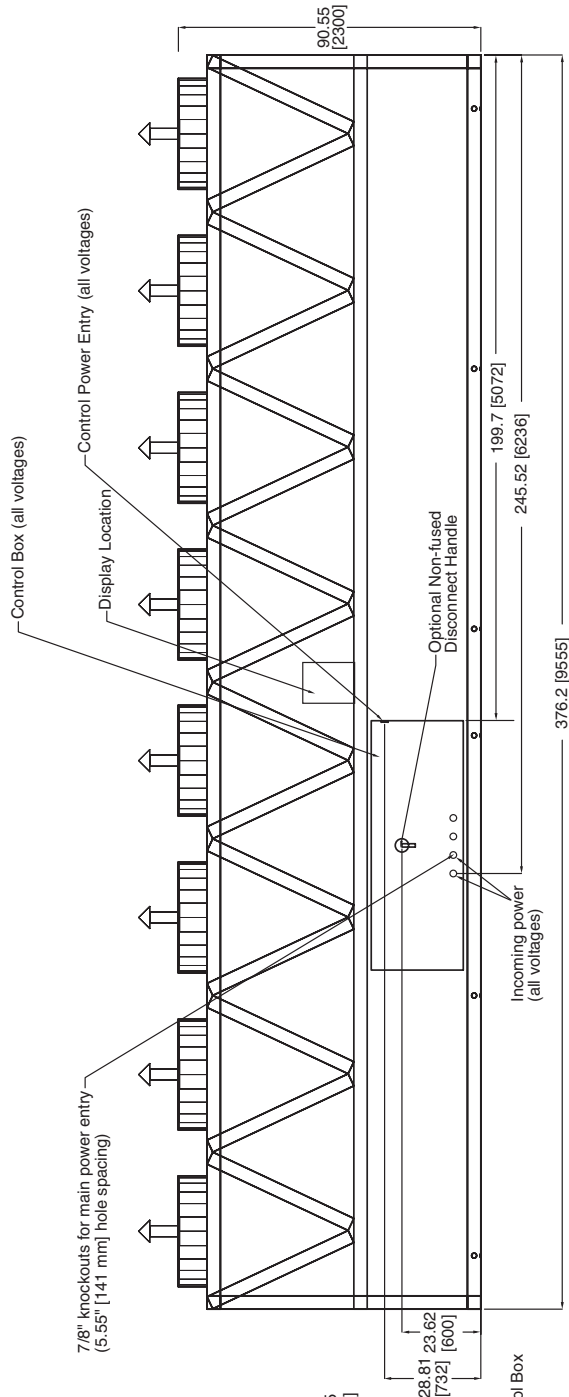
**Fig. 6 — 30XA220,240 Air-Cooled Liquid Chiller Dimensions (cont)**

- NOTES:**
- Unit must have clearances as follows:  
 Top — Do not restrict  
 Sides and Ends — 6 ft from solid surface.
  - Temperature relief devices are located on liquid line and economizer assemblies and have 1/4-in. flare connection.
  - 3/8-in. NPT vents and drains located in each cooler head at each end of cooler.
  - Drawing depicts unit with single-point power standard condenser fans and standard two-pass cooler. Refer to the Packaged Chiller Builder program for other configurations.
  - Dimensions are shown in inches; dimensions in brackets are in millimeters.

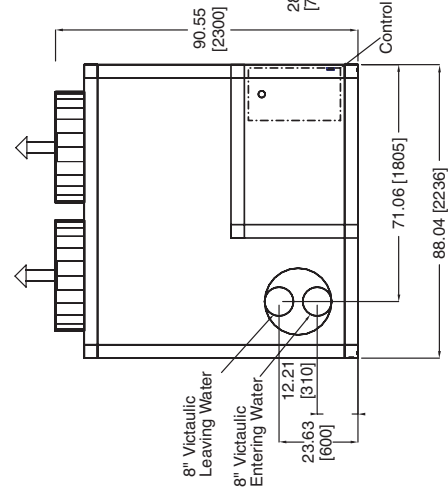
30XA UNIT	A	B
260	44.22 (1123)	216.16 (5490)
280	44.30 (1125)	215.86 (5483)
300	44.32 (1126)	216.18 (5491)



**TOP VIEW**



**BACK VIEW**



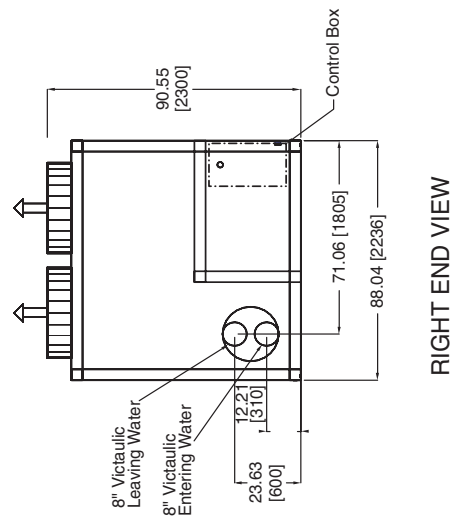
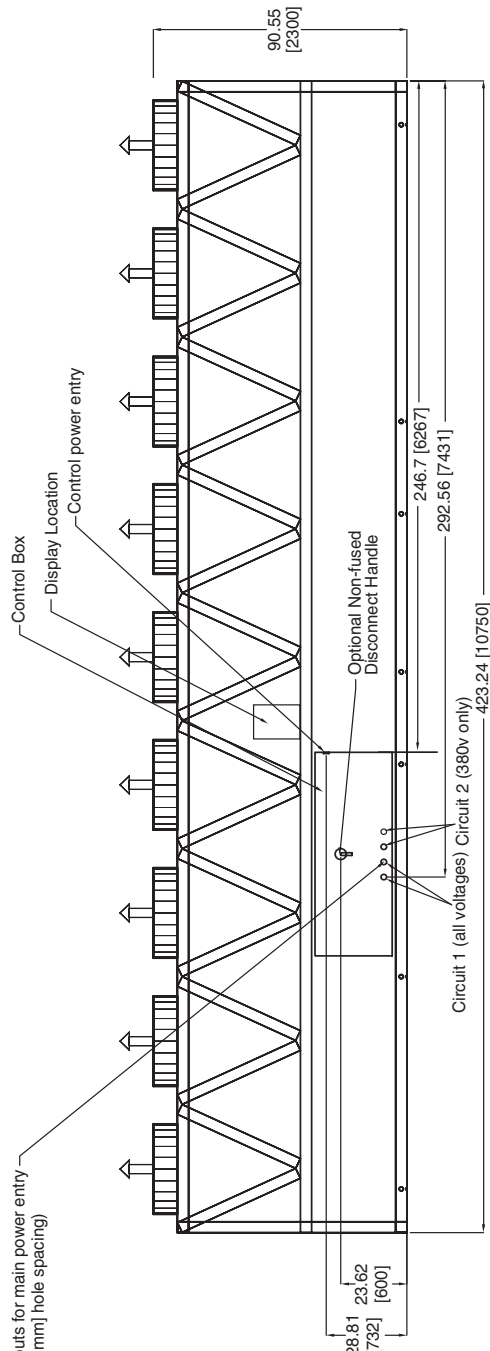
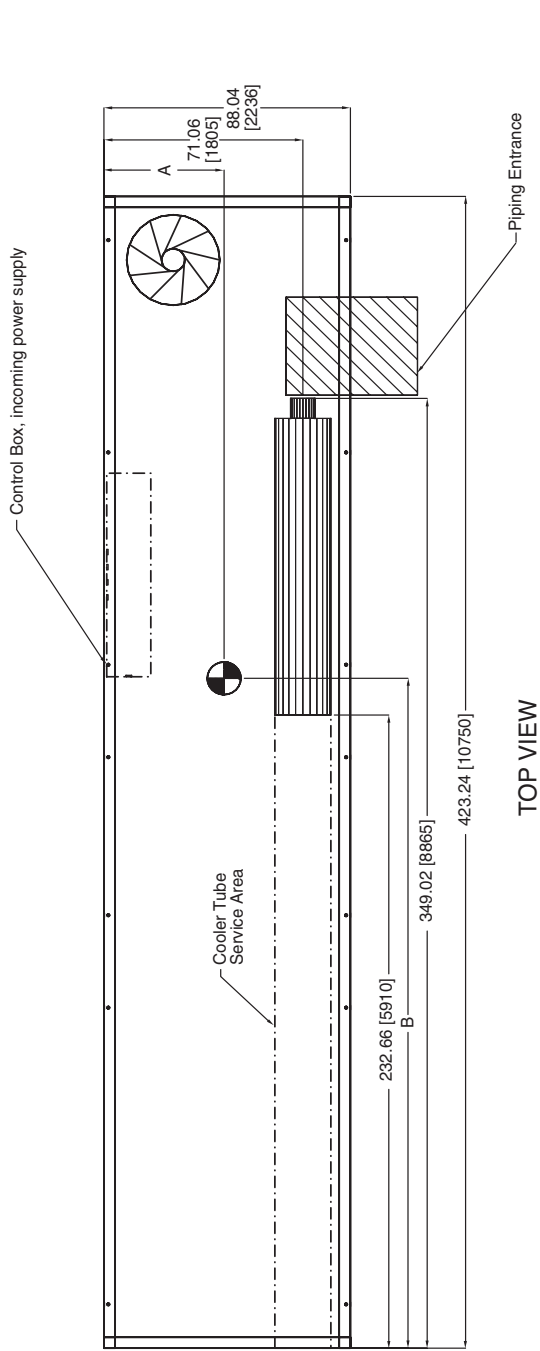
**RIGHT END VIEW**

**Fig. 7 — 30XA260-300 Air-Cooled Liquid Chiller Dimensions**

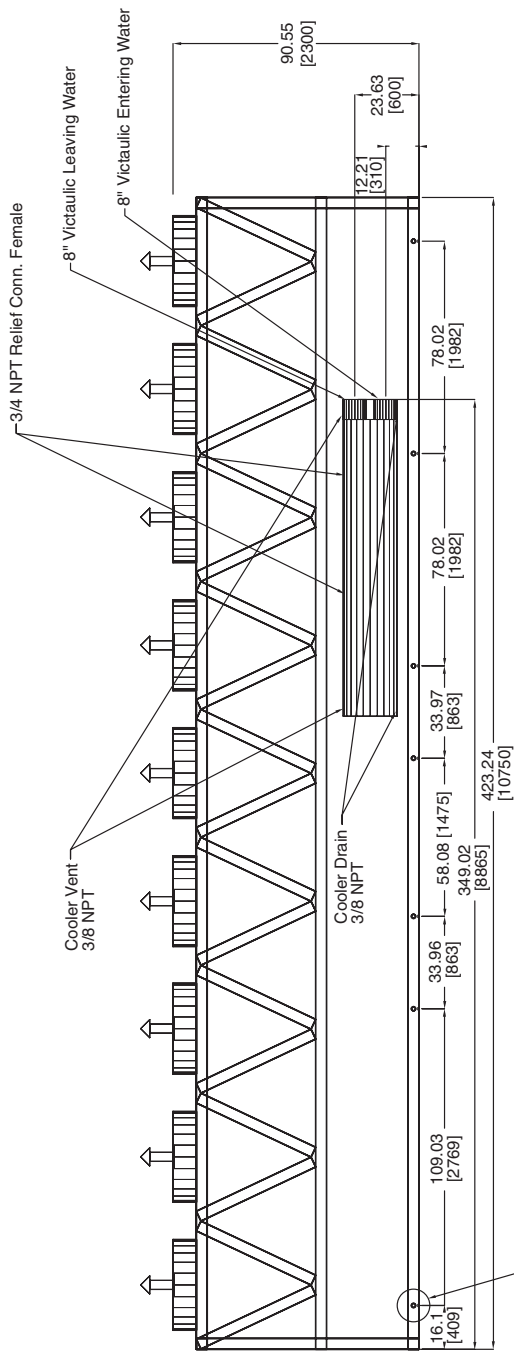


- NOTES:**
- Unit must have clearances as follows:
    - Top — Do not restrict
    - Sides and Ends — 6 ft from solid surface.
  - Temperature relief devices are located on liquid line and economizer assemblies and have 1/4-in. flare connection.
  - 3/8-in. NPT vents and drains located in each cooler head at each end of cooler.
  - Drawing depicts unit with single-point power, and dual-point power (380 v), standard condenser fans and standard two-pass cooler. Refer to the Packaged Chiller Builder program for other configurations.
  - Dimensions are shown in inches; dimensions in brackets are in millimeters.

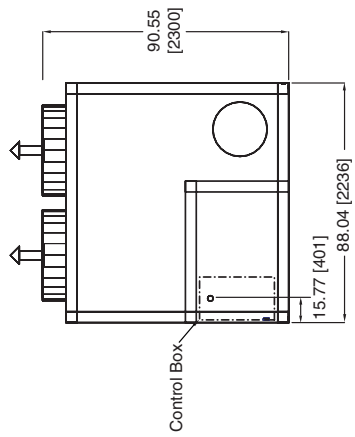
30XA UNIT	A	B
325	42.92 (1090)	246.16 (6252)
350	42.92 (1090)	246.72 (6267)



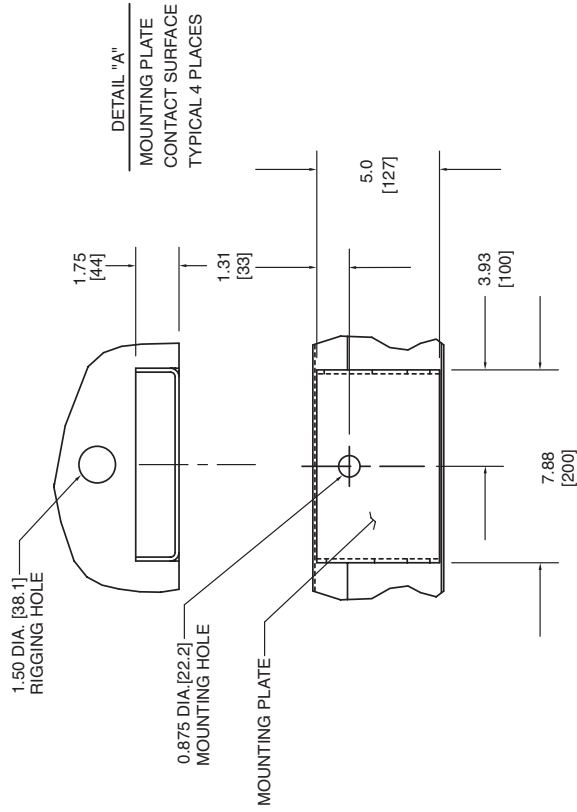
**Fig. 8 — 30XA325,350 Air-Cooled Liquid Chiller Dimensions**



**FRONT VIEW**

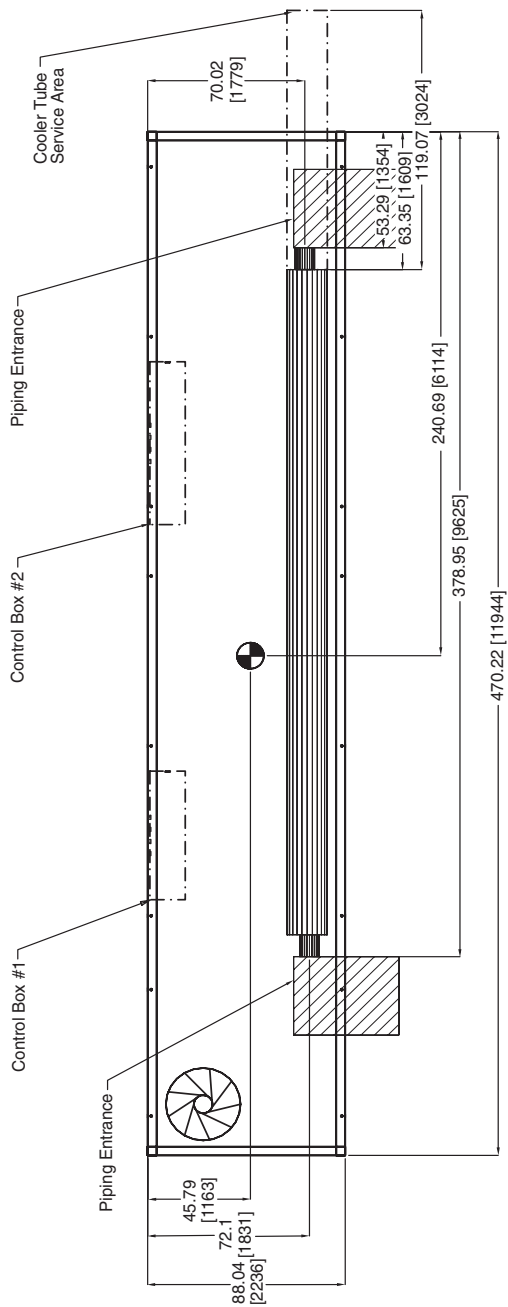


**LEFT END VIEW**

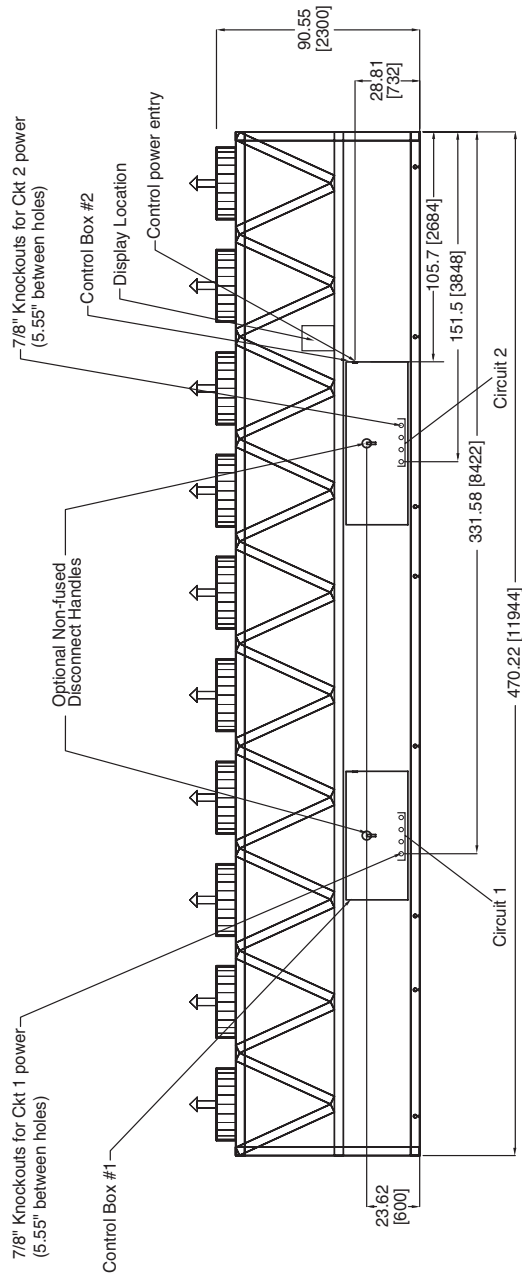


**Fig. 8 — 30XA325,350 Air-Cooled Liquid Chiller Dimensions (cont)**

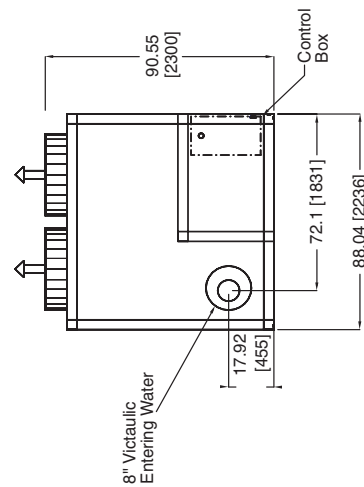
- NOTES:**
- Unit must have clearances as follows:
    - Top — Do not restrict
    - Sides and Ends — 6 ft from solid surface.
  - Temperature relief devices are located on liquid line and economizer assemblies and have 1/4-in. flare connection.
  - 3/8-in. NPT vents and drains located in each cooler head at each end of cooler.
  - Drawing depicts unit with dual-point power standard condenser fans and standard one-pass cooler. Refer to the Packaged Chiller Builder program for other configurations.
  - Actual cooler consists of two separate coolers piped in series at the factory. Piping may be split for rigging.
  - Dimensions are shown in inches; dimensions in brackets are in millimeters.



**TOP VIEW**



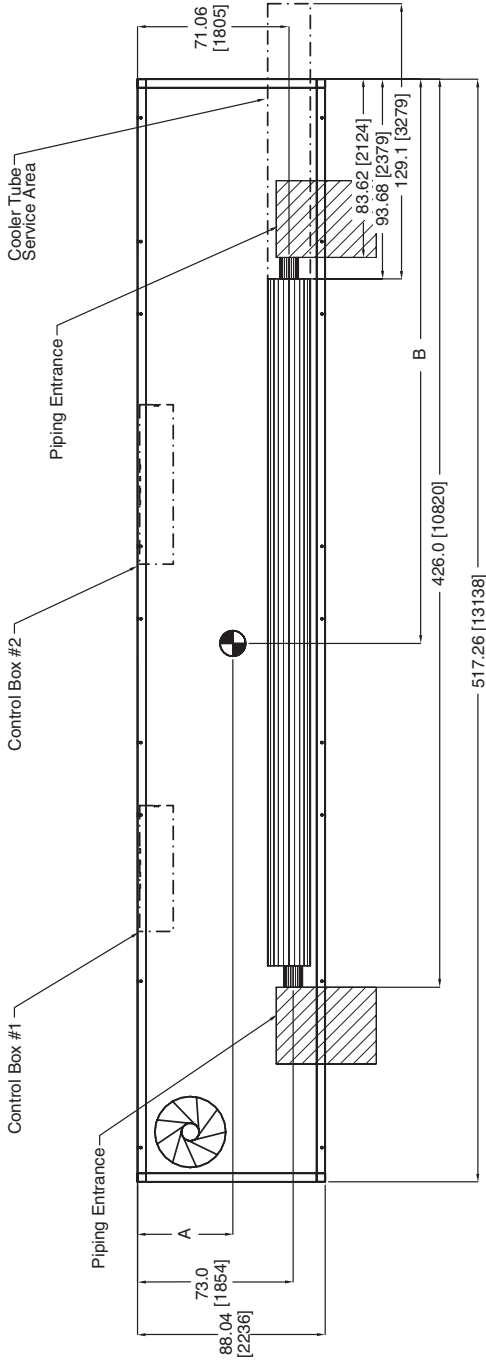
**BACK VIEW**



**RIGHT END VIEW**

**Fig. 9 — 30XA400 Air-Cooled Liquid Chiller Dimensions**

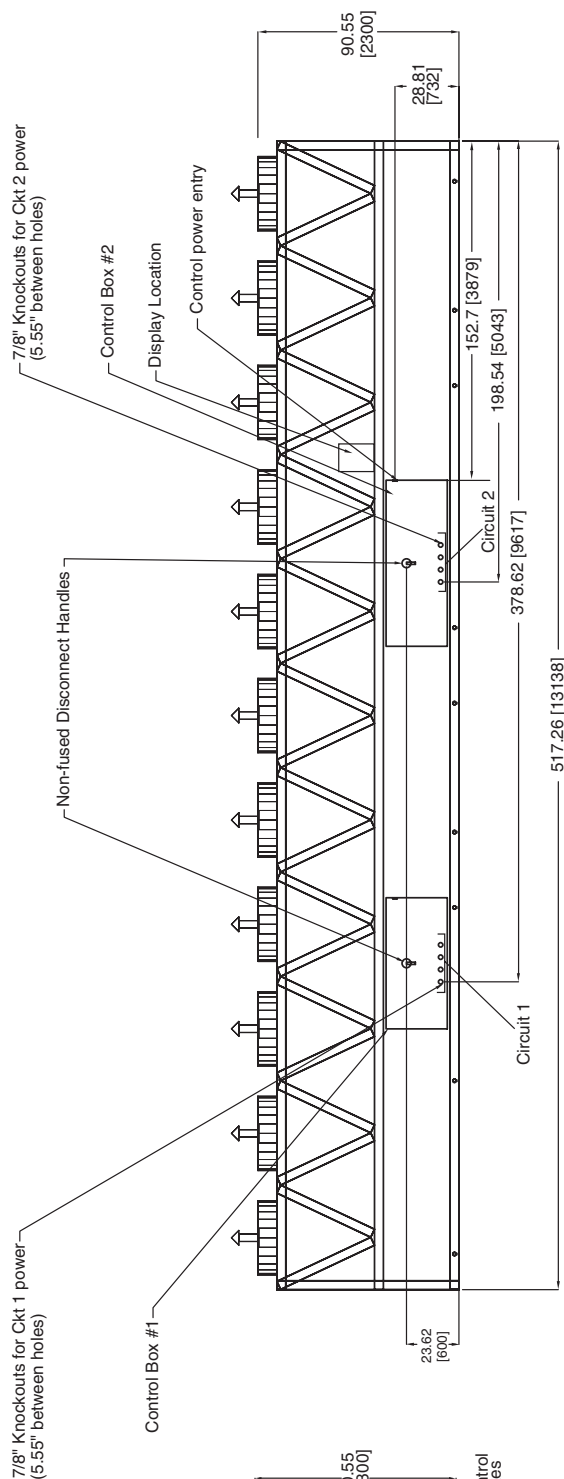




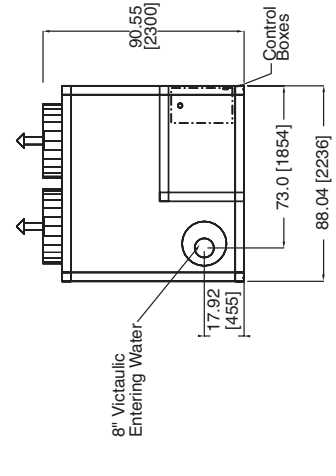
**TOP VIEW**

- NOTES:**
1. Unit must have clearances as follows:  
Top — Do not restrict  
Sides and Ends — 6 ft from solid surface.
  2. Temperature relief devices are located on liquid line and economizer assemblies and have 1/4-in. flare connection.
  3. 3/8-in. NPT vents and drains located in each cooler head at each end of cooler.
  4. Drawing depicts unit with dual-point power standard condenser fans and standard one-pass cooler. Refer to the Packaged Chiller Builder program for other configurations.
  5. Actual cooler consists of two separate coolers piped in series at the factory. Piping may be split for rigging.
  6. Dimensions are shown in inches; dimensions in brackets are in millimeters.

30XA UNIT	A	B
450	44.71 (1136)	264.7 (6723)
500	44.78 (1137)	263.99 (6705)

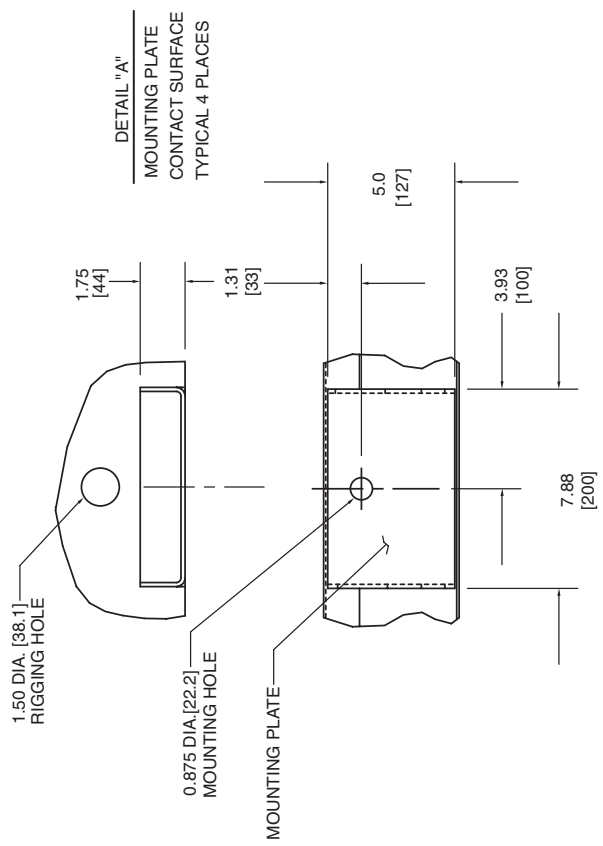
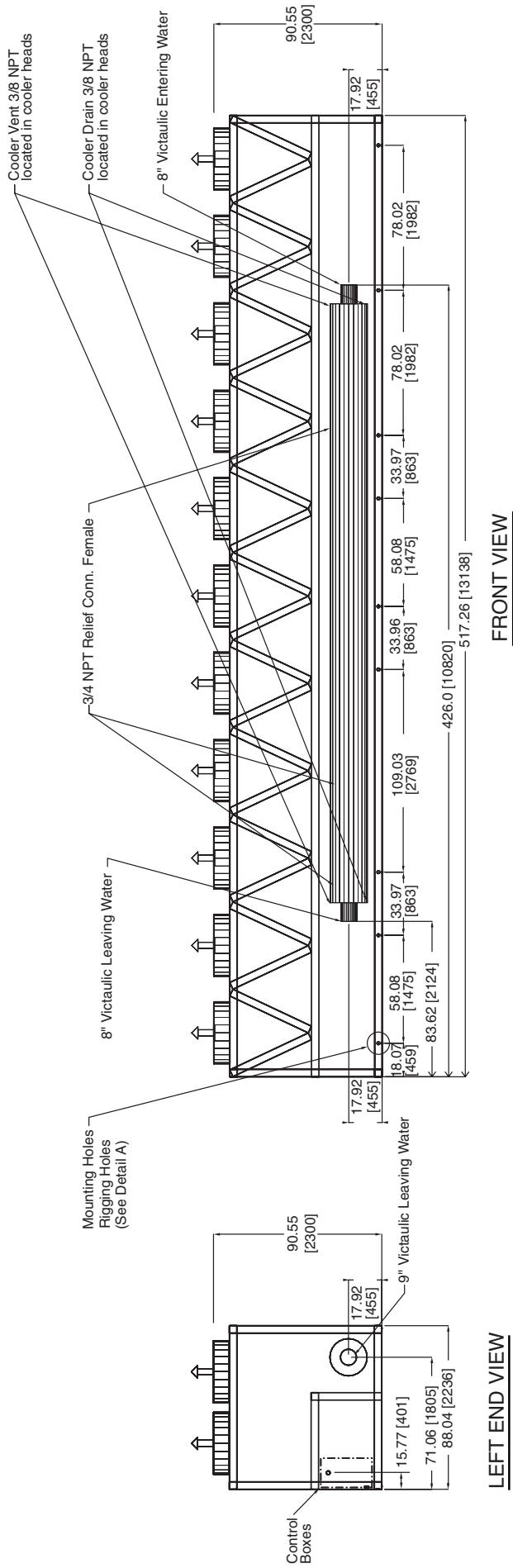


**BACK VIEW**



**RIGHT END VIEW**

**Fig. 10 — 30XA450,500 Air-Cooled Liquid Chiller Dimensions**



**Fig. 10 — 30XA450,500 Air-Cooled Liquid Chiller Dimensions (cont)**

**Unit Weights — Standard Units**  
**Unit Weights — English**

30XA UNIT SIZE	MOUNTING WEIGHT (lb)																
	A	B	C	D	Total												
080	2059	1785	1778	2051	7674												
30XA UNIT SIZE	MOUNTING WEIGHT (lb)																
	A	B	C	D	E	F	Total										
090	1273	2188	822	1023	2127	1271	8704										
100	1299	2244	853	1054	2184	1297	8931										
110	1312	2284	872	1079	2222	1303	9071										
120	1346	2322	874	1082	2255	1337	9216										
30XA UNIT SIZE	MOUNTING WEIGHT (lb)																
	A	B	C	D	E	F	G	H	Total								
140	2007	1554	938	1254	1291	957	1695	1809	11,505								
160	2061	1581	953	1281	1321	974	1715	1862	11,748								
30XA UNIT SIZE	MOUNTING WEIGHT (lb)																
	A	B	C	D	E	F	G	H	I	J	Total						
180	979	1558	1239	1998	1261	1298	2016	915	1363	962	13,590						
200	984	1574	1263	2020	1267	1308	2029	923	1375	968	13,712						
30XA UNIT SIZE	MOUNTING WEIGHT (lb)																
	A	B	C	D	E	F	G	H	I	J	K	L	Total				
220	883	1266	1697	1603	898	1286	1329	918	1468	1169	1307	902	14,727				
240	900	1288	1723	1626	901	1289	1331	921	1477	1179	1331	920	14,887				
260	566	1572	1701	834	2607	1084	1599	2521	871	1404	1528	566	16,853				
280	569	1594	1734	843	2640	1087	1601	2533	875	1429	1549	569	17,022				
300	578	1617	1762	862	2720	1103	1633	2607	887	1444	1570	578	17,362				
30XA UNIT SIZE	MOUNTING WEIGHT (lb)																
	A	B	C	D	E	F	G	H	I	J	K	L	M	N	Total		
325	856	856	1054	1607	859	2697	1143	1639	2485	880	1722	1322	856	856	18,834		
350	860	860	1059	1623	869	2752	1153	1666	2539	885	1727	1326	860	860	19,040		
30XA UNIT SIZE	MOUNTING WEIGHT (lb)																
	A	B	C	D	E	F	G	H	I	J	K	L	M	N	O	P	Total
400	924	1311	1588	3119	1332	866	2368	1148	1643	2440	824	1342	2306	1069	1354	945	24,578
450	933	1256	2276	2398	982	1134	2184	2207	2866	2089	1629	1343	1556	1501	1293	953	26,600
500	921	1314	2325	2452	987	1139	2194	2217	2875	2098	1633	1348	1575	1519	1357	941	26,894

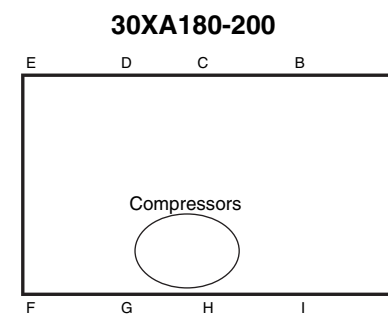
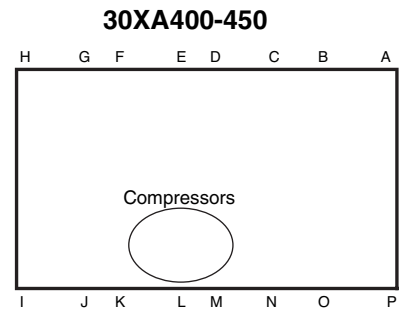
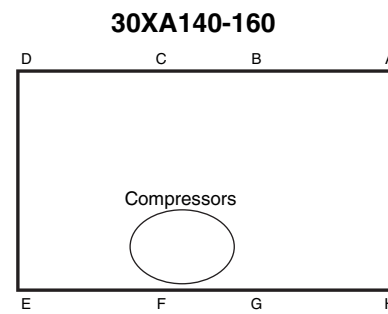
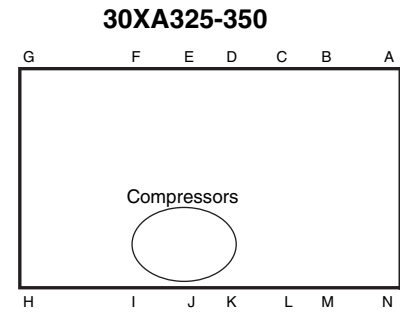
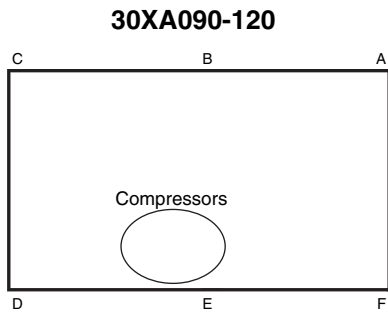
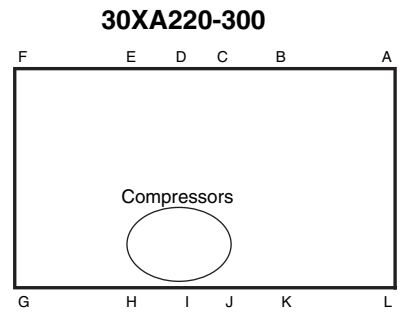
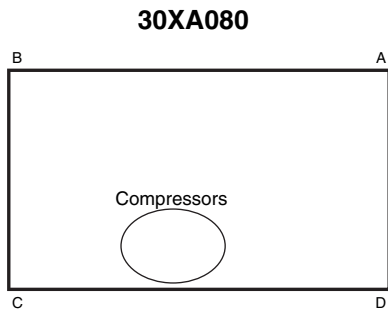
NOTE: Condenser Coil: Aluminum Fins/Copper Tubing.

**Unit Weights — SI**

30XA UNIT SIZE	MOUNTING WEIGHTS (kg)																
	A	B	C	D	Total												
080	934	810	807	930	3481												
30XA UNIT SIZE	MOUNTING WEIGHT (kg)																
	A	B	C	D	E	F	Total										
090	578	992	373	464	965	576	3948										
100	589	1018	387	478	991	588	4051										
110	595	1036	396	489	1008	591	4115										
120	611	1053	397	491	1023	607	4181										
30XA UNIT SIZE	MOUNTING WEIGHT (kg)																
	A	B	C	D	E	F	G	H	Total								
140	910	705	425	569	585	434	769	821	5219								
160	935	717	432	581	599	442	778	845	5329								
30XA UNIT SIZE	MOUNTING WEIGHT (kg)																
	A	B	C	D	E	F	G	H	I	J	Total						
180	444	707	562	906	572	589	915	415	618	436	6164						
200	446	714	573	916	575	593	920	419	624	439	6220						
30XA UNIT SIZE	MOUNTING WEIGHT (kg)																
	A	B	C	D	E	F	G	H	I	J	K	L	Total				
220	401	574	770	727	407	583	603	416	666	530	593	409	6680				
240	408	584	782	738	409	585	604	418	670	535	604	417	6753				
260	257	713	772	378	1182	492	725	1144	395	637	693	257	7644				
280	258	723	787	382	1197	493	726	1149	397	648	703	258	7721				
300	262	734	799	391	1234	501	741	1182	402	655	712	262	7876				
30XA UNIT SIZE	MOUNTING WEIGHT (kg)																
	A	B	C	D	E	F	G	H	I	J	K	L	M	N	Total		
325	388	388	478	729	390	1224	518	744	1127	399	781	600	388	388	8543		
350	390	390	480	736	394	1248	523	756	1152	401	784	601	390	390	8636		
30XA UNIT SIZE	MOUNTING WEIGHT (kg)																
	A	B	C	D	E	F	G	H	I	J	K	L	M	N	O	P	Total
400	419	595	720	1415	604	393	1074	521	745	1107	374	609	1046	485	614	428	11,149
450	423	570	1032	1088	446	514	991	1001	1300	948	739	609	706	681	586	432	12,066
500	418	596	1055	1112	448	516	995	1005	1304	952	741	611	714	689	616	427	12,199

NOTE: Condenser Coil: Aluminum Fins/Copper Tubing.

**Fig. 11 — Unit Mounting Weights**



**Fig. 11 — Unit Mounting Weights (cont)**

**Table 1A — Physical Data, 30XA080-500 — English**

UNIT 30XA	080	090	100	110	120	140	160	180	200	220
<b>OPERATING WEIGHT (lb)</b> Al/Cu Condenser Coils	7,674	8,704	8,931	9,071	9,216	11,505	11,748	13,590	13,712	14,727
<b>REFRIGERANT TYPE</b> Refrigerant Charge (lb) Ckt A/Ckt B/Ckt C	R-134a, EXV Controlled System 86/86/—   97/97/—   108/108/—   135/108/—   135/135/—   202/115/—   225/135/—   205/205/—   225/225/—   270/225/—									
<b>COMPRESSORS</b> Quantity Speed (rpm) (Qty) Compressor Nominal Capacity (tons) Ckt A (Qty) Compressor Nominal Capacity (tons) Ckt B (Qty) Compressor Nominal Capacity (tons) Ckt C Oil Charge (gal), Ckt A/Ckt B/Ckt C Minimum Capacity Step (%) Standard Optional	Semi-Hermetic Twin Rotary Screws 2   2   2   2   2   2   2   2   2   2   2 3500 (1) 45*   (1) 45   (1) 50   (1) 60   (1) 60   (1) 60   (1) 90   (1) 100   (1) 90   (1) 100   (1) 120 (1) 45*   (1) 45   (1) 50   (1) 50   (1) 60   (1) 50   (1) 60   (1) 60   (1) 90   (1) 100   (1) 100 N/A   N/A   N/A   N/A   N/A   N/A   N/A   N/A   N/A   N/A   N/A 5.5/5.5/—   5.5/5.5/—   5.5/5.5/—   5.5/5.5/—   5.5/5.5/—   5.5/5.5/—   6.25/5.5/—   6.25/5.5/—   6.25/6.25/—   6.25/6.25/—   6.75/6.25/— 15   15   15   14   15   11   11   15   15   15   14 9   9   9   8   10   7   8   10   10   10   10									
<b>COOLER</b> Net Fluid Volume (gal.) Maximum Refrigerant Pressure (psig) Maximum Fluid Side Pressure (psig)	Flooded, Shell and Tube Type 16.5   18.5   18.5   20.0   23.0   25.5   27.5   31.5   34.0   37.0 220   220   220   220   220   220   220   220   220   220   220 300   300   300   300   300   300   300   300   300   300   300									
<b>WATER CONNECTIONS</b> Drain (NPT, in.) Standard, Inlet and Outlet, Victaulic (in.) Number of passes Minus 1 Pass, Inlet and Outlet, Victaulic (in.) Number of passes Plus 1 Pass, Inlet and Outlet, Victaulic (in.) Number of Passes	3/8   3/8   3/8   3/8   3/8   3/8   3/8   3/8   3/8   3/8   3/8 5   5   5   5   5   5   5   6   6   6   6 2   2   2   2   2   2   2   2   2   2   2 5   5   5   5   5   5   5   8   8   8   8 1   1   1   1   1   1   1   1   1   1   1 4   4   4   4   4   5   5   6   6   6   6 3   3   3   3   3   3   3   3   3   3   3									
<b>CONDENSER FANS</b> Fan Speed (rpm) Standard/High Ambient† No. Blades...Diameter (in.) No. Fans (Ckt A/Ckt B/Ckt C) Total Airflow (cfm) 850 rpm Total Airflow (cfm) 1140 rpm	Shrouded Axial Type, Vertical Discharge 850/—   850/—   850/—   850/—   850/—   850/1140   850/1140   850/1140   850/1140   850/1140   850/1140 9...30   9...30   9...30   9...30   9...30   9...30   9...30   9...30   9...30   9...30   9...30 3/3/—   4/4/—   4/4/—   4/4/—   4/4/—   4/4/—   6/4/—   6/4/—   6/6/—   6/6/—   7/6/— 55,800   74,400   74,400   74,400   74,400   74,400   93,000   93,000   111,600   111,600   120,900 —   —   —   —   —   —   124,000   124,000   148,800   148,800   161,200									
<b>CONDENSER COILS</b> No. Coils (Ckt A/Ckt B/Ckt C) Total Face Area (sq ft)	3/3/—   4/4/—   4/4/—   4/4/—   4/4/—   6/4/—   6/4/—   6/6/—   6/6/—   7/6/— 141   188   188   188   188   234   234   281   281   305									
<b>CHASSIS DIMENSIONS (ft-in.)</b> Length Width Height	11-10                       15-9                       19-8               23-7           27-6 7-4 <sup>25</sup> / <sub>32</sub> 7-6 <sup>7</sup> / <sub>16</sub>									

UNIT 30XA	240	260	280	300	325	350	400	450	500	
<b>OPERATING WEIGHT (lb)</b> Al/Cu Condenser Coils	14,887	16,853	17,022	17,362	18,834	19,040	24,578	26,600	26,894	
<b>REFRIGERANT TYPE</b> Refrigerant Charge (lb) Ckt A/Ckt B/Ckt C	R-134a, EXV Controlled System 270/270/—   375/220/—   375/270/—   415/270/—   375/375/—   415/375/—   270/270/375   415/205/415   415/270/415									
<b>COMPRESSORS</b> Quantity Speed (rpm) (Qty) Compressor Nominal Capacity (tons) Ckt A (Qty) Compressor Nominal Capacity (tons) Ckt B (Qty) Compressor Nominal Capacity (tons) Ckt C Oil Charge (gal), Ckt A/Ckt B/Ckt C Minimum Capacity Step (%) Standard Optional	Semi-Hermetic Twin Rotary Screws 2   2   2   2   2   2   2   3   3   3 3500 (1) 120   (1) 165   (1) 165   (1) 185   (1) 165   (1) 185   (1) 185   (1) 120   (1) 90   (1) 120 (1) 120   (1) 100   (1) 120   (1) 120   (1) 120   (1) 165   (1) 165   (1) 120   (1) 185   (1) 185 N/A   N/A   N/A   N/A   N/A   N/A   N/A   (1) 165   (1) 185   (1) 185 6.75/6.75/—   7.5/6.75/—   7.5/6.75/—   7.5/6.75/—   7.5/6.75/—   7.5/7.5/—   7.5/7.5/—   6.75/6.75/7.5   7.5/6.25/7.5   7.5/6.75/7.5									
<b>COOLER</b> Net Fluid Volume (gal.) Maximum Refrigerant Pressure (psig) Maximum Fluid Side Pressure (psig)	Flooded, Shell and Tube Type 39.0   42.0   44.0   48.5   50.5   53.4   68.0   75.0   83.0 220   220   220   220   220   220   220   220   220   220 300   300   300   300   300   300   300   150   150   150									
<b>WATER CONNECTIONS</b> Drain (NPT, in.) Standard, Inlet and Outlet, Victaulic (in.) Number of passes Minus 1 Pass, Inlet and Outlet, Victaulic (in.) Number of passes Plus 1 Pass, Inlet and Outlet, Victaulic (in.) Number of Passes	3/8   3/8   3/8   3/8   3/8   3/8   3/8   3/8   3/8   3/8 6   8   8   8   8   8   8   8   8   8 2   2   2   2   2   2   2   1   1   1 8   8   8   8   8   8   8   —   —   — 1   1   1   1   1   1   1   —   —   — 6   8   8   8   8   8   8   —   —   — 3   3   3   3   3   3   3   —   —   —									
<b>CONDENSER FANS</b> Fan Speed (rpm) Standard/High Ambient† No. Blades...Diameter (in.) No. Fans (Ckt A/Ckt B/Ckt C) Total Airflow (cfm) 850 rpm Total Airflow (cfm) 1140 rpm	Shrouded Axial Type, Vertical Discharge 850/1140   850/1140   850/1140   850/1140   850/1140   850/1140   850/1140   850/1140   850/1140   850/1140 9...30   9...30   9...30   9...30   9...30   9...30   9...30   9...30   9...30   9...30 7/6/—   9/6/—   10/6/—   10/6/—   9/9/—   9/9/—   9/9/—   6/6/8   8/6/8   8/6/8 120,900   139,500   148,800   148,800   148,800   167,400   186,000   186,000   204,600   204,600 161,200   186,000   198,400   198,400   223,200   223,200   223,200   248,000   272,800   272,800									
<b>CONDENSER COILS</b> No. Coils (Ckt A/Ckt B/Ckt C) Total Face Area (sq ft)	7/6/—   9/6/—   10/6/—   10/6/—   9/9/—   9/9/—   6/6/8   8/6/8   8/6/8 305   352   375   375   422   422   469   516   516									
<b>CHASSIS DIMENSIONS (ft-in.)</b> Length Width Height	27-6                       31-5                       35-4           39-3           43-2 7-4 <sup>3</sup> / <sub>4</sub> 7-6 <sup>7</sup> / <sub>16</sub>									

**LEGEND**

- Cu** — Copper
- Al** — Aluminum
- EXV** — Electronic Expansion Valve
- N/A** — Not Applicable

\*30XA080 unit does not have an economizer.

†The high ambient temperature option is not available on 30XA080-120 units.

**Table 1B — 30XA080-500 — SI**

UNIT 30XA	080	090	100	110	120	140	160	180	200	220
<b>OPERATING WEIGHT (kg)</b> Al-Cu Condenser Coils	3 481	3 948	4 051	4 115	4 181	5 219	5 329	6 164	6 220	6 680
<b>REFRIGERANT TYPE</b> Refrigerant Charge (kg) Ckt A/Ckt B/Ckt C	R-134a, EXV Controlled System 39/39/—   44/44/—   49/49/—   49/44/—   102/102/—   91.6/52.2/—   102/61.2/—   93/93/—   102/102/—   122.5/102/—									
<b>COMPRESSORS</b> Quantity Speed (r/s)	Semi-Hermetic Twin Rotary Screws 2   2   2   2   2   58.3   2   2   2   2									
(Qty) Compressor Nominal Capacity (tons) Ckt A	(1) 45*	(1) 45	(1) 50	(1) 60	(1) 60	(1) 90	(1) 100	(1) 90	(1) 100	(1) 120
(Qty) Compressor Nominal Capacity (tons) Ckt B	(1) 45*	(1) 45	(1) 50	(1) 50	(1) 60	(1) 50	(1) 60	(1) 90	(1) 100	(1) 100
(Qty) Compressor Nominal Capacity (tons) Ckt C	N/A	N/A	N/A	N/A	N/A	N/A	N/A	N/A	N/A	N/A
Oil Charge (liters), Ckt A/Ckt B/Ckt C	20.8/20.8/—	20.8/20.8/—	20.8/20.8/—	20.8/20.8/—	20.8/20.8/—	23.7/20.8/—	23.7/23.7/—	23.7/23.7/—	23.7/23.7/—	25.6/23.7/—
Minimum Capacity Step (%) Standard Optional	15 9	15 9	15 9	14 8	15 10	11 7	11 8	15 10	15 10	14 10
<b>COOLER</b> Net Fluid Volume (liters) Maximum Refrigerant Pressure (kPa) Maximum Fluid Side Pressure (kPa)	Flooded, Shell and Tube Type 62.5   70.0   70.0   75.7   87.1   96.5   104.1   119.2   128.7   140.1 1516.8   1516.8   1516.8   1516.8   1516.8   1516.8   1516.8   1516.8   1516.8   1516.8 2 068   2 068   2 068   2 068   2 068   2 068   2 068   2 068   2 068   2 068									
<b>WATER CONNECTIONS</b> Drain (NPT, in.) Standard, Inlet and Outlet, Victaulic (in.) Number of passes Minus 1 Pass, Inlet and Outlet, Victaulic (in.) Number of passes Plus 1 Pass, Inlet and Outlet, Victaulic (in.) Number of Passes	3/8 5 2 5 1 4 3	3/8 5 2 5 1 4 3	3/8 5 2 5 1 4 3	3/8 5 2 5 1 4 3	3/8 5 2 5 1 4 3	3/8 5 2 5 1 4 3	3/8 5 2 5 1 4 3	3/8 5 2 5 1 4 3	3/8 5 2 5 1 4 3	3/8 5 2 5 1 4 3
<b>CONDENSER FANS</b> Fan Speed (r/s) Standard/High Ambient† No. Blades...Diameter (mm) No. Fans (Ckt A/Ckt B/Ckt C) Total Airflow (L/s) 14.2 r/s Total Airflow (L/s) 19.0 r/s	Shrouded Axial Type, Vertical Discharge 14.2/—   14.2/—   14.2/—   14.2/—   14.2/—   14.2/19.0   14.2/19.0   14.2/19.0   14.2/19.0   14.2/19.0 9...762   9...762   9...762   9...762   9...762   9...762   9...762   9...762   9...762   9...762 3/3/—   4/4/—   4/4/—   4/4/—   4/4/—   6/4/—   6/4/—   6/4/—   6/6/—   6/6/— 26 335   35 113   35 113   35 113   35 113   43 891   43 891   43 891   52 669   52 669 —   —   —   —   —   58 522   58 522   58 522   70 226   70 226									
<b>CONDENSER COILS</b> No. Coils (Ckt A/Ckt B/Ckt C) Total Face Area (sq m)	3/3/— 13	4/4/— 17	4/4/— 17	4/4/— 17	4/4/— 17	6/4/— 22	6/4/— 22	6/6/— 26	6/6/— 26	7/6/— 28
<b>CHASSIS DIMENSIONS (mm)</b> Length Width Height	3 606   4 800   2 255   5 994   7 188   8 382 2296.9									

UNIT 30XA	240	260	280	300	325	350	400	450	500
<b>OPERATING WEIGHT (kg)</b> Al-Cu Condenser Coils	6 753	7 644	7 721	7 876	8 543	8 636	11 149	12 066	12 199
<b>REFRIGERANT TYPE</b> Refrigerant Charge (kg) Ckt A/Ckt B/Ckt C	R-134a, EXV Controlled System 122.5/122.5/   170.1/99.8/   170.1/122.5/   188.3/122.5/   170.1/170.1/   188.3/170.1/   122.5/122.5/   188.3/102/   188.3/188.3/   188.3/188.3/								
<b>COMPRESSORS</b> Quantity Speed (r/s)	Semi-Hermetic Twin Rotary Screws 2   2   2   2   2   2   3   3   3								
(Qty) Compressor Nominal Capacity (tons) Ckt A	(1) 120	(1) 165	(1) 165	(1) 185	(1) 165	(1) 185	(1) 120	(1) 90	(1) 120
(Qty) Compressor Nominal Capacity (tons) Ckt B	(1) 120	(1) 100	(1) 120	(1) 120	(1) 165	(1) 165	(1) 120	(1) 185	(1) 185
(Qty) Compressor Nominal Capacity (tons) Ckt C	N/A	N/A	N/A	N/A	N/A	N/A	(1) 165	(1) 185	(1) 185
Oil Charge (liter), Ckt A/Ckt B/Ckt C	25.6/25.6/—	28.4/25.6/—	28.4/25.6/—	28.4/25.6/—	28.4/28.4/—	28.4/28.4/—	25.6/25.6/28.4	28.4/23.7/28.4	28.4/25.6/28.4
Minimum Capacity Step (%) Standard Optional	15 10	10 8	13 9	12 7	15 10	14 10	9 6	6 4	7 5
<b>COOLER</b> Net Fluid Volume (liters) Maximum Refrigerant Pressure (kPa) Maximum Fluid Side Pressure (kPa)	Flooded, Shell and Tube Type 147.6   159.0   166.6   183.6   191.2   202.1   257.4   283.9   314.2 1516.8   1516.8   1516.8   1516.8   1516.8   1516.8   1516.8   1516.8   1516.8 2 068   2 068   2 068   2 068   2 068   2 068   1 034   1 034   1 034								
<b>WATER CONNECTIONS</b> Drain (NPT, in.) Standard, Inlet and Outlet, Victaulic (in.) Number of passes Minus 1 Pass, Inlet and Outlet, Victaulic (in.) Number of passes Plus 1 Pass, Inlet and Outlet, Victaulic (in.) Number of Passes	3/8 6 2 8 1 6 3	3/8 8 2 8 1 8 3	3/8 8 2 8 1 8 3	3/8 8 2 8 1 8 3	3/8 8 2 8 1 8 3	3/8 8 2 8 1 8 3	3/8 8 2 8 1 8 3	3/8 8 2 8 1 8 3	3/8 8 2 8 1 8 3
<b>CONDENSER FANS</b> Fan Speed (r/s) Standard/High Ambient† No. Blades...Diameter (mm) No. Fans (Ckt A/Ckt B/Ckt C) Total Airflow (L/s) 14.2 r/s Total Airflow (L/s) 19.0 r/s	Shrouded Axial Type, Vertical Discharge 14.2/19.0   14.2/19.0   14.2/19.0   14.2/19.0   14.2/19.0   14.2/19.0   14.2/19.0   14.2/19.0   14.2/19.0 9...762   9...762   9...762   9...762   9...762   9...762   9...762   9...762   9...762 7/6/—   9/6/—   10/6/—   10/6/—   9/9/—   9/9/—   6/6/8   8/6/8   8/6/8 57 059   65 837   70 226   70 226   79 004   79 004   87 782   96 561   96 561 76 078   87 782   93 634   93 634   93 634   105 339   117 043   128 747   128 747								
<b>CONDENSER COILS</b> No. Coils (Ckt A/Ckt B/Ckt C) Total Face Area (sq m)	7/6/— 28	9/6/— 33	10/6/— 35	10/6/— 35	9/9/— 39	9/9/— 39	6/6/8 44	8/6/8 48	8/6/8 48
<b>CHASSIS DIMENSIONS (mm)</b> Length Width Height	8 382   9 576   10 770   11 964   13 158 2 300								

**LEGEND**

- Cu — Copper
- Al — Aluminum
- EXV — Electronic Expansion Valve
- N/A — Not Applicable

\*30XA080 unit does not have an economizer.

†The high ambient temperature option is not available on 30XA080-120 units.

RIGGING UNIT (See Fig. 12-14) — The 30XA080-500 units are designed for overhead rigging and it is important that this method be used. Holes are provided in frame base channels, marked for rigging (see rigging label on unit). Field-supplied shackles are required to facilitate lifting. Secure the shackles to the base rails at the points noted on the rigging label. See Table 2 for the number of lifting points for each unit.

Do not use a forklift truck to move the units.

**Table 2 — Number of Lifting Points for 30XA080-500**

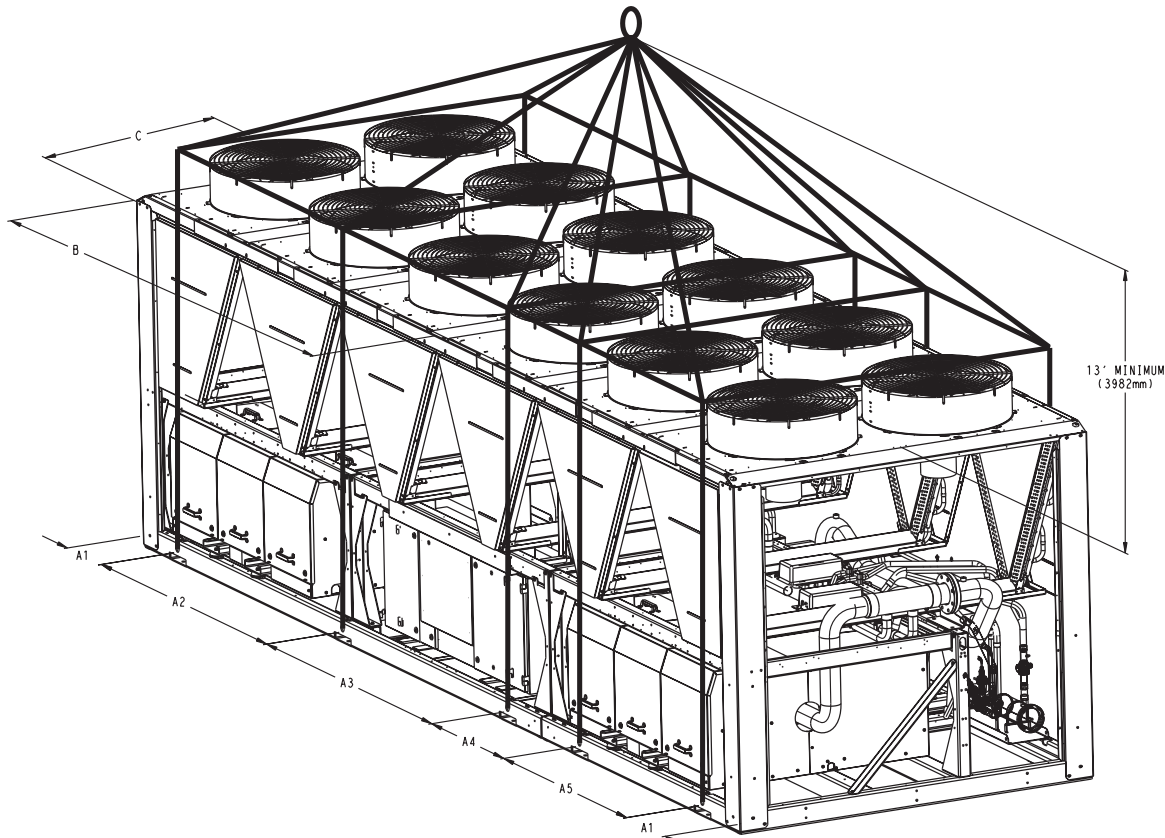
30XA UNIT SIZE	NUMBER OF LIFTING POINTS
080	4
090-120	6
140, 160	8
180, 200	10
220-400	12
450, 500	14

Use spreader bars to keep cables or chains clear of unit sides. As further protection plywood sheets may be placed against sides of unit, behind cables or chains. Run cables or chains to a central suspension point so that angle from horizontal is not less than 45 degrees. Raise and set unit down carefully.

See Fig. 12-14 for rigging centers of gravity.

For shipping, some domestic units and all export units are mounted on a wooden skid under entire base of unit. Skid can be removed before unit is moved to installation site. Lift the unit from above to remove skid. See Fig. 12-14 for rigging center of gravity. On export units, the top skid can be used as the spreader bars. If the unit was shipped with a shipping bag, the bag must be removed to gain access to the rigging holes in the base rail.

If overhead rigging is not available, the unit can be moved on rollers or dragged. When unit is moved on rollers, the unit skid, if equipped, must be removed. To lift the unit, use jacks at the rigging points. Use a minimum number of rollers to distribute the load such that the rollers are no more than 6 ft (1.8 m) apart. If the unit is to be dragged, lift the unit as described above, and place unit on a pad. Apply moving force to the pad, and not the unit. When in its final location, raise the unit and remove the pad. If the unit was shipped with coil protection, it must be removed before start-up. The shipping bag for export units must be removed before start-up.



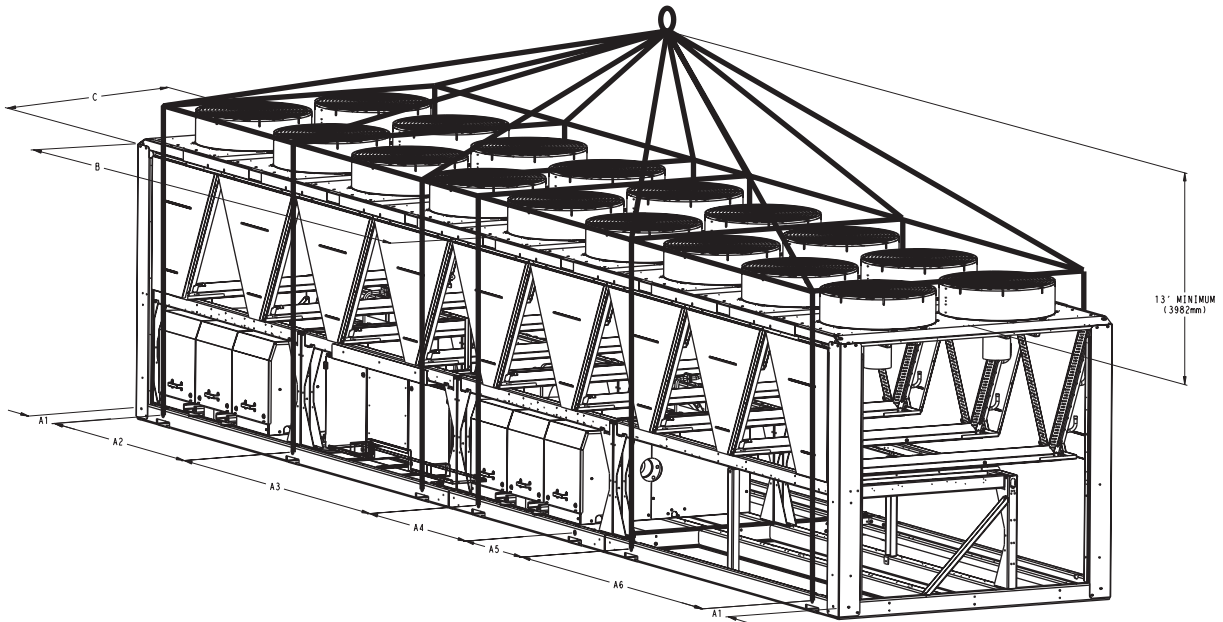
**CAUTION- NOTICE TO RIGGERS:**  
ALL PANELS MUST BE IN PLACE WHEN RIGGING. DO NOT ATTEMPT TO FORK THESE UNITS IF NO SKID IS SUPPLIED.

**NOTES:**

1. 1.50 IN. DIA. (38.1mm) LIFTING HOLES PROVIDED FOR FIELD SUPPLIED CLEVIS.
2. RIG WITH A MINIMUM OF 25FT (7620mm) LENGTH CHAINS OR CABLES.
3. IF CENTRAL LIFTING POINT IS USED, IT MUST BE A MINIMUM OF 13FT (3962mm) ABOVE THE TOP OF THE UNIT.
4. SPREADER BARS MADE FROM STEEL OR DOUBLE NAILED, AND NOTCHED 2X6'S APPROXIMATELY 8 FT (2438mm) LONG MUST BE PLACED JUST ABOVE THE TOP OF THE UNIT (AND STACKS) TO REDUCE THE RISK OF DAMAGE TO THE TOP OF THE UNIT AND COILS.
5. IF OVERHEAD RIGGING IS NOT AVAILABLE, THE UNIT CAN BE MOVED ON ROLLERS OR DRAGGED. WHEN UNIT IS MOVED ON ROLLERS, THE UNIT SKID, IF EQUIPPED, MUST BE REMOVED. TO LIFT THE UNIT, USE JACKS AT THE RIGGING POINTS. USE A MINIMUM OF ONE ROLLER EVERY 6FT (1829mm) TO DISTRIBUTE THE LOAD. IF THE UNIT IS TO BE DRAGGED, LIFT THE UNIT AS DESCRIBED ABOVE, AND PLACE UNIT ON A PAD. APPLY MOVING FORCE TO THE PAD, NOT THE UNIT. WHEN IN ITS FINAL LOCATION, RAISE THE UNIT AND REMOVE THE PAD.
6. CHECK BILL OF LADING FOR SHIPPING WEIGHT OF THE UNIT.

MODEL NUMBER	MAX. SHIPPING WT. WITHOUT PACKAGING		MAX. SHIPPING WT. WITH PACKAGING		LIFTING HOLES										CENTER OF GRAVITY					
	LB	KG	LB	KG	"A1"		"A2"		"A3"		"A4"		"A5"		"B"		"C"			
					IN.	MM	IN.	MM	IN.	MM	IN.	MM	IN.	MM	IN.	MM	IN.	MM		
30XA080	7594	3452	8574	3897	16.1	408.9	109.03	2769.3	---	---	---	---	---	---	75.5	1919	43.9	1114		
30XA090	8611	3914	9681	4400	16.1	408.9	78.02	1981.7	78.02	1981.7	---	---	---	---	101.3	2573	44.1	1120		
30XA100	8837	4017	9907	4503	16.1	408.9	78.02	1981.7	78.02	1981.7	---	---	---	---	101.0	2566	44.1	1120		
30XA110	8968	4076	10038	4563	16.1	408.9	78.02	1981.7	78.02	1981.7	---	---	---	---	100.6	2556	44.1	1120		
30XA120	9102	4137	10172	4624	16.1	408.9	78.02	1981.7	78.02	1981.7	---	---	---	---	101.1	2569	44.1	1120		
30XA140	11373	5170	12533	5697	16.1	408.9	62.02	1575.3	32.00	812.7	109.03	2769.3	---	---	119.4	3033	44.6	1134		
30XA160	11603	5274	12763	5802	16.1	408.9	62.02	1575.3	32.00	812.7	109.03	2769.3	---	---	119.6	3039	44.6	1133		
30XA180	13420	6100	14670	6668	16.1	408.9	78.02	1981.7	78.02	1981.7	32.00	812.7	62.02	1575.3	139.2	3536	46.1	1171		
30XA200	13525	6148	14775	6716	16.1	408.9	78.02	1981.7	78.02	1981.7	32.00	812.7	62.02	1575.3	139.3	3538	46.1	1172		

**Fig. 12 — Unit Rigging Label Detail 30XA080-200**



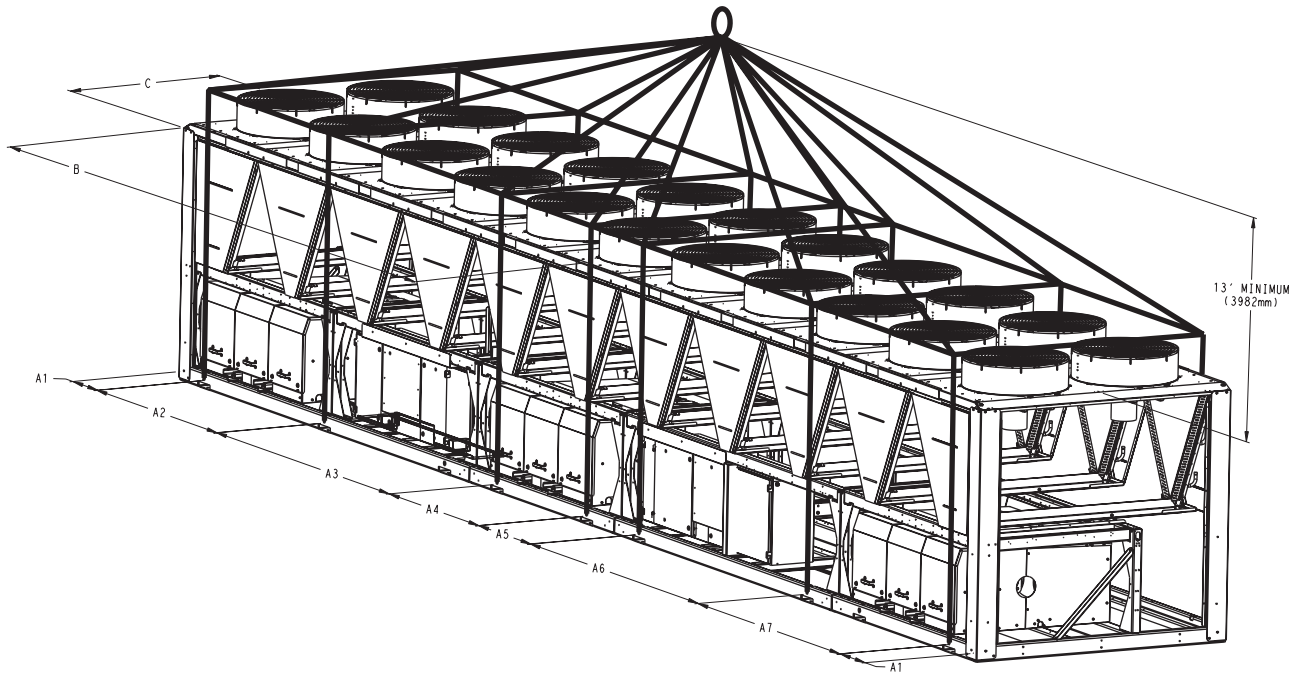
**CAUTION- NOTICE TO RIGGERS:**  
 ALL PANELS MUST BE IN PLACE WHEN RIGGING. DO NOT ATTEMPT TO FORK THESE UNITS IF NO SKID IS SUPPLIED.

**NOTES:**

1. 1.50 IN. DIA. (38.1mm) LIFTING HOLES PROVIDED FOR FIELD SUPPLIED CLEVIS.
2. RIG WITH A MINIMUM OF 25FT (7620mm) LENGTH CHAINS OR CABLES.
3. IF CENTRAL LIFTING POINT IS USED, IT MUST BE A MINIMUM OF 13FT (3962mm) ABOVE THE TOP OF THE UNIT.
4. SPREADER BARS MADE FROM STEEL OR DOUBLE NAILED, AND NOTCHED 2X6'S APPROXIMATELY 8 FT (2438mm) LONG MUST BE PLACED JUST ABOVE THE TOP OF THE UNIT (AND STACKS) TO REDUCE THE RISK OF DAMAGE TO THE TOP OF THE UNIT AND COILS.
5. IF OVERHEAD RIGGING IS NOT AVAILABLE, THE UNIT CAN BE MOVED ON ROLLERS OR DRAGGED. WHEN UNIT IS MOVED ON ROLLERS, THE UNIT SKID, IF EQUIPPED, MUST BE REMOVED. TO LIFT THE UNIT, USE JACKS AT THE RIGGING POINTS. USE A MINIMUM OF ONE ROLLER EVERY 6FT (1829mm) TO DISTRIBUTE THE LOAD. IF THE UNIT IS TO BE DRAGGED, LIFT THE UNIT AS DESCRIBED ABOVE, AND PLACE UNIT ON A PAD. APPLY MOVING FORCE TO THE PAD, NOT THE UNIT. WHEN IN ITS FINAL LOCATION, RAISE THE UNIT AND REMOVE THE PAD.
6. CHECK BILL OF LADING FOR SHIPPING WEIGHT OF THE UNIT.

MODEL NUMBER	MAX. SHIPPING WT. WITHOUT PACKAGING		MAX. SHIPPING WT. WITH PACKAGING		LIFTING HOLES												CENTER OF GRAVITY			
					"A1"		"A2"		"A3"		"A4"		"A5"		"A6"		"B"		"C"	
	LB	KG	LB	KG	IN.	MM	IN.	MM	IN.	MM	IN.	MM	IN.	MM	IN.	MM	IN.	MM	IN.	MM
30XA220	14522	6601	15862	7210	16.1	408.9	62.02	1575.3	32.00	812.7	109.03	2769.3	32.00	812.7	62.02	1575.3	157.9	4010	46.2	1173
30XA240	14668	6667	16008	7276	16.1	408.9	62.02	1575.3	32.00	812.7	109.03	2769.3	32.00	812.7	62.02	1575.3	158.5	4025	46.2	1174
30XA260	16615	7552	18045	8202	16.1	408.9	78.02	1981.7	78.02	1981.7	32.00	812.7	78.02	1981.7	78.02	1981.7	160.1	4066	44.2	1123
30XA280	16769	7622	18199	8272	16.1	408.9	78.02	1981.7	78.02	1981.7	32.00	812.7	78.02	1981.7	78.02	1981.7	160.4	4074	44.3	1125
30XA300	17082	7765	18512	8415	16.1	408.9	78.02	1981.7	78.02	1981.7	32.00	812.7	78.02	1981.7	78.02	1981.7	160.1	4066	44.3	1126
30XA325	18539	8427	20059	9118	16.1	408.9	78.02	1981.7	110.02	2794.5	62.02	1575.3	32.00	812.7	109.03	2769.3	177.1	4499	42.9	1090
30XA350	18727	8512	20247	9203	16.1	408.9	78.02	1981.7	110.02	2794.5	62.02	1575.3	32.00	812.7	109.03	2769.3	176.6	4485	42.9	1090

**Fig. 13 — Unit Rigging Label Detail 30XA220-350**



**CAUTION- NOTICE TO RIGGERS:**  
 ALL PANELS MUST BE IN PLACE WHEN RIGGING. DO NOT ATTEMPT TO FORK THESE UNITS IF NO SKID IS SUPPLIED.

**NOTES:**

1. 1.50 IN. DIA. (38.1mm) LIFTING HOLES PROVIDED FOR FIELD SUPPLIED CLEVIS.
2. RIG WITH A MINIMUM OF 25FT (7620mm) LENGTH CHAINS OR CABLES.
3. IF CENTRAL LIFTING POINT IS USED, IT MUST BE A MINIMUM OF 13FT (3962mm) ABOVE THE TOP OF THE UNIT.
4. SPREADER BARS MADE FROM STEEL OR DOUBLE NAILED, AND NOTCHED 2X6'S APPROXIMATELY 8 FT (2438mm) LONG MUST BE PLACED JUST ABOVE THE TOP OF THE UNIT (AND STACKS) TO REDUCE THE RISK OF DAMAGE TO THE TOP OF THE UNIT AND COILS.
5. IF OVERHEAD RIGGING IS NOT AVAILABLE, THE UNIT CAN BE MOVED ON ROLLERS OR DRAGGED. WHEN UNIT IS MOVED ON ROLLERS, THE UNIT SKID, IF EQUIPPED, MUST BE REMOVED. TO LIFT THE UNIT, USE JACKS AT THE RIGGING POINTS. USE A MINIMUM OF ONE ROLLER EVERY 6FT (1829mm) TO DISTRIBUTE THE LOAD. IF THE UNIT IS TO BE DRAGGED, LIFT THE UNIT AS DESCRIBED ABOVE, AND PLACE UNIT ON A PAD. APPLY MOVING FORCE TO THE PAD, NOT THE UNIT. WHEN IN ITS FINAL LOCATION, RAISE THE UNIT AND REMOVE THE PAD.
6. CHECK BILL OF LADING FOR SHIPPING WEIGHT OF THE UNIT.

MODEL NUMBER	MAX. SHIPPING WT. WITHOUT PACKAGING		MAX. SHIPPING WT. WITH PACKAGING		LIFTING HOLES										CENTER OF GRAVITY							
					"A1"		"A2"		"A3"		"A4"		"A5"		"A6"		"A7"		"B"		"C"	
	LB	KG	LB	KG	IN.	MM	IN.	MM	IN.	MM	IN.	MM	IN.	MM	IN.	MM	IN.	MM	IN.	MM	IN.	MM
30XA400	24214	11006	25824	11738	16.1	408.9	78.02	1981.7	110.02	2794.5	78.02	1981.7	110.02	2794.5	62.02	1575.3	---	---	229.6	5831	45.8	1163
30XA450	26175	11898	27875	12671	16.1	408.9	78.02	1981.7	110.02	2794.5	62.02	1575.3	32.00	812.7	109.03	2769.3	94.02	2388.1	252.6	6416	44.7	1136
30XA500	26436	12017	28136	12789	16.1	408.9	78.02	1981.7	110.02	2794.5	62.02	1575.3	32.00	812.7	109.03	2769.3	94.02	2388.1	253.3	6434	44.8	1137

**Fig. 14 — Unit Rigging Label Detail 30XA400-500**

**Step 3 — Cooler Fluid and Drain Piping Connections** — See Fig. 15-18 for piping applications.

**CAUTION**

Remove the chilled water flow switch, entering and leaving water thermistors before welding connecting piping. Reinstall flow switch and thermistors after welding is complete. Failure to remove these devices may cause unit damage.

**GENERAL** — The factory-installed victaulic connections allow clamp-on connection of water lines to the coolers in all 30XA units. A flow sensor is factory-installed in the side of the entering fluid nozzle. See Fig. 19. See Table 3 for 30XA unit operating range. See Fig. 16 for cooler option dimensions.

**DUAL CHILLER CONTROL** — The *ComfortLink™* controller allows 2 chillers (piped in parallel or series) to operate as a single chilled water plant with standard control functions coordinated through the master chiller controller. This standard *ComfortLink* feature requires a communication link between the 2 chillers.

There are several advantages to this type of control:

- redundancy (multiple circuits)
- better low load control, (lower tonnage capability)
- lower rigging lift weights (2 machines rather than one large machine)
- chiller lead-lag operation (evens the wear between the two machines)

**Dual Chiller Leaving Water Sensor** — If the Dual Chiller algorithm is used, and the machines are installed in parallel, a dual chilled water sensor must be installed for each module. Install the well in the common leaving water header. See Fig. 17.

**Minimum Loop Volume** — The preferred minimum loop volume is dependent on the type of application. In order to obtain

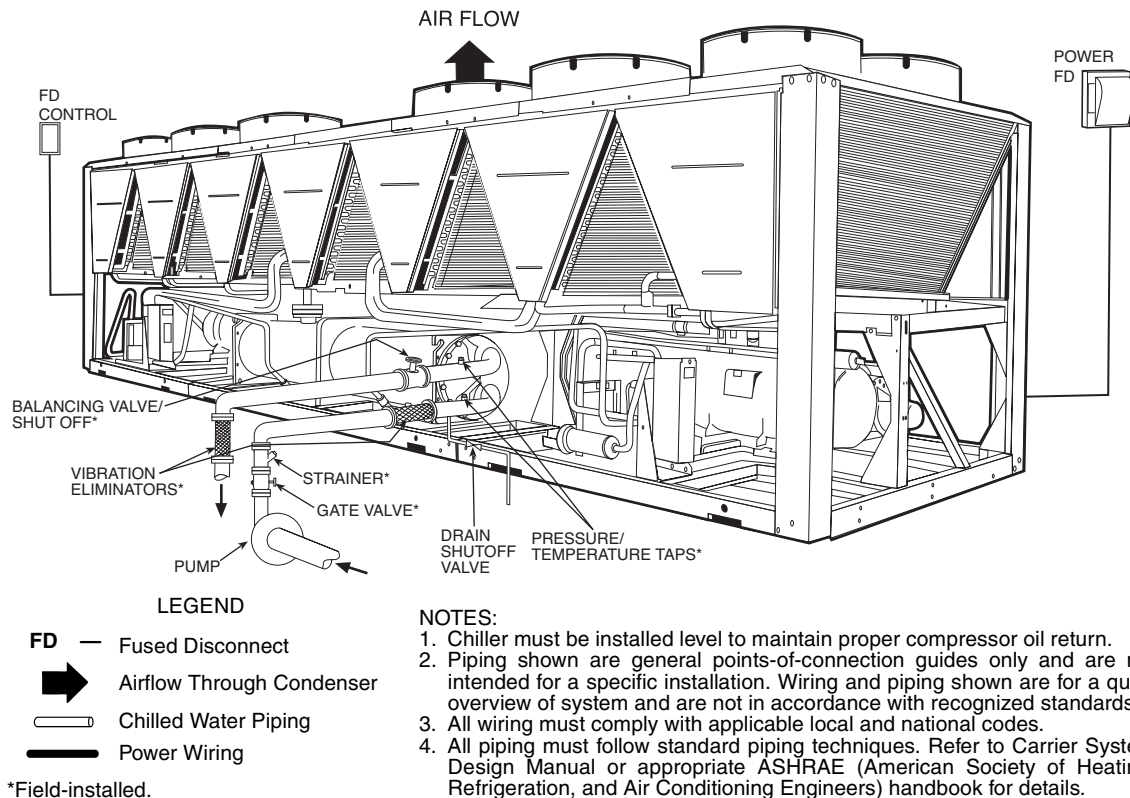
leaving water temperature stability for comfort cooling applications, a minimum of 3 gallons per ton (3.25 liters per kW) is required on all unit sizes. For process cooling applications, applications where high stability is critical, or operation at ambient temperatures below 32 F (0° C) is expected, the loop volume should be increased to 6 to 10 gallons per ton (6.46 to 10.76 liters per kW) of cooling. In order to achieve this volume, it may be necessary to add a water storage tank to the water loop. If a storage tank is added to the system, it should be properly vented so that the tank can be completely filled and all air eliminated. Failure to do so could cause lack of pump stability and poor system operation. Any storage tank that is placed in the water loop should have internal baffles to allow thorough mixing of the fluid. See Fig. 20.

**System Piping** — Proper system design and installation procedures should be followed closely. The system must be constructed with pressure tight components and thoroughly tested for installation leaks.

Installation of water systems should follow sound engineering practice as well as applicable local and industry standards. Improperly designed or installed systems may cause unsatisfactory operation and/or system failure. Consult a water treatment specialist or appropriate literature for information regarding filtration, water treatment, and control devices.

**Parallel Dual Chiller Operation** — Parallel chiller operation is the recommended option for dual chiller control. In this case, each chiller must control its own dedicated pump or isolation valve. Balancing valves are recommended to insure proper flow in each chiller. Two field-supplied and installed dual chiller leaving water temperature sensors are required, one for each module for this function to operate properly.

Consider adding additional isolation valves to isolate each chiller to allow for service on a machine, and still allow for partial capacity from the other chiller. See Fig 17.



**Fig. 15 — 30XA Typical Piping and Wiring**

**Table 3 — 30XA Minimum and Maximum Cooler Flow Rates\***

ITEM			MINIMUM		MAXIMUM		NOMINAL	
Cooler Leaving Water Temperature†			40 F (4.4 C)		60 F (15 C)		—	
Cooler Entering Water Temperature**			45 F (7.2 C)		70 F (21.1 C)		—	
30XA UNIT SIZE	Cooler	Number of Passes	Minimum Flow Rate		Maximum Flow Rate		Nominal Flow Rate	
			(gpm)	(L/s)	(gpm)	(L/s)	(gpm)	(L/s)
080	Standard	2	95	6.0	379	23.9	180.4	11.4
	Plus one pass	3	43	2.7	192	12.1		
	Minus one pass	1	196	12.4	782	49.3		
090	Standard	2	101	6.4	403	25.4	201.9	12.7
	Plus one pass	3	43	2.7	200	12.6		
	Minus one pass	1	229	14.4	917	57.9		
100	Standard	2	101	6.4	403	25.4	225.5	14.2
	Plus one pass	3	43	2.7	200	12.6		
	Minus one pass	1	229	14.4	917	57.9		
110	Standard	2	125	7.9	501	31.6	244.9	15.5
	Plus one pass	3	61	3.8	244	15.4		
	Minus one pass	1	254	16.0	1014	64.0		
120	Standard	2	125	7.9	501	31.6	264.8	16.7
	Plus one pass	3	73	4.6	293	18.5		
	Minus one pass	1	281	17.7	1124	70.9		
140	Standard	2	134	8.5	538	33.9	317.8	20.1
	Plus one pass	3	73	4.6	293	18.5		
	Minus one pass	1	324	20.4	1296	81.8		
160	Standard	2	165	10.4	660	41.6	365.1	23.0
	Plus one pass	3	98	6.2	391	24.7		
	Minus one pass	1	354	22.3	1418	89.5		
180	Standard	2	202	12.7	807	50.9	409.6	25.8
	Plus one pass	3	73	4.6	391	24.7		
	Minus one pass	1	416	26.2	1662	104.9		
200	Standard	2	223	14.1	892	56.3	463.9	29.3
	Plus one pass	3	98	6.2	391	24.7		
	Minus one pass	1	458	28.9	1833	115.6		
220	Standard	2	235	14.8	941	59.4	505.9	31.9
	Plus one pass	3	122	7.7	489	30.9		
	Minus one pass	1	501	31.6	2004	126.4		
240	Standard	2	266	16.8	1063	67.1	545.8	34.4
	Plus one pass	3	147	9.3	587	37.0		
	Minus one pass	1	538	33.9	2151	135.7		
260	Standard	2	257	16.2	1027	64.8	600.3	37.9
	Plus one pass	3	141	8.9	562	35.5		
	Minus one pass	1	584	36.8	2334	147.3		
280	Standard	2	293	18.5	1173	74.0	642.2	40.5
	Plus one pass	3	141	8.9	562	35.5		
	Minus one pass	1	620	39.1	2481	156.5		
300	Standard	2	327	20.6	1308	82.5	687.5	43.4
	Plus one pass	3	174	11.0	697	44.0		
	Minus one pass	1	687	43.3	2750	173.5		
325	Standard	2	361	22.8	1442	91.0	733.4	46.3
	Plus one pass	3	211	13.3	843	53.2		
	Minus one pass	1	724	45.7	2897	182.8		
350	Standard	2	379	23.9	1516	95.6	775.4	48.9
	Plus one pass	3	244	15.4	978	61.7		
	Minus one pass	1	767	48.4	3068	193.6		
400	Standard	1	501	31.6	2004	126.4	917.6	57.9
	Plus one pass	—	—	—	—	—		
	Minus one pass	—	—	—	—	—		
450	Standard	1	501	—	2004	—	1019.3	64.3
	Plus one pass	—	—	—	—	—		
	Minus one pass	—	—	—	—	—		
500	Standard	1	501	—	2004	—	1092.8	68.9
	Plus one pass	—	—	—	—	—		
	Minus one pass	—	—	—	—	—		

\*Maximum ambient temperature and percent of unit capacity will vary based on unit load and return water temperature. All models are qualified for use at 125 F (46 C). Some models may require the high ambient fan option. Contact a local Carrier representative to obtain performance data using the Carrier electronic catalog.

†For applications requiring cooler leaving water temperature operation at less than 40 F (4.4 C), the units require the use of antifreeze and application may require one of the special order brine option. Contact a local Carrier representative for more information.

\*\*For applications requiring cooler entering water temperature operation at less than 45 F (7.2 C), contact a local Carrier representative for unit selection using the Carrier electronic catalog.

**NOTES:**

1. The 30XA units will start with loop temperatures up to 95 F (35 C).
2. Nominal flow rates required at ARI conditions 44 F (7 C) leaving fluid temperature, 54 F (12 C) entering water temperature, 95 F (35 C) ambient. Fouling factor 0.00010 ft<sup>2</sup>-hr-F/Btu (0.000018 m<sup>2</sup>-K/kW).
3. To obtain proper temperature control, cooler loop fluid volume must be at least 3 gal/ton (3.23 L/kW) of chiller nominal capacity for air conditioning and at least 6 gal/ton (6.5 L/kW) for process applications or systems that must operate in low ambient temperatures (below 32 F [0° C]).
4. Where winds of 5 mph (2.2 m/s) or greater are anticipated at outdoor ambient temperatures below 32 F (0° C), wind baffles are required.
5. Requires optional or accessory low ambient kit for operation below 32 F (0° C).

ENGLISH

30XA UNIT SIZE*	STANDARD COOLER					PLUS ONE PASS COOLER					MINUS ONE PASS COOLER				
	Distance to Leaving Water Connection (in.)	Height Leaving Water Connection (in.)	Distance to Entering Water Connection (in.)	Height Entering Water Connection (in.)	Victaulic Connection Size (in.)	Distance to Leaving Water Connection (in.)	Height Leaving Water Connection (in.)	Distance to Entering Water Connection (in.)	Height Entering Water Connection (in.)	Victaulic Connection Size (in.)	Distance to Leaving Water Connection (in.)	Height Leaving Water Connection (in.)	Distance to Entering Water Connection (in.)	Height Entering Water Connection (in.)	Victaulic Connection Size (in.)
080	121.2	19.1	121.2	10.8	5.0	15	19.6	121.2	10.3	4.0	-2.2	14.9	124.8	14.9	5.0
090	120.9	19.1	120.9	10.8	5.0	12	19.6	120.9	10.3	4.0	-2.5	14.9	124.5	14.9	5.0
100	120.9	19.1	120.9	10.8	5.0	12	19.6	120.9	10.3	4.0	-2.5	14.9	124.5	14.9	5.0
110	120.9	19.1	120.9	10.8	5.0	12	19.6	120.9	10.3	4.0	-2.5	14.9	124.5	14.9	5.0
120	120.9	19.1	120.9	10.8	5.0	12	19.6	120.9	10.3	4.0	-2.5	14.9	124.5	14.9	5.0
140	121.5	21.3	121.5	10.6	5.0	12	21.3	121.5	10.6	5.0	-2.2	15.9	124.8	15.9	6.0
160	121.5	21.3	121.5	10.6	5.0	12	21.3	121.5	10.6	5.0	-2.2	15.9	124.8	15.9	6.0
180	171.7	22.5	171.7	11.3	6.0	53.6	22.4	180.9	11.4	6.0	53.6	13.2	180.6	13.2	8.0
200	171.7	22.5	171.7	11.3	6.0	53.2	22.4	180.9	11.4	6.0	53.2	13.2	180.2	13.2	8.0
220	224.7	22.5	224.7	11.3	6.0	100.6	22.4	227.6	11.4	6.0	100.6	13.2	227.6	13.2	8.0
240	224.7	22.5	224.7	11.3	6.0	100.6	22.4	227.6	11.4	6.0	100.6	13.2	227.6	13.2	8.0
260	304.7	23.6	304.7	12.2	8.0	180.3	23.4	310.3	12.5	8.0	180.3	16.3	310.3	16.3	8.0
280	304.7	23.6	304.7	12.2	8.0	180.3	23.4	310.3	12.5	8.0	180.3	16.3	310.3	16.3	8.0
300	304.7	23.6	304.7	12.2	8.0	180.3	23.4	310.3	12.5	8.0	180.3	16.3	310.3	16.3	8.0
325	349.0	23.6	349.0	12.2	8.0	224.7	23.4	354.7	12.5	8.0	224.7	16.3	354.7	16.3	8.0
350	349.0	23.6	349.0	12.2	8.0	224.7	23.4	354.7	12.5	8.0	224.7	16.3	354.7	16.3	8.0

SI

30XA UNIT SIZE*	STANDARD COOLER					PLUS ONE PASS COOLER					MINUS ONE PASS COOLER				
	Distance to Leaving Water Connection (mm)	Height Leaving Water Connection (mm)	Distance to Entering Water Connection (mm)	Height Entering Water Connection (mm)	Victaulic Connection Size (mm)	Distance to Leaving Water Connection (mm)	Height Leaving Water Connection (mm)	Distance to Entering Water Connection (mm)	Height Entering Water Connection (mm)	Victaulic Connection Size (mm)	Distance to Leaving Water Connection (mm)	Height Leaving Water Connection (mm)	Distance to Entering Water Connection (mm)	Height Entering Water Connection (mm)	Victaulic Connection Size (mm)
080	3077.8	484.0	3077.8	274.2	127.0	37.9	497.2	3077.8	261.0	101.6	-55.1	379.1	3170.7	379.1	127.0
090	3069.6	484.0	3069.6	274.2	127.0	29.7	497.2	3069.6	261.0	101.6	-63.2	379.1	3162.6	379.1	127.0
100	3069.6	484.0	3069.6	274.2	127.0	29.7	497.2	3069.6	261.0	101.6	-63.2	379.1	3162.6	379.1	127.0
110	3069.6	484.0	3069.6	274.2	127.0	29.7	497.2	3069.6	261.0	101.6	-63.2	379.1	3162.6	379.1	127.0
120	3069.6	484.0	3069.6	274.2	127.0	29.7	497.2	3069.6	261.0	101.6	-63.2	379.1	3162.6	379.1	127.0
140	3085.8	540.5	3085.8	268.7	127.0	30.1	540.5	3085.8	268.7	127.0	-55.0	404.6	3170.8	404.6	152.4
160	3085.8	540.5	3085.8	268.7	127.0	30.1	540.5	3085.8	268.7	127.0	-55.0	404.6	3170.8	404.6	152.4
180	4512.3	571.0	4512.3	287.0	152.4	136.1	569.5	4512.3	288.5	152.4	1361.4	336.0	4587.2	336.0	203.2
200	4502.4	571.0	4502.4	287.0	152.4	135.1	569.5	4502.4	288.5	152.4	1351.6	336.0	4577.4	336.0	203.2
220	5706.2	600.2	5706.2	310.1	203.2	255.3	569.5	5706.2	316.5	203.2	255.3	336.0	5781.1	336.0	203.2
240	5706.2	600.2	5706.2	310.1	203.2	255.3	569.5	5706.2	316.5	203.2	255.3	336.0	5781.1	336.0	203.2
260	7739.6	600.2	7739.6	310.1	203.2	4580.8	593.9	7739.6	316.5	203.2	4580.8	413.3	7882.8	413.3	203.2
280	7739.6	600.2	7739.6	310.1	203.2	4580.8	593.9	7739.6	316.5	203.2	4580.8	413.3	7882.8	413.3	203.2
300	7739.6	600.2	7739.6	310.1	203.2	4580.8	593.9	7739.6	316.5	203.2	4580.8	413.3	7882.8	413.3	203.2
325	8865.1	600.2	8865.1	310.1	203.2	5706.4	593.9	8865.1	316.5	203.2	5706.4	413.3	9008.4	413.3	203.2
350	8865.1	600.2	8865.1	310.1	203.2	5706.4	593.9	8865.1	316.5	203.2	5706.4	413.3	9008.4	413.3	203.2

\*30XA400-500 units are equipped with standard coolers only. Refer to unit dimensional drawings for cooler dimensions.  
NOTE: Refer to dimensional drawings for all other unit dimensions.

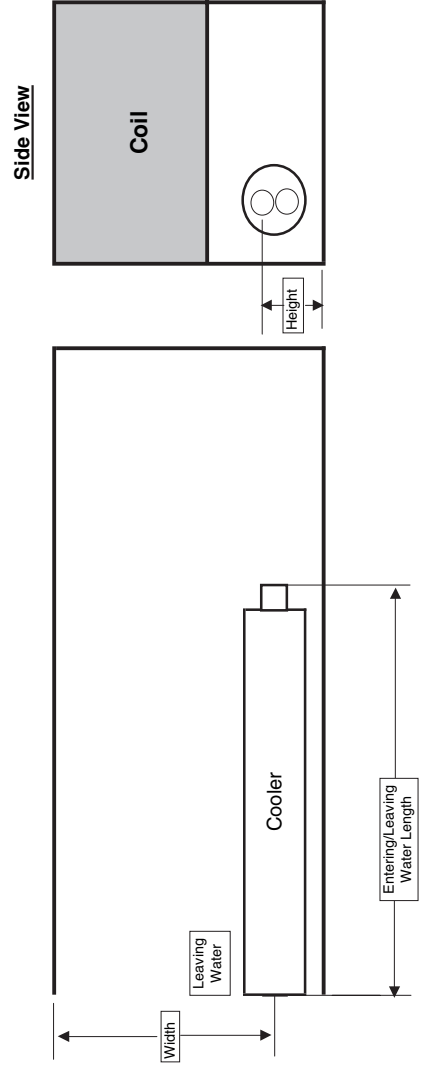
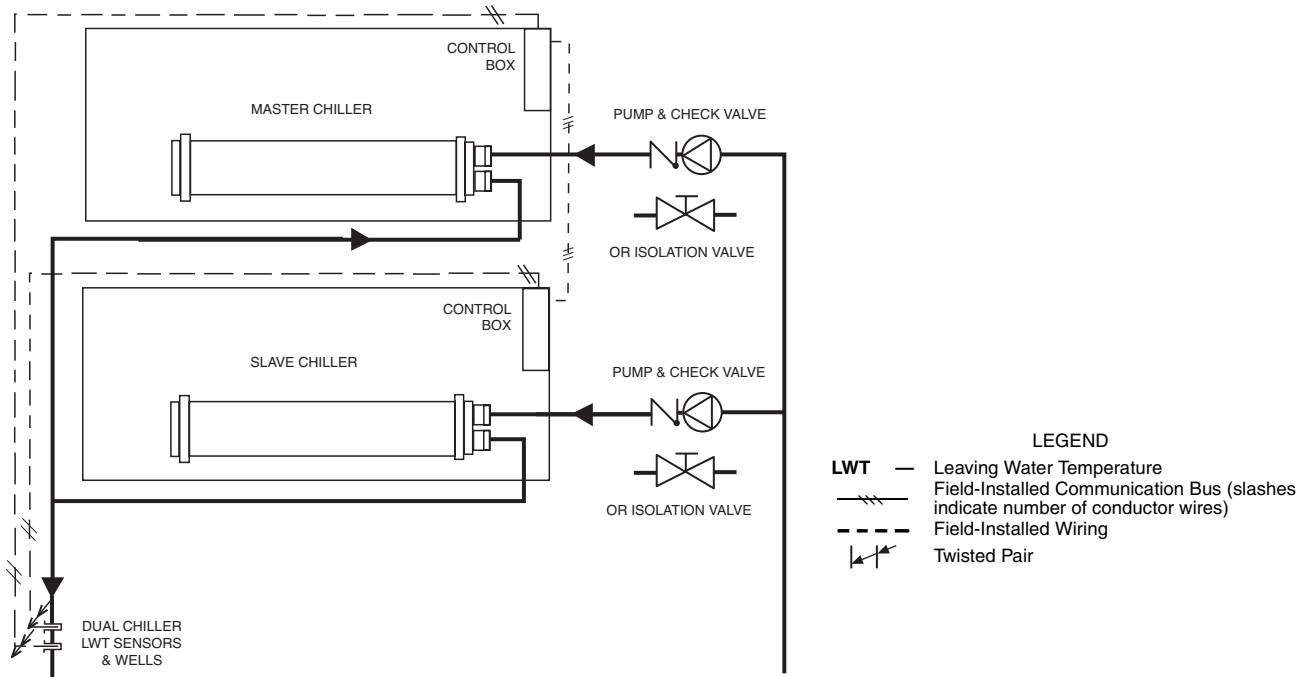
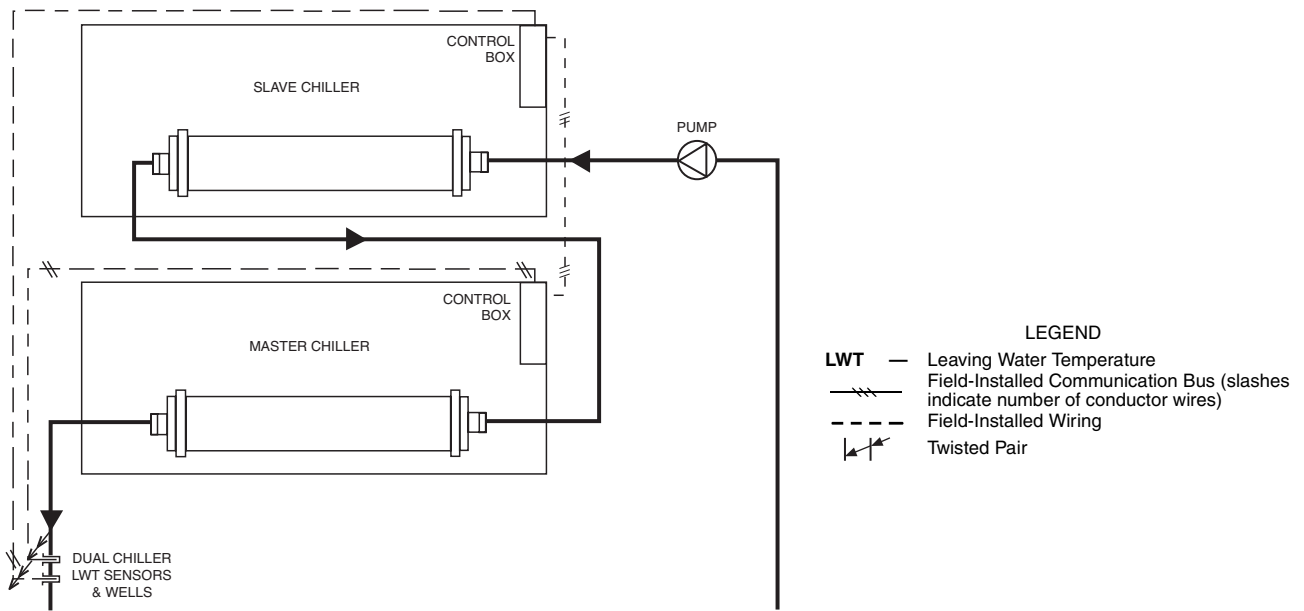


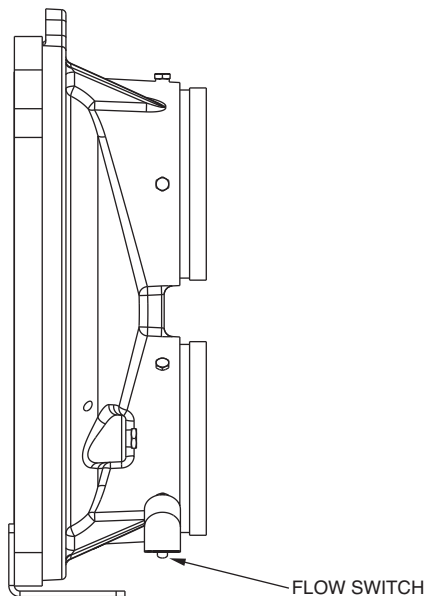
Fig. 16 — Cooler Option Dimensions



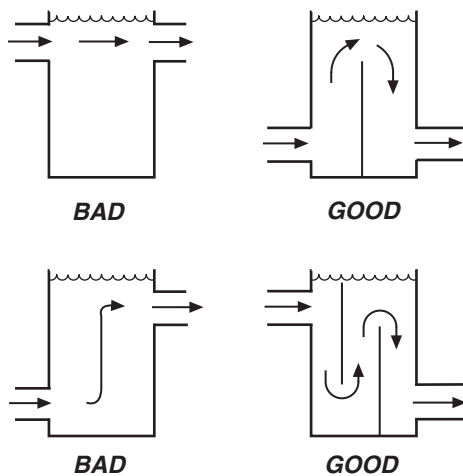
**Fig. 17 — Parallel Dual Chiller Operation**



**Fig. 18 — Series Dual Chiller Operation**



**Fig. 19 — Flow Switch**



**Fig. 20 — Tank Baffling**

**Series Dual Chiller Operation** — Series chiller operation is an alternate control method supported by the *ComfortLink™* control system. Certain applications might require that the two chillers be connected in series. For nominal 10° F (5.6° C) cooler ranges, use the Minus 1 Pass cooler arrangements to reduce the fluid-side pressure drop. Use the standard cooler pass arrangement for low flow, high cooler temperature rise applications. Two field-supplied and installed dual chiller leaving water temperature sensors are required, one for each module for this function to operate properly.

Consider adding additional piping and isolation valves to isolate each chiller to allow for service on a machine, and still allow for partial capacity from the other chiller. See Fig. 18.

**COOLER FLUID, VENT, AND DRAIN** — The inlet (return) fluid connection is always the lower of the 2 cooler connections. See Fig. 2-10 for locations. A screen strainer with a minimum size of 20 mesh must be installed a maximum of 10 ft from the unit to prevent debris from damaging internal tubes of the cooler. Outlet (supply) fluid connection is the upper connection of the 2 cooler connections. The cooler has victaulic connections to connect the field-supplied piping. Plan the piping arrangement in accordance with good piping practices and ensure that the piping does not cross in front of the cooler head. Use flexible connections on cooler piping to reduce vibration transmission. Offset the piping to permit removal of

the cooler head for maintenance. Install pipe hangers where needed. Make sure no weight or stress is placed on the water nozzle.

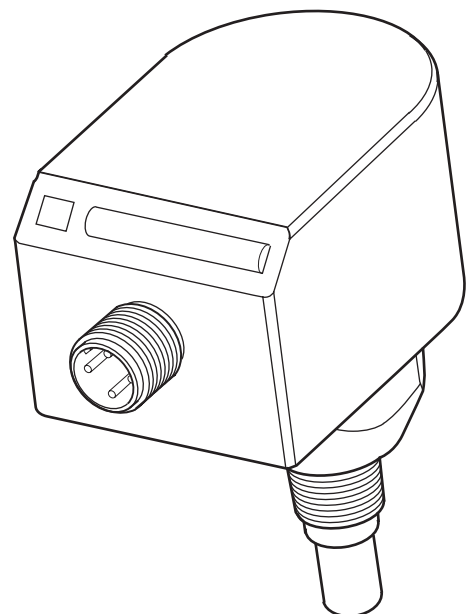
Provide openings in fluid piping for pressure gages and thermometers (if used). These openings should be 5 to 10 pipe diameters from the unit leaving water nozzle. For thorough mixing and temperature stabilization, wells in the leaving fluid pipe should extend at least 2 in. (50 mm) into the pipe.

Although the cooler has an air vent, it is recommended that a field-supplied air vent be installed in the system to facilitate servicing. Field-supplied shut-off and balancing valves should also be installed to facilitate servicing and flow balancing. Locate valves in return and supply fluid lines as close to the chiller as possible. Locate air vent at highest point of the cooler fluid system. See Fig. 15.

Provide drain connections at all low points to permit complete drainage of the system.

**COOLER PUMP CONTROL** — It is recommended that cooler pump control be utilized on all chillers unless the chilled water pump runs continuously or the chilled water system contains a suitable antifreeze solution. Proper configuration of the cooler pump control is required to prevent possible cooler freeze-up. A thermal flow sensor is factory installed in the entering fluid nozzle to prevent operation without flow through the cooler. See Fig. 21. The sensor contacts are factory wired. The factory-installed flow sensor and cooler interlock must be wired in series. Install TB5-1 and TB5-2 if using a cooler pump interlock and connect it to these terminals. It is also recommended that the chiller be interlocked with the chiller water pump starter to provide additional freeze protection. See the Field Control Power Connections section on page 34 for proper connection of the cooler pump interlock. The cooler pump relay will remain energized for 30 seconds after all compressors stop due to an off command. In the event a freeze protection alarm is generated, the cooler pump relay will be energized whether the cooler pump control is configured to “ON” or “OFF”. The cooler pump relay is also energized anytime a compressor is started and when certain alarms are generated. The cooler pump relay should be used as an override to the external pump control if cooler pump control is not utilized.

**IMPORTANT:** Chilled water pump control and cooler pump interlock wiring are required to prevent possible cooler freeze up due to loss of fluid flow. Refer to field wiring diagram for installation details.



**Fig. 21 — Thermal Flow Sensor**

**BRINE UNITS** — Special factory modifications to the units are required to allow them to operate at fluid temperatures less than 34 F (1.1 C). Be sure that the fluid has sufficient inhibited glycol or other suitable corrosion-resistant antifreeze solution to prevent cooler freeze-up.

**WATER TREATMENT** — Untreated or improperly treated water may result in corrosion, scaling, erosion, or algae. The services of a qualified water treatment specialist should be obtained to develop and monitor a treatment program.

### ⚠ CAUTION

Water must be within design flow limits, clean, and treated to ensure proper chiller performance and reduce the potential of tube damage due to corrosion, scaling, erosion, and algae. Carrier assumes no responsibility for chiller damage resulting from untreated or improperly treated water.

**NOTE:** Do not use automobile anti-freeze, or any other fluid that is not approved for heat exchanger duty. Only use appropriately inhibited glycols, concentrated to provide adequate protection for the temperature considered.

**PREPARATION FOR YEAR-ROUND OPERATION** — In areas where the piping or unit is exposed to 32 F (0° C) or lower ambient temperatures, freeze-up protection is required using inhibited glycol or other suitable corrosion-resistant anti-freeze solution and electric heater tapes. Heater tapes on piping should have a rating for area ambient temperatures and be covered with a suitable thickness of closed-cell insulation. Route power for the heater tapes from a separately fused disconnect. Mount the disconnect within sight from the unit per local or NEC (National Electric Code) codes. Identify disconnect at heater tape power source with a warning that power must not be turned off except when servicing unit.

**IMPORTANT:** Adding antifreeze solution is the only certain means of protecting the unit from freeze-up if heater fails or electrical power is interrupted or lost while temperatures are below 32 F (0° C).

**IMPORTANT:** Before starting the unit, be sure all of the air has been purged from the system.

A drain connection is located at the bottom of the cooler head. See Fig. 2-10 for connection location. Install shut-off valves to the drain line before filling the system with fluid.

**Low Ambient Temperature Head Pressure Control** — If the unit is equipped with the low ambient temperature head pressure control option, field-fabricated and field-installed wind baffles are required if the wind velocity is anticipated to be greater than 5 mph (8 km/h). Two different baffles may be required, facing the control box. Wind baffles should be constructed with minimum 18-gage galvanized sheet metal or other suitable corrosion-resistance material with cross breaks for strength. See Fig. 22. Use field-supplied screws to attach baffles to the corner posts of the machine. Be sure to hem or turn a flange on all edges to eliminate sharp edges on the baffles.

### ⚠ WARNING

To avoid possibility of electrical shock, open all disconnects before installing or servicing this accessory.

### ⚠ CAUTION

To avoid damage to the refrigerant coils and electrical components, use extreme care when drilling screw holes and screwing in fasteners.

Mount the smaller height baffle on units with a control box located on the end of the unit. It is recommended that the upper notches be used for mounting the baffles. This reduces the risk of damaging the coil while drilling a mounting hole. Loosen the upper corner post bolts and slide the baffle under the bolt and washer. Tighten the bolt. Drill holes in the bottom of the flange of the baffle and mount with two screws to secure the bottom of the baffle to the corner post. Repeat the process for the opposite end. See Fig. 22.

**PREPARATION FOR WINTER SHUTDOWN** — If the unit is not operational during the winter months, at the end of cooling season complete the following steps.

### ⚠ CAUTION

Failure to remove power before draining heater equipped coolers can result in heater tape and insulation damage.

1. If the cooler will not be drained do not shut off power disconnect during off-season shutdown. If the cooler is drained, open the circuit breaker for the heater, CB-HT (circuit breaker heater) or shut off power during off-season shutdown.
2. Draining the fluid from the system is highly recommended.
3. Isolate the cooler from the rest of the system with water shutoff valves.
4. Completely fill the cooler with a mixture of half water and half inhibited glycol solution (or other suitable corrosion-inhibitive antifreeze) for 15° F (8.3° C) below the expected low ambient temperature conditions.
5. Leave the cooler filled with the antifreeze solution for the winter, or drain if desired. Be sure to deenergize heaters (if installed) as explained in Step 1 to prevent damage. Use an approved method of disposal when removing antifreeze solution.
6. At the beginning of the next cooling season, be sure that there is refrigerant pressure on each circuit before refilling cooler, add recommended inhibitor, and reset the CB-HT (circuit breaker heater) (if opened) or restore power.

## Step 4 — Make Electrical Connections

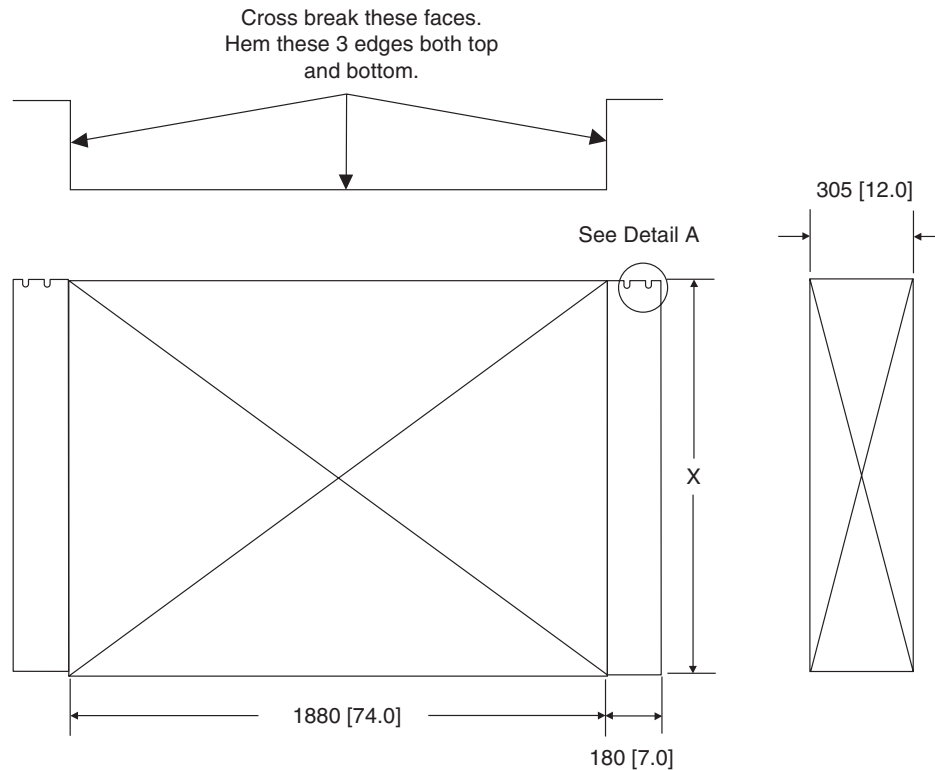
### ⚠ WARNING

Electrical shock can cause personal injury and death. Shut off all power to this equipment during installation. There may be more than one disconnect switch. Tag all disconnect locations to alert others not to restore power until work is completed.

**POWER SUPPLY** — The electrical characteristics of the available power supply must agree with the unit nameplate rating. Supply voltage must be within the limits shown. See Tables 4-6 for electrical and configuration data.

**FIELD POWER CONNECTIONS** (See Fig. 23) — All power wiring must comply with applicable local and national codes. Install field-supplied, branch circuit fused disconnect(s) of a type that can be locked off or open. Disconnect(s) must be located within sight and readily accessible from the unit in compliance with NEC Article 440-14 (U.S.A.). See Tables 4 and 5 for unit electrical data. See Table 6 for compressor and fan electrical data.

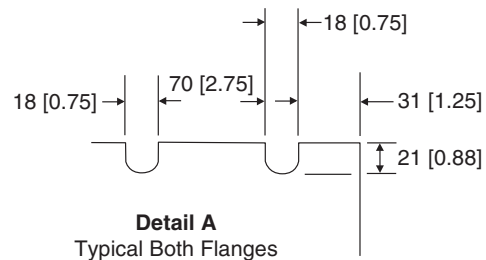
**IMPORTANT:** The 30XA units have a factory-installed option available for a non-fused disconnect for unit power supply. If the unit is equipped with this option, all field power wiring should be made to the non-fused disconnect since no terminal blocks are supplied.



POSITION	BAFFLE HEIGHT (X)	
	RIGHT END	LEFT END
<b>30XA080-120</b> (Facing the control box end)	1040 [41.0]	635 [25.0]
<b>30XA140-500</b> (Facing the control box end)	1040 [41.0]	1040 [41.0]

**NOTES:**

1. Material: 18 ga. Corrosion Resistant Sheet Metal.
2. Dimensions are in mm [inches].



**Fig. 22 — Field-Fabricated and Field-Installed Wind Baffles**

Maximum wire size that the unit terminal block or non-fused disconnect will accept is 500 kcmil.

The 30XA units require 1 or 2 power supplies, depending on the unit and circuit voltage. See Tables 4 and 5 for the number of power supplies required for each unit.

**FIELD CONTROL POWER CONNECTIONS** (See Fig. 23) — Units with a power supply of all voltages require 115-1-60 control circuit power, unless the control option is installed.

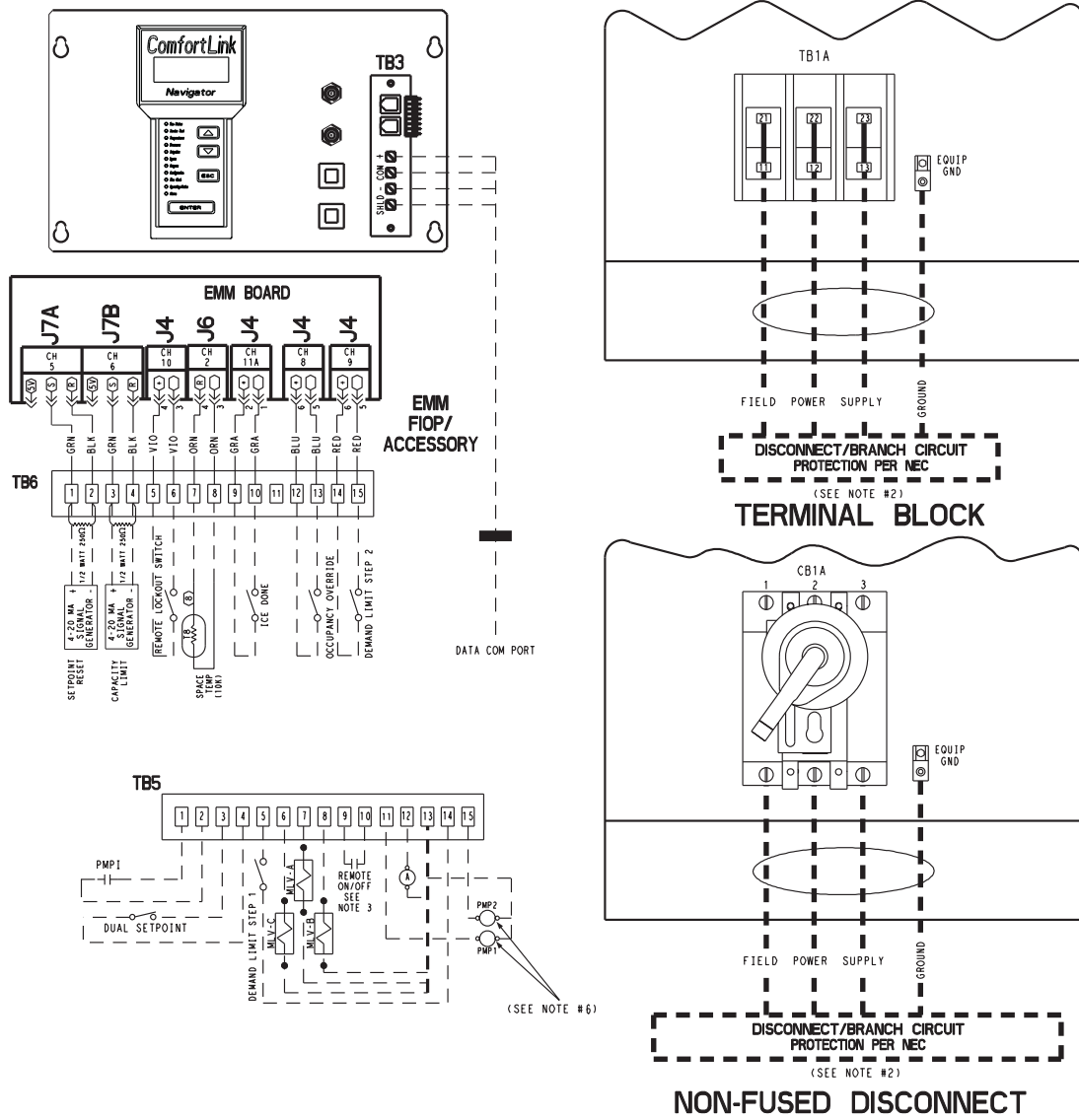
Terminals TB5-1 and TB5-2 are provided for field installation of a chilled water (fluid) pump interlock (CWPI). The chilled water (fluid) flow sensor (CWFS) is factory installed. These devices are to be installed in series. Contacts must be rated for dry-circuit applications capable of handling a 24-vac at 50 mA load.

An accessory remote on-off switch can be wired into TB5-9 and TB5-10. To use this feature, remove the factory-installed jumper and install the device in series. Contacts must be rated for dry-circuit applications capable of handling a 24-vac at 50 mA load.

**⚠ CAUTION**

Do not use interlocks or other safety device contacts connected between TB5-9 and TB5-10 as remote on-off. Connection of safeties or other interlocks between these 2 terminals will result in an electrical bypass if the ENABLE-OFF-REMOTE contact switch is in the ENABLE position. If remote on-off unit control is required, a field-supplied relay must be installed in the unit control box and wired as shown in Fig. 22. Failure to wire the remote on-off as recommended may result in tube freeze damage.

Terminals 11 and 13 of TB5 are for control of the chilled water pump 1 (PMP1) starter. Terminals 13 and 15 of TB5 are for control of the chilled water pump 2 (PMP2) starter.



- NOTES:**
1. Factory wiring is in accordance with UL 1995 standards. Field modifications or additions must be in compliance with all applicable codes.
  2. Wiring for main field supply must be rated 75 C minimum. Use copper for all units.  
Incoming wire size range for units 080-120, all voltages is 4-500 kcmil.  
Incoming wire size range for units 140-240, 200/230 v is 1/0-500 kcmil.  
Incoming wire size range for units 140-240, 380, 460, 575 v is 4-500 kcmil.  
Incoming wire size range for units 260-500, 380, 460, 575 v is 1/0-500 kcmil.
  3. Terminals 9 and 10 of TB5 are for field external connections for remote on-off. The contacts must be rated for dry circuit application capable of handling a 24 vac load up to 50 mA.
  4. Terminals 1 and 2 of TB5 are for external connections of chilled water pump interlock. The contacts must be rated for dry circuit application capable of handling a 24 vac load up to 50 mA.
  5. Terminals 11 and 13 of TB5 are for control of chilled water pump 1 (PMP1) starter. Terminals 13 and 15 of TB5 are for control of chilled water pump 2 (PMP2) starter. The maximum load allowed for the chilled water pump relay is 5 va sealed, 10 va inrush at 24 v. Field power supply is not required.
  6. For control of chilled water pumps, a set of normally open contacts rated for dry circuit application must be supplied from field-supplied pump starter relay. Connect contacts to violet and pink wires in harness from main base board channel 18. Wires in harness are marked PMP1-13 and PMP1-14.
  7. Terminals 12 and 13 of TB5 are for an alarm relay. The maximum load allowed for the alarm relay is 10 va sealed, 25 va inrush at 24 v. Field power supply is not required.
  8. Make appropriate connections to TB6 as shown for energy management board options. The contacts for occupancy override, demand limit and ice done options must be rated for dry circuit application capable of handling a 24 vac load up to 50 mA.

- LEGEND**
- A — Alarm
  - EMM — Energy Management
  - MLV — Minimum Load Valve
  - NEC — National Electric Code
  - PMP — Chilled Water Pump
  - PMP1 — Chilled Water Pump Interlock
  - TB — Terminal Block
  - Field Power Wiring
  - - - Field Control Wiring
  - Factory Installed Wiring

**Fig. 23 — Control and Power Wiring Schematic, 30XA080-500**

**Table 4 — 30XA080-500 Electrical Data (Standard Condenser Fan Motors)**

UNIT 30XA	VOLTAGE (3 Ph, 60 Hz)	VOLTAGE RANGE		MAIN POWER SUPPLY QTY REQD	MCA	MOCP	ICF		REC FUSE SIZE	CONTROL CIRCUIT	
		Min	Max				XL	WD		Voltage (1 Ph, 60 Hz)	MCA and MOCP
080	200	187	220	1	347.6	450	1257.6	521.6	400	115	30
	230	207	253	1	315.5	400	1100.2	460.2	350	115	30
	380	342	418	1	183.5	250	662.7	275.7	225	115	30
	460	414	506	1	157.7	200	550.1	230.1	175	115	30
	575	518	633	1	121.2	150	437.9	181.9	150	115	30
090	200	187	220	1	368.0	500	1274.0	538.0	450	115	30
	230	207	253	1	334.0	450	1115.1	475.1	400	115	30
	380	342	418	1	194.5	250	671.6	284.6	225	115	30
	460	414	506	1	167.0	225	557.6	237.6	200	115	30
	575	518	633	1	128.5	175	443.8	187.8	150	115	30
100	200	187	220	1	401.3	500	1564.8	644.8	450	115	30
	230	207	253	1	364.6	500	1368.7	568.7	400	115	30
	380	342	418	1	212.7	250	824.7	340.7	250	115	30
	460	414	506	1	182.3	250	684.4	284.4	200	115	30
	575	518	633	1	139.5	175	544.7	224.7	175	115	30
110	200	187	220	1	446.2	600	—	644.8	500	115	30
	230	207	253	1	405.7	500	—	568.7	450	115	30
	380	342	418	1	236.4	300	824.7	340.7	300	115	30
	460	414	506	1	202.4	250	684.4	284.4	225	115	30
	575	518	633	1	155.5	200	544.7	224.7	175	115	30
120	200	187	220	1	482.2	600	—	680.8	600	115	30
	230	207	253	1	438.6	600	—	601.6	500	115	30
	380	342	418	1	255.3	350	843.6	359.6	300	115	30
	460	414	506	1	218.4	300	700.4	300.4	250	115	30
	575	518	633	1	168.4	225	557.5	237.5	200	115	30
140	200	187	220	1	588.5	800	—	911.1	700	115	30
	230	207	253	1	534.7	800	—	800.7	700	115	30
	380	342	418	1	311.2	450	1255.9	480.9	350	115	30
	460	414	506	1	267.3	400	1040.4	400.4	350	115	30
	575	518	633	1	205.0	300	829.5	317.5	250	115	30
160	200	187	220	2	465.6/264.9	800/450	—/—	902.8/463.5	600/350	115	30
	230	207	253	2	423.5/241.0	700/400	—/—	786.0/404.0	600/300	115	30
	380	342	418	1	361.1	500	1564.9	590.9	450	115	30
	460	414	506	1	309.7	450	1296.4	491.4	350	115	30
	575	518	633	1	238.1	350	1034.3	390.3	300	115	30
180	200	187	220	2	407.2/407.2	700/700	—/—	729.8/729.8	500/500	115	30
	230	207	253	2	370.0/370.0	600/600	—/—	636.0/636.0	450/450	115	30
	380	342	418	1	391.5	500	1336.2	561.2	450	115	30
	460	414	506	1	336.6	450	1109.6	469.6	400	115	30
	575	518	633	1	258.3	350	882.8	370.8	300	115	30
200	200	187	220	2	465.6/465.6	800/800	—/—	902.8/902.8	600/600	115	30
	230	207	253	2	423.5/423.5	700/700	—/—	786.0/786.0	600/600	115	30
	380	342	418	1	447.2	600	1651.0	677.0	500	115	30
	460	414	506	1	383.9	500	1370.6	565.6	450	115	30
	575	518	633	1	294.8	400	1091.0	447.0	350	115	30
220	200	187	220	2	554.7/548.0	800/800	—/—	909.4/902.8	700/600	115	30
	230	207	253	2	504.2/423.5	800/700	—/—	792.0/786.0	600/600	115	30
	380	342	418	1	494.5	700	1654.6	680.6	600	115	30
	460	414	506	1	424.7	600	1373.6	568.6	500	115	30
	575	518	633	1	326.3	450	1093.4	449.4	400	115	30
240	200	187	220	2	554.7/548.0	800/800	—/—	909.4/902.8	700/700	115	30
	230	207	253	2	504.2/498.2	800/800	—/—	792.0/786.0	600/600	115	30
	380	342	418	1	529.5	700	1689.5	715.5	600	115	30
	460	414	506	1	455.0	600	1403.9	598.9	600	115	30
	575	518	633	1	349.6	450	1116.7	472.7	400	115	30
260	380	342	418	1	600.2	800	2376.9	917.9	700	115	30
	460	414	506	1	516.5	700	1969.6	764.6	600	115	30
	575	518	633	1	396.4	500	1570.2	606.2	450	115	30
280	380	342	418	1	638.2	800	2414.9	955.9	800	115	30
	460	414	506	1	549.8	800	2002.9	797.9	700	115	30
	575	518	633	1	422.0	600	1595.9	631.9	500	115	30
300	380	342	418	1	710.3	1000	2415.4	956.4	800	115	30
	460	414	506	1	610.9	800	2002.9	797.9	700	115	30
	575	518	633	1	468.7	600	1595.9	631.9	600	115	30
325	380	342	418	2	426.0/426.0	700/700	2202.7/2202.7	743.7/743.7	500/500	115	30
	460	414	506	1	624.3	800	2077.5	872.5	700	115	30
	575	518	633	1	479.1	600	1652.9	688.9	600	115	30
350	380	342	418	2	497.6/426.0	800/700	2202.7/2202.7	743.7/743.7	600/500	115	30
	460	414	506	1	685.5	800	2077.5	872.5	800	115	30
	575	518	633	1	525.7	700	1652.9	688.9	600	115	30
400	380	342	418	2	419.4/561.9	700/700	2196.1/1722.0	737.1/748.0	500/700	115	50
	460	414	506	2	340.9/452.0	500/600	1794.0/1400.9	589.0/595.9	450/500	115	50
	575	518	633	2	261.4/347.2	450/450	1435.2/1114.3	471.2/470.3	350/400	115	50
450	380	342	418	2	490.9/685.4	800/1000	2196.1/2390.5	737.1/931.5	600/500	115	50
	460	414	506	2	402.0/553.6	700/ 800	1794.0/1945.6	589.0/740.6	500/700	115	50
	575	518	633	2	308.0/424.4	500/ 600	1435.2/1551.6	471.2/587.6	400/500	115	50
500	380	342	418	2	490.9/745.1	800/1000	2196.1/2450.2	737.1/991.2	600/1000	115	50
	460	414	506	2	402.0/604.9	700/ 800	1794.0/1996.9	589.0/791.9	500/ 700	115	50
	575	518	633	2	308.0/463.9	500/ 600	1435.2/1591.1	471.2/627.1	400/ 600	115	50

**LEGEND**

- ICF — Instantaneous Current Flow
- MCA — Minimum Circuit Amps
- MOCP — Maximum Overcurrent Protection
- WD — Wye-Delta
- XL — Across-the-Line

**NOTES:**

1. Units are suitable for use on electrical systems where voltage supplied to the unit terminals is not below or above the listed minimum and maximum limits. Maximum allowable phase imbalance is: voltage, 2%; amps 10%.
2. Cooler heater is wired into the control circuit so it is always operable as long as the control power supply disconnect is on, even if any safety device is open.
3. For MCA that is less than or equal to 380 amps, 3 conductors are required.  
For MCA between 381-760 amps, 6 conductors are required.  
For MCA between 761-1140 amps, 9 conductors are required.  
For MCA between 1141-1520 amps, 12 conductors are required.  
Calculation of conductors required is based on 75 C copper wire.

4. Wiring for main field supply must be rated 75 C minimum. Use copper for all units.
  - a. Incoming wire size range for the terminal block is no. 4 AWG (American Wire Gage) to 500 kcmil.
  - b. Incoming wire size range of non-fused disconnect with MCA up to 599.9 amps is 3/0 to 500 kcmil.
  - c. Incoming wire size range of non-fused disconnect with MCA from 600 to 799.9 amps is 1/0 to 500 kcmil.
  - d. Incoming wire size range of non-fused disconnect with MCA from 800 to 1199.9 amps is 250 kcmil to 500 kcmil.
5. Data provided circuit 1/circuit 2 where there are two circuits.

**Table 5 — 30XA140-500 Electrical Data (High Ambient Temperature Option)**

UNIT 30XA	VOLTAGE (3 Ph, 60 Hz)	VOLTAGE RANGE		MAIN POWER SUPPLY QTY REQD	MCA	MOCP	ICF		REC FUSE SIZE	CONTROL CIRCUIT	
		Min	Max				XL	WD		Voltage (1 Ph, 60 Hz)	MCA and MOCP
140	200	187	220	1	618.8	800	—	957.8	700	115	30
	230	207	253	1	561.9	800	—	842.9	700	115	30
	380	342	418	1	327.9	450	1281.3	506.3	400	115	30
	460	414	506	1	282.0	400	1062.5	422.5	350	115	30
	575	518	633	1	216.2	300	846.3	334.3	250	115	30
160	200	187	220	2	477.9/273.7	800/450	—	934.4/484.6	600/350	115	30
	230	207	253	2	434.8/249.1	700/400	—	814.8/423.2	600/300	115	30
	380	342	418	1	374.5	500	1588.4	614.4	450	115	30
	460	414	506	1	321.5	450	1317.0	512.0	400	115	30
	575	518	633	1	247.0	350	1049.9	405.9	300	115	30
180	200	187	220	2	422.4/422.4	700/700	—	761.4/761.4	500/500	115	30
	230	207	253	2	383.8/383.8	600/600	—	664.8/664.8	450/450	115	30
	380	342	418	1	410.3	500	1363.7	588.7	450	115	30
	460	414	506	1	353.1	450	1133.6	493.6	400	115	30
	575	518	633	1	271.0	350	901.1	389.1	300	115	30
200	200	187	220	2	477.9/477.9	800/800	—	934.4/934.4	600/600	115	30
	230	207	253	2	434.8/434.8	700/700	—	814.8/814.8	600/600	115	30
	380	342	418	1	463.4	600	1677.3	703.3	600	115	30
	460	414	506	1	398.1	500	1393.6	588.6	450	115	30
	575	518	633	1	305.6	400	1108.5	464.5	350	115	30
220	200	187	220	2	567.4/477.9	800/800	—	946.3/934.4	700/600	115	30
	230	207	253	2	516.0/434.8	800/700	—	825.6/814.8	700/600	115	30
	380	342	418	1	511.0	700	1683.8	709.8	600	115	30
	460	414	506	1	439.3	600	1399.1	594.1	500	115	30
	575	518	633	1	337.3	450	1112.8	468.8	400	115	30
240	200	187	220	2	567.4/555.5	800/800	—	946.3/934.4	700/700	115	30
	230	207	253	2	516.0/505.2	800/800	—	825.6/814.8	700/600	115	30
	380	342	418	1	543.9	700	1716.7	742.7	600	115	30
	460	414	506	1	467.8	600	1427.6	622.6	600	115	30
	575	518	633	1	359.2	450	1134.7	490.7	400	115	30
260	380	342	418	1	616.2	800	2411.8	952.8	700	115	30
	460	414	506	1	530.6	700	2000.1	795.1	600	115	30
	575	518	633	1	407.0	500	1593.4	629.4	500	115	30
280	380	342	418	1	649.1	800	2444.7	985.7	800	115	30
	460	414	506	1	559.1	700	2028.6	823.6	700	115	30
	575	518	633	1	428.9	600	1615.3	651.3	500	115	30
300	380	342	418	1	721.7	1000	2451.2	992.2	1000	115	30
	460	414	506	1	621.2	800	2034.1	829.1	700	115	30
	575	518	633	1	476.3	600	1619.6	655.6	600	115	30
325	380	342	418	2	405.9/405.9	600/600	2201.5/2201.5	742.5/742.5	500/500	115	30
	460	414	506	1	639.9	800	2109.4	904.4	800	115	30
	575	518	633	1	490.7	600	1677.1	713.1	600	115	30
350	380	342	418	2	472.0/405.9	800/600	2201.5/2201.5	742.5/742.5	600/500	115	30
	460	414	506	1	696.4	800	2109.4	904.4	800	115	30
	575	518	633	1	533.8	700	1677.1	713.1	600	115	30
400	380	342	418	2	399.4/537.4	600/700	2195.0/1710.2	736.0/736.2	500/600	115	50
	460	414	506	2	344.0/462.3	500/600	1814.0/1422.2	609.0/617.2	450/600	115	50
	575	518	633	2	264.0/354.9	400/450	1450.4/1130.4	486.4/486.4	350/400	115	50
450	380	342	418	2	465.5/652.2	700/800	2195.0/2381.7	736.0/922.7	600/800	115	50
	460	414	506	2	401.0/561.6	600/800	1814.0/1974.6	609.0/769.6	500/700	115	50
	575	518	633	2	307.2/430.5	500/600	1450.4/1573.7	486.4/609.7	400/500	115	50
500	380	342	418	2	465.5/708.7	700/1000	2195.0/2438.2	736.0/979.2	600/800	115	50
	460	414	506	2	401.0/610.2	600/ 800	1814.0/2023.2	609.0/818.2	500/700	115	50
	575	518	633	2	307.2/467.7	500/ 600	1450.4/1611.0	486.4/647.0	400/600	115	50

**LEGEND**

- ICF — Instantaneous Current Flow
- MCA — Minimum Circuit Amps
- MOCP — Maximum Overcurrent Protection
- WD — Wye-Delta
- XL — Across-the-Line

**NOTES:**

1. The high ambient option is not available on 30XA080-120 units.
2. Units are suitable for use on electrical systems where voltage supplied to the unit terminals is not below or above the listed systems minimum and maximum limits. Maximum allowable phase imbalance is: voltage, 2%; amps 10%.
3. Cooler heater is wired into the control circuit so it is always operable as long as the control power supply disconnect is on, even if any safety device is open.

4. For MCA that is less than or equal to 380 amps, 3 conductors are required.  
For MCA between 381-760 amps, 6 conductors are required.  
For MCA between 761-1140 amps, 9 conductors are required.  
For MCA between 1141-1520 amps, 12 conductors are required.  
Calculation of conductors required is based on 75 C copper wire.
5. Wiring for main field supply must be rated 75 C minimum. Use copper for all units.
  - a. Incoming wire size range for the terminal block is no. 4 AWG (American Wire Gage) to 500 kcmil.
  - b. Incoming wire size range of non-fused disconnect with MCA up to 599.9 amps is 3/0 to 500 kcmil.
  - c. Incoming wire size range of non-fused disconnect with MCA from 600 to 799.9 amps is 1/0 to 500 kcmil.
  - d. Incoming wire size range of non-fused disconnect with MCA from 800 to 1199.9 amps is 250 kcmil to 500 kcmil.
6. Data provided circuit 1/circuit 2 where there are two circuits.

**Table 6 — Compressor and Fan Electrical Data**

30XA UNIT SIZE	UNIT VOLTAGE V-Hz (3 Ph, 60 Hz)	NUMBER OF COND FANS*	CONDENSER FANS		COMPRESSOR											
					A				B				C			
			FLA		LRA (All Units)		RLA		LRA (All Units)		RLA		LRA (All Units)		RLA	
			High Ambient Temp Cond. Fans (1140 rpm)	Standard Cond. Fans (850 rpm)	XL	WD	High Ambient Temp Cond. Fans (1140 rpm)	Standard Cond. Fans (850 rpm)	XL	WD	High Ambient Temp Cond. Fans (1140 rpm)	Standard Cond. Fans (850 rpm)	XL	WD	High Ambient Temp Cond. Fans (1140 rpm)	Standard Cond. Fans (850 rpm)
080	200	6	11.9	6.6	1081.0	345.0	130.9	136.8	1081.0	345.0	130.9	136.8	—	—	—	—
	230	6	10.8	6.0	940.0	300.0	118.9	124.2	940.0	300.0	118.9	124.2	—	—	—	—
	380	6	6.5	3.6	569.0	182.0	68.8	71.9	569.0	182.0	68.8	71.9	—	—	—	—
	460	6	5.5	3.0	470.0	150.0	59.4	62.1	470.0	150.0	59.4	62.1	—	—	—	—
	575	6	4.3	2.4	376.0	120.0	45.4	47.5	376.0	120.0	45.4	47.5	—	—	—	—
090	200	8	11.9	6.6	1081.0	345.0	134.3	140.0	1081.0	345.0	134.3	140.0	—	—	—	—
	230	8	10.8	6.0	940.0	300.0	122.0	127.1	940.0	300.0	122.0	127.1	—	—	—	—
	380	8	6.5	3.6	569.0	182.0	70.6	73.5	569.0	182.0	70.6	73.5	—	—	—	—
	460	8	5.5	3.0	470.0	150.0	61.0	63.6	470.0	150.0	61.0	63.6	—	—	—	—
	575	8	4.3	2.4	376.0	120.0	46.6	48.6	376.0	120.0	46.6	48.6	—	—	—	—
100	200	8	11.9	6.6	1357.0	437.0	148.4	154.8	1357.0	437.0	148.4	154.8	—	—	—	—
	230	8	10.8	6.0	1180.0	380.0	134.9	140.7	1180.0	380.0	134.9	140.7	—	—	—	—
	380	8	6.5	3.6	714.0	230.0	78.3	81.6	714.0	230.0	78.3	81.6	—	—	—	—
	460	8	5.5	3.0	590.0	190.0	67.5	70.4	590.0	190.0	67.5	70.4	—	—	—	—
	575	8	4.3	2.4	472.0	152.0	51.3	53.5	472.0	152.0	51.3	53.5	—	—	—	—
110	200	8	11.9	6.6	1357.0	437.0	180.9	190.7	1357.0	437.0	180.9	190.7	—	—	—	—
	230	8	10.8	6.0	1180.0	380.0	164.7	173.6	1180.0	380.0	164.7	173.6	—	—	—	—
	380	8	6.5	3.6	714.0	230.0	95.4	100.6	714.0	230.0	95.4	100.6	—	—	—	—
	460	8	5.5	3.0	590.0	190.0	82.0	86.4	590.0	190.0	82.0	86.4	—	—	—	—
	575	8	4.3	2.4	472.0	152.0	62.9	66.3	472.0	152.0	62.9	66.3	—	—	—	—
120	200	8	11.9	6.6	1357.0	437.0	180.9	190.7	1357.0	437.0	180.9	190.7	—	—	—	—
	230	8	10.8	6.0	1180.0	380.0	164.7	173.6	1180.0	380.0	164.7	173.6	—	—	—	—
	380	8	6.5	3.6	714.0	230.0	95.4	100.6	714.0	230.0	95.4	100.6	—	—	—	—
	460	8	5.5	3.0	590.0	190.0	82.0	86.4	590.0	190.0	82.0	86.4	—	—	—	—
	575	8	4.3	2.4	472.0	152.0	62.9	66.3	472.0	152.0	62.9	66.3	—	—	—	—
140	200	10	11.9	6.6	2162.0	690.0	280.8	293.9	2162.0	690.0	280.8	293.9	—	—	—	—
	230	10	10.8	6.0	1880.0	600.0	255.2	267.2	1880.0	600.0	255.2	267.2	—	—	—	—
	380	10	6.5	3.6	1138.0	363.0	147.7	154.6	1138.0	363.0	147.7	154.6	—	—	—	—
	460	10	5.5	3.0	940.0	300.0	127.6	133.6	940.0	300.0	127.6	133.6	—	—	—	—
	575	10	4.3	2.4	752.0	240.0	97.5	102.0	752.0	240.0	97.5	102.0	—	—	—	—
160	200	6/4	11.9	6.6	2714.0	863.0	325.2	340.6	2714.0	863.0	325.2	340.6	—	—	—	—
	230	6/4	10.8	6.0	2360.0	750.0	296.0	310.0	2360.0	750.0	296.0	310.0	—	—	—	—
	380	10	6.5	3.6	1428.0	454.0	171.3	179.4	1428.0	454.0	171.3	179.4	—	—	—	—
	460	10	5.5	3.0	1180.0	375.0	147.6	154.6	1180.0	375.0	147.6	154.6	—	—	—	—
	575	10	4.3	2.4	944.0	300.0	112.9	118.2	944.0	300.0	112.9	118.2	—	—	—	—
180	200	6/6	11.9	6.6	2162.0	690.0	280.8	293.9	2162.0	690.0	280.8	293.9	—	—	—	—
	230	6/6	10.8	6.0	1880.0	600.0	255.2	267.2	1880.0	600.0	255.2	267.2	—	—	—	—
	380	12	6.5	3.6	1138.0	363.0	147.7	154.6	1138.0	363.0	147.7	154.6	—	—	—	—
	460	12	5.5	3.0	940.0	300.0	127.6	133.6	940.0	300.0	127.6	133.6	—	—	—	—
	575	12	4.3	2.4	752.0	240.0	97.5	102.0	752.0	240.0	97.5	102.0	—	—	—	—
200	200	6/6	11.9	6.6	2714.0	863.0	325.2	340.6	2714.0	863.0	325.2	340.6	—	—	—	—
	230	6/6	10.8	6.0	2360.0	750.0	296.0	310.0	2360.0	750.0	296.0	310.0	—	—	—	—
	380	12	6.5	3.6	1428.0	454.0	171.3	179.4	1428.0	454.0	171.3	179.4	—	—	—	—
	460	12	5.5	3.0	1180.0	375.0	147.6	154.6	1180.0	375.0	147.6	154.6	—	—	—	—
	575	12	4.3	2.4	944.0	300.0	112.9	118.2	944.0	300.0	112.9	118.2	—	—	—	—
220	200	7/6	11.9	6.6	2714.0	863.0	387.3	406.6	2714.0	863.0	387.3	406.6	—	—	—	—
	230	7/6	10.8	6.0	2360.0	750.0	352.3	369.8	2360.0	750.0	352.3	369.8	—	—	—	—
	380	13	6.5	3.6	1428.0	454.0	204.2	214.3	1428.0	454.0	204.2	214.3	—	—	—	—
	460	13	5.5	3.0	1180.0	375.0	176.1	184.9	1180.0	375.0	176.1	184.9	—	—	—	—
	575	13	4.3	2.4	944.0	300.0	134.8	141.5	944.0	300.0	134.8	141.5	—	—	—	—
240	200	7/6	11.9	6.6	2714.0	863.0	387.3	406.6	2714.0	863.0	387.3	406.6	—	—	—	—
	230	7/6	10.8	6.0	2360.0	750.0	352.3	369.8	2360.0	750.0	352.3	369.8	—	—	—	—
	380	13	6.5	3.6	1428.0	454.0	204.2	214.3	1428.0	454.0	204.2	214.3	—	—	—	—
	460	13	5.5	3.0	1180.0	375.0	176.1	184.9	1180.0	375.0	176.1	184.9	—	—	—	—
	575	13	4.3	2.4	944.0	300.0	134.8	141.5	944.0	300.0	134.8	141.5	—	—	—	—
260	380	15	6.5	3.6	2143.0	684.0	277.9	293.0	2143.0	684.0	277.9	293.0	—	—	—	—
	460	15	5.5	3.0	1770.0	565.0	240.4	253.5	1770.0	565.0	240.4	253.5	—	—	—	—
	575	15	4.3	2.4	1416.0	452.0	183.7	193.7	1416.0	452.0	183.7	193.7	—	—	—	—
	380	16	6.5	3.6	2143.0	684.0	277.9	293.0	2143.0	684.0	277.9	293.0	—	—	—	—
	460	16	5.5	3.0	1770.0	565.0	240.4	253.5	1770.0	565.0	240.4	253.5	—	—	—	—
280	380	16	6.5	3.6	2143.0	684.0	277.9	293.0	2143.0	684.0	277.9	293.0	—	—	—	—
	460	16	5.5	3.0	1770.0	565.0	240.4	253.5	1770.0	565.0	240.4	253.5	—	—	—	—
	575	16	4.3	2.4	1416.0	452.0	183.7	193.7	1416.0	452.0	183.7	193.7	—	—	—	—
	380	16	6.5	3.6	2143.0	684.0	277.9	293.0	2143.0	684.0	277.9	293.0	—	—	—	—
	460	16	5.5	3.0	1770.0	565.0	240.4	253.5	1770.0	565.0	240.4	253.5	—	—	—	—
300	380	16	6.5	3.6	2143.0	684.0	277.9	293.0	2143.0	684.0	277.9	293.0	—	—	—	—
	460	16	5.5	3.0	1770.0	565.0	240.4	253.5	1770.0	565.0	240.4	253.5	—	—	—	—
	575	16	4.3	2.4	1416.0	452.0	183.7	193.7	1416.0	452.0	183.7	193.7	—	—	—	—
	380	16	6.5	3.6	2143.0	684.0	277.9	293.0	2143.0	684.0	277.9	293.0	—	—	—	—
	460	16	5.5	3.0	1770.0	565.0	240.4	253.5	1770.0	565.0	240.4	253.5	—	—	—	—
325	380	9/9	6.5	3.6	2143.0	684.0	277.9	293.0	2143.0	684.0	277.9	293.0	—	—	—	—
	460	18	5.5	3.0	1770.0	565.0	240.4	253.5	1770.0	565.0	240.4	253.5	—	—	—	—
	575	18	4.3	2.4	1416.0	452.0	183.7	193.7	1416.0	452.0	183.7	193.7	—	—	—	—
	380	9/9	6.5	3.6	2143.0	684.0	277.9	293.0	2143.0	684.0	277.9	293.0	—	—	—	—
	460	18	5.5	3.0	1770.0	565.0	240.4	253.5	1770.0	565.0	240.4	253.5	—	—	—	—
350	380	18	6.5	3.6	2143.0	684.0	277.9	293.0	2143.0	684.0	277.9	293.0	—	—	—	—
	460	18	5.5	3.0	1770.0	565.0	240.4	253.5	1770.0	565.0	240.4	253.5	—	—	—	—
	575	18	4.3	2.4	1416.0	452.0	183.7	193.7	1416.0	452.0	183.7	193.7	—	—	—	—
	380	18	6.5	3.6	2143.0	684.0	277.9	293.0	2143.0	684.0	277.9	293.0	—	—	—	—
	460	18	5.5	3.0	1770.0	565.0	240.4	253.5	1770.0	565.0	240.4	253.5	—	—	—	—
400	380	8/12	6.5	3.6	1428.0	454.0	204.2	214.3	1428.0	454.0	204.2	214.3	293.0	2143.0	277.9	293.0
	460	8/12	5.5	3.0	1180.0	375.0	176.1	184.9	1180.0	375.0	176.1	184.9	253.5	1770.0	240.4	253.5
	575	8/12	4.3	2.4	944.0	300.0										

CARRIER COMFORT NETWORK® COMMUNICATION BUS WIRING (See Fig. 24) — The communication bus wiring is a shielded, 3-conductor cable with drain wire and is field supplied and installed in the field.

The system elements are connected to the communication bus in a daisy chain arrangement. The positive pin of each system element communication connector must be wired to the positive pins of the system elements on either side of it. This is also required for the negative and signal ground pins of each system element. Wiring connections for CCN (Carrier Comfort Network) should be made at TB (terminal block) 3. Consult the CCN Contractor's Manual for further information. See Fig. 24.

NOTE: Conductors and drain wire must be 20 AWG (American Wire Gage) minimum stranded, tinned copper. Individual conductors must be insulated with PVC, PVC/nylon, vinyl, Teflon, or polyethylene. An aluminum/polyester 100% foil shield and an outer jacket of PVC, PVC/nylon, chrome vinyl, or Teflon with a minimum operating temperature range of -4 F (-20 C) to 140 F (60 C) is required. See Table 7 for a list of manufacturers that produce CCN bus wiring that meet these requirements.

**Table 7 — CCN Communication Bus Wiring**

MANUFACTURER	PART NUMBER	
	Regular Wiring	Plenum Wiring
Alpha	1895	—
American	A21451	A48301
Belden	8205	884421
Columbia	D6451	—
Manhattan	M13402	M64430
Quabik	6130	—

It is important when connecting to a CCN communication bus that a color coding scheme be used for the entire network to simplify the installation. It is recommended that red be used for the signal positive, black for the signal negative, and white for the signal ground. Use a similar scheme for cables containing different colored wires. At each system element, the shields of its communication bus cables must be tied together. If the communication bus is entirely within one building, the resulting continuous shield must be connected to a ground at one point only. If the communication bus cable exits from one building and enters another, the shields must be connected to grounds at the lightning suppressor in each building where the cable enters or exits the building (one point per building only).

To connect the unit to the network:

1. Turn off power to the control box.
2. Cut the CCN wire and strip the ends of the red (+), white (ground), and black (-) conductors. Substitute appropriate colors for different colored cables.

3. Connect the red wire to (+) terminal on TB3 of the plug, the white wire to COM terminal, and the black wire to the (-) terminal.
4. The RJ14 CCN connector on TB3 can also be used, but is only intended for temporary connection (for example, a laptop computer running service tool).

**IMPORTANT:** A shorted CCN bus cable will prevent some routines from running and may prevent the unit from starting. If abnormal conditions occur, disconnect the machine from the CCN. If conditions return to normal, check the CCN connector and cable. Run new cable if necessary. A short in one section of the bus can cause problems with all system elements on the bus.

NON-CCN COMMUNICATION WIRING — The 30XA units offer several non-CCN translators. Refer to the separate installation instructions for additional wiring steps.

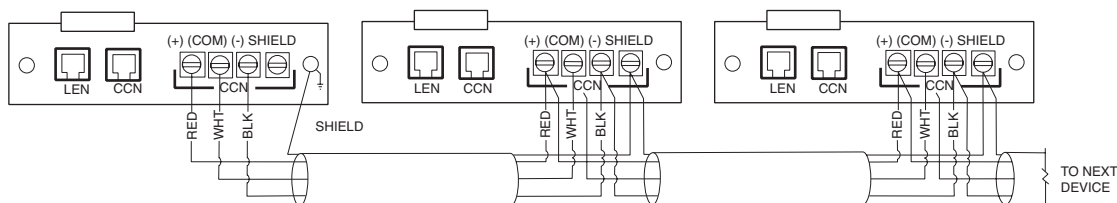
FIELD CONTROL OPTION WIRING — Install field control wiring options. Some options, such as 4 to 20 mA demand limit that requires the Energy Management Module, may require that accessories be installed first (if not factory installed) for terminal connections.

DUAL CHILLER LEAVING WATER SENSOR — If the dual chiller algorithm is used and the machines are installed in parallel, an additional chilled water sensor must be installed for each chiller. Install the wells in the common leaving water header. See Fig. 25. DO NOT relocate the chiller's leaving water thermistors. They must remain in place for the unit to operate properly.

The thermistor well is a 1/4 in. NPT fitting for securing the well in the piping. The piping must be drilled and tapped for the well. Select a location that will allow for removal of the thermistor without any restrictions.

Once the well is inserted, install the thermistors. Insert the thermistor into the well until the o-ring reaches the well body. Use the nut on the thermistor to secure the thermistor in place. Once the thermistor is in place, it is recommended that a thermistor wire loop be made and secured with a wire tie to the chilled water pipe. See Fig. 26.

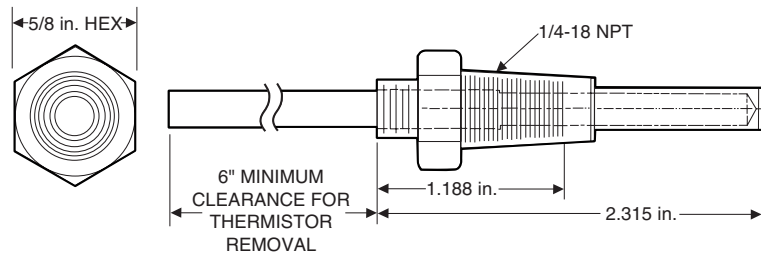
For dual chiller control a CCN bus must be connected between the two modules. See the Carrier Comfort Network Communication Bus Wiring section for additional information.



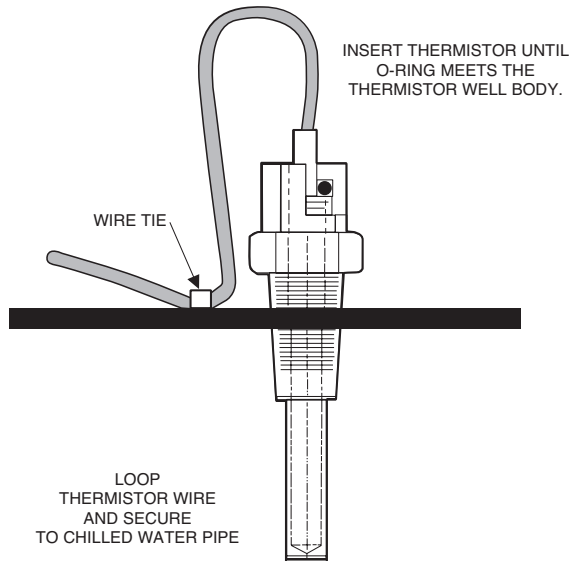
**LEGEND**

- CCN — Carrier Comfort Network
- LEN — Local Equipment Network

**Fig. 24 — TB3 — CCN Wiring**



**Fig. 25 — Dual Leaving Water Thermistor Well**



**Fig. 26 — Dual Leaving Water Thermistor**

**Step 5 — Install Accessories** — A number of accessories are available to provide the following optional features (for details, refer to the Controls and Troubleshooting guide shipped with the unit).

**ENERGY MANAGEMENT MODULE** — The Energy Management Module is used for any of the following types of temperature reset, demand limit and ice features:

- 4 to 20 mA inputs for cooling set point reset and capacity limit (requires field-supplied 4 to 20 mA generator)
- 0 to 10 v output for percentage total capacity running
- 24 v discrete outputs for shutdown and running relays
- 10k space temperature input

Discrete inputs for occupancy override, demand limit switch 2 (step 1 demand limit is wired to the base board, requires field-supplied dry contacts), remote lockout switch and ice done switch (requires field-supplied dry contacts)

**REMOTE ENHANCED DISPLAY** — For applications where remote monitoring of the equipment is required; the remote enhanced display provides an indoor display, capable of monitoring any equipment on the Carrier Comfort Network® (CCN) bus. A CCN bus is required.

**LOW AMBIENT TEMPERATURE OPERATION** — If outdoor ambient operating temperatures below 32 F (0° C) are expected, refer to separate installation instructions for low-ambient operation using the low ambient temperature head pressure control accessory.

**MINIMUM LOAD ACCESSORY** — Contact a local Carrier representative for more details if a minimum load accessory is required for a specific application. For installation details, refer to separate installation instructions supplied with the accessory package.

**UNIT SECURITY/PROTECTION ACCESSORIES** — For applications with unique security and/or protection requirements, several options are available for unit protection. Security grilles and hail guards are available. Contact a local Carrier representative for more details. For installation details, refer to separate installation instructions supplied with the accessory package.

**COMMUNICATION ACCESSORIES** — A number of communication options are available to meet any requirement. Contact a local Carrier representative for more details. For installation details, refer to separate installation instructions supplied with the accessory package.

**SERVICE OPTIONS** — Two accessories are available to aid in servicing 30XA units: a ground fault convenience outlet (GFI-CO) and a remote service port.

The GFI-CO is a convenience outlet with a 4-amp GFI receptacle.

The remote service port is housed in a weather-proof enclosure with a communication port to plug in the Navigator™ device.

Contact a local Carrier representative for more details. For installation details, refer to separate installation instructions supplied with each accessory package.

**CONTROL TRANSFORMER** — The control transformer accessory eliminates the need for a separate power supply.

**Step 6 — Leak Test Unit** — The 30XA units are shipped with a complete operating charge of R-134A (see Tables 1A and 1B) and should be under sufficient pressure to conduct a leak test.

**IMPORTANT:** These units are designed for use with R-134a only. DO NOT USE ANY OTHER refrigerant in these units.

Perform a leak test to ensure that leaks have not developed during unit shipment. Dehydration of the system is not required unless the entire refrigerant charge has been lost. There are several O-ring face seal fittings utilized in the oil line piping. If a leak is detected at any of these fittings, open the system and inspect the O-ring surface for foreign matter or damage. Do not reuse O-rings. Repair any leak found following good refrigeration practice.

**⚠ CAUTION**

**DO NOT OVERTIGHTEN THESE FITTINGS.** Overtightening will result in O-ring damage.

**Step 7 — Refrigerant Charging**

**DEHYDRATION** — Refer to Carrier Standard Service Techniques Manual, Chapter 1, Refrigerants, Sections 6 and 7 for details. Do not use compressor to evacuate system.

## REFRIGERANT CHARGE

**IMPORTANT:** These units are designed for use with R-134a only. **DO NOT USE ANY OTHER** refrigerant in these units.

The liquid charging method is recommended for complete charging or when additional charge is required.

### **⚠ CAUTION**

When charging, circulate water through the cooler at all times to prevent freezing. Freezing damage is considered abuse and may void the Carrier warranty.

### **⚠ CAUTION**

**DO NOT OVERCHARGE** system. Overcharging results in higher discharge pressure with higher cooling fluid consumption, possible compressor damage, and higher power consumption.

The 30XA units are shipped from the factory with a full charge of R-134a. The unit should not need to be charged at installation unless a leak was detected in Step 6 — Leak Test Unit section. If dehydration and recharging is necessary, use industry standard practices or refer to Carrier Standard Service Techniques Manual as required.



