



# Controls, Start-Up, Operation, Service and Troubleshooting

## CONTENTS

	Page	Page
<b>SAFETY CONSIDERATIONS</b> .....	2	
<b>GENERAL</b> .....	2-4	
Conventions Used in This Manual.....	2	
Display Module Usage.....	3	
• NAVIGATOR™ DISPLAY MODULE		
<b>CONTROLS</b> .....	4-41	
General.....	4	
Main Base Board (MBB).....	4	
Compressor Protection Module (CPM).....	6	
Electronic Expansion Valve (EXV) Board.....	9	
Fan Boards.....	11	
Enable-Off-Remote Contact Switch (SW1).....	13	
Emergency On/Off Switch (SW2).....	13	
Energy Management Module (EMM).....	13	
Local Equipment Network.....	14	
Board Addresses.....	14	
Control Module Communication.....	14	
• RED LED		
• GREEN LED		
• YELLOW LED		
Carrier Comfort Network® (CCN) Interface.....	15	
Configuration Options.....	15	
• RAMP LOADING		
• MINUTES OFF TIME		
Dual Chiller Control.....	15	
• DUAL CHILLER PUMP CONTROL FOR PARALLEL APPLICATIONS		
• DUAL CHILLER PUMP CONTROL FOR SERIES CHILLER APPLICATIONS		
Capacity Control.....	16	
• EQUAL LOADING		
• STAGE LOADING		
• CAPACITY CONTROL OVERRIDES		
Head Pressure Control.....	22	
• LOW AMBIENT TEMPERATURE HEAD PRESSURE CONTROL OPTION		
• LOW AMBIENT TEMPERATURE HEAD PRESSURE CONTROL OPERATING INSTRUCTIONS		
Machine Control Methods.....	29	
• SWITCH CONTROL		
• TIME SCHEDULE		
• CCN CONTROL		
• UNIT RUN STATUS		
Cooling Set Point Selection.....	30	
• SET POINT 1		
• SET POINT 2		
• 4 TO 20 mA INPUT		
• DUAL SWITCH		
• ICE MODE		
• SET POINT OCCUPANCY		
Temperature Reset.....	31	
Demand Limit.....	32	
• 1-STEP SWITCH CONTROLLED		
• 2-STEP SWITCH CONTROLLED		
• EXTERNALLY POWERED (4 to 20 mA Controlled)		
• CCN LOADSHED CONTROLLED		
Remote Alarm and Alert Relays.....	40	
PRE-START-UP.....	41	
System Check.....	41	
START-UP.....	42-48	
Actual Start-Up.....	42	
Operating Limitations.....	42	
• TEMPERATURES		
• VOLTAGE		
• MINIMUM FLUID LOOP VOLUME		
• FLOW RATE REQUIREMENTS		
OPERATION.....	48-55	
Sequence of Operation.....	48	
• ACTUATED BALL VALVE (ABV)		
Dual Chiller Sequence of Operation.....	49	
• PARALLEL PUMP OPERATION		
Operating Modes.....	49	
Sensors.....	52	
• THERMISTORS		
• TRANSDUCERS		
SERVICE.....	56-66	
Economizer Assembly.....	56	
Electronic Expansion Valve (EXV).....	56	
• MAIN EXV CONTROL		
• ECONOMIZER EXV CONTROL		
• EXV TROUBLESHOOTING PROCEDURE		
Compressor Assembly.....	59	
• COMPRESSOR OIL SYSTEM		
Cooler.....	61	
• SUCTION SERVICE VALVE		
• FREEZE PROTECTION		
• LOW FLUID TEMPERATURE		
• LOSS OF FLUID FLOW PROTECTION		
• TUBE PLUGGING		
• RETUBING		
• TIGHTENING COOLER HEAD BOLTS		
• INSPECTING/CLEANING HEAT EXCHANGERS		
• WATER TREATMENT		
• CHILLED WATER FLOW SWITCH		
Condenser Coil Maintenance and Cleaning Recommendations.....	64	
• REMOVE SURFACE LOADED FIBERS		
• PERIODIC CLEAN WATER RINSE		
• ROUTINE CLEANING OF COIL SURFACES		
Condenser Fans.....	65	
Refrigerant Circuit.....	65	
• LEAK TESTING		
• REFRIGERANT CHARGE		
Safety Devices.....	66	
• COMPRESSOR PROTECTION		
• OIL SEPARATOR HEATERS		
• COOLER PROTECTION		
Relief Devices.....	66	
• PRESSURE RELIEF VALVES		

## CONTENTS (cont)

MAINTENANCE.....	66
Recommended Maintenance Schedule .....	66
TROUBLESHOOTING.....	66-86
Alarms and Alerts .....	67
• DIAGNOSTIC ALARM CODES AND POSSIBLE CAUSES	
Service Test .....	82
APPENDIX A — LOCAL DISPLAY TABLES... ..	87-100
APPENDIX B — CCM TABLES .....	101-112
APPENDIX C — 30XA080-500 CPM DIP SWITCH ADDRESSES.....	113-116
APPENDIX D — PIPING AND INSTRUMENTATION .....	117
INDEX .....	118
START-UP CHECKLIST FOR 30XA LIQUID CHILLERS .....	CL-1 to CL-8

## SAFETY CONSIDERATIONS

Installing, starting up, and servicing this equipment can be hazardous due to system pressures, electrical components, and equipment location (roof, elevated structures, etc.). Only trained, qualified installers and service technicians should install, start up, and service this equipment. When working on this equipment, observe precautions in the literature, and on tags, stickers, and labels attached to the equipment, and any other safety precautions that apply. Follow all safety codes. Wear safety glasses and work gloves. Use care in handling, rigging, and setting this equipment, and in handling all electrical components.

### ⚠ WARNING

Electrical shock can cause personal injury and death. Shut off all power to this equipment during installation and service. There may be more than one disconnect switch. Tag all disconnect locations to alert others not to restore power until work is completed.

### ⚠ WARNING

DO NOT VENT refrigerant relief valves within a building. Outlet from relief valves must be vented in accordance with the latest edition of ANSI/ASHRAE (American National Standards Institute/American Society of Heating, Refrigerating and Air Conditioning Engineers) 15 (Safety Code for Mechanical Refrigeration). The accumulation of refrigerant in an enclosed space can displace oxygen and cause asphyxiation. Provide adequate ventilation in enclosed or low overhead areas. Inhalation of high concentrations of vapor is harmful and may cause heart irregularities, unconsciousness or death. Misuse can be fatal. Vapor is heavier than air and reduces the amount of oxygen available for breathing. Product causes eye and skin irritation. Decomposition products are hazardous.

### ⚠ WARNING

DO NOT attempt to unbrazed factory joints when servicing this equipment. Compressor oil is flammable and there is no way to detect how much oil may be in any of the refrigerant lines. Cut lines with a tubing cutter as required when performing service. Use a pan to catch any oil that may come out of the lines and as a gage for how much oil to add to system. DO NOT re-use compressor oil.

### ⚠ CAUTION

This unit uses a microprocessor-based electronic control system. Do not use jumpers or other tools to short out components, or to bypass or otherwise depart from recommended procedures. Any short-to-ground of the control board or accompanying wiring may destroy the electronic modules or electrical components.

### ⚠ CAUTION

To prevent potential damage to heat exchanger tubes, always run fluid through heat exchanger when adding or removing refrigerant charge. Use appropriate antifreeze solutions in cooler fluid loop to prevent the freezing of heat exchanger or interconnecting piping when the equipment is exposed to temperatures below 32 F (0° C). Proof of flow switch is factory installed on all models. Do NOT remove power from this chiller during winter shut down periods without taking precaution to remove all water from heat exchanger. Failure to properly protect the system from freezing may constitute abuse and may void warranty.

### ⚠ CAUTION




Compressors require specific rotation. Test condenser fan(s) first to ensure proper phasing. Swap any two incoming power leads to correct condenser fan rotation before starting compressors. Operating the unit without testing the condenser fan(s) for proper phasing could result in equipment damage.

## GENERAL



This publication contains Controls, Operation, Start-Up, Service and Troubleshooting information for the 30XA080-500 air-cooled liquid chillers with electronic controls. The 30XA chillers are equipped with *ComfortLink*<sup>TM</sup> controls and electronic expansion valves.

**Conventions Used in This Manual** — The following conventions for discussing configuration points for the Navigator<sup>TM</sup> module will be used in this manual.

Point names will be written with the mode name first, then any sub-modes, then the point name, each separated by an arrow symbol (→). Names will also be shown in bold and italics. As an example, the Lead/Lag Circuit Select Point, which is located in the Configuration mode, Option sub-mode, would be written as *Configuration* →*OPTN*→*LLCS*.

This path name will show the user how to navigate through the local display to reach the desired configuration. The user would scroll through the modes and sub-modes using the  and  keys. The arrow symbol in the path name represents pressing  to move into the next level of the menu structure.

When a value is included as part of the path name, it will be shown at the end of the path name after an equals sign. If the value represents a configuration setting, an explanation will be shown in parenthesis after the value. As an example, *Configuration*→*OPTN*→*LLCS* = 1 (Circuit A leads).

Pressing the  and  keys simultaneously will scroll an expanded text description of the point name or value across the display. The expanded description is shown in the local display tables but will not be shown with the path names in text.

The CCM (Carrier Comfort Network<sup>®</sup>) point names are also referenced in the local display tables for users configuring the unit with CCM software instead of the local display. The CCM tables are located in Appendix B of the manual.

## Display Module Usage

NAVIGATOR™ DISPLAY MODULE — The Navigator module provides a mobile user interface to the *ComfortLink™* control system. The display has up and down arrow keys, an **ENTER** key, and an **ESCAPE** key. These keys are used to navigate through the different levels of the display structure. Press the **ESCAPE** key until ‘Select a Menu Item’ is displayed to move through the top 11 mode levels indicated by LEDs on the left side of the display. See Fig. 1. See Table 1 and Appendix A for more details about the display menu structure.

Once within a Mode or sub-mode, a “>” indicates the currently selected item on the display screen. Pressing the **ENTER** and **ESCAPE** keys simultaneously will put the Navigator module into expanded text mode where the full meaning of all sub-modes, items and their values can be displayed. Pressing the **ENTER** and **ESCAPE** keys when the display says ‘Select Menu Item’ (Mode LED level) will return the Navigator module to its default menu of rotating display items (those items in *Run Status* → *VIEW*). In addition, the password will be disabled, requiring that it be entered again before changes can be made to password protected items. Press the **ESCAPE** key to exit out of the expanded text mode.

NOTE: When the Language Selection (*Configuration* → *DISP* → *LANG*), variable is changed, all appropriate display expansions will immediately change to the new language. No power-off or control reset is required when reconfiguring languages.

When a specific item is located, the item name appears on the left of the display, the value will appear near the middle of the display and the units (if any) will appear on the far right of the display. Press the **ENTER** key at a changeable item and the value will begin to flash. Use the up and down arrow keys to change the value, and confirm the value by pressing the **ENTER** key.

Changing item values or testing outputs is accomplished in the same manner. Locate and display the desired item. Press **ENTER** so that the item value flashes. Use the arrow keys to change the value or state and press the **ENTER** key to accept it. Press the **ESCAPE** key to return to the next higher level of structure. Repeat the process as required for other items.

Items in the Configuration and Service Test modes are password protected. The words **Enter Password** will be displayed when required, with 1111 also being displayed. The default password is 0111. Use the arrow keys to change each number and press **ENTER** to enter the digit. Continue with the remaining digits of the password. The password can only be changed through CCN operator interface software such as *ComfortWORKS®*, *ComfortVIEW™* and *Service Tool*.

**Adjusting the Contrast** — The contrast of the display can be adjusted to suit ambient conditions. To adjust the contrast of the Navigator module, press the **ESCAPE** key until the display reads, “Select a menu item.” Using the arrow keys move to the Configuration mode. Press **ENTER** to obtain access to this mode. The display will read:

```
> TEST OFF
METR OFF
LANG ENGLISH
```

Pressing **ENTER** will cause the “OFF” to flash. Use the up or down arrow to change “OFF” to “ON.” Pressing **ENTER** will illuminate all LEDs and display all pixels in the view screen. Pressing **ENTER** and **ESCAPE** simultaneously allows the user to adjust the display contrast. The display will read:

```
Adjust Contrast
-----+-----
```

Use the up or down arrows to adjust the contrast. The screen’s contrast will change with the adjustment. Press **ENTER** to accept the change. The Navigator module will keep this setting as long as it is plugged in to the LEN bus.

**Adjusting the Backlight Brightness** — The backlight of the display can be adjusted to suit ambient conditions. The factory default is set to the highest level. To adjust the backlight of the Navigator module, press the **ESCAPE** key until the display reads, “Select a menu item.” Using the arrow keys move to the Configuration mode. Press **ENTER** to obtain access to this mode. The display will read:

```
> TEST OFF
METR OFF
LANG ENGLISH
```

Pressing **ENTER** will cause the “OFF” to flash. Use the up or down arrow keys to change “OFF” to “ON”. Pressing **ENTER** will illuminate all LEDs and display all pixels in the view screen. Pressing the up and down arrow keys simultaneously allows the user to adjust the display brightness. The display will read:

```
Adjust Brightness
-----+-----
```

Use the up or down arrow keys to adjust screen brightness. Press **ENTER** to accept the change. The Navigator module will keep this setting as long as it is plugged in to the LEN bus.



Fig. 1 — Accessory Navigator Display Module

**Table 1 — ComfortLink™ Display Menu Structure**

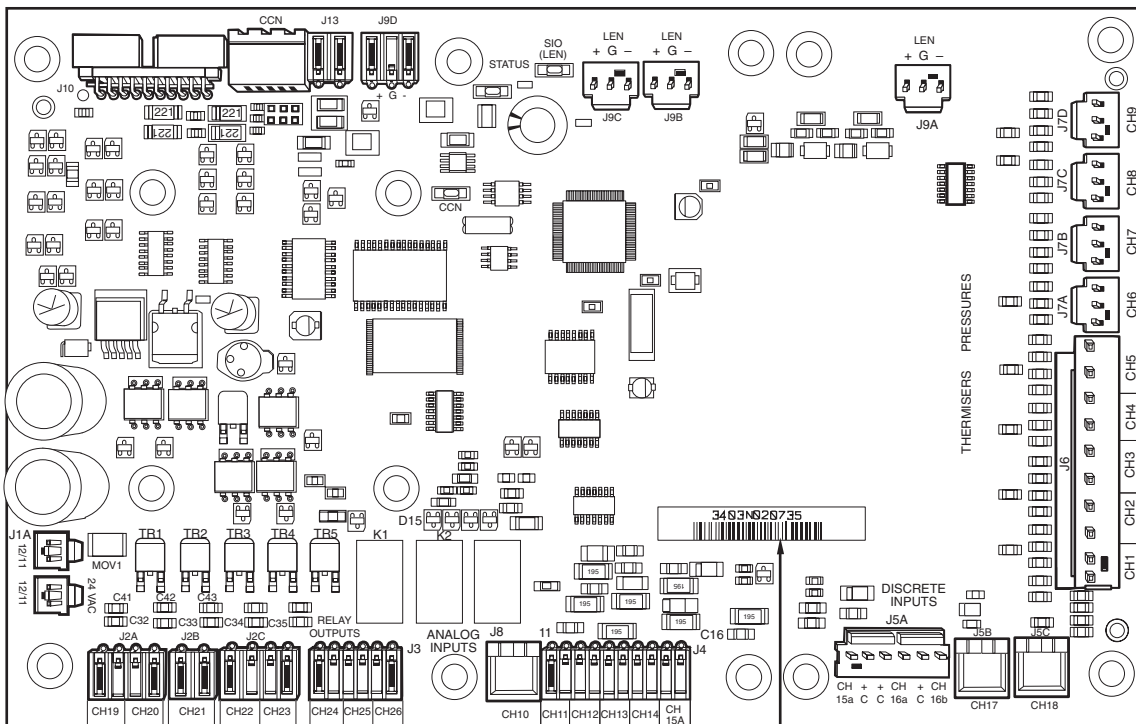
MODE										
RUN STATUS	SERVICE TEST	TEMPERATURES	PRESSURES	SET POINTS	INPUTS	OUTPUTS	CONFIGURATION	TIME CLOCK	OPERATING MODES	ALARMS
Auto Display (VIEW)	Manual Test Mode (TEST)	Unit Temperatures (UNIT)	Circuit A Pressures (PRC.A)	Cooling Setpoints (COOL)	General Inputs (GEN.I)	Circuit A Outputs (CIR.A)	Display Configuration (DISP)	Time of Day (TIME)	Operating Control Type (SLCT)	Reset Current Alarms (R.ALM)
Remote User Interface (R.CCN)	Quick Test Mode (QUIC)	Circuit A Temperatures (CIR.A)	Circuit B Pressures (PRC.B)	Heating Setpoints (HEAT)		Circuit B Outputs (CIR.B)	Unit Configuration (UNIT)	Day, Date (DATE)	Operating Modes (MODE)	Current Alarms (ALRM)
Machine Starts/Hours (RUN)		Circuit B Temperatures (CIR.B)	Circuit C Pressures (PRC.C)	Misc. Setpoints (MISC)		Circuit C Outputs (CIR.C)	Service Configurations (SERV)	Schedule 1 (SCH1)		Alarm History (H.ALM)
Compressor Run Hours (HOUR)		Circuit C Temperatures (CIR.C)				General Outputs (GEN.O)	Options Configuration (OPTN)	Schedule 2 (SCH2)		
Compressor Starts (STRT)							Reset, Demand Limit, Master/Slave (RSET)	Holidays (HOLI)		
Fan Run Hours (FAN)								Service Maintenance Configuration (MCFG)		
Compressor Disable (CPUN)										
Predictive Maintenance (MAIN)										
Software Versions (VERS)										

**CONTROLS**

**General** — The 30XA air-cooled liquid chillers contain the ComfortLink™ electronic control system that controls and monitors all operations of the chiller. The control system is composed of several components as listed in the following sections. All machines have at the very least a Main Base Board (MBB), Navigator™ module, electronic expansion valve board (EXV), fan board, Compressor Protection board, Emergency On/Off switch, an Enable-Off- Remote Contact switch.

**Main Base Board (MBB)** — The MBB is the heart of the ComfortLink control system, which contains the major portion of operating software and controls the operation of the

machine. See Fig. 2. The MBB continuously monitors input/output channel information received from its inputs and from all other modules. The MBB receives inputs from status and feedback switches, pressure transducers and thermistors. The MBB also controls several outputs. Some inputs and outputs to control the machine are located on other boards, but are transmitted to or from the MBB via the internal communications bus. Information is transmitted between modules via a 3-wire communication bus or LEN (Local Equipment Network). The CCN (Carrier Comfort Network®) bus is also supported. Connections to both LEN and CCN buses are made at TB3. For a complete description of Main Base Board inputs and outputs and their channel identifications, see Table 2.



LOCATION OF SERIAL NUMBER

**Fig. 2 — Main Base Board**

**Table 2 — Main Base Board Inputs and Outputs**

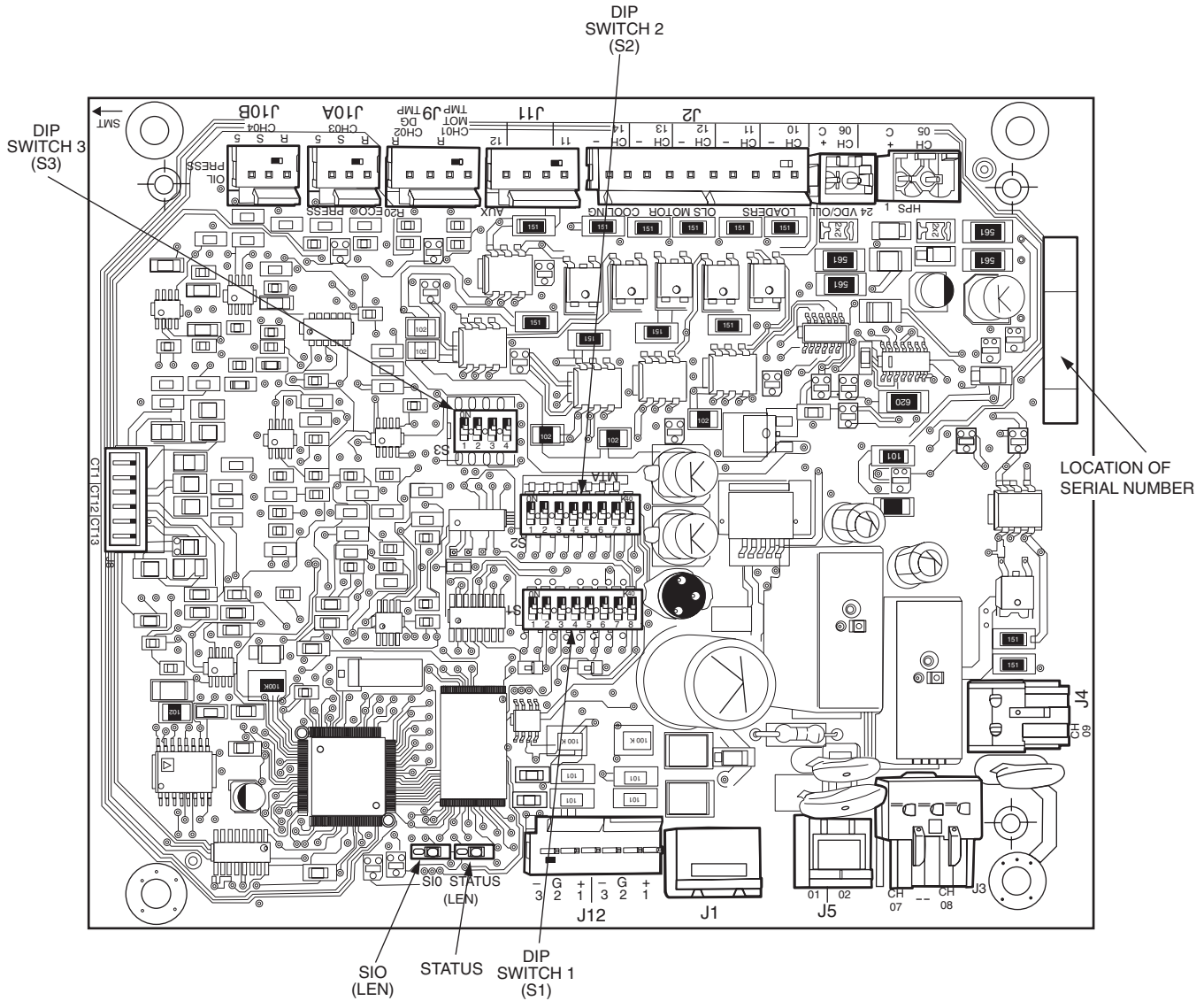
DESCRIPTION	INPUT/OUTPUT	I/O TYPE	NAVIGATOR™ MODULE POINT NAME	CONNECTION POINT	
				Pin	Notation
Power (24 vac supply)	—	—	—	MBB-J1, MBB-J1A, MBB-J1B	
				11	24 vac
				12	Ground
Local Equipment Network	—	—	—	MBB-J9A, MBB-J9B, MBB-J9C	
				+	
				G	
Carrier Communication Network	—	—	—	MBB-J12	
				+	
				G	
Chilled Water Flow Switch	CWFS	Switch	<b>INPUTS</b> → <b>GEN.I</b> → <b>LOCK</b>	MBB-J5B-CH17	
				17	
Demand Limit Switch No. 1	Demand Limit SW1	Switch	<b>INPUTS</b> → <b>GEN.I</b> → <b>DLS1</b>	MBB-J4-CH13	
Circuit A Discharge Pressure Transducer	DPTA	Pressure Transducer	<b>PRESSURES</b> → <b>PRC.A</b> → <b>DP.A</b>	MBB-J7A-CH6	
				5V	5 vdc Ref.
				S	Signal
				R	Return
Circuit B Discharge Pressure Transducer	DPTB	Pressure Transducer	<b>PRESSURES</b> → <b>PRC.B</b> → <b>DP.B</b>	MBB-J7C-CH8	
				5V	5 vdc Ref.
				S	Signal
				R	Return
Dual Chiller LWT Thermistor	DUAL	5k Thermistor	<b>TEMPERATURES</b> → <b>UNIT</b> → <b>CHWS</b>	MBB-J6-CH3	
Dual Set Point Input	Dual Set Point	Switch	<b>INPUTS</b> → <b>GEN.I</b> → <b>DUAL</b>	MBB-J4-CH12	
Entering Water Thermistor	EWT	5k Thermistor	<b>TEMPERATURES</b> → <b>UNIT</b> → <b>EWT</b>	MBB-J6-CH2	
Leaving Water Thermistor	LWT	5k Thermistor	<b>TEMPERATURES</b> → <b>UNIT</b> → <b>LWT</b>	MBB-J6-CH1	
Outdoor Air Thermistor	OAT	5k Thermistor	<b>TEMPERATURES</b> → <b>UNIT</b> → <b>OAT</b>	MBB-J6-CH4	
External Chilled Water Pump Interlock	PMPI	Switch	<b>INPUTS</b> → <b>GEN.I</b> → <b>LOCK</b>	MBB-J4-CH15A	
Circuit A Suction Pressure Transducer	SPTA	Pressure Transducer	<b>PRESSURES</b> → <b>PRC.A</b> → <b>SP.A</b>	MBB-J7B-CH7	
				5V	5 vdc Ref.
				S	Signal
Circuit B Suction Pressure Transducer	SPTB	Pressure Transducer	<b>PRESSURES</b> → <b>PRC.B</b> → <b>SP.B</b>	MBB-J7D-CH9	
				5V	5 vdc Ref.
				S	Signal
				R	Return
Unit Status	Remote Contact-Off-Enable	Switch	<b>INPUTS</b> → <b>GEN.I</b> → <b>ONOF</b>	MBB-J4-CH11	
Alarm Relay	ALM R	Relay	<b>OUTPUTS</b> → <b>GEN.O</b> → <b>ALRM</b>	MBB-J3-CH24	
Alert Relay	ALT R	Relay	<b>OUTPUTS</b> → <b>GEN.O</b> → <b>ALRT</b>	MBB-J3-CH25	
Cooler Heater	CL-HT	Contactora	<b>OUTPUTS</b> → <b>GEN.O</b> → <b>CO.HT</b>	MBB-J3-CH26	
Isolation Valve A	ISVA	Contactora	<b>OUTPUTS</b> → <b>GEN.O</b> → <b>BVL.A</b>	MBB-J2A-CH19	
Isolation Valve B	ISVB	Contactora	<b>OUTPUTS</b> → <b>GEN.O</b> → <b>BVL.B</b>	MBB-J2A-CH20	
Isolation Valve C (Size 400-500)	ISVC	Contactora	<b>OUTPUTS</b> → <b>GEN.O</b> → <b>BVL.C</b>	MBB-J2C-CH22	
Oil Heater A (Size 080 only)	OIL HT_A	Contactora	<b>OUTPUTS</b> → <b>CIR.A</b> → <b>HT.A</b>	MBB-J2C-CH22	
Oil Heater B (Size 080 only)	OIL HT_A	Contactora	<b>OUTPUTS</b> → <b>CIR.B</b> → <b>HT.B</b>	MBB-J2C-CH23	

LEGEND

I/O — Input or Output  
 LWT — Leaving Water Temperature

**Compressor Protection Module (CPM)** — There is one CPM per compressor. See Fig. 3. The device controls the compressor contactors, oil solenoid, loading/unloading the solenoid, motor cooling solenoid (30XA080 only) and the oil separator heater (30XA090-500). The CPM also monitors the compressor motor temperature, high pressure switch, oil level switch, discharge gas temperature, oil pressure transducer, motor current, MTA setting and economizer pressure transducer. The CPM responds to commands from the MBB (Main Base

Board) and sends the MBB the results of the channels it monitors via the LEN (Local Equipment Network). The CPM has three DIP switch input banks, Switch 1 (S1), Switch 2 (S2), and Switch 3 (S3). The CPM board S1 DIP switch configures the board for the type of starter, the location and type of the current transformer's and contactor failure instructions. See Table 3 for description of DIP switch 1 (S1) inputs. See Appendix C for DIP switch settings.



**Fig. 3 — Compressor Protection Module**

**Table 3 — DIP Switch 1 (S1) Inputs**

DIP SWITCH POSITION	FUNCTION	SETTING	MEANING
1	Starter Configuration	OFF	Across-the-line Start
		ON	Y-Delta Start
2, 3	Current Transformer (CT) Position	OFF, OFF	CT is located in the main line
		OFF, ON	CT is located in the Delta of the motor
		ON, OFF	Reserved for future use
		ON, ON	Invalid; will cause MTA configuration alarm
4, 5, 6	Current Transformer (CT) Selection	OFF, OFF, OFF	100A/1V CT1
		OFF, OFF, ON	100A/0.503V CT2
		OFF, ON, OFF	100A/0.16V CT3
		OFF, ON, ON	Invalid; will cause MTA configuration alarm
		ON, OFF, OFF	Invalid; will cause MTA configuration alarm
		ON, OFF, ON	Invalid; will cause MTA configuration alarm
		ON, ON, OFF	Invalid; will cause MTA configuration alarm
ON, ON, ON	Invalid; will cause MTA configuration alarm		
7	Contactor Failure Action	OFF	All units should be off
		ON	Used when Shunt Trip is available in the unit
8	Not Used	—	—

The CPM board dip switch S2 setting determines the must trip amps (MTA) setting. See Appendix C for DIP switch settings. The MTA setting which is calculated using the settings S2 must match the MTA setting in the software or an MTA alarm will be generated.

See below for CPM board S3 address information. See Table 4 for CPM inputs and outputs.

CPM-A DIP Switch	1	2	3	4
Address:	OFF	OFF	OFF	OFF

CPM-B DIP Switch	1	2	3	4
Address:	OFF	OFF	ON	OFF

CPM-C DIP Switch	1	2	3	4
Address:	OFF	OFF	OFF	ON

NOTE: The CPM-A and CPM-B DIP switches are for all units. The CPM-C DIP switches are for 30XA400-500 units.

**Table 4 — Compressor Protection Module Inputs and Outputs\***

DESCRIPTION	INPUT/OUTPUT	I/O TYPE	NAVIGATOR™ MODULE POINT NAME	CONNECTION POINT	
				Pin	Notation
Power (24 vac supply)	—	—	—	CPM-X-J1	
				11	24 vac
				12	Ground
Local Equipment Network	—	—	—	CPM-X-JP12	
				1	+
				2	G
				3	-
				CPM-X-J12	
				1	+
2	G				
3	-				
Circuit X High Pressure Switch	HPS-X	Switch	Not available	CPM-X-J7-CH05	
				1	
Oil Level Switch	Oil LS X	Switch	<b>OUTPUTS</b> →CIR.X→OLS.X	CPM-X-J6-CH06	
				1	
Must Trip Amps†	MTA	8-Pin DIP Switch	<b>CONFIGURATION</b> →UNIT MTA.X		
				2	
Configuration Switch†	SW1	4-Pin DIP Switch	Not available		
				2	
Compressor X Motor Temperature	MTR-X	NTC Thermistor	<b>TEMPERATURES</b> →CIR.X DGT.X	CPM-X-J9-CH01	
				1	
Compressor X Discharge Gas Temperature	DGT X	NTC Thermistor	<b>TEMPERATURES</b> →CIR.X DGT.X	CPM-X-J9-CH02	
				1	
Oil Pressure Transducer	OPT X	Pressure Transducer	<b>PRESSURES</b> →PRC.X→OP.X	CPM-X-J10B-CH04	
				5V	+ , 5 vdc ref
Economizer Pressure Transducer	EPT X	Pressure Transducer	<b>PRESSURES</b> →PRC.X→ECP.X	CPM-X-J10A	
				5V	+ , 5 vdc ref
Compressor Current X Phase A**		Current Sensor	Not available	CPM-X-J8-CH01	
				1	
Compressor Current X Phase B		Current Sensor	<b>INPUTS</b> →CUR.X	CPM-X-J8-CH02	
				1	
Compressor Current X Phase C**		Current Sensor	Not available	CPM-X-J8-CH3	
				1	
Compressor X 1M Contactor	C X 1M	Contactor	<b>OUTPUTS</b> →CIR.X→CP.X	CPM-X-J1-CH07	
				1	
Compressor X 2M Contactor	C X 2M	Contactor	Not available	CPM-X-J2-CH8	
				1	
Compressor X S Contactor	C X S	Contactor	Not available	CPM-X-J2-CH9	
				1	
Oil Heater Relay X (090-500)	Oil HTR X	Contactor	<b>OUTPUTS</b> →CIR.X HT.X	CPM-X-J2-CH10	
				1	
Oil Solenoid X	Oil solenoid-X	Solenoid	<b>OUTPUTS</b> →CIR.X→OLS.X	CPM-X-J2-CH12	
				1	
Load Solenoid X	Loading Solenoid-X	Solenoid	<b>OUTPUTS</b> →CIR.A→SL1.X	CPM-X-J2-CH13	
				1	
Unload Solenoid X	Unloading Solenoid-X	Solenoid	<b>OUTPUTS</b> →CIR.A→SL2.X	CPM-X-J2-CH14	
				1	
Motor Cooling Solenoid X (080)	Gas Cooling Solenoid-X	Solenoid	<b>OUTPUTS</b> →CIR.X→DGT.X	CPM-X-J2-CH10	
				1	

\*\*X" denotes the circuit, A, B or C.

†See Appendix C for MTA settings.

\*\*Average current .x depending on circuit A, B, or C.

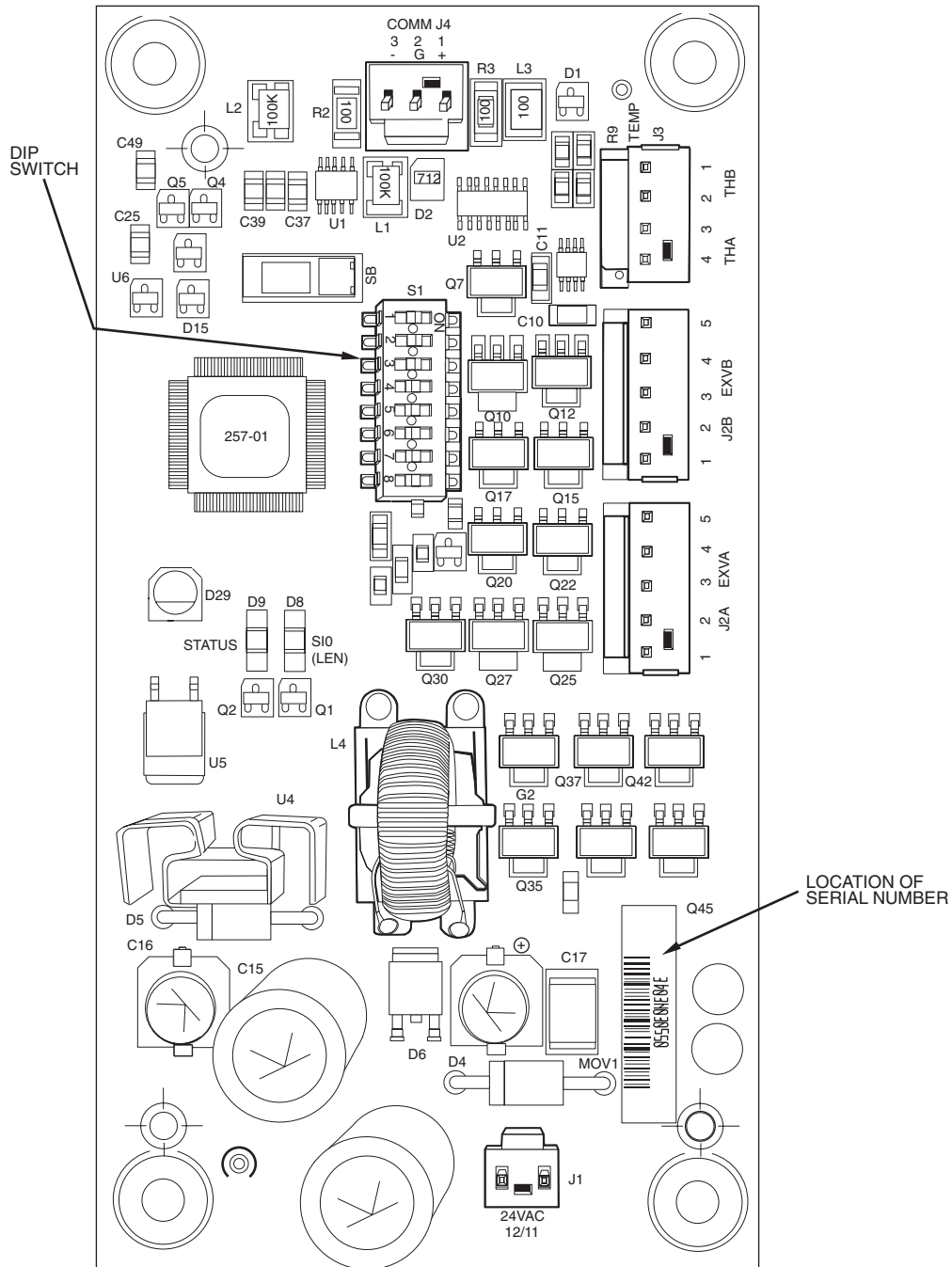
**Electronic Expansion Valve (EXV) Board —**  
 The 30XA080 unit has one EXV board. The 30XA090-500 units have one EXV board per circuit. See Fig. 4. The board is responsible for monitoring the suction gas temperature and economizer gas temperature thermistors. The board also signals the main EXV and economizer EXV (ECEXV) motors to open or close. The electronic expansion valve board responds to commands from the MBB and sends the MBB the results of the channels it monitors via the LEN (Local Equipment Network). See below for DIP switch information. See Tables 5 and 6 for EXV inputs and outputs.

EXV BOARD B (090-500) DIP SWITCH	1	2	3	4	5	6	7	8
Address:	OFF	ON	ON	ON	ON	ON	OFF	ON

EXV BOARD C (400-500) DIP SWITCH	1	2	3	4	5	6	7	8
Address:	ON	OFF	ON	ON	ON	ON	OFF	ON

EXV BOARD A (080-450) DIP SWITCH	1	2	3	4	5	6	7	8
Address:	ON	ON	ON	ON	ON	ON	OFF	ON



**Fig. 4 — EXV Board**

**Table 5 — EXVA Board Inputs and Outputs (30XA080)**

DESCRIPTION	INPUT/OUTPUT	I/O TYPE	NAVIGATOR™ MODULE POINT NAME	CONNECTION POINT	
				Pin	Notation
Power (24 vac supply)	—	—	—	EXVA-J1	
				11	24 vac
				12	Ground
Local Equipment Network	—	—	—	EXVA-J4	
				1	+
				2	G
				3	—
Circuit A Suction Gas Thermistor	SGTA	5k Thermistor	<i>TEMPERATURES</i> → <i>CIR.A</i> → <i>SGT.A</i>	EXVA-J3	
				TH	
				A	
Circuit B Suction Gas Thermistor	SGTB	5k Thermistor	<i>TEMPERATURES</i> → <i>CIR.B</i> → <i>SGT.B</i>	EXVA-J3	
				TH	
				B	
Circuit A EXV	EXV-A	Stepper Motor	<i>OUTPUTS</i> → <i>CIR.A</i> → <i>EXV.A</i>	EXVA-J2A	
				1	
				2	
				3	
				4	
Circuit B EXV	EXV-B	Stepper Motor	<i>OUTPUTS</i> → <i>CIR.B</i> → <i>EXV.B</i>	EXVA-J2B	
				1	
				2	
				3	
				4	

**Table 6 — EXV A,B,C Board Inputs and Outputs\* (30XA090-500)**

DESCRIPTION	INPUT/OUTPUT	I/O TYPE	NAVIGATOR MODULE POINT NAME	CONNECTION POINT	
				Pin	Notation
Power (24 vac supply)	—	—	—	EXVX-J1	
				11	24 vac
				12	Ground
Local Equipment Network	—	—	—	EXVX-J4	
				1	+
				2	G
				3	—
Circuit X Suction Gas Thermistor	SGT X	5k Thermistor	<i>TEMPERATURES</i> → <i>CIR.X</i> → <i>SGT.X</i>	EXVX-J3	
				TH	
				A	
Circuit X Economizer Gas Thermistor	ECT X	5k Thermistor	<i>TEMPERATURES</i> → <i>CIR.X</i> → <i>ECT.X</i>	EXVX-J3	
				TH	
				B	
Circuit X EXV	EXV-X	Stepper Motor	<i>OUTPUTS</i> → <i>CIR.X</i> → <i>EXV.X</i>	EXVX-J2A	
				1	
				2	
				3	
				4	
Circuit X Economizer EXV	ECEXV-X	Stepper Motor	<i>OUTPUTS</i> → <i>CIR.X</i> → <i>ECO.X</i>	EXVX-J2A	
				1	
				2	
				3	
				4	

\*"X" denotes the circuit, A, B or C.

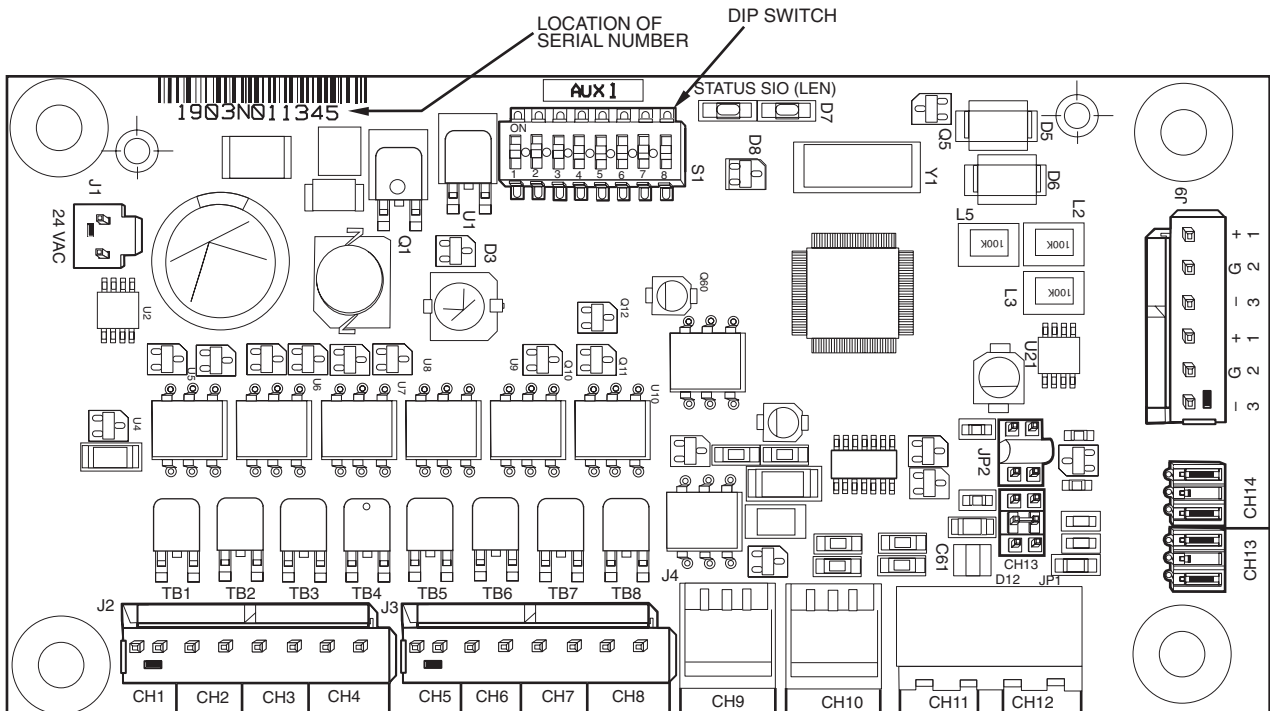
**Fan Boards** — At least one fan board is installed in each unit. See Fig. 5A and 5B. There are two types of fan boards, with and without an analog output signal for the low ambient temperature head pressure control fan speed controllers. If a unit does not have low ambient temperature head pressure control installed, it will not have the analog connection terminals. The fan board responds to commands from the MBB and sends the MBB the results of the channels it monitors via the Local Equipment Network (LEN). See below for fan board A, B and C DIP switch addresses. See Tables 7-9 for inputs and outputs.

FAN BOARD (080) DIP SWITCH	1	2	3	4	5	6	7	8
Address:	OFF	ON	OFF	OFF	ON	OFF	ON	OFF

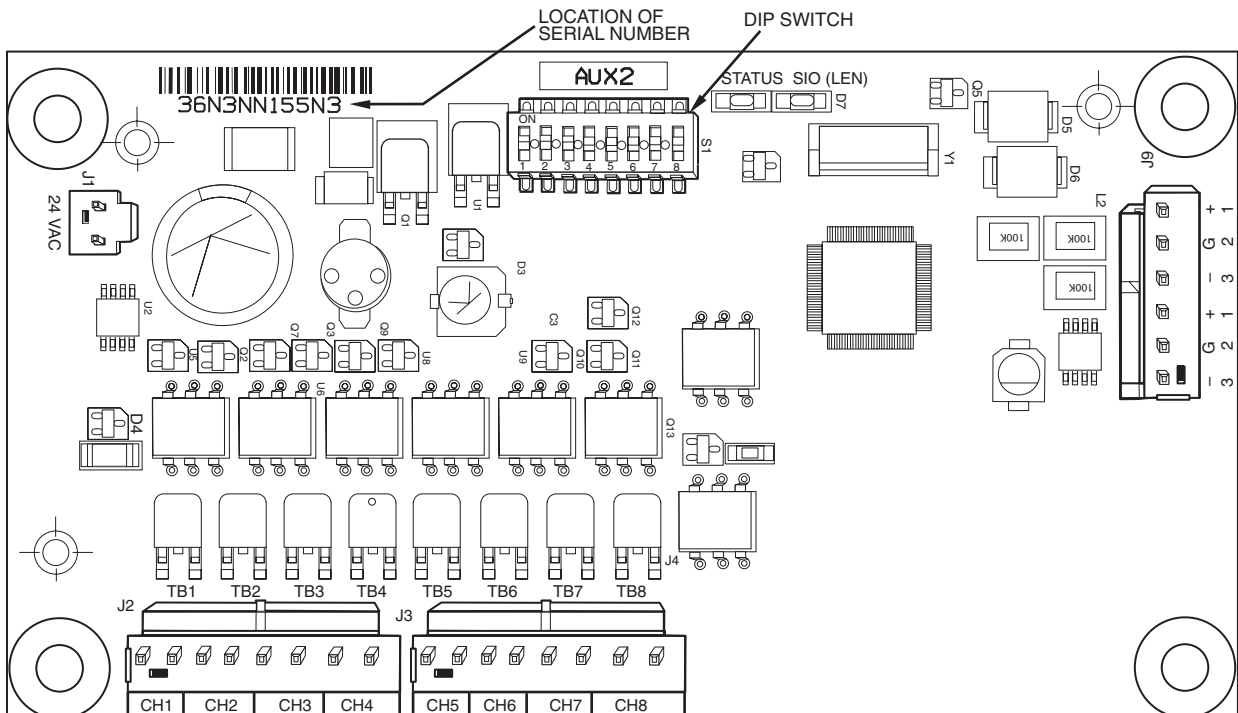
FAN BOARD A (090-500) DIP SWITCH	1	2	3	4	5	6	7	8
Address:	OFF	ON	OFF	OFF	ON	OFF	ON	OFF

FAN BOARD B (140-500) DIP SWITCH	1	2	3	4	5	6	7	8
Address:	ON	ON	OFF	OFF	ON	OFF	ON	OFF

FAN BOARD C (400-500) DIP SWITCH	1	2	3	4	5	6	7	8
Address:	OFF	OFF	ON	OFF	ON	OFF	ON	OFF



**Fig. 5A — Fan Board (AUX 1) with Low Ambient Temperature Head Pressure Control**



**Fig. 5B — Fan Board (AUX 2) without Low Ambient Temperature Head Pressure Control**

**Table 7 — Fan Board A Outputs (30XA080-120)**

DESCRIPTION	INPUT/OUTPUT	I/O TYPE	NAVIGATOR™ MODULE POINT NAME	CONNECTION POINT	
				Pin	Notation
Power (24 vac supply)	—	—	—	FBA-J1	
				11	24 vac
				12	Ground
Local Equipment Network	—	—	—	FBA-J9	
				+	
				G	
				-	
				+	
				G	
Circuit A Low Ambient Temperature Head Pressure Control Speed Signal	MM-A*	0-10 VDC	<b>OUTPUTS→CIR.A→SPD.A</b>	FBA-CH9	
				+	
Circuit B Low Ambient Temperature Head Pressure Control Speed Signal	MM-B*	0-10 VDC	<b>OUTPUTS→CIR.B→SPD.B</b>	FBA-CH10	
				+	
Fan Contactor A1	FCA1	Contactora		FBA-J2-CH1	
Fan Contactor A2	FCA2	Contactora		FBA-J2-CH2	
Fan Contactor A3	FCA3	Contactora		FBA-J2-CH3	
Fan Contactor A4	FCA4	Contactora		FBA-J2-CH4 (090-120)	
Fan Contactor B1	FCB1	Contactora		FBA-J3-CH5	
Fan Contactor B2	FCB2	Contactora		FBA-J3-CH6	
Fan Contactor B3	FCB3	Contactora		FBA-J3-CH7	
Fan Contactor B4	FCB4	Contactora		FBA-J3-CH8 (090-120)	

\*Output only on low ambient temperature head pressure control (AUX1).

**Table 8 — Fan Board X Outputs (30XA140-350)**

DESCRIPTION	INPUT/OUTPUT	I/O TYPE	NAVIGATOR MODULE POINT NAME	CONNECTION POINT	
				Pin	Notation
Power (24 vac supply)	—	—	—	FBX-J1	
				11	24 vac
				12	Ground
Local Equipment Network	—	—	—	FBX-J9	
				+	
				G	
				-	
				+	
				G	
Circuit X Low Ambient Temperature Head Pressure Control Speed Signal	MM-n*	0-10 VDC	<b>OUTPUTS→CIR.X→SPD.X</b>	FBX-CH9	
				+	
Fan Contactor X1	FCX1	Contactora		FBX-J2-CH01	
Fan Contactor X2	FCX2	Contactora		FBX-J2-CH02	
Fan Contactor X3	FCX3	Contactora		FBX-J2-CH03	
Fan Contactor X4	FCX4	Contactora		FBX-J2-CH04	
Fan Contactor X5	FCX5	Contactora		FBX-J3-CH05	
Fan Contactor X6	FCX6	Contactora		FBX-J3-CH06	
Fan Contactor X7	FCX7	Contactora		FBX-J3-CH07	
Fan Contactor X8	FCX8	Contactora		FBX-J3-CH08	

\*Output only on units with low ambient temperature head pressure control installed (AUX1).

NOTES:

1. Fan Board B used on 30XA140-350.
2. "X" indicates circuit A or circuit B.
3. See Fig. 9 for which contactor is used with circuit A or B.

**Table 9 — Fan Board C Inputs and Outputs (30XA400-500)**

DESCRIPTION	INPUT/OUTPUT	I/O TYPE	NAVIGATOR MODULE POINT NAME	CONNECTION POINT (Unit Size)	
				Pin	Notation
Power (24 vac supply)	—	—	—	FBC-J1	
				11	24 vac
				12	Ground
Local Equipment Network	—	—	—	FBC-J9	
				+	
				G	
				-	
				+	
				G	
Circuit C Discharge Pressure Transducer	DPTC	Pressure Transducer	<i>PRESSURES</i> → <i>PRC.C</i> → <i>DP.C</i>	FBC-J7-CH13	
Circuit C Suction Pressure Transducer	SPTC	Pressure Transducer	<i>PRESSURES</i> → <i>PRC.C</i> → <i>SP.C</i>	FBC-J8-CH14	
Circuit C Low Ambient Temperature Head Pressure Control Speed Signal	MM-C	0-10 VDC	<i>OUTPUTS</i> → <i>CIR.C</i> → <i>SPD.C</i>	FBC-CH9	
				+	
				-	
Fan Contactor C1	FCC1	Contact		FBC-J2-CH1	
Fan Contactor C2	FCC2	Contact		FBC-J2-CH2	
Fan Contactor C3	FCC3	Contact		FBC-J2-CH3	
Fan Contactor C4	FCC4	Contact		FBC-J2-CH4	
Fan Contactor C5	FCC5	Contact		FBC-J3-CH5	
Fan Contactor C6	FCC6	Contact		FBC-J3-CH6	
Fan Contactor C7	FCC7	Contact		FBC-J3-CH7	
Fan Contactor C8	FCC8	Contact		FBC-J3-CH8	

**Enable-Off-Remote Contact Switch (SW1) —**

This switch is installed in all units and provides the owner and service person with a local means of enabling or disabling the machine. It is a 3-position switch used to control the chiller. When switched to the Enable position the chiller is under its own control. Move the switch to the Off position to shut the chiller down. Move the switch to the Remote Contact position and a field-installed dry contact can be used to start the chiller. The contacts must be capable of handling a 24-vac, 50-mA load. In the Enable and Remote Contact (dry contacts closed) positions, the chiller is allowed to operate and respond to the scheduling configuration, CCN configuration and set point data.

**Emergency On/Off Switch (SW2) —** This switch is installed in all units. The Emergency On/Off switch should only be used when it is required to shut the chiller off immediately. Power to all modules is interrupted when this switch is off and all outputs from these modules will be turned off.

**Energy Management Module (EMM) —** The EMM is available as a factory-installed option or as a field-installed

accessory. See Fig. 6. The EMM receives 4 to 20 mA inputs for the temperature reset, cooling set point and demand limit functions. The EMM also receives the switch inputs for the field-installed second stage 2-step demand limit and ice done functions. The EMM communicates the status of all inputs with the MBB, and the MBB adjusts the control point, capacity limit, and other functions according to the inputs received. See Table 10.

<b>⚠ CAUTION</b>
Care should be taken when interfacing with other manufacturer’s control systems due to possible power supply differences, full wave bridge versus half wave rectification, which could lead to equipment damage. The two different power supplies cannot be mixed. <i>ComfortLink™</i> controls use half wave rectification. A signal isolation device should be utilized if incorporating a full wave bridge rectifier signal generating device is used.

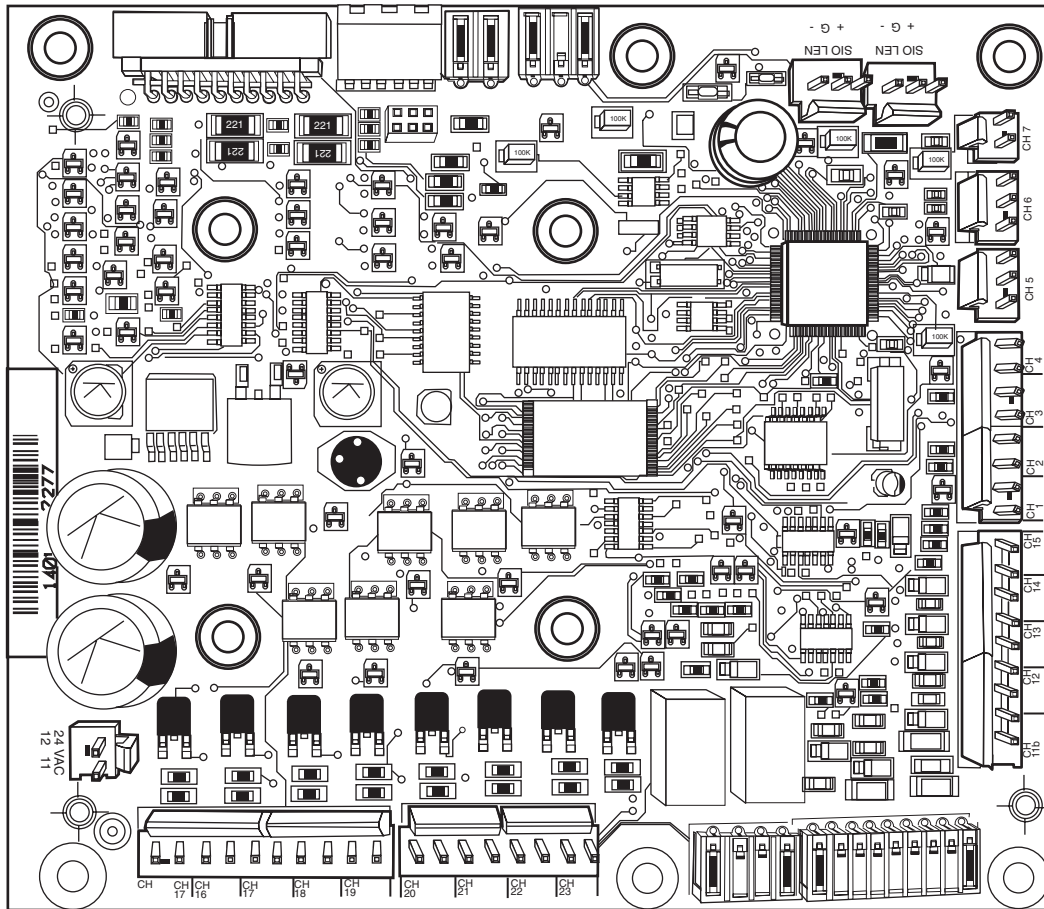


Fig. 6 — Energy Management Module

Table 10 — Energy Management Module (EMM) Inputs and Outputs

INPUT	DESCRIPTION	I/O TYPE	I/O POINT NAME	CONNECTION POINT
4-20 mA Demand Limit	4-20 mA Demand Limit	4-20 mA	<i>INPUTS</i> → <i>GEN.I</i> → <i>DMND</i>	EMM-J7B-CH6
4-20 mA Temperature Reset/Cooling Setpoint	4-20 mA Temperature Reset/Cooling Set point	4-20 mA	<i>INPUTS</i> → <i>GEN.I</i> → <i>RSET</i>	EMM-J7A-CH5
Demand Limit SW2	Demand Limit Step 2	Switch Input	<i>INPUTS</i> → <i>GEN.I</i> → <i>DLS2</i>	EMM-J4-CH9
Ice Done	Ice Done Switch	Switch Input	<i>INPUTS</i> → <i>GEN.I</i> → <i>ICE.D</i>	EMM-J4-CH11A
Occupancy Override	Occupied Schedule Override	Switch Input	<i>INPUTS</i> → <i>GEN.I</i> → <i>OCCS</i>	EMM-J4-CH8
Remote Lockout Switch	Chiller Lockout	Switch Input	<i>INPUTS</i> → <i>GEN.I</i> → <i>RLOC</i>	EMM-J4-CH10
SPT	Space Temperature Thermistor	10k Thermistor	<i>TEMPERATURE</i> → <i>UNIT</i> → <i>SPT</i>	EMM-J6-CH2
OUTPUT	DESCRIPTION	I/O TYPE	I/O POINT NAME	CONNECTION POINT
% Total Capacity		0-10 vdc	<i>OUTPUTS</i> → <i>GEN.O</i> → <i>CATO</i>	EMM-J8-CH7
RUN R	Run Relay	Relay	<i>OUTPUTS</i> → <i>GEN.O</i> → <i>RUN</i>	EMM-J3-CH25
SHD R	Shutdown Relay	Relay	<i>OUTPUTS</i> → <i>GEN.O</i> → <i>SHUT</i>	EMM-J3-CH24

NOTE: Used on 30XA080-500.

**Local Equipment Network** — Information is transmitted between modules via a 3-wire communication bus or LEN (Local Equipment Network). External connection to the LEN bus is made at TB3.

**Board Addresses** — All boards (except the Main Base Board, Energy Management Module Board, and Compressor Protection Module Board) have 8-position DIP switches. Addresses for all boards are listed with the Input/Output Tables for each board.

**Control Module Communication**

**RED LED** — Proper operation of the control boards can be visually checked by looking at the red status LEDs (light-emitting diodes). When operating correctly, the red status LEDs will blink in unison at a rate of once every 2 seconds. If the red LEDs are not blink in unison, verify that correct power is being supplied to all modules. Be sure that the Main Base

Board (MBB) is supplied with the current software. If necessary, reload current software. If the problem still persists, replace the MBB. A red LED that is lit continuously or blinking at a rate of once per second or faster indicates that the board should be replaced.

**GREEN LED** — All boards have a green LEN (SIO) LED which should be blinking whenever power is on. If the LEDs are not blinking as described check LEN connections for potential communication errors at the board connectors. See Input/Output Table 2, and 4-10 for LEN Connector designations. A 3-wire bus accomplishes communication between modules. These 3 wires run in parallel from module to module. The J9A connector on the MBB provides communication directly to the Navigator™ display module.

**YELLOW LED** — The MBB has one yellow LED. The Carrier Comfort Network® (CCN) LED will blink during times of network communication.

## Carrier Comfort Network® (CCN) Interface —

All 30XA units can be connected to the CCN, if desired. The communication bus wiring is a shielded, 3-conductor cable with drain wire and is field supplied and installed. The system elements are connected to the communication bus in a daisy chain arrangement. The positive pin of each system element communication connector must be wired to the positive pins of the system elements on either side of it, that is also required for the negative and signal ground pins of each system element. Wiring connections for CCN should be made at TB3. Consult the CCN Contractor's Manual for further information. See Fig. 7.

NOTE: Conductors and drain wire must be 20 AWG (American Wire Gage) minimum stranded, tinned copper. Individual conductors must be insulated with PVC, PVC/nylon, vinyl, Teflon, or polyethylene. An aluminum/polyester 100% foil shield and an outer jacket of PVC, PVC/nylon, chrome vinyl, or Teflon with a minimum operating temperature range of -20 C to 60 C is required. See Table 11 for recommended wire manufacturers and part numbers.

**Table 11 — CCN Communication Bus Wiring**

MANUFACTURER	PART NUMBER	
	Regular Wiring	Plenum Wiring
Alpha	1895	—
American	A21451	A48301
Belden	8205	884421
Columbia	D6451	—
Manhattan	M13402	M64430
Quabik	6130	—

It is important when connecting to a CCN communication bus that a color-coding scheme be used for the entire network to simplify the installation. It is recommended that red be used for the signal positive, black for the signal negative, and white for the signal ground. Use a similar scheme for cables containing different colored wires.

At each system element, the shields of its communication bus cables must be tied together. If the communication bus is entirely within one building, the resulting continuous shield must be connected to a ground at one point only. If the communication bus cable exits from one building and enters another, the shields must be connected to grounds at the lightning suppressor in each building where the cable enters or exits the building (one point per building only). To connect the unit to the network:

1. Turn off power to the control box.
2. Cut the CCN wire and strip the ends of the red (+), white (ground), and black (-) conductors. (Substitute appropriate colors for different colored cables.)

3. Connect the red wire to (+) terminal on TB3 of the plug, the white wire to COM terminal, and the black wire to the (-) terminal.
4. The RJ14 CCN connector on TB3 can also be used, but is only intended for temporary connection (for example, a laptop computer running Service Tool).

**IMPORTANT:** A shorted CCN bus cable will prevent some routines from running and may prevent the unit from starting. If abnormal conditions occur, disconnect the CCN bus. If conditions return to normal, check the CCN connector and cable. Run new cable if necessary. A short in one section of the bus can cause problems with all system elements on the bus.

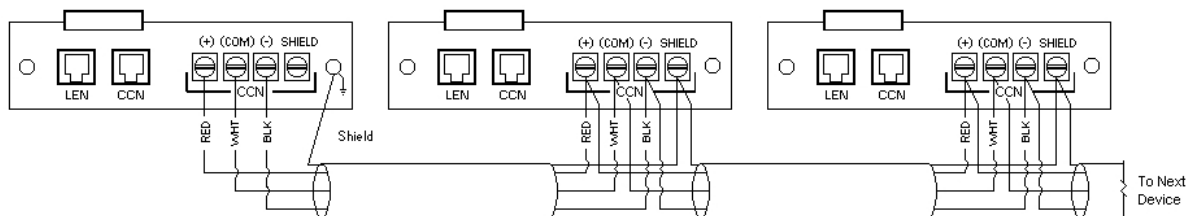
## Configuration Options

**RAMP LOADING** (*Configuration* → *OPTN* → *RLS*), limits the rate of change of leaving fluid temperature. If the unit is in a Cooling mode and configured for Ramp Loading, the control makes 2 comparisons before deciding to change stages of capacity. The control calculates a temperature difference between the control point and leaving fluid temperature. If the difference is greater than 4° F (2.2° C) and the rate of change (°F or °C per minute) is more than the configured Cool Ramp Loading (*Setpoints* → *COOL* → *CRMP*), the control does not allow any changes to the current stage of capacity.

**MINUTES OFF TIME** (*Configuration* → *OPTN* → *DELY*) is a time delay added to the start when the machine is commanded ON. This is a field configurable item from 1 to 15 minutes. The factory default is 1 minute. This feature is useful when multiple units are installed. Staggering the start will reduce the inrush potential.

**Dual Chiller Control** — The dual chiller routine is available for the control of two units installed in series or parallel supplying chilled fluid on a common loop. One chiller must be configured as the master chiller, the other as the slave chiller. For parallel chiller application, an additional leaving fluid temperature thermistor (Dual Chiller LWT) must be installed in the common chilled water piping as described in the Installation Instructions for both the master and slave chillers. See the Field Wiring section in the 30XA Installation Instructions for Dual Chiller LWT sensor control wiring. A chilled water flow switch is factory-installed for each chiller.

**DUAL CHILLER PUMP CONTROL FOR PARALLEL APPLICATIONS** — It is recommended that a dedicated pump be used for each unit. Chiller must start and stop its own water pump located on its own piping. If pumps are not dedicated for each chiller, chiller isolation valves are required: each chiller must open and close its own isolation valve.



**Fig. 7 — ComfortLink™ CCN Communication Wiring**

**DUAL PUMP CONTROL FOR SERIES CHILLER APPLICATIONS** — If pump control is required, the chiller pump needs to be controlled by the master chiller only. The control of the slave chiller is directed through commands emitted by the master chiller. The slave chiller has no action in master/slave operations; it shall only verify that CCN communication with its master is present. See the Dual Chiller Sequence of Operation section on page 49.

Use dual chiller control to designate a lead chiller between the master and slave chiller. Configure the Lead/Lag Balance Select (**Configuration**→**RSET**→**LLBL**) to **ENBL** to base the selection on the Lead/Lag Balance Delta (**Configuration**→**RSET**→**LLBD**) between the master and slave run hours. If the run hour difference between the master and the slave remains less than **LLBD**, the chiller designated as the lead will remain the lead chiller. The Lead/Lag changeover between the master and the slave chiller due to hour balance will occur during chiller operating odd days, such as day 1, day 3, and day 5 of the month, at 12:00 a.m. If a lead chiller is not designated, the master chiller will always be designated the lead chiller.

The dual chiller control algorithm has the ability to be configured for series or parallel operation. To configure chillers in series, set **Configuration**→**RSET**→**SERI** to **YES** for series operation, or **NO** for parallel operation. Both the master and slave chiller must be configured the same.

The dual chiller control algorithm has the ability to delay the start of the lag chiller in two ways. The Lead Pulldown Time (**Configuration**→**RSET**→**LPUL**) provides a field configurable time delay of 0 to 60 minutes. This time delay gives the lead chiller a chance to remove the heat that the chilled water loop picked up while being inactive during an unoccupied period. The Lead Pulldown Time parameter is a one-time time delay initiated after starting the lead chiller, manually or by a schedule, before checking whether to start an additional chiller. This routine provides the lead chiller an opportunity to pull down the loop temperature before starting another chiller. The second time delay, Lead/Lag Delay (**Configuration**→**RSET**→**LLDY**) is a time delay imposed between the last stage of the lead chiller and the start of the lag chiller. This prevents enabling the lag chiller until the lead/lag delay timer has expired. See Tables 12 and 13.

**Capacity Control** — The control system cycles compressors and positions the slide valve of each compressor to maintain the user-configured leaving chilled fluid temperature set point. Entering fluid temperature is used by the Main Base Board (MBB) to determine the temperature drop across the cooler and is used in determining the optimum time to add or subtract capacity. Return fluid temperature, space temperature (requires additional sensor), or outdoor-air temperature reset features can automatically reset the leaving chilled fluid temperature set point. It can also be reset from an external 4 to 20-mA signal (requires Energy Management Module). Temperature reset requires a temperature sensor and the Energy Management Module.

The control has an automatic lead-lag feature built in for circuit and compressor starts. If enabled, the control will determine which circuit (**Configuration**→**OPTN**→**LLCS=0**) and compressor to start to even the wear. The compressor wear factor (combination of starts and run hours) is used to determine which compressor starts.

$$\text{Compressor Wear Factor} = (\text{Compressor Starts}) + 0.1 (\text{Compressor Run Hours})$$

In this case, the circuit with the lowest compressor wear factor is the circuit that starts first. The following settings will determine what circuit starts first:

**Configuration**→**OPTN**→**LLCS=1**, **Circuit A starts**

**Configuration**→**OPTN**→**LLCS=2**, **Circuit B starts**

**Configuration**→**OPTN**→**LLCS=3**, **Circuit C starts**

If Minimum Load Control is enabled (**Configuration**→**UNIT**→**HGBP=1**), the valve will be operational only during the first stage of cooling.

**EQUAL LOADING** (**Configuration**→**OPTN**→**LOAD=0**) — The circuit which has started will maintain minimum stage of capacity and slide valve fully unloaded; when additional capacity is required the next circuit with the lowest compressor wear factor is started with the slide valve at minimum position. As additional capacity is required the slide valve for a circuit will be adjusted in approximately 5% increments to match capacity requirements. The control will alternate between circuits to maintain the same percentage of capacity on each circuit. See Fig. 8.

**STAGE LOADING** — If stage-loading is selected (**Configuration**→**OPTN**→**LOAD=1**), the circuit which has started will gradually load the slide valve to match capacity requirements until the circuit is fully loaded. Once the circuit is fully loaded and additional capacity is required, the control will start an additional circuit fully unloaded and gradually unload the circuit which was fully loaded to match capacity requirements.

The capacity control algorithm runs every 30 seconds. The algorithm attempts to maintain the Control Point at the desired set point. Each time the capacity control algorithm runs, the control reads the entering and leaving fluid temperatures. The control determines the rate at which conditions are changing and calculates 2 variables based on these conditions. Next, a capacity ratio is calculated using the 2 variables to determine whether or not to make any changes to the current stages of capacity. This ratio value ranges from -100 to +100%. If the next change of capacity is a compressor, the control starts (stops) a compressor when the ratio reaches +100% (-100%). If the next change of capacity is to reposition the slide valve, the control energizes both slide valve solenoids when ratio is +60% and deenergizes both slide valve solenoids when ratio is -60%. If installed, the minimum load valve solenoid will be energized with the first stage of capacity. Minimum load valve value is fixed at 10 tons in the total capacity calculation. The control will also use the minimum load valve solenoid as the last stage of capacity before turning off the last compressor. A delay of 90 seconds occurs after each capacity step change. A delay of 3 minutes occurs after each compressor capacity step change.

**Table 12 — Configuring the Master Chiller**

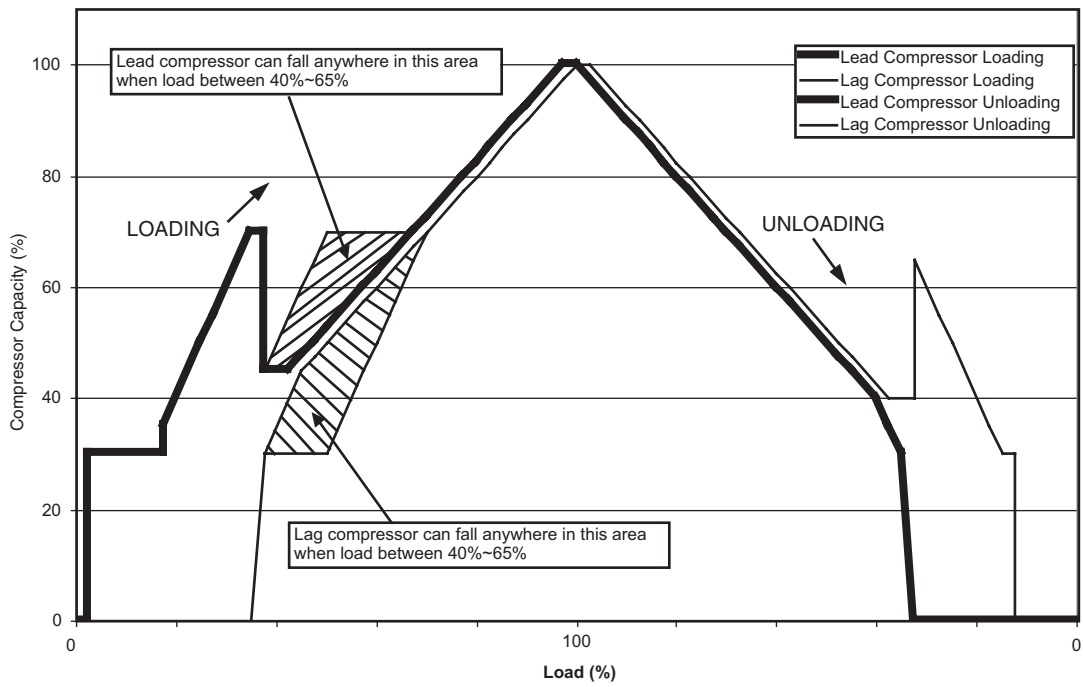
MODE	KEYPAD ENTRY	DISPLAY	ITEM EXPANSION	COMMENT
CONFIGURATION	ENTER	DISP		
	↓	UNIT		
	↓	SERV		
	↓	OPTN		
	ENTER	CCNA	CCN Address	Confirm address of chiller. The master and slave chiller must have different addresses.
	ENTER	1		Factory default address is 1.
	ESCAPE	CCNA		
	↓	CCNB	CCN Bus Number	Confirm the bus number of the chiller. The master and slave chiller must be on the same bus.
	ENTER	0		Factory default is 0.
	ESCAPE	CCNB		
	ESCAPE	OPTN		
	↓	RSET	Reset Cool and Heat Tmp	
	ENTER	CRST	Cooling Reset Type	
	↓ x 5	MSSL	Master/Slave Select	
	ENTER	0	Disable	
	ENTER	0	Disable	Flashing to indicate Edit mode. May require Password.
	↑	1	Master	Use up arrows to change value to 1.
	ENTER	1		Accepts the change.
	ESCAPE	MSSL		
	↓	SLVA	Slave Address	
	ENTER	1		
	ENTER	1		Flashing to indicate Edit mode.
	↑	2		Use up arrows to change value to 2. This address must match the address of the slave chiller.
	ENTER	2		Accepts the change.
	ESCAPE	SLVA		
	↓	LLBL	Lead/Lag Balance Select	
	ENTER	DSBL		Factory Default is DSBL.
	ESCAPE	LLBL		
	↓	LLBD	Lead/Lag Balance Delta	
	ENTER	168		Factory Default is 168.
	ESCAPE	LLBD		
	↓	LLDY	Lead/Lag Delay	
	ENTER	10		Factory Default is 10.
	ESCAPE	LLDY		
	↓	LAGP	Lag Unit Pump Select	
	ENTER	0	Off if U Stp	Factory Default is 0, Off if unit is stopped.
	ESCAPE	LAGP		
	↓	LPUL	Lead Pulldown Time	
	ENTER	0		Factory Default is 0.
	ESCAPE			
ESCAPE			At mode level.	
ENTER	SER1	Chillers in Series		
OPERATING MODES	ENTER	OPER	Operating Control Type	
	ENTER	0	Switch Control	Master chiller should be configured for job requirements, Switch Control, Time Schedule, or CCN.
	ESCAPE			At mode level.

NOTE: **Bold** values indicate sub-mode level.

**Table 13 — Configuring the Slave Chiller**

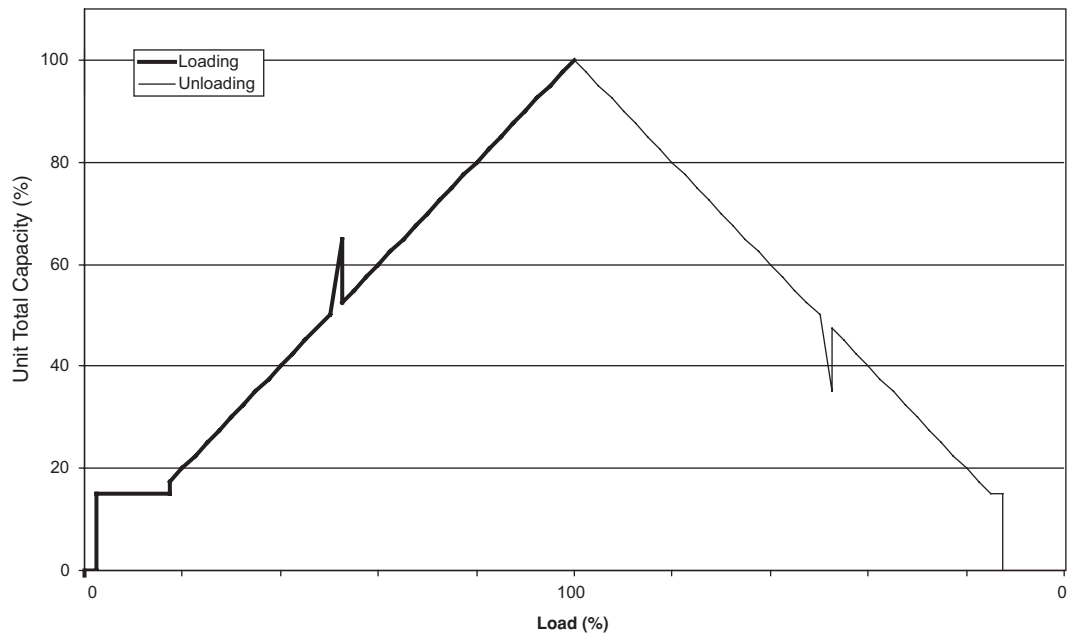
MODE	KEYPAD ENTRY	DISPLAY	ITEM EXPANSION	COMMENT
<b>CONFIGURATION</b>	ENTER	<b>DISP</b>		
	↓	<b>UNIT</b>		
	↓	<b>SERV</b>		
	↓	<b>OPTN</b>		
	ENTER	CCNA	CCN Address	Confirm address of chiller. The master and slave chiller must have different addresses.
	ENTER	1		Factory default address is 1. The slave chiller address must match what was programmed in the Master Chiller SLVA item.
	ENTER	1		Flashing to indicate Edit Mode.
	↑	2		This item must match Master Chiller SLVA item.
	ENTER	2		Accepts the change.
	ESCAPE	CCNA		
	↓	CCNB	CCN Bus Number	Confirm the bus number of the chiller. The master and slave chiller must be on the same bus.
	ENTER	0		Factory default bus number is 0.
	ESCAPE	CCNB		
	ESCAPE	<b>OPTN</b>		
	↓	<b>RSET</b>	Reset Cool and Heat Tmp	
	ENTER	CRST	Cooling Reset Type	
	↓ x 5	MSSL	Master/Slave Select	
	ENTER	0	Disable	
	ENTER	0	Disable	Flashing to indicate Edit mode. May require Password
	↑	2	Slave	Use up arrows to change value to 2.
	ENTER	2		Accepts the change.
	ESCAPE	MSSL		
	↓	SLVA	Slave Address	Not required.
	↓	LLBL	Lead/Lag Balance Select	Not required.
	↓	LLBD	Lead/Lag Balance Delta	Not required.
	↓	LLDY	Lead/Lag Delay	Not required.
	↓	LAGP	Lag Unit Pump Select	Not required.
	↓	LPUL	Lead Pulldown Time	Not required.
	ESCAPE			
	ESCAPE			At mode level
	ENTER	SER1	Chillers in Series	
	<b>OPERATING MODES</b>	ENTER	<b>OPER</b>	Operating Control Type
ENTER		0	Switch Control	
ENTER		0		Flashing to indicate Edit Mode.
↑		2	CCN Control	Use up arrows to change value to 2. NOTE: Must be configured for CCN.
ENTER		2		Accepts the value.
ESCAPE		<b>OPER</b>		
ESCAPE				At mode level

NOTE: **Bold** values indicate sub-mode level.



**Equal Circuit Loading**

Unit Loading Unloading (Staged circuit loading)



**Staged Circuit Loading**

**Fig. 8 — Compressor Loading and Unloading**

CAPACITY CONTROL OVERRIDES (*Run Status* → *VIEW* → *CAPS*) — The following overrides will modify the normal operation routine. If any of the following override conditions listed below is satisfied, it shall determine the capacity change instead of the normal control. Overrides are listed by priority order and are often linked to unit operating modes. See Table 14 for a list of operating modes and corresponding overrides.

**Override #1: Cooler Freeze Protection** — This override attempts to avoid the freeze protection alarm. If the Leaving Water Temperature is less than Brine Freeze Set Point (*Configuration* → *SERV* → *LOSP*) + 2.0° F (1.1° C) then a stage of capacity is removed.

NOTE: The freeze set point is 34 F (1.1 C) for fresh water systems (*Configuration* → *SERV* → *FLUD*=1). The freeze set point is Brine Freeze Set Point (*Configuration* → *SERV* → *LOSP*), for Medium Temperature Brine systems (*Configuration* → *SERV* → *FLUD*=2).

**Override #2: Circuit A Low Saturated Suction Temperature in Cooling**

**Override #3: Circuit B Low Saturated Suction Temperature in Cooling**

**Override #4: Circuit C Low Saturated Suction Temperature in Cooling** — These overrides attempt to avoid the low suction temperature alarms, and is active only when more than one compressor in a circuit is ON. The slide valve in the affected circuit will be decreased in position if the Saturated Suction Temperature is less than Brine Freeze Set Point (*Configuration* → *SERV* → *LOSP*) –18.0 F (–10 C) for 90 seconds, or the Saturated Suction Temperature is less than –4 F (–20 C).

**Override #5: Low Temperature Cooling and High Temperature Heating** — This override removes one stage of capacity when the difference between the Control Point (*Run Status* → *VIEW* → *CTPT*) and the Leaving Water Temperature (*Run Status* → *VIEW* → *LWT*) reaches a predetermined limit and the rate of change of the water is 0 or still decreasing.

**Override #6: Low Temperature Cooling and High Temperature Heating** — This override removes two stages of capacity when the Entering Water Temperature (*Run Status* → *VIEW* → *EWT*) is less than the Control Point (*Run Status* → *VIEW* → *CTPT*).

**Override #7: Ramp Loading** — No capacity stage increase will be made if the unit is configured for ramp loading (*Configuration* → *OPTN* → *RLS*=*ENBL*) and if the difference between the Leaving Water Temperature and the Control Point is greater than 4° F (2.2° C) and the rate of change of the leaving water is greater than Cool Ramp Loading Rate (*Setpoints* → *COOL* → *CRMP*). Operating mode 5 (MD05) will be in effect.

**Override #8: Service Manual Test Override** — The manual test consists in adding a stage of capacity every 30 seconds, until the control enables all of the requested compressors and Minimum Load Control selected in the *ComfortLink*™ display Service Test menu. All safeties and higher priority overrides are monitored and acted upon.

**Override #9: Demand Limit** — This override mode is active when a command to limit the capacity is received. If the current unit capacity is greater than the active capacity limit value, a stage is removed. If the current capacity is lower than the capacity limit value, the control will not add a stage that will result in the new capacity being greater than the capacity limit value. Operating mode 4 (MD04) will be in effect.

**Override #10: Cooler Interlock Override** — This override prohibits compressor operation until the Cooler Interlock (*Inputs* → *GEN.I* → *LOCK*) is closed.

**Override #11: High Temperature Cooling and Low Temperature Heating** — This override algorithm runs once when the unit is switched to ON. If the difference between the Leaving Water Temperature (*Run Status* → *VIEW* → *LWT*) and the Control Point (*Run Status* → *VIEW* → *CTPT*) exceeds a calculated value and the rate of change of the water temperature is greater than a fixed value.

value and the rate of change of the water temperature is greater than –0.1° F/min, a stage will be added.

**Table 14 — Operating Modes and Corresponding Overrides**

OPERATING MODES		OVERRIDES	
1	Startup Delay in Effect	—	
2	Second Setpoint in Use	—	
3	Reset in Effect	—	
4	Demand Limit Active	9	Demand Limit
5	Ramp Loading Active	7	Ramp Loading
6	Cooler Heater Active	—	
7	Cooler Pumps Rotation	—	
8	Pump Periodic Start	—	
9	Night Low Noise Active	—	
10	System Manager Active	13	Minimum On/Off and Off/On Time Delay
		22	Minimum On Time Delay
11	Mast Slave Ctrl Active	—	
12	Auto Changeover Active	—	
13	Free Cooling Active	—	
14	Reclaim Active	—	
15	Electric Heat Active	—	
16	Heating Low EWT Lockout	—	
17	Condenser Pumps Rotation	—	
18	Ice Mode in Effect	—	
19	Defrost Active on Cir A	—	
20	Defrost Active on Cir B	—	
21	Low Suction Circuit A	23	Circuit A Low Saturated Suction Circuit A Low Refrigerant
22	Low Suction Circuit B	24	Circuit B Low Saturated Suction Circuit B Low Refrigerant
23	Low Suction Circuit C	25	Circuit C Low Saturated Suction Circuit C Low Refrigerant
24	High DGT Circuit A	26	High Discharge Gas Override Circuit A
25	High DGT Circuit B	27	High Discharge Gas Override Circuit B
26	High DGT Circuit C	28	High Discharge Gas Override Circuit C
27	High Pres Override Cir A	16	Circuit A High Pressure Override
28	High Pres Override Cir B	17	Circuit B High Pressure Override
29	High Pres Override Cir C	18	Circuit C High Pressure Override
30	Low Superheat Circuit A	—	
31	Low Superheat Circuit B	—	
32	Low Superheat Circuit C	—	
33	High Compressor Current Circuit A	41	Circuit A High Current Override
34	High Compressor Current Circuit B	42	Circuit B High Current Override
35	High Compressor Current Circuit C	43	Circuit C High Current Override

**Override #12: High Temperature Cooling and Low Temperature Heating** — This override runs only when Minimum Load Control is Enabled, (*Configuration* → *SERV* → *HGBP*) is 1, 2 or 3. This override will add a stage of capacity if the next stage is Minimum Load Control, when the difference between the Leaving Water Temperature (*Run Status* → *VIEW* → *LWT*) and the Control Point (*Run Status* → *VIEW* → *CTPT*) exceeds a calculated value and the rate of change of the water temperature is greater than a fixed value.

Override #13: Minimum On/Off and Off/On Time Delay — Whenever a capacity change has been made, the control will remain at this capacity stage for the next 90 seconds. During this time, no capacity control algorithm calculations will be made. If the capacity step is a compressor, an additional 90-second delay is added to the previous hold time (see Override #22). This override allows the system to stabilize before another capacity stage is added or removed. If a condition of a higher priority override occurs, the higher priority override will take precedence. Operating Mode 10 (MD10) will be in effect.

Override #14: Slow Change Override — This override prevents compressor stage changes when the leaving temperature is close to the control point and slowly moving towards the control point.

Override #15: System Manager Capacity Control — If a Chillervisor module is controlling the unit and the Chillervisor module is controlling multiple chillers, the unit will increase capacity to attempt to load to the demand limited value.

Override #16: Circuit A High Pressure Override

Override #17: Circuit B High Pressure Override

Override #18: Circuit C High Pressure Override — This override attempts to avoid a high pressure failure. The algorithm is run every 4 seconds. If the Saturated Condensing Temperature for the circuit is above the High Pressure Threshold (**Configuration** → **SERV** → **HP.TH**) then the position of slide valve will be unloaded.

Override #19: Standby Mode — This override algorithm will not allow a compressor to run if the unit is in Standby mode, (**Run Status** → **VIEW** → **HC.ST=2**).

Override #22: Minimum On Time Delay — In addition to Override #13 Minimum On/Off and Off/On Time Delay, for compressor capacity changes, an *additional* 90-second delay will be added to Override #13 delay. No compressor will be deenergized until 3 minutes have elapsed since the last compressor has been turned ON. When this override is active, the capacity control algorithm calculations will be performed, but no capacity reduction will be made until the timer has expired. A control with higher precedence will override the Minimum On Time Delay.

Override #23: Circuit A Low Saturated Suction Temperature in Cooling

Override #24: Circuit B Low Saturated Suction Temperature in Cooling

Override #25: Circuit C Low Saturated Suction Temperature in Cooling — If the circuit is operating in an area close to the operational limit of the compressor, the circuit capacity will remain at the same point or unload to raise the saturated suction temperature. This algorithm will be active if at least 1 compressor in the circuit is on and one of the following conditions is true:

1. Saturated Suction Temperature is less than the Brine Freeze Setpoint (**Configuration** → **SERV** → **LOSP**) – 6° F (3.3° C).
2. Saturated Suction Temperature is less than the Brine Freeze Setpoint (**Configuration** → **SERV** → **LOSP**) and the circuit approach (Leaving Water Temperature – Saturated Suction Temperature) is greater than 15° F (8.3° C) and the Circuit Superheat (Discharge Gas Temperature – Saturated Discharge Temperature) is greater than 25° F (13.9° C).

NOTE: The freeze set point is 34 F (1.1 C) for fresh water systems (**Configuration** → **SERV** → **FLUD=1**). The freeze set point is Brine Freeze Set Point (**Configuration** → **SERV** → **LOSP**), for Medium Temperature Brine systems (**Configuration** → **SERV** → **FLUD=2**).

If any of these conditions are met, the appropriate operating mode, 21 (Circuit A), 22 (Circuit B) or 23 (Circuit C) will be in effect.

Override #26: Circuit A High Discharge Gas Override

Override #27: Circuit B High Discharge Gas Override

Override #28: Circuit C High Discharge Gas Override — When the temperature is above the limit curve minus 2° F (1.1° C) increase in capacity will not be allowed. This override will remain active until the DGT goes below the limit curve by –3° F (–1.7° C).

Override #34: Circuit A Low Refrigerant Charge

Override #35: Circuit B Low Refrigerant Charge

Override #36: Circuit C Low Refrigerant Charge — The capacity override attempts to protect the compressor from starting with no refrigerant in the circuit. This algorithm runs only when the circuit is not operational (no compressors are ON). There are several criteria that will enable this override:

1. The saturated suction temperature or saturated discharge temperature is less than –13 F (–10.6 C).
2. All of these conditions must be true:
  - a. The saturated suction temperature or saturated discharge temperature is less than leaving water temperature by more than 5.4° F (3.0° C).
  - b. Saturated suction temperature or saturated discharge temperature is less than 41 F (5 C).
  - c. Outdoor air temperature is less than 32 F (0° C).
  - d. Saturated suction temperature or saturated discharge temperature is less than the outdoor air temperature by more than 5.4° F (3.0° C).
3. All of these conditions must be true:
  - a. The saturated suction temperature or saturated discharge temperature is less than leaving water temperature by more than 5.4° F (3.0° C).
  - b. Saturated suction temperature or saturated discharge temperature is less than 41 F (5 C).
  - c. Saturated suction temperature or saturated discharge temperature is less than the brine freeze point (**Configuration** → **SERV** → **LOSP**) by more than 6° F (3.3° C).

NOTE: The freeze set point is 34 F (1.1 C) for fresh water systems (**Configuration** → **SERV** → **FLUD=1**). The freeze set point is brine freeze set point (**Configuration** → **SERV** → **LOSP**), for medium temperature brine systems (**Configuration** → **SERV** → **FLUD=2**).
4. All of these conditions must be true:
  - a. The saturated suction temperature or saturated discharge temperature is less than leaving water temperature by more than 5.4° F (3.0° C).
  - b. Saturated suction temperature or saturated discharge temperature is less than 41 F (5 C).
  - c. Saturated suction temperature or saturated discharge temperature is less than the outdoor air temperature by more than 9° F (5° C).

If any of these conditions 1, 2, 3 or 4 are met, the appropriate operating mode, 21 (Circuit A), 22 (Circuit B) or 23 (Circuit C) will be in effect.

Override #41: Circuit A High Current Override

Override #42: Circuit B High Current Override

Override #43: Circuit C High Current Override

This override attempts to avoid an overcurrent failure. The algorithm is run every 4 seconds. If the compressor current is greater than 79% of must trip amps (MTA) but less than 85% MTA then the capacity will be held at current capacity. If the compressor current is greater than 85% MTA then capacity will be reduced by repositioning the slide valve until the current is less than 85% MTA (**Configuration** → **UNIT** → **MTA.X**).

Override #44: Circuit A High Suction Superheat at Part Load  
Override #45: Circuit B High Suction Superheat at Part Load  
Override #46: Circuit C High Suction Superheat at Part Load — If the compressor of the circuit is on, the compressor current is no more than 30% of the MTA, main EXV is more than 90% open and the suction superheat is higher than the superheat control point for more than 5 minutes, the circuit will be shut down.

Override #50: Circuit A MCHX MOP Control  
Override #51: Circuit B MCHX MOP Control  
Override #52: Circuit C MCHX MOP Control — This override is not currently used or supported.

Override #53: Circuit A Delay for Unloading the Slide Valve  
Override #54: Circuit B Delay for Unloading the Slide Valve  
Override #55: Circuit C Delay for Unloading the Slide Valve — If the compressor is stopped normally, no slide valve delay is applied. If the circuit is shut down by locked rotor alarm, full delay is applied before the compressor is allowed to start (20 minutes for a compressor with 165 to 185 tons of nominal capacity, 8 minutes for a compressor with 90 to 120 tons of nominal capacity, and 5 minutes for a compressor with 45 to 60 tons of nominal capacity). If a compressor is shut off on an alarm, this delay is adjusted based on the last nominal capacity of the last compressor.

NOTE: Refer to Tables 1A and 1B in the 30XA Installation Instructions for unit compressor nominal capacity.

Override #56: Circuit A Delay for Refrigeration Isolation Valve to Open

Override #57: Circuit B Delay for Refrigeration Isolation Valve to Open

Override #58: Circuit C Delay for Refrigeration Isolation Valve to Open — This override allows the discharge motorized ball valve to open before the compressor starts. The delay is 2 minutes and 30 seconds.

Override #59: Circuit A Low Oil Level

Override #60: Circuit B Low Oil Level

Override #61: Circuit C Low Oil Level — This override is only effective when the circuit is not running. It shall prevent the circuit from starting up with a low oil level. If this override occurs three times, the low oil level alarm will be tripped.

**Head Pressure Control** — The Main Base Board (MBB) controls the condenser fans to maintain the lowest condensing temperature possible, and thus the highest unit efficiency. The MBB uses the saturated condensing temperature input from the discharge pressure transducer to control the fans. Head pressure control is maintained through a calculated set point which is automatically adjusted based on actual saturated condensing and saturated suction temperatures so that the compressor(s) is (are) always operating within the manufacturer's specified envelope (see Fig. 9). Each time a fan is added the calculated head pressure set point will be raised

25° F (13.9° C) for 35 seconds to allow the system to stabilize. The control will automatically reduce the unit capacity as the saturated condensing temperature approaches an upper limit. See capacity overrides 16-18. The control will indicate through an operating mode that high ambient unloading is in effect. If the saturated condensing temperature in a circuit exceeds the calculated maximum, the circuit will be stopped. For these reasons, there are no head pressure control methods or set points to enter. The control will turn off a fan stage when the condensing temperature is below the minimum head pressure requirement for the compressor. Fan sequences are shown in Fig. 9.

**LOW AMBIENT TEMPERATURE HEAD PRESSURE CONTROL OPTION** — Units will start and operate down to 32 F (0° C) as standard. Operation to -20 F (-29 C) requires optional low ambient head pressure control as well as wind baffles (field fabricated and installed to all units for operation below 32 F [0° C]) if wind velocity is anticipated to be greater than 5 mph (8 kp/h). Inhibited propylene glycol or other suitable corrosion-resistant anti-freeze solution must be field supplied and installed in all units for unit operation below 34 F (1.1 C). Solution must be added to fluid loop to protect loop down to 15° F (8.3° C) below minimum operating ambient temperature. Concentration should be based on expected minimum temperature and either "Burst" or "Freeze" protection levels. At least 6 gal per ton (6.5 l/kW) of water volume is the recommended minimum for a moderate system load.

For low-ambient temperature operation, the lead fan on a circuit can be equipped with low ambient temperature head pressure control option or accessory. The controller adjusts fan speed to maintain the calculated head pressure set point.

**LOW AMBIENT TEMPERATURE HEAD PRESSURE CONTROL OPERATING INSTRUCTIONS** — The 30XA low ambient control is a variable speed drive (VFD) that varies the speed of the lead condenser fan in each circuit to maintain the calculated head pressure control set point. The fan speed varies in proportion to the 0 to 10 vdc analog signal produced by the AUX1 fan board. The display indicates motor speed in Hz by default.

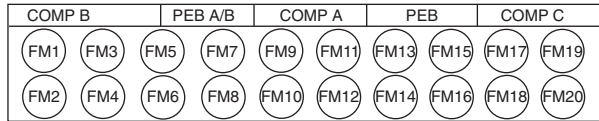
**Operation** — The low ambient temperature head pressure controller is pre-configured to operate from a 0 to 10 vdc analog input signal present on terminals 3(AIN+) and 4(AIN-). Jumpers between terminals 2 and 4 and terminals 5 and 8 (5 and 9 for 575-v drives) are required for proper operation. The drive is enabled based on an increase in the analog input signal above 0 vdc. Output is varied from 0 Hz to 60 Hz as the analog signal increases from 0 vdc to 10 vdc. When the signal is at 0 vdc the drive holds the fan at 0 rpm. The head pressure control set point is not adjustable. The MBB determines the control set point as required.

<p>30XA080</p>	Fan Output Ckt A	1	2	3	4	5	6	7	—		
	Contactor Number	FC A1	FC A2	FC A3	—	FC B1	FC B2	FC B3	—		
	Fan Position	FM5	FM3	FM6	—	FM1	FM4	FM2	—		
	Fan Output Ckt B	1	2	3	4	5	6	7	—		
<p>30XA090-120</p>	Fan Output Ckt A	1	2	3	4	5	6	7	8		
	Contactor Number	FC A1	FC A2	FC A3	FC A4	FC B1	FC B2	FC B3	FC B4		
	Fan Position	FM7	FM5	FM8	FM6	FM1	FM3	FM2	FM4		
	Fan Output Ckt B	1	2	3	4	5	6	7	8		
<p>30XA140, 160</p>	Fan Output Ckt A	1	2	3	4	5	6	—	—		
	Contactor Number	FC A1	FC A2	FC A3	FC A4	FC A5	FC A6	—	—		
	Fan Position	FM9	FM7	FM5	FM10	FM8	FM6	—	—		
	Fan Output Ckt B	1	2	3	4	—	—	—	—		
<p>30XA180,200</p>	Fan Output Ckt A	1	2	3	4	5	6	—	—		
	Contactor Number	FC A1	FC A2	FC A3	FC A4	FC A5	FC A6	—	—		
	Fan Position	FM11	FM9	FM7	FM12	FM10	FM8	—	—		
	Fan Output Ckt B	1	2	3	4	5	6	—	—		
<p>30XA220, 240</p>	Fan Output Ckt A	1	2	3	4	5	6	7	—		
	Contactor Number	FC A1	FC A2	FC A3	FC A4	FC A5	FC A6	FC A7	—		
	Fan Position	FM13	FM11	FM9	FM7	FM14	FM12	FM10	—		
	Fan Output Ckt B	1	2	3	4	5	6	—	—		
<p>30XA260</p>	Fan Output Ckt A	1	2	3	4	5	6	7	8		
	Contactor Number	FC A1	FC A2	FC A3	FC A4	FC A5	FC A6	FC A7	FC A8	FC A9	
	Fan Position	FM15	FM13	FM11	FM9	FM7	FM16	FM14	FM12	FM10	
	Fan Output Ckt B	1	2	3	4	5	6	—	—		
<p>30XA280</p>	Fan Output Ckt A	1	2	3	4	5	6	7	8		
	Contactor Number	FC A1	FC A2	FC A3	FC A4	FC A5	FC A6	FC A7	FC A8	FC A9	
	Fan Position	FM15	FM13	FM11	FM9	FM7	FM16	FM14	FM12	FM10	
	Fan Output Ckt B	1	2	3	4	5	6	7	—		
<p>30XA300</p>	Fan Output Ckt A	1	2	3	4	5	6	7	8		
	Contactor Number	FC A1	FC A2	FC A3	FC A4	FC A5	FC A6	FC A7	FC A8	FC A9	FC A10
	Fan Position	FM15	FM13	FM11	FM9	FM7	FM16	FM14	FM12	FM10	FM8
	Fan Output Ckt B	1	2	3	4	5	6	—	—		
<p>30XA325, 350</p>	Fan Output Ckt A	1	2	3	4	5	6	7	8		
	Contactor Number	FC A1	FC A2	FC A3	FC A4	FC A5	FC A6	FC A7	FC A8	FC A9	
	Fan Position	FM17	FM15	FM13	FM11	FM9	FM18	FM16	FM14	FM12	
	Fan Output Ckt B	1	2	3	4	5	6	7	8		
<p>30XA325, 350</p>	Contactor Number	FC B1	FC B2	FC B3	FC B4	FC B5	FC B6	—	—		
	Fan Position	FM1	FM3	FM5	FM2	FM4	FM6	—	—		
	Fan Output Ckt B	1	2	3	4	5	6	7	8		
	Contactor Number	FC B1	FC B2	FC B3	FC B4	FC B5	FC B6	FC B7	FC B8	FC B9	
Fan Position	FM1	FM3	FM5	FM7	FM10	FM2	FM4	FM6	FM8		

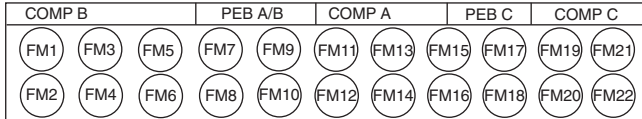
LEGEND

**Ckt** — Circuit  
**COMP** — Compressor  
**FC** — Fan Contactor  
**FM** — Fan Motor  
**PEB** — Power Electrical Box

Fig. 9 — Fan Staging



30XA400



30XA450, 500

Fan Output Ckt A	1	2	3	4	5	6	—	—
Contactor Number	FC A1	FC A2	FC A3	FC A4	FC A5	FC A6	—	—
Fan Position	FM11	FM9	FM7	FM12	FM10	FM8	—	—
Fan Output Ckt B	1	2	3	4	5	6	—	—
Contactor Number	FC B1	FC B2	FC B3	FC B4	FC B5	FC B6	—	—
Fan Position	FM1	FM3	FM5	FM2	FM4	FM6	—	—
Fan Output Ckt C	1	2	3	4	5	6	7	8
Contactor Number	FC C1	FC C2	FC C3	FC C4	FC C5	FC C6	FC C7	FC C8
Fan Position	FM19	FM17	FM15	FM13	FM20	FM18	FM16	FM14

Fan Output Ckt A	1	2	3	4	5	6	7	8
Contactor Number	FC A1	FC A2	FC A3	FC A4	FC A5	FC A6	FC A7	FC A8
Fan Position	FM13	FM11	FM9	FM7	FM14	FM12	FM10	FM8
Fan Output Ckt B	1	2	3	4	5	6	—	—
Contactor Number	FC B1	FC B2	FC B3	FC B4	FC B5	FC B6	—	—
Fan Position	FM1	FM3	FM5	FM2	FM4	FM6	—	—
Fan Output Ckt C	1	2	3	4	5	6	7	8
Contactor Number	FC C1	FC C2	FC C3	FC C4	FC C5	FC C6	FC C7	FC C8
Fan Position	FM21	FM19	FM17	FM15	FM22	FM20	FM18	FM16

LEGEND

- Ckt — Circuit
- COMP — Compressor
- FC — Fan Contactor
- FM — Fan Motor
- PEB — Power Electrical Box

Fig. 9 — Fan Staging (cont)

**Replacement** — If the controller is replaced the parameters in Table 15 must be configured. See Fig. 10 and 11.

Table 15 — Head Pressure Control Parameters

PARAMETER	VALUE	DESCRIPTION
P0010	1	Enter Quick Commissioning
P0311	1140*	Rated Motor Speed
	850†	
P3900	1	End of Quick Commissioning
P0003**	3	User Access Level
P1210 **	6	Automatic Restart
P1310	10%	Continuous Boost

\*6-pole motors.  
 †8-pole motors.  
 \*\*Remove jumper from terminals 5 and 8 before configuring parameter. Reinstall jumper after configuration is complete.

DIP switch settings:

DIP switch 1 is not used.

DIP switch 2 is the motor frequency. (OFF = 50 Hz, ON = 60 Hz)

**Drive Programming** — Parameter values can be altered via the operator panel. The operator panel features a five-digit, seven-segment display for displaying parameter numbers and values, alarm and fault messages, set points, and actual values. See Fig. 12 and 13. See Table 16 for additional information on the operator panel.

NOTE: The operator panel motor control functions are disabled by default. To control the motor via the operator panel, parameter P0700 should be set to 1 and P1000 set to 1. The operator panel can be fitted to and removed from the drive while power is applied. If the operator panel has been set as the I/O control (P0700 = 1), the drive will stop if the operator panel is removed.

**Changing Parameters with the Operator Panel** — See Fig. 13 for the procedure for changing the value of parameter P0004. Modifying the value of an indexed parameter is illustrated in Fig. 13 using the example of P0719. Follow the same procedure to alter other parameters using the operator panel.

NOTE: In some cases when changing parameter values the display on the operator panel displays **P----**. This means the drive is busy with tasks of higher priority.

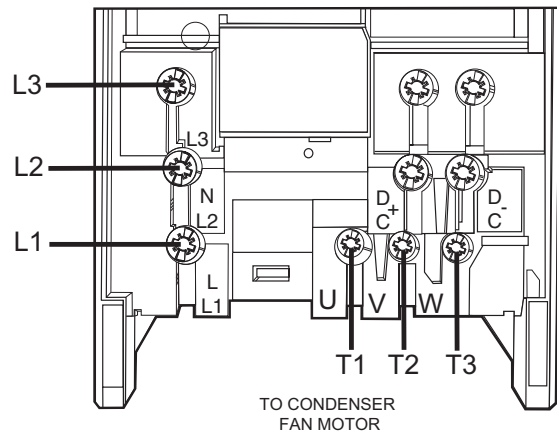


Fig. 10 — Low Ambient Temperature Control Power Wiring

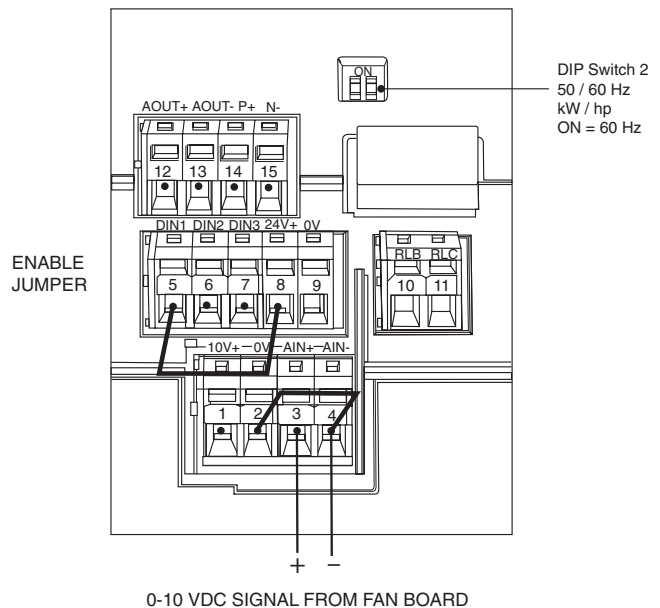


Fig. 11 — Low Ambient Temperature Control Signal Wiring



**Fig. 12 — Low Ambient Temperature Controller**

Changing Single Digits in Parameter Values — For changing the parameters value rapidly, the single digits of the display can be changed by performing the following actions:

Ensure the operator panel is in the parameter value changing level as described in the Changing Parameters with the Operator Panel section.

1. Press **Fn** (function button), which causes the farthest right digit to blink.
2. Change the value of this digit by pressing **▲** or **▼**.
3. Pressing **Fn** (function button) again to cause the next digit to blink.
4. Perform steps 2 to 4 until the required value is displayed.
5. Press **P** (parameter button) to exit the parameter value changing level.

**NOTE:** The function button may also be used to acknowledge a fault condition.

Quick Commissioning (P0010=1) — It is **important** that parameter P0010 is used for commissioning and P0003 is used to select the number of parameters to be accessed. The P0010 parameter allows a group of parameters to be selected that will enable quick commissioning. Parameters such as motor settings and ramp settings are included. At the end of the quick commissioning sequences, P3900 should be selected, which, when set to 1, will carry out the necessary motor calculations and clear all other parameters (not included in P0010=1 to the default settings. This will only occur in Quick Commissioning mode. See Fig. 14.

Reset to Factory Default — To reset all parameters to the factory default settings, the following parameters should be set as follows:

1. Jumpers must be in place from terminals 2 and 4 and 5 and 8 (5 and 9 for 575v drives only).
2. Remove the keypad (pull out from top) and verify that DIP switch 1 is OFF and 2 is ON. Replace keypad.
3. Power up the drive. Press Parameter **P** key. Press **▲** to Parameter **P0010**.
4. Press **P**, then **▲** to change the 0 to a 1. Press **P** again to accept the change.
5. Press **▲** to Parameter **P0311**. Press **P** and press **▼** to change this value to 1140 for 6-pole motors or 850 for units with 8-pole motors. Press **P** to accept.



















**CHANGING P0004 — PARAMETER FILTER FUNCTION**









STEP	RESULT ON DISPLAY
1 Press <b>P</b> to access parameters	r0000
2 Press <b>▲</b> until P0004 is displayed	P0004
3 Press <b>P</b> to access the parameter value level	0
4 Press <b>▲</b> or <b>▼</b> to the required value	7
5 Press <b>P</b> to confirm and store the value	P0004
6 Only the command parameters are visible to the user.	

**CHANGING P0719 AN INDEXED PARAMETER SELECTION OF COMMAND/SETPOINT SOURCE**










STEP	RESULT ON DISPLAY
1 Press <b>P</b> to access parameters	r0000
2 Press <b>▲</b> until P0719 is displayed	P0719
3 Press <b>P</b> to access the parameter value level	r0000
4 Press <b>P</b> to display current set value	0
5 Press <b>▲</b> or <b>▼</b> to the required value	12
6 Press <b>P</b> to conform and store the value	P0719
7 Press <b>▼</b> until r0000 is displayed	r0000
8 Press <b>P</b> to return the display to the standard drive display (as defined by the customer)	

**Fig. 13 — Changing Parameters with the Operator Panel**

6. Press  to Parameter **P3900**. Press  and use  to change this value to 1. Press  to accept.
7. The drive will finish standard programming. Remove one end of the jumper wire from terminal 8.
8. Press  again and go to Parameter **P0003**. Press  and use  to change this value to 3. Press  to accept.
9. Press  to Parameter **P1210**. Press  and use  to change this value to 6. Press  to accept.
10. Press  to Parameter **P1310**. Press  and use  to change this value to 10%. Press  to accept.
11. Press the Function  key and then . The display will read 0.00 Hz.

12. Replace the wire jumper in terminal 8.
13. The drive is now active. Check fan rotation prior to testing. If the fan is spinning forward, further adjustment is needed. Fan should sit still when commanded speed is 0%. If the fan is spinning forward slightly, press  and  to Parameter **P0761**. Press  and use  to change this value to 0.1. Press  to accept. Check the fan. If rotation has stopped no further adjustment is required. If the fan is still rotating forward, press  and use  to change this value to 0.2. Press  to accept. Repeat as needed until the fan is holding still or is just barely moving in either direction. Do NOT enter a value greater than 0.5 for this parameter without first contacting your Carrier representative.

**Table 16 — Low Ambient Temperature Controller Operator Panel**

PANEL/BUTTON	FUNCTION	DESCRIPTION
	Indicates Status	The LCD displays the settings currently used by the converter.
	Start Converter	The Start Converter button is disabled by default. To enable this button set P0700 = 1.
	Stop Converter	Press the Stop Converter button to cause the motor to come to a standstill at the selected ramp down rate. Disabled by default, to enable set P0700 = 1. Press the Stop Converter button twice (or hold) to cause the motor to coast to a standstill. This function is always enabled.
	Change Direction	Press the Change Direction button to change the direction of rotation of the motor. Reverse is indicated by a minus (-) sign or a flashing decimal point. Disabled by default, to enable set P0700 = 1.
	Jog Motor	Press the Jog Motor button while the inverter has no output to cause the motor to start and run at the preset jog frequency. The motor stops when the button is released. The Jog Motor button is not enabled when the motor is running.
	Functions	The Functions button can be used to view additional information. Press and hold the button to display the following information starting from any parameter during operation: 1. DC link voltage (indicated by d – units V). 2. Output current. (A) 3. Output frequency (Hz) 4. Output voltage (indicated by o – units V). 5. The value selected in P0005 (If P0005 is set to show any of the above [3, 4, or 5] then this will not be shown when toggling through the menu). Press the Functions button repeatedly to toggle through displayed values. <b>Jump Function</b> Press of the Fn button from any parameter (rXXXX or PXXXX) to immediately jump to r0000, when another parameter can be changed, if required. Return to r0000 and press the Functions button again to return.
	Access Parameters	Allows access to the parameters.
	Increase Value	Press the Increase Value button to increase the displayed value. To change the Frequency Setpoint using the operator panel set P1000 = 1.
	Decrease Value	Press the Decrease Value button to decrease the displayed value. To change the Frequency Setpoint using the operating panel set P1000 = 1.

Troubleshooting with the Operating Panel — Warnings and faults are displayed on the operating panel with Axxx and Fxxx. The individual messages are shown in Table 17.

If the motor fails to start, check the following:

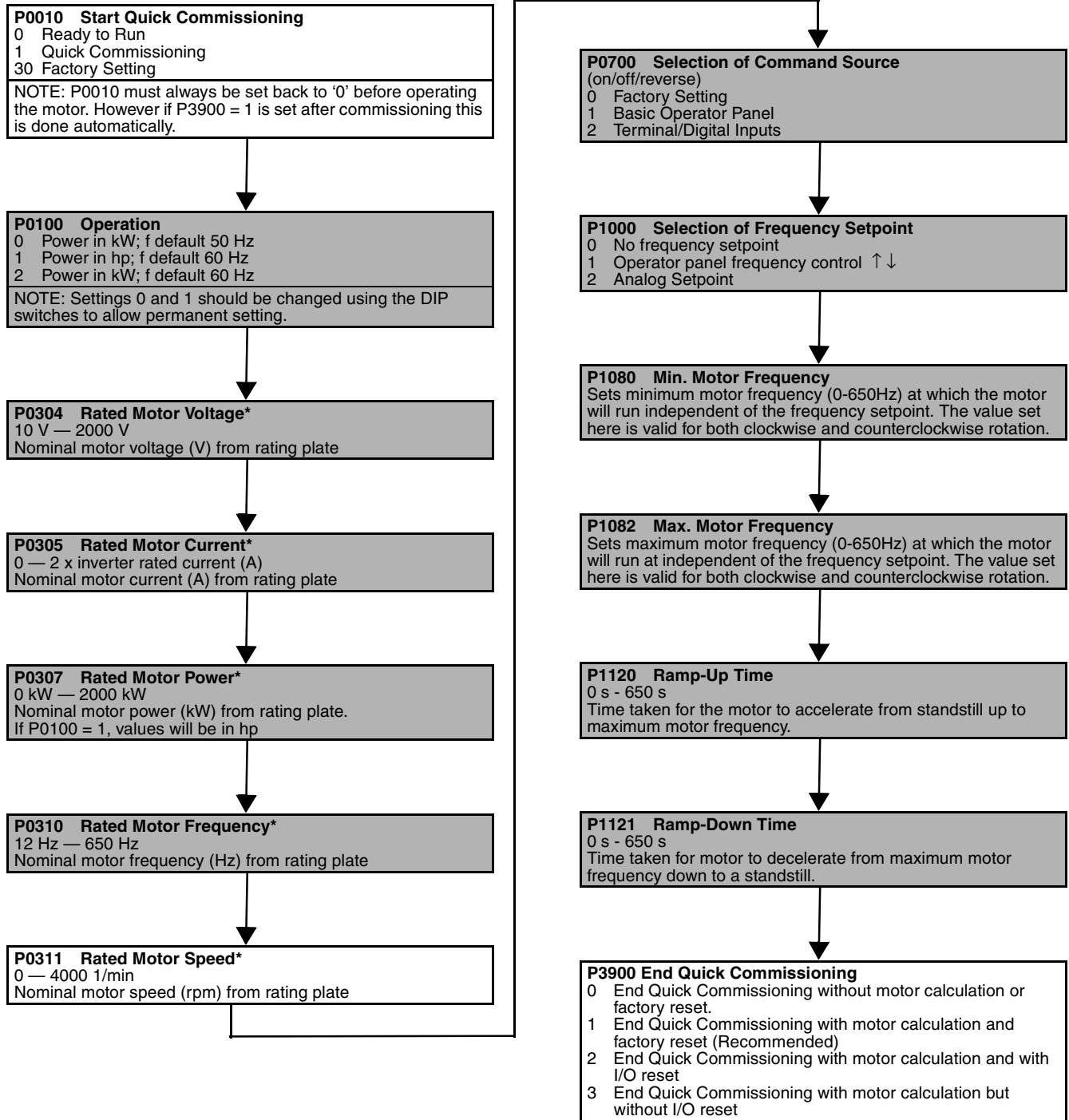
- Power is present on T1, T2 and T3.
- Configuration jumpers are in place.
- Control signal between 1 vdc and 10 vdc is present on terminals 3 and 4.
- P0010 = 0.

- P0700 = 2.

Fault Messages (Tables 17 and 18) — In the event of a failure, the drive switches off and a fault code appears on the display.

NOTE: To reset the fault code, one of the following methods can be used:

1. Cycle the power to the drive.
2. Press the **Fn** button on the operator panel.



\*Motor-specific parameters — see motor rating plate.

NOTE: Shaded boxes are for reference only.

**Fig. 14 — Low Ambient Temperature Controller Flow Chart Quick Commissioning**


**Table 17 — Low Ambient Temperature Controller Fault Messages**

FAULT	POSSIBLE CAUSES	TROUBLESHOOTING
<b>F0001 Overcurrent</b>	<ul style="list-style-type: none"> <li>Motor power does not correspond to the inverter power</li> <li>Motor lead short circuit</li> <li>Ground fault</li> </ul>	Check the following: <ol style="list-style-type: none"> <li>Motor power (P0307) must correspond to inverter power (P0206)</li> <li>Motor cable and motor must have no short-circuits or ground faults</li> <li>Motor parameters must match the motor in use</li> <li>Motor must not be obstructed or overloaded</li> </ol> After Steps 1-4 have been checked, increase the ramp time (P1120) and reduce the boost level (P1310, P1311, P1312).
<b>F0002 Overvoltage</b>	<ul style="list-style-type: none"> <li>DC-link voltage (r0026) exceeds trip level (P2172)</li> <li>Overvoltage can be caused either by too high main supply voltage or if motor is in regenerative mode</li> <li>Regenerative mode can be caused by fast ramp downs or if the motor is driven from an active load</li> </ul>	Check the following: <ol style="list-style-type: none"> <li>Supply voltage (P0210) must lie within limits indicated on rating plate</li> <li>DC-link voltage controller must be enabled (P1240) and have parameters set correctly</li> <li>Ramp-down time (P1121) must match inertia of load</li> </ol>
<b>F0003 Undervoltage</b>	<ul style="list-style-type: none"> <li>Main supply failed</li> <li>Shock load outside specified limits</li> </ul>	Check the following: <ol style="list-style-type: none"> <li>Supply voltage (P0210) must lie within limits indicated on rating plate</li> <li>Supply must not be susceptible to temporary failures or voltage reductions</li> </ol>
<b>F0004 Drive Overtemperature</b>	<ul style="list-style-type: none"> <li>Ambient temperature outside of limits</li> <li>Fan failure</li> </ul>	Check the following: <ol style="list-style-type: none"> <li>Fan must turn when inverter is running</li> <li>Pulse frequency must be set to default value</li> <li>Air inlet and outlet points are not obstructed</li> <li>Ambient temperature could be higher than specified for the drive.</li> </ol>
<b>F0005 Drive I<sup>2</sup>t</b>	<ul style="list-style-type: none"> <li>Drive overloaded</li> <li>Duty cycle too demanding</li> <li>Motor power (P0307) exceeds drive power capability (P0206)</li> </ul>	Check the following: <ol style="list-style-type: none"> <li>Load duty cycle must lie within specified limits</li> <li>Motor power (P0307) must match drive power (P0206)</li> </ol>
<b>F0011 Motor Overtemperature I<sup>2</sup>t</b>	<ul style="list-style-type: none"> <li>Motor overloaded</li> <li>Motor data incorrect</li> <li>Long time period operating at low speeds</li> </ul>	<ol style="list-style-type: none"> <li>Check motor data</li> <li>Check loading on motor</li> <li>Boost settings too high (P1310, P1311, P1312)</li> <li>Check parameter for motor thermal time constant</li> <li>Check parameter for motor I<sup>2</sup>t warning level</li> </ol>
<b>F0041 Stator Resistance Measurement Failure</b>	Stator resistance measurement failure	<ol style="list-style-type: none"> <li>Check if the motor is connected to the drive</li> <li>Check that the motor data has been entered correctly</li> </ol>
<b>F0051 Parameter EEPROM Fault</b>	Reading or writing of the non-volatile parameter storage has failed	<ol style="list-style-type: none"> <li>Factory reset and new parameters set</li> <li>Replace drive</li> </ol>
<b>F0052 Powerstack Fault</b>	Reading of the powerstack information has failed or the data is invalid	Replace drive
<b>F0060 Asic Timeout</b>	Internal communications failure	<ol style="list-style-type: none"> <li>Acknowledge fault</li> <li>Replace drive if repeated</li> </ol>
<b>F0070 Communications Board Set Point Error</b>	No setpoint received from communications board during telegram off time	<ol style="list-style-type: none"> <li>Check connections to the communications board</li> <li>Check the master</li> </ol>
<b>F0071 No Data for RS232 Link During Telegram Off Time</b>	No response during telegram off time via BOP link	<ol style="list-style-type: none"> <li>Check connections to the communications board</li> <li>Check the master</li> </ol>
<b>F0072 No Data from RS485 Link During Telegram Off Time</b>	No response during telegram off time via COM link	<ol style="list-style-type: none"> <li>Check connections to the communications board</li> <li>Check the master</li> </ol>
<b>F0080 Analog Input - Lost Input Signal</b>	<ul style="list-style-type: none"> <li>Broken wire</li> <li>Signal out of limits</li> </ul>	Check connection to analog input
<b>F0085 External Fault</b>	External fault is triggered via terminal inputs	Disable terminal input for fault trigger
<b>F0101 Stack Overflow</b>	Software error or processor failure	<ol style="list-style-type: none"> <li>Run self test routines</li> <li>Replace drive</li> </ol>
<b>F0221 PI Feedback Below Minimum Value</b>	PID Feedback below minimum value P2268	<ol style="list-style-type: none"> <li>Change value of P2268</li> <li>Adjust feedback gain</li> </ol>
<b>F0222 PI Feedback Above Maximum Value</b>	PID Feedback above maximum value P2267	<ol style="list-style-type: none"> <li>Change value of P2267</li> <li>Adjust feedback gain</li> </ol>
<b>F0450 (Service Mode Only) BIST Tests Failure</b>	Fault value <ol style="list-style-type: none"> <li>Some of the power section tests have failed</li> <li>Some of the control board tests have failed</li> <li>Some of the functional tests have failed</li> <li>Some of the IO module tests have failed</li> <li>The Internal RAM has failed its check on power-up</li> </ol>	<ol style="list-style-type: none"> <li>Inverter may run but certain actions will not function correctly</li> <li>Replace drive</li> </ol>

LEGEND

- ASIC** — Application Specific Instruction
- BIST** — Built-in Self Test
- BOP** — Basic Operating Panel
- I<sup>2</sup>t** — Current Squared Time
- PI** — Proportional Integral
- PID** — Proportional Integral Derivative

NOTE: To reset the fault code, one of the following methods can be used:

- Cycle the power to the drive.
- Press the  button on the operator panel.

**Table 18 — Alarm Messages**

FAULT	POSSIBLE CAUSES	TROUBLESHOOTING
<b>A0501 Current Limit</b>	<ul style="list-style-type: none"> <li>• Motor power does not correspond to the drive power</li> <li>• Motor leads are too short</li> <li>• Ground fault</li> </ul>	<ol style="list-style-type: none"> <li>1. Check whether the motor power corresponds to the drive power</li> <li>2. Check that the cable length limits have not been exceeded</li> <li>3. Check motor cable and motor for short-circuits and ground faults</li> <li>4. Check whether the motor parameters correspond with the motor being used</li> <li>5. Check the stator resistance</li> <li>6. Increase the ramp-up-time</li> <li>7. Reduce the boost</li> <li>8. Check whether the motor is obstructed or overloaded</li> </ol>
<b>A0502 Overvoltage Limit</b>	<ul style="list-style-type: none"> <li>• Mains supply too high</li> <li>• Load regenerative</li> <li>• Ramp-down time too short</li> </ul>	<ol style="list-style-type: none"> <li>1. Check that mains supply voltage is within allowable range</li> <li>2. Increase ramp down times</li> </ol> <p>NOTE: If the vdc-max controller is active, ramp-down times will be automatically increased</p>
<b>A0503 Undervoltage Limit</b>	<ul style="list-style-type: none"> <li>• Mains supply too low</li> <li>• Short mains interruption</li> </ul>	Check main supply voltage (P0210)
<b>A0504 Drive Overtemperature</b>	Warning level of inverter heat-sink temperature (P0614) is exceeded, resulting in pulse frequency reduction and/or output frequency reduction (depending on parameters set (P0610))	<ol style="list-style-type: none"> <li>1. Check if ambient temperature is within specified limits</li> <li>2. Check load conditions and duty cycle</li> <li>3. Check if fan is turning when drive is running</li> </ol>
<b>A0505 Drive I<sup>2</sup>t</b>	Warning level is exceeded; current will be reduced if parameters set (P0610 = 1)	Check if duty cycle is within specified limits
<b>A0506 Drive Duty Cycle</b>	Heatsink temperature and thermal junction model are outside of allowable range	Check if duty cycle is within specified limits
<b>A0511 Motor Overtemperature I<sup>2</sup>t</b>	Motor overloaded	<p>Check the following:</p> <ol style="list-style-type: none"> <li>1. P0611 (motor I<sup>2</sup>t time constant) should be set to appropriate value</li> <li>2. P0614 (motor I<sup>2</sup>t overload warning level) should be set to suitable level</li> <li>3. Are long periods of operation at low speed occurring</li> <li>4. Check that boost settings are not too high</li> </ol>
<b>A0541 Motor Data Identification Active</b>	Motor data identification (P1910) selected or running	Wait until motor identification is finished
<b>A0600 RTOS Overrun Warning</b>	Software error	—

LEGEND

I<sup>2</sup>t — Current Squared Time

**Machine Control Methods** — Three variables control how the machine operates. One variable controls the machine On-Off function. The second controls the set point operation. The third variable controls the Heat-Cool operation. Table 19 illustrates how the control method and cooling set point select variables direct the operation of the chiller and the set point to which it controls. Table 19 also provides the On/Off state of the machine for the given combinations.

Machine On/Off control is determined by the configuration of the Operating Type Control (*Operating Modes* → *SLCT* → *OPER*). Options to control the machine locally via a switch, from a local Time Schedule, or via a Carrier Comfort Network command are offered.

**SWITCH CONTROL** — In this Operating Type Control, the Enable/Off/Remote Contact switch controls the machine locally. All models are factory configured with *OPER*=0 (Switch Control). With the *OPER* set to 0, simply switching the Enable/Off/Remote Contact switch to the Enable or Remote Contact position (external contacts closed) will put the chiller in an occupied state. The unit Occupied Status (*Run Status* → *VIEW* → *OCC*) will change from **NO** to **YES**. The Status Unit Control Type (*Run Status* → *VIEW* → *CTRL*) will change from **0** (Local Off) when the switch is Off to **1** (Local On) when in the Enable position or Remote Contact position with external contacts closed.

**TIME SCHEDULE** — In this Operating Type Control, the machine operates under a local schedule programmed by the user as long as the Enable/Off/Remote Contact switch is in the Enable or Remote Contact position (external contacts closed). To operate under this Operating Type Control, *Operating Modes* → *SLCT* must be set to *OPER*=1. Two Internal Time Schedules are available. Time Schedule 1 (*Time Clock* → *SCH1*) is used for single set point On-Off control. Time Schedule 2 (*Time Clock* → *SCH2*) is used for dual set point On-Off and Occupied-Unoccupied set point control. The control will use the operating schedules as defined under the Time Clock mode in the Navigator™ display module.

**CCN Global Time Schedule** — A CCN Global Schedule can be utilized. The schedule number can be set anywhere from 65 to 99 for operation under a CCN global schedule. The 30XA chillers can be configured to follow a CCN Global Time Schedule broadcast by another system element. The ComfortVIEW™ Network Manager's Configure and Modify commands or the Service Tool's Modify/Names function must be used to change the number of the Occupancy Equipment Part Table Name (OCC1P01E) to the Global Schedule Number. The Schedule Number can be set from 65 to 99 (OCC1P65E to OCC1P99E).

The Occupancy Supervisory Part table name (OCC1P01S) number must be changed to configure the unit to broadcast a Global Time Schedule. The Schedule Number can be set from 65 to 99 (OCC1P65S to OCC1P99S). When OCC1PxxS is set to a value greater than 64, an occupancy flag is broadcast over the CCN every time it transitions from occupied to unoccupied or vice-versa. By configuring their appropriate Time Schedule decisions to the same number, other devices on the network can follow this same schedule. The Enable/Off/Remote Contact must be in the Enable position or Remote Contact position with the contacts closed for the unit to operate. The Status Unit Control Type (*Run Status* → *VIEW* → *STAT*) will be **0** (Local Off) when the switch is Off. The Status Unit Control Type will be **2** (CCN) when the Enable/Off/Remote Contact switch input is On.

**CCN CONTROL** — An external CCN device such as Chiller-ervisor controls the On/Off state of the machine. This CCN device forces the variable CHIL\_S\_S between Start/Stop to control the chiller. The Status Unit Control Type (*Run Status* → *VIEW* → *STAT*) will be **0** (Local Off) when the Enable/Off/Remote Contact switch is Off. The Status Unit Control Type will be **2** (CCN) when the Enable/Off/Remote Contact switch input is Closed and the CHIL\_S\_S variable is Stop or Start.

**Table 19 — Control Methods and Cooling Set Points**

PARAMETER							ACTIVE SET POINT	
Control Method (OPER)	Heat Cool Select (HC.SE)	Setpoint Select (SP.SE)	Ice Mode Enable (ICE.M)	Ice Done (ICE.D)	Dual Setpoint Switch (DUAL)	Setpoint Occupied (SP.OC)		
0 (Switch Ctrl)	0 (Cool)	1 (Setpoint1)	Enable	—	—	—	CSP.1	
				Open	Closed	—	CSP.3	
		2 (Setpoint2)	Enable	—	—	—	—	CSP.2
				Open	Closed	—	CSP.3	
		3 (4-20mA Setp)	—	—	—	—	—	4-20 mA
				—	—	—	—	—
		4 (Dual Setp Sw)	Enable	—	Open	Open	—	CSP.1
					Closed	Closed	—	CSP.2
—	Open			Open	—	CSP.1		
	Closed			Closed	—	CSP.2		
1 (Time Sched)	0 (Cool)	0 (Setpoint Occ)	Enable	—	—	Occupied	CSP.1	
				—	—	Unoccupied	CSP.2	
				Open	—	Unoccupied	CSP.3	
				Closed	—	Unoccupied	CSP.2	
2 (CCN)	0 (Cool)	—	Enable	—	—	Occupied	CSP.1	
				—	—	Unoccupied	CSP.2	
				Open	—	Unoccupied	CSP.3	

— = No Effect

UNIT RUN STATUS (*Run Status* →VIEW→STAT) — As the unit transitions from off to on and back to off, the Unit Run Status will change based on the unit’s operational status. The variables are: **0** (Off), **1** (Running), **2** (Stopping), and **3** (Delay).

- 0 indicates the unit is Off due to the Enable/Off/Remote Contact Switch, a time schedule or CCN command.
- 1 indicates the unit is operational.
- 2 indicates the unit is shutting down due to the command to shut down from the Enable/Off/Remote Contact Switch, a time schedule or CCN command.
- 3 indicates the unit has received a command to start from Enable/Off/Remote Contact Switch, a time schedule or CCN command, and is waiting for the start-up timer (*Configuration* →OPTN→DELY) to expire.

**Cooling Set Point Selection (Operating Modes** →SLCT→SP.SE) — Several options for controlling the Leaving Chilled Water Set Point are offered and are configured by the Cooling Set Point Select variables. In addition to the Cooling Set Point Select, Ice Mode Enable (*Configuration* →OPTN→ICE.M), and Heat Cool Select (*Operating Modes* →SLCT→HC.SE) variables also have a role in determining the set point of the machine. All units are shipped from the factory with the Heat Cool Select variable set to HC.SE=0 (Cooling). All set points are based on Leaving Water Control, (*Configuration* →SERV→EWTO=NO).

In all cases, there are limits on what values are allowed for each set point. These values depend on the Cooler Fluid Type (*Configuration* →SERV→FLUD) and the Brine Freeze Set point (*Configuration* →SERV→LOSP). See Table 20.

**Table 20 — Configuration Set Point Limits**

SET POINT LIMIT	COOLER FLUID TYPE, FLUD	
	1 = Water	2 = Medium Brine
Minimum*	38 F (3.3 C)	14 F (-10.0 C)
Maximum	60 F (15.5 C)	

\*The minimum set point for Medium Temperature Brine applications is related to the Brine Freeze Point. The set point is limited to be no less than the Brine Freeze Point +5° F (2.8° C). See Table 19.

SET POINT 1 (*Operating Modes* →SLCT→SP.SE=1) — When Set Point Select is configured to 1, the unit’s active set point is based on Cooling Set Point 1 (*Set Point* →COOL→CSP.1).

SET POINT 2 (*Operating Modes* →SLCT→SP.SE=2) — When Set Point Select is configured to 2, the unit’s active set point is based on Cooling Set Point 2 (*Set Point* →COOL→CSP.2).

4 TO 20 mA INPUT (*Operating Modes* →SLCT→SP.SE=3) — When Set Point Select is configured to 3, the unit’s active set point is based on an external 4 to 20 mA signal input to the Energy Management Module (EMM).

See Table 19 for Control Methods and Cooling Set Points. The following equation is used to control the set point. See Fig. 15.

$$\text{Set Point} = 10 + 70(\text{mA} - 4)/16 \text{ (deg F)}$$

$$\text{Set Point} = -12.2 + 38.9(\text{mA} - 4)/16 \text{ (deg C)}$$

DUAL SWITCH (*Operating Modes* →SLCT→SP.SE=4) — When Set Point Select is configured to 4, the unit’s active set point is based on Cooling Set Point 1 (*Set Point* →COOL→CSP.1) when the Dual Set Point switch contacts are open and Cooling Set Point 2 (*Set Point* →COOL→CSP.2) when they are closed.

ICE MODE — Operation of the machine to make and store ice can be accomplished many ways. The Energy Management Module and an Ice Done Switch is required for operation in the Ice Mode. In this configuration, the machine can operate with up to three cooling set points: Cooling Set Point 1 (Occupied) (*Set Point* →COOL→CSP.1), Cooling Set Point 2 (Unoccupied) (*Set Point* →COOL→CSP.2), and Ice Set Point (*Set Point* →COOL→CSP.3).

SET POINT OCCUPANCY (*Operating Modes* →SLCT→SP.SE=0) — When Set point Select is configured to 0, the unit’s active set point is based on Cooling Set Point 1 (*Set Point* →COOL→CSP.1) during the occupied period while operating under *Time Clock* →SCH1. If the *Time Clock* →SCH2 is in use, the unit’s active set point is based on Cooling Set Point 1 (*Set Point* →COOL→CSP.1) during the occupied period and Cooling Set Point 2 (*Set Point* →COOL→CSP.2) during the unoccupied period.

## 4-20 mA Set Point Control

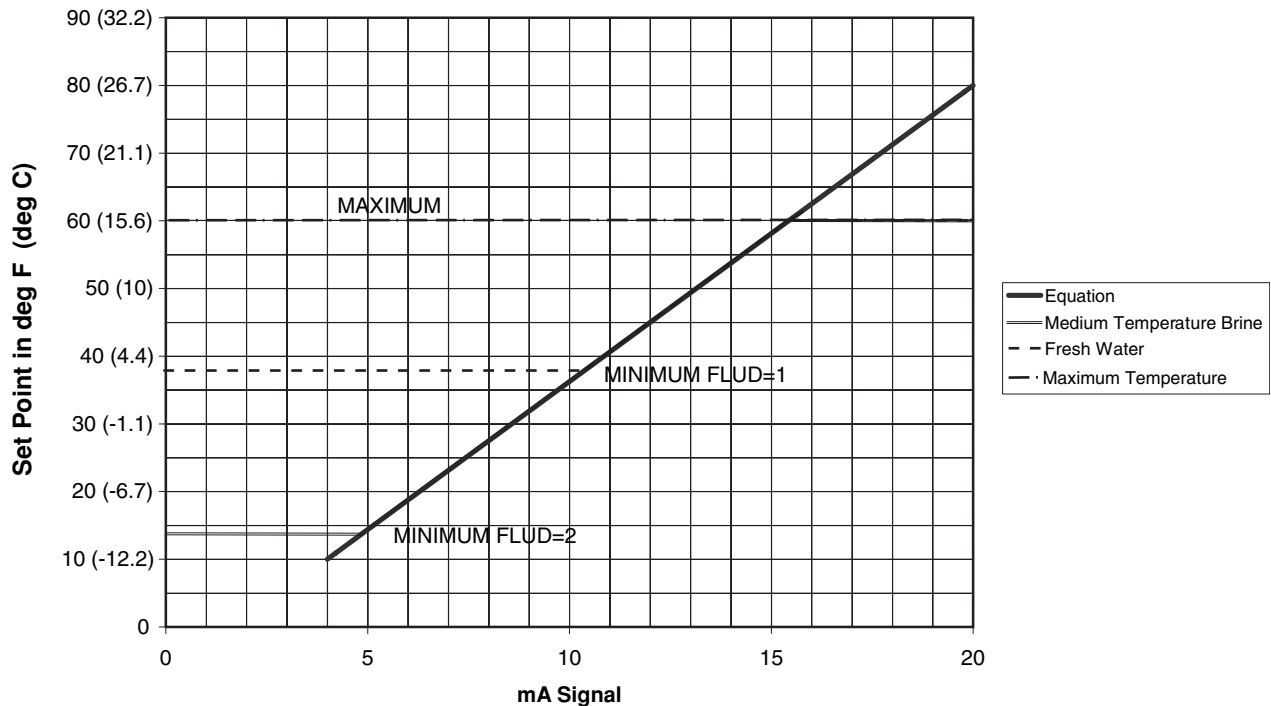


Fig. 15 — Set Point Control

**Temperature Reset** — Temperature reset is a value added to the basic leaving fluid temperature set point. The sum of these values is the control point. When a non-zero temperature reset is applied, the chiller controls to the control point, not the set point. The control system is capable of handling leaving-fluid temperature reset based on cooler fluid temperature difference. Because the change in temperature through the cooler is a measure of the building load, the temperature difference reset is in effect an average building load reset method. The control system is also capable of temperature reset based on outdoor-air temperature (OAT), space temperature (SPT), or from an externally powered 4 to 20 mA signal. An accessory sensor must be used for SPT reset (33ZCT55SPT). The Energy Management Module (EMM) is required for temperature reset using space temperature or a 4 to 20 mA signal.

Under normal operation, the chiller will maintain a constant leaving fluid temperature approximately equal to the chilled fluid set point. As the cooler load varies, the cooler fluid temperature difference will change in proportion to the load as shown in Fig. 16. Usually the chiller size and leaving-fluid temperature set point are selected based on a full-load condition. At part load, the fluid temperature set point may be lower than required. If the leaving fluid temperature were allowed to increase at part load, the efficiency of the machine would increase.

Delta T reset allows for the leaving temperature set point to be reset upward as a function of the fluid temperature difference or, in effect, the building load.

NOTE: Delta T reset should not be used with variable Cooler Flow Rate Systems.

To use Delta T Reset, four variables must be configured. They are: Cooling Reset Type (*Configuration* → *RSET* → *CRST*), Delta T No Reset Temp (*Setpoints* → *COOL* → *CRT1*), Delta T Full Reset Temp (*Setpoints* → *COOL* → *CRT2*) and Degrees Cool Reset (*Setpoints* → *COOL* → *DGRC*). In the following example using Delta T Reset, the

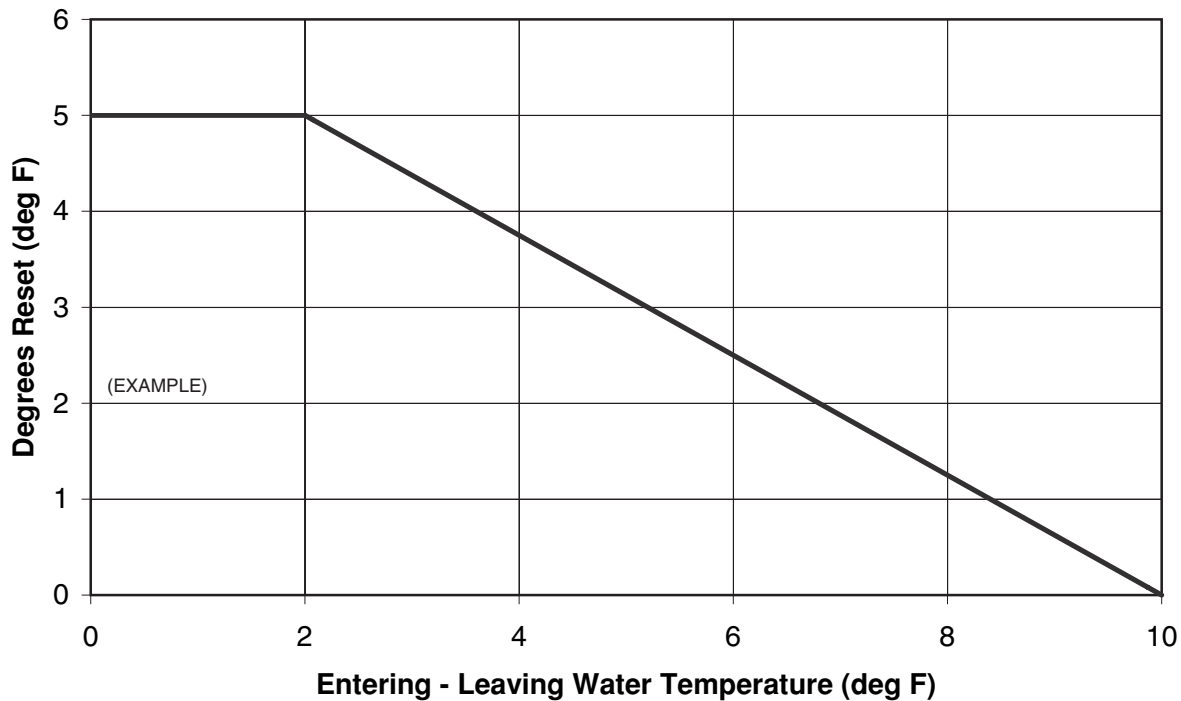
chilled water temperature will be reset by 5.0° F (2.8° C) when the  $\Delta T$  is 2° F (1.1° C) and 0° F (0° C) reset when the  $\Delta T$  is 10° F. The variable *CRT1* should be set to the cooler temperature difference where no chilled water temperature reset should occur. The variable *CRT2* should be set to the cooler temperature difference where the maximum chilled water temperature reset should occur. The variable *DGRC* should be set to the maximum amount of reset desired. To verify that reset is functioning correctly proceed to *Run Status* → *VIEW*, and subtract the active set point (*SETP*) from the control point (*CTPT*) to determine the degrees reset. See Fig. 16 and Table 21.

Other, indirect means of estimating building load and controlling temperatures reset are also available and are discussed below. See Fig. 17.

To use Outdoor Air Temperature Reset, four variables must be configured. They are: Cooling Reset Type (*Configuration* → *RSET* → *CRST*), OAT No Reset Temp (*Setpoints* → *COOL* → *CRO1*), OAT Full Reset Temp (*Setpoints* → *COOL* → *CRO2*) and Degrees Cool Reset (*Setpoints* → *COOL* → *DGRC*). In the following example, the outdoor air temperature reset example provides 0° F (0° C) chilled water set point reset at 85.0 F (29.4 C) outdoor-air temperature and 10.0° F (5.5° C) reset at 55.0 F (12.8 C) outdoor-air temperature. See Fig. 18 and Table 22.

To use Space Temperature Reset in addition to the Energy Management Module and a space temperature sensor, four variables must be configured. They are: Cooling Reset Type (*Configuration* → *RSET* → *CRST*), Space T No Reset Temp (*Setpoints* → *COOL* → *CRS1*), Space T Full Reset Temp (*Setpoints* → *COOL* → *CRS2*) and Degrees Cool Reset (*Setpoints* → *COOL* → *DGRC*). In the following space temperature reset example, 0° F (0° C) chilled water set point reset at 72.0 F (22.2 C) space temperature and 6.0° F (3.3° C) reset at 68.0 F (20.0 C) space temperature. See Fig. 19 and Table 23.

## Water Temperature Difference Reset



**Entering - Leaving Water Temperature (deg F)**  
**Fig. 16 — Water Temperature Difference (Delta T) Reset**

To use 4 to 20 mA Temperature Reset in addition to the Energy Management Module, four variables must be configured. They are: Cooling Reset Type (*Configuration* → *RSET* → *CRST*), Current No Reset Val (*Setpoints* → *COOL* → *CRV1*), Current Full Reset Val (*Setpoints* → *COOL* → *CRV2*) and Degrees Cool Reset (*Setpoints* → *COOL* → *DGRC*). In the following example, at 4 mA no reset takes place. At 20 mA, 5° F (2.8° C) chilled water set point reset is required. See Fig. 20 and Table 24.

### ⚠ CAUTION

Care should be taken when interfacing with other control systems due to possible power supply differences such as a full wave bridge versus a half wave rectification. Connection of control devices with different power supplies may result in permanent damage. *ComfortLink*™ controls incorporate power supplies with half wave rectification. A signal isolation device should be utilized if the signal generator incorporates a full wave bridge rectifier.

**Demand Limit** — Demand Limit is a feature that allows the unit capacity to be limited during periods of peak energy usage. There are three types of demand limiting that can be configured. The first type is through 2-step switch control, which will reduce the maximum capacity to 2 user-configurable percentages. The second type is by 4 to 20 mA signal input which will reduce the maximum capacity linearly between 100% at a 4 mA input signal (no reduction) down to the user-configurable level at a 20 mA input signal. The third type uses the CCN Loadshed module and has the ability to limit the current operating capacity to maximum and further reduce the capacity if required.

NOTE: One-step Demand Limit is standard.

The 2-step switch control and 4 to 20-mA input signal types of demand limiting require the Energy Management Module (EMM).

To use Demand Limit, select the type of demand limiting to use. Then configure the Demand Limit set points based on the type selected.

**1-STEP SWITCH CONTROLLED** — One-step Demand Limit control does not require the Energy Management Module. To configure Demand Limit for 1-step switch control two parameters must be configured: Demand Limit Select (*Configuration* → *RSET* → *DMDC*), and Switch Limit Setpoint 1 (*Setpoints* → *MISC* → *DLS1*). Demand Limit step is controlled by a relay switch input field wired to TB5-5 and TB5-14 for Switch 1. See the 2-Step Switch Controlled section for example.

**2-STEP SWITCH CONTROLLED** — If using 2-step Demand Limit control, an Energy Management Module must be installed. One-step Demand Limit control does not require the Energy Management Module. To configure Demand Limit for 2-step switch control, three parameters must be configured: Demand Limit Select (*Configuration* → *RSET* → *DMDC*), Switch Limit Setpoint 1 (*Setpoints* → *MISC* → *DLS1*) and Switch Limit Setpoint 2 (*Setpoints* → *MISC* → *DLS2*). In the following example, Demand Limit Switch 1 is 60% and Demand Limit Switch 2 is 40%. Demand Limit steps are controlled by two relay switch inputs field wired to TB5-5 and TB5-14 for Switch 1 and TB6-14 and TB6-15 for Switch 2. See Table 25.

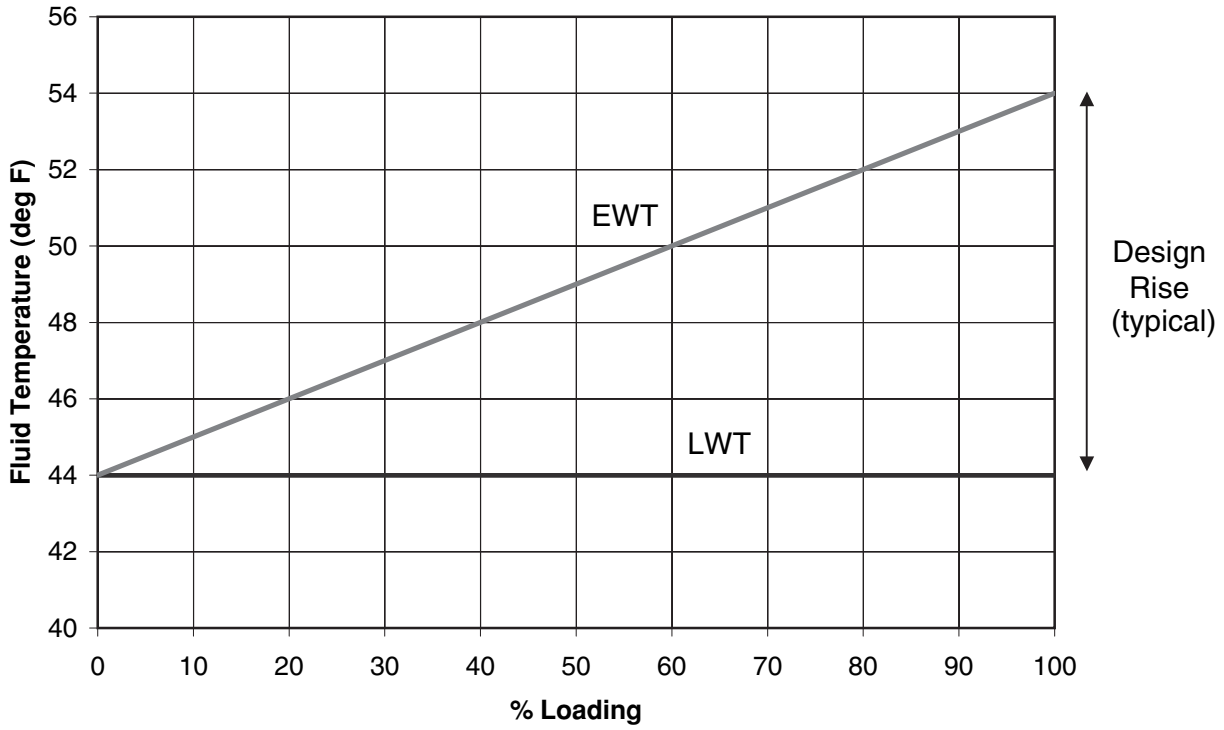
For Demand Limit by percent capacity switch control, closing the % capacity demand limit contact will put the unit on the first demand limit level. The unit will not exceed the percentage of capacity entered as Demand Limit Switch 1 set point. Closing contacts on the second demand limit switch prevents the unit from exceeding the capacity entered as Demand Limit Switch 2 set point. The demand limit % capacity that is set to the lowest demand takes priority if both demand limit inputs are closed. If the demand limit percentage does not match unit staging, the unit will limit capacity to the closest capacity step without exceeding the value. To disable demand limit configure *DMDC* to 0.

**Table 21 — Return Water Reset Configuration**

MODE	KEYPAD ENTRY	DISPLAY	ITEM EXPANSION	COMMENT	
<b>CONFIGURATION</b>	ENTER	<b>DISP</b>			
	↓	<b>UNIT</b>			
	↓	<b>SERV</b>			
	↓	<b>OPTN</b>			
	↓	<b>RSET</b>	Reset Cool and Heat Tmp		
	ENTER	CRST	Cooling Reset Type		
	ENTER	0	No Reset		
	ENTER	0	No Reset	Flashing to indicate Edit mode. May require Password	
	↓ / ↑	2	Delta T Temp	Use up or down arrows to change value to 2.	
	ENTER	2		Accepts the change.	
	ESCAPE	CRST			
	ESCAPE			At mode level	
	<b>SETPOINTS</b>	↓ / ↑			Change to Setpoints Mode
		ENTER	<b>COOL</b>	Cooling Setpoints	
ENTER		CSP.1	Cooling Setpoint 1		
↓ x 4		CRV.2			
↓		CRT1	Delta T No Reset Temp	Cooler Temperature difference where no temperature reset is required.	
ENTER		0		Value of CRT1	
ENTER		0		Flashing to indicate Edit mode	
↑		10.0		Value of No Temperature Reset, 10 from the example.	
ENTER		10.0		Accepts the change.	
ESCAPE		CRT1			
↓		CRT2	Delta T Full Reset Temp	Cooler Temperature difference where full temperature reset, DGRC is required.	
ENTER		0		Value of CRT2.	
ENTER		0		Flashing to indicate Edit mode	
↑		2.0		Value of full Temperature Reset, 2 from the example.	
ENTER		2.0		Accepts the change.	
ESCAPE		CRT2			
↓ x 4		CRS2			
↓		DGRC	Degrees Cool Reset	Amount of temperature reset required.	
ENTER		0		Value of DGRC	
ENTER		0		Flashing to indicate Edit mode	
↑		5.0		Amount of Temperature Reset required, 5 from the example.	
ENTER		5.0		Accepts the change.	
ESCAPE		DGRC			

NOTE: **Bold** values indicate sub-mode level.

### Chilled Water Temperature Control



LEGEND

- EWT — Entering Water Temperature
- LWT — Leaving Water Temperature

Fig. 17 — Chilled Water Temperature Control

### OAT Temperature Reset

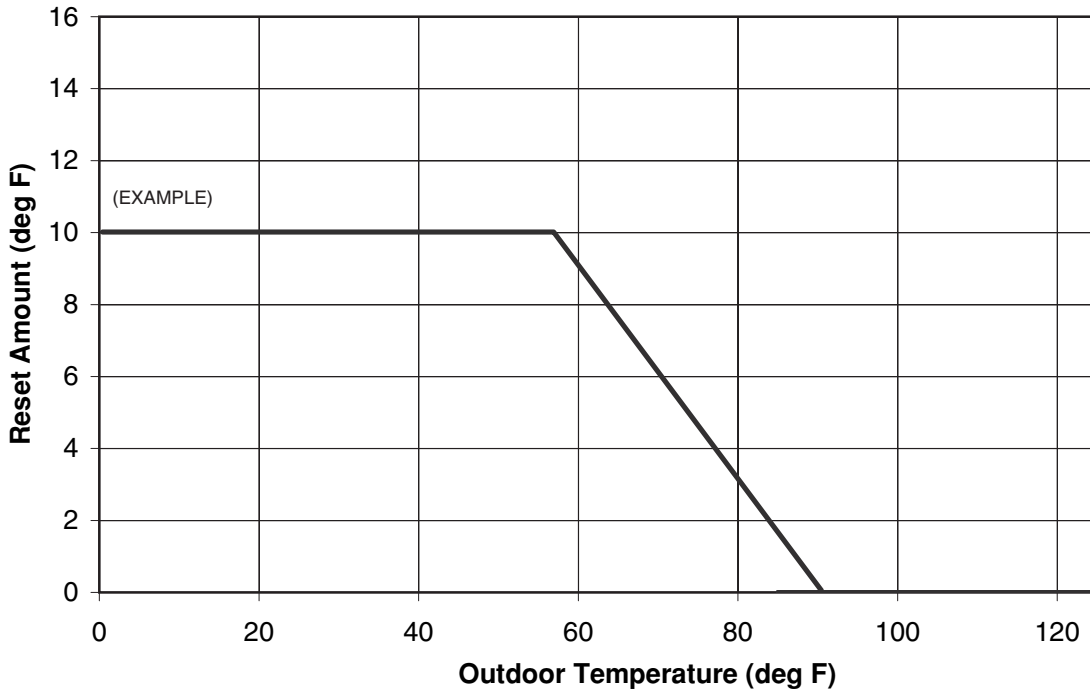


Fig. 18 — OAT Reset

**Table 22 — OAT Reset Configuration**

MODE	KEYPAD ENTRY	DISPLAY	ITEM EXPANSION	COMMENT	
<b>CONFIGURATION</b>	ENTER	<b>DISP</b>			
	↓	<b>UNIT</b>			
	↓	<b>SERV</b>			
	↓	<b>OPTN</b>			
	↓	<b>RSET</b>	Reset Cool and Heat Tmp		
	ENTER	CRST	Cooling Reset Type		
	ENTER	0	No Reset		
	ENTER	0	No Reset	Flashing to indicate Edit mode. May require Password	
	↓ / ↑	1	Out Air Temp	Use up or down arrows to change value to 1.	
	ENTER	1		Accepts the change.	
	ESCAPE	CRST			
	ESCAPE			At mode level	
	<b>SETPOINTS</b>	↓ / ↑			Change to Setpoints Mode
		ENTER	<b>COOL</b>	Cooling Setpoints	
ENTER		CSP.1	Cooling Setpoint 1		
↓ x 6		CRT.2			
↓		CRO1	OAT No Reset Temp	Outdoor Temperature where no temperature reset is required.	
ENTER		0		Value of CRO1	
ENTER		0		Flashing to indicate Edit mode	
↑		85.0		Value of No Temperature Reset, 85 from the example.	
ENTER		85.0		Accepts the change.	
ESCAPE		CRO1			
↓		CRO2	OAT Full Reset Temp	Outdoor Temperature where full temperature reset, DGRC is required.	
ENTER		0		Value of CRO2.	
ENTER		0		Flashing to indicate Edit mode	
↑		55.0		Value of full Temperature Reset, 55 from the example.	
ENTER		55.0		Accepts the change.	
ESCAPE		CRO2			
↓		CRS1			
↓		CRS2			
↓		DGRC	Degrees Cool Reset	Amount of temperature reset required.	
ENTER		0		Value of DGRC	
ENTER		0		Flashing to indicate Edit mode	
↑		10.0		Amount of Temperature Reset required, 10 from the example.	
ENTER		10.0		Accepts the change.	
ESCAPE	DGRC				

NOTE: **Bold** values indicate sub-mode level.

### Space Temperature Reset

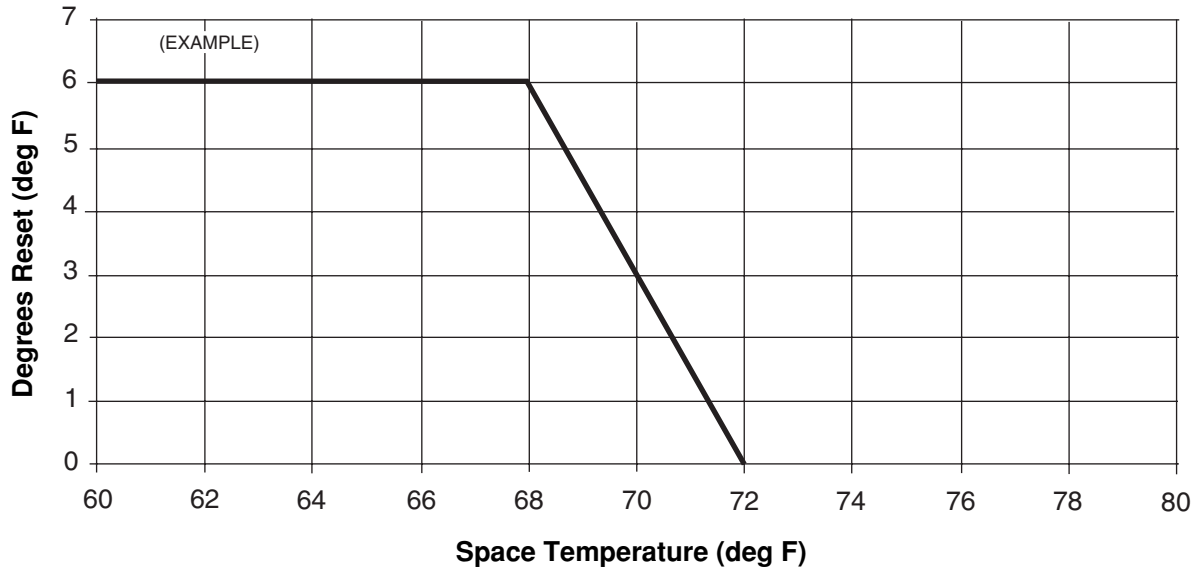


Fig. 19 — Space Temperature Reset

### 4-20 mA Temperature Reset

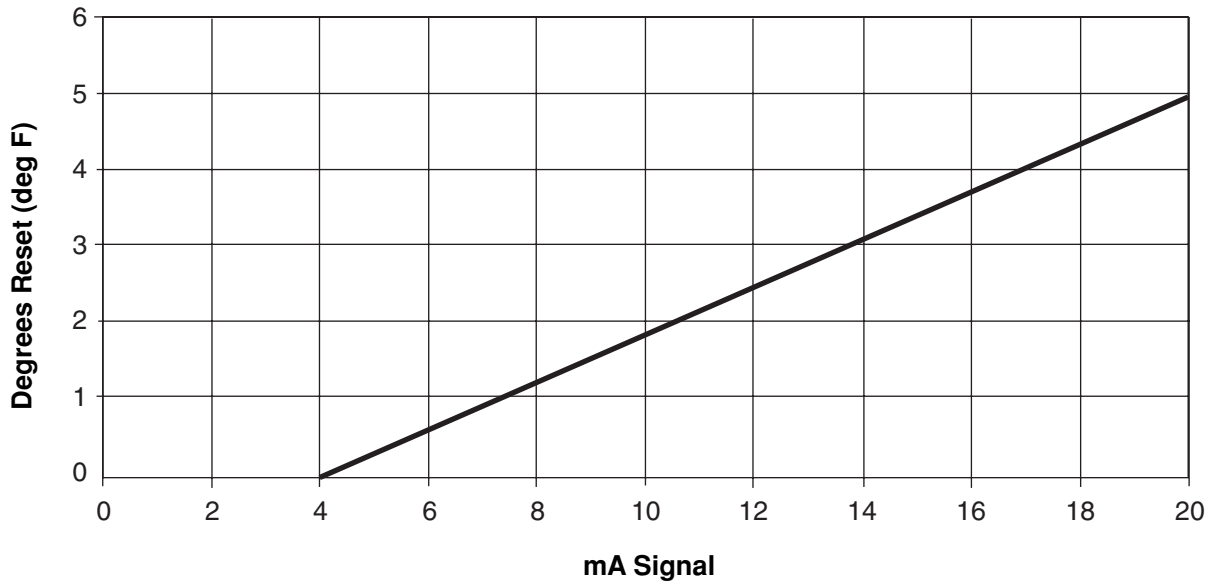


Fig. 20 — 4 to 20 mA Temperature Reset

**Table 23 — Space Temperature Reset Configuration**

MODE	KEYPAD ENTRY	DISPLAY	ITEM EXPANSION	COMMENT	
<b>CONFIGURATION</b>	ENTER	<b>DISP</b>			
	↓	<b>UNIT</b>			
	↓	<b>SERV</b>			
	↓	<b>OPTN</b>			
	↓	<b>RSET</b>	Reset Cool and Heat Tmp		
	ENTER	CRST	Cooling Reset Type		
	ENTER	0	No Reset		
	ENTER	0	No Reset	Flashing to indicate Edit mode. May require Password	
	↓ / ↑	4	Space Temp	Use up or down arrows to change value to 4.	
	ENTER	4		Accepts the change.	
	ESCAPE	CRST			
	ESCAPE			At mode level	
	<b>SETPOINTS</b>	↓ / ↑			Change to Setpoints Mode
		ENTER	<b>COOL</b>	Cooling Setpoints	
ENTER		CSP.1	Cooling Setpoint 1		
↓ x 8		CRO2			
↓		CRS1	Space T No Reset Temp	Space Temperature where no temperature reset is required.	
ENTER		0		Value of CRS1	
ENTER		0		Flashing to indicate Edit mode	
↑		72.0		Value of No Temperature Reset, 72 from the example.	
ENTER		72.0		Accepts the change.	
ESCAPE		CRS1			
↓		CRS2	Space T Full Reset Temp	Space Temperature where full temperature reset, DGRC is required.	
ENTER		0		Value of CRS2.	
ENTER		0		Flashing to indicate Edit mode	
↑		68.0		Value of full Temperature Reset, 68 from the example.	
ENTER		68.0		Accepts the change.	
ESCAPE		CRS2			
↓		DGRC	Degrees Cool Reset	Amount of temperature reset required.	
ENTER		0		Value of DGRC	
ENTER		0		Flashing to indicate Edit mode	
↑		6.0		Amount of Temperature Reset required, 6 from the example.	
ENTER	6.0		Accepts the change.		
ESCAPE	DGRC				

NOTE: **Bold** values indicate sub-mode level.

**Table 24 — 4 to 20 mA Temperature Reset Configuration**

MODE	KEYPAD ENTRY	DISPLAY	ITEM EXPANSION	COMMENT	
<b>CONFIGURATION</b>	ENTER	<b>DISP</b>			
	↓	<b>UNIT</b>			
	↓	<b>SERV</b>			
	↓	<b>OPTN</b>			
	↓	<b>RSET</b>	Reset Cool and Heat Tmp		
	ENTER	CRST	Cooling Reset Type		
	ENTER	0	No Reset		
	ENTER	0	No Reset	Flashing to indicate Edit mode. May require Password	
	↓ / ↑	3	4-20 mA Input	Use up or down arrows to change value to 3.	
	ENTER	3		Accepts the change.	
	ESCAPE	CRST			
	ESCAPE			At mode level	
	<b>SETPOINTS</b>	↓ / ↑			Change to Setpoints Mode
		ENTER	<b>COOL</b>	Cooling Setpoints	
ENTER		CSP.1	Cooling Setpoint 1		
↓ x 2		CSP.3	Cooling Setpoint 3		
↓		CRV1	Current No Reset Val	Outdoor Temperature where no temperature reset is required.	
ENTER		0		Value of CRV1	
ENTER		0		Flashing to indicate Edit mode	
↑		4.0		Value of No Temperature Reset, 4 from the example.	
ENTER		4.0		Accepts the change.	
ESCAPE		CRV1			
↓		CRV2	Current Full Reset Val	Current value where full temperature reset, DGRC is required.	
ENTER		0		Value of CRV2.	
ENTER		0		Flashing to indicate Edit mode	
↑		20.0		Value of full Temperature Reset, 20 from the example.	
ENTER		20.0		Accepts the change.	
ESCAPE		CRV2			
↓ x 6		CRS2			
↓		DGRC	Degrees Cool Reset	Amount of temperature reset required.	
ENTER		0		Value of DGRC	
ENTER		0		Flashing to indicate Edit mode	
↑		5.0		Amount of Temperature Reset required, 5 from the example.	
ENTER		5.0		Accepts the change.	
ESCAPE		DGRC			

NOTE: **Bold** values indicate sub-mode level.

**Table 25 — 2-Step Demand Limit Configuration**

MODE	KEYPAD ENTRY	DISPLAY	ITEM EXPANSION	COMMENT
<b>CONFIGURATION</b>	ENTER	<b>DISP</b>		
	↓	<b>UNIT</b>		
	↓	<b>SERV</b>		
	↓	<b>OPTN</b>		
	↓	<b>RSET</b>	Reset Cool and Heat Tmp	
	ENTER	<b>CRST</b>		
	↓	<b>HRST</b>		
	↓	<b>DMDC</b>	Demand Limit Select	
	ENTER	0	None	
	ENTER	0	None	Flashing to indicate Edit mode. May require Password
	↓ / ↑	1	Switch	Use up or down arrows to change value to 1.
	ENTER	1		Accepts the change.
	ESCAPE	<b>DMDC</b>		
	ESCAPE			At mode level
	<b>SETPOINTS</b>	↓ / ↑		
ENTER		<b>COOL</b>	Cooling Setpoints	
↓		<b>HEAT</b>		
↓		<b>MISC</b>	Miscellaneous Setpoints	
ENTER		<b>DLS1</b>	Switch Limit Setpoint 1	
ENTER		0	None	Current value for DLS1.
ENTER		0	None	Flashing to indicate Edit mode. May require Password
↑		60	Switch	Use arrows to change value to 60 from the example.
ENTER		60		Accepts the change.
ESCAPE		<b>DLS1</b>		
↓		<b>DLS2</b>	Switch Limit Setpoint 2	
ENTER		0		Current value of DLS2
ENTER		0		Flashing to indicate Edit mode
↑		40		Use arrows to change the value for DLS2 to 40 from the example.
ENTER		40		Accepts the change.
ESCAPE		<b>DLS2</b>		
ESCAPE x 2		<b>DGRC</b>	<b>SETPOINTS</b>	

NOTE: **Bold** values indicate sub-mode level.

**EXTERNALLY POWERED (4 to 20 mA Controlled)** — The Energy Management Module is required for 4 to 20 mA demand limit control. To configure demand limit for 4 to 20 mA control three parameters must be configured. They are: Demand Limit Select (*Configuration* → *RSET* → *DMDC*), mA for 100% Demand Limit (*Configuration* → *RSET* → *DMMX*) and mA for 0% Demand Limit (*Configuration* → *RSET* → *DMZE*). In the following example, a 4 mA signal is Demand Limit 100% and a 20 mA Demand Limit signal is 0%. The 4 to 20 mA signal is connected to TB6-1 and TB6-2. The demand limit is a linear interpolation between the two values entered. See Table 26 and Fig. 21.

In Fig. 21, if the machine receives a 12 mA signal, the machine controls will limit the capacity to 50%.

**CCN LOADSHED CONTROLLED** — To configure Demand Limit for CCN Loadshed control the unit Operating Type Control must be in CCN control, (*Operating Modes* → *SLCT* → *SP.SE=2*) and be controlled by a Chillervisor module. The Chillervisor module can force the demand limit variable and directly control the capacity of the machine. Additionally, the unit's set point will be artificially lowered to force the chiller to load to the demand limit value.

**Remote Alarm and Alert Relays** — The 30XA chiller can be equipped with a remote alert and remote alarm annunciator contacts. Both relays connected to these contacts must be rated for a maximum power draw of 10 va sealed, 25 va inrush at 24 volts. The alarm relay, indicating that the complete unit has been shut down can be connected to TB5-12 and TB5-13. Refer to unit wiring diagrams. For an alert relay, indicating that at least 1 circuit is off due to the alert, a field-supplied and installed relay must be connected between MBB-J3-CH25-3 and TB5-13.

<b>⚠ CAUTION</b>
Care should be taken when interfacing with other control systems due to possible power supply differences such as a full wave bridge versus a half wave rectification. Connection of control devices with different power supplies may result in permanent damage. <i>ComfortLink™</i> controls incorporate power supplies with half wave rectification. A signal isolation device should be utilized if the signal generator incorporates a full wave bridge rectifier.

**Table 26 — Externally Powered Demand Limit Configuration**

MODE	KEYPAD ENTRY	DISPLAY	ITEM EXPANSION	COMMENT
CONFIGURATION	ENTER	DISP		
	↓	UNIT		
	↓	SERV		
	↓	OPTN		
	↓	RSET	Reset Cool and Heat Tmp	
	ENTER	CRST		
	↓	HRST		
	↓	DMDC	Demand Limit Select	
	ENTER	0	None	
	ENTER	0	None	Flashing to indicate Edit mode. May require Password
	↑	2	4-20 mA Input	Use up arrows to change value to 2.
	ENTER	2		Accepts the change.
	ESCAPE	DMDC		
	↓	DMMX	mA for 100% Demand Limit	
	ENTER	0		
	ENTER	0		Flashing to indicate Edit mode
	↑	4.0		Use up arrows to change the value to 4.
	ESCAPE	DMMX		
	↓	DMZE	mA for 0% Demand Limit	
	ENTER	0		
	ENTER	0		Flashing to indicate Edit mode
	↑	20.0		Use up arrows to change value to 20.
	ESCAPE	DMZE		

NOTE: **Bold** values indicate sub-mode level.

## 4-20 mA Demand Limit

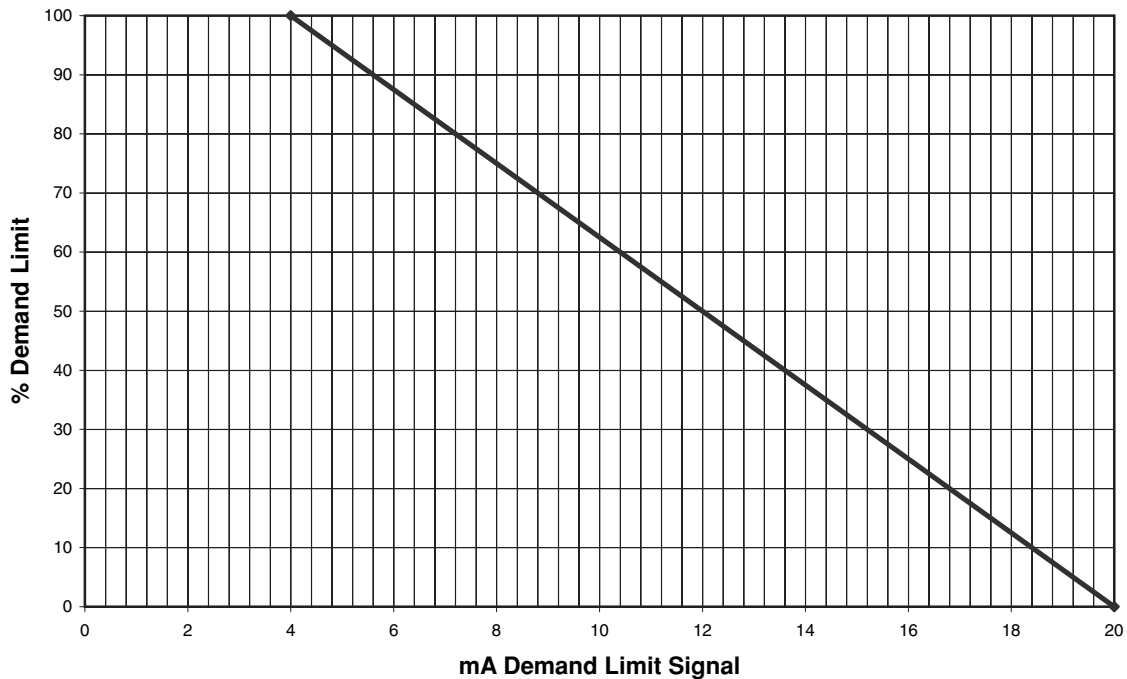


Fig. 21 — Demand Limit

### PRE-START-UP

**IMPORTANT:** Complete the Start-Up Checklist for 30XA Liquid Chillers at the end of this publication.

The Checklist assures proper start-up of a unit, and provides a record of unit condition, application requirements, system information, and operation at initial start-up.

Do not attempt to start the chiller until the following checks have been completed.

#### System Check

1. Check auxiliary components, such as the chilled fluid circulating pump, air-handling equipment, or other equipment to which the chiller supplies liquid are operational. Consult manufacturer's instructions. If the unit has field-installed accessories, be sure all are properly installed and wired correctly. Refer to unit wiring diagrams.
2. Open compressor suction (if equipped) and discharge shutoff valves.
3. Open liquid line, oil line, and economizer service valves.
4. Fill the chiller fluid circuit with clean water (with recommended inhibitor added) or other non-corrosive fluid to be cooled. Bleed all air out of high points of system. An air vent is included with the cooler. If outdoor temperatures are expected to be below 32 F (0° C), sufficient inhibited propylene glycol or other suitable corrosion inhibited antifreeze should be added to the chiller water circuit to prevent possible freeze-up.
5. Check tightness of all electrical connections.
6. Electrical power source must agree with unit nameplate.
7. Oil separator heaters must be firmly seated under the oil separator, and must be energized for 24 hours prior to start-up.
8. Verify power supply phase sequence. Fan motors are 3 phase. Check rotation of fans by using the quick test. Fan rotation is counterclockwise as viewed from top of unit. If fan is not turning counterclockwise, reverse 2 of the power wires at the main terminal block.
9. Perform service test to verify proper operation.

are expected to be below 32 F (0° C), sufficient inhibited propylene glycol or other suitable corrosion inhibited antifreeze should be added to the chiller water circuit to prevent possible freeze-up.

The chilled water loop must be cleaned before the unit is connected. Units supplied with the accessory hydronic package include a run-in screen. If the run-in screen is left in the suction guide/strainer, it is recommended that the Service Maintenance be set to alert the operator within 24 hours of start-up to be sure that the run-in screen in the suction guide/strainer is removed. To set the time for the parameter, go to **Time Clock** → **MCFG** → **W.FIL**. Values for this item are counted as days. Refer to the hydronic pump package literature if unit is equipped with the optional hydronic pump package.

## START-UP

### ⚠ CAUTION

Do not manually operate contactors. Serious damage to the machine may result.

**Actual Start-Up** — *Actual start-up should be done only under supervision of a qualified refrigeration technician.*

1. Be sure all oil, discharge, suction service valves (if equipped) and liquid line service valves are open.
2. Using the Navigator™ display, set leaving-fluid set point (**Set Point** → **COOL** → **CSP.1**). No cooling range adjustment is necessary.
3. If optional control functions or accessories are being used, the unit must be properly configured. Refer to Configuration Options section for details.
4. Complete the Start-Up Checklist to verify all components are operating properly.
5. Turn Enable/Off/Remote contact switch to Enable position.
6. Allow unit to operate and confirm that everything is functioning properly. Check to see that leaving fluid temperature agrees with leaving set point Control Point (**Run Status** → **VIEW** → **CTPT**).

## Operating Limitations

**TEMPERATURES** — Unit operating temperature limits are listed in Table 27.

**Table 27 — Temperature Limits for Standard Units**

TEMPERATURE	F	C
Maximum Ambient Temperature	125	52
Minimum Ambient Temperature	32	0
Maximum Cooler EWT*	95	35
Maximum Cooler LWT	60	15
Minimum Cooler LWT†	40	4.4

### LEGEND

**EWT** — Entering Fluid (Water) Temperature  
**LWT** — Leaving Fluid (Water) Temperature

\*For sustained operation, EWT should not exceed 85 F (29.4 C).  
 †Unit requires brine modification for operation below this temperature.

**Low Ambient Temperature Operation** — If unit operating temperatures below 32 F (0° C) are expected, refer to separate unit installation instructions for low ambient temperature operation using accessory low ambient temperature head pressure control, if not equipped. Contact your Carrier representative for details.

**NOTE:** If wind velocity is expected to be greater than 5 mph (8 km/h) wind baffles and brackets must be field-fabricated and installed for all units using accessory low ambient head pressure control. See the 30XA Installation Instructions or the low ambient temperature head pressure control accessory installation instructions for more information.

### ⚠ CAUTION

Brine duty application (below 40 F [4.4 C] LCWT) for chiller normally requires factory modification. Contact a Carrier Representative for details regarding specific applications. Operation below 40 F (4.4 C) LCWT without modification can result in compressor failure.

## VOLTAGE

**Main Power Supply** — Minimum and maximum acceptable supply voltages are listed in the Installation Instructions.

**Unbalanced 3-Phase Supply Voltage** — Never operate a motor where a phase imbalance between phases is greater than 2%.

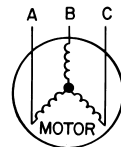
To determine percent voltage imbalance:

$$\% \text{ Voltage Imbalance} = 100 \times \frac{\text{max voltage deviation from avg voltage}}{\text{average voltage}}$$

The maximum voltage deviation is the largest difference between a voltage measurement across 2 legs and the average across all 3 legs.

Example: Supply voltage is 240-3-60.

AB = 243v  
 BC = 236v  
 AC = 238v



1. Determine average voltage:

$$\begin{aligned} \text{Average voltage} &= \frac{243+236+238}{3} \\ &= \frac{717}{3} \\ &= 239 \end{aligned}$$

2. Determine maximum deviation from average voltage:

(AB) 243 – 239 = 4 v  
 (BC) 239 – 236 = 3 v  
 (AC) 239 – 238 = 1 v

Maximum deviation is 4 v.

3. Determine percent voltage imbalance:

$$\begin{aligned} \% \text{ Voltage Imbalance} &= 100 \times \frac{4}{239} \\ &= 1.7\% \end{aligned}$$

This voltage imbalance is satisfactory as it is below the maximum allowable of 2%.

**IMPORTANT:** If the supply voltage phase imbalance is more than 2%, contact the local electric utility company immediately. Do not operate unit until imbalance condition is corrected.

**MINIMUM FLUID LOOP VOLUME** — To obtain proper temperature control, loop fluid volume must be at least 3 gallons per ton (3.25 L per kW) of chiller nominal capacity for air conditioning and at least 6 gallons per ton (6.5 L per kW) for process applications or systems that must operate at low ambient temperatures (below 32 F [0° C]). Refer to application information in Product Data literature for details.

**FLOW RATE REQUIREMENTS** — Standard chillers should be applied with nominal flow rates within those listed in the Minimum and Maximum Cooler Flow Rates table. Higher or lower flow rates are permissible to obtain lower or higher temperature rises. Minimum flow rates must be exceeded to assure turbulent flow and proper heat transfer in the cooler. See Table 28. See Fig. 22A-22C for cooler pressure drop curves.

### ⚠ CAUTION

Operation below minimum flow rate could generate alarms, which could result in damage to the cooler.

Consult application data section in the Product Data literature and job design requirements to determine flow rate requirements for a particular installation.

**Table 28 — 30XA Minimum and Maximum Cooler Flow Rates**

ITEM			MINIMUM		MAXIMUM		NOMINAL	
Cooler Leaving Water Temperature*			40 F (4.4 C)		60 F (15 C)		—	
Cooler Entering Water Temperature†			45 F (7.2 C)		70 F (21.1 C)		—	
30XA UNIT SIZE	Cooler	Number of Passes	Minimum Flow Rate		Maximum Flow Rate		Nominal Flow Rate	
			(gpm)	(L/s)	(gpm)	(L/s)	(gpm)	(L/s)
080	Standard	2	95	6.0	379	23.9	180.4	11.4
	Plus one pass	3	43	2.7	192	12.1		
	Minus one pass	1	196	12.4	782	49.3		
090	Standard	2	101	6.4	403	25.4	201.9	12.7
	Plus one pass	3	43	2.7	200	12.6		
	Minus one pass	1	229	14.4	917	57.9		
100	Standard	2	101	6.4	403	25.4	225.5	14.2
	Plus one pass	3	43	2.7	200	12.6		
	Minus one pass	1	229	14.4	917	57.9		
110	Standard	2	125	7.9	501	31.6	244.9	15.5
	Plus one pass	3	61	3.8	244	15.4		
	Minus one pass	1	254	16.0	1014	64.0		
120	Standard	2	125	7.9	501	31.6	264.8	16.7
	Plus one pass	3	73	4.6	293	18.5		
	Minus one pass	1	281	17.7	1124	70.9		
140	Standard	2	134	8.5	538	33.9	317.8	20.1
	Plus one pass	3	73	4.6	293	18.5		
	Minus one pass	1	324	20.4	1296	81.8		
160	Standard	2	165	10.4	660	41.6	365.1	23.0
	Plus one pass	3	98	6.2	391	24.7		
	Minus one pass	1	354	22.3	1418	89.5		
180	Standard	2	202	12.7	807	50.9	409.6	25.8
	Plus one pass	3	73	4.6	391	24.7		
	Minus one pass	1	416	26.2	1662	104.9		
200	Standard	2	223	14.1	892	56.3	463.9	29.3
	Plus one pass	3	98	6.2	391	24.7		
	Minus one pass	1	458	28.9	1833	115.6		
220	Standard	2	235	14.8	941	59.4	505.9	31.9
	Plus one pass	3	122	7.7	489	30.9		
	Minus one pass	1	501	31.6	2004	126.4		
240	Standard	2	266	16.8	1063	67.1	545.8	34.4
	Plus one pass	3	147	9.3	587	37.0		
	Minus one pass	1	538	33.9	2151	135.7		
260	Standard	2	257	16.2	1027	64.8	600.3	37.9
	Plus one pass	3	141	8.9	562	35.5		
	Minus one pass	1	584	36.8	2334	147.3		
280	Standard	2	293	18.5	1173	74.0	642.2	40.5
	Plus one pass	3	141	8.9	562	35.5		
	Minus one pass	1	620	39.1	2481	156.5		
300	Standard	2	327	20.6	1308	82.5	687.5	43.4
	Plus one pass	3	174	11.0	697	44.0		
	Minus one pass	1	687	43.3	2750	173.5		
325	Standard	2	361	22.8	1442	91.0	733.4	46.3
	Plus one pass	3	211	13.3	843	53.2		
	Minus one pass	1	724	45.7	2897	182.8		
350	Standard	2	379	23.9	1516	95.6	775.4	48.9
	Plus one pass	3	244	15.4	978	61.7		
	Minus one pass	1	767	48.4	3068	193.6		
400	Standard	1	501	31.6	2004	126.4	917.6	57.9
	Plus one pass	—	—	—	—	—		
	Minus one pass	—	—	—	—	—		
450	Standard	1	501	—	2004	—	1019.3	64.3
	Plus one pass	—	—	—	—	—		
	Minus one pass	—	—	—	—	—		
500	Standard	1	501	—	2004	—	1092.8	68.9
	Plus one pass	—	—	—	—	—		
	Minus one pass	—	—	—	—	—		

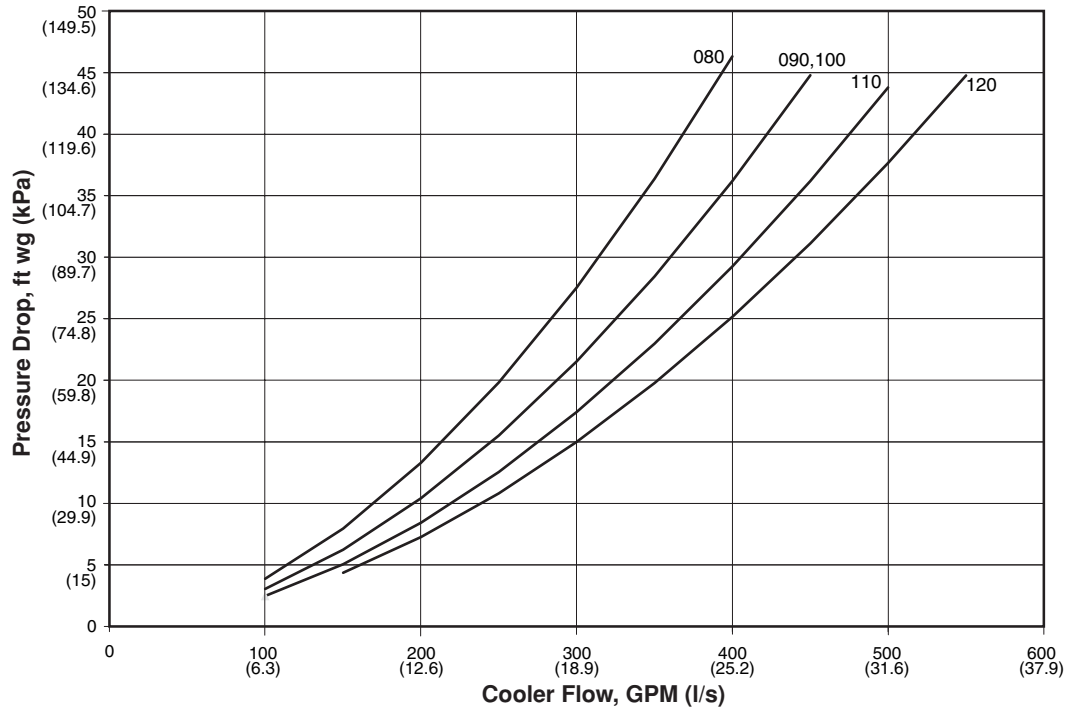
\*For applications requiring cooler leaving water temperature operation at less than 40 F (4.4 C), the units require the use of antifreeze and application may require one of the special order brine option. Contact a local Carrier representative for more information.

†For applications requiring cooler entering water temperature operation at less than 45 F (7.2 C), contact a local Carrier representative for unit selection using the Carrier electronic catalog.

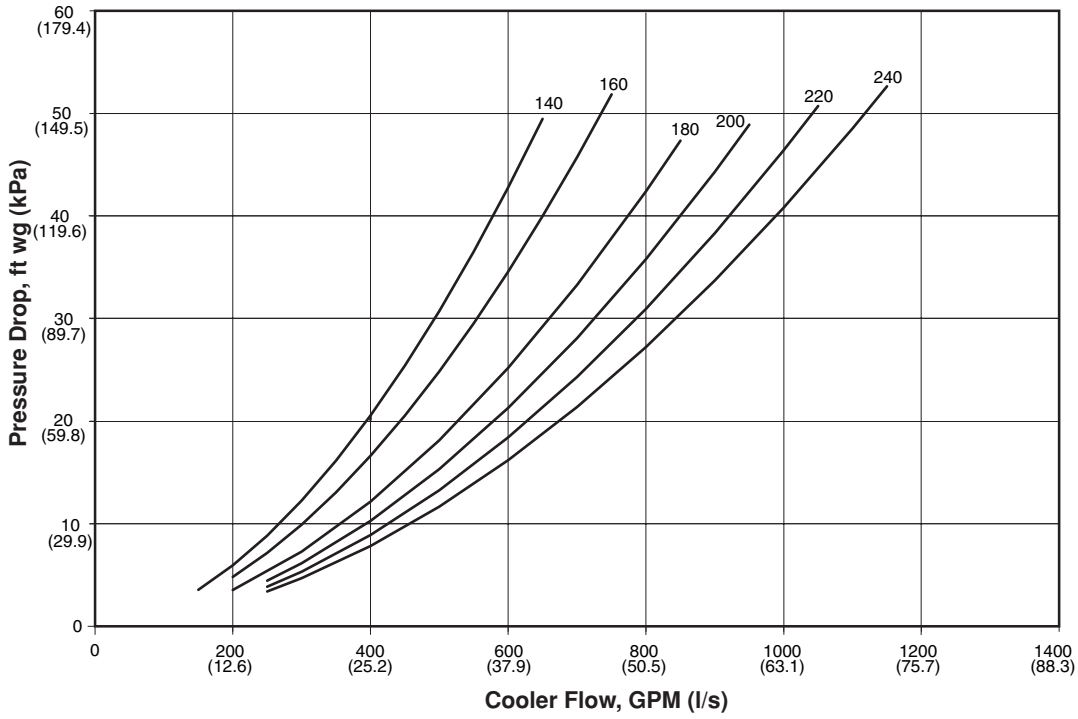
**NOTES:**

1. The 30XA units will start with loop temperatures up to 95 F (35 C).
2. Nominal flow rates required at ARI conditions 44 F (7 C) leaving fluid temperature, 54 F (12 C) entering water temperature, 95 F (35 C) ambient. Fouling factor 0.00010 ft<sup>2</sup>-hr-F/Btu (0.000018 m<sup>2</sup>-K/kW).
3. To obtain proper temperature control, cooler loop fluid volume must be at least 3 gal/ton (3.23 L/kW) of chiller nominal capacity for air conditioning and at least 6 gal/ton (6.5 L/kW) for process applications or systems that must operate in low ambient temperatures (below 32 F [0° C]).

**30XA080-120**

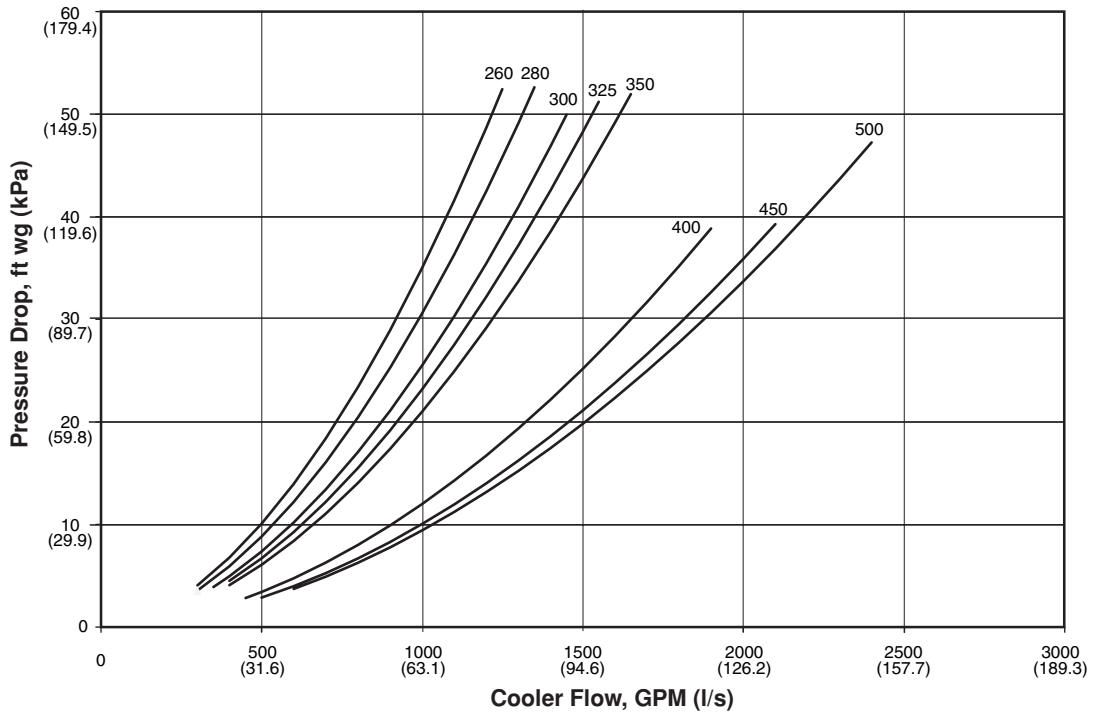


**30XA140-240**



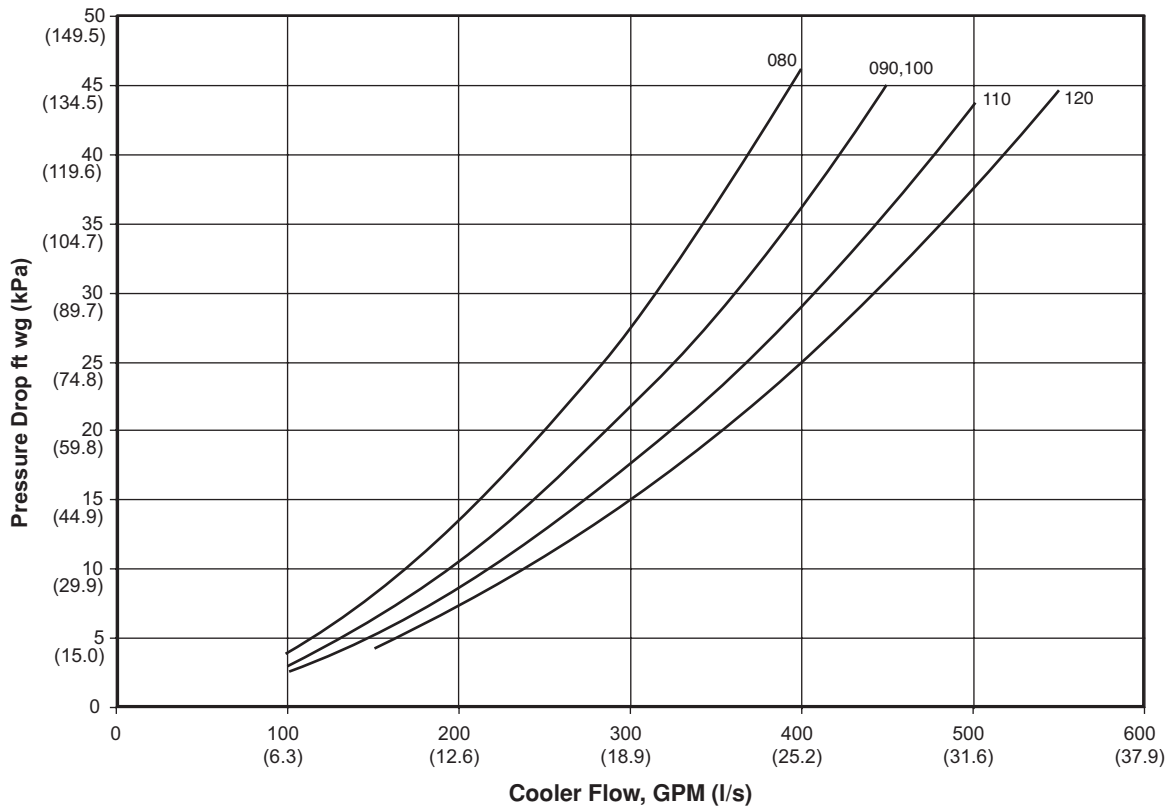
**Fig. 22A — Cooler Pressure Drop Curves, Standard**

**30XA260-500**



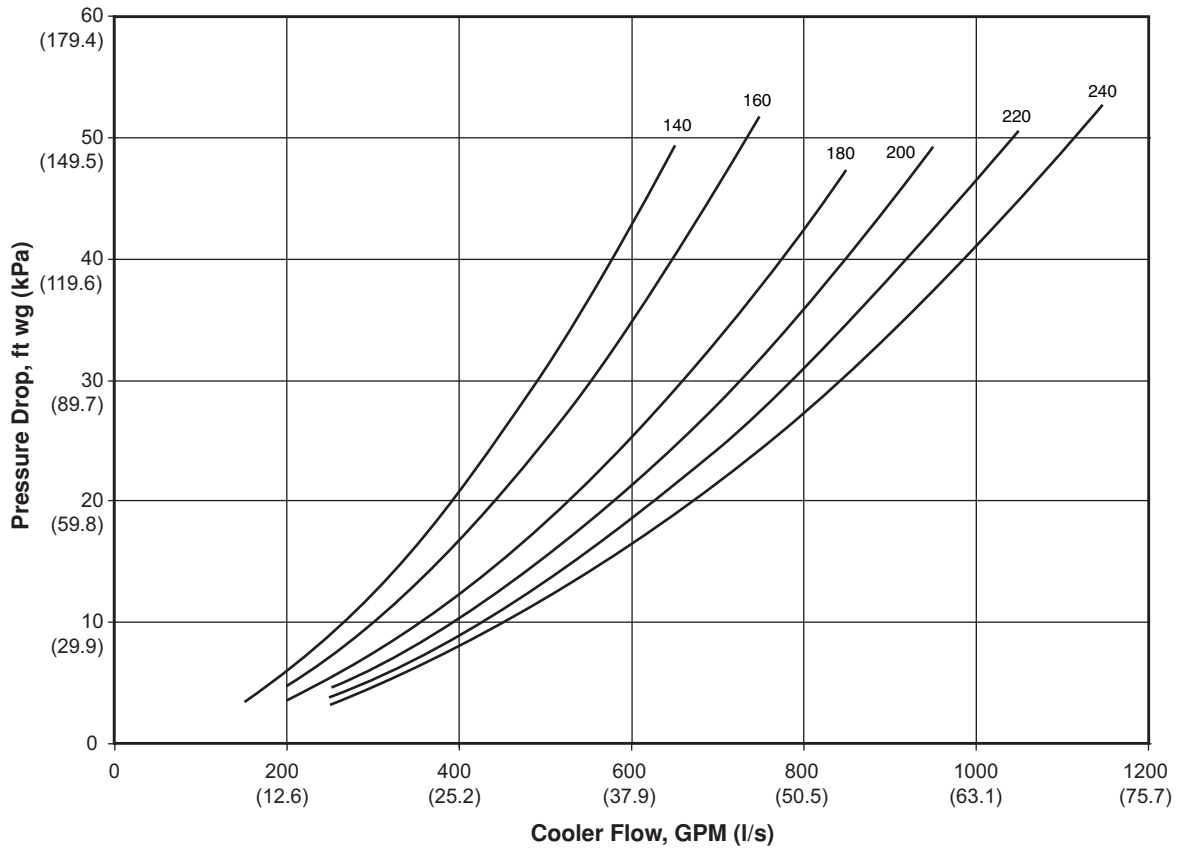
**Fig. 22A — Cooler Pressure Drop Curves, Standard (cont)**

**30XA080-120**

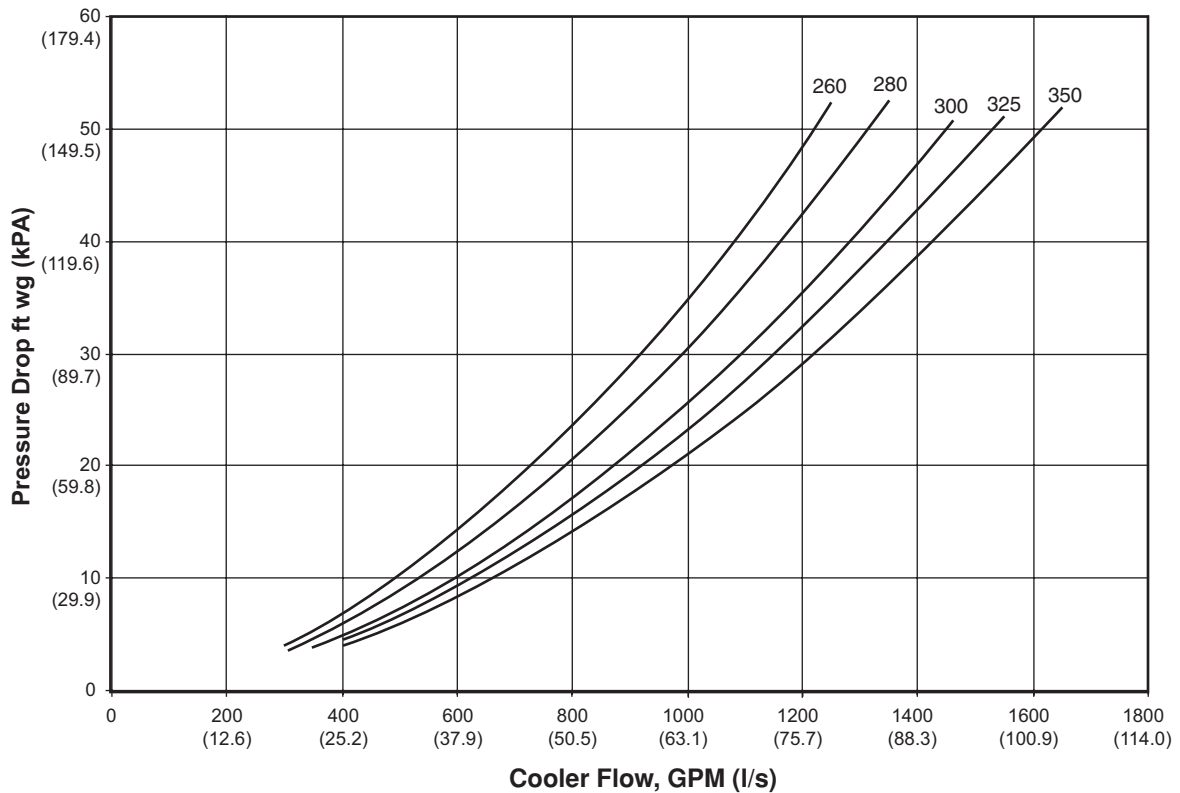


**Fig. 22B — Cooler Pressure Drop Curves, Plus One-Pass**

**30XA140-240**



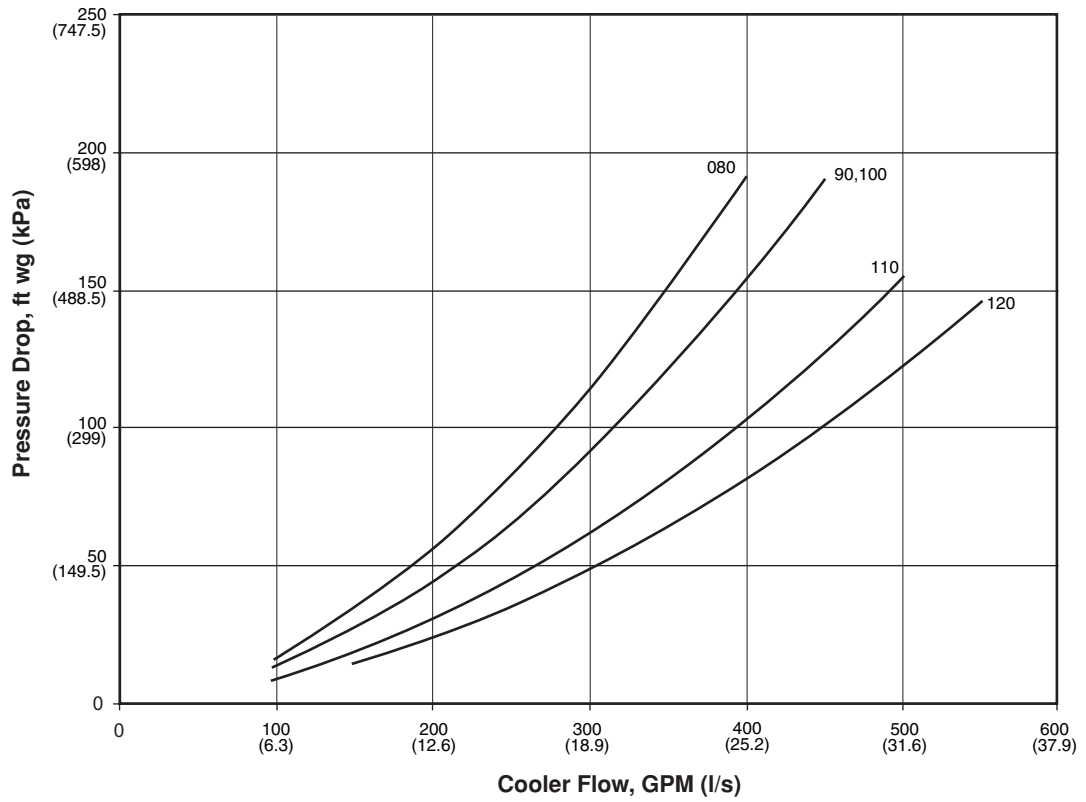
**30XA260-350**



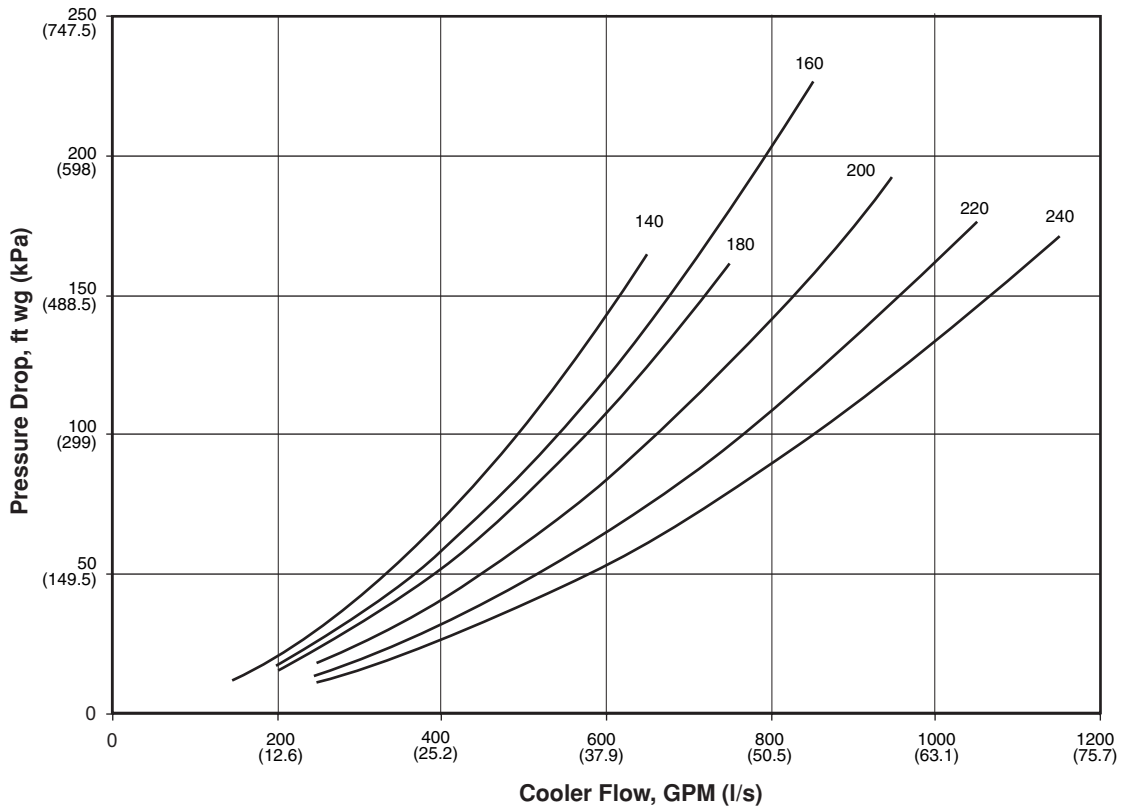
NOTE: Plus-one-pass coolers are not available for 30XA400-500 units.

**Fig. 22B — Cooler Pressure Drop Curves, Plus One-Pass (cont)**

**30XA080-120**



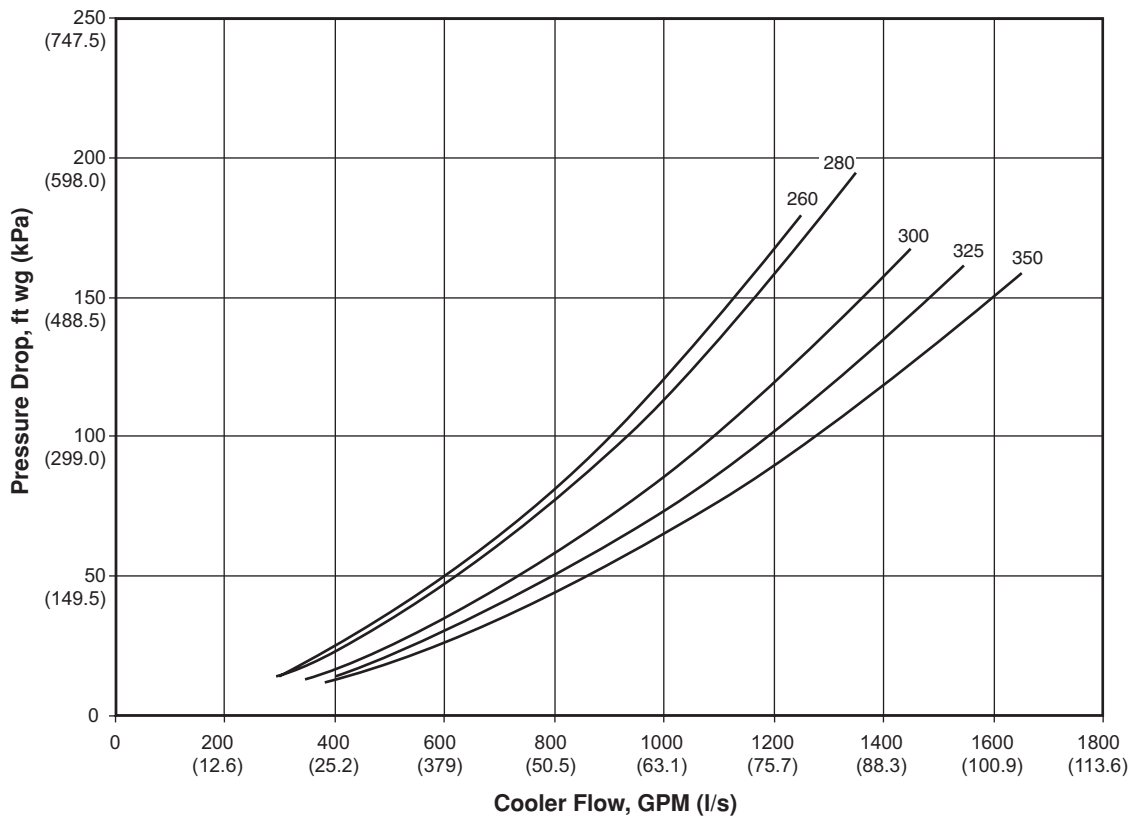
**30XA140-240**



NOTE: Minus-one-pass coolers are not available for 30XA400-500 units.

**Fig. 22C — Cooler Pressure Drop Curves, Minus One-Pass**

## 30XA260-500



NOTE: Minus-one-pass coolers are not available for 30XA400-500 units.

**Fig. 22C — Cooler Pressure Drop Curves, Minus One-Pass (cont)**

## OPERATION

**Sequence of Operation** — With a command to start the chiller, the cooler pump will start. After verifying water flow, the control will monitor the entering and leaving water temperature. If the need for mechanical cooling is determined, the control decides which circuit and compressor to start. The control will start the required compressor completely unloaded and deenergize the oil separator heater (if already energized). The control will continue to load this circuit by moving the slide valve to satisfy cooling requirements. Once fully loaded, the control will start additional circuits to satisfy the load as required. Shutdown of each circuit under normal conditions occurs in the opposite sequence to loading. Once the A circuit is fully unloaded the compressor is shut off and the EXV will close completely.

If the outside air temperature is less than the brine freeze point plus 17° F (9.4° C) then the circuit will perform a pump down cycle. The EXV will be closed and the compressor continued to operate until the saturated suction temperature (SST) is 10° F (5.6° C) lower than the starting SST or 10° F (5.6° C) less than the brine freeze point. Once the compressor is shut off the actuated ball valve (located in the discharge line) will be closed.

**ACTUATED BALL VALVE (ABV)** — There is either one or two discharge ABVs located in the discharge line of each circuit of the unit. See Fig. 23 for a typical ABV assembly with enclosure. The ABV is a motorized ball valve, which is used to close the discharge line to prevent refrigerant migrating from condenser to the cooler when the circuit is off. The valve will

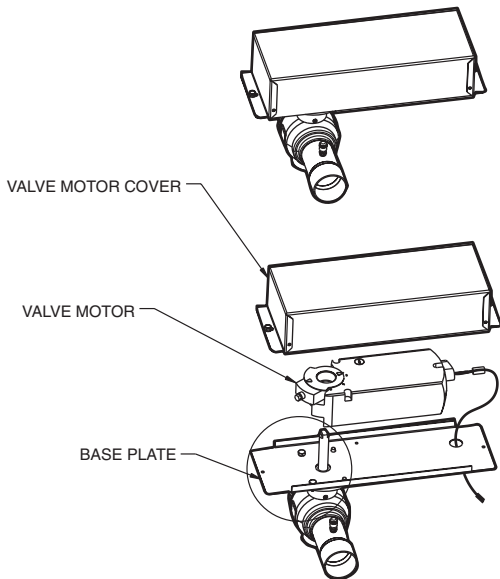
be opened before the compressor is started and will normally close when pressure equalizes between suction and discharge lines. If the outside air temperature is less than the brine freeze point plus 17° F (9.4° C) then the valve will close immediately without waiting for pressure equalization.

See Fig. 24 for a view of a fully open ball valve with the actuator removed. The flat surface at the top of the valve shaft is parallel to the discharge line. The ball valve motor mounting plate should be perpendicular to the discharge line at all times. If not, adjust it by loosening the set screw on the side of the valve, reposition assembly and tighten set screw.

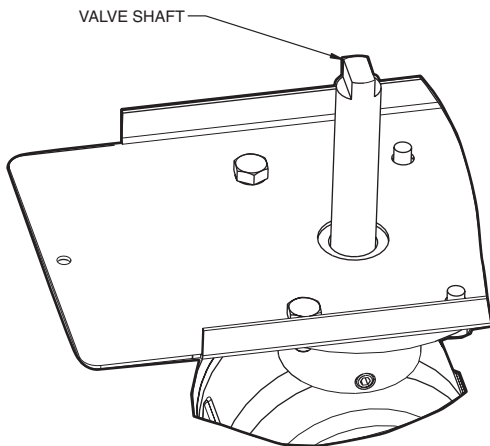
See Fig. 25 for a view of the ball valve motor mounting with a fully open valve. The motor actuator arm should be at a counterclockwise position, with the valve shaft in a parallel position. If not in a parallel position, loosen the clamping screw and push the disengagement button to rotate the actuator arm until it stops. Retighten the clamping screw.

**ABV Manual Operation** — The ABV can be operated manually as a discharge service valve by completing the following steps:

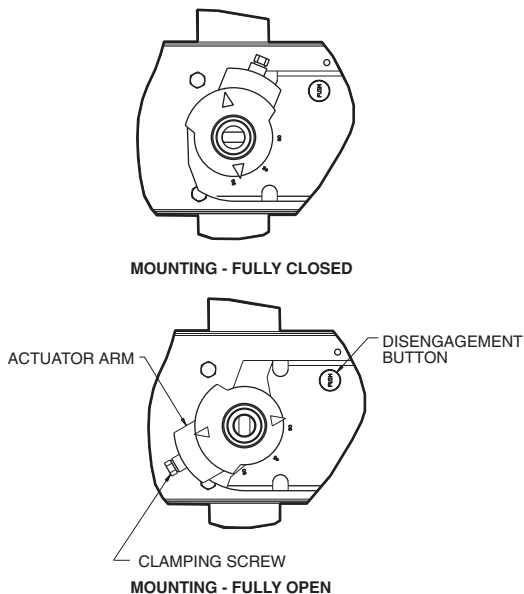
1. Remove the actuator cover.
2. With the compressor off hold down the **Push** button.
3. Close the ABV by turning the shaft adapter by hand or with a wrench so that the flats on the end of the shaft are perpendicular to the discharge line.
4. Release the **Push** button.



**Fig. 23 — Typical ABV Assembly with Enclosure**



**Fig. 24 — Fully Open Ball Valve with Actuator Removed**



**Fig. 25 — Ball Valve Motor**

**Dual Chiller Sequence of Operation** — With a command to start the chiller, the master chiller determines which chiller will become the lead chiller based on the configuration of *Configuration*→*RSET*→*LLBL* and *Configuration*→*RSET*→*LLBD*. The lead chiller is always started first and the lag chiller is held at zero percent capacity by the master chiller forcing the lag demand limit value to 0%. If Lead Pulldown Time (*Configuration*→*RSET*→*LPUL*) has been configured, the lead chiller will continue to operate alone for that specified time. After the Lead Pulldown Time (*Configuration*→*RSET*→*LPUL*) timer has elapsed and when the lead chiller is fully loaded, either all available compression is on or at the master demand limit value, then the lag start timer (*Configuration*→*RSET*→*LLDY*) is initiated. When the pulldown timer and lag start timer has elapsed and the Combined Leaving Chilled Water Temperature is more than 3° F (1.7° C) above the set point, then the lag chiller is started. If the lag chiller's water pump was not started when the machines went into occupied mode, the lag chiller water pump will be started. The lag chiller will start with the master chiller forcing the lag chiller demand limit value (LAG\_LIM) to the master's demand limit value. If lead/lag capacity balance is selected, once the lag chiller has started, the master shall try to keep the difference in capacity between lead and lag less than 20%. The master shall then be responsible for water loop capacity calculation, and will determine which chiller, the lead or lag, will increase or decrease capacity. When the load reduces, the lag chiller will be the first chiller to unload. To accomplish this, the lead chiller set point is decreased by 4° F (-2.2° C) until the lag chiller unloads.

To configure the two chillers for dual chiller operation, follow the example shown Dual Chiller Control section. Both chillers must have the Control Method variable (*Operating Modes*→*SLCT*→*OPER*) set to 2 (CCN Control). In the example the master chiller will be configured with a CCN address of '1' and the slave chiller with a CCN address of '2' (*Configuration*→*OPTN*→*CCNA*). The master and slave chillers can be addressed from 1 to 239. Each device connected to the network must have its own unique address. Both chillers must have the same CCN Bus Number (*Configuration*→*OPTN*→*CCNB*). Lead/Lag Chiller Enable must be set for both chillers by configuring Master/Slave Select (*Configuration*→*RSET*→*MSSL*). The master chiller Master/Slave Select must be set to 1 (Master). The slave chiller Master/Slave Select must be set to 2 (Slave). Also in this example, the master chiller will be configured to use Lead/Lag Balance (*Configuration*→*RSET*→*LLBL*) to rotate the lead chiller after 168 hours of operation. The Lag Start Delay (*Configuration*→*RSET*→*LLBD*) will be set for 10 minutes. This prevents the Lag chiller from starting until the lead chiller is fully loaded and the delay has elapsed.

**PARALLEL PUMP OPERATION** — For series chiller operation, the pump is always controlled by the master chiller. The lead chiller's water pump will be started. The lag chiller's water pump shall be maintained off if *Configuration*→*RSET*→*LAGP*=0. The internal algorithm of lead chiller will control capacity of the lead chiller.

### Operating Modes

Operating modes correspond to some capacity control overrides in the Capacity Control Override section.

See Table 14 on page 20 for a list of operating modes and which capacity control override (if any) applies to the following operating modes.

MODE 1 (MD01) — Startup Delay in Effect

*Criteria for Mode* — Tested when the unit is started. This mode is active when the Minutes Off Time (*Configuration*→*OPTN*→*DELY*) timer is active.

*Action Taken* — The unit will not start until the timer has expired.

**Termination** — The mode will terminate when the timer expires.

**Possible Causes** — This mode is in effect only due to the Minutes Off Time timer.

MODE 2 (MD02) — Second Setpoint in Use

**Criteria for Mode** — Tested when the unit is ON. This mode is active when Cooling Setpoint 2 (*Setpoints*→*COOL*→*CSP.2*) or Ice Setpoint (*Setpoints*→*COOL*→*CSP.3*) is in use. While in this mode, the Active Setpoint (*Run Status*→*VIEW*→*SETP*) will show the *CSP.2* or *CSP.3* value.

**Action Taken** — The unit will operate to the Cooling Setpoint 2 (*CSP.2*) or Ice Setpoint (*CSP.3*).

**Termination** — This mode will terminate when the Cooling Setpoint 2 (*CSP.2*) or Ice Setpoint (*CSP.3*) is no longer in use.

**Possible Causes** — This mode is in effect only due to programming options.

MODE 3 (MD03) — Reset in Effect

**Criteria for Mode** — Tested when the unit is ON. This mode is active when Temperature Reset (*Configuration*→*RSET*→*CRST*) is enabled either by *CRST=1* (Outside Air Temperature), *CRST=2* (Return Water), *CRST=3* (4-20 mA Input), or *CRST=4* (Space Temperature) and is active.

**Action Taken** — The Active Setpoint (*Run Status*→*VIEW*→*SETP*) will be modified according to the programmed information and will be displayed as the Control Point (*Run Status*→*VIEW*→*CTPT*).

**Termination** — This mode will terminate when the Temperature Reset is not modifying the active leaving water set point, so *SETP* is the same as *CTPT*.

**Possible Causes** — This mode is in effect only due to programming options.

MODE 4 (MD04) — Demand Limit Active

**Criteria for Mode** — Tested when the unit is ON. This mode is active when Demand Limit (*Configuration*→*RSET*→*DMDC*) is enabled either by *DMDC=1* (Switch), *DMDC=2* (4-20 mA Input) or the Night Time Low Sound Capacity Limit (*Configuration*→*OPTN*→*LS.LT*).

**Action Taken** — The Active Demand Limit Value (*Run Status*→*VIEW*→*LIM*) will display the current demand limit according to the programmed information and the unit's capacity will be reduced to the amount shown or lower.

**Termination** — This mode will terminate when the Demand Limit command has been removed.

**Possible Causes** — This mode is in effect only due to programming options.

MODE 5 (MD05) — Ramp Loading Active

**Criteria for Mode** — Tested when the unit is ON. This mode is active when Ramp Loading (*Configuration*→*OPTN*→*RL.S*) is enabled and the following conditions are met:

1. The leaving water temperature is more than 4° F (2.2° C) from the Control Point (*Run Status*→*VIEW*→*CTPT*), and
2. The rate of change of the leaving water temperature is greater than the Cool Ramp Loading (*Set Points*→*COOL*→*CRMP*).

**Action Taken** — The control will limit the percent capacity increase until one of the two conditions in Mode 5 is no longer true.

**Termination** — This mode will terminate once either conditions in Mode 5 is no longer true.

**Possible Causes** — This mode is in effect only due to programming options.

MODE 6 (MD06) — Cooler Heater Active

**Criteria for Mode** — Tested whether the unit is ON or OFF. This mode is active when the cooler heater is energized, if the

Outdoor Air Temperature (*Temperature*→*UNIT*→*OAT*) is less than the calculated value, (Freeze Setpoint + Cooler Heater Delta T Setpoint [*Configuration*→*SERV*→*HTR*] default - 2° F [1.1° C]) and either the Leaving Water Temperature (*Temperature*→*UNIT*→*LWT*) or the Entering Water Temperature (*Temperature*→*UNIT*→*EWT*) are less than or equal to the Freeze Setpoint + Cooler Heater Delta T Setpoint (*HTR*).

The Freeze Setpoint is 34 F (1.1 C), for fresh water systems (*Configuration*→*SERV*→*FLUD=1*). The Freeze Setpoint is Brine Freeze Setpoint (*Configuration*→*SERV*→*LOSP*), for Medium Temperature Brine systems, (*Configuration*→*SERV*→*FLUD=2*).

**Action Taken** — The cooler heater will be energized.

**Termination** — The cooler heater will be deenergized when both the Entering Water Temperature (*EWT*) and Leaving Water Temperature (*LWT*) are above the Freeze Setpoint + Cooler Heater Delta T Setpoint (*HTR*).

**Possible Causes** — This mode will be enabled for freeze protection. If the temperatures are not as described above, check the accuracy of the outside air, entering and leaving water thermistors.

MODE 7 (MD07) — Cooler Pumps Rotation

**Criteria for Mode** — Tested whether the unit is ON or OFF. This mode is active when the Cooler Pump Sequence (*Configuration*→*OPTN*→*PUMP=2*) (2 Pumps Automatic Changeover) and the Pump Rotation Delta Timer (*Configuration*→*OPTN*→*ROT.P*) has expired.

**Action Taken** — The control will switch the operation of the pumps. The lead pump will be operating normally. The lag pump will be started, becoming the lead, and then the original lead pump will be shut down.

**Termination** — This mode will terminate when the pump operation has been completed.

**Possible Causes** — This mode is in effect only due to programming options.

MODE 8 (MD08) — Pump Periodic Start

**Criteria for Mode** — This mode is active when the cooler pump is started for the Periodic Pump Start configuration (*Configuration Mode*→*OPTN*→*PM.PS=YES*).

**Action Taken** — If the pump has not run that day, a pump will be started and will run for 2 seconds at 2:00 PM. If the machine is equipped with dual pumps, Pump no. 1 will run on even days (such as day 2, 4, 6 of the month). Pump no. 2 will run on odd days (such as day 1, 3, 5 of the month).

**Termination** — This mode will terminate when the pump shuts down.

**Possible Causes** — This mode is in effect only due to programming options.

MODE 9 (MD09) — Night Low Noise Active

**Criteria for Mode** — This mode is active when the Night Time Low Noise Option has been configured and the time is within the configured time. Programming a Night Low Noise Start Time (*Configuration*→*OPTN*→*LS.ST*) and a Night Low Noise End Time (*Configuration Mode*→*OPTN*→*LS.ND*) configures the option.

**Action Taken** — The control will raise the head pressure set point to reduce the number of condenser fans on, thereby reducing the sound of the machine. Additionally, if the Night Time Low Sound Capacity Limit (*Configuration*→*OPTN*→*LS.LT*) has been configured, the unit's capacity will be limited to the programmed level.

**Termination** — This mode will terminate once the Night Low Noise End Time (*LS.ND*) has been reached.

**Possible Causes** — This mode is in effect only due to programming options.

MODE 10 (MD10) — System Manager Active

Criteria for Mode — Tested when the unit is ON or OFF. This mode is active if a System Manager such as Building Supervisor, Chillervisor System Manager, or another CCN device is controlling the machine.

Action Taken — The machine will respond to the specific command received from the System Manager.

Termination — The mode will be terminated if the System Manager control is released.

Possible Causes — This mode is in effect only due to programming options.

MODE 11 (MD11) — Mast Slave Ctrl Active

Criteria for Mode — Tested if the machine is ON. This mode is active if the Master Slave Control has been enabled. Having 2 machines programmed, one as the master (*Configuration* → *RSET* → *MSSL=1* [Master]) and the other as a slave (*Configuration* → *RSET* → *MSSL=2* [Slave]).

Action Taken — Both the master and slave machine will respond to the capacity control commands issued by the master controller. This may include control point changes and demand limit commands.

Termination — This mode will terminate when the Master Slave Control has been disabled.

Possible Causes — This mode is in effect only due to programming options.

MODE 12 (MD12) — Auto Changeover Active

Criteria for Mode — This mode is not supported for Cooling Only units.

Action Taken — None.

Termination — None.

Possible Causes — This mode is in effect only due to programming options.

MODE 13 (MD13) — Free Cooling Active

Criteria for Mode — This mode is not supported for Cooling Only units.

Action Taken — None.

Termination — None.

Possible Causes — This mode is in effect only due to programming options.

MODE 14 (MD14) — Reclaim Active

Criteria for Mode — This mode is not supported for Cooling Only units.

Action Taken — None.

Termination — None.

Possible Causes — This mode is in effect only due to programming options.

MODE 15 (MD15) — Electric Heat Active

Criteria for Mode — This mode is not supported for Cooling Only units.

Action Taken — None.

Termination — None.

Possible Causes — This mode is in effect only due to programming options.

MODE 16 (MD16) — Heating Low EWT Lockout

Criteria for Mode — This mode is not supported for Cooling Only units.

Action Taken — None.

Termination — None.

Possible Causes — This mode is in effect only due to programming options.

MODE 17 (MD17) — Condenser Pumps Rotation

Criteria for Mode — This mode is not supported for Cooling Only units.

Action Taken — None.

Termination — None.

Possible Causes — This mode is in effect only due to programming options.

MODE 18 (MD18) — Ice Mode in Effect

Criteria for Mode — Tested when the unit is ON. This mode is active when Ice Setpoint (*Setpoints* → *COOL* → *CSP.3*) is in use. While in this mode, the Active Setpoint (*Run Status* → *VIEW* → *SETP*) will show the *CSP.3* value.

Action Taken — The unit will operate to the Ice Setpoint (*CSP.3*).

Termination — This mode will terminate when the Ice Setpoint (*CSP.3*) is no longer in use.

Possible Causes — This mode is in effect only due to programming options.

MODE 19 (MD19) — Defrost Active on Cir A

MODE 20 (MD20) — Defrost Active on Cir B

Criteria for Mode — This mode is not supported for Cooling Only units.

Action Taken — None.

Termination — None.

Possible Causes — This mode is in effect only due to programming options.

MODE 21 (MD21) — Low Suction Circuit A

MODE 22 (MD22) — Low Suction Circuit B

MODE 23 (MD23) — Low Suction Circuit C

Criteria for Mode — The criteria are tested when the circuit is ON. The appropriate circuit mode will be active if one of the following conditions is true:

1. If the circuit's saturated suction temperature (SST) is more than 6° F (3.3° C) less than the freeze point and both the cooler approach (Leaving Water Temperature – SST) and superheat (Suction Gas Temperature – SST) are greater than 15° F (8.3° C).
2. If the circuit is ON and the circuit's SST is more than 18° F (10.0° C) below the freeze point for more than 90 seconds.
3. If the circuit's saturated suction temperature is more than 6° F (3.3° C) below the freeze point for more than 3 minutes.

For a fresh water system (*Configuration* → *SERV* → *FLUD=1*), the freeze point is 34° F (1.1° C). For medium temperature brine systems, (*Configuration* → *SERV* → *FLUD=2*), the freeze point is Brine Freeze Set Point (*Configuration* → *SERV* → *LOSP*).

Action Taken — For criterion 1, no additional capacity will be added. For criteria 2 and 3 capacity will be decreased on the circuit.

Termination — The mode will terminate when the circuit's SST is greater than the freeze point minus 6° F (3.3° C) or the circuit has alarmed.

Possible Causes — If this condition is encountered, see Possible Causes for Alarms 56-58 on page 75.

MODE 24 (MD24) — High DGT Circuit A

MODE 25 (MD25) — High DGT Circuit B

MODE 26 (MD26) — High DGT Circuit C

Criteria for Mode — This mode is not supported for Cooling Only units.

**Action Taken** — None.

**Termination** — None.

**Possible Causes** — This mode is in effect only due to programming options.

MODE 27 (MD27) — High Pres Override Cir A

MODE 28 (MD28) — High Pres Override Cir B

MODE 29 (MD29) — High Pres Override Cir C

**Criteria for Mode** — Tested when the circuit is ON. The appropriate circuit mode will be active if the discharge pressure for the circuit, Discharge Pressure Circuit A (**Pressure** → **PRC.A** → **DP.A**), Discharge Pressure Circuit B (**Pressure** → **PRC.B** → **DP.B**), or Discharge Pressure Circuit C (**Pressure** → **PRC.A** → **DP.C**), is greater than the High Pressure Threshold (**Configuration** → **SERV** → **HP.TH**).

**Action Taken** — The capacity of the affected circuit will be reduced. Two minutes following the capacity reduction, the circuit's saturated condensing temperature ( $SCT_{t+2}$ ) is calculated and stored. The affected circuit will not be allowed to add capacity for at least 5 minutes following the capacity reduction. If after 5 minutes, the circuit's saturated condensing temperature is less than  $SCT_{t+2} - 3^\circ \text{F}$  ( $1.7^\circ \text{C}$ ), and then if required, percent capacity will be added.

If additional capacity is required, the control will look for other circuits to add capacity.

**Termination** — This mode will terminate once the circuit's saturated condensing temperature is less than  $SCT_{t+2} - 3^\circ \text{F}$  ( $1.7^\circ \text{C}$ ).

**Possible Causes** — If this condition is encountered, see Possible Causes for Alarm A1.03. on page 80.

MODE 30 (MD30) — Low Superheat Circuit A

MODE 31 (MD31) — Low Superheat Circuit B

MODE 32 (MD32) — Low Superheat Circuit C

**Criteria for Mode** — Tested when the circuit is ON. The appropriate circuit mode will be active if the circuit's superheat (discharge gas temperature — SCT) is less than  $18^\circ \text{F}$  ( $10^\circ \text{C}$ ).

**Action Taken** — No additional capacity will be added until the circuit's superheat is greater than  $18^\circ \text{F}$  ( $10^\circ \text{C}$ ).

The control will look for other circuits to add capacity if additional steps of capacity are required.

**Termination** — This mode will terminate once the affected circuit's superheat is greater than  $18^\circ \text{F}$  ( $10^\circ \text{C}$ ).

**Possible Causes** — If this condition is encountered, see Possible Causes for Alarms P.11, P.12 and P.13 on page 76.

MODE 33 (MD33) — High Compressor Current Circuit A

MODE 34 (MD34) — High Compressor Current Circuit B

MODE 35 (MD35) — High Compressor Current Circuit C

**Criteria for Mode** — Tested when the circuit is ON with at least one compressor ON. The appropriate circuit mode will be active if the circuit's current is great than 79% of MTA value for the compressor.

**Action Taken** — No additional circuit capacity will be added if the circuit's current is greater than 79% of MTA value for the compressor.

If additional capacity is required, the control will look for other circuits to add capacity.

**Termination** — This mode will terminate once the affected circuit compressor current is less than 79% MTA value.

**Possible Causes** — If this condition is encountered, see Possible Causes for Alarms P.11, P.12 and P.13 on page 76.

**Sensors** — The electronic control uses up to 17 thermistors to sense temperatures and up to 12 transducers to sense pressure for controlling chiller operation. These sensors are outlined below.

**THERMISTORS** (Tables 29-30B) — Thermistors that are monitoring the chiller's operation include: Cooler Entering Water, Cooler Leaving Water, Dual Chiller Leaving Water, Compressor Suction Gas Temperature, Compressor Discharge Gas Temperature, Economizer Temperature, Compressor Motor Temperature, and Outdoor Air Temperature Thermistors. These thermistors are  $5 \text{ k}\Omega$  at  $77 \text{ F}$  ( $25 \text{ C}$ ) and are identical in temperature versus resistance. The Space Temperature Thermistor is  $10 \text{ k}\Omega$  at  $77 \text{ F}$  ( $25 \text{ C}$ ) and has a different temperature vs. resistance.

**Cooler Leaving Water Sensor** — On all sizes, this thermistor is installed in a friction fit well in the leaving water nozzle of the cooler. See Fig. 26 and 27.

**Cooler Entering Water Sensor** — On all sizes, this thermistor is factory-installed in a friction fit well in the entering water nozzle of the cooler.

**Compressor Return Gas Temperature** — On all sizes, this thermistor is factory-installed in a friction fit well located on the compressor of each circuit. There is one thermistor for each circuit.

**Compressor Discharge Gas Temperature** — On all sizes, this thermistor is factory-installed in a friction fit well located in the discharge end of the compressor for the circuit. There is one thermistor for each circuit.

**Economizer Temperature** — On all sizes, this thermistor is factory-installed in a friction fit well located in the economizer line for the circuit. There is one thermistor for each circuit.

**Compressor Motor Temperature** — On all sizes, this thermistor is embedded in the motor windings. There are two thermistors in each compressor. One spare is provided.

**Outdoor Air Temperature** — This sensor is factory-installed to the back of the control box.

**Remote Space Temperature** — This sensor (part no. 33ZCT55SPT) is a field-installed accessory mounted in the indoor space and is used for water temperature reset. The sensor should be installed as a wall-mounted thermostat would be (in the conditioned space where it will not be subjected to either a cooling or heating source or direct exposure to sunlight, and 4 to 5 ft above the floor).

Space temperature sensor wires are to be connected to terminals in the unit main control box. See Fig. 28. The space temperature sensor includes a terminal block (SEN) and a RJ11 female connector. The RJ11 connector is used access into the Carrier Comfort Network® (CCN) at the sensor. See Fig. 26 and 27.

To connect the space temperature sensor (see Fig. 28):

1. Using a 20 AWG twisted pair conductor cable rated for the application, connect one wire of the twisted pair to one SEN terminal and connect the other wire to the other SEN terminal located under the cover of the space temperature sensor.
2. Connect the other ends of the wires to terminals 7 and 8 on TB6 located in the unit control box.

Units on the CCN can be monitored from the space at the sensor through the RJ11 connector, if desired. To wire the RJ11 connector into the CCN:

1. Cut the CCN wire and strip ends of the red (+), white (ground), and black (–) conductors. (If another wire color scheme is used, strip ends of appropriate wires.)

2. Insert and secure the red (+) wire to terminal 5 of the space temperature sensor terminal block.
3. Insert and secure the white (ground) wire to terminal 4 of the space temperature sensor.
4. Insert and secure the black (-) wire to terminal 2 of the space temperature sensor.

**IMPORTANT:** The cable selected for the RJ11 connector wiring **MUST** be identical to the CCN communication bus wire used for the entire network. Refer to Table 11 for acceptable wiring.

5. Connect the other end of the communication bus cable to the remainder of the CCN communication bus.

**NOTE:** The Energy Management Module (EMM) is required for this accessory.

**TRANSDUCERS** — There are four pressure transducers per circuit, and two different types of transducers: low pressure (green connector) and high pressure (black connector).

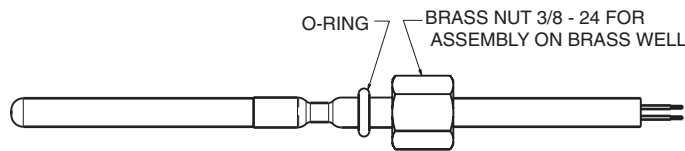
Low Pressure Type: Suction Pressure Transducer (SPT), Economizer Pressure Transducer (EPT).

High Pressure Type: Discharge Pressure Transducer (DPT), Oil Pressure Transducer (OPT). See Fig. 29 for transducer locations.

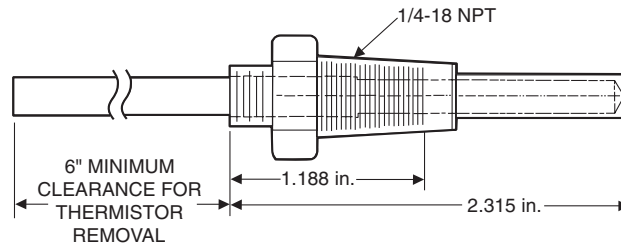
**Table 29 — Thermistor Identification**

THERMISTOR ID	DESCRIPTION	RESISTANCE AT 77 F (25 C)	CONNECTION POINT
EWT	Entering Water Thermistor	5k $\Omega$	MBB-J6-CH2
LWT	Leaving Water Thermistor	5k $\Omega$	MBB-J6-CH1
OAT	Outdoor Air Thermistor	5k $\Omega$	MBB-J6-CH4
SGTA*	Circuit A Suction Gas Thermistor	5k $\Omega$	EXVA-J3-THA
SGTB*	Circuit B Suction Gas Thermistor	5k $\Omega$	EXVB-J3-THA
SGTC	Circuit C Suction Gas Thermistor	5k $\Omega$	EXVC-J3-THA
DGTA	Circuit A Discharge Gas Thermistor	5k $\Omega$	CPM-A-J9-CH02
DGTB	Circuit B Discharge Gas Thermistor	5k $\Omega$	CPM-B-J9-CH02
DGTC	Circuit C Discharge Gas Thermistor	5k $\Omega$	CPM-C-J9-CH02
ECTA	Circuit A Economizer Thermistor	5k $\Omega$	EXVA-J3-THB
ECTB	Circuit B Economizer Thermistor	5k $\Omega$	EXVB-J3-THB
ECTC	Circuit C Economizer Thermistor	5k $\Omega$	EXVC-J3-THB
DUAL	Dual Chiller LWT Thermistor	5k $\Omega$	MBB-J6-CH3
CAMT	Circuit A Motor Temperature	5k $\Omega$	CPM-A-J9-CH01
CBMT	Circuit B Motor Temperature	5k $\Omega$	CPM-B-J9-CH01
CCMT	Circuit C Motor Temperature	5k $\Omega$	CPM-C-J9-CH01
SPT	Space Temperature Thermistor	10k $\Omega$	EMM-J6-CH2

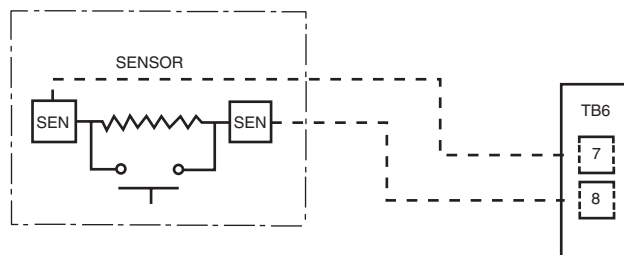
\*SGTA and SGTB for 30XA080 units are connected to the EXVA board.



**Fig. 26 — 5K Thermistor (Sensor 00PG00008105A, Connector: HY06AM016)**



**Fig. 27 — Dual Leaving Water Thermistor Well (00PPG0000800A)**



**Fig. 28 — Typical Remote Space Temperature Sensor (33ZCT55SPT) Wiring**

Table 30A — 5K Thermistor Temperature (°F) vs Resistance

TEMP (F)	RESISTANCE (Ohms)	TEMP (F)	RESISTANCE (Ohms)	TEMP (F)	RESISTANCE (Ohms)
-25	98,010	59	7,686	143	1,190
-24	94,707	60	7,665	144	1,165
-23	91,522	61	7,468	145	1,141
-22	88,449	62	7,277	146	1,118
-21	85,486	63	7,091	147	1,095
-20	82,627	64	6,911	148	1,072
-19	79,871	65	6,735	149	1,050
-18	77,212	66	6,564	150	1,029
-17	74,648	67	6,399	151	1,007
-16	72,175	68	6,238	152	986
-15	69,790	69	6,081	153	965
-14	67,490	70	5,929	154	945
-13	65,272	71	5,781	155	925
-12	63,133	72	5,637	156	906
-11	61,070	73	5,497	157	887
-10	59,081	74	5,361	158	868
-9	57,162	75	5,229	159	850
-8	55,311	76	5,101	160	832
-7	53,526	77	4,976	161	815
-6	51,804	78	4,855	162	798
-5	50,143	79	4,737	163	782
-4	48,541	80	4,622	164	765
-3	46,996	81	4,511	165	750
-2	45,505	82	4,403	166	734
-1	44,066	83	4,298	167	719
0	42,679	84	4,196	168	705
1	41,339	85	4,096	169	690
2	40,047	86	4,000	170	677
3	38,800	87	3,906	171	663
4	37,596	88	3,814	172	650
5	36,435	89	3,726	173	638
6	35,313	90	3,640	174	626
7	34,231	91	3,556	175	614
8	33,185	92	3,474	176	602
9	32,176	93	3,395	177	591
10	31,202	94	3,318	178	581
11	30,260	95	3,243	179	570
12	29,351	96	3,170	180	561
13	28,473	97	3,099	181	551
14	27,624	98	3,031	182	542
15	26,804	99	2,964	183	533
16	26,011	100	2,898	184	524
17	25,245	101	2,835	185	516
18	24,505	102	2,773	186	508
19	23,789	103	2,713	187	501
20	23,096	104	2,655	188	494
21	22,427	105	2,597	189	487
22	21,779	106	2,542	190	480
23	21,153	107	2,488	191	473
24	20,547	108	2,436	192	467
25	19,960	109	2,385	193	461
26	19,393	110	2,335	194	456
27	18,843	111	2,286	195	450
28	18,311	112	2,239	196	445
29	17,796	113	2,192	197	439
30	17,297	114	2,147	198	434
31	16,814	115	2,103	199	429
32	16,346	116	2,060	200	424
33	15,892	117	2,018	201	419
34	15,453	118	1,977	202	415
35	15,027	119	1,937	203	410
36	14,614	120	1,898	204	405
37	14,214	121	1,860	205	401
38	13,826	122	1,822	206	396
39	13,449	123	1,786	207	391
40	13,084	124	1,750	208	386
41	12,730	125	1,715	209	382
42	12,387	126	1,680	210	377
43	12,053	127	1,647	211	372
44	11,730	128	1,614	212	367
45	11,416	129	1,582	213	361
46	11,112	130	1,550	214	356
47	10,816	131	1,519	215	350
48	10,529	132	1,489	216	344
49	10,250	133	1,459	217	338
50	9,979	134	1,430	218	332
51	9,717	135	1,401	219	325
52	9,461	136	1,373	220	318
53	9,213	137	1,345	221	311
54	8,973	138	1,318	222	304
55	8,739	139	1,291	223	297
56	8,511	140	1,265	224	289
57	8,291	141	1,240	225	282
58	8,076	142	1,214		

Table 30B — 5K Thermistor Temperature (°C) vs Resistance/Voltage

TEMP (C)	RESISTANCE (Ohms)	TEMP (C)	RESISTANCE (Ohms)	TEMP (C)	RESISTANCE (Ohms)
-32	100,260	15	7,855	62	1,158
-31	94,165	16	7,499	63	1,118
-30	88,480	17	7,161	64	1,079
-29	83,170	18	6,840	65	1,041
-28	78,125	19	6,536	66	1,006
-27	73,580	20	6,246	67	971
-26	69,250	21	5,971	68	938
-25	65,205	22	5,710	69	906
-24	61,420	23	5,461	70	876
-23	57,875	24	5,225	71	836
-22	54,555	25	5,000	72	805
-21	51,450	26	4,786	73	775
-20	48,536	27	4,583	74	747
-19	45,807	28	4,389	75	719
-18	43,247	29	4,204	76	693
-17	40,845	30	4,028	77	669
-16	38,592	31	3,861	78	645
-15	38,476	32	3,701	79	623
-14	34,489	33	3,549	80	602
-13	32,621	34	3,404	81	583
-12	30,866	35	3,266	82	564
-11	29,216	36	3,134	83	547
-10	27,633	37	3,008	84	531
-9	26,202	38	2,888	85	516
-8	24,827	39	2,773	86	502
-7	23,532	40	2,663	87	489
-6	22,313	41	2,559	88	477
-5	21,163	42	2,459	89	466
-4	20,079	43	2,363	90	456
-3	19,058	44	2,272	91	446
-2	18,094	45	2,184	92	436
-1	17,184	46	2,101	93	427
0	16,325	47	2,021	94	419
1	15,515	48	1,944	95	410
2	14,749	49	1,871	96	402
3	14,026	50	1,801	97	393
4	13,342	51	1,734	98	385
5	12,696	52	1,670	99	376
6	12,085	53	1,609	100	367
7	11,506	54	1,550	101	357
8	10,959	55	1,493	102	346
9	10,441	56	1,439	103	335
10	9,949	57	1,387	104	324
11	9,485	58	1,337	105	312
12	9,044	59	1,290	106	299
13	8,627	60	1,244	107	285
14	8,231	61	1,200		

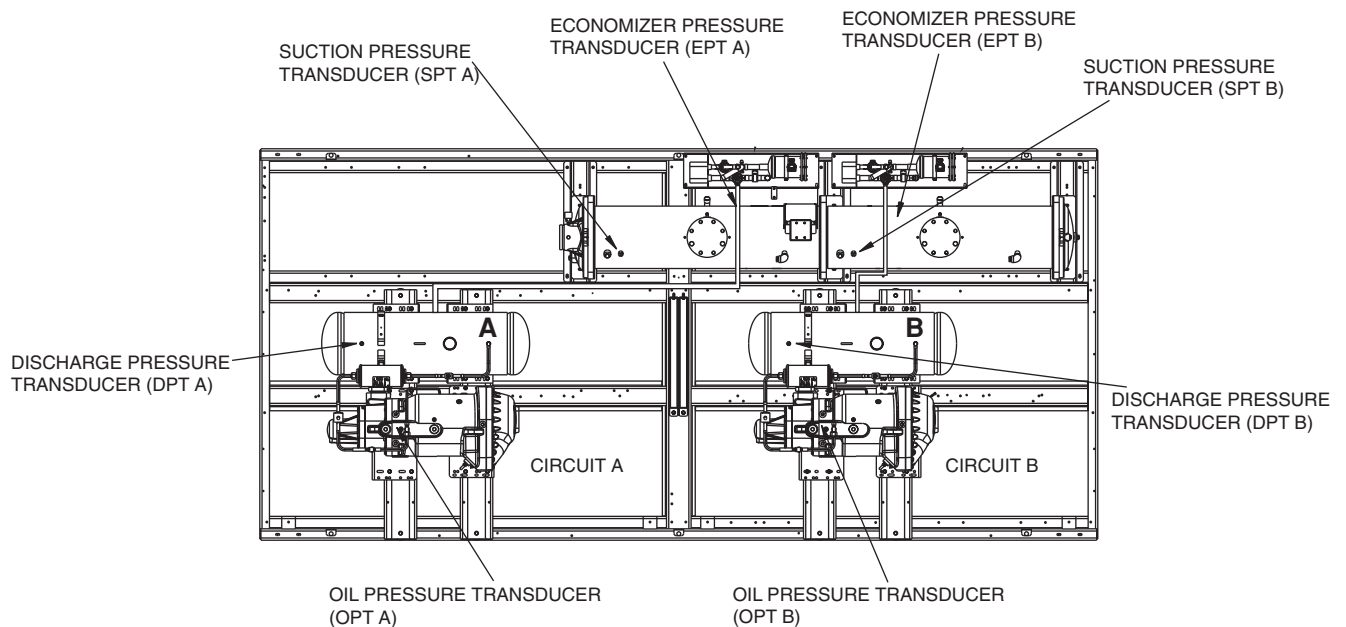


Fig. 29 — Transducer Locations

## SERVICE

**Economizer Assembly** — Each circuit on 30XA090-500 units have an economizer assembly. The 30XA080 unit is non-economized and has one main electronic expansion valve. The 30XA080 unit is controlled the same way as units with a separate economizer assembly. See Fig. 30.

**Electronic Expansion Valve (EXV)** — See Fig. 31 for a cutaway view of the EXV. High-pressure liquid refrigerant enters valve through the top. As refrigerant passes through the orifice, pressure drops and refrigerant changes to a 2-phase condition (liquid and vapor). To control refrigerant flow for different operating conditions, an actuator moves up and down over the orifice and modulates the orifice size. A sleeve is moved by a linear stepper motor. The stepper motor moves in increments and is controlled directly by the EXV module. As the stepper motor rotates, motion is transferred into linear movement by the lead screw. The large number of steps and long stroke results in very accurate control of the refrigerant flow. The stepper motor has either 3690 (main) or 2785 (economizer) steps.

**MAIN EXV CONTROL** — Each circuit has a thermistor located in a well in the discharge line of the compressor (DGT) and another one located in the compressor motor cavity (SGT). Each circuit also has discharge and suction pressure transducer. Discharge and suction pressure as measured by the transducers are converted to saturated temperatures. The main control logic for the EXV uses discharge superheat to control the position of the EXV. The difference between the temperature of the discharge gas and the saturated discharge temperature is the superheat. The EXV module controls the position of the electronic expansion valve stepper motor to maintain the discharge superheat set point.

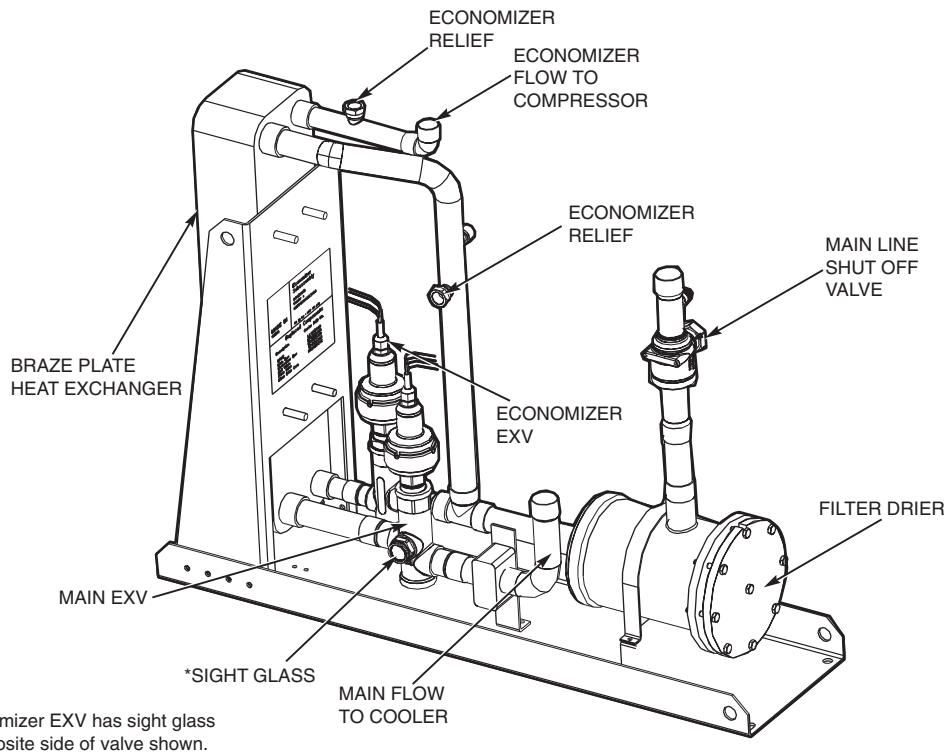
The EXV control logic has several overrides, which are also used to control the position of the EXV.

- Approach between SST and LWT
- Maximum Operating Pressure (MOP)

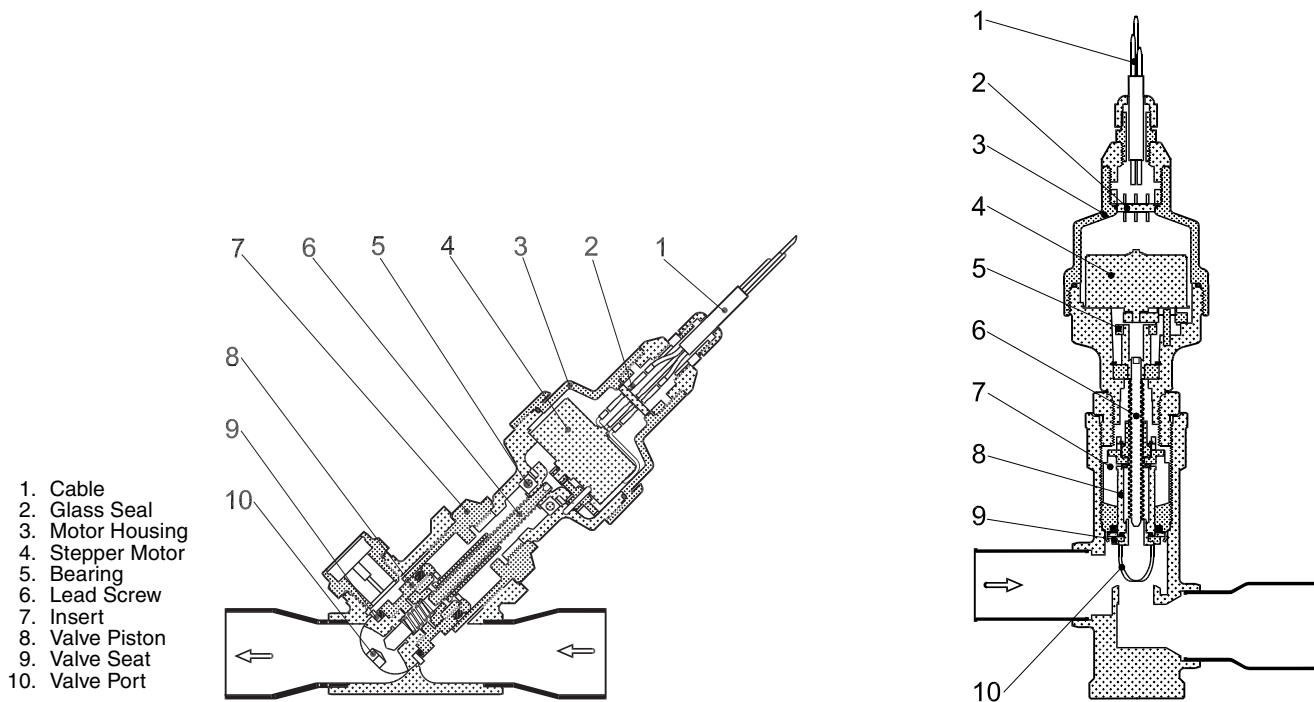
**Approach** — If the approach (pinch), which is the difference between leaving fluid temperature and saturated suction temperature, is equal to or less than the pinch set point then the EXV will not open any further even though discharge superheat set point is not met. Pinch set point is calculated using suction superheat, discharge superheat and pinch offset. Pinch offset is used to adjust calculated pinch set point to accuracy of transducers and thermistors.

**MOP** — The EXV is also used to limit cooler saturated suction temperature to 55 F (12.8 C). This makes it possible for the chiller to start at higher cooler fluid temperatures without overloading the compressor. This is commonly referred to as MOP (maximum operating pressure). If the SST is equal to or greater than the MOP set point then the MBB will try to control the EXV position to maintain the MOP set point which will result in discharge superheat to meet the set point.

The discharge superheat leaving the compressor is maintained between approximately 18° and 25° F (10° and 14° C), or less. Because EXV status is communicated to the Main Base Board (MBB) and is controlled by the EXV modules, it is possible to track the valve position. The unit is then protected against loss of charge and a faulty valve. During initial start-up, the EXV is fully closed. After an initialization period, valve position is tracked by the EXV module by constantly monitoring the amount of valve movement.



**Fig. 30 — Economizer Assembly**



**Fig. 31 — Cutaway Views of the Electronic Expansion Valve**

**ECONOMIZER EXV CONTROL** — The economizer EXV is controlled by the circuit EXV board. There is an economizer gas temperature thermistor and economizer pressure transducer located in the line, which runs from the economizer assembly to the compressor. The economizer pressure is converted to saturated temperature and is used to calculate economizer superheat. Economizer superheat equals economizer temperature minus saturated economizer temperature. The economizer EXV only operates during normal conditions when the capacity of the circuit is approximately 75% plus or minus 5% capacity. Once the capacity of the circuit is greater than 75% the MBB will start controlling the economizer EXV to maintain economizer superheat set point, which is approximately 8° to 12° F (4.4° to 6.7° C). If the circuit capacity is less than 75%, the economizer EXV will be closed.

The economizer EXV has one override. If the discharge gas temperature exceeds 195 F (90.6 C) the economizer EXV will start to open. The EXV will be controlled to maintain discharge gas temperature at approximately 195 F (90.6 C).

If it appears that main EXV or economizer EXV is not properly controlling circuit operation to maintain correct superheat, there are a number of checks that can be made using test functions and initialization features built into the microprocessor control. See the Service Test section to test EXVs.

**EXV TROUBLESHOOTING PROCEDURE** — There are two different economizer EXVs. Both of the economizer EXVs have a total of 2785 steps. There are three different main EXVs, which all have a total of 3690 steps. The EXV motor moves at 150 steps per second. Commanding the valve to either 0% or 100% will add an additional 160 steps to the move, to ensure the valve is open or closed completely.

Follow the steps below to diagnose and correct EXV problems. Check EXV motor operation first. Switch the Enable/Off/Remote (EOR) Contact switch to the Off position. Press **[ESCAPE]** on the Navigator™ module until the highest operating level is displayed. Use the arrow keys to select the Service Test mode and press **[ENTER]**. The display will read **TEST**.

Use the arrow keys until display shows **QUIC**. Press **[ENTER]** (password entry may be required) and use **[▲]** or **[▼]** to change **OFF** to **ON**. The Quick Test sub-mode is now enabled. Move the arrow down to the appropriate circuit EXV, Circuit A EXV % Open (**Service Test**→**QUIC**→**EXV.A**), Circuit B EXV % Open (**Service Test**→**QUIC**→**EXV.B**), or Circuit C EXV % Open (**Service Test**→**QUIC**→**EXV.C**), and press **[ENTER]**. The current value of **0** will be displayed. Press **[ENTER]** and the value will be flashing. Using the **[▲]** increase the EXV position to select 100% valve position (hold **[▲]** for quick movement) and press **[ENTER]**. The actuator should be felt moving through the EXV. Press **[ENTER]** again twice if necessary to confirm this has occurred. This will attempt to force the EXV to 100% again. To close the valve, press **[ENTER]**, select 0% with **[▼]** and press **[ENTER]**. The actuator should knock when it reaches the bottom of its stroke. See Table 31 for a list of EXV modes and submodes.

**Table 31 — EXV Modes and Submodes**

EXV TYPE AND CIRCUIT	NAVIGATOR™ PATH
EXV, Circuit A	<b>Service Test Mode</b> → <b>QUIC</b> → <b>EXV.A</b>
EXV, Circuit B	<b>Service Test Mode</b> → <b>QUIC</b> → <b>EXV.B</b>
EXV, Circuit C	<b>Service Test Mode</b> → <b>QUIC</b> → <b>EXV.C</b>
Economizer EXV, Circuit A	<b>Service Test Mode</b> → <b>QUIC</b> → <b>ECO.A</b>
Economizer EXV, Circuit B	<b>Service Test Mode</b> → <b>QUIC</b> → <b>ECO.B</b>
Economizer EXV, Circuit C	<b>Service Test Mode</b> → <b>QUIC</b> → <b>ECO.C</b>

If the valve is not working properly, continue with the following test procedure:

Check the 8-position DIP switch on the board for the proper address (see page 9). Check the EXV output signals at appropriate terminals on the EXV module. For 30XA080 units, connect the positive test lead to EXV-J2A terminal 5 for Circuit A and to EXV-J2B terminal 5 for Circuit B.

For 30XA090-500 units connect positive test lead to EXV(X)-J2A terminal 5 for EXV(X) and EXV(X)-J2B terminal 5 for Economizer EXV(X). Using the Service Test procedure on page 57, move the valve output under test to 100%. DO NOT short meter leads together or pin 5 to any other pin, as board damage will occur. During the next several seconds, carefully connect the negative test lead to pins 1,2,3 and 4 in succession. Digital voltmeters will average this signal and display approximately 6 vdc. If the output remains at a constant voltage other than 6 vdc or shows 0 volts, remove the connector to the valve and recheck.

Press **ENTER** and select 0% to close the valve.

NOTE: 12 vdc is the output from the EXV board when the valve is stationary.

See Tables 4 and 5. If a problem still exists, replace the EXV board. If the reading is correct, the expansion valve and EXV wiring should be checked. Check the EXV connector and interconnecting wiring.

1. Check color-coding and wire connections. Make sure they are connected to the correct terminals at the EXV board and EXV plug and that the cables are not crossed.
2. Check for continuity and tight connection at all pin terminals.

Check the resistance of the EXV motor windings. For 30XA080 units remove the EXV module plug EXV-J2A for Circuit A EXV and EXV-J2B for Circuit B EXV. For 30XA090-500 units remove the EXV module plug EXV(X)-J2A for main EXV and EXV(X)-J2B for economizer EXV. Check the resistance of the two windings between pins 1 and 3 for one winding and pins 2 and 4 for the other winding. The resistance should be 52 ohms ( $\pm 5.2$  ohms). Also check pins 1-4 for any shorts to ground.

#### Inspecting/Opening Electronic Expansion Valves

**IMPORTANT:** Obtain replacement gaskets before opening EXV. Do not re-use gaskets.

To check the physical operation of an EXV, the following steps must be performed.

1. Close the liquid line service valve of the circuit to be checked. Put the Enable/Off/Remote Contact switch in the Off position. Using the Navigator module, enter the Service Test mode and change **Service Test**→**TEST**→**T.REQ** from **OFF** to **ON**. A password may be required. Switch the EOR switch to the Enable position. Under the COMP sub-mode, enable one of the compressors (**Service Test**→**TEST**→**CP.xn**) for the circuit. Let compressor run until gage on suction pressure port reads 10 psig (68.9 kPa). Press **ENTER**, **▼** and **ENTER** to turn the compressor off. The compressor will turn off. Immediately after the compressor shuts off, manually close the actuated ball valve (ABV) (See the Actuated Ball Valve section for instructions), close the discharge valve and liquid line service valve. If the unit is equipped with suction service valves and economizer service valves, close both valves. Closing the valves will minimize the amount of charge that will have to be removed from the system after pump down.
2. Remove any remaining refrigerant from the system low side using proper recovering techniques. The economizer assembly has a  $1/4$  Schraeder connection which can be

used to remove charge from the inlet of the EXVs. Turn off the line voltage power supply to the compressors.

### ⚠ CAUTION

Ensure refrigerant is removed from both the inlet and outlet of EXV assemblies. Equipment damage could result.

3. The expansion valve motor is hermetically sealed inside the top portion of the valve. See Fig. 31. Disconnect the EXV plug. Carefully unscrew the motor portion from the body of the valve. The EXV operator will come out with the motor portion of the device. Reconnect the EXV plug.
4. Enter the appropriate EXV test step under the (**Service Test**→**QUIC**) sub-mode in the Service Test mode. Locate the desired item **Service Test**→**QUIC**→**EXV.A**, **Service Test**→**QUIC**→**EXV.B**, or **Service Test**→**QUIC**→**EXV.C**. Press **ENTER** twice to make the valve position of 0% flash. Press and hold **▲** until 100% is displayed and press **ENTER**. Observe the operation of the lead screw. See Fig. 31. The motor should be turning, raising the operator closer to the motor. Motor actuator movement should be smooth and uniform from fully closed to fully open position. Press **ENTER** twice, use **▼** to select 0% and press **ENTER** again to check open to closed operation. If the valve is properly connected to the processor and receiving correct signals, yet does not operate as described above, the sealed motor portion of the valve should be replaced.

#### Installing EXV Motor

**IMPORTANT:** Obtain replacement gasket before opening EXV. Do not re-use gaskets.

If re-installing the motor, be sure to use a new gasket in the assembly. See Fig. 32. It is easier to install the motor assembly with the piston in the fully closed position. Insert the motor into the body of the EXV. Tighten the motor to the body to 36 ft-lb (50 N-m) and then tighten the valve another 30 degrees.

**Moisture Liquid Indicator** — Clear flow of liquid refrigerant indicates sufficient charge in system. Bubbles in the sight glass indicate undercharged system or presence of noncondensables. Moisture in system, measured in parts per million (ppm), changes color of indicator. See Table 32. Change filter drier at first sign of moisture in system.

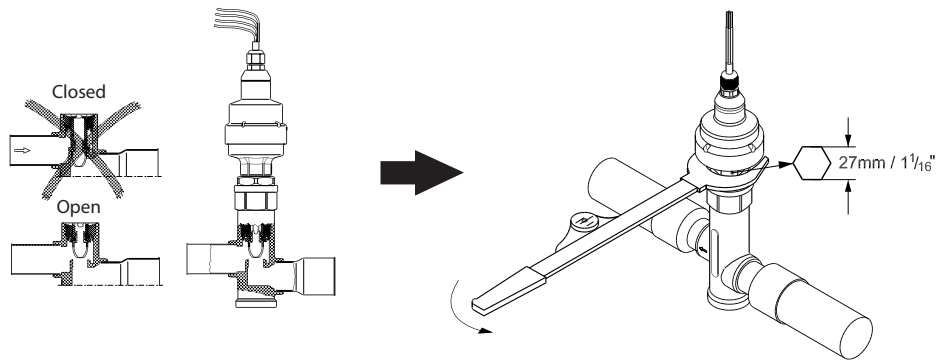
**Table 32 — Color Indicators when Moisture is Present in Refrigerant**

COLOR INDICATOR	R-134A, 75 F (24 C) (ppm)	R-134A, 125 F (52 C) (ppm)
Green — Dry	<8	<12
Yellow-green — Caution	8-66	12-95
Yellow — Wet	>66	>95

**IMPORTANT:** Unit must be in operation at least 12 hours before moisture indicator can give an accurate reading.

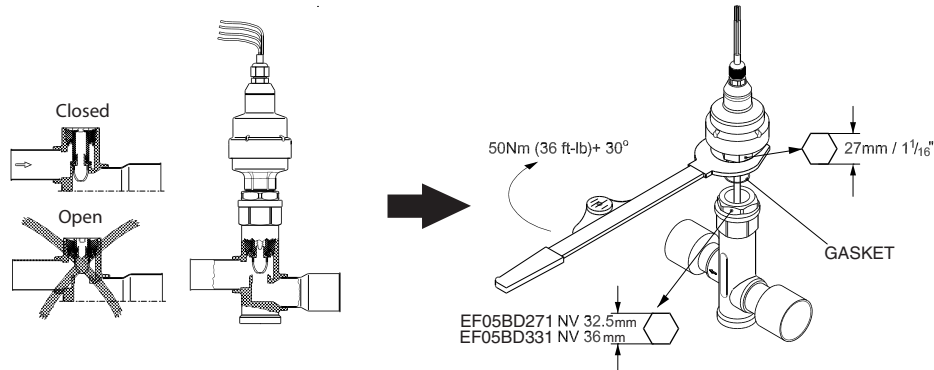
With unit running, indicating element must be in contact with liquid refrigerant to give true reading.

## DISASSEMBLY



NOTE: Open valve in Quick Test sub-mode before disassembling.

## ASSEMBLY



### NOTES:

1. Push down on valve piston to close valve before assembling.
2. After valve is assembled close valve in Quick Test sub-mode or cycle power before opening service valve.

**Fig. 32 — Disassembly and Assembly of EXV Motor**

**Filter Drier** — Whenever moisture-liquid indicator shows presence of moisture, replace filter drier(s). There is one filter drier assembly on each circuit with either one or two cores. The 30XA080-120 units have one core per circuit. The 30XA140 and 160 units have two cores, one for circuit A and one for circuit B. The 30XA180-500 units have two cores per circuit. Refer to the Carrier Standard Service Techniques Manual, Chapter 1, Refrigerants, for details on servicing filter driers.

**Liquid Line Service Valve** — This valve is located immediately ahead of filter drier, and has a 1/4-in. Schrader connection for field charging. In combination with compressor discharge service valve, each circuit can be pumped down into the high side for servicing.

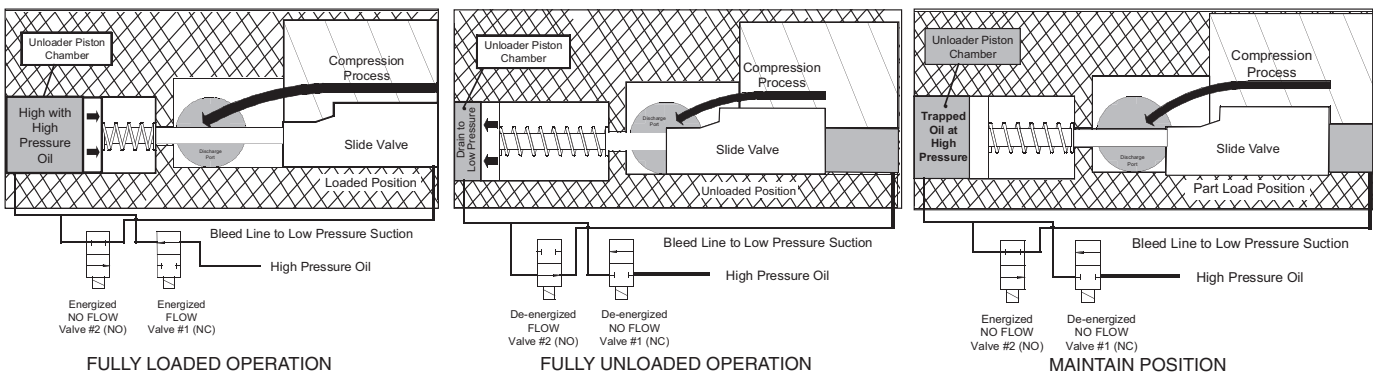
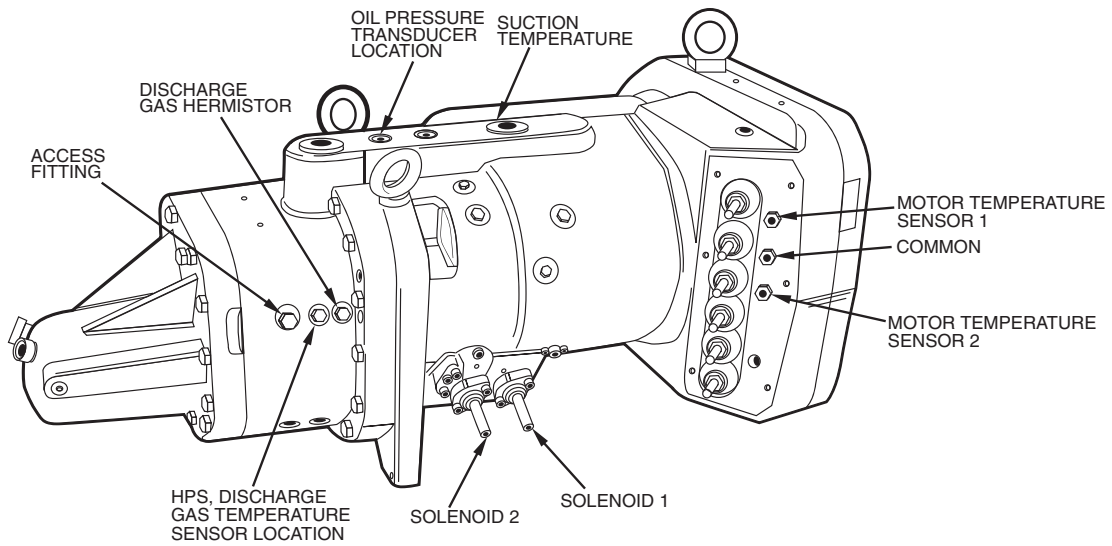
**Compressor Assembly** — The 30XA units utilize screw compressors with a modulating slide valve which varies capacity from 30% to 100% of compressor capacity for each circuit. See Fig. 33 for a view of a typical 06T compressor. The slide valve position is varied by opening and closing the 2 solenoid valves located on the compressor. To unload the compressor, both solenoids are deenergized. To increase in capacity both solenoid valves are energized together which will cause the slide valve to slide towards the fully loaded position. To stop the loading process solenoid 2 is energized and solenoid 1 is deenergized. This will cause the slide valve to maintain its current position. There is no positive feedback for the position of the slide valve. The control utilizes compressor current as an indicator of the slide valve position. Once the

calculated position of the slide valve reaches 100% circuit capacity, the control will try to increase capacity again if the compressor current continues to increase. The control will continue to load the compressor until the compressor current no longer increases. At that time the control will energize both solenoids and the circuit will be considered fully loaded.

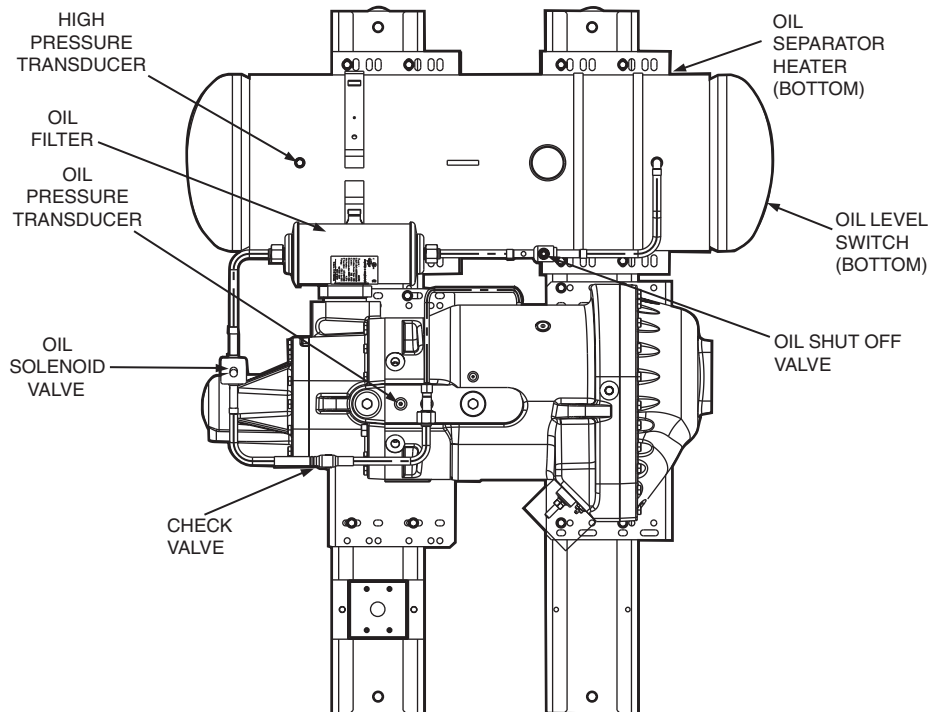
**COMPRESSOR OIL SYSTEM** — Each compressor/circuit has its own oil system which includes an oil filter, oil solenoid, check valve, oil level switch, oil separator heater, oil pressure transducer, and an oil shut-off valve. A typical oil system is shown in Fig. 34. See Table 33.

**Table 33 — Unit Oil Quantities**

30XA UNIT SIZE	OIL CHANGE (gal, [liters])		
	Circuit A	Circuit B	Circuit C
080,120	5.5 [20.8]	5.5 [20.8]	—
140,160	6.25 [23.7]	5.5 [20.8]	—
180,200	6.25 [23.7]	6.25 [23.7]	—
220	6.75 [25.6]	6.25 [23.7]	—
240	6.75 [25.6]	6.75 [25.6]	—
260	7.50 [28.4]	6.75 [25.6]	—
280,300	7.50 [28.4]	6.75 [25.6]	—
325,350	7.50 [28.4]	7.50 [28.4]	—
400	6.75 [25.6]	6.75 [25.6]	7.50 [28.4]
450	6.75 [25.6]	6.25 [23.7]	7.50 [28.4]
500	7.50 [28.4]	6.75 [25.6]	7.50 [28.4]



**Fig. 33 — Typical 06T Compressor**



**Fig. 34 — Typical Oil System**

**Oil Charge** — When additional oil or a complete charge is required it must meet the following specifications:

- Manufacturer . . . . .Castrol Icematic® SW-220XL
- Oil Type . . . . . Inhibited polyolester-based synthetic compressor lubricant for use with screw compressors.
- ISO Viscosity Grade . . . . . 220

Do not reuse drained oil or any oil that has been exposed to the atmosphere.

Oil is available in the following quantities from your local Carrier representative:

QUANTITY	TOTALINE PART NO.
1 Quart	P903-2325
1 Gallon	P903-2301
5 Gallon	P903-2305

If unsure if there is low oil charge in the system, follow the steps below:

1. If the unit shuts off repeatedly from a low oil level alert it may be an indication of inadequate oil charge; however, it could also indicate that the oil is not being reclaimed from the low-side of the system.
2. Begin running the unit at full load for 1½ hours. Use the manual Test Mode feature of Service Test if the unit does not normally run at full load.

NOTE: An adequate load must be available.

3. After running the unit for 1½ hours at full load, allow the unit to restart and run normally. If low oil alarms persist, continue with the following steps.
4. Close the liquid line service valve and place a pressure gage on top of the cooler. Enable the Service Test feature using the Navigator™ module and turn the Enable/Off/Remote switch to the enable position. Start the desired circuit by turning it on under the TEST function: CPA for compressor A, CP.B for compressor B, or CPC for compressor C.
5. When the compressor starts successfully observe the cooler pressure when the pressure reads 10 psig (68.9 kPa), turn the Emergency Switch (SW2) to the OFF position. The compressor should stop within 10 seconds.
6. Open the liquid line service valve and allow the unit to restart normally. If low oil level alarms persist, continue with the following steps.
7. If none of the previous steps were successful, the unit is low on oil charge. Add oil to the oil separator using the ¼ in. Schrader-type fitting that the discharge pressure transducer is mounted to.
8. To facilitate the oil charging process, ensure that the unit is not running when adding oil. The system is under pressure even when the unit is not running, so it is necessary to use a suitable pump to add oil to the system.
9. Using a suitable pump, add ½ gal (1.9 l) of oil to the system. Continue adding oil in ½ gal (1.9 l) increments until the problem is resolved, up to a maximum of 1.5 gal (5.7 l). If it is necessary to add factory oil charge levels to the system contact your local Carrier representative.

**Oil Filter Maintenance** — Each circuit has one oil filter located externally to the compressor. Oil line pressure drop is monitored by the control. Oil line pressure drop is calculated by subtracting oil pressure (OP) from discharge pressure (DP). If the oil line pressure drop exceeds 30 psi (206.8 kPa) for 5 minutes the control will generate a High Oil Filter Pressure Drop alert. The High Oil Filter Pressure Drop alert will not shut down the compressor, but instead indicates that the oil filter is dirty. If oil pressure line losses exceed 50 psi

(344.7 kPa) then the control will shut down the circuit on Maximum Oil Filter Differential Pressure Failure.

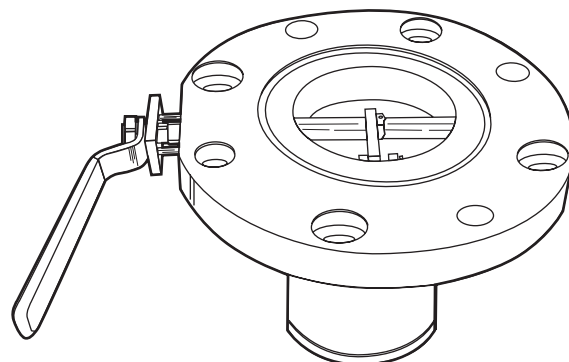
**⚠ CAUTION**

Compressor oil is pressurized. Use proper safety precautions when relieving pressure.

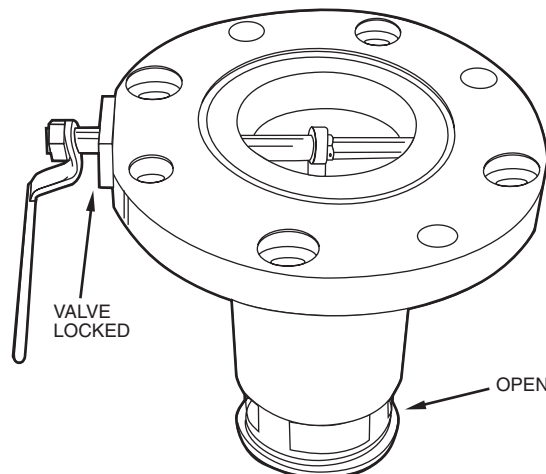
**Replacing the Oil Filter** — Close the oil line ball valve located in front of the oil filter. Connect a charging hose to the Schrader port located downstream of the valve and bleed off oil trapped between the service valve and the oil solenoid valve. A quart of oil is typically what is removed during this process. Remove the charging hose. Unscrew the nuts from both ends of the oil filter and remove the oil filter. Remove the protective caps from the new oil filter and install, being careful not to lose or damage the new O-ring located on the new oil filter. Draw a vacuum at the Schrader port. Remove the charging hose and open the oil line ball valve. Check both fittings for leaks.

**Cooler**

**SUCTION SERVICE VALVE** — The suction service valve is a factory-installed option for 30XA units. It is located in the suction outlet of the cooler. The suction service valve is bolted between the cooler outlet and the suction flange piping. The suction service valve shaft has a locking device located on the shaft to lock the valve in either a fully open position or a fully closed position. The locking device must be pulled out prior to moving the valve handle to a fully open or a fully closed position. See Fig. 35A and 35B.



**Fig. 35A — Suction Service Valve Locking Device, Closed and Unlocked**



**Fig. 35B — Suction Service Valve Locking Device, Open and Locked**

**FREEZE PROTECTION** — All coolers are equipped with cooler heaters and are controlled by the Main Base Board. The control logic uses the unit status, outdoor air temperature, and the saturated suction temperatures for all circuits to decide if the cooler heater should be energized.

The cooler heaters can only be energized when the state of the unit is OFF. The cooler heaters will be energized if the outdoor-air temperature is less than the Cooler Heater Set Point and the lowest circuit Saturated Suction Temperature is less than the heater set point plus 6° F (3.3° C). See Table 34.

The cooler heater set point = freeze point + Cooler Heater DT Setp (*Configuration* → *SERV* → *HTR*).

If the entering or leaving water temperature is less than the Heater Set Point and the outdoor air temperature is less than the Heater Set Point -2° F (1.1° C), then the heater will be turned on.

If the Entering or Leaving Water Temperature is less than the Brine Freeze Setpoint (*Configuration* → *SERV* → *LOSP*) +1.0° F (0.5° C), then the heater will be turned on along with the pump.

The entire cooler is covered with closed-cell insulation applied over the heater. The heater plus insulation protects cooler against low ambient temperature freeze-up to 0° F (-17.8 C).

**IMPORTANT:** If unit is installed in an area where ambient temperatures fall below 32 F (0° C), a suitable corrosion-inhibited antifreeze solution or cooler heater must be used in the chilled water circuit.

**LOW FLUID TEMPERATURE** — Main Base Board is programmed to shut chiller down if leaving fluid temperature drops below 34 F (1.1 C) for cooler fluid type water or below Brine Freeze Setpoint (*Configuration* → *SERV* → *LOSP*) for cooler fluid type brine. The unit will shut down without a pumpout. When fluid temperature rises to 6° F (3.3° C) above the leaving fluid set point, safety resets and chiller restarts. Reset is automatic as long as this is the first occurrence.

**LOSS OF FLUID FLOW PROTECTION** — All 30XA machines include an integral flow switch that protects the cooler against loss of cooler flow.

**TUBE PLUGGING** — A leaky tube can be plugged until retubing can be done. The number of tubes plugged determines how soon the cooler *must* be retubed. All tubes in the cooler may be removed. Loss of unit capacity and efficiency as well as increased pump power will result from plugging tubes. Failed tubes should be replaced as soon as possible. Up to 10% of the total number of tubes can be plugged before retubing is necessary. Fig. 36 shows an Elliott tube plug and a cross-sectional view of a plug in place. See Tables 35 and 36 for plug components. If the tube failure occurs in both circuits using tube plugs will not correct the problem. Contact your local Carrier representative for assistance.

**⚠ CAUTION**

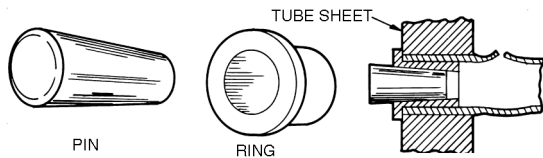
Use extreme care when installing plugs to prevent damage to the tube sheet section between the holes.

**Table 34 — Cooler Heater Operation Examples**

OAT F (C)	UNIT STATUS	BRINE FREEZE POINT F (C)	COOLER DELTA T F (C)	COOLER HEATER SETPOINT F (C)	SSTA F (C)	SSTB F (C)	SSTC F (C)	COOLER HEATER STATUS	COMMENTS
50 (10)	OFF	36 (2.2)	6 (3.3)	42 (5.6)	N/A	N/A	N/A	OFF	OAT >42 F (5.6 C)
40 (4.4)	OFF	36 (2.2)	6 (3.3)	42 (5.6)	41 (5)	N/A	N/A	ON	SSTA <42 F (5.6 C)
40 (4.4)	OFF	15 (-9.4)	6 (3.3)	21 (-6.1)	41 (5)	N/A	N/A	OFF	SSTA >21 F (-6.1 C)
40 (4.4)	OFF	36 (2.2)	6 (3.3)	42 (5.6)	52.1 (11.2)	52.1 (11.2)	52.1 (11.2)	OFF	All SST Temperatures >52 F (11.2 C)
40 (4.4)	ON	36 (2.2)	6 (3.3)	42 (5.6)	N/A	N/A	N/A	OFF	Unit Status ON

**LEGEND**

- OAT** — Outdoor-Air Temperature
- SSTA** — Saturated Suction Temperature, Circuit A
- SSTB** — Saturated Suction Temperature, Circuit B
- SSTC** — Saturated Suction Temperature, Circuit C



**Fig. 36 — Elliott Tube Plug**

**Table 35 — Plug Component Parts**

COMPONENTS FOR PLUGGING	PART NUMBER
<b>For Tubes</b>	
Brass Pin	853103-1*
Brass Ring	853002-640 or 657* (measure tube before ordering)
<b>For Holes without tubes</b>	
Brass Pin	853103-1A
Brass Ring	85102-738
Loctite	No. 675 †
Locquic	"N"†
Roller Extension	S82-112/11

\*Order directly from Elliot Tube Company, Dayton, OH or RCD.  
†Can be obtained locally.

**Table 36 — Plug Parts**

PLUG COMPONENT	SIZE	
	in.	mm
Tube sheet hole diameter	0.756	19.20
Tube OD	0.750	19.05
Tube ID after rolling (includes expansion due to clearance.)	0.650 to 0.667	16.51 to 16.94

NOTE: Tubes replaced along heat exchanger head partitions must be flush with tube sheet (both ends).

**RETUBING** — When retubing is required, obtain service of qualified personnel experienced in boiler maintenance and repair. Most standard procedures can be followed when retubing the coolers. An 8% crush is recommended when rolling replacement tubes into the tubesheet.

The following Elliott Co. tube rolling tools are required:

- Expander Assembly (113123)
- Cage (2134123)
- Mandrel (213123)
- Rolls (2115122)

Place one drop of Loctite No. 675 or equivalent on top of tube prior to rolling. This material is intended to "wick" into the area of the tube that is not rolled into the tube sheet, and prevent fluid from accumulating between the tube and the tube sheet. New tubes must also be rolled into the center tubesheet to prevent circuit to circuit leaks.

**TIGHTENING COOLER HEAD BOLTS**

**Preparation** — When reassembling cooler heads, always check the condition of the O-rings first. The O-ring should be replaced if there is visible signs of deterioration, cuts or damage. Apply a thin film of grease to the O-ring before installation. This will aid in holding the O-ring in the groove while the head is installed. Torque all bolts to the following specification and in sequence:

3/4-in. Diameter Perimeter Bolts (Grade 5) . . . 200 to 225 ft-lb (271 to 305 N-m)

1. Install all bolts finger tight.
2. Bolt tightening sequence is outlined in Fig. 37. Follow the numbering or lettering sequence so that pressure is evenly applied to O-ring.
3. Apply torque in one-third steps until required torque is reached. Load *all* bolts to each one-third step before proceeding to next one-third step.
4. No less than one hour later, retighten all bolts to required torque values.
5. After refrigerant is restored to system, check for refrigerant leaks using recommended industry practices.
6. Replace cooler insulation.

**INSPECTING/CLEANING HEAT EXCHANGERS** — Inspect and clean cooler tubes at the end of the first operating season. Because these tubes have internal ridges, a rotary-type tube cleaning system is necessary to fully clean the tubes. Tube condition in the cooler will determine the scheduled frequency for cleaning, and will indicate whether water treatment is adequate in the chilled water/brine circuit. Inspect the entering and leaving water thermistor wells for signs of corrosion or scale. Replace the well if corroded or remove any scale if found.

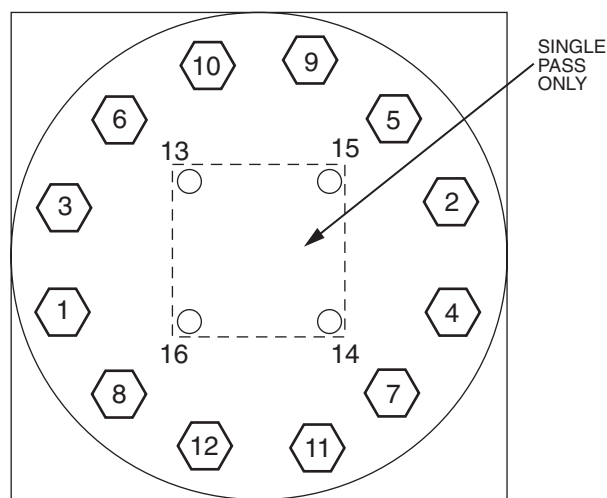
**⚠ CAUTION**

Hard scale may require chemical treatment for its prevention or removal. Consult a water treatment specialist for proper treatment procedures.

**WATER TREATMENT** — Untreated or improperly treated water may result in corrosion, scaling, erosion or algae. The services of a qualified water treatment specialist should be obtained to develop and monitor a treatment program.

**⚠ CAUTION**

Water must be within design flow limits, clean and treated to ensure proper machine performance and reduce the potential of tubing damage due to corrosion, scaling, and algae. Carrier assumes no responsibility for cooler damage resulting from untreated or improperly treated water.



**Fig. 37 — Cooler Head Recommended Bolt Torque Sequence**

**CHILLED WATER FLOW SWITCH** — A factory-installed flow switch is installed in the entering water nozzle for all machines. See Fig. 38 and 39. This is a thermal-dispersion flow switch. Figure 38 shows typical installation. If nuisance trips of the sensor are occurring, follow the steps below to correct:

When power is supplied to the device, a warm-up period is initiated. During this period, the green LED is lit and turned off as each LED to the left is successively lit until the left most red LED is lit. The warm-up period may take up to 30 seconds. When some flow is detected but not enough for machine operation, a red LED illuminates at the far left. With increasing flow, successive red LEDs illuminate. When the switch determines flow is present, an amber LED illuminates indicating the switch has closed. This is not an indication that minimum flow has been met. Increasing flow above the amber LED indication illuminates the first green LED. Each successive green LED indicates greater flow. The switch closure does not indicate minimum flow requirements have been met for the machine. One green LED lit can indicate minor fluctuations in flow, while an increase in flashing green LEDs can indicate higher flow rate, with a lower instance of nuisance alarms.

1. Check to confirm that all strainers are clean, valves are open and pumps are running. For the case of variable frequency drive (VFD) controlled pumps, ensure the minimum speed setting has not been changed.
2. Measure the pressure drop across the cooler. Use the cooler pressure drop curves on pages 44-48 to calculate the flow and compare this to system requirements.
3. If the measured flow rate through the cooler agrees with the system requirements. The green LED should be lit a minimum of 2 bars away from the amber light.
4. If the contacts do not close with the amber LED lit then check the wiring connection to the MBB. If the input signal is not closed, then the switch needs to be replaced.

**Condenser Coil Maintenance and Cleaning Recommendation** — Routine cleaning of coil surfaces is essential to maintain proper operation of the unit. Elimination of contamination and removal of harmful residues will greatly increase the life of the coil and extend the life of the unit. The following maintenance and cleaning procedures are recommended as part of the routine maintenance activities to extend the life of the coil.

**REMOVE SURFACE LOADED FIBERS** — Surface loaded fibers or dirt should be removed with a vacuum cleaner. If a vacuum cleaner is not available, a soft non-metallic bristle brush may be used. In either case, the tool should be applied in the direction of the fins. Coil surfaces can be easily damaged (fin edges can be easily bent over and damage to the coating of a protected coil) if the tool is applied across the fins.

**NOTE:** Use of a water stream, such as a garden hose, against a surface loaded coil will drive the fibers and dirt into the coil. This will make cleaning efforts more difficult. Surface loaded fibers must be completely removed prior to using low velocity clean water rinse.

**PERIODIC CLEAN WATER RINSE** — A periodic clean water rinse is very beneficial for coils that are applied in coastal or industrial environments. However, it is very important that the water rinse is made with very low velocity water stream to avoid damaging the fin edges. Monthly cleaning as described below is recommended.

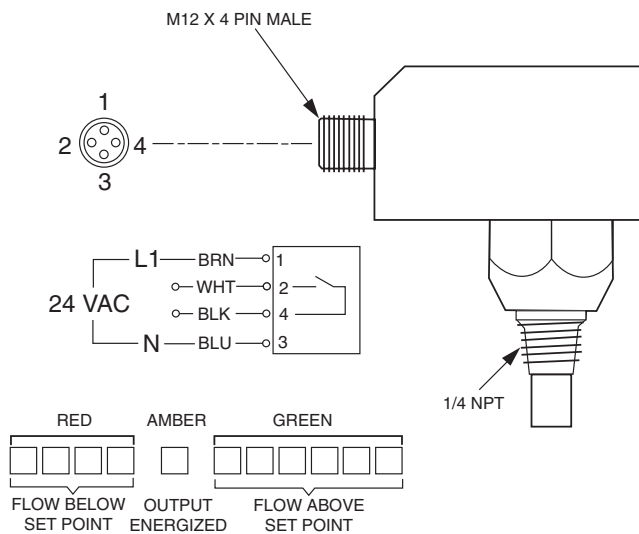
**ROUTINE CLEANING OF COIL SURFACES** — Monthly cleaning with Totaline® environmentally sound coil cleaner is essential to extend the life of coils. This cleaner is available from Carrier Replacement parts division as part number P902-0301 for a one gallon container, and part number P902-0305 for a 5 gallon container. It is recommended that all coils, including standard aluminum, pre-coated, copper/copper or E-coated coils be cleaned with the Totaline environmentally

sound coil cleaner as described below. Coil cleaning should be part of the unit's regularly scheduled maintenance procedures to ensure long life of the coil. Failure to clean the coils may result in reduced durability in the environment.

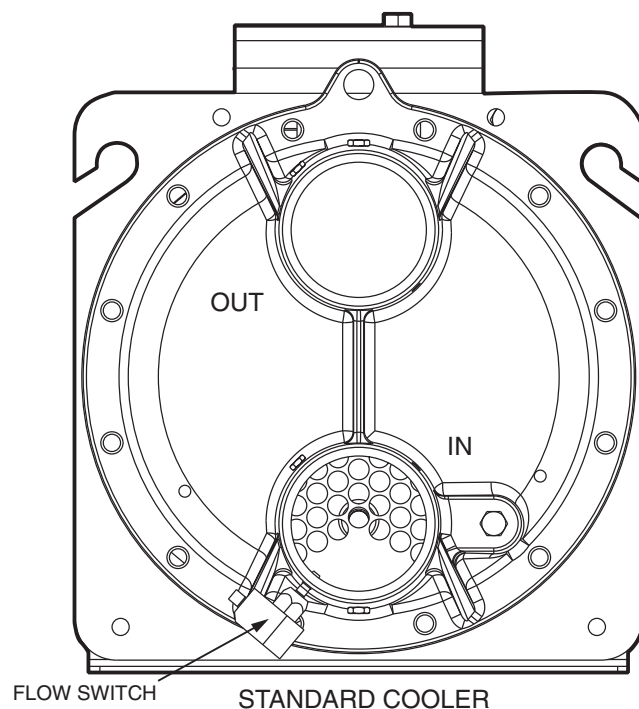
Avoid the use of:

- coil brighteners
- acid cleaning prior to painting
- high pressure washers
- poor quality water for cleaning

Totaline environmentally sound coil cleaner is non-flammable, hypo allergenic, non bacterial, and a USDA accepted biodegradable agent that will not harm the coil or surrounding components such as electrical wiring, painted metal surfaces, or insulation. Use of non-recommended coil cleaners is strongly discouraged since coil and unit durability could be affected.



**Fig. 38 — Chilled Water Flow Switch LED Display**



**Fig. 39 — Flow Switch**

### Totaline® Environmentally Sound Coil Cleaner Application Equipment

- 2½ gallon garden sprayer
- Water rinse with low velocity spray nozzle

#### **▲ CAUTION**

Harsh chemicals, household bleach or acid or basic cleaners should not be used to clean outdoor or indoor coils of any kind. These cleaners can be very difficult to rinse out of the coil and can accelerate corrosion at the fin/tube interface where dissimilar materials are in contact. If there is dirt below the surface of the coil, use the Totaline environmentally sound coil cleaner as described above.

#### **▲ CAUTION**

High velocity water from a pressure washer, garden hose, or compressed air should never be used to clean a coil. The force of the water or air jet will bend the fin edges and increase airside pressure drop. Reduced unit performance or nuisance unit shutdown may occur.

### Totaline Environmentally Sound Coil Cleaner Application Instructions

1. Proper eye protection such as safety glasses is recommended during mixing and application.
2. Remove all surface loaded fibers and dirt with a vacuum cleaner as described above.
3. Thoroughly wet finned surfaces with clean water and a low velocity garden hose, being careful not to bend fins.
4. Mix Totaline environmentally sound coil cleaner in a 2½ gallon garden sprayer according to the instructions included with the cleaner. The optimum solution temperature is 100 F.

NOTE: Do **NOT USE** water in excess of 130 F, as the enzymatic activity will be destroyed.

5. Thoroughly apply Totaline environmentally sound coil cleaner solution to all coil surfaces including finned area, tube sheets and coil headers.

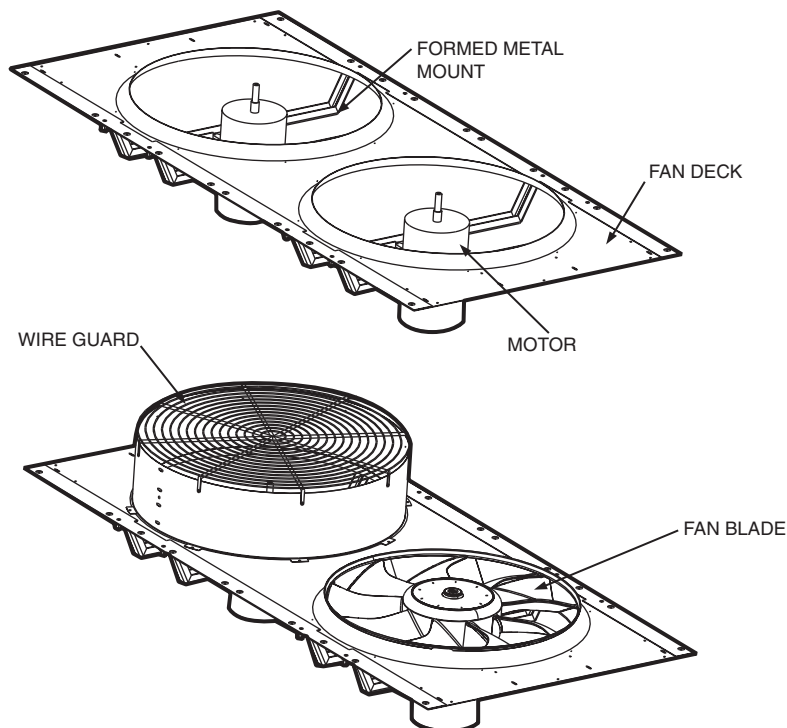
6. Hold garden sprayer nozzle close to finned areas and apply cleaner with a vertical, up-and-down motion. Avoid spraying in horizontal pattern to minimize potential for fin damage.
7. Ensure cleaner thoroughly penetrates deep into finned areas.
8. Interior and exterior finned areas must be thoroughly cleaned.
9. Finned surfaces should remain wet with cleaning solution for 10 minutes.
10. Ensure surfaces are not allowed to dry before rinsing. Reapplying cleaner as needed to ensure 10-minute saturation is achieved.
11. Thoroughly rinse all surfaces with low velocity clean water using downward rinsing motion of water spray nozzle. Protect fins from damage from the spray nozzle.

**Condenser Fans** — A formed metal mount bolted to fan deck supports each fan and motor assembly. A shroud and a wire guard provide protection from the rotating fan. See Fig. 40. The exposed end of the fan motor shaft is protected from weather by grease. If fan motor must be removed for service or replacement, be sure to regrease fan shaft and reinstall fan guard. The fan motor has a step in the motor shaft. For proper performance, fan should be positioned such that it is securely seated on this step. Tighten the bolt.

### **Refrigerant Circuit**

**LEAK TESTING** — Units are shipped with complete operating charge of refrigerant R-134a (see Physical Data tables supplied in the 30XA installation instructions) and should be under sufficient pressure to conduct a leak test. If there is no pressure in the system, introduce enough nitrogen to search for the leak. Repair the leak using good refrigeration practices. After leaks are repaired, system must be evacuated and dehydrated.

**REFRIGERANT CHARGE** — Refer to Physical Data tables supplied in the 30XA installation instructions). Immediately ahead of filter drier in each circuit is a factory-installed liquid line service valve. Each valve has a ¼-in. Schrader connection for charging liquid refrigerant.



**Fig. 40 — Fan Mounting**

**Charging with Unit Off and Evacuated** — Close liquid line service valve before charging. Weigh in charge shown on unit nameplate. Open liquid line service valve; start unit and allow it to run several minutes fully loaded. Check for a clear sight glass. Be sure clear condition is liquid and not vapor.

**Charging with Unit Running** — If charge is to be added while unit is operating, all condenser fans and compressors must be operating. It may be necessary to block condenser coils at low ambient temperatures to raise condensing pressure to approximately 198 psig (1365 kPa) to turn all condenser fans on. Do not totally block a coil to do this. Partially block all coils in uniform pattern. Charge each circuit until sight glass shows clear liquid, and has a liquid line temperature of 103 F (39 C) for 30XA080-350 units and 108 F (42 C) for 30XA400-500 units.

Add 5 lb (2.3 kg) of liquid charge into the entering filter drier using the fitting located on the tube entering the bottom of the cooler. This fitting is located between the electronic expansion valve (EXV) and the cooler.

Allow the system to stabilize and then recheck the liquid temperature. If needed, add additional liquid charge, 5 lb (2.3 kg) at a time, allowing the system to stabilize between each charge addition. Slowly add charge as the sight glass begins to clear to avoid overcharging.

**IMPORTANT:** When adjusting refrigerant charge, circulate fluid through cooler continuously to prevent freezing and possible damage to the cooler. Do not overcharge, and never charge liquid into the low-pressure side of system.

**Safety Devices** — The 30XA chillers contain many safety devices and protection logic built into the electronic control. Following is a description of the major safeties.

**COMPRESSOR PROTECTION**

**Motor Overload** — The compressor protection modules (CPM) protect each compressor against overcurrent. Do not bypass the current transducers or make any changes to the factory-installed and configured headers. The configuration of these headers defines the Must Trip Amps (MTA) at which the CPM will turn the compressors off. Determine the cause for trouble and correct the problem before resetting the CPM. See Appendix C for MTA settings and configuration headers.

Each CPM board also reads the status of each compressor's high-pressure switch. All compressors have factory-installed high-pressure switches. See Table 37.

**Table 37 — High-pressure Switch Settings**

UNIT	SWITCH SETTING	
	psig	kPa
30XA	304.5 ±14.5	2099 ±100

If the switch opens during operation, the compressor will be shut down. The CPM will reset automatically when the switch closes, however, a manual reset of the control is required to restart the compressor.

**OIL SEPARATOR HEATERS** — Each oil separator circuit has a heater mounted on the underside of the vessel. The heater is deenergized anytime the compressor is on. If the compressor is off and outdoor-air temperature (OAT) is greater than 100 F (37.8 C) the heater is deenergized. The heater will also be deenergized if OAT – SST >32 F (17.8° C) and the OAT – LWT > 32 F (17.8° C).

**COOLER PROTECTION**

**Low Water Temperature** — Microprocessor is programmed to shut the chiller down if the leaving fluid temperature drops below 34 F (1.1 C) for water or more than 8° F (4.4° C) below set point for Fluid Type = brine. When the fluid temperature rises 6° F (3.3° C) above the leaving fluid set point, the safety resets and the chiller restarts. Reset is automatic as long as this is the first occurrence of the day.

**IMPORTANT:** If unit is installed in an area where ambient temperatures fall below 32 F (0° C), a suitable corrosion-inhibited antifreeze solution or cooler heater must be used in the chilled water circuit.

**Relief Devices** — Fusible plugs are located in each circuit between the condenser and the liquid line shutoff valve.

**PRESSURE RELIEF VALVES** — Valves are installed in each circuit and are located on all coolers. These valves are designed to relieve if an abnormal pressure condition arises. Relief valves on all coolers relieve at 220 psi (1517 kPa). These valves should not be capped. If a valve relieves, it should be replaced. If the valve is not replaced, it may relieve at a lower pressure, or leak due to trapped dirt from the system which may prevent resealing.

Pressure relief valves located on cooler shells have 3/4-in. NPT connections for relief. Some local building codes require that relieved gases be exhausted to a specific location. This connection allows conformance to this requirement.

**MAINTENANCE**

**Recommended Maintenance Schedule** — The following are only recommended guidelines. Jobsite conditions may dictate that maintenance schedule is performed more often than recommended.

Routine:

For machines with E-coat condenser coils:

- Check condenser coils for debris; clean as necessary with Carrier approved coil cleaner.
- Periodic clean water rinse, especially in coastal and industrial applications.

Every month:

- Check condenser coils for debris; clean as necessary with Carrier approved coil cleaner.
- Check moisture indicating sight glass for possible refrigerant loss and presence of moisture.

Every 3 months (for all machines):

- Check refrigerant charge.
- Check all refrigerant joints and valves for refrigerant leaks; repair as necessary.
- Check chilled water flow switch operation.
- Check all condenser fans for proper operation.
- Check oil filter pressure drop.
- Check oil separator heater operation.

Every 12 months (for all machines):

- Check all electrical connections; tighten as necessary.
- Inspect all contactors and relays; replace as necessary.
- Check accuracy of thermistors; replace if greater than ±2° F (1.2° C) variance from calibrated thermometer.
- Check accuracy of transducers; replace if greater than ±5 psi (34.47 kPa) variance.
- Check to be sure that the proper concentration of anti-freeze is present in the chilled water loop, if applicable.
- Verify that the chilled water loop is properly treated.
- Check refrigerant filter driers for excessive pressure drop; replace as necessary.
- Check chilled water strainers, clean as necessary.
- Check cooler heater operation.
- Check condition of condenser fan blades and that they are securely fastened to the motor shaft.
- Perform Service Test to confirm operation of all components.
- Check for excessive cooler approach (Leaving Chilled Water Temperature – Saturated Suction Temperature) which may indicate fouling. Clean cooler vessel if necessary.
- Obtain oil analysis; change as necessary.

**TROUBLESHOOTING**

See Table 38 for an abbreviated list of symptoms, possible causes and possible remedies.

**Table 38 — Troubleshooting**

SYMPTOM	POSSIBLE CAUSE	POSSIBLE REMEDY
<b>Unit Does Not Run</b>	Check for power to unit	<ul style="list-style-type: none"> <li>• Check overcurrent protection device.</li> <li>• Check non-fused disconnect (if equipped).</li> <li>• Restore power to unit.</li> </ul>
	Wrong or incorrect unit configuration	Check unit configuration.
	Active alarm	Check Alarm status. See the Alarms and Alerts section and follow troubleshooting instructions.
	Active operating mode	Check for Operating Modes. See the Operating Modes section and follow troubleshooting instructions.
<b>Unit Operates too Long or Continuously</b>	Low refrigerant charge	Check for leak and add refrigerant.
	Compressor or control contacts welded	Replace contactor or relay.
	Air in chilled water loop	Purge water loop.
	Non-condensables in refrigerant circuit.	Remove refrigerant and recharge.
	Inoperative EXV	<ul style="list-style-type: none"> <li>• Check EXV, clean or replace.</li> <li>• Check EXV cable, replace if necessary.</li> <li>• Check EXV board for output signal.</li> </ul>
	Load too high	Unit may be undersized for application
<b>Circuit Does Not Run</b>	Active alarm	Check Alarm status. See the Alarms and Alerts section and follow troubleshooting instructions.
	Active operating mode	Check for Operating Modes. See the Operating Modes section and follow troubleshooting instructions.
<b>Circuit Does Not Load</b>	Active alarm	Check Alarm status. See the Alarms and Alerts section and follow troubleshooting instructions.
	Active operating mode	Check for Operating Modes. See the Operating Modes section and follow troubleshooting instructions.
	Low saturated suction temperature	See Operating Modes 21, 22 and 23.
	High circuit suction superheat	The circuit capacity is not allowed increase if circuit superheat is greater than 36 F (20 C). See Alarms 59-61 for potential causes.
	Low suction superheat	The circuit capacity is not allowed to increase if the circuit superheat is less than 18° F (10° C). See Alarms 62-64 for potential causes.
<b>Compressor Does Not Run</b>	Active alarm	Check Alarm status. See the Alarms and Alerts section and follow troubleshooting instructions.
	Active operating mode	Check for Operating Modes. See the Operating Modes section and follow troubleshooting instructions.
	Inoperative compressor contactor	<ul style="list-style-type: none"> <li>• Check control wiring.</li> <li>• Check scroll protection module.</li> <li>• Check contactor operation, replace if necessary.</li> </ul>
<b>Chilled Water Pump is ON, but the Machine is OFF</b>	Cooler freeze protection	Chilled water loop temperature too low. Check cooler heater.

**LEGEND**

**EXV** — Electronic Expansion Valve

**Alarms and Alerts** — The integral control system constantly monitors the unit and generates warnings when abnormal or fault conditions occur. Alarms may cause either a circuit (Alert) or the whole machine (Alarm) to shut down. Alarms and Alerts are assigned codes as described in Fig. 41. The alarm/alert indicator LED on the Navigator™ module is illuminated when any alarm or alert condition is present. If an Alert is active, the Alarm Indicator LED will blink. If an Alarm is active, the Alarm Indicator LED will remain on. Currently active Alerts and Alarms can be found in *Alarms* → *ALRM* → *ALMI* to *ALM5*.

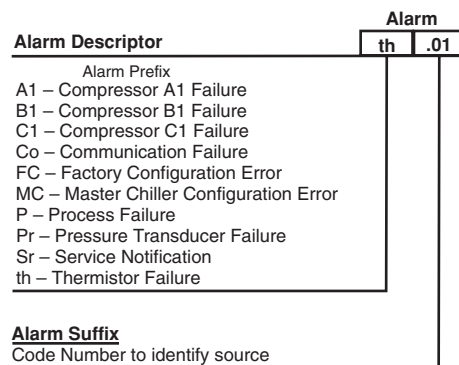
The controller generates two types of alarms. Automatic reset alarms will reset without any intervention if the condition that caused the alarm corrects itself. Manual reset alarms require the service technician to check for the alarm cause and reset the alarm. The following method must be followed to reset manual alarms:

Before resetting any alarm, first determine the cause of the alarm and correct it. Enter the Alarms mode indicated by the LED on the side of the Navigator display. Press **ENTER** and sub-mode *Alarm* → *R.ALM* (Reset All Current Alarms) is displayed. Press **ENTER**. The control will prompt the user for a password, by displaying PASS WORD. Press **ENTER** to display 1111. Press **ENTER** for each character. The default password is 0111. Use the arrow keys to change each individual

character. Use the up or down arrow keys to toggle the display to **YES** and press **ENTER**. The alarms will be reset. Indicator light will be turned off when switched correctly. Do not reset the chiller at random without first investigating and correcting the cause(s) of the failure.

Each alarm is described by a three or four-digit code. The first one or two digits indicate the alarm source and are listed in Fig. 41. The last two digits pinpoint the problem. See Table 39.

An alarm example is shown in Fig. 41.



**Fig. 41 — Alarm Description**

**Table 39 — Alarm Codes**

PREFIX CODE	SUFFIX CODE	ALARM NUMBER	ALARM DESCRIPTION	REASON FOR ALARM	ACTION TAKEN BY CONTROL	RESET TYPE	PROBABLE CAUSE			
th	01	1	Cooler Entering Fluid Thermistor	Temperature measured by the controller is outside of the range of -40 F to 245 F	Unit be shut down or not allowed to start	Automatic	Faulty Sensor, wiring error or failed main base board			
	02	2	Cooler Leaving Fluid Thermistor		None			Configuration error		
	03	3	Circuit A Defrost Thermistor							
	04	4	Circuit B Defrost Thermistor							
	06	5	Condenser Entering Fluid Thermistor							
	07	6	Condenser Leaving Fluid Thermistor							
	08	7	Reclaim Condenser Entering Thermistor							
	09	8	Reclaim Condenser Leaving Thermistor							
	10	9	OAT Thermistor				Unit be shut down or not allowed to start		Faulty Sensor, wiring error or failed main base board	
	11	10	Master/Slave Common Fluid Thermistor				Dual chiller deactivated. Master and slave machines operate in stand-alone mode			
	12	11	Circuit A Suction Gas Thermistor				Circuit shut down or not allowed to start		Faulty Sensor, wiring error, failed EXV or CPM board	
	13	12	Circuit B Suction Gas Thermistor							
	14	13	Circuit C Suction Gas Thermistor							
	15	14	Circuit A Discharge Gas Thermistor							
	16	15	Circuit B Discharge Gas Thermistor							
	17	16	Circuit C Discharge Gas Thermistor							
	18	17	Circuit A Condenser Sub-cooling Liquid Thermistor				None		Configuration error	
	19	18	Circuit B Condenser Sub-cooling Liquid Thermistor				Alarm tripped		Faulty Sensor, wiring error, failed EMM board	
	21	19	Space Temperature Thermistor							
	23	20	Cooler heater feedback thermistor		None		Configuration error			
	24	21	Circuit A Economizer Gas Thermistor		Circuit economizer function disabled		Faulty Sensor, wiring error, failed EXV board			
	25	22	Circuit B Economizer Gas Thermistor							
	26	23	Circuit C Economizer Gas Thermistor							
	Pr	01	24		Circuit A Discharge Transducer		Measured voltage is 0 dc	Circuit shut down or not allowed to start	Automatic	Faulty transducer, wiring error, failed main base board or fan board
		02	25		Circuit B Discharge Transducer					
03		26	Circuit C Discharge Transducer							
04		27	Circuit A Suction Transducer							
05		28	Circuit B Suction Transducer							
06		29	Circuit C Suction Transducer							
07		30	Circuit A Reclaim Pump-down Pressure Transducer	None	Configuration error					
08		31	Circuit B Reclaim Pump-down Pressure Transducer							
10		32	Circuit A Oil Pressure Transducer							
11		33	Circuit B Oil Pressure Transducer	Circuit shut down or not allowed to start	Faulty transducer, wiring error, failed CPM board					
12		34	Circuit C Oil Pressure Transducer							
13		35	Circuit A Economizer Pressure Transducer							
14		36	Circuit B Economizer Pressure Transducer							

LEGEND

- CCN — Carrier Comfort Network®
- CPM — Compressor Protection Module
- EMM — Energy Management Module
- EXV — Electronic Expansion Valve
- MOP — Maximum Operating Pressure
- MTA — Must Trip Amps
- OAT — Outdoor Air Temperature
- SST — Saturated Suction Temperature
- UL — Underwriters' Laboratories

\*NRC2 is the Energy Management Board.

**Table 39 — Alarm Codes (cont)**

PREFIX CODE	SUFFIX CODE	ALARM NUMBER	ALARM DESCRIPTION	REASON FOR ALARM	ACTION TAKEN BY CONTROL	RESET TYPE	PROBABLE CAUSE
<b>Pr</b>	15	37	Circuit C Economizer Pressure Transducer	Measured voltage is 0 dc	Circuit shut down or not allowed to start	Automatic	Faulty transducer, wiring error, failed CPM board
<b>Co</b>	A1	38	Loss of communication with Compressor Board A	No communication with CPM board	Affected compressor shut down	Automatic	Wrong CPM address, wrong unit configuration, wiring error, power loss, failed CPM board
	B1	39	Loss of communication with Compressor Board B				
	C1	40	Loss of communication with Compressor Board C				
	E1	41	Loss of communication with EXV Board A	No communication with EXV board	Affected compressor shut down	Automatic	Wrong EXV board address, wrong unit configuration, wiring error, power loss, failed EXV board
	E2	42	Loss of communication with EXV Board B				
	E3	43	Loss of communication with EXV Board C				
	F1	44	Loss of communication with Fan Board 1	No communication with fan board	Circuit A/B shut down or not allowed to start (080-120 ton), Circuit A shut down or not allowed to start (130-500 ton)	Automatic	Wrong board address, wrong unit configuration, wiring error, loss of power, failed board
	F2	45	Loss of communication with Fan Board 2	No communication with fan board	Circuit B shut down or not allowed to start (130-500 ton)	Automatic	Wrong board address, wrong unit configuration, wiring error, loss of power, failed board
	F3	46	Loss of communication with Fan Board 3	No communication with fan board	Circuit C shut down or not allowed to start (400-500 ton)	Automatic	Wrong board address, wrong unit configuration, wiring error, loss of power, failed board
	01	47	Loss of communication with Free Cooling Board 1	No communication with free cooling board	None	Automatic	Configuration error
	02	48	Loss of communication with Free Cooling Board 2				
	03	49	Loss of communication with Energy Management NRCP2* Board	No communication with EMM board	Disable or not allow EMM functions 3 step and 4-20 mA and space temperature reset, occupancy override and ice build)	Automatic	Wrong module address, wrong unit configuration, wiring error, power loss to module, failed module
	04	50	Loss of communication with Heat Reclaim Board	No communication with Free Cooling Board	None	Automatic	Configuration error
05	51	Loss of communication with AUX Board 6					
<b>P</b>	01	52	Cooler Freeze Protection	Entering or leaving thermostat sensed a temperature at or below freeze point	Unit shut down or not allowed to start	Automatic, first occurrence in 24 hours; manual if multiple alarms within 24 hours	Faulty thermistor, faulty wiring, low water flow, low loop volume, fouled cooler, or freeze conditions
	02	53	Condenser Freeze Protection Circuit A	—	None	Automatic	Configuration error
	03	54	Condenser Freeze Protection Circuit B				
	04	55	Condenser Freeze Protection Circuit C				
	05	56	Circuit A Low Suction Temperature	Low saturated suction temperatures detected for a period of time	Circuit shut down	Automatic, first occurrence in 24 hours; manual if multiple alarms within 24 hours	Faulty thermistor, faulty wiring, low water flow, low loop volume, fouled cooler, or freeze conditions
	06	57	Circuit B Low Suction Temperature				
	07	58	Circuit C Low Suction Temperature				
	08	59	Circuit A High Suction Superheat	EXV>98%, suction superheat > 30 F, and SST<MOP for more than 5 minutes	Circuit shut down	Manual	Faulty transducer, faulty wiring, faulty thermistor, faulty EXV, low refrigerant charge, plugged or restricted liquid line
	09	60	Circuit B High Suction Superheat				
	10	61	Circuit C High Suction Superheat				

**LEGEND**

- |   |  |
|---|--|
| <b>CCN</b> — Carrier Comfort Network®     | <b>MTA</b> — Must Trip Amps                |
| <b>CPM</b> — Compressor Protection Module | <b>OAT</b> — Outdoor Air Temperature       |
| <b>EMM</b> — Energy Management Module     | <b>SST</b> — Saturated Suction Temperature |
| <b>EXV</b> — Electronic Expansion Valve   | <b>UL</b> — Underwriters' Laboratories     |
| <b>MOP</b> — Maximum Operating Pressure   |  |

\*NRCP2 is the Energy Management Board.

**Table 39 — Alarm Codes (cont)**

PREFIX CODE	SUFFIX CODE	ALARM NUMBER	ALARM DESCRIPTION	REASON FOR ALARM	ACTION TAKEN BY CONTROL	RESET TYPE	PROBABLE CAUSE
P	11	62	Circuit A Low Suction Superheat	EXV<5% and either the suction superheat is less than the set point by at least 5 F or the suction temperature is greater than MOP set point for more than 5 minutes	Circuit shut down	Manual	Faulty transducer, faulty wiring, faulty thermistor, faulty EXV, or incorrect configuration
	12	63	Circuit B Low Suction Superheat				
	13	64	Circuit C Low Suction Superheat				
	14	65	Interlock Failure	Lockout Switch Closes	Unit shut down or not allowed to start	Automatic	Lock Switch Closed
	28	66	Electrical Box Thermostat Failure/Reverse Rotation	Not supported	—	—	—
	29	67	Loss of communication with System Manager	Loss of communication with an external control device for more than 2 minutes	Unit change to stand-alone operation	Automatic	Faulty communication wiring, no power supply to the external controller
	30	68	Master/Slave communication Failure	Communication between the master and slave machines lost	Unit change to stand-alone operation	Automatic	Faulty communication wiring, no power or control power to the main base board of either module
	67	69	Circuit A Low Oil Pressure	Oil pressure and suction pressure differential is less than the set point	Circuit shut down	Automatic, first occurrence in 24 hours; manual if multiple alarms within 24 hours	Plugged oil filter, faulty oil transducer, oil check valve stuck, plugged oil strainer
	68	70	Circuit B Low Oil Pressure				
	69	71	Circuit C Low Oil Pressure				
	70	72	Circuit A Max Oil Filter Differential Pressure	Difference between discharge pressure and oil pressure is greater than 50 psi for more than 30 seconds	Circuit shut down	Manual	Plugged oil filter, closed oil valve, bad oil solenoid, oil check valve stuck, faulty oil transducer
	71	73	Circuit B Max Oil Filter Differential Pressure				
	72	74	Circuit C Max Oil Filter Differential Pressure				
	84	75	Circuit A High Oil Filter Drop Pressure	Difference between discharge pressure and oil pressure is greater than 30 psi for more than 5 minutes	Alarm tripped	Manual	Plugged filter
	85	76	Circuit B High Oil Filter Drop Pressure				
	86	77	Circuit C High Oil Filter Drop Pressure				
	75	78	Circuit A Low Oil Level	Oil level switch open	Circuit shut down or not allowed to start	Automatic, first occurrence in 24 hours; manual if multiple alarms within 24 hours	Low oil level, faulty switch, wiring error, failed CPM board
	76	79	Circuit B Low Oil Level				
77	80	Circuit C Low Oil Level					
MC	nn	81	Master chiller configuration error Number 01 to nn	Wrong or incompatible configuration data	Unit not allowed to start in Master-slave control	Automatic	Configuration error
FC	n0	82	No factory configuration	No Configuration	Unit not allowed to start	Automatic	Configuration error
	nn	83	Illegal factory configuration Number 01 to 04	Wrong or incompatible configuration data	Unit not allowed to start	Automatic	Configuration error (see Table 40)
P	31	84	Unit is in CCN emergency stop	Emergency stop command has been received	Unit shut down or not allowed to start	Automatic	Carrier Comfort Network® Emergency Stop command received
	32	85	Cooler pump #1 fault	Pump interlock status does not match pump status	Unit shuts down, if available, another pump will start	Manual	Faulty contacts, wiring error or low control voltage. Configuration error.
	33	86	Cooler pump #2 fault				
	15	87	Condenser Flow Switch Failure	—	None	Manual	Configuration error
	34	88	Circuit A Reclaim Operation Failure	—	None	Manual	Configuration error
	35	89	Circuit B Reclaim Operation Failure				
	37	90	Circuit A — Repeated high discharge gas overrides	Multiple capacity overrides due to high saturated discharge temperature	Circuit shut down	Automatic	Condenser air recirculation, dirty or plugged condenser coils, inaccurate discharge transducer, faulty condenser fan
	38	91	Circuit B — Repeated high discharge gas overrides				
39	92	Circuit C — Repeated high discharge gas overrides					

**LEGEND**

- |   |  |
|---|--|
| <b>CCN</b> — Carrier Comfort Network®     | <b>MTA</b> — Must Trip Amps                |
| <b>CPM</b> — Compressor Protection Module | <b>OAT</b> — Outdoor Air Temperature       |
| <b>EMM</b> — Energy Management Module     | <b>SST</b> — Saturated Suction Temperature |
| <b>EXV</b> — Electronic Expansion Valve   | <b>UL</b> — Underwriters' Laboratories     |
| <b>MOP</b> — Maximum Operating Pressure   |  |

\*NRCP2 is the Energy Management Board.

**Table 39 — Alarm Codes (cont)**

PREFIX CODE	SUFFIX CODE	ALARM NUMBER	ALARM DESCRIPTION	REASON FOR ALARM	ACTION TAKEN BY CONTROL	RESET TYPE	PROBABLE CAUSE
P	40	93	Circuit A — Repeated low suction temp overrides	Multiple capacity overrides due to low saturated suction temperature	Circuit shut down	Automatic	Inaccurate transducer, faulty EXV, low refrigerant charge, plugged or restricted liquid line filter drier.
	41	94	Circuit B — Repeated low suction temp overrides				
	42	95	Circuit C — Repeated low suction temp overrides				
	43	96	Low entering water temperature in heating	Not supported	—	—	—
	73	97	Condenser pump #1 default	—	None	Manual	Configuration error
	74	98	Condenser pump #2 default				
	78	99	Circuit A High Discharge Temperature	Discharge gas temperature is higher than 212 F for more than 90 seconds	Circuit shut down	Manual	Faulty transducer/high pressure switch, low/restricted condenser flow
	79	100	Circuit B High Discharge Temperature				
	80	101	Circuit C High Discharge Temperature				
	81	102	Circuit A Low Economizer Pressure	The economizer pressure is below the suction pressure more than 14.5 psi for more than 10 seconds	Circuit shut down	Manual	Faulty transducer, faulty main base board, faulty wiring, closed suction service valve, faulty EXV
	82	103	Circuit B Low Economizer Pressure				
	83	104	Circuit C Low Economizer Pressure				
	87	105	Circuit A Slide Valve Control Unverifiable	If 100% load current is less than 1.3 times of 30% load current, or 30% load current is greater than 0.78 times of expected 100% load current	Alarm tripped	Manual	Slide valve stuck, inaccurate initial current reading
	88	106	Circuit B Slide Valve Control Unverifiable				
	89	107	Circuit C Slide Valve Control Unverifiable				
	90	108	Cooler flow switch set point configuration failure	—	None	Manual	Configuration error
91	109	Cooler flow switch failure	Flow switch open	Unit shut down	Manual if unit is running, automatic otherwise	Faulty flow switch, low cooler flow, faulty wiring, faulty cooler pump, faulty main base board	
Sr	nn	110	Service maintenance alert Number # nn	Field programmed elapsed time has expired for maintenance time	None	Manual	Maintenance required
A1, B1, C1	01	111-01, 112-01, 113-01	Compressor Motor temperature too high	Compressor temperature higher than 232 F for more than 90 seconds	Circuit shut down	Manual	Motor cooling solenoid or economizer EXV failure, faulty CPM board, low refrigerant charge
	02	111-02, 112-02, 113-02	Compressor Motor temperature out of range	Compressor temperature reading out of the range of -40 F to 245 F	Circuit shut down	Manual	Faulty thermistor, faulty wiring, faulty CPM board
	03	111-03, 112-03, 113-03	Compressor High pressure switch protection	HPS input on CPM board open	Circuit shut down	Manual	Loss of condenser air flow, operation beyond compressor envelope, faulty high pressure switch, faulty wiring, faulty CPM board
	04	111-04, 112-04, 113-04	Compressor Over current	CPM board detects high motor current compared with MTA setting	Circuit shut down	Manual	Operating beyond chiller envelope, incorrect configuration
	05	111-05, 112-05, 113-05	Compressor Locked rotor	CPM board detects locked rotor current compared with MTA setting	Circuit shut down	Manual	Compressor motor failure, unloader slide valve failure, compressor mechanical failure
	06	111-06, 112-06, 113-06	Compressor Phase loss L1	CPM board detects current unbalance greater than 65% for more than 1 second	Circuit shut down	Manual	Blown fuse, wiring error, loose terminals
	07	111-07, 112-07, 113-07	Compressor Phase loss L2				
	08	111-08, 112-08, 113-08	Compressor Phase loss L3				
	09	111-09, 112-09, 113-09	Compressor Low current alarm	CPM detects motor current less than a certain percentage of the MTA setting	Circuit shut down	Manual	Power supply disconnected, blown fuse, wiring error, contact deenergized, faulty current toroid.

LEGEND

- |   |  |
|---|--|
| <b>CCN</b> — Carrier Comfort Network®     | <b>MTA</b> — Must Trip Amps                |
| <b>CPM</b> — Compressor Protection Module | <b>OAT</b> — Outdoor Air Temperature       |
| <b>EMM</b> — Energy Management Module     | <b>SST</b> — Saturated Suction Temperature |
| <b>EXV</b> — Electronic Expansion Valve   | <b>UL</b> — Underwriters' Laboratories     |
| <b>MOP</b> — Maximum Operating Pressure   |  |

\*NRCP2 is the Energy Management Board.

**Table 39 — Alarm Codes (cont)**

PREFIX CODE	SUFFIX CODE	ALARM NUMBER	ALARM DESCRIPTION	REASON FOR ALARM	ACTION TAKEN BY CONTROL	RESET TYPE	PROBABLE CAUSE
A1, B1, C1	10	111-10, 112-10, 113-10	Compressor Y delta starter current increase failure alarm	If the delta mode current is not 25% greater than the current in Y mode	Circuit shut down	Manual	Power supply to delta contactor not connected, faulty delta contactor or wiring, faulty CPM board
	11	111-11, 112-11, 113-11	Compressor Contactor failure	CPM board detects greater than 15% of MTA current for 10 seconds after shutting off the compressor contactor. Oil solenoid is energized.	Circuit shut down	Manual	Faulty contactor, contactor welded, wiring error
	12	111-12, 112-12, 113-12	Compressor Unable to stop motor	CPM board detects greater than 15% of MTA current for 10 seconds after three attempts	Circuit shut down	Manual	Faulty contactor, contactor welded, wiring error
	13	111-13, 112-13, 113-13	Compressor Phase reversal	CPM board detects phase reversal from current toroid	Circuit shut down	Manual	Terminal block power supply lead not in correct phase. Power supply leads going through toroid crossed
	14	111-14, 112-14, 113-14	Compressor MTA configuration fault	MTA setting is out of the allowed MTA range	Circuit shut down	Manual	Incorrect MTA setting, faulty CPM board
	15	111-15, 112-15, 113-15	Compressor Configuration switch mismatch	CPM board MTA setting do not match factory configuration	Circuit shut down	Manual	Incorrect CPM dipswitch setting, incorrect factory MTA setting, faulty CPM board
	16	111-16, 112-16, 113-16	Compressor Unexpected switch setting change	CPM board dipswitch S1 setting changed	Circuit shut down	Manual	Incorrect CPM dipswitch setting, faulty CPM board
	17	111-17, 112-17, 113-17	Compressor Power on reset	CPM board detects a power failure	Circuit shut down	Manual	Power supply interruption
	18	111-18, 112-18, 113-18	Compressor UL 1998 critical section software error	Software error	Circuit shut down	Manual	Electric noise, faulty CPM board
	19	111-19, 112-19, 113-19	Compressor UL 1998 current measure dual channel mismatch	Software error	Circuit shut down	Manual	Electric noise, faulty CPM board

**LEGEND**

- |   |  |
|---|--|
| <b>CCN</b> — Carrier Comfort Network®     | <b>MTA</b> — Must Trip Amps                |
| <b>CPM</b> — Compressor Protection Module | <b>OAT</b> — Outdoor Air Temperature       |
| <b>EMM</b> — Energy Management Module     | <b>SST</b> — Saturated Suction Temperature |
| <b>EXV</b> — Electronic Expansion Valve   | <b>UL</b> — Underwriters' Laboratories     |
| <b>MOP</b> — Maximum Operating Pressure   |  |

\*NRCP2 is the Energy Management Board.

**DIAGNOSTIC ALARM CODES AND POSSIBLE CAUSES**

Thermistor Failure

Alarm 1 — Cooler Fluid Entering (th.01)

Alarm 2 — Cooler Fluid Leaving (th.02)

*Criteria for Trip* — This alarm criterion is tested whether the unit is on or off if the temperature as measured by the thermistor is outside of the range -40 to 245 F (-40 to 118.3 C).

*Action to be Taken* — The unit shuts down normally, or is not allowed to start.

*Reset Method* — Automatic, the alarm will reset once the thermistor reading is within the expected range.

*Possible Causes* — If this condition is encountered, check the following items:

- sensor wiring to the Main Base Board
- sensor accuracy

See the Thermistors section on page 52 for thermistor description, identifiers and connections.

Defrost Thermistor Failure

Alarm 3 — Circuit A (th.03)

Alarm 4 — Circuit B (th.04)

NOTE: These alarms are not used or supported. If this condition is encountered, confirm machine configuration.

Thermistor Failure

Alarm 5 — Condenser Entering Fluid (th.06)

Alarm 6 — Condenser Leaving Fluid (th.07)

NOTE: These alarms are not used or supported. If this condition is encountered, confirm machine configuration.

Condenser Reclaim Thermistor

Alarm 7 — Reclaim Entering Fluid (th.08)

Alarm 8 — Reclaim Leaving Fluid (th.09)

NOTE: Alarms 7 and 8 are not used or supported. If this condition is encountered, confirm machine configuration.

Alarm 9 — Outdoor Air Temperature Thermistor Failure (th.10)

*Criteria for Trip* — This alarm criterion is tested whether the unit is ON or OFF. The alarm is tripped if the temperature measured by the outdoor air thermistor sensor is outside the range of -40 to 245 F (-40 to 118.3 C).

*Action to be Taken* — The unit shuts down normally, or is not allowed to start.

*Reset Method* — Automatic, the alarm will reset once the thermistor reading is within the expected range.

*Possible Causes* — If this condition is encountered, check the following items:

- sensor wiring to the Main Base Board
- a faulty thermistor

See the Thermistors section on page 52 for thermistor description, identifiers and connections.

#### Alarm 10 — Master/Slave Common Fluid Thermistor (th.11)

*Criteria for Trip* — This alarm criterion is tested whether the unit is ON or OFF. The alarm will be tripped if the unit is configured as a master or a slave (MSSL), leaving temperature control is selected (EWTO), and if the temperature measured by the CHWS (chilled water sensor) fluid sensor is outside the range of –40 to 245 F (–40 to 118.3 C).

*Action to be Taken* — Master/slave operation is disabled and the chiller returns to stand alone mode.

*Reset Method* — Reset is automatic when the thermistor reading is inside the range of –40 to 245 F (–40 to 118.3 C).

*Possible Causes* — If this condition is encountered, check the following items:

- sensor wiring to the Main Base Board
- a faulty thermistor

See the Thermistors section on page 52 for thermistor description, identifiers and connections.

#### Suction Gas Thermistor

Alarm 11 — Circuit A (th.12)

Alarm 12 — Circuit B (th.13)

Alarm 13 — Circuit C (th.14)

*Criteria for Trip* — This alarm criterion is tested whether the unit is ON or OFF. If the suction gas temperature as measured by the thermistor is outside of the range –40 to 245 F (–40 to 118.3 C).

*Action to be Taken* — The affected circuit shuts down normally.

*Reset Method* — Automatic, once the thermistor reading is within the expected range. The affected circuit will restart once the alarm has cleared.

*Possible Causes* — If this condition is encountered, check the following items:

- sensor wiring to the EXV board
- board for a faulty channel
- a faulty thermistor

See the Thermistors section on page 52 for thermistor description, identifiers and connections.

#### Circuit Discharge Gas Thermistor Sensor Failure

Alarm 14 — Circuit A (th.15)

Alarm 15 — Circuit B (th.16)

Alarm 16 — Circuit C (th.17)

*Criteria for Trip* — This alarm criterion is tested whether the unit is ON or OFF. The alarm is tripped if the temperature measured by the Outdoor Air Thermistor sensor is outside the range of –40 to 245 F (–40 to 118.3 C).

*Action to be Taken* — The unit shuts down normally, or is not allowed to start.

*Reset Method* — Automatic, the alarm will reset once the thermistor reading is within the expected range.

*Possible Causes* — If this condition is encountered, check the following items:

- sensor wiring to the CPM board
- a faulty thermistor
- a faulty channel on the board

See the Thermistors section on page 52 for thermistor description, identifiers and connections.

#### Condenser Subcooling Liquid Thermistor

Alarm 17 — Circuit A (th.18)

Alarm 18 — Circuit B (th.19)

NOTE: Alarms 17 and 18 are not used or supported. If this condition is encountered, confirm machine configuration.

#### Alarm 19 — Space Temperature Sensor Failure (th.21)

*Criteria for Trip* — This alarm criterion is checked whether the unit is ON or OFF and if Space Temperature Reset has been enabled. This alarm is generated if the outdoor-air temperature as measured by the thermistor is outside of the range –40 to 245 F (–40 to 118.3 C).

*Action to be Taken* — Unit operates under normal control. Temperature Reset based on Space Temperature is disabled.

*Reset Method* — Automatic, once the thermistor reading is within the expected range. The Space Temperature Reset will resume once the alarm has cleared.

*Possible Causes* — If this condition is encountered, check the following items:

- sensor wiring to the Energy Management Module
- board for a faulty channel
- a faulty thermistor

For thermistor descriptions, identifiers and connections, see the Thermistors section.

#### Alarm 20 — Cooler Heater Feedback Sensor Thermistor (th.23)

NOTE: Alarm 20 is not used or supported. If this condition is encountered, confirm machine configuration.

#### Economizer Gas Thermistor

Alarm 21 — Circuit A (th.24)

Alarm 22 — Circuit B (th.25)

Alarm 23 — Circuit C (th.26)

*Criteria for Trip* — This alarm criterion is tested whether the unit is ON or OFF. The alarm is tripped if the Economizer gas reading is outside the range of –40 to 245 F (–40 to 118.3 C).

*Action to be Taken* — The unit shuts down normally, or is not allowed to start.

*Reset Method* — Automatic, the alarm will reset once the thermistor reading is within the expected range.

*Possible Causes* — If this condition is encountered, check the following items:

- sensor wiring to the EXV board
- a faulty thermistor
- a faulty channel on the board

See the Thermistors section on page 52 for thermistor description, identifiers and connections.

#### Discharge Transducer

Alarm 24 — Circuit A (Pr.01)

Alarm 25 — Circuit B (Pr.02)

Alarm 26 — Circuit C (Pr.03)

*Criteria for Trip* — The criterion is tested whether the circuit is ON or OFF. This alarm is generated if the voltage as sensed by the MBB or Fan Board C (FBC) is 0 vdc, which corresponds to the Navigator™ display of –7 psi (–48.3 kPa).

*Action to be Taken* — The circuit is shut down normally, or not allowed to start.

*Reset Method* — Automatic, once the transducer voltage is greater than 0 vdc, which corresponds to the Navigator display of a value greater than –7 psi (–48.3 kPa).

*Possible Causes* — If this condition is encountered, check the following items:

- sensor wiring to Main Base Board (Alarms 24 and 25)
- sensor wiring to Fan Board C (Alarm 26)
- board for a faulty channel
- for a faulty transducer
- confirm unit configuration

### Suction Pressure Transducer Failure

Alarm 27 — Circuit A (Pr.04)

Alarm 28 — Circuit B (Pr.05)

Alarm 29 — Circuit C (Pr.06)

*Criteria for Trip* — The criteria are tested whether the circuit is ON or OFF. The alarm is generated if one of the following criteria is met:

1. If the voltage as sensed by the MBB or Fan Board C is 0 vdc, which corresponds to the Navigator™ display of -7 psi (-48.3 kPa).
2. The circuit is ON in cooling mode and the Saturated Suction Temperature (SST) for the circuit is greater than the Entering Water Temperature for more than 60 seconds.

*Action to be Taken* — The circuit is shut down immediately, or not allowed to start.

#### *Reset Method*

1. Automatic, once the transducer voltage is greater than 0 vdc, which corresponds to the Navigator display of a value greater than -7 psi (-48.3 kPa).
2. Automatic once the circuit's saturated suction temperature is lower than the Leaving Water Temperature by 3° F (1.6° C). If this criterion trips the alarm 3 times within a 24-hour period, the alarm changes to a manual reset.

*Possible Causes* — If this condition is encountered, check the following items:

- sensor wiring to Main Base Board (Alarms 27 and 28)
- sensor wiring to Fan Board C (Alarm 29)
- board for a faulty channel
- faulty transducer
- faulty leaving water temperature sensor
- unit configuration

### Reclaim Pumpdown Pressure Transducer

Alarm 30 — Circuit A (Pr.07)

Alarm 31 — Circuit B (Pr.08)

NOTE: Alarms 30 and 31 are not used or supported. If this condition is encountered, confirm machine configuration.

### Oil Pressure Transducer

Alarm 32 — Circuit A (Pr.10)

Alarm 33 — Circuit B (Pr.11)

Alarm 34 — Circuit C (Pr.12)

*Criteria for Trip* — The criteria are tested whether the circuit is ON or OFF. The alarm is generated if one of the following criteria is met:

1. If the voltage as sensed by the MBB or Fan Board C is 0 vdc, which corresponds to the Navigator display of -7 psi (-48.3 kPa).
2. The circuit is OFF and outside air temperature is below 35.6 F (2 C).
3. The circuit is OFF and the fluid type is brine.

*Action to be Taken* — The circuit is shut down immediately, or not allowed to start.

*Reset Method* — Automatic, once the transducer voltage is greater than 0 vdc.

*Possible Causes* — If this condition is encountered, check the following items:

- sensor wiring to CPM board
- board for a faulty channel
- faulty transducer
- plugged oil filter
- faulty oil solenoid valve coil
- stuck oil solenoid valve
- confirm unit configuration

### Economizer Pressure Transducer Failure

Alarm 35 — Circuit A (Pr. 13)

Alarm 36 — Circuit B (Pr. 14)

Alarm 37 — Circuit C (Pr. 15)

*Criteria for Trip* — The criteria are tested whether the circuit is ON or OFF. The alarm is generated if the voltage as sensed by the MBB or Fan Board C is 0 vdc, which corresponds to the Navigator display of -7 psi (-48.3 kPa).

*Action to be Taken* — The circuit is shut down immediately, or not allowed to start.

*Reset Method* — Automatic, once the transducer voltage is greater than 0 vdc, which corresponds to the Navigator display of a value greater than -7 psi (-48.3 kPa).

*Possible Causes* — If this condition is encountered, check the following items:

- sensor wiring to EXV Board
- EXV board for a faulty channel
- faulty transducer
- faulty economizer EXV or EXV wiring
- faulty economizer EXV channel on the board
- closed or partially closed suction service valve
- confirm unit configuration

### Loss of Communication with Compressor Board

Alarm 38 — Compressor Board A (Co.A1)

Alarm 39 — Compressor Board B (Co.B1)

Alarm 40 — Compressor Board C (Co.C1)

*Criteria for Trip* — The alarm criterion is tested whether the unit is ON or OFF. If communication with the Compressor Protection Module Board (CPM) is lost for a period of 10 seconds, the alarm will be generated.

*Action to be Taken* — The affected compressor will be shut down.

*Reset Method* — Automatic, if communication is established. If called for, the compressor will start normally.

*Possible Causes* — If this condition is encountered, check the following items:

- power supply to the affected CPM board
- address of the CPM
- local equipment network (LEN) wiring
- confirm unit configuration

### Loss of Communication with EXV Board

Alarm 41 — Circuit A, EXV Board A (Co.A1)

Alarm 42 — Circuit B, EXV Board B (Co.B2)

Alarm 43 — Circuit C, EXV Board C (Co.C3)

*Criteria for Trip* — The alarm criterion is tested whether the unit is ON or OFF. If communication with EXVA, B or C is lost for a period of 10 seconds, the alarm will be triggered.

*Action to be Taken* — If running, Circuit A, B or C will shut down normally. If Circuit A, B or C is not operating, it will not be allowed to start.

*Reset Method* — Automatic, if communication is established, the unit will start normally.

*Possible Causes* — If this condition is encountered, check the following items:

- power supply to EXVA, B or C
- address of the EXV board
- local equipment network (LEN) wiring
- confirm unit configuration

### Alarm 44 — Loss of Communication with Fan Board 1 (Co.F1)

*Criteria for Trip* — The criterion is tested whether the unit is ON or OFF. If communication with Fan Board A is lost for a period of 10 seconds, the alarm will be triggered.

*Action to be Taken* — If the number of fans per circuit is greater than four fans per circuit, Circuit A will shut down normally if they are running. Circuit B will continue to run. If the circuit or circuits controlled by the board are not running, then they will not be allowed to start.

*Reset Method* — Automatic, if communication is established, the unit will start normally.

*Possible Causes* — If this condition is encountered, check the following items:

- power supply to Fan Board A
- address of the Fan Board A
- local equipment network (LEN) wiring
- confirm unit configuration

#### Alarm 45 — Loss of Communication with Fan Board 2 (Co.F2)

*Criteria for Trip* — The criterion is tested whether the unit is ON or OFF, and only if Circuit A or B has more than four fans per circuit.

NOTE: Fan Board B controls Circuit B only.

*Action to be Taken* — If communication with Fan Board B is lost for a period of 10 seconds, the alarm will be triggered. If running, Circuit B will shut down normally. If Circuit B is not running, then it will not be allowed to start.

*Reset Method* — Automatic, if communication is established, the unit will start normally.

*Possible Causes* — If this condition is encountered, check the following items:

- power supply to Fan Board B
- address of the Fan Board B
- local equipment network (LEN) wiring
- confirm unit configuration

#### Alarm 46 — Loss of Communication with Fan Board 3 (Co.F3)

*Criteria for Trip* — The criterion is tested whether the unit is ON or OFF, and on units with three circuits only. If communication with Fan Board C is lost for a period of 10 seconds, the alarm will be triggered.

*Action to be Taken* — If running, Circuit C will shut down normally. If the circuit is not running, then it will not be allowed to start.

*Reset Method* — Automatic, if communication is established, the unit will start normally.

*Possible Causes* — If this condition is encountered, check the following items:

- power supply to Fan Board C
- address of the Fan Board C
- local equipment network (LEN) wiring
- confirm unit configuration

#### Loss of Communication with Free Cooling Board

Alarm 47 — Board 1 (Co.01)

Alarm 48 — Board 2 (Co.02)

NOTE: Alarms 47 and 48 are not used or supported. If this condition is encountered, confirm machine configuration.

#### Alarm 49 — Loss of Communication with Energy Management Module Board (Co.03)

*Criteria for Trip* — The criterion is tested whether the unit is ON or OFF and when a function that requires the Energy Management Module (EMM) is configured. If communication with the EMM is lost for a period of 10 seconds, the alarm will be triggered.

*Action to be Taken* — If any function controlled by the EMM (3-Step and 4-20 mA Demand Limit, 4-20 mA and Space Temperature Reset, Occupancy Override, and Ice Build) is

active, that function will be terminated. If an EMM function is programmed, and communication is lost, the function will not be allowed to start.

*Reset Method* — Automatic, if communication is established, the functions will be enabled.

*Possible Causes* — If this condition is encountered, check the following items:

- The EMM is installed, (**Configuration**→**UNIT**→**EMM**). If (**EMM=YES**), check for a control option that requires the EMM that may be enabled (correct configuration if not correct).
- power supply to EMM
- address of the EMM
- local equipment network (LEN) wiring
- confirm unit configuration to be sure that no options that require the EMM are enabled

#### Alarm 50 — Loss of Communication with Heat Reclaim Board (Co.O4)

NOTE: Alarm 50 is not used or supported. If this condition is encountered, confirm machine configuration.

#### Alarm 51 — Loss of Communication with AUX Board 6 (Co.O5)

NOTE: Alarm 51 is not used or supported. If this condition is encountered, confirm machine configuration.

#### Alarm 52 — Cooler Freeze Protection (P.01)

*Criteria for Trip* — The alarm criteria are checked whether the unit is ON or OFF. If the entering or leaving water thermistor senses a temperature at the freeze point or less, the alarm will be generated. For a fresh water system (**Configuration**→**SERV**→**FLUD=1**), the freeze point is 34 F (1.1 C). For medium temperature brine systems (**Configuration**→**SERV**→**FLUD=2**), the freeze point is Brine Freeze Set Point (**Configuration**→**SERV**→**LOSP**).

*Action to be Taken* — Unit shut down or not allowed to start. Chilled water pump will be started.

*Reset Method* — Automatic, first occurrence in 24 hours if LWT rises to 6° F (3° C) above set point. Manual, if more than one occurrence in 24 hours.

*Possible Causes* — If this condition is encountered, check the following items:

- entering and leaving fluid thermistors for accuracy
- water flow rate
- loop volume — low loop volume at nominal flow rates can in extreme cases bypass cold water to the cooler
- freezing conditions
- heater tape and other freeze protection items for proper operation
- glycol concentration and adjust **LOSP** accordingly
- If the Leaving Water Set Point is above 40 F (4.4 C) and there is glycol in the loop, consider using the Medium Temperature Brine option (**Configuration**→**SERV**→**FLUD=2**) to utilize the brine freeze point instead of 34 F (1.1 C)

#### Condenser Freeze Protection

Alarm 53 — Circuit A (P.02)

Alarm 54 — Circuit B (P.03)

Alarm 55 — Circuit C (P.04)

NOTE: Alarms 53-55 are not used or supported. If this condition is encountered, confirm machine configuration.

#### Low Saturated Suction Temperature

Alarm 56 — Circuit A (P.05)

Alarm 57 — Circuit B (P.06)

Alarm 58 — Circuit C (P.07)

*Criteria for Trip* — The criteria are tested only when the circuit is ON. This alarm is generated if one of the following criteria is met:

- If the circuit Saturated Suction Temperature is below -13 F (-25 C) for more than 30 seconds.
- If the circuit Saturated Suction Temperature is below -22 F (-30 C) for more than 8 seconds.
- If the circuit Saturated Suction Temperature is below -40 F (-40 C) for more than 3 seconds.

*Action to be Taken* — The circuit is shut down immediately.

Prior to the alarm trip, the control will take action to avoid the alarm. See Operating Modes 21, 22 and 23 on page 51.

*Reset Method* — Automatic, first occurrence in 24 hours. Manual, if more than one occurrence in 24 hours.

*Possible Causes* — If this condition is encountered, check the following items:

- sensor wiring to Main Base Board (Alarm 56 and 57) or Fan Board C (Alarm 58)
- board for a faulty channel
- faulty suction transducer
- cooler water flow
- loop volume
- EXV operation
- liquid line refrigerant restriction, filter drier, service valve, etc
- refrigerant charge
- If the Leaving Water Set Point is above 40 F (4.4 C) and there is glycol in the loop, consider using the Medium Temperature Brine option (*Configuration* → *SERV* → *FLUD* = 2) to utilize the brine freeze point instead of 34 F (1.1 C).

#### High Suction Superheat

Alarm 59 — Circuit A (P.08)

Alarm 60 — Circuit B (P.09)

Alarm 61 — Circuit C (P.10)

*Criteria for Trip* — The criteria are tested only when the circuit is ON. This alarm is generated if *all* of the following criteria are met:

- The EXV position is equal to or greater than 98%.
- The circuit's Suction Superheat (Suction Gas Temperature - Saturated Suction Temperature) is greater than the superheat control set point.
- The circuit's Saturated Suction Temperature is less than Maximum Operating Pressure (MOP) set point (*Configuration* → *SERV* → *MOP*) for more than 5 minutes.

*Action to be Taken* — The circuit is shut down normally.

*Reset Method* — Manual.

*Possible Causes* — If this condition is encountered, check the following items:

- suction pressure transducer wiring to Main Base Board (Alarm 59 and 60) or Fan Board C (Alarm 61)
- board for a faulty channel
- a faulty suction transducer
- suction gas thermistor wiring to EXV Board 1 (Alarm 41) or to EXV Board 2 (Alarm 43)
- suction gas thermistor sensor for accuracy
- for EXV Board 1 (Alarm 41) or EXV Board 2 (Alarm 42) faulty channel
- EXV operation
- a liquid line refrigerant restriction, filter drier, service valve, etc
- refrigerant charge

#### Low Suction Superheat

Alarm 62 — Circuit A (P.11)

Alarm 63 — Circuit B (P.12)

Alarm 64 — Circuit C (P.13)

*Criteria for Trip* — The criteria are tested when the circuit is ON. This alarm is generated if the following criterion is met:

The EXV position is equal to or less than 5% and the circuit's Suction Superheat (Suction Gas Temperature - Saturated Suction Temperature) is less than the Suction Superheat Set Point (*Configuration* → *SERV* → *SHP.A*, *Configuration* → *SERV* → *SHP.B*, or *Configuration* → *SERV* → *SHP.C*) by at least 5° F (2.8° C) or the circuit Saturated Suction Temperature is greater than Maximum Operating Pressure (MOP) set point (*Configuration* → *SERV* → *MOP*) for more than 5 minutes.

*Action to be Taken* — The circuit is shut down normally.

*Reset Method* — Automatic, first occurrence in 24 hours. Manual, if more than one occurrence in 24 hours.

*Possible Causes* — If this condition is encountered, check the following items:

- suction pressure transducer wiring to Main Base Board (Alarm 62 and 63) or Fan Board C (Alarm 64)
- board for a faulty channel
- faulty suction transducer
- suction gas thermistor wiring to EXV Board 1 (Alarm 41) or to EXV Board 2 (Alarm 42)
- suction gas thermistor sensor for accuracy
- EXV Board 1 (Alarm 41) or EXV Board 2 (Alarm 42) faulty channel
- EXV operation
- confirm maximum operating pressure set point
- refrigerant charge level

#### Alarm 65 — Interlock Failure (P.14)

*Criteria for Trip* — The criteria are tested whether the unit is ON or OFF. This alarm is generated if the lockout switch (located in the Energy Management Module) is closed during normal operation.

*Action to be Taken* — All compressors are shut down immediately without going through pumpdown. and is not allowed to start.

*Reset Method* — Automatic, first occurrence in 24 hours. Manual, if more than one occurrence in 24 hours.

*Possible Causes* — If this condition is encountered, check the following items:

- chilled water flow switch operation
- water flow. Be sure all water isolation valves are open and check water strainer for a restriction
- interlock wiring circuit
- power supply to the pump
- control signal to the pump controller
- chilled water pump operation
- cooler pump contactor for proper operation

#### Alarm 66 — Electrical Box Thermostat Failure/Reverse Rotation (P.28)

NOTE: Alarm 66 is not used or supported. If this condition is encountered, confirm machine configuration.

#### Alarm 67 — Loss of Communication with System Manager (P.29)

*Criteria for Trip* — The criterion is tested whether the unit is ON or OFF. This alarm is generated if the System Manager had established communications with the machine and is then lost for more than 2 minutes.

*Action to be Taken* — The action to be taken by the control depends on the configuration. If Auto Start when SM lost is enabled, (*Configuration* → *SERV* → *AU.SM* = YES), then the unit will force the CCN Chiller Start Stop to ENBL and clear all forced points from the System Manager. The unit will revert to stand-alone operation.

*Reset Method* — Automatic, once communication is re-established.

*Possible Causes* — If this condition is encountered, check the following items:

- communication wiring
- power supply to the System Manager and unit controls

#### Alarm 68 — Master/Slave Communication Failure (P.30)

*Criteria for Trip* — The criterion is tested whether the units are ON or OFF and a Master and Slave machine has been configured, (*Configuration* → *RSET* → *MSSL=1* and *Configuration* → *RSET* → *MSSL=2*). If communication is lost for more than 3 minutes, this alarm is generated.

*Action to be Taken* — Dual chiller control will be disabled and each unit will operate in Stand-Alone mode.

*Reset Method* — Automatic, once communication is re-established.

*Possible Causes* — If this condition is encountered, check the following items:

- CCN wiring
- control power to each Main Base Board, master and slave
- confirm correct configuration

#### Low Oil Pressure

Alarm 69 — Circuit A (P.67)

Alarm 70 — Circuit B (P.68)

Alarm 71 — Circuit C (P.69)

*Criteria for Trip* — The criteria are tested only when the compressor is ON. The alarm is generated if one of the following occurs, where:

*oil* = oil pressure transducer reading for the appropriate compressor

*sp* = suction pressure reading for the affected circuit

*dp* = discharge pressure reading for the affected circuit

**oil\_sp1 = 0.7 x (dp-sp) + sp**

**oil\_sp2 = sp + 7.2 psi (15 seconds after start)**

**oil\_sp2 = sp + 14.5 psi (45 seconds after start)**

- If the compressor starts with the ambient temperature (OAT less than 3.6° F [2° C]) the oil pressure monitoring is delayed by 30 seconds.

*Action to be Taken* — The affected compressor will be stopped. The other compressors will continue to operate.

*Reset Method* — Manual.

*Possible Causes* — If this condition is encountered, check the following items:

- sensor wiring to the CPM Board
- board for a faulty channel
- faulty transducer
- plugged oil filter
- faulty oil solenoid valve coil
- stuck oil solenoid valve
- stuck check valve
- manual shut off valve to ensure it is not fully open
- confirm unit configuration

#### Max Oil Filter Differential Pressure Failure

Alarm 72 — Circuit A (P.70)

Alarm 73 — Circuit B (P.71)

Alarm 74 — Circuit C (P.72)

*Criteria for Trip* — The criterion is tested when the compressor has been operating for at least 5 seconds. The alarm is generated if the difference between the Circuit Discharge Pressure and the Compressor Oil Pressure is greater than 50 psi (345 kPa) for more than 30 seconds.

*Action to be Taken* — The affected compressor will be turned off.

*Reset Method* — Manual

*Possible Causes* — If this condition is encountered, check the following items:

- check the discharge and oil sensor wiring to the Main Base Board and CPM board
- boards for a faulty channel
- faulty transducer
- plugged oil filter
- faulty oil solenoid valve coil
- stuck oil solenoid valve
- stuck check valve
- manual shut off valve to ensure it is not fully open

Check the power supply to the System Manager and unit controls.

#### High Oil Filter Pressure Drop

Alarm 75 — Circuit A (P.84)

Alarm 76 — Circuit B (P.85)

Alarm 77 — Circuit C (P.84)

*Criteria for Trip* — The criterion is tested when the compressor has been operating for at least 5 seconds. The alarm is generated if the difference between the Circuit Discharge Pressure and the Compressor Oil Pressure is greater than 30 psi for more than 5 minutes.

*Action to be Taken* — The compressor will continue to run.

*Reset Method* — Manual

*Possible Causes* — If this condition is encountered, check the following items:

- discharge and oil sensor wiring to the Main Base Board and CPM board
- boards for a faulty channel
- faulty transducer
- plugged oil filter
- faulty oil solenoid valve coil
- stuck oil solenoid valve
- stuck check valve
- manual shut off valve to ensure it is not fully open

Check the power supply to the System Manager and unit controls.

#### Low Oil Level Failure

Alarm 78 — Circuit A (P.75)

Alarm 79 — Circuit B (P.76)

Alarm 80 — Circuit C (P.77)

*Criteria for Trip* — The criteria are tested whether the compressor is on or off. The alarm is generated if:

- The compressor is not running and an increase in capacity is required and the compressor is not started.
- The compressor is running and the oil level switch is open for more than 45 seconds.

*Action to be Taken* — The affected compressor will be turned off.

*Reset Method* — Automatic, when the oil level is elevated, first three times the alarm is tripped in a 24-hour period. Manual if alarm is tripped more than three times in a 24-hour period.

*Possible Causes* — If this condition is encountered, check the following items:

- oil level in the oil separator
- oil level switch wiring to the CPM board
- CPM board for a faulty channel
- faulty oil level switch

#### Alarm 81 — Master Chiller Configuration Error (MC.nn)

*Criteria for Trip* — The criterion is tested whether the unit is ON or OFF. The units must be configured as a Master and Slave machine (*Configuration* → *RSET* → *MSSL=1* and *Configuration* → *RSET* → *MSSL=2*), and one of the following configuration errors has been found. The “nn” refers to the error code listed in Table 40.

**Table 40 — Master/Slave Alarm Code**

MC ERROR CODE	MASTER	SLAVE	DESCRIPTION
01	X	X	The master or slave water pump is not configured while the control of the lag unit pump is required ( <i>lag_pump = 1</i> )
02	X		Master and slave units have the same network address.
03	X		There is no slave configured at the slave address
04	X		Slave <i>pump_seq</i> incorrect configuration
05	X		There is a conflict between the master and the slave LWT option: the master is configured for EWT control while the slave is configured for LWT control.
06	X		There is a conflict between the master and the slave LWT option: the master is configured for LWT control while the slave is configured for EWT control.
07	X		There is a conflict between the master and the slave pump option: the master is configured for lag pump control while the slave is not configured for lag pump control.
08	X		There is a conflict between the master and the slave pump option: the master is not configured for lag pump control while the slave is configured for lag pump control.
09	X	X	The slave chiller is in local or remote control ( <i>chilstat = 3</i> )
10	X	X	The slave chiller is down due to fault ( <i>chilstat = 5</i> )
11	X		The master chiller operating type is not Master: <i>master_oper_typ</i>
12	X	X	No communication with slave.
13	X		Master and slave heat cool status are not the same.

**LEGEND**

EWT — Entering Water Temperature  
 LWT — Leaving Water Temperature

*Action to be Taken* — Unit not allowed to start in Master Slave control.

*Reset Method* — Automatic

*Possible Causes* — If this condition is encountered, check the following:

- CCN wiring.
- Control power to each Main Base Board, master and slave.
- Move to first position.
- Confirm unit configuration.

**Alarm 82 — Initial Factory Configuration Required (FC.n0)**

*Criteria for Trip* — The criterion is tested whether the unit is ON or OFF. The alarm will be generated if the *Configuration →UNIT →TONS=0*.

*Action to be Taken* — The unit is not allowed to start.

*Reset Method* — Automatic after factory configuration is complete. The configuration must be manually completed.

*Possible Causes* — If this condition is encountered, confirm the unit configuration.

**Alarm 83 — Illegal Configuration (FC.nn)**

*Criteria for Trip* — The criterion is tested whether the unit is ON or OFF. The alarm will be generated if the one of the following configuration errors is detected by the control. The “nn” refers to the error code listed in Table 41.

**Table 41 — Illegal Configuration Alarm Code**

FC ERROR CODE	DESCRIPTION
01	Unit size is unknown.
02	Reclaim option selected for Heat Pump machine.
03	Hot Gas Bypass configured for a Heat Pump machine.
04	Number of Fans controlled by low ambient temperature head pressure control is greater than expected.

*Action to be Taken* — The unit is not allowed to start.

*Reset Method* — Automatic after reconfiguration is completed.

*Possible Causes* — If this condition is encountered, confirm the unit configuration (*Configuration →UNIT*).

**Alarm 84 — Unit is in Emergency Stop (P.31)**

*Criteria for Trip* — The criterion is tested whether the units are ON or OFF and when the machine receives a Carrier Comfort Network® (CCN) command for an Emergency Stop.

*Action to be Taken* — Unit will stop, or will not allowed to start.

*Reset Method* — Automatic, once a return to normal command is received.

*Possible Causes* — If this condition is encountered, check for CCN Emergency Stop command.

**Cooler Pump Fault**

Alarm 85 — Pump 1 Fault (P.32)

Alarm 86 — Pump 2 Fault (P.33)

*Criteria for Trip* — The criterion is tested whether the units are ON or OFF. This alarm will be generated if the cooler pump interlock opens. When starting the pump, the control must read an open circuit for 3 consecutive reads. If the pump is operating and the circuit opens, the alarm will be generated immediately.

*Action to be Taken* — The pump and machine will be shut down. If there is another pump available, the control will start that pump, restart the machine and clear the alarm. If no other pump is available, the unit will remain OFF.

*Reset Method* — Manual.

*Possible Causes* — If this condition is encountered, check the following items:

- interlock wiring circuit
- control signal to the pump controller
- cooler pump contactor for proper operation
- control voltage for proper voltage (on 208-volt systems, be sure the proper tap on TRAN1 is utilized)

**Alarm 87 — Condenser Flow Switch Failure (P.15)**

NOTE: Alarm 87 is not used or supported. If this condition is encountered, confirm machine configuration.

**Reclaim Operation Failure**

Alarm 88 — Circuit A (P.34)

Alarm 89 — Circuit B (P.35)

### Repeated High Discharge Gas Overrides

Alarm 90 — Circuit A (P.37)

Alarm 91 — Circuit B (P.38)

Alarm 92 — Circuit C (P.39)

*Criteria for Trip* — The criterion is tested when the circuit is ON. This alarm will be tripped if the circuit capacity is reduced more than 8 times in 30 minutes due to high discharge gas temperatures. If no override occurs in a 30-minute period, the counter is reset.

*Action to be Taken* — The affected circuit will be shut down.

*Reset Method* — Automatic, after 30 minutes. If the alarm is cleared via the Manual method, the counter will be reset to zero.

*Possible Causes* — If this condition is encountered, check the following items:

- Maximum Condensing Temperature (MCT) for the proper setting
- noncondensables in the refrigerant circuit
- condenser air re-circulation
- proper refrigerant charge (overcharged)
- operation beyond the limit of the machine
- condenser coils for debris or restriction
- condenser fans and motors for proper rotation and operation
- discharge service valve to be sure that it is open. Check the discharge pressure transducer for accuracy
- confirm unit configuration

### Repeated Low Suction Temperature Protection

Alarm 93 — Circuit A (P.40)

Alarm 94 — Circuit B (P.41)

Alarm 95 — Circuit C (P.42)

*Criteria for Trip* — The criterion is tested when the circuit is ON. If the circuit operates and if more than 8 successive circuit capacity decreases (stop the compressor) have occurred because of low suction temperature protection overrides, the circuit alarm will be tripped. If no override has occurred for more than 30 minutes, the override counter will be reset to zero (LOSP).

*Action to be Taken* — ALARM\_LED will be set to blinking. Alert relay will be energized.

*Reset Method* — Automatic, when the override counter returns to zero. If the alarm is cleared via the Manual method, the counter will be forced to zero.

*Possible Causes* — If this condition is encountered, check the following items:

- suction transducer for accuracy
- suction transducer wiring
- EXV operation
- proper refrigerant charge (undercharged)
- evaporator loop for low water flow
- evaporator leaving water temperature
- suction service valve to be sure it is open. Discharge pressure transducer for accuracy
- confirm unit configuration

### Alarm 96 — Low Entering Water Temperature in Heating (P.43)

NOTE: Alarm 96 is not used or supported. If this condition is encountered, confirm machine configuration.

### Condenser Default

Alarm 97 — Pump 1 (P.73)

Alarm 98 — Pump 2 (P.74)

NOTE: Alarms 97 and 98 are not used or supported. If this condition is encountered, confirm machine configuration.

### High Discharge Temperature

Alarm 99 — Circuit A (P.78)

Alarm 100 — Circuit B (P.79)

Alarm 101 — Circuit C (P.80)

*Criteria for Trip* — The criterion is tested when the compressor is operating. This alarm will be tripped if the discharge gas temperature is higher than 212 F (100 C) for more than 90 seconds.

*Action to be Taken* — The affected compressor will be stopped.

*Reset Method* — Manual.

*Possible Causes* — If this condition is encountered, check the following items:

- Maximum Condensing Temperature (MCT) for the proper setting
- noncondensables in the refrigerant circuit
- condenser air re-circulation
- proper refrigerant charge (overcharged)
- operation beyond the limit of the machine
- condenser coils for debris or restriction
- condenser fans and motors for proper rotation and operation
- the discharge service valve to be sure that it is open, check the discharge pressure transducer for accuracy
- confirm unit configuration

### Low Economizer Pressure

Alarm 102 — Circuit A (P.81)

Alarm 103 — Circuit B (P.82)

Alarm 104 — Circuit C (P.83)

*Criteria for Trip* — The criterion is tested when the compressor is operating to prevent pumpdown conditions when the suction service valve is closed. This alarm will be tripped if the economizer pressure is below the suction pressure more than 1 bar (14.5 psi) for more than 10 seconds.

*Action to be Taken* — The affected compressor will be stopped.

*Reset Method* — Manual.

*Possible Causes* — If this condition is encountered, check the following items:

- suction service valve is closed
- sensor wiring to the EXV boards
- boards for faulty channels
- faulty transducer
- economizer EXV operation

### Slide Valve Control Unverifiable

Alarm 105 — Circuit A (P.87)

Alarm 106 — Circuit B (P.88)

Alarm 107 — Circuit C (P.89)

*Criteria for Trip* — The criteria are tested when the compressor is operating. This alarm will be tripped if:

- The circuit is operating at 100% of capacity and the measured current is less than 1.15 times the current at fully unloaded 30% for more than one minute.
- The circuit is operating and is at a minimum load (30% of capacity) and the measured current is greater than 0.78 expected current at 100% of capacity.

*Action to be Taken* — The affected compressor will continue to run.

*Reset Method* — Manual.

*Possible Causes* — If this condition is encountered, check the following items:

- faulty unloader solenoid valves
- faulty unloader solenoid coils
- wiring of the unloader solenoid valves
- CPM board for faulty channels
- current transformer reading for accuracy

Alarm 108 — Cooler Flow Switch Setpoint Configuration Failure (P.90)

NOTE: Alarm 108 is not used or supported. If this condition is encountered, confirm machine configuration.

Alarm 109 — Cooler Flow Switch Failure (P.91)

*Criteria for Trip* — The criteria are tested when the unit is on or off. This alarm will be tripped when the unit is on if:

- The flow switch fails to close after the Off/On delay.
- If the master/slave control is active, the unit is the lag chiller and if the cooler flow switch fails to close within one minute after the cooler pump was restarted. The alarm is ignored if the lag cooler pump is stopped as a result of master/slave control.
- The flow switch is opened during normal operation.

The alarm will be tripped when the unit is off if:

- The cooler pump control is enabled (PUMP=0) and the cooler flow switch is checked when the pump is enabled (P.LOC) and the cooler flow switch is closed after the cooler pump is commended OFF for more than 2 minutes.
- The flow switch fails to close after the Off/On delay after the cooler pump has been turned off to protect the cooler from freezing (PUMP=0).

*Action to be Taken* — For criteria for trip A1 and A2, the compressors will not be started.

For criteria for trip A3, all compressors will be stopped without going through pumpdown. Cooler pump will be stopped with no delay.

For criteria for trip B1, the unit will not start.

*Reset Method* — Manual if at least one compressor is operating. Automatic if no compressors are operating.

*Possible Causes* — If this condition is encountered, check the following items:

- a faulty flow switch
- flow switch wiring
- Main Base Board for a faulty channel

Alarm 110 — Service Maintenance Alert (Sr.nn)

*Criteria for Trip* — This alert is tested whether the unit is ON or OFF and when the Servicing Alert decisions listed under **Time Clock**→**MCFG** have been enabled. The alarm will be generated if the one of the following configuration errors is detected by the control. The “nn” refers to the error code listed in Table 42.

**Table 42 — Service Maintenance Alert Codes**

CODE	DESCRIPTION
Sr-01	Circuit A Loss of Refrigerant Charge
Sr-02	Circuit B Loss of Refrigerant Charge
Sr-03	Circuit C Loss of Refrigerant Charge
Sr-04	Water Loop Size Warning
Sr-05	Air Exchanger Cleanliness Warning
Sr-06	Cooler Pump 1 Servicing Required
Sr-07	Cooler Pump 2 Servicing Required
Sr-08	Condenser Pump 1 Servicing Required
Sr-09	Condenser Pump 2 Servicing Required
Sr-10	Water Filter Servicing Required
Sr-11	Compressor A Oil Filter Servicing Required
Sr-12	Compressor B Oil Filter Servicing Required
Sr-13	Compressor C Oil Filter Servicing Required

*Action to be Taken* — None.

*Reset Method* — Manual, after the service has been completed.

*Possible Causes* — If the Sr-01, 02, or 03 conditions are encountered, check the following items:

- sensor wiring to the Main Base Board

- sensor for accuracy

Compressor Motor Temperature Too High

Alarm 111-01 — Circuit A (A1.01)

Alarm 112-01 — Circuit B (B1.01)

Alarm 113-01 — Circuit C (C1.01)

*Criteria for Trip* — The alarm criteria are checked when the compressor is ON. This alarm will be generated if:

- The temperature is greater than 250 F (121 C) and it has been greater than 212 F (100 C) for 10 consecutive seconds.
- The compressor temperature is greater than 232 F (111 C) for 90 seconds (but less than 250 F [121 C]).

*Action to be Taken* — The circuit shuts down immediately.

*Reset Method* — Manual

*Possible Causes* — If this condition is encountered, check the following items:

- faulty wiring and loose plugs
- faulty CPM board

Compressor Motor Temperature Out of Range

Alarm 111-02 — Circuit A (A1.02)

Alarm 112-02 — Circuit B (B1.02)

Alarm 113-02 — Circuit C (C1.02)

*Criteria for Trip* — The alarm criterion is checked when the compressor is ON. This alarm will be generated if: the temperature is greater than 250 F (121 C) and it has NOT been greater than 212 F (100 C) for 10 consecutive seconds.

*Action to be Taken* — The compressor will be stopped.

*Reset Method* — Manual

*Possible Causes* — If this condition is encountered, check the following items:

- faulty compressor temperature thermistor
- faulty wiring and loose plugs
- faulty CPM board

Compressor High Pressure Switch Protection

Alarm 111-03 — Circuit A (A1.03)

Alarm 112-03 — Circuit B (B1.03)

Alarm 113-03 — Circuit C (C1.03)

*Criteria for Trip* — The alarm criterion is checked when the compressor is ON. This alarm will be generated if the circuit high-pressure switch (HPS) opens for more than 200 ms (milliseconds). The CPM board monitors the HPS switch.

*Action to be Taken* — The compressor will be stopped.

*Reset Method* — Manual

*Possible Causes* — If this condition is encountered, check the following items:

- condenser fan or contactor failure or loss of condenser air flow
- compressor operating beyond the operation envelope
- faulty high pressure switch or wiring
- faulty CPM board

Compressor Overcurrent

Alarm 111-04 — Circuit A (A1.04)

Alarm 112-04 — Circuit B (B1.04)

Alarm 113-04 — Circuit C (C1.04)

*Criteria for Trip* — The alarm criterion is checked when the compressor is ON. This alarm will be generated if the CPM board detects a high motor current compared with the MTA (must trip amps) setting for more than 1.7 seconds.

*Action to be Taken* — The compressor will be stopped.

*Reset Method* — Manual

*Possible Causes* — If this condition is encountered, check the following items:

- Compressor operating beyond the operation envelope.
- Incorrect MTA setting.

#### Compressor Locked Rotor

Alarm 111-05 — Circuit A (A1.05)

Alarm 112-05 — Circuit B (B1.05)

Alarm 113-05 — Circuit C (C1.05)

*Criteria for Trip* — The alarm criterion is checked during start-up when the compressor is ON. This alarm will be generated if the CPM board detects a high motor current compared with the MTA (must trip amps) setting for more than 450 ms.

*Action to be Taken* — The compressor will be stopped.

*Reset Method* — Manual

*Possible Causes* — If this condition is encountered, check the following items:

- compressor mechanical failure
- unloader slide valve failure
- compressor motor failure

#### Compressor Phase Loss

Alarm 111-06 — Circuit A L1 (A1.06)

Alarm 112-06 — Circuit B L1 (B1.06)

Alarm 113-06 — Circuit C L1 (C1.06)

Alarm 111-07 — Circuit A L2 (A1.07)

Alarm 112-07 — Circuit B L2 (B1.07)

Alarm 113-07 — Circuit C L2 (C1.07)

Alarm 111-08 — Circuit A L3 (A1.08)

Alarm 112-08 — Circuit B L3 (B1.08)

Alarm 113-08 — Circuit C L3 (C1.08)

*Criteria for Trip* — The alarm criteria are checked during startup when the compressor is ON. This alarm will be generated if:

- The current unbalance on any of the 3 phases is greater than 65% for more than 1 second continuously during start-up.
- The current unbalance on any of the 3 phases is greater than 65% for more than 200 ms continuously during runtime.

*Action to be Taken* — The compressor will be stopped.

*Reset Method* — Manual

*Possible Causes* — If this condition is encountered, check the following items:

- power failure
- blown fuse or tripped circuit breaker
- power wiring errors or loose terminals

#### Compressor Low Current

Alarm 111-09 — Circuit A (A1.09)

Alarm 112-09 — Circuit B (B1.09)

Alarm 113-09 — Circuit C (C1.09)

*Criteria for Trip* — The alarm criteria are checked when the compressor is ON. This alarm will be generated if:

- The current is less than 15% MTA on all three legs for more than 450 ms for Wye-Delta start units.
- If the current is less than 15% of MTA on all three legs for more than 1 second for direct start units.

*Action to be Taken* — The compressor will be stopped.

*Reset Method* — Manual

*Possible Causes* — If this condition is encountered, check the following items:

- power failure
- blown fuse or tripped circuit breaker
- deenergized contactor
- faulty current toroid

#### Compressor Wye-Delta Starter Current Increase Failure

Alarm 111-10 — Circuit A (A1.10)

Alarm 112-10 — Circuit B (B1.10)

Alarm 113-10 — Circuit C (C1.10)

*Criteria for Trip* — The alarm criterion is checked during compressor start-up. This alarm will be generated if the current in Delta mode is not more than 25% greater than the current in Y mode within 550 ms.

*Action to be Taken* — The compressor will be stopped.

*Reset Method* — Manual

*Possible Causes* — If this condition is encountered, check the following items:

- power supply failure to the delta contactor
- faulty wiring to the delta contactor
- faulty CPM board
- faulty current toroid

#### Compressor Contactor Failure

Alarm 111-11 — Circuit A (A1.11)

Alarm 112-11 — Circuit B (B1.11)

Alarm 113-11 — Circuit C (C1.11)

*Criteria for Trip* — The alarm criterion is checked during compressor shut-down. This alarm will be generated if the current is greater than 15% of the MTA on at least one phase for 10 continuous seconds.

*Action to be Taken* — The compressor will be stopped.

*Reset Method* — Manual

*Possible Causes* — If this condition is encountered, check the following items:

- faulty or welded contactor
- faulty wiring
- faulty CPM board

#### Compressor Unable to Stop Motor

Alarm 111-12 — Circuit A (A1.12)

Alarm 112-12 — Circuit B (B1.12)

Alarm 113-12 — Circuit C (C1.12)

*Criteria for Trip* — The alarm criterion is checked during compressor shut-down. This alarm will be generated if after three attempts to turn off the compressor outputs and the current is still greater than 15% of the MTA on at least one phase for 10 continuous seconds.

*Action to be Taken* — The compressor will be stopped.

*Reset Method* — Manual

*Possible Causes* — If this condition is encountered, check the following items:

- faulty or welded contactor
- faulty wiring

#### Compressor Phase Reversal

Alarm 111-13 — Circuit A (A1.13)

Alarm 112-13 — Circuit B (B1.13)

Alarm 113-13 — Circuit C (C1.13)

*Criteria for Trip* — The alarm criterion is checked during compressor start-up. This alarm will be generated if the CPM board detects a phase reversal from the current toroid.

*Action to be Taken* — The compressor will be stopped.

*Reset Method* — Manual

*Possible Causes* — If this condition is encountered, check the following items:

- if power supply lead at the terminal block is not operating at the correct phase
- if power supply is crossed when going through the current toroid

#### Compressor MTA Configuration Fault

Alarm 111-14 — Circuit A (A1.14)

Alarm 112-14 — Circuit B (B1.14)

Alarm 113-14 — Circuit C (C1.14)

*Criteria for Trip* — The alarm criterion is checked whether the compressor is ON or OFF. This alarm will be generated if the MTA setting is out of the allowed MTA range.

*Action to be Taken* — The compressor will be stopped.

*Reset Method* — Manual

*Possible Causes* — If this condition is encountered, check the following items:

- incorrect MTA settings
- faulty CPM board

#### Compressor Configuration Switch Mismatch

Alarm 111-15 — Circuit A (A1.15)

Alarm 112-15 — Circuit B (B1.15)

Alarm 113-15 — Circuit C (C1.15)

*Criteria for Trip* — The alarm criterion is checked whether the compressor is ON or OFF. This alarm will be generated if the CPM board S1 and S2 setting does not match software configuration.

*Action to be Taken* — The compressor will be stopped.

*Reset Method* — Manual

*Possible Causes* — If this condition is encountered, check the following items:

- incorrect CPM board settings
- faulty CPM board

#### Compressor Unexpected Switch Setting Change

Alarm 111-16 — Circuit A (A1.16)

Alarm 112-16 — Circuit B (B1.16)

Alarm 113-16 — Circuit C (C1.16)

*Criteria for Trip* — The alarm criterion is checked when the compressor is ON. This alarm will be generated if the CPM board S1 setting has changed.

*Action to be Taken* — The compressor will be stopped.

*Reset Method* — Manual

*Possible Causes* — If this condition is encountered, check the following items:

- incorrect CPM board settings
- faulty CPM board

#### Compressor Power on Reset

Alarm 111-17 — Circuit A (A1.17)

Alarm 112-17 — Circuit B (B1.17)

Alarm 113-17 — Circuit C (C1.17)

*Criteria for Trip* — The alarm criterion is checked when the compressor is ON. This alarm will be generated if the CPM board detects a power failure.

*Action to be Taken* — The compressor will be stopped.

*Reset Method* — Manual

*Possible Causes* — If this condition is encountered, check for power interruptions.

#### Compressor UL 1998 Critical Section Software Error

Alarm 111-18 — Circuit A (A1.18)

Alarm 112-18 — Circuit B (B1.18)

Alarm 113-18 — Circuit C (C1.18)

*Criteria for Trip* — The alarm criterion is checked when the compressor is ON. This alarm will be generated if the CPM board detects a software error.

*Action to be Taken* — The compressor will be stopped.

*Reset Method* — Manual

*Possible Causes* — If this condition is encountered, check the following items:

- electrical noise
- faulty CPM board

#### Compressor UL 1998 Current Measure Dual Channel Mismatch

Alarm 111-19 — Circuit A (A1.19)

Alarm 112-19 — Circuit B (B1.19)

Alarm 113-19 — Circuit C (C1.19)

*Criteria for Trip* — The alarm criterion is checked when the compressor is ON. This alarm will be generated if the CPM board detects a software error.

*Action to be Taken* — The compressor will be stopped.

*Reset Method* — Manual

*Possible Causes* — If this condition is encountered, check the following items:

- electrical noise
- faulty CPM board

**Service Test** — Main power and control circuit power must be on for Service Test.

The Service Test function is used to verify proper operation of various devices within the chiller, such as condenser fan(s), compressors, minimum load valve solenoid (if installed), cooler pump(s) and remote alarm relay. This is helpful during the start-up procedure to determine if devices are installed correctly. See Fig. 42-44 for 30XA wiring diagrams.

To use the Service Test mode, the Enable/Off/Remote Contact switch must be in the OFF position. Use the display keys to move to the Service Test mode. The items are described in the Service Test table. There are two sub-modes available. **Service Test**→**T.REQ** allows for manual control of the compressors and minimum load control. In this mode the compressors will operate only on command. The capacity control and head pressure control algorithms will be active. The condenser fans will operate along with the EXVs. There must be a load on the chiller to operate for an extended period of time. All circuit safeties will be honored during the test. **Service Test**→**QUIC** allows for test of EXVs, condenser fans, pumps, low ambient head pressure control speed control, oil separator, cooler heaters, oil solenoids, unloader solenoids and status points (alarm relays, running status and chiller capacity). This mode allows for the testing of non-refrigeration items. If there are no keys pressed for 5 minutes, the active test mode will be disabled.

To enter the Manual Control mode, the Enable/Off/Remote Contact switch must be in the OFF position. Move the LED to the Service Test mode. Press **ENTER** to access **TEST**. Press **ENTER** to access **T.REQ**. Press **ENTER** and the display will show **OFF**. Press **ENTER** and **OFF** will flash. Enter the password if required. Use either arrow key to change the **T.REQ** value to **ON** and press **ENTER**. Place the Enable/Off/Remote Switch in the enable position. Manual Control mode is now active. Press the arrow keys to move to the appropriate item. To activate an item locate the item, press **ENTER** and the display will show **OFF**. Press **ENTER** and **OFF** will flash. Use either arrow key to change the value to **ON** and press **ENTER**. The item should be active. To turn the item off, locate the item, press **ENTER** and the display will show **ON**. The chiller must be enabled by turning the Enable/Off/Remote Contact switch to Enable. Press **ENTER** and **ON** will flash. Use either arrow key to change the value to **OFF** and press **ENTER**. The item should be inactive.

To enter the Quick Test mode, the Enable/Off/Remote Contact switch must be in the OFF position. Move the LED to the Service Test mode. Press **ENTER** to access **TEST**. Use the **▼** key until the display reads **QUIC**. Press **ENTER** to access **Q.REQ**. Press **ENTER** and the display will show **OFF**. Press **ENTER** and **OFF** will flash. Enter the password if required. Use either arrow key to change the **QUIC** value to **ON** and press **ENTER**. Quick Test mode is now active. Follow the same instructions for the Manual Control mode to activate a component.

Example — Test the condenser fan A1 (see Table 43).

Power must be applied to the unit. Enable/Off/Remote Contact switch must be in the OFF position.

Test the condenser fans, cooler pump(s) and alarm relay by changing the item values from OFF to ON. These discrete outputs are then turned off if there is no keypad activity for 10 minutes. Test the compressor and minimum load valve solenoid (if installed) outputs in a similar manner. The minimum load valve solenoids will be turned off if there is no keypad activity for 10 minutes. Compressors will stay on until the operator turns them off. The Service Test mode will remain

enabled for as long as there is one or more compressors running. All safeties are monitored during this test and will turn a compressor, circuit or the machine off if required. Any other mode or sub-mode can be accessed, viewed, or changed during the Manual Control mode only. The **STAT** item (**Run Status** → **VIEW**) will display “0” as long as the Service mode is enabled. The **TEST** sub-mode value must be changed back to OFF before the chiller can be switched to Enable or Remote contact for normal operation.

NOTE: There may be up to a one-minute delay before the selected item is energized.

**Table 43 — Testing Circuit A Oil Solenoid**

MODE (Red LED)	SUB-MODE	KEYPAD ENTRY	ITEM	DISPLAY EXPANSION	VALUE DESCRIPTION (Units)	COMMENT
SERVICE TEST		ENTER		Service Test Mode		
	TEST	↓		Manual Sequence		
	QUIC	ENTER	Q.REQ			
			PASS WORD			Password may be required
		ENTER			0111	
		ENTER ENTER ENTER ENTER				Each ENTER will lock in the next digit. If 0111 is not the password, use the arrow keys to change the password digit and press ENTER when correct.
		ENTER	Q.REQ			Returns to the original field
		ENTER			OFF	
		ENTER			OFF	OFF will flash
		↓			ON	The Enable/Off/Remote Contact switch must be in the OFF position.
		ESCAPE	Q.REQ			
		↓	EXV.A			
		↓	Press 15 times.			
		↓	OLG.A	Oil Solenoid cir.A		
		ENTER			OFF	
		ENTER			OFF	OFF will flash
		↑			ON	
		ENTER			ON	OLS.A will turn on.
		ENTER			ON	1 will flash
		↓			OFF	
	ENTER			OFF	OLS.A will turn off.	

**LEGEND FOR FIG. 42-44**

- |   |   |
|---|---|
| <b>ALM</b> — Isolation                    | <b>ISO</b> — Isolation                                    |
| <b>CB</b> — Circuit Breaker               | <b>MBB</b> — Main Base Board                              |
| <b>CPM</b> — Compressor Protection Module | <b>MLV</b> — Minimum Load Value                           |
| <b>CWFS</b> — Chilled Water Flow Switch   | <b>MM</b> — Low Ambient Temperature Head Pressure Control |
| <b>EMM</b> — Energy Management Module     | <b>PMP</b> — Pump   |
| <b>EXV</b> — Electronic Expansion Valve   | <b>SGT</b> — Saturated Gas Temperature                    |
| <b>FIOP</b> — Factory-Installed Option    | <b>TB</b> — Terminal Block                                |
| <b>HTR</b> — Heater                       |   |

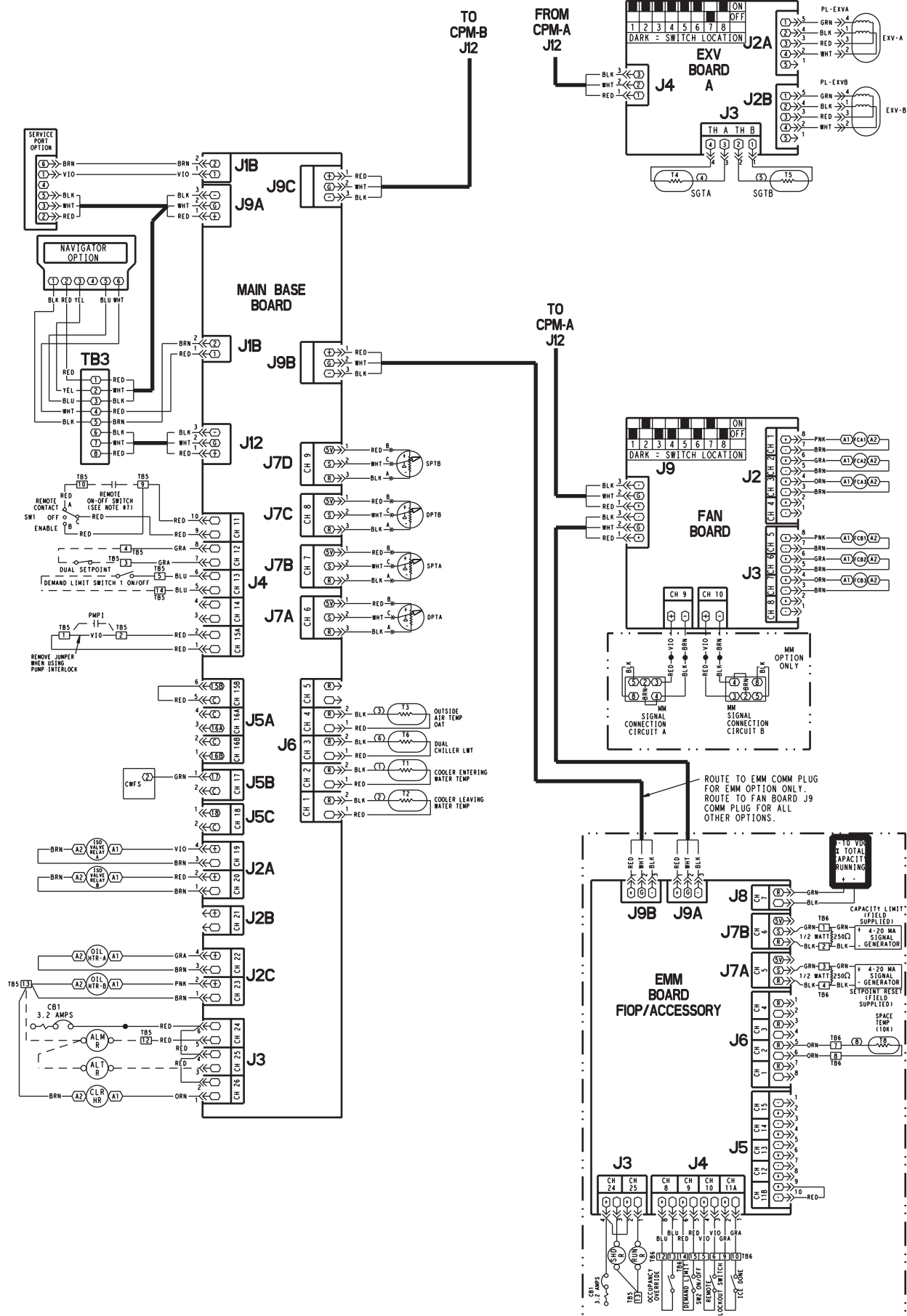


Fig. 42 — 30XA080 Low Voltage Control Schematic

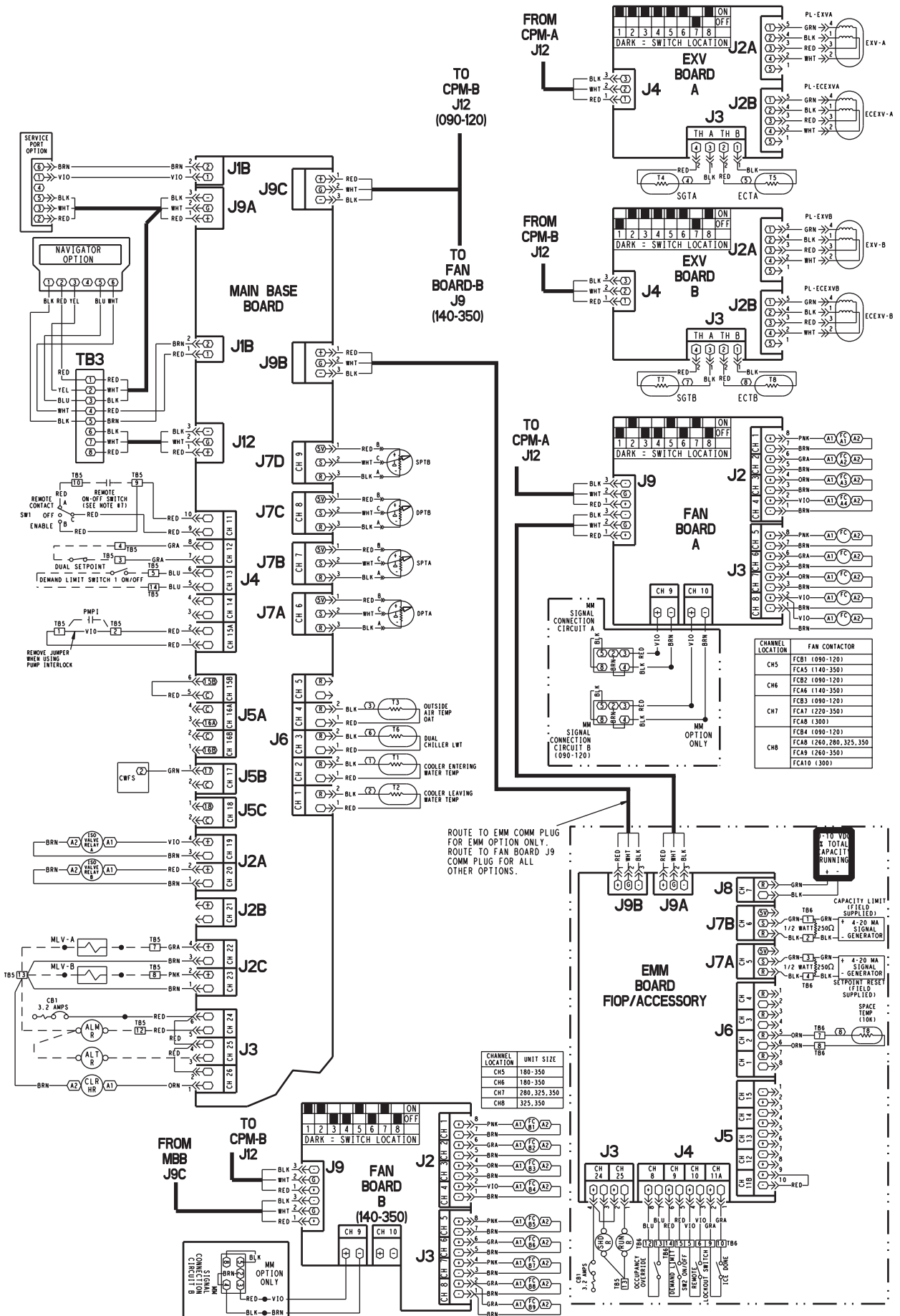


Fig. 43 — 30XA090-350 Low Voltage Control Schematic

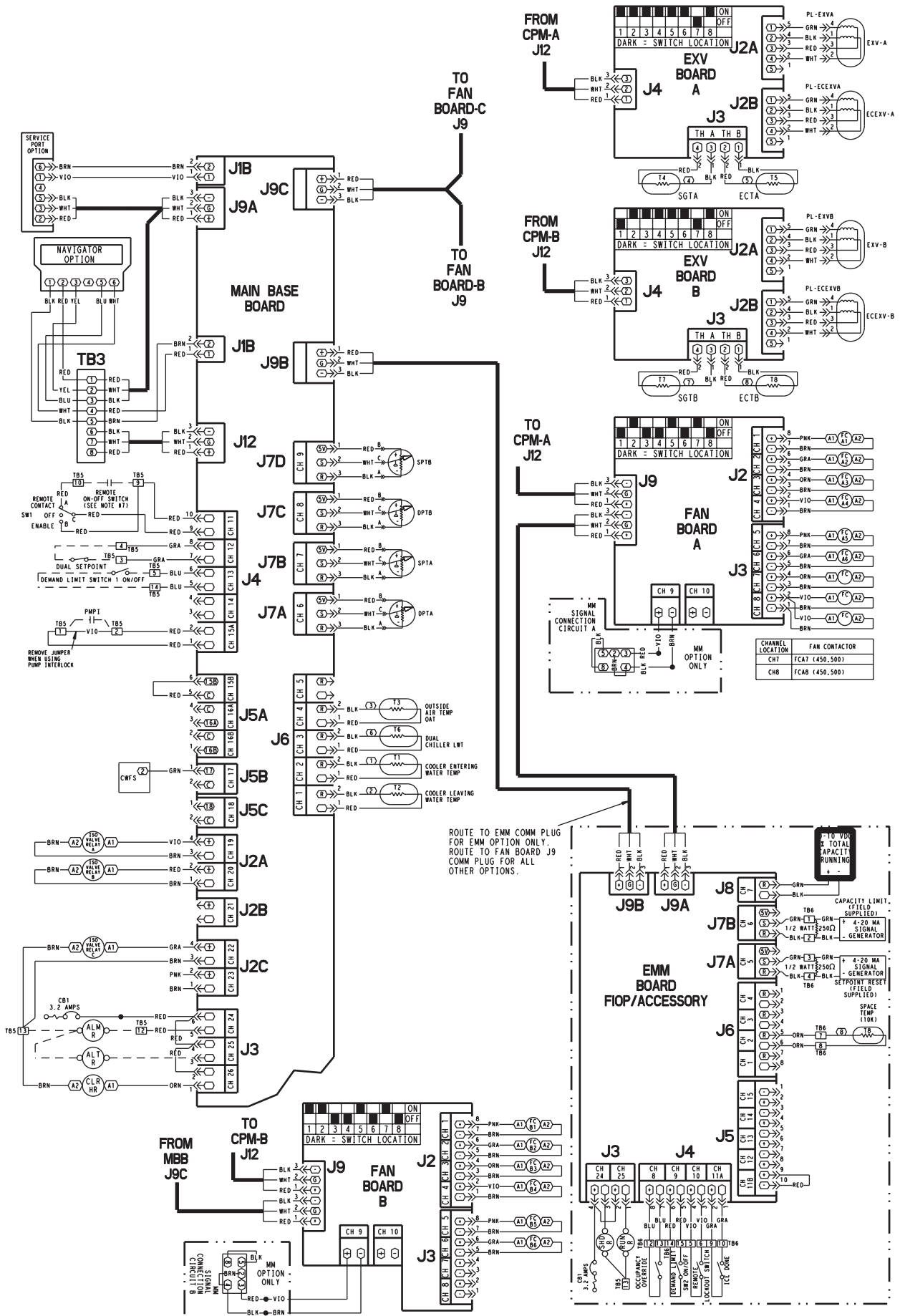


Fig. 44 — 30XA400-500 Low Voltage Control Schematic

# APPENDIX A — LOCAL DISPLAY TABLES

## MODE — RUN STATUS

ITEM	EXPANSION	UNITS	RANGE	COMMENT	WRITE STATUS	CCN TABLE	CCN POINT	PAGE NO.
<b>VIEW</b>	AUTO DISPLAY							
→EWT	Entering Fluid Temp	XXXX.X (deg F/deg C)	0-100			STATEGEN	COOL_EWT	83 20
→LWT	Leaving Fluid Temp	XXX.X (deg F/deg C)	0-100			STATEGEN	COOL_LWT	20
→SETP	Active Setpoint	XXX.X (deg F/deg C)	0-100			GENUNIT	SP	50, 51
→CTPT	Control Point	XXX.X (deg F/deg C)	0-100			GENUNIT	CTRL_PNT	20, 42, 50
→STAT	Unit Run Status		Off Running Stopping Delay			GENUNIT	STATUS	29, 30
→OCC	Occupied		NO/YES			GENUNIT	CHIL_OCC	29
→CTRL	Status Unit Control Type		Local Off Local On CCN Remote			GENUNIT GENUNIT	ctr_type	29
→CAP	Percent Total Capacity	XXX (%)	0-100			GENUNIT	CAP_T	
→CAP.A	Percent Capacity Cir A	XXX (%)	0-100			GENUNIT	CAP_A_T	
→CAP.B	Percent Capacity Cir B	XXX (%)	0-100			GENUNIT	CAP_B_T	
→CAP.C	Percent Capacity Cir C	XXX (%)	0-100			GENUNIT	CAP_C_T	
→CAP.S	Capacity Indicator	XX	0-32			MAINT	OVER_CAP	20
→LIM	Active Demand Limit Val	XXX (%)	0-100			GENUNIT	DEM_LIM	50
→CURR	Actual Chiller Current	XXX (amps)	0-4000			GENUNIT	TOT_CURR	
→CUR.L	Chiller Current Limit	XXX (amps)	0-4000			GENUNIT	CURR_LIM	
→ALRM	Alarm State		0=Normal 1=Partial 2=Shutdown			GENUNIT	ALM	
→HC.ST	Heat Cool Status		0=Cooling 1=Heating 2=Standby	Heating and Standby not supported.		GENUNIT	HEATCOOL	21
→RC.ST	Reclaim Select Status		NO/YES	Not supported.		GENUNIT	reclaim_sel	
→TIME	Time of Day	XX.XX	00:00-23:59			N/A	TIME	
→MNTH	Month of Year		1=January 2=February 3=March 4=April 6=May 6=June 7=July 8=August 9=September 10=October 11=November 12=December			N/A	moy	
→DATE	Day of Month	XX	1-31			N/A	dom	
→YEAR	Year of Century	XX	00-99			N/A	yoc	
<b>RUN</b>	<b>MACHINE STARTS/HOURS</b>							
→HRS.U	Machine Operating Hours	XXXX (hours)	0-999000*		forcible		hr_mach	
→STR.U	Machine Starts	XXXX	0-9999*		forcible	STRTHOUR	st_mach	
→HR.P1	Water Pump 1 Run Hours	XXXX (hours)	0-999000*	Not supported.	forcible	FANHOURS	hr_cpum1	
→HR.P2	Water Pump 2 Run Hours	XXXX (hours)	0-999000*	Not supported.	forcible	FANHOURS	hr_cpum2	
→HR.P3	Condenser Pump 1 Hours	XXXX (hours)	0-999999*	Not supported.	forcible	FANHOURS	hr_hpump1	
→HR.P4	Condenser Pump 2 Hours	XXXX (hours)	0-999999*	Not supported.	forcible	FANHOURS	hr_hpump2	
<b>HOOR</b>	<b>COMPRESSOR RUN HOURS</b>							
→HR.A	Compressor A Run Hours	XXXX (hours)	0-999000*		forcible	STRTHOUR	hr_cp_a	
→HR.B	Compressor B Run Hours	XXXX (hours)	0-999000*		forcible	STRTHOUR	hr_cp_b	
→HR.C	Compressor C Run Hours	XXXX (hours)	0-999000*		forcible	STRTHOUR	hr_cp_c	
<b>STRT</b>	<b>COMPRESSOR STARTS</b>							
→ST.A	Compressor A Starts	XXXX	0-999000*		forcible	STRTHOUR	st_cp_a	
→ST.B	Compressor B Starts	XXXX	0-999000*		forcible	STRTHOUR	st_cp_b	
→ST.C	Compressor C Starts	XXXX	0-999000*		forcible	STRTHOUR	st_cp_c	
<b>FAN</b>	<b>FAN RUN HOURS</b>							
→FR.A1	Fan 1 Run Hours Cir A	XXXX (hours)	0-999999*		forcible	FANHOURS	hr_fana1	
→FR.A2	Fan 2 Run Hours Cir A	XXXX (hours)	0-999999*		forcible	FANHOURS	hr_fana2	
→FR.A3	Fan 3 Run Hours Cir A	XXXX (hours)	0-999999*		forcible	FANHOURS	hr_fana3	
→FR.A4	Fan 4 Run Hours Cir A	XXXX (hours)	0-999999*		forcible	FANHOURS	hr_fana4	
→FR.A5	Fan 5 Run Hours Cir A	XXXX (hours)	0-999999*		forcible	FANHOURS	hr_fana5	
→FR.A6	Fan 6 Run Hours Cir A	XXXX (hours)	0-999999*		forcible	FANHOURS	hr_fana6	
→FR.A7	Fan 7 Run Hours Cir A	XXXX (hours)	0-999999*		forcible	FANHOURS	hr_fana7	
→FR.A8	Fan 8 Run Hours Cir A	XXXX (hours)	0-999999*		forcible	FANHOURS	hr_fana8	
→FR.A9	Fan 9 Run Hours Cir A	XXXX (hours)	0-999999*		forcible	FANHOURS	hr_fana9	
→F.A10	Fan 10 Run Hours Cir A	XXXX (hours)	0-999999*		forcible	FANHOURS	hrfana10	
→FR.B1	Fan 1 Run Hours Cir B	XXXX (hours)	0-999999*		forcible	FANHOURS	hr_fanb1	
→FR.B2	Fan 2 Run Hours Cir B	XXXX (hours)	0-999999*		forcible	FANHOURS	hr_fanb2	
→FR.B3	Fan 3 Run Hours Cir B	XXXX (hours)	0-999999*		forcible	FANHOURS	hr_fanb3	
→FR.B4	Fan 4 Run Hours Cir B	XXXX (hours)	0-999999*		forcible	FANHOURS	hr_fanb4	
→FR.B5	Fan 5 Run Hours Cir B	XXXX (hours)	0-999999*		forcible	FANHOURS	hr_fanb5	
→FR.B6	Fan 6 Run Hours Cir B	XXXX (hours)	0-999999*		forcible	FANHOURS	hr_fanb6	
→FR.B7	Fan 7 Run Hours Cir B	XXXX (hours)	0-999999*		forcible	FANHOURS	hr_fanb7	
→FR.B8	Fan 8 Run Hours Cir B	XXXX (hours)	0-999999*		forcible	FANHOURS	hr_fanb8	
→FR.B9	Fan 9 Run Hours Cir B	XXXX (hours)	0-999999*		forcible	FANHOURS	hr_fanb9	
→F.B10	Fan 10 Run Hours Cir B	XXXX (hours)	0-999999*		forcible	FANHOURS	hrfanb10	
→FR.C1	Fan 1 Run Hours Cir C	XXXX (hours)	0-999999*		forcible	FANHOURS	hr_fanc1	
→FR.C2	Fan 2 Run Hours Cir C	XXXX (hours)	0-999999*		forcible	FANHOURS	hr_fanc2	
→FR.C3	Fan 3 Run Hours Cir C	XXXX (hours)	0-999999*		forcible	FANHOURS	hr_fanc3	
→FR.C4	Fan 4 Run Hours Cir C	XXXX (hours)	0-999999*		forcible	FANHOURS	hr_fanc4	
→FR.C5	Fan 5 Run Hours Cir C	XXXX (hours)	0-999999*		forcible	FANHOURS	hr_fanc5	
→FR.C6	Fan 6 Run Hours Cir C	XXXX (hours)	0-999999*		forcible	FANHOURS	hr_fanc6	
→FR.C7	Fan 7 Run Hours Cir C	XXXX (hours)	0-999999*		forcible	FANHOURS	hr_fanc7	
→FR.C8	Fan 8 Run Hours Cir C	XXXX (hours)	0-999999*		forcible	FANHOURS	hr_fanc8	
→FR.C9	Fan 9 Run Hours Cir C	XXXX (hours)	0-999999*		forcible	FANHOURS	hr_fanc9	
→F.C10	Fan 10 Run Hours Cir C	XXXX (hours)	0-999999*		forcible	FANHOURS	hrfanc10	

## APPENDIX A — LOCAL DISPLAY TABLES (cont)

### MODE — RUN STATUS (cont)

ITEM	EXPANSION	UNITS	RANGE	COMMENT	WRITE STATUS	CCN TABLE	CCN POINT	PAGE NO.
<b>CP.UN</b> → <b>A.UN</b> → <b>B.UN</b> → <b>C.UN</b>	COMPRESSOR DISABLE Compressor A Disable Compressor B Disable Compressor C Disable		NO/YES NO/YES NO/YES		forcible forcible forcible	CP_UNABL CP_UNABL CP_UNABL	un_cp_a un_cp_b un_cp_c	
<b>MAIN</b> → <b>CHRG</b> → <b>WATE</b> → <b>PMP.1</b> → <b>PMP.2</b> → <b>PMP.3</b> → <b>PMP.4</b> → <b>W.FIL</b> → <b>A.FIL</b> → <b>B.FIL</b> → <b>C.FIL</b>	PREDICTIVE MAINTENANCE Refrigerant Charge Water Loop Size Pump 1 (Days) Pump 2 (Days) Cond Pump 1 (Days) Cond Pump 1 (Days) Water Filter Comp A Oil Filter (days) Comp B Oil Filter (days) Comp C Oil Filter (days)	(days) (days)  (days)	NO/YES NO/YES	Not supported.		SERMAINT SERMAINT SERMAINT SERMAINT SERMAINT SERMAINT SERMAINT SERMAINT SERMAINT SERMAINT	charge_m wloop_m cpump1_m cpump2_m hpump1_m hpump2_m wfilte_m ofilta_m ofiltb_m ofiltc_m	
<b>VERS</b> → <b>APPL</b> → <b>MARQ</b> → <b>NAVI</b> → <b>EXVA</b> → <b>EXVB</b> → <b>EXVC</b> → <b>AUX1</b> → <b>AUX2</b> → <b>AUX3</b> → <b>AUX4</b> → <b>AUX5</b> → <b>AUX6</b> → <b>CPMA</b> → <b>CPMB</b> → <b>CPMC</b> → <b>EMM</b> → <b>R.BRD</b>	SOFTWARE VERSIONS CSA-XXXXXXXX XXXXXX-XX-XX XXXXXX-XX-XX XXXXXX-XX-XX XXXXXX-XX-XX XXXXXX-XX-XX XXXXXX-XX-XX XXXXXX-XX-XX XXXXXX-XX-XX XXXXXX-XX-XX XXXXXX-XX-XX XXXXXX-XX-XX XXXXXX-XX-XX XXXXXX-XX-XX XXXXXX-XX-XX XXXXXX-XX-XX XXXXXX-XX-XX XXXXXX-XX-XX XXXXXX-XX-XX XXXXXX-XX-XX			Press ENTER and ESCAPE simultaneously to read version information			PD5_APPL STDU Navigator EXV_BRDA EXV_BRDB EXV_BRDC AUX_BRD1 AUX_BRD2 AUX_BRD3 AUX_BRD4 AUX_BRD5 AUX_BRD6 SPM_CPA SPM_CPB SPM_CPC EMM_NRCP REC_NRCP	

\*As data in all of these categories can exceed 9999 the following display strategy is used:  
 From 0-9999 display as 4 digits.  
 From 9999-99999 display xx.xK  
 From 99900-999999 display as xxxK.

## APPENDIX A — LOCAL DISPLAY TABLES (cont)

### MODE — SERVICE TEST

ITEM	EXPANSION	UNITS	RANGE	COMMENT	WRITE STATUS	CCN TABLE	CCN POINT	PAGE NO.
<b>TEST</b>	MANUAL TEST MODE							
→ <b>T.REQ</b>	Manual Sequence		OFF/ON	Remote-Off-Enable Switch must be set to <b>OFF</b> Position	forcible	N/A	service_test	58, 82
→ <b>CP.A</b>	Compressor A Output				forcible	N/A	comp_serv_a	58
→ <b>SLI.A</b>	Slide Valve Capacity A		OFF/ON unchanged increase decrease	Remote-Off-Enable Switch must be set to <b>ENABLE</b> Position	forcible		comp_ser_sid_a	
→ <b>CP.B</b>	Compressor B Output		OFF/ON		forcible	N/A	comp_serv_b	58
→ <b>SLI.B</b>	Slide Valve Capacity B		unchanged increase decrease		forcible		comp_ser_sid_b	
→ <b>CP.C</b>	Compressor C Output		OFF/ON		forcible	N/A	comp_serv_c	58
→ <b>SLI.C</b>	Slide Valve Capacity C		unchanged increase decrease		forcible		comp_ser_sid_c	
<b>QUIC</b>	QUICK TEST MODE							
→ <b>Q.REQ</b>	Manual Sequence		OFF/ON	Remote-Off-Enable Switch must be set to <b>OFF</b> Position	forcible	N/A		82
→ <b>EXV.A</b>	Circuit A EXV % Open	XXX (%)	0-100		forcible	N/A		57, 58
→ <b>EXV.B</b>	Circuit B EXV % Open	XXX (%)	0-100		forcible	N/A		57, 58
→ <b>EXV.C</b>	Circuit C EXV % Open	XXX (%)	0-100		forcible	N/A		57, 58
→ <b>ECO.A</b>	Circ A ECO EXV %	XXX (%)	0-100		forcible			
→ <b>ECO.B</b>	Circ B ECO EXV %	XXX (%)	0-100		forcible			
→ <b>ECO.C</b>	Circ C ECO EXV %	XXX (%)	0-100		forcible			
→ <b>FAN.A</b>	Circuit A Fan Stages	X	0-8		forcible	N/A		
→ <b>FAN.B</b>	Circuit B Fan Stages	X	0-8		forcible	N/A		
→ <b>FAN.C</b>	Circuit C Fan Stages	X	0-8		forcible	N/A		
→ <b>SPD.A</b>	Cir A Varifan position	XXX (%)	0-100		forcible	N/A		
→ <b>SPD.B</b>	Cir B Varifan position	XXX (%)	0-100		forcible	N/A		
→ <b>SPD.C</b>	Cir C Varifan position	XXX (%)	0-100		forcible	N/A		
→ <b>HT.A</b>	Oil Heater Circuit A		OFF/ON		forcible			
→ <b>SL1.A</b>	Slide Valve 1 Cir A		OFF/ON		forcible			
→ <b>SL2.A</b>	Slide Valve 2 Cir B		OFF/ON		forcible			
→ <b>OLS.A</b>	Oil Solenoid Cir A		OFF/ON		forcible			
→ <b>DGT.A</b>	DGT Cool Solenoid A		OFF/ON		forcible			
→ <b>HT.B</b>	Oil Heater Circuit B		OFF/ON		forcible			
→ <b>SL1.B</b>	Slide Valve 1 Cir B		OFF/ON		forcible			
→ <b>SL2.B</b>	Slide Valve 2 Cir B		OFF/ON		forcible			
→ <b>OLS.B</b>	Oil Solenoid Cir A		OFF/ON		forcible			
→ <b>DGT.B</b>	DGT Cool Solenoid B		OFF/ON		forcible			
→ <b>HT.C</b>	Oil Heater Circuit C		OFF/ON		forcible			
→ <b>SL1.C</b>	Slide Valve 1 Cir C		OFF/ON		forcible			
→ <b>SL2.C</b>	Slide Valve 2 Cir C		OFF/ON		forcible			
→ <b>OLS.C</b>	Oil Solenoid Cir A		OFF/ON		forcible			
→ <b>DGT.C</b>	DGT Cool Solenoid C		OFF/ON		forcible			
→ <b>FRV.A</b>	Free Cooling Heater A		OPEN/CLSE	Not supported.	forcible	N/A		
→ <b>FRP.A</b>	Refrigerant Pump A		OFF/ON	Not supported.	forcible	N/A		
→ <b>FRV.B</b>	Free Cooling Heater B		OPEN/CLSE	Not supported.	forcible	N/A		
→ <b>FRP.B</b>	Refrigerant Pump B		OFF/ON	Not supported.	forcible	N/A		
→ <b>FRV.C</b>	Free Cooling Heater C		OPEN/CLSE	Not supported.	forcible	N/A		
→ <b>FRP.C</b>	Refrigerant Pump C		OFF/ON	Not supported.	forcible	N/A		
→ <b>RV.A</b>	4 Way Valve Circuit A		OPEN/CLSE	Not supported.	forcible	N/A		
→ <b>RV.B</b>	4 Way Valve Circuit B		OPEN/CLSE	Not supported.	forcible	N/A		
→ <b>HR1.A</b>	Air Cond Enter Valve A		OPEN/CLSE	Not supported.	forcible	N/A		
→ <b>HR2.A</b>	Air Cond Leaving Valv A		OPEN/CLSE	Not supported.	forcible	N/A		
→ <b>HR3.A</b>	Water Cond Enter Valv A		OPEN/CLSE	Not supported.	forcible	N/A		
→ <b>HR4.A</b>	Water Cond Leav Valve A		OPEN/CLSE	Not supported.	forcible	N/A		
→ <b>HR1.B</b>	Air Cond Enter Valve B		OPEN/CLSE	Not supported.	forcible	N/A		
→ <b>HR2.B</b>	Air Cond Leaving Valv B		OPEN/CLSE	Not supported.	forcible	N/A		
→ <b>HR3.B</b>	Water Cond Enter Valv B		OPEN/CLSE	Not supported.	forcible	N/A		
→ <b>HR4.B</b>	Water Cond Leav Valve B		OPEN/CLSE	Not supported.	forcible	N/A		
→ <b>PMP.1</b>	Water Exchanger Pump 1		OFF/ON	Not supported.	forcible	N/A		
→ <b>PMP.2</b>	Water Exchanger Pump 2		OFF/ON	Not supported.	forcible	N/A		
→ <b>PMP.3</b>	Condenser Pump 1		OFF/ON	Not supported.	forcible			
→ <b>PMP.4</b>	Condenser Pump 2		OFF/ON	Not supported.	forcible			
→ <b>CL.HT</b>	Cooler Heater Output		OFF/ON			N/A		
→ <b>BVL.A</b>	Ball Valve Position A		OPEN/CLSE					
→ <b>BVL.B</b>	Ball Valve Position B		OPEN/CLSE					
→ <b>BVL.C</b>	Ball Valve Position C		OPEN/CLSE					
→ <b>CP.HT</b>	Condenser Heater Output		OFF/ON	Not supported.	forcible	N/A		
→ <b>Q.RDY</b>	Chiller Ready Status		OFF/ON		forcible	N/A		
→ <b>Q.RUN</b>	Chiller Running Status		OFF/ON		forcible	N/A		
→ <b>SHUT</b>	Customer Shutdown Stat		OFF/ON		forcible	N/A		
→ <b>CATO</b>	Chiller Capacity in 0-10v	XX.X (vdc)	OFF/ON		forcible	N/A		
→ <b>ALRM</b>	Alarm Relay		OFF/ON		forcible	N/A		
→ <b>ALRT</b>	Alert Relay		OFF/ON		forcible	N/A		

## APPENDIX A — LOCAL DISPLAY TABLES (cont)

### MODE — TEMPERATURE

ITEM	EXPANSION	UNITS	RANGE	COMMENT	WRITE STATUS	CCN TABLE	CCN POINT	PAGE NO.
<b>UNIT</b>	<b>UNIT TEMPERATURES</b>							
→ <b>CEWT</b>	Cooler Entering Fluid	XXX.X (deg F/deg C)	-40-245 F (-40-118 C)			STATEGEN	COOL_EWT	5, 50
→ <b>CLWT</b>	Cooler Leaving Fluid	XXX.X (deg F/deg C)	-40-245 F (-40-118 C)			STATEGEN	COOL_LWT	5, 50
→ <b>CD.LT</b>	Condenser Entering Fluid	XXX.X (deg F/deg C)	-40-245 F (-40-118 C)	Not supported.			COND_LWT	
→ <b>CD.ET</b>	Condenser Leaving Fluid	XXX.X (deg F/deg C)	-40-245 F (-40-118 C)	Not supported.			COND_EWT	
→ <b>OAT</b>	Outside Air Temperature	XXX.X (deg F/deg C)	-40-245 F (-40-118 C)			GENUNIT	OAT	5, 50
→ <b>CHWS</b>	Lead/Lag Leaving Fluid	XXX.X (deg F/deg C)	-40-245 F (-40-118 C)			STATEGEN	CHWS	5
→ <b>HEWT</b>	Heat Reclaim Entering	XXX.X (deg F/deg C)	-40-245 F (-40-118 C)	Not supported.		RECLAIM	HR_EWT	
→ <b>HLWT</b>	Heat Reclaim Leaving	XXX.X (deg F/deg C)	-40-245 F (-40-118 C)	Not supported.		RECLAIM	HR_LWT	
→ <b>SPT</b>	Optional Space Temp	XXX.X (deg F/deg C)	-40-245 F (-40-118 C)			STATEGEN	SPACETMP	14
→ <b>THHR</b>	Cooler Heater Temp	XXX.X (deg F/deg C)	-40-245 F (-40-118 C)				TH_HEATER	
<b>CIR.A</b>	<b>CIRCUIT A TEMPERATURES</b>							
→ <b>SCT.A</b>	Sat Cond Temp Circ A	XXX.X (deg F/deg C)	-40-245 F (-40-118 C)			CIRCA_AN	SCT_A	
→ <b>SST.A</b>	Sat Suction Temp Circ A	XXX.X (deg F/deg C)	-40-245 F (-40-118 C)			CIRCA_AN	SST_A	
→ <b>DGT.A</b>	Discharge Gas Temp Cir A	XXX.X (deg F/deg C)	-40-245 F (-40-118 C)				DGT_A	8
→ <b>SGT.A</b>	Suction Gas Temp Circ A	XXX.X (deg F/deg C)	-40-245 F (-40-118 C)			CIRCA_AN	SUCT_T_A	10
→ <b>SUP.A</b>	Superheat Temp Circ A	XXX.X (ΔF/ΔC)				CIRCA_AN	SH_A	
→ <b>ECT.A</b>	Economizer Gas Temp A	XXX.X (deg F/deg C)	-40-245 F (-40-118 C)				ECO_TP_A	10
→ <b>ESH.A</b>	Economizer Superheat A	XXX.X (deg F/deg C)	-40-245 F (-40-118 C)				ECO_SH_A	
→ <b>CTP.A</b>	Motor Temperature Cir A	XXX.X (deg F/deg C)	-40-245 F (-40-118 C)				CP_TMP_A	
→ <b>DEF.A</b>	Defrost Temp Circ A	XXX.X (deg F/deg C)	-40-245 F (-40-118 C)	Not supported.		N/A	DEFRT_A	
<b>CIR.B</b>	<b>CIRCUIT B TEMPERATURES</b>							
→ <b>SCT.B</b>	Sat Cond Temp Circ B	XXX.X (deg F/deg C)	-40-245 F (-40-118 C)			CIRCB_AN	SCT_B	
→ <b>SST.B</b>	Sat Suction Temp Circ B	XXX.X (deg F/deg C)	-40-245 F (-40-118 C)			CIRCB_AN	SST_B	
→ <b>DGT.B</b>	Discharge Gas Temp Cir B	XXX.X (deg F/deg C)	-40-245 F (-40-118 C)				DGT_B	8
→ <b>SGT.B</b>	Suction Gas Temp Circ B	XXX.X (deg F/deg C)	-40-245 F (-40-118 C)			CIRCB_AN	SUCT_T_B	10
→ <b>SUP.B</b>	Superheat Temp Circ B	XXX.X (ΔF/ΔC)				CIRCB_AN	SH_B	
→ <b>ECT.B</b>	Economizer Gas Temp B	XXX.X (deg F/deg C)	-40-245 F (-40-118 C)				ECO_TP_B	10
→ <b>ESH.B</b>	Economizer Superheat B	XXX.X (deg F/deg C)	-40-245 F (-40-118 C)				ECO_SH_B	
→ <b>CTP.B</b>	Motor Temperature Cir B	XXX.X (deg F/deg C)	-40-245 F (-40-118 C)				CP_TMP_B	
→ <b>DEF.B</b>	Defrost Temp Circ B	XXX.X (deg F/deg C)	-40-245 F (-40-118 C)	Not supported.		N/A	DEFRT_B	
<b>CIR.C</b>	<b>CIRCUIT C TEMPERATURES</b>							
→ <b>SCT.C</b>	Sat Cond Temp Circ C	XXX.X (deg F/deg C)	-45-245 F (-43-118 C)			CIRCC_AN CIRCC_AN	SCT_C	
→ <b>SST.C</b>	Sat Suction Temp Circ C	XXX.X (deg F/deg C)	-45-245 F (-43-118 C)			CIRCC_AN	SST_C	
→ <b>DGT.C</b>	Discharge Gas Temp Cir C	XXX.X (deg F/deg C)	-40-245 F (-40-118 C)				DGT_C	88
→ <b>SGT.C</b>	Suction Gas Temp Circ C	XXX.X (deg F/deg C)	-45-245 F (-43-118 C)			CIRCC_AN	SUCT_T_C	
→ <b>SUP.C</b>	Superheat Temp Circ C	XXX.X (ΔF/ΔC)				CIRCC_AN	SH_C	
→ <b>ECT.C</b>	Economizer Gas Temp C	XXX.X (deg F/deg C)					ECO_TP_C	10
→ <b>ESH.C</b>	Economizer Superheat C	XXX.X (deg F/deg C)					ECO_SH_C	
→ <b>CTP.C</b>	Motor Temperature Cir C	XXX.X (deg F/deg C)					CP_TMP_C	

## APPENDIX A — LOCAL DISPLAY TABLES (cont)

### MODE — PRESSURE

ITEM	EXPANSION	UNITS	RANGE	COMMENT	WRITE STATUS	CCN TABLE	CCN POINT	PAGE NO.
<b>PRC.A</b>	CIRCUIT A PRESSURES							
→ <b>DP.A</b>	Discharge Pressure Cir A	XXX.X (psig/kPa)				CIRCA_AN	DP_A	52
→ <b>SP.A</b>	Suction Pressure Circ A	XXX.X (psig/kPa)				CIRCA_AN	SP_A	5
→ <b>OP.A</b>	Oil Pressure Circ A	XXX.X (psig/kPa)					OP_A	8
→ <b>DOP.A</b>	Oil Pressure Diff A	XXX.X (psig/kPa)					DOP_A	
→ <b>ECP.A</b>	Economizer Pressure A	XXX.X (psig/kPa)					ECON_P_A	8
→ <b>PDP.A</b>	Reclaim Pressure A	XXX.X (psig/kPa)		Not supported.			PMPD_P_A	
<b>PRC.B</b>	CIRCUIT B PRESSURES							
→ <b>DP.B</b>	Discharge Pressure Cir B	XXX.X (psig/kPa)				CIRCB_AN	DP_B	52
→ <b>SP.B</b>	Suction Pressure Circ B	XXX.X (psig/kPa)				CIRCB_AN	SP_B	5
→ <b>OP.B</b>	Oil Pressure Circ B	XXX.X (psig/kPa)					OP_B	8
→ <b>DOP.B</b>	Oil Pressure Diff B	XXX.X (psig/kPa)					DOP_B	
→ <b>ECP.B</b>	Economizer Pressure B	XXX.X (psig/kPa)					ECON_P_B	8
→ <b>PDP.B</b>	Reclaim Pressure B	XXX.X (psig/kPa)		Not supported.			PMPD_P_B	
<b>PRC.C</b>	CIRCUIT A PRESSURES							
→ <b>DP.C</b>	Discharge Pressure Cir C	XXX.X (psig/kPa)				CIRCC_AN	DP_C	13, 52
→ <b>SP.C</b>	Suction Pressure Circ C	XXX.X (psig/kPa)				CIRCC_AN	SP_C	13
→ <b>OP.C</b>	Oil Pressure Circ C	XXX.X (psig/kPa)					OP_C	8
→ <b>DOP.C</b>	Oil Pressure Diff C	XXX.X (psig/kPa)					DOP_C	
→ <b>ECP.C</b>	Economizer Pressure C	XXX.X (psig/kPa)					ECON_P_C	8
→ <b>PDP.C</b>	Reclaim Pressure C	XXX.X (psig/kPa)		Not supported.			PMPD_P_C	

**APPENDIX A — LOCAL DISPLAY TABLES (cont)**

**MODE — SET POINTS**

ITEM	EXPANSION	UNITS	RANGE	COMMENT	WRITE STATUS	CCN TABLE	CCN POINT	PAGE NO.
<b>COOL</b> →CSP.1	COOLING SETPOINTS Cooling Setpoint 1	XXXX.X (deg F/deg C)	-20-70 F (-29-21 C), Default = 44.0		forcible	SETPOINT	csp1	30, 42
→CSP.2	Cooling Setpoint 2	XXXX.X (deg F/deg C)	-20-70 F (-29-21 C), Default = 44.0		forcible	SETPOINT	csp2	30, 50
→CSP.3	Ice Setpoint	XXXX.X (deg F/deg C)	-20-70 F (-29-21 C), Default = 44.0		forcible	SETPOINT	ice_sp	30, 50, 51
→CRV1	Current No Reset Val	XX.X (mA)	0-20, Default = 0		forcible	SETPOINT	v_cr_no	32
→CRV2	Current Full Reset Val	XX.X (mA)	0-20, Default = 0		forcible	SETPOINT	v_cr_fu	32
→CRT1	Delta T No Reset Temp	XXX.X (ΔF/ΔC)	0-125 F (0-69.4 C), Default = 0		forcible	SETPOINT	dt_cr_no	31
→CRT2	Delta T Full Reset Temp	XXX.X (ΔF/ΔC)	0-125 F (0-69.4 C), Default = 0		forcible	SETPOINT	dt_cr_fu	31
→CRO1	OAT No Reset Temp	XXX.X (deg F/deg C)	0-125 F (-18-52 C), Default = 14.0		forcible	SETPOINT	oatcr_no	31
→CRO2	OAT Full Reset Temp	XXX.X (deg F/deg C)	0-25 F (-18-52 C), Default = 14.0		forcible	SETPOINT	oatcr_fu	31
→CRS1	Space T No Reset Temp	XXX.X (deg F/deg C)	0-125 F (-18-52 C), Default = 14.0		forcible	SETPOINT	spacr_no	31
→CRS2	Space T Full Reset Temp	XXX.X (deg F/deg C)	0-125 F (-18-52 C), Default = 14.0		forcible	SETPOINT	spacr_fu	31
→DGRC	Degrees Cool Reset	XX.X (ΔF/ΔC)	-30-30 F (-16.7-16.7 C), Default = 0		forcible	SETPOINT	cr_deg	31
→CAUT	Cool Changeover Setpt	XX.X (deg F/deg C)	Default = 75.0	Not supported.	forcible	SETPOINT	cauto_sp	
→CRMP	Cool Ramp Loading	X.X	0.2-2.0 ΔF (0.1-1.1 ΔC), Default = 1.0		forcible	SETPOINT	cramp_sp	15, 20, 50
<b>HEAT</b> →HSP.1	HEATING SETPOINTS Heating Setpoint 1	XXX.X (deg F/deg C)	Default = 100	Not supported.	forcible	SETPOINT	HSP.1	
→HSP.2	Heating Setpoint 2	XXX.X (deg F/deg C)	Default = 100	Not supported.	forcible	SETPOINT	HSP.2	
→HRV1	Current to Reset Val	XX.X (mA)	Default = 0	Not supported.	forcible	SETPOINT	v_hr_no	
→HRV2	Current Full Reset Val	XX.X (mA)	Default = 0	Not supported.	forcible	SETPOINT	v_hr_fu	
→HRT1	Delta T No Reset Temp	XXX.X (ΔF/ΔC)	Default = 0	Not supported.	forcible	SETPOINT	dt_hr_no	
→HRT2	Delta T Full Reset Temp	XXX.X (ΔF/ΔC)	Default = 0	Not supported.	forcible	SETPOINT	dt_hr_fu	
→HRO1	OAT No Reset Temp	XXX.X (deg F/deg C)	Default = 14.0	Not supported.	forcible	SETPOINT	oathr_no	
→HRO2	OAT Full Reset Temp	XXX.X (deg F/deg C)	Default = 14.0	Not supported.	forcible	SETPOINT	oathr_fu	
→DGRH	Degrees Heat Reset	XX.X (ΔF/ΔC)	Default = 0	Not supported.	forcible	SETPOINT	DGRH	
→HAUT	Heat Changeover Setpt	XX.X (deg F/deg C)	Default = 64	Not supported.	forcible	SETPOINT	haut_sp	
→HRMP	Heat Ramp Loading	X.X	Default = 1.0	Not supported.	forcible	SETPOINT	hramp_sp	
<b>MISC</b> →DLS1	MISC SETPOINTS Switch Limit Setpoint 1	XXX (%)	0-100, Default = 100		forcible	SETPOINT	lim_sp1	32
→DLS2	Switch Limit Setpoint 2	XXX (%)	0-100, Default = 100		forcible	SETPOINT	lim_sp2	32
→DLS3	Switch Limit Setpoint 3	XXX (%)	0-100, Default = 100		forcible	SETPOINT	lim_sp3	
→W.SCT	Water Val Cond Stp	XXX.X (deg F/deg C)	80-140 F (26.7-60 C)	Not supported.		SETPOINT	w_sct_sp	
→RSP	Heat Reclaim Setpoint	XXX.X (deg F/deg C)	Default = 122	Not supported.	forcible	SETPOINT	rsp	
→RDB	Reclaim Deadband	XX.X (ΔF/ΔC)	Default = 9.0	Not supported.	forcible	SETPOINT	hr_deadb	

## APPENDIX A — LOCAL DISPLAY TABLES (cont)

### MODE — INPUTS

ITEM	EXPANSION	UNITS	RANGE	COMMENT	WRITE STATUS	CCN TABLE	CCN POINT	PAGE NO.
<b>GEN.I</b>	GENERAL INPUTS							
→ <b>ONOF</b>	On Off Switch		OPEN/CLSE			STATEGEN	ONOF	5
→ <b>LOCK</b>	Cooler Interlock		OPEN/CLSE			STATEGEN	LOCK_1	5, 20
→ <b>COND</b>	Condenser Flow Switch		OPEN/CLSE	Not supported.		STATEGEN	CONFLOW	
→ <b>DLS1</b>	Demand Limit Switch 1		OPEN/CLSE			STATEGEN	LIM_SW1	5
→ <b>DLS2</b>	Demand Limit Switch 2		OPEN/CLSE			STATEGEN	LIM_SW2	14
→ <b>ICE.D</b>	Ice Done		OFF/ON			STATEGEN	ICE_SW	14
→ <b>DUAL</b>	Dual Setpoint Switch		OFF/ON			STATEGEN	SETP_SW	5
→ <b>ELEC</b>	Electrical Box Safety		OPEN/CLSE	Not supported.		STATEGEN	ELEC_BOX	
→ <b>PUMP</b>	Pump Run Feedback		OPEN/CLSE	Not supported.		STATEGEN	PUMP_DEF	
→ <b>OCCS</b>	Occupancy Override Swit		OFF/ON			STATEGEN	OCC_OVSW	14
→ <b>RECL</b>	Heat Reclaim Switch		OFF/ON	Not supported.		STATEGEN	RECL_SW	
→ <b>HC.SW</b>	Heat Cool Switch Status		OFF/ON	Not supported.		STATEGEN	HC_SW	
→ <b>RLOC</b>	Remote Interlock Switch		OPEN/CLSE			STATEGEN	REM-LOCK	14
→ <b>OIL.A</b>	Oil Level Circuit A		LOW/HIGH			STATEGEN	OIL_L_A	
→ <b>OIL.B</b>	Oil Level Circuit B		LOW/HIGH			STATEGEN	OIL_L_B	
→ <b>OIL.C</b>	Oil Level Circuit C		LOW/HIGH			STATEGEN	OIL_L_C	
→ <b>CUR.A</b>	Motor Current Circuit A	XXX.X (amps)	0-600			STATEGEN	CURR_A	8
→ <b>CUR.B</b>	Motor Current Circuit B	XXX.X (amps)	0-600			STATEGEN	CURR_B	8
→ <b>CUR.C</b>	Motor Current Circuit C	XXX.X (amps)	0-600			STATEGEN	CURR_C	8
→ <b>DMND</b>	4-20 mA Demand Signal	XXX.X (mA)	4 to 20			STATEGEN	LIM_ANAL	14
→ <b>RSET</b>	4-20 mA Reset/Setpoint	XXX.X (mA)	4 to 20			STATEGEN	SP_RESET	14

**APPENDIX A — LOCAL DISPLAY TABLES (cont)**

**MODE — OUTPUTS**

ITEM	EXPANSION	UNITS	RANGE	COMMENT	WRITE STATUS	CCN TABLE	CCN POINT	PAGE NO.
<b>CIR.A</b>	<b>CIRCUIT A OUTPUTS</b>							
→CP.A	Compressor A Relay		OFF/ON			CIRCA_D	CP_A	8
→HT.A	Oil Heater Circuit A		OFF/ON				OIL_HT_A	5, 8
→SL1.A	Slide Valve 1 Cir A		OFF/ON				SLID1_A	8
→SL2.A	Slide Valve 2 Cir A		OFF/ON				SLID2_A	8
→OLS.A	Oil Solenoid Cir A		OFF/ON				OIL_SL_A	8
→FAN.A	Circuit A Fan Stages	X	0-6			CIRCA_D	FAN_ST_A	
→SPD.A	Circ A Varifan Position	XXX (%)	0-100			CIRCA_AN	hd_pos_a	12
→EXV.A	Circuit A EXV % Open	XXX (%)	0-100			CIRCA_AN	EXV_A	10
→ECO.A	Circ A EXV ECO % Open	XXX (%)	0-100				EXV_EC_A	10
→DGT.A	DGT Cool Solenoid A		OFF/ON				dgt_gascool_a	8
→FRPA	Refrigerant Pump Out A		OFF/ON	Not supported.		CIRCA_D	FR_PMP_A	
→FRH.A	Free Cooling Heater A		OFF/ON	Not supported.		CIRCA_D	FR_HEATA	
→HR1.A	Air Cond Enter Valve A		OPEN/CLSE	Not supported.		RECLAIM	hr_ca_a	
→HR2.A	Air Cond Leaving Valv A		OPEN/CLSE	Not supported.		RECLAIM	hr_la_a	
→HR3.A	Water Cond Enter Valv A		OPEN/CLSE	Not supported.		RECLAIM	hr_en_a	
→HR4.A	Water Cond Leav Valve A		OPEN/CLSE	Not supported.		RECLAIM	hr_lw_a	
→RV.A	4 Way Valve Circuit A		OPEN/CLSE	Not supported.		CIRCA_D	RV_A	
<b>CIR.B</b>	<b>CIRCUIT B OUTPUTS</b>							
→CP.B	Compressor B Relay		OFF/ON			CIRCB_D	CP_B	8
→HT.B	Oil Heater Circuit B		OFF/ON			CIRCB_D	OIL_HT_B	5, 8
→SL1.B	Slide Valve 1 Cir B		OFF/ON				SLID1_B	8
→SL2.B	Slide Valve 2 Cir B		OFF/ON				SLID2_B	8
→OLS.B	Oil Solenoid Cir B		OFF/ON				OIL_SL_B	8
→FAN.B	Circuit B Fan Stages	X	0-6			CIRCB_D	FAN_ST_B	
→SPD.B	Circ B Varifan Position	XXX (%)	0-100			CIRCB_AN	hd_pos_b	12
→EXV.B	Circuit B EXV % Open	XXX (%)	0-100			CIRCB_AN	EXV_B	10
→ECO.B	Circ B EXV ECO % Open	XXX (%)	0-100				EXV_EC_B	10
→DGT.B	DGT Cool Solenoid B		OFF/ON				dgt_gascool_b	
→FRP.B	Refrigerant Pump Out B		OFF-ON	Not supported.		CIRCB_D	FR_PMP_B	
→FRH.B	Free Cooling Heater B		OFF-ON	Not supported.		CIRCA_D	FR_HEATB	
→HR1.B	Air Cond Enter Valve B		OPEN/CLSE	Not supported.		RECLAIM	hr_ca_b	
→HR2.B	Air Cond Leaving Valv B		OPEN/CLSE	Not supported.		RECLAIM	hr_la_b	
→HR3.B	Water Cond Enter Valv B		OPEN/CLSE	Not supported.		RECLAIM	hr_en_b	
→HR4.B	Water Cond Leav Valve B		OPEN/CLSE	Not supported.		RECLAIM	hr_lw_b	
→RV.B	4 Way Valve Circuit B		OPEN/CLSE	Not supported.		CIRCB_D	RV_B	
<b>CIR.C</b>	<b>CIRCUIT C OUTPUTS</b>							
→CP.C	Compressor C Relay	OFF/ON				CIRCC_D	CP_C	8
→HT.C	Oil Heater Circuit C	OFF/ON				CIRCC_D	OIL_HT_C	8
→SL1.C	Slide Valve 1 Cir C		OFF/ON				SLID1_C	8
→SL2.C	Slide Valve 2 Cir C		OFF/ON				SLID2_C	8
→OLS.C	Oil Solenoid Cir C		OFF/ON				OIL_SL_C	8
→FAN.C	Circuit C Fan Stages	X	0-6			CIRCC_D	FAN_ST_C	
→SPD.C	Circ C Varifan Position	XXX (%)	0-100			CIRCC_AN	hd_pos_c	13
→EXV.C	Circuit C EXV % Open	XXX (%)	0-100			CIRCC_AN	EXV_C	
→ECO.C	Circ C EXV ECO % Open	XXX (%)	0-100				EXV_EC_C	10
→DGT.C	DGT Cool Solenoid C		OFF/ON				dgt_gascool_c	
→FRP.C	Refrigerant Pump Out C	OFF/ON		Not supported.		CIRCC_D	FR_PMP_C	
→FRHC	Free Cooling Heater C	OFF/ON		Not supported.		CIRCC_D	FR_HEATC	
<b>GEN.O</b>	<b>GENERAL OUTPUTS</b>							
→PMP.1	Water Exchanger Pump 1		OFF/ON			STATEGEN	CPUMP_1	
→PMP.2	Water Exchanger Pump 2		OFF/ON			STATEGEN	CPUMP_2	
→PMP.3	Condenser Pump 1		OFF/ON	Not supported.			HPUMP_1	
→PMP.4	Condenser Pump 2		OFF/ON	Not supported.			HPUMP_2	
→CO.HT	Cooler Heater Output		OFF/ON			STATEGEN	COOLHEAT	5
→BVL.A	Ball Valve Position A		OPEN/CLOSE				ref_iso_a	5
→BVL.B	Ball Valve Position B		OPEN/CLOSE				ref_iso_b	5
→BVL.C	Ball Valve Position C		OPEN/CLOSE				ref_iso_c	5
→CN.HT	Condenser Heat Output		OFF/ON			RECLAIM	cond_htr	
→REDY	Chiller Ready Status		OFF/ON	Not supported.	forcible	RECLAIM	READY	
→RUN	Chiller Running Status		OFF/ON		forcible	STATEGEN	RUNNING	14
→SHUT	Customer Shutdown Stat		OFF/ON		forcible	STATEGEN	SHUTDOWN	14
→CATO	Chiller Capacity 0-10 v	XX.X			forcible	STATEGEN	CAPT_010	14
→ALRM	Alarm Relay		OFF/ON			STATEGEN	ALARM	5
→ALRT	Alert Relay		OFF/ON			STATEGEN	ALERT	5



**APPENDIX A — LOCAL DISPLAY TABLES (cont)**

**MODE — CONFIGURATION (cont)**

ITEM	EXPANSION	UNITS	RANGE	COMMENT	DEFAULT	CCN TABLE	CCN POINT	PAGE NO.
<b>OPTN</b>	OPTIONS CONFIGURATION							
→ <b>CCNA</b>	CCN Address	XXX	1-239		1	N/A	CCNA	49
→ <b>CCNB</b>	CCN Bus Number	XXX	0-239		0	N/A	CCNB	49
→ <b>BAUD</b>	CCN Baud Rate		2400 4800 9600 19200 38400		9600	N/A	BAUD	
→ <b>LOAD</b>	Loading Sequence Select		Equal Staged		EQUAL	USER	lead_cir	16
→ <b>LLCS</b>	Lead/Lag Circuit Select		Automatic Cir A Leads Cir B Leads Cir C Leads		AUTOMATIC	USER	seq_typ	
→ <b>RL.S</b>	Ramp Load Select		ENBL/DSBL		DSBL	USER	ramp_sel	15, 20, 50
→ <b>DELY</b>	Minutes Off Time	XX (Minutes)	1 to 15		1	USER	off_on_d	15, 30, 49
→ <b>ICE.M</b>	Ice Mode Enable		ENBL/DSBL		DSBL	USER	ice_cnfg	30
→ <b>HPUM</b>	Condenser Pumps Sequence	X	No Pump 1 Pump Only 2 Pumps Auto PMP 1 Manual PMP 2 Manual	Not supported.	NO PUMP		hpum_seq	
→ <b>PUMP</b>	Cooler Pumps Sequence		No Pump 1 Pump Only 2 Pumps Auto PMP 1 Manual PMP 2 Manual		NO PUMP	USER	pump_seq	50
→ <b>ROT.P</b>	Pump Rotation Delay	XXXX (hours)	24 to 3000	Not supported.	48	USER	pump_del	50
→ <b>PM.PS</b>	Periodic Pump Start		NO-YES	Not supported.	NO	USER	pump_per	50
→ <b>PSBY</b>	Stop Pump In Standby		NO-YES	Not supported.	NO	USER	pump_sby	
→ <b>P.LOC</b>	Flow Checked if Pmp Off		NO-YES	Not supported.	YES	USER	pump_loc	
→ <b>LS.ST</b>	Night Low Noise Start	XX.XX	00.00-23.59		00.00	USER	nh_start	50
→ <b>LS.ND</b>	Night Low Noise End	XX.XX	00-00-23.59		00.00	USER	nh_end	50
→ <b>LS.LT</b>	Low Noise Capacity Lim	XXX (%)	0-100		100	USER	nh_limit	50
→ <b>RV.AL</b>	Reverse Alarms Relay		NO-YES		NO	USER	al_rever	
→ <b>OATH</b>	Heat Mode OAT Threshold	XX.X (deg F/deg C)		Not supported.	5 F	USER	heat_th	
→ <b>FREE</b>	Free Cooling OAT Limit	XX.X (deg F/deg C)		Not supported.	32.0	USER	free_oat	
→ <b>CUR.S</b>	Current Limit Select		NO/YES		NO		curr_sel	
→ <b>CUR.F</b>	Current Limit at 100%	XXXX	0 to 5000		2000		curr_ful	
→ <b>EHST</b>	Elec Stag OAT Threshold	XX.XX (deg F/deg C)	23 -70 F (-5-21 C)		41	USER	ehs_th	
→ <b>EHSB</b>	Last Heat Elec Backup		NO-YES		NO	USER	ehs_back	
→ <b>E.DEF</b>	Quick EHS in Defrost		NO-YES		NO	USER	ehs_defr	
→ <b>EHSP</b>	Elec Heating Pulldown	XX (min)		Not supported.	0	USER	ehs_pull	
→ <b>AUTO</b>	Auto Changeover Select		NO-YES	Not supported.	NO	USER	auto_sel	
<b>RSET</b>	RESET, DEMAND LIMIT, MASTER/SLAVE							
→ <b>CRST</b>	Cooling Reset Type		No Reset Out Air Temp Delta T Temp 4-20 mA Input Space Temp		NO RESET	USER	cr_sel	31, 32, 50
→ <b>HRST</b>	Heating Reset Type		No Reset Out Air Temp Delta T Temp 4-20 mA Input	Not supported.	NO RESET	USER	hr_sel	
→ <b>DMDC</b>	Demand Limit Select		None Switch 4-20 mA Input		NONE	USER	lim_sel	32, 40, 50
→ <b>DMMX</b>	mA for 100% Demand Limit	XX.X (mA)			0.0	USER	lim_mx	40
→ <b>DMZE</b>	mA for 0% Demand Limit	XX.X (mA)			0.0	USER	lim_ze	40
→ <b>MSSL</b>	Master/Slave Select		Disable Master Slave		DISABLE	MST_SLV	ms_sel	49, 51, 77
→ <b>SLVA</b>	Slave Address	XXX	1-236		2	MST_SLV	slv_addr	
→ <b>LLBL</b>	Lead/Lag Balance Select		Always Lead Lag if Fail Runtime Sel		Always Lead	MST_SLV	ll_bal	16, 49
→ <b>LLBD</b>	Lead/Lag Balance Delta	XXX (hours)	40-400		168	MST_SLV	ll_bal_d	16, 49
→ <b>LLDY</b>	Lead/Lag Delay	XX (minutes)	2-30		10	MST_SLV	lsrt_tim	49
→ <b>LL.ER</b>	Start if Error Higher	XX.X (deg F/deg C)	3-18		4	MST_SLV	start_dt	
→ <b>LAG.M</b>	Lag Minimum Running Time	XXX (min)	0-150		0	MST_SLV	lag_mini	
→ <b>LAGP</b>	Lag Unit Pump Select		OFF if U stp ON if U stp		OFF if U stp	MST_SLV	lag_pump	49
→ <b>LPUL</b>	Lead Pulldown Time	XX (minutes)	0-60		0	MST_SLV	lead_pul	16, 49
→ <b>SER1</b>	Chillers in Series		NO/YES				ll_serie	16



**APPENDIX A — LOCAL DISPLAY TABLES (cont)**

**MODE — TIMECLOCK (cont)**

ITEM	EXPANSION	UNITS	RANGE	COMMENT	WRITE STATUS	CCN TABLE	CCN POINT	PAGE NO.
<b>SCH1</b>	<b>SCHEDULE 1</b>							
→PER.7	Period 7 Occ/Unocc Sel							
→PER.7→OCC.7	Occupied Time	XX.XX	00:00-23:59		forcible	OCCP01S	OCCTOD7	
→PER.7→UNO.7	Unoccupied Time	XX.XX	00:00-23:59		forcible	OCCP01S	UNOCTOD7	
→PER.7→MON.7	Monday Select		NO/YES		forcible	OCCP01S	DOW7	
→PER.7→TUE.7	Tuesday Select		NO/YES		forcible	OCCP01S	DOW7	
→PER.7→WED.7	Wednesday Select		NO/YES		forcible	OCCP01S	DOW7	
→PER.7→THU.7	Thursday Select		NO/YES		forcible	OCCP01S	DOW7	
→PER.7→FRI.7	Friday Select		NO/YES		forcible	OCCP01S	DOW7	
→PER.7→SAT.7	Saturday Select		NO/YES		forcible	OCCP01S	DOW7	
→PER.7→SUN.7	Sunday Select		NO/YES		forcible	OCCP01S	DOW7	
→PER.7→HOL.7	Holiday Select		NO/YES		forcible	OCCP01S	DOW7	
→PER.8	Period 8 Occ/Unocc Sel							
→PER.8→OCC.8	Occupied Time	XX.XX	00:00-23:59		forcible	OCCP01S	OCCTOD8	
→PER.8→UNO.8	Unoccupied Time	XX.XX	00:00-23:59		forcible	OCCP01S	UNOCTOD8	
→PER.8→MON.8	Monday Select		NO/YES		forcible	OCCP01S	DOW8	
→PER.8→TUE.8	Tuesday Select		NO/YES		forcible	OCCP01S	DOW8	
→PER.8→WED.8	Wednesday Select		NO/YES		forcible	OCCP01S	DOW8	
→PER.8→THU.8	Thursday Select		NO/YES		forcible	OCCP01S	DOW8	
→PER.8→FRI.8	Friday Select		NO/YES		forcible	OCCP01S	DOW8	
→PER.8→SAT.8	Saturday Select		NO/YES		forcible	OCCP01S	DOW8	
→PER.8→SUN.8	Sunday Select		NO/YES		forcible	OCCP01S	DOW8	
→PER.8→HOL.8	Holiday Select		NO/YES		forcible	OCCP01S	DOW8	
<b>SCH2</b>	<b>SCHEDULE 2</b>							29
→PER.1	Period 1 Occ/Unocc Sel							
→PER.1→OCC.1	Occupied Time	XX.XX	00:00-23:59		forcible	OCC2P02S	OCCTOD1	
→PER.1→UNO.1	Unoccupied Time	XX.XX	00:00-23:59		forcible	OCC2P02S	UNOCTOD1	
→PER.1→MON.1	Monday Select		NO/YES		forcible	OCC2P02S	DOW1	
→PER.1→TUE.1	Tuesday Select		NO/YES		forcible	OCC2P02S	DOW1	
→PER.1→WED.1	Wednesday Select		NO/YES		forcible	OCC2P02S	DOW1	
→PER.1→THU.1	Thursday Select		NO/YES		forcible	OCC2P02S	DOW1	
→PER.1→FRI.1	Friday Select		NO/YES		forcible	OCC2P02S	DOW1	
→PER.1→SAT.1	Saturday Select		NO/YES		forcible	OCC2P02S	DOW1	
→PER.1→SUN.1	Sunday Select		NO/YES		forcible	OCC2P02S	DOW1	
→PER.1→HOL.1	Holiday Select		NO/YES		forcible	OCC2P02S	DOW1	
→PER.2	Period 2 Occ/Unocc Sel							
→PER.2→OCC.2	Occupied Time	XX.XX	00:00-23:59		forcible	OCC2P02S	OCCTOD	
→PER.2→UNO.2	Unoccupied Time	XX.XX	00:00-23:59		forcible	OCC2P02S	UNOCTOD2	
→PER.2→MON.2	Monday Select		NO/YES		forcible	OCC2P02S	DOW2	
→PER.2→TUE.2	Tuesday Select		NO/YES		forcible	OCC2P02S	DOW2	
→PER.2→WED.2	Wednesday Select		NO/YES		forcible	OCC2P02S	DOW2	
→PER.2→THU.2	Thursday Select		NO/YES		forcible	OCC2P02S	DOW2	
→PER.2→FRI.2	Friday Select		NO/YES		forcible	OCC2P02S	DOW2	
→PER.2→SAT.2	Saturday Select		NO/YES		forcible	OCC2P02S	DOW2	
→PER.2→SUN.2	Sunday Select		NO/YES		forcible	OCC2P02S	DOW2	
→PER.2→HOL.2	Holiday Select		NO/YES		forcible	OCC2P02S	DOW2	
→PER.3	Period 3 Occ/Unocc Sel							
→PER.3→OCC.3	Occupied Time	XX.XX	00:00-23:59		forcible	OCC2P02S	OCCTOD	
→PER.3→UNO.3	Unoccupied Time	XX.XX	00:00-23:59		forcible	OCC2P02S	UNOCTOD3	
→PER.3→MON.3	Monday Select		NO/YES		forcible	OCC2P02S	DOW3	
→PER.3→TUE.3	Tuesday Select		NO/YES		forcible	OCC2P02S	DOW3	
→PER.3→WED.3	Wednesday Select		NO/YES		forcible	OCC2P02S	DOW3	
→PER.3→THU.3	Thursday Select		NO/YES		forcible	OCC2P02S	DOW3	
→PER.3→FRI.3	Friday Select		NO/YES		forcible	OCC2P02S	DOW3	
→PER.3→SAT.3	Saturday Select		NO/YES		forcible	OCC2P02S	DOW3	
→PER.3→SUN.3	Sunday Select		NO/YES		forcible	OCC2P02S	DOW3	
→PER.3→HOL.3	Holiday Select		NO/YES		forcible	OCC2P02S	DOW3	
→PER.4	Period 4 Occ/Unocc Sel							
→PER.4→OCC.4	Occupied Time	XX.XX	00:00-23:59		forcible	OCC2P02S	OCCTOD4	
→PER.4→UNO.4	Unoccupied Time	XX.XX	00:00-23:59		forcible	OCC2P02S	UNOCTOD4	
→PER.4→MON.4	Monday Select		NO/YES		forcible	OCC2P02S	DOW4	
→PER.4→TUE.4	Tuesday Select		NO/YES		forcible	OCC2P02S	DOW4	
→PER.4→WED.4	Wednesday Select		NO/YES		forcible	OCC2P02S	DOW4	
→PER.4→THU.4	Thursday Select		NO/YES		forcible	OCC2P02S	DOW4	
→PER.4→FRI.4	Friday Select		NO/YES		forcible	OCC2P02S	DOW4	
→PER.4→SAT.4	Saturday Select		NO/YES		forcible	OCC2P02S	DOW4	
→PER.4→SUN.4	Sunday Select		NO/YES		forcible	OCC2P02S	DOW4	
→PER.4→HOL.4	Holiday Select		NO/YES		forcible	OCC2P02S	DOW4	
→PER.5	Period 5 Occ/Unocc Sel							
→PER.5→OCC.5	Occupied Time	XX.XX	00:00-23:59		forcible	OCC2P02S	OCCTOD5	
→PER.5→UNO.5	Unoccupied Time	XX.XX	00:00-23:59		forcible	OCC2P02S	UNOCTOD5	
→PER.5→MON.5	Monday Select		NO/YES		forcible	OCC2P02S	DOW5	
→PER.5→TUE.5	Tuesday Select		NO/YES		forcible	OCC2P02S	DOW5	
→PER.5→WED.5	Wednesday Select		NO/YES		forcible	OCC2P02S	DOW5	
→PER.5→THU.5	Thursday Select		NO/YES		forcible	OCC2P02S	DOW5	
→PER.5→FRI.5	Friday Select		NO/YES		forcible	OCC2P02S	DOW5	
→PER.5→SAT.5	Saturday Select		NO/YES		forcible	OCC2P02S	DOW5	
→PER.5→SUN.5	Sunday Select		NO/YES		forcible	OCC2P02S	DOW5	
→PER.5→HOL.5	Holiday Select		NO/YES		forcible	OCC2P02S	DOW5	
→PER.6	Period 6 Occ/Unocc Sel							
→PER.6→OCC.6	Occupied Time	XX.XX	00:00-23:59		forcible	OCC2P02S	OCCTOD6	
→PER.6→UNO.6	Unoccupied Time	XX.XX	00:00-23:59		forcible	OCC2P02S	UNOCTOD6	
→PER.6→MON.6	Monday Select		NO/YES		forcible	OCC2P02S	DOW6	
→PER.6→TUE.6	Tuesday Select		NO/YES		forcible	OCC2P02S	DOW6	
→PER.6→WED.6	Wednesday Select		NO/YES		forcible	OCC2P02S	DOW6	
→PER.6→THU.6	Thursday Select		NO/YES		forcible	OCC2P02S	DOW6	
→PER.6→FRI.6	Friday Select		NO/YES		forcible	OCC2P02S	DOW6	
→PER.6→SAT.6	Saturday Select		NO/YES		forcible	OCC2P02S	DOW6	
→PER.6→SUN.6	Sunday Select		NO/YES		forcible	OCC2P02S	DOW6	
→PER.6→HOL.6	Holiday Select		NO/YES		forcible	OCC2P02S	DOW6	



## APPENDIX A — LOCAL DISPLAY TABLES (cont)

### MODE — OPERATING MODE

ITEM	EXPANSION*	UNITS	RANGE	COMMENT	WRITE STATUS	CCN TABLE	CCN POINT	PAGE NO.
<b>SLCT</b> → <b>OPER</b>	OPERATING CONTROL TYPE Operating Control Type		Switch Ctrl Time Sched CCN Control	Default = Switch Ctrl	forcible	N/A	N/A	29, 49
→ <b>SP.SE</b>	Setpoint Select		Setpoint Occ Setpoint1 Setpoint2	Default = Setpoint Occ	forcible	N/A	N/A	30, 40
→ <b>HC.SE</b>	Heat Cool Select		4-20mA Setp Dual Setp Sw Cooling Heating	Default = Cooling Not supported. Not supported.	forcible	GENUNIT	HC_SEL	30
→ <b>RL.SE</b>	Reclaim Select		Auto Chgover Heat Cool Sw No Yes Switch Ctrl	Not supported. Default = No Not supported. Not supported.	forcible	GENUNIT	RECL_SET	
<b>MODE*</b> → <b>MD01</b> → <b>MD02</b> → <b>MD03</b> → <b>MD04</b> → <b>MD05</b> → <b>MD06</b>	OPERATING MODES First Active Mode Second Active Mode Third Active Mode Fourth Active Mode Fifth Active Mode Sixth Active Mode		0-32 0-32 0-32 0-32 0-32 0-32			MODES MODES MODES MODES MODES MODES		

\*Up to six current operating modes will be displayed.

NOTE: See operating modes starting on page 49.

### MODE — ALARMS

ITEM	EXPANSION*	UNITS	RANGE	COMMENT	WRITE STATUS	CCN TABLE	CCN POINT	PAGE NO.
<b>R.ALM</b>	RESET ALL CURRENT ALARM		NO/YES		forcible	N/A	N/A	
<b>ALRM†</b>	CURRENTLY ACTIVE ALARMS Current Alarm 1 Current Alarm 2 Current Alarm 3 Current Alarm 4 Current Alarm 5					GENUNIT GENUNIT GENUNIT GENUNIT GENUNIT	alarm_1 alarm_2 alarm_3 alarm_4 alarm_5	67
<b>H.ALM**</b>	ALARM HISTORY Alarm History #1 Alarm History #2  Alarm History #49 Alarm History #50					ALRMHIST ALRMHIST ALRMHIST ALRMHIST ALRMHIST	alm_history_01 alm_history_02  alm_history_49 alm_history_50	

\*Expanded display will be actual alarm description.

†History of up to five past alarms will be displayed.

\*\*History of fifty past alarms will be displayed.

**APPENDIX B — CCN TABLES**  
**STATUS DISPLAY TABLES**

TABLE	DISPLAY NAME	RANGE	UNITS	POINT NAME	WRITE STATUS
CIRCA_AN	CIRCUIT A ANALOG VALUES				
	Percent Total Capacity	0 - 100	%	CAPA_T	
	Discharge Pressure	nnn.n	psi	DP_A	
	Suction Pressure	nnn.n	psi	SP_A	
	Economizer Pressure	nnn.n	psi	ECON_P_A	
	Oil Pressure	nnn.n	psi	OP_A	
	Oil Pressure Difference	nnn.n	psi	DOP_A	
	Motor Current	nnn.n	AMPS	CURREN_A	
	Motor Temperature	nnnn	°F	CP_TMP_A	
	Discharge Gas Temp	nnnn	°F	DGT_A	
	Economizer Gas Temp	nnnn	°F	ECO_TP_A	
	Saturated Condensing Tmp	±nnn.n	°F	SCT_A	
	Saturated Suction Temp	±nnn.n	°F	SST_A	
	Compressor Suction Temp	±nnn.n	°F	SUCT_T_A	
	EXV Position	0 - 100	%	EXV_A	
Head Press Actuator Pos	0 - 100	%	hd_pos_a		
CIRCA_D	CIRCUIT A DISCRETE				
	Compressor Output	ON/OFF		COMP_A	
	Slide Valve 1 Output	ON/OFF		SLID_1_A	
	Slide Valve 2 Output	ON/OFF		SLID_2_A	
	Oil Heater Output	ON/OFF		OIL_HT_A	
	Oil Solenoid Output	ON/OFF		OIL_SL_A	
	Oil Level Input	Low/High		OIL_L_A	
	DGT Cooling Solenoid	ON/OFF		GASCOOLA	
	FANS OUTPUT				
	Fan Output DO # 1	ON/OFF		fan_a1	
	Fan Output DO # 2	ON/OFF		fan_a2	
	Fan Output DO # 3	ON/OFF		fan_a3	
	Fan Output DO # 4	ON/OFF		fan_a4	
	Fan Output DO # 5	ON/OFF		fan_a5	
	Fan Output DO # 6	ON/OFF		fan_a6	
	Fan Output DO # 7	ON/OFF		fan_a7	
	Fan Output DO # 8	ON/OFF		fan_a8	
	Fan Staging Number	0-10		FAN_ST_A	
	FREE COOLING OUTPUT				
	Refrigerant Pump Out*	ON/OFF		FR_PMP_A	
	Circuit Heater Output*	ON/OFF		FR_HEATA	
	MISCELLANEOUS				
	Ball Valve Position	OPEN/CLSE		ISO_REFA	
	Ball Valve Closing Out	ON/OFF		ISO_CL_A	
	Ball Valve Opening Out	ON/OFF		ISO_OP_A	
	4 Way Refrigerant Valve*	ON/OFF		RV_A	
	CIRCB_AN	CIRCUIT B ANALOG VALUES			
Percent Total Capacity		0 - 100	%	CAPB_T	
Discharge Pressure		nnn.n	psi	DP_B	
Suction Pressure		nnn.n	psi	SP_B	
Economizer Pressure		nnn.n	psi	ECON_P_B	
Oil Pressure		nnn.n	psi	OP_B	
Oil Pressure Difference		nnn.n	psi	DOP_B	
Motor Current		nnn.n	AMPS	CURREN_B	
Motor Temperature		nnnn	°F	CP_TMP_B	
Discharge Gas Temp		nnnn	°F	DGT_B	
Economizer Gas Temp		nnnn	°F	ECO_TP_B	
Saturated Condensing Tmp		±nnn.n	°F	SCT_B	
Saturated Suction Temp		±nnn.n	°F	SST_B	
Compressor Suction Temp		±nnn.n	°F	SUCT_T_B	
EXV Position		0-100	%	EXV_B	
Head Press Actuator Pos	0-100	%	hd_pos_b		
CIRCB_D	CIRCUIT B DISCRETE				
	Compressor Output	ON/OFF		COMP_B	
	Slide Valve 1 Output	ON/OFF		SLID_1_B	
	Slide Valve 2 Output	ON/OFF		SLID_2_B	
	Oil Heater Output	ON/OFF		OIL_HT_B	
	Oil Solenoid Output	ON/OFF		OIL_SL_B	
	Oil Level Input	Low/High		OIL_L_B	
	DGT Cooling Solenoid	ON/OFF		GASCOOLB	
	FANS OUTPUT				
	Fan Output DO # 1	ON/OFF		fan_b1	
	Fan Output DO # 2	ON/OFF		fan_b2	
	Fan Output DO # 3	ON/OFF		fan_b3	
	Fan Output DO # 4	ON/OFF		fan_b4	
	Fan Output DO # 5	ON/OFF		fan_b5	
	Fan Output DO # 6	ON/OFF		fan_b6	
	Fan Output DO # 7	ON/OFF		fan_b7	
	Fan Output DO # 8	ON/OFF		fan_b8	
	Fan Staging Number	0-10		FAN_ST_B	
	FREE COOLING OUTPUT				
	Refrigerant Pump Out*	ON/OFF		FR_PMP_B	
	Circuit Heater Output*	ON/OFF		FR_HEATB	
	MISCELLANEOUS				
	Ball Valve Position	OPEN/CLSE		ISO_REFB	
	Ball Valve Closing Out	ON/OFF		ISO_CL_B	
	Ball Valve Opening Out	ON/OFF		ISO_OP_B	
	4 Way Refrigerant Valve*	ON/OFF		RV_B	

\*Not supported.

## APPENDIX B — CCN TABLES (cont)

### STATUS DISPLAY TABLES (cont)

TABLE	DISPLAY NAME	RANGE	UNITS	POINT NAME	WRITE STATUS
CIRCC_AN	CIRCUIT C ANALOG VALUES				
	Percent Total Capacity	0-100	%	CAPC_T	
	Discharge Pressure	nnn.n	psi	DP_C	
	Suction Pressure	nnn.n	psi	SP_C	
	Economizer Pressure	nnn.n	psi	ECON_P_C	
	Oil Pressure	nnn.n	psi	OP_C	
	Oil Pressure Difference	nnn.n	psi	DOP_C	
	Motor Current	nnn.n	AMPS	CURREN_C	
	Motor Temperature	nnnn	°F	CP_TMP_C	
	Discharge Gas Temp	nnnn	°F	DGT_C	
	Economizer Gas Temp	nnnn	°F	ECO_TP_C	
	Saturated Condensing Tmp	±nnn.n	°F	SCT_C	
	Saturated Suction Temp	±nnn.n	°F	SST_C	
	Compressor Suction Temp	±nnn.n	°F	SUCT_T_C	
EXV Position	0-100	%	EXV_C		
Head Press Actuator Pos	0-100	%	hd_pos_c		
CIRCC_D	CIRCUIT C DISCRETE				
	Compressor Output	On/Off		COMP_C	
	Slide Valve 1 Output	On/Off		SLID_1_C	
	Slide Valve 2 Output	On/Off		SLID_2_C	
	Oil Heater Output	On/Off		OIL_HT_C	
	Oil Solenoid Output	On/Off		OIL_SL_C	
	Oil Level Input	Low/High		OIL_L_C	
	DGT Cooling Solenoid	On/Off		GASCOOLC	
	FANS OUTPUT				
	Fan Output DO # 1	On/Off		fan_c1	
	Fan Output DO # 2	On/Off		fan_c2	
	Fan Output DO # 3	On/Off		fan_c3	
	Fan Output DO # 4	On/Off		fan_c4	
	Fan Output DO # 5	On/Off		fan_c5	
	Fan Output DO # 6	On/Off		fan_c6	
	Fan Output DO # 7	On/Off		fan_c7	
	Fan Output DO # 8	On/Off		fan_c8	
	Fan Staging Number	0-10		FAN_ST_C	
	FREE COOLING OUT				
	Refrigerant Pump Out*	On/Off		FR_PMP_C	
Circuit Heater Output*	On/Off		FR_HEATC		
MISCELLANEOUS					
Ball Valve Position	OPEN/CLSE		ISO_REFC		
Ball Valve Closing Out	On/Off		ISO_CL_C		
Ball Valve Opening Out	On/Off		ISO_OP_C		
4 Way Refrigerant Valve*	On/Off		RV_C		
FAN HOURS	FAN OPERATING HOURS				
	Circuit A Fan #1 Hours	nnnnn	hours	hr_fana1	
	Circuit A Fan #2 Hours	nnnnn	hours	hr_fana2	
	Circuit A Fan #3 Hours	nnnnn	hours	hr_fana3	
	Circuit A Fan #4 Hours	nnnnn	hours	hr_fana4	
	Circuit A Fan #5 Hours	nnnnn	hours	hr_fana5	
	Circuit A Fan #6 Hours	nnnnn	hours	hr_fana6	
	Circuit A Fan #7 Hours	nnnnn	hours	hr_fana7	
	Circuit A Fan #8 Hours	nnnnn	hours	hr_fana8	
	Circuit A Fan #9 Hours	nnnnn	hours	hr_fana9	
	Circuit A Fan #10 Hours	nnnnn	hours	hrfana10	
	Circuit B Fan #1 Hours	nnnnn	hours	hr_fanb1	
	Circuit B Fan #2 Hours	nnnnn	hours	hr_fanb2	
	Circuit B Fan #3 Hours	nnnnn	hours	hr_fanb3	
	Circuit B Fan #4 Hours	nnnnn	hours	hr_fanb4	
	Circuit B Fan #5 Hours	nnnnn	hours	hr_fanb5	
	Circuit B Fan #6 Hours	nnnnn	hours	hr_fanb6	
	Circuit B Fan #7 Hours	nnnnn	hours	hr_fanb7	
	Circuit B Fan #8 Hours	nnnnn	hours	hr_fanb8	
	Circuit B Fan #9 Hours	nnnnn	hours	hr_fanb9	
	Circuit B Fan #10 Hours	nnnnn	hours	hrfanb10	
	Circuit C Fan #1 Hours	nnnnn	hours	hr_fanc1	
	Circuit C Fan #2 Hours	nnnnn	hours	hr_fanc2	
	Circuit C Fan #3 Hours	nnnnn	hours	hr_fanc3	
	Circuit C Fan #4 Hours	nnnnn	hours	hr_fanc4	
	Circuit C Fan #5 Hours	nnnnn	hours	hr_fanc5	
	Circuit C Fan #6 Hours	nnnnn	hours	hr_fanc6	
	Circuit C Fan #7 Hours	nnnnn	hours	hr_fanc7	
	Circuit C Fan #8 Hours	nnnnn	hours	hr_fanc8	
	Circuit C Fan #9 Hours	nnnnn	hours	hr_fanc9	
Circuit C Fan #10 Hours	nnnnn	hours	hr_fanc10		

\*Not supported.

## APPENDIX B — CCN TABLES (cont)

### STATUS DISPLAY TABLES (cont)

TABLE	DISPLAY NAME	RANGE	UNITS	POINT NAME	WRITE STATUS	
GENUNIT	Operating Type Control Type	L-Off-Local Off (ComfortLink Controls= On/Off Switch=Opened) L-On-Local On L-Sched-Local On/Off State based on Time Schedules CCN-Unit is in CCN Control Remote-On/Off Based on Remote Contact (not applied to ComfortLink Display) Master-Unit Operation in Lead/Lag and it is a Master		OPER_TYP		
	Run Status	Local CCN Remote 0 = Off 1 = Running 2 = Stopping 3 = Delay 4 = Tripout 5 = Ready 6 = Override 7 = Defrost 8 = Run Test 9 = Test		ctr_type  STATUS		
	CCN Chiller Start/Stop Chiller Occupied? Minutes Left for Start Heat/Cool Status	Enable/Disable Yes/No 0-15 0 = Cool 1 = Heat 2 = Stand-by 3 = Both	min	CHIL_S_S CHIL_OCC min_left HEATCOOL	forcible forcible	
	Heat/Cool Select	0 = Cool 1 = Heat 2 = Auto		HC_SEL	forcible	
	Heat Reclaim Select Free Cooling Selct Alarm State	Yes/No Yes/No 0 = Normal 1 = Partial 2 = Shutdown		RECL_SEL FC_DSBLE ALM	forcible* forcible	
	Current Alarm 1 Current Alarm 2 Current Alarm 3 Current Alarm 4 Current Alarm 5	nnnnn nnnnn nnnnn nnnnn nnnnn		alarm_1 alarm_2 alarm_3 alarm_4 alarm_5		
	Percent Total Capacity Active Demand Limit Val Lag Capacity Limit Value	nnn nnn nnn	% % %	CAP_T DEM_LIM LAG_LIM	forcible*	
	Actual Chiller Current Chiller Current Limit Current Setpoint Setpoint Occupied? Setpoint Control	nnn nnn ±nnn.n Yes/No Setpt 1 Setpt 2 Ice_sp 4-20mA Auto	amps amps °F	TOT_CURR CURR_LIM SP SP_OCC sp_ctrl	forcible† forcible forcible	
	Control Point Controlled Water Temp External Temperature Emergency Stop	±nnn.n ±nnn.n ±nnn.n Enable/Disable	°F °F °F	CTRL_PNT CTRL_WT OAT EMSTOP	forcible* forcible forcible	
	MODES	Startup Delay in Effect	Yes/No	—	Mode_01	
		Second Setpoint in Use	Yes/No	—	Mode_02	
		Reset in Effect	Yes/No	—	Mode_03	
		Demand Limit Active	Yes/No	—	Mode_04	
		Ramp Loading Active	Yes/No	—	Mode_05	
		Cooler Heater Active	Yes/No	—	Mode_06	
		Cooler Pumps Rotation	Yes/No	—	Mode_07	
		Pump Periodic Start	Yes/No	—	Mode_08	
		Night Low Noise Active	Yes/No	—	Mode_09	
		System Manager Active	Yes/No	—	Mode_10	
		Master Slave Active	Yes/No	—	Mode_11	
		Auto Changeover Active	Yes/No	—	Mode_12	
		Free Cooling Active	Yes/No	—	Mode_13	
		Reclaim Active	Yes/No	—	Mode_14	
		Electric Heat Active	Yes/No	—	Mode_15	
		Heating Low EWT Lockout	Yes/No	—	Mode_16	
		Condenser Pumps Rotation	Yes/No	—	Mode_17	
		Ice Mode in Effect	Yes/No	—	Mode_18	
		Defrost Active On Cir A	Yes/No	—	Mode_19	
		Defrost Active On Cir B	Yes/No	—	Mode_20	
		Low Suction Circuit A	Yes/No	—	Mode_21	
		Low Suction Circuit B	Yes/No	—	Mode_22	
		Low Suction Circuit C	Yes/No	—	Mode_23	
		High DGT Circuit A	Yes/No	—	Mode_24	
High DGT Circuit B		Yes/No	—	Mode_25		
High DGT Circuit C		Yes/No	—	Mode_26		
High Pres Override Cir A		Yes/No	—	Mode_27		
High Pres Override Cir B		Yes/No	—	Mode_28		
High Pres Override Cir C		Yes/No	—	Mode_29		
Low Superheat Circuit A		Yes/No	—	Mode_30		
Low Superheat Circuit B		Yes/No	—	Mode_31		
Low Superheat Circuit C		Yes/No	—	Mode_32		

\*Not supported.

†The forced value will be used.

## APPENDIX B — CCN TABLES (cont)

### STATUS DISPLAY TABLES (cont)

TABLE	DISPLAY NAME	RANGE	UNITS	POINT NAME	WRITE STATUS
RECLAIM*	Heat Reclaim Select	Yes/no		RECL_SEL	
	Reclaim Condenser Pump	On/Off		CONDPUMP	
	Reclaim Condenser Flow	On/Off		CONDFLOW	
	Reclaim Condenser Heater	On/Off		cond_htr	
	Reclaim Entering Fluid	±nnn.n	°F	HR_EWT	
	Reclaim Leaving Fluid	±nnn.n	°F	HR_LWT	
	Reclaim Fluid Setpoint	±nnn.n	°F	RSP	forcible
	Reclaim Valve Position	±nnn.n	%	hr_v_pos	
	HEAT RECLAIM CIRCUIT A				
	Reclaim Status Circuit A	n		hrstat_a	
	Pumpdown Pressure Cir A	±nnn.n	psi	PD_P_A	
	Sub Condenser Temp Cir A	±nnn.n	°F	hr_subta	
	Pumpdown Saturated Tmp A	±nnn.n	°F	hr_sat_a	
	Subcooling Temperature A	±nnn.n	°F	hr_subca	
	Air Cond Entering Valv A	On/Off		hr_ea_a	
	Water Cond Enter Valve A	On/Off		hr_ew_a	
	Air Cond Leaving Valve A	On/Off		hr_la_a	
	Water Cond Leaving Val A	On/Off		hr_lw_a	
	HEAT RECLAIM CIRCUIT B				
	Reclaim Status Circuit B	n		hrstat_b	
	Pumpdown Pressure Cir B	±nnn.n	psi	PD_P_B	
	Sub Condenser Temp Cir B	±nnn.n	°F	hr_subtb	
	Pumpdown Saturated Tmp B	±nnn.n	°F	hr_sat_b	
	Subcooling Temperature B	±nnn.n	°F	hr_subcb	
	Air Cond Entering Valv B	On/Off		hr_ea_b	
	Water Cond Enter Valve B	On/Off		hr_ew_b	
	Air Cond Leaving Valve B	On/Off		hr_la_b	
	Water Cond Leaving Val B	On/Off		hr_lw_b	
STATEGEN	UNIT DISCRETE IN				
	On/Off – Remote Switch	Open/Clse		ONOFF_SW	
	Remote Heat/Cool Switch	Open/Clse		HC_SW	
Current Control	Off, On Cool, On Heat, On Auto			on_ctrl	
Remote Reclaim Switch	Open/Clse			RECL_SW	
Remote Setpoint Switch	Open/Clse			SETP_SW	
Limit Switch 1 Status	Open/Clse			LIM_SW1	
Limit Switch 2 Status	Open/Clse			LIM_SW2	
Occupied Override Switch	Open/Clse			OCC_OVSW	
Ice Done Storage Switch	Open/Clse			ICE_SW	
Cooler Flow Switch	Open/Clse			FLOW_SW	
Cooler Pump Run Status*	Open/Clse			CPUMPDEF	
Condenser Flow Status*	On/Off			CONDFLOW	
Remote Interlock Status	Open/Clse			REM_LOCK	
Electrical Box Interlock*	Open/Clse			ELEC_BOX	
UNIT DISCRETE OUT					
Electrical Heat Stage*	0-4/Off			EHS_STEP	
Cooler Pump #1 Command*	On/Off			CPUMP_1	forcible
Cooler Pump #2 Command*	On/Off			CPUMP_2	forcible
Rotate Cooler Pumps ?*	Yes/No			ROTCPUMP	forcible
Condenser Pump #1 Out*	On/Off			HPUMP_1	forcible
Condenser Pump #2 Out*	On/Off			HPUMP_2	forcible
Rotate Condenser Pumps?*	Yes/No			ROTHPUMP	forcible
Cooler Heater Command	On/Off			COOLHEAT	forcible
Shutdown Indicator State	On/Off			SHUTDOWN	
Alarm Relay Status	On/Off			ALARMOUT	
Alert Relay Status	On/Off			ALERT	
Ready or Running Status	On/Off			READY	
Running Status	On/Off			RUNNING	
UNIT ANALOG					
Cooler Flow Setpoint Out*	On/Off			SET_FLOW	
Cooler Entering Fluid	±nnn.n		°F	COOL_EWT	
Cooler Leaving Fluid	±nnn.n		°F	COOL_LWT	
Condenser Entering Fluid*	±nnn.n		°F	COND_EWT	
Condenser Leaving Fluid*	±nnn.n		°F	COND_LWT	
Cooler Heater Temp	±nnn.n		°F	HEATER	
Optional Space Temp	±nnn.n		°F	SPACETMP	
CHWS Temperature	±nnn.n		°F	CHWSTEMP	
Reset /Setpnt 4-20mA Sgnl	±nn.n		ma	SP_RESET	
Limit 4-20mA Signal	±nn.n		ma	LIM_ANAL	
Chiller Capacity Signal	±nn.n		volts	CAPT_010	
STRTHOUR	Machine Operating Hours	nnnnn	hours	HR_MACH	
	Machine Starts Number	nnnnn		st_mach	
	Compressor A Hours	nnnnn	hours	HR_CP_A	
Compressor A Starts	nnnnn		st_cp_a		
Compressor B Hours	nnnnn	hours	HR_CP_B		
Compressor B Starts	nnnnn		st_cp_b		
Compressor C Hours	nnnnn	hours	HR_CP_C		
Compressor C Starts	nnnnn		st_cp_c		
WATER PUMPS*					
Cooler Pump #1 Hours	nnnnn	hours		hr_cpum1	
Cooler Pump #2 Hours	nnnnn	hours		hr_cpum2	
Condenser Pump #1 Hours	nnnnn	hours		hr_hpum1	
Condenser Pump #2 Hours	nnnnn	hours		hr_hpum2	
DEFROST CYCLES*					
Circuit A Defrost Numer	nnnnn			nb_def_a	
Circuit B Defrost Number	nnnnn			nb_def_b	

\*Not supported.

## APPENDIX B — CCN TABLES (cont)

### CONFIGURATION TABLES

TABLE	DISPLAY NAME	RANGE	DEFAULT	UNITS	POINT NAME
Ctrl_ID	Device Name	8 chars	PD5_RBRQ		
	Description	24 chars	PRO-DIALOG 5 30RB&30HP		
	Location	24 chars			
	Software Part Number	16 chars	CSA-SR-20C4600nn		
	Model Number	20 chars			
	Serial Number	12 chars			
	Reference Number	24 chars			
ALARMDEF	Alarm Routing Control	0-11111111	00000000		ALRM_CNT
	Alarm Equipment Priority	0-7	4		EQP_TYP
	Comm Failure Retry Time	1-240	10	min	RETRY_TM
	Realarm Time	1-255	30	min	RE_ALARM
	Alarm System Name	8 chars	PRO_RGRW		ALRM_NAM
BRODEFS	Activate	0=Unused 1=Broadcast time, date, holiday flag and OAT. 2=For Standalone chiller. Daylight savings time & holiday determi- nation will be done without broadcasting through the bus.	2	—	Ccnbroadcast
	OAT Broadcast	Bus # 0 to 239 Element #0 to 239	0 0		Oatbusnm Oatlocad
	DAYLIGHT SAVING SELECT ENTERING	Disable/Enable	Disable		dayl_sel
	Month	1 to 12	3		Startmon
	Day of week* (1=Monday)	1 to 7	7		Startdow
	Week Number of Month†	1 to 5	5		Startwom
	LEAVING				
	Month	1 to 12	10		Stopmon
	Day of week* (1=Monday)	1 to 7	7		Stoptdow
	Week Number of Month†	1 to 5	5		stopwom
HOLIDAY/HOLDY01S to HOLDY16S	Holiday Start Month	0-12	0		HOL_MON
	Start Day	0-31	0		HOL_DAY
	Duration (days)	0-99	0		HOL_LEN
OCCDEFCS/ OCCPC01S and OCCPC02S	Timed Override Hours	0-4	0		OVR_EXT
	Period 1 DOW (MTWTFSSH)	0/1	11111111		DOW1
	Occupied From	00:00-24:00	00:00		OCCTOD1
	Occupied To	00:00-24:00	24:00		UNOCTOD1
	Period 2 DOW (MTWTFSSH)	0/1	11111111		DOW1
	Occupied From	00:00-24:00	00:00		OCCTOD1
	Occupied To	00:00-24:00	00:00		UNOCTOD2
	Period 3 DOW (MTWTFSSH)	0/1	00000000		DOW3
	Occupied From	00:00-24:00	00:00		OCCTOD3
	Occupied To	00:00-24:00	00:00		UNOCTOD3
	Period 4 DOW (MTWTFSSH)	0/1	00000000		DOW4
	Occupied From	00:00-24:00	00:00		OCCTOD4
	Occupied To	00:00-24:00	00:00		UNOCTOD4
	Period 5 DOW (MTWTFSSH)	0/1	00000000		DOW5
	Occupied From	00:00-24:00	00:00		OCCTOD5
	Occupied To	00:00-24:00	00:00		UNOCTOD5
	Period 6 DOW (MTWTFSSH)	0/1	00000000		DOW6
	Occupied From	00:00-24:00	00:00		OCCTOD6
	Occupied To	00:00-24:00	00:00		UNOCTOD6
	Period 7 DOW (MTWTFSSH)	0/1	00000000		DOW7
	Occupied From	00:00-24:00	00:00		OCCTOD7
	Occupied To	00:00-24:00	00:00		UNOCTOD7
	Period 8 DOW (MTWTFSSH)	0/1	00000000		DOW8
	Occupied From	00:00-24:00	00:00		OCCTOD8
	Occupied To	00:00-24:00	00:00		UNOCTOD8

\*Day of week where daylight savings time will occur in the morning (at 2:00 am). Daylight savings time occurs on Sunday (7) morning, 1 hour shall be added when entering and 1 hour subtracted when leaving.

†Date once selected (from 1) shall occur in the week number entered. 1: If day of week selected is 7 (Sunday) time change will occur the first Sunday (week

number 1) in the month. 5: If day of week selected is 7 (Sunday) time change will occur the last Sunday of the month (week number 4 or 5).

NOTE: nn is software version.

## APPENDIX B — CCN TABLES (cont)

### CONFIGURATION TABLES (cont)

TABLE	DISPLAY NAME	RANGE	DEFAULT	UNITS	POINT NAME
DISPCNF	Metric Display on STDU Language Selection	Yes/No 0=English 1=Espanol 2=Francais 3=Portugues 4=Translated	No 0		DISPUNIT LANGUAGE

**NOTES:**

1. Enter unit size. This item allows the controls to determine capacity of each compressor and the total number of fans on each circuit based on a compressor arrangement array (can be viewed in table FACTORY2). It is not necessary to enter compressor capacity and number of fans on each circuit. See Tables 1A and 1B in the 30XA Installation Instructions for more information.
2. Number of fans controlled directly by a variable speed fan actuator using 0 to 10 vdc signal. This will enable the controls to determine the remaining discrete fan staging outputs from the total fans on each circuit.
3. Used for extra functions with the purpose of energy management such as occupancy override switch, ice storage, setpoint reset, and demand limit.
4. Compressor capacity will be automatically be determined if unit size entered in FACTORY1 table matches the values in the unit compressor configuration table.
5. Total number of fans includes fans controlled by a variable speed fan. This value will be automatically populated if unit size entered in FACTORY1 table matches the values in the unit compressor configuration table.

TABLE	DISPLAY NAME	RANGE	DEFAULT	UNITS	POINT NAME
MST_SLV	MASTER SLAVE CONTROL Master/Slave Select	0=Disable 1=Master 2=Slave	0		ms_sel
	Master Control Type	1=Local Control 2=Remote Control 3=CCN Control	1		ms_ctrl
	Slave Address	1 to 236	2		slv_addr
	Lead Lag Select	0=Always Lead 1=Lag Once Failed Only 2=Lead/Lag Runtime Sec	0		lead_sel
	Lead/Lag Balance Delta	40 to 400	168	hours	ll_bal_d
	Lag Start Timer	2 to 30	10	min	lstr_tim
	Lead Pulldown Time	0 to 60	0	minutes	lead_pul
	Start if Error Higher		4° ΔF		start_dlt
	Lag Minimum Running Time		0 min		lag_mini
	Lag Unit Pump Control	0=Stop if Unit Stops 1=Run if Unit Stops	0		lag_pump
Chiller in Series	Yes/No	No		ll_serie	

## APPENDIX B — CCN TABLES (cont)

### CONFIGURATION TABLES (cont)

TABLE	DISPLAY NAME	RANGE	DEFAULT	UNITS	POINT NAME	
USER	Circuit Loading Sequence	0-3 0=Auto, 1=A Lead, 2=B Lead, 3=C Lead	0		lead_cir	
	Staged Loading Sequence	No/Yes	No	Min	seq_typ	
	Ramp Loading Select	No/Yes	No		ramp_sel	
	Unit Off to On Delay	1-15	1		off_on_d	
	Condenser Pumps Sequence	0/1/2/3/4	0		hpumpseq	
	Cooler Pumps Sequence	0-4 0=No Pump 1=One Pump Only 2=Two Pumps Auto 3=Pump#1 Manual 4=Pump#2 Manual	0		pump_seq	
	Pump Auto Rotation Delay*	24-3000	48	hours	pump_del	
	Pump Sticking Protection*	No/Yes	No		pump_per	
	Stop Pump During Standby*	No/Yes	No		pump_sby	
	Flow Checked if C Pump Off	No/Yes	Yes		pump_loc	
	Auto Changeover Select*	No/Yes	No		auto_sel	
	Cooling Reset Select	0-4	0	cr_sel		
	Heating Reset Select*	0-4 1=OAT, 0=None 2=Delta T, 3=4-20mA Control 4=Space Temp	0		hr_sel	
	Demand Limit Type Select	0-2 0=None 1=Switch Control 2=4-20mA Control	0		lim_sel	
	mA For 100% Demand Limit	0-20	0		lim_mx	
	mA For 0% Demand Limit	0-20	0		lim_ze	
	Current Limit Select	No/Yes	No		curr_sel	
	Current Limit at 100%	0 to 2000	2000	amps	curr_ful	
	Heating OAT Threshold	-4-32	5		heat_th	
	Boiler OAT Threshold	5-59	14	°F	boil_th	
	Free Cooling OAT Limit*	-4-37.4	32	°F	free_oat	
	Elec Stage OAT Threshold*	23-70	41	°F	ehs_th	
	1 Elec Stage for backup*	No/Yes	No	minutes	ehs_back	
	Electrical Pulldown Time*	0-60	0		ehs_pull	
	Quick EHS for Defrost*	No/Yes	No		ehs_defr	
	<b>NIGHT CONTROL</b>					
	Start Hour	00:00-24:00	00:00	00:00	%	nh_start
	End Hour	00:00-24:00	00:00	00:00		nh_end
	Capacity Limit	0-100	100	100		nh_cnfg
	Ice Mode Enable	No/Yes	No	No		ice_cnfg
	Reverse Alarms Relay	No/Yes	No	No		al_rever
	Pass For All User Config	No/Yes	No	No	all_pass	

**NOTES:**

- Flow checked if pump off needed when a command is sent to the primary pump to prevent cooler from freezing in winter conditions. Command will set the cooler flow switch to closed while the controls stop the cooler pump. The controls may then generate an alarm. If this decision is active, the cooler flow switch is not checked when the cooler pump is stopped.
- If cooling reset select set point has been selected the set point based on 4-20mA input signal through *ComfortLink™* control, then a 4-20 mA reset

- function shall be ignored. Configuration 3 (4-20mA Control) and 4 (Space Temperature) shall require an Energy Management Module.
- Configuration 2 (4-20mA Control) shall require an Energy Management Module. Configuration 1 Switch Demand limit provides 3 step demand limit if an Energy Management Module is present. Otherwise, only one step is allowed.
- Reverse Alarms Relay configuration will be deenergized when an alarm and alert relay is present and will be energized when no alarm is present.

## APPENDIX B — CCN TABLES (cont)

### SETPOINT CONFIGURATION TABLES

TABLE	DISPLAY NAME	RANGE	DEFAULT	UNITS	POINT NAME	
SETPOINT	COOLING					
	Cooling Setpoint 1	-20-70	44.0	°F	csp1	
	Cooling Setpoint 2	-20-70	44.0	°F	csp2	
	Cooling Ice Setpoint	-20-70	44.0	°F	ice_sp	
	OAT No Reset Value	14-125	14.0	°F	oatcr_no	
	OAT Full Reset Value	14-125	14.0	°F	oatcr_fu	
	Delta T No Reset Value	0-25	0.0	°F	dt_cr_no	
	Delta T Full Reset Value	0-25	0.0	°F	dt_cr_fu	
	Current No Reset Value	0-20	0.0	ma	v_cr_no	
	Current Full Reset Value	0-20	0.0	ma	v_cr_fu	
	Space T No Reset Value	14-125	14.0	°F	spacr_no	
	SpaceT Full Reset Value	14-125	14.0	°F	spacr_fu	
	Cooling Reset Deg. Value	-30-30	0.0	°F	cr_deg	
	Cooling Ramp Loading	0.2-2.0	1.0	°F	cramp_sp	
	HEATING*					
	Heating Setpoint 1	80-140	100.0	°F	hsp1	
	Heating Setpoint 2	80-140	100.0	°F	hsp2	
	OAT No Reset Value	14-125	14.0	°F	oathr_no	
	OAT Full Reset Value	14-125	14.0	°F	oathr_fu	
	Delta T No Reset Value	0-25	0.0	°F	dt_hr_no	
	Delta T Full Reset Value	0-25	0.0	°F	dt_hr_fu	
	Current No Reset Value	0-20	0.0	ma	v_hr_no	
	Current Full Reset Value	0-20	0.0	ma	v_hr_fu	
	Heating Reset Deg. Value	-30-30	0.0	°F	hr_deg	
	Heating Ramp Loading	0.2-2.0	1.0	°F	hramp_sp	
	AUTO CHANGEOVER*					
	Cool Changeover Setpt	39-122	75.0	°F	cauto_sp	
	Heat Changeover Setpt	32-115	64.0	°F	hauto_sp	
	MISCELLANEOUS					
	Switch Limit Setpoint 1	0-100	100	%	lim_sp1	
	Switch Limit Setpoint 2	0-100	100	%	lim_sp2	
	Switch Limit Setpoint 3	0-100	100	%	lim_sp3	
	Reclaim Setpoint*	95-140	122.0	°F	rsp	
	Reclaim Deadband*	5-27	9.0	°F	hr_deadb	
	Water Val Condensing Stp*	80 to 120	86	°F	w_sct_sp	

\*Not supported.

### MAINTENANCE DISPLAY TABLES

TABLE	DISPLAY NAME	RANGE	UNITS	POINT NAME	WRITE STATUS	
BOARD_PN	EXV Board Circuit A	XXXXXXXXXX		exv_brda		
	EXV Board Circuit B	XXXXXXXXXX		exv_brdb		
	EXV Board Circuit C	XXXXXXXXXX		exv_brdc		
	AUX Board #1 Part Number	XXXXXXXXXX		aux_brd1		
	AUX Board #2 Part Number	XXXXXXXXXX		aux_brd2		
	AUX Board #3 Part Number	XXXXXXXXXX		aux_brd3		
	AUX Board #4 Part Number	XXXXXXXXXX		aux_brd4		
	AUX Board #5 Part Number	XXXXXXXXXX		aux_brd5		
	EMM NRCP2 Board	XXXXXXXXXX		emm_nrcp		
	Reclaim NRCP2 Board	XXXXXXXXXX		rec_nrcp		
	TCPM Board Comp A	XXXXXXXXXX		cpa_vers		
	Must Trip Amps	0-600	amps	cpa_mtam		
	S1 Config Switch (8 to 1)	00000000	0	cpa_s1_m		
	TCPM Board Comp B	nnnn		cpb_vers		
	Must Trip Amps	0-600	amps	cpb_mtam		
	S1 Config Switch (8 to 1)	00000000	0	cpb_s1_m		
	TCPM Board Comp C	XXXXXXXXXX		cpc_vers		
Must Trip Amps	0-600	amps	cpc_mtam			
S1 Config Switch (8 to 1)	00000000	0	cpc_s1_m			
CUR_PHASE	Current Phase 1 Comp A	0-600	amps	cpa_cur1		
	Current Phase 2 Comp A	0-600	amps	cpa_cur2		
	Current Phase 3 Comp A	0-600	amps	cpa_cur3		
	Current Phase 1 Comp B	0-600	amps	cpb_cur1		
	Current Phase 2 Comp B	0-600	amps	cpb_cur2		
	Current Phase 3 Comp B	0-600	amps	cpb_cur3		
	Current Phase 1 Comp C	0-600	amps	cpc_cur1		
	Current Phase 2 Comp C	0-600	amps	cpc_cur2		
	Current Phase 3 Comp C	0-600	amps	cpc_cur3		
	DEFROSTM*	CIR A DEFROST CONTROL				
		Exchanger Frost Factor	0-100	%	frost_a	
		Next Sequence Allowed in Defrost Active?	nnn	minutes	def_se_a	
Defrost Temperature		True/False		mode[19]		
Defrost Duration		±nnn.n	°F	DEFRT_A		
Fan Sequence Started ?		nnn	minutes	defr_dua		
Override State		n		def_fa_a		
Mean SST Calculation		nn		over_d_a		
Delta: OAT - Mean SST		±nnn.n	°F	sst_dm_a		
Reference Delta		±nnn.n	°F	delt_a		
Delta - Reference Delta		±nnn.n	°F	delt_r_a		
Frost Integrator Gain		±nnn.n	°F	del_v_a		
Defrost Fan Start Cal A		n.n		fr_int_a		
Defrost Fan Offset Cal A		0.00	psi	def_ca_a		
		0.00	psi	def_of_a		
CIR B DEFROST CONTROL						
Exchanger Frost Factor		0-100	%	frost_b		
Next Sequence Allowed in Defrost Active?		nnn	minutes	def_se_b		
Defrost Temperature		True/False		mode[20]		
Defrost Duration		±nnn.n	°F	DEFRT_B		
Fan Sequence Started?		nnn	minutes	defr_dub		
Override State		n		def_fa_b		
Mean SST calculation		nn		over_d_b		
Delta: OAT - Mean SST		±nnn.n	°F	sst_dm_b		
Reference Delta		±nnn.n	°F	delt_b		
Delta - Reference Delta		±nnn.n	°F	delt_r_b		
Frost Integrator Gain	±nnn.n	°F	del_v_b			
Defrost Fan Start Cal B	n.n		fr_int_b			
Defrost Fan Offset Cal B	0.00	psi	def_ca_b			
	0.00	psi	def_of_b			

\*Not supported.

NOTES: Tables for display only. Forcing shall not be supported on this maintenance screen.

**APPENDIX B — CCN TABLES (cont)**  
**MAINTENANCE DISPLAY TABLES (cont)**

TABLE	DISPLAY NAME	RANGE	UNITS	POINT NAME	WRITE STATUS	
FANCTRL	Cir A SCT Control Point	±nnn.n	°F	sct_sp_a		
	Cir A SCT Candidate	±nnn.n	°F	sct_fu_a		
	Cir A Fan Cycle Counter	±nnn.n		fancyc_a		
	Cir A Optimal Fan Count	±nnn.n		fancop_a		
	Cir B SCT Control Point	±nnn.n	°F	sct_sp_b		
	Cir B SCT Candidate	±nnn.n	°F	sct_fu_b		
	Cir B Fan Cycle Counter	±nnn.n		fancyc_b		
	Cir B Optimal Fan Count	±nnn.n		fancop_b		
	Cir C SCT Control Point	±nnn.n	°F	sct_sp_c		
	Cir C SCT Candidate	±nnn.n	°F	sct_fu_c		
	Cir C Fan Cycle Counter	±nnn.n		fancyc_c		
	Cir C Optimal Fan Count	±nnn.n		fancop_c		
LAST_POR	Power On 1: day-mon-year	nnnnnn	ddmmyy	date_on1		
	Power On 1: hour-minute	nnnn	hhmm	time_on1		
	PowerDown 1:day-mon-year	nnnnnn	ddmmyy	date_of1		
	PowerDown 1:hour-minute	nnnn	hhmm	time_of1		
	Power On 2: day-mon-year	nnnnnn	ddmmyy	date_on2		
	Power On 2: hour-minute	nnnn	hhmm	time_on2		
	PowerDown 2:day-mon-year	nnnnnn	ddmmyy	date_of2		
	PowerDown 2:hour-minute	nnnn	hhmm	time_of2		
	Power On 3: day-mon-year	nnnnnn	ddmmyy	date_on3		
	Power On 3: hour-minute	nnnn	hhmm	time_on3		
	PowerDown 3:day-mon-year	nnnnnn	ddmmyy	date_of3		
	PowerDown 3:hour-minute	nnnn	hhmm	time_of3		
	Power On 4: day-mon-year	nnnnnn	ddmmyy	date_on4		
	Power On 4: hour-minute	nnnn	hhmm	time_on4		
	PowerDown 4:day-mon-year	nnnnnn	ddmmyy	date_of4		
	PowerDown 4:hour-minute	nnnn	hhmm	time_of4		
	Power On 5: day-mon-year	nnnnnn	ddmmyy	date_on5		
	Power On 5: hour-minute	nnnn	hhmm	time_on5		
	PowerDown 5:day-mon-year	nnnnnn	ddmmyy	date_of5		
	PowerDown 5:hour-minute	nnnn	hhmm	time_of5		
LOADFACT	CAPACITY CONTROL					
	Average Ctrl Water Temp	±nnn.n	°F	ctrl_avg		
	Differential Water Temp	±nnn.n	°F	diff_wt		
	Water Delta T	±nnn.n	^F	delta_t		
	Control Point	±nnn.n	°F	CTRL_PNT		
	Reset Amount	±nnn.n	^F	reset		
	Controlled Temp Error	±nnn.n	^F	tp_error		
	Actual Capacity	nnn	%	cap_t		
	Actual Capacity Limit	nnn	%	cap_lim		
	Actual Chiller Current	nnnn	lamps	TOT_CURR		
	Chiller Current Limit	nnnn	amps	CURR_LIM		
	Current At 30% Load A	nnnn	amps	cur_30_a		
	Current At 30% Load B	nnnn	amps	cur_30_b		
	Current At 30% Load C	nnnn	amps	cur_30_c		
	Current At 100% Load A	nnnn	amps	cur100_a		
	Current At 100% Load B	nnnn	amps	cur100_b		
	Current At 100% Load C	nnnn	amps	cur100_c		
	Current Z Multiplier Val	±n.n		zm		
	Load/Unload Factor	±nnn.n	0/0	smz		
	Active Capacity Override	nn		over_cap		
	EHS CAPACITY CONTROL					
	EHS Ctrl Override	nn		over_ehs		
	Requested Electric Stage	nn		eh_stage		
	Electrical Pulldown?	True/False		ehspulld		
	EXV_CTRL	EXV CONTROL				
		EXV Position Circuit A	nnn.n	%	EXV_A	
		Discharge Superheat A	nnn.n	%	DSH_A	
Suction Superheat A		nn.n	^F	SH_A		
Suction SH Control Pt A		nn.n	^F	sh_sp_a		
Cooler Exchange DT Cir A		nn.n	^F	pinch_a		
Cooler Pinch Ctl Point A		nn.n	^F	pinch_spa		
EXV Override Circuit A		nn		ov_exv_a		
EXV Position Circuit B		nnn.n	%	EXV_B		
Discharge Superheat B		nnn.n	%	DSH_B		
Suction Superheat B		nn.n	^F	SH_B		
Suction SH Control Pt B		nn.n	^F	sh_sp_b		
Cooler Exchange DT Cir B		nn.n	^F	pinch_b		
Cooler Pinch Ctl Point B		nn.n	^F	pinch_spb		
EXV Override Circuit B		nn		ov_exv_b		
EXV Position Circuit C		nnn.n	%	EXV_C		
Discharge Superheat C		nnn.n	%	DSH_C		
Suction Superheat C		nn.n	^F	SH_C		
Suction SH Control Pt C		nn.n	^F	sh_sp_c		
Cooler Exchange DT Cir C		nn.n	^F	pinch_c		
Cooler Pinch Ctl Point C		nn.n	^F	pinch_spc		
EXV Override Circuit C		nn		ov_exv_c		
ECONOMIZER CONTROL						
Economizer Position A		nnn.n	%	EXV_EC_A		
Economizer Superheat A		nn.n	^F	eco_sha		
Economizer SH Setpoint A		nn.n	^F	ecsh_spa		
EXV Override Circuit A		nn		ov_eco_a		
Economizer Position B		nnn.n	%	EXV_EC_B		
Economizer Superheat B		nn.n	^F	eco_shb		
Economizer SH Setpoint B		nn.n	^F	ecsh_spb		
EXV Override Circuit B	nn		ov_eco_b			
Economizer Position C	nnn.n	%	EXV_EC_C			
Economizer Superheat C	nn.n	^F	eco_shc			
Economizer SH Setpoint C	nn.n	^F	ecsh_spc			
EXV Override Circuit C	nn		ov_eco_c			

## APPENDIX B — CCN TABLES (cont)

### MAINTENANCE DISPLAY TABLES (cont)

TABLE	DISPLAY NAME	RANGE	UNITS	POINT NAME	WRITE STATUS
MSTSLAVE	MASTER/SLAVE CONTROL Unit is Master or Slave Master Control Type* Master/Slave Ctrl Active Lead Unit is the: Slave Chiller State†  Slave Chiller Total Cap Lag Start Delay** Lead/Lag Hours Delta* Lead/Lag Changeover?*** Lead Pulldown? Master/Slave Error Max Available Capacity?†† Slave Lagstat	Disable/Master/Slave Local/Remote/CCN True/False Master/Slave 0=Chiller is off 1=Valid Run State in CCN Mode 2=Unused for this control 3=Chiller is in local mode 4=Power fail restart in progress 5=Shutdown due to fault 6=Communication failure 0-100 1-30 ±nnnnn Yes/No Yes/No nn True/False 0=Unit not configured as a slave chiller 1=Slave pump configuration error (ms_error=1) 2=Unit configured as slave chiller with lwt_opt=no (entering water control) with pump control (lag_pump=0) 3=Unit configured as slave chiller with lwt_opt=yes (leaving water control) with pump control (lag_pump=0) 4=Unit Configured as slave chiller with lwt_opt=no (entering water control) with no pump control (lag_pump=1) 5=Unit configured as slave chiller with lwt_opt=yes (leaving water control) with no pump control (lag_pump=1)	% minutes hours	mstslv ms_ctrl ms_activ lead_sel slv_stat  slv_capt l_strt_d ll_hr_d ll_chang ll_pull ms_error cap_max lagstat	

\*Always CCN for the slave chiller.

†Slave chiller chillstat value

\*\*This decision is consistent for Master chiller only. It shall be set by default to 0 for the slave chiller.

††This item is true when chiller has loaded its total available capacity tonnage.

TABLE	DISPLAY NAME	RANGE	UNITS	POINT NAME	WRITE STATUS
OCCMAINT	Current Mode (1=occup.) Current Occp Period # Timed-Override in Effect Timed-Override Duration Current Occupied Time Current Unoccupied Time Next Occupied Day Next Occupied Time Next Unoccupied Day Next Unoccupied Time Prev Unoccupied Day Prev Unoccupied Time	0/1 1 to 8 Yes/No 0-4 00:00-23:59 00:00-23:59 Mon-Sun 00:00-23:59 Mon-Sun 00:00-23:59 Mon-Sun 00:00-23:59	hours	MODE PER_NO OVERLAST OVR_HRS STRTTIME ENDTIME NXTOCCDAY NXTOCTIM NXTUNDAY NXTUNTIM PRVUNDAY PRVUNTIM	

TABLE	DISPLAY NAME	RANGE	UNITS	POINT NAME	WRITE STATUS
PR_LIMIT	Discharge A Temp Average Discharge A Temp Rate Discharge A Gas Limit Suction A Temp Average Discharge B Temp Average Discharge B Temp Rate Discharge B Gas Limit Suction B Temp Average Discharge C Temp Average Discharge C Temp Rate Discharge C Gas Limit Suction C Temp Average	±nnn.n ±nnn.n ±nnn.n ±nnn.n ±nnn.n ±nnn.n ±nnn.n ±nnn.n ±nnn.n ±nnn.n ±nnn.n ±nnn.n	°F °F °F °F °F °F °F °F °F °F °F °F	sdt_m_a sdt_mr_a sdtlim_a sst_m_a sdt_m_b sdt_mr_b sdtlim_b sst_m_b sdt_m_c sdt_mr_c sdtlim_c sst_m_c	

NOTE: Table for display only. Used for Cooling and Heat Pump Compressor Envelope.

TABLE	DISPLAY NAME	RANGE	UNITS	POINT NAME	WRITE STATUS
SERMAINT	Reset Maintenance Alert 1 to 11: reset individually 12: reset all  OPERATION WARNINGS 1 — Refrigerant Charge 2 — Water Loop Size  GENERAL SERVICING DELAYS 3 — Cooler Pump 1 (days)* 4 — Cooler Pump 2 (days)* 5 — Condenser Pump 1 (days)* 6 — Condenser Pump 2 (days)* 7 — Water Filter (days)* 8 — Cp A Oil Filter (days) 9 — Cp B Oil Filter (days) 10 — CP.C Oil Filter (days)	nn  Normal/Low/Disable Normal/Low/Disable  0-1000/Alert/Disable 0-1000/Alert/Disable 0-1000/Alert 0-1000/Alert 0-1000/Alert/Disable 0-1000/Alert 0-1000/alert 0-1000/Alert		S_RESET  charge_m wloop_m  cpump1_m cpump2_m hpump1_m hpump2_m wfilte_m oilfa_m oilfilb_m oilfic_m	forcible

\*Not supported.

## APPENDIX B — CCN TABLES (cont)

### SERVICE CONFIGURATION TABLES

TABLE	DISPLAY NAME	RANGE	DEFAULT	UNITS	POINT NAME	WRITE STATUS
TABLE USED FOR DISABLE COMPRESSORS						
CP_UNABL	Compressor A Disable Compressor B Disable Compressor C Disable	No/Yes No/Yes No/Yes	No No No		un_cp_a un_cp_b un_cp_c	
FACTORY	Unit Type  Unit Capacity Model NB Fans on Varifan Cir A NB Fans on Varifan Cir B NB Fans on Varifan Cir C Soft Starter Select Wye Delta Start Select Air Cooled Reclaim Sel Free Cooling Select Electrical Heat Stages* Boiler Command Select Power Frequency 60HZ Sel Power Supply Voltage Energy Management Module Cooler heater select Condenser Water Val Sel* Hot Gas Bypass Select  MCHX Exchanger Select High Tiers Display Selec  Factory Password	1 (Cooling Only), 2 (Heat Pump) 3 (Water Cooled) 4 (Heat Machine) 0 to 1800 0 to 6 0 to 6 0 to 6 Yes/No Yes/No Yes/No Yes/No 0 to 4 Yes/No Yes/No 200 to 660 Yes/No Yes/No Yes/No 0-Hot gas bypass valve (not used) 1=Used for Startup only 2=Close Control 3=High Ambient (if High pressure mode is active, close control shall be active) Yes/No No = Use ComfortLink™ display as user interface (factory installed) Yes = Use High Tiers Display as user interface (factory installed) 0 to 9999	1  0 0 0 0 No No No No 0 No No volt No No No 0  No Yes  113	tons	unit_typ  unitsize varfan_a varfan_b varfan_c softstar wye_delt recl_opt freecool ehs_sel boil_sel freq_60H voltage emm_nrpc heat_sel cond_val hgbp_sel  mchx_sel highdisp  fac_pass	
FACTORY2	Compressor A Config Must Trip Amps S1 Config Switch (8 to 1)  Compressor B Config Must Trip Amps S1 Config Switch (8 to 1)  Compressor C Config Must Trip Amps S1 Config Switch (8 to 1)  Circuit A Total Fans NB Circuit B Total Fans NB Circuit C Total Fans NB EXV A Maximum Steps Numb EXV B Maximum Steps Numb EXV C Maximum Steps Numb Economizer A Steps Numb Economizer B Steps Numb Economizer C Steps Numb	0 to 600 00000000 (8 position dip switch configuration)  0 to 600 00000000 (8 position dip switch configuration)  0 to 600 00000000 (8 position dip switch configuration)  2 to 8 2 to 8 0 to 8 0/15000  0/15000  0/15000  0/15000 0/15000 0/15000	0 0  0 0  0 0  0 0  0 0  3690 3690 3690		cpa_mtac cpa_s1_c  cpb_mtac cpb_s1_c  cpc_mtac cpc_s1_c  nb_fan_a nb_fan_b nb_fan_c exva_max  exvb_max  exvc_max  eco_cnfa eco_cnfb eco_cnfc	

**NOTES:**

1. Table used to disable compressors for maintenance purposes. The capacity control will consider that these compressors (once set to YES) are failed manually (no alarm will appear).

2. All data will be re-initialized to "NO" at Power on reset on units using pro\_dialog display. For ComfortLink™ display, data shall be saved.

TABLE	DISPLAY NAME	RANGE	DEFAULT	UNITS	POINT NAME	WRITE STATUS
MAINTCFG	MAINTENANCE CONFIG Servicing Alert Refrigerant Charge Ctrl Water Loop Control CPump 1 Ctl Delay (days)* CPump 2 Ctl Delay (days)* HPump 1 Ctl Delay (days)* HPump 2 Ctl Delay (days)* Water Filter Ctrl (days)* Oil Filter A Ctrl (days) Oil Filter B Ctrl (days) Oil Filter C Ctrl (days)	Enable/Disable Enable/Disable Enable/Disable 0-1000 0-1000 0-1000 0-1000 0-1000 0 to 1000 0 to 1000 0 to 1000	Disable Disable Disable 0 0 0 0 0 0 0 0		s_alert charge_c wloop_c cpump1_c cpump2_c hpump1_c hpump2_c wfilte_c oilfia_c oilfib_c oilfic_c	

\*Not supported.

## APPENDIX B — CCN TABLES (cont)

### SERVICE CONFIGURATION TABLES

TABLE	DISPLAY NAME	RANGE	DEFAULT	UNITS	POINT NAME	WRITE STATUS
SERVICE	Cooler Fluid Type	1-3	1		flui_typ	
	Brine Flow Switch SP		10	°F	flow_sp	
	Brine Freeze Setpoint		14	ΔF	lowestsp	
	Condenser Fluid Type	1/2	1	-	cond_typ	
	Entering Fluid Control	Yes/No	No		ewt_opt	
	Prop PID Gain Varifan	-20.0-20.0	2.0		hd_pg	
	Int PID Gain Varifan	-5.0-5.0	0.2		hd_ig	
	Deri PID Gain Varifan	-20.0-20.0	0.4		hd_dg	
	EXV A Superheat Setpoint	5-15	7.2		sh_sp_a	
	EXV B Superheat Setpoint	5-15	7.2		sh_sp_b	
	EXV C Superheat Setpoint	5-15	7.2		sh_sp_c	
	Pinch offset circuit A	-3.0-3.0	0		pinoff_a	
	Pinch offset circuit B	-3.0-3.0	0		pinoff_b	
	Pinch offset circuit C	-3.0-3.0	0		pinoff_c	
	EXV MOP Setpoint	40-55	55		mop_sp	
	High Pressure Threshold	500-640	609		hp_th	
	Cooler Heater Delta Spt	1-6	2		heatersp	
	Auto Start When SM Lost	Enable/Disable	Disable		auto_sm	
	Recl Valve Min Position*	0-50	20		min_3w	
	Recl Valve Max Position*	20-100	100		max_3w	
	Economizer SH Setpoint A	5-15	7.2		esh_sp_a	
	Economizer SH Setpoint B	5-15	7.2		esh_sp_b	
	Economizer SH Setpoint C	5-15	7.2		esh_sp_c	
	User Password	0-150	11		use_pass	

\*Not supported.

NOTE: This table shall be downloadable at any time. However, modified value shall not be used by tasks until the unit is in OFF state. This shall not apply to the Varifan gains that shall be modified at any time and used immediately by the head pressure control tasks even if the unit is in operation.

TABLE	DISPLAY NAME	RANGE	UNITS	POINT NAME	WRITE STATUS
TABLE TO BE USED FOR RUN TIMES UPDATE IN CASE OF CONTROL RETROFIT					
UPDHRFAN	FAN Operating Hours				
	Circuit A Fan #1 Hours	nnnnn	hours	hr_fana1	
	Circuit A Fan #2 Hours	nnnnn	hours	hr_fana2	
	Circuit A Fan #3 Hours	nnnnn	hours	hr_fana3	
	Circuit A Fan #4 Hours	nnnnn	hours	hr_fana4	
	Circuit A Fan #5 Hours	nnnnn	hours	hr_fana5	
	Circuit A Fan #6 Hours	nnnnn	hours	hr_fana6	
	Circuit A Fan #7 Hours	nnnnn	hours	hr_fana7	
	Circuit A Fan #8 Hours	nnnnn	hours	hr_fana8	
	Circuit A Fan #9 Hours	nnnnn	hours	hr_fana9	
	Circuit A Fan #10 Hours	nnnnn	hours	hrfana10	
	Circuit B Fan #1 Hours	nnnnn	hours	hr_fanb1	
	Circuit B Fan #2 Hours	nnnnn	hours	hr_fanb2	
	Circuit B Fan #3 Hours	nnnnn	hours	hr_fanb3	
	Circuit B Fan #4 Hours	nnnnn	hours	hr_fanb4	
	Circuit B Fan #5 Hours	nnnnn	hours	hr_fanb5	
	Circuit B Fan #6 Hours	nnnnn	hours	hr_fanb6	
	Circuit B Fan #7 Hours	nnnnn	hours	hr_fanb7	
	Circuit B Fan #8 Hours	nnnnn	hours	hr_fanb8	
	Circuit B Fan #9 Hours	nnnnn	hours	hr_fanb9	
	Circuit B Fan #10 Hours	nnnnn	hours	hrfanb10	
	Circuit C Fan #1 Hours	nnnnn	hours	hr_fanc1	
	Circuit C Fan #2 Hours	nnnnn	hours	hr_fanc2	
	Circuit C Fan #3 Hours	nnnnn	hours	hr_fanc3	
	Circuit C Fan #4 Hours	nnnnn	hours	hr_fanc4	
	Circuit C Fan #5 Hours	nnnnn	hours	hr_fanc5	
	Circuit C Fan #6 Hours	nnnnn	hours	hr_fanc6	
	Circuit C Fan #7 Hours	nnnnn	hours	hr_fanc7	
	Circuit C Fan #8 Hours	nnnnn	hours	hr_fanc8	
	Circuit C Fan #9 Hours	nnnnn	hours	hr_fanc9	
	Circuit C Fan #10 Hours	nnnnn	hours	hrfanc10	
	WATER PUMP #1 Hours*	nnnnn	hours	hr_cpum1	
	WATER PUMP #2 Hours*	nnnnn	hours	hr_cpum2	

\*Not supported.

NOTE: This table shall be used for purposes of transplanting the devices on time in the event of a module hardware failure or software upgrade via downloading. It shall be usable only if all items are still null. Afterwards, its access shall be denied.

TABLE	DISPLAY NAME	RANGE	UNITS	POINT NAME	WRITE STATUS
TABLE TO BE USED FOR RUN TIMES UPDATE IN CASE OF CONTROL RETROFIT					
UPDTHOUR	Machine Operating Hours	nnnnn	hours	hr_mach	
	Machine Starts	nnnnn		st_mach	
	Compressor A Hours	nnnnn	hours	hr_cp_a	
	Compressor A Starts	nnnnn		st_cp_a	
	Compressor B Hours	nnnnn	hours	hr_cp_b	
	Compressor B Starts	nnnnn		st_cp_b	
	Compressor C Hours	nnnnn	hours	hr_cp_c	
	Compressor C Starts	nnnnn		st_cp_c	
	Circuit A Defrost Number*	nnnnn		nb_def_a	
	Circuit B Defrost Number*	nnnnn		nb_def_b	

\*Not supported.

NOTE: This table shall be used for purposes of transplanting the devices on time in the event of a module hardware failure or software upgrade via downloading. It shall be usable only if all items are still null. Afterwards, its access shall be denied.



## APPENDIX C — 30XA080-500 CPM DIP SWITCH ADDRESSES (cont)

### ACROSS-THE-LINE START (cont)

30XA UNIT SIZE	VOLTAGE (3 ph, 60 Hz)	CPM DIP SWITCHES	CIRCUIT A								CIRCUIT B								CIRCUIT C								MTA SETTING CIRCUIT A	MTA SETTING CIRCUIT B	MTA SETTING CIRCUIT C	
			1	2	3	4	5	6	7	8	1	2	3	4	5	6	7	8	1	2	3	4	5	6	7	8				
200	575	S1	OFF	ON	OFF	ON	OFF	OFF	OFF	OFF	ON	OFF	ON	OFF	OFF	OFF	OFF	—								176	176	—		
		S2	OFF	OFF	ON	OFF	OFF	OFF	ON	OFF	OFF	ON	OFF	OFF	OFF	ON	OFF	—												
	460	S1	OFF	ON	OFF	ON	OFF	OFF	OFF	OFF	ON	OFF	ON	OFF	OFF	OFF	OFF	—								230	230	—		
		S2	ON	ON	ON	ON	ON	ON	ON	ON	ON	ON	ON	ON	ON	ON	ON	—												
	380	S1	OFF	ON	OFF	OFF	ON	OFF	OFF	OFF	ON	OFF	ON	OFF	OFF	OFF	OFF	—								266	266	—		
		S2	OFF	OFF	ON	OFF	OFF	OFF	OFF	OFF	OFF	ON	OFF	OFF	OFF	OFF	OFF	—												
	230	S1	OFF	ON	OFF	OFF	ON	OFF	OFF	OFF	ON	OFF	ON	OFF	OFF	OFF	OFF	—								462	462	—		
		S2	OFF	OFF	OFF	OFF	OFF	OFF	OFF	OFF	OFF	ON	ON	ON	ON	ON	ON	—												
	200	S1	OFF	ON	OFF	OFF	ON	OFF	OFF	OFF	ON	OFF	ON	OFF	OFF	OFF	OFF	—								506	506	—		
		S2	OFF	OFF	OFF	OFF	OFF	OFF	ON	OFF	OFF	OFF	OFF	OFF	OFF	OFF	ON	ON	—											
220	575	S1	OFF	ON	OFF	ON	OFF	OFF	OFF	OFF	ON	OFF	ON	OFF	OFF	OFF	OFF	—								210	176	—		
		S2	ON	OFF	ON	OFF	ON	OFF	ON	OFF	ON	OFF	ON	OFF	ON	OFF	ON	—												
	460	S1	OFF	ON	OFF	OFF	ON	OFF	OFF	OFF	ON	OFF	ON	OFF	OFF	OFF	OFF	—								274	230	—		
		S2	OFF	ON	ON	OFF	OFF	OFF	OFF	OFF	ON	ON	ON	ON	ON	ON	ON	—												
	380	S1	OFF	ON	OFF	OFF	ON	OFF	OFF	OFF	ON	OFF	ON	OFF	OFF	OFF	OFF	—								318	266	—		
		S2	ON	OFF	OFF	OFF	ON	OFF	OFF	OFF	OFF	ON	OFF	OFF	OFF	OFF	OFF	—												
	230	S1	OFF	ON	OFF	OFF	ON	OFF	OFF	OFF	ON	OFF	ON	OFF	OFF	OFF	OFF	—								550	462	—		
		S2	ON	ON	OFF	ON	OFF	OFF	ON	OFF	OFF	OFF	OFF	OFF	OFF	OFF	OFF	—												
	200	S1	OFF	ON	OFF	OFF	ON	OFF	OFF	OFF	ON	OFF	ON	OFF	OFF	OFF	OFF	—								602	506	—		
		S2	OFF	OFF	OFF	ON	ON	OFF	ON	OFF	OFF	OFF	OFF	OFF	OFF	OFF	ON	ON	—											
240	575	S1	OFF	ON	OFF	ON	OFF	OFF	OFF	OFF	ON	OFF	ON	OFF	OFF	OFF	OFF	—								210	210	—		
		S2	ON	OFF	ON	OFF	ON	OFF	ON	OFF	ON	OFF	ON	OFF	ON	OFF	ON	—												
	460	S1	OFF	ON	OFF	OFF	ON	OFF	OFF	OFF	ON	OFF	ON	OFF	OFF	OFF	OFF	—								274	274	—		
		S2	OFF	ON	ON	OFF	OFF	OFF	OFF	OFF	ON	ON	ON	ON	ON	ON	ON	—												
	380	S1	OFF	ON	OFF	OFF	ON	OFF	OFF	OFF	ON	OFF	ON	OFF	OFF	OFF	OFF	—								318	318	—		
		S2	ON	OFF	OFF	OFF	ON	OFF	OFF	OFF	ON	OFF	OFF	OFF	OFF	OFF	OFF	—												
	230	S1	OFF	ON	OFF	OFF	ON	OFF	OFF	OFF	ON	OFF	ON	OFF	OFF	OFF	OFF	—								550	550	—		
		S2	ON	ON	OFF	ON	OFF	OFF	ON	OFF	OFF	OFF	OFF	OFF	OFF	OFF	OFF	—												
	200	S1	OFF	ON	OFF	OFF	ON	OFF	OFF	OFF	ON	OFF	ON	OFF	OFF	OFF	OFF	—								602	602	—		
		S2	OFF	OFF	OFF	ON	ON	OFF	ON	OFF	OFF	OFF	OFF	OFF	OFF	ON	ON	—												
260	575	S1	OFF	ON	OFF	OFF	ON	OFF	OFF	OFF	ON	OFF	ON	OFF	OFF	OFF	OFF	—								286	176	—		
		S2	ON	OFF	ON	OFF	ON	OFF	ON	OFF	ON	OFF	ON	OFF	ON	OFF	ON	—												
	460	S1	OFF	ON	OFF	OFF	ON	OFF	OFF	OFF	ON	OFF	ON	OFF	OFF	OFF	OFF	—								374	230	—		
		S2	ON	ON	ON	ON	ON	OFF	OFF	OFF	ON	ON	ON	ON	ON	ON	ON	—												
	380	S1	OFF	ON	OFF	OFF	ON	OFF	OFF	OFF	ON	OFF	ON	OFF	OFF	OFF	OFF	—								434	266	—		
		S2	OFF	ON	ON	ON	ON	OFF	ON	OFF	OFF	ON	OFF	OFF	OFF	OFF	OFF	—												
280	575	S1	OFF	ON	OFF	OFF	ON	OFF	OFF	OFF	ON	OFF	ON	OFF	OFF	OFF	OFF	—								286	210	—		
		S2	ON	OFF	ON	OFF	ON	OFF	ON	OFF	ON	OFF	ON	OFF	ON	OFF	ON	—												
	460	S1	OFF	ON	OFF	OFF	ON	OFF	OFF	OFF	ON	OFF	ON	OFF	OFF	OFF	OFF	—								374	274	—		
		S2	ON	ON	ON	ON	ON	OFF	OFF	OFF	ON	ON	ON	ON	ON	ON	ON	—												
	380	S1	OFF	ON	OFF	OFF	ON	OFF	OFF	OFF	ON	OFF	ON	OFF	OFF	OFF	OFF	—								434	318	—		
		S2	OFF	ON	ON	ON	ON	OFF	ON	OFF	OFF	ON	OFF	OFF	OFF	OFF	OFF	—												
300	575	S1	OFF	ON	OFF	OFF	ON	OFF	OFF	OFF	ON	OFF	ON	OFF	OFF	OFF	OFF	—								338	210	—		
		S2	OFF	ON	ON	OFF	ON	OFF	ON	OFF	ON	OFF	ON	OFF	ON	OFF	ON	—												
	460	S1	OFF	ON	OFF	OFF	ON	OFF	OFF	OFF	ON	OFF	ON	OFF	OFF	OFF	OFF	—								446	274	—		
		S2	ON	OFF	OFF	OFF	ON	ON	OFF	OFF	ON	ON	OFF	OFF	OFF	OFF	OFF	—												
	380	S1	OFF	ON	OFF	OFF	ON	OFF	OFF	OFF	ON	OFF	ON	OFF	OFF	OFF	OFF	—								514	318	—		
		S2	OFF	ON	OFF	OFF	ON	OFF	ON	OFF	OFF	ON	OFF	OFF	OFF	OFF	OFF	—												
325	575	S1	OFF	ON	OFF	OFF	ON	OFF	OFF	OFF	ON	OFF	ON	OFF	OFF	OFF	OFF	—								286	286	—		
		S2	ON	OFF	OFF	ON	OFF	OFF	OFF	ON	OFF	OFF	ON	OFF	OFF	OFF	OFF	—												
	460	S1	OFF	ON	OFF	OFF	ON	OFF	OFF	OFF	ON	OFF	ON	OFF	OFF	OFF	OFF	—								374	374	—		
		S2	ON	ON	ON	ON	ON	OFF	OFF	OFF	ON	ON	ON	ON	ON	ON	ON	—												
	380	S1	OFF	ON	OFF	OFF	ON	OFF	OFF	OFF	ON	OFF	ON	OFF	OFF	OFF	OFF	—								434	434	—		
		S2	OFF	ON	ON	ON	ON	OFF	ON	OFF	OFF	ON	ON	ON	ON	ON	ON	—												
350	575	S1	OFF	ON	OFF	OFF	ON	OFF	OFF	OFF	ON	OFF	ON	OFF	OFF	OFF	OFF	—								338	286	—		
		S2	OFF	ON	ON	OFF	ON	OFF	ON	OFF	ON	OFF	ON	OFF	ON	OFF	ON	—												
	460	S1	OFF	ON	OFF	OFF	ON	OFF	OFF	OFF	ON	OFF	ON	OFF	OFF	OFF	OFF	—								446	374	—		
		S2	ON	OFF	OFF	OFF	ON	ON	OFF	OFF	ON	ON	ON	ON	ON	ON	ON	—												
	380	S1	OFF	ON	OFF	OFF	ON	OFF	OFF	OFF	ON	OFF	ON	OFF	OFF	OFF	OFF	—								514	434	—		
		S2	OFF	ON	OFF	OFF	ON	OFF	ON	OFF	OFF	ON	ON	ON	ON	ON	ON	—												
400	575	S1	OFF	ON	OFF	ON	OFF	OFF	OFF	OFF	ON	OFF	ON	OFF	OFF	OFF	OFF	OFF	OFF	OFF	OFF	OFF	OFF	OFF	OFF	OFF	OFF	210	210	286
		S2	ON	OFF	ON	OFF	ON	OFF	ON	OFF	ON	OFF	ON	OFF	ON	OFF	ON	OFF	ON	OFF	ON	OFF	ON	OFF	ON	OFF	OFF	OFF		
	460	S1	OFF	ON	OFF	OFF	ON	OFF	OFF	OFF	ON	OFF	ON	OFF	OFF	OFF	OFF	OFF	OFF	OFF	OFF	OFF	OFF	OFF	OFF	OFF	OFF	274	274	374
		S2	OFF	ON	ON	OFF	OFF	OFF	OFF	OFF	ON	ON	ON	ON	ON	ON	ON	ON	ON	ON	ON	ON	ON	ON	ON	ON	ON	OFF	OFF	
	380	S1	OFF	ON	OFF	OFF	ON	OFF	OFF	OFF	ON	OFF	ON	OFF	OFF	OFF	OFF	OFF	OFF	OFF	OFF	OFF	OFF	OFF	OFF	OFF	OFF	318	318	434
		S2	ON	OFF	OFF	OFF	ON	OFF	OFF	OFF	ON	OFF	OFF	OFF	OFF	OFF	OFF	OFF	OFF	OFF	OFF	OFF	OFF	OFF	OFF	OFF	OFF	OFF	OFF	
450	575	S1	OFF	ON	OFF	ON	OFF	OFF	OFF	OFF	ON	OFF	ON	OFF	OFF	OFF	OFF	OFF	OFF	OFF	OFF	OFF	OFF	OFF	OFF	OFF	OFF	338	152	338
		S2	OFF	OFF	OFF	ON	ON	ON	OFF	OFF	OFF	ON	ON	ON	ON	ON	ON	ON	ON	ON	ON	ON	ON	ON	ON	ON	ON	ON	ON	
	460	S1	OFF	ON	OFF	ON	OFF	OFF	OFF	OFF	ON	OFF	ON	OFF	OFF	OFF	OFF	OFF	OFF	OFF	OFF	OFF	OFF	OFF	OFF	OFF	OFF	446	198	446
		S2	ON	ON	ON	ON	ON	OFF	ON	OFF	ON	OFF	OFF	ON	ON	OFF	ON	OFF	ON	OFF	ON	OFF	ON	OFF	ON	OFF	OFF	OFF	OFF	
	380	S1	OFF	ON	OFF	ON	OFF	OFF	OFF	OFF	ON	OFF	ON	OFF	OFF	OFF	OFF	OFF	OFF	OFF	OFF	OFF	OFF	OFF	OFF	OFF	OFF	514	230	514
		S2	ON	ON	ON	ON	ON	OFF	ON	OFF	ON	OFF	OFF	ON	ON	OFF	ON	OFF	ON	OFF	ON	OFF	ON	OFF	ON	OFF	OFF	OFF	OFF	
500	575	S1	OFF	ON	OFF	ON	OFF	OFF	OFF	OFF	ON	OFF	ON	OFF	OFF	OFF	OFF	OFF	OFF	OFF	OFF	OFF	OFF	OFF	OFF	OFF	OFF	338	210	338
		S2	ON	OFF	ON	OFF	ON	OFF	ON	OFF	ON	ON	ON	ON	ON	ON	ON	ON	ON	ON	ON	ON	ON	ON	ON	ON	ON	ON	ON	
	460	S1	OFF	ON	OFF	ON	OFF	OFF	OFF	OFF	ON	OFF	ON	OFF	OFF	OFF	OFF	OFF	OFF	OFF	OFF	OFF	OFF	OFF	OFF	OFF	OFF	446	274	446
		S2	OFF	ON	ON	ON	ON	OFF	ON	OFF	ON	OFF	OFF	ON	ON	OFF	ON	OFF	ON	OFF	ON	OFF	ON	OFF	ON	OFF	OFF	OFF	OFF	
	380	S1	OFF	ON	OFF	ON	OFF	OFF	OFF	OFF	ON	OFF	ON	OFF	OFF	OFF	OFF	OFF	OFF	OFF	OFF	OFF	OFF	OFF	OFF	OFF	OFF	514	318	514
		S2	ON	OFF	OFF	OFF	ON	OFF	OFF	OFF	ON	OFF	OFF	OFF	OFF	OFF	OFF	OFF	OFF	OFF	OFF	OFF	OFF	OFF	OFF	OFF	OFF	OFF	OFF	

**LEGEND**

**CPM** — Compressor Protection Module  
**MTA** — Must Trip Amps

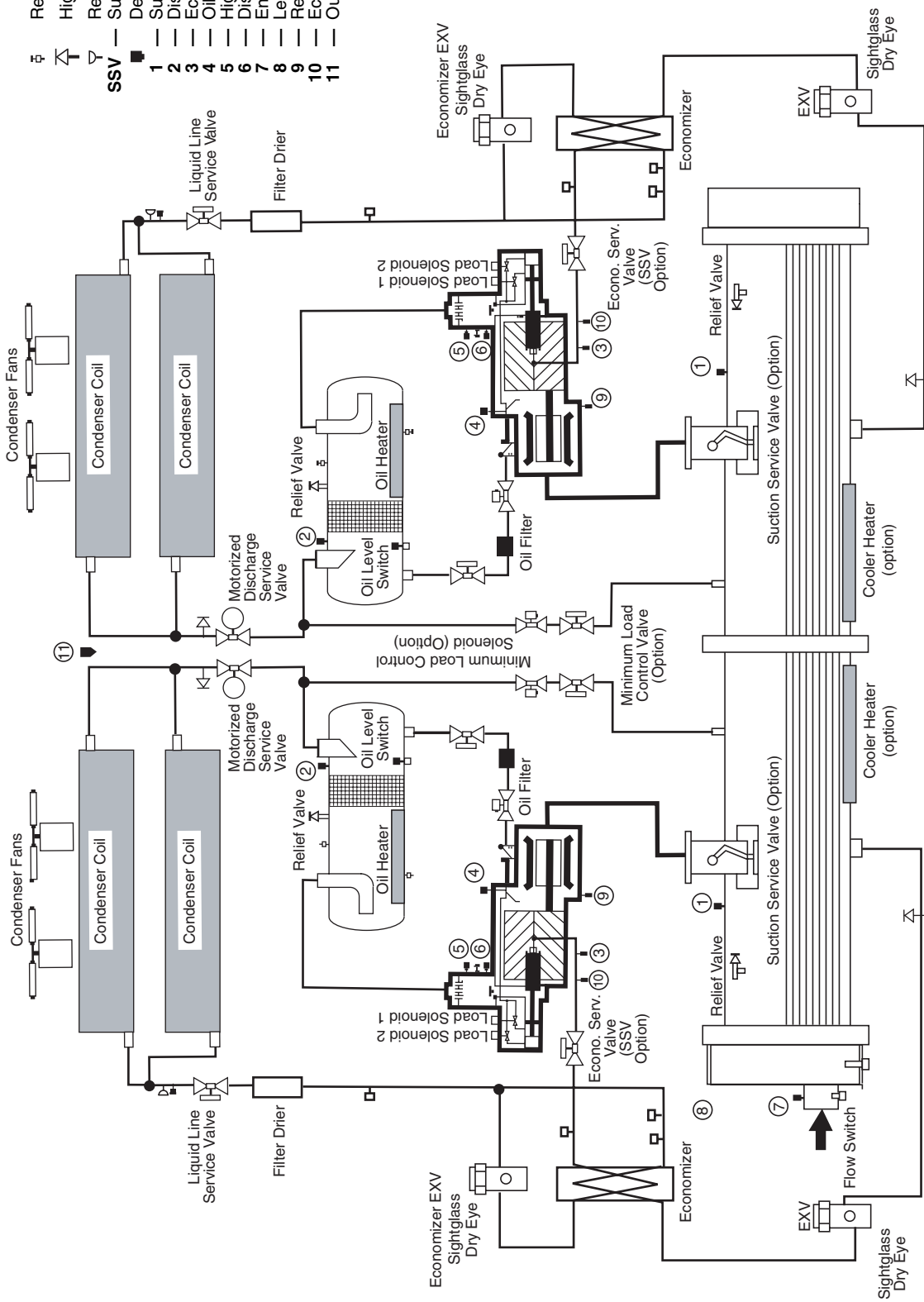
\*The 30XA080 unit does not have an additional economizer.





**LEGEND**

- ⊕ Refrigerant Access Fitting
- ⊕ High Flow Shrader Valve
- ⊕ Refrigerant Access Fitting
- SSV Suction Service Valve
- Device Connection
- 1 Suction Pressure
- 2 Discharge Pressure
- 3 Economizer Pressure
- 4 Oil Pressure
- 5 High Pressure Switch
- 6 Discharge Gas Thermistor
- 7 Entering Water Thermistor
- 8 Leaving Water Thermistor
- 9 Return Gas Thermistor
- 10 Economizer Gas Thermistor
- 11 Outside Air Thermistor



**APPENDIX D — PIPING AND INSTRUMENTATION**

## INDEX

- Actual start-up 42
- Alarms and alerts 67
  - Alarm codes 68-72
  - Alarm descriptors 72-82
- Capacity control 16
  - Capacity control overrides 20
  - Compressor stages and circuit cycling 16
  - Compressor starts and run hours 16
- CCN
  - ComfortLink™ CCN communication wiring 15
  - Interface 15
- CCN control 29
- CCN global schedule 29
- CCN tables 101-112
- Condenser coils
  - Cleaning E-coated coils 64
- Condenser fans 65
- Configuration set point limits 30
- Control methods 29
  - CCN control 29
  - CCN global schedule 29
  - Switch control 29
  - Time schedule 29
  - Unit run status 30
- Controls 4-41
  - Board addresses 14
  - Capacity control 16
  - Carrier Comfort Network® interface 15
  - ComfortLink display menu structure 4
  - Configuring the master chiller 17
  - Configuring the slave chiller 18
  - Control methods 29
  - Control module communication 14
  - Demand limit 32
  - Dual chiller control 15
  - Electronic expansion valve (EXV) Board 9
  - Emergency on/off switch 13
  - Enable-off-remote contact switch 13
  - Energy management module (EMM) 13, 14
    - inputs and outputs 14
  - EXV board inputs and outputs 10
  - Fan board A outputs 12
  - Fan board C inputs and outputs 13
  - Fan board X outputs 12
  - Fan boards 11
  - Local equipment network 14
  - Low ambient temperature head pressure control 22
  - Machine control 29
  - Main Base Board 4
  - Main Base Board inputs and outputs 5
  - Navigator™ module 3
  - Ramp loading 15
  - Remote alarm and alert relays 40
  - Temperature reset 31
- Cooler head bolts
  - Tightening 63
- Cooler protection 66
  - Chilled water flow switch 64
  - Freeze protection 62
  - Loss of fluid flow protection 62
  - Low fluid temperature 62
  - Plug components 63
  - Tightening cooler head bolts 63
  - Tube plugging 62
- Cooling set point selection 30
  - 4 to 20 mA input 30
  - Configuration set point limits 30
  - Control methods and cooling set points table, 30
  - Dual switch 30
  - Ice mode 30
  - Set point 1 30
  - Set point 2 30
  - Set point occupancy 30
- Demand limit 32
  - 2-step switch controlled 32
  - 2-step switch controlled configuration table 39
  - CCN loadshed controlled 40
  - Demand limit signal 41
  - Externally powered 40
  - Externally powered demand limit configuration table 40
- Electronic expansion valve 56
  - Cutaway view of 57
  - Filter drier 59
  - Inspecting/opening 58
  - Installing motor 58
  - Liquid line service valve 59
  - Moisture liquid indicator 58
  - Troubleshooting procedure 57
- Freeze protection 62
- Head pressure control. *See* low ambient temperature head pressure control
- Loss of fluid flow protection 62
- Low ambient head pressure control 22
  - Fan Staging 23, 24
  - Operating instructions 22
- Low fluid temperature 62
- Machine control 29
- Maintenance 66
- Minimum and maximum cooler flow rates 43
- Minimum fluid loop volume 42
- Navigator display
  - ComfortLink alarms mode 4, 100
  - ComfortLink configuration mode 4, 95, 96
  - ComfortLink inputs mode 4, 93
  - ComfortLink operating mode 4, 100
  - ComfortLink outputs mode 4, 94
  - ComfortLink pressure mode 4, 91
  - ComfortLink run status mode 4, 87, 88
  - ComfortLink service test mode 4, 82, 89
  - ComfortLink set points mode 4, 92
  - ComfortLink temperature mode 4, 90
  - ComfortLink time clock mode 4, 97-99
- Navigator module 3
  - Adjusting the backlight brightness 3
  - Adjusting the contrast 3
  - ComfortLink display menu structure 4
- Operating limitations 42
  - Flow rate requirements 42
  - Minimum and maximum cooler flow rates 43
  - Minimum fluid loop volume 42
  - Voltage 42
- Plug components 63
- Recommended maintenance schedule 66
  - Every 12 months 66
  - Every 3 months 66
  - Monthly 66
  - Routine 66
- Refrigerant circuit 65
- Refrigerant feed components
  - Electronic expansion valve 56
- Relief devices 66
- Safety considerations 2
- Safety devices 66
  - Compressor protection 66
- Service 56-66
  - Coil maintenance and cleaning 64
  - Compressors 59
  - Condenser fans 65
  - Cooler protection 61
  - Electronic expansion valve (EXV) 56
  - Refrigerant circuit 65
  - Relief devices 66
  - Safety devices 66
- Start-up 42-48
  - Actual start-up 42
  - Operating limitations 42
  - Pre-start-up 41
  - System check 41
- Start-up and operation. *See* Start-up Checklist
- Start-up checklist CL-1 to CL-8
- Switch control 29
- System check 41
- Temperature limits
  - Low ambient operation 22
- Temperature reset 31
  - 4 to 20mA temperature reset 36
  - 4 to 20mA temperature reset configuration table 38
  - Chilled water temperature control 34
  - Outdoor air temperature reset 34
  - Outdoor air temperature reset configuration table 35
  - Return water reset configuration 33
  - Space temperature reset 36
  - Space temperature reset configuration 37
- Thermistors 52
  - Compressor return gas temperature 52
  - Cooler entering fluid sensor 52
  - Cooler leaving fluid sensor 52
  - Dual chiller LWT 53
  - Outdoor air temperature 52
  - Remote space temperature 52
  - Typical space temperature sensor wiring 53
- Time schedule 29
- Transducers 53, 55
- Troubleshooting 66-86
  - Service test 82
- Tube plugging 62

## START-UP CHECKLIST FOR 30XA LIQUID CHILLERS

### A. PROJECT INFORMATION

Job Name \_\_\_\_\_ Installing Contractor \_\_\_\_\_  
 Address \_\_\_\_\_ Sales Office \_\_\_\_\_  
 City \_\_\_\_\_ State \_\_\_\_\_ Zip \_\_\_\_\_ Start-up Performed By \_\_\_\_\_

#### Design Information

	CAPACITY	EWT	LWT	FLUID TYPE	FLOW RATE	P.D.	AMBIENT
<b>Cooler</b>							

#### Unit

Model \_\_\_\_\_ Serial \_\_\_\_\_

#### Compressors

Compressor A  
 Model \_\_\_\_\_ Serial \_\_\_\_\_

Compressor B  
 Model \_\_\_\_\_ Serial \_\_\_\_\_

Compressor C  
 Model \_\_\_\_\_ Serial \_\_\_\_\_

Cooler  
 Model \_\_\_\_\_ Serial \_\_\_\_\_

### B. PRELIMINARY EQUIPMENT CHECK (This section to be completed by installing contractor)

1. Is there any physical damage?  Yes  No  
 Will this prevent start-up?  Yes  No  
 Description \_\_\_\_\_

2. Unit is installed level as per the installation instructions.  Yes  No  
 3. Power supply agrees with the unit nameplate.  Yes  No  
 4. Correct control voltage \_\_\_\_\_ vac.  Yes  No  
 5. Electrical power wiring is installed properly.  Yes  No  
 6. Unit is properly grounded.  Yes  No  
 7. Electrical circuit protection has been sized and installed properly.  Yes  No  
 8. All terminals are tight.  Yes  No  
 9. All plug assemblies are tight.  Yes  No  
 10. All cables, thermistors and transducers have been inspected for cross wires.  Yes  No  
 11. All thermistors are fully inserted into wells.  Yes  No  
 12. Oil separator heaters energized for 24 hours before start-up.  Yes  No  
 13. Relief valve vent piping per local codes.  Yes  No

#### Chilled Water System Check

1. All chilled water valves are open.  Yes  No  
 2. All piping is connected properly.  Yes  No  
 3. All air has been purged from the system.  Yes  No  
 4. Chilled water pump is operating with the correct rotation.  Yes  No  
 5. Chilled water pump starter interlocked with chiller.  Yes  No  
 6. Chilled water flow switch operational.  Yes  No  
 7. Inlet piping to cooler includes a 20 mesh strainer.  Yes  No  
 8. Water loop volume greater than 3 gal/ton for air conditioning  
 or 6 gal/ton for process cooling and low ambient operation.  Yes  No  
 9. Proper loop freeze protection provided to \_\_\_\_ °F (°C).  
 Antifreeze type \_\_\_\_\_ Concentration \_\_\_\_%.  Yes  No  
 (If antifreeze solution is not utilized on 30XA machines and the  
 minimum outdoor ambient is below 32 F (0° C) then items 10 and 11  
 have to be completed to provide cooler freeze protection to -20 F.  
 Refer to Installation Instructions for proper cooler winterization procedure.)  
 10. Outdoor piping wrapped with electric heater tape.  Yes  No  
 11. Cooler heaters installed and operational.  Yes  No  
 12. Is the Unit equipped with low ambient head pressure control?  
 a. If yes, are wind baffles installed?  Yes  No

Manufacturer reserves the right to discontinue, or change at any time, specifications or designs without notice and without incurring obligations.

**C. UNIT START-UP**

- 1. All liquid line service valves are open.  Yes  No
- 2. Verify actuated ball valve (ABV) operation.  Yes  No
- 3. All suction service valves are open.  Yes  No
- 4. Economizer service valves open.  Yes  No
- 5. Oil service valves open.  Yes  No
- 6. Leak check unit. Locate, repair and report any refrigerant leaks.  Yes  No
- 7. Voltage at terminal block is within unit nameplate range.  Yes  No

Check voltage imbalance: A-B \_\_\_\_\_ A-C \_\_\_\_\_ B-C \_\_\_\_\_

Average voltage = \_\_\_\_\_ (A-B + A-C + B-C)/3

Maximum deviation from average voltage = \_\_\_\_\_

Voltage imbalance = \_\_\_\_\_ % (max. deviation / average voltage) X 100

Is voltage imbalance less than 2%.  Yes  No

(DO NOT start chiller if voltage imbalance is greater than 2%.

Contact local utility for assistance.)

8. Verify cooler flow rate

Pressure entering cooler \_\_\_\_\_ psig

Pressure leaving cooler \_\_\_\_\_ psig

Cooler pressure drop \_\_\_\_\_ psig

Psig x 2.31 ft./psi = \_\_\_\_\_ ft of water

Kpa x 0.334 m/psi = \_\_\_\_\_ mm of water

Cooler flow rate \_\_\_\_\_ gpm (l/s) (See Cooler Pressure Drop Curve)

**Start and operate machine**

- 1. Complete component test utilizing Quick Test Mode (*Service Test* → *Quick*)
- 2. Check refrigerant and oil charge. Record charge information.
- 3. Record compressor and condenser fan motor current.
- 4. Record operating data.
- 5. Provide operating instructions to owner's personnel.

Circuit A                      Circuit B                      Circuit C

**Refrigerant Charge**

Additional charge required      \_\_\_\_\_                      \_\_\_\_\_                      \_\_\_\_\_

**Oil Charge**

Additional charge required      \_\_\_\_\_                      \_\_\_\_\_                      \_\_\_\_\_

**Record Software Versions**

**MODE — RUN STATUS**

SUB-MODE	ITEM	DISPLAY	ITEM EXPANSION
VERS	APPL		CSA-SR- _____

(Press ENTER & ESCAPE simultaneously to obtain software versions)

CUT ALONG DOTTED LINE

# Record Configuration Information

## MODE — CONFIGURATION

SUB-MODE	ITEM	ITEM EXPANSION	DISPLAY	DEFAULT	ENTRY
DISP	TEST	Test Display LED's	ON/OFF	OFF	ON/OFF
	METR	Metric Display	US-METR	US	US/METR
	LANG	Language	x	English	
UNIT	TYPE	Unit Type	x	Air-Cooled	Air-Cooled
	TONS	Unit Size	XXX		
	VAR.A	NB Fans on Varifan Cir A	0-6	0: No low ambient temperature head pressure control 1: low ambient temperature head pressure control installed	
	VAR.B	NB Fans on Varifan Cir B	0-6	0: No low ambient temperature head pressure control 1: low ambient temperature head pressure control installed	
	VAR.C	NB Fans on Varifan Cir C	0-6	0: No low ambient temperature head pressure control 1: low ambient temperature head pressure control installed	
	VOLT	Power Supply Voltage	XXX		
	60HZ	60HZ frequency	NO-YES	YES	YES
	STAR	Soft Starter Select	NO-YES	NO	NO/YES
	Y.D	Wye Delta Start Select	NO-YES		NO/YES
	MTA.A	Must Trip Amps cir A	XXX		
	R.MT.A	Read Must Trip Amps A	XXX		
	MTA.B	Must Trip Amps cir B	XXX		
	R.MT.B	Read Must Trip Amps B	XXX		
	MTA.C	Must Trip Amps cir C	XXX		
	R.MT.C	Read Must Trip Amps C	XXX		
	C.SW.A	S1 Config switch cir A	XXX		
	R.CS.A	Read S1 Config switch A	XXX		
	C.SW.B	S1 Config switch cir B	XXX		
	R.CS.B	Read S1 Config switch B	XXX		
	C.SW.C	S1 Config switch cir C	XXX		
	R.CS.C	Read S1 Config switch C	XXX		
	RECL	Heat Reclaim Select	NO-YES	NO*	NO
	EHS	Electrical Heater Stage	0-4	0*	0
	EMM	EMM module installed	NO-YES	NO	NO/YES
	PAS.E	Password Enable	ENBL/DSBL	ENBL	ENBL/DSBL
	PASS	Factory Password	XXX	0111	
	CO.HT	Cooler Heater Select	NO-YES	YES	YES
	CON.V	Condenser Valve Select	NO-YES	NO*	NO
	FREE	Free cooling Select	NO-YES	NO*	NO/YES
	HGBP	Hot Gas Bypass Select	NO-YES	NO	NO/YES
MCHX	MCHX Exchanger Select	NO-YES	NO	NO/YES	
HI.TI	High Tiers display Selec	NO-YES	NO	YES/NO	
SERV	FLUD	Cooler Fluid Type	WATER-BRINE	WATER	WATER/BRINE
	CFLU	Condenser Fluid Type	WATER-BRINE	WATER	WATER/BRINE
	MOP	EXV MOP Setpoint	XX.X	55	55 F
	HP.TH	High Pressure Threshold	XXX.X	290	
	SHP.A	Cir A Superheat Setp	XX.X	21.6	21.6 F
	SHP.B	Cir B Superheat Setp	XX.X	21.6	21.6 F
	SHP.C	Cir C Superheat Setp	XX.X	21.6	21.6 F
	HTR	Cooler Heater DT Setp	XX.X	2.0 (Number of degrees added to brine freeze set point to enable cooler heater.)	2 F
	EWTO	Entering water control	NO-YES	NO	NO/ YES
	AU.SM	Auto Start when SM lost	NO-YES	NO	NO/ YES
	LOSP	Brine Freeze Setpoint	XX.X	14	
	FL.SP	Brine Flow Switch Setp	XX.X	55*	55*
	HD.PG	Varifan Proportion Gain	XX.X	2.0	2.0
	HD.DG	Varifan Derivative Gain	XX.X	0.4	0.4
	HD.IG	Varifan Integral Gain	XX.X	0.2	0.2
	HR.MI	Reclaim Water Valve Min	XXX.X	20*	20%
	HR.MA	Reclaim Water Valve Max	XXX.X	100*	100%

\*Not supported.

**MODE — CONFIGURATION (cont)**

SUB-MODE	ITEM	ITEM EXPANSION	DISPLAY	DEFAULT	ENTRY
OPTN	CCNA	CCN ADDRESS	XXX	1	
	CCNB	CCN BUS NUMBER	XXX	0	
	BAUD	CCN BAUD RATE	X	3	
	LOAD	Loading Sequence Select	X	EQUAL	<input type="checkbox"/> Equal <input type="checkbox"/> Staged
	LLCS	Lead/Lag Circuit Select	X	AUTOMATIC	
	RL.S	Ramp Load Select	ENBL-DSBL	DSBL	<input type="checkbox"/> Enable <input type="checkbox"/> Disable
	DELY	Minutes Off Time	XX	1	1 min
	ICE.M	Ice Mode Enable	ENBL-DSBL	DSBL	<input type="checkbox"/> Enable <input type="checkbox"/> Disable
	HPUM	Condenser Pumps Sequence*	X		0
	PUMP	Cooler Pumps Sequence*	X	0	0/1/2/3/4
	ROT.P	Pump Rotation delay*	XX	48	48 Hours
	PM.PS	Periodic Pump Start*	NO-YES	NO	NO
	PSBY	Stop Pump In Standby*	NO-YES	NO	NO
	P.LOC	Flow checked if Pmp Off	NO-YES	NO	YES
	LS.ST	Night Low Noise Start	XX.XX	00.00	00:00
	LS.ND	Night Low noise End	XX.XX	00.00	00:00
	LS.LT	Low noise Capacity Lim	XXX	100	100%
	RV.AL	Reverse Alarms Relay	NO-YES		NO / YES
	OATH	Heat Mode OAT Threshold*	XX.X	5 F	5 F
	FREE	Free Cooling OAT Limit*	XX.X	32.0	32 F
	CUR.S	Current Limit Select	NO-YES	NO	NO
	CUR.F	Current Limit at 100%	XXXX	2000	
	EHST	Elec Stag OAT Threshold*	XX.XX	41	41F
	EHSB	Last Heat Elec Backup*	NO-YES	NO	NO
	E.DEF	Quick EHS in Defrost*	NO-YES	NO	NO
	EHSP	Elec Heating pulldown*	XX	0	0 min
	AUTO	Auto Changeover Select*	NO-YES	NO	NO
RSET	CRST	Cooling Reset Type	X	0	<input type="checkbox"/> NO RESET <input type="checkbox"/> OUT AIR TEMP <input type="checkbox"/> DELTA T TEMP <input type="checkbox"/> 4-20mA INPUT <input type="checkbox"/> SPACE TEMP
	HRST	Heating Reset Type*	X	0	0
	DMDC	Demand Limit Select	X	0	<input type="checkbox"/> NONE <input type="checkbox"/> SWITCH <input type="checkbox"/> 4-20mA INPUT
	DMMX	mA for 100% demand lim	XX.X	0.0	0 mA
	DMZE	mA for 0% demand limit	XX.X	0.0	10 mA
	MSSL	Master/Slave Select	X	0	0
	SLVA	Slave Address	XXX	2	2
	LLBL	Lead/Lag Balance Select	X	DSBL	<input type="checkbox"/> Enable <input type="checkbox"/> Disable
	LLBD	Lead/Lag Balance Delta	XXX	168	168 Hours
	LLDY	Lag Start Delay	XX	10	10 min
	LL.ER	Start If Error Higher	XX.X		4 F
	LAG.M	Lag Minimum Running Tim	XXX		0 min
	LAGP	Lag Unit Pump Select	X	0	0
	LPUL	Lead Pulldown Time	XX	0	0 min
	SERI	Chillers in series	NO-YES		NO/YES

\*Not supported.

CUT ALONG DOTTED LINE

CUT ALONG DOTTED LINE

### MODE — SETPOINT

SUB-MODE	ITEM	ITEM EXPANSION	DISPLAY	DEFAULT	ENTRY
COOL	CSP.1	Cooling Setpoint 1	XXX.X	44.0	
	CSP.2	Cooling Setpoint 2	XXX.X	44.0	
	CSP.3	Ice Setpoint	XXX.X	44.0	
	CRV.1	Current no Reset Val	XXX.X	0	
	CRV.2	Current Full Reset Val	XXX.X	0	
	CRT.1	Delta T No Reset Temp	XXX.X	0	
	CRT.2	Delta T Full Reset Temp	XXX.X	0	
	CRO.1	OAT No Reset Temp	XXX.X	14.0	
	CRO.2	OAT Full Reset Temp	XXX.X	14.0	
	CRS.1	Space T No Reset Temp	XXX.X	14.0	
	CRS.2	Space T Full Reset Temp	XXX.X	14.0	
	DGRC	Degrees Cool Reset	XX.X	0	
	CAUT	Cool Changeover Setpt*	XXX.X	75	—
	CRMP	Cool Ramp Loading	X.X	1.0	
HEAT	HSP.1	Heating Setpoint 1*	XXX.X	100.0	—
	HSP.2	Heating Setpoint 2*	XXX.X	100.0	—
	HRV.1	Current No Reset Val*	XXX.X	0	—
	HRV.2	Current Full Reset Val*	XXX.X	0	—
	HRT.1	Delta T No Reset Temp*	XXX.X	0	—
	HRT.2	Delta T Full Reset Temp*	XXX.X	0	—
	HRO.1	OAT T No Reset Temp*	XXX.X	14.0	—
	HRO.2	OAT Full Reset Temp*	XXX.X	14.0	—
	DGRH	Degrees Heat Reset*	XX.X	0	—
	HAUT	Heat Changeover Setpt*	XX.X	64.0	—
	HRMP	Heat Ramp Loading*	X.X	1.0	
MISC	DLS.1	Switch Limit Setpoint 1	XXX	100	
	DLS.2	Switch Limit Setpoint 2	XXX	100	
	DLS.3	Switch Limit Setpoint 3	XXX	100	
	W.SCT	Water Val Condensing Stp	XXX.X	—	
	RSP	Head Reclaim Setpoint*	XXX.X	122	—
	RDB	Reclaim deadband*	XXX.X	9.0	—

\*Not supported.

### MODE — OPERATING MODE

SUB-MODE	ITEM	ITEM EXPANSION	DISPLAY	DEFAULT	ENTRY
SLCT	OPER	Operating Control Type	X	—	<input type="checkbox"/> SWITCH CTRL <input type="checkbox"/> TIME SCHED <input type="checkbox"/> CCN CONTROL
	SP.SE	Setpoint Select	X	—	<input type="checkbox"/> SETPOINTOCC <input type="checkbox"/> SETPOINT1 <input type="checkbox"/> SETPOINT2
	HC.SE	Heat Cool Select*	X	COOLING	COOLING
	RL.SE	Reclaim Select*	X	NO	NO

\*Not supported.

**Component Test — Complete the following tests to make sure all peripheral components are operational before the compressors are started.**

**MODE — SERVICE TEST**

**To Enable Service Test Mode, move Enable/Off/Remote Contact Switch to OFF. Configure TEST to ON. Move Switch to ENABLE.**

SUB-MODE	ITEM	ITEM EXPANSION	DISPLAY	CHECK WHEN COMPLETE
TEST*	T.REQ	Manual Sequence	OFF-ON	
	CP.A	Compressor A Output	OFF-ON	
	SLI.A	Slide Valve Capacity A	0-2	
	CP.B	Compressor B Output	OFF-ON	
	SLI.B	Slide Valve Capacity B	0-2	
	CPC	Compressor C Output	OFF-ON	
	SLI.C	Slide Valve Capacity C	0-2	
QUIC†	Q.REQ	QUICK TEST MODE	OFF-ON	
	EXV.A	Circuit A EXV % Open	XXX	
	EXV.B	Circuit B EXV % Open	XXX	
	EXV.C	Circuit C EXV % Open	XXX	
	ECO.A	Circ A eco EXV % Open	XXX	
	ECO.B	Circ B eco EXV % Open	XXX	
	ECO.C	Circ C eco EXV % Open	XXX	
	FAN.A	Circuit A Fan Stages	X	
	FAN.B	Circuit B Fan Stages	X	
	FAN.C	Circuit C Fan Stages	X	
	SPD.A	Cir A Head Press Speed	XXX	
	SPD.B	Cir B Varifan position	XXX	
	SPD.C	Cir C Varifan position	XXX	
	HT.A	Oil Heater Circuit A	OFF-ON	
	SL1.A	Slide Valve 1 Cir A	OFF-ON	
	SL2.A	Slide Valve 2 Cir A	OFF-ON	
	HGPA	Hot Gas Bypass A Output	OFF-ON	
	OLS.A	Oil Solenoid Cir A	OFF-ON	
	DGT.A	DGT Cool Solenoid A	OFF-ON	
	HT.B	Oil Heater Circuit B	OFF-ON	
	SL1.B	Slide Valve 1 Cir B	OFF-ON	
	SL2.B	Slide Valve 2 Cir B	OFF-ON	
	HGPB	Hot Gas Bypass B Output	OFF-ON	
	OLS.B	Oil Solenoid Cir B	OFF-ON	
	DGT.B	DGT Cool Solenoid B	OFF-ON	
	HT.C	Oil Heater Circuit C	OFF-ON	
	SL1.C	Slide Valve 1 Cir C	OFF-ON	
	SL2.C	Slide Valve 2 Cir C	OFF-ON	
	HGPC	Hot Gas Bypass C Output	OFF-ON	
	OLS.C	Oil Solenoid Cir C	OFF-ON	
	DGT.C	DGT Cool Solenoid C	OFF-ON	
	FRV.A	Free Cooling Heater A	OPEN-CLSE	
	FRP.A	Refrigerant Pump A	OFF-ON	
	FRV.B	Free Cooling Heater B	OPEN-CLSE	
	FRP.B	Refrigerant Pump B	OFF-ON	
	FRV.C	Free Cooling Heater C	OPEN-CLSE	
	FRP.C	Refrigerant Pump C	OFF-ON	
	RV.A	4 Way Valve Circuit A	OPEN-CLSE	
	RV.B	4 Way Valve Circuit B	OPEN-CLSE	

\*Place the Enable/Off/Remote Contact switch to the Off position prior to configuring **T.REQ** to ON. Configure the desired item to ON, then place the Enable/Off/Remote Contact switch to the Enable position.

†Place the Enable/Off/Remote Contact switch to the Off position prior to configuring **Q.REQ** to ON. The switch should be in the Off position to perform Quick Test.

CUT ALONG DOTTED LINE

CUT ALONG DOTTED LINE

## MODE — SERVICE TEST (cont)

**To Enable Service Test Mode, move Enable/Off/Remote Contact Switch to OFF.  
Configure TEST to ON. Move Switch to ENABLE.**

SUB-MODE	ITEM	ITEM EXPANSION	DISPLAY	CHECK WHEN COMPLETE
QUIC† (cont)	HR1.A	Air Cond Enter Valve A	OPEN-CLSE	
	HR2.A	Air Cond Leaving Valv A	OPEN-CLSE	
	HR3.A	Water Cond Enter Valv A	OPEN-CLSE	
	HR4.A	Water Cond Leav Valve A	OPEN-CLSE	
	HR1.B	Air Cond Enter Valve B	OPEN-CLSE	
	HR2.B	Air Cond Leaving Valv B	OPEN-CLSE	
	HR3.B	Water Cond Enter Valv B	OPEN-CLSE	
	HR4.B	Water Cond Leav Valve B	OPEN-CLSE	
	PMP.1	Water Exchanger Pump 1	OFF-ON	
	PMP.2	Water Exchanger Pump 2	OFF-ON	
	PMP.3	Condenser Pump 1	OFF-ON	
	PMP.4	Condenser Pump 2	OFF-ON	
	CL.HT	Cooler heater Output	OFF-ON	
	BVL.A	Ball Valve Position A	OPEN-CLSE	
	BVL.B	Ball Valve Position B	OPEN-CLSE	
	BVL.C	Ball Valve Position C	OPEN-CLSE	
	CP.HT	Condenser Heater Output	OFF-ON	
	Q.RDY	Chiller Ready status	OFF-ON	
	Q.RUN	Chiller Running status	OFF-ON	
	SHUT	Customer Shutdown Stat	OFF-ON	
	CATO	Chiller capacity in 0-10v	nn.n	
	ALRM	Alarm Relay	OFF-ON	
	ALRT	Alert Relay	OFF-ON	

\*Place the Enable/Off/Remote Contact switch to the Off position prior to configuring **T.REQ** to ON. Configure the desired item to ON, then place the Enable/Off/Remote Contact switch to the Enable position.

†Place the Enable/Off/Remote Contact switch to the Off position prior to configuring **Q.REQ** to ON. The switch should be in the Off position to perform Quick Test.

### Operating Data:

Record the following information from the Run Status, Temperatures and Outputs Modes when machine is in a stable operating condition.

#### TEMPERATURES

COOLER ENTERING FLUID                    EWT \_\_\_\_\_  
 COOLER LEAVING FLUID                   LWT \_\_\_\_\_  
 CONTROL POINT                            CTPT \_\_\_\_\_  
 CAPACITY                                    CAP \_\_\_\_\_  
 OUTSIDE AIR TEMPERATURE            OAT \_\_\_\_\_  
 LEAD/LAG LEAVING FLUID              CHWS \_\_\_\_\_ (Dual Chiller Control Only)

CIRCUIT A	CIRCUIT B	CIRCUIT C
SCT.A _____	SCT.B _____	SCT.C _____
SST.A _____	SST.B _____	SST.C _____
DGT.A _____	DGT.B _____	DGT.C _____
SGT.A _____	SGT.B _____	SGT.C _____
SUP.A _____	SUP.B _____	SUP.C _____
ECT.A _____	ECT.B _____	ECT.C _____
ESH.A _____	ESH.B _____	ESH.C _____
CTP.A _____	CTP.B _____	CTP.C _____
EXV.A _____	EXV.B _____	EXV.C _____
ECO.A _____	ECO.B _____	ECO.C _____

NOTE: EXV A,B,C positions are found in the output mode.

#### COMPRESSOR MOTOR CURRENT

	L1	L2	L3
COMPRESSOR A1	_____	_____	_____
COMPRESSOR B1	_____	_____	_____
COMPRESSOR C1	_____	_____	_____

