



# Controls, Operation, and Troubleshooting

## CONTENTS

	Page		Page
<b>SAFETY CONSIDERATIONS</b> .....	2	• INSTALLATION	
<b>GENERAL</b> .....	2-12	• CONFIGURATION	
<b>Rooftop Information</b> .....	2	• OPERATING SEQUENCE	
<b>VAV Control System</b> .....	2	<b>Smoke Control Modes</b> .....	19
<b>Processor Board</b> .....	2	• FIRE SHUT DOWN MODE	
• P1 — LEAVING-AIR SET POINT		• PRESSURIZATION MODE	
• P2 — ECONOMIZER POSITION		• EVACUATION MODE	
• P3 — RESET LIMIT		• SMOKE PURGE MODE	
• P4 — DEMAND LIMIT		• INSTALLATION	
• P5 — ECONOMIZER MINIMUM POSITION		• CONFIGURATION	
• P6 — WARM-UP SET POINT		• OPERATING SEQUENCE	
• P7 — SASP RESET TEMPERATURE		<b>Air Pressure Tubing</b> .....	20
• PROCESSOR BOARD OUTPUTS		• INLET GUIDE VANES	
• CONFIGURATION HEADER AND DIP SWITCH		• VARIABLE FREQUENCY DRIVE	
ASSEMBLY		• MODULATING POWER EXHAUST	
<b>Relay Board</b> .....	5	<b>Variable Frequency Drive (VFD)</b> .....	22
<b>Display Board</b> .....	5	<b>START-UP</b> .....	23-28
<b>Thermistors</b> .....	5	<b>Initial Check</b> .....	23
• T1 — LEAVING-AIR TEMPERATURE		<b>Configuration Header</b> .....	24
THERMISTOR		<b>DIP Switches</b> .....	24
• T2 — RETURN-AIR TEMPERATURE		<b>Adjusting Set Points</b> .....	25
THERMISTOR		<b>Potentiometers</b> .....	25
• T3 — SATURATED CONDENSING		<b>Supply Fan Control with IGV Option</b> .....	25
TEMPERATURE, CIRCUIT 1		<b>Supply Fan Control with VFD Option</b> .....	26
• T4 — SATURATED CONDENSING		<b>Modulating Power Exhaust</b>	
TEMPERATURE, CIRCUIT 2		(Option or Accessory) .....	27
• T10 — RESET TEMPERATURE		<b>START UNIT</b> .....	28-31
<b>Compressor Operation</b> .....	7	<b>Quick Test Program</b> .....	28
• CONTROL RELAY (CR)		<b>OPERATING INFORMATION</b> .....	31-39
<b>Accessory Board</b> .....	7	<b>Digital Display</b> .....	31
• P3 — RESET LIMIT		• CODES 0 THROUGH 6, CAPACITY STEPS	
• P5 — ECONOMIZER MINIMUM POSITION		• CODES 20 THROUGH 30 AND 88, OPERATIONAL	
• P6 — MORNING WARM-UP TEMPERATURE		STATUS	
<b>Single-Step Demand Unit</b> .....	7	• CODES 51 THROUGH 87, OVERLOAD	
<b>Demand Limit Control Module (DLCM)</b> .....	7	INFORMATION	
<b>Economizer</b> .....	10	<b>Operating Sequence</b> .....	32
• ENTHALPY CONTROL		• SIZE 034, 038 AND 048-074 UNITS	
• DIFFERENTIAL ENTHALPY		• SIZE 044 UNITS	
<b>Temperature Reset</b> .....	12	<b>Head Pressure Control</b> .....	33
<b>CONTROLS INSTALLATION</b> .....	12-23	<b>Supply Fan Control with IGV</b> .....	34
<b>Control Wiring</b> .....	12	<b>Supply Fan Control with VFD</b> .....	34
• NIGHT SETBACK THERMOSTAT		<b>Modulating Power Exhaust (Option or</b>	
• SPACE TEMPERATURE RESET ACCESSORY		<b>Accessory Except FY,JY Units)</b> .....	35
(50DJ900021)		<b>Unit Staging</b> .....	35
• SINGLE-STEP DEMAND LIMIT		<b>TROUBLESHOOTING</b> .....	39-51
POTENTIOMETER		<b>Checking Display Codes</b> .....	39
• ACCESSORY 2-STEP DEMAND LIMIT		<b>Complete Unit Stoppage</b> .....	39
<b>Space Temperature Reset</b> .....	16	<b>Single Circuit Stoppage</b> .....	40
• INSTALLATION		<b>Restart Procedure</b> .....	40
• CONFIGURATION		<b>Overload Codes</b> .....	41
• OPERATING SEQUENCE		<b>VAV Diagnostic Information</b> .....	41
<b>Demand Limit</b> .....	17	• CODES 51 AND 55: COMPRESSOR FAILURE	
• SINGLE-STEP DEMAND LIMIT		• CODES 59 AND 60: LOW-PRESSURE SWITCH	
• TWO-STEP DEMAND LIMIT		• CODES 63 AND 64: OIL PRESSURE SWITCH	

## CONTENTS (cont)

Page

• CODE 70: ILLEGAL UNIT CONFIGURATION	
• CODES 71 TO 76: THERMISTOR/RESISTOR FAILURE	
• CODE 81: RESET THERMISTOR OR POTENTIOMETER FAILURE	
• CODE 82: LEAVING-AIR TEMPERATURE SET POINT POTENTIOMETER FAILURE	
• CODE 83: ECONOMIZER FEEDBACK POTENTIOMETER FAILURE	
• CODE 84: RESET LIMIT POTENTIOMETER FAILURE	
• CODE 85: DEMAND LIMIT POTENTIOMETER (P4) FAILURE	
• CODE 86: MINIMUM POSITION ECONOMIZER POTENTIOMETER FAILURE	
• CODE 87: WARM-UP TEMPERATURE SET POINT FAILURE	
<b>Thermistor Troubleshooting</b> .....	43
<b>Electronic Controls Checkout</b> .....	43
• PROCESSOR BOARD CHECKOUT	
• RELAY BOARD TROUBLESHOOTING	
• DISPLAY BOARD CHECKOUT	
• ACCESSORY BOARD CHECKOUT	
• TWO-STEP DEMAND LIMIT CONTROL MODULE (DLCM) TROUBLESHOOTING	
<b>Enthalpy Sensor Checkout</b> .....	47
<b>Economizer Motor</b> .....	48
<b>VFD Status Monitoring</b> .....	48
• NORMAL STATUS MONITORING	
• AUTOMATIC STATUS MONITORING	
• TRIPPED STATUS MONITORING	

## SAFETY CONSIDERATIONS

Installing, starting up, and servicing this equipment can be hazardous due to system pressures, electrical components; and equipment location (roof, elevated structures, etc.). Only trained, qualified installers and service mechanics should install, start up, and service this equipment.

When working on this equipment, observe precautions in the literature; on tags, stickers, and labels attached to the equipment, and any other safety precautions that apply. Follow all safety codes. Wear safety glasses and work gloves. Use care in handling, rigging, and setting this equipment, and in handling all electrical components.

### ⚠ WARNING

Electrical shock can cause personal injury and death. Shut off all power to this equipment during installation and service. There may be more than one disconnect switch. Tag all disconnect locations to alert others not to restore power until work is completed.

### ⚠ WARNING

This unit uses a microprocessor-based electronic control system. *Do not* use jumpers or other tools to short out components, or to bypass or otherwise depart from recommended procedures. Any short-to-ground of the control board or accompanying wiring may destroy the electronic modules or electrical components.

## GENERAL

**IMPORTANT:** This literature contains controls, operation, and troubleshooting data for 48FK,JK and 50FK,FY,JK,JY variable air volume rooftop units. Use this guide in conjunction with the separate Installation Instructions literature packaged with the unit.

Carrier 48FK,JK and 50FK,FY,JK,JY units provide ventilation, cooling, and heating (when equipped) in Variable Air Volume (VAV) applications. These units contain factory-installed controls which provide full system management. The unit controls also perform self diagnostic tests at unit start-up, monitor operation of the unit, and provide alarms. Information on system operation and status are sent to the central processors by various sensors that are located at the unit and in the conditioned space. Each unit is equipped with a display board.

**Rooftop Information** — The rooftop controls cycle evaporator-fan motor, compressors, and unloaders to maintain the proper temperature conditions. The controls also cycle condenser fans to maintain suitable head pressure. Safeties are continuously monitored to prevent the unit from operating under abnormal conditions. The controls provide control of economizer and cycle or control heating as required.

The controls also allow the service person to operate a ‘quick test’ so that all the controlled components can be checked for proper operation.

**IMPORTANT:** The field-supplied and installed switch (or timeclock) **MUST BE CLOSED** to put unit into the Occupied mode. Unit **WILL NOT START** until this is accomplished. See base unit installation instructions literature for details.

**VAV Control System** — The 30 to 75-ton VAV rooftop units contain a microprocessor-based electronic control system that controls and monitors the rooftop unit functions.

The VAV control system is composed of several components:

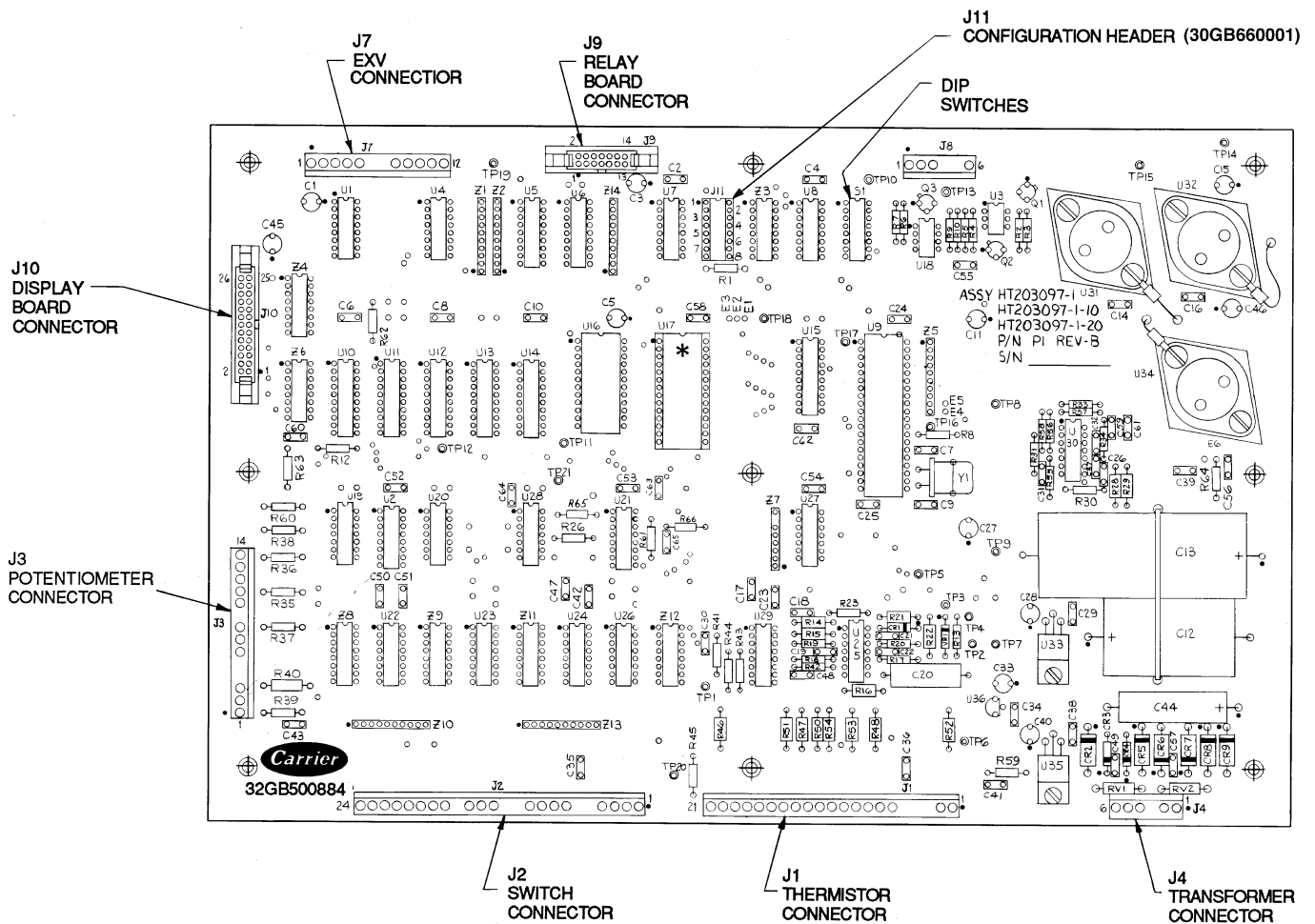
- processor board
- relay board
- display board
- thermistors
- compressor operation feedback (control relay)
- accessory board
- temperature reset package\*
- single-step demand limit\*
- two-step demand limit control module\*

\*Field-installed accessories.

The VAV control system monitors and controls the following functions of the rooftop unit:

- leaving-air temperature (unit capacity)
- morning warm-up or electric heat (if equipped)
- head pressure control, fan cycling
- economizer position
- diagnostic display
- unit check-out (quick test)
- supply air temperature reset (if equipped)
- demand limiting (if equipped)

**Processor Board** — The processor board, shown in Fig. 1, contains the logic and the necessary hardware to drive the outputs and the display board. The processor board is enclosed by a sheet metal cover and a heater. The heater is controlled by a thermostat to keep the processor temperature above 32 F (0° C). All electrical connections are made to the processor board through wire and ribbon cables.



**LEGEND**

- DIP — Dual In-Line Package
- EPROM — Erasable, Programmable Read-Only Memory
- EXV — Electronic Expansion Valve

\*EPROM HT204485-1-XX where "XX" is the current revision number.

NOTE: Processor Board is positioned in unit with J3 and J10 connections at the bottom.

**⚠ WARNING**

Do not remove label covering EPROM. Removal causes program to be erased.

**Fig. 1 — Processor Board**

Several temperature inputs are connected to the processor. There are either 4 or 5 thermistors (depending on the field-installed accessories) which input temperature data into the processor through pin terminal connector J1. See Table 1 and Fig. 2.

Several status switches are also monitored. These switches are connected to the processor at pin terminal connector J2. See Fig. 3 and Table 2.

**Table 1 — Pin Terminal Connector J1 Thermistor Inputs**

CONNECTOR J1 TERMINAL NO.	TEMPERATURE INPUT	UNIT SIZE 034-074
1,2	Reset Temperature*	T10
14,15	Saturated Condensing Temp., Circuit 2	T4
16,17	Saturated Condensing Temp., Circuit 1	T3
18,19	Return-Air Temperature	T2
20,21	Leaving-Air Temperature	T1

**LEGEND**

T — Thermistor

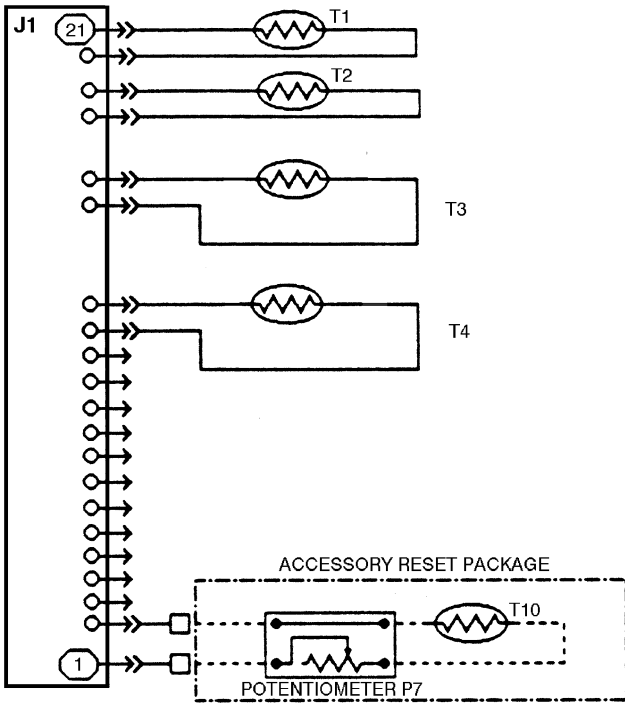
\*If equipped with accessory temperature reset package.

NOTE: Terminal numbers 3-13 are not used on these units.

In addition to the unit status switch inputs, the processor board also accepts inputs from several potentiometers. These potentiometers control various operational characteristics of the system. Inputs are received by the processor through pin terminal connector J3. See Fig. 4.

All of the potentiometers must be set before the unit is started in order for the unit to function properly. See Start-Up, Potentiometers section on page 25 for information on establishing set points. Each of the potentiometers has a valid range that is used by the control. The valid range is defined as the potentiometer's resistance value that the control will not consider to be in error. This is usually between 10% and 90% of the potentiometer's total resistance. The control has been programmed to accept an operational range for the potentiometer, which may not be the same as the valid range.

J1 THERMISTOR CONNECTOR



LEGEND

- T — Thermistor
- - - Field Wiring
- - - Accessory

Fig. 2 — Pin Terminal Connector J1 Thermistor Inputs

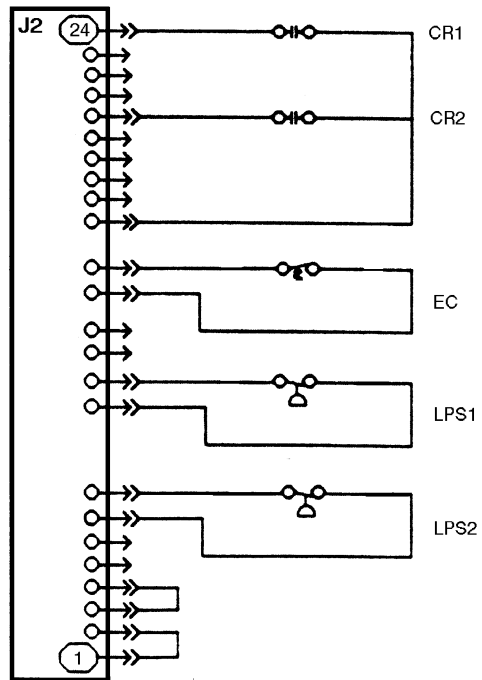
Table 2 — Pin Terminal Connector J2 Status Switch Inputs

CONNECTOR J2 TERMINAL NO.	STATUS SWITCH	UNIT SIZE 034-074
1,2	Oil Pressure, Circuit 2	Jumpered
3,4	Oil Pressure, Circuit 1	Jumpered
7,8	Loss Of Charge, Circuit 2	LPS2
9,10	Loss of Charge, Circuit 1	LPS1
13,14	Economizer Changeover	EC
15,20	Compressor Fault Signal	CR2
15,24	Compressor Fault Signal	CR1

LEGEND

- CR — Control Relay
- EC — Enthalpy Control
- LPS — Low-Pressure Switch

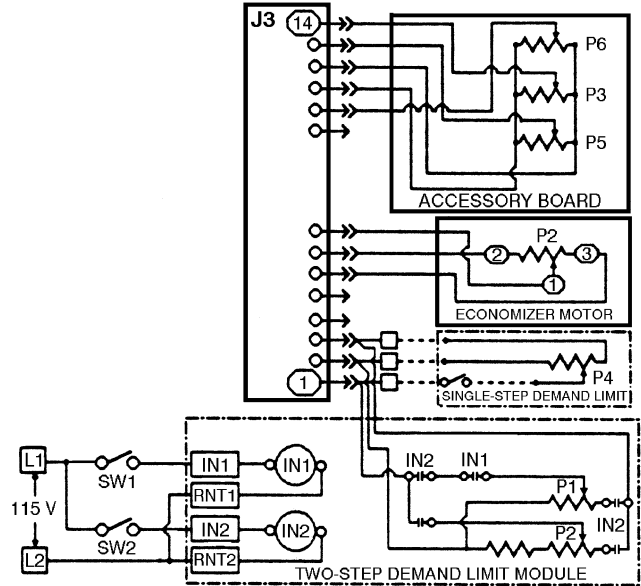
NOTE: Terminal numbers 5, 6, 11, 12, 16-19, and 21-23 are not used on these units.



LEGEND

- CR — Control Relay
- EC — Enthalpy Control
- LPS — Low-Pressure Switch

Fig. 3 — Pin Terminal Connector J2 Status Switch Inputs



LEGEND

- IN — Input
- P — Potentiometer
- RNT — Return
- SW — Switch
- Factory Wiring
- - - Field Wiring
- - - Accessory

Fig. 4 — Pin Terminal Connector J3 Potentiometer Inputs

The potentiometer locations and functions are as follows:

**P1 — LEAVING-AIR SET POINT** — This potentiometer is located on the display board. The leaving-air set point is the cooling mode control temperature which the VAV control system will attempt to maintain at Thermistor T1 by control of economizer position and/or cycling unloaders and compressors.

**P2 — ECONOMIZER POSITION** — Economizer feedback potentiometer is located on the economizer motor. The micro-processor is programmed to indicate an alarm if the travel during initialization is less than 10% of the total potentiometer's resistance. An alarm condition will also be signaled if the potentiometer fails during operation, indicating that the damper blades are stuck. If either situation occurs, the processor will try to drive the economizer dampers closed.

**P3 — RESET LIMIT** — This potentiometer is located on the accessory board (provided standard from the factory) in the unit main control box and establishes the maximum amount of reset that can be applied to the leaving-air set point (P1). Reset is limited by the P1 default of 70 F. This potentiometer is used only when accessory, field-installed temperature reset is used. If temperature reset is used, DIP (dual, in-line package) switch 2 must be in the ON position.

**P4 — DEMAND LIMIT** — This potentiometer is located near TRAN4 in the unit control box. The demand limit potentiometer is used only if accessory, field-installed demand limit is used, and if DIP switch 5 is in the ON position. For single-step demand limit, a field-installed 5 to 20 Kohm potentiometer must be used.

**P5 — ECONOMIZER MINIMUM POSITION** — This potentiometer is on the accessory board (provided standard from the factory) located in the unit main control box. This potentiometer specifies the minimum opening position for the optional economizer. If a fault condition is detected by the processor, an alarm condition will be signaled and the economizer dampers will close.

**P6 — WARM-UP SET POINT** — This potentiometer is on the accessory board (provided standard from the factory) located in the unit main control box. This potentiometer establishes the set point temperature for the Morning Warm-Up function. When the temperature is reached, Morning Warm-Up is terminated and VAV operation begins. DIP switch 4 must be in the ON position if morning warm-up heat is to be used.

**P7 — SASP (SUPPLY AIR SET POINT) RESET TEMPERATURE** — This 10 Kohm potentiometer is used only if the accessory, field-installed temperature reset package is installed. This potentiometer determines the temperature at which reset will begin. It is located on the accessory temperature reset board. DIP switch 2 must be in the ON position to enable SASP reset.

**PROCESSOR BOARD OUTPUTS** — The processor board also controls outputs through the relay board. The relay board plugs into the processor board using a ribbon cable.

In addition, the processor board controls the display board. The display board is connected to the processor board by a ribbon cable, and has an LED (light-emitting diode) display showing the status of the unit and diagnostic information.

**CONFIGURATION HEADER AND DIP SWITCH ASSEMBLY** — The processor board is programmed to control a variety of air conditioning units. To tailor the processor to the particular unit being controlled, 2 devices are used. One is the configuration header, and the other is the DIP switch assembly.

The configuration header (part no. 30GB660001) is a series of 8 small wires that are broken or unbroken in a pattern to indicate several unique characteristics of the unit. The configuration header is factory set and should not be changed. Changing the factory setting may cause the unit to malfunction.

The DIP switches configure the unit for several field-installed options, as well as for several other options that may be unique to the unit. The DIP switches are located under a plastic enclosure which must be removed for access. The switches can be field adjusted, but must be adjusted only when the unit control circuit breaker is off.

**Relay Board** — The relay board is used to control 24-v and 115-v loads. See Fig. 5. The relay board is connected to the processor board by a ribbon cable at pin J9. Electrical connections to the relay board are made through pins J5 (115 v) and J6 (24 v). The relay board has eight 24-v relays and five 115-v relays. See Table 3.

**Display Board** — The display board is located in the main unit control box and is connected to the J10 port of the processor board through a ribbon cable. The display board contains the leaving-air set point potentiometer P1; a 2-digit, LED display; and the display button (see Fig. 6). The LED display is used to convey the operating information and operational error codes.

**Thermistors** — The processor uses up to 5 thermistors to sense the temperatures at various points in the system. See Table 1 and Fig. 7-14. All the thermistors have identical temperature versus resistance and voltage drop characteristics, and are monitored by the processor for a short or open circuit. The valid range for a thermistor is 362,640 to 219 ohms. Thermistor details and locations are as follows:

**T1 — LEAVING-AIR TEMPERATURE THERMISTOR** — This thermistor is located in the unit supply fan discharge. It provides information for the processor to stage the number of capacity steps required to maintain a desired leaving-air temperature.

**T2 — RETURN-AIR TEMPERATURE THERMISTOR** — This thermistor is located in the mixed-air portion of the unit cabinet. The thermistor's primary function is to provide morning warm-up information. This sensor will also provide differential information for the processor during cooling operation (such as the rate of change for a capacity step).

**T3 — SATURATED CONDENSING TEMPERATURE, CIRCUIT 1** — This thermistor is located on the condenser coil return bend. See Fig. 13 and 14. It controls the staging of the unit condenser fans based on the condensing temperature of the refrigerant at the designated position on the condenser coil.

**T4 — SATURATED CONDENSING TEMPERATURE, CIRCUIT 2** — This thermistor is located on the condenser coil return bend. See Fig. 13 and 14. It controls the staging of the unit condenser fans based on the condensing temperature of the refrigerant at the designated position on the condenser coil.

**T10 — RESET TEMPERATURE** — This thermistor is used only if the accessory temperature reset package is used. It provides occupied space temperature information to the processor, which determines whether or not reset is required. The thermistor is remotely mounted outside the unit in the conditioned space.

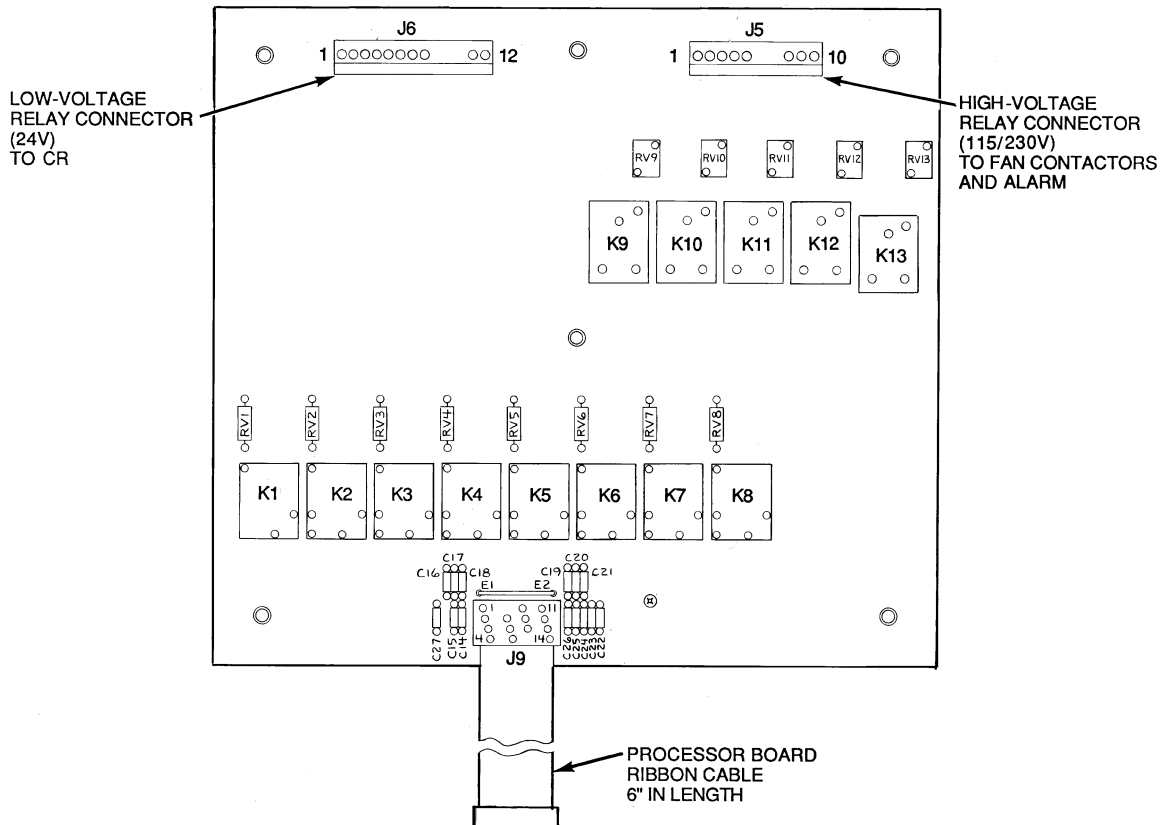
**Table 3 — Output Pin and Terminal Assignments**

OUTPUT PIN-TERMINAL	NAME	RATING	DEVICE
J6-1	Stage 1 Compressor Relay (K1)*	24 vac	CR1
J6-2	Stage 2 Compressor Relay (K2)*		U2**
J6-3	Stage 3 Compressor Relay (K3)*		U1
J6-4	Stage 4 Compressor Relay (K4)†		Not Used
J6-5	Stage 5 Compressor Relay (K5)†		CR2
J6-6	Stage 6 Compressor Relay (K6)†		Not Used
J6-7	Economizer Open Relay (K7)		EOR
J6-8	Economizer Close Relay (K8)		ECR
J5-1	Supply Fan Relay (K9)	115 vac	IFC
J5-2	Morning Warm-Up Relay (K10)		HIR
J5-3	Stage 1 Condenser Fan Relay (K11)		OFC2/OFC3 ††
J5-4	Stage 2 Condenser Fan Relay (K12)		OFC4 ††
J5-5	External Alarm Relay (K13)		ALM

**LEGEND**

- ALM — Alarm
- CR — Control Relay
- ECR — Economizer Close Relay
- EOR — Economizer Open Relay
- HIR — Heat Interlock Relay
- IFC — Indoor (Evaporator) Fan Contactor
- OFC — Outdoor (Condenser) Fan Contactor
- U — Unloader

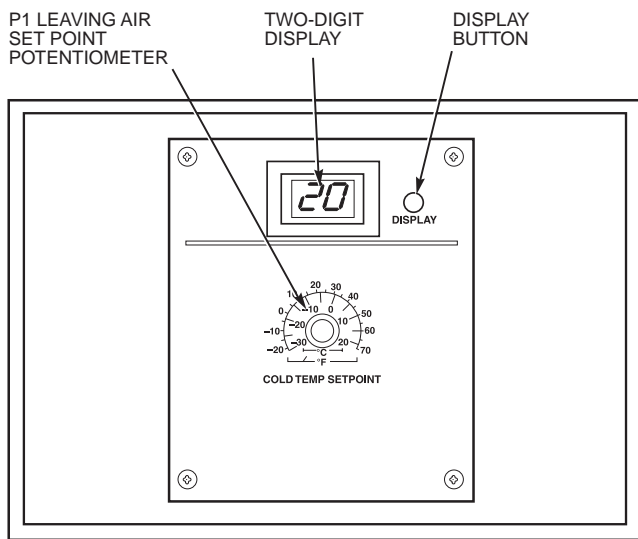
- \*Circuit 1.
- †Circuit 2.
- \*\*U2 is not used on 044 units.
- ††OFC2 on 034-048 units; OFC3 on 054-074 units.
- ‖ Used on 054-074 units only.



**LEGEND**

- CR — Control Relay
- J — Terminal Pin Connectors
- K — Relay

**Fig. 5 — Relay Board**



**Fig. 6 — Display/Set Point Board**

### Compressor Operation

**CONTROL RELAY (CR)** — This relay provides information to the processor about compressor operation (one control relay per compressor). The relay controls and protects the compressor and also controls the crankcase heater.

A control signal to check the safety statuses and to start the compressor is sent from the relay board. This signal travels through all of the safeties: the high-pressure switch, and the internal protector and on to the control relay coil. Once the control relay coil has been energized, the control relay completes a feedback circuit for the processor, informs the processor of the status of the compressor safeties, energizes the compressor contactor coil, and deenergizes the crankcase heaters. A fault will be detected by the processor if the control relay opens during operation or start-up. The processor will lock the compressor or the circuit off by deenergizing the appropriate relay(s) on the relay board and energizing an alarm signal.

**Accessory Board** — The accessory board is standard (factory supplied) in the VAV rooftop units. See Fig. 15. This board is located in the control box of each unit. Each board has a prewired connector supplied with it to connect directly to the processor board. It has 3 potentiometers: P3, P5, and P6.

**P3 — RESET LIMIT** — The processor board is programmed for occupied space temperature reset. In order for reset to work, the accessory temperature reset board must be used. Potentiometer P3 is the maximum set point temperature to which the supply air can be reset.

**P5 — ECONOMIZER MINIMUM POSITION** — This potentiometer controls the set point for the minimum position of the economizer.

**P6 — MORNING WARM-UP TEMPERATURE** — This potentiometer controls the morning warm-up temperature set point.

**Single-Step Demand Limit** — The single step demand limit provides a means to limit the capacity of the VAV unit using an external switch. Single step demand limit will limit the compressor displacement based on the ratio of the wiper arm to the full scale resistance. The exact percentage of capacity reduction differs depending on the number of capacity steps.

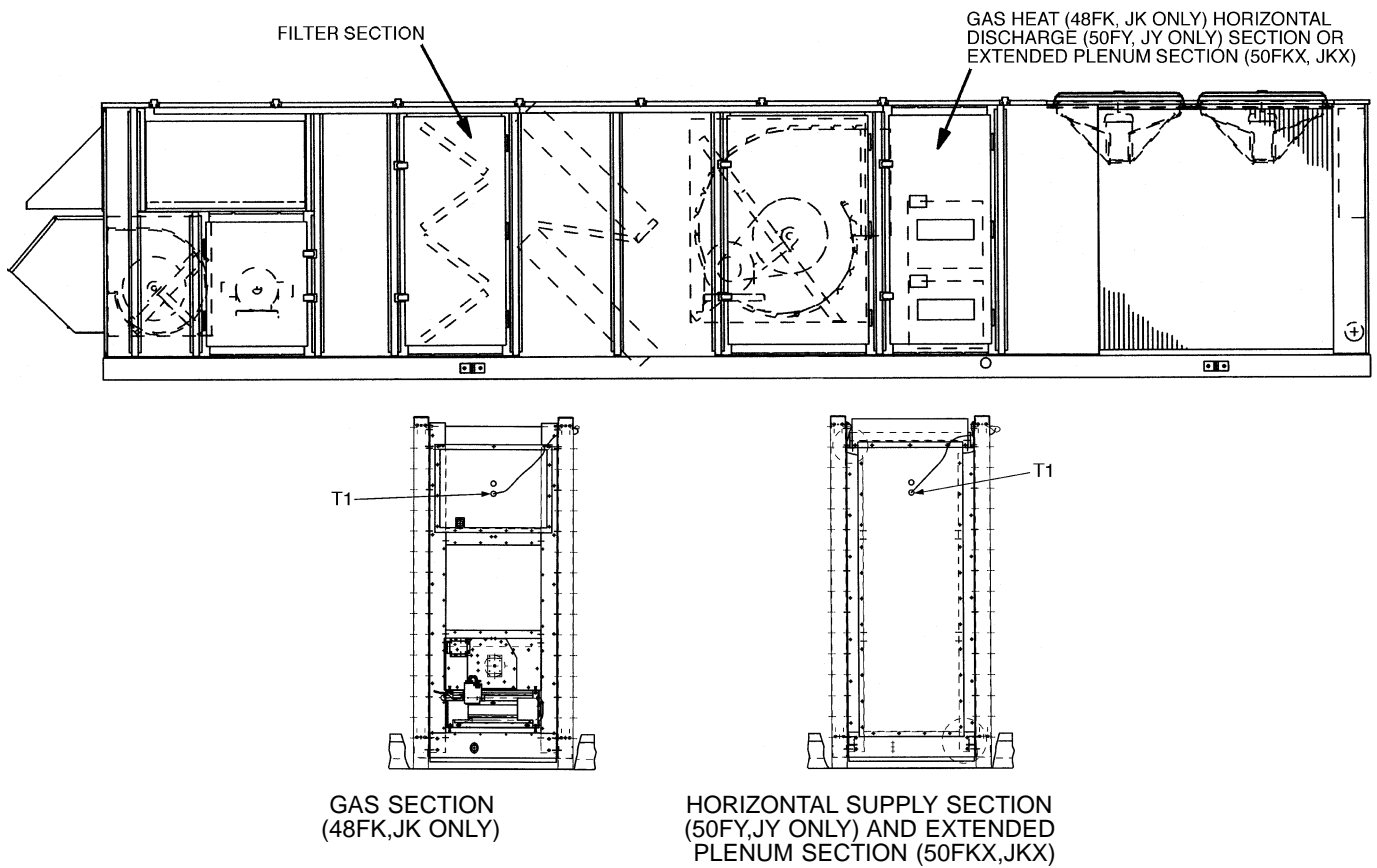
A 3-wire, 5 to 20 Kohm, field-supplied potentiometer (P4) is required for this option. The potentiometer should be wired to the processor J3 connections. In order to control the demand limit, the wiper arm of the potentiometer should be switched open and closed based on the demand limit requirement. The control switch is also field-supplied and installed.

If the wiper arm wire is open, all capacity stages can be used. When the wiper arm wire is closed, the capacity is reduced by the amount set on potentiometer P4.

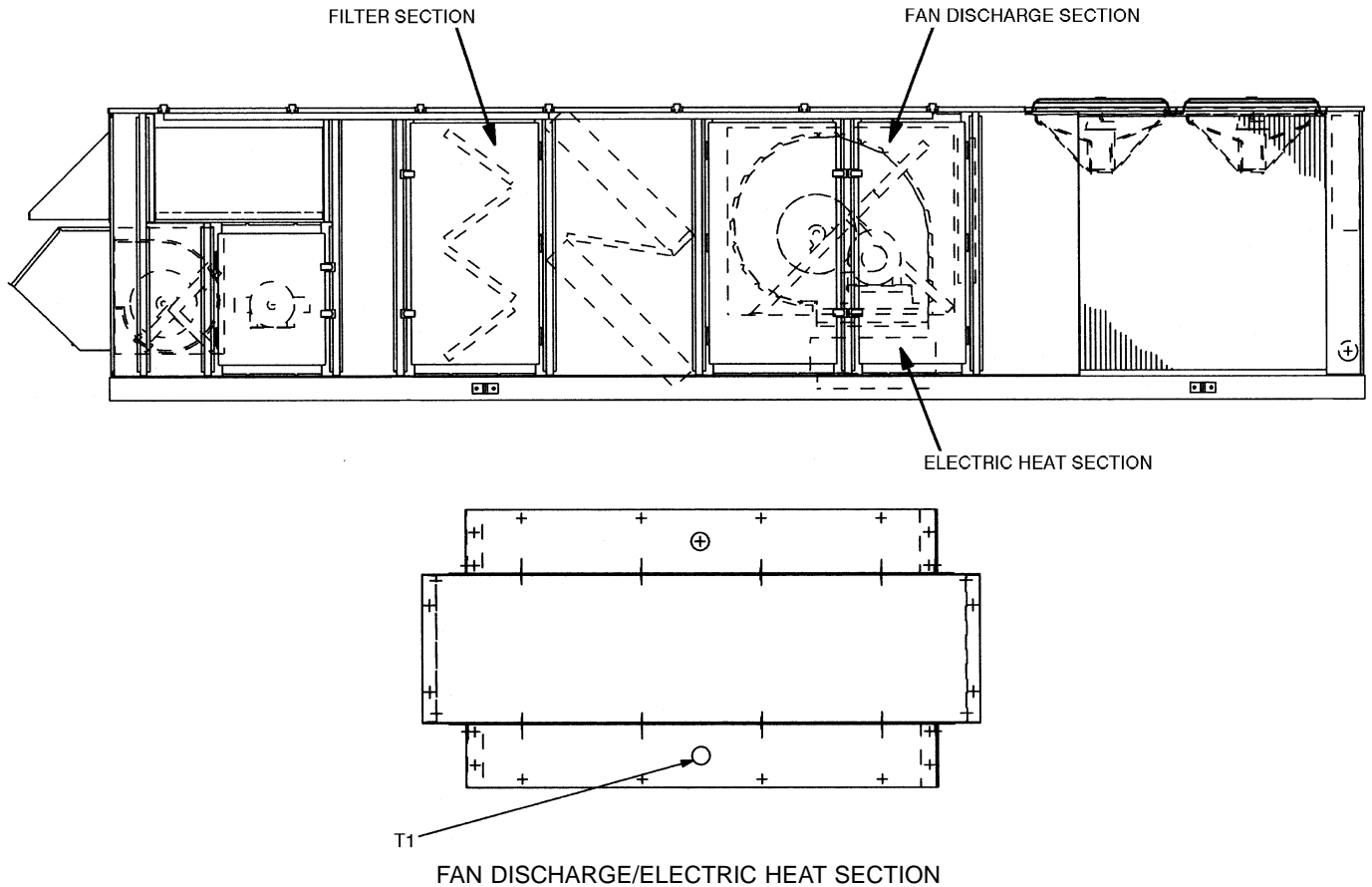
**Demand Limit Control Module (DLCM)** — The DLCM provides a 2-step demand limit control using an external switch. The first step is between 50% and 100% of the maximum compressor displacement. See Fig. 16. The second step is between 0% and 49% of the maximum compressor displacement. The exact percentage differs depending on the number of capacity steps.

Two adjustable potentiometers are used to set the 2 demand limit points. Potentiometer P1 is used to set a demand limit between 50% and 100% of the unit capacity. Potentiometer P2 is used to set a demand limit between 0% and 49% of unit capacity.

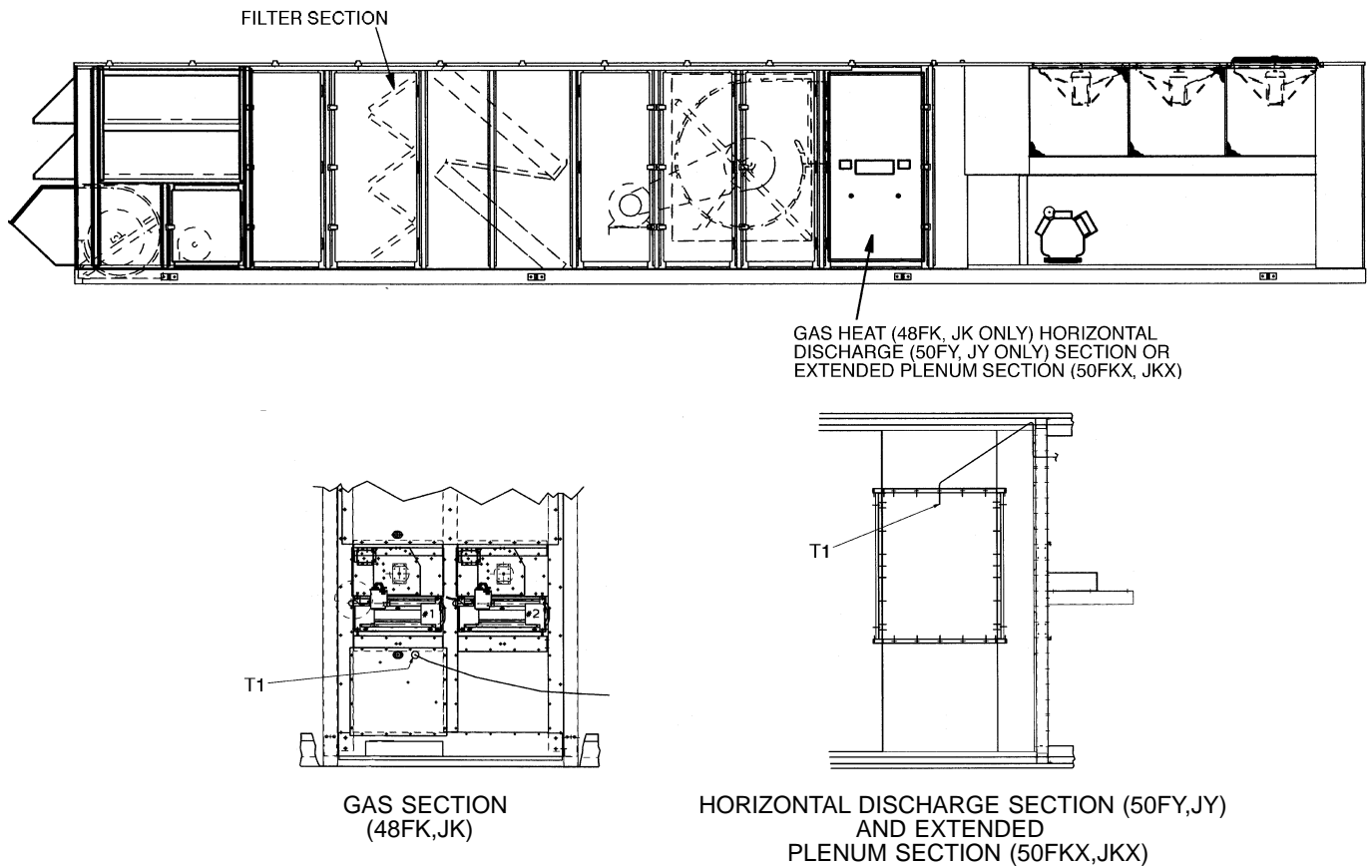
If no power is supplied to the demand limit control module, all capacity stages can be used. When power is supplied to terminal IN1 only, the first step of the demand limit control is energized and the capacity is reduced by the amount set on potentiometer P1. When power is supplied to terminal IN2 only, or to both IN1 and IN2, the capacity is reduced by the amount set on potentiometer P2.



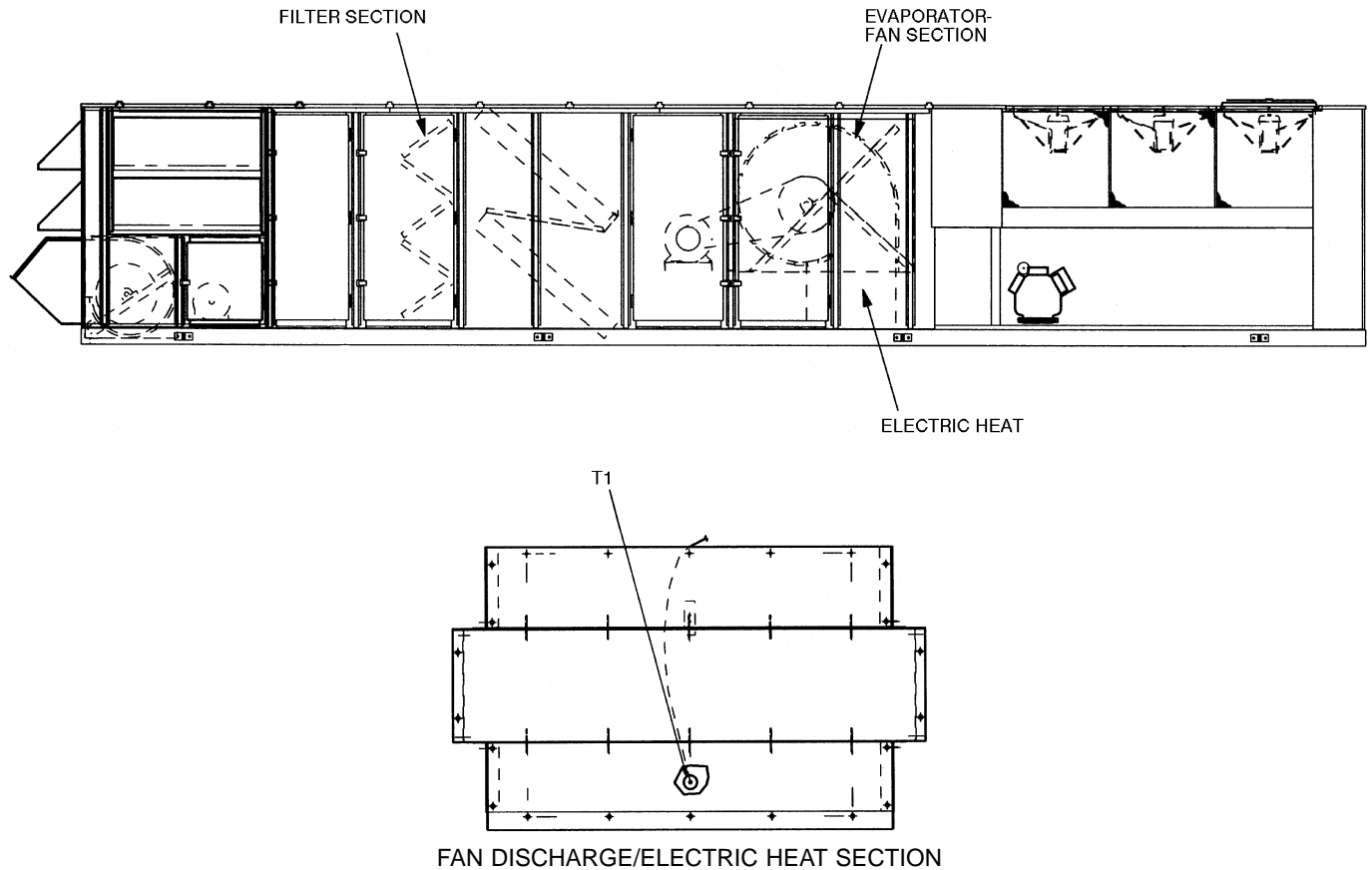
**Fig. 7 — Thermistor T1 Location, 48FK,JK, 50FY,JY and 50FKX,JKX 034-048 Units**



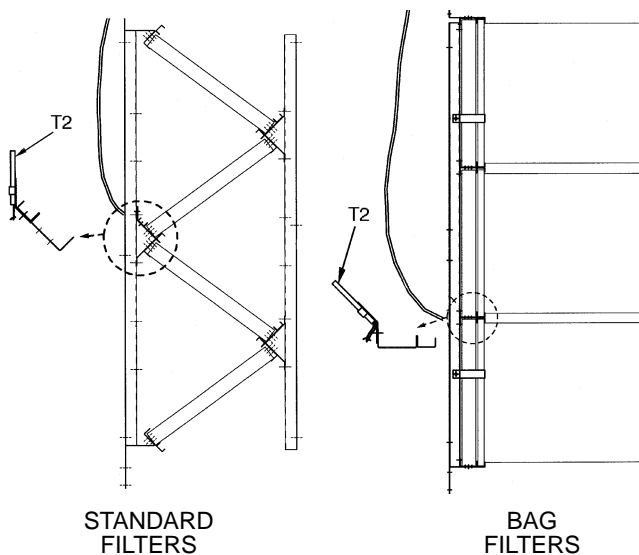
**Fig. 8 — Thermistor T1 Location, 50FK,JK034-048 Units**



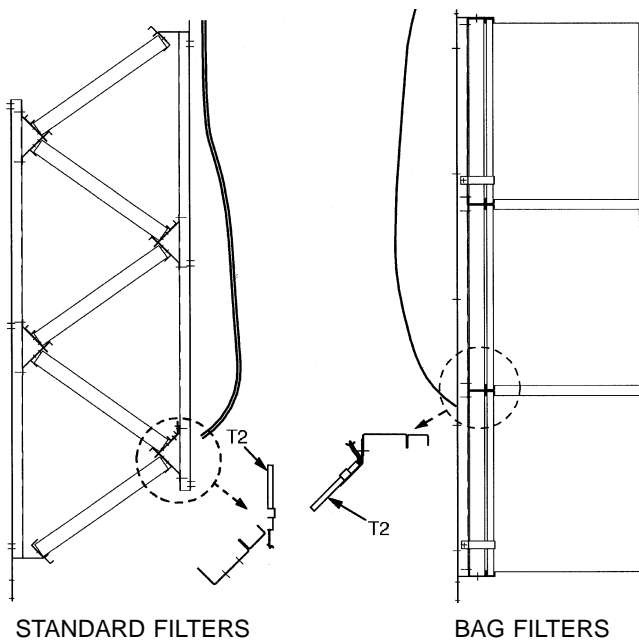
**Fig. 9 — Thermistor T1 Location, 48FK, JK, 50FY, JY and 50FKX, JKX 054-074 Units**



**Fig. 10 — Thermistor T1 Location, 50FK, JK054-074 Units**



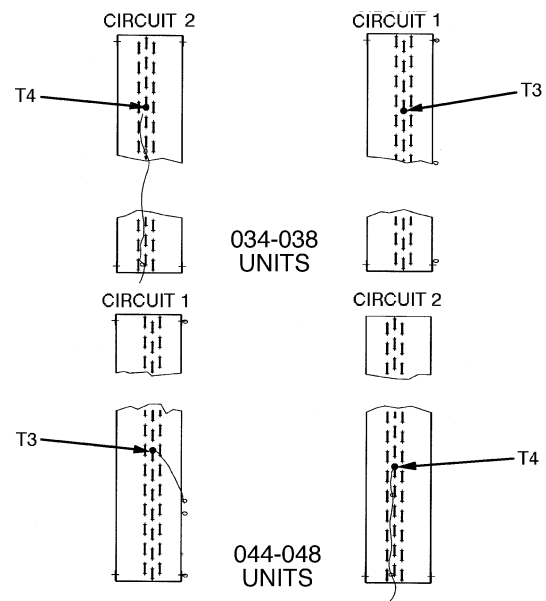
**Fig. 11 — Thermistor T2 Location, Size 034-048 Units**



**Fig. 12 — Thermistor T2 Location, Size 054-074 Units**

**Economizer** — Economizer control is used to control the outside and return air dampers of the unit, to satisfy space cooling demand using all outside air (when permitted), and to satisfy cooling in conjunction with compressor operation (when conditions permit). During Occupied periods, the outside-air dampers will be at the user-configured Minimum Damper Position (at P5 on accessory board). During Unoccupied periods, the outside-air dampers will be closed.

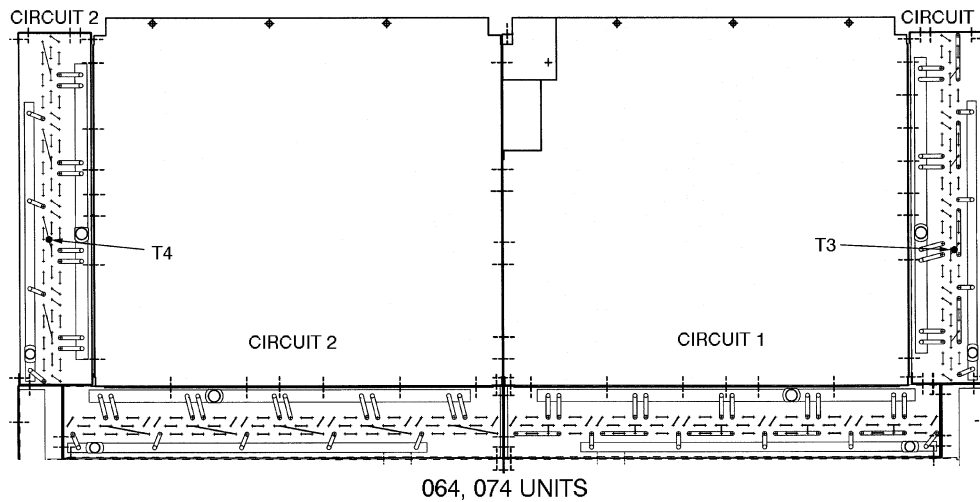
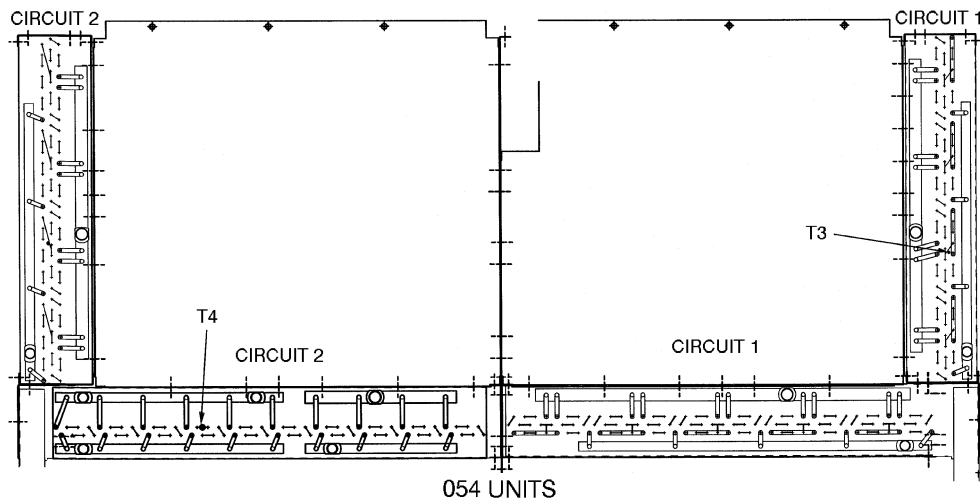
The economizer is available as a factory-installed option. The user can install an accessory differential enthalpy sensor to enhance economizer control. Refer to the installation section for field wiring of the sensor.



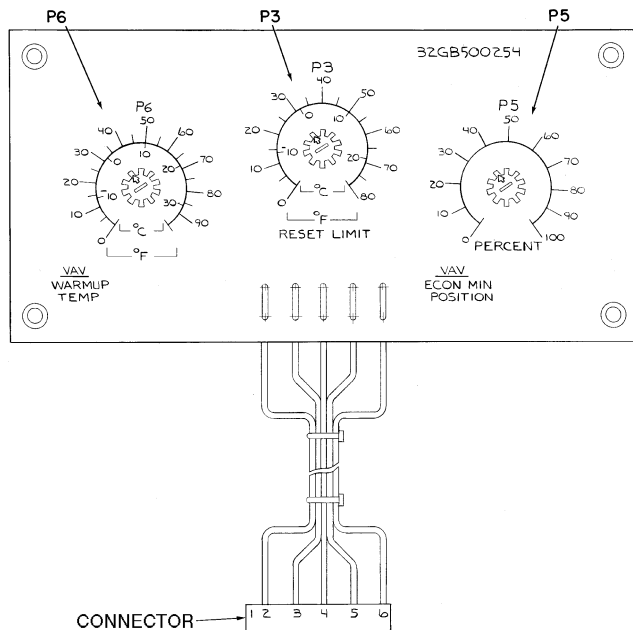
**Fig. 13 — Thermistor T3 and T4 Locations, Size 034-048 Units**

**ENTHALPY CONTROL** — Outside air enthalpy control is standard with the factory-installed economizer option. Enthalpy is sensed by a controller located behind the end outside air hood. The control can be accessed by removing the upper hood filter. See Fig. 17.

**DIFFERENTIAL ENTHALPY** — Added efficiencies in economizer control can be gained by installing a differential enthalpy sensor in the return air duct. When differential enthalpy control is installed, the economizer control will use the air stream with lower enthalpy (outside air or return air) to provide for lower compressor operating costs during integrated economizer cycle operation. The differential enthalpy sensor is installed in the return-air duct.

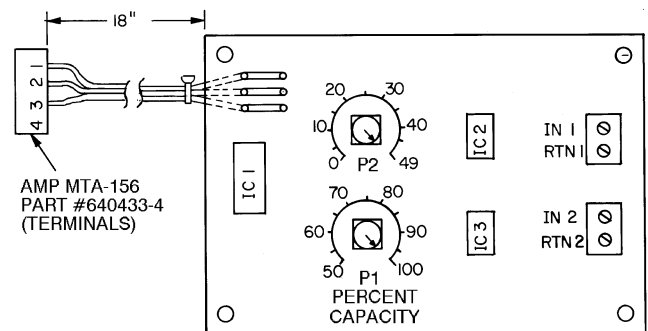


**Fig. 14 — Thermistor T3 and T4 Locations, 054-074 Units**



- LEGEND**
- ECON** — Economizer
  - MIN** — Minimum
  - P** — Potentiometer
  - VAV** — Variable-Air Volume

**Fig. 15 — Accessory Relay Board  
(Standard; Factory Supplied)**



- LEGEND**
- IC** — Integrated Circuit
  - IN** — Input
  - P** — Potentiometer
  - RTN** — Return

**Fig. 16 — Two-Step Demand Limit Module**

## CONTROLS INSTALLATION

The VAV units may be used in applications with additional control features, options, or accessories. Refer to the appropriate accessory installation instructions for more information on installing that accessory. Unit control box component arrangement is shown in Fig. 18 and 19. Control options and accessories available for VAV units are:

- smoke control modes
- differential enthalpy sensor
- electric heaters
- modulating power exhaust
- Motormaster® I control
- space temperature reset
- night setback thermostat (field-supplied)
- single step demand limit
- two-step demand limit
- inlet guide vanes
- variable frequency drive
- variable frequency drive remote display kit

**Control Wiring** — A switch or timeclock (field supplied) must be wired in to control when unit will go into and out of Occupied mode. Connect switch or timeclock between terminals 1 and 2 on terminal block 3 (sizes 034-048) or terminal block 4 (sizes 054-074) in unit control box. See Fig. 20. The circuit potential is 24 v.

Variable air volume units equipped with warm-up heat require that room terminals be controlled to go fully open when unit goes into the Heating mode. Heating interlock relay (HIR) is provided for this function. The relay is located in the unit control box. When unit goes into Heating mode, interlock relay is energized providing switch closure or opening (depending on how field power source is set up) to open the room terminals. Field connections for interlock relays are terminals 3 and 4 (for normally open contacts) and terminals 3 and 7 (for normally closed contacts) on terminal block 3 (sizes 034-048) or terminals block 4 (sizes 054-074). See Fig. 21. Note that a field-supplied power source is required.

There are no required 115-volt field wiring connections, therefore no provisions have been made in the unit for running 115-volt wiring. If any of the field-installed options requiring 115-volt connections are desired, the unit must be modified in the field for 115-volt wiring. Options requiring 24-volt or 115-volt control wiring are shown in Fig. 22-25.

**NIGHT SETBACK THERMOSTAT** — Wire field-supplied thermostat (suitable for 24-v circuit) between terminals 1 and 2 on terminal block 3 (sizes 034-048) or terminal block 4 (sizes 054-074). This thermostat is used to bypass the timeclock occupied/unoccupied switch and is used to operate unit during unoccupied times at more economical temperatures. (See Fig. 20.)

**SPACE TEMPERATURE RESET ACCESSORY (50DJ900021)** — Consists of a thermistor (T10) and a reset board with a potentiometer (P7) that is used to set space temperature at which reset starts. Mount reset board in unit control box or other convenient place. Wire thermistor in series with P7 and connect to terminals 12 and 15 on terminal block 3 (sizes 034-048) or terminal block 4 (sizes 054-074) in unit control box. If there is a long run to conditioned space, it is necessary to splice additional wire to thermistor. The reset board has 2 pressure connectors for field wiring. (See Fig. 22.)

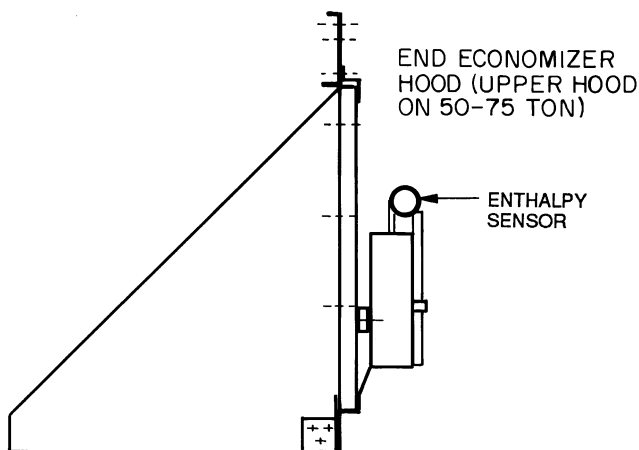


Fig. 17 — Enthalpy Sensor Location

**Temperature Reset** — Accessory temperature reset allows the unit to automatically adjust (“reset”) the supply-air temperature set point to a higher value once most of the space cooling load has been met. When the space conditions are satisfied, the VAV terminals will close to the minimum position. All VAV units will sense the decrease in actual leaving-air temperature and the unit controls respond by reducing capacity stages to maintain user-established supply-air set point temperature. When VAV units are also equipped with optional supply duct pressure controls (either inlet guide vanes [IGV] or variable frequency drive package), the unit also senses an increase in duct static pressure and responds by closing IGV dampers or slowing fan wheel speed to maintain user-configured set points for supply duct pressure. Allowing the supply-air temperature to be reset to a higher value maintains air circulation in the space without costly overcooling.

The accessory package is required for temperature reset. The accessory includes:

- thermistor T10, to monitor space temperature
- reset temperature potentiometer P7, to establish start temperature for reset operation
- reset limit potentiometer P3, to establish maximum level of modified supply-air temperature

More than one space sensor may be used if an average space temperature is desired for initiating temperature reset. Refer to installation section for sensor part number and wiring schematic.

Temperature reset will start when space temperature (at T10) drops to the set point at P7. When Temperature Reset is active, the LED (light-emitting diode) display will show code 21. Automatic adjustment of supply-air temperature set point will end when modified SASP equals reset limit set point at P3. (See formula for automatic modification of SASP in Controls Installation, Space Temperature Reset section on page 16.)

COMPONENT ARRANGEMENT

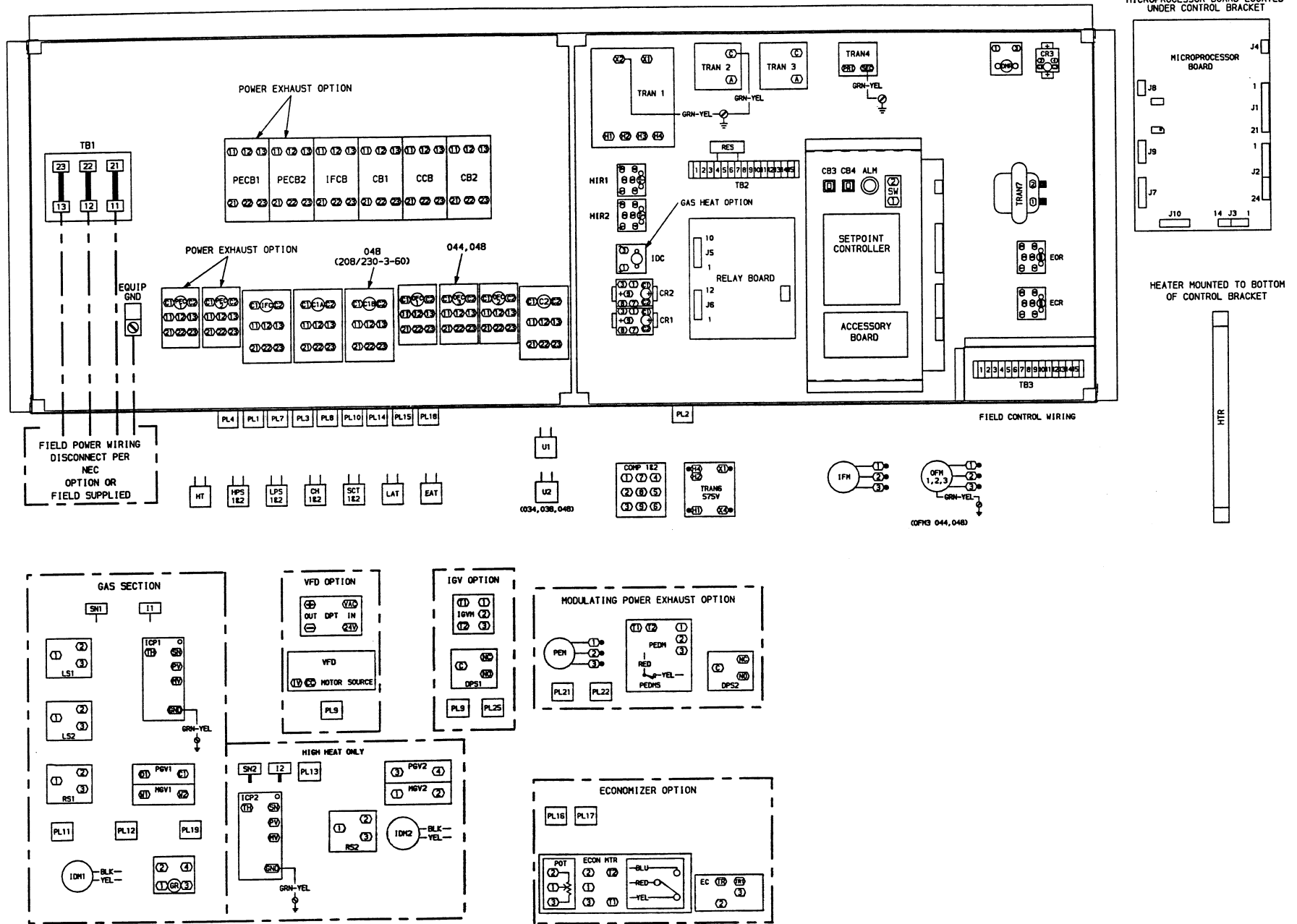


Fig. 18 — Unit Control Box Arrangement, Sizes 034-048



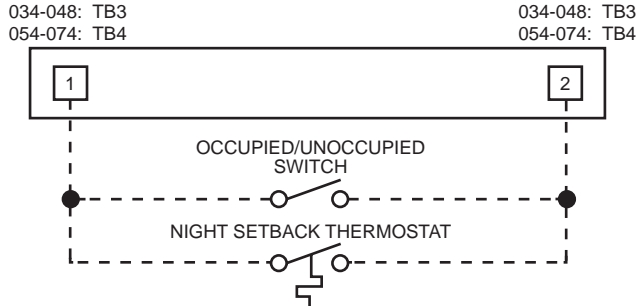
**SINGLE-STEP DEMAND LIMIT POTENTIOMETER** — Potentiometer is a field-supplied, 3-wire potentiometer with a resistance of 5 to 20 Kohms. Connect 3 wires from potentiometer to terminals 8, 9 and 10 on terminal block 3 (sizes 034-048) or terminal block 4 (sizes 054-074) in unit control box, as shown in Fig. 23.

**ACCESSORY 2-STEP DEMAND LIMIT (Fig. 25)** — Install the 2-step demand limit module in unit control box as close as possible to the processor board. Mount using four no. 8 × 3/4-in. long screws.

**24-Volt Connection** — The 2-step demand limit module is equipped with a connector for hookup to processor board.

Prior to hookup, plugs and wires running between terminals 1, 2 and 3 on J3 of the processor board and terminals 1, 2 and 3 on terminal block 3 in unit control box must be removed. After removing these plugs, attach connector from demand limit module to terminals 1, 2 and 3 on processor board. The 115-volt wiring for field-controlled input signals must be completed before demand limit board will operate.

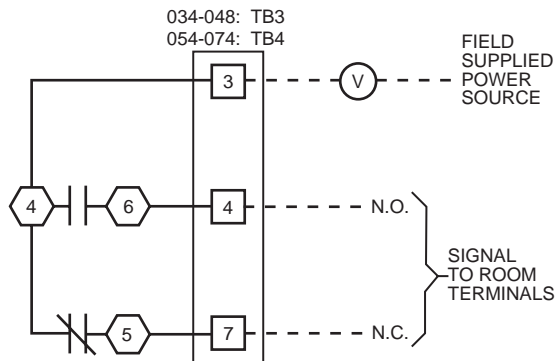
**115-Volt Connection** — Field-controlled input signals to the accessory 2-step demand limit module. Connect field input signals to terminal strips INT1 and INT2 located on the module (see Fig. 24). These are pressure-type terminals. The terminals will accept up to 12-gage wire. See Fig. 25 for wiring details.



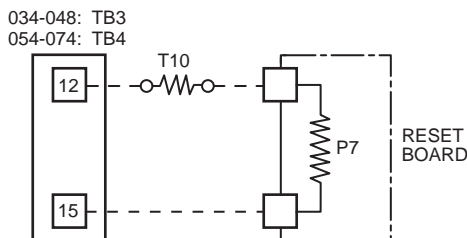
NOTES:

1. Occ/Unocc switch closes when occupied.
2. Night setback thermostat closes when in night setback heating.

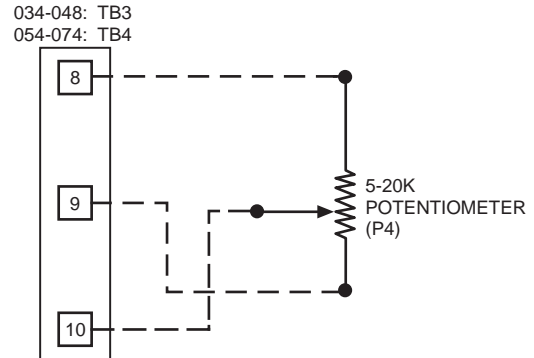
**Fig. 20 — Occupied/Unoccupied Switch with Night Setback Thermostat**



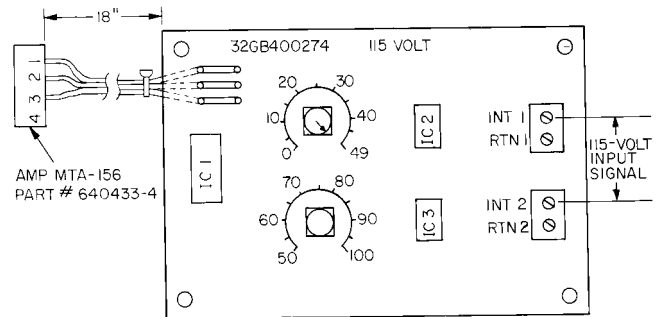
**Fig. 21 — Heat Interlock Relay**



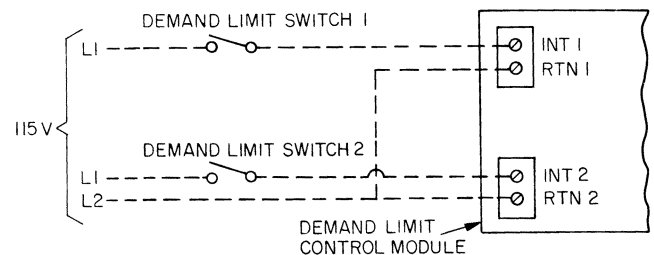
**Fig. 22 — Accessory Reset Board**



**Fig. 23 — Single-Step Demand Limit**



**Fig. 24 — Two-Step Demand Limit Module**



NOTES:

1. Demand limit switches are field supplied and wired.
2. Demand limit control module terminal blocks will accept up to 12-gage wire.
3. - - - is field wiring.

**Fig. 25 — 115-Volt Field Wiring to Accessory 2-Step Demand Limit Control Module**

## Space Temperature Reset

**INSTALLATION** — Install the accessory temperature reset package in accordance with instructions provided with the accessory kit.

Mount the reset board in the unit control box (or other suitable location) per instructions.

Locate the thermistor T10 in a suitable location in the occupied space per instructions.

Wire T10 to the reset board and to the unit control terminal block per Fig. 26. Wire the other terminal on the reset board to the unit control terminal block per Fig. 22.

If multiple sensors are required to average the space temperature, see Fig. 26. Use only Carrier Part Number HH79NZ014 sensor, in arrangements of 4 or 9 sensors, with total wiring not to exceed 1000 ft.

To enable reset function, change DIP (dual in-line package) switch 2 to position ON. (Disconnect control power before changing DIP switch positions; reconnect power after all changes have been made.)

**CONFIGURATION** — Set points for reset operation are established at potentiometers P7 and P3 (on the reset board).

**Potentiometer P7** — Reset temperature set point (temperature at which reset function will start). Maximum of 80 F, minimum 0° F. Set below normal room cooling set point level to sense overcooling in the occupied space.

**NOTE:** It is difficult to accurately set the P7 potentiometer to the desired set point. Use the procedure below.

Proper setting of the P7 potentiometer may be made on a resistance basis. The microprocessor initiates reset when it detects a resistance of the thermistor plus the potentiometer of 13,084 ohm. The potentiometer set point may be calculated using the following formula:

$$P7_R = 13,084 - T10_R$$

Where:

$P7_R$  = the desired set point of the P7 potentiometer in ohms

$T10_R$  = the resistance of the T10 thermistor for the desired set point

**EXAMPLE:**

T10 desired set point is 70 F.

$T10_R$  from Table 4 for 70 F is 5929 ohms.

$$P7_R = 13,084 - 5929$$

$$P7_R = 7155 \text{ ohms}$$

Using an ohmmeter, set the P7 potentiometer to 7155 ohms to achieve a reset initiation set point of 70 F.

**Potentiometer P3** — Reset limit set point (maximum temperature value for modified supply air set point). Maximum of 70 F, minimum 40 F. Set between leaving air set point (P1) and 70 F (maximum range permitted by control).

**OPERATING SEQUENCE** — If space temperature is above reset set point ( $T10 > P7$ ), no reset will occur.

If space temperature is equal to or less than reset set point ( $T10 \leq P7$ ), the LED will display 20 and reset will begin.

Control will automatically adjust leaving air temperature by the following formula:

$$MSP = SP + [(P3 - SP) / 3] \times (P7 - T10)$$

where:

MSP = Modified Leaving-Air Set Point

SP = Leaving-Air Set Point

P3 = Maximum Leaving-Air Temperature (reset limit)

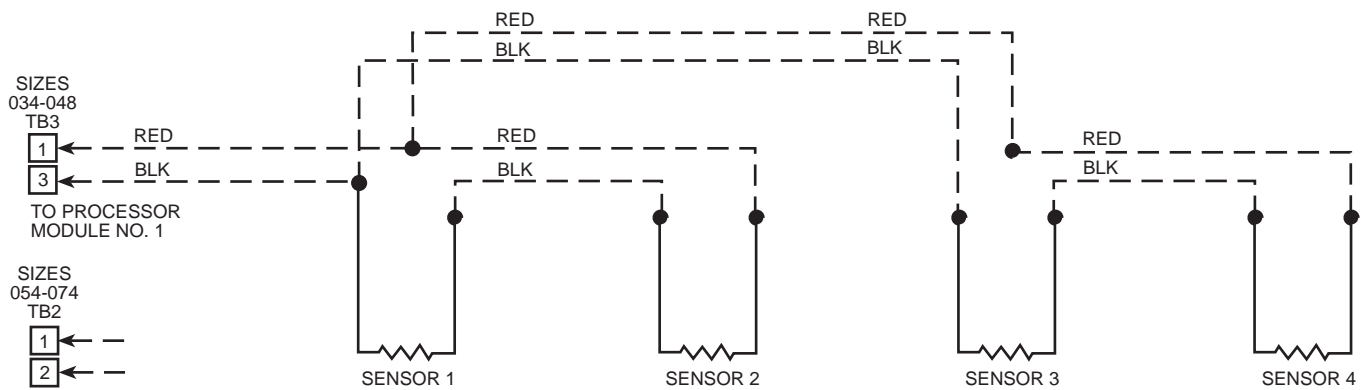
P7 = Reset Initiation Temperature (reset set point)

T10 = Actual Space Temperature

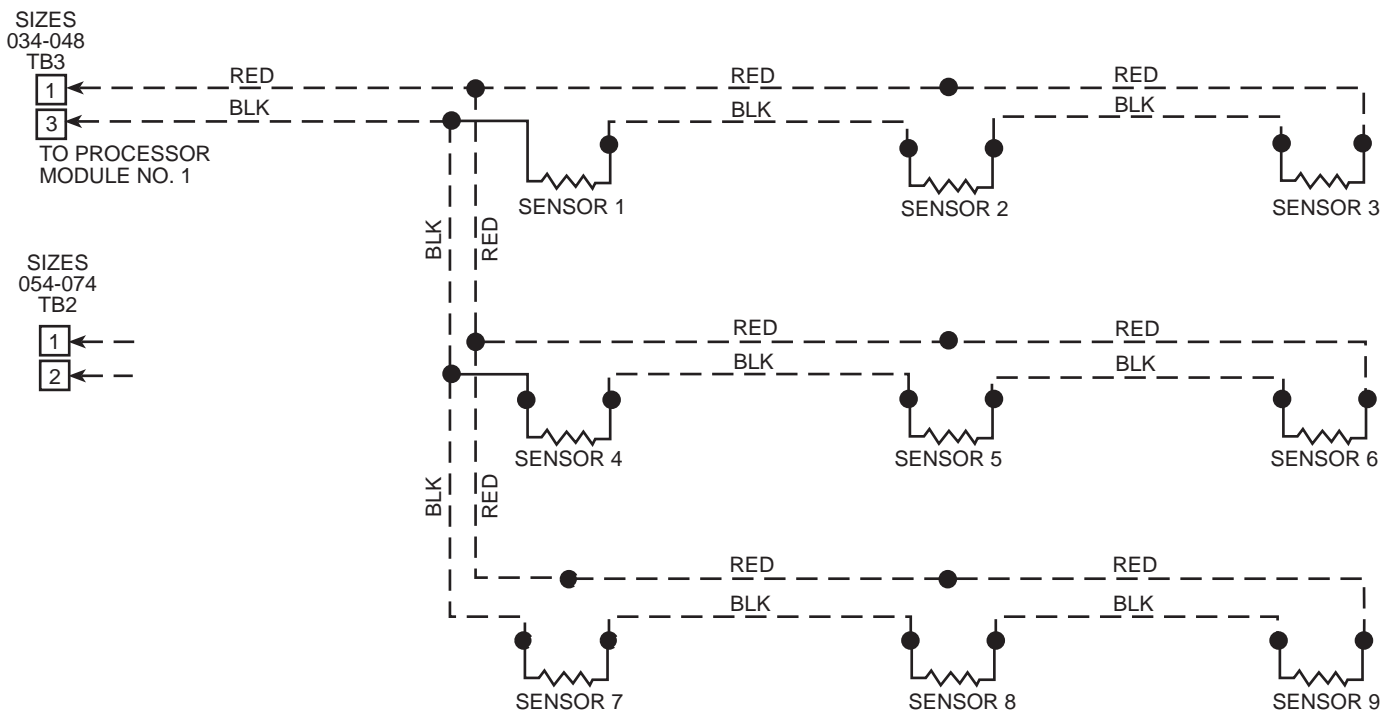
3 = Ratio for reset (F) (fixed parameter)

**Table 4 — Thermistor Resistance and Voltage Drop Characteristics**

TEMP (F)	RESISTANCE (Ohms)	VOLTAGE DROP (v)
31.0	16813.8	3.582
32.0	16345.7	3.553
33.0	15892.2	3.523
34.0	15452.7	3.494
35.0	15026.7	3.464
36.0	14613.9	3.434
37.0	14213.6	3.404
38.0	13825.5	3.373
39.0	13449.2	3.343
40.0	13084.2	3.312
41.0	12730.1	3.281
42.0	12386.6	3.250
43.0	12053.3	3.219
44.0	11730.0	3.187
45.0	11416.1	3.156
46.0	11111.5	3.124
47.0	10815.8	3.093
48.0	10528.7	3.061
49.0	10250.0	3.029
50.0	9979.3	2.997
51.0	9716.5	2.965
52.0	9461.3	2.933
53.0	9213.4	2.901
54.0	8972.6	2.869
55.0	8738.6	2.837
56.0	8511.4	2.805
57.0	8290.6	2.772
58.0	8076.1	2.740
59.0	7867.7	2.708
60.0	7665.1	2.676
61.0	7468.3	2.644
62.0	7277.1	2.612
63.0	7091.2	2.581
64.0	6910.6	2.549
65.0	6735.1	2.517
66.0	6564.4	2.486
67.0	6398.6	2.454
68.0	6237.5	2.423
69.0	6080.8	2.391
70.0	5928.6	2.360
71.0	5780.6	2.329
72.0	5636.8	2.299
73.0	5497.0	2.268
74.0	5361.2	2.237
75.0	5229.1	2.207
76.0	5100.8	2.177
77.0	4976.0	2.147
78.0	4854.8	2.117
79.0	4736.9	2.088
80.0	4622.4	2.058



SPACE TEMPERATURE AVERAGING — 4 SENSOR APPLICATION



SPACE TEMPERATURE AVERAGING — 9 SENSOR APPLICATION

**Fig. 26 — Space Temperature Sensor Averaging**

**Demand Limit** — The demand limit function provides a means to limit the cooling capacity of the VAV unit using an external discrete switch function. When enabled by the closure of the external switch, the control will limit the available compressor staging capacity according to user set points established at demand limit potentiometer(s).

The unit controls support two types of demand limit: single-step and 2-step control.

**SINGLE-STEP DEMAND LIMIT** — This function will limit the total compressor staging based on the ratio of the set point potentiometer's wiper arm position to the full scale resistance of the potentiometer. The exact percentage of capacity reduction differs depending on the number of capacity steps.

A field-supplied potentiometer is required for this function. See installation section for specification on potentiometer and field wiring.

**TWO-STEP DEMAND LIMIT** — Two-step demand limit is provided with the installation of the accessory Demand Limit Control Module kit plus installation of 2 field-supplied control switches (SPST-NO each). This accessory control provides for a first step reduction of 50% to 100% of the maximum compressor staging; the second step provides for reduction between 0% and 49%. The exact percentage of capacity reduction differs depending on the number of capacity steps.

When demand limit is active, the LED display will show code 22.

## INSTALLATION

**Single-Step Demand Limit** — A 3-wire 5 to 20 K-ohm potentiometer must be field-supplied and installed. A single-pole normally open switch is also required (field-supplied and -installed). Locate the potentiometer (designated P4) and the switch in a suitable location (external from the unit or in the unit control box).

Connect the potentiometer end terminals to terminals 8 and 9 on control terminal block TB3 (sizes 034-048) or TB4 (sizes 054-074) (see Fig 23). Connect the switch terminals to the potentiometer wiper arm terminal and to terminal 10 on TB3 or TB4.

To enable demand limit function, change DIP switch 5 to position ON. (Disconnect control power before changing DIP switch positions. Reconnect power after all changes have been made.)

Set the potentiometer P4 to desired capacity reduction value.

**Two-Step Demand Limit** — Install the demand limit control module (DLCM) according to the installation instructions provided with the accessory. Disconnect existing leads at connector J3 on the processor board (see instructions) and connect the plug from the DLCM harness to connector J3.

Connect the field input control power wires (from the external control relays) at the terminal strips marked IN1, RTN1, IN2 and RTN2 (see Fig. 24 and 25).

To enable demand limit function, change DIP switch 5 to position ON. (Disconnect control power before hanging DIP switch positions. Reconnect power after all changes have been made.)

Set the potentiometers DLCM-P1 and DLCM-P2 to desired capacity reduction values.

Check the operation of demand limit function by using the Quick Test procedures.

## CONFIGURATION

**Single-Step Demand Limit** — Field-installed potentiometer P4 establishes capacity reduction value for demand limit operation. Set this potentiometer between 0% and 100%. The

exact percentage of capacity reduction differs depending on the number of capacity steps.

**Two-Step Demand Limit** — Potentiometer P1 and P2 (located on the accessory demand limit control module) establish the capacity reduction values for each step of demand limit. Set potentiometer DLCM-P1 between 50% and 100%. Set potentiometer DLCM-P2 between 0% and 49%. The exact percentage of capacity reduction differs depending on the number of capacity steps.

## OPERATING SEQUENCE

**Single-Step Demand Limit** — If the field control switch to the wiper arm terminal is open, all capacity stages will be available (no demand limit in effect). When the field control switch is closed, the compressor cooling capacity is reduced by the amount set on potentiometer P4.

When demand limit is in effect, the LED display will show code 22. If a potentiometer setting or input is out of range, the control will terminate the demand limit function and show code 84 at the display LED.

**Two-Step Demand Limit** — If the field control switches are both open (no power supplied to the Demand Limit Control Module), all capacity stages will be available (no demand limit in effect). When control power is supplied to terminal IN1 only (field switch SW1 closes), the first step of the demand limit is energized and the compressor cooling capacity is reduced by the amount set on potentiometer DLCM-P1. When control power is supplied to terminal IN2 (field switch SW2 closes), the second step of the demand limit is energized and compressor cooling capacity is reduced by the amount set on potentiometer DLCM-P2.

When demand limit is in effect, the LED display will show code 22. If a potentiometer setting or input is out of range, the control will terminate the demand limit function and show code 84 at the display LED.

**Smoke Control Modes** — It is common practice to use rooftop units for aid in building smoke control in the event of a building fire. The available functions include: Fire Shutdown, Pressurization, Evacuation, and Smoke Purge. These functions are enhanced when multiple rooftop units are used to zone a building.

Implementation of the various Smoke Control modes on these units requires the installer to modify the unit wiring to add contacts (via either manual switches or relays) that will selectively interrupt and override standard factory control sequences. See Table 5.

**FIRE SHUTDOWN MODE** — Fire Shutdown mode terminates all unit operation (cooling, heating, supply fan and power exhaust). This mode prevents recirculation of contaminated air back into the space or the admission into the space of unsuitable outside air.

**PRESSURIZATION MODE** — Pressurization mode is intended to keep smoke out of a zone. Factory-installed optional economizer is required for this function. Pressurization is accomplished by:

- opening the economizer (option)
- running the supply fan (optional inlet guide vanes open or optional VFD (variable frequency drive) at normal duct static pressure set point)
- closing the power exhaust dampers (if installed as option or accessory)
- shutting off the power exhaust fans (if installed as option or accessory)

This allows the space to be overpressurized relative to adjacent zones and prevents or slows entry of smoke into this space from adjacent zones.

**EVACUATION MODE** — Evacuation mode removes smoke or undesirable air from interior spaces without reintroducing unsuitable air. Factory-installed, optional economizer with optional or accessory power exhaust are required for this function. Evacuation is accomplished by:

- turning supply fan off
- opening the economizer (option required for this function)
- running the exhaust fans (must be provided via option or accessory)
- opening the exhaust dampers

**SMOKE PURGE MODE** — Smoke Purge mode removes smoke from the interior spaces and replaces it with fresh outside air. Factory-option economizer with optional or accessory power exhaust are required for this function. Smoke purge is accomplished by:

- turning supply fan on
- opening the economizer (option required for this function)
- running the exhaust fans (must be provided via option or accessory)
- opening the exhaust dampers

**INSTALLATION** — To enable one or more of the possible smoke control modes available with these units, determine the switches required for the desired mode(s) from Table 6, field-supply and install the appropriate switches and field wire per Fig. 27. Switch functions are shown in Table 7.

**Table 5 — Smoke Control Modes**

FUNCTION	MODE			
	Fire Shutdown	Pressurization	Evacuation*	Smoke Purge*
Supply Fan	Off	On	Off	On
IGV/VFD†	—	Open/On	—	Open/On
Economizer	Closed	Open	Open	Open
Return Air Damper	Open	Closed	Closed	Closed
Exhaust Fans	Off	Off	On	On
Exhaust Damper	Closed	Closed	Open	Open

**LEGEND**

- IGV — Inlet Guide Vane
- VAV — Variable Air Volume
- VFD — Variable Frequency Drive

\*Power exhaust option/accessory required for this mode.  
 †Applicable to VAV units with appropriate options.

**CONFIGURATION** — No set points required for Smoke Control modes. Modes are activated by energizing all switches appropriate for each Smoke Control mode.

**OPERATING SEQUENCE**

**Fire Shutdown** — At command from the field switches (see Table 6), all unit operation (cooling, heating, supply fan and power exhaust) will terminate.

**Pressurization** — At command from the field switches for Pressurization mode (see Table 6):

1. Economizer dampers will open
2. The HIR function will energize, opening room terminals to full-open (heating) positions.
3. Supply fan will run. (If equipped with IGV: control vanes will open. If equipped with VFD: the VFD will control to duct static set point or best available with all terminals open.)
4. Power exhaust dampers (if equipped) will close.
5. Power exhaust fans (if equipped) will turn off.

**Evacuation** — At command from the field switches for Evacuation mode (see Table 6):

1. Supply fan will turn off.
2. Economizer dampers will open.
3. Exhaust fans will run at maximum capacity.
4. Exhaust dampers will open.

**Smoke Purge** — At command from the field switches for Smoke Purge mode (see Table 6):

1. Economizer dampers will open.
2. The HIR function will energize, opening room terminals to full-open (heating) positions.
3. Supply fan will run. (If equipped with IGV: Control vanes will open. If equipped with VFD: the VFD will control to duct static set point or best available with all terminals open.)
4. Exhaust fans will run at maximum capacity.
5. Exhaust dampers will open.

**Table 6 — Smoke Control Switches Required for Each Mode**

FIRE SHUTDOWN	PRESSURIZATION	EVACUATION (Modulating Power Exhaust)	SMOKE PURGE
SW-1	SW-1	SW-1	SW-1
SW-2	SW-2	SW-2	SW-2
	SW-4	SW-3	SW-3
	SW-5	SW-5	SW-4
	SW-6	SW-6	SW-9A/B
	SW-9A/B	SW-7	
		SW-8	

NOTE: All switches are shown in “as installed” (power OFF or deenergized) position. In these positions, none of these modes will be activated; normal unit operation is permitted by the base unit controls. To initiate any mode, all switches listed under this mode in the table must be energized, causing the depicted contact position to change from depicted positions to energized positions. Switches may be manually or electrically operated.

**Table 7 — Switch Functions**

SWITCH NUMBER	CONFIGURATION	VOLTAGE	FUNCTION
SW-1	N.C.	115	Deenergize 115-v (OFC, Comp, IFC, Electric Heaters)
SW-2	N.C.	115	Deenergize TRAN7 (Process Board)
SW-3	N.O.	24	Energize EOR (Open Economizer Outside Air Dampers)
SW-4	N.O.	115	Energize IFC and CR-3 (IGV/VFD)
SW-5	N.C.	115	Isolate IFC and PEC for Separate Operation
SW-6	N.O.	115	Energize PEC (Power Exhaust)
SW-7	N.O.	24	Open PED at DPS
SW-8	N.C.	24	Block Auto-Close at DPS (Due to Low BP)
SW-9A/B	A: N.O. B: N.C.	115 max	Single Room Terminals to Open (HIR1)

**LEGEND**

- BP — Building Pressure
- DPS — Differential Pressure Switch
- EOR — Economizer Open Relay
- HIR — Heat Interlock Relay
- IFC — Indoor Fan Contactor
- IGV — Inlet Guide Vane
- N.C. — Normally Closed
- N.O. — Normally Open
- PEC — Power Exhaust Contactor
- PED — Power Exhaust Damper
- OFC — Outdoor Fan Contactor
- VFD — Variable Frequency Drive

**Air Pressure Tubing** — Before options such as inlet guide vanes (IGV), variable frequency drive (VFD), and/or modulating power exhaust can operate properly, the pneumatic tubing for pressure sensing must be installed. Use fire-retardant plenum tubing (field-supplied). Tubing size depends on type of control device (see Table 8 below). Tubing must be run from the appropriate sensing location (in the duct or in the building space) to the control device location in the unit.

**Table 8 — Tubing Size**

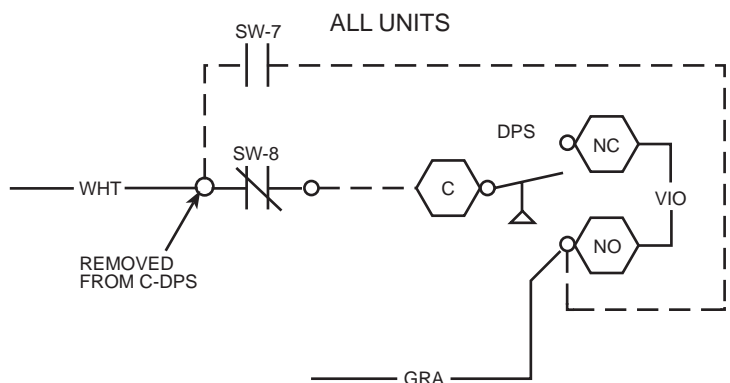
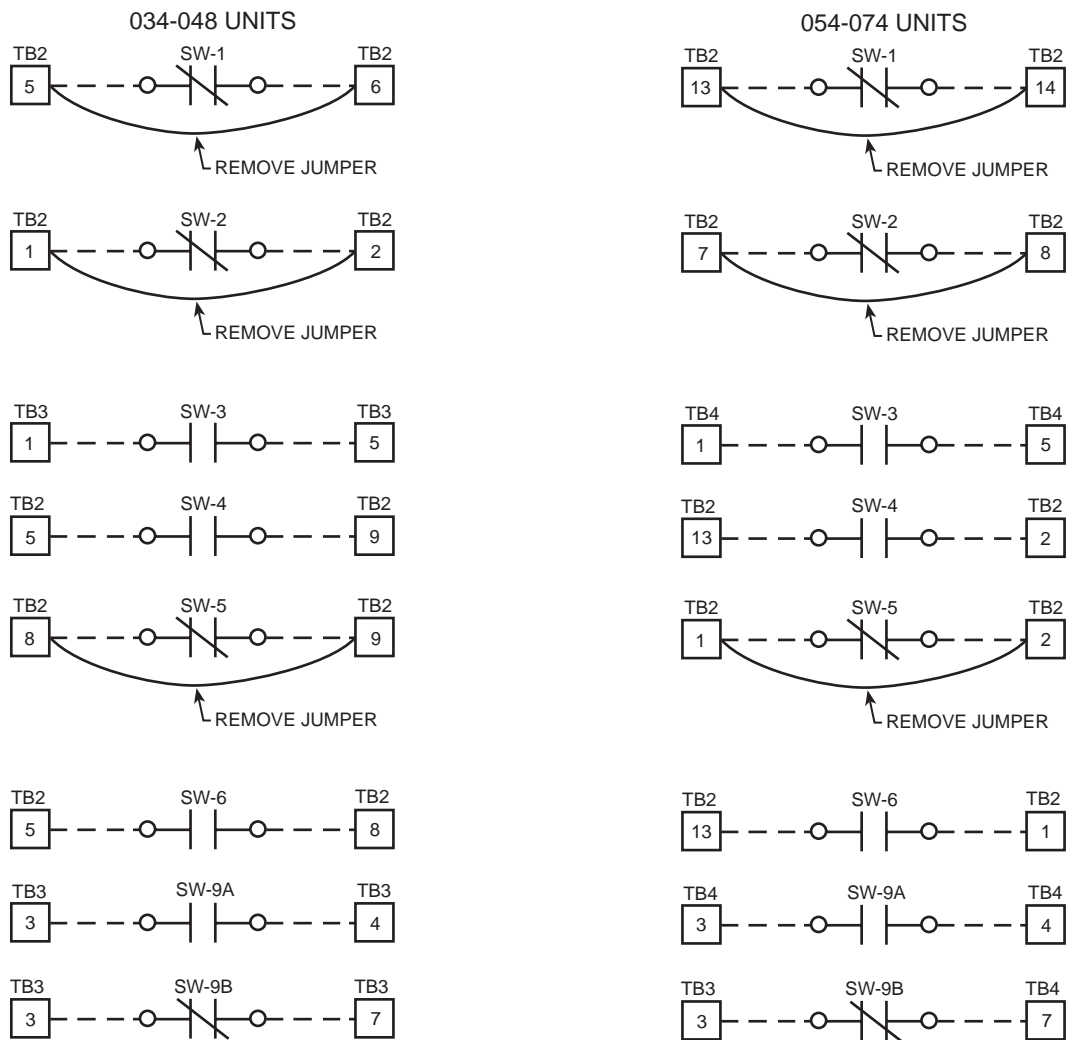
OPTION	UNITS	NOMINAL TUBE SIZE (in.)
Inlet Guide Vanes (IGV)	ALL	3/8
Variable Frequency Drive (VFD)	ALL	1/4
Modulating Power Exhaust	FK,FKX,JK,JKX	3/8

**INLET GUIDE VANES** — The tubing for the duct pressure (DP) control option should sample supply duct pressure about 2/3 of the way out from the unit in the main trunk duct, at a location where a constant duct pressure is desired.

The inlet guide vanes are controlled by a differential pressure switch (DPS). On sizes 034-048, the DPS is located in the auxiliary control box at the economizer end of the unit (see Fig. 28). On sizes 054-074, the DPS is located in the supply fan section. See Fig. 29. Use a nominal 3/8-in. plastic tubing.

**VARIABLE FREQUENCY DRIVE** — The tubing for the duct pressure (DP) control option should sample supply duct pressure about 2/3 of the way out from the unit in the main trunk duct, at a location where a constant duct pressure is desired.

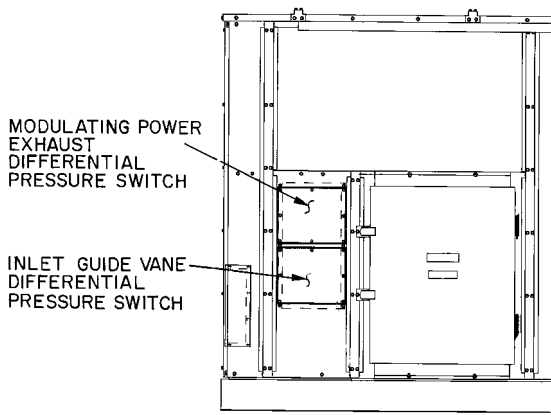
The duct pressure is sensed by a pressure transducer. The pressure transducer output is directed to the VFD. On 034-048 units the DP transducer is located in the auxiliary control box. On 054-074 units, the DP transducer is located in the supply fan section. See Fig. 29. Use a nominal 1/4-in. plastic tubing.



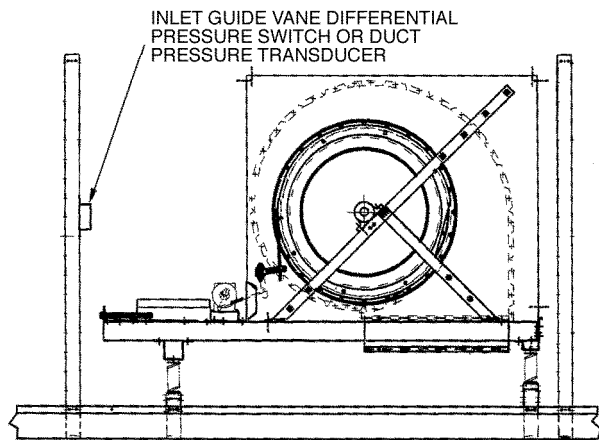
LEGEND

- DPS — Differential Pressure Switch
- SW — Switch
- TB — Terminal Block

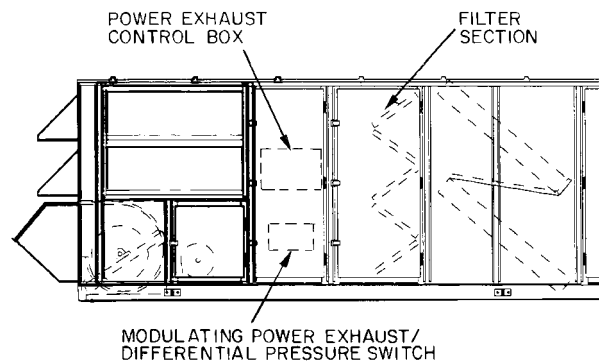
Fig. 27 — Smoke Control Wiring



**Fig. 28 — Modulating Power Exhaust and Inlet Guide Vane Differential Pressure Switch (Sizes 034-048)**



**Fig. 29 — Inlet Guide Vane Differential Pressure Switch or Duct Pressure Transducer (Sizes 054-074)**



**Fig. 30 — Modulating Power Exhaust Differential Pressure Switch (Sizes 054-074)**

**MODULATING POWER EXHAUST** — The tubing for the building pressure control (achieved via the Modulating Power Exhaust option) should sample building pressure in the area near the entrance lobby (or other appropriate and sensitive location) so that location is controlled as closely to design pressures as possible.

A differential pressure switch (DPS) is used to control the actuator on the modulating discharge damper in exhaust fan no. 1. The building pressure (BP) DPS is located in the auxiliary control box of the unit. See Fig. 28 and 30. Use a nominal 3/8-in. plastic tubing.

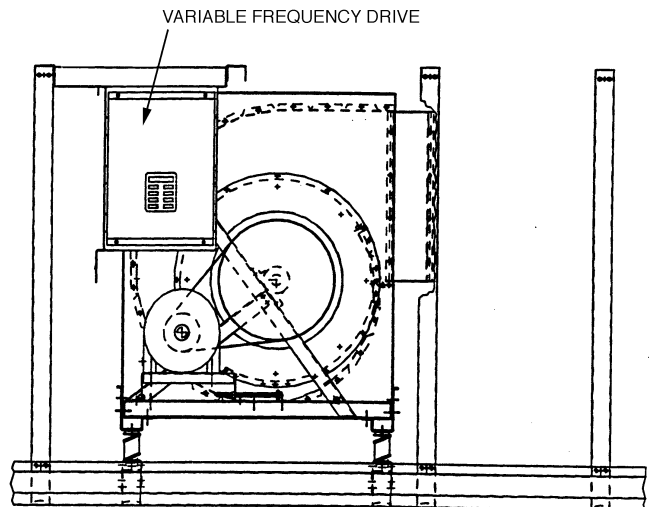
For instructions on adjusting BP control set points, refer to Service, Adjustments section in this book.

**Variable Frequency Drive (VFD)** — The optional VFD is used to modulate supply fan airflow to maintain duct static pressure on VAV applications. The VFD is located in the supply fan section (see Fig. 31 and 32), and can be accessed by opening the fan section access door.

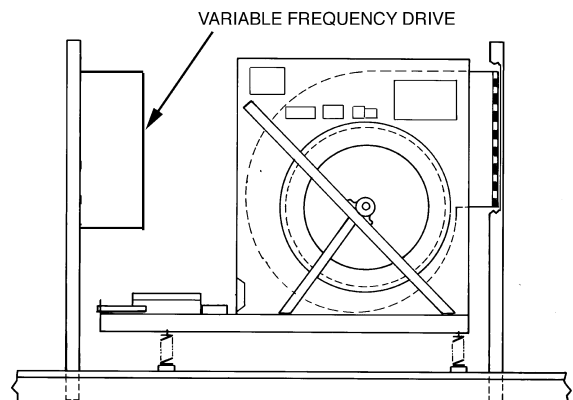
The unit is supplied with a pressure transducer capable of measuring from 0.0 to 5.0 in. wg. The pressure transducer will send a 4 to 20 mA signal to the VFD to modulate the speed of the indoor fan motor to precisely control the fan to the desired static pressure set point. The VFD is factory set at 2.5 in. wg duct static pressure. Refer to the Operating Sequence section for more information on the VFD.

The VFD has been programmed and wired at the factory for this application. No further adjustments (except for Duct Static Pressure Set Point) should be necessary at start-up. See Fig. 33 for VFD arrangement (including keypad display unit). Factory jumper wire configurations are shown in the Supply Fan Control with VFD option section on page 26.

A separate service manual for the factory-installed VFD is supplied with each unit. Refer to the VFD manual for more information on the VFD controls.



**Fig. 31 — Variable Frequency Drive, Sizes 034-048**



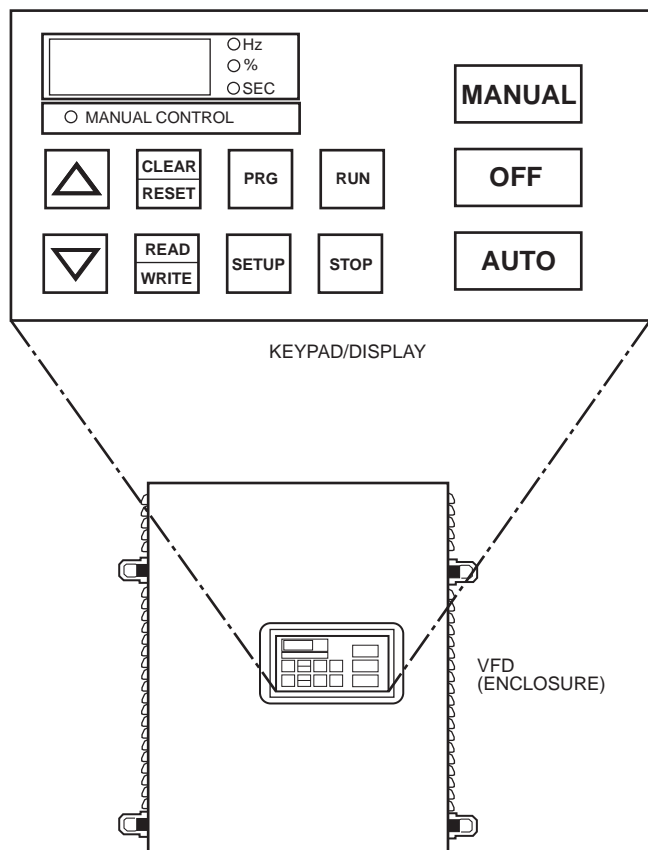
**Fig. 32 — Variable Frequency Drive, Sizes 054-074**

## START-UP

### Initial Check

**IMPORTANT:** Do not attempt to start unit, even momentarily, until all items on the Controls Start-Up Checklist (in installation instructions) and the following steps have been completed.

1. Verify unit has been installed per the Installation Instructions included in the unit installation packet.
2. Verify that all auxiliary components (sensors, controls, etc.) have been installed and wired to the unit control boxes per these instructions, the unit Installation Instructions, and the unit wiring label diagrams.
3. Verify that air pressure hoses (static, duct, etc.) are properly attached, routed, and free from pinches or crimps that may affect proper control operation.
4. Set any control configurations that are required (field-installed accessories, etc.). The unit is factory configured for all appropriate factory-installed options with the applicable controls programmed to the default values.
5. Check and adjust unit set points. See Table 9.
6. Check tightness of all electrical connections.
7. Perform quick test (see Quick Test Program section on page 28).



**Fig. 33 — Variable Frequency Drive Keypad**

**Table 9 — Potentiometer Inputs and Ranges**

POTENTIOMETER	DESCRIPTION	LOCATION	CONTROL VALID RANGE	DEFAULT VALUE
P1	Leaving Air Set Point	Display Board	45 to 70 F	45 F if $-22\text{ F} < P1 < 45\text{ F}$ 70 F if $P1 > 70\text{ F}$ OR IF $P1 < -22\text{ F}$
P2*	Economizer Position	Economizer Motor	0 to 100%	None (0 if P2 is bad)
P3	Reset Limit	Accessory Board	0 to 80 F	None (limited to 70 F maximum)
P4†	Demand Limit, Single-Step	Main Control Box	0 to 100%	None
DLCM-P1	Demand Limit, 2-Step	DLCM Board	50 to 100%	None
DLCM-P2		DLCM Board	0 to 49%	None
P5*	Minimum Economizer Position	Accessory Board	0 to 100%	None
P6	Warm-Up Set Point	Accessory Board	40 to 80 F	40 F if $0^\circ\text{ F} < P6 < 40\text{ F}$ OR IF $P6 < 95\text{ F}$ OR IF $P6 < 0$ 80 F if $80\text{ F} < P6 < 95\text{ F}$
P7**	Reset Temperature	Reset Board	40 to 100 F	None

\*Optional factory-installed economizer is required. Potentiometer P2 is not a set point.

†Accessory two-step demand limit module is required (which has 2 potentiometers), or a 5 to 20 Kohm field-supplied potentiometer is required for single-step demand limit.

\*\*Accessory temperature reset is required.

NOTE: Potentiometers P1-P6 input data to pin terminal connector J3. Potentiometer P7 inputs data to pin terminal connector J7.

**Configuration Header** — The configuration header is a series of 8 small wires that are broken (open circuit) or unbroken (closed circuit) in a pattern to indicate several unique characteristics of the unit. The configuration header is factory set and should not be changed; changing the factory setting may cause the unit to malfunction.

Before start-up, visually check the configuration header against the factory setting for the unit size. See Table 10 for factory settings. See Table 11 for purpose for each jumper.

<b>⚠ CAUTION</b>
Disconnect control power before changing the settings of the DIP switches. To disconnect control power, open the control circuit breaker.

**DIP SWITCH NO. 1** — Supply Air Set Point (SASP) Reset Type. Factory setting is OFF. Do not change.

**DIP Switch NO. 2** — SASP Reset Enabled. Factory setting is OFF (no SASP reset enabled). If SASP reset has been installed, enable it by changing switch position to ON.

**DIP SWITCH NO. 3** — Economizer option. If economizer option has been installed, this switch will be ON. If there is no economizer installed, this switch will be OFF. Confirm setting per Table 10. Change only if in error.

**DIP SWITCH NO. 4** — Morning Warm-Up. For 48FK,JK models, this switch will be ON (morning warm-up enabled). For 50FK,JK units with factory-installed electric heaters, this switch will be ON. For all other units, this switch will be OFF. If accessory electric heaters are installed (for 50FK,JK without plenum option), change this switch to ON.

**DIP SWITCH NO. 5** — Demand Limit. Factory setting is OFF (demand limit not enabled). If Demand Limit (single-step or 2-step accessory) has been installed, change this switch to ON.

**DIP SWITCHES NO. 6 AND NO. 7** — Unloader Configuration. These are factory set to match unit size. Confirm settings per Table 12. Change only if in error.

**Table 10 — Configuration Header and DIP Switch Factory Settings**

JUMPER OR SWITCH NO.	UNIT SIZES 034-038, 048-074		UNIT SIZE 044	
	Header Position	Switch Position	Header Position	Switch Position
1	□	Off	□	Off
2	■	Off	■	Off
3	■	On/Off*	■	On/Off*
4	□	On/Off*	□	On/Off*
5	□	Off	□	Off
6	■	Off	■	On
7	□	On	□	Off
8	■	Off	■	Off

**LEGEND**

- DIP** — Dual, In-Line Package
- — Broken Jumper (open circuit)
- — Unbroken Jumper (closed circuit)
- \*Depending on factory-installed options or field-installed accessories.

**Table 11 — Configuration Header Jumpers**

JUMPER NUMBER	FUNCTION	FACTORY SETTING	MEANING
1,2	Unit Type	□ ■	VAV Rooftop Unit
3	Qty Compressors	■ □ □	2 Compressors
6	Expansion Valve	■	TXV
7	Power Frequency	□	60 Hz
8	Not Used	■	No Significance

**LEGEND**

- TXV** — Thermostatic Expansion Valve
- VAV** — Variable-Air Volume
- — Broken Jumper (open circuit)
- — Unbroken Jumper (closed circuit)

**DIP Switches** — The DIP switches configure the unit for several factory-installed options and field-installed accessories, plus factory unloaders. The DIP switches are located under a plastic enclosure which must be removed for access. See Fig. 1. The switches can be field adjusted. Switches must only be adjusted when control power is deenergized. See Table 12 for DIP switch purposes and Table 10 for factory settings of the switch positions.

**Table 12 — DIP Switches**

SWITCH NO.	FUNCTION	SWITCH POSITION*	MEANING
1	Reset Mode	Off	Space or Outdoor-Air Reset (DO NOT CHANGE)
2	Reset Select	On Off	Reset Used Reset Not Used
3	Economizer	On Off	Enable Economizer Disable Economizer†
4	Morning Warm-Up	On Off	Enable Morning Warm-Up** Disable Morning Warm-Up**
5	Demand Limit	On Off	Enable Demand Limit Disable Demand Limit
6,7	Unloaders	Off, Off On, Off Off, On	No Unloaders 1 Unloader 2 Unloaders
8	Not Used	Off	No Significance

**DIP** — Dual, In-Line Package

- \*Control circuit breaker must be off before changing the setting of the DIP switch.
- †No economizer.
- \*\*And/or electric heat (50FK,JK units without plenum only).

**Adjusting Set Points** — Set points for unit operation are established via potentiometer settings. Set points for Supply Fan controls are set at the VFD keypad (if installed) or at the IGV differential pressure switch (DPS1) (if IGV option installed). Set points for modulating power exhaust (option or accessory) are set at the differential pressure switch (DPS2).

**Potentiometers** — All of the set point potentiometers must be set before the unit is started in order for the unit to function properly. Each of the potentiometers has a valid range that is used by the control. The valid range is defined as the potentiometer's resistance value that the control will not consider to be in error. This is usually between 10% and 90% of the potentiometer's total resistance. The control has been programmed to accept an operational range for the potentiometer, which may not be the same as the valid range.

Potentiometer inputs and ranges are summarized in Table 9. Information on individual set point potentiometers (including function, location and range data) are shown below:

**SUPPLY AIR SET POINT (Leaving-Air Temperature) (P1)** — This potentiometer establishes the set point for cooling cycle operation of the VAV unit. The VAV control uses a valid control range of 45 to 70 F, and the potentiometer has a valid range of -22 to 70 F. If the set point is between -22 and 45 F, the control will use a value of 45 F. If the set point is outside the valid range (less than -22 F or greater than 70 F), an alarm condition will be signaled and a default value of 70 F will be used.

**ECONOMIZER MINIMUM POSITION (P5)** — This potentiometer specifies the minimum opening position for the optional economizer during running periods. It has both a valid range and an operational range of 0 to 100%.

**SASP RESET TEMPERATURE (P7)** — This potentiometer establishes the space temperature at which the control will initiate the reset of the SASP (i.e., the unit control begins to raise the base SASP, to prevent overcooling of the space). The potentiometer has a valid range of 40 to 100 F. Refer to Space Temperature Reset section on page 16 for further discussion of SASP Reset operation.

**RESET LIMIT (P3)** — Used in conjunction with P7 potentiometer, this potentiometer establishes the maximum temperature for the modified SASP value during the Reset function. This potentiometer has a valid range of 0° to 80 F.

**DEMAND LIMIT, SINGLE-STEP (P4)** — This potentiometer establishes the maximum amount of compressor capacity permitted by the unit control when single-step demand limit operation is implemented (by closing contact set to potentiometer wiper arm). This potentiometer is field-supplied and -installed and will be located in the main control box. The valid range is 0% to 100%, which is also the operational range.

If the wiper arm is open, all capacity stages can be used. When the wiper arm is closed, the capacity is reduced by the amount set on potentiometer P4.

**DEMAND LIMIT, 2-STEP** — The accessory 2-step demand limit control is a 2-potentiometer system. The demand limit control board (DLCM) accessory board is

field-installed in the main control box; the 2 control potentiometers are located on the DLCM. Potentiometer DLCM-P1 establishes the maximum amount of compressor capacity available when SW1 is closed and has a valid range is 50% to 100%. Potentiometer DLCM-P2 establishes the maximum amount of compressor capacity available when SW2 is closed and has a valid range is 0% to 49%.

If no power is supplied to the DLCM, all capacity stages can be used. When power is supplied to terminal IN1 only, the first step of demand limit control is energized and the capacity is reduced by the amount set on potentiometer P1. When power is supplied to IN2 (or IN1 and IN2), the capacity is reduced by the amount set on potentiometer P2.

**MORNING WARM-UP (P6)** — This potentiometer establishes the set point temperature for the Morning Warm-Up function. This is the temperature at which the morning warm-up sequence is terminated and VAV cooling operation begins. The valid control range is 0° to 95 F, but the control is programmed to accept a range of 40 to 80 F. If the set point is between 0° and 40 F, the control will use a value of 40 F. If the set point is between 80 and 95 F, the control will use a value of 80 F. If the set point is outside the valid range (less than 0° F or greater than 95 F, an alarm condition will be signaled and a default value of 40 F will be used.

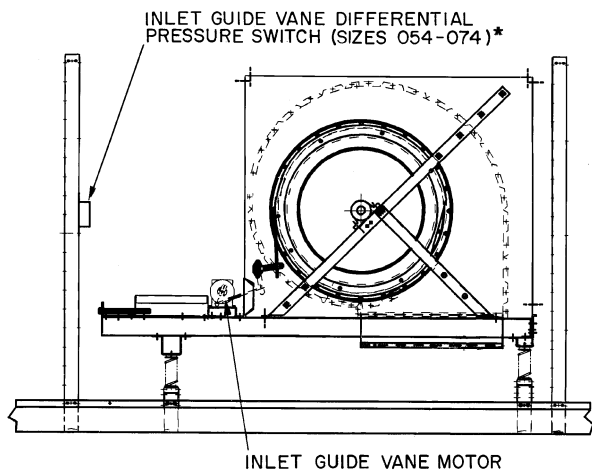
**Supply Fan Control with IGV Option** — The inlet guide vane option will modulate the supply fan airflow in order to maintain the static pressure in the supply duct. The set point for duct static pressure is established at the differential pressure switch for the IGV control.

**SIZE 034-048 UNITS** — The inlet guide vane differential pressure switch is located in the auxiliary control box mounted in the corner under the side air hood that is next to the access door marked FILTER SECTION. To gain access to this control box, remove the auxiliary control box cover. When replacing cover, be sure to properly secure it in order to prevent water from being drawn into the unit. See Fig. 34 and 35.

**SIZE 054-074 UNITS** — The inlet guide vane differential pressure switch is mounted on an upright located behind the evaporator-fan motor. See Fig. 34 and 35.

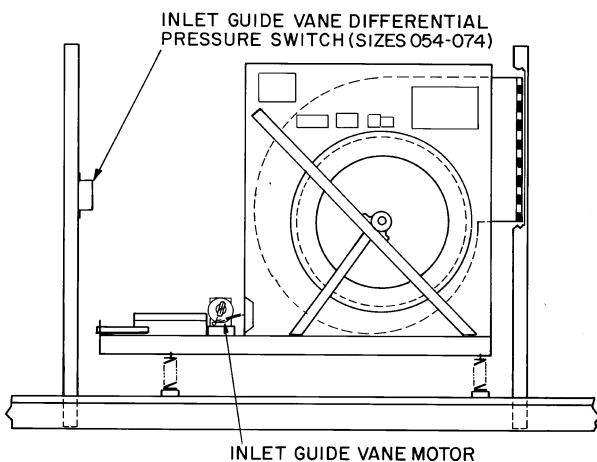
The IGV differential pressure switch has an adjustable set point range of 1.1 to 3.5 in. wg. and a factory setting of 1.9 in. wg.

To adjust set point, turn set point adjusting screw (see Fig. 36) clockwise to decrease set point and counterclockwise to increase set point. This switch also has an adjustable null span. The null span is the pressure change that can be made without contacts opening or closing. It is adjustable from 0.06 in. wg to 0.17 in. wg when set point is at minimum position (1.1 in. wg) and 0.11 in. wg to 0.31 in. wg when set point is at maximum position (3.5 in. wg). To adjust null span, turn a null adjusting screw (Fig. 36) clockwise to decrease span and counterclockwise to increase span. All switches leave factory with null span set at maximum position. The smaller the null span, the closer the pressure will be maintained to desired set point.



\*The inlet guide vane differential pressure switch for the 034-048 units is located in the back of the unit in the auxiliary control box. Its location is not shown in this figure.

**Fig. 34 — Inlet Guide Vane Motor, 50FK,JK034-074 Units**



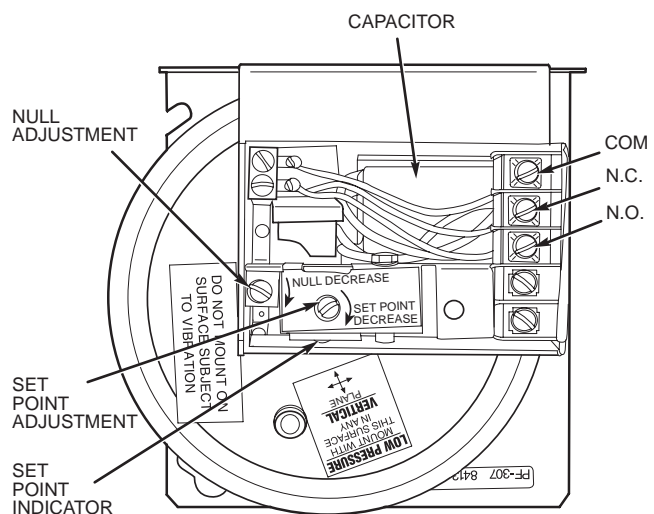
\*The inlet guide vane differential pressure switch for the 034-048 units is located in the back of the unit in the auxiliary control box. Its location is not shown in this figure.

**Fig. 35 — Inlet Guide Vane Motor, 48FK,JK, 50FY,JY, and 50FKX,FJX034-074 Units**

**Supply Fan Control with VFD Option** — The VFD option will modulate Supply Fan motor (and thus wheel) speed to maintain the static pressure in the ductwork. Set point for the VFD option is set at the VFD, using the display keyboard on the front of the VFD enclosure.

**NOTE:** The VFD will always provide the proper phase sequence to the indoor-fan motor. The indoor-fan motor operates in proper rotation regardless of the phase sequence to the unit. If, upon start-up, the outdoor fans operate backwards but the indoor fan operates in the correct direction, reverse any two leads to the main terminal block. All fans will then operate in the correct direction.

To set the duct static pressure, perform the following steps. The factory setting is 2.5 in. wg. The duct transducer has a range from 0 to 5 in. wg. The transducer output is 4 to 20 mA, therefore, 0 to 5 in. wg is proportional to the 4 to 20 mA and must be expressed to the VFD in terms of percentage of the frequency range. Refer to Table 13. The set point value is a percentage of the maximum output frequency. Locate the duct static pressure closest to that desired and use the corresponding set point value. If necessary, interpolation between duct static pressures is permissible.



**COM** — Common  
**N.C.** — Normally Closed  
**N.O.** — Normally Open

**Fig. 36 — Differential Pressure Switch for Inlet Guide Vane and Static Pressure Control Option and Modulating Power Exhaust Option**

To set the VFD, the VFD must be powered up; however, since it is located near the indoor air fan, operation of the fan is not desirable. To disable the fan, perform the following procedure:

1. Open the indoor fan circuit breaker.

**⚠ WARNING**

A high voltage potential can exist with the indoor fan circuit breaker open. The charge LED, located in the top right-hand corner of the VFD control board, will indicate charged capacitors. **DO NOT TOUCH** internal high voltage parts if the LED is lit.

2. Remove the jumper between CC and ST on the terminal strip of the VFD (see Fig. 37).
3. Close the indoor fan circuit breaker. The VFD now is powered but the fan will not operate.
4. An accessory remote display kit and the VFD handheld keypad display should be used in conjunction with the supplied VFD manual to troubleshoot any problems with the VFD. To manually operate the VFD, connect the cable from the accessory display kit to the connector on the VFD enclosure. Carefully route the cable to the access door and step outside the unit and close the access door on the cable.
5. The VFD keypad and display will be used to enter the set point. To access this field, press the “PRG” key until the display reads “S.PrG” (Speed Group Parameters). Press the arrow key until “Sr1” is displayed. This is the VFD set point listed in Table 13.
6. Press the “READ/WRITE” key. The set point value will be displayed. Use the up-arrow or down-arrow key to adjust the set point value to the value desired.
7. Press the “READ/WRITE” key again to enter the new value.

**Table 13 — VFD Supply Air Pressure Set Point**

PRESSURE (in. wg)	CONTROL (mA)	VFD SET POINT
0	4.0	0
0.25	4.8	3
0.50	5.6	6
0.75	6.4	9
1.00	7.2	12
1.25	8.0	15
1.50	8.8	18
1.75	9.6	21
2.00	10.4	24
2.25	11.2	27
2.50	12.0	30
2.75	12.8	33
3.00	13.6	36
3.25	14.4	39
3.50	15.2	42

VFD — Variable Frequency Drive

8. Check the factory default values.

**IMPORTANT:** The Carrier factory default values for the VFD may be different than the default values of the manufacturer. Refer to the Carrier literature when checking default values. The following default values have been changed from the manufacturer settings to more closely match the VFD operation to a Carrier VAV unit.

SETUP PARAMETERS (Item 6, Point 1, Output Frequency) — The default value should be 20.

JUMP FREQUENCY GROUP (Item 7, PID Set Point Control Select) — The default value is 1.

JUMP FREQUENCY GROUP (Item 8, Proportional Gain) — The default value is 100.

JUMP FREQUENCY GROUP (Item 9, Integral Gain) — The default value is 50.

SPEED GROUP PARAMETERS (Item 2, Multi-Speed Run Frequency No. 1) — The default value is 30.

SPEED GROUP PARAMETERS (Item 2, Fire Speed Override Frequency) — The default value is 60.

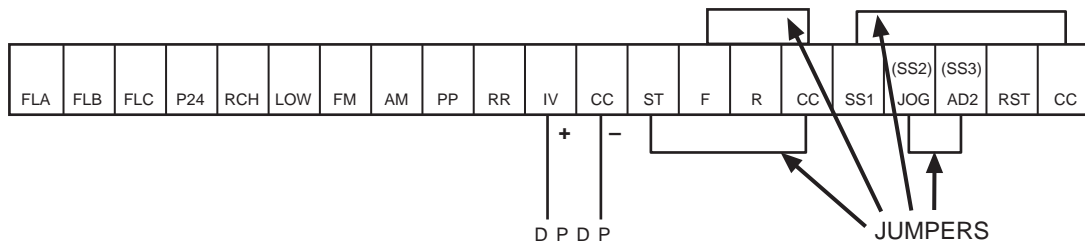
9. When finished operating the VFD, disconnect the accessory display cable.
10. Open the indoor fan circuit breaker.
11. Replace the jumper between CC and ST on the terminal strip of the VFD.
12. Close the indoor fan circuit breaker; the VFD now is powered and the fan will operate.

**Modulating Power Exhaust (Option or Accessory)** — The Modulating Power Exhaust system will maintain space pressure by modulating power exhaust fan no. 1 and staging power exhaust fan no. 2. Building pressure set point is established at the modulating power exhaust differential pressure switch (DPS).

SIZE 034-048 UNITS — The modulating power exhaust differential pressure switch is located in the auxiliary control box mounted in the corner next to the power exhaust motor door. To gain access to this control box, remove the auxiliary control box cover. When replacing cover, be sure to properly secure it in order to prevent water from being drawn into the unit. See Fig. 28.

SIZE 054-074 UNITS — The modulating power exhaust differential pressure switch is mounted below the auxiliary control box next to the access door labeled FILTER SECTION. See Fig. 30.

**DIFFERENTIAL PRESSURE SWITCH** — The modulating power exhaust DPS has a set point range of 0.5 in. wg to -0.5 in. wg. Factory setting is +0.1 in. wg. To adjust set point, turn set point adjusting screw (see Fig. 36) clockwise to decrease set point and counterclockwise to increase set point. This switch also has an adjustable null span. The null span is the pressure change that can be made without contacts opening or closing. It is adjustable from 0.06 in. wg to 0.14 in. wg when set point is at minimum position (-0.5 in. wg) and 0.07 in. wg to 0.14 in. wg when set point is at maximum position (+0.5 in. wg). To adjust null span, turn null adjusting screw (Fig. 36) clockwise to decrease span and counterclockwise to increase span. All switches leave factory with null span set at maximum position. The smaller the null span, the closer the pressure will be maintained to desired set point.



DP — Duct Pressure Transducer

NOTE: Terminal strip is located inside the VFD at the bottom.

**Fig. 37 — VFD Factory-Installed Jumpers**

## START UNIT

To start unit:

1. Close the unit-mounted ON/OFF switch (located in the main control box).
2. Close the field-supplied and -installed timeclock (or control) switch (contacts located at Terminals 1 and 2 (TB3 for 034-048, TB4 for 054-074).

**IMPORTANT:** The field-supplied and installed switch (or timeclock) **MUST BE CLOSED** to put unit in Occupied mode. Unit **WILL NOT START** until this is accomplished.

3. Initialization mode begins (see Operating Information section on page 31 for complete description of sequences and display codes).
4. Run Quick Test. If the display button is pressed during the initialization mode period, the unit will run its self-diagnostic routine. When this is in effect, an **88** will appear in the display screen. Refer to Quick Test Program section below, for instructions on completing the Quick Test program.

### Quick Test Program — Turn on power to unit.

**IMPORTANT:** The field-supplied switch (or timeclock) must be closed to put unit into the occupied mode.

The quick test program utilizes the 2-digit LED display (see Fig. 6) on the set point board to show status of all input and output signals to microprocessor. Display action and quick test procedures are described below.

The quick test program is a 33-step program that provides a means of checking all input and output signals of controls prior to unit start-up. This check ensures that all control options, thermistors, and control switches are in proper working order.

When unit control circuit is switched to occupied mode, a **20** will appear on the display. Immediately press display button once. An **88** will appear on the display and alarm light on display board will be energized. This indicates that control system is ready to run quick test program.

**IMPORTANT:** Do not allow unit control circuit to remain energized with **20** showing on display for more than 2 minutes. If display button is not pressed within this time period, control will attempt to start unit.

For each step of the 33-step program, display button must be pressed twice. On first press, step number is displayed; second press initiates required action and appropriate code is displayed.

**NOTE:** The step number is a numeral followed by a decimal point (a 2-digit number has a decimal point after each numeral). The action code number is one or 2 digits with no decimal point(s).

**IMPORTANT:** Once quick test is initiated, display button must be pressed at least once every 10 minutes for control to remain in quick test mode. If button is not pressed within this time, control will attempt to start the unit.

To recheck any step in quick test program, control must be recycled by turning unit control switch off for a few seconds, and then turning it back on again. Restart quick test program as described above and proceed through quick test steps. Press display button twice for each step until step to be rechecked is reached.

The quick test program is divided into 3 sections as described below and shown in Tables 14-16.

1. Quick Test Steps 1.-1.3. — Unit Configuration and Switch Check

The microprocessor in unit control system is programmed by 2 switch assemblies located on processor board (Fig. 1). The configuration header is factory set and cannot be changed in the field. The DIP switch assembly contains 8 microswitches that must be set in accordance with the various options selected by the customer. All DIP switches should be checked and set to proper position for options selected prior to the quick test. See Configuration of Header and DIP Switch Assembly section on page 5 for factory switch settings. The DIP switch functions and display codes are shown in Table 14.

2. Quick Test Steps 1.4.-2.3. — Thermistor and Set Point Potentiometer Check

In these steps, the microprocessor checks resistance values of all sensors and set point potentiometers to ensure that they are functional, connected properly, and set within proper range for unit configuration.

Nominal resistance values for all sensors range from 363,000 to 219 ohms in accordance with Table 17. Normal display code for good sensors and potentiometers is 1. A display code of 0 indicates a faulty potentiometer, thermistor or wiring. A 0 display also indicates that option is not being used.

Table 15 shows thermistor and set point potentiometer functions and quick test display codes.

**Table 14 — Quick Test, Unit Configuration and Switch Check**

QUICK TEST STEP NO.	NORMAL DISPLAY	DESCRIPTION	CONTROL SWITCH
1.	01	Type Unit — Air-Cooled VAV	Configuration Header
2.	2	No. of Compressors	Configuration Header
3.	2 1	No. of Unloaders (034,038,048, 054-074) (044)	DIP Switch No. 6 and 7
4.	60	60-Hertz Power	Configuration Header
5.	0 or 1	0 — No Reset (Switch Off) 1 — Reset On (Switch On)	DIP Switch No. 2
6.	0 or 1	0 — No Economizer (Switch Off) 1 — Economizer On (Switch On)	DIP Switch No. 3
7.	0 or 1	0 — No Warm-Up (Switch Off) 1 — Warm-Up Used (Switch On)	DIP Switch No. 4
8.	0 or 1	0 — Demand Limit Not Used (Switch Off) 1 — Demand Limit Used (Switch On)	DIP Switch No. 5
9.	0 or 1	0 — Enthalpy Switch Open 1 — Enthalpy Switch Closed	EC
1.0.	1	1 — Low-Pressure Switch Closed	Low-Pressure Switch 1
1.1.	1	1 — Low-Pressure Switch Closed	Low-Pressure Switch 2
1.2.	1	No Circuit 1 Oil Pressure Switch	None*
1.3.	1	No Circuit 2 Oil Pressure Switch	None*

**LEGEND**

**DIP** — Dual, In-Line Package  
**EC** — Enthalpy Control  
**VAV** — Variable Air Volume

\*Units are not equipped with oil pressure switches.

**Table 15 — Quick Test, Thermistor and Potentiometer Check**

QUICK TEST STEP NO.	NORMAL DISPLAY	DESCRIPTION	THERMISTOR OR POTENTIOMETER*
1.4.	1	1 — Thermistor OK 0 — Thermistor Faulty	Leaving Air Thermistor (T1)
1.5.	1	1 — Thermistor OK 0 — Thermistor Faulty	Entering Air Thermistor (T2)
1.6.	1	1 — Thermistor OK 0 — Thermistor Faulty	Circuit 1 Condenser Thermistor (T3)
1.7.	1	1 — Thermistor OK 0 — Thermistor Faulty	Circuit 2 Condenser Thermistor (T4)
1.8.	1	1 — Thermistor or Potentiometer OK 0 — Thermistor or Potentiometer Faulty or Option not used	Accessory Space Temperature Thermistor (T10) or Accessory Reset Potentiometer (P7)
1.9.	1	1 — Potentiometer OK 0 — Potentiometer Faulty	Supply-Air Set Point Potentiometer (P1)
2.0.	1	1 — Potentiometer OK 0 — Potentiometer Faulty or Option not used	Accessory Reset Limit Potentiometer (P3)
2.1.	1	1 — Potentiometer OK 0 — Potentiometer Faulty or Option not used	Accessory Demand Limit Potentiometer (P4)
2.2.	1	1 — Potentiometer OK 0 — Potentiometer Faulty or Option not used	Minimum Position Economizer Potentiometer (P5)
2.3.	1	1 — Potentiometer OK 0 — Potentiometer Faulty or Option not used	Warm-Up Set Point Potentiometer (P6)

\*Potentiometer P2 is not listed since it is not part of the quick test. If on unit start-up a Code 83 is displayed, check potentiometer P2.

**Table 16 — Quick Test, Output Relay Check**

QUICK TEST STEP NO.	NORMAL DISPLAY	DESCRIPTION	RELAY NUMBER
2.4.	1	1 — Open Economizer or Open Relay if no Economizer	K7
2.5.	1	1 — Close Economizer or Close Relay if no Economizer	K8
2.6.	1	1 — Energize Fan Relay and Heat Relay	K9* and K10
2.7.	1	Energize Stage 1 Condenser Fan(s)	K11
2.8.	1	Energize Stage 2 Condenser Fan(s)	K12
2.9.	0 then 1 then 0	Energize Compressor 1†	K1
3.0.	0	Energize Unloader 2; Not Used (044)	K2
3.1.	0	Energize Unloader 1	K3
3.2.	0 then 1 then 0	Energize Compressor 2†	K5
3.3.	0	Not Used	K6

CR — Control Relay

\*K9 (fan relay) will remain on for duration of quick test.

†Compressor will be energized for 10 seconds. Zero indicates open CR; 1 indicates closed CR.

**Table 17 — Sensor Resistance Values**

TEMP (F)	RESISTANCE (Ohms)	TEMP (F)	RESISTANCE (Ohms)	TEMP (F)	RESISTANCE (Ohms)
-60	362,640	45	11,396	150	1,020
-55	297,140	50	9,950	155	929
-50	245,245	55	8,709	160	844
-45	202,841	60	7,642	165	768
-40	168,250	65	6,749	170	699
-35	139,960	70	5,944	175	640
-30	116,820	75	5,249	180	585
-25	98,420	80	4,644	185	535
-20	82,665	85	4,134	190	490
-15	69,685	90	3,671	195	449
-10	58,915	95	3,265	200	414
-5	50,284	100	2,913	205	380
0	42,765	105	2,600	210	350
5	36,475	110	2,336	215	323
10	31,216	115	2,092	220	299
15	26,786	120	1,879	225	276
20	23,164	125	1,689	230	255
25	19,978	130	1,527	235	236
30	17,276	135	1,377	240	219
35	14,980	140	1,244		
40	13,085	145	1,126		

**3. Quick Test Steps 2.4.-3.3. — Output Relay Check**

These quick test steps allow microprocessor to check output signals from relay boards in unit control system. In addition, operation of all the condenser fans, compressors, and economizer (if equipped) are checked at each step.

Normal display for Steps 2.4. through 2.8. is 1. In Steps 2.9. through 3.2., each compressor and unloader is started and allowed to run for approximately 10 seconds. At start-up, a 0 will appear on the display followed by a 1 (Steps 2.9. and 3.2.) in a few seconds. Steps 3.0. and 3.1. will always be 0 since there are unloaders, and Step 3.3. will always be zero since it is not used.

At end of the 10-second time period, a 0 will return to the display board indicating that test step has been successfully completed (Steps 2.9. and 3.2.). The 1 indicates that was tested.

Fan and compressor operating sequence for quick test Steps 2.4. through 3.3. are shown in Table 16.

If the quick test steps do not operate as described above, a defect exists in one or more of the following: relay being tested, electronic control, or unit wiring. Determine problem and correct.

**OPERATING INFORMATION**

**Digital Display** — The VAV control system uses a 2-digit LED display located on the display board to display operational information and diagnostic codes.

**CODES 0 THROUGH 6, CAPACITY STEPS** — These codes indicate the number of cooling stages active at the time the display button is pressed. The highest code indicated on the display will be 6 for the 034,038 and 048-074 units, and 4 for the 044 units.

Capacity steps are directly related to pin terminal connector J6 output. At step zero, the unit has no mechanical cooling on, and the economizer may or may not be operating (depending on the outdoor air conditions). Once a cooling load is detected (T1 thermistor reads above the supply-air set point), the economizer will begin modulating to meet the

load if the outdoor enthalpy is good. As long as the outdoor-air enthalpy is acceptable, no mechanical cooling will take place until the economizer dampers are fully open. The rest of the steps and the operational sequence vary due to the number of compressors and unloaders. Refer to Operating Sequence section on page 32 for the unit stages of operation.

**CODES 20 THROUGH 30 AND 88, OPERATIONAL STATUS** — These codes indicate special operational modes, such as initialization, morning warm-up, temperature reset, demand limit, or an internal failure of the board. Codes 23-25 and 27-29 are not used on these units.

**Initialization** — When the control is turned on, the display shows a [20] for approximately 2 minutes to indicate that the control is in the initialization mode. During this time, the economizer dampers open and close to determine the resistance range of the economizer position potentiometer (P2) for full economizer operation. The processor loads the necessary constants for proper unit operation and checks the thermistors and other potentiometers for their values and validity. After the initialization period, the display screen goes blank until the display button is pressed. If the display button is pressed during the 2-minute initialization period, the control goes into the Quick Test mode.

**Temperature Reset** — If the unit is equipped with the accessory temperature reset package, and DIP switch 2 is in the ON position, the unit will reset the supply-air temperature to a calculated value when necessary. When this condition is in effect, a [21] will appear in the display.

**Demand Limit** — If the unit is equipped with the accessory demand limit control module or the field-supplied, single-step demand limit potentiometer, and DIP switch 5 is in the ON position, the unit will limit the capacity stages to a predetermined value. When this condition is in effect, a [22] will appear in the display.

**Morning Warm-Up** — If the morning warm-up heat routine is enabled using DIP switch 4, and conditions of the occupied space warrant, the unit will begin the morning warm-up routine. When this condition is in effect, a [26] will appear in the display.

**Internal Failure** — If the unit detects an internal fault (such as a time measurement failure), or detects an incorrect voltage on an input channel, a [30] will be displayed, and the unit will shut down.

**Quick Test** — If the display button is pressed during the initialization period of the processor, the unit will run its self-diagnostic routine. When this is in effect, an [88] will appear in the display screen.

**CODES 51 THROUGH 87, OVERLOAD INFORMATION** — These codes indicate diagnostic information when there is a unit problem such as a faulty thermistor, potentiometer, or compressor fault. Refer to VAV Diagnostic Information section on page 41 for more details. Codes 52-54, 56-58, 61, 62, 65-69, 73, 74, and 77-80 are not used on these units.

Under normal operation, only the stage number is displayed when the display button is pressed. If a status or overload code is displayed, the display will rotate every 2 seconds and will display up to 3 codes. Overload information takes priority over all other codes. The codes are stored in the microprocessor as long as the board remains energized.

**Operating Sequence** — The sequence presented below assumes that the unit is equipped with heat for morning warm-up and an economizer. If these items are not enabled with the appropriate DIP switches, the processor bypasses these subroutines. This sequence is also based on an EPROM (erasable, programmable, read-only memory) processor chip with the identification ‘HT204485-1-XX,’ where ‘XX’ is replaced by a 2-digit number representing the current software version. See Fig. 1 for EPROM chip location.

When power is applied to the occupied mode relay (OMR) through the closure of either a field-installed timeclock or a field-installed switch in the occupied space, the unit will begin its initialization mode.

A 20 will appear in the display screen, and the initialization period will last approximately 2 minutes. During this time, the economizer dampers open and close to determine the resistance range for full economizer operation of the economizer position potentiometer (P2). The processor loads the necessary constants for unit operation, and also checks the thermistors and other potentiometers for their values and validity. After the initialization period, the screen goes blank until the display button is pressed.

**▲ CAUTION**

Use caution during this time (after initialization when the screen is blank), because the unit supply and return fans could start at any time. Personal injury could result from contact with rotating fans.

Once the initialization period is complete, the supply fan begins operation. While the fan is operating, the economizer dampers are closed and return air from the building is being circulated. After 2 minutes, the processor checks the resistance value of thermistor T2. If T2 temperature sensed is 5° F or more below the set point of the morning warm-up potentiometer (P6), the unit will begin the morning warm-up routine, and a 26 will be displayed.

Unit heat will be energized through the heat interlock relay (HIR), and all of the occupied space air terminals open. The unit will continue heating the space until the return-air temperature is within 2° F of set point. The unit will then shut off the heat and continue to circulate air. The unit will cycle in and out of the heating mode until the return-air temperature reaches the morning warm-up set point (P6). Once morning warm-up has been terminated, the unit cannot return to morning warm-up until the unit is powered down and restarted. This action signals a return to the Occupied mode. NOTE: Occupied heat is NOT AVAILABLE on these units.

Once out of the morning warm-up routine, the unit will begin its cooling routine based on the leaving-air set point (P1). At step zero, the unit has no mechanical cooling on, and the economizer may or may not be operational. The economizer will move to the minimum position determined by potentiometer P5 if no cooling load is detected. Once a cooling load is detected by thermistor T1 sensing a temperature higher than the cooling demand set point (P1), the economizer will begin modulating to meet the load if the outdoor enthalpy is good. The processor will attempt to maintain a supply-air temperature of  $P1 \pm 2^\circ \text{F}$  by modulating the economizer dampers.

No mechanical cooling will take place until the economizer dampers are fully open (if the outdoor-air enthalpy permits). If the economizer is unable to meet the cooling

demand, then mechanical cooling is used in conjunction with the economizer. If the economizer is unable to meet the load due to unacceptable outdoor-air enthalpy, the dampers will return to the minimum position as determined by P5.

Compressors, unloaders, and condenser fans will be cycled to maintain a leaving-air temperature 2° F below the potentiometer P1 set point once the mechanical cooling stages begin. Each unit’s cycling is slightly different, and is based on the number of compressors and unloaders. The operational loading sequence of compressors is as follows:

During the start-up of the lead compressor for each circuit, the low-pressure switch will be bypassed for 180 seconds to prevent nuisance trips of the low-pressure switch. After start-up, a low-pressure trip will be ignored for 30 seconds by the processor.

**SIZE 034,038 AND 048-074 UNITS** — These units have 2 compressors and 2 unloaders on compressor 1. See Fig. 38 and 39 for compressor and condenser-fan motor locations. The operating sequence is as follows:

- Stage 1 Relays K1, K2, and K3 are energized. Compressor no. 1 starts with both unloaders energized. Compressor no. 1 runs at  $\frac{1}{3}$  capacity. The crankcase heater for this compressor has been deenergized, and the first stage of condenser fans have been energized. Outdoor (condenser) fan motor no. 1 (OFM1) has started on all units.
- Stage 2 Relays K1 and K3 are energized. Compressor no. 1 is running with unloader 1 (U1) energized. The compressor is now operating at  $\frac{2}{3}$  capacity.
- Stage 3 Relay K1 is energized. Compressor no. 1 is fully loaded.
- Stage 4 Relays K1, K2, K3, and K5 are energized. Compressor no. 1 is running at  $\frac{1}{3}$  capacity, and compressor no. 2 is running at full capacity. The crankcase heater for compressor no. 2 has been deenergized.
- Stage 5 Relays K1, K3, and K5 are energized. Compressor no. 1 is running at  $\frac{2}{3}$  capacity, and compressor no. 2 is running at full capacity.
- Stage 6 Relays K1 and K5 are energized. Both compressors are running fully loaded.

Size 034 and 038 units have 2 condenser fans, one of which is controlled by the microprocessor. The OFM1 is energized with compressor no. 1. The OFM2 is controlled by the processor and is cycled based on input from circuit thermistor T3 or T4.

Size 048 units have one fan that can be controlled by the processor. The other 2 are controlled by the compressors. The OFM1 is energized by compressor no. 1, and OFM3 is energized by compressor no. 2. The OFM2 is cycled by the processor based on input from either circuit (thermistors T3 and T4).

On size 054,064 units, the first 2 condenser fans energize with the compressors; compressor no. 1 controls OFM1, and compressor no. 2 controls OFM2. The OFM3 and OFM4 are staged by the microprocessor based on the condensing temperature input from thermistor T3 or T4.

On size 074 units, the first 3 condenser fans energize with the compressors; compressor no. 1 controls OFM1, and compressor no. 2 controls OFM2 and OFM3. The OFM4 and OFM5 are staged by the microprocessor based on condensing temperature input from either circuit’s T3 or T4 thermistor.

**SIZE 044 UNITS** — These units have 2 compressors and 1 unloader on compressor no. 1. See Fig. 38 for compressor and condenser fan motor locations. The unit operating sequence is as follows:

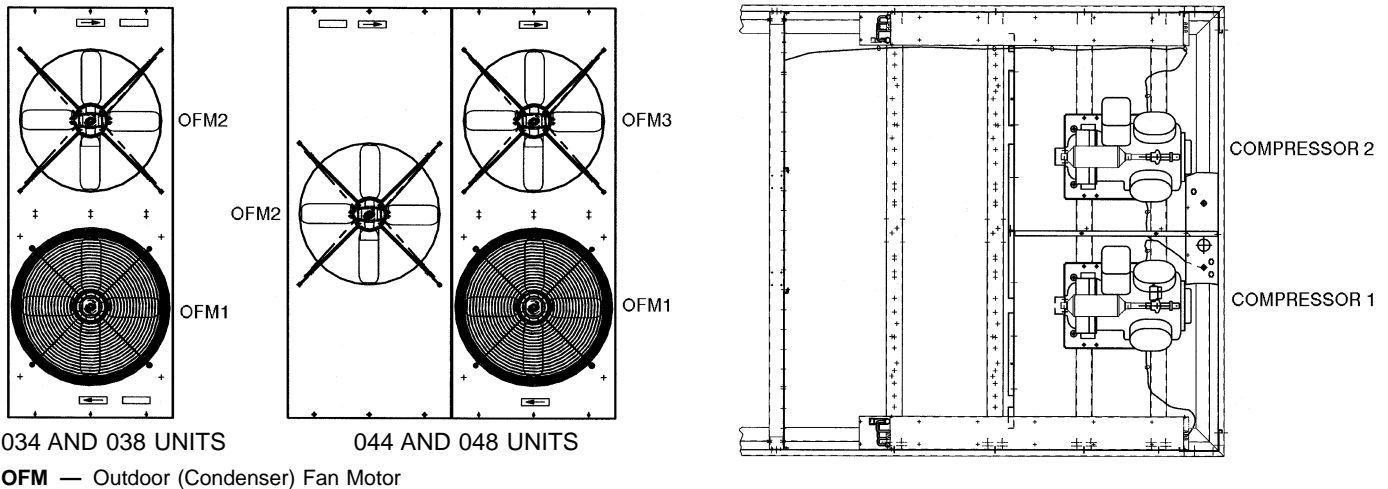
- Stage 1 Relays K1 and K3 are energized. Compressor no. 1 starts with the unloader energized. Compressor no. 1 is running at ½ capacity. The crankcase heater on compressor no. 1 has been deenergized, and the first stage condenser fan has been energized. Outdoor (condenser) fan motor no. 1 (OFM1) has started.
- Stage 2 Relay K1 is energized. Compressor no. 1 is fully loaded.
- Stage 3 Relays K1, K3, and K5 are energized. Compressor no. 1 is running at ½ capacity, and compressor no. 2 is running at full capacity. The crankcase heater for compressor no. 2 is deenergized. The second stage condenser fan has been energized. Both OFM1 and OFM3 are operating.
- Stage 4 Relays K1 and K5 are energized. Both compressors are running fully loaded.

Size 044 units have one fan that can be controlled by the processor. The other 2 are controlled by the compressors. The OFM1 is energized by compressor no. 1, and OFM3 is energized by compressor no. 2. The OFM2 is cycled by the processor based on input from either circuit (thermistors T3 and T4).

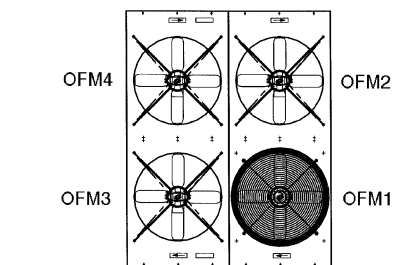
**Head Pressure Control** — All units have as standard a basic head pressure control function which allows the units to operate in cooling down to 45 F. If cooling is required at outdoor ambient temperatures lower than 45 F, refer to accessory head pressure control literature for details.

Head pressure control is handled by the processor. The processor attempts to maintain the head pressure by cycling the condenser-fan motors. No condenser fans will be running without a call for mechanical cooling. Thermistors T3 and T4 provide the condensing temperature information to the processor. These VAV rooftop units have dual refrigeration circuits, and the higher circuit temperature will govern unit operation. If the condensing temperature is above 133 F (236 psig), a condenser fan stage will be added. If the condensing temperature is 78 F (142 psig) or less, the number of condenser fans operating will be decreased. After each fan stage, the processor will wait one minute for the head pressures to stabilize before changing again, unless thermistor T3 or T4 senses a temperature greater than 125 F (278 psig), in which case all condenser fans are started.

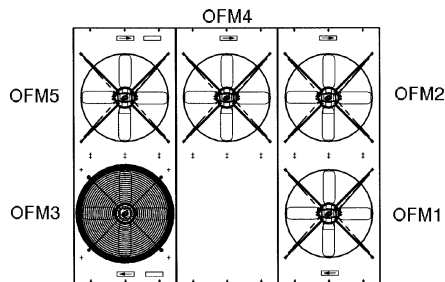
During start-up, if the outdoor ambient is above 70 F (as sensed by thermistor T3 or T4), the first-stage, processor-controlled fans are turned on to prevent excessive discharge pressures.



**Fig. 38 — Component Arrangement, 034-048 Units**



054, 064 UNITS



074 UNIT

OFM — Outdoor (Condenser) Fan Motor

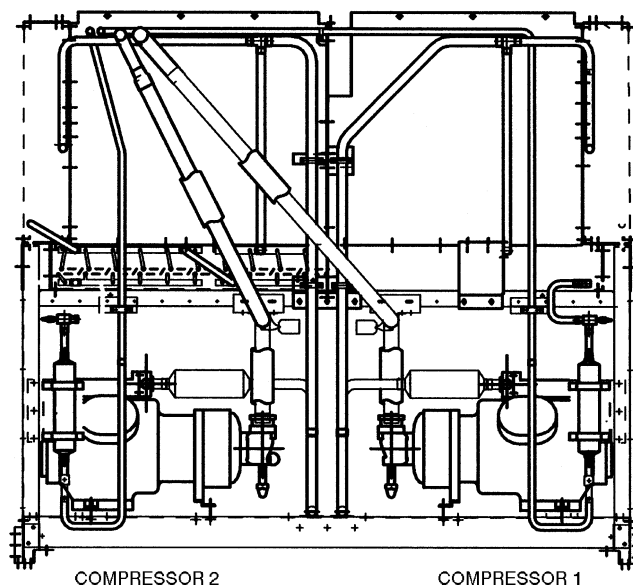


Fig. 39 — Component Arrangement, 054-074 Units

**Supply Fan Control with IGV** — In most VAV units, the supply fan static pressure is controlled by inlet guide vanes. The inlet guide vanes operate independently from the microprocessor. The supply static pressure is controlled by a differential pressure switch. If the unit is equipped with a return fan, building pressure is controlled by another differential pressure switch.

For example, assume that set point on supply fan differential switch is 1.9 in. wg. If pressure in supply duct goes above 1.9 in. wg, switch will make to the normally open contact and energize inlet guide vane motor to drive inlet guide vanes to a more closed position, thus reducing airflow and lowering duct pressure. Once set point pressure is reached, switch will open and deenergize inlet guide vane motor. If pressure in supply duct is below 1.9 in. wg, the switch will make to the normally closed contact and energize inlet guide vane motor to drive inlet guide vane to a more open position; increasing airflow and raising duct pressure. Once again, once desired pressure has been reached, switch will open and deenergize inlet guide vane motor. How far above or below the set point setting the switch goes before energizing depends on setting of null span (null span is pressure change that can be made without contacts opening or closing). If null span is at maximum position, pressure will vary from 0.17 in. wg to 0.31 in. wg depending on set point (if set point is at minimum setting, null span will be 0.17 in. wg, while

if it is at maximum position, the null span will be 0.31 in. wg) before switch acts. If null span is adjusted to a minimum setting, duct pressure will vary from 0.06 in. wg to 0.11 in. wg (again depending on switch set point) before switch acts. Setting null span to minimum position will result in a smaller pressure fluctuation than if it is set at maximum position.

**Supply Fan Control with VFD** — When equipped with the VFD option, the supply fan static pressure is controlled by modulating the fan wheel speed. The VFD operates independently from the microprocessor. A duct pressure transducer monitors duct static pressure. The transducer output (4 to 20 mA) is directed into the VFD. The VFD adjusts supply fan motor speed (which changes wheel speed) as measured duct pressure varies from set point as established at the VFD. The VFD will modulate fan speed until the duct pressure set point is achieved.

NOTE: The VFD will always provide the proper phase sequence to the supply fan motor. This motor will operate in proper rotation regardless of the phase sequence to the unit. If, upon start-up, the outdoor fans operate backwards but the indoor fan operates in the correct direction, reverse any two leads to the main terminal block. All fans will then operate in the correct direction.

**Modulating Power Exhaust (Option or Accessory except FY,JY units)** —

The power exhaust assembly consists of two parallel and independent belt-drive forward curve fans. The fans, motors, and drives are located over the return air opening of the unit, in a plenum beneath the outside air intake plenum. The fans discharge air horizontally out the back of the unit through individual barometric backdraft dampers with hoods. (See Fig. 40 and 41.) Operation is interlocked with economizer operation. Sheet metal installation is shown in Fig. 42 and 43.

Fan no. 1 is equipped with a variable position discharge damper located in the outlet of the fan housing. This damper is controlled by an actuator (PEDM), based on signals from the building pressure differential pressure switch (DPS). Available range on the DPS is  $-0.50$  to  $+0.50$  in. wg, adjustable. Building pressure is sensed by a pick-up (field-supplied and -installed) located in the occupied space.

Operation of the modulating power exhaust is a combination modulating/staged control, with fan no. 1 providing modulating control from 0 to 100%, and fan no. 2 being staged On/Off according to damper position on fan no. 1.

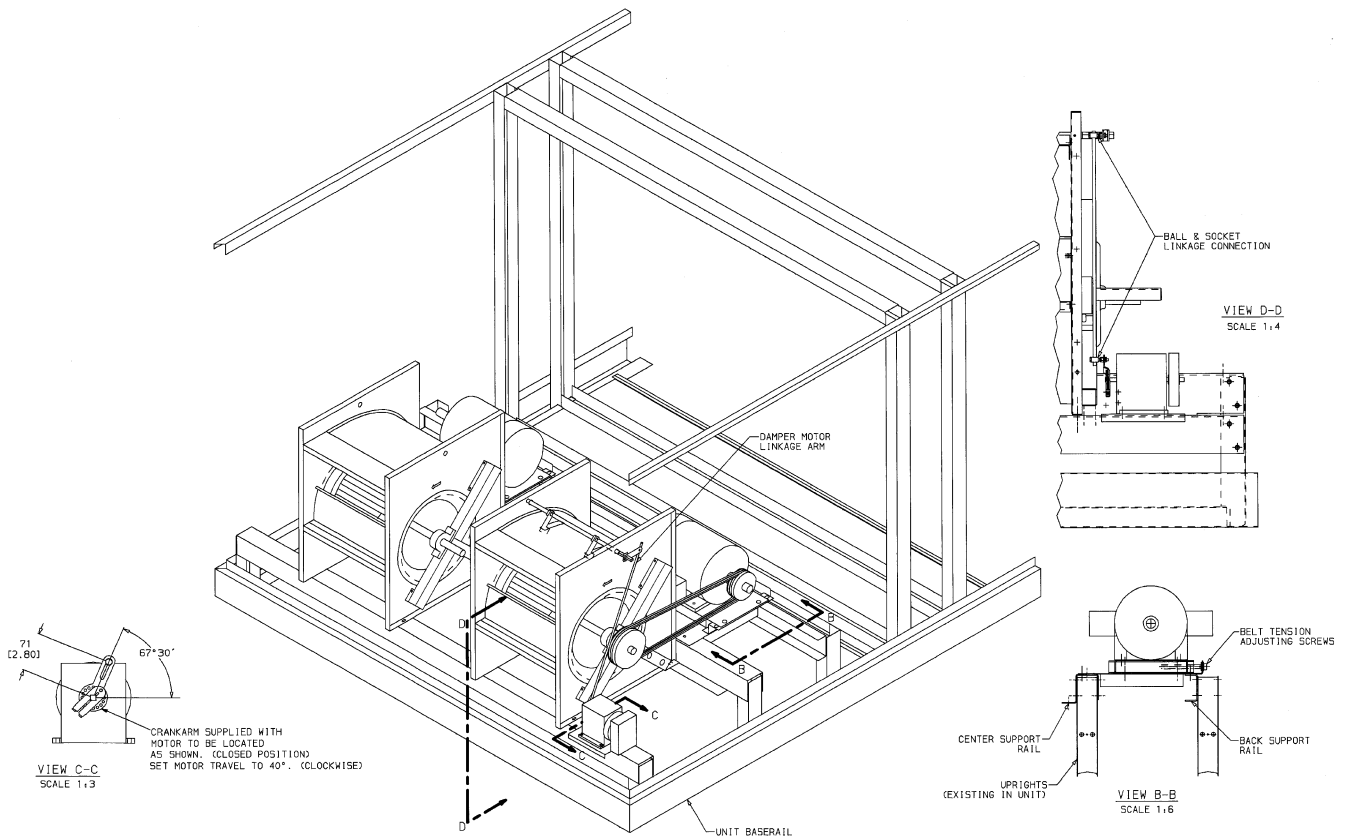
As the economizer actuator opens past 17% open, auxiliary switch DMS1 closes, energizing fan contactor PEC1. Fan motor no. 1 starts and runs.

Capacity of fan no. 1 is controlled by the position of the outlet damper. As building pressure increases above set point, the DPS will close its contact and drive the power exhaust damper motor (PEDM) open until set point is achieved. DPS then opens its control contacts and PEDM maintains current position.

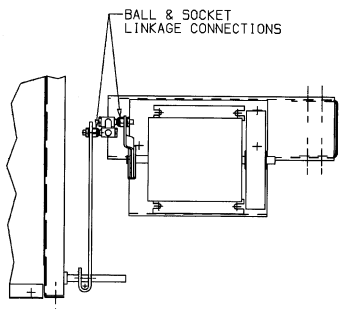
When space demand moves PEDM to 90% of full-open position, auxiliary switch PEDMS closes, energizing fan contactor PEC2. Fan motor no. 2 starts and runs. Increased exhaust airflow will lower space pressure, causing DPS to drive PEDM back towards its closed position, until the set point is achieved.

If space pressure decreases until PEDM position is reduced to 10% of open position, PEDMS will open, deenergizing fan contactor PEC2 and shutting off fan no. 2.

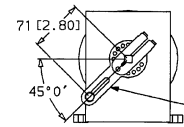
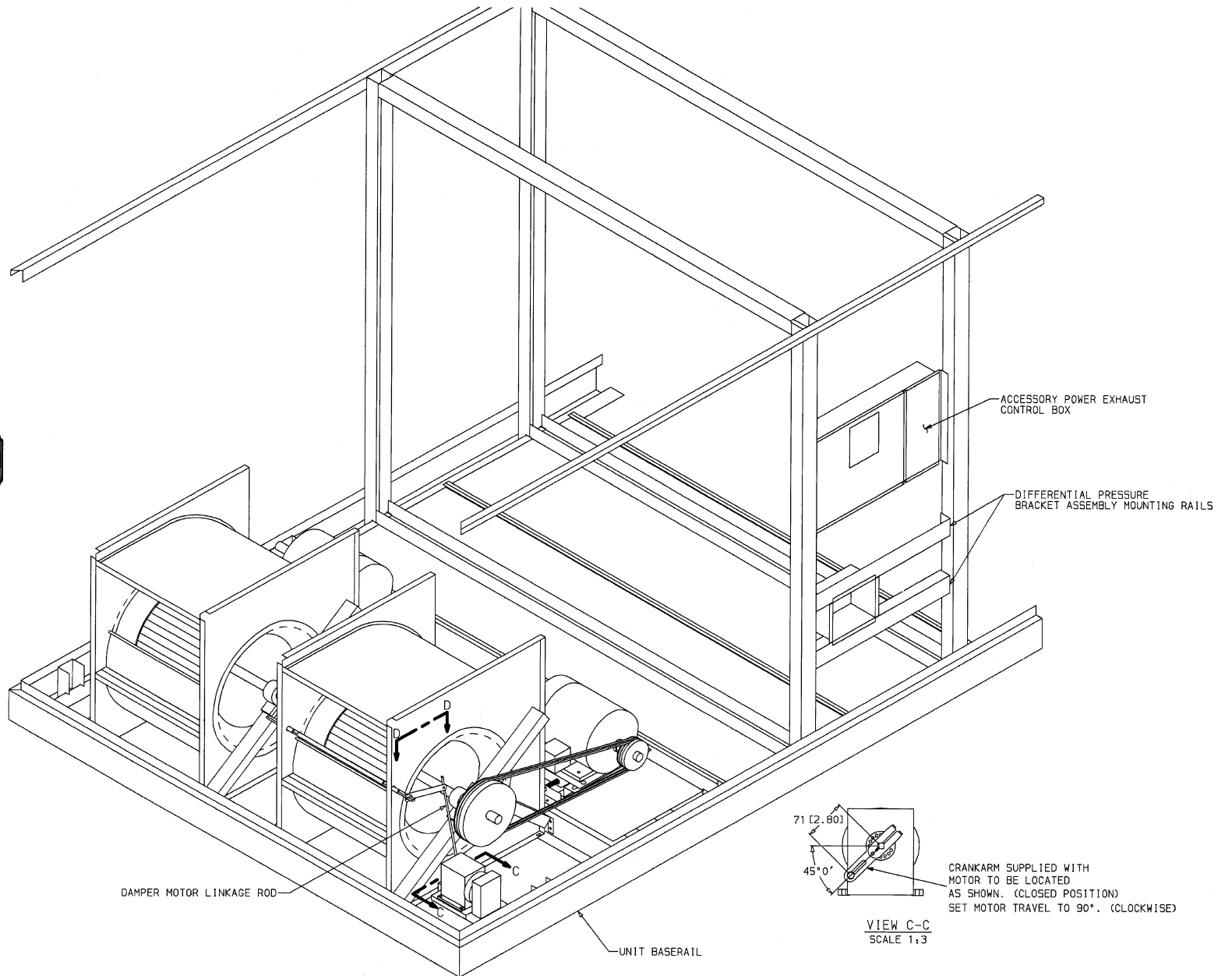
**Unit Staging** — Compressor loading and unloading sequences are shown in Table 18.



**Fig. 40 — Modulating Power Exhaust Component Locations; Sizes 034-048**



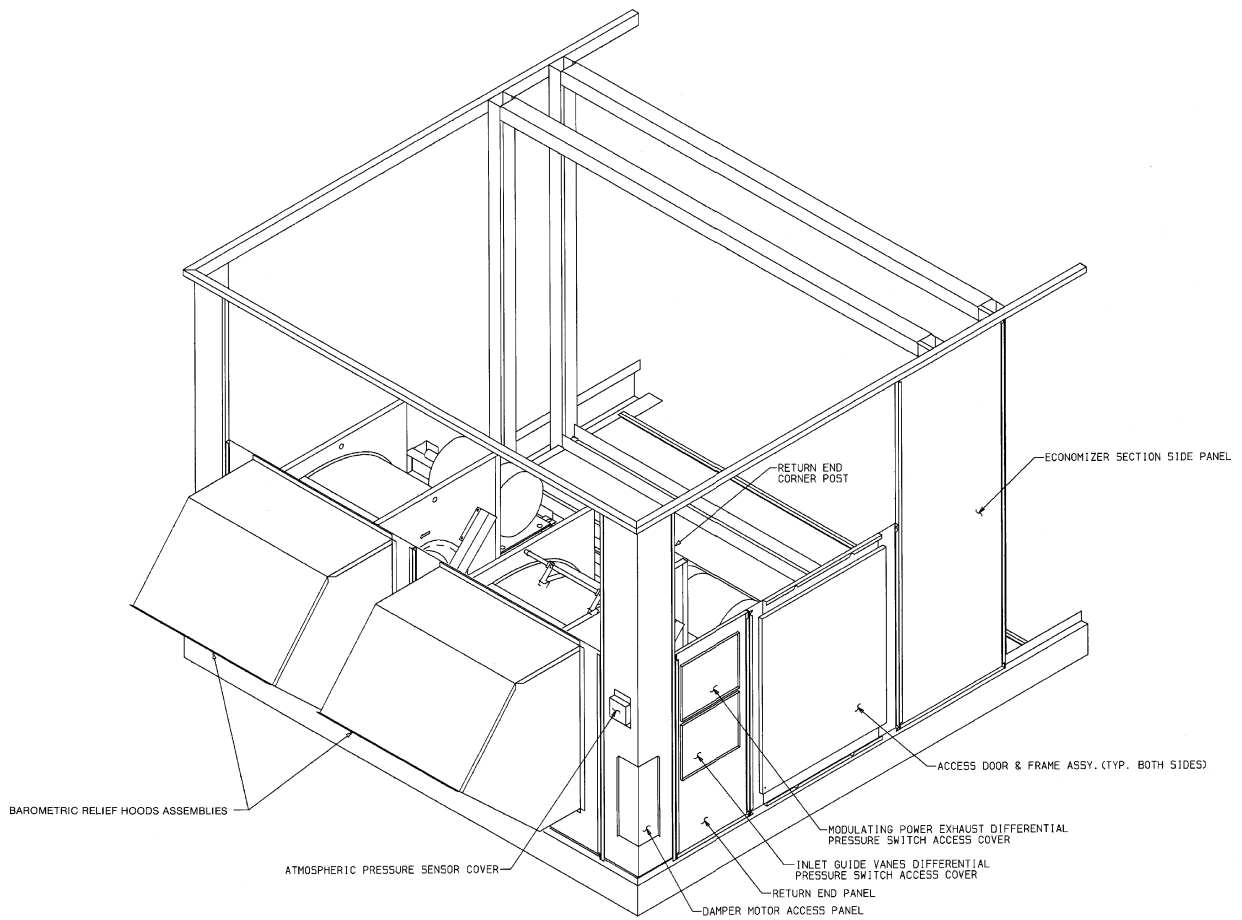
VIEW D-D  
SCALE 1:3



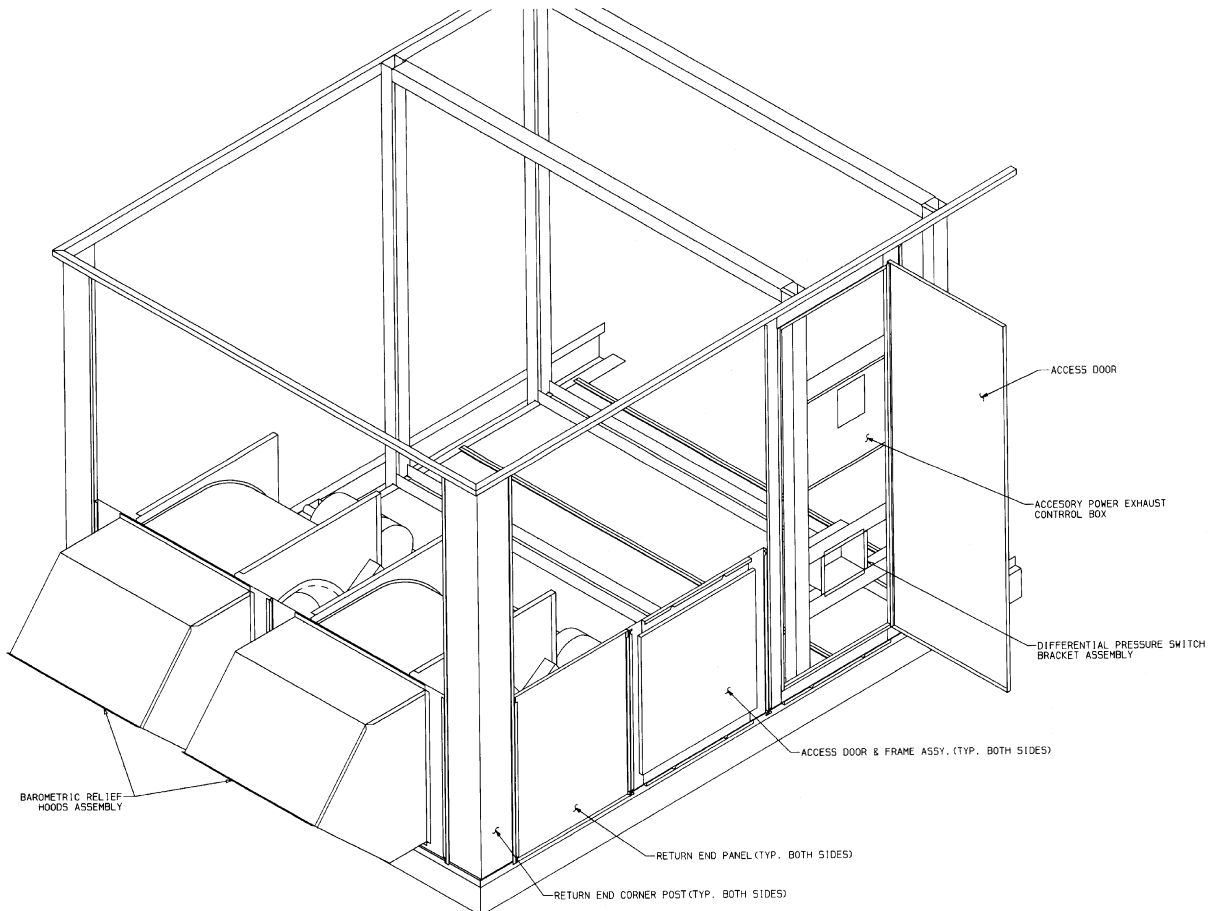
CRANKARM SUPPLIED WITH MOTOR TO BE LOCATED AS SHOWN. (CLOSED POSITION) SET MOTOR TRAVEL TO 90°. (CLOCKWISE)

VIEW C-C  
SCALE 1:3

Fig. 41 — Modulating Power Exhaust Component Locations; Sizes 054-074



**Fig. 42 — Modulating Power Exhaust Return End Sheet Metal Skin Detail; Sizes 034-048**



**Fig. 43 — Modulating Power Exhaust Return End Sheet Metal Skin Detail; Sizes 054-074**

**Table 18 — Compressor Loading and Unloading Sequences**

COOLING STAGE	SIZE 034 UNITS					
	Lead Circuit			Lag Circuit	Active Cylinders	Percent Capacity
	Comp 1	Unloader U1	Unloader U2	Comp 2		
0	OFF	OFF	OFF	OFF	0	0
1	ON	ON	ON	OFF	2	17
2	ON	ON	OFF	OFF	4	33
3	ON	OFF	OFF	OFF	6	50
4	ON	ON	ON	ON	8	67
5	ON	ON	OFF	ON	10	83
6	ON	OFF	OFF	ON	12	100

COOLING STAGE	SIZE 038 UNITS					
	Lead Circuit			Lag Circuit	Active Cylinders	Percent Capacity
	Comp 1	Unloader U1	Unloader U2	Comp 2		
0	OFF	OFF	OFF	OFF	0	0
1	ON	ON	ON	OFF	2	14
2	ON	ON	OFF	OFF	4	28
3	ON	OFF	OFF	OFF	6	42
4	ON	ON	ON	ON	6	72
5	ON	ON	OFF	ON	8	86
6	ON	OFF	OFF	ON	10	100

COOLING STAGE	SIZE 044 UNITS					
	Lead Circuit		Lag Circuit		Active Cylinders	Percent Capacity
	Comp 1	Unloader U1	Comp 2			
0	OFF	OFF	OFF		0	0
1	ON	ON	OFF		2	25
2	ON	OFF	OFF		4	50
3	ON	ON	ON		6	75
4	ON	OFF	ON		8	100

COOLING STAGE	SIZE 048 UNITS					
	Lead Circuit			Lag Circuit	Active Cylinders	Percent Capacity
	Comp 1	Unloader U1	Unloader U2	Comp 2		
0	OFF	OFF	OFF	OFF	0	0
1	ON	ON	ON	OFF	2	19
2	ON	ON	OFF	OFF	4	38
3	ON	OFF	OFF	OFF	6	58
4	ON	ON	ON	ON	6	62
5	ON	ON	OFF	ON	8	81
6	ON	OFF	OFF	ON	10	100

**Table 18 — Compressor Loading and Unloading Sequences (cont)**

COOLING STAGE	SIZE 054 UNITS						
	Lead Circuit			Lag Circuit		Active Cylinders	Percent Capacity
	Comp 1	Unloader U1	Unloader U2	Comp 2			
0	OFF	OFF	OFF	OFF		0	0
1	ON	ON	ON	OFF		2	20
2	ON	ON	OFF	OFF		4	40
3	ON	OFF	OFF	OFF		6	60
4	ON	ON	OFF	ON		10	80
5	ON	OFF	OFF	ON		12	100

COOLING STAGE	SIZE 064 UNITS						
	Lead Circuit			Lag Circuit		Active Cylinders	Percent Capacity
	Comp 1	Unloader U1	Unloader U2	Comp 2			
0	OFF	OFF	OFF	OFF		0	0
1	ON	ON	ON	OFF		2	17
2	ON	ON	OFF	OFF		4	33
3	ON	OFF	OFF	OFF		6	50
4	ON	ON	ON	ON		8	67
5	ON	ON	OFF	ON		10	83
6	ON	OFF	OFF	ON		12	100

COOLING STAGE	SIZE 074 UNITS						
	Lead Circuit			Lag Circuit		Active Cylinders	Percent Capacity
	Comp 1	Unloader U1	Unloader U2	Comp 2			
0	OFF	OFF	OFF	OFF		0	0
1	ON	ON	ON	OFF		2	14
2	ON	ON	OFF	OFF		4	29
3	ON	OFF	OFF	OFF		6	43
4	ON	ON	ON	ON		8	71
5	ON	ON	OFF	ON		10	86
6	ON	OFF	OFF	ON		12	100

**TROUBLESHOOTING**

By using the display module, actual operating conditions of the unit are displayed while it is running. The Quick Test function allows proper operation of compressors, compressor unloaders, fans, and other components to be checked while unit is stopped. If an operating fault is detected, an alarm is generated and an alarm code(s) is displayed. For checking specific items, see Table 19.

**Checking Display Codes —** To view the digital display codes, press the button located to the right of the LED display/set point board in the control box. See Table 20 for Operational Status Codes. See Table 21 for Overload Codes.

**Complete Unit Stoppage —** If the unit is off, there are several conditions that can cause this situation to occur:

- Remote ON/OFF circuit in Unoccupied mode.
- Unit ON/OFF switch moved to OFF position.
- Programmed schedule at the timeclock.
- General power failure.
- Blown fuse in the control power feed.
- Open control circuit fuse.
- Operation of the unit blocked by the demand limit function.
- Unit supply-air temperature (T1) thermistor failure.
- Supply-air fan is not operating.
- High duct static pressure.

**Table 19 — Controls Troubleshooting**

SYMPTOM(S)	PROBABLE CAUSE(S)	SOLUTION(S)
Controls do not seem to be operating.	Remote on-off function may be keeping controls off.	Check status.
Evaporator fan does not run.	1. Circuit breaker open. 2. Inverter overload (if equipped).	1. Find cause and reset circuit breaker. 2. Find cause and reset.
Compressor does not run.	1. Circuit breaker is open. 2. There is no demand for cooling. 3. The control is locking out cooling operation.  4. Demand Limit in effect.	1. Find cause and reset circuit breaker. 2. Correct operation. 3. Check rotating display for alarm codes. Resolve alarm cause and reset control by changing to standby and back to run mode. 4. Check Demand Limit Settings.
Condenser fans do not turn on.	Circuit breaker is open.	Find cause and reset circuit breaker
Cooling demand exists and economizer modulates, but compression is not operating.	Compression cannot be initiated until economizer damper is 90% open.	Correct operation.

**Table 20 — Operation Status Codes**

CODE	MEANING
0	0 cooling stages active
1	1 cooling stage active
2	2 cooling stages active
3	3 cooling stages active
4	4 cooling stages active
5	5 cooling stages active
6	6 cooling stages active
20	Initialization mode (Allow 2 minutes for initialization. To initiate Quick Test, press the Display button while 20 is displayed.)
21	Temperature Reset in effect
22	Demand Limit in effect
26	Morning Warm-Up in effect
30	Internal failure detected
88	Self-diagnostic mode in effect

**Single Circuit Stoppage** — If a single circuit stops, there are several potential causes:

- Open contacts in the compressor high-pressure switch.
- Low refrigerant pressure.
- Thermistor failure.
- Unit supply-air temperature thermistor (T1) failure.
- Compressor circuit breaker trip.
- Operation of the circuit blocked by the demand limit function.

**Restart Procedure** — Before attempting to restart the machine, check the display for alarm codes to determine the cause of the shutdown. If the unit, circuit, or compressor stops more than once as a result of a safety device, determine and correct the cause before attempting to start the unit again.

After the cause of the shutdown has been corrected, unit restart may be automatic or manual depending upon the fault.

**Overload Codes** — Overload codes are warnings of abnormal or fault conditions, and may cause either one circuit or the whole unit to shut down. They are assigned code numbers as described below.

Table 21 contains a description of each overload code error and possible cause. Manual reset is accomplished by moving the ON/OFF Switch to the OFF position, then back to ON.

**VAV Diagnostic Information** — The microprocessor contains extensive self-diagnostic information. The 2-digit LED display is used to display the diagnostic codes and the alarm light (located next to display) is energized whenever a diagnostic code is tripped. When a problem is suspected, always check the display first for diagnostic information.

Table 21 details diagnostic codes and a brief description of the possible causes.

NOTE: Codes 52-54, 56-58, 61, 62, 65-69, 73, 74, and 77-80 are not used on these units.

**IMPORTANT:** The microprocessor memory and the display will be cleared if the power to the microprocessor is shut off. DO NOT attempt to bypass, short, or modify the control circuit or electronic boards in any way to correct a problem. This could result in a hazardous operating condition.

**CODES 51 AND 55: COMPRESSOR FAILURE** — If control relay (CR) opens while compressor should be operating, compressor will stop and microprocessor will energize alarm light and display a code of 51 or 55 (depending on compressor) when display button is pushed. The compressor will be locked off; to reset, the ON-OFF switch must be turned to OFF and then to ON position.

Code 51 is for compressor 1, and Code 55 is for compressor 2. Other codes are not used for these units.

The microprocessor has also been programmed to indicate a compressor failure if CR switch is closed when compressor is not supposed to be on.

If a failure occurs, the following are possible causes:

**High-Pressure Switch Open** — The high-pressure switch for each compressor is wired in series with 24-v power that energizes CR. If high-pressure switch opens during operation, CR will stop compressor and this will be detected by microprocessor through the feedback contacts.

**Internal Thermostat** — The internal thermostat in each compressor is also wired in series with 24-v power that energizes CR. If thermostat fails or switch opens during operation of compressor, compressor will shut down and failure is detected through feedback contacts.

**CR Failure** — If CR fails with large relay either open or closed, microprocessor will detect this, lock compressor off, and indicate an error.

**Relay Board Failure** — If small 24-v relay on the relay board fails, microprocessor will detect this through feedback contacts and indicate an error.

**Processor Board Failure** — If hardware that monitors feedback switch fails and processor board fails to energize the relay board relay to ON position, an error may be indicated.

The control does not detect compressor circuit breaker failures.

**Wiring Problem** — A wiring error or a loose wire may cause the feedback circuit to be broken.

**Table 21 — Overload Codes**

DISPLAY	DESCRIPTION OF FAILURE	ACTION TAKEN BY CONTROL	RESET METHOD	PROBABLE CAUSE
51 55	Compressor 1 failure Compressor 2 failure	Circuit 1 shut off Circuit 2 shut off	Manual	High-pressure switch or high discharge gas thermostat switch trip, compressor ground current > 2.5 amp or compressor board relay on when it is not supposed to be on. Wiring error between electronic control and compressor protection module.
59 60	Loss-of-charge circuit 1 Loss-of-charge circuit 2	Circuit 1 shut off Circuit 2 shut off	Manual Manual	This indicates either a low refrigerant charge, or a loss-of-charge switch failure.
63 64	Low oil pressure circuit 1 Low oil pressure circuit 2	Circuit 1 shut off Circuit 2 shut off	Manual Manual	Not used; Check jumper on processor board.
70	Illegal unit configuration	Unit will not start	Manual	Configuration error (see Note 1).
71 72 75	Leaving-air thermistor failure Entering-air thermistor failure Circuit 1 Saturated Condensing Thermistor	Unit shut off Use default value Unit shut off	Auto. Auto. Auto.	Thermistor or resistor failure, wiring error, or thermistor or resistor not connected to the processor board.
76	Circuit 2 Saturated Condensing Thermistor	Unit shut off	Auto.	
81	Reset temperature thermistor failure	Stop reset	Auto.	Potentiometer improperly connected, potentiometer setting out of range, potentiometer failure or wiring error.
82	Leaving-air set point potentiometer failure	Use default value	Auto.	
83	Economizer potentiometer failure	Close economizer	Auto.	
84	Reset limit set point potentiometer failure	Stop reset	Auto.	
85	Demand limit potentiometer failure	Stop demand limit	Auto.	
86 87	Minimum economizer potentiometer failure Warm-up set point potentiometer failure	Close economizer Use default value	Auto. Auto.	

NOTES:

1. Illegal unit configuration caused by missing programmable header or both unloader DIP switches on.
2. All auto. reset failures that cause the unit to stop will restart when the error has been corrected.
3. All manual reset errors must be reset by turning the control switch off and then back on.
4. Valid resistance range for the thermistors is 363,000 to 585 ohms.
5. Codes 52-54, 56-58, 61, 62, 65-69, 73, 74, and 77-80 are not used on these units.

**CODES 59 AND 60: LOW-PRESSURE SWITCH** — These codes are used to indicate a low-pressure switch failure.

The processor monitors the low-pressure switch. If the switch opens, either by low refrigerant charge, circuit failure, or wiring error, the circuit is locked off. Code 59 indicates a failure of the lead circuit, and as a result, that circuit will be shut down. Code 60 indicates a failure of the lag circuit, and as a result, that circuit will be shut down. These codes will only be displayed when the display button is pressed. To reset the circuit, the ON-OFF switch must be turned to OFF, then ON position.

**CODES 63 AND 64: OIL PRESSURE SWITCH** — These codes are used to indicate an oil pressure switch failure. Since the units do not have oil pressure switches, these codes are not used. The terminals on the processor board must be jumpered together or an error will occur. If these errors occur, check jumper between J2-1 and J2-2 for a code 63, or between J2-3 and J2-4 for a code 64 to be sure jumper is properly connected. To reset the circuit, the ON-OFF switch must be turned to OFF and then to ON position.

**CODE 70: ILLEGAL UNIT CONFIGURATION** — If the unit configuration header is not installed and properly configured, and/or if DIP switches are not properly set, unit will not start, and an error code of 70 will be indicated on display board when display button is pushed. Check the header and DIP switch settings.

**CODES 71 TO 76: THERMISTOR/RESISTOR FAILURE** — If measured temperature of a thermistor is less than -60 F (363,000 ohms) or greater than 180 F (585 ohms), the appropriate sensor error code (Table 21) will be displayed when the display button is pushed. The unit will be shut down. Thermistor failures will automatically reset once the error has been corrected. If a failure occurs, the following are possible causes:

Thermistor or Resistor Failure — A shorted or open thermistor or resistor will cause the failure.

Wiring Failure — If a wiring error exists that causes a shorted or open circuit, this will cause a failure.

Processor Board Failure — If circuitry on processor board fails, this could cause an error.

The codes are designated as follows:

- Code 71 Leaving-Air Thermistor Failure
- Code 72 Entering-Air Thermistor Failure
- Code 73 Not used
- Code 74 Not used
- Code 75 Circuit 1 Saturated Condensing Thermistor
- Code 76 Circuit 2 Saturated Condensing Thermistor

**CODE 81: RESET THERMISTOR OR POTENTIOMETER FAILURE** — This is a unique code since the reset temperature potentiometer (P7) is in series with the space temperature thermistor (T10). If either one of these components fail, reset will be terminated. This error will automatically reset once the situation is corrected. If an error is detected, the most probable cause is one of the following:

- Thermistor Failure — A shorted or open thermistor will cause the failure.
- Potentiometer Failure — If the potentiometer is outside of the valid range (40 to 90 F), a failure will result.
- Wiring Problem — If the circuit is open, a failure will be detected.
- Processor Board Failure — If the processor board fails (hardware), an alarm will be detected.

**CODE 82: LEAVING-AIR TEMPERATURE SET POINT POTENTIOMETER FAILURE** — If leaving-air set point potentiometer (P1 — located on display board) fails, control will use a default value. A failure will cause an error code of **82** to be displayed on display board when display button is pushed; alarm light will also be energized. A failure is determined by establishing a range of -22 F to 70 F as a valid range. Anything outside this range will be treated as a failure. If setting is outside the -22 F to 70 F range, alarm light will be energized and an error code of **82** will be displayed when display button is pushed; the control will use a set point of 70 F. If set point is between -22 F and 45 F, control will use a set point of 45 F and no error code will be indicated. If potentiometer returns to normal, control will automatically reset.

**NOTE:** The full range of the potentiometer is not used for the cooling set point range of 45 F to 70 F. The full scale resistance of the potentiometer is 10 Kohms.

If a failure occurs, one of the following is a probable cause:

Incorrect Potentiometer Setting — A potentiometer turned fully clockwise or counterclockwise is outside the valid range and will cause a failure.

Faulty Wiring — If wiring is incorrect between potentiometer and processor board or display board, a failure will result.

Potentiometer Failure — If potentiometer is shorted or open, a failure will result.

**CODE 83: ECONOMIZER FEEDBACK POTENTIOMETER FAILURE** — If potentiometer on economizer motor (P2) fails, control will use a default value of 0% and economizer outdoor-air dampers will close. The failure will energize alarm light and cause an error code of **83** to be displayed when display button is pushed. This potentiometer is a 5 to 15 Kohm potentiometer. If potentiometer returns to normal, control will automatically reset. If a failure occurs, one of the following is the probable cause.

Faulty Wiring — If the wiring between processor board and potentiometer is wrong, this will cause a failure.

Potentiometer Failure — If potentiometer is shorted or open, this will cause a failure.

Economizer Damper Stuck — The control has been programmed to indicate an error if potentiometer travel is less than 10% of the full range. This would happen if dampers or damper linkage were hung up and could not move properly.

**CODE 84: RESET LIMIT POTENTIOMETER FAILURE** — This code is applicable only if reset is being used. If reset is being used, DIP switch 2 must be in the ON position. This potentiometer (P3) is located on the accessory board. If potentiometer setting is less than 0° F or greater than 80 F, alarm light will be energized, a diagnostic code of **84** will be displayed if display button is pushed, and reset will be terminated. The full-scale resistance of potentiometer is 10 Kohms, but when installed on the accessory board in parallel with the other 2 potentiometers, measured resistance will be 3.3 Kohms. This failure will automatically reset once potentiometer returns to normal. If a failure occurs, one of the following is the probable cause:

DIP Switch Problem — DIP switch 2 is in the ON position and the accessory board is not installed (accessory board is standard on these units so it should always be on the unit).

**Incorrect Potentiometer Setting** — A potentiometer turned fully clockwise or counterclockwise is outside the valid range and will result in a failure.

**Faulty Wiring** — If the wiring between the potentiometer and the processor board is incorrect, a failure will result.

**Potentiometer Failure** — If potentiometer is shorted or open, a failure will occur.

**CODE 85: DEMAND LIMIT POTENTIOMETER (P4) FAILURE** — Used only if demand limit is being used. If demand limit is used, DIP switch 5 must be in the ON position.

Two types of demand limit are available: a field-supplied and installed single-step control consisting of a 10 Kohm, 3-wire linear potentiometer and an accessory 2-step control are available from Carrier. The single-step control has a single potentiometer while 2-step control has 2 potentiometers (mounted on the demand limit board, see Fig. 25).

For both types of demand limit, the control uses only 80% of the total potentiometer resistance. If resistance of potentiometer is less than 10% or greater than 90%, alarm light will be energized, a diagnostic code of **85** will be displayed when the display button is pushed, and demand limit will be terminated. If a failure occurs, it is probably due to one of the following:

**Potentiometer Failure** — If a potentiometer is shorted or open, a failure will occur.

**Incorrect Potentiometer Setting** — A potentiometer turned fully clockwise or counterclockwise will put potentiometer out of range resulting in an error.

**Faulty Wiring** — If wiring between the potentiometer and the processor board is incorrect, an error will occur.

**DIP Switch 5** — If DIP switch 5 is in the ON position and potentiometer is not installed, an error will occur.

**CODE 86: MINIMUM POSITION ECONOMIZER POTENTIOMETER FAILURE** — If potentiometer P5 (on accessory board) setting is less than 0% or greater than 100%, alarm light will be energized, a code of **86** will be displayed when display button is pushed and economizer outdoor air dampers will move to the fully closed position.

The potentiometer full-scale resistance is 10 Kohm, but when installed in parallel with the other 2 potentiometers on the accessory board, measured resistance will be 3.3 Kohm.

This failure will automatically reset when potentiometer returns to normal.

If a failure occurs, one of the following is the probable cause:

**DIP Switch 3** — If this switch is in the ON position and the accessory board is not installed (accessory board is standard on these units, so it should always be on the unit).

**Incorrect Potentiometer Setting** — If potentiometer is turned fully clockwise or counterclockwise, potentiometer will be out of the allowable range, and an error will result.

**Faulty Wiring** — If wiring between the potentiometer and the processor board is incorrect, an error will occur.

**Potentiometer Failure** — If potentiometer is shorted or open, potentiometer will be out of range and an error will result.

**CODE 87: WARM-UP TEMPERATURE SET POINT FAILURE** — Applicable only if morning warm-up is used. Whether or not unit is equipped with electric resistance heaters, use of the morning warm-up function is recommended if the unit is shut down at night or over weekends. In this application, cooling will remain off and the outdoor-air damper will stay closed until heat load from the occupied space elevates return-air temperature to the warm-up set point. If warm-up function is used, DIP switch 4 must be in the ON position. The

potentiometer (P6) is located on the accessory board. If potentiometer is set at less than 0° F or more than 95 F, alarm light will be energized, a diagnostic code of **87** will appear on the display when display button is pushed, and control will use a default value of 40 F. If setting is between 0° F and 40 F, control will use a value of 40 F but no diagnostic code will be displayed; if setting is between 80 F and 95 F, control will use a value of 80 F but no diagnostic code will be displayed.

The potentiometer full-scale resistance is 10 Kohm, but when wired in parallel with other potentiometers on the accessory board, measured resistance is 3.3 Kohm.

The failure will automatically reset once potentiometer returns to normal. If a failure occurs, one of the following is the probable cause:

**DIP Switch 4** — If this switch is in the ON position and the accessory board is not installed (accessory board is standard on these units, so it should always be on the unit).

**Incorrect Potentiometer Setting** — If potentiometer is turned fully clockwise or counterclockwise, potentiometer will be out of the allowable range, resulting in an error.

**Faulty Wiring** — If the wiring between the potentiometer and the processor board is incorrect, an error will occur.

**Potentiometer Failure** — If potentiometer is shorted or open, potentiometer will be out of range, resulting in an error.

**Thermistor Troubleshooting** — The VAV control system uses thermistors to measure temperatures of the entering and supply air, as well as the saturated condensing temperatures of the refrigerant circuits. The resistance versus temperature and electrical characteristics for all thermistors in the system are identical. To obtain an accurate reading, a high-impedance meter (such as a digital meter) must be used.

Thermistors in the VAV control system have a 5 vdc signal applied across them any time the unit control circuit is energized. The voltage drop across the thermistor is directly proportional to the temperature and resistance of the thermistor.

To determine temperatures at the various thermistor locations, disconnect the thermistor from the processor board and measure the resistance across the appropriate thermistor using a high-quality digital ohmmeter. Use the resistance reading to determine the thermistor temperature.

The microprocessor has been programmed to check the operation of the thermistors. If the measured temperature is outside of the range of -24 to 225 F or 98,010 to 282 ohms, then it will be treated as a sensor failure and a diagnostic code will be displayed. See Table 17 for sensor temperatures versus resistance drop. It is also possible to check the operation of the thermistors using the quick test routine.

If a thermistor has failed or the wire is damaged, replace the complete assembly. Do not attempt to splice the wires or repair the assembly.

**Electronic Controls Checkout** — The following will help determine whether a processor board, a relay board, display set point board, accessory board, or 2-step demand limit module is faulty.

Before checking out any board, do the following:

1. At initial start-up, enter the Quick Test mode. This test will determine if all components are connected and operating properly.
2. If system has been operating and a malfunction occurs, check display for diagnostic codes. Use diagnostic chart located on inner panel of access door to control box section of unit; this chart will help determine probable cause of failure.

These 2 steps will help determine if a component other than a board is at fault or if the problem is external to control circuit.

A volt-ohmmeter will be needed to troubleshoot boards. A digital meter is preferred but a Simpson 260 or equivalent will work.

**⚠ CAUTION**

To prevent damage to solid-state electronic components on boards, meter probes should only be placed on terminals and test points listed in following sections. Do not short the electrical components, and use extreme care while working on the processor board.

**PROCESSOR BOARD CHECKOUT** — Refer to Fig. 44 and 45 for location of terminal pins and test points.

**Step 1 — Check Transformer Input to the Board** — Connector J4 is used to connect the control transformer to the processor board.

1. Set the volt-ohmmeter to ac voltage with a range setting of approximately 30 v.
2. Turn control switch to ON position.
3. Check voltage at following terminals on pin terminal connector J4:

TERMINALS	VOLTAGE (AC)
1 to 2	15.3 to 20.9
4 to 6	16.2 to 22.0
5 to 6	8.1 to 11.0
5 to 4	8.1 to 11.0

4. If voltage is not within range, check primary side.  
115-v transformer — 104 to 127 vac  
230-v transformer — 207 to 254 vac
5. If primary voltage is not correct, check system fuse, transformer, ON-OFF switch, and wiring. If these are okay, contact power company.
6. If primary voltage is correct, but secondary voltage ( $24\text{ v} \pm 10\%$ ) is incorrect, replace transformer.
7. Turn control switch to OFF position.

**Step 2 — Check Processor Board Power Supply**

1. Set meter to approximately 20 vdc.
2. Turn power to OFF position.
3. Connect negative lead to TP18.
4. Turn power switch to ON position and press display button to enter Quick Test mode.
5. Check voltage between TP18 and each of the following test pins:

TEST PIN	VOLTAGE (DC)
TP3	+10
TP4	+12
TP6	+5
TP10	+5
TP14	+12
TP15	+12
TP7	-5*

\*If not using a digital meter, leads must be reversed.

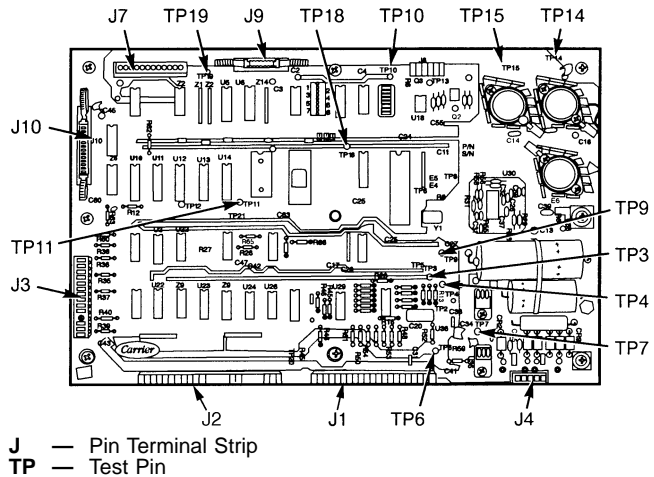
6. If voltage is incorrect, replace processor board.
7. Turn power to ON position.

**Step 3 — Check Voltage Tolerance Circuitry**

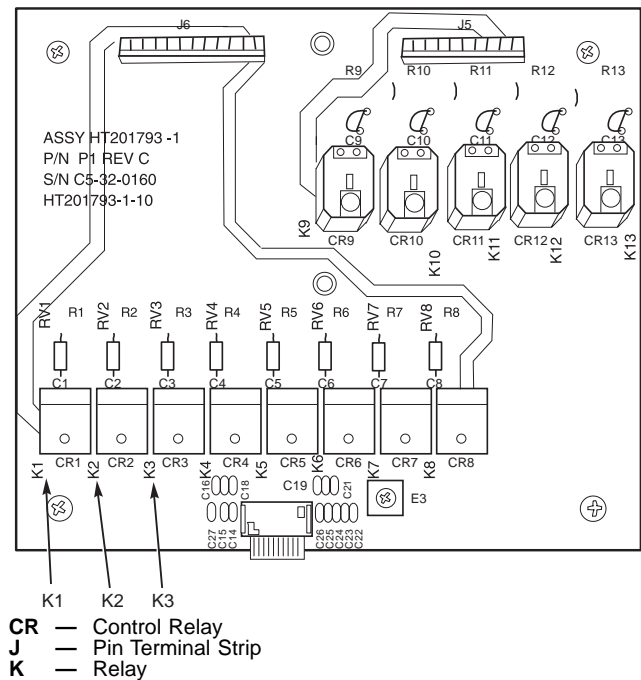
1. Turn power to OFF position.
2. Negative test probe on TP18 and system in Quick Test mode.
3. Check voltage TP18 to TP9.
4. If voltage is greater than +1 vdc, recheck transformer input voltage.
5. If transformer is okay, replace processor board.
6. Turn power to ON position.

**Step 4 — Check Processor Reset Line**

1. Turn power to OFF position.
2. Negative probe on TP18.
3. Check voltage TP18 to TP11.
4. If voltage is greater than +3 vdc, reset power and re-check.
5. If voltage is still incorrect, replace processor board.
6. Turn power to ON position.



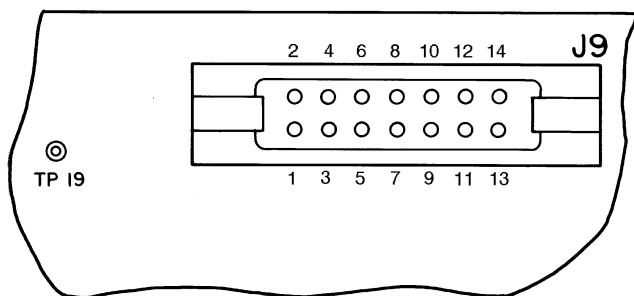
**Fig. 44 — Processor Board Test Points**



**Fig. 45 — Relay Board Test Points**

**Step 5 — Check Relay Board Outputs from the Processor Board** — This step involves checking the output signals from relays K1-K3 on the relay board.

1. Turn power to OFF position.
2. Connect negative test probe to TP19 (meter still set to dc).
3. Turn switch to ON position and enter Quick Test mode.
4. Connect positive test probe to terminal 14 on pin terminal connector J9, and check voltage from TP19 to terminal 14 on pin terminal connector J9.
5. If not  $+12 \pm 1$  vdc, replace processor board.
6. Turn switch to OFF position.
7. Remove negative test probe from TP19. Connect positive test probe to TP15.
8. Turn switch to ON position and go into Quick Test mode.
9. Place negative lead on terminals shown in Table 22, and check voltage between TP15 and terminals shown in Table 22 on pin terminal connector J9. See Fig. 46 for J9 details.



**Fig. 46 — Relay Board Pin Terminal Connector (J9)**

**Table 22 — Voltage Reading**

QUICK TEST STEP NO.	J9 PIN NUMBERS												
	1	2	3	4	5	6	7	8	9	10	11	12	13
<b>1.-2.3.</b>	0	0	0	0	0	0	0	0	0	0	0	0	12
<b>2.4.</b>	0	0	0	0	0	0	12	0	0	0	0	0	12
<b>2.5.</b>	0	0	0	0	0	0	0	12	0	0	0	0	12
<b>2.6.</b>	0	0	0	0	0	0	0	12	0	12	0	0	12
<b>2.7.</b>	0	0	0	0	0	0	0	12	0	0	12	0	12
<b>2.8.</b>	0	0	0	0	0	0	0	12	0	0	0	12	12
<b>2.9.</b>	<b>12</b>	0	0	0	0	0	0	12	0	0	0	0	12
<b>3.0.</b>	0	<b>12</b>	0	0	0	0	0	12	0	0	0	0	12
<b>3.1.</b>	0	0	<b>12</b>	0	0	0	0	12	0	0	0	0	12
<b>3.2.</b>	0	0	0	0	<b>12</b>	0	0	12	0	0	0	0	12
<b>3.3.</b>	0	0	0	0	0	<b>12</b>	0	12	0	0	0	0	12

**NOTES:**

1. Pins shown in **boldface type** will only be energized for 10 seconds. All other pins will be energized continuously while at the proper quick test step. The control will only stand in the quick test routine for 10 minutes unless the display button is pressed.
2. Acceptable range for the voltage reading:  
0 v — 0 to 4 v  
12 v — 11 to 13 v
3. If any of these voltages are not measured, replace the processor board.

**Step 6 — Display Board Connection Checkout**

1. Turn power to OFF position.
2. Disconnect the ribbon cable.
3. Connect negative lead of meter to TP18.
4. Turn power to ON position and go into Quick Test mode.

5. Place the other lead on terminals shown in table below, and check voltage at pin terminals on pin terminal connector J10 (see Fig. 47 for pin terminal connector J10 details):

PIN TERMINAL	VOLTAGE (DC)
<b>17</b>	5
<b>18</b>	5
<b>20*</b>	2.5
<b>22*</b>	2.5
<b>24</b>	5

\*Voltage reading is dependent on the meter's impedance. Readings may vary with different meters.

6. If voltage is not correct, replace processor board.

**Step 7 — Potentiometer Connection Checkout.**

1. Turn power to OFF position.
2. Remove plug connection from pin terminal strip J3.
3. Connect negative meter lead to terminal 2 of J3.
4. Turn switch to ON position and go into Quick Test mode.
5. Place the other lead on terminals shown in table below, and check voltage at pin terminals on terminal connector J3:

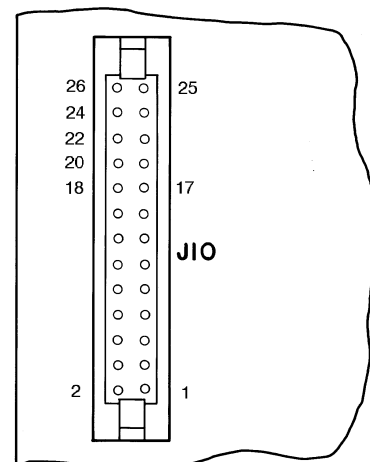
PIN TERMINAL	VOLTAGE (DC)
<b>1*</b>	2.5
<b>3</b>	5
<b>6</b>	5
<b>8*</b>	2.5
<b>10*</b>	2.5
<b>12</b>	5
<b>13*</b>	2.5
<b>14*</b>	2.5

\*Voltage reading is dependent on the meter's impedance. Readings may vary with different meters.

6. If voltage is not correct, replace processor board.

**Step 8 — Thermistor Input Connector Checkout**

1. Turn power to OFF position.
2. Remove the thermistor connections from pin terminal connector J1, and mark them for later replacement.
3. Connect the negative test lead to test pin TP18.
4. Turn power to ON position, and enter the Quick Test routine.
5. Place the other lead on terminals shown in Table 23, and check the voltages.
6. If voltages are incorrect (per Table 23), replace processor board.
7. Turn power to OFF position, and replace the thermistor connections removed in Step 2.
8. Turn power to ON position.



**Fig. 47 — Display Board Pin Terminal Connector (J10)**

**Table 23 — Pin Terminal Connector J1 Voltages**

PIN TERMINAL	VOLTAGE (vdc ± 0.25 v)
1	0
2	5
6	0
7	5
8	0
9	5
10	0
11	5
12	0
13	5
14	0
15	5
16	0
17	5
18	0
19	5
20	0
21	5

**Step 9 – Thermistor Input Connector Checkout**

1. Turn power to OFF position.
2. Disconnect all plugs for pin terminal connector J2 and mark them for later replacement.
3. Connect a negative test lead to test pin TP18.
4. Turn power to ON position, and enter the Quick Test routine.
5. Place the other lead on terminals shown in Table 24, and check the voltages.
6. If voltages are incorrect (per Table 24), replace processor board.
7. Turn power to OFF position, and replace the plugs removed in Step 2.
8. Turn power to ON position.

**Table 24 — Pin Terminal Connector J2 Voltages**

PIN TERMINAL	VOLTAGE (vdc ± 0.25 v)
1	0
2	5
3	0
4	5
7	0
8	5
9	0
10	5
13	0
14	5
15	5
17	5
18	5
19	5
20	5
21	5
22	5
23	5
24	5

If Steps 1 through 9 have been completed and the unit still will not function properly, replace the processor board.

**RELAY BOARD TROUBLESHOOTING** — The relay board contains 13 electromechanical relays. The small relays are 24 vac, and the large relays are 115 vac. These relays are controlled by the processor through the ribbon cable attached to the relay board.

The following procedure can be used to check out the operation of the relays. To do this, turn the control ON/OFF switch to the OFF position, and remove the wiring connectors connected to pin terminal connectors J5 and J6. Set the meter for resistance. If the contacts do not close at the required quick test step, check the relay outputs from the processor board.

**Relay Board Checkout (Fig. 5)**

*Step 1 — Low-voltage relay resistance check.*

1. Turn switch to OFF position.
2. Remove plug connection from terminal strip J6.
3. Set meter to measure resistance. Connect negative test lead to both terminals 11 and 12 of J6.
4. Turn switch to ON position and go into quick test mode.
5. Place other meter lead on terminals shown in Table 25 and check resistances at each quick test step.
6. If these resistances are not correct and relay board outputs from processor board have been checked out, replace relay board.

*Step 2 — High-voltage relay resistance check.*

1. Turn switch to OFF position.
2. Remove plug connection from terminal connector J5.
3. Connect negative test lead to terminal 8.
4. Check the resistance between terminals 8 and 5 before entering Quick Test mode. The resistance should be infinity.
5. Turn switch to ON position and go into Quick Test mode.
6. Place other meter lead on terminals shown in Table 26 and check resistance at each quick test step.
7. If these resistances are not correct and relay board outputs from processor board have been checked per Processor Board Checkout section on page 44, replace relay board.

**DISPLAY BOARD CHECKOUT**

**Step 1 — Check the Output Voltage from Processor Board to the Relay Board** — Refer to Step 6 — Display Board Connection Checkout section on page 45.

**Table 25 — Terminal Strip J6 Connection Resistance Reading**

QUICK TEST STEP NO.	J6 PIN NUMBERS							
	1	2	3	4	5	6	7	8
<b>1. to 2.3.</b>	∞	∞	∞	∞	∞	∞	∞	∞
<b>2.4.</b>	∞	∞	∞	∞	∞	∞	0	∞
<b>2.5.</b>	∞	∞	∞	∞	∞	∞	∞	0
<b>2.6.</b>	∞	∞	∞	∞	∞	∞	∞	∞
<b>2.7.</b>	∞	∞	∞	∞	∞	∞	∞	∞
<b>2.8.</b>	∞	∞	∞	∞	∞	∞	∞	∞
<b>2.9.</b>	<b>0</b>	∞	∞	∞	∞	∞	∞	∞
<b>3.0.</b>	∞	<b>0</b>	∞	∞	∞	∞	∞	∞
<b>3.1.</b>	∞	∞	<b>0</b>	∞	∞	∞	∞	∞
<b>3.2.</b>	∞	∞	∞	∞	<b>0</b>	∞	∞	∞
<b>3.3.</b>	∞	∞	∞	∞	∞	<b>0</b>	∞	∞

∞ — Infinity

NOTE: Pins shown in **boldface** type will be energized for only 10 seconds. All other pins will be energized continuously while at the proper quick test step. The control will remain in the Quick Test mode for only 10 minutes unless the display button is pressed.

**Table 26 — Terminal Strip J5 Connector Resistance Reading**

QUICK TEST STEP NO.	J5 PIN NUMBERS				
	1	2	3	4	5
1. to 2.5.	∞	∞	∞	∞	0
2.6	0	0	∞	∞	0
2.7.	0	∞	0	∞	0
2.8.	0	∞	∞	0	0
2.9. to 3.3.	0	∞	∞	∞	0

∞ — Infinity

**Step 2 — Check the Display LEDs**

1. Enter Quick Test mode.
2. If 88 is not displayed, replace display board.

**Step 3 — Check Set Point Potentiometer** — Advance the display to quick test step 1.9. to determine if this potentiometer is set and connected properly.

**Step 4 — Check Display Switch** — Press switch. If switch does not click, it is faulty and the display will be energized continuously. The switch is an integral part of display board and cannot be replaced separately.

**ACCESSORY BOARD CHECKOUT** — The accessory board can be completely checked using quick test steps 2.0., 2.2., and 2.3. It can also be checked out as follows:

1. Remove the accessory board connector from the processor board and connect an ohmmeter to terminals 3 and 4 on the connector. Numbers are marked on the connector. See Fig. 15.
2. Set the meter to 10,000 ohms. The resistance value obtained should be 3,333 ohms. Adjust the potentiometers and the resistance value should not change.
3. Connect the ohmmeter to terminals 3 and 6. As the reset limit potentiometer is turned clockwise, resistance should increase from 0 to approximately 3,400 ohms.
4. Connect the ohmmeter to terminals 3 and 5. As the economizer minimum position potentiometer is turned clockwise, resistance should increase from 0 to approximately 3,400 ohms.
5. Connect the ohmmeter to terminals 3 and 2. As the warm-up set point potentiometer is turned clockwise, resistance should increase from 0 to approximately 3,400 ohms.

If any of the Steps 1 through 5 result in any other ohm reading, replace the board; it cannot be serviced.

**TWO-STEP DEMAND LIMIT CONTROL MODULE (DLCM) TROUBLESHOOTING** — If a problem is suspected in the DLCM board, use the following test procedure:

The board can only be checked when it is connected to the processor and the processor is energized so that the DLCM is supplied with 5 vdc power. The terminals referenced are shown in Fig. 16. Potentiometers P1 and P2 refer to the DLCM potentiometers.

**IMPORTANT:** Be careful to avoid damaging the connector or the processor board when taking the voltage readings.

- Test under the following conditions:
- No power to IN1 or IN2  
Terminal 1 to 2 should read 4.5 vdc ±0.1 v  
Terminal 2 to 3 should read 5.0 vdc ±0.1 v
  - Power to IN2 or to both IN1 and IN2, and P2 set at 24%  
Terminal 1 to 2 should read 1.5 vdc ± 0.1 v

NOTE: Voltage should vary between 0.5 vdc and 2.5 vdc as the setting of P2 is varied between 0% and 49%.

- Terminal 2 to 3 should read 5.0 vdc ± 0.1 v
- Power to IN1 only and P1 set at 50%  
Terminal 1 to 2 should read 2.5 vdc ± 0.1 v  
Terminal 2 to 3 should read 5.0 vdc ± 0.1 v

NOTE: Voltage should vary between 0.5 vdc and 2.5 vdc as the setting of P2 is varied between 50% and 100%.

NOTE: If the voltages listed in these 3 tests are not obtained during testing, the DLCM board must be replaced.

**Enthalpy Sensor Checkout** — To test operation of enthalpy sensor, see Table 27.

**Table 27 — Enthalpy Sensor Checkout**

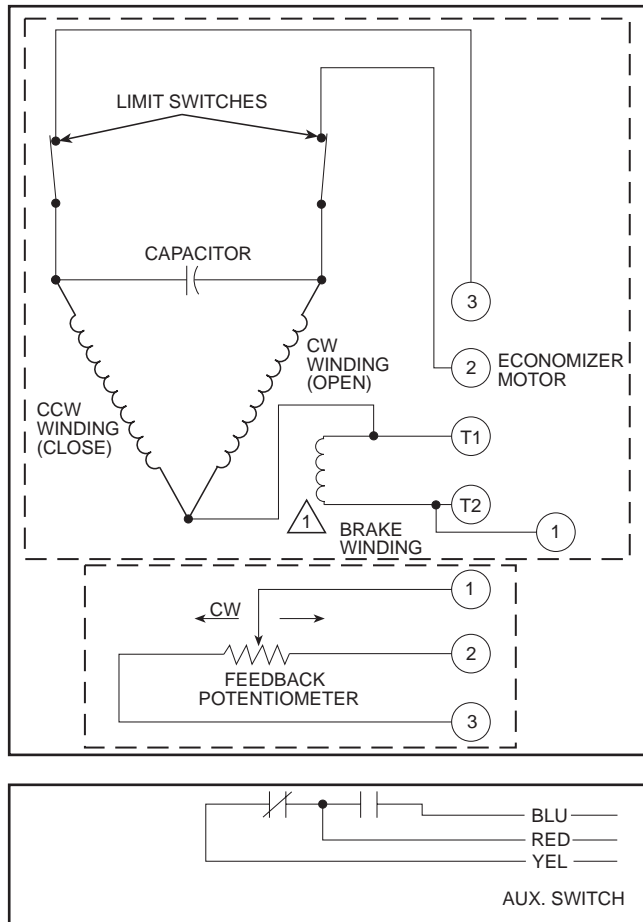
TEST	EXPECTED RESULT AND RESPONSE
<i>Outdoor-air sensor:</i> Enthalpy sensor + terminal should be connected to + terminal on motor. Connect the positive terminal of a DC milliammeter to the S terminal of the sensor and the negative terminal of the meter to S <sub>O</sub> terminal of the enthalpy board.	Milliammeter reading should be between 3 and 24 mA if sensor is operating correctly. If reading is 0 mA, the sensor is either wired backwards or is defective.
<i>Indoor-air sensor:</i> Enthalpy sensor + terminal should be connected to + terminal on motor. Connect the positive terminal of a DC milliammeter to the S terminal of the sensor and the negative terminal of the meter to S <sub>R</sub> terminal of the enthalpy board.	Milliammeter reading should be between 3 and 24 mA if sensor is operating correctly. If reading is 0 mA, the sensor is either wired backwards or is defective.

**Economizer Motor** — All control of the motor (i.e., enthalpy changeover, minimum position control and mixed air control) is accomplished from the main unit microprocessor through a relay board. Service and installation instructions for the unit should be consulted to verify proper operation of these controls. The economizer motor may be checked out separately. See Fig. 48 for VAV economizer motor connection information.

**Motor Test**

Apply 24 volt AC power to terminals T1 and T2 of motor. Connections to motor terminals 2 and 3 must be disconnected

<u>A Motor Test</u>	<u>A Expected Result and Response</u>
Jumper 1 to 2 at motor	Motor drives open; if not, replace motor.
<u>B Motor Test</u>	<u>B Expected Result and Response</u>
Jumper 1 to 3 at motor	Motor drives closed; if not, replace motor.



**LEGEND**  
**CCW** — Counterclockwise  
**CW** — Clockwise

**Fig. 48 — Damper Motor Connection Diagram (VAV)**

**VFD Status Monitoring** — The inverter operates with varying levels of supply voltage and current. A variable output frequency of voltage and current is generated to drive the motor load. These input and output levels of operating voltage and current are continually monitored by the inverter. It also monitors for overtemperature, input and output terminal settings, and condition of the microprocessor with associated memory elements. These operating settings and variables have a certain value or “status” associated with them and are used for inverter operation. They can also be monitored by the operator to show the setup and conditions existing at any time. Three types of status monitoring are used. Refer to the separate VFD Operational Manual for tables of the displays and explanation of codes.

**NORMAL STATUS MONITORING** — Normal status monitoring occurs during normal operation. The ST-CC terminal must be closed to run. The display values are for factory settings where no trips or errors occurred. The display will change only if a new value is programmed into the associated group adjustment range or if trips or errors have occurred. Scrolling occurs by repeatedly pressing the “READ/WRITE” key after output frequency is displayed.

**AUTOMATIC STATUS MONITORING** — Automatic status monitoring displays abnormal status conditions that can occur during normal inverter operation. These conditions will cause warnings and error messages to be displayed but will not cause the inverter to trip. These displays usually appear during the time that the abnormal condition is occurring and will go away when it is corrected. The abnormal condition should be corrected as soon as possible.

**TRIPPED STATUS MONITORING** — Tripped status monitoring displays abnormal status conditions that can occur during normal inverter operation. These abnormal conditions will cause the inverter to trip “off” (stop normal operations). They are usually caused by excessive power dissipation in either the inverter or motor, or by other circuit abnormalities. A tripped status monitoring display usually appears during the time that the abnormal condition is occurring and then remains on the display after the inverter trips off. The inverter will remain off and the tripped status will remain displayed until the inverter is attended to (reset) by the operator. Most conditions which cause the inverter to trip, occur very rapidly and the operator usually will not be aware that the trip conditions are in process until the inverter has stopped. Each of the trip statuses are automatically recorded in the non-volatile EPROM memory of the inverter. An ordered semi-permanent record of each trip (up to four) is created and can be viewed during the normal status monitoring “scroll.” These recorded trips are viewed immediately after the keypad’s software version, in the order that they occurred, as the “READ/WRITE” key is pressed. These trips remain in the memory until replaced by new trips.

## LEGEND AND NOTES FOR FIG. 49

<b>BP</b>	— Building Pressure	<b>LAT</b>	— Leaving-Air Temperature
<b>C</b>	— Contactor	<b>LPS</b>	— Low-Pressure Switch
<b>CCB</b>	— Control Circuit Breaker	<b>MPER</b>	— Modulating Power Exhaust Relay
<b>COMP</b>	— Compressor	<b>MTR</b>	— Motor
<b>CR</b>	— Control Relay	<b>MV</b>	— Main Valve
<b>DPT</b>	— Discharge Pressure Transducer	<b>NC</b>	— Normally Closed
<b>EC</b>	— Enthalpy Control	<b>NO</b>	— Normally Open
<b>ECR</b>	— Economizer Close Relay	<b>OFM</b>	— Outdoor (Condenser) Fan Motor
<b>EOR</b>	— Economizer Open Relay	<b>PCB</b>	— Power Exhaust Circuit Breaker
<b>EQUIP</b>	— Equipment	<b>PEC</b>	— Power Exhaust Contactor
<b>FS</b>	— Fan Status Switch	<b>PEM</b>	— Power Exhaust Motor
<b>GND</b>	— Ground	<b>P, PL</b>	— Plug
<b>HIR</b>	— Heat Interlock Relay	<b>PS</b>	— Power Supply (5 VDC)
<b>HPS</b>	— High-Pressure Switch	<b>PSIO</b>	— Processor Module
<b>HR</b>	— Heater Relay	<b>RCB</b>	— Return Fan Circuit Breaker
<b>HSIO</b>	— Keypad and Display Module	<b>RES</b>	— Resistor
<b>HV</b>	— High Voltage	<b>RFC</b>	— Return Fan Contactor
<b>IDC</b>	— Induced Draft Contactor	<b>RFM</b>	— Return Fan Motor
<b>IDM</b>	— Induced Draft Motor	<b>TB</b>	— Terminal Block
<b>IFC</b>	— Indoor (Evaporator) Fan Contactor	<b>U</b>	— Unloader
<b>IGV</b>	— Inlet Guide Vanes	<b>VFD</b>	— Variable Frequency Drive
<b>IGVM</b>	— Inlet Guide Vanes Motor		

### NOTES:

1. Connect TRAN1 to  $\langle H4 \rangle$  for 460 v units. Connect to  $\langle H3 \rangle$  for 230 v units. If 208/230 v units are run with a 208 v power supply connect to  $\langle H2 \rangle$ .
2. Connect TRAN2 to BLK lead for 460 v units. Connect to ORN lead for 230 v units. If 208/230 v units are run with a 208 v power supply connect to RED lead.
3. Circuit breaker must trip amps are equal to or less than 156% FLA for CB1 and CB2. All others are 140%.
4. If any of the original wire furnished must be replaced, it must be replaced with type 90° C wire or its equivalent.
5. Number(s) indicates the line location of contacts. A bracket over (2) numbers signifies single pole double throw contacts. An underlined number signifies a normally closed contact. Plain numbers (no lines), signify a normally opened contact.
6. Condenser fan motors are thermally protected.
7. Three phase motors are protected under primary single phasing conditions.

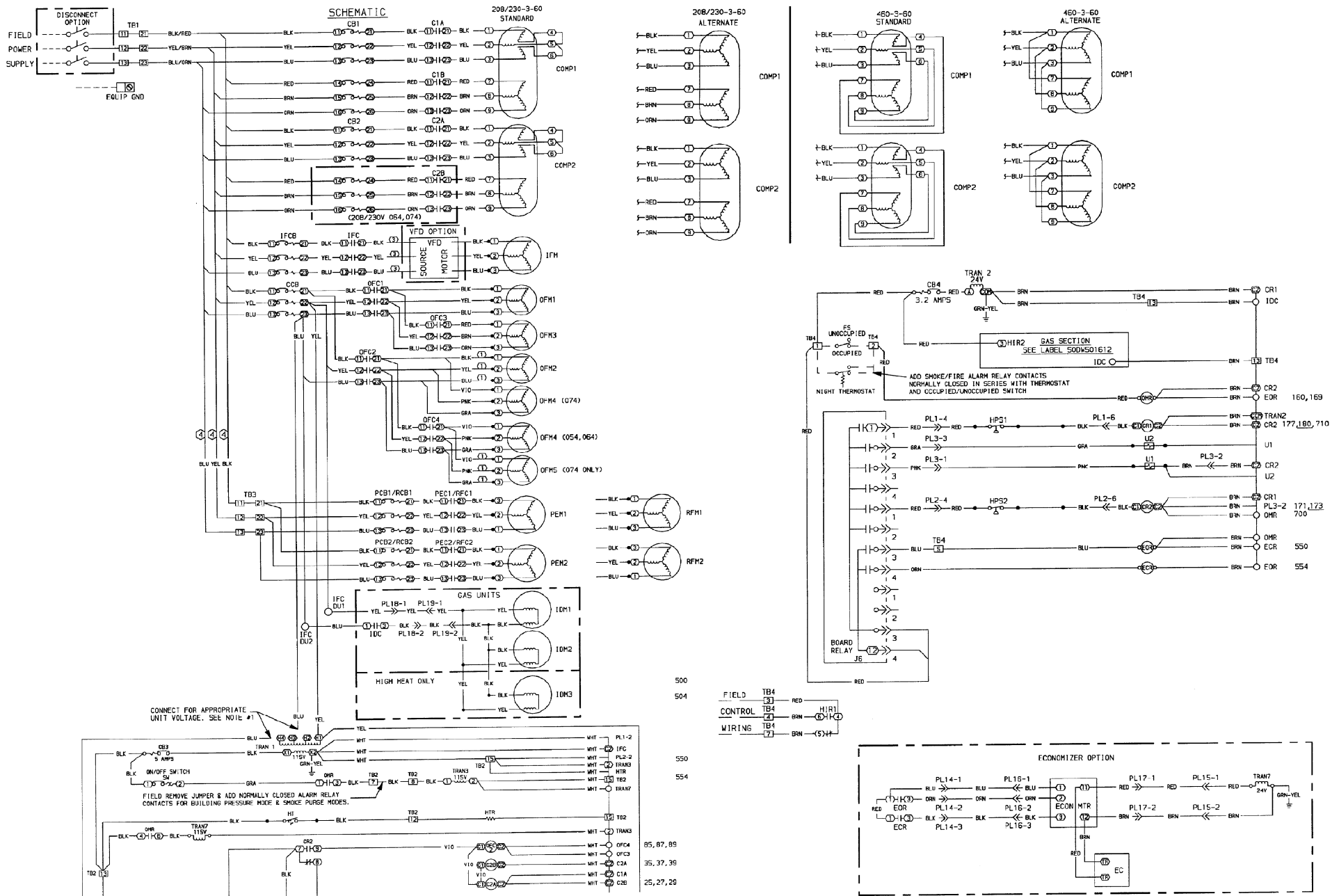


Fig. 49 — Typical Wiring Schematic; 48FK, JK and 50FK, FY, JK, JY Units (054-074 Shown)

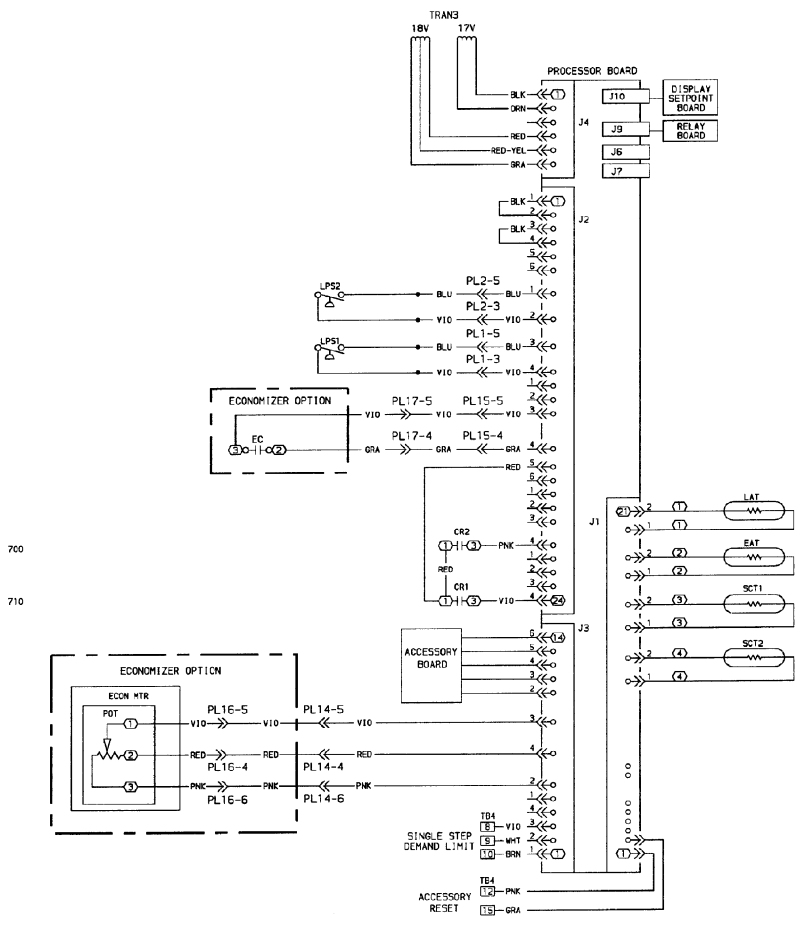
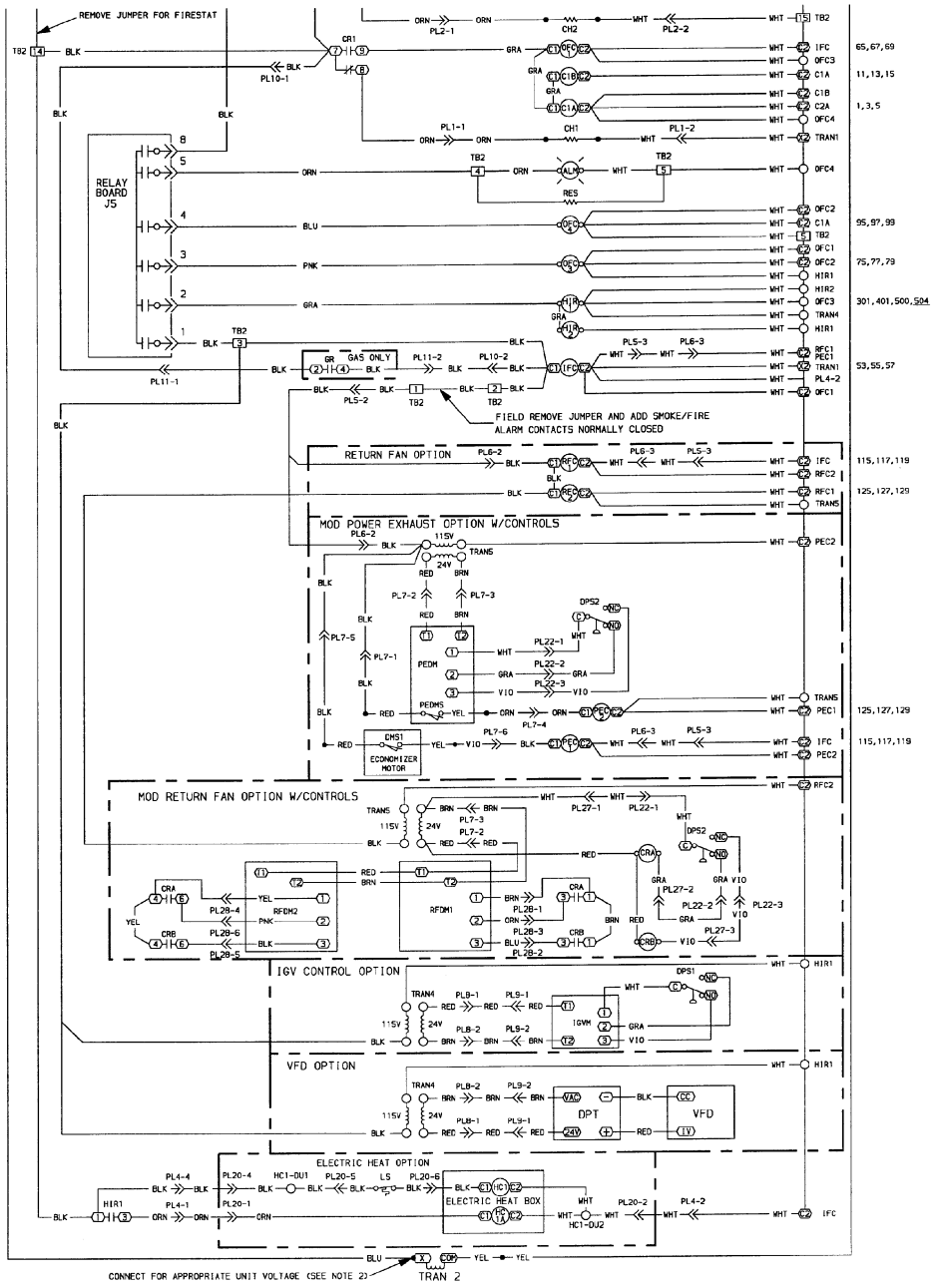


Fig. 49 — Typical Wiring Schematic; 48FK,JK and 50FK,FY,JK,JY Units (054-074 Shown) (cont)

## SERVICE TRAINING

**Packaged Service Training** programs are an excellent way to increase your knowledge of the equipment discussed in this manual, including:

- Unit Familiarization
- Installation Overview
- Maintenance
- Operating Sequence

A large selection of product, theory, and skills programs are available, using popular video-based formats and materials. All include video and/or slides, plus companion book.

**Classroom Service Training** which includes “hands-on” experience with the products in our labs can mean increased confidence that really pays dividends in faster troubleshooting and fewer callbacks. Course descriptions and schedules are in our catalog.

**CALL FOR FREE CATALOG 1-800-962-9212**

Packaged Service Training     Classroom Service Training