

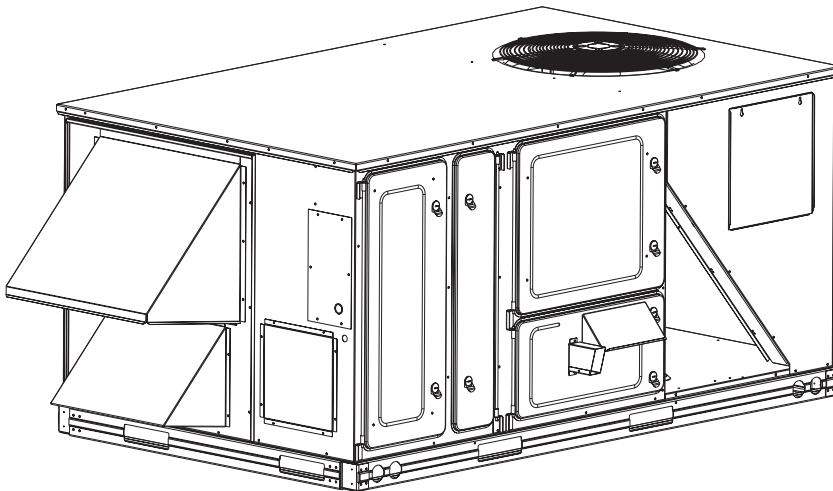

## Product Data

**CENTURION 48PG03-28**  
**Ultra High Efficiency Single Package**  
**Gas Heating/Electric Cooling**  
**Commercial Rooftop Units with**  
**PURON® (R-410A) Refrigerant and**  
**Optional COMFORTLINK™ Controls**  
2 to 25 Nominal Tons



Carrier's CENTURION 48PG Series commercial packaged rooftops offer:

- Puron environmentally sound refrigerant (R-410A)
- Ultra-high efficiencies up to 14.8 SEER and 12.5 EER
- Industry leading sound ratings as low as 72 dB
- TXV refrigerant metering with cooling operation up to 125 F
- Factory-installed Humidi-MiZer™ adaptive dehumidification system
- Hinged access doors with double wall construction
- Convertible duct airflow configuration from vertical to horizontal
- Models with internally sloped, slide-out condensate pan
- Slide-out filter rack with up to 4-in. capabilities
- Slide-out blower motor assembly

## Features/Benefits

**Carrier's Centurion 48PG commercial packaged rooftop unit is the most efficient, easiest to service, and most reliable rooftop unit utilizing Puron refrigerant.**

### Premium performance

The Centurion 48PG Series provides ARI (Air Conditioning and Refrigeration Institute) certified cooling SEERs (Seasonal Energy Efficiency Ratios) up to 14.8, EERs (Energy Efficiency Ratio) up to 12.5 and IPLVs (Integrated Part-Load Values) up to 13.3. Gas heating efficiencies are as high as 82%.



# Features/Benefits (cont)



The 48PG unit well exceeds ASHRAE (American Society of Heating, Refrigeration and Air Conditioning Engineers) 90.1 and ENERGY STAR® levels. These efficiency ratings ensure low operating costs, qualify for attractive utility rebates in many areas and earn credits for Leadership in Energy and Environmental Design (LEED™) issued by Green Building Council.

These units offer ultra-high energy efficiency and environmental benefits by utilizing Carrier's Puron® (R-410A) refrigerant that eliminates all concerns of mandated refrigerant phase out of R-22 (HCFC) in 2010. Each unit has been specifically designed for use with Puron refrigerant to provide years of optimum efficiency.

## Easy installation

The 48PG rooftop units accommodate easy installation.

**Field-convertible units** easily switch from vertical to horizontal configuration. Units come factory standard with vertical discharge and return duct configuration but can be easily converted in the field for horizontal airflow. If needed, a factory option can be ordered to specifically meet your exact configuration, further saving installation costs.

The entire Centurion 48PG Series from 2 to 25 ton only uses 5 roof curb sizes. The contractor can order and install the roof curb early in the construction stage, before decisions on size requirements are made.

Unit controls provide optimum flexibility to meet any application or customer requests. A choice of either base electro-mechanical controls or the popular integrated intelligent *ComfortLink™* controls can be ordered from the factory.

Large component areas facilitate easy installation for electrical, gas or any other field accessory that may be required.

All units feature rigid base rails with rigging holes for easier maneuvering, rigging, and lifting to and on the job site. Durable packaging protects all units during shipment and storage.

A full range of time saving factory-installed options are available such as power exhaust, hail guards, breakers, smoke detectors, and air management devices. All factory options are pre-engineered and certified.

**Large and accessible wiring terminal boards**, located in the base unit control box, facilitate connections to room thermostat, outdoor thermostat(s), and economizer. Hinged service panels are provided, permitting easy access.

**Thru-the-curb power and control wiring connections** route through both the curb and unit, minimizing roof penetrations. Connections are located in an enclosed area away from harsh ambient conditions, eliminating water entry. Both power and control connections are made on the same side of the unit to simplify installation. In addition, color-coded and labeled wires permit easy tracing and diagnostics.

The Carrier Centurion units with *ComfortLink* controls will operate in the cooling mode down to 0° F ambient temperature, eliminating the need for expensive aftermarket low ambient controllers while providing comfort in the harshest environments.

## Easy maintenance and service

Maintaining and servicing a rooftop unit has never been easier thanks to the new Centurion design. Integrated hinged access panels for the filter, indoor-fan motor/blower assembly, compressors, control box, and gas heat areas provide quick access to major components.

**Each hinged panel has multiple heavy-duty quarter-turn latches** and is permanently mounted to the unit, thereby eliminating the concern of a dropped or wind-blown panel puncturing delicate roof materials. Door tie downs are also provided to ensure panels remain stationary, eliminating any panel blowback conditions.

**Indoor fan system slides out for easy access.** Blower wheels, motors, belts, and bearings can be easily serviced and maintained.

**Evaporator and condenser coils are of a single slab/single pass design** that facilitates optimum cleaning without unit disassembly or coils separation as with hybrid type coil designs. Each coil has a dedicated access door to ensure ease of cleaning.

**Optional ComfortLink controls** provide temperature, pressure readings and all diagnostics electronically on the unit by utilizing a large visual display on the Scrolling Marquee. All messages are largely displayed in full text so no decoding is required. All sensor information can be accessed at the Scrolling Marquee, so no gages are needed. If remote capabilities are necessary, *ComfortLink* provides network capabilities as well.

## Optional Humidi-MiZer™ adaptive dehumidification system

Carrier's Humidi-MiZer adaptive dehumidification system is an all-inclusive factory-installed option that can be ordered with any Centurion 48PG03-28 rooftop unit to meet the demand for providing a flexible and high performing solution to accommodate all of these design related issues.

This system expands the envelope of operation of Carrier's Centurion rooftop products to provide unprecedented flexibility to meet year-round comfort conditions.

The Humidi-MiZer adaptive dehumidification system has the industry's only dual dehumidification mode setting. The Humidi-MiZer system includes two new modes of operation.

# Table of contents

Features/Benefits . . . . .	1-4
Model Number Nomenclature . . . . .	5
ARI Capacity Ratings . . . . .	6-9
Physical Data . . . . .	10-15
Options and Accessories . . . . .	16,17
Base Unit Dimensions . . . . .	18-21
Accessory Dimensions . . . . .	22-29
Selection Procedure . . . . .	30
Performance Data . . . . .	31-140
Electrical Data . . . . .	141-148
Typical Wiring Schematics . . . . .	149-156
Controls . . . . .	157-163
Application Data . . . . .	164,165
Guide Specifications . . . . .	166-172



The Centurion 48PG03-28 rooftop coupled with the Humidi-MiZer system is capable of operating in normal design cooling mode, subcooling mode, and hot gas reheat mode. Normal design cooling mode is when the unit will operate under its normal sequence of operation by cycling compressors to maintain comfort conditions.

Subcooling mode will operate to satisfy part load type conditions when the space requires combined sensible and a higher proportion of latent load control. Hot Gas Reheat mode will operate when outdoor temperatures diminish and the need for latent capacity is required for sole humidity control. Hot Gas Reheat mode will provide neutral air for maximum dehumidification operation.

**Optional fan and filter indicator switches** will alert necessary personnel when filters require changing or the system fan is not operating properly.

**Dedicated hinged filter door and with an Easy Glide™ slide out filter tracks** make air filter replacement easy. This eliminates the need to reach within the unit. All filters are a standard off-the-shelf size for easy availability and lower replacement costs.

Compressors are located in a dedicated insulated compartment that allows troubleshooting without creating air bypass that causes mis-readings and diagnostics.

### **Indoor air quality begins with Carrier rooftops**

Two-in. disposable filters are factory furnished as standard in every unit with the capability of accommodating 4-in. filters as well as factory-installed MERV-8 pleated filters. The same track is used so no special field kits are required on 48PG03-16 units. On 48PG20-28 units a factory-installed option is available.

**Internally sloped condensate pans** are self-draining to ensure minimizing biological growth in rooftop units in accordance with ASHRAE Standard 62.

All 48PG03-16 units use a high impact polycarbonate slide-out condensate pan while the 48PG20-28 units use an epoxy powder-coated steel condensate pan.

Unit uses foil-faced cleanable insulation that is securely fastened. Selected panels are mechanically fastened for added support. All edges are either

sealed or encapsulated so no fibers enter the airstream.

**Optional tilt-out economizers (sizes 03-14)** with single enthalpy controls maximize building humidity control.

**Built-in capability for DCV** (demand control ventilation) is standard and integrates with CO<sub>2</sub> sensors, both as a factory-installed option or a field-installed accessory.

**Belt-driven evaporator fans** provide quiet and efficient operation. The belt-driven evaporator-fan with variable-pitch pulleys allows adjustment to available static pressure to meet the job requirements of even the most demanding applications. Multiple motor and drive options are available to match system airflow and static pressure requirements.

### **Durable, dependable construction**

**Weather-resistant cabinets** are constructed of galvanized steel and all exterior panels are coated with a prepainted baked enamel finish. The paint finish is a non-chalking type that provides years of maximum aesthetic protection.

**Fully-insulated cabinets** include non-fibrous, foil-faced cleanable insulation that is mechanically secured and encapsulated in unit design.

Totally enclosed condenser-fan, gas heat vent motor, and evaporator fan motor use permanently lubricated bearings to provide additional unit dependability. The shaft-down design of the condenser fan also ensures protection from the continued harsh environments.

### **Quality and reliability**

To assure optimum life expectancy and performance, every rooftop unit is factory run tested prior to shipping to the job site. Individual components are also tested at many levels to assure that only the best parts make it into the Carrier rooftop units. All units are manufactured in a facility registered to ISO 9001:2000.

**Reliable, fully hermetic scroll compressors** with crankcase heater(s) are mounted on a dedicated formed pad and are secured for quiet operation.

**A TXV (thermostatic expansion valve)** for refrigerant metering on each circuit allows efficient operation up to 125 F ambient cooling temperature, with removable power head.

Each circuit contains a solid core liquid line filter drier specifically designed for Puron® refrigerant systems.

Units contain provisions to eliminate internal damage if a blower motor belt breaks or comes off during operation. Specially located stop bars or strategically located belt drive eliminates damages to sensitive areas such as coils, piping and metering devices.

**Standard warranty coverage** provides one-year parts warranty, 5-year compressor warranty, and 10-year aluminized gas heat exchanger warranty (15 years on stainless steel heat exchanger).

### **Integrated economizers and outdoor air management**

During a call for cooling, if the outdoor-air temperature is below the control changeover set point, unit control modulates the economizer outdoor-air damper open to achieve the set point. If economizer cooling is not sufficient, additional compressor stages are energized in addition to the economizer. If the outdoor-air temperature is above the changeover set point, the first stage of compression is activated and the economizer stays at minimum position. Economizer operation is controlled by a thermistor that senses outdoor-air temperature.

**Gear driven, spring return, close on power loss economizers** with dry bulb or single enthalpy are available as a factory-installed option as well as two-position motorized dampers, manual dampers and power exhaust. All provide the flexibility to meet any application needs or codes.

### **Ultra low sound**

**Outdoor sound levels of 72 dB** are the lowest in the industry for this type of equipment. Low sound levels allow for maximum installation flexibility and greater indoor environmental comfort, and reduce or eliminate the need for expensive sound barriers required by many others.

### **Integrated gas heating unit controller (IGC) provides 2-stage heating capacity control on all sizes.**

All ignition components are contained in the compact IGC that is easily accessible for servicing. The IGC control board, designed and manufactured exclusively for Carrier rooftop units, provides built-in diagnostic capability. An

# Features/Benefits (cont)



LED (light-emitting diode) simplifies troubleshooting by providing visual fault notification and system status confirmation.

The IGC also contains an anti-cycle protection for gas heat operation. After 4 continuous automatic cycles on the unit high-temperature limit switch, the gas heat operation is disabled, and an error code is issued. This feature greatly improves reliability of the rooftop unit.

The IGC also contains burner control logic for accurate and dependable gas ignition. This LED fault-notification system reduces service person troubleshooting time and minimizes service costs. The IGC can also maximize heating efficiency by controlling evaporator fan on and off delays.

## Efficient, dependable operation

**Tubular, dimpled gas heat exchangers** optimize heat transfer for improved efficiency. The tubular design permits hot gases to make multiple passes across the path of the supply air. The dimpled design creates a turbulent gas flow to maximize heating efficiency. The extra thick Alumagard™ heat exchanger coating provides corrosion resistance and ensures long life. An optional stainless steel heat exchanger is also available.

**The induced draft combustion system** eliminates the unsightly appearance of flue stacks and diminishes the effects of wind on heating operations. The inducer fan draws hot combustion gas through the heat exchanger at the optimum rate for the most effective heat transfer. Induced draft heating systems are safer than positive pressure, forced draft heating systems. With the induced draft heating system, the heat exchanger operates under negative pressure, preventing flue gas leakage into the indoor supply air.

During the Heating mode, the evaporator-fan relay automatically starts the evaporator fan after the heat exchanger warms up to a suitable temperature. The 30-second fan delay prevents cold air from entering the supply duct system when the conditioned space is calling for heat to maximize efficiency.

**The direct-spark ignition system** saves operating expense when compared to pilot ignition systems. No

crossover tube is required, therefore no sooting or pilot fouling problems can occur.

## Safety is built in

All 48PG units have a flame rectification sensor to quickly sense the burner flame. Fast shutdown is a certainty since the sensor reacts quickly to any flame outage or system failure. In the event of a shutdown, an error code is issued at the IGC board.

**Heating safety controls** will shut down the unit if there is a problem. If excessive temperatures develop, limit switches shut off the gas valve. After 4 continuous short cycles of the high-temperature limit switch, the IGC board locks out the gas heat cycle to prevent any further short cycles. This safety feature is provided exclusively on Carrier rooftop units. The rollout switch also deenergizes the gas valve in the event of a flame rollout.

## ComfortLink™ control option

The *ComfortLink* control is your link to a world of simple and easy to use rooftop units that offer outstanding performance and value. When used with a space temperature sensor, the *ComfortLink* control's intelligence maintains control over the economizer and condenser fans and optimizes the performance of the refrigeration circuits as conditions change resulting in the following features:

- better control of temperature and humidity
- superior reliability
- automatic redundancy
- low ambient cooling operation to 0° F
- more accurate diagnostics, at unit or remote

The *ComfortLink* Scrolling Marquee is very easy to use. The messages are displayed in easy to understand English, no decoding is required. A scrolling readout provides detailed explanations of control information. Only four, large, easy-to-use buttons are required to maneuver through the entire menu. The readout is designed to be visible even in the brightest sunlight. A handheld Navigator™ accessory or System Pilot™ device can be used for added service flexibility.

The *ComfortLink* control provides unparalleled service diagnostic information. Temperature and pressure can

be read directly from the display with no need for separate gages. Other data, such as compressor cycles, unit run time hours, current alarms, can also be accessed. A history of alarms is also available for viewing.

The service run test can be very helpful when troubleshooting. The user can run test major components to determine the root cause of a problem. The unit can be run-tested before an installation is complete to ensure satisfactory start-up.

To ensure reliability, the *ComfortLink* control prevents reverse compressor rotation.

No laptop computers are required for start-up. Time schedules are built in and the Scrolling Marquee display provides easy access to set points.

The *ComfortLink* control accepts input from a CO<sub>2</sub> sensor and a smoke detector. Both are available as factory-installed options or as field-installed accessories.

**ComfortLink controls are fully communicating** and are cable-ready for connection to the Carrier Comfort Network® (CCN) communication network. The control communicates at 38.4 kilobaud. This provides high-speed communications for remote monitoring via the Internet. Multiple Centurion rooftop units can be daisy-chained together using a 3-wire communication bus at the rooftop level. The *ComfortLink*/CCN system is a peer-to-peer system, rather than a polling system. This results in lower cost installations.

The Centurion rooftop units have a terminal strip on board, therefore, the Centurion units can operate with a standard thermostat. Expensive interface devices are not required.

## 3V™ control system

The Centurion rooftop unit is linkage compatible for use with the 3V zoning system. Carrier's 3V control system provides optimized equipment control through airside linkage. Linkage allows the Centurion rooftop unit to adjust its supply air temperature set points and occupancy schedules to run in the most efficient manner. The 3V zoning system maintains precise temperature control in the space by regulating the flow of conditioned air into the space using Carrier's VVT® Zone and Bypass Controllers.

*ComfortLink*™

# Model number nomenclature



48PG D C 0 6 A A A 6 - - B B

**48PG** – Single Packaged Rooftop Unit With PURON® Refrigerant Gas Heat Electric Cooling, Constant Volume

**Gas Heat Options**

- D – Low Gas Heat with Aluminized Steel Heat Exchanger
- E – Medium Gas Heat with Aluminized Steel Heat Exchanger
- F – High Gas Heat with Aluminized Steel Heat Exchanger
- L\* – Low Gas Heat with Stainless Steel Heat Exchanger
- M\* – Medium Gas Heat with Stainless Steel Heat Exchanger
- N\* – High Gas Heat with Stainless Steel Heat Exchanger

**Base Unit Control Type**

- C – Integrated ComfortLink™ Controls with Visual Display
- M – Electro-Mechanical Controls†

**Unit Size-Nominal Tons**

03 – 2	12 – 10
04 – 3	14 – 12 1/2
05 – 4	16 – 15
06 – 5	20 – 18
07 – 6	24 – 20
08 – 7 1/2	28 – 25
09 – 8 1/2	

**Controls Options**

- – None
- A – CO2 Sensor
- B – Return Air Smoke Detector
- C – CO2 Sensor, Return Air Smoke Detector
- D – Fan and Filter Switches
- E – CO2 Sensor, Fan and Filter Switches
- F – CO2 Sensor, Return Air Smoke Detector, Fan and Filter Switches
- G – Return Air Smoke Detector, Fan and Filter Switches
- H – Return and Supply Air Smoke Detectors
- J – CO2 Sensor, Return and Supply Air Smoke Detectors
- K – CO2 Sensor, Fan and Filter Switches, Return and Supply Air Smoke Detectors
- L – Fan and Filter Switches, Return and Supply Air Smoke Detectors

\*2-5 ton models low NOx combined with stainless steel exchanger.  
†Humidi-MiZer system is not available with electro-mechanical controls.

**Factory - Installed Options**  
Refer to Price Pages for Option Codes

Not Used

Design Change

**Voltage**

- 1 – 575-3-60
- 3 – 208/230-1-60
- 5 – 208/230-3-60
- 6 – 460-3-60

**Coil Protection Options**

- – Al/Cu Condenser Coil, Al/Cu Evaporator Coil
- A – Pre-Coated Al/Cu Condenser Coil, Al/Cu Evaporator Coil
- B – E-Coated Al/Cu Condenser Coil, Al/Cu Evaporator Coil
- C – E-Coated Al/Cu Condenser Coil, E-Coated Al/Cu Evaporator Coil
- D – Cu/Cu Condenser Coil, Al/Cu Evaporator Coil
- E – Cu/Cu Condenser Coil, Cu/Cu Evaporator Coil
- F – E-Coated Cu/Cu Condenser Coil, Al/Cu Evaporator Coil
- G – E-Coated Cu/Cu Condenser Coil, Cu/Cu Evaporator Coil
- H – E-Coated Cu/Cu Condenser Coil, E-Coated Cu/Cu Evaporator Coil
- J – Humidi-MiZer™ Adaptive Dehumidification System

**Indoor Fan Motor Options**

- A – Low Range Vertical
- B – Mid-Low Range Vertical
- C – Mid-High Range Vertical
- D – High Range Vertical
- E – Low Range Horizontal
- F – Mid-Low Range Horizontal
- G – Mid-High Range Horizontal
- H – High Range Horizontal
- J – Low Range Vertical with Phase Loss
- K – Mid-Low Range Vertical with Phase Loss
- L – Mid-High Range Vertical with Phase Loss
- M – High Range Vertical with Phase Loss
- N – Low Range Horizontal with Phase Loss
- P – Mid-Low Range Horizontal with Phase Loss
- Q – Mid-High Range Horizontal with Phase Loss
- R – High Range Horizontal with Phase Loss



**Quality Assurance**

Certified to ISO 9001:2000



Well exceeds ASHRAE 90.1 Energy Star Standards.



DEALER DESIGN AWARDS

the NEWS | GOLD



# ARI\* capacity ratings



UNIT 48PG	NOMINAL CAPACITY (Tons)	NET COOLING CAPACITY (Btuh)	TOTAL POWER (kW)	SEER	EER†	SOUND RATING (dB)	IPLV**
03	2	24,000	2.1	14.0	11.4	75	—
04	3	35,800	3.1	14.0	11.7	73	—
05	4	47,500	4.0	14.8	12.0	72	—
06	5	58,500	4.9	14.6	12.0	78	—
07	6	69,000	5.8	—	12.0	78	—
08	7 <sup>1/2</sup>	88,000	7.0	—	12.5	80	13.3
09	8 <sup>1/2</sup>	102,000	8.4	—	12.2	80	13.3
12	10	119,000	9.9	—	12.0	80	13.1
14	12 <sup>1/2</sup>	150,000	13.2	—	11.4	83	12.1
16	15	182,000	15.9	—	11.4	84	12.7
20	18	202,000	17.4	—	11.6	81.7	12.4
24	20	238,000	20.5	—	11.6	84.6	12.0
28††	25	298,000	27.2	—	11.0	84.6	12.0

## LEGEND

- ASHRAE** — American Society of Heating, Refrigeration and Air Conditioning Engineers  
**db** — Dry Bulb  
**dB** — Decibel  
**EER** — Energy Efficiency Ratio  
**IPLV** — Integrated Part-Load Values  
**SEER** — Seasonal Energy Efficiency Ratio  
**wb** — Wet Bulb

\*Air Conditioning and Refrigeration Institute.

†ARI does not require EER ratings for units with capacity below 65,000 Btuh.

\*\*IPLV values are calculated based on control configuration T.CTL = 2 (2 Stage Y1).

††Size 28 unit is not listed with ARI, but is tested to ARI Standards.

## NOTES:

1. Tested in accordance with ARI Standards 210-94 and 360-95 (16-24 sizes).
2. Ratings are net values, reflecting the effects of circulating fan heat.

## 3. Ratings are based on:

**Cooling Standard:** 80 F db, 67 F wb indoor entering-air temperature and 95 F db air entering outdoor unit.

**IPLV Standard:** 80 F db, 67 F wb indoor entering-air temperature and 80 F db outdoor entering-air temperature.

4. All 48PG units are in compliance with ENERGY STAR® and ASHRAE 90.1 2001 Energy Standard for minimum SEER and EER requirements.
5. Units are rated in accordance with ARI sound standards 270 or 370.



ARI Standard  
210/240 UAC



ARI Standard  
340/360





**HEATING CAPACITIES AND EFFICIENCIES — 48PG03-28**  
**VERTICAL AND HORIZONTAL SUPPLY UNITS WITH NATURAL GAS (Single Phase)**

UNIT 48PG		HEATING INPUT (Btuh)	HEATING CAPACITY† (Btuh)	TEMPERATURE RISE Min - Max (F)	MINIMUM HEATING CFM**	THERMAL EFFICIENCY (%)	AFUE (%)†
Standard	Stainless Steel						
—	N03*	51,000	39,400	25 - 70	500	81.0	80.0
F03	—	56,000	43,300	25 - 70	600	81.0	80.0
—	L04*	51,000	39,400	25 - 70	500	81.0	80.0
D04	—	56,000	43,300	25 - 70	600	81.0	80.0
E04	M04*	75,000	58,800	20 - 60	940	81.0	80.0
F04	N04*	113,000	89,900	30 - 75	1,130	81.0	80.0
—	L05*	51,000	39,400	25 - 70	500	81.0	80.0
D05	—	56,000	43,300	25 - 70	600	81.0	80.0
E05	M05*	75,000	58,800	20 - 60	940	81.0	80.0
F05	N05*	113,000	89,900	30 - 75	1,130	81.0	80.0
—	L06*	75,000	58,800	20 - 60	940	81.0	80.0
D06	—	113,000	89,900	30 - 75	1,130	81.0	80.0
E06	M06*	113,000	89,900	30 - 75	1,130	81.0	80.0
F06	N06*	151,000	121,500	45 - 75	1,510	81.0	80.0

**VERTICAL AND HORIZONTAL SUPPLY UNITS WITH NATURAL GAS (Three Phase)**

UNIT 48PG		HEATING INPUT Stage 2 (Btuh)	HEATING INPUT Stage 1 (Btuh)	OUTPUT CAPACITY Stage 2 (Btuh)	TEMPERATURE RISE Min - Max (F)	MINIMUM HEATING CFM**	THERMAL EFFICIENCY (%)
Standard	Stainless Steel						
—	L04*	51,000	35,700	41,300	25 - 70	500	81.0
D04	—	56,000	39,200	45,400	25 - 70	600	81.0
E04	M04*	75,000	52,500	60,800	20 - 60	940	81.0
F04	N04*	113,000	79,100	91,500	30 - 75	1,130	81.0
—	L05*	51,000	35,700	41,300	25 - 70	500	81.0
D05	—	56,000	39,200	45,400	25 - 70	600	81.0
E05	M05*	75,000	52,500	60,800	20 - 60	940	81.0
F05	N05*	113,000	79,100	91,500	30 - 75	1,130	81.0
—	L06*	75,000	52,500	60,800	20 - 60	940	81.0
D06	—	113,000	79,100	91,500	30 - 75	1,130	81.0
E06	M06*	113,000	79,100	91,500	30 - 75	1,130	81.0
F06	N06*	151,000	105,700	122,300	45 - 75	1,510	81.0
—	L07	75,000	52,500	60,800	20 - 60	940	81.0
D07	—	113,000	79,100	91,500	30 - 75	1,130	81.0
E07	M07	113,000	79,100	91,500	30 - 75	1,130	81.0
F07	N07	151,000	105,700	122,300	45 - 75	1,510	81.0
—	L08	136,000	95,200	111,500	20 - 50	2,060	82.0
D08	—	181,000	126,700	148,400	20 - 65	2,110	82.0
E08	M08	181,000	126,700	148,400	20 - 65	2,110	82.0
F08	N08	226,000	158,200	185,300	35 - 70	2,450	82.0
—	L09	136,000	95,200	111,500	20 - 50	2,060	82.0
D09	—	181,000	126,700	148,400	20 - 65	2,110	82.0
E09	M09	181,000	126,700	148,400	20 - 65	2,110	82.0
F09	N09	226,000	158,200	185,300	35 - 70	2,450	82.0
—	L12	181,000	126,700	148,400	20 - 65	2,110	82.0
D12	—	226,000	158,200	185,300	35 - 70	2,450	82.0
E12	M12	226,000	158,200	185,300	35 - 70	2,450	82.0
F12	N12	249,000	174,300	204,200	30 - 60	3,150	82.0
—	L14	181,000	126,700	148,400	20 - 65	2,110	82.0
D14	—	226,000	158,200	185,300	35 - 70	2,450	82.0
E14	M14	226,000	158,200	185,300	35 - 70	2,450	82.0
F14	N14	249,000	174,300	204,200	30 - 60	3,150	82.0
—	L16	220,000	176,000	178,000	25 - 55	3,040	81.0
D16	—	310,000	248,000	251,000	30 - 60	3,870	81.0
E16	M16	310,000	248,000	251,000	30 - 60	3,870	81.0
F16	N16	400,000	320,000	324,000	35 - 65	4,670	81.0
—	L20	250,000	199,000	205,000	15 - 45	4,218	82.0
D20	—	365,000	281,000	296,000	25 - 55	4,977	81.0
E20	M20	365,000	281,000	296,000	25 - 55	4,977	81.0
F20	N20	400,000	317,000	328,000	25 - 55	5,522	82.0
—	L24	250,000	199,000	205,000	15 - 45	4,218	82.0
D24	—	365,000	281,000	296,000	25 - 55	4,977	81.0
E24	M24	365,000	281,000	296,000	25 - 55	4,977	81.0
F24	N24	400,000	317,000	328,000	25 - 55	5,522	82.0
—	L28	250,000	199,000	205,000	15 - 45	4,218	82.0
D28	—	365,000	281,000	296,000	25 - 55	4,977††	81.0
E28	M28	365,000	281,000	296,000	25 - 55	4,977††	81.0
F28	N28	400,000	317,000	328,000	25 - 55	5,522††	82.0

**VERTICAL AND HORIZONTAL SUPPLY UNITS WITH LP GAS (Single Phase)**

UNIT 48PG		HEATING INPUT (Btuh)	HEATING CAPACITY† (Btuh)	TEMPERATURE RISE Min - Max (F)	MINIMUM HEATING CFM**	THERMAL EFFICIENCY (%)	AFUE (%)†
Standard	Stainless Steel						
F03	N03	55,000	42,500	25 - 70	600	81.0	80.0
D04	L04	55,000	42,500	25 - 70	600	81.0	80.0
E04	M04	74,000	58,000	20 - 60	940	81.0	80.0
F04	N04	111,000	88,400	30 - 75	1,130	81.0	80.0
—	L05	55,000	42,500	25 - 70	600	81.0	80.0
D05	—	74,000	58,000	20 - 60	940	81.0	80.0
E05	M05	74,000	58,000	20 - 60	940	81.0	80.0
F05	N05	111,000	88,400	30 - 75	1,130	81.0	80.0
—	L06	74,000	58,000	20 - 60	940	81.0	80.0
D06	—	111,000	88,400	30 - 75	1,130	81.0	80.0
E06	M06	111,000	88,400	30 - 75	1,130	81.0	80.0
F06	N06	148,000	119,100	45 - 75	1,510	81.0	80.0

**LEGEND**

**AFUE** — Annual Fuel Utilization Efficiency  
**ASHRAE** — American Society of Heating, Refrigeration and Air Conditioning Engineers  
**LP** — Liquid Propane

\*These models are certified for NOx emissions less than 40 ng/J. Fully compliant with California SCAQMD Rule 1111.

†Annual Fuel Utilization Efficiency (AFUE) and Heating Capacity of single-phase units are calculated according to ASHRAE Standard 103-1993.

\*\*Minimum Heating cfm must be maintained to ensure proper heating operation.  
 ††7000 cfm minimum recommended above 1.0 in. wg external static pressure.

**NOTES:**

1. Minimum allowable temperature of mixed air entering the heat exchanger during first stage heating is 45 F. Both stages of heat must be energized when the temperature of the mixed air entering the heat exchanger is below 45 F for standard heat exchangers or 35 F for optional stainless steel heat exchangers.
2. Propane operation requires field-installed accessory kit.
3. All data is applicable to 2000 ft of altitude.

# ARI\* capacity ratings (cont)



## HEATING CAPACITIES AND EFFICIENCIES — 48PG03-28 (cont) VERTICAL AND HORIZONTAL SUPPLY UNITS WITH LP GAS (Three Phase)

UNIT 48PG		HEATING INPUT Stage 2 (Btuh)	HEATING INPUT Stage 1 (Btuh)	OUTPUT CAPACITY Stage 2 (Btuh)	TEMPERATURE RISE Min - Max (F)	MINIMUM HEATING CFM**	THERMAL EFFICIENCY (%)
Standard	Stainless Steel						
D04	L04	55,000	38,500	44,600	25 - 70	600	81.0
E04	M04	74,000	51,800	60,000	20 - 60	940	81.0
F04	N04	111,000	77,700	90,000	30 - 75	1,130	81.0
D05	L05	55,000	38,500	44,600	25 - 70	600	81.0
E05	M05	74,000	51,800	60,000	20 - 60	940	81.0
F05	N05	111,000	77,700	90,000	30 - 75	1,130	81.0
D06	L06	74,000	51,800	60,000	20 - 60	940	81.0
E06	M06	111,000	77,700	90,000	30 - 75	1,130	81.0
F06	N06	148,000	103,600	120,000	45 - 75	1,510	81.0
D07	L07	74,000	51,800	60,000	20 - 60	940	81.0
E07	M07	111,000	77,700	90,000	30 - 75	1,130	81.0
F07	N07	148,000	103,600	120,000	45 - 75	1,510	81.0
D08	L08	130,000	91,000	106,600	20 - 50	2,060	82.0
E08	M08	174,000	121,800	142,700	20 - 65	2,110	82.0
F08	N08	217,000	151,900	178,000	35 - 70	2,450	82.0
D09	L09	130,000	91,000	106,600	20 - 50	2,060	82.0
E09	M09	174,000	121,800	142,700	20 - 65	2,110	82.0
F09	N09	217,000	151,900	178,000	35 - 70	2,450	82.0
D12	L12	174,000	121,800	142,700	20 - 65	2,110	82.0
E12	M12	217,000	151,900	178,000	35 - 70	2,450	82.0
F12	N12	239,000	167,300	196,000	30 - 60	3,150	82.0
D14	L14	174,000	121,800	142,700	20 - 65	2,110	82.0
E14	M14	217,000	151,900	178,000	35 - 70	2,450	82.0
F14	N14	239,000	167,300	196,000	30 - 60	3,150	82.0
D16	L16	214,000	171,000	172,000	25 - 55	3,040	81.0
E16	M16	305,000	244,000	246,000	30 - 60	3,870	81.0
F16	N16	396,000	317,000	320,000	35 - 65	4,670	81.0

### VERTICAL SUPPLY UNITS WITH LP GAS (Three Phase)

UNIT 48PG		HEATING INPUT Stage 2 (Btuh)	HEATING INPUT Stage 1 (Btuh)	OUTPUT CAPACITY Stage 2 (Btuh)	TEMPERATURE RISE Min - Max (F)	MINIMUM HEATING CFM**	THERMAL EFFICIENCY (%)
Standard	Stainless Steel						
D20	L20	250,000	207,000	205,000	15 - 45	4,218	82.0
E20	M20	365,000	291,000	296,000	25 - 55	4,480	81.0
F20	N20	400,000	331,000	328,000	25 - 55	5,522	82.0
D24	L24	250,000	207,000	205,000	15 - 45	4,218	82.0
E24	M24	365,000	291,000	296,000	25 - 55	4,480	81.0
F24	N24	400,000	331,000	328,000	25 - 55	5,522	82.0
D28	L28	250,000	207,000	205,000	15 - 45	4,218	82.0
E28	M28	365,000	291,000	296,000	25 - 55	4,480	81.0
F28	N28	400,000	331,000	328,000	25 - 55	5,522	82.0

### HORIZONTAL SUPPLY UNITS WITH LP GAS (Three Phase)

UNIT 48PG		HEATING INPUT Stage 2 (Btuh)	HEATING INPUT Stage 1 (Btuh)	OUTPUT CAPACITY Stage 2 (Btuh)	TEMPERATURE RISE Min - Max (F)	MINIMUM HEATING CFM**	THERMAL EFFICIENCY (%)
Standard	Stainless Steel						
D20	L20	225,000	207,000	185,000	15 - 45	3,807	82.0
E20	M20	329,000	291,000	266,000	25 - 55	4,480	81.0
F20	N20	350,000	331,000	292,000	25 - 55	4,916	82.0
D24	L24	225,000	207,000	185,000	15 - 45	3,807	82.0
E24	M24	329,000	291,000	266,000	25 - 55	4,480	81.0
F24	N24	350,000	331,000	292,000	25 - 55	4,916	82.0
D28	L28	225,000	207,000	185,000	15 - 45	3,807	82.0
E28	M28	329,000	291,000	266,000	25 - 55	4,480††	81.0
F28	N28	350,000	331,000	292,000	25 - 55	4,916††	82.0

#### LEGEND

- AFUE** — Annual Fuel Utilization Efficiency  
**ASHRAE** — American Society of Heating, Refrigeration and Air Conditioning Engineers  
**LP** — Liquid Propane

\*These models are certified for NOx emissions less than 40 ng/J. Fully compliant with California SCAQMD Rule 1111.

†Annual Fuel Utilization Efficiency (AFUE) and Heating Capacity of single-phase units are calculated according to ASHRAE Standard 103-1993.

\*\*Minimum Heating cfm must be maintained to ensure proper heating operation.

††7000 cfm minimum recommended above 1.0 in. wg external static pressure.

#### NOTES:

1. Minimum allowable temperature of mixed air entering the heat exchanger during first stage heating is 45 F. Both stages of heat must be energized when the temperature of the mixed air entering the heat exchanger is below 45 F for standard heat exchangers or 35 F for optional stainless steel heat exchangers.
2. Propane operation requires field-installed accessory kit.
3. All data is applicable to 2000 ft of altitude.



## OPERATION AIR QUANTITY LIMITS

### 48PG03-16 VERTICAL AND HORIZONTAL UNITS

UNIT 48PG	COOLING (cfm)		HEATING (cfm)*	
	Min	Max	Min	Max
03	600	1000	600	1680
04 (Low Heat)	900	1500	600	1680
04 (Med Heat)	900	1500	940	2810
04 (High Heat)	900	1500	1130	2820
05 (Low Heat)	1200	2000	600	1680
05 (Med Heat)	1200	2000	940	2810
05 (High Heat)	1200	2000	1130	2820
06 (Low Heat)	1500	2500	940	2810
06 (Med Heat)	1500	2500	1130	2820
06 (High Heat)	1500	2500	1510	2520
07 (Low Heat)	1800	3000	940	2810
07 (Med Heat)	1800	3000	1130	2820
07 (High Heat)	1800	3000	1510	2520
08 (Low Heat)	2250	3750	2060	5160
08 (Med Heat)	2250	3750	2110	6870
08 (High Heat)	2250	3750	2450	4900
09 (Low Heat)	2550	4250	2060	5160
09 (Med Heat)	2550	4250	2110	6870
09 (High Heat)	2550	4250	2450	4900
12 (Low Heat)	3000	5000	2110	6870
12 (Med Heat)	3000	5000	2450	4900
12 (High Heat)	3000	5000	3150	6300
14 (Low Heat)	3750	6250	2110	6870
14 (Med Heat)	3750	6250	2450	4900
14 (High Heat)	3750	6250	3150	6300
16 (Low Heat)	4500	7500	3040	6680
16 (Med Heat)	4500	7500	3870	7750
16 (High Heat)	4500	7500	4670	8680

\*Consult tables on pages 7 and 8 if using a stainless steel heat exchanger.

### 48PG20-28 UNITS

48PG	COOLING		GAS HEAT	HEATING (NAT. GAS, VERTICAL)	HEATING (NAT. GAS, HORIZONTAL)	HEATING (PROPANE, VERTICAL)	HEATING (PROPANE, HORIZONTAL)
	Minimum Cfm	Maximum Cfm		Minimum Cfm	Minimum Cfm	Minimum Cfm	Minimum Cfm
20	5000	9,000	High Heat (8 Cell)	5522	5522	5522	4920
			Medium Heat (8 Cell)	4977	4977	4480	4480
			Low Heat (5 Cell)	4218	4218	4218	3796
24	5500	10,000	High Heat (8 Cell)	5522	5522	5522	4920
			Medium Heat (8 Cell)	4977	4977	4480	4480
			Low Heat (5 Cell)	4218	4218	4218	3796
28	6500	12,000	High Heat (8 Cell)	5522	5470*	5522	4920*
			Medium Heat (8 Cell)	4977	4977*	4480	4480*
			Low Heat (5 Cell)	4218	4218	4218	3796

\*7000 cfm minimum recommended above 1.0 in. wg external static pressure.

### OUTDOOR SOUND POWER (TOTAL UNIT)

UNIT 48PG	A-WEIGHTED* (dB)	OCTAVE BAND LEVELS dB							
		63	125	250	500	1000	2000	4000	8000
03	75.0	82.6	79.9	75.7	73.3	70.0	64.3	58.4	50.5
04	73.2	79.8	77.2	74.1	70.1	68.0	63.6	58.4	51.9
05	71.9	79.7	79.6	72.6	69.6	66.0	61.4	56.4	48.5
06	78.5	82.2	82.6	79.5	75.7	73.9	68.6	64.0	56.3
07	78.5	87.5	83.0	78.5	76.3	73.8	68.4	63.8	56.5
08	80.0	91.7	83.6	81.0	77.9	75.0	69.9	66.0	59.3
09	79.9	89.1	82.7	80.0	77.7	75.0	70.2	66.3	57.8
12	80.0	90.4	83.1	80.9	77.8	75.2	70.0	66.1	57.6
14	83.3	86.4	85.9	85.3	81.8	78.2	72.2	67.9	59.9
16	84.0	90.3	85.2	83.5	81.1	79.0	73.7	70.5	65.4
20	81.7	90.2	84.8	80.7	79.0	77.6	71.4	66.7	60.7
24	84.9	90.0	86.3	83.6	82.9	80.3	74.9	71.4	66.5
28	84.9	90.0	86.3	83.6	82.9	80.3	74.9	71.4	66.5

**LEGEND**

**dB** — Decibel

\*Sound Rating ARI or Tone Adjusted, A-Weighted Sound Power Level in dB. For sizes 03-12, the sound rating is in accordance with ARI Standard 270-1995. For sizes 14-28, the sound rating is in accordance with ARI 370-2001.

# Physical data



## PHYSICAL DATA — 48PG03-07

BASE UNIT 48PG	03	04	05	06	07
NOMINAL CAPACITY (Tons)	2	3	4	5	6
OPERATING WEIGHT (lb)					
Unit*	774	786	901	921	961
Economizer					
Vertical	40	40	40	40	40
Horizontal	50	50	50	50	50
Humidi-MiZer™ System	22	22	31	27	26
Roof Curb					
14-in.	122	122	122	122	122
24-in.	184	184	184	184	184
COMPRESSOR					
Quantity	1	1	Fully Hermetic Scroll		1
Oil Type			Copeland 3MA		
Number of Refrigerant Circuits	1	1	1	1	1
Oil (oz)	38	42	42	66	56
REFRIGERANT TYPE			R-410A (Puron® Refrigerant)		
Expansion Device	TXV	TXV	TXV	TXV	TXV
Operating Charge (lb) — Standard Unit	7.3	9.0	15.7	16.6	19.0
Operating Charge (lb) — Humidi-MiZer Unit	11.75	13.50	25.00	22.00	22.70
CONDENSER COIL			Enhanced Copper Tubes, Aluminum Lanced Fins		
Condenser A (Outer)					
Rows...Fins/in.	1...17	1...17	2...17	2...17	2...17
Face Area (sq ft)	12.6	12.6	12.6	12.6	12.6
Condenser B (Inner)					
Rows...Fins/in.	—	1...17	2...17	2...17	2...17
Face Area (sq ft)	—	12.6	12.6	12.6	12.6
Humidi-MiZer Coil			Enhanced Copper Tubes and Aluminum Lanced Fins		
Rows...Fins/in.	1...17	1...17	1...17	1...17	1...17
Face Area (sq ft)	6.4	6.4	9.3	9.3	9.3
CONDENSER FAN			Propeller		
Quantity...Diameter (in.)	1...24	1...24	1...24	1...24	1...24
Nominal Cfm (Total, all fans)	3500	3500	3500	4500	4500
Motor Hp	1/8	1/8	1/8	1/4	1/4
Nominal Rpm — High Speed	825	825	825	1100	1100
Nominal Rpm — Low Speed	300	300	300	300	300
EVAPORATOR COIL			Enhanced Copper Tubes, Aluminum Double-Wavy Fins, Face Split		
Rows...Fins/in.	2...15	2...15	2...15	3...15	4...15
Face Area (sq ft)	9.3	9.3	9.3	9.3	9.3
EVAPORATOR FAN			Centrifugal Type, Belt Drive		
Quantity...Size (in.)	Low 1...12 x 9	Low 1...12 x 9	Low 1...12 x 9	Low 1...12 x 9	Low 1...12 x 9
Type Drive	Low Belt	Low Belt	Low Belt	Low Belt	Low Belt
Nominal Cfm	800	1200	1600	2000	2400
Maximum Continuous Bhp	Low 0.85	Low 0.85	High 1.60/2.40†	High 1.60/2.40†	High 2.40
Motor Nominal Rpm	1620	1620	1725	1725	1725
Motor Frame Size	Low 48Y	Low 48Y	High 48Y	High 56Y	High 56Y
Fan Rpm Range	Low 482-736	Low 482-736	High 596-910	High 690-978	High 796-1128
Motor Bearing Type	Ball	Ball	Ball	Ball	Ball
Maximum Fan Rpm	2000	2000	2000	2000	2000
Motor Pulley Pitch Diameter Range (in.)	Low 1.9-2.9	Low 1.9-2.9	High 1.9-2.9	High 2.4-3.4	High 2.4-3.4
Fan Pulley Pitch Diameter (in.)	Low 6.8	Low 6.8	High 5.5	High 6.0	High 5.2
Nominal Motor Shaft Diameter (in.)	Low 1/2	Low 1/2	High 1/2	High 5/8	High 5/8
Belt...Pitch Length (in.)	Low 49.3	Low 49.3	High 49.3	High 49.3	High 49.3
Belt...Type	Low AX	Low AX	High AX	High AX	High AX
Pulley Center Line Distance Min. (in.)	Low 16.2	Low 16.2	High 16.2	High 16.2	High 16.2
Pulley Center Line Distance Max. (in.)	Low 20.2	Low 20.2	High 20.2	High 20.2	High 20.2
Speed Change per Full Turn of Movable Pulley Flange (rpm)	Low 48	Low 48	High 59	High 66	High 58
Movable Pulley Maximum Full Turns from Closed Position	Low 5	Low 5	High 5	High 5	High 5
Factory Pulley Setting (rpm)	Low 736	Low 736	High 910	High 978	High 1128
Fan Shaft Diameter at Pulley (in.)	Low 3/4	Low 3/4	High 3/4	High 3/4	High 3/4
GAS HEAT SECTION					
Rollout Switch					
Open Temperature (F)	Low N/A	Med 195	High 195	High 225	High 225
Closed Temperature (F)	Low 195	Med 115	High 115	High 175	High 175
Standard Units					
Gas Input (Btuh)	Stage 1/Stage 2 PGD/L — PGE/M — PGF/N 56,000	56,000 39,200/ 56,000 52,500/ 75,000 79,100/113,000	56,000 39,200/ 56,000 52,500/ 75,000 79,100/113,000	56,000 52,500/ 75,000 79,100/113,000 105,700/151,000	56,000 52,500/ 75,000 79,100/113,000 105,700/151,000
Low NOx Units	PGD/L — PGE/M — PGF/N 56,000	56,000 56,000 75,000 113,000	56,000 56,000 75,000 113,000	56,000 75,000 113,000 151,000	56,000 75,000 113,000 151,000
Burner Orifice Diameter (in. ...drill size)**					
Natural Gas	0.0820...45	0.0820...45	0.0820...45	0.0820...45	0.0820...45
Liquid Propane	0.0650...52	0.0650...52	0.0650...52	0.0650...52	0.0650...52
Thermostat Heat Anticipator Setting (amps)					
First Stage	0.3	0.3	0.3	0.3	0.3
Second Stage	0.4	0.4	0.4	0.4	0.4
Manifold Pressure (in. wg)					
Natural Gas	3.5	3.5	3.5	3.5	3.5
Liquid Propane	3.5	3.5	3.5	3.5	3.5
Gas Valve Quantity	1	1	1	1	1
Gas Supply Pressure Range (in. wg)	5.0-13.0	5.0-13.0	5.0-13.0	5.0-13.0	5.0-13.0
Field Gas Connection Size (in.)	1/2	1/2	1/2	1/2	1/2
HIGH-PRESSURE SWITCH (psig)					
Cutout	660 ± 10	660 ± 10	660 ± 10	660 ± 10	660 ± 10
Reset (Auto.)	505 ± 20	505 ± 20	505 ± 20	505 ± 20	505 ± 20
RETURN-AIR FILTERS			Throwaway Type		
Quantity...Size (in.)	4...16 x 20 x 2	4...16 x 20 x 2	4...16 x 20 x 2	4...16 x 20 x 2	4...16 x 20 x 2

LEGEND

TXV — Thermostatic Expansion Valve

\*Aluminum Evaporator Coil/Aluminum Condenser Coil.

†Single phase/three phase.

\*\*For applications less than 2000 ft elevation.



PHYSICAL DATA — 48PG08-14

BASE UNIT 48PG	08	09	12	14
<b>NOMINAL CAPACITY (Tons)</b>	7½	8½	10	12½
<b>OPERATING WEIGHT (lb)</b>				
Unit*	1217	1224	1324	1400
Economizer				
Vertical	57	57	57	57
Horizontal	59	59	59	59
Humidi-MiZer™ System	45	45	44	45
Roof Curb				
14-in.	180	180	180	180
24-in.	268	268	268	268
<b>COMPRESSOR</b>		Fully Hermetic Scroll		
Quantity	2	2	2	2
Oil Type	Copeland 3MA	Copeland 3MA	Copeland 3MA	Copeland 3MA
Sys A	Copeland 3MA	Copeland 3MA	Copeland 3MA	Copeland 3MA
Sys B	Copeland 3MA	Copeland 3MA	Copeland 3MA	Copeland 3MA
Number of Refrigerant Circuits	2	2	2	2
Oil (oz)	42	42	66	56
Sys A	42	42	66	56
Sys B	42	42	66	56
<b>REFRIGERANT TYPE</b>		R-410A (Puron® Refrigerant)		
Expansion Device	TXV	TXV	TXV	TXV
Operating Charge (lb)	11.8	11.3	13.7	17.2
Sys A	11.8	11.3	13.7	17.2
Sys B	23.5	22.6	27.4	34.4
Operating Charge Total All Systems (lb)				
Unit with Humidi-MiZer System				
Operating Charge (lb)	16.5	16.25	17.7	22.5
Sys A	16.7	16.25	18.2	21.8
Sys B	33.2	32.5	35.9	44.3
<b>CONDENSER COIL</b>		Enhanced Copper Tubes, Aluminum Lanced Fins, Face Split		
Condenser A (Outer)				
Rows...Fins/in.	2...17	2...17	2...17	3...17
Face Area (sq ft)	17.4	17.4	17.4	17.4
Condenser B (Inner)				
Rows...Fins/in.	2...17	2...17	2...17	3...17
Face Area (sq ft)	17.4	17.4	17.4	17.4
Humidi-MiZer Coil		Copper Enhanced Tubes with Aluminum Lanced Fins		
Rows...Fins/in.	1...17	1...17	1...17	1...17
Face Area (sq ft)	14.9	14.9	14.9	14.9
<b>CONDENSER FAN</b>		Propeller		
Quantity...Diameter (in.)	2...24	2...24	2...24	2...24
Nominal Cfm (Total, all fans)	7204	7204	8241	7300
Motor Hp	¼	¼	⅓	⅓
Nominal Rpm	1100	1100	1100	1100
<b>EVAPORATOR COIL</b>		Enhanced Copper Tubes, Aluminum Double-Wavy Fins, Face Split		
Rows...Fins/in.	3...15	3...15	4...15	4...15
Face Area (sq ft)	14.9	14.9	14.9	14.9
<b>EVAPORATOR FAN</b>		Centrifugal Type, Belt Drive		
Quantity...Size (in.)	1...15 x 15	1...15 x 15	1...15 x 15	1...15 x 15
Low	1...15 x 15	1...15 x 15	1...15 x 15	1...15 x 15
High	1...15 x 15	1...15 x 15	1...15 x 15	1...15 x 15
Type Drive	Belt	Belt	Belt	Belt
Low	Belt	Belt	Belt	Belt
High	Belt	Belt	Belt	Belt
Nominal Cfm	3000	3400	4000	5000
Maximum Continuous Bhp				
Low	2.4	2.4	3.1	3.7
High	3.1	3.7	5.25	5.25
Motor Nominal Rpm	1725	1725	1725	1725
Motor Frame Size				
Low	56Y	56Y	56Y	56Y
High	56Y	56Y	56Y	56Y
Fan Rpm Range				
Low	568-771	568-771	690-893	690-893
High	812-1015	812-1015	852-1055	852-1055
Motor Bearing Type	Ball	Ball	Ball	Ball
Maximum Fan Rpm	1600	1600	1600	1600
Motor Pulley Pitch Diameter Range (in.)				
Low	2.8-3.8	2.8-3.8	3.4-4.4	3.4-4.4
High	4.0-5.0	4.0-5.0	4.6-5.6	4.6-5.6
Fan Pulley Pitch Diameter				
Low	8.5	8.5	8.5	8.5
High	8.5	8.5	8.5	8.5
Nominal Motor Shaft Diameter (in.)				
Low	5/8	5/8	7/8	7/8
High	7/8	7/8	7/8	7/8
Belt...Pitch Length (in.)				
Low	63.3	63.3	63.3	63.3
High	65.3	65.3	65.3	65.3
Belt...Type	AX	AX	AX	AX
Low	AX	AX	AX	AX
High	AX	AX	AX	AX
Pulley Center Line Distance Min. (in.)	21.0	21.0	21.0	21.0
Low	21.0	21.0	21.0	21.0
High	21.0	21.0	21.0	21.0
Pulley Center Line Distance Max. (in.)				
Low	23.4	23.4	23.4	23.4
High	23.4	23.4	23.4	23.4
Speed Change per Full Turn of Movable Pulley Flange (rpm)				
Low	41	41	41	41
High	41	41	41	41
Movable Pulley Maximum Full Turns from Closed Position				
Low	5	5	5	5
High	5	5	5	5
Factory Pulley Setting (rpm)				
Low	568	568	690	690
High	812	812	852	852
Fan Shaft Diameter at Pulley (in.)	1	1	1	1
<b>GAS HEAT SECTION</b>				
Rollout Switch				
Open Temperature (F)				
Low	225	225	225	225
Med	225	225	225	225
High	225	225	225	225
Closed Temperature (F)				
Low	175	175	175	175
Med	175	175	175	175
High	175	175	175	175
Gas Input (Btuh)				
Stage 1 /Stage 2				
PCD/L	95,200/136,000	95,200/136,000	126,700/181,000	126,700/181,000
PGE/M	126,700/181,000	126,700/181,000	158,200/226,000	158,200/226,000
PGF/N	158,200/226,000	158,200/226,000	174,300/249,000	174,300/249,000
Burner Orifice Diameter (in. ...drill size)†				
Natural Gas	0.089...43	0.089...43	0.089...43	0.089...43
Liquid Propane	0.070...50	0.070...50	0.070...50	0.070...50
Thermostat Heat Anticipator Setting (amps)				
First Stage	.14	.14	.14	.14
Second Stage	.20	.20	.20	.20
Manifold Pressure (in. wg)				
Natural Gas	3.5	3.5	3.5	3.5
Liquid Propane	3.5	3.5	3.5	3.5
Gas Valve Quantity	1	1	1	1
Gas Supply Pressure Range (in. wg)	5.0-13.0	5.0-13.0	5.0-13.0	5.0-13.0
Field Gas Connection Size (in.)	¾	¾	¾	¾
<b>HIGH-PRESSURE SWITCH (psig)</b>				
Cutout	660 ± 10	660 ± 10	660 ± 10	660 ± 10
Reset (Auto.)	505 ± 20	505 ± 20	505 ± 20	505 ± 20
<b>RETURN-AIR FILTERS</b>		Throwaway		
Quantity...Size (in.)	4...20 x 25 x 2	4...20 x 25 x 2	4...20 x 25 x 2	4...20 x 25 x 2

LEGEND

\*Aluminum Evaporator Coil/Aluminum Condenser Coil.  
†For applications less than 2000 ft elevation.

TXV — Thermostatic Expansion Valve

# Physical data (cont)



## PHYSICAL DATA — 48PG16

<b>BASE UNIT 48PG</b>		<b>16</b>
<b>NOMINAL CAPACITY (Tons)</b>		<b>15</b>
<b>OPERATING WEIGHT (lb)</b>		
Unit*		1895
Economizer		149
Humidi-MiZer™ System		64
Roof Curb		
14-in.		240
24-in.		360
<b>COMPRESSOR</b>		Fully Hermetic Scroll
Quantity		3
Oil Type	Sys A	Copeland 3MA
	Sys B	Copeland 3MA
	Sys C	Copeland 3MA
Number of Refrigerant Circuits		3
Oil (oz)	Sys A	66
	Sys B	66
	Sys C	66
<b>REFRIGERANT TYPE</b>		R-410A (Puron® Refrigerant)
Expansion Device		TXV
Operating Charge (lb)	Sys A	13.5
	Sys B	15.0
	Sys C	15.0
Operating Charge Total All Systems (lb)		43.5
Unit with Humidi-MiZer System		
Operating Charge (lb)	Sys A	18.8
	Sys B	16.7
	Sys C	18.8
Total All Systems (lb)		54.3
<b>CONDENSER COIL</b>		Enhanced Copper Tubes, Aluminum Lanced Fins, Face Split
Condenser A (Outer)		
Rows...Fins/in.		2...17
Face Area (sq ft)		26.6
Condenser B (Inner)		
Rows...Fins/in.		2...17
Face Area (sq ft)		30.2
<b>Humidi-MiZer Coil</b>		Copper Enhanced Tubes with Aluminum Lanced Fins
Rows...Fins/in.		1...17
Face Area (sq ft)		22.2
<b>CONDENSER FAN</b>		Propeller
Quantity...Diameter (in.)		3...24
Nominal Cfm (Total, all fans)		12,500
Motor Hp		1/8
Nominal Rpm		1100
<b>EVAPORATOR COIL</b>		Enhanced Copper Tubes, Aluminum Double-Wavy Fins, Face Split
Rows...Fins/in.		3...15
Face Area (sq ft)		22.2
<b>EVAPORATOR FAN</b>		Centrifugal Type, Belt Drive
Quantity...Size (in.)		1...15x15, 1...12x12
Type Drive	Low	1...15x15, 1...12x12
	Mid-Low	1...15x15, 1...12x12
	High	1...15x15, 1...12x12
	Low	Belt
	Mid-Low	Belt
	High	Belt
Nominal Cfm		6000
Maximum Continuous Bhp	Low	3.7
	Mid-Low	5.25
	High	7.5
Motor Frame Size	Low	56
	Mid-Low	56
	High	S213T
Fan Rpm Range	Low	710- 879
	Mid-Low	872-1066
	High	1066-1260
Motor Bearing Type		Ball
Motor Pulley Pitch Diameter Min. (in.)	Low	4.2
	Mid-Low	4.2
	High	4.2
Motor Pulley Pitch Diameter Max. (in.)	Low	5.2
	Mid-Low	5.2
	High	6.2
Fan Pulley Pitch Diameter (in.)	Low	10.2
	Mid-Low	8.5
	High	8.5
Nominal Motor Shaft Diameter (in.)	Low	7/8
	Mid-Low	7/8
	High	1 1/8
Belt...Pitch Length (in.)	Low	49.3
	Mid-Low	47.8
	High	43.8
Belt...Type	Low	AX
	Mid-Low	BX
	High	BX
Pulley Center Line Distance Min. (in.)	Low	14.2
	Mid-Low	10.8
	High	8.6
Pulley Center Line Distance Max. (in.)	Low	10.8
	Mid-Low	14.2
	High	12
Speed Change (rpm)	Low	34
	Mid-Low	41
	High	41
Movable Turns	Low	5
	Mid-Low	5
	High	5
Factory Pulley Setting (rpm)	Low	812
	Mid-Low	983
	High	1191
Fan Shaft Diameter at Pulley (in.)		1 9/16
<b>GAS HEAT SECTION</b>		
Rollout Switch		
Open Temperature (F)	Low	195
	High	195
Closed Temperature (F)	Low	115
	High	115
Gas Input (Btu/h)	Stage 1/Stage 2	176,000/220,000
		248,000/310,000
		320,000/400,000
Burner Orifice Diameter (in. ...drill size)†		
Natural Gas	Std	0.1285...30
Liquid Propane	Alt	0.1015...38
Thermostat Heat Anticipator Setting (amps)		
First Stage		.14
Second Stage		.20
Manifold Pressure (in. wg)		
Natural Gas	Std	3.0
Liquid Propane	Alt	3.0
Gas Valve Quantity		1
Gas Supply Pressure Range (in. wg)		5.0-13.0
Field Gas Connection Size (in.)		3/4
<b>HIGH-PRESSURE SWITCH (psig)</b>		
Cutout		660 ± 10
Reset (Auto.)		505 ± 20
<b>RETURN-AIR FILTERS</b>		Throwaway
Quantity...Size (in)		8...20 x 20 x 2

LEGEND  
TXV — Thermostatic Expansion Valve

\*Aluminum Evaporator Coil/Aluminum Condenser Coil.  
†For applications less than 2000 ft elevation.



PHYSICAL DATA — 48PG20-28

UNIT 48PG	20		24		28	
VOLTAGE	208/230 and 460	575	208/230 and 460	575	208/230 and 460	575
NOMINAL CAPACITY (Tons)	18	18	20	20	25	25
OPERATING WEIGHT (lb) 48 Series (Low Heat) A1/AI	2480	2480	2588	2588	2773	2773
COMPRESSOR	Fully Hermetic Scroll					
Quantity	2	2	2	2	3	3
Number of Refrigerant Circuits	2	2	2	2	2	2
Oil (ounces) Comp A1, A2, B1	85, NA, 85	85, NA, 85	85, NA, 85	85, NA, 85	85, 85, 85	85, 85, 85
REFRIGERANT TYPE	Puron® Refrigerant (R-410A)					
Expansion Device	TXV	TXV	TXV	TXV	TXV	TXV
Change Type						
Operating Charge (lb)						
Circuit A	25.3	25.3	35.7	35.7	49.3	49.3
Circuit B	25.3	25.3	33.5	33.5	24.3	24.3
Total Charge	50.6	50.6	69.2	69.2	73.6	73.6
OPERATING CHARGE (lb) — Unit with Humidi-MiZer™ System						
Circuit A	42.9	42.9	46.5	46.5	66.1	66.1
Circuit B	39.8	39.8	44.5	44.5	35.7	35.7
Total Charge	82.7	82.7	91.0	91.0	101.8	101.8
CONDENSER COIL	Enhanced Copper Tubes, Aluminum Lanced Fins					
Rows...Fins/inch	2...17	2...17	3...17	3...17	3...17	3...17
Width (in.)	60	60	60	60	60	60
Total Face area (sq. ft)	33.46	33.46	33.46	33.46	33.46	33.46
CONDENSER FAN	Propeller					
Nominal Cfm (Total, all fans)	14,000	14,000	21,000	21,000	21,000	21,000
Quantity...Diameter (in.)	4...22	4...22	6...22	6...22	6...22	6...22
Motor Hp...Rpm	1/4...1100	1/4...1100	1/4...1100	1/4...1100	1/4...1100	1/4...1100
Watts input (Total)	1400	1400	2100	2100	2100	2100
HUMIDI-MIZER COIL						
Weight	80	80	80	80	100	100
Rows...Fins/inch	2...15	2...15	2...15	2...15	2...15	2...15
Width (in.)	32	32	32	32	44	44
Total Face Area (sq ft)	12.4	12.4	12.4	12.4	17.1	17.1
EVAPORATOR COIL	Enhanced Copper Tubes, Face Split, Aluminum Double-Wavy Fins					
Rows...Fins/inch	4...15	4...15	4...15	4...15	4...15	4...15
Length of Tube Sheets (in.)	69.4	69.4	69.4	69.4	69.4	69.4
Width (in.)	48	48	48	48	60	60
Total Face area (sq. ft)	23.13	23.13	23.13	23.13	28.92	28.92
EVAPORATOR FAN	Centrifugal, Belt Type					
Quantity...Size (in.)	2...15 x 11	2...15 x 11	2...15 x 11	2...15 x 11	2...15 x 11	2...15 x 11
Type Drive	Belt	Belt	Belt	Belt	Belt	Belt
Nominal Cfm	7000	7000	8000	8000	10,000	10,000
Motor Bearing Type	Ball	Ball	Ball	Ball	Ball	Ball
Maximum Allowable Fan Rpm	1400	1400	1400	1400	1400	1400
FURNACE SECTION						
Rollout Switch Cutout Temp (F)	225	225	225	225	225	225
Burner Orifice Diameter (in. ...drill size)	0.136...29	0.136...29	0.136...29	0.136...29	0.136...29	0.136...29
Gas	Natural	Natural	Natural	Natural	Natural	Natural
Thermostat Heat Anticipator Setting						
Stage 1 (amps)	0.98	0.98	0.98	0.98	0.98	0.98
Stage 2 (amps)	0.44	0.44	0.44	0.44	0.44	0.44
Gas Input (Btuh) HIGH HEAT						
Stage 1	317,000	317,000	317,000	317,000	317,000	317,000
Stage 2	400,000	400,000	400,000	400,000	400,000	400,000
Efficiency (Steady State) %	82	82	82	82	82	82
Temperature Rise Range	25-55	25-55	25-55	25-55	25-55	25-55
Gas Input (Btuh) MEDIUM HEAT						
Stage 1	281,000	281,000	281,000	281,000	281,000	281,000
Stage 2	365,000	365,000	365,000	365,000	365,000	365,000
Efficiency (Steady State) %	81	81	81	81	81	81
Temperature Rise Range	25-55	25-55	25-55	25-55	25-55	25-55
Gas Input (Btuh) LOW HEAT						
Stage 1	199,000	199,000	199,000	199,000	199,000	199,000
Stage 2	250,000	250,000	250,000	250,000	250,000	250,000
Efficiency (Steady State) %	82	82	82	82	82	82
Temperature Rise Range	15-45	15-45	15-45	15-45	15-45	15-45
Manifold Pressure						
Natural Gas (in. wg)	3.00	3.00	3.00	3.00	3.00	3.00
Natural Gas (in. wg)	2.95	2.95	2.95	2.95	2.95	2.95
Gas Valve Quantity	1	1	1	1	1	1
Gas Valve Pressure Range (in. wg)	5.5-13.0	5.5-13.0	5.5-13.0	5.5-13.0	5.5-13.0	5.5-13.0
Min-Max Allowable (psig)	.235-.469	.235-.469	.235-.469	.235-.469	.235-.469	.235-.469
Field Gas Connection Size (in...FPT)	3/4	3/4	3/4	3/4	3/4	3/4
HIGH-PRESSURE SWITCHES (psig)						
Cutout	630 ± 10	630 ± 10	630 ± 10	630 ± 10	630 ± 10	630 ± 10
Reset (Auto)	505 ± 20	505 ± 20	505 ± 20	505 ± 20	505 ± 20	505 ± 20
OUTDOOR AIR INLET SCREENS						
Quantity...Size (in.)	3...20 x 25	3...20 x 25	3...20 x 25	3...20 x 25	3...20 x 25	3...20 x 25
RETURN-AIR FILTERS						
Quantity...Size (in.)	9...16 x 25 x 2	9...16 x 25 x 2	9...16 x 25 x 2	9...16 x 25 x 2	9...20 x 25 x 2	9...20 x 25 x 2

LEGEND

TXV — Thermostatic Expansion Valve

# Physical data (cont)



## FAN MOTOR AND DRIVE DATA — VERTICAL SUPPLY/RETURN — 48PG20-28

48PG	20		24		28	
	208/230,460	575	208/230,460	575	208/230,460	575
<b>LOW RANGE</b>						
Motor Hp	3.7	5	3.7	5	5	5
Motor Nominal Rpm	1750	1750	1750	1750	1750	1750
Maximum Continuous Bhp	4.26/4.26,4.26	5.75	4.26/4.26,4.26	5.75	5.37/5.75,5.75	5.75
Maximum Continuous Watts	3700	5015	3700	5015	4578/5115	5015
Motor Frame Size	56HZ	S184T	56HZ	S184T	S184T	S184T
Motor Shaft Diameter (in.)	$\frac{7}{8}$	$\frac{1}{8}$	$\frac{7}{8}$	$\frac{1}{8}$	$\frac{1}{8}$	$\frac{1}{8}$
Fan Rpm Range	685-939	751-954	685-939	751-954	687-873	687-873
Motor Pulley Min. Pitch Diameter (in.)	2.7	3.7	2.7	3.7	3.7	3.7
Motor Pulley Max. Pitch Diameter (in.)	3.7	4.7	3.7	4.7	4.7	4.7
Blower Pulley Pitch Diameter (in.)	6.8	8.6	6.8	8.6	9.4	9.4
Blower Pulley Shaft Diameter (in.)	$\frac{13}{16}$	$\frac{13}{16}$	$\frac{13}{16}$	$\frac{13}{16}$	$\frac{13}{16}$	$\frac{13}{16}$
Blower Pulley Type	Fixed	Fixed	Fixed	Fixed	Fixed	Fixed
Pulley Center Line Distance (in.)	11.293-13.544	9.81-13.055	11.293-13.544	9.81-13.055	9.81-13.055	9.81-13.055
Belt, Quantity...Type...Length (in.)	1...BX38...39.8	1...BX40...41.8	1...BX38...39.8	1...BX40...41.8	1...BX41...42.8	1...BX41...42.8
Speed Change Per Turn — Moveable Pulley (rpm)	42	34	42	34	31	31
Moveable Pulley Maximum Full Turns	6	6	6	6	6	6
Factory Speed Setting (rpm)	812	853	812	853	780	780
<b>MID-LOW RANGE</b>						
Motor Hp	5	5	5	5	5	5
Motor Nominal Rpm	1750	1750	1750	1750	1750	1750
Maximum Continuous Bhp	5.37/5.75,5.75	5.75	5.37/5.75,5.75	5.75	5.37/5.75,5.75	5.75
Maximum Continuous Watts	4578/5115	5015	4578/5115	5015	4578/5115	5015
Motor Frame Size	S184T	S184T	S184T	S184T	S184T	S184T
Motor Shaft Diameter (in.)	$\frac{1}{8}$	$\frac{1}{8}$	$\frac{1}{8}$	$\frac{1}{8}$	$\frac{1}{8}$	$\frac{1}{8}$
Fan Rpm Range	949-1206	949-1206	949-1206	949-1206	805-1007	805-1007
Motor Pulley Min. Pitch Diameter (in.)	3.7	3.7	3.7	3.7	4.8	4.8
Motor Pulley Max. Pitch Diameter (in.)	4.7	4.7	4.7	4.7	6	6
Blower Pulley Pitch Diameter (in.)	6.8	6.8	6.8	6.8	10.4	10.4
Blower Pulley Shaft Diameter (in.)	$\frac{13}{16}$	$\frac{13}{16}$	$\frac{13}{16}$	$\frac{13}{16}$	$\frac{13}{16}$	$\frac{13}{16}$
Blower Pulley Type	Fixed	Fixed	Fixed	Fixed	Fixed	Fixed
Pulley Center Line Distance (in.)	9.81-13.055	9.81-13.055	9.81-13.055	9.81-13.055	9.81-13.055	9.81-13.055
Belt, Quantity...Type...Length (in.)	1...BX38...39.8	1...BX38...39.8	1...BX38...39.8	1...BX38...39.8	1...BX45...46.8	1...BX45...46.8
Speed Change Per Turn — Moveable Pulley (rpm)	43	43	43	43	34	34
Moveable Pulley Maximum Full Turns	6	6	6	6	6	6
Factory Speed Setting (rpm)	1078	1078	1178	1078	906	906
<b>MID-HIGH RANGE</b>						
Motor Hp	7.5	7.5	7.5	7.5	7.5	7.5
Motor Nominal Rpm	1750	1750	1750	1750	1750	1750
Maximum Continuous Bhp	7.66/8.51,8.63	8.63	7.66/8.51,8.63	8.63	7.66/8.51,8.63	8.63
Maximum Continuous Watts	6458/7586	7586	6458/7586	7586	6458/7586	7586
Motor Frame Size	S213T	S213T	S213T	S213T	S213T	S213T
Motor Shaft Diameter (in.)	$\frac{13}{8}$	$\frac{13}{8}$	$\frac{13}{8}$	$\frac{13}{8}$	$\frac{13}{8}$	$\frac{13}{8}$
Fan Rpm Range	941-1176	941-1176	941-1176	941-1176	941-1176	941-1176
Motor Pulley Min. Pitch Diameter (in.)	4.8	4.8	4.8	4.8	4.8	4.8
Motor Pulley Max. Pitch Diameter (in.)	6.0	6.0	6.0	6.0	6.0	6.0
Blower Pulley Pitch Diameter (in.)	8.9	8.9	8.9	8.9	8.9	8.9
Blower Pulley Shaft Diameter (in.)	$\frac{13}{16}$	$\frac{13}{16}$	$\frac{13}{16}$	$\frac{13}{16}$	$\frac{13}{16}$	$\frac{13}{16}$
Blower Pulley Type	Fixed	Fixed	Fixed	Fixed	Fixed	Fixed
Pulley Center Line Distance (in.)	9.025-12.179	9.025-12.179	9.025-12.179	9.025-12.179	9.025-12.179	9.025-12.179
Belt, Quantity...Type...Length (in.)	1...BX42...43.8	1...BX42...43.8	1...BX42...43.8	1...BX42...43.8	1...BX42...43.8	1...BX42...43.8
Speed Change Per Turn — Moveable Pulley (rpm)	39	39	39	39	39	39
Moveable Pulley Maximum Full Turns	6	6	6	6	6	6
Factory Speed Setting (rpm)	1059	1059	1059	1059	1059	1059
<b>HIGH RANGE</b>						
Motor Hp	10	10	10	10	10	10
Motor Nominal Rpm	1750	1750	1750	1750	1750	1750
Maximum Continuous Bhp	9.94/10.45,11.19	11.50	9.94/10.45,11.19	11.50	9.94/10.45,11.19	11.50
Maximum Continuous Watts	8284/9330	9711	8284/9330	9711	8284/9330	9711
Motor Frame Size	S215T	S215T	S215T	S215T	S215T	S215T
Motor Shaft Diameter (in.)	$\frac{13}{8}$	$\frac{13}{8}$	$\frac{13}{8}$	$\frac{13}{8}$	$\frac{13}{8}$	$\frac{13}{8}$
Fan Rpm Range	1014-1297	1014-1297	1014-1297	1014-1297	1014-1297	1014-1297
Motor Pulley Min. Pitch Diameter (in.)	4.3	4.3	4.3	4.3	4.3	4.3
Motor Pulley Max. Pitch Diameter (in.)	5.5	5.5	5.5	5.5	5.5	5.5
Blower Pulley Pitch Diameter (in.)	7.4	7.4	7.4	7.4	7.4	7.4
Blower Pulley Shaft Diameter (in.)	$\frac{13}{16}$	$\frac{13}{16}$	$\frac{13}{16}$	$\frac{13}{16}$	$\frac{13}{16}$	$\frac{13}{16}$
Blower Pulley Type	Fixed	Fixed	Fixed	Fixed	Fixed	Fixed
Pulley Center Line Distance (in.)	9.025-12.179	9.025-12.179	9.025-12.179	9.025-12.179	9.025-12.179	9.025-12.179
Belt, Quantity...Type...Length (in.)	2...BX38...39.8	2...BX38...39.8	2...BX38...39.8	2...BX38...39.8	2...BX38...39.8	2...BX38...39.8
Speed Change Per Turn — Moveable Pulley (rpm)	47	47	47	47	47	47
Moveable Pulley Maximum Full Turns	6	6	6	6	6	6
Factory Speed Setting (rpm)	1156	1156	1156	1156	1156	1156

NOTE: See page 138 for evaporator fan motor specifications.



FAN MOTOR AND DRIVE DATA — HORIZONTAL SUPPLY/RETURN — 48PG20-28

48PG	20		24		28	
	208/230,460	575	208/230,460	575	208/230,460	575
<b>LOW RANGE</b>						
Motor Hp	—	—	—	—	5	5
Motor Nominal Rpm	—	—	—	—	1750	1750
Maximum Continuous Bhp	—	—	—	—	5.37/5.75,5.75	5.75
Maximum Continuous Watts	—	—	—	—	4578/5115	5015
Motor Frame Size	—	—	—	—	S184T	S184T
Motor Shaft Diameter (in.)	—	—	—	—	1 <sup>1</sup> / <sub>8</sub>	1 <sup>1</sup> / <sub>8</sub>
Fan Rpm Range	—	—	—	—	687-873	687-873
Motor Pulley Min. Pitch Diameter (in.)	—	—	—	—	3.7	3.7
Motor Pulley Max. Pitch Diameter (in.)	—	—	—	—	4.7	4.7
Blower Pulley Pitch Diameter (in.)	—	—	—	—	9.4	9.4
Blower Pulley Shaft Diameter (in.)	—	—	—	—	1 <sup>3</sup> / <sub>16</sub>	1 <sup>3</sup> / <sub>16</sub>
Blower Pulley Type	—	—	—	—	Fixed	Fixed
Pulley Center Line Distance (in.)	—	—	—	—	9.81-13.055	9.81-13.055
Belt, Quantity...Type...Length (in.)	—	—	—	—	1...BX41...42.8	1...BX41...42.8
Speed Change Per Turn — Moveable Pulley (rpm)	—	—	—	—	31	31
Moveable Pulley Maximum Full Turns	—	—	—	—	6	6
Factory Speed Setting (rpm)	—	—	—	—	780	780
<b>MID-LOW RANGE</b>						
Motor Hp	3.7	5	3.7	5	5	5
Motor Nominal Rpm	1750	1750	1750	1750	1750	1750
Maximum Continuous Bhp	4.26/4.26,4.26	5.75	4.26/4.26,4.26	5.75	5.37/5.75,5.75	5.75
Maximum Continuous Watts	3700	5015	3700	5015	4578/5115	5015
Motor Frame Size	56HZ	S184T	56HZ	S184T	S184T	S184T
Motor Shaft Diameter (in.)	7 <sup>7</sup> / <sub>8</sub>	1 <sup>1</sup> / <sub>8</sub>	7 <sup>7</sup> / <sub>8</sub>	1 <sup>1</sup> / <sub>8</sub>	1 <sup>1</sup> / <sub>8</sub>	1 <sup>1</sup> / <sub>8</sub>
Fan Rpm Range	896-1227	873-1108	896-1227	873-1108	805-1007	805-1007
Motor Pulley Min. Pitch Diameter (in.)	2.7	3.7	2.7	3.7	4.8	4.8
Motor Pulley Max. Pitch Diameter (in.)	3.7	4.7	3.7	4.7	6.0	6.0
Blower Pulley Pitch Diameter (in.)	5.2	7.4	5.2	7.4	10.4	10.4
Blower Pulley Shaft Diameter (in.)	1 <sup>3</sup> / <sub>16</sub>	1 <sup>3</sup> / <sub>16</sub>	1 <sup>3</sup> / <sub>16</sub>	1 <sup>3</sup> / <sub>16</sub>	1 <sup>3</sup> / <sub>16</sub>	1 <sup>3</sup> / <sub>16</sub>
Blower Pulley Type	Fixed	Fixed	Fixed	Fixed	Fixed	Fixed
Pulley Center Line Distance (in.)	11.293-13.544	9.81-13.055	11.293-13.544	9.81-13.055	9.81-13.055	9.81-13.055
Belt, Quantity...Type...Length (in.)	1...BX35...36.8	1...BX38...39.8	1...BX35...36.8	1...BX38...39.8	1...BX45...46.8	1...BX45...46.8
Speed Change Per Turn — Moveable Pulley (rpm)	55	39	55	39	34	34
Moveable Pulley Maximum Full Turns	6	6	6	6	6	6
Factory Speed Setting (rpm)	1062	991	1062	991	906	906
<b>MID-HIGH RANGE</b>						
Motor Hp	5	5	5	5	7.5	7.5
Motor Nominal Rpm	1750	1750	1750	1750	1750	1750
Maximum Continuous Bhp	5.37/5.75,5.75	5.75	5.37/5.75,5.75	5.75	7.66/8.51,8.63	8.63
Maximum Continuous Watts	4578/5115	5015	4578/5115	5015	6458/7586	7586
Motor Frame Size	S184T	S184T	S184T	S184T	S213T	S213T
Motor Shaft Diameter (in.)	1 <sup>1</sup> / <sub>8</sub>	1 <sup>1</sup> / <sub>8</sub>	1 <sup>1</sup> / <sub>8</sub>	1 <sup>1</sup> / <sub>8</sub>	1 <sup>3</sup> / <sub>8</sub>	1 <sup>3</sup> / <sub>8</sub>
Fan Rpm Range	1113-1414	1113-1414	1113-1414	1113-1414	941-1176	941-1176
Motor Pulley Min. Pitch Diameter (in.)	3.7	3.7	3.7	3.7	4.8	4.8
Motor Pulley Max. Pitch Diameter (in.)	4.7	4.7	4.7	4.7	6.0	6.0
Blower Pulley Pitch Diameter (in.)	5.8	5.8	5.8	5.8	8.9	8.9
Blower Pulley Shaft Diameter (in.)	1 <sup>3</sup> / <sub>16</sub>	1 <sup>3</sup> / <sub>16</sub>	1 <sup>3</sup> / <sub>16</sub>	1 <sup>3</sup> / <sub>16</sub>	1 <sup>3</sup> / <sub>16</sub>	1 <sup>3</sup> / <sub>16</sub>
Blower Pulley Type	Fixed	Fixed	Fixed	Fixed	Fixed	Fixed
Pulley Center Line Distance (in.)	9.81-13.055	9.81-13.055	9.81-13.055	9.81-13.055	9.025-12.179	9.025-12.179
Belt, Quantity...Type...Length (in.)	1...BX35...36.8	1...BX35...36.8	1...BX35...36.8	1...BX35...36.8	1...BX42...43.8	1...BX42...43.8
Speed Change Per Turn — Moveable Pulley (rpm)	50	50	50	50	39	39
Moveable Pulley Maximum Full Turns	6	6	6	6	6	6
Factory Speed Setting (rpm)	1264	1264	1264	1264	1059	1059
<b>HIGH RANGE</b>						
Motor Hp	7.5	7.5	7.5	7.5	10	10
Motor Nominal Rpm	1750	1750	1750	1750	1750	1750
Maximum Continuous Bhp	7.66/8.51,8.63	8.63	7.66/8.51,8.63	8.63	9.94/10.45,11.19	11.50
Maximum Continuous Watts	6458/7586	7586	6458/7586	7586	8284/9330	9711
Motor Frame Size	S213T	S213T	S213T	S213T	S215T	S215T
Motor Shaft Diameter (in.)	1 <sup>3</sup> / <sub>8</sub>	1 <sup>3</sup> / <sub>8</sub>	1 <sup>3</sup> / <sub>8</sub>	1 <sup>3</sup> / <sub>8</sub>	1 <sup>3</sup> / <sub>8</sub>	1 <sup>3</sup> / <sub>8</sub>
Fan Rpm Range	1096-1339	1096-1339	1096-1339	1096-1339	1014-1297	1014-1297
Motor Pulley Min. Pitch Diameter (in.)	5.4	5.4	5.4	5.4	4.3	4.3
Motor Pulley Max. Pitch Diameter (in.)	6.6	6.6	6.6	6.6	5.5	5.5
Blower Pulley Pitch Diameter (in.)	8.6	8.6	8.6	8.6	7.4	7.4
Blower Pulley Shaft Diameter (in.)	1 <sup>3</sup> / <sub>16</sub>	1 <sup>3</sup> / <sub>16</sub>	1 <sup>3</sup> / <sub>16</sub>	1 <sup>3</sup> / <sub>16</sub>	1 <sup>3</sup> / <sub>16</sub>	1 <sup>3</sup> / <sub>16</sub>
Blower Pulley Type	Fixed	Fixed	Fixed	Fixed	Fixed	Fixed
Pulley Center Line Distance (in.)	9.025-12.179	9.025-12.179	9.025-12.179	9.025-12.179	9.025-12.179	9.025-12.179
Belt, Quantity...Type...Length (in.)	1...BX42...43.8	1...BX42...43.8	1...BX42...43.8	1...BX42...43.8	1...BX38...39.8	1...BX38...39.8
Speed Change Per Turn — Moveable Pulley (rpm)	41	41	41	41	47	47
Moveable Pulley Maximum Full Turns	6	6	6	6	6	6
Factory Speed Setting (rpm)	1218	1218	1218	1218	1156	1156

NOTE: See page 138 for evaporator fan motor specifications.

# Options and accessories



ITEM	FACTORY-INSTALLED OPTIONS	FIELD-INSTALLED ACCESSORIES
Intelligent <i>ComfortLink</i> ™ Controls	X	
Electro-Mechanical Controls	X	
Humidi-MiZer™ Adaptive Dehumidification System	X	
Economizer With Single Enthalpy Sensor	X	X
Differential Enthalpy Sensor		X
Economizer with Dry Bulb Sensor	X	
Differential Dry Bulb Sensor		X
Line-Side Powered 115-volt GFI Convenience Outlet	X	
Non-Powered 115-volt GFI Convenience Outlet	X	
HACR Breaker	X	
Non-Fused Disconnect Switch	X	
Manual Outdoor Air Damper	X	X
Two-Position Motorized Outdoor Air Damper	X	X
Barometric Relief Damper	X	X
Power Exhaust	X	X
Condenser Coil Hail Guard Grille	X	X
MERV-8 Pleated Return Air Filters	X	
4-in. Filter Capabilities (20-28)	X	
CO <sub>2</sub> Sensor	X	X
Return Air Smoke Detector	X	X
Return and Supply Air Smoke Detectors	X	X
Fan and Plugged Filter Switches	X	X
Horizontal Duct Configuration	X	X
Low Range Fan Performance Motor/Drive	X	
Mid-Low Fan Performance Motor/Drive	X	
Mid-High Fan Performance Motor/Drive	X	
High Fan Performance Motor/Drive	X	
Phase Loss Protection	X	X
Pre-Coated Aluminum Fin/Copper Tube Coil	X	
Copper Fin/Copper Tube Coil	X	
E-Coated Aluminum Fin/Copper Tube Coil	X	
E-Coated Copper Fin/Copper Tube Coil	X	
Stainless Steel Heat Exchanger	X	
Low NOx Gas Models (2-5 ton only)	X	
14-in. Full Perimeter Roof Curb		X
24-in. Full Perimeter Roof Curb		X
Roof Curb Burglar Bars		X
Adapter Curbs (03-16)		X
Liquefied Propane (LP) Gas Conversion Kits		X
High Altitude Gas Kits		X
Flue Gas Discharge Deflector (03-14)		X
Thru-The-Curb Gas Connection Kit (03-16)		X
Thru-The-Bottom Gas Connection Kit (03-16)		X
Thermostats and Subbases		X
Electronic Programmable Thermostats		X

LEGEND

- GFI — Ground Fault Interrupt
- HACR — Heating, Air Conditioning, and Refrigeration
- MERV — Minimum Efficiency Reporting Value



## WEIGHT ADDERS

OPTION/ACCESSORY	OPTION/ACCESSORY WEIGHTS													
	48PG03		48PG04		48PG05		48PG06		48PG07		48PG08		48PG09	
	lb	kg	lb	kg	lb	kg	lb	kg	lb	kg	lb	kg	lb	kg
Humidi-MiZer™ Adaptive Dehumidification System	22	10	22	10	31	14	27	12	26	12	45	20	45	20
Barometric Relief Damper	10	5	10	5	10	5	10	5	10	5	15	7	15	7
Power Exhaust	30	14	30	14	30	14	30	14	30	14	40	18	40	18
Economizer	55	25	55	25	55	25	55	25	65	29	65	29	65	29
Cu Condenser Coils	100	45	100	45	100	45	100	45	100	45	162	73	162	73
Cu Condenser and Evaporator Coils	175	79	175	79	175	79	175	79	175	79	250	113	250	113
Low Gas Heat	30	14	30	14	30	14	30	14	30	14	50	23	50	23
Medium Gas Heat	45	20	45	20	45	20	45	20	45	20	65	29	65	29
High Gas Heat	60	27	60	27	60	27	60	27	60	27	75	34	75	34
Roof Curb (14 in.)	145	66	145	66	145	66	145	66	145	66	175	79	175	79
Roof Curb (24 in.)	155	70	155	70	155	70	155	70	155	70	190	86	190	86
Optional Indoor Motor/Drive	10	5	10	5	10	5	10	5	10	5	15	7	15	7
Hail Guard	50	23	50	23	50	23	50	23	50	23	65	29	65	29
CO <sub>2</sub> Sensor	5	2	5	2	5	2	5	2	5	2	5	2	5	2
Return Smoke Detector	5	2	5	2	5	2	5	2	5	2	5	2	5	2
Supply Smoke Detector	5	2	5	2	5	2	5	2	5	2	5	2	5	2
Plugged Filter Indicator	2	1	2	1	2	1	2	1	2	1	2	1	2	1
Fan Status	2	1	2	1	2	1	2	1	2	1	2	1	2	1
Non-Fused Disconnect	15	7	15	7	15	7	15	7	15	7	15	7	15	7
HACR Breaker	20	9	20	9	20	9	20	9	20	9	20	9	20	9
Line-Side Powered Convenience Outlet	35	16	35	16	35	16	35	16	35	16	35	16	35	16
Non-Powered Convenience Outlet	20	9	20	9	20	9	20	9	20	9	20	9	20	9
Enthalpy Sensor	2	1	2	1	2	1	2	1	2	1	2	1	2	1
Differential Enthalpy Sensor	3	1	3	1	3	1	3	1	3	1	3	1	3	1
4-In. Filter Capability	NO ADDITIONAL WEIGHT													
Two-Position Motorized Damper	30	14	30	14	30	14	30	14	30	14	35	16	35	16
Manual Damper	30	14	30	14	30	14	30	14	30	14	35	16	35	16

NOTE: All weights do not include packaging.

OPTION/ACCESSORY	OPTION/ACCESSORY WEIGHTS (cont)											
	48PG12		48PG14		48PG16		48PG20		48PG24		48PG28	
	lb	kg	lb	kg	lb	kg	lb	kg	lb	kg	lb	kg
Humidi-MiZer™ Adaptive Dehumidification System	44	20	45	20	64	29	80	36	80	36	100	45
Barometric Relief Damper	15	7	15	7	15	7	50	23	50	23	50	23
Power Exhaust	40	18	40	18	44	20	125	57	125	57	125	57
Economizer	65	29	65	29	149	68	170	77	170	77	195	88
Cu Condenser Coils	162	73	162	73	240	109	202	92	290	132	290	132
Cu Condenser and Evaporator Coils	250	113	250	113	375	170	330	150	418	190	453	205
Low Gas Heat	50	23	50	23	80	36	85	39	85	39	85	39
Medium Gas Heat	65	50	65	29	—	—	90	41	90	41	90	41
High Gas Heat	75	34	75	34	102	46	113	51	113	51	113	51
Roof Curb (14 in.)	175	79	175	79	240	109	305	138	305	138	270	122
Roof Curb (24 in.)	190	86	190	86	360	163	385	175	385	175	345	156
Optional Indoor Motor/Drive	15	7	15	7	73	33	73	33	73	33	40	18
Hail Guard	65	29	65	29	97	44	100	45	100	45	100	45
CO <sub>2</sub> Sensor	5	2	5	2	5	2	5	2	5	2	5	2
Return Smoke Detector	5	2	5	2	5	2	5	2	5	2	5	2
Supply Smoke Detector	5	2	5	2	5	2	5	2	5	2	5	2
Plugged Filter Indicator	2	1	2	1	2	1	2	1	2	1	2	1
Fan Status	2	1	2	1	2	1	2	1	2	1	2	1
Non-Fused Disconnect	15	7	15	7	15	7	15	7	15	7	15	7
HACR Breaker	20	9	20	9	20	9	20	9	20	9	20	9
Line-Side Powered Convenience Outlet	35	16	35	16	35	16	35	16	35	16	35	16
Non-Powered Convenience Outlet	20	9	20	9	9	4	20	9	20	9	20	9
Enthalpy Sensor	2	1	2	1	2	1	2	1	2	1	2	1
Differential Enthalpy Sensor	3	1	3	1	3	1	3	1	3	1	3	1
4-In. Filter Capability	NO ADDITIONAL WEIGHT				4	2	10	5	10	5	15	7
Two-Position Motorized Damper	35	16	35	16	35	16	40	18	40	18	40	18
Manual Damper	35	16	35	16	35	16	25	11	25	11	25	11

NOTE: All weights do not include packaging.

# Base unit dimensions — 48PG03-07



UNIT	STD. WEIGHT (LBS.)	UNIT WEIGHT (LBS.)	CORNER WEIGHT (A) (LBS.)	CORNER WEIGHT (B) (LBS.)	CORNER WEIGHT (C) (LBS.)	CORNER WEIGHT (D) (LBS.)
48PG03	174	351	170	77	142	65
48PG04	186	357	173	78	145	66
48PG05	201	409	198	90	166	75
48PG06	221	418	202	92	169	77
48PG07	261	436	211	96	177	80

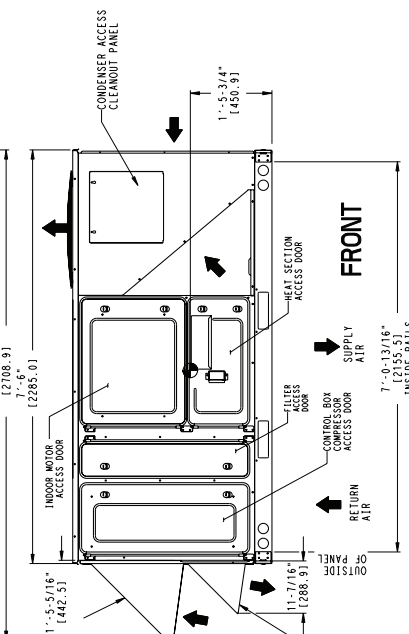
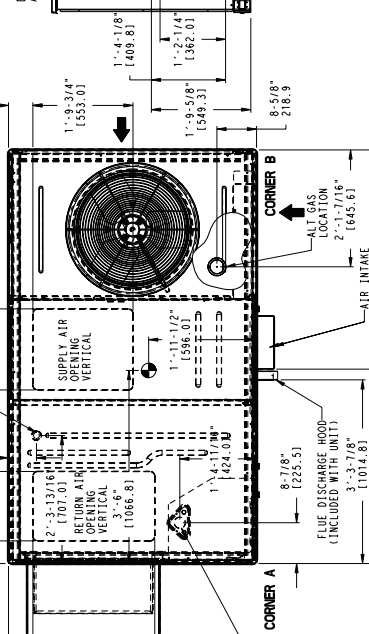
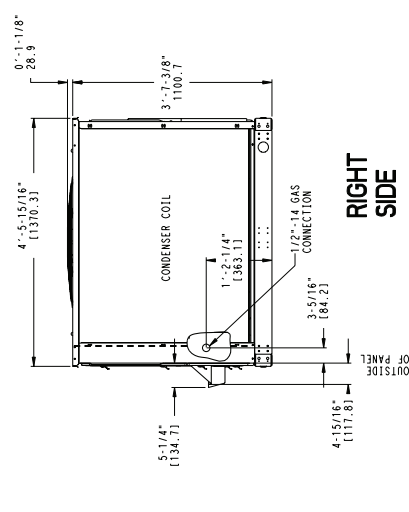
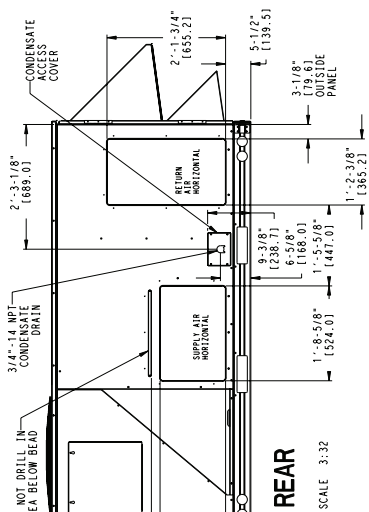

- NOTES:**
- WEIGHTS SHOWN ARE FOR BASE UNIT WEIGHT. UNIT WEIGHTS INCLUDE CONDENSATE PANS AND DRIP TRAYS. FOR WEIGHTS OF OPTIONAL EQUIPMENT, CONSULT PRODUCT DATA BOOK.
  - DO NOT LOCATE ADJACENT UNITS WITH FLUE DISCHARGE FACING ECONOMIZER INLET.
  - MINIMUM CLEARANCE (LOCAL CODES OR JURISDICTIONS MAY PREVAIL):
    - FRONT 48 INCHES TO COMBUSTIBLE SURFACES, 18 INCHES WHEN NOT LOCATING ROOF CURB (11 INCH BOTTOM OF BASE PAN TO COMBUSTIBLE SURFACES); 60 INCHES TO BOTTOM OF BASE PAN TO RIGHT SIDE (FROM AND BACK SIDES) 36 INCHES FOR PROPER CONDENSER AIR FLOW.
    - BETWEEN UNITS, 12 INCHES TO ASSURE PROPER CONDENSER AIR FLOW.
    - BETWEEN UNIT AND UNROUNDING SURFACE CONTROL BOX SIDE 36 INCHES PER NECK LOCK OF CONCRETE WALL AND OTHER GROUNDED SURFACES CONTROL BOX SIDE (42 INCHES) PER NEC.
    - CLEARANCE IN FRONT OF INDOOR MOTOR ACCESS FOR BLOWER SLED
    - CLEARANCE FOR COMPLETE CONDENSATE PAN REMOVAL 4'6"
    - ON UNITS WITH ECONOMIZER ALLOW 3'6" FROM LEFT SIDE
    - HORIZONTAL SUPPLY AND RETURN (6 INCHES)
  - DAMPERS DESIGNED TO BE ATTACHED TO ACCESSORY ROOF CURB ONLY. UNITS MOUNTED TO SUPPLY, RETURN, OR CROSS BRACES AS DONE ON ACCESSORY ROOF CURB.
  - DIMENSIONS IN ( ) ARE IN MILLIMETERS OR KILOGRAMS.
  - WITH THE EXCEPTION OF CLEARANCE FOR THE CONDENSER COIL, COMBUSTIBLE SURFACES AND THE DAMPER/POWER EXHAUST AS STATED IN NOTE 2, A REMOVABLE FENCE OR BARRICADE REQUIRES NO CLEARANCE.
  - DIMENSIONS ARE FROM OUTSIDE OF BASE RAIL. ALLOW 0" - 3/16" (8) ON EACH SIDE FOR TOP COVER DRIP EDGE.
  - UNITS MAY BE INSTALLED ON COMBUSTIBLE FLOORS MADE FROM CLASS A, B, C ROOF COVERING MATERIAL IF SET ON BASE RAILS.









# Accessory dimensions — 48PG03-07



## ROOF CURB — 48PG03-07

UNIT SIZE	*A*	ROOF CURB ACCESSORY
48PG	1'-2" (356)	CRRFCURB020A00
03-07	2'-0" (610)	CRRFCURB032A00

UNIT SIZE	*C*	CONNECTOR ACCESSORY PACKAGE
48PG	1'-2" (356)	CRRCASER003A00
03-07	1'-2" (356)	CRRCASER003A00

- NOTES:
1. ROOF CURB ACCESSORY IS SHIPPED UNASSEMBLED.
  2. BOLT HEADS TO BE ON INSIDE OF FLANGE. CLEARANCE IS (111) 0-0-7/16" TIP ALL CORNERS. DIMENSIONS IN ( ) ARE IN MILLIMETERS.
  3. DIMENSIONS IN ( ) ARE IN MILLIMETERS.
  4. ROOF CURB GALVANIZED STEEL.
  5. ATTACH DUCTWORK TO CURB (FLANGES ON DUCT REST ON CURB).
  6. SERVICE CLEARANCE 4 (1) ON EACH SIDE.
  7. GAS SERVICE PLATE IS PART OF A SEPARATELY SHIPPED ACCESSORY PACKAGE.
  8. GAS SERVICE PLATE CAN BE USED WITH EITHER ACCESSORY ROOF CURB.

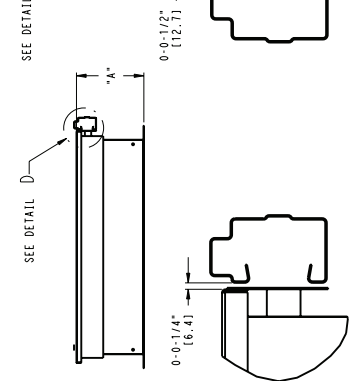
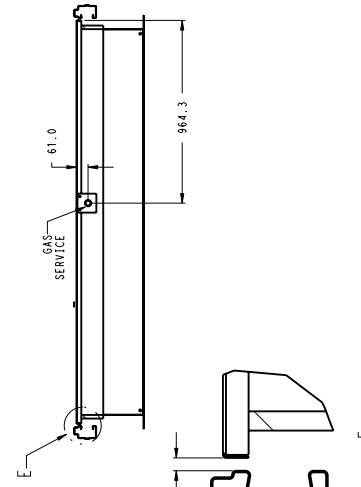
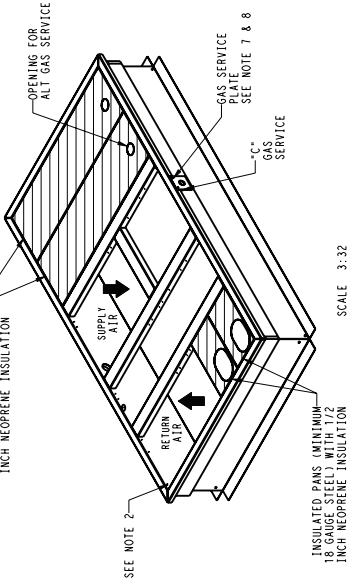
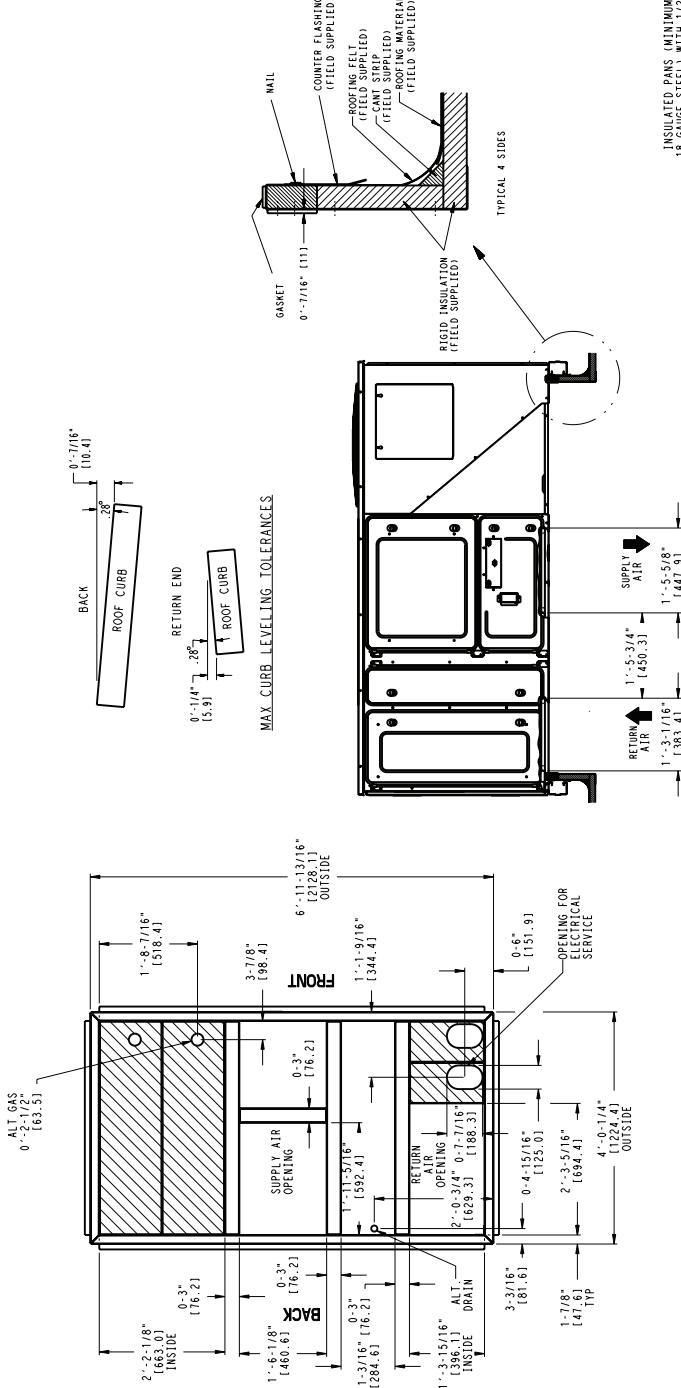

**CURB ADAPTOR — 48PG03-07 (Part No. CRADCURB001A00)**

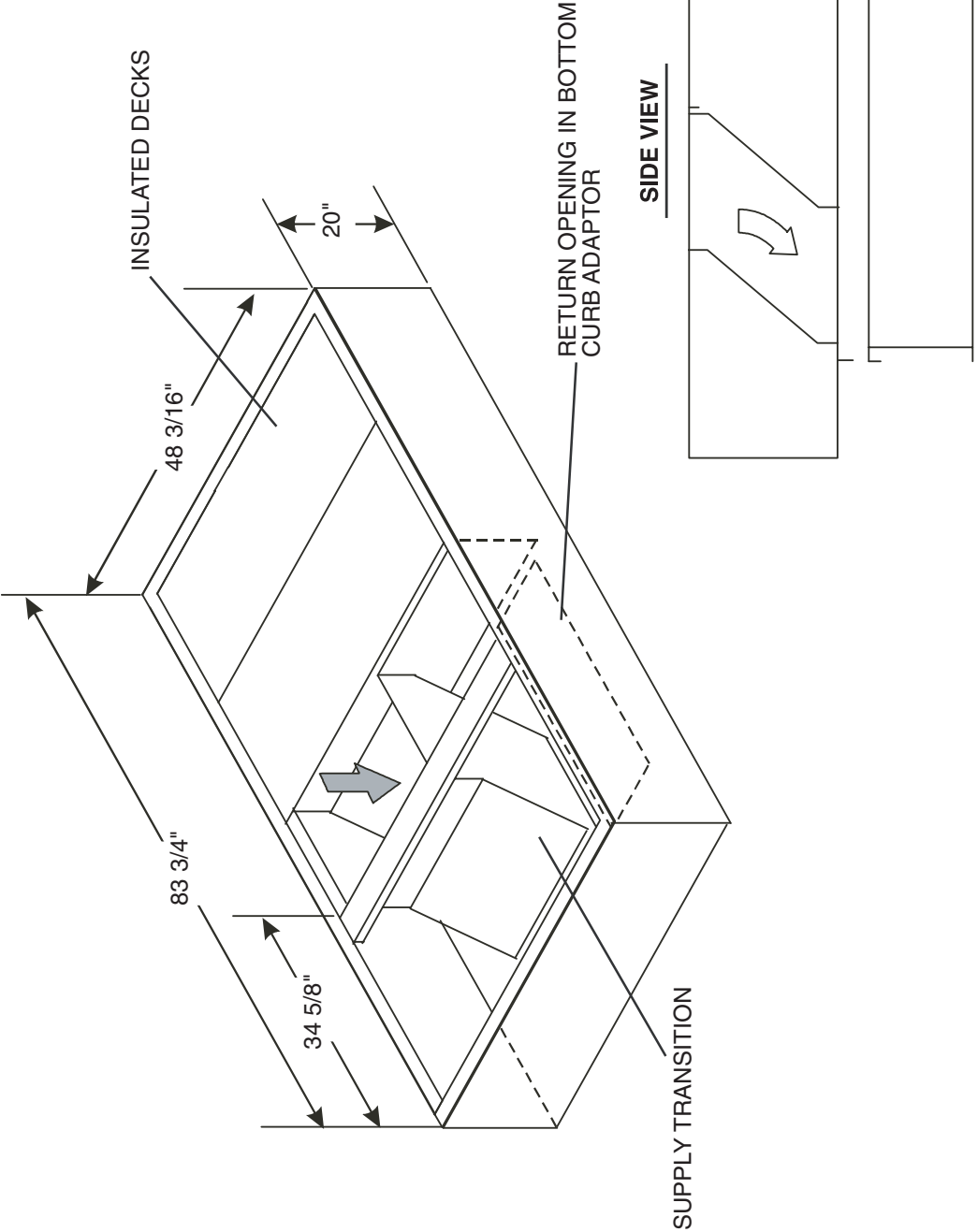

# Accessory dimensions — 48PG08-14



## ROOF CURB — 48PG08-14

UNIT SIZE 48PG	"A"	ROOF CURB ACCESSORY
08-14	1'-2" (356)	CRFCURB031A00
	2'-0" (610)	CRFCURB033A00

  

UNIT SIZE 48PG	"C"	CONNECTOR ACCESSORY PACKAGE
08-14	3/4" NPT	CRGASR0005A00

- NOTES:
- 1 ROOF CURB ACCESSORY IS SHIPPED UNASSEMBLED.
  - 2 BOLT HEADS TO BE ON INSIDE OF FLANGE. CLEARANCE IS (11) 0'-0-7/16" TYP ALL CORNERS.
  - 3 DIMENSIONS IN ( ) ARE IN MILLIMETERS.
  - 4 ROOF CURB GALVANIZED STEEL.
  - 5 ATTACH DUCTWORK TO CURB (FLANGES ON DUCT REST ON CURB).
  - 6 SERVICE CLEARANCE 4 FT ON EACH SIDE.
  - 7 GAS SERVICE PLATE IS PART OF A SEPARATELY SHIPPED ACCESSORY PACKAGE.
  - 8 GAS SERVICE PLATE CAN BE USED WITH EITHER ACCESSORY ROOFCURB.

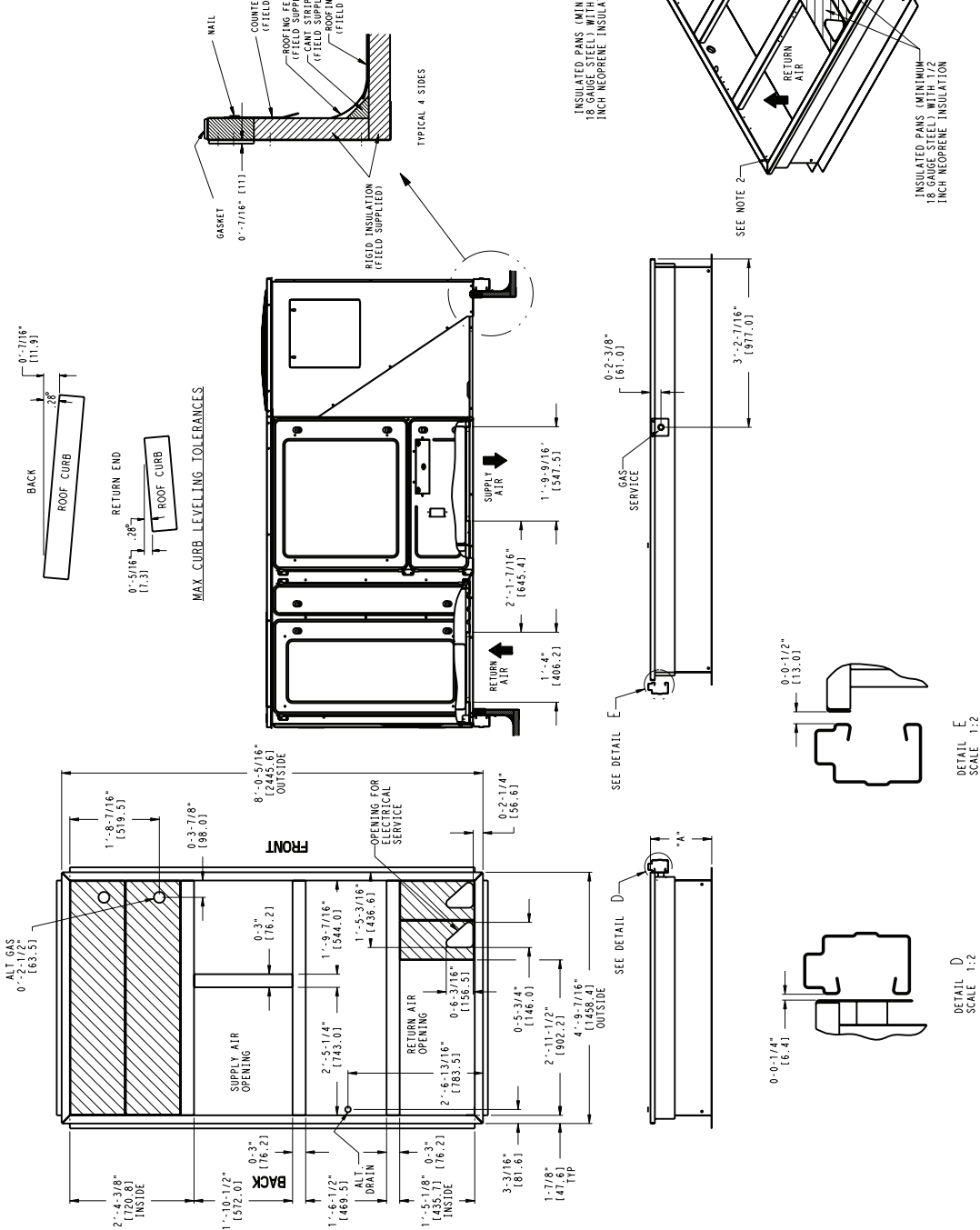

**CURB ADAPTOR — 48PG08-14 (Part No. CRADCURB002A00)**

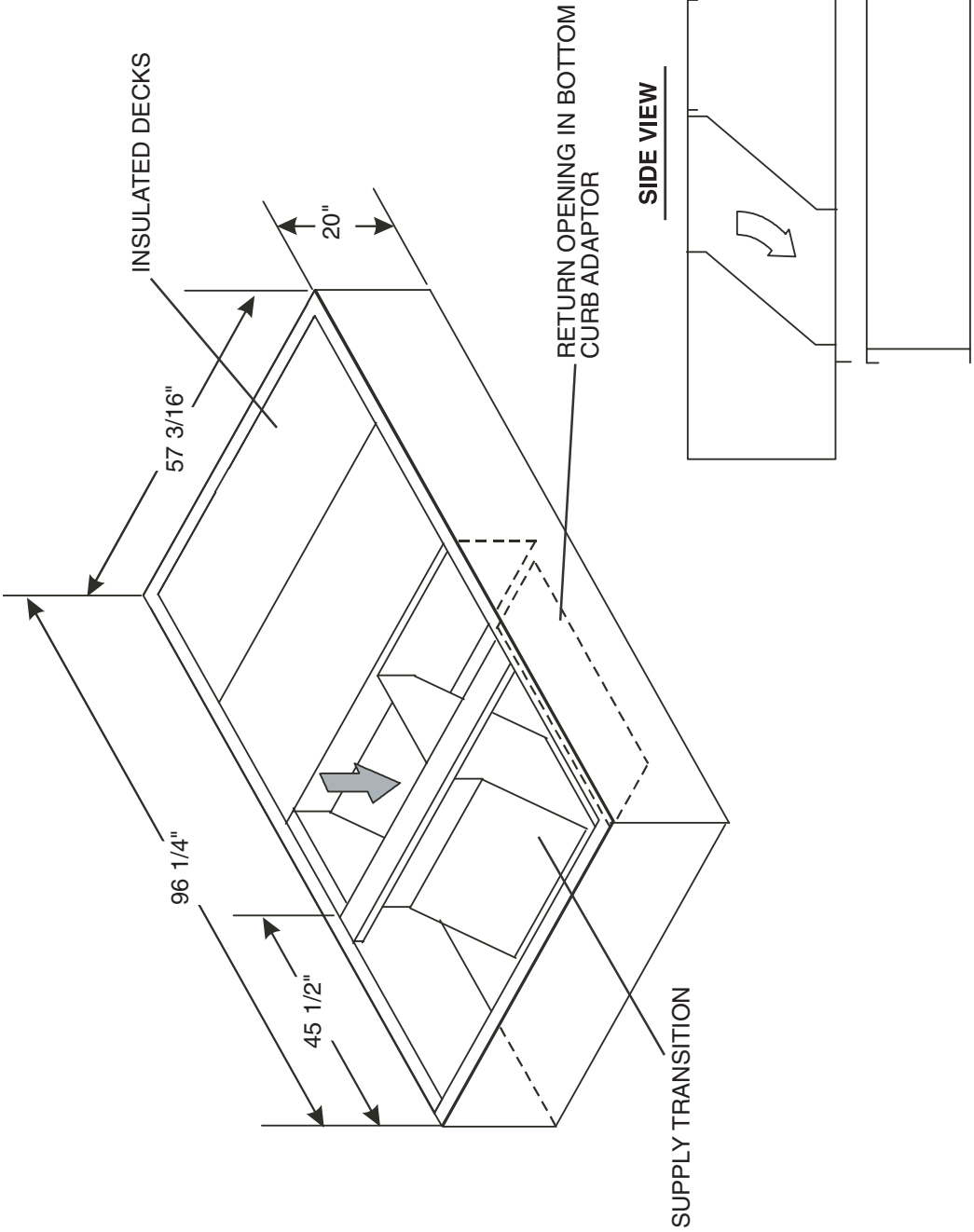

# Accessory dimensions — 48PG16



UNIT SIZE	"A"	ROOF CURB ACCESSORY
16	1'-2" (356)	CRRCURB034A00
	2'-0" (610)	CRRCURB035A00

UNIT SIZE	"C"	CONNECTOR ACCESSORY PACKAGE
16	1" NPT	CRGASER006A00

- NOTES:
- 1 ROOF CURB ACCESSORY IS SHIPPED UNASSEMBLED.
  - 2 BOLT HEADS TO BE ON INSIDE OF FLANGE. CLEARANCE IS (11) 0-0-7/16" TIP ALL CORNERS.
  - 3 DIMENSIONS IN ( ) ARE IN MILLIMETERS.
  - 4 ROOF CURB IS GALVANIZED STEEL.
  - 5 ATTACH DUCTWORK TO CURB (FLANGES ON DUCT REST ON CURB)
  - 6 SERVICE CLEARANCE 4" (1) ON EACH SIDE
  - 7 GAS SERVICE PLATE IS PART OF A SEPARATELY SHIPPED ACCESSORY PACKAGE.
  - 8 GAS SERVICE PLATE CAN BE USED WITH EITHER ACCESSORY ROOF CURB.

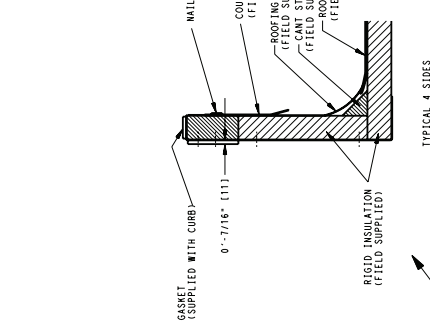

↑ DIRECTION OF AIR FLOW

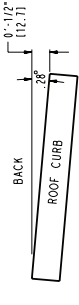
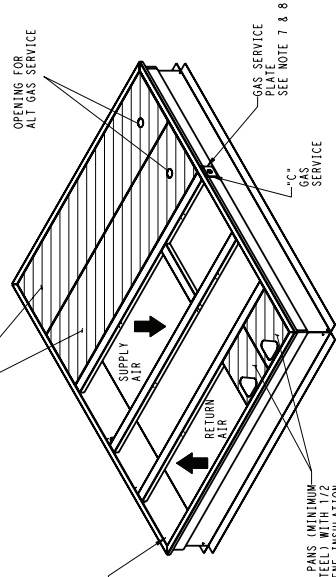

MAX. CURB LEVELING TOLERANCES

0'-7/16" (111.1) RETURN END

0'-7/16" (111.1) ROOF CURB

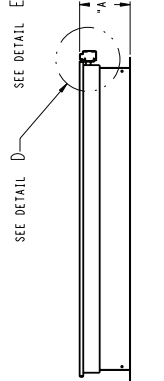
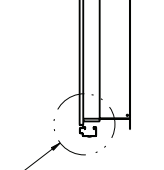
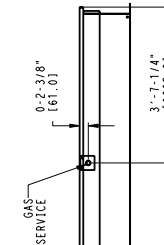
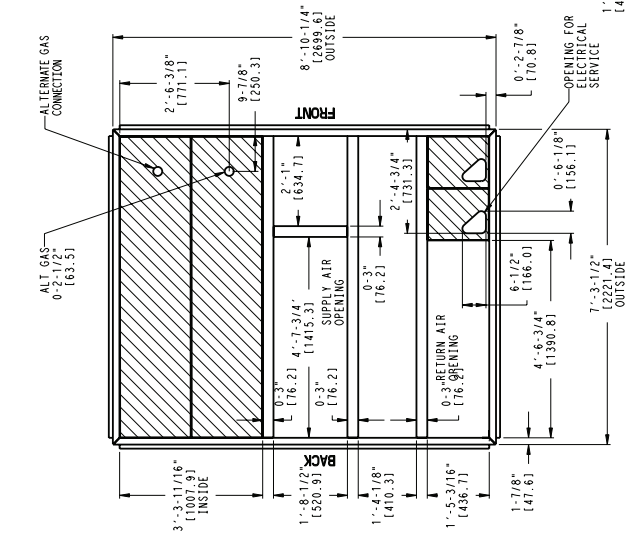
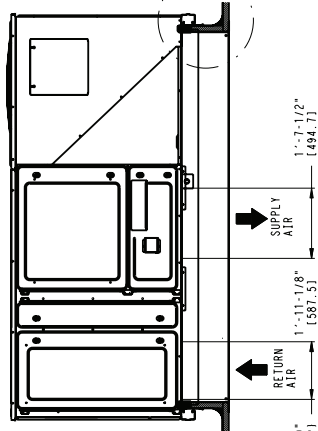

DETAIL E  
SCALE 1:5

DETAIL D  
SCALE 1:5

**ACCESSORY DIMENSION CURB ADAPTOR — 48PG16**

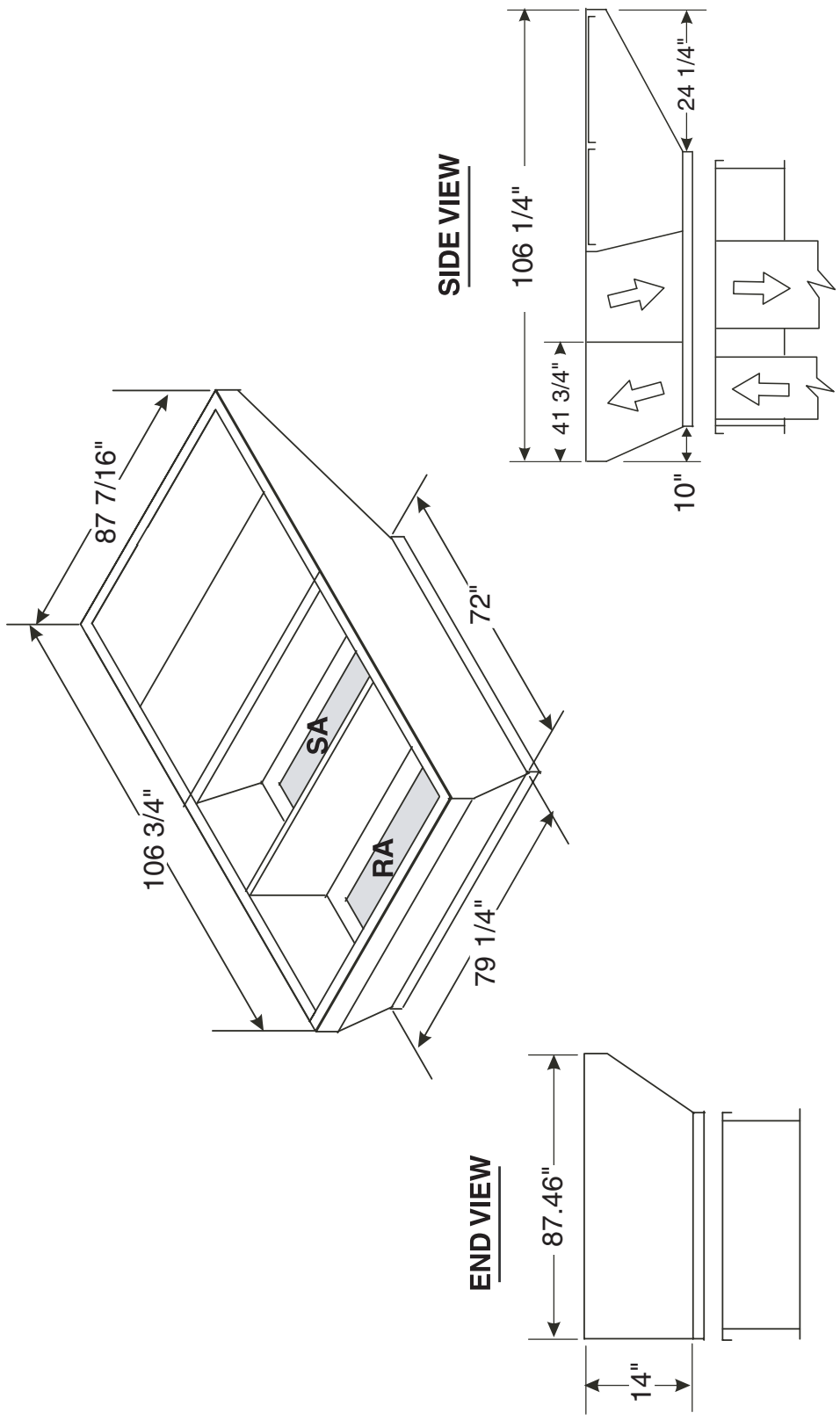

## ROOF CURB — 48PG20-28

MAX CURB LEVELING TOLERANCES:

ROOF CURB	A	B		
DEG.	IN.	DEG.	IN.	
CRFCURB018C00	.28	.57	.28	.42
CRFCURB019C00	.28	.63	.28	.42

- NOTES:
1. ROOF CURB ACCESSORY IS SHIPPED DISASSEMBLED.
  2. DIMENSIONS IN ( ) ARE IN MILLIMETERS.
  3. DIRECTION OF AIRFLOW.
  4. ROOF CURB: 16 GA. (1.60mm) STAINLESS STEEL.
  5. TO PREVENT THE HAZARD OF STAGNANT WATER BUILD-UP IN THE UNIT DO NOT EXCEED CURB LEVELING TOLERANCES.
  6. CLEARANCE BETWEEN UNIT BASE RAIL AND CURB FLANGE IS 1/4" IN. (6 MM) ON EACH SIDE.

ROOF CURB ACCESSORY	CURB HEIGHT	DESCRIPTION	C	D	
CRFCURB018C00	1'-2" (356)	ROOF CURB 14" HIGH	3'-1 15/16" (963)	9'-6 7/16" (2906)	PG 28
CRFCURB019C00	2'-0" (610)	ROOF CURB 24" HIGH	3'-1 15/16" (963)	9'-6 7/16" (2906)	PG 28
CRFCURB036A00	1'-2" (356)	ROOF CURB 14" HIGH	4'-3 9/16" (1310)	10'-8 1/16" (3279)	PG 20, 24
CRFCURB037A00	2'-0" (610)	ROOF CURB 24" HIGH	4'-3 9/16" (1310)	10'-8 1/16" (3279)	PG 20, 24

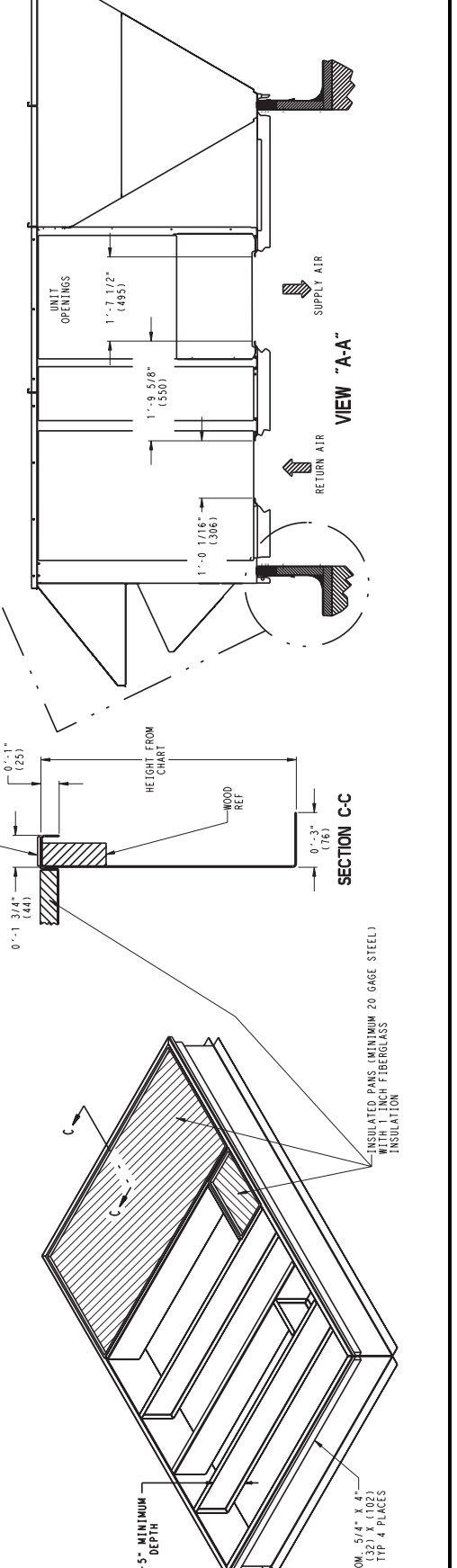
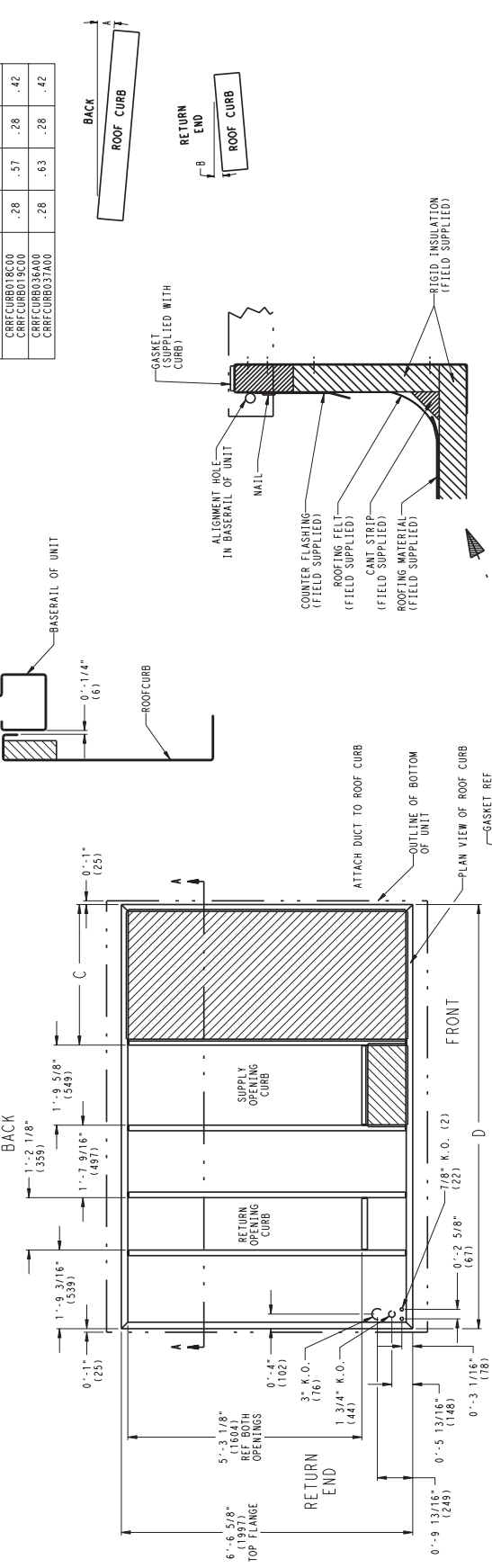

# ROOF CURB SUPPORT

- NOTES:
1. ROOFCURB SUPPORT ACCESSORY IS SHIPPED DISASSEMBLED.
  2. DIMENSIONS IN ( ) ARE IN MILLIMETERS.
  3. ROOFCURB SUPPORT: 16 GAGE (VA03-56) STEEL.

ROOFCURB ACCESSORY	CURB HEIGHT	DESCRIPTION
CRTSUCT001A00	1'-2" (356)	ROOF CURB SUPPORT 14" HIGH
CRTSUCT002A00	2'-0" (610)	ROOF CURB SUPPORT 24" HIGH

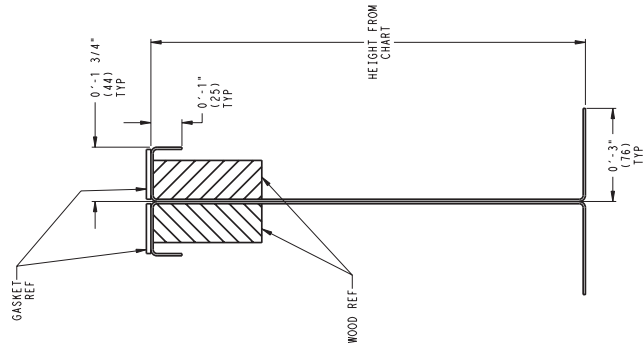
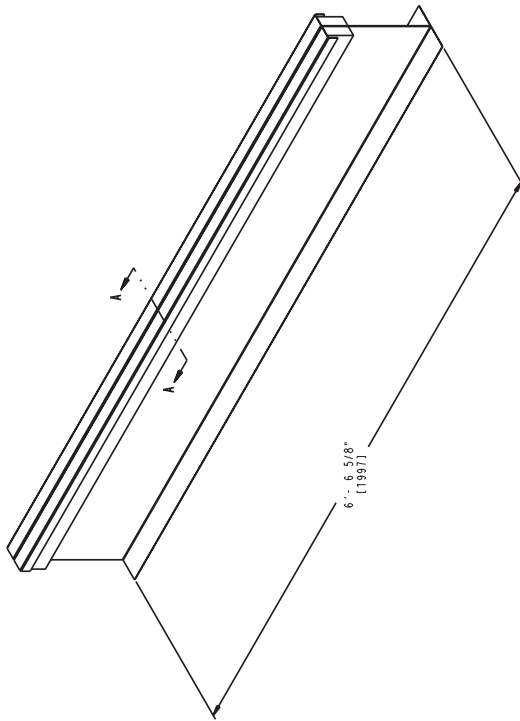

SECTION A-A

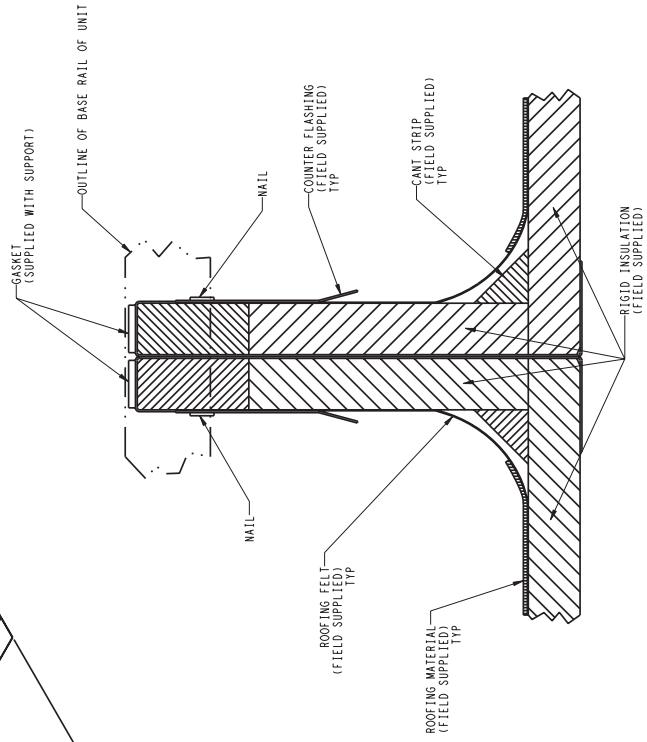

# Selection procedure (with 48PGE06 example)



## I Determine cooling and heating requirements at design conditions.

Given:

Required Gross Cooling Capacity (TC) . . . . . 57,000 Btuh  
 Gross Sensible Heat Capacity (SHC) . . . . . 37,000 Btuh  
 Required Heating Capacity . . . . . 90,000 Btuh  
 Condenser Entering Air Temperature . . . . . 95 F Summer  
 Indoor Air Temperature . . . . . 80 F edb, 67 F ewb  
 Evaporator Air Quantity . . . . . 1,700 cfm  
 External Static Pressure . . . . . 0.60 in. wg  
 Electrical Characteristics (V-Ph-Hz) . . . . . 230-3-60  
 Vertical supply required.

## II Select unit based on required cooling capacity.

Enter Cooling Capacities table for 48PGE06 at condenser entering temperature of 95 F, evaporator air quantity of 1,700 cfm, and indoor air temperature of 80/67 F. The 48PGE06 unit will provide a total cooling capacity of 60,300 Btuh and a SHC of 41,800 Btuh. For evaporator air temperatures other than 80 F, calculate SHC correction using formula in notes under cooling capacity tables.

Unit meets design conditions for TC and SHC.

NOTE: Unit ratings are gross capacities and do not include the effect of indoor fan motor heat. To calculate net capacities, see Step V.

## III Select heating capacity of unit to provide design condition requirement.

In Heating Capacities and Efficiencies table, note that 48PGE06 (medium heat) unit will provide 91,500 Btuh with an input of 113,000 Btuh.

## IV Determine fan speed and power requirements at design conditions.

Before entering the Fan Performance tables, calculate the total static pressure required based on unit components. Tabulated fan performance includes unit casing, filters, and wet evaporator coil.

Calculate pressure drop:

Design External Static Pressure 0.60  
 Additional Static Pressure + 0.00  
 0.60 in. wg (ESP)

Enter Fan Performance tables for 48PGE06 (medium heat units, vertical supply) at 1,700 cfm and 0.60 in. wg. The rpm is 826 and the Bhp is 0.6. The factory-installed 1½ hp motor and standard drive are sufficient for this operation.

## V Determine net cooling capacities.

Cooling capacities are gross capacities and do not include indoor (evaporator) fan motor (IFM) heat. To determine input power to the motor, enter the Fan Performance tables for 48PGE06 (medium heat units) at 1,700 cfm and 0.60 in. wg. Calculated input watts to the motor are 613.

Input Watts = (746 x Bhp)/(motor eff)  
 Input Watts = (746 x 0.6)/0.73  
 Input Watts = 613

Determine net cooling capacity and net sensible cooling capacity using the following formulas:

IFM Heat = Input Watts x 3.412 Btuh/Watt  
 = 613 x 3.412  
 = 2091 Btuh

Net Capacity = Gross Capacity – IFM Heat  
 = 60,300 – 2091  
 = 58,208 Btuh

Net Sensible Cap. = Gross Sensible Cap. – IFM Heat  
 = 41,800 – 2091  
 = 39,709 Btuh

The calculations show that a 48PGE06 unit is the correct selection for the given conditions.

## VI Select the unit that corresponds to power source available.

The electrical data table shows that the 230-3-60 unit is available.

# Performance data



## COOLING CAPACITIES

### 48PG03 (2 Tons) — STANDARD UNIT AND UNIT WITH HUMIDI-MIZER™ SYSTEM IN COOLING MODE

Temp (F) Air Ent Condenser (Edb)	Air Entering Evaporator — Cfm																					
	600						800						1000									
	Air Entering Evaporator — Ewb (F)																					
	80	76	72	67	62	58	54	80	76	72	67	62	58	54	80	76	72	67	62	58	54	
60	TC	33.7	31.7	29.8	27.4	25.2	23.5	23.0	35.6	33.6	31.6	29.2	26.9	25.4	25.4	36.9	34.9	32.9	30.4	28.0	27.3	27.3
	SHC	9.1	11.7	14.2	17.1	20.0	22.2	22.6	9.3	12.5	15.7	19.5	23.2	25.0	25.0	9.4	13.3	17.0	21.6	26.0	26.8	26.8
	kW	0.92	0.91	0.91	1.09	1.09	0.90	0.90	0.93	0.92	0.91	0.91	0.90	0.90	0.90	0.93	0.93	0.92	0.91	0.91	0.90	0.90
	BF	0.00	0.00	0.21	0.18	0.17	0.17	0.33	0.00	0.00	0.20	0.19	0.18	0.25	0.44	0.00	0.25	0.20	0.20	0.20	0.36	0.52
70	TC	32.7	30.8	28.9	26.6	24.5	22.8	22.5	34.6	32.6	30.6	28.3	26.0	24.8	24.8	35.8	33.7	31.8	29.4	27.1	26.5	26.5
	SHC	8.8	11.4	13.9	16.9	19.7	21.8	22.1	8.9	12.2	15.4	19.2	22.9	24.4	24.4	9.1	12.9	16.7	21.4	25.6	26.1	26.1
	kW	1.10	1.10	1.09	1.09	1.09	1.08	1.08	1.11	1.11	1.10	1.09	1.09	1.09	1.09	1.12	1.11	1.11	1.10	1.09	1.09	1.09
	BF	0.00	0.00	0.19	0.16	0.16	0.17	0.35	0.00	0.00	0.18	0.17	0.17	0.27	0.46	0.00	0.24	0.19	0.18	0.20	0.37	0.53
75	TC	32.2	30.3	28.4	26.2	24.0	22.4	22.2	34.0	32.0	30.1	27.8	25.6	24.4	24.4	35.1	33.1	31.2	28.8	26.6	26.1	26.1
	SHC	8.7	11.2	13.7	16.7	19.6	21.5	21.8	8.8	12.0	15.2	19.0	22.8	24.0	24.0	8.9	12.7	16.5	21.2	25.3	25.7	25.7
	kW	1.20	1.20	1.19	1.19	1.19	1.18	1.18	1.21	1.21	1.20	1.20	1.19	1.19	1.19	1.22	1.21	1.21	1.20	1.19	1.19	1.19
	BF	0.00	0.00	0.18	0.15	0.15	0.17	0.36	0.00	0.00	0.18	0.17	0.17	0.28	0.46	0.00	0.23	0.19	0.18	0.20	0.38	0.54
85	TC	31.1	29.3	27.4	25.2	23.1	21.7	21.5	32.6	30.7	28.9	26.7	24.5	23.7	23.7	33.8	31.8	29.9	27.6	25.5	25.3	25.3
	SHC	8.3	10.7	13.3	16.3	19.2	20.8	21.2	8.4	11.6	14.8	18.6	22.4	23.3	23.3	8.6	12.3	16.1	20.8	24.6	24.9	24.9
	kW	1.42	1.42	1.41	1.41	1.40	1.40	1.39	1.43	1.42	1.42	1.41	1.40	1.40	1.40	1.43	1.43	1.42	1.41	1.41	1.41	1.41
	BF	0.00	0.00	0.17	0.15	0.14	0.20	0.37	0.00	0.28	0.17	0.16	0.16	0.30	0.48	0.00	0.21	0.18	0.17	0.22	0.40	0.55
95	TC	30.0	28.1	26.2	24.1	22.1	20.8	20.8	31.3	29.4	27.6	24.9	23.4	22.8	22.8	32.3	30.4	28.6	26.4	24.5	24.3	24.3
	SHC	8.1	10.3	12.9	15.9	18.9	20.5	20.4	8.0	11.2	14.3	17.9	21.8	22.4	22.4	8.1	11.9	15.7	20.3	23.5	23.9	23.9
	kW	1.65	1.66	1.65	1.64	1.64	1.63	1.63	1.67	1.67	1.66	1.65	1.64	1.64	1.64	1.68	1.67	1.66	1.65	1.64	1.64	1.64
	BF	0.00	0.00	0.16	0.14	0.13	0.19	0.39	0.00	0.23	0.16	0.15	0.16	0.33	0.50	0.00	0.20	0.18	0.17	0.25	0.42	0.57
105	TC	28.5	26.8	25.0	23.0	21.1	20.0	20.0	29.8	28.0	26.3	24.2	22.2	21.9	21.9	30.7	28.9	27.2	25.0	23.3	23.3	23.3
	SHC	7.5	9.9	12.4	15.4	18.4	19.7	19.7	7.6	10.7	13.9	17.7	21.2	21.5	21.5	7.6	11.4	15.2	19.8	22.9	22.9	22.9
	kW	1.93	1.92	1.92	1.91	1.90	1.89	1.89	1.93	1.93	1.93	1.91	1.90	1.90	1.90	1.95	1.94	1.93	1.92	1.91	1.91	1.91
	BF	0.00	0.00	0.15	0.13	0.12	0.22	0.42	0.00	0.21	0.16	0.15	0.17	0.35	0.52	0.00	0.19	0.17	0.17	0.26	0.44	0.58
115	TC	27.0	25.3	23.7	21.8	19.9	19.1	19.1	28.2	26.5	24.8	22.9	21.0	20.9	20.9	29.0	27.2	25.6	23.6	22.2	22.2	22.2
	SHC	7.1	9.5	12.0	14.9	17.9	18.8	18.8	7.1	10.3	13.4	17.2	20.3	20.6	20.6	7.2	10.9	14.7	19.3	21.9	21.9	21.9
	kW	2.21	2.21	2.20	2.19	2.18	2.17	2.17	2.23	2.22	2.21	2.20	2.18	2.18	2.18	2.24	2.23	2.22	2.21	2.19	2.19	2.19
	BF	0.00	0.00	0.14	0.13	0.12	0.25	0.44	0.00	0.18	0.16	0.15	0.19	0.38	0.54	0.00	0.18	0.17	0.16	0.29	0.47	0.60
125	TC	25.3	23.7	22.2	20.5	18.7	18.2	18.2	26.3	24.7	23.2	21.4	19.8	19.8	19.8	27.1	25.4	23.9	22.0	21.0	21.0	21.0
	SHC	6.6	9.0	11.4	14.4	17.3	17.9	17.9	6.6	9.7	12.8	16.6	19.5	19.5	19.5	6.7	10.4	14.1	18.7	20.6	20.6	20.6
	kW	2.53	2.52	2.51	2.53	2.50	2.50	2.50	2.54	2.54	2.52	2.51	2.52	2.52	2.52	2.56	2.54	2.53	2.51	2.50	2.50	2.50
	BF	0.00	0.21	0.13	0.12	0.12	0.29	0.47	0.00	0.17	0.15	0.14	0.21	0.41	0.56	0.00	0.18	0.17	0.16	0.33	0.50	0.62

#### LEGEND

- BF — Bypass Factor
- Edb — Entering Dry-Bulb
- Ewb — Entering Wet-Bulb
- kW — Compressor Motor Power Input
- ldb — Leaving Dry-Bulb
- lwb — Leaving Wet-Bulb
- SHC — Sensible Heat Capacity (1000 Btuh) Gross
- TC — Total Capacity (1000 Btuh) Gross

#### NOTES:

1. Direct interpolation is permissible. Do not extrapolate.
2. The following formulas may be used:

$$t_{ldb} = t_{edb} - \frac{\text{sensible capacity (Btuh)}}{1.10 \times \text{cfm}}$$

$t_{lwb}$  = Wet-bulb temperature corresponding to enthalpy of air leaving evaporator coil ( $h_{lwb}$ )

$$h_{lwb} = h_{ewb} - \frac{\text{total capacity (Btuh)}}{4.5 \times \text{cfm}}$$

Where:  $h_{ewb}$  = Enthalpy of air entering evaporator coil

3. The SHC is based on 80 F edb temperature of air entering evaporator coil.  
Below 80 F edb, subtract (corr factor x cfm) from SHC.  
Above 80 F edb, add (corr factor x cfm) to SHC.

BYPASS FACTOR (BF)	ENTERING AIR DRY-BULB TEMP (F)					
	79	78	77	76	75	under 75
	81	82	83	84	85	over 85
	Correction Factor					
.05	1.04	2.07	3.11	4.14	5.18	Use formula shown below.
.10	.98	1.96	2.94	3.92	4.90	
.20	.87	1.74	2.62	3.49	4.36	
.30	.76	1.53	2.29	3.05	3.82	

Interpolation is permissible.

Correction Factor =  $1.09 \times (1 - BF) \times (edb - 80)$ .

4. Cooling capacities for 48PG03-16 units with Humidi-MiZer system in Cooling mode are the same as standard units.

# Performance data (cont)



## COOLING CAPACITIES (cont)

### 48PG03 (2 Tons) — UNIT WITH HUMIDI-MIZER™ SYSTEM IN SUBCOOLING MODE

Temp (F) Air Ent Condenser (Edb)		Air Entering Evaporator — CFM													
		600							800						
		Air Entering Evaporator — Ewb (F)													
		80	76	72	67	62	57	54	80	76	72	67	62	57	54
75	TC	33.7	31.4	29.2	26.4	23.7	20.9	19.2	35.4	33.1	30.8	27.9	25.0	22.1	20.4
	SHC	8.6	10.8	12.9	15.6	18.4	20.9	19.2	10.2	12.3	14.4	17.0	19.6	22.1	20.4
	kW	1.19	1.19	1.21	1.22	1.23	1.24	1.25	1.19	1.19	1.21	1.22	1.23	1.24	1.3
85	TC	30.5	28.4	26.3	23.6	20.9	18.3	16.7	32.4	30.2	28.0	25.2	22.4	19.6	17.9
	SHC	4.5	7.2	9.9	13.3	16.7	20.1	22.1	6.3	8.9	11.6	14.8	18.1	21.4	23.4
	kW	1.41	1.41	1.42	1.43	1.44	1.45	1.45	1.41	1.41	1.42	1.43	1.44	1.45	1.5
95	TC	27.4	25.4	23.3	20.8	18.2	15.6	14.1	29.5	27.3	25.1	22.4	19.7	17.0	15.4
	SHC	0.3	3.6	6.9	11.0	15.0	15.6	14.1	2.4	5.5	8.7	12.7	16.6	17.0	15.4
	kW	1.62	1.62	1.63	1.64	1.64	1.65	1.65	1.62	1.62	1.63	1.64	1.64	1.65	1.7
105	TC	24.3	22.4	20.4	17.9	15.5	13.0	11.5	26.5	24.4	22.3	19.7	17.1	14.4	12.9
	SHC	-3.8	0.0	3.8	8.6	13.4	13.0	11.5	-1.6	2.2	5.9	10.5	15.1	14.4	12.9
	kW	1.84	1.84	1.85	1.85	1.85	1.85	1.85	1.84	1.84	1.85	1.85	1.85	1.85	1.9
115	TC	21.2	19.3	17.4	15.1	12.7	10.4	8.9	23.5	21.4	19.4	16.9	14.4	11.9	10.4
	SHC	-7.9	-3.6	0.8	6.3	11.7	10.4	8.9	-5.5	-1.2	3.0	8.3	13.6	11.9	10.4
	kW	2.06	2.06	2.06	2.06	2.06	2.06	2.05	2.06	2.06	2.06	2.06	2.06	2.06	2.1
125	TC	18.1	16.3	14.5	12.2	10.0	7.7	6.4	20.5	18.5	16.6	14.2	11.7	9.3	7.9
	SHC	-12.1	-7.2	-2.2	3.9	10.0	7.7	6.4	-9.4	-4.6	0.2	6.2	11.7	9.3	7.9
	kW	2.28	2.28	2.27	2.27	2.26	2.26	2.26	2.28	2.28	2.27	2.27	2.26	2.26	2.3

### 48PG03 (2 Tons) — UNIT WITH HUMIDI-MIZER SYSTEM IN SUBCOOLING MODE (cont)

Temp (F) Air Ent Condenser (Edb)		Air Entering Evaporator — CFM						
		1000						
		Air Entering Evaporator — Ewb (F)						
		80	76	72	67	62	57	54
75	TC	36.9	34.5	32.1	29.1	26.1	23.1	21.3
	SHC	11.5	13.5	15.5	18.1	20.6	23.1	21.3
	kW	1.19	1.19	1.21	1.22	1.23	1.24	1.25
85	TC	33.9	31.6	29.3	26.4	23.5	20.6	18.8
	SHC	7.7	10.3	12.8	16.0	19.2	22.4	24.3
	kW	1.41	1.41	1.42	1.43	1.44	1.45	1.45
95	TC	31.0	28.8	26.5	23.7	20.9	18.1	16.4
	SHC	4.0	7.0	10.1	14.0	17.9	18.1	16.4
	kW	1.62	1.62	1.63	1.64	1.64	1.65	1.65
105	TC	28.1	26.0	23.8	21.0	18.3	15.6	13.9
	SHC	0.2	3.8	7.4	12.0	16.5	15.6	13.9
	kW	1.84	1.84	1.85	1.85	1.85	1.85	1.85
115	TC	25.2	23.1	21.0	18.4	15.7	13.1	11.5
	SHC	-3.6	0.6	4.7	9.9	15.1	13.1	11.5
	kW	2.06	2.06	2.06	2.06	2.06	2.06	2.05
125	TC	22.3	20.3	18.2	15.7	13.1	10.6	9.1
	SHC	-7.3	-2.7	2.0	7.9	13.1	10.6	9.1
	kW	2.28	2.28	2.27	2.27	2.26	2.26	2.26

#### LEGEND

- Edb** — Entering Dry-Bulb
- Ewb** — Entering Wet-Bulb
- kW** — Compressor Motor Power Input
- ldb** — Leaving Dry-Bulb
- lwb** — Leaving Wet-Bulb
- SHC** — Sensible Heat Capacity (1000 Btuh) Gross
- TC** — Total Capacity (1000 Btuh) Gross

#### NOTES:

1. Direct interpolation is permissible. Do not extrapolate.
2. The following formulas may be used:

$$t_{ldb} = t_{edb} - \frac{\text{sensible capacity (Btuh)}}{1.10 \times \text{cfm}}$$

$t_{lwb}$  = Wet-bulb temperature corresponding to enthalpy of air leaving evaporator coil ( $h_{lwb}$ )

$$h_{lwb} = h_{ewb} - \frac{\text{total capacity (Btuh)}}{4.5 \times \text{cfm}}$$

Where:  $h_{ewb}$  = Enthalpy of air entering evaporator coil



**COOLING CAPACITIES (cont)**

**48PG03 (2 Tons) — UNIT WITH HUMIDI-MIZER™ SYSTEM IN HOT GAS REHEAT MODE**

Temp (F) Air Ent Condenser (Edb)		Air Entering Evaporator — Ewb (F)								
		75 Dry Bulb 62.5 Wet Bulb (50% RH)			75 Dry Bulb 64 Wet Bulb (55% RH)			75 Dry Bulb 65.3 Wet Bulb (60% RH)		
		Air Entering Evaporator — Cfm								
		700	800	900	700	800	900	700	800	900
80	TC	9.9	10.4	10.9	10.6	11.2	11.7	11.2	11.8	12.3
	SHC	2.0	2.6	3.1	0.8	1.3	1.8	-0.3	0.2	0.7
	kW	1.28	1.28	1.28	1.29	1.29	1.29	1.29	1.29	1.29
75	TC	10.6	11.2	11.6	11.3	11.9	12.4	12.0	12.5	13.0
	SHC	2.6	3.1	3.6	1.4	1.9	2.4	0.4	0.9	1.4
	kW	1.26	1.26	1.26	1.27	1.27	1.27	1.27	1.27	1.27
70	TC	11.4	11.9	12.3	12.1	12.6	13.1	12.7	13.2	13.7
	SHC	3.1	3.6	4.0	2.0	2.5	3.0	1.1	1.6	2.0
	kW	1.24	1.24	1.24	1.25	1.25	1.25	1.25	1.25	1.25
60	TC	12.9	13.4	13.7	13.6	14.0	14.4	14.2	14.6	15.0
	SHC	4.2	4.6	5.0	3.3	3.7	4.1	2.5	2.9	3.3
	kW	1.20	1.20	1.20	1.21	1.21	1.21	1.22	1.22	1.22
50	TC	14.5	14.8	15.1	15.1	15.5	15.8	15.7	16.1	16.4
	SHC	5.2	5.6	5.9	4.5	4.9	5.2	3.9	4.3	4.6
	kW	1.17	1.17	1.17	1.17	1.17	1.17	1.18	1.18	1.18
40	TC	16.0	16.3	16.5	16.6	16.9	17.2	17.2	17.5	17.7
	SHC	6.3	6.6	6.9	5.8	6.1	6.4	5.4	5.7	6.0
	kW	1.13	1.13	1.13	1.14	1.14	1.14	1.15	1.15	1.15

**LEGEND**

- Edb** — Entering Dry-Bulb
- Ewb** — Entering Wet-Bulb
- kW** — Compressor Motor Power Input
- ldb** — Leaving Dry-Bulb
- lwb** — Leaving Wet-Bulb
- RH** — Relative Humidity
- SHC** — Sensible Heat Capacity (1000 Btuh) Gross
- TC** — Total Capacity (1000 Btuh) Gross

**NOTES:**

1. Direct interpolation is permissible. Do not extrapolate.
2. The following formulas may be used:

$$t_{ldb} = t_{edb} - \frac{\text{sensible capacity (Btuh)}}{1.10 \times \text{cfm}}$$

$t_{lwb}$  = Wet-bulb temperature corresponding to enthalpy of air leaving evaporator coil ( $h_{lwb}$ )

$$h_{lwb} = h_{ewb} - \frac{\text{total capacity (Btuh)}}{4.5 \times \text{cfm}}$$

Where:  $h_{ewb}$  = Enthalpy of air entering evaporator coil

# Performance data (cont)



## COOLING CAPACITIES (cont)

### 48PG04 (3 Tons) — STANDARD UNIT AND UNIT WITH HUMIDI-MIZER™ SYSTEM IN COOLING MODE

Temp (F) Air Ent Condenser (Edb)	Air Entering Evaporator — Cfm																					
	900						1200						1500									
	Air Entering Evaporator — Ewb (F)																					
	80	76	72	67	62	58	54	80	76	72	67	62	58	54	80	76	72	67	62	58	54	
60	TC	49.5	46.3	43.4	39.9	36.7	34.3	33.1	52.8	49.6	46.4	42.7	39.2	37.0	36.7	54.6	51.3	48.2	44.4	40.9	39.4	39.4
	SHC	13.7	17.4	20.7	25.2	29.4	32.5	33.1	14.1	18.3	23.2	28.8	34.1	35.0	36.7	14.2	19.6	25.3	32.0	38.2	39.4	39.4
	kW	1.66	1.64	1.62	1.60	1.59	1.57	1.57	1.67	1.66	1.64	1.62	1.60	1.59	1.58	1.69	1.67	1.65	1.63	1.61	1.60	1.60
	BF	0.00	0.17	0.21	0.18	0.18	0.19	0.36	0.00	0.33	0.20	0.19	0.20	0.32	0.47	0.00	0.25	0.20	0.20	0.22	0.38	0.54
70	TC	48.1	45.1	42.3	38.8	35.6	33.1	32.3	51.0	47.9	44.8	41.2	37.9	35.8	35.8	52.6	49.5	46.5	42.8	39.3	38.4	38.4
	SHC	13.2	17.0	20.4	24.8	29.0	31.8	32.3	13.5	17.8	22.7	28.3	33.7	35.8	35.8	13.6	19.1	24.7	31.4	37.4	38.4	38.4
	kW	1.88	1.87	1.86	1.84	1.83	1.81	1.81	1.90	1.88	1.87	1.85	1.83	1.83	1.83	1.91	1.90	1.88	1.86	1.84	1.84	1.84
	BF	0.00	0.18	0.19	0.17	0.17	0.20	0.38	0.00	0.29	0.19	0.18	0.19	0.29	0.48	0.00	0.24	0.20	0.20	0.23	0.39	0.55
75	TC	47.4	44.4	41.6	38.1	35.0	32.5	31.9	50.0	46.9	43.9	40.5	37.2	35.3	35.3	51.6	48.5	45.5	42.0	38.6	37.8	37.8
	SHC	13.0	16.7	20.1	24.5	28.8	31.3	31.9	13.2	17.6	22.4	28.0	32.1	35.3	35.3	13.3	18.8	24.4	31.2	36.9	37.8	37.8
	kW	2.01	2.00	1.99	1.97	1.95	1.94	1.94	2.03	2.01	2.00	1.98	1.97	1.95	1.95	2.04	2.02	2.01	1.99	1.98	1.97	1.97
	BF	0.00	0.18	0.18	0.17	0.17	0.20	0.39	0.00	0.27	0.19	0.18	0.19	0.31	0.49	0.00	0.24	0.20	0.20	0.23	0.40	0.56
85	TC	45.7	42.8	40.0	36.8	33.7	31.3	31.0	47.9	45.0	42.2	38.8	35.6	34.1	34.1	49.4	46.4	43.6	40.1	37.0	36.5	36.5
	SHC	12.5	16.1	19.6	24.0	28.2	30.4	31.0	12.6	17.1	21.8	27.4	32.9	34.1	34.1	12.7	18.2	23.7	30.5	35.9	36.5	36.5
	kW	2.30	2.28	2.27	2.25	2.23	2.22	2.21	2.31	2.30	2.28	2.26	2.24	2.23	2.23	2.32	2.31	2.29	2.27	2.25	2.24	2.24
	BF	0.00	0.19	0.17	0.16	0.16	0.21	0.41	0.00	0.24	0.18	0.18	0.18	0.33	0.51	0.00	0.23	0.20	0.20	0.24	0.42	0.58
95	TC	43.7	41.0	38.3	35.2	32.2	29.9	29.9	45.7	42.9	40.2	36.0	34.0	32.9	32.9	47.0	44.1	41.5	38.3	35.3	35.1	35.1
	SHC	11.8	15.2	19.0	23.4	27.5	29.9	29.9	11.9	16.5	21.1	26.1	32.1	32.9	32.9	12.0	17.5	23.0	29.7	34.9	35.1	35.1
	kW	2.60	2.58	2.57	2.54	2.53	2.51	2.51	2.61	2.60	2.58	2.53	2.54	2.53	2.53	2.63	2.61	2.59	2.57	2.54	2.54	2.54
	BF	0.00	0.29	0.16	0.15	0.16	0.22	0.43	0.00	0.22	0.18	0.18	0.18	0.35	0.52	0.00	0.22	0.20	0.20	0.26	0.45	0.59
105	TC	41.5	39.0	36.4	33.5	30.7	28.9	28.8	43.2	40.6	38.1	35.2	32.3	31.6	31.6	44.4	41.7	39.2	36.2	33.6	33.6	33.6
	SHC	11.1	14.5	18.3	22.7	26.9	28.9	28.8	11.2	15.8	20.4	26.0	30.9	31.6	31.6	11.3	16.8	22.3	28.9	33.6	33.6	33.6
	kW	2.92	2.91	2.89	2.87	2.85	2.85	2.85	2.94	2.93	2.91	2.89	2.87	2.86	2.86	2.95	2.94	2.91	2.89	2.87	2.87	2.87
	BF	0.00	0.29	0.15	0.15	0.16	0.25	0.45	0.00	0.21	0.18	0.17	0.20	0.38	0.55	0.00	0.22	0.20	0.20	0.28	0.47	0.61
115	TC	39.0	36.6	34.3	31.6	29.1	27.5	27.5	40.6	38.1	35.8	33.1	30.5	30.1	30.1	41.6	39.1	36.8	34.0	32.0	32.0	32.0
	SHC	10.4	13.9	17.6	22.0	26.1	27.5	27.5	10.5	15.0	19.6	25.2	29.7	30.1	30.1	10.5	16.0	21.5	28.1	32.0	32.0	32.0
	kW	3.29	3.27	3.26	3.24	3.22	3.20	3.20	3.30	3.29	3.27	3.25	3.23	3.22	3.22	3.31	3.30	3.28	3.25	3.24	3.24	3.24
	BF	0.00	0.22	0.15	0.15	0.15	0.28	0.47	0.00	0.20	0.17	0.17	0.22	0.41	0.57	0.00	0.21	0.20	0.20	0.32	0.50	0.63
125	TC	36.3	34.1	32.0	29.5	27.1	26.1	26.1	37.6	35.3	33.3	30.7	28.5	28.4	28.4	38.4	36.2	34.1	31.6	30.0	30.0	30.0
	SHC	9.5	13.1	16.8	21.1	25.3	26.1	26.1	9.6	14.2	18.7	24.2	28.1	28.4	28.4	9.6	15.1	20.5	27.2	30.0	30.0	30.0
	kW	3.67	3.66	3.64	3.62	3.60	3.59	3.59	3.68	3.67	3.65	3.63	3.61	3.61	3.61	3.69	3.68	3.66	3.64	3.62	3.62	3.62
	BF	0.00	0.19	0.15	0.15	0.15	0.32	0.50	0.00	0.19	0.17	0.17	0.25	0.45	0.59	0.00	0.21	0.20	0.20	0.36	0.53	0.65

#### LEGEND

- BF — Bypass Factor
- Edb — Entering Dry-Bulb
- Ewb — Entering Wet-Bulb
- kW — Compressor Motor Power Input
- ldb — Leaving Dry-Bulb
- lwb — Leaving Wet-Bulb
- SHC — Sensible Heat Capacity (1000 Btu/h) Gross
- TC — Total Capacity (1000 Btu/h) Gross

#### NOTES:

1. Direct interpolation is permissible. Do not extrapolate.
2. The following formulas may be used:

$$t_{ldb} = t_{edb} - \frac{\text{sensible capacity (Btu/h)}}{1.10 \times \text{cfm}}$$

$$t_{lwb} = \text{Wet-bulb temperature corresponding to enthalpy of air leaving evaporator coil } (h_{lwb})$$

$$h_{lwb} = h_{ewb} - \frac{\text{total capacity (Btu/h)}}{4.5 \times \text{cfm}}$$

Where:  $h_{ewb}$  = Enthalpy of air entering evaporator coil

3. The SHC is based on 80 F edb temperature of air entering evaporator coil.  
Below 80 F edb, subtract (corr factor x cfm) from SHC.  
Above 80 F edb, add (corr factor x cfm) to SHC.

BYPASS FACTOR (BF)	ENTERING AIR DRY-BULB TEMP (F)					
	79	78	77	76	75	under 75
	81	82	83	84	85	over 85
	Correction Factor					
.05	1.04	2.07	3.11	4.14	5.18	Use formula shown below.
.10	.98	1.96	2.94	3.92	4.90	
.20	.87	1.74	2.62	3.49	4.36	
.30	.76	1.53	2.29	3.05	3.82	

Interpolation is permissible.  
Correction Factor =  $1.09 \times (1 - BF) \times (edb - 80)$ .

4. Cooling capacities for 48PG03-16 units with Humidi-MiZer system in Cooling mode are the same as standard units.



**COOLING CAPACITIES (cont)**

**48PG04 (3 Tons) — UNIT WITH HUMIDI-MIZER™ SYSTEM IN SUBCOOLING MODE**

Temp (F) Air Ent Condenser (Edb)		Air Entering Evaporator — CFM													
		900							1200						
		Air Entering Evaporator — Ewb (F)													
		80	76	72	67	62	57	54	80	76	72	67	62	57	54
75	TC	49.2	46.2	43.1	39.3	35.6	31.8	29.5	52.1	48.9	45.7	41.7	37.8	33.8	31.4
	SHC	15.4	18.6	21.8	25.8	29.8	31.8	29.5	17.9	21.0	24.1	27.9	31.7	33.8	31.4
	kW	1.97	1.97	1.97	1.97	1.97	1.98	1.98	1.97	1.97	1.97	1.97	1.97	1.98	1.98
85	TC	45.1	42.2	39.3	35.7	32.0	28.4	26.2	48.1	45.0	41.9	38.1	34.3	30.4	28.1
	SHC	9.9	13.9	17.9	22.8	27.8	32.8	35.8	12.7	16.6	20.4	25.3	30.1	34.9	37.8
	kW	2.27	2.27	2.27	2.27	2.27	2.27	2.27	2.27	2.27	2.27	2.27	2.27	2.27	2.27
95	TC	41.0	38.2	35.4	32.0	28.5	25.0	22.9	44.1	41.1	38.2	34.5	30.8	27.1	24.9
	SHC	4.3	9.1	13.9	19.9	25.9	25.0	22.9	7.5	12.2	16.8	22.6	28.4	27.1	24.9
	kW	2.58	2.58	2.57	2.57	2.56	2.56	2.56	2.58	2.58	2.57	2.57	2.56	2.56	2.56
105	TC	36.9	34.2	31.6	28.3	25.0	21.7	19.7	40.0	37.2	34.4	30.8	27.3	23.8	21.6
	SHC	-1.2	4.4	10.0	17.0	24.0	21.7	19.7	2.3	7.7	13.2	20.0	26.7	23.8	21.6
	kW	2.89	2.89	2.88	2.87	2.86	2.85	2.85	2.89	2.89	2.88	2.87	2.86	2.85	2.85
115	TC	32.8	30.3	27.7	24.6	21.4	18.3	16.4	36.0	33.3	30.6	27.2	23.8	20.4	18.4
	SHC	-6.7	-0.3	6.1	14.1	21.4	18.3	16.4	-2.9	3.3	9.5	17.3	23.8	20.4	18.4
	kW	3.20	3.20	3.18	3.17	3.15	3.14	3.13	3.20	3.20	3.18	3.17	3.15	3.14	3.13
125	TC	28.7	26.3	23.9	20.9	17.9	14.9	13.1	31.9	29.4	26.8	23.5	20.3	17.1	15.1
	SHC	-12.3	-5.1	2.1	11.1	17.9	14.9	13.1	-8.1	-1.1	5.9	14.7	20.3	17.1	15.1
	kW	3.51	3.51	3.48	3.47	3.45	3.43	3.42	3.51	3.51	3.48	3.47	3.45	3.43	3.42

**48PG04 (3 Tons) — UNIT WITH HUMIDI-MIZER SYSTEM IN SUBCOOLING MODE (cont)**

Temp (F) Air Ent Condenser (Edb)		Air Entering Evaporator — CFM						
		1500						
		Air Entering Evaporator — Ewb (F)						
		80	76	72	67	62	57	54
75	TC	54.5	51.2	47.8	43.7	39.5	35.4	32.9
	SHC	19.9	22.9	25.8	29.6	33.3	35.4	32.9
	kW	1.97	1.97	1.97	1.97	1.97	1.98	1.98
85	TC	50.5	47.3	44.1	40.1	36.1	32.0	29.6
	SHC	15.0	18.7	22.4	27.1	31.8	36.5	39.3
	kW	2.27	2.27	2.27	2.27	2.27	2.27	2.27
95	TC	46.5	43.4	40.3	36.5	32.6	28.7	26.4
	SHC	10.0	14.5	19.0	24.7	30.4	28.7	26.4
	kW	2.58	2.58	2.57	2.57	2.56	2.56	2.56
105	TC	42.5	39.5	36.6	32.9	29.1	25.4	23.2
	SHC	5.1	10.4	15.6	22.3	28.9	25.4	23.2
	kW	2.89	2.89	2.88	2.87	2.86	2.85	2.85
115	TC	38.5	35.7	32.8	29.3	25.7	22.1	20.0
	SHC	0.1	6.2	12.2	19.8	25.7	22.1	20.0
	kW	3.20	3.20	3.18	3.17	3.15	3.14	3.13
125	TC	34.5	31.8	29.1	25.6	22.2	18.8	16.7
	SHC	-4.8	2.0	8.9	17.4	22.2	18.8	16.7
	kW	3.51	3.51	3.48	3.47	3.45	3.43	3.42

**LEGEND**

- Edb** — Entering Dry-Bulb
- Ewb** — Entering Wet-Bulb
- kW** — Compressor Motor Power Input
- ldb** — Leaving Dry-Bulb
- lwb** — Leaving Wet-Bulb
- SHC** — Sensible Heat Capacity (1000 Btuh) Gross
- TC** — Total Capacity (1000 Btuh) Gross

**NOTES:**

1. Direct interpolation is permissible. Do not extrapolate.
2. The following formulas may be used:

$$t_{ldb} = t_{edb} - \frac{\text{sensible capacity (Btuh)}}{1.10 \times \text{cfm}}$$

$$t_{lwb} = \text{Wet-bulb temperature corresponding to enthalpy of air leaving evaporator coil } (h_{lwb})$$

$$h_{lwb} = h_{ewb} - \frac{\text{total capacity (Btuh)}}{4.5 \times \text{cfm}}$$

Where:  $h_{ewb}$  = Enthalpy of air entering evaporator coil

# Performance data (cont)



## COOLING CAPACITIES (cont)

### 48PG04 (3 Tons) — UNIT WITH HUMIDIFIER™ SYSTEM IN HOT GAS REHEAT MODE

Temp (F) Air Ent Condenser (Edb)		Air Entering Evaporator — Ewb (F)								
		75 Dry Bulb 62.5 Wet Bulb (50% RH)			75 Dry Bulb 64 Wet Bulb (55% RH)			75 Dry Bulb 65.3 Wet Bulb (60% RH)		
		Air Entering Evaporator — Cfm								
		1050	1200	1350	1050	1200	1350	1050	1200	1350
80	TC	15.6	16.4	17.1	16.8	17.6	18.3	17.8	18.6	19.4
	SHC	5.9	6.8	7.5	4.3	5.1	5.9	2.9	3.7	4.5
	kW	0.11	0.11	0.11	1.40	1.40	1.40	2.52	2.52	2.52
75	TC	16.0	16.7	17.4	17.1	17.9	18.6	18.1	18.9	19.6
	SHC	6.7	7.5	8.2	5.2	6.0	6.7	3.9	4.7	5.4
	kW	0.25	0.25	0.25	1.46	1.46	1.46	2.51	2.51	2.51
70	TC	16.4	17.1	17.7	17.5	18.2	18.8	18.4	19.2	19.8
	SHC	7.5	8.2	8.9	6.1	6.9	7.5	4.9	5.7	6.3
	kW	0.39	0.39	0.39	1.52	1.52	1.52	2.51	2.51	2.51
60	TC	17.1	17.7	18.3	18.2	18.8	19.3	19.1	19.7	20.3
	SHC	9.1	9.7	10.3	7.9	8.6	9.2	7.0	7.6	8.2
	kW	0.67	0.67	0.67	1.65	1.65	1.65	2.50	2.50	2.50
50	TC	17.9	18.4	18.9	18.9	19.4	19.9	19.7	20.2	20.7
	SHC	10.6	11.2	11.7	9.7	10.3	10.8	9.0	9.6	10.1
	kW	0.95	0.95	0.95	1.78	1.78	1.78	2.50	2.50	2.50
40	TC	18.7	19.1	19.5	19.6	20.0	20.4	20.3	20.7	21.1
	SHC	12.2	12.7	13.1	11.6	12.1	12.5	11.0	11.5	12.0
	kW	1.24	1.24	1.24	1.91	1.91	1.91	2.49	2.49	2.49

#### LEGEND

**Edb** — Entering Dry-Bulb  
**Ewb** — Entering Wet-Bulb  
**kW** — Compressor Motor Power Input  
**ldb** — Leaving Dry-Bulb  
**lwb** — Leaving Wet-Bulb  
**RH** — Relative Humidity  
**SHC** — Sensible Heat Capacity (1000 Btuh) Gross  
**TC** — Total Capacity (1000 Btuh) Gross

#### NOTES:

1. Direct interpolation is permissible. Do not extrapolate.
2. The following formulas may be used:

$$t_{ldb} = t_{edb} - \frac{\text{sensible capacity (Btuh)}}{1.10 \times \text{cfm}}$$

$t_{lwb}$  = Wet-bulb temperature corresponding to enthalpy of air leaving evaporator coil ( $h_{lwb}$ )

$$h_{lwb} = h_{ewb} - \frac{\text{total capacity (Btuh)}}{4.5 \times \text{cfm}}$$

Where:  $h_{ewb}$  = Enthalpy of air entering evaporator coil



**COOLING CAPACITIES (cont)**

**48PG05 (4 Tons) — STANDARD UNIT AND UNIT WITH HUMIDI-MIZER™ SYSTEM IN COOLING MODE**

Temp (F) Air Ent Condenser (Edb)	Air Entering Evaporator — Cfm																					
	1200						1600						2000									
	Air Entering Evaporator — Ewb (F)																					
	80	76	72	67	62	58	54	80	76	72	67	62	58	54	80	76	72	67	62	58	54	
60	TC	66.6	62.4	58.4	53.6	49.1	45.7	44.5	70.5	66.2	61.9	57.0	52.3	49.2	49.2	72.9	68.3	64.1	59.1	54.3	52.7	52.7
	SHC	18.3	23.4	27.8	33.8	39.6	43.4	44.5	18.6	24.3	31.0	38.6	45.8	49.2	49.2	18.7	26.1	33.7	42.7	51.0	52.7	52.7
	kW	2.22	2.18	2.14	2.10	2.06	2.03	2.02	2.26	2.22	2.17	2.13	2.09	2.06	2.06	2.28	2.24	2.20	2.15	2.11	2.09	2.09
	BF	0.00	0.00	0.00	0.24	0.22	0.23	0.37	0.00	0.00	0.27	0.23	0.23	0.30	0.47	0.00	0.00	0.26	0.24	0.25	0.39	0.55
70	TC	64.4	60.3	56.4	51.8	47.5	44.1	43.3	67.9	63.6	59.5	54.8	50.4	47.8	47.8	70.0	65.6	61.6	56.8	52.1	51.1	51.1
	SHC	17.6	22.6	27.2	33.2	38.9	42.3	43.3	17.8	23.7	30.2	37.8	45.1	47.8	47.8	17.9	25.3	32.8	41.9	49.7	51.1	51.1
	kW	2.53	2.49	2.45	2.41	2.37	2.33	2.33	2.57	2.52	2.48	2.43	2.39	2.37	2.37	2.59	2.55	2.50	2.46	2.41	2.40	2.40
	BF	0.00	0.00	0.36	0.22	0.20	0.24	0.39	0.00	0.00	0.25	0.22	0.22	0.31	0.49	0.00	0.36	0.25	0.24	0.26	0.41	0.56
75	TC	63.2	59.1	55.4	50.8	46.6	43.4	42.7	66.4	62.3	58.3	53.7	49.4	47.0	47.0	68.4	64.1	60.2	55.6	51.1	50.3	50.3
	SHC	17.2	22.2	26.9	32.8	38.6	41.8	42.7	17.4	23.4	29.8	37.3	44.7	47.0	47.0	17.5	24.9	32.4	41.4	49.1	50.3	50.3
	kW	2.70	2.66	2.62	2.57	2.53	2.50	2.50	2.74	2.69	2.65	2.60	2.56	2.54	2.54	2.76	2.71	2.67	2.62	2.57	2.57	2.57
	BF	0.00	0.00	0.29	0.22	0.20	0.24	0.40	0.00	0.00	0.24	0.22	0.22	0.33	0.50	0.00	0.33	0.25	0.24	0.27	0.42	0.57
85	TC	60.6	56.7	53.1	48.8	44.7	41.7	41.3	63.5	59.5	55.7	51.4	47.2	45.4	45.4	65.3	61.2	57.5	53.1	49.0	48.5	48.5
	SHC	16.3	21.3	26.1	32.0	37.7	40.3	41.3	16.5	22.6	28.9	36.5	43.6	45.4	45.4	16.6	24.0	31.4	40.5	47.6	48.5	48.5
	kW	3.06	3.02	2.98	2.93	2.89	2.86	2.86	3.10	3.05	3.01	2.96	2.92	2.90	2.90	3.12	3.07	3.03	2.98	2.94	2.93	2.93
	BF	0.00	0.00	0.26	0.20	0.19	0.27	0.41	0.00	0.00	0.23	0.21	0.22	0.35	0.51	0.00	0.30	0.24	0.23	0.28	0.44	0.58
95	TC	57.9	54.2	50.7	46.6	42.7	39.9	39.9	60.4	56.5	53.1	48.9	44.9	43.7	43.7	62.0	58.1	54.6	50.5	46.6	46.5	46.6
	SHC	15.5	20.1	25.2	31.2	36.8	39.9	39.9	15.6	21.7	28.0	35.5	42.4	43.7	43.7	15.7	23.1	30.5	39.5	46.6	46.5	46.6
	kW	3.46	3.42	3.38	3.33	3.29	3.26	3.26	3.49	3.45	3.41	3.36	3.32	3.30	3.30	3.51	3.47	3.43	3.38	3.33	3.33	3.33
	BF	0.00	0.00	0.23	0.19	0.19	0.24	0.43	0.00	0.36	0.22	0.21	0.22	0.37	0.53	0.00	0.27	0.23	0.23	0.28	0.46	0.60
105	TC	54.8	51.4	48.0	44.2	41.9	38.3	38.3	57.0	53.4	50.2	46.3	42.6	41.9	41.9	58.3	54.8	51.6	47.7	44.5	44.5	44.5
	SHC	14.5	19.1	24.3	30.2	31.0	38.3	38.3	14.6	20.8	27.0	34.5	41.0	41.9	41.9	14.7	22.1	29.5	38.4	44.2	44.5	44.5
	kW	3.90	3.86	3.81	3.77	3.70	3.70	3.70	3.93	3.88	3.84	3.79	3.75	3.74	3.74	3.95	3.90	3.86	3.81	3.77	3.77	3.77
	BF	0.00	0.00	0.21	0.18	0.18	0.27	0.45	0.00	0.28	0.21	0.21	0.23	0.40	0.55	0.00	0.26	0.23	0.23	0.32	0.48	0.61
115	TC	51.3	48.2	45.2	41.6	38.3	36.6	36.6	53.2	50.0	47.1	43.5	40.2	39.9	39.9	54.3	51.2	48.3	44.7	42.2	42.2	42.2
	SHC	13.5	18.3	23.2	29.2	34.9	36.6	36.6	13.5	19.7	25.9	33.4	39.3	39.9	39.9	13.6	21.0	28.3	37.3	42.2	42.2	42.2
	kW	4.36	4.32	4.29	4.24	4.20	4.18	4.18	4.39	4.35	4.31	4.27	4.22	4.22	4.22	4.41	4.36	4.33	4.28	4.25	4.25	4.25
	BF	0.00	0.00	0.19	0.18	0.18	0.30	0.48	0.00	0.24	0.21	0.20	0.26	0.42	0.57	0.00	0.24	0.23	0.23	0.34	0.51	0.63
125	TC	47.4	44.5	41.9	38.7	35.7	34.6	34.6	48.9	46.0	43.4	40.3	37.5	37.5	37.5	49.9	47.0	44.5	41.3	39.5	39.5	39.5
	SHC	12.3	17.2	22.1	28.0	33.5	34.6	34.6	12.3	18.6	24.7	32.2	37.5	37.5	37.5	12.4	19.8	27.1	35.9	39.5	39.5	39.5
	kW	4.86	4.82	4.79	4.75	4.71	4.70	4.70	4.88	4.84	4.81	4.77	4.73	4.73	4.73	4.90	4.86	4.82	4.78	4.76	4.76	4.76
	BF	0.00	0.26	0.18	0.17	0.18	0.34	0.50	0.00	0.22	0.20	0.20	0.27	0.46	0.59	0.01	0.23	0.22	0.23	0.38	0.54	0.66

**LEGEND**

- BF** — Bypass Factor
- Edb** — Entering Dry-Bulb
- Ewb** — Entering Wet-Bulb
- kW** — Compressor Motor Power Input
- ldb** — Leaving Dry-Bulb
- lwb** — Leaving Wet-Bulb
- SHC** — Sensible Heat Capacity (1000 Btuh) Gross
- TC** — Total Capacity (1000 Btuh) Gross

**NOTES:**

1. Direct interpolation is permissible. Do not extrapolate.
2. The following formulas may be used:

$$t_{ldb} = t_{edb} - \frac{\text{sensible capacity (Btuh)}}{1.10 \times \text{cfm}}$$

$$t_{lwb} = \text{Wet-bulb temperature corresponding to enthalpy of air leaving evaporator coil } (h_{lwb})$$

$$h_{lwb} = h_{ewb} - \frac{\text{total capacity (Btuh)}}{4.5 \times \text{cfm}}$$

Where:  $h_{ewb}$  = Enthalpy of air entering evaporator coil

3. The SHC is based on 80 F edb temperature of air entering evaporator coil.  
Below 80 F edb, subtract (corr factor x cfm) from SHC.  
Above 80 F edb, add (corr factor x cfm) to SHC.

BYPASS FACTOR (BF)	ENTERING AIR DRY-BULB TEMP (F)					
	79	78	77	76	75	under 75
	81	82	83	84	85	over 85
	Correction Factor					
.05	1.04	2.07	3.11	4.14	5.18	Use formula shown below.
.10	.98	1.96	2.94	3.92	4.90	
.20	.87	1.74	2.62	3.49	4.36	
.30	.76	1.53	2.29	3.05	3.82	

Interpolation is permissible.  
Correction Factor =  $1.09 \times (1 - BF) \times (edb - 80)$ .

4. Cooling capacities for 48PG03-16 units with Humidi-MiZer system in Cooling mode are the same as standard units.

# Performance data (cont)



## COOLING CAPACITIES (cont)

### 48PG05 (4 Tons) — UNIT WITH HUMIDI-MIZER™ SYSTEM IN SUBCOOLING MODE

Temp (F) Air Ent Condenser (Edb)		Air Entering Evaporator — CFM													
		1200							1600						
		Air Entering Evaporator — Ewb (F)													
		80	76	72	67	62	57	54	80	76	72	67	62	57	54
75	TC	64.0	59.5	55.0	49.3	43.7	38.1	34.7	68.0	63.3	58.5	52.6	46.7	40.7	37.2
	SHC	17.3	21.4	25.4	30.5	35.7	38.1	34.7	21.0	24.9	28.8	33.7	38.5	40.7	37.2
	kW	2.51	2.51	2.49	2.48	2.46	2.45	2.45	2.51	2.51	2.49	2.48	2.46	2.45	2.45
85	TC	60.0	55.5	51.0	45.4	39.8	34.2	30.9	64.1	59.4	54.6	48.7	42.8	36.9	33.3
	SHC	10.1	15.2	20.3	26.6	33.0	39.4	43.2	14.2	19.1	24.0	30.2	36.3	42.4	46.1
	kW	2.94	2.94	2.91	2.89	2.87	2.85	2.84	2.94	2.94	2.91	2.89	2.87	2.85	2.84
95	TC	56.0	51.5	47.1	41.5	35.9	30.4	27.0	60.2	55.4	50.7	44.8	38.9	33.0	29.5
	SHC	2.8	9.0	15.1	22.7	30.4	30.4	27.0	7.5	13.4	19.3	26.7	34.0	33.0	29.5
	kW	3.37	3.37	3.33	3.30	3.27	3.24	3.22	3.37	3.37	3.33	3.30	3.27	3.24	3.22
105	TC	52.0	47.5	43.1	37.6	32.1	26.5	23.2	56.2	51.5	46.8	40.9	35.0	29.2	25.6
	SHC	-4.4	2.8	9.9	18.8	27.8	26.5	23.2	0.8	7.7	14.6	23.2	31.8	29.2	25.6
	kW	3.81	3.81	3.75	3.71	3.67	3.63	3.61	3.81	3.81	3.75	3.71	3.67	3.63	3.61
115	TC	48.0	43.6	39.2	33.7	28.2	22.7	19.4	52.3	47.6	42.9	37.0	31.2	25.3	21.8
	SHC	-11.6	-3.4	4.7	14.9	25.1	22.7	19.4	-6.0	1.9	9.8	19.7	29.6	25.3	21.8
	kW	4.24	4.24	4.17	4.12	4.07	4.03	4.00	4.24	4.24	4.17	4.12	4.07	4.03	4.00
125	TC	44.0	39.6	35.2	29.7	24.3	18.8	15.5	48.3	43.7	39.0	33.1	27.3	21.5	18.0
	SHC	-18.8	-9.6	-0.4	11.0	22.5	18.8	15.5	-12.7	-3.8	5.1	16.2	27.3	21.5	18.0
	kW	4.68	4.68	4.59	4.53	4.48	4.42	4.39	4.68	4.68	4.59	4.53	4.48	4.42	4.39

### 48PG05 (4 Tons) — UNIT WITH HUMIDI-MIZER SYSTEM IN SUBCOOLING MODE (cont)

Temp (F) Air Ent Condenser (Edb)		Air Entering Evaporator — CFM						
		2000						
		Air Entering Evaporator — Ewb (F)						
		80	76	72	67	62	57	54
75	TC	71.3	66.4	61.4	55.2	49.0	42.8	39.1
	SHC	23.8	27.6	31.4	36.1	40.8	42.8	39.1
	kW	2.51	2.51	2.49	2.48	2.46	2.45	2.45
85	TC	67.4	62.5	57.6	51.4	45.2	39.0	35.3
	SHC	17.5	22.2	27.0	32.9	38.8	44.8	48.3
	kW	2.94	2.94	2.91	2.89	2.87	2.85	2.84
95	TC	63.6	58.6	53.7	47.5	41.3	35.1	31.4
	SHC	11.1	16.8	22.6	29.7	36.9	35.1	31.4
	kW	3.37	3.37	3.33	3.30	3.27	3.24	3.22
105	TC	59.7	54.7	49.8	43.6	37.5	31.3	27.6
	SHC	4.8	11.5	18.2	26.5	34.9	31.3	27.6
	kW	3.81	3.81	3.75	3.71	3.67	3.63	3.61
115	TC	55.8	50.8	45.9	39.8	33.6	27.5	23.8
	SHC	-1.6	6.1	13.8	23.4	33.0	27.5	23.8
	kW	4.24	4.24	4.17	4.12	4.07	4.03	4.00
125	TC	51.9	47.0	42.0	35.9	29.7	23.6	19.9
	SHC	-8.0	0.7	9.4	20.2	29.7	23.6	19.9
	kW	4.68	4.68	4.59	4.53	4.48	4.42	4.39

#### LEGEND

**Edb** — Entering Dry-Bulb  
**Ewb** — Entering Wet-Bulb  
**kW** — Compressor Motor Power Input  
**ldb** — Leaving Dry-Bulb  
**lwb** — Leaving Wet-Bulb  
**SHC** — Sensible Heat Capacity (1000 Btuh) Gross  
**TC** — Total Capacity (1000 Btuh) Gross

#### NOTES:

- Direct interpolation is permissible. Do not extrapolate.
- The following formulas may be used:

$$t_{ldb} = t_{edb} - \frac{\text{sensible capacity (Btuh)}}{1.10 \times \text{cfm}}$$

$$t_{lwb} = \text{Wet-bulb temperature corresponding to enthalpy of air leaving evaporator coil } (h_{lwb})$$

$$h_{lwb} = h_{ewb} - \frac{\text{total capacity (Btuh)}}{4.5 \times \text{cfm}}$$

Where:  $h_{ewb}$  = Enthalpy of air entering evaporator coil



**COOLING CAPACITIES (cont)**

**48PG05 (4 Tons) — UNIT WITH HUMIDI-MIZER™ SYSTEM IN HOT GAS REHEAT MODE**

Temp (F) Air Ent Condenser (Edb)		Air Entering Evaporator — Ewb (F)								
		75 Dry Bulb 62.5 Wet Bulb (50% RH)			75 Dry Bulb 64 Wet Bulb (55% RH)			75 Dry Bulb 65.3 Wet Bulb (60% RH)		
		Air Entering Evaporator — Cfm								
		1200	1600	2000	1200	1600	2000	1200	1600	2000
80	TC	16.7	19.1	21.0	18.7	21.2	23.1	20.5	23.0	25.0
	SHC	2.4	4.5	6.2	0.8	3.0	4.6	-0.5	1.6	3.3
	kW	2.47	2.47	2.47	2.46	2.46	2.46	2.45	2.45	2.45
75	TC	17.3	19.5	21.3	19.2	21.5	23.3	20.9	23.3	25.1
	SHC	2.6	4.5	6.1	1.1	3.1	4.7	-0.2	1.8	3.4
	kW	2.48	2.48	2.48	2.48	2.48	2.48	2.48	2.48	2.48
70	TC	17.8	19.9	21.6	19.7	21.9	23.5	21.3	23.5	25.2
	SHC	2.7	4.6	6.0	1.3	3.2	4.7	0.1	2.0	3.5
	kW	2.50	2.50	2.50	2.50	2.50	2.50	2.50	2.50	2.50
60	TC	19.0	20.8	22.2	20.6	22.5	24.0	22.1	24.0	25.5
	SHC	3.0	4.6	5.9	1.8	3.4	4.7	0.8	2.4	3.7
	kW	2.54	2.54	2.54	2.55	2.55	2.55	2.56	2.56	2.56
50	TC	20.1	21.6	22.8	21.6	23.2	24.4	22.9	24.5	25.8
	SHC	3.3	4.6	5.7	2.3	3.7	4.8	1.5	2.9	4.0
	kW	2.58	2.58	2.58	2.60	2.60	2.60	2.61	2.61	2.61
40	TC	21.2	22.5	23.4	22.6	23.8	24.8	23.7	25.0	26.0
	SHC	3.6	4.6	5.5	2.8	3.9	4.8	2.2	3.3	4.2
	kW	2.62	2.62	2.62	2.65	2.65	2.65	2.67	2.67	2.67

**LEGEND**

- Edb** — Entering Dry-Bulb
- Ewb** — Entering Wet-Bulb
- kW** — Compressor Motor Power Input
- ldb** — Leaving Dry-Bulb
- lwb** — Leaving Wet-Bulb
- RH** — Relative Humidity
- SHC** — Sensible Heat Capacity (1000 Btuh) Gross
- TC** — Total Capacity (1000 Btuh) Gross

**NOTES:**

1. Direct interpolation is permissible. Do not extrapolate.
2. The following formulas may be used:

$$t_{ldb} = t_{edb} - \frac{\text{sensible capacity (Btuh)}}{1.10 \times \text{cfm}}$$

$$t_{lwb} = \text{Wet-bulb temperature corresponding to enthalpy of air leaving evaporator coil (} h_{lwb} \text{)}$$

$$h_{lwb} = h_{ewb} - \frac{\text{total capacity (Btuh)}}{4.5 \times \text{cfm}}$$

Where:  $h_{ewb}$  = Enthalpy of air entering evaporator coil

# Performance data (cont)



## COOLING CAPACITIES (cont)

48PG06 (5 Tons) — STANDARD UNIT AND UNIT WITH HUMIDI-MIZER™ SYSTEM IN COOLING MODE

Temp (F) Air Ent Condenser (Edb)	Air Entering Evaporator — Cfm																												
	1500							1700							2000							2500							
	Air Entering Evaporator — Ewb (F)																												
	80	76	72	67	62	58	54	80	76	72	67	62	58	54	80	76	72	67	62	58	54	80	76	72	67	62	58	54	
60	TC	83.9	78.6	73.6	67.9	62.6	58.8	57.3	86.2	80.8	75.9	69.9	64.5	60.5	59.8	88.6	83.2	78.1	72.0	66.7	63.2	63.2	91.2	85.8	80.8	74.9	69.4	67.6	67.6
	SHC	23.0	29.6	35.7	43.4	51.1	55.7	57.2	23.3	30.3	37.6	45.9	54.5	58.2	59.8	23.4	31.6	39.9	49.6	59.3	63.1	63.1	23.5	33.4	43.2	55.3	65.6	67.5	67.5
	KW/BF	2.54/0.00	2.52/0.17	2.50/0.17	2.49/0.16	2.46/0.16	2.45/0.20	2.45/0.37	2.54/0.00	2.52/0.24	2.50/0.17	2.49/0.17	2.47/0.17	2.46/0.24	2.46/0.41	2.55/0.00	2.53/0.22	2.51/0.17	2.47/0.17	2.47/0.18	2.47/0.29	2.47/0.47	2.56/0.00	2.54/0.22	2.52/0.20	2.50/0.19	2.48/0.22	2.47/0.39	2.47/0.55
70	TC	81.1	76.2	71.3	65.8	60.6	56.7	55.7	83.2	78.2	73.3	67.6	62.3	58.2	58.2	85.4	80.2	75.4	69.4	64.4	61.4	61.5	87.8	82.6	78.0	72.2	67.0	65.8	65.7
	SHC	22.1	28.8	34.9	42.6	50.1	54.2	55.6	22.3	29.2	36.6	45.1	53.5	58.1	58.1	22.5	30.6	38.8	48.6	58.1	61.4	61.4	22.6	32.5	42.2	54.2	64.1	65.7	65.7
	KW/BF	2.93/0.00	2.91/0.17	2.90/0.16	2.88/0.16	2.86/0.21	2.84/0.39	2.84/0.00	2.94/0.28	2.93/0.16	2.90/0.16	2.88/0.17	2.86/0.24	2.85/0.44	2.85/0.00	2.96/0.22	2.93/0.17	2.91/0.17	2.86/0.18	2.87/0.31	2.86/0.49	2.86/0.00	2.97/0.22	2.95/0.20	2.92/0.20	2.90/0.19	2.88/0.23	2.87/0.41	2.87/0.56
75	TC	79.9	74.9	70.1	64.7	59.5	55.6	54.8	81.7	76.7	71.9	66.3	61.0	57.5	57.4	83.8	78.6	73.9	68.1	63.2	60.6	60.6	85.9	81.0	76.4	70.8	65.7	64.8	64.8
	SHC	21.7	28.3	34.4	42.1	49.4	53.6	54.8	21.9	28.8	36.1	44.6	52.5	57.4	57.4	22.0	30.1	38.3	48.1	57.5	60.5	60.5	22.0	31.9	41.7	53.6	63.3	64.7	64.7
	KW/BF	3.15/0.00	3.13/0.18	3.11/0.16	3.09/0.16	3.06/0.21	3.05/0.40	3.04/0.00	3.16/0.26	3.14/0.16	3.11/0.16	3.09/0.18	3.07/0.24	3.05/0.44	3.05/0.00	3.17/0.22	3.15/0.17	3.12/0.17	3.07/0.18	3.07/0.32	3.06/0.50	3.06/0.00	3.19/0.22	3.16/0.20	3.14/0.20	3.11/0.19	3.08/0.24	3.08/0.42	3.08/0.58
85	TC	76.9	72.1	67.5	62.2	57.2	53.7	53.3	78.5	73.6	68.9	63.7	58.8	55.7	55.7	80.3	75.3	70.9	65.4	60.6	58.6	58.6	82.0	77.5	73.2	67.8	63.0	62.5	62.5
	SHC	20.8	27.1	33.5	41.1	48.7	52.0	53.2	20.9	27.9	34.9	43.6	51.7	55.6	55.6	21.0	29.1	37.2	46.8	56.0	58.5	58.6	20.9	30.9	40.6	52.3	61.4	62.5	62.5
	KW/BF	3.60/0.00	3.58/0.23	3.56/0.15	3.53/0.15	3.50/0.23	3.48/0.42	3.62/0.00	3.59/0.22	3.56/0.17	3.53/0.16	3.50/0.17	3.49/0.24	3.49/0.46	3.49/0.00	3.63/0.22	3.60/0.17	3.57/0.18	3.53/0.19	3.51/0.34	3.50/0.52	3.50/0.00	3.64/0.22	3.61/0.20	3.59/0.20	3.55/0.20	3.52/0.25	3.52/0.44	3.52/0.58
95	TC	73.6	68.8	64.5	59.5	54.8	51.5	51.5	74.9	70.2	66.0	60.3	56.2	53.6	53.6	76.4	71.8	67.7	62.4	57.9	56.5	56.5	77.9	73.7	69.7	64.6	60.1	60.1	60.1
	SHC	19.7	25.8	32.4	40.1	47.4	51.4	51.4	19.8	26.9	33.9	41.8	50.7	53.6	53.6	19.8	28.0	36.1	45.9	54.6	56.4	56.4	19.8	29.7	39.4	51.2	60.0	60.0	60.1
	KW/BF	4.10/0.00	4.06/0.27	4.03/0.15	4.00/0.15	3.97/0.23	3.96/0.44	4.11/0.00	4.07/0.21	4.04/0.16	4.02/0.16	3.99/0.17	3.97/0.29	3.97/0.48	3.97/0.00	4.12/0.20	4.09/0.17	4.06/0.17	3.98/0.20	3.99/0.37	3.98/0.53	3.98/0.00	4.13/0.22	4.10/0.20	4.07/0.20	4.03/0.19	4.00/0.26	4.00/0.46	4.00/0.60
105	TC	69.8	65.3	61.3	56.6	52.1	49.4	49.3	71.0	66.5	62.6	57.9	53.4	51.4	51.5	72.1	68.0	64.2	59.2	55.0	54.1	54.1	73.3	69.8	66.0	61.2	57.7	57.4	57.5
	SHC	18.6	24.9	31.2	38.9	46.2	49.3	49.3	18.6	25.7	32.7	41.3	49.2	51.4	51.4	18.6	26.8	34.8	44.6	52.8	54.1	54.1	18.5	28.5	38.1	49.9	56.2	57.4	57.4
	KW/BF	4.64/0.00	4.61/0.20	4.58/0.15	4.54/0.15	4.50/0.26	4.48/0.46	4.65/0.00	4.62/0.19	4.59/0.15	4.55/0.17	4.51/0.32	4.50/0.50	4.50/0.00	4.50/0.00	4.66/0.20	4.63/0.17	4.60/0.17	4.52/0.21	4.52/0.39	4.51/0.55	4.51/0.00	4.68/0.22	4.65/0.20	4.62/0.20	4.57/0.20	4.55/0.33	4.54/0.51	4.54/0.62
115	TC	65.6	61.5	57.8	53.4	49.0	47.0	47.1	66.5	62.6	59.0	54.5	50.4	49.0	49.0	67.4	63.8	60.3	55.8	51.8	51.5	51.4	68.3	65.3	61.9	57.5	54.5	54.6	54.6
	SHC	17.3	23.7	30.0	37.7	44.8	47.0	47.0	17.3	24.5	31.4	39.9	47.7	49.0	49.0	17.3	25.5	33.5	43.2	50.5	51.4	51.4	17.2	27.1	36.7	48.4	54.5	54.5	54.5
	KW/BF	5.21/0.00	5.17/0.18	5.14/0.15	5.10/0.14	5.06/0.30	5.03/0.49	5.22/0.00	5.18/0.18	5.15/0.16	5.11/0.16	5.07/0.18	5.06/0.36	5.06/0.52	5.06/0.00	5.23/0.20	5.20/0.17	5.16/0.17	5.07/0.23	5.08/0.42	5.08/0.57	5.08/0.00	5.24/0.22	5.22/0.20	5.18/0.20	5.13/0.33	5.11/0.51	5.11/0.64	
125	TC	60.8	57.2	53.8	49.7	45.7	44.5	44.5	61.4	58.1	54.7	50.7	46.7	46.2	46.2	62.0	59.1	56.0	51.7	48.4	48.4	48.4	62.6	60.3	57.4	53.3	51.0	51.1	51.1
	SHC	15.9	22.3	28.5	36.1	42.9	44.4	44.5	15.8	23.1	29.9	38.4	45.2	46.2	46.2	15.8	24.0	32.0	41.6	47.8	48.3	48.3	15.6	25.5	35.0	46.7	51.0	51.0	51.0
	KW/BF	5.81/0.00	5.77/0.17	5.74/0.15	5.70/0.14	5.65/0.34	5.63/0.51	5.82/0.00	5.79/0.18	5.75/0.16	5.71/0.16	5.67/0.20	5.66/0.40	5.66/0.55	5.66/0.00	5.83/0.20	5.80/0.18	5.76/0.17	5.66/0.27	5.68/0.46	5.68/0.60	5.68/0.00	5.84/0.23	5.81/0.21	5.78/0.20	5.73/0.38	5.71/0.54	5.71/0.64	

**LEGEND**

- BF — Bypass Factor
- Edb — Entering Dry-Bulb
- Ewb — Entering Wet-Bulb
- kW — Compressor Motor Power Input
- ldb — Leaving Dry-Bulb
- lwb — Leaving Wet-Bulb
- SHC — Sensible Heat Capacity (1000 Btuh) Gross
- TC — Total Capacity (1000 Btuh) Gross

**NOTES:**

1. Direct interpolation is permissible. Do not extrapolate.
2. The following formulas may be used:

$$t_{ldb} = t_{edb} - \frac{\text{sensible capacity (Btuh)}}{1.10 \times \text{cfm}}$$

t<sub>lwb</sub> = Wet-bulb temperature corresponding to enthalpy of air leaving evaporator coil (h<sub>lwb</sub>)

$$h_{lwb} = h_{ewb} - \frac{\text{total capacity (Btuh)}}{4.5 \times \text{cfm}}$$

Where: h<sub>ewb</sub> = Enthalpy of air entering evaporator coil

3. The SHC is based on 80 F edb temperature of air entering evaporator coil. Below 80 F edb, subtract (corr factor x cfm) from SHC. Above 80 F edb, add (corr factor x cfm) to SHC.

BYPASS FACTOR (BF)	ENTERING AIR DRY-BULB TEMP (F)					
	79	78	77	76	75	under 75
	81	82	83	84	85	over 85
	Correction Factor					
.05	1.04	2.07	3.11	4.14	5.18	Use formula shown below.
.10	.98	1.96	2.94	3.92	4.90	
.20	.87	1.74	2.62	3.49	4.36	
.30	.76	1.53	2.29	3.05	3.82	

Interpolation is permissible.  
Correction Factor = 1.09 x (1 - BF) x (edb - 80).

4. Cooling capacities for 48PG03-16 units with Humidi-MiZer system in Cooling mode are the same as standard units.



**COOLING CAPACITIES (cont)**

**48PG06 (5 Tons) — UNIT WITH HUMIDI-MIZER™ SYSTEM IN SUBCOOLING MODE**

Temp (F) Air Ent Condenser (Edb)		Air Entering Evaporator — CFM													
		1500							2000						
		Air Entering Evaporator — Ewb (F)													
		80	76	72	67	62	57	54	80	76	72	67	62	57	54
75	TC	81.2	74.8	68.5	60.5	52.5	44.6	39.8	97.6	88.4	79.3	67.8	56.4	45.0	38.1
	SHC	21.4	26.7	32.0	38.5	45.1	44.6	39.8	25.7	30.8	35.9	42.2	48.5	45.0	38.1
	kW	3.14	3.14	3.11	3.09	3.07	3.05	3.04	3.14	3.14	3.11	3.09	3.07	3.05	3.04
85	TC	76.0	70.5	65.0	58.1	51.2	44.3	40.1	87.9	79.9	72.0	62.1	52.1	42.2	36.3
	SHC	11.4	18.0	24.6	32.9	41.1	49.4	54.3	16.2	22.6	29.0	37.0	45.0	52.9	57.7
	kW	3.63	3.63	3.58	3.55	3.52	3.50	3.48	3.63	3.63	3.58	3.55	3.52	3.50	3.48
95	TC	70.9	66.2	61.5	55.7	49.8	44.0	40.4	78.2	71.5	64.7	56.3	47.9	39.4	34.4
	SHC	1.3	9.3	17.2	27.2	37.1	44.0	40.4	6.7	14.4	22.1	31.7	41.4	39.4	34.4
	kW	4.11	4.11	4.05	4.01	3.98	3.94	3.92	4.11	4.11	4.05	4.01	3.98	3.94	3.92
105	TC	65.7	61.9	58.0	53.2	48.4	43.6	40.8	68.5	63.0	57.5	50.5	43.6	36.7	32.5
	SHC	-8.8	0.5	9.8	21.5	33.1	43.6	40.8	-2.9	6.2	15.2	26.5	37.8	36.7	32.5
	kW	4.59	4.59	4.52	4.48	4.43	4.39	4.36	4.59	4.59	4.52	4.48	4.43	4.39	4.36
115	TC	60.6	57.6	54.6	50.8	47.1	43.3	41.1	58.8	54.5	50.2	44.8	39.3	33.9	30.7
	SHC	-18.9	-8.2	2.4	15.8	29.1	42.4	41.1	-12.4	-2.1	8.3	21.3	34.2	33.9	30.7
	kW	5.07	5.07	4.99	4.94	4.89	4.84	4.80	5.07	5.07	4.99	4.94	4.89	4.84	4.80
125	TC	55.4	53.3	51.1	48.4	45.7	43.0	41.4	49.2	46.0	42.9	39.0	35.1	31.2	28.8
	SHC	-28.9	-16.9	-4.9	10.1	25.1	40.1	41.4	-21.9	-10.3	1.4	16.0	30.6	31.2	28.8
	kW	5.55	5.55	5.46	5.40	5.34	5.28	5.25	5.55	5.55	5.46	5.40	5.34	5.28	5.25

**48PG06 (5 Tons) — UNIT WITH HUMIDI-MIZER SYSTEM IN SUBCOOLING MODE (cont)**

Temp (F) Air Ent Condenser (Edb)		Air Entering Evaporator — CFM						
		2500						
		Air Entering Evaporator — Ewb (F)						
		80	76	72	67	62	57	54
75	TC	115.1	103.0	90.9	75.7	60.6	45.4	36.3
	SHC	29.1	34.0	38.9	45.0	51.2	45.4	36.3
	kW	3.14	3.14	3.11	3.09	3.07	3.05	3.04
85	TC	100.6	90.1	79.5	66.4	53.2	40.0	32.1
	SHC	20.0	26.2	32.4	40.2	47.9	55.7	60.4
	kW	3.63	3.63	3.58	3.55	3.52	3.50	3.48
95	TC	86.1	77.1	68.2	57.0	45.8	34.6	27.9
	SHC	10.8	18.4	25.9	35.3	44.7	34.6	27.9
	kW	4.11	4.11	4.05	4.01	3.98	3.94	3.92
105	TC	71.5	64.2	56.8	47.6	38.4	29.2	23.7
	SHC	1.7	10.5	19.4	30.4	38.4	29.2	23.7
	kW	4.59	4.59	4.52	4.48	4.43	4.39	4.36
115	TC	57.0	51.2	45.5	38.3	31.1	23.8	19.5
	SHC	-7.4	2.7	12.9	25.5	31.1	23.8	19.5
	kW	5.07	5.07	4.99	4.94	4.89	4.84	4.80
125	TC	42.5	38.3	34.1	28.9	23.7	18.5	15.3
	SHC	-16.5	-5.1	6.4	20.7	23.7	18.5	15.3
	kW	5.55	5.55	5.46	5.40	5.34	5.28	5.25

**LEGEND**

- Edb** — Entering Dry-Bulb
- Ewb** — Entering Wet-Bulb
- kW** — Compressor Motor Power Input
- ldb** — Leaving Dry-Bulb
- lwb** — Leaving Wet-Bulb
- SHC** — Sensible Heat Capacity (1000 Btuh) Gross
- TC** — Total Capacity (1000 Btuh) Gross

**NOTES:**

1. Direct interpolation is permissible. Do not extrapolate.
2. The following formulas may be used:

$$t_{ldb} = t_{edb} - \frac{\text{sensible capacity (Btuh)}}{1.10 \times \text{cfm}}$$

$$t_{lwb} = \text{Wet-bulb temperature corresponding to enthalpy of air leaving evaporator coil } (h_{lwb})$$

$$h_{lwb} = h_{ewb} - \frac{\text{total capacity (Btuh)}}{4.5 \times \text{cfm}}$$

Where:  $h_{ewb}$  = Enthalpy of air entering evaporator coil

# Performance data (cont)



## COOLING CAPACITIES (cont)

### 48PG06 (5 Tons) — UNIT WITH HUMIDI-MIZER™ SYSTEM IN HOT GAS REHEAT MODE

Temp (F) Air Ent Condenser (Edb)		Air Entering Evaporator — Ewb (F)								
		75 Dry Bulb 62.5 Wet Bulb (50% RH)			75 Dry Bulb 64 Wet Bulb (55% RH)			75 Dry Bulb 65.3 Wet Bulb (60% RH)		
		Air Entering Evaporator — Cfm								
		1750	2000	2250	1750	2000	2250	1750	2000	2250
80	TC	24.2	25.7	27.0	26.0	27.5	28.8	27.6	29.1	30.5
	SHC	5.6	6.4	7.2	3.4	4.2	5.0	1.5	2.3	3.1
	kW	3.08	3.08	3.08	3.07	3.07	3.07	3.07	3.07	3.07
75	TC	24.5	25.9	27.1	26.3	27.7	28.9	27.8	29.2	30.5
	SHC	5.3	6.1	6.8	3.3	4.1	4.8	1.5	2.3	3.0
	kW	3.10	3.10	3.10	3.10	3.10	3.10	3.10	3.10	3.10
70	TC	24.8	26.1	27.2	26.5	27.8	29.0	28.0	29.3	30.5
	SHC	5.1	5.8	6.5	3.2	3.9	4.6	1.5	2.2	2.9
	kW	3.13	3.13	3.13	3.13	3.13	3.13	3.14	3.14	3.14
60	TC	25.4	26.5	27.5	27.0	28.1	29.1	28.3	29.5	30.5
	SHC	4.5	5.2	5.8	2.9	3.6	4.1	1.5	2.2	2.7
	kW	3.18	3.18	3.18	3.19	3.19	3.19	3.21	3.21	3.21
50	TC	26.0	27.0	27.8	27.4	28.4	29.3	28.6	29.6	30.5
	SHC	4.0	4.6	5.1	2.7	3.2	3.7	1.5	2.1	2.6
	kW	3.23	3.23	3.23	3.26	3.26	3.26	3.28	3.28	3.28
40	TC	26.6	27.4	28.1	27.9	28.7	29.4	29.0	29.8	30.5
	SHC	3.5	4.0	4.4	2.4	2.9	3.3	1.5	2.0	2.4
	kW	3.28	3.28	3.28	3.32	3.32	3.32	3.35	3.35	3.35

#### LEGEND

- Edb** — Entering Dry-Bulb
- Ewb** — Entering Wet-Bulb
- kW** — Compressor Motor Power Input
- ldb** — Leaving Dry-Bulb
- lwb** — Leaving Wet-Bulb
- RH** — Relative Humidity
- SHC** — Sensible Heat Capacity (1000 Btuh) Gross
- TC** — Total Capacity (1000 Btuh) Gross

#### NOTES:

1. Direct interpolation is permissible. Do not extrapolate.
2. The following formulas may be used:

$$t_{ldb} = t_{edb} - \frac{\text{sensible capacity (Btuh)}}{1.10 \times \text{cfm}}$$

$$t_{lwb} = \text{Wet-bulb temperature corresponding to enthalpy of air leaving evaporator coil (} h_{lwb} \text{)}$$

$$h_{lwb} = h_{ewb} - \frac{\text{total capacity (Btuh)}}{4.5 \times \text{cfm}}$$

Where:  $h_{ewb}$  = Enthalpy of air entering evaporator coil



**COOLING CAPACITIES (cont)**

**48PG07 (6 Tons) — STANDARD UNIT AND UNIT WITH HUMIDI-MIZER™ SYSTEM IN COOLING MODE**

Temp (F) Air Ent Condenser (Edb)	Air Entering Evaporator — Cfm																					
	1800						2400						3000									
	Air Entering Evaporator — Ewb (F)																					
	80	76	72	67	62	58	54	80	76	72	67	62	58	54	80	76	72	67	62	58	54	
60	TC	96.6	90.8	85.2	78.6	72.3	67.8	67.1	101.4	95.7	90.2	83.4	77.1	74.1	74.1	104.6	98.7	93.1	86.3	80.1	79.2	79.2
	SHC	26.2	33.5	41.8	51.4	60.7	65.7	66.6	26.4	36.3	46.8	59.5	71.9	73.5	73.4	26.6	38.8	51.3	66.8	77.8	78.6	78.6
	kW	2.95	2.90	2.86	2.82	2.79	2.76	2.76	2.98	2.94	2.90	2.85	2.81	2.80	2.80	3.01	2.97	2.92	2.87	2.83	2.82	2.82
	BF	0.00	0.00	0.15	0.13	0.12	0.18	0.36	0.00	0.29	0.13	0.11	0.11	0.29	0.47	0.00	0.18	0.13	0.12	0.20	0.39	0.54
70	TC	93.4	88.3	82.7	76.1	70.0	65.5	65.5	97.8	92.3	86.9	80.5	74.4	72.0	72.0	100.9	95.1	89.7	83.2	77.3	77.3	77.3
	SHC	25.1	32.3	40.9	50.5	60.0	65.0	65.0	25.3	35.3	45.7	58.6	70.6	71.4	71.4	25.5	37.7	50.1	65.8	76.7	76.7	76.6
	kW	3.36	3.33	3.28	3.23	3.19	3.17	3.17	3.40	3.35	3.31	3.27	3.22	3.21	3.21	3.42	3.38	3.33	3.28	3.24	3.24	3.24
	BF	0.00	0.00	0.14	0.11	0.10	0.17	0.38	0.00	0.22	0.13	0.10	0.11	0.31	0.48	0.00	0.17	0.13	0.11	0.20	0.40	0.55
75	TC	91.6	86.6	81.1	75.0	68.8	65.4	64.6	95.8	90.5	85.2	79.0	73.0	70.9	70.9	98.7	93.2	87.9	81.5	76.0	76.1	76.1
	SHC	24.6	31.7	40.3	50.4	59.6	64.9	64.1	24.7	34.8	45.2	58.0	69.9	70.3	70.3	24.9	37.2	49.6	65.2	75.4	75.4	75.4
	kW	3.59	3.55	3.51	3.46	3.42	3.38	3.39	3.62	3.58	3.54	3.49	3.44	3.43	3.43	3.65	3.60	3.56	3.51	3.47	3.47	3.47
	BF	0.00	0.00	0.13	0.09	0.10	0.17	0.38	0.00	0.20	0.12	0.10	0.12	0.32	0.49	0.00	0.16	0.12	0.11	0.21	0.41	0.56
85	TC	87.9	82.9	78.0	71.9	66.4	62.7	62.7	91.8	86.7	81.7	75.7	70.0	68.8	68.8	94.5	89.1	84.0	77.9	73.4	73.4	73.4
	SHC	23.4	31.0	39.3	49.0	58.8	62.2	62.1	23.6	33.6	44.0	56.8	68.0	68.2	68.2	23.7	35.9	48.4	63.9	72.8	72.8	72.8
	kW	4.07	4.03	3.99	3.93	3.89	3.87	3.87	4.11	4.06	4.02	3.97	3.92	3.91	3.91	4.14	4.08	4.04	3.98	3.95	3.95	3.95
	BF	0.00	0.00	0.12	0.10	0.08	0.20	0.40	0.00	0.17	0.11	0.10	0.13	0.34	0.50	0.00	0.15	0.12	0.11	0.23	0.43	0.57
95	TC	83.9	79.2	74.6	68.8	63.4	60.6	60.6	87.4	82.5	77.8	72.1	66.7	66.3	66.3	89.8	84.7	79.9	74.1	70.5	70.5	70.5
	SHC	22.2	29.8	38.1	47.9	57.4	60.1	60.1	22.3	32.4	42.7	55.5	65.2	65.7	65.7	22.5	34.7	47.2	62.4	69.9	69.9	69.9
	kW	4.61	4.56	4.52	4.46	4.41	4.39	4.39	4.64	4.59	4.54	4.49	4.44	4.44	4.44	4.67	4.61	4.56	4.51	4.48	4.48	4.48
	BF	0.00	0.00	0.11	0.09	0.09	0.23	0.42	0.00	0.15	0.10	0.09	0.16	0.36	0.52	0.00	0.14	0.11	0.11	0.26	0.45	0.59
105	TC	79.5	75.1	70.7	65.4	60.1	58.2	58.2	82.7	78.0	73.6	68.2	63.6	63.4	63.4	84.8	80.0	75.4	69.9	67.3	67.3	67.3
	SHC	20.8	28.6	36.7	46.5	55.9	57.7	57.7	21.0	31.1	41.3	54.0	62.1	62.9	62.9	21.1	33.3	45.7	60.9	66.7	66.7	66.7
	kW	5.18	5.13	5.09	5.03	4.98	4.96	4.96	5.22	5.16	5.12	5.06	5.01	5.01	5.01	5.24	5.18	5.13	5.08	5.05	5.05	5.05
	BF	0.00	0.23	0.10	0.08	0.08	0.25	0.44	0.00	0.13	0.10	0.09	0.20	0.38	0.54	0.00	0.12	0.10	0.11	0.30	0.47	0.61
115	TC	74.6	70.5	66.4	61.4	56.5	55.3	55.3	77.4	73.0	68.9	63.9	60.2	60.2	60.2	79.2	74.7	70.4	65.4	63.6	63.6	63.6
	SHC	19.4	27.1	35.2	44.9	54.0	54.9	54.8	19.5	29.6	39.8	52.3	59.7	59.7	59.7	19.6	31.8	44.2	59.0	63.1	63.1	63.1
	kW	5.79	5.74	5.70	5.64	5.58	5.57	5.57	5.82	5.77	5.73	5.67	5.62	5.62	5.62	5.84	5.79	5.74	5.69	5.66	5.66	5.66
	BF	0.00	0.16	0.09	0.08	0.09	0.29	0.47	0.00	0.11	0.09	0.09	0.21	0.41	0.56	0.00	0.11	0.10	0.11	0.33	0.50	0.63
125	TC	69.0	65.2	61.4	56.9	52.4	52.3	52.3	71.2	67.3	63.4	58.9	56.4	56.4	56.4	72.7	68.7	64.8	60.2	59.3	59.3	59.3
	SHC	17.7	25.5	33.4	43.1	51.6	51.8	51.8	17.8	27.9	38.0	50.4	56.0	55.9	55.9	17.8	30.1	42.4	56.9	58.8	58.8	58.8
	kW	6.43	6.38	6.34	6.28	6.22	6.22	6.22	6.45	6.41	6.36	6.31	6.27	6.27	6.27	6.46	6.42	6.38	6.32	6.31	6.31	6.31
	BF	0.00	0.12	0.08	0.08	0.11	0.33	0.50	0.00	0.10	0.09	0.09	0.26	0.45	0.59	0.00	0.11	0.10	0.12	0.38	0.53	0.65

**LEGEND**

- BF** — Bypass Factor
- Edb** — Entering Dry-Bulb
- Ewb** — Entering Wet-Bulb
- kW** — Compressor Motor Power Input
- ldb** — Leaving Dry-Bulb
- lwb** — Leaving Wet-Bulb
- SHC** — Sensible Heat Capacity (1000 Btu/h) Gross
- TC** — Total Capacity (1000 Btu/h) Gross

**NOTES:**

1. Direct interpolation is permissible. Do not extrapolate.
2. The following formulas may be used:

$$t_{ldb} = t_{edb} - \frac{\text{sensible capacity (Btu/h)}}{1.10 \times \text{cfm}}$$

$t_{lwb}$  = Wet-bulb temperature corresponding to enthalpy of air leaving evaporator coil ( $h_{lwb}$ )

$$h_{lwb} = h_{ewb} - \frac{\text{total capacity (Btu/h)}}{4.5 \times \text{cfm}}$$

Where:  $h_{ewb}$  = Enthalpy of air entering evaporator coil

3. The SHC is based on 80 F edb temperature of air entering evaporator coil.  
Below 80 F edb, subtract (corr factor x cfm) from SHC.  
Above 80 F edb, add (corr factor x cfm) to SHC.

BYPASS FACTOR (BF)	ENTERING AIR DRY-BULB TEMP (F)					
	79	78	77	76	75	under 75
	81	82	83	84	85	over 85
	Correction Factor					
.05	1.04	2.07	3.11	4.14	5.18	Use formula shown below.
.10	.98	1.96	2.94	3.92	4.90	
.20	.87	1.74	2.62	3.49	4.36	
.30	.76	1.53	2.29	3.05	3.82	

Interpolation is permissible.  
Correction Factor = 1.09 x (1 - BF) x (edb - 80).

4. Cooling capacities for 48PG03-16 units with Humidi-MiZer system in Cooling mode are the same as standard units.

# Performance data (cont)



## COOLING CAPACITIES (cont)

### 48PG07 (6 Tons) — UNIT WITH HUMIDI-MIZER™ SYSTEM IN SUBCOOLING MODE

Temp (F) Air Ent Condenser (Edb)		Air Entering Evaporator — CFM													
		1800							2400						
		Air Entering Evaporator — Ewb (F)													
		80	76	72	67	62	57	54	80	76	72	67	62	57	54
75	TC	94.5	88.8	83.2	76.0	68.9	61.8	57.6	102.2	96.0	89.9	82.3	74.6	67.0	62.4
	SHC	26.2	32.7	39.3	47.5	55.7	61.8	57.6	32.2	38.5	44.8	52.7	60.6	67.0	62.4
	kW	3.69	3.69	3.63	3.59	3.55	3.51	3.49	3.69	3.69	3.63	3.59	3.55	3.51	3.49
85	TC	87.0	81.5	76.1	69.3	62.5	55.7	51.6	94.4	88.5	82.6	75.3	68.0	60.6	56.2
	SHC	14.0	22.2	30.4	40.7	51.0	61.2	67.4	20.8	28.7	36.6	46.5	56.5	66.4	72.3
	kW	4.26	4.26	4.18	4.13	4.08	4.03	4.00	4.26	4.26	4.18	4.13	4.08	4.03	4.00
95	TC	79.4	74.2	69.0	62.5	56.1	49.6	45.7	86.6	81.0	75.3	68.3	61.3	54.3	50.1
	SHC	1.9	11.8	21.6	34.0	46.3	49.6	45.7	9.4	18.9	28.5	40.4	52.4	64.3	76.2
	kW	4.82	4.82	4.73	4.67	4.60	4.54	4.51	4.82	4.82	4.73	4.67	4.60	4.54	4.51
105	TC	71.8	66.9	62.0	55.8	49.6	43.4	39.7	78.8	73.4	68.1	61.4	54.7	48.0	43.9
	SHC	-10.2	1.3	12.8	27.2	41.6	43.4	39.7	-2.0	9.1	20.3	34.3	48.3	62.3	76.2
	kW	5.39	5.39	5.27	5.20	5.13	5.06	5.02	5.39	5.39	5.27	5.20	5.13	5.06	5.02
115	TC	64.3	59.6	54.9	49.0	43.2	37.3	33.8	71.0	65.9	60.8	54.4	48.0	41.6	37.8
	SHC	-22.4	-9.2	4.0	20.4	36.9	37.3	33.8	-13.5	-0.7	12.1	28.2	44.2	60.2	76.2
	kW	5.95	5.95	5.82	5.74	5.66	5.57	5.53	5.95	5.95	5.82	5.74	5.66	5.57	5.53
125	TC	56.7	52.3	47.8	42.3	36.7	31.2	27.8	63.2	58.3	53.5	47.4	41.4	35.3	31.7
	SHC	-34.5	-19.7	-4.9	13.7	32.2	31.2	27.8	-24.9	-10.4	4.0	22.0	40.1	58.1	76.1
	kW	6.52	6.52	6.37	6.28	6.18	6.09	6.03	6.52	6.52	6.37	6.28	6.18	6.09	6.03

### 48PG07 (6 Tons) — UNIT WITH HUMIDI-MIZER SYSTEM IN SUBCOOLING MODE (cont)

Temp (F) Air Ent Condenser (Edb)		Air Entering Evaporator — CFM						
		3000						
		Air Entering Evaporator — Ewb (F)						
		80	76	72	67	62	57	54
75	TC	108.4	102.0	95.5	87.4	79.3	71.2	66.3
	SHC	36.9	43.0	49.1	56.7	64.4	71.2	66.3
	kW	3.69	3.69	3.63	3.59	3.55	3.51	3.49
85	TC	100.5	94.2	88.0	80.2	72.5	64.7	60.0
	SHC	26.1	33.8	41.5	51.1	60.7	70.4	76.2
	kW	4.26	4.26	4.18	4.13	4.08	4.03	4.00
95	TC	92.5	86.5	80.5	73.1	65.6	58.2	53.7
	SHC	15.2	24.5	33.8	45.5	57.1	68.2	79.3
	kW	4.82	4.82	4.73	4.67	4.60	4.54	4.51
105	TC	84.5	78.8	73.1	65.9	58.8	51.7	47.4
	SHC	4.4	15.3	26.2	39.8	53.5	67.2	80.9
	kW	5.39	5.39	5.27	5.20	5.13	5.06	5.02
115	TC	76.5	71.1	65.6	58.8	52.0	45.2	41.1
	SHC	-6.5	6.0	18.5	34.2	49.8	65.5	81.2
	kW	5.95	5.95	5.82	5.74	5.66	5.57	5.53
125	TC	68.5	63.4	58.2	51.7	45.2	38.7	34.8
	SHC	-17.3	-3.2	10.9	28.5	45.2	61.9	78.6
	kW	6.52	6.52	6.37	6.28	6.18	6.09	6.03

#### LEGEND

- Edb** — Entering Dry-Bulb
- Ewb** — Entering Wet-Bulb
- kW** — Compressor Motor Power Input
- ldb** — Leaving Dry-Bulb
- lwb** — Leaving Wet-Bulb
- SHC** — Sensible Heat Capacity (1000 Btuh) Gross
- TC** — Total Capacity (1000 Btuh) Gross

#### NOTES:

1. Direct interpolation is permissible. Do not extrapolate.
2. The following formulas may be used:

$$t_{ldb} = t_{edb} - \frac{\text{sensible capacity (Btuh)}}{1.10 \times \text{cfm}}$$

$$t_{lwb} = \text{Wet-bulb temperature corresponding to enthalpy of air leaving evaporator coil } (h_{lwb})$$

$$h_{lwb} = h_{ewb} - \frac{\text{total capacity (Btuh)}}{4.5 \times \text{cfm}}$$

Where:  $h_{ewb}$  = Enthalpy of air entering evaporator coil



**COOLING CAPACITIES (cont)**

**48PG07 (6 Tons) — UNIT WITH HUMIDI-MIZER™ SYSTEM IN HOT GAS REHEAT MODE**

Temp (F) Air Ent Condenser (Edb)		Air Entering Evaporator — Ewb (F)								
		75 Dry Bulb 62.5 Wet Bulb (50% RH)			75 Dry Bulb 64 Wet Bulb (55% RH)			75 Dry Bulb 65.3 Wet Bulb (60% RH)		
		Air Entering Evaporator — Cfm								
		2100	2400	2700	2100	2400	2700	1750	2000	2700
80	TC	30.0	32.4	34.6	32.1	34.6	36.8	30.6	33.1	38.8
	SHC	11.4	11.4	11.4	8.5	8.5	8.5	6.0	6.0	6.0
	kW	3.34	3.34	3.34	3.35	3.35	3.35	3.35	3.35	3.35
75	TC	30.3	32.6	34.6	32.4	34.7	36.8	30.9	33.3	38.7
	SHC	11.0	11.0	11.0	8.3	8.3	8.3	5.9	5.9	5.9
	kW	3.35	3.35	3.35	3.36	3.36	3.36	3.37	3.37	3.37
70	TC	30.6	32.8	34.7	32.6	34.8	36.8	31.2	33.5	38.5
	SHC	10.6	10.6	10.6	8.0	8.0	8.0	5.8	5.8	5.8
	kW	3.37	3.37	3.37	3.38	3.38	3.38	3.39	3.39	3.39
60	TC	31.2	33.1	34.8	33.0	35.0	36.7	31.9	33.9	38.3
	SHC	9.7	9.7	9.7	7.5	7.5	7.5	5.7	5.7	5.7
	kW	3.39	3.39	3.39	3.41	3.41	3.41	3.43	3.43	3.43
50	TC	31.9	33.5	34.9	33.5	35.1	36.6	32.6	34.3	38.1
	SHC	8.8	8.8	8.8	7.0	7.0	7.0	5.5	5.5	5.5
	kW	3.41	3.41	3.41	3.44	3.44	3.44	3.47	3.47	3.47
40	TC	32.5	33.8	35.0	33.9	35.3	36.5	33.3	34.7	37.9
	SHC	8.0	8.0	8.0	6.5	6.5	6.5	5.3	5.3	5.3
	kW	3.43	3.43	3.43	3.47	3.47	3.47	3.51	3.51	3.51

**LEGEND**

- Edb** — Entering Dry-Bulb
- Ewb** — Entering Wet-Bulb
- kW** — Compressor Motor Power Input
- ldb** — Leaving Dry-Bulb
- lwb** — Leaving Wet-Bulb
- RH** — Relative Humidity
- SHC** — Sensible Heat Capacity (1000 Btuh) Gross
- TC** — Total Capacity (1000 Btuh) Gross

**NOTES:**

1. Direct interpolation is permissible. Do not extrapolate.
2. The following formulas may be used:

$$t_{ldb} = t_{edb} - \frac{\text{sensible capacity (Btuh)}}{1.10 \times \text{cfm}}$$

$$t_{lwb} = \text{Wet-bulb temperature corresponding to enthalpy of air leaving evaporator coil (} h_{lwb} \text{)}$$

$$h_{lwb} = h_{ewb} - \frac{\text{total capacity (Btuh)}}{4.5 \times \text{cfm}}$$

Where:  $h_{ewb}$  = Enthalpy of air entering evaporator coil

# Performance data (cont)



## COOLING CAPACITIES (cont)

### 48PG08 (7 1/2 Tons) — STANDARD UNIT AND UNIT WITH HUMIDI-MIZER™ SYSTEM IN COOLING MODE

Temp (F) Air Ent Condenser (Edb)	Air Entering Evaporator — Cfm																						
	2250						3000						3750										
	Air Entering Evaporator — Ewb (F)																						
	80	76	72	67	62	58	54	80	76	72	67	62	58	54	80	76	72	67	62	58	54		
60	TC	125.6	116.3	106.2	97.2	89.2	81.7	78.5	132.0	122.8	113.8	103.9	94.9	88.7	88.4	137.0	128.0	118.7	108.2	98.9	97.2	95.7	
	SHC	38.0	46.5	53.9	64.8	76.9	80.1	78.5	97.6	49.8	60.6	74.3	88.4	88.7	88.4	39.4	53.7	66.9	83.3	96.6	97.2	95.7	
	kW	3.35	3.45	3.51	3.49	3.44	3.48	3.50	3.43	3.49	3.50	3.49	3.47	3.49	3.49	3.43	3.43	3.43	3.50	3.49	3.48	3.43	3.46
	BF	0.00	0.00	0.14	0.22	0.15	0.25	0.38	0.00	0.00	0.25	0.21	0.19	0.35	0.48	0.01	0.24	0.22	0.21	0.25	0.39	0.55	0.55
70	TC	120.8	112.1	103.6	94.2	86.6	79.1	77.5	127.6	119.6	110.4	100.8	91.4	87.2	86.6	131.9	123.2	114.6	105.1	96.0	93.5	93.4	
	SHC	36.4	44.5	53.3	63.7	76.3	77.9	77.5	37.4	49.1	59.7	74.4	86.3	87.2	86.6	37.9	51.8	65.8	84.9	96.0	93.5	93.4	
	kW	4.01	4.05	4.05	4.04	4.01	4.03	4.03	4.06	4.06	4.05	4.03	4.04	4.03	4.04	4.04	4.05	4.05	4.03	4.00	4.01	4.05	4.05
	BF	0.00	0.00	0.10	0.21	0.13	0.27	0.39	0.00	0.16	0.23	0.17	0.20	0.31	0.49	0.01	0.27	0.20	0.15	0.21	0.41	0.56	0.56
75	TC	119.1	110.4	101.9	92.7	84.5	78.8	77.3	125.4	117.5	109.2	99.4	89.7	85.0	86.2	129.6	120.9	112.7	102.7	93.9	92.0	92.2	
	SHC	35.9	44.0	52.7	63.2	74.5	78.8	77.3	36.7	48.5	60.5	75.0	85.7	85.0	86.2	37.2	51.1	65.3	82.6	92.2	92.0	92.2	
	kW	4.31	4.35	4.35	4.34	4.33	4.32	4.33	4.36	4.36	4.31	4.31	4.31	4.34	4.34	4.36	4.35	4.35	4.34	4.34	4.34	4.34	4.35
	BF	0.00	0.00	0.09	0.20	0.16	0.18	0.39	0.00	0.28	0.15	0.14	0.20	0.38	0.49	0.01	0.26	0.20	0.18	0.29	0.42	0.56	0.56
85	TC	114.3	106.7	98.4	89.3	81.1	75.7	74.7	120.7	112.5	104.8	95.4	86.1	83.9	83.1	124.1	115.8	108.0	98.4	91.3	89.5	90.5	
	SHC	34.3	42.8	51.5	62.1	72.5	75.7	74.7	35.2	47.0	59.1	73.7	83.6	83.9	83.1	35.6	49.6	63.8	81.1	90.0	89.5	90.5	
	kW	5.01	5.01	5.00	4.99	4.98	4.97	4.97	4.96	4.96	4.97	4.97	4.99	4.98	4.98	5.01	5.00	5.01	4.99	4.99	4.99	4.97	4.97
	BF	0.00	0.00	0.24	0.18	0.17	0.24	0.41	0.00	0.22	0.14	0.13	0.20	0.34	0.51	0.01	0.23	0.19	0.18	0.30	0.44	0.57	0.57
95	TC	109.5	102.5	94.7	85.6	77.7	72.6	73.1	114.9	106.8	99.8	90.7	82.5	81.7	80.1	118.4	110.5	103.0	93.8	86.5	86.3	87.3	
	SHC	32.8	41.8	50.6	60.8	71.7	72.6	73.1	33.5	44.8	57.2	70.8	82.2	81.7	80.1	33.9	48.5	63.1	81.0	86.5	86.3	87.3	
	kW	5.72	5.71	5.71	5.71	5.70	5.69	5.68	5.71	5.72	5.71	5.71	5.70	5.69	5.70	5.70	5.70	5.71	5.70	5.71	5.71	5.70	5.70
	BF	0.00	0.00	0.18	0.16	0.14	0.26	0.42	0.01	0.26	0.15	0.16	0.20	0.35	0.53	0.01	0.18	0.15	0.14	0.32	0.46	0.59	0.59
105	TC	104.4	97.5	90.3	82.0	74.1	70.7	71.1	108.9	101.8	94.5	86.1	79.0	77.9	77.6	112.2	104.5	96.9	88.5	83.5	83.1	83.0	
	SHC	31.2	40.3	49.5	60.7	70.3	70.7	71.1	31.7	43.6	55.6	70.3	79.0	77.9	77.6	32.1	46.2	60.2	77.9	83.5	83.1	83.0	
	kW	6.49	6.51	6.50	6.49	6.47	6.46	6.47	6.49	6.50	6.49	6.50	6.48	6.48	6.49	6.51	6.52	6.51	6.51	6.50	6.49	6.49	
	BF	0.00	0.00	0.12	0.11	0.14	0.25	0.44	0.01	0.17	0.13	0.12	0.18	0.38	0.54	0.01	0.20	0.18	0.16	0.34	0.47	0.61	0.61
115	TC	98.4	91.8	84.7	77.1	69.8	67.6	67.9	102.5	95.5	88.8	80.8	74.9	74.6	73.6	105.2	98.1	91.0	83.0	78.9	79.3	78.4	
	SHC	29.3	38.2	46.9	58.2	68.4	67.6	67.9	29.8	42.0	53.6	68.2	74.9	74.6	73.6	30.1	44.5	58.4	75.5	78.9	79.3	78.4	
	kW	7.35	7.38	7.38	7.36	7.34	7.33	7.34	7.35	7.38	7.36	7.36	7.34	7.35	7.35	7.38	7.38	7.38	7.37	7.37	7.36	7.37	
	BF	0.00	0.10	0.16	0.13	0.13	0.28	0.46	0.01	0.12	0.13	0.12	0.25	0.41	0.56	0.01	0.17	0.16	0.17	0.33	0.50	0.63	0.63
125	TC	91.6	85.4	79.1	71.9	65.1	63.9	64.0	95.6	88.9	82.5	75.0	69.6	69.5	69.2	97.8	91.1	84.5	76.8	74.4	74.5	73.7	
	SHC	27.2	36.2	45.1	55.9	65.8	63.9	64.0	27.7	39.5	50.8	65.2	69.6	69.5	69.2	28.0	42.2	56.3	73.2	74.4	74.5	73.7	
	kW	8.30	8.32	8.31	8.30	8.28	8.27	8.26	8.32	8.32	8.32	8.30	8.29	8.28	8.29	8.32	8.32	8.31	8.31	8.30	8.29	8.29	8.29
	BF	0.00	0.19	0.14	0.13	0.14	0.32	0.49	0.01	0.16	0.15	0.14	0.26	0.45	0.59	0.02	0.18	0.16	0.16	0.37	0.53	0.65	0.65

#### LEGEND

- BF — Bypass Factor
- Edb — Entering Dry-Bulb
- Ewb — Entering Wet-Bulb
- kW — Compressor Motor Power Input
- ldb — Leaving Dry-Bulb
- lwb — Leaving Wet-Bulb
- SHC — Sensible Heat Capacity (1000 Btu/h) Gross
- TC — Total Capacity (1000 Btu/h) Gross

#### NOTES:

1. Direct interpolation is permissible. Do not extrapolate.
2. The following formulas may be used:

$$t_{ldb} = t_{edb} - \frac{\text{sensible capacity (Btu/h)}}{1.10 \times \text{cfm}}$$

$$t_{lwb} = \text{Wet-bulb temperature corresponding to enthalpy of air leaving evaporator coil } (h_{lwb})$$

$$h_{lwb} = h_{ewb} - \frac{\text{total capacity (Btu/h)}}{4.5 \times \text{cfm}}$$

Where:  $h_{ewb}$  = Enthalpy of air entering evaporator coil

3. The SHC is based on 80 F edb temperature of air entering evaporator coil.  
Below 80 F edb, subtract (corr factor x cfm) from SHC.  
Above 80 F edb, add (corr factor x cfm) to SHC.

BYPASS FACTOR (BF)	ENTERING AIR DRY-BULB TEMP (F)					
	79	78	77	76	75	under 75
	81	82	83	84	85	over 85
	Correction Factor					
.05	1.04	2.07	3.11	4.14	5.18	Use formula shown below.
.10	.98	1.96	2.94	3.92	4.90	
.20	.87	1.74	2.62	3.49	4.36	
.30	.76	1.53	2.29	3.05	3.82	

Interpolation is permissible.  
Correction Factor =  $1.09 \times (1 - BF) \times (edb - 80)$ .

4. Cooling capacities for 48PG03-16 units with Humidi-MiZer system in Cooling mode are the same as standard units.



**COOLING CAPACITIES (cont)**

<b>48PG08 (7½ Tons) — UNIT WITH HUMIDI-MIZER™ SYSTEM IN SUBCOOLING MODE</b>															
<b>Temp (F) Air Ent Condenser (Edb)</b>		<b>Air Entering Evaporator — CFM</b>													
		<b>2250</b>							<b>3000</b>						
		<b>Air Entering Evaporator — Ewb (F)</b>													
		<b>80</b>	<b>76</b>	<b>72</b>	<b>67</b>	<b>62</b>	<b>57</b>	<b>54</b>	<b>80</b>	<b>76</b>	<b>72</b>	<b>67</b>	<b>62</b>	<b>57</b>	<b>54</b>
<b>75</b>	<b>TC</b>	112.2	104.6	97.1	87.7	78.3	68.9	63.3	132.0	121.9	111.7	99.1	86.5	73.8	66.3
	<b>SHC</b>	32.3	40.8	49.2	59.8	70.3	68.9	63.3	38.3	46.6	54.9	65.2	75.6	73.8	66.3
	<b>kW</b>	4.15	4.15	4.15	4.15	4.15	4.15	4.16	4.15	4.15	4.15	4.15	4.15	4.15	4.16
<b>85</b>	<b>TC</b>	104.9	98.2	91.6	83.3	74.9	66.6	61.6	118.8	110.0	101.1	90.0	79.0	67.9	61.3
	<b>SHC</b>	18.2	28.7	39.1	52.3	65.4	78.5	86.4	24.6	35.0	45.3	58.2	71.2	84.1	91.9
	<b>kW</b>	4.81	4.81	4.80	4.80	4.79	4.78	4.78	4.81	4.81	4.80	4.80	4.79	4.78	4.78
<b>95</b>	<b>TC</b>	97.6	91.8	86.0	78.8	71.6	64.4	60.0	105.7	98.1	90.5	81.0	71.5	62.0	56.3
	<b>SHC</b>	4.0	16.5	29.1	44.8	60.4	64.4	60.0	11.0	23.4	35.8	51.3	66.7	62.0	56.3
	<b>kW</b>	5.48	5.48	5.46	5.44	5.43	5.42	5.41	5.48	5.48	5.46	5.44	5.43	5.42	5.41
<b>105</b>	<b>TC</b>	90.3	85.4	80.5	74.3	68.2	62.1	58.4	92.5	86.2	79.8	71.9	64.0	56.0	51.3
	<b>SHC</b>	-10.2	4.4	19.0	37.2	55.5	62.1	58.4	-2.6	11.8	26.2	44.3	62.3	56.0	51.3
	<b>kW</b>	6.15	6.15	6.11	6.09	6.07	6.05	6.03	6.15	6.15	6.11	6.09	6.07	6.05	6.03
<b>115</b>	<b>TC</b>	83.0	79.0	74.9	69.9	64.8	59.8	56.8	79.4	74.3	69.2	62.8	56.5	50.1	46.3
	<b>SHC</b>	-24.4	-7.7	8.9	29.7	50.5	59.8	56.8	-16.3	0.2	16.7	37.3	56.5	50.1	46.3
	<b>kW</b>	6.82	6.82	6.77	6.74	6.71	6.68	6.66	6.82	6.82	6.77	6.74	6.71	6.68	6.66
<b>125</b>	<b>TC</b>	75.7	72.5	69.4	65.4	61.5	57.5	55.1	66.3	62.4	58.6	53.8	49.0	44.2	41.3
	<b>SHC</b>	-38.6	-19.9	-1.2	22.2	45.6	57.5	55.1	-29.9	-11.4	7.1	30.3	49.0	44.2	41.3
	<b>kW</b>	7.48	7.48	7.42	7.38	7.35	7.31	7.28	7.48	7.48	7.42	7.38	7.35	7.31	7.28

**48PG08 (7½ Tons) — UNIT WITH HUMIDI-MIZER SYSTEM IN SUBCOOLING MODE (cont)**

<b>Temp (F) Air Ent Condenser (Edb)</b>		<b>Air Entering Evaporator — CFM</b>						
		<b>3750</b>						
		<b>Air Entering Evaporator — Ewb (F)</b>						
		<b>80</b>	<b>76</b>	<b>72</b>	<b>67</b>	<b>62</b>	<b>57</b>	<b>54</b>
<b>75</b>	<b>TC</b>	152.6	139.8	127.0	111.0	95.0	79.0	69.4
	<b>SHC</b>	42.9	51.1	59.3	69.5	79.8	79.0	69.4
	<b>kW</b>	4.15	4.15	4.15	4.15	4.15	4.15	4.16
<b>85</b>	<b>TC</b>	133.4	122.2	111.0	97.1	83.2	69.2	60.9
	<b>SHC</b>	29.7	40.0	50.2	63.0	75.8	88.5	96.2
	<b>kW</b>	4.81	4.81	4.80	4.80	4.79	4.78	4.78
<b>95</b>	<b>TC</b>	114.1	104.6	95.1	83.2	71.4	59.5	52.4
	<b>SHC</b>	16.5	28.8	41.1	56.4	71.4	59.5	52.4
	<b>kW</b>	5.48	5.48	5.46	5.44	5.43	5.42	5.41
<b>105</b>	<b>TC</b>	94.9	87.0	79.2	69.4	59.6	49.7	43.9
	<b>SHC</b>	3.3	17.6	31.9	49.8	59.6	49.7	43.9
	<b>kW</b>	6.15	6.15	6.11	6.09	6.07	6.05	6.03
<b>115</b>	<b>TC</b>	75.7	69.5	63.3	55.5	47.8	40.0	35.4
	<b>SHC</b>	-9.9	6.5	22.8	43.2	47.8	40.0	35.4
	<b>kW</b>	6.82	6.82	6.77	6.74	6.71	6.68	6.66
<b>125</b>	<b>TC</b>	56.4	51.9	47.3	41.6	35.9	30.3	26.9
	<b>SHC</b>	-23.0	-4.7	13.7	36.7	35.9	30.3	26.9
	<b>kW</b>	7.48	7.48	7.42	7.38	7.35	7.31	7.28

**LEGEND**

- Edb** — Entering Dry-Bulb
- Ewb** — Entering Wet-Bulb
- kW** — Compressor Motor Power Input
- ldb** — Leaving Dry-Bulb
- lwb** — Leaving Wet-Bulb
- SHC** — Sensible Heat Capacity (1000 Btuh) Gross
- TC** — Total Capacity (1000 Btuh) Gross

**NOTES:**

1. Direct interpolation is permissible. Do not extrapolate.
2. The following formulas may be used:

$$t_{ldb} = t_{edb} - \frac{\text{sensible capacity (Btuh)}}{1.10 \times \text{cfm}}$$

$$t_{lwb} = \text{Wet-bulb temperature corresponding to enthalpy of air leaving evaporator coil } (h_{lwb})$$

$$h_{lwb} = h_{ewb} - \frac{\text{total capacity (Btuh)}}{4.5 \times \text{cfm}}$$

Where:  $h_{ewb}$  = Enthalpy of air entering evaporator coil

# Performance data (cont)



## COOLING CAPACITIES (cont)

### 48PG08 (7 1/2 Tons) — UNIT WITH HUMIDI-MIZER™ SYSTEM IN HOT GAS REHEAT MODE (CIRCUIT A ONLY)

Temp (F) Air Ent Condenser (Edb)		Air Entering Evaporator — Ewb (F)								
		75 Dry Bulb 62.5 Wet Bulb (50% RH)			75 Dry Bulb 64 Wet Bulb (55% RH)			75 Dry Bulb 65.3 Wet Bulb (60% RH)		
		Air Entering Evaporator — Cfm								
		2625	3000	3375	2625	3000	3375	2625	3000	3375
50	TC	8.2	9.1	9.8	17.0	17.8	18.6	24.5	25.4	26.1
	SHC	-0.9	-0.9	-0.9	-0.1	-0.1	-0.1	0.6	0.6	0.6
	kW	2.16	2.16	2.16	2.11	2.11	2.11	2.06	2.06	2.06
40	TC	5.8	6.4	7.0	12.8	13.4	14.0	18.8	19.5	20.0
	SHC	-0.6	-0.6	-0.6	0.1	0.1	0.1	0.6	0.6	0.6
	kW	2.17	2.17	2.17	2.14	2.14	2.14	2.10	2.10	2.10
30	TC	3.3	3.8	4.2	8.5	9.0	9.4	13.0	13.5	13.9
	SHC	-0.3	-0.3	-0.3	0.2	0.2	0.2	0.6	0.6	0.6
	kW	2.18	2.18	2.18	2.16	2.16	2.16	2.15	2.15	2.15

### 48PG08 (7 1/2 Tons) — UNIT WITH HUMIDI-MIZER SYSTEM IN HOT GAS REHEAT MODE (ALL CIRCUITS)

Temp (F) Air Ent Condenser (Edb)		Air Entering Evaporator — Ewb (F)								
		75 Dry Bulb 62.5 Wet Bulb (50% RH)			75 Dry Bulb 64 Wet Bulb (55% RH)			75 Dry Bulb 65.3 Wet Bulb (60% RH)		
		Air Entering Evaporator — Cfm								
		2625	3000	3375	2625	3000	3375	2625	3000	3375
80	TC	28.9	30.6	32.0	30.9	32.6	34.1	32.6	34.3	35.8
	SHC	7.6	9.7	11.6	3.0	5.1	6.9	-0.9	1.1	2.8
	kW	4.20	4.20	4.20	4.20	4.20	4.20	4.21	4.21	4.21
75	TC	30.3	31.8	33.2	32.2	33.8	35.2	33.8	35.5	36.9
	SHC	8.8	10.8	12.6	4.5	6.5	8.3	0.9	2.8	4.5
	kW	4.13	4.13	4.13	4.14	4.14	4.14	4.14	4.14	4.14
70	TC	31.6	33.1	34.4	33.5	35.0	36.4	35.1	36.7	38.0
	SHC	9.9	11.9	13.7	6.0	7.9	9.6	2.7	4.5	6.1
	kW	4.06	4.06	4.06	4.07	4.07	4.07	4.08	4.08	4.08
60	TC	34.4	35.7	36.8	36.1	37.5	38.7	37.7	39.0	40.3
	SHC	12.3	14.1	15.7	9.1	10.8	12.4	6.2	7.9	9.5
	kW	3.92	3.92	3.92	3.94	3.94	3.94	3.96	3.96	3.96
50	TC	37.1	38.2	39.2	38.7	39.9	41.0	40.2	41.4	42.5
	SHC	14.7	16.3	17.8	12.1	13.7	15.1	9.8	11.4	12.8
	kW	3.78	3.78	3.78	3.81	3.81	3.81	3.83	3.83	3.83

#### LEGEND

- BF** — Bypass Factor
- Edb** — Entering Dry-Bulb
- Ewb** — Entering Wet-Bulb
- kW** — Compressor Motor Power Input
- ldb** — Leaving Dry-Bulb
- lwb** — Leaving Wet-Bulb
- RH** — Relative Humidity
- SHC** — Sensible Heat Capacity (1000 Btuh) Gross
- TC** — Total Capacity (1000 Btuh) Gross

#### NOTES:

1. Direct interpolation is permissible. Do not extrapolate.
2. The following formulas may be used:

$$t_{ldb} = t_{edb} - \frac{\text{sensible capacity (Btuh)}}{1.10 \times \text{cfm}}$$

$t_{lwb}$  = Wet-bulb temperature corresponding to enthalpy of air leaving evaporator coil ( $h_{lwb}$ )

$$h_{lwb} = h_{ewb} - \frac{\text{total capacity (Btuh)}}{4.5 \times \text{cfm}}$$

Where:  $h_{ewb}$  = Enthalpy of air entering evaporator coil



## COOLING CAPACITIES (cont)

**48PG09 (8 1/2 Tons) — STANDARD UNIT AND UNIT WITH HUMIDI-MIZER™ SYSTEM IN COOLING MODE**

Temp (F) Air Ent Condenser (Edb)	Air Entering Evaporator — Cfm																												
	2550							3000							3400							4250							
	Air Entering Evaporator — Ewb (F)																												
	80	76	72	67	62	58	54	80	76	72	67	62	58	54	80	76	72	67	62	58	54	80	76	72	67	62	58	54	
60	TC	146.3	136.3	126.9	115.0	104.6	96.8	94.1	151.8	141.9	131.8	119.7	108.9	101.2	100.3	155.8	145.6	135.4	123.6	112.1	105.2	105.1	161.5	151.0	140.6	128.6	116.9	113.4	113.3
	SHC	41.4	51.4	60.9	72.2	83.6	91.3	94.1	42.2	53.0	64.9	78.2	91.3	98.3	100.3	42.8	55.0	68.3	83.8	97.9	103.0	105.1	43.5	58.9	74.6	93.5	109.5	113.4	113.3
	kW	4.36	4.36	4.37	4.37	4.37	4.38	4.35	4.36	4.36	4.37	4.37	4.37	4.37	4.38	4.35	4.36	4.36	4.38	4.38	4.38	4.39	4.34	4.35	4.36	4.37	4.37	4.39	4.39
BF	0.00	0.00	0.15	0.24	0.21	0.22	0.34	0.00	0.00	0.00	0.28	0.23	0.21	0.26	0.41	0.00	0.00	0.25	0.21	0.21	0.31	0.45	0.00	0.15	0.24	0.22	0.24	0.37	0.53
70	TC	142.0	132.3	123.1	111.5	101.8	93.7	92.0	146.9	137.5	127.7	116.3	105.4	98.6	97.9	150.7	140.8	130.9	119.3	108.2	102.6	102.5	156.2	145.7	135.7	123.9	112.9	109.9	110.0
	SHC	39.9	49.9	59.6	70.9	83.0	90.3	92.0	40.6	51.1	63.5	77.3	90.0	96.3	97.9	41.2	53.6	66.7	82.3	96.3	100.3	102.5	41.9	57.3	72.9	91.8	108.2	109.9	110.0
	kW	5.03	5.03	5.04	5.03	5.03	5.02	5.02	5.02	5.03	5.04	5.03	5.03	5.02	5.03	5.03	5.03	5.04	5.04	5.04	5.03	5.03	5.04	5.02	5.03	5.04	5.04	5.04	5.04
BF	0.00	0.00	0.13	0.22	0.19	0.21	0.36	0.00	0.00	0.00	0.25	0.20	0.20	0.27	0.42	0.00	0.00	0.23	0.20	0.21	0.33	0.47	0.00	0.14	0.23	0.21	0.23	0.39	0.54
75	TC	139.5	130.2	121.0	110.0	99.7	92.2	90.8	144.3	134.9	125.4	114.1	103.4	96.9	96.7	147.9	138.2	128.4	117.1	106.5	101.0	100.6	153.4	142.8	132.9	121.2	110.8	108.7	107.7
	SHC	39.1	49.1	58.8	70.7	81.7	89.1	90.8	39.8	50.6	62.7	76.5	89.2	95.0	96.7	40.3	52.8	65.9	81.4	96.1	99.0	100.6	41.0	56.4	72.0	90.6	106.6	108.7	107.7
	kW	5.39	5.39	5.39	5.38	5.37	5.36	5.36	5.38	5.39	5.39	5.39	5.38	5.37	5.38	5.40	5.40	5.40	5.40	5.39	5.38	5.38	5.34	5.40	5.40	5.40	5.40	5.39	5.39
BF	0.00	0.00	0.12	0.20	0.19	0.22	0.37	0.00	0.00	0.00	0.24	0.20	0.20	0.28	0.43	0.00	0.00	0.22	0.20	0.20	0.33	0.47	0.00	0.14	0.23	0.22	0.24	0.40	0.55
85	TC	134.3	125.6	116.5	105.9	96.3	89.3	88.3	139.4	129.5	120.3	109.4	99.5	93.8	93.8	142.5	132.5	123.2	112.1	102.2	98.1	98.0	146.6	136.8	127.3	116.3	106.6	105.2	105.1
	SHC	37.4	46.8	57.2	69.2	80.8	87.0	88.3	38.2	49.1	60.9	74.5	87.7	92.1	93.8	38.6	51.1	64.1	79.3	94.1	98.1	98.0	39.1	54.5	70.1	89.1	103.4	105.2	105.1
	kW	6.15	6.15	6.14	6.13	6.11	6.09	6.09	6.15	6.15	6.14	6.14	6.12	6.11	6.10	6.12	6.16	6.16	6.15	6.13	6.12	6.12	6.17	6.16	6.16	6.16	6.14	6.13	6.13
BF	0.00	0.00	0.25	0.19	0.17	0.23	0.38	0.00	0.00	0.00	0.22	0.19	0.19	0.30	0.44	0.00	0.16	0.21	0.20	0.20	0.32	0.49	0.00	0.29	0.22	0.20	0.26	0.42	0.56
95	TC	129.6	120.2	111.6	101.4	92.2	86.0	85.6	133.2	123.7	114.9	104.8	95.2	90.7	90.7	135.8	126.5	117.6	107.3	97.7	94.7	94.6	139.8	130.2	121.3	110.8	102.1	101.3	101.2
	SHC	35.9	44.9	55.5	67.4	79.0	84.4	85.6	36.3	47.4	59.0	73.0	86.2	88.9	90.7	36.6	49.2	62.1	77.7	91.8	95.1	94.6	37.1	52.5	68.1	87.0	99.6	101.3	101.2
	kW	6.96	6.97	6.96	6.93	6.90	6.88	6.87	6.98	6.97	6.96	6.94	6.91	6.90	6.89	6.99	6.99	6.98	6.96	6.93	6.92	6.92	7.00	7.00	6.98	6.97	6.94	6.94	6.94
BF	0.00	0.00	0.22	0.18	0.17	0.24	0.40	0.00	0.00	0.00	0.20	0.18	0.18	0.32	0.46	0.00	0.13	0.20	0.19	0.20	0.34	0.51	0.00	0.26	0.21	0.20	0.28	0.44	0.58
105	TC	123.1	114.3	106.2	96.6	87.7	83.1	82.4	126.5	118.0	109.4	99.6	90.5	87.2	87.2	128.8	120.2	111.6	101.8	92.7	90.9	90.8	132.5	123.6	114.6	105.0	97.7	97.0	96.9
	SHC	33.7	43.3	53.5	65.5	77.1	81.4	82.4	34.2	45.7	57.1	71.0	84.0	87.2	87.2	34.4	47.7	60.1	75.7	89.3	90.9	90.8	35.0	50.6	66.4	84.9	95.1	97.0	96.9
	kW	7.86	7.84	7.83	7.79	7.75	7.72	7.72	7.86	7.85	7.84	7.80	7.77	7.75	7.74	7.88	7.85	7.85	7.82	7.78	7.77	7.77	7.77	7.88	7.87	7.88	7.84	7.81	7.80
BF	0.00	0.00	0.20	0.17	0.16	0.27	0.42	0.00	0.14	0.19	0.17	0.18	0.31	0.48	0.00	0.22	0.20	0.18	0.20	0.37	0.52	0.00	0.23	0.19	0.20	0.31	0.46	0.59	
115	TC	116.1	108.2	100.4	91.2	82.8	78.9	78.8	118.9	111.0	103.2	94.0	85.5	83.4	83.3	120.9	112.9	105.1	95.8	87.7	86.7	86.7	123.9	115.8	107.8	98.3	92.8	92.3	92.3
	SHC	31.6	41.6	51.4	63.4	74.9	78.9	78.8	31.9	43.4	55.1	68.9	81.3	83.4	83.3	32.1	45.0	58.1	73.4	85.5	86.7	86.7	32.5	48.7	64.8	84.4	90.5	92.3	92.3
	kW	8.79	8.77	8.75	8.70	8.65	8.62	8.62	8.79	8.79	8.76	8.73	8.68	8.66	8.66	8.80	8.79	8.77	8.74	8.70	8.68	8.68	8.82	8.81	8.78	8.75	8.73	8.72	8.72
BF	0.00	0.00	0.18	0.16	0.16	0.26	0.45	0.00	0.25	0.17	0.17	0.19	0.34	0.50	0.00	0.23	0.18	0.18	0.23	0.40	0.55	0.00	0.18	0.16	0.16	0.35	0.48	0.61	
125	TC	107.3	100.4	93.7	85.4	77.6	75.6	74.8	110.4	103.0	96.0	87.5	80.2	79.3	77.6	112.1	104.8	97.4	89.0	82.4	82.5	82.2	114.7	107.4	99.7	91.2	87.4	87.3	87.3
	SHC	28.9	39.1	49.2	62.3	73.9	75.9	74.8	29.3	41.2	52.6	67.7	78.3	79.3	77.6	29.5	42.6	55.4	72.4	80.7	82.8	82.2	29.8	45.9	62.1	81.5	87.8	87.3	87.3
	kW	9.74	9.74	9.71	9.69	9.63	9.62	9.65	9.79	9.77	9.73	9.70	9.64	9.62	9.59	9.79	9.79	9.76	9.71	9.66	9.67	9.65	9.80	9.80	9.76	9.72	9.70	9.70	9.70
BF	0.00	0.00	0.16	0.11	0.12	0.30	0.48	0.00	0.17	0.17	0.13	0.20	0.38	0.54	0.00	0.20	0.17	0.14	0.27	0.43	0.57	0.00	0.19	0.16	0.16	0.35	0.51	0.63	

**LEGEND**

- BF — Bypass Factor
- Edb — Entering Dry-Bulb
- Ewb — Entering Wet-Bulb
- kW — Compressor Motor Power Input
- ldb — Leaving Dry-Bulb
- lwb — Leaving Wet-Bulb
- SHC — Sensible Heat Capacity (1000 Btuh) Gross
- TC — Total Capacity (1000 Btuh) Gross

**NOTES:**

1. Direct interpolation is permissible. Do not extrapolate.
2. The following formulas may be used:

$$t_{ldb} = t_{edb} - \frac{\text{sensible capacity (Btuh)}}{1.10 \times \text{cfm}}$$

$$t_{lwb} = \text{Wet-bulb temperature corresponding to enthalpy of air leaving evaporator coil } (h_{lwb})$$

$$h_{lwb} = h_{ewb} - \frac{\text{total capacity (Btuh)}}{4.5 \times \text{cfm}}$$

Where:  $h_{ewb}$  = Enthalpy of air entering evaporator coil

3. The SHC is based on 80 F edb temperature of air entering evaporator coil. Below 80 F edb, subtract (corr factor x cfm) from SHC. Above 80 F edb, add (corr factor x cfm) to SHC.

BYPASS FACTOR (BF)	ENTERING AIR DRY-BULB TEMP (F)					
	79	78	77	76	75	under 75
	81	82	83	84	85	over 85
Correction Factor						
.05	1.04	2.07	3.11	4.14	5.18	Use formula shown below.
.10	.98	1.96	2.94	3.92	4.90	
.20	.87	1.74	2.62	3.49	4.36	
.30	.76	1.53	2.29	3.05	3.82	

Interpolation is permissible.  
Correction Factor = 1.09 x (1 - BF) x (edb - 80).

4. Cooling capacities for 48PG03-16 units with Humidi-MiZer system in Cooling mode are the same as standard units.

# Performance data (cont)



## COOLING CAPACITIES (cont)

48PG09 (8 1/2 Tons) — UNIT WITH HUMIDI-MIZER™ SYSTEM IN SUBCOOLING MODE															
Temp (F) Air Ent Condenser (Edb)		Air Entering Evaporator — CFM													
		2550							3400						
		Air Entering Evaporator — Ewb (F)													
		80	76	72	67	62	57	54	80	76	72	67	62	57	54
75	TC	127.2	119.0	110.8	100.5	90.3	80.1	73.9	148.1	137.4	126.7	113.4	100.1	86.7	78.7
	SHC	36.6	45.8	54.9	66.4	77.9	80.1	73.9	46.4	55.2	64.1	75.3	86.4	86.7	78.7
	kW	5.23	5.23	5.19	5.17	5.14	5.12	5.10	5.23	5.23	5.19	5.17	5.14	5.12	5.10
85	TC	121.4	113.7	106.0	96.4	86.8	77.2	71.5	137.1	127.2	117.3	104.9	92.5	80.1	72.7
	SHC	21.7	33.1	44.5	58.7	72.9	87.2	95.7	32.4	43.5	54.6	68.5	82.3	96.2	104.5
	kW	6.04	6.04	5.99	5.95	5.92	5.88	5.86	6.04	6.04	5.99	5.95	5.92	5.88	5.86
95	TC	115.6	108.4	101.2	92.3	83.3	74.4	69.0	126.1	117.0	107.8	96.3	84.9	73.4	66.6
	SHC	6.8	20.4	34.0	51.0	68.0	74.4	69.0	18.5	31.8	45.1	61.7	78.2	73.4	66.6
	kW	6.86	6.86	6.78	6.74	6.69	6.64	6.61	6.86	6.86	6.78	6.74	6.69	6.64	6.61
105	TC	109.8	103.1	96.5	88.2	79.8	71.5	66.5	115.2	106.8	98.3	87.8	77.3	66.8	60.5
	SHC	-8.1	7.7	23.5	43.3	63.0	71.5	66.5	4.6	20.1	35.5	54.9	74.2	66.8	60.5
	kW	7.68	7.68	7.58	7.52	7.46	7.40	7.37	7.68	7.68	7.58	7.52	7.46	7.40	7.37
115	TC	104.0	97.8	91.7	84.0	76.4	68.7	64.1	104.2	96.5	88.9	79.3	69.7	60.1	54.4
	SHC	-23.0	-5.0	13.0	35.5	58.1	68.7	64.1	-9.3	8.4	26.0	48.1	69.7	60.1	54.4
	kW	8.49	8.49	8.38	8.31	8.24	8.16	8.12	8.49	8.49	8.38	8.31	8.24	8.16	8.12
125	TC	98.2	92.6	86.9	79.9	72.9	65.8	61.6	93.3	86.3	79.4	70.8	62.1	53.5	48.3
	SHC	-37.9	-17.7	2.5	27.8	53.1	65.8	61.6	-23.2	-3.4	16.5	41.3	62.1	53.5	48.3
	kW	9.31	9.31	9.18	9.09	9.01	8.93	8.88	9.31	9.31	9.18	9.09	9.01	8.93	8.88

## 48PG09 (8 1/2 Tons) — UNIT WITH HUMIDI-MIZER SYSTEM IN SUBCOOLING MODE (cont)

Temp (F) Air Ent Condenser (Edb)		Air Entering Evaporator — CFM						
		4250						
		Air Entering Evaporator — Ewb (F)						
		80	76	72	67	62	57	54
75	TC	169.4	156.2	143.0	126.5	110.0	93.5	83.6
	SHC	54.1	62.8	71.4	82.3	93.1	93.5	83.6
	kW	5.23	5.23	5.19	5.17	5.14	5.12	5.10
85	TC	153.1	140.9	128.7	113.5	98.2	83.0	73.8
	SHC	41.0	51.8	62.6	76.2	89.7	103.3	111.4
	kW	6.04	6.04	5.99	5.95	5.92	5.88	5.86
95	TC	136.9	125.7	114.5	100.5	86.5	72.5	64.1
	SHC	27.8	40.8	53.9	70.1	86.4	72.5	64.1
	kW	6.86	6.86	6.78	6.74	6.69	6.64	6.61
105	TC	120.7	110.5	100.3	87.5	74.7	61.9	54.3
	SHC	14.7	29.9	45.1	64.0	74.7	61.9	54.3
	kW	7.68	7.68	7.58	7.52	7.46	7.40	7.37
115	TC	104.5	95.2	86.0	74.5	62.9	51.4	44.5
	SHC	1.6	18.9	36.3	58.0	62.9	51.4	44.5
	kW	8.49	8.49	8.38	8.31	8.24	8.16	8.12
125	TC	88.2	80.0	71.8	61.5	51.2	40.9	34.7
	SHC	-11.6	8.0	27.5	51.9	51.2	40.9	34.7
	kW	9.31	9.31	9.18	9.09	9.01	8.93	8.88

### LEGEND

- Edb** — Entering Dry-Bulb
- Ewb** — Entering Wet-Bulb
- kW** — Compressor Motor Power Input
- ldb** — Leaving Dry-Bulb
- lwb** — Leaving Wet-Bulb
- SHC** — Sensible Heat Capacity (1000 Btuh) Gross
- TC** — Total Capacity (1000 Btuh) Gross

### NOTES:

1. Direct interpolation is permissible. Do not extrapolate.
2. The following formulas may be used:

$$t_{ldb} = t_{edb} - \frac{\text{sensible capacity (Btuh)}}{1.10 \times \text{cfm}}$$

$$t_{lwb} = \text{Wet-bulb temperature corresponding to enthalpy of air leaving evaporator coil } (h_{lwb})$$

$$h_{lwb} = h_{ewb} - \frac{\text{total capacity (Btuh)}}{4.5 \times \text{cfm}}$$

Where:  $h_{ewb}$  = Enthalpy of air entering evaporator coil



**COOLING CAPACITIES (cont)**

**48PG09 (8 1/2 Tons) — UNIT WITH HUMIDI-MIZER™ SYSTEM IN HOT GAS REHEAT MODE (CIRCUIT A ONLY)**

Temp (F) Air Ent Condenser (Edb)		Air Entering Evaporator — Ewb (F)								
		75 Dry Bulb 62.5 Wet Bulb (50% RH)			75 Dry Bulb 64 Wet Bulb (55% RH)			75 Dry Bulb 65.3 Wet Bulb (60% RH)		
		Air Entering Evaporator — Cfm								
		2975	3400	3825	2975	3400	3825	2975	3400	3825
50	TC	21.8	21.8	21.8	24.5	24.5	24.5	26.8	26.8	26.8
	SHC	8.3	8.3	8.3	5.3	5.3	5.3	2.6	2.6	2.6
	kW	2.64	2.64	2.64	2.63	2.63	2.63	2.62	2.62	2.62
40	TC	20.9	20.9	20.9	23.1	23.1	23.1	25.0	25.0	25.0
	SHC	6.6	6.6	6.6	4.1	4.1	4.1	2.0	2.0	2.0
	kW	2.70	2.70	2.70	2.70	2.70	2.70	2.71	2.71	2.71
30	TC	20.1	20.1	20.1	21.8	21.8	21.8	23.3	23.3	23.3
	SHC	4.8	4.8	4.8	3.0	3.0	3.0	1.4	1.4	1.4
	kW	2.75	2.75	2.75	2.77	2.77	2.77	2.79	2.79	2.79

**48PG09 (8 1/2 Tons) — UNIT WITH HUMIDI-MIZER SYSTEM IN HOT GAS REHEAT MODE (ALL CIRCUITS)**

Temp (F) Air Ent Condenser (Edb)		Air Entering Evaporator — Ewb (F)								
		75 Dry Bulb 62.5 Wet Bulb (50% RH)			75 Dry Bulb 64 Wet Bulb (55% RH)			75 Dry Bulb 65.3 Wet Bulb (60% RH)		
		Air Entering Evaporator — Cfm								
		2975	3400	3825	2975	3400	3825	2975	3400	3825
80	TC	35.9	37.9	39.7	37.5	39.6	41.5	39.0	41.1	43.0
	SHC	9.6	12.7	15.5	4.8	7.8	10.6	0.6	3.6	6.4
	kW	5.16	5.16	5.16	5.16	5.16	5.16	5.16	5.16	5.16
75	TC	37.7	39.6	41.4	39.3	41.3	43.1	40.7	42.8	44.6
	SHC	10.7	13.7	16.4	6.2	9.2	11.8	2.4	5.3	7.9
	kW	5.10	5.10	5.10	5.10	5.10	5.10	5.11	5.11	5.11
70	TC	39.5	41.3	43.0	41.1	43.0	44.7	42.5	44.5	46.2
	SHC	11.8	14.7	17.3	7.7	10.5	13.1	4.2	6.9	9.4
	kW	5.03	5.03	5.03	5.04	5.04	5.04	5.05	5.05	5.05
60	TC	43.0	44.7	46.2	44.7	46.4	47.9	46.1	47.8	49.3
	SHC	14.1	16.7	19.0	10.7	13.2	15.5	7.7	10.2	12.5
	kW	4.90	4.90	4.90	4.93	4.93	4.93	4.95	4.95	4.95
50	TC	46.6	48.1	49.4	48.2	49.7	51.1	49.6	51.2	52.5
	SHC	16.4	18.7	20.8	13.6	15.9	18.0	11.3	13.5	15.6
	kW	4.77	4.77	4.77	4.81	4.81	4.81	4.84	4.84	4.84

**LEGEND**

- Edb** — Entering Dry-Bulb
- Ewb** — Entering Wet-Bulb
- kW** — Compressor Motor Power Input
- ldb** — Leaving Dry-Bulb
- lwb** — Leaving Wet-Bulb
- RH** — Relative Humidity
- SHC** — Sensible Heat Capacity (1000 Btuh) Gross
- TC** — Total Capacity (1000 Btuh) Gross

**NOTES:**

1. Direct interpolation is permissible. Do not extrapolate.
2. The following formulas may be used:

$$t_{ldb} = t_{edb} - \frac{\text{sensible capacity (Btuh)}}{1.10 \times \text{cfm}}$$

$t_{lwb}$  = Wet-bulb temperature corresponding to enthalpy of air leaving evaporator coil ( $h_{lwb}$ )

$$h_{lwb} = h_{ewb} - \frac{\text{total capacity (Btuh)}}{4.5 \times \text{cfm}}$$

Where:  $h_{ewb}$  = Enthalpy of air entering evaporator coil

# Performance data (cont)



## COOLING CAPACITIES (cont)

48PG12 (10 Tons) — STANDARD UNIT AND UNIT WITH HUMIDI-MIZER™ SYSTEM IN COOLING MODE

Temp (F) Air Ent Condenser (Edb)	Air Entering Evaporator — Cfm																												
	3000							3500							4000							5000							
	Air Entering Evaporator — Ewb (F)																												
	80	76	72	67	62	58	54	80	76	72	67	62	58	54	80	76	72	67	62	58	54	80	76	72	67	62	58	54	
60	TC	172.0	160.6	149.2	135.7	123.6	114.8	112.9	177.7	165.6	154.8	140.4	128.4	121.0	120.2	182.3	170.7	158.7	144.9	132.4	125.3	126.7	189.2	176.6	164.7	150.6	138.5	136.2	136.1
	SHC	47.1	59.8	72.7	87.2	102.3	110.9	112.9	47.9	62.2	77.0	94.0	112.4	118.6	120.2	48.5	65.2	81.6	101.5	120.4	125.3	126.7	49.5	69.9	90.3	115.5	134.3	136.2	136.1
	kW	5.28	5.21	5.14	5.09	5.00	4.95	4.93	5.37	5.28	5.22	5.12	5.03	4.99	4.99	5.37	5.29	5.23	5.15	5.07	5.04	5.01	5.43	5.35	5.27	5.18	5.11	5.09	5.09
70	BF	0.00	0.00	0.12	0.12	0.10	0.15	0.32	0.00	0.00	0.14	0.12	0.10	0.21	0.39	0.00	0.20	0.12	0.11	0.12	0.25	0.43	0.00	0.15	0.11	0.10	0.17	0.35	0.51
	TC	166.1	155.5	144.2	131.6	119.9	111.5	110.0	171.9	160.8	149.4	136.3	124.2	117.4	116.3	176.5	164.7	153.4	140.2	127.8	122.9	122.9	182.2	170.4	158.8	145.2	133.9	132.4	132.0
	SHC	45.2	57.6	70.1	85.7	100.6	108.4	110.0	46.0	60.6	75.2	93.0	109.9	115.6	116.3	46.7	63.3	80.0	100.0	118.3	122.9	122.9	47.4	68.1	88.8	113.9	128.7	132.4	132.0
75	kW	6.10	6.02	5.95	5.86	5.78	5.72	5.71	6.11	6.06	5.97	5.89	5.82	5.76	5.76	6.15	6.08	6.00	5.92	5.84	5.80	5.80	6.20	6.11	6.03	5.94	5.88	5.87	5.87
	BF	0.00	0.00	0.15	0.11	0.10	0.16	0.34	0.00	0.00	0.12	0.10	0.10	0.22	0.40	0.00	0.17	0.11	0.10	0.12	0.27	0.45	0.00	0.12	0.09	0.09	0.21	0.37	0.53
	TC	163.7	152.7	142.0	129.4	117.7	109.7	108.2	169.0	157.7	146.8	134.0	122.1	115.5	115.2	173.1	161.6	150.5	137.4	125.2	121.1	120.6	178.6	166.9	155.6	142.3	131.6	130.4	130.2
85	SHC	44.4	56.7	69.6	84.8	99.4	107.0	108.2	45.1	59.6	74.4	92.4	109.4	113.6	115.2	45.7	62.2	79.0	99.3	117.0	121.1	120.6	46.3	67.0	87.9	113.1	128.9	130.4	130.2
	kW	6.51	6.43	6.35	6.27	6.20	6.14	6.14	6.54	6.47	6.39	6.29	6.22	6.19	6.18	6.56	6.49	6.41	6.32	6.24	6.22	6.22	6.60	6.52	6.44	6.35	6.28	6.28	6.28
	BF	0.00	0.00	0.12	0.11	0.10	0.17	0.35	0.00	0.00	0.12	0.11	0.09	0.10	0.24	0.41	0.00	0.16	0.10	0.09	0.12	0.28	0.46	0.00	0.12	0.09	0.09	0.19	0.38
95	TC	157.6	147.0	136.5	124.3	113.2	106.4	105.2	162.2	151.4	141.0	128.5	117.2	111.5	111.2	165.8	154.8	144.2	131.8	120.5	117.5	117.6	170.7	159.5	148.7	136.1	126.5	126.0	125.8
	SHC	42.4	55.0	68.1	82.9	97.8	104.6	105.2	43.0	57.7	72.4	90.3	107.1	111.5	111.2	43.4	60.2	77.1	97.5	114.5	117.5	117.6	43.9	64.8	85.6	111.0	125.1	126.0	125.8
	kW	7.38	7.31	7.23	7.16	7.08	7.03	7.02	7.43	7.34	7.27	7.18	7.10	7.08	7.08	7.44	7.36	7.28	7.20	7.14	7.11	7.12	7.48	7.39	7.31	7.23	7.17	7.17	7.17
105	BF	0.00	0.00	0.09	0.10	0.09	0.18	0.37	0.00	0.17	0.10	0.09	0.10	0.24	0.43	0.00	0.13	0.09	0.08	0.12	0.30	0.47	0.00	0.11	0.08	0.08	0.21	0.40	0.58
	TC	142.8	133.3	124.0	113.1	103.2	97.9	98.0	146.5	136.8	127.4	116.4	106.0	103.6	103.5	149.0	139.3	129.8	118.7	109.3	108.3	108.2	153.5	142.4	133.1	121.9	115.9	115.8	115.7
	SHC	37.6	50.4	63.3	78.9	93.8	97.9	98.0	38.0	53.0	67.9	86.1	101.4	103.6	103.5	38.3	55.2	72.2	93.0	107.3	108.3	108.2	38.9	59.4	80.5	105.8	115.9	115.8	115.7
115	kW	9.39	9.31	9.24	9.16	9.09	9.06	9.06	9.41	9.34	9.27	9.18	9.10	9.10	9.10	9.43	9.35	9.28	9.20	9.13	9.14	9.14	9.48	9.38	9.31	9.23	9.19	9.20	9.20
	BF	0.00	0.15	0.08	0.07	0.08	0.21	0.39	0.00	0.13	0.08	0.08	0.09	0.26	0.45	0.00	0.11	0.08	0.08	0.13	0.32	0.49	0.00	0.10	0.08	0.08	0.25	0.42	0.57
	TC	133.9	125.2	116.5	106.4	96.8	93.9	93.7	136.6	128.0	119.3	109.0	100.0	98.9	98.8	137.7	129.6	121.4	111.0	103.6	103.1	103.0	141.0	131.5	123.6	113.7	109.9	109.8	109.7
125	SHC	34.8	47.8	60.7	76.4	91.1	93.9	93.7	35.0	50.1	65.1	83.4	97.7	98.9	98.8	34.9	52.2	69.3	90.1	102.5	103.1	103.0	35.3	56.1	77.5	102.6	109.9	109.8	109.7
	kW	10.49	10.43	10.36	10.28	10.19	10.17	10.17	10.51	10.45	10.38	10.30	10.22	10.23	10.22	10.50	10.45	10.40	10.32	10.26	10.26	10.26	10.54	10.46	10.41	10.34	10.32	10.32	10.32
	BF	0.00	0.11	0.07	0.06	0.07	0.25	0.44	0.00	0.09	0.07	0.06	0.12	0.32	0.49	0.00	0.09	0.07	0.06	0.19	0.38	0.54	0.00	0.08	0.07	0.08	0.30	0.47	0.61

LEGEND

- BF — Bypass Factor
- Edb — Entering Dry-Bulb
- Ewb — Entering Wet-Bulb
- kW — Compressor Motor Power Input
- ldb — Leaving Dry-Bulb
- lwb — Leaving Wet-Bulb
- SHC — Sensible Heat Capacity (1000 Btuh) Gross
- TC — Total Capacity (1000 Btuh) Gross

NOTES:

1. Direct interpolation is permissible. Do not extrapolate.
2. The following formulas may be used:

$$t_{ldb} = t_{edb} - \frac{\text{sensible capacity (Btuh)}}{1.10 \times \text{cfm}}$$

$$t_{lwb} = \text{Wet-bulb temperature corresponding to enthalpy of air leaving evaporator coil } (h_{lwb})$$

$$h_{lwb} = h_{ewb} - \frac{\text{total capacity (Btuh)}}{4.5 \times \text{cfm}}$$

Where:  $h_{ewb}$  = Enthalpy of air entering evaporator coil

3. The SHC is based on 80 F edb temperature of air entering evaporator coil. Below 80 F edb, subtract (corr factor x cfm) from SHC. Above 80 F edb, add (corr factor x cfm) to SHC.

BYPASS FACTOR (BF)	ENTERING AIR DRY-BULB TEMP (F)					
	79	78	77	76	75	under 75
	81	82	83	84	85	over 85
	Correction Factor					
.05	1.04	2.07	3.11	4.14	5.18	Use formula shown below.
.10	.98	1.96	2.94	3.92	4.90	
.20	.87	1.74	2.62	3.49	4.36	
.30	.76	1.53	2.29	3.05	3.82	

Interpolation is permissible.  
Correction Factor =  $1.09 \times (1 - BF) \times (edb - 80)$ .

4. Cooling capacities for 48PG03-16 units with Humidi-Mizer system in Cooling mode are the same as standard units.



### COOLING CAPACITIES (cont)

#### 48PG12 (10 Tons) — UNIT WITH HUMIDI-MIZER™ SYSTEM IN SUBCOOLING MODE

Temp (F) Air Ent Condenser (Edb)		Air Entering Evaporator — CFM													
		3000						4000							
		Air Entering Evaporator — Ewb (F)													
		80	76	72	67	62	57	54	80	76	72	67	62	57	54
75	TC	149.0	139.0	128.9	116.3	103.7	91.1	83.5	176.9	163.6	150.3	133.7	117.0	100.4	90.4
	SHC	36.7	49.2	61.6	77.2	92.7	91.1	83.5	47.4	59.7	72.0	87.4	102.9	100.4	90.4
	kW	6.34	6.34	6.26	6.22	6.17	6.12	6.09	6.34	6.34	6.26	6.22	6.17	6.12	6.09
85	TC	140.1	131.0	121.9	110.6	99.2	87.8	81.0	160.8	149.0	137.1	122.3	107.5	92.7	83.8
	SHC	17.0	32.3	47.7	66.8	86.0	105.2	116.7	28.4	43.6	58.9	77.9	97.0	116.0	127.5
	kW	7.33	7.33	7.23	7.16	7.10	7.04	7.00	7.33	7.33	7.23	7.16	7.10	7.04	7.00
95	TC	131.1	123.0	114.9	104.8	94.7	84.6	78.6	144.7	134.3	123.9	110.9	97.9	85.0	77.2
	SHC	-2.7	15.5	33.7	56.5	79.3	84.6	78.6	9.4	27.6	45.7	68.4	91.1	85.0	77.2
	kW	8.32	8.32	8.19	8.11	8.03	7.95	7.90	8.32	8.32	8.19	8.11	8.03	7.95	7.90
105	TC	122.1	115.1	108.0	99.1	90.3	81.4	76.1	128.6	119.7	110.7	99.6	88.4	77.2	70.5
	SHC	-22.5	-1.4	19.8	46.1	72.5	81.4	76.1	-9.5	11.5	32.6	58.9	85.2	77.2	70.5
	kW	9.31	9.31	9.16	9.06	8.96	8.87	8.81	9.31	9.31	9.16	9.06	8.96	8.87	8.81
115	TC	113.2	107.1	101.0	93.4	85.8	78.2	73.6	112.5	105.0	97.6	88.2	78.9	69.5	63.9
	SHC	-42.2	-18.2	5.8	35.8	65.8	78.2	73.6	-28.5	-4.5	19.5	49.4	78.9	69.5	63.9
	kW	10.30	10.30	10.12	10.01	9.90	9.78	9.71	10.30	10.30	10.12	10.01	9.90	9.78	9.71
125	TC	104.2	99.1	94.0	87.7	81.3	75.0	71.2	96.4	90.4	84.4	76.9	69.4	61.8	57.3
	SHC	-62.0	-35.1	-8.2	25.5	59.1	75.0	71.2	-47.4	-20.6	6.3	39.9	69.4	61.8	57.3
	kW	11.29	11.29	11.09	10.96	10.83	10.70	10.62	11.29	11.29	11.09	10.96	10.83	10.70	10.62

#### 48PG12 (10 Tons) — UNIT WITH HUMIDI-MIZER SYSTEM IN SUBCOOLING MODE (cont)

Temp (F) Air Ent Condenser (Edb)		Air Entering Evaporator — CFM						
		5000						
		Air Entering Evaporator — Ewb (F)						
		80	76	72	67	62	57	54
75	TC	205.8	189.1	172.5	151.6	130.8	110.0	97.5
	SHC	55.9	68.1	80.3	95.6	110.9	110.0	97.5
	kW	6.34	6.34	6.26	6.22	6.17	6.12	6.09
85	TC	182.3	167.6	152.9	134.5	116.0	97.6	86.6
	SHC	37.5	52.7	67.9	86.8	105.8	124.7	136.1
	kW	7.33	7.33	7.23	7.16	7.10	7.04	7.00
95	TC	158.8	146.0	133.2	117.3	101.3	85.3	75.7
	SHC	19.2	37.3	55.4	78.0	100.6	85.3	75.7
	kW	8.32	8.32	8.19	8.11	8.03	7.95	7.90
105	TC	135.3	124.5	113.6	100.1	86.5	72.9	64.8
	SHC	0.9	21.9	42.9	69.1	86.5	72.9	64.8
	kW	9.31	9.31	9.16	9.06	8.96	8.87	8.81
115	TC	111.8	102.9	94.0	82.9	71.7	60.6	53.9
	SHC	-17.5	6.5	30.4	60.3	71.7	60.6	53.9
	kW	10.30	10.30	10.12	10.01	9.90	9.78	9.71
125	TC	88.3	81.4	74.4	65.7	57.0	48.2	43.0
	SHC	-35.8	-8.9	17.9	51.4	57.0	48.2	43.0
	kW	11.29	11.29	11.09	10.96	10.83	10.70	10.62

**LEGEND**

- Edb** — Entering Dry-Bulb
- Ewb** — Entering Wet-Bulb
- kW** — Compressor Motor Power Input
- ldb** — Leaving Dry-Bulb
- lwb** — Leaving Wet-Bulb
- SHC** — Sensible Heat Capacity (1000 Btu/h) Gross
- TC** — Total Capacity (1000 Btu/h) Gross

**NOTES:**

1. Direct interpolation is permissible. Do not extrapolate.
2. The following formulas may be used:

$$t_{ldb} = t_{edb} - \frac{\text{sensible capacity (Btu/h)}}{1.10 \times \text{cfm}}$$

$$t_{lwb} = \text{Wet-bulb temperature corresponding to enthalpy of air leaving evaporator coil } (h_{lwb})$$

$$h_{lwb} = h_{ewb} - \frac{\text{total capacity (Btu/h)}}{4.5 \times \text{cfm}}$$

Where:  $h_{ewb}$  = Enthalpy of air entering evaporator coil

# Performance data (cont)



## COOLING CAPACITIES (cont)

### 48PG12 (10 Tons) — UNIT WITH HUMIDI-MIZER™ SYSTEM IN HOT GAS REHEAT MODE (CIRCUIT A ONLY)

Temp (F) Air Ent Condenser (Edb)		Air Entering Evaporator — Ewb (F)								
		75 Dry Bulb 62.5 Wet Bulb (50% RH)			75 Dry Bulb 64 Wet Bulb (55% RH)			75 Dry Bulb 65.3 Wet Bulb (60% RH)		
		Air Entering Evaporator — Cfm								
		3500	4000	4500	3500	4000	4500	3500	4000	4500
50	TC	27.7	30.4	32.8	29.7	32.5	34.9	31.4	34.3	36.8
	SHC	12.1	12.1	12.1	8.6	8.6	8.6	5.5	5.5	5.5
	kW	3.11	3.11	3.11	3.10	3.10	3.10	3.08	3.08	3.08
40	TC	27.6	29.8	31.7	29.3	31.6	33.5	30.8	33.1	35.1
	SHC	9.8	9.8	9.8	7.0	7.0	7.0	4.5	4.5	4.5
	kW	3.16	3.16	3.16	3.17	3.17	3.17	3.17	3.17	3.17
30	TC	27.5	29.1	30.6	28.9	30.6	32.1	30.2	31.9	33.4
	SHC	7.5	7.5	7.5	5.4	5.4	5.4	3.5	3.5	3.5
	kW	3.21	3.21	3.21	3.23	3.23	3.23	3.25	3.25	3.25

### 48PG12 (10 Tons) — UNIT WITH HUMIDI-MIZER SYSTEM IN HOT GAS REHEAT MODE (ALL CIRCUITS)

Temp (F) Air Ent Condenser (Edb)		Air Entering Evaporator — Ewb (F)								
		75 Dry Bulb 62.5 Wet Bulb (50% RH)			75 Dry Bulb 64 Wet Bulb (55% RH)			75 Dry Bulb 65.3 Wet Bulb (60% RH)		
		Air Entering Evaporator — Cfm								
		3500	4000	4500	3500	4000	4500	3500	4000	4500
80	TC	49.3	50.8	52.1	52.0	53.6	55.0	54.5	56.0	57.5
	SHC	13.4	17.1	20.4	6.9	10.4	13.6	1.2	4.7	7.8
	kW	6.10	6.10	6.10	6.12	6.12	6.12	6.14	6.14	6.14
75	TC	51.2	52.6	54.0	53.9	55.4	56.8	56.3	57.8	59.2
	SHC	14.7	18.2	21.4	8.7	12.1	15.2	3.4	6.7	9.7
	kW	6.02	6.02	6.02	6.04	6.04	6.04	6.06	6.06	6.06
70	TC	53.1	54.5	55.8	55.7	57.2	58.6	58.1	59.6	61.0
	SHC	16.0	19.4	22.5	10.4	13.7	16.7	5.6	8.8	11.7
	kW	5.94	5.94	5.94	5.97	5.97	5.97	5.99	5.99	5.99
60	TC	56.9	58.3	59.5	59.4	60.9	62.2	61.7	63.1	64.5
	SHC	18.7	21.8	24.6	14.0	17.0	19.7	10.0	12.9	15.5
	kW	5.77	5.77	5.77	5.81	5.81	5.81	5.85	5.85	5.85
50	TC	60.7	62.0	63.3	63.1	64.5	65.8	65.3	66.7	68.0
	SHC	21.3	24.1	26.6	17.6	20.3	22.7	14.3	17.0	19.4
	kW	5.61	5.61	5.61	5.66	5.66	5.66	5.70	5.70	5.70

#### LEGEND

**Edb** — Entering Dry-Bulb  
**Ewb** — Entering Wet-Bulb  
**kW** — Compressor Motor Power Input  
**ldb** — Leaving Dry-Bulb  
**lwb** — Leaving Wet-Bulb  
**RH** — Relative Humidity  
**SHC** — Sensible Heat Capacity (1000 Btuh) Gross  
**TC** — Total Capacity (1000 Btuh) Gross

#### NOTES:

- Direct interpolation is permissible. Do not extrapolate.
- The following formulas may be used:

$$t_{ldb} = t_{edb} - \frac{\text{sensible capacity (Btuh)}}{1.10 \times \text{cfm}}$$

$t_{lwb}$  = Wet-bulb temperature corresponding to enthalpy of air leaving evaporator coil ( $h_{lwb}$ )

$$h_{lwb} = h_{ewb} - \frac{\text{total capacity (Btuh)}}{4.5 \times \text{cfm}}$$

Where:  $h_{ewb}$  = Enthalpy of air entering evaporator coil



### COOLING CAPACITIES (cont)

#### 48PG14 (12 1/2 Tons) — STANDARD UNIT AND UNIT WITH HUMIDI-MIZER™ SYSTEM IN COOLING MODE

Temp (F) Air Ent Condenser (Edb)	Air Entering Evaporator — Cfm																					
	3750							4375							5000							
	Air Entering Evaporator — Ewb (F)																					
	80	76	72	67	62	58	54	80	76	72	67	62	58	54	80	76	72	67	62	58	54	
60	TC	215.9	202.7	187.9	171.5	156.2	145.7	141.5	224.4	210.3	195.7	178.2	162.7	153.2	151.1	229.5	215.9	201.0	183.7	167.7	158.4	157.1
	SHC	58.5	74.4	88.7	106.6	124.1	136.3	140.3	60.0	76.8	95.3	115.4	135.8	146.7	149.9	60.5	80.8	100.6	124.1	146.6	152.9	155.9
	kW BF	7.52 0.00	7.35 0.00	7.14 0.09	6.93 0.19	6.69 0.19	6.55 0.19	6.50 0.33	7.66	7.46 0.00	7.25 0.00	7.02 0.18	6.80 0.17	6.67 0.23	6.63 0.39	7.77 0.00	7.54 0.00	7.34 0.18	7.10 0.17	6.87 0.17	6.74 0.30	6.74 0.44
70	TC	205.9	196.4	182.8	166.6	152.1	142.0	137.6	214.9	203.1	189.2	172.9	157.5	148.1	146.1	219.9	208.0	194.0	177.5	161.8	154.3	152.9
	SHC	55.3	71.9	87.2	105.1	122.8	135.1	136.4	57.0	74.9	92.6	113.8	133.9	142.4	144.9	57.6	78.1	98.1	122.3	143.9	148.5	151.7
	kW BF	8.69 0.00	8.32 0.00	8.12 0.22	7.88 0.17	7.67 0.16	7.51 0.18	7.45 0.35	8.79	8.43 0.00	8.22 0.19	7.98 0.16	7.75 0.16	7.60 0.25	7.58 0.41	8.90 0.00	8.50 0.13	8.29 0.17	8.04 0.15	7.81 0.17	7.71 0.32	7.68 0.46
75	TC	200.9	193.4	179.8	163.4	149.3	138.5	136.8	210.2	199.3	185.9	169.9	154.9	144.8	145.1	215.1	204.2	190.8	174.6	159.4	152.4	151.0
	SHC	53.7	70.9	86.2	103.3	121.3	129.4	135.6	55.5	73.8	91.8	112.9	133.2	139.1	143.9	56.1	77.0	97.1	121.3	143.3	146.5	149.8
	kW BF	9.27 0.00	8.83 0.00	8.63 0.20	8.39 0.18	8.17 0.16	8.01 0.23	7.97 0.35	9.36	8.93 0.00	8.73 0.17	8.49 0.15	8.26 0.15	8.11 0.27	8.10 0.41	9.47 0.00	9.01 0.11	8.81 0.16	8.56 0.15	8.33 0.16	8.23 0.33	8.21 0.46
85	TC	190.9	186.3	173.0	158.0	144.0	134.5	132.3	200.6	191.5	178.9	163.4	149.1	140.7	141.0	205.4	195.7	182.8	167.3	153.2	147.3	146.8
	SHC	50.5	67.9	83.6	101.9	119.5	126.6	131.1	52.5	71.3	89.4	110.5	130.9	135.9	139.8	53.2	74.3	94.5	118.8	140.8	146.1	145.6
	kW BF	10.43 0.00	9.94 0.00	9.72 0.18	9.48 0.15	9.25 0.14	9.09 0.24	9.15 0.37	10.49	10.02 0.00	9.82 0.15	9.57 0.14	9.34 0.14	9.20 0.28	9.20 0.43	10.60 0.00	10.09 0.24	9.88 0.15	9.63 0.14	9.41 0.16	9.32 0.30	9.31 0.48
95	TC	180.9	177.7	165.9	151.5	138.1	128.8	127.7	191.1	182.8	170.5	156.0	142.7	135.8	135.4	195.8	184.8	174.2	159.9	146.2	142.2	141.8
	SHC	47.4	65.3	81.0	99.5	117.3	124.2	126.5	49.5	68.5	86.4	107.9	128.0	134.6	134.2	50.2	70.9	91.5	116.1	137.2	141.0	140.6
	kW BF	11.59 0.00	11.10 0.00	10.90 0.16	10.65 0.14	10.42 0.13	10.26 0.23	10.33 0.39	11.63	11.19 0.00	10.98 0.15	10.73 0.13	10.51 0.14	10.39 0.26	10.38 0.45	11.73 0.00	11.35 0.21	11.05 0.14	10.81 0.13	10.57 0.16	10.50 0.32	10.50 0.49
105	TC	170.9	162.4	157.2	143.8	131.3	124.3	123.2	181.6	171.8	161.6	148.3	135.5	130.5	130.4	186.2	174.0	163.4	151.1	138.3	136.3	136.0
	SHC	44.2	72.4	77.9	96.6	114.5	119.7	122.0	46.5	65.1	83.3	105.0	124.7	129.3	129.2	47.3	67.6	88.4	112.9	132.1	136.1	134.8
	kW BF	12.75 0.00	12.24 0.14	12.14 0.14	11.90 0.13	11.66 0.13	11.54 0.26	11.51 0.41	12.76	12.49 0.00	12.22 0.11	11.99 0.12	11.75 0.14	11.66 0.29	11.65 0.47	12.86 0.00	12.62 0.18	12.35 0.12	12.04 0.13	11.81 0.18	11.77 0.35	11.76 0.51
115	TC	160.9	147.8	139.9	135.3	123.8	117.8	118.0	172.1	160.7	150.6	138.2	127.0	124.6	124.4	176.6	163.1	152.6	131.6	130.9	129.8	129.7
	SHC	41.0	77.8	88.3	93.4	111.1	116.6	116.8	43.6	61.7	79.8	101.4	120.9	123.4	123.2	44.3	64.2	85.3	123.4	124.9	128.6	128.5
	kW BF	13.91 0.00	13.48 0.10	13.32 0.10	13.22 0.11	13.00 0.12	12.86 0.25	12.87 0.44	13.90	13.80 0.00	13.57 0.11	13.33 0.12	13.06 0.14	13.01 0.32	13.01 0.49	14.00 0.00	13.89 0.15	13.65 0.10	13.16 0.11	13.14 0.22	13.12 0.38	13.11 0.54
125	TC	150.9	144.5	135.2	141.7	114.1	108.5	108.2	159.6	149.6	139.6	128.1	118.7	116.7	116.5	158.6	152.2	141.8	121.3	121.1	120.7	120.6
	SHC	37.8	53.0	64.8	58.4	104.2	107.3	107.0	39.8	58.3	76.4	97.7	113.4	115.5	115.3	39.1	60.9	82.2	117.4	118.0	119.5	119.4
	kW BF	15.07 0.00	15.00 0.10	14.83 0.13	15.01 0.14	14.33 0.06	14.32 0.24	14.20 0.43	15.27	15.10 0.00	14.91 0.09	14.68 0.11	14.46 0.19	14.44 0.36	14.42 0.52	15.23 0.00	15.15 0.11	14.95 0.07	14.51 0.09	14.52 0.25	14.50 0.42	14.53 0.57

#### LEGEND

- BF — Bypass Factor
- Edb — Entering Dry-Bulb
- Ewb — Entering Wet-Bulb
- kW — Compressor Motor Power Input
- ldb — Leaving Dry-Bulb
- lwb — Leaving Wet-Bulb
- SHC — Sensible Heat Capacity (1000 Btuh) Gross
- TC — Total Capacity (1000 Btuh) Gross

#### NOTES:

- Direct interpolation is permissible. Do not extrapolate.
- The following formulas may be used:

$$t_{ldb} = t_{edb} - \frac{\text{sensible capacity (Btuh)}}{1.10 \times \text{cfm}}$$

$t_{lwb}$  = Wet-bulb temperature corresponding to enthalpy of air leaving evaporator coil ( $h_{lwb}$ )

$$h_{lwb} = h_{ewb} - \frac{\text{total capacity (Btuh)}}{4.5 \times \text{cfm}}$$

Where:  $h_{ewb}$  = Enthalpy of air entering evaporator coil

- The SHC is based on 80 F edb temperature of air entering evaporator coil. Below 80 F edb, subtract (corr factor x cfm) from SHC. Above 80 F edb, add (corr factor x cfm) to SHC.

BYPASS FACTOR (BF)	ENTERING AIR DRY-BULB TEMP (F)					
	79	78	77	76	75	under 75
	81	82	83	84	85	over 85
	Correction Factor					
.05	1.04	2.07	3.11	4.14	5.18	Use formula shown below.
.10	.98	1.96	2.94	3.92	4.90	
.20	.87	1.74	2.62	3.49	4.36	
.30	.76	1.53	2.29	3.05	3.82	

Interpolation is permissible.

$$\text{Correction Factor} = 1.09 \times (1 - \text{BF}) \times (\text{edb} - 80).$$

- Cooling capacities for 48PG03-16 units with Humidi-MiZer system in Cooling mode are the same as standard units.

#### 48PG14 (12 1/2 Tons) — STANDARD UNIT AND UNIT WITH HUMIDI-MIZER SYSTEM IN COOLING MODE (cont)

Temp (F) Air Ent Condenser (Edb)	Air Entering Evaporator — Cfm							
	6250							
	Air Entering Evaporator — Ewb (F)							
	80	76	72	67	62	58	54	
60	TC	238.1	223.0	208.4	191.0	175.0	169.4	169.6
	SHC	61.7	86.2	110.7	140.2	163.5	168.2	168.4
	kW BF	7.88 0.00	7.66 0.23	7.45 0.17	7.20 0.16	6.98 0.21	6.93 0.36	6.91 0.52
70	TC	228.4	215.2	201.0	184.3	169.0	165.5	165.6
	SHC	58.8	83.7	108.3	138.2	159.4	164.3	164.4
	kW BF	8.97 0.00	8.61 0.21	8.40 0.16	8.15 0.15	7.93 0.22	7.89 0.37	7.88 0.53
75	TC	223.5	211.1	197.1	181.0	165.8	163.1	162.7
	SHC	57.4	82.5	107.1	137.0	158.2	161.9	161.5
	kW BF	9.52 0.00	9.12 0.20	8.91 0.16	8.67 0.15	8.43 0.22	8.40 0.38	8.40 0.54
85	TC	213.8	200.7	188.7	173.3	159.7	157.9	157.5
	SHC	54.5	79.5	104.3	134.3	151.8	156.7	156.3
	kW BF	10.61 0.00	10.31 0.18	9.98 0.15	9.74 0.15	9.52 0.25	9.50 0.40	9.49 0.55
95	TC	204.1	190.2	179.6	164.5	153.3	151.9	151.8
	SHC	51.7	76.6	101.2	131.2	146.1	150.7	150.6
	kW BF	11.71 0.00	11.50 0.15	11.15 0.15	10.89 0.14	10.70 0.28	10.68 0.42	10.67 0.57
105	TC	194.4	179.8	168.2	154.1	141.0	145.4	145.2
	SHC	48.8	73.6	97.8	127.5	141.0	144.2	144.0
	kW BF	12.80 0.00	12.69 0.13	12.44 0.14	12.20 0.14	11.96 0.30	11.94 0.45	11.94 0.59
115	TC	181.4	169.4	156.7	143.7	138.0	137.8	137.7
	SHC	45.0	70.7	94.3	123.7	136.8	136.6	136.5
	kW BF	14.10 0.00	13.88 0.10	13.74 0.12	13.50 0.13	13.30 0.30	13.29 0.48	13.28 0.61
125	TC	161.8	158.6	145.3	133.3	128.5	128.3	125.3
	SHC	39.4	66.8	90.8	120.0	127.3	127.1	131.6
	kW BF	15.30 0.00	15.27 0.12	15.03 0.11	14.80 0.13	14.70 0.35	14.71 0.51	14.64 0.09

# Performance data (cont)



## COOLING CAPACITIES (cont)

### 48PG14 (12<sup>1</sup>/<sub>2</sub> Tons) — UNIT WITH HUMIDI-MIZER™ SYSTEM IN SUBCOOLING MODE

Temp (F) Air Ent Condenser (Edb)		Air Entering Evaporator — CFM													
		3750						5000							
		Air Entering Evaporator — Ewb (F)													
		80	76	72	67	62	57	54	80	76	72	67	62	57	54
75	TC	191.8	179.8	167.9	152.9	138.0	123.0	114.0	223.0	207.7	192.4	173.2	154.1	134.9	123.4
	SHC	46.4	61.5	76.6	95.4	114.3	123.0	114.0	61.8	76.8	91.8	110.5	129.2	134.9	123.4
	kW	9.28	9.28	8.97	8.77	8.58	8.38	8.27	9.28	9.28	8.97	8.77	8.58	8.38	8.27
85	TC	179.9	169.7	159.5	146.7	134.0	121.3	113.6	200.5	187.9	175.2	159.4	143.6	127.7	118.2
	SHC	23.2	41.7	60.3	83.5	106.8	130.0	143.9	39.7	58.2	76.6	99.7	122.8	145.9	159.8
	kW	10.40	10.40	10.05	9.84	9.63	9.41	9.28	10.40	10.40	10.05	9.84	9.63	9.41	9.28
95	TC	167.9	159.5	151.1	140.6	130.1	119.6	113.3	178.1	168.1	158.1	145.6	133.1	120.6	113.1
	SHC	-0.1	22.0	44.1	71.6	99.2	119.6	113.3	17.6	39.5	61.5	89.0	116.5	120.6	113.1
	kW	11.51	11.51	11.14	10.91	10.67	10.44	10.30	11.51	11.51	11.14	10.91	10.67	10.44	10.30
105	TC	156.0	149.3	142.7	134.4	126.1	117.9	112.9	155.6	148.2	140.9	131.7	122.6	113.4	107.9
	SHC	-23.3	2.3	27.8	59.7	91.7	117.9	112.9	-4.6	20.9	46.4	78.3	110.2	113.4	107.9
	kW	12.63	12.63	12.22	11.97	11.72	11.46	11.31	12.63	12.63	12.22	11.97	11.72	11.46	11.31
115	TC	144.0	139.2	134.3	128.3	122.2	116.1	112.5	133.1	128.4	123.7	117.9	112.1	106.3	102.8
	SHC	-46.5	-17.5	11.6	47.8	84.1	116.1	112.5	-26.7	2.3	31.3	67.6	103.9	106.3	102.8
	kW	13.75	13.75	13.31	13.04	12.76	12.49	12.33	13.75	13.75	13.31	13.04	12.76	12.49	12.33
125	TC	132.1	129.0	125.9	122.1	118.3	114.4	112.1	110.6	108.6	106.6	104.1	101.6	99.1	97.6
	SHC	-69.7	-37.2	-4.7	35.9	76.6	114.4	112.1	-48.8	-16.3	16.2	56.9	97.5	99.1	97.6
	kW	14.86	14.86	14.39	14.10	13.81	13.52	13.34	14.86	14.86	14.39	14.10	13.81	13.52	13.34

### 48PG14 (12<sup>1</sup>/<sub>2</sub> Tons) — UNIT WITH HUMIDI-MIZER SYSTEM IN SUBCOOLING MODE (cont)

Temp (F) Air Ent Condenser (Edb)		Air Entering Evaporator — CFM						
		6250						
		Air Entering Evaporator — Ewb (F)						
		80	76	72	67	62	57	54
75	TC	255.7	236.8	218.0	194.4	170.9	147.3	133.2
	SHC	74.3	89.1	104.0	122.6	141.1	147.3	133.2
	kW	9.28	9.28	8.97	8.77	8.58	8.38	8.27
85	TC	222.2	206.9	191.7	172.6	153.5	134.5	123.0
	SHC	53.0	71.4	89.8	112.8	135.8	158.8	172.6
	kW	10.40	10.40	10.05	9.84	9.63	9.41	9.28
95	TC	188.6	177.0	165.3	150.8	136.2	121.6	112.9
	SHC	31.7	53.7	75.6	103.0	130.4	121.6	112.9
	kW	11.51	11.51	11.14	10.91	10.67	10.44	10.30
105	TC	155.1	147.1	139.0	128.9	118.9	108.8	102.7
	SHC	10.5	35.9	61.4	93.3	118.9	108.8	102.7
	kW	12.63	12.63	12.22	11.97	11.72	11.46	11.31
115	TC	121.6	117.2	112.7	107.1	101.5	96.0	92.6
	SHC	-10.8	18.2	47.2	83.5	101.5	96.0	92.6
	kW	13.75	13.75	13.31	13.04	12.76	12.49	12.33
125	TC	88.1	87.2	86.4	85.3	84.2	83.1	82.5
	SHC	-32.1	0.5	33.0	73.7	84.2	83.1	82.5
	kW	14.86	14.86	14.39	14.10	13.81	13.52	13.34

#### LEGEND

**Edb** — Entering Dry-Bulb  
**Ewb** — Entering Wet-Bulb  
**kW** — Compressor Motor Power Input  
**ldb** — Leaving Dry-Bulb  
**lwb** — Leaving Wet-Bulb  
**SHC** — Sensible Heat Capacity (1000 Btu/h) Gross  
**TC** — Total Capacity (1000 Btu/h) Gross

#### NOTES:

- Direct interpolation is permissible. Do not extrapolate.
- The following formulas may be used:

$$t_{ldb} = t_{edb} - \frac{\text{sensible capacity (Btu/h)}}{1.10 \times \text{cfm}}$$

$t_{lwb}$  = Wet-bulb temperature corresponding to enthalpy of air leaving evaporator coil ( $h_{lwb}$ )

$$h_{lwb} = h_{ewb} - \frac{\text{total capacity (Btu/h)}}{4.5 \times \text{cfm}}$$

Where:  $h_{ewb}$  = Enthalpy of air entering evaporator coil



**COOLING CAPACITIES (cont)**

**48PG14 (12½ Tons) — UNIT WITH HUMIDI-MIZER™ SYSTEM IN HOT GAS REHEAT MODE (CIRCUIT A ONLY)**

Temp (F) Air Ent Condenser (Edb)		Air Entering Evaporator — Ewb (F)								
		75 Dry Bulb 62.5 Wet Bulb (50% RH)			75 Dry Bulb 64 Wet Bulb (55% RH)			75 Dry Bulb 65.3 Wet Bulb (60% RH)		
		Air Entering Evaporator — Cfm								
		4375	5000	5625	4375	5000	5625	4375	5000	5625
50	TC	33.8	36.6	39.1	34.0	36.8	39.4	34.1	37.0	39.6
	SHC	14.8	14.8	14.8	9.0	9.0	9.0	3.9	3.9	3.9
	kW	4.57	4.57	4.57	4.59	4.59	4.59	4.61	4.61	4.61
40	TC	35.4	37.7	39.8	35.7	38.1	40.2	36.0	38.4	40.5
	SHC	14.2	14.2	14.2	9.6	9.6	9.6	5.6	5.6	5.6
	kW	4.61	4.61	4.61	4.65	4.65	4.65	4.68	4.68	4.68
30	TC	37.0	38.8	40.4	37.5	39.4	41.0	38.0	39.8	41.4
	SHC	13.5	13.5	13.5	10.1	10.1	10.1	7.2	7.2	7.2
	kW	4.65	4.65	4.65	4.70	4.70	4.70	4.75	4.75	4.75

**48PG14 (12½ Tons) — UNIT WITH HUMIDI-MIZER SYSTEM IN HOT GAS REHEAT MODE (ALL CIRCUITS)**

Temp (F) Air Ent Condenser (Edb)		Air Entering Evaporator — Ewb (F)								
		75 Dry Bulb 62.5 Wet Bulb (50% RH)			75 Dry Bulb 64 Wet Bulb (55% RH)			75 Dry Bulb 65.3 Wet Bulb (60% RH)		
		Air Entering Evaporator — Cfm								
		4375	5000	5625	4375	5000	5625	4375	5000	5625
80	TC	65.0	67.5	69.7	67.2	69.7	72.0	69.1	71.7	74.0
	SHC	20.6	26.5	31.9	10.7	16.4	21.5	2.1	7.6	12.6
	kW	8.61	8.61	8.61	8.67	8.67	8.67	8.72	8.72	8.72
75	TC	66.8	69.2	71.4	69.0	71.5	73.7	70.9	73.4	75.7
	SHC	22.0	27.6	32.8	12.8	18.2	23.2	4.8	10.0	14.8
	kW	8.55	8.55	8.55	8.62	8.62	8.62	8.68	8.68	8.68
70	TC	68.6	71.0	73.1	70.8	73.3	75.4	72.7	75.2	77.4
	SHC	23.4	28.8	33.8	14.9	20.1	24.8	7.5	12.5	17.1
	kW	8.49	8.49	8.49	8.57	8.57	8.57	8.64	8.64	8.64
60	TC	72.3	74.5	76.5	74.5	76.8	78.9	76.4	78.7	80.9
	SHC	26.2	31.1	35.6	19.1	23.8	28.1	12.9	17.4	21.6
	kW	8.38	8.38	8.38	8.47	8.47	8.47	8.55	8.55	8.55
50	TC	75.9	78.1	80.0	78.1	80.3	82.3	80.1	82.3	84.3
	SHC	29.0	33.4	37.5	23.2	27.5	31.4	18.2	22.4	26.2
	kW	8.26	8.26	8.26	8.37	8.37	8.37	8.46	8.46	8.46

**LEGEND**

- Edb** — Entering Dry-Bulb
- Ewb** — Entering Wet-Bulb
- kW** — Compressor Motor Power Input
- ldb** — Leaving Dry-Bulb
- lwb** — Leaving Wet-Bulb
- RH** — Relative Humidity
- SHC** — Sensible Heat Capacity (1000 Btuh) Gross
- TC** — Total Capacity (1000 Btuh) Gross

**NOTES:**

1. Direct interpolation is permissible. Do not extrapolate.
2. The following formulas may be used:

$$t_{ldb} = t_{edb} - \frac{\text{sensible capacity (Btuh)}}{1.10 \times \text{cfm}}$$

$$t_{lwb} = \text{Wet-bulb temperature corresponding to enthalpy of air leaving evaporator coil } (h_{lwb})$$

$$h_{lwb} = h_{ewb} - \frac{\text{total capacity (Btuh)}}{4.5 \times \text{cfm}}$$

Where:  $h_{ewb}$  = Enthalpy of air entering evaporator coil

# Performance data (cont)



## COOLING CAPACITIES (cont)

48PG16 (15 Tons) — STANDARD UNIT AND UNIT WITH HUMIDI-MIZER™ SYSTEM IN COOLING MODE

Temp (F) Air Ent Condenser (Edb)		Air Entering Evaporator — Cfm													
		4500						5250							
		Air Entering Evaporator — Ewb (F)													
		80	76	72	67	62	58	54	80	76	72	67	62	58	54
60	TC	265.1	247.6	230.2	210.2	192.2	178.3	175.3	276.7	257.1	239.0	218.7	199.1	186.1	185.0
	SHC	73.4	91.5	109.5	132.7	156.9	172.5	175.3	74.1	93.8	116.9	144.4	170.6	184.9	185.0
	kW	8.72	8.60	8.47	8.35	8.19	8.10	8.07	8.80	8.68	8.55	8.39	8.25	8.15	8.16
	BF	0.00	0.00	0.24	0.14	0.10	0.12	0.30	0.00	0.00	0.18	0.12	0.11	0.17	0.37
70	TC	257.4	240.4	223.6	204.0	185.5	172.1	170.9	266.7	248.8	231.7	211.0	192.5	180.9	180.2
	SHC	62.0	88.6	107.4	131.3	153.8	167.6	170.9	71.8	91.1	115.2	141.6	168.5	178.4	180.2
	kW	9.92	9.78	9.65	9.48	9.35	9.25	9.23	9.98	9.86	9.70	9.55	9.40	9.31	9.30
	BF	0.00	0.00	0.19	0.11	0.10	0.14	0.32	0.00	0.00	0.14	0.11	0.10	0.20	0.39
75	TC	252.7	236.3	219.4	200.1	182.4	169.1	167.6	266.6	244.3	227.1	207.1	188.8	178.1	177.2
	SHC	68.7	87.1	106.0	129.5	153.0	166.8	167.6	71.8	90.6	113.6	140.4	167.0	176.0	177.2
	kW	10.55	10.41	10.27	10.12	9.96	9.86	9.85	10.66	10.48	10.33	10.17	10.01	9.94	9.93
	BF	0.00	0.00	0.17	0.11	0.09	0.13	0.33	0.00	0.00	0.13	0.11	0.09	0.21	0.40
85	TC	243.4	227.3	211.1	192.2	175.1	163.5	162.8	256.3	234.0	217.4	198.6	180.8	172.5	172.3
	SHC	65.6	83.6	103.3	126.8	150.0	163.4	162.8	68.4	87.8	110.2	137.4	163.5	172.5	172.3
	kW	11.89	11.76	11.61	11.45	11.30	11.19	11.19	12.01	11.81	11.67	11.51	11.35	11.28	11.28
	BF	0.00	0.00	0.13	0.09	0.08	0.13	0.35	0.00	0.07	0.12	0.10	0.09	0.22	0.41
95	TC	232.1	216.8	201.5	183.6	166.9	157.6	157.5	238.2	222.4	207.0	188.8	171.9	166.3	166.1
	SHC	61.9	79.7	99.9	123.4	146.2	157.6	157.5	62.7	84.2	106.6	133.5	159.4	166.3	166.1
	kW	13.36	13.22	13.09	12.92	12.76	12.67	12.67	13.42	13.28	13.14	12.97	12.81	12.76	12.75
	BF	0.00	0.00	0.11	0.09	0.08	0.16	0.37	0.00	0.23	0.11	0.09	0.09	0.24	0.43
105	TC	219.4	205.0	190.5	173.7	158.0	151.1	150.9	224.6	209.8	195.5	178.5	162.6	159.2	159.0
	SHC	57.8	76.4	95.9	119.4	142.1	151.1	150.9	58.5	80.2	102.4	129.4	154.8	159.2	159.0
	kW	14.94	14.82	14.68	14.52	14.36	14.28	14.28	15.01	14.87	14.73	14.57	14.41	14.37	14.37
	BF	0.00	0.06	0.10	0.08	0.08	0.19	0.40	0.00	0.16	0.10	0.09	0.09	0.27	0.45
115	TC	205.1	191.6	178.4	162.9	148.2	143.7	143.5	209.5	196.1	182.7	167.0	152.6	151.0	150.9
	SHC	53.3	72.2	91.5	114.9	137.5	143.7	143.5	53.8	75.8	97.9	124.9	149.2	151.0	150.9
	kW	16.64	16.52	16.39	16.23	16.08	16.02	16.02	16.70	16.58	16.44	16.28	16.12	16.11	16.11
	BF	0.00	0.18	0.09	0.08	0.08	0.23	0.42	0.00	0.13	0.09	0.08	0.11	0.31	0.48
125	TC	188.7	177.1	164.9	150.5	137.3	135.0	134.9	192.3	180.1	168.5	154.0	141.8	141.6	141.4
	SHC	48.2	67.5	86.6	110.0	132.0	135.0	134.9	48.6	70.7	92.9	119.8	141.8	141.6	141.4
	kW	18.41	18.33	18.21	18.05	17.89	17.87	17.86	18.46	18.36	18.25	18.09	17.95	17.95	17.95
	BF	0.00	0.13	0.08	0.07	0.08	0.28	0.46	0.00	0.11	0.09	0.08	0.13	0.35	0.51

48PG16 (15 Tons) — STANDARD UNIT AND UNIT WITH HUMIDI-MIZER SYSTEM IN COOLING MODE (cont)

Temp (F) Air Ent Condenser (Edb)		Air Entering Evaporator — Cfm													
		6000						7500							
		Air Entering Evaporator — Ewb (F)													
		80	76	72	67	62	58	54	80	76	72	67	62	58	54
60	TC	288.3	267.2	246.2	224.4	205.0	194.8	194.1	295.2	276.6	255.2	233.5	213.5	209.3	208.7
	SHC	74.8	99.6	124.5	154.2	184.2	192.1	194.1	77.9	107.4	137.0	174.3	206.6	209.3	208.7
	kW	8.89	8.74	8.59	8.44	8.29	8.23	8.22	8.96	8.81	8.66	8.50	8.35	8.32	8.32
	BF	0.00	0.00	0.15	0.13	0.11	0.25	0.42	0.00	0.23	0.14	0.13	0.15	0.34	0.50
70	TC	276.9	254.9	237.3	216.8	197.7	189.8	188.9	282.1	263.2	245.5	224.6	205.4	203.1	203.1
	SHC	73.9	96.4	121.6	152.2	181.6	189.8	188.9	73.9	103.5	134.0	171.3	202.2	203.1	203.1
	kW	10.06	9.90	9.75	9.59	9.44	9.37	9.38	10.11	9.96	9.82	9.65	9.51	9.49	9.49
	BF	0.00	0.08	0.13	0.11	0.11	0.25	0.44	0.00	0.19	0.13	0.12	0.16	0.36	0.52
75	TC	273.1	249.9	232.7	212.4	193.8	186.6	186.4	276.0	257.7	240.2	219.7	201.8	200.2	199.9
	SHC	72.7	95.0	120.1	150.7	180.0	186.6	186.4	72.1	101.9	132.3	169.6	198.5	200.2	199.9
	kW	10.70	10.52	10.38	10.21	10.06	10.00	10.00	10.74	10.59	10.44	10.27	10.13	10.12	10.12
	BF	0.00	0.17	0.13	0.11	0.11	0.26	0.44	0.00	0.17	0.13	0.12	0.17	0.37	0.52
85	TC	265.7	238.7	222.4	203.0	185.1	180.5	180.2	263.0	245.7	229.2	209.5	193.9	193.4	193.1
	SHC	70.4	91.5	116.7	147.2	175.8	180.5	180.2	68.2	98.2	128.6	165.7	193.0	193.4	193.1
	kW	12.08	11.86	11.72	11.55	11.39	11.35	11.35	12.08	11.93	11.79	11.61	11.47	11.47	11.47
	BF	0.00	0.20	0.11	0.10	0.11	0.28	0.46	0.00	0.16	0.12	0.12	0.19	0.39	0.54
95	TC	242.8	226.7	211.3	193.1	176.3	173.8	173.6	249.1	232.9	217.3	198.6	186.3	185.5	185.3
	SHC	63.3	87.8	112.8	143.3	171.0	173.8	173.6	64.1	94.2	124.5	161.5	183.3	185.5	185.3
	kW	13.47	13.33	13.18	13.02	12.85	12.83	12.83	13.55	13.40	13.25	13.07	12.95	12.95	12.95
	BF	0.00	0.16	0.11	0.10	0.11	0.31	0.48	0.00	0.15	0.12	0.11	0.23	0.41	0.56
105	TC	228.5	213.8	199.2	182.1	167.0	166.0	165.8	234.1	219.1	204.5	187.1	176.9	176.7	176.6
	SHC	58.9	83.7	108.6	139.0	165.0	166.0	165.8	59.7	89.8	120.1	157.1	176.9	176.7	176.6
	kW	15.05	14.92	14.78	14.61	14.45	14.44	14.44	15.13	14.99	14.84	14.67	14.56	14.56	14.56
	BF	0.00	0.14	0.10	0.10	0.13	0.34	0.50	0.00	0.14	0.12	0.11	0.25	0.44	0.58
115	TC	212.8	199.2	186.0	170.1	157.8	157.2	157.0	217.4	204.0	190.4	174.4	167.0	166.8	166.7
	SHC	54.2	79.0	103.9	134.3	156.3	157.2	157.0	54.8	85.2	115.4	152.1	167.0	166.8	166.7
	kW	16.74	16.62	16.48	16.32	16.18	16.18	16.18	16.81	16.68	16.54	16.38	16.29	16.29	16.29
	BF	0.00	0.13	0.10	0.09	0.17	0.37	0.53	0.00	0.13	0.11	0.11	0.29	0.47	0.60
125	TC	195.0	183.5	171.2	156.5	147.2	147.0	146.9	198.5	186.7	174.9	160.1	155.6	155.5	155.4
	SHC	48.9	74.1	98.9	129.1	147.2	147.0	146.9	49.4	79.8	110.0	146.2	155.6	155.5	155.4
	kW	18.51	18.41	18.28	18.13	18.02	18.02	18.01	18.57	18.44	18.33	18.17	18.12	18.12	18.11
	BF	0.00	0.11	0.09	0.09	0.21	0.41	0.56	0.00	0.12	0.11	0.12	0.34	0.50	0.63

LEGEND

- BF — Bypass Factor
- Edb — Entering Dry-Bulb
- Ewb — Entering Wet-Bulb
- kW — Compressor Motor Power Input
- ldb — Leaving Dry-Bulb
- lwb — Leaving Wet-Bulb
- SHC — Sensible Heat Capacity (1000 Btuh) Gross
- TC — Total Capacity (1000 Btuh) Gross

NOTES:

1. Direct interpolation is permissible. Do not extrapolate.
2. The following formulas may be used:

$$t_{ldb} = t_{edb} - \frac{\text{sensible capacity (Btuh)}}{1.10 \times \text{cfm}}$$

$$t_{lwb} = \text{Wet-bulb temperature corresponding to enthalpy of air leaving evaporator coil } (h_{lwb})$$

$$h_{lwb} = h_{ewb} - \frac{\text{total capacity (Btuh)}}{4.5 \times \text{cfm}}$$

Where:  $h_{ewb}$  = Enthalpy of air entering evaporator coil

3. The SHC is based on 80 F edb temperature of air entering evaporator coil. Below 80 F edb, subtract (corr factor x cfm) from SHC. Above 80 F edb, add (corr factor x cfm) to SHC.

BYPASS FACTOR (BF)	ENTERING AIR DRY-BULB TEMP (F)					
	79	78	77	76	75	under 75
	81	82	83	84	85	over 85
Correction Factor						
.05	1.04	2.07	3.11	4.14	5.18	Use formula shown below.
.10	.98	1.96	2.94	3.92	4.90	
.20	.87	1.74	2.62	3.49	4.36	
.30	.76	1.53	2.29	3.05	3.82	

Interpolation is permissible.  
Correction Factor =  $1.09 \times (1 - BF) \times (edb - 80)$ .

4. Cooling capacities for 48PG03-16 units with Humidi-MiZer system in Cooling mode are the same as standard units.



**COOLING CAPACITIES (cont)**

**48PG16 (15 Tons) — UNIT WITH HUMIDI-MIZER™ SYSTEM IN SUBCOOLING MODE**

Temp (F) Air Ent Condenser (Edb)		Air Entering Evaporator — CFM													
		4500							6000						
		Air Entering Evaporator — Ewb (F)													
		80	76	72	67	62	57	54	80	76	72	67	62	57	54
75	TC	235.9	218.6	201.4	179.8	158.2	136.6	123.6	267.2	246.0	224.8	198.3	171.7	145.2	129.3
	SHC	56.0	72.0	88.1	108.1	128.1	136.6	123.6	65.6	84.3	103.0	126.3	149.7	145.2	129.3
	kW	10.07	10.07	9.81	9.64	9.48	9.32	9.22	9.89	9.89	9.85	9.82	9.79	9.77	9.75
85	TC	222.6	207.0	191.3	171.7	152.1	132.5	120.8	244.4	225.5	206.5	182.9	159.2	135.6	121.4
	SHC	32.5	52.2	71.9	96.5	121.2	145.8	160.6	38.3	61.2	84.2	112.9	141.6	170.3	187.6
	kW	11.62	11.62	11.30	11.10	10.90	10.70	10.58	11.41	11.41	11.34	11.30	11.25	11.21	11.19
95	TC	209.4	195.3	181.2	163.7	146.1	128.5	118.0	221.5	204.9	188.3	167.5	146.7	125.9	113.5
	SHC	8.9	32.3	55.7	85.0	114.2	128.5	118.0	10.9	38.1	65.4	99.5	133.6	125.9	113.5
	kW	13.16	13.16	12.79	12.55	12.32	12.09	11.95	12.93	12.93	12.84	12.78	12.72	12.66	12.62
105	TC	196.1	183.6	171.2	155.6	140.1	124.5	115.2	198.7	184.4	170.0	152.1	134.2	116.3	105.6
	SHC	-14.6	12.5	39.6	73.4	107.3	124.5	115.2	-16.5	15.0	46.6	86.0	125.5	116.3	105.6
	kW	14.71	14.71	14.28	14.01	13.74	13.47	13.31	14.45	14.45	14.33	14.25	14.18	14.10	14.06
115	TC	182.8	171.9	161.1	147.6	134.0	120.5	112.4	175.9	163.8	151.8	136.8	121.7	106.7	97.7
	SHC	-38.2	-7.4	23.4	61.8	100.3	120.5	112.4	-43.9	-8.1	27.8	72.6	117.4	106.7	97.7
	kW	16.25	16.25	15.77	15.46	15.16	14.86	14.68	15.97	15.97	15.82	15.73	15.64	15.55	15.49
125	TC	169.5	160.3	151.1	139.5	128.0	116.5	109.6	153.0	143.3	133.5	121.4	109.2	97.1	89.8
	SHC	-61.7	-27.3	7.2	50.3	93.4	116.5	109.6	-71.3	-31.2	9.0	59.2	109.2	97.1	89.8
	kW	17.80	17.80	17.26	16.92	16.58	16.24	16.04	17.49	17.49	17.32	17.21	17.10	16.99	16.93

**48PG16 (15 Tons) — UNIT WITH HUMIDI-MIZER SYSTEM IN SUBCOOLING MODE (cont)**

Temp (F) Air Ent Condenser (Edb)		Air Entering Evaporator — CFM						
		7500						
		Air Entering Evaporator — Ewb (F)						
		80	76	72	67	62	57	54
75	TC	298.1	273.0	247.9	216.5	185.1	153.7	134.9
	SHC	74.2	95.2	116.3	142.6	168.8	153.7	134.9
	kW	9.75	9.75	9.88	9.96	10.04	10.12	10.17
85	TC	265.9	243.7	221.6	193.9	166.2	138.6	122.0
	SHC	43.4	69.3	95.1	127.5	159.8	192.1	211.5
	kW	11.25	11.25	11.38	11.45	11.53	11.61	11.66
95	TC	233.6	214.4	195.3	171.3	147.4	123.4	109.0
	SHC	12.6	43.3	74.0	112.4	147.4	123.4	109.0
	kW	12.75	12.75	12.87	12.95	13.03	13.11	13.15
105	TC	201.3	185.1	168.9	148.7	128.5	108.2	96.1
	SHC	-18.3	17.3	52.8	97.3	128.5	108.2	96.1
	kW	14.25	14.25	14.37	14.45	14.52	14.60	14.64
115	TC	169.0	155.8	142.6	126.1	109.6	93.1	83.2
	SHC	-49.1	-8.7	31.7	82.2	109.6	93.1	83.2
	kW	15.75	15.75	15.87	15.94	16.02	16.09	16.13
125	TC	136.7	126.5	116.3	103.5	90.7	77.9	70.2
	SHC	-79.9	-34.7	10.5	67.1	90.7	77.9	70.2
	kW	17.25	17.25	17.37	17.44	17.51	17.58	17.63

**LEGEND**

- Edb** — Entering Dry-Bulb
- Ewb** — Entering Wet-Bulb
- kW** — Compressor Motor Power Input
- ldb** — Leaving Dry-Bulb
- lwb** — Leaving Wet-Bulb
- SHC** — Sensible Heat Capacity (1000 Btuh) Gross
- TC** — Total Capacity (1000 Btuh) Gross

**NOTES:**

1. Direct interpolation is permissible. Do not extrapolate.
2. The following formulas may be used:

$$t_{ldb} = t_{edb} - \frac{\text{sensible capacity (Btuh)}}{1.10 \times \text{cfm}}$$

$$t_{lwb} = \text{Wet-bulb temperature corresponding to enthalpy of air leaving evaporator coil } (h_{lwb})$$

$$h_{lwb} = h_{ewb} - \frac{\text{total capacity (Btuh)}}{4.5 \times \text{cfm}}$$

Where:  $h_{ewb}$  = Enthalpy of air entering evaporator coil

# Performance data (cont)



## COOLING CAPACITIES (cont)

### 48PG16 (15 Tons) — UNIT WITH HUMIDI-MIZER™ SYSTEM IN HOT GAS REHEAT MODE

Temp (F) Air Ent Condenser (Edb)		Air Entering Evaporator — Ewb (F)								
		75 Dry Bulb 62.5 Wet Bulb (50% RH)			75 Dry Bulb 64 Wet Bulb (55% RH)			75 Dry Bulb 65.3 Wet Bulb (60% RH)		
		Air Entering Evaporator — Cfm								
		5250	6000	6750	5250	6000	6750	5250	6000	6750
80	TC	49.5	51.9	54.0	52.6	55.0	57.2	55.2	57.7	60.0
	SHC	1.8	3.6	5.1	-14.3	-11.8	-9.6	-28.3	-25.1	-22.3
	kW	12.33	12.39	12.45	12.47	12.46	12.52	12.46	12.52	12.58
75	TC	52.9	55.2	57.3	55.9	58.3	60.5	58.5	61.0	63.2
	SHC	3.6	5.2	6.6	-11.5	-9.2	-7.2	-24.6	-21.6	-19.0
	kW	11.98	12.03	12.08	12.11	12.11	12.16	12.11	12.17	12.22
70	TC	56.3	58.6	60.6	59.2	61.6	63.7	61.8	64.3	66.5
	SHC	5.4	6.8	8.0	-8.7	-6.6	-4.8	-20.8	-18.2	-15.8
	kW	11.62	11.67	11.72	11.75	11.75	11.80	11.76	11.82	11.87
60	TC	63.0	65.2	67.2	65.9	68.2	70.3	68.4	70.8	72.9
	SHC	8.9	10.0	10.9	-3.0	-1.4	0.0	-13.3	-11.2	-9.3
	kW	10.90	10.94	10.98	11.04	11.04	11.08	11.07	11.11	11.16
50	TC	69.7	71.9	73.8	72.5	74.8	76.8	75.0	77.3	79.4
	SHC	12.5	13.2	13.7	2.7	3.8	4.8	-5.8	-4.2	-2.9
	kW	10.18	10.22	10.25	10.33	10.32	10.36	10.37	10.41	10.45
40	TC	76.4	78.5	80.4	79.2	81.4	83.3	81.6	83.8	85.8
	SHC	16.1	16.4	16.6	8.4	9.0	9.6	1.7	2.7	3.6
	kW	9.47	9.50	9.52	9.61	9.61	9.64	9.68	9.71	9.73

#### LEGEND

**Edb** — Entering Dry-Bulb  
**Ewb** — Entering Wet-Bulb  
**kW** — Compressor Motor Power Input  
**ldb** — Leaving Dry-Bulb  
**lwb** — Leaving Wet-Bulb  
**RH** — Relative Humidity  
**SHC** — Sensible Heat Capacity (1000 Btuh) Gross  
**TC** — Total Capacity (1000 Btuh) Gross

#### NOTES:

- Direct interpolation is permissible. Do not extrapolate.
- The following formulas may be used:

$$t_{ldb} = t_{edb} - \frac{\text{sensible capacity (Btuh)}}{1.10 \times \text{cfm}}$$

$$t_{lwb} = \text{Wet-bulb temperature corresponding to enthalpy of air leaving evaporator coil } (h_{lwb})$$

$$h_{lwb} = h_{ewb} - \frac{\text{total capacity (Btuh)}}{4.5 \times \text{cfm}}$$

Where:  $h_{ewb}$  = Enthalpy of air entering evaporator coil



**COOLING CAPACITIES (cont)**

**48PG20 (18 Tons) — STANDARD UNIT**

Temp (F) Air Ent Condenser (Edb)		Air Entering Evaporator — Cfm													
		5400						6300							
		Air Entering Evaporator — Ewb (F)													
		80	76	72	67	62	57	54	80	76	72	67	62	57	54
60	TC	306	290	274	254	234	214	203	307	291	276	256	236	216	204
	SHC	131	142	152	166	179	193	201	138	148	159	172	185	198	204
	KW	7.9	7.9	7.9	7.8	7.8	7.8	7.8	8.1	8.0	8.0	8.0	7.9	7.9	7.9
	BF	0.00	0.23	0.11	0.04	0.08	0.21	0.42	0.00	0.25	0.13	0.05	0.09	0.23	0.44
70	TC	290	275	260	241	222	203	191	292	277	261	242	223	204	193
	SHC	110	125	140	158	177	195	191	119	133	147	165	183	201	193
	KW	9.9	9.8	9.8	9.7	9.7	9.6	9.6	10.1	10.0	9.9	9.9	9.8	9.7	9.7
	BF	0.00	0.24	0.13	0.06	0.10	0.22	0.43	0.00	0.26	0.15	0.07	0.12	0.24	0.45
75	TC	282	267	252	234	215	197	186	284	269	254	236	217	198	187
	SHC	100	117	134	154	175	196	186	109	125	142	162	182	198	187
	KW	10.9	10.8	10.7	10.7	10.6	10.5	10.5	11.0	11.0	10.9	10.8	10.7	10.7	10.6
	BF	0.00	0.25	0.14	0.08	0.11	0.23	0.44	0.00	0.27	0.16	0.08	0.13	0.25	0.46
85	TC	266	252	238	220	203	185	174	269	254	240	222	204	187	176
	SHC	80	101	121	147	173	185	174	90	110	130	155	180	187	176
	KW	12.8	12.7	12.6	12.5	12.4	12.3	12.3	13.0	12.9	12.8	12.7	12.6	12.5	12.4
	BF	0.00	0.27	0.16	0.10	0.13	0.25	0.46	0.00	0.29	0.18	0.11	0.15	0.27	0.48
95	TC	251	237	224	207	190	173	163	253	240	226	209	192	175	165
	SHC	60	84	109	139	170	173	163	71	95	119	149	179	175	165
	KW	14.8	14.7	14.6	14.4	14.3	14.2	14.1	15.0	14.9	14.8	14.6	14.5	14.3	14.2
	BF	0.00	0.28	0.18	0.12	0.15	0.26	0.47	0.00	0.31	0.21	0.13	0.18	0.29	0.50
105	TC	235	222	209	193	177	161	152	238	225	212	196	180	163	154
	SHC	40	68	96	132	167	161	152	52	80	108	142	177	163	154
	KW	16.7	16.6	16.5	16.3	16.1	16.0	15.9	17.0	16.9	16.7	16.5	16.3	16.2	16.1
	BF	0.00	0.31	0.20	0.14	0.17	0.29	0.50	0.00	0.33	0.23	0.15	0.20	0.31	0.52
115	TC	219	207	195	180	165	149	140	222	210	198	182	167	152	143
	SHC	20	52	84	124	165	149	140	33	65	96	136	167	152	143
	KW	18.7	18.5	18.4	18.2	18.0	17.8	17.7	19.0	18.8	18.6	18.4	18.2	18.0	17.9
	BF	0.00	0.33	0.22	0.16	0.19	0.31	0.52	0.00	0.35	0.25	0.17	0.23	0.33	0.54
125	TC	203	192	180	166	152	138	129	207	195	184	169	155	140	132
	SHC	10	35	72	117	152	138	129	14	49	85	129	155	140	132
	KW	20.6	20.5	20.3	20.1	19.8	19.6	19.5	21.0	20.8	20.6	20.3	20.1	19.8	19.7
	BF	0.00	0.35	0.24	0.18	0.21	0.33	0.54	0.00	0.37	0.27	0.19	0.25	0.35	0.56

**48PG20 (18 Tons) — STANDARD UNIT (cont)**

Temp (F) Air Ent Condenser (Edb)		Air Entering Evaporator — Cfm													
		7200						8100							
		Air Entering Evaporator — Ewb (F)													
		80	76	72	67	62	57	54	80	76	72	67	62	57	54
60	TC	309	293	277	257	237	217	205	310	294	278	258	238	217	205
	SHC	143	154	164	177	189	202	205	148	158	168	181	193	205	205
	KW	8.2	8.2	8.1	8.1	8.0	8.0	8.0	8.3	8.2	8.2	8.2	8.1	8.1	8.0
	BF	0.00	0.26	0.15	0.05	0.11	0.24	0.45	0.00	0.28	0.17	0.05	0.12	0.26	0.47
70	TC	294	278	263	244	224	205	194	295	279	264	245	225	206	195
	SHC	125	139	153	171	188	205	194	131	145	159	176	193	206	195
	KW	10.2	10.1	10.1	10.0	9.9	9.8	9.8	10.3	10.2	10.2	10.1	10.0	9.9	9.9
	BF	0.00	0.28	0.17	0.07	0.14	0.26	0.47	0.00	0.30	0.19	0.07	0.16	0.28	0.49
75	TC	286	271	256	237	218	199	188	287	272	257	238	219	200	189
	SHC	116	132	148	168	188	199	188	123	138	154	173	193	200	189
	KW	11.2	11.1	11.0	11.0	10.9	10.8	10.7	11.3	11.2	11.2	11.1	11.0	10.9	10.8
	BF	0.00	0.29	0.18	0.08	0.15	0.27	0.48	0.00	0.31	0.20	0.09	0.17	0.29	0.50
85	TC	271	256	242	224	206	188	177	272	258	243	225	207	189	178
	SHC	98	118	138	162	187	188	177	105	125	144	168	192	189	178
	KW	13.2	13.1	13.0	12.9	12.7	12.6	12.5	13.3	13.2	13.1	13.0	12.9	12.7	12.6
	BF	0.00	0.31	0.21	0.11	0.18	0.29	0.50	0.00	0.33	0.23	0.11	0.20	0.31	0.52
95	TC	256	242	228	211	194	177	166	257	244	230	212	195	178	168
	SHC	80	104	127	157	186	177	166	88	111	134	163	192	178	168
	KW	15.2	15.1	15.0	14.8	14.6	14.5	14.4	15.4	15.2	15.1	14.9	14.7	14.6	14.5
	BF	0.00	0.33	0.23	0.13	0.20	0.31	0.52	0.00	0.35	0.25	0.14	0.22	0.33	0.54
105	TC	240	227	214	198	182	165	155	242	229	216	200	183	167	157
	SHC	62	90	117	151	182	165	155	71	98	125	158	183	167	157
	KW	17.2	17.1	16.9	16.7	16.5	16.3	16.2	17.4	17.2	17.1	16.9	16.6	16.4	16.3
	BF	0.00	0.35	0.25	0.15	0.23	0.33	0.54	0.00	0.37	0.27	0.16	0.25	0.35	0.56
115	TC	225	213	200	185	169	154	144	227	215	202	187	171	155	146
	SHC	44	75	106	145	169	154	144	54	84	115	153	171	155	146
	KW	19.2	19.0	18.9	18.6	18.4	18.2	18.0	19.4	19.2	19.0	18.8	18.5	18.3	18.2
	BF	0.00	0.37	0.28	0.17	0.26	0.35	0.56	0.00	0.39	0.30	0.19	0.28	0.37	0.58
125	TC	210	198	186	172	157	142	134	212	200	189	174	159	144	135
	SHC	26	61	96	139	157	142	134	37	71	105	148	159	144	135
	KW	21.2	21.0	20.8	20.5	20.3	20.0	19.9	21.4	21.2	21.0	20.7	20.4	20.2	20.0
	BF	0.00	0.39	0.30	0.20	0.28	0.37	0.58	0.00	0.41	0.32	0.21	0.30	0.39	0.60

# Performance data (cont)



## COOLING CAPACITIES (cont)

48PG20 (18 Tons) — STANDARD UNIT (cont)								
Temp (F) Air Ent Condenser (Edb)		Air Entering Evaporator — Cfm						
		9000						
		Air Entering Evaporator — Ewb (F)						
		80	76	72	67	62	57	54
60	TC	311	295	279	258	238	218	206
	SHC	153	162	172	184	196	209	206
	kW	8.4	8.3	8.3	8.2	8.2	8.1	8.1
	BF	0.00	0.29	0.18	0.05	0.13	0.27	0.48
70	TC	296	281	265	246	226	207	195
	SHC	136	150	163	180	197	207	195
	kW	10.4	10.3	10.3	10.2	10.1	10.0	9.9
	BF	0.00	0.31	0.20	0.07	0.17	0.29	0.50
75	TC	289	273	258	239	220	201	190
	SHC	128	143	158	178	197	201	190
	kW	11.4	11.3	11.2	11.1	11.0	10.9	10.9
	BF	0.00	0.32	0.21	0.09	0.18	0.30	0.51
85	TC	274	259	245	227	208	190	179
	SHC	111	130	149	173	197	190	179
	kW	13.5	13.3	13.2	13.1	12.9	12.8	12.7
	BF	0.00	0.34	0.24	0.11	0.21	0.32	0.53
95	TC	259	245	231	214	196	179	169
	SHC	95	118	140	169	196	179	169
	kW	15.5	15.3	15.2	15.0	14.8	14.7	14.6
	BF	0.00	0.36	0.26	0.14	0.23	0.34	0.55
105	TC	244	231	218	201	184	168	158
	SHC	78	105	131	164	184	168	158
	kW	17.5	17.4	17.2	17.0	16.8	16.5	16.4
	BF	0.00	0.38	0.28	0.17	0.25	0.36	0.57
115	TC	229	217	204	188	172	157	147
	SHC	62	92	122	160	172	157	147
	kW	19.6	19.4	19.2	18.9	18.7	18.4	18.3
	BF	0.00	0.40	0.30	0.20	0.29	0.38	0.59
125	TC	214	202	190	175	160	146	137
	SHC	46	79	113	156	160	146	137
	kW	21.6	21.4	21.1	20.9	20.6	20.3	20.1
	BF	0.00	0.42	0.32	0.22	0.31	0.40	0.61

### LEGEND

- BF** — Bypass Factor
- Edb** — Entering Dry-Bulb
- Ewb** — Entering Wet-Bulb
- kW** — Compressor Motor Power Input
- ldb** — Leaving Dry-Bulb
- lwb** — Leaving Wet-Bulb
- SHC** — Sensible Heat Capacity (1000 Btuh) Gross
- TC** — Total Capacity (1000 Btuh) Gross

### NOTES:

- Direct interpolation is permissible. Do not extrapolate.
- The following formulas may be used:

$$t_{ldb} = t_{edb} - \frac{\text{sensible capacity (Btuh)}}{1.10 \times \text{cfm}}$$

$$t_{lwb} = \text{Wet-bulb temperature corresponding to enthalpy of air leaving evaporator coil } (h_{lwb})$$

$$h_{lwb} = h_{ewb} - \frac{\text{total capacity (Btuh)}}{4.5 \times \text{cfm}}$$

Where:  $h_{ewb}$  = Enthalpy of air entering evaporator coil

- The SHC is based on 80 F edb temperature of air entering evaporator coil. Below 80 F edb, subtract (corr factor x cfm) from SHC. Above 80 F edb, add (corr factor x cfm) to SHC.

BYPASS FACTOR (BF)	ENTERING AIR DRY-BULB TEMP (F)					
	79	78	77	76	75	under 75
	81	82	83	84	85	over 85
	Correction Factor					
.05	1.04	2.07	3.11	4.14	5.18	Use formula shown below.
.10	.98	1.96	2.94	3.92	4.90	
.20	.87	1.74	2.62	3.49	4.36	
.30	.76	1.53	2.29	3.05	3.82	

Interpolation is permissible.

$$\text{Correction Factor} = 1.09 \times (1 - \text{BF}) \times (\text{edb} - 80).$$



**COOLING CAPACITIES (cont)**

**48PG20 (18 Tons) — UNIT WITH HUMIDI-MIZER™ SYSTEM — COOLING MODE**

Temp (F) Air Entering Condenser (Edb)		Air Entering Evaporator — Cfm													
		5400							6300						
		Air Entering Evaporator — Ewb (F)													
		80	76	72	67	62	57	54	80	76	72	67	62	57	54
60	TC	308	290	273	252	231	209	196	312	295	277	256	234	212	199
	SHC	122	133	144	159	173	187	195	130	141	152	166	179	193	199
	kW	8.0	8.0	8.0	8.0	8.0	8.0	8.0	8.1	8.1	8.1	8.1	8.1	8.1	8.1
	BF	0.00	0.23	0.11	0.04	0.08	0.21	0.42	0.00	0.25	0.13	0.05	0.09	0.23	0.44
70	TC	294	277	260	240	219	198	185	299	282	265	244	223	201	189
	SHC	104	119	134	153	172	191	185	113	128	143	161	179	198	189
	kW	10.1	10.1	10.1	10.1	10.1	10.1	10.1	10.3	10.3	10.3	10.3	10.3	10.3	10.3
	BF	0.00	0.24	0.13	0.06	0.10	0.22	0.43	0.00	0.26	0.15	0.07	0.12	0.24	0.45
75	TC	287	271	254	233	213	192	180	293	276	259	238	217	196	183
	SHC	95	112	129	150	171	192	180	105	122	138	159	179	196	183
	kW	11.1	11.1	11.1	11.1	11.1	11.1	11.1	11.3	11.3	11.3	11.3	11.3	11.3	11.3
	BF	0.00	0.25	0.14	0.08	0.11	0.23	0.44	0.00	0.27	0.16	0.08	0.13	0.25	0.46
85	TC	273	257	241	221	201	181	168	280	263	247	226	206	185	173
	SHC	76	97	118	144	170	181	168	88	109	129	154	179	185	173
	kW	13.3	13.3	13.3	13.2	13.2	13.2	13.1	13.6	13.5	13.5	13.4	13.4	13.3	13.3
	BF	0.00	0.27	0.16	0.10	0.13	0.25	0.46	0.00	0.29	0.18	0.11	0.15	0.27	0.48
95	TC	260	244	228	208	189	169	157	267	251	235	215	194	174	162
	SHC	58	83	108	138	169	169	157	72	96	120	150	180	174	162
	kW	15.5	15.5	15.4	15.3	15.2	15.2	15.1	15.8	15.7	15.7	15.6	15.5	15.4	15.3
	BF	0.00	0.28	0.18	0.12	0.15	0.26	0.47	0.00	0.31	0.21	0.13	0.18	0.29	0.50
105	TC	246	231	215	196	177	158	146	254	238	222	203	183	163	152
	SHC	40	69	97	133	168	158	146	55	83	110	145	180	163	152
	kW	17.7	17.6	17.5	17.4	17.3	17.2	17.1	18.1	17.9	17.8	17.7	17.5	17.4	17.3
	BF	0.00	0.31	0.20	0.14	0.17	0.29	0.50	0.00	0.33	0.23	0.15	0.20	0.31	0.52
115	TC	232	217	202	184	165	146	135	241	226	210	191	172	153	141
	SHC	22	54	86	127	165	146	135	38	70	101	140	172	153	141
	kW	19.9	19.8	19.7	19.5	19.3	19.2	19.1	20.3	20.1	20.0	19.8	19.6	19.4	19.3
	BF	0.00	0.33	0.22	0.16	0.19	0.31	0.52	0.00	0.35	0.25	0.17	0.23	0.33	0.54
125	TC	219	204	189	171	153	135	124	228	213	198	179	160	142	130
	SHC	4	40	76	121	153	135	124	22	57	92	136	160	142	130
	kW	22.2	22.0	21.8	21.6	21.4	21.2	21.0	22.5	22.4	22.2	21.9	21.7	21.4	21.3
	BF	0.00	0.35	0.24	0.18	0.21	0.33	0.54	0.00	0.37	0.27	0.19	0.25	0.35	0.56

**48PG20 (18 Tons) — UNIT WITH HUMIDI-MIZER SYSTEM — COOLING MODE (cont)**

Temp (F) Air Entering Condenser (Edb)		Air Entering Evaporator — Cfm													
		7200							8100						
		Air Entering Evaporator — Ewb (F)													
		80	76	72	67	62	57	54	80	76	72	67	62	57	54
60	TC	316	298	281	259	237	215	202	319	301	283	261	239	217	204
	SHC	137	148	158	171	185	198	202	143	153	163	176	189	202	204
	kW	8.2	8.2	8.2	8.2	8.2	8.2	8.2	8.3	8.3	8.3	8.3	8.3	8.3	8.3
	BF	0.00	0.26	0.15	0.05	0.11	0.24	0.45	0.00	0.28	0.17	0.05	0.12	0.26	0.47
70	TC	303	286	269	248	226	205	192	307	290	272	251	229	207	194
	SHC	122	136	150	168	186	203	192	128	142	156	174	191	207	194
	kW	10.4	10.4	10.4	10.4	10.4	10.4	10.4	10.5	10.5	10.5	10.5	10.5	10.5	10.5
	BF	0.00	0.28	0.17	0.07	0.14	0.26	0.47	0.00	0.30	0.19	0.07	0.16	0.28	0.49
75	TC	297	280	263	242	221	199	187	301	284	267	245	224	202	189
	SHC	114	130	146	166	186	199	187	121	137	153	172	192	202	189
	kW	11.5	11.5	11.5	11.5	11.5	11.4	11.4	11.6	11.6	11.6	11.6	11.6	11.5	11.5
	BF	0.00	0.29	0.18	0.08	0.15	0.27	0.48	0.00	0.31	0.20	0.09	0.17	0.29	0.50
85	TC	285	268	252	231	210	189	176	290	273	256	234	213	192	179
	SHC	98	118	138	163	187	189	176	107	126	145	170	194	192	179
	kW	13.8	13.7	13.7	13.6	13.5	13.5	13.4	13.9	13.9	13.8	13.7	13.7	13.6	13.6
	BF	0.00	0.31	0.21	0.11	0.18	0.29	0.50	0.00	0.33	0.23	0.11	0.20	0.31	0.52
95	TC	273	256	240	220	199	179	166	278	261	245	224	203	182	170
	SHC	83	106	130	159	188	179	166	92	115	138	167	196	182	170
	kW	16.0	15.9	15.9	15.7	15.6	15.5	15.5	16.2	16.1	16.0	15.9	15.8	15.7	15.6
	BF	0.00	0.33	0.23	0.13	0.20	0.31	0.52	0.00	0.35	0.25	0.14	0.22	0.33	0.54
105	TC	261	245	228	208	188	168	156	266	250	233	213	193	172	160
	SHC	67	94	122	155	188	168	156	78	104	131	164	193	172	160
	kW	18.3	18.2	18.1	17.9	17.7	17.6	17.5	18.5	18.4	18.2	18.1	17.9	17.7	17.6
	BF	0.00	0.35	0.25	0.15	0.23	0.33	0.54	0.00	0.37	0.27	0.16	0.25	0.35	0.56
115	TC	248	233	217	197	177	158	146	254	238	222	202	182	162	150
	SHC	52	83	113	152	177	158	146	63	94	124	161	182	162	150
	kW	20.6	20.4	20.2	20.0	19.8	19.6	19.5	20.8	20.6	20.4	20.2	20.0	19.8	19.6
	BF	0.00	0.37	0.28	0.17	0.26	0.35	0.56	0.00	0.39	0.30	0.19	0.28	0.37	0.58
125	TC	236	221	205	186	167	147	136	243	227	211	192	172	152	140
	SHC	36	71	105	148	167	147	136	49	83	117	159	172	152	140
	kW	22.8	22.6	22.4	22.2	21.9	21.7	21.5	23.1	22.9	22.6	22.4	22.1	21.8	21.7
	BF	0.00	0.39	0.30	0.20	0.28	0.37	0.58	0.00	0.41	0.32	0.21	0.30	0.39	0.60

# Performance data (cont)



## COOLING CAPACITIES (cont)

48PG20 (18 Tons) — UNIT WITH HUMIDI-MIZER™ SYSTEM — COOLING MODE (cont)								
Temp (F) Air Entering Condenser (Edb)		Air Entering Evaporator — Cfm						
		9000						
		Air Entering Evaporator — Ewb (F)						
		80	76	72	67	62	57	54
60	TC	321	304	286	264	241	219	206
	SHC	148	158	168	181	193	206	206
	kW	8.4	8.4	8.4	8.4	8.4	8.4	8.4
	BF	0.00	0.29	0.18	0.05	0.13	0.27	0.48
70	TC	310	293	275	253	231	209	196
	SHC	134	148	162	179	196	209	196
	kW	10.6	10.6	10.6	10.6	10.6	10.6	10.6
	BF	0.00	0.31	0.20	0.07	0.17	0.29	0.50
75	TC	305	287	270	248	226	205	192
	SHC	128	143	158	178	197	205	192
	kW	11.8	11.7	11.7	11.7	11.7	11.6	11.6
	BF	0.00	0.32	0.21	0.09	0.18	0.30	0.51
85	TC	293	276	259	238	216	195	182
	SHC	114	133	152	176	199	195	182
	kW	14.1	14.0	13.9	13.9	13.8	13.7	13.6
	BF	0.00	0.34	0.24	0.11	0.21	0.32	0.53
95	TC	282	265	248	227	206	185	173
	SHC	100	123	146	174	202	185	173
	kW	16.4	16.3	16.2	16.0	15.9	15.8	15.7
	BF	0.00	0.36	0.26	0.14	0.23	0.34	0.55
105	TC	271	254	238	217	196	176	163
	SHC	87	113	139	172	196	176	163
	kW	18.7	18.5	18.4	18.2	18.0	17.8	17.7
	BF	0.00	0.38	0.28	0.17	0.25	0.36	0.57
115	TC	260	243	227	207	186	166	154
	SHC	73	103	133	170	186	166	154
	kW	21.0	20.8	20.6	20.4	20.1	19.9	19.8
	BF	0.00	0.40	0.30	0.20	0.29	0.38	0.59
125	TC	249	233	216	196	176	156	144
	SHC	60	93	126	168	176	156	144
	kW	23.3	23.1	22.8	22.5	22.3	22.0	21.8
	BF	0.00	0.42	0.32	0.22	0.31	0.40	0.61

### LEGEND

- BF** — Bypass Factor
- Edb** — Entering Dry-Bulb
- Ewb** — Entering Wet-Bulb
- kW** — Compressor Motor Power Input
- ldb** — Leaving Dry-Bulb
- lwb** — Leaving Wet-Bulb
- SHC** — Sensible Heat Capacity (1000 Btuh) Gross
- TC** — Total Capacity (1000 Btuh) Gross

### NOTES:

1. Direct interpolation is permissible. Do not extrapolate.
2. The following formulas may be used:

$$t_{ldb} = t_{edb} - \frac{\text{sensible capacity (Btuh)}}{1.10 \times \text{cfm}}$$

$$t_{lwb} = \text{Wet-bulb temperature corresponding to enthalpy of air leaving evaporator coil (} h_{lwb} \text{)}$$

$$h_{lwb} = h_{ewb} - \frac{\text{total capacity (Btuh)}}{4.5 \times \text{cfm}}$$

Where:  $h_{ewb}$  = Enthalpy of air entering evaporator coil

3. The SHC is based on 80 F edb temperature of air entering evaporator coil.

Below 80 F edb, subtract (corr factor x cfm) from SHC.

Above 80 F edb, add (corr factor x cfm) to SHC.

BYPASS FACTOR (BF)	ENTERING AIR DRY-BULB TEMP (F)					
	79	78	77	76	75	under 75
	81	82	83	84	85	over 85
	Correction Factor					
.05	1.04	2.07	3.11	4.14	5.18	Use formula shown below.
.10	.98	1.96	2.94	3.92	4.90	
.20	.87	1.74	2.62	3.49	4.36	
.30	.76	1.53	2.29	3.05	3.82	

Interpolation is permissible.

$$\text{Correction Factor} = 1.09 \times (1 - \text{BF}) \times (\text{edb} - 80).$$



**COOLING CAPACITIES (cont)**

**48PG20 (18 Tons) — UNIT WITH HUMIDI-MIZER™ SYSTEM — SUBCOOLING MODE**

Temp (F) Air Entering Condenser (Edb)		Air Entering Evaporator — Cfm													
		5400							6300						
		Air Entering Evaporator — Ewb (F)													
		80	76	72	67	62	57	54	80	76	72	67	62	57	54
60	TC	316	297	279	256	233	211	197	320	301	283	260	237	214	200
	SHC	128	139	149	163	176	190	197	135	146	156	169	182	195	200
	KW	8.2	8.2	8.2	8.2	8.2	8.2	8.2	8.4	8.4	8.4	8.4	8.4	8.4	8.4
70	TC	299	281	263	241	219	196	183	304	286	268	245	223	200	186
	SHC	102	117	132	151	169	188	183	111	126	140	158	176	194	186
	KW	10.2	10.2	10.2	10.2	10.2	10.2	10.2	10.4	10.4	10.4	10.4	10.4	10.4	10.4
75	TC	291	273	255	233	211	189	176	296	278	260	238	216	193	180
	SHC	90	107	124	145	166	187	176	99	116	132	153	173	193	180
	KW	11.3	11.3	11.2	11.2	11.1	11.1	11.1	11.6	11.5	11.5	11.4	11.3	11.3	11.2
85	TC	274	257	240	218	197	175	162	280	263	245	223	202	180	166
	SHC	64	85	106	133	159	175	162	75	95	116	142	167	180	166
	KW	13.4	13.4	13.3	13.2	13.1	13.0	13.0	13.7	13.6	13.5	13.4	13.3	13.2	13.1
95	TC	258	241	224	203	182	161	148	265	247	230	209	187	166	153
	SHC	39	64	89	120	152	161	148	51	75	100	130	161	166	153
	KW	15.6	15.4	15.3	15.2	15.1	14.9	14.8	15.9	15.7	15.6	15.5	15.3	15.1	15.0
105	TC	241	225	208	188	167	147	135	249	232	215	194	173	152	140
	SHC	13	42	72	108	145	147	135	26	55	84	119	155	152	140
	KW	17.7	17.5	17.4	17.2	17.0	16.8	16.7	18.0	17.9	17.7	17.5	17.3	17.1	17.0
115	TC	225	209	193	173	153	133	121	233	217	200	180	159	139	127
	SHC	-12	21	54	96	138	133	121	2	35	68	108	149	139	127
	KW	19.8	19.6	19.4	19.2	19.0	18.7	18.6	20.2	20.0	19.8	19.5	19.3	19.0	18.9
125	TC	208	192	177	157	138	119	107	217	201	185	165	145	125	113
	SHC	-38	0	37	84	131	119	107	-22	15	51	97	143	125	113
	KW	21.9	21.7	21.5	21.2	20.9	20.7	20.5	22.3	22.1	21.9	21.6	21.2	20.9	20.8

**48PG20 (18 Tons) — UNIT WITH HUMIDI-MIZER SYSTEM — SUBCOOLING MODE (cont)**

Temp (F) Air Entering Condenser (Edb)		Air Entering Evaporator — Cfm													
		7200							8100						
		Air Entering Evaporator — Ewb (F)													
		80	76	72	67	62	57	54	80	76	72	67	62	57	54
60	TC	323	305	286	263	239	216	202	326	307	289	265	242	218	204
	SHC	142	152	162	174	187	199	202	147	157	166	179	191	203	204
	KW	8.5	8.5	8.5	8.5	8.5	8.5	8.5	8.6	8.6	8.6	8.6	8.6	8.6	8.6
70	TC	308	290	272	249	226	203	189	312	293	275	252	229	206	192
	SHC	118	132	147	164	182	199	189	125	138	152	169	187	204	192
	KW	10.6	10.6	10.6	10.6	10.6	10.6	10.6	10.7	10.7	10.7	10.7	10.7	10.7	10.7
75	TC	301	282	264	242	219	196	183	304	286	268	245	222	199	185
	SHC	107	123	139	159	179	196	183	113	129	145	165	184	199	185
	KW	11.8	11.7	11.6	11.6	11.5	11.4	11.4	11.9	11.8	11.8	11.7	11.6	11.5	11.5
85	TC	285	268	250	228	206	183	170	290	272	254	231	209	186	173
	SHC	84	104	124	149	174	183	170	91	111	131	155	180	186	173
	KW	13.9	13.8	13.7	13.6	13.5	13.4	13.3	14.1	14.0	13.9	13.8	13.6	13.5	13.4
95	TC	270	253	236	214	192	170	157	275	258	240	218	196	174	160
	SHC	60	85	109	139	169	170	157	69	93	116	146	175	174	160
	KW	16.1	16.0	15.8	15.7	15.5	15.3	15.2	16.3	16.2	16.0	15.8	15.6	15.5	15.3
105	TC	255	238	221	200	178	157	144	261	243	226	204	183	161	148
	SHC	37	65	94	129	164	157	144	47	74	102	136	171	161	148
	KW	18.3	18.1	17.9	17.7	17.5	17.3	17.1	18.5	18.3	18.1	17.9	17.7	17.4	17.3
115	TC	240	223	207	186	165	144	131	246	229	212	191	170	148	136
	SHC	14	46	78	119	159	144	131	24	56	88	127	167	148	136
	KW	20.5	20.3	20.0	19.8	19.5	19.2	19.1	20.7	20.5	20.3	20.0	19.7	19.4	19.2
125	TC	225	209	192	172	151	131	119	232	215	198	177	156	136	123
	SHC	-9	27	63	108	151	131	119	2	38	73	118	156	136	123
	KW	22.7	22.4	22.1	21.8	21.5	21.2	21.0	22.9	22.7	22.4	22.0	21.7	21.4	21.2

# Performance data (cont)



## COOLING CAPACITIES (cont)

**48PG20 (18 Tons) — UNIT WITH HUMIDI-MIZER™ SYSTEM — SUBCOOLING MODE (cont)**

Temp (F) Air Entering Condenser (Edb)		Air Entering Evaporator — Cfm						
		9000						
		Air Entering Evaporator — Ewb (F)						
		80	76	72	67	62	57	54
60	TC	329	310	291	267	244	220	206
	SHC	151	161	171	183	195	207	206
	kW	8.7	8.7	8.7	8.7	8.7	8.7	8.7
70	TC	315	296	278	254	231	208	194
	SHC	130	143	157	174	191	208	194
	kW	10.8	10.8	10.8	10.8	10.8	10.8	10.8
75	TC	308	289	271	248	225	202	188
	SHC	119	135	150	169	189	202	188
	kW	12.0	12.0	11.9	11.8	11.7	11.6	11.6
85	TC	294	276	257	235	212	189	176
	SHC	98	117	136	161	185	189	176
	kW	14.3	14.1	14.0	13.9	13.7	13.6	13.5
95	TC	280	262	244	222	199	177	163
	SHC	76	99	123	152	181	177	163
	kW	16.5	16.3	16.2	16.0	15.8	15.6	15.5
105	TC	266	248	230	208	186	164	151
	SHC	55	82	109	143	177	164	151
	kW	18.7	18.5	18.3	18.0	17.8	17.6	17.4
115	TC	252	234	217	195	174	152	139
	SHC	33	64	96	135	174	152	139
	kW	20.9	20.7	20.4	20.1	19.8	19.5	19.4
125	TC	238	221	203	182	161	140	127
	SHC	12	47	82	126	161	140	127
	kW	23.1	22.9	22.6	22.2	21.9	21.5	21.3

### LEGEND

**Edb** — Entering Dry-Bulb  
**Ewb** — Entering Wet-Bulb  
**kW** — Compressor Motor Power Input  
**ldb** — Leaving Dry-Bulb  
**lwb** — Leaving Wet-Bulb  
**SHC** — Sensible Heat Capacity (1000 Btuh) Gross  
**TC** — Total Capacity (1000 Btuh) Gross

### NOTES:

- Direct interpolation is permissible. Do not extrapolate.
- The following formulas may be used:

$$t_{ldb} = t_{edb} - \frac{\text{sensible capacity (Btuh)}}{1.10 \times \text{cfm}}$$

$t_{lwb}$  = Wet-bulb temperature corresponding to enthalpy of air leaving evaporator coil ( $h_{lwb}$ )

$$h_{lwb} = h_{ewb} - \frac{\text{total capacity (Btuh)}}{4.5 \times \text{cfm}}$$

Where:  $h_{ewb}$  = Enthalpy of air entering evaporator coil

## 48PG20 (18 Tons) — UNIT WITH HUMIDI-MIZER SYSTEM — HOT GAS REHEAT MODE — ALL CIRCUITS

Temp (F) Air Ent Condenser (Edb)		Air Entering Evaporator — Ewb (F)														
		75 Dry Bulb 62.5 Wet Bulb (50% RH)					75 Dry Bulb 64 Wet Bulb (55% RH)					75 Dry Bulb 65.3 Wet Bulb (60% RH)				
		Air Entering Evaporator — Cfm														
		5400	6300	7200	8100	9000	5400	6300	7200	8100	9000	5400	6300	7200	8100	9000
80	TC	79	82	85	87	88	85	88	91	93	95	90	94	96	98	100
	SHC	17	23	28	32	35	8	14	19	23	26	0	6	11	15	19
	kW	12.1	12.2	12.2	12.2	12.3	12.2	12.2	12.2	12.3	12.3	12.4	12.2	12.3	12.3	12.4
75	TC	82	85	87	89	91	88	91	93	96	97	93	96	99	101	103
	SHC	21	26	31	35	38	13	18	23	27	30	5	11	16	20	23
	kW	11.8	11.9	11.9	11.9	12.0	11.9	11.9	12.0	12.0	12.1	11.9	12.0	12.1	12.1	12.1
70	TC	85	88	90	92	94	91	94	96	98	100	96	99	101	103	105
	SHC	25	30	34	38	41	17	22	27	30	33	11	16	20	24	27
	kW	11.5	11.6	11.6	11.6	11.7	11.6	11.6	11.7	11.7	11.8	11.7	11.7	11.8	11.8	11.8
60	TC	92	94	96	98	99	97	99	101	103	104	102	104	106	108	109
	SHC	33	37	41	44	46	27	31	35	38	40	21	26	29	32	35
	kW	10.9	11.0	11.0	11.0	11.1	11.0	11.1	11.1	11.1	11.2	11.1	11.1	11.2	11.2	11.2
50	TC	98	100	102	103	104	103	105	107	108	109	107	110	111	113	114
	SHC	41	44	47	50	52	36	40	43	45	47	32	35	38	41	43
	kW	10.3	10.4	10.4	10.4	10.4	10.4	10.5	10.5	10.5	10.6	10.5	10.6	10.6	10.6	10.7

## 48PG20 (18 Tons) — UNIT WITH HUMIDI-MIZER SYSTEM — HOT GAS REHEAT MODE — CIRCUIT A ONLY

Temp (F) Air Entering Condenser (Edb)		Air Entering Evaporator — Ewb (F)														
		75 Dry Bulb 62.5 Wet Bulb (50% RH)					75 Dry Bulb 64 Wet Bulb (55% RH)					75 Dry Bulb 65.3 Wet Bulb (60% RH)				
		Air Entering Evaporator — Cfm														
		5400	6300	7200	8100	9000	5400	6300	7200	8100	9000	5400	6300	7200	8100	9000
50	TC	48	51	54	56	59	49	53	56	58	60	51	54	57	60	62
	SHC	21	24	27	29	31	15	19	21	24	26	10	14	17	19	21
	kW	5.4	5.4	5.5	5.5	5.5	5.4	5.5	5.5	5.5	5.5	5.4	5.5	5.5	5.5	5.5
40	TC	51	54	56	58	59	53	55	58	60	61	54	57	59	61	63
	SHC	23	25	28	30	31	18	21	23	25	27	14	17	20	22	23
	kW	5.3	5.3	5.3	5.3	5.3	5.3	5.3	5.3	5.4	5.4	5.3	5.4	5.4	5.4	5.4

### LEGEND

**Edb** — Entering Dry-Bulb  
**Ewb** — Entering Wet-Bulb  
**kW** — Compressor Motor Power Input  
**ldb** — Leaving Dry-Bulb  
**lwb** — Leaving Wet-Bulb  
**RH** — Relative Humidity  
**SHC** — Sensible Heat Capacity (1000 Btuh) Gross  
**TC** — Total Capacity (1000 Btuh) Gross

### NOTES:

- Direct interpolation is permissible. Do not extrapolate.
- The following formulas may be used:

$$t_{ldb} = t_{edb} - \frac{\text{sensible capacity (Btuh)}}{1.10 \times \text{cfm}}$$

$t_{lwb}$  = Wet-bulb temperature corresponding to enthalpy of air leaving evaporator coil ( $h_{lwb}$ )

$$h_{lwb} = h_{ewb} - \frac{\text{total capacity (Btuh)}}{4.5 \times \text{cfm}}$$

Where:  $h_{ewb}$  = Enthalpy of air entering evaporator coil



### COOLING CAPACITIES (cont)

#### 48PG24 (20 Tons) — STANDARD UNIT

Temp (F) Air Ent Condenser (Edb)		Air Entering Evaporator — Cfm													
		6,000							7,000						
		Air Entering Evaporator — Ewb (F)													
		80	76	72	67	62	57	54	80	76	72	67	62	57	54
60	TC	372	350	328	300	272	244	228	375	352	330	302	274	246	230
	SHC	162	172	181	193	205	217	224	170	179	188	200	211	222	229
	KW	8.6	8.6	8.6	8.6	8.6	8.6	8.6	8.8	8.7	8.7	8.7	8.7	8.7	8.7
	BF	0.00	0.14	0.08	0.03	0.04	0.12	0.33	0.00	0.15	0.09	0.04	0.05	0.13	0.34
70	TC	356	334	312	284	257	229	213	359	337	315	287	259	232	215
	SHC	140	153	167	184	201	217	228	149	162	175	191	208	224	215
	KW	10.8	10.8	10.8	10.7	10.7	10.7	10.7	11.0	11.0	11.0	10.9	10.9	10.8	10.8
	BF	0.00	0.17	0.11	0.04	0.06	0.16	0.36	0.00	0.19	0.12	0.05	0.06	0.17	0.39
75	TC	348	326	304	276	249	222	205	351	329	307	279	252	224	208
	SHC	128	144	159	179	198	218	229	138	153	168	187	206	224	208
	KW	12.0	11.9	11.9	11.8	11.8	11.7	11.7	12.2	12.1	12.1	12.0	12.0	11.9	11.9
	BF	0.00	0.19	0.13	0.05	0.07	0.18	0.38	0.00	0.20	0.14	0.06	0.08	0.19	0.41
85	TC	331	310	288	261	234	207	190	335	313	292	264	237	210	193
	SHC	106	125	145	169	194	219	233	117	136	155	179	203	210	193
	KW	14.2	14.1	14.1	14.0	13.9	13.8	13.8	14.5	14.4	14.3	14.2	14.1	14.0	14.0
	BF	0.00	0.22	0.16	0.08	0.11	0.21	0.41	0.00	0.24	0.17	0.10	0.12	0.23	0.44
95	TC	315	293	272	245	218	192	175	319	298	276	249	222	195	179
	SHC	83	107	130	160	190	219	237	96	119	142	171	199	195	179
	KW	16.5	16.4	16.3	16.2	16.1	16.0	15.9	16.8	16.7	16.6	16.4	16.3	16.2	16.1
	BF	0.00	0.26	0.20	0.13	0.14	0.25	0.45	0.00	0.28	0.22	0.16	0.15	0.27	0.48
105	TC	299	277	256	230	203	176	161	304	282	261	234	207	180	164
	SHC	60	88	116	151	185	220	241	74	101	128	162	196	180	164
	KW	18.7	18.6	18.5	18.4	18.2	18.1	18.0	19.1	18.9	18.8	18.6	18.5	18.3	18.2
	BF	0.00	0.29	0.23	0.16	0.18	0.28	0.48	0.00	0.31	0.25	0.19	0.19	0.30	0.51
115	TC	282	261	240	214	188	161	146	288	266	245	219	192	165	149
	SHC	38	70	101	141	181	221	244	53	84	115	154	193	165	149
	KW	21.0	20.8	20.7	20.5	20.4	20.2	20.1	21.4	21.2	21.0	20.8	20.7	20.5	20.3
	BF	0.00	0.33	0.27	0.19	0.21	0.31	0.52	0.00	0.35	0.29	0.23	0.23	0.33	0.55
125	TC	266	245	224	198	172	146	131	272	251	230	203	177	151	135
	SHC	15	51	87	132	176	221	248	32	67	102	146	189	151	135
	KW	23.2	23.1	22.9	22.7	22.5	22.3	22.2	23.7	23.5	23.3	23.1	22.8	22.6	22.5
	BF	0.00	0.36	0.30	0.23	0.25	0.35	0.55	0.00	0.39	0.32	0.28	0.27	0.38	0.58

#### 48PG24 (20 Tons) — STANDARD UNIT (cont)

Temp (F) Air Ent Condenser (Edb)		Air Entering Evaporator — Cfm													
		8,000							9,000						
		Air Entering Evaporator — Ewb (F)													
		80	76	72	67	62	57	54	80	76	72	67	62	57	54
60	TC	377	355	332	304	276	248	231	379	356	334	306	278	249	232
	SHC	177	185	194	205	216	227	231	182	191	199	210	221	231	232
	KW	8.9	8.9	8.9	8.8	8.8	8.8	8.8	9.0	9.0	9.0	8.9	8.9	8.9	8.9
	BF	0.00	0.15	0.09	0.04	0.05	0.13	0.34	0.00	0.16	0.10	0.05	0.06	0.14	0.35
70	TC	362	339	317	289	261	234	217	364	342	319	291	263	235	218
	SHC	157	169	182	198	214	230	217	163	176	188	204	219	234	218
	KW	11.2	11.2	11.1	11.1	11.0	11.0	10.9	11.4	11.3	11.3	11.2	11.1	11.1	11.0
	BF	0.00	0.20	0.13	0.06	0.07	0.18	0.41	0.00	0.22	0.13	0.06	0.07	0.20	0.44
75	TC	354	332	310	282	254	226	210	356	334	312	284	256	228	211
	SHC	146	161	176	194	213	226	210	154	168	182	200	218	228	211
	KW	12.4	12.3	12.3	12.2	12.1	12.0	12.0	12.5	12.5	12.4	12.3	12.2	12.1	12.1
	BF	0.00	0.22	0.15	0.08	0.08	0.21	0.44	0.00	0.23	0.16	0.09	0.09	0.22	0.47
85	TC	339	317	295	267	239	212	195	341	319	297	269	242	214	197
	SHC	126	145	164	187	210	212	195	135	153	171	194	217	214	197
	KW	14.7	14.6	14.5	14.4	14.3	14.2	14.1	14.9	14.8	14.7	14.6	14.4	14.3	14.2
	BF	0.00	0.25	0.18	0.13	0.13	0.24	0.47	0.00	0.27	0.20	0.15	0.13	0.26	0.50
95	TC	323	301	279	252	225	198	181	326	304	282	255	227	200	183
	SHC	106	129	151	180	208	198	181	115	137	160	187	215	200	183
	KW	17.0	16.9	16.8	16.6	16.5	16.3	16.3	17.2	17.1	17.0	16.8	16.6	16.5	16.4
	BF	0.00	0.30	0.23	0.18	0.16	0.29	0.52	0.00	0.32	0.25	0.21	0.17	0.31	0.55
105	TC	308	286	264	237	210	183	167	311	289	268	240	213	186	169
	SHC	86	113	139	172	205	183	167	96	122	148	181	213	186	169
	KW	19.3	19.2	19.0	18.9	18.7	18.5	18.4	19.6	19.4	19.2	19.0	18.9	18.7	18.5
	BF	0.00	0.33	0.26	0.23	0.21	0.32	0.55	0.00	0.36	0.28	0.26	0.22	0.34	0.58
115	TC	292	271	249	222	196	169	153	296	275	253	226	199	171	155
	SHC	66	96	127	165	196	169	153	77	107	137	174	199	171	155
	KW	21.7	21.5	21.3	21.1	20.9	20.7	20.5	21.9	21.7	21.5	21.3	21.1	20.8	20.7
	BF	0.00	0.38	0.31	0.27	0.24	0.36	0.58	0.00	0.40	0.33	0.31	0.26	0.38	0.60
125	TC	277	256	234	208	181	154	138	281	260	238	211	184	157	141
	SHC	46	80	115	157	181	154	138	58	92	126	168	184	157	141
	KW	24.0	23.8	23.6	23.3	23.1	22.8	22.7	24.2	24.0	23.8	23.5	23.3	23.0	22.8
	BF	0.00	0.41	0.35	0.32	0.29	0.40	0.60	0.00	0.44	0.37	0.37	0.31	0.43	0.63

# Performance data (cont)



## COOLING CAPACITIES (cont)

48PG24 (20 Tons) — STANDARD UNIT (cont)								
Temp (F) Air Ent Condenser (Edb)		Air Entering Evaporator — Cfm						
		10,000						
		Air Entering Evaporator — Ewb (F)						
		80	76	72	67	62	57	54
60	TC	381	358	335	307	279	251	234
	SHC	187	196	204	214	225	235	234
	kW	9.1	9.1	9.1	9.0	9.0	9.0	8.9
	BF	0.00	0.16	0.10	0.05	0.06	0.14	0.35
70	TC	366	343	321	293	265	237	220
	SHC	169	181	193	208	224	237	220
	kW	11.5	11.4	11.4	11.3	11.2	11.1	11.1
	BF	0.00	0.23	0.14	0.07	0.08	0.21	0.47
75	TC	359	336	314	286	258	230	213
	SHC	160	174	188	206	223	230	213
	kW	12.7	12.6	12.5	12.4	12.3	12.2	12.2
	BF	0.00	0.25	0.17	0.10	0.09	0.23	0.49
85	TC	344	322	299	271	244	216	199
	SHC	142	160	177	200	222	216	199
	kW	15.0	14.9	14.8	14.7	14.5	14.4	14.3
	BF	0.00	0.29	0.21	0.17	0.14	0.27	0.53
95	TC	329	307	285	257	229	202	185
	SHC	123	145	167	194	221	202	185
	kW	17.4	17.2	17.1	16.9	16.8	16.6	16.5
	BF	0.00	0.34	0.26	0.23	0.18	0.33	0.59
105	TC	314	292	270	243	215	188	171
	SHC	105	131	156	188	215	188	171
	kW	19.7	19.6	19.4	19.2	19.0	18.8	18.7
	BF	0.00	0.38	0.30	0.29	0.23	0.36	0.61
115	TC	300	278	256	229	201	174	157
	SHC	87	116	146	183	201	174	157
	kW	22.1	21.9	21.7	21.4	21.2	21.0	20.8
	BF	0.00	0.43	0.35	0.35	0.27	0.40	0.63
125	TC	285	263	241	214	187	160	144
	SHC	69	102	135	177	187	160	144
	kW	24.4	24.2	24.0	23.7	23.4	23.1	23.0
	BF	0.00	0.47	0.39	0.41	0.33	0.46	0.65

### LEGEND

- BF** — Bypass Factor
- Edb** — Entering Dry-Bulb
- Ewb** — Entering Wet-Bulb
- kW** — Compressor Motor Power Input
- ldb** — Leaving Dry-Bulb
- lwb** — Leaving Wet-Bulb
- SHC** — Sensible Heat Capacity (1000 Btuh) Gross
- TC** — Total Capacity (1000 Btuh) Gross

### NOTES:

- Direct interpolation is permissible. Do not extrapolate.
- The following formulas may be used:

$$t_{ldb} = t_{edb} - \frac{\text{sensible capacity (Btuh)}}{1.10 \times \text{cfm}}$$

$$t_{lwb} = \text{Wet-bulb temperature corresponding to enthalpy of air leaving evaporator coil (} h_{lwb} \text{)}$$

$$h_{lwb} = h_{ewb} - \frac{\text{total capacity (Btuh)}}{4.5 \times \text{cfm}}$$

Where:  $h_{ewb}$  = Enthalpy of air entering evaporator coil

- The SHC is based on 80 F edb temperature of air entering evaporator coil. Below 80 F edb, subtract (corr factor x cfm) from SHC. Above 80 F edb, add (corr factor x cfm) to SHC.

BYPASS FACTOR (BF)	ENTERING AIR DRY-BULB TEMP (F)					
	79	78	77	76	75	under 75
	81	82	83	84	85	over 85
	Correction Factor					
.05	1.04	2.07	3.11	4.14	5.18	Use formula shown below.
.10	.98	1.96	2.94	3.92	4.90	
.20	.87	1.74	2.62	3.49	4.36	
.30	.76	1.53	2.29	3.05	3.82	

Interpolation is permissible.

$$\text{Correction Factor} = 1.09 \times (1 - \text{BF}) \times (\text{edb} - 80).$$



**COOLING CAPACITIES (cont)**

**48PG24 (20 Tons) — UNIT WITH HUMIDI-MIZER™ SYSTEM — COOLING MODE**

Temp (F) Air Entering Condenser (Edb)		Air Entering Evaporator — Cfm													
		6000							7000						
		Air Entering Evaporator — Ewb (F)													
		80	76	72	67	62	57	54	80	76	72	67	62	57	54
60	TC	351	330	309	284	258	232	217	354	334	313	287	261	235	220
	SHC	145	158	172	189	205	222	217	155	168	181	197	213	229	220
	kW	9.0	9.0	9.0	9.0	9.0	9.0	9.0	9.1	9.1	9.1	9.1	9.1	9.1	9.1
	BF	0.00	0.14	0.08	0.03	0.04	0.12	0.33	0.00	0.15	0.09	0.04	0.05	0.13	0.34
70	TC	336	316	295	270	244	219	204	340	320	299	274	248	222	207
	SHC	121	140	158	180	203	219	204	133	151	168	190	212	222	207
	kW	11.2	11.2	11.2	11.1	11.1	11.0	11.0	11.4	11.4	11.3	11.3	11.2	11.1	11.1
	BF	0.00	0.17	0.11	0.04	0.06	0.16	0.36	0.00	0.19	0.12	0.05	0.06	0.17	0.39
75	TC	329	308	288	263	238	212	197	333	313	292	267	241	216	200
	SHC	110	130	151	176	201	212	197	123	142	162	187	211	216	200
	kW	12.4	12.3	12.3	12.2	12.1	12.0	12.0	12.6	12.5	12.4	12.3	12.3	12.2	12.1
	BF	0.00	0.19	0.13	0.05	0.07	0.18	0.38	0.00	0.20	0.14	0.06	0.08	0.19	0.41
85	TC	314	294	274	249	224	199	184	319	299	279	254	228	203	188
	SHC	86	111	136	168	199	199	184	101	125	149	180	210	203	188
	kW	14.7	14.6	14.5	14.3	14.2	14.1	14.0	14.9	14.8	14.7	14.5	14.4	14.2	14.2
	BF	0.00	0.22	0.16	0.08	0.11	0.21	0.41	0.00	0.24	0.17	0.10	0.12	0.23	0.44
95	TC	299	280	260	235	210	186	171	305	285	265	240	215	190	175
	SHC	63	93	122	159	196	186	171	79	108	137	173	209	190	175
	kW	16.9	16.8	16.7	16.5	16.3	16.1	16.0	17.2	17.0	16.9	16.7	16.5	16.3	16.2
	BF	0.00	0.26	0.20	0.13	0.14	0.25	0.45	0.00	0.28	0.22	0.16	0.15	0.27	0.48
105	TC	285	265	246	221	197	172	158	291	272	252	227	202	177	162
	SHC	40	74	108	151	194	172	158	58	91	124	166	202	177	162
	kW	19.2	19.0	18.9	18.6	18.4	18.2	18.0	19.5	19.3	19.1	18.9	18.6	18.4	18.2
	BF	0.00	0.29	0.23	0.16	0.18	0.28	0.48	0.00	0.31	0.25	0.19	0.19	0.30	0.51
115	TC	270	251	231	207	183	159	144	277	258	238	214	189	164	150
	SHC	16	55	94	143	191	159	144	36	74	112	159	189	164	150
	kW	21.5	21.3	21.1	20.8	20.5	20.2	20.1	21.8	21.6	21.3	21.0	20.7	20.4	20.3
	BF	0.00	0.33	0.27	0.19	0.21	0.31	0.52	0.00	0.35	0.29	0.23	0.23	0.33	0.55
125	TC	255	236	217	193	169	146	131	263	244	225	200	176	151	137
	SHC	10	37	80	134	189	146	131	15	57	99	152	176	151	137
	kW	23.8	23.5	23.3	22.9	22.6	22.3	22.1	24.1	23.9	23.6	23.2	22.9	22.5	22.3
	BF	0.00	0.36	0.30	0.23	0.25	0.35	0.55	0.00	0.39	0.32	0.28	0.27	0.38	0.58

**48PG24 (20 Tons) — UNIT WITH HUMIDI-MIZER SYSTEM — COOLING MODE (cont)**

Temp (F) Air Entering Condenser (Edb)		Air Entering Evaporator — Cfm													
		8000							9000						
		Air Entering Evaporator — Ewb (F)													
		80	76	72	67	62	57	54	80	76	72	67	62	57	54
60	TC	357	337	316	290	263	237	222	360	339	318	292	265	239	223
	SHC	163	176	188	204	220	236	222	171	183	195	210	225	239	223
	kW	9.2	9.2	9.2	9.2	9.2	9.2	9.1	9.3	9.3	9.3	9.3	9.2	9.2	9.2
	BF	0.00	0.15	0.09	0.04	0.05	0.13	0.34	0.00	0.16	0.10	0.05	0.06	0.14	0.35
70	TC	344	323	303	277	251	225	209	347	326	305	279	253	227	211
	SHC	143	160	177	198	220	225	209	152	168	185	206	226	227	211
	kW	11.6	11.5	11.5	11.4	11.3	11.2	11.2	11.7	11.6	11.6	11.5	11.4	11.3	11.3
	BF	0.00	0.20	0.13	0.06	0.07	0.18	0.41	0.00	0.22	0.13	0.06	0.07	0.20	0.44
75	TC	337	317	296	270	244	219	203	341	320	299	273	247	221	205
	SHC	133	152	172	196	220	219	203	142	161	180	203	227	221	205
	kW	12.7	12.7	12.6	12.5	12.4	12.3	12.2	12.9	12.8	12.7	12.6	12.5	12.4	12.3
	BF	0.00	0.22	0.15	0.08	0.08	0.21	0.44	0.00	0.23	0.16	0.09	0.09	0.22	0.47
85	TC	324	303	283	257	232	206	191	328	307	286	260	235	209	193
	SHC	113	137	160	190	220	206	191	123	147	170	199	228	209	193
	kW	15.1	14.9	14.8	14.7	14.5	14.4	14.3	15.2	15.1	15.0	14.8	14.6	14.5	14.4
	BF	0.00	0.25	0.18	0.13	0.13	0.24	0.47	0.00	0.27	0.20	0.15	0.13	0.26	0.50
95	TC	310	290	270	244	219	194	178	315	294	274	248	222	197	181
	SHC	93	121	149	184	219	194	178	104	132	160	194	222	197	181
	kW	17.4	17.2	17.1	16.9	16.7	16.4	16.3	17.6	17.4	17.2	17.0	16.8	16.6	16.4
	BF	0.00	0.30	0.23	0.18	0.16	0.29	0.52	0.00	0.32	0.25	0.21	0.17	0.31	0.55
105	TC	297	277	257	232	206	181	166	302	281	261	235	210	184	169
	SHC	73	105	138	179	206	181	166	86	118	150	189	210	184	169
	kW	19.7	19.5	19.3	19.1	18.8	18.5	18.4	19.9	19.7	19.5	19.2	18.9	18.7	18.5
	BF	0.00	0.33	0.26	0.23	0.21	0.32	0.55	0.00	0.36	0.28	0.26	0.22	0.34	0.58
115	TC	284	264	244	219	194	169	154	289	268	248	223	198	172	157
	SHC	53	90	127	173	194	169	154	67	103	139	185	198	172	157
	kW	22.1	21.8	21.6	21.3	20.9	20.6	20.4	22.3	22.0	21.7	21.4	21.1	20.8	20.6
	BF	0.00	0.38	0.31	0.27	0.24	0.36	0.58	0.00	0.40	0.33	0.31	0.26	0.38	0.60
125	TC	270	250	231	206	181	156	141	276	256	236	210	185	160	145
	SHC	32	74	115	167	181	156	141	48	89	129	180	185	160	145
	kW	24.4	24.1	23.8	23.4	23.1	22.7	22.5	24.6	24.3	24.0	23.6	23.2	22.9	22.6
	BF	0.00	0.41	0.35	0.32	0.29	0.40	0.60	0.00	0.44	0.37	0.37	0.31	0.43	0.63

# Performance data (cont)



## COOLING CAPACITIES (cont)

### 48PG24 (20 Tons) — UNIT WITH HUMIDI-MIZER™ SYSTEM — COOLING MODE (cont)

Temp (F) Air Entering Condenser (Edb)	Air Entering Evaporator — Cfm							
	10,000							
	Air Entering Evaporator — Ewb (F)							
	80	76	72	67	62	57	54	
60	TC	362	341	320	294	267	241	225
	SHC	177	189	201	216	230	241	225
	kW	9.4	9.4	9.4	9.3	9.3	9.3	9.3
	BF	0.00	0.16	0.10	0.05	0.06	0.14	0.35
70	TC	350	329	308	281	255	229	213
	SHC	159	175	192	212	232	229	213
	kW	11.8	11.7	11.6	11.6	11.5	11.4	11.3
	BF	0.00	0.23	0.14	0.07	0.08	0.21	0.47
75	TC	343	322	301	275	249	223	207
	SHC	150	169	187	210	233	223	207
	kW	13.0	12.9	12.8	12.7	12.6	12.4	12.4
	BF	0.00	0.25	0.17	0.10	0.09	0.23	0.49
85	TC	331	310	289	263	237	211	195
	SHC	132	155	178	206	235	211	195
	kW	15.3	15.2	15.1	14.9	14.7	14.5	14.4
	BF	0.00	0.29	0.21	0.17	0.14	0.27	0.53
95	TC	318	298	277	251	225	199	184
	SHC	115	142	169	203	225	199	184
	kW	17.7	17.5	17.3	17.1	16.9	16.7	16.5
	BF	0.00	0.34	0.26	0.23	0.18	0.33	0.59
105	TC	306	285	265	239	213	187	172
	SHC	97	128	160	199	213	187	172
	kW	20.1	19.8	19.6	19.3	19.0	18.8	18.6
	BF	0.00	0.38	0.30	0.29	0.23	0.36	0.61
115	TC	293	273	252	227	201	175	160
	SHC	79	115	150	195	201	175	160
	kW	22.4	22.2	21.9	21.5	21.2	20.9	20.7
	BF	0.00	0.43	0.35	0.35	0.27	0.40	0.63
125	TC	281	260	240	214	189	164	148
	SHC	61	101	141	191	189	164	148
	kW	24.8	24.5	24.2	23.8	23.4	23.0	22.7
	BF	0.00	0.47	0.39	0.41	0.33	0.46	0.65

### LEGEND

- BF — Bypass Factor
- Edb — Entering Dry-Bulb
- Ewb — Entering Wet-Bulb
- kW — Compressor Motor Power Input
- ldb — Leaving Dry-Bulb
- lwb — Leaving Wet-Bulb
- SHC — Sensible Heat Capacity (1000 Btuh) Gross
- TC — Total Capacity (1000 Btuh) Gross

### NOTES:

1. Direct interpolation is permissible. Do not extrapolate.
2. The following formulas may be used:

$$t_{ldb} = t_{edb} - \frac{\text{sensible capacity (Btuh)}}{1.10 \times \text{cfm}}$$

$$t_{lwb} = \text{Wet-bulb temperature corresponding to enthalpy of air leaving evaporator coil (} h_{lwb} \text{)}$$

$$h_{lwb} = h_{ewb} - \frac{\text{total capacity (Btuh)}}{4.5 \times \text{cfm}}$$

Where:  $h_{ewb}$  = Enthalpy of air entering evaporator coil

3. The SHC is based on 80 F edb temperature of air entering evaporator coil. Below 80 F edb, subtract (corr factor x cfm) from SHC. Above 80 F edb, add (corr factor x cfm) to SHC.

BYPASS FACTOR (BF)	ENTERING AIR DRY-BULB TEMP (F)					
	79	78	77	76	75	under 75
	81	82	83	84	85	over 85
	Correction Factor					
.05	1.04	2.07	3.11	4.14	5.18	Use formula shown below.
.10	.98	1.96	2.94	3.92	4.90	
.20	.87	1.74	2.62	3.49	4.36	
.30	.76	1.53	2.29	3.05	3.82	

Interpolation is permissible.

$$\text{Correction Factor} = 1.09 \times (1 - \text{BF}) \times (\text{edb} - 80).$$



**COOLING CAPACITIES (cont)**

**48PG24 (20 Tons) — UNIT WITH HUMIDI-MIZER™ SYSTEM — SUBCOOLING MODE**

Temp (F) Air Entering Condenser (Edb)		Air Entering Evaporator — Cfm													
		6000							7000						
		Air Entering Evaporator — Ewb (F)													
		80	76	72	67	62	57	54	80	76	72	67	62	57	54
60	TC	352	330	309	283	257	230	214	357	336	314	288	261	234	218
	SHC kW	149 9.1	159 9.1	169 9.0	181 9.0	194 9.0	206 9.0	214 9.0	158 9.2	168 9.2	177 9.2	189 9.1	201 9.1	213 9.1	218 9.1
70	TC	335	314	293	267	241	215	199	342	320	299	273	246	220	204
	SHC kW	122 11.3	136 11.3	150 11.2	168 11.2	186 11.1	204 11.0	199 11.0	133 11.5	147 11.4	161 11.4	178 11.3	195 11.2	212 11.1	204 11.1
75	TC	327	306	285	259	233	207	192	334	313	292	265	239	213	197
	SHC kW	108 12.5	125 12.4	141 12.3	162 12.2	182 12.1	203 12.0	192 12.0	121 12.6	137 12.5	152 12.5	172 12.4	192 12.2	212 12.1	197 12.1
85	TC	310	290	269	243	218	192	177	318	297	276	250	224	198	182
	SHC kW	82 14.8	102 14.6	123 14.5	149 14.4	175 14.2	192 14.1	177 14.0	96 14.9	116 14.8	136 14.7	161 14.5	186 14.3	198 14.2	182 14.1
95	TC	293	273	253	228	202	177	162	303	282	261	235	209	184	168
	SHC kW	55 17.0	80 16.9	105 16.7	136 16.5	167 16.3	177 16.1	162 16.0	71 17.2	95 17.0	119 16.9	149 16.7	179 16.4	184 16.2	168 16.1
105	TC	277	257	237	212	187	162	147	287	266	246	220	195	169	154
	SHC kW	28 19.3	57 19.1	86 18.9	123 18.6	159 18.4	162 18.1	147 18.0	46 19.5	74 19.3	102 19.1	137 18.8	173 18.5	169 18.3	154 18.1
115	TC	260	240	221	196	171	147	132	271	251	231	205	180	155	139
	SHC kW	1 21.6	35 21.3	68 21.1	110 20.8	152 20.5	147 20.1	132 20.0	20 21.8	53 21.5	85 21.3	126 21.0	166 20.6	155 20.3	139 20.1
125	TC	244	224	205	180	156	131	117	256	236	215	190	165	140	125
	SHC kW	-25 23.8	12 23.5	50 23.3	97 22.9	144 22.5	131 22.2	117 22.0	-5 24.1	32 23.8	69 23.5	114 23.1	160 22.7	140 22.4	125 22.1

**48PG24 (20 Tons) — UNIT WITH HUMIDI-MIZER SYSTEM — SUBCOOLING MODE (cont)**

Temp (F) Air Entering Condenser (Edb)		Air Entering Evaporator — Cfm													
		8000							9000						
		Air Entering Evaporator — Ewb (F)													
		80	76	72	67	62	57	54	80	76	72	67	62	57	54
60	TC	362	340	319	292	265	238	221	366	344	322	295	268	240	224
	SHC kW	167 9.3	176 9.3	185 9.2	196 9.2	208 9.2	219 9.1	221 9.1	174 9.4	183 9.3	192 9.3	203 9.3	214 9.2	225 9.2	224 9.2
70	TC	347	326	304	277	251	224	208	352	330	308	281	254	227	211
	SHC kW	143 11.6	156 11.5	170 11.5	186 11.4	203 11.3	219 11.2	208 11.1	152 11.7	164 11.6	177 11.5	193 11.4	209 11.3	225 11.3	211 11.2
75	TC	340	318	297	270	244	217	201	345	323	301	274	247	220	204
	SHC kW	131 12.8	147 12.7	162 12.6	181 12.5	200 12.3	217 12.2	201 12.1	140 12.8	155 12.7	170 12.6	189 12.5	207 12.4	220 12.3	204 12.2
85	TC	325	304	282	256	229	203	187	331	309	288	261	234	207	191
	SHC kW	108 15.1	127 14.9	146 14.8	171 14.6	195 14.4	203 14.3	187 14.2	118 15.2	137 15.0	156 14.9	179 14.7	203 14.5	207 14.3	191 14.2
95	TC	310	289	268	242	215	189	173	316	295	274	247	220	194	178
	SHC kW	84 17.4	107 17.2	131 17.0	160 16.8	190 16.6	189 16.3	173 16.2	96 17.5	119 17.3	141 17.1	170 16.9	199 16.6	194 16.4	178 16.3
105	TC	295	274	253	227	201	175	159	302	281	260	233	207	180	164
	SHC kW	60 19.7	88 19.4	115 19.2	150 18.9	184 18.7	175 18.4	159 18.2	73 19.8	100 19.6	127 19.3	161 19.1	194 18.8	180 18.5	164 18.3
115	TC	280	260	239	213	187	161	146	288	267	246	220	193	167	151
	SHC kW	37 22.0	68 21.7	100 21.4	140 21.1	179 20.8	161 20.4	146 20.2	51 22.1	82 21.8	113 21.6	152 21.2	190 20.9	167 20.5	151 20.3
125	TC	266	245	225	199	173	147	132	274	253	232	206	180	153	138
	SHC kW	13 24.3	49 24.0	85 23.7	129 23.3	173 22.9	147 22.5	132 22.3	28 24.4	63 24.1	98 23.8	142 23.4	180 23.0	153 22.6	138 22.4

# Performance data (cont)



## COOLING CAPACITIES (cont)

48PG24 (20 Tons) — UNIT WITH HUMIDI-MIZER™ SYSTEM — SUBCOOLING MODE (cont)							
Temp (F) Air Entering Condenser (Edb)	Air Entering Evaporator — Cfm						
	10,000						
	Air Entering Evaporator — Ewb (F)						
	80	76	72	67	62	57	54
60	TC 369	347	325	298	270	243	226
	SHC 180	189	197	208	218	229	226
	kW 9.4	9.4	9.4	9.3	9.3	9.2	9.2
70	TC 356	334	312	285	257	230	214
	SHC 159	171	184	200	215	230	214
	kW 11.8	11.7	11.6	11.5	11.4	11.3	11.2
75	TC 349	327	305	278	251	223	207
	SHC 148	163	177	195	213	223	207
	kW 12.9	12.8	12.7	12.6	12.5	12.3	12.3
85	TC 335	314	292	265	238	210	194
	SHC 127	146	164	187	210	210	194
	kW 15.2	15.1	15.0	14.8	14.6	14.4	14.3
95	TC 322	300	279	252	225	198	181
	SHC 106	128	151	179	207	198	181
	kW 17.6	17.4	17.2	17.0	16.7	16.5	16.3
105	TC 309	287	265	238	211	185	168
	SHC 85	111	137	170	203	185	168
	kW 19.9	19.7	19.4	19.1	18.8	18.6	18.4
115	TC 295	274	252	225	198	172	155
	SHC 63	94	124	162	198	172	155
	kW 22.2	22.0	21.7	21.3	21.0	20.6	20.4
125	TC 282	260	239	212	185	159	143
	SHC 42	76	111	154	185	159	143
	kW 24.6	24.2	23.9	23.5	23.1	22.7	22.5

### LEGEND

- Edb — Entering Dry-Bulb
- Ewb — Entering Wet-Bulb
- kW — Compressor Motor Power Input
- ldb — Leaving Dry-Bulb
- lwb — Leaving Wet-Bulb
- SHC — Sensible Heat Capacity (1000 Btuh) Gross
- TC — Total Capacity (1000 Btuh) Gross

### NOTES:

1. Direct interpolation is permissible. Do not extrapolate.
2. The following formulas may be used:

$$t_{ldb} = t_{edb} - \frac{\text{sensible capacity (Btuh)}}{1.10 \times \text{cfm}}$$

$t_{lwb}$  = Wet-bulb temperature corresponding to enthalpy of air leaving evaporator coil ( $h_{lwb}$ )

$$h_{lwb} = h_{ewb} - \frac{\text{total capacity (Btuh)}}{4.5 \times \text{cfm}}$$

Where:  $h_{ewb}$  = Enthalpy of air entering evaporator coil

## 48PG24 (20 Tons) — UNIT WITH HUMIDI-MIZER SYSTEM — HOT GAS REHEAT MODE — ALL CIRCUITS

Temp (F) Air Ent Condenser (Edb)	Air Entering Evaporator — Ewb (F)														
	75 Dry Bulb 62.5 Wet Bulb (50% RH)					75 Dry Bulb 64 Wet Bulb (55% RH)					75 Dry Bulb 65.3 Wet Bulb (60% RH)				
	Air Entering Evaporator — Cfm														
	6000	7000	8000	9000	10,000	6000	7000	8000	9000	10,000	6000	7000	8000	9000	10,000
80	TC 98	104	108	112	115	101	107	112	116	119	104	110	115	119	122
	SHC 22	30	38	44	51	11	19	26	33	39	2	10	17	23	29
	kW 15.2	15.2	15.3	15.3	15.3	15.3	15.3	15.3	15.4	15.4	15.4	15.4	15.4	15.4	15.4
75	TC 103	108	112	116	119	106	112	116	120	123	109	115	119	123	126
	SHC 27	35	42	49	55	17	25	32	38	44	9	16	23	29	35
	kW 14.7	14.7	14.7	14.8	14.8	14.8	14.8	14.8	14.9	14.9	14.9	14.9	14.9	14.9	14.9
70	TC 108	113	117	120	123	111	116	120	123	126	114	119	123	127	130
	SHC 32	39	47	53	59	23	30	37	43	49	15	22	29	35	41
	kW 14.2	14.2	14.2	14.3	14.3	14.3	14.3	14.3	14.4	14.4	14.4	14.4	14.4	14.4	14.4
60	TC 117	121	125	127	130	120	125	128	131	134	123	128	131	134	137
	SHC 41	49	56	62	67	34	41	48	54	59	28	35	41	47	52
	kW 13.2	13.2	13.2	13.2	13.3	13.3	13.3	13.3	13.4	13.4	13.4	13.4	13.4	13.4	13.5
50	TC 126	130	133	135	137	130	133	136	139	141	133	137	140	142	144
	SHC 51	58	65	70	76	46	52	59	64	69	41	47	53	59	64
	kW 12.2	12.2	12.2	12.2	12.2	12.3	12.3	12.3	12.3	12.3	12.4	12.4	12.4	12.4	12.5

## 48PG24 (20 Tons) — UNIT WITH HUMIDI-MIZER SYSTEM — HOT GAS REHEAT MODE — CIRCUIT A ONLY

Temp (F) Air Entering Condenser (Edb)	Air Entering Evaporator — Ewb (F)														
	75 Dry Bulb 62.5 Wet Bulb (50% RH)					75 Dry Bulb 64 Wet Bulb (55% RH)					75 Dry Bulb 65.3 Wet Bulb (60% RH)				
	Air Entering Evaporator — Cfm														
	6000	7000	8000	9000	10,000	6000	7000	8000	9000	10,000	6000	7000	8000	9000	10,000
50	TC 68	75	82	87	92	69	77	84	89	94	71	79	86	91	96
	SHC 28	35	41	46	50	22	29	35	40	44	16	24	30	35	39
	kW 6.7	6.7	6.7	6.7	6.7	6.7	6.7	6.7	6.7	6.7	6.7	6.7	6.7	6.7	6.7
40	TC 72	78	83	87	91	74	80	85	89	93	75	82	87	91	95
	SHC 30	36	40	44	48	25	31	36	40	43	21	27	32	36	39
	kW 6.5	6.5	6.5	6.6	6.6	6.5	6.5	6.6	6.6	6.6	6.5	6.6	6.6	6.6	6.6

### LEGEND

- Edb — Entering Dry-Bulb
- Ewb — Entering Wet-Bulb
- kW — Compressor Motor Power Input
- ldb — Leaving Dry-Bulb
- lwb — Leaving Wet-Bulb
- RH — Relative Humidity
- SHC — Sensible Heat Capacity (1000 Btuh) Gross
- TC — Total Capacity (1000 Btuh) Gross

### NOTES:

1. Direct interpolation is permissible. Do not extrapolate.
2. The following formulas may be used:

$$t_{ldb} = t_{edb} - \frac{\text{sensible capacity (Btuh)}}{1.10 \times \text{cfm}}$$

$t_{lwb}$  = Wet-bulb temperature corresponding to enthalpy of air leaving evaporator coil ( $h_{lwb}$ )

$$h_{lwb} = h_{ewb} - \frac{\text{total capacity (Btuh)}}{4.5 \times \text{cfm}}$$

Where:  $h_{ewb}$  = Enthalpy of air entering evaporator coil



### COOLING CAPACITIES (cont)

#### 48PG28 (25 Tons) — STANDARD UNIT

Temp (F) Air Ent Condenser (Edb)		Air Entering Evaporator — Cfm													
		7,500							8,250						
		Air Entering Evaporator — Ewb (F)													
		80	76	72	67	62	57	54	80	76	72	67	62	57	54
60	TC	457	432	407	375	343	312	293	460	434	409	377	345	313	294
	SHC	184	199	214	233	251	270	281	193	209	224	243	262	281	293
	KW	12.3	12.3	12.3	12.3	12.3	12.3	12.3	12.5	12.4	12.4	12.4	12.4	12.4	12.4
	BF	0.00	0.21	0.10	0.04	0.06	0.16	0.26	0.00	0.23	0.11	0.05	0.06	0.17	0.28
70	TC	436	411	387	356	325	294	275	439	414	389	358	327	296	277
	SHC	158	178	199	224	250	275	275	168	188	209	235	261	287	277
	KW	15.2	15.2	15.1	15.1	15.1	15.0	15.0	15.4	15.3	15.3	15.2	15.2	15.2	15.1
	BF	0.00	0.21	0.10	0.04	0.06	0.16	0.26	0.00	0.23	0.11	0.05	0.06	0.17	0.28
75	TC	425	401	377	346	316	285	267	428	404	379	349	318	287	269
	SHC	145	168	191	220	249	277	267	155	178	202	231	260	287	269
	KW	16.6	16.6	16.6	16.5	16.5	16.4	16.4	16.8	16.8	16.7	16.7	16.6	16.5	16.5
	BF	0.00	0.22	0.11	0.05	0.07	0.17	0.27	0.00	0.24	0.12	0.06	0.08	0.18	0.29
85	TC	404	380	356	327	297	267	250	408	384	360	330	300	270	252
	SHC	119	147	176	211	247	267	250	129	158	187	223	259	270	252
	KW	19.5	19.5	19.4	19.3	19.2	19.2	19.1	19.7	19.7	19.6	19.5	19.4	19.3	19.2
	BF	0.00	0.23	0.13	0.06	0.09	0.19	0.29	0.00	0.25	0.14	0.07	0.10	0.20	0.31
95	TC	383	360	336	308	279	250	233	387	363	340	311	282	253	235
	SHC	93	127	161	203	245	250	233	103	138	172	215	258	253	235
	KW	22.1	22.0	21.9	21.8	21.8	21.7	21.6	22.7	22.6	22.5	22.3	22.2	22.1	22.0
	BF	0.00	0.23	0.13	0.06	0.09	0.19	0.29	0.00	0.25	0.14	0.07	0.10	0.20	0.31
105	TC	361	339	316	288	260	232	215	366	343	320	292	264	235	218
	SHC	67	106	145	194	243	232	215	77	117	157	207	256	235	218
	KW	25.3	25.2	25.1	24.9	24.8	24.6	24.5	25.6	25.4	25.3	25.2	25.0	24.8	24.7
	BF	0.00	0.24	0.13	0.07	0.09	0.19	0.29	0.00	0.26	0.14	0.08	0.10	0.20	0.31
115	TC	340	318	296	269	242	215	198	345	323	301	273	246	218	202
	SHC	41	86	130	186	241	215	198	52	97	142	198	246	218	202
	KW	28.2	28.1	27.9	27.7	27.6	27.4	27.3	28.5	28.3	28.2	28.0	27.8	27.6	27.5
	BF	0.00	0.25	0.14	0.08	0.10	0.20	0.30	0.00	0.27	0.15	0.09	0.11	0.22	0.32
125	TC	319	297	276	250	223	197	181	324	302	281	254	228	201	185
	SHC	16	65	115	177	223	197	181	26	77	127	190	228	201	185
	KW	31.1	30.9	30.8	30.5	30.3	30.1	30.0	31.4	31.2	31.0	30.8	30.6	30.3	30.2
	BF	0.00	0.25	0.15	0.09	0.11	0.21	0.31	0.00	0.27	0.16	0.10	0.12	0.23	0.33

#### 48PG28 (25 Tons) — STANDARD UNIT (cont)

Temp (F) Air Ent Condenser (Edb)		Air Entering Evaporator — Cfm													
		9,500							10,750						
		Air Entering Evaporator — Ewb (F)													
		80	76	72	67	62	57	54	80	76	72	67	62	57	54
60	TC	463	437	412	380	348	315	296	465	440	414	382	350	317	298
	SHC	207	222	238	257	277	296	296	219	235	250	270	290	309	298
	KW	12.6	12.6	12.6	12.6	12.5	12.5	12.5	12.8	12.7	12.7	12.7	12.6	12.6	12.6
	BF	0.00	0.24	0.12	0.05	0.07	0.18	0.30	0.00	0.26	0.12	0.06	0.07	0.20	0.32
70	TC	442	417	392	361	330	299	280	445	420	395	364	332	301	282
	SHC	181	202	223	250	276	299	280	193	215	236	263	290	301	282
	KW	15.6	15.5	15.5	15.4	15.4	15.3	15.3	15.7	15.7	15.6	15.6	15.5	15.4	15.4
	BF	0.00	0.24	0.12	0.05	0.07	0.18	0.30	0.00	0.26	0.12	0.06	0.07	0.20	0.32
75	TC	432	408	383	352	321	290	272	436	411	386	355	324	292	274
	SHC	168	192	216	246	276	290	272	180	205	229	259	290	292	274
	KW	17.0	17.0	16.9	16.8	16.8	16.7	16.6	17.2	17.2	17.1	17.0	16.9	16.8	16.8
	BF	0.00	0.25	0.13	0.06	0.08	0.20	0.31	0.00	0.27	0.13	0.07	0.09	0.21	0.33
85	TC	412	388	364	334	303	273	255	416	391	367	337	306	276	258
	SHC	143	172	201	238	275	273	255	155	185	215	252	290	276	258
	KW	20.0	19.9	19.8	19.7	19.6	19.5	19.4	20.2	20.1	20.0	19.9	19.7	19.6	19.5
	BF	0.00	0.26	0.15	0.07	0.10	0.22	0.33	0.00	0.28	0.16	0.08	0.11	0.23	0.36
95	TC	392	368	345	315	286	256	239	396	372	348	319	289	259	241
	SHC	117	152	187	231	275	256	239	129	165	201	245	289	259	241
	KW	22.9	22.8	22.7	22.6	22.4	22.3	22.2	23.2	23.0	22.9	22.7	22.6	22.4	22.3
	BF	0.00	0.26	0.15	0.07	0.10	0.22	0.33	0.00	0.28	0.16	0.08	0.11	0.23	0.36
105	TC	371	348	325	297	268	239	222	376	353	329	301	272	243	225
	SHC	91	132	172	223	268	239	222	104	145	186	238	272	243	225
	KW	25.9	25.7	25.6	25.4	25.2	25.0	24.9	26.1	26.0	25.8	25.6	25.4	25.2	25.1
	BF	0.00	0.28	0.15	0.08	0.10	0.22	0.33	0.00	0.29	0.16	0.09	0.11	0.23	0.36
115	TC	351	329	306	278	250	222	206	356	333	311	283	254	226	209
	SHC	65	112	158	216	250	222	206	78	125	172	231	254	226	209
	KW	28.8	28.7	28.5	28.3	28.0	27.8	27.7	29.1	28.9	28.7	28.5	28.3	28.0	27.9
	BF	0.00	0.29	0.16	0.09	0.12	0.23	0.35	0.00	0.31	0.17	0.10	0.12	0.25	0.37
125	TC	330	309	287	260	233	206	189	336	314	292	264	237	209	193
	SHC	40	92	143	208	233	206	189	52	105	158	224	237	209	193
	KW	31.8	31.6	31.4	31.1	30.9	30.6	30.4	32.1	31.9	31.6	31.4	31.1	30.8	30.6
	BF	0.00	0.29	0.17	0.10	0.13	0.24	0.36	0.00	0.31	0.18	0.11	0.13	0.26	0.38

# Performance data (cont)



## COOLING CAPACITIES (cont)

48PG28 (25 Tons) — STANDARD UNIT (cont)								
Temp (F) Air Ent Condenser (Edb)		Air Entering Evaporator — Cfm						
		12,000						
		Air Entering Evaporator — Ewb (F)						
		80	76	72	67	62	57	54
60	TC	468	442	416	384	351	319	299
	SHC	230	246	262	282	302	319	299
	kW	12.9	12.8	12.8	12.8	12.7	12.7	12.7
	BF	0.00	0.27	0.13	0.06	0.08	0.21	0.34
70	TC	448	423	397	366	334	303	284
	SHC	204	226	248	275	302	303	284
	kW	15.9	15.8	15.7	15.7	15.6	15.5	15.5
	BF	0.00	0.27	0.13	0.06	0.08	0.21	0.34
75	TC	438	413	388	357	326	294	276
	SHC	192	216	241	272	303	294	276
	kW	17.4	17.3	17.2	17.1	17.0	16.9	16.9
	BF	0.00	0.29	0.14	0.07	0.09	0.22	0.35
85	TC	419	394	370	339	309	278	260
	SHC	166	197	227	265	303	278	260
	kW	20.4	20.2	20.1	20.0	19.9	19.7	19.6
	BF	0.00	0.30	0.17	0.08	0.12	0.25	0.38
95	TC	399	375	351	322	292	262	244
	SHC	140	177	213	259	292	262	244
	kW	23.4	23.2	23.1	22.9	22.7	22.5	22.4
	BF	0.00	0.30	0.17	0.08	0.12	0.25	0.38
105	TC	380	356	333	304	275	245	228
	SHC	115	157	199	252	275	245	228
	kW	26.3	26.2	26.0	25.8	25.6	25.4	25.2
	BF	0.00	0.31	0.17	0.09	0.12	0.25	0.38
115	TC	360	337	315	286	258	229	212
	SHC	89	137	185	245	258	229	212
	kW	29.3	29.1	28.9	28.7	28.4	28.2	28.0
	BF	0.00	0.33	0.18	0.10	0.13	0.26	0.39
125	TC	341	318	296	268	241	213	196
	SHC	64	118	171	239	241	213	196
	kW	32.3	32.1	31.9	31.6	31.3	31.0	30.8
	BF	0.00	0.33	0.20	0.11	0.14	0.27	0.40

- LEGEND
- BF — Bypass Factor
  - Edb — Entering Dry-Bulb
  - Ewb — Entering Wet-Bulb
  - kW — Compressor Motor Power Input
  - ldb — Leaving Dry-Bulb
  - lwb — Leaving Wet-Bulb
  - SHC — Sensible Heat Capacity (1000 Btuh) Gross
  - TC — Total Capacity (1000 Btuh) Gross

NOTES:

1. Direct interpolation is permissible. Do not extrapolate.
2. The following formulas may be used:

$$t_{ldb} = t_{edb} - \frac{\text{sensible capacity (Btuh)}}{1.10 \times \text{cfm}}$$

$$t_{lwb} = \text{Wet-bulb temperature corresponding to enthalpy of air leaving evaporator coil } (h_{lwb})$$

$$h_{lwb} = h_{ewb} - \frac{\text{total capacity (Btuh)}}{4.5 \times \text{cfm}}$$

Where:  $h_{ewb}$  = Enthalpy of air entering evaporator coil

3. The SHC is based on 80 F edb temperature of air entering evaporator coil. Below 80 F edb, subtract (corr factor x cfm) from SHC. Above 80 F edb, add (corr factor x cfm) to SHC.

BYPASS FACTOR (BF)	ENTERING AIR DRY-BULB TEMP (F)					
	79	78	77	76	75	under 75
	81	82	83	84	85	over 85
	Correction Factor					
.05	1.04	2.07	3.11	4.14	5.18	Use formula shown below.
.10	.98	1.96	2.94	3.92	4.90	
.20	.87	1.74	2.62	3.49	4.36	
.30	.76	1.53	2.29	3.05	3.82	

Interpolation is permissible.

$$\text{Correction Factor} = 1.09 \times (1 - \text{BF}) \times (\text{edb} - 80).$$



**COOLING CAPACITIES (cont)**

**48PG28 (25 Tons) — UNIT WITH HUMIDI-MIZER™ SYSTEM — COOLING MODE**

Temp (F) Air Entering Condenser (Edb)		Air Entering Evaporator — Cfm													
		7500							8250						
		Air Entering Evaporator — Ewb (F)													
		80	76	72	67	62	57	54	80	76	72	67	62	57	54
60	TC	447	423	398	367	337	306	288	449	425	400	369	339	308	289
	SHC	182	198	213	233	253	273	284	190	206	222	242	262	282	289
	kW	11.9	11.9	11.8	11.8	11.8	11.7	11.7	12.0	12.0	11.9	11.9	11.8	11.8	11.8
	BF	0.00	0.21	0.10	0.04	0.06	0.16	0.26	0.00	0.23	0.11	0.05	0.06	0.17	0.28
70	TC	426	402	379	349	319	289	271	429	405	381	351	321	291	273
	SHC	155	176	197	224	251	277	271	163	184	206	233	260	287	273
	kW	15.1	15.0	14.9	14.8	14.7	14.6	14.5	15.2	15.1	15.0	14.9	14.7	14.6	14.5
	BF	0.00	0.21	0.10	0.04	0.06	0.16	0.26	0.00	0.23	0.11	0.05	0.06	0.17	0.28
75	TC	416	392	369	339	310	281	263	419	395	371	342	312	283	265
	SHC	141	165	189	219	249	279	263	149	173	198	229	259	283	265
	kW	16.7	16.6	16.4	16.3	16.1	16.0	15.9	16.8	16.7	16.5	16.4	16.2	16.0	15.9
	BF	0.00	0.22	0.11	0.05	0.07	0.17	0.27	0.00	0.24	0.12	0.06	0.08	0.18	0.29
85	TC	395	372	349	321	292	264	247	398	375	352	323	295	266	249
	SHC	114	144	173	210	247	264	247	122	152	182	220	257	266	249
	kW	19.9	19.7	19.5	19.2	19.0	18.8	18.6	20.0	19.8	19.6	19.4	19.1	18.8	18.7
	BF	0.00	0.23	0.13	0.06	0.09	0.19	0.29	0.00	0.25	0.14	0.07	0.10	0.20	0.31
95	TC	374	352	330	302	274	247	230	378	355	333	305	277	249	232
	SHC	87	122	157	201	245	247	230	94	130	166	211	255	249	232
	kW	23.0	22.8	22.5	22.2	21.9	21.6	21.4	23.2	23.0	22.7	22.4	22.0	21.7	21.5
	BF	0.00	0.23	0.13	0.06	0.09	0.19	0.29	0.00	0.25	0.14	0.07	0.10	0.20	0.31
105	TC	353	332	310	283	257	230	214	357	335	314	287	260	233	216
	SHC	60	101	141	192	243	230	214	67	108	150	202	253	233	216
	kW	26.2	25.9	25.6	25.2	24.8	24.4	24.1	26.5	26.1	25.8	25.3	24.9	24.5	24.2
	BF	0.00	0.24	0.13	0.07	0.09	0.19	0.29	0.00	0.26	0.14	0.08	0.10	0.20	0.31
115	TC	332	311	291	265	239	213	197	337	316	295	268	242	216	200
	SHC	33	79	125	183	239	213	197	40	87	134	193	242	216	200
	kW	29.4	29.0	28.6	28.1	27.7	27.2	26.9	29.7	29.3	28.9	28.3	27.8	27.3	27.0
	BF	0.00	0.25	0.14	0.08	0.10	0.20	0.30	0.00	0.27	0.15	0.09	0.11	0.22	0.32
125	TC	311	291	271	246	221	196	181	316	296	275	250	225	199	184
	SHC	6	58	109	174	221	196	181	13	65	118	184	225	199	184
	kW	32.6	32.1	31.7	31.1	30.6	30.0	29.6	32.9	32.4	31.9	31.3	30.7	30.1	29.8
	BF	0.00	0.25	0.15	0.09	0.11	0.21	0.31	0.00	0.27	0.16	0.10	0.12	0.23	0.33

**48PG28 (25 Tons) — UNIT WITH HUMIDI-MIZER SYSTEM — COOLING MODE (cont)**

Temp (F) Air Entering Condenser (Edb)		Air Entering Evaporator — Cfm													
		9500							10,750						
		Air Entering Evaporator — Ewb (F)													
		80	76	72	67	62	57	54	80	76	72	67	62	57	54
60	TC	452	427	403	372	341	310	291	454	429	405	373	342	311	293
	SHC	201	217	234	254	275	295	291	211	227	244	265	286	307	293
	kW	12.1	12.1	12.0	12.0	11.9	11.8	11.8	12.2	12.2	12.1	12.0	12.0	11.9	11.8
	BF	0.00	0.24	0.12	0.05	0.07	0.18	0.30	0.00	0.26	0.12	0.06	0.07	0.20	0.32
70	TC	432	408	384	354	323	293	275	435	410	386	356	326	295	277
	SHC	173	195	218	245	273	293	275	183	205	228	257	285	295	277
	kW	15.4	15.3	15.1	15.0	14.8	14.7	14.6	15.5	15.4	15.3	15.1	14.9	14.7	14.6
	BF	0.00	0.24	0.12	0.05	0.07	0.18	0.30	0.00	0.26	0.12	0.06	0.07	0.20	0.32
75	TC	422	398	374	345	315	285	267	425	401	377	347	317	287	269
	SHC	159	184	210	241	272	285	267	168	194	220	252	284	287	269
	kW	17.0	16.8	16.7	16.5	16.3	16.1	16.0	17.2	17.0	16.8	16.6	16.4	16.2	16.0
	BF	0.00	0.25	0.13	0.06	0.08	0.20	0.31	0.00	0.27	0.13	0.07	0.09	0.21	0.33
85	TC	402	379	356	327	298	269	251	405	382	359	329	300	271	254
	SHC	131	162	193	232	271	269	251	140	172	204	243	283	271	254
	kW	20.3	20.0	19.8	19.5	19.2	18.9	18.8	20.4	20.2	20.0	19.6	19.3	19.0	18.8
	BF	0.00	0.26	0.15	0.07	0.10	0.22	0.33	0.00	0.28	0.16	0.08	0.11	0.23	0.36
95	TC	382	359	337	309	281	252	235	386	363	340	312	283	255	238
	SHC	104	141	177	223	269	252	235	112	150	188	235	282	255	238
	kW	23.5	23.2	22.9	22.5	22.2	21.8	21.6	23.7	23.4	23.1	22.7	22.3	21.9	21.7
	BF	0.00	0.26	0.15	0.07	0.10	0.22	0.33	0.00	0.28	0.16	0.08	0.11	0.23	0.36
105	TC	362	340	318	291	263	236	220	366	344	322	294	267	239	222
	SHC	76	119	161	214	263	236	220	84	128	171	226	267	239	222
	kW	26.8	26.4	26.0	25.6	25.1	24.6	24.4	27.0	26.6	26.2	25.7	25.2	24.8	24.5
	BF	0.00	0.28	0.15	0.08	0.10	0.22	0.33	0.00	0.29	0.16	0.09	0.11	0.23	0.36
115	TC	342	321	299	273	246	220	204	346	325	303	277	250	223	207
	SHC	48	97	145	206	246	220	204	56	106	155	217	250	223	207
	kW	30.0	29.6	29.1	28.6	28.0	27.5	27.1	30.3	29.8	29.4	28.8	28.2	27.6	27.3
	BF	0.00	0.29	0.16	0.09	0.12	0.23	0.35	0.00	0.31	0.17	0.10	0.12	0.25	0.37
125	TC	322	301	281	255	229	203	188	327	306	285	259	233	207	191
	SHC	21	75	129	197	229	203	188	28	84	139	209	233	207	191
	kW	33.3	32.7	32.2	31.6	31.0	30.3	29.9	33.6	33.0	32.5	31.8	31.1	30.5	30.1
	BF	0.00	0.29	0.17	0.10	0.13	0.24	0.36	0.00	0.31	0.18	0.11	0.13	0.26	0.38

# Performance data (cont)



## COOLING CAPACITIES (cont)

48PG28 (25 Tons) — UNIT WITH HUMIDI-MIZER™ SYSTEM — COOLING MODE (cont)								
Temp (F) Air Entering Condenser (Edb)		Air Entering Evaporator — Cfm						
		12,000						
		Air Entering Evaporator — Ewb (F)						
		80	76	72	67	62	57	54
60	TC	456	431	406	375	344	313	294
	SHC	220	237	254	275	297	313	294
	kW	12.3	12.3	12.2	12.1	12.0	11.9	11.9
	BF	0.00	0.27	0.13	0.06	0.08	0.21	0.34
70	TC	437	413	388	358	327	297	279
	SHC	191	214	238	267	296	297	279
	kW	15.6	15.5	15.3	15.2	15.0	14.8	14.7
	BF	0.00	0.27	0.13	0.06	0.08	0.21	0.34
75	TC	427	403	379	349	319	289	271
	SHC	177	203	230	262	295	289	271
	kW	17.3	17.1	16.9	16.7	16.5	16.2	16.1
	BF	0.00	0.29	0.14	0.07	0.09	0.22	0.35
85	TC	408	385	361	332	302	273	255
	SHC	149	181	213	254	294	273	255
	kW	20.6	20.3	20.1	19.8	19.4	19.1	18.9
	BF	0.00	0.30	0.17	0.08	0.12	0.25	0.38
95	TC	389	366	343	314	286	257	240
	SHC	120	159	197	245	286	257	240
	kW	23.9	23.6	23.2	22.8	22.4	22.0	21.7
	BF	0.00	0.30	0.17	0.08	0.12	0.25	0.38
105	TC	369	347	325	297	269	241	225
	SHC	92	136	181	237	269	241	225
	kW	27.2	26.8	26.4	25.9	25.4	24.9	24.5
	BF	0.00	0.31	0.17	0.09	0.12	0.25	0.38
115	TC	350	328	307	280	253	226	209
	SHC	63	114	165	228	253	226	209
	kW	30.5	30.0	29.6	29.0	28.3	27.7	27.4
	BF	0.00	0.33	0.18	0.10	0.13	0.26	0.39
125	TC	331	310	289	262	236	210	194
	SHC	35	92	149	220	236	210	194
	kW	33.8	33.3	32.7	32.0	31.3	30.6	30.2
	BF	0.00	0.33	0.20	0.11	0.14	0.27	0.40

### LEGEND

- BF — Bypass Factor
- Edb — Entering Dry-Bulb
- Ewb — Entering Wet-Bulb
- kW — Compressor Motor Power Input
- ldb — Leaving Dry-Bulb
- lwb — Leaving Wet-Bulb
- SHC — Sensible Heat Capacity (1000 Btuh) Gross
- TC — Total Capacity (1000 Btuh) Gross

### NOTES:

1. Direct interpolation is permissible. Do not extrapolate.
2. The following formulas may be used:

$$t_{ldb} = t_{edb} - \frac{\text{sensible capacity (Btuh)}}{1.10 \times \text{cfm}}$$

$t_{lwb}$  = Wet-bulb temperature corresponding to enthalpy of air leaving evaporator coil ( $h_{lwb}$ )

$$h_{lwb} = h_{ewb} - \frac{\text{total capacity (Btuh)}}{4.5 \times \text{cfm}}$$

Where:  $h_{ewb}$  = Enthalpy of air entering evaporator coil

3. The SHC is based on 80 F edb temperature of air entering evaporator coil. Below 80 F edb, subtract (corr factor x cfm) from SHC. Above 80 F edb, add (corr factor x cfm) to SHC.

BYPASS FACTOR (BF)	ENTERING AIR DRY-BULB TEMP (F)					
	79	78	77	76	75	under 75
	81	82	83	84	85	over 85
	Correction Factor					
.05	1.04	2.07	3.11	4.14	5.18	Use formula shown below.
.10	.98	1.96	2.94	3.92	4.90	
.20	.87	1.74	2.62	3.49	4.36	
.30	.76	1.53	2.29	3.05	3.82	

Interpolation is permissible.

$$\text{Correction Factor} = 1.09 \times (1 - \text{BF}) \times (\text{edb} - 80).$$



**COOLING CAPACITIES (cont)**

**48PG28 (25 Tons) — UNIT WITH HUMIDI-MIZER™ SYSTEM — SUBCOOLING MODE**

Temp (F) Air Entering Condenser (Edb)		Air Entering Evaporator — Cfm													
		7500							8250						
		Air Entering Evaporator — Ewb (F)													
		80	76	72	67	62	57	54	80	76	72	67	62	57	54
60	TC	448	423	397	366	334	303	284	451	426	400	368	337	305	286
	SHC	183	198	213	231	250	268	279	191	206	221	240	259	278	286
	kW	13.1	13.0	12.9	12.8	12.7	12.6	12.5	13.1	13.0	12.9	12.8	12.7	12.6	12.6
70	TC	425	400	376	345	314	284	265	429	404	379	348	317	286	268
	SHC	147	167	188	214	240	265	265	155	176	197	223	249	275	268
	kW	16.0	15.9	15.8	15.6	15.4	15.2	15.1	16.1	15.9	15.8	15.6	15.4	15.3	15.2
75	TC	413	389	365	334	304	274	256	417	393	368	338	307	277	258
	SHC	129	152	176	205	234	264	256	136	160	184	214	244	274	258
	kW	17.5	17.3	17.2	17.0	16.8	16.6	16.4	17.5	17.4	17.2	17.0	16.8	16.6	16.5
85	TC	390	367	343	314	284	255	237	395	371	347	317	288	258	240
	SHC	93	122	151	188	224	255	237	100	130	159	197	234	258	240
	kW	20.5	20.2	20.0	19.8	19.5	19.2	19.1	20.5	20.3	20.1	19.8	19.5	19.2	19.1
95	TC	367	344	321	293	264	236	218	372	349	326	297	268	239	222
	SHC	56	92	127	170	214	236	218	63	99	135	179	224	239	222
	kW	23.4	23.1	22.9	22.5	22.2	21.9	21.7	23.5	23.2	22.9	22.6	22.2	21.9	21.7
105	TC	344	322	300	272	244	216	200	350	327	305	277	249	220	204
	SHC	20	61	102	153	204	216	200	26	68	110	162	214	220	204
	kW	26.4	26.0	25.7	25.3	24.9	24.5	24.3	26.4	26.1	25.8	25.4	24.9	24.5	24.3
115	TC	321	299	278	251	224	197	181	327	305	284	256	229	202	185
	SHC	-16	31	78	136	194	197	181	-10	37	85	145	204	202	185
	kW	29.3	28.9	28.6	28.1	27.6	27.1	26.9	29.4	29.0	28.6	28.1	27.7	27.2	26.9
125	TC	298	277	256	230	204	178	162	305	284	262	236	209	183	167
	SHC	-52	0	53	119	184	178	162	-47	7	60	127	194	183	167
	kW	32.3	31.8	31.4	30.9	30.3	29.8	29.5	32.3	31.9	31.5	30.9	30.4	29.8	29.5

**48PG28 (25 Tons) — UNIT WITH HUMIDI-MIZER SYSTEM — SUBCOOLING MODE (cont)**

Temp (F) Air Entering Condenser (Edb)		Air Entering Evaporator — Cfm													
		9500							10,750						
		Air Entering Evaporator — Ewb (F)													
		80	76	72	67	62	57	54	80	76	72	67	62	57	54
60	TC	455	429	404	372	340	308	289	433	407	375	342	310	291	
	SHC	203	218	233	253	272	291	289	213	229	244	264	284	303	291
	kW	13.1	13.1	13.0	12.9	12.8	12.7	12.6	13.2	13.1	13.0	12.9	12.8	12.7	12.6
70	TC	433	408	383	352	321	290	271	437	412	387	355	324	292	273
	SHC	165	187	208	235	262	289	271	175	197	219	246	274	292	273
	kW	16.1	16.0	15.8	15.7	15.5	15.3	15.2	16.1	16.0	15.9	15.7	15.5	15.3	15.2
75	TC	422	398	373	342	311	280	262	426	402	377	346	314	283	265
	SHC	147	171	196	226	257	280	262	156	181	206	238	269	283	265
	kW	17.6	17.4	17.3	17.0	16.8	16.6	16.5	17.6	17.5	17.3	17.1	16.9	16.7	16.5
85	TC	400	376	352	322	292	262	244	405	381	357	326	296	266	247
	SHC	109	140	171	209	247	262	244	118	149	181	220	259	266	247
	kW	20.6	20.3	20.1	19.8	19.6	19.3	19.1	20.6	20.4	20.1	19.9	19.6	19.3	19.1
95	TC	379	355	332	302	273	244	226	384	360	337	307	277	248	230
	SHC	72	109	145	191	237	244	226	80	117	155	202	249	248	230
	kW	23.5	23.2	23.0	22.6	22.3	21.9	21.7	23.6	23.3	23.0	22.7	22.3	22.0	21.8
105	TC	357	334	311	283	254	226	208	363	340	317	288	259	230	212
	SHC	34	77	120	174	228	226	208	42	86	130	185	240	230	212
	kW	26.5	26.1	25.8	25.4	25.0	24.6	24.3	26.5	26.2	25.9	25.4	25.0	24.6	24.4
115	TC	335	313	291	263	235	207	191	342	319	296	268	240	212	195
	SHC	-3	46	95	156	218	207	191	4	54	104	167	230	212	195
	kW	29.4	29.1	28.7	28.2	27.7	27.2	27.0	29.5	29.1	28.7	28.2	27.8	27.3	27.0
125	TC	313	292	270	243	216	189	173	320	298	276	249	222	194	178
	SHC	-40	15	70	139	208	189	173	-34	22	79	150	220	194	178
	kW	32.4	32.0	31.5	31.0	30.4	29.9	29.6	32.5	32.0	31.6	31.0	30.5	29.9	29.6

# Performance data (cont)



## COOLING CAPACITIES (cont)

48PG28 (25 Tons) — UNIT WITH HUMIDI-MIZER™ SYSTEM — SUBCOOLING MODE (cont)												
Temp (F) Air Entering Condenser (Edb)		Air Entering Evaporator — Cfm										
		12,000										
		Air Entering Evaporator — Ewb (F)										
		80	76	72	67	62	57	54				
60	TC	461	435	409	377	345	312	293				
	SHC	222	238	254	274	294	312	293				
	kW	13.2	13.1	13.0	12.9	12.8	12.7	12.6				
70	TC	440	415	390	358	326	295	276				
	SHC	184	206	228	257	285	295	276				
	kW	16.2	16.0	15.9	15.7	15.5	15.3	15.2				
75	TC	430	405	380	349	317	286	267				
	SHC	164	190	216	248	280	286	267				
	kW	17.7	17.5	17.3	17.1	16.9	16.7	16.5				
85	TC	409	385	360	330	299	268	250				
	SHC	126	158	190	230	270	268	250				
	kW	20.6	20.4	20.2	19.9	19.6	19.3	19.2				
95	TC	389	365	341	311	281	251	233				
	SHC	87	126	164	212	260	251	233				
	kW	23.6	23.3	23.0	22.7	22.3	22.0	21.8				
105	TC	368	344	321	292	263	233	216				
	SHC	48	93	138	195	251	233	216				
	kW	26.6	26.2	25.9	25.5	25.1	24.6	24.4				
115	TC	347	324	302	273	244	216	199				
	SHC	10	61	113	177	241	216	199				
	kW	29.5	29.1	28.8	28.3	27.8	27.3	27.0				
125	TC	326	304	282	254	226	198	182				
	SHC	-29	29	87	159	226	198	182				
	kW	32.5	32.1	31.6	31.1	30.5	30.0	29.6				

### LEGEND

- Edb — Entering Dry-Bulb
- Ewb — Entering Wet-Bulb
- kW — Compressor Motor Power Input
- ldb — Leaving Dry-Bulb
- lwb — Leaving Wet-Bulb
- SHC — Sensible Heat Capacity (1000 Btuh) Gross
- TC — Total Capacity (1000 Btuh) Gross

### NOTES:

1. Direct interpolation is permissible. Do not extrapolate.
2. The following formulas may be used:

$$t_{ldb} = t_{edb} - \frac{\text{sensible capacity (Btuh)}}{1.10 \times \text{cfm}}$$

$t_{lwb}$  = Wet-bulb temperature corresponding to enthalpy of air leaving evaporator coil ( $h_{lwb}$ )

$$h_{lwb} = h_{ewb} - \frac{\text{total capacity (Btuh)}}{4.5 \times \text{cfm}}$$

Where:  $h_{ewb}$  = Enthalpy of air entering evaporator coil

48PG28 (25 Tons) — UNIT WITH HUMIDI-MIZER SYSTEM — HOT GAS REHEAT MODE — ALL CIRCUITS																
Temp (F) Air Ent Condenser (Edb)		Air Entering Evaporator — Ewb (F)														
		75 Dry Bulb 62.5 Wet Bulb (50% RH)					75 Dry Bulb 64 Wet Bulb (55% RH)					75 Dry Bulb 65.3 Wet Bulb (60% RH)				
		Air Entering Evaporator — Cfm														
		7400	8250	9500	10,750	12,000	7400	8250	9500	10,750	12,000	7400	8250	9500	10,750	12,000
80	TC	107	111	116	121	124	112	116	122	126	130	116	121	126	131	135
	SHC	19	24	31	37	42	12	17	24	30	35	6	11	18	24	29
	kW	19.9	20.0	20.0	20.1	20.1	20.0	20.1	20.1	20.2	20.2	20.1	20.1	20.2	20.3	20.3
75	TC	113	117	122	127	130	119	123	128	132	135	123	127	132	137	140
	SHC	22	27	33	39	45	16	21	27	33	38	10	15	21	27	32
	kW	19.3	19.3	19.4	19.4	19.5	19.3	19.4	19.5	19.5	19.6	19.4	19.5	19.6	19.6	19.7
70	TC	120	124	129	132	136	125	129	134	138	141	130	134	139	143	146
	SHC	25	30	36	42	47	19	24	30	36	41	14	19	25	31	35
	kW	18.6	18.7	18.7	18.8	18.8	18.7	18.8	18.8	18.9	18.9	18.8	18.8	18.9	19.0	19.0
60	TC	134	137	141	144	147	139	142	146	150	153	144	147	151	154	157
	SHC	32	36	41	46	51	27	31	36	41	46	23	27	32	37	42
	kW	17.3	17.3	17.4	17.4	17.5	17.4	17.4	17.5	17.5	17.6	17.5	17.6	17.6	17.6	17.7
50	TC	148	150	154	156	159	153	156	159	162	164	157	160	163	166	169
	SHC	38	42	47	51	55	34	38	43	47	51	31	35	40	44	48
	kW	16.0	16.0	16.1	16.1	16.1	16.1	16.1	16.2	16.2	16.2	16.2	16.3	16.3	16.3	16.4

48PG28 (25 Tons) — UNIT WITH HUMIDI-MIZER SYSTEM — HOT GAS REHEAT MODE — CIRCUIT A ONLY																
Temp (F) Air Entering Condenser (Edb)		Air Entering Evaporator — Ewb (F)														
		75 Dry Bulb 62.5 Wet Bulb (50% RH)					75 Dry Bulb 64 Wet Bulb (55% RH)					75 Dry Bulb 65.3 Wet Bulb (60% RH)				
		Air Entering Evaporator — Cfm														
		7400	8250	9500	10,750	12,000	7400	8250	9500	10,750	12,000	7400	8250	9500	10,750	12,000
50	TC	104	106	109	111	113	107	109	112	114	116	109	111	114	117	119
	SHC	44	49	55	60	64	32	37	43	48	52	21	26	32	38	42
	kW	10.9	10.9	10.9	10.9	10.9	10.9	10.9	10.9	10.9	10.9	10.9	10.9	10.9	10.9	10.9
40	TC	110	112	114	116	117	113	114	117	119	120	115	117	119	121	123
	SHC	50	54	59	63	66	40	44	49	53	57	32	36	41	45	49
	kW	10.4	10.4	10.4	10.4	10.4	10.4	10.4	10.4	10.4	10.4	10.4	10.4	10.5	10.5	10.5

### LEGEND

- Edb — Entering Dry-Bulb
- Ewb — Entering Wet-Bulb
- kW — Compressor Motor Power Input
- ldb — Leaving Dry-Bulb
- lwb — Leaving Wet-Bulb
- RH — Relative Humidity
- SHC — Sensible Heat Capacity (1000 Btuh) Gross
- TC — Total Capacity (1000 Btuh) Gross

### NOTES:

1. Direct interpolation is permissible. Do not extrapolate.
2. The following formulas may be used:

$$t_{ldb} = t_{edb} - \frac{\text{sensible capacity (Btuh)}}{1.10 \times \text{cfm}}$$

$t_{lwb}$  = Wet-bulb temperature corresponding to enthalpy of air leaving evaporator coil ( $h_{lwb}$ )

$$h_{lwb} = h_{ewb} - \frac{\text{total capacity (Btuh)}}{4.5 \times \text{cfm}}$$

Where:  $h_{ewb}$  = Enthalpy of air entering evaporator coil



## FAN PERFORMANCE — VERTICAL SUPPLY/RETURN UNITS

### 48PGD03 (Low Heat Units)

Airflow (Cfm)	Available External Static Pressure (in. wg)									
	0.2		0.4		0.6		0.8		1.0	
	Rpm	Bhp	Rpm	Bhp	Rpm	Bhp	Rpm	Bhp	Rpm	Bhp
600	407	0.05	551	0.10	663	0.15	759	0.21	843	0.27
650	413	0.06	555	0.11	667	0.17	763	0.22	847	0.29
700	419	0.06	560	0.12	671	0.18	766	0.24	851	0.30
750	425	0.07	565	0.13	676	0.19	770	0.25	854	0.32
800	433	0.08	570	0.14	680	0.20	774	0.27	858	0.34
850	440	0.08	575	0.15	685	0.22	779	0.29	862	0.36
900	448	0.09	581	0.16	690	0.23	783	0.30	866	0.38
950	456	0.10	587	0.17	695	0.24	788	0.32	871	0.40
1000	465	0.11	594	0.18	700	0.26	792	0.34	875	0.42

### 48PGD03 (Low Heat Units) (cont)

Airflow (Cfm)	Available External Static Pressure (in. wg)									
	1.2		1.4		1.6		1.8		2.0	
	Rpm	Bhp	Rpm	Bhp	Rpm	Bhp	Rpm	Bhp	Rpm	Bhp
600	920	0.33	990	0.40	1056	0.47	1117	0.54	1176	0.62
650	923	0.35	994	0.42	1059	0.49	1121	0.57	1179	0.65
700	927	0.37	997	0.44	1063	0.52	1124	0.60	1182	0.68
750	931	0.39	1001	0.47	1066	0.54	1128	0.62	1186	0.71
800	934	0.41	1004	0.49	1070	0.57	1131	0.65	1189	0.74
850	938	0.44	1008	0.52	1073	0.60	1135	0.68	1193	0.77
900	942	0.46	1012	0.54	1077	0.63	1138	0.71	1196	0.80
950	946	0.48	1016	0.57	1081	0.65	1142	0.74	1200	0.83
1000	950	0.51	1020	0.59	1085	0.68	1146	0.78	1204	0.87

LEGEND

Bhp — Brake Horsepower

NOTES:

1. Motor drive range is 482 to 736 rpm for low range motor/drive and 656 to 1001 rpm for high range motor/drive. All other rpms require a field-supplied drive.
2. Maximum continuous bhp is 0.85 for low range motor/drive and 0.85 for high range motor/drive.
3. See page 90 for General Fan Performance Notes.

### 48PGD04 (Low Heat Units)

Airflow (Cfm)	Available External Static Pressure (in. wg)									
	0.2		0.4		0.6		0.8		1.0	
	Rpm	Bhp	Rpm	Bhp	Rpm	Bhp	Rpm	Bhp	Rpm	Bhp
900	448	0.09	581	0.16	690	0.23	783	0.30	866	0.38
950	456	0.10	587	0.17	695	0.24	788	0.32	871	0.40
1000	465	0.11	594	0.18	700	0.26	792	0.34	875	0.42
1050	474	0.12	600	0.20	706	0.27	797	0.36	880	0.44
1100	483	0.13	607	0.21	711	0.29	803	0.38	884	0.46
1150	493	0.14	614	0.22	717	0.31	808	0.40	889	0.49
1200	503	0.16	622	0.24	724	0.33	813	0.42	894	0.51
1250	513	0.17	630	0.25	730	0.34	819	0.44	899	0.54
1300	524	0.19	638	0.27	737	0.36	825	0.46	905	0.56
1350	535	0.20	646	0.29	744	0.38	831	0.48	910	0.59
1400	546	0.22	655	0.31	751	0.41	837	0.51	916	0.61
1450	557	0.24	664	0.33	759	0.43	844	0.53	922	0.64
1500	569	0.25	673	0.35	766	0.45	851	0.56	928	0.67

### 48PGD04 (Low Heat Units) (cont)

Airflow (Cfm)	Available External Static Pressure (in. wg)									
	1.2		1.4		1.6		1.8		2.0	
	Rpm	Bhp	Rpm	Bhp	Rpm	Bhp	Rpm	Bhp	Rpm	Bhp
900	942	0.46	1012	0.54	1077	0.63	1138	0.71	1196	0.80
950	946	0.48	1016	0.57	1081	0.65	1142	0.74	1200	0.83
1000	950	0.51	1020	0.59	1085	0.68	1146	0.78	—	—
1050	955	0.53	1024	0.62	1089	0.71	1150	0.81	—	—
1100	959	0.56	1028	0.65	1093	0.74	1154	0.84	—	—
1150	963	0.58	1032	0.68	1097	0.78	—	—	—	—
1200	968	0.61	1037	0.71	1101	0.81	—	—	—	—
1250	973	0.64	1041	0.74	1105	0.84	—	—	—	—
1300	978	0.66	1046	0.77	—	—	—	—	—	—
1350	983	0.69	1051	0.80	—	—	—	—	—	—
1400	988	0.72	1056	0.83	—	—	—	—	—	—
1450	994	0.75	—	—	—	—	—	—	—	—
1500	1000	0.79	—	—	—	—	—	—	—	—

LEGEND

Bhp — Brake Horsepower

NOTES:

1. Motor drive range is 482 to 736 rpm for low range motor/drive and 796 to 1128 rpm for high range motor/drive. All other rpms require a field-supplied drive.
2. Maximum continuous bhp is 0.85 for low range motor/drive and 0.85 for high range motor/drive.
3. See page 90 for General Fan Performance Notes.

# Performance data (cont)



## FAN PERFORMANCE — VERTICAL SUPPLY/RETURN UNITS (cont)

### 48PGE04 (Medium Heat Units)

Airflow (Cfm)	Available External Static Pressure (in. wg)									
	0.2		0.4		0.6		0.8		1.0	
	Rpm	Bhp	Rpm	Bhp	Rpm	Bhp	Rpm	Bhp	Rpm	Bhp
900	452	0.09	584	0.16	693	0.23	786	0.31	870	0.38
950	460	0.10	590	0.17	698	0.25	791	0.32	874	0.40
1000	469	0.11	597	0.18	703	0.26	796	0.34	878	0.42
1050	479	0.12	604	0.20	709	0.28	801	0.36	883	0.45
1100	488	0.13	611	0.21	715	0.29	806	0.38	888	0.47
1150	498	0.15	619	0.23	721	0.31	812	0.40	893	0.49
1200	509	0.16	627	0.24	728	0.33	817	0.42	898	0.52
1250	519	0.17	635	0.26	735	0.35	823	0.44	903	0.54
1300	530	0.19	643	0.28	742	0.37	829	0.47	909	0.57
1350	542	0.21	652	0.29	749	0.39	836	0.49	915	0.59
1400	553	0.22	661	0.31	756	0.41	842	0.51	921	0.62
1450	565	0.24	670	0.33	764	0.44	849	0.54	927	0.65
1500	577	0.26	680	0.36	772	0.46	856	0.57	933	0.68

### 48PGE04 (Medium Heat Units) (cont)

Airflow (Cfm)	Available External Static Pressure (in. wg)									
	1.2		1.4		1.6		1.8		2.0	
	Rpm	Bhp	Rpm	Bhp	Rpm	Bhp	Rpm	Bhp	Rpm	Bhp
900	945	0.46	1016	0.55	1081	0.63	1143	0.72	1201	0.81
950	950	0.49	1019	0.57	1085	0.66	1146	0.75	1204	0.84
1000	954	0.51	1023	0.60	1089	0.69	1150	0.78	—	—
1050	958	0.53	1028	0.63	1093	0.72	1154	0.81	—	—
1100	963	0.56	1032	0.65	1097	0.75	1158	0.85	—	—
1150	967	0.59	1036	0.68	1101	0.78	—	—	—	—
1200	972	0.61	1041	0.71	1105	0.81	—	—	—	—
1250	977	0.64	1045	0.74	1110	0.85	—	—	—	—
1300	982	0.67	1050	0.78	—	—	—	—	—	—
1350	987	0.70	1055	0.81	—	—	—	—	—	—
1400	993	0.73	1060	0.84	—	—	—	—	—	—
1450	999	0.76	—	—	—	—	—	—	—	—
1500	1004	0.79	—	—	—	—	—	—	—	—

LEGEND

Bhp — Brake Horsepower

NOTES:

1. Motor drive range is 482 to 736 rpm for low range motor/drive and 796 to 1128 rpm for high range motor/drive. All other rpms require a field-supplied drive.
2. Maximum continuous bhp is 0.85 for low range motor/drive and 0.85 for high range motor/drive.
3. See page 90 for General Fan Performance Notes.

### 48PGF04 (High Heat Units)

Airflow (Cfm)	Available External Static Pressure (in. wg)									
	0.2		0.4		0.6		0.8		1.0	
	Rpm	Bhp	Rpm	Bhp	Rpm	Bhp	Rpm	Bhp	Rpm	Bhp
900	459	0.10	590	0.16	698	0.24	792	0.31	876	0.39
950	468	0.11	597	0.18	704	0.25	797	0.33	881	0.41
1000	477	0.12	604	0.19	710	0.27	802	0.35	885	0.43
1050	488	0.13	611	0.20	716	0.28	807	0.37	890	0.45
1100	498	0.14	619	0.22	722	0.30	813	0.39	895	0.48
1150	509	0.15	627	0.23	729	0.32	819	0.41	900	0.50
1200	520	0.17	636	0.25	736	0.34	825	0.43	906	0.53
1250	531	0.18	644	0.27	743	0.36	831	0.45	911	0.55
1300	543	0.20	653	0.28	751	0.38	838	0.48	917	0.58
1350	555	0.21	663	0.30	759	0.40	845	0.50	923	0.61
1400	567	0.23	672	0.32	767	0.42	852	0.53	930	0.63
1450	579	0.25	682	0.35	775	0.45	859	0.55	936	0.66
1500	592	0.27	692	0.37	784	0.47	867	0.58	943	0.69

### 48PGF04 (High Heat Units) (cont)

Airflow (Cfm)	Available External Static Pressure (in. wg)									
	1.2		1.4		1.6		1.8		2.0	
	Rpm	Bhp	Rpm	Bhp	Rpm	Bhp	Rpm	Bhp	Rpm	Bhp
900	953	0.47	1023	0.56	1089	0.64	1151	0.73	1210	0.82
950	957	0.49	1027	0.58	1093	0.67	1155	0.76	—	—
1000	961	0.52	1031	0.61	1097	0.70	1159	0.80	—	—
1050	965	0.54	1035	0.64	1101	0.73	1162	0.83	—	—
1100	970	0.57	1040	0.67	1105	0.76	—	—	—	—
1150	975	0.60	1044	0.69	1109	0.80	—	—	—	—
1200	980	0.62	1049	0.73	1114	0.83	—	—	—	—
1250	985	0.65	1054	0.76	—	—	—	—	—	—
1300	990	0.68	1059	0.79	—	—	—	—	—	—
1350	996	0.71	1064	0.82	—	—	—	—	—	—
1400	1002	0.74	—	—	—	—	—	—	—	—
1450	1008	0.78	—	—	—	—	—	—	—	—
1500	1014	0.81	—	—	—	—	—	—	—	—

LEGEND

Bhp — Brake Horsepower

NOTES:

1. Motor drive range is 482 to 736 rpm for low range motor/drive and 796 to 1128 rpm for high range motor drive. All other rpms require a field-supplied drive.
2. Maximum continuous bhp is 0.85 for low range motor/drive and 0.85 for high range motor/drive.
3. See page 90 for General Fan Performance Notes.



## FAN PERFORMANCE — VERTICAL SUPPLY/RETURN UNITS (cont)

### 48PGD05 (Low Heat Units)

Airflow (Cfm)	Available External Static Pressure (in. wg)									
	0.2		0.4		0.6		0.8		1.0	
	Rpm	Bhp	Rpm	Bhp	Rpm	Bhp	Rpm	Bhp	Rpm	Bhp
1200	504	0.16	613	0.23	710	0.31	798	0.40	881	0.49
1300	527	0.19	632	0.27	725	0.35	810	0.44	890	0.54
1400	551	0.22	652	0.31	741	0.40	823	0.49	900	0.59
1500	576	0.26	673	0.35	759	0.44	838	0.54	912	0.65
1600	600	0.30	694	0.40	777	0.50	854	0.60	926	0.71
1700	626	0.35	716	0.45	797	0.55	871	0.66	941	0.78
1800	651	0.40	739	0.51	817	0.62	889	0.73	957	0.85
1900	677	0.46	762	0.57	838	0.69	908	0.80	974	0.93
2000	703	0.52	785	0.64	859	0.76	927	0.88	992	1.01

### 48PGD05 (Low Heat Units) (cont)

Airflow (Cfm)	Available External Static Pressure (in. wg)									
	1.2		1.4		1.6		1.8		2.0	
	Rpm	Bhp	Rpm	Bhp	Rpm	Bhp	Rpm	Bhp	Rpm	Bhp
1200	957	0.59	1030	0.70	1098	0.80	1163	0.91	1225	1.03
1300	964	0.64	1035	0.75	1102	0.86	1166	0.98	1227	1.10
1400	973	0.70	1042	0.81	1107	0.92	1170	1.04	1231	1.17
1500	983	0.76	1050	0.87	1114	0.99	1176	1.12	1235	1.24
1600	994	0.82	1060	0.94	1122	1.06	1183	1.19	1241	1.32
1700	1007	0.89	1071	1.02	1132	1.14	1191	1.27	1248	1.41
1800	1021	0.97	1083	1.10	1143	1.23	1200	1.36	1256	1.50
1900	1037	1.05	1097	1.18	1155	1.32	1211	1.45	1266	1.60
2000	1053	1.14	1111	1.27	1168	1.41	1223	1.55	1276	1.70

LEGEND

**Bhp** — Brake Horsepower  
 High Range Motor/Drive Required

NOTES:

1. Motor drive range is 596 to 910 rpm for low range motor/drive and 828 to 1173 rpm for high range motor/drive. All other rpms require a field-supplied drive.
2. Maximum continuous bhp is 0.85 for low range motor/drive and 1.60 (single phase) and 2.40 (3 phase) for high range motor/drive.
3. See page 90 for General Fan Performance Notes.

### 48PGE05 (Medium Heat Units)

Airflow (Cfm)	Available External Static Pressure (in. wg)									
	0.2		0.4		0.6		0.8		1.0	
	Rpm	Bhp	Rpm	Bhp	Rpm	Bhp	Rpm	Bhp	Rpm	Bhp
1200	509	0.16	618	0.24	714	0.32	802	0.41	884	0.50
1300	533	0.19	637	0.27	730	0.36	814	0.45	894	0.55
1400	557	0.23	658	0.31	746	0.40	828	0.50	905	0.60
1500	582	0.27	679	0.36	764	0.45	843	0.55	917	0.66
1600	608	0.31	701	0.40	783	0.50	860	0.61	931	0.72
1700	634	0.36	723	0.46	803	0.56	877	0.67	947	0.79
1800	660	0.41	747	0.52	824	0.63	896	0.74	963	0.86
1900	686	0.47	770	0.58	846	0.70	915	0.82	981	0.94
2000	713	0.54	795	0.66	868	0.78	935	0.90	999	1.02

### 48PGE05 (Medium Heat Units) (cont)

Airflow (Cfm)	Available External Static Pressure (in. wg)									
	1.2		1.4		1.6		1.8		2.0	
	Rpm	Bhp	Rpm	Bhp	Rpm	Bhp	Rpm	Bhp	Rpm	Bhp
1200	961	0.60	1033	0.70	1101	0.81	1166	0.92	1228	1.03
1300	968	0.65	1039	0.76	1106	0.87	1169	0.98	1230	1.10
1400	977	0.70	1046	0.82	1111	0.93	1174	1.05	1234	1.17
1500	987	0.77	1054	0.88	1118	1.00	1180	1.12	1239	1.25
1600	999	0.83	1065	0.95	1127	1.07	1187	1.20	1245	1.33
1700	1013	0.90	1076	1.03	1137	1.15	1196	1.28	1253	1.42
1800	1027	0.98	1089	1.11	1148	1.24	1206	1.37	1261	1.51
1900	1043	1.06	1103	1.20	1161	1.33	1217	1.47	1271	1.61
2000	1060	1.16	1118	1.29	1175	1.43	1229	1.57	1282	1.72

LEGEND

**Bhp** — Brake Horsepower  
 High Range Motor/Drive Required

NOTES:

1. Motor drive range is 596 to 910 rpm for low range motor/drive and 828 to 1173 rpm for high range motor/drive. All other rpms require a field-supplied drive.
2. Maximum continuous bhp is 0.85 for low range motor/drive and 1.60 (single phase) and 2.40 (3 phase) for high range motor/drive.
3. See page 90 for General Fan Performance Notes.

# Performance data (cont)



## FAN PERFORMANCE — VERTICAL SUPPLY/RETURN UNITS (cont)

### 48PGF05 (High Heat Units)

Airflow (Cfm)	Available External Static Pressure (in. wg)									
	0.2		0.4		0.6		0.8		1.0	
	Rpm	Bhp	Rpm	Bhp	Rpm	Bhp	Rpm	Bhp	Rpm	Bhp
1200	520	0.17	628	0.24	723	0.33	811	0.41	892	0.51
1300	545	0.20	648	0.28	739	0.37	823	0.46	902	0.56
1400	570	0.24	668	0.32	756	0.41	837	0.51	913	0.61
1500	596	0.28	691	0.37	775	0.46	853	0.56	927	0.67
1600	623	0.32	714	0.42	795	0.52	870	0.62	942	0.73
1700	650	0.37	737	0.48	816	0.58	889	0.69	958	0.80
1800	677	0.43	762	0.54	838	0.65	909	0.76	976	0.88
1900	705	0.50	787	0.61	861	0.72	929	0.84	994	0.97
2000	734	0.57	813	0.68	884	0.80	951	0.93	1014	1.06

### 48PGF05 (High Heat Units) (cont)

Airflow (Cfm)	Available External Static Pressure (in. wg)									
	1.2		1.4		1.6		1.8		2.0	
	Rpm	Bhp	Rpm	Bhp	Rpm	Bhp	Rpm	Bhp	Rpm	Bhp
1200	968	0.61	1040	0.71	1108	0.82	1172	0.93	1233	1.04
1300	976	0.66	1046	0.77	1112	0.88	1176	1.00	1237	1.11
1400	985	0.72	1054	0.83	1119	0.95	1181	1.07	1241	1.19
1500	996	0.78	1063	0.90	1127	1.02	1188	1.14	1247	1.27
1600	1009	0.85	1074	0.97	1136	1.09	1196	1.22	1254	1.35
1700	1024	0.92	1087	1.05	1147	1.17	1205	1.31	1262	1.44
1800	1039	1.00	1100	1.13	1159	1.26	1216	1.40	1272	1.54
1900	1056	1.09	1116	1.22	1173	1.36	1229	1.50	1283	1.64
2000	1074	1.19	1132	1.32	1188	1.46	1242	1.61	1295	1.75

LEGEND

Bhp — Brake Horsepower

High Range Motor/Drive Required

NOTES:

1. Motor drive range is 596 to 910 rpm for low range motor/drive and 828 to 1173 rpm for high range motor/drive. All other rpms require a field-supplied drive.
2. Maximum continuous bhp is 0.85 for low range motor/drive and 1.60 (single phase) and 2.40 (3 phase) for high range motor/drive.
3. See page 90 for General Fan Performance Notes.

### 48PGD06 (Low Heat Units)

Airflow (Cfm)	Available External Static Pressure (in. wg)									
	0.2		0.4		0.6		0.8		1.0	
	Rpm	Bhp	Rpm	Bhp	Rpm	Bhp	Rpm	Bhp	Rpm	Bhp
1500	593	0.27	688	0.37	773	0.46	851	0.56	925	0.67
1600	620	0.32	711	0.42	793	0.52	868	0.62	939	0.73
1700	646	0.37	734	0.47	813	0.58	886	0.69	955	0.80
1800	673	0.43	758	0.53	835	0.64	905	0.76	972	0.88
1900	700	0.49	783	0.60	857	0.72	925	0.84	990	0.96
2000	728	0.56	807	0.68	879	0.80	946	0.92	1009	1.05
2100	755	0.63	833	0.76	903	0.88	968	1.01	1029	1.14
2200	783	0.71	858	0.84	926	0.97	990	1.11	1050	1.24
2300	811	0.80	884	0.94	950	1.07	1012	1.21	1071	1.35
2400	840	0.90	910	1.04	975	1.18	1035	1.33	1092	1.47
2500	868	1.00	937	1.15	1000	1.30	1059	1.45	1115	1.60

### 48PGD06 (Low Heat Units) (cont)

Airflow (Cfm)	Available External Static Pressure (in. wg)									
	1.2		1.4		1.6		1.8		2.0	
	Rpm	Bhp	Rpm	Bhp	Rpm	Bhp	Rpm	Bhp	Rpm	Bhp
1500	995	0.78	1061	0.89	1125	1.01	1186	1.14	1245	1.26
1600	1007	0.85	1072	0.96	1134	1.09	1194	1.22	1252	1.35
1700	1021	0.92	1084	1.04	1145	1.17	1203	1.30	1260	1.44
1800	1036	1.00	1098	1.13	1157	1.26	1214	1.39	1269	1.53
1900	1053	1.08	1112	1.22	1170	1.35	1226	1.49	1280	1.63
2000	1070	1.18	1128	1.31	1184	1.45	1238	1.60	1291	1.74
2100	1088	1.28	1145	1.42	1199	1.56	1253	1.71	1304	1.86
2200	1107	1.38	1162	1.53	1216	1.68	1268	1.83	1318	1.98
2300	1127	1.50	1181	1.65	1233	1.80	1284	1.95	1333	2.11
2400	1147	1.62	1200	1.77	1251	1.93	1300	2.09	1349	2.25
2500	1168	1.75	1220	1.91	1270	2.07	1318	2.23	1365	2.40

LEGEND

Bhp — Brake Horsepower

High Range Motor/Drive Required (3 phase)

NOTES:

1. Motor drive range is 690 to 978 rpm for low range motor/drive and 929 to 1261 rpm for high range motor/drive. All other rpms require a field-supplied drive.
2. Maximum continuous bhp is 0.85 (single phase) and 2.40 (3 phase) for low range motor/drive and 1.60 (single phase) and 2.40 (3 phase) for high range motor/drive.
3. See page 90 for General Fan Performance Notes.



## FAN PERFORMANCE — VERTICAL SUPPLY/RETURN UNITS (cont)

### 48PGE06 (Medium Heat Units)

Airflow (Cfm)	Available External Static Pressure (in. wg)									
	0.2		0.4		0.6		0.8		1.0	
	Rpm	Bhp	Rpm	Bhp	Rpm	Bhp	Rpm	Bhp	Rpm	Bhp
1500	607	0.29	700	0.38	784	0.47	861	0.57	934	0.68
1600	634	0.33	724	0.43	804	0.53	879	0.64	950	0.75
1700	662	0.39	748	0.49	826	0.60	898	0.71	967	0.82
1800	690	0.45	773	0.55	848	0.67	918	0.78	985	0.90
1900	719	0.51	799	0.63	872	0.74	940	0.86	1004	0.98
2000	748	0.59	825	0.70	896	0.83	962	0.95	1024	1.08
2100	777	0.67	852	0.79	920	0.92	985	1.05	1045	1.18
2200	807	0.75	879	0.88	946	1.01	1008	1.15	1067	1.29
2300	837	0.85	907	0.98	971	1.12	1032	1.26	1090	1.40
2400	867	0.95	935	1.09	998	1.24	1057	1.38	1113	1.53
2500	897	1.06	963	1.21	1024	1.36	1082	1.51	1137	1.66

### 48PGE06 (Medium Heat Units) (cont)

Airflow (Cfm)	Available External Static Pressure (in. wg)									
	1.2		1.4		1.6		1.8		2.0	
	Rpm	Bhp	Rpm	Bhp	Rpm	Bhp	Rpm	Bhp	Rpm	Bhp
1500	1004	0.79	1070	0.91	1133	1.03	1194	1.15	1253	1.28
1600	1017	0.86	1081	0.98	1143	1.11	1203	1.24	1260	1.37
1700	1032	0.94	1094	1.06	1155	1.19	1213	1.32	1269	1.46
1800	1048	1.02	1109	1.15	1168	1.28	1224	1.42	1279	1.56
1900	1066	1.11	1125	1.24	1182	1.38	1237	1.52	1291	1.66
2000	1084	1.21	1142	1.35	1197	1.49	1251	1.63	1304	1.78
2100	1104	1.31	1160	1.45	1214	1.60	1267	1.75	1318	1.90
2200	1124	1.43	1179	1.57	1231	1.72	1283	1.87	1333	2.03
2300	1145	1.55	1198	1.70	1250	1.85	1300	2.01	1349	2.17
2400	1167	1.68	1219	1.83	1269	1.99	1318	2.15	1366	2.31
2500	1189	1.82	1240	1.97	1290	2.14	1337	2.30	—	—

LEGEND

**Bhp** — Brake Horsepower

NOTES:

1. Motor drive range is 690 to 978 rpm for low range motor/drive and 929 to 1261 rpm for high range motor/drive. All other rpms require a field-supplied drive.
2. Maximum continuous bhp is 0.85 (single phase) and 2.40 (3 phase) for low range motor/drive and 1.60 (single phase) and 2.40 (3 phase) for high range motor/drive.
3. See page 90 for General Fan Performance Notes.

### 48PGF06 (High Heat Units)

AIRFLOW (CFM)	AVAILABLE EXTERNAL STATIC PRESSURE (in. wg)									
	0.2		0.4		0.6		0.8		1.0	
	Rpm	Bhp	Rpm	Bhp	Rpm	Bhp	Rpm	Bhp	Rpm	Bhp
1500	620	0.30	711	0.39	794	0.49	871	0.59	944	0.70
1600	648	0.35	736	0.45	816	0.55	890	0.65	960	0.76
1700	677	0.40	762	0.51	838	0.61	910	0.72	978	0.84
1800	707	0.47	788	0.58	862	0.69	931	0.80	997	0.92
1900	737	0.54	815	0.65	887	0.77	954	0.89	1017	1.01
2000	767	0.61	843	0.73	912	0.85	977	0.98	1039	1.11
2100	798	0.70	871	0.82	938	0.95	1001	1.08	1061	1.21
2200	829	0.79	900	0.92	965	1.05	1026	1.19	1084	1.33
2300	861	0.89	929	1.03	992	1.17	1052	1.31	1108	1.45
2400	893	1.00	959	1.15	1020	1.29	1078	1.43	1133	1.58
2500	925	1.12	989	1.27	1048	1.42	1105	1.57	1158	1.72

### 48PGF06 (High Heat Units) (cont)

AIRFLOW (CFM)	AVAILABLE EXTERNAL STATIC PRESSURE (in. wg)									
	1.2		1.4		1.6		1.8		2.0	
	Rpm	Bhp	Rpm	Bhp	Rpm	Bhp	Rpm	Bhp	Rpm	Bhp
1500	1013	0.81	1078	0.92	1141	1.05	1202	1.17	1260	1.30
1600	1027	0.88	1091	1.00	1152	1.13	1211	1.25	1269	1.39
1700	1043	0.96	1105	1.08	1165	1.21	1222	1.35	1278	1.48
1800	1060	1.05	1120	1.18	1179	1.31	1235	1.44	1290	1.59
1900	1078	1.14	1137	1.27	1194	1.41	1249	1.55	1302	1.70
2000	1098	1.24	1155	1.38	1210	1.52	1264	1.67	1316	1.81
2100	1119	1.35	1174	1.49	1228	1.64	1280	1.79	1331	1.94
2200	1140	1.47	1195	1.62	1247	1.77	1298	1.92	1348	2.08
2300	1163	1.60	1216	1.75	1267	1.90	1317	2.06	1365	2.22
2400	1186	1.73	1238	1.89	1288	2.05	1336	2.21	1384	2.37
2500	1210	1.88	1261	2.04	1309	2.20	1357	2.37	—	—

LEGEND

**Bhp** — Brake Horsepower

NOTES:

1. Motor drive range is 690 to 978 rpm for low range motor/drive and 929 to 1261 rpm for high range motor/drive. All other rpms require a field-supplied drive.
2. Maximum continuous bhp is 0.85 (single phase) and 2.40 (3 phase) for low range motor/drive and 1.60 (single phase) and 2.40 (3 phase) for high range motor/drive.
3. See page 90 for General Fan Performance Notes.

# Performance data (cont)



## FAN PERFORMANCE — VERTICAL SUPPLY/RETURN UNITS (cont)

48PGD07 (Low Heat Units)										
Airflow (Cfm)	Available External Static Pressure (in. wg)									
	0.2		0.4		0.6		0.8		1.0	
	Rpm	Bhp	Rpm	Bhp	Rpm	Bhp	Rpm	Bhp	Rpm	Bhp
1800	686	0.44	769	0.55	845	0.66	915	0.77	982	0.89
1900	714	0.51	794	0.62	868	0.73	936	0.85	1000	0.98
2000	742	0.58	820	0.70	891	0.82	957	0.94	1020	1.07
2100	770	0.66	846	0.78	915	0.91	979	1.03	1040	1.17
2200	799	0.74	872	0.87	939	1.00	1002	1.13	1061	1.27
2300	828	0.83	899	0.97	964	1.10	1025	1.24	1083	1.39
2400	856	0.93	926	1.07	989	1.22	1049	1.36	1105	1.51
2500	886	1.04	953	1.19	1015	1.33	1073	1.48	1128	1.64
2600	915	1.15	980	1.31	1040	1.46	1097	1.62	1151	1.77
2700	944	1.28	1008	1.44	1067	1.60	1122	1.76	1175	1.92
2800	974	1.41	1035	1.58	1093	1.74	1147	1.91	1199	2.08
2900	1003	1.55	1063	1.72	1120	1.90	1173	2.07	1223	2.24
3000	1033	1.70	1092	1.88	1146	2.06	1198	2.24	—	—

48PGD07 (Low Heat Units) (cont)										
Airflow (Cfm)	Available External Static Pressure (in. wg)									
	1.2		1.4		1.6		1.8		2.0	
	Rpm	Bhp	Rpm	Bhp	Rpm	Bhp	Rpm	Bhp	Rpm	Bhp
1800	1045	1.02	1106	1.14	1165	1.28	1222	1.41	1277	1.55
1900	1062	1.10	1121	1.24	1179	1.37	1234	1.51	1288	1.66
2000	1080	1.20	1138	1.34	1193	1.48	1247	1.62	1300	1.77
2100	1099	1.30	1155	1.44	1209	1.59	1262	1.73	1313	1.89
2200	1118	1.41	1173	1.56	1226	1.71	1278	1.86	1328	2.01
2300	1138	1.53	1192	1.68	1244	1.83	1294	1.99	1343	2.15
2400	1159	1.66	1212	1.81	1262	1.97	1312	2.13	1360	2.29
2500	1181	1.79	1232	1.95	1282	2.11	1330	2.27	—	—
2600	1203	1.93	1253	2.10	1301	2.26	—	—	—	—
2700	1226	2.08	1275	2.25	—	—	—	—	—	—
2800	1249	2.25	—	—	—	—	—	—	—	—
2900	—	—	—	—	—	—	—	—	—	—
3000	—	—	—	—	—	—	—	—	—	—

LEGEND  
Bhp — Brake Horsepower

- NOTES:
1. Motor drive range is 796 to 1128 rpm for low range motor/drive and 1150 to 1438 rpm for high range motor/drive. All other rpms require a field-supplied drive.
  2. Maximum continuous bhp is 2.40 for low range motor/drive and 3.10 for high range motor/drive.
  3. See page 90 for General Fan Performance Notes.

48PGE07 (Medium Heat Units)										
Airflow (Cfm)	Available External Static Pressure (in. wg)									
	0.2		0.4		0.6		0.8		1.0	
	Rpm	Bhp	Rpm	Bhp	Rpm	Bhp	Rpm	Bhp	Rpm	Bhp
1800	703	0.46	784	0.57	859	0.68	928	0.80	994	0.92
1900	732	0.53	811	0.64	882	0.76	950	0.88	1014	1.00
2000	761	0.61	838	0.72	907	0.85	972	0.97	1034	1.10
2100	791	0.69	865	0.81	932	0.94	996	1.07	1056	1.20
2200	822	0.78	893	0.91	958	1.04	1020	1.18	1079	1.31
2300	852	0.88	921	1.01	985	1.15	1045	1.29	1102	1.43
2400	883	0.98	950	1.13	1011	1.27	1070	1.41	1125	1.56
2500	914	1.10	978	1.25	1039	1.39	1096	1.55	1150	1.70
2600	945	1.22	1008	1.38	1066	1.53	1122	1.69	1175	1.84
2700	976	1.36	1037	1.52	1094	1.68	1148	1.84	1200	2.00
2800	1007	1.50	1067	1.67	1122	1.83	1175	2.00	1226	2.17
2900	1039	1.65	1097	1.82	1151	2.00	1203	2.17	1252	2.34
3000	1071	1.82	1127	2.00	1180	2.17	1230	2.35	—	—

48PGE07 (Medium Heat Units) (cont)										
Airflow (Cfm)	Available External Static Pressure (in. wg)									
	1.2		1.4		1.6		1.8		2.0	
	Rpm	Bhp	Rpm	Bhp	Rpm	Bhp	Rpm	Bhp	Rpm	Bhp
1800	1057	1.04	1117	1.17	1176	1.30	1232	1.44	1287	1.58
1900	1075	1.13	1134	1.27	1191	1.40	1246	1.54	1299	1.69
2000	1094	1.23	1151	1.37	1207	1.51	1260	1.65	1312	1.80
2100	1114	1.34	1170	1.48	1224	1.63	1276	1.77	1327	1.93
2200	1135	1.46	1189	1.60	1242	1.75	1293	1.90	1343	2.06
2300	1157	1.58	1209	1.73	1261	1.88	1311	2.04	1359	2.20
2400	1179	1.71	1231	1.87	1281	2.02	1329	2.19	1377	2.35
2500	1202	1.85	1252	2.01	1301	2.18	1349	2.34	—	—
2600	1226	2.01	1275	2.17	1323	2.34	—	—	—	—
2700	1250	2.17	1298	2.34	—	—	—	—	—	—
2800	1275	2.34	—	—	—	—	—	—	—	—
2900	—	—	—	—	—	—	—	—	—	—
3000	—	—	—	—	—	—	—	—	—	—

LEGEND  
Bhp — Brake Horsepower

- NOTES:
1. Motor drive range is 796 to 1128 rpm for low range motor/drive and 1150 to 1438 rpm for high range motor/drive. All other rpms require a field-supplied drive.
  2. Maximum continuous bhp is 2.40 for low range motor/drive and 3.10 for high range motor/drive.
  3. See page 90 for General Fan Performance Notes.



FAN PERFORMANCE — VERTICAL SUPPLY/RETURN UNITS (cont)

48PGF07 (High Heat Units)

Airflow (Cfm)	Available External Static Pressure (in. wg)									
	0.2		0.4		0.6		0.8		1.0	
	Rpm	Bhp	Rpm	Bhp	Rpm	Bhp	Rpm	Bhp	Rpm	Bhp
1800	719	0.48	799	0.59	872	0.70	941	0.82	1006	0.94
1900	749	0.55	826	0.67	897	0.79	964	0.91	1027	1.03
2000	780	0.63	855	0.75	923	0.88	988	1.00	1049	1.13
2100	812	0.72	884	0.85	950	0.97	1012	1.10	1072	1.24
2200	844	0.82	913	0.95	977	1.08	1038	1.22	1096	1.36
2300	876	0.92	943	1.06	1005	1.20	1064	1.34	1120	1.48
2400	908	1.04	973	1.18	1033	1.32	1091	1.47	1145	1.62
2500	941	1.16	1003	1.31	1062	1.46	1118	1.61	1171	1.76
2600	974	1.29	1034	1.45	1092	1.60	1146	1.76	1198	1.92
2700	1007	1.43	1066	1.59	1121	1.76	1174	1.92	1225	2.08
2800	1040	1.59	1097	1.75	1151	1.92	1203	2.09	1252	2.26
2900	1073	1.75	1129	1.93	1181	2.10	1232	2.27	—	—
3000	1107	1.93	1161	2.11	1212	2.29	—	—	—	—

48PGF07 (High Heat Units) (cont)

Airflow (Cfm)	Available External Static Pressure (in. wg)									
	1.2		1.4		1.6		1.8		2.0	
	Rpm	Bhp	Rpm	Bhp	Rpm	Bhp	Rpm	Bhp	Rpm	Bhp
1800	1069	1.06	1129	1.19	1187	1.33	1243	1.46	1297	1.61
1900	1088	1.16	1146	1.29	1202	1.43	1257	1.57	1310	1.72
2000	1108	1.26	1165	1.40	1220	1.54	1273	1.69	1325	1.84
2100	1129	1.38	1184	1.52	1238	1.67	1290	1.82	1340	1.97
2200	1151	1.50	1205	1.65	1257	1.80	1308	1.95	1357	2.11
2300	1174	1.63	1227	1.78	1278	1.93	1327	2.09	1375	2.25
2400	1198	1.77	1249	1.92	1299	2.08	1347	2.25	—	—
2500	1223	1.92	1273	2.08	1321	2.24	—	—	—	—
2600	1248	2.08	1297	2.24	—	—	—	—	—	—
2700	1274	2.25	—	—	—	—	—	—	—	—
2800	—	—	—	—	—	—	—	—	—	—
2900	—	—	—	—	—	—	—	—	—	—
3000	—	—	—	—	—	—	—	—	—	—

LEGEND  
Bhp — Brake Horsepower

NOTES:  
1. Motor drive range is 796 to 1128 rpm for low range motor/drive and 1150 to 1438 rpm for high range motor/drive. All other rpms require a field-supplied drive.  
2. Maximum continuous bhp is 2.40 for low range motor/drive and 3.10 for high range motor/drive.  
3. See page 90 for General Fan Performance Notes.

48PGD08 (Low Heat Units)

Airflow (Cfm)	Available External Static Pressure (in. wg)									
	0.2		0.4		0.6		0.8		1.0	
	Rpm	Bhp	Rpm	Bhp	Rpm	Bhp	Rpm	Bhp	Rpm	Bhp
2250	464	0.35	541	0.46	612	0.58	677	0.70	739	0.83
2400	479	0.40	554	0.52	622	0.64	686	0.77	745	0.90
2550	496	0.46	568	0.58	633	0.71	695	0.84	753	0.98
2700	512	0.53	582	0.65	646	0.79	705	0.92	762	1.07
2850	530	0.60	597	0.73	658	0.87	716	1.01	771	1.16
3000	547	0.68	612	0.82	672	0.96	728	1.11	782	1.26
3150	565	0.77	628	0.91	686	1.06	741	1.21	793	1.37
3300	583	0.86	644	1.01	701	1.17	754	1.32	805	1.49
3450	602	0.97	661	1.12	716	1.28	768	1.44	817	1.61
3600	621	1.08	678	1.24	732	1.41	782	1.57	831	1.75
3750	640	1.20	696	1.37	748	1.54	797	1.71	844	1.89

48PGD08 (Low Heat Units) (cont)

Airflow (Cfm)	Available External Static Pressure (in. wg)									
	1.2		1.4		1.6		1.8		2.0	
	Rpm	Bhp	Rpm	Bhp	Rpm	Bhp	Rpm	Bhp	Rpm	Bhp
2250	797	0.96	852	1.10	905	1.25	955	1.40	1003	1.55
2400	802	1.04	856	1.19	908	1.34	957	1.49	1005	1.65
2550	808	1.13	861	1.28	912	1.43	960	1.59	1007	1.75
2700	816	1.22	867	1.37	917	1.53	965	1.70	1011	1.86
2850	824	1.31	874	1.47	923	1.64	970	1.81	1015	1.98
3000	833	1.42	882	1.58	930	1.75	976	1.93	1020	2.11
3150	843	1.53	891	1.70	937	1.88	982	2.05	1026	2.24
3300	854	1.66	900	1.83	946	2.01	990	2.19	1033	2.38
3450	865	1.79	911	1.97	955	2.15	998	2.34	1040	2.53
3600	877	1.93	922	2.11	965	2.30	1007	2.49	1048	2.69
3750	889	2.08	933	2.26	976	2.46	1017	2.65	1057	2.86

LEGEND  
Bhp — Brake Horsepower  
———— High Range Motor/Drive Required

NOTES:  
1. Motor drive range is 568 to 771 rpm for low range motor/drive and 812 to 1015 rpm for high range motor/drive. All other rpms require a field-supplied drive.  
2. Maximum continuous bhp is 2.40 for low range motor/drive and 3.10 for high range motor/drive.  
3. See page 90 for General Fan Performance Notes.

# Performance data (cont)



## FAN PERFORMANCE — VERTICAL SUPPLY/RETURN UNITS (cont)

### 48PGE08 (Medium Heat Units)

Airflow (Cfm)	Available External Static Pressure (in. wg)									
	0.2		0.4		0.6		0.8		1.0	
	Rpm	Bhp	Rpm	Bhp	Rpm	Bhp	Rpm	Bhp	Rpm	Bhp
2250	463	0.35	541	0.46	611	0.58	677	0.70	738	0.83
2400	481	0.41	556	0.52	623	0.64	687	0.77	747	0.90
2550	499	0.47	571	0.59	637	0.72	698	0.85	756	0.99
2700	518	0.54	587	0.66	650	0.80	710	0.93	766	1.08
2850	537	0.62	603	0.75	665	0.88	722	1.03	777	1.18
3000	556	0.70	620	0.84	680	0.98	735	1.13	789	1.28
3150	575	0.79	637	0.93	695	1.08	749	1.24	801	1.40
3300	595	0.89	655	1.04	711	1.19	764	1.35	814	1.52
3450	615	1.00	673	1.16	727	1.32	778	1.48	828	1.65
3600	635	1.12	691	1.28	744	1.44	794	1.62	842	1.79
3750	655	1.24	710	1.41	761	1.58	810	1.76	856	1.94

### 48PGE08 (Medium Heat Units) (cont)

Airflow (Cfm)	Available External Static Pressure (in. wg)									
	1.2		1.4		1.6		1.8		2.0	
	Rpm	Bhp	Rpm	Bhp	Rpm	Bhp	Rpm	Bhp	Rpm	Bhp
2250	797	0.96	852	1.10	904	1.25	954	1.40	1002	1.55
2400	803	1.04	857	1.19	909	1.34	958	1.49	1006	1.65
2550	811	1.13	864	1.28	914	1.44	963	1.60	1009	1.76
2700	820	1.23	871	1.38	921	1.54	968	1.71	1014	1.88
2850	829	1.33	879	1.49	928	1.66	974	1.83	1019	2.00
3000	840	1.44	888	1.61	936	1.78	981	1.95	1026	2.13
3150	851	1.56	898	1.73	944	1.90	989	2.08	1033	2.27
3300	862	1.69	909	1.86	954	2.04	998	2.23	1040	2.41
3450	875	1.82	920	2.00	964	2.19	1007	2.38	1049	2.57
3600	888	1.97	932	2.15	975	2.34	1017	2.54	1058	2.73
3750	901	2.12	944	2.31	987	2.51	1028	2.71	1068	2.91

LEGEND

Bhp — Brake Horsepower

High Range Motor/Drive Required

NOTES:

1. Motor drive range is 568 to 771 rpm for low range motor/drive and 812 to 1015 rpm for high range motor/drive. All other rpms require a field-supplied drive.
2. Maximum continuous bhp is 2.40 for low range motor/drive and 3.10 for high range motor/drive.
3. See page 90 for General Fan Performance Notes.

### 48PGF08 (High Heat Units)

Airflow (Cfm)	Available External Static Pressure (in. wg)									
	0.2		0.4		0.6		0.8		1.0	
	Rpm	Bhp	Rpm	Bhp	Rpm	Bhp	Rpm	Bhp	Rpm	Bhp
2250	468	0.36	545	0.46	615	0.58	680	0.71	741	0.83
2400	486	0.41	560	0.53	627	0.65	691	0.78	750	0.91
2550	505	0.48	576	0.60	641	0.72	702	0.86	760	1.00
2700	524	0.55	592	0.68	655	0.81	714	0.95	771	1.09
2850	544	0.63	609	0.76	670	0.90	728	1.04	782	1.19
3000	564	0.71	627	0.85	686	1.00	741	1.14	794	1.30
3150	584	0.81	645	0.95	702	1.10	756	1.26	807	1.42
3300	604	0.91	663	1.06	719	1.22	771	1.38	821	1.54
3450	625	1.02	682	1.18	736	1.34	787	1.51	835	1.68
3600	646	1.15	701	1.31	753	1.48	803	1.65	850	1.82
3750	667	1.28	720	1.45	771	1.62	819	1.80	865	1.98

### 48PGF08 (High Heat Units) (cont)

Airflow (Cfm)	Available External Static Pressure (in. wg)									
	1.2		1.4		1.6		1.8		2.0	
	Rpm	Bhp	Rpm	Bhp	Rpm	Bhp	Rpm	Bhp	Rpm	Bhp
2250	799	0.97	854	1.11	907	1.26	957	1.40	1005	1.56
2400	807	1.05	860	1.20	912	1.35	961	1.50	1008	1.66
2550	815	1.14	867	1.29	918	1.45	966	1.61	1013	1.77
2700	824	1.24	875	1.40	925	1.56	972	1.72	1018	1.89
2850	834	1.35	884	1.51	932	1.67	979	1.84	1024	2.02
3000	845	1.46	894	1.63	941	1.80	986	1.97	1030	2.15
3150	857	1.58	904	1.75	950	1.93	995	2.11	1038	2.29
3300	869	1.71	916	1.89	960	2.07	1004	2.25	1046	2.44
3450	882	1.85	928	2.03	971	2.22	1014	2.41	1055	2.60
3600	896	2.00	940	2.19	983	2.38	1025	2.57	1065	2.77
3750	910	2.16	953	2.35	995	2.55	1036	2.75	1076	2.95

LEGEND

Bhp — Brake Horsepower

High Range Motor/Drive Required

NOTES:

1. Motor drive range is 568 to 771 rpm for low range motor/drive and 812 to 1015 rpm for high range motor/drive. All other rpms require a field-supplied drive.
2. Maximum continuous bhp is 2.40 for low range motor/drive and 3.10 for high range motor/drive.
3. See page 90 for General Fan Performance Notes.



## FAN PERFORMANCE — VERTICAL SUPPLY/RETURN UNITS (cont)

### 48PGD09 (Low Heat Units)

Airflow (Cfm)	Available External Static Pressure (in. wg)									
	0.2		0.4		0.6		0.8		1.0	
	Rpm	Bhp	Rpm	Bhp	Rpm	Bhp	Rpm	Bhp	Rpm	Bhp
2550	496	0.46	568	0.58	633	0.71	695	0.84	753	0.98
2700	512	0.53	582	0.65	646	0.79	705	0.92	762	1.07
2850	530	0.60	597	0.73	658	0.87	716	1.01	771	1.16
3000	547	0.68	612	0.82	672	0.96	728	1.11	782	1.26
3150	565	0.77	628	0.91	686	1.06	741	1.21	793	1.37
3300	583	0.86	644	1.01	701	1.17	754	1.32	805	1.49
3450	602	0.97	661	1.12	716	1.28	768	1.44	817	1.61
3600	621	1.08	678	1.24	732	1.41	782	1.57	831	1.75
3750	640	1.20	696	1.37	748	1.54	797	1.71	844	1.89
3900	659	1.33	713	1.50	764	1.68	812	1.86	858	2.05
4050	679	1.47	731	1.65	781	1.83	828	2.02	873	2.21
4200	698	1.62	750	1.81	798	2.00	844	2.19	888	2.38

### 48PGD09 (Low Heat Units) (cont)

Airflow (Cfm)	Available External Static Pressure (in. wg)									
	1.2		1.4		1.6		1.8		2.0	
	Rpm	Bhp	Rpm	Bhp	Rpm	Bhp	Rpm	Bhp	Rpm	Bhp
2550	808	1.13	861	1.28	912	1.43	960	1.59	1007	1.75
2700	816	1.22	867	1.37	917	1.53	965	1.70	1011	1.86
2850	824	1.31	874	1.47	923	1.64	970	1.81	1015	1.98
3000	833	1.42	882	1.58	930	1.75	976	1.93	1020	2.11
3150	843	1.53	891	1.70	937	1.88	982	2.05	1026	2.24
3300	854	1.66	900	1.83	946	2.01	990	2.19	1033	2.38
3450	865	1.79	911	1.97	955	2.15	998	2.34	1040	2.53
3600	877	1.93	922	2.11	965	2.30	1007	2.49	1048	2.69
3750	889	2.08	933	2.26	976	2.46	1017	2.65	1057	2.86
3900	903	2.24	945	2.43	987	2.63	1027	2.83	1067	3.03
4050	916	2.40	958	2.60	999	2.81	1038	3.01	1077	3.22
4200	930	2.58	971	2.79	1011	3.00	1050	3.21	1088	3.42

LEGEND

**Bhp** — Brake Horsepower  
 High Range Motor/Drive Required

NOTES:

1. Motor drive range is 568 to 771 rpm for low range motor/drive and 812 to 1015 rpm for high range motor/drive. All other rpms require a field-supplied drive.
2. Maximum continuous bhp is 2.40 for low range motor/drive and 3.70 for high range motor/drive.
3. See page 90 for General Fan Performance Notes.

### 48PGE09 (Medium Heat Units)

Airflow (Cfm)	Available External Static Pressure (in. wg)									
	0.2		0.4		0.6		0.8		1.0	
	Rpm	Bhp	Rpm	Bhp	Rpm	Bhp	Rpm	Bhp	Rpm	Bhp
2550	499	0.47	571	0.59	637	0.72	698	0.85	756	0.99
2700	518	0.54	587	0.66	650	0.80	710	0.93	766	1.08
2850	537	0.62	603	0.75	665	0.88	722	1.03	777	1.18
3000	556	0.70	620	0.84	680	0.98	735	1.13	789	1.28
3150	575	0.79	637	0.93	695	1.08	749	1.24	801	1.40
3300	595	0.89	655	1.04	711	1.19	764	1.35	814	1.52
3450	615	1.00	673	1.16	727	1.32	778	1.48	828	1.65
3600	635	1.12	691	1.28	744	1.44	794	1.62	842	1.79
3750	655	1.24	710	1.41	761	1.58	810	1.76	856	1.94
3900	675	1.38	728	1.55	778	1.73	826	1.91	871	2.10
4050	695	1.52	747	1.71	796	1.89	842	2.08	886	2.27
4200	716	1.68	766	1.87	814	2.06	859	2.25	902	2.45

### 48PGE09 (Medium Heat Units) (cont)

Airflow (Cfm)	Available External Static Pressure (in. wg)									
	1.2		1.4		1.6		1.8		2.0	
	Rpm	Bhp	Rpm	Bhp	Rpm	Bhp	Rpm	Bhp	Rpm	Bhp
2550	811	1.13	864	1.28	914	1.44	963	1.60	1009	1.76
2700	820	1.23	871	1.38	921	1.54	968	1.71	1014	1.88
2850	829	1.33	879	1.49	928	1.66	974	1.83	1019	2.00
3000	840	1.44	888	1.61	936	1.78	981	1.95	1026	2.13
3150	851	1.56	898	1.73	944	1.90	989	2.08	1033	2.27
3300	862	1.69	909	1.86	954	2.04	998	2.23	1040	2.41
3450	875	1.82	920	2.00	964	2.19	1007	2.38	1049	2.57
3600	888	1.97	932	2.15	975	2.34	1017	2.54	1058	2.73
3750	901	2.12	944	2.31	987	2.51	1028	2.71	1068	2.91
3900	915	2.29	957	2.48	999	2.68	1039	2.89	1078	3.09
4050	929	2.47	971	2.67	1011	2.87	1051	3.08	1089	3.29
4200	944	2.65	985	2.86	1024	3.07	1063	3.28	1100	3.50

LEGEND

**Bhp** — Brake Horsepower  
 High Range Motor/Drive Required

NOTES:

1. Motor drive range is 568 to 771 rpm for low range motor/drive and 812 to 1015 rpm for high range motor/drive. All other rpms require a field-supplied drive.
2. Maximum continuous bhp is 2.40 for low range motor/drive and 3.70 for high range motor/drive.
3. See page 90 for General Fan Performance Notes.

# Performance data (cont)



## FAN PERFORMANCE — VERTICAL SUPPLY/RETURN UNITS (cont)

### 48PGF09 (High Heat Units)

Airflow (Cfm)	Available External Static Pressure (in. wg)									
	0.2		0.4		0.6		0.8		1.0	
	Rpm	Bhp	Rpm	Bhp	Rpm	Bhp	Rpm	Bhp	Rpm	Bhp
2550	505	0.48	576	0.60	641	0.72	702	0.86	760	1.00
2700	524	0.55	592	0.68	655	0.81	714	0.95	771	1.09
2850	544	0.63	609	0.76	670	0.90	728	1.04	782	1.19
3000	564	0.71	627	0.85	686	1.00	741	1.14	794	1.30
3150	584	0.81	645	0.95	702	1.10	756	1.26	807	1.42
3300	604	0.91	663	1.06	719	1.22	771	1.38	821	1.54
3450	625	1.02	682	1.18	736	1.34	787	1.51	835	1.68
3600	646	1.15	701	1.31	753	1.48	803	1.65	850	1.82
3750	667	1.28	720	1.45	771	1.62	819	1.80	865	1.98
3900	688	1.42	740	1.60	789	1.77	836	1.96	881	2.14
4050	709	1.57	760	1.75	808	1.94	854	2.13	898	2.32
4200	730	1.73	780	1.92	827	2.12	871	2.31	914	2.51

### 48PGF09 (High Heat Units) (cont)

Airflow (Cfm)	Available External Static Pressure (in. wg)									
	1.2		1.4		1.6		1.8		2.0	
	Rpm	Bhp	Rpm	Bhp	Rpm	Bhp	Rpm	Bhp	Rpm	Bhp
2550	815	1.14	867	1.29	918	1.45	966	1.61	1013	1.77
2700	824	1.24	875	1.40	925	1.56	972	1.72	1018	1.89
2850	834	1.35	884	1.51	932	1.67	979	1.84	1024	2.02
3000	845	1.46	894	1.63	941	1.80	986	1.97	1030	2.15
3150	857	1.58	904	1.75	950	1.93	995	2.11	1038	2.29
3300	869	1.71	916	1.89	960	2.07	1004	2.25	1046	2.44
3450	882	1.85	928	2.03	971	2.22	1014	2.41	1055	2.60
3600	896	2.00	940	2.19	983	2.38	1025	2.57	1065	2.77
3750	910	2.16	953	2.35	995	2.55	1036	2.75	1076	2.95
3900	925	2.33	967	2.53	1008	2.73	1048	2.93	1087	3.14
4050	940	2.52	981	2.72	1021	2.92	1060	3.13	1099	3.35
4200	956	2.71	996	2.92	1035	3.13	1074	3.34	1111	3.56

LEGEND

- Bhp — Brake Horsepower
- High Range Motor/Drive Required

NOTES:

1. Motor drive range is 568 to 771 rpm for low range motor/drive and 812 to 1015 rpm for high range motor/drive. All other rpms require a field-supplied drive.
2. Maximum continuous bhp is 2.40 for low range motor/drive and 3.70 for high range motor/drive.
3. See page 90 for General Fan Performance Notes.

### 48PGD12 (Low Heat Units)

Airflow (Cfm)	Available External Static Pressure (in. wg)									
	0.2		0.4		0.6		0.8		1.0	
	Rpm	Bhp	Rpm	Bhp	Rpm	Bhp	Rpm	Bhp	Rpm	Bhp
3000	566	0.72	630	0.86	688	1.00	744	1.15	797	1.31
3200	593	0.85	653	0.99	710	1.15	763	1.30	814	1.46
3400	620	0.99	678	1.15	732	1.30	783	1.47	832	1.64
3600	647	1.15	702	1.31	754	1.48	804	1.65	851	1.83
3800	674	1.33	728	1.50	778	1.67	825	1.85	871	2.03
4000	702	1.52	753	1.70	802	1.88	848	2.07	892	2.26
4200	729	1.73	779	1.92	826	2.11	870	2.31	913	2.50
4400	757	1.96	805	2.16	850	2.36	894	2.56	935	2.77
4600	785	2.21	832	2.42	875	2.63	917	2.84	958	3.05
4800	814	2.49	858	2.70	901	2.92	941	3.14	981	3.36
5000	842	2.78	885	3.01	926	3.23	966	3.46	1004	3.69

### 48PGD12 (Low Heat Units) (cont)

Airflow (Cfm)	Available External Static Pressure (in. wg)									
	1.2		1.4		1.6		1.8		2.0	
	Rpm	Bhp	Rpm	Bhp	Rpm	Bhp	Rpm	Bhp	Rpm	Bhp
3000	847	1.47	896	1.63	943	1.80	988	1.98	1032	2.16
3200	863	1.63	910	1.80	955	1.98	999	2.16	1042	2.35
3400	879	1.81	925	1.99	969	2.17	1012	2.36	1054	2.55
3600	897	2.01	941	2.19	984	2.38	1026	2.58	1066	2.78
3800	915	2.22	958	2.41	1000	2.61	1040	2.81	1080	3.02
4000	935	2.45	976	2.65	1017	2.86	1056	3.06	1095	3.28
4200	955	2.71	995	2.91	1035	3.12	1073	3.34	1110	3.55
4400	976	2.98	1015	3.19	1053	3.41	1090	3.63	—	—
4600	997	3.27	1035	3.49	—	—	—	—	—	—
4800	1019	3.59	—	—	—	—	—	—	—	—
5000	—	—	—	—	—	—	—	—	—	—

LEGEND

- Bhp — Brake Horsepower
- High Range Motor/Drive Required

NOTES:

1. Motor drive range is 690 to 893 rpm for low range motor/drive and 852 to 1055 rpm for high range motor/drive. All other rpms require a field-supplied drive.
2. Maximum continuous bhp is 3.10 for low range motor/drive and 3.70 for high range motor/drive.
3. See page 90 for General Fan Performance Notes.



FAN PERFORMANCE — VERTICAL SUPPLY/RETURN UNITS (cont)

48PGE12 (Medium Heat Units)

Airflow (Cfm)	Available External Static Pressure (in. wg)									
	0.2		0.4		0.6		0.8		1.0	
	Rpm	Bhp	Rpm	Bhp	Rpm	Bhp	Rpm	Bhp	Rpm	Bhp
3000	574	0.74	636	0.87	695	1.02	750	1.17	802	1.32
3200	601	0.87	661	1.01	717	1.17	770	1.32	820	1.49
3400	629	1.02	686	1.17	740	1.33	791	1.49	840	1.66
3600	657	1.18	712	1.34	764	1.51	813	1.68	860	1.86
3800	686	1.36	739	1.53	788	1.71	836	1.89	881	2.07
4000	715	1.56	765	1.74	813	1.93	859	2.12	903	2.31
4200	744	1.78	792	1.97	839	2.17	883	2.36	925	2.56
4400	773	2.03	820	2.22	864	2.43	907	2.63	949	2.84
4600	802	2.29	848	2.50	891	2.71	932	2.92	972	3.13
4800	832	2.58	876	2.79	917	3.01	958	3.23	996	3.45
5000	862	2.88	904	3.11	944	3.34	983	3.56	—	—

48PGE12 (Medium Heat Units) (cont)

Airflow (Cfm)	Available External Static Pressure (in. wg)									
	1.2		1.4		1.6		1.8		2.0	
	Rpm	Bhp	Rpm	Bhp	Rpm	Bhp	Rpm	Bhp	Rpm	Bhp
3000	853	1.48	901	1.65	948	1.82	993	2.00	1037	2.18
3200	869	1.65	916	1.83	961	2.00	1005	2.19	1048	2.37
3400	887	1.84	932	2.02	976	2.20	1019	2.39	1060	2.58
3600	905	2.04	949	2.23	992	2.42	1033	2.61	1074	2.81
3800	925	2.26	967	2.46	1009	2.65	1049	2.86	1088	3.06
4000	945	2.50	987	2.70	1027	2.91	1066	3.12	1104	3.33
4200	967	2.76	1007	2.97	1046	3.18	1084	3.40	1121	3.62
4400	988	3.05	1027	3.26	1065	3.48	1102	3.70	—	—
4600	1011	3.35	1049	3.57	—	—	—	—	—	—
4800	1034	3.68	—	—	—	—	—	—	—	—
5000	—	—	—	—	—	—	—	—	—	—

LEGEND

Bhp — Brake Horsepower  
 — High Range Motor/Drive Required

NOTES:

1. Motor drive range is 690 to 893 rpm for low range motor/drive and 852 to 1055 rpm for high range motor/drive. All other rpms require a field-supplied drive.
2. Maximum continuous bhp is 3.10 for low range motor/drive and 3.70 for high range motor/drive.
3. See page 90 for General Fan Performance Notes.

48PGF12 (High Heat Units)

Airflow (Cfm)	Available External Static Pressure (in. wg)									
	0.2		0.4		0.6		0.8		1.0	
	Rpm	Bhp	Rpm	Bhp	Rpm	Bhp	Rpm	Bhp	Rpm	Bhp
3000	578	0.74	640	0.88	698	1.03	753	1.18	805	1.33
3200	606	0.88	665	1.03	721	1.18	774	1.34	824	1.50
3400	635	1.03	691	1.18	745	1.34	795	1.51	844	1.68
3600	663	1.20	718	1.36	769	1.53	818	1.70	865	1.88
3800	693	1.38	745	1.56	794	1.73	841	1.91	886	2.10
4000	722	1.59	772	1.77	820	1.95	865	2.14	909	2.33
4200	752	1.81	800	2.00	846	2.20	889	2.39	932	2.59
4400	781	2.06	828	2.26	872	2.46	914	2.66	955	2.87
4600	811	2.33	856	2.54	899	2.75	940	2.96	980	3.17
4800	841	2.62	884	2.84	926	3.05	966	3.28	1004	3.50
5000	871	2.94	913	3.16	953	3.39	992	3.62	—	—

48PGF12 (High Heat Units) (cont)

Airflow (Cfm)	Available External Static Pressure (in. wg)									
	1.2		1.4		1.6		1.8		2.0	
	Rpm	Bhp	Rpm	Bhp	Rpm	Bhp	Rpm	Bhp	Rpm	Bhp
3000	856	1.49	904	1.66	951	1.83	996	2.01	1040	2.19
3200	873	1.67	919	1.84	965	2.02	1008	2.20	1051	2.39
3400	891	1.85	936	2.03	980	2.22	1022	2.41	1064	2.60
3600	910	2.06	954	2.25	996	2.44	1037	2.63	1078	2.83
3800	930	2.29	972	2.48	1014	2.68	1054	2.88	1093	3.09
4000	951	2.53	992	2.73	1032	2.94	1071	3.15	1109	3.36
4200	973	2.80	1013	3.00	1051	3.22	1089	3.43	1126	3.65
4400	995	3.08	1034	3.30	1072	3.52	—	—	—	—
4600	1018	3.39	1056	3.61	—	—	—	—	—	—
4800	—	—	—	—	—	—	—	—	—	—
5000	—	—	—	—	—	—	—	—	—	—

LEGEND

Bhp — Brake Horsepower  
 — High Range Motor/Drive Required

NOTES:

1. Motor drive range is 690 to 893 rpm for low range motor/drive and 852 to 1055 rpm for high range motor/drive. All other rpms require a field-supplied drive.
2. Maximum continuous bhp is 3.10 for low range motor/drive and 3.70 for high range motor/drive.
3. See page 90 for General Fan Performance Notes.

# Performance data (cont)



## FAN PERFORMANCE — VERTICAL SUPPLY/RETURN UNITS (cont)

48PGD14 (Low Heat Units)										
Airflow (Cfm)	Available External Static Pressure (in. wg)									
	0.2		0.4		0.6		0.8		1.0	
	Rpm	Bhp	Rpm	Bhp	Rpm	Bhp	Rpm	Bhp	Rpm	Bhp
3750	667	1.28	721	1.45	772	1.62	820	1.80	866	1.98
3950	695	1.47	747	1.65	796	1.83	842	2.01	887	2.20
4150	723	1.68	772	1.86	820	2.05	865	2.25	908	2.44
4350	750	1.90	799	2.10	844	2.30	888	2.50	930	2.70
4550	778	2.15	825	2.35	869	2.56	911	2.77	952	2.98
4750	807	2.42	851	2.63	894	2.85	935	3.06	975	3.28
4950	835	2.71	878	2.93	920	3.15	960	3.38	998	3.61
5150	863	3.02	905	3.25	946	3.48	984	3.72	1022	3.95
5350	892	3.36	933	3.60	972	3.84	1009	4.08	1046	4.32
5550	920	3.72	960	3.97	998	4.22	1035	4.47	1070	4.72
5750	949	4.10	987	4.36	1024	4.62	1060	4.88	1095	5.14
5950	978	4.52	1015	4.78	1051	5.05	—	—	—	—
6150	1006	4.96	1043	5.23	—	—	—	—	—	—
6250	1021	5.19	—	—	—	—	—	—	—	—

48PGD14 (Low Heat Units) (cont)										
Airflow (Cfm)	Available External Static Pressure (in. wg)									
	1.2		1.4		1.6		1.8		2.0	
	Rpm	Bhp	Rpm	Bhp	Rpm	Bhp	Rpm	Bhp	Rpm	Bhp
3750	911	2.17	954	2.36	996	2.55	1037	2.75	1076	2.95
3950	930	2.39	972	2.59	1012	2.79	1052	3.00	1091	3.21
4150	950	2.64	991	2.85	1030	3.05	1069	3.27	1106	3.48
4350	971	2.91	1010	3.12	1048	3.34	1086	3.55	1123	3.78
4550	992	3.20	1030	3.41	1068	3.64	1104	3.86	1140	4.09
4750	1013	3.50	1051	3.73	1087	3.96	1123	4.19	1158	4.43
4950	1036	3.84	1072	4.07	1108	4.31	1142	4.55	1176	4.79
5150	1058	4.19	1094	4.43	1129	4.68	1162	4.93	1196	5.18
5350	1082	4.57	1116	4.82	1150	5.07	—	—	—	—
5550	1105	4.98	1139	5.23	—	—	—	—	—	—
5750	—	—	—	—	—	—	—	—	—	—
5950	—	—	—	—	—	—	—	—	—	—
6150	—	—	—	—	—	—	—	—	—	—
6250	—	—	—	—	—	—	—	—	—	—

**LEGEND**

**Bhp** — Brake Horsepower  
 High Range Motor/Drive Required

**NOTES:**

1. Motor drive range is 690 to 893 rpm for low range motor/drive and 852 to 1055 rpm for high range motor/drive. All other rpms require a field-supplied drive.
2. Maximum continuous bhp is 3.70 for low range motor/drive and 5.25 for high range motor/drive.
3. See this page for General Fan Performance Notes.

### GENERAL NOTES FOR FAN PERFORMANCE DATA TABLES

1. Static pressure losses (i.e., economizer, etc.) must be added to external static pressure before entering Fan Performance table.
2. Interpolation is permissible. Do not extrapolate.
3. Fan performance is based on wet coils, clean filters, and casing losses. See Accessory/FIOP Static Pressure information on pages 130 and 131.
4. Extensive motor and drive testing on these units ensures that the full horsepower range of the motor can be utilized with confidence. Using your fan motors up to the bhp rating shown will not result in nuisance tripping or premature motor failure. Unit warranty will not be affected.
5. Use of a field-supplied motor may affect wire size. Recalculate the unit power supply MCA and MOCP if required. Contact your Carrier representative for details.
6. Use the following formula to calculate input watts:  

$$\text{Input Watts} = \text{Bhp} \times (746/\text{Motor Eff})$$



FAN PERFORMANCE — VERTICAL SUPPLY/RETURN UNITS (cont)

48PGE14 (Medium Heat Units)										
Airflow (Cfm)	Available External Static Pressure (in. wg)									
	0.2		0.4		0.6		0.8		1.0	
	Rpm	Bhp	Rpm	Bhp	Rpm	Bhp	Rpm	Bhp	Rpm	Bhp
3750	679	1.31	732	1.49	782	1.66	830	1.84	876	2.02
3950	708	1.51	759	1.69	807	1.87	853	2.06	897	2.25
4150	737	1.73	786	1.92	832	2.11	877	2.30	920	2.50
4350	766	1.96	813	2.16	858	2.36	901	2.56	943	2.76
4550	795	2.22	841	2.43	884	2.63	926	2.84	966	3.06
4750	825	2.50	869	2.72	911	2.93	951	3.15	990	3.37
4950	854	2.80	897	3.03	938	3.25	977	3.48	1015	3.71
5150	884	3.13	925	3.36	965	3.60	1003	3.83	1040	4.07
5350	914	3.49	954	3.73	992	3.97	1029	4.21	1065	4.46
5550	944	3.86	982	4.11	1020	4.36	1056	4.62	1091	4.87
5750	974	4.27	1011	4.53	1048	4.79	1083	5.05	—	—
5950	1004	4.70	1040	4.97	1076	5.24	—	—	—	—
6150	1034	5.17	—	—	—	—	—	—	—	—
6250	—	—	—	—	—	—	—	—	—	—

48PGE14 (Medium Heat Units) (cont)										
Airflow (Cfm)	Available External Static Pressure (in. wg)									
	1.2		1.4		1.6		1.8		2.0	
	Rpm	Bhp	Rpm	Bhp	Rpm	Bhp	Rpm	Bhp	Rpm	Bhp
3750	920	2.21	963	2.40	1004	2.59	1045	2.79	1084	3.00
3950	940	2.44	982	2.64	1022	2.84	1061	3.05	1100	3.26
4150	961	2.70	1001	2.90	1041	3.11	1079	3.33	1116	3.54
4350	983	2.97	1022	3.19	1060	3.40	1097	3.62	1134	3.85
4550	1005	3.27	1043	3.49	1080	3.72	1117	3.94	1152	4.17
4750	1028	3.59	1065	3.82	1101	4.05	1137	4.29	1171	4.52
4950	1052	3.94	1088	4.17	1123	4.41	1157	4.65	1191	4.90
5150	1076	4.31	1111	4.55	1145	4.80	1179	5.05	—	—
5350	1100	4.70	1134	4.95	1168	5.21	—	—	—	—
5550	1125	5.13	—	—	—	—	—	—	—	—
5750	—	—	—	—	—	—	—	—	—	—
5950	—	—	—	—	—	—	—	—	—	—
6150	—	—	—	—	—	—	—	—	—	—
6250	—	—	—	—	—	—	—	—	—	—

LEGEND

**Bhp** — Brake Horsepower  
**—** High Range Motor/Drive Required

NOTES:

1. Motor drive range is 690 to 893 rpm for low range motor/drive and 852 to 1055 rpm for high range motor/drive. All other rpms require a field-supplied drive.
2. Maximum continuous bhp is 3.70 for low range motor/drive and 5.25 for high range motor/drive.
3. See page 90 for General Fan Performance Notes.

# Performance data (cont)



## FAN PERFORMANCE — VERTICAL SUPPLY/RETURN UNITS (cont)

48PGF14 (High Heat Units)										
Airflow (Cfm)	Available External Static Pressure (in. wg)									
	0.2		0.4		0.6		0.8		1.0	
	Rpm	Bhp	Rpm	Bhp	Rpm	Bhp	Rpm	Bhp	Rpm	Bhp
3750	685	1.33	738	1.51	788	1.68	835	1.86	881	2.04
3950	715	1.54	765	1.71	813	1.90	859	2.08	903	2.27
4150	744	1.76	793	1.94	839	2.13	883	2.33	926	2.53
4350	774	2.00	821	2.19	865	2.39	908	2.59	950	2.80
4550	804	2.26	849	2.47	892	2.67	934	2.88	974	3.10
4750	834	2.54	877	2.76	919	2.98	959	3.19	998	3.42
4950	864	2.85	906	3.08	946	3.30	985	3.53	1023	3.76
5150	894	3.19	935	3.42	974	3.65	1012	3.89	1049	4.13
5350	924	3.55	964	3.79	1002	4.03	1039	4.28	1074	4.52
5550	955	3.94	993	4.19	1030	4.44	1066	4.69	1101	4.94
5750	985	4.35	1023	4.61	1058	4.87	1093	5.13	—	—
5950	1016	4.79	1052	5.06	—	—	—	—	—	—
6150	—	—	—	—	—	—	—	—	—	—
6250	—	—	—	—	—	—	—	—	—	—

48PGF14 (High Heat Units) (cont)										
Airflow (Cfm)	Available External Static Pressure (in. wg)									
	1.2		1.4		1.6		1.8		2.0	
	Rpm	Bhp	Rpm	Bhp	Rpm	Bhp	Rpm	Bhp	Rpm	Bhp
3750	925	2.23	968	2.42	1009	2.62	1050	2.82	1089	3.02
3950	946	2.47	987	2.67	1027	2.87	1067	3.08	1105	3.29
4150	967	2.73	1007	2.93	1047	3.14	1085	3.36	1122	3.58
4350	990	3.01	1029	3.22	1067	3.44	1104	3.66	1140	3.89
4550	1012	3.31	1050	3.53	1087	3.76	1123	3.99	1159	4.22
4750	1036	3.64	1073	3.87	1109	4.10	1144	4.34	1178	4.57
4950	1060	3.99	1096	4.23	1131	4.47	1165	4.71	1199	4.96
5150	1084	4.37	1119	4.61	1153	4.86	1187	5.11	—	—
5350	1109	4.77	1143	5.02	—	—	—	—	—	—
5550	1135	5.20	—	—	—	—	—	—	—	—
5750	—	—	—	—	—	—	—	—	—	—
5950	—	—	—	—	—	—	—	—	—	—
6150	—	—	—	—	—	—	—	—	—	—
6250	—	—	—	—	—	—	—	—	—	—

LEGEND

**Bhp** — Brake Horsepower  
**—** High Range Motor/Drive Required

NOTES:

1. Motor drive range is 690 to 893 rpm for low range motor/drive and 852 to 1055 rpm for high range motor/drive. All other rpms require a field-supplied drive.
2. Maximum continuous bhp is 3.70 for low range motor/drive and 5.25 for high range motor/drive.
3. See page 90 for General Fan Performance Notes.



## FAN PERFORMANCE — VERTICAL SUPPLY/RETURN UNITS (cont)

48PGD16 (Low Heat Units)										
Airflow (Cfm)	Available External Static Pressure (in. wg)									
	0.2		0.4		0.6		0.8		1.0	
	Rpm	Bhp	Rpm	Bhp	Rpm	Bhp	Rpm	Bhp	Rpm	Bhp
4500	606	0.91	693	1.25	764	1.58	827	1.91	884	2.23
4800	633	1.05	718	1.41	789	1.77	851	2.12	907	2.47
5100	661	1.21	744	1.60	814	1.98	875	2.35	930	2.73
5400	689	1.39	771	1.80	839	2.20	899	2.60	954	3.00
5700	717	1.58	797	2.01	864	2.44	924	2.87	978	3.29
6000	745	1.80	824	2.25	890	2.70	949	3.15	1002	3.60
6300	774	2.04	851	2.51	916	2.98	974	3.46	1027	3.93
6600	803	2.30	878	2.78	942	3.28	1000	3.78	1052	4.27
6900	832	2.58	906	3.08	969	3.61	1025	4.13	1077	4.65
7200	861	2.89	933	3.41	996	3.95	1051	4.50	1102	5.04
7500	891	3.22	961	3.76	1023	4.32	1078	4.89	1128	5.46

48PGD16 (Low Heat Units) (cont)										
Airflow (Cfm)	Available External Static Pressure (in. wg)									
	1.2		1.4		1.6		1.8		2.0	
	Rpm	Bhp	Rpm	Bhp	Rpm	Bhp	Rpm	Bhp	Rpm	Bhp
4500	937	2.56	987	2.88	1034	3.21	1079	3.53	1122	3.86
4800	959	2.82	1008	3.16	1054	3.51	1098	3.85	1141	4.20
5100	981	3.09	1030	3.46	1075	3.83	1119	4.20	1161	4.56
5400	1004	3.39	1052	3.78	1097	4.17	1140	4.56	1181	4.95
5700	1028	3.70	1075	4.12	1119	4.53	1161	4.94	1202	5.35
6000	1051	4.04	1098	4.47	1142	4.91	1183	5.34	1224	5.77
6300	1075	4.39	1121	4.85	1165	5.31	1206	5.76	1246	6.22
6600	1100	4.76	1145	5.25	1188	5.73	1229	6.21	1268	6.68
6900	1125	5.16	1169	5.67	1212	6.17	1252	6.67	1291	7.17
7200	1149	5.58	1194	6.11	1236	6.64	1276	7.16	—	—
7500	1175	6.02	1219	6.58	1260	7.13	—	—	—	—

**LEGEND**

- Bhp** — Brake Horsepower
- Mid-Low Range Motor/Drive Required
- High Range Motor/Drive Required

**NOTES:**

1. Motor drive range is 710 to 879 rpm for low range motor/drive and 872 to 1066 rpm for mid-low range motor/drive, and 1066 to 1260 rpm for high range motor/drive. All other rpms require a field-supplied drive.
2. Maximum continuous bhp is 3.70 for low range motor/drive and 5.25 for mid-low range motor/drive, and 7.50 for high range motor/drive.
3. See page 90 for General Fan Performance Notes.

# Performance data (cont)



## FAN PERFORMANCE — VERTICAL SUPPLY/RETURN UNITS (cont)

48PGE16 (Medium Heat Units)										
Airflow (Cfm)	Available External Static Pressure (in. wg)									
	0.2		0.4		0.6		0.8		1.0	
	Rpm	Bhp	Rpm	Bhp	Rpm	Bhp	Rpm	Bhp	Rpm	Bhp
4500	646	1.05	727	1.40	795	1.74	856	2.07	911	2.40
4800	678	1.23	756	1.60	822	1.96	882	2.31	937	2.67
5100	709	1.42	785	1.82	851	2.20	909	2.58	962	2.96
5400	741	1.64	815	2.06	879	2.47	936	2.87	989	3.27
5700	774	1.88	846	2.32	908	2.75	964	3.18	1016	3.60
6000	806	2.14	876	2.60	937	3.06	993	3.52	1043	3.96
6300	839	2.42	907	2.91	967	3.40	1021	3.88	1071	4.35
6600	872	2.74	938	3.25	997	3.76	1050	4.26	1100	4.76
6900	905	3.08	970	3.61	1027	4.15	1080	4.68	1128	5.20
7200	938	3.45	1002	4.01	1058	4.57	1109	5.12	1157	5.66
7500	972	3.85	1034	4.43	1089	5.01	1139	5.59	1186	6.16

48PGE16 (Medium Heat Units) (cont)										
Airflow (Cfm)	Available External Static Pressure (in. wg)									
	1.2		1.4		1.6		1.8		2.0	
	Rpm	Bhp	Rpm	Bhp	Rpm	Bhp	Rpm	Bhp	Rpm	Bhp
4500	963	2.72	1012	3.05	1058	3.38	1103	3.71	1145	4.05
4800	988	3.02	1036	3.37	1081	3.72	1125	4.07	1167	4.42
5100	1012	3.33	1060	3.70	1105	4.07	1147	4.45	1189	4.82
5400	1038	3.67	1085	4.06	1129	4.45	1171	4.85	1211	5.24
5700	1064	4.02	1110	4.44	1153	4.86	1195	5.27	1235	5.69
6000	1091	4.41	1136	4.85	1179	5.29	1219	5.72	1259	6.16
6300	1118	4.82	1162	5.28	1204	5.74	1245	6.20	1283	6.66
6600	1146	5.25	1189	5.74	1231	6.23	1270	6.71	—	—
6900	1173	5.72	1216	6.23	1257	6.74	1296	7.24	—	—
7200	1202	6.21	1244	6.74	1284	7.28	—	—	—	—
7500	1230	6.73	1272	7.29	—	—	—	—	—	—

LEGEND

- Bhp** — Brake Horsepower
- Mid-Low Range Motor/Drive Required
- High Range Motor/Drive Required

NOTES:

1. Motor drive range is 710 to 879 rpm for low range motor/drive and 872 to 1066 rpm for mid-low range motor/drive, and 1066 to 1260 rpm for high range motor/drive. All other rpms require a field-supplied drive.
2. Maximum continuous bhp is 3.70 for low range motor/drive and 5.25 for mid-low range motor/drive, and 7.50 for high range motor/drive.
3. See page 90 for General Fan Performance Notes.



FAN PERFORMANCE — VERTICAL SUPPLY/RETURN UNITS (cont)

48PGF16 (High Heat Units)

Airflow (Cfm)	Available External Static Pressure (in. wg)									
	0.2		0.4		0.6		0.8		1.0	
	Rpm	Bhp	Rpm	Bhp	Rpm	Bhp	Rpm	Bhp	Rpm	Bhp
4500	660	1.11	739	1.46	806	1.80	867	2.13	922	2.46
4800	693	1.29	769	1.67	835	2.03	894	2.39	948	2.74
5100	725	1.50	800	1.90	864	2.29	922	2.67	975	3.05
5400	759	1.73	831	2.15	894	2.57	950	2.97	1002	3.37
5700	792	1.98	862	2.43	924	2.87	979	3.30	1030	3.73
6000	826	2.26	894	2.73	954	3.20	1009	3.65	1059	4.11
6300	860	2.57	926	3.06	985	3.55	1038	4.04	1088	4.51
6600	894	2.90	959	3.42	1016	3.94	1069	4.44	1117	4.94
6900	929	3.26	992	3.81	1048	4.35	1099	4.88	1147	5.41
7200	963	3.66	1024	4.23	1079	4.79	1130	5.35	1177	5.90
7500	998	4.08	1058	4.68	1111	5.27	1161	5.85	1207	6.42

48PGF16 (High Heat Units) (cont)

Airflow (Cfm)	Available External Static Pressure (in. wg)									
	1.2		1.4		1.6		1.8		2.0	
	Rpm	Bhp	Rpm	Bhp	Rpm	Bhp	Rpm	Bhp	Rpm	Bhp
4500	974	2.79	1022	3.12	1069	3.46	1113	3.79	1155	4.13
4800	999	3.10	1047	3.45	1092	3.80	1135	4.16	1177	4.51
5100	1025	3.42	1072	3.80	1116	4.17	1159	4.55	1200	4.93
5400	1051	3.77	1097	4.17	1141	4.57	1183	4.97	1224	5.36
5700	1078	4.15	1124	4.57	1167	4.99	1208	5.41	1248	5.83
6000	1106	4.55	1151	5.00	1193	5.44	1234	5.88	1273	6.32
6300	1134	4.98	1178	5.45	1220	5.92	1260	6.38	1298	6.84
6600	1163	5.44	1206	5.93	1247	6.42	1286	6.91	—	—
6900	1191	5.93	1234	6.44	1274	6.96	—	—	—	—
7200	1221	6.45	1263	6.99	—	—	—	—	—	—
7500	1250	7.00	—	—	—	—	—	—	—	—

LEGEND

Bhp — Brake Horsepower

— Mid-Low Range Motor/Drive Required

— High Range Motor/Drive Required

NOTES:

1. Motor drive range is 710 to 879 rpm for low range motor/drive and 872 to 1066 rpm for mid-low range motor/drive, and 1066 to 1260 rpm for high range motor/drive. All other rpms require a field-supplied drive.
2. Maximum continuous bhp is 3.70 for low range motor/drive and 5.25 for mid-low range motor/drive, and 7.50 for high range motor/drive.
3. See page 90 for General Fan Performance Notes.

# Performance data (cont)



## FAN PERFORMANCE — VERTICAL SUPPLY/RETURN UNITS (cont)

### 48PGD20 (Low Heat Units)

Airflow (Cfm)	Available External Static Pressure (in. wg)									
	0.2		0.4		0.6		0.8		1.0	
	Rpm	Bhp	Rpm	Bhp	Rpm	Bhp	Rpm	Bhp	Rpm	Bhp
5000	590	1.47	663	1.74	727	2.01	786	2.26	840	2.52
5500	633	1.82	703	2.11	764	2.40	820	2.67	<b>A</b> 872	2.94
6000	677	2.21	744	2.53	<b>A</b> 803	2.84	<b>A</b> 857	3.13	907	3.42
6500	722	2.67	<b>A</b> 786	3.01	842	3.33	894	3.64	<b>942</b>	<b>3.95</b>
7000	<b>A</b> 767	3.17	828	3.53	883	3.88	933	4.21	<b>B</b> 979	4.53
7500	813	3.74	871	4.12	<b>924</b>	<b>4.48</b>	<b>B</b> 972	4.83	1017	5.18
8000	859	4.36	<b>915</b>	<b>4.77</b>	<b>B</b> 966	5.15	<b>B</b> 1012	5.52	1056	5.88
8500	906	5.05	<b>B</b> 959	5.47	<b>C</b> 1008	5.87	<b>C</b> 1053	6.26	<b>C</b> 1096	6.64
9000	<b>C</b> 952	5.81	<b>C</b> 1004	6.25	1051	6.67	1095	7.07	1136	7.47

### 48PGD20 (Low Heat Units) (cont)

Airflow (Cfm)	Available External Static Pressure (in. wg)									
	1.2		1.4		1.6		1.8		2.0	
	Rpm	Bhp	Rpm	Bhp	Rpm	Bhp	Rpm	Bhp	Rpm	Bhp
5000	891	2.77	<b>940</b>	<b>3.02</b>	987	3.27	1032	3.52	1076	3.77
5500	<b>A</b> 921	3.21	968	3.48	1014	3.74	1057	4.01	1099	4.27
6000	954	3.70	<b>B</b> 999	3.99	<b>B</b> 1042	4.27	<b>B</b> 1084	4.55	<b>B</b> 1125	4.83
6500	<b>B</b> 988	4.25	<b>B</b> 1032	4.55	<b>B</b> 1073	4.85	1114	5.14	1153	5.44
7000	1024	4.85	1066	5.17	1106	5.48	<b>C</b> 1145	5.79	1183	6.10
7500	1060	5.51	1101	5.84	<b>C</b> 1140	6.17	1178	6.50	<b>D</b> 1215	6.82
8000	1098	6.23	<b>C</b> 1138	6.58	1176	6.92	1213	7.26	1249	7.60
8500	<b>C</b> 1137	7.01	1175	7.38	<b>D</b> 1212	7.74	<b>D</b> 1248	8.09	1283	8.45
9000	1176	7.86	<b>D</b> 1214	8.24	1250	8.61	1285	8.99	<b>1319</b>	<b>9.36</b>

#### LEGEND

**Bhp** — Brake Horsepower Input to Fan

**Boldface** indicates field-supplied drive required.

#### NOTES:

1. Motor drive ranges:

(A) Low Range: 685-939 rpm, 4.26 bhp (208/230 and 460-v), 751-954 rpm, 5.75 bhp (575-v)

(B) Mid-Low Range: 949-1206 rpm, 5.37 bhp (208-v), 5.75 bhp (230 and 460-v), 5.75 bhp (575-v)

(C) Mid-High Range: 941-1176 rpm, 7.66 bhp (208-v), 8.51 bhp (230-v), 8.63 bhp (460 and 575-v)

(D) High Range: 1014-1297 rpm, 9.94 bhp (208-v), 10.45 bhp (230-v), 11.19 bhp (460-v), 11.50 bhp (575-v)

All other rpms require field-supplied drive.

2. See page 90 for general fan performance notes.



FAN PERFORMANCE — VERTICAL SUPPLY/RETURN UNITS (cont)

48PGE20 (Medium Heat Units)

Airflow (Cfm)	Available External Static Pressure (in. wg)									
	0.2		0.4		0.6		0.8		1.0	
	Rpm	Bhp	Rpm	Bhp	Rpm	Bhp	Rpm	Bhp	Rpm	Bhp
5000	<b>607</b>	<b>1.53</b>	<b>677</b>	<b>1.80</b>	740	2.06	797	2.31	850	2.57
5500	<b>652</b>	<b>1.90</b>	719	2.19	779	2.47	<b>A</b> 833	2.74	<b>A</b> 884	3.01
6000	699	2.32	<b>A</b> 763	2.63	<b>A</b> 819	2.93	<b>A</b> 872	3.22	<b>A</b> 921	3.50
6500	746	2.79	<b>A</b> 807	3.12	861	3.44	911	3.75	958	4.05
7000	<b>A</b> 794	3.33	851	3.68	904	4.02	952	4.34	<b>B</b> 998	4.66
7500	842	3.93	<b>897</b>	<b>4.30</b>	<b>947</b>	<b>4.65</b>	<b>B</b> 994	5.00	1038	5.33
8000	<b>891</b>	<b>4.59</b>	<b>943</b>	<b>4.98</b>	<b>B</b> 991	5.35	1036	5.71	1079	6.07
8500	940	5.32	<b>B</b> 990	5.72	<b>C</b> 1036	6.11	<b>C</b> 1080	6.49	<b>C</b> 1121	6.87
9000	<b>C</b> 990	6.12	<b>C</b> 1037	6.54	<b>C</b> 1082	6.95	<b>C</b> 1124	7.35	1163	7.73

48PGE20 (Medium Heat Units) (cont)

Airflow (Cfm)	Available External Static Pressure (in. wg)									
	1.2		1.4		1.6		1.8		2.0	
	Rpm	Bhp	Rpm	Bhp	Rpm	Bhp	Rpm	Bhp	Rpm	Bhp
5000	900	2.82	949	3.06	995	3.31	1040	3.56	1083	3.81
5500	<b>A</b> 933	3.27	979	3.54	1023	3.80	1066	4.06	1108	4.33
6000	967	3.79	<b>B</b> 1011	4.07	<b>B</b> 1054	4.35	<b>B</b> 1095	4.62	<b>B</b> 1135	4.90
6500	1003	4.35	1046	4.65	1087	4.94	1127	5.24	1165	5.53
7000	<b>B</b> 1041	4.98	1082	5.29	1122	5.60	<b>C</b> 1160	5.91	1197	6.22
7500	1079	5.67	1119	5.99	<b>C</b> 1158	6.32	1195	6.64	<b>D</b> 1231	6.96
8000	1119	6.42	<b>C</b> 1158	6.76	1195	7.10	<b>D</b> 1231	7.44	1267	7.78
8500	<b>C</b> 1160	7.23	1198	7.59	<b>D</b> 1234	7.95	1269	8.30	<b>1303</b>	<b>8.65</b>
9000	<b>D</b> 1202	8.12	<b>D</b> 1238	8.49	1273	8.87	<b>1308</b>	<b>9.23</b>	<b>1341</b>	<b>9.60</b>

LEGEND

**Bhp** — Brake Horsepower Input to Fan

**Boldface** indicates field-supplied drive required.

NOTES:

1. Motor drive ranges:

- (A) Low Range: 685-939 rpm, 4.26 bhp (208/230 and 460-v), 751-954 rpm, 5.75 bhp (575-v)
  - (B) Mid-Low Range: 949-1206 rpm, 5.37 bhp (208-v), 5.75 bhp (230 and 460-v), 5.75 bhp (575-v)
  - (C) Mid-High Range: 941-1176 rpm, 7.66 bhp (208-v), 8.51 bhp (230-v), 8.63 bhp (460 and 575-v)
  - (D) High Range: 1014-1297 rpm, 9.94 bhp (208-v), 10.45 bhp (230-v), 11.19 bhp (460-v), 11.50 bhp (575-v)
- All other rpms require field-supplied drive.

2. See page 90 for general fan performance notes.

# Performance data (cont)



## FAN PERFORMANCE — VERTICAL SUPPLY/RETURN UNITS (cont)

### 48PGF20 (High Heat Units)

Airflow (Cfm)	Available External Static Pressure (in. wg)									
	0.2		0.4		0.6		0.8		1.0	
	Rpm	Bhp	Rpm	Bhp	Rpm	Bhp	Rpm	Bhp	Rpm	Bhp
5000	<b>607</b>	<b>1.53</b>	<b>677</b>	<b>1.80</b>	740	2.06	797	2.31	850	2.57
5500	<b>652</b>	<b>1.90</b>	719	2.19	779	2.47	<b>A</b> 833	2.74	<b>A</b> 884	3.01
6000	699	2.32	<b>A</b> 763	2.63	<b>A</b> 819	2.93	<b>A</b> 872	3.22	<b>A</b> 921	3.50
6500	746	2.79	<b>A</b> 807	3.12	<b>A</b> 861	3.44	911	3.75	958	4.05
7000	<b>A</b> 794	3.33	851	3.68	904	4.02	952	4.34	<b>B</b> 998	4.66
7500	842	3.93	<b>897</b>	<b>4.30</b>	<b>947</b>	<b>4.65</b>	<b>B</b> 994	5.00	1038	5.33
8000	<b>891</b>	<b>4.59</b>	<b>943</b>	<b>4.98</b>	<b>B</b> 991	5.35	1036	5.71	1079	6.07
8500	<b>940</b>	<b>5.32</b>	<b>B</b> 990	5.72	<b>C</b> 1036	6.11	<b>C</b> 1080	6.49	<b>C</b> 1121	6.87
9000	<b>C</b> 990	6.12	<b>C</b> 1037	6.54	<b>C</b> 1082	6.95	<b>C</b> 1124	7.35	1163	7.73

### 48PGF20 (High Heat Units) (cont)

Airflow (Cfm)	Available External Static Pressure (in. wg)									
	1.2		1.4		1.6		1.8		2.0	
	Rpm	Bhp	Rpm	Bhp	Rpm	Bhp	Rpm	Bhp	Rpm	Bhp
5000	900	2.82	949	3.06	995	3.31	1040	3.56	1083	3.81
5500	<b>A</b> 933	3.27	979	3.54	1023	3.80	1066	4.06	1108	4.33
6000	967	3.79	<b>B</b> 1011	4.07	<b>B</b> 1054	4.35	<b>B</b> 1095	4.62	<b>B</b> 1135	4.90
6500	1003	4.35	1046	4.65	1087	4.94	1127	5.24	1165	5.53
7000	<b>B</b> 1041	4.98	1082	5.29	1122	5.60	<b>C</b> 1160	5.91	1197	6.22
7500	1079	5.67	1119	5.99	<b>C</b> 1158	6.32	1195	6.64	<b>D</b> 1231	6.96
8000	1119	6.42	<b>C</b> 1158	6.76	1195	7.10	<b>D</b> 1231	7.44	1267	7.78
8500	<b>C</b> 1160	7.23	1198	7.59	<b>D</b> 1234	7.95	1269	8.30	<b>1303</b>	<b>8.65</b>
9000	<b>D</b> 1202	8.12	<b>D</b> 1238	8.49	1273	8.87	<b>1308</b>	<b>9.23</b>	<b>1341</b>	<b>9.60</b>

#### LEGEND

**Bhp** — Brake Horsepower Input to Fan

**Boldface** indicates field-supplied drive required.

#### NOTES:

1. Motor drive ranges:

(A) Low Range: 685-939 rpm, 4.26 bhp (208/230 and 460-v), 751-954 rpm, 5.75 bhp (575-v)

(B) Mid-Low Range: 949-1206 rpm, 5.37 bhp (208-v), 5.75 bhp (230 and 460-v), 5.75 bhp (575-v)

(C) Mid-High Range: 941-1176 rpm, 7.66 bhp (208-v), 8.51 bhp (230-v), 8.63 bhp (460 and 575-v)

(D) High Range: 1014-1297 rpm, 9.94 bhp (208-v), 10.45 bhp (230-v), 11.19 bhp (460-v), 11.50 bhp (575-v)

All other rpms require field-supplied drive.

2. See page 90 for general fan performance notes.



FAN PERFORMANCE — VERTICAL SUPPLY/RETURN UNITS (cont)

48PGD24 (Low Heat Units)

Airflow (Cfm)	Available External Static Pressure (in. wg)									
	0.2		0.4		0.6		0.8		1.0	
	Rpm	Bhp	Rpm	Bhp	Rpm	Bhp	Rpm	Bhp	Rpm	Bhp
5,500	<b>633</b>	<b>1.82</b>	703	2.11	764	2.40	820	2.67	A 872	2.94
6,000	<b>677</b>	<b>2.21</b>	744	2.53	A 803	2.84	A 857	3.13	A 907	3.42
6,500	722	2.67	A 786	3.01	A 842	3.33	A 894	3.64	<b>942</b>	<b>3.95</b>
7,000	A 767	3.17	828	3.53	883	3.88	933	4.21	B 979	4.53
7,500	813	3.74	871	4.12	<b>924</b>	<b>4.48</b>	B 972	4.83	B 1017	5.18
8,000	<b>859</b>	<b>4.36</b>	<b>915</b>	<b>4.77</b>	B 966	5.15	B 1012	5.52	1056	5.88
8,500	<b>906</b>	<b>5.05</b>	B 959	5.47	1008	5.87	1053	6.26	C 1096	6.64
9,000	952	5.81	1004	6.25	C 1051	6.67	C 1095	7.07	1136	7.47
9,500	C 999	6.63	C 1049	7.09	C 1094	7.53	C 1137	7.95	1177	8.36
10,000	1047	7.53	1094	8.00	1138	8.46	D 1180	8.90	D 1219	9.33

48PGD24 (Low Heat Units) (cont)

Airflow (Cfm)	Available External Static Pressure (in. wg)									
	1.2		1.4		1.6		1.8		2.0	
	Rpm	Bhp	Rpm	Bhp	Rpm	Bhp	Rpm	Bhp	Rpm	Bhp
5,500	A 921	3.21	968	3.48	1014	3.74	1057	4.01	1099	4.27
6,000	954	3.70	B 999	3.99	B 1042	4.27	B 1084	4.55	B 1125	4.83
6,500	B 988	4.25	B 1032	4.55	B 1073	4.85	1114	5.14	1153	5.44
7,000	1024	4.85	1066	5.17	1106	5.48	C 1145	5.79	1183	6.10
7,500	1060	5.51	1101	5.84	C 1140	6.17	1178	6.50	D 1215	6.82
8,000	1098	6.23	C 1138	6.58	C 1176	6.92	D 1213	7.26	D 1249	7.60
8,500	C 1137	7.01	1175	7.38	1212	7.74	D 1248	8.09	1283	8.45
9,000	1176	7.86	1214	8.24	D 1250	8.61	1285	8.99	<b>1319</b>	<b>9.36</b>
9,500	D 1216	8.77	D 1253	9.17	1288	9.56	<b>1322</b>	<b>9.95</b>	<b>1355</b>	<b>10.33</b>
10,000	1256	9.75	1292	10.16	<b>1327</b>	<b>10.57</b>	<b>1360</b>	<b>10.98</b>	<b>1393</b>	<b>11.38</b>

LEGEND

**Bhp** — Brake Horsepower Input to Fan

**Boldface** indicates field-supplied drive required.

NOTES:

1. Motor drive ranges:

- (A) Low Range: 685-939 rpm, 4.26 bhp (208/230 and 460-v), 751-954 rpm, 5.75 bhp (575-v)
- (B) Mid-Low Range: 949-1206 rpm, 5.37 bhp (208-v), 5.75 bhp (230 and 460-v), 5.75 bhp (575-v)
- (C) Mid-High Range: 941-1176 rpm, 7.66 bhp (208-v), 8.51 bhp (230-v), 8.63 bhp (460 and 575-v)
- (D) High Range: 1014-1297 rpm, 9.94 bhp (208-v), 10.45 bhp (230-v), 11.19 (460-v), 11.50 (575-v)

All other rpms require field-supplied drive.

2. See page 90 for general fan performance notes.

# Performance data (cont)



## FAN PERFORMANCE — VERTICAL SUPPLY/RETURN UNITS (cont)

48PGE24 (Medium Heat Units)										
Airflow (Cfm)	Available External Static Pressure (in. wg)									
	0.2		0.4		0.6		0.8		1.0	
	Rpm	Bhp	Rpm	Bhp	Rpm	Bhp	Rpm	Bhp	Rpm	Bhp
5,500	<b>652</b>	<b>1.90</b>	719	2.19	779	2.47	833	2.74	A 884	3.01
6,000	699	2.32	A 763	2.63	A 819	2.93	A 872	3.22	A 921	3.50
6,500	A 746	2.79	A 807	3.12	A 861	3.44	911	3.75	B 958	4.05
7,000	A 794	3.33	851	3.68	904	4.02	952	4.34	B 998	4.66
7,500	842	3.93	<b>897</b>	<b>4.30</b>	<b>947</b>	<b>4.65</b>	B 994	5.00	1038	5.33
8,000	<b>891</b>	<b>4.59</b>	<b>943</b>	<b>4.98</b>	B 991	5.35	1036	5.71	1079	6.07
8,500	940	5.32	B 990	5.72	1036	6.11	1080	6.49	C 1121	6.87
9,000	C 990	6.12	1037	6.54	C 1082	6.95	C 1124	7.35	1163	7.73
9,500	1039	7.00	C 1085	7.43	1128	7.85	1168	8.27	D 1207	8.67
10,000	1089	7.95	1133	8.40	D 1174	8.83	D 1213	9.26	D 1251	9.69

48PGE24 (Medium Heat Units) (cont)										
Airflow (Cfm)	Available External Static Pressure (in. wg)									
	1.2		1.4		1.6		1.8		2.0	
	Rpm	Bhp	Rpm	Bhp	Rpm	Bhp	Rpm	Bhp	Rpm	Bhp
5,500	A 933	3.27	979	3.54	1023	3.80	1066	4.06	1108	4.33
6,000	967	3.79	B 1011	B 4.07	B 1054	4.35	B 1095	4.62	B 1135	4.90
6,500	B 1003	4.35	B 1046	B 4.65	B 1087	4.94	1127	5.24	1165	5.53
7,000	B 1041	4.98	1082	5.29	1122	5.60	C 1160	5.91	1197	6.22
7,500	1079	5.67	C 1119	5.99	C 1158	6.32	1195	6.64	D 1231	6.96
8,000	C 1119	6.42	C 1158	6.76	1195	7.10	D 1231	7.44	1267	7.78
8,500	1160	7.23	1198	7.59	D 1234	7.95	1269	8.30	<b>1303</b>	<b>8.65</b>
9,000	D 1202	8.12	D 1238	8.49	1273	8.87	<b>1308</b>	<b>9.23</b>	<b>1341</b>	<b>9.60</b>
9,500	D 1244	9.07	1279	9.46	<b>1314</b>	<b>9.85</b>	<b>1347</b>	<b>10.24</b>	<b>1379</b>	<b>10.62</b>
10,000	1287	10.10	<b>1321</b>	<b>10.51</b>	<b>1355</b>	<b>10.91</b>	<b>1387</b>	<b>11.31</b>	—	—

### LEGEND

**Bhp** — Brake Horsepower Input to Fan

**Boldface** indicates field-supplied drive required.

### NOTES:

1. Motor drive ranges:

- (A) Low Range: 685-939 rpm, 4.26 bhp (208/230 and 460-v), 751-954 rpm, 5.75 bhp (575-v)
- (B) Mid-Low Range: 949-1206 rpm, 5.37 bhp (208-v), 5.75 bhp (230 and 460-v), 5.75 bhp (575-v)
- (C) Mid-High Range: 941-1176 rpm, 7.66 bhp (208-v), 8.51 bhp (230-v), 8.63 bhp (460 and 575-v)
- (D) High Range: 1014-1297 rpm, 9.94 bhp (208-v), 10.45 bhp (230-v), 11.19 (460-v), 11.50 (575-v)

All other rpms require field-supplied drive.

2. See page 90 for general fan performance notes.



## FAN PERFORMANCE — VERTICAL SUPPLY/RETURN UNITS (cont)

48PGF24 (High Heat Units)										
Airflow (Cfm)	Available External Static Pressure (in. wg)									
	0.2		0.4		0.6		0.8		1.0	
	Rpm	Bhp	Rpm	Bhp	Rpm	Bhp	Rpm	Bhp	Rpm	Bhp
5,500	<b>652</b>	<b>1.90</b>	719	2.19	779	2.47	833	2.74	A 884	3.01
6,000	699	2.32	A 763	2.63	A 819	2.93	A 872	3.22	A 921	3.50
6,500	A 746	2.79	A 807	3.12	A 861	3.44	A 911	3.75	B 958	4.05
7,000	A 794	3.33	851	3.68	904	4.02	952	4.34	B 998	4.66
7,500	842	3.93	<b>897</b>	<b>4.30</b>	<b>947</b>	<b>4.65</b>	B 994	5.00	1038	5.33
8,000	<b>891</b>	<b>4.59</b>	<b>943</b>	<b>4.98</b>	B 991	5.35	1036	5.71	1079	6.07
8,500	<b>940</b>	<b>5.32</b>	B 990	5.72	1036	6.11	1080	6.49	C 1121	6.87
9,000	990	6.12	1037	6.54	C 1082	6.95	C 1124	7.35	1163	7.73
9,500	C 1039	7.00	C 1085	7.43	1128	7.85	1168	8.27	D 1207	8.67
10,000	1089	7.95	1133	8.40	D 1174	8.83	D 1213	9.26	D 1251	9.69

48PGF24 (High Heat Units) (cont)										
Airflow (Cfm)	Available External Static Pressure (in. wg)									
	1.2		1.4		1.6		1.8		2.0	
	Rpm	Bhp	Rpm	Bhp	Rpm	Bhp	Rpm	Bhp	Rpm	Bhp
5,500	A 933	3.27	979	3.54	1023	3.80	1066	4.06	1108	4.33
6,000	967	3.79	B 1011	4.07	B 1054	4.35	B 1095	4.62	B 1135	4.90
6,500	B 1003	4.35	B 1046	4.65	B 1087	4.94	1127	5.24	1165	5.53
7,000	B 1041	4.98	1082	5.29	1122	5.60	C 1160	C 5.91	1197	6.22
7,500	1079	5.67	C 1119	5.99	C 1158	6.32	1195	6.64	D 1231	6.96
8,000	C 1119	6.42	C 1158	6.76	1195	7.10	D 1231	7.44	1267	7.78
8,500	C 1160	7.23	1198	7.59	D 1234	7.95	1269	8.30	<b>1303</b>	<b>8.65</b>
9,000	1202	8.12	D 1238	8.49	1273	8.87	<b>1308</b>	<b>9.23</b>	<b>1341</b>	<b>9.60</b>
9,500	D 1244	9.07	1279	9.46	<b>1314</b>	<b>9.85</b>	<b>1347</b>	<b>10.24</b>	<b>1379</b>	<b>10.62</b>
10,000	1287	10.10	<b>1321</b>	<b>10.51</b>	<b>1355</b>	<b>10.91</b>	<b>1387</b>	<b>11.31</b>	—	—

LEGEND

**Bhp** — Brake Horsepower Input to Fan

**Boldface** indicates field-supplied drive required.

NOTES:

1. Motor drive ranges:

- (A) Low Range: 685-939 rpm, 4.26 bhp (208/230 and 460-v), 751-954 rpm, 5.75 bhp (575-v)
- (B) Mid-Low Range: 949-1206 rpm, 5.37 bhp (208-v), 5.75 bhp (230 and 460-v), 5.75 bhp (575-v)
- (C) Mid-High Range: 941-1176 rpm, 7.66 bhp (208-v), 8.51 bhp (230-v), 8.63 bhp (460 and 575-v)
- (D) High Range: 1014-1297 rpm, 9.94 bhp (208-v), 10.45 bhp (230-v), 11.19 (460-v), 11.50 (575-v)

All other rpms require field-supplied drive.

2. See page 90 for general fan performance notes.

# Performance data (cont)



## FAN PERFORMANCE — VERTICAL SUPPLY/RETURN UNITS (cont)

48PGD28 (Low Heat Units)										
Airflow (Cfm)	Available External Static Pressure (in. wg)									
	0.2		0.4		0.6		0.8		1.0	
	Rpm	Bhp	Rpm	Bhp	Rpm	Bhp	Rpm	Bhp	Rpm	Bhp
6,500	750	2.28	A 806	2.62	A 854	2.93	B 898	3.25	B 943	3.59
7,000	A 797	2.78	A 853	3.17	899	3.50	B 941	3.84	B 982	4.18
7,500	845	3.34	900	3.78	B 945	4.15	985	4.51	1024	4.87
8,000	892	3.97	B 948	4.48	991	4.88	1030	5.26	1067	5.64
8,500	B 939	4.68	995	5.25	1038	5.69	C 1076	6.10	C 1112	6.50
9,000	986	5.46	1042	6.10	C 1085	6.59	C 1122	7.04	1157	7.46
9,500	1033	6.32	C 1090	7.04	1132	7.59	1169	8.07	1203	8.52
10,000	C 1079	7.26	1137	8.07	1180	8.67	D 1216	9.19	D 1249	9.68
10,500	1126	8.28	D 1184	9.20	D 1227	9.86	D 1263	10.43	1296	10.95
11,000	1172	9.40	D 1232	10.42	1274	11.15	—	—	—	—
11,500	D 1219	10.61	—	—	—	—	—	—	—	—
12,000	—	—	—	—	—	—	—	—	—	—
12,500	—	—	—	—	—	—	—	—	—	—

48PGD28 (Low Heat Units) (cont)										
Airflow (Cfm)	Available External Static Pressure (in. wg)									
	1.2		1.4		1.6		1.8		2.0	
	Rpm	Bhp	Rpm	Bhp	Rpm	Bhp	Rpm	Bhp	Rpm	Bhp
6,500	B 988	3.97	1035	4.40	1082	4.87	C 1130	5.39	1177	5.95
7,000	1024	4.56	C 1066	4.98	C 1109	5.43	1153	5.94	1197	6.48
7,500	C 1063	5.25	1101	5.66	C 1141	6.10	1181	6.59	D 1222	7.12
8,000	1104	6.03	1140	6.44	1176	6.88	D 1213	7.36	D 1251	7.87
8,500	1146	6.91	1180	7.33	1214	7.77	D 1249	8.24	1283	8.74
9,000	1190	7.89	D 1222	8.32	D 1255	8.77	1287	9.24	<b>1319</b>	<b>9.74</b>
9,500	D 1235	8.97	1266	9.42	1296	9.88	<b>1327</b>	<b>10.36</b>	<b>1357</b>	<b>10.86</b>
10,000	1280	10.16	<b>1310</b>	<b>10.63</b>	<b>1340</b>	<b>11.10</b>	—	—	—	—
10,500	<b>1326</b>	<b>11.45</b>	—	—	—	—	—	—	—	—
11,000	—	—	—	—	—	—	—	—	—	—
11,500	—	—	—	—	—	—	—	—	—	—
12,000	—	—	—	—	—	—	—	—	—	—
12,500	—	—	—	—	—	—	—	—	—	—

### LEGEND

**Bhp** — Brake Horsepower Input to Fan

**Boldface** indicates field-supplied drive required.

### NOTES:

1. Motor drive ranges:

- (A) Low Range: 687-873 rpm, 5.37 bhp (208-v), 5.75 bhp (230 and 460-v), 5.75 bhp (575-v)
- (B) Mid-Low Range: 805-1007 rpm, 5.37 bhp (208-v), 5.75 bhp (230 and 460-v), 5.75 bhp (575-v)
- (C) Mid-High Range: 941-1176 rpm, 7.66 bhp (208-v), 8.51 bhp (230-v), 8.63 bhp (460 and 575-v)
- (D) High Range: 1014-1297 rpm, 9.94 bhp (208-v), 10.45 bhp (230-v), 11.19 bhp (460-v), 11.50 bhp (575-v)

All other rpms require field-supplied drive.

2. See page 90 for general fan performance notes.



FAN PERFORMANCE — VERTICAL SUPPLY/RETURN UNITS (cont)

48PGE28 (Medium Heat Units)										
Airflow (Cfm)	Available External Static Pressure (in. wg)									
	0.2		0.4		0.6		0.8		1.0	
	Rpm	Bhp	Rpm	Bhp	Rpm	Bhp	Rpm	Bhp	Rpm	Bhp
6,500	A 775	2.43	A 825	2.75	A 871	3.05	915	3.37	B 959	3.72
7,000	826	2.98	875	3.22	B 918	3.58	B 959	3.98	B 1000	4.34
7,500	878	3.60	B 925	3.89	B 966	4.28	1005	4.69	1043	5.05
8,000	B 929	4.31	975	4.73	1015	5.11	1052	5.48	C 1088	5.86
8,500	981	5.11	1026	5.56	C 1064	5.97	C 1100	6.37	1134	6.76
9,000	1033	6.00	C 1076	6.49	1114	6.94	1148	7.36	1181	7.77
9,500	C 1085	6.98	1128	7.53	1164	8.00	1198	8.45	D 1229	8.89
10,000	1137	8.08	1179	8.66	D 1214	9.18	D 1247	9.65	1278	10.12
10,500	D 1190	9.28	D 1230	9.91	D 1265	10.46	1297	10.97	<b>1327</b>	<b>11.47</b>
11,000	1242	10.60	1282	11.28	—	—	—	—	—	—
11,500	—	—	—	—	—	—	—	—	—	—
12,000	—	—	—	—	—	—	—	—	—	—
12,500	—	—	—	—	—	—	—	—	—	—

48PGE28 (Medium Heat Units) (cont)										
Airflow (Cfm)	Available External Static Pressure (in. wg)									
	1.2		1.4		1.6		1.8		2.0	
	Rpm	Bhp	Rpm	Bhp	Rpm	Bhp	Rpm	Bhp	Rpm	Bhp
6,500	B 1004	4.11	1050	4.55	1098	5.04	C 1145	5.57	1192	6.14
7,000	1041	4.73	C 1083	5.15	C 1126	5.62	1170	6.14	D 1214	6.70
7,500	C 1081	5.44	1120	5.86	1159	6.32	1199	6.82	1240	7.36
8,000	1124	6.26	1160	6.68	1196	7.13	D 1233	7.62	1270	8.15
8,500	1168	7.17	1202	7.60	D 1235	8.06	1269	8.54	<b>1304</b>	<b>9.05</b>
9,000	D 1214	8.20	D 1245	8.64	1277	9.10	<b>1309</b>	<b>9.58</b>	<b>1341</b>	<b>10.09</b>
9,500	1260	9.33	1290	9.79	<b>1320</b>	<b>10.25</b>	<b>1351</b>	<b>10.74</b>	<b>1381</b>	<b>11.25</b>
10,000	<b>1308</b>	<b>10.58</b>	<b>1337</b>	<b>11.05</b>	—	—	—	—	—	—
10,500	—	—	—	—	—	—	—	—	—	—
11,000	—	—	—	—	—	—	—	—	—	—
11,500	—	—	—	—	—	—	—	—	—	—
12,000	—	—	—	—	—	—	—	—	—	—
12,500	—	—	—	—	—	—	—	—	—	—

LEGEND

**Bhp** — Brake Horsepower Input to Fan

**Boldface** indicates field-supplied drive required.

NOTES:

1. Motor drive ranges:

- (A) Low Range: 687-873 rpm, 5.37 bhp (208-v), 5.75 bhp (230 and 460-v), 5.75 bhp (575-v)
- (B) Mid-Low Range: 805-1007 rpm, 5.37 bhp (208-v), 5.75 bhp (230 and 460-v), 5.75 bhp (575-v)
- (C) Mid-High Range: 941-1176 rpm, 7.66 bhp (208-v), 8.51 bhp (230-v), 8.63 bhp (460 and 575-v)
- (D) High Range: 1014-1297 rpm, 9.94 bhp (208-v), 10.45 bhp (230-v), 11.19 bhp (460-v), 11.50 bhp (575-v)

All other rpms require field-supplied drive.

2. See page 90 for general fan performance notes.

# Performance data (cont)



## FAN PERFORMANCE — VERTICAL SUPPLY/RETURN UNITS (cont)

48PGF28 (High Heat Units)										
Airflow (Cfm)	Available External Static Pressure (in. wg)									
	0.2		0.4		0.6		0.8		1.0	
	Rpm	Bhp	Rpm	Bhp	Rpm	Bhp	Rpm	Bhp	Rpm	Bhp
6,500	A 775	2.43	A 825	2.75	A 871	3.05	915	3.37	B 959	3.72
7,000	826	2.98	875	3.22	B 918	3.58	B 959	3.98	B 1000	4.34
7,500	878	3.60	B 925	3.89	B 966	4.28	1005	4.69	1043	5.05
8,000	B 929	4.31	975	4.73	1015	5.11	1052	5.48	C 1088	5.86
8,500	981	5.11	1026	5.56	C 1064	5.97	C 1100	6.37	1134	6.76
9,000	1033	6.00	C 1076	6.49	1114	6.94	1148	7.36	1181	7.77
9,500	C 1085	6.98	1128	7.53	1164	8.00	1198	8.45	D 1229	8.89
10,000	1137	8.08	1179	8.66	D 1214	9.18	D 1247	9.65	1278	10.12
10,500	D 1190	9.28	D 1230	9.91	D 1265	10.46	1297	10.97	<b>1327</b>	<b>11.47</b>
11,000	1242	10.60	1282	11.28	—	—	—	—	—	—
11,500	—	—	—	—	—	—	—	—	—	—
12,000	—	—	—	—	—	—	—	—	—	—
12,500	—	—	—	—	—	—	—	—	—	—

48PGF28 (High Heat Units) (cont)										
Airflow (Cfm)	Available External Static Pressure (in. wg)									
	1.2		1.4		1.6		1.8		2.0	
	Rpm	Bhp	Rpm	Bhp	Rpm	Bhp	Rpm	Bhp	Rpm	Bhp
6,500	B 1004	4.11	1050	4.55	1098	5.04	C 1145	5.57	1192	6.14
7,000	1041	4.73	C 1083	5.15	C 1126	5.62	1170	6.14	D 1214	6.70
7,500	C 1081	5.44	1120	5.86	1159	6.32	1199	6.82	1240	7.36
8,000	1124	6.26	1160	6.68	1196	7.13	D 1233	7.62	1270	8.15
8,500	1168	7.17	1202	7.60	D 1235	8.06	1269	8.54	<b>1304</b>	<b>9.05</b>
9,000	D 1214	8.20	D 1245	8.64	1277	9.10	<b>1309</b>	<b>9.58</b>	<b>1341</b>	<b>10.09</b>
9,500	1260	9.33	1290	9.79	<b>1320</b>	<b>10.25</b>	<b>1351</b>	<b>10.74</b>	<b>1381</b>	<b>11.25</b>
10,000	<b>1308</b>	<b>10.58</b>	<b>1337</b>	<b>11.05</b>	—	—	—	—	—	—
10,500	—	—	—	—	—	—	—	—	—	—
11,000	—	—	—	—	—	—	—	—	—	—
11,500	—	—	—	—	—	—	—	—	—	—
12,000	—	—	—	—	—	—	—	—	—	—
12,500	—	—	—	—	—	—	—	—	—	—

### LEGEND

**Bhp** — Brake Horsepower Input to Fan

**Boldface** indicates field-supplied drive required.

### NOTES:

1. Motor drive ranges:

- (A) Low Range: 687-873 rpm, 5.37 bhp (208-v), 5.75 bhp (230 and 460-v), 5.75 bhp (575-v)
  - (B) Mid-Low Range: 805-1007 rpm, 5.37 bhp (208-v), 5.75 bhp (230 and 460-v), 5.75 bhp (575-v)
  - (C) Mid-High Range: 941-1176 rpm, 7.66 bhp (208-v), 8.51 bhp (230-v), 8.63 bhp (460 and 575-v)
  - (D) High Range: 1014-1297 rpm, 9.94 bhp (208-v), 10.45 bhp (230-v), 11.19 bhp (460-v), 11.50 bhp (575-v)
- All other rpms require field-supplied drive.

2. See page 90 for general fan performance notes.



## FAN PERFORMANCE — HORIZONTAL SUPPLY AND RETURN UNITS

### 48PGD03 (Low Heat Units)

Airflow (Cfm)	Available External Static Pressure (in. wg)									
	0.2		0.4		0.6		0.8		1.0	
	Rpm	Bhp	Rpm	Bhp	Rpm	Bhp	Rpm	Bhp	Rpm	Bhp
600	387	0.05	529	0.09	641	0.14	736	0.20	821	0.25
650	391	0.05	532	0.10	643	0.15	738	0.21	822	0.27
700	397	0.06	535	0.11	646	0.16	741	0.22	824	0.28
750	402	0.06	539	0.12	649	0.17	743	0.23	826	0.30
800	408	0.07	543	0.12	652	0.18	745	0.25	829	0.31
850	415	0.08	547	0.13	655	0.20	748	0.26	831	0.33
900	422	0.08	552	0.14	659	0.21	751	0.28	834	0.35
950	430	0.09	557	0.15	662	0.22	754	0.29	837	0.37
1000	437	0.10	562	0.16	666	0.23	758	0.31	839	0.38

### 48PGD03 (Low Heat Units) (cont)

Airflow (Cfm)	Available External Static Pressure (in. wg)									
	1.2		1.4		1.6		1.8		2.0	
	Rpm	Bhp	Rpm	Bhp	Rpm	Bhp	Rpm	Bhp	Rpm	Bhp
600	897	0.31	967	0.38	1032	0.45	1094	0.51	1152	0.59
650	899	0.33	969	0.40	1034	0.47	1096	0.54	1154	0.61
700	900	0.35	970	0.42	1036	0.49	1097	0.56	1155	0.64
750	902	0.37	972	0.44	1038	0.51	1099	0.59	1157	0.66
800	904	0.38	974	0.46	1039	0.53	1101	0.61	1159	0.69
850	907	0.40	976	0.48	1041	0.56	1102	0.64	1160	0.72
900	909	0.42	978	0.50	1043	0.58	1104	0.66	1162	0.75
950	911	0.44	981	0.52	1045	0.61	1106	0.69	1164	0.78
1000	914	0.46	983	0.55	1048	0.63	1109	0.72	1166	0.81

**LEGEND**

**Bhp** — Brake Horsepower

**NOTES:**

1. Motor drive range is 482 to 736 rpm for low range motor/drive and 656 to 1001 rpm for high range motor/drive. All other rpms require a field-supplied drive.
2. Maximum continuous bhp is 0.85 for low range motor/drive and 0.85 for high range motor/drive motors.
3. See page 90 for General Fan Performance Notes.

### 48PGD04 (Low Heat Units)

Airflow (Cfm)	Available External Static Pressure (in. wg)									
	0.2		0.4		0.6		0.8		1.0	
	Rpm	Bhp	Rpm	Bhp	Rpm	Bhp	Rpm	Bhp	Rpm	Bhp
900	422	0.08	552	0.14	659	0.21	751	0.28	834	0.35
950	430	0.09	557	0.15	662	0.22	754	0.29	837	0.37
1000	437	0.10	562	0.16	666	0.23	758	0.31	839	0.38
1050	446	0.11	568	0.17	671	0.25	761	0.32	843	0.40
1100	454	0.12	573	0.19	675	0.26	765	0.34	846	0.42
1150	463	0.13	580	0.20	680	0.28	769	0.36	849	0.44
1200	473	0.14	586	0.21	685	0.29	773	0.37	853	0.46
1250	482	0.15	593	0.23	691	0.31	778	0.39	857	0.48
1300	492	0.16	601	0.24	697	0.32	783	0.41	861	0.50
1350	503	0.18	608	0.26	703	0.34	788	0.43	865	0.53
1400	513	0.19	616	0.27	709	0.36	793	0.45	870	0.55
1450	524	0.21	624	0.29	716	0.38	799	0.48	875	0.58
1500	535	0.23	633	0.31	722	0.40	804	0.50	880	0.60

### 48PGD04 (Low Heat Units) (cont)

Airflow (Cfm)	Available External Static Pressure (in. wg)									
	1.2		1.4		1.6		1.8		2.0	
	Rpm	Bhp	Rpm	Bhp	Rpm	Bhp	Rpm	Bhp	Rpm	Bhp
900	909	0.42	978	0.50	1043	0.58	1104	0.66	1162	0.75
950	911	0.44	981	0.52	1045	0.61	1106	0.69	1164	0.78
1000	914	0.46	983	0.55	1048	0.63	1109	0.72	1166	0.81
1050	917	0.48	986	0.57	1050	0.66	1111	0.75	1168	0.84
1100	920	0.51	988	0.59	1053	0.68	1113	0.78	—	—
1150	923	0.53	991	0.62	1055	0.71	1116	0.81	—	—
1200	926	0.55	994	0.64	1058	0.74	1118	0.84	—	—
1250	930	0.58	997	0.67	1061	0.77	—	—	—	—
1300	933	0.60	1001	0.70	1064	0.80	—	—	—	—
1350	937	0.63	1004	0.73	1067	0.83	—	—	—	—
1400	941	0.65	1008	0.75	—	—	—	—	—	—
1450	945	0.68	1012	0.78	—	—	—	—	—	—
1500	950	0.71	1016	0.81	—	—	—	—	—	—

**LEGEND**

**Bhp** — Brake Horsepower

**NOTES:**

1. Motor drive range is 482 to 736 rpm for low range motor/drive and 796 to 1128 rpm for high range motor/drive. All other rpms require a field-supplied drive.
2. Maximum continuous bhp is 0.85 for low range motor/drive and 0.85 for high range motor/drive.
3. See page 90 for General Fan Performance Notes.

# Performance data (cont)



## FAN PERFORMANCE — HORIZONTAL SUPPLY AND RETURN UNITS (cont)

48PGE04 (Medium Heat Units)										
Airflow (Cfm)	Available External Static Pressure (in. wg)									
	0.2		0.4		0.6		0.8		1.0	
	Rpm	Bhp	Rpm	Bhp	Rpm	Bhp	Rpm	Bhp	Rpm	Bhp
900	425	0.08	554	0.14	661	0.21	754	0.28	837	0.35
950	433	0.09	560	0.15	665	0.22	757	0.29	840	0.37
1000	442	0.10	565	0.16	669	0.24	761	0.31	843	0.39
1050	450	0.11	571	0.18	674	0.25	764	0.33	846	0.41
1100	459	0.12	577	0.19	679	0.26	768	0.34	849	0.43
1150	469	0.13	584	0.20	684	0.28	773	0.36	853	0.45
1200	478	0.14	591	0.22	689	0.29	777	0.38	857	0.47
1250	488	0.16	598	0.23	695	0.31	782	0.40	861	0.49
1300	498	0.17	606	0.25	701	0.33	787	0.42	865	0.51
1350	509	0.18	614	0.26	707	0.35	792	0.44	870	0.53
1400	520	0.20	622	0.28	714	0.37	798	0.46	874	0.56
1450	531	0.21	630	0.30	721	0.39	803	0.48	879	0.58
1500	542	0.23	639	0.32	728	0.41	809	0.51	885	0.61

48PGE04 (Medium Heat Units) (cont)										
Airflow (Cfm)	Available External Static Pressure (in. wg)									
	1.2		1.4		1.6		1.8		2.0	
	Rpm	Bhp	Rpm	Bhp	Rpm	Bhp	Rpm	Bhp	Rpm	Bhp
900	912	0.43	982	0.50	1047	0.59	1108	0.67	1167	0.75
950	915	0.45	984	0.53	1049	0.61	1110	0.70	1168	0.78
1000	917	0.47	987	0.55	1051	0.64	1113	0.72	1170	0.81
1050	920	0.49	989	0.57	1054	0.66	1115	0.75	1173	0.85
1100	923	0.51	992	0.60	1056	0.69	1117	0.78	—	—
1150	926	0.53	995	0.62	1059	0.72	1120	0.81	—	—
1200	930	0.56	998	0.65	1062	0.75	1122	0.84	—	—
1250	933	0.58	1001	0.68	1065	0.77	—	—	—	—
1300	937	0.61	1005	0.70	1068	0.80	—	—	—	—
1350	941	0.63	1008	0.73	1071	0.83	—	—	—	—
1400	945	0.66	1012	0.76	—	—	—	—	—	—
1450	950	0.68	1016	0.79	—	—	—	—	—	—
1500	955	0.71	1020	0.82	—	—	—	—	—	—

**LEGEND**

**Bhp** — Brake Horsepower

**NOTES:**

1. Motor drive range is 482 to 736 rpm for low range motor/drive and 796 to 1128 rpm for high range motor/drive. All other rpms require a field-supplied drive.
2. Maximum continuous bhp is 0.85 for low range motor/drive and 0.85 for high range motor/drive.
3. See page 90 for General Fan Performance Notes.

48PGF04 (High Heat Units)										
Airflow (Cfm)	Available External Static Pressure (in. wg)									
	0.2		0.4		0.6		0.8		1.0	
	Rpm	Bhp	Rpm	Bhp	Rpm	Bhp	Rpm	Bhp	Rpm	Bhp
900	432	0.09	560	0.15	667	0.21	760	0.28	843	0.36
950	441	0.09	566	0.16	671	0.23	763	0.30	846	0.37
1000	450	0.10	572	0.17	676	0.24	767	0.31	849	0.39
1050	459	0.11	578	0.18	680	0.25	771	0.33	852	0.41
1100	468	0.12	585	0.19	686	0.27	775	0.35	856	0.43
1150	478	0.14	592	0.21	691	0.28	780	0.37	860	0.45
1200	489	0.15	600	0.22	697	0.30	784	0.39	864	0.47
1250	499	0.16	608	0.24	703	0.32	790	0.41	868	0.50
1300	510	0.18	616	0.25	710	0.34	795	0.43	873	0.52
1350	521	0.19	624	0.27	717	0.36	801	0.45	878	0.54
1400	533	0.21	633	0.29	724	0.38	807	0.47	883	0.57
1450	545	0.23	642	0.31	731	0.40	813	0.49	888	0.59
1500	556	0.24	652	0.33	739	0.42	819	0.52	894	0.62

48PGF04 (High Heat Units) (cont)										
Airflow (Cfm)	Available External Static Pressure (in. wg)									
	1.2		1.4		1.6		1.8		2.0	
	Rpm	Bhp	Rpm	Bhp	Rpm	Bhp	Rpm	Bhp	Rpm	Bhp
900	919	0.43	989	0.51	1055	0.60	1117	0.68	1175	0.77
950	921	0.45	991	0.54	1057	0.62	1119	0.71	1177	0.80
1000	924	0.48	994	0.56	1059	0.65	1121	0.74	1179	0.83
1050	927	0.50	996	0.58	1061	0.67	1123	0.77	—	—
1100	930	0.52	999	0.61	1064	0.70	1125	0.80	—	—
1150	934	0.54	1002	0.63	1067	0.73	1128	0.83	—	—
1200	937	0.57	1005	0.66	1070	0.76	—	—	—	—
1250	941	0.59	1009	0.69	1073	0.79	—	—	—	—
1300	945	0.62	1013	0.72	1076	0.82	—	—	—	—
1350	949	0.64	1016	0.74	1080	0.85	—	—	—	—
1400	954	0.67	1020	0.77	—	—	—	—	—	—
1450	959	0.70	1025	0.80	—	—	—	—	—	—
1500	964	0.73	1029	0.84	—	—	—	—	—	—

**LEGEND**

**Bhp** — Brake Horsepower

**NOTES:**

1. Motor drive range is 482 to 736 rpm for low range motor/drive and 796 to 1128 rpm for high range motor/drive. All other rpms require a field-supplied drive.
2. Maximum continuous bhp is 0.85 for low range motor/drive and 0.85 for high range motor/drive.
3. See page 90 for General Fan Performance Notes.



## FAN PERFORMANCE — HORIZONTAL SUPPLY AND RETURN UNITS (cont)

### 48PGD05 (Low Heat Units)

Airflow (Cfm)	Available External Static Pressure (in. wg)									
	0.2		0.4		0.6		0.8		1.0	
	Rpm	Bhp	Rpm	Bhp	Rpm	Bhp	Rpm	Bhp	Rpm	Bhp
1200	436	0.12	559	0.19	661	0.27	753	0.35	839	0.45
1300	456	0.14	574	0.22	673	0.30	762	0.39	845	0.49
1400	477	0.17	592	0.25	687	0.34	774	0.43	853	0.53
1500	500	0.20	611	0.29	703	0.38	787	0.48	864	0.58
1600	523	0.24	631	0.33	721	0.43	801	0.53	877	0.63
1700	548	0.28	652	0.38	739	0.48	818	0.58	891	0.69
1800	573	0.32	674	0.43	759	0.54	835	0.64	906	0.76
1900	600	0.37	697	0.48	779	0.60	854	0.71	923	0.83
2000	627	0.43	720	0.55	801	0.67	873	0.79	941	0.91

### 48PGD05 (Low Heat Units) (cont)

Airflow (Cfm)	Available External Static Pressure (in. wg)									
	1.2		1.4		1.6		1.8		2.0	
	Rpm	Bhp	Rpm	Bhp	Rpm	Bhp	Rpm	Bhp	Rpm	Bhp
1200	918	0.54	993	0.64	1063	0.75	1130	0.86	1193	0.97
1300	922	0.58	995	0.69	1064	0.80	1130	0.91	1193	1.03
1400	929	0.63	1000	0.74	1067	0.85	1132	0.97	1194	1.09
1500	937	0.69	1006	0.80	1072	0.91	1136	1.03	1196	1.16
1600	947	0.74	1015	0.86	1079	0.98	1141	1.10	1201	1.23
1700	959	0.81	1025	0.93	1088	1.05	1148	1.18	1207	1.31
1800	973	0.88	1037	1.00	1098	1.13	1157	1.26	1214	1.39
1900	988	0.95	1050	1.08	1110	1.21	1168	1.35	1223	1.48
2000	1004	1.04	1065	1.17	1123	1.30	1179	1.44	1234	1.58

**LEGEND**

**Bhp** — Brake Horsepower  
 High Range Motor/Drive Required

**NOTES:**

1. Motor drive range is 596 to 910 rpm for low range motor/drive and 828 to 1173 rpm for high range motor/drive. All other rpms require a field-supplied drive.
2. Maximum continuous bhp is 0.85 for low range motor/drive and 1.60 (single phase) and 2.40 (3 phase) for high range motor/drive.
3. See page 90 for General Fan Performance Notes.

### 48PGE05 (Medium Heat Units)

Airflow (Cfm)	Available External Static Pressure (in. wg)									
	0.2		0.4		0.6		0.8		1.0	
	Rpm	Bhp	Rpm	Bhp	Rpm	Bhp	Rpm	Bhp	Rpm	Bhp
1200	443	0.12	564	0.20	666	0.27	758	0.36	842	0.45
1300	463	0.15	580	0.22	678	0.31	767	0.40	849	0.49
1400	485	0.17	598	0.26	693	0.34	778	0.44	858	0.54
1500	508	0.21	617	0.30	709	0.39	792	0.48	869	0.59
1600	532	0.24	638	0.34	727	0.43	807	0.54	882	0.64
1700	558	0.28	660	0.39	746	0.49	824	0.59	896	0.70
1800	584	0.33	682	0.44	766	0.55	842	0.66	912	0.77
1900	611	0.38	706	0.50	788	0.61	861	0.72	930	0.84
2000	639	0.44	731	0.56	810	0.68	882	0.80	948	0.92

### 48PGE05 (Medium Heat Units) (cont)

Airflow (Cfm)	Available External Static Pressure (in. wg)									
	1.2		1.4		1.6		1.8		2.0	
	Rpm	Bhp	Rpm	Bhp	Rpm	Bhp	Rpm	Bhp	Rpm	Bhp
1200	922	0.55	996	0.65	1066	0.75	1133	0.86	1196	0.97
1300	926	0.59	999	0.69	1068	0.80	1133	0.92	1196	1.03
1400	933	0.64	1004	0.75	1071	0.86	1136	0.98	1197	1.10
1500	942	0.69	1011	0.80	1077	0.92	1140	1.04	1200	1.17
1600	952	0.75	1020	0.87	1084	0.99	1146	1.11	1205	1.24
1700	965	0.82	1030	0.94	1093	1.06	1153	1.19	1211	1.32
1800	979	0.89	1043	1.01	1104	1.14	1163	1.27	1220	1.41
1900	995	0.97	1057	1.09	1116	1.22	1174	1.36	1229	1.50
2000	1012	1.05	1072	1.18	1130	1.32	1186	1.46	1240	1.60

**LEGEND**

**Bhp** — Brake Horsepower  
 High Range Motor/Drive Required

**NOTES:**

1. Motor drive range is 596 to 910 rpm for low range motor/drive and 828 to 1173 rpm for high range motor/drive. All other rpms require a field-supplied drive.
2. Maximum continuous bhp is 0.85 for low range motor/drive and 1.60 (single phase) and 2.40 (3 phase) for high range motor/drive.
3. See page 90 for General Fan Performance Notes.

# Performance data (cont)



## FAN PERFORMANCE — HORIZONTAL SUPPLY AND RETURN UNITS (cont)

### 48PGF05 (High Heat Units)

Airflow (Cfm)	Available External Static Pressure (in. wg)									
	0.2		0.4		0.6		0.8		1.0	
	Rpm	Bhp	Rpm	Bhp	Rpm	Bhp	Rpm	Bhp	Rpm	Bhp
1200	456	0.13	574	0.20	675	0.28	766	0.37	850	0.46
1300	477	0.16	591	0.23	688	0.32	776	0.41	857	0.50
1400	500	0.18	610	0.27	703	0.36	788	0.45	867	0.55
1500	524	0.22	630	0.31	720	0.40	802	0.50	879	0.60
1600	550	0.26	652	0.35	739	0.45	819	0.55	893	0.66
1700	576	0.30	675	0.40	759	0.50	836	0.61	908	0.72
1800	604	0.35	699	0.46	781	0.57	856	0.68	925	0.79
1900	633	0.41	724	0.52	804	0.63	876	0.75	944	0.87
2000	662	0.47	750	0.59	828	0.71	898	0.83	964	0.95

### 48PGF05 (High Heat Units) (cont)

Airflow (Cfm)	Available External Static Pressure (in. wg)									
	1.2		1.4		1.6		1.8		2.0	
	Rpm	Bhp	Rpm	Bhp	Rpm	Bhp	Rpm	Bhp	Rpm	Bhp
1200	929	0.56	1003	0.66	1073	0.76	1139	0.87	1202	0.98
1300	934	0.60	1006	0.71	1075	0.82	1140	0.93	1202	1.05
1400	941	0.65	1012	0.76	1079	0.87	1143	0.99	1204	1.11
1500	951	0.71	1020	0.82	1085	0.94	1148	1.06	1208	1.18
1600	963	0.77	1029	0.89	1093	1.01	1155	1.13	1214	1.26
1700	976	0.84	1041	0.96	1103	1.08	1163	1.21	1221	1.34
1800	991	0.91	1054	1.04	1115	1.16	1174	1.30	1230	1.43
1900	1008	0.99	1070	1.12	1129	1.25	1186	1.39	1241	1.53
2000	1026	1.08	1086	1.21	1144	1.35	1199	1.49	1253	1.63

#### LEGEND

Bhp — Brake Horsepower  
 High Range Motor/Drive Required

#### NOTES:

1. Motor drive range is 596 to 910 rpm for low range motor/drive and 828 to 1173 rpm for high range motor/drive. All other rpms require a field-supplied drive.
2. Maximum continuous bhp is 0.85 for low range motor/drive and 1.60 (single phase) and 2.40 (3 phase) for high range motor/drive.
3. See page 90 for General Fan Performance Notes.

### 48PGD06 (Low Heat Units)

Airflow (Cfm)	Available External Static Pressure (in. wg)									
	0.2		0.4		0.6		0.8		1.0	
	Rpm	Bhp	Rpm	Bhp	Rpm	Bhp	Rpm	Bhp	Rpm	Bhp
1500	521	0.22	628	0.31	718	0.40	800	0.49	877	0.60
1600	546	0.25	649	0.35	737	0.45	816	0.55	890	0.65
1700	572	0.30	671	0.40	757	0.50	834	0.61	906	0.72
1800	599	0.35	695	0.45	777	0.56	852	0.67	922	0.79
1900	627	0.40	719	0.51	799	0.63	872	0.74	940	0.86
2000	655	0.46	745	0.58	822	0.70	893	0.82	959	0.94
2100	684	0.53	771	0.66	846	0.78	915	0.91	979	1.03
2200	714	0.61	797	0.74	871	0.87	938	1.00	1001	1.13
2300	744	0.69	824	0.83	896	0.96	961	1.10	1022	1.24
2400	775	0.78	852	0.92	922	1.06	985	1.21	1045	1.35
2500	806	0.88	880	1.03	948	1.18	1010	1.32	1069	1.47

### 48PGD06 (Low Heat Units) (cont)

Airflow (Cfm)	Available External Static Pressure (in. wg)									
	1.2		1.4		1.6		1.8		2.0	
	Rpm	Bhp	Rpm	Bhp	Rpm	Bhp	Rpm	Bhp	Rpm	Bhp
1500	949	0.70	1018	0.82	1083	0.93	1146	1.05	1207	1.18
1600	961	0.77	1027	0.88	1091	1.00	1153	1.13	1212	1.26
1700	974	0.83	1039	0.95	1101	1.08	1161	1.21	1219	1.34
1800	988	0.91	1052	1.03	1112	1.16	1171	1.29	1227	1.43
1900	1004	0.99	1066	1.11	1125	1.25	1182	1.38	1238	1.52
2000	1022	1.07	1082	1.20	1139	1.34	1195	1.48	1249	1.62
2100	1040	1.17	1099	1.30	1155	1.44	1209	1.59	1262	1.73
2200	1060	1.27	1117	1.41	1172	1.55	1225	1.70	1277	1.85
2300	1081	1.38	1136	1.52	1190	1.67	1242	1.82	1292	1.98
2400	1102	1.50	1156	1.65	1209	1.80	1259	1.96	1309	2.12
2500	1124	1.62	1177	1.78	1228	1.94	1278	2.10	1326	2.26

#### LEGEND

Bhp — Brake Horsepower

#### NOTES:

1. Motor drive range is 690 to 978 rpm for low range motor/drive and 929 to 1261 rpm for high range motor/drive. All other rpms require a field-supplied drive.
2. Maximum continuous bhp is 0.85 (single phase) and 2.40 (3 phase) for low range motor/drive and 1.60 (single phase) and 2.40 (3 phase) for high range motor/drive.
3. See page 90 for General Fan Performance Notes.



**FAN PERFORMANCE — HORIZONTAL SUPPLY AND RETURN UNITS (cont)**

48PGE06 (Medium Heat Units)										
Airflow (Cfm)	Available External Static Pressure (in. wg)									
	0.2		0.4		0.6		0.8		1.0	
	Rpm	Bhp	Rpm	Bhp	Rpm	Bhp	Rpm	Bhp	Rpm	Bhp
1500	536	0.23	640	0.32	729	0.41	811	0.51	887	0.61
1600	563	0.27	663	0.36	749	0.46	828	0.56	901	0.67
1700	590	0.31	686	0.42	770	0.52	846	0.62	917	0.74
1800	619	0.37	711	0.47	792	0.58	866	0.69	935	0.81
1900	648	0.43	737	0.54	816	0.65	887	0.77	954	0.89
2000	678	0.49	764	0.61	840	0.73	909	0.85	975	0.98
2100	709	0.56	792	0.69	865	0.81	933	0.94	996	1.07
2200	740	0.65	820	0.78	891	0.91	957	1.04	1019	1.17
2300	772	0.73	849	0.87	918	1.01	982	1.14	1042	1.28
2400	804	0.83	879	0.97	946	1.12	1008	1.26	1066	1.40
2500	837	0.94	909	1.09	974	1.24	1034	1.38	1092	1.53

48PGE06 (Medium Heat Units) (cont)										
Airflow (Cfm)	Available External Static Pressure (in. wg)									
	1.2		1.4		1.6		1.8		2.0	
	Rpm	Bhp	Rpm	Bhp	Rpm	Bhp	Rpm	Bhp	Rpm	Bhp
1500	958	0.72	1027	0.83	1092	0.95	1154	1.07	1214	1.20
1600	971	0.78	1037	0.90	1101	1.02	1162	1.15	1221	1.28
1700	985	0.85	1049	0.97	1111	1.10	1171	1.23	1228	1.36
1800	1001	0.93	1063	1.05	1124	1.18	1182	1.32	1238	1.45
1900	1018	1.01	1079	1.14	1138	1.27	1194	1.41	1249	1.55
2000	1036	1.10	1096	1.24	1153	1.37	1208	1.51	1262	1.66
2100	1056	1.20	1114	1.34	1170	1.48	1224	1.63	1276	1.78
2200	1077	1.31	1134	1.45	1188	1.60	1241	1.75	1292	1.90
2300	1099	1.43	1154	1.57	1207	1.72	1259	1.88	1309	2.03
2400	1122	1.55	1176	1.70	1228	1.86	1278	2.02	1327	2.18
2500	1146	1.69	1198	1.84	1249	2.00	1298	2.16	1346	2.33

LEGEND

Bhp — Brake Horsepower

NOTES:

1. Motor drive range is 690 to 978 rpm for low range motor/drive and 929 to 1261 rpm for high range motor/drive. All other rpms require a field-supplied drive.
2. Maximum continuous bhp is 0.85 (single phase) and 2.40 (3 phase) for low range motor/drive and 1.60 (single phase) and 2.40 (3 phase) for high range motor/drive.
3. See page 90 for General Fan Performance Notes.

48PGF06 (High Heat Units)										
Airflow (Cfm)	Available External Static Pressure (in. wg)									
	0.2		0.4		0.6		0.8		1.0	
	Rpm	Bhp	Rpm	Bhp	Rpm	Bhp	Rpm	Bhp	Rpm	Bhp
1500	551	0.24	653	0.33	741	0.42	821	0.52	896	0.62
1600	579	0.28	676	0.38	761	0.48	839	0.58	912	0.69
1700	608	0.33	701	0.43	783	0.54	858	0.64	929	0.76
1800	638	0.39	727	0.49	807	0.60	879	0.71	948	0.83
1900	668	0.45	755	0.56	831	0.68	902	0.79	968	0.91
2000	700	0.52	783	0.64	857	0.76	925	0.88	990	1.01
2100	732	0.60	812	0.72	884	0.85	950	0.97	1013	1.11
2200	765	0.68	842	0.81	912	0.95	976	1.08	1037	1.21
2300	799	0.78	873	0.92	940	1.05	1002	1.19	1062	1.33
2400	833	0.88	904	1.03	969	1.17	1030	1.31	1087	1.46
2500	867	1.00	936	1.15	999	1.30	1058	1.44	1114	1.60

48PGF06 (High Heat Units) (cont)										
Airflow (Cfm)	Available External Static Pressure (in. wg)									
	1.2		1.4		1.6		1.8		2.0	
	Rpm	Bhp	Rpm	Bhp	Rpm	Bhp	Rpm	Bhp	Rpm	Bhp
1500	968	0.73	1035	0.85	1100	0.97	1162	1.09	1222	1.21
1600	981	0.80	1047	0.92	1110	1.04	1171	1.16	1229	1.29
1700	996	0.87	1060	0.99	1121	1.12	1181	1.25	1238	1.38
1800	1013	0.95	1075	1.08	1135	1.21	1193	1.34	1248	1.48
1900	1031	1.04	1092	1.17	1150	1.30	1206	1.44	1261	1.58
2000	1051	1.14	1110	1.27	1166	1.41	1221	1.55	1275	1.69
2100	1072	1.24	1129	1.38	1185	1.52	1238	1.67	1290	1.82
2200	1094	1.35	1150	1.50	1204	1.64	1256	1.79	1307	1.95
2300	1118	1.48	1172	1.62	1225	1.77	1275	1.93	1325	2.09
2400	1142	1.61	1195	1.76	1246	1.92	1296	2.07	1344	2.24
2500	1168	1.75	1219	1.91	1269	2.07	1317	2.23	1365	2.40

LEGEND

Bhp — Brake Horsepower

NOTES:

1. Motor drive range is 690 to 978 rpm for low range motor/drive and 929 to 1261 rpm for high range motor/drive. All other rpms require a field-supplied drive.
2. Maximum continuous bhp is 0.85 (single phase) and 2.40 (3 phase) for low range motor/drive and 1.60 (single phase) and 2.40 (3 phase) for high range motor/drive.
3. See page 90 for General Fan Performance Notes.

# Performance data (cont)



## FAN PERFORMANCE — HORIZONTAL SUPPLY AND RETURN UNITS (cont)

48PGD07 (Low Heat Units)										
Airflow (Cfm)	Available External Static Pressure (in. wg)									
	0.2		0.4		0.6		0.8		1.0	
	Rpm	Bhp	Rpm	Bhp	Rpm	Bhp	Rpm	Bhp	Rpm	Bhp
1800	614	0.36	707	0.47	788	0.58	863	0.69	932	0.80
1900	642	0.42	732	0.53	811	0.64	883	0.76	950	0.88
2000	671	0.48	758	0.60	835	0.72	905	0.84	970	0.97
2100	701	0.55	785	0.68	859	0.80	927	0.93	991	1.06
2200	731	0.63	812	0.76	884	0.89	950	1.02	1012	1.16
2300	762	0.72	840	0.85	910	0.99	975	1.13	1035	1.27
2400	793	0.81	869	0.95	937	1.10	999	1.24	1058	1.38
2500	825	0.91	898	1.06	964	1.21	1025	1.36	1082	1.51
2600	856	1.03	927	1.18	991	1.33	1051	1.49	1107	1.64
2700	889	1.15	957	1.31	1019	1.47	1077	1.63	1132	1.79
2800	921	1.28	987	1.44	1048	1.61	1104	1.78	1158	1.94
2900	953	1.42	1017	1.59	1076	1.76	1132	1.94	1184	2.11
3000	986	1.57	1048	1.75	1106	1.93	1160	2.10	1211	2.28

48PGD07 (Low Heat Units) (cont)										
Airflow (Cfm)	Available External Static Pressure (in. wg)									
	1.2		1.4		1.6		1.8		2.0	
	Rpm	Bhp	Rpm	Bhp	Rpm	Bhp	Rpm	Bhp	Rpm	Bhp
1800	997	0.92	1060	1.05	1121	1.18	1179	1.31	1235	1.45
1900	1014	1.01	1075	1.13	1134	1.27	1191	1.40	1246	1.54
2000	1032	1.09	1092	1.23	1149	1.36	1204	1.50	1258	1.65
2100	1051	1.19	1109	1.33	1165	1.47	1219	1.61	1272	1.76
2200	1071	1.30	1128	1.44	1183	1.58	1235	1.73	1287	1.88
2300	1093	1.41	1148	1.56	1201	1.70	1253	1.86	1303	2.01
2400	1115	1.53	1168	1.68	1220	1.84	1271	1.99	1320	2.15
2500	1137	1.66	1190	1.82	1241	1.98	1290	2.14	1338	2.30
2600	1161	1.80	1212	1.96	1262	2.12	1310	2.29	—	—
2700	1185	1.95	1235	2.12	1284	2.28	—	—	—	—
2800	1209	2.11	1259	2.28	—	—	—	—	—	—
2900	1235	2.28	—	—	—	—	—	—	—	—
3000	—	—	—	—	—	—	—	—	—	—

LEGEND  
Bhp — Brake Horsepower

- NOTES:
1. Motor drive range is 796 to 1128 rpm for low range motor/drive and 1150 to 1438 rpm for high range motor/drive. All other rpms require a field-supplied drive.
  2. Maximum continuous bhp is 2.40 for low range motor/drive and 3.10 for high range motor/drive.
  3. See page 90 for General Fan Performance Notes.

48PGE07 (Medium Heat Units)										
Airflow (Cfm)	Available External Static Pressure (in. wg)									
	0.2		0.4		0.6		0.8		1.0	
	Rpm	Bhp	Rpm	Bhp	Rpm	Bhp	Rpm	Bhp	Rpm	Bhp
1800	633	0.38	723	0.49	803	0.60	876	0.71	944	0.83
1900	663	0.44	750	0.56	827	0.67	898	0.79	964	0.91
2000	694	0.51	777	0.63	852	0.75	921	0.87	985	1.00
2100	725	0.59	806	0.71	878	0.84	945	0.96	1007	1.09
2200	757	0.67	835	0.80	905	0.93	969	1.06	1030	1.20
2300	789	0.76	864	0.90	932	1.04	995	1.17	1055	1.31
2400	822	0.86	894	1.01	960	1.15	1022	1.29	1079	1.44
2500	855	0.98	925	1.12	989	1.27	1049	1.42	1105	1.57
2600	889	1.10	956	1.25	1018	1.40	1076	1.56	1131	1.71
2700	923	1.23	988	1.39	1048	1.55	1105	1.71	1158	1.87
2800	957	1.37	1020	1.53	1079	1.70	1134	1.87	1186	2.03
2900	991	1.52	1052	1.69	1109	1.86	1163	2.04	1214	2.21
3000	1026	1.68	1085	1.86	1140	2.04	1193	2.22	1243	2.40

48PGE07 (Medium Heat Units) (cont)										
Airflow (Cfm)	Available External Static Pressure (in. wg)									
	1.2		1.4		1.6		1.8		2.0	
	Rpm	Bhp	Rpm	Bhp	Rpm	Bhp	Rpm	Bhp	Rpm	Bhp
1800	1010	0.95	1072	1.07	1132	1.20	1190	1.33	1246	1.47
1900	1027	1.03	1088	1.16	1146	1.30	1203	1.43	1258	1.57
2000	1047	1.13	1106	1.26	1162	1.40	1218	1.54	1271	1.68
2100	1067	1.23	1124	1.37	1180	1.51	1234	1.65	1286	1.80
2200	1089	1.34	1145	1.48	1199	1.63	1251	1.78	1302	1.93
2300	1111	1.46	1166	1.60	1218	1.76	1269	1.91	1319	2.07
2400	1135	1.59	1188	1.74	1239	1.89	1289	2.05	1338	2.21
2500	1159	1.73	1211	1.88	1261	2.04	1310	2.20	1357	2.37
2600	1184	1.87	1235	2.03	1284	2.20	1331	2.37	—	—
2700	1210	2.03	1259	2.20	1307	2.37	—	—	—	—
2800	1236	2.20	1284	2.37	—	—	—	—	—	—
2900	1263	2.38	—	—	—	—	—	—	—	—
3000	—	—	—	—	—	—	—	—	—	—

LEGEND  
Bhp — Brake Horsepower

- NOTES:
1. Motor drive range is 796 to 1128 rpm for low range motor/drive and 1150 to 1438 rpm for high range motor/drive. All other rpms require a field-supplied drive.
  2. Maximum continuous bhp is 2.40 for low range motor/drive and 3.10 for high range motor/drive.
  3. See page 90 for General Fan Performance Notes.



## FAN PERFORMANCE — HORIZONTAL SUPPLY AND RETURN UNITS (cont)

### 48PGF07 (High Heat Units)

Airflow (Cfm)	Available External Static Pressure (in. wg)									
	0.2		0.4		0.6		0.8		1.0	
	Rpm	Bhp	Rpm	Bhp	Rpm	Bhp	Rpm	Bhp	Rpm	Bhp
1800	651	0.40	739	0.51	817	0.62	889	0.73	957	0.85
1900	683	0.47	767	0.58	843	0.69	912	0.81	978	0.93
2000	715	0.54	796	0.66	869	0.78	937	0.90	1000	1.03
2100	748	0.62	826	0.75	896	0.87	962	1.00	1024	1.13
2200	781	0.71	856	0.84	925	0.97	988	1.10	1048	1.24
2300	815	0.81	888	0.95	954	1.08	1015	1.22	1074	1.36
2400	850	0.92	919	1.06	983	1.20	1043	1.35	1100	1.49
2500	885	1.04	952	1.18	1014	1.33	1072	1.48	1127	1.63
2600	920	1.17	985	1.32	1045	1.47	1101	1.63	1155	1.79
2700	956	1.31	1018	1.47	1076	1.63	1131	1.79	1184	1.95
2800	992	1.46	1052	1.62	1108	1.79	1162	1.96	1213	2.12
2900	1028	1.62	1086	1.79	1141	1.96	1193	2.14	1243	2.31
3000	1064	1.80	1121	1.98	1174	2.15	1225	2.33	—	—

### 48PGF07 (High Heat Units) (cont)

Airflow (Cfm)	Available External Static Pressure (in. wg)									
	1.2		1.4		1.6		1.8		2.0	
	Rpm	Bhp	Rpm	Bhp	Rpm	Bhp	Rpm	Bhp	Rpm	Bhp
1800	1022	0.97	1083	1.10	1143	1.23	1201	1.36	1256	1.50
1900	1041	1.06	1101	1.19	1159	1.32	1215	1.46	1269	1.60
2000	1061	1.16	1119	1.29	1176	1.43	1230	1.57	1283	1.72
2100	1083	1.26	1140	1.40	1194	1.55	1248	1.69	1299	1.84
2200	1106	1.38	1161	1.52	1214	1.67	1266	1.82	1317	1.98
2300	1130	1.51	1183	1.65	1236	1.81	1286	1.96	1335	2.12
2400	1155	1.64	1207	1.80	1258	1.95	1307	2.11	1355	2.27
2500	1180	1.79	1231	1.95	1281	2.11	1329	2.27	—	—
2600	1207	1.95	1257	2.11	1305	2.27	—	—	—	—
2700	1234	2.11	1283	2.28	—	—	—	—	—	—
2800	1262	2.29	—	—	—	—	—	—	—	—
2900	—	—	—	—	—	—	—	—	—	—
3000	—	—	—	—	—	—	—	—	—	—

**LEGEND**

**Bhp** — Brake Horsepower

**NOTES:**

1. Motor drive range is 796 to 1128 rpm for low range motor/drive and 1150 to 1438 rpm for high range motor/drive. All other rpms require a field-supplied drive.
2. Maximum continuous bhp is 2.40 for low range motor/drive and 3.10 for high range motor/drive.
3. See page 90 for General Fan Performance Notes.

### 48PGD08 (Low Heat Units)

Airflow (Cfm)	Available External Static Pressure (in. wg)									
	0.2		0.4		0.6		0.8		1.0	
	Rpm	Bhp	Rpm	Bhp	Rpm	Bhp	Rpm	Bhp	Rpm	Bhp
2250	409	0.29	493	0.39	567	0.50	636	0.62	700	0.75
2400	422	0.33	503	0.44	576	0.56	642	0.68	704	0.81
2550	436	0.38	515	0.49	585	0.62	650	0.74	710	0.88
2700	450	0.43	527	0.55	595	0.68	658	0.81	717	0.95
2850	465	0.49	539	0.62	606	0.75	667	0.89	724	1.03
3000	480	0.56	552	0.69	617	0.83	676	0.97	732	1.12
3150	496	0.63	566	0.77	629	0.91	687	1.06	741	1.21
3300	511	0.70	579	0.85	641	1.00	698	1.16	751	1.31
3450	527	0.79	593	0.94	653	1.10	709	1.26	761	1.42
3600	543	0.88	608	1.04	666	1.21	721	1.37	772	1.54
3750	560	0.98	622	1.15	680	1.32	733	1.49	783	1.66

### 48PGD08 (Low Heat Units) (cont)

Airflow (Cfm)	Available External Static Pressure (in. wg)									
	1.2		1.4		1.6		1.8		2.0	
	Rpm	Bhp	Rpm	Bhp	Rpm	Bhp	Rpm	Bhp	Rpm	Bhp
2250	760	0.88	817	1.01	871	1.16	923	1.30	972	1.45
2400	763	0.94	819	1.09	872	1.23	923	1.38	972	1.54
2550	768	1.02	822	1.16	874	1.32	924	1.47	973	1.63
2700	773	1.10	826	1.25	877	1.40	927	1.56	974	1.73
2850	779	1.18	831	1.34	881	1.50	929	1.66	976	1.83
3000	786	1.27	837	1.43	886	1.60	933	1.77	979	1.94
3150	793	1.37	843	1.54	891	1.70	938	1.88	983	2.06
3300	802	1.48	851	1.65	898	1.82	943	2.00	987	2.18
3450	811	1.59	859	1.76	905	1.94	949	2.12	992	2.31
3600	820	1.71	867	1.89	912	2.07	956	2.26	998	2.45
3750	830	1.84	876	2.02	920	2.21	963	2.40	1005	2.60

**LEGEND**

**Bhp** — Brake Horsepower

**————** High Range Motor/Drive Required.

**NOTES:**

1. Motor drive range is 568 to 771 rpm for low range motor/drive and 812 to 1015 rpm for high range motor/drive. All other rpms require a field-supplied drive.
2. Maximum continuous bhp is 2.40 for low range motor/drive and 3.10 for high range motor/drive.
3. See page 90 for General Fan Performance Notes.

# Performance data (cont)



## FAN PERFORMANCE — HORIZONTAL SUPPLY AND RETURN UNITS (cont)

### 48PGE08 (Medium Heat Units)

Airflow (Cfm)	Available External Static Pressure (in. wg)									
	0.2		0.4		0.6		0.8		1.0	
	Rpm	Bhp	Rpm	Bhp	Rpm	Bhp	Rpm	Bhp	Rpm	Bhp
2250	408	0.28	492	0.39	567	0.50	635	0.62	699	0.74
2400	424	0.33	505	0.44	577	0.56	644	0.68	706	0.81
2550	440	0.38	519	0.50	588	0.62	653	0.75	713	0.88
2700	457	0.44	532	0.56	600	0.69	662	0.82	721	0.96
2850	473	0.50	547	0.63	612	0.77	673	0.90	730	1.05
3000	490	0.57	561	0.71	625	0.85	684	0.99	740	1.14
3150	507	0.65	576	0.79	638	0.94	695	1.08	750	1.24
3300	524	0.73	591	0.88	651	1.03	708	1.19	760	1.34
3450	542	0.82	606	0.98	665	1.13	720	1.29	772	1.46
3600	559	0.92	622	1.08	679	1.24	733	1.41	783	1.58
3750	577	1.02	638	1.19	694	1.36	746	1.53	795	1.71

### 48PGE08 (Medium Heat Units) (cont)

Airflow (Cfm)	Available External Static Pressure (in. wg)									
	1.2		1.4		1.6		1.8		2.0	
	Rpm	Bhp	Rpm	Bhp	Rpm	Bhp	Rpm	Bhp	Rpm	Bhp
2250	760	0.88	817	1.01	871	1.16	923	1.30	972	1.45
2400	765	0.95	820	1.09	874	1.24	924	1.39	973	1.54
2550	770	1.03	825	1.17	877	1.32	927	1.48	975	1.64
2700	777	1.11	830	1.26	881	1.42	930	1.58	977	1.74
2850	784	1.20	836	1.35	886	1.51	934	1.68	981	1.85
3000	793	1.29	843	1.45	892	1.62	939	1.79	985	1.96
3150	801	1.40	851	1.56	899	1.73	945	1.91	990	2.09
3300	811	1.51	859	1.68	906	1.85	951	2.03	995	2.21
3450	821	1.63	868	1.80	914	1.98	958	2.16	1001	2.35
3600	831	1.75	878	1.93	923	2.11	966	2.30	1008	2.49
3750	843	1.89	888	2.07	932	2.26	974	2.45	1016	2.65

#### LEGEND

**Bhp** — Brake Horsepower  
 High Range Motor/Drive Required

#### NOTES:

1. Motor drive range is 568 to 771 rpm for low range motor/drive and 812 to 1015 rpm for high range motor/drive. All other rpms require a field-supplied drive.
2. Maximum continuous bhp is 2.40 for low range motor/drive and 3.10 for high range motor/drive.
3. See page 90 for General Fan Performance Notes.

### 48PGF08 (High Heat Units)

Airflow (Cfm)	Available External Static Pressure (in. wg)									
	0.2		0.4		0.6		0.8		1.0	
	Rpm	Bhp	Rpm	Bhp	Rpm	Bhp	Rpm	Bhp	Rpm	Bhp
2250	413	0.29	496	0.39	571	0.51	639	0.63	703	0.75
2400	429	0.34	510	0.45	581	0.57	647	0.69	709	0.82
2550	446	0.39	524	0.51	593	0.63	657	0.76	717	0.89
2700	464	0.45	538	0.57	605	0.70	667	0.83	726	0.97
2850	481	0.52	553	0.65	618	0.78	678	0.92	735	1.06
3000	499	0.59	569	0.72	632	0.86	690	1.01	746	1.16
3150	517	0.67	584	0.81	646	0.95	703	1.10	756	1.26
3300	535	0.75	600	0.90	660	1.05	715	1.21	768	1.37
3450	553	0.85	617	1.00	675	1.16	729	1.32	780	1.48
3600	571	0.95	633	1.11	690	1.27	742	1.44	792	1.61
3750	590	1.06	650	1.23	705	1.40	756	1.57	805	1.74

### 48PGF08 (High Heat Units) (cont)

Airflow (Cfm)	Available External Static Pressure (in. wg)									
	1.2		1.4		1.6		1.8		2.0	
	Rpm	Bhp	Rpm	Bhp	Rpm	Bhp	Rpm	Bhp	Rpm	Bhp
2250	763	0.88	820	1.02	874	1.16	925	1.31	974	1.46
2400	768	0.96	824	1.10	877	1.25	927	1.40	976	1.55
2550	774	1.04	829	1.18	881	1.33	930	1.49	978	1.65
2700	781	1.12	834	1.27	885	1.43	934	1.59	981	1.75
2850	789	1.21	841	1.37	891	1.53	939	1.70	985	1.87
3000	798	1.31	849	1.47	897	1.64	944	1.81	990	1.98
3150	808	1.42	857	1.58	905	1.75	951	1.93	995	2.11
3300	818	1.53	866	1.70	913	1.88	958	2.06	1001	2.24
3450	829	1.65	876	1.83	921	2.01	965	2.19	1008	2.38
3600	840	1.78	886	1.96	931	2.15	974	2.34	1016	2.53
3750	852	1.92	897	2.11	941	2.30	983	2.49	1024	2.69

#### LEGEND

**Bhp** — Brake Horsepower  
 High Range Motor/Drive Required

#### NOTES:

1. Motor drive range is 568 to 771 rpm for low range motor/drive and 812 to 1015 rpm for high range motor/drive. All other rpms require a field-supplied drive.
2. Maximum continuous bhp is 2.40 for low range motor/drive and 3.10 for high range motor/drive.
3. See page 90 for General Fan Performance Notes.



## FAN PERFORMANCE — HORIZONTAL SUPPLY AND RETURN UNITS (cont)

### 48PGD09 (Low Heat Units)

Airflow (Cfm)	Available External Static Pressure (in. wg)									
	0.2		0.4		0.6		0.8		1.0	
	Rpm	Bhp	Rpm	Bhp	Rpm	Bhp	Rpm	Bhp	Rpm	Bhp
2550	436	0.38	515	0.49	585	0.62	650	0.74	710	0.88
2700	450	0.43	527	0.55	595	0.68	658	0.81	717	0.95
2850	465	0.49	539	0.62	606	0.75	667	0.89	724	1.03
3000	480	0.56	552	0.69	617	0.83	676	0.97	732	1.12
3150	496	0.63	566	0.77	629	0.91	687	1.06	741	1.21
3300	511	0.70	579	0.85	641	1.00	698	1.16	751	1.31
3450	527	0.79	593	0.94	653	1.10	709	1.26	761	1.42
3600	543	0.88	608	1.04	666	1.21	721	1.37	772	1.54
3750	560	0.98	622	1.15	680	1.32	733	1.49	783	1.66
3900	576	1.08	637	1.26	693	1.44	745	1.61	794	1.79
4050	593	1.19	652	1.38	707	1.56	758	1.75	806	1.93
4200	610	1.32	668	1.51	721	1.70	771	1.89	818	2.08

### 48PGD09 (Low Heat Units) (cont)

Airflow (Cfm)	Available External Static Pressure (in. wg)									
	1.2		1.4		1.6		1.8		2.0	
	Rpm	Bhp	Rpm	Bhp	Rpm	Bhp	Rpm	Bhp	Rpm	Bhp
2550	768	1.02	822	1.16	874	1.32	924	1.47	973	1.63
2700	773	1.10	826	1.25	877	1.40	927	1.56	974	1.73
2850	779	1.18	831	1.34	881	1.50	929	1.66	976	1.83
3000	786	1.27	837	1.43	886	1.60	933	1.77	979	1.94
3150	793	1.37	843	1.54	891	1.70	938	1.88	983	2.06
3300	802	1.48	851	1.65	898	1.82	943	2.00	987	2.18
3450	811	1.59	859	1.76	905	1.94	949	2.12	992	2.31
3600	820	1.71	867	1.89	912	2.07	956	2.26	998	2.45
3750	830	1.84	876	2.02	920	2.21	963	2.40	1005	2.60
3900	841	1.98	886	2.16	929	2.35	971	2.55	1012	2.75
4050	852	2.12	896	2.31	938	2.51	980	2.71	1020	2.91
4200	863	2.27	906	2.47	948	2.67	989	2.88	1028	3.09

**LEGEND**

**Bhp** — Brake Horsepower  
 High Range Motor/Drive Required

**NOTES:**

1. Motor drive range is 568 to 771 rpm for low range motor/drive and 812 to 1015 rpm for high range motor/drive. All other rpms require a field-supplied drive.
2. Maximum continuous bhp is 2.40 for low range motor/drive and 3.70 for high range motor/drive.
3. See page 90 for General Fan Performance Notes.

### 48PGE09 (Medium Heat Units)

Airflow (Cfm)	Available External Static Pressure (in. wg)									
	0.2		0.4		0.6		0.8		1.0	
	Rpm	Bhp	Rpm	Bhp	Rpm	Bhp	Rpm	Bhp	Rpm	Bhp
2550	440	0.38	519	0.50	588	0.62	653	0.75	713	0.88
2700	457	0.44	532	0.56	600	0.69	662	0.82	721	0.96
2850	473	0.50	547	0.63	612	0.77	673	0.90	730	1.05
3000	490	0.57	561	0.71	625	0.85	684	0.99	740	1.14
3150	507	0.65	576	0.79	638	0.94	695	1.08	750	1.24
3300	524	0.73	591	0.88	651	1.03	708	1.19	760	1.34
3450	542	0.82	606	0.98	665	1.13	720	1.29	772	1.46
3600	559	0.92	622	1.08	679	1.24	733	1.41	783	1.58
3750	577	1.02	638	1.19	694	1.36	746	1.53	795	1.71
3900	594	1.13	654	1.31	708	1.49	759	1.66	808	1.84
4050	612	1.25	670	1.44	723	1.62	773	1.80	821	1.99
4200	630	1.38	686	1.57	738	1.76	787	1.95	834	2.14

### 48PGE09 (Medium Heat Units) (cont)

Airflow (Cfm)	Available External Static Pressure (in. wg)									
	1.2		1.4		1.6		1.8		2.0	
	Rpm	Bhp	Rpm	Bhp	Rpm	Bhp	Rpm	Bhp	Rpm	Bhp
2550	770	1.03	825	1.17	877	1.32	927	1.48	975	1.64
2700	777	1.11	830	1.26	881	1.42	930	1.58	977	1.74
2850	784	1.20	836	1.35	886	1.51	934	1.68	981	1.85
3000	793	1.29	843	1.45	892	1.62	939	1.79	985	1.96
3150	801	1.40	851	1.56	899	1.73	945	1.91	990	2.09
3300	811	1.51	859	1.68	906	1.85	951	2.03	995	2.21
3450	821	1.63	868	1.80	914	1.98	958	2.16	1001	2.35
3600	831	1.75	878	1.93	923	2.11	966	2.30	1008	2.49
3750	843	1.89	888	2.07	932	2.26	974	2.45	1016	2.65
3900	854	2.03	898	2.22	941	2.41	983	2.61	1024	2.81
4050	866	2.18	909	2.37	951	2.57	992	2.77	1032	2.98
4200	878	2.34	921	2.54	962	2.74	1002	2.95	1041	3.16

**LEGEND**

**Bhp** — Brake Horsepower  
 High Range Motor/Drive Required

**NOTES:**

1. Motor drive range is 568 to 771 rpm for low range motor/drive and 812 to 1015 rpm for high range motor/drive. All other rpms require a field-supplied drive.
2. Maximum continuous bhp is 2.40 for low range motor/drive and 3.70 for high range motor/drive.
3. See page 90 for General Fan Performance Notes.

# Performance data (cont)



## FAN PERFORMANCE — HORIZONTAL SUPPLY AND RETURN UNITS (cont)

48PGF09 (High Heat Units)										
Airflow (Cfm)	Available External Static Pressure (in. wg)									
	0.2		0.4		0.6		0.8		1.0	
	Rpm	Bhp	Rpm	Bhp	Rpm	Bhp	Rpm	Bhp	Rpm	Bhp
2550	446	0.39	524	0.51	593	0.63	657	0.76	717	0.89
2700	464	0.45	538	0.57	605	0.70	667	0.83	726	0.97
2850	481	0.52	553	0.65	618	0.78	678	0.92	735	1.06
3000	499	0.59	569	0.72	632	0.86	690	1.01	746	1.16
3150	517	0.67	584	0.81	646	0.95	703	1.10	756	1.26
3300	535	0.75	600	0.90	660	1.05	715	1.21	768	1.37
3450	553	0.85	617	1.00	675	1.16	729	1.32	780	1.48
3600	571	0.95	633	1.11	690	1.27	742	1.44	792	1.61
3750	590	1.06	650	1.23	705	1.40	756	1.57	805	1.74
3900	608	1.18	667	1.35	720	1.53	771	1.71	819	1.89
4050	627	1.30	684	1.49	736	1.67	786	1.85	832	2.04
4200	646	1.44	701	1.63	752	1.82	801	2.01	846	2.20

48PGF09 (High Heat Units) (cont)										
Airflow (Cfm)	Available External Static Pressure (in. wg)									
	1.2		1.4		1.6		1.8		2.0	
	Rpm	Bhp	Rpm	Bhp	Rpm	Bhp	Rpm	Bhp	Rpm	Bhp
2550	774	1.04	829	1.18	881	1.33	930	1.49	978	1.65
2700	781	1.12	834	1.27	885	1.43	934	1.59	981	1.75
2850	789	1.21	841	1.37	891	1.53	939	1.70	985	1.87
3000	798	1.31	849	1.47	897	1.64	944	1.81	990	1.98
3150	808	1.42	857	1.58	905	1.75	951	1.93	995	2.11
3300	818	1.53	866	1.70	913	1.88	958	2.06	1001	2.24
3450	829	1.65	876	1.83	921	2.01	965	2.19	1008	2.38
3600	840	1.78	886	1.96	931	2.15	974	2.34	1016	2.53
3750	852	1.92	897	2.11	941	2.30	983	2.49	1024	2.69
3900	864	2.07	908	2.26	951	2.46	993	2.65	1033	2.86
4050	877	2.23	920	2.42	962	2.62	1003	2.83	1042	3.03
4200	890	2.40	933	2.60	974	2.80	1013	3.01	1052	3.22

LEGEND

Bhp — Brake Horsepower  
 — High Range Motor/Drive Required

NOTES:

1. Motor drive range is 568 to 771 rpm for low range motor/drive and 812 to 1015 rpm for high range motor/drive. All other rpms require a field-supplied drive.
2. Maximum continuous bhp is 2.40 for low range motor/drive and 3.70 for high range motor/drive.
3. See page 90 for General Fan Performance Notes.

48PGD12 (Low Heat Units)										
AIRFLOW (CFM)	AVAILABLE EXTERNAL STATIC PRESSURE (in. wg)									
	0.2		0.4		0.6		0.8		1.0	
	Rpm	Bhp	Rpm	Bhp	Rpm	Bhp	Rpm	Bhp	Rpm	Bhp
3000	502	0.60	571	0.73	634	0.87	693	1.01	748	1.16
3200	525	0.70	592	0.85	652	0.99	709	1.14	762	1.30
3400	549	0.82	613	0.97	671	1.13	726	1.29	777	1.45
3600	573	0.95	634	1.11	691	1.28	743	1.44	793	1.61
3800	597	1.10	656	1.27	711	1.44	762	1.62	810	1.79
4000	621	1.26	678	1.44	731	1.62	781	1.80	828	1.99
4200	645	1.43	700	1.62	752	1.81	800	2.00	846	2.20
4400	669	1.62	723	1.83	772	2.02	819	2.22	864	2.42
4600	694	1.83	745	2.04	794	2.25	839	2.46	883	2.67
4800	719	2.06	768	2.28	815	2.50	860	2.71	902	2.93
5000	743	2.30	791	2.53	837	2.76	880	2.98	922	3.21

48PGD12 (Low Heat Units) (cont)										
AIRFLOW (CFM)	AVAILABLE EXTERNAL STATIC PRESSURE (in. wg)									
	1.2		1.4		1.6		1.8		2.0	
	Rpm	Bhp	Rpm	Bhp	Rpm	Bhp	Rpm	Bhp	Rpm	Bhp
3000	800	1.32	851	1.48	899	1.64	946	1.82	992	1.99
3200	813	1.46	862	1.63	909	1.80	955	1.98	999	2.16
3400	827	1.62	874	1.79	920	1.97	964	2.15	1007	2.34
3600	841	1.79	887	1.97	932	2.15	975	2.34	1017	2.53
3800	857	1.97	901	2.16	945	2.35	986	2.55	1027	2.75
4000	873	2.18	916	2.37	958	2.56	999	2.77	1039	2.97
4200	889	2.39	932	2.59	973	2.80	1013	3.00	1051	3.22
4400	907	2.63	948	2.83	988	3.04	1027	3.26	1065	3.48
4600	925	2.88	965	3.09	1004	3.31	1042	3.53	—	—
4800	943	3.15	982	3.37	1020	3.59	—	—	—	—
5000	962	3.44	1000	3.67	—	—	—	—	—	—

LEGEND

Bhp — Brake Horsepower  
 — High Range Motor/Drive Required

NOTES:

1. Motor drive range is 690 to 893 rpm for low range motor/drive and 852 to 1055 rpm for high range motor/drive. All other rpms require a field-supplied drive.
2. Maximum continuous bhp is 3.10 for low range motor/drive and 3.70 for high range motor/drive.
3. See page 90 for General Fan Performance Notes.



## FAN PERFORMANCE — HORIZONTAL SUPPLY AND RETURN UNITS (cont)

### 48PGE12 (Medium Heat Units)

Airflow (Cfm)	Available External Static Pressure (in. wg)									
	0.2		0.4		0.6		0.8		1.0	
	Rpm	Bhp	Rpm	Bhp	Rpm	Bhp	Rpm	Bhp	Rpm	Bhp
3000	510	0.61	579	0.75	641	0.89	699	1.03	754	1.18
3200	535	0.72	600	0.87	660	1.01	716	1.16	769	1.32
3400	560	0.84	623	1.00	680	1.15	734	1.31	785	1.48
3600	585	0.98	645	1.14	701	1.31	753	1.47	802	1.65
3800	610	1.14	668	1.31	722	1.48	772	1.65	820	1.83
4000	635	1.30	691	1.48	743	1.66	792	1.85	839	2.03
4200	661	1.49	715	1.68	765	1.87	813	2.06	858	2.25
4400	687	1.69	739	1.89	788	2.09	834	2.29	878	2.49
4600	713	1.91	763	2.12	811	2.33	855	2.53	898	2.74
4800	739	2.15	788	2.37	834	2.58	877	2.80	919	3.02
5000	765	2.41	812	2.63	857	2.86	899	3.08	940	3.31

### 48PGE12 (Medium Heat Units) (cont)

Airflow (Cfm)	Available External Static Pressure (in. wg)									
	1.2		1.4		1.6		1.8		2.0	
	Rpm	Bhp	Rpm	Bhp	Rpm	Bhp	Rpm	Bhp	Rpm	Bhp
3000	806	1.34	856	1.50	905	1.66	951	1.84	997	2.01
3200	820	1.48	868	1.65	915	1.82	961	2.00	1005	2.18
3400	834	1.64	881	1.82	927	2.00	971	2.18	1014	2.37
3600	850	1.82	896	2.00	940	2.19	983	2.38	1024	2.57
3800	866	2.01	911	2.20	954	2.39	995	2.59	1036	2.79
4000	884	2.22	927	2.42	969	2.61	1009	2.82	1049	3.02
4200	902	2.45	944	2.65	984	2.85	1024	3.06	1062	3.28
4400	920	2.69	961	2.90	1001	3.11	1039	3.33	1077	3.55
4600	939	2.96	979	3.17	1018	3.39	1055	3.61	—	—
4800	959	3.24	998	3.46	1035	3.69	—	—	—	—
5000	979	3.54	—	—	—	—	—	—	—	—

**LEGEND**

**Bhp** — Brake Horsepower  
 High Range Motor/Drive Required

**NOTES:**

1. Motor drive range is 690 to 893 rpm for low range motor/drive and 852 to 1055 rpm for high range motor/drive. All other rpms require a field-supplied drive.
2. Maximum continuous bhp is 3.10 for low range motor/drive and 3.70 for high range motor/drive.
3. See page 90 for General Fan Performance Notes.

### 48PGF12 (High Heat Units)

Airflow (Cfm)	Available External Static Pressure (in. wg)									
	0.2		0.4		0.6		0.8		1.0	
	Rpm	Bhp	Rpm	Bhp	Rpm	Bhp	Rpm	Bhp	Rpm	Bhp
3000	514	0.62	583	0.75	645	0.89	702	1.04	757	1.19
3200	540	0.73	605	0.88	665	1.02	720	1.18	773	1.33
3400	565	0.86	628	1.01	685	1.17	739	1.33	790	1.49
3600	591	1.00	651	1.16	706	1.33	758	1.49	808	1.66
3800	617	1.16	675	1.33	728	1.50	778	1.67	826	1.85
4000	643	1.33	699	1.51	750	1.69	799	1.87	845	2.06
4200	670	1.52	723	1.71	773	1.90	820	2.09	865	2.28
4400	696	1.72	748	1.92	796	2.12	842	2.32	885	2.52
4600	723	1.95	772	2.16	819	2.37	864	2.57	906	2.78
4800	749	2.19	797	2.41	843	2.63	886	2.84	927	3.06
5000	776	2.46	823	2.69	867	2.91	909	3.14	949	3.36

### 48PGF12 (High Heat Units) (cont)

Airflow (Cfm)	Available External Static Pressure (in. wg)									
	1.2		1.4		1.6		1.8		2.0	
	Rpm	Bhp	Rpm	Bhp	Rpm	Bhp	Rpm	Bhp	Rpm	Bhp
3000	809	1.35	859	1.51	908	1.67	954	1.85	999	2.02
3200	823	1.50	872	1.66	919	1.84	964	2.01	1008	2.20
3400	839	1.66	886	1.83	931	2.01	975	2.20	1018	2.39
3600	855	1.84	900	2.02	944	2.21	987	2.40	1029	2.59
3800	872	2.04	916	2.22	959	2.42	1000	2.61	1041	2.81
4000	890	2.25	933	2.44	974	2.64	1015	2.85	1054	3.05
4200	908	2.48	950	2.68	990	2.89	1030	3.10	1068	3.31
4400	927	2.73	968	2.94	1007	3.15	1046	3.37	1083	3.59
4600	947	3.00	987	3.21	1025	3.43	1062	3.65	—	—
4800	967	3.28	1006	3.51	—	—	—	—	—	—
5000	988	3.59	—	—	—	—	—	—	—	—

**LEGEND**

**Bhp** — Brake Horsepower  
 High Range Motor/Drive Required

**NOTES:**

1. Motor drive range is 690 to 893 rpm for low range motor/drive and 852 to 1055 rpm for high range motor/drive. All other rpms require a field-supplied drive.
2. Maximum continuous bhp is 3.10 for low range motor/drive and 3.70 for high range motor/drive.
3. See page 90 for General Fan Performance Notes.

# Performance data (cont)



## FAN PERFORMANCE — HORIZONTAL SUPPLY AND RETURN UNITS (cont)

48PGD14 (Low Heat Units)										
Airflow (Cfm)	Available External Static Pressure (in. wg)									
	0.2		0.4		0.6		0.8		1.0	
	Rpm	Bhp	Rpm	Bhp	Rpm	Bhp	Rpm	Bhp	Rpm	Bhp
3750	591	1.06	651	1.23	706	1.40	757	1.57	806	1.75
3950	615	1.22	672	1.40	726	1.57	776	1.75	823	1.94
4150	639	1.39	695	1.58	746	1.76	795	1.95	841	2.14
4350	663	1.58	717	1.77	767	1.97	814	2.17	859	2.36
4550	688	1.78	740	1.99	788	2.19	834	2.40	878	2.60
4750	712	2.00	763	2.22	810	2.43	855	2.65	897	2.86
4950	737	2.24	786	2.47	832	2.69	875	2.91	917	3.14
5150	762	2.50	809	2.73	853	2.97	896	3.20	937	3.43
5350	787	2.77	832	3.02	876	3.26	917	3.50	957	3.75
5550	811	3.07	856	3.33	898	3.58	938	3.83	977	4.08
5750	836	3.39	879	3.65	920	3.92	960	4.18	998	4.44
5950	861	3.72	903	4.00	943	4.28	982	4.55	1019	4.81
6150	886	4.09	927	4.37	966	4.66	1004	4.94	1040	5.21
6250	899	4.28	939	4.57	977	4.85	1015	5.14	—	—

48PGD14 (Low Heat Units) (cont)										
Airflow (Cfm)	Available External Static Pressure (in. wg)									
	1.2		1.4		1.6		1.8		2.0	
	Rpm	Bhp	Rpm	Bhp	Rpm	Bhp	Rpm	Bhp	Rpm	Bhp
3750	853	1.93	898	2.11	941	2.30	983	2.49	1025	2.69
3950	869	2.12	912	2.31	955	2.51	996	2.71	1036	2.91
4150	885	2.34	928	2.53	969	2.74	1009	2.94	1048	3.15
4350	902	2.57	944	2.77	984	2.98	1023	3.19	1061	3.41
4550	920	2.81	961	3.03	1000	3.24	1038	3.46	1075	3.68
4750	938	3.08	978	3.30	1016	3.52	1053	3.75	1090	3.98
4950	957	3.36	996	3.59	1033	3.82	1069	4.05	1105	4.29
5150	976	3.67	1014	3.90	1050	4.14	1086	4.38	1121	4.62
5350	995	3.99	1032	4.23	1068	4.48	1103	4.72	1137	4.97
5550	1015	4.33	1051	4.58	1086	4.84	1120	5.09	—	—
5750	1035	4.70	1070	4.96	1105	5.22	—	—	—	—
5950	1055	5.08	—	—	—	—	—	—	—	—
6150	—	—	—	—	—	—	—	—	—	—
6250	—	—	—	—	—	—	—	—	—	—

LEGEND

Bhp — Brake Horsepower  
 — High Range Motor/Drive Required

NOTES:

1. Motor drive range is 690 to 893 rpm for low range motor/drive and 852 to 1055 rpm for high range motor/drive. All other rpms require a field-supplied drive.
2. Maximum continuous bhp is 3.70 for low range motor/drive and 5.25 for high range motor/drive.
3. See page 90 for General Fan Performance Notes.



FAN PERFORMANCE — HORIZONTAL SUPPLY AND RETURN UNITS (cont)

48PGE14 (Medium Heat Units)										
Airflow (Cfm)	Available External Static Pressure (in. wg)									
	0.2		0.4		0.6		0.8		1.0	
	Rpm	Bhp	Rpm	Bhp	Rpm	Bhp	Rpm	Bhp	Rpm	Bhp
3750	604	1.10	662	1.26	717	1.43	767	1.61	816	1.78
3950	629	1.26	686	1.44	738	1.62	787	1.80	834	1.98
4150	655	1.44	709	1.63	760	1.82	808	2.00	853	2.20
4350	681	1.64	733	1.83	782	2.03	829	2.23	873	2.43
4550	706	1.85	757	2.06	805	2.26	850	2.47	893	2.68
4750	732	2.09	782	2.30	828	2.52	872	2.73	914	2.95
4950	759	2.34	806	2.56	851	2.79	894	3.01	935	3.24
5150	785	2.61	831	2.85	874	3.08	916	3.31	956	3.54
5350	811	2.91	856	3.15	898	3.39	939	3.63	978	3.88
5550	838	3.22	881	3.48	922	3.73	961	3.98	999	4.23
5750	864	3.56	906	3.82	946	4.08	985	4.34	1022	4.60
5950	891	3.92	931	4.19	970	4.46	1008	4.73	1044	5.00
6150	917	4.31	957	4.59	995	4.87	1032	5.15	—	—
6250	931	4.51	970	4.80	1007	5.08	—	—	—	—

48PGE14 (Medium Heat Units) (cont)										
Airflow (Cfm)	Available External Static Pressure (in. wg)									
	1.2		1.4		1.6		1.8		2.0	
	Rpm	Bhp	Rpm	Bhp	Rpm	Bhp	Rpm	Bhp	Rpm	Bhp
3750	862	1.96	907	2.15	950	2.34	992	2.53	1033	2.73
3950	879	2.17	923	2.36	965	2.56	1006	2.76	1045	2.96
4150	897	2.39	939	2.59	980	2.79	1020	3.00	1059	3.21
4350	915	2.63	957	2.84	996	3.05	1035	3.26	1073	3.48
4550	934	2.89	975	3.10	1013	3.32	1051	3.54	1088	3.76
4750	954	3.16	993	3.39	1031	3.61	1068	3.84	1104	4.07
4950	974	3.46	1012	3.69	1049	3.92	1085	4.16	1120	4.39
5150	994	3.78	1032	4.02	1068	4.25	1103	4.50	1137	4.74
5350	1015	4.12	1051	4.36	1087	4.61	1121	4.86	1155	5.11
5550	1036	4.48	1072	4.73	1106	4.99	1140	5.24	—	—
5750	1058	4.86	1092	5.12	—	—	—	—	—	—
5950	—	—	—	—	—	—	—	—	—	—
6150	—	—	—	—	—	—	—	—	—	—
6250	—	—	—	—	—	—	—	—	—	—

LEGEND

Bhp — Brake Horsepower  
 — High Range Motor/Drive Required

NOTES:

1. Motor drive range is 690 to 893 rpm for low range motor/drive and 852 to 1055 rpm for high range motor/drive. All other rpms require a field-supplied drive.
2. Maximum continuous bhp is 3.70 for low range motor/drive and 5.25 for high range motor/drive.
3. See page 90 for General Fan Performance Notes.

# Performance data (cont)



## FAN PERFORMANCE — HORIZONTAL SUPPLY AND RETURN UNITS (cont)

48PGF14 (High Heat Units)										
Airflow (Cfm)	Available External Static Pressure (in. wg)									
	0.2		0.4		0.6		0.8		1.0	
	Rpm	Bhp	Rpm	Bhp	Rpm	Bhp	Rpm	Bhp	Rpm	Bhp
3750	611	1.12	669	1.28	723	1.45	773	1.63	821	1.80
3950	637	1.28	693	1.46	745	1.64	794	1.82	840	2.01
4150	663	1.47	717	1.66	767	1.84	815	2.03	860	2.22
4350	690	1.67	742	1.87	790	2.06	836	2.26	880	2.46
4550	716	1.89	766	2.10	813	2.30	858	2.51	901	2.72
4750	743	2.13	791	2.35	837	2.56	880	2.77	922	2.99
4950	770	2.39	816	2.62	861	2.84	903	3.06	944	3.29
5150	796	2.67	842	2.90	885	3.14	926	3.37	965	3.60
5350	823	2.97	867	3.22	909	3.46	949	3.70	988	3.94
5550	850	3.29	893	3.55	933	3.80	972	4.05	1010	4.30
5750	877	3.64	918	3.90	958	4.16	996	4.42	1033	4.68
5950	904	4.01	944	4.28	983	4.55	1020	4.82	1056	5.09
6150	931	4.41	970	4.69	1008	4.97	1044	5.24	—	—
6250	945	4.61	983	4.90	1020	5.18	—	—	—	—

48PGF14 (High Heat Units) (cont)										
Airflow (Cfm)	Available External Static Pressure (in. wg)									
	1.2		1.4		1.6		1.8		2.0	
	Rpm	Bhp	Rpm	Bhp	Rpm	Bhp	Rpm	Bhp	Rpm	Bhp
3750	868	1.99	912	2.17	955	2.36	997	2.56	1038	2.76
3950	885	2.19	928	2.39	970	2.58	1011	2.79	1051	2.99
4150	904	2.42	946	2.62	986	2.82	1026	3.03	1065	3.24
4350	923	2.66	963	2.87	1003	3.08	1042	3.30	1079	3.52
4550	942	2.93	982	3.14	1021	3.36	1058	3.58	1095	3.81
4750	962	3.21	1001	3.43	1039	3.66	1075	3.88	1111	4.12
4950	983	3.51	1020	3.74	1057	3.97	1093	4.21	1128	4.45
5150	1004	3.84	1040	4.07	1076	4.31	1111	4.56	1146	4.80
5350	1025	4.18	1061	4.43	1096	4.67	1130	4.92	1164	5.18
5550	1046	4.55	1082	4.80	1116	5.06	—	—	—	—
5750	1068	4.94	1103	5.20	—	—	—	—	—	—
5950	—	—	—	—	—	—	—	—	—	—
6150	—	—	—	—	—	—	—	—	—	—
6250	—	—	—	—	—	—	—	—	—	—

LEGEND

**Bhp** — Brake Horsepower  
**————** High Range Motor/Drive Required

NOTES:

1. Motor drive range is 690 to 893 rpm for low range motor/drive and 852 to 1055 rpm for high range motor/drive. All other rpms require a field-supplied drive.
2. Maximum continuous bhp is 3.70 for low range motor/drive and 5.25 for high range motor/drive.
3. See page 90 for General Fan Performance Notes.



## FAN PERFORMANCE — HORIZONTAL SUPPLY/RETURN UNITS (cont)

### 48PGD16 (Low Heat Units)

Airflow (Cfm)	Available External Static Pressure (in. wg)									
	0.2		0.4		0.6		0.8		1.0	
	Rpm	Bhp	Rpm	Bhp	Rpm	Bhp	Rpm	Bhp	Rpm	Bhp
4500	633	1.01	709	1.32	771	1.62	826	1.91	877	2.20
4800	663	1.18	738	1.52	799	1.84	853	2.15	903	2.46
5100	694	1.37	768	1.73	828	2.07	881	2.41	930	2.74
5400	725	1.57	797	1.96	857	2.33	909	2.68	957	3.04
5700	757	1.80	828	2.22	886	2.61	938	2.99	985	3.36
6000	788	2.05	858	2.49	916	2.91	967	3.31	1013	3.71
6300	820	2.33	888	2.79	945	3.24	996	3.66	1042	4.08
6600	852	2.63	919	3.12	975	3.59	1025	4.04	1070	4.48
6900	884	2.95	949	3.47	1005	3.96	1055	4.44	1099	4.90
7200	916	3.31	980	3.85	1036	4.37	1084	4.87	1129	5.36
7500	949	3.69	1011	4.25	1066	4.80	1114	5.33	1158	5.84

### 48PGD16 (Low Heat Units) (cont)

Airflow (Cfm)	Available External Static Pressure (in. wg)									
	1.2		1.4		1.6		1.8		2.0	
	Rpm	Bhp	Rpm	Bhp	Rpm	Bhp	Rpm	Bhp	Rpm	Bhp
4500	925	2.50	971	2.80	1015	3.10	1059	3.41	1101	3.73
4800	950	2.77	994	3.09	1037	3.41	1079	3.73	1120	4.06
5100	975	3.07	1019	3.40	1060	3.74	1101	4.08	1140	4.42
5400	1002	3.39	1044	3.74	1085	4.09	1124	4.45	1162	4.81
5700	1029	3.73	1070	4.10	1110	4.47	1148	4.84	1185	5.22
6000	1056	4.10	1097	4.49	1136	4.88	1173	5.27	1210	5.66
6300	1084	4.49	1124	4.90	1162	5.31	1199	5.72	1235	6.13
6600	1112	4.91	1152	5.34	1189	5.77	1226	6.20	1260	6.63
6900	1141	5.36	1180	5.81	1217	6.26	1252	6.71	1287	7.15
7200	1170	5.84	1208	6.31	1245	6.78	1280	7.25	—	—
7500	1199	6.35	1237	6.84	1273	7.33	—	—	—	—

**LEGEND**

- Bhp** — Brake Horsepower
- Mid-Low Range Motor/Drive Required
- High Range Motor/Drive Required

**NOTES:**

- Motor drive range is 710 to 879 rpm for low range motor/drive and 872 to 1066 rpm for mid-low range motor/drive, and 1066 to 1260 rpm for high range motor/drive. All other rpms require a field-supplied drive.
- Maximum continuous bhp is 3.70 for low range motor/drive and 5.25 for mid-low range motor/drive, and 7.50 for high range motor/drive.
- See page 90 for General Fan Performance Notes.

# Performance data (cont)



## FAN PERFORMANCE — HORIZONTAL SUPPLY/RETURN UNITS (cont)

48PGE16 (Medium Heat Units)										
Airflow (Cfm)	Available External Static Pressure (in. wg)									
	0.2		0.4		0.6		0.8		1.0	
	Rpm	Bhp	Rpm	Bhp	Rpm	Bhp	Rpm	Bhp	Rpm	Bhp
4500	664	1.13	735	1.44	795	1.74	849	2.04	900	2.34
4800	698	1.33	767	1.66	826	1.99	878	2.30	927	2.62
5100	732	1.55	800	1.91	857	2.25	908	2.59	956	2.93
5400	767	1.79	832	2.17	889	2.54	939	2.90	985	3.26
5700	801	2.05	865	2.46	920	2.86	970	3.24	1015	3.61
6000	836	2.35	899	2.78	953	3.20	1001	3.60	1046	4.00
6300	871	2.67	932	3.13	985	3.57	1033	4.00	1077	4.42
6600	906	3.02	966	3.50	1018	3.97	1065	4.42	1108	4.87
6900	941	3.40	1000	3.91	1051	4.40	1097	4.88	1140	5.35
7200	977	3.81	1034	4.35	1084	4.87	1130	5.37	1171	5.86
7500	1012	4.26	1068	4.83	1118	5.37	1162	5.89	1203	6.41

48PGE16 (Medium Heat Units) (cont)										
Airflow (Cfm)	Available External Static Pressure (in. wg)									
	1.2		1.4		1.6		1.8		2.0	
	Rpm	Bhp	Rpm	Bhp	Rpm	Bhp	Rpm	Bhp	Rpm	Bhp
4500	947	2.64	993	2.95	1038	3.26	1081	3.58	1123	3.90
4800	974	2.94	1018	3.26	1061	3.59	1102	3.92	1143	4.26
5100	1001	3.26	1044	3.60	1086	3.95	1126	4.29	1165	4.65
5400	1029	3.61	1071	3.97	1112	4.33	1151	4.69	1189	5.06
5700	1058	3.99	1099	4.37	1139	4.75	1177	5.13	1214	5.51
6000	1088	4.40	1128	4.79	1166	5.19	1203	5.59	1239	5.99
6300	1118	4.84	1157	5.25	1195	5.67	1231	6.08	1266	6.50
6600	1148	5.31	1187	5.74	1224	6.18	1259	6.61	1294	7.05
6900	1179	5.81	1217	6.26	1253	6.72	1288	7.17	—	—
7200	1211	6.34	1248	6.82	1283	7.30	—	—	—	—
7500	1242	6.91	1279	7.41	—	—	—	—	—	—

LEGEND

- Bhp** — Brake Horsepower
- Mid-Low Range Motor/Drive Required
- High Range Motor/Drive Required

NOTES:

1. Motor drive range is 710 to 879 rpm for low range motor/drive and 872 to 1066 rpm for mid-low range motor/drive, and 1066 to 1260 rpm for high range motor/drive. All other rpms require a field-supplied drive.
2. Maximum continuous bhp is 3.70 for low range motor/drive and 5.25 for mid-low range motor/drive, and 7.50 for high range motor/drive.
3. See page 90 for General Fan Performance Notes.



FAN PERFORMANCE — HORIZONTAL SUPPLY/RETURN UNITS (cont)

48PGF16 (High Heat Units)

Airflow (Cfm)	Available External Static Pressure (in. wg)									
	0.2		0.4		0.6		0.8		1.0	
	Rpm	Bhp	Rpm	Bhp	Rpm	Bhp	Rpm	Bhp	Rpm	Bhp
4500	705	1.31	771	1.62	828	1.92	881	2.23	931	2.54
4800	743	1.54	806	1.87	862	2.20	913	2.53	961	2.85
5100	781	1.80	842	2.16	896	2.51	946	2.85	993	3.20
5400	819	2.09	878	2.47	931	2.84	979	3.21	1025	3.57
5700	857	2.41	915	2.82	966	3.21	1013	3.60	1057	3.98
6000	896	2.76	952	3.19	1002	3.61	1048	4.02	1091	4.43
6300	935	3.15	989	3.60	1038	4.05	1083	4.48	1125	4.91
6600	974	3.57	1027	4.05	1074	4.52	1118	4.97	1159	5.42
6900	1013	4.03	1064	4.54	1111	5.03	1153	5.51	1194	5.98
7200	1052	4.54	1102	5.06	1148	5.58	1189	6.08	1229	6.57
7500	1092	5.08	1140	5.63	1185	6.17	1226	6.69	1264	7.21

48PGF16 (High Heat Units) (cont)

Airflow (Cfm)	Available External Static Pressure (in. wg)									
	1.2		1.4		1.6		1.8		2.0	
	Rpm	Bhp	Rpm	Bhp	Rpm	Bhp	Rpm	Bhp	Rpm	Bhp
4500	979	2.85	1024	3.16	1069	3.49	1112	3.82	1154	4.15
4800	1007	3.18	1051	3.51	1094	3.85	1136	4.20	1176	4.55
5100	1037	3.54	1080	3.90	1121	4.25	1161	4.61	1200	4.97
5400	1068	3.94	1109	4.31	1149	4.68	1188	5.06	1226	5.44
5700	1099	4.37	1140	4.76	1178	5.15	1216	5.54	1253	5.94
6000	1132	4.83	1171	5.24	1209	5.65	1245	6.06	1281	6.47
6300	1165	5.33	1203	5.76	1240	6.19	1275	6.61	—	—
6600	1198	5.87	1235	6.32	1271	6.76	—	—	—	—
6900	1232	6.45	1268	6.91	—	—	—	—	—	—
7200	1266	7.06	—	—	—	—	—	—	—	—
7500	—	—	—	—	—	—	—	—	—	—

LEGEND

Bhp — Brake Horsepower

— Mid-Low Range Motor/Drive Required

— High Range Motor/Drive Required

NOTES:

1. Motor drive range is 710 to 879 rpm for low range motor/drive and 872 to 1066 rpm for mid-low range motor/drive, and 1066 to 1260 rpm for high range motor/drive. All other rpms require a field-supplied drive.
2. Maximum continuous bhp is 3.70 for low range motor/drive and 5.25 for mid-low range motor/drive, and 7.50 for high range motor/drive.
3. See page 90 for General Fan Performance Notes.

# Performance data (cont)



## FAN PERFORMANCE — HORIZONTAL SUPPLY AND RETURN UNITS (cont)

### 48PGD20 (Low Heat Units)

Airflow (Cfm)	Available External Static Pressure (in. wg)									
	0.2		0.4		0.6		0.8		1.0	
	Rpm	Bhp	Rpm	Bhp	Rpm	Bhp	Rpm	Bhp	Rpm	Bhp
5000	<b>862</b>	<b>2.65</b>	917	2.93	F 969	3.21	F 1019	3.17	F 1066	3.52
5500	F 937	3.26	F 988	3.56	F 1036	3.53	F 1083	3.90	G 1127	4.28
6000	1013	3.58	1060	3.96	<b>1105</b>	<b>4.35</b>	1149	4.75	G 1191	5.16
6500	<b>1089</b>	<b>4.48</b>	G 1133	4.89	G 1175	5.31	G 1216	5.73	H 1256	6.17
7000	G 1166	5.52	H 1207	5.96	H 1247	6.41	H 1285	6.86	H 1323	7.32
7500	H 1243	6.71	H 1282	7.18	H 1319	7.66	<b>1355</b>	<b>8.14</b>	<b>1391</b>	<b>8.63</b>
8000	1320	8.07	<b>1356</b>	<b>8.57</b>	—	—	—	—	—	—
8500	—	—	—	—	—	—	—	—	—	—
9000	—	—	—	—	—	—	—	—	—	—

### 48PGD20 (Low Heat Units) (cont)

Airflow (Cfm)	Available External Static Pressure (in. wg)									
	1.2		1.4		1.6		1.8		2.0	
	Rpm	Bhp	Rpm	Bhp	Rpm	Bhp	Rpm	Bhp	Rpm	Bhp
5000	F 1112	3.88	F 1156	4.25	G 1199	4.63	G 1240	5.02	G 1280	5.42
5500	1171	4.67	G 1212	5.06	G 1253	5.47	H 1292	5.88	H 1331	6.30
6000	G 1232	5.57	H 1271	6.00	H 1310	6.43	<b>1348</b>	<b>6.87</b>	<b>1384</b>	<b>7.31</b>
6500	H 1295	6.61	H 1333	7.06	<b>1369</b>	<b>7.52</b>	—	—	—	—
7000	<b>1360</b>	<b>7.80</b>	<b>1396</b>	<b>8.27</b>	—	—	—	—	—	—
7500	—	—	—	—	—	—	—	—	—	—
8000	—	—	—	—	—	—	—	—	—	—
8500	—	—	—	—	—	—	—	—	—	—
9000	—	—	—	—	—	—	—	—	—	—

#### LEGEND

**Bhp** — Brake Horsepower Input to Fan

**Boldface** indicates field-supplied drive required.

#### NOTES:

- Motor drive ranges:
  - (E) Low Range: Not Used
  - (F) Mid-Low Range: 896-1227 rpm, 4.26 bhp (208/230 and 460-v), 873-1108 rpm, 5.75 bhp (575-v)
  - (G) Mid-High Range: 1113-1414 rpm, 5.37 bhp (208-v), 5.75 bhp (230 and 460-v), 5.75 bhp (575-v)
  - (H) High Range: 1096-1339 rpm, 7.66 bhp (208-v), 8.51 bhp (230-v), 8.63 bhp (460 and 575-v)

All other rpms require field-supplied drive.
- See page 90 for general fan performance notes.



## FAN PERFORMANCE — HORIZONTAL SUPPLY AND RETURN UNITS (cont)

### 48PGE20 (Medium Heat Units)

Airflow (Cfm)	Available External Static Pressure (in. wg)									
	0.2		0.4		0.6		0.8		1.0	
	Rpm	Bhp	Rpm	Bhp	Rpm	Bhp	Rpm	Bhp	Rpm	Bhp
5000	<b>875</b>	<b>2.74</b>	931	3.04	<b>F</b> 984	3.34	<b>F</b> 1035	3.33	<b>F</b> 1083	3.69
5500	<b>F</b> 952	3.38	<b>F</b> 1003	3.32	<b>F</b> 1053	3.70	<b>F</b> 1100	4.09	<b>G</b> 1145	4.49
6000	1029	3.74	1077	4.15	<b>G</b> 1123	4.56	<b>G</b> 1167	4.98	<b>G</b> 1210	5.41
6500	<b>1106</b>	<b>4.67</b>	<b>G</b> 1151	5.11	<b>G</b> 1194	5.56	<b>H</b> 1236	6.01	<b>H</b> 1276	6.47
7000	<b>G</b> 1184	5.75	<b>H</b> 1226	6.23	<b>H</b> 1266	6.71	<b>H</b> 1306	7.19	<b>1344</b>	<b>7.68</b>
7500	<b>H</b> 1262	7.00	1302	7.50	<b>1340</b>	<b>8.01</b>	<b>1377</b>	<b>8.53</b>	—	—
8000	<b>1341</b>	<b>8.41</b>	—	—	—	—	—	—	—	—
8500	—	—	—	—	—	—	—	—	—	—
9000	—	—	—	—	—	—	—	—	—	—

### 48PGE20 (Medium Heat Units) (cont)

Airflow (Cfm)	Available External Static Pressure (in. wg)									
	1.2		1.4		1.6		1.8		2.0	
	Rpm	Bhp	Rpm	Bhp	Rpm	Bhp	Rpm	Bhp	Rpm	Bhp
5000	<b>F</b> 1130	4.07	<b>G</b> 1174	4.45	<b>G</b> 1218	4.84	<b>G</b> 1259	5.23	<b>G</b> 1300	5.63
5500	<b>G</b> 1189	4.90	<b>G</b> 1232	5.31	<b>G</b> 1273	5.72	<b>H</b> 1313	6.15	<b>1352</b>	<b>6.58</b>
6000	<b>H</b> 1251	5.85	<b>H</b> 1292	6.29	<b>H</b> 1331	6.74	<b>1369</b>	<b>7.19</b>	—	—
6500	1315	6.94	<b>1354</b>	<b>7.41</b>	<b>1391</b>	<b>7.89</b>	—	—	—	—
7000	<b>1381</b>	<b>8.18</b>	—	—	—	—	—	—	—	—
7500	—	—	—	—	—	—	—	—	—	—
8000	—	—	—	—	—	—	—	—	—	—
8500	—	—	—	—	—	—	—	—	—	—
9000	—	—	—	—	—	—	—	—	—	—

#### LEGEND

**Bhp** — Brake Horsepower Input to Fan

**Boldface** indicates field-supplied drive required.

#### NOTES:

1. Motor drive ranges:

(E) Low Range: Not Used

(F) Mid-Low Range: 896-1227 rpm, 4.26 bhp (208/230 and 460-v), 873-1108 rpm, 5.75 bhp (575-v)

(G) Mid-High Range: 1113-1414 rpm, 5.37 bhp (208-v), 5.75 bhp (230 and 460-v), 5.75 bhp (575-v)

(H) High Range: 1096-1339 rpm, 7.66 bhp (208-v), 8.51 bhp (230-v), 8.63 bhp (460 and 575-v)

All other rpms require field-supplied drive.

2. See page 90 for general fan performance notes.

# Performance data (cont)



## FAN PERFORMANCE — HORIZONTAL SUPPLY AND RETURN UNITS (cont)

48PGF20 (High Heat Units)										
Airflow (Cfm)	Available External Static Pressure (in. wg)									
	0.2		0.4		0.6		0.8		1.0	
	Rpm	Bhp	Rpm	Bhp	Rpm	Bhp	Rpm	Bhp	Rpm	Bhp
5000	<b>875</b>	<b>2.74</b>	931	3.04	F 984	3.34	F 1035	3.33	F 1083	3.69
5500	F 952	3.38	F 1003	3.32	F 1053	3.70	F 1100	4.09	G 1145	4.49
6000	1029	3.74	1077	4.15	G 1123	4.56	G 1167	4.98	G 1210	5.41
6500	<b>1106</b>	<b>4.67</b>	G 1151	5.11	G 1194	5.56	H 1236	6.01	H 1276	6.47
7000	G 1184	5.75	H 1226	6.23	H 1266	6.71	H 1306	7.19	<b>1344</b>	<b>7.68</b>
7500	H 1262	7.00	1302	7.50	<b>1340</b>	<b>8.01</b>	<b>1377</b>	<b>8.53</b>	—	—
8000	<b>1341</b>	<b>8.41</b>	<b>1378</b>	<b>8.95</b>	—	—	—	—	—	—
8500	—	—	—	—	—	—	—	—	—	—
9000	—	—	—	—	—	—	—	—	—	—

48PGF20 (High Heat Units) (cont)										
Airflow (Cfm)	Available External Static Pressure (in. wg)									
	1.2		1.4		1.6		1.8		2.0	
	Rpm	Bhp	Rpm	Bhp	Rpm	Bhp	Rpm	Bhp	Rpm	Bhp
5000	F 1130	4.07	G 1174	4.45	G 1218	4.84	G 1259	5.23	G 1300	5.63
5500	G 1189	4.90	1232	5.31	G 1273	5.72	H 1313	6.15	<b>1352</b>	<b>6.58</b>
6000	H 1251	5.85	H 1292	6.29	H 1331	6.74	<b>1369</b>	<b>7.19</b>	—	—
6500	1315	6.94	<b>1354</b>	<b>7.41</b>	<b>1391</b>	<b>7.89</b>	—	—	—	—
7000	<b>1381</b>	<b>8.18</b>	—	—	—	—	—	—	—	—
7500	—	—	—	—	—	—	—	—	—	—
8000	—	—	—	—	—	—	—	—	—	—
8500	—	—	—	—	—	—	—	—	—	—
9000	—	—	—	—	—	—	—	—	—	—

LEGEND

**Bhp** — Brake Horsepower Input to Fan

**Boldface** indicates field-supplied drive required.

NOTES:

- Motor drive ranges:  
 (E) Low Range: Not Used  
 (F) Mid-Low Range: 896-1227 rpm, 4.26 bhp (208/230 and 460-v), 873-1108 rpm, 5.75 bhp (575-v)  
 (G) Mid-High Range: 1113-1414 rpm, 5.37 bhp (208-v), 5.75 bhp (230 and 460-v), 5.75 bhp (575-v)  
 (H) High Range: 1096-1339 rpm, 7.66 bhp (208-v), 8.51 bhp (230-v), 8.63 bhp (460 and 575-v)  
 All other rpms require field-supplied drive.
- See page 90 for general fan performance notes.



FAN PERFORMANCE — HORIZONTAL SUPPLY AND RETURN UNITS (cont)

48PGD24 (Low Heat Units)										
Airflow (Cfm)	Available External Static Pressure (in. wg)									
	0.2		0.4		0.6		0.8		1.0	
	Rpm	Bhp	Rpm	Bhp	Rpm	Bhp	Rpm	Bhp	Rpm	Bhp
5,500	F 937	3.26	F 988	3.56	F 1036	3.53	F 1083	3.90	G 1127	4.28
6,000	F 1013	3.58	F 1060	3.96	<b>1105</b>	<b>4.35</b>	G 1149	4.75	G 1191	5.16
6,500	<b>1089</b>	<b>4.48</b>	G 1133	4.89	G 1175	5.31	G 1216	5.73	H 1256	6.17
7,000	G 1166	5.52	H 1207	5.96	H 1247	6.41	H 1285	6.86	H 1323	7.32
7,500	H 1243	6.71	H 1282	7.18	H 1319	7.66	<b>1355</b>	<b>8.14</b>	<b>1391</b>	<b>8.63</b>
8,000	H 1320	8.07	<b>1356</b>	<b>8.57</b>	—	—	—	—	—	—
8,500	—	—	—	—	—	—	—	—	—	—
9,000	—	—	—	—	—	—	—	—	—	—
9,500	—	—	—	—	—	—	—	—	—	—
10,000	—	—	—	—	—	—	—	—	—	—

48PGD24 (Low Heat Units) (cont)										
Airflow (Cfm)	Available External Static Pressure (in. wg)									
	1.2		1.4		1.6		1.8		2.0	
	Rpm	Bhp	Rpm	Bhp	Rpm	Bhp	Rpm	Bhp	Rpm	Bhp
5,500	G 1171	4.67	G 1212	5.06	G 1253	5.47	H 1292	5.88	1331	6.30
6,000	G 1232	5.57	H 1271	6.00	H 1310	6.43	<b>1348</b>	<b>6.87</b>	<b>1384</b>	<b>7.31</b>
6,500	H 1295	6.61	H 1333	7.06	<b>1369</b>	<b>7.52</b>	—	—	—	—
7,000	<b>1360</b>	<b>7.80</b>	<b>1396</b>	<b>8.27</b>	—	—	—	—	—	—
7,500	—	—	—	—	—	—	—	—	—	—
8,000	—	—	—	—	—	—	—	—	—	—
8,500	—	—	—	—	—	—	—	—	—	—
9,000	—	—	—	—	—	—	—	—	—	—
9,500	—	—	—	—	—	—	—	—	—	—
10,000	—	—	—	—	—	—	—	—	—	—

LEGEND

Bhp — Brake Horsepower Input to Fan

**Boldface** indicates field-supplied drive required.

NOTES:

1. Motor drive ranges:

(E) Low Range: Not Used

(F) Mid-Low Range: 896-1227 rpm, 4.26 bhp (208/230 and 460-v), 873-1108 rpm, 5.75 bhp (575-v)

(G) Mid-High Range: 1113-1414 rpm, 5.37 bhp (208-v), 5.75 bhp (230 and 460-v), 5.75 bhp (575-v)

(H) High Range: 1096-1339 rpm, 7.66 bhp (208-v), 8.51 bhp (230-v), 8.63 bhp (460 and 575-v)

All other rpms require field-supplied drive.

2. See page 90 for general fan performance notes.

# Performance data (cont)



## FAN PERFORMANCE — HORIZONTAL SUPPLY AND RETURN UNITS (cont)

48PGE24 (Medium Heat Units)										
Airflow (Cfm)	Available External Static Pressure (in. wg)									
	0.2		0.4		0.6		0.8		1.0	
	Rpm	Bhp	Rpm	Bhp	Rpm	Bhp	Rpm	Bhp	Rpm	Bhp
5,500	F 952	3.38	F 1003	3.32	F 1053	3.70	F 1100	4.09	G 1145	4.49
6,000	1029	3.74	F 1077	4.15	G 1123	4.56	G 1167	4.98	G 1210	5.41
6,500	<b>1106</b>	<b>4.67</b>	G 1151	5.11	G 1194	5.56	H 1236	6.01	H 1276	6.47
7,000	G 1184	5.75	1226	6.23	H 1266	6.71	H 1306	7.19	<b>1344</b>	<b>7.68</b>
7,500	H 1262	7.00	H 1302	7.50	<b>1340</b>	<b>8.01</b>	<b>1377</b>	<b>8.53</b>	—	—
8,000	<b>1341</b>	<b>8.41</b>	—	—	—	—	—	—	—	—
8,500	—	—	—	—	—	—	—	—	—	—
9,000	—	—	—	—	—	—	—	—	—	—
9,500	—	—	—	—	—	—	—	—	—	—
10,000	—	—	—	—	—	—	—	—	—	—

48PGE24 (Medium Heat Units) (cont)										
Airflow (Cfm)	Available External Static Pressure (in. wg)									
	1.2		1.4		1.6		1.8		2.0	
	Rpm	Bhp	Rpm	Bhp	Rpm	Bhp	Rpm	Bhp	Rpm	Bhp
5,500	G 1189	4.90	G 1232	5.31	G 1273	5.72	H 1313	6.15	<b>1352</b>	<b>6.58</b>
6,000	H 1251	5.85	H 1292	6.29	H 1331	6.74	<b>1369</b>	<b>7.19</b>	—	—
6,500	H 1315	6.94	<b>1354</b>	<b>7.41</b>	<b>1391</b>	<b>7.89</b>	—	—	—	—
7,000	<b>1381</b>	<b>8.18</b>	—	—	—	—	—	—	—	—
7,500	—	—	—	—	—	—	—	—	—	—
8,000	—	—	—	—	—	—	—	—	—	—
8,500	—	—	—	—	—	—	—	—	—	—
9,000	—	—	—	—	—	—	—	—	—	—
9,500	—	—	—	—	—	—	—	—	—	—
10,000	—	—	—	—	—	—	—	—	—	—

LEGEND

**Bhp** — Brake Horsepower Input to Fan

**Boldface** indicates field-supplied drive required.

NOTES:

- Motor drive ranges:  
 (E) Low Range: Not Used  
 (F) Mid-Low Range: 896-1227 rpm, 4.26 bhp (208/230 and 460-v), 873-1108 rpm, 5.75 bhp (575-v)  
 (G) Mid-High Range: 1113-1414 rpm, 5.37 bhp (208-v), 5.75 bhp (230 and 460-v), 5.75 bhp (575-v)  
 (H) High Range: 1096-1339 rpm, 7.66 bhp (208-v), 8.51 bhp (230-v), 8.63 bhp (460 and 575-v)  
 All other rpms require field-supplied drive.
- See page 90 for general fan performance notes.



FAN PERFORMANCE — HORIZONTAL SUPPLY AND RETURN UNITS (cont)

48PGF24 (High Heat Units)										
Airflow (Cfm)	Available External Static Pressure (in. wg)									
	0.2		0.4		0.6		0.8		1.0	
	Rpm	Bhp	Rpm	Bhp	Rpm	Bhp	Rpm	Bhp	Rpm	Bhp
5,500	<b>F</b> 952	3.38	<b>F</b> 1003	3.32	<b>F</b> 1053	3.70	<b>F</b> 1100	4.09	<b>G</b> 1145	4.49
6,000	1029	3.74	1077	4.15	<b>G</b> 1123	4.56	<b>G</b> 1167	4.98	1210	5.41
6,500	<b>1106</b>	<b>4.67</b>	<b>G</b> 1151	5.11	1194	5.56	<b>H</b> 1236	6.01	<b>H</b> 1276	6.47
7,000	<b>G</b> 1184	5.75	1226	6.23	<b>H</b> 1266	6.71	1306	7.19	<b>1344</b>	<b>7.68</b>
7,500	<b>H</b> 1262	7.00	<b>H</b> 1302	7.50	<b>1340</b>	<b>8.01</b>	<b>1377</b>	<b>8.53</b>	—	—
8,000	<b>1341</b>	<b>8.41</b>	—	—	—	—	—	—	—	—
8,500	—	—	—	—	—	—	—	—	—	—
9,000	—	—	—	—	—	—	—	—	—	—
9,500	—	—	—	—	—	—	—	—	—	—
10,000	—	—	—	—	—	—	—	—	—	—

48PGF24 (High Heat Units) (cont)										
Airflow (Cfm)	Available External Static Pressure (in. wg)									
	1.2		1.4		1.6		1.8		2.0	
	Rpm	Bhp	Rpm	Bhp	Rpm	Bhp	Rpm	Bhp	Rpm	Bhp
5,500	<b>G</b> 1189	4.90	<b>G</b> 1232	5.31	<b>G</b> 1273	5.72	<b>H</b> 1313	6.15	<b>1352</b>	<b>6.58</b>
6,000	<b>H</b> 1251	5.85	<b>H</b> 1292	6.29	<b>H</b> 1331	6.74	<b>1369</b>	<b>7.19</b>	—	—
6,500	1315	6.94	<b>1354</b>	<b>7.41</b>	<b>1391</b>	<b>7.89</b>	—	—	—	—
7,000	<b>1381</b>	<b>8.18</b>	—	—	—	—	—	—	—	—
7,500	—	—	—	—	—	—	—	—	—	—
8,000	—	—	—	—	—	—	—	—	—	—
8,500	—	—	—	—	—	—	—	—	—	—
9,000	—	—	—	—	—	—	—	—	—	—
9,500	—	—	—	—	—	—	—	—	—	—
10,000	—	—	—	—	—	—	—	—	—	—

LEGEND

**Bhp** — Brake Horsepower Input to Fan

**Boldface** indicates field-supplied drive required.

NOTES:

1. Motor drive ranges:

(E) Low Range: Not Used

(F) Mid-Low Range: 896-1227 rpm, 4.26 bhp (208/230 and 460-v), 873-1108 rpm, 5.75 bhp (575-v)

(G) Mid-High Range: 1113-1414 rpm, 5.37 bhp (208-v), 5.75 bhp (230 and 460-v), 5.75 bhp (575-v)

(H) High Range: 1096-1339 rpm, 7.66 bhp (208-v), 8.51 bhp (230-v), 8.63 bhp (460 and 575-v)

All other rpms require field-supplied drive.

2. See page 90 for general fan performance notes.

# Performance data (cont)



## FAN PERFORMANCE — HORIZONTAL SUPPLY AND RETURN UNITS (cont)

48PGD28 (Low Heat Units)										
Airflow (Cfm)	Available External Static Pressure (in. wg)									
	0.2		0.4		0.6		0.8		1.0	
	Rpm	Bhp	Rpm	Bhp	Rpm	Bhp	Rpm	Bhp	Rpm	Bhp
6,500	<b>E</b> 786	2.50	<b>E</b> 819	2.70	<b>E</b> 857	2.96	899	3.25	<b>F</b> 943	3.59
7,000	842	3.09	<b>E</b> 871	3.30	905	3.55	<b>F</b> 943	3.85	<b>F</b> 983	4.19
7,500	<b>F</b> 898	3.77	<b>F</b> 925	3.99	<b>F</b> 955	4.24	989	4.54	1026	4.88
8,000	955	4.55	<b>F</b> 979	4.77	1007	5.03	1037	5.33	1070	5.67
8,500	1012	5.42	1034	5.65	1059	5.92	<b>G</b> 1087	6.22	<b>G</b> 1117	6.56
9,000	<b>G</b> 1069	6.41	<b>G</b> 1090	6.65	<b>G</b> 1113	6.92	1138	7.23	1165	7.57
9,500	1127	7.51	1146	7.76	1167	8.04	1190	8.35	1215	8.69
10,000	<b>H</b> 1184	8.74	<b>H</b> 1202	8.99	<b>H</b> 1221	9.28	<b>H</b> 1243	9.59	<b>H</b> 1266	9.93
10,500	1242	10.09	<b>H</b> 1258	10.35	<b>H</b> 1276	10.64	1296	10.96	<b>1318</b>	<b>11.31</b>
11,000	—	—	—	—	—	—	—	—	—	—
11,500	—	—	—	—	—	—	—	—	—	—
12,000	—	—	—	—	—	—	—	—	—	—
12,500	—	—	—	—	—	—	—	—	—	—

48PGD28 (Low Heat Units) (cont)										
Airflow (Cfm)	Available External Static Pressure (in. wg)									
	1.2		1.4		1.6		1.8		2.0	
	Rpm	Bhp	Rpm	Bhp	Rpm	Bhp	Rpm	Bhp	Rpm	Bhp
6,500	<b>F</b> 988	3.97	1035	4.39	1082	4.87	<b>G</b> 1129	5.39	1177	5.95
7,000	1024	4.57	<b>G</b> 1066	4.98	<b>G</b> 1109	5.43	<b>G</b> 1153	5.93	1197	6.48
7,500	<b>G</b> 1063	5.25	<b>G</b> 1102	5.66	<b>G</b> 1141	6.11	1181	6.59	<b>H</b> 1221	7.11
8,000	1105	6.04	1140	6.45	1176	6.89	1213	7.36	1250	7.87
8,500	1149	6.94	1181	7.34	1215	7.78	<b>H</b> 1249	8.25	1283	8.74
9,000	1194	7.94	<b>H</b> 1225	8.35	<b>H</b> 1256	8.79	1287	9.25	<b>1319</b>	<b>9.74</b>
9,500	<b>H</b> 1242	9.07	1270	9.47	1298	9.91	<b>1328</b>	<b>10.37</b>	<b>1358</b>	<b>10.87</b>
10,000	1290	10.31	<b>1316</b>	<b>10.72</b>	<b>1343</b>	<b>11.16</b>	—	—	—	—
10,500	—	—	—	—	—	—	—	—	—	—
11,000	—	—	—	—	—	—	—	—	—	—
11,500	—	—	—	—	—	—	—	—	—	—
12,000	—	—	—	—	—	—	—	—	—	—
12,500	—	—	—	—	—	—	—	—	—	—

### LEGEND

**Bhp** — Brake Horsepower Input to Fan

**Boldface** indicates field-supplied drive required.

### NOTES:

1. Motor drive ranges:

(E) Low Range: 687-873 rpm, 5.37 bhp (208-v), 5.75 bhp (230 and 460-v), 5.75 bhp (575-v)

(F) Mid-Low Range: 805-1007 rpm, 5.37 bhp (208-v), 5.75 bhp (230 and 460-v), 5.75 bhp (575-v)

(G) Mid-High Range: 941-1176 rpm, 7.66 bhp (208-v), 8.51 bhp (230-v), 8.63 bhp (460 and 575-v)

(H) High Range: 1014-1297 rpm, 9.94 bhp (208-v), 10.45 bhp (230-v), 11.19 bhp (460-v), 11.50 bhp (575-v)

All other rpms require field-supplied drive.

2. See page 90 for general fan performance notes.



FAN PERFORMANCE — HORIZONTAL SUPPLY AND RETURN UNITS (cont)

48PGE28 (Medium Heat Units)										
Airflow (Cfm)	Available External Static Pressure (in. wg)									
	0.2		0.4		0.6		0.8		1.0	
	Rpm	Bhp	Rpm	Bhp	Rpm	Bhp	Rpm	Bhp	Rpm	Bhp
6,500	E 799	2.58	E 833	2.79	E 872	3.05	914	3.36	F 958	3.71
7,000	856	3.19	887	3.41	F 921	3.67	F 958	3.98	F 999	4.33
7,500	F 913	3.89	F 941	4.12	F 972	4.39	1006	4.69	1042	5.04
8,000	971	4.69	996	4.93	1024	5.20	1055	5.51	G 1088	5.86
8,500	1029	5.60	1052	5.85	G 1078	6.12	G 1106	6.44	1136	6.78
9,000	G 1087	6.62	G 1108	6.87	1132	7.16	1158	7.47	1185	7.82
9,500	1145	7.75	1165	8.02	1187	8.31	1211	8.63	H 1236	8.99
10,000	H 1203	9.01	H 1222	9.29	H 1243	9.59	H 1265	9.92	1288	10.28
10,500	1261	10.40	H 1279	10.69	<b>1299</b>	<b>11.00</b>	<b>1319</b>	<b>11.34</b>	—	—
11,000	—	—	—	—	—	—	—	—	—	—
11,500	—	—	—	—	—	—	—	—	—	—
12,000	—	—	—	—	—	—	—	—	—	—
12,500	—	—	—	—	—	—	—	—	—	—

48PGE28 (Medium Heat Units) (cont)										
Airflow (Cfm)	Available External Static Pressure (in. wg)									
	1.2		1.4		1.6		1.8		2.0	
	Rpm	Bhp	Rpm	Bhp	Rpm	Bhp	Rpm	Bhp	Rpm	Bhp
6,500	F 1005	4.12	1052	4.57	1100	5.06	G 1148	5.60	1195	6.17
7,000	1041	4.72	G 1084	5.16	G 1128	5.64	1172	6.17	H 1217	6.74
7,500	G 1080	5.43	G 1119	5.86	1160	6.33	1201	6.84	H 1242	7.40
8,000	1122	6.24	1158	6.66	1195	7.13	H 1233	7.63	1272	8.17
8,500	1167	7.16	1200	7.58	H 1234	8.04	1269	8.53	<b>1304</b>	<b>9.06</b>
9,000	H 1214	8.21	H 1244	8.62	1275	9.07	<b>1308</b>	<b>9.56</b>	<b>1340</b>	<b>10.08</b>
9,500	1262	9.37	1290	9.78	<b>1319</b>	<b>10.23</b>	<b>1349</b>	<b>10.71</b>	<b>1379</b>	<b>11.23</b>
10,000	<b>1312</b>	<b>10.66</b>	<b>1338</b>	<b>11.08</b>	—	—	—	—	—	—
10,500	—	—	—	—	—	—	—	—	—	—
11,000	—	—	—	—	—	—	—	—	—	—
11,500	—	—	—	—	—	—	—	—	—	—
12,000	—	—	—	—	—	—	—	—	—	—
12,500	—	—	—	—	—	—	—	—	—	—

LEGEND

Bhp — Brake Horsepower Input to Fan

**Boldface** indicates field-supplied drive required.

NOTES:

- Motor drive ranges:  
 (E) Low Range: 687-873 rpm, 5.37 bhp (208-v), 5.75 bhp (230 and 460-v), 5.75 bhp (575-v)  
 (F) Mid-Low Range: 805-1007 rpm, 5.37 bhp (208-v), 5.75 bhp (230 and 460-v), 5.75 bhp (575-v)  
 (G) Mid-High Range: 941-1176 rpm, 7.66 bhp (208-v), 8.51 bhp (230-v), 8.63 bhp (460 and 575-v)  
 (H) High Range: 1014-1297 rpm, 9.94 bhp (208-v), 10.45 bhp (230-v), 11.19 bhp (460-v), 11.50 bhp (575-v)  
 All other rpms require field-supplied drive.
- See page 90 for general fan performance notes.

# Performance data (cont)



## FAN PERFORMANCE — HORIZONTAL SUPPLY AND RETURN UNITS (cont)

### 48PGF28 (High Heat Units)

Airflow (Cfm)	Available External Static Pressure (in. wg)									
	0.2		0.4		0.6		0.8		1.0	
	Rpm	Bhp	Rpm	Bhp	Rpm	Bhp	Rpm	Bhp	Rpm	Bhp
6,500	E 799	2.58	E 833	2.79	E 872	3.05	914	3.36	F 958	3.71
7,000	856	3.19	887	3.41	F 921	3.67	F 958	3.98	F 999	4.33
7,500	F 913	3.89	F 941	4.12	F 972	4.39	1006	4.69	1042	5.04
8,000	971	4.69	996	4.93	1024	5.20	1055	5.51	G 1088	5.86
8,500	1029	5.60	1052	5.85	G 1078	6.12	G 1106	6.44	1136	6.78
9,000	G 1087	6.62	G 1108	6.87	1132	7.16	1158	7.47	1185	7.82
9,500	1145	7.75	1165	8.02	1187	8.31	H 1211	8.63	H 1236	8.99
10,000	H 1203	9.01	H 1222	9.29	H 1243	9.59	H 1265	9.92	1288	10.28
10,500	1261	10.40	H 1279	10.69	<b>1299</b>	<b>11.00</b>	<b>1319</b>	<b>11.34</b>	—	—
11,000	—	—	—	—	—	—	—	—	—	—
11,500	—	—	—	—	—	—	—	—	—	—
12,000	—	—	—	—	—	—	—	—	—	—
12,500	—	—	—	—	—	—	—	—	—	—

### 48PGF28 (High Heat Units) (cont)

Airflow (Cfm)	Available External Static Pressure (in. wg)									
	1.2		1.4		1.6		1.8		2.0	
	Rpm	Bhp	Rpm	Bhp	Rpm	Bhp	Rpm	Bhp	Rpm	Bhp
6,500	F 1005	4.12	1052	4.57	1100	5.06	1148	5.60	1195	6.17
7,000	1041	4.72	1084	5.16	G 1128	5.64	G 1172	6.17	H 1217	6.74
7,500	G 1080	5.43	G 1119	5.86	1160	6.33	1201	6.84	H 1242	7.40
8,000	1122	6.24	1158	6.66	1195	7.13	H 1233	7.63	1272	8.17
8,500	1167	7.16	1200	7.58	H 1234	8.04	1269	8.53	<b>1304</b>	<b>9.06</b>
9,000	H 1214	8.21	H 1244	8.62	1275	9.07	<b>1308</b>	<b>9.56</b>	<b>1340</b>	<b>10.08</b>
9,500	1262	9.37	1290	9.78	<b>1319</b>	<b>10.23</b>	<b>1349</b>	<b>10.71</b>	<b>1379</b>	<b>11.23</b>
10,000	<b>1312</b>	<b>10.66</b>	<b>1338</b>	<b>11.08</b>	—	—	—	—	—	—
10,500	—	—	—	—	—	—	—	—	—	—
11,000	—	—	—	—	—	—	—	—	—	—
11,500	—	—	—	—	—	—	—	—	—	—
12,000	—	—	—	—	—	—	—	—	—	—
12,500	—	—	—	—	—	—	—	—	—	—

#### LEGEND

**Bhp** — Brake Horsepower Input to Fan

**Boldface** indicates field-supplied drive required.

#### NOTES:

1. Motor drive ranges:

(E) Low Range: 687-873 rpm, 5.37 bhp (208-v), 5.75 bhp (230 and 460-v), 5.75 bhp (575-v)

(F) Mid-Low Range: 805-1007 rpm, 5.37 bhp (208-v), 5.75 bhp (230 and 460-v), 5.75 bhp (575-v)

(G) Mid-High Range: 941-1176 rpm, 7.66 bhp (208-v), 8.51 bhp (230-v), 8.63 bhp (460 and 575-v)

(H) High Range: 1014-1297 rpm, 9.94 bhp (208-v), 10.45 bhp (230-v), 11.19 bhp (460-v), 11.50 bhp (575-v)

All other rpms require field-supplied drive.

2. See page 90 for general fan performance notes.

### ACCESSORY/FIOP PRESSURE DROP (in. wg)\* — 48PG03-07

AIRFLOW (CFM)	ECONOMIZER (Vertical) (Sizes 03-07)	ECONOMIZER (Horizontal) (Sizes 03-07)	HUMIDI-MIZER™ SYSTEM (Sizes 03-04)	HUMIDI-MIZER SYSTEM (Sizes 05-07)
600	0.01	0.03	0.01	—
800	0.01	0.05	0.02	—
1000	0.02	0.07	0.03	—
1200	0.03	0.10	0.04	0.02
1400	0.04	0.14	0.04	0.03
1600	0.06	0.17	0.05	0.03
1800	0.07	0.22	—	0.04
2000	0.09	0.26	—	0.04
2200	0.11	0.31	—	0.05
2400	0.13	0.37	—	0.06
2600	0.15	0.43	—	0.06
2800	0.18	0.49	—	0.07
3000	0.21	0.56	—	0.08

#### LEGEND

**FIOP** — Factory-Installed Option

\*The static pressure must be added to the external static pressure. The sum and the evaporator entering-air cfm should then be used in conjunction with the Fan Performance tables to determine blower rpm and watts.



**ACCESSORY/FIOP PRESSURE DROP (in. wg) \*  
— 48PG08-14**

AIRFLOW (CFM)	ECONOMIZER (Vertical)	ECONOMIZER (Horizontal)	HUMIDI-MIZER™ SYSTEM
2250	0.05	0.10	0.03
2650	0.06	0.13	0.03
3050	0.08	0.17	0.04
3450	0.09	0.21	0.05
3850	0.10	0.26	0.06
4250	0.12	0.31	0.07
4650	0.13	0.37	0.08
5050	0.15	0.44	0.09
5450	0.17	0.50	0.10
5850	0.18	0.58	0.11
6250	0.20	0.66	0.12

**LEGEND**

**FIOP** — Factory-Installed Option

\*The static pressure must be added to the external static pressure. The sum and the evaporator entering-air cfm should then be used in conjunction with the Fan Performance tables to determine blower rpm and watts.

**ACCESSORY/FIOP PRESSURE DROP (in. wg) \*  
— 48PG16**

AIRFLOW (CFM)	ECONOMIZER		HUMIDI-MIZER SYSTEM
	Vertical	Horizontal	
4500	0.03	0.31	0.02
4800	0.04	0.35	0.02
5100	0.04	0.38	0.03
5400	0.05	0.41	0.03
5700	0.05	0.45	0.04
6000	0.06	0.49	0.04
6300	0.06	0.52	0.05
6600	0.07	0.56	0.05
6900	0.08	0.61	0.06
7200	0.08	0.65	0.07
7500	0.09	0.69	0.07

**LEGEND**

**FIOP** — Factory-Installed Option

\*The static pressure must be added to the external static pressure. The sum and the evaporator entering-air cfm should then be used in conjunction with the Fan Performance tables to determine blower rpm and watts.

**ACCESSORY/FIOP STATIC PRESSURE (in. wg) \*  
— 48PG20-28**

COMPONENT	CFM									
	4,000	4,500	5,000	5,500	6,000	6,500	7,000	7,500	8,000	
Economizer	0.02	0.03	0.04	0.05	0.06	0.07	0.08	0.09	0.10	
Humidi-MiZer™ (20, 24)	—	—	—	0.10	0.17	0.25	0.32	0.40	0.47	
Humidi-MiZer (28)	—	—	—	—	—	0.05	0.13	0.21	0.29	

COMPONENT	CFM							
	8,500	9,000	9,500	10,000	10,500	11,000	11,500	12,000
Economizer	0.11	0.12	0.13	0.15	0.16	0.17	0.19	0.20
Humidi-MiZer (20, 24)	0.54	0.60	0.68	0.74	—	—	—	—
Humidi-MiZer (28)	0.38	0.44	0.51	0.59	0.66	0.72	0.80	0.86

**LEGEND**

**FIOP** — Factory-Installed Option

\*The static pressure must be added to the external static pressure. The sum and the evaporator entering-air cfm should then be used in conjunction with the Fan Performance tables to determine blower rpm and watts.

**POWER EXHAUST PERFORMANCE — 48PG03-16**

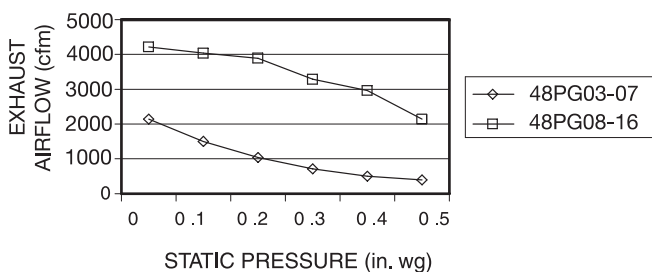

**BAROMETRIC RELIEF FLOW CAPACITY — 48PG03-16**

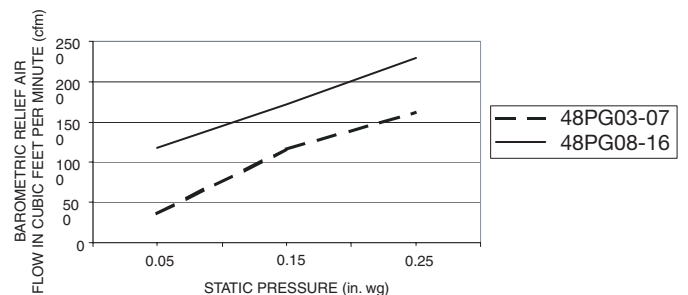

**OUTDOOR AIR DAMPER LEAKAGE — 48PG03-16**

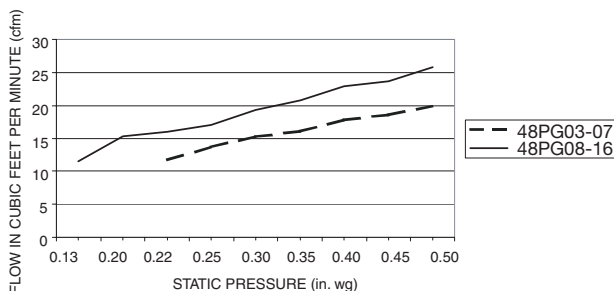

# Performance data (cont)



## POWER EXHAUST FAN PERFORMANCE — 48PG20-28

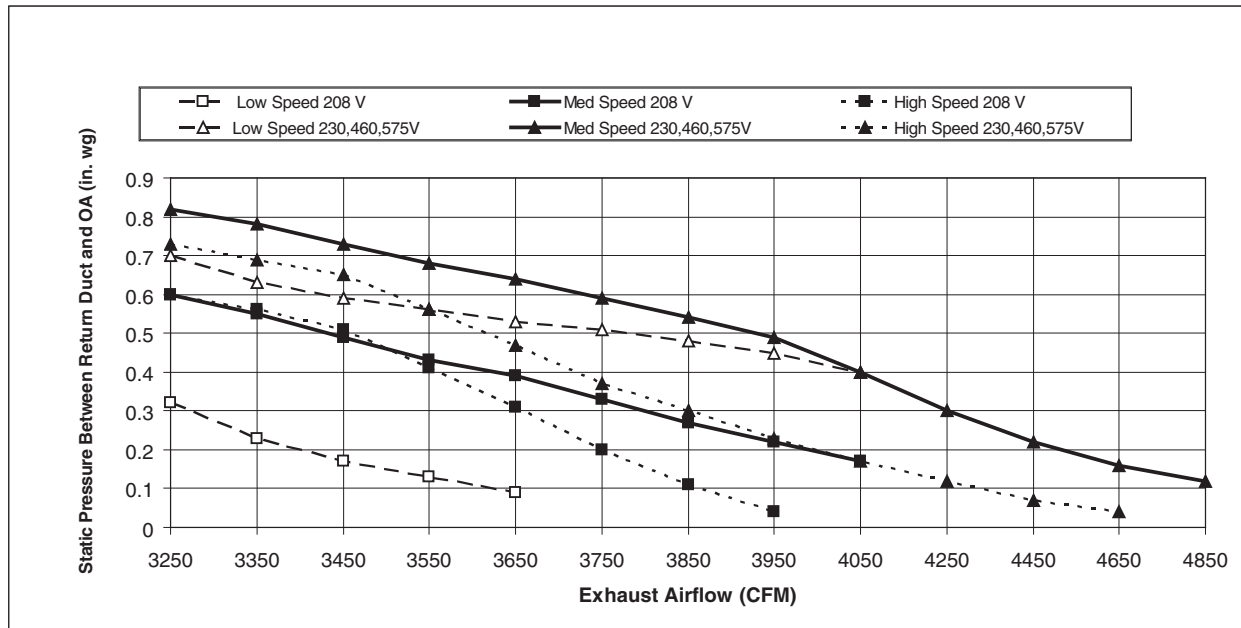

## 48PG03-07 TWO-POSITION DAMPER PERFORMANCE

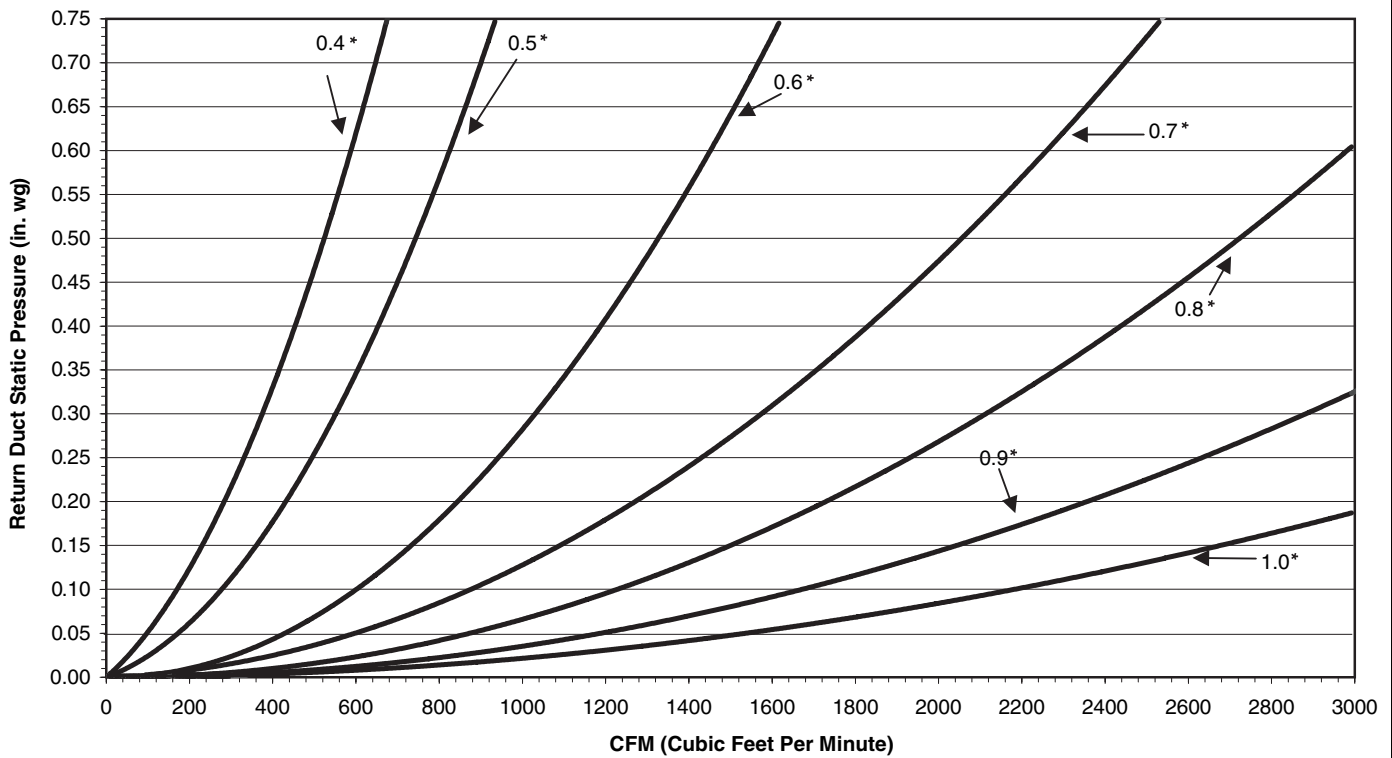

\*Two-position damper position (outdoor air marking on actuator).

### 48PG08-14 TWO-POSITION DAMPER PERFORMANCE

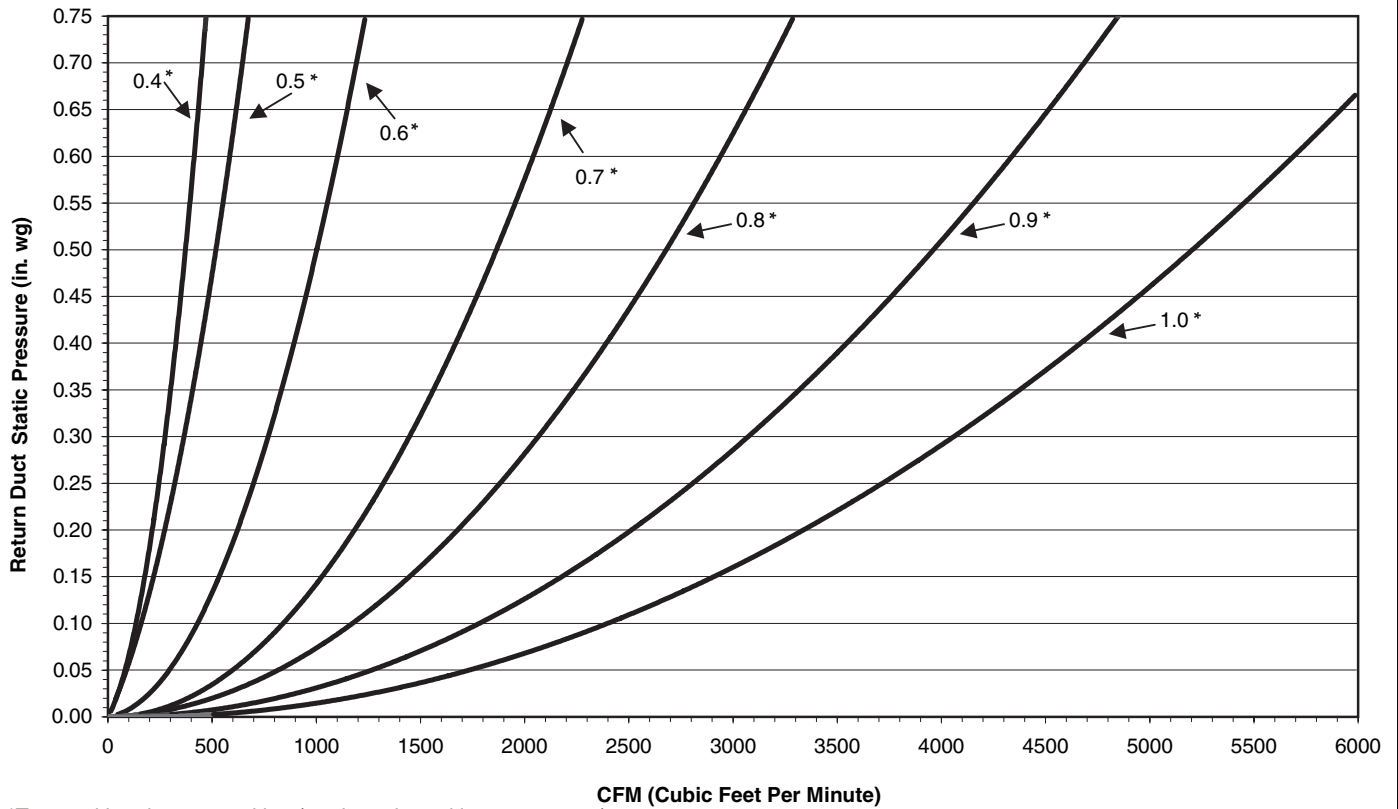

\*Two-position damper position (outdoor air marking on actuator).

### 48PG16 TWO-POSITION DAMPER PERFORMANCE

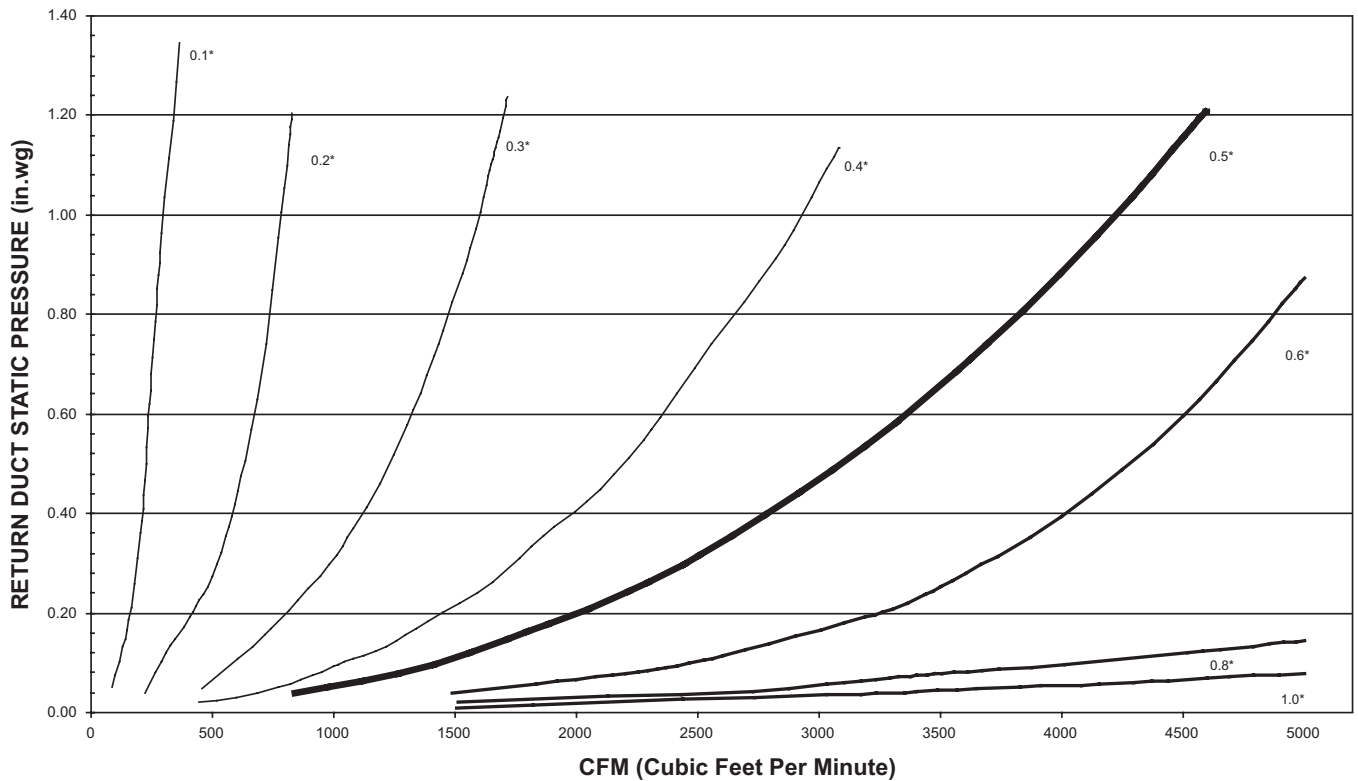

\*Two-position damper position (outdoor air marking on actuator).

# Performance data (cont)

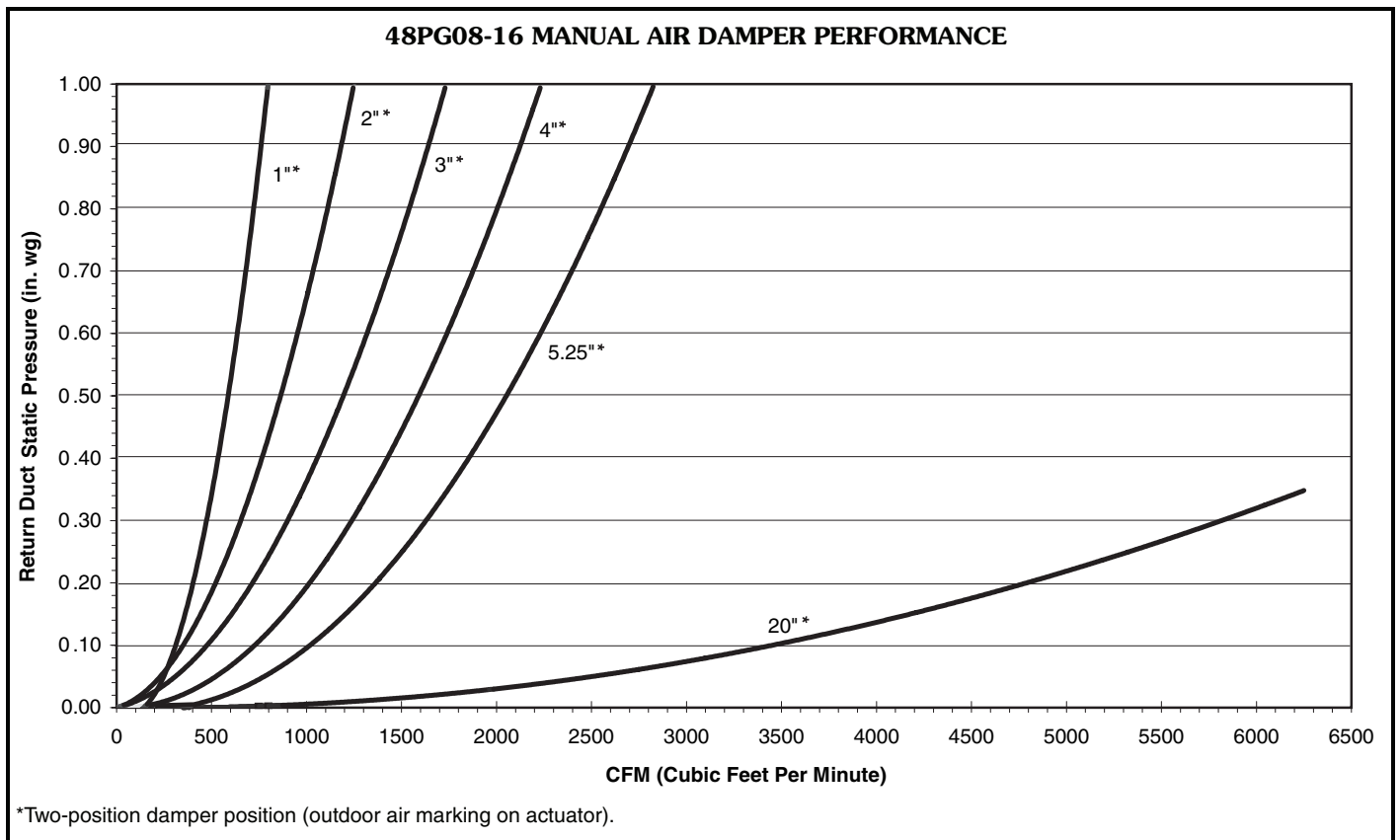
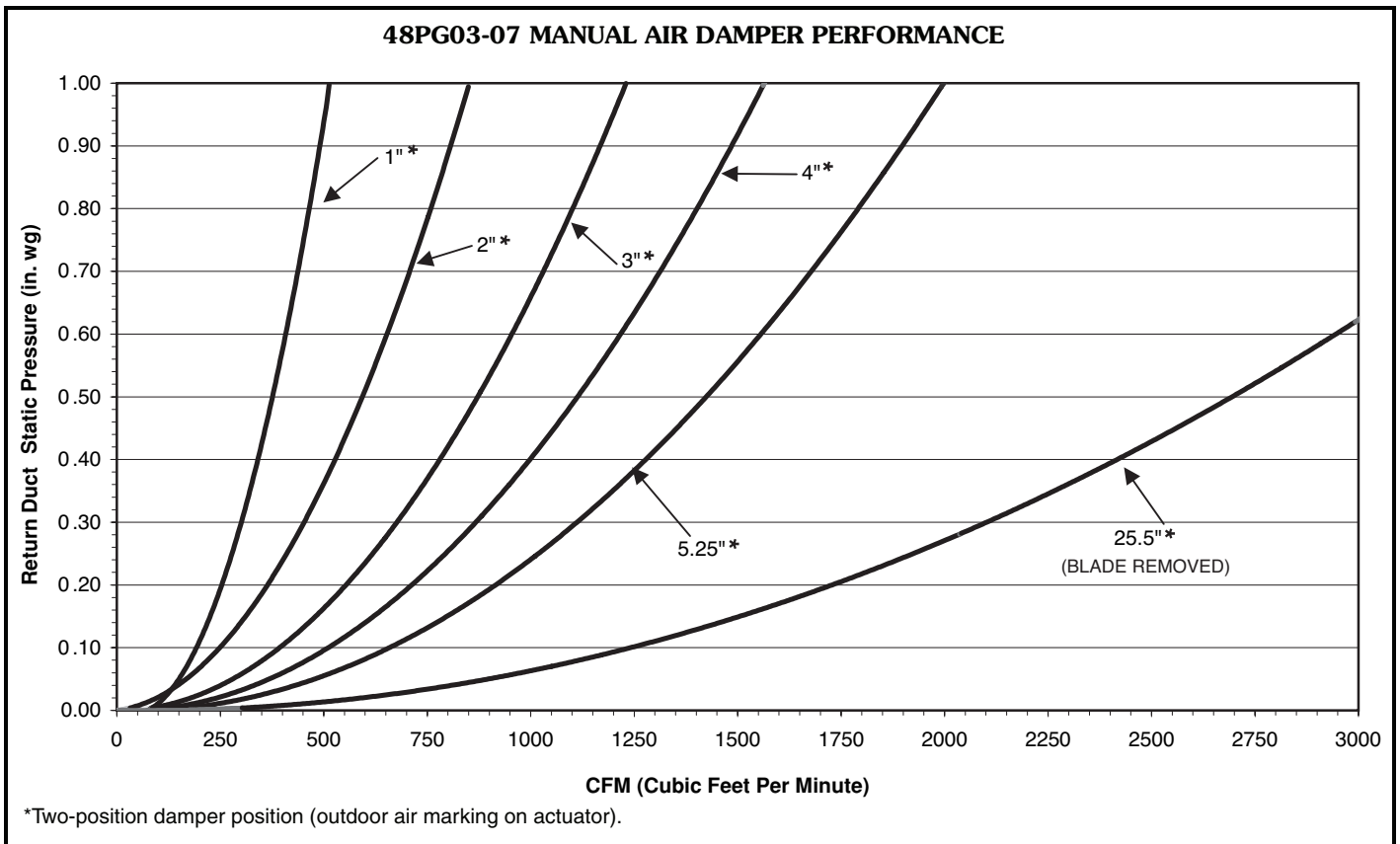



**ALTITUDE COMPENSATION\* — 48PG03-07**

ELEVATION (ft)	NATURAL GAS ORIFICE SIZE†	LP ORIFICE SIZE†
0-1,999	45	52
2,000	47	52
3,000	47	53
4,000	47	53
5,000	48	53
6,000	48	53
7,000	48	53
8,000	49	54
9,000	49	54
10,000	50	54
11,000	51	54
12,000	51	55
13,000	52	55
14,000	52	56

\*As the height above sea level increases, there is less oxygen per cubic foot of air. Therefore, heat input rate should be reduced at higher altitudes. Includes a 4% input reduction per each 1000 ft.

†Orifices available through your local Carrier dealer.

**ALTITUDE COMPENSATION\* — 48PG08-14**

ELEVATION (ft)	NATURAL GAS ORIFICE SIZE†	LP ORIFICE SIZE†
0-1,999	43	50
2,000	44	51
3,000	44	51
4,000	44	51
5,000	45	51
6,000	45	52
7,000	47	52
8,000	47	52
9,000	47	53
10,000	48	53
11,000	49	53
12,000	50	54
13,000	50	54
14,000	51	55

\*As the height above sea level increases, there is less oxygen per cubic foot of air. Therefore, heat input rate should be reduced at higher altitudes. Includes a 4% input reduction per each 1000 ft.

†Orifices available through your local Carrier dealer.

**ALTITUDE COMPENSATION\* — 48PG16**

ELEVATION (ft)	NATURAL GAS ORIFICE SIZE†	LP ORIFICE SIZE†
0-1,999	30	38
2,000	30	40
3,000	31	40
4,000	31	41
5,000	31	41
6,000	31	42
7,000	32	42
8,000	32	43
9,000	32	43
10,000	35	44
11,000	36	44
12,000	37	45
13,000	38	46
14,000	39	47

\*As the height above sea level increases, there is less oxygen per cubic foot of air. Therefore, heat input rate should be reduced at higher altitudes. Includes a 4% input reduction per each 1000 ft.

†Orifices available through your local Carrier dealer.

**ALTITUDE COMPENSATION\* — 48PG20-28 (Natural Gas)**

ELEVATION (ft)	NATURAL GAS ORIFICE SIZE†			
	Low Heat	Medium Heat	High Heat (6 Cell)	High Heat (8 Cell)
0-1,999	29	30	29	29
2,000	29	30	29	29
3,000	30	31	30	30
4,000	30	31	30	30
5,000	30	31	30	30
6,000	30	31	30	30
7,000	31	32	31	31
8,000	31	32	31	31
9,000	31	32	31	31
10,000	32	33	32	32

\*As the height above sea level increases, there is less oxygen per cubic foot of air. Therefore, heat input rate should be reduced at higher altitudes. Includes a 4% input reduction per each 1000 ft.

†Orifices available through your local Carrier dealer.

**ALTITUDE COMPENSATION\* — 48PG20-28 (Propane Gas)**

ELEVATION (ft)	PROPANE GAS ORIFICE SIZE†			
	Low Heat	Medium Heat	High Heat (6 Cell)	High Heat (8 Cell)
0-1,999	35	38	35	35
2,000	36	39	36	36
3,000	36	39	36	36
4,000	37	40	37	37
5,000	37	40	37	37
6,000	38	41	38	38
7,000	39	42	39	39
8,000	40	43	40	40
9,000	41	44	41	41
10,000	42	45	42	42

\*As the height above sea level increases, there is less oxygen per cubic foot of air. Therefore, heat input rate should be reduced at higher altitudes. Includes a 4% input reduction per each 1000 ft.

†Orifices available through your local Carrier dealer.

**ALTITUDE DERATING FACTOR\* — 48PG03-28**

ELEVATION (feet)	MAXIMUM HEATING (Btu/ft³)
0-2,000	1,100
2,001-3,000	1,050
3,001-4,000	1,000
4,001-5,000	950
5,001-6,000	900

\*Derating of the gas heating equipment to compensate for the effects of altitude is always required. Orifice change is not required if the fuel heating value (at sea level) is below the limits listed in the table above. Derating conditions must be 4% per thousand feet above sea level. For example, at 4000 ft, if the heating value of the gas exceeds 1000 Btu/ft³, the unit will require a 16% derating. For elevations above 6000 ft, the same formula applies. For example, at 7000 ft, the unit will require a 28% derating of the maximum heating value per the National Fuel Gas Code.

# Performance data (cont)



## EVAPORATOR FAN MOTOR SPECIFICATIONS — 48PG03-16

48PG	DRIVE	VOLTAGE/PHASE	EFFICIENCY	MAX BHP	MAX AMPS
03	Low	208/1ph	0.73	0.85	4.0
		230/1ph	0.73	0.85	4.0
	High	208/1ph	0.73	0.85	4.0
		230/1ph	0.73	0.85	4.0
04	Low	208/1ph	0.73	0.85	4.0
		230/1ph	0.73	0.85	4.0
		208/3ph	0.73	0.85	4.0
		230/3ph	0.73	0.85	4.0
		460/3ph	0.73	0.85	2.0
		575/3ph	0.73	0.85	1.6
	High	208/1ph	0.73	0.85	4.0
		230/1ph	0.73	0.85	4.0
		208/3ph	0.73	0.85	4.0
		230/3ph	0.73	0.85	4.0
		460/3ph	0.73	0.85	2.0
		575/3ph	0.73	0.85	1.6
05	Low	208/1ph	0.73	0.85	4.0
		230/1ph	0.73	0.85	4.0
		208/3ph	0.73	0.85	4.0
		230/3ph	0.73	0.85	4.0
		460/3ph	0.73	0.85	2.0
		575/3ph	0.73	0.85	1.6
	High	208/1ph	0.78	1.6	8.3
		230/1ph	0.78	1.6	8.3
		208/3ph	0.80	2.4	6.4
		230/3ph	0.80	2.4	6.4
		460/3ph	0.80	2.4	3.2
		575/3ph	0.80	2.4	2.4
06	Low	208/1ph	0.73	0.85	4.0
		230/1ph	0.73	0.85	4.0
		208/3ph	0.80	2.4	6.4
		230/3ph	0.80	2.4	6.4
		460/3ph	0.80	2.4	3.2
		575/3ph	0.80	2.4	2.4
	High	208/1ph	0.78	1.6	8.3
		230/1ph	0.78	1.6	8.3
		208/3ph	0.80	2.4	6.4
		230/3ph	0.80	2.4	6.4
		460/3ph	0.80	2.4	3.2
		575/3ph	0.80	2.4	2.4
07	Low	208/3ph	0.80	2.4	6.4
		230/3ph	0.80	2.4	6.4
		460/3ph	0.80	2.4	3.2
		575/3ph	0.80	2.4	2.4
	High	208/3ph	0.84	3.1	8.8
		230/3ph	0.84	3.1	8.8
		460/3ph	0.84	3.1	4.4
		575/3ph	0.82	3.1	4.2

**NOTES:**

1. Extensive motor and electrical testing ensures that the motors can be utilized with confidence up to the maximum applied bhp, watts, and amps. Using the fan motor up to the maximum ratings shown will not result in nuisance tripping or premature motor failure. Unit warranty will not be affected.

2. Convert bhp to watts using the following formula:

$$\text{watts} = \frac{\text{bhp (746)}}{\text{motor efficiency}}$$

3. The EPACT (Energy Policy Act of 1992) regulates energy requirements for specific types of indoor fan motors. Motors regulated by EPACT include any general purpose, T-frame (three-digit, 143 and larger), single-speed, foot mounted, polyphase, squirrel cage induction motors of NEMA (National Electrical Manufacturers Association) design A and B, manufactured for use in the United States. Ranging from 1 to 200 Hp, these continuous-duty motors operate on 230 and 460 volt, 60 Hz power. If a motor does not fit into these specifications, the motor does not have to be replaced by an EPACT-compliant energy-efficient motor. Variable-speed motors are exempt from EPACT compliance requirements. Therefore, the indoor fan motors for Carrier 48PG03-16 units are exempt from these requirements.



**EVAPORATOR FAN MOTOR SPECIFICATIONS — 48PG03-16 (cont)**

48PG	DRIVE	VOLTAGE/PHASE	EFFICIENCY	MAX BHP	MAX AMPS
08	Low	208/3ph	0.80	2.4	6.4
		230/3ph	0.80	2.4	6.4
		460/3ph	0.80	2.4	3.2
		575/3ph	0.80	2.4	2.4
	High	208/3ph	0.84	3.1	8.8
		230/3ph	0.84	3.1	8.8
		460/3ph	0.84	3.1	4.4
		575/3ph	0.82	3.1	4.2
09	Low	208/3ph	0.80	2.4	6.4
		230/3ph	0.80	2.4	6.4
		460/3ph	0.80	2.4	3.2
		575/3ph	0.80	2.4	2.4
	High	208/3ph	0.83	3.7	11.0
		230/3ph	0.83	3.7	11.0
		460/3ph	0.83	3.7	5.5
		575/3ph	0.82	3.7	4.2
12	Low	208/3ph	0.84	3.1	8.8
		230/3ph	0.84	3.1	8.8
		460/3ph	0.84	3.1	4.4
		575/3ph	0.82	3.1	4.2
	High	208/3ph	0.83	3.7	11.0
		230/3ph	0.83	3.7	11.0
		460/3ph	0.83	3.7	5.5
		575/3ph	0.82	3.7	4.2
14	Low	208/3ph	0.83	3.7	11.0
		230/3ph	0.83	3.7	11.0
		460/3ph	0.83	3.7	5.5
		575/3ph	0.82	3.7	4.2
	High	208/3ph	0.81	5.25	14.8
		230/3ph	0.81	5.25	14.8
		460/3ph	0.81	5.25	7.4
		575/3ph	0.81	5.25	5.9
16	Low	208/3ph	0.83	3.7	10.3
		230/3ph	0.83	3.7	10.3
		460/3ph	0.83	3.7	5.2
		575/3ph	0.83	3.7	4.2
	Mid-Low	208/3ph	0.81	5.25	12.7
		230/3ph	0.81	5.25	12.7
		460/3ph	0.81	5.25	6.4
		575/3ph	0.81	5.25	5.9
	High	208/3ph	0.89	7.5	19.4
		230/3ph	0.89	7.5	19.4
		460/3ph	0.89	7.5	9.7
		575/3ph	0.81	7.5	7.8

**NOTES:**

1. Extensive motor and electrical testing ensures that the motors can be utilized with confidence up to the maximum applied bhp, watts, and amps. Using the fan motor up to the maximum ratings shown will not result in nuisance tripping or premature motor failure. Unit warranty will not be affected.

2. Convert bhp to watts using the following formula:

$$\text{watts} = \frac{\text{bhp (746)}}{\text{motor efficiency}}$$

3. The EPACT (Energy Policy Act of 1992) regulates energy requirements for specific types of indoor fan motors. Motors regulated by EPACT include any general purpose, T-frame (three-digit, 143 and larger), single-speed, foot mounted, polyphase, squirrel cage induction motors of NEMA (National Electrical Manufacturers Association) design A and B, manufactured for use in the United States. Ranging from 1 to 200 Hp, these continuous-duty motors operate on 230 and 460 volt, 60 Hz power. If a motor does not fit into these specifications, the motor does not have to be replaced by an EPACT-compliant energy-efficient motor. Variable-speed motors are exempt from EPACT compliance requirements. Therefore, the indoor fan motors for Carrier 48PG03-16 units are exempt from these requirements.

# Performance data (cont)



## EVAPORATOR FAN MOTOR SPECIFICATIONS — 48PG20-28

UNIT 48PG	DRIVE	ORIENTATION	VOLTAGE	EFFICIENCY %	MAX BHP	MAX AMPS
20	Low	Vertical	208	85.8	4.26	10.6
			230	85.8	4.26	9.6
			460	85.8	4.26	4.8
			575	87.5	5.75	6.0
	Mid-Low	Vertical	208	87.5	5.37	15.8
			230	87.5	5.75	15.4
			460	87.5	5.75	7.7
			575	87.5	5.75	6.0
	Mid-High	Vertical	208	88.5	7.66	22.0
			230	88.5	8.51	22.0
			460	88.5	8.63	11.6
			575	88.5	8.63	9.4
	High	Vertical	208	89.5	9.94	28.0
			230	89.5	10.45	28.0
			460	89.5	11.19	15.0
			575	89.5	11.50	12.0
	Low	Horizontal	208	N/A	N/A	N/A
			230	N/A	N/A	N/A
			460	N/A	N/A	N/A
			575	N/A	N/A	N/A
Mid-Low	Horizontal	208	85.8	4.26	10.6	
		230	85.8	4.26	9.6	
		460	85.8	4.26	4.8	
		575	87.5	5.75	6.0	
Mid-High	Horizontal	208	87.5	5.37	15.8	
		230	87.5	5.75	15.4	
		460	87.5	5.75	7.7	
		575	87.5	5.75	6.0	
High	Horizontal	208	88.5	7.66	22.0	
		230	88.5	8.51	22.0	
		460	88.5	8.63	11.6	
		575	88.5	8.63	9.4	
24	Low	Vertical	208	85.8	4.26	10.6
			230	85.8	4.26	9.6
			460	85.8	4.26	4.8
			575	87.5	5.75	6.0
	Mid-Low	Vertical	208	87.5	5.37	15.8
			230	87.5	5.75	15.4
			460	87.5	5.75	7.7
			575	87.5	5.75	6.0
	Mid-High	Vertical	208	88.5	7.66	22.0
			230	88.5	8.51	22.0
			460	88.5	8.63	11.6
			575	88.5	8.63	9.4
	High	Vertical	208	89.5	9.94	28.0
			230	89.5	10.45	28.0
			460	89.5	11.19	15.0
			575	89.5	11.50	12.0
	Low	Horizontal	208	N/A	N/A	N/A
			230	N/A	N/A	N/A
			460	N/A	N/A	N/A
			575	N/A	N/A	N/A
Mid-Low	Horizontal	208	85.8	4.26	10.6	
		230	85.8	4.26	9.6	
		460	85.8	4.26	4.8	
		575	87.5	5.75	6.0	
Mid-High	Horizontal	208	87.5	5.37	15.8	
		230	87.5	5.75	15.4	
		460	87.5	5.75	7.7	
		575	87.5	5.75	6.0	
High	Horizontal	208	88.5	7.66	22.0	
		230	88.5	8.51	22.0	
		460	88.5	8.63	11.6	
		575	88.5	8.63	9.4	



**EVAPORATOR FAN MOTOR SPECIFICATIONS — 48PG20-28 (cont)**

UNIT 48PG	DRIVE	ORIENTATION	VOLTAGE	EFFICIENCY %	MAX BHP	MAX AMPS
28	Low	Vertical	208	87.5	5.37	15.8
			230	87.5	5.75	15.4
			460	87.5	5.75	7.7
			575	87.5	5.75	6.0
	Mid-Low	Vertical	208	87.5	5.37	15.8
			230	87.5	5.75	15.4
			460	87.5	5.75	7.7
			575	87.5	5.75	6.0
	Mid-High	Vertical	208	88.5	7.66	22.0
			230	88.5	8.51	22.0
			460	88.5	8.63	11.6
			575	88.5	8.63	9.4
	High	Vertical	208	89.5	9.94	28.0
			230	89.5	10.45	28.0
			460	89.5	11.19	15.0
			575	89.5	11.50	12.0
	Low	Horizontal	208	87.5	5.37	15.8
			230	87.5	5.75	15.4
			460	87.5	5.75	7.7
			575	87.5	5.75	6.0
	Mid-Low	Horizontal	208	87.5	5.37	15.8
			230	87.5	5.75	15.4
			460	87.5	5.75	7.7
	Mid-High	Horizontal	208	88.5	7.66	22.0
			230	88.5	8.51	22.0
			460	88.5	8.63	11.6
	High	Horizontal	208	88.5	8.63	9.4
			230	89.5	9.94	28.0
460			89.5	10.45	28.0	
575			89.5	11.19	15.0	
High	Horizontal	208	89.5	9.94	28.0	
		230	89.5	10.45	28.0	
		460	89.5	11.19	15.0	
		575	89.5	11.50	12.0	

**NOTES:**

1. Extensive motor and electrical testing ensures that the motors can be utilized with confidence up to the maximum applied bhp, watts, and amps. Using the fan motor up to the maximum ratings shown will not result in nuisance tripping or premature motor failure. Unit warranty will not be affected.

2. All indoor-fan motors 5 hp and larger meet the minimum efficiency requirements as established by the Energy Policy Act of 1992 (EPACT) effective October 24, 1997.

**FAN RPM AT MOTOR PULLEY SETTINGS\* — 48PG03-16**

UNIT 48PG	DRIVE	MOTOR PULLEY TURNS OPEN										
		0	1/2	1	1 1/2	2	2 1/2	3	3 1/2	4	4 1/2	5
03	Low	736	710	685	660	634	609	583	558	533	507	482
	High	1001	966	932	897	863	828	794	759	725	690	656
04	Low	736	710	685	660	634	609	583	558	533	507	482
	High	1128	1095	1062	1028	995	962	929	896	863	829	796
05	Low	910	878	847	815	784	753	721	690	659	627	596
	High	1173	1139	1104	1070	1035	1001	966	932	897	863	828
06	Low	978	949	920	891	863	834	805	776	748	719	690
	High	1261	1227	1194	1161	1128	1095	1062	1028	995	962	929
07	Low	1128	1095	1062	1028	995	962	929	896	863	829	796
	High	1438	1409	1380	1351	1323	1294	1265	1236	1208	1179	1150
08	Low	771	751	731	710	690	670	649	629	609	589	568
	High	1015	994	974	954	934	913	893	873	852	832	812
09	Low	771	751	731	710	690	670	649	629	609	589	568
	High	1015	994	974	954	934	913	893	873	852	832	812
12	Low	893	873	852	832	812	791	771	751	731	710	690
	High	1055	1035	1015	994	974	954	934	913	893	873	852
14	Low	893	873	852	832	812	791	771	751	731	710	690
	High	1055	1035	1015	994	974	954	934	913	893	873	852
16	Low	879	863	846	829	812	795	778	761	744	727	710
	Mid-Low	1066	1047	1027	1008	988	969	950	930	911	892	872
	High	1260	1240	1221	1202	1182	1163	1144	1124	1105	1085	1066

\*Approximate fan rpm shown, based on 1725 rpm motor.

NOTE: Factory speed setting is at 5 turns open.

# Performance data (cont)



## FAN RPM AT MOTOR PULLEY SETTINGS\* — 48PG20-28

UNIT 48PG		DRIVE	MOTOR PULLEY TURNS OPEN												
			0	1/2	1	1 1/2	2	2 1/2	3	3 1/2	4	4 1/2	5	5 1/2	6
20 and 24 (230 and 460 volt)	Vertical	Low	685	706	727	749	770	791	812	833	854	876	897	918	939
		Mid-Low	949	970	992	1013	1035	1056	1078	1099	1120	1142	1163	1185	1206
		Mid-High	941	961	980	1000	1019	1039	1059	1078	1098	1117	1137	1156	1176
		High	1014	1038	1061	1085	1108	1132	1156	1179	1203	1226	1250	1273	1297
	Horizontal	Low	n/a	n/a	n/a	n/a	n/a	n/a	n/a	n/a	n/a	n/a	n/a	n/a	n/a
		Mid-Low	896	924	951	979	1006	1034	1062	1089	1117	1144	1172	1199	1227
		Mid-High	1113	1138	1163	1188	1213	1238	1264	1289	1314	1339	1364	1389	1414
		High	1096	1116	1137	1157	1177	1197	1218	1238	1258	1278	1299	1319	1339
20 and 24 (575 volt)	Vertical	Low	751	768	785	802	819	836	853	869	886	903	920	937	954
		Mid-Low	949	970	992	1013	1035	1056	1078	1099	1120	1142	1163	1185	1206
		Mid-High	941	961	980	1000	1019	1039	1059	1078	1098	1117	1137	1156	1176
		High	1014	1038	1061	1085	1108	1132	1156	1179	1203	1226	1250	1273	1297
	Horizontal	Low	n/a	n/a	n/a	n/a	n/a	n/a	n/a	n/a	n/a	n/a	n/a	n/a	n/a
		Mid-Low	873	893	912	932	951	971	991	1010	1030	1049	1069	1088	1108
		Mid-High	1113	1138	1163	1188	1213	1238	1264	1289	1314	1339	1364	1389	1414
		High	1096	1116	1137	1157	1177	1197	1218	1238	1258	1278	1299	1319	1339
28 (all voltages)	Vertical	Low	687	703	718	734	749	765	780	796	811	827	842	858	873
		Mid-Low	805	822	839	856	872	889	906	923	940	957	973	990	1007
		Mid-High	941	961	980	1000	1019	1039	1059	1078	1098	1117	1137	1156	1176
		High	1014	1038	1061	1085	1108	1132	1156	1179	1203	1226	1250	1273	1297
	Horizontal	Low	687	703	718	734	749	765	780	796	811	827	842	858	873
		Mid-Low	805	822	839	856	872	889	906	923	940	957	973	990	1007
		Mid-High	941	961	980	1000	1019	1039	1059	1078	1098	1117	1137	1156	1176
		High	1014	1038	1061	1085	1108	1132	1156	1179	1203	1226	1250	1273	1297

LEGEND

n/a — not available

\*Approximate fan rpm shown.

NOTE: Factory pulley speed setting is at 3 turns open.

## ELECTRICAL DATA — UNITS WITHOUT OPTIONAL CONVENIENCE OUTLET — 48PG03-07

UNIT 48PG	NOMINAL POWER SUPPLY Volts-Ph-Hz	VOLTAGE RANGE		COMPRESSOR		OFM		COMBUSTION FAN MOTOR FLA	POWER EXHAUST FLA (ea)	IFM TYPE	IFM FLA	POWER SUPPLY		DISCONNECT SIZE										
		Min	Max	RLA	LRA	Qty	FLA (ea)					MCA	MOCP	FLA	LRA									
03	208/230-1-60	187	253	12.8	60	1	1.0	0.52	—	Low	4.9	21.9/21.9	30/30	22/22	74/74									
										High	4.9	21.9/21.9	30/30	22/22	74/74									
										1.4	Low	4.9	23.3/23.3	30/30	23/23	76/76								
											High	4.9	23.3/23.3	30/30	23/23	76/76								
										—	Low	4.9	25.2/25.2	30/30	24/24	97/97								
											High	4.9	25.2/25.2	30/30	24/24	97/97								
04	208/230-1-60	187	253	15.4	83	1	1.0	0.52	—	Low	4.9	25.2/25.2	30/30	24/24	97/97									
										High	4.9	25.2/25.2	30/30	24/24	97/97									
										1.4	Low	4.9	26.6/26.6	40/40	26/26	99/99								
											High	4.9	26.6/26.6	40/40	26/26	99/99								
										—	Low	4.9	20.3/20.3	30/30	20/20	91/91								
											High	4.9	20.3/20.3	30/30	20/20	91/91								
	208/230-3-60	187	253	11.5	77	1	1.0	0.52	—	Low	4.9	21.7/21.7	30/30	22/22	93/93									
										High	4.9	21.7/21.7	30/30	22/22	93/93									
										1.4	Low	2.1	9.0	15	9	42								
											High	2.1	9.0	15	9	42								
										0.6	Low	2.1	9.6	15	10	43								
											High	2.1	9.6	15	10	43								
	460-3-60	414	506	5.1	35	1	0.5	0.30	—	Low	2.1	8.0	15	8	37									
										High	2.1	8.0	15	8	37									
										1.4	Low	2.1	9.4	15	10	39								
											High	2.1	9.4	15	10	39								
										—	Low	2.1	11.5	15	11	53								
											High	2.1	11.5	15	11	53								
575-3-60	518	633	4.3	31	1	0.5	0.24	—	Low	2.1	10.4	15	10	42										
									High	2.1	10.4	15	10	42										
									1.4	Low	2.0	10.3	15	10	48									
										High	2.0	10.3	15	10	48									
									—	Low	4.9	40.0/40.0	60/60	38/38	160/160									
										High	7.0	42.1/42.1	60/60	41/41	185/185									
05	208/230-1-60	187	253	20.5	109	1	1.0	0.52	—	Low	4.9	32.9/32.9	50/50	32/32	125/125									
										High	7.0	35.0/35.5	50/50	34/34	150/150									
										1.4	Low	4.9	24.2/24.2	30/30	24/24	105/105								
											High	5.2	24.5/24.5	30/30	24/24	123/123								
										—	Low	4.9	25.6/25.6	30/30	25/25	107/107								
											High	5.2	25.9/25.9	30/30	26/26	125/125								
	208/230-3-60	187	253	14.6	91	1	1.0	0.52	—	Low	2.1	11.5	15	11	53									
										High	2.6	12.0	15	12	62									
										0.6	Low	2.1	12.1	15	12	54								
											High	2.6	12.6	15	12	63								
										—	Low	2.1	9.0	15	9	40								
											High	2.0	8.9	15	9	46								
	460-3-60	414	506	7.1	46	1	0.5	0.30	—	Low	2.1	10.4	15	10	42									
										High	2.0	10.3	15	10	48									
										1.4	Low	4.9	40.0/40.0	60/60	38/38	160/160								
											High	7.0	42.1/42.1	60/60	41/41	185/185								
										575-3-60	518	633	5.1	34	1	0.5	0.24	—	Low	4.9	41.4/41.4	60/60	40/40	162/162
																			High	7.0	43.5/43.5	60/60	42/42	187/187
1.4	Low	5.2	28.7/28.7	45/45	28/28	156/156																		
	High	5.2	28.7/28.7	45/45	28/28	156/156																		
—	Low	5.2	30.1/30.1	45/45	30/30	158/158																		
	High	5.2	30.1/30.1	45/45	30/30	158/158																		
06	208/230-1-60	187	253	26.9	145	1	1.5	0.52	—	Low	2.6	13.0	20	13	67									
										High	2.6	13.0	20	13	67									
										0.6	Low	2.6	13.6	20	13	68								
											High	2.6	13.6	20	13	68								
										—	Low	2.0	10.4	15	10	53								
											High	2.0	10.4	15	10	53								
	208/230-3-60	187	253	17.6	123	1	1.5	0.52	—	Low	2.0	11.8	15	12	55									
										High	2.0	11.8	15	12	55									
										1.4	Low	5.2	32.3/32.3	50/50	31/31	182/182								
											High	7.5	34.6/34.6	50/50	34/34	208/208								
										—	Low	5.2	33.7/33.7	50/50	33/33	184/184								
											High	7.5	36.0/36.0	50/50	36/36	210/210								
	460-3-60	414	506	9.6	75	1	0.8	0.30	—	Low	2.6	15.4	25	15	92									
										High	3.4	16.2	25	16	105									
										0.6	Low	2.6	16.0	25	16	93								
											High	3.4	16.8	25	17	106								
										—	Low	2.0	12.3	15	12	67								
											High	2.8	13.1	20	13	78								
575-3-60	518	633	7.6	54	1	0.8	0.24	—	Low	2.0	13.7	20	14	69										
									High	2.8	14.5	20	14	80										

- LEGEND**
- FLA — Full Load Amps
  - HACR — Heating, Air Conditioning and Refrigeration
  - IFM — Indoor (Evaporator) Fan Motor
  - LRA — Locked Rotor Amps
  - MCA — Minimum Circuit Amps
  - MOCP — Maximum Overcurrent Protection
  - NEC — National Electrical Code
  - OFM — Outdoor (Condenser) Fan Motor
  - RLA — Rated Load Amps

**NOTES:**

1. In compliance with NEC requirements for multimotor and combination load equipment (refer to NEC Articles 430 and 440), the overcurrent protective device for the unit shall be fuse or HACR breaker. Canadian units may be fuse or circuit breaker.

**2. Unbalanced 3-Phase Supply Voltage**

Never operate a motor where a phase imbalance in supply voltage is greater than 2%. Use the following formula to determine the percent of voltage imbalance.

$$\% \text{ Voltage Imbalance} = 100 \times \frac{\text{max voltage deviation from average voltage}}{\text{average voltage}}$$



Example: Supply voltage is 230-3-60.

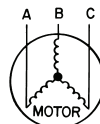

AB = 224 v  
BC = 231 v  
AC = 226 v

$$\text{Average Voltage} = \frac{224 + 231 + 226}{3} = \frac{681}{3} = 227$$

Determine maximum deviation from average voltage.

(AB) 227 - 224 = 3 v  
(BC) 231 - 227 = 4 v  
(AC) 227 - 226 = 1 v

Maximum deviation is 4 v.

Determine percent of voltage imbalance.

$$\% \text{ Voltage Imbalance} = 100 \times \frac{4}{227} = 1.76\%$$

This amount of phase imbalance is satisfactory as it is below the maximum allowable 2%.

**IMPORTANT:** If the supply voltage phase imbalance is more than 2%, contact your local electric utility company immediately.

# Electrical data (cont)



## ELECTRICAL DATA — UNITS WITHOUT OPTIONAL CONVENIENCE OUTLET — 48PG08-14

UNIT 48PG	NOMINAL POWER SUPPLY (V-Ph-Hz)	VOLTAGE RANGE		COMPRESSOR (Each)		OFM		COMBUSTION FAN MOTOR FLA	PWR EXH FLA (ea)	IFM TYPE	IFM FLA	POWER SUPPLY		DISCONNECT SIZE	
		Min	Max	RLA	LRA	Qty	FLA (ea)					MCA	MOCP	FLA	LRA
08	208/230-3-60	187	253	13.5	88	2	1.5	0.52	—	Low High	5.2 7.5	38.6/38.6 40.9/40.9	50/50 50/50	40/40 43/43	212/212 238/238
									3.0	Low High	5.2 7.5	41.6/41.6 43.9/43.9	50/50 50/50	44/44 47/47	216/216 242/242
	460-3-60	414	506	6.4	39	2	0.8	0.30	—	Low High	2.6 3.4	18.6 19.4	25 25	20 20	97 110
									1.2	Low High	2.6 3.4	19.8 20.6	25 25	21 22	100 113
	575-3-60	518	633	5.1	34	2	0.8	0.24	—	Low High	2.0 2.8	15.1 15.9	20 20	16 17	83 94
									3.0	Low High	2.0 2.8	18.1 18.9	20 25	19 20	87 98
09	208/230-3-60	187	253	16.0	91	2	1.5	0.52	—	Low High	5.2 10.2	44.2/44.2 49.2/49.2	60/60 60/60	46/46 52/52	218/218 261/261
									3.0	Low High	5.2 10.2	47.2/47.2 52.2/52.2	60/60 60/60	50/50 55/55	222/222 265/265
	460-3-600	414	506	7.1	46	2	0.8	0.30	—	Low High	2.6 4.8	20.2 22.4	25 25	21 24	111 133
									1.2	Low High	2.6 4.8	21.4 23.6	25 30	23 25	114 136
	575-3-60	518	633	5.6	37	2	0.8	0.24	—	Low High	2.0 2.8	16.2 17	20 20	17 18	89 100
									3.0	Low High	2.0 2.8	19.2 20	25 25	20 21	93 104
12	208/230-3-60	187	253	17.6	123	2	1.9	0.52	—	Low High	7.5 10.2	50.9/50.9 53.6/53.6	60/60 60/60	53/53 57/57	310/310 327/327
									3.0	Low High	7.5 10.2	53.9/53.9 56.6/56.6	60/60 70/70	57/57 60/60	314/314 331/331
	460-3-60	414	506	7.7	50	2	1.0	0.30	—	Low High	3.4 4.8	22.7 24.1	30 30	24 26	132 141
									1.2	Low High	3.4 4.8	23.9 25.3	30 30	25 27	135 144
	575-3-60	518	633	6.1	40	2	0.8	0.24	—	Low High	2.8 2.8	18.1 18.1	20 20	19 19	106 106
									3.0	Low High	2.8 2.8	21.1 21.1	25 25	23 23	110 110
14	208/230-3-60	187	253	22.4	149	2	1.9	0.52	—	Low High	10.2 15.0	64.4/64.4 69.2/69.2	80/80 90/90	68/68 73/73	379/379 388/388
									3.0	Low High	10.2 15.0	67.4/67.4 72.2/72.2	80/80 90/90	71/71 77/77	383/383 392/392
	460-3-60	414	506	10.6	75	2	1.0	0.30	—	Low High	4.8 7.4	30.7 33.3	40 40	32 35	191 195
									1.2	Low High	4.8 7.4	31.9 34.5	40 45	34 37	194 198
	575-3-60	518	633	7.7	54	2	0.8	0.24	—	Low High	2.8 5.6	21.7 24.5	25 30	23 26	134 148
									3.0	Low High	2.8 5.6	24.7 27.5	30 30	26 29	138 152

### LEGEND

- FLA — Full Load Amps
- HACR — Heating, Air Conditioning and Refrigeration
- IFM — Indoor (Evaporator) Fan Motor
- LRA — Locked Rotor Amps
- MCA — Minimum Circuit Amps
- MOCP — Maximum Overcurrent Protection
- NEC — National Electrical Code
- OFM — Outdoor (Condenser) Fan Motor
- RLA — Rated Load Amps



Example: Supply voltage is 230-3-60.

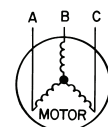

- AB = 224 v
- BC = 231 v
- AC = 226 v

$$\text{Average Voltage} = \frac{224 + 231 + 226}{3} = \frac{681}{3} = 227$$

Determine maximum deviation from average voltage.

- (AB) 227 - 224 = 3 v
- (BC) 231 - 227 = 4 v
- (AC) 227 - 226 = 1 v

Maximum deviation is 4 v.

Determine percent of voltage imbalance.

$$\% \text{ Voltage Imbalance} = 100 \times \frac{4}{227} = 1.76\%$$

This amount of phase imbalance is satisfactory as it is below the maximum allowable 2%.

**IMPORTANT:** If the supply voltage phase imbalance is more than 2%, contact your local electric utility company immediately.

### NOTES:

1. In compliance with NEC requirements for multimotor and combination load equipment (refer to NEC Articles 430 and 440), the overcurrent protective device for the unit shall be fuse or HACR breaker. Canadian units may be fuse or circuit breaker.
2. **Unbalanced 3-Phase Supply Voltage**  
Never operate a motor where a phase imbalance in supply voltage is greater than 2%. Use the following formula to determine the percent of voltage imbalance.

$$\% \text{ Voltage Imbalance} = 100 \times \frac{\text{max voltage deviation from average voltage}}{\text{average voltage}}$$



ELECTRICAL DATA — UNITS WITHOUT OPTIONAL CONVENIENCE OUTLET — 48PG16

UNIT 48PG	NOMINAL POWER SUPPLY (V-Ph-Hz)	VOLTAGE RANGE		COMPRESSOR						OFM FLA		COMBUSTION FAN MOTOR FLA	PWR EXH FLA*	IFM TYPE	IFM FLA	POWER SUPPLY		DISCONNECT SIZE	
				No. 1		No. 2		No. 3		Qty	FLA (ea)					MCA	MOCP	FLA	LRA
		Min	Max	RLA	LRA	RLA	LRA	RLA	LRA										
16	208/230-3-60	187	253	18.1	137	18.1	137	17.6	123	3	1.9	0.52	—	Low	10.2	74.2/74.2	90/ 90	80/80	482/482
														Mid-Low	15.0	79.0/79.0	90/ 90	86/86	491/491
														High	19.4	83.8/83.8	100/100	91/91	529/529
														Low	10.2	77.2/77.2	90/ 90	84/84	486/486
														Mid-Low	15.0	82.0/82.0	100/100	89/89	495/495
														High	19.4	86.8/86.8	100/100	94/94	533/533
	460-3-60	414	506	9.0	62	9.0	62	7.7	50	3	1.0	0.30	—	Low	4.8	35.8	40	39	217
														Mid-Low	7.4	38.4	45	42	221
														High	9.7	40.8	50	44	240
														Low	4.8	37	45	40	220
														Mid-Low	7.4	39.6	45	43	224
														High	9.7	42	50	46	243
	575-3-60	518	633	6.8	50	6.8	50	6.1	40	3	0.8	0.24	—	Low	2.8	26.6	30	29	168
														Mid-Low	5.6	29.4	35	32	182
														High	7.8	31.9	35	34	197
														Low	2.8	29.6	35	32	172
														Mid-Low	5.6	32.4	35	35	186
														High	7.8	34.9	40	38	201

LEGEND

- FLA — Full Load Amps
- HACR — Heating, Air Conditioning and Refrigeration
- IFM — Indoor (Evaporator) Fan Motor
- LRA — Locked Rotor Amps
- MCA — Minimum Circuit Amps
- MOCP — Maximum Overcurrent Protection
- NEC — National Electrical Code
- OFM — Outdoor (Condenser) Fan Motor
- RLA — Rated Load Amps



\*Power exhaust FLA is the sum of the FLA of two power exhaust motors.

NOTES:

1. In compliance with NEC requirements for multimotor and combination load equipment (refer to NEC Articles 430 and 440), the overcurrent protective device for the unit shall be fuse or HACR breaker. Canadian units may be fuse or circuit breaker.

2. **Unbalanced 3-Phase Supply Voltage**

Never operate a motor where a phase imbalance in supply voltage is greater than 2%. Use the following formula to determine the percent of voltage imbalance.

% Voltage Imbalance

$$= 100 \times \frac{\text{max voltage deviation from average voltage}}{\text{average voltage}}$$

Example: Supply voltage is 230-3-60.

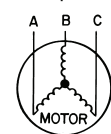

AB = 224 v  
BC = 231 v  
AC = 226 v

$$\begin{aligned} \text{Average Voltage} &= \frac{224 + 231 + 226}{3} \\ &= \frac{681}{3} \\ &= 227 \end{aligned}$$

Determine maximum deviation from average voltage.

(AB) 227 - 224 = 3 v  
(BC) 231 - 227 = 4 v  
(AC) 227 - 226 = 1 v

Maximum deviation is 4 v.

Determine percent of voltage imbalance.

$$\begin{aligned} \% \text{ Voltage Imbalance} &= 100 \times \frac{4}{227} \\ &= 1.76\% \end{aligned}$$

This amount of phase imbalance is satisfactory as it is below the maximum allowable 2%.

**IMPORTANT:** If the supply voltage phase imbalance is more than 2%, contact your local electric utility company immediately.

# Electrical data (cont)



## ELECTRICAL DATA — UNITS WITHOUT OPTIONAL POWERED CONVENIENCE OUTLET — 48PG20-28

UNIT SIZE 48PG	NOMINAL VOLTAGE (3 Ph, 60 Hz)	VOLTAGE RANGE		COMPRESSOR						OFM		IFM		POWER EXHAUST			COMBUSTION FAN MOTOR	POWER SUPPLY*		POWER SUPPLY UNITS WITH OPTIONAL HACR BREAKER		DISCONNECT SIZE	
				No. 1		No. 2		No. 3															
		Min	Max	RLA	LRA	RLA	LRA	RLA	LRA	Qty	Hp	FLA (ea)	Hp	FLA	Qty	Hp	FLA (ea)	FLA	MCA	MOCP	MCA	MOCP	FLA
20	208/230	187	253	28.2	208	28.2	208	—	—	4	0.25	1.5	3.7	10.6/ 9.6	—	—	—	0.5	80/ 79	100/100	80/ 80	100/100	84/ 83
													2	1	5.9	92/ 91	100/100		92/ 92	100/100	98/ 96		
													5	16.7/15.2	—	—	—		98/ 85	100/100	86/ 86	100/100	91/ 89
													2	1	5.9	98/ 96	100/100		98/ 98	100/100	105/103		
	7.5	24.2/22	—	—	—	94/ 91	100/100	94/ 94	100/100	100/ 97													
	2	1	5.9	105/103	125/125	105/105	125/125	113/111															
	10	30.8/28	—	—	—	101/ 97	125/100	101/101	125/125	107/104													
	2	1	5.9	113/109	125/125	113/113	125/125	121/118															
	3.7	4.8	—	—	—	42	50	42	50	44													
	2	1	3.1	48	60	48	60	51															
	5	7.6	—	—	—	45	60	45	60	47													
	2	1	3.1	51	60	51	60	55															
7.5	11	—	—	—	48	60	48	60	51														
2	1	3.1	55	60	55	60	58																
10	14	—	—	—	51	60	51	60	55														
2	1	3.1	58	60	58	60	62																
5	6.1	—	—	—	38	50	38	50	40														
2	1	2.4	43	50	43	50	45																
7.5	9	—	—	—	41	50	41	50	43														
2	1	2.4	45	50	45	50	49																
10	11	—	—	—	43	50	43	50	45														
2	1	2.4	47	60	47	60	51																
24	208/230	187	253	32.1	240	32.1	240	—	—	6	0.25	1.5	3.7	10.6/ 9.6	—	—	—	0.5	92/ 91	100/100	92/ 92	100/100	96/ 95
													2	1	5.9	104/103	125/125		104/104	125/125	110/109		
													5	16.7/15.2	—	—	—		98/ 96	100/100	98/ 98	100/100	103/102
													2	1	5.9	110/108	125/125		110/110	125/125	117/115		
	7.5	24.2/22	—	—	—	105/103	125/125	105/105	125/125	112/109													
	2	1	5.9	117/115	125/125	117/117	125/125	126/123															
	10	30.8/28	—	—	—	112/109	125/125	112/112	125/125	120/116													
	2	1	5.9	124/121	150/150	124/124	150/150	133/130															
	3.7	4.8	—	—	—	44	50	44	50	46													
	2	1	3.1	50	60	50	60	53															
	5	7.6	—	—	—	46	60	46	60	49													
	2	1	3.1	53	60	53	60	56															
7.5	11	—	—	—	50	60	50	60	53														
2	1	3.1	56	60	56	60	60																
10	14	—	—	—	53	60	53	60	56														
2	1	3.1	59	60	59	60	63																
5	6.1	—	—	—	39	50	39	50	41														
2	1	2.4	44	50	44	50	47																
7.5	9	—	—	—	42	50	42	50	45														
2	1	2.4	47	50	47	50	50																
10	11	—	—	—	44	50	44	50	47														
2	1	2.4	49	60	49	60	52																
28	208/230	187	253	28.2	208	28.2	208	28.2	208	6	0.25	1.5	5	16.7/15.2	—	—	—	0.5	117/116	125/125	117/117	125/125	127/125
													2	1	5.9	129/128	150/150		129/129	150/150	140/139		
													7.5	24.2/22	—	—	—		125/123	150/150	125/125	150/150	135/133
													2	1	5.9	137/134	150/150		137/137	150/150	149/147		
	10	30.8/28	—	—	—	132/129	150/150	132/132	150/150	143/140													
	2	1	5.9	144/140	150/150	144/144	150/150	157/153															
	5	7.6	—	—	—	62	70	62	70	67													
	2	1	3.1	68	80	68	80	74															
	7.5	11	—	—	—	65	80	65	80	71													
	2	1	3.1	71	80	71	80	78															
	10	14	—	—	—	68	80	68	80	74													
	2	1	3.1	74	80	74	80	81															
5	6.1	—	—	—	52	60	52	60	56														
2	1	2.4	57	60	57	60	62																
7.5	9	—	—	—	55	60	55	60	59														
2	1	2.4	60	60	60	60	65																
10	11	—	—	—	57	60	57	60	62														
2	1	2.4	62	70	62	70	67																

**LEGEND**

- FLA — Full Load Amps
- HACR — Heating, Air Conditioning and Refrigeration
- IFM — Indoor (Evaporator) Fan Motor
- LRA — Locked Rotor Amps
- MCA — Minimum Circuit Amps
- MOCP — Maximum Overcurrent Protection
- NEC — National Electrical Code
- OFM — Outdoor (Condenser) Fan Motor
- RLA — Rated Load Amps



EXAMPLE: Supply voltage is 460-3-60.

- AB = 452 v
- BC = 464 v
- AC = 455 v

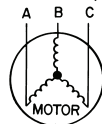

$$\text{Average Voltage} = \frac{452 + 464 + 455}{3} = \frac{1371}{3} = 457$$

Determine maximum deviation from average voltage.

- (AB) 457 - 452 = 5 v
- (BC) 464 - 457 = 7 v
- (AC) 457 - 455 = 2 v

Maximum deviation is 7 v.

Determine percent voltage imbalance.

$$\% \text{ Voltage Imbalance} = 100 \times \frac{7}{457} = 1.53\%$$

This amount of phase imbalance is satisfactory as it is below the maximum allowable 2%.

**IMPORTANT:** If the supply voltage phase imbalance is more than 2%, contact your local electric utility company immediately.

\*Fuse or HACR circuit breaker.

**NOTES:**

1. In compliance with NEC requirements for multimotor and combination load equipment (refer to NEC Articles 430 and 440), the overcurrent protective device for the unit shall be fuse or HACR breaker. Canadian units may be fuse or circuit breaker.

**2. Unbalanced 3-Phase Supply Voltage**

Never operate a motor where a phase imbalance in supply voltage is greater than 2%. Use the following formula to determine the percent voltage imbalance.

% Voltage Imbalance

$$= 100 \times \frac{\text{max voltage deviation from average voltage}}{\text{average voltage}}$$



**ELECTRICAL DATA — UNITS WITH OPTIONAL POWERED CONVENIENCE OUTLET — 48PG03-07**

UNIT 48PG	NOMINAL POWER SUPPLY Volts-Ph-Hz	VOLTAGE RANGE		COMPRESSOR		OFM		COMBUSTION FAN MOTOR FLA	POWER EXHAUST FLA (ea)	IFM TYPE	IFM FLA	POWER SUPPLY		DISCONNECT SIZE		
		Min	Max	RLA	LRA	Qty	FLA (ea)					MCA	MOCP	FLA	LRA	
03	208/230-1-60	187	253	12.8	60	1	1.0	0.52	—	Low	4.9	26.7/26.7	30/30	27/27	79/ 79	
										High	4.9	26.7/26.7	30/30	27/27	79/ 79	
										1.4	Low	4.9	28.1/28.1	40/40	29/29	81/ 81
											High	4.9	28.1/28.1	40/40	29/29	81/ 81
											Low	4.9	30.0/30.0	45/45	30/30	102/102
											High	4.9	30.0/30.0	45/45	30/30	102/102
04	208/230-1-60	187	253	15.4	83	1	1.0	0.52	—	Low	4.9	31.4/31.4	45/45	32/32	104/104	
										High	4.9	31.4/31.4	45/45	32/32	104/104	
										1.4	Low	4.9	25.1/25.1	30/30	26/26	96/ 96
											High	4.9	25.1/25.1	30/30	26/26	96/ 96
											Low	4.9	26.5/26.5	30/30	27/27	98/ 98
											High	4.9	26.5/26.5	30/30	27/27	98/ 98
	208/230-3-60	187	253	11.5	77	1	1.0	0.52	—	Low	2.1	11.2	15	11	44	
										High	2.1	11.2	15	11	44	
										0.6	Low	2.1	11.8	15	12	45
											High	2.1	11.8	15	12	45
											Low	2.1	9.7	15	10	39
											High	2.1	9.7	15	10	39
460-3-60	414	506	5.1	35	1	0.5	0.30	—	Low	2.1	11.1	15	12	41		
									High	2.1	11.1	15	12	41		
									1.4	Low	2.1	11.1	15	12	41	
										High	2.1	11.1	15	12	41	
										Low	2.1	13.7	20	14	55	
										High	2.1	13.7	20	14	55	
575-3-60	518	633	4.3	31	1	0.5	0.24	—	Low	2.1	10.7	15	11	42		
									High	2.1	10.7	15	11	42		
									0.6	Low	2.1	14.3	20	14	56	
										High	2.1	14.3	20	14	56	
										Low	2.1	10.7	15	11	42	
										High	2.1	10.7	15	11	42	
05	208/230-1-60	187	253	20.5	109	1	1.0	0.52	—	Low	4.9	36.3/36.3	50/50	36/36	128/128	
										High	4.9	36.3/36.3	50/50	36/36	128/128	
										1.4	Low	4.9	37.7/37.7	50/50	37/37	130/130
											High	4.9	37.7/37.7	50/50	37/37	130/130
											Low	4.9	39.8/39.8	60/60	40/40	155/155
											High	4.9	39.8/39.8	60/60	40/40	155/155
	208/230-3-60	187	253	14.6	91	1	1.0	0.52	—	Low	4.9	29.0/29.0	40/40	29/29	110/110	
										High	4.9	29.0/29.0	40/40	29/29	110/110	
										1.4	Low	4.9	30.4/30.4	40/40	31/31	112/112
											High	4.9	30.4/30.4	40/40	31/31	112/112
											Low	2.1	13.7	20	14	55
											High	2.1	13.7	20	14	55
460-3-60	414	506	7.1	46	1	0.5	0.30	—	Low	2.1	14.2	20	14	64		
									High	2.1	14.2	20	14	64		
									0.6	Low	2.1	14.3	20	14	56	
										High	2.1	14.3	20	14	56	
										Low	2.1	10.7	15	11	42	
										High	2.1	10.7	15	11	42	
575-3-60	518	633	5.1	34	1	0.5	0.24	—	Low	2.1	12.1	15	12	44		
									High	2.1	12.1	15	12	44		
									1.4	Low	2.1	12.1	15	12	50	
										High	2.1	12.1	15	12	50	
										Low	4.9	44.8/44.8	60/60	44/44	165/165	
										High	4.9	44.8/44.8	60/60	44/44	165/165	
06	208/230-1-60	187	253	26.9	145	1	1.5	0.52	—	Low	4.9	46.2/46.2	60/60	46/46	190/190	
										High	4.9	46.2/46.2	60/60	46/46	190/190	
										1.4	Low	4.9	48.3/48.3	60/60	48/48	192/192
											High	4.9	48.3/48.3	60/60	48/48	192/192
											Low	5.2	33.5/33.5	50/50	33/33	161/161
											High	5.2	33.5/33.5	50/50	33/33	161/161
	208/230-3-60	187	253	17.6	123	1	1.5	0.52	—	Low	5.2	34.9/34.9	50/50	35/35	163/163	
										High	5.2	34.9/34.9	50/50	35/35	163/163	
										1.4	Low	5.2	34.9/34.9	50/50	35/35	163/163
											High	5.2	34.9/34.9	50/50	35/35	163/163
											Low	2.6	15.2	20	15	69
											High	2.6	15.2	20	15	69
460-3-60	414	506	7.7	50	1	0.8	0.30	—	Low	2.6	15.8	20	16	70		
									High	2.6	15.8	20	16	70		
									0.6	Low	2.6	15.8	20	16	70	
										High	2.6	15.8	20	16	70	
										Low	2.0	12.1	15	12	55	
										High	2.0	12.1	15	12	55	
575-3-60	518	633	6.1	40	1	0.8	0.24	—	Low	2.0	13.5	20	14	57		
									High	2.0	13.5	20	14	57		
									1.4	Low	2.0	13.5	20	14	57	
										High	2.0	13.5	20	14	57	
										Low	5.2	37.1/37.1	50/50	37/37	187/187	
										High	5.2	37.1/37.1	50/50	37/37	187/187	
07	208/230-3-60	187	253	20.5	149	1	1.5	0.52	—	Low	7.5	39.4/39.4	50/50	39/39	213/213	
										High	7.5	39.4/39.4	50/50	39/39	213/213	
										1.4	Low	5.2	38.5/38.5	50/50	38/38	189/189
											High	5.2	38.5/38.5	50/50	38/38	189/189
											Low	7.5	40.8/40.8	60/60	41/41	215/215
											High	7.5	40.8/40.8	60/60	41/41	215/215
	460-3-60	414	506	9.6	75	1	0.8	0.30	—	Low	2.6	17.6	25	17	94	
										High	3.4	18.4	25	18	107	
										0.6	Low	2.6	18.2	25	18	95
											High	3.4	19.0	25	19	108
											Low	2.0	14.0	20	14	69
											High	2.8	14.8	20	15	80
575-3-60	518	633	7.6	54	1	0.8	0.24	—	Low	2.0	15.4	20	16	71		
									High	2.8	16.2	20	16	82		
									1.4	Low	2.0	15.4	20	16	71	
										High	2.8	16.2	20	16	82	

**LEGEND**

- FLA — Full Load Amps
- HACR — Heating, Air Conditioning and Refrigeration
- Indoor — Indoor (Evaporator) Fan Motor
- IFM — Indoor (Evaporator) Fan Motor
- LRA — Locked Rotor Amps
- MCA — Minimum Circuit Amps
- MOCP — Maximum Overcurrent Protection
- NEC — National Electrical Code
- OFM — Outdoor (Condenser) Fan Motor
- RLA — Rated Load Amps



Example: Supply voltage is 230-3-60.

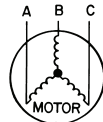

- AB = 224 v
- BC = 231 v
- AC = 226 v

$$\text{Average Voltage} = \frac{224 + 231 + 226}{3} = \frac{681}{3} = 227$$

Determine maximum deviation from average voltage.

- (AB) 227 - 224 = 3 v
- (BC) 231 - 227 = 4 v
- (AC) 227 - 226 = 1 v

Maximum deviation is 4 v.

Determine percent of voltage imbalance.

$$\% \text{ Voltage Imbalance} = 100 \times \frac{4}{227} = 1.76\%$$

This amount of phase imbalance is satisfactory as it is below the maximum allowable 2%.

**IMPORTANT:** If the supply voltage phase imbalance is more than 2%, contact your local electric utility company immediately.

- NOTES:**
- In compliance with NEC requirements for multimotor and combination load equipment (refer to NEC Articles 430 and 440), the overcurrent protective device for the unit shall be fuse or HACR breaker. Canadian units may be fuse or circuit breaker.

**2. Unbalanced 3-Phase Supply Voltage**

Never operate a motor where a phase imbalance in supply voltage is greater than 2%. Use the following formula to determine the percent of voltage imbalance.

$$\% \text{ Voltage Imbalance} = 100 \times \frac{\text{max voltage deviation from average voltage}}{\text{average voltage}}$$

# Electrical data (cont)



## ELECTRICAL DATA — UNITS WITH OPTIONAL POWERED CONVENIENCE OUTLET — 48PG08-14

UNIT 48PG	NOMINAL POWER SUPPLY (V-Ph-Hz)	VOLTAGE RANGE		COMPRESSOR (Each)		OFM		COMBUSTION FAN MOTOR FLA	PWR EXH FLA (ea)	IFM TYPE	IFM FLA	POWER SUPPLY		DISCONNECT SIZE	
		Min	Max	RLA	LRA	Qty	FLA (ea)					MCA	MOCP	FLA	LRA
08	208/230-3-60	187	253	13.5	88	2	1.5	0.52	—	Low High	5.2 7.5	43.4/43.4 45.7/45.7	50/50 50/50	46/46 49/49	217/217 243/243
									3.0	Low High	5.2 7.5	46.4/46.4 48.7/48.7	50/50 60/60	49/49 52/52	221/221 247/247
	460-3-60	414	506	6.4	39	2	0.8	0.30	—	Low High	2.6 3.4	20.8 21.6	25 25	22 23	99 112
									1.2	Low High	2.6 3.4	22 22.8	25 25	23 24	102 115
	575-3-60	518	633	5.1	34	2	0.8	0.24	—	Low High	2.0 2.8	16.8 17.6	20 20	18 19	85 96
									3.0	Low High	2.0 2.8	19.8 20.6	25 25	21 22	89 100
09	208/230-3-60	187	253	16.0	91	2	1.5	0.52	—	Low High	5.2 10.2	49.0/49.0 54.0/54.0	60/60 60/60	52/52 58/58	223/223 266/266
									3.0	Low High	5.2 10.2	52.0/52.0 57.0/57.0	60/60 70/70	55/55 61/61	227/227 270/270
	460-3-60	414	506	7.1	46	2	0.8	0.30	—	Low High	2.6 4.8	22.4 24.6	25 30	24 26	113 135
									1.2	Low High	2.6 4.8	23.6 25.8	30 30	25 28	116 138
	575-3-60	518	633	5.6	37	2	0.8	0.24	—	Low High	2.0 2.8	17.9 18.7	20 25	19 20	91 102
									3.0	Low High	2.0 2.8	20.9 21.7	25 25	22 23	95 106
12	208/230-3-60	187	253	17.6	123	2	1.9	0.52	—	Low High	7.5 10.2	55.7/55.7 58.4/58.4	70/70 70/70	59/59 62/62	315/315 332/332
									3.0	Low High	7.5 10.2	58.7/58.7 61.4/61.4	70/70 70/70	62/62 66/66	319/319 336/336
	460-3-60	414	506	7.7	50	2	1.0	0.30	—	Low High	3.4 4.8	24.9 26.3	30 30	26 28	134 143
									1.2	Low High	3.4 4.8	26.1 27.5	30 30	28 29	137 146
	575-3-60	518	633	6.1	40	2	0.8	0.24	—	Low High	2.8 2.8	19.8 19.8	25 25	21 21	108 108
									3.0	Low High	2.8 2.8	22.8 22.8	25 25	24 24	112 112
14	208/230-3-60	187	253	22.4	149	2	1.9	0.52	—	Low High	10.2 15.0	69.2/69.2 74.0/74.0	90/90 90/90	73/73 79/79	384/384 393/393
									3.0	Low High	10.2 15.0	72.2/72.2 77.0/77.0	90/90 90/90	77/77 82/82	388/388 397/397
	460-3-60	414	506	10.6	75	2	1.0	0.30	—	Low High	4.8 7.4	32.9 35.5	40 45	35 38	193 197
									1.2	Low High	4.8 7.4	34.1 36.7	40 45	36 39	196 200
	575-3-60	518	633	7.7	54	2	0.8	0.24	—	Low High	2.8 5.6	23.4 26.2	30 30	25 28	136 150
									3.0	Low High	2.8 5.6	26.4 29.2	30 35	28 31	140 154

### LEGEND

- FLA — Full Load Amps
- HACR — Heating, Air Conditioning and Refrigeration
- IFM — Indoor (Evaporator) Fan Motor
- LRA — Locked Rotor Amps
- MCA — Minimum Circuit Amps
- MOCP — Maximum Overcurrent Protection
- NEC — National Electrical Code
- OFM — Outdoor (Condenser) Fan Motor
- RLA — Rated Load Amps



Example: Supply voltage is 230-3-60.

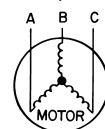

- AB = 224 v
- BC = 231 v
- AC = 226 v

$$\text{Average Voltage} = \frac{224 + 231 + 226}{3} = \frac{681}{3} = 227$$

Determine maximum deviation from average voltage.

- (AB) 227 - 224 = 3 v
- (BC) 231 - 227 = 4 v
- (AC) 227 - 226 = 1 v

Maximum deviation is 4 v.

Determine percent of voltage imbalance.

$$\% \text{ Voltage Imbalance} = 100 \times \frac{4}{227} = 1.76\%$$

This amount of phase imbalance is satisfactory as it is below the maximum allowable 2%.

**IMPORTANT:** If the supply voltage phase imbalance is more than 2%, contact your local electric utility company immediately.

### NOTES:

1. In compliance with NEC requirements for multimotor and combination load equipment (refer to NEC Articles 430 and 440), the overcurrent protective device for the unit shall be fuse or HACR breaker. Canadian units may be fuse or circuit breaker.

### 2. Unbalanced 3-Phase Supply Voltage

Never operate a motor where a phase imbalance in supply voltage is greater than 2%. Use the following formula to determine the percent of voltage imbalance.

% Voltage Imbalance

$$= 100 \times \frac{\text{max voltage deviation from average voltage}}{\text{average voltage}}$$



**ELECTRICAL DATA — UNITS WITH OPTIONAL POWERED CONVENIENCE OUTLET — 48PG16**

UNIT 48PG	NOMINAL POWER SUPPLY (V-Ph-Hz)	VOLTAGE RANGE		COMPRESSOR						OFM FLA		COMBUSTION FAN MOTOR FLA	PWR EXH FLA*	IFM TYPE	IFM FLA	POWER SUPPLY		DISCONNECT SIZE	
				No. 1		No. 2		No. 3		Qty	FLA (ea)					MCA	MOCP	FLA	LRA
		Min	Max	RLA	LRA	RLA	LRA	RLA	LRA										
16	208/230-3-60	187	253	18.1	137	18.1	137	17.6	123	3	1.9	0.52	—	Low	10.2	79.0/79.0	90/ 90	86/ 86	487/487
														Mid-Low	15.0	83.8/83.8	100/100	91/ 91	496/496
														High	19.4	88.6/88.6	100/100	96/ 96	534/534
														Low	10.2	82.0/82.0	100/100	89/ 89	491/491
														Mid-Low	15.0	86.8/86.8	100/100	95/ 95	500/500
														High	19.4	91.6/91.6	100/100	100/100	538/538
	460-3-60	414	506	9.0	62	9.0	62	7.7	50	3	1.0	0.30	—	Low	4.8	38.0	45	41	219
														Mid-Low	7.4	40.6	45	44	223
														High	9.7	43.0	50	47	242
														Low	4.8	39.2	45	42	222
														Mid-Low	7.4	41.8	50	45	226
														High	9.7	44.2	50	48	245
	575-3-60	518	633	6.8	50	6.8	50	6.1	40	3	0.8	0.24	—	Low	2.8	28.3	35	31	170
														Mid-Low	5.6	31.1	35	34	184
														High	7.8	33.6	40	36	199
														Low	2.8	31.3	35	34	174
														Mid-Low	5.6	34.1	40	37	188
														High	7.8	36.6	40	40	203

**LEGEND**

- FLA** — Full Load Amps
- HACR** — Heating, Air Conditioning and Refrigeration
- IFM** — Indoor (Evaporator) Fan Motor
- LRA** — Locked Rotor Amps
- MCA** — Minimum Circuit Amps
- MOCP** — Maximum Overcurrent Protection
- NEC** — National Electrical Code
- OFM** — Outdoor (Condenser) Fan Motor
- RLA** — Rated Load Amps



Example: Supply voltage is 230-3-60.

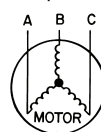

- AB = 224 v
- BC = 231 v
- AC = 226 v

$$\begin{aligned} \text{Average Voltage} &= \frac{224 + 231 + 226}{3} \\ &= \frac{681}{3} \\ &= 227 \end{aligned}$$

Determine maximum deviation from average voltage.

- (AB) 227 - 224 = 3 v
- (BC) 231 - 227 = 4 v
- (AC) 227 - 226 = 1 v

Maximum deviation is 4 v.

Determine percent of voltage imbalance.

$$\begin{aligned} \% \text{ Voltage Imbalance} &= 100 \times \frac{4}{227} \\ &= 1.76\% \end{aligned}$$

This amount of phase imbalance is satisfactory as it is below the maximum allowable 2%.

**IMPORTANT:** If the supply voltage phase imbalance is more than 2%, contact your local electric utility company immediately.

\*Power exhaust FLA is the sum of the FLA of two power exhaust motors.

**NOTES:**

1. In compliance with NEC requirements for multimotor and combination load equipment (refer to NEC Articles 430 and 440), the overcurrent protective device for the unit shall be fuse or HACR breaker. Canadian units may be fuse or circuit breaker.

**2. Unbalanced 3-Phase Supply Voltage**

Never operate a motor where a phase imbalance in supply voltage is greater than 2%. Use the following formula to determine the percent of voltage imbalance.

% Voltage Imbalance

$$= 100 \times \frac{\text{max voltage deviation from average voltage}}{\text{average voltage}}$$

# Electrical data (cont)



## ELECTRICAL DATA — UNITS WITH OPTIONAL POWERED CONVENIENCE OUTLET — 48PG20-28

UNIT SIZE 48PG	NOMINAL VOLTAGE (3 Ph, 60 Hz)	VOLTAGE RANGE		COMPRESSOR						OFM			IFM		POWER EXHAUST		COMBUSTION FAN MOTOR	POWER SUPPLY*		POWER SUPPLY UNITS WITH OPTIONAL HACR BREAKER		DISCONNECT SIZE	
				No. 1		No. 2		No. 3															
		Min	Max	RLA	LRA	RLA	LRA	RLA	LRA	Qty	Hp	FLA (ea)	Hp	FLA	Qty	Hp	FLA (ea)	FLA	MCA	MOCP	MCA	MOCP	FLA
20	208/230	187	253	28.2	208	28.2	208	—	—	4	0.25	1.5	3.7	10.6/ 9.6	—	—	—	0.5	85/ 84	100/100	85/ 85	100/100	90/ 89
													5	16.7/15.2	2	1	5.9		97/ 96	100/100	97/ 97	100/100	103/102
													7.5	24.2/22	2	1	5.9		91/ 90	100/100	91/ 91	100/100	97/ 95
													10	30.8/28	—	—	—		103/101	125/125	103/103	125/125	110/109
													—	—	—	—	—		99/ 96	100/100	99/ 99	100/100	105/103
													—	—	—	—	—		110/108	125/125	110/110	125/125	119/116
	460	414	506	15.4	104	15.4	104	—	—	4	0.25	0.7	3.7	4.8	—	—	—	0.3	45	60	45	60	48
													5	7.6	2	1	3.1		51	60	51	60	55
													7.5	11	2	1	3.1		48	60	48	60	51
													10	14	—	—	—		54	60	54	60	58
													—	—	—	—	—		51	60	51	60	55
													—	—	—	—	—		58	60	58	60	62
	575	518	633	12.8	83	12.8	83	—	—	4	0.25	0.7	5	6.1	—	—	—	0.24	44	50	46	50	49
													7.5	9	2	1	2.4		46	50	46	50	49
													10	11	—	—	—		44	50	44	50	46
													—	—	—	—	—		48	60	48	60	52
													—	—	—	—	—		46	50	46	50	49
													—	—	—	—	—		50	60	50	60	54
24	208/230	187	253	32.1	240	32.1	240	—	—	6	0.25	1.5	3.7	10.6/ 9.6	—	—	—	0.5	97/ 96	100/100	97/ 97	100/100	102/101
													5	16.7/15.2	2	1	5.9		109/108	125/125	109/109	125/125	116/115
													7.5	24.2/22	2	1	5.9		103/101	125/125	103/103	125/125	109/107
													10	30.8/28	—	—	—		115/113	125/125	115/115	125/125	123/121
													—	—	—	—	—		110/108	125/125	110/110	125/125	118/115
													—	—	—	—	—		122/120	150/150	122/122	150/150	131/129
	460	414	506	15.4	110	15.4	110	—	—	6	0.25	0.7	3.7	4.8	—	—	—	0.3	47	60	47	60	49
													5	7.6	2	1	3.1		53	60	53	60	56
													7.5	11	2	1	3.1		49	60	49	60	52
													10	14	—	—	—		56	60	56	60	60
													—	—	—	—	—		53	60	53	60	56
													—	—	—	—	—		59	60	59	60	63
	575	518	633	12.8	88	12.8	88	—	—	6	0.25	0.7	5	6.1	—	—	—	0.24	42	50	42	50	45
													7.5	9	2	1	2.4		47	50	47	50	50
													10	11	—	—	—		45	50	45	50	48
													—	—	—	—	—		50	60	50	60	54
													—	—	—	—	—		47	50	47	50	50
													—	—	—	—	—		52	60	52	60	56
28	208/230	187	253	28.2	208	28.2	208	28.2	208	6	0.25	1.5	5	16.7/15.2	—	—	—	0.5	122/121	150/125	122/122	150/150	133/131
													7.5	24.2/22	2	1	5.9		134/133	150/150	134/134	150/150	146/144
													10	30.8/28	—	—	—		130/128	150/150	130/130	150/150	141/139
													—	—	—	—	—		142/139	150/150	142/142	150/150	155/152
													—	—	—	—	—		137/134	150/150	137/137	150/150	149/146
													—	—	—	—	—		149/145	175/150	149/149	175/175	162/159
	460	414	506	15.4	104	15.4	104	15.4	104	6	0.25	0.7	5	7.6	—	—	—	0.3	65	80	65	80	70
													7.5	11	2	1	3.1		71	80	71	80	77
													10	14	—	—	—		68	80	68	80	74
													—	—	—	—	—		74	80	74	80	81
													—	—	—	—	—		71	80	71	80	78
													—	—	—	—	—		77	90	77	90	85
575	518	633	12.8	83	12.8	83	12.8	83	6	0.25	0.7	5	6.1	—	—	—	0.24	55	60	55	60	59	
												7.5	9	2	1	2.4		60	60	60	60	65	
												10	11	—	—	—		58	60	58	60	63	
												—	—	—	—	—		63	70	63	70	68	
												—	—	—	—	—		60	60	60	60	65	
												—	—	—	—	—		65	70	65	70	71	

**LEGEND**

- FLA — Full Load Amps
- HACR — Heating, Air Conditioning and Refrigeration
- IFM — Indoor (Evaporator) Fan Motor
- LRA — Locked Rotor Amps
- MCA — Minimum Circuit Amps
- MOCP — Maximum Overcurrent Protection
- NEC — National Electrical Code
- OFM — Outdoor (Condenser) Fan Motor
- RLA — Rated Load Amps



EXAMPLE: Supply voltage is 460-3-60.

- AB = 452 v
- BC = 464 v
- AC = 455 v

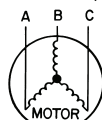

$$\text{Average Voltage} = \frac{452 + 464 + 455}{3} = \frac{1371}{3} = 457$$

Determine maximum deviation from average voltage.

- (AB) 457 - 452 = 5 v
- (BC) 464 - 457 = 7 v
- (AC) 457 - 455 = 2 v

Maximum deviation is 7 v.

Determine percent voltage imbalance.

$$\% \text{ Voltage Imbalance} = 100 \times \frac{7}{457} = 1.53\%$$

This amount of phase imbalance is satisfactory as it is below the maximum allowable 2%.

**IMPORTANT:** If the supply voltage phase imbalance is more than 2%, contact your local electric utility company immediately.

3. The optional powered convenience outlet full load amps (FLA) are 5, 3, and 3 for 208/230, 460, 575-v units, respectively.

# Typical wiring schematics



## TYPICAL CONTROL WIRING SCHEMATIC — 48PG03-16 WITH COMFORTLINK™ CONTROLS

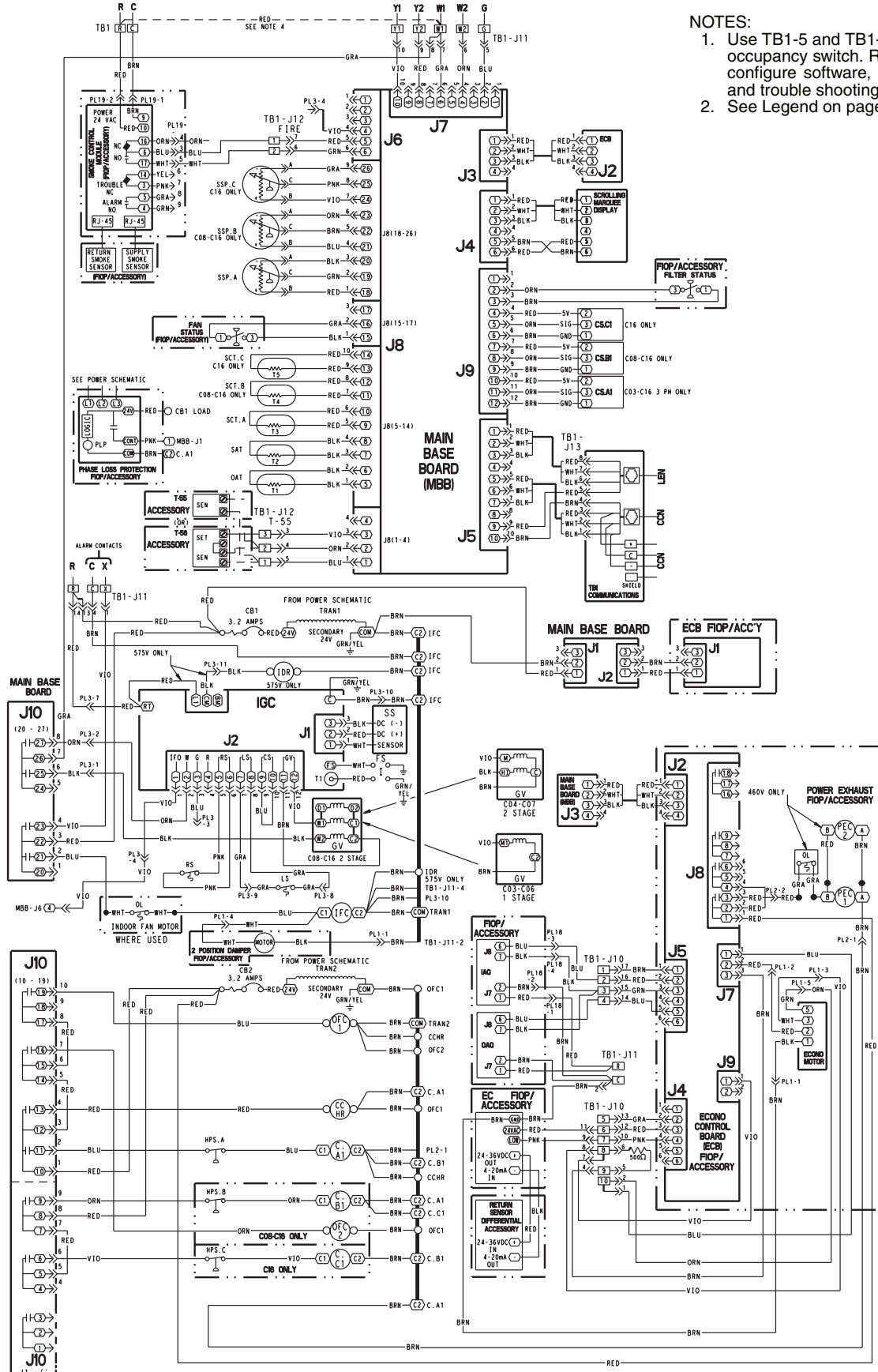

- NOTES:
1. Use TB1-5 and TB1-6 for remote occupancy switch. Remember to configure software, see controls and trouble shooting guide.
  2. See Legend on page 151.

# Typical wiring schematics (cont)



## TYPICAL CONTROL WIRING SCHEMATIC — 48PG03-16 WITH HUMIDI-MIZER™ SYSTEM

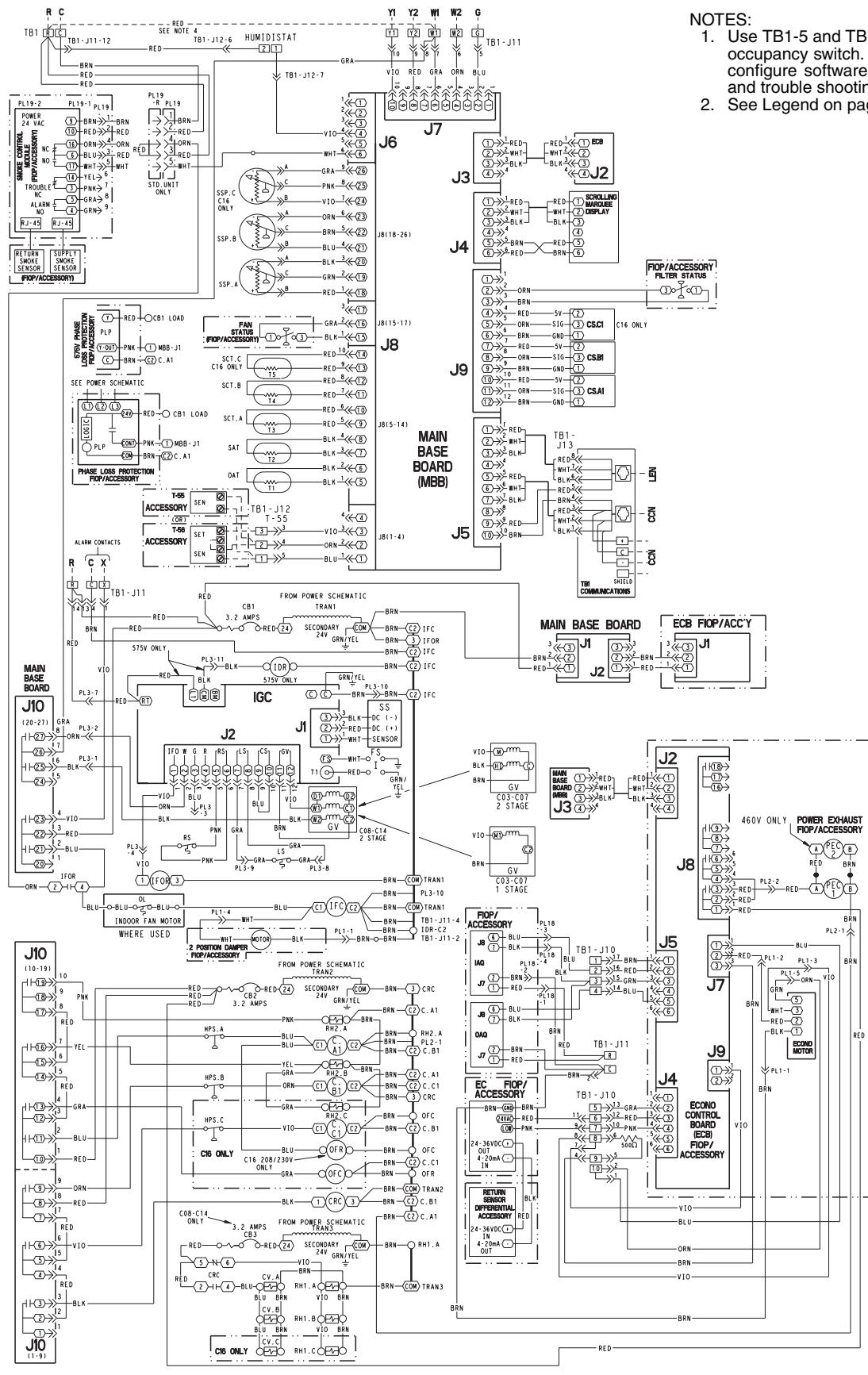

- NOTES:
1. Use TB1-5 and TB1-6 for remote occupancy switch. Remember to configure software, see controls and trouble shooting guide.
  2. See Legend on page 151.

### TYPICAL POWER SCHEMATIC — 48PG03-16

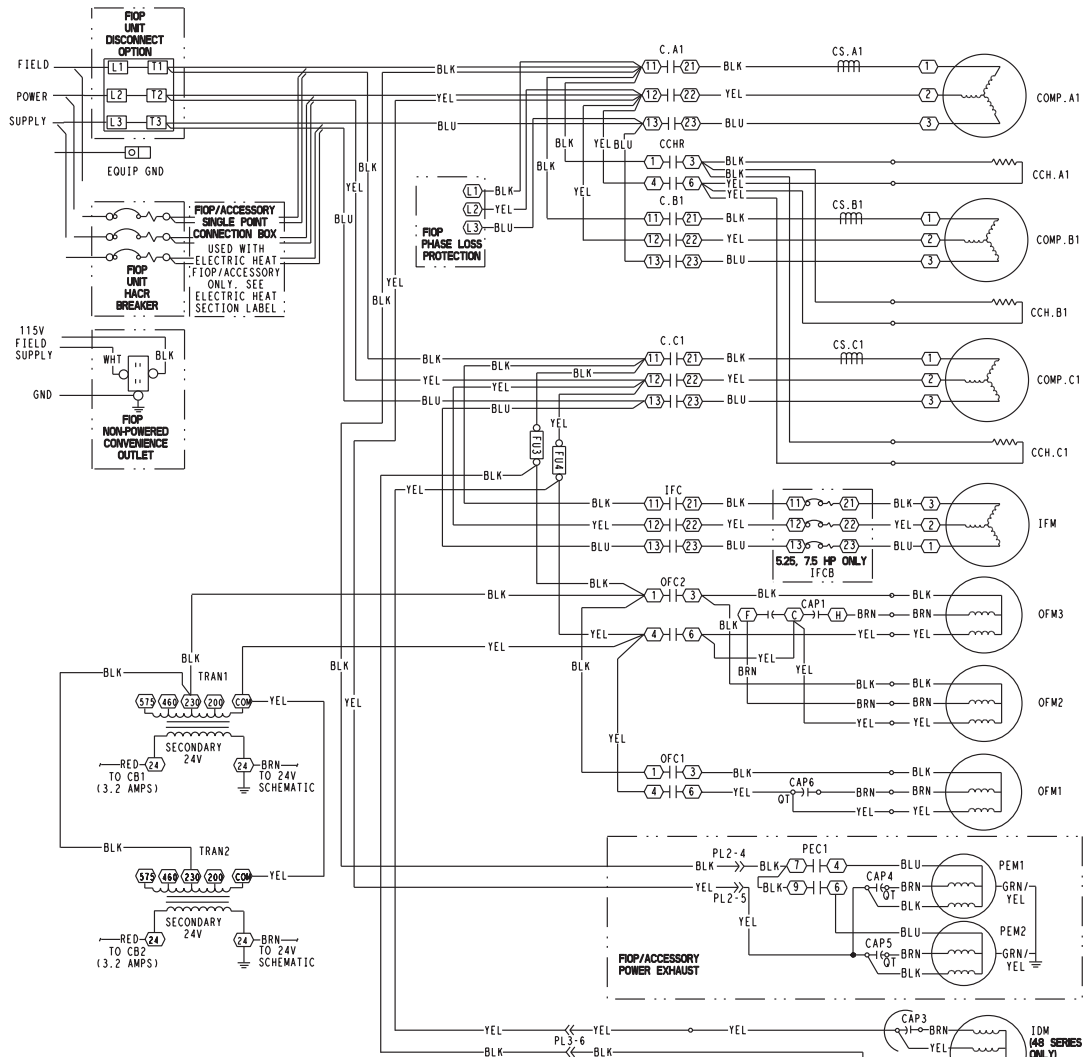

**LEGEND**

(X) TERMINAL (MARKED)  
 ( ) TERMINAL (UNMARKED)  
 --- FACTORY WIRING  
 - - - FIELD CONTROL WIRING  
 - - - FIELD POWER WIRING  
 - - - ACCESSORY OR OPTIONAL WIRING  
 - - - TO INDICATE COMMON  
 - - - POTENTIAL ONLY:  
 - - - NOT TO REPRESENT WIRING.

- NOTES:**
- IF ANY OF THE ORIGINAL WIRE FURNISHED MUST BE REPLACED, IT MUST BE REPLACED WITH TYPE 90°C OR ITS EQUIVALENT.
  - THREE PHASE MOTORS ARE PROTECTED UNDER PRIMARY SINGLE PHASING CONDITIONS.
  - USE COPPER CONDUCTORS ONLY.
  - RED JUMPER WIRE MUST BE ADDED BETWEEN R AND W1 FOR SPACE TEMPERATURE MODE AND TEMPORARILY DURING SERVICE-TEST MODE WHEN THE HEATERS NEED TO OPERATE.
  - TRAN1 AND 2 ARE WIRED FOR 230V ON 208/230V UNITS. IF UNIT IS TO BE RUN WITH 208V POWER SUPPLY, DISCONNECT BLK WIRE FROM 230V TERMINAL AND CONNECT TO 200V TERMINAL.

---A CIRCUIT A  
 ---B CIRCUIT B  
 ---C CIRCUIT C  
 C COMPRESSOR CONTACTOR  
 CB CAPACITOR  
 CCH CRANKCASE HEATER  
 CCHR CRANKCASE HEATER RELAY  
 CCN CARRIER COMFORT NETWORK  
 COMP COMPRESSOR  
 CRC COOLING-REHEAT CONTROL  
 CS CURRENT SENSOR  
 CV COOLING VALVE  
 EC ENTHALPY CONTROL  
 ECB ECONOMIZER CONTROL BOARD  
 FIOF FACTORY INSTALLED OPTION  
 FS FLAME SENSOR  
 FU FUSE  
 GND GROUND  
 GV GAS VALVE  
 HPS HIGH PRESSURE SWITCH  
 IAO IGNITOR  
 IAQ INDOOR AIR QUALITY  
 IDM INDOOR DRAFT MOTOR  
 IDR INDOUCED DRAFT RELAY  
 IFC INDOOR FAN CONTACTOR  
 IFCB INDOOR FAN CIRCUIT BREAKER  
 IFM INDOOR FAN MOTOR  
 IFOR INDOOR FAN ON RELAY  
 IGC INTEGRATED GAS CONTROLLER  
 LFN LOCAL EQUIPMENT NETWORK  
 LS LIMIT SWITCH  
 MBB MAIN BASE BOARD  
 OAO OUTDOOR AIR QUALITY  
 OAT OUTDOOR AIR TEMPERATURE  
 OFC OUTDOOR FAN CONTACTOR  
 OFM OUTDOOR FAN MOTOR  
 OL OVERLOAD  
 PEC POWER EXHAUST CONTACTOR  
 PEM POWER EXHAUST MOTOR  
 PF PLUGGED FILTER (STATUS)  
 PL PLUG

**PHASE LOSS PROTECTION**  
 QUADRUPLE TERMINAL  
 RH1 REHEAT 1 VALVE  
 RH2 REHEAT 2 VALVE  
 RS ROLLOUT SWITCH  
 SAT SUPPLY AIR TEMPERATURE  
 SCT SATURATED CONDENSING TEMP  
 SSP SATURATED SUCTION PRESSURE  
 TB TERMINAL BLOCK  
 TRAN TRANSFORMER

**THERMOSTAT/IGC MARKINGS**  
 BM BLOWER MOTOR  
 C COMMON  
 CM COMBUSTION MOTOR  
 CS CENTRIFUGAL SWITCH  
 FAN FAN  
 G INDOOR FAN ON  
 LI LINE 1  
 RT THERMOSTAT POWER  
 W1 POWER SUPPLY  
 W2 SPEED SENSOR  
 SS THERMOSTAT HEAT  
 W1 1st STAGE OF HEATING  
 W2 2nd STAGE OF HEATING  
 X ALARM OUTPUT  
 Y1 1st STAGE OF COOLING  
 Y2 2nd STAGE OF COOLING

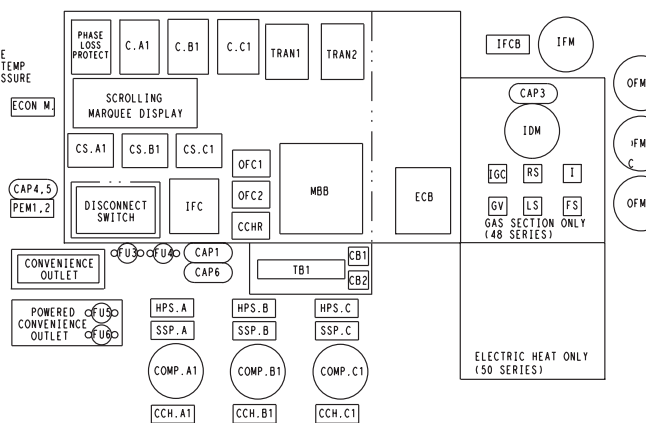

# Typical wiring schematics (cont)



## TYPICAL POWER SCHEMATIC — 48PG03-16 WITH HUMIDI-MIZER™ SYSTEM

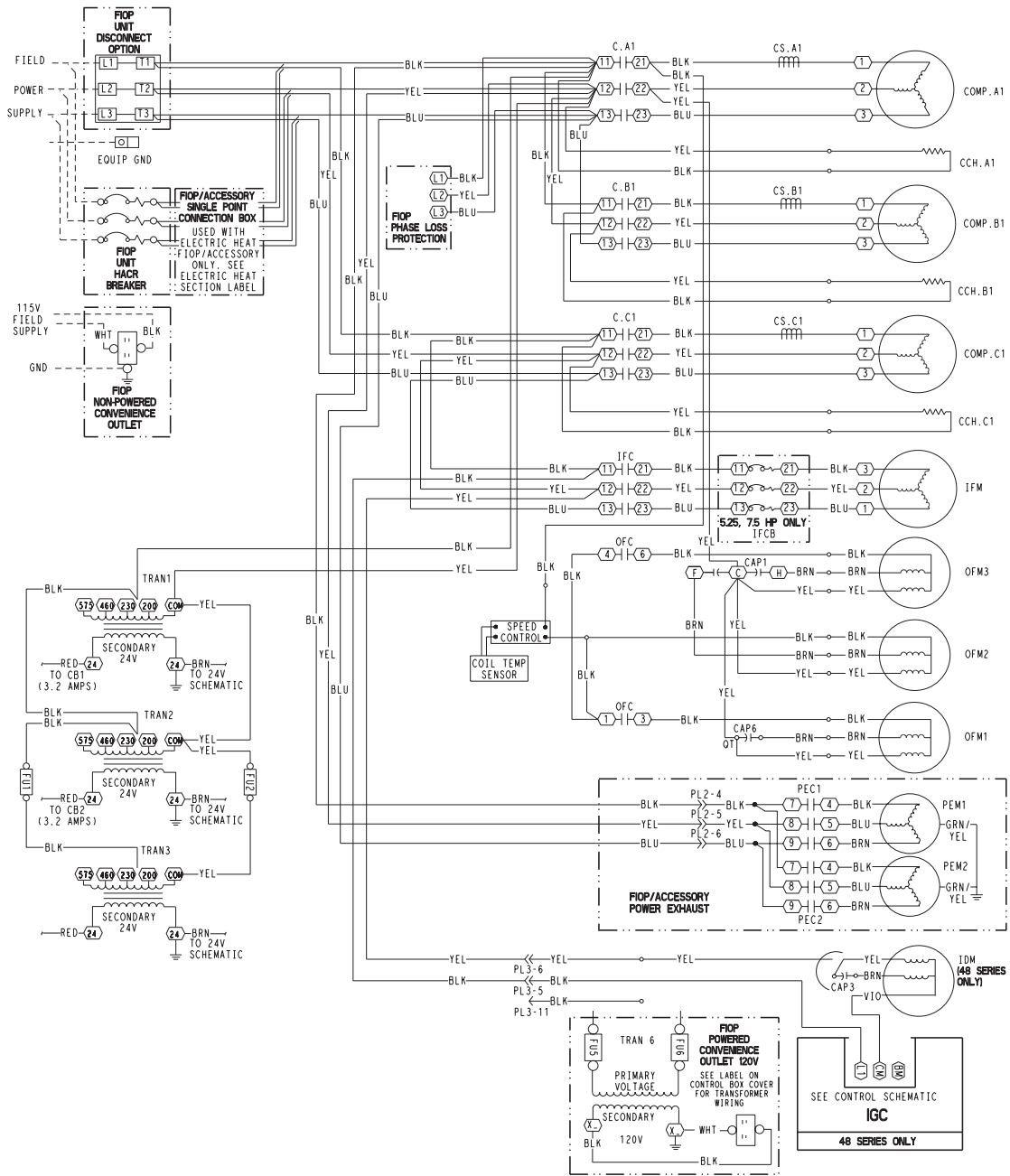

See legend on page 151.

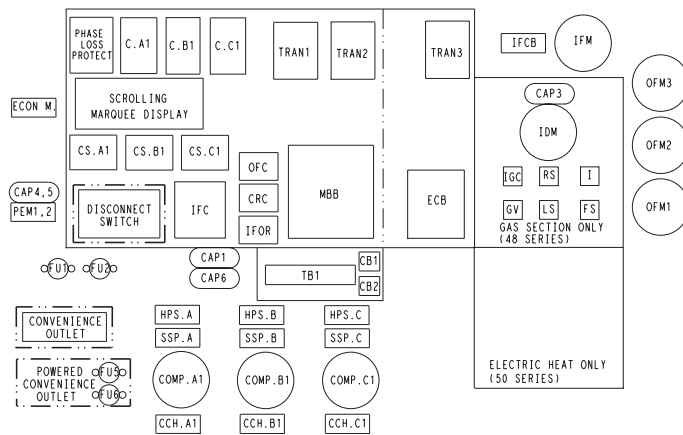

**TYPICAL UNIT COMPONENT LOCATIONS — 48PG03-14 (SIZES 03-07 SHOWN)**

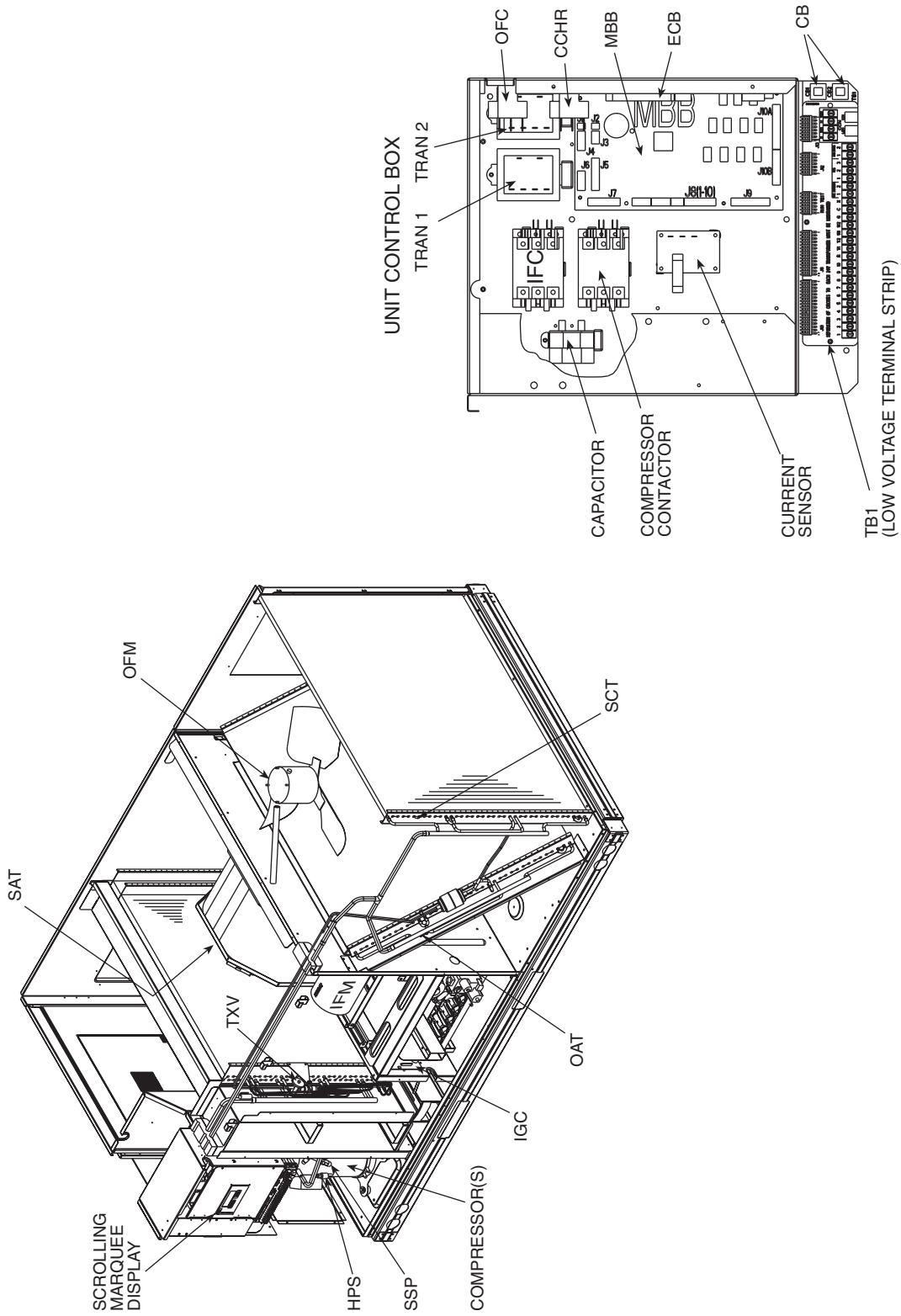

NOTE: See legend on page 151.

# Typical wiring schematics (cont)



## LOW VOLTAGE CONTROL SCHEMATIC — 48PG20-28 UNITS

- NOTES:
1. Use TB2-5 and TB2-6 for remote occupancy switch. Remember to configure software, see controls and trouble shooting guide.
  2. See Legend on page 156.

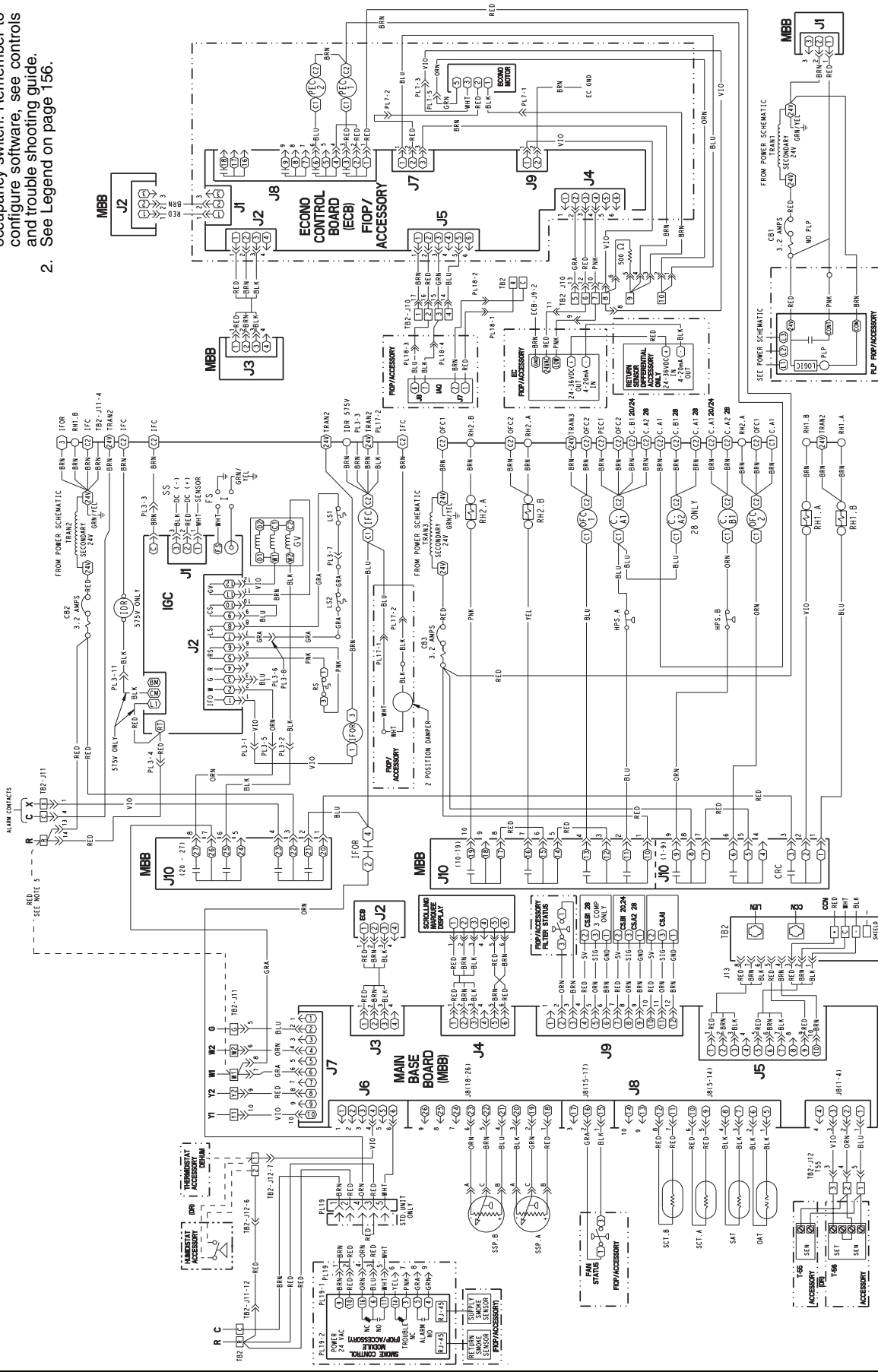

### POWER SCHEMATIC — 48PG20-28 UNITS

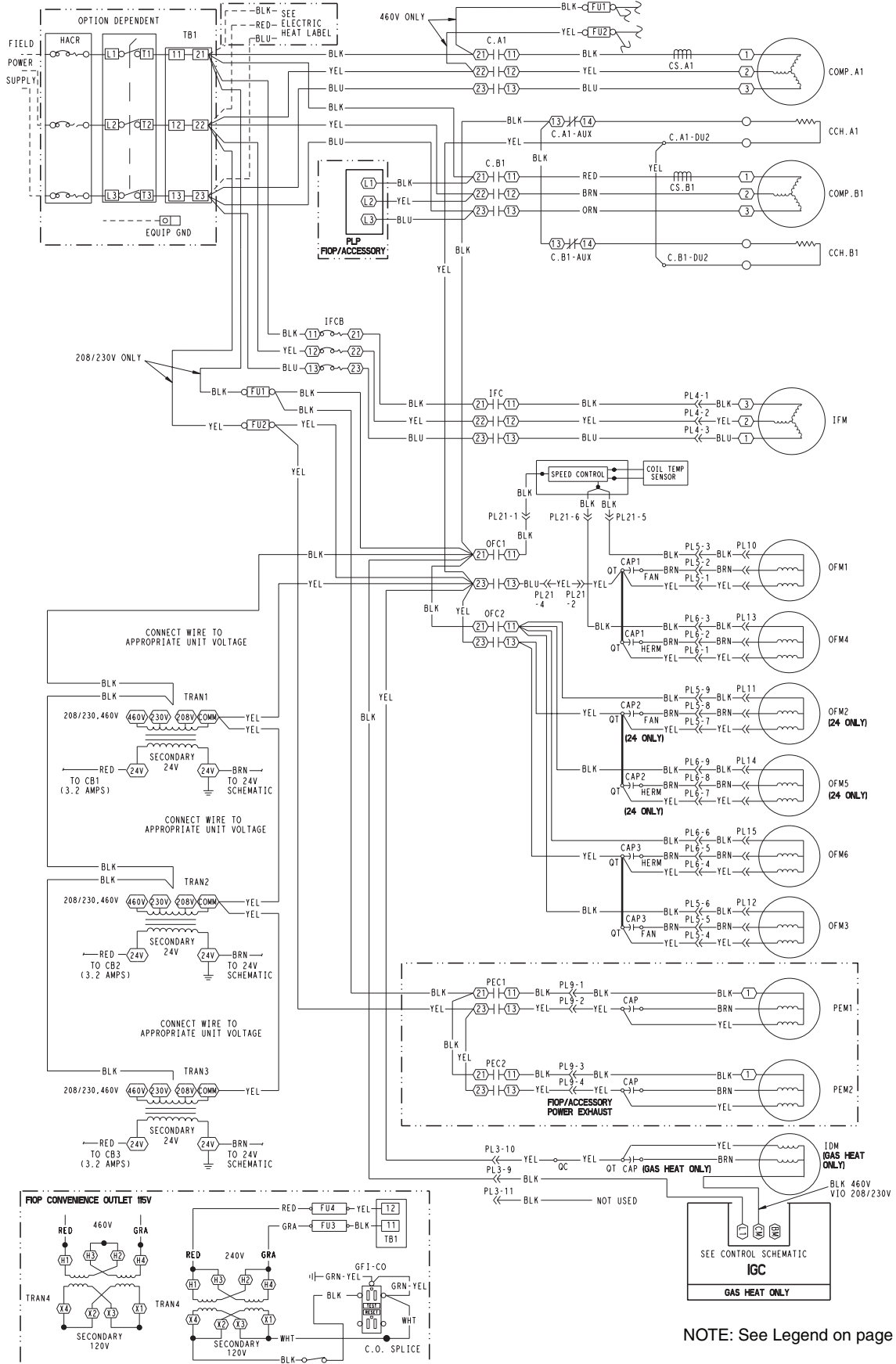

NOTE: See Legend on page 156.



# Controls



## Operating sequence, 48PG03-16 units

### Heating

NOTE: The 48PG units have 1 or 2 stages of gas heat.

When the thermostat calls for heating, power is sent to W on the IGC (integrated gas unit controller) board. An LED (light-emitting diode) on the IGC board will be on during normal operation. A check is made to ensure that the rollout switch and limit switch are closed and the induced-draft motor is running. The induced-draft motor is then energized, and when speed is proven with the hall effect sensor on the motor, the ignition activation period begins. The burners will ignite within 5 seconds.

If the burners do not light, there is a 22-second delay before another 5-second attempt. If the burners still do not light, this sequence is repeated for 15 minutes. After the 15 minutes have elapsed, if the burners still have not lit, heating is locked out. To reset the control, break 24-v power to the thermostat.

When ignition occurs the IGC board will continue to monitor the condition of the rollout and limit switches, the hall effect sensor, as well as the flame sensor. If the unit is controlled through a room thermostat set for fan auto., 45 seconds after ignition occurs, the indoor-fan motor will be energized (and the outdoor-air dampers will open to their minimum position). If for some reason the overtemperature limit opens prior to the start of the indoor fan blower, on the next attempt, the 45-second delay will be shortened to 5 seconds less than the time from initiation of heat to when the limit tripped. Gas will not be interrupted to the burners and heating will continue. Once modified, the fan on delay will not change back to 45 seconds unless power is reset to the control.

On units with 2 stages of heat, when additional heat is required, W2 closes and initiates power to the second stage of the main gas valve. When the thermostat is satisfied, W1 and W2 open and the gas valve closes, interrupting the flow of gas to the main burners. If the call for W1 lasted less than 1 minute, the heating cycle will not terminate until 1 minute after W1 became active. If the unit is controlled through a room thermostat set for fan auto., the indoor-fan motor will continue to operate for an additional 45 seconds then stop. If the overtemperature limit opens after the indoor motor is stopped within 10 minutes of W1 becoming inactive, on the next cycle the time will be extended by 15 seconds. The maximum delay is 3 minutes. Once modified, the fan off delay will not change back to 45 seconds unless power is reset to the control.

A LED indicator is provided on the IGC to monitor operation. The IGC is located by removing the heat section side panel. During normal operation, the LED is continuously on.

For units with economizers, the outdoor-air damper stays at the Economizer Minimum Position while the evaporator fan is operating. The outdoor-air damper is closed when the indoor fan is not operating.

## IGC LED INDICATIONS

ERROR CODE	LED INDICATION
Normal Operation	On
Hardware Failure	Off
Fan On/Off Delay Modified	1 Flash
Limit Switch Fault	2 Flashes
Flame Sense Fault	3 Flashes
Five Consecutive Limit Switch Faults	4 Flashes
Ignition Lockout Fault	5 Flashes
Inducer Switch Fault	6 Flashes
Rollout Switch Fault	7 Flashes
Internal Control Fault	8 Flashes

### LEGEND

**IGC** — Integrated Gas Unit Controller  
**LED** — Light-Emitting Diode

### NOTES:

1. There is a 3-second pause between error code displays.
2. If more than one error code exists, all applicable error codes will be displayed in numerical sequence.
3. Error codes on the IGC will be lost if power to the unit is interrupted.

### Cooling

**Economizer control** — If the economizer is available for cooling, the unit will always try to meet demand using the economizer before turning on a compressor. The economizer is available for cooling when:

- the outdoor temperature is below the Economizer High Temperature Lockout (ECL.H) and above the Economizer Low Temperature Lockout (ECL.L)
- the outdoor enthalpy is low.

If the economizer is not available for cooling, the economizer will move to the Economizer Minimum Position (MIN.P).

If the economizer is available for cooling and yet it is unable to meet demand, the unit will continue to modulate the economizer while cycling the compressors to increase total cooling capacity.

If the indoor fan is not operating, the economizer will be closed.

The 48PG units can also be equipped with optional CO<sub>2</sub> sensors for additional indoor air quality control. Consult the Controls and Troubleshooting Guide for more information on IAQ features.

**Cooling using space sensor (T55 or T56) control** — To operate the unit in Space Sensor mode, Unit Control Type must be set to Space Sensor (3) and a wire must be added between R and W1 on TB1 (see controls schematic). While in this mode, the unit tries to maintain the Space Temperature (SPT) at one of 4 different set points: the Occupied Cool Set Point (OCSP), the Unoccupied Cool Set Point (UCSP), the Occupied Heat Set Point (OHSP), or the Unoccupied Heat Set Point (UHSP). The building's occupancy is affected by a number of different factors (see Controls and Troubleshooting Guide for details). When the building is occupied, the occupied set points are active. When the building is unoccupied, the unoccupied set points are active. In Space Sensor mode, the control will switch automatically between cooling and heating to maintain temperature. However, to minimize unnecessary cool to heat and heat to cool changes, there is a 10-minute delay after the last stage turns off before the control will switch modes.

# Controls (cont)



To maintain temperature while cooling, the unit will turn on compressors as needed when the economizer is either unavailable or not providing enough cooling. The minimum on-time for each compressor is 3 minutes and the minimum off-time is 5 minutes.

Units with 1 compressor (48PG03-07) have 1 stage of cooling. Units with 2 compressors (48PG08-14) have 2 stages of cooling. Units with 3 compressors (48PG16) have 2 stages of cooling. The economizer is not considered a stage of cooling even though it can provide cooling in certain situations. In general, the minimum time between increasing stages (from 1 to 2 and from 2 to 3) is 7.5 minutes, however, the minimum time between stages can be further reduced in certain situations (see Controls and Troubleshooting Guide). The minimum time between decreasing stages (3 to 1 and 2 to 0) is 5 minutes.

Consult the Controls and Troubleshooting Guide for additional information on configuring the controls for space sensor control and adjusting the minimum compressor on-time, minimum compressor off-time, and the minimum time between decreasing stages.

**Cooling using thermostat control** — Thermostat cooling begins when the Y1 input is energized. If the economizer is available for cooling, the economizer will try to maintain the Supply Air Temperature (SAT) at either the Low Cool Supply Air Set Point (LCS) for a Y1 call or the High Cool Supply Air Set Point (HCS) for a Y2 call. If the economizer operates at 100% for 5 minutes or the economizer cooling is not available, the unit will begin to stage compressors. While the compressors are operating, the economizer will try to maintain its position at 100%. However, if low suction pressures are experienced, the economizer will begin to close in order to protect the compressors from damage.

Three different compressor-staging algorithms are available with *ComfortLink™* control. They are called Adaptive, 1-stage Y1 and 2-stage Y1. In Adaptive mode, once compressor staging begins (see above), at least one compressor will run as long as there is a Y1 call. On a three-circuit machine with only a Y1 call, the second circuit will cycle depending upon the trend in the supply-air temperature (SAT). If there is a Y2 call, compressors will stage up to the maximum number available.

The 1-stage Y1 and 2-stage Y1 modes are identical if there are only two circuits. In both cases, the stages follow the thermostat calls directly. For either mode, all stages will operate immediately if there is a Y2 call.

If fan request G is energized, but Y1 is not energized, the indoor fan will operate and the economizer position will be maintained at MIN.P.

## Operating sequence, 48PG20-28 units Heating

NOTE: The 48PG units have 2 stages of gas heat.

When the thermostat calls for heating, power is sent to W on the IGC (integrated gas unit controller) board. An LED (light-emitting diode) on the IGC board will be on during normal operation. A check is made to ensure that the rollout switch and limit switch are closed and the induced-draft motor is running. The induced-draft motor is then energized, and when speed is proven with the hall effect sensor

on the motor, the ignition activation period begins. The burners will ignite within 5 seconds.

If the burners do not light, there is a 22-second delay before another 5-second attempt. If the burners still do not light, this sequence is repeated for 15 minutes. After the 15 minutes have elapsed, if the burners still have not lit, heating is locked out. To reset the control, break 24-v power to the thermostat.

When ignition occurs the IGC board will continue to monitor the condition of the rollout and limit switches, the hall effect sensor, as well as the flame sensor. If the unit is controlled through a room thermostat set for fan auto., 45 seconds after ignition occurs, the indoor-fan motor will be energized (and the outdoor-air dampers will open to their minimum position). If for some reason the overtemperature limit opens prior to the start of the indoor fan blower, on the next attempt, the 45-second delay will be shortened to 5 seconds less than the time from initiation of heat to when the limit tripped. Gas will not be interrupted to the burners and heating will continue. Once modified, the fan on delay will not change back to 45 seconds unless power is reset to the control.

When additional heat is required, W2 closes and initiates power to the second stage of the main gas valve. When the thermostat is satisfied, W1 and W2 open and the gas valve closes, interrupting the flow of gas to the main burners. If the call for W1 lasted less than 1 minute, the heating cycle will not terminate until 1 minute after W1 became active. If the unit is controlled through a room thermostat set for fan auto., the indoor-fan motor will continue to operate for an additional 45 seconds then stop. If the overtemperature limit opens after the indoor motor is stopped within 10 minutes of W1 becoming inactive, on the next cycle the time will be extended by 15 seconds. The maximum delay is 3 minutes. Once modified, the fan off delay will not change back to 45 seconds unless power is reset to the control.

A LED indicator is provided on the IGC to monitor operation. The IGC is located by removing the heat section side panel. During normal operation, the LED is continuously on.

For units with economizers, the outdoor-air damper stays at the Economizer Minimum Position while the evaporator fan is operating. The outdoor-air damper is closed when the indoor fan is not operating.

### IGC LED INDICATIONS

ERROR CODE	LED INDICATION
Normal Operation	On
Hardware Failure	Off
Fan On/Off Delay Modified	1 Flash
Limit Switch Fault	2 Flashes
Flame Sense Fault	3 Flashes
Five Consecutive Limit Switch Faults	4 Flashes
Ignition Lockout Fault	5 Flashes
Inducer Switch Fault	6 Flashes
Rollout Switch Fault	7 Flashes
Internal Control Fault	8 Flashes

#### LEGEND

IGC — Integrated Gas Unit Controller  
 LED — Light-Emitting Diode

#### NOTES:

1. There is a 3-second pause between error code displays.
2. If more than one error code exists, all applicable error codes will be displayed in numerical sequence.
3. Error codes on the IGC will be lost if power to the unit is interrupted.

## Cooling

**Economizer control** — If the economizer is available for cooling, the unit will always try to meet demand using the economizer before turning on a compressor. The economizer is available for cooling when:

- the outdoor temperature is below the Economizer High Temperature Lockout (ECL.H) and above the Economizer Low Temperature Lockout (ECL.L)
- the outdoor enthalpy is low.

If the economizer is not available for cooling, the economizer will move to the Economizer Minimum Position (MIN.P).

If the economizer is available for cooling and yet it is unable to meet demand, the unit will continue to modulate the economizer while cycling the compressors to increase total cooling capacity.

If the indoor fan is not operating, the economizer will be closed.

The 48PG units can also be equipped with optional CO<sub>2</sub> sensors for additional indoor air quality control. Consult the Controls and Troubleshooting Guide for more information on IAQ features.

**Cooling using space sensor (T55 or T56) control** — To operate the unit in Space Sensor mode, Unit Control Type must be set to Space Sensor (3) and a wire must be added between R and W1 on TB2 (see controls schematic). While in this mode, the unit tries to maintain the Space Temperature (SPT) at one of 4 different set points: the Occupied Cool Set Point (OCSP), the Unoccupied Cool Set Point (UCSP), the Occupied Heat Set Point (OHSP), or the Unoccupied Heat Set Point (UHSP). The building's occupancy is affected by a number of different factors (see Controls and Troubleshooting Guide for details). When the building is occupied, the occupied set points are active. When the building is unoccupied, the unoccupied set points are active. In Space Sensor mode, the control will switch automatically between cooling and heating to maintain temperature. However, to minimize unnecessary cool to heat and heat to cool changes, there is a 10-minute delay after the last stage turns off before the control will switch modes.

To maintain temperature while cooling, the unit will turn on compressors as needed when the economizer is either unavailable or not providing enough cooling. The minimum on-time for each compressor is 3 minutes and the minimum off-time is 5 minutes.

All units have 2 stages of cooling. The 48PG20 and 24 units have 2 compressors. The 48PG28 units have 3 compressors. The economizer is not considered a stage of cooling even though it can provide cooling in certain situations. In general, the minimum time between increasing stages (from 1 to 2 and from 2 to 3) is 7.5 minutes, however, the minimum time between stages can be further reduced in certain situations (see Controls and Troubleshooting Guide). The minimum time between decreasing stages (3 to 1 and 2 to 0) is 5 minutes.

Consult the Controls and Troubleshooting Guide for additional information on configuring the controls for space sensor control and adjusting the minimum compressor on-time, minimum compressor off-time, and the minimum time between decreasing stages.

**Cooling using thermostat control** — Thermostat cooling begins when the Y1 input is energized. If the economizer is available for cooling, the economizer will try to maintain the Supply Air Temperature (SAT) at either the Low Cool Supply Air Set Point (LCS) for a Y1 call or the High Cool Supply Air Set Point (HCS) for a Y2 call. If the economizer operates at 100% for 5 minutes or the economizer cooling is not available, the unit will begin to stage compressors. While the compressors are operating, the economizer will try to maintain its position at 100%. However, if low suction pressures are experienced, the economizer will begin to close in order to protect the compressors from damage.

Three different compressor-staging algorithms are available with *ComfortLink*<sup>™</sup> control. They are called Adaptive, 1-stage Y1 and 2-stage Y1. In Adaptive mode, once compressor staging begins (see above), at least one compressor will run as long as there is a Y1 call. In addition, internal timers affect the rate at which compressors are turned on and off.

The 1-stage Y1 and 2-stage Y1 modes are identical. In both cases, the stages follow the thermostat calls directly. For either mode, all stages will operate immediately if there is a Y2 call.

If fan request G is energized, but Y1 is not energized, the indoor fan will operate and the economizer position will be maintained at MIN.P.

## Optional Humidi-MiZer<sup>™</sup> dehumidification system

Units with the factory-equipped Humidi-MiZer option are capable of providing multiple modes of improved dehumidification as a variation of the normal cooling cycle. The Humidi-MiZer option includes additional valves in the liquid line and discharge line of each refrigerant circuit, a small reheat condenser coil downstream of the evaporator, and Motormaster<sup>®</sup> variable-speed control of some or all outdoor fans. Operation of the revised refrigerant circuit for each mode is described below.

NOTE: x = refrigerant circuit A, B, or C.

# Controls (cont)



## 48PG03-16

**Normal Cooling** — Refrigerant flows from the outdoor condenser through the normally open Cooling Valve (CV.x) to the expansion device. Reheat1 Valve (RH1.x) and Reheat2 Valve (RH2.x) are closed.

**Reheat 1 (Subcooling Mode) — 48PG03-16** — This mode increases latent cooling and decreases sensible cooling compared to normal cooling. Refrigerant flows from the outdoor condenser, through the normally open Reheat1 Valve (RH1.x), and through the reheat condenser coil to the expansion device. Cooling Valve (CV.x) and Reheat2 Valve (RH2.x) are closed.

## Reheat 2 (Hot Gas Reheat Mode) — 48PG03-16

This mode provides maximum latent cooling with little to no sensible capacity. This mode can operate to provide dehumidification when there is no cooling demand. Like Reheat1 mode, refrigerant flows from the outdoor condenser, through the normally open Reheat1 Valve (RH1.x), and through the reheat condenser coil to the expansion device. The Cooling Valve (CV.x) is closed. Reheat2 Valve (RH2.x) is open which provides some compressor discharge gas to the reheat condenser to further increase the reheat of the evaporator airstream.

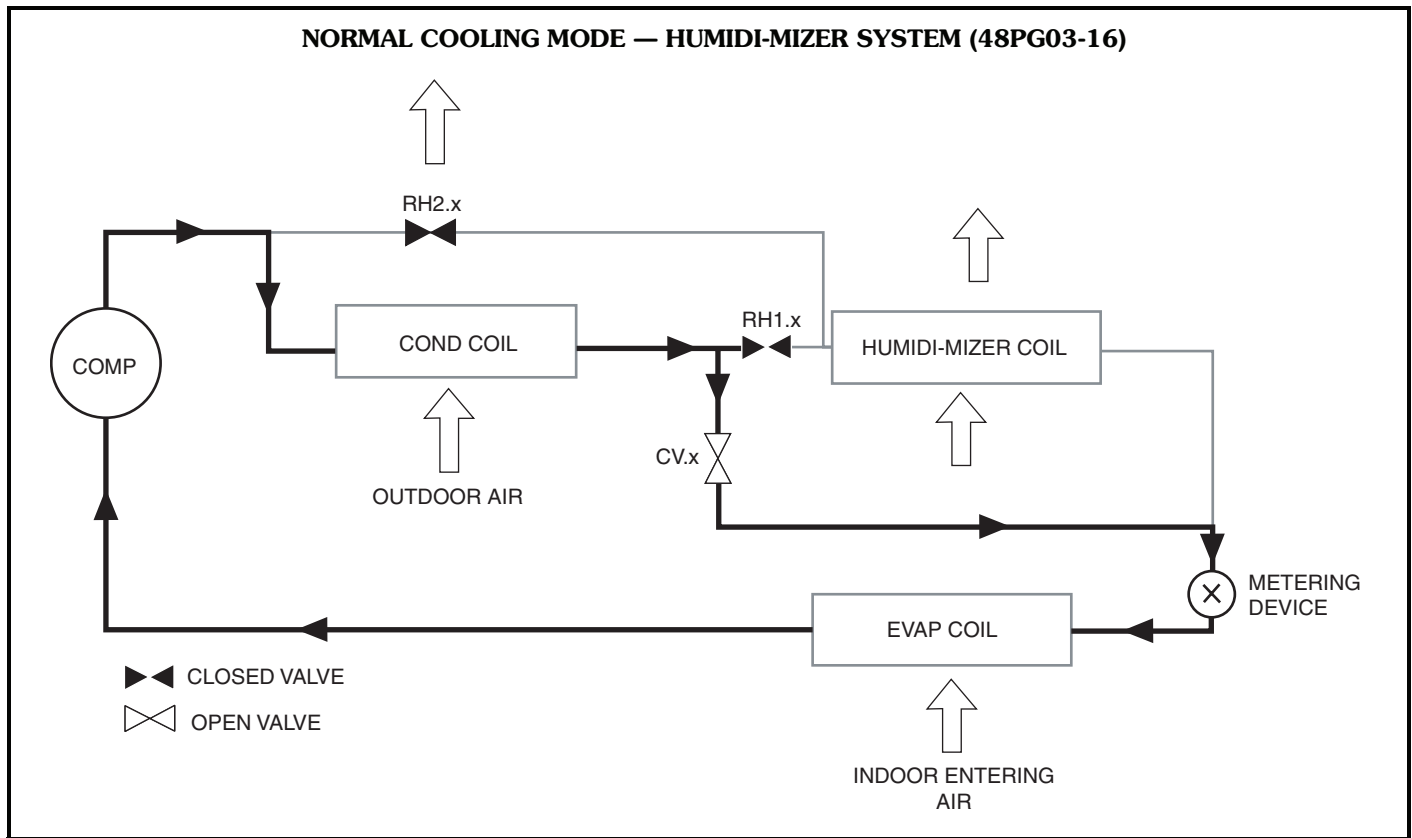

**SUBCOOLING MODE (Reheat1) — HUMIDI-MIZER™ SYSTEM (48PG03-16)**

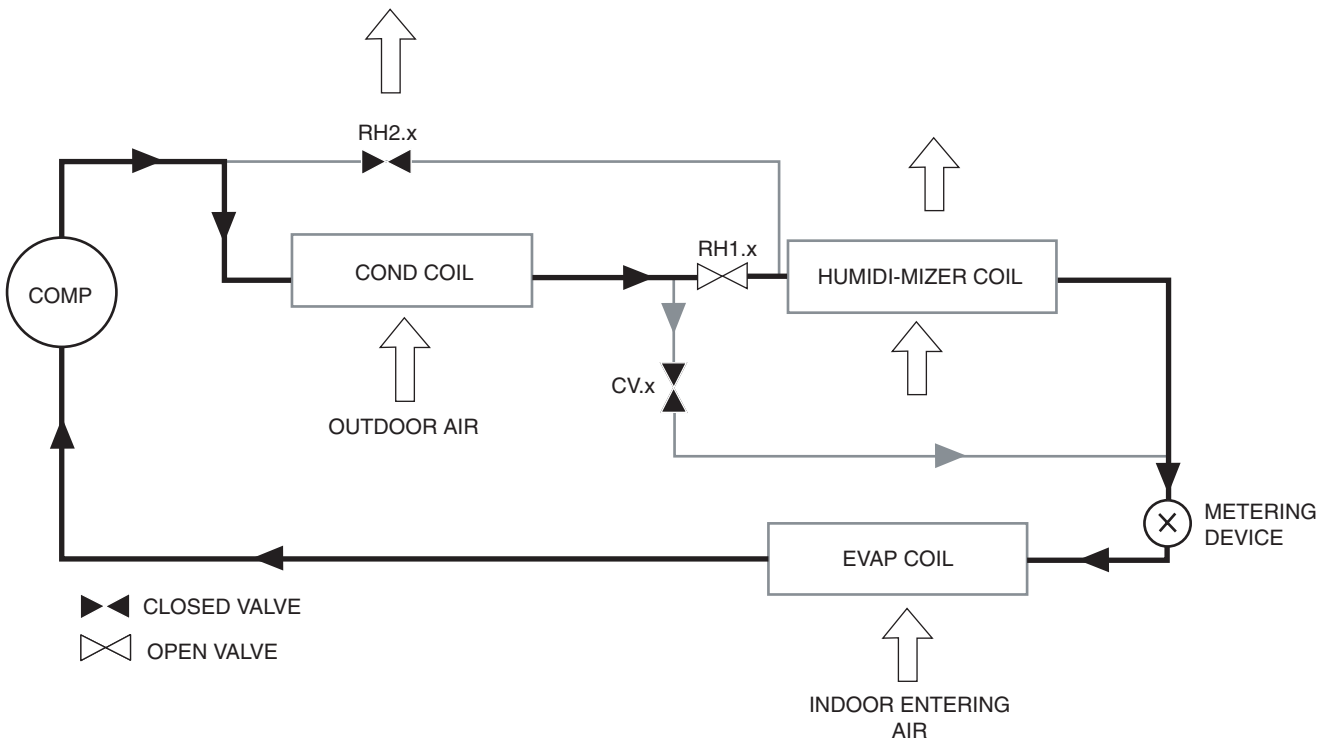

**HOT GAS REHEAT MODE (Reheat2) — HUMIDI-MIZER SYSTEM (48PG03-16)**

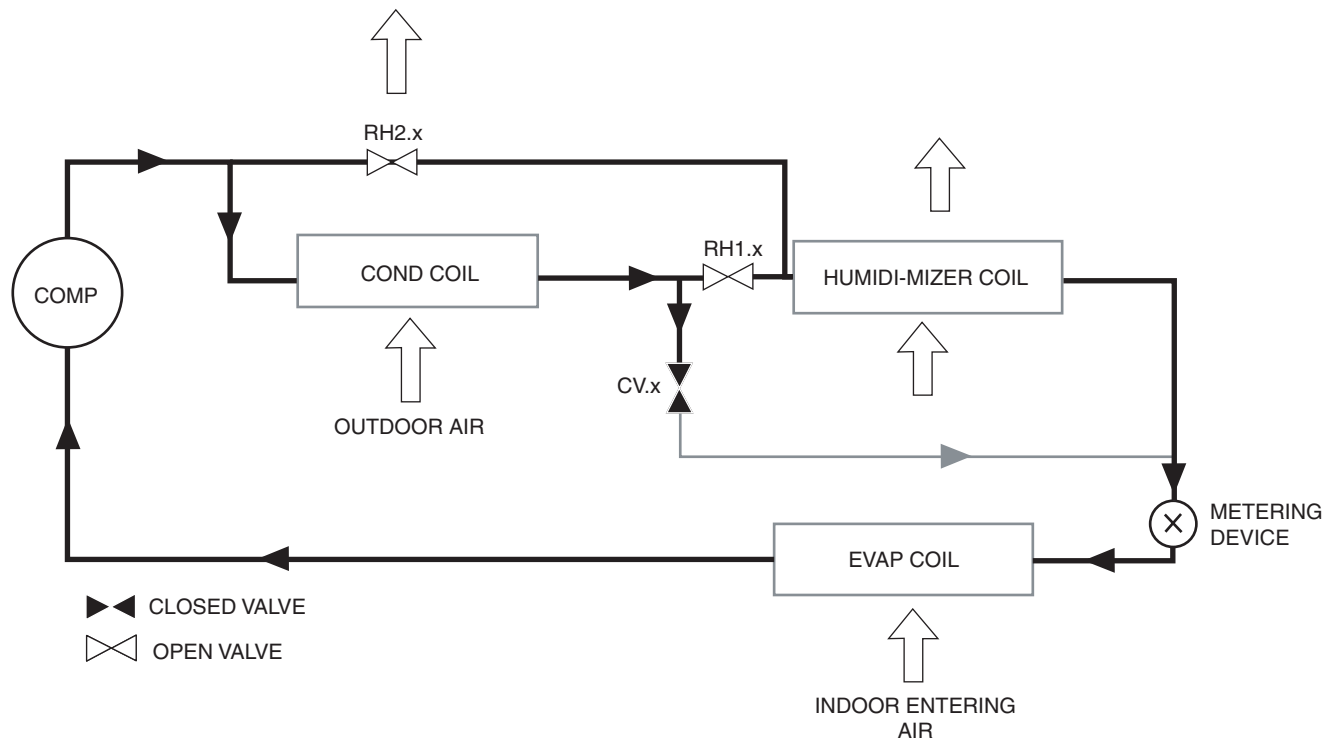

# Controls (cont)



## 48PG20-28

**Normal Cooling** — Refrigerant flows from the outdoor condenser through the deenergized 3-way (RH1.x) to the expansion device. Reheat2 Valve (RH2.x) is closed.

**Reheat 1 (Subcooling Mode)** — This mode increases latent cooling and decreases sensible cooling compared to normal cooling. Refrigerant flows from the outdoor condenser, through the energized 3-way Valve (RH1.x), and through the reheat condenser coil to the expansion device. Reheat2 Valve (RH2.x) is closed.

**Reheat 2 (Hot Gas Reheat Mode)** — This mode provides maximum latent cooling with little to no sensible capacity. This mode can operate to provide dehumidification when there is no cooling demand. Like Reheat1 mode, refrigerant flows from the outdoor condenser, through the energized 3-way Valve (RH1.x), and through the reheat condenser coil to the expansion device. Reheat2 Valve (RH2.x) is open which provides some compressor discharge gas to the reheat condenser to further increase the reheat of the evaporator airstream.

Units with multiple circuits can operate with additional staging of the cooling and dehumidification capacity. When there is only cooling demand, based on a space

temperature sensor or thermostat, one or more circuits will operate in normal cooling mode. When there is only dehumidification demand, based on a space humidity sensor or switch, all circuits will operate in Reheat2 mode. When there is both cooling demand and dehumidification demand, all circuits will operate in either Reheat1 or Reheat2 mode, with the portion of Reheat1 circuits determined from the cooling demand.

Outdoor fan control for Humidi-MiZer™ system units includes a Motormaster® variable-speed control of some or all outdoor fans, depending on unit model size. The Motormaster control automatically adjusts the outdoor fan speed to maintain approximately 80 to 100 F condenser temperature for circuit A at all outdoor ambient temperatures. Some model sizes have additional on/off staging of some outdoor fans. This staging is controlled by both outdoor temperature and condenser coil temperature.

Compressor staging control for Humid-MiZer units requires that circuit A always operate when either circuits B or C are on. This applies to normal operation, service test, and for control alarm responses. This operation difference is required due to the fact that the Motormaster outdoor fan control senses circuit A only.

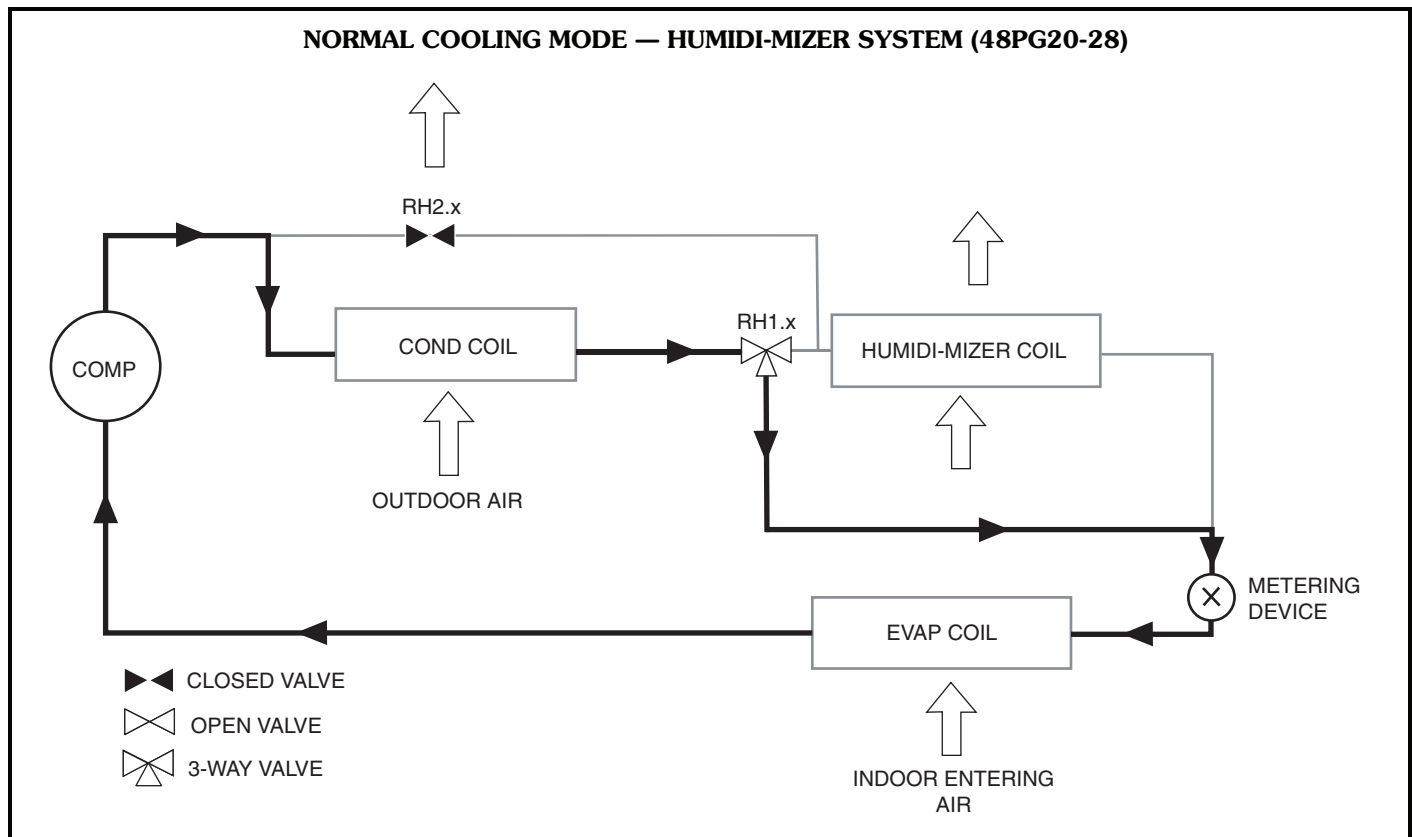

**SUBCOOLING MODE (Reheat1) — HUMIDI-MIZER™ SYSTEM (48PG20-28)**

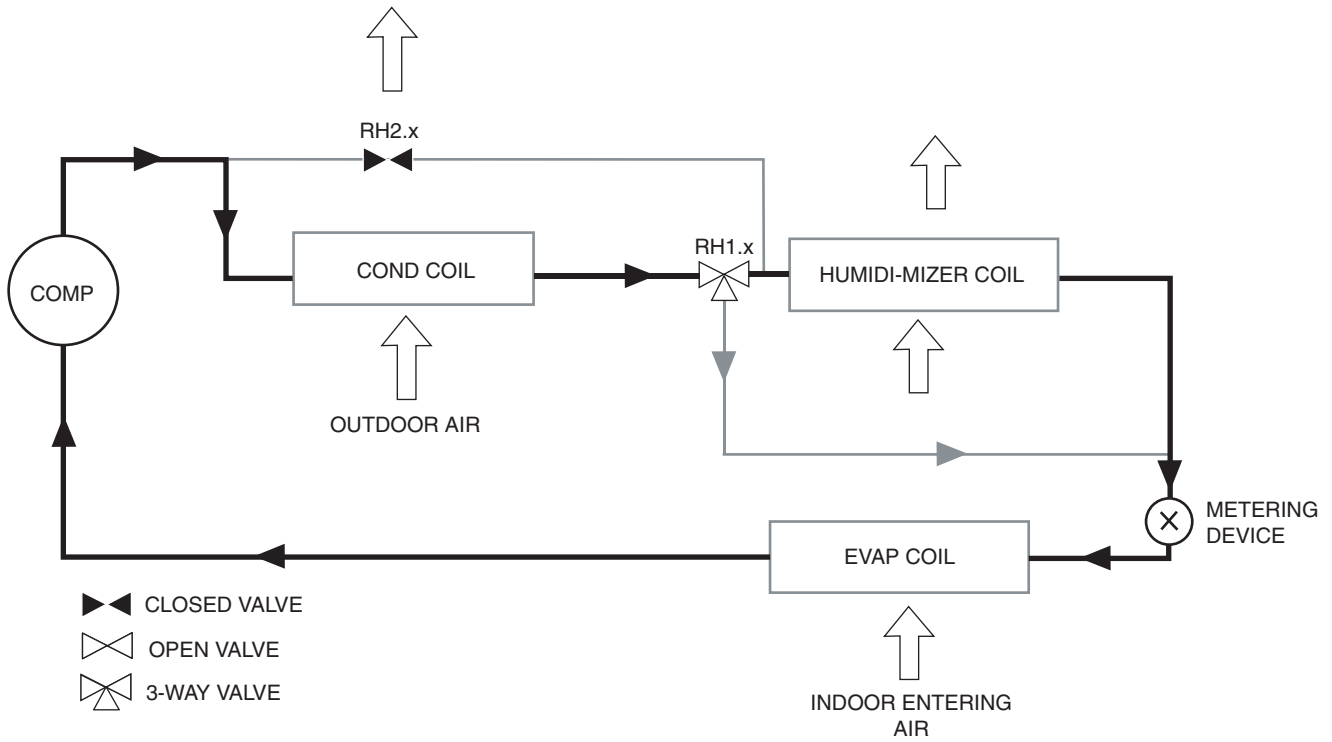

**HOT GAS REHEAT MODE (Reheat2) — HUMIDI-MIZER SYSTEM (48PG20-28)**

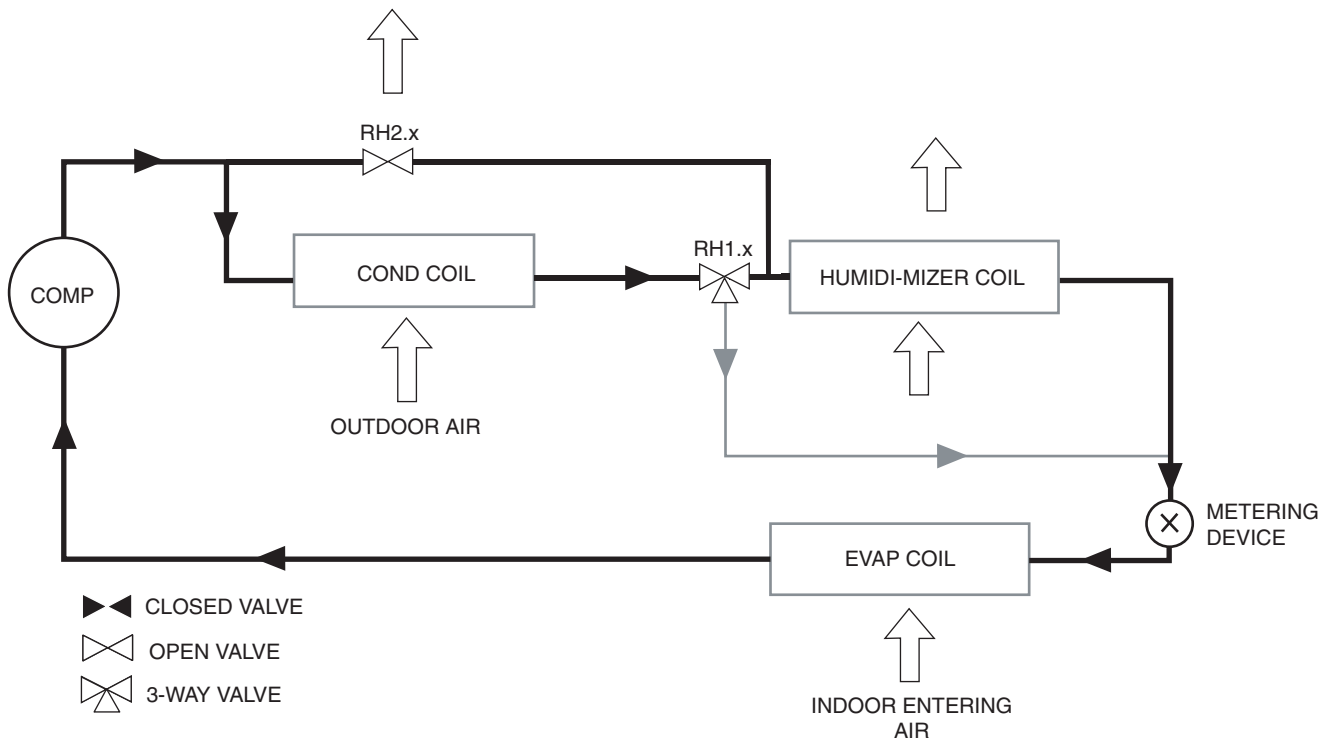

# Application data



## Ductwork

Ductwork should be attached to the curb on all units. Interior installation may proceed before unit is set in place on roof. If ductwork will be attached to the unit, do not drill in condensate drain pan area — leaks may result.

## Thru-the-bottom service connections

Roof curb connections allow field power wires and control wires to enter through the roof curb opening and bottom of unit.

## Thermostat/space temperature sensor (T55, T56, or T58)

Either a 2-stage cooling thermostat or a space temperature sensor is required for all units. A field-supplied jumper is required when using a space temperature sensor. The jumper is placed between terminals R and W1 on the unit thermostat terminal block (TB1 or TB2). Refer to wiring diagram for details.

## Heating-to-cooling changeover

All units are automatic changeover from heating to cooling when automatic changeover thermostat and subbase or space temperature sensors are used.

## Airflow

Units are draw-thru on cooling and blow-thru on heating.

## Maximum airflow

To minimize the possibility of condensate blow-off from evaporator, airflow through units should not exceed 500 cfm/nominal ton.

## Minimum airflow

The minimum airflow for cooling is 300 cfm/nominal ton. Operation Air Quantity Limits table on page 9 for minimum airflow cfm for heating.

**IMPORTANT:** The minimum heating cfm must be maintained to ensure proper operation in the Heating mode. The minimum heating cfm value takes precedence over the minimum cooling cfm value.

## Minimum ambient cooling operation temperature

All units with *ComfortLink™* controls are designed to operate at outdoor temperatures down to 0° F. Electrical-mechanical operation down to 40 F.

## Maximum operating outdoor-air temperature

For cooling, this temperature is 125 F. Refer to the Cooling Capacity tables on pages 31-78 for further details.

## High altitude

A change to the gas orifice may be required at high altitudes. Refer to Altitude Compensation charts on page 135.

## Minimum heating entering air temperature

The minimum temperature of air entering the dimpled heat exchanger is 50 F continuous and 45 F intermittent for aluminum heat exchangers and 40 F continuous and 35 F intermittent for stainless steel heat exchangers. To operate at lower mixed-air temperatures, a field-supplied outdoor-air thermostat must be used to initiate both stages of heat when the temperature is below the minimum required temperature to ensure full fire operation. Wire the outdoor-air thermostat (part no. HH22AG106) in series with the second stage gas valve as shown below. Set the outdoor-air thermostat at 35 F for stainless steel heat exchangers or 45 F for aluminum heat exchangers. This temperature setting will bring on the second stage of heat whenever the ambient temperature is below the thermostat set point. Indoor comfort may be compromised when heating is initiated using low entering air temperatures with insufficient heating temperature rise.

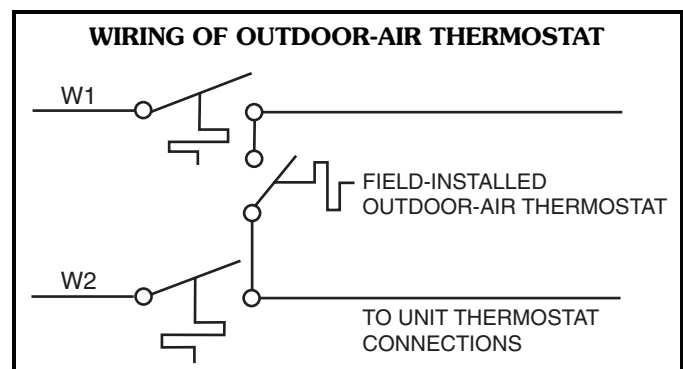

## Motor data

Due to Carrier's internal unit design (draw-thru over the motor), air path, and specially designed motors, the full horsepower (maximum continuous bhp) listed in the Physical Data table and the notes following each Fan Performance table can be utilized with extreme confidence.

Using Carrier motors with the values listed in the Physical and Fan Performance Data tables *will not* result in nuisance tripping or premature motor failure. The unit warranty will not be affected.



## Condenser coil protection (*Enviro-Shield*<sup>™</sup>)

**Pre-coated aluminum-fin coils** have a durable epoxy-phenolic coating applied to the fin prior to the fin stamping process to provide protection in mildly corrosive coastal environments. Pre-coated coils have an inert barrier between the aluminum fin and copper tube. This barrier electrically disconnects the dissimilar metals to minimize the potential for galvanic corrosion. This economical option provides substantial corrosion protection for mild coastal environments beyond the standard uncoated coil construction.

**Copper-fin coils** provide increased corrosion resistance in moderate coastal environments where industrial air pollution is not present. All copper coils eliminate bi-metallic construction to eliminate the potential for galvanic corrosion. Use of copper fin coils in industrial environments is not recommended due to potential attack from sulfur, sulfur oxide, nitrogen oxides, carbon and several other industrial air-borne contaminants. In moderate seacoast environments, copper-fin coils have extended life compared to standard or pre-coated aluminum-fin coils.

**E-Coated aluminum-fin coils** undergo a precisely controlled scientific process that bonds an impermeable epoxy coating to the specially prepared fin coil surface. E-Coating produces a smooth, consistent coating that is less brittle, more resilient and more durable than previous postcoating processes. E-Coated aluminum-fin coils offer economical protection and improved coil life in industrial and combined coastal and industrial environments.

**E-Coated copper-fin coils** provide maximum protection in virtually all environments, this option combines the continuous, impenetrable barrier of the E-Coating process with the natural resistance of an all-copper construction. E-Coated copper-fin coil assemblies ensure long life in severe coastal conditions.

## Indoor air quality

An indoor air quality sensor, which senses CO<sub>2</sub>, is a factory-installed option. The sensor in conjunction with the economizer is used to maintain indoor air quality. By selecting this option, the minimum economizer position can be reduced because the control will adjust economizer position to maintain indoor air quality to the desired set point. A wall-mounted indoor air quality sensor is a field-installed accessory.

## Enthalpy sensor

Enthalpy switches are available as field-installed accessories. If only one switch is used, it is used to measure return air enthalpy. If two switches are used they should be wired in a differential configuration to measure the difference in the return and outdoor enthalpies. The enthalpy switches signify when the outdoor air is suitable for free cooling.

## Plugged filter indicator

A plugged filter indicator (filter status switch) is available as a factory-installed option and a field-installed accessory. By measuring the pressure differential across the evaporator section, it signals when the evaporator filters should be cleaned.

## Fan status

A fan status switch is available as a factory-installed option and a field-installed accessory. By sensing the pressure differential generated by the indoor fan, it signals the *ComfortLink*<sup>™</sup> system when the indoor fan blower is operating and therefore it is very useful for detecting broken belts, etc.

### CONDENSER COIL PROTECTION APPLICATIONS

DESCRIPTION ( <i>Enviro-Shield</i> <sup>™</sup> Option)	ENVIRONMENT					
	Standard, Non-Corrosive	Mild Coastal	Moderate Coastal	Severe Coastal	Industrial	Combined Coastal and Industrial
Standard, Al/Cu	X					
Pre-Coated Al/Cu		X				
Cu/Cu			X			
E-Coated Al/Cu					X	X
E-Coated Cu/Cu				X		

#### LEGEND

<b>Al/Cu</b>	—	Aluminum Fin with Copper Tube Coil	<b>E-Coated</b>	—	Extremely Flexible and Durable Epoxy Coating Uniformly Applied to the Coil Surfaces
<b>Cu/Cu</b>	—	Copper Fin with Copper Tube Coil	<b>Pre-Coated</b>	—	Epoxy Coating Applied to Fin Stock Material
<b><i>Enviro-Shield</i></b>	—	Family of Coil Protection Options			

# Guide specifications



## Unit with Gas Heat — Constant Volume Application with Puron® R-410A Refrigerant

### HVAC Guide Specifications

Size Range: **2 to 25 Tons, Nominal Cooling**  
**56,000 to 400,000 Btuh**  
**Nominal (Input Heating) (Gas Units)**

Carrier Model Numbers:  
**48PGD/L, 48PGE/M, 48PGF/N**



### Part 1 — General

#### 1.01 SYSTEM DESCRIPTION

Unit is an outdoor rooftop mounted, electrically controlled heating and cooling unit utilizing fully hermetic scroll compressors with on demand crank-case heaters for cooling duty and induced draft gas combustion for heating duty. Supply air shall be discharged downward or horizontally, as shown on contract drawings.

Units shall be of ultra high cooling efficiency and utilize environmentally friendly Puron (R-410A) refrigerant.

#### 1.02 QUALITY ASSURANCE

- A. Unit shall well exceed ASHRAE 90.1-2001 Energy Efficiency Standards. All units shall be ENERGY STAR qualified.  
On 03 to 06 sizes — SEER shall be as high as 14.8.  
On 06 to 16 sizes — EER shall be as high as 12.5 and on sizes 20 to 28 — EER shall be as high as 11.6.
- B. Unit shall be rated in accordance with ARI Standards 210 (03-12) and 360 on all others. All units shall be designed in accordance with UL Standard 1995. Unit shall be rated in accordance with ARI sound standards 270 or 370.
- C. Unit shall be designed to conform to ASHRAE 15.
- D. Unit shall be UL and UL, Canada, tested and certified in accordance with ANSI Z21.47 Standards as a total package.
- E. Roof curb shall be designed to conform to NRCA Standards.
- F. Insulation and adhesive shall meet NFPA 90A requirements for flame spread and smoke generation.
- G. Unit casing shall be capable of withstanding 500-hour salt spray exposure per ASTM B117 (scribed specimen).
- H. Unit shall be manufactured in a facility registered to ISO 9001:2000.

- I. Each unit shall be subjected to a completely automated run testing on the assembly line.

#### 1.03 DELIVERY, STORAGE, AND HANDLING

Unit shall be stored and handled per manufacturer's recommendations.

### Part 2 — Products

#### 2.01 EQUIPMENT (STANDARD)

##### A. General:

The 48PG unit shall be a fully factory assembled, pre-tested, single-piece heating and cooling unit. Contained within the unit enclosure shall be all factory wiring, piping, controls, Puron refrigerant charge (R-410A), and special features required prior to field start-up. Outdoor sound ratings on sizes 03-06 shall be as low as 72 dB, on sizes 08 to 16 as low as 80 dB and on sizes 20 to 28 as low as 82 dB.

##### B. Unit Cabinet:

1. Constructed of galvanized steel, bonderized and coated with a pre-painted baked enamel finish on all externally exposed surfaces. Internal surfaces shall be of a primer coated finish.
2. All airstream interior surfaces shall be insulated with a minimum 1/2-in. thick, 1 lb density foil-faced cleanable insulation. Insulation shall be bonded with a thermosetting resin (8 to 12% by weight nominal, phenol formaldehyde typical), and coated with an acrylic or other material that meets the NFPA 90 flame retardance requirements and has an "R" value of 3.70. Insulation shall also be encapsulated with panel design or tape edges ensuring secure fit.
3. Cabinet panels shall be hinged with integrated non-corrosive hinges. Large area hinged access panels for the filter, compressors, evaporator fan, and control box and heat section areas. Each panel shall use multiple quarter-turn latches and handles. Each major external hinged access panel shall be double-wall construction and permanently attached to the rooftop unit. Panels shall also include tiebacks.
4. Return air filters shall be accessible through a dedicated hinged access panel and be on a slide-out track using standard size filters. Filter shall be standard off the shelf sizes and be the size per cabinet. Capability for 2 or 4 inch filters shall be on all sizes.
5. Holes shall be provided in the base rails (minimum 16 gage) for rigging shackles and level travel and movement during overhead rigging operations.
6. Fork lift slots shall be available from three sides of the unit (end and 2 sides) for sizes 03-14 and two sides of the unit (end and side) for other sizes.

7. Unit shall have a factory-installed internally sloped condensate drain pan, providing a minimum 3/4-in.-14 NPT connection to prevent standing water from accumulating. Pan shall be fabricated of high impact polycarbonate material and shall slide out for cleaning and or maintenance on 03-16 sizes. An alternate vertical drain (3/4-in. NPT) connection is also available. Pan shall be fabricated of epoxy powder coated steel for other sizes. All drain pans conform to ASHRAE 62 self-draining provisions.
8. Unit shall have standard thru-the-bottom power and control wiring connection capability.

C. Fans:

1. Indoor blower (evaporator fan):
  - a. Centrifugal supply air blower shall have rubber-isolated, cartridge type ball bearings (03-16) or pillow-block ball bearings (20-28) and adjustable belt drive.
  - b. Fan wheel shall be made from steel with a corrosion resistant finish. It shall be a dynamically balanced, double-inlet type with forward-curved blades.
  - c. The indoor fan system (blower wheels, motors, belts, and both bearings) shall slide out for easy access.
  - d. Evaporator-fan motors shall be continuous operation, open drip-proof. Bearings shall be sealed, permanently lubricated ball-bearing type for longer life and lower maintenance.
  - e. On sizes 03 to 16, fan belt shall be located on opposite side of evaporator coil to prevent damage from broken fan belts. On 20 to 28 sizes a fan belt catch system shall be used.
2. Condenser fans shall be of the direct-driven propeller type, with corrosion-resistant aluminum blades riveted to corrosion-resistant steel supports. They shall be dynamically balanced and discharge air upwards. Condenser-fan motors shall be totally enclosed, thermally protected, and be of a shaft down design to protect from direct contact from harsh environments.
3. Induced-draft blower shall be of the direct-driven, single inlet, forward-curved, centrifugal type. It shall be made from aluminized steel with a corrosion-resistant finish and shall be dynamically balanced.

D. Compressor(s):

1. Fully hermetic, scroll type with on demand crankcase heaters, internal high-pressure and temperature protection.
2. Factory mounted on rubber grommets and internally spring mounted for vibration isolation.
3. Be mounted on dedicated mounting plate to ensure secure design and reduced sound levels.

E. Coils:

1. Standard evaporator and condenser coils shall have aluminum lanced plate fins mechanically bonded to seamless internally grooved copper tubes with all joints brazed.
2. Dual circuit models (08-28) shall have face-split type evaporator coil.
3. Condenser and evaporator coils shall be single slab, single pass design to facilitate easy coil cleaning. Composite coils or coils that require unit top panels removed shall be unacceptable.
4. Coils shall be leak tested at 170 psig and pressure tested at 1875 psig.
5. Optional Coils:
  - a. Optional pre-coated aluminum-fin coils shall have a durable epoxy-phenolic coating to provide protection in mildly corrosive coastal environments. Coating shall be applied to the aluminum fin stock prior to the fin stamping process to create an inert barrier between the aluminum fin and copper tube. Epoxy-phenolic barrier shall minimize galvanic action between dissimilar metals.
  - b. Optional copper-fin coils shall be constructed of copper fins mechanically bonded to copper tubes and copper tube sheets. Galvanized steel tube sheets shall not be acceptable. A polymer strip shall prevent coil assembly from contacting the sheet metal coil pan to minimize potential for galvanic corrosion between coil and pan. All copper construction shall provide protection in moderate coastal environments.
  - c. Optional E-Coated aluminum-fin coils shall have a flexible epoxy polymer coating uniformly applied to all coil surface areas without material bridging between fins. Coating process shall ensure complete coil encapsulation. Color shall be high gloss black with gloss — 60 deg of 65 to 90% per ASTM D523-89. Uniform dry film thickness from 0.8 to 1.2 mil on all surface areas including fin edges. Superior hardness characteristics of 2H per ASTM D3363-92A and cross-hatch adhesion of 4B-5B per ASTM D3359-93. Impact resistance shall be up to 160 in./lb (ASTM D2794-93). Humidity and water immersion resistance shall be up to minimum 1000 and 250 hours respectively (ASTM D2247-92 and ASTM D870-92). Corrosion durability shall be confirmed through testing to be no less than 1000 hours salt spray per ASTM B117-90. Coil construction shall be aluminum fins mechanically bonded to copper tubes. E-Coated aluminum-fin coils shall provide protection in industrial and industrial and coastal combined environments.

d. Optional E-Coated copper-fin coils shall have a flexible epoxy polymer coating uniformly applied to all coil surface areas without material bridging between fins. Coating process shall ensure complete coil encapsulation. Color shall be high gloss black with gloss — 60 deg of 65 to 90% per ASTM D523-89. Uniform dry film thickness from 0.8 to 1.2 mil on all surface areas including fin edges. Superior hardness characteristics of 2H per ASTM D3363-92A and cross-hatch adhesion of 4B-5B per ASTM D3359-93. Impact resistance shall be up to 160 in./lb (ASTM D2794-93). Humidity and water immersion resistance shall be up to minimum 1000 and 250 hours respectively (ASTM D2247-92 and ASTM D870-92). Corrosion durability shall be confirmed through testing to be no less than 1000 hours salt spray per ASTM B117-90. Coil construction shall be copper fins mechanically bonded to copper tubes with copper tube sheets. Galvanized steel tube sheets shall not be acceptable. A polymer strip shall prevent coil assembly from contacting sheet metal coil pan to maintain coating integrity and minimize corrosion potential between coil and pan. E-Coated copper-fin coils shall provide protection in severe coastal environments.

## F. Heating Section:

1. Induced-draft combustion type with energy saving direct-spark ignition system and redundant main gas valve with 2-stage capability on all 3-phase units.
2. Heat Exchanger:
  - a. The standard aluminized heat exchanger shall be of the tubular-section type constructed of a minimum of 20-gage steel coated with a nominal 1.2 mil aluminum-silicone alloy for corrosion resistance.
  - b. The optional stainless steel heat exchanger shall be of the tubular-section type, constructed of a minimum of 20-gage type 409 stainless steel, including stainless steel tubes, vestibule plate, and collector box.
3. Burners shall be of the in-shot type constructed of aluminum-coated steel.
4. All gas piping shall enter the unit at a single location. Gas entry shall be capable through side or bottom for unit.
5. All factory-installed orifices are for operation up to 2,000 feet of altitude. For altitudes between 2,000 ft and 7,000 ft, a factory certified kit shall be furnished for field installation.
6. The integrated gas controller (IGC) board shall include gas heat operation fault notification using an LED (light-emitting diode).

7. Unit shall be equipped with anti-cycle protection with one short cycle on unit flame rollout switch or 4 continuous short cycles on the high-temperature limit switch. Fault indication shall be made using an LED.
8. The IGC board shall contain algorithms that modify evaporator-fan operation to prevent future cycling on high-temperature limit switch.
9. The LED shall be visible without removal of control box access panel.
10. Gas burner tray, when disconnected, shall easily slide out for maintenance.

## G. Refrigerant Components:

Each refrigerant circuit shall include:

1. Balanced port thermostatic expansion valve (TXV) with removable power element.
2. Solid core refrigerant filter driers with pressure ports.
3. Refrigerant pressure gage ports and connections on suction, discharge, and liquid lines.

## H. Filter Section:

1. Standard filter section shall consist of factory-installed 2-in. thick disposable fiberglass filters and shall be on a dedicated slide out track to easily facilitate access and replacement.
2. Filter section shall use standard size filters and be of common sizes within cabinet sizes.
3. Optional MERV-8 pleated filters of commercially available sizes shall be available.
4. Standard 2-in. filter rack shall be field convertible to 4-in. by removing a spacer rack on 03-16 sizes. A 4-in. filter capability shall be available as factory-installed option on the other sizes.

## I. Controls and Safeties:

1. Unit *ComfortLink™* Controls:
  - a. Scrolling Marquee display.
  - b. CCN (Carrier Comfort Network®) capable.
  - c. Unit control with standard suction pressure transducers and condensing temperature thermistors.
  - d. Shall provide a 5° F temperature difference between cooling and heating set points to meet ASHRAE 90.1 Energy Standard.
  - e. Shall provide and display a current alarm list and an alarm history list.
  - f. Automatic compressor redundancy on units without Humidi-MiZer™ system.
  - g. Service run test capability.
  - h. Shall accept input from a CO<sub>2</sub> sensor (both indoor and outdoor).
  - i. Configurable alarm light shall be provided which activates when certain types of alarms occur.



- j. Compressor minimum run time (3 minutes) and minimum off time (5 minutes) are provided.
- k. Service diagnostic mode.
- l. Economizer control (optional).
- m. Multiple capacity stages (on size 08-28 units).
- n. Unit shall be complete with self-contained low-voltage control circuit.
- o. Unit shall have 0° F low ambient cooling operation.

2. Safeties:

- a. Unit shall incorporate a solid-state compressor lockout that provides optional reset capability at the space thermostat, should any of the following safety devices trip and shut off compressor:
  - 1) Compressor lockout protection provided for either internal or external overload.
  - 2) Low-pressure protection.
  - 3) Freeze protection (evaporator coil).
  - 4) High-pressure protection (high pressure switch or internal).
  - 5) Compressor reverse rotation protection (*ComfortLink™* units only).
  - 6) Loss of charge protection.
  - 7) Start assist on single-phase units.
- b. Supply-air sensor shall be located in the unit and detect both heating and cooling operation.
- c. Induced draft heating section shall be provided with the following minimum protections:
  - 1) High-temperature limit switch.
  - 2) Induced-draft motor speed sensor.
  - 3) Flame rollout switch.
  - 4) Flame proving controls.
  - 5) Redundant gas valve.

J. Operating Characteristics:

- 1. Unit shall be capable of starting and running at 125 F ambient outdoor temperature per maximum load criteria of ARI Standard 210 (03-12 sizes) and 360 (16-28 sizes).
- 2. Unit with *ComfortLink* controls will operate in cooling down to an outdoor ambient temperature of 0° F. Electro-mechanical shall operate down to 40 F.
- 3. Unit shall be provided with fan time delay to prevent cold air delivery in Heating mode.

K. Electrical Requirements:

All unit power wiring shall enter unit cabinet at a single location — side or bottom.

L. Motors:

- 1. Compressor motors shall be cooled by refrigerant gas passing through motor windings and

shall have line break thermal and current overload protection.

- 2. Evaporator fan motor shall have permanently lubricated, sealed bearings and inherent automatic-reset thermal overload protection or manual reset calibrated circuit breakers. Evaporator motors are designed specifically for Carrier and do *not* have conventional horsepower (hp) ratings listed on the motor nameplate. Motors are designed and qualified in the “air-over” location downstream of the cooling coil and carry a maximum continuous bhp rating that is the maximum application bhp rating for the motor; no “safety factors” above that rating may be applied.
- 3. All evaporator fan motors 5 hp and larger shall meet the minimum efficiency requirements as established by the Energy Policy Act of 1992 (EPACT), effective October 24, 1997.
- 4. Totally enclosed condenser-fan motor shall have permanently lubricated, sealed bearings, and inherent automatic-reset thermal overload protection.
- 5. Induced-draft motor shall have permanently lubricated sealed bearings and inherent automatic-reset thermal overload protection.

M. Special Features:

Certain features are not applicable when the features designated \* are specified. For assistance in amending the specifications, contact your local Carrier Sales Office.

- \* 1. Full Perimeter Roof Curbs (Horizontal and Vertical):
  - a. Formed of 14-gage galvanized steel with wood nailer strip and shall be capable of supporting entire unit weight. Shall be interlocking design.
  - b. Permits installing and securing ductwork to curb prior to mounting unit on the curb. Field assembly required.
  - c. Shall be available in both 14-in. and 24-in. height.
- \* 2. Adapter Roof Curb:

Shall be available for fit up to previously installed Carrier DJ, TJ, LJ, TF, HJ, TM roof curb (03-14 sizes).
- \* 3. Integrated Economizer:
  - a. Tilt-out economizer (16-28 slide out) shall be furnished and installed complete with outside air dampers and controls.
  - b. Low-leakage, opposing, gear-driven dampers with UL approved gears.
  - c. Capable of introducing up to 100% outdoor air for minimum ventilation as well as free cooling.

# Guide specifications (cont)



- d. Damper actuator shall be electronic 4 to 20 mA/2 to 10 vdc fully modulating design.
  - e. Economizer outdoor hood shall be pre-painted and fully assembled on 03 to 16 sizes. Economizer outdoor hood requires field assemble on other sizes.
  - f. Economizer shall be available for both field or factory installation.
- \* 4. Two-Position Motorized Outdoor Air Damper:
- a. The damper shall admit up to 50% outdoor air. Spring return damper closes when unit is off.
  - b. The package shall include a multiple-blade damper and motors.
  - c. Shall be available as factory-installed option and field-installed accessory.
- \* 5. Manual Outdoor Air Damper:
- a. The damper shall admit up to 33% outdoor air.
  - b. Shall include hood, damper plate, and screen (03-16 sizes) or cleanable aluminum filter (20-28 sizes).
  - c. Shall be available as factory-installed option and field-installed accessory.
- \* 6. Barometric Relief Damper Package:
- a. Package shall include damper, seals, hardware, and hoods to relieve excess internal pressure.
  - b. Integrated barometric relief capabilities on economizer shall be available on 03-16 sizes.
  - c. Damper shall close due to gravity upon unit shutdown.
- \* 7. Power Exhaust:
- a. For 03-16 sizes, package shall include two (2) propeller exhaust fans, 0.25 Hp (03-07) or 0.5 Hp (08-16) 208-230 v, 460 v direct-drive motor on each, and damper for units with economizer to control over-pressurization of building. Single-stage control.
  - b. For 20-28 sizes, package shall include two (2) centrifugal exhaust fans, 1 Hp 208-230, 460 v (factory-wired for 460 v) three-speed direct-drive motor on each, and damper for units with economizer to control over-pressurization of building. Two-stage exhaust capability through *ComfortLink™* control shall be available.
  - c. Power exhaust shall fit on both vertical and horizontal configured unit.
  - d. Power exhaust shall be available for both field or factory installation.
8. Single Enthalpy Sensor:  
The enthalpy sensor shall provide economizer control based on outdoor air enthalpy. The economizer control shall include logic to calculate the wet bulb and dry bulb temperatures of the outdoor air.
9. Differential Enthalpy Sensor:
- a. For use with economizer only.
  - b. Capable of comparing heat content (temperature and humidity) of outdoor air and indoor air and controlling economizer cut-in point at the most economical level.
10. Convenience Outlet:
- a. Optional factory-installed powered convenience outlet shall be internally mounted with an externally accessible 115-v, 2-plug female receptacle with hinged cover. Shall include 15 amp GFI with independent fuse protection and service receptacle disconnect. The convenience outlet is powered from the line side of the disconnect or circuit breaker with a factory-installed step down transformer, therefore it will not be affected by the position of the disconnect or circuit breaker.
  - b. Optional factory-installed non-powered convenience outlet shall be internally mounted with an externally accessible 115-v, 2-plug female receptacles with hinged cover. There is no step down transformer installed from the factory.
- \*11. Non-Fused Disconnect Switch:  
Shall be factory-installed, internally mounted, NEC and UL approved. Non-fused switch shall provide unit power shutoff. Shall be accessible from outside the unit and shall provide power off lockout capability.
- \*12. HACR Circuit Breaker:  
Shall be factory-installed, internally mounted, NEC and UL approved. HACR breaker shall provide unit power shutoff. Shall be accessible from outside the unit and shall provide power off lockout capability.
13. CO<sub>2</sub> Sensor:  
The duct-mounted or wall-mounted CO<sub>2</sub> sensor shall have the ability to monitor CO<sub>2</sub> levels and relay information to the controller. The controller will use CO<sub>2</sub> level information to modulate the economizer and provide demand control ventilation. The sensor shall be available as field or factory-installed.
14. Return Air/Supply Air Smoke Detector:  
The smoke detector shall send input to the controller to shut down the unit in case smoke is detected. The smoke detector shall be factory installed in the return air section or shall be available as a field-installed accessory.
15. Filter Status:  
The filter status switch shall be a pressure switch and will indicate a dirty filter. The switch shall be available as field or factory-installed.



16. Fan Status:

The fan status switch shall be a pressure switch and will indicate indoor fan operation. The switch shall be available as field or factory-installed.
- \*17. MERV-8 Pleated Return Air Filters:

The filters shall be MERV-8 efficient. The filters shall be 2-in., pleated filters.
- \*18. Four-in. Return Air Filter Capability:
  - a. The unit shall be capable of accepting field-supplied 4-in. filters by removing a spacer rack on 03-16 sizes standard units.
  - b. The unit with factory-installed option of 4-in. filter capability (20-28) shall be capable of accepting field-supplied 4-in. filters by removal of the factory-supplied 2-in. filters and filter retainer.
- \*19. Low Range Fan Performance Motor/Drive:

This motor/drive option shall provide low range motor and drive capability to enhance evaporator fan performance.
- \*20. Mid-Low Fan Performance Motor/Drive (16-28 sizes):

This motor/drive shall provide low to medium motor and drive capability to enhance evaporator fan performance.
- \*21. Mid-High Fan Performance Motor/Drive (20-28 sizes):

This motor/drive option shall provide medium to high motor and drive capability to enhance evaporator fan performance.
- \*22. High Fan Performance Motor/Drive:

This motor/drive offering shall provide high range motor and drive capability to enhance evaporator fan performance.
23. Hail Guard, Condenser Coil Grille:

Shall protect the condenser coil from hail, flying debris, and damage by large objects without increasing unit clearances.
24. Horizontal Kit:
  - a. Horizontal kit shall contain all the necessary hardware to convert a vertical airflow unit to a horizontal airflow unit (16-28 sizes).
  - b. The unit shall also be available as a horizontal airflow unit directly from the factory.
25. Phase Loss Protection (3-phase units only):

Shall provide unit shutdown when an electrical phase loss is detected – automatic reset type.
26. Roof Curb Burglar Bar:

Shall be 1/2-in diameter rod with 9-in. on center design grid pattern. Shall mount in roof curb openings.
- \*27. Electronic Programmable Thermostat:

Capable of using deluxe full-featured electronic thermostat.
- \*28. Thermostats and Subbases:

To provide staged heating and cooling in addition to automatic (or manual) changeover and fan control.
29. Flue Discharge Deflector:

Aluminum flue discharge deflector directs unit flue exhaust vertically instead of horizontally. UL listed.
30. Liquefied Propane Conversion Kit:

Kit shall contain all the necessary hardware and instructions to convert a standard natural gas unit for use with liquefied propane gas.
31. Natural Gas High Altitude Kit:

Shall provide the necessary orifices and instructions required to operate unit in altitude from 2,000 ft to 7,000 ft.
32. Thru-The-Curb Gas Connection Kit:

Shall provide hardware for through the curb routing of gas piping. Minimize roof penetration.
33. Thru-The-Bottom Gas Connection Kit:

Shall provide hardware for through the unit bottom routing of gas piping. Minimize roof penetration.
34. Gas Heat options (sizes 04-06):
  - a. Single-stage gas heat shall be provided in lieu of two-stage heat.
  - b. NOx reduction shall be provided to reduce nitrous oxide emissions to meet the California Air Quality Management NOx requirement of 40 nanograms/joule or less.
  - c. Primary tubes on low NOx units shall be 409 stainless steel. Other components shall be aluminized steel.
35. Humidi-MiZer™ Adaptive Dehumidification System:
  - a. The Humidi-MiZer dehumidification system shall be factory-installed in the 48PG03-28 rooftop units, and shall provide greater dehumidification of the occupied space by two modes of dehumidification operations beside its normal design cooling mode:
    - 1) Subcooling mode further subcools the hot liquid refrigerant leaving the condenser coil when both temperature and humidity in the space are not satisfied.

# Guide specifications (cont)



- 2) Hot gas reheat mode shall mix a portion of the hot gas from the discharge of the compressor with the hot liquid refrigerant leaving the condenser coil to create a two-phase heat transfer in the system, resulting in a neutral leaving-air temperature when only humidity in the space is not satisfied.
- b. The system shall consist of a subcooling/reheat dehumidification coil located downstream of the standard evaporator coil. This dehumidification coil is a single-row coil on 48PG03-16 units. This dehumidification coil is a two-row coil on 48PG20-28 units.
- c. The system shall include crankcase heater(s) for the scroll compressor(s).
- d. The system shall include a low outdoor air temperature switch to lock out both subcooling and hot gas reheat mode when the outdoor-air temperature is below 40 F.
- e. The system shall include a Motormaster® low ambient control to ensure the normal design cooling mode capable of down to 0° F low ambient operation.
- f. The system shall include a low-pressure switch on the suction line to ensure low pressure start-up of hot gas reheat mode at lower outdoor temperature condition.
- g. The system operation may be controlled by a field-installed, wall-mounted humidistat. The dehumidification circuit will then operate only when needed. Field connections for the humidistat are made in the low-voltage compartment of the unit control box. The sensor can be set for any level between 55% and 80% relative humidity.
- h. The system shall include a thermostatic expansion valve (TXV) to ensure a positive superheat condition.
- i. For units with two or three compressors (sizes 08-28), depending on the conditions required to maintain the space set points, one or all the compressors can operate in subcooling mode, one compressor could operate in subcooling mode while the other(s) operate in hot gas reheat mode, or one or all the compressors can operate in hot gas reheat mode.

