



# Product Data

## 48TM004-028 48HJ004-017 Single-Package Rooftop Units Gas Heating/Electric Cooling ASHRAE 90.1 Compliant

3 to 25 Nominal Tons

Carrier Comfort System

### PremierLink

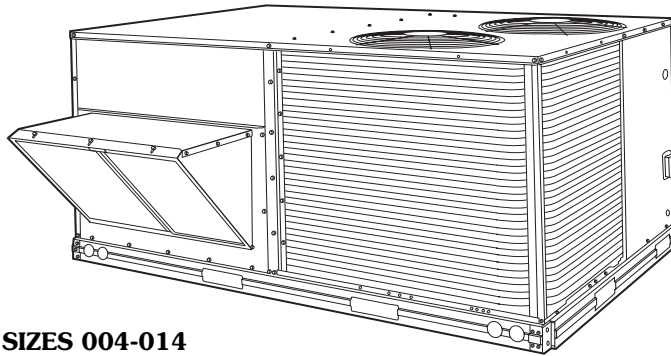

**SIZES 004-014**

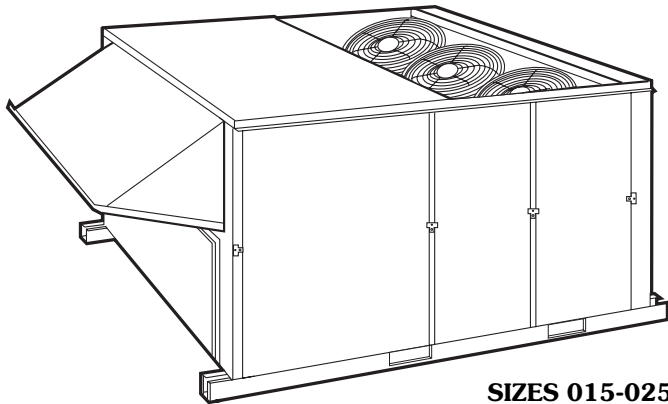

**SIZES 015-025**

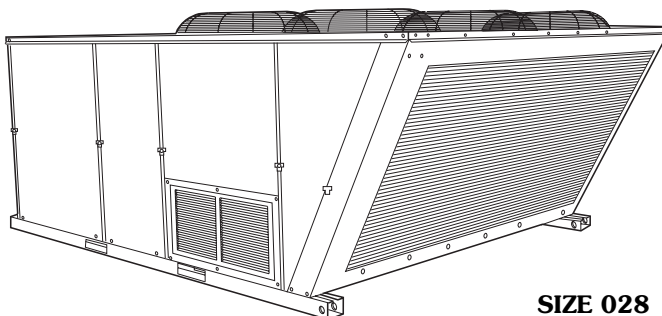

**SIZE 028**

**Standard-Efficiency (TM) units meet minimum ASHRAE 90.1 energy efficiency requirements. High-Efficiency (HJ) units well exceed ASHRAE 90.1 energy efficiency requirements. Gas heating with electric cooling rooftop units offer:**

- Pre-painted galvanized steel cabinet for long life and quality appearance
- Commercial strength base rails with built-in rigging capability
- Convertible design for vertical or horizontal supply/return (004-014 only)
- Non-corrosive, sloped condensate drain pan, meets ASHRAE 62 (IAQ)
- Two-inch return-air filters
- A wide assortment of factory-installed options available, including high static drives that provide additional performance range
- Factory-installed PremierLink™ digital communicating controls
- Optional gear driven economizer (EconoMi\$er or EconoMi\$er2) with CO<sub>2</sub> ventilation control (2 to 10 vac actuator)
- Optional gear-driven economizer (EconoMi\$er or EconoMi\$er2) with 4 to 20 mA actuator for PremierLink and 3rd Party EMS controls

#### Heat Options

- Exclusive integrated gas control board with diagnostics
- Alumagard™ heat exchanger coating
- Induced-draft fan for gas combustion
- Tubular, dimpled heat exchangers
- Natural gas
- LP conversion kits
- Low NO<sub>x</sub> (size 004-006 only)
- Optional stainless steel heat exchangers.

**ASHRAE  
90.1  
COMPLIANT**

# Table of contents



	Page
Features/Benefits . . . . .	2-5
Options and Accessories . . . . .	6-14
Controls . . . . .	15-32
Application Data . . . . .	33-42
Typical Piping and Wiring — sizes 004-014 . . . . .	43
Typical Piping and Wiring — sizes 015-028 . . . . .	44
Typical Wiring Schematic — sizes 004-014 . . . . .	45,46
Typical Wiring Schematic — sizes 015-028 . . . . .	47-49
<b>48TM004-014 (3 to 12<sup>1</sup>/<sub>2</sub> ton)</b>	
Model Number Nomenclature . . . . .	50
ARI Capacity Ratings . . . . .	50,51
Physical Data . . . . .	52-55
Base Unit Dimensions . . . . .	56-58
Accessory Dimensions . . . . .	59,60
Selection Procedure . . . . .	61,62
Performance Data . . . . .	63-91
Electrical Data . . . . .	92-95
Guide Specifications . . . . .	96-101
<b>48TM016-028 (15 to 25 ton)</b>	
Model Number Nomenclature . . . . .	102
ARI Capacity Ratings . . . . .	103
Physical Data . . . . .	104,105
Base Unit Dimensions . . . . .	106-108
Accessory Dimensions . . . . .	109-112
Selection Procedure . . . . .	112
Performance Data . . . . .	113-121
Electrical Data . . . . .	122
Guide Specifications . . . . .	123-127
<b>48HJ004-014 (3 to 12<sup>1</sup>/<sub>2</sub> ton)</b>	
Model Number Nomenclature . . . . .	128
ARI Capacity Ratings . . . . .	129,130
Physical Data . . . . .	131-134
Base Unit Dimensions . . . . .	135,136
Accessory Dimensions . . . . .	137,138
Selection Procedure . . . . .	139-141
Performance Data . . . . .	142-165
Electrical Data . . . . .	166,167
Guide Specifications . . . . .	168-173
<b>48HJ015,017 (12 to 15 ton)</b>	
Model Number Nomenclature . . . . .	174
ARI Capacity Ratings . . . . .	175
Physical Data . . . . .	176,177
Base Unit Dimensions . . . . .	178
Accessory Dimensions . . . . .	179-181
Selection Procedure . . . . .	182
Performance Data . . . . .	183-191
Electrical Data . . . . .	192
Guide Specifications . . . . .	193-197

## Features/Benefits

**Every compact one-piece unit arrives fully assembled, charged, tested, and ready to run.**

### 48 Series — gas heat models

All ignition components are contained in the compact IGC (integrated gas controller) which is easily accessible for servicing. The IGC control board, designed and manufactured exclusively for Carrier rooftop units, provides built-in diagnostic capability. An LED (light-emitting diode) simplifies troubleshooting by providing visual fault notification and system status confirmation.

The IGC also contains an exclusive anti-cycle protection for gas heat operation. After 4 continuous cycles on the unit high-temperature limit switch, the gas heat operation is disabled, and an error code is issued. This feature greatly improves reliability of the rooftop unit.

The IGC also contains burner control logic for accurate and dependable gas ignition. The LED is visible without removing the unit control box access panel. This LED fault-notification system reduces service person troubleshooting time and minimizes service costs. The IGC also maximizes heating efficiency by controlling evaporator-fan on and off delays.

Tubular, dimpled gas heat exchangers optimize heat transfer for improved efficiency. The tubular design permits hot gases to make multiple passes across the path of the supply air. The dimpled design creates a turbulent gas flow to maximize heating efficiency.

The efficient in-shot burners and all ignition components are contained in an easily removable, compact assembly.

The California Air Quality Management Districts NO<sub>x</sub> requirement of 40 nanograms/joule or less is met on 004-006 size Low NO<sub>x</sub> models.

The extra thick Alumagard™ heat exchanger coating provides corrosion resistance and ensures long life (optional stainless steel heat exchangers are available).

The unsightly appearance of flue stacks is eliminated and the effects of wind on heating operations are diminished by the induced draft combustion system. The inducer fan draws hot combustion gas through the heat exchanger at the optimum rate for the most effective heat transfer. The heat exchanger operates under negative



pressure, preventing flue gas leakage into the indoor supply air.

During the Heating mode, the evaporator-fan relay automatically starts the evaporator fan after the heat exchanger warms up to a suitable temperature. The 30-second fan delay prevents cold air from entering the supply duct system when the conditioned space is calling for heat to maximize efficiency.

The direct-spark ignition system saves operating expense when compared to pilot ignition systems. No crossover tube is required, therefore no sooting or pilot fouling problems can occur.

All standard units are designed for natural gas, but an accessory LP (liquid propane) conversion kit is available.

All units have a flame rectification sensor to quickly sense the burner flame and ignite burners almost immediately. Fast shutdown is a certainty since the sensor reacts quickly to any flame outage or system failure. In the event of a shutdown, an error code is issued at the IGC board.

Safety is also assured due to the heating safety controls which will shut down the unit if there is a problem. If excessive temperatures develop, limit switches shut off the gas valve. After 4 continuous short cycles of the high-temperature limit switch, the IGC board locks out the gas heat cycle to prevent any further short cycles. This safety feature is provided exclusively on Carrier rooftop units. The rollout switch also deenergizes the gas valve in the event of a flame rollout.

### **Quiet, efficient operation and dependable performance**

Compressors have vibration isolators for quiet operation. Efficient fan and motor design permits operation at low sound levels.

Unit sizes 008-028 offer lower utility costs through part-load operation using 2 stages of cooling.

Quiet and efficient operation is provided by belt-driven evaporator fans (standard on all units over 5 tons). The belt-driven evaporator-fan is equipped with variable-pitch pulleys which allow adjustment within the rpm ranges of the factory-supplied pulleys.

Increased operating efficiency is achieved through computer-designed coils featuring staggered internally enhanced copper tubes. Fins are ripple-edged for strength, lanced, and double waved for higher heat transfer.

### **Durable, dependable construction**

Designed for durability in any climate, the weather-resistant cabinets are constructed of galvanized steel and bonded, and all exterior panels are coated with a prepainted baked enamel finish. The paint finish is non-chalking, and is capable of withstanding ASTM B117 500-hour Salt Spray Test. All internal cabinet panels are primed, permitting longer life and a more attractive appearance for the entire unit.

In addition, all size 004-014 units are designed with a single, continuous top piece to eliminate any possible leaks at seams or gasketing. Totally enclosed condenser-fan motors and permanently lubricated bearings provide additional unit dependability.

### **Easy installation and conversion**

**All units are shipped in the vertical duct configuration** for fit-up to standard roof curbs. (3 different curb sizes fit unit sizes 004-007, 008-014, and 015-028 respectively.) The contractor can order and install the roof curb early in the construction stage, before decisions on size requirements are made.

All units feature a base rail design with forklift slots and rigging holes for easier maneuvering. Durable packaging protects all units during shipment and storage.

The units can be easily converted from a vertical to a horizontal duct configuration by relocating the panels supplied with the unit (size 004-014 only).

**To convert 004-014 units** from vertical to horizontal discharge, simply relocate 2 panels. The same basic unit can be used for a variety of applications and can be quickly modified at the jobsite.

**To convert 015-028 units** from vertical to horizontal discharge, use the optional horizontal supply/return adapter roof curb.

**Convenient duct openings** in the unit basepans permit side-by-side or concentric duct connections (see Application data section) without requiring internal unit modification.

**NOTE:** On units using horizontal supply and return, the accessory barometric relief or power exhaust **MUST** be installed on the return ductwork.

**Thru-the-bottom service connection capability** comes standard with the rooftop unit to allow power and control wiring and gas connections to

be routed through the unit's basepan, thereby minimizing roof penetrations (to prevent water leaks). (Thru-the-bottom gas connection requires thru-the-bottom accessory kit.) Power, gas and control connections are made on the same side of the unit to simplify installation.

### **The non-corrosive sloped condensate drain pan (size 004-014)**

permits either an external horizontal side condensate drain (outside the roof curb) or an internal vertical bottom drain (inside the roof curb). Both options require an external, field-supplied P-trap.

**Standard 2-in. throwaway filters** are easily accessed through a removable panel located above the air intake hood. No tools are required to change unit filters.

**Belt-driven evaporator-fan motors** (optional on TM units under 6 tons) allow maximum on-site flexibility without changing motors or drives.

**Low voltage wiring connections** are easily made thanks to the large terminal board which is located for quick, convenient access.

In addition, color-coded wires permit easy tracing and diagnostics.

### **Proven compressor reliability**

Design techniques feature computer-programmed balance between compressor, condenser, and evaporator. Carrier-specified hermetic compressors are equipped with compressor overcurrent and overtemperature protection to ensure dependability.

All units have Carrier's exclusive Acutrol™ (004-014) or TXV (thermostatic expansion valve) metering device (015-028) which precisely controls refrigerant flow, preventing slugging and flood-back, while maintaining optimum unit performance. Refrigerant filter driers are standard.

### **Integrated economizers and outdoor-air dampers**

Available as options or accessories, economizers and manual outdoor-air dampers introduce outdoor air which mixes with the conditioned air, improving indoor-air quality and often reducing energy consumption.

During a first stage call for cooling, if the outdoor-air temperature is below the economizer control changeover set point, the mixed-air sensor modulates the economizer outdoor-air damper open to take advantage of free cooling provided by the outside air. When second-stage cooling is called for, the compressor is energized in

# Features/Benefits (cont)



addition to the economizer. If the outdoor-air temperature is above the changeover set point, the first stage of compression is activated and the economizer damper stays at minimum position. Field-installed Durablade economizer operation is controlled by a dry-bulb thermostat that senses outdoor-air temperature.

Accessory upgrade kits allow for control by differential dry-bulb temperature (outdoor vs return), outdoor air enthalpy changeover, or more precise differential enthalpy control.

Units can also utilize the factory-installed or field-installed EconoMi\$er (for sizes 015-028) or EconoMi\$er2 (for sizes 004-014). These economizers are microprocessor controlled and incorporate a parallel, blade gear driven damper system. In addition, a spring return is built into the damper actuator to provide reliable close-on-power-loss. The EconoMi\$er2 (available for sizes 004-014) comes equipped with up to 90% barometric relief capability for high outdoor airflow applications. Optional field-installed barometric relief package is available for use on 015-028 size units.

In addition, single-stage power exhaust is available as a field-installed accessory for EconoMi\$er2 (size 004-014) and EconoMi\$er (size 015-028) to help maintain proper building pressure.

For units without economizer, year-round ventilation is enhanced by a manual outdoor-air damper. On 004-014 units, a 25% or 50% manual damper is available as a field-installed accessory. Unit sizes 015-028 are equipped with a manual 25% damper.

## Service options

Servicing a rooftop unit has never been easier with the new factory-installed service options for these rooftop units. These options include the following:

- Hinged access panels are provided for the filter/indoor-fan motor, compressors, evaporator fan, and control box areas (TM016-028; HJ004-017). Quick access to major components is accomplished by simply unlatching and swinging open the various panels. Each hinged panel is permanently mounted to the unit, thereby eliminating the concern of a dropped or wind-blown panel puncturing delicate roof materials. The 4 extended access panels are also equipped with “tie back” retaining devices to hold the door in the open position while servicing the unit.

- An external, covered, 115-v Ground Fault Interrupt (GFI) receptacle is provided as a convenient power source for drills, lights, refrigerant recovery units, or other electrical service tools. A factory-supplied step down transformer is connected to the “load” side of the unit main power connection (size 004-014). For sizes 015-028, connect the outlet to a field-supplied and properly fused branch circuit power supply.
- Slide out “motor-drive-blower” reduces service time (only on 48HJ017).
- An integral non-fused disconnect switch within the rooftop unit reduces installation time, labor and material costs. Safety is assured by an interlock which prevents access to the control box unless the switch is in the OFF position. In addition, the externally mounted handle incorporates power lockout capability to further protect service personnel.

## Carrier PremierLink™ Controls add reliability, efficiency, and simplification

The PremierLink direct digital controls can be ordered as a factory-installed option or as a field-installed accessory. Designed and manufactured exclusively by Carrier, the controls can be used to actively monitor and control all modes of operations, as well as monitor the following diagnostics and features: unit number, zone temperature, zone set point, zone humidity set point, discharge air temperatures, fan status, stages of heating, stages of cooling, damper position, outdoor-air temperature, outdoor humidity level, filter status, fire shutdown status, IAQ set point, enthalpy status, differential enthalpy status, heat/cool lockout, CFM set point, pre-occupancy purge, economizer controls and early morning warm-up.

This controller has a 38.4K baud communications capability and is compatible with *ComfortLink™* Controls, CCN and *ComfortVIEW™* Software. The Scrolling Marquee and Navigator are optional tools that can be used for programming and monitoring the unit for optimal performance. The addition of the Carrier CO<sub>2</sub> sensor in the conditioned space provides ASHRAE 62-99 compliance and Demand Control Ventilation.

The PremierLink peer-to-peer, Internet ready communicating control is designed specifically for Constant Volume and Variable Volume and Temperature applications. This comprehensive

controls system allows all Carrier 3 to 25 ton rooftops to be daisy chained together on a roof to create a fully functional HVAC (heating, ventilation, and air conditioning) automation system.

## Carrier Apollo microprocessor controls add reliability, efficiency, and simplification.

Apollo controls are designed and manufactured exclusively by Carrier, the controls can be used to actively monitor and control all modes of operation. The Apollo communicating controls are factory-installed into the rooftop unit control box, and come equipped with built-in diagnostic capabilities. Light-emitting diodes (LEDs) simplify troubleshooting by indicating thermostat commands for both stages of heating and cooling, evaporator fan operation, and economizer operation. The Apollo communicating controls are designed to work specifically with the Carrier TEMP and VVT® (variable volume and temperature) thermostats. The standard rooftop control system is readily adaptable to all conventional and programmable thermostats. In addition, units are suitable for integration into building monitor control systems if required. This system gives the units the flexibility to communicate with almost any thermostat or building control system.

## Indoor-air quality begins with Carrier rooftops

Sloped condensate pans minimize biological growth in rooftop units in accordance with ASHRAE (American Society of Heating, Refrigeration, and Air Conditioning Engineers) Standard 62. Two-inch filters with optional dirty filter indicator switch provide for greater particle reduction in the return air. The face-split evaporator coils improve the dehumidification capability of standard units, maximize building humidity control.

Optional proportional reacting CO<sub>2</sub> sensor is available with the EconoMi\$er2 (size 004-014) and EconoMi\$er (size 015-028) outdoor air damper option/accessory to aid the IAQ benefits.

## Exclusive MoistureMi\$er™ dehumidification package (48HJ units only)

The MoistureMi\$er dehumidification package is a result of recent advances by Carrier in controlling comfort levels. This factory-installed option significantly improves the dehumidification capability of the rooftop unit and helps control humidity levels in the building.

## ROOFTOP UNIT WITH ENERGY\$RECYCLER (3 TO 12<sup>1</sup>/<sub>2</sub> TON UNITS ONLY)

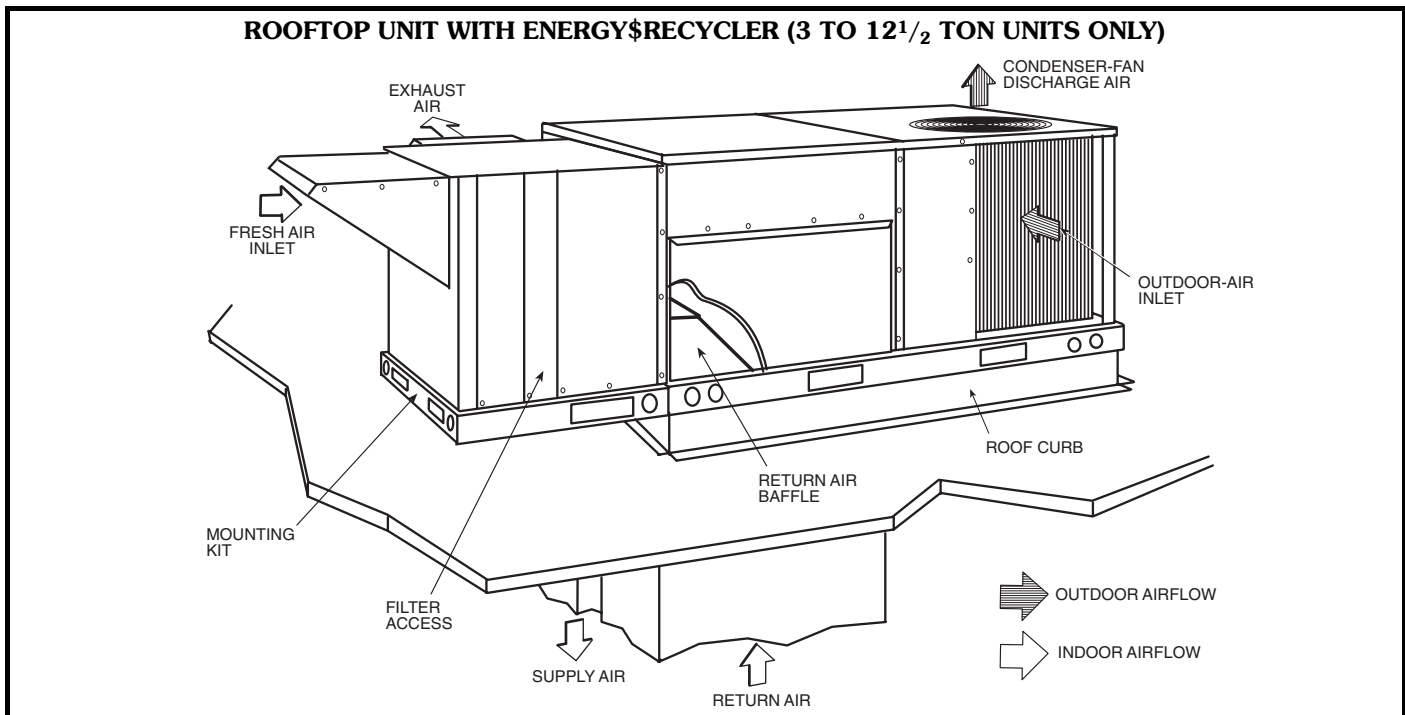

This option provides increased dehumidification by cooling the hot liquid refrigerant leaving the condenser coil. The MoistureMi\$er package consists of a subcooling coil located on the leaving-air side of the evaporator coil. The location of this coil in the indoor airstream enhances the latent capacity of the 48HJ units by as much as 40%. Many buildings suffer from humidity damage or poor indoor air quality due to humid conditions. The improved latent capacity provided by the MoistureMi\$er option reduces the building's humidity, eliminating potential property damage and making the space more comfortable.

The MoistureMi\$er option is the ideal IAQ (indoor-air quality) option for hot and humid regions. The operation of the MoistureMi\$er package can be controlled by a field-installed, wall mounted humidistat or thermidistat. The circuit activates only when needed (using the accessory humidistat) as opposed to some dehumidification systems that operate continuously. The

humidistat can be set for any humidity level between 20% and 80% relative humidity. The thermidistat can be set for any humidity level between 50% and 90% relative humidity.

### Energy\$Recycler — the IAQ solution for today's "tight" buildings

Indoor-air quality (IAQ) generally refers to the level of pollutants inside a building. These pollutants include cigarette smoke, carbon dioxide exhaled by occupants, radon gas, car exhaust, paint fumes, and odors.

Concern over increased indoor air pollutants has been spurred by several issues: 1) changes in new building construction methods and retrofit of older buildings have reduced air infiltration rates; 2) Synthetic materials release airborne particles, odors, and chemicals; and 3) HVAC (heating, ventilation, and air conditioning) systems that bring in minimal fresh air.

In 1989, IAQ concerns caused ASHRAE to recommend increased ventilation for all public buildings. Simply introducing fresh air into a building, however, is not always practical or cost effective. Additional ventilation can overload HVAC systems and increase energy costs.

Carrier's 62AQ Energy\$Recycler unit solves this dilemma by providing increased fresh air while keeping increased costs to a minimum. In addition, the Energy\$Recycler helps reduce humidity levels, which helps to prevent deterioration of building materials and retards the growth of mold and mildew.

The 62AQ Energy\$Recycler unit provides the best solution to retaining the energy-conserving benefits of today's tighter building construction while improving indoor-air quality.

The Energy\$Recycler can be integrally mounted in size 004-014 units; also available as a free standing unit for all sizes.

# Options and accessories



ITEM	OPTION*	ACCESSORY†
100% Open Two-Position Damper (004-014)		X
25% Open Two-Position Damper		X
Apollo Direct Digital Communicating Controls (DDC)	X	
Barometric Relief Damper (015-028) (Not for use with horizontal roof curb)		X
Condenser Coil Grille (004-014)		X
Condenser Coil Hail Guard Assembly (004-025)		X
Convenience Outlet	X	
Copper Fins Indoor and Outdoor Coil	X	
Copper Fins Outdoor Coil	X	
Double Wall in Unit Airstream (015-028)	X	
Durablade Integrated Economizer (004-014)		X
E-Coat Indoor Coil (Aluminum) (48HJ004-014)	X	
E-Coat Outdoor Coil (Aluminum)	X	
E-Coat Outdoor Coil (Copper)	X	
EconoMi\$er (015-028)	X	X
EconoMi\$er2 (004-014)	X	X
Electronic Programmable Thermostat		X
Energy\$Recycler Mounting Kit (004-014)		X
Energy\$Recycler Supply Air Blower (004-014)		X
Energy\$Recycler Transformer for 460 v (004-014)		X
Energy\$Recycler Unit (004-014)†††	X	X
Enthalpy or Differential Enthalpy Sensor		X
Fan/Filter Status		X
Flue Discharge Deflector (004-014)		X
Flue Shield (004-014)		X
High-Static Motor and Drive	X	
Hinged Access Panels (48HJ004-017, 48TM016-028)	X	
Horizontal Adapter Curb (015-028)		X
Hot Gas Bypass (015-028)	X**	
Humidistat		X
Indoor Air Quality (CO <sub>2</sub> ) Sensor (EconoMi\$er or EconoMi\$er2 Only)		X
Johnson METASYS Control	X**	
Light Commercial Thermidistat		X
Low Ambient Kit		X
Low NO <sub>x</sub> (004-006)	X	
LP (Liquid Propane) Conversion Kit		X
Manual Outdoor-Air Damper		X
MoistureMi\$er™ Dehumidification Package (48HJ004-017)	X	
Motormaster® I, II, III, IV Head Pressure Control (Cycle Control)		X
Novar Control (004-028)	X††	
Outdoor Air Enthalpy Sensor (EconoMi\$er or EconoMi\$er2 Only)		X
Power Exhaust (no barometric relief 015-028)		X
Power Exhaust Transformer for 575 v (004-014)		X
Power Exhaust with Barometric Relief (004-014)		X
Pre-coat Aluminum Fins on Outdoor Coil	X	
PremierLink™ DDC Communicating Control	X	X***
Return Air Enthalpy Sensor (EconoMi\$er or EconoMi\$er2 Only)		X
Return Air Temperature Sensor (EconoMi\$er or EconoMi\$er2 Only)		X
Roof Curbs (Vertical and Horizontal Discharge)		X
Smoke Detectors (DEC Special Order Only, 004-028)	X	
Stainless Steel Condensate Pan (015-028)	X**	
Temp Control for EconoMi\$er or EconoMi\$er2		X
Thermostats and Subbases		X
Thru-the-Bottom Utility Connections (Size 004-014)		X
Time Guard® II Control Circuit		X
Unit-Mounted Non-Fused Disconnect (Size 004-028)	X††	
UVC Lamps (Size 004-028)	X**	X
Winter Start Time Delay (Size 015-028)		X

\*Factory-installed.

†Field-installed.

\*\*Design Enhancement Center (DEC) special order only for size 015-028.

††Available as a factory-installed option on size 004-014 or as DEC special order only (size 015-028).

\*\*\*Refer to Systems and Controls price pages.

†††Available as accessory or option on 48HJ004-014; accessory only on 48TM004-014.

## NOTES:

1. Refer to unit price pages or contact your local representative for accessory and option package information.
2. Some options may increase product lead times.

**LOW AMBIENT CONTROL**  
**SIZES 004-014\***

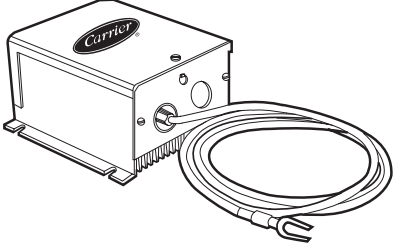
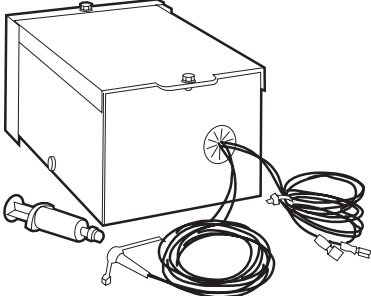
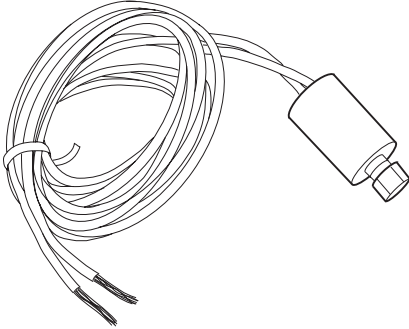
CONTROL DEVICE	APPLICATION
<p><b>Standard Low Ambient Temperature Cooling</b></p> <p><b>Motormaster® I — Single-phase solid state variable speed motor controller, based on condenser saturated temperature.</b></p> <p><b>P/N 32LT-900---301</b></p> 	<p align="center">25° F -20 F</p> <p align="center">Sizes 004-014. All voltages.</p> <p>Motor changeout required for all voltages. Stepdown transformer required for 460-3-60 and 575-3-60 applications.</p>
<p><b>Motormaster II — Fan cycling controller based on condenser/liquid temperature.</b></p> <p><b>P/N CPLOWAMB001A00</b></p> 	<p align="center">0° F</p> <p align="center">Sizes 004-014.</p> <p>All voltages. No motor changeout required.</p>
<p><b>Motormaster IV — Fan cycling controller based on liquid pressure.</b></p> <p><b>P/N 32LH-900---003</b></p> 	<p align="center">0° F</p> <p align="center">Sizes 004-014.</p> <p>All voltages. No motor changeout required.</p>

\*Carrier recommends using an optional economizer which allows use of the cool outdoor air as "free cooling." This method is preferred over low ambient controls, except for applications with poor outdoor air quality or excessive humidity.

# Options and accessories (cont)



## LOW AMBIENT CONTROL (cont)

SIZES 015-028\*

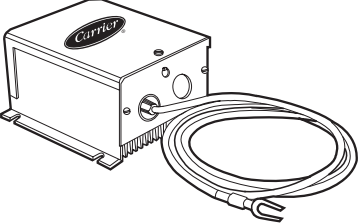
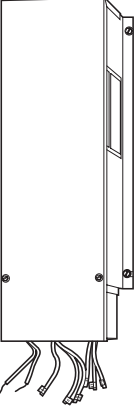
CONTROL DEVICE	APPLICATION
<p><b>Standard Low Ambient Temperature Cooling</b>  <b>Motormaster® I — Single-phase solid state variable speed motor controller, based on condenser saturated temperature.</b>  <b>P/N 32LT-900---301</b></p> 	<p>40° F                      -20 F                      Sizes 015, 016, 017, 020. All voltages.                      Motor changeout required for 460-3-60 and 575-3-60.                      Stepdown transformer required for 460-3-60 and 575-3-60 applications.                      Required: (1) CRLOWAMB001A00 — Low Ambient Kit                      (2) CRWINSTR001A00 — Winter Start Package</p>
<p><b>Motormaster III — Three-phase solid state variable speed motor controller based on condenser saturated temperature.</b>  <b>P/N 30GT-910---079</b></p> 	<p>-20 F                      Size 025. All voltages.                      Motor changeout required for all voltages.                      Stepdown transformer required for 575-3-60.                      Required: (2) CRWINSTR001A00 — Winter Start Package</p>
<p><b>Low Ambient Kit — Fan sequencing controller, based on ambient temperature.</b>  <b>P/N CRLOWAMB001A00</b></p>	<p>20 F                      Sizes 015, 017. All voltages.                      10 F                      Sizes 016, 020, 028. All voltages.                      Required (2) CRWINSTR001A00 — Winter Start Package</p>
<p><b>25° F Low Ambient Kit — Fan sequencing controller, based on ambient temperature.</b>  <b>P/N CRLOWAMB002A00</b></p>	<p>25 F                      Size 025. All voltages.                      Required (1) CRWINSTR001A00 — Winter Start Package</p>

\*Carrier recommends using an optional economizer which allows use of the cool outdoor air as "free cooling." This method is preferred over low ambient controls, except for applications with poor outdoor air quality or excessive humidity.

### ENVIRO-SHIELD™ CONDENSER COIL OPTIONS\*

Condenser coil options are available to match coil construction to site conditions for the best corrosion durability. Pre-coated coils provide protections in mild coastal environments. All copper coils are best suited for moderate coastal applications, while E-coated coils provide superior protection in severe coastal and industrial applications.

### CONDENSER COIL PROTECTION APPLICATIONS

DESCRIPTION (Enviro-Shield Option)	ENVIRONMENT†					
	Standard, Non-Corrosive	Mild Coastal	Moderate Coastal	Severe Coastal	Industrial	Combined Coastal and Industrial
Standard, Al/Cu	X					
Pre-Coated Al/Cu		X				
Cu/Cu			X			
E-Coated Al/Cu					X	
E-Coated Cu/Cu				X		X

#### LEGEND

- Al/Cu — Aluminum Fin with Copper Tube Coil
- Cu/Cu — Copper Fin with Copper Tube Coil
- Enviro-Shield — Family of Coil Protection Options
- E-Coated — Extremely flexible and durable epoxy coating uniformly applied to the coil surfaces.
- Pre-Coated — Epoxy Coating Applied to Fin Stock Material

\*E-Coated Al/Cu Condenser Coil and E-Coated Al/Cu Evaporator Coil available as an option for 48HJ004-014 units only.  
 †See "Selection Guide: Environmental Corrosion Protection" Catalog No. 811-217 for more information.

### MOISTUREMi\$er™ DEHUMIDIFICATION PACKAGE (HJ004-017)

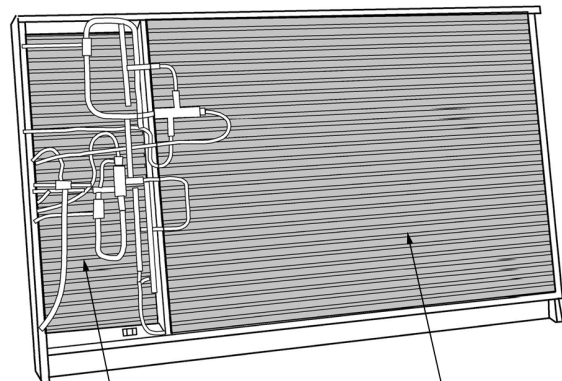
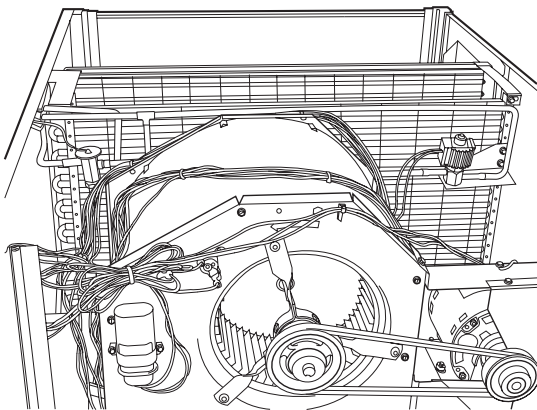

STANDARD INDOOR COIL      DEHUMIDIFICATION COIL

The MoistureMi\$er dehumidification package is a factory-installed option that provides increased dehumidification by cooling the hot liquid refrigerant leaving the condenser coil. The MoistureMi\$er package consists of a subcooling coil located on the leaving-air side of the evaporator coil. The location of this coil in the indoor airstream enhances the latent capacity of the units by as much as 40%. The MoistureMi\$er package includes the subcooling coil and low-pressure switches, and operation can be controlled by a field-installed, wall-mounted humidistat or thermidistat.

## FACTORY-INSTALLED APOLLO COMMUNICATING CONTROLS

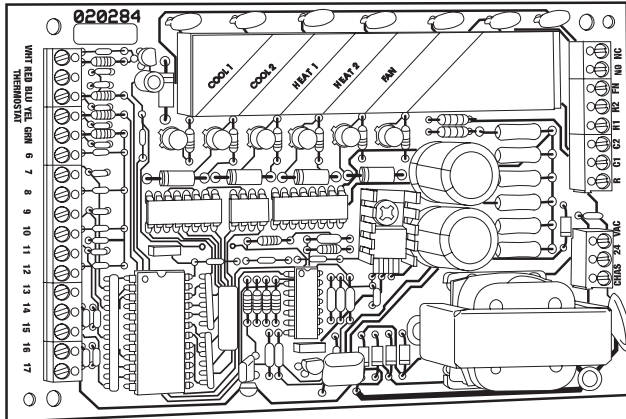

The Apollo direct digital controls are designed exclusively by Carrier, and are used to actively monitor and control all modes of operation as well as to monitor evaporator-fan status, filter status, supply-air temperature, outdoor-air temperature, and indoor-air quality. They are designed to work in conjunction with Carrier TEMP and VVT® (Variable Volume/Variable Temperature) system thermostats.

## ELECTRONIC PROGRAMMABLE THERMOSTAT

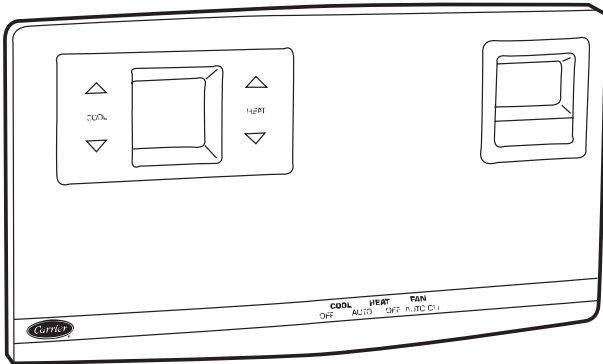

Carrier's electronic programmable thermostat provides efficient temperature control by allowing you to program heating and cooling set-backs and set ups with provisions for weekends and holidays. Accessory remote sensing package is also available to provide tamperproof control in high traffic spaces. Used in conjunction with factory-installed Apollo control, this thermostat provides a 5-minute recycle timer between modes of operation for short-cycle protection.

## TIME GUARD® II CONTROL

Time Guard II Control automatically prevents compressor from re-starting for at least 5 minutes after a shutdown. Accessory prevents short cycling of compressor if the thermostat is changed rapidly. Time Guard II control mounts in the control compartment of unit.

## PREMIERLINK™ COMMUNICATING CONTROLS

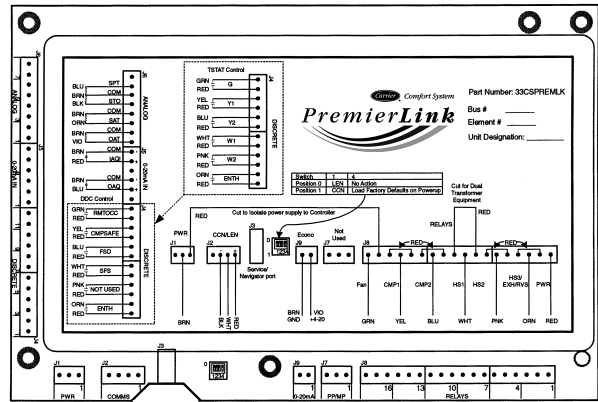

Carrier's newest CCN rooftop control for 3 to 25 ton units. PremierLink control is plug and play compatible with ComfortLink™ controls and is DCV (Demand Control Ventilation) and Internet ready.

## CARRIER COMMERCIAL THERMOSTAT

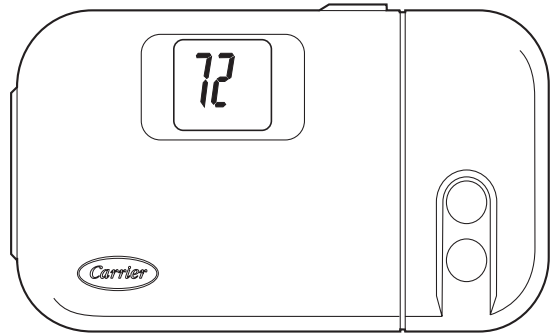

Designed specifically for use with Carrier commercial systems, this Carrier programmable thermostat features LED occupied/unoccupied displays and setback mode which can override continuous fan operation.

## HUMIDISTAT

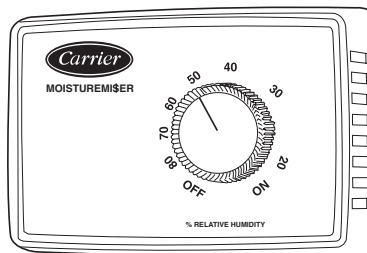

Field-installed, wall-mounted humidistat is used to control operation of the MoistureMiSer™ dehumidification package. The humidistat controls the occupied space humidity at a user-selected setting between 20% and 80% relative humidity.

## THERMIDISTAT

Field-installed, wall-mounted device combines temperature and humidity control in one device. The dehumidifier output is used to control the MoistureMiSer dehumidification package. The occupied space humidity has a set point range between 50% and 90% relative humidity and provides constant fan operation in occupied mode.

## ECONOMISER AND ECONOMISER2

Factory-installed EconoMiSer or EconoMiSer2 control utilizes a microprocessor-based control, gear driven damper system, low pressure drop characteristics, built-in spring return (for close upon power loss). Integral barometric relief available for sizes 004-014 only. Available with 4 to 20 mA actuator and no microprocessor control for use with PremierLink™ or third party control.

### SIZES 004-014 — ECONOMISER2

#### ECONOMISER2 (004-014 Shown)

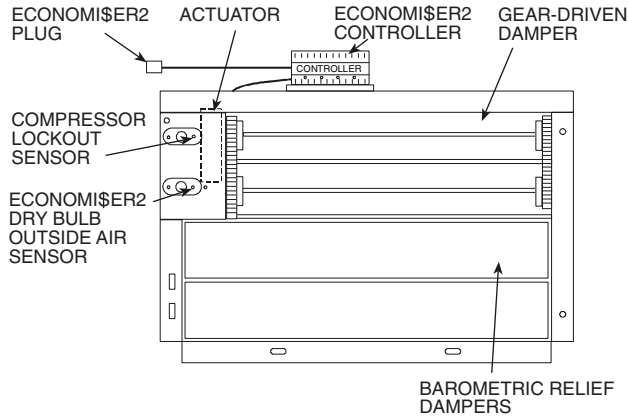

#### ECONOMISER2 CONTROLLER POTENTIOMETER AND LED LOCATIONS

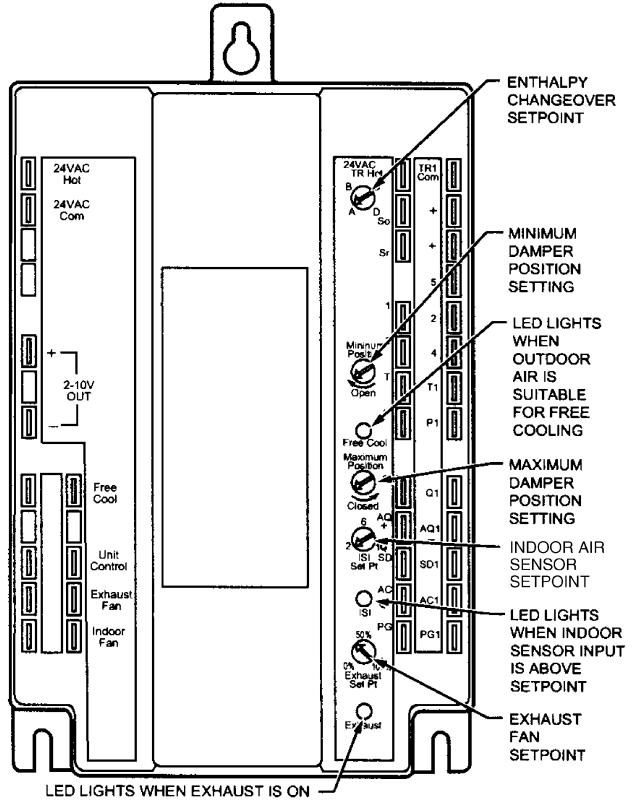

### SIZES 015-028 — ECONOMISER

#### ECONOMISER MICROPROCESSOR CONTROLLER

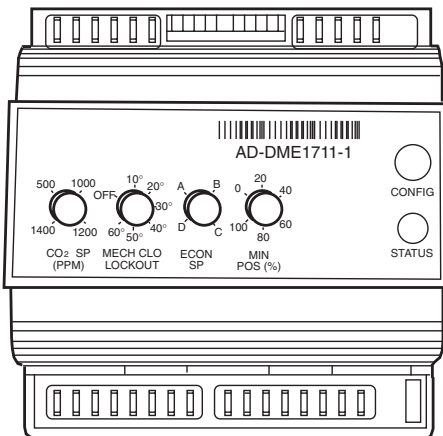

Inputs for Dry Bulb, Enthalpy, Differential Temperature or Enthalpy, CO<sub>2</sub> Sensor, or Potentiometer

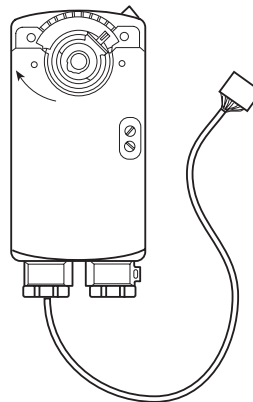

**ECONOMISER STEPPER MOTOR**

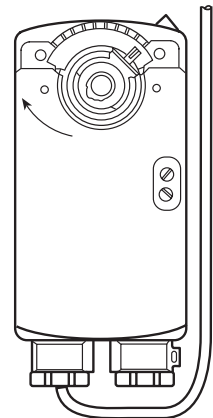

**4-20 mA ECONOMISER ACTUATOR (For PremierLink or 3rd party control)**

# Options and accessories (cont)



## UNIT-MOUNTED DISCONNECT (Sizes 004-014)

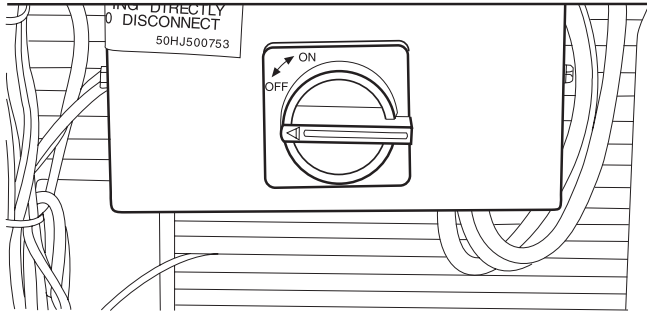
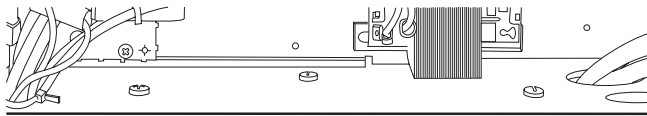

Factory-installed, internally-mounted, NEC (National Electrical Code) and UL (Underwriters' Laboratories) approved non-fused switch provides unit power shutoff with disconnect lockout protection capability. The switch is accessible from outside the unit.

## UNIT-MOUNTED DISCONNECT (Sizes 015-028)

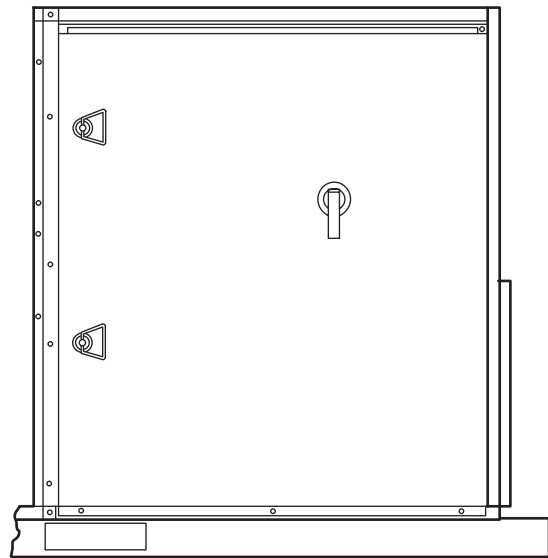

## CONVENIENCE OUTLET

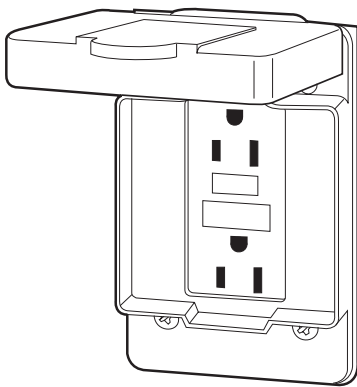

Factory-installed, internally mounted and externally accessible 115-v female receptacle. Includes 15-amp GFI (Ground Fault Interrupter) receptacle with independent fuse protection. A factory-supplied step down transformer is wired to the "load" side of the unit's main power connection (sizes 004-014). For sizes 015-028, voltage required to operate convenience outlet is provided by a field-installed transformer.

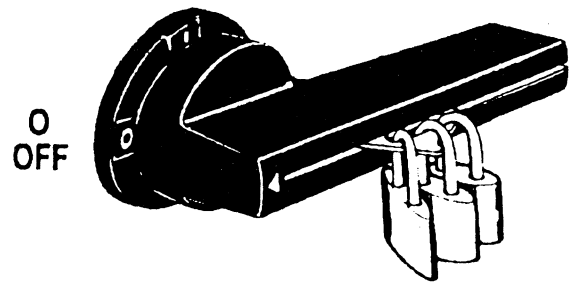
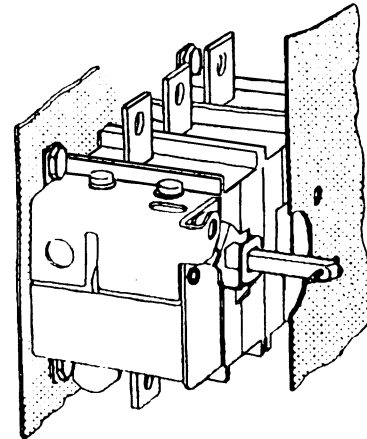

Factory-installed, internally-mounted, NEC (National Electrical Code) and UL (Underwriters' Laboratories) approved non-fused switch provides unit power shutoff with disconnect lockout protection capability. The control box access door is interlocked with the non-fused disconnect. The non-fused disconnect must be in the OFF position to open this door. The switch is accessible from outside the unit.

**HAIL GUARD (004-025 Only)**

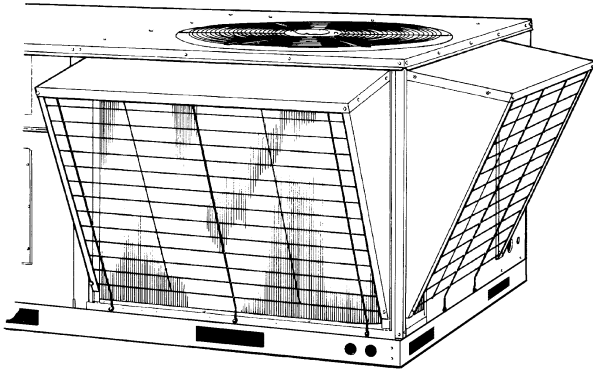

Condenser coil hail guard accessory (field installed) protects coils against damage from hail and other flying debris.

**COIL GUARD GRILLE (004-014 Only)**

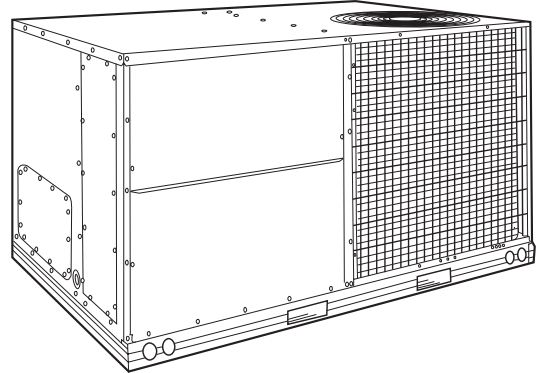

Coil guard grille protects coils against large objects and vandalism.

**CONTROL BOX HINGED PANEL OPTION\*,  
48HJ004-007 UNITS WITH APOLLO CONTROL  
SHOWN**

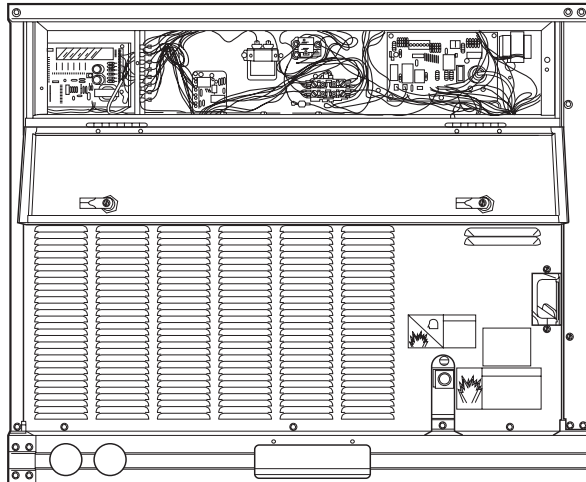

**CONTROL BOX HINGED PANEL OPTION\*,  
48HJ008-014 UNITS SHOWN**

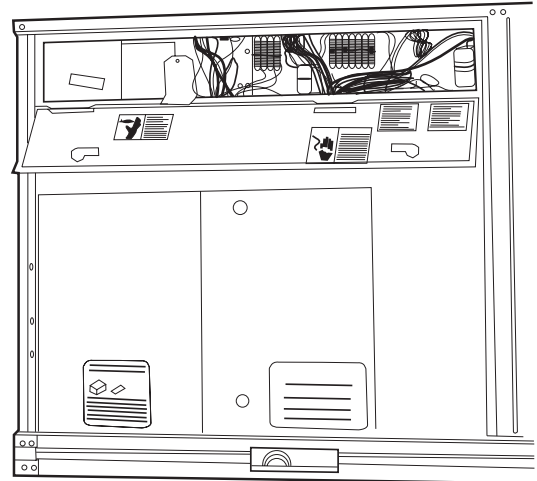

**COMPRESSOR HINGED PANEL OPTION\*,  
48HJ008-014 UNITS SHOWN**

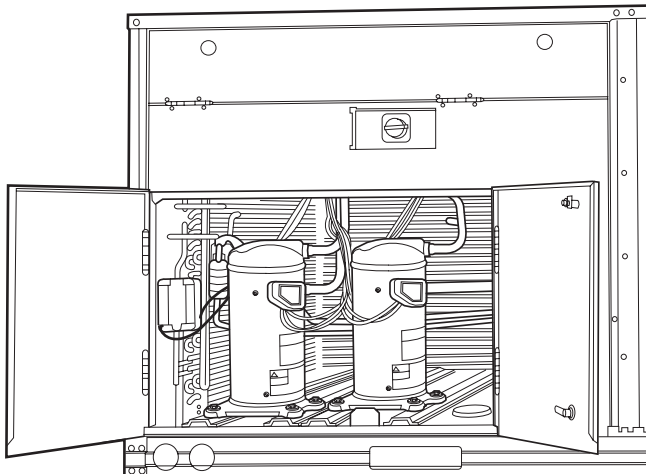

**COMPRESSOR HINGED PANEL OPTION\*,  
48HJ004-006 UNITS SHOWN**

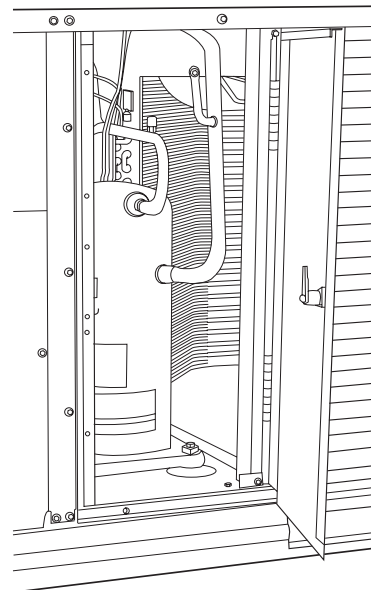

\*Hinged panels not available on TM sizes 004-014.

This is included as a factory-installed option. It permits quick and simple compressor access.

# Options and accessories (cont)



## EVAPORATOR-FAN HINGED PANEL OPTION\*

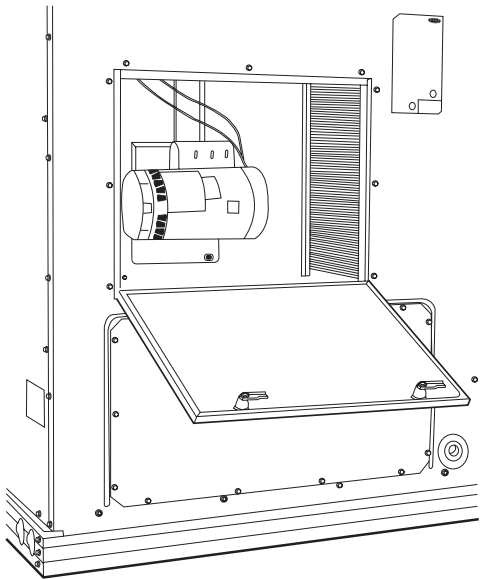

This is included as a factory-installed option. It permits quick and simple evaporator-fan access.

## FILTER HINGED PANEL OPTION\*

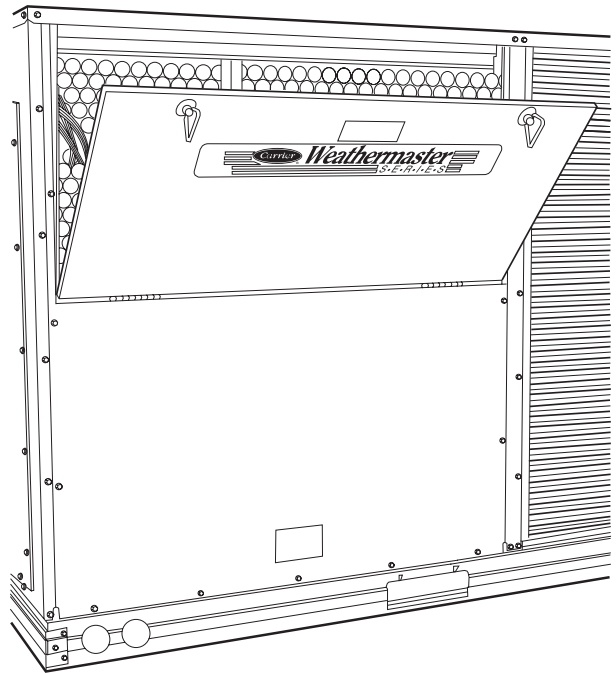

This is included as a factory-installed option. It permits tool-less filter access.

\*Hinged panels not available on TM004-014 sizes.

## BAROMETRIC RELIEF OR POWER EXHAUST (015-028 Shown)

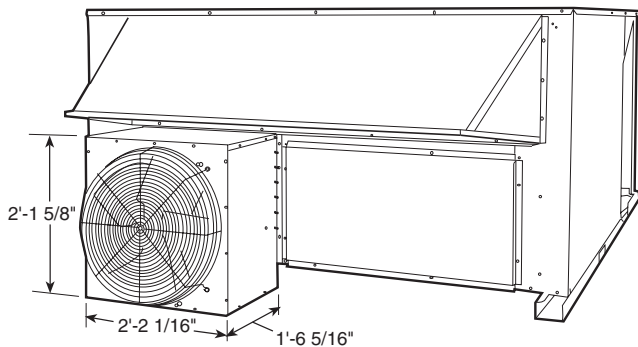

When used with accessory/optional economizer, the barometric relief or power exhaust accessory helps to relieve building overpressurization.

NOTE: This is not available with horizontal supply adapter curb.

## LP CONVERSION KIT

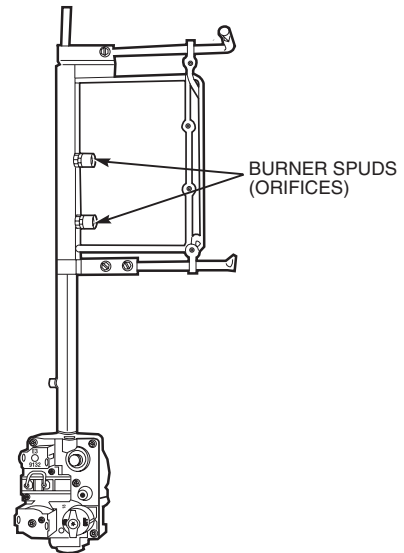

LP conversion kit allows the unit to utilize a liquid propane fuel supply in areas where natural gas is not available. Kit may be used at elevations as high as 2000 ft. (Kit shown is for sizes 004-007.)

# Controls



**PremierLink™ Direct Digital controls** — The Premier-Link Direct Digital Controls (DDC) require the use of a Carrier electronic thermostat or a CCN connection for time broadcast to initiate its internal timeclock. This is necessary for broadcast of time of day functions (occupied/unoccupied).

PremierLink Features:

- Equipment Control Functions
  - Cooling Stages
  - Heating Stages
  - Indoor-Fan Motor
  - 4-Way Valve
- Economizer Control Functions
  - Dry Bulb Control
  - Enthalpy Control
  - Differential Enthalpy
  - Power Exhaust

- Advanced Control Functions
  - Smoke Detection
  - Optimal Start (90.1)
  - Unoccupied Free Cool
  - Smart Staging and Optimal Staging
- Network Protocol
  - CCN
  - Internet Ready 38.4 K baud rate
- Diagnostics/Advanced Service Features
  - Diagnostics
  - Onboard display
- Scheduling
  - Via Communicating Stat
- User Interface
  - Navigator (LEN protocol)
  - LID2B (CCN)
  - PC w/Carrier software (CCN)

## CCN POINTS FOR PREMIERLINK CONTROL

DESCRIPTION	STATUS	UNITS	POINT	LIMITS	ACCESS
Space Temperature	xxx.x	dF	SPT	-40.0 to 245.0 dF	R/W
Supply Air Temperature	xxx.x	dF	SAT	-40.0 to 245.0 dF	R/W
Outside Air Temperature	xxx.x	dF	OAT	-40.0 to 245.0 dF	R/W
Control Setpoint	xxx.x	dF	CLSP		R
Cooling % Total Capacity	xxx	%	CCAP	0 to 100 %	R
Heating % Total Capacity	xxx	%	HCAP	0 to 100 %	R
Economizer Active	No/Yes		ECOS	0 to 1	R
Supply Fan Relay	Off/On		SF	0 to 1	R/W
Supply Fan Status	Off/On		SFS	0 to 1	R
Economizer Position	xxx.x	%	ECONPOS	0.0 to 100.0 %	R/W
Current Min Damper Pos	xxx.x	%	IQMP	0.0 to 100.0 %	R
Filter Status	Clean/Dirty		FLTS	0 to 1	R/W
Remote Occupied Mode	Off/On		RMTOCC	0 to 1	R/W
Heat Stage 1	Off/On		HS1	0 to 1	R
Heat Stage 2	Off/On		HS2	0 to 1	R
Heat 3/Exhaust/Rev Valve	Off/On		H3_EX_RV	0 to 1	R
Enthalpy	Low/High		ENTH	0 to 1	R/W
Indoor Air Quality	xxxx.x		IAQI	0.0 to 5000.0	R/W
Indoor Air Quality Setpt	xxxx.x		IAQS	0.0 to 5000.0	R
Outdoor Air Quality	xxxx.x		OAQ	0.0 to 5000.0	R/W
Fire Shutdown	Normal/Alarm		FSD	0 to 1	R/W
SPT Offset	xx.x	^F	STO	-15.0 to 15.0 ^F	R/W
Compressor 1	Off/On		CMP1	0 to 1	R
Compressor 2	Off/On		CMP2	0 to 1	R
Compressor Safety	Off/On		CMPSAFE	0 to 1	R

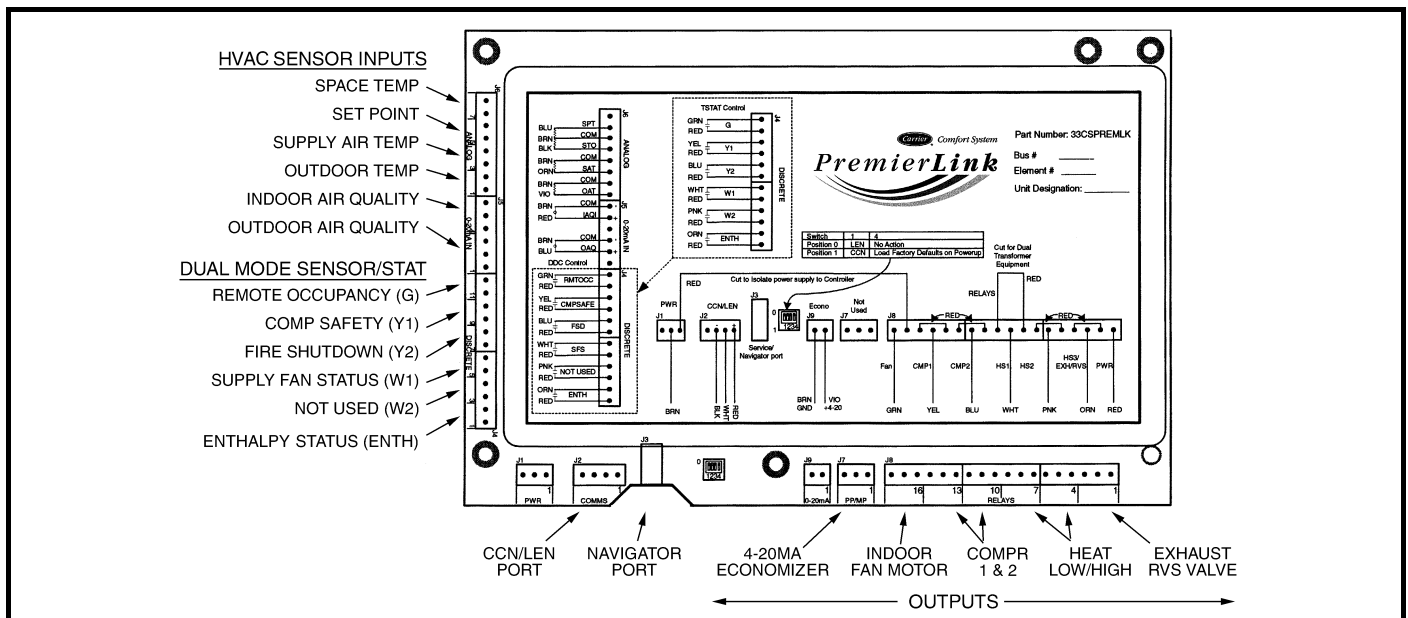

# Controls (cont)



## TYPICAL CCN/3rd PARTY INTERFACE

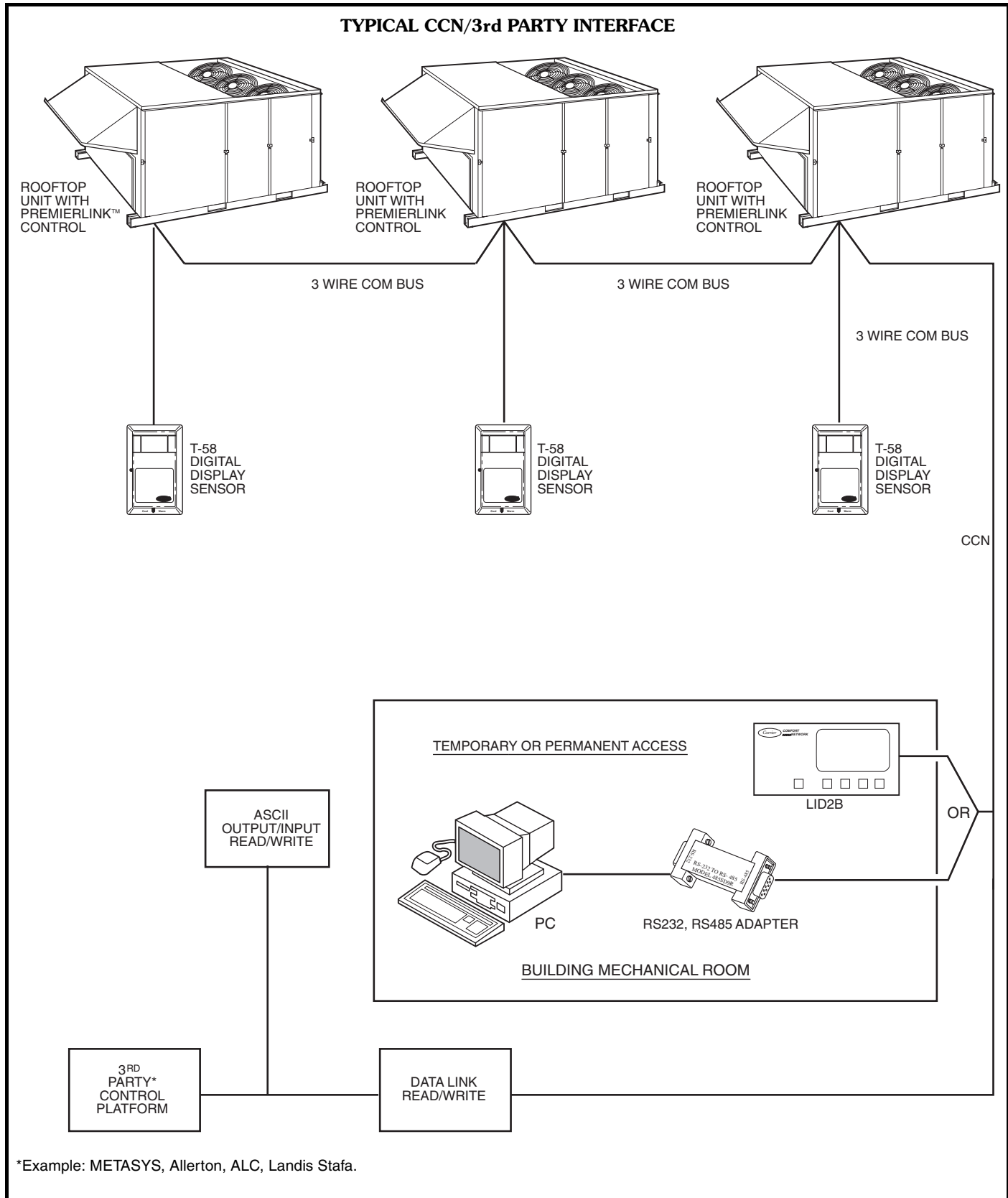

\*Example: METASYST, Allerton, ALC, Landis Stafa.

### Typical LEN (Local Equipment Network) mode

Allows unit software access with Navigator™ or Scrolling Marquee accessories. Both have unit diagnosis and

configuration abilities. Thermostat required for stand-alone operation, timeclock required to provide unit schedule (occupied/unoccupied) for sensor applications.

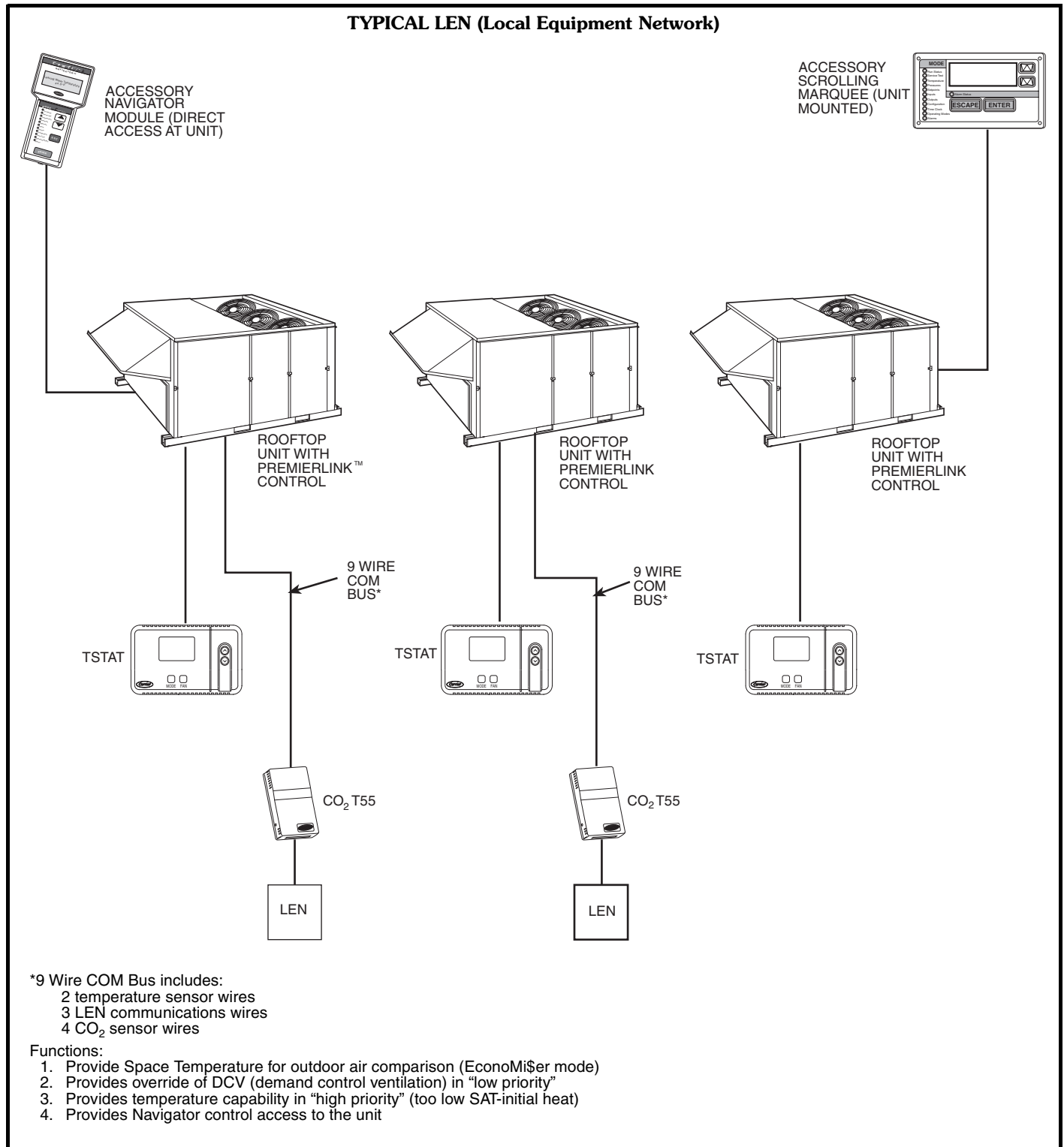

# Controls (cont)

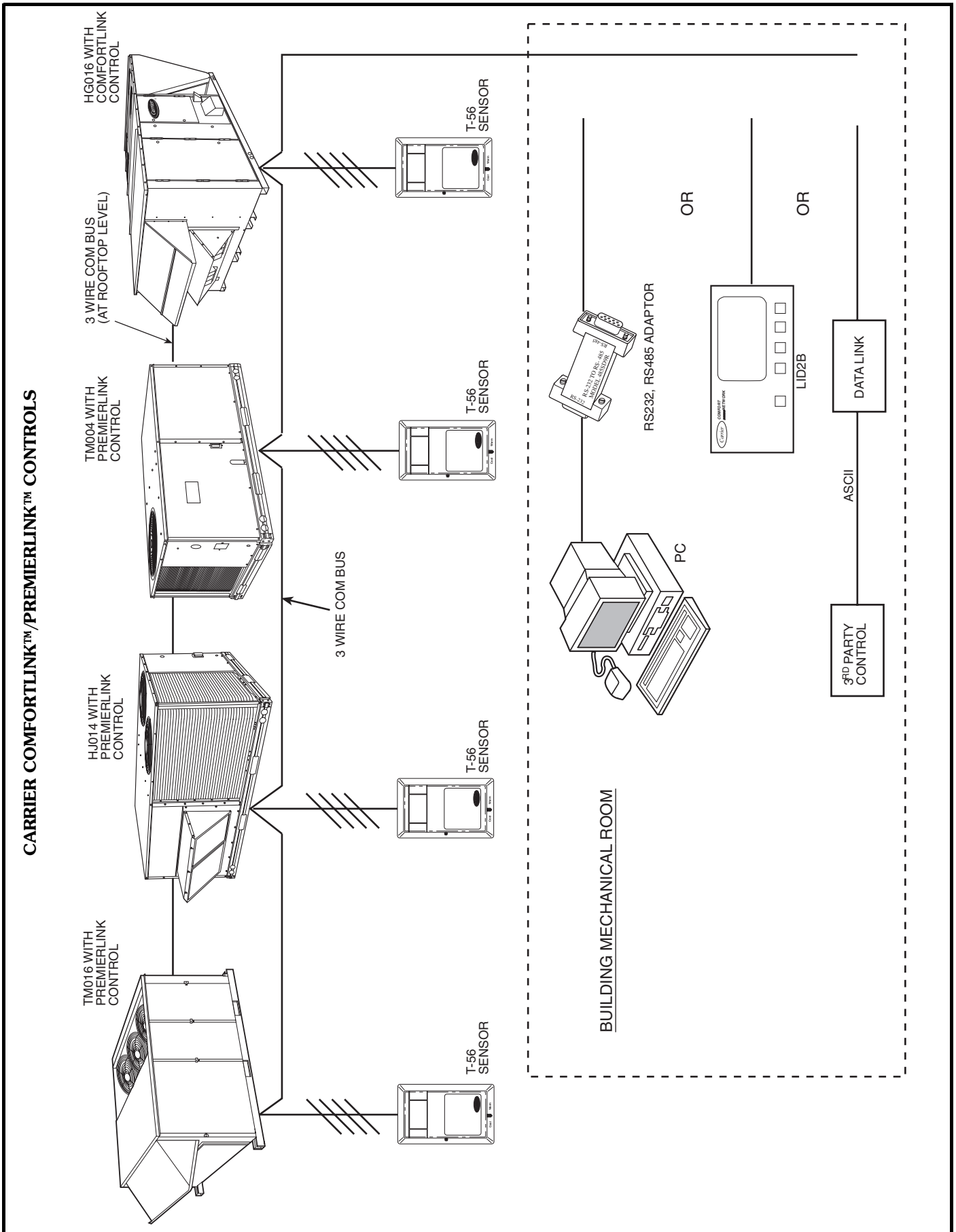

### TYPICAL PREMIERLINK™ CONTROLS WIRING

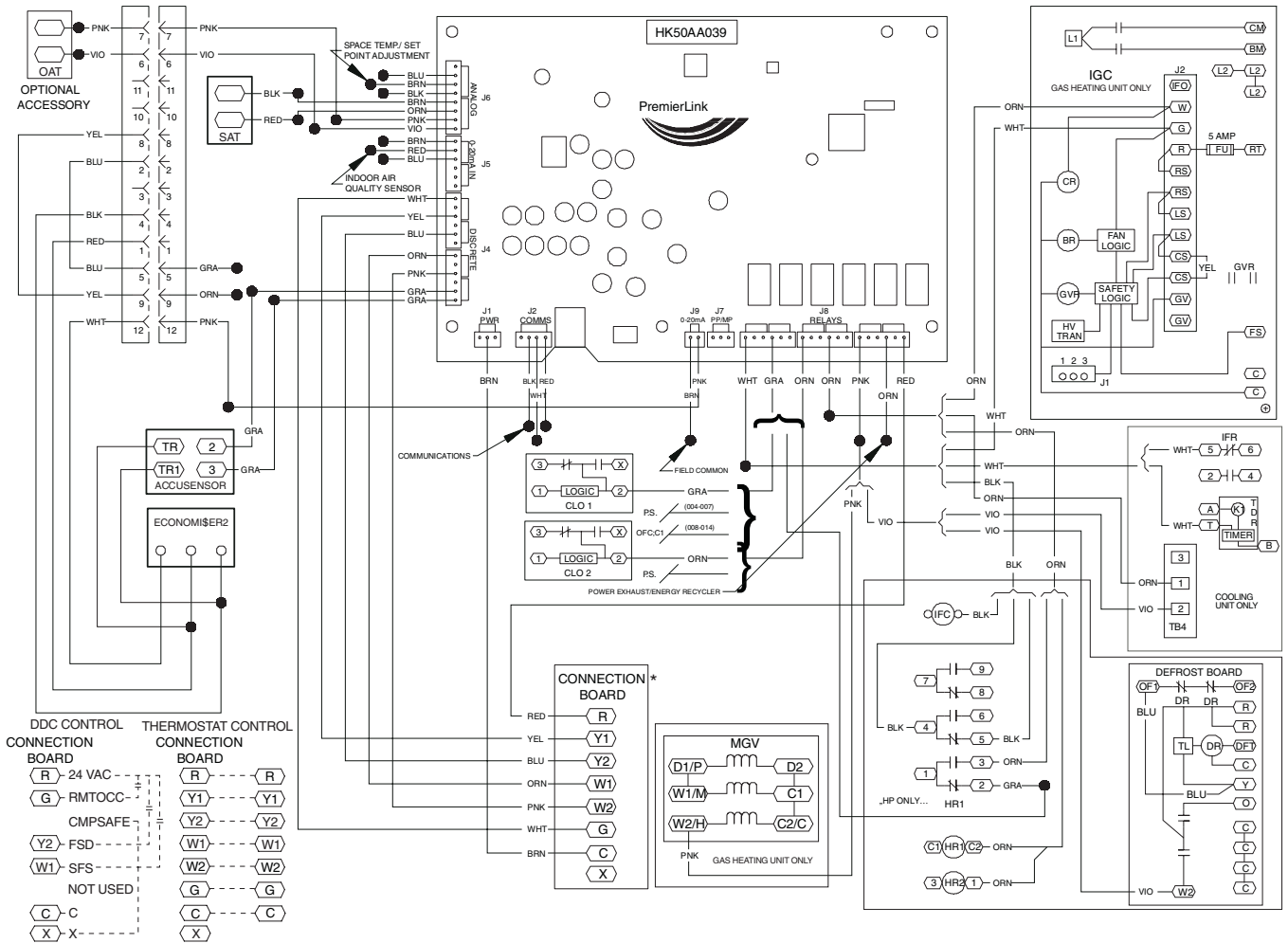

- CLO** — Compressor Lockout
- COMMS** — Communications
- HR** — Heating Relay
- IFC** — Indoor Fan Contactor
- IFR** — Indoor Fan Relay

**LEGEND**

- IGC** — Integrated Gas Unit Controller
- MGV** — Main Gas Valve
- OAT** — Outdoor Air Temperature Sensor
- PWR** — Power
- SAT** — Supply Air Temperature Sensor

\*When connecting DDC or thermostat controls, wire to connection board. Do not wire directly to PremierLink board.

# Controls (cont)



## TEMP systems

A TEMP System is a network of communicating Carrier TEMP System Thermostats and rooftop, factory-mounted Apollo direct digital controls, each serving its own zone and heating/cooling unit. Networking allows your building manager to easily access each of your systems from a single location...whether they are in the same building or located throughout town.

The TEMP System's inherently flexible, modular base design supports the **exact** number of independent, single

zone systems you require...no more, no less, no compromises.

Ideal for department stores, small office buildings, fast food chains, schools, and hotels, a TEMP System is a cost-effective way to maintain comfortable building environments.

NOTE: Unit temperature rise must not be exceeded for proper unit operation.

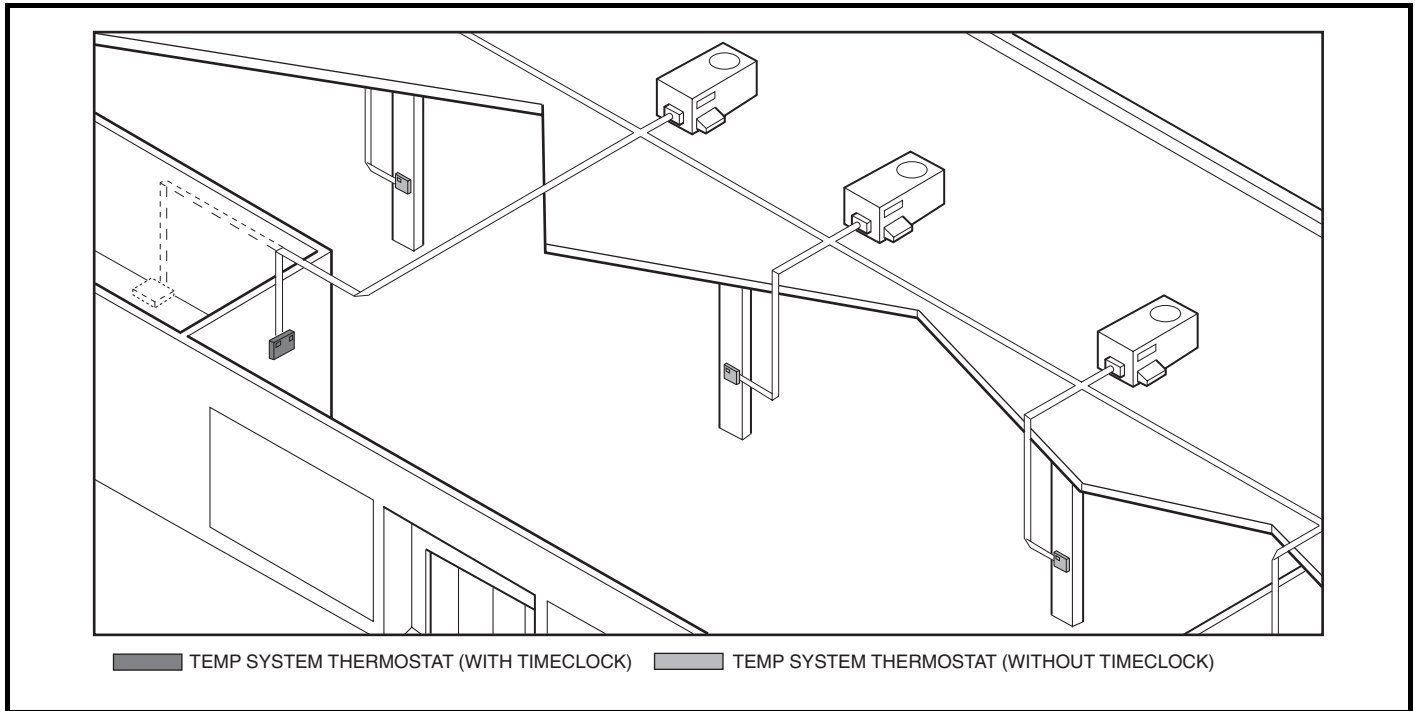

## STANDARD UNIT TYPICAL FIELD THERMOSTAT WIRING

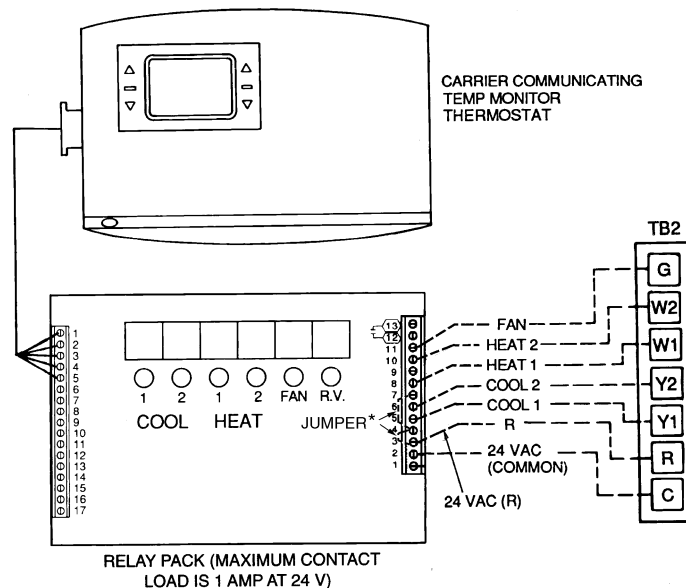

## Variable Volume/Variable Temperature VVT® Systems

VVT Systems are dedicated to total building comfort. Carrier thermostats, zone dampers, and HVAC equipment with factory-mounted direct digital controls continually monitor and adjust their operation to ensure uninterrupted and personalized comfort for all occupants.

Through the use of communicating electronic controls, VVT Systems are able to provide the comfort of a multiple

zone system while using the installation, operating and maintenance economics of single zone equipment... virtually putting an end to the cost vs. comfort compromise.

NOTE: Unit temperature rise must not be exceeded for proper unit operation.

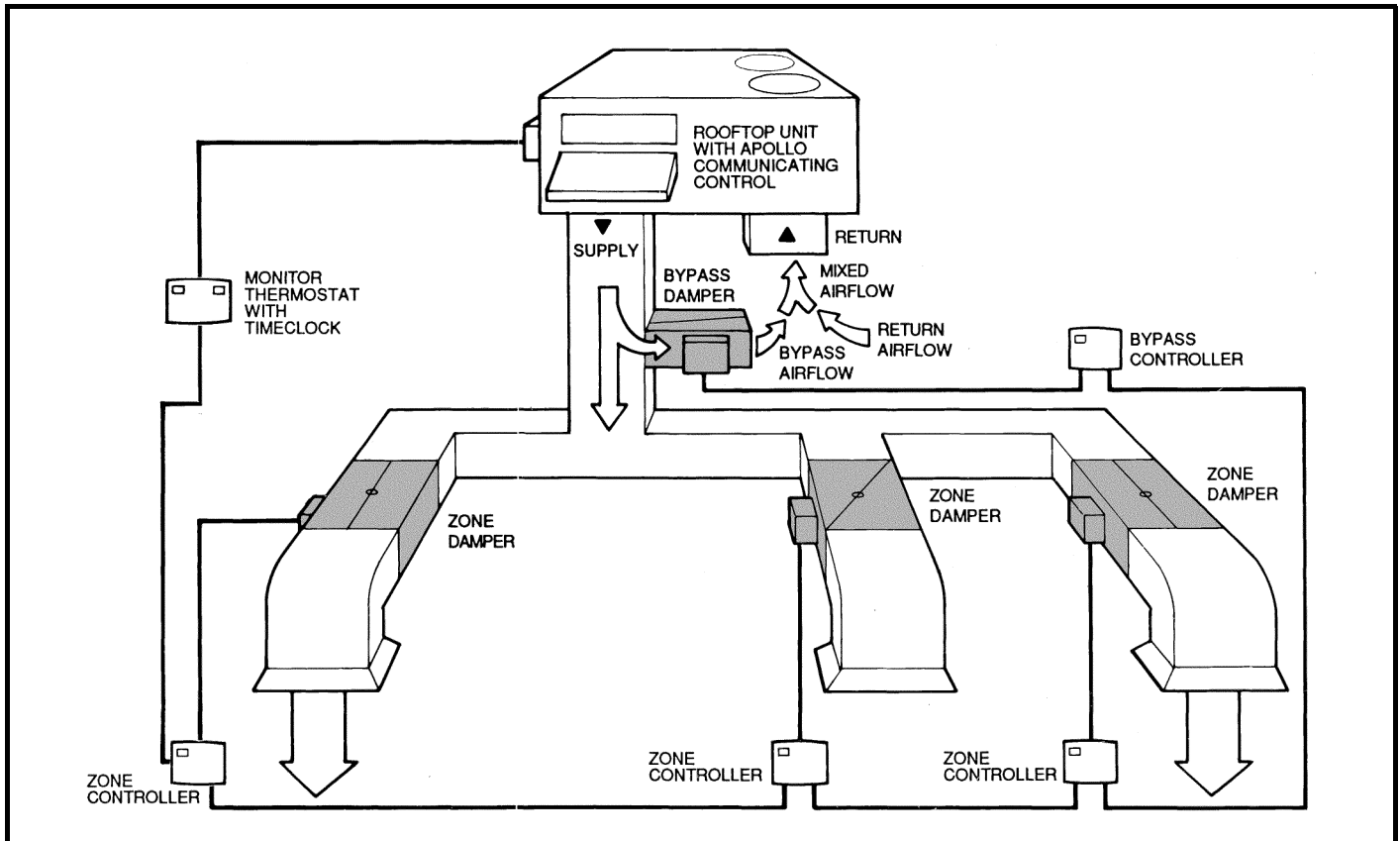

# Controls (cont)



## VVT® application guidelines

**General** — The VVT system is a zoning system that allows a single-zone heating/cooling system to operate as a multiple-zone system. For this system to function correctly and not adversely affect the reliability of the heating/cooling system, the information provided here must be followed.

There are two parts of the VVT system installation that are important for successful operation: the bypass damper and the HVAC (Heating, Ventilation, and Air-Conditioning) equipment configuration settings. The following information will provide important details for these two items as well as specific instructions for the rooftop units. This information is intended as a supplement to the Installation Instructions shipped with the equipment.

**Bypass damper** — The bypass damper and controller serve to accomplish two functions in the VVT system. First, the bypass damper keeps supply duct pressure and velocity down at partial load. This permits the VVT system to utilize standard low-velocity, low-pressure supply ductwork, duct insulation, and duct sealing methods. Without the bypass damper, the restriction of the zone dampers that are closing at partial loads would cause duct static pressure to climb, adding stress to all supply duct materials. Accompanying velocity and noise would create problems in the conditioned space.

Second, when the bypass damper is set up correctly, it ensures that the airflow through the HVAC equipment remains above the minimum required levels. (See capacity ratings for minimum heating cfm required for proper operation of the rooftop heating system. These minimum heating cfm levels must be maintained during all phases of heating operation. The heating cfm values take precedence over listed minimum cooling cfm values.) This permits the use of constant volume rooftop units on VVT applications. Without the bypass damper, the restriction of the zone dampers that are closing at partial loads will reduce the airflow through the unit to below the minimum levels.

The installer is responsible for ensuring that the bypass controller is configured and the system is balanced so that the minimum airflow is higher than 300 cfm/ton (40 L/s per kW). To accomplish proper configuration set the System Setup Enable Function (Category 5, option 7) to ON. This will close the bypass damper and force all of the zone dampers to open. The air balance should be completed after the zones minimum airflow has been set, verifying the total airflow through the equipment is above the minimum airflow level.

**VVT bypass design layout** — Particular attention must be given to bypass duct layout. It has been a source of VVT system operating problems when neglected. Proper layout consists of the five factors:

1. Proper location of the bypass
2. Adequately sizing the bypass
3. Avoiding short-circuiting of supply and return air
4. Proper location of the static pickup
5. Facilitating the mixing of bypass air with return air

The recommended location of the bypass damper is for it to duct the bypass air either into the ceiling plenum or into unoccupied spaces. See figure below for a typical installation. This method of installation prevents interference with intended fresh air intake through the unit and economizer operation.

It is highly recommended that the bypass damper is **not** ducted between the rooftop unit's supply duct and the return duct as shown in the diagram below. This type of installation may result in the return duct becoming pressurized causing many problems such as:

- Preventing intended fresh intake for ventilation from entering the unit.
- Preventing proper operation of the economizer and causing mechanical cooling to energize needlessly.
- Preventing proper mixing of bypass air and return air resulting in low return temperatures in cooling, and high return temperature in heating.

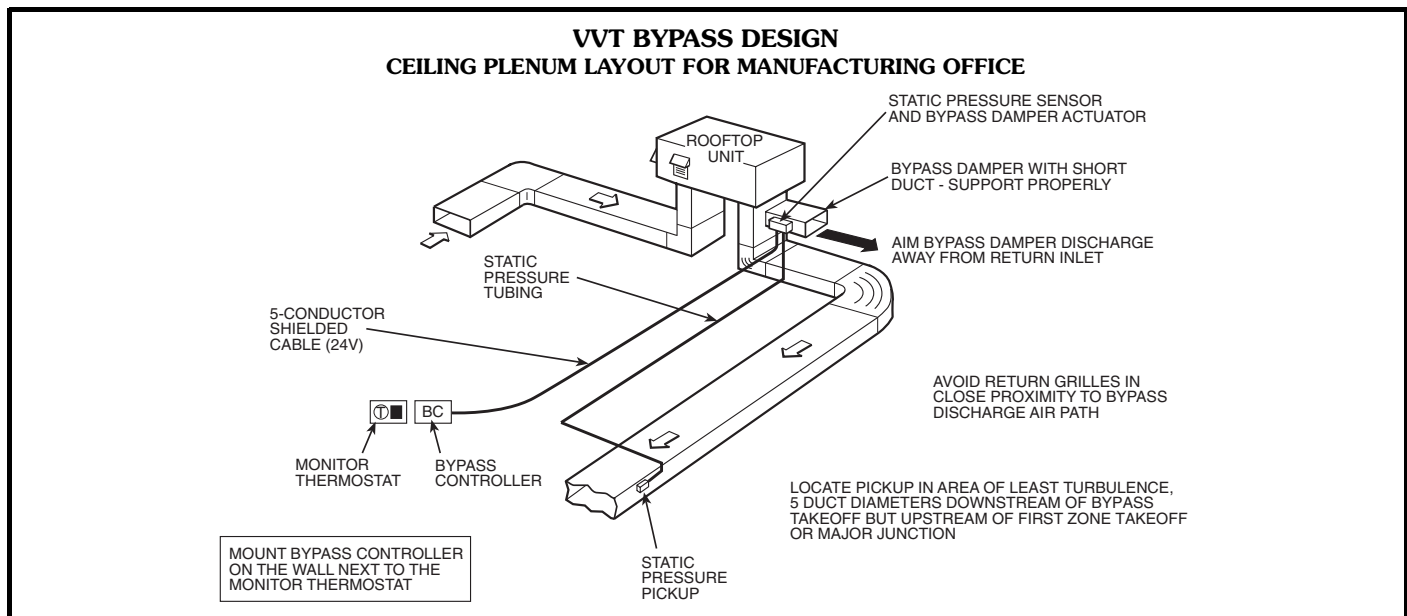

If the diversity within the space does not vary much, then bypass can be installed as shown in the diagram below successfully. Care must be taken to ensure that maximum bypass air at part load conditions does not exceed 25% of the full load airflow.

The bypass junction *must be* installed with sufficient duct length between it and the unit to allow complete mixing of the bypass air and the return air. Without adequate mixing, comfort control will be lost as the equipment will be cycled off and equipment failures may result if left at the extremes. When the HVAC equipment uses an economizer, a back-draft damper needs to be installed between the connection of the bypass duct and the closet room return air grille.

**Bypass controller considerations** — Besides considering the minimum and maximum cfm's required, as in the system design guidelines, the following are a few system concerns to consider when designing a bypass damper in a VVT® system.

1. The maximum amount of air being bypassed should match an equivalent amount of cfm of unconditioned air based on the ability of the system to unload. For example: If the equipment has two compressors and one unloader, then the refrigeration portion of the equipment is capable of unloading to about 25% of unit capacity. Therefore the designer should make sure the system will use 25% of the system cfm for comfort conditioning and bypass 75% of the conditioned air before energizing the compressors. This will ensure that the system will have enough return air mixing with the bypassed air to keep the compressor running. Make sure that the compressor does not cycle too frequently based on the leaving air temperature limits since this could lessen the reliability of the compressors. The heating equipment will only be able to unload 50%. The system may be designed to cycle based on the leaving air temperature limits depending on the rise designed in the heat exchanger and the amount of outside air being brought in. Although this

is not efficient, the equipment reliability should not be a problem.

2. Be sure to verify the pressure drop across the bypass when in full bypass. The bypass should maintain the system pressure without causing 100% of the air to be bypassed. Tables are provided in the Comfort Systems Controls manual which will indicate the sound and performance criteria of Carrier dampers. Calculate bypass of 4500 cfm on a unit with a nominal airflow of 6000 cfm and external static pressure of 0.50 in. wg. The ZD-16 has two entries in the table of 1475 and 1574. Three ZD-16 dampers in parallel could be used for the job. The 16-in. damper will not operate full open to produce these results, so it will be necessary to balance the system and set the maximum damper position to achieve these results in the field.
3. These airflows were tested at 0.50 in. wg and provided NC levels of 42 and 44 respectively. A noise criteria of around 40 would be acceptable for a ducted bypass with internally lined duct but probably not for externally lined ducts since the noise could be transmitted to the return registers. Duct design is important to consider in bypass design since improper noise levels can require the use of other dampers to achieve the same bypassed cfm with reduced noise. For the example above, two 35D, 16-in. dampers can move the same air at a NC level of 29.5 Radiated. These dampers can be ordered with sound attenuators to lessen radiated noise also. Use the damper test criteria to make the selection.
4. If designing a system with an economizer, be sure to include power exhaust on the equipment to prevent conditioned air from migrating out the return registers into the space in a over pressure condition. This condition can be identified since the doors will most likely stand open. The same condition can occur if there is a large exhaust system in the building for labs or restrooms.

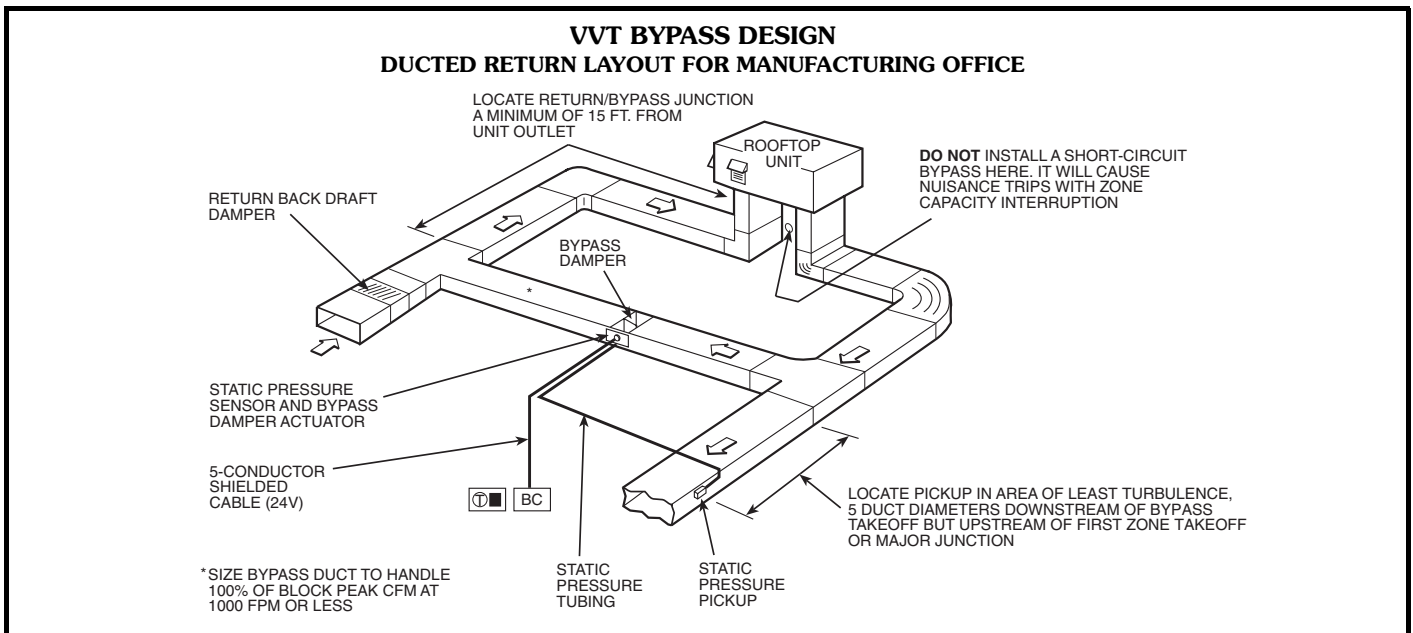

# Controls (cont)



**Monitor thermostat configuration** — The monitor thermostat controls the operation of its own zone and of each associated zone controller. The monitor thermostat determines system operation from the information received from each device that it controls. The monitor thermostat must be configured for proper control of the system. Part of the configuration is Category 4.0, which deals with HVAC settings. The Category 4.0 HVAC Equipment table shows the default settings for this category.

NOTE: In the majority of cases only categories 4.5, 4.6, 4.7, 4.8 and 4.15 will require changing by the installer.

Leaving-air temperature (LAT) monitoring must be always used. This function prevents the HVAC equipment from operating in a range that will cause equipment safety trips, leading to shortened equipment life.

The Constant Volume Electric Cooling/Gas Heating tables provide the recommended cooling and heating limits that the monitor thermostat configures for 4.5, First Stage Cooling Limit; 4.6, Second Stage Cooling Limit; 4.7, First Stage Heating Limit; and 4.8, Second Stage Heating Limit.

There are tradeoffs involved in the selection of the system mode demand, monitor thermostat configurations 4.15. Lower setting levels tend to improve comfort but tend to increase operating costs and reduce equipment reliability. Buildings that have large core areas that are likely to make a call when others are not should use lower system mode demand levels. For buildings with zones that have more similar load patterns from zone to zone, or smaller zones or more uniformly sized zones, a higher setting should be used.

## CATEGORY 4.0 HVAC EQUIPMENT — DEFAULT SETTINGS

SETTING	DESCRIPTION	CURRENT DEFAULT
4.1	Fan Operation	Off
4.2	Time Guard® Device between modes	On
4.3	Time Guard Device Override	Off
4.4	LAT Monitoring	On
4.5	First Stage Cooling Limit (F)	45 F
4.6	Second Stage Cooling Limit	50 F
4.7	First Stage Heating Limit	110 F
4.8	Second Stage Heating Limit	105 F
4.9	Auxiliary Relay (0= No Control, 1=Occupied Schedule, 2=IAQ, 3=Reversing Valve, 4=Economizer)	0
4.10	Optimize Staging	On
4.11	Cooling Temperature lockout	On
4.12	Cooling Lockout Set Point	45 F
4.13	Heating Temperature Lockout	Off
4.14	Heating Lockout Set Point	60 F
4.15	System Mode Demand	3
4.16	System Mode Re-Select (minutes)	30
4.17	Minimum Heat Run Time	5
4.18	Minimum Cool Run Time	3
4.19	Pre-occupancy Purge	Off
4.20	Fan Switch (0=Thermostat Switch Position, 1=Fan Switch On, 2=Fan Switch Off)	0
4.21	Cool Switch (0=Thermostat Switch Position, 1=Cool Switch Auto, 2=Cool Switch Off)	0
4.22	Heat Switch (0=Thermostat Switch Position, 1=Heat Switch Auto, 2=Heat Switch Off)	0

**DX coil sensor installation** — The use of a DX (direct expansion) coil sensor is recommended. The DX temperature sensor should be installed in the ductwork as close to the equipment as possible. Care must be taken not to have the sensor within “line of sight” of the equipment’s heating elements. Radiation from the heat can cause the sensor to read an elevated reading.

The majority of the units referred to by these application guidelines are two compressor units. The monitor thermostat has the ability to read only one DX coil sensor, which can only be installed within the equipment on a single compressor unit. All of the LAT settings have been determined assuming supply duct temperatures versus coil temperatures. Be sure the DX coil sensor option is turned on. Category 5.6 under the monitor configurations, should be ON.

**Application guidelines** — The units are constant volume units and will require the use a bypass damper and controller. Refer to page 22 for details regarding the use and installation of the bypass damper.

These units use a TXV metering device. Use of optional, factory-installed hot gas bypass (HGBP) is recommended for VVT® applications to aid in low load performance operation.

Electrical connection from the VVT system to the units will be the typical thermostat connections from the relay pack to the unit.

Refer to the table below for LAT set points.

## CONSTANT VOLUME ELECTRIC COOLING/GAS HEATING (F) (015-028) UNITS

UNIT 48	CATEGORY 4.0 HVAC SETTINGS			
	4.5	4.6	4.7	4.8
HJD015	45	49	112	125
HJF015	45	49	123	140
HJD017	64	50	112	125
HJF017	64	50	116	130
TMD016	64	50	112	125
TMF016	64	50	116	130
TMD020	70	59	112	125
TMF020	70	59	116	130
TMD025	64	49	112	125
TMF025	64	49	116	130
TMD028	70	59	112	125
TMF028	70	59	116	130

## Carrier Apollo controls

The Apollo direct digital controls are ordered as a factory-installed option. Designed and manufactured exclusively by Carrier, the controls can be used to actively monitor and control all modes of operation, as well as to monitor evaporator-fan status, filter status, indoor-air quality (humidity and carbon dioxide), supply-air temperature, outdoor-air temperature, and field-provided sensors.

The Apollo communicating controls are factory-installed into the rooftop unit control box, and come equipped with built-in diagnostic capabilities. Light-emitting diodes (LEDs) simplify troubleshooting by indicating thermostat commands for both stages of heating and cooling, evaporator fan operation, and economizer operation. The Apollo communicating controls are designed to work specifically with the Carrier TEMP and VVT® (variable volume and temperature) thermostats. The Apollo controls allow the use of an IAQ (Indoor-Air Quality) sensor. The Apollo controls, combined with Carrier thermostats, incorporate a 5-minute recycle delay timer between modes of operation to prevent short cycling.

The standard rooftop control system is readily adaptable to all conventional and programmable thermostats. In addition, units are suitable for integration into building monitor control systems if required. This system gives the units the flexibility to communicate with almost any thermostat or building control system.

# INDOOR-AIR QUALITY AND APOLLO CONTROLS WIRING

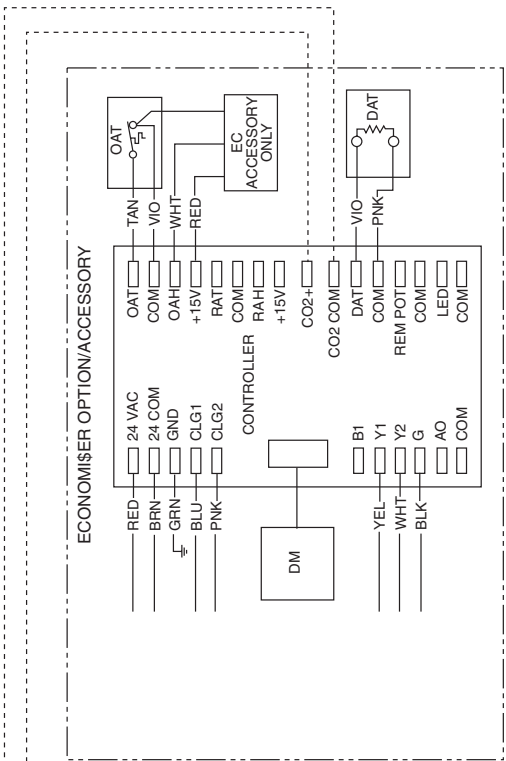

## LEGEND

- CO<sub>2</sub> Carbon Dioxide
- COM Common
- DAT Discharge Air Thermistor
- DM Damper Motor
- DX Direct Expansion Coil Sensor
- EC Enthalpy Control
- HVAC Heating, Ventilation, and Air Conditioning
- IAQ Indoor-Air Quality
- NC Normally Closed
- OAT Outdoor-Air Thermostat
- RV Reversing Valve
- SAT Supply-Air Temperature Sensor
- TEMP Temperature
- TRAN Transformer
- VTS Carrier TEMP System
- VWT® Variable Volume and Temperature

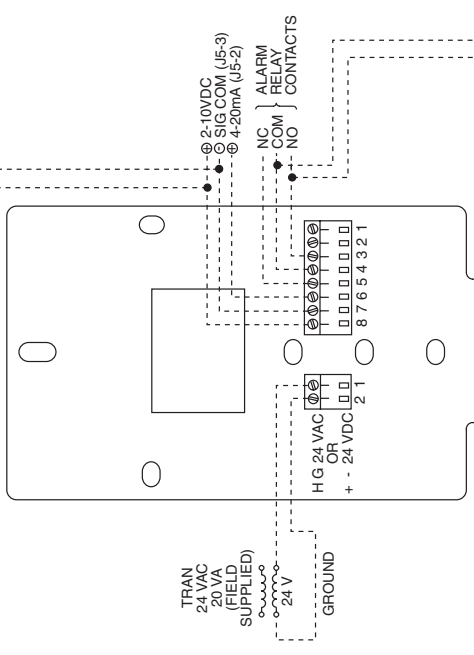

INDOOR AIR QUALITY (CO<sub>2</sub>) SENSOR (8325SENCO2) TYPICAL WIRING DIAGRAM

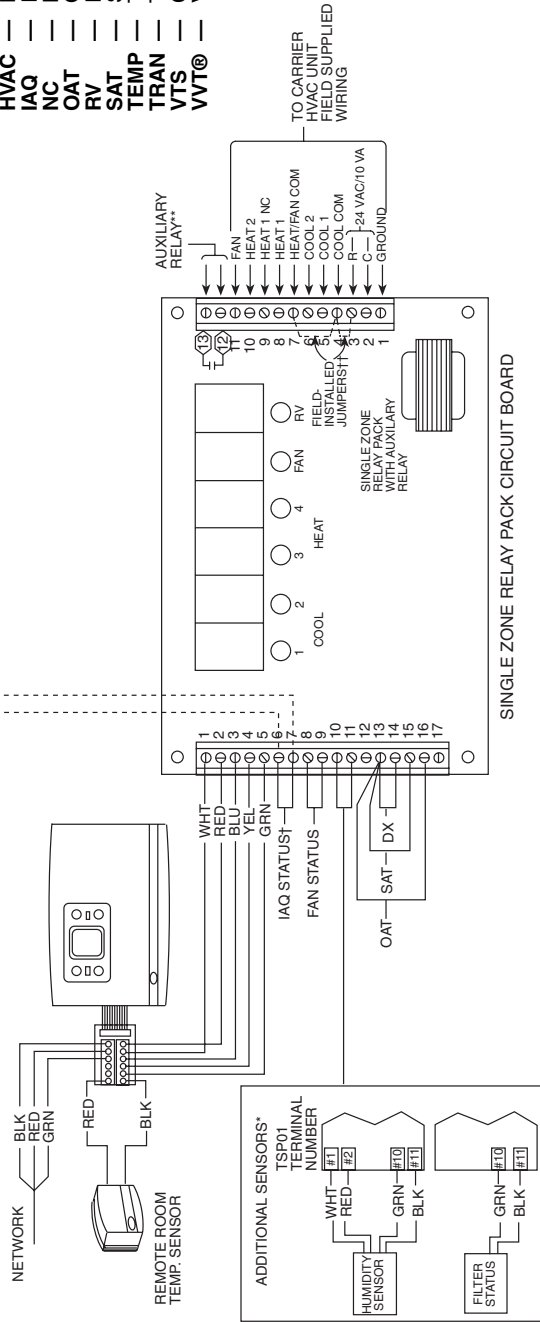

**NOTE:** When single zone relay pack is used on a VVT Monitor Only System, the monitor thermostat cannot control a damper.

\*Filter status switch and humidity sensor cannot function simultaneously. Only one sensor can be wired.

†Such as a CO<sub>2</sub> sensor.

\*\*Set auxiliary option to "2" — IAQ Control per VTS or VVT Installation Instructions.

## TYPICAL APOLLO THERMOSTAT WIRING — SIZES 004-007

USE THIS SENSOR WIRING DIAGRAM WHEN USING THERMOSTATS WITH CARRIER NUMBERS 33CSVM(T)-04, -16, -32 AND 33CSTM(T)-01.

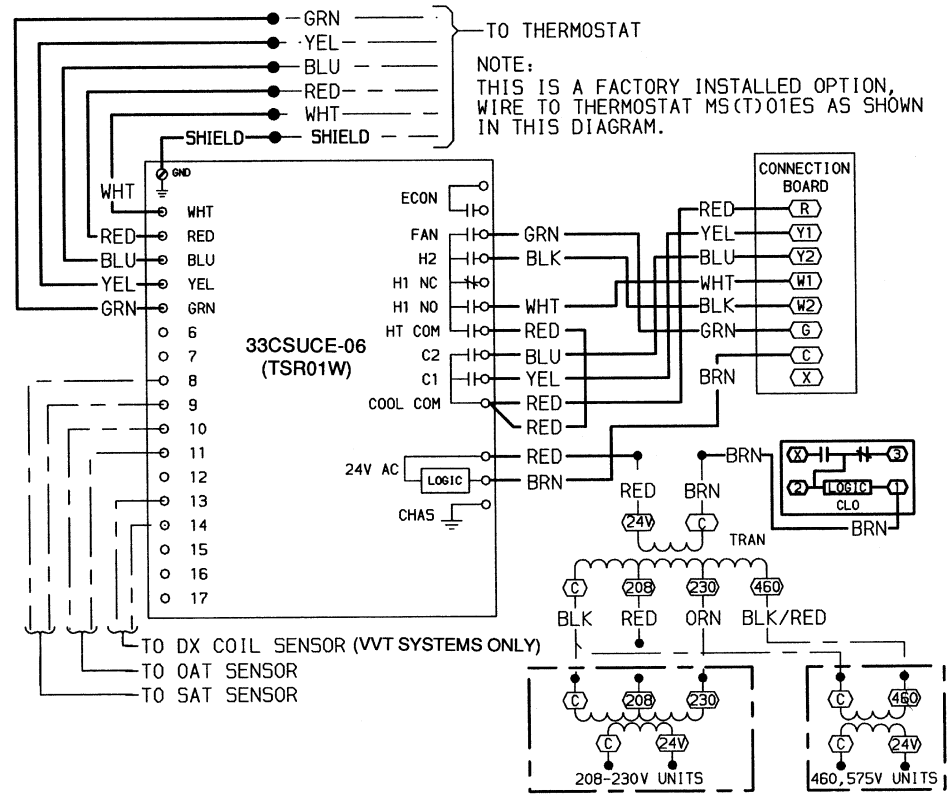
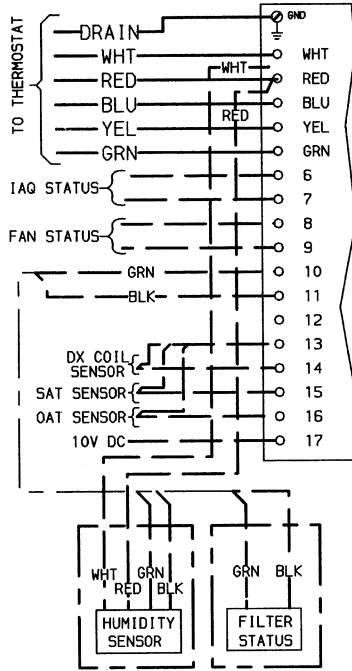

## TYPICAL APOLLO THERMOSTAT WIRING — SIZES 008-014

USE THIS SENSOR WIRING DIAGRAM WHEN USING THERMOSTATS WITH CARRIER NUMBERS 33CSVM(T)-04, -16, -32 AND 33CSTM(T)-01.

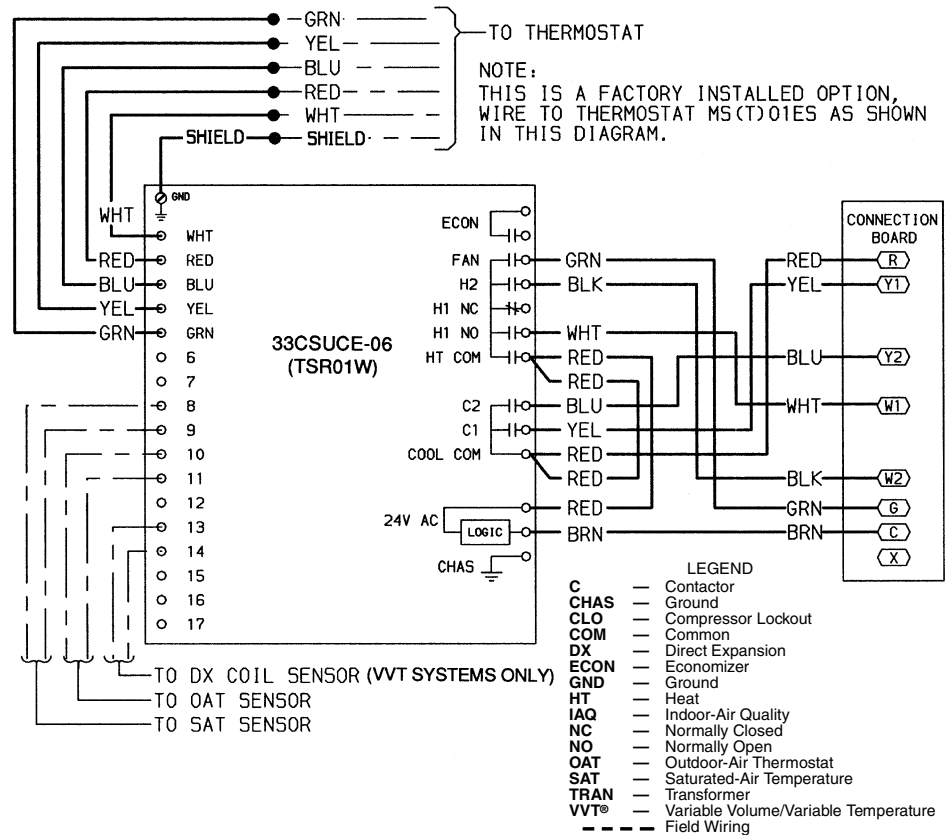
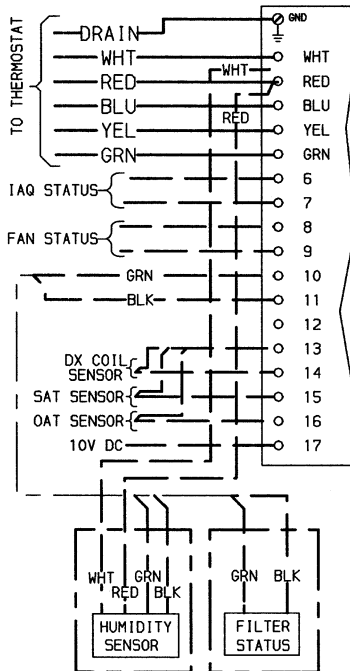

### FIRE AND SMOKE CONTROL WIRING — SIZE 004-014

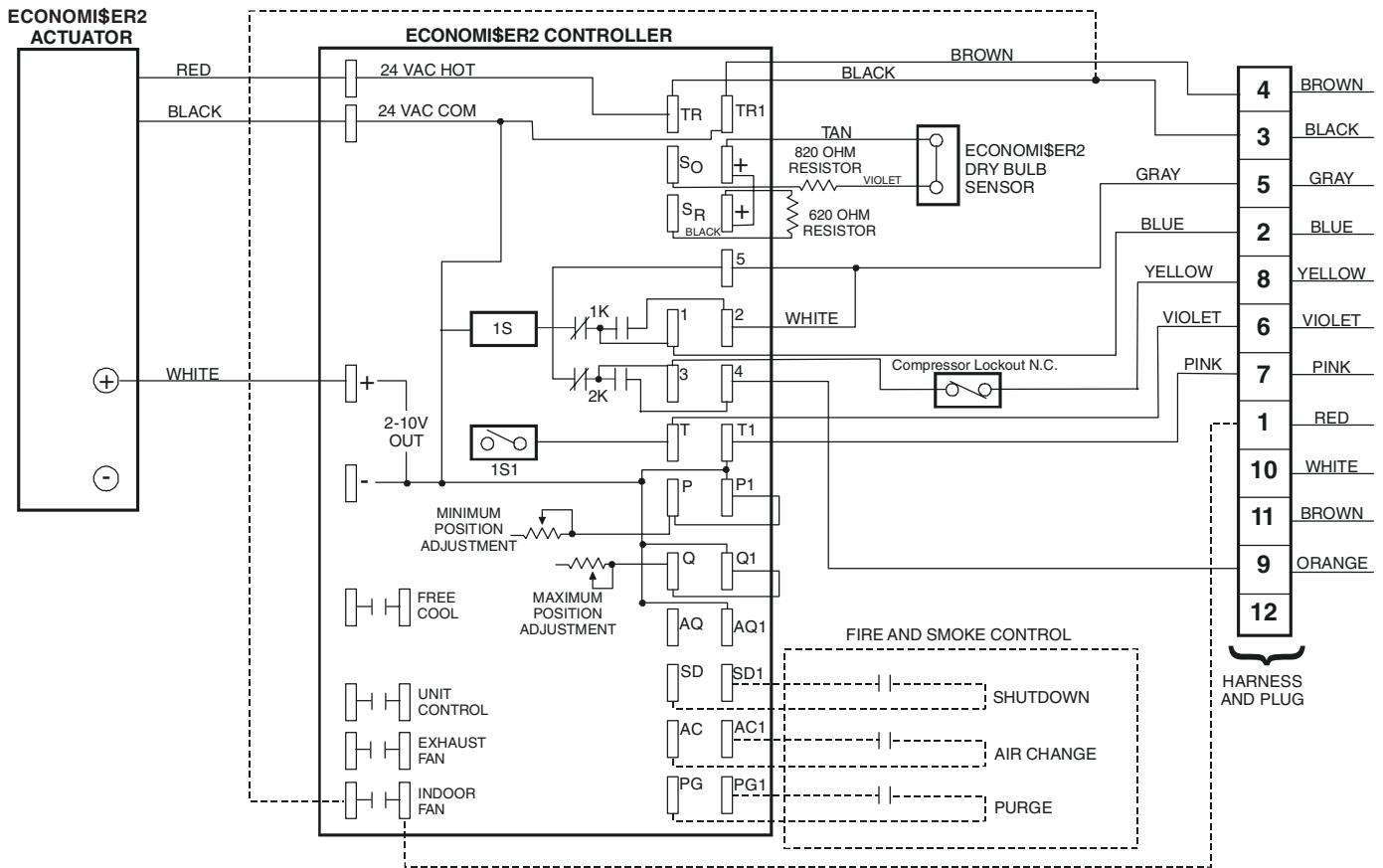

#### LEGEND

- |   |   |
|---|---|
| <p><b>IGC</b> — Integrated Gas Unit Controller</p> <p> Terminal (Marked)</p> <p> Terminal (Unmarked)</p> <p> Terminal Block</p> | <p> Splice</p> <p> Factory Wiring</p> <p> Field Wiring</p> <p> Option/Accessory Wiring</p> <p> To Indicate Common Potential Only, Not To Represent Wiring</p> |
|---|---|

**WARNING on Application and Use of Duct Smoke Detector.**

Do not use Duct Smoke Detectors as a substitute for an open area detector protection required by the National Fire Protection Association. Failure to install separate open area detector protection system could result in bodily injury (including death) and property damage.

Duct Smoke sensor will NOT sense smoke if the ventilation system is not operating, or the air is moving at less than 500 feet per minute, or the detector cover is not installed, or if there is no electric power to the detector.

Duct Smoke sensor will NOT function, and permanent detector damage may occur, below 32 F and above 131 F. If loss of ventilation can result in temperatures outside this range, permanent detector damage may occur that will prevent detector from activating when smoke is present.

Install and operate the Detector in accordance with manufacturer's instructions. Test and maintain detectors as recommended in NFPA 72. Failure to comply may prevent detector from activating when smoke is present.

NOTE: Rooftop indoor fan has a 30-second "ON" delay and "OFF" delay provided by the IGC board.

## TYPICAL SMOKE CONTROL/FIRE SHUTDOWN WIRING — SIZE 015-028

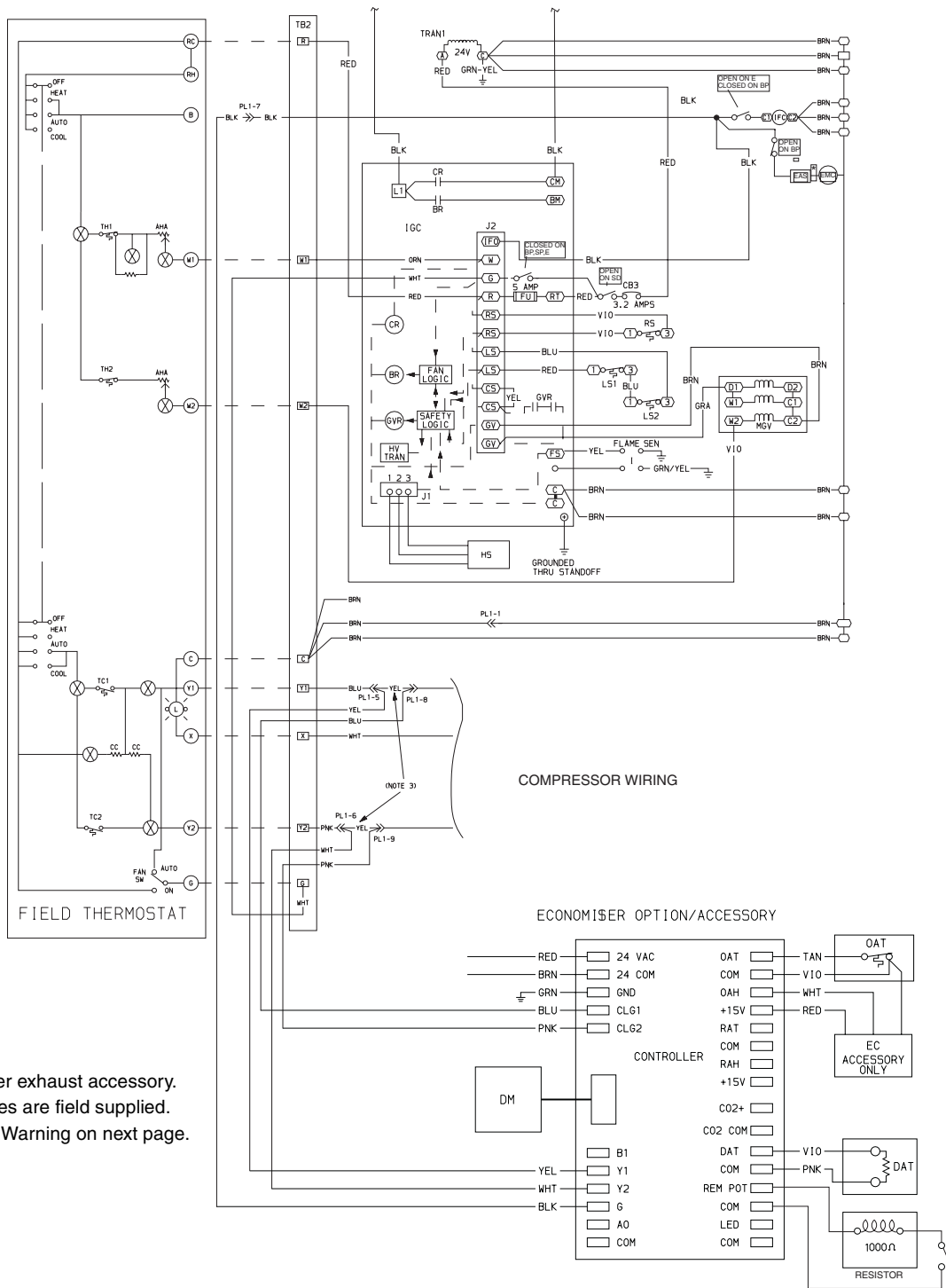

\*Included in power exhaust accessory.  
NOTE: All switches are field supplied.  
See Legend and Warning on next page.









### OPERATING MODES

- BP** — Building Pressurization: Evaporator fan on, economizer energized to fully open position, power exhaust disabled.
- E** — Evacuation: Evaporator fan off, economizer energized to fully open position, power exhaust on (open).
- SD** — Complete Unit Shutdown: Breaks 24-v power to the thermostat.
- SP** — Smoke Purge: Evaporator fan on, economizer energized to fully open position, power exhaust on.

### LEGEND

**AHA** — Adjustable Heat Anticipator  
**C** — Contactor, Compressor  
**CB** — Circuit Breaker  
**CC** — Cooling Compensator  
**CLO** — Compressor Lockout  
**CR** — Control Relay  
**DAT** — Discharge Air Thermistor  
**EAS** — Economizer Actuator  
     Auxiliary Switch  
**EC** — Enthalpy Control  
**EMC** — Economizer Motor Contactor  
**FU** — Fuse  
**GVR** — Gas Valve Relay  
**HS** — Hall Effect Sensor  
**HV** — High Voltage

**I** — Ignitor  
**IFCB** — Indoor-Fan Circuit Breaker  
**IGC** — Integrated Gas Unit Controller  
**L** — Light  
**LS** — Limit Switch  
**MGV** — Main Gas Valve  
**OAT** — Outdoor-Air Thermostat  
**PL** — Plug Assembly  
**RS** — Rollout Switch  
**SW** — Switch  
**TB** — Terminal Block  
**TC** — Thermostat Cooling  
**TH** — Thermostat Heating  
**TRAN** — Transformer

 Terminal (Marked)  
 Terminal (Unmarked)  
 Terminal Block  
 Splice  
 Factory Wiring  
 Field Wiring  
 Option/Accessory Wiring  
 To Indicate Common Potential Only, Not To Represent Wiring

WARNING on Application and Use of Duct Smoke Detector.

Do not use Duct Smoke Detectors as a substitute for an open area detector protection required by the National Fire Protection Association. Failure to install separate open area detector protection system could result in bodily injury (including death) and property damage.

Duct Smoke sensor will NOT sense smoke if the ventilation system is not operating, or the air is moving at less than 500 feet per minute, or the detector cover is not installed, or if there is no electric power to the detector.

Duct Smoke sensor will NOT function, and permanent detector damage may occur, below 32 F and above 131 F. If loss of ventilation can result in temperatures outside this range, permanent detector damage may occur that will prevent detector from activating when smoke is present.

Install and operate the Detector in accordance with manufacturer's instructions. Test and maintain detectors as recommended in NFPA 72. Failure to comply may prevent detector from activating when smoke is present.

NOTE: Rooftop indoor fan has a 30-second "ON" delay and "OFF" delay provided by the IGC board.

# Controls (cont)



## Operating sequence, 004-014 size units

**Cooling, units without economizer** — When thermostat calls for cooling, terminals G and Y1 are energized. The indoor (evaporator) fan contactor (IFC) and compressor contactor no. 1 (C1) are energized, and evaporator-fan motor (IFM), compressor no. 1, and condenser fan(s) start. The liquid line solenoid valve for compressor no. 1 is de-energized open. The condenser-fan motor(s) runs continuously while unit is cooling. For units with 2 stages of cooling, if the thermostat calls for a second stage of cooling by energizing Y2, compressor contactor no. 2 (C2) is energized and compressor no. 2 starts.

**Heating, units without economizer** — When the thermostat calls for heating, terminal W1 is energized. In order to prevent thermostat short-cycling, the unit is locked into the Heating mode for at least 1 minute when W1 is energized. The induced-draft motor (IDM) is then energized 20 seconds before the burner ignition sequence begins. The indoor (evaporator) fan motor (IFM) is energized 45 seconds after a flame is proven. On units equipped for two stages of heat, when additional heat is needed, W2 is energized and the high-fire solenoid on the main gas valve (MGV) is energized. When the thermostat is satisfied and W1 is deenergized, the IFM stops after a 45-second time-off delay.

**Cooling, units with Durablade economizer** — When the outdoor-air temperature is above the OAT (outdoor-air thermostat) setting and the room thermostat calls for cooling, compressor contactor no. 1 is energized to start compressor no. 1 and the outdoor (condenser) fan motor (OFM). The indoor (evaporator) fan motor (IFM) is energized and the economizer damper moves to the minimum position. Upon a further call for cooling, compressor contactor no. 2 will be energized, starting compressor no. 2 (008-014 only). After the thermostat is satisfied, the damper moves to the fully closed position when using an auto fan or to the minimum position when using a continuous fan.

When the outdoor-air temperature is below the OAT setting and the thermostat calls for cooling, the economizer dampers move to the minimum position. If the supply-air temperature is above 57 F, the damper continues to open until it reaches the fully open position or until the supply-air temperature drops below 52 F.

When the supply-air temperature falls to between 57 F and 52 F, the damper will remain at an intermediate open position. If the supply-air temperature falls below 52 F, the damper will modulate closed until it reaches the minimum position or until the supply-air temperature is above 52 F. When the thermostat is satisfied and the indoor-fan motor is still in operation, the damper will move to the minimum open setting. If the thermostat is satisfied and the indoor-fan motor is deenergized, the damper will move to the fully closed position.

If the outdoor air alone cannot satisfy the cooling requirements of the conditioned space, economizer cooling is integrated with mechanical cooling, providing second-stage cooling. Compressor no. 1 and the condenser fan will be energized and the position of the economizer damper will be determined by the supply-air temperature. Compressor no. 2 is locked out.

When the second stage of cooling is satisfied, the compressor and OFM will be deenergized. The damper position will be determined by the supply-air temperature.

After a 30-second delay, the IFM shuts off. If the thermostat fan selector switch is in the ON position, the IFM will run continuously.

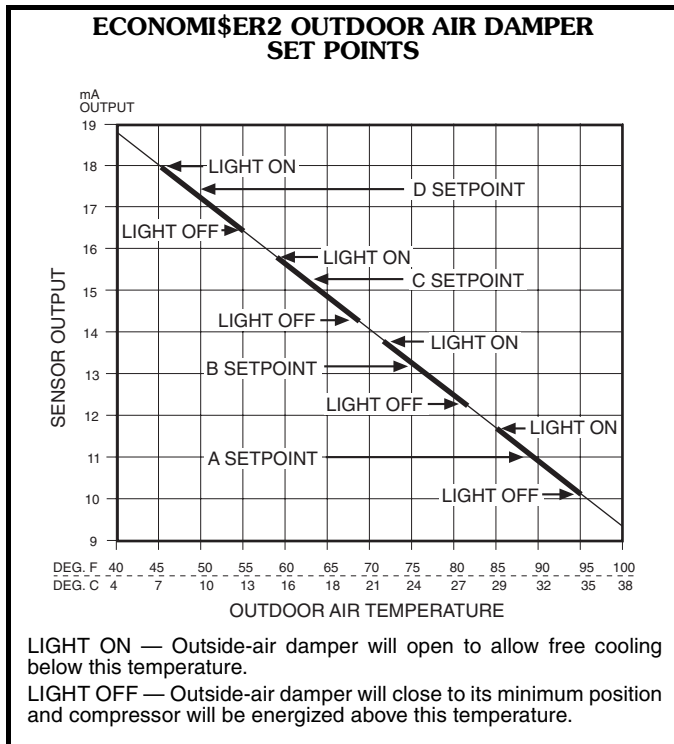



**Cooling, units with EconoMi\$er2** — When free cooling is not available, the compressors will be controlled by the zone thermostat. When free cooling is available, the outdoor-air damper is positioned through the use of a Proportional-Integral (PI) control process to provide a 55 F supply-air temperature into the zone. If the mixed-air temperature is below the lower end of the set point of 50 F, then the outside-air dampers will modulate to minimum position. If the measured temperature is within the range of 50 to 56 F, then the outside dampers will hold their current position. If the mixed air temperature is above 56 F, then the outside-air dampers will modulate open until the temperature is within range or they modulate to the fully open position.

If outdoor air alone cannot satisfy the cooling requirements of the conditioned space, and the OAT is above the outdoor air mechanical lockout temperature set point (fixed; opens at 35 F, closes at 50 F), the EconoMi\$er2 integrates free cooling with mechanical cooling as follows:

Y1 = 1st stage cooling using EconoMi\$er2 damper for free cooling

Y2 = 1st stage cooling using EconoMi\$er2 damper for free cooling plus compressor no. 1

NOTE: During EconoMi\$er operation (damper above minimum position) compressor no. 2 will **not** operate (sizes 008-014).

High ambient temperature (dry bulb) lockout (fixed): opens at 76 F, closes at 52 F.

If the enthalpy of the outside air is too high, the outside-air dampers will modulate to minimum position.

If mechanical cooling is utilized with free cooling, the outdoor-air damper will be locked into its current position at the time the compressor is started. If the increase in cooling capacity causes the supply-air temperature to drop below 45 F, then the outdoor-air damper position will be decreased to the minimum position. If the supply temperature continues to fall, the outdoor-air damper will close.

If optional power exhaust is installed, as the outdoor-air damper opens and closes, the power exhaust fans will be energized and deenergized.

If field-installed accessory CO<sub>2</sub> sensors are connected to the EconoMi\$er2 control, a PI-controlled demand ventilation strategy will begin to operate. As the CO<sub>2</sub> level in the zone increases above the CO<sub>2</sub> set point, the minimum position of the damper will be increased proportionally. As the CO<sub>2</sub> level decreases because of the increase in fresh air, the outdoor-air damper will be proportionally closed.

**Heating, units with economizer** — When the thermostat calls for heating, terminal W1 is energized. In order to prevent thermostat short-cycling, the unit is locked into the Heating mode for at least 1 minute when W1 is energized. The induced-draft motor is then energized and the burner ignition sequence begins. The indoor (evaporator) fan motor (IFM) is energized 45 seconds after a flame is ignited and the damper moves to the minimum position. On units equipped for two stages of heat, when additional heat is needed, W2 is energized and the high-fire solenoid on the main gas valve (MGV) is energized. When the thermostat is satisfied and W1 is deenergized, the IFM stops after a 45-second time-off delay. The economizer damper then moves to the fully closed position. When using continuous fan, the damper will remain in the minimum position.

# Controls (cont)



## Operating sequence, 015-028 size units

**Cooling, units without economizer** — When thermostat calls for cooling, terminals G and Y1 are energized. The indoor (evaporator) fan contactor (IFC) and compressor contactor no. 1 (C1) are energized, and evaporator-fan motor (IFM), compressor no. 1 and condenser fan(s) start. The condenser-fan motor(s) runs continuously while unit is cooling. When the thermostat calls for a second stage of cooling by energizing Y2, compressor contactor no. 2 (C2) is energized and compressor no. 2 starts.

**Heating, units without economizer** — When the thermostat calls for heating, power is sent to W on the IGC (integrated gas unit controller) board. An LED (light-emitting diode) on the IGC board will be on during normal operation. A check is made to ensure that the rollout switch and limit switch are closed. The induced-draft motor is then energized, and when speed is proven with the hall effect sensor on the motor, the ignition activation period begins. The burners will ignite within 5 seconds.

If the burners do not light, there is a 22-second delay before another 5-second attempt. If the burners still do not light, this sequence is repeated for 15 minutes. After the 15 minutes have elapsed, if the burners still have not lighted, heating is locked out. To reset the control, break 24-v power to the thermostat.

When ignition occurs the IGC board will continue to monitor the condition of the rollout and limit switches, the hall effect sensor, as well as the flame sensor. If the unit is controlled through a room thermostat set for fan auto., 45 seconds after ignition occurs, the indoor-fan motor will be energized. If for some reason the overtemperature limit opens prior to the start of the indoor fan blower, on the next attempt, the 45-second delay will be shortened to 5 seconds less than the time from initiation of heat to when the limit tripped. Gas will not be interrupted to the burners and heating will continue. Once modified, the fan on delay will not change back to 45 seconds unless power is reset to the control.

When additional heat is required, W2 closes and initiates power to the second stage of the main gas valve. When the thermostat is satisfied, W1 and W2 open and the gas valve closes, interrupting the flow of gas to the main burners. If the call for W1 lasted less than 1 minute, the heating cycle will not terminate until 1 minute after W1 became active. If the unit is controlled through a room thermostat set for fan auto., the indoor-fan motor will continue to operate for an additional 45 seconds then stop. If the overtemperature limit opens after the indoor motor is stopped within 10 minutes of W1 becoming inactive, on the next cycle the time will be extended by 15 seconds. The maximum delay is 3 minutes. Once modified, the fan off delay will not change back to 45 seconds unless power is reset to the control.

An LED indicator is provided on the IGC to monitor operation. The IGC is located by removing the side panel and viewing the IGC through the view port located in the control box access panel. During normal operation, the LED is continuously on.

**Cooling, units with EconoMi\$er** — When the outdoor-air temperature (OAT) is *above* the ECON SP set point and the room thermostat calls for Stage 1 cooling (R to G +

Y1), the indoor (evaporator) fan motor (IFM) is energized and the EconoMi\$er damper modulates to minimum position. The compressor contactor is energized to start the compressor and outdoor (condenser) fan motor (OFM). After the thermostat is satisfied, the damper modulates to the fully closed position when the IFM is deenergized.

When the OAT is *below* the ECON SP setting and the room thermostat calls for Stage 1 cooling (R to G + Y1), the EconoMi\$er modulates to the minimum position when the IFM is energized. The EconoMi\$er provides Stage 1 of cooling by modulating the return and outdoor air dampers to maintain a 55 F supply air set point. If the supply-air temperature (SAT) is greater than 57 F, the EconoMi\$er modulates open, allowing a greater amount of outdoor air to enter the unit. If the SAT drops below 53 F, the outdoor air damper modulates closed to reduce the amount of outdoor air. When the SAT is between 53 and 57 F, the EconoMi\$er maintains its position.

If outdoor air alone cannot satisfy the cooling requirements of the conditioned space, and the OAT is above the MECH CLG LOCKOUT set point (adjustable to 10 to 60 F or off), the EconoMi\$er integrates free cooling with mechanical cooling. This is accomplished by the strategies below.

NOTE: Compressor has a 2-minute Minimum On, Minimum Off, and Interstage delay timer.

1. If Y1 is energized, and the room thermostat calls for Y2 (2-stage thermostat), compressor no. 1 and OFM are energized. The EconoMi\$er damper is maintained at its current position.
2. If Y1 is energized for more than 20 minutes, and Y2 is not energized (whether or not a 2-stage thermostat is used), compressor no. 1 and OFM are energized. The EconoMi\$er damper is maintained at its current position.
3. If Y1 is energized, and compressor no. 1 is already energized (see Step 2) and the room thermostat calls for Y2, the compressor continues to operate. If Y2 remains energized for more than 20 minutes, compressor no. 2 is energized.

NOTE: Compressor no. 2 cannot be energized unless there is a signal for Y2 from the space thermostat.

4. If compressor no. 2 is energized, and the Y2 signal from the thermostat is satisfied, compressors 1 and 2 are deenergized. Reasserting Y2 will start compressor no. 1 and (after a 20-minute interstage delay) compressor no. 2.
5. If compressor no. 1 is energized and the thermostat is satisfied, compressor no. 1, the OFM, and IFM are deenergized and the EconoMi\$er modulates closed.

When the OAT is below the MECH CLG LOCKOUT set point, the compressors remain off.

**Heating, units with economizer** — Outdoor-air damper stays at VENT position while evaporator fan is operating. Refer to Heating, Units Without Economizer.

# Application data



## Condensate drain pan

A sloped condensate drain pan is supplied on all units. The condensate pan must be externally trapped. Condensate drains are located on both the bottom and end of the unit.

## Ductwork

All ductwork must be attached to flanges. If no flanges are present, they must be field supplied. Secure vertical discharge ductwork to roof curb. For horizontal discharge applications, attach ductwork to flanges. Field-supplied flanges can be attached to horizontal discharge openings and all ductwork attached to flanges.

### To convert from vertical discharge to horizontal discharge (Durablade economizer only):

1. Remove economizer/two-position damper to gain access to return duct opening.
2. Move the horizontal-discharge duct opening covers to the vertical discharge openings.
3. Rotate economizer 90 degrees (until the economizer/two-position damper motor faces the condenser section).
4. Rotate the barometric relief damper 90 degrees.
5. Install block-off plate over the opening on the access panel.

## Thermostat

Use of 2-stage cooling thermostat is recommended for all units equipped with economizer. A 2-stage cooling thermostat is required for size 015-028 units with integrated economizer.

## Heating-to-cooling changeover

All units are automatic changeover from heating to cooling when automatic changeover thermostat and subbase are used.

## Airflow

Units are draw-thru on cooling and blow-thru on heating.

### Maximum airflow

To minimize possibility of condensate blow-off from evaporator, airflow through units should not exceed 500 cfm/ton (sizes 004-025) and 11,250 cfm (size 028).

### Minimum airflow

Minimum airflow for cooling is 300 cfm/ton (size 004-025) and 280 cfm/ton (028 units). Refer to Heating Capacities table for minimum heating airflow.

### Minimum ambient operating temperature

Minimum ambient operating temperature for size 004-014 standard units is 25 F. With accessory Motormaster® I units can operate at outdoor temperatures down to -20 F.

Unit sizes 015-028 are designed to operate at outdoor temperatures down to 40 F (4.4 C). With accessory Motormaster I or Motormaster III control, units can operate at outdoor temperatures down to -20 F.

NOTE: Under most application circumstances, if the rooftop unit is equipped with an economizer, low ambient controls are not required. Unless the outdoor air is unsatisfactory for free cooling due to high temperature, excessive humidity, or poor air quality, outdoor air should be used.

### Maximum operating outdoor-air temperature

Maximum outdoor operating temperature for cooling is shown below (60 Hz):

48TM004-008,012	115 F
48TM009,014	125 F
48TM016-025	120 F
48TM028	125 F
48HJ004-015	125 F
48HJ017	120 F

### High altitudes

These may require a change to the gas orifice. Refer to Altitude Compensation tables.

### Minimum temperature heating

Minimum temperature of air entering the dimpled heat exchanger is 50 F continuous and 45 F intermittent. To operate at lower return-air temperatures, a field-supplied outdoor-air temperature control must be used to initiate both stages of heat when the temperature is below 45 F. Indoor comfort may be compromised when heating is initiated using low entering air temperatures with insufficient heating temperature rise.

### Motor data

Due to Carrier's internal unit design (draw-thru over the motor), air path, and specially designed motors, the full horsepower (maximum continuous bhp) listed in the Physical Data tables and the notes following each Fan Performance table can be utilized with extreme confidence.

Using Carrier motors to the values listed in the Physical Data, Fan Performance, and Evaporator-Fan Motor Data tables *will not* result in nuisance tripping or premature motor failure. In addition, the unit warranty will not be affected.

### Carrier PremierLink™ Controls

The Carrier PremierLink Controls can be used with any thermostat.

### Apollo communicating controls

Apollo communicating controls must be used with a Carrier master thermostat.

### Thru-the-bottom connections

The accessory thru-the-bottom connections are needed to ensure proper connections when routing wiring and piping through the basepan and roof curb. This accessory is used for electric and control power only or electric, control power, and gas piping depending on which accessory is selected.

# Application data (cont)



## Concentric duct details

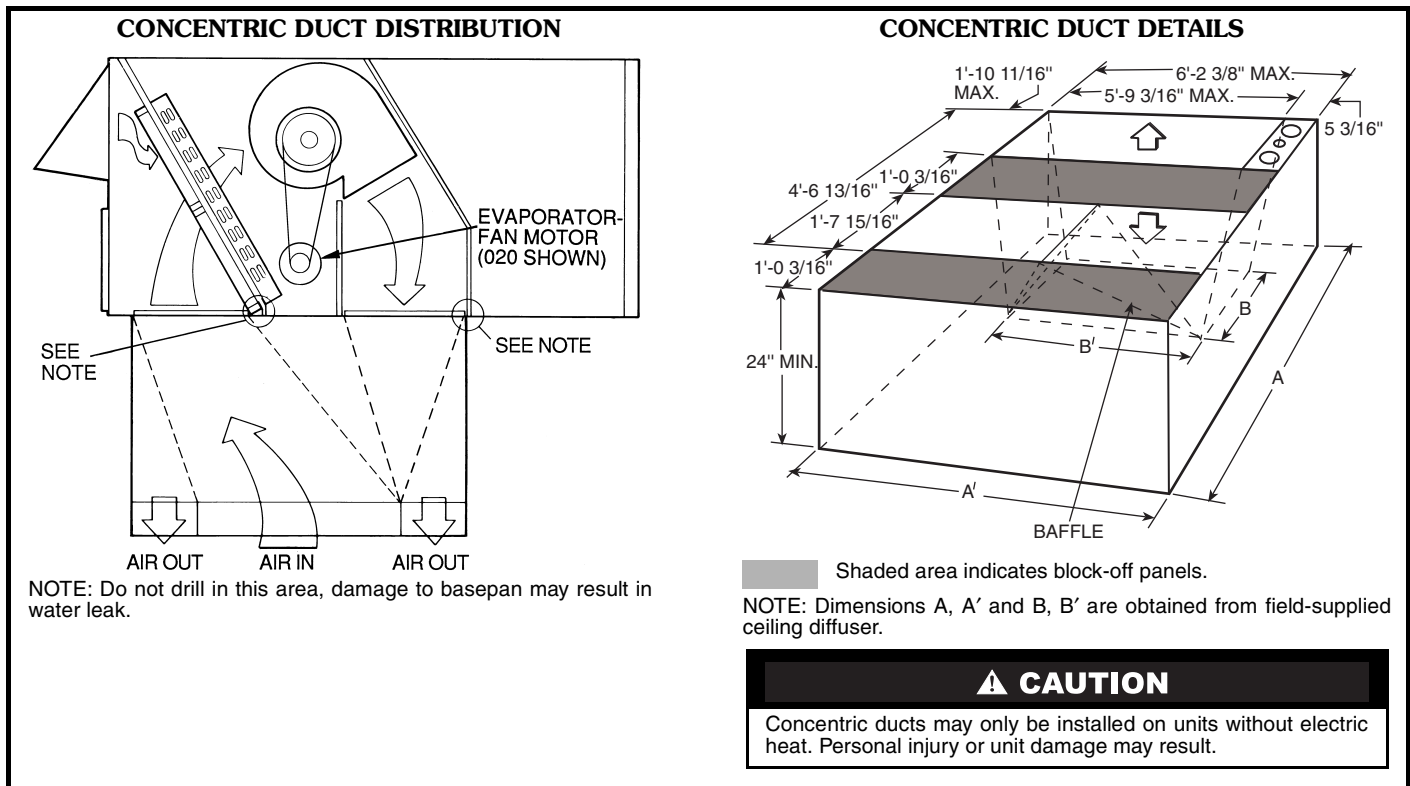

### Field-supplied fan drives

If the factory drive sets must be changed to obtain other wheel speeds, consult the nearest Browning Manufacturing Co. sales office with the required new wheel speed and the data from Physical Data tables (center distances, motor and fan shaft diameters, motor horsepower) for a modified drive set selection. For minor speed changes, the fan sheave size should be changed. (Do not reduce the size of the motor sheave; this will result in reduced belt horsepower ratings and reduced belt life.)

### Condenser coil protection

**Pre-coated aluminum-fin coils** have a durable epoxy-phenolic coating applied to the fin prior to the fin stamping process to provide protection in mildly corrosive coastal environments. Pre-coated coils have an inert barrier between the aluminum fin and copper tube. This barrier electrically disconnects the dissimilar metals to minimize the potential for galvanic corrosion. This economical option provides substantial corrosion protection beyond the standard uncoated coil construction.

**Copper-fin coils** provide increased corrosion resistance in moderate coastal environments where industrial air pollution is not present. All copper coils eliminate bi-metallic

construction to eliminate the potential for galvanic corrosion. Application in industrial environments is not recommended due to potential attack from sulfur, sulfur oxide, nitrogen oxides, carbon and several other industrial airborne contaminants. In moderate seacoast environments, copper-fin coils have extended life compared to standard or pre-coated aluminum-fin coils.

**E-Coated aluminum-fin coils** undergo a precisely controlled scientific process that bonds an impermeable epoxy coating to the specially prepared fin coil surface. E-Coating produces a smooth, consistent coating that is less brittle, more resilient and more durable than previous postcoating processes. E-Coated aluminum-fin coils offer economical protection and improved coil life in many contaminated environments.

**E-Coated copper-fin coils** provide maximum protection in virtually all environments, this option combines the continuous, impenetrable barrier of the E-Coating process with the natural resistance of an all-copper construction. E-Coated copper-fin coil assemblies ensure long life, even in environments that combine harsh coastal conditions with industrial contamination.

## MoistureMi\$er™ dehumidification package (48HJ004-017)

This option for 48HJ units provides greater dehumidification by further subcooling the hot liquid refrigerant leaving the condenser coil. The MoistureMi\$er package consists of a subcooling coil located on the leaving-air side of the evaporator coil. The location of the coil in the indoor air-stream enhances the latent capacity of the rooftop units by up to 40%.

Many buildings suffer damage or have poor indoor-air quality due to overly humid conditions. Building humidity must be controlled for the following reasons:

### 1. Indoor-Air Quality:

Humidity is a major factor in the growth and propagation of mold and mildew in a building. The mold and mildew can spread quickly and grow in carpets and ductwork and on walls, and often causes cases of sick building syndrome. This syndrome can lead to employee absenteeism due to illness, lower worker productivity, and increased health care costs. The American Society of Heating, Refrigeration, and Air Conditioning Engineers (ASHRAE) recommends that relative humidity levels in buildings be maintained below 70%.

### 2. Comfort Levels:

High humidity levels cause the occupied space to become uncomfortable, because humidity interferes with the body's natural cooling process (evaporation at the skin surface).

### 3. Humidity Damage:

Humidity causes property damage, such as stained wallpaper and ceiling tiles. Humidity can also damage books and artwork, and create strong odors in carpets. In addition, humidity can contribute to unacceptable product quality in industrial processes.

### 4. Improper Ventilation:

Buildings in hot and humid geographical areas cannot be properly ventilated due to high humidity levels outdoors, resulting in poor indoor-air quality.

### 5. Equipment Inefficiency:

Humidity can cause inefficient operation of refrigerators and freezers.

### 6. Increased Energy Costs:

Because of high humidity levels and less comfortable conditions, thermostat set points are lowered to force the HVAC (heating, ventilation, and air conditioning) equipment to run longer and work harder to lower the humidity levels. Also, in an attempt to control humidity, system designers typically oversize HVAC equipment and add reheat capability to get the desired latent capacity. This results in higher initial equipment costs, as well as increased energy expenses throughout the life of the unit.

**Applications** — There are many different rooftop unit applications that are susceptible to problems caused by high humidity levels. Some common applications include:

### 1. Restaurants:

The kitchen areas of restaurants have many humidity-producing activities, such as dish washing and cooking.

### 2. Supermarkets:

High humidity levels cause inefficiency in operation of refrigeration and freezer systems.

### 3. Museums and Libraries:

Humidity can damage books and artwork.

### 4. Gymnasiums, Locker Rooms, and Health Clubs:

Shower areas and human perspiration cause uncomfortable occupied space conditions.

### 5. Hot and Humid Climates:

The southeastern United States is a good example of this application. The MoistureMi\$er dehumidification package becomes particularly useful when increased amounts of the hot and humid outdoor air need to be brought into the building for proper ventilation.

**MoistureMi\$er dehumidification package design effects** — To fully understand the operation of the MoistureMi\$er dehumidification package, refer to the pressure enthalpy curve, and analyze the MoistureMi\$er package effects on the refrigerant in the rooftop unit. The pressure enthalpy curve shows the refrigerant cycle for an rooftop unit.

Standard unit refrigerant cycle — At point no. 1 in the pressure enthalpy curve, vapor leaving the compressor at a high pressure and a high temperature enters the condenser. The condenser removes heat from the refrigerant, lowers its temperature, and changes it to a liquid. At point no. 2, the liquid leaves the condenser and enters a fixed expansion device that lowers the pressure of the refrigerant. At point no. 3, the liquid enters the evaporator coil, where the refrigerant increases in temperature and changes back to a vapor. At point no. 4, the vapor leaves the evaporator and reenters the compressor.

Refrigerant cycle using MoistureMi\$er Dehumidification Package — When a subcooler coil is added to the rooftop unit, the refrigerant is affected in such a way that the unit latent capacity is increased. The refrigerant cycle follows the same path from point no. 1 to point no. 2 as the standard refrigerant cycle without a subcooler (see the pressure enthalpy curve). However, at point no. 2, the liquid refrigerant enters the subcooler coil where the temperature is lowered further. At point no. 2A, this subcooled liquid enters the TXV, which drops the pressure of the liquid. At point no. 2B, the liquid enters the Acutrol™ device. The refrigerant leaves this device as a saturated vapor and enters the evaporator at point no. 2C. The improved refrigeration effect can now be seen between point no. 2C and point no. 3. The increase in the total refrigeration effect is the additional enthalpy gained from point no. 2C to point no. 3. However, the subcooler coil rejects this added refrigeration effect to the air downstream of the evaporator coil, thus maximizing the overall latent effect. This improved latent effect is a direct result of the addition of the MoistureMi\$er subcooler coil to the refrigerant cycle.

# Application data (cont)



**Latent capacity effects** — Refer to the psychrometric chart to see how the sensible heat factor decreases when the optional MoistureMi\$er™ dehumidification package is installed. This chart contains data for the 5-ton unit operation, both with and without the MoistureMi\$er package, at 1750 cfm. Point no. 1 on the chart represents the return-air dry bulb (80 F) and wet bulb (67 F) conditions. Point no. 2 represents the supply-air conditions for a standard rooftop unit without the MoistureMi\$er dehumidification package. Point no. 3 represents the supply-air conditions for a rooftop unit with the MoistureMi\$er package. By connecting point no. 1 and point no. 2 on the chart and finding the intersection on the sensible heat factor scale, the sensible heat factor is 0.73. Connect point no. 1 and point no. 3, and see that the sensible heat factor is 0.58. This is a 17.5% increase in latent capacity for the given conditions. This increase in latent capacity allows the rooftop units to remove more moisture from the conditioned space; thus lowering the humidity levels.

**Dehumidification effects** — Further evidence of dehumidification can be seen by analyzing the pounds of water per pound of dry air found in the supply air. At point no. 2 in the psychrometric chart, there are 65 grains (0.0092 lb) of moisture per pound of dry air. At point no. 3, there are 58 grains (0.0083 lb) of moisture per pound of dry air. This is a 12.1% decrease in the amount of water in the supply air.

**MoistureMi\$er dehumidification package operating performance** — MoistureMi\$er dehumidification package operation does not affect the electrical data. The electrical data remains the same either with or without the MoistureMi\$er package.

The operating and shipping weights will be slightly increased with the addition of the MoistureMi\$er subcooler. See the Physical Data tables for added base unit weight with this option.

Refer to cooling performance data, both with and without the MoistureMi\$er dehumidification package. Note the greatly improved latent capacity with the MoistureMi\$er dehumidification package.

Static pressure is also slightly affected by the addition of the MoistureMi\$er dehumidification package. Refer to the static pressure drop table when using this option.

## MoistureMi\$er dehumidification package features and benefits

- The MoistureMi\$er dehumidification package can improve the humidity control of your rooftop equipment by up to 40%. This greatly reduces the risk of sick building syndrome by reducing biological growth in both ductwork and the rest of the building.
- The MoistureMi\$er dehumidification package improves comfort levels in the building by better controlling the humidity. This improved comfort level allows building tenants to raise the cooling set point on the thermostats for accumulated energy savings.
- Better humidity control lowers the risk of humidity-induced property damage.

- The MoistureMi\$er dehumidification package permits building refrigerators and freezers to operate more efficiently due to lower relative humidity levels. This is the perfect solution for supermarket applications.
- The MoistureMi\$er subcooling circuit can be operated by a humidity sensor or thermidstat (combination humidistat/thermostat). If the sensor is used, the MoistureMi\$er circuit will then only operate when needed. If the humidity levels in the occupied space are acceptable (such as in the spring and fall seasons), the MoistureMi\$er circuit will not operate. The rooftop unit is then able to operate to its full sensible potential, which provides more efficient performance and energy savings.
- At lower outdoor temperatures, rooftop units with dehumidification devices are subject to low suction pressure conditions. The MoistureMi\$er dehumidification package contains a low-pressure switch that deactivates the MoistureMi\$er under low suction pressure conditions without deactivating the compressors.
- Improved humidity control allows increased outdoor-air ventilation in hot and humid geographical areas. Humidity control also helps to improve the indoor-air quality of the building.
- The MoistureMi\$er dehumidification package is factory installed. There are no additional field installation costs. There is also no need to purchase a roof curb from another manufacturer, as standard Carrier roof curbs will accommodate the rooftop units which have the MoistureMi\$er dehumidification package option installed.
- The MoistureMi\$er dehumidification package is engineered and manufactured by Carrier Corporation for Carrier rooftop units. All application support, service, and warranty issues can therefore be handled through one company.
- The slightly lower sensible capacities obtained when using the MoistureMi\$er dehumidification package allow the unit to operate for an extended period of time. The more the unit operates, the more air is exposed to the subcooling coil. This rooftop unit increased latent capacity results in lower relative humidity levels in the occupied space.
- It is no longer necessary to oversize equipment and add reheat devices to properly dehumidify your building. In a typical scenario, a building owner may need 39,000 Btuh of sensible capacity and 23,000 Btuh of latent capacity (62,000 total Btuh). To accomplish this without the MoistureMi\$er dehumidification package, a 7<sup>1</sup>/<sub>2</sub>-ton unit with a reheat device would be necessary to attain the higher latent capacity required. This results in a large up-front expense to oversize the equipment from a standard 5-ton to a 7<sup>1</sup>/<sub>2</sub>-ton unit.

The building owner can now purchase a 5-ton unit with the MoistureMi\$er dehumidification package for a small additional up-front charge, and no reheat device will be necessary to satisfy the cooling requirements. This reduces both installation costs and operating costs throughout the life of the product.

# PRESSURE ENTHALPY CURVE

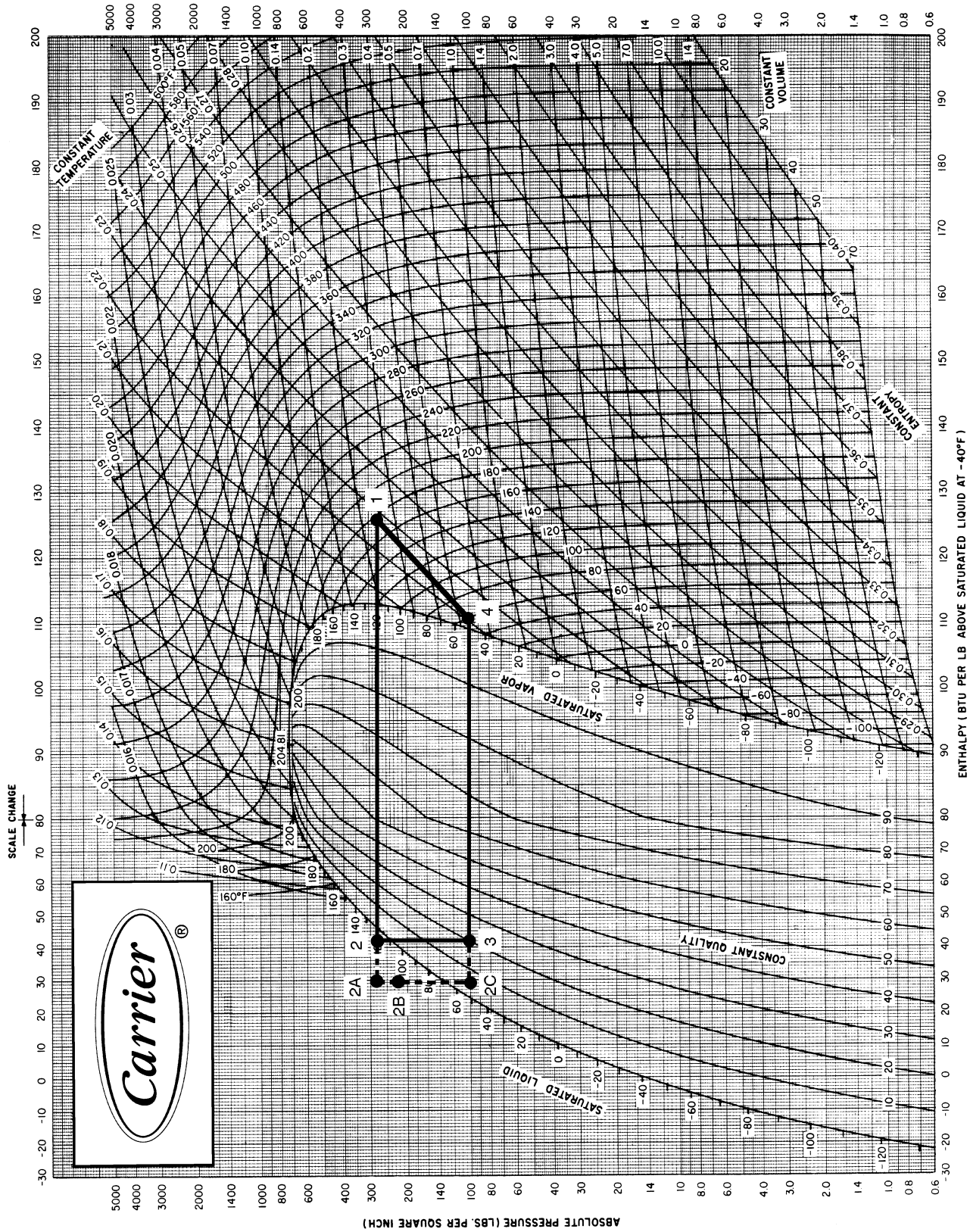

NOTE: Numbers 1 through 4 indicate point numbers referred to in MoistureMiser™ Dehumidification Package Design Effects section.

PSYCHROMETRIC CHART (48HJ006 SHOWN)

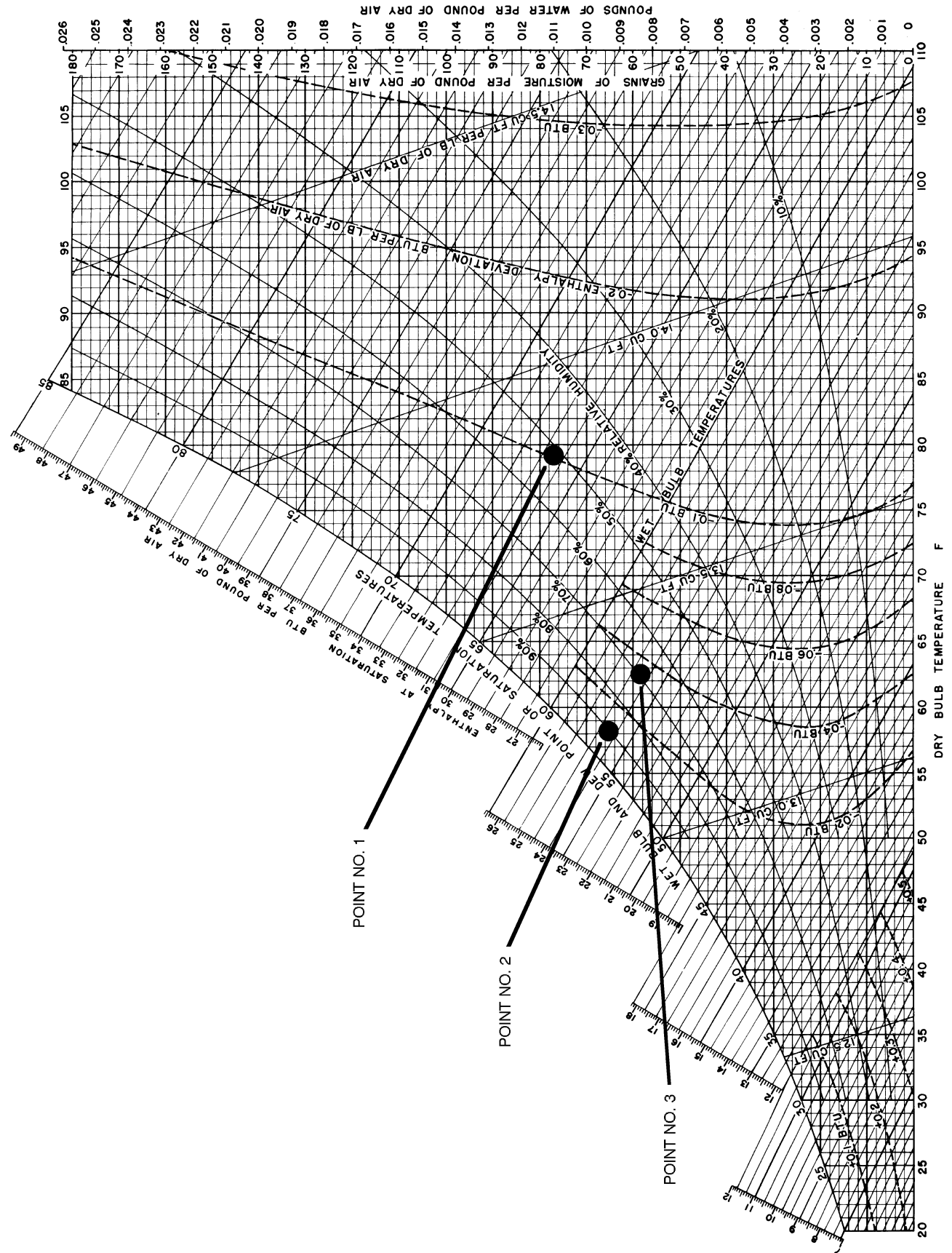

**UNITS WITH MOISTUREMI\$ER™ OPTION (48HJ004-007 Shown)**

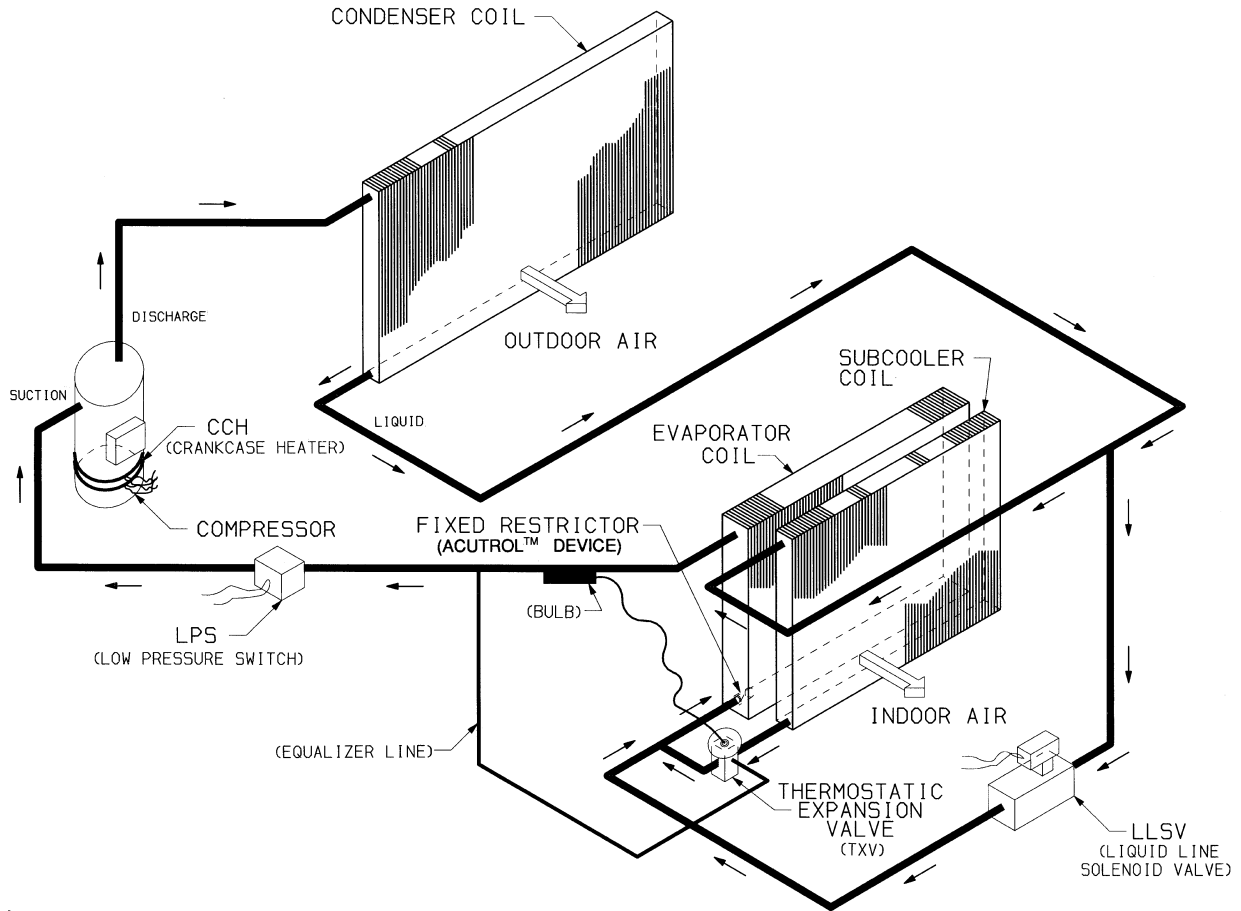

**TYPICAL MOISTUREMI\$ER DEHUMIDIFICATION PACKAGE HUMIDISTAT WIRING — 48HJ004-014 (208/230-V UNIT SHOWN)**

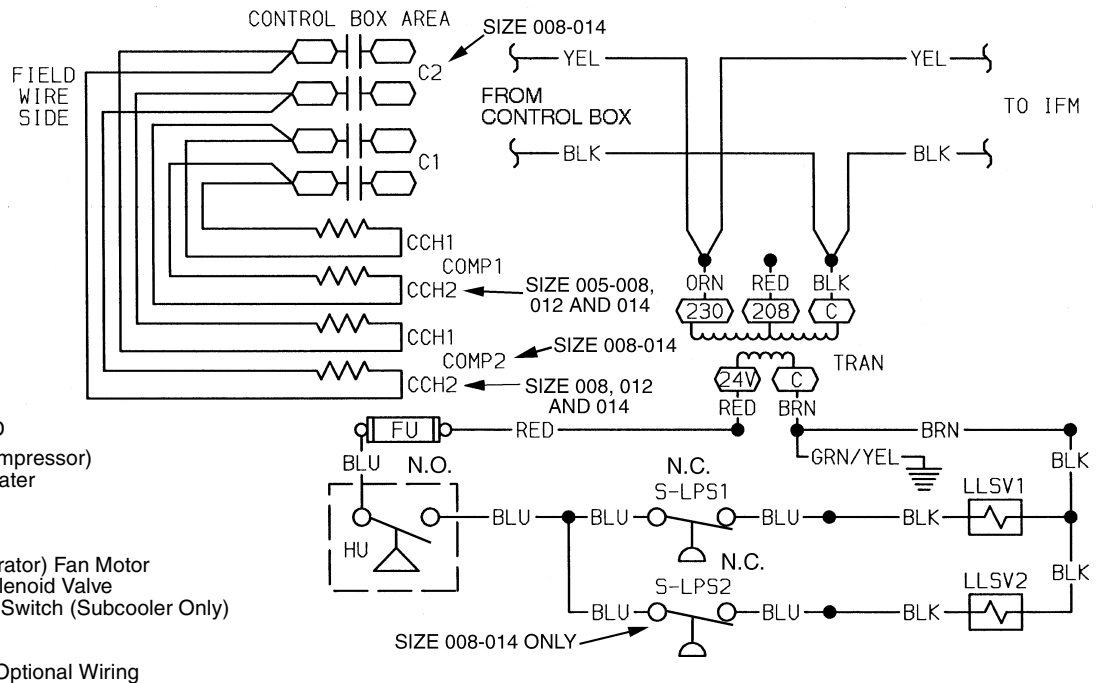

# Application data (cont)



## 62AQ TYPICAL WIRING SCHEMATIC (Sizes 004-014) 48HJ WITH 62AQ OPTION

### NOTES:

1. If any of the original wire furnished must be replaced, it must be replaced with 90° C wire or its equivalent.
2. Three phase motors are protected under primary single phasing conditions.
3. Thermostat: HH07AT170, 172.  
Subbase: HH93AZ176, 177, 178, and 179.
4. Set heat anticipator at .14 amp for 1st stage and .14 amp for 2nd stage.
5. Use copper conductors only.
6. TRAN is wired for 230-v unit. If unit is to be run with 208-v power supply, disconnect BLK wire from 230-v tap (ORN) and connect to 208-v tap (RED). Insulate end of 230-v tap.
7. IGC not applicable to 50HJ units.

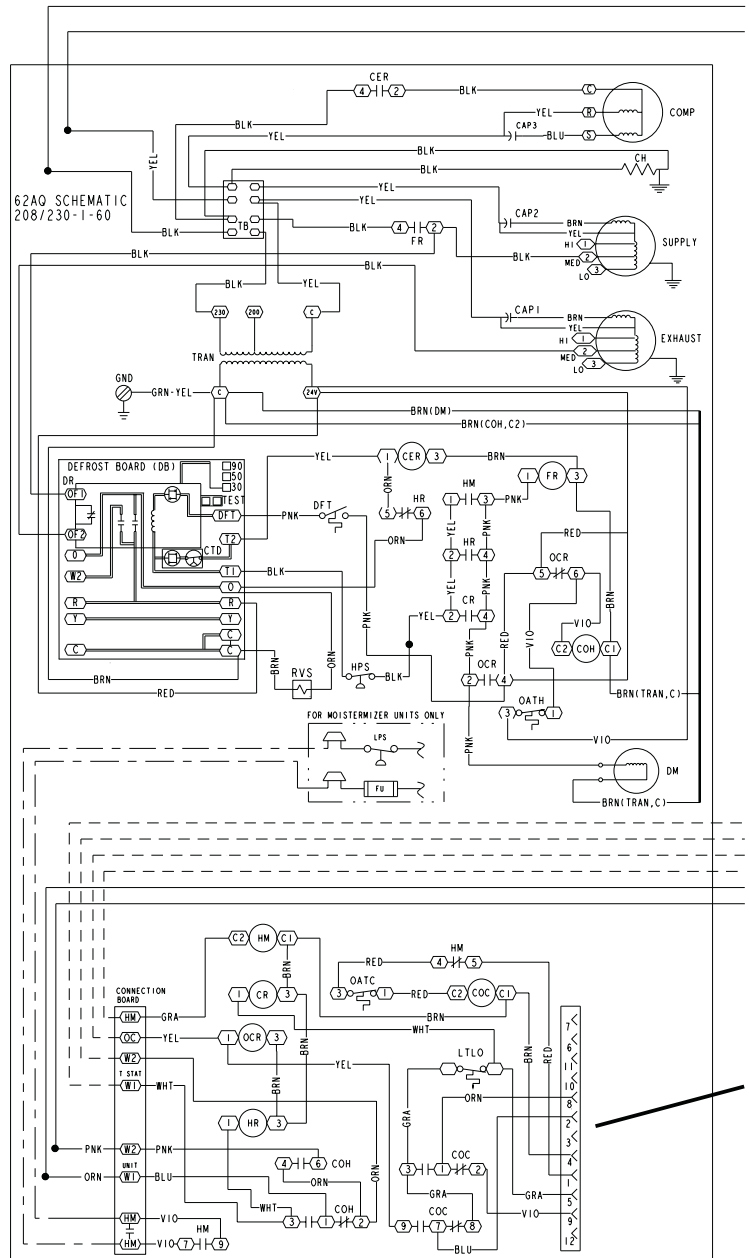
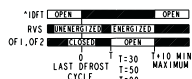
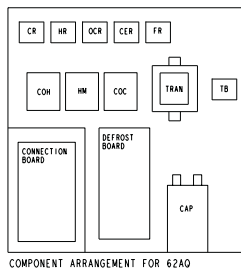
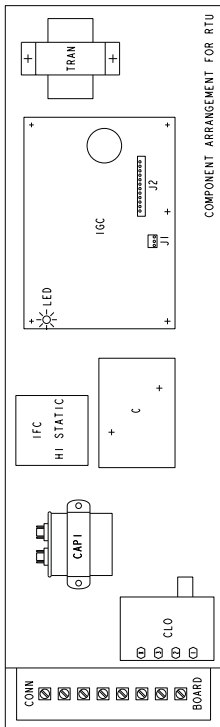

### LEGEND

- C** — Contactor
- CAP** — Capacitor
- CH** — Crankcase Heater
- CLO** — Compressor Lockout
- COC** — Cool Changeover Relay
- COH** — Heat Changeover Relay
- COMP** — Compressor Motor
- CR** — Cooling Relay
- CTD** — Compressor Time Delay
- DB** — Defrost Board
- DFT** — Defrost Thermostat
- DM** — Damper Motor
- DR** — Defrost Relay
- EQUIP** — Equipment
- FPT** — Freeze-Up Protection Thermostat
- FR** — Fan Relay
- FU** — Fuse
- GND** — Ground
- HM** — Humidity Relay
- HPS** — High-Pressure Switch
- HR** — Heating Relay
- HS** — Hall Effect Sensor

- I** — Ignitor
- IDM** — Induced Draft Motor
- IFC** — Indoor Fan Contactor
- IFM** — Indoor Fan Motor
- IGC** — Integrated Gas Unit Control
- LTLO** — Low Temp Cooling Lockout
- LPS** — Low-Pressure Switch
- LS** — Limit Switch
- MGV** — Main Gas Valve
- OATC** — Outdoor-Air Thermostat (Cool)
- OATH** — Outdoor-Air Thermostat (Heat)
- OCR** — Occupied Relay
- OF** — Outdoor Fan
- OFM** — Outdoor Fan Motor
- OLR** — Overload Relay
- PL** — Plug Assembly
- QT** — Quadruple Terminal
- RS** — Rollout Switch
- RVS** — Reversing Valve Solenoid
- SEN** — Sensor
- TB** — Terminal Block
- TRAN** — Transformer

- Field Splice
- Marked Wire
- Terminal (Marked)
- Terminal (Unmarked)
- Terminal Block
- Splice
- Splice (Marked)
- Factory Wiring
- Field Control Wiring
- Field Power Wiring
- Accessory or Optional Wiring
- To indicate common potential only. Not to represent wiring.

**62AQ TYPICAL WIRING SCHEMATIC (Sizes 004-014) 48HJ WITH 62AQ OPTION (cont)**

SCHEMATIC  
208/230-3-60

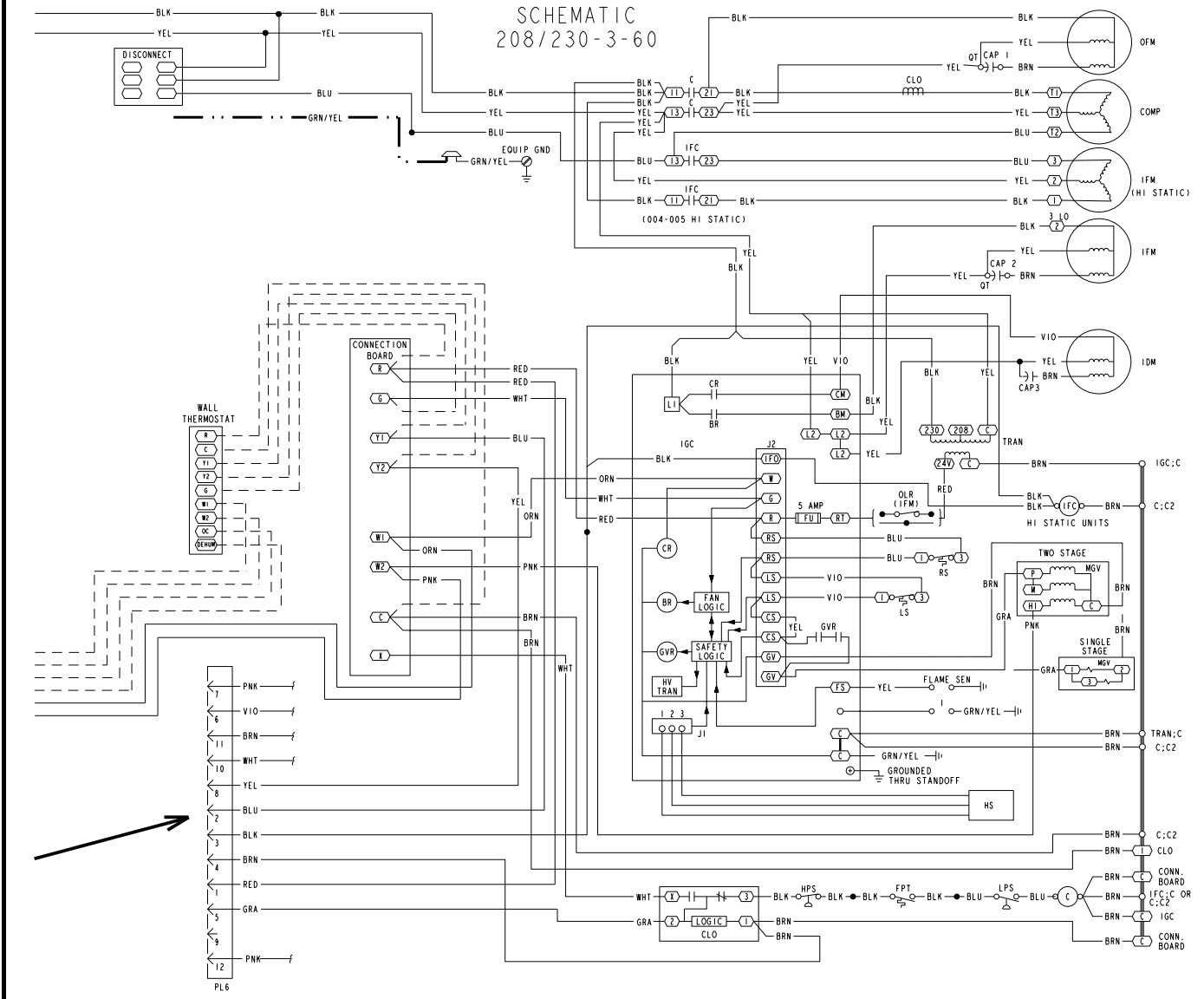



# Typical piping and wiring — sizes 004-014



## VERTICAL DISCHARGE DUCTING

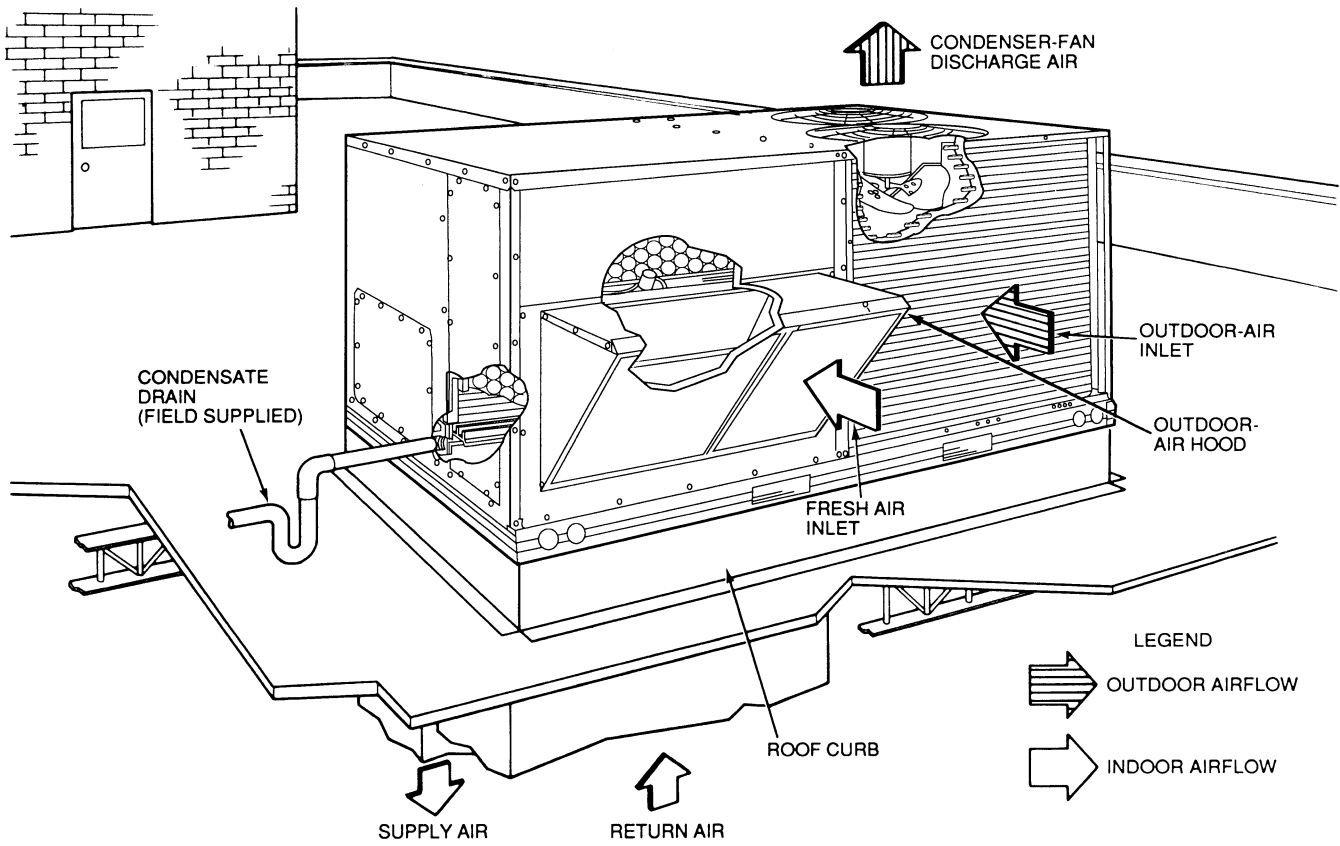

## HORIZONTAL DISCHARGE DUCTING

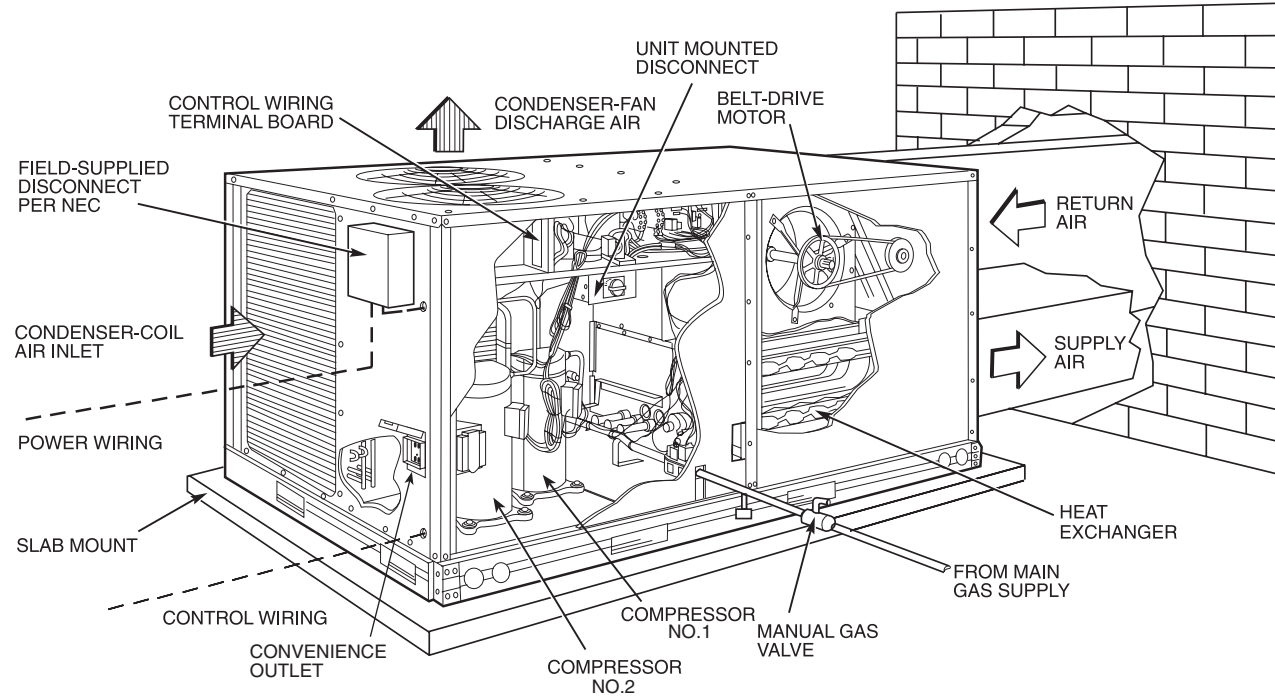

NEC — National Electrical Code

# Typical piping and wiring — sizes 015-028

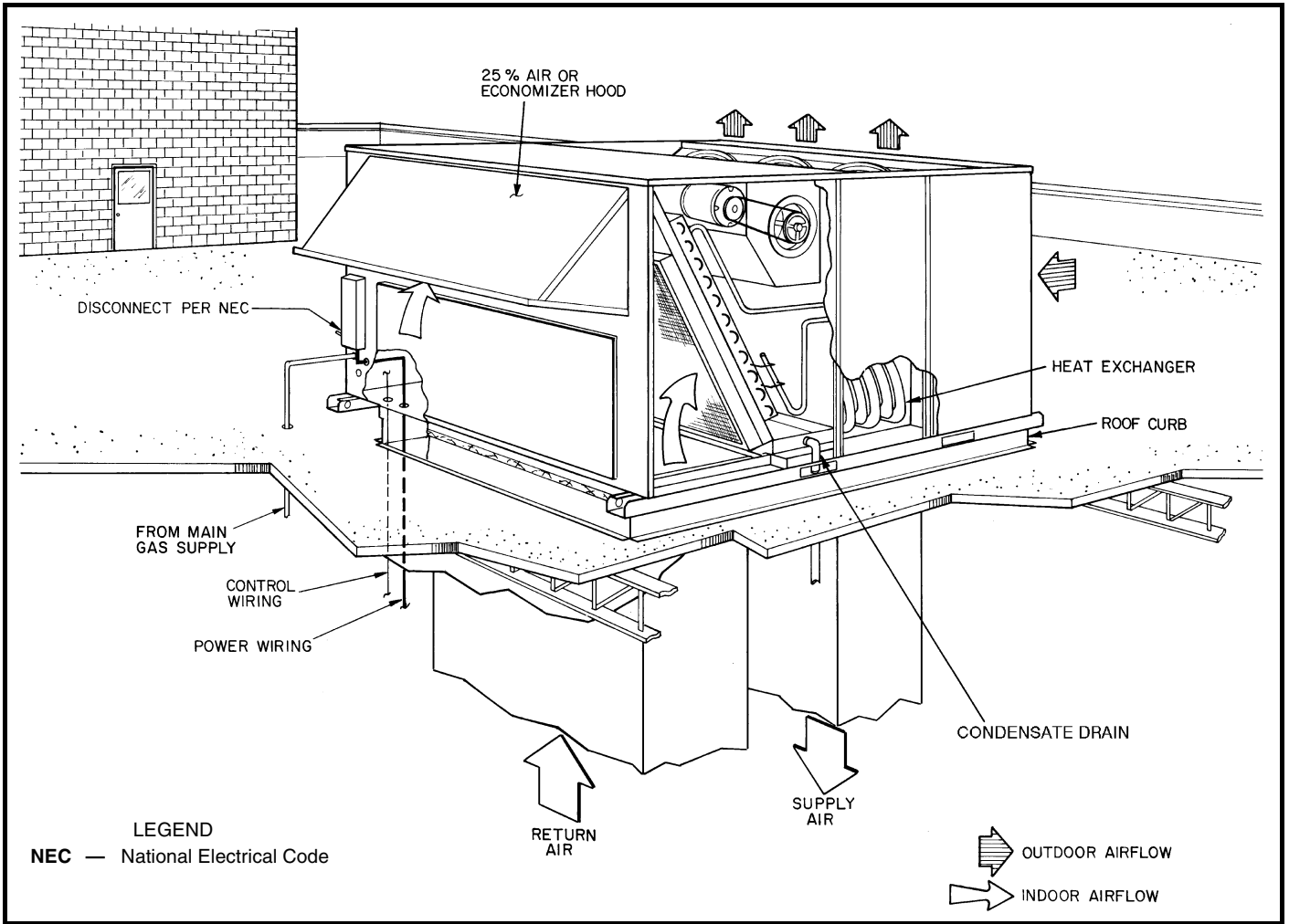

# Typical wiring schematic — sizes 004-014 (48TM008, 460-3-60 shown)



CIRCUIT BREAKER	VOLTS	MFG. PT. NO.		MUST TRIP AMPS
CB	24 V	POTTER & BRUMFIELD W2BX-1024-3.2		3.2
		Heinemann	Airpax	
CB1 (014 Std)	460-3-60	CF3-Z228-41	219-3-2600-486	8.5

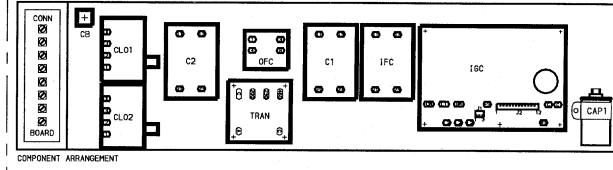
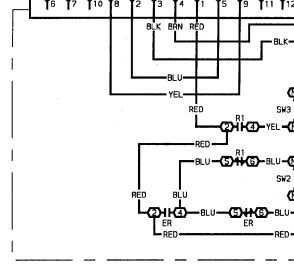
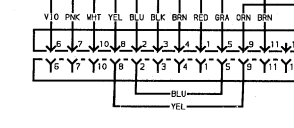
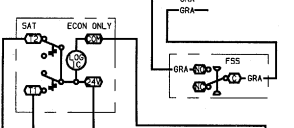
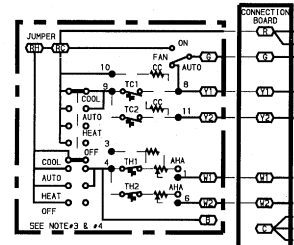
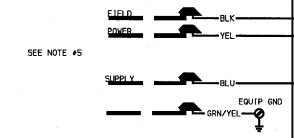
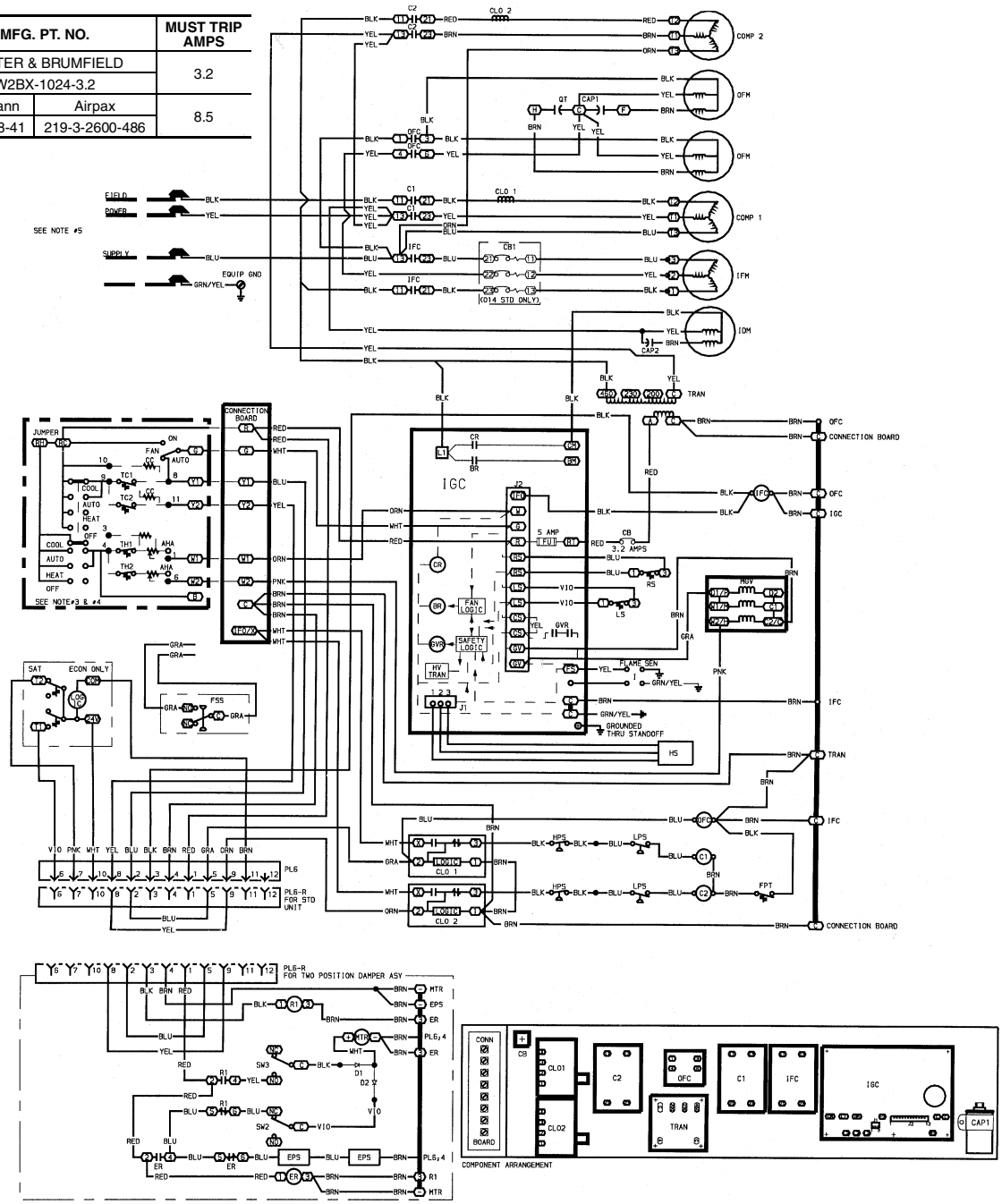

# Typical wiring schematic — sizes 004-014 (48TM008, 460-3-60 shown) (cont)

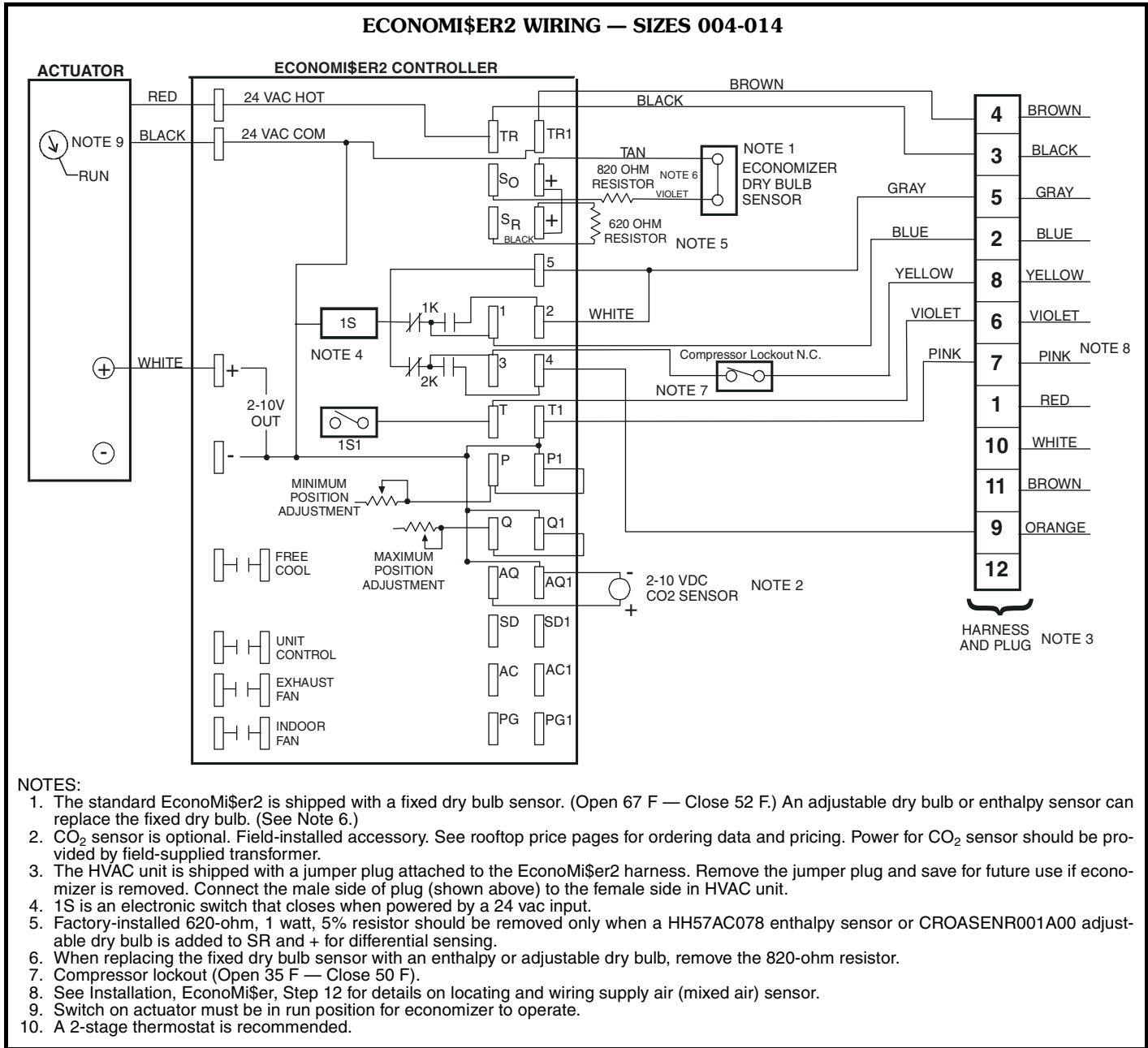

# Typical wiring schematic — sizes 015-028 (48TM016, 208/230-v shown)

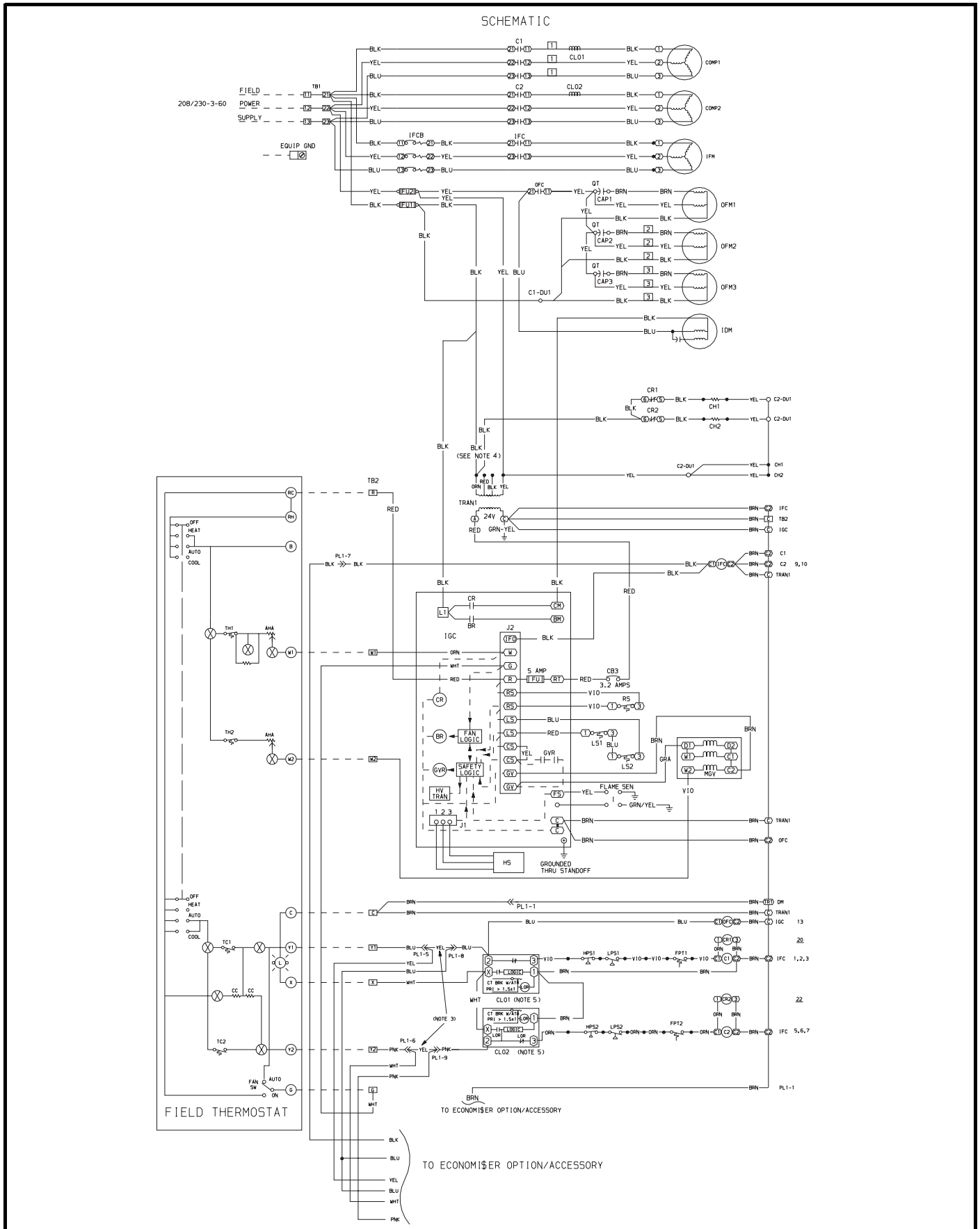

# Typical wiring schematic — sizes 015-028 (48TM016, 208/230-v shown) (cont)

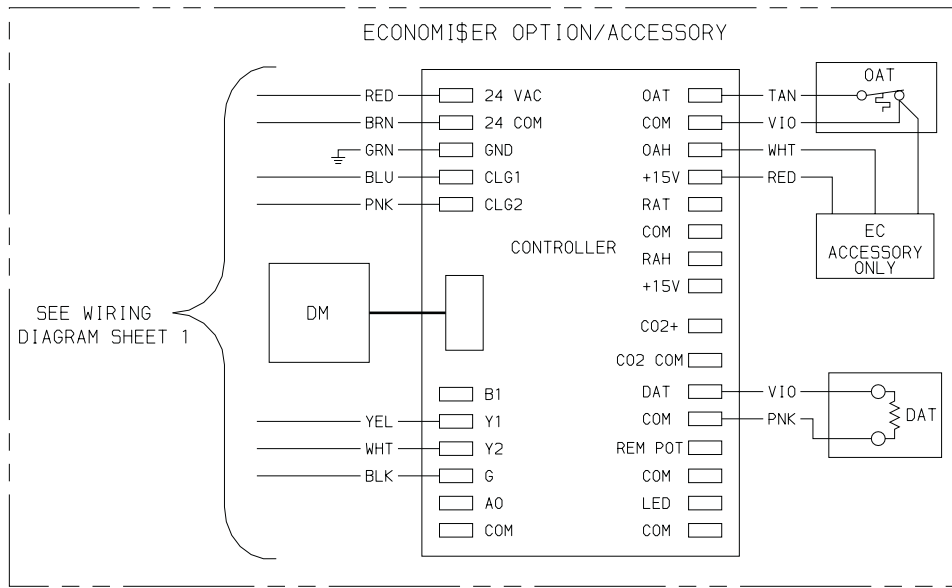

## LEGEND

**AHA** — Adjustable Heat Anticipator  
**C** — Contactor, Compressor  
**CAP** — Capacitor  
**CB** — Circuit Breaker  
**CC** — Cooling Compensator  
**CH** — Crankcase Heater  
**CLO** — Compressor Lockout  
**COMP** — Compressor Motor  
**CR** — Control Relay  
**CT** — Current Transformer  
**DAT** — Discharge Air Thermistor  
**DM** — Damper Motor  
**DU** — Dummy Terminal  
**EC** — Enthalpy Control  
**EQUIP** — Equipment  
**FPT** — Freeze Protection Thermostat  
**FU** — Fuse  
**GND** — Ground  
**HPS** — High-Pressure Switch  
**HS** — Hall Effect Sensor

**HV** — High Voltage  
**I** — Ignitor  
**IDM** — Induced-Draft Motor  
**IFC** — Indoor-Fan Contactor  
**IFCB** — Indoor-Fan Circuit Breaker  
**IFM** — Indoor-Fan Motor  
**IGC** — Integrated Gas Unit Controller  
**L** — Light  
**LOR** — Lockout Relay  
**LPS** — Low-Pressure Switch  
**LS** — Limit Switch  
**MAT** — Mixed-Air Thermostat  
**MGV** — Main Gas Valve  
**OAT** — Outdoor-Air Thermostat  
**OFC** — Outdoor-Fan Contactor  
**OFM** — Outdoor-Fan Motor  
**PL** — Plug Assembly  
**PRI** — Primary  
**QT** — Quadruple Terminal  
**RS** — Rollout Switch

**SW** — Switch  
**TB** — Terminal Block  
**TC** — Thermostat, Cooling  
**TH** — Thermostat, Heating  
**TRAN** — Transformer  
 Terminal (Marked)  
 Terminal (Unmarked)  
 Terminal Block  
 Splice  
 Factory Wiring  
 Field Wiring  
 To indicate common potential only, not to represent wiring.

## NOTES:

- Compressor and/or fan motor(s) thermally protected. Three-phase motors protected against primary single-phasing conditions.
- If any of the original wire furnished must be replaced, it must be replaced with Type 90° C or its equivalent.
- Jumpers are omitted when unit is equipped with economizer.
- On 208/230-v unit TRAN1 is factory wired to ORN lead for 230-v power supply. If unit is to run on 208-v power supply, TRAN1 must be rewired as follows: Disconnect the BLK wire on TRAN1 and connect it to 208-v RED wire and insulate 230-v ORN wire.
- The CLO locks out the compressor to prevent short cycling on compressor overload and safety devices. Before replacing CLO, check these devices.

### ECONOMI\$ER WIRING — SIZES 015-028

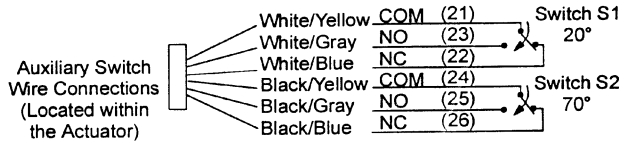
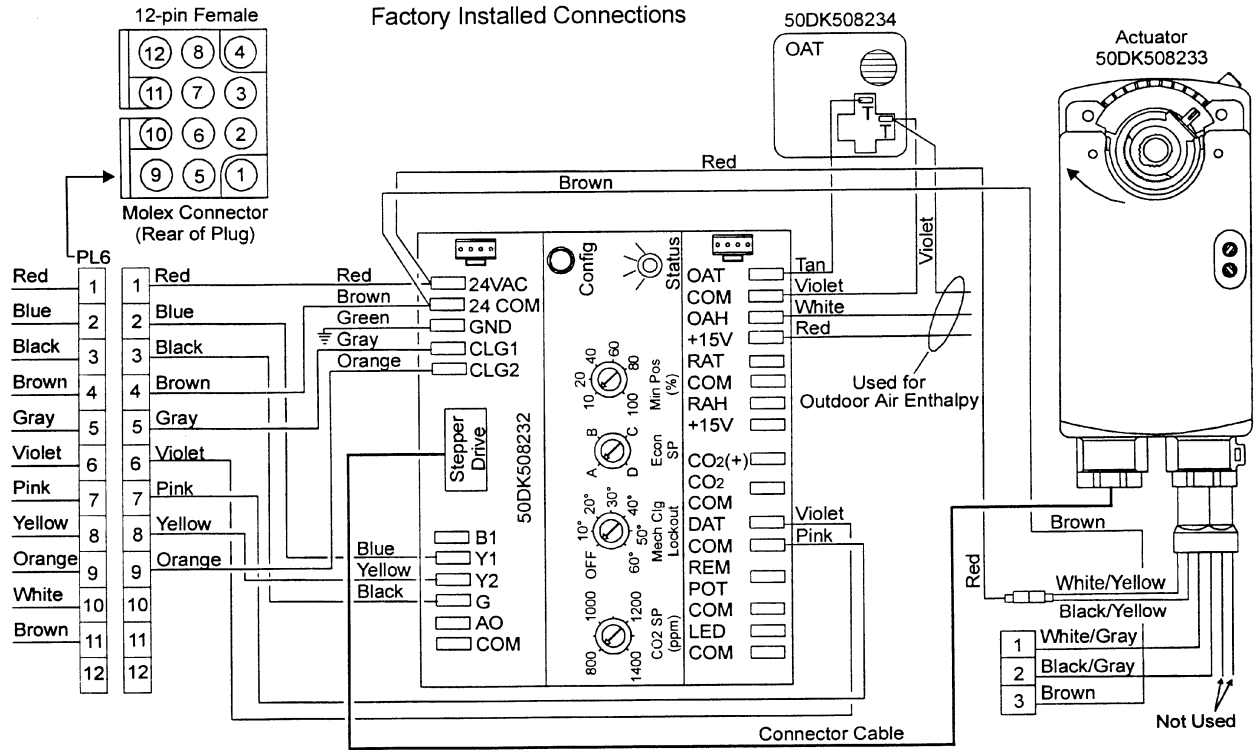

### NON-FUSED DISCONNECT (OPTIONAL)

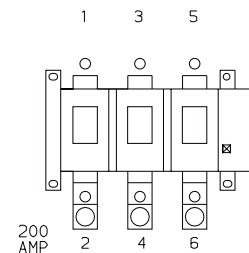
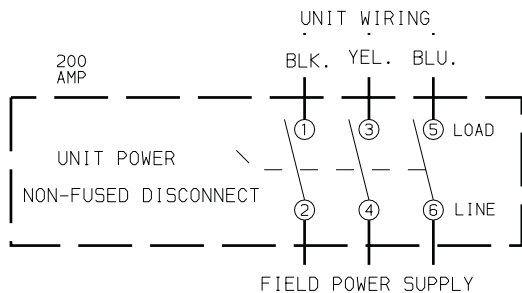
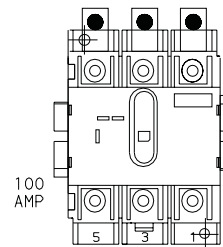
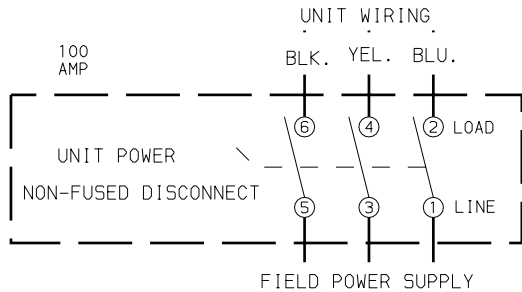

**NOTES:**

1. If the Non-Fused Disconnect Service Option is ordered for size 015-028 units, the Non-Fused Disconnect will be factory-installed.
2. The Disconnect takes the place of TB-1 as shown on the unit wiring diagram label and the component arrangement label.

# Model number nomenclature



48TM004-014

## 48TM004-014 3 to 12½ Tons — ASHRAE 90.1 Compliant

Example: **48 TM D 006 P M F 6 - 1 HA**

**48** – Packaged Rooftop  
Electric Cooling/  
Natural Gas Heat

**TM** – Constant Volume, Standard Efficiency

**Heat Options:**  
49 States

**D** – Low Heat  
**E** – Medium Heat  
**F** – High Heat

**California Compliant**

**L** – Low NOx Low Heat  
**M** – Low NOx Medium Heat  
**N** – Low NOx High Heat

**Tons Nominal Capacity**

**004** – 3 Tons  
**005** – 4 Tons  
**006** – 5 Tons  
**007** – 6 Tons  
**008** – 7-1/2 Tons  
**009** – 8-1/2 Tons  
**012** – 10 Tons  
**014** – 12-1/2 Tons

**Controls and Sensors**

– – None  
**K** – Novar ETM2024 Control\*  
**N** – Novar ETM3051 Control\*  
**P** – PremierLink™ DDC Control  
**Z** – Apollo Control

**FIOP†**

**Packaging**  
**1** – Domestic  
**3** – Export

**Design Changes**

**Voltage**

**1** – 575-3-60  
**3** – 208/230-1-60  
**5** – 208/230-3-60  
**6** – 460-3-60

**Coil Protection Options (fin/tube)**

– – Al/Cu Cond & Evap  
**B** – Cu/Cu Cond & Evap  
**C** – Cu/Cu Cond & Al/Cu Evap  
**F** – E-Coat Al/Cu Cond & Al/Cu Evap  
**G** – E-Coat Cu/Cu Cond & Al/Cu Evap  
**V** – Al/Cu Pre-Coat Cond Fin & Al/Cu Evap

**Indoor Motor Options**

– – Standard Motor & Drive  
**A** – Alternate Motor  
**M** – High-Static Indoor Motor

**LEGEND**

**Al** — Aluminum  
**Cu** — Copper  
**FIOP** — Factory-Installed Option

\*Contact factory for availability and application information.

†Refer to 48TM Price Pages or contact your local Carrier representative for FIOP code table.

### Quality Assurance



## ARI\* capacity ratings

UNIT 48TM	NOMINAL TONS	NET COOLING CAPACITY (Btuh)	TOTAL kW	SEER†	EER**	SOUND RATING (Bels)	IPLV††
004	3	35,000	4.0	10.0	8.7	8.1	N/A
005	4	47,000	5.3	10.0	8.8	8.1	N/A
006	5	57,000	6.7	10.0	8.5	8.1	N/A
007	6	71,000	7.0	—	10.1	8.0	N/A
008	7½	88,000	8.7	—	10.1	8.2	10.5
009	8½	100,000	9.9	—	10.1	8.2	10.4
012	10	114,000	11.3	—	10.1	8.4	11.0
014	12½	136,000	14.3	—	9.5	8.6	9.7

**LEGEND**

**Bels** — Sound Levels (1 bel = 10 decibels)  
**db** — Dry Bulb  
**EER** — Energy Efficiency Ratio  
**IPLV** — Integrated Part-Load Values  
**SEER** — Seasonal Energy Efficiency Ratio  
**wb** — Wet Bulb

\*Air Conditioning and Refrigeration Institute.

†The SEER values shown for sizes 004, 005, and 006 are for units with the optional belt drive motors; SEER rating for these units with the standard direct drive motor is 9.7.

\*\*ARI does not require EER ratings for units with capacity below 65,000 Btuh. For these units, the EER rating at ARI standard conditions is provided for information only.

††The IPLV applies only to two-stage cooling units.

**NOTES:**

1. Rated in accordance with ARI Standards 210/240, latest revision (for sizes 004-012) or 360, latest revision (for size 014) and 270, latest revision.

2. ARI ratings are net values, reflecting the effects of circulating fan heat.
3. Ratings are based on:



**Cooling Standard:** 80 F db, 67 F wb indoor entering-air temperature and 95 F db air entering outdoor unit.

**IPLV Standard:** 80 F db, 67 F wb indoor entering-air temperature and 80 F db outdoor entering-air temperature.

4. All 48TM004-014 units are in compliance with ASHRAE 90.1 2001 Energy Standard for minimum SEER and EER requirements. Refer to state and local codes or visit the following website: <http://solstice.crest.org/efficiency/bcap> to determine if compliance with this standard pertains to a given geographical area of the United States.

California, Maryland, Washington, Wyoming and various local and state building codes adopted the ASHRAE 90.1 efficiency standard on October 29, 2001.



**HEATING CAPACITIES AND EFFICIENCIES**  
**208/230-1-60 — SINGLE STAGE GAS HEAT**

UNIT 48TM	INPUT CAPACITY		OUTPUT CAPACITY		TEMPERATURE RISE (°F)	MINIMUM HEATING AIRFLOW (CFM)	EFFICIENCY	
	1st Stage	2nd Stage	1st Stage	2nd Stage			AFUE (%)	Steady State (%)
E004	74,000	—	57,000	—	15-45	1180	80	80
F004	115,000	—	89,000	—	55-85	970	80	80
D005	74,000	—	57,000	—	15-45	1180	80	80
E005	115,000	—	91,000	—	35-65	1300	80	80
F005	150,000	—	118,000	—	50-80	1370	80	80
D006	74,000	—	57,000	—	15-45	1180	80	80
E006	115,000	—	91,000	—	35-65	1300	80	80
F006	150,000	—	118,000	—	50-80	1370	80	80

**208/230-1-60 — SINGLE STAGE GAS HEAT — LOW NO<sub>x</sub>**

UNIT 48TM	INPUT CAPACITY		OUTPUT CAPACITY		TEMPERATURE RISE (°F)	MINIMUM HEATING AIRFLOW (CFM)	EFFICIENCY	
	1st Stage	2nd Stage	1st Stage	2nd Stage			AFUE (%)	Steady State (%)
M004	60,000	—	49,000	—	20-50	910	80	80
N004	90,000	—	73,000	—	30-60	1130	80	80
L005	60,000	—	49,000	—	20-50	910	80	80
M005	90,000	—	73,000	—	30-60	1130	80	80
N005	120,000	—	98,000	—	40-70	1300	80	80
L006	60,000	—	49,000	—	20-50	910	80	80
M006	90,000	—	73,000	—	30-60	1130	80	80
N006	120,000	—	98,000	—	40-70	1300	80	80

**208/230/460-3-60 — SINGLE STAGE GAS HEAT — LOW NO<sub>x</sub>**

UNIT 48TM	INPUT CAPACITY		OUTPUT CAPACITY		TEMPERATURE RISE (°F)	MINIMUM HEATING AIRFLOW (CFM)	EFFICIENCY	
	1st Stage	2nd Stage	1st Stage	2nd Stage			AFUE (%)	Steady State (%)
M004	60,000	—	49,000	—	20-50	910	80	80
N004	90,000	—	73,000	—	30-60	1130	80	80
L005	60,000	—	49,000	—	20-50	910	80	80
M005	90,000	—	73,000	—	30-60	1130	80	80
N005	120,000	—	98,000	—	40-70	1300	80	80
L006	60,000	—	49,000	—	20-50	910	80	80
M006	90,000	—	73,000	—	30-60	1130	80	80
N006	120,000	—	98,000	—	40-70	1300	80	80

**208/230/460/575-3-60 — SINGLE STAGE GAS HEAT**

UNIT 48TM	INPUT CAPACITY		OUTPUT CAPACITY		TEMPERATURE RISE (°F)	MINIMUM HEATING AIRFLOW (CFM)	EFFICIENCY	
	1st Stage	2nd Stage	1st Stage	2nd Stage			AFUE (%)	Steady State (%)
E004	74,000	—	40,000	59,200	15-45	1220	80	80
D005	74,000	—	40,000	59,200	15-45	1220	80	80
E005	115,000	—	65,600	92,000	35-65	1320	80	80
D006	74,000	—	40,000	59,200	15-45	1220	80	80
E006	115,000	—	65,600	92,000	35-65	1320	80	80
D007	74,000	—	40,000	59,200	15-45	1220	80	80
E007	115,000	—	65,600	92,000	35-65	1320	80	80
D008	125,000	—	72,000	100,000	20-50	1860	80	80
D009	125,000	—	72,000	100,000	20-50	1860	80	80

**208/230/460/575-3-60 — 2-STAGE GAS HEAT**

UNIT 48TM	INPUT CAPACITY		OUTPUT CAPACITY		TEMPERATURE RISE (°F)	MINIMUM HEATING AIRFLOW (CFM)	EFFICIENCY	
	1st Stage	2nd Stage	1st Stage	2nd Stage			AFUE (%)	Steady State (%)
F004	82,000	115,000	65,600	92,000	55-85	1010	80	80
F005	120,000	150,000	96,000	120,000	50-80	1390	80	80
F006	120,000	150,000	96,000	120,000	50-80	1390	80	80
F007	120,000	150,000	96,000	120,000	50-80	1390	80	80
E008	120,000	180,000	96,000	144,000	35-65	2060	80	80
F008	180,000	224,000	144,000	179,200	45-75	2180	80	80
E009	120,000	180,000	96,000	144,000	35-65	2060	80	80
F009	180,000	224,000	144,000	179,200	45-75	2180	80	80
D012	120,000	180,000	90,000	144,000	35-65	2060	80	80
E012	180,000	224,000	144,000	179,200	35-65	2510	80	80
F012	200,000	250,000	160,000	200,000	40-70	2650	80	80
D014	180,000	224,000	144,000	179,200	35-65	2510	80	80
E014	200,000	250,000	160,000	200,000	40-70	2650	80	80

# Physical data — 48TM004-007



48TM004-014

UNIT SIZE 48TM		E/F/M/N004	D/E/F/L/M/N005	D/E/F/L/M/N006	D/E/F007
<b>NOMINAL CAPACITY (tons)</b>		3	4	5	6
<b>OPERATING WEIGHT (lb)</b>					
Unit					
AI/AI*		460	470	490	615
AI/Cu*		465	476	497	626
Cu/Cu*		468	482	505	637
Economizer					
EconoMiser2		50	50	50	50
Roof Curb†		115	115	115	115
<b>COMPRESSOR</b>			Reciprocating		Scroll
Quantity		1	1	1	1
No. Cylinders (per Circuit)		2	2	2	2
Oil (oz)		50	50	50	60
<b>REFRIGERANT TYPE</b>		R-22			
Expansion Device		Acutrol™ Metering Device			
Operating Charge (lb-oz)					
Circuit 1		4-5	6-6	7-14	11-0
Circuit 2		—	—	—	—
<b>CONDENSER COIL</b>		Enhanced Copper Tubes, Aluminum Lanced Fins			
Rows...Fins/in.		1...17	2...17	2...17	2...17
Total Face Area (sq ft)		8.36	8.36	10.42	16.5
<b>CONDENSER FAN</b>		Propeller Type			
Nominal Cfm		3500	4000	4000	4100
Quantity...Diameter (in.)		1...22.0	1...22.0	1...22.0	1...22.0
Motor Hp...Rpm		1/4...1100	1/4...1100	1/4...1100	1/4...1100
Watts Input (Total)		325	325	325	320
<b>EVAPORATOR COIL</b>		Enhanced Copper Tubes, Aluminum Double-Wavy Fins			
Rows...Fins/in.		2...15	2...15	3...15	4...15
Total Face Area (sq ft)		4.17	5.5	5.5	5.5
<b>EVAPORATOR FAN</b>		Centrifugal Type			
Quantity...Size (in.)		1...10 x 10	1...10 x 10	1...11 x 10	1...10 x 10
Alt		1...10 x 10	1...10 x 10	1...10 x 10	—
High-Static		1...10 x 10	1...10 x 10	1...10 x 10	1...10 x 10
<b>Type Drive</b>					
Std		Direct	Direct	Direct	Belt
Alt		Belt	Belt	Belt	—
High-Static		Belt	Belt	Belt	Belt
<b>Nominal Cfm</b>		1200	1600	2000	2100
<b>Maximum Continuous Bhp</b>					
Std		.34	.75	1.20	2.40
Alt		1.20	1.20	1.30/2.40**	—
High-Static		2.40	2.40	2.90	2.90
<b>Motor Frame Size</b>		48	48	48	56
Alt		48	48	56	—
High-Static		56	56	56	56
<b>Nominal Rpm High/Low</b>					
Std		860/800	1075/970	1075/970	—
Alt		1620	1620	1725	—
High-Static		1725	1725	1725	1725
<b>Fan Rpm Range</b>					
Std		—	—	—	1070-1460
Alt		760-1000	835-1185	900-1300	—
High-Static		1075-1455	1075-1455	1300-1685	1300-1685
<b>Motor Bearing Type</b>		Ball	Ball	Ball	Ball
<b>Maximum Allowable Rpm</b>		2100	2100	2100	2100
<b>Motor Pulley Pitch Diameter Min/Max (in.)</b>					
Std		—	—	—	2.8/3.8
Alt		1.9/2.9	1.9/2.9	2.4/3.4	—
High-Static		2.8/3.8	2.8/3.8	3.4/4.4	3.4/4.4
<b>Nominal Motor Shaft Diameter (in.)</b>					
Std		1/2	1/2	1/2	5/8
Alt		1/2	1/2	5/8	—
High-Static		5/8	5/8	7/8	7/8
<b>Fan Pulley Pitch Diameter (in.)</b>					
Std		—	—	—	4.5
Alt		4.5	4.0	4.5	—
High-Static		4.5	4.5	4.5	4.5
<b>Belt, Quantity...Type...Length (in.)</b>					
Std		—	—	—	1...A...40
Alt		1...A...34	1...A...34	1...A...39	—
High-Static		1...A...39	1...A...39	1...A...40	1...A...40
<b>Pulley Center Line Distance (in.)</b>					
Std		—	—	—	14.7-15.5
Alt		10.0-12.4	10.0-12.4	14.7-15.5	—
High-Static		10.0-12.4	10.0-12.4	14.7-15.5	14.7-15.5
<b>Speed Change per Full Turn of Movable Pulley Flange (rpm)</b>					
Std		—	—	—	80
Alt		48	70	80	—
High-Static		65	65	60	60
<b>Movable Pulley Maximum Full Turns From Closed Position</b>					
Std		—	—	—	5
Alt		5	5	5	—
High-Static		6	6	5	5
<b>Factory Setting</b>					
Std		—	—	—	3
Alt		3	3	3	—
High-Static		3 1/2	3 1/2	3 1/2	3 1/2
<b>Factory Speed Setting (rpm)</b>					
Std		—	—	—	1225
Alt		856	975	1060	—
High-Static		1233	1233	1396	1396
<b>Fan Shaft Diameter at Pulley (in.)</b>					
Std		5/8	5/8	5/8	5/8

**LEGEND**

- AI — Aluminum
- Bhp — Brake Horsepower
- Cu — Copper

\*Evaporator coil fin material/condenser coil fin material. Contact your local representative for details about coated fins.

†Weight of 14-in. roof curb.

\*\*Single phase/three-phase.

††Rollout switch lockout is manually reset by interrupting power to unit or resetting thermostat.

\*\*\*Three-phase standard high heat models have heating input values as shown. Single-phase standard high heat models have one-stage heating with heating input values as follows:

48TMF004 — 115,000 Btuh

48TMF005.006 — 150,000 Btuh

†††California SCAQMD compliant Low NO<sub>x</sub> models have combustion products that are controlled to 40 nanograms per joule or less.

NOTE: High-static motor not available on single-phase units.



UNIT SIZE 48TM		E/F/M/N004	D/E/FL/M/N005	D/E/FL/M/N006	D/E/F007
<b>FURNACE SECTION</b>					
Rollout Switch Cutout					
Temp (F)††		195	195	195	195
Burner Orifice Diameter (in. ...drill size)					
Natural Gas					
	Std	TMD	.113...33	.113...33	.113...33
		TME	.113...33	.113...33	.113...33
		TMF	.113...33	.129...30	.129...30
		TML	—	.102...38	—
		TMM	.102...38	.102...38	—
		TMN	.102...38	.116...32	—
Liquid Propane¶		Alt	TMD	.089...43	.089...43
			TME	.089...43	.089...43
			TMF	.089...43	.104...37
			TML	—	.082...45
			TMM	.082...45	—
			TMN	.082...45	—
Thermostat Heat Anticipator Setting (amps)					
208/230 v and 575 Stage 1		.14	.14	.14	.14
Stage 2		.14	.14	.14	.14
460 v Stage 1		.14	.14	.14	.14
Stage 2		.14	.14	.14	.14
Gas Input (Btuh) Standard Units		TMD	—/74,000	—/74,000	—/74,000
(Stage 1/Stage 2)		TME	—/115,000	—/115,000	—/115,000
Low NOx Units		TMF***	82,000/115,000	120,000/150,000	120,000/150,000
		TML†††	—	60,000	—
		TMM†††	60,000	90,000	—
		TMN†††	90,000	120,000	—
Efficiency (Steady State) (%)		80	80	80	80
Temperature Rise Range		TMD	—	15-45	15-45
		TME	15-45	35-65	35-65
		TMF	55-85	50-80	50-80
		TML	—	20-50	—
		TMM	20-50	30-60	—
		TMN	30-60	40-70	—
Manifold Pressure (in. wg)					
Natural Gas		Std	3.5	3.5	3.5
Liquid Propane		Alt	3.5	3.5	3.5
Gas Valve Quantity			1	1	1
Gas Valve Pressure Range					
Psig			0.180-0.487	0.180-0.487	0.180-0.487
in. wg			5.0-13.5	5.0-13.5	5.0-13.5
Field Gas Connection Size (in.)			1/2	1/2	1/2
<b>HIGH-PRESSURE SWITCH (psig)</b>					
Standard Compressor			450 ± 50		500 ± 50
Internal Relief (Differential)					
Cutout			428		428
Reset (Auto.)			320		320
<b>LOW-PRESSURE SWITCH (psig)</b>					
Cutout			7 ± 3		
Reset (Auto.)			22 ± 7		
<b>FREEZE PROTECTION THERMOSTAT (F)</b>					
Opens			30 ± 5		
Closes			45 ± 5		
<b>OUTDOOR-AIR INLET SCREENS</b>					
Quantity...Size (in.)			Cleanable		
			1...20 x 24 x 1		
<b>RETURN-AIR FILTERS</b>					
Quantity...Size (in.)			Throwaway		
			2...16 x 25 x 2		

**LEGEND**

- Al** — Aluminum
- Bhp** — Brake Horsepower
- Cu** — Copper

\*Evaporator coil fin material/condenser coil fin material. Contact your local representative for details about coated fins.

†Weight of 14-in. roof curb.

\*\*Single phase/three-phase.

††Rollout switch lockout is manually reset by interrupting power to unit or resetting thermostat.

\*\*\*Three-phase standard high heat models have heating input values as shown. Single-phase standard high heat models have one-stage heating with heating input values as follows:

- 48TMF004 — 115,000 Btuh
- 48TMF005,006 — 150,000 Btuh

†††California SCAQMD compliant Low NO<sub>x</sub> models have combustion products that are controlled to 40 nanograms per joule or less.

¶An LP kit is available as an accessory. Kit may be used at elevations as high as 2000 ft.

NOTE: High-static motor not available on single-phase units.

# Physical data — 48TM008-014



48TM004-014

UNIT SIZE 48TM		D/E/F008	D/E/F009	D/E/F012	D/E/O14
NOMINAL CAPACITY (tons)		7½	8½	10	12½
OPERATING WEIGHT (lb)					
Unit					
Al/Al*		870	880	1035	1050
Al/Cu*		881	896	1057	1077
Cu/Cu*		893	907	1080	1100
Economizer					
EconoMiSer2		75	75	75	75
Roof Curb†		143	143	143	143
COMPRESSOR		Reciprocating	Scroll	Scroll	Scroll
Quantity		2	2	2	2
No. Cylinders (per Circuit)		2	2	2	2
Oil (oz) (each compressor)		42	53	50	60
REFRIGERANT TYPE		R-22			
Expansion Device		Acutrol™ Metering Device			
Operating Charge (lb-oz)					
Circuit 1		7-10	7-14	8-10	9-8
Circuit 2		8-2	8-5	8-8	9-5
CONDENSER COIL		Enhanced Copper Tubes, Aluminum Lanced Fins			
Rows...Fins/in.		2...17	2...17	2...17	2...17
Total Face Area (sq ft)		20.50	20.50	25.00	25.00
CONDENSER FAN		Propeller Type			
Nominal Cfm		6500	6500	7000	7000
Quantity...Diameter (in.)		2...22	2...22	2...22	2...22
Motor Hp...Rpm		¼...1100	¼...1100	¼...1100	¼...1100
Watts Input (Total)		650	650	650	650
EVAPORATOR COIL		Enhanced Copper Tubes, Aluminum Double-Wavy Fins, Face Split			
Rows...Fins/in.		3...15	3...15	3...15	4...15
Total Face Area (sq ft)		8.9	8.9	10.0	11.1
EVAPORATOR FAN		Centrifugal Type			
Quantity...Size (in.)		Std 1...15 x 15	1...15 x 15	1...15 x 15	1...15 x 15
		Alt 1...15 x 15	—	1...15 x 15	1...15 x 15
		High-Static 1...15 x 15	1...15 x 15	1...15 x 15	—
Type Drive		Std Belt	Belt	Belt	Belt
		Alt Belt	—	Belt	Belt
		High-Static Belt	Belt	Belt	—
Nominal Cfm		2900	3000	3200	5000
Maximum Continuous Bhp		Std 2.40	2.40	2.40	3.70
		Alt 2.40	—	2.90	5.25
		High-Static 3.70	3.70	5.25	—
Motor Frame Size		Std 56	56	56	56
		Alt 56	—	56	56
		High-Static 56	56	56	—
Fan Rpm Range		Std 590-840	685-935	685-935	860-1080
		Alt 685-935	—	835-1085	900-1260
		High-Static 860-1080	860-1080	830-1130	—
Motor Bearing Type		Ball	Ball	Ball	Ball
Maximum Allowable Rpm		2100	2100	2100	2100
Motor Pulley Pitch Diameter Min/Max (in.)		Std 2.4/3.4	2.8/3.8	2.8/3.8	4.0/5.0
		Alt 2.8/3.8	—	3.4/4.4	3.1/4.1
		High-Static 4.0/5.0	4.0/5.0	2.8/3.8	—
Nominal Motor Shaft Diameter (in.)		Std 5/8	5/8	5/8	7/8
		Alt 5/8	—	7/8	7/8
		High-Static 7/8	7/8	7/8	—
Fan Pulley Pitch Diameter (in.)		Std 7.0	7.0	7.0	8.0
		Alt 7.0	—	7.0	5.9
		High-Static 8.0	8.0	5.8	—
Belt, Quantity...Type...Length (in.)		Std 1...A...49	1...A...49	1...A...49	1...A...52
		Alt 1...A...49	—	1...A...49	1...BX...46
		High-Static 1...A...55	1...A...55	1...BX...46	—
Pulley Center Line Distance (in.)		Std 16.75-19.25	16.75-19.25	15.85-17.50	15.85-17.50
		Alt 16.75-19.25	—	15.85-17.50	15.85-17.50
		High-Static 16.75-19.25	16.75-19.25	15.85-17.50	—
Speed Change per Full Turn of Movable Pulley Flange (rpm)		Std 50	50	50	44
		Alt 50	—	50	50
		High-Static 60	60	60	—
Movable Pulley Maximum Full Turns From Closed Position		Std 5	5	5	5
		Alt 5	—	5	6
		High-Static 5	5	6	—
Factory Setting		Std 5	5	5	5
		Alt 5	—	5	5
		High-Static 5	5	5	—
Factory Speed Setting (rpm)		Std 590	685	685	860
		Alt 685	—	835	960
		High-Static 860	860	887	—
Fan Shaft Diameter at Pulley (in.)		1	1	1	1



48TM004-014

UNIT SIZE 48TM		D/E/F008	D/E/F009	D/E/F012	D/E014
<b>FURNACE SECTION</b>					
Rollout Switch Cutout					
Temp (F)††					
Burner Orifice Diameter (in. ....drill size)					
Natural Gas					
Std	TMD	.120...31	.120...31	.120...31	.120...31
	TME	.120...31	.120...31	.120...31	.129...30
	TMF	.120...31	.120...31	.129...30	—
Alt	TMD	.096...41	.096...41	.096...41	.096...41
	TME	.096...41	.096...41	.096...41	.102...38
	TMF	.096...41	.096...41	.102...38	—
Liquid Propane					
Thermostat Heat Anticipator Setting (amps)					
208/230 v and 575 Stage 1					
Stage 2					
460 v Stage 1					
Stage 2					
Gas Input (Btuh) Stage 1					
TMD	TMD	125,000	125,000	120,000	180,000
	TME	120,000	120,000	180,000	200,000
	TMF	180,000	180,000	200,000	—
Stage 2	TMD	—	—	180,000	224,000
	TME	180,000	180,000	224,000	250,000
	TMF	224,000	224,000	250,000	—
Efficiency (Steady State) (%)					
Temperature Rise Range					
TMD	TMD	80	80	80	80
	TME	20-50	20-50	35-65	35-65
	TMF	35-65	35-65	35-65	40-70
Alt	TMD	45-75	45-75	40-70	—
	TME	—	—	—	—
	TMF	—	—	—	—
Manifold Pressure (in. wg)					
Natural Gas					
Liquid Propane					
Gas Valve Quantity					
Gas Valve Pressure Range					
Psig					
in. wg					
Field Gas Connection Size (in.)					
TMD	TMD	0.180-0.487	0.180-0.487	0.180-0.487	0.180-0.487
	TME	5.0-13.5	5.0-13.5	5.0-13.5	5.0-13.5
	TMF	—	—	—	—
HIGH-PRESSURE SWITCH (psig)					
Standard Compressor					
Internal Relief (Differential)					
Cutout					
Reset (Auto.)					
LOW-PRESSURE SWITCH (psig)					
Cutout					
Reset (Auto.)					
FREEZE PROTECTION THERMOSTAT (F)					
Opens					
Closes					
OUTDOOR-AIR INLET SCREENS					
Quantity...Size (in.)					
RETURN-AIR FILTERS					
Quantity...Size (in.)					

**LEGEND**

- Al — Aluminum
- Bhp — Brake Horsepower
- Cu — Copper

\*Evaporator coil fin material/condenser coil fin material. Contact your local representative for details about coated fins.

†Weight of 14-in. roof curb.

\*\*Single phase/three-phase.

††Rollout switch lockout is manually reset by interrupting power to unit or resetting thermostat.

# Base unit dimensions — 48TM004-006



48TM004-014

CONNECTION SIZES	
A	1 3/8" DIA. (351) FIELD POWER SUPPLY HOLE
B	2" DIA. (51) POWER SUPPLY KNOCK-OUT
C	2 1/2" DIA. (64) POWER SUPPLY KNOCK-OUT
D	7/8" DIA. (22) FIELD CONTROL WIRING HOLE
E	3/4" - 1/4 NPT CONDENSATE DRAIN
F	1/2" - 1/4 NPT GAS CONNECTION

BOTTOM POWER CHART USE THESE ACCESSORY PACKAGES	
CRBTPM001A00, 3A00 (1/2", 3/4")	REQ'D HOLE SIZES (MAX.)
1/2"	7/8" (22.2)
3/4"	1 1/8" (28.6)
24V POWER GAS	1 1/4" (31.8)

UNIT	STD. UNIT (DURABLE/ECONOMIZER) WEIGHT		ECONOMIZER WEIGHT		CORNER WEIGHT		CORNER WEIGHT		(D) CORNER WEIGHT		"A" PANEL LENGTH							
	LBS.	KG.	LBS.	KG.	LBS.	KG.	LBS.	KG.	LBS.	KG.	LBS.	KG.						
48T_004	460	209	34	15.4	50	22.7	90	40.9	140	63.5	105	47.6	159	72.1	56	25.4	1'-10 3/8"	[566.0]
48T_005	470	213	→	→	→	→	142	64.4	106	48.1	162	73.5	60	27.2	1'-10 3/8"	[566.0]	→	→
48T_006	490	222	→	→	→	→	150	68.0	115	52.2	160	72.6	65	29.5	1'-0 3/8"	[315.0]	→	→

1. DIMENSIONS IN [ ] ARE IN MILLIMETERS.

2. CENTER OF GRAVITY.

3. DIRECTION OF AIR FLOW.

4. ON VERTICAL DISCHARGE UNITS, DUCTWORK TO BE ATTACHED TO ACCESSORY SUPPLY LINES SHOULD BE ATTACHED TO HORIZONTAL DISCHARGE OPENINGS, AND ALL DUCTWORK SHOULD BE ATTACHED TO THE FLANGES.

5. MINIMUM CLEARANCE (LOCAL CODES OR JURISDICTION MAY PREVAIL):  
 a. BETWEEN UNIT, FLUE SIDE AND COMBUSTIBLE SURFACES, 36 IN., 18 IN. WHEN USING ACCESSORY FLUE DISCHARGE DEFLECTOR.  
 b. BOTTOM OF UNIT TO COMBUSTIBLE SURFACES WHEN NOT USING SURFACES WHEN NOT USING CURBY OIL INCHES.  
 c. CONDENSER COIL FOR PROPER AIR FLOW, 36 INCHES ONE SIDE, 12 INCHES THE OTHER. THE SIDE GETTING THE GREATER CLEARANCE IS OPTIONAL.  
 d. OVERHEAD, 60 INCHES TO ASSURE PROPER CONDENSER FAN OPERATION.

e. BETWEEN UNITS, UNCONTROLLED SURFACES, 42 IN. PER NEC.  
 f. BETWEEN UNITS, UNCONTROLLED SURFACES, CONTROL BOX 36 IN. PER NEC.  
 g. BETWEEN UNIT AND BLOCK OR CONCRETE WALLS AND OTHER GROUNDED SURFACES, CONTROL BOX SIDE, 42 IN. PER NEC.  
 h. HORIZONTAL SUPPLY AND RETURN END, 0 INCHES WHEN THE ALTERNATE CONDENSATE DRAIN IS USED.

6. WITH THE EXCEPTION OF THE CLEARANCE FOR THE CONDENSER COIL AND COMBUSTION SIDE AS STATED IN NOTE 5, b, c, AND A REMOVABLE FENCE OR BARRICADE REQUIRES NO CLEARANCE.

7. UNITS MAY BE INSTALLED ON COMBUSTIBLE FLOORS MADE OF WOOD OR CLASS A, B, OR C ROOF COVERING MATERIAL IF SET ON BASERAIL.

8. THE VERTICAL CENTER OF GRAVITY IS 1'-6" (457) UP FROM CORNER "D".

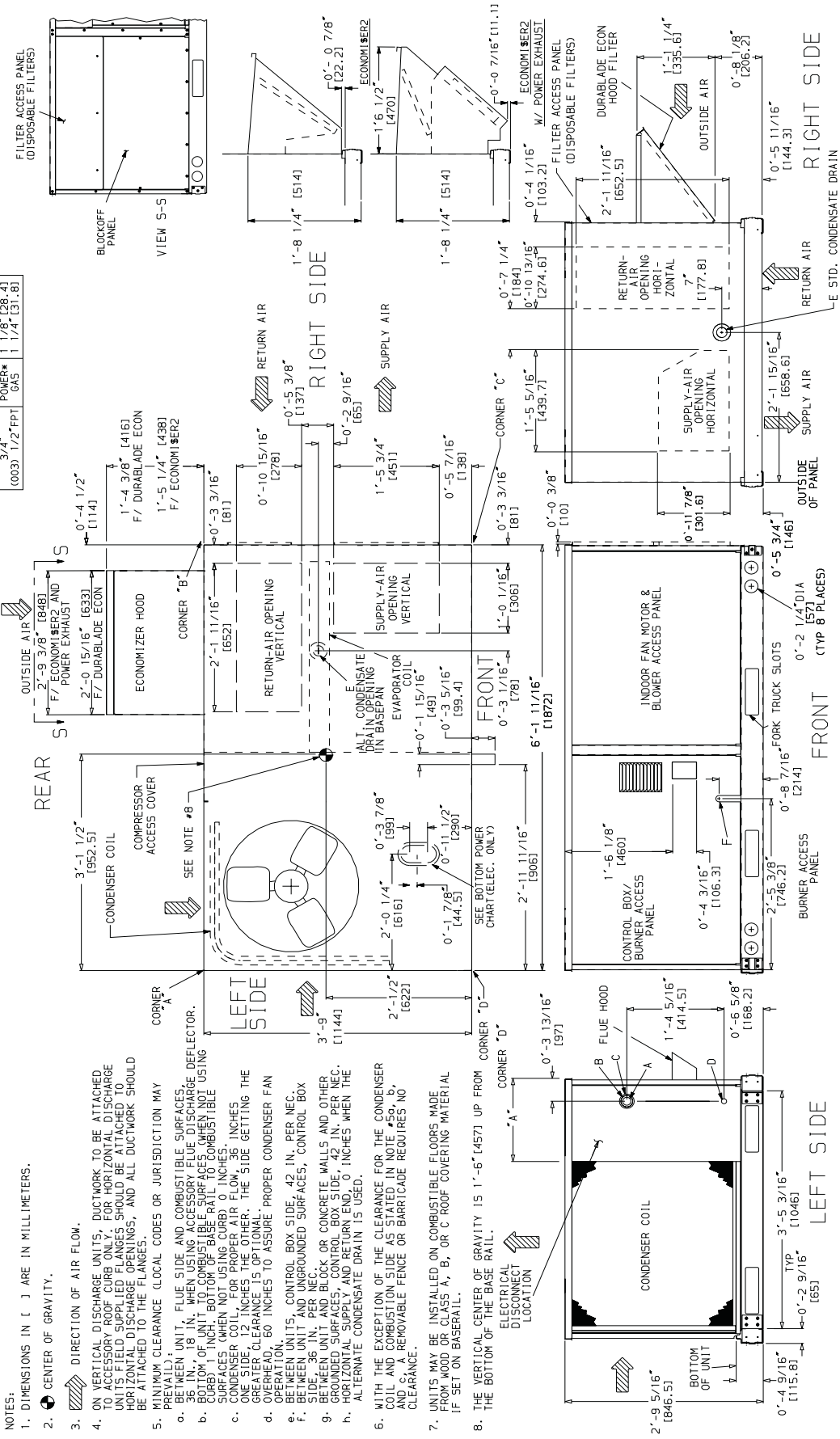

# Base unit dimensions — 48TM007



48TM004-014

UNIT	STD. WEIGHT LBS.	UNIT WEIGHT LBS.	ECONOMIZER WEIGHT LBS.	(A) CORNER WEIGHT LBS.	(B) CORNER WEIGHT LBS.	(C) CORNER WEIGHT LBS.	(D) CORNER WEIGHT LBS.	FT. - IN.	MM								
48TM007	615	279	34	15.4	50	22.7	90	40.9	147	66.7	64.4	180	72.6	166	75.3	2'-9 5/16"	846.5

CONNECTION SIZES	REO'D. HOLE SIZES (MAX.)
A 1 3/8" DIA. [35] FIELD POWER SUPPLY HOLE	WIRE 1/2"
B 2" DIA. [51] POWER SUPPLY KNOCK-OUT	CONDUIT 3/4"
C 1 3/4" DIA. [44] CHARGING PORT HOLE	USE 24V POWER
D 7/8" DIA. [22] FIELD CONTROL WIRING HOLE	7/8" [22.2]
E 3/4" -14 NPT CONDENSATE DRAIN	POWER 1 1/8" [28.4]
F 1/2" -14 NPT GAS CONNECTION	
G 2 1/2" DIA. [64] POWER SUPPLY KNOCK-OUT	

**BOTTOM POWER CHART:**  
THESE HOLES REQ'D FOR USE WITH ACCESSORY PACKAGES - CRIMP/ARMOITACO (1/2", 3/4")

**REAR ACCESS PANEL (DISPOSABLE FILTERS):**

**VIEW S-S**

**RIGHT SIDE**

**FRONT**

**LEFT SIDE**

**REAR**

**CONDENSER COIL**

**EVAPORATOR COIL**

**OPTIONAL ECONOMIZER HOOD**

**RETURN AIR VERTICAL**

**SUPPLY AIR VERTICAL**

**CONTROL BOX/COMPRESSOR/BURNER ACCESS PANEL**

**INDOOR FAN MOTOR & BLOWER ACCESS PANEL**

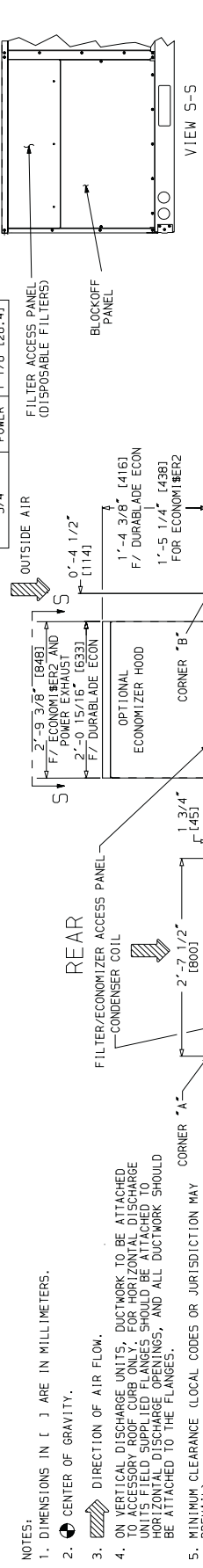

**NOTES:**

1. DIMENSIONS IN [ ] ARE IN MILLIMETERS.
2. Ⓞ CENTER OF GRAVITY.
3. ↻ DIRECTION OF AIR FLOW.
4. ON VERTICAL DISCHARGE UNITS, DUCTWORK TO BE ATTACHED TO ACCESSORY ROOF CURB ONLY. FOR HORIZONTAL DISCHARGE UNITS, FIELD SUPPLIED FLANGES SHOULD BE ATTACHED TO DISCHARGE UNITS, AND ALL DUCTWORK SHOULD BE ATTACHED TO THE FLANGES.
5. MINIMUM CLEARANCE (LOCAL CODES OR JURISDICTION MAY PREVAIL):
  - a. BETWEEN UNIT, FLUE SIDE AND COMBUSTIBLE SURFACES, 36 IN., 18 IN. WHEN USING ACCESSORY FLUE DISCHARGE DEFLECTOR CURB ON UNIT TO COMBUSTIBLE SURFACES (WHEN NOT USING BOTTOM OF BASE RAIL TO COMBUSTIBLE SURFACES (WHEN NOT USING CURB) 0 INCHES.
  - b. BETWEEN UNIT AND UNGRAUNDED SURFACES, CONTROL BOX SIDE, 36 IN. PER NEC.
  - c. CONDENSER COIL, FOR PROPER AIR FLOW, 36 INCHES ONE SIDE, 12 INCHES THE OTHER. THE SIDE GETTING THE GREATER CLEARANCE IS OPTIONAL.
  - d. OVERHEAD, 60 INCHES TO ASSURE PROPER CONDENSER FAN OPERATION.
  - e. BETWEEN UNIT AND UNGRAUNDED SURFACES, CONTROL BOX SIDE, 36 IN. PER NEC.
  - f. BETWEEN UNIT AND UNGRAUNDED SURFACES, CONTROL BOX SIDE, 36 IN. PER NEC.
  - g. BETWEEN UNIT AND BLOCK OR CONCRETE WALLS AND OTHER GROUNDED SURFACES, CONTROL BOX SIDE, 42 IN. PER NEC.
  - h. HORIZONTAL SUPPLY AND RETURN END, 0 INCHES WHEN THE ALTERNATE CONDENSATE DRAIN IS USED.
6. WITH THE EXCEPTION OF THE CLEARANCE FOR THE CONDENSER COIL AND COMBUSTION SIDE AS STATED IN NOTE #5, a, b, AND c, A REMOVABLE FENCE OR BARRICADE REQUIRES NO CLEARANCE.
7. UNITS MAY BE INSTALLED ON COMBUSTIBLE FLOORS MADE OF WOOD OR CLASS A, B, OR C ROOF COVERING MATERIAL IF SET ON BASE RAIL.
8. THE VERTICAL CENTER OF GRAVITY IS 1'-6" (457) UP FROM FROM THE BOTTOM OF THE BASE RAIL.

# Base unit dimensions — 48TM008-014



48TM004-014

UNIT	STD. UNIT WEIGHT LBS.   KG.	DURABLE ECON WEIGHT LBS.   KG.	ECONOMIZER WEIGHT LBS.   KG.	ECONOMIZER W/ P.E. WEIGHT LBS.   KG.	CORNER WEIGHT (A) LBS.   KG.	CORNER WEIGHT (B) LBS.   KG.	CORNER WEIGHT (C) LBS.   KG.	CORNER WEIGHT (D) LBS.   KG.	"j" FT. - IN.   MM	"k" FT. - IN.   MM	"l" FT. - IN.   MM
48TM008	870   395	44   20	75   34.1	145   65.9	189	86   38.6	109   49.0	127   57.4	3'-5 5/16"   1050	2'-9 11/16"   856	2'-2 7/16"   672
48TM009	880   399	40   18.1	75   34.1	145   65.9	191	87   39.4	110   49.7	129   58.1	3'-5 5/16"   1050	2'-9 11/16"   856	2'-2 7/16"   672
48TM012	1035   469	40   18.1	75   34.1	145   65.9	225   102	102   46.3	285   129	151   68.0	4'-1 5/16"   1253	3'-0 3/8"   924	2'-10 7/16"   875
48TM014	1050   475	40   18.1	75   34.1	145   65.9	228   103	103   46.7	289   131	153   69.0	4'-1 5/16"   1253	3'-0 3/8"   924	2'-10 7/16"   875

- NOTES:
1. DIMENSIONS IN [ ] ARE IN MILLIMETERS.
  2. CENTER OF GRAVITY.
  3. DIRECTION OF AIR FLOW.
  4. ON VERTICAL DISCHARGE UNITS, DUCTWORK TO BE ATTACHED TO ACCESSORY ROOF CURB ONLY. FOR HORIZONTAL DISCHARGE UNITS FIELD SUPPLIED FLANGES SHOULD BE ATTACHED TO ROOF CURB. DISCHARGE OPENINGS, AND ALL DUCTWORK SHOULD BE ATTACHED TO THE FLANGES.
  5. MINIMUM CLEARANCE (LOCAL CODES OR JURISDICTION MAY VARY):
    - a. 48 INCHES: UNIT, FLUE SIDE AND COMBUSTIBLE SURFACES.
    - b. 48 INCHES: 18 INCHES WHEN USING ACCESSORY FLUE DISCHARGE DEFLECTOR.
    - c. 48 INCHES: 18 INCHES WHEN USING ACCESSORY FLUE DISCHARGE DEFLECTOR.
    - d. 48 INCHES: 18 INCHES WHEN USING ACCESSORY FLUE DISCHARGE DEFLECTOR.
    - e. 48 INCHES: 18 INCHES WHEN USING ACCESSORY FLUE DISCHARGE DEFLECTOR.
    - f. 48 INCHES: 18 INCHES WHEN USING ACCESSORY FLUE DISCHARGE DEFLECTOR.
    - g. 48 INCHES: 18 INCHES WHEN USING ACCESSORY FLUE DISCHARGE DEFLECTOR.
    - h. 48 INCHES: 18 INCHES WHEN USING ACCESSORY FLUE DISCHARGE DEFLECTOR.
  6. WITH THE EXCEPTION OF THE CLEARANCE FOR THE CONDENSER COIL AND COMBUSTION SIDE AS STATED IN NOTE #5, b, c, d, e, f, g, h, MINIMUM CLEARANCE TO COMBUSTIBLE SURFACES IS 18 INCHES. MINIMUM CLEARANCE TO COMBUSTIBLE SURFACES IS 18 INCHES. MINIMUM CLEARANCE TO COMBUSTIBLE SURFACES IS 18 INCHES. MINIMUM CLEARANCE TO COMBUSTIBLE SURFACES IS 18 INCHES.
  7. UNITS MAY BE INSTALLED ON COMBUSTIBLE FLOORS MADE OF CONCRETE, BRICK, OR MASONRY. UNITS MAY BE INSTALLED ON COMBUSTIBLE FLOORS MADE OF CONCRETE, BRICK, OR MASONRY. UNITS MAY BE INSTALLED ON COMBUSTIBLE FLOORS MADE OF CONCRETE, BRICK, OR MASONRY.
  8. THE VERTICAL CENTER OF GRAVITY IS 1'-7" (483) FOR 008 AND 009, 1'-7" (483) FOR 012 AND 014 UNITS. THE VERTICAL CENTER OF GRAVITY IS 1'-7" (483) FOR 008 AND 009, 1'-7" (483) FOR 012 AND 014 UNITS.

CONNECTION SIZES

A	1 3/8" DIA. (133) FIELD POWER SUPPLY HOLE
B	1 1/2" DIA. (127) FIELD POWER SUPPLY HOLE
C	1 3/4" DIA. (143) CHARGING PORT HOLE
D	7/8" DIA. (223) FIELD CONTROL WIRING HOLE
E	3/4" - 1/4" NPT GAS CONN. 48HJ008-009, 48TM008
F	3/4" - 1/4" NPT GAS CONN. 48HJ012-014, 48HJ014-015, 48TM012, 48TM014
G	2" DIA. (51) POWER SUPPLY KNOCK-OUT

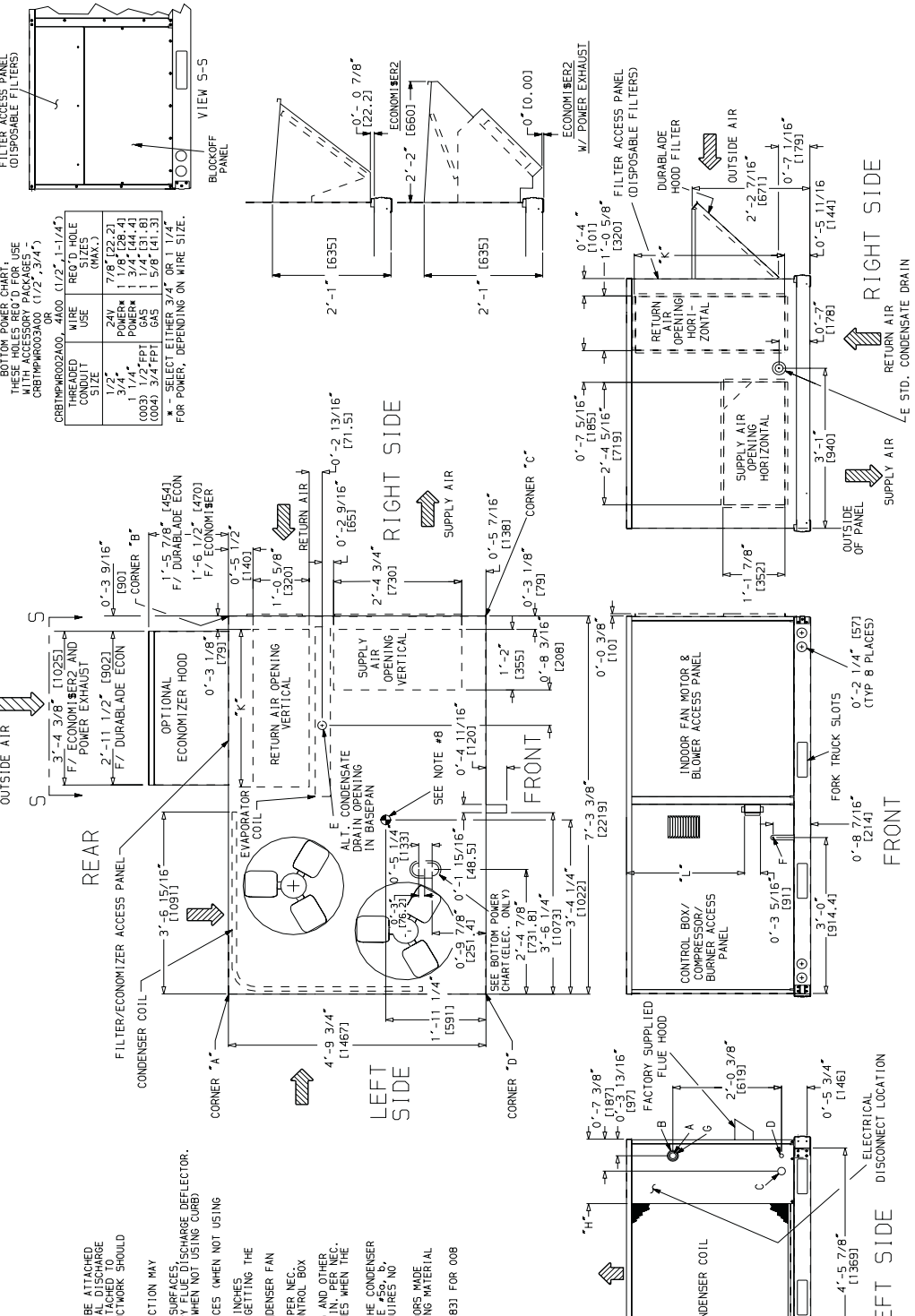

BOTTOM POWER CHART WITH ACCESSORY PACKAGES - CREDITED TO 008 (1/2", 3/4")

THREAD SIZE	WIRE USE	REC'D HOLE SIZES (MAX.)
1/2"	24V POWER	7/8" (22.2)
3/4"	POWER	1 1/8" (28.4)
(003)	1/2" FPT GAS	1 1/4" (31.8)
(004)	3/4" FPT GAS	1 5/8" (41.3)

\* - SELECT EITHER 3/4" OR 1 1/4" FOR POWER, DEPENDING ON WIRE SIZE.

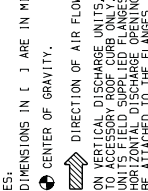
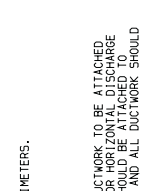
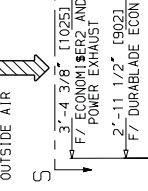
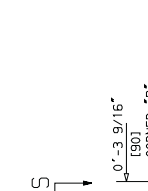

# Accessory dimensions — 48TM004-007



48TM004-014

CONNECTOR PKG. ACCY.	B	C	D ALT DRAIN HOLE	GAS	POWER	CONTROL
CRBTMPWR001A00	1'-9 <sup>11</sup> / <sub>16</sub> " [551]	1'-4" [406]	1 <sup>3</sup> / <sub>4</sub> " [44.5]	3/4"	3/4" [19] NPT	1/2"
CRBTMPWR002A00				[19] NPT	1/4" [31.7]	[12.7]
CRBTMPWR003A00				1/2"	3/4" [19] NPT	1/2"
CRBTMPWR004A00				3/4" [19] NPT	1 1/4" [31.7]	[12.7]

ROOF CURB ACCESSORY	A	UNIT SIZE
CRRFCURB001A00	1'-2" [356]	48TM004-007
CRRFCURB002A00	2'-0" [610]	

**NOTES:**

1. Roof curb accessory is shipped disassembled.
2. Insulated panels.
3. Dimensions in [ ] are in millimeters.
4. Roof curb: galvanized steel.
5. Attach ductwork to curb (flanges of duct rest on curb).
6. Service clearance: 4 ft on each side.
7. Direction of airflow.
8. Connector packages CRBTMPWR001A00 and 002A00 are for thru-the-curb type gas. Packages CRBTMPWR003A00 and 004A00 are for thru-the-bottom type gas connections.

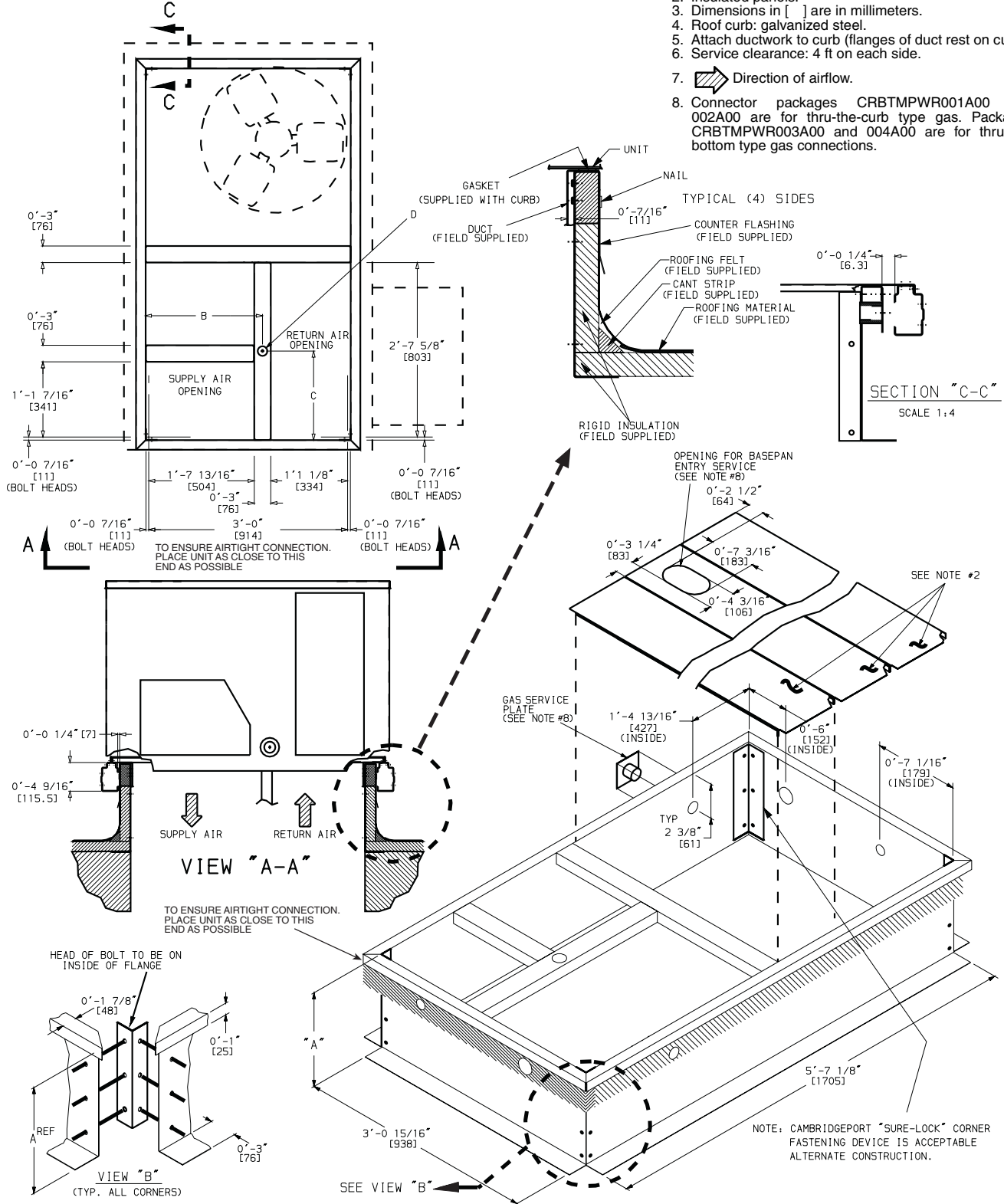

# Accessory dimensions — 48TM008-014



48TM004-014

CONNECTOR PKG. ACCY.	B	C	D ALT DRAIN HOLE	GAS	POWER	CONTROL
CRBTMPWR001A00	2'-8 <sup>7</sup> / <sub>16</sub> " [827]	1'-10 <sup>15</sup> / <sub>16</sub> " [583]	1 <sup>3</sup> / <sub>4</sub> " [44.5]	3/4" [19] NPT	3/4" [19] NPT	1/2" [12.7] NPT
CRBTMPWR002A00				1 1/4" [31.7]	1 1/2" [38.1]	
CRBTMPWR003A00				3/4" [19] NPT	3/4" [19] NPT	1/2" [12.7] NPT
CRBTMPWR004A00				3/4" [19] NPT	1 1/4" [31.7]	1/2" [12.7] NPT

ROOF CURB ACCESSORY	"A"	UNIT SIZE
CRRFCURB003A00	1'-2" [356]	48TM008-014
CRRFCURB004A00	2'-0" [610]	

- NOTES:
- Roof curb accessory is shipped disassembled.
  - Insulated panels: 1-in. thick polyurethane foam, 1<sup>3</sup>/<sub>4</sub> lb density.
  - Dimensions in [ ] are in millimeters.
  - Roof curb: 16-gage steel.
  - Attach ductwork to curb (flanges of duct rest on curb).
  - Service clearance 4 ft on each side.
  - Direction of airflow.
  - Connector packages CRBTMPWR001A00 and 2A00 are for thru-the-curb gas type. Packages CRBTMPWR003A00 and 4A00 are for thru-the-bottom type gas connections.

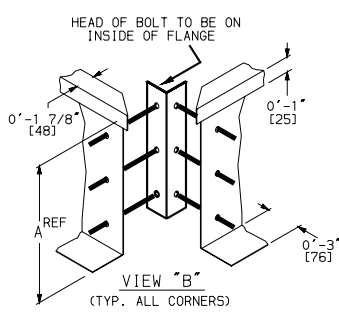
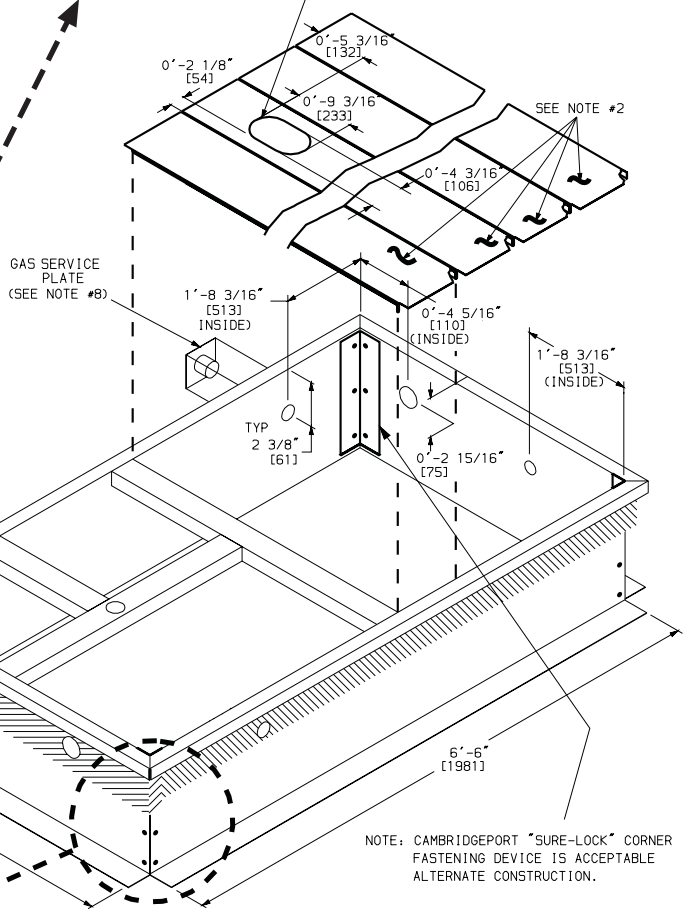
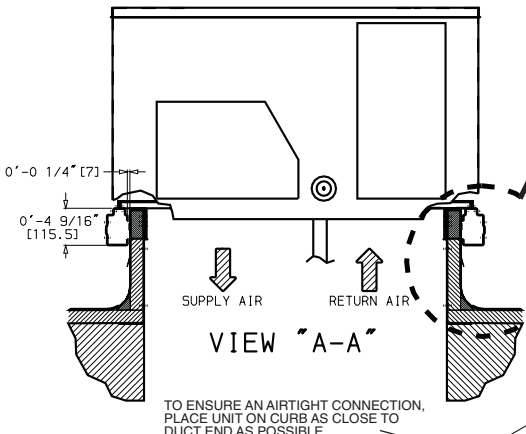
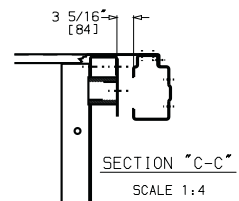
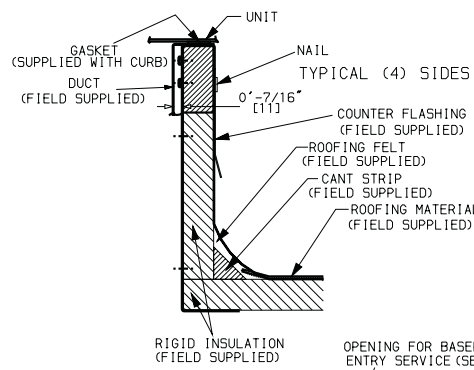
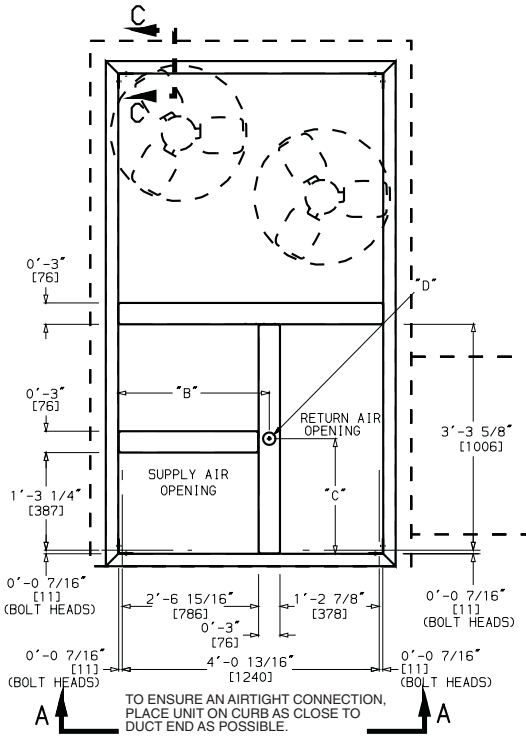

NOTE: CAMBRIDGEPORT "SURE-LOCK" CORNER FASTENING DEVICE IS ACCEPTABLE ALTERNATE CONSTRUCTION.

# Selection procedure (with 48TM007 example)



48TM004-014

## I Determine cooling and heating loads at design conditions.

Given:

- Required Gross Cooling Capacity (TC) . . .83,000 Btuh
- Gross Sensible Heat Capacity (SHC) . . .46,000 Btuh
- Required Heating Capacity . . . . .60,000 Btuh
- Outdoor Entering-Air Temperature db . . . . .95 F
- Outdoor Entering-Air Temperature wb . . . . .75 F
- Outdoor-Air Entering Airflow Cfm . . . . . 450 Cfm
- Outdoor-Air Winter Design Temperature . . . . . 0° F
- Indoor-Air Winter Design Temperature . . . . . 70 F
- Air to room including outdoor air . . . . . 2000 Cfm
- External Static Pressure . . . . . Supply — 0.60 in. wg  
Return — 0.2 in. wg
- Indoor-Air Temperature db (room air) . . . . . 78 F
- Indoor-Air Temperature wb (room air) . . . . . 65 F
- Indoor-Air Exhaust Cfm . . . . . 450 Cfm
- Electrical Characteristics (V-Ph-Hz) . . . . . 230-3-60
- Vertical discharge unit with Energy\$Recycler required.

## II Determine fan speed and power requirements at design conditions.

Before entering the Fan Performance tables, calculate the total static pressure required based on unit component.

NOTE: When the Energy\$Recycler is used, an economizer is not needed. From the given find:

- External static pressure supply . . . . . 0.6 in. wg
- External static pressure return . . . . . 0.2 in. wg
- Accessory static — None . . . . . 0.0 in. wg
- Total Static . . . . . 0.8 in. wg

Enter the Fan Performance table for vertical discharge, standard motor, 48TM007 at 0.80 in. wg and 2000 cfm. The rpm is 1303, bhp is 1.41, and Watts is 1258.

NOTE: Convert to Fan Heat using the formula below.

$$\text{Indoor Fan Heat} = \text{watts} \times 3.413 \text{ Btuh/watt}$$

$$= 1258 \times 3.413 = 4294 \text{ Btuh}$$

## III Select Energy\$Recycler based on Outdoor Entering Cfm.

Refer to the Energy\$Recycler Product Data literature and enter the Cooling Ratings table in the Capacities section. At 450 cfm entering outdoor airflow, choose Model 62AQ060.

Using 450 cfm outdoor supply airflow, 95 F OD DB, and 75 F OD WB find performance of the 62AQ060 at these conditions:

- Energy\$Recycler Gross Cooling Capacity is . . . . . 13,000 Btuh
- Energy\$Recycler Gross Sensible Capacity is . . . . . 10,090 Btuh
- Compressor power is . . . . . 1.06 kW
- Energy\$Recycler Leaving db is . . . . . 73.0 F
- Energy\$Recycler Leaving wb is . . . . . 66.9 F

## IV Using the simplified\* method below, calculate the approximate mixed air temperature for the rooftop unit evaporator coil.

Using the outdoor-air entering cfm, the room cfm and the room exhaust airflow with their respective db and wb temperatures, determine the db and wb entering the rooftop evaporator coil.

a) Estimate the mixed air db to the evaporator coil.

$$t \text{ mix db} = ((\text{cfm oa} \times t \text{ oa db}) + ((\text{cfm ra} - \text{cfm exh}) \times t \text{ ra db})) / (\text{cfm oa} + (\text{cfm ra} - \text{cfm exh}))$$

$$((450 \text{ cfm} \times 73.0 \text{ F}) + ((2000 \text{ cfm} - 450 \text{ cfm}) \times 78 \text{ F})) / (450 \text{ cfm} + (2000 \text{ cfm} - 450 \text{ cfm}))$$

Mixed air into the rooftop evaporator coil = 76.9 F db

b) Estimate the mixed air wb to the evaporator coil.

$$t \text{ mix wb}^* = ((\text{cfm oa} \times t \text{ oa wb}) + ((\text{cfm ra} - \text{cfm exh}) \times t \text{ ra wb})) / (\text{cfm oa} + (\text{cfm ra} - \text{cfm exh}))$$

$$((450 \text{ cfm} \times 66.9 \text{ F}) + ((2000 \text{ cfm} - 450 \text{ cfm}) \times 65 \text{ F})) / (450 \text{ cfm} + (2000 \text{ cfm} - 450 \text{ cfm}))$$

Mixed air temperature into the rooftop evaporator = 65.40 F wb

\*Simplified method of determining wet bulb (wb) temperature of mixture. This approximation is used because the wb lines in the area of the psychrometric chart in the area used in the calculation is relatively linear, providing a close approximation. A more accurate solution can be found using the E-Cat program.

### LEGEND

- cfm — cubic feet per minute of air
- db — dry bulb
- exh — Energy\$Recycler discharge
- mix — mixture of outdoor + return air
- oa — outside air leaving Energy\$Recycler
- ra — return air
- sa — supply air at coil (sa = oa + ra - exh)
- t — temperature
- wb — wet bulb

## V Determine the cooling load requirement for the rooftop unit.

- Customer load is . . . . . 83,000 Btuh
- Less TC supplied by the Energy\$Recycler . . . . . -13,000 Btuh
- Rooftop cooling load required is . . . . . 70,000 Btuh

## VI Select the rooftop unit based on mixed air entering conditions and cooling load.

Enter cooling capacity table at outdoor entering temperature 95 F, mixed air entering evaporator at 2000 cfm, 76.9 F db, and 65.4 F wb. Interpolation is required.

The 48TM007 will provide a total gross cooling capacity of 72,200 Btuh, a sensible cooling of 49,200 Btuh, and a kW rating of 5.76.

Since these values were not at 80 F entering db, they were calculated based on the notes following the Cooling Capacity tables.

NOTE: Unit ratings are gross capacities and do not include the effect of evaporator-fan motor heat. To calculate net capacities see Steps VII and VIII.

# Selection procedure (with 48TM007 example) (cont)



48TM004-014

## VII Select net heating capacity of unit to meet design condition requirements.

Enter the Heating Capacities and Efficiencies rating table. The 48TMD007 unit will provide 59,200 Btuh of heating.

Enter the 62AQ060 Heating rating table at 450 cfm. At 70 F and 0° F find the heating value for the Energy\$Recycler to be 15.2 MBtuh.

The customer heat requirement is 60,000 Btuh.

Rooftop Heat Capacity	59,200 Btuh
Rooftop fan heat from Step II	4,294 Btuh
Energy\$Recycler Heat Capacity	15,200 Btuh
add Energy\$Recycler optional supply fan heat if supplied	<u>0 Btuh</u>

Total Unit heat with Energy\$Recycler 78,694 Btuh  
 The required heating capacity is 60,000 Btuh. The total unit net heating capacity is 78,694 Btuh. The 48TMD007 unit is sufficient.

## VIII Determine net cooling capacity.

Cooling capacities are gross capacities and do not include indoor (evaporator) or optional Energy\$Recycler supply fan heat.

Determine net cooling capacity using the following formula:

Net Capacity = (Gross Capacity Rooftop Unit + Energy\$Recycler) – (Indoor [evaporator] fan motor [IFM] Heat + Optional Energy\$Recycler Supply Fan Motor Heat)

Gross Total Cooling	
Rooftop unit	72,200 Btuh
Energy\$Recycler	<u>13,000 Btuh</u>
Total	85,200 Btuh
Less	
IFM heat (from Step II)	<4,294> Btuh
Opt. Energy\$Recycler Supply Fan Motor Heat	<u>none</u>
Net Total Capacity	80,906 Btuh
Gross Sensible Cooling	
Rooftop unit	49,200 Btuh
Energy\$Recycler	<u>10,090 Btuh</u>
Total	59,290 Btuh
Less	
IFM heat (from Step II)	<4,294> Btuh
Opt. Energy\$Recycler Supply Fan Motor Heat	<u>none</u>
Net Sensible Capacity	54,996 Btuh

## IX Determine the operating watts of the rooftop unit and Energy\$Recycler unit.

Cooling with Energy\$Recycler in operation:

a) Rooftop unit:

Using the 48TM007 cooling capacity table and the calculations described in Step VI of this procedure, determine:

compressor watts	5,760 watts
Indoor fan motor from Step II	1,258 watts
Outdoor fan motor from Physical Data table find 1/4 hp†	

Assume OD motor efficiency is 0.75.

$$\begin{aligned} \text{Watts} &= (746 \times \text{hp}) / (\text{motor Eff}) \\ &= (746 \times 1/4) / (0.75) \\ &= 249 \text{ watts} \end{aligned}$$

†Dual circuit units will have two outdoor fans, double values.

b) Energy\$Recycler:

Compressor watts from 62AQ060 Cooling Ratings table	1,060 watts
Optional supply fan from fan curves	none selected
Exhaust fan operating watts from 62AQ060 Exhaust Fan Performance Curve at 230-v, 450 cfm, 0.2 in. wg, Static =	110 watts
Total watts for the unit in operation at design conditions	8,437 watts

## X Electrical data RLA, FLA, LRA, MCA and MOCP.

### Separate Power Supply:

If the 62AQ is wired for separate power see the Electrical Data table.

### Single Power Supply with Unit:

The unit is 230 v-3-60 Hz, so from the 48TM Electrical Data table, find unit electrical data. For the rooftop unit with standard indoor fan motor the data is MCA = 32.4 amps, MOCP = 40 amps, Min Unit Disconnect Size FLA = 31, and LRA = 180.

For this example follow the steps outlined in the Application Data section of the Energy\$Recycler Product Data for single power supply for all rooftop units except 62AQ on 460-v power supply. For other size and voltage conditions follow corresponding steps also outlined in the Energy\$Recycler Product Data Application data section.

From the Single Power Supply table (Electrical Data, Energy\$Recycler Product Data) find 230 v, for 62AQ060300, "X" = 8.1 amps and "Y" = 9.3 amps. Add "X" amps to the MCA and MOCP and add "Y" amps to the minimum disconnect size.

	MCA	MOCP	FLA	LRA
48TM	32.4	40	31	180
62AQ	<u>8.1</u>	<u>8.1</u>	<u>9.0</u>	<u>31.7</u>
Total	40.5	48.1	40.0	211.7

(MOCP calculation is 48.1. Round the value down to 45. 45 is greater than the MCA of 40.5, therefore 45 is the correct MOCP.)

The wiring to the unit must be suitable for the MCA calculated above.

The overcurrent protective device for the combination load is equal to 45, thus a single non-fused disconnect may be used for BOTH the MAIN UNIT and the 62AQ provided that the wire supplying the 62AQ is sized for at least 20 amps. No further subfusing is required.

In this example a 60-amp disconnect would be used for the combined load of the 48TM007 and the 62AQ060 Energy\$Recycler unit.

# Performance data



## COOLING CAPACITIES

48TM004-014

48TM004 (3 TONS)										
Temp (F) Air Entering Condenser (Edb)		Temp (F) Air Entering Evaporator — Cfm/BF								
		900/0.11			1200/0.14			1500/0.17		
		Temp (F) Air Entering Evaporator — Ewb								
	72	67	62	72	67	62	72	67	62	
75	TC	42.8	38.9	35.0	44.8	40.8	37.0	45.8	41.9	38.2
	SHC	20.0	24.5	28.7	21.8	27.5	32.8	23.0	30.0	36.0
	kW	2.91	2.81	2.70	2.99	2.88	2.78	3.02	2.92	2.82
85	TC	40.8	36.9	33.3	42.5	38.7	35.0	43.6	39.9	36.1
	SHC	19.4	23.7	27.9	21.0	26.8	31.8	22.6	29.7	35.1
	kW	3.14	3.01	2.90	3.20	3.08	2.97	3.24	3.14	3.02
95	TC	38.7	34.9	31.4	40.4	36.6	33.0	41.4	37.6	34.1
	SHC	18.6	22.9	27.0	20.3	26.0	30.9	22.0	28.8	34.0
	kW	3.35	3.21	3.09	3.42	3.29	3.16	3.47	3.35	3.22
105	TC	36.5	32.8	29.2	38.1	34.3	30.9	39.0	35.2	32.4
	SHC	17.8	22.1	25.9	19.6	25.2	29.8	21.2	28.0	32.3
	kW	3.55	3.41	3.27	3.63	3.49	3.35	3.68	3.54	3.43
115	TC	34.3	30.7	26.9	35.7	32.1	28.8	36.5	32.9	30.6
	SHC	17.0	21.3	24.8	19.0	24.4	28.8	20.5	27.1	30.6
	kW	3.76	3.60	3.45	3.84	3.68	3.54	3.88	3.74	3.64

48TM005 (4 TONS)										
Temp (F) Air Entering Condenser (Edb)		Temp (F) Air Entering Evaporator — Cfm/BF								
		1200/0.12			1600/0.15			2000/0.18		
		Temp (F) Air Entering Evaporator — Ewb								
	72	67	62	72	67	62	72	67	62	
75	TC	57.9	53.1	48.3	60.4	55.9	51.3	62.2	57.3	52.9
	SHC	27.2	33.3	39.2	29.4	37.2	44.8	31.4	40.3	49.1
	kW	4.07	3.93	3.79	4.17	4.03	3.90	4.24	4.08	3.96
85	TC	55.7	50.8	45.3	57.7	53.4	48.5	59.4	55.0	50.2
	SHC	26.4	32.5	37.8	28.4	36.7	43.6	30.5	40.3	47.9
	kW	4.40	4.24	4.08	4.47	4.35	4.20	4.54	4.42	4.25
95	TC	52.9	48.1	42.5	55.2	50.5	45.7	56.7	52.0	47.4
	SHC	25.5	31.5	36.4	27.6	35.6	42.2	29.7	39.2	46.7
	kW	4.70	4.54	4.36	4.78	4.63	4.47	4.87	4.70	4.56
105	TC	50.1	45.3	39.8	52.3	47.6	42.8	53.6	48.9	44.9
	SHC	24.4	30.3	35.1	26.7	34.5	40.7	28.8	38.1	44.6
	kW	5.00	4.81	4.62	5.10	4.91	4.73	5.17	4.99	4.84
115	TC	47.3	42.6	37.2	49.3	44.6	40.0	50.5	45.9	42.4
	SHC	23.4	29.2	33.7	25.9	33.3	39.3	27.8	37.1	42.4
	kW	5.30	5.07	4.88	5.42	5.19	4.99	5.48	5.28	5.12

48TM006 (5 TONS)										
Temp (F) Air Entering Condenser (Edb)		Temp (F) Air Entering Evaporator — Cfm/BF								
		1500/0.07			2000/0.09			2500/0.12		
		Temp (F) Air Entering Evaporator — Ewb								
	72	67	62	72	67	62	72	67	62	
75	TC	71.0	63.8	55.4	74.5	67.2	59.2	76.5	69.7	62.1
	SHC	33.9	41.5	47.9	37.4	47.4	55.8	40.6	52.8	61.8
	kW	5.04	4.82	4.62	5.20	4.97	4.76	5.29	5.06	4.87
85	TC	69.2	61.0	54.2	72.9	65.6	57.2	75.2	68.1	61.5
	SHC	33.4	40.5	47.3	37.0	46.9	54.9	40.1	52.3	61.3
	kW	5.50	5.27	5.02	5.66	5.41	5.18	5.75	5.50	5.29
95	TC	65.5	56.6	50.4	69.4	60.9	53.1	71.2	63.3	57.8
	SHC	32.1	38.8	45.6	35.8	45.3	52.6	39.1	50.9	57.8
	kW	5.88	5.62	5.37	6.01	5.76	5.53	6.12	5.87	5.67
105	TC	61.9	53.1	47.1	65.4	56.6	50.5	67.1	58.8	54.5
	SHC	30.8	37.5	44.1	34.5	43.7	50.2	37.9	49.3	54.5
	kW	6.25	5.99	5.72	6.38	6.13	5.91	6.50	6.23	6.06
115	TC	58.2	49.7	43.7	61.4	52.3	47.8	63.0	54.3	51.2
	SHC	29.5	36.1	42.5	33.2	42.1	47.8	36.7	47.6	51.2
	kW	6.63	6.35	6.08	6.75	6.49	6.29	6.88	6.59	6.46

48TM007 (6 TONS)													
Temp (F) Air Entering Condenser (Edb)		Temp (F) Air Entering Evaporator — Cfm/BF											
		1800/0.06			2100/0.07			2400/0.09			3000/0.11		
		Temp (F) Air Entering Evaporator — Ewb											
	72	67	62	72	67	62	72	67	62	72	67	62	
75	TC	81.3	77.8	71.3	82.7	78.7	72.9	84.2	79.7	74.6	85.3	82.5	76.7
	SHC	38.2	51.3	61.6	40.2	54.2	65.9	42.3	57.1	70.2	43.7	64.0	76.4
	kW	4.69	4.63	4.52	4.73	4.65	4.56	4.77	4.67	4.60	4.80	4.75	4.63
85	TC	78.8	75.6	69.0	81.1	77.1	70.7	83.3	78.6	72.3	85.0	80.5	75.0
	SHC	37.7	50.4	60.5	40.0	53.9	64.9	42.2	57.5	69.2	44.3	63.6	74.9
	kW	5.21	5.16	5.05	5.27	5.20	5.09	5.34	5.24	5.13	5.39	5.29	5.17
95	TC	77.1	73.3	66.9	79.2	74.8	68.5	81.3	76.2	70.1	82.0	78.0	73.3
	SHC	37.0	49.9	59.7	39.4	53.3	64.0	41.8	56.8	68.3	43.5	63.4	73.2
	kW	5.80	5.78	5.65	5.87	5.81	5.70	5.94	5.85	5.74	5.95	5.88	5.8
105	TC	75.4	70.7	62.9	76.6	72.1	64.8	77.9	73.4	66.7	79.7	74.9	70.9
	SHC	36.7	48.7	58.2	38.6	52.3	62.2	40.6	55.9	66.3	43.0	62.4	70.9
	kW	6.49	6.45	6.26	6.53	6.48	6.32	6.56	6.51	6.38	6.61	6.53	6.46
115	TC	72.1	67.9	59.0	73.6	69.0	61.1	75.2	70.1	63.3	76.7	71.9	68.1
	SHC	35.3	47.5	57.2	37.6	51.2	60.2	39.9	54.8	63.3	42.2	61.5	68.1
	kW	7.20	7.17	6.94	7.25	7.18	7.01	7.29	7.20	7.08	7.35	7.26	7.15

### LEGEND

- BF — Bypass Factor
- Edb — Entering Dry-Bulb
- Ewb — Entering Wet-Bulb
- kW — Compressor Motor Power Input
- Ldb — Leaving Dry-Bulb
- Lwb — Leaving Wet-Bulb
- SHC — Sensible Heat Capacity (1000 Btu/h) Gross
- TC — Total Capacity (1000 Btu/h) Gross

### NOTES:

- Direct interpolation is permissible. Do not extrapolate.
- The following formulas may be used:

$$t_{ldb} = t_{edb} - \frac{\text{sensible capacity (Btu/h)}}{1.10 \times \text{cfm}}$$

$$t_{lwb} = \text{Wet-bulb temperature corresponding to enthalpy of air leaving evaporator coil } (h_{lwb})$$

$$h_{lwb} = h_{ewb} - \frac{\text{total capacity (Btu/h)}}{4.5 \times \text{cfm}}$$

Where:  $h_{ewb}$  = Enthalpy of air entering evaporator coil.

- The SHC is based on 80 F edb temperature of air entering evaporator coil. Below 80 F edb, subtract (corr factor x cfm) from SHC. Above 80 F edb, add (corr factor x cfm) to SHC.

BYPASS FACTOR (BF)	ENTERING AIR DRY-BULB TEMP (F)					
	79	78	77	76	75	under 75
	81	82	83	84	85	over 85
	Correction Factor					
.05	1.04	2.07	3.11	4.14	5.18	Use formula shown below.
.10	.98	1.96	2.94	3.92	4.90	
.20	.87	1.74	2.62	3.49	4.36	
.30	.76	1.53	2.29	3.05	3.82	

Interpolation is permissible.

$$\text{Correction Factor} = 1.10 \times (1 - \text{BF}) \times (\text{edb} - 80)$$

# Performance data (cont)



48TM004-014

## COOLING CAPACITIES (cont)

### LEGEND

- BF — Bypass Factor
- Edb — Entering Dry-Bulb
- Ewb — Entering Wet-Bulb
- kW — Compressor Motor Power Input
- Ldb — Leaving Dry-Bulb
- Lwb — Leaving Wet-Bulb
- SHC — Sensible Heat Capacity (1000 Btuh) Gross
- TC — Total Capacity (1000 Btuh) Gross

### NOTES:

1. Direct interpolation is permissible. Do not extrapolate.
2. The following formulas may be used:

$$t_{lab} = t_{edb} - \frac{\text{sensible capacity (Btuh)}}{1.10 \times \text{cfm}}$$

$$t_{lwb} = \text{Wet-bulb temperature corresponding to enthalpy of air leaving evaporator coil } (h_{lwb})$$

$$h_{lwb} = h_{ewb} - \frac{\text{total capacity (Btuh)}}{4.5 \times \text{cfm}}$$

- Where:  $h_{ewb}$  = Enthalpy of air entering evaporator coil.
3. The SHC is based on 80 F edb temperature of air entering evaporator coil. Below 80 F edb, subtract (corr factor x cfm) from SHC. Above 80 F edb, add (corr factor x cfm) to SHC.

BYPASS FACTOR (BF)	ENTERING AIR DRY-BULB TEMP (F)					
	79	78	77	76	75	under 75
	81	82	83	84	85	over 85
<b>Correction Factor</b>						
.05	1.04	2.07	3.11	4.14	5.18	Use formula shown below.
.10	.98	1.96	2.94	3.92	4.90	
.20	.87	1.74	2.62	3.49	4.36	
.30	.76	1.53	2.29	3.05	3.82	

Interpolation is permissible.  
Correction Factor =  $1.10 \times (1 - BF) \times (edb - 80)$ .

48TM008 (7 1/2 TONS)													
Temp (F) Air Entering Condenser (Edb)	Temp (F) Air Entering Evaporator — Cfm/BF												
	2250/0.10			2800/0.11			3000/0.11			3750/0.14			
	72	67	62	72	67	62	72	67	62	72	67	62	
75	TC	105.8	97.6	88.7	108.9	101.1	92.6	109.5	101.9	93.5	112.4	104.6	96.4
	SHC	50.9	63.6	75.4	54.1	69.8	84.0	55.2	71.9	86.5	59.9	79.7	94.9
	kW	6.34	6.05	5.77	6.46	6.19	5.93	6.50	6.25	5.96	6.62	6.37	6.09
85	TC	101.1	92.9	84.0	104.8	96.4	87.7	105.6	97.2	88.5	107.7	99.6	92.2
	SHC	49.4	62.0	73.3	53.1	68.4	81.9	54.4	70.6	84.4	58.5	78.2	92.0
	kW	6.80	6.51	6.21	6.94	6.66	6.37	6.98	6.69	6.41	7.08	6.82	6.57
95	TC	96.6	87.7	78.9	99.9	91.0	82.4	100.5	91.6	83.6	102.3	93.9	87.7
	SHC	47.8	59.9	70.8	51.7	66.5	79.5	52.9	68.8	81.3	57.2	76.6	87.7
	kW	7.26	6.96	6.64	7.42	7.10	6.78	7.46	7.14	6.83	7.54	7.24	7.03
105	TC	91.0	82.1	72.9	93.7	85.2	76.8	94.3	85.9	78.2	96.6	87.9	83.0
	SHC	45.9	57.9	67.9	49.6	64.4	76.4	50.9	66.7	77.8	55.8	74.5	83.0
	kW	7.70	7.37	7.08	7.81	7.51	7.22	7.86	7.54	7.28	7.97	7.67	7.47
115	TC	85.2	76.0	67.9	87.7	79.1	71.6	88.1	79.7	73.1	90.2	81.7	78.2
	SHC	43.9	55.4	65.1	47.8	62.2	71.6	49.2	64.4	73.1	54.4	72.5	78.0
	kW	8.13	7.79	7.47	8.25	7.92	7.67	8.29	7.95	7.74	8.41	8.08	7.93

48TM009 (8 1/2 TONS)													
Temp (F) Air Entering Condenser (Edb)	Temp (F) Air Entering Evaporator — Cfm/BF												
	2550/0.08			3000/0.09			3400/0.11			4250/0.13			
	72	67	62	72	67	62	72	67	62	72	67	62	
75	TC	117.7	104.1	93.4	121.3	107.5	97.2	122.9	109.0	98.7	124.4	111.1	101.8
	SHC	55.7	64.7	76.6	59.3	70.6	85.0	61.3	74.7	91.4	66.8	82.1	99.7
	kW	6.42	6.34	6.26	6.46	6.38	6.30	6.47	6.39	6.33	6.50	6.41	6.35
85	TC	113.8	100.4	89.2	117.9	103.8	93.4	119.6	105.3	94.7	122.1	107.5	97.2
	SHC	54.3	63.3	75.0	58.0	69.4	83.8	60.4	73.4	89.1	65.2	81.7	97.0
	kW	7.35	7.26	7.17	7.41	7.31	7.24	7.43	7.33	7.24	7.46	7.37	7.28
95	TC	109.6	96.2	85.3	113.3	99.7	89.2	115.4	101.1	90.3	118.3	103.2	93.1
	SHC	52.9	61.9	73.1	56.5	67.9	81.7	59.1	71.9	87.3	64.0	80.3	93.1
	kW	8.37	8.27	8.16	8.42	8.33	8.24	8.46	8.34	8.22	8.51	8.40	8.31
105	TC	105.6	92.1	81.3	108.8	95.2	84.6	110.4	96.4	86.3	113.2	98.4	89.1
	SHC	51.4	60.4	71.6	55.2	66.4	80.0	57.5	70.3	85.3	62.5	78.3	89.1
	kW	9.49	9.37	9.27	9.55	9.44	9.34	9.57	9.45	9.35	9.61	9.49	9.41
115	TC	100.4	87.9	76.8	103.1	90.4	80.3	105.1	91.7	82.1	107.6	93.5	85.0
	SHC	49.4	58.6	69.6	52.9	64.7	78.3	55.8	68.5	81.9	60.6	76.6	85.0
	kW	10.63	10.56	10.46	10.70	10.62	10.55	10.74	10.62	10.54	10.80	10.68	10.58
125	TC	95.8	83.0	72.0	98.5	85.5	74.9	99.8	86.6	77.5	101.4	88.2	80.7
	SHC	48.0	56.8	67.5	51.6	62.9	74.9	54.0	66.9	77.5	58.2	74.6	80.7
	kW	11.97	11.83	11.61	12.02	11.89	11.73	12.05	11.92	11.80	12.09	11.97	11.86

48TM012 (10 TONS)													
Temp (F) Air Entering Condenser (Edb)	Temp (F) Air Entering Evaporator — Cfm/BF												
	3000/0.095			4000/0.125			5000/0.15						
	72	67	62	72	67	62	72	67	62	72	67	62	
75	TC	138.2	127.0	114.0	145.0	132.9	122.0	149.1	136.6	125.9			
	SHC	68.0	84.1	99.1	74.5	95.1	114.7	81.1	106.3	125.3			
	kW	8.37	8.07	7.80	8.57	8.24	7.95	8.72	8.36	8.07			
85	TC	132.3	121.7	105.9	138.4	127.2	116.6	142.5	130.2	120.9			
	SHC	65.5	81.9	95.5	72.4	93.3	112.2	78.9	103.6	120.8			
	kW	8.92	8.63	8.35	9.15	8.81	8.52	9.29	8.92	8.65			
95	TC	126.3	115.7	98.4	131.8	121.0	108.8	135.2	124.2	116.1			
	SHC	63.3	79.8	91.6	70.3	91.4	107.8	76.2	101.9	116.0			
	kW	9.54	9.24	8.91	9.75	9.42	9.11	9.87	9.55	9.28			
105	TC	120.2	106.5	89.5	124.9	113.8	100.3	128.3	117.2	109.9			
	SHC	61.5	76.2	86.7	68.1	89.3	100.3	74.4	100.1	109.9			
	kW	10.23	9.87	9.51	10.40	10.06	9.78	10.52	10.19	9.99			
115	TC	117.1	99.8	85.7	122.2	105.7	95.1	124.8	111.8	104.6			
	SHC	60.5	73.7	84.9	67.6	86.3	95.1	74.1	98.6	104.6			
	kW	10.51	10.13	9.77	10.70	10.34	10.10	10.80	10.46	10.29			

48TM014 (12 1/2 TONS)													
Temp (F) Air Entering Condenser (Edb)	Temp (F) Air Entering Evaporator — Cfm/BF												
	3750/0.08			4300/0.09			5000/0.11			6250/0.13			
	72	67	62	72	67	62	72	67	62	72	67	62	
75	TC	164.6	152.0	139.9	167.3	155.3	142.6	170.9	158.2	146.2	173.9	162.0	151.0
	SHC	81.3	101.9	121.7	84.5	108.1	130.0	88.9	115.9	139.8	96.7	128.7	150.8
	kW	10.24	9.96	9.71	10.31	10.05	9.78	10.42	10.12	9.84	10.50	10.23	9.95
85	TC	159.9	147.1	133.6	162.6	150.2	137.4	166.3	153.0	141.3	169.5	156.8	147.1
	SHC	79.7	99.9	119.1	83.1	106.3	128.0	88.3	114.1	137.7	96.1	127.4	146.9
	kW	11.38	11.05	10.82	11.45	11.14	10.87	11.58	11.20	10.97	11.66	11.32	11.08
95	TC	154.2	141.5	124.4	157.2	144.6	129.3	159.9	147.6	134.5	164.0	150.9	142.3
	SHC	77.9	98.0	114.8	81.8	104.5	124.1	86.3	112.5	133.8	94.4	125.8	142.2
	kW	12.59	12.26	11.95	12.68	12.36	12.04	12.75	12.44	12.15	12.88	12.54	12.31
105	TC	147.8	134.2	114.0	150.7	137.2	119.1	153.3	140.4	136.4	156.4	143.7	136.7
	SHC	75.4	95.2	109.5	79.6	101.9	118.2	84.4	110.6	126.5	92.2	124.0	136.6
	kW	13.84	13.48	13.12	13.92	13.58	13.24	14.01	13.69	13.37	14.06	13.80	13.58
115	TC	139.7	120.4	102.8	142.1	124.2	109.1	145.5	127.5	117.1	148.4	133.2	128.1
	SHC	72.5	89.8	102.6	76.7	97.0	109.1	82.1	105.7	116.6	90.4	120.1	128.0
	kW	15.03	14.70	14.34	15.12	14.80	15.24	15.24	14.90	14.65	15.35	15.04	14.86
125	TC	130.5	107.0	92.5	132.8	109.7	93.5	135.5	112.7	105.0	138.2	121.1	118.3
	SHC	69.8	84.4	92.4	73.7	91.5	99.2	79.0	99.9	104.9	87.7	114.6	118.3
	kW	16.32	15.91	15.67	16.43	16.00	15.79	16.52	16.11	15.97	16.59	16.21	16.10



### FAN PERFORMANCE — VERTICAL DISCHARGE UNITS

#### 48TM004 (3 TONS) — STANDARD MOTOR (DIRECT DRIVE)

Airflow (Cfm)	Low Speed						High Speed					
	208 V			230, 460, 575 V			208 V			230, 460, 575 V		
	ESP	Bhp	Watts	ESP	Bhp	Watts	ESP	Bhp	Watts	ESP	Bhp	Watts
900	0.49	0.21	253	0.50	0.23	277	0.51	0.26	307	0.55	0.31	363
1000	0.42	0.23	270	0.43	0.25	292	0.43	0.27	321	0.51	0.32	374
1100	0.37	0.24	287	0.38	0.26	307	0.39	0.28	335	0.46	0.33	385
1200	0.33	0.26	304	0.33	0.27	323	0.34	0.29	349	0.40	0.34	397
1300	0.27	0.27	321	0.28	0.29	338	0.28	0.31	364	0.34	0.34	408
1400	0.20	0.29	338	0.23	0.30	354	0.25	0.32	378	—	—	—
1500	0.16	0.30	355	0.18	0.31	369	0.20	0.33	392	—	—	—

LEGEND

Refer to page 87 for general Fan Performance Data notes.

- Bhp — Brake Horsepower Input to Fan
- ESP — External Static Pressure (in. wg)
- FIOF — Factory-Installed Option

#### 48TM004 (3 TONS) — ALTERNATE MOTOR (BELT DRIVE)\*

Airflow (Cfm)	External Static Pressure (in. wg)																	
	0.1			0.2			0.3			0.4			0.5			0.6		
	Rpm	Bhp	Watts	Rpm	Bhp	Watts	Rpm	Bhp	Watts	Rpm	Bhp	Watts	Rpm	Bhp	Watts	Rpm	Bhp	Watts
900	581	0.12	119	673	0.18	179	736	0.22	219	805	0.25	249	865	0.29	288	911	0.34	338
1000	644	0.19	189	709	0.22	219	782	0.28	279	835	0.30	298	900	0.35	348	937	0.38	378
1100	687	0.22	219	746	0.26	259	806	0.30	298	867	0.35	348	929	0.40	398	964	0.40	398
1200	733	0.26	259	785	0.32	318	843	0.35	348	903	0.41	408	960	0.47	467	994	0.50	497
1300	754	0.29	288	826	0.38	378	891	0.43	428	942	0.48	477	991	0.53	527	1047	0.60	597
1400	810	0.35	348	868	0.45	448	937	0.51	507	984	0.57	567	1032	0.62	617	1067	0.67	666
1500	841	0.42	418	911	0.53	527	985	0.61	607	1029	0.66	656	1073	0.72	716	1109	0.77	766

#### 48TM004 (3 TONS) — ALTERNATE MOTOR (BELT DRIVE)\* (cont)

Airflow (Cfm)	External Static Pressure (in. wg)																	
	0.7			0.8			0.9			1.0			1.1			1.2		
	Rpm	Bhp	Watts	Rpm	Bhp	Watts	Rpm	Bhp	Watts	Rpm	Bhp	Watts	Rpm	Bhp	Watts	Rpm	Bhp	Watts
900	957	0.39	388	988	0.43	428	1039	0.47	448	1061	0.51	487	1083	0.54	527	1105	0.58	567
1000	992	0.44	438	1039	0.49	487	1061	0.55	507	1088	0.60	547	1111	0.66	587	1136	0.72	627
1100	1013	0.49	487	1068	0.55	547	1091	0.61	577	1109	0.66	607	1127	0.73	637	1145	0.80	666
1200	1045	0.56	557	1090	0.64	637	1109	0.68	647	1156	0.73	676	1203	0.81	706	1250	0.86	736
1300	1075	0.64	637	1122	0.70	696	1152	0.76	716	1190	0.82	756	1228	0.87	796	1266	0.94	836
1400	1110	0.73	726	1160	0.78	766	1181	0.83	806	1237	0.88	845	1293	0.94	885	1349	0.99	925
1500	1150	0.78	816	1190	0.84	855	1225	0.89	895	1271	0.95	945	1317	1.00	995	1383	1.05	1044

LEGEND

Refer to page 87 for general Fan Performance Data notes.

- Bhp — Brake Horsepower Input to Fan
- FIOF — Factory-Installed Option
- Watts — Input Watts to Motor

NOTES:

1. **Boldface** indicates field-supplied drive is required.
2.  indicates field-supplied motor and drive are required.
3. Maximum continuous bhp is 1.2 and the maximum continuous watts are 1000.

\*Motor drive range is 760 to 1000 rpm. All other rpms require a field-supplied drive.

#### 48TM004 (3 TONS) — HIGH-STATIC MOTOR (BELT DRIVE)\*

Airflow (Cfm)	External Static Pressure (in. wg)														
	0.2			0.4			0.6			0.8			1.0		
	Rpm	Bhp	Watts	Rpm	Bhp	Watts	Rpm	Bhp	Watts	Rpm	Bhp	Watts	Rpm	Bhp	Watts
900	673	0.18	179	805	0.25	249	911	0.34	338	988	0.43	428	1061	0.47	487
1000	709	0.22	219	835	0.30	298	937	0.38	378	1039	0.49	487	1086	0.55	547
1100	746	0.26	259	867	0.35	348	964	0.40	398	1068	0.55	547	1109	0.61	607
1200	785	0.32	318	903	0.41	408	994	0.50	497	1090	0.64	637	1156	0.68	676
1300	826	0.38	378	942	0.48	477	1047	0.60	597	1122	0.70	696	1190	0.76	756
1400	868	0.45	448	984	0.57	567	1067	0.67	666	1160	0.84	766	1237	0.85	845
1500	911	0.53	527	1029	0.66	656	1109	0.77	766	1190	1.00	855	1271	0.95	945

#### 48TM004 (3 TONS) — HIGH-STATIC MOTOR (BELT DRIVE)\* (cont)

Airflow (Cfm)	External Static Pressure (in. wg)														
	1.2			1.4			1.6			1.8			2.0		
	Rpm	Bhp	Watts	Rpm	Bhp	Watts	Rpm	Bhp	Watts	Rpm	Bhp	Watts	Rpm	Bhp	Watts
900	1105	0.57	567	1140	0.63	622	1170	0.68	674	1198	0.73	723	1224	0.77	771
1000	1136	0.63	627	1172	0.69	688	1203	0.75	745	1232	0.80	799	1258	0.86	852
1100	1145	0.67	666	1181	0.73	731	1213	0.80	792	1242	0.85	850	1268	0.91	906
1200	1210	0.74	736	1248	0.81	808	1282	0.88	875	1312	0.94	939	1340	1.01	1000
1300	1266	0.84	836	1306	0.92	917	1341	1.00	993	1373	1.07	1066	1402	1.14	1136
1400	1349	0.93	925	1391	1.02	1015	1429	1.11	1100	1463	1.19	1180	1494	1.26	1257
1500	1383	1.05	1044	1426	1.15	1146	1465	1.25	1242	1500	1.34	1332	1532	1.43	1419

LEGEND

Refer to page 87 for general Fan Performance Data notes.

- Bhp — Brake Horsepower Input to Fan
- FIOF — Factory-Installed Option
- Watts — Input Watts to Motor

NOTES:

1. **Boldface** indicates field-supplied drive is required.
2. Maximum continuous bhp is 2.4 and the maximum continuous watts are 2120.

\*Motor drive range is 1075 to 1455 rpm. All other rpms require a field-supplied drive.

# Performance data (cont)



## FAN PERFORMANCE — VERTICAL DISCHARGE UNITS (cont)

48TM004-014

### 48TM005 (4 TONS) — STANDARD MOTOR (DIRECT DRIVE)

Airflow (Cfm)	Low Speed						High Speed					
	208 V			230, 460, 575 V			208 V			230, 460, 575 V		
	ESP	Bhp	Watts	ESP	Bhp	Watts	ESP	Bhp	Watts	ESP	Bhp	Watts
1200	0.68	0.41	458	0.74	0.45	506	0.74	0.51	572	0.85	0.56	632
1300	0.61	0.42	471	0.67	0.46	521	0.66	0.52	589	0.78	0.58	651
1400	0.53	0.45	503	0.59	0.49	556	0.59	0.54	616	0.70	0.60	681
1500	0.45	0.47	536	0.51	0.52	593	0.52	0.56	631	0.63	0.62	698
1600	0.36	0.49	557	0.42	0.54	616	0.45	0.58	654	0.56	0.64	723
1700	0.26	0.52	584	0.32	0.57	646	0.37	0.60	678	0.48	0.66	750
1800	0.15	0.54	610	0.22	0.60	674	0.30	0.62	698	0.41	0.68	772
1900	0.04	0.56	629	0.11	0.62	696	0.23	0.64	720	0.34	0.70	796
2000	—	—	—	—	—	—	0.16	0.66	744	0.26	0.73	823

LEGEND

Refer to page 87 for general Fan Performance Data notes.

- Bhp — Brake Horsepower Input to Fan
- ESP — External Static Pressure (in. wg)
- FIOP — Factory-Installed Option

### 48TM005 (4 TONS) — ALTERNATE MOTOR (BELT DRIVE)\*

Airflow (Cfm)	External Static Pressure (in. wg)																				
	0.1			0.2			0.3			0.4			0.6			0.7			0.8		
	Rpm	Bhp	Watts	Rpm	Bhp	Watts	Rpm	Bhp	Watts	Rpm	Bhp	Watts	Rpm	Bhp	Watts	Rpm	Bhp	Watts	Rpm	Bhp	Watts
1200	596	0.20	210	665	0.25	263	722	0.31	320	779	0.36	378	872	0.48	504	915	0.54	567	957	0.60	630
1300	633	0.24	252	699	0.30	315	754	0.36	378	809	0.42	441	902	0.55	578	943	0.61	641	984	0.67	704
1400	672	0.30	315	735	0.36	378	788	0.42	441	840	0.48	504	933	0.62	651	972	0.69	720	1011	0.75	788
1500	711	0.35	368	770	0.42	441	822	0.49	510	873	0.55	578	963	0.69	725	1002	0.77	804	1041	0.84	858
1600	751	0.42	441	835	0.49	515	871	0.56	588	907	0.63	662	993	0.77	787	1033	0.85	869	1072	0.93	950
1700	791	0.49	515	873	0.57	599	907	0.65	678	941	0.72	757	1024	0.87	889	1064	0.96	976	1103	1.04	1063
1800	831	0.58	609	881	0.66	693	929	0.74	772	976	0.81	851	1057	0.97	991	1095	1.06	1078	1132	1.14	1165
1900	872	0.67	704	919	0.75	788	965	0.84	877	1011	0.92	967	1091	1.08	1104	1127	1.17	1191	1162	1.25	1277
2000	913	0.77	809	958	0.86	904	1002	0.95	993	1046	1.03	1082	1125	1.21	1237	1160	1.30	1323	1195	1.38	1410

### 48TM005 (4 TONS) — ALTERNATE MOTOR (BELT DRIVE)\* (cont)

Airflow (Cfm)	External Static Pressure (in. wg)																				
	0.9			1.0			1.1			1.2			1.4			1.6			1.8		
	Rpm	Bhp	Watts	Rpm	Bhp	Watts	Rpm	Bhp	Watts	Rpm	Bhp	Watts	Rpm	Bhp	Watts	Rpm	Bhp	Watts	Rpm	Bhp	Watts
1200	993	0.65	678	1028	0.69	725	1056	0.72	751	1083	0.74	778	1134	0.80	935	1185	0.88	965	1331	0.99	1000
1300	1021	0.74	772	1058	0.80	841	1090	0.85	888	1121	0.89	935	1171	0.94	988	1219	1.00	999	1268	1.10	1029
1400	1049	0.82	837	1086	0.89	885	1120	0.96	950	1153	1.00	976	1210	1.12	1071	1257	1.17	1105	1307	1.25	1190
1500	1077	0.92	922	1113	0.99	985	1147	1.06	1054	1180	1.13	1081	1241	1.27	1215	1295	1.37	1294	1339	1.43	1350
1600	1107	1.00	998	1141	1.09	1084	1174	1.17	1134	1207	1.25	1196	1269	1.40	1339	1326	1.54	1454	1376	1.65	1558
1700	1137	1.12	1128	1171	1.20	1194	1203	1.29	1278	1235	1.37	1310	1296	1.53	1463	1354	1.70	1605	1407	1.84	1738
1800	1167	1.23	1239	1202	1.32	1313	1233	1.41	1398	1263	1.49	1425	1323	1.67	1597	1381	1.85	1747	1436	2.02	1907
1900	1197	1.35	1360	1232	1.45	1442	1263	1.54	1532	1294	1.63	1559	1351	1.81	1731	1408	2.00	1889	1463	2.19	2068
2000	1229	1.48	1491	1262	1.58	1572	1294	1.68	1671	1325	1.78	1702	1362	1.97	1884	1436	2.16	2040	1489	2.36	2229

LEGEND

Refer to page 87 for general Fan Performance Data notes.

- Bhp — Brake Horsepower Input to Fan
- FIOP — Factory-Installed Option
- Watts — Input Watts to Motor

NOTES:

1. **Boldface** indicates field-supplied drive is required.
2. **Shaded** indicates field-supplied motor and drive are required.
3. Maximum continuous bhp is 1.2 and the maximum continuous watts are 1000.

\*Motor drive range is 835 to 1185 rpm. All other rpms require a field-supplied drive.

### 48TM005 (4 TONS) — HIGH-STATIC MOTOR (BELT DRIVE)\*

Airflow (Cfm)	External Static Pressure (in. wg)														
	0.2			0.4			0.6			0.8			1.0		
	Rpm	Bhp	Watts	Rpm	Bhp	Watts	Rpm	Bhp	Watts	Rpm	Bhp	Watts	Rpm	Bhp	Watts
1200	665	0.25	263	779	0.36	378	872	0.48	504	957	0.60	630	1028	0.69	725
1300	699	0.30	315	809	0.42	441	902	0.55	578	984	0.67	704	1058	0.80	841
1400	735	0.36	378	840	0.48	504	933	0.62	651	1011	0.75	788	1086	0.89	885
1500	770	0.42	441	873	0.55	578	963	0.69	725	1041	0.84	858	1113	0.99	985
1600	835	0.49	515	907	0.63	662	993	0.77	787	1072	0.93	950	1141	1.09	1084
1700	873	0.57	599	941	0.72	757	1024	0.87	889	1103	1.04	1063	1171	1.20	1194
1800	881	0.66	693	976	0.81	851	1057	0.97	991	1132	1.14	1165	1202	1.32	1313
1900	919	0.75	788	1011	0.92	967	1091	1.08	1104	1162	1.25	1277	1232	1.45	1442
2000	958	0.86	904	1046	1.03	1082	1125	1.21	1237	1195	1.38	1410	1262	1.58	1572

### 48TM005 (4 TONS) — HIGH-STATIC MOTOR (BELT DRIVE)\* (cont)

Airflow (Cfm)	External Static Pressure (in. wg)														
	1.2			1.4			1.6			1.8			2.0		
	Rpm	Bhp	Watts	Rpm	Bhp	Watts	Rpm	Bhp	Watts	Rpm	Bhp	Watts	Rpm	Bhp	Watts
1200	1083	0.74	778	1134	0.80	935	1185	0.88	965	1331	0.99	1000	1374	1.09	1083
1300	1121	0.89	935	1171	0.94	988	1219	1.00	999	1268	1.10	1029	1309	1.21	1203
1400	1153	1.00	967	1210	1.12	1071	1257	1.17	1105	1307	1.25	1190	1349	1.37	1367
1500	1180	1.13	1081	1241	1.27	1215	1295	1.37	1294	1339	1.43	1350	1382	1.57	1564
1600	1207	1.25	1196	1269	1.40	1339	1326	1.54	1454	1376	1.65	1558	1420	1.81	1805
1700	1235	1.37	1310	1296	1.53	1463	1354	1.70	1605	1407	1.84	1738	1452	2.02	2013
1800	1263	1.49	1425	1323	1.67	1597	1381	1.85	1747	1436	2.02	1907	1482	2.22	2210
1900	1294	1.63	1559	1351	1.81	1731	1408	2.00	1889	1463	2.19	2068	—	—	—
2000	1325	1.78	1702	1362	1.97	1894	1436	2.16	2040	1489	2.36	2229	—	—	—

LEGEND

Refer to page 87 for general Fan Performance Data notes.

- Bhp — Brake Horsepower Input to Fan
- FIOP — Factory-Installed Option
- Watts — Input Watts to Motor

NOTES:

1. **Boldface** indicates field-supplied drive is required.
2. Maximum continuous bhp is 2.4 and the maximum continuous watts are 2120.

\*Motor drive range is 1075 to 1455 rpm. All other rpms require a field-supplied drive.



## FAN PERFORMANCE — VERTICAL DISCHARGE UNITS (cont)

48TM004-014

### 48TM006 (5 TONS) — STANDARD MOTOR (DIRECT DRIVE)

Airflow (Cfm)	Low Speed						Medium Speed						High Speed					
	208 V			230,460,575 V			208 V			230,460,575 V			208 V			230,460,575 V		
	ESP	Bhp	Watts	ESP	Bhp	Watts	ESP	Bhp	Watts	ESP	Bhp	Watts	ESP	Bhp	Watts	ESP	Bhp	Watts
1500	0.69	0.67	750	1.01	0.71	791	1.00	0.70	782	1.20	0.76	845	1.22	0.79	875	1.28	0.85	949
1600	0.49	0.70	780	0.85	0.74	824	0.85	0.74	821	1.06	0.79	883	1.09	0.82	913	1.17	0.89	988
1700	0.29	0.73	810	0.70	0.77	857	0.70	0.77	861	0.93	0.83	921	0.97	0.85	950	1.06	0.92	1027
1800	0.09	0.75	839	0.54	0.80	891	0.55	0.81	900	0.80	0.86	959	0.84	0.89	988	0.95	0.96	1066
1900	—	—	—	0.39	0.83	924	0.40	0.84	940	0.67	0.90	997	0.72	0.92	1025	0.84	0.99	1105
2000	—	—	—	0.23	0.86	957	0.25	0.88	979	0.54	0.93	1035	0.59	0.95	1063	0.73	1.03	1144
2100	—	—	—	0.08	0.89	990	0.10	0.91	1018	0.41	0.96	1073	0.46	0.99	1101	0.62	1.06	1183
2200	—	—	—	—	—	—	—	—	—	0.28	1.00	1111	0.34	1.02	1138	0.51	1.10	1222
2300	—	—	—	—	—	—	—	—	—	0.15	1.03	1149	0.21	1.06	1176	0.40	1.13	1261
2400	—	—	—	—	—	—	—	—	—	0.02	1.07	1187	0.09	1.09	1213	0.29	1.17	1300
2500	—	—	—	—	—	—	—	—	—	—	—	—	—	—	0.18	1.20	1340	

LEGEND

Refer to page 87 for general Fan Performance Data notes.

Bhp — Brake Horsepower Input to Fan  
 ESP — External Static Pressure (in. wg)  
 FIOP — Factory-Installed Option

### 48TM006 (5 TONS) — ALTERNATE MOTOR (BELT DRIVE)\*

Airflow (Cfm)	External Static Pressure (in. wg)																	
	0.1			0.2			0.4			0.6			0.8			1.0		
	Rpm	Bhp	Watts	Rpm	Bhp	Watts	Rpm	Bhp	Watts	Rpm	Bhp	Watts	Rpm	Bhp	Watts	Rpm	Bhp	Watts
1500	729	0.36	368	788	0.42	429	896	0.56	572	981	0.69	705	1070	0.85	869	1144	1.01	1032
1600	770	0.42	429	826	0.49	501	930	0.64	654	1015	0.78	797	1098	0.94	961	1173	1.11	1134
1700	811	0.50	511	864	0.57	582	964	0.72	736	1051	0.88	899	1124	1.03	1053	1203	1.21	1237
1800	852	0.58	593	903	0.66	674	999	0.82	838	1085	0.98	1001	1155	1.13	1155	1231	1.32	1349
1900	893	0.68	695	942	0.76	777	1035	0.92	940	1119	1.10	1124	1191	1.26	1288	1288	1.43	1461
2000	935	0.78	797	982	0.87	889	1070	1.04	1063	1153	1.22	1247	1227	1.40	1431	1287	1.57	1604
2100	977	0.89	910	1022	0.99	1012	1107	1.17	1196	1187	1.35	1380	1260	1.54	1574	1323	1.72	1758
2200	1019	1.02	1042	1063	1.12	1145	1144	1.30	1328	1222	1.49	1523	1294	1.70	1737	1359	1.89	1931
2300	1061	1.16	1185	1104	1.26	1288	1182	1.47	1502	1258	1.65	1686	1328	1.80	1901	1393	2.07	2115
2400	1103	1.30	1328	1145	1.41	1441	1220	1.61	1645	1293	1.80	1860	1362	2.03	2074	1426	2.26	2310
2500	1145	1.46	1492	1186	1.57	1604	1259	1.78	1819	1329	2.00	2044	1397	2.22	2269	1460	2.45	2504

LEGEND

Bhp — Brake Horsepower Input to Fan  
 FIOP — Factory-Installed Option  
 Watts — Input Watts to Motor

\*Motor drive range is 900 to 1300 rpm. All other rpms require a field-supplied drive.

Refer to page 87 for general Fan Performance Data notes.

NOTES:

- Boldface** indicates field-supplied drive is required.
- Grey shading** indicates field-supplied motor and drive are required.
- Maximum continuous bhp is 1.30 for single-phase units and 2.40 for 3-phase units and the maximum continuous watts are 2120.

### 48TM006 (5 TONS) — ALTERNATE MOTOR (BELT DRIVE)\* (cont)

Airflow (Cfm)	External Static Pressure (in. wg)								
	1.2			1.4			1.6		
	Rpm	Bhp	Watts	Rpm	Bhp	Watts	Rpm	Bhp	Watts
1500	1226	1.19	1216	1301	1.46	1492	1380	1.69	1757
1600	1242	1.28	1308	1318	1.49	1523	1392	1.78	1800
1700	1270	1.39	1420	1335	1.58	1615	1408	1.80	1850
1800	1300	1.52	1553	1361	1.71	1747	1423	1.91	1952
1900	1329	1.64	1676	1391	1.80	1891	1448	2.05	2095
2000	1355	1.77	1809	1420	1.99	2034	1477	2.21	2258
2100	1381	1.91	1952	1449	2.14	2167	—	—	—
2200	1413	2.08	2126	1474	2.30	2350	—	—	—
2300	1449	2.26	2310	—	—	—	—	—	—
2400	1485	2.47	2524	—	—	—	—	—	—
2500	—	—	—	—	—	—	—	—	—

### 48TM006 (5 TONS) — HIGH-STATIC MOTOR (BELT DRIVE)\*

Airflow (Cfm)	External Static Pressure (in. wg)														
	0.2			0.4			0.6			0.8			1.0		
	Rpm	Bhp	Watts	Rpm	Bhp	Watts	Rpm	Bhp	Watts	Rpm	Bhp	Watts	Rpm	Bhp	Watts
1500	808	0.42	429	914	0.56	572	1001	0.69	705	1084	0.85	869	1168	1.01	1032
1600	846	0.49	501	950	0.64	654	1034	0.78	797	1111	0.94	961	1194	1.11	1134
1700	884	0.57	592	983	0.72	736	1068	0.88	899	1145	1.03	1053	1218	1.21	1237
1800	942	0.66	674	1018	0.82	838	1105	0.98	1001	1179	1.13	1155	1246	1.32	1349
1900	965	0.78	777	1057	0.92	940	1143	1.10	1124	1212	1.26	1288	1280	1.43	1481
2000	1008	0.87	889	1096	1.04	1063	1177	1.22	1247	1247	1.40	1431	1300	1.57	1604
2100	1051	0.99	1012	1136	1.17	1196	1210	1.35	1380	1284	1.54	1574	1347	1.72	1758
2200	1095	1.12	1145	1173	1.30	1328	1245	1.49	1523	1322	1.70	1737	1380	1.89	1931
2300	1140	1.28	1288	1210	1.47	1502	1284	1.65	1686	1356	1.80	1901	1418	2.07	2115
2400	1185	1.41	1441	1249	1.61	1645	1323	1.80	1860	1389	2.03	2074	1456	2.26	2310
2500	1231	1.57	1604	1289	1.78	1819	1363	2.00	2044	1424	2.22	2269	1500	2.45	2504

### 48TM006 (5 TONS) — HIGH-STATIC MOTOR (BELT DRIVE)\* (cont)

Airflow (Cfm)	External Static Pressure (in. wg)														
	1.2			1.4			1.6			1.8			2.0		
	Rpm	Bhp	Watts	Rpm	Bhp	Watts	Rpm	Bhp	Watts	Rpm	Bhp	Watts	Rpm	Bhp	Watts
1500	1199	1.19	1216	1126	1.46	1492	1250	1.69	1757	1301	1.91	1944	1349	2.12	2164
1600	1263	1.28	1308	1275	1.49	1523	1299	1.78	1800	1352	2.01	2047	1401	2.23	2280
1700	1295	1.39	1420	1351	1.58	1615	1352	1.80	1850	1407	2.03	2070	1459	2.26	2305
1800	1319	1.52	1553	1389	1.71	1747	1453	1.91	1952	1494	2.15	2197	1548	2.40	2446
1900	1343	1.64	1676	1415	1.80	1891	1478	2.05	1095	1538	2.31	2358	1594	2.57	2625
2000	1374	1.77	1809	1438	1.99	2034	1505	2.21	2258	1566	2.49	2542	1624	2.77	2830
2100	1409	1.91	1952	1465	2.14	2167	1533	2.45	2501	1596	2.77	2821	1654	3.08	3141
2200	1442	2.08	2126	1498	2.30	2350	1568	2.64	2688	1632	2.97	3031	1691	3.31	3375
2300	1475	2.26	2310	1554	2.64	2698	1627	3.03	3091	1693	3.42	3486	1755	3.81	3881
2400	1565	2.47	2524	1649	2.89	2948	1726	3.31	3379	—	—	—	—	—	—
2500	1596	2.95	3010	1682	3.45	3522	1760	3.96	4036	—	—	—	—	—	—

LEGEND

Refer to page 87 for general Fan Performance Data notes.

Bhp — Brake Horsepower Input to Fan  
 FIOP — Factory-Installed Option  
 Watts — Input Watts to Motor

NOTES:

- Boldface** indicates field-supplied drive is required.
- Grey shading** indicates field-supplied motor and drive are required.
- Maximum continuous bhp is 2.9 and the maximum continuous watts are 2562.

\*Motor drive range is 1300 to 1685 rpm. All other rpms require a field-supplied drive.

# Performance data (cont)



## FAN PERFORMANCE — VERTICAL DISCHARGE UNITS (cont)

48TM004-014

48TM007 (6 TONS) — STANDARD MOTOR (BELT DRIVE)\*

Airflow (Cfm)	External Static Pressure (in. wg)																	
	0.1			0.2			0.4			0.6			0.8			1.0		
	Rpm	Bhp	Watts	Rpm	Bhp	Watts	Rpm	Bhp	Watts	Rpm	Bhp	Watts	Rpm	Bhp	Watts	Rpm	Bhp	Watts
1800	942	0.70	646	978	0.66	700	1063	0.82	771	1147	0.97	891	1248	1.20	1081	1322	1.33	1190
1900	982	0.80	739	1023	0.78	779	1097	0.91	843	1175	1.11	1006	1266	1.29	1156	1356	1.47	1310
2000	1022	0.91	835	1068	0.90	867	1132	1.01	924	1218	1.23	1106	1303	1.41	1258	1397	1.52	1353
2100	1063	0.99	916	1115	1.00	998	1180	1.17	1056	1261	1.35	1207	1340	1.53	1361	1428	1.66	1473
2200	1104	1.13	1039	1159	1.15	1081	1214	1.28	1148	1310	1.52	1353	1375	1.63	1447	1459	1.80	1595
2300	1130	1.26	1156	1202	1.29	1140	1248	1.38	1233	1358	1.69	1499	1410	1.72	1526	1488	1.93	1709
2400	1174	1.37	1258	1237	1.41	1224	1292	1.55	1378	1392	1.81	1604	1460	1.90	1683	1532	2.14	1892
2500	1201	1.48	1361	1272	1.53	1335	1335	1.71	1517	1427	1.94	1718	1518	2.16	1910	1575	2.35	2076
2600	1246	1.62	1491	1320	1.68	1482	1368	1.81	1604	1458	2.06	1823	1562	2.42	2136	1620	2.59	2283
2700	1285	1.75	1613	1361	1.82	1595	1400	1.91	1691	1490	2.19	1936	1602	2.64	2326	1666	2.85	2504
2800	1304	1.87	1726	1402	1.95	1639	1439	2.08	1840	1543	2.43	2145	1642	2.86	2512	—	—	—
2900	1345	2.07	1910	1446	2.16	1814	1477	2.16	1989	1585	2.65	2335	—	—	—	—	—	—
3000	1378	2.26	2084	1489	2.36	2032	1529	2.52	2223	1598	2.73	2444	—	—	—	—	—	—

48TM007 (6 TONS) — STANDARD MOTOR (BELT DRIVE)\* (cont)

Airflow (Cfm)	External Static Pressure (in. wg)								
	1.2			1.4			1.6		
	Rpm	Bhp	Watts	Rpm	Bhp	Watts	Rpm	Bhp	Watts
1800	1395	1.46	1301	1475	1.56	1387	1542	1.71	1517
1900	1430	1.58	1404	1504	1.69	1499	1556	1.82	1613
2000	1459	1.67	1482	1532	1.82	1613	1588	1.97	1744
2100	1489	1.80	1595	1567	1.99	1761	1626	2.16	1910
2200	1528	1.95	1726	1603	2.17	1919	1666	2.37	2093
2300	1561	2.13	1884	1637	2.35	2076	1710	2.54	2272
2400	1584	2.28	2015	1671	2.55	2249	1756	2.70	2467
2500	1633	2.53	2232	1698	2.72	2405	—	—	—
2600	1675	2.77	2436	—	—	—	—	—	—
2700	—	—	—	—	—	—	—	—	—
2800	—	—	—	—	—	—	—	—	—
2900	—	—	—	—	—	—	—	—	—
3000	—	—	—	—	—	—	—	—	—

LEGEND

- Bhp — Brake Horsepower Input to Fan
- FIOF — Factory-Installed Option
- Watts — Input Watts to Motor

\*Motor drive range is 1070 to 1460 rpm. All other rpms require a field-supplied drive.

Refer to page 87 for general Fan Performance Data notes.

NOTES:

1. **Boldface** indicates field-supplied drive is required.
2. **Shaded** indicates field-supplied motor and drive are required.
3. Maximum continuous bhp is 2.40 and the maximum continuous watts are 2120.

48TM007 (6 TONS) — HIGH-STATIC MOTOR (BELT DRIVE)\*

Airflow (Cfm)	External Static Pressure (in. wg)														
	0.2			0.4			0.6			0.8			1.0		
	Rpm	Bhp	Watts	Rpm	Bhp	Watts	Rpm	Bhp	Watts	Rpm	Bhp	Watts	Rpm	Bhp	Watts
1800	978	0.66	700	1063	0.82	771	1147	0.97	891	1248	1.20	1081	1322	1.33	1190
1900	1023	0.78	779	1097	0.91	843	1175	1.11	1006	1266	1.29	1156	1356	1.47	1310
2000	1068	0.90	867	1132	1.01	924	1218	1.23	1106	1303	1.41	1258	1397	1.52	1353
2100	1115	1.00	988	1180	1.17	1056	1261	1.35	1207	1340	1.53	1361	1428	1.66	1473
2200	1159	1.15	1081	1214	1.28	1148	1310	1.52	1353	1375	1.63	1447	1459	1.80	1595
2300	1202	1.29	1140	1248	1.38	1233	1358	1.69	1499	1410	1.72	1526	1488	1.93	1709
2400	1237	1.41	1224	1292	1.55	1378	1392	1.81	1604	1460	1.90	1683	1532	2.14	1892
2500	1272	1.53	1335	1335	1.71	1517	1427	1.94	1718	1518	2.16	1910	1575	2.35	2076
2600	1320	1.68	1482	1368	1.81	1604	1458	2.06	1823	1562	2.42	2136	1620	2.59	2283
2700	1361	1.82	1595	1400	1.91	1691	1490	2.19	1936	1602	2.64	2326	1666	2.85	2504
2800	1402	1.95	1639	1439	2.08	1840	1543	2.43	2145	1642	2.86	2512	1775	3.62	3290
2900	1446	2.16	1814	1477	2.16	1989	1585	2.65	2335	1753	3.58	3262	—	—	—
3000	1489	2.36	2032	1529	2.52	2223	1598	2.73	2444	1767	3.69	3360	—	—	—

48TM007 (6 TONS) — HIGH-STATIC MOTOR (BELT DRIVE)\* (cont)

Airflow (Cfm)	External Static Pressure (in. wg)														
	1.2			1.4			1.6			1.8			2.0		
	Rpm	Bhp	Watts	Rpm	Bhp	Watts	Rpm	Bhp	Watts	Rpm	Bhp	Watts	Rpm	Bhp	Watts
1800	1395	1.46	1301	1475	1.56	1387	1542	1.71	1517	1607	1.94	1761	1667	2.16	1967
1900	1430	1.58	1404	1504	1.69	1499	1556	1.82	1613	1621	2.06	1874	1682	2.30	2093
2000	1459	1.67	1482	1532	1.82	1613	1588	1.97	1744	1655	2.23	2029	1717	2.49	2266
2100	1489	1.80	1595	1567	1.99	1761	1626	2.16	1910	1694	2.44	2224	1758	2.73	2485
2200	1528	1.95	1726	1603	2.17	1919	1666	2.37	2093	1736	2.68	2441	—	—	—
2300	1561	2.13	1884	1637	2.35	2076	1710	2.54	2272	1782	2.87	2616	—	—	—
2400	1584	2.28	2015	1671	2.55	2249	1756	2.70	2467	—	—	—	—	—	—
2500	1633	2.53	2232	1698	2.72	2405	1779	3.13	2848	—	—	—	—	—	—
2600	1675	2.77	2436	1768	3.26	2964	—	—	—	—	—	—	—	—	—
2700	1776	3.45	3141	—	—	—	—	—	—	—	—	—	—	—	—
2800	—	—	—	—	—	—	—	—	—	—	—	—	—	—	—
2900	—	—	—	—	—	—	—	—	—	—	—	—	—	—	—
3000	—	—	—	—	—	—	—	—	—	—	—	—	—	—	—

LEGEND

- Bhp — Brake Horsepower Input to Fan
- FIOF — Factory-Installed Option
- Watts — Input Watts to Motor

Refer to page 87 for general Fan Performance Data notes.

NOTES:

1. **Boldface** indicates field-supplied drive is required.
2. **Shaded** indicates field-supplied motor and drive are required.
3. Maximum continuous bhp is 2.9 and the maximum continuous watts are 2562.

\*Motor drive range is 1300 to 1685 rpm. All other rpms require a field-supplied drive.



FAN PERFORMANCE — VERTICAL DISCHARGE UNITS (cont)

48TM004-014

48TM008 (7 1/2 TONS) — STANDARD MOTOR AND DRIVE AND ALTERNATE DRIVE (BELT DRIVE)\*

Airflow (Cfm)	External Static Pressure (in. wg)														
	0.2			0.4			0.6			0.8			1.0		
	Rpm	Bhp	Watts	Rpm	Bhp	Watts	Rpm	Bhp	Watts	Rpm	Bhp	Watts	Rpm	Bhp	Watts
2250	514	0.55	562	593	0.76	723	662	0.99	907	724	1.22	1097	781	1.78	1318
2300	521	0.57	577	600	0.79	747	668	1.02	932	730	1.26	1131	786	1.50	1335
2400	536	0.63	623	613	0.85	795	680	1.09	989	741	1.34	1199	796	1.59	1413
2500	551	0.69	669	626	0.93	859	693	1.17	1056	753	1.43	1275	808	1.69	1499
2550	559	0.72	692	634	0.97	891	700	1.21	1089	759	1.48	1318	814	1.74	1543
2600	567	0.75	716	641	1.00	916	706	1.25	1123	764	1.52	1353	819	1.79	1587
2700	582	0.83	779	655	1.08	981	719	1.34	1199	776	1.61	1430	831	1.89	1674
2800	598	0.90	835	670	1.17	1056	732	1.43	1275	789	1.71	1517	842	2.00	1770
2900	614	0.98	899	684	1.25	1123	745	1.53	1361	802	1.81	1604	854	2.11	1866
3000	630	1.07	973	699	1.35	1207	759	1.63	1447	815	1.92	1700	866	2.23	1971
3100	646	1.16	1047	714	1.45	1292	773	1.74	1543	828	2.04	1805	878	2.35	2076
3200	662	1.26	1131	729	1.55	1378	787	1.86	1648	841	2.16	1910	891	2.48	2188
3300	679	1.36	1216	744	1.66	1473	801	1.98	1753	854	2.29	2023	904	2.61	2300
3400	695	1.47	1310	759	1.78	1578	816	2.10	1858	867	2.42	2136	917	2.75	2420
3500	712	1.59	1413	774	1.90	1683	830	2.23	1971	881	2.56	2257	930	2.90	2546
3600	729	1.71	1517	790	2.03	1796	845	2.37	2093	895	2.71	2386	943	3.05	2670
3700	745	1.84	1630	805	2.17	1919	860	2.52	2223	909	2.87	2521	956	3.22	2807
3750	754	1.91	1691	813	2.24	1980	868	2.59	2283	917	2.95	2587	963	3.30	2870

48TM008 (7 1/2 TONS) — STANDARD MOTOR AND DRIVE AND ALTERNATE DRIVE (BELT DRIVE)\* (cont)

Airflow (Cfm)	External Static Pressure (in. wg)								
	1.2			1.4			1.6		
	Rpm	Bhp	Watts	Rpm	Bhp	Watts	Rpm	Bhp	Watts
2250	841	1.81	1604	902	2.25	1989	939	2.60	2292
2300	843	1.83	1621	905	2.28	2015	943	2.62	2309
2400	849	1.88	1665	910	2.31	2041	952	2.74	2411
2500	859	1.96	1735	912	2.31	2050	963	2.81	2470
2550	864	2.01	1779	915	2.34	2067	968	2.81	2479
2600	869	2.06	1823	918	2.37	2093	973	2.81	2487
2700	880	2.17	1919	927	2.47	2180	976	2.84	2495
2800	892	2.29	2023	938	2.58	2275	983	2.92	2562
2900	903	2.42	2136	949	2.71	2386	993	3.03	2653
3000	915	2.54	2240	961	2.85	2504	1003	3.17	2767
3100	926	2.67	2352	972	3.00	2629	1015	3.32	2886
3200	938	2.81	2470	983	3.14	2743	1026	3.47	3002
3300	950	2.95	2587	995	3.30	2870	—	—	—
3400	963	3.10	2710	1007	3.45	2987	—	—	—
3500	976	3.25	2831	—	—	—	—	—	—
3600	988	3.41	2956	—	—	—	—	—	—
3700	—	—	—	—	—	—	—	—	—
3750	—	—	—	—	—	—	—	—	—

LEGEND

- Bhp** — Brake Horsepower Input to Fan
- FLOP** — Factory-Installed Option
- Watts** — Input Watts to Motor

Refer to page 87 for general Fan Performance Data notes.

NOTES:

1. **Boldface** indicates alternate or field-supplied drive is required.
2.  indicates field-supplied motor and drive are required.
3. Maximum continuous bhp is 2.40 and the maximum continuous watts are 2120.

\*Standard drive range is 590 to 840 rpm. Alternate drive range is 685 to 935 rpm. All other rpms require a field-supplied drive.

# Performance data (cont)



## FAN PERFORMANCE — VERTICAL DISCHARGE UNITS (cont)

48TM004-014

### 48TM008 (7½ TONS) — HIGH-STATIC MOTOR (BELT DRIVE)\*

Airflow (Cfm)	External Static Pressure (in. wg)																	
	0.2			0.4			0.6			0.8			1.0			1.2		
	Rpm	Bhp	Watts	Rpm	Bhp	Watts	Rpm	Bhp	Watts	Rpm	Bhp	Watts	Rpm	Bhp	Watts	Rpm	Bhp	Watts
2250	514	0.55	562	593	0.76	723	662	0.99	907	724	1.22	1097	781	1.48	1318	841	1.81	1604
2300	521	0.57	577	600	0.79	747	668	1.02	932	730	1.26	1131	786	1.50	1335	843	1.83	1621
2400	536	0.63	623	613	0.85	795	680	1.09	989	741	1.34	1199	796	1.59	1413	849	1.88	1665
2500	551	0.69	689	626	0.93	859	693	1.17	1056	753	1.43	1275	808	1.69	1499	859	1.96	1735
2550	559	0.72	692	634	0.97	891	700	1.21	1089	759	1.48	1318	814	1.74	1543	864	2.01	1779
2600	567	0.75	716	641	1.00	916	706	1.25	1123	764	1.52	1353	819	1.79	1587	869	2.06	1823
2700	582	0.83	779	655	1.08	981	719	1.34	1199	776	1.61	1430	831	1.89	1674	880	2.17	1919
2800	598	0.90	835	670	1.17	1056	732	1.43	1275	789	1.71	1517	842	2.00	1770	892	2.29	2023
2900	614	0.98	899	684	1.25	1123	745	1.53	1361	802	1.81	1604	854	2.11	1866	903	2.42	2136
3000	630	1.07	973	699	1.35	1207	759	1.63	1447	815	1.92	1700	866	2.23	1971	915	2.54	2240
3100	646	1.16	1047	714	1.45	1292	773	1.74	1543	828	2.04	1805	878	2.35	2076	926	2.67	2352
3200	662	1.26	1131	729	1.55	1378	787	1.86	1648	841	2.16	1910	891	2.48	2188	938	2.81	2470
3300	697	1.36	1216	744	1.66	1473	801	1.98	1753	854	2.29	2023	904	2.61	2300	950	2.95	2587
3400	695	1.47	1310	759	1.79	1578	816	2.10	1858	867	2.42	2136	917	2.75	2420	963	3.10	2710
3500	712	1.59	1413	774	1.90	1683	830	2.23	1971	881	2.56	2257	930	2.90	2546	976	3.25	2831
3600	729	1.71	1517	780	2.03	1796	845	2.37	2093	895	2.71	2386	943	3.05	2670	988	3.41	2956
3700	745	1.84	1630	805	2.17	1919	860	2.52	2223	909	2.87	2521	956	3.22	2807	1019	3.90	3431
3750	754	1.91	1691	813	2.24	1980	868	2.59	2283	917	2.95	2587	963	3.30	2870	1026	4.00	3517

### 48TM008 (7½ TONS) — HIGH-STATIC MOTOR (BELT DRIVE)\* (cont)

Airflow (Cfm)	External Static Pressure (in. wg)											
	1.4			1.6			1.8			2.0		
	Rpm	Bhp	Watts	Rpm	Bhp	Watts	Rpm	Bhp	Watts	Rpm	Bhp	Watts
2250	902	2.25	1989	939	2.60	2292	979	2.94	2589	1015	3.29	2892
2300	905	2.28	2015	943	2.62	2309	983	2.96	2609	1020	3.31	2914
2400	910	2.31	2041	952	2.74	2411	992	3.10	2729	1029	3.46	3048
2500	912	2.31	2050	963	2.81	2470	1004	3.18	2798	1041	3.55	3126
2550	915	2.34	2067	968	2.81	2479	1009	3.18	2798	1047	3.55	3126
2600	918	2.37	2093	973	2.81	2487	1014	3.18	2798	1052	3.55	3126
2700	927	2.47	2180	976	2.84	2495	1017	3.21	2828	1055	3.59	3159
2800	938	2.58	2275	983	2.92	2562	1024	3.30	2908	1063	3.69	3248
2900	949	2.71	2386	993	3.03	2653	1035	3.43	3017	1074	3.83	3370
3000	961	2.85	2504	1003	3.17	2767	1045	3.59	3157	1084	4.01	3526
3100	972	3.00	2629	1015	3.32	2886	1058	3.76	3306	1097	4.20	3693
3200	983	3.14	2743	1026	3.47	3002	1069	3.83	3456	—	—	—
3300	995	3.30	2870	1043	3.80	3341	—	—	—	—	—	—
3400	1007	3.45	2987	1056	3.97	3493	—	—	—	—	—	—
3500	1030	3.82	3362	—	—	—	—	—	—	—	—	—
3600	1043	4.01	3528	—	—	—	—	—	—	—	—	—
3700	—	—	—	—	—	—	—	—	—	—	—	—
3750	—	—	—	—	—	—	—	—	—	—	—	—

#### LEGEND

- Bhp** — Brake Horsepower Input to Fan
- FIOP** — Factory-Installed Option
- Watts** — Input Watts to Motor

Refer to page 87 for general Fan Performance Data notes.

#### NOTES:

1. **Boldface** indicates field-supplied drive is required.
2.  indicates field-supplied motor and drive are required.
3. Maximum continuous bhp is 3.7 and the maximum continuous watts are 3313.

\*Motor drive range is 860 to 1080 rpm. All other rpms require a field-supplied drive.



FAN PERFORMANCE — VERTICAL DISCHARGE UNITS (cont)

48TM004-014

48TM009 (8 1/2 TONS) — STANDARD MOTOR (BELT DRIVE)\*

Airflow (Cfm)	External Static Pressure (in. wg)														
	0.2			0.4			0.6			0.8			1.0		
	Rpm	Bhp	Watts	Rpm	Bhp	Watts	Rpm	Bhp	Watts	Rpm	Bhp	Watts	Rpm	Bhp	Watts
2550	559	0.72	692	634	0.97	891	700	1.21	1089	759	1.48	1318	814	1.74	1543
2600	567	0.75	716	641	1.00	916	706	1.25	1123	764	1.52	1353	819	1.79	1587
2700	582	0.83	779	655	1.08	981	719	1.34	1199	776	1.61	1430	831	1.89	1674
2800	598	0.90	835	670	1.17	1056	732	1.43	1275	789	1.71	1517	842	2.00	1770
2900	614	0.98	899	684	1.25	1123	745	1.53	1361	802	1.81	1604	854	2.11	1866
3000	630	1.07	973	690	1.35	1207	759	1.63	1447	815	1.92	1700	866	2.23	1971
3100	646	1.16	1047	714	1.45	1292	773	1.74	1543	828	2.04	1805	878	2.35	2076
3200	662	1.26	1131	729	1.55	1378	787	1.86	1648	841	2.16	1910	891	2.48	2188
3300	679	1.36	1216	744	1.66	1473	801	1.98	1753	854	2.29	2023	904	2.61	2300
3400	695	1.47	1310	759	1.78	1578	816	2.10	1858	867	2.42	2136	917	2.75	2420
3500	712	1.59	1413	774	1.90	1683	830	2.23	1971	881	2.56	2257	930	2.90	2546
3600	729	1.71	1517	790	2.03	1796	845	2.37	2093	895	2.71	2386	943	3.05	2670
3700	745	1.84	1630	805	2.17	1919	860	2.52	2223	909	2.87	2521	956	3.22	2807
3750	754	1.91	1691	813	2.24	1980	868	2.59	2283	917	2.95	2587	963	3.30	2870
3800	762	1.98	1753	821	2.31	2041	875	2.66	2343	924	3.03	2653	970	3.38	2933
3900	779	2.12	1875	836	2.46	2171	890	2.82	2479	938	3.19	2783	—	—	—
4000	796	2.27	2006	852	2.61	2300	905	2.98	2612	953	3.37	2925	—	—	—
4100	813	2.42	2136	868	2.78	2445	920	3.15	2751	—	—	—	—	—	—
4200	830	2.59	2283	884	2.95	2587	935	3.33	2894	—	—	—	—	—	—
4250	839	2.68	2360	890	3.04	2661	—	—	—	—	—	—	—	—	—

48TM009 (8 1/2 TONS) — STANDARD MOTOR (BELT DRIVE)\* (cont)

Airflow (Cfm)	External Static Pressure (in. wg)								
	1.2			1.4			1.6		
	Rpm	Bhp	Watts	Rpm	Bhp	Watts	Rpm	Bhp	Watts
2550	864	2.01	1779	915	2.34	2067	968	2.81	2479
2600	869	2.06	1823	918	2.37	2093	973	2.81	2487
2700	880	2.17	1919	927	2.47	2180	976	2.84	2495
2800	892	2.29	2023	938	2.58	2275	983	2.92	2562
2900	903	2.42	2136	949	2.71	2386	993	3.03	2653
3000	915	2.54	2240	961	2.85	2504	1003	3.17	2767
3100	926	2.67	2352	972	3.00	2629	1016	3.32	2886
3200	938	2.81	2470	983	3.14	2743	1026	3.47	3002
3300	950	2.95	2587	995	3.30	2870	—	—	—
3400	963	3.10	2710	1007	3.45	2987	—	—	—
3500	976	3.25	2831	—	—	—	—	—	—
3600	988	3.41	2956	—	—	—	—	—	—
3700	—	—	—	—	—	—	—	—	—
3750	—	—	—	—	—	—	—	—	—
3800	—	—	—	—	—	—	—	—	—
3900	—	—	—	—	—	—	—	—	—
4000	—	—	—	—	—	—	—	—	—
4100	—	—	—	—	—	—	—	—	—
4200	—	—	—	—	—	—	—	—	—
4250	—	—	—	—	—	—	—	—	—

LEGEND

**Bhp** — Brake Horsepower Input to Fan  
**FIOP** — Factory-Installed Option  
**Watts** — Input Watts to Motor

\*Motor drive range is 685 to 935 rpm. All other rpms require a field-supplied drive.

Refer to page 87 for general Fan Performance Data notes.

NOTES:

1. **Boldface** indicates field-supplied drive is required.
2. **Shaded** indicates field-supplied motor and drive are required.
3. Maximum continuous bhp is 2.4 and the maximum continuous watts are 2120.

# Performance data (cont)



## FAN PERFORMANCE — VERTICAL DISCHARGE UNITS (cont)

48TM004-014

### 48TM009 (8½ TONS) — HIGH-STATIC MOTOR (BELT DRIVE)\*

Airflow (Cfm)	External Static Pressure (in. wg)														
	0.2			0.4			0.6			0.8			1.0		
	Rpm	Bhp	Watts	Rpm	Bhp	Watts	Rpm	Bhp	Watts	Rpm	Bhp	Watts	Rpm	Bhp	Watts
2550	559	0.72	692	634	0.97	891	700	1.21	1089	759	1.48	1318	814	1.74	1543
2600	567	0.75	716	641	1.00	916	706	1.25	1123	764	1.52	1353	819	1.79	1587
2700	582	0.83	779	655	1.08	981	719	1.34	1199	776	1.61	1430	831	1.89	1674
2800	598	0.90	835	670	1.17	1056	732	1.43	1275	789	1.71	1517	842	2.00	1770
2900	614	0.98	899	684	1.25	1123	745	1.53	1361	802	1.81	1604	854	2.11	1866
3000	630	1.07	973	690	1.35	1207	759	1.63	1447	816	1.92	1700	866	2.23	1971
3100	646	1.16	1047	714	1.45	1292	773	1.74	1543	828	2.04	1805	878	2.35	2076
3200	662	1.26	1131	729	1.55	1378	787	1.86	1648	841	2.18	1910	891	2.48	2188
3300	679	1.36	1216	744	1.66	1473	801	1.98	1753	854	2.29	2023	904	2.61	2300
3400	695	1.47	1310	759	1.76	1578	816	2.10	1858	867	2.42	2136	917	2.75	2420
3500	712	1.59	1413	744	1.90	1683	830	2.23	1971	881	2.56	2257	930	2.90	2546
3600	729	1.71	1517	790	2.03	1796	845	2.37	2093	895	2.71	2386	943	3.05	2670
3700	745	1.84	1630	805	2.17	1919	860	2.52	2223	909	2.87	2521	956	3.22	2807
3750	754	1.91	1691	813	2.24	1980	868	2.59	2283	917	2.95	2587	963	3.30	2870
3800	762	1.98	1753	821	2.31	2041	875	2.66	2343	924	3.03	2653	970	3.38	2933
3900	779	2.12	1875	836	2.46	2171	890	2.82	2479	938	3.19	2783	981	3.65	3209
4000	796	2.27	2006	852	2.61	2300	905	2.98	2612	953	3.37	2925	996	3.85	3390
4100	813	2.42	2136	868	2.78	2445	920	3.15	2751	974	3.74	3294	—	—	—
4200	830	2.59	2283	884	2.95	2587	935	3.33	2894	990	3.96	3482	—	—	—
4250	839	2.68	2360	890	3.04	2661	965	3.88	3412	—	—	—	—	—	—

### 48TM009 (8½ TONS) — HIGH-STATIC MOTOR (BELT DRIVE)\* (cont)

Airflow (Cfm)	External Static Pressure (in. wg)														
	1.2			1.4			1.6			1.8			2.0		
	Rpm	Bhp	Watts	Rpm	Bhp	Watts	Rpm	Bhp	Watts	Rpm	Bhp	Watts	Rpm	Bhp	Watts
2550	864	2.01	1779	915	2.34	2067	968	2.81	2479	991	3.02	2654	1012	3.21	2827
2600	869	2.06	1823	918	2.37	2093	973	2.81	2487	996	3.02	2654	1017	3.21	2827
2700	880	2.17	1919	927	2.47	2180	976	2.84	2495	999	3.05	2682	1021	3.25	2857
2800	892	2.29	2023	938	2.58	2275	983	2.92	2562	1006	3.13	2758	1028	3.34	2938
2900	903	2.42	2136	949	2.71	2386	993	3.03	2653	1017	3.25	2862	1038	3.46	3048
3000	915	2.54	2240	961	2.85	2504	1003	3.17	2767	1027	3.40	2994	1049	3.62	3189
3100	926	2.67	2352	972	3.00	2629	1016	3.32	2886	1040	3.65	3136	1062	3.80	3340
3200	938	2.81	2470	983	3.14	2743	1026	3.47	3002	1050	3.72	3277	1073	3.97	3491
3300	950	2.95	2587	995	3.30	2870	1022	3.58	3146	1046	3.84	3377	1069	4.09	3597
3400	963	3.10	2710	1007	3.45	2987	1034	3.74	3289	1059	4.01	3530	—	—	—
3500	976	3.25	2831	1007	3.56	3137	1034	3.86	3399	1058	4.15	3648	—	—	—
3600	988	3.41	2956	1019	3.74	3292	1047	4.05	3566	—	—	—	—	—	—
3700	992	3.59	3161	1023	3.94	3467	—	—	—	—	—	—	—	—	—
3750	999	3.68	3240	1030	4.04	3554	—	—	—	—	—	—	—	—	—
3800	1006	3.77	3318	1038	4.14	3640	—	—	—	—	—	—	—	—	—
3900	1017	4.07	3580	—	—	—	—	—	—	—	—	—	—	—	—
4000	—	—	—	—	—	—	—	—	—	—	—	—	—	—	—
4100	—	—	—	—	—	—	—	—	—	—	—	—	—	—	—
4200	—	—	—	—	—	—	—	—	—	—	—	—	—	—	—
4250	—	—	—	—	—	—	—	—	—	—	—	—	—	—	—

#### LEGEND

- Bhp** — Brake Horsepower Input to Fan
- FIOP** — Factory-Installed Option
- Watts** — Input Watts to Motor

\*Motor drive range is 860 to 1080 rpm. All other rpms require a field-supplied drive.

Refer to page 87 for general Fan Performance Data notes.

#### NOTES:

1. **Boldface** indicates field-supplied drive is required.
2.  indicates field-supplied motor and drive are required.
3. Maximum continuous bhp is 3.7 and the maximum continuous watts are 3313.



FAN PERFORMANCE — VERTICAL DISCHARGE UNITS (cont)

48TM004-014

48TM012 (10 TONS) — STANDARD MOTOR AND ALTERNATE MOTOR*																		
Airflow (Cfm)	External Static Pressure (in. wg)																	
	0.2			0.4			0.6			0.8			1.0			1.2		
	Rpm	Bhp	Watts	Rpm	Bhp	Watts	Rpm	Bhp	Watts	Rpm	Bhp	Watts	Rpm	Bhp	Watts	Rpm	Bhp	Watts
3000	592	0.76	723	661	0.93	859	722	1.09	989	779	1.26	1131	829	1.42	1267	880	1.58	1404
3100	607	0.83	779	676	1.01	924	734	1.17	1056	791	1.34	1199	840	1.51	1344	890	1.68	1491
3200	622	0.90	835	690	1.09	989	746	1.25	1123	803	1.43	1275	852	1.60	1422	900	1.77	1569
3300	638	0.98	899	705	1.17	1056	759	1.33	1190	815	1.52	1353	864	1.70	1508	910	1.88	1665
3400	653	1.06	965	719	1.26	1131	772	1.43	1275	826	1.62	1439	876	1.81	1604	921	1.98	1753
3500	669	1.15	1039	733	1.35	1207	786	1.53	1361	838	1.72	1526	888	1.91	1691	933	2.10	1858
3600	684	1.24	1114	747	1.44	1284	800	1.64	1456	850	1.82	1613	900	2.03	1796	945	2.22	2014
3700	700	1.33	1190	760	1.54	1370	814	1.75	1552	863	1.92	1700	912	2.14	1892	957	2.34	2117
3800	715	1.43	1275	774	1.64	1456	828	1.86	1648	875	2.04	1805	924	2.26	1997	969	2.47	2230
3900	731	1.54	1370	787	1.74	1543	843	1.98	1753	888	2.16	1910	936	2.38	2151	981	2.60	2344
4000	747	1.64	1456	801	1.85	1639	857	2.10	1858	902	2.30	2032	948	2.51	2265	993	2.74	2469
4100	763	1.76	1560	816	1.97	1744	872	2.23	1971	916	2.44	2203	960	2.64	2380	1005	2.88	2596
4200	778	1.88	1665	831	2.10	1884	886	2.36	2084	929	2.58	2326	972	2.78	2505	1016	3.03	2735
4300	794	2.00	1770	846	2.23	1971	900	2.50	2256	943	2.73	2460	985	2.93	2642	1028	3.17	2866
4400	810	2.13	1884	861	2.37	2093	913	2.64	2380	958	2.89	2605	999	3.09	2791	1040	3.32	3010
4500	826	2.27	2006	876	2.52	2273	927	2.78	2505	973	3.04	2744	1012	3.26	2952	1051	3.50	3159
4600	842	2.41	2177	892	2.67	2406	940	2.92	2633	987	3.21	2904	1022	3.41	3098	1062	3.66	3309
4700	858	2.55	2300	907	2.83	2551	954	3.08	2782	1002	3.38	3068	1034	3.58	3258	1074	3.83	3463
4800	874	2.70	2433	922	2.99	2698	968	3.24	2933	1005	3.56	3244	1046	3.75	3423	1085	4.00	3621
4900	890	2.86	2578	938	3.16	2857	982	3.42	3096	1008	3.75	3421	1058	3.93	3593	1097	4.18	3784
5000	906	3.03	2735	953	3.33	3020	996	3.59	3259	1021	3.94	3606	1070	4.11	3768	1108	4.36	3950

48TM012 (10 TONS) — STANDARD MOTOR AND ALTERNATE MOTOR* (cont)						
Airflow (Cfm)	External Static Pressure (in. wg)					
	1.4			1.6		
	Rpm	Bhp	Watts	Rpm	Bhp	Watts
3000	924	1.73	1534	970	1.89	1736
3100	935	1.84	1695	977	2.00	1828
3200	946	1.95	1786	987	2.11	1920
3300	957	2.06	1878	998	2.23	2022
3400	967	2.17	1971	1009	2.35	2125
3500	976	2.29	2074	1020	2.48	2238
3600	986	2.41	2177	1030	2.61	2353
3700	998	2.54	2291	1039	2.74	2469
3800	1010	2.67	2406	1049	2.87	2587
3900	1022	2.81	2533	1060	3.02	2726
4000	1034	2.96	2670	1072	3.17	2866
4100	1046	3.11	2810	1084	3.32	3010
4200	1058	3.26	2952	1092	3.47	3154
4300	1067	3.42	3080	1103	3.63	3307
4400	1078	3.58	3225	1113	3.79	3465
4500	1089	3.75	3373	1123	3.96	3629
4600	1100	3.92	3526	1134	4.13	3798
4700	1111	4.10	3683	1144	4.31	3972
4800	1122	4.28	3843	1155	4.49	4152
4900	1133	4.47	4008	1165	4.67	4337
5000	1144	4.66	4177	1175	4.86	4528

LEGEND

- Bhp** — Brake Horsepower Input to Fan
- FIOP** — Factory-Installed Option
- Watts** — Input Watts to Motor

\*Standard drive range is 685 to 935 rpm. Alternate motor drive range is 835 to 1085 rpm. All other rpms require a field-supplied drive. Refer to page 87 for general Fan Performance Data notes.

NOTES:

1. **Boldface** indicates field-supplied drive is required.
2.  indicates high-static motor and drive are required. See high-static data on next page.
3. **Boldface** indicates field-supplied motor and drive are required.
4. Maximum continuous bhp is 2.4 for the standard motor, and 2.9 for the alternate motor. Maximum continuous watts are 2120 for the standard motor, and 2615 for the alternate motor.

# Performance data (cont)



## FAN PERFORMANCE — VERTICAL DISCHARGE UNITS (cont)

48TM004-014

### 48TM012 (10 TONS) — HIGH-STATIC MOTOR\*

Airflow (Cfm)	External Static Pressure (in. wg)																	
	0.2			0.4			0.6			0.8			1.0			1.2		
	Rpm	Bhp	Watts	Rpm	Bhp	Watts	Rpm	Bhp	Watts	Rpm	Bhp	Watts	Rpm	Bhp	Watts	Rpm	Bhp	Watts
3000	592	0.76	723	661	0.93	859	722	1.09	989	779	1.26	1131	829	1.42	1267	880	1.58	1404
3100	607	0.83	779	676	1.01	924	734	1.17	1056	791	1.34	1199	840	1.51	1344	890	1.68	1491
3200	622	0.90	835	690	1.09	989	746	1.25	1123	803	1.43	1275	852	1.60	1422	900	1.77	1569
3300	638	0.98	899	705	1.17	1056	759	1.33	1190	815	1.52	1353	864	1.70	1508	910	1.88	1665
3400	653	1.06	965	719	1.26	1131	772	1.43	1275	826	1.62	1439	876	1.81	1604	921	1.98	1753
3500	669	1.15	1039	733	1.35	1207	786	1.53	1361	838	1.72	1526	888	1.91	1691	933	2.10	1858
3600	684	1.24	1114	747	1.44	1284	800	1.64	1456	850	1.82	1613	900	2.03	1796	945	2.22	2014
3700	700	1.33	1190	760	1.54	1370	814	1.75	1552	863	1.92	1700	912	2.14	1892	957	2.34	2117
3800	715	1.43	1275	774	1.64	1456	828	1.86	1648	875	2.04	1805	924	2.26	1997	969	2.47	2230
3900	731	1.54	1370	787	1.74	1543	843	1.98	1753	888	2.16	1910	936	2.38	2151	981	2.60	2344
4000	747	1.64	1456	801	1.85	1639	857	2.10	1858	902	2.30	2032	948	2.51	2265	993	2.74	2469
4100	763	1.76	1560	816	1.97	1744	872	2.23	1971	916	2.44	2203	960	2.64	2380	1005	2.88	2596
4200	778	1.88	1665	831	2.10	1884	886	2.36	2084	929	2.58	2326	972	2.78	2505	1016	3.03	2735
4300	794	2.00	1770	846	2.23	1971	900	2.50	2256	943	2.73	2460	985	2.93	2642	1028	3.17	2866
4400	810	2.13	1884	861	2.37	2093	913	2.64	2380	958	2.89	2605	999	3.09	2791	1040	3.32	3010
4500	826	2.27	2006	876	2.52	2273	927	2.78	2505	973	3.04	2744	1012	3.26	2952	1051	3.50	3159
4600	842	2.41	2177	892	2.67	2406	940	2.92	2633	987	3.21	2904	1022	3.41	3098	1062	3.66	3309
4700	858	2.55	2300	907	2.83	2551	954	3.08	2782	1002	3.38	3068	1034	3.58	3258	1074	3.83	3463
4800	874	2.70	2433	922	2.99	2698	968	3.24	2933	1005	3.56	3244	1046	3.75	3423	1085	4.00	3621
4900	890	2.86	2578	938	3.16	2857	982	3.42	3096	1008	3.75	3421	1058	3.93	3593	1097	4.18	3784
5000	906	3.03	2735	953	3.33	3020	996	3.59	3259	1021	3.94	3606	1070	4.11	3768	1108	4.36	3950

### 48TM012 (10 TONS) — HIGH-STATIC MOTOR\* (cont)

Airflow (Cfm)	External Static Pressure (in. wg)											
	1.4			1.6			1.8			2.0		
	Rpm	Bhp	Watts	Rpm	Bhp	Watts	Rpm	Bhp	Watts	Rpm	Bhp	Watts
3000	924	1.73	1534	970	1.89	1736	1019	2.00	1828	1066	2.30	2082
3100	935	1.84	1695	977	2.00	1828	1026	2.17	1971	1070	2.44	2203
3200	946	1.95	1786	987	2.11	1920	1029	2.28	2065	1075	2.51	2265
3300	957	2.06	1878	998	2.23	2022	1037	2.40	2169	1082	2.58	2326
3400	967	2.17	1971	1009	2.35	2125	1047	2.53	2282	1087	2.70	2433
3500	976	2.29	2074	1020	2.48	2238	1058	2.66	2397	1095	2.84	2560
3600	986	2.41	2177	1030	2.61	2353	1069	2.80	2523	1106	2.98	2688
3700	998	2.54	2291	1039	2.74	2469	1081	2.94	2651	1117	3.13	2829
3800	1010	2.67	2406	1049	2.87	2587	1091	3.08	2782	1128	3.29	2981
3900	1022	2.81	2533	1060	3.02	2726	1100	3.23	2923	1130	3.46	3143
4000	1034	2.93	2670	1072	3.17	2866	1110	3.38	3068	<b>1138</b>	<b>3.65</b>	<b>3320</b>
4100	1046	3.11	2810	1084	3.32	3010	1118	3.52	3208	<b>1146</b>	<b>3.84</b>	<b>3508</b>
4200	1058	3.26	2952	1092	3.47	3154	1127	3.68	3357	<b>1154</b>	<b>4.05</b>	<b>3709</b>
4300	1067	3.42	3080	1103	3.63	3307	<b>1137</b>	<b>3.83</b>	<b>3510</b>	<b>1161</b>	<b>4.27</b>	<b>3922</b>
4400	1078	3.58	3225	1113	3.79	3465	<b>1146</b>	<b>3.99</b>	<b>3668</b>	<b>1169</b>	<b>4.51</b>	<b>4147</b>
4500	1089	3.75	3373	1123	3.96	3629	<b>1156</b>	<b>4.15</b>	<b>3830</b>	<b>1177</b>	<b>4.75</b>	<b>4385</b>
4600	1100	3.92	3526	<b>1134</b>	<b>4.13</b>	<b>3798</b>	<b>1165</b>	<b>4.31</b>	<b>3996</b>	1185	5.01	4635
4700	1111	4.10	3683	<b>1144</b>	<b>4.31</b>	<b>3972</b>	<b>1175</b>	<b>4.48</b>	<b>4166</b>	1192	5.28	4896
4800	1122	4.28	3843	<b>1155</b>	<b>4.49</b>	<b>4152</b>	<b>1184</b>	<b>4.64</b>	<b>4341</b>	1200	5.56	5171
4900	<b>1133</b>	<b>4.47</b>	<b>4008</b>	<b>1165</b>	<b>4.67</b>	<b>4337</b>	1194	4.81	4519	1208	5.85	5457
5000	<b>1144</b>	<b>4.66</b>	<b>4177</b>	1175	4.86	4528	1203	4.99	4702	1215	6.15	5755

#### LEGEND

- Bhp** — Brake Horsepower Input to Fan
- FIOP** — Factory-Installed Option
- Watts** — Input Watts to Motor

\*High-static motor drive range is 830 to 1130 rpm. All other rpms require a field-supplied drive.

Refer to page 87 for general Fan Performance Data notes.

#### NOTES:

1. **Boldface** indicates field-supplied drive is required.
2. **Shaded** indicates field-supplied motor and drive are required.
3. Maximum continuous bhp is 5.25 for the high-static motor. Maximum continuous watts are 4400 for the high-static motor.



FAN PERFORMANCE — VERTICAL DISCHARGE UNITS (cont)

48TM004-014

48TM014 (12½ TONS) — STANDARD MOTOR AND ALTERNATE MOTOR (BELT DRIVE)*																		
Airflow (Cfm)	External Static Pressure (in. wg)																	
	0.2			0.4			0.6			0.8			1.0			1.2		
	Rpm	Bhp	Watts	Rpm	Bhp	Watts	Rpm	Bhp	Watts	Rpm	Bhp	Watts	Rpm	Bhp	Watts	Rpm	Bhp	Watts
3750	737	1.41	1300	798	1.64	1486	854	1.84	1658	909	2.12	1893	961	2.35	2097	1014	2.61	2325
3800	745	1.46	1340	805	1.69	1531	861	1.89	1700	915	2.17	1940	967	2.41	2149	1019	2.67	2378
3900	761	1.56	1423	820	1.80	1624	875	2.01	1802	928	2.29	2044	979	2.55	2272	1029	2.80	2494
4000	777	1.67	1514	836	1.92	1725	889	2.14	1914	941	2.40	2140	991	2.68	2387	1040	2.94	2620
4100	793	1.79	1615	851	2.05	1836	904	2.27	2027	955	2.52	2246	1004	2.82	2512	1052	3.08	2746
4200	810	1.91	1717	867	2.18	1948	918	2.41	2149	968	2.65	2361	1017	2.96	2638	1064	3.23	2882
4300	826	2.04	1828	883	2.32	2070	933	2.55	2272	982	2.79	2485	1030	3.11	2773	1076	3.40	3037
4400	842	2.17	1940	898	2.46	2193	948	2.70	2405	996	2.93	2611	1043	3.25	2901	1088	3.56	3184
4500	859	2.31	2061	914	2.60	2316	962	2.85	2539	1010	3.09	2755	1056	3.40	3037	<b>1101</b>	<b>3.73</b>	<b>3341</b>
4600	876	2.45	2184	930	2.76	2459	977	3.01	2683	1024	3.26	2910	1070	3.55	3175	<b>1114</b>	<b>3.90</b>	<b>3498</b>
4700	892	2.60	2316	945	2.91	2593	992	3.18	2837	1039	3.43	3065	<b>1083</b>	<b>3.71</b>	<b>3322</b>	<b>1126</b>	<b>4.07</b>	<b>3655</b>
4800	909	2.76	2468	961	3.07	2737	1008	3.36	3001	1053	3.61	3230	<b>1097</b>	<b>3.88</b>	<b>3479</b>	<b>1140</b>	<b>4.25</b>	<b>3822</b>
4900	926	2.93	2611	977	3.24	2891	1024	3.54	3166	<b>1068</b>	<b>3.80</b>	<b>3405</b>	<b>1111</b>	<b>4.06</b>	<b>3646</b>	<b>1153</b>	<b>4.41</b>	<b>3971</b>
5000	942	3.11	2773	993	3.41	3047	<b>1039</b>	<b>3.73</b>	<b>3341</b>	<b>1080</b>	<b>3.99</b>	<b>3581</b>	<b>1125</b>	<b>4.25</b>	<b>3822</b>	<b>1166</b>	<b>4.59</b>	<b>4139</b>
5100	959	3.29	2937	1009	3.60	3221	<b>1055</b>	<b>3.92</b>	<b>3516</b>	<b>1097</b>	<b>4.19</b>	<b>3767</b>	<b>1139</b>	<b>4.46</b>	<b>4018</b>	<b>1180</b>	<b>4.78</b>	<b>4316</b>
5200	976	3.47	3101	<b>1025</b>	<b>3.78</b>	<b>3387</b>	<b>1071</b>	<b>4.12</b>	<b>3702</b>	<b>1112</b>	<b>4.40</b>	<b>3962</b>	<b>1153</b>	<b>4.67</b>	<b>4214</b>	<b>1194</b>	<b>4.98</b>	<b>4503</b>
5300	993	3.67	3285	<b>1041</b>	<b>3.98</b>	<b>3572</b>	<b>1086</b>	<b>4.33</b>	<b>3897</b>	<b>1127</b>	<b>4.61</b>	<b>4158</b>	<b>1168</b>	<b>4.90</b>	<b>4428</b>	<b>1208</b>	<b>5.19</b>	<b>4698</b>
5400	<b>1010</b>	<b>3.87</b>	<b>3470</b>	<b>1057</b>	<b>4.18</b>	<b>3757</b>	<b>1102</b>	<b>4.54</b>	<b>4093</b>	<b>1142</b>	<b>4.84</b>	<b>4372</b>	<b>1182</b>	<b>5.13</b>	<b>4642</b>	—	—	—
5500	<b>1027</b>	<b>4.07</b>	<b>3655</b>	<b>1073</b>	<b>4.39</b>	<b>3953</b>	<b>1118</b>	<b>4.76</b>	<b>4298</b>	<b>1157</b>	<b>5.07</b>	<b>4586</b>	—	—	—	—	—	—
5600	<b>1043</b>	<b>4.29</b>	<b>3860</b>	<b>1090</b>	<b>4.61</b>	<b>4158</b>	<b>1133</b>	<b>4.99</b>	<b>4512</b>	—	—	—	—	—	—	—	—	—
5700	<b>1060</b>	<b>4.51</b>	<b>4065</b>	<b>1106</b>	<b>4.83</b>	<b>4363</b>	<b>1149</b>	<b>5.22</b>	<b>4726</b>	—	—	—	—	—	—	—	—	—
5800	<b>1077</b>	<b>4.74</b>	<b>4279</b>	<b>1122</b>	<b>5.07</b>	<b>4586</b>	—	—	—	—	—	—	—	—	—	—	—	—
5900	<b>1094</b>	<b>4.98</b>	<b>4503</b>	—	—	—	—	—	—	—	—	—	—	—	—	—	—	—
6000	<b>1111</b>	<b>5.22</b>	<b>4726</b>	—	—	—	—	—	—	—	—	—	—	—	—	—	—	—
6100	—	—	—	—	—	—	—	—	—	—	—	—	—	—	—	—	—	—
6250	—	—	—	—	—	—	—	—	—	—	—	—	—	—	—	—	—	—

48TM014 (12½ TONS) — STANDARD MOTOR AND ALTERNATE MOTOR (BELT DRIVE)\* (cont)

Airflow (Cfm)	External Static Pressure (in. wg)											
	1.4			1.6			1.8			2.0		
	Rpm	Bhp	Watts	Rpm	Bhp	Watts	Rpm	Bhp	Watts	Rpm	Bhp	Watts
3750	1065	2.87	2557	1113	3.12	2783	1158	3.36	2997	1197	3.56	3180
3800	1070	2.94	2620	1118	3.19	2846	1163	3.44	3074	1203	3.65	3267
3900	1079	3.07	2737	1128	3.34	2983	1173	3.60	3221	<b>1214</b>	<b>3.83</b>	<b>3433</b>
4000	1089	3.22	2873	1137	3.49	3120	<b>1183</b>	<b>3.76</b>	<b>3368</b>	<b>1225</b>	<b>4.00</b>	<b>3590</b>
4100	1100	3.36	3001	1147	3.65	3267	<b>1193</b>	<b>3.93</b>	<b>3525</b>	<b>1236</b>	<b>4.19</b>	<b>3767</b>
4200	1110	3.51	3138	<b>1157</b>	<b>3.81</b>	<b>3414</b>	<b>1202</b>	<b>4.09</b>	<b>3674</b>	<b>1245</b>	<b>4.38</b>	<b>3943</b>
4300	1121	3.67	3285	<b>1167</b>	<b>3.97</b>	<b>3562</b>	<b>1212</b>	<b>4.27</b>	<b>3841</b>	<b>1255</b>	<b>4.56</b>	<b>4111</b>
4400	<b>1133</b>	<b>3.84</b>	<b>3442</b>	<b>1178</b>	<b>4.14</b>	<b>3720</b>	<b>1222</b>	<b>4.44</b>	<b>3999</b>	<b>1265</b>	<b>4.74</b>	<b>4279</b>
4500	<b>1144</b>	<b>4.00</b>	<b>3590</b>	<b>1188</b>	<b>4.31</b>	<b>3878</b>	<b>1232</b>	<b>4.62</b>	<b>4167</b>	<b>1274</b>	<b>4.93</b>	<b>4456</b>
4600	<b>1157</b>	<b>4.19</b>	<b>3767</b>	<b>1199</b>	<b>4.49</b>	<b>4046</b>	<b>1242</b>	<b>4.81</b>	<b>4344</b>	<b>1284</b>	<b>5.13</b>	<b>4642</b>
4700	<b>1169</b>	<b>4.38</b>	<b>3943</b>	<b>1210</b>	<b>4.68</b>	<b>4223</b>	<b>1252</b>	<b>5.00</b>	<b>4521</b>	—	—	—
4800	<b>1181</b>	<b>4.58</b>	<b>4130</b>	<b>1222</b>	<b>4.87</b>	<b>4400</b>	<b>1263</b>	<b>5.20</b>	<b>4707</b>	—	—	—
4900	<b>1194</b>	<b>4.77</b>	<b>4307</b>	<b>1234</b>	<b>5.09</b>	<b>4605</b>	—	—	—	—	—	—
5000	<b>1207</b>	<b>4.97</b>	<b>4493</b>	—	—	—	—	—	—	—	—	—
5100	<b>1220</b>	<b>5.18</b>	<b>4689</b>	—	—	—	—	—	—	—	—	—
5200	—	—	—	—	—	—	—	—	—	—	—	—
5300	—	—	—	—	—	—	—	—	—	—	—	—
5400	—	—	—	—	—	—	—	—	—	—	—	—
5500	—	—	—	—	—	—	—	—	—	—	—	—
5600	—	—	—	—	—	—	—	—	—	—	—	—
5700	—	—	—	—	—	—	—	—	—	—	—	—
5800	—	—	—	—	—	—	—	—	—	—	—	—
5900	—	—	—	—	—	—	—	—	—	—	—	—
6000	—	—	—	—	—	—	—	—	—	—	—	—
6100	—	—	—	—	—	—	—	—	—	—	—	—
6250	—	—	—	—	—	—	—	—	—	—	—	—

LEGEND

- Bhp** — Brake Horsepower Input to Fan
- FIOP** — Factory-Installed Option
- Watts** — Input Watts to Motor

\*Standard drive range is 860 to 1080 rpm. Alternate motor drive range is 900 to 1260 rpm. All other rpms require a field-supplied drive.

Refer to page 87 for general Fan Performance Data notes.

NOTES:

1. **Boldface** indicates alternate motor and drive are required.
2.  indicates field-supplied motor and drive are required.
3. Maximum continuous bhp is 3.70 for the standard motor and 5.25 for the alternate motor. Maximum continuous watts are 3313 for the standard motor and 4400 for the alternate motor.

# Performance data (cont)



## FAN PERFORMANCE — HORIZONTAL DISCHARGE UNITS

48TM004-014

### 48TM004 (3 TONS) — STANDARD MOTOR (DIRECT DRIVE)

Airflow (Cfm)	Low Speed						High Speed					
	208 V			230, 460, 575 V			208 V			230, 460, 575 V		
	ESP	Bhp	Watts	ESP	Bhp	Watts	ESP	Bhp	Watts	ESP	Bhp	Watts
900	0.54	0.21	253	0.57	0.23	277	0.55	0.26	307	0.60	0.31	363
1000	0.49	0.23	270	0.51	0.25	292	0.52	0.27	321	0.53	0.32	374
1100	0.43	0.24	287	0.45	0.26	307	0.46	0.28	335	0.49	0.33	385
1200	0.39	0.26	304	0.40	0.27	323	0.38	0.29	349	0.43	0.34	397
1300	0.33	0.27	321	0.35	0.29	338	0.35	0.31	364	0.36	0.34	408
1400	0.26	0.29	338	0.28	0.30	354	0.29	0.32	378	—	—	—
1500	0.21	0.30	355	0.23	0.31	369	0.24	0.33	392	—	—	—

LEGEND

Refer to page 87 for general Fan Performance Data notes.

- Bhp** — Brake Horsepower Input to Fan
- ESP** — External Static Pressure (in. wg)
- FIOP** — Factory-Installed Option

### 48TM004 (3 TONS) — ALTERNATE MOTOR (BELT DRIVE)\*

Airflow (Cfm)	External Static Pressure (in. wg)																	
	0.1			0.2			0.3			0.4			0.5			0.6		
	Rpm	Bhp	Watts	Rpm	Bhp	Watts	Rpm	Bhp	Watts	Rpm	Bhp	Watts	Rpm	Bhp	Watts	Rpm	Bhp	Watts
900	526	0.06	70	584	0.08	99	656	0.12	139	734	0.22	219	818	0.25	269	875	0.27	269
1000	570	0.09	109	627	0.13	149	738	0.19	189	800	0.26	259	848	0.29	288	895	0.31	308
1100	614	0.13	149	670	0.16	189	758	0.23	229	812	0.29	288	863	0.32	308	914	0.35	348
1200	658	0.16	189	710	0.23	229	780	0.28	279	840	0.32	318	889	0.36	358	938	0.40	398
1300	703	0.20	239	752	0.27	269	808	0.32	318	868	0.37	368	916	0.41	408	963	0.45	448
1400	725	0.29	288	776	0.31	308	845	0.38	378	891	0.42	418	937	0.47	467	983	0.51	507
1500	755	0.33	328	816	0.38	378	870	0.43	428	924	0.48	477	969	0.53	527	1014	0.58	577

### 48TM004 (3 TONS) — ALTERNATE MOTOR (BELT DRIVE)\* (cont)

Airflow (Cfm)	External Static Pressure (in. wg)																	
	0.7			0.8			0.9			1.0			1.1			1.2		
	Rpm	Bhp	Watts	Rpm	Bhp	Watts	Rpm	Bhp	Watts	Rpm	Bhp	Watts	Rpm	Bhp	Watts	Rpm	Bhp	Watts
900	924	0.32	308	953	0.35	348	989	0.38	388	1028	0.42	438	1074	0.45	487	1120	0.50	537
1000	936	0.35	348	977	0.39	388	1020	0.44	438	1064	0.48	477	1124	0.52	537	1185	0.55	597
1100	960	0.39	388	1005	0.43	428	1052	0.49	487	1100	0.52	527	1163	0.56	587	1225	0.60	647
1200	988	0.45	448	1038	0.50	497	1076	0.53	527	1136	0.59	577	1201	0.61	647	1266	0.64	716
1300	1012	0.51	507	1061	0.56	557	1094	0.61	607	1172	0.65	647	1239	0.69	716	1306	0.72	786
1400	1027	0.56	557	1071	0.60	597	1108	0.67	666	1208	0.70	706	1278	0.75	786	1347	0.79	865
1500	1056	0.63	627	1097	0.68	676	1117	0.70	696	1245	0.74	776	1315	0.80	865	1385	0.85	955

LEGEND

Refer to page 87 for general Fan Performance Data notes.

- Bhp** — Brake Horsepower Input to Fan
- FIOP** — Factory-Installed Option
- Watts** — Input Watts to Motor

NOTES:

1. **Boldface** indicates field-supplied drive is required.
2. Maximum continuous bhp is 1.20 and maximum continuous watts are 1000.

\*Motor drive range is 760 to 1000 rpm. All other rpms require a field-supplied drive.

### 48TM004 (3 TONS) — HIGH-STATIC MOTOR (BELT DRIVE)\*

Airflow (Cfm)	External Static Pressure (in. wg)														
	0.2			0.4			0.6			0.8			1.0		
	Rpm	Bhp	Watts	Rpm	Bhp	Watts	Rpm	Bhp	Watts	Rpm	Bhp	Watts	Rpm	Bhp	Watts
900	584	0.08	99	734	0.22	219	875	0.27	269	953	0.36	348	1028	0.42	438
1000	627	0.13	149	800	0.26	259	895	0.31	308	977	0.39	388	1064	0.48	477
1100	670	0.16	189	812	0.29	288	914	0.35	348	1005	0.43	428	1100	0.52	527
1200	710	0.23	229	840	0.32	318	938	0.40	398	1038	0.50	497	1136	0.59	577
1300	752	0.27	269	868	0.37	368	963	0.45	448	1061	0.56	557	1172	0.65	647
1400	776	0.31	308	891	0.42	418	983	0.51	507	1071	0.60	597	1208	0.70	706
1500	816	0.38	378	924	0.48	477	1014	0.58	577	1097	0.68	676	1245	0.74	776

### 48TM004 (3 TONS) — HIGH-STATIC MOTOR (BELT DRIVE)\* (cont)

Airflow (Cfm)	External Static Pressure (in. wg)														
	1.2			1.4			1.6			1.8			2.0		
	Rpm	Bhp	Watts	Rpm	Bhp	Watts	Rpm	Bhp	Watts	Rpm	Bhp	Watts	Rpm	Bhp	Watts
900	1120	0.54	537	1155	0.59	589	1186	0.64	639	1215	0.69	685	1240	0.73	730
1000	1185	0.60	597	1222	0.66	655	1255	0.71	709	1285	0.77	761	1312	0.82	811
1100	1225	0.65	647	1263	0.71	709	1298	0.77	769	1328	0.83	825	1357	0.88	879
1200	1266	0.72	716	1306	0.79	786	1341	0.86	851	1373	0.92	914	1402	0.98	973
1300	1306	0.79	786	1347	0.87	862	1383	0.94	934	1416	1.01	1003	1446	1.07	1068
1400	1347	0.87	865	1389	0.95	950	1427	1.03	1029	1461	1.11	1104	1492	1.18	1176
1500	1385	0.96	955	1428	1.05	1048	1467	1.14	1135	1502	1.22	1218	1534	1.30	1298

LEGEND

Refer to page 87 for general Fan Performance Data notes.

- Bhp** — Brake Horsepower Input to Fan
- FIOP** — Factory-Installed Option
- Watts** — Input Watts to Motor

NOTES:

1. **Boldface** indicates field-supplied drive is required.
2. Maximum continuous bhp is 2.4 and maximum continuous watts are 2120.

\*Motor drive range is 1075 to 1455 rpm. All other rpms require a field-supplied drive.



## FAN PERFORMANCE — HORIZONTAL DISCHARGE UNITS (cont)

48TM004-014

### 48TM005 (4 TONS) — STANDARD MOTOR (DIRECT DRIVE)

Airflow (Cfm)	Low Speed						High Speed					
	208 V			230, 460, 575 V			208 V			230, 460, 575 V		
	ESP	Bhp	Watts	ESP	Bhp	Watts	ESP	Bhp	Watts	ESP	Bhp	Watts
1200	0.75	0.41	458	0.81	0.45	506	0.87	0.51	572	0.92	0.56	632
1300	0.68	0.42	471	0.74	0.46	521	0.79	0.52	589	0.85	0.58	651
1400	0.60	0.45	503	0.66	0.49	556	0.71	0.54	616	0.77	0.60	681
1500	0.51	0.47	536	0.58	0.52	593	0.64	0.56	631	0.70	0.62	698
1600	0.42	0.49	557	0.49	0.54	616	0.56	0.58	654	0.63	0.64	723
1700	0.32	0.52	584	0.39	0.57	646	0.48	0.60	678	0.55	0.66	750
1800	0.21	0.54	610	0.29	0.60	674	0.41	0.62	698	0.48	0.68	772
1900	0.09	0.56	629	0.18	0.62	696	0.33	0.64	720	0.41	0.70	796
2000	—	—	—	0.06	0.65	731	0.26	0.66	744	0.33	0.73	823

LEGEND

Refer to page 87 for general Fan Performance Data notes.

- Bhp — Brake Horsepower Input to Fan  
 ESP — External Static Pressure (in. wg)  
 FIOP — Factory-Installed Option

### 48TM005 (4 TONS) — ALTERNATE MOTOR (BELT DRIVE)\*

Airflow (Cfm)	External Static Pressure (in. wg)																				
	0.1			0.2			0.3			0.4			0.6			0.7			0.8		
	Rpm	Bhp	Watts	Rpm	Bhp	Watts	Rpm	Bhp	Watts	Rpm	Bhp	Watts	Rpm	Bhp	Watts	Rpm	Bhp	Watts	Rpm	Bhp	Watts
1200	569	0.18	189	641	0.23	242	701	0.29	299	761	0.34	357	859	0.46	483	901	0.52	546	943	0.58	609
1300	604	0.22	231	673	0.28	294	731	0.34	352	788	0.39	410	887	0.52	546	928	0.59	615	968	0.65	683
1400	640	0.27	284	705	0.33	347	761	0.39	410	817	0.45	473	914	0.59	620	955	0.66	688	996	0.72	757
1500	676	0.32	336	738	0.38	399	793	0.45	468	847	0.51	536	940	0.65	683	982	0.73	767	1024	0.81	851
1600	713	0.38	399	772	0.44	462	825	0.51	536	877	0.58	609	967	0.73	767	1009	0.81	851	1051	0.89	935
1700	750	0.45	473	806	0.51	536	857	0.59	615	908	0.66	693	997	0.81	851	1037	0.90	940	1077	1.01	1030
1800	788	0.52	546	841	0.59	620	890	0.67	704	939	0.75	788	1026	0.91	956	1065	1.01	1040	1104	1.07	1124
1900	826	0.60	630	876	0.68	714	924	0.76	799	971	0.84	883	1056	1.01	1061	1094	1.10	1151	1132	1.18	1240
2000	864	0.70	735	912	0.77	809	958	0.86	898	1004	0.94	988	1087	1.12	1177	1125	1.21	1271	1162	1.30	1366

### 48TM005 (4 TONS) — ALTERNATE MOTOR (BELT DRIVE)\* (cont)

Airflow (Cfm)	External Static Pressure (in. wg)																				
	0.9			1.0			1.1			1.2			1.4			1.6			1.8		
	Rpm	Bhp	Watts	Rpm	Bhp	Watts	Rpm	Bhp	Watts	Rpm	Bhp	Watts	Rpm	Bhp	Watts	Rpm	Bhp	Watts	Rpm	Bhp	Watts
1200	987	0.64	652	1030	0.70	695	1068	0.79	792	1106	0.87	889	1134	0.98	998	1189	1.12	1138	1245	1.21	1358
1300	1006	0.71	709	1044	0.77	736	1086	0.84	833	1128	0.91	930	1183	1.10	1052	1226	1.23	1215	1297	1.35	1406
1400	1033	0.79	797	1069	0.86	838	1104	0.93	925	1139	1.01	1012	1218	1.14	1090	1286	1.34	1282	1320	1.48	1463
1500	1060	0.88	891	1095	0.95	930	1129	1.02	1022	1162	1.09	1114	1228	1.24	1186	1303	1.40	1339	1343	1.60	1530
1600	1087	1.01	1001	1123	1.05	1073	1156	1.13	1150	1185	1.20	1226	1250	1.35	1291	1319	1.51	1444	1382	1.68	1607
1700	1114	1.07	1108	1151	1.15	1185	1183	1.23	1262	1215	1.31	1339	1276	1.48	1415	1334	1.64	1569	1398	1.80	1722
1800	1141	1.17	1221	1178	1.26	1318	1211	1.35	1390	1243	1.43	1461	1303	1.61	1540	1359	1.78	1702	1418	1.95	1865
1900	1168	1.28	1371	1204	1.37	1502	1238	1.47	1548	1271	1.56	1594	1330	1.74	1664	1386	1.93	1846	1439	2.11	2018
2000	1197	1.39	1485	1231	1.48	1604	1265	1.59	1666	1298	1.69	1727	1358	1.89	1808	1413	2.08	1989	1466	2.27	2171

LEGEND

Refer to page 87 for general Fan Performance Data notes.

- Bhp — Brake Horsepower Input to Fan  
 FIOP — Factory-Installed Option  
 Watts — Input Watts to Motor

NOTES:

- Boldface** indicates field-supplied drive is required.
- Grey background** indicates field-supplied motor and drive are required.
- Maximum continuous bhp is 1.20 and the maximum continuous watts are 1000.

\*Motor drive range is 835 to 1185 rpm. All other rpms require a field-supplied drive.

### 48TM005 (4 TONS) — HIGH-STATIC MOTOR (BELT DRIVE)\*

Airflow (Cfm)	External Static Pressure (in. wg)														
	0.2			0.4			0.6			0.8			1.0		
	Rpm	Bhp	Watts	Rpm	Bhp	Watts	Rpm	Bhp	Watts	Rpm	Bhp	Watts	Rpm	Bhp	Watts
1200	641	0.23	242	761	0.34	357	859	0.46	483	943	0.58	609	1030	0.70	695
1300	673	0.28	294	788	0.39	410	887	0.52	546	968	0.65	683	1044	0.77	736
1400	705	0.33	347	817	0.45	473	914	0.59	620	996	0.72	757	1069	0.86	838
1500	738	0.38	399	847	0.51	536	940	0.65	683	1024	0.81	851	1095	0.95	930
1600	772	0.44	462	877	0.58	609	967	0.73	767	1051	0.89	935	1123	1.05	1073
1700	806	0.51	536	908	0.66	693	997	0.81	851	1077	1.01	1030	1151	1.15	1185
1800	841	0.59	620	939	0.75	789	1026	0.91	956	1104	1.07	1124	1178	1.26	1318
1900	876	0.68	714	971	0.84	883	1056	1.01	1061	1132	1.18	1240	1204	1.37	1502
2000	912	0.77	809	1004	0.94	988	1087	1.12	1177	1162	1.30	1366	1231	1.48	1604

### 48TM005 (4 TONS) — HIGH-STATIC MOTOR (BELT DRIVE)\* (cont)

Airflow (Cfm)	External Static Pressure (in. wg)														
	1.2			1.4			1.6			1.8			2.0		
	Rpm	Bhp	Watts	Rpm	Bhp	Watts	Rpm	Bhp	Watts	Rpm	Bhp	Watts	Rpm	Bhp	Watts
1200	1106	0.87	889	1134	0.98	998	1189	1.12	1138	1245	1.21	1358	1292	1.35	1345
1300	1128	0.91	930	1183	1.10	1052	1226	1.23	1215	1297	1.35	1406	1346	1.51	1500
1400	1139	1.01	1012	1218	1.14	1090	1286	1.34	1282	1320	1.48	1463	1370	1.65	1645
1500	1162	1.09	1114	1228	1.24	1186	1303	1.40	1339	1343	1.60	1530	1393	1.79	1778
1600	1185	1.20	1226	1250	1.35	1291	1319	1.51	1444	1382	1.68	1607	1434	1.88	1867
1700	1215	1.31	1339	1276	1.48	1415	1334	1.64	1569	1389	1.80	1722	1451	2.01	2001
1800	1243	1.43	1461	1303	1.61	1540	1359	1.78	1702	1418	1.95	1865	1471	2.18	2167
1900	1271	1.56	1594	1330	1.74	1664	1386	1.93	1846	1439	2.11	2018	1493	2.36	2345
2000	1298	1.69	1727	1358	1.89	1808	1413	2.08	1989	1468	2.27	2171	—	—	—

LEGEND

Refer to page 87 for general Fan Performance Data notes.

- Bhp — Brake Horsepower Input to Fan  
 FIOP — Factory-Installed Option  
 Watts — Input Watts to Motor

NOTES:

- Boldface** indicates field-supplied drive is required.
- Maximum continuous bhp is 2.4 and maximum continuous watts are 2120.

\*Motor drive range is 1075 to 1455 rpm. All other rpms require a field-supplied drive.

# Performance data (cont)



## FAN PERFORMANCE — HORIZONTAL DISCHARGE UNITS (cont)

48TM004-014

48TM006 (5 TONS) — STANDARD MOTOR (DIRECT DRIVE)																		
Airflow (Cfm)	Low Speed						Medium Speed						High Speed					
	208V			230, 460, 575 V			208 V			230, 460, 575 V			208 V			230, 460, 575 V		
	ESP	Bhp	Watts	ESP	Bhp	Watts	ESP	Bhp	Watts	ESP	Bhp	Watts	ESP	Bhp	Watts	ESP	Bhp	Watts
1500	0.74	0.67	750	1.06	0.71	791	1.07	0.70	782	1.27	0.76	845	1.26	0.79	875	1.33	0.85	949
1600	0.54	0.70	780	0.90	0.74	824	0.92	0.74	821	1.13	0.79	883	1.14	0.82	913	1.22	0.89	988
1700	0.34	0.73	810	0.75	0.77	857	0.77	0.77	861	1.00	0.83	921	1.01	0.85	950	1.11	0.92	1027
1800	0.14	0.75	839	0.59	0.80	891	0.62	0.81	900	0.87	0.86	959	0.89	0.88	988	1.00	0.96	1066
1900	—	—	—	0.44	0.83	924	0.47	0.84	940	0.74	0.90	997	0.77	0.92	1025	0.89	0.99	1105
2000	—	—	—	0.28	0.86	957	0.32	0.88	979	0.61	0.93	1035	0.64	0.95	1063	0.78	1.03	1144
2100	—	—	—	0.13	0.89	990	0.17	0.91	1018	0.48	0.96	1073	0.51	0.99	1101	0.67	1.06	1183
2200	—	—	—	—	—	—	0.02	0.95	1058	0.35	1.00	1111	0.39	1.02	1138	0.56	1.10	1222
2300	—	—	—	—	—	—	—	—	—	0.22	1.03	1149	0.26	1.06	1176	0.45	1.13	1261
2400	—	—	—	—	—	—	—	—	—	0.09	1.07	1187	0.14	1.09	1213	0.34	1.17	1300
2500	—	—	—	—	—	—	—	—	—	—	—	—	—	—	0.23	1.20	1340	

LEGEND

Refer to page 87 for general Fan Performance Data notes.

Bhp — Brake Horsepower Input to Fan  
 ESP — External Static Pressure (in. wg)  
 FIOP — Factory-Installed Option

48TM006 (5 TONS) — ALTERNATE MOTOR (BELT DRIVE)*																		
Airflow (Cfm)	External Static Pressure (in. wg)																	
	0.1			0.2			0.4			0.6			0.8			1.0		
	Rpm	Bhp	Watts	Rpm	Bhp	Watts	Rpm	Bhp	Watts	Rpm	Bhp	Watts	Rpm	Bhp	Watts	Rpm	Bhp	Watts
1500	730	0.34	357	789	0.40	420	896	0.53	557	990	0.67	704	1072	0.83	872	1153	1.00	1051
1600	770	0.40	420	826	0.46	483	931	0.61	641	1020	0.75	788	1101	0.91	956	1178	1.09	1145
1700	811	0.47	494	865	0.54	567	966	0.69	725	1051	0.84	883	1133	1.01	1061	1205	1.18	1240
1800	852	0.55	578	905	0.62	651	1002	0.78	820	1084	0.93	977	1163	1.10	1156	1235	1.29	1355
1900	894	0.54	567	945	0.72	757	1037	0.88	925	1119	1.04	1093	1194	1.21	1271	1266	1.40	1471
2000	936	0.74	778	984	0.82	862	1072	0.98	1030	1154	1.16	1219	1226	1.33	1397	1297	1.53	1608
2100	978	0.85	893	1024	0.93	977	1108	1.10	1156	1192	1.29	1355	1259	1.47	1545	1327	1.66	1744
2200	1021	0.97	1019	1064	1.05	1103	1145	1.22	1282	1225	1.43	1503	1294	1.62	1702	1359	1.80	1902
2300	1064	1.10	1156	1104	1.18	1240	1183	1.36	1429	1260	1.57	1650	1330	1.78	1870	1392	1.97	2070
2400	1107	1.24	1303	1145	1.32	1387	1222	1.45	1524	1296	1.73	1818	1365	1.94	2038	1426	2.15	2259
2500	1150	1.39	1460	1186	1.48	1555	1262	1.68	1765	1331	1.89	1986	1400	2.12	2227	1461	2.34	2459

LEGEND

Bhp — Brake Horsepower Input to Fan  
 FIOP — Factory-Installed Option  
 Watts — Input Watts to Motor

\*Motor drive range is 900 to 1300 rpm. All other rpms require a field-supplied drive.

Refer to page 87 for general Fan Performance Data notes.

NOTES:

- 1.** **Boldface** indicates field-supplied drive is required.
- 2.** **■** indicates field-supplied motor and drive are required.
- 3.** Maximum continuous bhp is 1.30 for single-phase units and 2.40 for 3-phase units and the maximum continuous watts are 2120.

48TM006 (5 TONS) — ALTERNATE MOTOR (BELT DRIVE)* (cont)												
Airflow (Cfm)	External Static Pressure (in. wg)											
	1.2			1.4			1.6			1.8		
	Rpm	Bhp	Watts	Rpm	Bhp	Watts	Rpm	Bhp	Watts	Rpm	Bhp	Watts
1500	1221	1.17	1229	1256	1.30	1366	1283	1.32	1387	1303	1.22	1282
1600	1252	1.27	1334	1311	1.45	1524	1340	1.58	1660	1330	1.61	1692
1700	1278	1.37	1439	1345	1.57	1650	1397	1.76	1849	1424	1.89	1986
1800	1303	1.48	1555	1371	1.69	1776	1433	1.90	1996	1480	2.09	2196
1900	1330	1.59	1671	1396	1.80	1902	1460	2.03	2133	1517	2.25	2364
2000	1362	1.73	1818	1422	1.94	2038	1485	2.16	2270	1544	2.40	2522
2100	1393	1.87	1965	1452	2.08	2185	1510	2.31	2427	1570	2.55	2674
2200	1423	2.02	2122	1483	2.24	2354	1538	2.46	2585	1594	2.71	2821
2300	1454	2.18	2291	1515	2.41	2532	1571	2.64	2758	1623	2.88	2976
2400	1485	2.36	2480	1544	2.59	2721	1604	2.84	2947	1657	3.07	3152
2500	1518	2.55	2679	1574	2.78	2905	1633	3.03	3134	1692	3.28	3345

48TM006 (5 TONS) — HIGH-STATIC MOTOR (BELT DRIVE)*																		
Airflow (Cfm)	External Static Pressure (in. wg)																	
	0.2			0.4			0.6			0.8			1.0			1.2		
	Rpm	Bhp	Watts	Rpm	Bhp	Watts	Rpm	Bhp	Watts	Rpm	Bhp	Watts	Rpm	Bhp	Watts	Rpm	Bhp	Watts
1500	789	0.40	420	896	0.53	557	990	0.67	704	1072	0.83	872	1153	1.00	1051	1221	1.17	1229
1600	826	0.46	483	931	0.61	641	1020	0.75	788	1101	0.91	956	1178	1.09	1145	1252	1.27	1334
1700	865	0.54	567	966	0.69	725	1051	0.84	883	1133	1.01	1061	1205	1.18	1240	1278	1.37	1439
1800	905	0.62	661	1002	0.78	820	1084	0.93	977	1163	1.10	1156	1235	1.29	1355	1303	1.48	1555
1900	945	0.72	757	1037	0.88	925	1119	1.04	1093	1194	1.21	1271	1266	1.40	1471	1330	1.59	1671
2000	984	0.82	862	1072	0.98	1030	1154	1.16	1219	1226	1.33	1397	1297	1.53	1608	1362	1.73	1818
2100	1024	0.93	977	1108	1.10	1156	1192	1.29	1355	1259	1.47	1545	1327	1.66	1744	1393	1.87	1965
2200	1064	1.05	1103	1145	1.22	1282	1225	1.43	1503	1294	1.62	1702	1359	1.80	1902	1423	2.02	2122
2300	1104	1.18	1240	1183	1.36	1429	1260	1.57	1650	1330	1.78	1870	1392	1.97	2070	1454	2.18	2291
2400	1145	1.32	1387	1222	1.45	1524	1296	1.73	1818	1365	1.94	2038	1426	2.15	2259	1485	2.36	2480
2500	1186	1.48	1555	1262	1.68	1765	1331	1.89	1986	1400	2.12	2227	1461	2.34	2459	1518	2.55	2679

48TM006 (5 TONS) — HIGH-STATIC MOTOR (BELT DRIVE)* (cont)												
Airflow (Cfm)	External Static Pressure (in. wg)											
	1.4			1.6			1.8			2.0		
	Rpm	Bhp	Watts	Rpm	Bhp	Watts	Rpm	Bhp	Watts	Rpm	Bhp	Watts
1500	1256	1.30	1366	1283	1.32	1387	1303	1.22	1282	1345	1.34	1390
1600	1311	1.45	1524	1340	1.58	1660	1330	1.61	1692	1373	1.77	1834
1700	1345	1.57	1650	1397	1.76	1849	1424	1.89	1986	1470	2.08	2153
1800	1371	1.69	1776	1433	1.90	1996	1480	2.09	2196	1528	2.30	2381
1900	1396	1.80	1902	1460	2.03	2133	1517	2.25	2364	1566	2.47	2563
2000	1422	1.94	2038	1485	2.16	2270	1544	2.40	2522	1594	2.64	2734
2100	1452	2.08	2185	1510	2.31	2427	1570	2.55	2674	1620	2.80	2905
2200	1483	2.24	2354	1538	2.46	2585	1594	2.71	2821	1645	2.98	3087
2300	1515	2.41	2532	1571	2.64	2758	1623	2.88	2976	1675	3.17	3280
2400	1544	2.59	2721	1604	2.84	2947	1657	3.07	3152	1710	3.38	3497
2500	1574	2.78	2905	1633	3.03	3134	1692	3.28	3345	1746	3.61	3736

LEGEND

Refer to page 87 for general Fan Performance Data notes.

Bhp — Brake Horsepower Input to Fan  
 FIOP — Factory-Installed Option  
 Watts — Input Watts to Motor

NOTES:

- 1.** **Boldface** indicates field-supplied drive is required.
- 2.** **■** indicates field-supplied motor and drive are required.
- 3.** Maximum continuous bhp is 2.9 and the maximum continuous watts are 2562.

\*Motor drive range is 1300 to 1685 rpm. All other rpms require a field-supplied drive.



FAN PERFORMANCE — HORIZONTAL DISCHARGE UNITS (cont)

48TM004-014

48TM007 (6 TONS) — STANDARD MOTOR (BELT DRIVE)\*

Airflow (Cfm)	External Static Pressure (in. wg)																	
	0.1			0.2			0.4			0.6			0.8			1.0		
	Rpm	Bhp	Watts	Rpm	Bhp	Watts	Rpm	Bhp	Watts	Rpm	Bhp	Watts	Rpm	Bhp	Watts	Rpm	Bhp	Watts
1800	885	0.63	623	942	0.73	700	1047	0.90	835	1139	1.05	956	1193	1.14	1031	1276	1.30	1165
1900	928	0.73	700	982	0.83	779	1084	1.02	932	1160	1.11	1006	1223	1.24	1114	1301	1.38	1233
2000	971	0.84	787	1022	0.94	867	1121	1.12	1014	1188	1.22	1097	1254	1.36	1216	1329	1.44	1284
2100	1015	0.97	891	1063	1.10	998	1140	1.18	1064	1196	1.27	1140	1272	1.45	1292	1354	1.58	1404
2200	1060	1.10	998	1104	1.20	1081	1159	1.23	1106	1229	1.41	1258	1306	1.53	1361	1363	1.70	1508
2300	1104	1.25	1123	1130	1.27	1140	1196	1.37	1224	1264	1.56	1387	1340	1.66	1473	1397	1.86	1648
2400	1138	1.30	1165	1174	1.37	1224	1245	1.57	1396	1305	1.63	1447	1373	1.84	1630	1440	1.95	1726
2500	1183	1.43	1275	1201	1.50	1335	1284	1.65	1465	1338	1.75	1552	1402	1.99	1761	1469	2.04	1805
2600	1210	1.58	1404	1246	1.67	1482	1312	1.76	1560	1366	1.96	1735	1435	2.10	1858	1494	2.19	1936
2700	1254	1.76	1560	1285	1.80	1595	1354	1.95	1726	1403	2.14	1892	1474	2.21	1954	1536	2.46	2171
2800	1274	1.82	1613	1304	1.85	1639	1374	2.12	1875	1459	2.25	1989	1514	2.42	2136	1570	2.66	2343
2900	1318	1.95	1726	1345	2.05	1814	1412	2.32	2050	1496	2.54	2240	1529	2.61	2300	1603	2.87	2521
3000	1362	2.20	1945	1378	2.30	2032	1451	2.40	2119	1534	2.66	2343	1560	2.81	2470	1611	3.01	2648

48TM007 (6 TONS) — STANDARD MOTOR (BELT DRIVE)\* (cont)

Airflow (Cfm)	External Static Pressure (in. wg)								
	1.2			1.4			1.6		
	Rpm	Bhp	Watts	Rpm	Bhp	Watts	Rpm	Bhp	Watts
1800	1341	1.40	1250	1413	1.55	1378	1474	1.58	1404
1900	1374	1.53	1361	1437	1.62	1439	1490	1.67	1482
2000	1396	1.66	1473	1460	1.68	1491	1509	1.77	1569
2100	1413	1.75	1552	1475	1.73	1534	1529	1.92	1700
2200	1434	1.81	1604	1487	1.85	1639	1554	2.07	1831
2300	1459	1.88	1665	1520	2.07	1831	1576	2.24	1980
2400	1502	2.06	1823	1552	2.24	1980	1604	2.42	2136
2500	1524	2.24	1980	1585	2.42	2136	1638	2.60	2292
2600	1552	2.40	2119	1616	2.63	2317	1671	2.80	2462
2700	1584	2.61	2300	1646	2.83	2487	1706	2.97	2653
2800	1624	2.85	2504	1677	2.99	2661	—	—	—
2900	1671	3.03	2725	—	—	—	—	—	—
3000	—	—	—	—	—	—	—	—	—

LEGEND

- Bhp — Brake Horsepower Input to Fan
- FIOF — Factory-Installed Option
- Watts — Input Watts to Motor

\*Motor drive range is 1070 to 1460 rpm. All other rpms require a field-supplied drive.

Refer to page 87 for general Fan Performance Data notes.

NOTES:

1. **Boldface** indicates field-supplied drive is required.
2.  indicates field-supplied motor and drive are required.
3. Maximum continuous bhp is 2.4 and maximum continuous watts are 2120.

48TM007 (6 TONS) — HIGH-STATIC MOTOR (BELT DRIVE)\*

Airflow (Cfm)	External Static Pressure (in. wg)																	
	0.2			0.4			0.6			0.8			1.0			1.2		
	Rpm	Bhp	Watts	Rpm	Bhp	Watts	Rpm	Bhp	Watts	Rpm	Bhp	Watts	Rpm	Bhp	Watts	Rpm	Bhp	Watts
1800	942	0.73	700	1047	0.90	835	1139	1.05	956	1193	1.14	1031	1276	1.30	1165	1341	1.40	1250
1900	982	0.83	779	1084	1.02	932	1160	1.11	1006	1223	1.24	1114	1301	1.38	1233	1374	1.53	1361
2000	1022	0.94	867	1121	1.12	1014	1188	1.22	1097	1254	1.36	1216	1329	1.44	1284	1396	1.66	1473
2100	1063	1.10	998	1140	1.18	1064	1196	1.27	1140	1272	1.45	1292	1354	1.58	1404	1413	1.75	1552
2200	1104	1.20	1081	1159	1.23	1106	1229	1.41	1258	1306	1.53	1361	1363	1.70	1508	1434	1.81	1604
2300	1130	1.27	1140	1196	1.37	1224	1264	1.56	1387	1340	1.66	1473	1397	1.86	1648	1459	1.88	1665
2400	1174	1.37	1224	1245	1.57	1396	1305	1.63	1447	1373	1.84	1630	1440	1.95	1726	1502	2.06	1823
2500	1201	1.50	1335	1284	1.65	1465	1338	1.75	1552	1402	1.99	1761	1469	2.04	1805	1524	2.24	1980
2600	1246	1.67	1482	1312	1.76	1560	1366	1.96	1735	1435	2.10	1858	1494	2.19	1936	1552	2.40	2119
2700	1285	1.80	1595	1354	1.95	1726	1403	2.14	1892	1474	2.21	1954	1536	2.46	2171	1584	2.61	2300
2800	1304	1.85	1639	1374	2.12	1875	1459	2.25	1989	1514	2.42	2136	1570	2.66	2343	1624	2.85	2504
2900	1345	2.05	1814	1412	2.32	2050	1496	2.54	2240	1529	2.61	2300	1603	2.87	2521	1671	3.03	2725
3000	1378	2.30	2032	1451	2.40	2119	1534	2.66	2343	1560	2.81	2470	1611	3.01	2648	1692	3.49	3140

48TM007 (6 TONS) — HIGH-STATIC MOTOR (BELT DRIVE)\* (cont)

Airflow (Cfm)	External Static Pressure (in. wg)											
	1.4			1.6			1.8			2.0		
	Rpm	Bhp	Watts	Rpm	Bhp	Watts	Rpm	Bhp	Watts	Rpm	Bhp	Watts
1800	1413	1.55	1378	1474	1.58	1404	1522	1.74	1564	1566	1.89	1704
1900	1437	1.62	1439	1490	1.67	1482	1538	1.84	1653	1583	2.00	1801
2000	1460	1.68	1491	1509	1.77	1569	1558	1.95	1752	1603	2.12	1909
2100	1475	1.73	1534	1529	1.92	1700	1578	2.11	1901	1624	2.30	2070
2200	1478	1.85	1639	1554	2.07	1831	1604	2.28	2049	1651	2.48	2232
2300	1520	2.07	1831	1576	2.24	1980	1627	2.46	2218	1674	2.68	2415
2400	1552	2.24	1980	1604	2.42	2136	1656	2.66	2396	1704	2.90	2609
2500	1585	2.42	2136	1638	2.60	2292	1691	2.86	2574	1740	3.12	2804
2600	1616	2.63	2317	1671	2.80	2462	1725	3.08	2772	1775	3.35	3019
2700	1646	2.83	2487	1706	2.97	2653	1761	3.27	2941	—	—	—
2800	1677	2.99	2661	1739	3.33	2998	1795	3.67	3299	—	—	—
2900	1742	3.43	3090	—	—	—	—	—	—	—	—	—
3000	1764	3.95	3558	—	—	—	—	—	—	—	—	—

LEGEND

- Bhp — Brake Horsepower Input to Fan
- FIOF — Factory-Installed Option
- Watts — Input Watts to Motor

\*Motor drive range is 1300 to 1685 rpm. All other rpms require a field-supplied drive.

Refer to page 87 for general Fan Performance Data notes.

NOTES:

1. **Boldface** indicates field-supplied drive is required.
2.  indicates field-supplied motor and drive are required.
3. Maximum continuous bhp is 2.9 and the maximum continuous watts are 2562.

# Performance data (cont)



## FAN PERFORMANCE — HORIZONTAL DISCHARGE UNITS (cont)

48TM004-014

### 48TM008 (7½ TONS) — STANDARD MOTOR AND DRIVE AND ALTERNATE DRIVE (BELT DRIVE)\*

Airflow (Cfm)	External Static Pressure (in. wg)																	
	0.2			0.4			0.6			0.8			0.9			1.0		
	Rpm	Bhp	Watts	Rpm	Bhp	Watts	Rpm	Bhp	Watts	Rpm	Bhp	Watts	Rpm	Bhp	Watts	Rpm	Bhp	Watts
2250	507	0.53	547	586	0.73	700	658	0.97	891	722	1.22	1097	752	1.34	1199	783	1.46	1301
2300	513	0.55	562	592	0.76	723	663	1.00	916	727	1.26	1131	756	1.38	1224	786	1.49	1327
2400	528	0.60	600	606	0.83	779	674	1.06	965	738	1.34	1199	766	1.46	1301	795	1.58	1404
2500	542	0.66	646	619	0.90	835	686	1.13	1022	748	1.41	1258	777	1.55	1370	806	1.68	1491
2550	550	0.69	669	627	0.94	867	692	1.17	1056	754	1.45	1292	783	1.60	1413	812	1.74	1543
2600	557	0.72	692	634	0.97	891	698	1.21	1089	759	1.49	1327	787	1.64	1456	816	1.79	1587
2700	573	0.79	747	648	1.05	956	711	1.29	1156	770	1.58	1404	798	1.73	1534	827	1.88	1665
2800	588	0.86	803	662	1.13	1022	723	1.38	1233	782	1.66	1473	809	1.82	1613	837	1.98	1753
2900	604	0.94	867	676	1.21	1089	737	1.48	1318	794	1.76	1560	821	1.92	1700	848	2.08	1840
3000	620	1.02	932	690	1.30	1165	750	1.58	1404	806	1.86	1648	832	2.02	1788	849	2.18	1927
3100	636	1.11	1006	704	1.39	1241	764	1.69	1499	818	1.97	1744	844	2.13	1884	870	2.29	2023
3200	652	1.21	1089	718	1.49	1327	778	1.80	1595	831	2.09	1849	856	2.25	1980	882	2.40	2119
3300	668	1.31	1173	732	1.59	1413	793	1.92	1700	844	2.21	1954	869	2.37	2093	894	2.53	2232
3400	684	1.41	1258	747	1.70	1508	807	2.04	1805	857	2.35	2076	882	2.51	2206	907	2.66	2343
3500	701	1.53	1361	762	1.82	1613	821	2.16	1910	871	2.48	2188	895	2.64	2326	919	2.80	2462
3600	717	1.65	1465	777	1.94	1718	835	2.29	2023	885	2.63	2317	908	2.79	2453	932	2.95	2587
3700	733	1.77	1569	792	2.07	1831	849	2.42	2136	899	2.78	2445	922	2.95	2579	945	3.11	2718
3750	742	1.84	1630	800	2.14	1892	856	2.49	2197	907	2.86	2512	929	3.03	2653	952	3.20	2719

### 48TM008 (7½ TONS) — STANDARD MOTOR AND DRIVE AND ALTERNATE DRIVE (BELT DRIVE)\* (cont)

Airflow (Cfm)	External Static Pressure (in. wg)								
	1.2			1.4			1.6		
	Rpm	Bhp	Watts	Rpm	Bhp	Watts	Rpm	Bhp	Watts
2250	843	1.81	1604	908	2.25	1989	955	2.59	2283
2300	846	1.84	1630	910	2.25	2015	959	2.61	2300
2400	853	1.88	1665	912	2.31	2041	967	2.68	2360
2500	859	1.94	1718	919	2.37	2093	971	2.73	2403
2550	864	1.99	1761	920	2.39	2110	974	2.76	2428
2600	868	2.04	1805	921	2.41	2136	976	2.78	2445
2700	878	2.16	1910	928	2.45	2162	983	2.88	2529
2800	889	2.29	2023	937	2.57	2266	986	2.91	2554
2900	900	2.41	2128	947	2.70	2377	993	3.01	2637
3000	910	2.52	2223	958	2.85	2504	1002	3.15	2751
3100	920	2.64	2326	968	2.99	2620	1012	3.30	2870
3200	931	2.76	2428	979	3.13	2735	1023	3.47	3002
3300	942	2.89	2537	989	3.26	2839	1034	3.63	3121
3400	954	3.02	2645	1000	3.40	2948	1044	3.79	3237
3500	966	3.15	2751	1011	3.55	3062	1054	3.94	3340
3600	978	3.30	2870	1022	3.69	3165	1065	4.10	3445
3700	990	3.45	2987	1034	3.84	3272	1076	4.26	3544
3750	997	3.54	3055	1040	3.93	3333	—	—	—

#### LEGEND

- Bhp** — Brake Horsepower Input to Fan
- FIOP** — Factory-Installed Option
- Watts** — Input Watts to Motor

\*Standard drive range is 590 to 840 rpm. Alternate drive range is 685 to 935 rpm. All other rpms require a field-supplied drive.

Refer to page 87 for general Fan Performance Data notes.

#### NOTES:

1. **Boldface** indicates field-supplied drive is required.
2.  indicates field-supplied motor and drive are required.
3. Maximum continuous bhp is 2.4 and maximum continuous watts are 2120.



FAN PERFORMANCE — HORIZONTAL DISCHARGE UNITS (cont)

48TM004-014

48TM008 (7½ TONS) — HIGH-STATIC MOTOR (BELT DRIVE)\*

Airflow (Cfm)	External Static Pressure (in. wg)																	
	0.2			0.4			0.6			0.8			1.0			1.2		
	Rpm	Bhp	Watts	Rpm	Bhp	Watts	Rpm	Bhp	Watts	Rpm	Bhp	Watts	Rpm	Bhp	Watts	Rpm	Bhp	Watts
2250	507	0.53	547	586	0.73	700	658	0.97	891	722	1.22	1097	783	1.46	1301	843	1.81	1604
2300	513	0.55	562	592	0.76	723	663	1.00	916	727	1.26	1131	786	1.49	1327	846	1.84	1630
2400	528	0.60	600	606	0.83	779	674	1.06	965	738	1.34	1199	795	1.58	1404	853	1.88	1665
2500	542	0.66	646	619	0.90	835	686	1.13	1022	748	1.41	1258	806	1.68	1491	859	1.94	1718
2550	550	0.69	669	627	0.94	867	692	1.17	1056	754	1.45	1292	812	1.74	1543	864	1.99	1761
2600	557	0.72	692	634	0.97	891	698	1.21	1089	759	1.49	1327	816	1.79	1587	868	2.04	1805
2700	573	0.79	747	649	1.05	956	711	1.29	1156	770	1.58	1404	827	1.88	1665	878	2.16	1910
2800	588	0.86	803	662	1.13	1022	723	1.38	1233	782	1.66	1473	837	1.98	1753	889	2.29	2023
2900	604	0.94	867	676	1.21	1089	737	1.48	1318	794	1.76	1560	848	2.08	1840	900	2.41	2128
3000	620	1.02	932	690	1.30	1165	750	1.58	1404	806	1.86	1648	849	2.18	1927	910	2.52	2223
3100	636	1.11	1006	704	1.39	1241	764	1.69	1499	818	1.97	1744	870	2.29	2023	920	2.64	2326
3200	652	1.21	1089	718	1.49	1327	778	1.80	1595	831	2.09	1849	882	2.40	2119	931	2.76	2428
3300	668	1.31	1173	732	1.59	1413	793	1.92	1700	844	2.21	1954	894	2.53	2232	942	2.89	2537
3400	684	1.41	1258	747	1.70	1508	807	2.04	1805	857	2.35	2076	907	2.66	2343	954	3.02	2645
3500	701	1.53	1361	762	1.82	1613	821	2.16	1910	871	2.48	2188	919	2.80	2462	966	3.15	2751
3600	717	1.65	1465	777	1.94	1718	835	2.29	2023	885	2.63	2317	932	2.95	2587	978	3.30	2870
3700	733	1.77	1569	792	2.07	1831	849	2.42	2136	899	2.78	2445	945	3.11	2718	990	3.45	2987
3750	742	1.84	1630	800	2.14	1892	856	2.49	2197	907	2.86	2512	952	3.20	2719	997	3.54	3055

48TM008 (7½ TONS) — HIGH-STATIC MOTOR (BELT DRIVE)\* (cont)

Airflow (Cfm)	External Static Pressure (in. wg)											
	1.4			1.6			1.8			2.0		
	Rpm	Bhp	Watts	Rpm	Bhp	Watts	Rpm	Bhp	Watts	Rpm	Bhp	Watts
2250	908	2.25	1989	955	2.59	2283	991	2.89	2543	1023	3.19	2805
2300	910	2.25	2015	959	2.61	2300	995	2.91	2563	1028	3.21	2827
2400	912	2.31	2041	967	2.68	2360	1003	2.99	2631	1036	3.30	2902
2500	919	2.37	2093	971	2.73	2403	1007	3.05	2681	1041	3.36	2956
2550	920	2.39	2110	974	2.76	2428	1010	3.08	2710	1044	3.40	2989
2600	921	2.41	2136	976	2.78	2445	1012	3.10	2730	1046	3.42	3011
2700	928	2.45	2162	983	2.88	2529	1020	3.21	2828	1053	3.54	3119
2800	937	2.57	2266	986	2.91	2554	1023	3.25	2857	1057	3.58	3151
2900	947	2.70	2377	993	3.01	2637	1030	3.36	2955	1064	3.70	3260
3000	958	2.85	2504	1002	3.15	2751	1039	3.51	3093	<b>1074</b>	<b>3.88</b>	<b>3411</b>
3100	968	2.99	2620	1012	3.30	2870	1050	3.68	3240	<b>1084</b>	<b>4.06</b>	<b>3574</b>
3200	979	3.13	2735	1023	3.47	3002	1061	3.87	3407	—	—	—
3300	989	3.26	2839	1034	3.63	3121	1072	4.05	3564	—	—	—
3400	1000	3.40	2948	1044	3.79	3237	—	—	—	—	—	—
3500	1011	3.55	3062	1054	3.94	3340	—	—	—	—	—	—
3600	1022	3.69	3165	1065	4.10	3445	—	—	—	—	—	—
3700	1034	3.84	3272	—	—	—	—	—	—	—	—	—
3750	1040	3.93	3333	—	—	—	—	—	—	—	—	—

LEGEND

- Bhp** — Brake Horsepower Input to Fan
- FIOF** — Factory-Installed Option
- Watts** — Input Watts to Motor

\*Motor drive range is 860 to 1080 rpm. All other rpms require a field-supplied drive.

Refer to page 87 for general Fan Performance Data notes.

NOTES:

1. **Boldface** indicates field-supplied drive is required.
2. **Grey shading** indicates field-supplied motor and drive are required.
3. Maximum continuous bhp is 3.7 and the maximum continuous watts are 3313.

# Performance data (cont)



## FAN PERFORMANCE — HORIZONTAL DISCHARGE UNITS (cont)

48TM004-014

### 48TM009 (8½ TONS) — STANDARD MOTOR (BELT DRIVE)\*

Airflow (Cfm)	External Static Pressure (in. wg)																	
	0.2			0.4			0.6			0.8			0.9			1.0		
	Rpm	Bhp	Watts	Rpm	Bhp	Watts	Rpm	Bhp	Watts	Rpm	Bhp	Watts	Rpm	Bhp	Watts	Rpm	Bhp	Watts
2550	550	0.69	669	627	0.94	867	692	1.17	1056	754	1.45	1292	783	1.60	1413	812	1.74	1543
2600	557	0.72	692	634	0.97	891	698	1.21	1089	759	1.49	1327	787	1.64	1456	816	1.79	1587
2700	573	0.79	747	648	1.05	956	711	1.29	1156	770	1.58	1404	798	1.73	1534	827	1.88	1665
2800	588	0.86	803	662	1.13	1022	723	1.38	1233	782	1.66	1473	809	1.82	1613	837	1.98	1753
2900	604	0.94	867	676	1.21	1089	737	1.48	1318	794	1.76	1560	821	1.92	1700	848	2.08	1840
3000	620	1.02	932	690	1.30	1165	750	1.58	1404	806	1.86	1648	832	2.02	1788	849	2.18	1927
3100	636	1.11	1006	704	1.39	1241	764	1.69	1499	818	1.97	1744	844	2.13	1884	870	2.29	2023
3200	652	1.21	1089	718	1.49	1327	778	1.80	1595	831	2.09	1849	856	2.25	1980	882	2.40	2119
3300	668	1.31	1173	732	1.59	1413	793	1.92	1700	844	2.21	1954	869	2.37	2093	894	2.53	2232
3400	684	1.41	1258	747	1.70	1508	807	2.04	1805	857	2.35	2076	882	2.51	2206	907	2.66	2343
3500	701	1.53	1361	762	1.82	1613	821	2.16	1910	871	2.48	2188	895	2.64	2326	919	2.80	2462
3600	717	1.65	1465	777	1.94	1718	835	2.29	2023	885	2.63	2317	908	2.79	2453	932	2.95	2587
3700	733	1.77	1569	792	2.07	1831	849	2.42	2136	899	2.78	2445	922	2.95	2579	945	3.11	2718
3750	742	1.84	1630	800	2.14	1892	856	2.49	2197	907	2.86	2512	929	3.03	2653	952	3.20	2719
3800	750	1.90	1683	807	2.21	1954	863	2.56	2257	914	2.93	2571	936	3.11	2847	958	3.28	2854
3900	767	2.04	1805	822	2.35	2076	877	2.71	2386	928	3.09	2702	950	3.27	2979	972	3.45	2987
4000	783	2.18	1927	838	2.50	2206	891	2.86	2512	942	3.26	2839	964	3.45	3187	986	3.63	3121
4100	800	2.34	2067	854	2.66	2343	905	3.02	2645	956	3.43	2971	978	3.62	3244	1000	3.81	3251
4200	817	2.49	2197	869	2.82	2479	920	3.19	2783	970	3.60	3099	992	3.80	3258	1015	4.00	3380
4250	826	2.58	2275	877	2.91	2554	928	3.28	2854	977	3.69	3165	999	3.90	3306	1022	4.10	3445

### 48TM009 (8½ TONS) — STANDARD MOTOR (BELT DRIVE)\* (cont)

Airflow (Cfm)	External Static Pressure (in. wg)								
	1.2			1.4			1.6		
	Rpm	Bhp	Watts	Rpm	Bhp	Watts	Rpm	Bhp	Watts
2550	864	1.99	1761	920	2.39	2110	974	2.76	2428
2600	868	2.04	1805	921	2.41	2136	976	2.78	2445
2700	878	2.16	1910	928	2.45	2162	983	2.88	2529
2800	889	2.29	2023	937	2.57	2266	986	2.91	2554
2900	900	2.41	2128	947	2.70	2377	993	3.01	2637
3000	910	2.52	2223	958	2.85	2504	1002	3.15	2751
3100	920	2.64	2326	968	2.99	2620	1012	3.30	2870
3200	931	2.76	2428	979	3.13	2735	1023	3.47	3002
3300	942	2.89	2537	989	3.26	2839	1034	3.63	3121
3400	954	3.02	2645	1000	3.40	2948	1044	3.79	3237
3500	966	3.15	2751	1011	3.55	3062	1054	3.94	3340
3600	978	3.30	2870	1022	3.69	3165	1065	4.10	3445
3700	990	3.45	2987	1034	3.84	3272	1076	4.26	3544
3750	997	3.54	3055	1040	3.93	3333	1082	5.27	3609
3800	1003	3.62	3114	1045	4.01	3387	1087	4.43	3643
3900	1015	3.80	3244	1057	4.18	3495	1098	4.60	3733
4000	1028	3.99	3373	1070	4.36	3603	1110	4.78	3820
4100	1042	4.18	3495	1082	4.56	3713	1122	4.97	3902
4200	1055	4.38	3614	1095	4.76	3811	1134	5.16	3971
4250	1062	4.49	3676	1102	4.87	3860	—	—	—

#### LEGEND

- Bhp** — Brake Horsepower Input to Fan
- FIOP** — Factory-Installed Option
- Watts** — Input Watts to Motor

\*Motor drive range is 685 to 935 rpm. All other rpms require a field-supplied drive.

Refer to page 87 for general Fan Performance Data notes.

#### NOTES:

1. **Boldface** indicates field-supplied drive is required.
2. **■** indicates field-supplied motor and drive are required.
3. Maximum continuous bhp is 2.4 and the maximum continuous watts are 2120.



FAN PERFORMANCE — HORIZONTAL DISCHARGE UNITS (cont)

48TM004-014

48TM009 (8½ TONS) — HIGH-STATIC MOTOR (BELT DRIVE)\*

Airflow (Cfm)	External Static Pressure (in. wg)														
	0.2			0.4			0.6			0.8			1.0		
	Rpm	Bhp	Watts	Rpm	Bhp	Watts	Rpm	Bhp	Watts	Rpm	Bhp	Watts	Rpm	Bhp	Watts
2550	550	0.69	669	627	0.94	867	692	1.17	1056	754	1.45	1292	812	1.74	1543
2600	557	0.72	692	634	0.97	891	698	1.21	1089	759	1.49	1327	816	1.79	1587
2700	573	0.79	747	648	1.05	956	711	1.29	1156	770	1.59	1404	827	1.88	1665
2800	688	0.86	803	662	1.13	1022	723	1.38	1233	782	1.68	1473	837	1.98	1753
2900	604	0.94	867	676	1.21	1089	737	1.48	1318	794	1.76	1560	848	2.08	1840
3000	620	1.02	932	690	1.30	1165	750	1.58	1404	806	1.86	1648	849	2.18	1927
3100	636	1.11	1006	704	1.39	1241	764	1.69	1499	818	1.97	1744	870	2.29	2023
3200	652	1.21	1089	718	1.49	1327	778	1.80	1595	831	2.09	1849	882	2.40	2119
3300	668	1.31	1173	732	1.59	1413	793	1.92	1700	844	2.21	1954	894	2.53	2232
3400	684	1.41	1258	747	1.70	1508	807	2.04	1805	857	2.35	2076	907	2.66	2343
3500	701	1.53	1361	762	1.82	1613	821	2.16	1910	871	2.48	2188	919	2.80	2462
3600	717	1.65	1465	777	1.94	1718	835	2.29	2023	885	2.36	2317	932	2.95	2587
3700	733	1.77	1569	792	2.07	1831	849	2.42	2136	899	2.78	2445	945	3.11	2718
3750	742	1.84	1630	800	2.14	1892	856	2.49	2197	907	2.86	2512	952	3.20	2719
3800	750	1.90	1683	807	2.21	1954	863	2.56	2257	914	2.93	2571	958	3.28	2854
3900	767	2.04	1805	822	2.35	2076	877	2.71	2386	928	3.09	2702	972	3.45	2987
4000	783	2.18	1927	838	2.50	2206	891	2.86	2512	942	3.26	2839	986	3.63	3121
4100	800	2.34	2067	854	2.66	2343	905	3.02	2645	956	3.43	2971	1000	3.81	3251
4200	817	2.49	2197	869	2.82	2479	920	3.19	2783	970	3.60	3099	1015	4.00	3380
4250	826	2.58	2275	877	2.91	2554	928	3.28	2854	977	3.69	3165	1022	4.10	3445

48TM009 (8½ TONS) — HIGH-STATIC MOTOR (BELT DRIVE)\* (cont)

Airflow (Cfm)	External Static Pressure (in. wg)														
	1.2			1.4			1.6			1.8			2.0		
	Rpm	Bhp	Watts	Rpm	Bhp	Watts	Rpm	Bhp	Watts	Rpm	Bhp	Watts	Rpm	Bhp	Watts
2550	864	1.99	1761	920	2.39	2110	974	2.76	2428	1005	3.04	2672	1034	3.31	2910
2600	868	2.04	1805	921	2.41	2136	976	2.78	2445	1008	3.06	2691	1037	3.33	2931
2700	878	2.16	1910	928	2.45	2162	893	2.88	2529	1015	3.17	2788	1044	3.45	3036
2800	889	2.92	2023	937	2.57	2266	986	2.91	2554	1018	3.20	2817	1047	3.49	3068
2900	900	2.41	2128	947	2.70	2377	993	3.01	2637	1025	3.31	2914	1055	3.61	3174
3000	910	2.52	2223	958	2.85	2504	1002	3.15	2751	1034	3.47	3049	1064	3.77	3321
3100	920	2.64	2326	968	2.99	2620	1012	3.30	2870	1045	3.63	3195	1075	3.95	3479
3200	931	2.76	2428	979	3.13	2735	1023	3.47	3002	1056	3.82	3359	1087	4.16	3659
3300	942	2.89	2537	989	3.26	2839	1034	3.63	3121	1067	3.99	3514	—	—	—
3400	954	3.02	2645	1000	3.40	2948	1044	3.79	3237	1078	4.17	3669	—	—	—
3500	966	3.15	2751	1011	3.55	3062	1054	3.94	3340	—	—	—	—	—	—
3600	978	3.30	2870	1022	3.69	3165	1065	4.10	3445	—	—	—	—	—	—
3700	990	3.45	2987	1034	3.84	3272	—	—	—	—	—	—	—	—	—
3750	997	3.54	3055	1040	3.93	3333	—	—	—	—	—	—	—	—	—
3800	1003	3.62	3114	1045	4.01	3387	—	—	—	—	—	—	—	—	—
3900	1015	3.80	3244	1057	4.18	3495	—	—	—	—	—	—	—	—	—
4000	1028	3.99	3373	—	—	—	—	—	—	—	—	—	—	—	—
4100	1042	4.28	3495	—	—	—	—	—	—	—	—	—	—	—	—
4200	—	—	—	—	—	—	—	—	—	—	—	—	—	—	—
4250	—	—	—	—	—	—	—	—	—	—	—	—	—	—	—

LEGEND

- Bhp** — Brake Horsepower Input to Fan
- FIOP** — Factory-Installed Option
- Watts** — Input Watts to Motor

Refer to page 87 for general Fan Performance Data notes.

NOTES:

1. **Boldface** indicates field-supplied drive is required.
2. **■** indicates field-supplied motor and drive are required.
3. Maximum continuous bhp is 3.7 and the maximum continuous watts are 3313.

\*Motor drive range is 860 to 1080 rpm. All other rpms require a field-supplied drive.

# Performance data (cont)



## FAN PERFORMANCE — HORIZONTAL DISCHARGE UNITS (cont)

48TM004-014

### 48TM012 (10 TONS) — STANDARD MOTOR AND ALTERNATE MOTOR\*

Airflow (Cfm)	External Static Pressure (in. wg)																	
	0.2			0.4			0.6			0.8			1.0			1.2		
	Rpm	Bhp	Watts	Rpm	Bhp	Watts	Rpm	Bhp	Watts	Rpm	Bhp	Watts	Rpm	Bhp	Watts	Rpm	Bhp	Watts
3000	552	0.68	661	632	0.87	810	701	1.05	956	761	1.22	1097	816	1.36	1216	871	1.54	1370
3100	565	0.74	708	644	0.93	859	711	1.12	1014	772	1.31	1173	825	1.45	1292	879	1.63	1447
3200	578	0.81	763	656	1.00	916	723	1.20	1081	782	1.39	1241	835	1.55	1378	887	1.71	1517
3300	591	0.88	818	668	1.08	973	734	1.28	1148	793	1.47	1310	845	1.65	1465	895	1.80	1595
3400	605	0.96	883	680	1.16	1047	745	1.36	1216	803	1.56	1387	856	1.75	1552	904	1.91	1691
3500	619	1.04	948	691	1.23	1106	755	1.44	1284	813	1.65	1465	867	1.86	1648	914	2.03	1796
3600	633	1.13	1022	703	1.31	1173	766	1.52	1353	824	1.74	1543	877	1.97	1744	924	2.15	1901
3700	648	1.23	1106	714	1.39	1241	777	1.61	1430	835	1.85	1639	887	2.07	1831	935	2.28	2015
3800	662	1.33	1190	726	1.51	1310	789	1.72	1526	846	1.95	1726	897	2.18	1927	946	2.40	2169
3900	677	1.44	1284	738	1.61	1387	801	1.82	1613	857	2.06	1823	908	2.29	2023	956	2.53	2282
4000	692	1.55	1378	750	1.73	1473	813	1.94	1718	868	2.17	1919	918	2.40	2119	967	2.66	2397
4100	707	1.67	1482	762	1.84	1560	825	2.05	1814	878	2.28	2015	929	2.53	2282	977	2.78	2505
4200	722	1.80	1595	775	1.97	1656	837	2.16	1910	889	2.40	2119	941	2.66	2397	987	2.91	2624
4300	737	1.94	1718	787	2.09	1761	848	2.27	2006	900	2.52	2273	952	2.80	2523	999	3.04	2744
4400	752	2.08	1840	800	2.21	1875	860	2.39	2110	912	2.66	2397	962	2.93	2642	1008	3.19	2885
4500	768	2.24	1980	814	2.35	1989	871	2.51	2265	924	2.80	2523	973	3.07	2772	1019	3.34	3029
4600	783	2.40	2119	827	2.50	2121	883	2.64	2380	937	2.95	2661	983	3.21	2904	1027	3.49	3176
4700	799	2.56	2309	841	2.64	2291	894	2.77	2496	949	3.10	2800	994	3.36	3049	1037	3.64	3323
4800	814	2.74	2469	855	2.80	2424	906	2.91	2624	961	3.26	2952	1004	3.50	3193	1047	3.80	3474
4900	826	2.89	2505	868	2.90	2578	918	3.05	2754	972	3.40	3088	1014	3.65	3341	1057	3.96	3629
5000	840	3.05	2702	883	3.10	2735	931	3.21	2904	980	3.56	3248	1025	3.80	3494	1067	4.13	3788

### 48TM012 (10 TONS) — STANDARD MOTOR AND ALTERNATE MOTOR\* (cont)

Airflow (Cfm)	External Static Pressure (in. wg)					
	1.4			1.6		
	Rpm	Bhp	Watts	Rpm	Bhp	Watts
3000	918	1.67	1482	967	1.89	1736
3100	928	1.78	1478	973	1.94	1778
3200	937	1.90	1745	981	2.04	1861
3300	946	2.00	1828	991	2.16	1963
3400	953	2.10	1912	1000	2.29	2074
3500	961	2.20	1997	1009	2.41	2177
3600	970	2.32	2099	1017	2.53	2282
3700	980	2.45	2212	1024	2.64	2380
3800	989	2.58	2326	1033	2.76	2487
3900	1000	2.73	2460	1042	2.91	2617
4000	1010	2.87	2587	1050	3.05	2743
4100	1017	3.01	2688	1059	3.19	2874
4200	1026	3.17	2809	1067	3.34	3010
4300	1035	3.32	2931	1075	3.50	3151
4400	1044	3.49	3056	1084	3.66	3297
4500	1053	3.65	3182	1092	3.82	3448
4600	1062	3.83	3311	1101	3.99	3604
4700	1071	4.00	3442	1109	4.16	3765
4800	1080	4.19	3574	1118	4.34	3931
4900	1089	4.38	3709	1126	4.52	4103
5000	1098	4.57	3846	—	—	—

#### LEGEND

- Bhp** — Brake Horsepower Input to Fan
- FIOP** — Factory-Installed Option
- Watts** — Input Watts to Motor

\*Standard motor drive range is 695 to 935 rpm. Alternate motor drive range is 835 to 1085 rpm. All other rpms require a field-supplied drive. Refer to page 87 for general Fan Performance Data notes.

#### NOTES:

1. **Boldface** indicates field-supplied drive is required.
2.  indicates optional high-static motor and drive are required. See high-static data on next page.
3. Maximum continuous bhp is 2.4 for the standard motor, 2.9 for the alternate motor. Maximum continuous watts are 2120 for the standard motor, 2615 for the alternate motor.



FAN PERFORMANCE — HORIZONTAL DISCHARGE UNITS (cont)

48TM004-014

48TM012 (10 TONS) — HIGH-STATIC MOTOR\*

Airflow (Cfm)	External Static Pressure (in. wg)																	
	0.2			0.4			0.6			0.8			1.0			1.2		
	Rpm	Bhp	Watts	Rpm	Bhp	Watts	Rpm	Bhp	Watts	Rpm	Bhp	Watts	Rpm	Bhp	Watts	Rpm	Bhp	Watts
3000	552	0.68	661	632	0.87	810	701	1.05	956	761	1.22	1097	816	1.36	1216	871	1.54	1370
3100	565	0.74	708	644	0.93	859	711	1.12	1014	772	1.31	1173	825	1.45	1292	879	1.63	1447
3200	578	0.81	763	656	1.00	916	723	1.20	1081	782	1.39	1241	835	1.55	1378	887	1.71	1517
3300	591	0.88	818	668	1.08	973	734	1.28	1148	793	1.47	1310	845	1.65	1465	895	1.80	1595
3400	605	0.96	883	680	1.16	1047	745	1.36	1216	803	1.56	1387	856	1.75	1552	904	1.91	1691
3500	619	1.04	948	691	1.23	1106	755	1.44	1284	813	1.65	1465	867	1.86	1648	914	2.03	1796
3600	633	1.13	1022	703	1.31	1173	766	1.52	1353	824	1.74	1543	877	1.97	1744	924	2.15	1901
3700	648	1.23	1106	714	1.39	1241	777	1.61	1430	835	1.85	1639	887	2.07	1831	935	2.28	2015
3800	662	1.33	1190	726	1.51	1310	789	1.72	1526	846	1.95	1726	897	2.18	1927	946	2.40	2169
3900	677	1.44	1284	738	1.61	1387	801	1.82	1613	857	2.06	1823	908	2.29	2023	956	2.53	2282
4000	692	1.55	1378	750	1.73	1473	813	1.94	1718	868	2.17	1919	918	2.40	2119	967	2.66	2397
4100	707	1.67	1482	762	1.84	1560	825	2.05	1814	878	2.28	2015	929	2.53	2282	977	2.78	2505
4200	722	1.80	1595	775	1.97	1656	837	2.16	1910	889	2.40	2119	941	2.66	2397	987	2.91	2624
4300	737	1.94	1718	787	2.09	1761	848	2.27	2006	900	2.52	2273	952	2.80	2523	999	3.04	2744
4400	752	2.08	1840	800	2.21	1875	860	2.39	2110	912	2.66	2397	962	2.93	2642	1008	3.19	2885
4500	768	2.24	1980	814	2.35	1989	871	2.51	2265	924	2.80	2523	973	3.07	2772	1019	3.34	3029
4600	783	2.40	2119	827	2.50	2121	883	2.64	2380	937	2.95	2661	983	3.21	2904	1027	3.49	3176
4700	799	2.56	2309	841	2.64	2291	894	2.77	2496	949	3.10	2800	994	3.36	3049	1037	3.64	3323
4800	814	2.74	2469	855	2.80	2424	906	2.91	2624	961	3.26	2952	1004	3.50	3193	1047	3.80	3474
4900	826	2.89	2505	868	2.90	2578	918	3.05	2754	972	3.40	3088	1014	3.65	3341	1057	3.96	3629
5000	840	3.05	2702	883	3.10	2735	931	3.21	2904	980	3.56	3248	1025	3.80	3494	1067	4.13	3788

48TM012 (10 TONS) — HIGH-STATIC MOTOR\* (cont)

Airflow (Cfm)	External Static Pressure (in. wg)											
	1.4			1.6			1.8			2.0		
	Rpm	Bhp	Watts	Rpm	Bhp	Watts	Rpm	Bhp	Watts	Rpm	Bhp	Watts
3000	918	1.67	1482	967	1.89	1736	1010	2.09	1903	1063	2.46	2221
3100	928	1.78	1478	973	1.94	1778	1018	2.17	1971	1070	2.51	2265
3200	937	1.90	1745	981	2.04	1861	1026	2.26	2048	1075	2.57	2318
3300	946	2.00	1828	991	2.16	1963	1032	2.32	2099	1080	2.64	2380
3400	953	2.10	1912	1000	2.29	2074	1041	2.44	2203	1083	2.65	2389
3500	961	2.20	1997	1009	2.41	2177	1051	2.57	2318	1090	2.74	2469
3600	970	2.32	2099	1017	2.53	2282	1061	2.72	2451	1099	2.88	2596
3700	980	2.45	2212	1024	2.64	2380	1069	2.87	2587	1102	2.96	2669
3800	989	2.58	2326	1033	2.76	2487	1070	2.92	2631	1108	3.08	2774
3900	1000	2.73	2460	1042	2.91	2624	1078	3.06	2754	1113	3.20	2890
4000	1010	2.87	2587	1050	3.05	2743	1085	3.19	2879	1119	3.34	3016
4100	1017	3.01	2688	1059	3.19	2874	1092	3.34	3013	1125	3.49	3152
4200	1026	3.17	2809	1067	3.34	3010	1099	3.50	3155	1130	3.65	3299
4300	1035	3.32	2931	1075	3.50	3151	1106	3.66	3304	<b>1136</b>	<b>3.82</b>	<b>3457</b>
4400	1044	3.49	3056	1084	3.66	3297	1113	3.83	3461	<b>1141</b>	<b>4.01</b>	<b>3625</b>
4500	1053	3.65	3182	1092	3.82	3448	1120	4.01	3626	<b>1147</b>	<b>4.20</b>	<b>3804</b>
4600	1062	3.83	3311	1101	3.99	3604	1127	4.20	3799	<b>1152</b>	<b>4.41</b>	<b>3994</b>
4700	1071	4.00	3442	1109	4.16	3765	<b>1134</b>	<b>4.40</b>	<b>3979</b>	<b>1158</b>	<b>4.63</b>	<b>4194</b>
4800	1080	4.19	3574	1118	4.34	3931	<b>1141</b>	<b>4.60</b>	<b>4168</b>	1164	4.86	4404
4900	1089	4.38	3709	1126	4.52	4103	<b>1148</b>	<b>4.81</b>	<b>4364</b>	1169	5.10	4625
5000	1098	4.57	3846	<b>1135</b>	<b>4.71</b>	<b>4279</b>	1155	5.03	4568	1175	5.35	4857

LEGEND

- Bhp** — Brake Horsepower Input to Fan
- FIOF** — Factory-Installed Option
- Watts** — Input Watts to Motor

\*High-static motor drive range is 830 to 1130 rpm. All other rpms require a field-supplied drive.

Refer to page 87 for general Fan Performance Data notes.

NOTES:

1. **Boldface** indicates field-supplied drive is required.
2. **Shaded** indicates field-supplied motor and drive are required.
3. Maximum continuous bhp is 5.25 for the high-static motor. Maximum continuous watts are 4400 for the high-static motor.

# Performance data (cont)



## FAN PERFORMANCE — HORIZONTAL DISCHARGE UNITS (cont)

48TM004-014

### 48TM014 (12 1/2 TONS)\*

Airflow (Cfm)	External Static Pressure (in. wg)																	
	0.2			0.4			0.6			0.8			1.0			1.2		
	Rpm	Bhp	Watts	Rpm	Bhp	Watts	Rpm	Bhp	Watts	Rpm	Bhp	Watts	Rpm	Bhp	Watts	Rpm	Bhp	Watts
3750	684	1.24	1162	755	1.48	1353	816	1.70	1540	875	1.94	1738	933	2.23	1988	989	2.49	2219
3800	691	1.28	1194	761	1.52	1390	822	1.75	1582	880	1.98	1776	937	2.28	2035	993	2.55	2272
3900	705	1.37	1267	773	1.62	1473	834	1.86	1674	891	2.08	1862	947	2.39	2131	1002	2.66	2370
4000	720	1.47	1349	786	1.71	1548	847	1.97	1768	902	2.19	1957	957	2.50	2228	1011	2.79	2485
4100	734	1.56	1423	800	1.82	1641	860	2.09	1871	914	2.31	2061	967	2.60	2316	1021	2.91	2593
4200	749	1.66	1506	813	1.92	1725	873	2.21	1974	926	2.44	2175	978	2.71	2414	1030	3.04	2710
4300	764	1.77	1598	826	2.04	1828	886	2.33	2079	938	2.57	2290	989	2.83	2521	1040	3.18	2837
4400	779	1.88	1691	840	2.16	1931	899	2.46	2193	951	2.71	2414	1000	2.96	2638	1050	3.31	2955
4500	793	1.99	1785	854	2.28	2035	912	2.59	2307	963	2.86	2548	1012	3.09	2755	1061	3.43	3065
4600	808	2.11	1888	868	2.42	2158	925	2.73	2459	975	3.00	2674	1024	3.25	2901	1071	3.56	3184
4700	822	2.24	2000	882	2.56	2281	937	2.86	2548	988	3.16	2819	1036	3.42	3056	1082	3.70	3313
4800	837	2.37	2114	896	2.71	2414	950	3.00	2674	1001	3.32	2964	1048	3.59	3212	1093	3.86	3461
4900	852	2.51	2237	910	2.86	2548	963	3.15	2810	1014	3.48	3111	1060	3.76	3368	1105	4.02	3609
5000	867	2.65	2361	924	3.01	2683	977	3.30	2946	1027	3.65	3267	1073	3.94	3535	1117	4.20	3776
5100	882	2.79	2485	938	3.17	2828	990	3.46	3092	1040	3.82	3424	1085	4.12	3702	1129	4.40	3962
5200	896	2.95	2629	952	3.33	2973	1003	3.63	3248	1053	4.00	3590	1098	4.30	3869	1141	4.60	4148
5300	911	3.11	2773	967	3.50	3129	1017	3.80	3405	1066	4.18	3757	1111	4.50	4055	1153	4.80	4335
5400	926	3.27	2919	981	3.68	3294	1030	3.98	3572	1079	4.35	3916	1124	4.70	4270	1166	5.01	4531
5500	940	3.44	3074	995	3.86	3461	1044	4.17	3748	1092	4.54	4093	1137	4.91	4437	1178	5.22	4726
5600	955	3.62	3239	1010	4.04	3627	1058	4.38	3943	1105	4.73	4270	1150	5.12	4633	—	—	—
5700	970	3.80	3405	1024	4.23	3804	1072	4.59	4139	1118	4.93	4456	—	—	—	—	—	—
5800	985	3.99	3581	1039	4.42	3981	1086	4.80	4335	1131	5.14	4652	—	—	—	—	—	—
5900	1000	4.18	3757	1053	4.62	4167	1100	5.02	4540	—	—	—	—	—	—	—	—	—
6000	1015	4.39	3953	1068	4.83	4363	—	—	—	—	—	—	—	—	—	—	—	—
6100	1030	4.59	4139	1083	5.04	4558	—	—	—	—	—	—	—	—	—	—	—	—
6250	1062	5.02	4560	—	—	—	—	—	—	—	—	—	—	—	—	—	—	—

### 48TM014 (12 1/2 TONS)\* (cont)

Airflow (Cfm)	External Static Pressure (in. wg)											
	1.4			1.6			1.8			2.0		
	Rpm	Bhp	Watts	Rpm	Bhp	Watts	Rpm	Bhp	Watts	Rpm	Bhp	Watts
3750	1041	2.75	2445	1086	2.98	2634	1122	3.16	2819	1146	3.28	2928
3800	1046	2.81	2503	1092	3.05	2719	1129	3.25	2901	1156	3.39	3028
3900	1055	2.94	2620	1102	3.20	2855	1143	3.42	3056	1174	3.59	3212
4000	1064	3.07	2737	1112	3.34	2983	1155	3.59	3212	1190	3.80	3405
4100	1072	3.20	2855	1121	3.49	3120	1165	3.76	3368	1203	3.99	3581
4200	1081	3.34	2983	1130	3.64	3258	1175	3.92	3516	1215	4.18	3757
4300	1090	3.48	3111	1139	3.79	3396	1185	4.08	3664	1226	4.36	3925
4400	1100	3.63	3248	1148	3.94	3535	1194	4.25	3822	1236	4.54	4093
4500	1109	3.78	3387	1157	4.09	3674	1203	4.42	3981	1246	4.72	4260
4600	1119	3.93	3525	1166	4.26	3832	1212	4.58	4130	1255	4.91	4437
4700	1129	4.09	3674	1175	4.43	3990	1221	4.76	4298	1264	5.09	4605
4800	1139	4.24	3813	1185	4.60	4148	1230	4.93	4456	—	—	—
4900	1150	4.38	3943	1194	4.77	4307	1239	5.12	4633	—	—	—
5000	1161	4.54	4093	1204	4.95	4475	—	—	—	—	—	—
5100	1172	4.71	4251	1214	5.13	4642	—	—	—	—	—	—
5200	1183	4.91	4419	—	—	—	—	—	—	—	—	—
5300	1194	5.08	4596	—	—	—	—	—	—	—	—	—
5400	—	—	—	—	—	—	—	—	—	—	—	—
5500	—	—	—	—	—	—	—	—	—	—	—	—
5600	—	—	—	—	—	—	—	—	—	—	—	—
5700	—	—	—	—	—	—	—	—	—	—	—	—
5800	—	—	—	—	—	—	—	—	—	—	—	—
5900	—	—	—	—	—	—	—	—	—	—	—	—
6000	—	—	—	—	—	—	—	—	—	—	—	—
6100	—	—	—	—	—	—	—	—	—	—	—	—
6250	—	—	—	—	—	—	—	—	—	—	—	—

LEGEND

- Bhp** — Brake Horsepower Input to Fan
- FIOP** — Factory-Installed Option
- Watts** — Input Watts to Motor

Refer to page 87 for general Fan Performance Data notes.

NOTES:

1. **Boldface** indicates field-supplied drive is required.
2. **Shaded** indicates alternate motor and drive are required.
3. Maximum continuous bhp is 3.7 for the standard motor, and 5.25 for the alternate motor. The maximum continuous watts are 3313 for the standard motor and 4400 for the alternate motor.

\*Standard motor drive range is 860 to 1080 rpm. Alternate motor drive range is 900 to 1260 rpm. All other rpms require a field-supplied drive.



**GENERAL NOTES FOR FAN PERFORMANCE DATA TABLES**

1. Values include losses for filters, unit casing, and wet coils. See page 90 for accessory/FIOP static pressure information.
2. Extensive motor and electrical testing on these units ensures that the full range of the motor can be utilized with confidence. Using your fan motors up to the wattage ratings shown will not result in nuisance tripping or premature motor failure. Unit warranty will not be affected. See Evaporator-Fan Motor Performance table on page 88 for additional information.
3. Use of a field-supplied motor may affect wire sizing. Contact your Carrier representative for details.
4. Interpolation is permissible. Do not extrapolate. (Belt drive units only)

**FAN RPM AT MOTOR PULLEY SETTINGS\***

UNIT 48TM	MOTOR PULLEY TURNS OPEN												
	0	1/2	1	1 1/2	2	2 1/2	3	3 1/2	4	4 1/2	5	5 1/2	6
004†	1000	976	952	928	904	880	856	832	808	784	760	—	—
004**	1455	1423	1392	1360	1328	1297	1265	1233	1202	1170	1138	1107	1075
005†	1185	1150	1115	1080	1045	1010	975	940	905	870	835	—	—
005**	1455	1423	1392	1360	1328	1297	1265	1233	1202	1170	1138	1107	1075
006†	1300	1260	1220	1180	1140	1100	1060	1020	980	940	900	—	—
006**	1685	1589	1557	1525	1493	1460	1428	1396	1364	1332	1300	—	—
007††	1460	1420	1380	1345	1305	1265	1225	1185	1150	1110	1070	—	—
007**	1685	1589	1557	1525	1493	1460	1428	1396	1364	1332	1300	—	—
008††	840	815	790	765	740	715	690	665	635	615	590	—	—
008 ll	935	910	885	860	835	810	785	760	735	710	685	—	—
008**	1080	1025	1007	988	970	952	933	915	897	878	860	—	—
009††	935	910	885	860	835	810	785	760	735	710	685	—	—
009**	1080	1025	1007	988	970	952	933	915	897	878	860	—	—
012††	935	910	885	860	835	810	785	760	735	710	685	—	—
012†	1085	1060	1035	1010	985	960	935	910	885	860	835	—	—
012**	1130	1112	1087	1062	1037	1012	987	962	937	912	887	862	830
014††	1080	1060	1035	1015	990	970	950	925	905	880	860	—	—
014†	1260	1220	1185	1155	1130	1100	1075	1045	1015	990	960	930	900

\*Approximate fan rpm shown.

†Indicates alternate motor and drive package.

\*\*Indicates high-static motor and drive package.

††Indicates standard motor and drive package.

ll Indicates alternate drive package only.

# Performance data (cont)



48TM004-014

## EVAPORATOR-FAN MOTOR EFFICIENCY

UNIT 48TM	MOTOR EFFICIENCY (%)
004,005	75
006	74/84*
007	84
008-012	80
014	87

\*Single phase/three-phase.

NOTE: All indoor-fan motors 5 hp and larger meet the minimum efficiency requirements as established by the Energy Policy Act of 1992 (EPACT) effective October 24, 1997.

## EVAPORATOR-FAN MOTOR PERFORMANCE

UNIT 48TM	EVAPORATOR-FAN MOTOR	UNIT VOLTAGE	MAXIMUM ACCEPTABLE CONTINUOUS BHP*	MAXIMUM ACCEPTABLE OPERATING WATTS	MAXIMUM AMP DRAW
004	Standard	208/230	0.34	440	2.8
		460			1.3
		575			1.3
	Alternate	208/230	1.20	1000	4.9
		460			2.1
		575			2.1
	High Static	208/230	2.40	2120	6.0
		460			3.0
		575			3.0
005	Standard	208/230	0.75	850	3.5
		460			1.8
		575			1.8
	Alternate	208/230	1.20	1000	4.9
		460			2.1
		575			2.1
	High Static	208/230	2.40	2120	6.0
		460			3.0
		575			3.0
006	Standard	208/230	1.20	1340	5.9
		460			3.2
		575			3.2
	Alternate	208/230	1.30/2.40†	2120	6.6/5.2†
		460			2.6
		575			3.0
	High Static	208/230	2.90	2562	8.6
		460			3.9
		575			3.9
007	Standard	208/230	2.40	2120	5.2
		460			3.0
		575			3.0
	High Static	208/230	2.90	2562	8.6
		460			3.9
		575			3.9
008	Standard, Alternate	208/230	2.40	2120	6.7
		460			3.0
		575			3.0
	High Static	208/230	3.70	3313	12.2
		460			5.5
		575			5.5
009	Standard	208/230	2.40	2120	6.7
		460			3.0
		575			3.0
	High Static	208/230	3.70	3313	12.2
		460			5.5
		575			5.5
012	Standard	208/230	2.40	2120	6.7
		460			3.0
		575			3.0
	Alternate	208/230	2.90	2615	8.6
		460			3.9
		575			3.9
High Static	208/230	5.25	4400	17.3	
	460			8.5	
	575			8.5	
014	Standard	208/230	3.70	3313	12.2
		460			5.5
		575			5.5
	Alternate	208/230	5.25	4400	17.3
		460			8.5
		575			8.5

LEGEND  
BHP — Brake Horsepower

\*Extensive motor and electrical testing on these units ensures that the full horsepower range of the motors can be utilized with confidence. Using your fan motors up to the horsepower ratings shown in this table will not result in nuisance tripping or premature motor failure. Unit warranty will not be affected.

†Single phase/three-phase.

NOTES:

1. All indoor-fan motors 5 hp and larger meet the minimum efficiency requirements as established by the Energy Policy Act of 1992 (EPACT) effective October 24, 1997.
2. High-static motor not available on single-phase units.

**VERTICAL ECONOMIZER PERFORMANCE DATA  
(48TM004-014)**

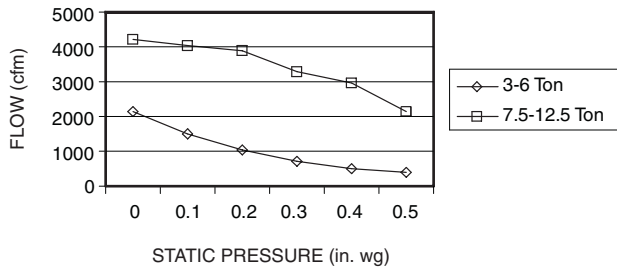

**VERTICAL POWER EXHAUST PERFORMANCE**

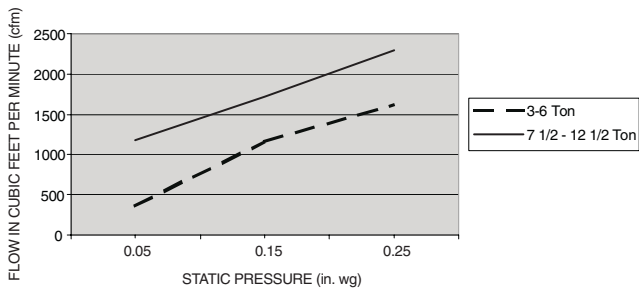

**BAROMETRIC RELIEF FLOW CAPACITY**

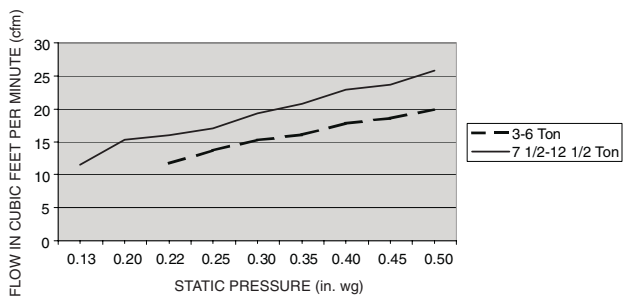

**OUTDOOR AIR DAMPER LEAKAGE**

**HORIZONTAL ECONOMIZER PERFORMANCE DATA**

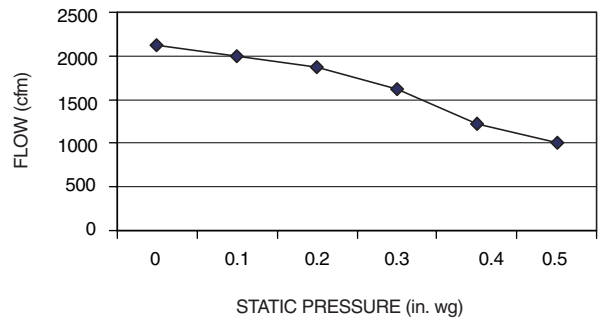

**HORIZONTAL POWER EXHAUST PERFORMANCE**

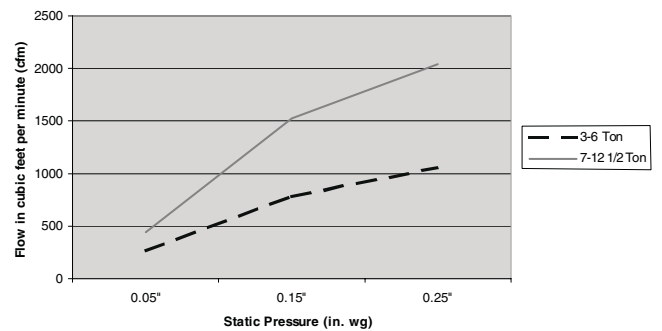

**BAROMETRIC RELIEF CAPACITY**

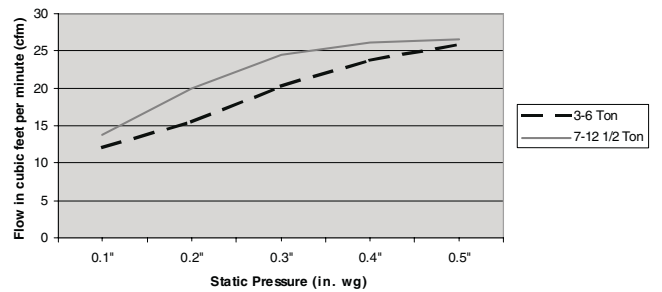

**OUTDOOR AIR DAMPER LEAKAGE**

# Performance data (cont)



## ACCESSORY STATIC PRESSURE\* (in. wg) — 48TM004-007

COMPONENT	CFM									
	900	1200	1400	1600	1800	2000	2200	2400	2600	3000
Durablade Economizer	0.05	0.05	0.05	0.05	0.05	0.05	0.05	0.05	0.05	0.05

\*The static pressure must be added to external static pressure. The sum and the evaporator entering-air cfm should then be used in conjunction with the Fan Performance tables to determine blower rpm and watts.

## ACCESSORY STATIC PRESSURE\* (in. wg) — 48TM008-014

COMPONENT	CFM									
	2200	2500	3000	3500	4000	4500	5000	5500	6000	6250
Durablade Economizer	0.02	0.02	0.03	0.04	0.05	0.06	0.07	0.08	0.09	0.09

\*The static pressure must be added to external static pressure. The sum and the evaporator entering-air cfm should be used in conjunction with the Fan Performance tables to determine indoor blower rpm and watts.

## ACCESSORY/FIOP ECONOMIZER2 STATIC PRESSURE\* (in. wg) — 48TM004-007

COMPONENT	CFM							
	1250	1500	1750	2000	2250	2500	2750	3000
Vertical EconoMiSer2	0.045	0.065	0.08	0.12	0.145	0.175	0.22	0.255
Horizontal EconoMiSer2	—	—	0.1	0.125	0.15	0.18	0.225	0.275

LEGEND  
FIOP — Factory-Installed Option

\*The static pressure must be added to external static pressure. The sum and the evaporator entering-air cfm should be used in conjunction with the Fan Performance tables to determine indoor blower rpm and watts.

## ACCESSORY/FIOP ECONOMIZER2 STATIC PRESSURE\* (in. wg) — 48TM008-014

COMPONENT	CFM													
	2250	2500	2750	3000	3250	3500	3750	4000	4250	4500	4750	5000	5250	6250
Vertical EconoMiSer2	0.06	0.075	0.09	0.115	0.13	0.15	0.17	0.195	0.22	0.25	0.285	0.325	0.36	—
Horizontal EconoMiSer2	—	0.1	0.125	0.15	0.18	0.21	0.25	0.275	0.3	0.34	0.388	—	—	—

LEGEND  
FIOP — Factory-Installed Option

\*The static pressure must be added to external static pressure. The sum and the evaporator entering-air cfm should be used in conjunction with the Fan Performance tables to determine blower rpm and watts.

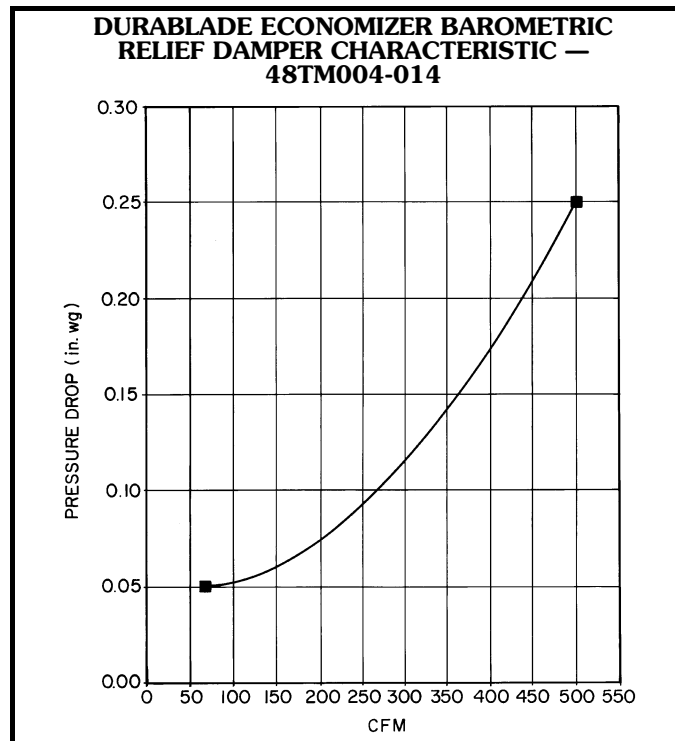



**SOUND POWER (Total Unit)**

UNIT 48TM	ARI RATING (Bels)	A-WEIGHTED (dB)	OCTAVE BANDS							
			63	125	250	500	1000	2000	4000	8000
004-006	8.1	80.5	56.8	75.8	72.4	72.9	74.8	75.4	71.3	69.1
007	8.0	80.0	59.1	68.9	68.7	71.9	74.0	68.9	65.7	59.0
008, 009	8.2	82.0	62.2	69.3	71.5	74.7	76.2	72.9	68.7	61.5
012	8.4	84.0	64.6	71.7	73.3	76.9	77.6	73.7	70.6	63.7
014	8.6	86.0	63.7	69.9	72.5	78.2	81.1	77.3	73.3	66.8

**ALTITUDE COMPENSATION\* — 48TM004-007 STANDARD UNITS**

ELEVATION (ft)	74,000 AND 115,000 BTUH NOMINAL INPUT		150,000 BTUH NOMINAL INPUT	
	Natural Gas Orifice Size†	Liquid Propane Orifice Size†	Natural Gas Orifice Size†	Liquid Propane Orifice Size†
0-2,000	33	43	30	37
2,000	36	44	31	39
3,000	36	45	31	40
4,000	37	45	32	41
5,000	38	46	32	42
6,000	40	47	34	43
7,000	41	48	35	43
8,000	42	49	36	44
9,000	43	50	37	45
10,000	44	50	39	46
11,000	45	51	41	47
12,000	46	52	42	48
13,000	47	52	43	49
14,000	48	53	44	50

\*As the height above sea level increases, there is less oxygen per cubic foot of air. Therefore, heat input rate should be reduced at higher altitudes.

†Orifices available through your Carrier distributor.

**ALTITUDE COMPENSATION\* — 48TM004-006 LOW NO<sub>x</sub> UNITS**

ELEVATION (ft)	60,000 AND 90,000 BTUH NOMINAL INPUT		120,000 BTUH NOMINAL INPUT	
	Natural Gas Orifice Size†	Liquid Propane Orifice Size†	Natural Gas Orifice Size	Liquid Propane Orifice Size†
0-2,000	38	45	32	42
2,000	40	47	33	43
3,000	41	48	35	43
4,000	42	49	36	44
5,000	43	49	37	45
6,000	43	50	38	45
7,000	44	50	39	46
8,000	45	51	41	47
9,000	46	52	42	48
10,000	47	52	43	49
11,000	48	53	44	50
12,000	49	53	44	51
13,000	50	54	46	52
14,000	51	54	47	52

\*As the height above sea level increases, there is less oxygen per cubic foot of air. Therefore, the input rate should be reduced at higher altitudes.

†Orifices are available through your local Carrier distributor.

**ALTITUDE COMPENSATION\* — 48TM008-014**

ELEVATION (ft)	125,000, 180,000, AND 224,000 BTUH NOMINAL INPUT		250,000 BTUH NOMINAL INPUT	
	Natural Gas Orifice Size†	Liquid Propane Orifice Size†	Natural Gas Orifice Size†	Liquid Propane Orifice Size†
0-2,000	31	41	30	38
2,000	32	42	30	39
3,000	32	42	31	40
4,000	32	42	32	41
5,000	33	43	33	42
6,000	34	43	34	43
7,000	35	44	35	43
8,000	36	44	36	44
9,000	37	45	37	44
10,000	38	46	38	45
11,000	39	47	39	45
12,000	40	47	40	46
13,000	41	48	41	47
14,000	42	48	42	47

\*As the height above sea level increases, there is less oxygen per cubic foot of air. Therefore, the input rate should be reduced at higher altitudes.

†Orifices are available through your local Carrier distributor.

**ALTITUDE DERATING FACTOR\***

ELEVATION	MAXIMUM HEATING VALUE AT SEA LEVEL (Btu/ft <sup>3</sup> )
0-2000	1100
2001-3000	1050
3001-4000	1000
4001-5000	950
5001-6000	900

\*Derating of the gas heating equipment to compensate for the effects of altitude is always required. Orifice change is not required if the fuel heating value (at sea level) is below the limits listed in the table above. Derating conditions must be 4% per thousand ft above sea level. For example, at 4000 ft, if the heating value of the gas exceeds 1000 Btu/ft<sup>3</sup>, the unit will require a 16% derating. For elevations above 6000 ft, the same formula applies. For example, at 7000 ft, the unit will require a 28% derating of the maximum heating value per the National Fuel Gas Code.

# Electrical data



48TM004-014

## ELECTRICAL DATA (Without Convenience Outlet)

UNIT 48TM	NOMINAL VOLTAGE	IFM TYPE	VOLTAGE RANGE		COMPR (ea)			OFM (ea)			IFM	COMBUSTION FAN MOTOR FLA	POWER SUPPLY*		DISCONNECT SIZE†						
			Min	Max	Qty	RLA	LRA	Qty	Hp	FLA			MCA	MOCPS**	FLA	LRA					
004 (3 Tons)	208/230-1-60	Std	187	254	1	16.2	96.0	1	1/4	1.4	3.5	.6	25.2/25.2	30/30	24/24	106/106					
		Alt															4.9	26.6/26.6	35/35	26/26	111/111
	208/230-3-60	Std	187	254	1	10.2	75.0	1	1/4	1.4	3.5	.6	17.7/17.7	25/25	17/17	85/ 85					
		Alt															4.9	19.1/19.1	25/25	19/19	90/ 90
		High																			
	460-3-60	Std	414	508	1	4.4	40.0	1	1/4	0.8	1.3	.3	7.6	15	7	44					
		Alt															2.1	8.4	15	8	48
		High																			
	575-3-60	Std	518	632	1	3.7	31.0	1	1/4	0.8	1.3	.3	5.5	15	6	35					
Alt		2.1															6.0	15	7	37	
High																					2.6
005 (4 Tons)	208/230-1-60	Std	187	254	1	23.3	118.0	1	1/4	1.4	3.5	.6	34.0/34.0	40/40	32/32	129/129					
		Alt															4.9	35.4/35.4	45/45	34/34	133/133
	208/230-3-60	Std	187	254	1	15.4	90.0	1	1/4	1.4	3.5	.6	24.2/24.2	30/30	23/23	101/101					
		Alt															4.9	25.6/25.6	30/30	25/25	105/105
		High																			
	460-3-60	Std	414	508	1	8.3	45.0	1	1/4	0.8	1.8	.3	13.0	20	13	51					
		Alt															2.1	13.3	20	13	53
		High																			
	575-3-60	Std	518	632	1	6.4	36.0	1	1/4	0.8	1.8	.3	9.2	15	10	41					
		Alt															2.1	9.3	15	10	42
		High																			
	006 (5 Tons)	208/230-1-60	Std	187	254	1	28.8	147.0	1	1/4	1.4	5.9	.6	43.3/43.3	60/60	42/42	161/161				
Alt			6.6															44.0/44.0	60/60	42/42	184/184
208/230-3-60		Std		187	254	1	16.0	114.0	1	1/4	1.4	5.9	.6	27.3/27.3	35/35	27/27	128/128				
		Alt	5.2															26.6/26.6	35/35	26/26	148/148
		High																			
460-3-60		Std	414	508	1	7.4	64.0	1	1/4	0.8	3.1	.3	13.2	20	13	71					
		Alt															2.6	13.5	20	13	81
		High																			
575-3-60		Std	518	632	1	6.2	52.0	1	1/4	0.8	3.1	.3	9.7	15	11	58					
		Alt															2.6	9.9	15	11	65
		High																			
007 (6 Tons)		208/230-3-60	Std	187	254	1	20.6	146.0	1	1/4	1.4	5.2	.6	32.4/32.4	40/40	31/31	180/180				
	High		7.5															34.7/34.7	40/40	34/34	205/205
	460-3-60	Std		414	508	1	9.5	73.0	1	1/4	0.9	2.6	.3	15.4	20	15	90				
		High	3.4															16.2	20	16	103
	575-3-60	Std		518	632	1	7.6	58.4	1	1/4	0.6	2.6	.3	11.4	15	12	79				
		High	3.4															11.9	15	13	86
008 (7 1/2 Tons)	208/230-3-60	Std		187	254	2	14.0	91.0	2	1/4	1.4	5.8	.6	40.1/40.1	45/45	42/42	229/229				
		Alt	5.8															40.1/40.1	45/45	42/42	229/229
		High																			
	460-3-60	Std	414	508	2	6.4	42.0	2	1/4	0.7	2.6	.3	18.4	20	19	108					
		Alt															2.6	18.4	20	19	108
		High																			
	575-3-60	Std	518	632	2	5.2	39.0	2	1/4	0.7	2.6	.3	14.9	20	16	97					
		Alt															2.6	14.9	20	16	97
		High																			
009 (8 1/2 Tons)	208/230-3-60	Std	187	254	2	17.3††	120.0††	2	1/4	1.4	5.8	.6	44.3/44.3	50/50	46/46	272/272					
		High															10.6	49.1/49.1	60/60	52/52	316/316
	460-3-60	Std	414	508	2	7.9††	70.0††	2	1/4	0.7	2.6	.3	21.0	25	22	149					
		High															4.8	23.2	30	24	171
	575-3-60	Std	518	632	2	5.5††	50.0††	2	1/4	0.7	2.6	.3	16.7	20	17	109					
		High															4.8	18.5	25	19	126

See Legend and Notes on page 93.



48TM004-014

**ELECTRICAL DATA (Without Convenience Outlet) (cont)**

UNIT 48TM	NOMINAL VOLTAGE	IFM TYPE	VOLTAGE RANGE		COMPR (ea)			OFM (ea)			IFM	COMBUSTION FAN MOTOR FLA	POWER SUPPLY*		DISCONNECT SIZE†	
			Min	Max	Qty	RLA	LRA	Qty	Hp	FLA			FLA	MCA	MOCP**	FLA
012 (10 Tons)	208/230-3-60	Std	187	254	2	16.0	125.0	2	1/4	1.4	5.8	.6	44.6/44.6	50/50	47/47	297/297
		Alt									7.5		46.3/46.3	60/60	49/49	316/316
		High									15.0		53.4/53.4	60/60	57/57	374/374
	460-3-60	Std	414	508	2	8.0	62.5	2	1/4	0.7	2.6	.3	22.0	25	24	188
		Alt									3.4		22.8	25	24	191
		High									7.4		26.8	30	29	182
	575-3-60	Std	518	632	2	6.3	50.0	2	1/4	0.7	2.6	.3	17.4	20	18	119
		Alt									3.4		18.0	20	19	151
		High									7.4		21.2	25	23	146
014 (12 1/2 Tons)	208/230-3-60	Std	187	254	2	19.0	156.0	2	1/4	1.4	10.6	.6	56.2/56.2	70/70***	59/59	359/359
		Alt									15.0		60.6/60.6	70/70***	64/64	378/378
	460-3-60	Std	414	508	2	9.0	75.0	2	1/4	0.7	4.8	.3	26.5	30	28	174
		Alt									7.4		29.1	35	31	213
	575-3-60	Std	518	632	2	7.4	54.0	2	1/4	0.7	4.8	.3	21.6	25	23	127
		Alt									7.4		23.7	30	25	159

**LEGEND**

- FLA** — Full Load Amps
- HACR** — Heating, Air Conditioning and Refrigeration
- IFM** — Indoor (Evaporator) Fan Motor
- LRA** — Locked Rotor Amps
- MCA** — Minimum Circuit Amps
- MOCP** — Maximum Overcurrent Protection
- NEC** — National Electrical Code
- OFM** — Outdoor (Condenser) Fan Motor
- RLA** — Rated Load Amps

\*The values listed in this table do not include power exhaust. See table below for power exhaust requirements.

†Used to determine minimum disconnect per NEC.

\*\*Fuse or HACR circuit breaker.

††Compressor no. 1 data indicated in table.

208/230-3-60: Compressor no. 2 RLA is 14.1 amps and LRA is 105 amps.

460-3-60: Compressor no. 2 RLA is 7.1 amps and LRA is 55 amps.

575-3-60: Compressor no. 2 RLA is 6.4 amps and LRA is 40 amps.

\*\*\*Fuse only.

**POWER EXHAUST ELECTRICAL DATA**

POWER EXHAUST PART NO.	MCA (230 v)	MCA (460 v)	MCA (575 v)	MOCP (for separate power source)
CRPWREXH021A00	N/A	0.9	N/A	15
CRPWREXH022A00	3.3	N/A	1.32	15
CRPWREXH023A00	N/A	1.8	N/A	15
CRPWREXH024A00	1.6	N/A	0.64	15
CRPWREXH025A00	N/A	0.9	N/A	15
CRPWREXH026A00	3.3	N/A	1.32	15
CRPWREXH027A00	N/A	1.8	N/A	15
CRPWREXH028A00	1.7	N/A	0.68	15
CRPWREXH029A00	N/A	1.0	N/A	15
CRPWREXH030A00	1.6	N/A	0.64	15

N/A — Not available

NOTE: If a single power source is to be used, size wire to include power exhaust MCA and MOCP.

Check MCA and MOCP when power exhaust is powered through the unit. Determine the new MCA including the power exhaust using the following formula:

MCA New = MCA unit only + MCA of Power Exhaust

For example, using a 48TMD006---5 unit with MCA = 28.9 and MOCP = 35, with CRPWREXH030A00 power exhaust.

MCA New = 28.9 amps + 1.6 amps = 30.5 amps

If the new MCA does not exceed the published MOCP, then MOCP would not change. The MOCP in this example is 35 amps and the MCA New is below 35; therefore the MOCP is acceptable. If "MCA New" is larger than the published MOCP, raise the MOCP to the next larger size. For separate power, the MOCP for the power exhaust will be 15 amps per NEC.

**NOTES:**

1. In compliance with NEC requirements for multimotor and combination load equipment (refer to NEC Articles 430 and 440), the overcurrent protective device for the unit shall be fuse or HACR breaker. Canadian units may be fuse or circuit breaker.

**2. Unbalanced 3-Phase Supply Voltage**

Never operate a motor where a phase imbalance in supply voltage is greater than 2%. Use the following formula to determine the percent of voltage imbalance.

% Voltage Imbalance

$$= 100 \times \frac{\text{max voltage deviation from average voltage}}{\text{average voltage}}$$

Example: Supply voltage is 460-3-60.

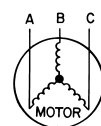

AB = 452 v  
BC = 464 v  
AC = 455 v

$$\text{Average Voltage} = \frac{452 + 464 + 455}{3}$$

$$= \frac{1371}{3}$$

$$= 457$$

Determine maximum deviation from average voltage.

(AB) 457 - 452 = 5 v

(BC) 464 - 457 = 7 v

(AC) 457 - 455 = 2 v

Maximum deviation is 7 v.

Determine percent of voltage imbalance.

$$\% \text{ Voltage Imbalance} = 100 \times \frac{7}{457}$$

$$= 1.53\%$$

This amount of phase imbalance is satisfactory as it is below the maximum allowable 2%.

**IMPORTANT:** If the supply voltage phase imbalance is more than 2%, contact your local electric utility company immediately.



# Electrical data (cont)



## ELECTRICAL DATA (With Convenience Outlet)

48TM004-014

UNIT 48TM	NOMINAL VOLTAGE	IFM TYPE	VOLTAGE RANGE		COMPR (ea)			OFM (ea)			IFM	COMBUSTION FAN MOTOR FLA	POWER SUPPLY*		DISCONNECT SIZE†						
			Min	Max	Qty	RLA	LRA	Qty	Hp	FLA			MCA	MOCPS**	FLA	LRA					
004 (3 Tons)	208/230-1-60	Std	187	254	1	16.2	96.0	1	1/4	1.4	3.5	.6	31.2/31.2	35/35	30/30	111/111					
		Alt															4.9	32.6/32.6	40/40	31/31	116/116
	208/230-3-60	Std	187	254	1	10.2	75.0	1	1/4	1.4	3.5	.6	22.5/22.5	25/25	23/23	90/ 90					
		Alt															4.9	23.9/23.9	30/30	25/25	95/ 95
		High															5.2	24.2/24.2	30/30	25/25	114/114
	460-3-60	Std	414	508	1	4.4	40.0	1	1/4	0.8	1.3	.3	9.8	15	10	47					
		Alt															2.1	10.6	15	11	50
		High															2.6	11.1	15	11	59
	575-3-60	Std	518	632	1	3.7	31.0	1	1/4	0.8	1.3	.3	7.2	15	8	36					
		Alt															2.1	7.7	15	9	39
		High															2.6	8.0	15	9	58
	005 (4 Tons)	208/230-1-60	Std	187	254	1	23.3	118.0	1	1/4	1.4	3.5	.6	40.0/40.0	45/45	38/38	134/134				
Alt			4.9															41.4/41.4	50/50	40/40	138/138
208/230-3-60		Std	187	254	1	15.4	90.0	1	1/4	1.4	3.5	.6	29.0/29.0	35/35	29/29	106/106					
		Alt															4.9	30.4/30.4	35/35	30/30	110/110
		High															5.2	30.7/30.7	35/35	31/31	129/129
460-3-60		Std	414	508	1	8.3	45.0	1	1/4	0.8	1.8	.3	15.2	20	15	53					
		Alt															2.1	15.5	20	15	55
		High															2.6	16.0	20	16	64
575-3-60		Std	518	632	1	6.4	36.0	1	1/4	0.8	1.8	.3	10.9	15	12	42					
		Alt															2.1	11.1	15	12	44
		High															2.6	11.4	15	12	51
006 (5 Tons)		208/230-1-60	Std	187	254	1	28.8	147.0	1	1/4	1.4	5.9	.6	49.3/49.3	60/60	47/47	166/166				
	Alt		6.6															50.0/50.0	60/60	48/48	188/188
	208/230-3-60	Std	187	254	1	16.0	114.0	1	1/4	1.4	5.9	.6	32.1/32.1	40/40	32/32	133/133					
		Alt															5.2	31.4/31.4	40/40	32/32	153/153
		High															7.5	33.7/33.7	40/40	34/34	179/179
	460-3-60	Std	414	508	1	7.4	64.0	1	1/4	0.8	3.1	.3	15.3	20	15	74					
		Alt															2.6	15.6	20	15	83
		High															3.4	15.6	20	16	96
	575-3-60	Std	518	632	1	6.2	52.0	1	1/4	0.8	3.1	.3	11.5	15	13	60					
		Alt															2.6	11.7	15	12	67
		High															3.4	11.7	15	13	77
	007 (6 Tons)	208/230-3-60	Std	187	254	1	20.6	146.0	1	1/4	1.4	5.2	.6	37.2/37.2	45/45	37/37	184/184				
High			7.5															39.5/39.5	45/45	39/39	210/210
460-3-60		Std	414	508	1	9.5	73.0	1	1/4	0.6	2.6	.3	17.6	20	17	92					
		High															3.4	18.4	25	18	105
575-3-60		Std	518	632	1	7.6	58.4	1	1/4	0.6	2.6	.3	13.1	20	14	77					
		High															3.4	13.7	20	15	90
008 (7 1/2 Tons)	208/230-3-60	Std	187	254	2	14.0	91.0	2	1/4	1.4	5.8	.6	44.9/44.9	50/50	48/48	234/234					
		Alt															5.8	44.9/44.9	50/50	48/48	234/234
		High															10.6	49.7/49.7	60/60	53/53	277/277
	460-3-60	Std	414	508	2	6.4	42.0	2	1/4	0.7	2.6	.3	20.6	25	22	110					
		High															4.8	22.8	30	24	132
	575-3-60	Std	518	632	2	5.2	39.0	2	1/4	0.7	2.6	.3	16.6	20	18	99					
Alt		2.6															16.6	20	18	99	
High		4.8															18.4	20	20	116	
009 (8 1/2 Tons)	208/230-3-60	Std	187	254	2	17.3††	120.0††	2	1/4	1.4	5.8	.6	49.1/49.1	60/60	52/52	277/277					
		High															10.6	53.9/53.9	60/60	57/57	320/320
	460-3-60	Std	414	508	2	7.9††	70.0††	2	1/4	0.7	2.6	.3	23.2	30	24	151					
		High															4.8	25.4	30	27	173
	575-3-60	Std	518	632	2	5.5††	50.0††	2	1/4	0.7	2.6	.3	18.4	25	19	111					
		High															4.8	20.2	25	21	128

See Legend and Notes on page 95.



48TM004-014

**ELECTRICAL DATA (With Convenience Outlet) (cont)**

UNIT 48TM	NOMINAL VOLTAGE	IFM TYPE	VOLTAGE RANGE		COMPR (ea)			OFM (ea)			IFM	COMBUSTION FAN MOTOR FLA	POWER SUPPLY*		DISCONNECT SIZE†		
			Min	Max	Qty	RLA	LRA	Qty	Hp	FLA			FLA	MCA	MOCP**	FLA	LRA
012 (10 Tons)	208/230-3-60	Std										5.8	.6	49.4/49.4	60/60	52/52	302/302
		Alt	187	254	2	16.0	125.0	2	1/4	1.4	7.5	51.9/51.9		60/60	54/54	321/321	
		High									15.0	58.6/58.6		70/70	63/63	369/369	
	460-3-60	Std										2.6	.3	24.2	30	26	151
		Alt	414	508	2	8.0	62.5	2	1/4	0.7	3.4	25.0		30	26	190	
		High									7.4	29.0		35	31	184	
	575-3-60	Std										2.6	.3	19.1	25	20	121
		Alt	518	632	2	6.3	50.0	2	1/4	0.7	3.4	19.7		25	21	152	
		High									7.4	22.9		25	25	148	
014 (12 1/2 Tons)	208/230-3-60	Std										10.6	.6	61.0/61.0	70/70***	65/65	364/364
		Alt	187	254	2	19.0	156.0	2	1/4	1.4	15.0	65.4/65.4		80/80***	70/70	383/383	
		High															
	460-3-60	Std										4.8	.3	28.7	35	30	176
		Alt	414	508	2	9.0	75.0	2	1/4	0.7	7.4	31.3		35	33	215	
		High															
	575-3-60	Std										4.8	.3	23.3	30	25	129
		Alt	518	632	2	8.3	58.4	2	1/4	0.7	7.4	25.4		30	27	160	
		High															

**LEGEND**

- FLA** — Full Load Amps
- HACR** — Heating, Air Conditioning and Refrigeration
- IFM** — Indoor (Evaporator) Fan Motor
- LRA** — Locked Rotor Amps
- MCA** — Minimum Circuit Amps
- MOCP** — Maximum Overcurrent Protection
- NEC** — National Electrical Code
- OFM** — Outdoor (Condenser) Fan Motor
- RLA** — Rated Load Amps

\*The values listed in this table do not include power exhaust. See table below for power exhaust requirements.

†Used to determine minimum disconnect per NEC.

\*\*Fuse or HACR circuit breaker.

††Compressor no. 1 data indicated in table.

208/230-3-60: Compressor no. 2 RLA is 14.1 amps and LRA is 105 amps.

460-3-60: Compressor no. 2 RLA is 7.1 amps and LRA is 55 amps.

575-3-60: Compressor no. 2 RLA is 6.4 amps and LRA is 40 amps.

\*\*\*Fuse only.

**POWER EXHAUST ELECTRICAL DATA**

POWER EXHAUST PART NO.	MCA (230 v)	MCA (460 v)	MCA (575 v)	MOCP (for separate power source)
CRPWREXH021A00	N/A	0.9	N/A	15
CRPWREXH022A00	3.3	N/A	1.32	15
CRPWREXH023A00	N/A	1.8	N/A	15
CRPWREXH024A00	1.6	N/A	0.64	15
CRPWREXH025A00	N/A	0.9	N/A	15
CRPWREXH026A00	3.3	N/A	1.32	15
CRPWREXH027A00	N/A	1.8	N/A	15
CRPWREXH028A00	1.7	N/A	0.68	15
CRPWREXH029A00	N/A	1.0	N/A	15
CRPWREXH030A00	1.6	N/A	0.64	15

N/A — Not available

NOTE: If a single power source is to be used, size wire to include power exhaust MCA and MOCP.

Check MCA and MOCP when power exhaust is powered through the unit. Determine the new MCA including the power exhaust using the following formula:

MCA New = MCA unit only + MCA of Power Exhaust

For example, using a 48HJD006---5 unit with MCA = 28.9 and MOCP = 35, with CRPWREXH030A00 power exhaust.

MCA New = 28.9 amps + 1.6 amps = 30.5 amps

If the new MCA does not exceed the published MOCP, then MOCP would not change. The MOCP in this example is 35 amps and the MCA New is below 35; therefore the MOCP is acceptable. If "MCA New" is larger than the published MOCP, raise the MOCP to the next larger size. For separate power, the MOCP for the power exhaust will be 15 amps per NEC.

**NOTES:**

1. In compliance with NEC requirements for multimotor and combination load equipment (refer to NEC Articles 430 and 440), the overcurrent protective device for the unit shall be fuse or HACR breaker. Canadian units may be fuse or circuit breaker.

**2. Unbalanced 3-Phase Supply Voltage**

Never operate a motor where a phase imbalance in supply voltage is greater than 2%. Use the following formula to determine the percent of voltage imbalance.

% Voltage Imbalance

$$= 100 \times \frac{\text{max voltage deviation from average voltage}}{\text{average voltage}}$$

Example: Supply voltage is 460-3-60.

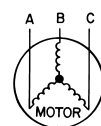

AB = 452 v

BC = 464 v

AC = 455 v

$$\text{Average Voltage} = \frac{452 + 464 + 455}{3}$$

$$= \frac{1371}{3}$$

$$= 457$$

Determine maximum deviation from average voltage.

(AB) 457 - 452 = 5 v

(BC) 464 - 457 = 7 v

(AC) 457 - 455 = 2 v

Maximum deviation is 7 v.

Determine percent of voltage imbalance.

$$\% \text{ Voltage Imbalance} = 100 \times \frac{7}{457}$$

$$= 1.53\%$$

This amount of phase imbalance is satisfactory as it is below the maximum allowable 2%.

**IMPORTANT:** If the supply voltage phase imbalance is more than 2%, contact your local electric utility company immediately.



## Packaged Rooftop Electric Cooling Unit with Gas Heat — Constant Volume Application

### HVAC Guide Specifications

Size Range: **3 to 12<sup>1</sup>/<sub>2</sub> Tons, Nominal (Cooling)**  
**60,000 to 250,000 Btuh, Nominal (Input Heating)**

Carrier Model Numbers:

**48TMD/L**  
**48TME/M**  
**48TMF/N**



### Part 1 — General

#### 1.01 SYSTEM DESCRIPTION

Outdoor rooftop mounted, electrically controlled heating and cooling unit utilizing a hermetic compressor(s) for cooling duty and gas combustion for heating duty. Unit shall discharge supply air vertically or horizontally as shown on contract drawings.

#### 1.02 QUALITY ASSURANCE

- A. Unit shall comply with minimum requirements of ASHRAE 90.1-2001 Energy Efficiency Standards.
- B. Unit shall be rated in accordance with ARI Standards 210/240 or 360 and 270. Designed in accordance with UL Standard 1995.
- C. Unit shall be designed to conform to ASHRAE 15, latest revision.
- D. Unit shall be UL-tested and certified in accordance with ANSI Z21.47 Standards and UL-listed and certified under Canadian standards as a total package for safety requirements.
- E. Roof curb shall be designed to conform to NRCA Standards.
- F. Insulation and adhesive shall meet NFPA 90A requirements for flame spread and smoke generation.
- G. Unit casing shall be capable of withstanding 500-hour salt spray exposure per ASTM B117 (scribed specimen).
- H. Unit shall be designed in accordance with ISO 9001, and shall be manufactured in a facility registered to ISO 9001:2000.
- I. Each unit shall be subjected to a completely automated run testing on the assembly line. Units contain a factory-supplied printout indicating tested pressures, amperages, data, and inspectors, providing certification of the unit status at the time of manufacture.

#### 1.03 DELIVERY, STORAGE, AND HANDLING

Unit shall be stored and handled per manufacturer's recommendations.

### Part 2 — Products

#### 2.01 EQUIPMENT (STANDARD)

##### A. General:

Factory assembled, single-piece heating and cooling unit. Contained within the unit enclosure shall be all factory wiring, piping, controls, refrigerant charge (R-22), and special features required prior to field start-up.

##### B. Unit Cabinet:

1. Unit cabinet shall be constructed of galvanized steel, and shall be bonderized and coated with a prepainted baked enamel finish on all externally exposed surfaces.
2. Evaporator fan compartment interior cabinet surfaces shall be insulated with a minimum 1/2-in. thick, 1 lb. density, flexible fiberglass insulation, neoprene coated on the air side. Aluminum foil-faced fiberglass insulation shall be used in the gas heat compartment.
3. Cabinet panels shall be easily removable for servicing.
4. Holes shall be provided in the base rails for rigging shackles to facilitate maneuvering and overhead rigging.
5. Unit shall have a factory-installed, sloped condensate drain pan made of a non-corrosive material, providing a minimum 3/4-in.-14 NPT. connection with both vertical and horizontal drains, and shall comply with ASHRAE Standard 62.
6. Unit shall have a factory-installed filter access panel to provide filter access with tool-less removal.
7. Unit shall have standard thru-the-bottom gas and power connection capability (accessory kit is required).

##### C. Fans:

1. Evaporator Fan:
  - a. Fan shall be direct or belt driven as shown on the equipment drawings. Belt drive shall include an adjustable-pitch motor pulley.
  - b. Fan wheel shall be double-inlet type with forward-curved blades.
  - c. Bearings shall be sealed, permanently lubricated ball-bearing type for longer life and lower maintenance.
2. Evaporator fan shall be made from steel with a corrosion-resistant finish and shall be dynamically balanced.
3. Condenser fan shall be of the direct-driven (with totally enclosed motors) propeller type and shall discharge air vertically.

4. Condenser fan shall have aluminum blades riveted to corrosion-resistant steel spiders and shall be dynamically balanced.
5. Induced-draft blower shall be of the direct-driven, single inlet, forward-curved centrifugal type, made from steel with a corrosion-resistant finish and shall be dynamically balanced.

D. Compressor(s):

1. Fully hermetic type, internally protected reciprocating (48TM004,005,006 and 008) or scroll-type (48TM007,009,012 and 014).
2. Factory mounted on rubber grommets and internally spring mounted for vibration isolation.
3. On independent circuits (008-014).

E. Coils:

1. Standard evaporator and condenser coils shall have aluminum lanced plate fins mechanically bonded to seamless internally grooved copper tubes with all joints brazed.
2. Dual compressor models (size 008-014) shall have face-split type evaporator coil (circuit no. 1 on bottom).
3. Optional coils:
  - a. Optional pre-coated aluminum-fin coils shall have a durable epoxy-phenolic coating to provide protection in mildly corrosive coastal environments. Coating shall be applied to the aluminum fin stock prior to the fin stamping process to create an inert barrier between the aluminum fin and copper tube. Epoxy-phenolic barrier shall minimize galvanic action between dissimilar metals.
  - b. Copper-fin coils shall be constructed of copper fins mechanically bonded to copper tubes and copper tube sheets. Galvanized steel tube sheets shall not be acceptable. A polymer strip shall prevent coil assembly from contacting the sheet metal coil pan to minimize potential for galvanic corrosion between coil and pan. All copper construction shall provide protection in moderate coastal environments.
  - c. E-Coated aluminum-fin coils shall have a flexible epoxy polymer coating uniformly applied to all coil surface areas without material bridging between fins. Coating process shall ensure complete coil encapsulation. Color shall be high gloss black with gloss — 60 deg of 65 to 90% per ASTM D523-89. Uniform dry film thickness from 0.8 to 1.2 mil on all surface areas including fin edges. Superior hardness characteristics of 2H per ASTM D3363-92A and cross-hatch adhesion of 4B-5B per ASTM D3359-93. Impact resistance shall be up to 160 in.-lb (ASTM D2794-93). Humidity and water immersion resistance shall be up to

minimum 1000 and 250 hours respectively (ASTM D2247-92 and ASTM D870-92). Corrosion durability shall be confirmed through testing to be no less than 1000 hours salt spray per ASTM B117-90. Coil construction shall be aluminum fins mechanically bonded to copper tubes.

- d. E-Coated copper-fin coils shall have a flexible epoxy polymer coating uniformly applied to all coil surface areas without material bridging between fins. Coating process shall ensure complete coil encapsulation. Color shall be high gloss black with gloss — 60 deg of 65 to 90% per ASTM D523-89. Uniform dry film thickness from 0.8 to 1.2 mil on all surface areas including fin edges. Superior hardness characteristics of 2H per ASTM D3363-92A and cross-hatch adhesion of 4B-5B per ASTM D3359-93. Impact resistance shall be up to 160 in.-lb (ASTM D2794-93). Humidity and water immersion resistance shall be up to minimum 1000 and 250 hours respectively (ASTM D2247-92 and ASTM D870-92). Corrosion durability shall be confirmed through testing to be no less than 1000 hours salt spray per ASTM B117-90. Coil construction shall be copper fins mechanically bonded to copper tubes with copper tube sheets. Galvanized steel tube sheets shall not be acceptable. A polymer strip shall prevent coil assembly from contacting sheet metal coil pan to maintain coating integrity and minimize corrosion potential between coil and pan.

F. Heating Section:

1. Induced-draft combustion type with energy saving direct-spark ignition system and redundant main gas valve.
2. The heat exchanger shall be of the tubular-section type constructed of a minimum of 20-gage steel coated with a nominal 1.2 mil aluminum-silicone alloy for corrosion resistance.
3. Burners shall be of the in-shot type constructed of aluminum-coated steel.
4. All gas piping shall enter the unit cabinet at a single location on side of unit (horizontal plane).
5. The integrated gas controller (IGC) board shall include gas heat operation fault notification using an LED (light-emitting diode).
6. Unit shall be equipped with anti-cycle protection with one short cycle on unit flame rollout switch or 4 continuous short cycles on the high-temperature limit switch. Fault indication shall be made using an LED.
7. The IGC board shall contain algorithms that modify evaporator-fan operation to prevent future cycling on high-temperature limit switch.

# Guide specifications — 48TM004-014 (cont)



48TM004-014

8. The LED shall be visible without removal of control box access panel.
  9. Optional Stainless Steel Heat Exchanger:
    - a. Complete stainless steel heat exchanger allows for greater application flexibility.
    - b. 409 stainless steel used in heat exchanger tubes and vestibule plate.
- G. Refrigerant Components:  
Refrigerant circuit components shall include:
1. Fixed orifice metering system (Acutrol™).
  2. Refrigerant filter drier.
  3. Service gage connections on suction, discharge, and liquid lines.
- H. Filter Section:
1. Standard filter section shall consist of factory-installed, low velocity, throwaway 2-in. thick fiberglass filters of commercially available sizes.
  2. Filter face velocity shall not exceed 320 fpm at nominal airflows.
  3. Filter section should use only one size filter.
  4. Filters shall be accessible through an access panel with “no-tool” removal.
- I. Controls and Safeties:
1. Unit Controls:  
Unit shall be complete with self-contained low-voltage control circuit protected by a fuse on the 24-v transformer side (48TM008-014 units have a resettable circuit breaker).
  2. Safeties:
    - a. Unit shall incorporate a solid-state compressor protector which provides anti-cycle reset capability at the space thermostat, should any of the following standard safety devices trip and shut off compressor.
      - 1) Compressor overtemperature, overcurrent.
      - 2) Loss-of-charge/low-pressure switch.
      - 3) Freeze-protection thermostat, evaporator coil.
      - 4) High-pressure switch.
      - 5) Automatic reset motor thermal overload protector.The lockout protection shall be easily disconnected at the control board, if necessary.
    - b. Heating section shall be provided with the following minimum protections:
      - 1) High-temperature limit switches.
      - 2) Induced draft motor speed sensor.
      - 3) Flame rollout switch.
      - 4) Flame proving controls.
- J. Operating Characteristics:
1. Unit shall be capable of starting and running at 115 F ambient outdoor temperature, meeting maximum load criteria of ARI Standard 210/240 or 360 at  $\pm 10\%$  voltage.
2. Compressor with standard controls shall be capable of operation down to 25 F ambient outdoor temperature.
- K. Electrical Requirements:  
All unit power wiring shall enter unit cabinet at a single factory-predrilled location.
- L. Motors:
1. Compressor motors shall be cooled by refrigerant gas passing through motor windings and shall have line break thermal and current overload protection.
  2. Evaporator-fan motor shall have permanently lubricated bearings and inherent automatic-reset thermal overload protection. Evaporator motors are designed specifically for Carrier and do *not* have conventional horsepower (HP) ratings listed on the motor nameplate. Motors are designed and qualified in the “air-over” location downstream of the cooling coil and carry a maximum continuous bhp rating that is the maximum application bhp rating for the motor; no “safety factors” above that rating may be applied.
  3. Totally enclosed condenser-fan motor shall have permanently lubricated bearings, and inherent automatic-reset thermal overload protection.
  4. Induced-draft motor shall have permanently lubricated sealed bearings and inherent automatic-reset thermal overload protection.
- M. Special Features:  
Certain features are not applicable when the features designated \* are specified. For assistance in amending the specifications, contact your local Carrier Sales Office.
- \* 1. Carrier PremierLink™ Controls:
- a. Shall be available as a factory-installed or as a field-installed accessory.
  - b. Shall work with CCN and ComfortVIEW™ software.
  - c. Shall be compatible with *ComfortLink*™ controllers.
  - d. Shall be ASHRAE 62-99 compliant.
  - e. Shall accept a CO<sub>2</sub> sensor in the conditioned space — Demand Control Ventilation (DCV) Ready.
  - f. Shall have baud communication rate of 38.4K or faster.
  - g. Shall be Internet Ready.
  - h. Shall include an integrated economizer controller. If an economizer is specified, the “EconoMi\$er2 with 4-20 mA actuator and no microprocessor control” is required.
- (48TM009, 014 are capable of operating at 125 F ambient outdoor air temperature.)

- \* 2. Direct Digital Controls (Apollo):
  - a. Shall be available as a factory-installed option.
  - b. Shall actively monitor all modes of operation, as well as evaporator-fan status, filter status, indoor-air quality, supply-air temperature, and outdoor-air temperature.
  - c. Shall work with Carrier TEMP and VVT® systems.
  - d. Shall have built-in diagnostics for thermostat commands for both staged heating and cooling, evaporator-fan operation, and economizer operation.
  - e. Shall be equipped with a 5-minute time delay between modes of operation.
- 3. Roof Curbs (Horizontal and Vertical):
  - a. Formed galvanized steel with wood nailer strip and shall be capable of supporting entire unit weight.
  - b. Permits installation and securing of ductwork to curb prior to mounting unit on the curb.
- \* 4. Integrated Economizers:
  - a. Integrated integral modulating type capable of simultaneous economizer and compressor operation. During economizer operation, only compressor no. 1 on sizes 008-014 will operate.
  - b. Available as a factory-installed option in vertical supply/return configuration only. (Available as a field-installed accessory for horizontal and/or vertical supply return configurations.)
  - c. Includes all hardware and controls to provide cooling with outdoor air.
  - d. Equipped with low-leakage dampers, not to exceed 2% leakage at 1 in. wg pressure differential.
  - e. Capable of introducing up to 100% outdoor air.
  - f. EconoMi\$er2 shall be equipped with a barometric relief damper.
  - g. Designed to close damper(s) during loss-of-power situations with emergency power supply (Durablade economizer) or spring return built into motor (EconoMi\$er2).
  - h. Dry bulb outdoor-air temperature sensor shall be provided as standard. Outdoor air sensor opens at 67 F, closes at 52 F and is non-adjustable. Enthalpy, differential temperature (adjustable), and differential enthalpy control shall be provided as field-installed accessories.
  - i. Durablade economizer is a guillotine-style damper, and the EconoMi\$er2 is a gear-driven parallel blade design.
  - j. EconoMi\$er2 microprocessor control shall provide control of internal building pressure through its accessory power exhaust function. Factory set at 100%, with a range of 0% to 100%.
  - k. EconoMi\$er2 shall be capable of control from a 4-20 mA signal through optional 4-20 mA design without microprocessor control (required for PremierLink™ or 3rd party control interface).
  - l. EconoMi\$er2 Microprocessor Minimum Damper Position Setting — potentiometer maintains the minimum airflow into the building during occupied period (damper position during heating).
  - m. EconoMi\$er2 Microprocessor Maximum Damper Position Setting — potentiometer allows installer to limit the amount of outdoor airflow into the building, when CO<sub>2</sub> overrides the mixed air sensor. Setting the maximum position of the damper prevents the introduction of large amounts of hot or cold air into the space.
  - n. EconoMi\$er2 Microprocessor IAQ control — modulates the outdoor-air damper to provide ventilation based on the optional 2-10 vdc CO<sub>2</sub> sensor input.
  - o. EconoMi\$er2 Microprocessor Purge or Shutdown modes: require optional Honeywell S963B1128 potentiometer (135 ohm).
  - p. Compressor lockout sensor (opens at 35 F, closes at 50 F).
- 5. Manual Outdoor-Air Damper:
 

Manual damper package shall consist of damper, birdscreen, and rainhood which can be preset to admit up to 50% outdoor air for year round ventilation.
- \* 6. 100% Two-Position Damper:
  - a. Two-position damper package shall include single blade damper and motor. Admits up to 100% outdoor air.
  - b. Damper shall close upon indoor (evaporator) fan shutoff.
  - c. Designed to close damper during loss of power situations.
  - d. Equipped with 15% barometric relief damper.
- \* 7. 25% Two-Position Damper:
  - a. Two-position damper package shall include single blade damper and motor. Admits up to 25% outdoor air.
  - b. Damper shall close upon indoor (evaporator) fan shutoff.



- \* 8. Head Pressure Control Package:  
Consists of solid-state control and condenser-coil temperature sensor to maintain condensing temperature between 90 F and 110 F at outdoor ambient temperatures down to -20 F by condenser-fan speed modulation or condenser-fan cycling and wind baffles.
- 9. LP (Liquid Propane) Conversion Kit:  
Package shall contain all the necessary hardware (spuds only) and instructions to convert a standard natural gas unit for use with liquefied propane.
- \* 10. Electronic Programmable Thermostat:  
Capable of using deluxe full-featured electronic thermostat. Shall use built-in compressor cycle delay control for both heating and cooling duty. Capable of working with Carrier direct digital controls.
- 11. Light Commercial Thermidistat:  
Field-installed wall-mounted thermostat is used to control temperature and activation of the Energy\$Recycler device. The thermidistat can be set for humidity settings from 50% to 90% relative humidity. Automatic humidity control adjusts indoor humidity based on the outdoor temperature sensor.
- \* 12. Flue Shield:  
Provides protection from the hot sides of the gas flue hood.
- \* 13. Thermostat and Subbase:  
Provides staged cooling and heating automatic (or manual) changeover, fan control, and indicator light.
- \* 14. Condenser Coil Hail Guard Assembly:  
Hail guard shall protect against damage from hail and flying debris.
- 15. Unit-Mounted, Non-Fused Disconnect Switch:  
Shall be factory-installed, internally mounted. NEC and UL approved non-fused switch shall provide unit power shutoff. Shall be accessible from outside the unit and shall provide power off lockout capability.
- 16. Convenience Outlet:  
Shall be factory-installed and internally mounted with easily accessible 115-v female receptacle. Shall include 15 amp GFI receptacle with independent fuse protection. Voltage required to operate convenience outlet shall be provided by a factory-installed step-down transformer. Shall be accessible from outside the unit.
- 17. Alternate Motor(s) and/or Drive(s) (004-006, 008, 012, 014):  
Alternate motor(s) and drive(s) shall be factory-installed to provide additional performance range.
- 18. High-Static Motor(s) and Drive(s) (004-012):  
High-static motor(s) and drive(s) shall be factory-installed to provide additional performance range.
- 19. Flue Discharge Deflector:  
Flue discharge deflector directs unit exhaust vertically instead of horizontally.
- 20. Condenser Coil Grille:  
The grille protects the condenser coil from damage by large objects without increasing unit clearances.
- 21. Compressor Cycle Delay:  
Unit shall be prevented from restarting for minimum of 5 minutes after shutdown.
- 22. Thru-the-Bottom Utility Connectors:  
Kit shall provide connectors to permit gas and electrical connections to be brought to the unit through the basepan.
- 23. Fan/Filter Status Switch:  
Provides status of indoor (evaporator) fan (ON/OFF) or filter (CLEAN/DIRTY). Status shall be displayed over communication bus when used with direct digital controls or with an indicator light at the thermostat.
- 24. Energy\$Recycler:  
The package shall be an outdoor rooftop or surface mounted, electronically controlled, air-to-air heat pump unit utilizing a hermetic compressor for cooling and heating duty.  
The Energy\$Recycler shall recover energy from building exhaust air and pre-condition ventilation air to allow higher ventilation requirements and minimizing energy cost.  
This accessory shall be available with the following:
  - a. A mounting kit for the Energy\$Recycler for cantilever mounting off of the rooftop unit without the use of a slab or a roof curb.
  - b. A supplementary supply air fan kit to provide increased air movement into the 62AQ unit.
  - c. A field-installed 460 v to 208/230 v transformer to provide power when the 208-230/1/60 62AQ0060 or 100 size Energy\$Recycler is used with a 460 v rooftop unit.
- 25. EconoMi\$er2 and Power Exhaust:  
Package shall provide control of internal building pressure. The power exhaust system shall exhaust up to 100% of return air (vertical only).

26. Power Exhaust Accessory for EconoMi\$er2:  
Power exhaust shall be used in conjunction with EconoMi\$er2 to provide system exhaust of up to 100% of return air (vertical only). The power exhaust is a field-installed accessory (separate vertical and horizontal design).  
NOTE: Horizontal power exhaust is intended to mount in return ductwork.  
As the outdoor-air damper opens and closes, *both* propeller fans are energized and de-energized through the end switch (potentiometer) located on the EconoMi\$er2 controller. The end switch is factory set at 100% of outdoor-air, and is adjustable 0-100% to meet specific job requirements. Available in 208/230-1-60 v or 460-3-60 v. An LED light on the controller indicates when the power exhaust is operating.
27. Outdoor Air Enthalpy Sensor:  
The outdoor air enthalpy sensor shall be used with the EconoMi\$er2 device to provide single enthalpy control. When used in conjunction with a return air enthalpy sensor, the EconoMi\$er2 device will provide differential enthalpy control. The sensor allows the EconoMi\$er2 controller to determine if outside air is suitable for free cooling.
28. Return Air Enthalpy Sensor:  
The return air enthalpy sensor shall be used with the EconoMi\$er2 device. When used in conjunction with an outdoor air enthalpy sensor, the EconoMi\$er2 device will provide differential enthalpy control.
29. Return Air Temperature Sensor:  
The return air temperature sensor shall be used with the EconoMi\$er2 device. When used in conjunction with the standard outdoor air temperature sensor, the EconoMi\$er2 device will provide differential temperature control.
30. Outdoor Air/Return Air Temperature Sensor (Adjustable):  
Optional sensor uses (4) ranges on EconoMi\$er2 microprocessor to control outdoor air damper and compressor operation.
31. Indoor Air Quality (CO<sub>2</sub>) Sensor:  
a. Shall have the ability to provide demand ventilation indoor air quality (IAQ) control through the EconoMi\$er2 with an IAQ sensor.  
b. The IAQ sensor shall be available in duct mount, wall mount, and wall mount with LED display. The set point shall have adjustment capability.  
c. Requires EconoMi\$er2, PremierLink™, or Apollo control options.
32. Power Exhaust Auxiliary Transformer:  
Field installed 575 v to 230 v transformer to provide power to the 230 v power exhaust when attached to a 575 v rooftop unit.
33. Gas Heat options (sizes 004-006):  
a. Single-stage gas heat shall be provided in lieu of two-stage heat (high heat only).  
b. NO<sub>x</sub> reduction shall be provided to reduce nitrous oxide emissions to meet the California Air Quality Management NO<sub>x</sub> requirement of 40 nanograms/joule or less.  
c. Primary tubes on low NO<sub>x</sub> units shall be 409 stainless steel. Other components shall be aluminized steel.
34. Ultra-Violet Germicidal Lamps:  
Ultra-violet germicidal lamps are designed to eliminate odor causing mold and fungus that may develop in the wet area of the evaporator section of the unit. The high output, low temperature germicidal lamps are field installed in the evaporator section of the unit, aimed at the evaporator coil and condensate pan. The short wavelength ultra-violet light inhibits and kills mold, fungus and microbial growth. The lamps have an output rating at 45 F in 400 fpm air-flow of 120 microwatts/cm<sup>2</sup> at 1 meter.
35. Humidistat:  
Field-installed, wall-mounted humidistat is used to control activation of the Energy\$Recycler device. The humidistat can be set for humidity levels between 20% and 80% relative humidity.

# Model number nomenclature



## 48TM016-028 (15 to 25 Tons) — ASHRAE 90.1 Compliant

Example: 48 TM D 025 P - F 6 - 1 YA

48 – Packaged Rooftop  
Electric Cooling/  
Natural Gas Heat

TM – Constant Volume, Standard Efficiency

### Heat Options

D – Low Heat  
F – High Heat  
M – Low Heat, Stainless Steel Heat Exchanger  
N – High Heat, Stainless Steel Heat Exchanger

### Nominal Capacity – Tons

016 – 15 Tons  
020 – 18 Tons  
025 – 20 Tons  
028 – 25 Tons

### Control/Service Options

– – Standard Controls  
G – Service Option (Non-fused D/C, 115v  
Convenience Outlet [field wired]  
Hinged Access Panels) with  
Standard Controls  
H – Hinged Access Panels with PremierLink™ Controller  
J – Hinged Access Panels  
P – PremierLink DDC Control  
S – Hinged Access Panels with  
Apollo Control  
X – Service Option with PremierLink Controller  
Y – Service Option with Apollo Control  
Z – Apollo Control Option

Factory-Installed Options Code\*

Packaging  
1 – Domestic

### Design Series

0 – Initial Design with Gear-Driven EconoMi\$er

### Voltage

1 – 575-3-60  
5 – 208/230-3-60  
6 – 460-3-60

### Coil Protection Options (fin/tube)

– – Al/Cu Condenser and Evaporator  
B – Cu/Cu Condenser and Evaporator  
C – Cu/Cu Condenser and Al/Cu Evaporator  
F – E-Coated Al/Cu Condenser  
G – E-Coated CU/CU Condenser  
V – Black Pre-Coated Condenser Fins

### Fan Drive Position (Standard Motor)

– – Standard Motor and Drive

48TM016-028

### LEGEND

Al — Aluminum  
Cu — Copper  
DDC — Direct Digital Controls  
FIOP — Factory-Installed Option

\*Refer to 48TM Price Pages or contact your local Carrier representative for FIOP code table.

## Quality Assurance



Certificate No FM 21837

### Approvals:

ISO 9001  
EN 9000:2000

# ARI\* capacity ratings



UNIT SIZE 48TMD	NOMINAL TONS	NET COOLING CAPACITY (Btuh)	TOTAL WATTS	EER	SOUND RATING (Bels)	IPLV
016	15	176,000	17,064	9.5	8.8	9.5
020	18	202,000	21,166	9.7	8.8	10.2
025	20	236,000	24,832	9.5	9.4	10.1
028	25	278,000	28,535	9.7	9.4	10.4

UNIT SIZE 48TMF	NOMINAL TONS	NET COOLING CAPACITY (Btuh)	TOTAL WATTS	EER	SOUND RATING (Bels)	IPLV
016	15	176,000	17,179	9.5	8.8	9.5
020	18	202,000	21,301	9.7	8.8	10.1
025	20	236,000	24,832	9.5	9.4	10.0
028	25	277,000	29,067	9.5	9.4	10.0

### LEGEND

- Bels** — Sound Levels (1 bel = 10 decibels)
- db** — Dry Bulb
- EER** — Energy Efficiency Ratio
- IPLV** — Integrated Part-Load Values
- wb** — Wet Bulb

\*Air Conditioning and Refrigeration Institute.

### NOTES:

1. Rated in accordance with ARI Standards 360-89 and 270-89.
2. ARI ratings are net values, reflecting the effects of circulating fan heat.
3. Ratings are based on:

**Cooling Standard:** 80 F db, 67 F wb indoor entering-air temperature and 95 F db air entering outdoor unit.

**IPLV Standard:** 80 F db, 67 F wb indoor entering-air temperature and 80 F db outdoor entering-air temperature.

4. All 48TM016-028 units are in compliance with ASHRAE 90.1 2001 Energy Standard for minimum SEER and EER requirements. Refer to state and local codes or visit the following web-site: <http://solstice.crest.org/efficiency/bcap> to determine if compliance with this standard pertains to a given geographical area of the United States.

California, Maryland, Washington, Wyoming and various local and state building codes adopted the ASHRAE 90.1 efficiency standard on October 29, 2001.

48TM016-028



## ARI HEATING CAPACITIES AND EFFICIENCIES — 48TM016-028

UNIT 48TM	HEATING INPUT (Btuh) Stage 2/Stage 1*	OUTPUT CAPACITY (Btuh)	TEMPERATURE RISE (F)	STEADY-STATE EFFICIENCY (%)	MINIMUM HEATING CFM
D016	275,000/206,000	223,000	15-45	81.0	3830
F016	360,000/270,000	292,000	20-50	81.0	3750
D020	275,000/206,000	223,000	15-45	81.0	4580
F020	360,000/270,000	292,000	20-50	81.0	5400
D025	275,000/206,000	223,000	15-45	81.0	4580
F025	360,000/270,000	292,000	20-50	81.0	5400
D028	275,000/206,000	223,000	15-45	81.0	4580
F028	360,000/270,000	292,000	20-50	81.0	5400

\*All units are 2-stage heat.

NOTE: Minimum allowable temperature of mixed-air entering the heat exchanger during first-stage heating is 45 F. There is no minimum mixed-air temperature limitation during second-stage heating. For entering-air temperatures below 45 F both stages of heat must be energized together to minimize condensation issues and ensure proper unit operation.

### AIR QUANTITY LIMITS — COOLING

UNIT 48TM	MINIMUM CFM	MAXIMUM CFM
016	4500	7,500
020	5400	9,000
025	6000	10,000
028	7000	11,250

### LOW OUTDOOR TEMPERATURE OPERATING LIMITS (F)

UNITS	TEMPERATURE
All	40
016, 020 and 028 with Low Ambient Kit	10
025 with Low Ambient Kit	25
All with Motormaster® Head Pressure Control	-20

# Physical data



48TM016-028

UNIT 48TM	016D/F	020D/F	025D/F	028D/F
<b>NOMINAL CAPACITY (tons)</b>	15	18	20	25
<b>OPERATING WEIGHT</b>	1800	1850	1900	2270
EconoMiSer	80	80	80	80
MoistureMiSer™ Dehumidification Package	40	40	40	40
<b>COMPRESSOR/MANUFACTURER</b>	Scroll, Copeland			
Quantity...Model (Ckt 1, Ckt 2)	1...ZR94KC, 1...ZR72KC	1...ZR108KC, 1...ZR94KC	1...ZR125KC, 1...ZR108KC	1...ZR140KC,* 1...ZR144KC
Capacity Stages (%)	60, 40	55, 45	55, 45	50, 50
Number of Refrigerant Circuits	2	2	2	2
Oil (oz) (Ckt 1, Ckt 2)	85, 60	106, 81	106, 106	136, 106
<b>REFRIGERANT TYPE</b>	R-22			
Expansion Device	TXV			
Operating Charge (lb-oz)	19-8	19-8	19-11	26-13
Circuit 1†	13-8	19-2	13-14	25-10
Circuit 2				
<b>CONDENSER COIL</b>	Cross-Hatched 3/8-in. Copper Tubes, Aluminum Lanced, Aluminum Pre-Coated, or Copper Plate Fins			
Rows...Fins/in.	4...15	4...15	4...15	3...15 (2 coils)
Total Face Area (sq ft)	21.7	21.7	21.7	43.4
<b>CONDENSER FAN</b>	Propeller Type			
Nominal Cfm	10,500	10,500	14,200	21,000
Quantity...Diameter (in.)	3...22	3...22	2...30	6...22
Motor Hp...Rpm	1/2...1050	1/2...1050	1...1075	1/2...1050
Watts Input (Total)	1100	1100	3400	2200
<b>EVAPORATOR COIL</b>	Cross-Hatched 3/8-in. Copper Tubes, Aluminum Lanced or Copper Plate Fins, Face Split			
Rows...Fins/in.	4...15	4...15	4...15	4...15
Total Face Area (sq ft)	17.5	17.5	17.5	17.5
<b>EVAPORATOR FAN</b>	Centrifugal Type			
Quantity...Size (in.)	2...12 x 12	2...12 x 12	2...12 x 12	2...12 x 12
Type Drive	Belt	Belt	Belt	Belt
Nominal Cfm	6000	7200	8000	10,000
Motor Hp	5	5	7.5	10
Motor Nominal Rpm	1745	1745	1745	1740
Maximum Continuous Bhp	6.13	5.90	8.7 [208/230, 575 v]	10.2 [208/230, 575 v]
Motor Frame Size	184T	184T	213T	215T
Nominal Rpm High/Low	—	—	—	—
Fan Rpm Range	873-1021 1025-1200	910-1095 1069-1287	1002-1151 1193-1369	1066-1283 1332-1550
Motor Bearing Type	Ball	Ball	Ball	Ball
Maximum Allowable Rpm	1550	1550	1550	1550
Motor Pulley Pitch Diameter	4.9/5.9	4.9/5.9	5.4/6.6	4.9/5.9
Min/Max (in.)	4.9/5.9	4.9/5.9	5.4/6.6	4.9/5.9
Nominal Motor Shaft Diameter (in.)	1 1/8	1 1/8	1 3/8	1 3/8
Fan Pulley Pitch Diameter (in.)	9.4	9.4	9.4	8.0
Nominal Fan Shaft Diameter (in.)	8.0	8.0	7.9	6.4
Belt, Quantity...Type...Length (in.)	17/16	17/16	17/16	17/16
Pulley Center Line Distance (in.)	1...BX...50	1...BX...50	1...BX...53	2...BX...50
Speed Change per Full Turn of Movable Pulley Flange (rpm)	1...BX...48	1...BX...48	1...BX...50	2...BX...47
Movable Pulley Maximum Full Turns From Closed Position	13.3-14.8	13.3-14.8	14.6-15.4	14.6-15.4
Factory Speed	37	37	37	36
Factory Speed Setting (rpm)	44	34	44	45
Fan Shaft Diameter at Pulley (in.)	6**	6††	6**	6††
	3.5	3.5	3.5	3.5
	965	1002	1120	1182
	1134	1178	1328	1470
	17/16	17/16	17/16	17/16

**LEGEND**

**Bhp** — Brake Horsepower  
**TXV** — Thermostatic Expansion Valve

\*The ZRU140KC compressor is a tandem compressor, consisting of a ZR72KC (25% total capacity) and a ZR68KC (24% total capacity).

†Circuit 1 uses the lower portion of the condenser coil and lower portion of the evaporator coils; and Circuit 2 uses the upper portion of both coils.

\*\*Pulley has 6 turns. Due to belt and pulley size, movable pulley cannot be set to 0 to 1 1/2 turns open.

††Pulley has 6 turns. Due to belt and pulley size, movable pulley cannot be set to 0 to 1/2 turns open.

\*\*\*Rollout switch is manual reset.

†††The 48TM028 unit requires 2-in. industrial-grade filters capable of handling face velocities up to 625 ft/min (such as American Air Filter no. 5700 or equivalent).

¶A Liquid Propane kit is available as an accessory.

NOTE: The 48TM016-028 units have a low-pressure switch (standard) located on the suction side.



UNIT 48TM	016D/F	020D/F	025D/F	028D/F
<b>FURNACE SECTION</b>				
Rollout Switch Cutout Temp (F)***	190	190	190	190
Burner Orifice Diameter (in. ...drill size)				
Natural Gas	0.1285...30/0.136...29	0.1285...30/0.136...29	0.1285...30/0.136...29	0.1285...30/0.136...29
Liquid Propane]]	0.1065...36/0.1065...36	0.1065...36/0.1065...36	0.1065...36/0.1065...36	0.1065...36/0.1065...36
Thermostat Heat Anticipator Setting (amps)				
208/230, 575 v	0.98	0.98	0.98	0.98
460 v	0.44	0.44	0.44	0.44
Gas Input	0.80	0.80	0.80	0.80
Efficiency (Steady-State) (%)	0.44	0.44	0.44	0.44
Temperature Rise Range	206,000/270,000	206,000/270,000	206,000/270,000	206,000/270,000
Manifold Pressure (in. wg)	275,000/360,000	275,000/360,000	275,000/360,000	275,000/360,000
Natural Gas	81	81	81	81
Liquid Propane]]	15-45/20-50	15-45/20-50	15-45/20-50	15-45/20-50
Gas Valve Quantity	3.3	3.3	3.3	3.3
Gas Valve Pressure Range	3.3	3.3	3.3	3.3
in. wg	1	1	1	1
psig	5.5-13.5	5.5-13.5	5.5-13.5	5.5-13.5
Field Gas Connection Size (in.-FPT)	0.235-0.487	0.235-0.487	0.235-0.487	0.235-0.487
	3/4	3/4	3/4	3/4
<b>HIGH-PRESSURE SWITCH (psig)</b>				
Cutout	426			
Reset (Auto)	320			
<b>LOW-PRESSURE SWITCH (psig)</b>				
Cutout	27			
Reset (Auto)	44			
<b>FREEZE PROTECTION THERMOSTAT (F)</b>				
Opens	30 ± 5			
Closes	45 ± 5			
<b>OUTDOOR-AIR INLET SCREENS</b>				
Quantity...Size (in.)	Cleanable			
	2...20 x 25 x 1			
	1...20 x 20 x 1			
<b>RETURN-AIR FILTERS</b>				
Quantity...Size (in.)	Throwaway†††			
	4...20 x 20 x 2			
	4...16 x 20 x 2			
<b>POWER EXHAUST</b>	1/2 Hp, 208/230-460 v Motor Direct Drive, Propeller-Fan (Factory-Wired for 460 v)			

LEGEND

**Bhp** — Brake Horsepower  
**TXV** — Thermostatic Expansion Valve

\*The ZRU140KC compressor is a tandem compressor, consisting of a ZR72KC (25% total capacity) and a ZR68KC (24% total capacity).  
†Circuit 1 uses the lower portion of the condenser coil and lower portion of the evaporator coils; and Circuit 2 uses the upper portion of both coils.  
\*\*Pulley has 6 turns. Due to belt and pulley size, movable pulley cannot be set to 0 to 1 1/2 turns open.  
††Pulley has 6 turns. Due to belt and pulley size, movable pulley cannot be set to 0 to 1/2 turns open.  
\*\*\*Rollout switch is manual reset.  
†††The 48TM028 unit requires 2-in. industrial-grade filters capable of handling face velocities up to 625 ft/min (such as American Air Filter no. 5700 or equivalent).  
†A Liquid Propane kit is available as an accessory. Kit may be used at elevations as high as 2000 ft.  
NOTE: The 48TM016-028 units have a low-pressure switch (standard) located on the suction side.

**OPERATING AND RIGGING WEIGHTS**

UNIT	BASE UNIT OPERATING WEIGHTS*							
	016		020		025		028	
	lb	kg	lb	kg	lb	kg	lb	kg
<b>48TMD/F</b>	1800	816	1850	839	1900	862	2270	1030

\*Base unit weight does not include copper coils, economizer, power exhaust, barometric relief or crating. See Options and Accessories table below for more information.

NOTE: For 016,020 unit, add 75 lb (34 kg) for domestic crating. For 025 unit, add 135 lb (61 kg). For 028 unit, add 175 lb (79 kg) for domestic crating. For export crating add 500 lb (227 kg).

**OPTIONS AND ACCESSORIES  
(Weight Adders)**

OPTION/ ACCESSORY	OPTION/ACCESSORY WEIGHTS							
	016		020		024		028	
	lb	kg	lb	kg	lb	kg	lb	kg
<b>Barometric Relief Damper</b>	50	23	50	23	50	23	50	23
<b>Power Exhaust</b>	85	39	85	39	85	39	85	39
<b>EconoMiSer</b>	80	36	80	36	80	36	80	36
<b>Cu Condenser Coil</b>	150	68	150	68	150	68	150	68
<b>Cu Condenser and Evaporator Coils</b>	280	127	280	127	280	127	280	127
<b>Roof Curb (14-in. curb)</b>	200	91	200	91	200	91	200	91
<b>Horizontal Adapter Curb (Pre-Assembled)</b>	250	113	250	113	250	113	250	113
<b>Horizontal Adapter Curb (Field-Assembled)</b>	348	156	343	156	343	156	343	156
<b>Hail Guard</b>	60	27	60	27	60	27	—	—

LEGEND

**Cu** — Copper

48TM016-028





# Base unit dimensions — 48TM028



48TM016-028

UNIT	STD. WEIGHT	UNIT WEIGHT	ECONOMIZER WEIGHT	CORNER A	CORNER B	CORNER C	CORNER D	DIM A	DIM B	DIM C
48TM028	2270 LBS 1030 KG	80 LBS 36 KG	532 LBS 242 KG	526 LBS 239 KG	583 LBS 259 KG	593 LBS 270 KG	4'-6" (1372)	3'-7 1/4" (1099)	1'-1 1/4" (641)	

## 48TM028

- NOTES:
- REFER TO PRINT FOR ROOF CURB ACCESSORY DIMENSIONS.
  - DIMENSIONS IN ( ) ARE IN MILLIMETERS.
  - CENTER OF GRAVITY.
  - INDICATES DIRECTION OF AIR FLOW.
  - MINIMUM CLEARANCE TO ACCESSORY ROOF CURB ONLY.
  - BEAR: 7'-0" (2134) FOR COIL REMOVAL; THIS DIMENSION CAN BE REDUCED TO 4'-0" (1219) IF CONDITIONS PERMIT COIL REMOVAL FROM THE TOP.
  - TO COMBUSTIBLE SURFACES, ALL FOUR SIDES (INCLUDES BEARING WALLS); 2'-0" (610) FOR PROPER CONDENSER COIL AIR FLOW.
  - FRONT: 4'-0" (1219) FOR CONTROL BOX ACCESS.
  - RIGHT SIDE: 4'-0" (1219) FOR PROPER OPERATION OF DAMPER AND POWER EXHAUST, IF SO EQUIPPED.
  - TOP: 6'-0" (1829) TO ASSURE PROPER CONDENSER FAN OPERATION; 3'-0" (914) TO ASSURE PROPER CONDENSER FAN OPERATION; 3'-0" (914) TO UNGROUNDED SURFACES, NON-COMBUSTIBLE.
  - CONTROL BOX SIDE: 3'-6" (1067) TO BLOCK OR CONCRETE WALLS, OR OTHER GROUNDED SURFACES.
  - LOCAL CODES OR JURISDICTION MAY PREVENT CONDENSER COIL REMOVAL FROM THE TOP OF THE UNIT AS STATED IN NOTE #6. A REMOVABLE FENCE OR BARRICADE REQUIRES NO CLEARANCE.
  - DIMENSIONS ARE FROM OUTSIDE OF CORNER POST.
  - ALLOW 0'-5/16" (B) ON EACH SIDE FOR TOP COVER DRIP EDGE.
  - SEE DRAWING 50TJ500995 FOR SERVICE OPTION DETAILS.

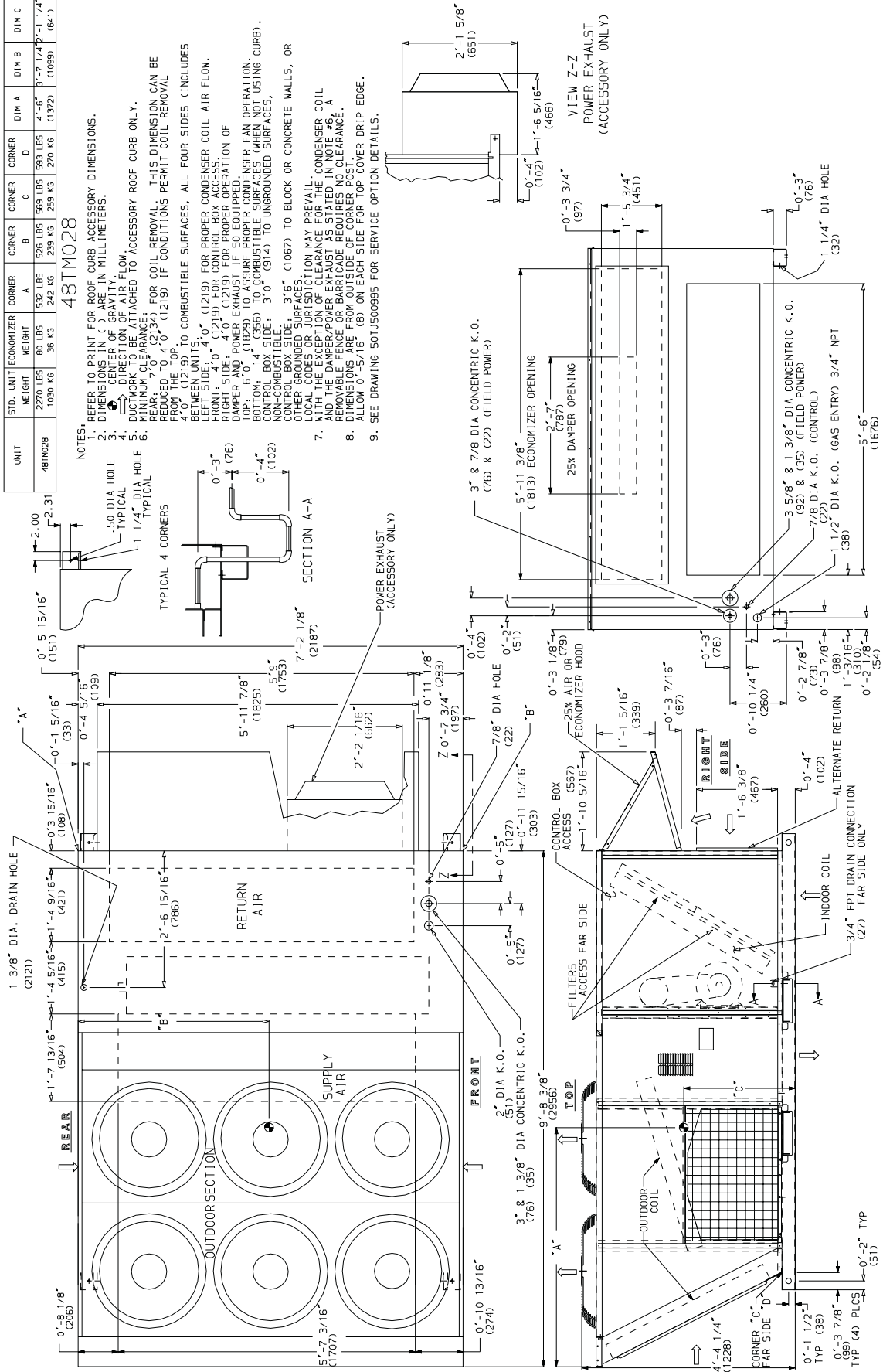





### HORIZONTAL SUPPLY/RETURN ADAPTER INSTALLATION (016-028 Only)

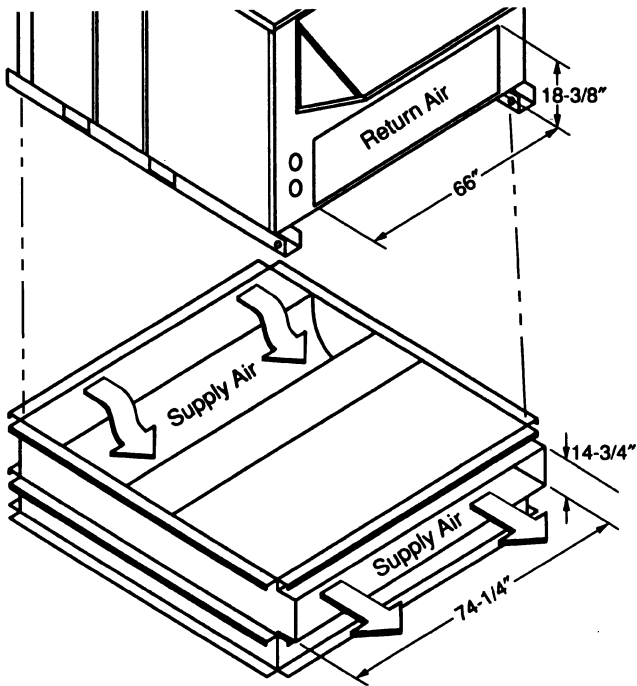

NOTE: CRRFCURB013A00 is a fully factory preassembled horizontal adapter and includes an insulated high static regain transition duct which substantially improves fan static performance.

The Barometric Relief Damper and Power Exhaust accessories must be installed in the Return Air Duct and are not available with the horizontal adapter.

For Horizontal return applications: The power exhaust relief must be installed in the return air duct.

The side panel at the side return opening is used to cover the bottom return air opening.

ACCESSORY PACKAGE NO.	CURB HEIGHT	DESCRIPTION
CRRFCURB013A00	1'-11" (584)	Pre-Assembled, High Static, Horizontal Adapter

48TM016-028

### FACTORY-INSTALLED CONVENIENCE OUTLET (016-028)

END VIEW

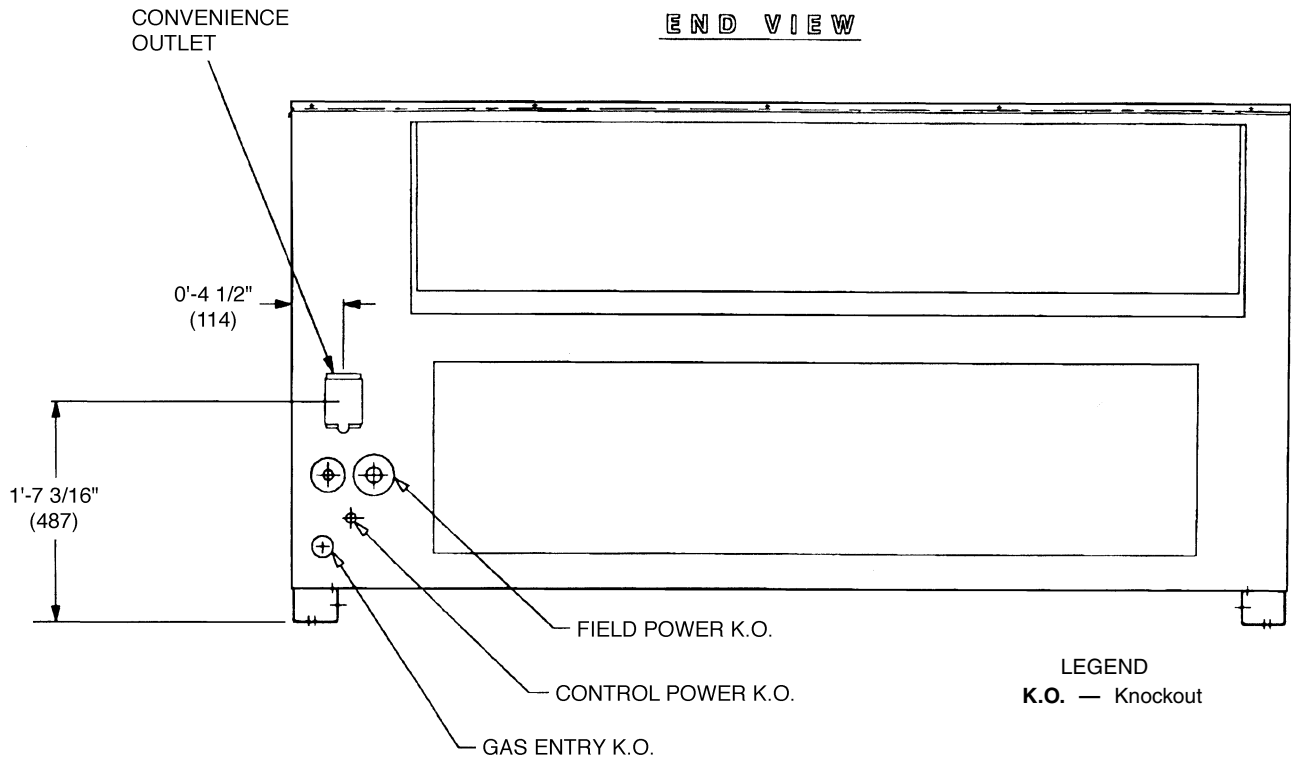

LEGEND  
K.O. — Knockout

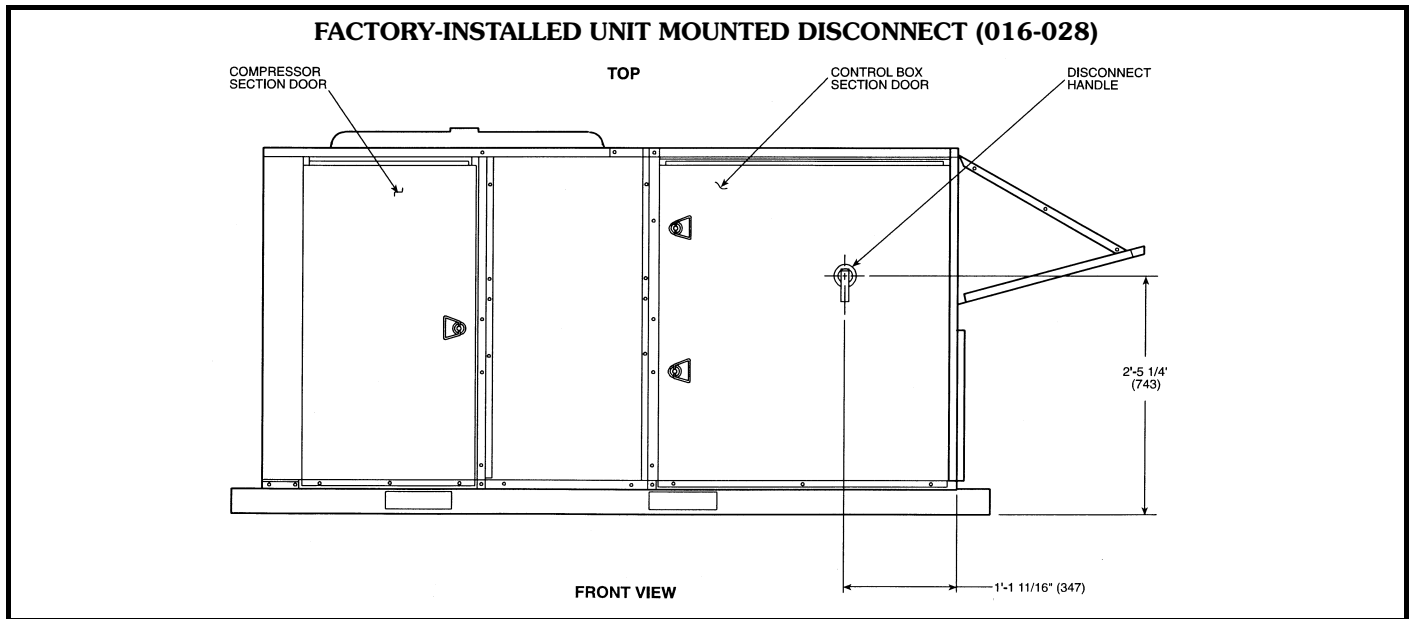

48TM016-028

## Selection procedure (with 48TM025 example)

### I Determine cooling and heating requirements at design conditions.

Given:

Required Cooling Capacity . . . . . 230,000 Btuh  
 Sensible Heat Capacity . . . . . 170,000 Btuh  
 Required Heating Capacity . . . . . 275,000 Btuh  
 Condenser Entering Air Temp . . . . . 95 F (Summer)  
 Evaporator Entering Air Temp . . . . . 80 F edb,  
 67 F ewb

Evaporator Air Quantity . . . . . 8,000 cfm  
 External Static Pressure . . . . . 0.6 in. wg  
 Electrical Characteristics (V-Ph-Hz) . . . . . 460-3-60  
 Vertical discharge unit with optional EconoMi\$er required.

edb — Entering dry-bulb  
 ewb — Entering wet-bulb

### II Select unit based on required cooling capacity.

Enter Cooling Capacities table for 48TMD025 (page 113) at condenser entering temperature 95 F, evaporator air entering at 8,000 cfm and 67 F wb. The unit will provide a total cooling capacity of 249,000 Btuh and a sensible heating capacity of 188,000 Btuh. For air entering evaporator at temperatures other than 80 F edb, calculate sensible heat capacity correction as required.

NOTE: Unit ratings are gross capacities and do not include the effect of evaporator-fan motor heat. To calculate net capacities, see Step V.

### III Select heating capacity of unit to provide design condition requirements.

In the ARI Heating Capacities and Efficiencies table note that the 48TMD025 will provide an output capacity of 223,000 Btuh, which is adequate for the given application.

### IV Determine fan speed and power requirements at design conditions.

Before entering the Fan Performance tables, calculate the total static pressure required based on unit components. From the given and the Accessory/FIOP Static Pressure table on page 121 find:

External static pressure	0.60 in. wg
EconoMi\$er static pressure	0.10 in. wg
Total static pressure	0.70 in. wg

Enter the Fan Performance table 48TMD025 at 8,000 cfm and 0.70 in. wg external static pressure. By interpolation, find that the rpm is 1172 and the watts are 5080.

### V Determine net cooling capacity.

Cooling capacities are gross capacities and do not include indoor (evaporator) fan motor (IFM) heat. Use the watts input power to the motor calculated in Section IV above.

IFM Watts = 5080

Determine net cooling capacity using the following formula:

$$\begin{aligned} \text{Net capacity} &= \text{Gross capacity} - \text{IFM heat} \\ &= 249,000 \text{ Btuh} - 5080 \text{ Watts} \\ & \qquad \qquad \qquad \left( 3.412 \frac{\text{Btuh}}{\text{Watts}} \right) \\ &= 249,000 \text{ Btuh} - 17,333 \text{ Btuh} \\ &= 231,667 \text{ Btuh} \end{aligned}$$

$$\begin{aligned} \text{Net sensible capacity} &= 188,000 \text{ Btuh} - 17,333 \text{ Btuh} \\ &= 170,667 \text{ Btuh} \end{aligned}$$

The calculations show that a 48TMD025 unit with the standard motor and standard low-medium static drive is the correct selection for the given conditions.

# Performance data



## COOLING CAPACITIES

Temp (F) Air Entering Condenser (Edb)		Air Entering Evaporator — Cfm/BF														
		4,500/0.02			5,250/0.03			6,000/0.04			6,750/0.04			7,500/0.05		
		Air Entering Evaporator — Ewb (F)														
		62	67	72	62	67	72	62	67	72	62	67	72	62	67	72
75	TC	180	195	212	185	200	216	188	203	218	193	205	219	197	207	222
	SHC	147	123	99	159	132	104	172	142	112	180	152	120	185	162	125
	KW	11.2	11.6	12.0	11.3	11.7	12.1	11.4	11.8	12.1	11.6	11.9	12.2	11.7	11.9	12.2
85	TC	174	189	204	179	193	208	183	197	211	187	199	212	191	201	213
	SHC	144	121	96	156	130	102	167	138	106	175	148	114	179	156	119
	KW	12.3	12.7	13.1	12.5	12.8	13.2	12.6	12.9	13.3	12.7	13.0	13.3	12.8	13.1	13.4
95	TC	167	182	196	172	186	200	175	189	202	180	191	204	184	193	205
	SHC	141	118	93	153	126	98	163	135	102	169	144	108	173	152	112
	KW	13.5	13.9	14.3	13.6	14.0	14.4	13.8	14.1	14.5	13.9	14.2	14.6	14.0	14.3	14.6
105	TC	160	173	187	164	177	190	168	180	192	172	181	193	177	183	194
	SHC	138	114	90	149	123	94	157	132	98	162	140	102	165	147	106
	KW	14.8	15.2	15.6	14.9	15.3	15.7	15.1	15.4	15.7	15.2	15.5	15.8	15.3	15.5	15.8
115	TC	152	165	178	156	168	179	161	170	180	165	172	182	168	173	182
	SHC	134	111	86	144	119	90	150	128	94	154	135	98	158	142	100
	KW	16.1	16.5	16.9	16.2	16.6	17.0	16.4	16.7	17.0	16.6	16.8	17.1	16.7	16.9	17.1
118	TC	149	162	174	153	165	176	158	167	—	162	168	—	166	170	—
	SHC	133	110	86	142	118	89	148	127	—	152	133	—	155	140	—
	KW	16.5	16.9	17.3	16.6	17.0	17.4	16.8	17.1	—	17.0	17.2	—	17.1	17.2	—
120	TC	148	160	—	152	—	—	156	—	—	—	—	—	—	—	—
	SHC	132	109	—	141	—	—	147	—	—	—	—	—	—	—	—
	KW	16.8	17.2	—	16.9	—	—	17.1	—	—	—	—	—	—	—	—

Temp (F) Air Entering Condenser (Edb)		Air Entering Evaporator — Cfm/BF														
		5,400/0.095			6,000/0.105			7,000/0.120			8,000/0.140			9,000/0.150		
		Air Entering Evaporator — Ewb (F)														
		62	67	72	62	67	72	62	67	72	62	67	72	62	67	72
75	TC	227	247	269	232	251	274	237	255	277	241	258	280	248	261	283
	SHC	200	167	134	215	178	141	231	194	152	241	205	160	248	219	167
	KW	15.9	16.5	17.2	16.1	16.7	17.3	16.3	16.8	17.5	16.5	16.9	17.6	16.7	17.0	17.7
85	TC	219	238	259	224	242	265	229	247	269	235	250	272	241	252	273
	SHC	197	164	131	210	175	137	225	188	145	234	200	153	240	214	163
	KW	17.2	17.8	18.5	17.4	17.9	18.6	17.6	18.1	18.8	17.8	18.3	19.0	18.0	18.3	19.0
95	TC	210	229	248	214	233	253	219	237	258	225	239	261	231	242	263
	SHC	192	160	126	205	171	133	218	183	141	225	194	148	231	206	156
	KW	18.5	19.2	19.9	18.7	19.3	20.0	19.0	19.5	20.2	19.2	19.6	20.3	19.4	19.7	20.4
105	TC	200	218	237	205	222	241	210	225	245	216	228	249	221	230	250
	SHC	186	155	123	199	166	129	210	178	136	216	190	143	221	201	150
	KW	19.9	20.5	21.2	20.1	20.7	21.3	20.4	20.8	21.5	20.6	21.0	21.7	20.8	21.0	21.8
115	TC	190	207	225	195	210	228	201	213	232	206	216	235	211	217	236
	SHC	181	151	118	193	161	124	201	173	132	206	185	139	211	196	146
	KW	21.3	21.9	22.6	21.5	22.1	22.8	21.8	22.2	22.9	22.0	22.4	23.1	22.2	22.4	23.1
120	TC	185	200	—	189	205	—	196	207	—	201	—	—	205	—	—
	SHC	179	149	—	189	159	—	196	171	—	201	—	—	205	—	—
	KW	22.1	22.6	—	22.3	22.8	—	22.5	22.9	—	22.7	—	—	22.9	—	—

Temp (F) Air Entering Condenser (Edb)		Air Entering Evaporator — Cfm/BF														
		6,000/0.04			7,000/0.05			8,000/0.06			9,000/0.07			10,000/0.08		
		Air Entering Evaporator — Ewb (F)														
		62	67	72	62	67	72	62	67	72	62	67	72	62	67	72
75	TC	237	258	282	242	264	288	247	268	291	252	271	295	258	274	298
	SHC	204	171	138	221	184	146	237	199	156	247	210	164	257	221	172
	KW	16.7	17.4	18.1	16.9	17.6	18.3	17.1	17.8	18.5	17.3	17.9	18.6	17.5	18.0	18.7
85	TC	229	249	272	234	254	278	239	260	283	245	262	286	250	265	287
	SHC	201	167	135	216	180	142	231	193	150	240	203	157	250	217	167
	KW	18.1	18.7	19.5	18.3	18.9	19.7	18.5	19.1	19.9	18.7	19.3	20.1	18.8	19.4	20.1
95	TC	220	239	261	225	245	267	230	249	271	235	251	275	241	255	277
	SHC	195	163	130	211	176	138	224	188	145	233	199	152	241	210	160
	KW	19.4	20.2	20.9	19.7	20.4	21.2	19.9	20.6	21.3	20.1	20.6	21.4	20.3	20.8	21.6
105	TC	209	228	249	216	234	254	220	237	259	225	240	262	230	242	263
	SHC	189	159	126	206	171	134	217	183	140	225	195	148	230	205	154
	KW	20.9	21.5	22.3	21.2	21.8	22.5	21.4	22.0	22.7	21.6	22.1	22.9	21.8	22.2	23.0
115	TC	200	217	237	205	222	241	211	225	244	216	227	248	221	229	249
	SHC	185	154	122	199	166	129	209	178	136	216	189	143	221	200	150
	KW	22.5	23.1	23.8	22.7	23.3	24.0	22.9	23.4	24.2	23.2	23.6	24.4	23.4	23.7	24.4
120	TC	194	211	230	199	216	—	205	218	—	210	—	—	214	—	—
	SHC	183	152	121	195	164	—	204	175	—	210	—	—	214	—	—
	KW	23.2	23.8	24.6	23.5	24.0	—	23.7	24.2	—	23.9	—	—	24.1	—	—

Temp (F) Air Entering Condenser (Edb)		Air Entering Evaporator — Cfm/BF																			
		7,000/0.05			8,000/0.06			9,000/0.07			10,000/0.08			11,250/0.09							
		Air Entering Evaporator — Ewb (F)																			
		57	62	67	72	57	62	67	72	57	62	67	72	57	62	67	72	57	62	67	72
75	TC	256	271	299	327	267	278	305	336	276	283	309	341	285	286	313	344	294	294	316	347
	SHC	256	232	196	267	249	208	166	276	265	220	173	285	281	232	182	294	294	252	198	198
	KW	18.0	18.3	18.9	19.6	18.3	18.5	19.1	19.8	18.5	18.7	19.2	19.9	18.7	18.8	19.4	20.1	19.0	19.0	19.5	20.2
85	TC	248	262	288	316	259	267	293	322	267	273	298	328	276	276	302	331	284	285	305	336
	SHC	248	228	192	254	239	191	161	267	259	216	169	276	274	228	175	284	284	244	187	187
	KW	20.0	20.4	20.9	21.5	20.3	20.4	21.0	21.7	20.6	20.6	21.2	21.9	20.8	20.8	21.3	22.0	21.0	21.0	21.5	22.1
95	TC	241	252	277	303	251	257	281	309	259	262	286	314	266	267	290	317	274	275	293	321
	SHC	241	223	187	249	231	198	157	259	254	210	164	266	265	222	171	274	275	238	180	180
	KW	22.4	22.6	23.1	23.7	22.6	22.7	23.3	23.9	22.8	22.9	23.4	24.0	23.0	23.0	23.5	24.2	23.2	23.2	23.6	24.2
105	TC	233	243	266	289	242	247	270	295	250	252	273	299	256	258	277	303	264	265	280	306
	SHC	233	218	182	242	233	194	152	250	248	206	159	256	257	217	166	264	265	232	176	176
	KW	24.9	25.1	25.6	26.2	25.2	25.3	25.8	26.3	25.4	25.4	25.9	26.5	25.6	25.6	26.0	26.6	25.8	25.8	26.1	26.7
115	TC	225	232	254	277	234	236	258	281	241	242	261	285	247	247	264	288	254	255	267	291
	SHC	225	214	178	240	234	228	189	241	241	201	155	247	247	211	162	253	255	227	171	171
	KW	27.9	27.9	28.5	29.0	28.1	28.6	29.2	28.2	28.2	28.7	29.2	29.8	28.4	28.4	28.8	29.3	28.7	28.7	28.9	29.5

# Performance data (cont)



## FAN PERFORMANCE — 48TM016-028 UNITS

### 48TMD016 (Low Heat Units)\*

Cfm	Available External Static Pressure (in. wg)														
	0.2			0.4			0.6			0.8			1.0		
	Rpm	Watts	Bhp	Rpm	Watts	Bhp	Rpm	Watts	Bhp	Rpm	Watts	Bhp	Rpm	Watts	Bhp
4500	753	1307	1.53	761	1330	1.56	840	1572	1.84	912	1822	2.14	980	2080	2.44
4800	747	1384	1.62	790	1515	1.78	866	1765	2.07	936	2023	2.37	1002	2289	2.68
5100	741	1465	1.72	820	1718	2.01	893	1977	2.32	961	2243	2.63	1025	2516	2.95
5700	810	1911	2.24	882	2182	2.56	950	2459	2.88	1014	2741	3.21	1075	3029	3.55
6000	844	2164	2.54	914	2444	2.87	980	2730	3.20	1042	3021	3.54	1100	3317	3.89
6300	879	2439	2.86	947	2729	3.20	1010	3023	3.55	1070	3322	3.90	1127	3626	4.25
6600	915	2737	3.21	980	3035	3.56	1041	3338	3.91	1099	3645	4.28	1155	3957	4.64
6900	950	3057	3.59	1013	3364	3.95	1072	3675	4.31	1129	3991	4.68	1183	4311	5.06
7200	986	3401	3.99	1047	3717	4.36	1104	4037	4.74	1159	4361	5.11	1211	4689	5.50
7500	1022	3770	4.42	1081	4095	4.80	1136	4423	5.19	1189	4755	5.58	1241	5091	5.97

### 48TMD016 (Low Heat Units)\* (cont)

Cfm	Available External Static Pressure (in. wg)														
	1.2			1.4			1.6			1.8			2.0		
	Rpm	Watts	Bhp	Rpm	Watts	Bhp	Rpm	Watts	Bhp	Rpm	Watts	Bhp	Rpm	Watts	Bhp
4500	1044	2345	2.75	1105	2619	3.07	1163	2899	3.40	1218	3187	3.74	1271	3481	4.08
4800	1065	2561	3.00	1124	2841	3.33	1180	3127	3.67	1235	3420	4.01	1287	3720	4.36
5100	1086	2795	3.28	1144	3082	3.61	1199	3375	3.96	1252	3674	4.31	1304	3979	4.67
5700	1132	3324	3.90	1187	3624	4.25	1240	3929	4.61	1291	4241	4.97	1341	4558	5.35
6000	1157	3619	4.24	1210	3925	4.60	1262	4239	4.97	1312	4557	5.34	1361	4880	5.72
6300	1182	3935	4.62	1234	4249	4.98	1285	4569	5.36	1334	4894	5.74	—	—	—
6600	1208	4274	5.01	1259	4595	5.39	1309	4922	5.77	—	—	—	—	—	—
6900	1235	4636	5.44	1285	4964	5.82	—	—	—	—	—	—	—	—	—
7200	1262	5021	5.89	—	—	—	—	—	—	—	—	—	—	—	—
7500	—	—	—	—	—	—	—	—	—	—	—	—	—	—	—

### 48TMD016 (Low Heat Units)\* (cont)

Cfm	Available External Static Pressure (in. wg)														
	2.2			2.4			2.6			2.8			3.0		
	Rpm	Watts	Bhp	Rpm	Watts	Bhp	Rpm	Watts	Bhp	Rpm	Watts	Bhp	Rpm	Watts	Bhp
4500	1322	3781	4.43	1372	4088	4.79	1419	4400	5.16	1466	4719	5.53	1511	5042	5.91
4800	1337	4025	4.72	1386	4337	5.09	1433	4655	5.46	1479	4978	5.84	—	—	—
5100	1353	4290	5.03	1401	4607	5.40	1448	4930	5.78	—	—	—	—	—	—
5700	1388	4881	5.72	—	—	—	—	—	—	—	—	—	—	—	—
6000	—	—	—	—	—	—	—	—	—	—	—	—	—	—	—
6300	—	—	—	—	—	—	—	—	—	—	—	—	—	—	—
6600	—	—	—	—	—	—	—	—	—	—	—	—	—	—	—
6900	—	—	—	—	—	—	—	—	—	—	—	—	—	—	—
7200	—	—	—	—	—	—	—	—	—	—	—	—	—	—	—
7500	—	—	—	—	—	—	—	—	—	—	—	—	—	—	—

#### LEGEND

- Bhp** — Brake Horsepower
- FIOP** — Factory-Installed Option
- Watts** — Input Watts to Motor

Refer to page 119 for general Fan Performance Data notes.

NOTE: Maximum continuous bhp for the standard motor is 6.13. The maximum continuous watts is 5180. Do not adjust motor rpm such that motor maximum bhp and/or watts is exceeded at the maximum operating cfm.

\*Standard low-medium static drive range is 873 to 1021 rpm. Alternate high-static drive range is 1025 to 1200. Other rpms require a field-supplied drive.

48TM016-028



FAN PERFORMANCE — 48TM016-028 UNITS (cont)

48TMF016 (High Heat Units)*															
Cfm	Available External Static Pressure (in. wg)														
	0.2			0.4			0.6			0.8			1.0		
	Rpm	Watts	Bhp	Rpm	Watts	Bhp	Rpm	Watts	Bhp	Rpm	Watts	Bhp	Rpm	Watts	Bhp
4500	753	1307	1.53	786	1404	1.65	861	1644	1.93	932	1893	2.22	997	2150	2.52
4800	747	1384	1.62	818	1603	1.88	890	1852	2.17	958	2108	2.47	1022	2373	2.78
5100	775	1571	1.84	850	1822	2.14	920	2079	2.44	986	2344	2.75	1048	2616	3.07
5700	849	2054	2.41	918	2323	2.73	982	2598	3.05	1044	2879	3.38	1102	3166	3.71
6000	886	2329	2.73	952	2607	3.06	1015	2891	3.39	1074	3180	3.73	1130	3474	4.08
6300	924	2628	3.08	987	2915	3.42	1047	3207	3.76	1105	3504	4.11	1160	3807	4.46
6600	962	2951	3.46	1023	3246	3.81	1081	3547	4.16	1136	3853	4.52	1190	4163	4.88
6900	1000	3298	3.87	1059	3603	4.23	1115	3912	4.59	1168	4225	4.96	1220	4543	5.33
7200	1038	3672	4.31	1095	3986	4.67	1149	4303	5.05	1201	4625	5.42	1251	4950	5.81
7500	1077	4072	4.78	1131	4394	5.15	1184	4720	5.54	1234	5050	5.92	—	—	—

48TMF016 (High Heat Units)* (cont)															
Cfm	Available External Static Pressure (in. wg)														
	1.2			1.4			1.6			1.8			2.0		
	Rpm	Watts	Bhp	Rpm	Watts	Bhp	Rpm	Watts	Bhp	Rpm	Watts	Bhp	Rpm	Watts	Bhp
4500	1060	2414	2.83	1119	2685	3.15	1175	2964	3.48	1230	3250	3.81	1282	3542	4.15
4800	1082	2644	3.10	1140	2922	3.43	1195	3207	3.76	1248	3498	4.10	1299	3795	4.45
5100	1106	2894	3.39	1163	3178	3.73	1216	3470	4.07	1268	3767	4.42	1319	4071	4.77
5700	1157	3459	4.06	1211	3757	4.41	1262	4061	4.76	1312	4371	5.13	1360	4686	5.50
6000	1184	3774	4.43	1236	4080	4.79	1287	4391	5.15	1335	4707	5.52	1382	5029	5.90
6300	1212	4114	4.83	1263	4427	5.19	1312	4745	5.57	1359	5067	5.94	—	—	—
6600	1241	4478	5.25	1290	4798	5.63	1338	5122	6.01	—	—	—	—	—	—
6900	1270	4866	5.71	—	—	—	—	—	—	—	—	—	—	—	—
7200	—	—	—	—	—	—	—	—	—	—	—	—	—	—	—
7500	—	—	—	—	—	—	—	—	—	—	—	—	—	—	—

48TM016-028

48TMF016 (High Heat Units)* (cont)															
Cfm	Available External Static Pressure (in. wg)														
	2.2			2.4			2.6			2.8			3.0		
	Rpm	Watts	Bhp	Rpm	Watts	Bhp	Rpm	Watts	Bhp	Rpm	Watts	Bhp	Rpm	Watts	Bhp
4500	1332	3841	4.50	1381	4145	4.86	1428	4456	5.23	1473	4772	5.60	1518	5095	5.98
4800	1349	4100	4.81	1397	4409	5.17	1443	4725	5.54	1488	5046	5.92	—	—	—
5100	1367	4380	5.14	1414	4695	5.51	1460	5016	5.88	—	—	—	—	—	—
5700	1407	5007	5.87	—	—	—	—	—	—	—	—	—	—	—	—
6000	—	—	—	—	—	—	—	—	—	—	—	—	—	—	—
6300	—	—	—	—	—	—	—	—	—	—	—	—	—	—	—
6600	—	—	—	—	—	—	—	—	—	—	—	—	—	—	—
6900	—	—	—	—	—	—	—	—	—	—	—	—	—	—	—
7200	—	—	—	—	—	—	—	—	—	—	—	—	—	—	—
7500	—	—	—	—	—	—	—	—	—	—	—	—	—	—	—

LEGEND

- Bhp** — Brake Horsepower
- FIOP** — Factory-Installed Option
- Watts** — Input Watts to Motor

Refer to page 119 for general Fan Performance Data notes.

NOTE: Maximum continuous bhp for the standard motor is 6.13. The maximum continuous watts is 5180. Do not adjust motor rpm such that motor maximum bhp and/or watts is exceeded at the maximum operating cfm.

\*Standard low-medium static drive range is 873 to 1021 rpm. Alternate high-static drive range is 1025 to 1200. Other rpms require a field-supplied drive.

# Performance data (cont)



## FAN PERFORMANCE — 48TM016-028 UNITS (cont)

### 48TMD020 (18 TONS) LOW HEAT UNITS\*

Airflow (Cfm)	Available External Static Pressure (in. wg)																	
	0.2			0.4			0.6			0.8			1.0			1.2		
	Rpm	Bhp	Watts	Rpm	Bhp	Watts	Rpm	Bhp	Watts	Rpm	Bhp	Watts	Rpm	Bhp	Watts	Rpm	Bhp	Watts
5,500	755	2.27	1908	831	2.58	2171	901	2.91	2443	968	3.24	2723	1031	3.58	3009	1091	3.93	3302
6,000	810	2.72	2287	881	3.04	2556	947	3.37	2833	1010	3.71	3116	1070	4.05	3406	1127	4.40	3702
6,500	866	3.22	2710	932	3.55	2985	994	3.88	3266	1054	4.23	3554	1111	4.57	3847	1166	4.93	4146
7,000	923	3.78	3177	985	4.11	3458	1044	4.45	3744	1100	4.80	4036	1155	5.15	4333	1207	5.51	4635
7,500	980	4.39	3690	1038	4.73	3976	1094	5.07	4267	1148	5.43	4564	1200	5.78	4864	1250	6.15	5170
8,000	1038	5.06	4251	1093	5.40	4542	1146	5.75	4838	1197	6.11	5138	1246	6.47	5443	1294	6.84	5752
8,500	1096	5.78	4859	1148	6.13	5156	1198	6.49	5456	1247	6.85	5761	1294	7.22	6070	1340	7.59	6382
9,000	1154	6.56	5517	1204	6.92	5818	1251	7.28	6123	1298	7.65	6432	1343	8.02	6745	1388	8.40	7062
9,500	1213	7.40	6224	1260	7.77	6531	1306	8.13	6840	1350	8.51	7154	1394	8.88	7471	1436	9.26	7791
10,000	1272	8.30	6983	1317	8.67	7294	1360	9.05	7608	1403	9.43	7926	1445	9.81	8247	1486	10.19	8570

### 48TMD020 (18 TONS) LOW HEAT UNITS\* (cont)

Airflow (Cfm)	Available External Static Pressure (in. wg)														
	1.4			1.6			1.8			1.9			2.0		
	Rpm	Bhp	Watts	Rpm	Bhp	Watts	Rpm	Bhp	Watts	Rpm	Bhp	Watts	Rpm	Bhp	Watts
5,500	1149	4.28	3602	1204	4.65	3907	1258	5.02	4217	1284	5.20	4375	1309	5.39	4533
6,000	1183	4.76	4003	1236	5.13	4310	1288	5.50	4622	1313	5.68	4780	1337	5.87	4939
6,500	1219	5.29	4450	1270	5.66	4759	1320	6.03	5073	1344	6.22	5232	1368	6.41	5391
7,000	1258	5.88	4942	1307	6.25	5253	1355	6.62	5569	1378	6.81	5729	1402	7.00	5890
7,500	1299	6.52	5480	1346	6.89	5794	1392	7.27	6113	1415	7.46	6273	1437	7.65	6435
8,000	1341	7.21	6065	1387	7.59	6383	1392	7.97	6704	1453	8.16	6866	1475	8.36	7028
8,500	1385	7.97	6699	1429	8.35	7019	1472	8.73	7343	1493	8.93	7506	1514	9.12	7670
9,000	1431	8.78	7382	1473	9.15	7705	1515	9.55	8032	1535	9.75	8196	—	—	—
9,500	1478	9.65	8114	1519	10.04	8441	—	—	—	—	—	—	—	—	—
10,000	—	—	—	—	—	—	—	—	—	—	—	—	—	—	—

LEGEND

**Bhp** — Brake Horsepower  
**FIOF** — Factory-Installed Option  
**Watts** — Input Watts to Motor

Refer to page 119 for general Fan Performance Data notes.

NOTE: Maximum continuous bhp is 5.90. The maximum continuous watts is 5180. Do not adjust motor rpm such that motor maximum bhp and/or watts is exceeded at the maximum operating cfm. See Evaporator Fan Motor Data tables for more information.

\*Standard low-medium static drive range is 910 to 1095 rpm. Alternate high-static drive range is 1069 to 1287. Other rpms require a field-supplied drive.

### 48TMF020 (18 TONS) HIGH HEAT UNITS\*

Airflow (Cfm)	Available External Static Pressure (in. wg)																	
	0.2			0.4			0.6			0.8			1.0			1.2		
	Rpm	Bhp	Watts	Rpm	Bhp	Watts	Rpm	Bhp	Watts	Rpm	Bhp	Watts	Rpm	Bhp	Watts	Rpm	Bhp	Watts
5,500	795	2.43	2043	866	2.74	2306	934	3.07	2578	998	3.40	2856	1059	3.74	3142	1117	4.08	3434
6,000	854	2.92	2452	921	3.24	2722	984	3.57	2998	1044	3.90	3281	1102	4.25	3570	1158	4.60	3865
6,500	914	3.46	2909	977	3.79	3184	1036	4.12	3465	1093	4.46	3752	1148	4.81	4045	1201	5.16	4343
7,000	975	4.06	3414	1034	4.39	3695	1090	4.73	3981	1144	5.08	4272	1196	5.43	4569	1246	5.79	4870
7,500	1037	4.72	3969	1092	5.06	4255	1145	5.41	4546	1196	5.76	4842	1256	6.12	5142	1294	6.48	5447
8,000	1099	5.44	4575	1150	5.79	4866	1201	6.14	5162	1249	6.50	5462	1297	6.86	5766	1343	7.22	6075
8,500	1161	6.22	5232	1210	6.57	5529	1258	6.93	5829	1304	7.29	6134	1349	7.66	6443	1393	8.03	6755
9,000	1223	7.07	5943	1270	7.43	6245	1315	7.79	6550	1360	8.16	6869	1403	8.53	7171	1445	8.90	7487
9,500	1286	7.98	6708	1331	8.34	7014	1374	8.71	7324	1416	9.08	7638	1457	9.46	7954	1498	9.84	8274
10,000	1349	8.95	7528	1392	9.32	7839	1433	9.70	8154	1473	10.07	8471	—	—	—	—	—	—

### 48TMF020 (18 TONS) HIGH HEAT UNITS\* (cont)

Airflow (Cfm)	Available External Static Pressure (in. wg)														
	1.4			1.6			1.8			1.9			2.0		
	Rpm	Bhp	Watts	Rpm	Bhp	Watts	Rpm	Bhp	Watts	Rpm	Bhp	Watts	Rpm	Bhp	Watts
5,500	1173	4.44	3732	1227	4.80	4036	1279	5.17	4345	1304	5.35	4502	1329	5.54	4629
6,000	1211	4.95	4165	1263	5.32	4471	1313	5.69	4782	1337	5.87	4939	1361	6.06	5097
6,500	1252	5.53	4646	1302	5.89	4954	1350	6.26	5267	1373	6.56	5425	1396	6.64	5584
7,000	1295	6.16	5176	1343	6.52	5487	1389	6.90	5802	1412	7.09	5961	1434	7.28	6121
7,500	1340	6.85	5756	1386	7.22	6070	1431	7.60	6387	1452	7.79	6547	1474	7.98	6709
8,000	1388	7.60	6388	1431	7.97	6704	1474	8.35	7024	1495	8.54	7186	1516	8.74	7348
8,500	1436	8.41	7071	1478	8.79	7390	1520	9.17	7713	1540	9.37	7876	—	—	—
9,000	1486	9.28	7807	1527	9.67	8130	—	—	—	—	—	—	—	—	—
9,500	1538	10.22	8597	—	—	—	—	—	—	—	—	—	—	—	—
10,000	—	—	—	—	—	—	—	—	—	—	—	—	—	—	—

LEGEND

**Bhp** — Brake Horsepower  
**FIOF** — Factory-Installed Option  
**Watts** — Input Watts to Motor

Refer to page 119 for general Fan Performance Data notes.

NOTE: Maximum continuous bhp is 5.90. The maximum continuous watts is 5180. Do not adjust motor rpm such that motor maximum bhp and/or watts is exceeded at the maximum operating cfm. See Evaporator Fan Motor Data tables for more information.

\*Standard low-medium static drive range is 910 to 1095 rpm. Alternate high-static drive range is 1069 to 1287. Other rpms require a field-supplied drive.

48TM016-028



FAN PERFORMANCE — 48TM016-028 UNITS (cont)

48TMD025 (Low Heat Units)\*

Cfm	Available External Static Pressure (in. wg)														
	0.2			0.4			0.6			0.8			1.0		
	Rpm	Watts	Bhp	Rpm	Watts	Bhp	Rpm	Watts	Bhp	Rpm	Watts	Bhp	Rpm	Watts	Bhp
6,000	824	2607	3.09	894	2844	3.37	961	3085	3.66	1023	3330	3.95	1083	3578	4.24
6,500	881	3030	3.59	947	3266	3.88	1009	3507	4.16	1069	3751	4.45	1126	3998	4.74
7,000	939	3488	4.14	1001	3725	4.42	1060	3965	4.70	1116	4208	4.99	1170	4454	5.28
7,500	998	3982	4.72	1055	4218	5.00	1111	4458	5.29	1165	4701	5.58	1217	4946	5.87
8,000	1056	4512	5.35	1111	4748	5.63	1164	4988	5.92	1215	5230	6.20	1264	5474	6.49
8,500	1116	5077	6.02	1167	5314	6.30	1218	5553	6.59	1266	5795	6.87	1314	6039	7.16
9,000	1175	5678	6.74	1224	5915	7.02	1272	6154	7.30	1319	6395	7.59	1364	6639	7.88
9,500	1235	6315	7.49	1282	6552	7.77	1327	6791	8.06	1372	7033	8.34	1415	7276	8.63
10,000	1295	6988	8.29	1340	7225	8.57	1383	7465	8.86	1426	7706	9.14	1468	7949	9.43

48TMD025 (Low Heat Units)\* (cont)

Cfm	Available External Static Pressure (in. wg)														
	1.2			1.4			1.6			1.8			2.0		
	Rpm	Watts	Bhp	Rpm	Watts	Bhp	Rpm	Watts	Bhp	Rpm	Watts	Bhp	Rpm	Watts	Bhp
6,000	1141	3829	4.54	1196	4082	4.84	1249	4337	5.15	1301	4596	5.45	1351	4856	5.76
6,500	1181	4247	5.04	1234	4499	5.34	1285	4753	5.64	1334	5009	5.94	1383	5267	6.25
7,000	1223	4702	5.58	1274	4953	5.88	1323	5205	6.18	1371	5460	6.48	1417	5716	6.78
7,500	1267	5194	6.16	1316	5443	6.46	1363	5694	6.76	1409	5947	7.06	1454	6202	7.36
8,000	1313	5721	6.79	1359	5970	7.08	1405	6220	7.38	1449	6472	7.68	1493	6726	7.98
8,500	1360	6285	7.46	1405	6533	7.75	1449	6783	8.05	1491	7034	8.34	1533	7286	8.64
9,000	1408	6885	8.17	1451	7132	8.46	1494	7381	8.76	1535	7631	9.05	—	—	—
9,500	1458	7521	8.92	1499	7768	9.22	1540	8016	9.51	—	—	—	—	—	—
10,000	1508	8193	9.72	1549	8440	10.01	—	—	—	—	—	—	—	—	—

48TMD025 (Low Heat Units)\* (cont)

Cfm	Available External Static Pressure (in. wg)														
	2.2			2.4			2.6			2.8			3.0		
	Rpm	Watts	Bhp	Rpm	Watts	Bhp	Rpm	Watts	Bhp	Rpm	Watts	Bhp	Rpm	Watts	Bhp
6,000	1399	5118	6.07	1446	5381	6.38	1492	5647	6.70	1537	5914	7.02	—	—	—
6,500	1429	5527	6.56	1475	5789	6.87	1520	6052	7.18	—	—	—	—	—	—
7,000	1462	5974	7.09	1507	6234	7.40	1550	6495	7.71	—	—	—	—	—	—
7,500	1498	6459	7.66	1540	6717	7.97	—	—	—	—	—	—	—	—	—
8,000	1535	6981	8.28	—	—	—	—	—	—	—	—	—	—	—	—
8,500	—	—	—	—	—	—	—	—	—	—	—	—	—	—	—
9,000	—	—	—	—	—	—	—	—	—	—	—	—	—	—	—
9,500	—	—	—	—	—	—	—	—	—	—	—	—	—	—	—
10,000	—	—	—	—	—	—	—	—	—	—	—	—	—	—	—

LEGEND

- Bhp — Brake Horsepower
- FIOP — Factory-Installed Option
- Watts — Input Watts to Motor

\*Standard low-medium static drive range is 1002 to 1151 rpm. Alternate high-static drive range is 1193 to 1369. Other rpms require a field-supplied drive.

Refer to page 119 for general Fan Performance Data notes.

NOTE: Maximum continuous bhp for the standard motor is 8.7 (for 208/230 and 575-v units) and 9.5 (for 460-v units). The maximum continuous watts is 7915 (for 208/230 and 575-v units) and 8640 (for 460-v units). Do not adjust motor rpm such that motor maximum bhp and/or watts is exceeded at the maximum operating cfm. See Evaporator Fan Motor Data tables for additional information.

48TM016-028

# Performance data (cont)



## FAN PERFORMANCE — 48TM016-028 UNITS (cont)

### 48TMF025 (High Heat Units)\*

Cfm	Available External Static Pressure (in. wg)														
	0.2			0.4			0.6			0.8			1.0		
	Rpm	Watts	Bhp	Rpm	Watts	Bhp	Rpm	Watts	Bhp	Rpm	Watts	Bhp	Rpm	Watts	Bhp
6,000	868	2752	3.26	934	2987	3.54	997	3227	3.83	1058	3470	4.12	1115	3716	4.41
6,500	929	3201	3.80	991	3436	4.08	1051	3675	4.36	1108	3917	4.65	1162	4163	4.94
7,000	991	3687	4.37	1049	3923	4.65	1105	4161	4.94	1159	4403	5.22	1211	4647	5.51
7,500	1054	4211	5.00	1109	4447	5.28	1161	4686	5.56	1213	4926	5.84	1262	5170	6.13
8,000	1117	4773	5.66	1168	5009	5.94	1218	5247	6.22	1267	5488	6.51	1314	5731	6.80
8,500	1180	5373	6.37	1229	5609	6.65	1277	5847	6.94	1323	6088	7.22	1368	6331	7.51
9,000	1244	6011	7.13	1290	6247	7.41	1335	6485	7.69	1380	6726	7.98	1423	6968	8.27
9,500	1308	6687	7.93	1352	6924	8.21	1395	7162	8.50	1437	7402	8.78	1479	7644	9.07
10,000	1372	7401	8.78	1414	7638	9.06	1455	7876	9.34	1496	8117	9.63	1535	8358	9.92

### 48TMF025 (High Heat Units)\* (cont)

Cfm	Available External Static Pressure (in. wg)														
	1.2			1.4			1.6			1.8			2.0		
	Rpm	Watts	Bhp	Rpm	Watts	Bhp	Rpm	Watts	Bhp	Rpm	Watts	Bhp	Rpm	Watts	Bhp
6,000	1171	3965	4.70	1224	4216	5.00	1276	4469	5.30	1326	4726	5.61	1374	4983	5.91
6,500	1215	4410	5.23	1266	4659	5.53	1316	4911	5.83	1364	5165	6.13	1411	5421	6.43
7,000	1262	4894	5.81	1311	5142	6.10	1358	5392	6.40	1404	5645	6.70	1449	5899	7.00
7,500	1310	5415	6.42	1357	5663	6.72	1403	5912	7.01	1447	6164	7.31	1490	6416	7.61
8,000	1360	5976	7.09	1405	6222	7.38	1449	6471	7.68	1492	6721	7.97	1533	6973	8.27
8,500	1412	6575	7.80	1455	6821	8.09	1497	7068	8.39	1538	7318	8.68	—	—	—
9,000	1465	7212	8.56	1506	7457	8.85	1547	7705	9.14	—	—	—	—	—	—
9,500	1519	7888	9.36	—	—	—	—	—	—	—	—	—	—	—	—
10,000	—	—	—	—	—	—	—	—	—	—	—	—	—	—	—

### 48TMF025 (High Heat Units)\* (cont)

Cfm	Available External Static Pressure (in. wg)														
	2.2			2.4			2.6			2.8			3.0		
	Rpm	Watts	Bhp	Rpm	Watts	Bhp	Rpm	Watts	Bhp	Rpm	Watts	Bhp	Rpm	Watts	Bhp
6,000	1422	5243	6.22	1468	5505	6.53	1513	5768	6.84	—	—	—	—	—	—
6,500	1456	5679	6.74	1501	5938	7.04	1544	6199	7.35	—	—	—	—	—	—
7,000	1493	6155	7.30	1536	6412	7.61	—	—	—	—	—	—	—	—	—
7,500	1533	6670	7.91	—	—	—	—	—	—	—	—	—	—	—	—
8,000	—	—	—	—	—	—	—	—	—	—	—	—	—	—	—
8,500	—	—	—	—	—	—	—	—	—	—	—	—	—	—	—
9,000	—	—	—	—	—	—	—	—	—	—	—	—	—	—	—
9,500	—	—	—	—	—	—	—	—	—	—	—	—	—	—	—
10,000	—	—	—	—	—	—	—	—	—	—	—	—	—	—	—

#### LEGEND

- Bhp** — Brake Horsepower
- FIOP** — Factory-Installed Option
- Watts** — Input Watts to Motor

Refer to page 119 for general Fan Performance Data notes.

\*Standard low-medium static drive range is 1002 to 1151 rpm. Alternate high-static drive range is 1193 to 1369. Other rpms require a field-supplied drive.

NOTE: Maximum continuous bhp for the standard motor is 8.7 (for 208/230 and 575-v units) and 9.5 (for 460-v units). The maximum continuous watts is 7915 (for 208/230 and 575-v units) and 8640 (for 460-v units). Do not adjust motor rpm such that motor maximum bhp and/or watts is exceeded at the maximum operating cfm. See Evaporator Fan Motor Data tables for additional information.

48TM016-028



## FAN PERFORMANCE — 48TM016-028 UNITS (cont)

### 48TMD028 (25 TONS) LOW HEAT UNITS\*

Airflow (Cfm)	Available External Static Pressure (in. wg)																	
	0.2			0.4			0.6			0.8			1.0			1.2		
	Rpm	Bhp	Watts	Rpm	Bhp	Watts	Rpm	Bhp	Watts	Rpm	Bhp	Watts	Rpm	Bhp	Watts	Rpm	Bhp	Watts
7,000	941	3.35	2,769	1002	3.80	3,140	1061	4.27	3528	1117	4.76	3,934	1171	5.27	4,356	1224	5.80	4,794
7,500	999	4.05	3,348	1057	4.53	3,742	1112	5.02	4152	1166	5.54	4,579	1218	6.07	5,020	1268	6.63	5,478
8,000	1058	4.85	4,007	1113	5.35	4,424	1165	5.87	4856	1216	6.41	5,304	1266	6.97	5,766	1314	7.55	6,243
8,500	1117	5.74	4,750	1169	6.28	5,190	1219	6.83	5645	1268	7.40	6,114	1315	7.98	6,597	1361	8.58	7,094
9,000	1177	6.75	5,583	1226	7.31	6,047	1274	7.89	6524	1320	8.48	7,015	1365	9.09	7,520	1410	9.72	8,037
9,500	1237	7.98	6,511	1284	8.46	6,999	1329	9.07	7499	1374	9.69	8,012	1417	10.33	8,538	1459	10.98	9,076
10,000	1297	9.12	7,450	1342	9.74	8,051	1385	10.37	8574	1428	11.02	9,110	1469	11.68	9,657	1510	12.36	10,217
10,500	1358	10.49	8,674	1400	11.14	9,209	1442	11.80	9755	1483	12.47	10,314	1523	13.16	10,883	—	—	—
11,000	1418	12.00	9,919	1459	12.67	10,478	—	—	—	—	—	—	—	—	—	—	—	—
11,250	1449	12.80	10,585	—	—	—	—	—	—	—	—	—	—	—	—	—	—	—

### 48TMD028 (25 TONS) LOW HEAT UNITS\* (cont)

Airflow (Cfm)	Available External Static Pressure (in. wg)								
	1.4			1.6			1.8		
	Rpm	Bhp	Watts	Rpm	Bhp	Watts	Rpm	Bhp	Watts
7,000	1274	6.35	5248	1323	6.92	5,718	1371	5.54	6204
7,500	1316	7.20	6960	1364	7.79	6,437	1410	6.41	6939
8,000	1360	8.14	6734	1406	8.76	7,239	1450	7.40	7759
8,500	1406	9.20	7605	1449	9.83	8,129	1492	8.48	8666
9,000	1453	10.36	8568	1495	11.02	9,111	1536	9.69	9667
9,500	1501	11.64	9627	1541	12.32	10,190	—	—	—
10,000	—	—	—	—	—	—	—	—	—
10,500	—	—	—	—	—	—	—	—	—
11,000	—	—	—	—	—	—	—	—	—
11,250	—	—	—	—	—	—	—	—	—

**LEGEND**

**Bhp** — Brake Horsepower  
**FIOF** — Factory-Installed Option  
**Watts** — Input Watts to Motor

\*Standard low-medium static drive range is 1066 to 1283 rpm. Alternate high-static drive range is 1332 to 1550. Other rpms require a field-supplied drive.

Refer to this page for general Fan Performance Data notes.

NOTE: Maximum continuous bhp is 10.20 (208/230, 575 v) or 11.80 (460 v) and the maximum continuous watts are 9510 (208/230, 575 v) or 11,000 (460 v). Do not adjust motor rpm such that motor maximum bhp and/or watts is exceeded at the maximum operating cfm. See Evaporator Fan Motor Data tables for more information.

48TM016-028

### 48TMF028 (25 TONS) HIGH HEAT UNITS\*

Airflow (Cfm)	Available External Static Pressure (in. wg)																	
	0.2			0.4			0.6			0.8			1.0			1.2		
	Rpm	Bhp	Watts	Rpm	Bhp	Watts	Rpm	Bhp	Watts	Rpm	Bhp	Watts	Rpm	Bhp	Watts	Rpm	Bhp	Watts
7,000	992	4.05	3,348	1051	4.44	3,668	1106	4.83	3995	1160	5.24	4331	1212	5.65	4675	1262	6.08	5026
7,500	1055	4.77	3,947	1110	5.17	4,277	1162	5.58	4615	1214	6.00	4960	1263	6.43	5312	1311	6.86	5672
8,000	1118	5.58	4,610	1170	5.99	4,950	1220	6.41	5298	1268	6.84	5653	1315	7.27	6014	1361	7.72	6382
8,500	1182	6.46	5,339	1231	6.88	5,690	1278	7.31	6047	1324	7.75	6411	1369	8.20	6782	1413	8.66	7158
9,000	1246	7.42	6,136	1292	7.86	6,498	1337	8.30	6865	1381	8.75	7239	1424	9.21	7618	1466	9.68	8003
9,500	1310	8.47	7,005	1354	8.92	7,377	1397	9.38	7754	1439	9.84	8137	1480	10.31	8525	1520	10.79	8918
10,000	1374	9.61	7,947	1416	10.07	8,329	1457	10.54	8715	1497	11.02	9107	1537	11.50	9504	—	—	—
10,500	1439	10.84	8,964	1479	11.32	9,356	1518	11.79	9752	—	—	—	—	—	—	—	—	—
11,000	1503	12.17	10,059	1542	12.65	10,460	—	—	—	—	—	—	—	—	—	—	—	—
11,250	1536	12.86	10,636	—	—	—	—	—	—	—	—	—	—	—	—	—	—	—

### 48TMF028 (25 TONS) HIGH HEAT UNITS\* (cont)

Airflow (Cfm)	Available External Static Pressure (in. wg)								
	1.4			1.6			1.8		
	Rpm	Bhp	Watts	Rpm	Bhp	Watts	Rpm	Bhp	Watts
7,000	1311	6.51	5385	1359	6.96	5751	1405	6.00	6124
7,500	1358	7.30	6039	1403	7.76	6412	1448	6.84	6792
8,000	1406	8.17	6767	1560	8.63	7137	1492	7.75	7524
8,500	1456	9.12	7541	1498	9.59	7929	1539	8.75	8323
9,000	1507	10.15	8393	1548	10.63	8790	—	—	—
9,500	—	—	—	—	—	—	—	—	—
10,000	—	—	—	—	—	—	—	—	—
10,500	—	—	—	—	—	—	—	—	—
11,000	—	—	—	—	—	—	—	—	—
11,250	—	—	—	—	—	—	—	—	—

**LEGEND**

**Bhp** — Brake Horsepower  
**FIOF** — Factory-Installed Option  
**Watts** — Input Watts to Motor

\*Standard low-medium static drive range is 1066 to 1283 rpm. Alternate high-static drive range is 1332 to 1550. Other rpms require a field-supplied drive.

Refer to this page for general Fan Performance Data notes.

NOTE: Maximum continuous bhp is 10.20 (208/230, 575 v) or 11.80 (460 v) and the maximum continuous watts are 9510 (208/230, 575 v) or 11,000 (460 v). Do not adjust motor rpm such that motor maximum bhp and/or watts is exceeded at the maximum operating cfm. See Evaporator Fan Motor Data tables for more information.

### GENERAL NOTES FOR FAN PERFORMANCE DATA TABLES

- Static pressure losses (i.e., EconoMi\$er) must be added to external static pressure before entering Fan Performance table.
- Interpolation is permissible. Do not extrapolate.
- Fan performance is based on wet coils, clean filters, and casing losses. See Accessory/FIOF Static Pressure table on page 121.
- Extensive motor and drive testing on these units ensures that the full horsepower and watts range of the motor can be utilized with confidence. Using your fan motors up to the watts or bhp rating shown will not result in nuisance tripping or premature motor failure. Unit warranty will not be affected.
- Use of a field-supplied motor may affect wire size. Contact your Carrier representative for details.

# Performance data (cont)



## HORIZONTAL SUPPLY/RETURN FAN PERFORMANCE WITH CRRFCURB013A00 HIGH STATIC REGAIN ADAPTER

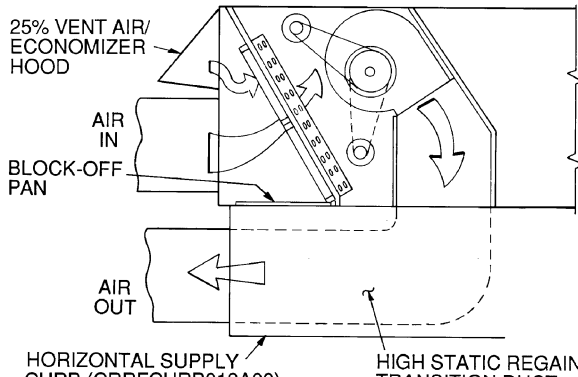

NOTE: The CRRFCURB013A00 high static regain adapter accessory may be used to provide horizontal supply/return.

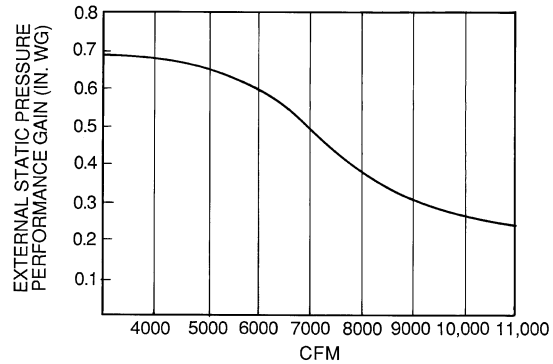

NOTE: The CRRFCURB013A00 horizontal supply/return adapter accessory improves 48TM016-028 fan performance by increasing external static pressure by amount shown above. To convert from in. wg to Pa use the following formula:  

$$\text{in. wg} \times 249.1 = \text{Pa}$$

48TM016-028

## FAN PERFORMANCE USING ACCESSORY POWER EXHAUST (48TM016-028)

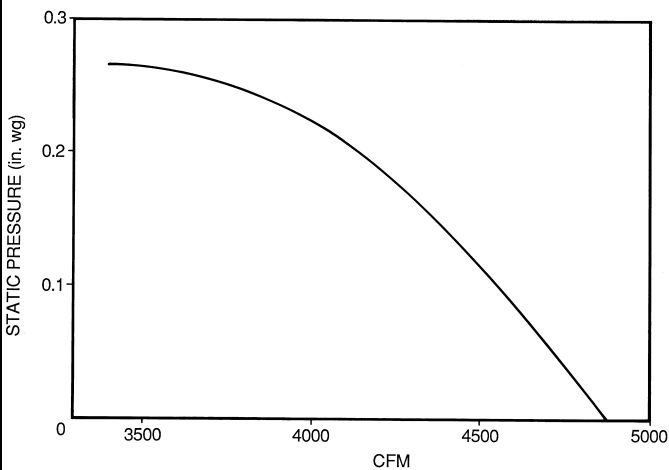

## ALTITUDE DERATING FACTOR\*

ELEVATION (ft)	MAXIMUM HEATING VALUE AT SEA LEVEL (Btu/ft <sup>3</sup> )
0-2,000	1,100
2,001-3,000	1,050
3,001-4,000	1,000
4,001-5,000	950
5,001-6,000	900

\*Derating of the gas heating equipment to compensate for the effects of altitude is always required. Orifice change is not required if the fuel heating value (at sea level) is below the limits listed in the table above. Derating conditions must be 4% per thousand ft above sea level. For example, at 4000 ft, if the heating value of the gas exceeds 1000 Btu/ft<sup>3</sup>, the unit will require a 16% derating. For elevations above 6000 ft, the same formula applies. For example, at 7000 ft, the unit will require a 28% derating of the maximum heating value per the National Fuel Gas Code.

## ALTITUDE COMPENSATION — 48TM016-028 (LP Gas Units)

ELEVATION (ft)	LIQUID PROPANE ORIFICE SIZE
	Low Heat and High Heat
0-2,000	36
2,000	37
3,000	38
4,000	38
5,000	39
6,000	40
7,000	41
8,000	41
9,000	42
10,000	43

## ALTITUDE COMPENSATION\* — 48TM016-028

ELEVATION (ft)	NATURAL GAS ORIFICE SIZE†	
	Low Heat	High Heat
0-3,000	30	29
3,000- 7,000	31	30
7,000- 9,000	32	31
9,000-10,000	33	31
above 10,000	35	32

\*Includes a 4% input reduction per each 1,000 feet.

†Orifices available through your Carrier dealer.



## OUTDOOR SOUND POWER

UNIT 48TM	SOUND RATING (60 Hz)	A-WEIGHTED (dB)	OCTAVE BANDS							
			63	125	250	500	1000	2000	4000	8000
016	8.8 Bels	87.6	90.8	88.7	86.4	84.3	83.5	78.4	75.6	66.8
020	8.8 Bels	87.8	90.8	88.7	86.4	84.3	83.5	78.4	75.6	66.8
025	9.4 Bels	94.4	99.7	93.0	93.7	91.8	89.7	85.9	80.7	74.4
028	9.4 Bels	94.1	98.7	92.3	93.8	90.9	89.6	85.9	80.3	74.3

LEGEND

Bels — Sound Levels (1 bel = 10 decibels)

### ACCESSORY/FIOP STATIC PRESSURE (in. wg)\* — 48TM016-028

COMPONENT	CFM									
	4500	5000	5400	6000	7200	7500	9000	10,000	11,250	
EconoMiSer	0.040	0.050	0.060	0.070	0.090	0.100	0.110	0.120	0.140	

LEGEND

FIOP — Factory-Installed Option

\*The static pressure must be added to external static pressure. The sum and the evaporator entering-air cfm should then be used in conjunction with the Fan Performance tables to determine blower rpm and watts.

### FAN RPM AT MOTOR PULLEY SETTINGS\*

UNIT 48TM	MOTOR PULLEY TURNS OPEN												
	0	1/2	1	1 1/2	2	2 1/2	3	3 1/2	4	4 1/2	5	5 1/2	6
016†	††	††	††	††	1021	1002	984	965	947	928	910	891	873
016**	††	††	††	††	1200	1178	1156	1134	1112	1091	1069	1047	1025
020†	††	††	1095	1077	1058	1040	1021	1002	984	965	947	928	910
020**	††	††	1287	1265	1243	1222	1200	1178	1156	1134	1112	1091	1069
025†	††	††	††	††	1151	1132	1114	1095	1077	1058	1040	1021	1002
025**	††	††	††	††	1369	1347	1325	1303	1281	1259	1237	1215	1193
028†	††	††	1283	1269	1247	1225	1203	1182	1160	1138	1116	1095	1066
028**	††	††	††	††	1551	1524	1497	1470	1443	1415	1388	1361	1332

\*Approximate fan rpm shown.

†Indicates standard drive package.

\*\*Indicates alternate drive package.

††Due to belt and pulley size, pulley cannot be set to this number of turns open.

### EVAPORATOR-FAN MOTOR DATA

UNIT 48TM	UNIT VOLTAGE	MAXIMUM ACCEPTABLE CONTINUOUS BHP*	MAXIMUM ACCEPTABLE CONTINUOUS BkW*	MAXIMUM ACCEPTABLE OPERATING WATTS	MAXIMUM AMP DRAW
016	208/230	6.13	4.57	5,180	15.8
	460				7.9
	575				6.0
020	208/230	5.90	4.40	5,180	15.8
	460				7.9
	575				6.0
025	208/230	8.70	6.49	7,915	22.0
	460				13.0
	575				10.0
028	208/230	10.20	7.61	9,510	28.0
	460				14.6
	575				13.0

LEGEND

BHP — Brake Horsepower

BkW — Brake Kilowatts

\*Extensive motor and electrical testing on these units ensures that the full horsepower (brake kilowatt) range of the motors can be utilized with confidence. Using your fan motors up to the horsepower (brake kilowatt) ratings shown in this table will not result in nuisance tripping or premature motor failure. Unit warranty will not be affected.

NOTE: All indoor-fan motors 5 hp and larger meet the minimum efficiency requirements as established by the Energy Policy Act of 1992 (EPACT) effective October 24, 1997.

### EVAPORATOR-FAN MOTOR EFFICIENCY

UNIT 48TM	MOTOR EFFICIENCY (%)
5 Hp	87.5
7.5 Hp	88.5
10 Hp	89.5

NOTE: All indoor-fan motors 5 hp and larger meet the minimum efficiency requirements as established by the Energy Policy Act of 1992 (EPACT) effective October 24, 1997.

48TM016-028

# Electrical data



48TM016-028

UNIT 48TM	NOMINAL VOLTAGE (3 Ph, 60 Hz)	VOLTAGE RANGE		COMPRESSOR						OFM			IFM		POWER EXHAUST		COMBUSTION FAN MOTOR		POWER SUPPLY	
				No. 1		No. 1A		No. 2												
				Min	Max	RLA	LRA	RLA	LRA	RLA	LRA	Qty	Hp	FLA (ea)	Hp	FLA	FLA	LRA	FLA	LRA
016	208/230	187	253	32.1	195	—	—	20.7	156	3	0.5	1.7	5.0	15.8/15.8	—	—	0.57	82/82	110/110	
	460	414	508	16.4	95	—	—	10	70	3	0.5	0.8	5.0	7.9	4.6	18.8	0.57	86/86	110/110	
	575	518	633	12	80	—	—	8.2	54	3	0.5	0.75	5.0	6.0	—	—	0.30	41	50	
020	208/230	187	253	30.1	225	—	—	28.8	195	3	0.5	1.7	5.0	15.8/15.8	2.3	6.0	0.30	43	50	
	460	414	508	15.5	114	—	—	14.7	95	3	0.5	0.8	5.0	7.9	—	—	0.57	31	40	
	575	518	632.5	12.1	80	—	—	10.7	80	3	0.5	0.75	5.0	6.0	2.1	4.8	0.57	34	40	
025	208/230	187	253	42	239	—	—	33.6	225	2	1	6.6	7.5	25.0/25.0	—	—	0.57	124/124	150/150	
	460	414	508	19.2	125	—	—	17.3	114	2	1	3.3	7.5	13.0	4.6	18.8	0.57	129/129	150/150	
	575	518	633	13.8	80.0	—	—	13.5	80.0	2	1.0	3.4	7.5	10.0	—	—	0.30	61	80	
028	208/230	187.2	253	20.7	156	20.7	156	47.1	245	6	0.5	1.7	10.0	28.0/28.0	2.3	6.0	0.30	63	80	
	460	414	508	10	75	10	75	19.6	125	6	0.5	0.8	10.0	14.6	—	—	0.57	48	60	
	575	517.5	632.5	8.2	54	8.2	54	15.8	100	6	0.5	0.8	10.0	13.0	2.1	4.8	0.57	50	60	

**LEGEND**

- FLA — Full Load Amps
- HACR — Heating, Air Conditioning and Refrigeration
- IFM — Indoor (Evaporator) Fan Motor
- LRA — Locked Rotor Amps
- MCA — Minimum Circuit Amps
- MOCP — Maximum Overcurrent Protection
- NEC — National Electrical Code
- OFM — Outdoor (Condenser) Fan Motor
- RLA — Rated Load Amps

\*Fuse or HACR circuit breaker.

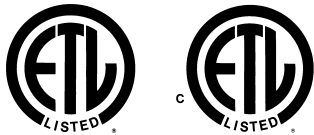

**NOTES:**

1. In compliance with NEC requirements for multimotor and combination load equipment (refer to NEC Articles 430 and 440), the overcurrent protective device for the unit shall be fuse or HACR breaker. Canadian units may be fuse or circuit breaker.
2. **Unbalanced 3-Phase Supply Voltage**  
Never operate a motor where a phase imbalance in supply voltage is greater than 2%. Use the following formula to determine the percent voltage imbalance.

**% Voltage Imbalance**

$$= 100 \times \frac{\text{max voltage deviation from average voltage}}{\text{average voltage}}$$

EXAMPLE: Supply voltage is 460-3-60.

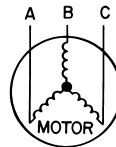

AB = 452 v  
BC = 464 v  
AC = 455 v

$$\text{Average Voltage} = \frac{452 + 464 + 455}{3}$$

$$= \frac{1371}{3}$$

$$= 457$$

Determine maximum deviation from average voltage.

(AB) 457 - 452 = 5 v  
(BC) 464 - 457 = 7 v  
(AC) 457 - 455 = 2 v

Maximum deviation is 7 v.

Determine percent voltage imbalance.

$$\% \text{ Voltage Imbalance} = 100 \times \frac{7}{457}$$

$$= 1.53\%$$

This amount of phase imbalance is satisfactory as it is below the maximum allowable 2%.

**IMPORTANT:** If the supply voltage phase imbalance is more than 2%, contact your local electric utility company immediately.

## Packaged Rooftop Electric Cooling Unit with Gas Heat — Constant Volume Application

### HVAC Guide Specifications

Size Range: **15 to 25 Tons, Nominal (Cooling)**  
**172,000 to 360,000 Btuh, Nominal**  
**(Input Heating) (Gas Units)**

Carrier Model Numbers: **48TMD, 48TMF**



### Part 1 — General

#### 1.01 SYSTEM DESCRIPTION

Unit is an outdoor rooftop mounted, electrically controlled heating and cooling unit utilizing scroll hermetic compressors for cooling duty and gas combustion for heating duty. Supply air shall be discharged downward or horizontally (with horizontal supply/return curb adapter assembly), as shown on contract drawings. Standard unit shall include a manual outdoor-air inlet.

#### 1.02 QUALITY ASSURANCE

- A. Units shall comply with the energy efficiency requirements of ASHRAE standard 90.1-2001.
- B. Unit shall be rated in accordance with ARI Standards 270 and 360 and all units shall be designed in accordance with UL Standard 1995.
- C. Unit shall be designed to conform to ASHRAE 15.
- D. Unit shall be ETL and ETL, Canada tested and certified in accordance with ANSI Z21.47 Standards as a total package.
- E. Roof curb shall be designed to conform to NRCA Standards.
- F. Insulation and adhesive shall meet NFPA 90A requirements for flame spread and smoke generation.
- G. Unit casing shall be capable of withstanding 500-hour salt spray exposure per ASTM B117 (scribed specimen).
- H. Unit shall be manufactured in a facility registered to ISO 9001:2000.

#### 1.03 DELIVERY, STORAGE, AND HANDLING

Unit shall be stored and handled per manufacturer's recommendations.

### Part 2 — Products

#### 2.01 EQUIPMENT (STANDARD)

##### A. General:

Each unit shall be a factory assembled, single-piece heating and cooling unit. Contained within the unit enclosure shall be all factory wiring, piping, controls, refrigerant charge (R-22), and special features required prior to field start-up.

##### B. Unit Cabinet:

1. Constructed of galvanized steel (G90 — 1.8 oz. of zinc per square foot [550 grams per square meter] of sheet metal), bonderized and primer-coated on both sides and coated with a baked polyester thermosetting powdercoating finish on the outer surface.

2. Indoor blower compartment interior surfaces shall be insulated with a minimum 1/2-in. thick, 1 lb density fiberglass insulation. Fiberglass insulation shall be bonded with a thermosetting resin (8 to 12% by weight nominal, phenol formaldehyde typical), and coated with an acrylic or other material that meets the NFPA 90 flame retardance requirements and has an "R" Value of 3.70. Aluminum foil-faced fiberglass insulation shall be used in the gas heat compartment.

3. Cabinet panels shall be easily removable for servicing. Cabinet panels are minimum 20 gage. Panels shall have 1/2-in. thick, 1.5-lb. density insulation.

4. Filters shall be accessible through an access panel.

5. Holes shall be provided in the base rails (minimum 12 gage) for rigging shackles to facilitate overhead rigging.

6. Unit shall contain a sloped drain pan, to prevent standing water from accumulating. Pan shall be fabricated of hot dipped zinc coated minimum spangle steel. Zinc coating shall be G90 designation according to ASTM Standard A653. Unit shall contain a factory-installed nonferrous main condensate drain connection.

##### C. Fans:

1. Indoor blower (evaporator fan):

- a. Fan shall be belt driven. Belt drive shall include an adjustable pulley. The standard fan drive shall have a factory-installed low-medium static pressure fan drive. The alternate fan drive option shall have a factory-installed high static pressure fan drive.

- b. Fan wheel shall be made from steel with a corrosion resistant finish. It shall be a dynamically balanced, double-inlet type with forward-curved blades.

2. Condenser fans shall be of the direct-driven propeller type, with corrosion-resistant blades riveted to corrosion-resistant steel supports. They shall be dynamically balanced and discharge air upwards.

3. Induced-draft blower shall be of the direct-driven, single inlet, forward-curved, centrifugal type. It shall be made from steel with a corrosion-resistant finish and shall be dynamically balanced.

##### D. Compressor(s):

1. Fully hermetic, scroll type, internally protected.
2. Factory spring-shock mounted and internally spring mounted for vibration isolation.
3. On electrically and mechanically independent refrigerant circuits.
4. All compressors shall have 70 W crankcase heaters.



## E. Coils:

1. Standard evaporator and condenser coils shall have aluminum plate fins mechanically bonded to seamless internally grooved copper tubes with all joints brazed.
2. Coils shall be leak tested at 150 psig (1034 kPa) and pressure tested at 450 psig (3103 kPa).

## F. Heating Section:

1. Induced-draft combustion type with energy saving direct-spark ignition system and redundant main gas valve.
2. a. The heat exchanger shall be of the tubular-section type constructed of a minimum of 20-gage steel coated with a nominal 1.2 mil aluminum-silicone alloy for corrosion resistance.  
b. The optional stainless steel heat exchangers shall be tubular-section design and shall be constructed of a minimum 20 gage, 409 stainless steel.
3. Burners shall be of the in-shot type constructed of aluminum-coated steel.
4. All gas piping shall enter the unit at a single location.
5. Gas piping shall be capable of being routed through the roof curb directly into unit.

## G. Refrigerant Components:

Refrigerant circuit components shall include:

1. Thermostatic expansion valve (TXV).
2. Filter driers.
3. Gage port and connections on suction, discharge, and liquid lines.

## H. Filter Section:

Standard filter section shall consist of 2 sizes of factory-installed 2-in. (51 mm) thick throwaway fiberglass filters of commercially available sizes. Filters shall be approximately 10% efficient with an air-side pressure drop of approximately 0.07 in. wg (clean).

## I. Controls and Safeties:

1. Unit Controls:
  - a. Economizer control (optional)
  - b. Capacity control (2-step)
  - c. Unit shall be complete with self-contained low-voltage control circuit.
2. Safeties:
  - a. Unit shall incorporate a solid-state compressor lockout which provides reset capability at the space thermostat, should any of the following safety devices trip and shut off compressor:
    - 1) Compressor lockout protection provided for either internal or external overload.
    - 2) Low-pressure switch.
    - 3) Dual freezestats (evaporator coil).

- 4) High-pressure switch.

b. Supply-air thermostat shall be located in the unit.

c. Heating section shall be provided with the following minimum protections:

- 1) High-temperature limit switch.
- 2) Induced-draft motor speed sensor.
- 3) Flame rollout switch.
- 4) Flame proving controls.
- 5) Redundant gas valve.

## J. Operating Characteristics:

1. Unit shall be capable of starting and running at 120 F (size 016-025) or 125 F (size 028) ambient outdoor temperature per maximum load criteria of ARI Standard 360.
2. Unit with standard controls will operate in cooling down to an outdoor ambient temperature of 40 F (4.4 C).
3. Unit shall be provided with fan time delay to prevent cold air delivery.

## K. Electrical Requirements:

All unit power wiring shall enter unit cabinet at a single location.

## L. Motors:

1. Compressor motors shall be cooled by refrigerant gas passing through motor windings and shall have line break thermal and current overload protection.
2. All fan motors shall have permanently lubricated, sealed bearings and inherent automatic-reset thermal overload protection or manual reset calibrated circuit breakers. Evaporator motors are designed specifically for Carrier and do *not* have conventional horsepower (HP) ratings listed on the motor nameplate. Motors are designed and qualified in the “air-over” location downstream of the cooling coil and carry a maximum continuous bhp rating that is the maximum application bhp rating for the motor; no “safety factors” above that rating may be applied.
3. All indoor-fan motors 5 hp and larger shall meet the minimum efficiency requirements as established by the Energy Policy Act of 1992 (EPACT) effective October 24, 1997.

## M. Special Features:

Certain features are not applicable when the features designated \* are specified. For assistance in amending the specifications, contact your local Carrier Sales Office.

- \* 1. Carrier PremierLink™ Controls:
- a. Shall be available as a factory-installed or as a field-installed accessory.
  - b. Shall work with CCN and ComfortVIEW™ software.
  - c. Shall be compatible with *ComfortLink*™ controllers.



- d. Shall be ASHRAE 62-99 compliant.
  - e. Shall accept a CO<sub>2</sub> sensor in the conditioned space — Demand Control Ventilation (DCV) Ready.
  - f. Shall have baud communication rate of 38.4K or faster.
  - g. Shall be Internet Ready.
  - h. Shall include an integrated economizer controller.
- \* 2. Direct Digital Controls (Apollo):
- a. Shall be available as a factory-installed option.
  - b. Shall actively monitor all modes of operation, as well as evaporator-fan status, filter status, indoor-air quality, supply-air temperature, and outdoor-air temperature.
  - c. Shall work with Carrier TEMP and VVT® systems.
  - d. Shall have built-in diagnostics for thermostat commands for both staged heating and cooling, evaporator-fan operation, and economizer operation.
  - e. Shall be equipped with a 5-minute time delay between modes of operation.
- \* 3. Direct Digital Communicating Controls:
- a. Shall be available as a factory-installed option.
  - b. Shall actively monitor all modes of operation, as well as evaporator-fan status, filter status, indoor-air quality, supply-air temperature, and outdoor-air temperature with field supplied sensors.
  - c. Shall work with Carrier TEMP and VVT® systems.
  - d. Shall have built-in diagnostics for thermostat commands for both staged heating and cooling, evaporator-fan operation, and economizer operation.
  - e. Shall be equipped with a 5-minute time delay between modes of operation.
4. Optional Coils:
- a. Optional pre-coated aluminum-fin coils shall have a durable epoxy-phenolic coating to provide protection in mildly corrosive coastal environments. Coating shall be applied to the aluminum fin stock prior to the fin stamping process to create an inert barrier between the aluminum fin and copper tube. Epoxy-phenolic barrier shall minimize galvanic action between dissimilar metals.
  - b. Optional copper-fin coils shall be constructed of copper fins mechanically bonded to copper tubes and copper tube sheets. Galvanized steel tube sheets shall not be acceptable. A polymer strip shall prevent coil assembly from contacting the sheet
- metal coil pan to minimize potential for galvanic corrosion between coil and pan. All copper construction shall provide protection in moderate coastal environments.
- c. Optional E-Coated aluminum-fin coils shall have a flexible epoxy polymer coating uniformly applied to all coil surface areas without material bridging between fins. Coating process shall ensure complete coil encapsulation. Color shall be high gloss black with gloss — 60 deg of 65 to 90% per ASTM D523-89. Uniform dry film thickness from 0.8 to 1.2 mil on all surface areas including fin edges. Superior hardness characteristics of 2H per ASTM D3363-92A and cross-hatch adhesion of 4B-5B per ASTM D3359-93. Impact resistance shall be up to 160 in./lb (ASTM D2794-93). Humidity and water immersion resistance shall be up to minimum 1000 and 250 hours respectively (ASTM D2247-92 and ASTM D870-92). Corrosion durability shall be confirmed through testing to be no less than 1000 hours salt spray per ASTM B117-90. Coil construction shall be aluminum fins mechanically bonded to copper tubes.
  - d. Optional E-Coated copper-fin coils shall have a flexible epoxy polymer coating uniformly applied to all coil surface areas without material bridging between fins. Coating process shall ensure complete coil encapsulation. Color shall be high gloss black with gloss — 60 deg of 65 to 90% per ASTM D523-89. Uniform dry film thickness from 0.8 to 1.2 mil on all surface areas including fin edges. Superior hardness characteristics of 2H per ASTM D3363-92A and cross-hatch adhesion of 4B-5B per ASTM D3359-93. Impact resistance shall be up to 160 in./lb (ASTM D2794-93). Humidity and water immersion resistance shall be up to minimum 1000 and 250 hours respectively (ASTM D2247-92 and ASTM D870-92). Corrosion durability shall be confirmed through testing to be no less than 1000 hours salt spray per ASTM B117-90. Coil construction shall be copper fins mechanically bonded to copper tubes with copper tube sheets. Galvanized steel tube sheets shall not be acceptable. A polymer strip shall prevent coil assembly from contacting sheet metal coil pan to maintain coating integrity and minimize corrosion potential between coil and pan.
5. Roof Curbs (Horizontal and Vertical):
- a. Formed of 16-gage galvanized steel with wood nailer strip and shall be capable of supporting entire unit weight.
  - b. Permits installing and securing ductwork to curb prior to mounting unit on the curb.



6. Horizontal Adapter Roof Curb:
 

Includes factory-assembled adapter and internal duct and substantially improves evaporator fan static performance (static regain).

**NOTE:** Power exhaust or barometric relief must be mounted in the return ductwork when used in conjunction with this accessory.
- \* 7. Integrated Economizer:
  - a. Integrated type capable of simultaneous economizer and compressor operation to provide cooling with outdoor air.
  - b. Equipped with low-leakage gear driven dampers not to exceed 2% leakage, at 1.0 in. wg (249 Pa) pressure differential.
  - c. Capable of introducing up to 100% outdoor air.
  - d. Equipped with dry-bulb temperature control to govern economizer changeover.
  - e. Equipped with a supply-air sensor that controls the economizer to a 55° F (30.5° C) control point.
  - f. Shall fit an outdoor-air opening of 17.75-in. high and 71.38-in. long (8.8 sq ft).
  - g. Actuator motor shall be a 24 v, 53 lb.ft. torque, spring return, direct coupled type design (close on loss of power).
  - h. Shall be capable of differential dry bulb outdoor air enthalpy and differential enthalpy control.
8. Two-Position Damper:
 

Two-position damper package shall include single blade damper and 24-v motor. Admits up to 25% outdoor air, and shall close upon unit shut-off. Damper shall cover 3.8-in. high by 17.75-in. wide (117.8 sq. in.) opening in return air upper panel.
9. Accessory Compressor Cycle Delay:
 

Compressor shall be prevented from restarting for a minimum of 5 minutes after shutdown.
- \*10. Thermostats and Subbases:
 

To provide staged heating and cooling in addition to automatic (or manual) changeover and fan control.
- \*11. Barometric Relief Damper Package:
  - a. Package shall include damper, seals, hardware, and hoods to relieve excess internal pressure.
  - b. Damper shall close due to gravity upon unit shutdown.
  - c. Damper package must be field-installed in return-air ductwork when used with optional side return connections.
- \*12. Power Exhaust:
 

Package shall include an exhaust (propeller style) fan, 1/2 Hp 208-230, 460 v (factory-wired for 460 v) direct drive motor, and damper for vertical flow units with economizer to control over-pressurization of building. Power Exhaust package must be field-installed in return-air ductwork when used with optional side return connections.
- \*13. Head Pressure Control Package:
 

Consists of an accessory outdoor-air package and a solid-state control with condenser coil temperature sensor for controlling condenser-fan motor speed to maintain condensing temperature between 90 F (32.2 C) and 100 F (43.3 C) at outdoor ambient temperature down to -20 F (-29.8 C). (Size 016-025 only.)
14. Low-Ambient Kits:
 

When used, allows units to operate at lower outdoor ambient temperatures. Sizes 016, 020, and 028 will operate down to 10 F. Size 025 will operate down to 25 F.
- \*15. Electronic Programmable Thermostat:
 

Capable of using deluxe full-featured electronic thermostat.
16. Liquid Propane Conversion Kit:
 

Kit shall contain all the necessary hardware and instructions to convert a standard natural gas unit for use with liquefied propane gas.
17. Service Option Package:
  - a. Hinged access panels for the filter, compressors, evaporator fan, and control box areas. Filter hinged access panels permit tool-less entry for changing filters. Evaporator fan hinged access panel shall be field-convertible to a tool-less entry by removing and discarding screws. Each external hinged access panel shall be permanently attached to the rooftop unit.
  - b. Convenience outlet: Shall be factory-installed and internally mounted with an externally accessible 115-v, 15 amp. GFI, female receptacle with hinged cover. Voltage and circuit protection required to operate convenience outlet shall be provided by a field-supplied and properly fused separate branch circuit.
  - c. Non-fused disconnect switch: Shall be factory-installed, internally mounted, NEC and UL approved non-fuse switch; shall provide unit power shutoff. The control access door shall be interlocked with the non-fused disconnect. The disconnect switch must be in the OFF position to open the control box access door. Shall be accessible from outside the unit and shall provide power off lockout capability.
18. Alternate Drive:
 

Shall provide higher static drive capability to enhance evaporator-fan performance rpm range.



19. Hail Guard (Size 016-025):  
Shall protect the condenser coil from hail, flying debris, and damage by large objects without increasing unit clearances.
20. Winter Start Time-Delay Relay:  
Used in conjunction with the accessory low-ambient kit or head pressure control device, permits operation in cooling at lower outdoor ambient temperatures. See price pages for more information.
21. Ultra-Violet Germicidal Lamps:  
Ultra-violet germicidal lamps are designed to eliminate odor causing mold and fungus that may develop in the wet area of the evaporator section of the unit. The high output, low temperature germicidal lamps are field installed in the evaporator section of the unit, aimed at the evaporator coil and condensate pan. The short wavelength ultra-violet light inhibits and kills mold, fungus and microbial growth. The lamps have an output rating at 45 F in 400 fpm air-flow of 120 microwatts/cm<sup>2</sup> at 1 meter.
22. Stainless Steel Condensate Pan:  
Stainless steel condensate pans shall be available for condensate collection.
23. Outdoor Air Enthalpy Sensor:  
The outdoor air enthalpy sensor shall be used with the EconoMi\$er device to provide single enthalpy control. When used in conjunction with a return air enthalpy sensor, the EconoMi\$er device will provide differential enthalpy control. The sensor allows the EconoMi\$er controller to determine if outside air is suitable for free cooling.
24. Return Air Enthalpy Sensor:  
The return air enthalpy sensor shall be used with the EconoMi\$er device. When used in conjunction with an outdoor air enthalpy sensor, the EconoMi\$er device will provide differential enthalpy control.
25. Return Air Temperature Sensor:  
The return air temperature sensor shall be used with the EconoMi\$er device. When used in conjunction with the standard outdoor air temperature sensor, the EconoMi\$er device will provide differential enthalpy control.

# Model number nomenclature



→ 48HJ004-014 (3 to 12 1/2 Tons) — ASHRAE 90.1 Compliant

Example: **48 HJ D 006 P M F 6 4 1 HA**

**48** – Packaged Rooftop Electric Cooling/ Natural Gas Heat

**HJ** – Constant Volume, High Efficiency

**Heat Options:  
49 States**

- D** – Low Heat
- E** – Medium Heat
- F** – High Heat

**California Compliant**

- G** – Non NOx Low Heat (3 Ph, Single Stg)
- H** – Non NOx Medium Heat (3 Ph, Single Stg)
- K** – Non NOx High Heat (3 Ph, Single Stg)
- L** – Low NOx Low Heat (Single Stg)
- M** – Low NOx Medium Heat (Single Stg)
- N** – Low NOx High Heat (Single Stg)

**Tons Nominal Capacity**

- 004** – 3 Tons
- 005** – 4 Tons
- 006** – 5 Tons
- 007** – 6 Tons
- 008** – 7-1/2 Tons
- 009** – 8-1/2 Tons
- 012** – 10 Tons
- 014** – 12-1/2 Tons

**Controls and Sensors\***

- – None
- G** – Hinged Access Panels
- H** – Hinged Panels & PremierLink™ Control
- K** – Novar ETM2024 Control†
- L** – Novar ETM2024 Control & Hinged Panels†
- N** – Novar ETM3051 Control†
- P** – PremierLink™ DDC Control
- R** – Novar ETM3051 & Hinged Panels†
- Y** – Apollo Control & Hinged Panels
- Z** – Apollo Control

**FIOPs\*\***

- Packaging**  
**1** – Domestic  
**3** – Export

**Design Changes**

**Voltage**

- 1** – 575-3-60
- 3** – 208/230-1-60
- 5** – 208/230-3-60
- 6** – 460-3-60

**Coil Protection Options (fin/tube)\***

- – Al/Cu Cond & Evap
- B** – Cu/Cu Cond & Evap
- C** – Cu/Cu Cond & Al/Cu Evap
- E** – E-Coat Al/Cu Cond & E-Coat Al/Cu Evap
- F** – E-Coat Al/Cu Cond & Al/Cu Evap
- G** – E-Coat Cu/Cu Cond & Al/Cu Evap
- V** – Al/Cu Pre-Coat Cond Fin & Al/Cu Evap

**Indoor Motor Options**

- – Standard Motor & Drive
- M** – High-Static Indoor Motor
- S** – MoistureMiSer™ Dehumidification Pkg.
- T** – MoistureMiSer & High Static Indoor Motor
- W** – MoistureMiSer – Cu/Cu Coil
- X** – MoistureMiSer, Cu/Cu w/High-Static Motor

48HJ004-014

**LEGEND**

- Al** — Aluminum
- Cu** — Copper
- FIOP** — Factory-Installed Option

\*\*Refer to 48HJ Price Pages or contact your local Carrier Representative for FIOP code table.

NOTE: Hinged Access Panels include: Filter Panel, Control Box Panel, Fan Motor Panel, Compressor Panel.

\*See below for options available for the 48HJ unit with 62AQ FIOP.  
 †Contact factory for availability and applications.

**Controls and Sensors (62AQ/RTU)**

- B** — 62AQ + Std. RTU Controls
- C** — 62AQ + Hinged Access Panels
- D** — 62AQ + Hinged Panels & PremierLink
- E** — 62AQ + PremierLink

**Coil Protection Options (fin/tube) (62AQ/RTU)**

- |  |  |
|--|--|
| <ul style="list-style-type: none"> <li><b>H</b> — 62AQ060 Al/Cu Supply + Exhaust / Al/Cu Cond &amp; Evap</li> <li><b>J</b> — 62AQ100 Al/Cu Supply + Exhaust / Al/Cu Cond &amp; Evap</li> <li><b>K</b> — 62AQ200 Al/Cu Supply + Exhaust / Al/Cu Cond &amp; Evap</li> <li><b>L</b> — 62AQ300 Al/Cu Supply + Exhaust / Al/Cu Cond &amp; Evap</li> <li><b>M</b> — 62AQ060 Cu/Cu Supply + Exhaust / Cu/Cu Cond &amp; Evap</li> <li><b>N</b> — 62AQ100 Cu/Cu Supply + Exhaust / Cu/Cu Cond &amp; Evap</li> <li><b>P</b> — 62AQ200 Cu/Cu Supply + Exhaust / Cu/Cu Cond &amp; Evap</li> <li><b>Q</b> — 62AQ300 Cu/Cu Supply + Exhaust / Cu/Cu Cond &amp; Evap</li> <li><b>R</b> — 62AQ060 Cu/Cu Supply + Exhaust / Al/Cu Cond &amp; Evap</li> <li><b>S</b> — 62AQ100 Cu/Cu Supply + Exhaust / Al/Cu Cond &amp; Evap</li> <li><b>T</b> — 62AQ200 Cu/Cu Supply + Exhaust / Al/Cu Cond &amp; Evap</li> <li><b>W</b> — 62AQ300 Cu/Cu Supply + Exhaust / Al/Cu Cond &amp; Evap</li> </ul> | <ul style="list-style-type: none"> <li><b>X</b> — 62AQ060 E-Ctd Al/Cu Supply, Std. Al/Cu Exhaust / E-Ctd Al/Cu Cond &amp; Std. Al/Cu Evap</li> <li><b>Y</b> — 62AQ100 E-Ctd Al/Cu Supply, Std. Al/Cu Exhaust / E-Ctd Al/Cu Cond &amp; Std. Al/Cu Evap</li> <li><b>Z</b> — 62AQ200 E-Ctd Al/Cu Supply, Std. Al/Cu Exhaust / E-Ctd Al/Cu Cond &amp; Std. Al/Cu Evap</li> <li><b>1</b> — 62AQ300 E-Ctd Al/Cu Supply, Std. Al/Cu Exhaust / E-Ctd Al/Cu Cond &amp; Std. Al/Cu Evap</li> <li><b>2</b> — 62AQ060 E-Ctd Al/Cu Supply &amp; Exhaust / E-Ctd Al/Cu Cond &amp; Std. Al/Cu Evap</li> <li><b>3</b> — 62AQ100 E-Ctd Al/Cu Supply &amp; Exhaust / E-Ctd Al/Cu Cond &amp; Std. Al/Cu Evap</li> <li><b>4</b> — 62AQ200 E-Ctd Al/Cu Supply &amp; Exhaust / E-Ctd Al/Cu Cond &amp; Std. Al/Cu Evap</li> <li><b>5</b> — 62AQ300 E-Ctd Al/Cu Supply &amp; Exhaust / E-Ctd Al/Cu Cond &amp; Std. Al/Cu Evap</li> <li><b>6</b> — 62AQ060 E-Ctd Al/Cu Supply &amp; Exhaust / E-Ctd Al/Cu Cond &amp; Evap</li> <li><b>7</b> — 62AQ100 E-Ctd Al/Cu Supply &amp; Exhaust / E-Ctd Al/Cu Cond &amp; Evap</li> <li><b>8</b> — 62AQ200 E-Ctd Al/Cu Supply &amp; Exhaust / E-Ctd Al/Cu Cond &amp; Evap</li> <li><b>9</b> — 62AQ300 E-Ctd Al/Cu Supply &amp; Exhaust / E-Ctd Al/Cu Cond &amp; Evap</li> </ul> |
|--|--|

**Quality Assurance**



# ARI\* capacity ratings



UNIT 48HJ	NOMINAL TONS	COOLING (Btuh)	TOTAL KW	SEER†	EER	SOUND RATING (Bels)	IPLV††
004	3	36,000	3.2	13.0	11.2**	7.6	N/A
005	4	46,000	4.1	13.0	11.1**	7.6	N/A
006	5	61,000	5.5	13.0	11.0**	8.0	N/A
007	6	73,000	6.7	—	11.0	8.0	N/A
008	7.5	90,000	8.2	—	11.0	8.2	11.6
009	8.5	102,000	9.4	—	10.8	8.2	10.9
012	10	120,000	10.9	—	11.0	8.4	11.4
014	12.5	138,000	14.4	—	9.6	8.6	10.3

### LEGEND

- Bels** — Sound Levels (1 bel = 10 decibels)  
**EER** — Energy Efficiency Ratio  
**IPLV** — Integrated Part-Load Value  
**SEER** — Seasonal Energy Efficiency Ratio

\*Air-Conditioning & Refrigeration Institute.

†Applies only to units with capacity of 65,000 Btuh or less.

\*\*ARI does not require EER ratings for unit with capacity below 65,000 Btuh. For these units, the EER rating at ARI standard conditions is provided for information only.

††The IPLV is not applicable to single-compressor units.

### NOTES:

- Rated in accordance with ARI Standard 210/240 (004-012 units) or 360 (014 units) and 270 (004-014 units).
- Ratings are net values, reflecting the effects of circulating fan heat.
- Ratings are based on:  
**Cooling Standard:** 80 F db, 67 wb indoor entering-air temperature and 95 F db outdoor entering-air temperature.  
**IPLV Standard:** 80 F db, 67 F wb indoor entering-air temperature and 80 F db outdoor entering-air temperature.



Sizes 004-012 Only



Sizes 014 Only

- All 48HJ004-014 units are in compliance with ASHRAE 90.1 2001 Energy Standard for minimum SEER and EER requirements. Refer to state and local codes or visit the following website: <http://solstice.crest.org/efficiency/bcap> to determine if compliance with this standard pertains to a given geographical area of the United States.

California, Maryland, Washington, Wyoming and various local and state building codes adopted the ASHRAE 90.1 efficiency standard on October 29, 2001.

## HEATING CAPACITIES AND EFFICIENCIES

### 208/230-1-60 — SINGLE STAGE GAS HEAT

UNIT 48HJ	INPUT CAPACITY		OUTPUT CAPACITY		TEMPERATURE RISE (°F)	MINIMUM HEATING AIRFLOW (CFM)	EFFICIENCY	
	1st Stage	2nd Stage	1st Stage	2nd Stage			AFUE (%)	Steady State (%)
E004	72,000	—	58,000	—	15-45	1200	82.8%	82.0
F004	115,000	—	90,000	—	55-85	980	80.0%	80.0
D005	72,000	—	58,000	—	15-45	1200	82.8%	82.0
E005	115,000	—	92,000	—	35-65	1320	81.0%	81.0
F005	150,000	—	118,000	—	50-80	1370	80.4%	80.0
D006	72,000	—	58,000	—	15-45	1200	82.8%	82.0
E006	115,000	—	92,000	—	35-65	1320	81.0%	81.0
F006	150,000	—	118,000	—	50-80	1370	80.4%	80.0

### 208/230-1-60 — SINGLE STAGE GAS HEAT — LOW NO<sub>x</sub>

UNIT 48HJ	INPUT CAPACITY		OUTPUT CAPACITY		TEMPERATURE RISE (°F)	MINIMUM HEATING AIRFLOW (CFM)	EFFICIENCY	
	1st Stage	2nd Stage	1st Stage	2nd Stage			AFUE (%)	Steady State (%)
M004	60,000	—	50,000	—	20-50	930	80.2%	81.2
N004	90,000	—	74,000	—	30-60	1150	81.0%	81.4
L005	60,000	—	50,000	—	20-50	930	80.2%	81.2
M005	90,000	—	74,000	—	30-60	1150	81.0%	81.4
N005	120,000	—	101,000	—	40-70	1340	80.7%	82.4
L006	60,000	—	50,000	—	20-50	930	80.2%	81.2
M006	90,000	—	74,000	—	30-60	1150	81.0%	81.4
N006	120,000	—	101,000	—	40-70	1340	80.7%	82.4

### 208/230/460-3-60 — SINGLE STAGE GAS HEAT — LOW NO<sub>x</sub>

UNIT 48HJ	INPUT CAPACITY		OUTPUT CAPACITY		TEMPERATURE RISE (°F)	MINIMUM HEATING AIRFLOW (CFM)	EFFICIENCY	
	1st Stage	2nd Stage	1st Stage	2nd Stage			AFUE (%)	Steady State (%)
M004	60,000	—	50,000	—	20-50	930	80.2%	81.2
N004	90,000	—	74,000	—	30-60	1150	81.0%	81.4
L005	60,000	—	50,000	—	20-50	930	80.2%	81.2
M005	90,000	—	74,000	—	30-60	1150	81.0%	81.4
N005	120,000	—	101,000	—	40-70	1340	80.7%	82.4
L006	60,000	—	50,000	—	20-50	930	80.2%	81.2
M006	90,000	—	74,000	—	30-60	1150	81.0%	81.4
N006	120,000	—	101,000	—	40-70	1340	80.7%	82.4

48HJ004-014

# ARI\* capacity ratings (cont)



## HEATING CAPACITIES AND EFFICIENCIES (cont)

### 208/230/460-3-60 — SINGLE STAGE GAS HEAT

UNIT 48HJ	INPUT CAPACITY		OUTPUT CAPACITY		TEMPERATURE RISE (°F)	MINIMUM HEATING AIRFLOW (CFM)	EFFICIENCY	
	1st Stage	2nd Stage	1st Stage	2nd Stage			AFUE (%)	Steady State (%)
H004	72,000	—	59,040	—	25-55	1000	82.0%	82.0
K004	115,000	—	93,150	—	55-85	1020	80.0%	81.0
G005	72,000	—	59,040	—	25-55	1000	82.0%	82.0
H005	115,000	—	93,150	—	30-60	1440	81.0%	81.0
K005	150,000	—	120,000	—	50-80	1390	80.0%	80.0
G006	72,000	—	59,040	—	15-45	1220	82.0%	82.0
H006	115,000	—	93,150	—	35-65	1330	81.0%	81.0
K006	150,000	—	120,000	—	50-80	1390	80.0%	80.0

### 208/230/460/575-3-60 — 2 STAGE GAS HEAT

UNIT 48HJ	INPUT CAPACITY		OUTPUT CAPACITY		TEMPERATURE RISE (°F)	MINIMUM HEATING AIRFLOW (CFM)	EFFICIENCY	
	1st Stage	2nd Stage	1st Stage	2nd Stage			AFUE (%)	Steady State (%)
E004	50,000	72,000	41,000	59,040	15-45	1220	82.0%	82.0
F004	82,000	115,000	65,600	93,150	55-85	1020	80.0%	80.0
D005	50,000	72,000	41,000	59,040	15-45	1220	82.0%	82.0
E005	82,000	115,000	66,420	93,150	35-65	1330	81.0%	81.0
F005	120,000	150,000	96,000	120,000	50-80	1390	80.0%	80.0
D006	50,000	72,000	41,000	59,040	15-45	1220	82.0%	82.0
E006	82,000	115,000	66,420	93,150	35-65	1330	81.0%	81.0
F006	120,000	150,000	96,000	120,000	50-80	1390	80.0%	80.0
D007	50,000	72,000	41,000	59,040	15-45	1220	82.0%	82.0
E007	82,000	115,000	66,420	93,150	35-65	1330	81.0%	81.0
F007	120,000	150,000	96,000	120,000	50-80	1390	80.0%	80.0
D008	90,000	125,000	73,800	102,500	20-50	1900	82.0%	82.0
E008	120,000	180,000	98,400	147,600	35-65	1440	82.0%	82.0
F008	180,000	224,000	147,600	183,680	45-75	2230	82.0%	82.0
D009	90,000	125,000	73,800	102,500	20-50	1900	82.0%	82.0
E009	120,000	180,000	98,400	147,600	35-65	1440	82.0%	82.0
F009	180,000	224,000	147,600	183,680	45-75	2230	82.0%	82.0
D012	120,000	180,000	98,400	147,600	35-65	1440	82.0%	82.0
E012	180,000	224,000	147,600	183,680	35-65	2570	82.0%	82.0
F012	200,000	250,000	160,000	200,000	40-70	2650	80.0%	80.0
D014	180,000	224,000	147,600	183,680	35-65	2570	82.0%	82.0
E014	200,000	250,000	160,000	200,000	40-70	2650	80.0%	80.0

48HJ004-014

# Physical data



BASE UNIT 48	HJE/F/H/K/M/N004	HJD/E/F/G/H/K/L/M/N005	HJD/E/F/G/H/K/L/M/N006	HJD/E/F007
<b>NOMINAL CAPACITY</b>	3	4	5	6
<b>OPERATING WEIGHT (lb)</b>				
Unit	530	540	560	635
With MoistureMiSer™ Dehumidification Package	548	558	578	653
EconoMiSer	50	50	50	50
Roof Curb	115	115	115	115
<b>COMPRESSOR</b>	Scroll			
Quantity	1	1	1	1
Oil (oz)	42	53	50	60
<b>REFRIGERANT TYPE</b>	R-22			
Expansion Device	Acutrol™ Metering Device			
Operating Charge (lb-oz)				
Standard Unit	5- 8	10-2	10- 0	12-8
Unit With MoistureMiSer Dehumidification Package	8-13	13-2	12-13	15-6
<b>CONDENSER FAN</b>	Propeller			
Quantity...Diameter (in.)	1...22	1...22	1...22	1...22
Nominal Cfm	3500	3500	4100	4100
Motor Hp...Rpm	1/4...825	1/4...825	1/4...1100	1/4...1100
Watts Input (Total)	180	180	320	320
<b>CONDENSER COIL</b>	Enhanced Copper Tubes, Aluminum Lanced Fins			
Standard Unit				
Rows...Fins/in.	1...17	2...17	2...17	2...17
Total Face Area (sq ft)	14.6	16.5	16.5	21.3
Unit with MoistureMiSer Dehumidification Package				
Rows...Fins/in.	1...17	1...17	1...17	1...17
Total Face Area (sq ft)	3.9	3.9	3.9	3.9
<b>EVAPORATOR COIL</b>	Enhanced Copper Tubes, Aluminum Double-Wavy Fins			
Rows...Fins/in.	2...15	2...15	4...15	4...15
Total Face Area (sq ft)	5.5	5.5	5.5	7.3
<b>EVAPORATOR FAN</b>	Centrifugal Type, Belt Drive			
Quantity...Size (in.)	1...10 x 10	1...10 x 10	1...10 x 10	1...10 x 10
Nominal Cfm	1200	1600	2000	2400
Maximum Continuous Bhp	Std 1.20	1.20	1.30/2.40*	2.40
	Hi-Static 2.40	2.40	2.90	2.90
Motor Frame Size	Std 48	48	48/56*	56
	Hi-Static 56	56	56	56
Fan Rpm Range	Std 760-1090	840-1185	1020-1460/1120-1585*	1120-1585
	Hi-Static 1075-1455	1075-1455	1300-1685	1300-1685
Motor Bearing Type	Ball	Ball	Ball	Ball
Maximum Fan Rpm	2100	2100	2100	2100
Motor Pulley Pitch Diameter A/B (in.)	Std 1.9/2.9	1.9/2.0	2.4/3.4	2.4/3.4
	Hi-Static 2.8/3.8	2.8/3.8	3.4/4.4	3.4/3.4
Nominal Motor Shaft Diameter (in.)	Std 1/2	1/2	5/8	5/8
	Hi-Static 5/8	5/8	5/8	7/8
Fan Pulley Pitch Diameter (in.)	Std 4.5	4.0	4.0	4.0
	Hi-Static 4.5	4.0	4.5	4.5
Belt — Type...Length (in.)	Std 1...A...36	1...A...36	1...4...40	1...A...38
	Hi-Static 1...A...39	1...A...39	1...A...40	1...A...40
Pulley Center Line Distance (in.)	10.0-12.4	10.0-12.4	14.7-15.5	14.7-15.5
Speed Change per Full Turn of Movable Pulley Flange (rpm)	Std 65	70	75	95
	Hi-Static 65	65	60	60
Movable Pulley Maximum Full Turns from Closed Position	Std 5	5	6	5
	Hi-Static 6	6	5	5
Factory Setting — Full Turns Open	Std 3	3	3	3
	Hi-Static 3 1/2	3 1/2	3 1/2	3 1/2
Factory Speed Setting (rpm)	Std 890	980	1240	1304
	Hi-Static 1233	1233	1396	1396
Fan Shaft Diameter at Pulley (in.)	5/8	5/8	5/8	5/8

**LEGEND**

**Bhp** — Brake Horsepower

\*Single phase/three phase.

†Indicates automatic reset.

\*\*60,000 and 72,000 Btuh heat input units have 2 burners. 90,000 and 120,000 Btuh heat input units have 3 burners. 115,000 Btuh heat input units and 150,000 Btuh Heat input units have 3 burners.

††An LP kit is available as an accessory. Kit may be used at elevations as high as 2000 ft.

||Three-phase standard models have heating inputs as shown. Single-phase standard models have one-stage heating with heating input values as follows:

HJD005-006,HJE004 — 72,000 Btuh

HJE005-006,HJF004 — 115,000 Btuh

HJF005-006 — 150,000 Btuh

\*\*\*California compliant three-phase models.

†††California SCAQMD compliant low NO<sub>x</sub> models have combustion products that are controlled to 40 nanograms per joule or less.

48HJ004-014

# Physical data (cont)



BASE UNIT 48	HJE/F/H/K/M/N004	HJD/E/F/G/H/K/L/M/N005	HJD/E/F/G/H/K/L/M/N006	HJD/E/F007
<b>FURNACE SECTION</b>				
Rollout Switch Cutout Temp (F)†	195	195	195	195
Burner Orifice Diameter (in. ...drill size)**				
Natural Gas — Std	HJE .113...33 HJF .113...33 —	HJD .113...33 HJE .113...33 HJF .129...30	HJD .113...33 HJE .113...33 HJF .129...30	HJD .113...33 HJE .113...33 HJF .129...30
	HJH .113...33 HJK .113...33 —	HJG .113...33 HJH .113...33 HJK .129...30	HJG .113...33 HJH .113...33 HJK .129...30	— — —
	HJM .102...38 HJN .102...38 —	HJL .102...38 HJM .102...38 HJN .116...32	HJL .102...38 HJM .102...38 HJN .116...32	— — —
Liquid Propane — Alt††	HJE .089...43 HJF .089...43 —	HJD .089...43 HJE .089...43 HJF .104...37	HJD .089...43 HJE .089...43 HJF .104...37	HJD .089...43 HJE .089...43 HJF .104...37
	HJH .089...43 HJK .089...43 —	HJG .089...45 HJH .089...45 HJK .102...38	HJG .089...43 HJH .089...43 HJK .104...37	— — —
	HJM .082...45 HJN .082...45 —	HJL .082...45 HJM .082...45 HJN .094...42	HJL .082...45 HJM .082...45 HJN .094...42	— — —
Thermostat Heat Anticipator Setting (amps)				
208/230/460/575 v				
First Stage	.14	.14	.14	.14
Second Stage	.14	.14	.14	.14
Gas Input (Btuh)				
First Stage/Second Stage	HJE   50,000/ 72,000 HJF   82,000/115,000 —	HJD   50,000/ 72,000 HJE   82,000/115,000 HJF   120,000/150,000	HJD   50,000/ 72,000 HJE   82,000/115,000 HJF   120,000/150,000	HJD   50,000/ 72,000 HJE   82,000/115,000 HJF   120,000/150,000
	HJH*** —/ 72,000 HJK*** —/115,000 —	HJG*** —/ 72,000 HJH*** —/115,000 HJK*** —/150,000	HJG*** —/ 72,000 HJH*** —/115,000 HJK*** —/150,000	— — —
	HJM††† —/ 60,000 HJN††† —/ 90,000 —	HJL††† —/ 60,000 HJM††† —/ 90,000 HJN††† —/120,000	HJL††† —/ 60,000 HJM††† —/ 90,000 HJN††† —/120,000	— — —
Efficiency (Steady State) (%)	HJE 82 HJF 80 —	HJD 82 HJE 81 HJF 80	HJD 82 HJE 81 HJF 80	HJD 82 HJE 81 HJF 80
	HJH 82 HJK 81 —	HJG 82 HJH 81 HJK 80	HJG 82 HJH 81 HJK 80	— — —
	HJM 81.2 HJN 81.4 —	HJL 81.2 HJM 81.4 HJN 82.4	HJL 81.2 HJM 81.4 HJN 82.4	— — —
Temperature Rise Range	HJE 15-45 HJF 55-85 —	HJD 15-45 HJE 35-65 HJF 50-80	HJD 15-45 HJE 35-65 HJF 50-80	HJD 15-45 HJE 35-65 HJF 50-80
	HJH 25-55 HJK 55-85 —	HJG 25-55 HJH 35-65 HJK 50-80	HJG 15-45 HJH 35-65 HJK 50-80	— — —
	HJM 20-50 HJN 30-60 —	HJL 20-50 HJM 30-60 HJN 40-70	HJL 20-50 HJM 30-60 HJN 40-70	— — —
Manifold Pressure (in. wg)				
Natural Gas — Std	3.5	3.5	3.5	3.5
Liquid Propane — Alt††	3.5	3.5	3.5	3.5
Maximum Static Pressure (in. wg)	1.0	1.0	1.0	1.0
Field Gas Connection Size (in.)	1/2	1/2	1/2	1/2
HIGH-PRESSURE SWITCH (psig)				
Standard Compressor Internal Relief			450 ± 50	
Cutout			428	
Reset (Auto.)			320	
LOSS-OF-CHARGE SWITCH/LOW-PRESSURE SWITCH (Liquid Line) (psig)				
Cutout			7 ± 3	
Reset (Auto.)			22 ± 5	
FREEZE PROTECTION THERMOSTAT				
Opens (F)			30 ± 5	
Closes (F)			45 ± 5	
OUTDOOR-AIR INLET SCREENS				
Quantity...Size (in.)			Cleanable 1...20 x 24 x 1	
RETURN-AIR FILTERS				
Quantity...Size (in.)			Throwaway 2...16 x 25 x 2	

48HJ004-014

**LEGEND**

**Bhp** — Brake Horsepower

\*Single phase/three phase.

†Indicates automatic reset.

\*\*60,000 and 72,000 Btuh heat input units have 2 burners. 90,000 and 120,000 Btuh heat input units have 3 burners. 115,000 Btuh heat input units and 150,000 Btuh Heat input units have 3 burners.

††An LP kit is available as an accessory. Kit may be used at elevations as high as 2000 ft.

||Three-phase standard models have heating inputs as shown. Single-phase standard models have one-stage heating with heating input values as follows:

HJD005-006,HJE004 — 72,000 Btuh

HJE005-006,HJF004 — 115,000 Btuh

HJF005-006 — 150,000 Btuh

\*\*\*California compliant three-phase models.

†††California SCAQMD compliant low NO<sub>x</sub> models have combustion products that are controlled to 40 nanograms per joule or less.



UNIT SIZE 48HJ	D/E/F008	D/E/F009	D/E/F012	D/E014
<b>NOMINAL CAPACITY (tons)</b>	7 <sup>1</sup> / <sub>2</sub>	8 <sup>1</sup> / <sub>2</sub>	10	12 <sup>1</sup> / <sub>2</sub>
<b>OPERATING WEIGHT (lb)</b>				
Unit	870	880	1035	1050
With MoistureMiSer™ Dehumidification Package	899	909	1068	1083
EconoMiSer2	75	75	75	75
Roof Curb	143	143	143	143
<b>COMPRESSOR</b>			Scroll	
Quantity	2	2	2	2
Oil (oz) (each compressor)	53	53	50	60
<b>REFRIGERANT TYPE</b>			R-22	
Expansion Device			Acutrol™ Metering Device	
Operating Charge (lb-oz)				
Standard Unit				
Circuit 1	7-10	7-14	9-6	9-8
Circuit 2	8- 2	8- 5	10-9	9-5
Unit With MoistureMiSer Dehumidification Package				
Circuit 1	10-10	10-11	13- 0	12-6
Circuit 2	12- 8	10-10	13- 5	12-2
<b>CONDENSER FAN</b>			Propeller	
Quantity...Diameter (in.)	2...22	2...22	2...22	2...22
Nominal Cfm	6500	6500	7000	7000
Motor Hp...Rpm	1/4...1100	1/4...1100	1/4...1100	1/4...1100
Watts Input (Total)	650	650	650	650
<b>CONDENSER COIL</b>			Enhanced Copper Tubes, Aluminum Lanced Fins	
Standard Unit				
Rows...Fins/in.	2...17	2...17	2...17	2...17
Total Face Area (sq ft)	20.5	20.5	25.0	25.0
Unit with MoistureMiSer Dehumidification Package				
Rows...Fins/in.	1...17	1...17	1...17	1...17
Total Face Area (sq ft)	6.3	6.3	8.4	8.4
<b>EVAPORATOR FAN</b>			Centrifugal	
Size (in.)	15 x 15	15 x 15	15 x 15	15 x 15
Type Drive	Belt	Belt	Belt	Belt
Nominal Cfm	3000	3400	4000	5000
Maximum Continuous Bhp	Std 2.90	2.90	3.70	5.25
	Hi-Static 4.20	4.20	5.25	—
Motor Frame	Std 56	56	56	56
Fan Rpm Range	Std 840-1085	840-1085	860-1080	900-1260
	Hi-Static 860-1080	860-1080	830-1130	—
Motor Bearing Type	Ball	Ball	Ball	Ball
Maximum Fan Rpm	2100	2100	2100	2100
Motor Pulley Pitch Diameter	Std 3.4/4.4	3.4/4.4	4.0/5.0	2.8/3.8
A/B (in.)	Hi-Static 4.0/5.0	4.0/5.0	2.8/3.8	—
Nominal Motor Shaft Diameter (in.)	7/8	7/8	7/8	7/8
Fan Pulley Pitch Diameter (in.)	Std 7.0	7.0	8.0	5.8
	Hi-Static 8.0	8.0	5.8	—
Belt — Type...Length (in.)	Std A...48	A...48	A...51	BX...46
	Hi-Static A...55	A...55	BX...46	—
Pulley Center Line Distance (in.)	16.75-19.25	16.75-19.25	15.85-17.50	15.85-17.50
Speed Change per Full Turn of	Std 50	50	45	60
Movable Pulley Flange (rpm)	Hi-Static 60	60	60	—
Movable Pulley Maximum Full	Std 5	5	5	6
Turns from Closed Position	Hi-Static 5	5	6	—
Factory Setting — Full Turns Open	Std 5	5	5	5
	Hi-Static 5	5	5	—
Factory Speed Setting (rpm)	Std 840	840	860	960
	Hi-Static 860	860	890	—
Fan Shaft Diameter at Pulley (in.)	1	1	1	1
<b>EVAPORATOR COIL</b>			Enhanced Copper Tubes, Aluminum Double-Wavy Fins, Face-Split	
Rows...Fins/in.	3...15	3...15	4...15	4...15
Total Face Area (sq ft)	8.9	8.9	11.1	11.1

LEGEND

Bhp — Brake Horsepower

\*Single phase/three phase.

†Indicates automatic reset.

\*\*72,000 Btuh heat input units have 2 burners.

††115,000 Btuh heat input units and 150,000 Btuh Heat input units have 3 burners.

†††An LP kit is available as an accessory. Kit may be used at elevations as high as 2000 ft.

48HJ004-014

# Physical data (cont)



UNIT SIZE 48HJ	D/E/F008	D/E/F009	D/E/F012	D/E014
<b>FURNACE SECTION</b>				
Rollout Switch Cutout Temp (F)†	195	195	195	195
Burner Orifice Diameter (in. ...drill size)**				
Natural Gas — Std	HJD .120...31 HJE .120...31 HJF .120...31	HJD .120...31 HJE .120...31 HJF .120...31	HJD .120...31 HJE .120...31 HJF .129...30	HJD .120...31 HJE .129...30
Liquid Propane — Alt††	HJD .096...41 HJE .096...41 HJF .096...41	HJD .096...41 HJE .096...41 HJF .096...41	HJD .096...41 HJE .096...41 HJF .102...38	HJD .096...41 HJE .102...38
Thermostat Heat Anticipator Setting (amps)				
Stage 1	HJD .14 HJE .14 HJF .14	HJD .14 HJE .14 HJF .14	HJD .14 HJE .14 HJF .14	HJD .14 HJE .14
Stage 2	HJD .14 HJE .20 HJF .20	HJD .14 HJE .20 HJF .20	HJD .20 HJE .20 HJF .20	HJD .20 HJE .20
Gas Input (Btuh)				
Stage 1	HJD 90,000 HJE 120,000 HJF 180,000	HJD 90,000 HJE 120,000 HJF 180,000	HJD 120,000 HJE 180,000 HJF 200,000	HJD 180,000 HJE 200,000
Stage 2	HJD 125,000 HJE 180,000 HJF 224,000	HJD 125,000 HJE 180,000 HJF 224,000	HJD 180,000 HJE 224,000 HJF 250,000	HJD 224,000 HJE 250,000
Efficiency (Steady State) (%)	HJD 82 HJE 82 HJF 82	HJD 82 HJE 82 HJF 82	HJD 82 HJE 82 HJF 80	HJD 82 HJE 80
Temperature Rise Range	HJD 20-50 HJE 35-65 HJF 45-75	HJD 20-50 HJE 35-65 HJF 45-75	HJD 35-65 HJE 35-65 HJF 40-70	HJD 35-65 HJE 40-70
Manifold Pressure (in. wg)				
Natural Gas — Std	3.5	3.5	3.5	3.5
Liquid Propane — Alt††	3.5	3.5	3.5	3.5
Field Gas Connection Size (in.)	HJD .50 HJE .75 HJF .75	HJD .50 HJE .75 HJF .75	HJD .75 HJE .75 HJF .75	HJD .75 HJE .75
<b>HIGH-PRESSURE SWITCH (psig)</b>				
Standard Compressor Internal Relief	450 ± 50			
Cutout	428			
Reset (Auto.)	320			
<b>LOSS-OF-CHARGE SWITCH/LOW-PRESSURE SWITCH (Liquid Line) (psig)</b>				
Cutout	7 ± 3			
Reset (Auto.)	22 ± 7			
<b>FREEZE PROTECTION THERMOSTAT</b>				
Opens (F)	30 ± 5			
Closes (F)	45 ± 5			
<b>OUTDOOR-AIR INLET SCREENS</b>				
Quantity...Size (in.)	Cleanable 1...20 x 25 x 1 1...16 x 25 x 1			
<b>RETURN-AIR FILTERS</b>				
Quantity...Size (in.)	4...16 x 20 x 2	4...16 x 20 x 2	4...20 x 20 x 2	4...20 x 20 x 2

**LEGEND**

**Bhp** — Brake Horsepower

\*Single phase/three phase.

†Indicates automatic reset.

\*\*72,000 Btuh heat input units have 2 burners.

115,000 Btuh heat input units and 150,000 Btuh Heat input units have 3 burners.

††An LP kit is available as an accessory. Kit may be used at elevations as high as 2000 ft.

48HJ004-014



# Base unit dimensions — 48HJ008-014



48HJ004-014

UNIT	STD. UNIT WEIGHT LBS., KG.	DURABLE ECON WEIGHT LBS., KG.	ECONOMIZER WEIGHT LBS., KG.	CORNER WEIGHT (A)		CORNER WEIGHT (B)		CORNER WEIGHT (C)		CORNER WEIGHT (D)	H FT.-IN. MM	J FT.-IN. MM	K FT.-IN. MM	L FT.-IN. MM										
				LBS.	KG.	LBS.	KG.	LBS.	KG.						LBS.	KG.								
48HJ008	870	395	44	20	75	34.1	145	65.9	189	86	161	73	239	109	280	127	2'-0 7/8"	632	3'-5 5/16"	1050	2'-9 11/16"	856	2'-2 7/16"	672
48HJ009	880	399	44	20	75	34.1	145	65.9	191	87	163	74	242	110	284	129	1'-2 7/8"	378	3'-5 5/16"	1050	2'-9 11/16"	856	2'-2 7/16"	672
48HJ012	1035	469	103	46	225	102	192	87	285	129	333	151	378	4'-1 5/16"	1253	3'-0 3/8"	924	2'-10 7/16"	875	2'-10 7/16"	875	2'-10 7/16"	875	
48HJ014	1050	476	103	46	228	103	195	88	289	131	338	153	378	4'-1 5/16"	1253	3'-0 3/8"	924	2'-10 7/16"	875	2'-10 7/16"	875	2'-10 7/16"	875	

1. DIMENSIONS IN [ ] ARE IN MILLIMETERS.  
 2. CENTER OF GRAVITY.  
 3. DIRECTION OF AIR FLOW.  
 4. ON VERTICAL DISCHARGE UNITS, DUCTWORK TO BE ATTACHED TO ACCESSORY ROOF CURB ONLY. FOR HORIZONTAL DISCHARGE UNITS, FIELD SUPPLIED FLANGES SHOULD BE ATTACHED TO BE ATTACHED TO THE FLANGES, AND ALL DUCTWORK SHOULD BE ATTACHED TO THE FLANGES.

5. MINIMUM CLEARANCE (LOCAL CODES OR JURISDICTION MAY VARY):  
 a. BETWEEN UNIT, FLUE SIDE AND COMBUSTIBLE SURFACES, 48 INCHES, 18 INCHES WHEN USING ACCESSORY FLUE DISCHARGE DEFLECTOR.  
 b. BETWEEN UNIT, COMBUSTIBLE SURFACES (WHEN NOT USING CURB), 60 INCHES.  
 c. BETWEEN UNIT, CONTROL BOX SIDE, 42 IN. PER NEC.  
 d. BETWEEN UNIT AND UNGROUNDED SURFACES, CONTROL BOX SIDE, 60 INCHES TO ASSURE PROPER CONDENSER FAN OPERATION.  
 e. BETWEEN UNIT AND BLOCK OR CONCRETE WALLS AND OTHER GROUNDED SURFACES, CONTROL BOX SIDE, 42 IN. PER NEC.  
 f. BETWEEN UNIT AND UNGROUNDED SURFACES, CONTROL BOX SIDE, 60 INCHES TO ASSURE PROPER CONDENSER FAN OPERATION.  
 g. HORIZONTAL SUPPLY AND RETURN ENDS, 0 INCHES WHEN THE COIL AND COMBUSTION SIDE AS STATED IN NOTE #59, b.  
 h. A REMOVABLE FENCE OR BARRICADE REQUIRES NO CLEARANCE.  
 6. THE VERTICAL CENTER OF GRAVITY IS 1'-7" (483) FOR 08 AND 09, 1'-11" (591) FOR 12 AND 14.  
 7. THE UNIT IS TO BE INSTALLED ON COMBUSTIBLE SURFACES FROM ROOF OR CLASS A, B, OR C ROOF COVERING MATERIAL IF SET ON BASE RAIL.  
 8. THE VERTICAL CENTER OF GRAVITY IS 1'-7" (483) FOR 08 AND 09, 1'-11" (591) FOR 12 AND 14.

CONNECTION SIZES:  
 A 1 3/8" DIA. (64) FIELD POWER SUPPLY HOLE  
 B 1 1/2" DIA. (64) POWER SUPPLY KNOCK-OUT  
 C 1 3/4" DIA. (64) CHARGING PORT HOLE  
 D 7/8" DIA. (22) FIELD CONTROL WIRING HOLE  
 E 3/4" - 1/4 NPT CONDENSATE DRAIN  
 F 1/2" - 1/4 NPT GAS COIN, 48HJ008, 009, 48HJ0008  
 G 1/2" - 1/4 NPT GAS COIN, 48HJ012, 014, 48HJ012, 014  
 H 2" DIA. (51) POWER SUPPLY KNOCK-OUT

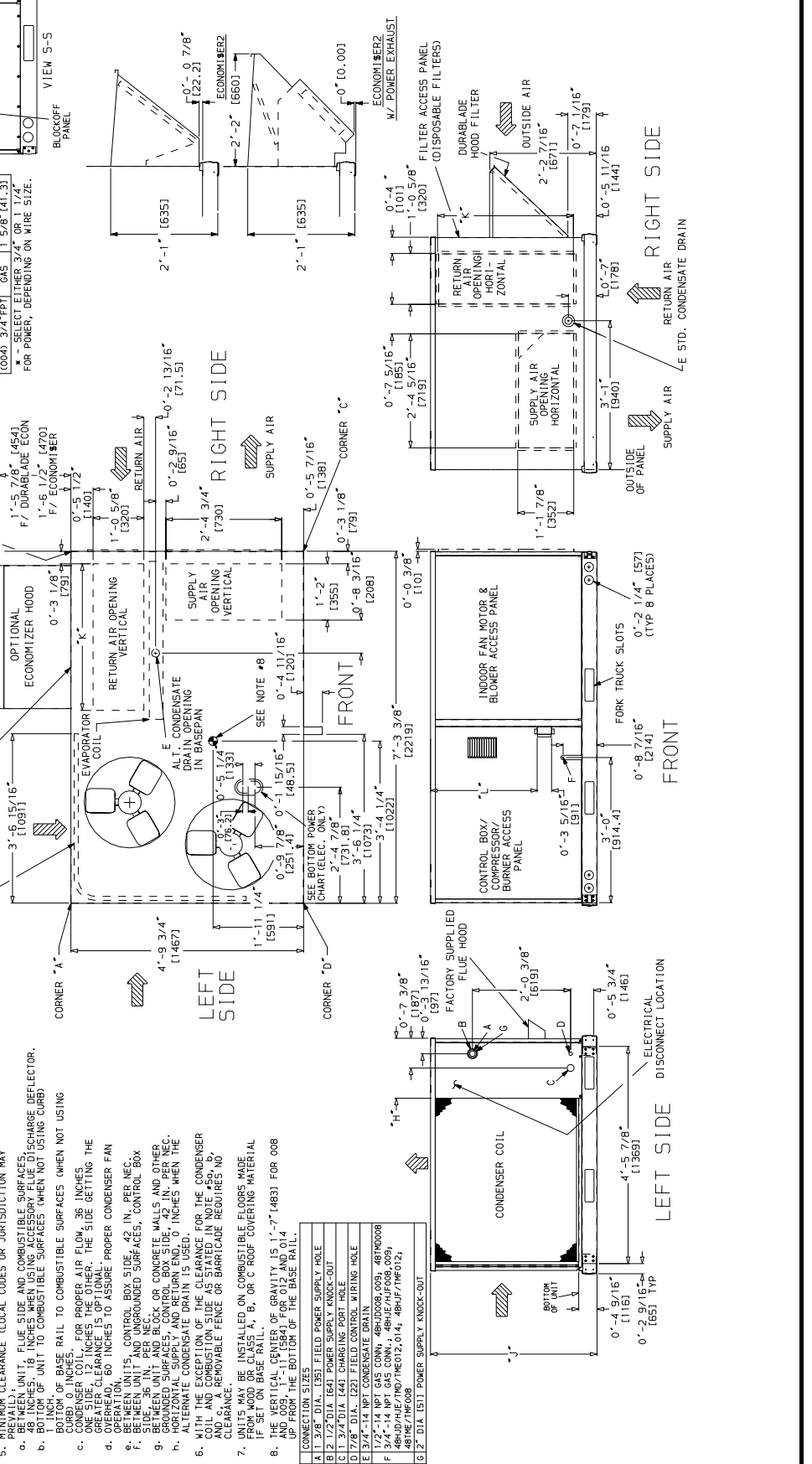



# Accessory dimensions — 48HJ008-014



CONNECTOR PKG. ACCY.	B	C	D ALT DRAIN HOLE	GAS	POWER	CONTROL
CRBTMPWR001A00	2'-8 <sup>7</sup> / <sub>16</sub> " [827]	1'-10 <sup>15</sup> / <sub>16</sub> " [583]	1 <sup>3</sup> / <sub>4</sub> " [44.5]	3/4" [19] NPT	3/4" [19] NPT	1/2" [12.7] NPT
CRBTMPWR002A00				1 1/4" [31.7]	1/2" [12.7] NPT	3/4" [19] NPT
CRBTMPWR003A00				3/4" [19] NPT	1 1/4" [31.7]	1/2" [12.7] NPT
CRBTMPWR004A00				3/4" [19] NPT	1 1/4" [31.7]	1/2" [12.7] NPT

ROOF CURB ACCESSORY	"A"	UNIT SIZE
CRRFCURB003A00	1'-2" [356]	48HJ008-014
CRRFCURB004A00	2'-0" [610]	

**NOTES:**

1. Roof curb accessory is shipped disassembled.
2. Insulated panels: 1-in. thick polyurethane foam, 1<sup>3</sup>/<sub>4</sub> lb density.
3. Dimensions in [ ] are in millimeters.
4. Roof curb: 16-gage steel.
5. Attach ductwork to curb (flanges of duct rest on curb).
6. Service clearance 4 ft on each side.
7. Direction of airflow.
8. Connector packages CRBTMPWR001A00 and 2A00 are for thru-the-curb gas type. Packages CRBTMPWR003A00 and 4A00 are for thru-the-bottom type gas connections.

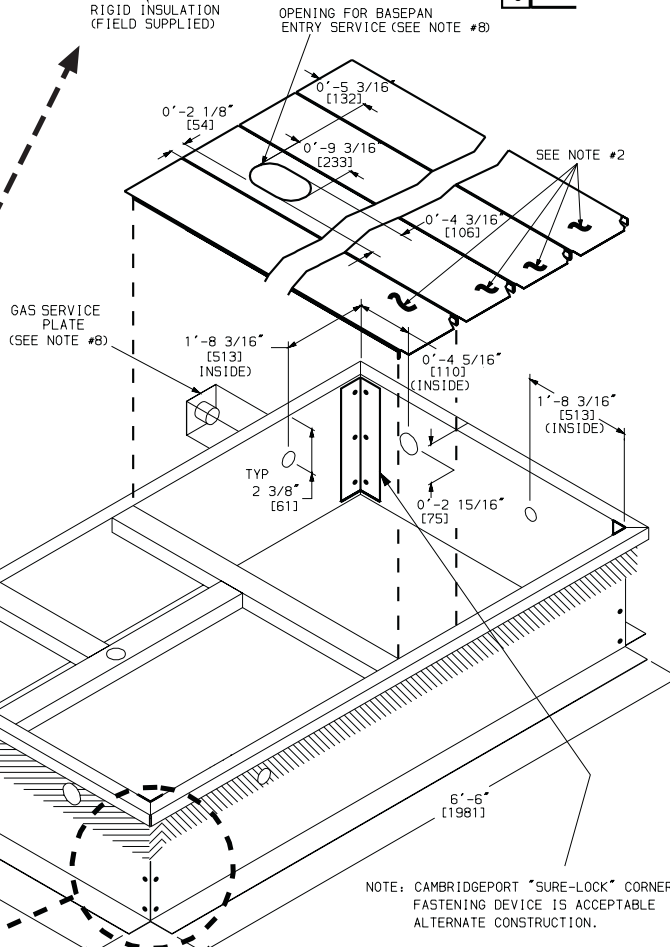
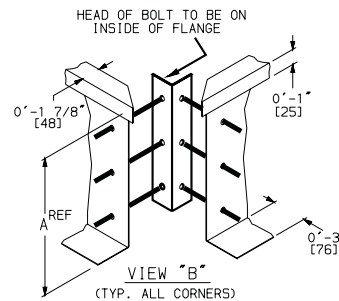
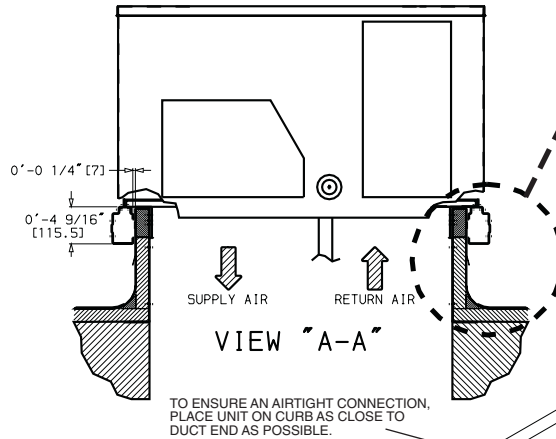
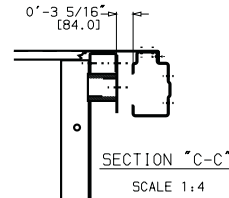
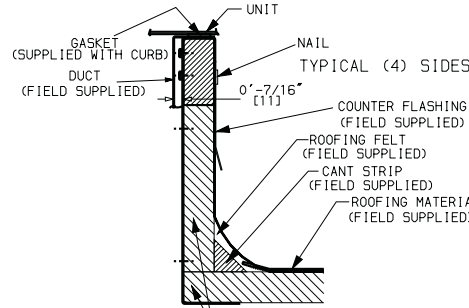
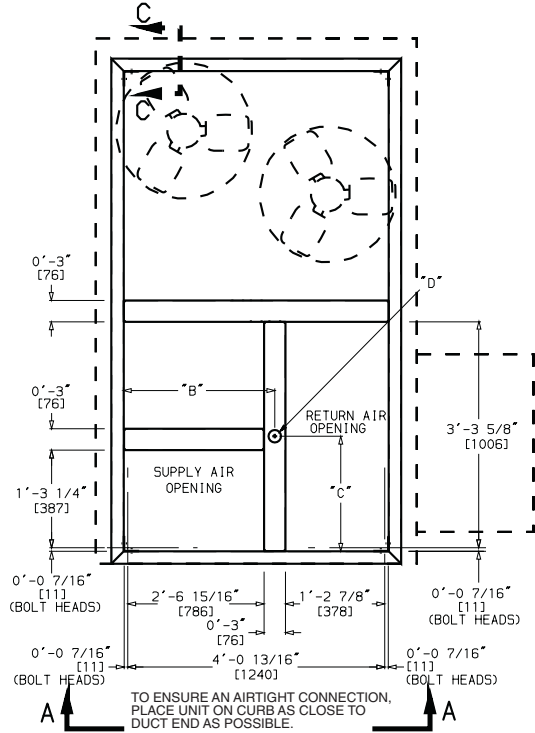

NOTE: CAMBRIDGEPORT "SURE-LOCK" CORNER FASTENING DEVICE IS ACCEPTABLE ALTERNATE CONSTRUCTION.

48HJ004-014



# Selection procedure (with 48HJ006 example)



## VII Select net heating capacity of unit to meet design condition requirements.

Enter the 62AQ060 Heating Rating table found in the Energy\$Recycler Product Data. At 450 cfm, 70 F and 0° F find the heating value for the Energy\$Recycler to be 15.2 Btuh. Since the Energy\$Recycler uses room air, the instantaneous heat is also the Integrated Heat Rating.

The customer heat requirement is 85,000 Btuh.  
 Fan heat from Step II 4,851 Btuh  
 Energy\$Recycler Heat Capacity 15,200 Btuh  
 add Energy\$Recycler optional supply fan heat if supplied + 0 Btuh

Total Unit heat with Energy\$Recycler 20,051 Btuh  
 Determine additional electric heat capacity in kW.

The required heating capacity is 85,000 Btuh. Therefore, 64,949 Btuh (85,000-20,051) additional heat is required.

The output capacity for the 48HJE006 is 92,000 Btuh, which is sufficient.

Total unit net heating capacity is 109,571 Btuh (89,000 + 20,571).

## VIII Determine net cooling capacity.

Cooling capacities are gross capacities and do not include indoor (evaporator) or optional Energy\$Recycler supply fan heat.

Determine net cooling capacity using the following formula:

Net Capacity = (Gross Capacity Rooftop Unit + Gross Capacity Energy\$Recycler) - (IFM Heat + Optional Energy\$Recycler Supply Fan motor heat)

Gross Total Cooling  
 Rooftop unit 59,420 Btuh  
 Energy\$Recycler 13,000 Btuh  
 Total 72,420 Btuh  
 Less  
 IFM heat (from Step II) -4,851 Btuh  
 Optional Energy\$Recycler Supply Fan Motor Heat none  
 Net Total Capacity 67,569 Btuh

Gross Sensible Cooling  
 Rooftop unit 43,420 Btuh  
 Energy\$Recycler 10,090 Btuh  
 Total 53,510 Btuh  
 Less  
 IFM heat (from Step II) -4,851 Btuh  
 Optional Energy\$Recycler Supply Fan Motor Heat none  
 Net Sensible Capacity 48,659 Btuh

## IX Determine the operating watts of the unit.

a) Cooling with Energy\$Recycler in operation:

Rooftop unit:  
 Compressor watts from cooling capacity tables . . . . . 4,440 watts  
 Indoor fan motor from Step II† . . . . 1,421 watts  
 Outdoor fan motor from Physical Data table find 1/4 hp†.  
 Assume OD motor efficiency is 0.75.  
 Watts = (746 x hp)/(motor Eff)  
 = (746 x 1/4)/(0.75)  
 = 249 watts

†Dual circuit units will have two indoor and two outdoor fans, double values.

b) Energy\$Recycler:

Compressor watts from Energy\$Recycler Product Data 1,060 watts  
 Optional supply fan from Energy\$Recycler Product Data fan curves none  
 Exhaust fan, from Energy\$Recycler Product Data fan curve at 450 cfm, 0.2 in. wg Static 110 watts  
 Total watts for the unit in operation at design conditions 7,200 watts

## X Electrical data RLA, FLA, LRA, MCA and MOCP.

### Separate Power Supply:

If the 62AQ is wired for separate power see the Electrical Data table.

### Single Power Supply with Unit:

The unit is 230-1-60 Hz. Look up the 48JH006 without convenience outlet in the Electrical Data Table. Find unit electrical data. For the rooftop unit the data is MCA = 46.3 amps, MOCP = 60 amps, Min Unit Disconnect Size FLA = 45, and LRA = 216.

From the Table of "X" and "Y" values in the Energy\$Recycler Product Data literature, find 230 v, for 62AQ060300, "X" = 8.1 amps and "Y" = 9.3 amps.

Add "X" amps to the MCA and MOCP and add "Y" amps to the minimum disconnect size.

	MCA	MOCP	FLA	LRA
SRT	46.3	60	45	216
62AQ	<u>8.1</u>	<u>8.1</u>	<u>9.3</u>	<u>31.7</u>
Total	54.4 amps	68.1** amps	54.3 amps	247.7 amps

\*\*The calculated MOCP is 68.1 amps; it is rounded down to 60 amps. Compare it to MCA; it must be larger than the MCA of 54.4 amps, so it is acceptable as is.

48HJ004-014



The wiring of the unit must be suitable for the MCA calculated above, and the Maximum Overcurrent Protection (MOCP) device must be selected to meet the calculated MOCP.

If the overcurrent protective device for the combination load is equal to or less than 60 amps, a single disconnect may be used for BOTH the main unit and the 62AQ provided that the wire ampacity supplying the 62AQ is sized for a minimum of 33% larger than the overcurrent protection device value (i.e., 60 amps  $\times$  0.33 = 20 amps), no further subfusing would be required.

If the overcurrent protection device is greater than 60 amps and the old overcurrent protection device was less than 60 amps, a FUSED disconnect no greater than 60 amps must be provided for the main unit and a SEPARATE FUSED disconnect must be provided for the 62AQ unit.

If the old overcurrent protection device is greater than 60 amps, a disconnect is required for the MAIN UNIT as well as a FUSED DISCONNECT for the 62AQ unit.

# Performance data



## COOLING CAPACITIES, STANDARD UNITS

Standard Ratings

### LEGEND

- BF** — Bypass Factor
- Edb** — Entering Dry Bulb
- Ewb** — Entering Wet Bulb
- kW** — Compressor Motor Power Input
- SHC** — Sensible Heat Capacity (1000 Btuh) Gross
- TC** — Total Capacity (1000 Btuh) Gross

### NOTES:

1. Direct interpolation is permissible. Do not extrapolate.
2. The following formulas may be used:

$$t_{db} = t_{edb} - \frac{\text{sensible capacity (Btuh)}}{1.10 \times \text{cfm}}$$

$$t_{lwb} = \text{Wet-bulb temperature corresponding to enthalpy of air leaving evaporator coil } (h_{lwb})$$

$$h_{lwb} = h_{ewb} - \frac{\text{total capacity (Btuh)}}{4.5 \times \text{cfm}}$$

Where:  $h_{ewb}$  = Enthalpy of air entering evaporator coil.

3. The SHC is based on 80 F edb temperature of air entering evaporator coil.

Below 80 F edb, subtract (corr factor x cfm) from SHC.

Above 80 F edb, add (corr factor x cfm) to SHC.

Correction Factor =  $1.10 \times (1 - BF) \times (edb - 80)$ .

### 48HJ004 (3 TONS)

Temp (F) Air Ent Condenser (Edb)	Temp (F) Air Entering Evaporator — Cfm/BF									
	900/0.14			1200/0.17			1500/0.20			
	Temp (F) Air Entering Evaporator — Ewb									
	72	67	62	72	67	62	72	67	62	
75	TC	41.9	38.7	35.7	43.5	40.8	37.7	44.8	41.8	39.0
	SHC	20.4	25.2	29.7	21.8	28.2	33.8	23.3	30.7	37.0
	kW	2.19	2.16	2.12	2.21	2.18	2.15	2.23	2.19	2.16
85	TC	40.7	37.5	34.5	42.1	39.3	36.4	43.5	40.4	37.6
	SHC	19.9	24.7	29.2	21.5	27.7	33.2	23.2	30.3	36.4
	kW	2.46	2.42	2.39	2.47	2.44	2.41	2.50	2.45	2.42
95	TC	39.3	36.1	33.1	40.8	37.8	34.9	42.0	38.9	36.1
	SHC	19.5	24.1	28.4	21.1	27.2	32.5	22.8	29.9	35.6
	kW	2.75	2.71	2.66	2.77	2.73	2.69	2.79	2.74	2.71
105	TC	37.7	34.6	31.7	39.3	36.2	33.4	40.1	37.2	34.7
	SHC	18.8	23.5	27.8	20.7	26.6	31.8	22.1	29.3	34.7
	kW	3.06	3.02	2.98	3.09	3.04	3.01	3.10	3.06	3.03
115	TC	36.0	33.0	29.7	37.4	34.5	31.5	38.1	35.5	33.2
	SHC	18.3	22.9	26.7	19.9	26.1	30.9	21.3	28.7	33.2
	kW	3.41	3.36	3.31	3.43	3.39	3.34	3.44	3.41	3.37
125	TC	34.2	31.3	27.8	35.6	32.7	29.4	36.3	33.6	31.9
	SHC	17.6	22.2	25.8	19.4	25.4	29.4	20.8	28.0	31.8
	kW	3.78	3.73	3.66	3.80	3.76	3.71	3.81	3.78	3.75

### 48HJ005 (4 TONS)

Temp (F) Air Ent Condenser (Edb)	Temp (F) Air Entering Evaporator — Cfm/BF												
	1200/0.17			1450/0.19			1600/0.21			2000/0.24			
	Temp (F) Air Entering Evaporator — Ewb (F)												
	72	67	62	72	67	62	72	67	62	72	67	62	
75	TC	54.0	50.7	44.2	55.9	52.2	47.7	56.4	52.8	49.1	58.1	54.5	50.6
	SHC	26.1	32.7	37.5	27.6	35.1	41.8	28.2	36.2	43.8	30.2	39.5	47.5
	kW	2.81	2.80	2.76	2.83	2.81	2.78	2.83	2.80	2.79	2.84	2.82	2.79
85	TC	52.2	48.9	41.9	54.1	50.4	45.9	54.5	51.0	47.2	55.3	52.3	48.7
	SHC	25.4	32.0	36.4	26.9	34.5	40.8	27.5	35.7	42.8	28.6	38.5	46.6
	kW	3.20	3.19	3.15	3.22	3.20	3.17	3.22	3.20	3.18	3.22	3.20	3.18
95	TC	50.7	46.9	39.5	51.9	48.4	43.5	52.5	48.9	45.2	53.9	50.1	46.7
	SHC	24.9	31.1	35.0	26.1	33.6	39.6	26.8	34.7	41.8	28.8	37.5	45.6
	kW	3.64	3.61	3.57	3.65	3.62	3.60	3.65	3.62	3.60	3.67	3.63	3.61
105	TC	48.8	44.5	36.7	49.8	46.2	40.7	50.2	46.7	42.1	51.5	48.2	44.7
	SHC	24.3	30.2	33.6	25.3	32.8	38.2	26.0	33.9	40.3	27.9	37.4	44.4
	kW	4.12	4.09	4.03	4.12	4.09	4.06	4.12	4.09	4.07	4.14	4.11	4.08
115	TC	46.5	41.1	34.3	47.7	43.3	37.0	48.0	44.4	38.5	48.9	45.7	42.0
	SHC	23.4	28.9	32.4	24.9	31.8	36.3	25.4	33.4	38.3	27.1	36.9	42.0
	kW	4.64	4.59	4.53	4.65	4.62	4.55	4.64	4.63	4.56	4.65	4.63	4.60
125	TC	43.8	37.5	32.4	45.1	39.0	33.8	45.3	40.1	35.4	46.3	42.6	38.8
	SHC	22.5	27.4	31.5	24.1	30.2	33.7	24.7	31.9	35.4	26.5	35.9	38.8
	kW	5.19	5.13	5.05	5.20	5.15	5.09	5.19	5.17	5.11	5.20	5.19	5.15

### 48HJ006 (5 TONS)

Temp (F) Air Ent Condenser (Edb)	Temp (F) Air Entering Evaporator — Cfm/BF												
	1500/0.08			1750/0.09			2000/0.11			2500/0.13			
	Temp (F) Air Entering Evaporator — Ewb (F)												
	72	67	62	72	67	62	72	67	62	72	67	62	
75	TC	70.8	65.4	58.5	72.5	67.3	61.1	73.0	68.4	62.8	74.8	70.3	64.8
	SHC	34.1	42.7	49.9	35.7	45.5	54.2	36.8	48.0	57.8	39.6	53.0	63.4
	kW	3.53	3.49	3.44	3.55	3.50	3.46	3.55	3.51	3.47	3.57	3.54	3.48
85	TC	68.9	63.2	55.3	70.5	65.1	57.9	72.2	66.4	60.2	73.2	68.1	62.9
	SHC	33.5	41.8	48.4	35.0	44.8	52.8	37.0	47.6	56.8	39.3	52.5	62.4
	kW	3.98	3.94	3.87	4.00	3.96	3.90	4.03	3.97	3.92	4.04	3.99	3.94
95	TC	66.8	60.6	52.4	68.3	62.5	54.3	69.3	63.8	56.6	71.2	65.6	60.6
	SHC	32.8	40.7	47.0	34.5	43.8	51.1	36.0	46.7	55.0	39.1	51.8	60.5
	kW	4.48	4.43	4.35	4.50	4.45	4.37	4.51	4.46	4.40	4.55	4.48	4.44
105	TC	64.3	57.7	49.9	65.9	59.8	51.7	66.9	61.1	54.1	68.4	62.8	58.4
	SHC	32.0	39.6	45.8	33.7	42.8	49.7	35.3	45.7	53.5	38.4	51.0	58.4
	kW	5.03	4.96	4.87	5.05	4.99	4.90	5.06	5.00	4.93	5.08	5.02	4.98
115	TC	61.5	54.8	47.3	62.8	56.7	49.1	64.0	58.2	51.6	65.4	59.9	56.1
	SHC	31.0	38.4	44.5	32.5	41.6	48.2	34.4	44.6	51.6	37.4	50.0	56.1
	kW	5.61	5.55	5.46	5.62	5.58	5.49	5.65	5.60	5.52	5.67	5.61	5.57
125	TC	58.7	51.6	44.5	59.9	53.4	46.2	60.8	54.9	49.0	62.2	56.8	53.5
	SHC	30.0	37.2	43.1	31.7	40.4	46.2	33.3	43.4	48.9	36.4	48.9	53.4
	kW	6.27	6.19	6.09	6.28	6.21	6.13	6.29	6.24	6.17	6.31	6.27	6.22

48HJ004-014



**COOLING CAPACITIES, STANDARD UNITS (cont)**

48HJ007 (6 TONS)													
Temp (F) Air Ent Condenser (Edb)		Temp (F) Air Entering Evaporator — Cfm/BF											
		1800/0.05			2100/0.06			2400/0.06			3000/0.08		
		Temp (F) Air Entering Evaporator — Ewb (F)											
		72	67	62	72	67	62	72	67	62	72	67	62
75	TC	86.7	80.7	74.4	88.8	82.7	76.6	90.5	84.4	78.2	92.6	86.3	81.0
	SHC	43.0	53.7	63.8	45.0	57.4	68.9	47.2	61.2	73.6	51.2	67.4	80.7
	kW	4.58	4.46	4.33	4.63	4.50	4.38	4.67	4.55	4.41	4.72	4.58	4.47
85	TC	84.1	78.2	72.0	86.4	80.3	74.1	88.2	81.7	75.7	90.2	84.0	78.8
	SHC	42.0	52.6	62.7	44.5	56.6	68.0	46.8	60.2	72.5	50.6	67.4	78.7
	kW	5.10	4.97	4.85	5.16	5.03	4.90	5.21	5.06	4.93	5.26	5.12	4.99
95	TC	81.3	75.3	69.2	83.4	77.3	71.3	85.1	78.9	72.9	87.2	80.6	76.2
	SHC	41.0	51.4	61.4	43.4	55.3	66.6	45.8	59.2	71.2	50.2	65.8	76.2
	kW	5.65	5.52	5.39	5.71	5.57	5.44	5.77	5.62	5.48	5.83	5.66	5.55
105	TC	77.9	72.0	66.1	80.0	73.8	68.0	81.6	75.3	69.6	83.4	77.1	73.2
	SHC	39.7	50.2	60.0	42.2	54.0	65.2	44.6	57.8	69.3	49.0	64.5	73.2
	kW	6.22	6.08	5.94	6.29	6.13	6.00	6.34	6.17	6.04	6.40	6.22	6.12
115	TC	74.7	68.4	61.8	75.9	70.0	64.1	77.6	71.3	66.5	78.7	73.0	70.1
	SHC	38.7	48.8	58.1	40.8	52.6	63.2	43.3	56.4	66.4	46.9	63.2	70.0
	kW	6.84	6.68	6.49	6.87	6.71	6.56	6.93	6.75	6.63	6.96	6.80	6.72
125	TC	70.3	63.6	57.2	71.8	65.5	59.1	72.9	66.8	61.9	74.0	68.6	66.4
	SHC	37.2	47.0	55.8	39.5	51.0	59.1	41.7	55.0	61.9	45.4	61.8	66.3
	kW	7.43	7.25	7.03	7.48	7.30	7.13	7.51	7.35	7.22	7.54	7.41	7.33

Standard Ratings

LEGEND

- BF — Bypass Factor
- Edb — Entering Dry Bulb
- Ewb — Entering Wet Bulb
- kW — Compressor Motor Power Input
- SHC — Sensible Heat Capacity (1000 Btuh) Gross
- TC — Total Capacity (1000 Btuh) Gross

NOTES:

1. Direct interpolation is permissible. Do not extrapolate.
2. The following formulas may be used:

$$t_{ldb} = t_{edb} - \frac{\text{sensible capacity (Btuh)}}{1.10 \times \text{cfm}}$$

$$t_{lwb} = \text{Wet-bulb temperature corresponding to enthalpy of air leaving evaporator coil } (h_{lwb})$$

$$h_{lwb} = h_{ewb} - \frac{\text{total capacity (Btuh)}}{4.5 \times \text{cfm}}$$

Where:  $h_{ewb}$  = Enthalpy of air entering evaporator coil.

3. The SHC is based on 80 F edb temperature of air entering evaporator coil.  
Below 80 F edb, subtract (corr factor x cfm) from SHC.  
Above 80 F edb, add (corr factor x cfm) to SHC.  
Correction Factor =  $1.10 \times (1 - BF) \times (edb - 80)$ .

48HJ008 (7 1/2 TONS)													
Temp (F) Air Ent Condenser (Edb)		Temp (F) Air Entering Evaporator — Cfm/BF											
		2250/0.10			3000/0.11			3750/0.14					
		Temp (F) Air Entering Evaporator — Ewb											
		72	67	62	72	67	62	72	67	62	72	67	62
75	TC	105.5	96.9	87.6	107.3	99.6	90.7	110.3	101.9	93.8	105.5	96.9	87.6
	SHC	50.6	63.6	75.7	53.3	69.2	83.7	58.0	76.6	92.2	50.6	63.6	75.7
	kW	5.15	5.07	5.04	5.16	5.11	5.06	5.20	5.13	5.07	5.15	5.07	5.04
85	TC	102.5	93.6	83.6	105.1	96.5	87.5	107.7	99.0	90.6	102.5	93.6	83.6
	SHC	49.7	62.4	73.9	52.8	68.4	82.2	57.3	75.9	90.0	49.7	62.4	73.9
	kW	5.86	5.79	5.73	5.89	5.82	5.77	5.93	5.86	5.78	5.86	5.79	5.73
95	TC	98.9	90.1	79.3	101.6	92.9	83.5	103.8	95.3	87.4	98.9	90.1	79.3
	SHC	48.5	61.2	71.9	51.9	67.2	80.2	56.2	74.9	87.3	48.5	61.2	71.9
	kW	6.65	6.58	6.49	6.69	6.61	6.53	6.72	6.64	6.57	6.65	6.58	6.49
105	TC	95.3	86.2	75.7	97.6	88.8	79.6	100.0	91.0	84.1	95.3	86.2	75.7
	SHC	47.3	59.6	70.2	50.7	65.9	78.0	55.3	73.6	84.1	47.3	59.6	70.2
	kW	7.51	7.44	7.31	7.55	7.48	7.36	7.59	7.50	7.41	7.51	7.44	7.31
115	TC	91.0	82.0	71.6	93.2	84.5	75.4	95.6	86.6	80.7	91.0	82.0	71.6
	SHC	45.9	58.0	68.1	49.3	64.2	75.3	54.2	72.1	80.7	45.9	58.0	68.1
	kW	8.43	8.33	8.20	8.46	8.37	8.27	8.52	8.42	8.34	8.43	8.33	8.20
125	TC	86.2	77.8	68.1	88.3	80.0	71.9	90.0	81.9	77.2	86.2	77.8	68.1
	SHC	44.1	56.4	66.3	47.5	62.6	71.8	52.1	70.1	77.2	44.1	56.4	66.3
	kW	9.38	9.29	9.14	9.43	9.34	9.24	9.47	9.38	9.32	9.38	9.29	9.14

48HJ009 (8 1/2 TONS)													
Temp (F) Air Ent Condenser (Edb)		Temp (F) Air Entering Evaporator — Cfm/BF											
		2550/0.08			3000/0.09			3400/0.11			4250/0.13		
		Temp (F) Air Entering Evaporator — Ewb											
		72	67	62	72	67	62	72	67	62	72	67	62
75	TC	119.5	105.7	94.8	123.1	109.1	98.7	124.8	110.7	100.2	126.3	112.8	103.4
	SHC	56.5	65.7	77.8	60.2	71.7	86.3	62.2	75.8	92.8	67.8	83.3	101.2
	kW	5.92	5.84	5.77	5.95	5.88	5.81	5.96	5.89	5.83	5.99	5.91	5.85
85	TC	115.5	101.9	90.6	119.7	105.4	94.8	121.4	106.9	96.1	124.0	109.1	98.7
	SHC	55.1	64.3	76.1	58.9	70.5	85.1	61.3	74.5	90.5	66.2	82.9	98.5
	kW	6.77	6.69	6.61	6.83	6.74	6.67	6.85	6.76	6.67	6.88	6.79	6.71
95	TC	111.3	97.7	86.6	115.0	101.2	90.6	117.2	102.6	91.7	120.1	104.8	94.5
	SHC	53.7	62.8	74.2	57.4	68.9	82.9	60.0	73.0	88.6	65.0	81.5	94.5
	kW	7.71	7.62	7.52	7.76	7.68	7.59	7.80	7.69	7.58	7.84	7.74	7.66
105	TC	107.2	93.5	82.5	110.5	96.7	85.9	112.1	97.9	87.6	114.9	99.9	90.5
	SHC	52.2	61.3	72.7	56.0	67.4	81.2	58.4	71.4	86.6	63.5	79.5	90.5
	kW	8.75	8.64	8.54	8.80	8.70	8.61	8.82	8.71	8.62	8.86	8.75	8.67
115	TC	101.9	89.2	78.0	104.7	91.8	81.5	106.7	93.1	83.3	109.2	94.9	86.3
	SHC	50.2	59.5	70.7	53.7	65.7	79.5	56.6	69.5	83.1	61.5	77.8	86.3
	kW	9.80	9.73	9.64	9.86	9.79	9.72	9.90	9.79	9.71	9.95	9.84	9.75
125	TC	97.3	84.3	73.1	100.0	86.8	76.0	101.3	87.9	78.7	102.9	89.5	81.9
	SHC	48.7	57.7	68.5	52.4	63.9	76.0	54.8	67.9	78.7	59.1	75.7	81.9
	kW	11.03	10.90	10.70	11.08	10.96	10.81	11.11	10.99	10.88	11.14	11.03	10.93

48HJ004-014

# Performance data (cont)



## COOLING CAPACITIES, STANDARD UNITS (cont)

48HJ012 (10 TONS)													
Temp (F) Air Ent Condenser (Edb)		Temp (F) Air Entering Evaporator — Cfm/BF											
		3000/0.03			3200/0.03			4000/0.04			5000/0.04		
		Temp (F) Air Entering Evaporator — Ewb											
		72	67	62	72	67	62	72	67	62	72	67	62
75	TC	140.3	129.4	115.0	141.2	130.4	118.1	145.2	134.0	122.1	147.5	136.6	125.3
	SHC	65.6	82.2	97.4	66.7	84.4	101.5	71.3	93.1	113.5	77.9	103.7	124.7
	KW	7.35	7.21	7.12	7.37	7.23	7.13	7.46	7.31	7.17	7.51	7.37	7.22
85	TC	137.7	125.3	110.0	138.9	126.6	113.6	142.6	130.6	117.7	144.6	133.3	122.3
	SHC	65.0	81.2	95.2	66.3	83.6	99.7	71.0	92.8	112.0	76.9	103.1	122.2
	KW	8.29	8.13	8.02	8.32	8.16	8.03	8.40	8.24	8.09	8.45	8.31	8.16
95	TC	133.8	120.7	103.0	135.1	121.9	107.2	138.8	125.8	112.8	141.7	128.5	118.5
	SHC	63.9	79.6	92.2	65.2	82.0	97.0	70.6	91.5	109.7	76.9	102.5	118.4
	KW	9.33	9.16	8.98	9.35	9.18	9.00	9.44	9.27	9.07	9.51	9.33	9.19
105	TC	128.7	115.4	96.5	129.8	116.6	99.7	133.7	120.3	107.1	136.7	122.8	114.5
	SHC	62.3	77.6	89.4	63.6	80.2	93.5	69.4	89.6	106.8	76.0	100.6	114.3
	KW	10.46	10.28	10.00	10.47	10.30	10.07	10.57	10.38	10.21	10.66	10.43	10.31
115	TC	123.2	109.1	90.8	124.3	110.3	92.2	127.9	114.4	100.8	130.9	116.8	110.1
	SHC	60.4	75.1	86.6	61.9	77.8	90.0	67.6	87.6	100.7	74.6	98.7	109.9
	KW	11.66	11.47	11.20	11.68	11.51	11.25	11.77	11.60	11.41	11.89	11.66	11.58
125	TC	117.5	101.8	86.2	118.5	103.0	87.4	121.6	107.1	96.0	124.1	110.3	104.8
	SHC	58.5	72.5	84.5	60.0	75.0	87.3	65.8	85.1	96.0	72.5	96.9	104.8
	KW	12.99	12.77	12.50	13.02	12.81	12.55	13.10	12.92	12.74	13.19	13.01	12.91

48HJ014 (12 1/2 TONS)													
Temp (F) Air Ent Condenser (Edb)		Temp (F) Air Entering Evaporator — Cfm/BF											
		3750/0.08			4300/0.09			5000/0.11			6250/0.13		
		Temp (F) Air Entering Evaporator — Ewb											
		72	67	62	72	67	62	72	67	62	72	67	62
75	TC	167.1	154.3	142.0	169.8	157.7	144.8	173.5	160.6	148.4	176.5	164.5	153.3
	SHC	82.5	103.5	123.6	85.8	109.7	132.0	90.3	117.7	141.9	98.2	130.7	153.1
	KW	9.44	9.18	8.95	9.50	9.26	9.01	9.60	9.33	9.07	9.68	9.43	9.17
85	TC	162.3	149.3	135.6	165.1	152.5	139.5	168.8	155.3	143.5	172.1	159.2	149.3
	SHC	80.9	101.4	120.9	84.4	107.9	129.9	89.6	115.8	139.8	97.6	129.3	149.1
	KW	10.49	10.18	9.97	10.55	10.27	10.02	10.67	10.32	10.11	10.75	10.43	10.21
95	TC	156.5	143.7	126.3	159.6	146.8	131.3	162.3	149.8	136.5	166.5	153.2	144.5
	SHC	79.1	99.5	116.5	83.0	106.1	126.0	87.6	114.2	135.8	95.8	127.7	144.4
	KW	11.60	11.30	11.01	11.69	11.39	11.10	11.75	11.47	11.20	11.87	11.56	11.35
105	TC	150.0	136.2	115.7	153.0	139.3	120.9	155.6	142.5	138.5	158.8	145.9	138.8
	SHC	76.5	96.7	111.2	80.8	103.5	120.0	85.7	112.3	128.4	93.6	125.9	138.7
	KW	12.76	12.42	12.09	12.83	12.52	12.20	12.91	12.62	12.32	12.96	12.72	12.52
115	TC	141.8	122.2	104.4	144.3	126.1	110.8	147.7	129.4	118.9	150.7	135.2	130.1
	SHC	73.6	91.2	104.2	77.9	98.5	110.8	83.4	107.3	118.4	91.8	121.9	129.9
	KW	13.85	13.55	13.22	13.94	13.64	13.35	14.05	13.73	13.50	14.15	13.86	13.70
125	TC	132.5	108.6	93.9	134.8	111.4	100.7	137.6	114.4	106.6	140.3	122.9	120.1
	SHC	70.9	85.7	93.8	74.8	92.9	100.7	80.2	101.4	106.5	89.0	116.3	120.1
	KW	15.04	14.66	14.44	15.14	14.75	14.55	15.23	14.85	14.72	15.29	14.94	14.84

Standard Ratings

### LEGEND

- BF — Bypass Factor
- Edb — Entering Dry Bulb
- Ewb — Entering Wet Bulb
- kW — Compressor Motor Power Input
- SHC — Sensible Heat Capacity (1000 Btuh) Gross
- TC — Total Capacity (1000 Btuh) Gross

### NOTES:

1. Direct interpolation is permissible. Do not extrapolate.
2. The following formulas may be used:

$$t_{db} = t_{edb} - \frac{\text{sensible capacity (Btuh)}}{1.10 \times \text{cfm}}$$

$$t_{lwb} = \text{Wet-bulb temperature corresponding to enthalpy of air leaving evaporator coil } (h_{lwb})$$

$$h_{lwb} = h_{ewb} - \frac{\text{total capacity (Btuh)}}{4.5 \times \text{cfm}}$$

Where:  $h_{ewb}$  = Enthalpy of air entering evaporator coil.

3. The SHC is based on 80 F edb temperature of air entering evaporator coil.  
Below 80 F edb, subtract (corr factor x cfm) from SHC.  
Above 80 F edb, add (corr factor x cfm) to SHC.  
Correction Factor =  $1.10 \times (1 - BF) \times (edb - 80)$ .

48HJ004-014



**COOLING CAPACITIES, UNITS WITH MOISTUREMISER™ OPTION**

48HJ004 (3 TONS)										
Temp (F) Air Ent Condenser (Edb)		Temp (F) Air Entering Evaporator — Cfm/BF								
		900/0.14			1200/0.17			1500/0.20		
		Temp (F) Air Entering Evaporator — Ewb								
		72	67	62	72	67	62	72	67	62
75	TC	41.3	37.3	34.3	43.5	39.2	35.9	45.5	41.6	38.2
	SHC	17.5	22.4	26.7	19.6	25.5	31.2	21.5	28.5	35.2
	kW	2.19	2.14	2.10	2.21	2.16	2.14	2.24	2.19	2.16
85	TC	38.6	34.4	31.6	41.3	37.5	33.3	43.5	38.6	35.5
	SHC	15.2	20.1	25.1	17.1	23.2	29.0	18.9	26.3	32.9
	kW	2.46	2.40	2.37	2.47	2.43	2.40	2.51	2.45	2.42
95	TC	35.9	31.4	28.8	39.2	35.9	30.6	41.3	35.7	32.9
	SHC	13.0	17.9	23.3	14.5	21.1	26.9	16.1	24.2	30.6
	kW	2.74	2.68	2.63	2.76	2.74	2.67	2.80	2.75	2.71
105	TC	33.8	29.7	27.4	36.3	32.2	28.7	38.1	32.8	30.4
	SHC	10.9	15.8	21.0	12.5	18.9	24.6	14.0	21.7	28.1
	kW	3.05	3.00	2.97	3.09	3.04	2.99	3.12	3.07	3.03
115	TC	31.8	28.0	25.5	33.2	28.7	26.5	34.9	30.0	27.9
	SHC	9.0	13.7	18.4	10.3	16.8	22.3	11.9	19.3	25.2
	kW	3.40	3.36	3.31	3.45	3.38	3.32	3.48	3.41	3.37
125	TC	28.7	26.3	23.4	29.7	25.5	22.9	31.3	27.1	25.5
	SHC	6.9	12.2	17.3	7.9	14.5	20.6	9.2	17.3	22.3
	kW	3.78	3.73	3.66	3.84	3.77	3.71	3.87	3.79	3.75

**LEGEND**

- BF** — Bypass Factor
- Edb** — Entering Dry Bulb
- Ewb** — Entering Wet Bulb
- kW** — Compressor Motor Power Input
- SHC** — Sensible Heat Capacity (1000 Btuh) Gross
- TC** — Total Capacity (1000 Btuh) Gross

**NOTES:**

1. Direct interpolation is permissible. Do not extrapolate.
2. The following formulas may be used:

$$t_{ldb} = t_{edb} - \frac{\text{sensible capacity (Btuh)}}{1.10 \times \text{cfm}}$$

$$t_{lwb} = \text{Wet-bulb temperature corresponding to enthalpy of air leaving evaporator coil (} h_{lwb} \text{)}$$

$$h_{lwb} = h_{ewb} - \frac{\text{total capacity (Btuh)}}{4.5 \times \text{cfm}}$$

Where:  $h_{ewb}$  = Enthalpy of air entering evaporator coil.

3. The SHC is based on 80 F edb temperature of air entering evaporator coil.  
Below 80 F edb, subtract (corr factor x cfm) from SHC.  
Above 80 F edb, add (corr factor x cfm) to SHC.  
Correction Factor =  $1.10 \times (1 - BF) \times (edb - 80)$ .

48HJ005 (4 TONS)													
Temp (F) Air Ent Condenser (Edb)		Temp (F) Air Entering Evaporator — Cfm/BF											
		1200/0.17			1450/0.19			1600/0.21			2000/0.24		
		Temp (F) Air Entering Evaporator — Ewb											
		72	67	62	72	67	62	72	67	62	72	67	62
75	TC	52.9	47.5	41.5	55.7	50.9	47.5	57.0	51.7	48.1	60.5	55.6	52.1
	SHC	22.7	28.4	33.4	26.1	34.1	38.9	25.9	33.7	41.6	29.4	39.1	47.5
	kW	2.87	2.86	2.82	2.89	2.87	2.84	2.89	2.86	2.85	2.90	2.88	2.85
85	TC	49.2	43.8	37.1	52.1	47.2	43.6	52.9	47.9	43.7	55.4	51.4	47.0
	SHC	19.8	25.5	30.4	22.2	29.5	35.8	22.4	31.1	38.7	24.2	36.0	44.3
	kW	3.26	3.25	3.21	3.28	3.26	3.23	3.28	3.26	3.24	3.28	3.26	3.24
95	TC	45.8	40.1	32.8	48.2	43.6	39.4	48.8	44.0	39.3	51.7	47.4	43.0
	SHC	17.2	22.5	27.3	18.4	24.8	32.6	19.0	28.1	35.9	20.7	33.0	41.0
	kW	3.71	3.68	3.64	3.72	3.69	3.67	3.72	3.69	3.67	3.74	3.70	3.68
105	TC	41.6	37.0	29.7	43.2	38.9	35.4	43.9	39.7	34.7	46.5	41.4	37.5
	SHC	13.5	19.5	23.9	14.7	21.7	29.2	15.0	23.7	30.6	16.4	27.8	35.1
	kW	4.20	4.17	4.11	4.20	4.17	4.14	4.20	4.17	4.15	4.22	4.19	4.16
115	TC	37.2	33.2	27.1	38.4	34.0	30.8	39.4	35.5	30.0	41.3	35.2	31.9
	SHC	9.9	16.4	20.7	11.3	18.5	25.6	11.2	19.7	25.4	12.4	22.4	28.6
	kW	4.73	4.68	4.62	4.74	4.71	4.64	4.73	4.72	4.65	4.74	4.72	4.69
125	TC	32.4	28.1	24.9	33.8	28.1	27.4	35.3	30.5	26.6	36.1	32.0	28.7
	SHC	7.2	12.9	18.3	8.4	14.5	21.9	16.8	21.1	21.2	9.5	18.3	24.1
	kW	5.29	5.23	5.15	5.30	5.25	5.19	5.29	5.27	5.21	5.30	5.29	5.25

48HJ006 (5 TONS)													
Temp (F) Air Ent Condenser (Edb)		Temp (F) Air Entering Evaporator — Cfm/BF											
		1500/0.08			1750/0.09			2000/0.11			2500/0.13		
		Temp (F) Air Entering Evaporator — Ewb											
		72	67	62	72	67	62	72	67	62	72	67	62
75	TC	69.9	62.7	56.2	74.7	67.3	61.0	78.5	71.2	64.8	81.7	75.5	69.3
	SHC	29.0	36.9	43.9	31.7	40.5	51.2	34.5	44.2	55.4	37.8	52.0	62.8
	kW	3.61	3.55	3.51	3.64	3.58	3.49	3.65	3.60	3.51	3.62	3.58	3.51
85	TC	65.9	59.1	51.7	70.6	63.2	56.3	75.5	66.8	60.7	78.1	70.8	65.1
	SHC	25.3	34.0	41.9	27.5	37.6	48.0	30.7	41.6	52.0	33.8	47.4	58.0
	kW	4.05	3.97	3.91	4.07	4.01	3.92	4.11	4.00	3.95	4.08	4.02	3.96
95	TC	61.9	55.2	47.7	66.5	58.8	51.3	70.4	61.9	55.7	74.2	65.9	60.6
	SHC	21.6	31.1	40.0	23.5	34.5	44.6	26.0	38.6	47.9	30.0	42.8	52.6
	kW	4.53	4.43	4.35	4.55	4.47	4.37	4.56	4.42	4.41	4.58	4.49	4.44
105	TC	57.7	51.1	44.9	61.8	54.5	47.7	65.1	57.2	50.8	68.4	60.3	56.1
	SHC	18.1	27.8	35.7	20.0	31.2	40.1	22.1	34.3	43.5	26.1	38.9	48.5
	kW	5.05	4.93	4.84	5.09	4.97	4.88	5.11	4.96	4.92	5.11	5.03	4.98
115	TC	53.4	47.2	42.0	56.6	50.0	44.2	59.6	52.5	46.2	62.6	54.9	51.6
	SHC	14.7	24.6	31.5	16.5	27.8	35.7	18.2	30.0	39.0	22.1	34.9	44.3
	kW	5.60	5.49	5.40	5.64	5.52	5.45	5.69	5.55	5.48	5.69	5.61	5.57
125	TC	48.7	42.0	36.9	51.3	45.0	39.0	54.1	46.8	40.9	56.9	49.2	45.9
	SHC	10.9	19.6	28.0	12.5	22.2	31.5	13.5	24.0	34.0	16.5	28.0	38.8
	kW	6.26	6.12	6.02	6.28	6.18	6.09	6.33	6.18	6.13	6.33	6.27	6.22

48HJ004-014

# Performance data (cont)



## COOLING CAPACITIES, UNITS WITH MOISTUREMI\$ER™ OPTION (cont)

48HJ007 (6 TONS)													
Temp (F) Air Ent Condenser (Edb)		Temp (F) Air Entering Evaporator — Cfm/BF											
		1800/0.05			2100/0.06			2400/0.06			3000/0.08		
		Temp (F) Air Entering Evaporator — Ewb											
		72	67	62	72	67	62	72	67	62	72	67	62
75	TC	82.6	75.6	68.5	84.9	78.0	70.9	85.9	79.5	73.5	89.1	82.7	77.0
	SHC	36.0	44.8	55.4	37.5	49.1	59.7	38.8	51.1	64.0	41.8	58.1	70.2
	kW	4.60	4.52	4.36	4.67	4.57	4.46	4.70	4.57	4.45	4.77	4.61	4.51
85	TC	78.2	71.6	64.5	80.9	73.4	65.8	82.0	74.4	67.9	85.8	78.2	72.3
	SHC	31.4	41.2	51.7	33.0	44.7	55.8	34.7	47.4	60.1	37.6	54.3	66.7
	kW	5.16	5.03	4.89	5.22	5.11	4.96	5.26	5.09	4.97	5.32	5.17	5.04
95	TC	73.8	67.4	60.2	76.3	68.3	60.5	77.5	69.3	62.3	82.0	72.8	67.5
	SHC	27.0	37.6	47.9	28.2	40.0	51.6	30.2	43.7	56.2	33.6	49.2	62.9
	kW	5.75	5.60	5.44	5.80	5.66	5.48	5.84	5.68	5.53	5.90	5.73	5.60
105	TC	68.4	62.6	55.9	71.4	64.3	56.2	72.1	64.6	58.3	75.7	67.0	62.4
	SHC	22.3	33.5	43.5	23.4	36.5	48.0	25.4	38.4	50.2	29.1	45.2	56.2
	kW	6.37	6.22	6.06	6.45	6.27	6.10	6.46	6.29	6.16	6.53	6.36	6.24
115	TC	63.4	57.8	50.7	66.0	60.1	51.5	66.4	59.6	54.5	68.8	60.8	57.5
	SHC	18.1	29.5	38.9	18.8	32.9	44.1	20.7	33.3	43.8	24.3	41.4	49.7
	kW	7.04	6.89	6.68	7.10	6.91	6.74	7.12	6.95	6.83	7.16	7.01	6.92
125	TC	55.5	49.6	45.8	58.4	52.4	46.1	57.6	52.1	49.5	59.2	52.8	53.1
	SHC	15.3	24.0	35.2	15.7	27.5	39.0	17.5	27.5	38.4	20.9	34.6	44.4
	kW	7.80	7.61	7.38	7.83	7.67	7.49	7.89	7.72	7.58	7.92	7.78	7.70

48HJ008 (7 1/2 TONS)										
Temp (F) Air Ent Condenser (Edb)		Temp (F) Air Entering Evaporator — Cfm/BF								
		2250/0.10			3000/0.11			3750/0.14		
		Temp (F) Air Entering Evaporator — Ewb								
		72	67	62	72	67	62	72	67	62
75	TC	98.4	91.1	81.1	103.7	97.9	91.8	105.8	101.3	94.1
	SHC	44.5	55.4	67.0	50.4	65.4	80.5	54.5	72.4	89.5
	kW	5.05	4.96	4.87	5.09	5.04	4.97	5.16	5.04	4.99
85	TC	94.2	85.8	76.9	100.3	92.4	85.2	103.5	96.8	89.0
	SHC	39.7	51.3	62.7	46.2	58.3	75.7	50.6	68.2	84.3
	kW	5.74	5.65	5.55	5.81	5.75	5.64	5.89	5.74	5.70
95	TC	89.9	80.5	72.6	96.9	86.8	78.6	101.1	92.2	83.8
	SHC	34.8	47.2	58.3	41.9	51.2	71.0	46.6	63.9	79.1
	kW	6.42	6.33	6.22	6.52	6.45	6.31	6.62	6.43	6.40
105	TC	84.6	75.3	68.0	91.6	81.3	73.4	94.5	86.3	78.4
	SHC	30.0	42.5	53.9	36.9	49.3	66.4	41.4	59.2	73.8
	kW	7.26	7.16	7.05	7.36	7.25	7.15	7.46	7.29	7.23
115	TC	79.2	70.1	63.3	86.2	75.8	68.1	87.9	80.3	72.9
	SHC	25.2	37.8	49.4	31.9	47.4	61.9	36.1	54.4	68.5
	kW	8.10	7.99	7.87	8.20	8.05	7.98	8.30	8.14	8.05
125	TC	72.8	64.5	57.2	78.0	69.8	62.3	81.6	73.2	69.2
	SHC	20.1	33.4	44.1	25.4	42.5	56.5	31.1	48.9	64.7
	kW	9.10	8.94	8.83	9.23	9.05	8.95	9.26	9.10	8.99

### LEGEND

- BF — Bypass Factor
- Edb — Entering Dry Bulb
- Ewb — Entering Wet Bulb
- kW — Compressor Motor Power Input
- SHC — Sensible Heat Capacity (1000 Btuh) Gross
- TC — Total Capacity (1000 Btuh) Gross

### NOTES:

1. Direct interpolation is permissible. Do not extrapolate.
2. The following formulas may be used:

$$t_{db} = t_{edb} - \frac{\text{sensible capacity (Btuh)}}{1.10 \times \text{cfm}}$$

$$t_{lwb} = \text{Wet-bulb temperature corresponding to enthalpy of air leaving evaporator coil } (h_{lwb})$$

$$h_{lwb} = h_{ewb} - \frac{\text{total capacity (Btuh)}}{4.5 \times \text{cfm}}$$

Where:  $h_{ewb}$  = Enthalpy of air entering evaporator coil.

3. The SHC is based on 80 F edb temperature of air entering evaporator coil.  
Below 80 F edb, subtract (corr factor x cfm) from SHC.  
Above 80 F edb, add (corr factor x cfm) to SHC.  
Correction Factor =  $1.10 \times (1 - BF) \times (edb - 80)$ .

48HJ004-014



**COOLING CAPACITIES, UNITS WITH MOISTUREMISER™ OPTION (cont)**

**48HJ009 (8 1/2 TONS)**

Temp (F) Air Ent Condenser (Edb)		Temp (F) Air Entering Evaporator — Cfm/BF											
		2550/0.08			3000/0.09			3400/0.11			4250/0.13		
		Temp (F) Air Entering Evaporator — Ewb											
		72	67	62	72	67	62	72	67	62	72	67	62
75	TC	112.4	102.2	92.6	115.2	106.4	96.4	119.6	110.3	101.3	127.6	117.6	108.0
	SHC	49.1	62.4	75.0	52.9	68.5	82.3	56.2	73.3	89.5	62.8	83.3	101.7
	KW	6.10	5.96	5.86	6.18	6.05	5.95	6.18	6.05	5.95	6.18	6.10	6.00
85	TC	105.7	95.7	86.5	110.0	100.6	91.0	114.0	103.7	94.6	118.2	110.9	101.2
	SHC	43.6	57.1	69.9	47.8	62.8	76.9	50.7	67.9	82.8	74.7	77.7	94.8
	KW	6.92	6.78	6.63	6.97	6.90	6.75	7.01	6.85	6.75	7.01	6.91	6.80
95	TC	98.9	89.1	80.4	104.7	94.8	85.5	108.4	97.0	87.9	108.8	104.1	94.3
	SHC	38.0	51.7	64.8	42.7	57.0	71.4	45.2	62.4	76.2	86.5	72.0	87.9
	KW	7.73	7.59	7.40	7.75	7.75	7.56	7.84	7.65	7.54	7.84	7.71	7.60
105	TC	91.8	82.3	73.8	97.3	87.6	78.6	100.4	89.8	80.8	102.3	95.3	85.8
	SHC	32.6	46.3	59.5	37.0	51.9	66.8	39.3	56.7	70.0	68.6	65.5	80.9
	KW	8.80	8.64	8.47	8.80	8.76	8.58	8.89	8.69	8.59	8.93	8.77	8.67
115	TC	84.7	75.5	67.3	89.8	80.5	71.7	92.5	82.5	73.8	95.8	86.6	77.4
	SHC	27.2	40.9	54.2	31.4	46.9	62.2	33.4	51.0	63.8	50.6	59.1	73.9
	KW	9.86	9.69	9.53	9.86	9.77	9.61	9.95	9.74	9.65	10.01	9.84	9.75
125	TC	77.6	68.7	60.7	82.4	73.3	64.8	84.5	75.3	66.7	89.3	77.8	68.9
	SHC	21.8	35.5	48.9	25.7	41.8	57.6	27.5	45.3	57.6	32.7	52.6	66.9
	KW	10.93	10.74	10.60	10.91	10.78	10.64	11.00	10.78	10.70	11.10	10.90	10.82

**48HJ012 (10 TONS)**

Temp (F) Air Ent Condenser (Edb)		Temp (F) Air Entering Evaporator — Cfm/BF											
		3000/0.03			3200/0.03			4000/0.04			5000/0.04		
		Temp (F) Air Entering Evaporator — Ewb											
		72	67	62	72	67	62	72	67	62	72	67	62
75	TC	134.3	122.5	111.4	135.8	124.3	113.0	138.4	129.5	123.5	143.3	136.5	130.2
	SHC	60.0	76.1	93.7	61.3	79.1	97.4	68.0	89.5	109.4	75.2	100.9	123.3
	KW	7.03	6.84	6.72	7.01	6.89	6.77	7.10	6.92	6.77	7.15	7.03	6.88
85	TC	127.6	115.4	104.6	128.9	118.1	107.0	132.5	121.5	116.6	137.2	128.0	122.9
	SHC	51.5	68.8	87.2	53.9	72.0	91.2	61.0	82.7	102.4	68.6	93.6	115.9
	KW	7.96	7.86	7.59	7.94	7.78	7.51	8.02	7.84	7.69	8.02	7.94	7.79
95	TC	120.9	108.3	97.8	121.9	111.8	101.0	126.5	113.4	109.7	131.1	119.4	115.5
	SHC	43.0	61.5	80.6	46.5	64.8	84.9	53.9	75.9	95.4	62.0	86.2	108.4
	KW	8.88	8.87	8.46	8.86	8.66	8.26	8.94	8.76	8.60	8.89	8.85	8.69
105	TC	112.0	99.9	90.4	113.1	103.2	93.4	117.2	105.0	100.7	122.1	110.5	105.9
	SHC	36.1	54.1	73.8	38.8	57.8	78.9	45.6	68.2	86.8	53.0	78.3	99.7
	KW	10.0	10.0	9.6	10.0	9.8	9.5	10.1	9.9	9.8	10.1	10.0	9.9
115	TC	103.0	91.5	83.1	104.3	94.6	85.9	107.8	96.7	91.7	113.0	101.6	96.4
	SHC	29.2	46.7	66.9	31.2	50.7	72.9	37.3	60.6	78.3	44.0	70.3	90.9
	KW	11.2	11.1	10.8	11.2	11.0	10.7	11.3	11.1	11.0	11.3	11.2	11.1
125	TC	94.1	83.1	75.7	95.5	86.0	78.3	98.5	88.3	82.7	104.0	92.7	86.8
	SHC	22.3	39.3	60.1	23.5	43.7	66.8	29.0	52.9	69.7	35.0	62.4	82.2
	KW	12.35	12.15	11.94	12.38	12.13	11.92	12.48	12.27	12.25	12.53	12.30	12.28

**48HJ014 (12 1/2 TONS)**

Temp (F) Air Ent Condenser (Edb)		Temp (F) Air Entering Evaporator — Cfm/BF											
		3750/0.08			4300/0.09			5000/0.11			6250/0.13		
		Temp (F) Air Entering Evaporator — Ewb											
		72	67	62	72	67	62	72	67	62	72	67	62
75	TC	156.3	144.2	132.3	160.0	148.4	136.2	162.8	150.6	138.2	169.0	157.5	145.6
	SHC	66.6	87.6	112.1	72.5	94.8	121.3	76.9	99.6	127.5	87.0	115.5	142.7
	KW	9.28	8.98	8.59	9.35	9.08	8.80	9.40	9.18	8.9	9.43	9.18	8.93
85	TC	147.6	136.2	123.7	150.7	140.1	127.2	154.1	140.8	127.9	161.1	148.0	135.4
	SHC	58.7	80.0	103.8	63.5	86.5	112.2	68.7	91.0	118.1	77.7	107.8	133.2
	KW	10.29	9.93	9.58	10.36	10.08	9.77	10.40	10.34	10.03	10.45	10.18	9.88
95	TC	138.9	128.2	115.1	141.4	131.8	118.3	145.3	131.0	117.6	153.1	138.4	125.1
	SHC	50.8	72.3	95.5	54.4	78.1	103.2	60.5	82.3	108.7	68.5	100.0	123.7
	KW	11.29	10.87	10.57	11.37	11.08	10.74	11.40	11.50	11.1	11.46	11.17	10.83
105	TC	129.1	117.8	105.8	131.7	121.0	108.7	134.8	119.9	107.7	140.9	126.9	115.9
	SHC	42.1	63.5	86.5	45.4	69.0	93.9	51.2	74.2	101.3	57.7	90.2	113.6
	KW	12.59	12.14	11.82	12.67	12.34	11.96	12.70	12.67	12.28	12.79	12.46	12.08
115	TC	119.2	107.3	96.4	122.1	110.2	99.0	124.2	108.8	97.8	128.7	115.3	106.7
	SHC	33.5	54.8	77.5	36.4	59.8	84.7	41.9	66.1	93.8	46.8	80.5	103.5
	KW	13.90	13.40	13.08	13.98	13.59	13.18	14.00	13.83	13.41	14.11	13.75	13.33
125	TC	109.4	96.9	87.1	112.4	99.4	89.3	113.7	97.7	87.8	116.5	103.8	97.5
	SHC	24.8	46.0	68.5	27.4	50.7	75.5	32.6	58.0	86.4	36.0	70.7	93.5
	KW	15.20	14.67	14.33	15.28	14.85	14.40	15.30	15.00	14.54	15.44	15.04	14.58

**LEGEND**

- BF — Bypass Factor
- Edb — Entering Dry Bulb
- Ewb — Entering Wet Bulb
- kW — Compressor Motor Power Input
- SHC — Sensible Heat Capacity (1000 Btuh) Gross
- TC — Total Capacity (1000 Btuh) Gross

**NOTES:**

1. Direct interpolation is permissible. Do not extrapolate.
2. The following formulas may be used:

$$t_{ldb} = t_{edb} - \frac{\text{sensible capacity (Btuh)}}{1.10 \times \text{cfm}}$$

$$t_{lwb} = \text{Wet-bulb temperature corresponding to enthalpy of air leaving evaporator coil (} h_{lwb} \text{)}$$

$$h_{lwb} = h_{ewb} - \frac{\text{total capacity (Btuh)}}{4.5 \times \text{cfm}}$$

Where:  $h_{ewb}$  = Enthalpy of air entering evaporator coil.

3. The SHC is based on 80 F edb temperature of air entering evaporator coil. Below 80 F edb, subtract (corr factor x cfm) from SHC. Above 80 F edb, add (corr factor x cfm) to SHC. Correction Factor =  $1.10 \times (1 - BF) \times (edb - 80)$ .

48HJ004-014

# Performance data (cont)



## FAN PERFORMANCE — VERTICAL DISCHARGE UNITS

### 48HJ004 (3 TONS) — STANDARD MOTOR (BELT DRIVE)

Airflow (Cfm)	External Static Pressure (in. wg)											
	0.1		0.2		0.3		0.4		0.5		0.6	
	Rpm	Bhp	Rpm	Bhp	Rpm	Bhp	Rpm	Bhp	Rpm	Bhp	Rpm	Bhp
900	581	0.12	673	0.18	736	0.22	805	0.25	865	0.29	911	0.34
1000	644	0.19	709	0.22	782	0.28	835	0.30	900	0.35	937	0.38
1100	687	0.22	746	0.26	806	0.30	867	0.35	929	0.40	964	0.40
1200	733	0.26	785	0.32	843	0.35	903	0.41	960	0.47	994	0.50
1300	754	0.29	826	0.38	891	0.43	942	0.48	991	0.53	1047	0.60
1400	810	0.35	868	0.45	937	0.51	984	0.57	1032	0.62	1067	0.67
1500	841	0.42	911	0.53	985	0.61	1029	0.66	1073	0.72	1109	0.77

### 48HJ004 (3 TONS) — STANDARD MOTOR (BELT DRIVE) (cont)

Airflow (Cfm)	External Static Pressure (in. wg)											
	0.7		0.8		0.9		1.0		1.1		1.2	
	Rpm	Bhp	Rpm	Bhp	Rpm	Bhp	Rpm	Bhp	Rpm	Bhp	Rpm	Bhp
900	957	0.39	988	0.43	1039	0.47	1061	0.51	1083	0.54	1105	0.58
1000	992	0.44	1039	0.49	1061	0.55	1088	0.60	1111	0.66	1136	0.72
1100	1013	0.49	1068	0.55	1091	0.61	1109	0.66	1127	0.73	1145	0.80
1200	1045	0.56	1090	0.64	1109	0.68	1156	0.73	1203	0.81	1250	0.86
1300	1075	0.64	1122	0.70	1152	0.76	1190	0.82	1228	0.87	1266	0.94
1400	1110	0.73	1160	0.78	1181	0.83	1237	0.88	1293	0.94	1349	0.99
1500	1150	0.78	1190	0.84	1225	0.89	1271	0.95	1371	1.00	1383	1.05

### 48HJ004 (3 TONS) — HIGH-STATIC MOTOR (BELT DRIVE)

Airflow (Cfm)	External Static Pressure (in. wg)									
	0.2		0.4		0.6		0.8		1.0	
	Rpm	Bhp	Rpm	Bhp	Rpm	Bhp	Rpm	Bhp	Rpm	Bhp
900	673	0.18	805	0.25	911	0.34	988	0.43	1061	0.47
1000	709	0.22	835	0.30	937	0.38	1039	0.49	1086	0.55
1100	746	0.28	867	0.35	964	0.40	1068	0.55	1109	0.61
1200	785	0.32	903	0.41	994	0.50	1090	0.64	1156	0.68
1300	826	0.38	942	0.48	1047	0.60	1122	0.70	1190	0.76
1400	868	0.45	984	0.57	1087	0.67	1160	0.84	1237	0.85
1500	911	0.53	1029	0.66	1109	0.77	1190	1.00	1271	0.95

### 48HJ004 (3 TONS) — HIGH-STATIC MOTOR (BELT DRIVE) (cont)

Airflow (Cfm)	External Static Pressure (in. wg)									
	1.2		1.4		1.6		1.8		2.0	
	Rpm	Bhp	Rpm	Bhp	Rpm	Bhp	Rpm	Bhp	Rpm	Bhp
900	1105	0.57	1140	0.63	1170	0.68	1198	0.73	1224	0.77
1000	1136	0.63	1172	0.69	1203	0.75	1232	0.80	1258	0.86
1100	1145	0.67	1181	0.73	1213	0.80	1242	0.85	1268	0.91
1200	1210	0.74	1248	0.81	1282	0.88	1312	0.94	1340	1.01
1300	1266	0.84	1306	0.92	1341	1.00	1373	1.07	1402	1.14
1400	1349	0.93	1391	1.02	1429	1.11	1463	1.19	1494	1.26
1500	1363	1.05	1406	1.15	1465	1.25	1500	1.34	1532	1.43

#### LEGEND

**Bhp** — Brake Horsepower Input to Fan  
**FIOP** — Factory-Installed Option

#### NOTES:

- Boldface** indicates field-supplied drive required. (See Note 2.)
- Motor drive range is 760 to 1090 rpm for standard motor; 1075 to 1455 rpm for high-static motor. All other rpms require a field-supplied drive.
- Maximum continuous bhp is 1.2 for standard motor, 2.4 for high-static motor.

Refer to page 161 for general Fan Performance Data notes.

48HJ004-014



## FAN PERFORMANCE — VERTICAL DISCHARGE UNITS (cont)

### 48HJ005 (4 TONS) — STANDARD MOTOR (BELT DRIVE)

Airflow (Cfm)	External Static Pressure (in. wg)													
	0.1		0.2		0.3		0.4		0.6		0.7		0.8	
	Rpm	Bhp	Rpm	Bhp	Rpm	Bhp	Rpm	Bhp	Rpm	Bhp	Rpm	Bhp	Rpm	Bhp
1200	596	0.20	665	0.25	722	0.31	779	0.36	872	0.48	915	0.54	957	0.60
1300	633	0.24	699	0.30	754	0.36	809	0.42	902	0.55	943	0.61	984	0.67
1400	672	0.30	735	0.36	788	0.42	840	0.48	933	0.62	972	0.69	1011	0.75
1500	711	0.35	770	0.42	822	0.49	873	0.55	963	0.69	1002	0.77	1041	0.84
1600	751	0.42	835	0.49	871	0.56	907	0.63	993	0.77	1033	0.85	1072	0.93
1700	791	0.49	873	0.57	907	0.65	941	0.72	1024	0.87	1064	0.96	1103	1.04
1800	831	0.58	881	0.66	929	0.74	976	0.81	1057	0.97	1095	1.06	1132	1.14
1900	872	0.67	919	0.75	965	0.84	1011	0.92	1091	1.08	1127	1.17	1162	1.25
2000	913	0.77	958	0.86	1002	0.95	1046	1.03	1125	1.21	1160	1.30	1195	1.38

### 48HJ005 (4 TONS) — STANDARD MOTOR (BELT DRIVE) (cont)

Airflow (Cfm)	External Static Pressure (in. wg)													
	0.9		1.0		1.1		1.2		1.4		1.6		1.8	
	Rpm	Bhp	Rpm	Bhp	Rpm	Bhp	Rpm	Bhp	Rpm	Bhp	Rpm	Bhp	Rpm	Bhp
1200	993	0.65	1028	0.69	1056	0.72	1083	0.74	1134	0.80	1185	0.88	1331	0.99
1300	1021	0.74	1058	0.80	1090	0.85	1121	0.89	1171	0.94	1219	1.00	1268	1.10
1400	1049	0.82	1086	0.89	1120	0.96	1153	1.00	1210	1.12	1257	1.17	1307	1.25
1500	1077	0.92	1113	0.99	1147	1.06	1180	1.13	1241	1.27	1295	1.37	1339	1.43
1600	1107	1.00	1141	1.09	1174	1.17	1207	1.25	1269	1.40	1326	1.54	1376	1.65
1700	1137	1.12	1171	1.20	1203	1.29	1235	1.37	1296	1.53	1354	1.70	1407	1.84
1800	1167	1.23	1202	1.32	1233	1.41	1263	1.49	1323	1.67	1381	1.85	1436	2.02
1900	1197	1.35	1232	1.45	1263	1.54	1294	1.63	1351	1.81	1408	2.00	1463	2.19
2000	1229	1.48	1262	1.58	1294	1.68	1325	1.78	1362	1.97	1436	2.16	1489	2.36

### 48HJ005 (4 TONS) — HIGH-STATIC MOTOR (BELT DRIVE)

Airflow (Cfm)	External Static Pressure (in. wg)									
	0.2		0.4		0.6		0.8		1.0	
	Rpm	Bhp	Rpm	Bhp	Rpm	Bhp	Rpm	Bhp	Rpm	Bhp
1200	665	0.25	779	0.36	872	0.48	957	0.60	1028	0.69
1300	699	0.30	809	0.42	902	0.55	984	0.67	1058	0.80
1400	735	0.36	840	0.48	933	0.62	1011	0.75	1086	0.89
1500	770	0.42	873	0.55	963	0.69	1041	0.84	1113	0.99
1600	835	0.49	907	0.63	993	0.77	1072	0.93	1141	1.09
1700	873	0.57	941	0.72	1024	0.87	1103	1.04	1171	1.20
1800	881	0.66	976	0.81	1057	0.97	1132	1.14	1202	1.32
1900	919	0.75	1011	0.92	1091	1.08	1162	1.25	1232	1.45
2000	958	0.86	1046	1.03	1125	1.21	1195	1.38	1262	1.58

### 48HJ005 (4 TONS) — HIGH-STATIC MOTOR (BELT DRIVE) (cont)

Airflow (Cfm)	External Static Pressure (in. wg)									
	1.2		1.4		1.6		1.8		2.0	
	Rpm	Bhp	Rpm	Bhp	Rpm	Bhp	Rpm	Bhp	Rpm	Bhp
1200	1083	0.74	1134	0.80	1185	0.88	1331	0.99	1374	1.09
1300	1121	0.89	1171	0.94	1219	1.00	1268	1.10	1309	1.21
1400	1153	1.00	1210	1.12	1257	1.17	1307	1.25	1349	1.37
1500	1180	1.13	1241	1.27	1295	1.37	1339	1.43	1382	1.57
1600	1207	1.25	1269	1.40	1326	1.54	1376	1.65	1420	1.81
1700	1235	1.37	1296	1.53	1354	1.70	1407	1.84	1452	2.02
1800	1263	1.49	1323	1.67	1381	1.85	1436	2.02	1482	2.22
1900	1294	1.63	1351	1.81	1408	2.00	1463	2.19	—	—
2000	1325	1.78	1362	1.97	1436	2.16	1489	2.36	—	—

**LEGEND**

**Bhp** — Brake Horsepower Input to Fan  
**FIOF** — Factory-Installed Option

Refer to page 161 for general Fan Performance Data notes.

**NOTES:**

1. **Boldface** indicates field-supplied drive required. (See Note 3.)

2.   indicates field-supplied motor and drive required.

3. Motor drive range is 840 to 1185 rpm for standard motor; 1075 to 1455 rpm for high-static motor. All other rpms require a field-supplied drive.

4. Maximum continuous bhp is 1.2 for standard motor, 2.4 for high-static motor.

48HJ004-014

# Performance data (cont)



## FAN PERFORMANCE — VERTICAL DISCHARGE UNITS (cont)

48HJ006 (5 TONS) — STANDARD MOTOR (BELT DRIVE) — SINGLE-PHASE UNITS

Airflow (Cfm)	External Static Pressure (in. wg)																	
	0.1		0.2		0.4		0.6		0.8		1.0		1.2		1.4		1.6	
	Rpm	Bhp	Rpm	Bhp	Rpm	Bhp	Rpm	Bhp	Rpm	Bhp	Rpm	Bhp	Rpm	Bhp	Rpm	Bhp	Rpm	Bhp
1500	771	0.37	828	0.44	935	0.58	1027	0.73	1107	0.88	1185	1.04	1257	1.20	1330	1.38	1411	1.59
1600	816	0.45	869	0.51	968	0.66	1056	0.81	1127	0.97	1215	1.14	1286	1.31	1353	1.49	1421	1.68
1700	902	0.61	940	0.60	1007	0.75	1094	0.91	1175	1.09	1245	1.26	1315	1.44	1381	1.52	1443	1.69
1800	942	0.70	978	0.66	1063	0.82	1147	0.97	1248	1.20	1322	1.33	1395	1.46	1475	1.56	1542	1.71
1900	982	0.80	1023	0.78	1097	0.91	1175	1.11	1266	1.29	1356	1.47	1430	1.58	1504	1.69	1556	1.82
2000	1022	0.91	1068	0.90	1132	1.01	1218	1.23	1303	1.41	1397	1.52	1459	1.67	1532	1.82	1588	1.97
2100	1063	0.99	1115	1.00	1180	1.17	1261	1.35	1340	1.53	1428	1.66	1489	1.80	1567	1.99	1626	2.16
2200	1104	1.13	1159	1.15	1214	1.28	1310	1.52	1375	1.63	1459	1.80	1528	1.95	1603	2.17	1666	2.37
2300	1130	1.26	1202	1.29	1248	1.38	1358	1.69	1410	1.72	1488	1.93	1561	2.13	1637	2.35	1710	2.54
2400	1174	1.37	1237	1.41	1292	1.55	1392	1.81	1460	1.90	1532	2.14	1584	2.28	1671	2.55	1756	2.70
2500	1201	1.48	1272	1.53	1335	1.71	1427	1.94	1518	2.16	1575	2.35	1633	2.53	1698	2.72	—	—

48HJ006 (5 TONS) — STANDARD MOTOR (BELT DRIVE) — THREE-PHASE UNITS

Airflow (Cfm)	External Static Pressure (in. wg)																	
	0.1		0.2		0.4		0.6		0.8		1.0		1.2		1.4		1.6	
	Rpm	Bhp	Rpm	Bhp	Rpm	Bhp	Rpm	Bhp	Rpm	Bhp	Rpm	Bhp	Rpm	Bhp	Rpm	Bhp	Rpm	Bhp
1500	771	0.37	828	0.44	935	0.58	1027	0.73	1107	0.88	1185	1.04	1257	1.20	1330	1.38	1411	1.59
1600	816	0.45	869	0.51	968	0.66	1056	0.81	1127	0.97	1215	1.14	1286	1.31	1353	1.49	1421	1.68
1700	902	0.61	940	0.60	1007	0.75	1094	0.91	1175	1.09	1245	1.26	1315	1.44	1381	1.52	1443	1.69
1800	942	0.70	978	0.66	1063	0.82	1147	0.97	1248	1.20	1322	1.33	1395	1.46	1475	1.56	1542	1.71
1900	982	0.80	1023	0.78	1097	0.91	1175	1.11	1266	1.29	1356	1.47	1430	1.58	1504	1.69	1556	1.82
2000	1022	0.91	1068	0.90	1132	1.01	1218	1.23	1303	1.41	1397	1.52	1459	1.67	1532	1.82	1588	1.97
2100	1063	0.99	1115	1.00	1180	1.17	1261	1.35	1340	1.53	1428	1.66	1489	1.80	1567	1.99	1626	2.16
2200	1104	1.13	1159	1.15	1214	1.28	1310	1.52	1375	1.63	1459	1.80	1528	1.95	1603	2.17	1666	2.37
2300	1130	1.26	1202	1.29	1248	1.38	1358	1.69	1410	1.72	1488	1.93	1561	2.13	1637	2.35	1710	2.54
2400	1174	1.37	1237	1.41	1292	1.55	1392	1.81	1460	1.90	1532	2.14	1584	2.28	1671	2.55	1756	2.70
2500	1201	1.48	1272	1.53	1335	1.71	1427	1.94	1518	2.16	1575	2.35	1633	2.53	1698	2.72	—	—

48HJ006 (5 TONS) — HIGH-STATIC MOTOR (BELT DRIVE)

Airflow (Cfm)	External Static Pressure (in. wg)									
	0.2		0.4		0.6		0.8		1.0	
	Rpm	Bhp	Rpm	Bhp	Rpm	Bhp	Rpm	Bhp	Rpm	Bhp
1500	808	0.42	914	0.56	1001	0.69	1084	0.85	1168	1.01
1600	846	0.49	950	0.64	1034	0.78	1111	0.94	1194	1.11
1700	884	0.57	983	0.72	1068	0.88	1145	1.03	1218	1.21
1800	924	0.66	1018	0.82	1105	0.98	1179	1.13	1246	1.32
1900	965	0.76	1057	0.92	1143	1.10	1212	1.26	1280	1.43
2000	1008	0.87	1096	1.04	1177	1.22	1247	1.40	1300	1.57
2100	1051	0.99	1136	1.17	1210	1.35	1284	1.54	1347	1.72
2200	1095	1.12	1173	1.30	1245	1.49	1322	1.70	1380	1.89
2300	1140	1.26	1210	1.47	1284	1.65	1356	1.80	1418	2.07
2400	1185	1.41	1249	1.61	1323	1.80	1389	2.03	1456	2.26
2500	1231	1.57	1289	1.78	1363	2.00	1424	2.22	1500	2.45

48HJ006 (5 TONS) — HIGH-STATIC MOTOR (BELT DRIVE) (cont)

Airflow (Cfm)	External Static Pressure (in. wg)									
	1.2		1.4		1.6		1.8		2.0	
	Rpm	Bhp	Rpm	Bhp	Rpm	Bhp	Rpm	Bhp	Rpm	Bhp
1500	1199	1.19	1126	1.46	1250	1.69	1301	1.91	1349	2.12
1600	1263	1.28	1275	1.49	1299	1.78	1352	2.01	1401	2.23
1700	1295	1.39	1351	1.58	1352	1.80	1407	2.03	1459	2.26
1800	1319	1.52	1389	1.71	1435	1.91	1494	2.15	1548	2.40
1900	1343	1.64	1415	1.80	1478	2.05	1538	2.31	1594	2.57
2000	1374	1.77	1438	1.99	1505	2.21	1566	2.49	1624	2.77
2100	1409	1.91	1465	2.14	1533	2.45	1596	2.77	1654	3.08
2200	1442	2.08	1498	2.30	1568	2.64	1632	2.97	1691	3.31
2300	1475	2.26	1554	2.64	1627	3.03	1693	3.42	1755	3.81
2400	1565	2.47	1649	2.89	1726	3.31	—	—	—	—
2500	1596	2.95	1682	3.45	1760	3.96	—	—	—	—

LEGEND

Bhp — Brake Horsepower Input to Fan  
 FIOP — Factory-Installed Option

Refer to page 161 for general Fan Performance Data notes.

NOTES:

1. **Boldface** indicates field-supplied drive required. (See Note 3.)

2.  indicates field-supplied motor and drive required.

3. Motor drive range is 1020 to 1460 rpm for single-phase standard motors, 1120 to 1585 for 3-phase standard motors, and 1300 to 1685 for high-static motors. All other rpms require a field-supplied drive.

4. Maximum continuous bhp is 1.30 for single-phase standard motors, 2.40 for 3-phase standard motors, and 2.90 for high-static motors.

48HJ004-014



## FAN PERFORMANCE — VERTICAL DISCHARGE UNITS (cont)

### 48HJ007 (6 TONS) — STANDARD MOTOR (BELT DRIVE)

Airflow (Cfm)	External Static Pressure (in. wg)																	
	0.1		0.2		0.4		0.6		0.8		1.0		1.2		1.4		1.6	
	Rpm	Bhp	Rpm	Bhp	Rpm	Bhp	Rpm	Bhp	Rpm	Bhp	Rpm	Bhp	Rpm	Bhp	Rpm	Bhp	Rpm	Bhp
1800	942	0.70	978	0.66	1063	0.82	1147	0.97	1248	1.20	1322	1.33	1395	1.46	1475	1.56	1542	1.71
1900	982	0.80	1023	0.78	1097	0.91	1175	1.11	1266	1.29	1356	1.47	1430	1.58	1504	1.69	1556	1.82
2000	1022	0.91	1068	0.90	1132	1.01	1218	1.23	1303	1.41	1397	1.52	1459	1.67	1532	1.82	1588	1.97
2100	1063	0.99	1115	1.00	1180	1.17	1261	1.35	1340	1.53	1428	1.66	1489	1.80	1567	1.99	1626	2.16
2200	1104	1.13	1159	1.15	1214	1.28	1310	1.52	1375	1.63	1459	1.80	1528	1.95	1603	2.17	1666	2.37
2300	1130	1.26	1202	1.29	1248	1.38	1358	1.69	1410	1.72	1488	1.93	1561	2.13	1637	2.35	1710	2.54
2400	1174	1.37	1237	1.41	1292	1.55	1392	1.81	1460	1.90	1532	2.14	1584	2.28	1671	2.55	1756	2.70
2500	1201	1.48	1272	1.53	1335	1.71	1427	1.94	1518	2.16	1575	2.35	1633	2.53	1698	2.72	—	—
2600	1246	1.62	1320	1.68	1368	1.81	1458	2.06	1562	2.42	1620	2.59	1675	2.77	—	—	—	—
2700	1285	1.75	1361	1.82	1400	1.91	1490	2.19	1602	2.64	1666	2.85	—	—	—	—	—	—
2800	1304	1.87	1402	1.95	1439	2.08	1543	2.43	1642	2.86	—	—	—	—	—	—	—	—
2900	1345	2.07	1446	2.16	1477	2.16	1585	2.65	—	—	—	—	—	—	—	—	—	—
3000	1378	2.26	1489	2.36	1529	2.52	1598	2.73	—	—	—	—	—	—	—	—	—	—

### 48HJ007 (6 TONS) — HIGH-STATIC MOTOR (BELT DRIVE)

Airflow (Cfm)	External Static Pressure (in. wg)									
	0.2		0.4		0.6		0.8		1.0	
	Rpm	Bhp	Rpm	Bhp	Rpm	Bhp	Rpm	Bhp	Rpm	Bhp
1800	978	0.66	1063	0.82	1147	0.97	1248	1.20	1322	1.33
1900	1023	0.78	1097	0.91	1175	1.11	1266	1.29	1356	1.47
2000	1068	0.90	1132	1.01	1218	1.23	1303	1.41	1397	1.52
2100	1115	1.00	1180	1.17	1261	1.35	1340	1.53	1428	1.66
2200	1159	1.15	1214	1.28	1310	1.52	1375	1.63	1459	1.80
2300	1202	1.29	1248	1.38	1358	1.69	1410	1.72	1488	1.93
2400	1237	1.41	1292	1.55	1392	1.81	1460	1.90	1532	2.14
2500	1272	1.53	1335	1.71	1427	1.94	1518	2.16	1575	2.35
2600	1320	1.68	1368	1.81	1458	2.06	1562	2.42	1620	2.59
2700	1361	1.82	1400	1.91	1490	2.19	1602	2.64	1666	2.85
2800	1402	1.95	1439	2.08	1543	2.43	1642	2.86	1775	3.62
2900	1446	2.16	1477	2.16	1585	2.65	1753	3.58	—	—
3000	1489	2.36	1529	2.52	1598	2.73	1767	3.69	—	—

### 48HJ007 (6 TONS) — HIGH-STATIC MOTOR (BELT DRIVE) (cont)

Airflow (Cfm)	External Static Pressure (in. wg)									
	1.2		1.4		1.6		1.8		2.0	
	Rpm	Bhp	Rpm	Bhp	Rpm	Bhp	Rpm	Bhp	Rpm	Bhp
1800	1395	1.46	1475	1.56	1542	1.71	1607	1.94	1667	2.16
1900	1430	1.58	1504	1.69	1556	1.82	1621	2.06	1682	2.30
2000	1459	1.67	1532	1.82	1588	1.97	1655	2.23	1717	2.49
2100	1489	1.80	1567	1.99	1626	2.16	1694	2.44	1758	2.73
2200	1528	1.95	1603	2.17	1666	2.37	1736	2.68	—	—
2300	1561	2.13	1637	2.35	1710	2.54	1782	2.87	—	—
2400	1584	2.28	1671	2.55	1756	2.70	—	—	—	—
2500	1633	2.53	1698	2.72	1779	3.13	—	—	—	—
2600	1675	2.77	1768	3.26	—	—	—	—	—	—
2700	1776	3.45	—	—	—	—	—	—	—	—
2800	—	—	—	—	—	—	—	—	—	—
2900	—	—	—	—	—	—	—	—	—	—
3000	—	—	—	—	—	—	—	—	—	—

**LEGEND**

**Bhp** — Brake Horsepower Input to Fan  
**FIOF** — Factory-Installed Option

Refer to page 161 for general Fan Performance Data notes.

**NOTES:**

1. **Boldface** indicates field-supplied drive required. (See Note 3.)

2.  indicates field-supplied motor and drive required.

3. Motor drive range is 1120 to 1585 rpm for standard motors, 1300 to 1685 rpm for high-static motors. All other rpms require a field-supplied drive.  
 4. Maximum continuous bhp is 2.40 for standard motors, 2.90 for high-static motors.

48HJ004-014

# Performance data (cont)



## FAN PERFORMANCE — VERTICAL DISCHARGE UNITS (cont)

48HJ008 (7½ TONS) — STANDARD MOTOR (BELT DRIVE)

Airflow (Cfm)	External Static Pressure (in. wg)															
	0.2		0.4		0.6		0.8		1.0		1.2		1.4		1.6	
	Rpm	Bhp	Rpm	Bhp	Rpm	Bhp	Rpm	Bhp	Rpm	Bhp	Rpm	Bhp	Rpm	Bhp	Rpm	Bhp
2200	506	0.52	586	0.72	656	0.95	718	1.18	776	1.43	838	1.78	898	2.21	935	2.58
2250	514	0.55	593	0.76	662	0.99	724	1.22	781	1.78	841	1.81	902	2.25	939	2.60
2300	521	0.57	600	0.79	668	1.02	730	1.26	786	1.50	843	1.83	905	2.28	943	2.62
2400	536	0.63	613	0.85	680	1.09	741	1.34	796	1.59	849	1.88	910	2.31	952	2.74
2500	551	0.69	626	0.93	693	1.17	753	1.43	808	1.69	859	1.96	912	2.31	963	2.81
2550	559	0.72	634	0.97	700	1.21	759	1.48	814	1.74	864	2.01	915	2.34	968	2.81
2600	567	0.75	641	1.00	706	1.25	764	1.52	819	1.79	869	2.06	918	2.37	973	2.81
2700	582	0.83	655	1.08	719	1.34	776	1.61	831	1.89	880	2.17	927	2.47	976	2.84
2800	598	0.90	670	1.17	732	1.43	789	1.71	842	2.00	892	2.29	938	2.58	983	2.92
2900	614	0.98	684	1.25	745	1.53	802	1.81	854	2.11	903	2.42	949	2.71	993	3.03
3000	630	1.07	699	1.35	759	1.63	815	1.92	866	2.23	915	2.54	961	2.85	1003	3.17
3100	646	1.16	714	1.45	773	1.74	828	2.04	878	2.35	926	2.67	972	3.00	1015	3.32
3200	662	1.26	729	1.55	787	1.86	841	2.16	891	2.48	938	2.81	983	3.14	1026	3.47
3300	679	1.36	744	1.66	801	1.98	854	2.29	904	2.61	950	2.95	995	3.30	—	—
3400	695	1.47	759	1.78	816	2.10	867	2.42	917	2.75	963	3.10	1007	3.45	—	—
3500	712	1.59	774	1.90	830	2.23	881	2.56	930	2.90	976	3.25	—	—	—	—
3600	729	1.71	790	2.03	845	2.37	895	2.71	943	3.05	988	3.41	—	—	—	—
3700	745	1.84	805	2.17	860	2.52	909	2.87	956	3.22	—	—	—	—	—	—
3750	754	1.91	813	2.24	868	2.59	917	2.95	963	3.30	—	—	—	—	—	—

48HJ008 (7½ TONS) — HIGH-STATIC MOTOR (BELT DRIVE)

Airflow (Cfm)	External Static Pressure (in. wg)									
	0.2		0.4		0.6		0.8		1.0	
	Rpm	Bhp	Rpm	Bhp	Rpm	Bhp	Rpm	Bhp	Rpm	Bhp
2200	506	0.52	586	0.72	656	0.95	718	1.18	776	1.43
2250	514	0.55	593	0.76	662	0.99	724	1.22	781	1.48
2300	521	0.57	600	0.79	668	1.02	730	1.26	786	1.50
2400	536	0.63	613	0.85	680	1.09	741	1.34	796	1.59
2500	551	0.69	626	0.93	693	1.17	753	1.43	808	1.69
2550	559	0.72	634	0.97	700	1.21	759	1.48	814	1.74
2600	567	0.75	641	1.00	706	1.25	764	1.52	819	1.79
2700	582	0.83	655	1.08	719	1.34	776	1.61	831	1.89
2800	598	0.90	670	1.17	732	1.43	789	1.71	842	2.00
2900	614	0.98	684	1.25	745	1.53	802	1.81	854	2.11
3000	630	1.07	699	1.35	759	1.63	815	1.92	866	2.23
3100	646	1.16	714	1.45	773	1.74	828	2.04	878	2.35
3200	662	1.26	729	1.55	787	1.86	841	2.16	891	2.48
3300	679	1.36	744	1.66	801	1.98	854	2.29	904	2.61
3400	695	1.47	759	1.78	816	2.10	867	2.42	917	2.75
3500	712	1.59	774	1.90	830	2.23	881	2.56	930	2.90
3600	729	1.71	790	2.03	845	2.37	895	2.71	943	3.05
3700	745	1.84	805	2.17	860	2.52	909	2.87	956	3.22
3750	754	1.91	813	2.24	868	2.59	917	2.95	963	3.30

48HJ008 (7½ TONS) — HIGH-STATIC MOTOR (BELT DRIVE) (cont)

Airflow (Cfm)	External Static Pressure (in. wg)									
	1.2		1.4		1.6		1.8		2.0	
	Rpm	Bhp	Rpm	Bhp	Rpm	Bhp	Rpm	Bhp	Rpm	Bhp
2200	838	1.78	898	2.21	935	2.58	974	2.92	1011	3.26
2250	841	1.81	902	2.25	939	2.60	979	2.94	1015	3.29
2300	843	1.83	905	2.28	943	2.62	983	2.96	1020	3.31
2400	849	1.88	910	2.31	952	2.74	992	3.10	1029	3.46
2500	859	1.96	912	2.31	963	2.81	1004	3.18	1041	3.55
2550	864	2.01	915	2.34	968	2.81	1009	3.18	1047	3.55
2600	869	2.06	918	2.37	973	2.81	1014	3.18	1052	3.55
2700	880	2.17	927	2.47	976	2.84	1017	3.21	1055	3.59
2800	892	2.29	938	2.58	983	2.92	1024	3.30	1063	3.69
2900	903	2.42	949	2.71	993	3.03	1035	3.43	1074	3.83
3000	915	2.54	961	2.85	1003	3.17	1045	3.59	1084	4.01
3100	926	2.67	972	3.00	1015	3.32	1058	3.76	1097	4.20
3200	938	2.81	983	3.14	1026	3.47	1069	3.93	1109	4.39
3300	950	2.95	995	3.30	1043	3.80	1086	4.30	1127	4.80
3400	963	3.10	1007	3.45	1055	3.97	1100	4.49	1141	5.02
3500	976	3.25	1030	3.82	1079	4.40	1125	4.97	1167	5.56
3600	988	3.41	1043	4.01	1093	4.61	1139	5.22	1181	5.83
3700	1019	3.90	1075	4.58	1127	5.27	1174	5.97	1218	6.67
3750	1026	4.00	1083	4.70	1135	5.41	1183	6.12	1227	6.83

LEGEND

**Bhp** — Brake Horsepower Input to Fan  
**FIOF** — Factory-Installed Option

Refer to page 161 for general Fan Performance Data notes.

NOTES:

1. **Boldface** indicates field-supplied drive required. (See Note 3.)

2.  indicates field-supplied motor and drive required.

3. Motor drive range is 840 to 1085 rpm for standard motors; 860 to 1080 rpm for high-static motors. All other rpms require a field-supplied drive.

4. Maximum continuous bhp is 2.90 for standard motors, 4.20 for high-static motors.

48HJ004-014



## FAN PERFORMANCE — VERTICAL DISCHARGE UNITS (cont)

**48HJ009 (8½ TONS) — STANDARD MOTOR (BELT DRIVE)**

Airflow (Cfm)	External Static Pressure (in. wg)															
	0.2		0.4		0.6		0.8		1.0		1.2		1.4		1.6	
	Rpm	Bhp	Rpm	Bhp	Rpm	Bhp	Rpm	Bhp	Rpm	Bhp	Rpm	Bhp	Rpm	Bhp	Rpm	Bhp
2550	559	0.72	634	0.97	700	1.21	759	1.48	814	1.74	864	2.01	915	2.34	968	2.81
2600	567	0.75	641	1.00	706	1.25	764	1.52	819	1.79	869	2.06	918	2.37	973	2.81
2700	582	0.83	655	1.08	719	1.34	776	1.61	831	1.89	880	2.17	927	2.47	976	2.84
2800	598	0.90	670	1.17	732	1.43	789	1.71	842	2.00	892	2.29	938	2.58	983	2.92
2900	614	0.98	684	1.25	745	1.53	802	1.81	854	2.11	903	2.42	949	2.71	993	3.03
3000	630	1.07	690	1.35	759	1.63	815	1.92	866	2.23	915	2.54	961	2.85	1003	3.17
3100	646	1.16	714	1.45	773	1.74	828	2.04	878	2.35	926	2.67	972	3.00	1016	3.32
3200	662	1.26	729	1.55	787	1.86	841	2.16	891	2.48	938	2.81	983	3.14	1026	3.47
3300	679	1.36	744	1.66	801	1.98	854	2.29	904	2.61	950	2.95	995	3.30	—	—
3400	695	1.47	759	1.78	816	2.10	867	2.42	917	2.75	963	3.10	1007	3.45	—	—
3500	712	1.59	774	1.90	830	2.23	881	2.56	930	2.90	976	3.25	—	—	—	—
3600	729	1.71	790	2.03	845	2.37	895	2.71	943	3.05	988	3.41	—	—	—	—
3700	745	1.84	805	2.17	860	2.52	909	2.87	956	3.22	—	—	—	—	—	—
3750	754	1.91	813	2.24	868	2.59	917	2.95	963	3.30	—	—	—	—	—	—
3800	762	1.98	821	2.31	875	2.66	924	3.03	970	3.38	—	—	—	—	—	—
3900	779	2.12	836	2.46	890	2.82	938	3.19	—	—	—	—	—	—	—	—
4000	796	2.27	852	2.61	905	2.98	953	3.37	—	—	—	—	—	—	—	—
4100	813	2.42	868	2.78	920	3.15	—	—	—	—	—	—	—	—	—	—
4200	830	2.59	884	2.95	935	3.33	—	—	—	—	—	—	—	—	—	—
4250	839	2.68	890	3.04	—	—	—	—	—	—	—	—	—	—	—	—
4300	847	2.76	900	3.13	—	—	—	—	—	—	—	—	—	—	—	—

**48HJ009 (8½ TONS) — HIGH-STATIC MOTOR (BELT DRIVE)**

Airflow (Cfm)	External Static Pressure (in. wg)									
	0.2		0.4		0.6		0.8		1.0	
	Rpm	Bhp	Rpm	Bhp	Rpm	Bhp	Rpm	Bhp	Rpm	Bhp
2550	559	0.72	634	0.97	700	1.21	759	1.48	814	1.74
2600	567	0.75	641	1.00	706	1.25	764	1.52	819	1.79
2700	582	0.83	655	1.08	719	1.34	776	1.61	831	1.89
2800	598	0.90	670	1.17	732	1.43	789	1.71	842	2.00
2900	614	0.98	684	1.25	745	1.53	802	1.81	854	2.11
3000	630	1.07	690	1.35	759	1.63	815	1.92	866	2.23
3100	646	1.16	714	1.45	773	1.74	828	2.04	878	2.35
3200	662	1.26	729	1.55	787	1.86	841	2.16	891	2.48
3300	679	1.36	744	1.66	801	1.98	854	2.29	904	2.61
3400	695	1.47	759	1.78	816	2.10	867	2.42	917	2.75
3500	712	1.59	774	1.90	830	2.23	881	2.56	930	2.90
3600	729	1.71	790	2.03	845	2.37	895	2.71	943	3.05
3700	745	1.84	805	2.17	860	2.52	909	2.87	956	3.22
3750	754	1.91	813	2.24	868	2.59	917	2.95	963	3.30
3800	762	1.98	821	2.31	875	2.66	924	3.03	970	3.38
3900	779	2.12	836	2.46	890	2.82	938	3.19	—	—
4000	796	2.27	852	2.61	905	2.98	953	3.37	—	—
4100	813	2.42	868	2.78	920	3.15	—	—	—	—
4200	830	2.59	884	2.95	935	3.33	—	—	—	—
4250	839	2.68	890	3.04	965	3.88	—	—	—	—
4300	847	2.76	900	3.13	976	3.99	—	—	—	—

**48HJ009 (8½ TONS) — HIGH-STATIC MOTOR (BELT DRIVE) (cont)**

Airflow (Cfm)	External Static Pressure (in. wg)									
	1.2		1.4		1.6		1.8		2.0	
	Rpm	Bhp	Rpm	Bhp	Rpm	Bhp	Rpm	Bhp	Rpm	Bhp
2550	864	2.01	915	2.34	968	2.81	991	3.02	1012	3.21
2600	869	2.06	918	2.37	973	2.81	996	3.02	1017	3.21
2700	880	2.17	927	2.47	976	2.84	999	3.05	1021	3.25
2800	892	2.29	938	2.58	983	2.92	1006	3.13	1028	3.34
2900	903	2.42	949	2.71	993	3.03	1017	3.25	1038	3.46
3000	915	2.54	961	2.85	1003	3.17	1027	3.40	1049	3.62
3100	926	2.67	972	3.00	1016	3.32	1040	3.56	1062	3.80
3200	938	2.81	983	3.14	1026	3.47	1050	3.72	1073	3.97
3300	950	2.95	995	3.30	1022	3.58	1046	3.84	1069	4.09
3400	963	3.10	1007	3.45	1034	3.74	1059	4.01	1081	4.27
3500	976	3.25	1007	3.56	1034	3.86	1058	4.15	1081	4.42
3600	988	3.41	1019	3.74	1047	4.05	1071	4.35	1094	4.63
3700	992	3.59	1023	3.94	1050	4.27	1075	4.58	1098	4.88
3750	999	3.68	1030	4.04	1058	4.38	1083	4.70	1106	5.00
3800	1006	3.77	1038	4.14	1066	4.48	1091	4.81	1114	5.12
3900	1017	4.07	1049	4.46	1077	4.84	1103	5.19	1127	5.53
4000	1034	4.30	1066	4.71	1095	5.11	1121	5.48	1145	5.84
4100	1057	4.77	1090	5.24	1119	5.67	1146	6.09	1170	6.49
4200	1074	5.05	1108	5.54	1138	6.00	1165	6.44	1190	6.86
4250	1109	5.88	1143	6.45	1174	6.98	1202	7.50	1228	7.98
4300	1121	6.05	1156	6.64	1188	7.19	1216	7.72	1242	8.22

**LEGEND**

**Bhp** — Brake Horsepower Input to Fan  
**FIOP** — Factory-Installed Option

Refer to page 161 for general Fan Performance Data notes.

**NOTES:**

1. **Boldface** indicates field-supplied drive required. (See Note 3.)

2.   indicates field-supplied motor and drive required.

3. Motor drive range is 840 to 1085 rpm for standard motors; 860 to 1080 rpm for high-static motors. All other rpms require a field-supplied drive.

4. Maximum continuous bhp is 2.90 for standard motors, 4.20 for high-static motors.

**48HJ004-014**

# Performance data (cont)



## FAN PERFORMANCE — VERTICAL DISCHARGE UNITS (cont)

### 48HJ012 (10 TONS) — STANDARD AND HIGH-STATIC MOTOR (BELT DRIVE)

Airflow (Cfm)	External Static Pressure (in. wg)																			
	0.2		0.4		0.6		0.8		1.0		1.2		1.4		1.6		1.8		2.0	
	Rpm	Bhp	Rpm	Bhp	Rpm	Bhp	Rpm	Bhp	Rpm	Bhp	Rpm	Bhp	Rpm	Bhp	Rpm	Bhp	Rpm	Bhp	Rpm	Bhp
3000	556	0.65	624	0.81	682	0.95	737	0.99	745	1.04	750	1.12	809	1.24	875	1.40	899	1.56	950	1.92
3100	569	0.70	636	0.87	693	1.01	748	1.08	755	1.12	757	1.20	862	1.38	903	1.53	943	1.88	971	2.21
3200	583	0.76	649	0.94	705	1.08	758	1.17	787	1.30	769	1.36	905	1.52	971	1.86	982	2.19	992	2.41
3300	597	0.83	662	1.00	717	1.16	770	1.29	815	1.37	780	1.43	965	1.82	991	2.10	1000	2.40	1025	2.59
3400	611	0.90	675	1.08	730	1.23	781	1.41	830	1.50	838	1.63	992	2.11	1015	2.43	1030	2.62	1050	2.72
3500	625	0.97	688	1.15	742	1.32	792	1.49	840	1.64	860	1.85	1011	2.45	1028	2.62	1072	2.74	1099	2.90
3600	639	1.04	701	1.23	755	1.41	803	1.57	850	1.87	890	2.21	1026	2.55	1063	2.75	1095	2.89	1119	3.08
3700	729	1.36	790	1.58	847	1.79	902	2.06	955	2.29	1008	2.55	1060	2.80	1108	3.05	1152	3.27	1190	3.46
3800	745	1.46	805	1.69	861	1.89	915	2.17	967	2.41	1019	2.67	1070	2.94	1118	3.19	1163	3.44	1203	3.65
3900	761	1.56	820	1.80	875	2.01	928	2.29	979	2.55	1029	2.80	1079	3.07	1128	3.34	1173	3.60	1214	3.83
4000	777	1.67	836	1.92	889	2.14	941	2.40	991	2.68	1040	2.94	1089	3.22	1137	3.49	1183	3.76	1225	4.00
4100	793	1.79	851	2.05	904	2.27	955	2.52	1004	2.82	1052	3.08	1100	3.36	1147	3.65	1193	3.93	1236	4.19
4200	810	1.91	867	2.18	918	2.41	968	2.65	1017	2.96	1064	3.23	1110	3.51	1157	3.81	1202	4.09	1245	4.38
4300	826	2.04	883	2.32	933	2.55	982	2.79	1030	3.11	1076	3.40	1121	3.67	1167	3.97	1212	4.27	1255	4.56
4400	842	2.17	898	2.46	948	2.70	996	2.93	1043	3.25	1088	3.56	1133	3.84	1178	4.14	1222	4.44	1265	4.74
4500	859	2.31	914	2.60	962	2.85	1010	3.09	1056	3.40	1101	3.73	1144	4.00	1188	4.31	1232	4.62	1274	4.93
4600	876	2.45	930	2.76	977	3.01	1024	3.26	1070	3.55	1114	3.90	1157	4.19	1199	4.49	1242	4.81	1284	5.13
4700	892	2.60	945	2.91	992	3.18	1039	3.43	1083	3.71	1126	4.07	1169	4.38	1210	4.68	1252	5.00	—	—
4800	909	2.77	961	3.07	1008	3.36	1053	3.61	1097	3.88	1140	4.25	1181	4.58	1222	4.87	1263	5.20	—	—
4900	926	2.93	977	3.24	1024	3.54	1068	3.80	1111	4.06	1153	4.41	1194	4.77	1234	5.09	—	—	—	—
5000	942	3.11	993	3.41	1039	3.73	1080	3.99	1125	4.25	1166	4.59	1207	4.97	—	—	—	—	—	—

LEGEND

Bhp — Brake Horsepower Input to Fan  
 FIOP — Factory-Installed Option

Refer to page 161 for general Fan Performance Data notes.

NOTES:

1. **Boldface** indicates field-supplied drive required. (See Note 3.)

2.  indicates high-static motor and drive required.

3. Motor drive range is 860 to 1080 rpm for standard motors; 830 to 1130 rpm for high-static motors. All other rpms require a field-supplied drive.

4. Maximum continuous bhp is 3.70 for standard motors, 5.25 for high-static motors.

### 48HJ014 (12 1/2 TONS) — STANDARD MOTOR (BELT DRIVE)

Airflow (Cfm)	External Static Pressure (in. wg)																			
	0.2		0.4		0.6		0.8		1.0		1.2		1.4		1.6		1.8		2.0	
	Rpm	Bhp	Rpm	Bhp	Rpm	Bhp	Rpm	Bhp	Rpm	Bhp	Rpm	Bhp	Rpm	Bhp	Rpm	Bhp	Rpm	Bhp	Rpm	Bhp
3700	—	—	—	—	—	—	902	2.06	955	2.29	1008	2.55	1060	2.80	1108	3.05	1152	3.27	1190	3.46
3800	—	—	—	—	<b>861</b>	<b>1.89</b>	915	2.17	967	2.41	1019	2.67	1070	2.94	1118	3.19	1163	3.44	1203	3.65
3900	—	—	—	—	<b>875</b>	<b>2.01</b>	928	2.29	979	2.55	1029	2.80	1079	3.07	1128	3.34	1173	3.60	1214	3.83
4000	—	—	—	—	<b>889</b>	<b>2.14</b>	941	2.40	991	2.68	1040	2.94	1089	3.22	1137	3.49	1183	3.76	1225	4.00
4100	—	—	—	—	904	2.27	955	2.52	1004	2.82	1052	3.08	1100	3.36	1147	3.65	1193	3.93	1236	4.19
4200	—	—	<b>867</b>	<b>2.18</b>	918	2.41	968	2.65	1017	2.96	1064	3.23	1110	3.51	1157	3.81	1202	4.09	1245	4.38
4300	—	—	<b>883</b>	<b>2.32</b>	933	2.55	982	2.79	1030	3.11	1076	3.40	1121	3.67	1167	3.97	1212	4.27	1255	4.56
4400	—	—	<b>898</b>	<b>2.46</b>	948	2.70	996	2.93	1043	3.25	1088	3.56	1133	3.84	1178	4.14	1222	4.44	<b>1265</b>	<b>4.74</b>
4500	—	—	914	2.60	962	2.85	1010	3.09	1056	3.40	1101	3.73	1144	4.00	1188	4.31	1232	4.62	<b>1274</b>	<b>4.93</b>
4600	<b>876</b>	<b>2.45</b>	930	2.76	977	3.01	1024	3.26	1070	3.55	1114	3.90	1157	4.19	1199	4.49	1242	4.81	<b>1284</b>	<b>5.13</b>
4700	<b>892</b>	<b>2.60</b>	945	2.91	992	3.18	1039	3.43	1083	3.71	1126	4.07	1169	4.38	1210	4.68	1252	5.00	—	—
4800	909	2.77	961	3.07	1008	3.36	1053	3.61	1097	3.88	1140	4.25	1181	4.58	1222	4.87	<b>1263</b>	<b>5.20</b>	—	—
4900	926	2.93	977	3.24	1024	3.54	1068	3.80	1111	4.06	1153	4.41	1194	4.77	1234	5.09	—	—	—	—
5000	942	3.11	993	3.41	1039	3.73	1080	3.99	1125	4.25	1166	4.59	1207	4.97	—	—	—	—	—	—
5100	959	3.29	1009	3.60	1055	3.92	1097	4.19	1139	4.46	1180	4.78	1220	5.18	—	—	—	—	—	—
5200	976	3.47	1025	3.78	1071	4.12	1112	4.40	1153	4.67	1194	4.98	—	—	—	—	—	—	—	—
5300	993	3.67	1041	3.98	1086	4.33	1127	4.61	1168	4.90	1208	5.19	—	—	—	—	—	—	—	—
5400	1010	3.87	1057	4.18	1102	4.54	1142	4.84	1182	5.13	—	—	—	—	—	—	—	—	—	—
5500	1027	4.07	1073	4.39	1118	4.76	1157	5.07	—	—	—	—	—	—	—	—	—	—	—	—
5600	1043	4.29	1090	4.61	1133	4.99	—	—	—	—	—	—	—	—	—	—	—	—	—	—
5700	1060	4.51	1106	4.83	1149	5.22	—	—	—	—	—	—	—	—	—	—	—	—	—	—
5800	1077	4.74	1122	5.07	—	—	—	—	—	—	—	—	—	—	—	—	—	—	—	—
5900	1094	4.98	—	—	—	—	—	—	—	—	—	—	—	—	—	—	—	—	—	—
6000	1111	5.22	—	—	—	—	—	—	—	—	—	—	—	—	—	—	—	—	—	—
6100	—	—	—	—	—	—	—	—	—	—	—	—	—	—	—	—	—	—	—	—
6200	—	—	—	—	—	—	—	—	—	—	—	—	—	—	—	—	—	—	—	—

LEGEND

Bhp — Brake Horsepower Input to Fan  
 FIOP — Factory-Installed Option

Refer to page 161 for general Fan Performance Data notes.

NOTES:

1. **Boldface** indicates field-supplied drive required. (See Note 2.)
2. Standard drive range is 900 to 1260 rpm.
3. Maximum continuous bhp is 5.25 for standard motor.

48HJ004-014



## FAN PERFORMANCE — HORIZONTAL DISCHARGE UNITS

### 48HJ004 (3 TONS) — STANDARD MOTOR (BELT DRIVE)

Airflow (Cfm)	External Static Pressure (in. wg)											
	0.1		0.2		0.3		0.4		0.5		0.6	
	Rpm	Bhp	Rpm	Bhp	Rpm	Bhp	Rpm	Bhp	Rpm	Bhp	Rpm	Bhp
900	526	0.06	584	0.08	656	0.12	734	0.22	818	0.25	875	0.27
1000	570	0.09	627	0.13	738	0.19	800	0.26	848	0.29	895	0.31
1100	614	0.13	670	0.16	758	0.23	812	0.29	863	0.32	914	0.35
1200	658	0.16	710	0.23	780	0.28	840	0.32	889	0.36	938	0.40
1300	703	0.20	752	0.27	808	0.32	868	0.37	916	0.41	963	0.45
1400	725	0.29	776	0.31	845	0.38	891	0.42	937	0.47	983	0.51
1500	755	0.33	816	0.38	870	0.43	924	0.48	969	0.53	1014	0.58

### 48HJ004 (3 TONS) — STANDARD MOTOR (BELT DRIVE) (cont)

Airflow (Cfm)	External Static Pressure (in. wg)											
	0.7		0.8		0.9		1.0		1.1		1.2	
	Rpm	Bhp	Rpm	Bhp	Rpm	Bhp	Rpm	Bhp	Rpm	Bhp	Rpm	Bhp
900	924	0.32	953	0.35	989	0.38	1028	0.42	1074	0.45	1120	0.50
1000	936	0.35	977	0.39	1020	0.44	1064	0.48	1124	0.52	1185	0.55
1100	960	0.39	1005	0.43	1052	0.49	1100	0.52	1163	0.56	1225	0.60
1200	988	0.45	1038	0.50	1076	0.53	1136	0.59	1201	0.61	1266	0.64
1300	1012	0.51	1061	0.56	1094	0.61	1172	0.65	1239	0.69	1306	0.72
1400	1027	0.56	1071	0.60	1108	0.67	1208	0.70	1278	0.75	1347	0.79
1500	1056	0.63	1097	0.68	1117	0.70	1245	0.74	1315	0.80	1385	0.85

### 48HJ004 (3 TONS) — HIGH-STATIC MOTOR (BELT DRIVE)

Airflow (Cfm)	External Static Pressure (in. wg)									
	0.2		0.4		0.6		0.8		1.0	
	Rpm	Bhp	Rpm	Bhp	Rpm	Bhp	Rpm	Bhp	Rpm	Bhp
900	584	0.08	734	0.22	875	0.27	953	0.36	1028	0.42
1000	627	0.13	800	0.26	895	0.31	977	0.39	1064	0.48
1100	670	0.16	812	0.29	914	0.35	1005	0.43	1100	0.52
1200	710	0.23	840	0.32	938	0.40	1038	0.50	1136	0.59
1300	752	0.27	868	0.37	963	0.45	1061	0.56	1172	0.65
1400	776	0.31	891	0.42	983	0.51	1071	0.60	1208	0.70
1500	816	0.38	924	0.48	1014	0.58	1097	0.68	1245	0.74

### 48HJ004 (3 TONS) — HIGH-STATIC MOTOR (BELT DRIVE) (cont)

Airflow (Cfm)	External Static Pressure (in. wg)									
	1.2		1.4		1.6		1.8		2.0	
	Rpm	Bhp	Rpm	Bhp	Rpm	Bhp	Rpm	Bhp	Rpm	Bhp
900	1120	0.54	1155	0.59	1186	0.64	1215	0.69	1240	0.73
1000	1185	0.60	1222	0.66	1255	0.71	1285	0.77	1312	0.82
1100	1225	0.65	1263	0.71	1298	0.77	1328	0.83	1357	0.88
1200	1266	0.72	1306	0.79	1341	0.86	1373	0.92	1402	0.98
1300	1306	0.79	1347	0.87	1383	0.94	1416	1.01	1446	1.07
1400	1347	0.87	1389	0.95	1427	1.03	1461	1.11	1492	1.18
1500	1385	0.96	1428	1.05	1467	1.14	1502	1.22	1534	1.30

**LEGEND**

**Bhp** — Brake Horsepower Input to Fan  
**FIOP** — Factory-Installed Option

Refer to page 161 for general Fan Performance Data notes.

**NOTES:**

- 1. Boldface** indicates field-supplied drive required. (See Note 2.)
- Motor drive range is 760 to 1090 rpm for standard motors; 1075 to 1455 rpm for high-static motors. All other rpms require a field-supplied drive.
- Maximum continuous bhp is 1.20 for standard motors; 2.40 for high-static motors.

48HJ004-014

# Performance data (cont)



## FAN PERFORMANCE — HORIZONTAL DISCHARGE UNITS (cont)

### 48HJ005 (4 TONS) — STANDARD MOTOR (BELT DRIVE)

Airflow (Cfm)	External Static Pressure (in. wg)													
	0.1		0.2		0.3		0.4		0.6		0.7		0.8	
	Rpm	Bhp	Rpm	Bhp	Rpm	Bhp	Rpm	Bhp	Rpm	Bhp	Rpm	Bhp	Rpm	Bhp
1200	569	0.18	641	0.23	701	0.29	761	0.34	859	0.46	901	0.52	943	0.58
1300	604	0.22	673	0.28	731	0.34	788	0.39	887	0.52	928	0.59	968	0.65
1400	640	0.27	705	0.33	761	0.39	817	0.45	914	0.59	955	0.66	996	0.72
1500	676	0.32	738	0.38	793	0.45	847	0.51	940	0.65	982	0.73	1024	0.81
1600	713	0.38	772	0.44	825	0.51	877	0.58	967	0.73	1009	0.81	1051	0.89
1700	750	0.45	806	0.51	857	0.59	908	0.66	997	0.81	1037	0.90	1077	1.01
1800	788	0.52	841	0.59	890	0.67	939	0.75	1026	0.91	1065	1.01	1104	1.07
1900	826	0.60	876	0.68	924	0.76	971	0.84	1056	1.01	1094	1.10	1132	1.18
2000	864	0.70	912	0.77	958	0.86	1004	0.94	1087	1.12	1125	1.21	1162	1.30

### 48HJ005 (4 TONS) — STANDARD MOTOR (BELT DRIVE) (cont)

Airflow (Cfm)	External Static Pressure (in. wg)													
	0.9		1.0		1.1		1.2		1.4		1.6		1.8	
	Rpm	Bhp	Rpm	Bhp	Rpm	Bhp	Rpm	Bhp	Rpm	Bhp	Rpm	Bhp	Rpm	Bhp
1200	987	0.64	1030	0.70	1068	0.79	1106	0.87	1134	0.98	1189	1.12	1245	1.21
1300	1006	0.71	1044	0.77	1086	0.84	1128	0.91	1183	1.10	1226	1.23	1297	1.35
1400	1033	0.79	1069	0.86	1104	0.93	1139	1.01	1218	1.14	1286	1.34	1320	1.48
1500	1060	0.88	1095	0.95	1129	1.02	1162	1.09	1228	1.24	1303	1.40	1343	1.60
1600	1087	1.01	1123	1.05	1156	1.13	1185	1.20	1250	1.35	1319	1.51	1382	1.68
1700	1114	1.07	1151	1.15	1183	1.23	1215	1.31	1276	1.48	1334	1.64	1398	1.80
1800	1141	1.17	1178	1.26	1211	1.35	1243	1.43	1303	1.61	1359	1.78	1418	1.95
1900	1168	1.28	1204	1.37	1238	1.47	1271	1.56	1330	1.74	1386	1.93	1439	2.11
2000	1197	1.39	1231	1.48	1265	1.59	1298	1.69	1358	1.89	1413	2.08	1466	2.27

### 48HJ005 (4 TONS) — HIGH-STATIC MOTOR (BELT DRIVE)

Airflow (Cfm)	External Static Pressure (in. wg)									
	0.2		0.4		0.6		0.8		1.0	
	Rpm	Bhp	Rpm	Bhp	Rpm	Bhp	Rpm	Bhp	Rpm	Bhp
1200	641	0.23	761	0.34	859	0.46	943	0.58	1030	0.70
1300	673	0.28	788	0.39	887	0.52	968	0.65	1044	0.77
1400	705	0.33	817	0.45	914	0.59	996	0.72	1069	0.86
1500	738	0.38	847	0.51	940	0.65	1024	0.81	1095	0.95
1600	772	0.44	877	0.58	967	0.73	1051	0.89	1123	1.05
1700	806	0.51	908	0.66	997	0.81	1077	1.01	1151	1.15
1800	841	0.59	939	0.75	1026	0.91	1104	1.07	1178	1.26
1900	876	0.68	971	0.84	1056	1.01	1132	1.18	1204	1.37
2000	912	0.77	1004	0.94	1087	1.12	1162	1.30	1231	1.48

### 48HJ005 (4 TONS) — HIGH-STATIC MOTOR (BELT DRIVE) (cont)

Airflow (Cfm)	External Static Pressure (in. wg)									
	1.2		1.4		1.6		1.8		2.0	
	Rpm	Bhp	Rpm	Bhp	Rpm	Bhp	Rpm	Bhp	Rpm	Bhp
1200	1106	0.87	1134	0.98	1189	1.12	1245	1.21	1292	1.35
1300	1128	0.91	1183	1.10	1226	1.23	1297	1.35	1346	1.51
1400	1139	1.01	1218	1.14	1286	1.34	1320	1.48	1370	1.65
1500	1162	1.09	1228	1.24	1303	1.40	1343	1.60	1393	1.79
1600	1185	1.20	1250	1.35	1319	1.51	1382	1.68	1434	1.88
1700	1215	1.31	1276	1.48	1334	1.64	1398	1.80	1451	2.01
1800	1243	1.43	1303	1.61	1359	1.78	1418	1.95	1471	2.18
1900	1271	1.56	1330	1.74	1386	1.93	1439	2.11	1493	2.36
2000	1298	1.69	1358	1.89	1413	2.08	1466	2.27	15.21	2.54

#### LEGEND

**Bhp** — Brake Horsepower Input to Fan  
**FIOP** — Factory-Installed Option

Refer to page 161 for general Fan Performance Data notes.

#### NOTES:

1. **Boldface** indicates field-supplied drive required. (See Note 3.)

2.   indicates field-supplied motor and drive required.

3. Motor drive range is 840 to 1185 rpm for standard units; 1075 to 1455 rpm for high-static motors. All other rpms require a field-supplied drive.

4. Maximum continuous bhp is 1.20 for standard motors; 2.40 for high-static motors.

48HJ004-014



## FAN PERFORMANCE — HORIZONTAL DISCHARGE UNITS (cont)

### 48HJ006 (5 TONS) — STANDARD MOTOR (BELT DRIVE) — SINGLE PHASE UNITS

Airflow (Cfm)	External Static Pressure (in. wg)																	
	0.1		0.2		0.4		0.6		0.8		1.0		1.2		1.4		1.6	
	Rpm	Bhp	Rpm	Bhp	Rpm	Bhp	Rpm	Bhp	Rpm	Bhp	Rpm	Bhp	Rpm	Bhp	Rpm	Bhp	Rpm	Bhp
1500	741	0.38	798	0.43	895	0.54	990	0.67	1073	0.80	1154	0.95	1218	1.12	1295	1.36	1360	1.40
1600	783	0.45	838	0.51	933	0.63	1016	0.75	1102	0.90	1182	1.04	1251	1.20	1310	1.40	1385	1.49
1700	825	0.53	878	0.60	969	0.72	1049	0.84	1134	1.00	1206	1.14	1281	1.31	1342	1.48	1398	1.53
1800	885	0.63	942	0.73	1047	0.90	1139	1.05	1193	1.14	1276	1.30	1341	1.40	1413	1.55	1474	1.58
1900	928	0.73	982	0.83	1084	1.02	1160	1.11	1223	1.24	1301	1.38	1374	1.53	1437	1.62	1490	1.67
2000	971	0.84	1022	0.94	1121	1.12	1188	1.22	1254	1.36	1329	1.44	1396	1.66	1460	1.68	1509	1.77
2100	1015	0.97	1063	1.10	1140	1.18	1196	1.27	1272	1.45	1354	1.58	1413	1.75	1475	1.73	1529	1.92
2200	1060	1.10	1104	1.20	1159	1.23	1229	1.41	1306	1.53	1363	1.70	1434	1.81	1487	1.85	1554	2.07
2300	1104	1.25	1130	1.27	1196	1.37	1264	1.56	1340	1.66	1397	1.86	1459	1.88	1520	2.07	1576	2.24
2400	1138	1.30	1174	1.37	1245	1.57	1305	1.63	1373	1.84	1440	1.95	1502	2.06	1552	2.24	1604	2.42
2500	1183	1.43	1201	1.50	1284	1.65	1338	1.75	1402	1.99	1469	2.04	1524	2.24	1585	2.42	1638	2.60

### 48HJ006 (5 TONS) — STANDARD MOTOR (BELT DRIVE) — 3 PHASE UNITS

Airflow (Cfm)	External Static Pressure (in. wg)																	
	0.1		0.2		0.4		0.6		0.8		1.0		1.2		1.4		1.6	
	Rpm	Bhp	Rpm	Bhp	Rpm	Bhp	Rpm	Bhp	Rpm	Bhp	Rpm	Bhp	Rpm	Bhp	Rpm	Bhp	Rpm	Bhp
1500	741	0.38	798	0.43	895	0.54	990	0.67	1073	0.80	1154	0.95	1218	1.12	1295	1.36	1360	1.40
1600	783	0.45	838	0.51	933	0.63	1016	0.75	1102	0.90	1182	1.04	1251	1.20	1310	1.40	1385	1.49
1700	825	0.53	878	0.60	969	0.72	1049	0.84	1134	1.00	1206	1.14	1281	1.31	1342	1.48	1398	1.53
1800	885	0.63	942	0.73	1047	0.90	1139	1.05	1193	1.14	1276	1.30	1341	1.40	1413	1.55	1474	1.58
1900	928	0.73	982	0.83	1084	1.02	1160	1.11	1223	1.24	1301	1.38	1374	1.53	1437	1.62	1490	1.67
2000	971	0.84	1022	0.94	1121	1.12	1188	1.22	1254	1.36	1329	1.44	1396	1.66	1460	1.68	1509	1.77
2100	1015	0.97	1063	1.10	1140	1.18	1196	1.27	1272	1.45	1354	1.58	1413	1.75	1475	1.73	1529	1.92
2200	1060	1.10	1104	1.20	1159	1.23	1229	1.41	1306	1.53	1363	1.70	1434	1.81	1487	1.85	1554	2.07
2300	1104	1.25	1130	1.27	1196	1.37	1264	1.56	1340	1.66	1397	1.86	1459	1.88	1520	2.07	1576	2.24
2400	1138	1.30	1174	1.37	1245	1.57	1305	1.63	1373	1.84	1440	1.95	1502	2.06	1552	2.24	1604	2.42
2500	1183	1.43	1201	1.50	1284	1.65	1338	1.75	1402	1.99	1469	2.04	1524	2.24	1585	2.42	1638	2.60

### 48HJ006 (5 TONS) — HIGH-STATIC MOTOR (BELT DRIVE)

Airflow (Cfm)	External Static Pressure (in. wg)									
	0.2		0.4		0.6		0.8		1.0	
	Rpm	Bhp	Rpm	Bhp	Rpm	Bhp	Rpm	Bhp	Rpm	Bhp
1500	789	0.40	896	0.53	990	0.67	1072	0.83	1153	1.00
1600	826	0.46	931	0.61	1020	0.75	1101	0.91	1178	1.09
1700	865	0.54	966	0.69	1051	0.84	1133	1.01	1205	1.18
1800	905	0.62	1002	0.78	1084	0.93	1163	1.10	1235	1.29
1900	945	0.72	1037	0.88	1119	1.04	1194	1.21	1266	1.40
2000	984	0.82	1072	0.98	1154	1.16	1226	1.33	1297	1.53
2100	1024	0.93	1108	1.10	1192	1.29	1259	1.47	1327	1.66
2200	1064	1.05	1145	1.22	1225	1.43	1294	1.62	1359	1.80
2300	1104	1.18	1183	1.36	1260	1.57	1330	1.78	1392	1.97
2400	1145	1.32	1222	1.45	1296	1.73	1365	1.94	1426	2.15
2500	1186	1.48	1262	1.68	1331	1.89	1400	2.12	1461	2.34

### 48HJ006 (5 TONS) — HIGH-STATIC MOTOR (BELT DRIVE) (cont)

Airflow (Cfm)	External Static Pressure (in. wg)									
	1.2		1.4		1.6		1.8		2.0	
	Rpm	Bhp	Rpm	Bhp	Rpm	Bhp	Rpm	Bhp	Rpm	Bhp
1500	1221	1.17	1256	1.30	1283	1.32	1303	1.22	1345	1.34
1600	1252	1.27	1311	1.45	1340	1.58	1330	1.61	1373	1.77
1700	1278	1.37	1345	1.57	1397	1.76	1424	1.89	1470	2.08
1800	1303	1.48	1371	1.69	1433	1.90	1480	2.09	1528	2.30
1900	1330	1.59	1396	1.80	1460	2.03	1517	2.25	1566	2.47
2000	1362	1.73	1422	1.94	1485	2.16	1544	2.40	1594	2.64
2100	1393	1.87	1452	2.08	1510	2.31	1570	2.55	1620	2.80
2200	1423	2.02	1483	2.24	1538	2.46	1594	2.71	1645	2.98
2300	1454	2.18	1515	2.41	1571	2.64	1623	2.88	1676	3.17
2400	1485	2.36	1544	2.59	1604	2.84	1657	3.07	1710	3.38
2500	1518	2.55	1574	2.78	1633	3.03	1692	3.28	1746	3.61

**LEGEND**

**Bhp** — Brake Horsepower Input to Fan  
**FIOP** — Factory-Installed Option

Refer to page 161 for general Fan Performance Data notes.

**NOTES:**

1. **Boldface** indicates field-supplied drive required. (See Note 3.)

2.   indicates field-supplied motor and drive required.

3. Motor drive range is 1020 to 1460 rpm for single-phase standard units, 1120 to 1585 for 3-phase standard units, and 1300 to 1685 for high-static units. All other rpms require a field-supplied drive.

4. Maximum continuous bhp is 1.30 for single-phase standard units, 2.40 for 3-phase standard motors, and 2.90 for high-static motors.

48HJ004-014

# Performance data (cont)



## FAN PERFORMANCE — HORIZONTAL DISCHARGE UNITS (cont)

### 48HJ007 (6 TONS) — STANDARD MOTOR (BELT DRIVE)

Airflow (Cfm)	External Static Pressure (in. wg)																	
	0.1		0.2		0.4		0.6		0.8		1.0		1.2		1.4		1.6	
	Rpm	Bhp	Rpm	Bhp	Rpm	Bhp	Rpm	Bhp	Rpm	Bhp	Rpm	Bhp	Rpm	Bhp	Rpm	Bhp	Rpm	Bhp
1800	885	0.63	942	0.73	1047	0.90	1139	1.05	1193	1.14	1276	1.30	1341	1.40	1413	1.55	1474	1.58
1900	928	0.73	982	0.83	1084	1.02	1160	1.11	1223	1.24	1301	1.38	1374	1.53	1437	1.62	1490	1.67
2000	971	0.84	1022	0.94	1121	1.12	1188	1.22	1254	1.36	1329	1.44	1396	1.66	1460	1.68	1509	1.77
2100	1015	0.97	1063	1.10	1140	1.18	1196	1.27	1272	1.45	1354	1.58	1413	1.75	1475	1.73	1529	1.92
2200	1060	1.10	1104	1.20	1159	1.23	1229	1.41	1306	1.53	1363	1.70	1434	1.81	1487	1.85	1554	2.07
2300	1104	1.25	1130	1.27	1196	1.37	1264	1.56	1340	1.66	1397	1.86	1459	1.88	1520	2.07	1576	2.24
2400	1138	1.30	1174	1.37	1245	1.57	1305	1.63	1373	1.84	1440	1.95	1502	2.06	1552	2.24	1604	2.42
2500	1183	1.43	1201	1.50	1284	1.65	1338	1.75	1402	1.99	1469	2.04	1524	2.24	1585	2.42	1638	2.60
2600	1210	1.58	1243	1.67	1312	1.76	1366	1.96	1435	2.10	1494	2.19	1552	2.40	1616	2.63	1671	2.80
2700	1254	1.76	1285	1.80	1354	1.95	1403	2.14	1474	2.21	1536	2.46	1584	2.61	1646	2.83	1706	2.97
2800	1274	1.82	1304	1.85	1374	2.12	1459	2.25	1514	2.42	1570	2.66	1624	2.85	1677	2.99	—	—
2900	1318	1.95	1345	2.05	1412	2.32	1496	2.45	1529	2.61	1603	2.87	1671	3.03	—	—	—	—
3000	1362	2.20	1378	2.30	1451	2.40	1534	2.66	1560	2.81	1611	3.01	—	—	—	—	—	—

### 48HJ007 (6 TONS) — HIGH-STATIC MOTOR (BELT DRIVE)

Airflow (Cfm)	External Static Pressure (in. wg)																			
	0.2		0.4		0.6		0.8		1.0		1.2		1.4		1.6		1.8		2.0	
	Rpm	Bhp	Rpm	Bhp	Rpm	Bhp	Rpm	Bhp	Rpm	Bhp	Rpm	Bhp	Rpm	Bhp	Rpm	Bhp	Rpm	Bhp	Rpm	Bhp
1800	942	0.73	1047	0.90	1139	1.05	1193	1.14	1276	1.30	1341	1.40	1413	1.55	1474	1.58	1522	1.74	1566	1.89
1900	982	0.83	1084	1.02	1160	1.11	1223	1.24	1301	1.38	1374	1.53	1437	1.62	1490	1.67	1538	1.84	1583	2.00
2000	1022	0.94	1121	1.12	1188	1.22	1264	1.36	1329	1.44	1396	1.66	1460	1.68	1509	1.77	1558	1.95	1603	2.12
2100	1063	1.10	1140	1.18	1196	1.27	1272	1.45	1354	1.58	1413	1.75	1475	1.73	1529	1.92	1578	2.11	1624	2.30
2200	1104	1.20	1159	1.23	1229	1.41	1306	1.53	1363	1.70	1434	1.81	1487	1.85	1554	2.07	1604	2.28	1651	2.48
2300	1130	1.27	1196	1.37	1264	1.56	1340	1.66	1397	1.86	1459	1.88	1520	2.07	1576	2.24	1627	2.46	1674	2.68
2400	1174	1.37	1245	1.57	1305	1.63	1373	1.84	1440	1.95	1502	2.06	1552	2.24	1604	2.42	1656	2.66	1704	2.90
2500	1201	1.50	1284	1.65	1338	1.75	1402	1.99	1469	2.04	1524	2.24	1585	2.42	1638	2.60	1691	2.86	1740	3.12
2600	1246	1.67	1312	1.76	1366	1.96	1435	2.10	1494	2.19	1552	2.40	1616	2.63	1671	2.80	1726	3.09	1775	3.35
2700	1285	1.80	1354	1.95	1403	2.14	1474	2.21	1536	2.46	1584	2.61	1646	2.83	1706	2.97	1761	3.27	—	—
2800	1304	1.85	1374	2.12	1459	2.25	1514	2.42	1570	2.66	1624	2.85	1677	2.99	1739	3.33	1795	3.67	—	—
2900	1345	2.05	1412	2.32	1496	2.54	1529	2.61	1603	2.87	1671	3.03	1742	3.43	—	—	—	—	—	—
3000	1378	2.30	1451	2.40	1534	2.66	1560	2.81	1611	3.01	1692	3.49	1764	3.95	—	—	—	—	—	—

#### LEGEND

Bhp — Brake Horsepower Input to Fan  
 FIOP — Factory-Installed Option

Refer to page 161 for general Fan Performance Data notes.

#### NOTES:

1. **Boldface** indicates field-supplied drive required. (See Note 3.)

2.   indicates field-supplied motor and drive required.

3. Motor drive range is 1120 to 1585 rpm for standard motors; 1300 to 1685 rpm for high-static motors. All other rpms require a field-supplied drive.

4. Maximum continuous bhp is 2.4 for standard motors; 2.9 for high-static motors.

48HJ004-014



FAN PERFORMANCE — HORIZONTAL DISCHARGE UNITS (cont)

48HJ008 (7½ TONS) — STANDARD MOTOR (BELT DRIVE)

Airflow (Cfm)	External Static Pressure (in. wg)																	
	0.2		0.4		0.6		0.8		0.9		1.0		1.2		1.4		1.6	
	Rpm	Bhp	Rpm	Bhp	Rpm	Bhp	Rpm	Bhp	Rpm	Bhp	Rpm	Bhp	Rpm	Bhp	Rpm	Bhp	Rpm	Bhp
2200	499	0.50	580	0.70	652	0.94	717	1.17	748	1.30	779	1.43	839	1.78	905	2.21	951	2.57
2250	507	0.53	586	0.73	658	0.97	722	1.22	752	1.34	783	1.46	843	1.81	908	2.25	955	2.59
2300	513	0.55	592	0.76	663	1.00	727	1.26	756	1.38	786	1.49	846	1.84	910	2.25	959	2.61
2400	528	0.60	606	0.83	674	1.06	738	1.34	766	1.46	795	1.58	853	1.88	912	2.31	967	2.68
2500	542	0.66	619	0.90	686	1.13	748	1.41	777	1.55	806	1.68	859	1.94	919	2.37	971	2.73
2550	550	0.69	627	0.94	692	1.17	754	1.45	783	1.60	812	1.74	864	1.99	920	2.39	974	2.76
2600	557	0.72	634	0.97	698	1.21	759	1.49	787	1.64	816	1.79	868	2.04	921	2.41	976	2.78
2700	573	0.79	648	1.05	711	1.29	770	1.58	798	1.73	827	1.88	878	2.16	928	2.45	983	2.88
2800	588	0.86	662	1.13	723	1.38	782	1.66	809	1.82	837	1.98	889	2.29	937	2.57	986	2.91
2900	604	0.94	676	1.21	737	1.48	794	1.76	821	1.92	848	2.08	900	2.41	947	2.70	993	3.01
3000	620	1.02	690	1.30	750	1.58	806	1.86	832	2.02	849	2.18	910	2.52	958	2.85	1002	3.15
3100	636	1.11	704	1.39	764	1.69	818	1.97	844	2.13	870	2.29	920	2.64	968	2.99	1012	3.30
3200	652	1.21	718	1.49	778	1.80	831	2.09	856	2.25	882	2.40	931	2.76	979	3.13	1023	3.47
3300	668	1.31	732	1.59	793	1.92	844	2.21	869	2.37	894	2.53	942	2.89	989	3.26	1034	3.63
3400	684	1.41	747	1.70	807	2.04	857	2.35	882	2.51	907	2.66	954	3.02	1000	3.40	1044	3.79
3500	701	1.53	762	1.82	821	2.16	871	2.48	895	2.64	919	2.80	966	3.15	1011	3.55	1054	3.94
3600	717	1.65	777	1.94	835	2.29	885	2.63	908	2.79	932	2.95	978	3.30	1022	3.69	1065	4.10
3700	733	1.77	792	2.07	849	2.42	899	2.78	922	2.95	945	3.11	990	3.45	1034	3.84	1076	4.26
3750	742	1.84	800	2.14	856	2.49	907	2.86	929	3.03	952	3.20	997	3.54	1040	3.93	1082	5.27

48HJ008 (7½ TONS) — HIGH-STATIC MOTOR (BELT DRIVE)

Airflow (Cfm)	External Static Pressure (in. wg)																			
	0.2		0.4		0.6		0.8		1.0		1.2		1.4		1.6		1.8		2.0	
	Rpm	Bhp	Rpm	Bhp	Rpm	Bhp	Rpm	Bhp	Rpm	Bhp	Rpm	Bhp	Rpm	Bhp	Rpm	Bhp	Rpm	Bhp	Rpm	Bhp
2200	499	0.50	580	0.70	652	0.94	717	1.17	779	1.43	839	1.78	905	2.21	951	2.57	986	2.87	1019	3.16
2250	507	0.53	586	0.73	658	0.97	722	1.22	783	1.46	843	1.81	908	2.25	955	2.59	991	2.89	1023	3.19
2300	513	0.55	592	0.76	663	1.00	727	1.26	786	1.49	846	1.84	910	2.25	959	2.61	995	2.91	1028	3.21
2400	528	0.60	606	0.83	674	1.06	738	1.34	795	1.58	853	1.88	912	2.31	967	2.68	1003	2.99	1036	3.30
2500	542	0.66	619	0.90	686	1.13	748	1.41	806	1.68	859	1.94	919	2.37	971	2.73	1007	3.05	1041	3.36
2550	550	0.69	627	0.94	692	1.17	754	1.45	812	1.74	864	1.99	920	2.39	974	2.76	1010	3.08	1044	3.40
2600	557	0.72	634	0.97	698	1.21	759	1.49	816	1.79	868	2.04	921	2.41	976	2.78	1012	3.10	1046	3.42
2700	573	0.79	648	1.05	711	1.29	770	1.58	827	1.88	878	2.16	928	2.45	983	2.88	1020	3.21	1053	3.54
2800	588	0.86	662	1.13	723	1.38	782	1.66	837	1.98	889	2.29	937	2.57	986	2.91	1023	3.25	1057	3.58
2900	604	0.94	676	1.21	737	1.48	794	1.76	848	2.08	900	2.41	947	2.70	993	3.01	1030	3.36	1064	3.70
3000	620	1.02	690	1.30	750	1.58	806	1.86	849	2.18	910	2.52	958	2.85	1002	3.15	1039	3.51	1074	3.88
3100	636	1.11	704	1.39	764	1.69	818	1.97	870	2.29	920	2.64	968	2.99	1012	3.30	1050	3.69	<b>1084</b>	<b>4.06</b>
3200	652	1.21	718	1.49	778	1.80	831	2.09	882	2.40	931	2.76	979	3.13	1023	3.47	1061	3.87	1096	4.27
3300	668	1.31	732	1.59	793	1.92	844	2.21	894	2.53	942	2.89	989	3.26	1034	3.63	1072	4.05	1108	4.47
3400	684	1.41	747	1.70	807	2.04	857	2.35	907	2.66	954	3.02	1000	3.40	1044	3.79	1083	4.23	1119	4.66
3500	701	1.53	762	1.82	821	2.16	871	2.48	919	2.80	966	3.15	1011	3.55	1054	3.94	1093	4.40	1129	4.85
3600	717	1.65	777	1.94	835	2.29	885	2.63	932	2.95	978	3.30	1022	3.69	1065	4.10	1105	4.57	1141	5.05
3700	733	1.77	792	2.07	849	2.42	899	2.78	945	3.11	990	3.45	1034	3.84	1076	4.26	1116	4.75	1153	5.24
3750	742	1.84	800	2.14	856	2.49	907	2.86	952	3.20	997	3.54	1040	3.93	1082	4.27	1122	4.78	1159	5.25

LEGEND

**Bhp** — Brake Horsepower Input to Fan  
**FIOF** — Factory-Installed Option

Refer to page 161 for general Fan Performance Data notes.

NOTES:

1. **Boldface** indicates field-supplied drive required. (See Note 3.)

2.   indicates field-supplied motor and drive required.

3. Motor drive range is 840 to 1085 rpm for standard motors; 860 to 1080 rpm for high-static motors. All other rpms require a field-supplied drive.

4. Maximum continuous bhp is 2.9 for standard motors, 4.2 for high-static motors.

48HJ004-014

# Performance data (cont)



## FAN PERFORMANCE — HORIZONTAL DISCHARGE UNITS (cont)

### 48HJ009 (8 1/2 TONS) — STANDARD MOTOR (BELT DRIVE)

Airflow (Cfm)	External Static Pressure (in. wg)																	
	0.2		0.4		0.6		0.8		0.9		1.0		1.2		1.4		1.6	
	Rpm	Bhp	Rpm	Bhp	Rpm	Bhp	Rpm	Bhp	Rpm	Bhp	Rpm	Bhp	Rpm	Bhp	Rpm	Bhp	Rpm	Bhp
2550	550	0.69	627	0.94	692	1.17	754	1.45	783	1.60	812	1.74	864	1.99	920	2.39	974	2.76
2600	557	0.72	634	0.97	698	1.21	759	1.49	787	1.64	816	1.79	868	2.04	921	2.41	976	2.78
2700	573	0.79	648	1.05	711	1.29	770	1.58	798	1.73	827	1.88	878	2.16	928	2.45	983	2.88
2800	588	0.86	662	1.13	723	1.38	782	1.66	809	1.82	837	1.98	889	2.29	937	2.57	986	2.91
2900	604	0.94	676	1.21	737	1.48	794	1.76	821	1.92	848	2.08	900	2.41	947	2.70	993	3.01
3000	620	1.02	690	1.30	750	1.58	806	1.86	832	2.02	859	2.18	910	2.52	958	2.85	1002	3.15
3100	636	1.11	704	1.39	764	1.69	818	1.97	844	2.13	870	2.29	920	2.64	968	2.99	1012	3.30
3200	652	1.21	718	1.49	778	1.80	831	2.09	856	2.25	882	2.40	931	2.76	979	3.13	1023	3.47
3300	668	1.31	732	1.59	793	1.92	844	2.21	869	2.37	894	2.53	942	2.89	989	3.26	1034	3.63
3400	684	1.41	747	1.70	807	2.04	857	2.35	882	2.51	907	2.66	954	3.02	1000	3.40	1044	3.79
3500	701	1.53	762	1.82	821	2.16	871	2.48	895	2.64	919	2.80	966	3.15	1011	3.55	1054	3.94
3600	717	1.65	777	1.94	835	2.29	885	2.63	908	2.79	932	2.95	978	3.30	1022	3.69	1065	4.10
3700	733	1.77	792	2.07	849	2.42	899	2.78	922	2.95	945	3.11	990	3.45	1034	3.84	1076	4.26
3750	742	1.84	800	2.14	856	2.49	907	2.86	929	3.03	952	3.20	997	3.54	1040	3.93	1082	4.27
3800	750	1.90	807	2.21	863	2.56	914	2.93	936	3.11	958	3.28	1003	3.62	1045	4.01	1087	4.43
3900	767	2.04	822	2.35	877	2.71	928	3.09	950	3.27	972	3.45	1015	3.80	1057	4.18	1098	4.60
4000	783	2.18	838	2.50	891	2.86	942	3.26	964	3.45	986	3.63	1028	3.99	1070	4.36	1110	4.78
4100	800	2.34	854	2.66	905	3.02	956	3.43	978	3.62	1000	3.81	1042	4.18	1082	4.56	1122	4.97
4200	817	2.49	869	2.82	920	3.19	970	3.60	992	3.80	1015	4.00	1055	4.38	1095	4.76	1134	5.16
4250	826	2.58	877	2.91	928	3.28	977	3.69	999	3.90	1022	4.10	1062	4.49	1102	4.87	—	—
4300	834	2.66	885	3.00	935	3.37	984	3.78	1006	3.99	1029	4.20	1069	4.59	1108	4.98	—	—

### 48HJ009 (8 1/2 TONS) — HIGH-STATIC MOTOR (BELT DRIVE)

Airflow (Cfm)	External Static Pressure (in. wg)																			
	0.2		0.4		0.6		0.8		1.0		1.2		1.4		1.6		1.8		2.0	
	Rpm	Bhp	Rpm	Bhp	Rpm	Bhp	Rpm	Bhp	Rpm	Bhp	Rpm	Bhp	Rpm	Bhp	Rpm	Bhp	Rpm	Bhp	Rpm	Bhp
2550	550	0.69	627	0.94	692	1.17	754	1.45	812	1.74	864	1.99	920	2.39	974	2.76	1005	3.04	1034	3.31
2600	557	0.72	634	0.97	698	1.21	759	1.49	816	1.79	868	2.04	921	2.41	976	2.78	1008	3.06	1037	3.33
2700	573	0.79	648	1.05	711	1.29	770	1.58	827	1.88	878	2.16	928	2.45	983	2.88	1015	3.17	1044	3.45
2800	588	0.86	662	1.13	723	1.38	782	1.66	837	1.98	889	2.29	937	2.57	986	2.91	1018	3.20	1047	3.49
2900	604	0.94	676	1.21	737	1.48	794	1.76	848	2.08	900	2.41	947	2.70	993	3.01	1025	3.31	1055	3.61
3000	620	1.02	690	1.30	750	1.58	806	1.86	849	2.18	910	2.52	958	2.85	1002	3.15	1034	3.47	1064	3.77
3100	636	1.11	704	1.39	764	1.69	818	1.97	870	2.29	920	2.64	968	2.99	1012	3.30	1045	3.63	1075	3.95
3200	652	1.21	718	1.49	778	1.80	831	2.09	882	2.40	931	2.76	979	3.13	1023	3.47	1056	3.82	<b>1087</b>	<b>4.16</b>
3300	668	1.31	732	1.59	793	1.92	844	2.21	894	2.53	942	2.89	989	3.26	1034	3.63	1067	3.99	1098	4.35
3400	684	1.41	747	1.70	807	2.04	857	2.35	907	2.66	954	3.02	1000	3.40	1044	3.79	1078	4.17	1109	4.54
3500	701	1.53	762	1.82	821	2.16	871	2.48	919	2.80	966	3.15	1011	3.55	1054	3.94	1088	4.33	1119	4.72
3600	717	1.65	777	1.94	835	2.29	885	2.63	932	2.95	978	3.30	1022	3.69	1065	4.10	1099	4.51	1131	4.91
3700	733	1.77	792	2.07	849	2.42	899	2.78	945	3.11	990	3.45	1034	3.84	1076	4.26	1111	4.69	1143	5.10
3750	742	1.84	800	2.14	856	2.49	907	2.86	952	3.20	997	3.54	1040	3.93	1082	4.27	1117	4.70	1149	5.12
3800	750	1.90	807	2.21	863	2.56	914	2.93	958	3.28	1003	3.62	1045	4.01	1087	4.43	1122	4.87	1155	5.31
3900	767	2.04	822	2.35	877	2.71	928	3.09	972	3.45	1015	3.80	1057	4.18	1098	4.60	1133	5.06	1166	5.51
4000	783	2.18	838	2.50	891	2.86	942	3.26	986	3.63	1028	3.99	1070	4.36	1110	4.78	1146	5.26	1179	5.73
4100	800	2.34	854	2.66	905	3.02	956	3.43	1000	3.81	1042	4.18	1082	4.56	1122	4.97	1158	5.47	1192	5.95
4200	817	2.49	869	2.82	920	3.19	970	3.60	1015	4.00	1055	4.38	1095	4.76	1134	5.16	1171	5.68	1204	6.18
4250	826	2.58	877	2.91	928	3.28	977	3.69	1022	4.10	1062	4.49	1102	4.87	1140	5.27	1177	5.80	1211	6.31
4300	834	2.66	885	3.00	935	3.37	984	3.78	1029	4.20	1069	4.59	1108	4.98	1147	5.38	1184	5.92	1218	6.45

#### LEGEND

**Bhp** — Brake Horsepower Input to Fan  
**FIOF** — Factory-Installed Option

Refer to page 161 for general Fan Performance Data notes.

#### NOTES:

1. Boldface indicates field-supplied drive required. (See Note 3.)

2.    indicates field-supplied motor and drive required.

3. Motor drive range is 840 to 1085 rpm for standard motors; 860 to 1080 rpm for high-static motors. All other rpms require a field-supplied drive.

4. Maximum continuous bhp is 2.9 for standard motors; 4.2 for high-static motors.

48HJ004-014



## FAN PERFORMANCE — HORIZONTAL DISCHARGE UNITS (cont)

### 48HJ012 (10 1/2 TONS) — STANDARD AND HIGH-STATIC MOTOR (BELT DRIVE)

Airflow (Cfm)	External Static Pressure (in. wg)																			
	0.2		0.4		0.6		0.8		1.0		1.2		1.4		1.6		1.8		2.0	
	Rpm	Bhp	Rpm	Bhp	Rpm	Bhp	Rpm	Bhp	Rpm	Bhp	Rpm	Bhp	Rpm	Bhp	Rpm	Bhp	Rpm	Bhp	Rpm	Bhp
3000	478	0.57	658	0.92	721	1.08	796	1.23	851	1.50	898	1.78	942	2.01	983	2.17	1023	2.46	1063	2.61
3100	500	0.62	669	0.97	731	1.16	808	1.30	861	1.57	907	1.86	951	2.09	992	2.24	1031	2.51	1070	2.75
3200	519	0.69	680	1.03	741	1.23	818	1.38	873	1.65	916	1.95	960	2.18	1000	2.32	1039	2.58	1077	2.88
3300	537	0.77	692	1.10	751	1.30	828	1.47	884	1.72	925	2.03	969	2.27	1009	2.41	1048	2.66	1086	2.95
3400	561	0.86	704	1.17	761	1.37	837	1.57	896	1.82	934	2.12	978	2.36	1018	2.51	1057	2.75	1094	3.02
3500	592	0.98	715	1.24	773	1.45	847	1.66	907	1.92	945	2.22	987	2.46	1027	2.60	1066	2.85	1102	3.12
3600	632	1.12	727	1.32	784	1.54	857	1.76	917	2.03	957	2.32	996	2.55	1036	2.71	1075	2.96	1111	3.22
3700	677	1.20	748	1.43	810	1.65	869	1.89	928	2.17	984	2.43	1036	2.68	1080	2.90	1114	3.07	1135	3.17
3800	691	1.28	761	1.52	822	1.75	880	1.98	937	2.28	993	2.55	1046	2.81	1092	3.05	1129	3.25	1156	3.39
3900	705	1.37	773	1.62	834	1.86	891	2.08	947	2.39	1002	2.66	1055	2.94	1102	3.20	1143	3.42	1174	3.59
4000	720	1.47	786	1.71	847	1.97	902	2.19	957	2.50	1011	2.79	1064	3.07	1112	3.34	1155	3.59	1190	3.80
4100	734	1.56	800	1.82	860	2.09	914	2.31	967	2.60	1021	2.91	1072	3.20	1121	3.49	1165	3.76	1203	3.99
4200	749	1.66	813	1.92	873	2.21	926	2.44	978	2.71	1030	3.04	1081	3.34	1130	3.64	1175	3.92	1215	4.18
4300	764	1.77	826	2.04	886	2.33	938	2.57	989	2.83	1040	3.18	1090	3.48	1139	3.79	1185	4.08	1226	4.36
4400	779	1.88	840	2.16	899	2.46	951	2.71	1000	2.96	1050	3.31	1100	3.63	1148	3.94	1194	4.25	1236	4.54
4500	793	1.99	854	2.28	912	2.59	963	2.86	1012	3.09	1061	3.43	1109	3.78	1157	4.09	1203	4.42	1246	4.72
4600	808	2.11	868	2.42	925	2.73	975	3.00	1024	3.25	1071	3.56	1119	3.93	1166	4.26	1212	4.58	1255	4.91
4700	822	2.24	882	2.56	937	2.86	988	3.16	1036	3.42	1082	3.70	1129	4.09	1175	4.43	1221	4.76	1264	5.09
4800	837	2.37	896	2.71	950	3.00	1001	3.32	1048	3.59	1093	3.86	1139	4.24	1185	4.60	1230	4.93	—	—
4900	852	2.51	910	2.86	963	3.15	1014	3.48	1060	3.76	1105	4.02	1150	4.38	1194	4.77	1239	5.12	—	—
5000	867	2.65	924	3.01	977	3.30	1027	3.65	1073	3.94	1117	4.20	1161	4.54	1204	4.95	—	—	—	—

LEGEND

**Bhp** — Brake Horsepower Input to Fan  
**FIOP** — Factory-Installed Option

Refer to this page for general Fan Performance Data notes.

NOTES:

1. **Boldface** indicates field-supplied drive required. (See Note 3.)

2.   indicates high-static motor and drive required.

3. Motor drive range is 860 to 1080 rpm for standard motors and 830 to 1130 for high-static motors. All other rpms require a field-supplied drive.

4. Maximum continuous bhp is 3.70 for standard motors and 5.25 for high-static motors.

### 48HJ014 (12 1/2 TONS) — STANDARD MOTOR (BELT DRIVE)

Airflow (Cfm)	External Static Pressure (in. wg)																			
	0.2		0.4		0.6		0.8		1.0		1.2		1.4		1.6		1.8		2.0	
	Rpm	Bhp	Rpm	Bhp	Rpm	Bhp	Rpm	Bhp	Rpm	Bhp	Rpm	Bhp	Rpm	Bhp	Rpm	Bhp	Rpm	Bhp	Rpm	Bhp
3700	—	—	—	—	—	—	<b>869</b>	<b>1.89</b>	928	2.17	984	2.43	1036	2.68	1080	2.90	1114	3.07	1135	3.17
3800	—	—	—	—	—	—	<b>880</b>	<b>1.98</b>	937	2.28	993	2.55	1046	2.81	1092	3.05	1129	3.25	1156	3.39
3900	—	—	—	—	—	—	<b>891</b>	<b>2.08</b>	947	2.39	1002	2.66	1055	2.94	1102	3.20	1143	3.42	1174	3.59
4000	—	—	—	—	—	—	902	2.19	957	2.50	1011	2.79	1064	3.07	1112	3.34	1155	3.59	1190	3.80
4100	—	—	—	—	<b>860</b>	<b>2.09</b>	914	2.31	967	2.60	1021	2.91	1072	3.20	1121	3.49	1165	3.76	1203	3.99
4200	—	—	—	—	<b>873</b>	<b>2.21</b>	926	2.44	978	2.71	1030	3.04	1081	3.34	1130	3.64	1175	3.92	1215	4.18
4300	—	—	—	—	<b>886</b>	<b>2.33</b>	938	2.57	989	2.83	1040	3.18	1090	3.48	1139	3.79	1185	4.08	1226	4.36
4400	—	—	—	—	<b>899</b>	<b>2.46</b>	951	2.71	1000	2.96	1050	3.31	1100	3.63	1148	3.94	1194	4.25	1236	4.54
4500	—	—	—	—	912	2.59	963	2.86	1012	3.09	1061	3.43	1109	3.78	1157	4.09	1203	4.42	1246	4.72
4600	—	—	<b>868</b>	<b>2.42</b>	925	2.73	975	3.00	1024	3.25	1071	3.56	1119	3.93	1166	4.26	1212	4.58	1255	4.91
4700	—	—	<b>882</b>	<b>2.56</b>	937	2.86	988	3.16	1036	3.42	1082	3.70	1129	4.09	1175	4.43	1221	4.76	1264	5.09
4800	—	—	<b>896</b>	<b>2.71</b>	950	3.00	1001	3.32	1048	3.59	1093	3.86	1139	4.24	1185	4.60	1230	4.93	—	—
4900	—	—	910	2.86	963	3.15	1014	3.48	1060	3.76	1105	4.02	1150	4.38	1194	4.77	1239	5.12	—	—
5000	<b>867</b>	<b>2.65</b>	924	3.01	977	3.30	1027	3.65	1073	3.94	1117	4.20	1161	4.54	1204	4.95	—	—	—	—
5100	<b>882</b>	<b>2.79</b>	938	3.17	990	3.46	1040	3.82	1085	4.12	1129	4.40	1172	4.71	1214	5.13	—	—	—	—
5200	<b>896</b>	<b>2.95</b>	952	3.33	1003	3.63	1053	4.00	1098	4.30	1141	4.60	1183	4.91	—	—	—	—	—	—
5300	911	3.11	967	3.50	1017	3.80	1066	4.18	1111	4.50	1153	4.80	1194	5.08	—	—	—	—	—	—
5400	926	3.27	981	3.68	1030	3.98	1079	4.35	1124	4.70	1166	5.01	—	—	—	—	—	—	—	—
5500	940	3.44	995	3.86	1044	4.17	1092	4.54	1137	4.91	1178	5.22	—	—	—	—	—	—	—	—
5600	955	3.62	1010	4.04	1058	4.38	1105	4.73	1150	5.12	—	—	—	—	—	—	—	—	—	—
5700	970	3.80	1024	4.23	1072	4.59	1118	4.93	—	—	—	—	—	—	—	—	—	—	—	—
5800	985	3.99	1039	4.42	1086	4.80	1131	5.14	—	—	—	—	—	—	—	—	—	—	—	—
5900	1000	4.18	1053	4.62	1100	5.02	—	—	—	—	—	—	—	—	—	—	—	—	—	—
6000	1015	4.39	1068	4.83	1114	5.25	—	—	—	—	—	—	—	—	—	—	—	—	—	—
6100	1030	4.59	1083	5.04	—	—	—	—	—	—	—	—	—	—	—	—	—	—	—	—
6200	1046	4.81	—	—	—	—	—	—	—	—	—	—	—	—	—	—	—	—	—	—

LEGEND

**Bhp** — Brake Horsepower Input to Fan  
**FIOP** — Factory-Installed Option

Refer to this page for general Fan Performance Data notes.

NOTES:

1. **Boldface** indicates field-supplied drive required. (See Note 2.)

2. Standard drive range is 900 to 1260 rpm.

3. Maximum continuous bhp is 5.25 for the standard motor.

### GENERAL NOTES FOR FAN PERFORMANCE DATA TABLES

1. Values include losses for filters, unit casing, and wet coils. See page 162 for accessory/FIOP static pressure information.
2. Extensive motor and electrical testing on these units ensures that the full range of the motor can be utilized with confidence. Using your fan motors up to the wattage ratings shown will not result in nuisance tripping or premature

motor failure. Unit warranty will not be affected. See Evaporator-Fan Motor Performance table on page 165 for additional information.

3. Use of a field-supplied motor may affect wire sizing. Contact your Carrier representative for details.
4. Interpolation is permissible. Do not extrapolate.

48HJ004-014

# Performance data (cont)



## SOUND POWER (TOTAL UNIT)

UNIT 48HJ	ARI RATING (Bels)	A-WEIGHTED (db)	OCTAVE BANDS							
			63	125	250	500	1000	2000	4000	8000
004,005	7.6	76.0	55.9	66.0	64.0	66.2	68.4	64.5	61.7	57.3
006,007	8.0	80.0	59.1	68.9	68.7	71.9	74.0	68.9	65.7	59.0
008,009	8.2	82.0	62.2	69.3	71.5	74.7	76.2	72.9	68.7	61.5
012	8.4	84.0	64.6	71.1	73.3	76.9	77.6	73.7	70.6	63.7
014	8.6	86.0	63.7	69.9	72.5	78.2	81.1	77.3	73.3	66.8

### LEGEND

ARI — Air Conditioning and Refrigeration Institute  
 Bels — Sound Levels (1 bel = 10 decibels)

## ACCESSORY ECONOMIZER STATIC PRESSURE DROP (in. wg)

### 48HJ004-007

UNIT	CFM								
	900	1200	1400	1600	1800	2000	2200	2400	2600
Durablade	0.05	0.05	0.05	0.05	0.05	0.05	0.05	0.05	0.05

## ACCESSORY ECONOMIZER STATIC PRESSURE DROP (in. wg)

### 48HJ008-014

UNIT	CFM								
	2200	2500	3000	3500	4000	4500	5000	5500	6000
Durablade	0.02	0.02	0.03	0.04	0.05	0.06	0.07	0.08	0.09

## ACCESSORY/FIOP ECONOMIZER2 STATIC PRESSURE\* (in. wg) — 48HJ004-007

COMPONENT	CFM							
	1250	1500	1750	2000	2250	2500	2750	3000
Vertical EconoMiSer2	0.045	0.065	0.08	0.12	0.145	0.175	0.22	0.255
Horizontal EconoMiSer2	—	—	0.1	0.125	0.15	0.18	0.225	0.275

### LEGEND

FIOP — Factory-Installed Option

\*The static pressure must be added to external static pressure. The sum and the evaporator entering-air cfm should be used in conjunction with the Fan Performance tables to determine indoor blower rpm and watts.

## ACCESSORY/FIOP ECONOMIZER2 STATIC PRESSURE\* (in. wg) — 48HJ008-014

COMPONENT	CFM													
	2250	2500	2750	3000	3250	3500	3750	4000	4250	4500	4750	5000	5250	6250
Vertical EconoMiSer2	0.06	0.075	0.09	0.115	0.13	0.15	0.17	0.195	0.22	0.25	0.285	0.325	0.36	—
Horizontal EconoMiSer2	—	0.1	0.125	0.15	0.18	0.21	0.25	0.275	0.3	0.34	0.388	—	—	—

### LEGEND

FIOP — Factory-Installed Option

\*The static pressure must be added to external static pressure. The sum and the evaporator entering-air cfm should be used in conjunction with the Fan Performance tables to determine indoor blower rpm and watts.

## FIOP MOISTUREMISER™ DEHUMIDIFICATION PACKAGE STATIC PRESSURE DROP (in. wg)

UNIT SIZE 48HJ	UNIT NOMINAL TONS	CFM PER TON		
		300	400	500
004	3	.04	.07	.09
005	4	.07	.12	.15
006	5	.09	.15	.21
007	6	.12	.20	.28
008	7 <sup>1/2</sup>	.08	.13	.18
009	8 <sup>1/2</sup>	.10	.15	.22
012	10	.08	.13	.18
014	12 <sup>1/2</sup>	.11	.18	.26

### LEGEND

FIOP — Factory-Installed Option

## EVAPORATOR-FAN MOTOR EFFICIENCY

UNIT SIZE 48HJ	EFFICIENCY%
004,005	75
006	74/84*
007	84
008,009	80
012	85
014	87

\*Single phase/3 phase.

NOTE: Convert bhp to watts using the following formula:

$$\text{watts} = \frac{\text{bhp (746)}}{\text{motor efficiency}}$$

48HJ004-014



## FAN RPM AT MOTOR PULLEY SETTING

STANDARD MOTOR*													
Unit 48HJ	MOTOR PULLEY TURNS OPEN												
	0	1/2	1	1 1/2	2	2 1/2	3	3 1/2	4	4 1/2	5	5 1/2	6
004	1090	1055	1025	990	960	925	890	860	825	795	760	—	—
005	1185	1150	1115	1080	1045	1015	980	945	910	875	840	—	—
006 (single-phase)	1460	1425	1385	1350	1315	1275	1240	1205	1165	1130	1095	1055	1020
006 (3-phase) and 007	1585	1540	1490	1445	1400	1350	1305	1260	1210	1165	1120	—	—
008,009	1085	1060	1035	1010	985	960	935	910	890	865	840	—	—
012	1080	1060	1035	1015	990	970	950	925	905	880	860	—	—
014	1260	1220	1185	1155	1130	1100	1075	1045	1015	990	960	930	900

\*Approximate fan rpm shown (standard motor/drive).

## FAN RPM AT MOTOR PULLEY SETTING

HIGH-STATIC MOTOR													
UNIT 48HJ	Motor Pulley Turns Open												
	0	1/2	1	1 1/2	2	2 1/2	3	3 1/2	4	4 1/2	5	5 1/2	6
004	1455	1423	1392	1360	1328	1297	1265	1233	1202	1170	1138	1107	1075
005	1455	1423	1392	1360	1328	1297	1265	1233	1202	1170	1138	1107	1075
006	1685	1589	1557	1525	1493	1460	1428	1396	1364	1332	1300	—	—
007	1685	1589	1557	1525	1493	1460	1428	1396	1364	1332	1300	—	—
008	1080	1025	1007	988	970	952	933	915	897	878	860	—	—
009	1080	1025	1007	988	970	952	933	915	897	878	860	—	—
012	1130	1112	1087	1062	1037	1212	987	962	937	912	887	962	830

### ALTITUDE COMPENSATION\* — 48HJ004-007 STANDARD UNITS

ELEVATION (ft)	72,000 AND 115,000 BTUH NOMINAL INPUT		150,000 BTUH NOMINAL INPUT	
	Natural Gas Orifice Size†	Liquid Propane Orifice Size†	Natural Gas Orifice Size†	Liquid Propane Orifice Size†
0-2,000	33	43	30	37
2,000	36	44	31	39
3,000	36	45	31	40
4,000	37	45	32	41
5,000	38	46	32	42
6,000	40	47	34	43
7,000	41	48	35	43
8,000	42	49	36	44
9,000	43	50	37	45
10,000	44	50	39	46
11,000	45	51	41	47
12,000	46	52	42	48
13,000	47	52	43	49
14,000	48	53	44	50

\*As the height above sea level increases, there is less oxygen per cubic foot of air. Therefore, heat input rate should be reduced at higher altitudes.  
†Orifices available through your Carrier distributor.

### ALTITUDE COMPENSATION\* — 48HJ004-006 LOW NO<sub>x</sub> UNITS

ELEVATION (ft)	60,000 AND 90,000 BTUH NOMINAL INPUT		120,000 BTUH NOMINAL INPUT	
	Natural Gas Orifice Size†	Liquid Propane Orifice Size†	Natural Gas Orifice Size	Liquid Propane Orifice Size†
0-2,000	38	45	32	42
2,000	40	47	33	43
3,000	41	48	35	43
4,000	42	49	36	44
5,000	43	49	37	45
6,000	43	50	38	45
7,000	44	50	39	46
8,000	45	51	41	47
9,000	46	52	42	48
10,000	47	52	43	49
11,000	48	53	44	50
12,000	49	53	44	51
13,000	50	54	46	52
14,000	51	54	47	52

\*As the height above sea level increases, there is less oxygen per cubic foot of air. Therefore, the input rate should be reduced at higher altitudes.  
†Orifices are available through your local Carrier distributor.

### ALTITUDE COMPENSATION\* — 48HJ008-014

ELEVATION (ft)	125,000, 180,000, AND 224,000 BTUH NOMINAL INPUT		250,000 BTUH NOMINAL INPUT	
	Natural Gas Orifice Size†	Liquid Propane Orifice Size†	Natural Gas Orifice Size†	Liquid Propane Orifice Size†
0-2,000	31	41	30	38
2,000	32	42	30	39
3,000	32	42	31	40
4,000	32	42	32	41
5,000	33	43	33	42
6,000	34	43	34	43
7,000	35	44	35	43
8,000	36	44	36	44
9,000	37	45	37	44
10,000	38	46	38	45
11,000	39	47	39	45
12,000	40	47	40	46
13,000	41	48	41	47
14,000	42	48	42	47

\*As the height above sea level increases, there is less oxygen per cubic foot of air. Therefore, the input rate should be reduced at higher altitudes.  
†Orifices are available through your local Carrier distributor.

48HJ004-014

# Performance data (cont)



## ALTITUDE DERATING FACTOR\*

ELEVATION	MAXIMUM HEATING VALUE AT SEA LEVEL (Btu/ft <sup>3</sup> )
0-2000	1100
2001-3000	1050
3001-4000	1000
4001-5000	950
5001-6000	900

\*Derating of the gas heating equipment to compensate for the effects of altitude is always required. Orifice change is not required if the fuel heating value (at sea level) is below the limits listed in the table at left. Derating conditions must be 4% per thousand ft above sea level. For example, at 4000 ft, if the heating value of the gas exceeds 1000 Btu/ft<sup>3</sup>, the unit will require a 16% derating. For elevations above 6000 ft, the same formula applies. For example, at 7000 ft, the unit will require a 28% derating of the maximum heating value per the National Fuel Gas Code.

### VERTICAL ECONOMIZER PERFORMANCE DATA (48HJ004-014)

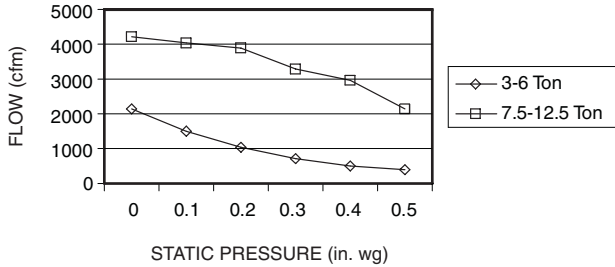

### VERTICAL POWER EXHAUST PERFORMANCE

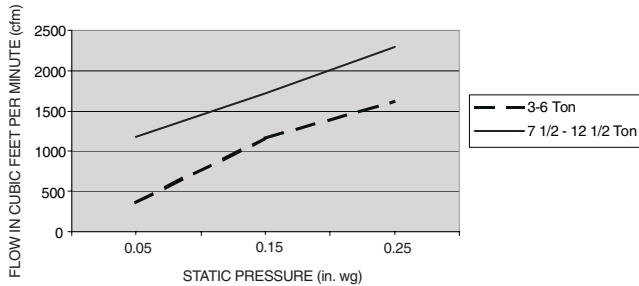

### BAROMETRIC RELIEF FLOW CAPACITY

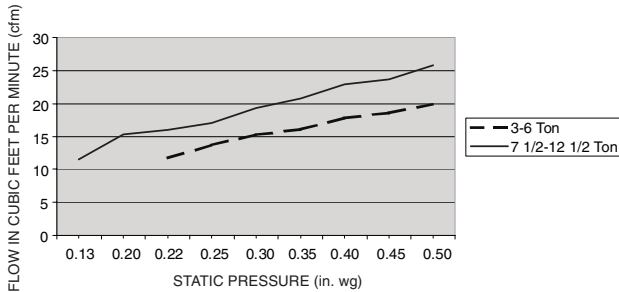

### OUTDOOR AIR DAMPER LEAKAGE

### HORIZONTAL ECONOMIZER PERFORMANCE DATA

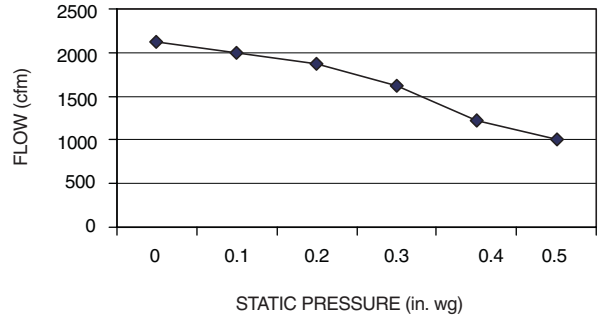

### HORIZONTAL POWER EXHAUST PERFORMANCE

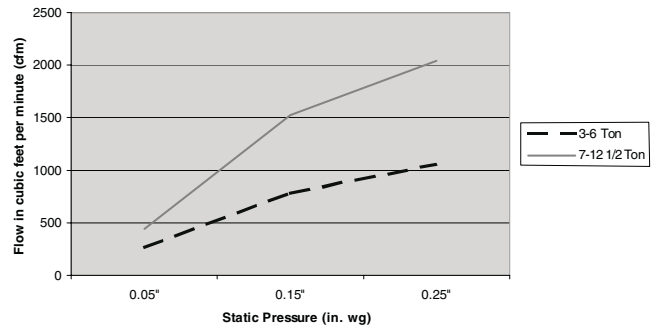

### BAROMETRIC RELIEF CAPACITY

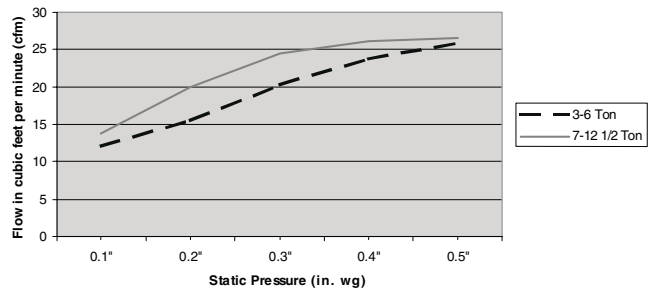

### OUTDOOR AIR DAMPER LEAKAGE

48HJ004-014



**EVAPORATOR-FAN MOTOR PERFORMANCE — STANDARD MOTOR**

UNIT 48HJ	UNIT PHASE	MAXIMUM CONTINUOUS BHP*	MAXIMUM OPERATING WATTS*	UNIT VOLTAGE	MAXIMUM AMP DRAW
004	Single	1.20	1000	208/230	4.9
				208/230	4.9
	Three	1.20	1000	460	2.2
				575	2.2
005	Single	1.20	1000	208/230	4.9
				208/230	4.9
	Three	1.20	1000	460	2.2
				575	2.2
006	Single	1.30	1650	208/230	10.1
				208/230	6.7
	Three	2.40	2120	460	3.0
				575	3.0
007	Three	2.40	2120	208/230	6.7
				460	3.0
				575	3.0
008,009	Three	2.90	2615	208/230	8.6
				460	3.9
				575	3.9
012	Three	3.70	3775	208/230	12.2
				460	5.5
				575	5.5
014	Three	5.25	4400	208/230	17.3
				460	8.5
				575	8.5

LEGEND

**Bhp** — Brake Horsepower

\*Extensive motor and electrical testing on these units ensures that the full horsepower and watts range of the motors can be utilized with confidence. Using your fan motors up to the ratings shown in this table will not result in nuisance tripping or premature motor failure. Unit warranty will not be affected.

**EVAPORATOR-FAN MOTOR PERFORMANCE — HIGH-STATIC MOTORS**

UNIT 48HJ	UNIT PHASE	MAXIMUM CONTINUOUS BHP*	MAXIMUM OPERATING WATTS*	UNIT VOLTAGE	MAXIMUM AMP DRAW
004	Three	2.40	2120	208/230	6.7
				460	3.0
				575	3.0
005	Three	2.40	2120	208/230	6.7
				460	3.0
				575	3.0
006	Three	2.90	2615	208/230	8.6
				460	3.9
				575	3.9
007	Three	2.90	2615	208/230	8.6
				460	3.9
				575	3.9
008,009	Three	4.20	3775	208/230	12.2
				460	5.5
				575	5.5
012	Three	5.25	4400	208/230	17.3
				460	8.5
				575	8.5

LEGEND

**Bhp** — Brake Horsepower

\*Extensive motor and electrical testing on these units ensures that the full horsepower and watts range of the motors can be utilized with confidence. Using your fan motors up to the ratings shown in this table will not result in nuisance tripping or premature motor failure. Unit warranty will not be affected.

48HJ004-014

## STANDARD MOTOR UNITS WITHOUT ELECTRICAL CONVENIENCE OUTLET

UNIT 48HJ	NOMINAL VOLTAGE (V-Ph-Hz)	VOLTAGE RANGE		Qty	COMPRESSOR (each)		OFM	IFM	COMBUSTION FAN MOTOR	POWER SUPPLY*		MINIMUM UNIT DISCONNECT SIZE†	
		Min	Max		FLA	LRA	FLA	FLA	MCA	MOCP**	FLA	LRA	
004 (3 Tons)	208/230-1-60	187	254	1	16.0	88.0	0.7	4.9	.60	25.6/25.6	35/35	25/25	101/101
	208/230-3-60	187	254		10.3	77.0	0.7	4.9	.60	18.5/18.5	25/25	18/18	90/90
	460-3-60	414	508		5.1	39.0	0.4	2.2	.30	9.0	15	9	46
	575-3-60	518	632		4.2	31.0	0.4	2.2	.30	7.3	15	7	37
005 (4 Tons)	208/230-1-60	187	254	1	23.7	129.0	0.7	4.9	.60	35.2/35.2	45/45	34/34	142/142
	208/230-3-60	187	254		13.5	99.0	0.7	4.9	.60	22.5/22.5	30/30	22/22	112/112
	460-3-60	414	508		7.4	49.5	0.4	2.2	.30	11.9	15	12	57
	575-3-60	518	632		5.8	40.0	0.4	2.2	.30	9.3	15	9	46
006 (5 Tons)	208/230-1-60	187	254	1	28.8	169.0	1.5	8.8	.60	46.3/46.3	60/60	45/45	216/216
	208/230-3-60	187	254		17.3	123.0	1.5	5.8	.60	28.9/28.9	35/35	28/28	168/168
	460-3-60	414	508		9.0	62.0	0.8	2.6	.30	14.7	20	14	84
	575-3-60	518	632		7.1	50.0	0.8	2.6	.30	11.6	15	11	68
007 (6 Tons)	208/230-3-60	187	254	1	20.5	156.0	1.4	5.8	.60	34.5/34.5	40/40	34/34	219/219
	460-3-60	414	508		9.6	75.0	0.6	2.6	.30	15.2	20	15	97
	575-3-60	518	632		7.7	56.0	0.6	2.6	.30	12.2	15	13	78
008 (7½ Tons)	208/230-3-60	187	254	2	12.4	88.0	1.4	7.5	.60	38.2/38.2	45/45	40/40	242/242
	460-3-60	414	508		6.4	44.0	0.7	3.4	.30	19.2	25	20	121
	575-3-60	518	632		4.8	34.0	0.7	3.4	.30	14.6	20	15	95
	208/230-3-60	187	254		15.0	99.0	1.4	7.5	.60	44.1/44.1	50/50	46/46	264/264
009 (8½ Tons)	460-3-60	414	508	2	8.2	49.5	0.7	3.4	.30	23.3	30	24	132
	575-3-60	518	632		5.8	40.0	0.7	3.4	.30	16.9	20	18	107
	208/230-3-60	187	254		17.6	125.0	1.4	10.6	.60	53/53	60/60	56/56	341/341
	460-3-60	414	508		8.3	62.5	0.7	4.8	.30	24.9	30	26	171
012 (10 Tons)	575-3-60	518	632	2	6.3	50.0	0.7	4.8	.30	19.1	25	20	136
	208/230-3-60	187	254		19.0	156.0	1.4	15.0	.60	60.6/60.6	70/70††	64/64	426/426
	460-3-60	414	508		9.0	70.0	0.7	7.4	.30	29.1	40	33	210
014 (12½ Tons)	575-3-60	518	632	2	7.4	54.0	0.7	7.4	.30	23.7	30	25	154

## STANDARD MOTOR UNITS WITH ELECTRICAL CONVENIENCE OUTLET

UNIT 48HJ	NOMINAL VOLTAGE (V-Ph-Hz)	VOLTAGE RANGE		Qty	COMPRESSOR (each)		OFM	IFM	COMBUSTION FAN MOTOR	POWER SUPPLY WITH OUTLET*		MINIMUM UNIT DISCONNECT SIZE†	
		Min	Max		FLA	LRA	FLA	FLA	MCA	MOCP**	FLA	LRA	
004 (3 Tons)	208/230-1-60	187	254	1	16.0	88.0	0.7	4.9	.60	31.6/31.6	40/40	30/30	106/106
	208/230-3-60	187	254		10.3	77.0	0.7	4.9	.60	24.5/24.5	30/30	24/24	95/95
	460-3-60	414	508		5.1	39.0	0.4	2.2	.30	11.7	15	11	48
	575-3-60	518	632		4.2	31.0	0.4	2.2	.30	9.5	15	9	38
005 (4 Tons)	208/230-1-60	187	254	1	23.7	129.0	0.7	4.9	.60	41.2/41.2	50/50	39/39	147/147
	208/230-3-60	187	254		13.5	99.0	0.7	4.9	.60	28.5/28.5	35/35	27/27	117/117
	460-3-60	414	508		7.4	49.5	0.4	2.2	.30	14.6	20	14	59
	575-3-60	518	632		5.8	40.0	0.4	2.2	.30	11.5	15	11	47
006 (5 Tons)	208/230-1-60	187	254	1	28.8	169.0	1.5	8.8	.60	52.3/52.3	60/60	50/50	221/221
	208/230-3-60	187	254		17.3	123.0	1.5	5.8	.60	34.9/34.9	40/40	34/34	173/173
	460-3-60	414	508		9.0	62.0	0.8	2.6	.30	17.4	20	17	87
	575-3-60	518	632		7.1	50.0	0.8	2.6	.30	13.8	20	13	70
007 (6 Tons)	208/230-3-60	187	254	1	20.5	156.0	1.4	5.8	.60	38.8/38.8	40/40	37/37	210/210
	460-3-60	414	508		9.6	75.0	0.6	2.6	.30	17.9	20	17	99
	575-3-60	518	632		7.7	56.0	0.6	2.6	.30	14.3	20	15	80
008 (7½ Tons)	208/230-3-60	187	254	2	12.4	88.0	1.4	7.5	.60	44.2/44.2	50/50	46/46	246/246
	460-3-60	414	508		6.4	44.0	0.7	3.4	.30	21.9	25	23	124
	575-3-60	518	632		4.8	34.0	0.7	3.4	.30	16.8	20	17	97
	208/230-3-60	187	254		15.0	99.0	1.4	7.5	.60	50.1/50.1	60/60	52/52	268/268
009 (8½ Tons)	460-3-60	414	508	2	8.2	49.5	0.7	3.4	.30	26.0	30	27	135
	575-3-60	518	632		5.8	40.0	0.7	3.4	.30	19.1	25	20	109
	208/230-3-60	187	254		17.6	125.0	1.4	10.6	.60	59/59	70/70††	61/61	345/345
	460-3-60	414	508		8.3	62.5	0.7	4.8	.30	27.6	30	29	173
012 (10 Tons)	575-3-60	518	632	2	6.3	50.0	0.7	4.8	.30	21.3	25	22	139
	208/230-3-60	187	254		19.0	156.0	1.4	15.0	.60	66.6/66.6	70/70††	70/70	430/430
	460-3-60	414	508		9.0	75.0	0.7	7.4	.30	31.8	45	33	210
014 (12½ Tons)	575-3-60	518	632	2	7.4	54.0	0.7	7.4	.30	25.9	30	27	156

### LEGEND

- FLA — Full Load Amps
- HACR — Heating, Air Conditioning and Refrigeration
- IFM — Indoor (Evaporator) Fan Motor
- LRA — Locked Rotor Amps
- MCA — Minimum Circuit Amps
- MOCP — Maximum Overcurrent Protection
- NEC — National Electrical Code
- OFM — Outdoor (Condenser) Fan Motor
- RLA — Rated Load Amps
- UL — Underwriters' Laboratories



\*The values listed in this table do not include power exhaust. See table at right for power exhaust requirements.

†Used to determine minimum disconnect per NEC.

\*\*Fuse or HACR circuit breaker.

††Fuse only.

### NOTES:

- In compliance with NEC requirements for multimotor and combination load equipment (refer to NEC Articles 430 and 440), the overcurrent protective device for the unit shall be fuse or HACR breaker. The UL, Canada units may be fuse or circuit breaker.
- Electrical data based on 95 F ambient outdoor-air temperature ± 10% voltage.

## POWER EXHAUST ELECTRICAL DATA

POWER EXHAUST PART NO.	MCA (230 v)	MCA (460 v)	MCA (575 v)	MOCP (for separate power source)
CRPWREXH021A00	N/A	0.9	N/A	15
CRPWREXH022A00	3.3	N/A	1.32	15
CRPWREXH023A00	N/A	1.8	N/A	15
CRPWREXH024A00	1.6	N/A	0.64	15
CRPWREXH025A00	N/A	0.9	N/A	15
CRPWREXH026A00	3.3	N/A	1.32	15
CRPWREXH027A00	N/A	1.8	N/A	15
CRPWREXH028A00	1.7	N/A	0.68	15
CRPWREXH029A00	N/A	1.0	N/A	15
CRPWREXH030A00	1.6	N/A	0.64	15

N/A — Not available

NOTE: If a single power source is to be used, size wire to include power exhaust MCA and MOCP.

Check MCA and MOCP when power exhaust is powered through the unit. Determine the new MCA including the power exhaust using the following formula:

MCA New = MCA unit only + MCA of Power Exhaust

For example, using a 48HJD006---5 unit with MCA = 28.9 and MOCP = 35, with CRPWREXH030A00 power exhaust.

MCA New = 28.9 amps + 1.6 amps = 30.5 amps

If the new MCA does not exceed the published MOCP, then MOCP would not change. The MOCP in this example is 35 amps and the MCA New is below 35; therefore the MOCP is acceptable. If "MCA New" is larger than the published MOCP, raise the MOCP to the next larger size. For separate power, the MOCP for the power exhaust will be 15 amps per NEC.



## HIGH-STATIC MOTOR UNITS WITHOUT ELECTRICAL CONVENIENCE OUTLET

UNIT 48HJ	NOMINAL VOLTAGE (V-Ph-Hz)	VOLTAGE RANGE		COMPRESSOR (each)			OFM (each)	IFM	COMBUSTION FAN MOTOR	POWER SUPPLY*		MINIMUM UNIT DISCONNECT SIZE†	
		Min	Max	Qty	RLA	LRA	FLA	FLA	RLA	MCA	MOCP**	FLA	LRA
004	208/230-3-60	187	254	1	10.3	77.0	0.7	5.8	0.6	19.4	25	19	120
	460-3-60	414	508		5.1	39.0	0.4	2.6	0.3	9.4	15	9	60
	575-3-60	518	632		4.2	31.0	0.4	2.6	0.3	7.7	15	8	48
005	208/230-3-60	187	254	1	13.5	99.0	0.7	5.8	0.6	23.4	30	23	142
	460-3-60	414	508		7.4	49.5	0.4	2.6	0.3	12.3	15	12	71
	575-3-60	518	632		5.8	40.0	0.4	2.6	0.3	9.7	15	9	57
006	208/230-3-60	187	254	1	17.3	123.0	1.5	7.5	0.6	30.6	35	30	187
	460-3-60	414	508		9.0	62.0	0.8	3.4	0.3	15.5	20	15	94
	575-3-60	518	632		7.1	50.0	0.8	3.4	0.3	12.2	15	12	76
007	208/230-3-60	187	254	1	20.5	156.0	1.4	7.5	0.6	34.5	40	34	219
	460-3-60	414	508		9.6	75.0	0.6	3.4	0.3	16	20	16	107
	575-3-60	518	632		7.7	56.0	0.6	3.4	0.3	12.8	20	13	88
008	208/230-3-60	187	254	2	12.4	88.0	1.4	10.6	0.6	41.3	45	44	267
	460-3-60	414	508		6.4	44.0	0.7	4.8	0.3	20.6	25	22	134
	575-3-60	632	518		4.8	34.0	0.7	4.8	0.3	15.8	20	17	95
009	208/230-3-60	187	254	2	15.0	99.0	1.4	10.6	0.6	47.2	60	50	264
	460-3-60	414	508		8.2	49.5	0.7	4.8	0.3	24.7	30	26	132
	575-3-60	518	632		5.8	40.0	0.7	4.8	0.3	18.0	20	19	107
012	208/230-3-60	187	254	2	17.6	125.0	1.4	15.0	0.6	57.4	70††	61	360
	460-3-60	414	508		8.3	62.5	0.7	7.4	0.3	27.5	30	29	181
	575-3-60	518	632		6.3	50.0	0.7	7.4	0.3	23.0	25	23	136

## HIGH-STATIC MOTOR UNITS WITH ELECTRICAL CONVENIENCE OUTLET

UNIT 48HJ	NOMINAL VOLTAGE (V-Ph-Hz)	VOLTAGE RANGE		COMPRESSOR (each)			OFM (each)	IFM	COMBUSTION FAN MOTOR	POWER SUPPLY*		MINIMUM UNIT DISCONNECT SIZE†	
		Min	Max	Qty	RLA	LRA	FLA	FLA	RLA	MCA	MOCP**	FLA	LRA
004	208/230-3-60	187	254	1	10.3	77.0	0.7	5.8	0.6	25.4	30	25	124
	460-3-60	414	508		5.1	39.0	0.4	2.6	0.3	12.1	15	12	63
	575-3-60	518	632		4.2	31.0	0.4	2.6	0.3	9.8	15	10	50
005	208/230-3-60	187	254	1	13.5	99.0	0.7	5.8	0.6	29.4	35	29	146
	460-3-60	414	508		7.4	49.5	0.4	2.6	0.3	15.0	20	14	73
	575-3-60	518	632		5.8	40.0	0.4	2.6	0.3	11.8	15	11	59
006	208/230-3-60	187	254	1	17.3	123.0	1.5	7.5	0.6	36.6	40	36	192
	460-3-60	414	508		9.0	62.0	0.8	3.4	0.3	18.2	20	18	96
	575-3-60	518	632		7.1	50.0	0.8	3.4	0.3	14.4	20	14	77
007	208/230-3-60	187	254	1	20.5	156.0	1.4	7.5	0.6	40.5	45	39	224
	460-3-60	414	508		9.6	75.0	0.6	3.4	0.3	18.7	25	18	109
	575-3-60	518	632		7.7	56.0	0.6	3.4	0.3	15.0	20	15	89
008	208/230-3-60	187	254	2	12.4	88.0	1.4	10.6	0.6	47.3	50	49	267
	460-3-60	414	508		6.4	44.0	0.7	4.8	0.3	23.3	25	24	134
	575-3-60	518	632		4.8	34.0	0.7	4.8	0.3	18.5	20	19	95
009	208/230-3-60	187	254	2	15.0	99.0	1.4	10.6	0.6	53.2	60	55	264
	460-3-60	414	508		8.2	49.5	0.7	4.8	0.3	27.4	30	28	132
	575-3-60	518	632		5.8	40.0	0.7	4.8	0.3	20.7	25	21	107
012	208/230-3-60	187	254	2	17.6	125.0	1.4	15.0	0.6	63.4	70††	66	360
	460-3-60	414	508		8.3	62.5	0.7	7.4	0.3	30.2	35	32	181
	575-3-60	518	632		6.3	50.0	0.7	7.4	0.3	25.7	30	25	147

**LEGEND**

- FLA — Full Load Amps
- HACR — Heating, Air Conditioning and Refrigeration
- IFM — Indoor (Evaporator) Fan Motor
- LRA — Locked Rotor Amps
- MCA — Minimum Circuit Amps
- MOCP — Maximum Overcurrent Protection
- NEC — National Electrical Code
- OFM — Outdoor (Condenser) Fan Motor
- RLA — Rated Load Amps
- UL — Underwriters' Laboratories



\*The values listed in this table do not include power exhaust. See table at right for power exhaust requirements.

†Used to determine minimum disconnect per NEC.

\*\*Fuse or HACR circuit breaker.

††Fuse only.

**NOTES:**

1. In compliance with NEC requirements for multimotor and combination load equipment (refer to NEC Articles 430 and 440), the overcurrent protective device for the unit shall be fuse or HACR breaker. The UL, Canada units may be fuse or circuit breaker.
2. Electrical data based on 95 F ambient outdoor-air temperature ± 10% voltage.

### POWER EXHAUST ELECTRICAL DATA

POWER EXHAUST PART NO.	MCA (230 v)	MCA (460 v)	MCA (575 v)	MOCP (for separate power source)
CRPWREXH021A00	N/A	0.9	N/A	15
CRPWREXH022A00	3.3	N/A	1.32	15
CRPWREXH023A00	N/A	1.8	N/A	15
CRPWREXH024A00	1.6	N/A	0.64	15
CRPWREXH025A00	N/A	0.9	N/A	15
CRPWREXH026A00	3.3	N/A	1.32	15
CRPWREXH027A00	N/A	1.8	N/A	15
CRPWREXH028A00	1.7	N/A	0.68	15
CRPWREXH029A00	N/A	1.0	N/A	15
CRPWREXH030A00	1.6	N/A	0.64	15

N/A — Not available

NOTE: If a single power source is to be used, size wire to include power exhaust MCA and MOCP.

Check MCA and MOCP when power exhaust is powered through the unit. Determine the new MCA including the power exhaust using the following formula:

MCA New = MCA unit only + MCA of Power Exhaust

For example, using a 48HJD006--5 unit with MCA = 28.9 and MOCP = 35, with CRPWREXH030A00 power exhaust.

MCA New = 28.9 amps + 1.6 amps = 30.5 amps

If the new MCA does not exceed the published MOCP, then MOCP would not change. The MOCP in this example is 35 amps and the MCA New is below 35; therefore the MOCP is acceptable. If "MCA New" is larger than the published MOCP, raise the MOCP to the next larger size. For separate power, the MOCP for the power exhaust will be 15 amps per NEC.

48HJD004-014

# Guide specifications — 48HJ004-014



## Packaged Rooftop Electric Cooling Unit with Gas Heat — Constant Volume Application

### HVAC Guide Specifications

Size Range: **3 to 12<sup>1</sup>/<sub>2</sub> Tons, Nominal (Cooling)**  
**60,000 to 250,000 Btuh, Nominal (Input Heating)**

Carrier Model Numbers:

**48HJD/L/G**  
**48HJE/M/H**  
**48HJF/N/K**



### Part 1 — General

#### 1.01 SYSTEM DESCRIPTION

Outdoor rooftop mounted, electrically controlled heating and cooling unit utilizing a hermetic compressor(s) for cooling duty and gas combustion for heating duty. Unit shall discharge supply air vertically or horizontally as shown on contract drawings.

#### 1.02 QUALITY ASSURANCE

- A. Unit well exceeds ASHRAE 90.1-2001 Energy Standards.
- B. Unit shall be rated in accordance with ARI Standards 210/240 or 360 and 270. Designed in accordance with UL Standard 1995.
- C. Unit shall be designed to conform to ASHRAE 15, latest revision.
- D. Unit shall be UL-tested and certified in accordance with ANSI Z21.47 Standards and UL-listed and certified under Canadian standards as a total package for safety requirements.
- E. Roof curb shall be designed to conform to NRCA Standards.
- F. Insulation and adhesive shall meet NFPA 90A requirements for flame spread and smoke generation.
- G. Unit casing shall be capable of withstanding 500-hour salt spray exposure per ASTM B117 (scribed specimen).
- H. Unit shall be designed in accordance with ISO 9001, and shall be manufactured in a facility registered to ISO 9001:2000.
- I. Each unit shall be subjected to a completely automated run testing on the assembly line. Units contain a factory-supplied printout indicating tested pressures, amperages, data, and inspectors; providing certification of the unit status at the time of manufacture.

#### 1.03 DELIVERY, STORAGE, AND HANDLING

Unit shall be stored and handled per manufacturer's recommendations.

### Part 2 — Products

#### 2.01 EQUIPMENT (STANDARD)

##### A. General:

Factory assembled, single-piece heating and cooling unit. Contained within the unit enclosure shall be all factory wiring, piping, controls, refrigerant charge (R-22), and special features required prior to field start-up.

##### B. Unit Cabinet:

1. Unit cabinet shall be constructed of galvanized steel, and shall be bonderized and coated with a prepainted baked enamel finish on all externally exposed surfaces.
2. Evaporator fan compartment interior cabinet surfaces shall be insulated with a minimum 1/2-in. thick, 1 lb. density, flexible fiberglass insulation, neoprene coated on the air side. Aluminum foil-faced fiberglass insulation shall be used in the gas heat compartment.
3. Cabinet panels shall be easily removable for servicing.
4. Holes shall be provided in the base rails for rigging shackles to facilitate maneuvering and overhead rigging.
5. Unit shall have a factory-installed, sloped condensate drain pan made of a non-corrosive material, providing a minimum 3/4-in.-14 NPT. connection with both vertical and horizontal drains, and shall comply with ASHRAE Standard 62.
6. Unit shall have a factory-installed filter access panel to provide filter access with tool-less removal.
7. Unit shall have standard thru-the-bottom gas and power connection capability (accessory kit is required).

##### C. Fans:

1. Evaporator Fan:
  - a. Fan shall be direct or belt driven as shown on the equipment drawings. Belt drive shall include an adjustable-pitch motor pulley.
  - b. Fan wheel shall be double-inlet type with forward-curved blades.
  - c. Bearings shall be sealed, permanently lubricated ball-bearing type for longer life and lower maintenance.
2. Evaporator fan shall be made from steel with a corrosion-resistant finish and shall be dynamically balanced.
3. Condenser fan shall be of the direct-driven (with totally enclosed motors) propeller type and shall discharge air vertically.



4. Condenser fan shall have aluminum blades riveted to corrosion-resistant steel spiders and shall be dynamically balanced.
5. Induced-draft blower shall be of the direct-driven, single inlet, forward-curved centrifugal type, made from steel with a corrosion-resistant finish and shall be dynamically balanced.

D. Compressor(s):

1. Fully hermetic type, internally protected scroll-type.
2. Factory mounted on rubber grommets and internally spring mounted for vibration isolation.
3. On independent circuits (008-014).

E. Coils:

1. Standard evaporator and condenser coils shall have aluminum lanced plate fins mechanically bonded to seamless internally grooved copper tubes with all joints brazed.
2. Dual compressor models (size 008-014) shall have face-split type evaporator coil (circuit no. 1 on bottom).
3. Optional Coils:
  - a. Optional pre-coated aluminum-fin coils shall have a durable epoxy-phenolic coating to provide protection in mildly corrosive coastal environments. Coating shall be applied to the aluminum fin stock prior to the fin stamping process to create an inert barrier between the aluminum fin and copper tube. Epoxy-phenolic barrier shall minimize galvanic action between dissimilar metals.
  - b. Copper-fin coils shall be constructed of copper fins mechanically bonded to copper tubes and copper tube sheets. Galvanized steel tube sheets shall not be acceptable. A polymer strip shall prevent coil assembly from contacting the sheet metal coil pan to minimize potential for galvanic corrosion between coil and pan. All copper construction shall provide protection in moderate coastal environments.
  - c. E-Coated aluminum-fin coils shall have a flexible epoxy polymer coating uniformly applied to all coil surface areas without material bridging between fins. Coating process shall ensure complete coil encapsulation. Color shall be high gloss black with gloss — 60 deg of 65 to 90% per ASTM D523-89. Uniform dry film thickness from 0.8 to 1.2 mil on all surface areas including fin edges. Superior hardness characteristics of 2H per ASTM D3363-92A and cross-hatch adhesion of 4B-5B per ASTM D3359-93. Impact resistance shall be up to 160 in.-lb (ASTM D2794-93). Humidity and water immersion resistance shall be up to minimum 1000 and 250 hours respectively

(ASTM D2247-92 and ASTM D870-92). Corrosion durability shall be confirmed through testing to be no less than 1000 hours salt spray per ASTM B117-90. Coil construction shall be aluminum fins mechanically bonded to copper tubes.

- d. E-Coated copper-fin coils shall have a flexible epoxy polymer coating uniformly applied to all coil surface areas without material bridging between fins. Coating process shall ensure complete coil encapsulation. Color shall be high gloss black with gloss — 60 deg of 65 to 90% per ASTM D523-89. Uniform dry film thickness from 0.8 to 1.2 mil on all surface areas including fin edges. Superior hardness characteristics of 2H per ASTM D3363-92A and cross-hatch adhesion of 4B-5B per ASTM D3359-93. Impact resistance shall be up to 160 in.-lb (ASTM D2794-93). Humidity and water immersion resistance shall be up to minimum 1000 and 250 hours respectively (ASTM D2247-92 and ASTM D870-92). Corrosion durability shall be confirmed through testing to be no less than 1000 hours salt spray per ASTM B117-90. Coil construction shall be copper fins mechanically bonded to copper tubes with copper tube sheets. Galvanized steel tube sheets shall not be acceptable. A polymer strip shall prevent coil assembly from contacting sheet metal coil pan to maintain coating integrity and minimize corrosion potential between coil and pan.

F. Heating Section:

1. Induced-draft combustion type with energy saving direct-spark ignition system and redundant main gas valve.
2. The heat exchanger shall be of the tubular-section type constructed of a minimum of 20-gage steel coated with a nominal 1.2 mil aluminum-silicone alloy for corrosion resistance.
3. Burners shall be of the in-shot type constructed of aluminum-coated steel.
4. All gas piping shall enter the unit cabinet at a single location on side of unit (horizontal plane).
5. The integrated gas controller (IGC) board shall include gas heat operation fault notification using an LED (light-emitting diode).
6. Unit shall be equipped with anti-cycle protection with one short cycle on unit flame rollout switch or 4 continuous short cycles on the high-temperature limit switch. Fault indication shall be made using an LED.
7. The IGC board shall contain algorithms that modify evaporator-fan operation to prevent future cycling on high-temperature limit switch.
8. The LED shall be visible without removal of control box access panel.

48HJ004-014

9. Optional Stainless Steel Heat Exchanger:
- Complete stainless steel heat exchanger allows for greater application flexibility.
  - 409 stainless steel used in heat exchanger tubes and vestibule plate.
- G. Refrigerant Components:
- Refrigerant circuit components shall include:
- Fixed orifice metering system (Acutrol™).
  - Refrigerant filter drier.
  - Service gage connections on suction, discharge, and liquid lines.
- H. Filter Section:
- Standard filter section shall consist of factory-installed, low velocity, throwaway 2-in. thick fiberglass filters of commercially available sizes.
  - Filter face velocity shall not exceed 320 fpm at nominal airflows.
  - Filter section should use only one size filter.
  - Filters shall be accessible through an access panel with “no-tool” removal.
- I. Controls and Safeties:
- Unit Controls:  
Unit shall be complete with self-contained low-voltage control circuit protected by a fuse on the 24-v transformer side (008-014 units have a resettable circuit breaker).
  - Safeties:
    - Unit shall incorporate a solid-state compressor protector which provides anti-cycle reset capability at the space thermostat, should any of the following standard safety devices trip and shut off compressor.
      - Compressor overtemperature, overcurrent.
      - Loss-of-charge/low-pressure switch.
      - Freeze-protection thermostat, evaporator coil.
      - High-pressure switch.
      - Automatic reset motor thermal overload protector.The lockout protection shall be easily disconnected at the control board, if necessary.
    - Heating section shall be provided with the following minimum protections:
      - High-temperature limit switches.
      - Induced draft motor speed sensor.
      - Flame rollout switch.
      - Flame proving controls.
- J. Operating Characteristics:
- Unit shall be capable of starting and running at 125 F ambient outdoor temperature, meeting maximum load criteria of ARI Standard 210/240 or 360 at  $\pm 10\%$  voltage.
  - Compressor with standard controls shall be capable of operation down to 25 F ambient outdoor temperature.
- K. Electrical Requirements:
- All unit power wiring shall enter unit cabinet at a single factory-predrilled location.
- L. Motors:
- Compressor motors shall be cooled by refrigerant gas passing through motor windings and shall have line break thermal and current overload protection.
  - Evaporator-fan motor shall have permanently lubricated bearings and inherent automatic-reset thermal overload protection. Evaporator motors are designed specifically for Carrier and do *not* have conventional horsepower (HP) ratings listed on the motor nameplate. Motors are designed and qualified in the “air-over” location downstream of the cooling coil and carry a maximum continuous bhp rating that is the maximum application bhp rating for the motor; no “safety factors” above that rating may be applied.
  - Totally enclosed condenser-fan motor shall have permanently lubricated bearings, and inherent automatic-reset thermal overload protection.
  - Induced-draft motor shall have permanently lubricated sealed bearings and inherent automatic-reset thermal overload protection.
- M. Special Features:
- Certain features are not applicable when the features designated \* are specified. For assistance in amending the specifications, contact your local Carrier Sales Office.
- \* 1. Carrier PremierLink™ Controls:
- Shall be available as a factory-installed or as a field-installed accessory.
  - Shall work with CCN and ComfortVIEW™ software.
  - Shall be compatible with *ComfortLink*™ controllers.
  - Shall be ASHRAE 62-99 compliant.
  - Shall accept a CO<sub>2</sub> sensor in the conditioned space — Demand Control Ventilation (DCV) Ready.
  - Shall have baud communication rate of 38.4K or faster.
  - Shall be Internet Ready.
  - Shall include an integrated economizer controller.
  - If an economizer is specified, the “EconoMiSer2 with 4-20 mA actuator and no microprocessor control” is required.
- \* 2. Direct Digital Controls (Apollo):
- Shall be available as a factory-installed option.
  - Shall actively monitor all modes of operation, as well as evaporator-fan status, filter



status, indoor-air quality, supply-air temperature, and outdoor-air temperature.

- c. Shall work with Carrier TEMP and VVT® systems.
- d. Shall have built-in diagnostics for thermostat commands for both staged heating and cooling, evaporator-fan operation, and economizer operation.
- e. Shall be equipped with a 5-minute time delay between modes of operation.

3. Roof Curbs (Horizontal and Vertical):

- a. Formed galvanized steel with wood nailer strip and shall be capable of supporting entire unit weight.
- b. Permits installation and securing of ductwork to curb prior to mounting unit on the curb.

\* 4. Integrated Economizers:

- a. Integrated integral modulating type capable of simultaneous economizer and compressor operation. During economizer operation, only compressor no. 1 on sizes 008-014 will operate.
- b. Available as a factory-installed option in vertical supply/return configuration only. (Available as a field-installed accessory for horizontal and/or vertical supply return configurations.)
- c. Includes all hardware and controls to provide cooling with outdoor air.
- d. Equipped with low-leakage dampers, not to exceed 2% leakage at 1 in. wg pressure differential.
- e. Capable of introducing up to 100% outdoor air.
- f. EconoMi\$er2 shall be equipped with a barometric relief damper.
- g. Designed to close damper(s) during loss-of-power situations with emergency power supply (Durablade economizer) or spring return built into motor (EconoMi\$er2).
- h. Dry bulb outdoor-air temperature sensor shall be provided as standard. Outdoor air sensor opens at 67 F, closes at 52 F and is non-adjustable. Enthalpy, differential temperature (adjustable), and differential enthalpy control shall be provided as field-installed accessories.
- i. Durablade economizer is a guillotine-style damper, and the EconoMi\$er2 is gear-driven parallel blade design.
- j. EconoMi\$er2 microprocessor control shall provide control of internal building pressure through its accessory power exhaust function. Factory set at 100%, with a range of 0% to 100%.
- k. EconoMi\$er2 shall be capable of control from a 4-20 mA signal through optional

4-20 mA design without microprocessor control (required for PremierLink™ or 3rd party control interface).

- l. EconoMi\$er2 Microprocessor Minimum Damper Position Setting — potentiometer maintains the minimum airflow into the building during occupied period (damper position during heating).
- m. EconoMi\$er2 Microprocessor Maximum Damper Position Setting — potentiometer allows installer to limit the amount of outdoor airflow into the building, when CO<sub>2</sub> overrides the mixed air sensor. Setting the maximum position of the damper prevents the introduction of large amounts of hot or cold air into the space.
- n. EconoMi\$er2 Microprocessor IAQ control — modulates the outdoor-air damper to provide ventilation based on the optional 2-10 vdc CO<sub>2</sub> sensor input.
- o. EconoMi\$er2 Microprocessor Purge or Shutdown modes: require optional Honeywell S963B1128 potentiometer (135 ohm).
- p. Compressor lockout sensor (opens at 35 F, closes at 50 F).

5. Manual Outdoor-Air Damper:

Manual damper package shall consist of damper, birdscreen, and rainhood which can be preset to admit up to 50% outdoor air for year round ventilation.

\* 6. 100% Two-Position Damper:

- a. Two-position damper package shall include single blade damper and motor. Admits up to 100% outdoor air.
- b. Damper shall close upon indoor (evaporator) fan shutoff.
- c. Designed to close damper during loss of power situations.
- d. Equipped with 15% barometric relief damper.

\* 7. 25% Two-Position Damper:

- a. Two-position damper package shall include single blade damper and motor. Admits up to 25% outdoor air.
- b. Damper shall close upon indoor (evaporator) fan shutoff.

\* 8. Head Pressure Control Package:

Consists of solid-state control and condenser-coil temperature sensor to maintain condensing temperature between 90 F and 110 F at outdoor ambient temperatures down to -20 F by condenser-fan speed modulation or condenser-fan cycling and wind baffles.

48HJ004-014



9. LP (Liquid Propane) Conversion Kit:  
Package shall contain all the necessary hardware and instructions to convert a standard natural gas unit for use with liquefied propane.
- \* 10. Electronic Programmable Thermostat:  
Capable of using deluxe full-featured electronic thermostat. Shall use built-in compressor cycle delay control for both heating and cooling duty. Capable of working with Carrier direct digital controls.
11. Light Commercial Thermostat:  
Field-installed wall-mounted thermostat is used to control temperature and activation of the dehumidification package. The thermostat can be set for humidity settings from 50% to 90% relative humidity. Automatic humidity control adjusts indoor humidity based on the outdoor temperature sensor.
- \* 12. Flue Shield:  
Provides protection from the hot sides of the gas flue hood.
- \* 13. Thermostat and Subbase:  
Provides staged cooling and heating automatic (or manual) changeover, fan control, and indicator light.
- \* 14. Condenser Coil Hail Guard Assembly:  
Hail guard shall protect against damage from hail and flying debris.
15. Unit-Mounted, Non-Fused Disconnect Switch:  
Shall be factory-installed, internally mounted. NEC and UL approved non-fused switch shall provide unit power shutoff. Shall be accessible from outside the unit and shall provide power off lockout capability.
16. Convenience Outlet:  
Shall be factory-installed and internally mounted with easily accessible 115-v female receptacle. Shall include 15 amp GFI receptacle with independent fuse protection. Voltage required to operate convenience outlet shall be provided by a factory-installed step-down transformer. Shall be accessible from outside the unit.
17. High-Static Indoor Fan Motor(s) and Drive(s) (004-012):  
High-static motor(s) and drive(s) shall be factory-installed to provide additional performance range.
18. Flue Discharge Deflector:  
Flue discharge deflector directs unit exhaust vertically instead of horizontally.
19. Condenser Coil Grille:  
The grille protects the condenser coil from damage by large objects without increasing unit clearances.
20. Compressor Cycle Delay:  
Unit shall be prevented from restarting for minimum of 5 minutes after shutdown.
21. Thru-the-Bottom Utility Connectors:  
Kit shall provide connectors to permit gas and electrical connections to be brought to the unit through the basepan.
22. Fan/Filter Status Switch:  
Provides status of indoor (evaporator) fan (ON/OFF) or filter (CLEAN/DIRTY). Status shall be displayed over communication bus when used with direct digital controls or with an indicator light at the thermostat.
23. Energy\$Recycler:  
The package shall be an outdoor rooftop or surface mounted, electronically controlled, air-to-air heat pump unit utilizing a hermetic compressor for cooling and heating duty.  
The Energy\$Recycler shall recover energy from building exhaust air and pre-condition ventilation air to allow higher ventilation requirements and minimizing energy cost.  
This option shall be available with the following:
  - a. A mounting kit for the Energy\$Recycler for cantilever mounting off of the rooftop unit with out the use of a slab or a roof curb.
  - b. A supplementary supply air fan kit to provide increased air movement into the 62AQ unit.
  - c. A field installed 460 v to 208/230 v transformer to provide power when the 208-230/1/60 62AQ060 or 100 size Energy\$Recycler is used with a 460 v rooftop unit.
24. EconoMi\$er2 and Power Exhaust:  
Package shall provide control of internal building pressure. The power exhaust system shall exhaust up to 100% of return air (vertical only).
25. Power Exhaust Accessory for EconoMi\$er2:  
Power exhaust shall be used in conjunction with EconoMi\$er2 to provide system exhaust of up to 100% of return air (vertical only). The power exhaust is a field-installed accessory (separate vertical and horizontal design).  
NOTE: Horizontal power exhaust is intended to mount in return ductwork.  
As the outdoor-air damper opens and closes, *both* propeller fans are energized and de-energized through the end switch (potentiometer) located on the EconoMi\$er2 controller. The end switch is factory set at 100% of outdoor-air, and is adjustable 0-100% to meet specific job requirements. Available in 208/230-1-60 v or 460-3-60 v. An LED light on the controller indicates when the power exhaust is operating.



26. Outdoor Air Enthalpy Sensor:

The outdoor air enthalpy sensor shall be used with the EconoMi\$er2 device to provide single enthalpy control. When used in conjunction with a return air enthalpy sensor, the EconoMi\$er2 device will provide differential enthalpy control. The sensor allows the EconoMi\$er2 controller to determine if outside air is suitable for free cooling.
27. Return Air Enthalpy Sensor:

The return air enthalpy sensor shall be used with the EconoMi\$er2 device. When used in conjunction with an outdoor air enthalpy sensor, the EconoMi\$er2 device will provide differential enthalpy control.
28. Return Air Temperature Sensor:

The return air temperature sensor shall be used with the EconoMi\$er2 device. When used in conjunction with the standard outdoor air temperature sensor, the EconoMi\$er2 device will provide differential temperature control.
29. Outdoor Air/Return Air Temperature Sensor (Adjustable):

Optional sensor uses (4) ranges on EconoMi\$er2 microprocessor to control outdoor-air damper and compressor operation.
30. Indoor Air Quality (CO<sub>2</sub>) Sensor:
  - a. Shall have the ability to provide demand ventilation indoor air quality (IAQ) control through the EconoMi\$er2 with an IAQ sensor.
  - b. The IAQ sensor shall be available in duct mount, wall mount, and wall mount with LED display. The set point shall have adjustment capability.
  - c. Require EconoMi\$er2, PremierLink™, or Apollo control options.
31. Power Exhaust Auxiliary Transformer:

Field installed 575 v to 230 v transformer to provide power to the 230 v power exhaust when attached to a 575 v rooftop unit.
32. Gas Heat options (sizes 004-006):
  - a. Single-stage gas heat shall be provided in lieu of two-stage heat.
  - b. NO<sub>x</sub> reduction shall be provided to reduce nitrous oxide emissions to meet the California Air Quality Management NO<sub>x</sub> requirement of 40 nanograms/joule or less.
- c. Primary tubes on low NO<sub>x</sub> units shall be 409 stainless steel. Other components shall be aluminized steel.
33. Ultra-Violet Germicidal Lamps:

Ultra-violet germicidal lamps are designed to eliminate odor causing mold and fungus that may develop in the wet area of the evaporator section of the unit. The high output, low temperature germicidal lamps are field installed in the evaporator section of the unit, aimed at the evaporator coil and condensate pan. The short wavelength ultra-violet light inhibits and kills mold, fungus and microbial growth. The lamps have an output rating at 45F in 400 fpm air-flow of 120 microwatts/cm<sup>2</sup> at 1 meter.
34. MoistureMi\$er™ Dehumidification Package:

The dehumidification package is a factory-installed option that provides increased dehumidification by further subcooling the hot liquid refrigerant leaving the condenser coil. The package consists of a subcooling coil located on the leaving airside of the evaporator coil. The location of this coil in the indoor air stream greatly enhances the latent capacity of the units.

The package shall be equipped with crankcase heater(s), low pressure switch(es) and thermostatic expansion valve(s) (TXV). Low pressure switch(es) prevents evaporator coil freeze-up and TXVs assure a positive superheat condition. If the operation of the subcooling coil is controlled by a field-installed, wall-mounted humidistat, the dehumidification circuit will then operate only when needed. Optional field connections for the humidistat are made in the low voltage compartment of the unit control box.
35. Humidistat:

Field-installed, wall-mounted humidistat is used to control activation of the dehumidification package. The humidistat can be set for humidity levels between 20% and 80% relative humidity.
36. Hinged Panel Option:

Hinged panel option provides hinged access panels for the filter, compressor, evaporator fan, and control box areas. Filter hinged panels permit tool-less entry for changing filters. Each hinged panel is permanently attached to the rooftop unit.

# Model number nomenclature



## 48HJ015,017 (12 and 15 Tons) — ASHRAE 90.1 Compliant

48 HJ D 017 Z - C 6 -- YA

48 – Single Package  
Rooftop Units, Gas  
Heating/Electric Cooling

HJ – Constant Volume, High Efficiency

**Heat Options**  
D – Low Heat  
F – High Heat

**Nominal Capacity – Tons**  
015 – 12 Tons  
017 – 15 Tons

**Service/Control Options**  
– – Standard Controls  
G – Service Option  
J – Hinged Access Panels  
S – Hinged Access Panels with  
Apollo Control  
Y – Service Option with Apollo Control  
Z – Apollo Control

**Outdoor Air and Fan Drive Options**

AA – EconoMi\$er and High Fan  
Drive Static Capability  
BA – Manual 25% Outside Air Damper  
and High Fan Drive Static Capability  
QA – EconoMi\$er and Low-Medium Fan  
Drive Static Capability  
YA – Manual 25% Outside Air Damper and  
Low-Medium Fan Drive Static Capability

**Voltage Description**

1 – 575-3-60  
5 – 208/230-3-60  
6 – 460-3-60

**Coil Protection Options (fin/tube)**

– – Al/Cu Condenser and Evaporator  
B – Cu/Cu Condenser and Evaporator  
C – Cu/Cu Condenser and Al/Cu Evaporator  
F – E-Coated Al/Cu Condenser and Al/Cu Evaporator  
G – E-Coated Cu/Cu Condenser and Al/Cu Evaporator  
V – Al/Cu Pre-Coated Condenser Fins

**LEGEND**

Al — Aluminum  
Cu — Copper

**Quality Assurance**



Certificate No FM 21837

**Approvals:**

ISO 9001  
EN 9000:2000

48HJ015,017

# ARI\* capacity ratings



UNIT 48HJD	NOMINAL TONS	NET COOLING CAPACITY (Btuh)	TOTAL WATTS	EER	SOUND RATING (Bels)	IPLV
015	12	134,000	12,209	10.60	8.8	11.4
017	15	180,000	17,064	10.50	8.8	11.4

UNIT 48HJF	NOMINAL TONS	NET COOLING CAPACITY (Btuh)	TOTAL WATTS	EER	SOUND RATING (Bels)	IPLV
015	12	134,000	12,218	10.60	8.8	11.4
017	15	180,000	17,179	10.50	8.8	11.1

## LEGEND

- Bels** — Sound Levels (1 bel = 10 decibels)  
**db** — Dry Bulb  
**EER** — Energy Efficiency Ratio  
**IPLV** — Integrated Part-Load Values  
**wb** — Wet Bulb

\*Air Conditioning and Refrigeration Institute.

## NOTES:

1. Rated in accordance with ARI Standards 360-89 and 270-89.
2. ARI ratings are net values, reflecting the effects of circulating fan heat.
3. Ratings are based on:



**Cooling Standard:** 80 F db, 67 F wb indoor entering-air temperature and 95 F db air entering outdoor unit.

**IPLV Standard:** 80 F db, 67 F wb indoor entering-air temperature and 80 F db outdoor entering-air temperature.

4. All 48HJ015,017 units are in compliance with ASHRAE 90.1 2001 Energy Standard for minimum SEER and EER requirements. Refer to state and local codes or visit the following website: <http://solstice.crest.org/efficiency/bcap> to determine if compliance with this standard pertains to a given geographical area of the United States.

California, Maryland, Washington, Wyoming and various local and state building codes adopted the ASHRAE 90.1 efficiency standard on October 29, 2001.

## ARI HEATING CAPACITIES AND EFFICIENCIES — 48HJ015,017

UNIT 48	HEATING INPUT (Btuh) Stage 2/Stage 1*	OUTPUT CAPACITY (Btuh)	TEMPERATURE RISE (F)	AGA STEADY STATE EFFICIENCY (%)	MINIMUM HEATING CFM†
HJD015	230,000/172,000	186,300	15-45	81.0	3830
HJF015	300,000/225,000	243,000	30-60	81.0	3750
HJD017	275,000/206,000	223,000	15-45	81.0	4580
HJF017	360,000/270,000	291,000	20-50	81.0	5400

\*All units are 2-stage heat.

†Minimum heating cfm must be maintained to ensure proper heating operation.

NOTE: Minimum allowable temperature of mixed air entering the heat exchanger during first stage heating is 45 F. There is no minimum mixed-air limitation during second-stage heating.

## LOW OUTDOOR AIR TEMPERATURE OPERATING LIMITS

UNIT SIZE	TEMPERATURE LIMIT (F)		
	Standard Unit	Unit With Low Ambient Kit	Unit With Motormaster® I Control
015, 017	40	20	-20

48HJ015,017

# Physical data



UNIT 48HJ	015D/F			017D/F		
	208/230	460	575	208/230	460	575
<b>NOMINAL CAPACITY (tons)</b>	12			15		
<b>OPERATING WEIGHT (lb)</b>						
Unit						
AI/AI*	1725			1800		
AI/Cu*	1875			1950		
Cu/Cu*	2005			2080		
EconoMiser	80			80		
Roof Curb†	200			200		
MoistureMiser™ Dehumidification Package	40			40		
<b>COMPRESSOR</b>						
Quantity...Model (Ckt 1, Ckt 2)	1...ZR72KC, 1...ZR57KC			1...ZR94KC, 1...ZR72KC		
Number of Refrigerant Circuits	2			2		
Loading (% of full capacity)	0,56,100			0,60,100		
Crankcase Heater Watts	70			70		
Oil (oz) (Ckt 1, Ckt 2)	60,66			85,60		
<b>REFRIGERANT TYPE</b>				R-22		
Expansion Device				TXV		
Operating Charge (lb)						
Circuit 1**	20.7			19.5		
Circuit 2	11.9			13.45		
<b>CONDENSER COIL</b>				Cross-Hatched 3/8-in. Copper Tubes, Aluminum Lanced, Aluminum Pre-Coated, or Copper Plate Fins		
Rows...Fins/in.	4...15			4...15		
Total Face Area (sq ft)	21.7			21.7		
<b>CONDENSER FAN</b>				Propeller Type		
Nominal Cfm	10,500			10,500		
Quantity...Diameter (in.)	3...22			3...22		
Motor Hp...Rpm	1/2...1050			1/2...1050		
Watts Input (Total)	1100			1100		
<b>EVAPORATOR COIL</b>				Cross-Hatched 3/8-in. Copper Tubes, Aluminum Lanced or Copper Plate Fins, Face Split		
Rows...Fins/in.	4...15			4...15		
Total Face Area (sq ft)	17.5			17.5		
<b>EVAPORATOR FAN</b>				Centrifugal Type		
Quantity...Size (in.)	2...10 X 10			2...12 X 12		
Type Drive	Belt			Belt		
Nominal Cfm	5200			6000		
Std Motor Hp	2.9			5		
Opt Motor Hp	3.7			N/A		
Motor Nominal Rpm	1725			N/A		
Std Maximum Continuous Bhp	3.13			3.38		
Opt Maximum Continuous Bhp	4.38			N/A		
Motor Frame Size	56H			184T		
Fan Rpm Range	Low-Medium Static 834-1064 High Static 1161-1426			1105-1321 N/A		
Motor Bearing Type	Ball			Ball		
Maximum Allowable Rpm	1550			1550		
Motor Pulley Pitch Dia.	Low-Medium Static 3.1/4.1 High Static 3.7/4.7			4.3/5.3 N/A		
Nominal Motor Shaft Diameter (in.)	7/8			1 1/8		
Fan Pulley Pitch Diameter (in.)	Low-Medium Static 6.0 High Static 5.2			6.4 N/A		
Nominal Fan Shaft Diameter (in.)	1 3/16			1 3/16		
Belt, Quantity...Type... Length (in.)	Low-Medium Static 1...BX...42 High Static 1...BX...42			1...BX...45 N/A		
Pulley Center Line Distance (in.)	13.5-15.5			13.3-14.8		
Speed Change per Full Turn of Movable Pulley Flange (Rpm)	Low-Medium Static 58 High Static 67			55 N/A		
Movable Pulley Maximum Full Turns From Closed Position	4††			4***		
Factory Speed	3.5			3.5		
Factory Speed Setting (Rpm)	Low-Medium Static 978 High Static 1327			1240 N/A		
<b>FURNACE SECTION</b>						
Rollout Switch Cutout Temp (F)‡	190			190		
Burner Orifice Diameter (in...drill size)						
Natural Gas	Std 0.1285...30/ 0.136...29			0.1285...30/ 0.136...29		
Liquid Propane¶	Alt 0.1065...36/0.1065...36			0.1065...36/0.1065...36		
Thermostat Heat Anticipator Setting						
208/230/460/575 v						
Stage 1 (amps)	0.98			0.98		
Stage 2 (amps)	0.44			0.44		
Gas Input (Btuh) Stage 1	172,000/225,000			206,000/270,000		
Stage 2	230,000/300,000			275,000/360,000		
Efficiency (Steady State) (%)	81			81		
Temperature Rise Range	15-45/30-60			15-45/20-50		
Manifold Pressure (in. wg)						
Natural Gas	Std 3.3			3.3		
Liquid Propane¶	Alt 3.3			3.3		
Gas Valve Quantity	1			1		
Gas Valve Pressure Range (Min-Max Allowable) (in. wg)	5.5-13.5			5.5-13.5		
(psig)	.235-.487			.235-.487		
Field Gas Connection Size (in.-FPT)	3/4			3/4		
<b>HIGH-PRESSURE SWITCH (psig)</b>						
Cutout				426		
Reset (Auto.)				320		
<b>LOW-PRESSURE SWITCH (psig)</b>						
Cutout				27		
Reset (Auto.)				44		
<b>FREEZE PROTECTION THERMOSTAT (F)</b>						
Opens				30 ± 5		
Closes				45 ± 5		
<b>OUTDOOR-AIR INLET SCREENS</b>				Cleanable		
Quantity...Size (in.)				2...20 x 25 x 1		
				1...20 x 20 x 1		
<b>RETURN-AIR FILTERS</b>				Throwaway		
Quantity...Size (in.)				4...20 x 20 x 2		
				4...16 x 20 x 2		

LEGEND

AI — Aluminum  
 Bhp — Brake Horsepower  
 Cu — Copper  
 TXV — Thermostatic Expansion Valve

\*Evaporator coil fin material/condenser coil fin material.

†Weight of 14-in. roof curb.

\*\*Circuit 1 uses the lower portion of condenser coil and lower portion of evaporator coils, and Circuit 2 uses the upper portion of both coils.

††Pulley has 6 turns. Due to belt and pulley style, moveable pulley cannot be set to 0 to 1 1/2 turns open (except size 025).

\*\*\*Due to belt and pulley style, moveable pulley cannot be set to 0 to 1/2 turns open.

‡Rollout switch is manual reset.

¶A Liquid Propane kit is available as an accessory. Kit may be used at elevations as high as 2000 ft.

48HJ015.017



## OPERATING AND RIGGING WEIGHTS

UNIT	BASE UNIT OPERATING WEIGHTS*			
	015		017	
	lb	kg	lb	kg
<b>48HJD/F</b>	1725	782	1800	816

\*Base unit weight does not include electric heaters, copper coils, economizer, power exhaust, barometric relief or crating. See Options and Accessories table below for more information.

NOTE: For 015 and 017 unit sizes add 75 lb (34 kg) for domestic crating. For export crating add 500 lb (227 kg).

## OPTIONS AND ACCESSORIES (Weight Adders)

OPTION/ ACCESSORY	OPTION/ACCESSORY WEIGHTS			
	48HJ015		48HJ017	
	lb	kg	lb	kg
<b>Barometric Relief Damper</b>	50	23	50	23
<b>Power Exhaust</b>	85	39	85	39
<b>EconoMiSer</b>	80	36	80	36
<b>Cu Condenser Coil</b>	150	68	150	68
<b>Cu Condenser and Evaporator Coils</b>	280	127	280	127
<b>Roof Curb (14-in. curb)</b>	200	91	200	91
<b>Horizontal Adapter Roof Curb (Preassembled)</b>	250	113	250	113
<b>Horizontal Adapter Roof Curb (Field-assembled)</b>	343	156	343	156
<b>Hail Guard</b>	60	27	60	27
<b>MoistureMiSer™ Dehumidification Package</b>	40	18	40	18

LEGEND

**Cu** — Copper

# Base unit dimensions — 48HJ015,017



48HJ015,017

UNIT	STD UNIT WEIGHT		ECONOMISER WEIGHT		CORNER A		CORNER B		CORNER C		CORNER D		DIM A		DIM B		DIM C	
	Lb	Kg	Lb	Kg	Lb	Kg	Lb	Kg	Lb	Kg	Lb	Kg	ft-in.	mm	ft-in.	mm	ft-in.	mm
48HJD, HJF015	1725	782	80	36	407	185	170	383	174	410	186	375	3-3	991	3-5	1051	1-10	559
48HJD, HJF017	1800	816	80	36	417	189	399	181	481	218	503	399	3-2	961	3-6	1070	1-10	559

- NOTES:
- Refer to print for roof curb accessory dimensions.
  - Dimensions in ( ) are in millimeters.
  - Center of Gravity.
  - Direction of airflow.
  - Ductwork to be attached to accessory roof curb only.
  - Minimum clearance:
    - Rear: 7'-0" (2134) for coil removal. This dimension can be reduced to 4'-0" (1219) if conditions permit coil removal from the top.
    - 4'-0" (1219) to combustible surfaces, all four sides (includes between units).
    - Left side: 4'-0" (1219) for proper condenser coil airflow.
    - Front: 4'-0" (1219) for control box access.
    - Right side: 4'-0" (1219) for proper operation of damper and power exhaust if so equipped.
    - Top: 6'-0" (1829) to assure proper condenser fan operation.
    - Bottom: 14" (356) to combustible surfaces (when not using curb).
    - Control box side: 3'-0" (914) to ungrounded surfaces, non-combustible.
    - Control box side: 3'-6" (1067) to block or concrete walls, or other grounded surfaces.
  - Local codes or jurisdiction may prevail.
  - With the exception of clearance for the condenser coil and the damper/power exhaust as stated in Note #6, a removable fence or barricade requires no clearance.
  - Dimensions are from outside of corner post. Allow 0'-5 1/16" (8) on each side for top cover drip edge.
  - See drawing 50TJ500352 for service option details.

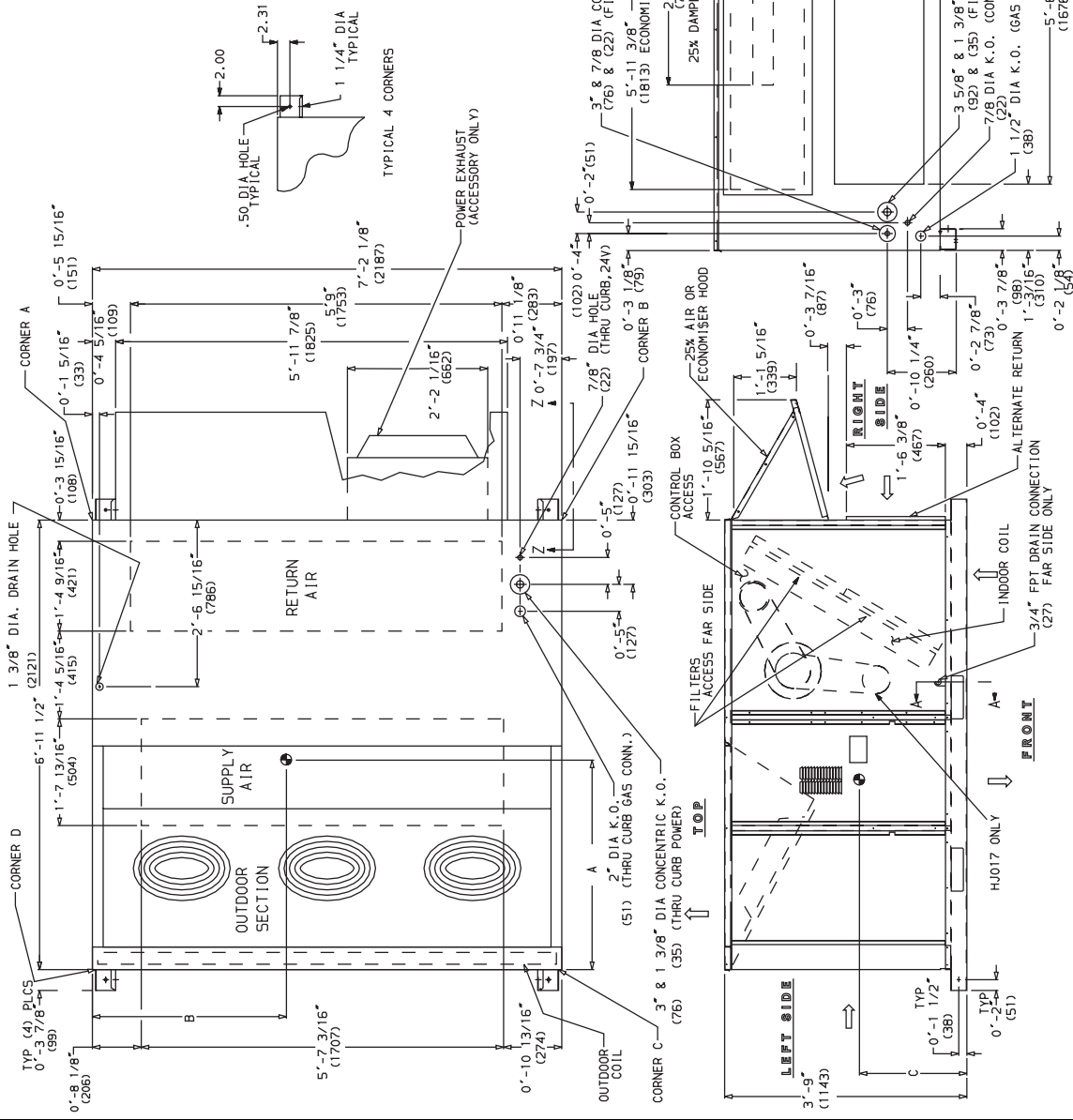

# Accessory dimensions



**NOTES:**

1. Roof curb accessory is shipped disassembled.
  2. Insulated panels: 1" thick neoprene coated 1 1/2 lb density.
  3. Dimensions in ( ) are in millimeters.
  4. Direction of airflow.
  5. Roof curb: 16 ga. (VA03-56) stl.
  6. A 90 degree elbow must be installed on the supply ductwork below the unit discharge for units equipped with electric heaters.
- NOTE: To prevent the hazard of stagnant water build-up in the drain pan of the indoor section, unit can only be pitched as shown.

PKG. NO. REF.	CURB HEIGHT	DESCRIPTION
CRRFCURB010A00	1'- 2" (305)	Standard Curb 14" High
CRRFCURB011A00	2'- 0" (610)	Standard Curb for Units Requiring High Installation
CRRFCURB012A00	2'- 0" (610)	Side Supply and Return Curb for High Installation
CRRFCURB013A00	1'-11" (584)	Horizontal Adapter with High Static Transition Duct

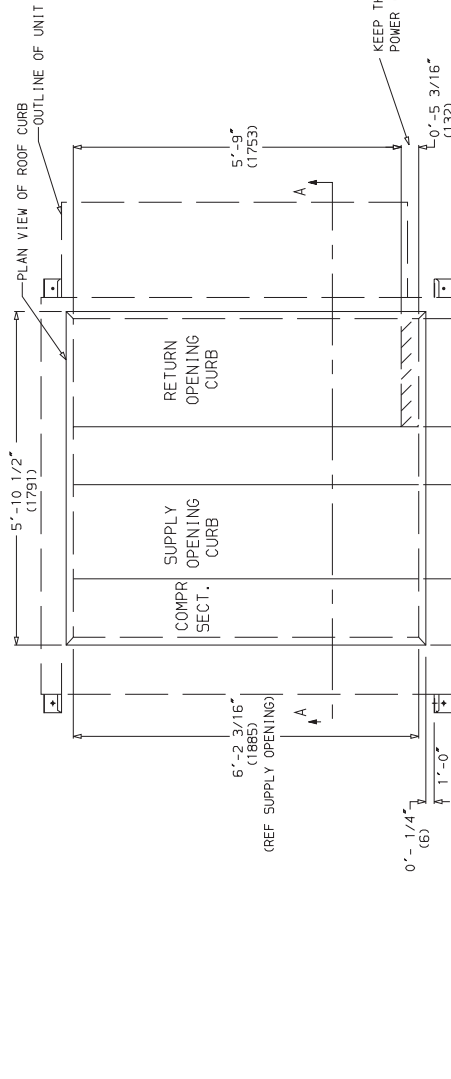

DIMENSIONS\* (degrees and inches)

UNIT	A		B	
	Deg.	in.	Deg.	in.
ALL	.28	.45	.28	.43

UNIT LEVELING TOLERANCES  
\*From edge of unit to horizontal.

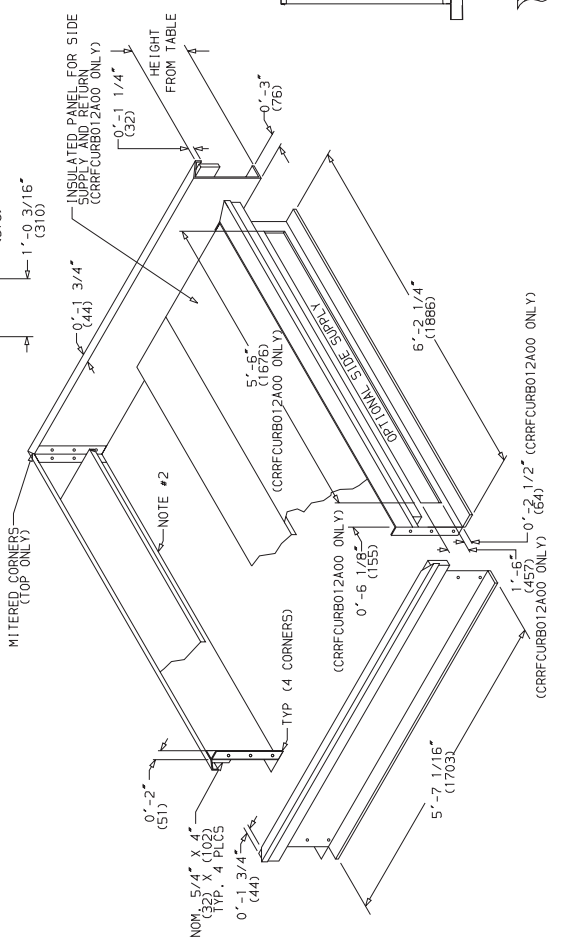

48HJ015.017

# Accessory dimensions (cont)



## HORIZONTAL SUPPLY/RETURN ADAPTER INSTALLATION

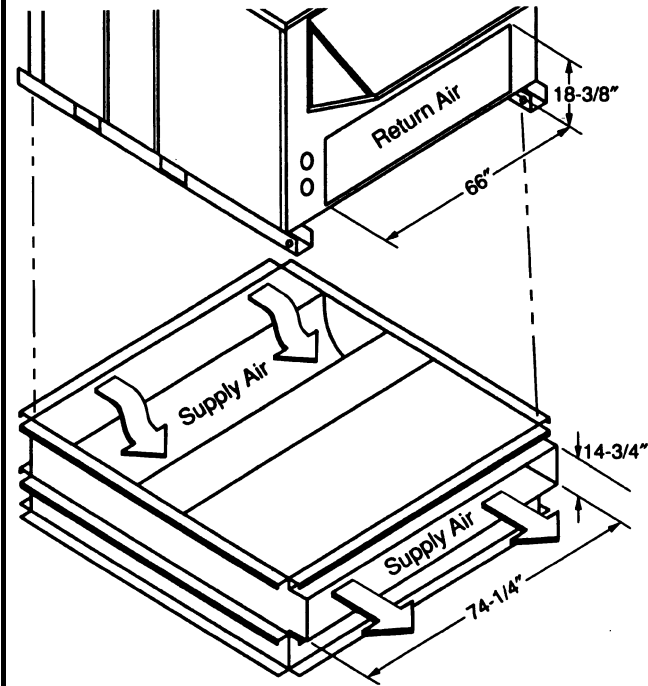

NOTE: CRRFCURB013A00 is a fully factory preassembled horizontal adapter and includes an insulated high static regain transition duct which substantially improves fan static performance.

The Barometric Relief Damper and Power Exhaust accessories are not available with the horizontal adapter.

The side panel at the side return opening is used to cover the bottom return air opening.

ACCESSORY PACKAGE NO.	CURB HEIGHT	DESCRIPTION
CRRFCURB013A00	1'-11" (584)	Pre-Assembled, High Static, Horizontal Adapter Roof Curb

## BAROMETRIC RELIEF/POWER EXHAUST

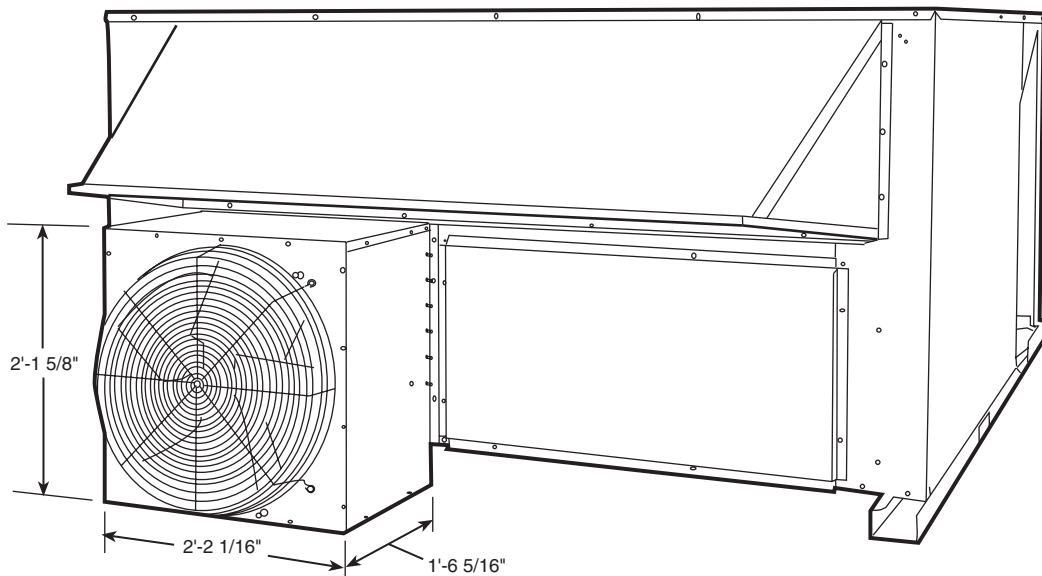

48HJ015.017

FACTORY-INSTALLED CONVENIENCE OUTLET

END VIEW

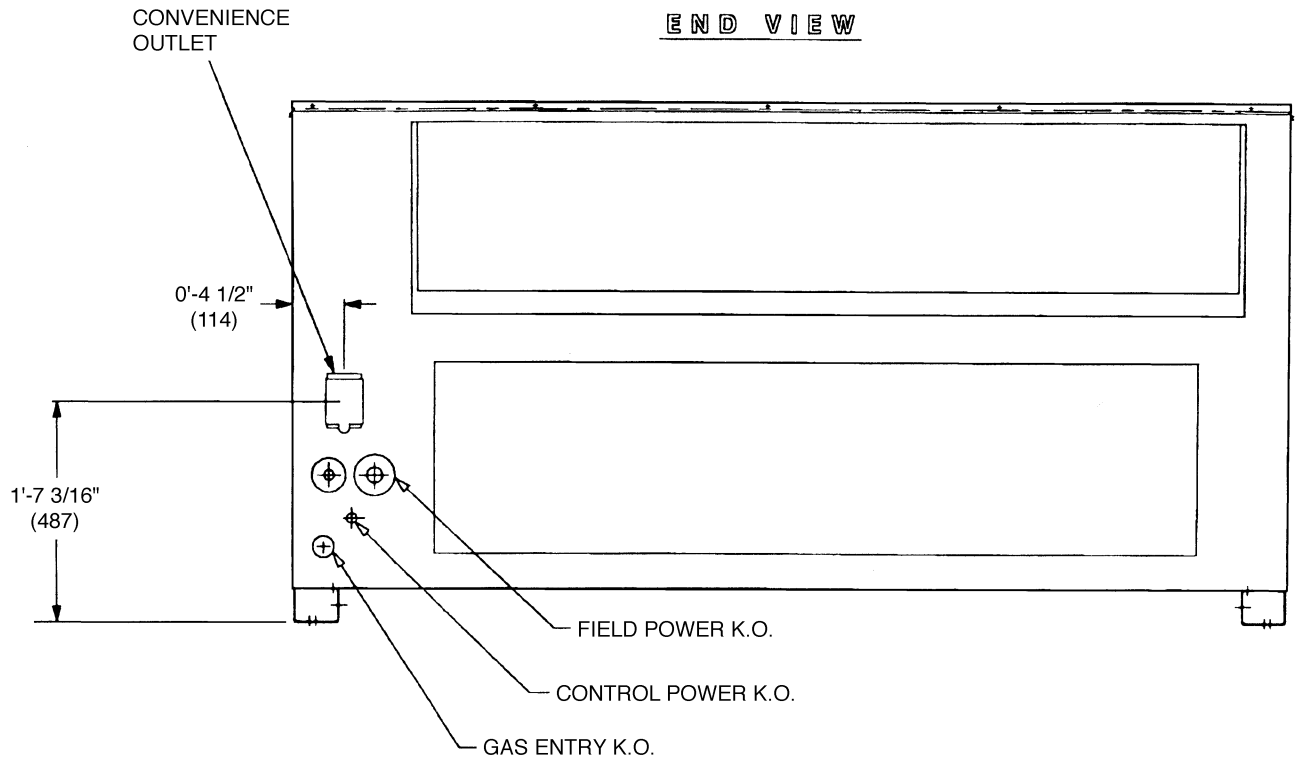

FACTORY-INSTALLED NON-FUSED DISCONNECT

TOP

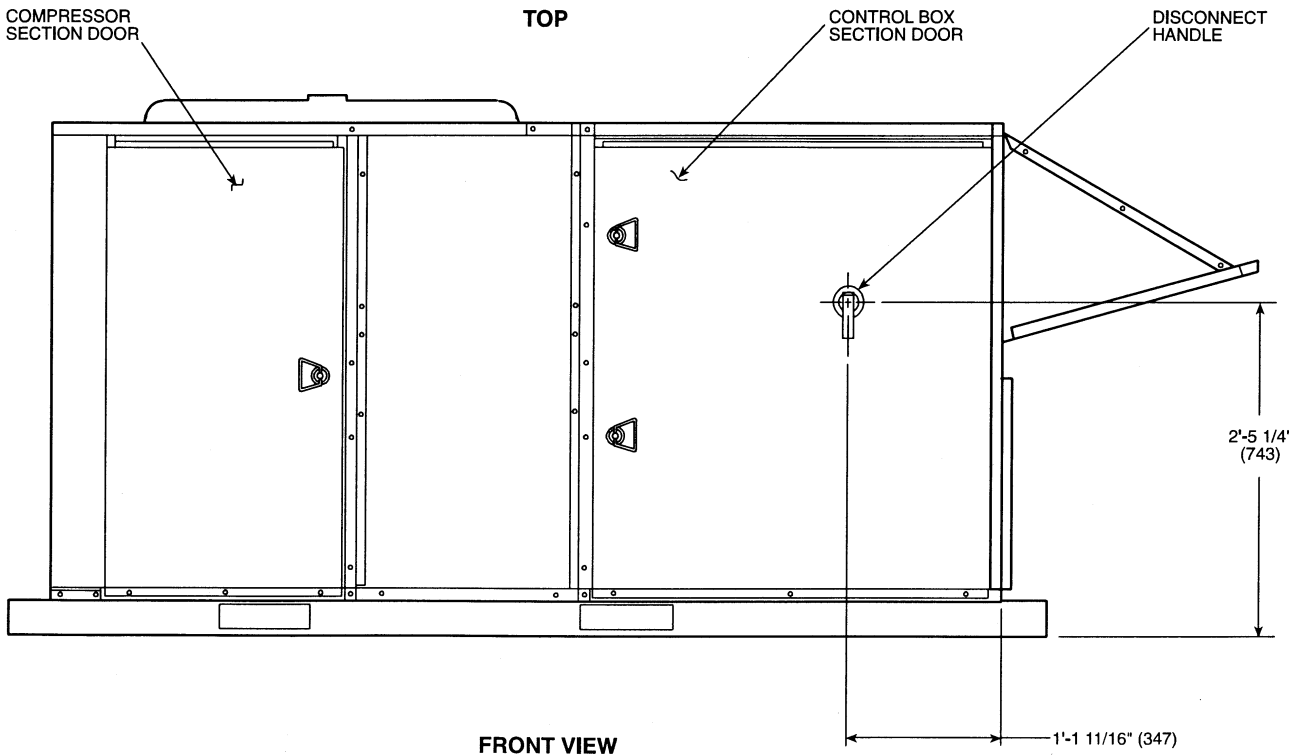

48HJ015,017

# Selection procedure (with 48HJ017 example)



## I Determine cooling and heating requirements at design conditions.

Given:

Required Gross Cooling Capacity (TC) . . . . . 168,000 Btuh  
Gross Sensible Heat Capacity (SHC) . . . . . 121,000 Btuh  
Required Heating Capacity . . . . . 190,000 Btuh  
Condenser Entering Air Temperature . . . . . 95 F Summer  
Indoor Air Temperature . . . . . 80 F edb, 67 F ewb  
Evaporator Air Quantity . . . . . 6,000 cfm  
External Static Pressure . . . . . 1.40 in. wg  
Electrical Characteristics (V-Ph-Hz) . . . . . 230-3-60  
Optional economizer required.

## II Select unit based on required cooling capacity.

Enter Cooling Capacities table for 48HJ017 at condenser entering temperature of 95 F, evaporator air quantity of 6,000 cfm, and indoor air temperature of 67 F. The 48HJ017 unit will provide a total cooling capacity of 190,000 Btuh and a SHC of 136,000 Btuh. For evaporator air temperatures other than 80 F, calculate SHC correction using formula in notes under cooling capacity tables.

Unit meets design conditions for TC and SHC.

NOTE: Unit ratings are gross capacities and do not include the effect of indoor fan motor heat. To calculate net capacities, see Step V.

## III Select heating capacity of unit to provide design condition requirement.

In Heating Capacities and Efficiencies table, note that 48HJD017 (low heat) unit will provide 223,000 Btuh with an input of 275,000 Btuh.

## IV Determine fan speed and power requirements at design conditions.

Before entering the Fan Performance tables, calculate the total static pressure required based on unit components. Tabulated fan performance includes filters and wet evaporator coil. Refer to Accessory/FIOP Static Pressure — 48HJ015,017 Units table for added pressure drops.

Calculate pressure drop:

Design External Static Pressure 1.40  
1.40 in. wg (ESP)

Enter Fan Performance tables for 48HJD017 (low heat units) at 6,000 cfm and 1.40 in. wg. The rpm is 1210 and the Bhp is 4.60. The factory-installed 5 hp motor and alternate high-static drive are sufficient for this operation.

## V Determine net cooling capacities.

Cooling capacities are gross capacities and do not include indoor (evaporator) fan motor (IFM) heat. To determine input power to the motor, enter the Fan Performance tables for 48HJD017 (low heat units) at 6,000 cfm and 1.40 in. wg. Input watts to the motor are 3925.

Determine net cooling capacity and net sensible cooling capacity using the following formulas:

$$\begin{aligned} \text{IFM Heat} &= \text{Input Watts} \times 3.412 \text{ Btuh/Watt} \\ &= 3925 \times 3.412 \\ &= 13,392 \text{ Btuh} \end{aligned}$$

$$\begin{aligned} \text{Net Capacity} &= \text{Gross Capacity} - \text{IFM Heat} \\ &= 190,000 - 13,392 \\ &= 176,608 \text{ Btuh} \end{aligned}$$

$$\begin{aligned} \text{Net Sensible Cap.} &= \text{Gross Sensible Cap.} - \text{IFM Heat} \\ &= 136,000 - 13,392 \\ &= 122,608 \text{ Btuh} \end{aligned}$$

The calculations show that a 48HJD017 unit is the correct selection for the given conditions.

## VI Select the unit that corresponds to power source available.

The electrical data table shows that the 230-3-60 unit is available.

## COOLING CAPACITIES

Temp (F) Air Entering (Edb)		Evaporator Air Quantity — Cfm/BF														
		3600/0.03			4375/0.04			5000/0.05045			5625/0.06			6250/0.07		
		Evaporator Air — Ewb (F)														
		62	67	72	62	67	72	62	67	72	62	67	72	62	67	72
75	TC	134	145	153	137	148	156	141	149	156	144	151	157	147	152	157
	SHC	111	93	72	124	103	77	130	109	77	134	114	79	137	119	79
	kW	7.9	8.1	8.2	8.0	8.2	8.3	8.1	8.2	8.3	8.1	8.2	8.3	8.2	8.2	8.3
85	TC	130	140	147	133	142	149	136	144	149	139	145	150	141	146	150
	SHC	109	90	68	120	97	72	127	106	73	130	110	76	132	112	76
	kW	8.9	9.1	9.2	8.9	9.1	9.2	9.0	9.1	9.2	9.1	9.2	9.2	9.1	9.2	9.2
95	TC	125	134	141	128	136	142	131	138	142	133	138	142	136	139	142
	SHC	106	87	66	117	94	69	122	99	71	124	104	72	127	108	73
	kW	9.9	10.1	10.2	10.0	10.1	10.2	10.1	10.2	10.2	10.1	10.2	10.2	10.2	10.2	10.2
105	TC	120	129	134	123	130	134	126	131	134	128	132	135	129	132	135
	SHC	104	85	63	114	91	67	117	95	67	119	100	68	120	105	70
	kW	11.1	11.2	11.3	11.1	11.3	11.3	11.2	11.3	11.4	11.2	11.3	11.4	11.3	11.3	11.4
115	TC	114	122	127	117	123	127	120	124	127	121	124	127	122	125	127
	SHC	100	81	60	109	87	62	111	93	64	113	95	66	114	98	66
	kW	12.3	12.5	12.6	12.4	12.5	12.6	12.4	12.5	12.6	12.5	12.5	12.6	12.5	12.5	12.6
117	TC	108	115	118	122	124	127	123	124	126	123	124	127	124	125	127
	SHC	98	78	57	89	77	64	91	79	64	91	80	66	92	81	66
	kW	13.6	13.8	13.9	12.6	12.7	12.7	12.6	12.7	12.7	12.7	12.7	12.7	12.7	12.7	12.7
120	TC	112	119	123	114	119	123	116	120	123	117	120	123	118	120	123
	SHC	100	80	59	106	85	61	108	89	62	109	92	64	110	96	64
	kW	12.9	13.1	13.2	13.0	13.1	13.2	13.1	13.2	13.2	13.1	13.2	13.2	13.1	13.2	13.2
125	TC	109	115	118	111	115	119	113	116	119	114	116	119	115	116	119
	SHC	98	79	57	103	84	59	105	88	61	106	90	64	107	93	63
	kW	13.6	13.8	13.9	13.7	13.8	13.9	13.7	13.8	13.9	13.8	13.8	13.9	13.8	13.8	13.9

Temp (F) Air Entering Condenser (Edb)		Evaporator Air Quantity — Cfm/BF														
		4500/0.02			5250/0.03			6000/0.04			6750/0.04			7500/0.05		
		Evaporator Air — Ewb (F)														
		62	67	72	62	67	72	62	67	72	62	67	72	62	67	72
75	TC	181	196	213	186	201	217	189	204	219	194	206	220	198	208	223
	SHC	147	124	99	160	133	105	173	143	113	181	153	120	186	163	125
	kW	11.2	11.6	12.0	11.3	11.7	12.1	11.4	11.8	12.1	11.6	11.9	12.2	11.7	11.9	12.2
85	TC	175	190	205	180	194	209	183	198	212	188	200	213	192	202	214
	SHC	145	121	97	157	130	102	168	139	106	175	148	115	180	157	119
	kW	12.3	12.7	13.1	12.5	12.8	13.2	12.6	12.9	13.3	12.7	13.0	13.3	12.8	13.1	13.4
95	TC	168	182	197	172	187	201	176	190	203	181	192	205	185	194	206
	SHC	142	118	93	154	127	98	164	136	102	170	144	108	174	153	113
	kW	13.5	13.9	14.3	13.6	14.0	14.4	13.8	14.1	14.5	13.9	14.2	14.6	14.0	14.3	14.6
105	TC	161	174	188	165	178	191	169	181	193	173	182	194	177	184	194
	SHC	138	115	91	150	124	95	158	132	98	162	140	103	166	148	107
	kW	14.8	15.2	15.6	14.9	15.3	15.7	15.1	15.4	15.7	15.2	15.5	15.8	15.3	15.5	15.8
115	TC	152	165	179	157	168	180	161	171	181	166	172	183	169	174	183
	SHC	134	111	87	145	120	91	151	128	94	155	136	98	158	142	101
	kW	16.1	16.5	16.9	16.2	16.6	17.0	16.4	16.7	17.0	16.6	16.8	17.1	16.7	16.9	17.1
120	TC	148	161	—	153	—	—	157	—	—	—	—	—	—	—	—
	SHC	132	110	—	142	—	—	147	—	—	—	—	—	—	—	—
	kW	16.8	17.2	—	16.9	—	—	17.1	—	—	—	—	—	—	—	—

### LEGEND

- BF — Bypass Factor
- Edb — Entering Dry-Bulb
- Ewb — Entering Wet-Bulb
- kW — Compressor Motor Power Input
- ldb — Leaving Dry-Bulb
- lwb — Leaving Wet-Bulb
- SHC — Sensible Heat Capacity (1000 Btuh) Gross
- TC — Total Capacity (1000 Btuh) Gross

3. The SHC is based on 80 F edb temperature of air entering evaporator coil. Below 80 F edb, subtract (corr factor x cfm) from SHC. Above 80 F edb, add (corr factor x cfm) to SHC.

BYPASS FACTOR (BF)	ENTERING AIR DRY-BULB TEMP (F)					
	79	78	77	76	75	under 75
	81	82	83	84	85	over 85
	Correction Factor					
.05	1.04	2.07	3.11	4.14	5.18	Use formula shown below.
.10	.98	1.96	2.94	3.92	4.90	
.20	.87	1.74	2.62	3.49	4.36	
.30	.76	1.53	2.29	3.05	3.82	

### NOTES:

1. Direct interpolation is permissible. Do not extrapolate.
2. The following formulas may be used:

$$t_{ldb} = t_{edb} - \frac{\text{sensible capacity (Btuh)}}{1.10 \times \text{cfm}}$$

$$t_{lwb} = \text{Wet-bulb temperature corresponding to enthalpy of air leaving evaporator coil (} h_{lwb} \text{)}$$

$$h_{lwb} = h_{ewb} - \frac{\text{total capacity (Btuh)}}{4.5 \times \text{cfm}}$$

Where:  $h_{ewb}$  = Enthalpy of air entering evaporator coil

Interpolation is permissible.  
Correction Factor =  $1.10 \times (1 - BF) \times (edb - 80)$ .

# Performance data (cont)



## COOLING CAPACITIES (cont)

### 48HJ015 (12 TONS) UNITS WITH MOISTUREMISER™ OPTION

Temp (F) Air Entering Condenser (Edb)		Evaporator Air Quantity — Cfm/BF														
		3600/0.03			4375/0.04			5000/0.05045			5625/0.06			6250/0.07		
		Evaporator Air — Ewb (F)														
		62	67	72	62	67	72	62	67	72	62	67	72	62	67	72
75	TC	—	139	153	130	144	153	135	145	155	138	147	159	145	149	156
	SHC	—	81	63	111	93	68	118	98	68	125	104	72	135	109	72
	kW	—	8.0	8.2	7.9	8.3	8.2	7.9	8.1	8.3	8.0	8.2	8.3	8.3	8.2	8.3
85	TC	—	133	142	125	137	146	129	138	146	132	140	148	135	142	148
	SHC	—	75	56	105	84	61	113	93	62	120	98	66	125	100	67
	kW	—	8.9	9.1	8.8	9.2	9.2	8.8	9.0	9.0	8.8	9.0	9.2	9.1	9.1	9.3
95	TC	—	126	135	119	129	137	123	132	139	125	133	139	128	135	139
	SHC	—	70	52	99	78	56	106	84	59	112	90	60	117	95	61
	kW	—	9.9	10.1	9.7	9.9	10.1	9.9	10.0	10.2	9.9	10.1	10.1	9.9	10.1	10.1
105	TC	105	119	127	110	122	130	113	124	130	115	125	131	118	126	132
	SHC	80	65	47	92	73	51	97	78	52	104	83	55	108	89	57
	kW	10.6	10.9	11.1	10.8	11.0	11.2	10.9	11.0	11.1	10.8	11.0	11.2	10.9	11.1	11.3
115	TC	90	108	119	97	112	121	97	115	122	100	116	123	106	118	123
	SHC	66	57	41	79	66	45	80	72	47	88	76	49	95	80	51
	kW	11.7	12.1	12.3	11.8	12.2	12.4	11.8	12.3	12.5	12.0	12.4	12.5	12.1	12.3	12.5
117	TC	86	100	111	98	112	121	99	114	121	102	116	123	107	117	123
	SHC	64	52	38	63	58	45	67	61	47	72	63	48	77	66	50
	kW	12.8	13.2	13.6	12.0	12.3	12.5	12.0	12.3	12.5	11.9	12.4	12.5	12.1	12.4	12.5
120	TC	90	102	114	90	107	117	91	109	118	93	111	119	99	113	119
	SHC	67	52	38	71	61	41	76	66	44	81	70	46	87	75	47
	kW	12.3	12.6	12.8	12.3	12.7	12.9	12.3	12.8	12.9	12.3	12.8	13.0	12.5	12.9	13.0
125	TC	83	95	109	85	97	112	87	103	113	88	105	114	90	107	114
	SHC	61	47	35	66	53	38	72	61	41	76	66	44	78	70	45
	kW	12.8	13.1	13.5	12.8	13.1	13.5	12.9	13.3	13.5	12.8	13.4	13.6	12.9	13.4	13.6

### 48HJ017 (15 TONS) UNITS WITH MOISTUREMISER™ OPTION

Temp (F) Air Entering Condenser (Edb)		Evaporator Air Quantity — Cfm/BF														
		4500/0.02			5250/0.03			6000/0.03905			6750/0.04			7500/0.05		
		Evaporator Air — Ewb (F)														
		62	67	72	62	67	72	62	67	72	62	67	72	62	67	72
75	TC	—	185	203	175	191	209	179	195	212	182	198	213	186	200	216
	SHC	—	105	82	141	115	88	154	125	96	165	135	104	174	145	109
	kW	—	11.3	11.7	11.0	11.4	11.8	11.1	11.5	11.9	11.2	11.6	11.9	11.3	11.7	12.0
85	TC	—	176	193	166	183	199	170	186	202	173	189	204	177	190	205
	SHC	—	98	74	134	108	81	145	116	85	156	126	93	162	134	97
	kW	—	12.3	12.7	12.1	12.9	13.4	12.1	12.6	13.5	12.2	12.7	13.5	12.7	12.2	12.7
95	TC	—	168	182	156	173	187	160	176	191	163	178	194	167	181	196
	SHC	—	91	66	126	100	72	137	108	76	146	116	82	153	125	86
	kW	—	13.7	13.5	13.1	13.6	13.9	13.2	13.6	14.1	13.3	13.4	14.3	13.5	13.9	14.6
105	TC	—	156	173	145	160	175	148	162	177	151	166	178	154	167	180
	SHC	—	83	59	117	90	62	127	98	66	136	106	70	141	112	74
	kW	—	14.5	15.3	14.2	14.8	15.1	14.4	14.5	15.1	14.4	14.9	14.9	14.2	14.6	14.9
115	TC	—	141	156	130	146	160	132	150	162	135	150	164	139	152	166
	SHC	—	72	47	104	79	52	112	86	55	119	93	59	127	100	63
	kW	—	15.6	15.9	15.2	15.8	16.2	15.3	16.1	16.3	15.4	16.0	16.4	15.8	16.1	16.4
118	TC	—	138	151	126	141	153	129	144	—	134	145	—	135	148	—
	SHC	—	68	43	100	74	46	108	83	—	120	88	—	124	96	—
	kW	—	16.1	16.5	15.7	16.1	16.5	15.8	16.3	—	16.0	16.3	—	15.9	16.3	—
120	TC	—	134	—	124	—	—	126	—	—	—	—	—	—	—	—
	SHC	—	65	—	99	—	—	106	—	—	—	—	—	—	—	—
	kW	—	16.2	—	15.9	—	—	16.0	—	—	—	—	—	—	—	—

#### LEGEND

- BF — Bypass Factor
- Edb — Entering Dry-Bulb
- Ewb — Entering Wet-Bulb
- kW — Compressor Motor Power Input
- ldb — Leaving Dry-Bulb
- lwb — Leaving Wet-Bulb
- SHC — Sensible Heat Capacity (1000 Btuh) Gross
- TC — Total Capacity (1000 Btuh) Gross

#### NOTES:

1. Direct interpolation is permissible. Do not extrapolate.
2. The following formulas may be used:

$$t_{ldb} = t_{edb} - \frac{\text{sensible capacity (Btuh)}}{1.10 \times \text{cfm}}$$

$t_{lwb}$  = Wet-bulb temperature corresponding to enthalpy of air leaving evaporator coil ( $h_{lwb}$ )

$$h_{lwb} = h_{ewb} - \frac{\text{total capacity (Btuh)}}{4.5 \times \text{cfm}}$$

Where:  $h_{ewb}$  = Enthalpy of air entering evaporator coil

3. The SHC is based on 80 F edb temperature of air entering evaporator coil. Below 80 F edb, subtract (corr factor x cfm) from SHC. Above 80 F edb, add (corr factor x cfm) to SHC.

BYPASS FACTOR (BF)	ENTERING AIR DRY-BULB TEMP (F)					
	79	78	77	76	75	under 75
	81	82	83	84	85	over 85
	Correction Factor					
.05	1.04	2.07	3.11	4.14	5.18	Use formula shown below.
.10	.98	1.96	2.94	3.92	4.90	
.20	.87	1.74	2.62	3.49	4.36	
.30	.76	1.53	2.29	3.05	3.82	

Interpolation is permissible.  
Correction Factor =  $1.10 \times (1 - BF) \times (edb - 80)$ .



FAN PERFORMANCE — 48HJ015,017 UNITS

48HJD015 WITH STANDARD MOTOR (Low Heat Units)\*

Cfm	Available External Static Pressure (in. wg)														
	0.2			0.4			0.6			0.8			1.0		
	Rpm	Watts	Bhp	Rpm	Watts	Bhp	Rpm	Watts	Bhp	Rpm	Watts	Bhp	Rpm	Watts	Bhp
3750	753	915	1.05	838	1066	1.23	945	1278	1.47	1044	1500	1.73	1138	1731	1.99
4000	755	991	1.14	865	1198	1.38	968	1414	1.63	1063	1639	1.89	1154	1873	2.15
4250	788	1129	1.30	894	1341	1.54	992	1562	1.80	1084	1791	2.06	1172	2029	2.33
4500	822	1280	1.47	923	1497	1.72	1017	1722	1.98	1106	1956	2.25	1191	2196	2.53
4750	857	1443	1.66	953	1666	1.92	1044	1896	2.18	1130	2133	2.45	1212	2377	2.73
5000	891	1620	1.86	984	1847	2.12	1071	2082	2.39	1154	2323	2.67	1234	2572	2.96
5250	927	1810	2.08	1015	2043	2.35	1099	2282	2.62	1180	2528	2.91	—	—	—
5500	962	2014	2.32	1047	2252	2.59	1129	2496	2.87	—	—	—	—	—	—
5750	998	2233	2.57	1080	2476	2.85	—	—	—	—	—	—	—	—	—
6000	1035	2466	2.84	—	—	—	—	—	—	—	—	—	—	—	—

48HJD015 WITH STANDARD MOTOR (Low Heat Units)\* (cont)

Cfm	Available External Static Pressure (in. wg)														
	1.2			1.4			1.6			1.8			2.0		
	Rpm	Watts	Bhp	Rpm	Watts	Bhp	Rpm	Watts	Bhp	Rpm	Watts	Bhp	Rpm	Watts	Bhp
3750	1226	1971	2.27	1311	2218	2.55	1391	2474	2.85	—	—	—	—	—	—
4000	1240	2116	2.43	1322	2366	2.72	1401	2623	3.02	—	—	—	—	—	—
4250	1255	2274	2.61	1335	2526	2.91	—	—	—	—	—	—	—	—	—
4500	1272	2444	2.81	1350	2700	3.10	—	—	—	—	—	—	—	—	—
4750	1291	2628	3.02	—	—	—	—	—	—	—	—	—	—	—	—
5000	—	—	—	—	—	—	—	—	—	—	—	—	—	—	—
5250	—	—	—	—	—	—	—	—	—	—	—	—	—	—	—
5500	—	—	—	—	—	—	—	—	—	—	—	—	—	—	—
5750	—	—	—	—	—	—	—	—	—	—	—	—	—	—	—
6000	—	—	—	—	—	—	—	—	—	—	—	—	—	—	—

48HJD015 WITH OPTIONAL MOTOR (Low Heat Units)\*

Cfm	Available External Static Pressure (in. wg)														
	0.2			0.4			0.6			0.8			1.0		
	Rpm	Watts	Bhp	Rpm	Watts	Bhp	Rpm	Watts	Bhp	Rpm	Watts	Bhp	Rpm	Watts	Bhp
3750	753	942	1.08	838	1091	1.25	945	1298	1.49	1044	1513	1.74	1138	1737	2.00
4000	755	1020	1.17	865	1223	1.41	968	1433	1.65	1063	1652	1.90	1154	1878	2.16
4250	788	1159	1.33	894	1366	1.57	992	1581	1.82	1084	1803	2.07	1172	2032	2.34
4500	822	1311	1.51	923	1522	1.75	1017	1740	2.00	1106	1966	2.26	1191	2197	2.53
4750	857	1474	1.70	953	1690	1.94	1044	1912	2.20	1130	2141	2.46	1212	2376	2.73
5000	891	1650	1.90	984	1871	2.15	1071	2097	2.41	1154	2329	2.68	1234	2567	2.95
5250	927	1840	2.12	1015	2065	2.37	1099	2295	2.64	1180	2530	2.91	1257	2771	3.19
5500	962	2042	2.35	1047	2272	2.61	1129	2506	2.88	1207	2745	3.16	1281	2989	3.44
5750	998	2259	2.60	1080	2492	2.87	1159	2730	3.14	1234	2973	3.42	1307	3221	3.70
6000	1035	2489	2.86	1114	2727	3.14	1189	2969	3.41	1262	3215	3.70	1333	3466	3.99

48HJD015 WITH OPTIONAL MOTOR (Low Heat Units)\* (cont)

Cfm	Available External Static Pressure (in. wg)														
	1.2			1.4			1.6			1.8			2.0		
	Rpm	Watts	Bhp	Rpm	Watts	Bhp	Rpm	Watts	Bhp	Rpm	Watts	Bhp	Rpm	Watts	Bhp
3750	1226	1968	2.26	1311	2206	2.54	1391	2451	2.82	1468	2702	3.11	1543	2959	3.40
4000	1240	2111	2.43	1322	2351	2.70	1401	2598	2.99	1476	2850	3.28	1549	3108	3.57
4250	1255	2267	2.61	1335	2509	2.89	1412	2757	3.17	1486	3011	3.46	—	—	—
4500	1272	2436	2.80	1350	2680	3.08	1425	2929	3.37	1497	3185	3.66	—	—	—
4750	1291	2616	3.01	1366	2863	3.29	1440	3115	3.58	1510	3372	3.88	—	—	—
5000	1310	2810	3.23	1384	3059	3.52	1456	3314	3.81	1525	3573	4.11	—	—	—
5250	1332	3018	3.47	1403	3269	3.76	1473	3526	4.05	—	—	—	—	—	—
5500	1354	3238	3.72	1424	3492	4.02	1491	3751	4.31	—	—	—	—	—	—
5750	1377	3473	3.99	1445	3730	4.29	—	—	—	—	—	—	—	—	—
6000	1401	3722	4.28	—	—	—	—	—	—	—	—	—	—	—	—

LEGEND

- Bhp** — Brake Horsepower
- FIOF** — Factory-Installed Option
- Watts** — Input Watts to Motor

\*Standard low-medium static drive range is 834 to 1064 rpm (for 208/230 and 460-v units) or 1105 to 1321 rpm (for 575-v units). Alternate high-static drive range is 1161 to 1426 (for 208/230 and 460-v units). The alternate high-static drive is not available for 575-v units. Other rpms require a field-supplied drive.

Refer to page 188 for general Fan Performance Data notes.

NOTE: Maximum continuous bhp for the standard motor is 3.13 (for 208/230 and 460-v units) or 3.38 (for 575-v units). The maximum continuous watts is 2700 (for 208/230 and 460-v units) or 3065 (for 575-v units). Do not adjust motor rpm such that motor maximum bhp and/or watts is exceeded at the maximum operating cfm. See Evaporator Fan Motor Data tables for more information.

48HJ015,017

# Performance data (cont)



## FAN PERFORMANCE — 48HJ015,017 UNITS (cont)

48HJD017 (Low Heat Units)*															
Cfm	Available External Static Pressure (in. wg)														
	0.2			0.4			0.6			0.8			1.0		
	Rpm	Watts	Bhp	Rpm	Watts	Bhp	Rpm	Watts	Bhp	Rpm	Watts	Bhp	Rpm	Watts	Bhp
4500	753	1307	1.53	761	1330	1.56	840	1572	1.84	912	1822	2.14	980	2080	2.44
4800	747	1384	1.62	790	1515	1.78	866	1765	2.07	936	2023	2.37	1002	2289	2.68
5100	741	1465	1.72	820	1718	2.01	893	1977	2.32	961	2243	2.63	1025	2516	2.95
5700	810	1911	2.24	882	2182	2.56	950	2459	2.88	1014	2741	3.21	1075	3029	3.55
6000	844	2164	2.54	914	2444	2.87	980	2730	3.20	1042	3021	3.54	1100	3317	3.89
6300	879	2439	2.86	947	2729	3.20	1010	3023	3.55	1070	3322	3.90	1127	3626	4.25
6600	915	2737	3.21	980	3035	3.56	1041	3338	3.91	1099	3645	4.28	1155	3957	4.64
6900	950	3057	3.59	1013	3364	3.95	1072	3675	4.31	1129	3991	4.68	1183	4311	5.06
7200	986	3401	3.99	1047	3717	4.36	1104	4037	4.74	1159	4361	5.11	1211	4689	5.50
7500	1022	3770	4.42	1081	4095	4.80	1136	4423	5.19	1189	4755	5.58	1241	5091	5.97

48HJD017 (Low Heat Units)* (cont)															
Cfm	Available External Static Pressure (in. wg)														
	1.2			1.4			1.6			1.8			2.0		
	Rpm	Watts	Bhp	Rpm	Watts	Bhp	Rpm	Watts	Bhp	Rpm	Watts	Bhp	Rpm	Watts	Bhp
4500	1044	2345	2.75	1105	2619	3.07	1163	2899	3.40	1218	3187	3.74	1271	3481	4.08
4800	1065	2561	3.00	1124	2841	3.33	1180	3127	3.67	1235	3420	4.01	1287	3720	4.36
5100	1086	2795	3.28	1144	3082	3.61	1199	3375	3.96	1252	3674	4.31	1304	3979	4.67
5700	1132	3324	3.90	1187	3624	4.25	1240	3929	4.61	1291	4241	4.97	1341	4558	5.35
6000	1157	3619	4.24	1210	3925	4.60	1262	4239	4.97	1312	4557	5.34	1361	4880	5.72
6300	1182	3935	4.62	1234	4249	4.98	1285	4569	5.36	1334	4894	5.74	—	—	—
6600	1208	4274	5.01	1259	4595	5.39	1309	4922	5.77	—	—	—	—	—	—
6900	1235	4636	5.44	1285	4964	5.82	—	—	—	—	—	—	—	—	—
7200	1262	5021	5.89	—	—	—	—	—	—	—	—	—	—	—	—
7500	—	—	—	—	—	—	—	—	—	—	—	—	—	—	—

48HJD017 (Low Heat Units)* (cont)															
Cfm	Available External Static Pressure (in. wg)														
	2.2			2.4			2.6			2.8			3.0		
	Rpm	Watts	Bhp	Rpm	Watts	Bhp	Rpm	Watts	Bhp	Rpm	Watts	Bhp	Rpm	Watts	Bhp
4500	1322	3781	4.43	1372	4088	4.79	1419	4400	5.16	1466	4719	5.53	1511	5042	5.91
4800	1337	4025	4.72	1386	4337	5.09	1433	4655	5.46	1479	4978	5.84	—	—	—
5100	1353	4290	5.03	1401	4607	5.40	1448	4930	5.78	—	—	—	—	—	—
5700	1388	4881	5.72	—	—	—	—	—	—	—	—	—	—	—	—
6000	—	—	—	—	—	—	—	—	—	—	—	—	—	—	—
6300	—	—	—	—	—	—	—	—	—	—	—	—	—	—	—
6600	—	—	—	—	—	—	—	—	—	—	—	—	—	—	—
6900	—	—	—	—	—	—	—	—	—	—	—	—	—	—	—
7200	—	—	—	—	—	—	—	—	—	—	—	—	—	—	—
7500	—	—	—	—	—	—	—	—	—	—	—	—	—	—	—

**LEGEND**

- Bhp** — Brake Horsepower
- FIOP** — Factory-Installed Option
- Watts** — Input Watts to Motor

Refer to page 188 for general Fan Performance Data notes.

NOTE: Maximum continuous bhp for the standard motor is 6.13. The maximum continuous watts is 5180. Do not adjust motor rpm such that motor maximum bhp and/or watts is exceeded at the maximum operating cfm. See Evaporator Fan Motor Data tables for more information.

\*Standard low-medium static drive range is 910 to 1095 rpm. Alternate high-static drive range is 1069 to 1287. Other rpms require a field-supplied drive.



## FAN PERFORMANCE — 48HJ015,017 UNITS (cont)

### 48HJF015 WITH STANDARD MOTOR (High Heat Units)\*

Cfm	Available External Static Pressure (in. wg)														
	0.2			0.4			0.6			0.8			1.0		
	Rpm	Watts	Bhp	Rpm	Watts	Bhp	Rpm	Watts	Bhp	Rpm	Watts	Bhp	Rpm	Watts	Bhp
3750	753	915	1.05	844	1077	1.24	949	1287	1.48	1047	1507	1.73	1139	1735	2.00
4000	764	1006	1.16	872	1211	1.39	972	1425	1.64	1067	1648	1.90	1156	1880	2.16
4250	798	1147	1.32	901	1357	1.56	997	1576	1.81	1089	1803	2.07	1175	2038	2.34
4500	832	1301	1.50	931	1516	1.74	1024	1739	2.00	1112	1970	2.27	1195	2209	2.54
4750	868	1467	1.69	962	1688	1.94	1051	1916	2.20	1136	2151	2.47	1217	2393	2.75
5000	903	1648	1.89	994	1873	2.15	1079	2106	2.42	1161	2345	2.70	1240	2590	2.98
5250	939	1842	2.12	1026	2073	2.38	1109	2309	2.66	1188	2553	2.94	—	—	—
5500	976	2050	2.36	1059	2286	2.63	1139	2528	2.91	—	—	—	—	—	—
5750	1012	2273	2.61	1093	2514	2.89	—	—	—	—	—	—	—	—	—
6000	1049	2511	2.89	—	—	—	—	—	—	—	—	—	—	—	—

### 48HJF015 WITH STANDARD MOTOR (High Heat Units)\* (cont)

Cfm	Available External Static Pressure (in. wg)														
	1.2			1.4			1.6			1.8			2.0		
	Rpm	Watts	Bhp	Rpm	Watts	Bhp	Rpm	Watts	Bhp	Rpm	Watts	Bhp	Rpm	Watts	Bhp
3750	1227	1973	2.27	1310	2218	2.55	1390	2471	2.84	—	—	—	—	—	—
4000	1241	2120	2.44	1323	2368	2.72	1400	2623	3.02	—	—	—	—	—	—
4250	1258	2281	2.62	1337	2531	2.91	—	—	—	—	—	—	—	—	—
4500	1275	2454	2.82	—	—	—	—	—	—	—	—	—	—	—	—
4750	1295	2642	3.04	—	—	—	—	—	—	—	—	—	—	—	—
5000	—	—	—	—	—	—	—	—	—	—	—	—	—	—	—
5250	—	—	—	—	—	—	—	—	—	—	—	—	—	—	—
5500	—	—	—	—	—	—	—	—	—	—	—	—	—	—	—
5750	—	—	—	—	—	—	—	—	—	—	—	—	—	—	—
6000	—	—	—	—	—	—	—	—	—	—	—	—	—	—	—

**LEGEND**

- Bhp** — Brake Horsepower
- FIOP** — Factory-Installed Option
- Watts** — Input Watts to Motor

Refer to page 188 for general Fan Performance Data notes.

NOTE: Maximum continuous bhp for the standard motor is 3.13 (for 208/230 and 460-v units) or 3.38 (for 575-v units). The maximum continuous watts is 2700 (for 208/230 and 460-v units) or 3065 (for 575-v units). Do not adjust motor rpm such that motor maximum bhp and/or watts is exceeded at the maximum operating cfm. See Evaporator Fan Motor Data tables for more information.

\*Standard low-medium static drive range is 834 to 1064 rpm (for 208/230 and 460-v units) or 1105 to 1321 rpm (for 575-v units). Alternate high-static drive range is 1161 to 1426 (for 208/230 and 460-v units). The alternate high-static drive is not available for 575-v units. Other rpms require a field-supplied drive.

### 48HJF015 WITH OPTIONAL MOTOR (High Heat Units)\*

Cfm	Available External Static Pressure (in. wg)														
	0.2			0.4			0.6			0.8			1.0		
	Rpm	Watts	Bhp	Rpm	Watts	Bhp	Rpm	Watts	Bhp	Rpm	Watts	Bhp	Rpm	Watts	Bhp
3750	753	942	1.08	844	1101	1.27	949	1306	1.50	1047	1520	1.75	1139	1741	2.00
4000	764	1035	1.19	872	1236	1.42	972	1444	1.66	1067	1661	1.91	1156	1885	2.17
4250	798	1177	1.35	901	1382	1.59	997	1594	1.83	1089	1814	2.09	1175	2041	2.35
4500	832	1331	1.53	931	1540	1.77	1024	1757	2.02	1112	1980	2.28	1195	2209	2.54
4750	868	1498	1.72	962	1711	1.97	1051	1932	2.22	1136	2158	2.48	1217	2390	2.75
5000	903	1677	1.93	994	1896	2.18	1079	2120	2.44	1161	2350	2.70	1240	2585	2.97
5250	939	1871	2.15	1026	2093	2.41	1109	2321	2.67	1188	2554	2.94	1264	2793	3.21
5500	976	2077	2.39	1059	2304	2.65	1139	2536	2.92	1215	2773	3.19	1289	3015	3.47
5750	1012	2298	2.64	1093	2529	2.91	1170	2765	3.18	1244	3005	3.46	1315	3250	3.74
6000	1049	2533	2.91	1127	2768	3.18	1201	3008	3.46	1273	3252	3.74	1342	3500	4.03

### 48HJF015 WITH OPTIONAL MOTOR (High Heat Units)\* (cont)

Cfm	Available External Static Pressure (in. wg)														
	1.2			1.4			1.6			1.8			2.0		
	Rpm	Watts	Bhp	Rpm	Watts	Bhp	Rpm	Watts	Bhp	Rpm	Watts	Bhp	Rpm	Watts	Bhp
3750	1227	1970	2.27	1310	2206	2.54	1390	2448	2.82	1467	2696	3.10	1541	2951	3.39
4000	1241	2116	2.43	1323	2353	2.71	1400	2597	2.99	1475	2847	3.27	1548	3102	3.57
4250	1258	2274	2.62	1337	2513	2.89	1413	2759	3.17	1486	3010	3.46	—	—	—
4500	1275	2445	2.81	1352	2687	3.09	1426	2934	3.37	1498	3187	3.67	—	—	—
4750	1295	2629	3.02	1369	2873	3.30	1442	3122	3.59	1511	3377	3.88	—	—	—
5000	1315	2826	3.25	1388	3073	3.53	1458	3324	3.82	1527	3581	4.12	—	—	—
5250	1337	3037	3.49	1408	3286	3.78	1477	3540	4.07	—	—	—	—	—	—
5500	1360	3262	3.75	1429	3513	4.04	1496	3769	4.34	—	—	—	—	—	—
5750	1384	3500	4.03	1452	3755	4.32	—	—	—	—	—	—	—	—	—
6000	1410	3753	4.32	—	—	—	—	—	—	—	—	—	—	—	—

**LEGEND**

- Bhp** — Brake Horsepower
- FIOP** — Factory-Installed Option
- Watts** — Input Watts to Motor

Refer to page 188 for general Fan Performance Data notes.

NOTE: Maximum continuous bhp for the optional motor is 4.38. The maximum continuous watts is 3775. Do not adjust motor rpm such that motor maximum bhp and/or watts is exceeded at the maximum operating cfm. See Evaporator Fan Motor Data tables for more information.

\*Standard low-medium static drive range is 834 to 1064 rpm. Alternate high-static drive range is 1161 to 1426. Other rpms require a field-supplied drive.

48HJ015,017

# Performance data (cont)



## FAN PERFORMANCE — 48HJ015,017 UNITS (cont)

48HJF017 (High Heat Units)*															
Cfm	Available External Static Pressure (in. wg)														
	0.2			0.4			0.6			0.8			1.0		
	Rpm	Watts	Bhp	Rpm	Watts	Bhp	Rpm	Watts	Bhp	Rpm	Watts	Bhp	Rpm	Watts	Bhp
4500	753	1307	1.53	786	1404	1.65	861	1644	1.93	932	1893	2.22	997	2150	2.52
4800	747	1384	1.62	818	1603	1.88	890	1852	2.17	958	2108	2.47	1022	2373	2.78
5100	775	1571	1.84	850	1822	2.14	920	2079	2.44	986	2344	2.75	1048	2616	3.07
5700	849	2054	2.41	918	2323	2.73	982	2598	3.05	1044	2879	3.38	1102	3166	3.71
6000	886	2329	2.73	952	2607	3.06	1015	2891	3.39	1074	3180	3.73	1130	3474	4.08
6300	924	2628	3.08	987	2915	3.42	1047	3207	3.76	1105	3504	4.11	1160	3807	4.46
6600	962	2951	3.46	1023	3246	3.81	1081	3547	4.16	1136	3853	4.52	1190	4163	4.88
6900	1000	3298	3.87	1059	3603	4.23	1115	3912	4.59	1168	4225	4.96	1220	4543	5.33
7200	1038	3672	4.31	1095	3986	4.67	1149	4303	5.05	1201	4625	5.42	1251	4950	5.81
7500	1077	4072	4.78	1131	4394	5.15	1184	4720	5.54	1234	5050	5.92	—	—	—

48HJF017 (High Heat Units)* (cont)															
Cfm	Available External Static Pressure (in. wg)														
	1.2			1.4			1.6			1.8			2.0		
	Rpm	Watts	Bhp	Rpm	Watts	Bhp	Rpm	Watts	Bhp	Rpm	Watts	Bhp	Rpm	Watts	Bhp
4500	1060	2414	2.83	1119	2685	3.15	1175	2964	3.48	1230	3250	3.81	1282	3542	4.15
4800	1082	2644	3.10	1140	2922	3.43	1195	3207	3.76	1248	3498	4.10	1299	3795	4.45
5100	1106	2894	3.39	1163	3178	3.73	1216	3470	4.07	1268	3767	4.42	1319	4071	4.77
5700	1157	3459	4.06	1211	3757	4.41	1262	4061	4.76	1312	4371	5.13	1360	4686	5.50
6000	1184	3774	4.43	1236	4080	4.79	1287	4391	5.15	1335	4707	5.52	1382	5029	5.90
6300	1212	4114	4.83	1263	4427	5.19	1312	4745	5.57	1359	5067	5.94	—	—	—
6600	1241	4478	5.25	1290	4798	5.63	1338	5122	6.01	—	—	—	—	—	—
6900	1270	4866	5.71	—	—	—	—	—	—	—	—	—	—	—	—
7200	—	—	—	—	—	—	—	—	—	—	—	—	—	—	—
7500	—	—	—	—	—	—	—	—	—	—	—	—	—	—	—

48HJF017 (High Heat Units)* (cont)															
Cfm	Available External Static Pressure (in. wg)														
	2.2			2.4			2.6			2.8			3.0		
	Rpm	Watts	Bhp	Rpm	Watts	Bhp	Rpm	Watts	Bhp	Rpm	Watts	Bhp	Rpm	Watts	Bhp
4500	1332	3841	4.50	1381	4145	4.86	1428	4456	5.23	1473	4772	5.60	1518	5095	5.98
4800	1349	4100	4.81	1397	4409	5.17	1443	4725	5.54	1488	5046	5.92	—	—	—
5100	1367	4380	5.14	1414	4695	5.51	1460	5016	5.88	—	—	—	—	—	—
5700	1407	5007	5.87	—	—	—	—	—	—	—	—	—	—	—	—
6000	—	—	—	—	—	—	—	—	—	—	—	—	—	—	—
6300	—	—	—	—	—	—	—	—	—	—	—	—	—	—	—
6600	—	—	—	—	—	—	—	—	—	—	—	—	—	—	—
6900	—	—	—	—	—	—	—	—	—	—	—	—	—	—	—
7200	—	—	—	—	—	—	—	—	—	—	—	—	—	—	—
7500	—	—	—	—	—	—	—	—	—	—	—	—	—	—	—

### LEGEND

- Bhp** — Brake Horsepower
- FIOP** — Factory-Installed Option
- Watts** — Input Watts to Motor

Refer to this page for general Fan Performance Data notes.

NOTE: Maximum continuous bhp for the standard motor is 6.13. The maximum continuous watts is 5180. Do not adjust motor rpm such that motor maximum bhp and/or watts is exceeded at the maximum operating cfm. See Evaporator Fan Motor Data tables for more information.

\*Standard low-medium static drive range is 910 to 1095 rpm. Alternate high-static drive range is 1069 to 1287. Other rpms require a field-supplied drive.

### GENERAL NOTES FOR FAN PERFORMANCE DATA TABLES

1. Static pressure losses (i.e., EconoMi\$er) must be added to external static pressure before entering Fan Performance table.
2. Interpolation is permissible. Do not extrapolate.
3. Fan performance is based on wet coils, clean filters, and casing losses. See Accessory/FIOP Static Pressure table on page 190.
4. Extensive motor and drive testing on these units ensures that the full horsepower and watts range of the motor can be utilized with

- confidence. Using your fan motors up to the watts or bhp rating shown will not result in nuisance tripping or premature motor failure. Unit warranty will not be affected.
5. Use of a field-supplied motor may affect wire size. Contact your Carrier representative for details.

### HORIZONTAL SUPPLY/RETURN FAN PERFORMANCE WITH CRRFCURB013A00 HIGH STATIC REGAIN ADAPTER

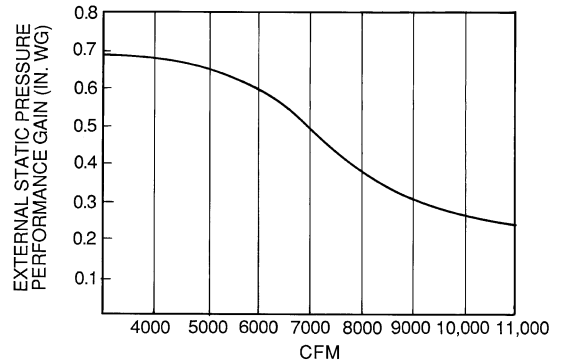
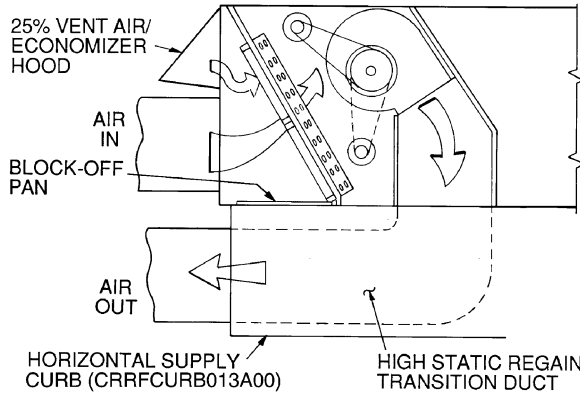

NOTE: The CRRFCURB013A00 high static regain adapter accessory may be used to provide horizontal supply/return.

NOTE: The CRRFCURB013A00 horizontal supply/return adapter accessory improves 48HJ015, 017 fan performance by increasing external static pressure by amount shown above. To convert from in. wg to Pa use the following formula:

$$\text{in. wg} \times 249.1 = \text{Pa}$$

### FAN PERFORMANCE USING ACCESSORY POWER EXHAUST (48HJ015,017)

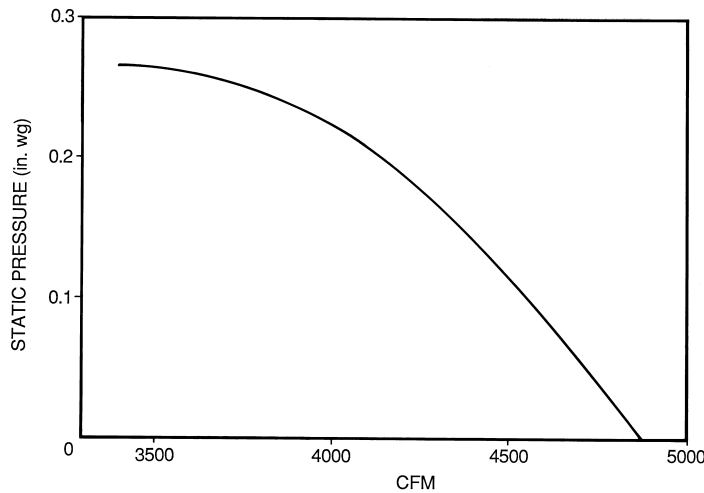

#### ALTITUDE COMPENSATION\* — 48HJ015,017

ELEVATION (ft)	NATURAL GAS ORIFICE SIZE†	
	Low Heat	High Heat
0-3,000	30	29
3,000- 7,000	31	30
7,000- 9,000	32	31
9,000-10,000	33	31
above 10,000	35	32

\*Includes a 4% input reduction per each 1,000 feet.  
†Orifices available through your Carrier dealer.

#### ALTITUDE DERATING FACTOR\*

ELEVATION (ft)	MAXIMUM HEATING VALUE AT SEA LEVEL (Btu/ft³)
0-2,000	1,100
2,001-3,000	1,050
3,001-4,000	1,000
4,001-5,000	950
5,001-6,000	900

\*Derating of the gas heating equipment to compensate for the effects of altitude is always required. Orifice change is not required if the fuel heating value (at sea level) is below the limits listed in the table above. Derating conditions must be 4% per thousand ft above sea level. For example, at 4000 ft, if the heating value of the gas exceeds 1000 Btu/ft³, the unit will require a 16% derating. For elevations above 6000 ft, the same formula applies. For example, at 7000 ft, the unit will require a 28% derating of the maximum heating value per the National Fuel Gas Code.

48HJ015,017

# Performance data (cont)



## ALTITUDE COMPENSATION — 48HJ015,017 (LP Gas Units)

ELEVATION (ft)	LIQUID PROPANE ORIFICE SIZE
	Low Heat and High Heat
0-2,000	36
2,000	37
3,000	38
4,000	38
5,000	39
6,000	40
7,000	41
8,000	41
9,000	42
10,000	43

## ACCESSORY/FIOP STATIC PRESSURE (in. wg)\* — 48HJ015,017

COMPONENT	CFM								
	4500	5000	5400	6000	7200	7500	9000	10,000	11,250
EconoMiSer	0.040	0.050	0.060	0.070	0.090	0.100	0.110	0.120	0.140
MoistureMiSer™ Dehumidification Package	0.045	0.048	0.060	0.071	0.103	0.111	0.160	0.197	0.250

### LEGEND

**FIOP** — Factory-Installed Option

\*The static pressure must be added to external static pressure. The sum and the evaporator entering-air cfm should then be used in conjunction with the Fan Performance tables to determine blower rpm and watts.

## OUTDOOR SOUND POWER

UNIT 48HJ	RATING (Bels)	A-WEIGHT (dB)	OCTAVE BANDS							
			63	125	250	500	1000	2000	4000	8000
015,017	8.8	87.6	90.8	88.7	86.4	84.3	83.5	78.4	75.6	66.8

### LEGEND

**Bels** — Sound Levels (1 bel = 10 decibels)



### FAN RPM AT MOTOR PULLEY SETTINGS\*

48HJ	0	1/2	1	1 1/2	2	2 1/2	3	3 1/2	4	4 1/2	5	5 1/2	6
015 (208/230, 460 v)†	††	††	††	††	1064	1035	1006	978	949	920	891	863	834
015 (208/230, 460 v)**	††	††	††	††	1426	1393	1360	1327	1294	1261	1227	1194	1161
015 (575 v)†	††	††	††	††	1321	1294	1267	1240	1213	1186	1159	1132	1105
017†	††	††	1095	1077	1058	1040	1021	1002	984	965	947	928	910
017**	††	††	1287	1265	1243	1222	1200	1178	1156	1134	1112	1091	1069

\*Approximate fan rpm shown.

†Indicates standard drive package.

\*\*Indicates alternate drive package.

††Due to belt and pulley style, pulley cannot be set to this number of turns open.

### EVAPORATOR FAN MOTOR SPECIFICATIONS

UNIT 48HJ	NOMINAL HP	VOLTAGE	MAX WATTS	EFF. %	MAX BHP	MAX BkW	MAX AMPS
015 (Standard Motor)	2.9	208	2700	85.8	3.13	2.34	9.46
	2.9	230	2700	85.8	3.13	2.34	8.6
	2.9	460	2700	85.8	3.13	2.34	4.3
	3	575	3065	81.7	3.38	2.53	3.9
015 (Optional Motor)	3.7	208	3775	85.8	4.38	3.27	10.5
	3.7	230	3775	85.8	4.38	3.27	10.5
	3.7	460	3775	85.8	4.38	3.27	4.8
017	5	208	5180	87.5	6.13	4.57	15.8
	5	230	5180	87.5	6.13	4.57	15.8
	5	460	5180	87.5	6.13	4.57	7.9
	5	575	5180	87.5	6.13	4.57	6.0

#### LEGEND

**BHP** — Brake Horsepower

**BkW** — Brake Kilowatts

### EVAPORATOR-FAN MOTOR EFFICIENCY

MOTOR HORSEPOWER	MOTOR EFFICIENCY (%)
3.0	81.7
2.9, 3.7	85.8
5.0	87.5

NOTE: All indoor-fan motors 5 hp and larger meet the minimum efficiency requirements as established by the Energy Policy Act of 1992 (EPACT) effective October 24, 1997.

# Electrical data



## ELECTRICAL DATA — 48HJ015,017

UNIT 48HJ	NOMINAL VOLTAGE (3 Ph, 60 Hz)	VOLTAGE RANGE		COMPRESSOR				OFM			IFM		POWER EXHAUST		COMBUSTION FAN MOTOR		POWER SUPPLY	
				No. 1		No. 2							FLA	LRA	FLA	LRA	FLA	LRA
		Min	Max	RLA	LRA	RLA	LRA	Qty	Hp	FLA (ea)	Hp	FLA	FLA	LRA	FLA	LRA	FLA	MCA
015 (Standard IFM)	208/230	187	253	20.7	156	19.3	123	3	0.5	1.7	2.9	8.8/ 8.4	—	—	0.57	59/59	70/70	
													4.6	18.8	0.57	64/63	80/80	
	460	414	508	10	70	10	62	3	0.5	0.8	2.9	4.2	—	—	0.30	29	35	
													2.3	6.0	0.30	31	40	
	575	518	633	8.2	54.0	7.9	50	3	0.5	0.8	3.0	3.9	—	—	0.57	24	30	
													2.1	4.8	0.57	26	30	
015 (Optional IFM)	208/230	187	253	20.7	156	19.3	123	3	0.5	1.7	3.7	11.0/10.5	—	—	0.57	61/61	80/80	
													4.6	18.8	0.57	66/65	80/80	
	460	414	508	10	70	10	62	3	0.5	0.8	3.7	4.8	—	—	0.30	30	35	
													2.3	6.0	0.30	32	40	
	017	208/230	187	253	32.1	195	20.7	156	3	0.5	1.7	5.0	15.8/15.8	—	—	0.57	82/82	110/110
														4.6	18.8	0.57	86/86	110/110
460		414	508	16.4	95	10	70	3	0.5	0.8	5.0	7.9	—	—	0.30	41	50	
													2.3	6.0	0.30	43	50	
575	518	633	12	80	8.2	54	3	0.5	0.75	5.0	6.0	—	—	0.57	31	40		
												2.1	4.8	0.57	34	40		

### LEGEND

- FLA — Full Load Amps
- HACR — Heating, Air Conditioning and Refrigeration
- IFM — Indoor (Evaporator) Fan Motor
- LRA — Locked Rotor Amps
- MCA — Minimum Circuit Amps
- MOCP — Maximum Overcurrent Protection
- NEC — National Electrical Code
- OFM — Outdoor (Condenser) Fan Motor
- RLA — Rated Load Amps

\*Fuse or HACR circuit breaker.

Example: Supply voltage is 460-3-60.

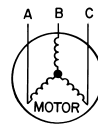

AB = 452 v  
BC = 464 v  
AC = 455 v

$$\begin{aligned} \text{Average Voltage} &= \frac{452 + 464 + 455}{3} \\ &= \frac{1371}{3} \\ &= 457 \end{aligned}$$

Determine maximum deviation from average voltage.

- (AB) 457 - 452 = 5 v
- (BC) 464 - 457 = 7 v
- (AC) 457 - 455 = 2 v

Maximum deviation is 7 v.

Determine percent of voltage imbalance.

$$\begin{aligned} \% \text{ Voltage Imbalance} &= 100 \times \frac{7}{457} \\ &= 1.53\% \end{aligned}$$

This amount of phase imbalance is satisfactory as it is below the maximum allowable 2%.

**IMPORTANT:** If the supply voltage phase imbalance is more than 2%, contact your local electric utility company immediately.

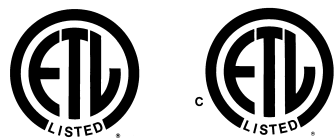

### NOTES:

1. In compliance with NEC requirements for multimotor and combination load equipment (refer to NEC Articles 430 and 440), the overcurrent protective device for the unit shall be fuse or HACR breaker. Canadian units may be fuse or circuit breaker.
2. **Unbalanced 3-Phase Supply Voltage**  
*Never operate a motor where a phase imbalance in supply voltage is greater than 2%. Use the following formula to determine the percent of voltage imbalance.*

% Voltage Imbalance

$$= 100 \times \frac{\text{max voltage deviation from average voltage}}{\text{average voltage}}$$

# Guide specifications — 48HJ015,017



## Packaged Rooftop Electric Cooling Unit with Gas Heat — Constant Volume Application

### HVAC Guide Specifications

Size Range: **12 to 15 Tons Nominal (Cooling)**  
**172,000 to 360,000 Btuh, Nominal**  
**(Input Heating) (Gas Units)**

Carrier Model Numbers: **48HJD, 48HJF**



### Part 1 — General

#### 1.01 SYSTEM DESCRIPTION

Unit is an outdoor rooftop mounted, electrically controlled heating and cooling unit utilizing scroll hermetic compressors for cooling duty and gas combustion for heating duty. Supply air shall be discharged downward or horizontally (with horizontal supply/return curb adapter assembly), as shown on contract drawings. Standard unit shall include a manual outdoor-air inlet.

#### 1.02 QUALITY ASSURANCE

- A. Units shall well exceed the energy efficiency requirements of ASHRAE standard 90.1-2001.
- B. Unit shall be rated in accordance with ARI Standards 270 and 360 and all units shall be designed in accordance with UL Standard 1995.
- C. Unit shall be designed to conform to ASHRAE 15.
- D. Unit shall be ETL and ETL, Canada tested and certified in accordance with ANSI Z21.47 Standards as a total package.
- E. Roof curb shall be designed to conform to NRCA Standards.
- F. Insulation and adhesive shall meet NFPA 90A requirements for flame spread and smoke generation.
- G. Unit casing shall be capable of withstanding 500-hour salt spray exposure per ASTM B117 (scribed specimen).
- H. Unit shall be manufactured in a facility registered to ISO 9001:2000.

#### 1.03 DELIVERY, STORAGE, AND HANDLING

Unit shall be stored and handled per manufacturer's recommendations.

### Part 2 — Products

#### 2.01 EQUIPMENT (STANDARD)

##### A. General:

Each unit shall be a factory assembled, single-piece heating and cooling unit. Contained within the unit enclosure shall be all factory wiring, piping, controls, refrigerant charge (R-22), and special features required prior to field start-up.

##### B. Unit Cabinet:

1. Constructed of galvanized steel (G90 — 1.8 oz. of zinc per square foot [550 grams per square meter] of sheet metal), bonderized and primer-coated on both sides and coated with a baked polyester thermosetting powdercoating finish on the outer surface.

2. Indoor blower compartment interior surfaces shall be insulated with a minimum 1/2-in. thick, 1 lb density fiberglass insulation. Fiberglass insulation shall be bonded with a thermosetting resin (8 to 12% by weight nominal, phenol formaldehyde typical), and coated with an acrylic or other material that meets the NFPA 90 flame retardance requirements and has an "R" Value of 3.70. Aluminum foil-faced fiberglass insulation shall be used in the gas heat compartment.

3. Cabinet panels shall be easily removable for servicing. Cabinet panels are minimum 20 gage. Panels shall have 1/2-in. thick, 1.5-lb. density insulation.

4. Filters shall be accessible through an access panel.

5. Holes shall be provided in the base rails (minimum 12 gage) for rigging shackles to facilitate overhead rigging.

6. Unit shall contain a sloped drain pan, to prevent standing water from accumulating. Pan shall be fabricated of hot dipped zinc coated minimum spangle steel. Zinc coating shall be G90 designation according to ASTM Standard A653. Unit shall contain a factory-installed nonferrous main condensate drain connection.

##### C. Fans:

1. Indoor blower (evaporator fan):

- a. Fan shall be belt driven. Belt drive shall include an adjustable pulley. The standard fan drive shall have a factory-installed low-medium static pressure fan drive. The alternate fan drive option shall have a factory-installed high static pressure fan drive.

- b. Fan wheel shall be made from steel with a corrosion resistant finish. It shall be a dynamically balanced, double-inlet type with forward-curved blades.

2. Condenser fans shall be of the direct-driven propeller type, with corrosion-resistant blades riveted to corrosion-resistant steel supports. They shall be dynamically balanced and discharge air upwards.

3. Induced-draft blower shall be of the direct-driven, single inlet, forward-curved, centrifugal type. It shall be made from steel with a corrosion-resistant finish and shall be dynamically balanced.

##### D. Compressor(s):

1. Fully hermetic, scroll type, internally protected.
2. Factory spring-shock mounted and internally spring mounted for vibration isolation.
3. On electrically and mechanically independent refrigerant circuits.
4. All compressors shall have 70 W crankcase heaters.

## E. Coils:

1. Standard evaporator and condenser coils shall have aluminum plate fins mechanically bonded to seamless internally grooved copper tubes with all joints brazed.
2. Coils shall be leak tested at 150 psig (1034 kPa) and pressure tested at 450 psig (3103 kPa).

## F. Heating Section:

1. Induced-draft combustion type with energy saving direct-spark ignition system and redundant main gas valve.
2. a. The heat exchanger shall be of the tubular-section type constructed of a minimum of 20-gage steel coated with a nominal 1.2 mil aluminum-silicone alloy for corrosion resistance.  
b. The optional stainless steel heat exchangers shall be tubular-section design and shall be constructed of a minimum 20 gage, 409 stainless steel.
3. Burners shall be of the in-shot type constructed of aluminum-coated steel.
4. All gas piping shall enter the unit at a single location.
5. Gas piping shall be capable of being routed through the roof curb directly into unit.

## G. Refrigerant Components:

Refrigerant circuit components shall include:

1. Thermostatic expansion valve (TXV).
2. Filter driers.
3. Gage port and connections on suction, discharge, and liquid lines.

## H. Filter Section:

Standard filter section shall consist of 2 sizes of factory-installed 2-in. (51 mm) thick throwaway fiberglass filters of commercially available sizes. Filters shall be approximately 10% efficient with an air-side pressure drop of approximately 0.07 in. wg (clean).

## I. Controls and Safeties:

1. Unit Controls:
  - a. Economizer control (optional)
  - b. Capacity control (2-step)
  - c. Unit shall be complete with self-contained low-voltage control circuit.
2. Safeties:
  - a. Unit shall incorporate a solid-state compressor lockout which provides reset capability at the space thermostat, should any of the following safety devices trip and shut off compressor:
    - 1) Compressor lockout protection provided for either internal or external overload.
    - 2) Low-pressure switch.
    - 3) Dual freezestats (evaporator coil).

- 4) High-pressure switch.

b. Supply-air thermostat shall be located in the unit.

c. Heating section shall be provided with the following minimum protections:

- 1) High-temperature limit switch.
- 2) Induced-draft motor speed sensor.
- 3) Flame rollout switch.
- 4) Flame proving controls.
- 5) Redundant gas valve.

## J. Operating Characteristics:

1. Unit shall be capable of starting and running at 120 F (size 017) or 125 F (size 015) ambient outdoor temperature per maximum load criteria of ARI Standard 360.
2. Unit with standard controls will operate in cooling down to an outdoor ambient temperature of 40 F (4.4 C).
3. Unit shall be provided with fan time delay to prevent cold air delivery.

## K. Electrical Requirements:

All unit power wiring shall enter unit cabinet at a single location.

## L. Motors:

1. Compressor motors shall be cooled by refrigerant gas passing through motor windings and shall have line break thermal and current overload protection.
2. All fan motors shall have permanently lubricated, sealed bearings and inherent automatic-reset thermal overload protection or manual reset calibrated circuit breakers. Evaporator motors are designed specifically for Carrier and do *not* have conventional horsepower (HP) ratings listed on the motor nameplate. Motors are designed and qualified in the “air-over” location downstream of the cooling coil and carry a maximum continuous bhp rating that is the maximum application bhp rating for the motor; no “safety factors” above that rating may be applied.
3. All indoor-fan motors 5 hp and larger shall meet the minimum efficiency requirements as established by the Energy Policy Act of 1992 (EPACT) effective October 24, 1997.

## M. Special Features:

Certain features are not applicable when the features designated \* are specified. For assistance in amending the specifications, contact your local Carrier Sales Office.

- \* 1. Carrier PremierLink™ Controls:
- a. Shall be available as a factory-installed or as a field-installed accessory.
  - b. Shall work with CCN and ComfortVIEW™ software.
  - c. Shall be compatible with *ComfortLink*™ controllers.



- d. Shall be ASHRAE 62-99 compliant.
- e. Shall accept a CO<sub>2</sub> sensor in the conditioned space — Demand Control Ventilation (DCV) Ready.
- f. Shall have baud communication rate of 38.4K or faster.
- g. Shall be Internet Ready.
- h. Shall include an integrated economizer controller.

\* 2. Direct Digital Controls (Apollo):

- a. Shall be available as a factory-installed option.
- b. Shall actively monitor all modes of operation, as well as evaporator-fan status, filter status, indoor-air quality, supply-air temperature, and outdoor-air temperature.
- c. Shall work with Carrier TEMP and VVT® systems.
- d. Shall have built-in diagnostics for thermostat commands for both staged heating and cooling, evaporator-fan operation, and economizer operation.
- e. Shall be equipped with a 5-minute time delay between modes of operation.

3. Optional Coils:

- a. Optional pre-coated aluminum-fin coils shall have a durable epoxy-phenolic coating to provide protection in mildly corrosive coastal environments. Coating shall be applied to the aluminum fin stock prior to the fin stamping process to create an inert barrier between the aluminum fin and copper tube. Epoxy-phenolic barrier shall minimize galvanic action between dissimilar metals.
- b. Optional copper-fin coils shall be constructed of copper fins mechanically bonded to copper tubes and copper tube sheets. Galvanized steel tube sheets shall not be acceptable. A polymer strip shall prevent coil assembly from contacting the sheet metal coil pan to minimize potential for galvanic corrosion between coil and pan. All copper construction shall provide protection in moderate coastal environments.
- c. Optional E-Coated aluminum-fin coils shall have a flexible epoxy polymer coating uniformly applied to all coil surface areas without material bridging between fins. Coating process shall ensure complete coil encapsulation. Color shall be high gloss black with gloss — 60 deg of 65 to 90% per ASTM D523-89. Uniform dry film thickness from 0.8 to 1.2 mil on all surface areas including fin edges. Superior hardness characteristics of 2H per ASTM D3363-92A and cross-hatch adhesion of 4B-5B per ASTM D3359-93. Impact resistance shall be up to 160 in./lb (ASTM D2794-93). Humidity

and water immersion resistance shall be up to minimum 1000 and 250 hours respectively (ASTM D2247-92 and ASTM D870-92). Corrosion durability shall be confirmed through testing to be no less than 1000 hours salt spray per ASTM B117-90. Coil construction shall be aluminum fins mechanically bonded to copper tubes.

- d. Optional E-Coated copper-fin coils shall have a flexible epoxy polymer coating uniformly applied to all coil surface areas without material bridging between fins. Coating process shall ensure complete coil encapsulation. Color shall be high gloss black with gloss — 60 deg of 65 to 90% per ASTM D523-89. Uniform dry film thickness from 0.8 to 1.2 mil on all surface areas including fin edges. Superior hardness characteristics of 2H per ASTM D3363-92A and cross-hatch adhesion of 4B-5B per ASTM D3359-93. Impact resistance shall be up to 160 in./lb (ASTM D2794-93). Humidity and water immersion resistance shall be up to minimum 1000 and 250 hours respectively (ASTM D2247-92 and ASTM D870-92). Corrosion durability shall be confirmed through testing to be no less than 1000 hours salt spray per ASTM B117-90. Coil construction shall be copper fins mechanically bonded to copper tubes with copper tube sheets. Galvanized steel tube sheets shall not be acceptable. A polymer strip shall prevent coil assembly from contacting sheet metal coil pan to maintain coating integrity and minimize corrosion potential between coil and pan.

4. Roof Curbs (Horizontal and Vertical):

- a. Formed of 16-gage galvanized steel with wood nailer strip and shall be capable of supporting entire unit weight.
- b. Permits installing and securing ductwork to curb prior to mounting unit on the curb.

5. Horizontal Adapter Roof Curb:

Includes factory-assembled adapter and internal duct and substantially improves evaporator fan static performance (static regain).

**NOTE:** Power exhaust or barometric relief must be mounted in the return ductwork when used in conjunction with this accessory.

\* 6. Integrated Economizer:

- a. Integrated type capable of simultaneous economizer and compressor operation to provide cooling with outdoor air.
- b. Equipped with low-leakage gear driven dampers not to exceed 2% leakage, at 1.0 in. wg (249 Pa) pressure differential.
- c. Capable of introducing up to 100% outdoor air.

48H015,017

- d. Equipped with dry-bulb temperature control to govern economizer changeover.
  - e. Equipped with a supply-air sensor that controls the economizer to a 55° F (30.5° C) control point.
  - f. Shall fit an outdoor-air opening of 17.75-in. high and 71.38-in. long (8.8 sq ft).
  - g. Actuator motor shall be a 24 v, 53 lb.ft. torque, spring return, direct coupled type design (close on loss of power).
  - h. Shall be capable of differential dry bulb outdoor air enthalpy and differential enthalpy control.
7. Two-Position Damper:  
Two-position damper package shall include single blade damper and 24-v motor. Admits up to 25% outdoor air, and shall close upon unit shutdown. Damper shall cover 3.8-in. high by 17.75-in. wide (117.8 sq. in.) opening in return air upper panel.
8. Accessory Compressor Cycle Delay:  
Compressor shall be prevented from restarting for a minimum of 5 minutes after shutdown.
- \* 9. Thermostats and Subbases:  
To provide staged heating and cooling in addition to automatic (or manual) changeover and fan control.
- \*10. Barometric Relief Damper Package:
- a. Package shall include damper, seals, hardware, and hoods to relieve excess internal pressure.
  - b. Damper shall close due to gravity upon unit shutdown.
  - c. Damper package must be field-installed in return-air ductwork when used with optional side return connections.
- \*11. Power Exhaust:  
Package shall include an exhaust (propeller style) fan, 1/2 Hp 208-230, 460 v (factory-wired for 460 v) direct drive motor, and damper for vertical flow units with economizer to control over-pressurization of building. Power Exhaust package must be field-installed in return-air ductwork when used with optional side return connections.
- \*12. Head Pressure Control Package:  
Consists of an accessory outdoor-air package and a solid-state control with condenser coil temperature sensor for controlling condenser-fan motor speed to maintain condensing temperature between 90 F (32.2 C) and 100 F (43.3 C) at outdoor ambient temperature down to -20 F (-29.8 C).
13. Low-Ambient Kits:  
When used, allows units to operate at lower outdoor ambient temperatures down to 20 F.
14. Electronic Programmable Thermostat:  
Capable of using deluxe full-featured electronic thermostat.
15. MoistureMi\$er™ Dehumidification Package:  
The dehumidification package is a factory-installed option that provides increased dehumidification by further subcooling the hot liquid refrigerant leaving the condenser coil. The package consists of a single row, 3/8 to 12.25 sq ft subcooling coil located on the leaving airside of the evaporator coil. The location of this coil in the indoor air stream greatly enhances the latent capacity of the unit.  
The package shall be equipped with low pressure switch(es) and TXVs. Low pressure switch(es) prevents evaporator coil freeze-up and TXVs assure a positive superheat condition. If the operation of the subcooling coil is controlled by a field-installed wall-mounted humidistat, the dehumidification circuit will then operate only when needed. Optional field connections for the humidistat are made in the low voltage compartment of the unit control box.
16. Winter Start Time-Delay Relay:  
Used in conjunction with the accessory low-ambient kit or head pressure control device, permits operation in cooling at lower outdoor ambient temperatures. See price pages for more information.
17. Liquid Propane Conversion Kit:  
Kit shall contain all the necessary hardware and instructions to convert a standard natural gas unit for use with liquefied propane gas.
18. Service Option Package:
- a. Hinged access panels for the filter, compressors, evaporator fan, and control box areas. Filter hinged access panels permit tool-less entry for changing filters. Evaporator fan hinged access panel shall be field-convertible to a tool-less entry by removing and discarding screws. Each external hinged access panel shall be permanently attached to the rooftop unit.
  - b. Convenience outlet: Shall be factory-installed and internally mounted with an externally accessible 115-v, 15 amp GFI, female receptacle with hinged cover. Voltage and circuit protection required to operate convenience outlet shall be provided by a field-supplied and properly fused separate branch circuit.
  - c. Non-fused disconnect switch: Shall be factory-installed, internally mounted, NEC and UL approved non-fuse switch; shall provide unit power shutoff. The control access door shall be interlocked with the non-fused disconnect. The disconnect switch must be



in the OFF position to open the control box access door. Shall be accessible from outside the unit and shall provide power off lockout capability.

19. Alternate Drive:

Shall provide higher static drive capability to enhance evaporator-fan performance rpm range.

20. Hail Guard:

Shall protect the condenser coil from hail, flying debris, and damage by large objects without increasing unit clearances.

21. Ultra-Violet Germicidal Lamps:

Ultra-violet germicidal lamps are designed to eliminate odor causing mold and fungus that may develop in the wet area of the evaporator section of the unit. The high output, low temperature germicidal lamps are field installed in the evaporator section of the unit, aimed at the evaporator coil and condensate pan. The short wavelength ultra-violet light inhibits and kills mold, fungus and microbial growth. The lamps have an output rating at 45 F in 400 fpm air-flow of 120 microwatts/cm<sup>2</sup> at 1 meter.

22. Stainless Steel Condensate Pan:

Stainless steel condensate pans shall be available for condensate collection.

23. Outdoor Air Enthalpy Sensor:

The outdoor air enthalpy sensor shall be used with the EconoMi\$er device to provide single

enthalpy control. When used in conjunction with a return air enthalpy sensor, the EconoMi\$er device will provide differential enthalpy control. The sensor allows the EconoMi\$er controller to determine if outside air is suitable for free cooling.

24. Return Air Enthalpy Sensor:

The return air enthalpy sensor shall be used with the EconoMi\$er device. When used in conjunction with an outdoor air enthalpy sensor, the EconoMi\$er device will provide differential enthalpy control.

25. Return Air Temperature Sensor:

The return air temperature sensor shall be used with the EconoMi\$er device. When used in conjunction with the standard outdoor air temperature sensor, the EconoMi\$er device will provide differential enthalpy control.

26. Humidistat:

Field-installed, wall-mounted humidistat is used to control activation of the dehumidification package. The humidistat can be set for humidity levels between 20% and 80% relative humidity.

27. Thermidistat:

Field-installed wall-mounted thermidistat is used to control temperature and activation of the dehumidification package. The thermidistat can be set for humidity settings from 50% to 90% relative humidity.

- 48HJ004-014 section *128-173*
- 48HJ015,017 section *174-197*
- 48TM004-014 section *50-101*
- 48TM016-028 section *102-127*
- Airflow
  - Configuration *33*
  - Maximum *33, 103*
  - Minimum *33, 51, 103, 129, 130, 175*
- Altitude compensation
  - 48HJ004-014 *163*
  - 48HJ015,017 *189, 190*
  - 48TM004-014 *91*
  - 48TM016-028 *120*
- Altitude derating factor *91, 120, 164, 189*
- Apollo controls *4, 10, 24-26, 33*
- Application data *33-42*
- ARI capacity ratings
  - 48HJ004-014 *129, 130*
  - 48HJ015,017 *175*
  - 48TM004-014 *50, 51*
  - 48TM016-028 *103*
- Barometric relief
  - 48HJ004-014 *164*
  - 48TM004-014 *89, 90*
- CCN 3rd party interface *16*
- CCN LEN *17*
- Changeover, heating to cooling *33*
- Coil guard grille *13*
- Concentric duct details *34*
- Condenser coil protection *9, 34*
- Controls *15-32*
- Convenience outlet *4, 12, 111, 181*
- Convert vertical to horizontal discharge *3, 33*
- Cooling capacities
  - 48HJ004-014 *142-144*
  - 48HJ004-014 with MoistureMi\$er™ option *145-147*
  - 48HJ015, 017 *183*
  - 48HJ015, 017 with MoistureMi\$er option *184*
  - 48TM004-014 *63, 64*
  - 48TM016-028 *113*
- Dimensions
  - Accessory
    - 48HJ004-014 *137, 138*
    - 48HJ015,017 *179-181*
    - 48TM004-014 *59, 60*
    - 48TM016-028 *109-112*
  - Base unit
    - 48HJ004-014 *135, 136*
    - 48HJ015,017 *178*
    - 48TM004-014 *56-58*
    - 48TM016-028 *106-108*
  - Energy\$Recycler *42*
- Drain pan *3, 33*
- Ductwork *3, 33*
- Durablade Economizer *30, 90, 162*
- EconoMi\$er *11, 48, 49*
- EconoMi\$er2 *11, 46, 89, 164*
  - Outdoor air leakage
    - 48HJ004-014 *164*
    - 48TM004-014 *89*
- Electrical data
  - 48HJ004-014 *166, 167*
  - 48HJ015,017 *192*
  - 48TM004-014 *92-95*
  - 48TM016-028 *122*
- Energy\$Recycler *5, 40-42*
- Evaporator fan motor
  - Efficiency
    - 48HJ004-014 *162*
    - 48HJ015,017 *191*
    - 48TM004-014 *88*
    - 48TM016-028 *121*
  - Performance
    - 48HJ004-014 (high-static motor) *165*
    - 48HJ004-014 (standard motor) *165*
    - 48HJ015,017 *191*
    - 48TM004-014 *88*
    - 48TM016-028 *121*
- Fan performance tables
  - 48HJ004-014 *148-161*
  - 48HJ015,017 *185-188*
  - 48HJ015,017 with horizontal adapter *189*
  - 48TM004-014 *65-86*
  - 48TM016-028 *114-119*
  - 48TM016-028 with horizontal adapter *120*
- Fan RPM at motor pulley settings
  - 48HJ004-014 *163*
  - 48HJ015,017 *191*
  - 48TM004-014 *87*
  - 48TM016-028 *121*
- Features/Benefits *1-5*
- Field-supplied fan drives *34*
- Guide specifications
  - 48HJ004-014 *168-173*
  - 48HJ015,017 *193-197*
  - 48TM004-014 *96-101*
  - 48TM015-028 *123-127*
- Hail guard *13*
- High altitudes *33*
- Hinged panels *13, 14*
- Humidistat *10, 39*
- Indoor Air Quality (IAQ) *4, 25*
- Low ambient controls *7, 8*
- LP conversion *14*
- Maximum operating temperature *33*
- Minimum ambient operating temperature *33, 103, 175*
- Minimum temperature *33, 103, 175*
- Model number nomenclature
  - 48HJ004-014 *128*
  - 48HJ015,017 *174*
  - 48TM004-014 *50*
  - 48TM016-028 *102*
- MoistureMi\$er dehumidification package *4, 5, 9, 35-39*
- Motormaster® options *7, 8*
- Options and accessories *6-14*
- Performance data
  - 48HJ004-014 *142-165*
  - 48HJ015,017 *183-191*
  - 48TM004-014 *63-91*
  - 48TM016-028 *113-121*
- Physical data
  - 48HJ004-014 *131-134*
  - 48HJ015,017 *176, 177*
  - 48TM004-014 *52-55*
  - 48TM016-028 *104, 105*
- Piping and wiring
  - 48HJ004-014 *43*
  - 48HJ015,017 *44*
  - 48TM004-014 *43*
  - 48TM016-028 *44*

Power exhaust	
48HJ015,017	180, 189
48TM016-028	120
with EconoMiSer	
48HJ004-014	164
48TM004-014	89
PremierLink™ controls	4, 10, 15-19, 33
Roof curb dimensions	
48HJ004-007	137
48HJ008-014	138
48HJ015,017	179
48TM004-007	59
48TM008-014	60
48TM016-025	109
48TM028	110
Selection procedure	
48HJ004-014	139-141
48HJ015,017	182
48TM004-014	61, 62
48TM016-028	112
Service options	4
Smoke control	27, 28
Sound data	
48HJ004-014	162
48HJ015,017	190
48TM004-014	91
48TM016-028	121
Static pressure drop	
Economizer	
48HJ004-014	162
48HJ015,017	190
48TM004-014	90
48TM016-028	121
MoistureMiSer	
48HJ004-014	162
48HJ015,017	190
TEMP systems	20
Thermidistat	10
Thermostat	
Options	10
Wiring	20, 26
Application data	33
Thru-the-bottom connections	3, 33
Unit-mounted disconnect	4, 12, 49, 112, 181
VVT® application guidelines	22-24
VVT systems	21
Wiring	
48HJ004-014	45, 46
48HJ015,017	47-49
48TM004-014	45, 46
48TM016-028	47-49
62AQ	40, 41



**Manufacturer reserves the right to discontinue, or change at any time, specifications or designs without notice and without incurring obligations.**